

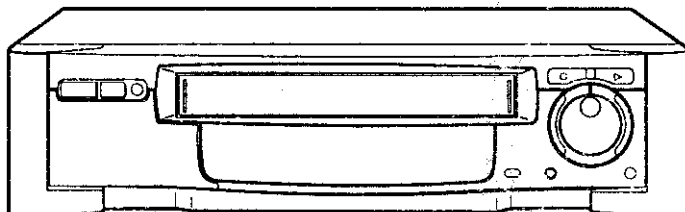

**MITSUBISHI**

# Service Manual

VIDEO CASSETTE RECORDER

**VHS**  
PAL

**MODEL**  
**HS-561V(B)**  
**HS-561V(E)**  
**HS-561V(EE)**  
**HS-561V(G)**  
**HS-561V(Y)**

Only cassettes marked VHS can be used with this video cassette recorder.

## SPECIFICATION

<b>Tape Format</b>	: VHS 1/2" high-density video cassette tape	<b>Video Input</b>	: 0.5 to 2.0Vp-p, 75Ω unbalanced EURO AV socket / RCA pin plug
<b>Power Source</b>	: AC 230V ; 50Hz [B, E, G, Y] AC 220V ; 50Hz [EE]	<b>Audio Input:Line</b>	: -8dBc, 50kΩ unbalanced EURO AV socket / RCA pin plug
<b>Power Consumption</b>	: Approx. 32W	<b>Video Output</b>	: 1.0Vp-p, 75Ω unbalanced EURO AV socket
<b>Television System</b>	: 625lines, 50fields System CCIR B&G PAL [E, G, Y] System CCIR I PAL [B] System CCIR B&G, D&K PAL [EE]	<b>Audio Output</b>	: -6dBs, 1kΩ unbalanced EURO AV socket and RCA pin plug
<b>Video Recording System</b>	: Azimuth helical scanning system	<b>TV Tuner</b>	<b>VHF</b> : 47~470MHz [E, G, Y] <b>UHF</b> : 47~300MHz [EE]
<b>Luminance</b>	: Frequency modulation recording	<b>Operating Temperature</b>	: 5°C to 40°C
<b>Colour Signal</b>	: Low frequency conversion subcarrier phase shift recording	<b>RF Channel Output</b>	: Set to Channel 36 [B, E, G, Y] Set to Channel 38 [EE] (Channel 32~40 selectable) [All] (Channel 24~27 selectable) [EE]
<b>Hi-Fi Audio Recording System</b>	: Azimuth helical scanning system, Frequency modulation, deep layer recording	<b>Weight</b>	: Approx. 5.4kg
<b>Linear Audio Track</b>	: 1 track	<b>Dimensions</b>	: 380(W)×94(H)×334(D)mm
<b>Tape Speed</b>	: 23.39mm/sec (PAL SP mode) 11.70mm/sec (PAL LP mode)	<b>Timer</b>	: 8 programmes for any channels in one month/every day/every week day 24 hour digital synchronized with oscillator frequency.
<b>Record/Playback Time</b>	: 240min. with E-240 cassette (PAL SP mode) 480min. with E-240 cassette (PAL LP mode)	<b>Channel Selection Deck</b>	: 60 position Up/Down + EXT : J Deck
<b>Heads:Video</b>	: 4 rotary heads		
<b>Hi-Fi Audio</b>	: 2 rotary heads		
<b>Audio/Control</b>	: 1 stationary head		
<b>Erase</b>	: 1 full track head		

●Weight and dimensions shown are approximate.

●Design and specifications are subject to change without notice.

**MITSUBISHI ELECTRIC**

## CONTENTS

<b>DISASSEMBLY</b> .....	1	2-18 ID Swing Lever, Revolution Lever, and Revolution Spring .....	34
<b>HOW TO EXECUTE CIRCUIT BOARD SERVICE</b> .....	3	2-19 Tension Arm, Tension Brake Belt, and Tension Spring .....	35
<b>MECHANICAL ADJUSTMENT TOOLS</b> .....	7	2-20 Takeup Reel Disk and Gear R (takeup side) .....	37
<b>ELECTRICAL ADJUSTMENT TOOLS</b> .....	8	2-21 Supply Reel Disk .....	38
<b>HOW TO INITIALIZE E<sup>2</sup>PROM</b> .....	9	2-22 Gear R (supply side) .....	39
<b>VCR OPERATION IN SERVICE</b>		2-23 Main Brake Release Lever .....	40
<b>POSITIONS [B] AND [C]</b> .....	9	2-24 Pinch Cam Cap, Pinch Roller Arm Assembly, Pinch Cam, Takeup Guide Gear, Gear Pinch, Takeup Guide Arm, and Takeup Guide Spring .....	41
<b>SERVICE POSITION</b> .....	10	2-25 Pinch Roller, Roller Cap, Pinch Spring, and Pinch Cam Spring .....	43
<b>ELECTRICAL ADJUSTMENTS</b> .....	11	2-26 Mode Switch .....	44
Servo Circuit Adjustment .....	14	2-27 FE Head .....	45
Audio Circuit Adjustment .....	14	2-28 Reel Belt and Belt Pulley .....	45
Hi-Fi Audio Circuit Adjustments .....	15	2-29 Loading Motor Assembly, Pulley Worm J, Loading Motor Belt, and Gear A .....	46
Dual Audio Circuit Adjustment .....	16	2-30 Main Gear J .....	47
Timer Circuit Adjustment .....	16	2-31 Gear Joint J .....	48
<b>MECHANICAL ADJUSTMENT</b>		2-32 Capstan Brake and Capstan Brake Spring .....	49
<b>AND REPLACEMENT</b> .....	17	2-33 Plate J, Roller B, and Cam Plate B .....	50
1. Cleaning of Deck .....	17	2-34 Cam Gear R, Change Lever, and Tension Off Lever .....	51
1-1 Video Head .....	17	2-35 Reel Idler Assembly .....	52
1-2 Tape Transport .....	17	2-36 Cam Plate C and Cam Spring C .....	53
1-3 Reel Disk Drive System .....	17	2-37 Loading Arm (SP, TU) .....	54
2. Replacement of Major Parts .....	18	2-38 Capstan Motor and Lead Card .....	55
2-1 Cassette Housing .....	18	2-39 A/C Head Assembly .....	56
2-2 Sense Gear, Driver Gear, Takeup Arm, and Arm Spring (TU) .....	19	2-40 A/C Head .....	57
2-3 Door Arm .....	22	2-41 Supply & Takeup Guide Rollers .....	58
2-4 Gear S and Gear T .....	22	2-42 Cleaning Roller, Cleaning Arm, Cleaning Lever, and Cleaning Spring .....	59
2-5 Wheel Gear .....	23	2-43 Supply & Takeup Tape Guide Assemblies .....	60
2-6 Supply Arm and Arm Spring (SP) .....	23	2-44 Drum base spring .....	61
2-7 Jut .....	26	2-45 Replacement of ASSY IMPEDANCE ROLLER .....	62
2-8 PCB-HA/AUDIO .....	26		
2-9 Brush .....	27		
2-10 Drum Assembly .....	27		
2-11 Upper Drum and Drum Motor .....	29		
2-12 Safety Spring and Safety Lever .....	30		
2-13 Safety Arm .....	31		
2-14 Sub Brake (SP) and Sub Spring (SP) .....	31		
2-15 Main Brake (SP) and Main Brake Spring J (SP) .....	32		
2-16 Sub Off Lever, Sub Brake (TU), and Sub Spring (TU) .....	33		
2-17 Main Brake (TU) and Main Brake Spring J (TU) .....	34		

# CONTENTS

3. Interchangeability Adjustment of the Mechanism .....	64
3-1 Adjustment of Back-Tension and Tension Pole Position .....	64
3-2 Check and Adjustment of FM Envelope .....	65
3-2-1 Guide Roller Adjustment .....	65
3-2-2 Adjustment of Supply Guide Roller Height .....	65
3-2-3 Adjustment of Takeup Guide Roller Height .....	65
3-2-4 Coarse Adjustment of Phase .....	66
3-2-5 Check of FM Waveform Flatness .....	66
3-2-6 Check 1: Tape Running Condition at the Guide Rollers .....	67
3-2-7 Replacement of Tape Guides .....	67
3-2-8 Check 2: Tape Running Condition on Guide Rollers .....	67
3-3 Adjustment of A/C Head .....	68
3-3-1 Adjustment of A/C Head Slant .....	68
3-3-2 Adjustment of A/C Head Azimuth and Height .....	68
3-4 Adjustment of Phase .....	69
3-5 Adjustment of Takeup Guide Arm Height .....	70
4. Servicing for Tape Jamming during the Loading Mode .....	71
(1) If the tape guides do not move (the pulley worm J does not turn); .....	71
(2) If the tape guides move (the pulley worm J turns); .....	74

<b>SPECIFICATION OF VPS RECORDING SYSTEM .....</b>	<b>75</b>
<b>GLOSSARY OF ABBREVIATIONS .....</b>	<b>76</b>
<b>CHIP PARTS REPLACEMENT .....</b>	<b>77</b>
<b>Parts List .....</b>	<b>78</b>
1. CABINET ASSEMBLY .....	78
2. PACKING PARTS .....	80
3. ELECTRICAL PARTS .....	82
4. DECK ASSEMBLY .....	

## DISASSEMBLY

**Note:** Any screw can be used between silver screw securing the boss of the molded parts and 669D220030 (preferred part) for replacement because they are compatible with each other.

### 1. Removal of Top Cover

- ① Remove the two Top Cover fastening screws (a) and (b) shown in Fig. 1 and remove the Top Cover in the direction shown by the arrows.

### 2. Removal of Front Panel

- ① Remove the Top Cover.  
(Refer to Para. 1 of the DISASSEMBLY.)
- ② Remove the Jog Dial and the Shuttle Ring.
- ③ Unfasten seven catches (c~i), two on the top, two on the side, and three on the bottom, and remove the Front Panel in the direction shown by the arrows.

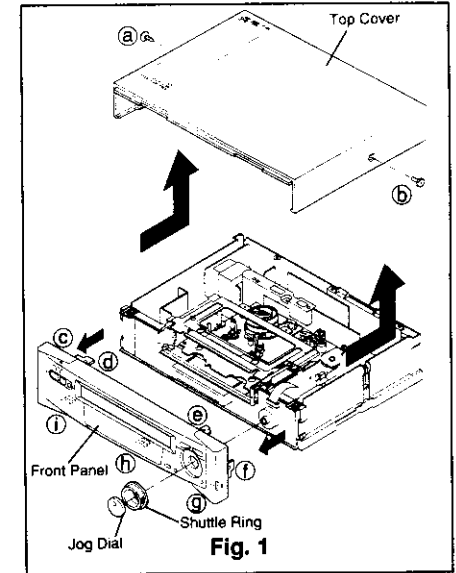

#### 4. Removal of Bottom Panel

- ① Remove five fastening screws (a~e) shown in Fig. 3.
- ② Push the two inside hooks (f and g), holding the Bottom Panel and slide the Bottom Panel toward the rear to remove it.

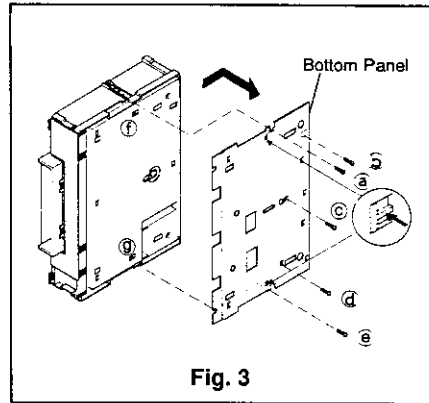

Fig. 3

#### 5. Removal of Assy Deck

- ① Remove the Top Cover.  
(Refer to Para. 1 of the DISASSEMBLY.)
- ② Remove the barrier.  
(Refer to Para. 3 of the DISASSEMBLY.)
- ③ Remove the three fastening screws (a, b and c) on the bottom of the set shown in Fig. 4.
- ④ Remove the five screws (d~h) holding the Assy Deck, shown in Fig. 5, and disconnect the connectors MR, ML, MM and ME.
- ⑤ Slowly raise the Assy Deck upward to remove it.

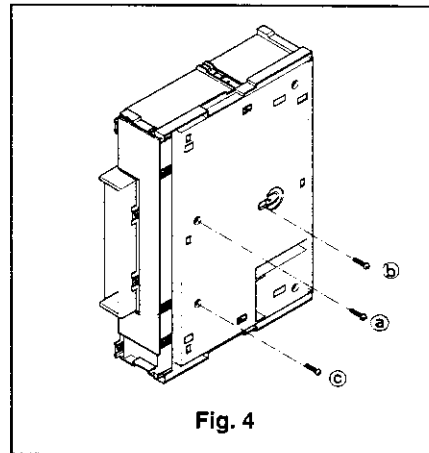

Fig. 4

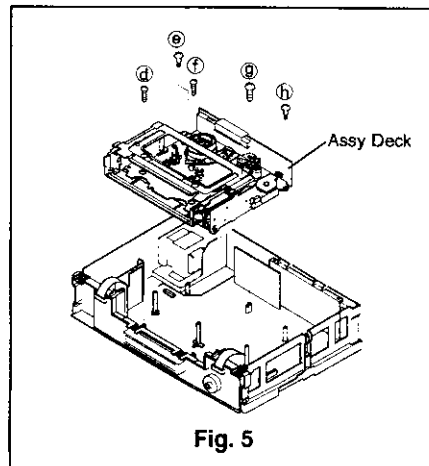

Fig. 5

## HOW TO EXECUTE CIRCUIT BOARD SERVICE

### CAUTION:

**BEFORE ATTEMPTING TO REMOVE OR REPAIR ANY PCB, UNPLUG THE POWER CORD FROM THE A.C. SOURCE.**

### LOCATION OF PRINT CIRCUIT BOARDS

#### Note:

- Take caution when removing flat cables to prevent any contact problem.
- Connect and disconnect the flat cables at right angles to the connector and make sure that it is completely secured.
- After servicing the PCB, restore the flat cable and leads to their former state.

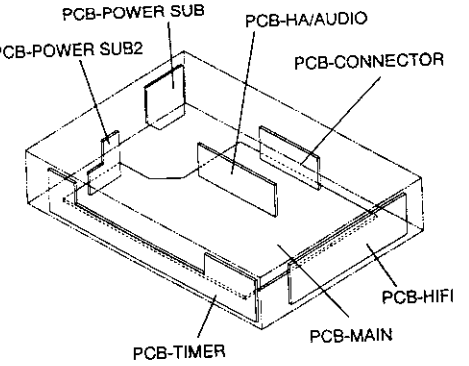

Fig. 6

### 1. PCB-MAIN

- ① Remove the Top Cover.  
(Refer to Para. 1 of the DISASSEMBLY.)
- ② Remove the barrier.  
(Refer to Para. 3 of the DISASSEMBLY.)  
Servicing on the components side is partially possible.
- ③ Remove the Front Panel.  
(Refer to Para. 2 of the DISASSEMBLY.)  
Remove eight fastening screws referred to as ③ and ④ in Para. 5 of the DISASSEMBLY. (Do not disconnect the connector ML, MM and ME.)
- ④ Raise the front side of the Assy Deck upward as shown in Fig. 7 and support it with a screw driver, etc. Servicing on the components side of the PCB is now possible.
- ⑤ If necessary to remove PCB-MAIN completely, remove the Assy Deck. (Refer to Para. 5 of the DISASSEMBLY.) Remove all connectors on the PCB-MAIN. Remove one fastening screw (a) on the bottom and two fastening screws (b and c) on the Antenna Cover shown in Fig. 8. Raise the PCB-MAIN upward to remove it.

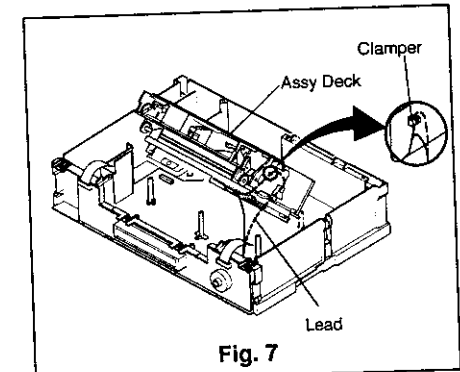

Fig. 7

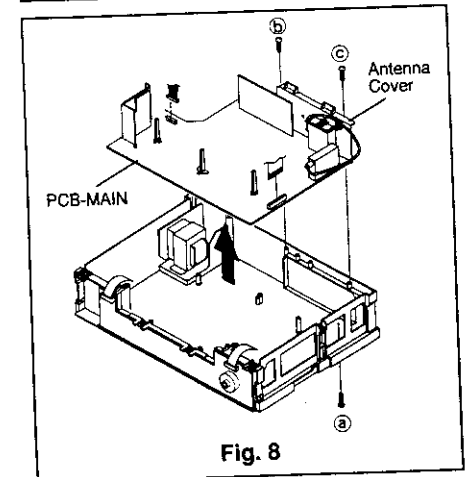

Fig. 8

**\* Service of Transistors  
(Q902, Q903, Q904 and Q911)**

- ① Disconnect the power plug.
- ② Remove the four screws (a, b, c and d: 669D222090) shown in Fig. 9.

NOTE: Check that each transistor (Q902, Q903, Q904 and Q911) is connected to the Heat Sink before turning the power on. If the power is turned on without installing the Heat Sink, Q902, Q903, Q904 and Q911 can be damaged.

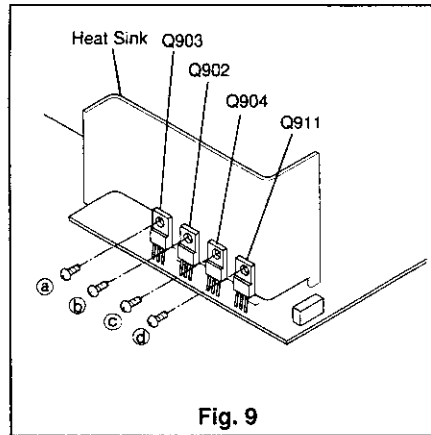

Fig. 9

**2. PCB-CONNECTOR**

- ① Remove the Top Cover.  
(Refer to Para. 1 of the DISASSEMBLY.)
- ② Remove the Barrier.  
(Refer to Para. 3 of the DISASSEMBLY.)
- ③ If it is necessary to remove the PCB-CONNECTOR comply with the following steps.
  - (1) Remove the PCB-MAIN.  
(Refer to the preceding paragraph.)
  - (2) Remove four screws (a, b, c and d), unfasten five catches (e~i) on the Antenna Cover as shown in Fig.10, and remove the Antenna Cover.
  - (3) Raise the PCB-CONNECTOR upward to remove it.

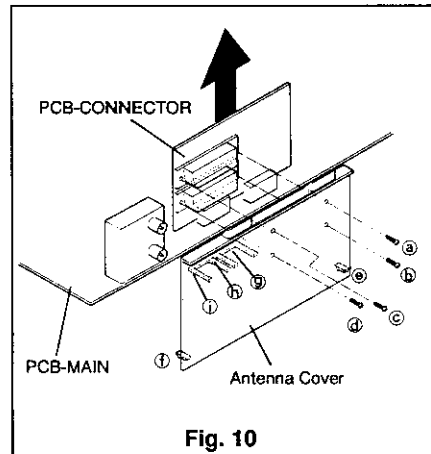

Fig. 10

**3. PCB-HIFI**

- ① Remove the Top Cover.  
(Refer to Para. 1 of the DISASSEMBLY.)  
Servicing on the component side is possible.
- ② If it is necessary to remove the PCB-HIFI, comply with the following steps.
  - (1) Remove a screw (a) and unfasten two snaps (b and c) as shown in Fig.11.
  - (2) Disconnect the connectors ( HB , HC ) and raise the PCB-HIFI upward to remove it.

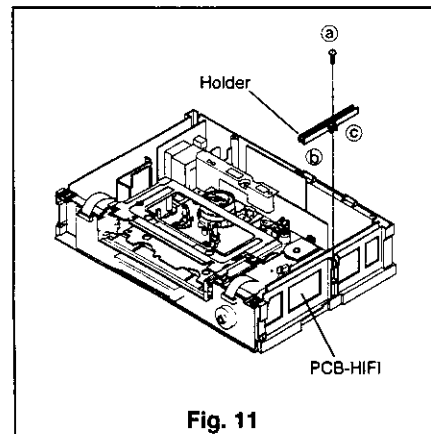

Fig. 11

**4. PCB-TIMER, Jog**

- ① Remove the Top Cover.  
(Refer to Para. 1 of the DISASSEMBLY.)
- ② Remove the Front Panel.  
(Refer to Para. 2 of the DISASSEMBLY.)
- ③ Remove five catches (a~e) shown in Fig. 12 to remove the PCB-TIMER.
- ④ Remove three catches (a, b and c) shown in Fig. 13 to remove the Jog.
- ⑤ Remove three catches (d, e and f), and remove the Holder Jog shown in Fig. 13.

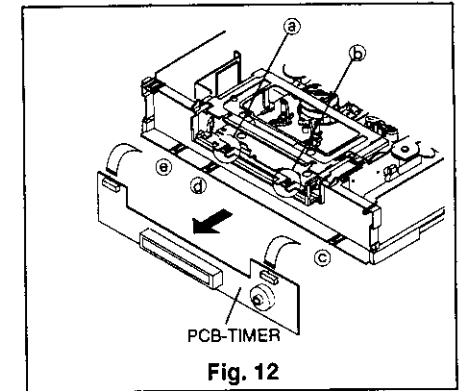

Fig. 12

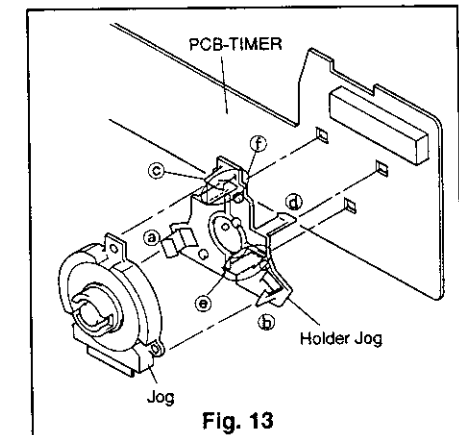

Fig. 13

**5. PCB-HA/AUDIO**

- ① Remove the Top Cover.  
(Refer to Para. 1 of the DISASSEMBLY.)
- ② Remove the barrier.  
(Refer to Para. 3 of the DISASSEMBLY.)  
Servicing on the copper side is possible.
- ③ If necessary, remove the Assy Deck.  
(Refer to Para. 5 of the DISASSEMBLY.)  
Raise the Shield Cover upward to remove it. Disconnect three terminals (a, b and c), remove three fastening screws (d, e and f) shown in Fig. 14. Disconnect the connectors of Head FE, A/C Head, and Motor CP then remove the PCB-HA/AUDIO.

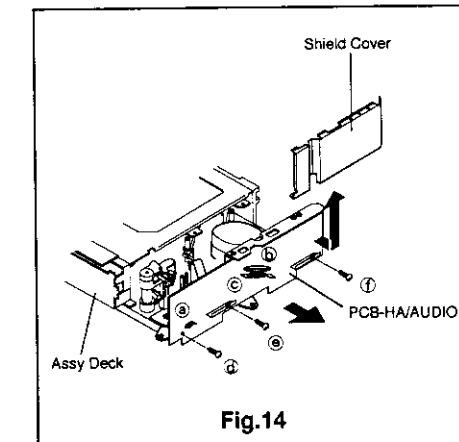
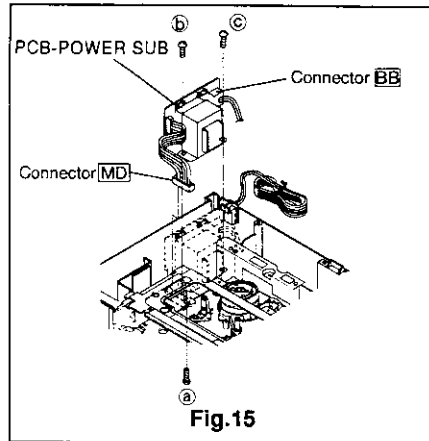

Fig.14

## 6. PCB-POWER SUB

- ① Remove the Top Cover.  
(Refer to Para. 1 of the DISASSEMBLY.)
- ② Remove the barrier.  
(Refer to Para. 3 of the DISASSEMBLY.)
- ③ Remove the holder of AC power cord from the Base Chassis shown in Fig. 15.
- ④ Disconnect connectors **BB** ( for the Power receptacle) and **MD** on the PCB-POWER SUB.
- ⑤ Remove one fastening screw (a) on the bottom, shown in Fig. 15, and two screws (b) and (c) : 669D221O40). Hold the transformer, and raise the PCB-POWER SUB to remove it.



## 7. PCB-POWER SUB2

- ① Remove the Top Cover.  
(Refer to Para. 1 of the DISASSEMBLY.)
- ② Remove the barrier.  
(Refer to Para. 3 of the DISASSEMBLY.)  
(Servicing for the solder side of PCB-CONNECTOR is available.)
- ③ Raise the PCB-POWER SUB2 shown in Fig. 16 upward to remove it.

### \* Service of Transistor (Q9A1)

- (1) Disconnect the power plug.
- (2) Remove the screw (a) shown in Fig. 16 to remove the Heat Sink 1 in the direction shown by an arrow.

NOTE: Install Q9A1 on the Heat Sink 1 and connect the PCB-POWER SUB2 to the PCB-MAIN. If the power is turned on without installing PCB-POWER SUB2 and Heat sink 1, Q9A1, Q902, Q903, Q904 and Q911 can be damaged.

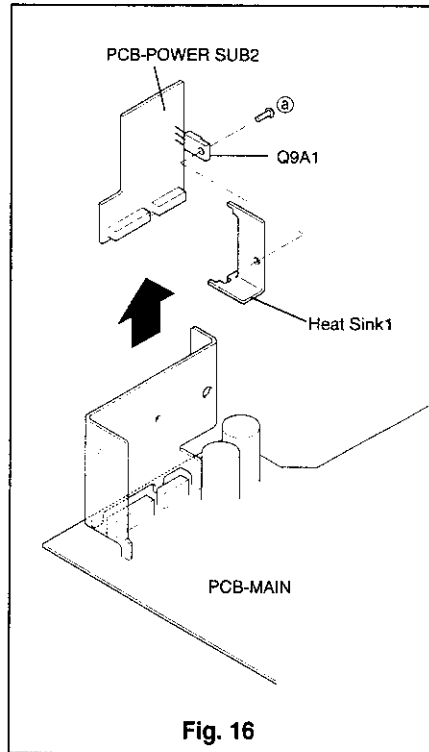

## MECHANICAL ADJUSTMENT TOOLS

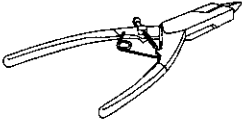
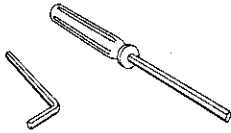
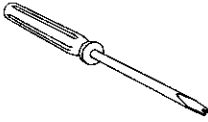
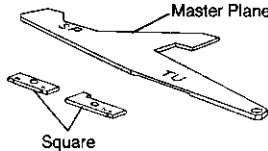
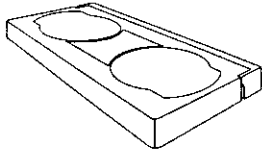
	PURPOSE	METHOD
<b>Grip ring fixer</b> (859C347O50) 	A tool for preventing the grip ring from opening excessively.	Opening the grip ring with the tips of this tool, install the grip ring on to the shaft.
<b>Hex Keys(1.5mm)</b>  (859C259O20) (859C259O50)	The hex keys are used for tightening or removing hexagonal socket head screws which fasten the guide rollers.	Insert the given size(1.5mm) hexagonal socket and turn.
<b>Adjustment Driver</b> (859C259O80) 	For adjustment of guide rollers.	Carefully insert and adjust guide rollers.
<b>Height adjusting Jig</b> • Master Plane (859C342O20) • Square (859C341O70) 	The master plane and the square are used for measuring height and perpendicularity of the reel disk and Takeup guide arm.	The gauge is applied to the part being measured.
<b>Back Tension Gauge</b> (859C345O80) 	The back tension gauge is used for measuring the tension of the tape on the supply side.	Load this gauge in the cassette housing and run in the play mode. Read the gauge indicator.
<b>Cotton gloves</b>	For changing, cleaning and handling of drum, heads and guides.	Use when handling all parts in the tape path.
<b>Grease</b> PG641 (859D055O30) G (859D055O50) MULTEMP SH-M (859D055O60)	Lubrication of various parts.	To be applied as specified.

## ELECTRICAL ADJUSTMENT TOOLS

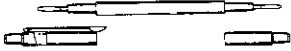
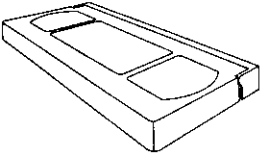
	PURPOSE	METHOD
<b>Adjustment Driver (859C338000)</b>  767-M  	The adjustment driver is intended to adjust variable resistors, trimmers, transformers etc.in the circuitry.	Select a tip suitable for the particular head of the component concerned and adjust.
<b>Alignment Tape</b> (PS-2 :859C339010) (PM6KH3 :859C339030) (PM3KE6(CH1) 25 :859C568050) (PMX :859C568070)  	Standard signals(VHS Standard) are recorded on the alignment tape and reproduced when required in the adjustment of servo circuit and interchangeability alignment.	Install and run in the play mode, the same as for an ordinary tape.

## HOW TO INITIALIZE THE E<sup>2</sup>PROM

The E<sup>2</sup>PROM is not initialized before shipping, so the E<sup>2</sup>PROM must be initialized when replaced.

**Initialize the E<sup>2</sup>PROM by following the steps below.**

1. Set the VCR to "CLOCK SET" mode.
2. Push **COUNTER RESET** button on the remote hand unit for 8 seconds.

## VCR OPERATION IN SERVICE POSITIONS [B] AND [C]

Refer to page 10 for Service Position Information.

### ■ To activate PB, REC, FF or REW Mode (Service position [B] only)

- Cover the END SENSOR first then START SENSOR with an infra-red opaque material e.g. black vinyl tape etc..
- The reel sensor must provide input "rotating" signals to the microprocessor. To provide a dummy reel rotating signal, connect TP2H to TP5J8 on PCB-MAIN.

### CAUTION:

Because the Start and End sensors are disabled there will be a risk of END of TAPE damage in REW and FF Modes.

### ■ Ejecting a tape

When TAPE EJECT is necessary, disconnect the main supply and reinstall the DECK ASSY to the Service Position [A], restore power then EJECT the tape.

### ■ Record Protection Method

- To protect TEST TAPE(s) from accidental Recording (erasure) during testing, connect TP5B (STBY 5V) to TP5K4 on PCB-MAIN .

### PCB-MAIN(Component side)

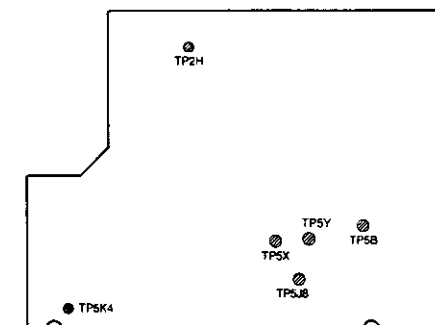

When replacing parts or performing service adjustments, place the unit in the service positions shown below. Refer to page 9 for additional information about Service Positions.

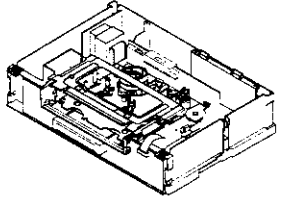
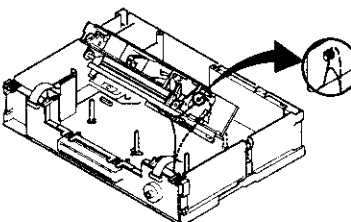
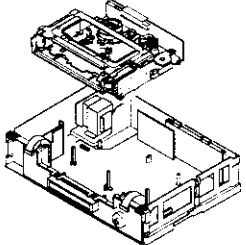
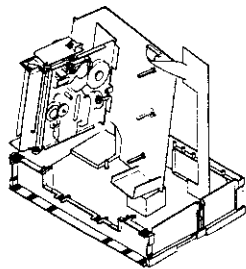
Service Position	Service Item
<p>(A)</p> 	<ul style="list-style-type: none"> <li>Remove the top cover and the front panel.</li> </ul> <p>(1) Worn parts on the deck (upper drum, pinch roller assembly, A/C head, and FE head) can be replaced.</p> <p>(2) Checks at test points may be made to isolate a problem to a specific circuit.</p>
<p>(B)</p> 	<ul style="list-style-type: none"> <li>Unfasten the clasper securing ML lead wire on the deck.</li> <li>Remove the screws holding the deck, raise the front of the deck upward, and hold it in place with a screw driver, etc.</li> </ul> <p>(1) Worn parts on the deck (reel belt, idler assembly, and capstan motor) can be replaced.</p> <p>(2) The performance of the deck can be checked.</p> <ul style="list-style-type: none"> <li>The REC safety switch does not operate in position (B).</li> <li>Set the deck to service position (A) and load the cassette tape. Then turn the power off and set the deck to service position (B). Cover the start and end sensors, and short-circuit test points TP2H to TP5J8. Turn the power on and play the tape. (Do not use the start or end portion of the tape.)</li> <li>If it is necessary to eject the tape, turn the power off and set the deck to the service position (A). Turn the power on again and eject the tape.</li> </ul>
<p>(C)</p> 	<ul style="list-style-type: none"> <li>Remove the screws holding the deck and disconnect the deck from the connector.</li> </ul> <p>(1) Parts on the deck (drum assembly, PCB-HA/AUDIO etc.) can be replaced.</p> <p>(2) The EE picture can be displayed with the deck removed by short-circuiting TP5X to TP5Y. (Short-circuit before turning the power on.) (Playback and recording operation can not be checked.)</p>
<p>(D)</p> 	<ul style="list-style-type: none"> <li>Remove the PCB-TIMER.</li> <li>Remove the deck with the PCB-MAIN attached.</li> <li>Position insulating cushions as, shown in Figure D, supporting the supply side of the Cassette Housing, the Deck Base and the PCB-MAIN.</li> </ul> <p><b>Note</b> Take care that the Deck, PCB-MAIN and inter connecting leads DO NOT touch the Power Transformer or the heat sink.</p> <p>(1) The foil side of the PCB-MAIN can be serviced in this position.</p> <p>* If the bottom cover is removed, IC5A0 and IC4A0 are accessible for service.</p>

## Electrical Adjustments

Perform only the alignments required. If proper equipment is not available, do not attempt an alignment.

### PRE-ADJUSTMENT SETTING

- Set the "COLOUR SYSTEM" to "PAL" mode in the MENU. (Only HS-561V(Y), (E), (G), (EE))
- Set the "STEREO/A2" to "OFF" mode in the MENU. (Only HS-561V(Y), (EE))
- Set the "NICAM" to "OFF" mode in the MENU. (Only HS-561V(B))
- Set the "NICAM/A2" to "OFF" mode in the MENU. (Only HS-561V(E))
- Set the "STEREO/2-TON" to "OFF" mode in the MENU. (Only HS-561V(G))
- Set the "TAPE OPTIMIZER" to "OFF" mode in the INITIAL SET-UP of MENU. (Only HS-561V(Y),(E), (B), (EE))
- Set the "BAND-OPTIMIERUNG" to "OFF" mode in the INITIAL SET-UP of MENU. (Only HS-561V(G))
- Set the "RENTAL PB" to "OFF" position.
- Set the "AUDIO MIX" to "OFF" mode in the MENU.

### MEASURING EQUIPMENT AND JIGS

- Oscilloscope (10:1 unless 1:1 specified.)
- Signal generator
- Frequency counter
- Audio tester
- Electrical tools

### TEST SIGNAL

#### Colour bar signal

In this manual, unless otherwise specified in particular, use colour bar signal in specifications below.

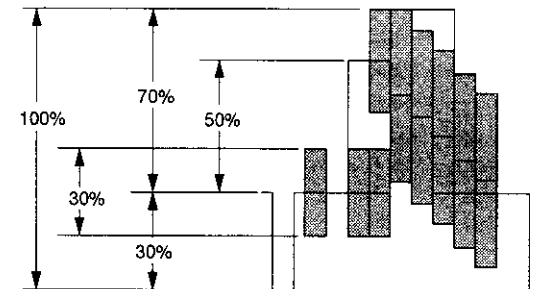

Split-Field colour bar(with 100% window)



# LOCATIONS

PCB-MAIN(Component side)

REAR

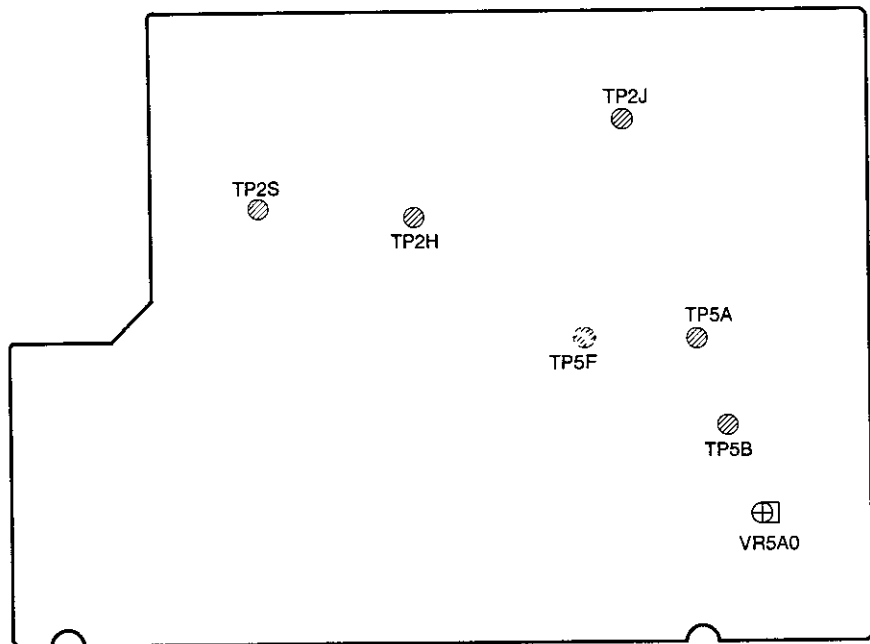

TOP

PCB-HIFI (Solder side)

TOP

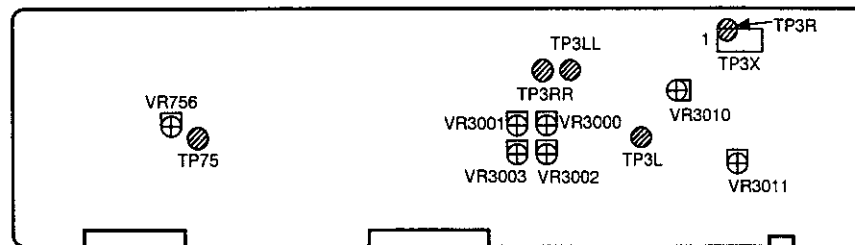

PCB-HA/AUDIO(Component side)

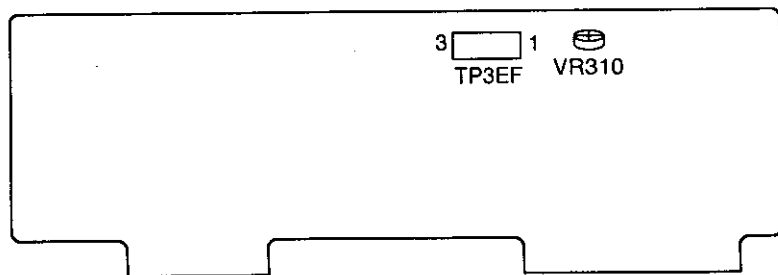

<b>[ Servo circuit ]</b>		<b>Adjustment purpose</b> Video switch over timing during playback.	
1. Playback Switching Point		<b>Symptom when incorrectly adjusted</b> Switching noise or jitter in the playback picture.	
<b>Measuring instrument and condition</b>		<b>VCR set up condition</b>	
Oscilloscope		Input signal	---
Test point	TP2J	Using tape	Alignment tape (PS2, stair step)
EXT trigger	TP2H	VCR condition	Playback
Measurement range	DIV 20mV TIM 50µs	Using Jig	---
<ol style="list-style-type: none"> <li>Playback an alignment tape (PS2, stair step).</li> <li>Short-circuit TP5A to TP5B. Confirm that the "DTR" displayed in Fluorescent Display flashes fast.</li> <li>Set the oscilloscope's slope to (-).</li> <li>Observe the waveform at TP2J.</li> <li>Adjust VR5A0 so that the trigger point is located at <math>6.5 \pm 1.0H</math> before the vertical synchronizing signal.</li> </ol>			
<b>PCB-MAIN (Component side)</b>			

<b>[ Audio circuit ]</b>		<b>Adjustment purpose</b> Audio bias level during recording.	
2. Audio Bias Level		<b>Symptom when incorrectly adjusted</b> Poor audio high frequency response or distortion.	
<b>Measuring instrument and condition</b>		<b>VCR set up condition</b>	
Audio tester		Input signal	---
Test point	TP3EF (pin ①, pin ③)	Using tape	A blank tape
EXT trigger	---	VCR condition	SP REC
Measurement range	---	Using Jig	High pass filter
<ol style="list-style-type: none"> <li>Supply no signal.</li> <li>Short-circuit EURO AV socket pin ② (AUDIO IN) and pin ④ (GND) using an electrolytic capacitor (16V or more 10µF).</li> <li>Set the VCR to SP REC mode.</li> <li>Observe the audio level at TP3EF pin ① and pin ③ with an Audio Tester using a high pass filter.</li> <li>Confirm that the monitor TV etc. does not affect the indication of the audio tester and then adjust VR310 so that the level is 2.6mVr.m.s.</li> </ol> <p><b>Note 1:</b> Be careful that the audio tester housing does not touch the VCR chassis.</p> <p><b>Note 2:</b> Never set the VCR to Play mode with the audio tester connected. (The audio amplifier will be over loaded.)</p>			
<b>PCB-HA/AUDIO (Component side)</b>			

<b>[ Hi-Fi Audio circuit ]</b>		<b>Adjustment purpose</b> Set up of FM carrier frequency for Hi-Fi audio.	
3. VCO		<b>Symptom when incorrectly adjusted</b> Buzz only.	
<b>Measuring instrument and condition</b>		<b>VCR set up condition</b>	
Frequency counter		Input signal	---
Test point	TP3L TP3X pin ① (TP3R)	Using tape	---
EXT trigger	---	VCR condition	STOP
Measurement range	---	Using Jig	---
<ol style="list-style-type: none"> <li>Set the CHANNEL position to "L1".</li> <li>Set the MONITOR button on the remote hand unit to "STEREO" mode.</li> <li>Short-circuit EURO AV socket pin ② (AUDIO IN) and pin ④ (GND) using an electrolytic capacitor (16V or more 10µF).</li> <li>Short-circuit TP3LL to TP 3X pin ③ (GND).</li> <li>Observe the frequency at TP3L.</li> <li>Adjust VR3002 so that the frequency is <math>1.300MHz \pm 3kHz</math>.</li> <li>Open-circuit TP3LL and TP 3X pin ③ (GND).</li> <li>Short-circuit TP3RR to TP 3X pin ③ (GND).</li> <li>Observe the frequency at TP3X pin ① (TP3R).</li> <li>Adjust VR3003 so that the frequency is <math>1.700MHz \pm 3kHz</math>.</li> <li>Open-circuit TP3RR to TP 3X pin ③ (GND).</li> <li>Observe the frequency at TP3L.</li> <li>Adjust VR3000 so that the frequency is <math>1.400MHz \pm 3kHz</math>.</li> <li>Observe the frequency at TP3X pin ① (TP3R).</li> <li>Adjust VR3001 so that the frequency is <math>1.800MHz \pm 3kHz</math>.</li> </ol>			
<b>PCB-HIFI (Solder side)</b>			

<b>[ Hi-Fi Audio circuit ]</b>		<b>Adjustment purpose</b> Output level of audio signal STOP mode.	
4. EE output Level (HS-561V(G) only)		<b>Symptom when incorrectly adjusted</b> Too small or too big sound.	
<b>Measuring instrument and condition</b>		<b>VCR set up condition</b>	
Audio tester		Input signal	1kHz, -8dBs
Test point	AUDIOOUT terminal (L-CH, R-CH)	Using tape	---
EXT trigger	---	VCR condition	STOP
Measurement range	---	Using Jig	---
<ol style="list-style-type: none"> <li>Set the CHANNEL position to "L1".</li> <li>Set the MONITOR button on the remote hand unit to "STEREO" mode.</li> <li>Set the REC-LEVEL-VR to centre position.</li> <li>Supply the signal (1kHz, -8dBs) to the AUDIO IN terminal (L-CH, R-CH).</li> <li>Observe the audio level at AUDIO OUT terminal (L-CH).</li> <li>Adjust VR3010 so that the L-CH audio level is -6dBs.</li> <li>Observe the audio level at AUDIO OUT terminal (R-CH).</li> <li>Adjust VR3011 so that the R-CH audio level is -6dBs.</li> </ol>			
<b>PCB-HIFI (Solder side)</b>			

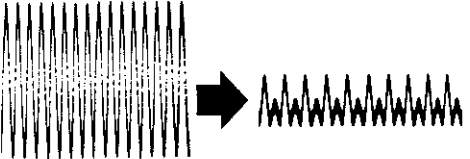
[ Dual Audio circuit ] 5. Channel Separation (HS-561 V(Y)/(E)/(G)/(EE) only)		<b>Adjustment purpose</b> Positioning of audio separation.									
		<b>Symptom when incorrectly adjusted</b> Mixing audio separation.									
<b>Measuring instrument and condition</b>		<b>VCR set up condition</b>									
Oscilloscope		Input signal	RF signal (Stereo sound)								
Test point	TP75	Using tape	---								
EXT trigger	---	VCR condition	STOP								
Measurement range	DIV 5mV TIM 2ms	Using Jig	---								
PCB-HIFI (Sloder side)		<ol style="list-style-type: none"> <li>Supply a Stereo mode RF signal.</li> </ol> <table border="1"> <tr> <td>PILOT</td> <td>50% AM MODULATION</td> </tr> <tr> <td>RIGHT CH</td> <td>1kHz, 100% FM MODULATION</td> </tr> <tr> <td>LEFT CH</td> <td>NO MODULATION</td> </tr> <tr> <td>RF INPUT</td> <td>70dB <math>\mu</math> (75 <math>\Omega</math> LOAD)</td> </tr> </table> <ol style="list-style-type: none"> <li>Observe the waveform at TP75.</li> <li>Adjust VR756 so that the audio output signal at L-CH is minimum.</li> </ol> <p><b>Note:</b> This adjustment should be done precisely because it determines the separation.</p>		PILOT	50% AM MODULATION	RIGHT CH	1kHz, 100% FM MODULATION	LEFT CH	NO MODULATION	RF INPUT	70dB $\mu$ (75 $\Omega$ LOAD)
PILOT	50% AM MODULATION										
RIGHT CH	1kHz, 100% FM MODULATION										
LEFT CH	NO MODULATION										
RF INPUT	70dB $\mu$ (75 $\Omega$ LOAD)										
											

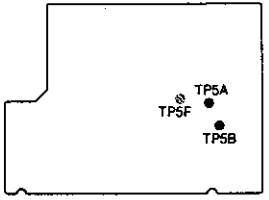
[ Timer circuit ] 6. Clock Frequency Correction		<b>Adjustment purpose</b> Accuracy of clock.	
		<b>Symptom when incorrectly adjusted</b> Poor clock accuracy.	
<b>Measuring instrument and condition</b>		<b>VCR set up condition</b>	
Frequency Counter		Input signal	---
Test point	TP5F	Using tape	---
EXT trigger	---	VCR condition	Power off
Measurement range	---	Using Jig	---
PCB-MAIN (Component side)		<ol style="list-style-type: none"> <li>Set the VCR to EJECT position (with the tape ejected from the VCR).</li> <li>Short-circuit TP5A to TP5B.</li> <li>Observe the frequency at TP5F.</li> <li>Be certain that the frequency is between 262.1000 ~ 262.1882kHz.</li> <li>Use the number buttons on the remote hand unit to enter the last three digits of the frequency counter reading (262.1@D@kHz). Enter the digits in @D@ sequence.</li> <li>Push the REC button on a remote hand unit.</li> <li>Open circuit TP5A to TP5B.</li> </ol>	
			

## MECHANICAL ADJUSTMENT AND REPLACEMENT

### 1. Cleaning of Deck

The following parts require cleaning whenever serviced to maintain satisfactory performance.

#### 1-1 Video Head

A. Clean the video heads by the following method. Dust and other foreign objects on the video heads disturbs the normal playback picture:

Dampen a video head cleaning cloth with alcohol. Hold the cloth against the drum and turn the drum slowly counterclockwise to clean.

#### NOTE:

Do not directly touch the head attached to the upper drum. The head is very hard but brittle to impact, especially in the vertical direction.

Do not apply force in the vertical direction.

B. Allow residual alcohol to dry thoroughly before running a tape. Otherwise, the liquid may stick to and damage the tape.

- Takeup guide pole
- Capstan shaft
- Takeup guide arm
- Supply guide roller
- Takeup guide roller
- Pinch roller

A. Clean the tape transport using gauze dampened with alcohol, except the supply guide roller, takeup guide roller and pinch roller. If Guide rollers and pinch roller are stained with dust, clean them with dry gauze or replace them with new parts.

B. Allow residual alcohol to dry thoroughly before running a tape. Otherwise the liquid may stick to and damage the tape.

#### 1-3 Reel Disk Drive System

Clean the reel disk braking surfaces and the reel belt.

A. Clean the reel disk braking surfaces with gauze dampened with alcohol.

• After the alcohol dries completely, perform "Adjustment of Back Tension and Tension Pole Position" (Item 3-1).

B. If the Reel belt is stained with dust, clean it with dry gauze or exchange it for a new part.

#### 1-2 Tape Transport (Refer to Fig. 1-1.)

Clean the following parts of the tape transport.

- Tension arm
- Supply guide pole
- FE head
- ASSY IMPEDANCE ROLLER
- Supply slant pole
- Upper and lower drum
- Takeup slant pole
- A/C head

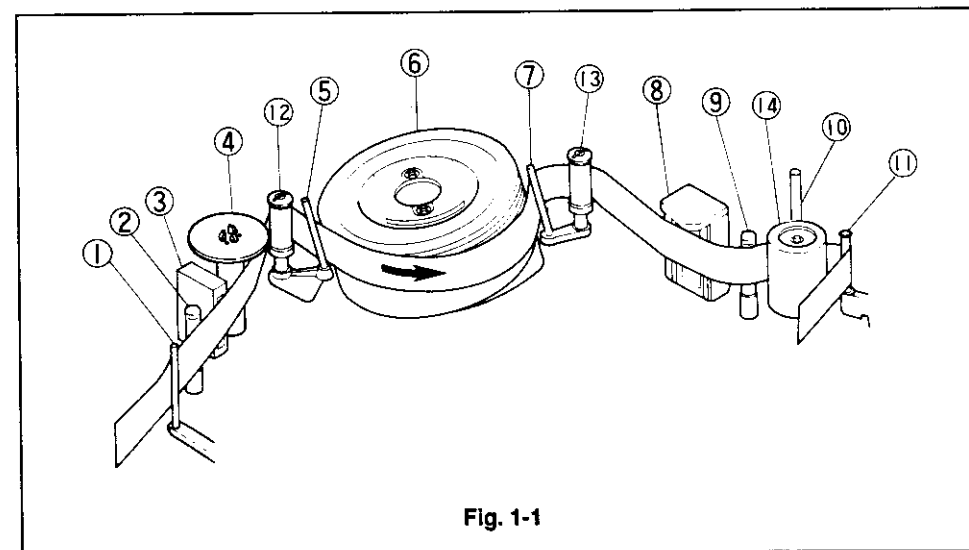

Fig. 1-1

## 2. Replacement of Major Parts

### 2-1 Cassette Housing

#### (Removal)

- ① Set the VCR to the eject mode.
- ② Remove the top cover and the front panel.
- ③ Unfasten the clamp holding the lead of the loading motor, which is attached to the side plate of the cassette housing. Unscrew the two cassette housing fastening screws (a and b). Slowly raise the cassette housing in the direction shown by the arrow. (Refer to Fig. 2-1-1.)

#### (Installation)

- ① Make sure that the holes (matching mark M) on the body and cogwheel of the mode switch align with each other as shown in Fig. 2-1-2. At the same time confirm that the hole of the gear pinch aligns with the matching marks of the gear joint J and the  $\nabla$  mark on the mode switch cogwheel, refer to Fig. 2-19-5. This indicates the J deck is in the EJECT mode.
- ② If the deck is not completely set to the eject position, turn part A of the pulley worm J by hand to set the eject position. (Refer to Fig. 2-1-4)  
Turn in the direction a ..... for loading  
Turn in the direction b ..... for unloading
- ③ Slowly lower the cassette housing onto the main plate of the deck.
- ④ Make sure the record safety lever enters between the insert guide of the cassette housing and the shaft as shown in Fig. 2-1-3. Align the four points (c, d, e and f), located on the bottom of the housing with the matching holes in the deck. Secure the cassette housing on the deck with the two screws (a and b). (Refer to Fig. 2-1-1.)

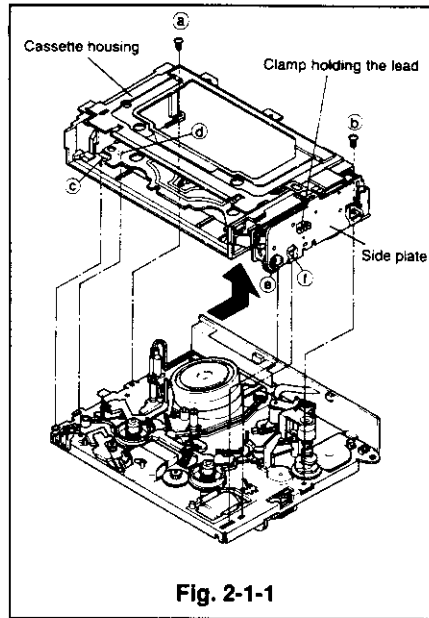

Fig. 2-1-1

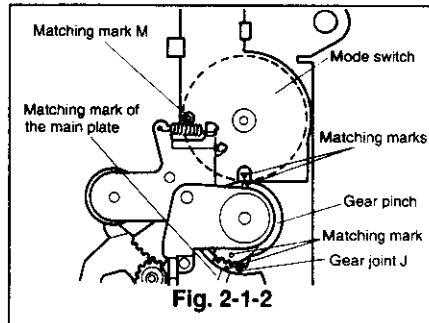

Fig. 2-1-2

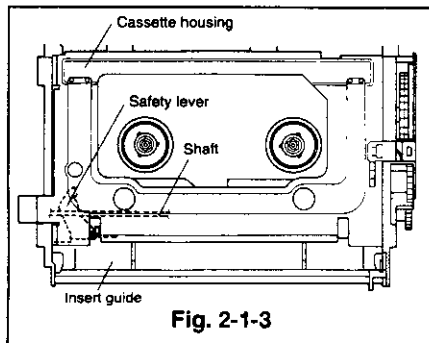

Fig. 2-1-3

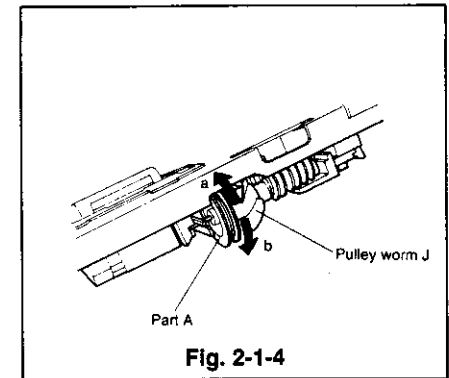

Fig. 2-1-4

### 2-2 Sens Gear, Drive Gear, Takeup Arm, and Arm Spring (TU)

#### (Removal)

- ① Remove the cassette housing. (Refer to Para. 2-1 for the removal method.)
- ② Unfasten the four catches (a, b, c and d) as shown in Fig. 2-2-1 and remove the side plate.
- ③ Remove the sens gear.
- ④ Pull the lock levers on both the supply and takeup sides, shown in Fig. 2-6-1, in the direction shown by the arrow to shift the bottom plate to the position shown in Fig. 2-6-2.
- ⑤ Remove the takeup arm.
- ⑥ To remove the drive gear from the sens gear, turn and pull the drive gear in the direction shown by the arrow shown in Fig. 2-2-3.
- ⑦ Remove the arm spring (TU) from the takeup arm as shown in Fig. 2-2-4.

#### (Installation)

- ① Apply the grease (MULTEMP SH-M)[859D055O60] to the area of the new takeup arm shown in Fig. 2-2-4.
- ② Apply the grease (MULTEMP SH-M)[859D055O60] to the area shown in Fig. 2-2-5 of the new sens gear.
- ③ Apply the grease (MULTEMP SH-M)[859D055O60] to the area shown in Fig. 2-2-6 of the new sens gear.
- ④ Place the clip spring on the drive gear hooking one end under the catch as shown in Fig. 2-2-5. Install the sens gear on the drive gear so that hole A aligns with hole B. Hold the sens gear while turning the drive gear clockwise, in so doing engage the other end of the clip spring with the catch of the sens gear. The projection A of the sens gear must enter the hole B of the drive gear.

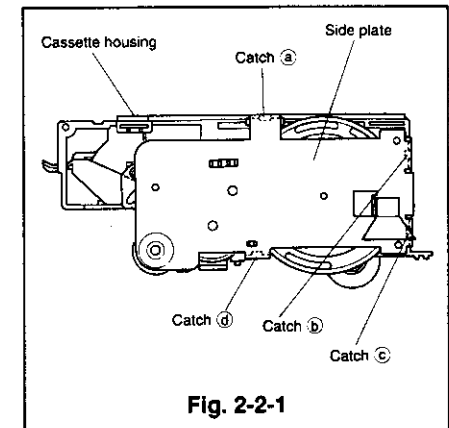

Fig. 2-2-1

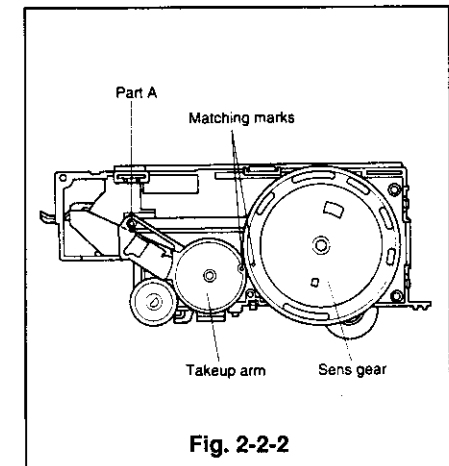

Fig. 2-2-2

- ⑤ Ensure the spring action is effective by holding the sens gear and turning the drive gear slightly clockwise, observing whether the drive gear returns when released.
- ⑥ Apply the grease (MULTEMP SH-M)[859D055O60] to the area of the new takeup arm shown in Fig. 2-2-7.
- ⑦ Install the takeup arm so that the shaft from the bottom plate enters between the takeup arm and takeup spring, after the bottom plate is in the position shown in Fig. 2-6-2.

**Note:** Install the takeup arm so that the engaging point between the supply arm and gear-S, and that between the takeup arm and gear-T are symmetrical as shown in Fig. 2-4-1.

- ⑧ Shift the bottom plate back to the eject position and install the sens gear so that the matching marks of the sens gear and the takeup arm align as shown in Fig. 2-2-2.
- ⑨ Install the side plate.
- ⑩ Install the cassette housing.  
(Refer to Para. 2-1 for the installation method.)

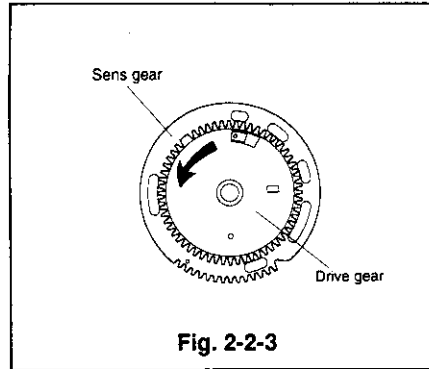

Fig. 2-2-3

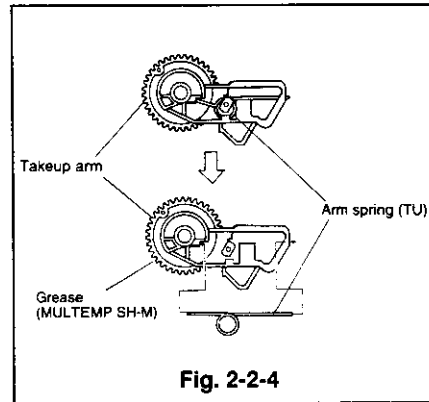

Fig. 2-2-4

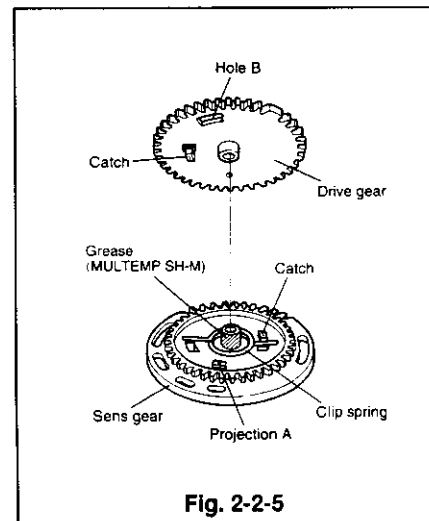

Fig. 2-2-5

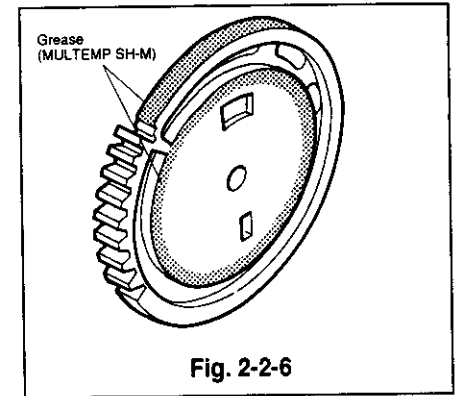

Fig. 2-2-6

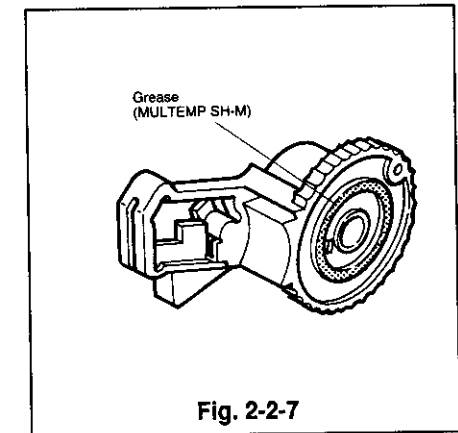

Fig. 2-2-7

### 2-3 Door Arm

(Removal)

- 1 Remove the cassette housing.  
(Refer to Para. 2-1 for the removal method.)
- 2 Remove the side plate, sens gear, and takeup arm.  
(Refer to Para. 2-2 for the removal method.)
- 3 Unfasten the catch shown in Fig. 2-3-1 to remove the door arm. (Pull the door arm at the same time as unfastening the catch.)

(Installation)

- 1 Fix the door arm to the shaft A shown in Fig. 2-3-1 and secure it with the catch so that the parts A and B are inside of the cassette housing, as shown in Fig. 2-3-2.
- 2 Install the takeup arm, sens gear, and side plate.  
(Refer to Para. 2-2 for the installation method.)
- 3 Install the cassette housing.  
(Refer to Para. 2-1 for the installation method.)

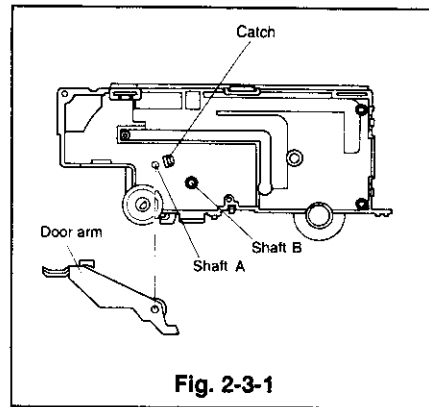

Fig. 2-3-1

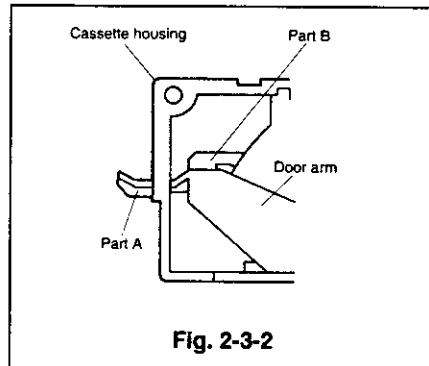

Fig. 2-3-2

### 2-4 Gear S and Gear T

(Removal)

- 1 Follow the removal method in Items 1 to 5 of Para. 2-2.
- 2 Unfasten the catch holding gear T from the inside of the cassette housing and remove the FL shaft to which the gear S and T are attached. (Refer to Fig. 2-4-2)
- 3 Pull out the gears S and T from the FL shaft.

(Installation)

- 1 Fix the gear S and T to the FL shaft.
- 2 Install the FL shaft, first the end attached to gear T and then the end with gear S.
- 3 Follow the installation method in Item 5 to 8 in Para. 2-2.

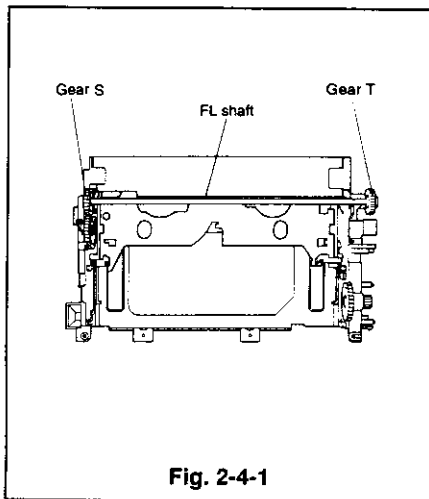

Fig. 2-4-1

### 2-5 Wheel Gear

(Removal)

- 1 Remove the cassette housing.  
(Refer to Para. 2-1 for the removal method.)
- 2 Remove the side plate and sense gear.  
(Refer to Para. 2-2 for the removal method.)
- 3 Unfasten the catch shown in Fig. 2-5-1 to remove the wheel gear.

(Installation)

- 1 Install the wheel gear in the position shown in Fig. 2-5-1, from the inside of the cassette housing.
- 2 Install the sens gear and side plate.  
(Refer to Para. 2-2 for the installation method.)
- 3 Install the cassette housing.  
(Refer to Para. 2-1 for the installation method.)

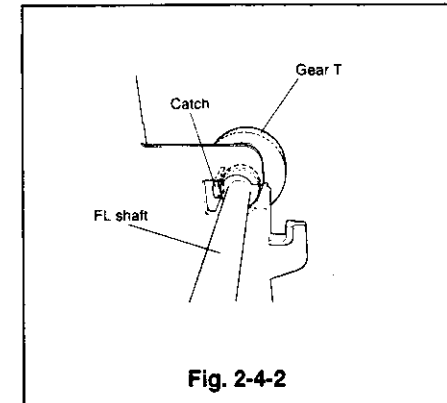

Fig. 2-4-2

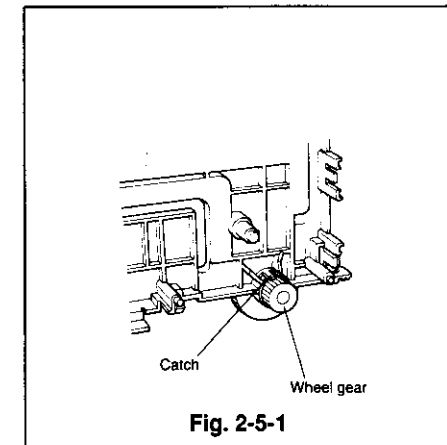

Fig. 2-5-1

### 2-6 Supply Arm and Arm Spring (SP)

(Removal)

- 1 Remove the cassette housing.  
(Refer to Para. 2-1 for the removal method.)
- 2 Remove the side plate.  
(Refer to Item 2 of Para. 2-2 for the removal method.)
- 3 Remove the sens gear.  
(Refer to Item 3 of Para. 2-2 for the removal method.)
- 4 Pull the lock levers on both the supply and takeup side, shown in Fig. 2-6-1, in the direction shown by the arrow to shift the bottom plate to the position shown in Fig. 2-6-2.
- 5 Remove the takeup arm.  
(Refer to Item 5 of Para. 2-2 for the removal method.)
- 6 Pull part A, fixed to the supply arm, in the direction shown by the arrow to remove the bottom plate.  
(Refer to Fig. 2-6-3.)

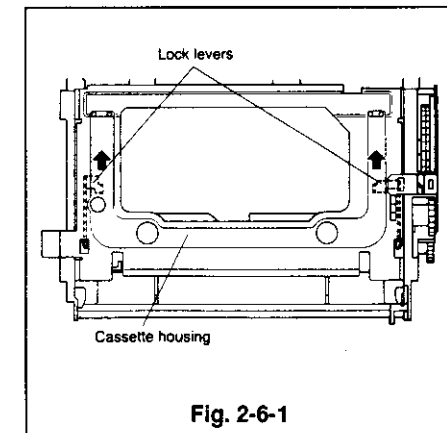
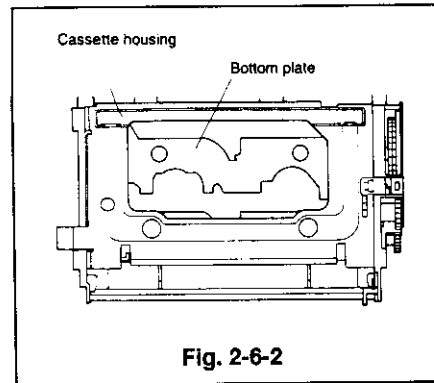

Fig. 2-6-1

- ⑦ Turn the supply arm in the direction shown by the arrow to shift part B, shown in Fig. 2-6-4, so that it aligns with the catch. Unfasten the catch to remove the supply arm.
- ⑧ Detach the arm spring from the supply arm as shown in Fig. 2-6-5.

(Installation)

- ① Attach the arm spring to the supply arm as shown in Fig. 2-6-5.
- ② Install the supply arm in the position shown in Fig. 2-6-4. (Align the catch with the part B of the supply arm.)
- ③ Insert the bottom plate so part A enters between the supply arm and the supply spring as shown in Fig. 2-6-3. Then install the bottom plate so that part C is in the position shown in Fig. 2-6-6.
- ④ Follow the installation method in Item ⑤ to ⑧ in Para. 2-2.



**Fig. 2-6-2**

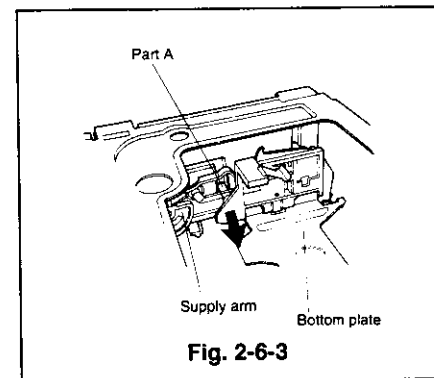

**Fig. 2-6-3**

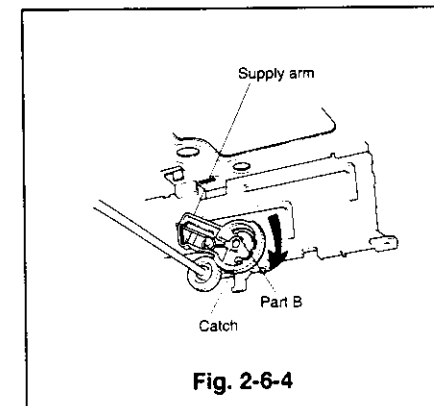

**Fig. 2-6-4**

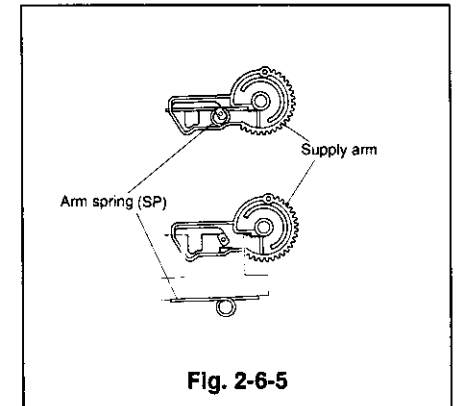

**Fig. 2-6-5**

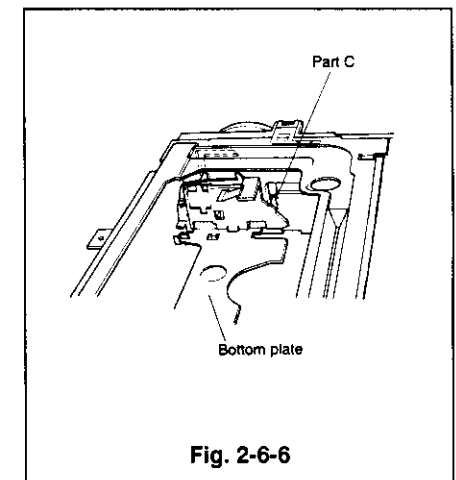

**Fig. 2-6-6**

## 2-7 Jut

(Removal)

- 1 Follow the removal method in Items ① to ⑥ of Para. 2-6.
- 2 Unfasten the four catches (a), (b), (c) and (d) shown in Fig. 2-7-1 to remove the jut and the jut spring.

(Installation)

- 1 Install the jut and the jut spring as shown in Fig. 2-7-1. (Insert the jut spring into the part A of the jut before installing the jut. Hook one end of the jut spring with the outside of the catch (a) and the other end with part B of the jut.)
- 2 Install the bottom plate according to the installation method in ③ of Para. 2-6.
- 3 Follow the installation method in Items ⑤ to ⑧ in Para. 2-2.

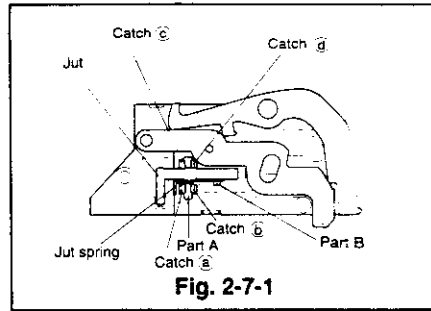

## 2-8 PCB-HA/AUDIO

(Removal)

- 1 Unfasten the hook and raise the head amp shield cover shown in Fig. 2-8-1 to remove it.
- 2 Unsolder the terminals of the mode switch, the drum motor, and the rotary transformer shown in Fig. 2-8-1.
- 3 Lift the stopper of the A/C head assembly in Fig. 2-8-4 slightly upward and disconnect the lead connector (bare wire), connecting the PCB-HA/AUDIO and the PCB-A/C-HEAD.
- 4 Disconnect the lead connector (point A), connected to the FE head. (Refer to Fig. 2-8-2.)
- 5 Reverse the deck and disconnect the lead card, connecting the PCB of the capstan motor and the PCB-HA/AUDIO. (Refer to Fig. 2-8-3.)
- 6 Remove the three screws (a), (b) and (c) and slowly pull the PCB-HA/AUDIO in the direction shown by the arrows. (Refer to Fig. 2-8-1.)

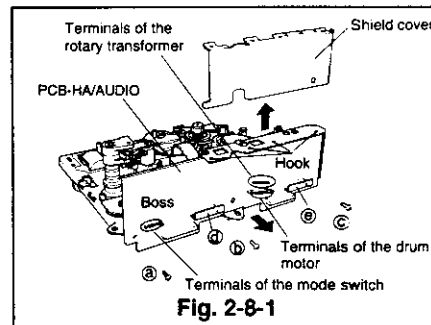

(Installation)

- 1 Insert the terminals of the mode switch, the drum motor, and the rotary transformer, and the boss, adjacent to the mode switch, in the matching holes on the PCB-HA/AUDIO and secure the PCB-HA/AUDIO with the three screws (a), (b) and (c) in the order, (b)→(c)→(a). (Refer to Fig. 2-8-1)
- 2 Solder the pins mentioned in Item ①.
- 3 Reverse the deck and reconnect the lead card connecting the PCB of the capstan motor and the PCB-HA/AUDIO. (Refer to Fig. 2-8-3) Take care not to fit lead card upside down.
- 4 Connect the lead connector, connected to the FE head, to the point A. (Refer to Fig. 2-8-2.)
- 5 Shift part B of the bare wire lead extended from the head amp slightly downward, lower the stopper, and connect it to the connector on the PCB-A/C-HEAD. (Refer to Fig. 2-8-4)

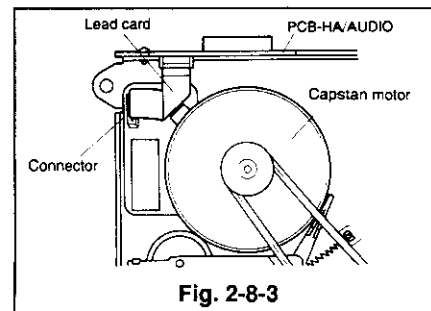
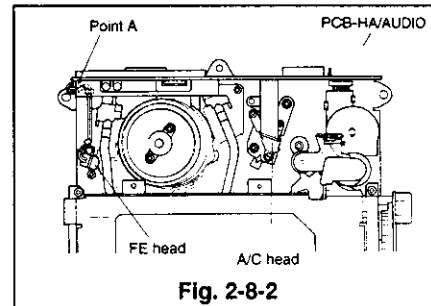

## 2-9 Brush (Refer to the Fig.2-9-1.)

(Removal)

- 1 Reverse the deck and remove the three screws (a), (b) and (c) to remove the brush.

(Installation)

- 1 Attach the brush on the position shown in Fig. 2-9-1 and secure it with the screws (a) and (b). Tighten screw (c).

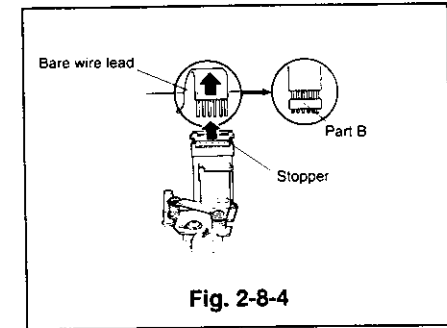

## 2-10 Drum Assembly

**Note:** When removing and installing the drum assembly, do not touch the tape running surface with your hands.

**Note:** Take care not to bend the PCB-HA/AUDIO.

(Removal)

- 1 Remove the cassette housing. (Refer to Para. 2-1 for the removal method.)
  - 2 Remove the PCB-HA/AUDIO. (Refer to Para. 2-8 for the removal method.)
  - 3 Unscrew the three screws (a), (b) and (c) on the reverse side of the deck and remove the drum assembly. (Refer to Fig. 2-10-1.)
  - 4 Slowly raise the drum assembly upward, take care not to touch other parts around it. (Do not touch the tape running surface of the drum with your hand.)
- Note:** During removal, support the drum assembly when it is not secured by fastening screws.

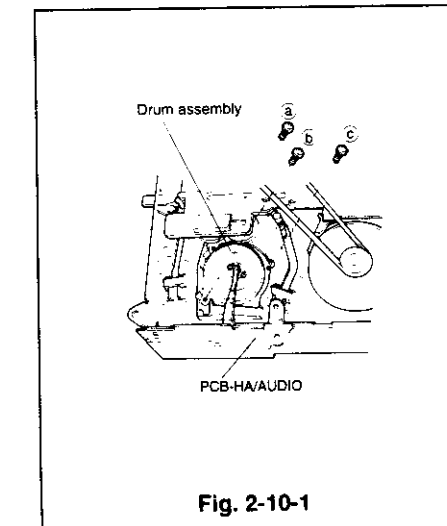
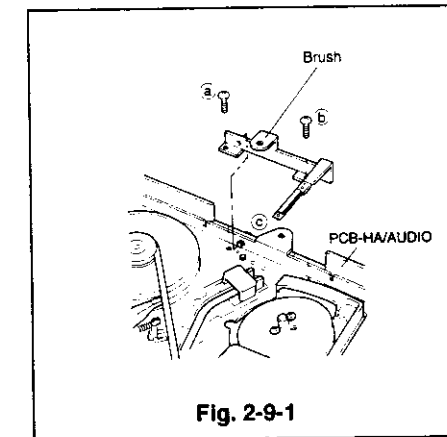



(Installation)

- ① Carefully place the new drum assembly on the main plate of the deck, take care not to touch other parts.
- ② Holding the drum assembly, reverse the deck and secure the drum assembly with the three screws (a), (b) and (c). (Tighten the screws in the order a→b→c and finally tighten again a.) (Refer to Fig. 2-10-1.)
- ③ Install the PCB-HA/AUDIO.  
(Refer to Para. 2-8 for the installation method.)
- ④ Install the cassette housing.  
(Refer to Para. 2-1 for the installation method.)

[Another Method]

(Removal)

- ① Remove the cassette housing.  
(Refer to Para. 2-1 for the removal method.)
- ② Unsolder the soldered pins on the terminal of the drum assembly and the terminal of the rotary transformer. (Refer to Fig. 2-10-2)
- ③ Unscrew the three screws (a), (b) and (c) on the reverse side of the deck and remove the drum assembly. (Refer to Fig. 2-10-1.)
- ④ Slightly raise the drum assembly in the opposite direction of the pins. Remove the pins of the drum assembly and of the rotary transformer from the PCB-HA/AUDIO. Slowly remove the drum assembly, take care not to touch other parts around it.

(Installation)

- ① Carefully place the drum assembly on the main plate, take care not to touch the other parts around it. The pins of the drum assembly and the rotary transformer must enter the holes of the PCB-HA/AUDIO.
- ② Secure the drum assembly with the three screws (a), (b) and (c) on the reverse side of the deck. (Tighten the screws in the order a→b→c and finally tighten a again.) (Refer to Fig. 2-10-1.)
- ③ Solder the pins of the drum assembly and the rotary transformer. (Refer to Fig. 2-10-2.)
- ④ Install the cassette housing.  
(Refer to Para. 2-1 for the installation method.)

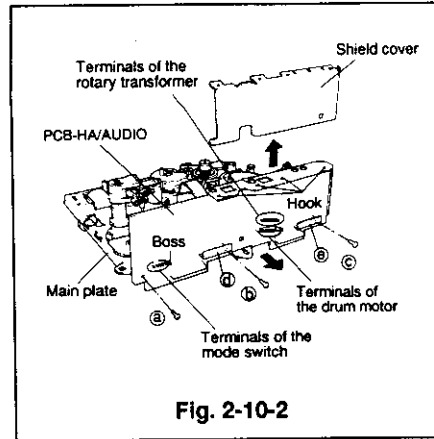

Fig. 2-10-2

## 2-11 Upper Drum and Drum Motor

**Note:** When only the upper drum is to be replaced, follow the procedure of Items ②-④ of the removal method and ②-④ of the installation method.

(Removal)

- ① Remove the drum assembly.  
(Refer to Para. 2-10 for the removal method.)
- ② Unsolder the terminals of each head on the upper drum.
- ③ Remove the screws holding the upper drum shown in Fig. 2-11-1.
- ④ Remove the upper drum slowly and carefully.
- ⑤ Remove the screws (a) and (b) shown in Fig. 2-11-1 to remove the rotor case and damper. Remove the screws (c), (d) and (e) to remove the drum motor.

(Installation)

**Note:** Handle the upper drum carefully as the video heads are fragile.

- ① Attach the rotary transformer and the drum motor so that the terminals of both face in the same direction, and secure them with the screws (c), (d) and (e). Secure the rotor case with the screws (a) and (b).
- ② Position the white painted (shaded) area of the upper drum so that the area is 90° apart from the hole of the lower drum shaft. Insert the upper drum. Take care not to touch the head terminals. [Fig. 2-11-2]
- ③ Secure the upper drum with the two fastening screws. (Tighten the screws alternately.)
- ④ Solder the terminals of each head.

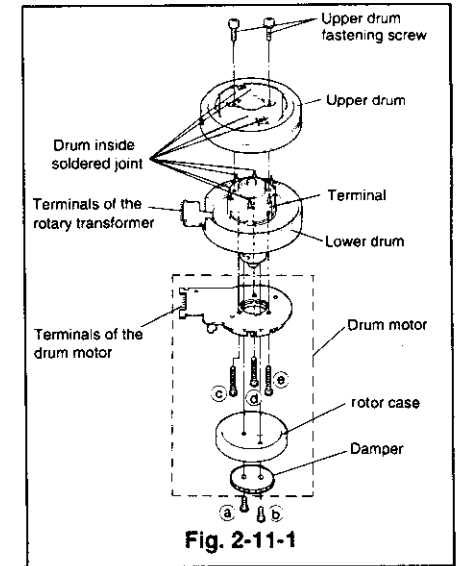

Fig. 2-11-1

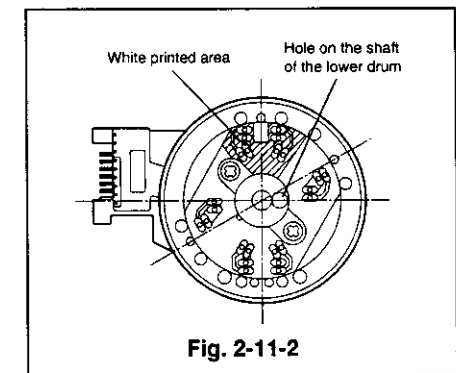

Fig. 2-11-2

## 2-12 Safety Spring and Safety Lever

### (Removal)

- 1 Remove the cassette housing. (Refer to Para. 2-1 for the removal method.)
- 2 Unhook the safety spring with a tweezers.
- 3 Turn the safety lever clockwise and remove by raising it upward as shown in Fig. 2-12-2.

### (Installation)

- 1 Install the safety lever so that part A aligns with the hole on the main plate, shown in Fig. 2-12-1, and part B with the hole of the safety arm on the reverse side of the deck.
- 2 Fix the safety spring to the shaft of the safety lever and hook it as shown in Fig. 2-12-3.
- 3 Install the cassette housing. (Refer to Para. 2-1 for the installation method.)

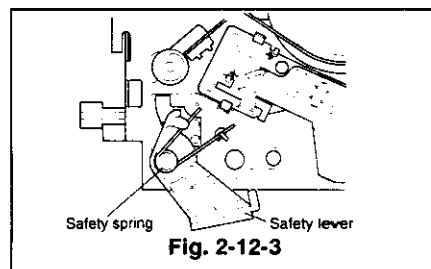
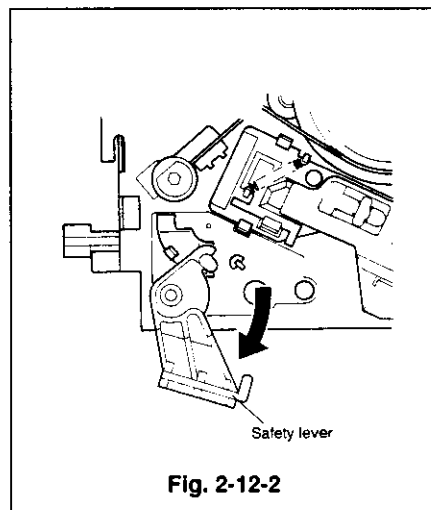
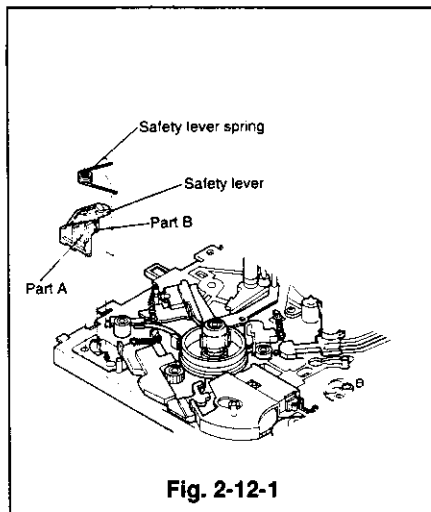

## 2-13 Safety Arm

### (Removal)

- 1 Remove the cassette housing. (Refer to Para. 2-1 for the removal method.)
- 2 Remove the safety spring and the safety lever. (Refer to Para. 2-12 for the removal method.)
- 3 Unfasten the catch to remove the safety arm. (Refer to Fig. 2-13-1).

### (Installation)

- 1 Reverse the deck and fix the safety arm to the shaft of the main plate so that its catch is within the range shown in Fig. 2-13-2.
- 2 Install the safety spring and the safety lever. (Refer to Para. 2-12 for the installation method.)
- 3 Install the cassette housing. (Refer to Para. 2-1 for the installation method.)

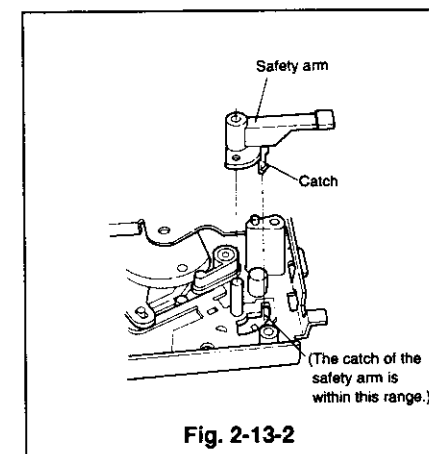
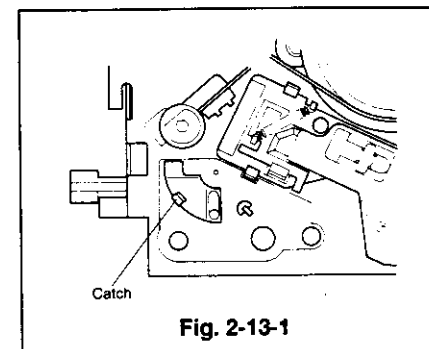

## 2-14 Sub Brake(SP) and Sub Spring(SP)

### (Removal)

- 1 Remove the cassette housing. (Refer to Para. 2-1 for the removal method.)
- 2 Detach the sub spring(SP).
- 3 Reverse the deck and unfasten the catch with a small screw driver, etc., to remove the sub brake(SP) as shown in Fig. 2-14-2.

### (Installation)

- 1 Install the sub brake(SP) with care not to score the tension brake belt (without loosening of the tension brake belt). (Refer to Fig. 2-14-1)
- 2 Attach the sub spring(SP).
- 3 Install the cassette housing. (Refer to Para. 2-1 for the installation method.)

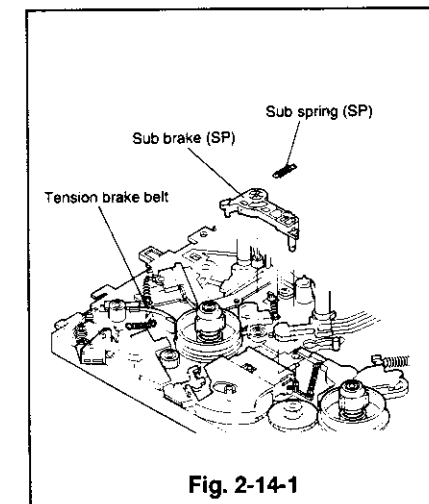

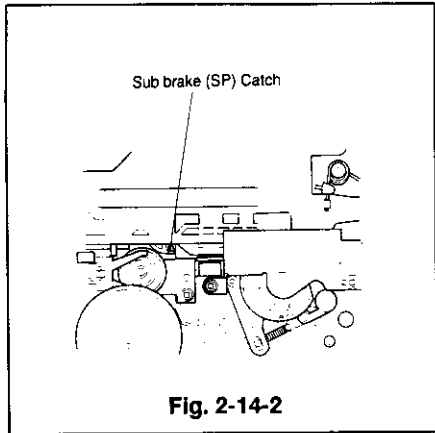

Fig. 2-14-2

**2-15 Main Brake (SP) and Main Brake Spring J(SP)  
(Refer to Fig. 2-15-1.)**

(Removal)

- ① Remove the cassette housing. (Refer to Para. 2-1 for the removal method.)
- ② Remove the sub brake(SP) and the sub spring(SP). (Refer to Para. 2-14 for the removal method.)
- ③ Unhook the main brake spring J(SP).
- ④ Raise the main brake(SP) upward to remove it.

(Installation)

- ① Install the main brake(SP) on the main plate and attach the main brake spring J(SP).
- ② Install the sub brake(SP) and the sub spring(SP). (Refer to Para. 2-14 for the installation method.)
- ③ Install the cassette housing. (Refer to Para. 2-1 for the installation method.)

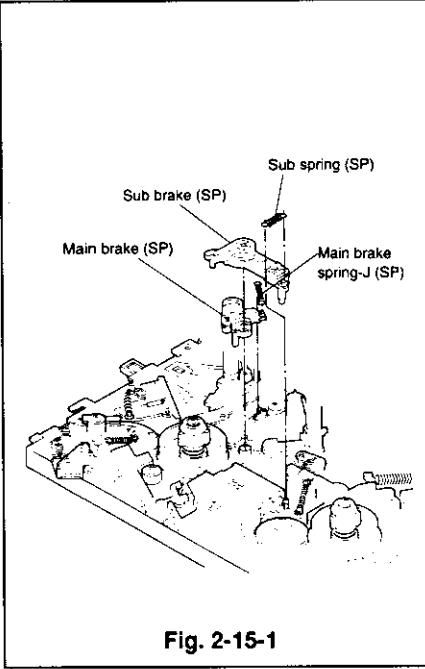

Fig. 2-15-1

**2-16 Sub Off Lever, Sub Brake (TU), and Sub Spring (TU)**

(Removal)

- ① Remove the cassette housing. (Refer to Para. 2-1 for the removal method.)
- ② Remove the sub brake (SP) and the sub spring (SP). (Refer to Para. 2-14 for the removal method.)
- ③ Unfasten the catch with a small screw driver, etc., and raise the sub off lever upward to remove it. (Refer to Fig. 2-16-2)
- ④ Remove the sub spring (TU). (Refer to Fig. 2-16-1.)
- ⑤ Unfasten the catch with a small screw driver, etc., and raise the sub brake (TU) upward to remove it as shown in Fig. 2-16-2.

(Installation)

- ① Apply the grease (PG-641)(859D055O30) to the area shown in Fig. 2-16-3.
- ② Install the sub brake (TU) on the main plate.
- ③ Install the sub off lever so that the hole A aligns with the boss of the sub brake (TU) as shown in Fig. 2-16-1.
- ④ Install the sub spring (TU).
- ⑤ Install the sub brake (SP) and the sub spring (SP). (Refer to Para. 2-14 for the installation method.)
- ⑥ Install the cassette housing. (Refer to Para. 2-1 for the installation method.)

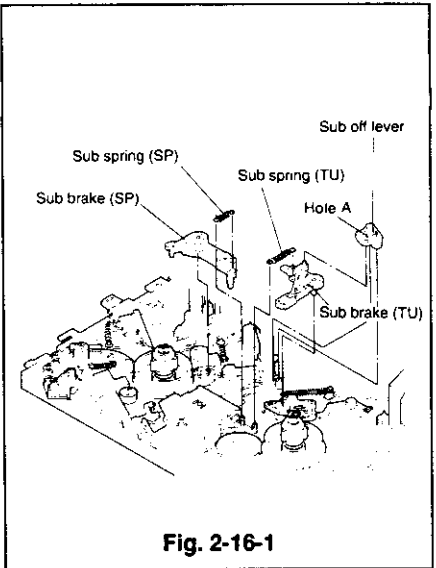

Fig. 2-16-1

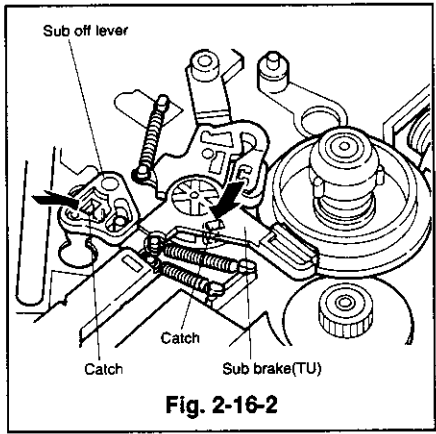

Fig. 2-16-2

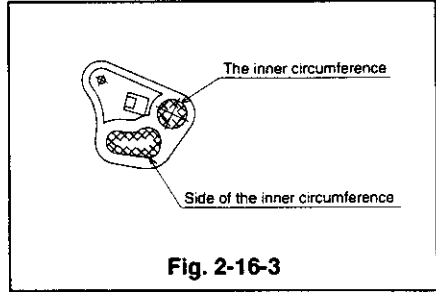

Fig. 2-16-3

## 2-17 Main Brake(TU) and Main Brake Spring J(TU)

### (Removal)

- 1 Remove the cassette housing. (Refer to Para. 2-1 for the removal method.)
- 2 Remove the sub brake(SP) and the sub spring(SP). (Refer to Para. 2-14 for the removal method.)
- 3 Remove the sub off lever, the sub brake(TU), and the sub spring(TU). (Refer to Para. 2-16 for the removal method.)
- 4 Remove the main brake spring J(TU) and raise the main brake(TU) upward to remove it. (Refer to Fig. 2-17-1.)

### (Installation)

- 1 Install the main brake(TU) on the main plate assembly so that the coupling portion with the main brake release lever is as shown in Fig. 2-17-2.
- 2 Install the main brake spring J(TU).
- 3 Install the sub brake(TU), the sub off lever, and the sub spring(TU). (Refer to Para. 2-16 for the installation method.)
- 4 Install the sub brake(SP) and the sub spring(SP). (Refer to Para. 2-14 for the installation method.)
- 5 Install the cassette housing. (Refer to Para. 2-1 for the installation method.)

## 2-18 ID Swing Lever, Revolution Lever, and Revolution Spring

### (Removal)

- 1 Remove the cassette housing. (Refer to Para. 2-1 for the removal method.)
- 2 Reverse the deck and remove the grip ring attached to the shaft G of the charge assembly.
- 3 Unfasten the two catches(A, B) to remove the charge assembly.
- 4 Remove the revolution spring with a tweezers.
- 5 Slide the revolution lever in the direction shown by the arrow and unfasten it from the catch C of the ID swing lever. (Refer to Fig. 2-18-1)
- 6 Detach the charge spring from the ID swing lever.

### (Installation)

- 1 Apply the grease(PG-641)[859D055O30] to the areas shown in Fig. 2-18-2 of the new revolution lever and the ID swing lever.

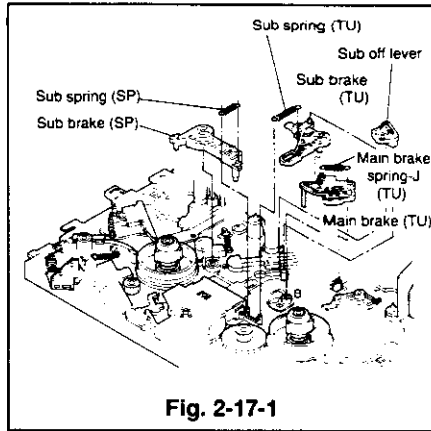

Fig. 2-17-1

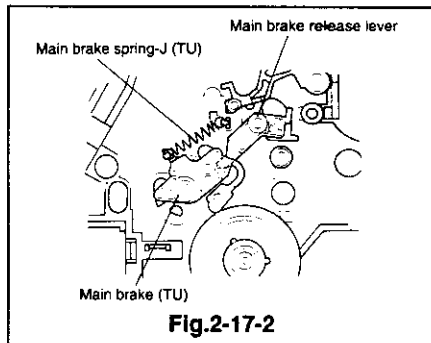

Fig.2-17-2

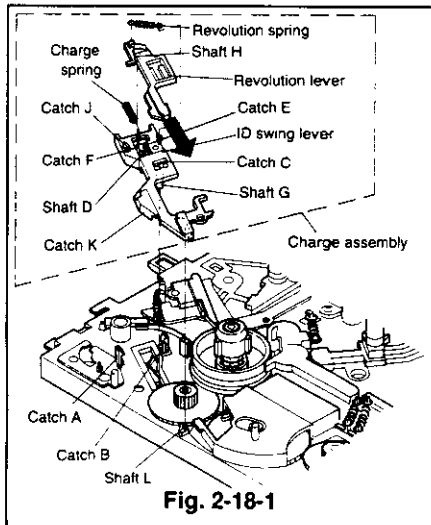

Fig. 2-18-1

- 2 Fix the charge spring to shaft D of the ID swing lever and compress it to hook its ends with the catches E and F. (Refer to Fig. 2-18-1)

**Note:** The charge spring should be installed in the directions shown below.

### (Longitudinal Direction)

The bent tip is attached on the shaft D.

### (Traverse Direction)

The wider semicircle is on the left as shown in

Fig. 2-18-1.

- 3 Align the shaft H of the revolution lever with the position shown in Fig. 2-18-1. Insert catch C of the ID swing lever into the hole of the revolution lever, pushing the charge spring with a revolution lever in the direction shown by the arrow. At the same time, hook the ends of the revolution lever with the catches J and K.
- 4 Attach the revolution spring with a tweezers.
- 5 Install the charge assembly so that shaft G enters into the oval hole of the charge lever on the reverse side of the deck and the groove of the charge assembly fits the shaft as shown in Fig. 2-18-1. Secure the charge assembly with the catch A and B.
- 6 Reverse the deck and fix the new grip ring to the shaft G of the charge assembly.
- 7 Install the cassette housing. (Refer to Para. 2-1 for the installation method.)

## 2-19 Tension Arm, Tension Brake Belt, and Tension Spring

**Note:** During removal and installation, take care not to change the shape of the tension brake belt.

### (Removal)

- 1 Remove the cassette housing. (Refer to Para. 2-1 for removal method.)
- 2 Supply a voltage (approximately 5V DC plus voltage on the red wire) to the loading motor and slide the tape guide assembly completely to the loaded position, to set it to the loaded position.
- 3 Remove the sub brake(SP) and the sub spring(SP). (Refer to Para. 2-14 for the removal method.)
- 4 Unfasten the catch of the part A on the tension brake belt and raise the part A to unfasten the tension brake belt from the supply reel disk. (Refer to Fig. 2-19-1)
- 5 Remove the tension spring, unfasten the catch shown in Fig. 2-19-2, and raise the tension arm upward to remove it.
- 6 Reverse the tension arm, unfasten the catch with a tweezers as shown in Fig. 2-19-3 to remove the tension brake belt.

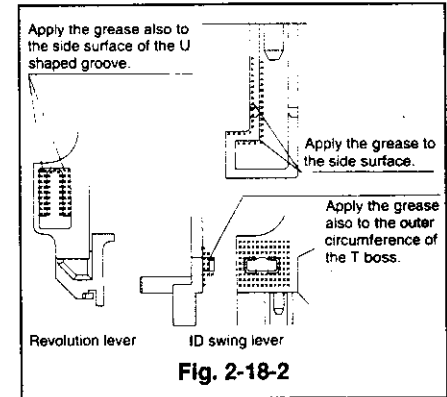

Fig. 2-18-2

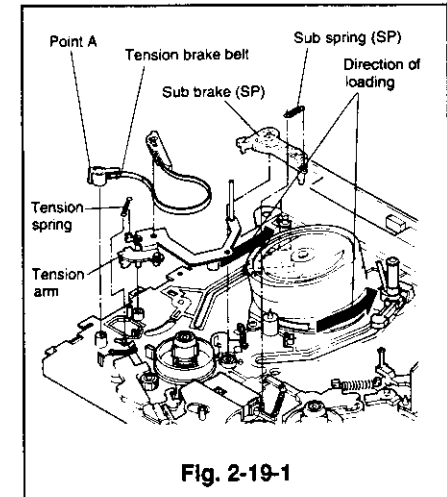

Fig. 2-19-1

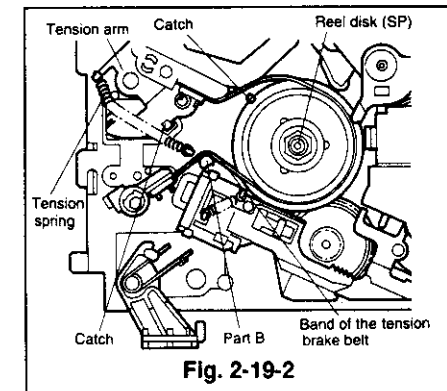

Fig. 2-19-2

(Installation)

- 1 Insert the catch in the position of the tension arm as shown in Fig. 2-19-3 to fasten the tension brake belt on the tension arm. (Take care not to let projection C, next to the catch of the tension brake belt touch the tension arm.)
- 2 Install the tension arm, where the tension brake belt is fastened, on the main plate.
- 3 Fasten the tension brake belt around the supply reel disk. (The band of the tension brake belt must pass the outside of the catch shown in Fig. 2-19-2 and inside of the part B.)
- 4 Attach the tension spring.
- 5 Install the sub brake(SP) and sub spring(SP). (Refer to Para. 2-14 for the installation method.)
- 6 Supply voltage (approximately 5V), reversing the polarity used in ② of the Removal method, to set the motor to the unloaded position.
- 7 Make sure that the holes (matching mark M) on the body and cogwheel of the mode switch align with each other as shown in Fig. 2-19-4. At the same time confirm that the hole of the gear pinch aligns with the matching marks of the gear joint J and the ▽mark on the mode switch cogwheel, refer to Fig. 2-19-5. This indicates the J deck is in the EJECT mode.
- 8 If the deck is not completely set to the eject mode, turn part D of the pulley worm J by hand to set the eject mode.

Turn in the direction a ..... for loading  
Turn in the direction b ..... for unloading  
(Refer to Fig. 2-19-6)

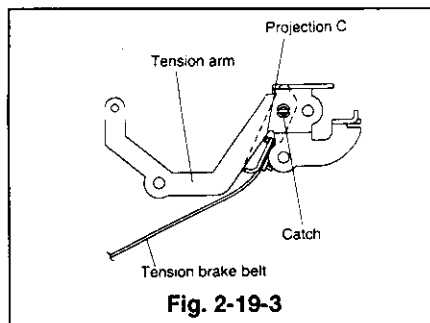

Fig. 2-19-3

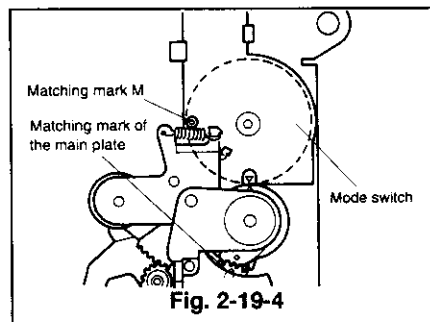

Fig. 2-19-4

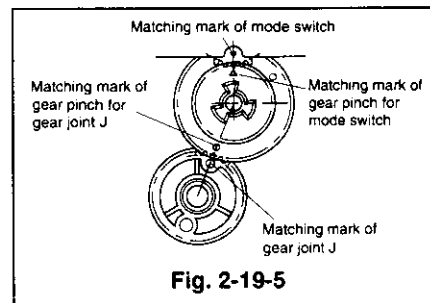

Fig. 2-19-5

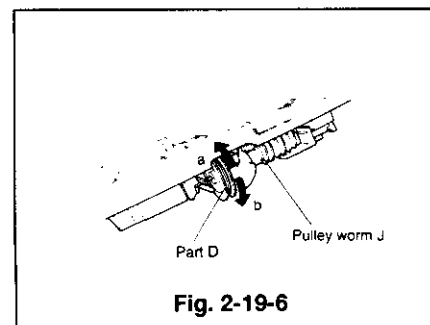

Fig. 2-19-6

## 2-20 Takeup Reel Disk and Gear R (takeup side)

(Removal)

- 1 Remove the cassette housing. (Refer to Para. 2-1 for the removal method.)
- 2 Remove the sub brake(SP) and the sub spring(SP). (Refer to Para. 2-14 for the removal method.)
- 3 Remove the sub off lever, the sub brake(TU), and the sub spring(TU). (Refer to Para. 2-16 for the removal method.)
- 4 Unfasten the catch shown in Fig. 2-20-1 and raise the takeup reel disk upward to remove it from the shaft.
- 5 Raise the gear R (takeup side) upward to remove it from the shaft. (Refer to Fig. 2-20-2.)

(Installation)

- 1 Install the gear R (takeup side) on the shaft. (Refer to Fig. 2-20-2.)
- 2 Install the takeup reel disk on the shaft. (Refer to Fig. 2-20-2.)
- 3 Install the height adjusting jig [master plane] (used for F deck: Part No.859C342020) in the specified position. (Insert the jig into hole A, shown in Fig. 2-20-3, so that the jig sets on part B and the end of part C. Take care that the jig does not touch the supply and takeup reel disks.)
- 4 Place the height adjusting jig [square] (used for E deck: Part No.859C341070) on the jig installed in Item ③ as shown in Fig. 2-20-4. Make sure that the height is correct (between A and B).
- 5 Adjust the height of the supply reel disk by varying the number of the washers (Part No.552C017020) under the disk.  
A) If it is high, remove washer(s).  
B) If it is low, add washer(s).
- 6 Install the sub brake(TU), the sub off lever, and the sub spring(TU). (Refer to Para. 2-16 for the installation method.)
- 7 Install the sub brake(SP) and the sub spring(SP). (Refer to Para. 2-14 for the installation method.)
- 8 Install the cassette housing. (Refer to Para. 2-1 for the installation method.)

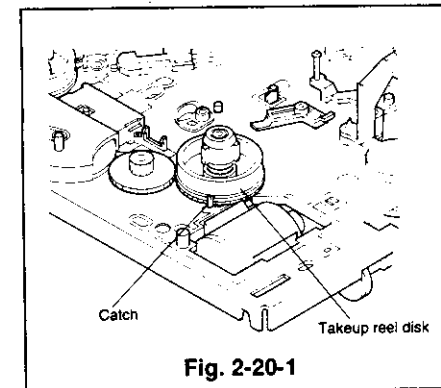

Fig. 2-20-1

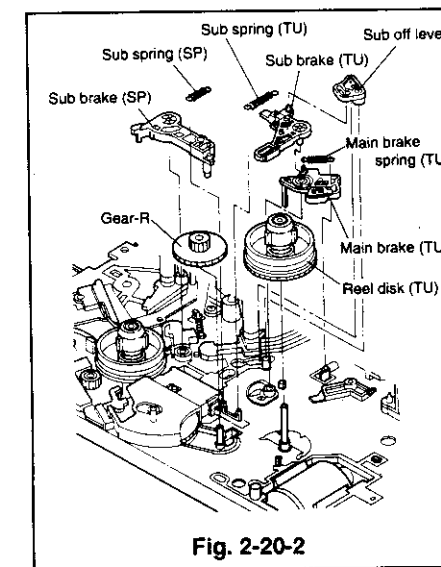

Fig. 2-20-2

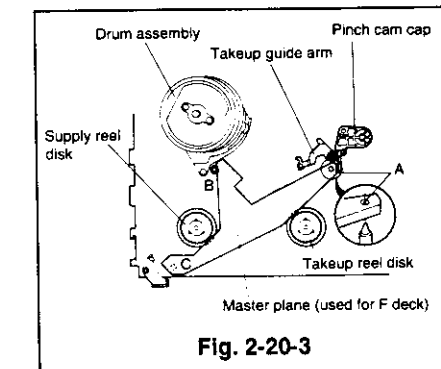
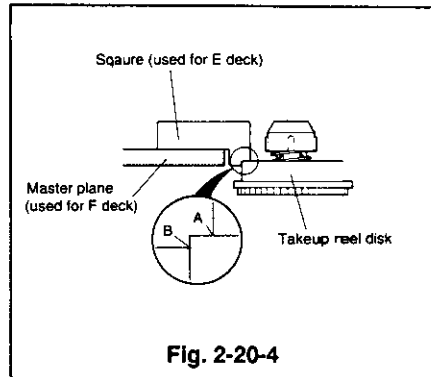

Fig. 2-20-3



## 2-21 Supply Reel Disk

### (Removal)

- ① Remove the cassette housing. (Refer to Para. 2-1 for the removal method.)
- ② Remove the sub brake(SP) and the sub spring(SP). (Refer to Para. 2-14 for the removal method.)
- ③ Raise the part B of the tension brake belt upward to unfasten the belt from the supply reel disk as shown in Fig. 2-21-2. (Refer to Para. 2-19 for the removal method.)
- ④ Unfasten the catch shown in Fig. 2-21-1 and raise the supply reel disk upward to remove it from the shaft.

### (Installation)

- ① Install the supply reel disk on the shaft.
- ② Install the height adjusting jig [master plane](used for F deck: Part No.859C342020) in the specified position. (Insert the jig into the hole A shown in Fig. 2-20-3 so that the jig sets on part B and the end of part C. Take care that the jig does not touch the supply and takeup reel disks.)
- ③ Place the height adjusting jig [square](used for E deck: Part No.859C341070) on the jig, previously installed placed in Item ②, as shown in Fig. 2-21-3. Make sure that the height is correct (between A and B).
- ④ Adjust the height of the supply reel disk by varying the number of the washers(Part No.552C017020) under the disk.
  - A) If it is high, remove washer(s).
  - B) If it is low, add washer(s).

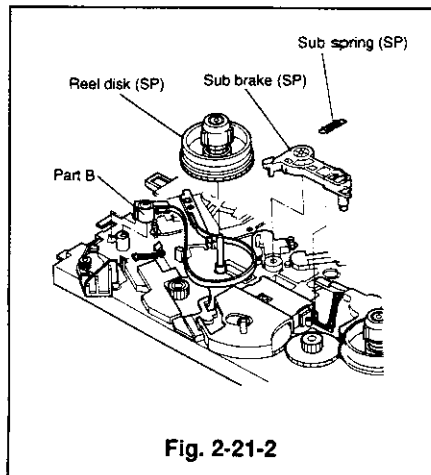
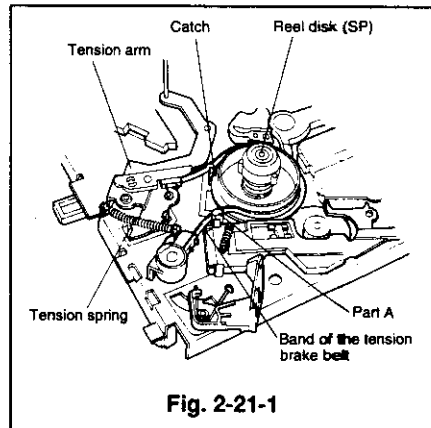

- ⑤ Fasten the tension brake belt round on the supply reel disk, taking care not to score the belt and route part B of the tension brake belt as shown in Fig. 2-21-2. (Refer to Para. 2-19 for the installation method.) (The band of the tension brake belt must pass outside of the catch shown in Fig. 2-21-1 and inside of the part A.)
- ⑥ Install the sub brake(SP) and the sub spring(SP). (Refer to Para. 2-14 for the installation method.)
- ⑦ Install the cassette housing. (Refer to Para. 2-1 for the installation method.)

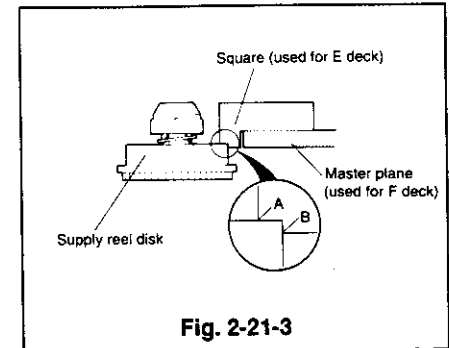

## 2-22 Gear R(supply side) (Refer to Fig. 2-22-1.)

### (Removal)

- ① Remove the cassette housing. (Refer to Para. 2-1 for the removal method.)
- ② Remove the sub brake(SP) and the sub spring(SP). (Refer to Para. 2-14 for the removal method.)
- ③ Unfasten the tension brake belt from the supply reel disk and remove the supply reel disk. (Refer to Para. 2-21 for the removal method.)
- ④ Remove the charge assembly. (Refer to item ② of Removal in Para. 2-18 for the removal method.)
- ⑤ Raise the gear R(SP) upward to remove it from the shaft.

### (Installation)

- ① Install the gear R(SP) on the shaft.
- ② Install the supply reel disk. (Refer to Para. 2-21 for the installation method.)
- ③ Install sub brake(SP) and sub spring(SP). (Refer to Para. 2-14 for the installation method.)
- ④ Install the charge assembly. (Refer to Item ⑤ of Para. 2-18 for the installation method.)
- ⑤ Install the cassette housing. (Refer to Para. 2-1 for the installation method.)

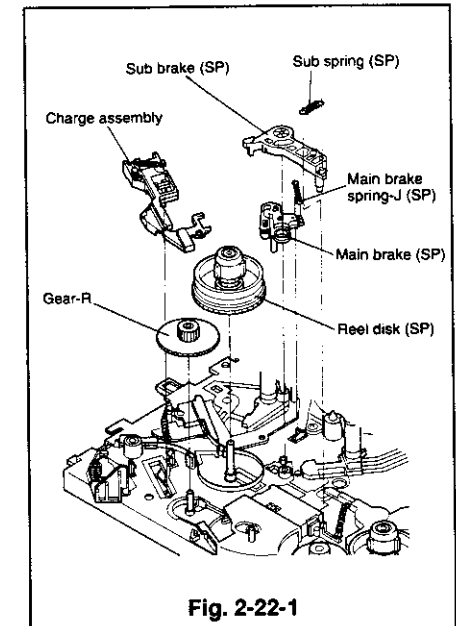

## 2-23 Main Brake Release Lever

(Refer to Fig. 2-23-1.)

### (Removal)

- 1 Remove the cassette housing. (Refer to Para. 2-1 for the removal method.)
- 2 Remove the sub brake(SP), and the sub spring(SP). (Refer to Para. 2-14 for the removal method.)
- 3 Remove the sub off lever, the sub brake(TU), and the sub spring(SP). (Refer to Para. 2-16 for the removal method.)
- 4 Remove the main brake(TU) and the main brake spring J(TU). (Refer to Para. 2-17 for the removal method.)
- 5 Shift catch A of the main brake release lever, and push catch B at the same time, in the direction shown by each arrow. Unfasten catch B from the main plate to remove the main brake release lever. (Refer to Fig. 2-23-2.)

### (Installation)

- 1 Install the main brake release lever so that the shaft enters the inside groove shown in Fig. 2-23-3 of the main gear J.
- 2 Install the main brake(TU) and the main brake spring J(TU). (Refer to Para. 2-17 for the installation method.)
- 3 Install the sub brake(TU), the sub off lever, and the sub spring(TU). (Refer to Para. 2-16 for the installation method.)
- 4 Install the sub brake(SP) and the sub spring(SP). (Refer to Para. 2-14 for the installation method.)
- 5 Install the cassette housing. (Refer to Para. 2-1 for the installation method.)

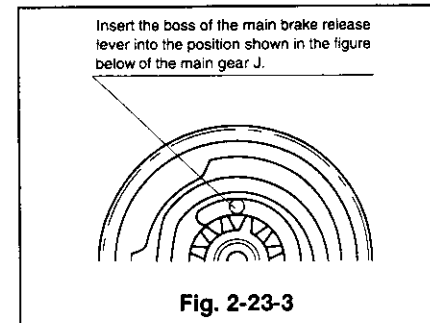
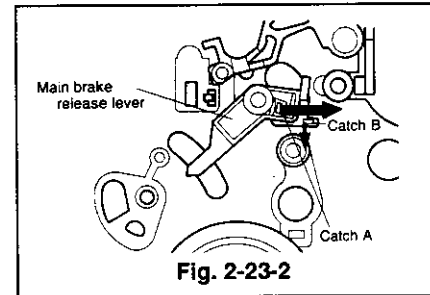
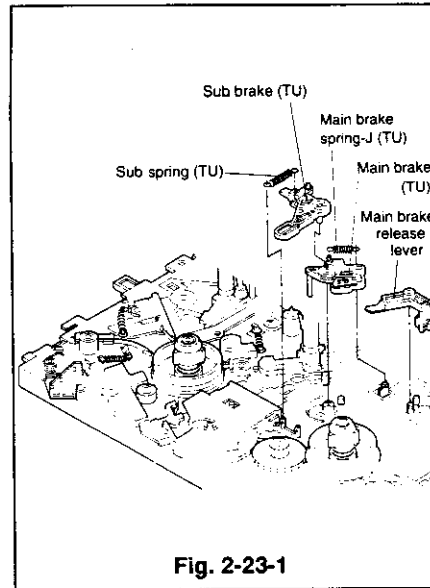

## 2-24 Pinch Cam Cap, Pinch Roller Arm Assembly, Pinch Cam, Takeup Guide Gear, Gear Pinch, Takeup Guide Arm, and Takeup Guide Spring

### (Removal)

- 1 Unfasten the catch shown in Fig. 2-24-1 and raise the pinch cam cap upward to remove it.
- 2 Raise the pinch roller arm assembly upward to remove it.
- 3 Raise the pinch cam and the takeup guide gear upward to remove them from the shaft.
- 4 Unfasten the two catches holding the mode switch and remove the gear pinch from the shaft, lift the mode switch only high enough to remove the gear pinch. (Take care not to break the pins of the mode switch.)
- 5 Remove the nut at the top of the takeup guide arm with a (5.5mm) box screw driver.
- 6 Raise the takeup guide arm upward to remove it.
- 7 Remove the takeup guide spring.

### (Installation)

- 1 Hook one end of the takeup guide spring with the takeup guide arm, fix the takeup guide spring to the shaft.
- 2 Apply grease (PG-641) [859D055O30] around the top of the new takeup guide arm (the surface which touches with the nut). Fix the takeup guide arm to the shaft, and secure it with the nut. (Set the takeup guide arm to the height shown in Fig. 2-24-2 temporarily.)
- 3 Lift the mode switch, only high enough to install the gear pinch and place the gear pinch under the mode switch. Fix the mode switch to the shaft so that the matching marks of the gear pinch align with those of the gear joint J and the mode switch as shown in Fig. 2-24-3.
- 4 Install the takeup guide gear so that the first cog of the takeup guide arm aligns with the matching mark on the takeup guide gear as shown in Fig. 2-24-4.
- 5 Apply grease (G) [859D055O50] to the area shown in Fig. 2-24-5 of the new pinch cam.
- 6 Turn the takeup guide arm clockwise while inserting the pinch cam into the gear pinch. Install the pinch cam so that it aligns with the triple catch. (Excessive rotation of the takeup guide arm will keep it from returning, since the takeup guide gear is caught on the pinch roller cam.)
- 7 Apply the grease (PG-641) [859D055O30] to the new pinch cam cap on the area shown in Fig. 2-24-7.
- 8 Install the pinch roller arm assembly and the pinch cam cap.

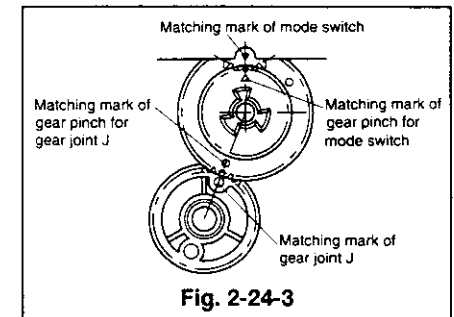
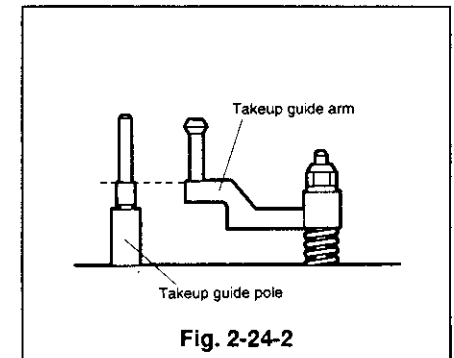
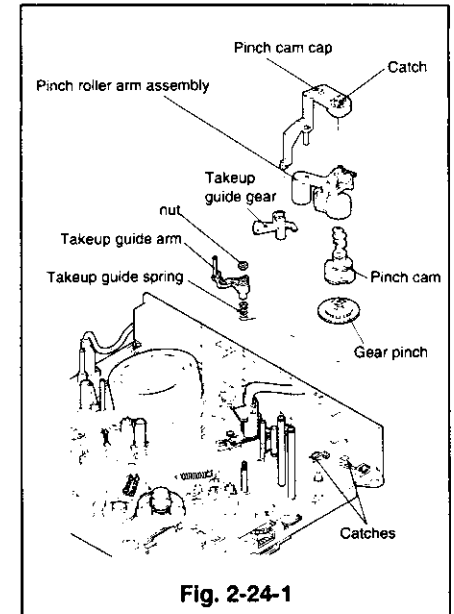

**[Adjustment of Takeup Guide Arm Height]**

Adjust the height of the takeup guide arm according to the following procedure.

- ① Place the height adjusting jig (for the F deck) in the reference position on the main plate (Refer to Fig. 2-20-3). Tighten the takeup guide arm fastening nut so that the lower flange of the takeup guide arm is level with point B of the height adjusting jig (for the E deck). (Refer to Fig. 2-24-6).

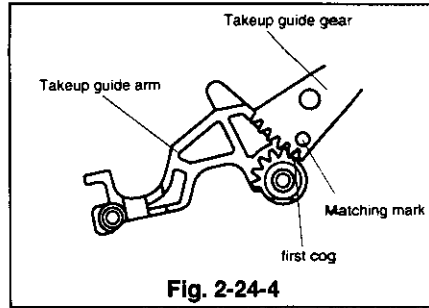

Fig. 2-24-4

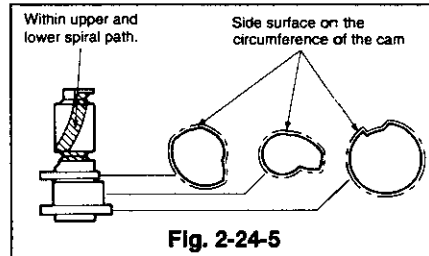

Fig. 2-24-5

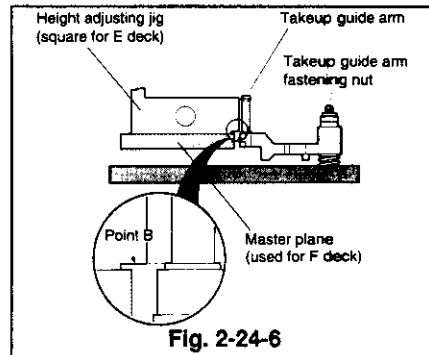

Fig. 2-24-6

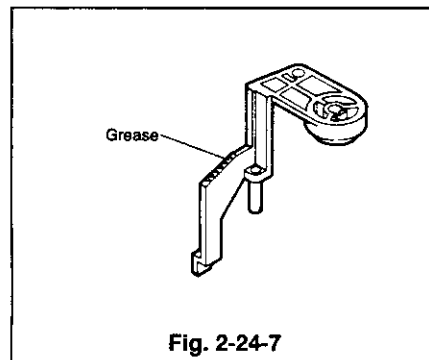

Fig. 2-24-7

**2-25 Pinch Roller, Roller Cap, Pinch Spring, and Pinch Cam Spring**

**Note:** During removal and installation, do not expand the pinch spring more than 18mm and the pinch cam spring more than 27mm.

(Removal)

- ① Pry the pinch roller and the roller cap to remove them as shown in Fig. 2-25-1.
- ② Remove the pinch spring and the pinch cam spring.

(Installation)

- ① Install the pinch cam spring and the pinch spring making sure that the pinch arm, the pinch slider, and the pinch lever are composed as shown in Fig. 2-25-2.
- ② Install the pinch roller so that the side, with the widest aluminium bushing, is on the roller cap side. Push the roller cap inside to secure the pinch roller. (Refer to Fig. 2-25-3)

**Note:** There are two types of pinch rollers as shown in Fig. 2-25-3. Each should be installed in the direction shown below.

(Type A)

The side on which aluminium is wider is attached the roller cap.

(Type B)

The convex portion is attached on the roller cap.

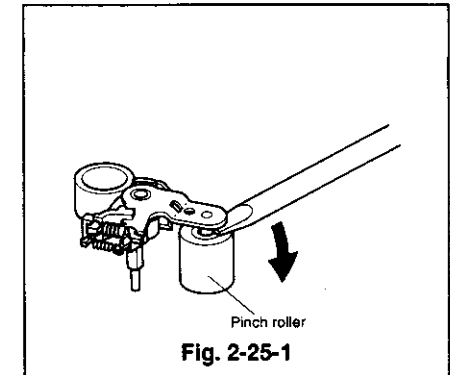

Fig. 2-25-1

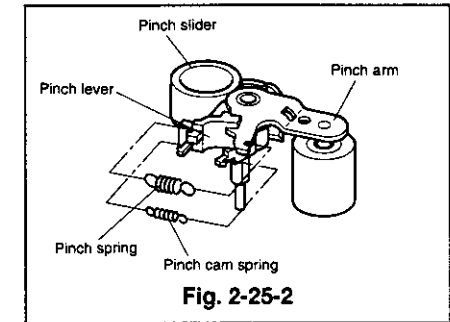

Fig. 2-25-2

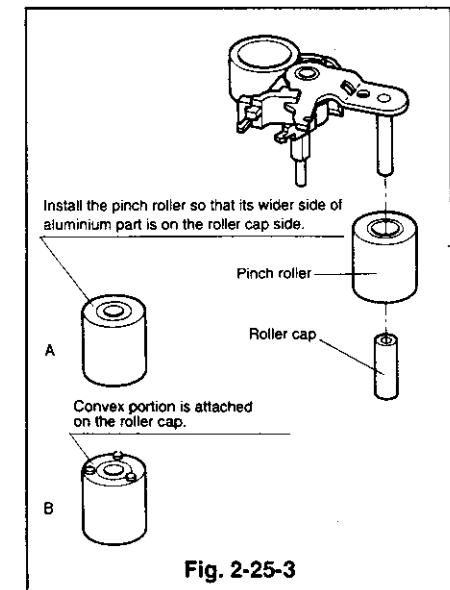

Fig. 2-25-3



## 2-26 Mode Switch

(Removal)

- 1 Remove the pinch cam cap, the pinch roller arm assembly, the pinch cam, and the takeup guide gear. (Refer to Para. 2-24 for the removal method.)
- 2 Unsolder the five soldered terminals connecting the PCB-HA/AUDIO to the mode switch. (Refer to Fig. 2-26-1.)
- 3 Unfasten two catches holding the mode switch. (Refer to Fig. 2-26-2.)
- 4 Slowly remove the mode switch, making sure that it is completely unsoldered.

(Installation)

- 1 Insert the five pins and the boss of the mode switch shown in Fig. 2-26-1 into the matching holes of the PCB-HA/AUDIO. Place the mode switch on the main plate so that the matching mark of the gear pinch aligns with that of the mode switch and fasten it with the catches as shown in Fig. 2-26-3. (Also make sure that the matching mark of the gear joint aligns with that of the gear pinch.)
- 2 Install the takeup guide gear, the pinch cam, the pinch roller arm assembly, and the pinch cam cap. (Refer to Para. 2-24 for the installation method.)

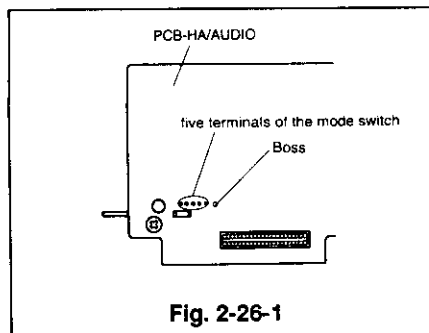

Fig. 2-26-1

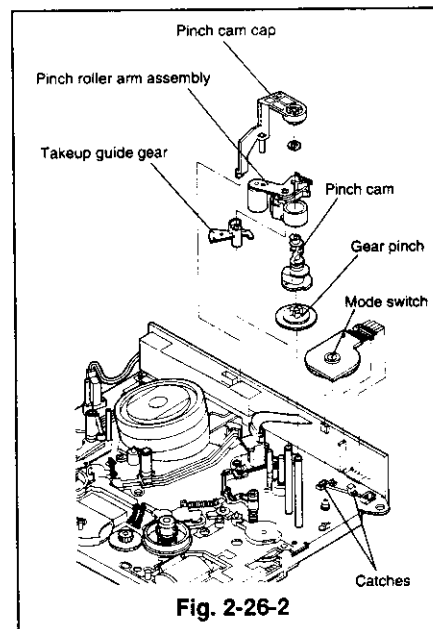

Fig. 2-26-2

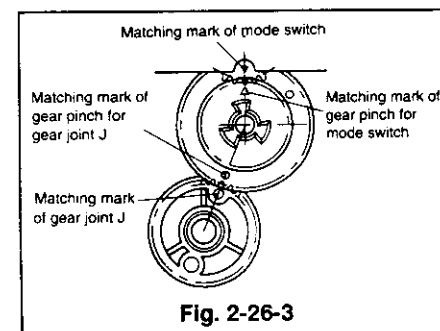

Fig. 2-26-3

## 2-27 FE Head (Refer to Fig. 2-27-1.)

(Removal)

- 1 Disconnect the lead connector, connected to the FE head.
- 2 Remove the screw (a) to remove the FE head.

(Installation)

- 1 Secure the FE head with the screw (a) and connect the lead connector to the FE head. (Route the lead connector, which is fastened with the catch as shown in Fig. 2-27-1, through the hook of the main plate.)

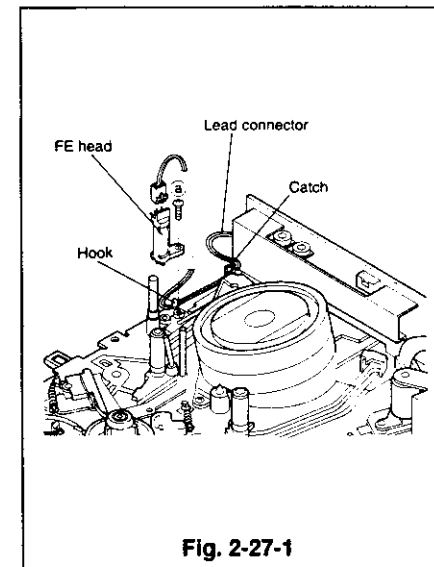

Fig. 2-27-1

## 2-28 Reel Belt and Belt Pulley

(Removal)

- 1 Unfasten the reel belt from the capstan motor and the belt pulley.
- 2 Release the belt pulley as shown in Fig. 2-28-1 and raise the belt pulley upward to remove it.

(Installation)

**Note:** When installing the reel belt, make sure it is clean and free of grease. (Clean with dry gauze only)

- 1 Fasten the belt pulley to the shaft. (When fixing the belt pulley to the shaft of the idler assembly, make sure that the three convex parts of the washer fixed to the shaft enter the matching dents.)
- 2 Secure the belt pulley with the new cut washer.
- 3 Install the reel belt on the capstan motor and the belt pulley, taking care that the belt is not twisted.

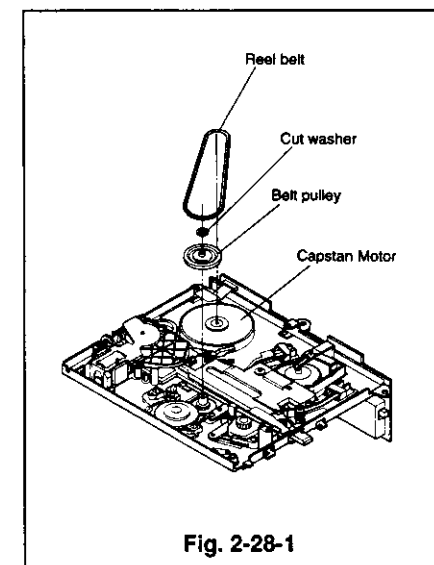

Fig. 2-28-1

## 2-29 Loading Motor Assembly, Pulley Worm J, Loading Motor Belt, and Gear A

(Removal)

- ① Unfasten the reel belt. (Refer to Para. 2-28 for the removal method.)
- ② Remove the three screws (Ⓐ, Ⓑ and Ⓒ) as shown in Fig. 2-29-2 and unfasten the three catches to remove the loading motor assembly (which holds the motor holder). (Refer to Fig. 2-29-1)
- ③ Remove the loading motor belt from the motor pulley. (Refer to Fig. 2-29-3.)
- ④ Unfasten the catches holding the motor holder to remove the loading motor assembly. (Refer to Fig. 2-29-3.)
- ⑤ Remove the pulley worm J, first the end attached to the part A shown in Fig. 2-29-3 and then the other end.
- ⑥ Remove the cut washer and unfasten the catch holding Gear A. Remove Gear A.
- ⑦ Pull the motor pulley to remove it from the loading motor.
- ⑧ Disconnect the wires from the loading motor.

(Installation)

- ① Solder the leads to the loading motor. (Red lead wire to the positive terminal and white lead wire to the negative terminal.)
- ② Install the motor pulley on the loading motor so that the space between the loading motor and the outer edge of the motor pulley is  $8.5 \pm 0.1$  mm. (Refer to Fig. 2-29-4)
- ③ Install the loading motor assembly so that the label on it faces part B, shown in Fig. 2-29-3.
- ④ Apply grease (G) [859D055O50] to the areas shown in Fig. 2-29-4 of the new pulley worm J. Install the pulley worm J, first the end attached to the part C shown in Fig. 2-29-3 and then the other end.
- ⑤ Fix the gear A to the shaft of the motor holder J and secure it with new cut washers.
- ⑥ Lift the end attached to the part A shown in Fig. 2-29-3 of the pulley worm J. Fasten the loading motor belt on the pulley worm J and the motor pulley, taking care not to twist the belt.
- ⑦ Install the loading motor assembly (which holds the motor holder) in the position shown in Fig. 2-29-2 and secure it with the three screws (Ⓐ, Ⓑ and Ⓒ).
- ⑧ Install the loading motor belt. (Refer to Para. 2-28 for the installation method.)

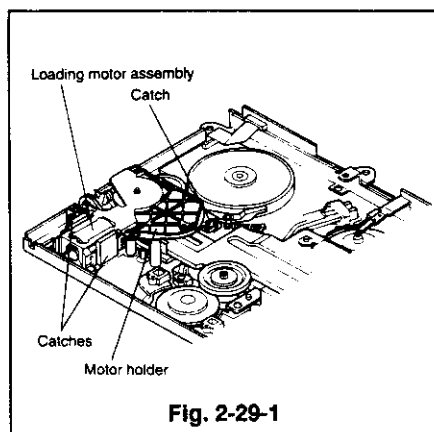

Fig. 2-29-1

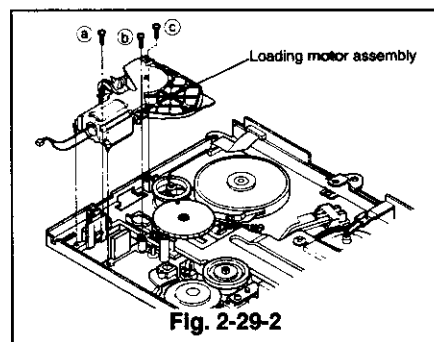

Fig. 2-29-2

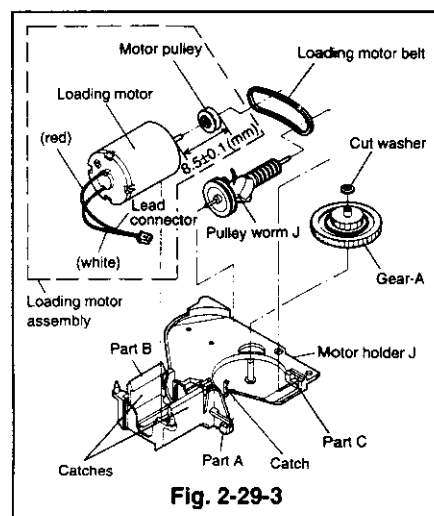

Fig. 2-29-3

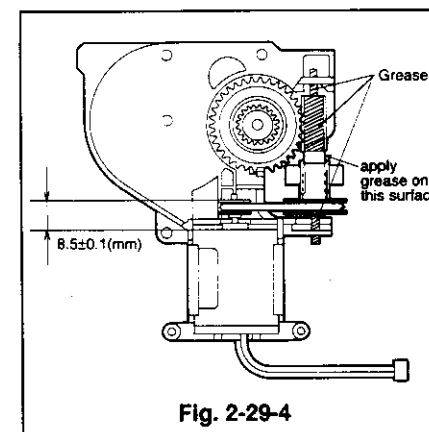

Fig. 2-29-4

## 2-30 Main Gear J

(Removal)

- ① Remove the reel belt. (Refer to Para. 2-28 for the removal method.)
- ② Remove the loading motor assembly (which holds the motor holder). (Refer to Para. 2-29 for the removal method.)
- ③ Remove the cut washer mounted on the main gear J.
- ④ Raise the main gear J upward to remove it.

(Installation)

- ① Apply grease (G) [859D055O50] to the outside cogs, the groove of the cam and to the inside small cogs of the new main gear J. (Refer to Fig. 2-30-2.)
- ② Make sure that the cam plate B is set to the right side, viewed from the bottom side of the deck. (Eject mode)
- ③ Push the axis of the main brake (TU) in the direction shown by the arrow until the main brake release lever moves freely. Turn the deck the right side up and shift the axis of the main brake release lever in the direction shown by the arrow. Then fix the main gear J to the shaft, with the axis of the main brake release lever held in place. Secure the main plate J with the cut washer. (Refer to Fig. 2-30-3) (Insert the pin of the capstan brake in the outside groove of the main gear J and align the matching marks of gear joint J and the main gear J.) (Refer to Fig. 2-30-4)
- ④ Install the loading motor assembly (which holds the motor holder) and the reel belt. (Refer to Para. 2-28 for the installation method.)

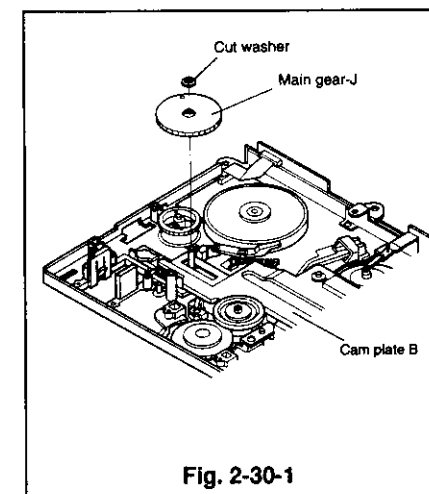

Fig. 2-30-1

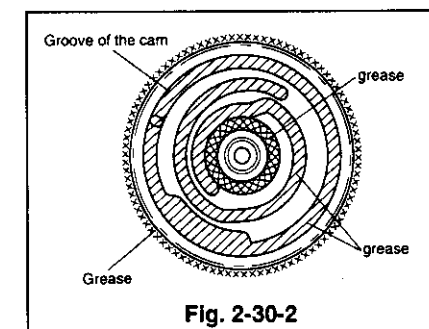
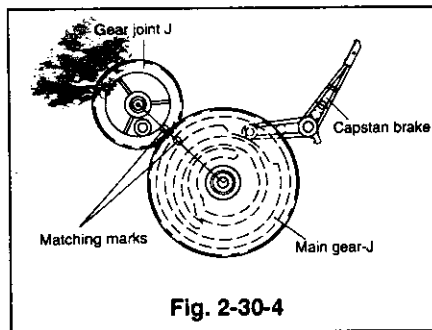
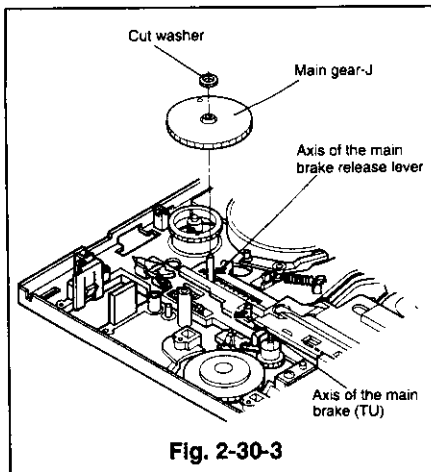

Fig. 2-30-2



### 2-31 Gear Joint J

(Removal)

- ① Remove the reel belt. (Refer to Para. 2-28 for the removal method.)
- ② Remove the loading motor assembly (which holds the motor holder). (Refer to Para. 2-29 for the removal method.)
- ③ Raise the gear joint J upward to remove it. (Refer to Fig. 2-31-1)

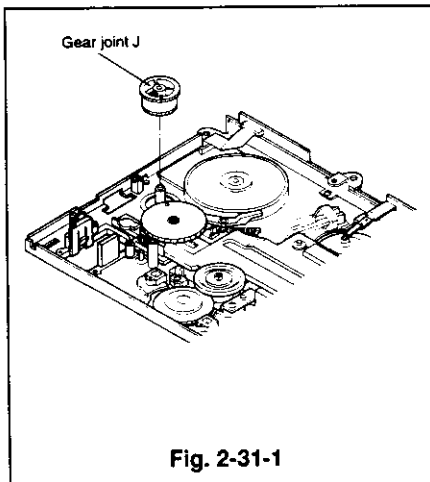

(Installation)

- ① Apply grease (PG-641)[859D055030] to the new gear joint J on the whole circumference of the small cogwheel as shown in Fig. 2-31-2.
- ② Fix the gear joint J to the shaft so that the matching mark of the gear joint J aligns with that of the main gear as shown in Fig. 2-30-4.
- ③ Turn the deck the right side up, make sure that the matching mark of the gear pinch aligns with that of the gear joint J. (When turning the deck, hold the gear joint J, in place.)(Refer to Fig. 2-31-3)
- ④ Install the loading motor assembly(which holds the motor holder). (Refer to Para. 2-29 for the installation method.)
- ⑤ Install the reel belt. (Refer to Para. 2-28 for the installation method.)

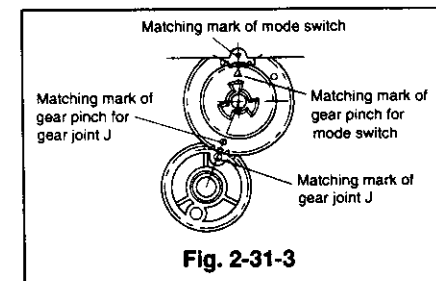
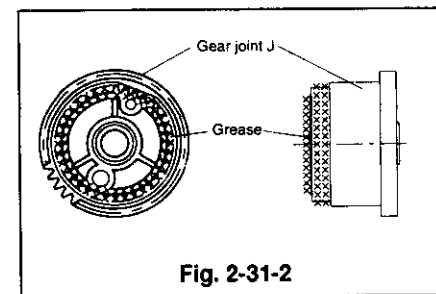

### 2-32 Capstan Brake and Capstan Brake Spring

(Removal)

- ① Remove the reel belt. (Refer to Para. 2-28 for the removal method.)
- ② Remove the loading motor assembly(which holds the motor holder). (Refer to Para. 2-29 for the removal method.)
- ③ Remove the main gear J. (Refer to Para. 2-30 for the removal method.)
- ④ Raise the capstan brake upward to remove it along with the capstan brake spring. (Refer to Fig. 2-32-1.)

(Installation)

- ① Install the capstan brake and the capstan brake spring.
- ② Install the main gear J. (Refer to Para. 2-30 for the installation method.)
- ③ Install the loading motor assembly(which holds the motor holder). (Refer to Para. 2-29 for the installation method.)
- ④ Fasten the reel belt. (Refer to Para. 2-28 for the installation method.)

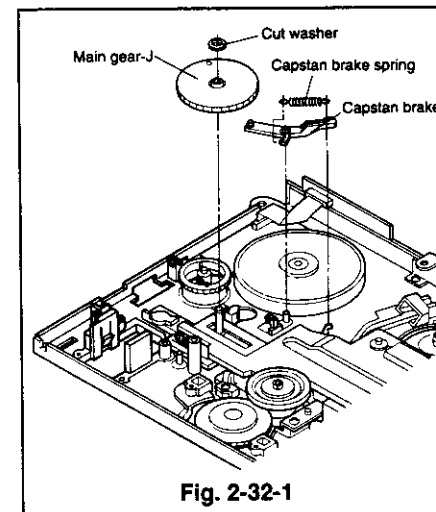

### 2-33 Plate J, Roller B, and Cam Plate B

#### (Removal)

- ① Remove the two screws (a) and (b) to remove the plate J. (Fig. 2-33-1)
- ② Take off the cut washer fixed to the shaft of the loading arm (TU) to remove the roller B.
- ③ Remove the reel belt. (Refer to Para. 2-28 for the removal method.)
- ④ Remove the belt pulley. (Refer to Para. 2-28 for the removal method.)
- ⑤ Remove the loading motor assembly (which holds the motor holder). (Refer to Para. 2-29 for the removal method.)
- ⑥ Remove the main gear J. (Refer to Para. 2-30 for the removal method.)
- ⑦ Slide the cam plate B to the left (the direction shown by the arrow) to remove it.

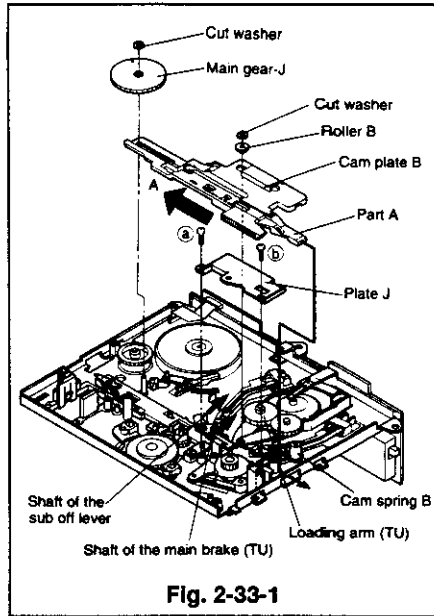

Fig. 2-33-1

#### (Installation)

- ① Apply grease (G) [859D055O50] to the area shown in Fig. 2-33-2 of the new cam plate B.
- ② Align the loading arms TU and SP so that the matching marks of the cogs align. (Refer to Fig. 2-37-3)
- ③ Passing part A of the cam plate B under cam spring B insert it into the hole on the side of the main plate, as shown by the continuous line. (Refer to Fig. 2-33-1)
- ④ While keeping the rear section of cam plate B raised, align the cam plate B and the cam gear R so that the ○ mark on the cam plate B aligns with the part A on the cam gear R as shown in Fig. 2-33-3 (Fig. A). Still keeping the rear of cam plate B raised, slide it to the right until the △ mark on cam plate B and aligns with the part B on the cam gear R, refer Fig. 2-33-3 (Fig. B). From this position lower the rear of the cam plate B unto the already aligned loading gears TU and SP, refer 2 above. Shift the sub off lever and the main brake TU in the directions shown by the arrows to install them. (Refer to Fig. 2-33-1)
- ⑤ Fix the roller B to the shaft of the loading arm (TU) and secure it with the new cut washer.
- ⑥ Install the plate J and secure it with the two screws (a) and (b).
- ⑦ Install the main gear J. (Refer to Para. 2-30 for the installation method.)
- ⑧ Install the loading motor assembly (which holds the motor holder). (Refer to Para. 2-29 for the installation method.)
- ⑨ Install the belt pulley. (Refer to Para. 2-28 for the installation method.)
- ⑩ Fasten the reel belt. (Refer to Para. 2-28 for the installation method.)

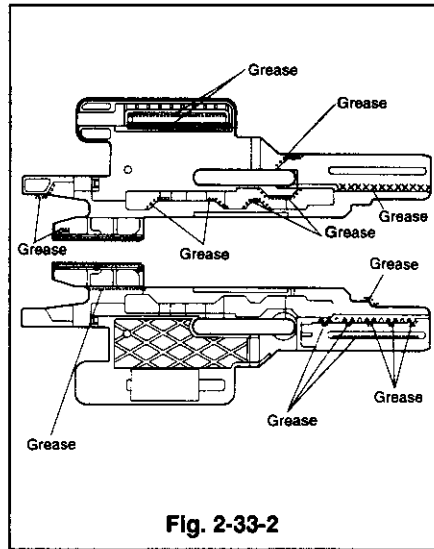

Fig. 2-33-2

### 2-34 Cam Gear R, Charge Lever, and Tension Off Lever

#### (Removal)

- ① Remove the cassette housing. (Refer to Para. 2-1 for the installation method.)
- ② Turn the deck the right side up and detach the tension spring. (Refer to Fig. 2-34-4.)
- ③ Remove the charge assembly. (Refer to item ② of Para. 2-18 for the removal method.)
- ④ Remove the reel belt and the pulley belt. (Refer to Para. 2-28 for the removal method.)
- ⑤ Remove the loading motor assembly (which holds the motor holder). (Refer to Para. 2-29 for the removal method.)
- ⑥ Remove the main gear J. (Refer to Para. 2-30 for the removal method.)
- ⑦ Remove the plate J, the roller B, and the cam plate B. (Refer to Para. 2-33 for the removal method.)
- ⑧ Raise the cam gear R upward to remove it. (Refer to Fig. 2-34-1.)
- ⑨ Remove the charge lever. (Refer to Fig. 2-34-1.)
- ⑩ Remove the tension off lever. (Refer to Fig. 2-34-1.)

#### (Installation)

- ① Let part A pass through part B shown in Fig. 2-34-1 to install the tension off lever.
- ② Fix the charge lever to the shaft.
- ③ Apply grease (PG-641) [859D055O30] to the area shown in Fig. 2-34-2 of the new cam gear R. (The groove and the flank of the outside circumference.)
- ④ Insert the cam gear R so that part A is on the upside, with the charge lever set fully to the right end. Slowly turn the charge lever in the direction shown by the arrow until it enters the groove in the cam gear R. (Refer to Fig. 2-34-3)
- ⑤ Install the cam plate B, the roller B, and the plate J. (Refer to Para. 2-33 for the installation method.)
- ⑥ Install the main gear J. (Refer to Para. 2-30 for the installation method.)
- ⑦ Install the loading motor assembly (which holds the motor holder). (Refer to Para. 2-29 for the installation method.)
- ⑧ Install the belt pulley and the reel belt. (Refer to Para. 2-28 for the installation method.)
- ⑨ Hook the tension spring in the position shown in Fig. 2-34-4.
- ⑩ Install the charge assembly. (Refer to item ⑤ of Para. 2-18 for the installation method.)
- ⑪ Install the cassette housing. (Refer to Para. 2-1 about the installation method.)

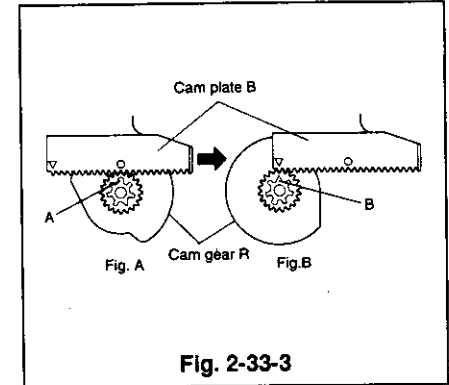

Fig. 2-33-3

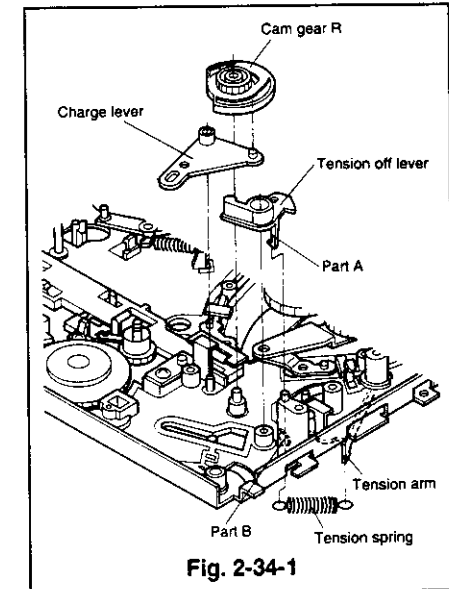

Fig. 2-34-1

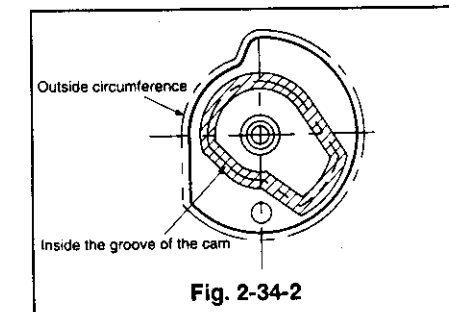

Fig. 2-34-2

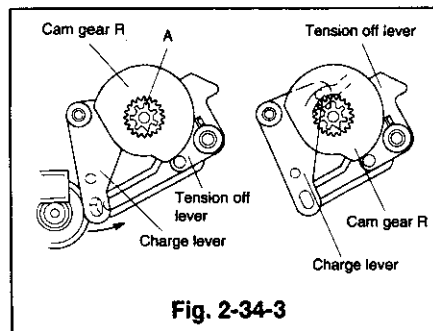

Fig. 2-34-3

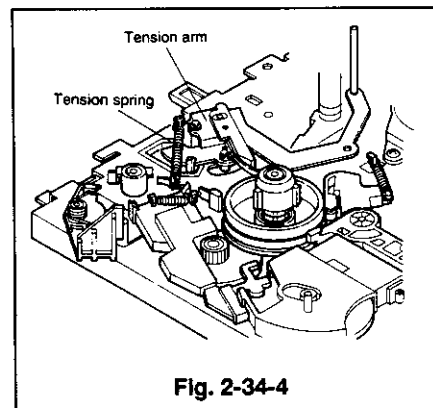

Fig. 2-34-4

## 2-35 Reel Idler Assembly

(Removal)

- ① Remove the reel belt and the belt pulley.  
(Refer to Para. 2-28 for the removal method.)
- ② Remove the two screws (a) and (b) holding the reel idler assembly.
- ③ Unfasten the two catches shown in Fig. 2-35-2 and push the reel idler assembly to remove it, with the deck right side up.

(Installation)

- ① Insert the part B of the reel idler assembly under the plate cam B as shown in Fig. 2-35-1 and ensure projection A enters the hole on the main plate. Position the reel idler assembly so that its screw holes are aligned and secure it with the two screws (a) and (b).  
(Fig. 2-35-3 shows its appearance, viewing from the top.)
- ② Install the belt pulley and the reel belt.  
(Refer to Para. 2-28 for the installation method.)

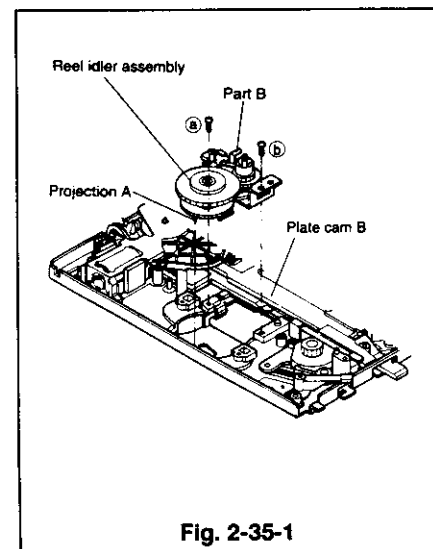

Fig. 2-35-1

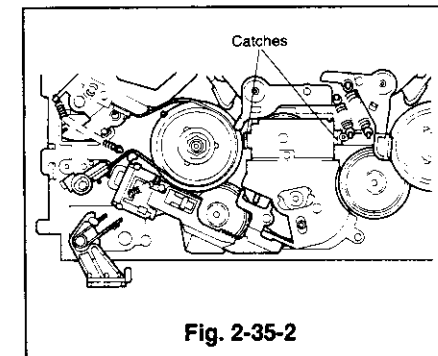

Fig. 2-35-2

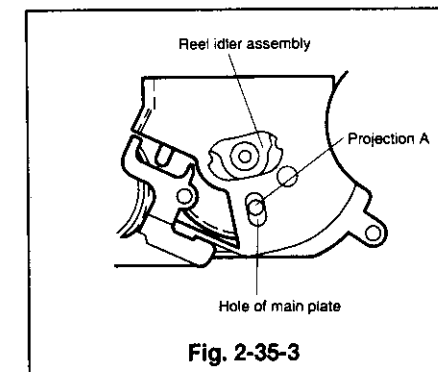

Fig. 2-35-3

## 2-36 Cam Plate C and Cam Spring C

(Removal)

- ① Remove the reel belt and the belt pulley. (Refer to Para. 2-28 for the removal method.)
- ② Remove the reel idler assembly. (Refer to Para. 2-35 for the removal method.)
- ③ Remove the loading motor assembly (which holds the motor holder). (Refer to Para. 2-29 for the removal method.)
- ④ Remove the main gear-J. (Refer to Para. 2-30 for the removal method.)
- ⑤ Remove the plate-J, the roller-B, and the cam plate-B. (Refer to Para. 2-33 for the removal method.)
- ⑥ Remove the cam spring-C. (Refer to Fig. 2-36-1.)
- ⑦ Slide the cam plate-C to the left end.
- ⑧ Unfasten the catch and raise the cam plate-C to remove it. (refer to Fig. 2-36-1.)

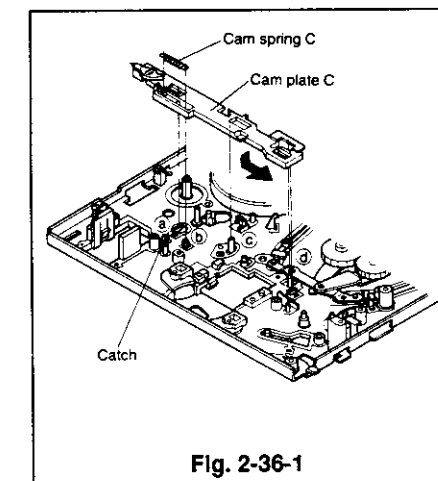

Fig. 2-36-1

#### (Installation)

- ① Apply specified grease to the area (A-I) shown in Fig. 2-36-2 of the new cam plate-C.  
Area A : (G) [859D055O50]  
Area B-I : (PG641) [859D055O30]
- ② Position the cam plate-C so that the four points (A), (B), (C) and (D) shown in Fig. 2-36-1 enter into the matching holes and slide it to the right end.
- ③ Install the cam spring-C.
- ④ Install the cam plate-B, the roller-B, and the plate-J.  
(Refer to Para. 2-33 for the installation method.)
- ⑤ Install the main gear-J.  
(Refer to Para. 2-30 for the installation method.)
- ⑥ Install the loading motor assembly (which holds the motor holder).  
(Refer to Para. 2-35 for the installation method.)
- ⑦ Install the reel idler assembly.  
(Refer to Para. 2-35 for the installation method.)
- ⑧ Install the belt pulley and the reel belt.  
(Refer to Para. 2-28 for the installation method.)

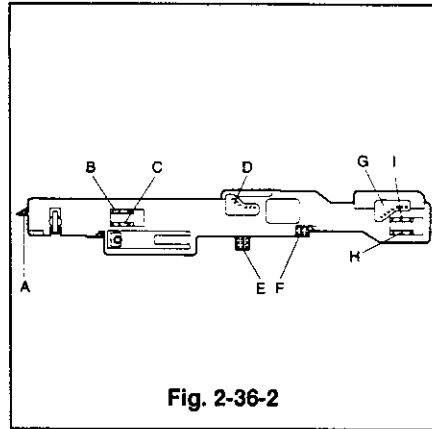

Fig. 2-36-2

#### 2-37 Loading Arm (SP, TU)

##### (Removal)

- ① Remove the reel belt and the belt pulley.  
(Refer to Para. 2-28 for the removal method.)
- ② Remove the loading motor assembly (which holds the motor holder).  
(Refer to Para. 2-29 for the removal method.)
- ③ Remove the main gear-J.  
(Refer to Para. 2-30 for the removal method.)
- ④ Remove the plate-J, the roller-B, and the cam plate-B.  
(Refer to Para. 2-33 for the removal method.)
- ⑤ Raise the loading arms upward, first SP and then TU, to remove them. (Refer to Fig. 2-37-1)

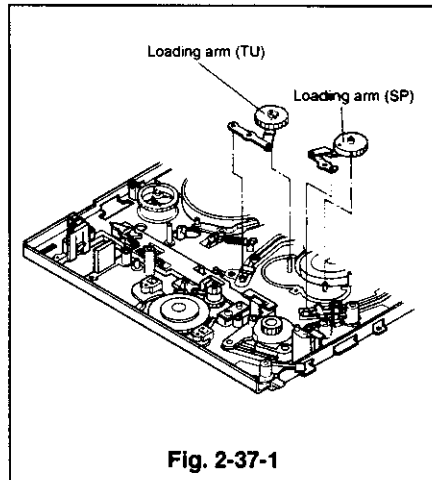

Fig. 2-37-1

##### (Installation)

- ① Move the takeup and supply tape guides to the unloaded position. If the supply tape guide is in the loaded position it will be necessary to shift the tension arm in the direction of the arrow in Fig. 2-37-2 at the same time moving the supply tape guide to the unloading position.
- ② Place the new loading arm (TU) in the position shown in Fig. 2-37-1, then place the loading arm (SP) in the position shown in Fig. 2-37-1 at the same time aligning the marks on the cogs, refer Fig. 2-37-3 (shaded area).
- ③ Apply grease (G) [859D055O50] to the area, which touches the cogwheel of the loading arm (TU) when the loading arms (SP and TU) are shifted fully to the loading direction, and grease (G) [859D055O50] to the gear portion which gears with the plate cam B.  
(Refer to Fig.2-37-4.)

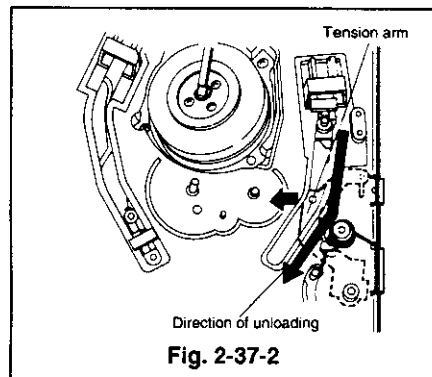

Fig. 2-37-2

- ④ Install the cam plate-B, the roller-B, and the plate-J.  
(Refer to Para. 2-33 for the installation method.)
- ⑤ Install the main gear-J.  
(Refer to Para. 2-30 for the installation method)
- ⑥ Install the loading motor assembly (which holds the motor holder).  
(Refer to Para. 2-29 for the installation method.)
- ⑦ Install the belt pulley and the reel belt.  
(Refer to Para. 2-28 for the installation method.)

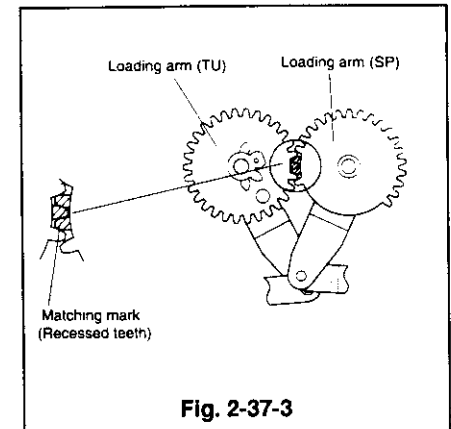

Fig. 2-37-3

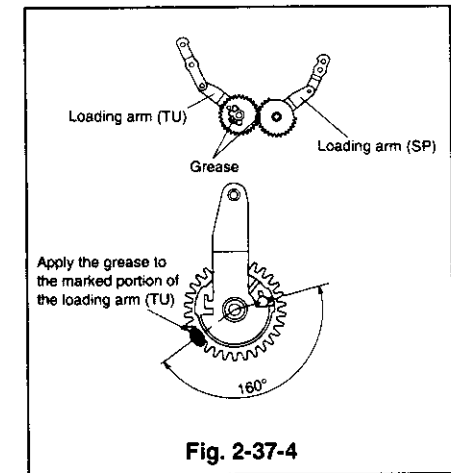

Fig. 2-37-4

#### 2-38 Capstan Motor and Lead Card

**Note:** During removal and installation of the capstan motor, take care not to touch or score the tape running surface, and ensure there is no grease on the outside of the motor's rim.

##### (Removal)

- ① Unfasten the reel belt.
- ② Disconnect the lead card, connected to the PCB of the capstan motor and the PCB-HA/AUDIO.  
(Refer to Fig. 2-38-1.)
- ③ Turn the deck the right side up, remove the three screws shown in Fig. 2-38-2 to remove the capstan motor.

**Note:** During removal, support the capstan motor assembly when it is not secured by its fastening screws. Take care not to touch other parts.

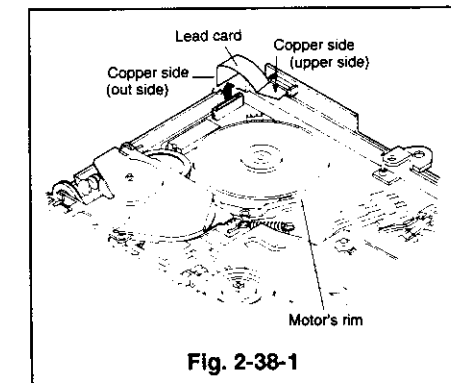

Fig. 2-38-1

(Installation)

- ① Reverse the deck, position the capstan motor so that the capstan brake is on the outside of the capstan motor.
- ② Turn the deck the right side up, secure the capstan motor with the three screws shown in Fig. 2-38-2.
- ③ Bend the new lead card as shown in Fig.2-38-3 and connect it to the connectors of the PCB of the capstan motor and the PCB-HA/AUDIO so that copper side appears as shown in Fig. 2-38-1. Take care not to touch the rotor of the capstan motor.
- ④ Install the reel belt.  
(Refer to Para. 2-28 for the installation method.)

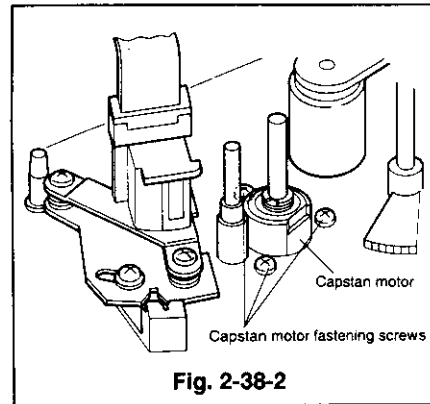

Fig. 2-38-2

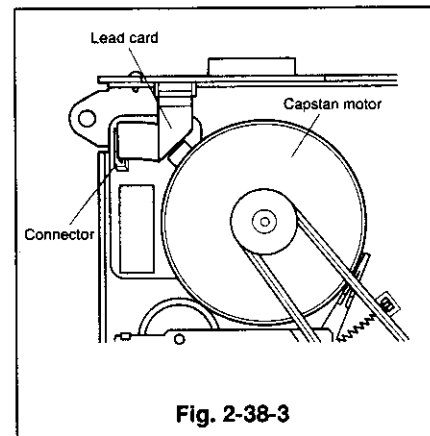

Fig. 2-38-3

### 2-39 A/C Head Assembly

(Removal)

- Note:** During installation of A/C head assembly, take care not to touch or score the tape running surface.
- ① Lift the stopper shown in Fig. 2-39-1 upward and disconnect the lead connector (bare wire), which is connected to the PCB-A/C-HEAD.
  - ② Remove the two screws (Ⓐ and Ⓑ) holding the A/C head assembly to the main plate, and to remove the A/C head assembly. (Refer to Fig. 2-39-2.)

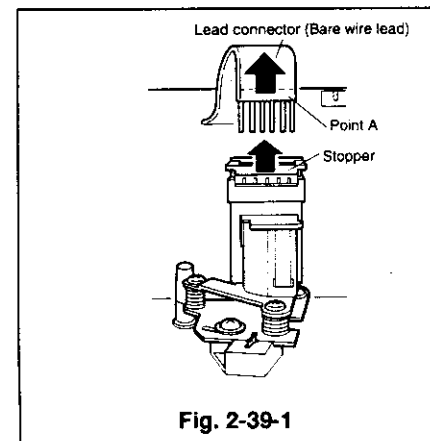

Fig. 2-39-1

(Installation)

- ① Make sure that the spring(A/C earth spring) is as shown in Fig. 2-39-3.
  - ② Place the A/C head assembly in the position shown in Fig. 2-39-2 and secure it with the two screws(Ⓐ and Ⓑ).
  - ③ Shift part A downward and lower the stopper. Connect the lead connector to the connector on the PCB-A/C-HEAD as shown in Fig. 2-39-1.
- Note:** Conduct the A/C head adjustment and the phase adjustment as outlined in Para. 3-3 and 3-4 after the new A/C head is installed.

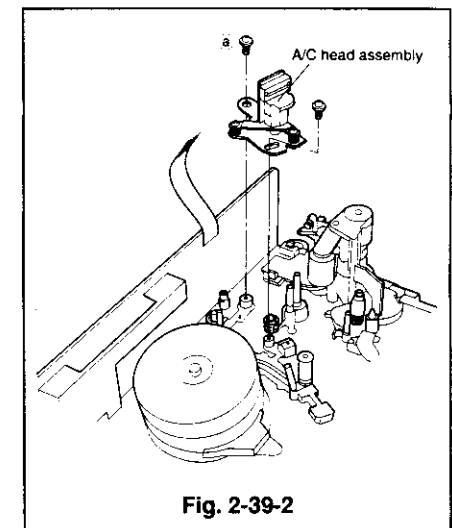

Fig. 2-39-2

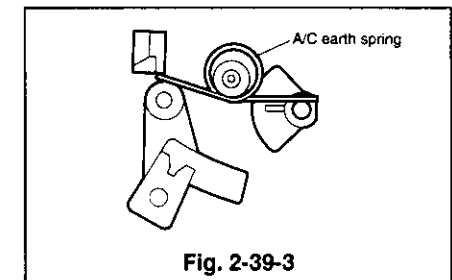

Fig. 2-39-3

### 2-40 A/C Head

(Removal)

- ① Disconnect the lead connector connected to the PCB-A/C-HEAD. (Refer to Item ① of Para. 2-39 for the removal method.)
- ② Remove the three screws(Ⓐ, Ⓑ and Ⓒ), shown in Fig. 2-40-1 to remove the A/C head.
- ③ Unsolder the PCB-A/C HEAD from the A/C head.(Refer to Fig. 2-40-1.

(Installation)

- ① Install the A/C head with the A/C spring and the three screws(Ⓐ, Ⓑ and Ⓒ) as shown in Fig. 2-40-1.
- Note:** When installing the A/C head on the A/C plate, the base plate of the A/C head must be parallel to the A/C plate and the spacing between them should be as specified in Fig. 2-40-2.

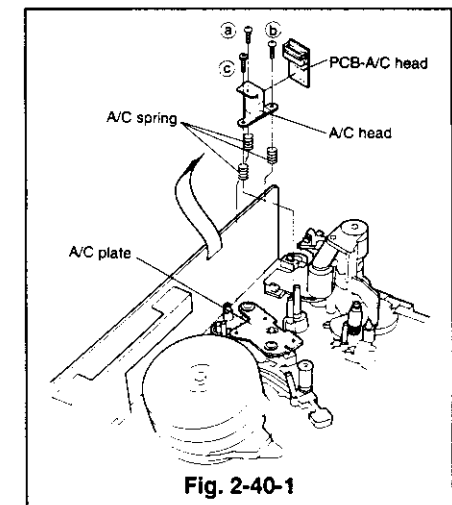
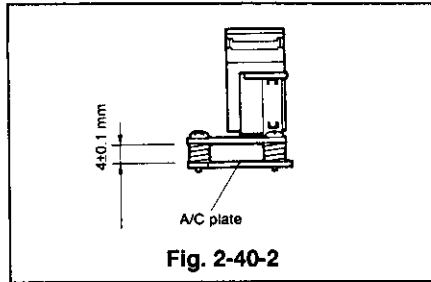

Fig. 2-40-1

- ② Connect the lead connector to the PCB-A/C-HEAD. (Refer to Item ③ of Para. 2-39 for the installation method.)
- ③ Perform the A/C head adjustment as outlined in Para. 3-3 and the phase adjustment as outlined in Para. 3-4.



### 2-41 Supply & Takeup Guide Rollers

(Removal)

- ① Loosen the set screws with a hexagon key so that the guide rollers rotate freely.
- ② Turn the height adjustment screws at the top of the guide rollers counterclockwise with a height adjustment screwdriver to loosen them. Lift the guide roller upward to remove them from the tape guides. (Refer to Fig. 2-41-1)

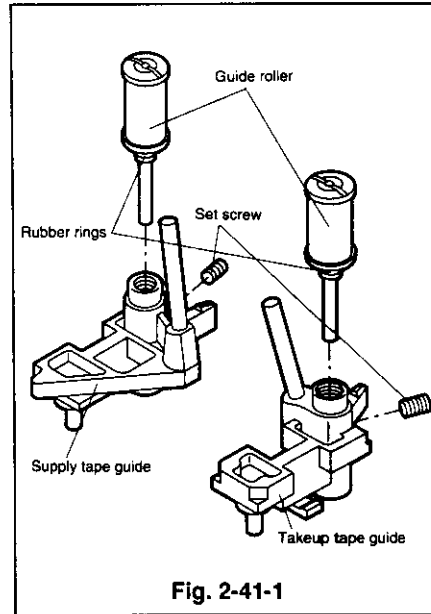

(Installation)

- ① Make sure that the rubber rings are fixed to the fastening thread portions of the new guide rollers.
- ② Perform the following steps ③ to ⑤ to seat in the rubber rings.
- ③ Slowly turn the guide rollers clockwise until the rubber rings are firmly seated.
- ④ Turn the guide rollers a further 1/6 of a turn clockwise and then turn them one turn counter-clockwise.
- ⑤ Slowly turn the guide rollers clockwise until they become firmly seated again. Turn the guide rollers a further 1/6 of a turn clockwise.
- ⑥ Secure the guide rollers lightly with the set screws. Perform the mechanism check and adjustment of the FM envelope as outlined in Para. 3-2.

### 2-42 Cleaning Roller, Cleaning Arm, Cleaning Lever, and Cleaning Spring

(Removal)

- ① Remove the PCB-HA/AUDIO. (Refer to Para. 2-8 for the removal method.)
- ② Unfasten the catch to remove the cleaning roller. (Refer to Fig. 2-42-1)
- ③ Turn part A of the cleaning assembly clockwise as shown in Fig. 2-42-2 to release the catch part B Fig. 2-42-2 and Fig. 2-42-3(c). Release the catch part E and remove the cleaning assembly from the shaft.
- ④ Remove the cleaning spring to detach the cleaning arm and the cleaning lever.

(Installation)

- ① Attach the cleaning arm to the cleaning lever and turn it clockwise as shown in Fig. 2-42-3(c). Make sure that the cleaning arm and the cleaning lever turn without binding.
- ② Hook one end of the cleaning spring with the boss (point C), projecting from the cleaning arm, and the other end to point D of the cleaning lever as shown in Fig. 2-42-3(d).
- ③ Place the cleaning assembly in the position shown in Fig. 2-42-1, and in the direction shown in Fig. 2-42-2(b). Turn the part A, shown in Fig. 2-42-2, counterclockwise to set the part B under the A/C plate of the A/C head assembly. Make sure that the spring hooks with the boss of the main plate shown in Fig. 2-42-2. Shift the part A in the direction shown by the arrow and release to make sure that it returns.
- ④ Insert the cleaning roller into the position shown in Fig. 2-42-1 to install it.

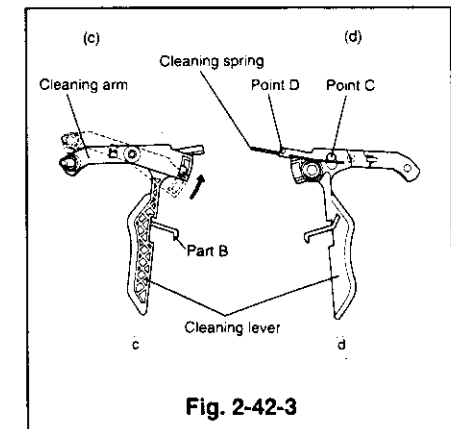
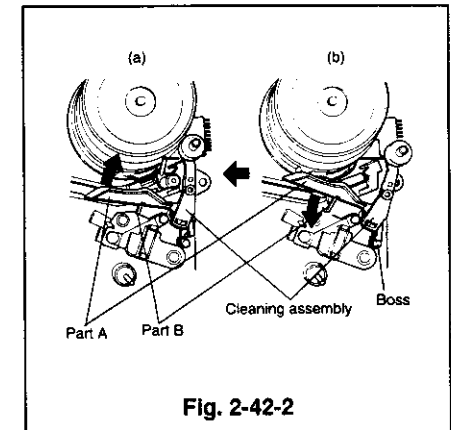
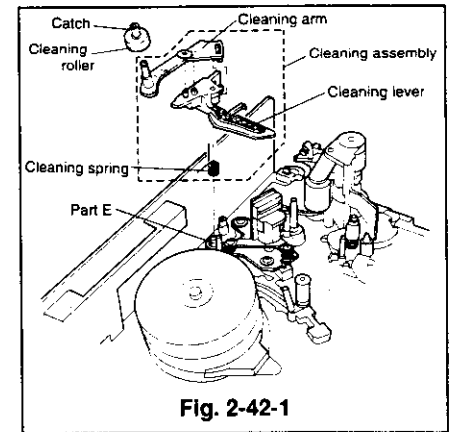



## 2-43 Supply & Takeup Tape Guide Assemblies

### (Removal)

- ① Remove the cassette housing.  
(Refer to Para. 2-1 for the removal method.)
- ② Remove the PCB-HA/AUDIO.  
(Refer to Para. 2-8 for the removal method.)
- ③ Remove the cleaning assembly.  
(Refer to item ④ of Para. 2-42 for the removal method.)
- ④ Unscrew the three screws (a, b and c) to remove the drum base together with the drum assembly.  
(Refer to Fig. 2-43-1.)
- ⑤ Slide the supply and takeup tape guide assemblies to the end of the loaded position by either of the following methods.
  - Supply voltage (approximately +5V voltage on the red wire) to the loading motor as in ② of the removal method in Para. 2-19.
  - Turn part A of pulley worm J by hand, in the direction shown by the arrow (a) as shown in Fig. 2-43-3. Raise the supply and takeup tape guide assemblies upward to remove them.

### (Installation)

- ① Apply grease (PG-641) [859D055O30] to the area shown in Fig. 2-43-2 of the supply tape guide assembly.
- ② Install the supply and takeup tape guide assemblies so that they respectively enter the holes at the ends of the loading arms (SP and TU) attached to the reverse side of the deck as shown in Fig. 2-43-1.
- ③ Slide the supply and takeup tape guide assemblies to the unloaded position, by either of the following methods so that the upper hole of the mode switch aligns with that of the cogwheel as shown in Fig. 2-43-4.
  - Supply voltage (approximately 5V), reversing the polarity used in ④ of the removal method, to the loading motor as ⑤ of the installation method in Para. 2-19.
  - Turn part A of the pulley worm J by hand, in the direction shown by the arrow (b) as shown in Fig. 2-43-3.
- ④ Make sure that the hole of the gear joint J aligns with the matching mark of the main plate, and the matching mark of the gear pinch with that of the mode switch as shown in Fig. 2-43-5.
- ⑤ Install the drum base on which the drum assembly is attached and secure it with the three screws (a, b and c) as shown in Fig. 2-43-1.  
(Tighten the screws in the order a→b→c.)
- ⑥ Install the cleaning assembly.  
(Refer to item ③ of Para. 2-42 for the installation method.)
- ⑦ Install the PCB-HA/AUDIO.  
(Refer to Para. 2-8 for the installation method.)
- ⑧ Install the cassette housing.  
(Refer to Para. 2-1 for the installation method.)

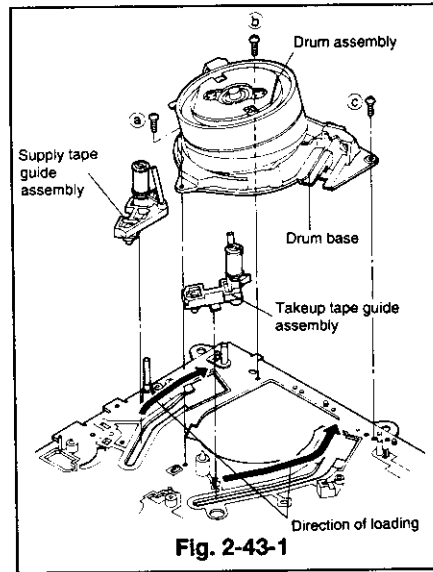

Fig. 2-43-1

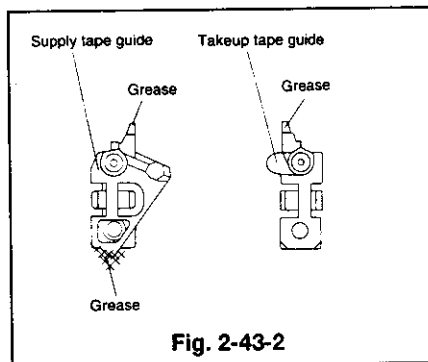

Fig. 2-43-2

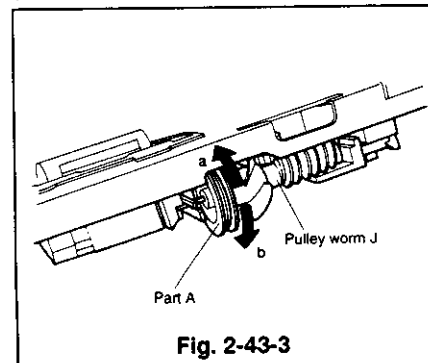

Fig. 2-43-3

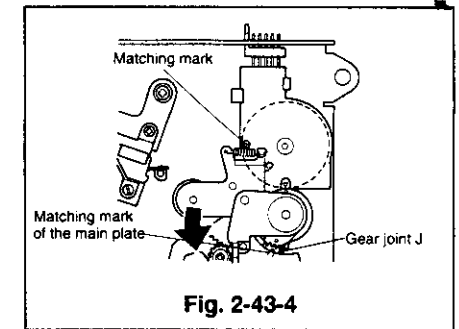

Fig. 2-43-4

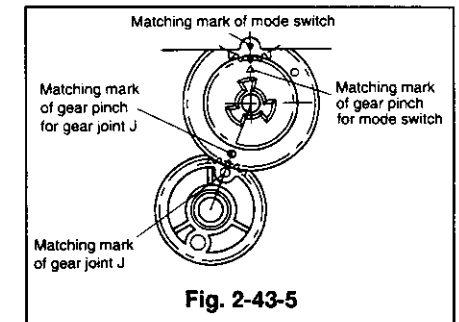

Fig. 2-43-5

## 2-44 Drum Base Spring

### (Removal)

- ① Remove the drum base spring between the drum base and the drum assembly. (Refer to Fig. 2-44-1.)
- Note:** If the drum base spring is difficult to remove, remove the drum assembly in advance. (Refer to Para.2-10)
- Note:** During removal and installation of the drum assembly, do not touch the tape running surface with your hands.

### (Installation)

- ① Set the drum base spring in the gap between the drum base and the drum assembly. Make sure that the drum base spring is secure enough not to fall out.
- ② Apply grease (PG-641) [859D055O30] to the area of the drum base spring as shown in Fig. 2-44-1.

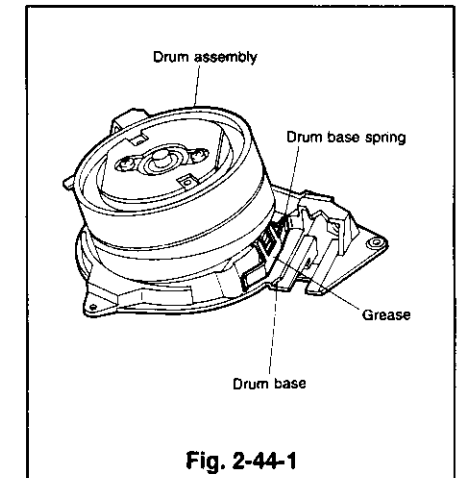

Fig. 2-44-1

## 2-45. Replacement of ASSY IMPEDANCE ROLLER

### (Removal)

- ① Unfasten the catch to remove the FLY WHEEL J.
- ② Remove the IMPEDANCE ROLLER SPRING-J from the catch ③ shown in Fig. 2-45-2.
- ③ Shift the ASSY IMPEDANCE ROLLER in the direction shown by the arrow. Unfasten the catch ④ and raise the ASSY IMPEDANCE ROLLER to remove it from the HOLDER TG.
- ④ Unfasten two catches of the HOLDER TG on the reverse side to remove the HOLDER TG. [Fig. 2-45-4]

### (Installation)

- ① Mount the HOLDER TG on the MAIN PLATE. [Fig. 2-45-4]
- ② Hook the one side of the IMPEDANCE ROLLER SPRING-J to the catch ③ and the other side to the catch ④ to install the IMPEDANCE ROLLER SPRING-J on the ASSY IMPEDANCE ROLLER. [Fig. 2-45-3]
- ③ Install the ASSY IMPEDANCE ROLLER, to which the IMPEDANCE ROLLER SPRING-J is attached, on the HOLDER TG.

**NOTE:** Installation of the ASSY IMPEDANCE ROLLER will be easier by pulling the PCB-HA/AUDIO slightly in the direction shown by the arrow in Fig. 2-45-4.

- ④ Make sure that the IMPEDANCE ROLLER SPRING-J is hooked at the catch ③ of the HOLDER TG shown in the Fig. 2-45-5.
- ⑤ Install the FLY WHEEL J on the ASSY IMPEDANCE ROLLER so that the side whose hole entrance is cut out diagonally looks up.
- ⑥ Make sure that three catches are tightly hooked on the FLY WHEEL. If they are not, hook them tightly with the tweezers. [Fig. 2-45-1]

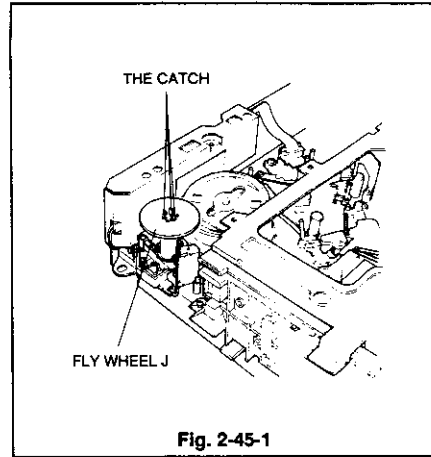

Fig. 2-45-1

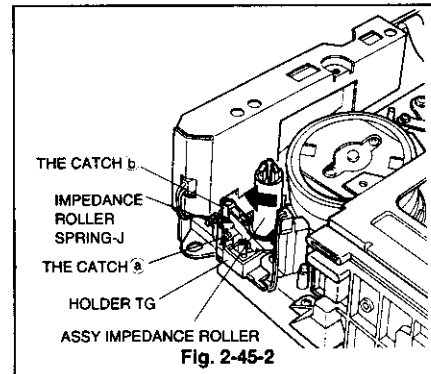

Fig. 2-45-2

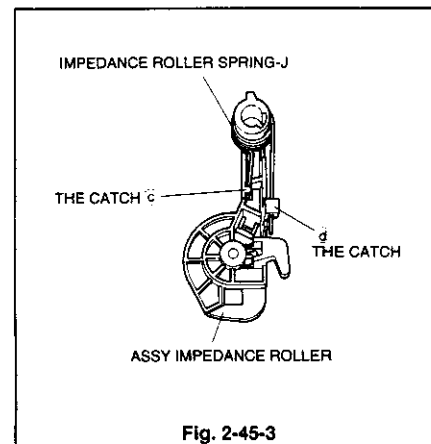

Fig. 2-45-3

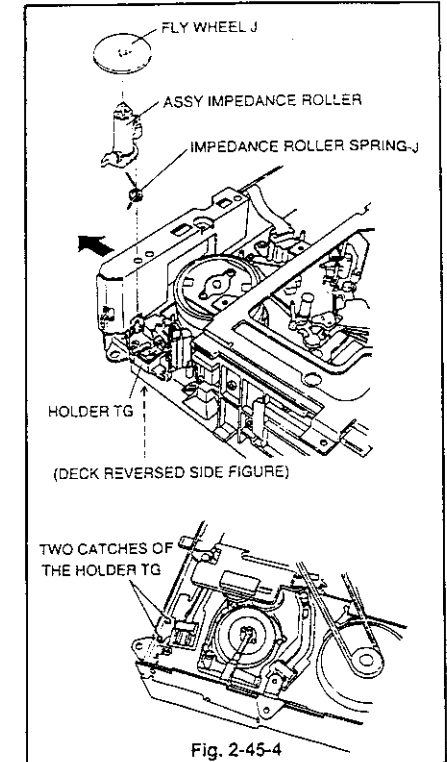

Fig. 2-45-4

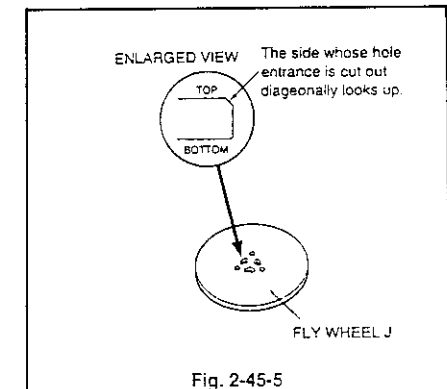

Fig. 2-45-5

### 3. Interchangeability Adjustment of the Mechanism

**Note1:** Tracking may need to be preset during interchangeability adjustments of the mechanism. Digital tracking is preset by short circuiting TP5A and TP5B on the PCB-MAIN.

**Note2:** The adjustments are performed in the playback mode, using the stair step signal of an alignment tape. Connect an oscilloscope to TP2A and external Trig. from TP2H, unless otherwise specified.

#### 3-1 Adjustment of Back-Tension and Tension Pole Position

Run a blank tape for several minutes to break in the reel disks and the transport before making the adjustment.

- ① Cut out the alignment tape [PM6KH3 : 859C339O30] as shown in Fig. 3-1-2. This allows the boss to be adjusted while playing the tape by inserting hexagon wrench through the round hole in the cassette housing shown in Fig. 3-1-1. (Take care not to allow fragments of the cassette case inside the cassette tape.)
- ② Playback an alignment tape which has a cut out.
- ③ Make sure that the tip section A of the tension arm is between the divisions "2" and "2.5" on the main plate. (Fig. 3-1-1) (The divisions are numbered from the right to left.)
- ④ If tip section A of the tension arm is to the right of "2", turn the boss clockwise. If A is to the left of "2.5", turn it counter-clockwise.
- ⑤ Insert a back tension measuring jig (Part No. 859C346060) and set the VCR to the playback mode.
- ⑥ When tape travel becomes steady, make sure that the reading of the Back Tension Measuring Jig is  $50 \pm 6g\text{-cm}$ .
- ⑦ If the reading is high, replace the tension spring.
- ⑧ When tape travel is steady, check visually to make sure that the runout of the tension pole is 1mm or less. (Fig. 3-1-3)
- ⑨ If the runout is not within the specified value, replace the reel disk.

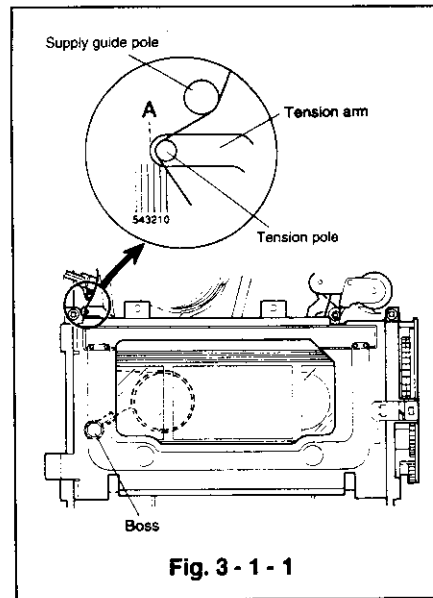

Fig. 3-1-1

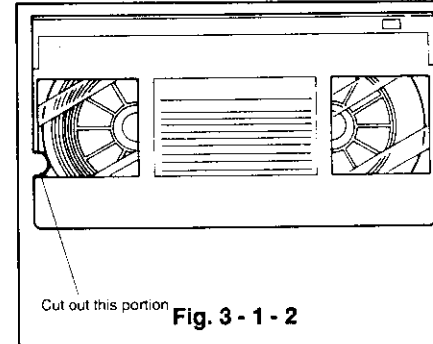

Fig. 3-1-2

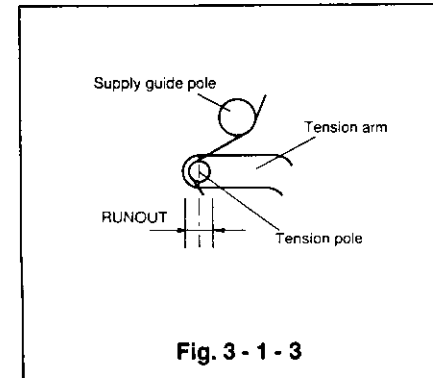

Fig. 3-1-3

### 3-2 Check and Adjustment of FM Envelope

#### 3-2-1 Guide Roller Adjustment

- ① Play back the alignment tape. [PM6KH3 : 859C339O30]
- ② Preset tracking. (Refer to NOTE 1 in Para. 3.)
- ③ Check if the FM waveform is flat like A. (Refer to Fig. 3-2-1)
- ④ Adjust the height of the supply guide roller if the leading portion (the entry side of the drum) of the FM waveform is not flat, like B or C. (Refer to Fig. 3-2-1) Adjust the height of the takeup guide roller if the trailing portion (the exit side of the drum) is not flat, like D or E.

#### 3-2-2 Adjustment of Supply Guide Roller Height

- ① Loosen the set screw until the supply guide roller is held lightly when rotated.
- ② The supply guide roller may be low if the leading portion (the entry side of the drum) of the FM waveform is like B, and high if like C. Turn the adjusting screw at the top of the roller to adjust the height of it so that the FM waveform is flat like A.
  - Turn the adjusting screw counter-clockwise if the roller is low.
  - Turn the adjusting screw clockwise if the roller is high.
- ③ Coarsely adjust the phase as in Item 3-3-4.

#### 3-2-3 Adjustment of Takeup Guide Roller Height

- ① Loosen the set screw until the takeup guide roller rotates lightly.
- ② The takeup guide roller may be low if the trailing portion (the exit side of the drum) of the FM waveform is like D, and high if like E. Turn the adjusting screw at the top of the roller to adjust the height so that the FM waveform is flat like A.
  - Turn the adjusting screw counter-clockwise if the roller is low.
  - Turn the adjusting screw clockwise if the roller is high.
- ③ Coarsely adjust the phase as in Item 3-2-4.

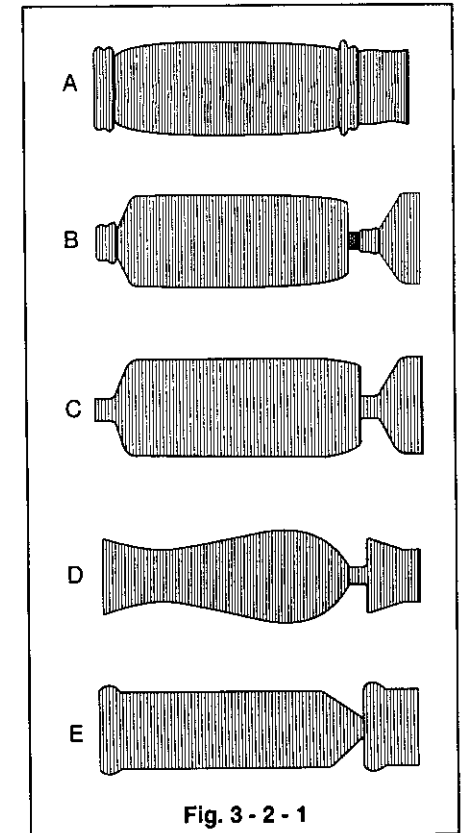

Fig. 3-2-1

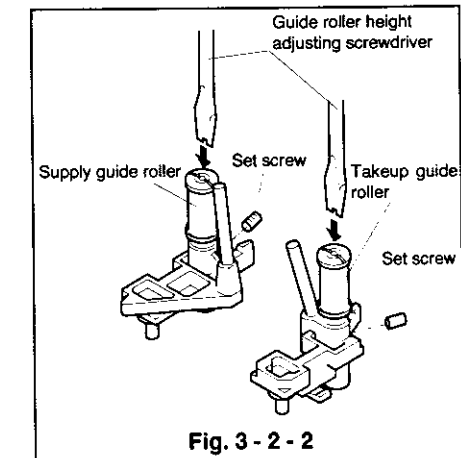

Fig. 3-2-2

### 3-2-4 Coarse Adjustment of Phase

- 1 Play back the alignment tape.  
[PM6KH3 : 859C339O30]
- 2 Preset tracking. (Refer to NOTE 1 in Para. 3.)
- 3 Check the FM waveform after checking and adjusting the guide rollers.
- 4 If the amplitude of the FM waveform is narrow like F because of out of phase, adjust it to maximum like G, as shown in Fig. 3-2-4 by the following procedure. Loosen the screw E, insert a screw driver into the groove at the Base A/C and the main plate, and shift the Base A/C right and left.
- 5 Tighten the screw E to secure the base-A/C in place.

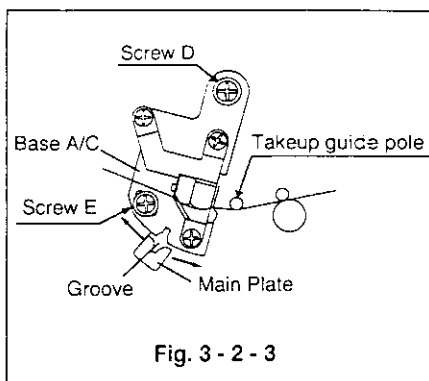

Fig. 3-2-3

### 3-2-5 Check of FM Waveform Flatness

- 1 Play back the alignment tape.  
[PM6KH3 : 859C339O30]
- Note:** In the following adjustment, follow the next procedure for automatic / manual-selection and adjustment of tracking.
- Turn the JOG dial while pressing the O.K.PROG. button on the VCR during playback.
  - To switch from manual tracking back to automatic digital tracking, press the O.K.PROG. button on the VCR during playback.
- 2 In the manual tracking mode, change tracking and make sure the amplitude is changeable while the FM signal remains flat.
  - 3 Adjust tracking so that the amplitude of the FM waveform is maximum. Set the oscilloscope so the amplitude of the FM waveform is 5 division.
  - 4 Adjust tracking so that the peak value of the FM waveform is 4 divisions. Check if the FM waveform B, C, D, and E are within the specified values shown in Fig. 3-2-5.
  - 5 If the waveform is not within the specified value, repeat the procedure for checking and adjustment of FM envelope in Item 3-2 from the beginning.

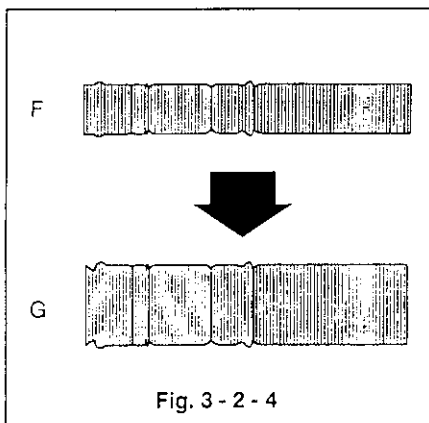

Fig. 3-2-4

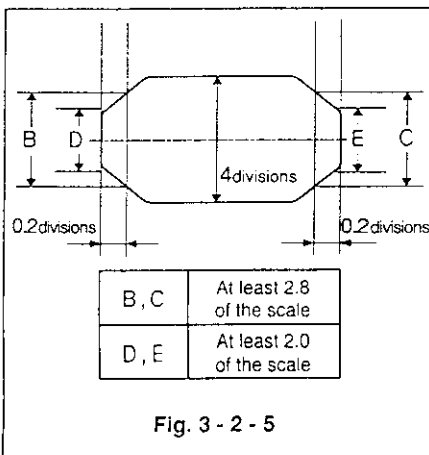

Fig. 3-2-5

### 3-2-6 Check 1: Tape Running Condition at the Guide Rollers (Refer to Fig. 3-2-6)

- 1 Play back the alignment tape.  
[PM6KH3 : 859C339O30 ]
- 2 Visually check if there is a space between the tape and the lower flange of the supply guide roller and takeup guide roller.
- 3 If there is no space, replace the tape guide as in Item 3-2-7.
- 4 If EITHER GUIDE ROLLER is replaced. Perform the GUIDE ROLLER adjustment in item 3-2-1. And the FM waveform flatness check in item 3-2-5.
- 5 Load and unload the tape several times, check that flatness of the FM waveform does not change.
- 6 If flatness changes, check if the A/C arm is loose. If it is not loose, replace the A/C arm and repeat the procedure for coarse adjustment of phase in Item 3-2-4.

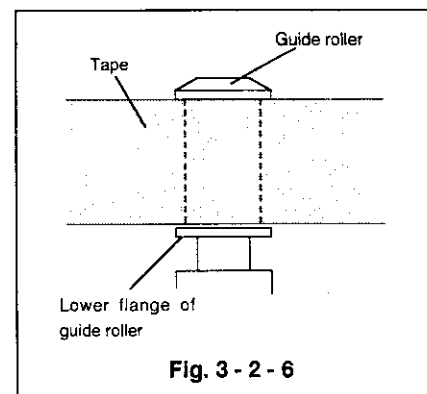

Fig. 3-2-6

### 3-2-7 Replacement of Tape Guides

- 1 If the current tape guide has no marking, replace it with one with a red mark.
- 2 If the current tape guide has a black mark, replace it with one with no mark. If this replacement is not effective, replace the tape guide with one with a red mark.
- 3 If the current tape guide has a red mark, replace it with another one with red mark.

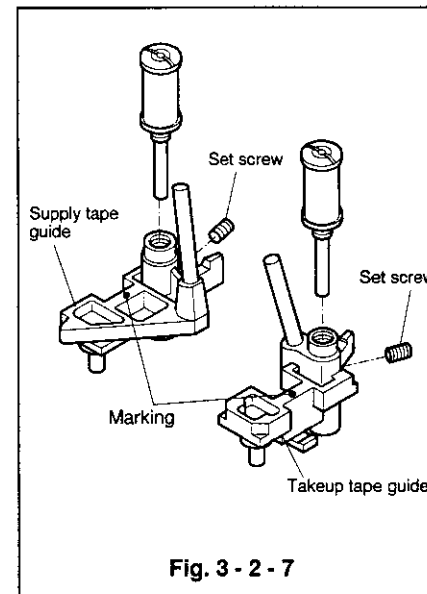

Fig. 3-2-7

### 3-2-8 Check 2: Tape Running Condition on Guide Rollers

- 1 Play back the alignment tape.  
[PM6KH3 : 859C339O30 ]
- 2 Lightly press and release the top of the supply guide roller and takeup guide roller. Check that the FM waveform is quickly restored to the previous level.
- 3 If the waveform is not quickly restored, replace the tape guide as in Item 3-2-7.
- 4 If the supply tape guide is replaced, check the guide roller as in Item 3-2-1, and if the takeup tape guide is replaced, check the guide roller as in Item 3-2-1. Perform the check FM waveform flatness check as in Item 3-2-5.
- 5 If satisfactory, tighten the set screw of the guide roller on the supply side and the takeup side.

Identification of Tape Guide Item Number  
(Example; Parts No. 635B059O10  
Item No. )

Item No. 1	No marking
Item No. 2	Marked with black magic marker
Item No. 3	Marked with red magic marker

\* The marking point is on the top of the tape guides shown in figure above.

### 3-3 Adjustment of A/C Head

#### 3-3-1 Adjustment of A/C Head Slant

- ① Playback a blank tape.
- ② Slowly turn the adjusting screw C counter-clockwise to crease the bottom of the tape slightly at the flange portion of the takeup tape guide.
- ③ Return adjusting screw C slowly to remove the crease.
- ④ Slowly turn adjusting screw C counter-clockwise again and stop turning just before the tape is creased.

#### 3-3-2 Adjustment of A/C Head Azimuth and Height

- ① If the height of the CTL head is different from the specified-value in Fig. 3-3-2, adjust the height by the adjusting screw A.
- ② If adjusting screw A is moved, repeat the procedure in Item 3-3-1 to adjust the A/C head Slant.
- ③ Connect the oscilloscope to the audio output terminal and set the VCR to the playback mode.
- ④ Playback the standard tape. [PM6K13 : 859C339O30]
- ⑤ Turn adjusting screw B to adjust azimuth so that the audio output level is maximum. Set the scope for an amplitude of 5 divisions.
- ⑥ After the adjustment of ⑤, pull out the screw driver and check if the audio output level is 4.5 divisions or more, when the maximum level (audio output) of ⑤ was set for 5 divisions.
- ⑦ If the audio output level is below the specified value, repeat the procedure ①-⑥.
- ⑧ Push the A/C head to the right and left (in the direction of A and A' in Fig. 3-3-1) and then release the A/C head. Check that the audio output level does not change. (Do not push past the point where the audio output level is reduced by 3/4 of its maximum value.)
- ⑨ Set the VCR to the playback mode and check if the change of the audio output level is less than 2dB.
- ⑩ If the change is over 2dB, adjust the A/C head slant again and recheck.
- ⑪ If not satisfactory, replace the takeup tape guide complying with the following procedure and repeat this adjustment.
  - If the original tape guide has no marking, replace it with the one with a black mark.
  - If the original tape guide has a black mark, replace it with one with a black mark.
  - If the original tape guide has a red mark, replace it with the one with a red mark. If this replacement is not effective, replace it with one with a black mark.

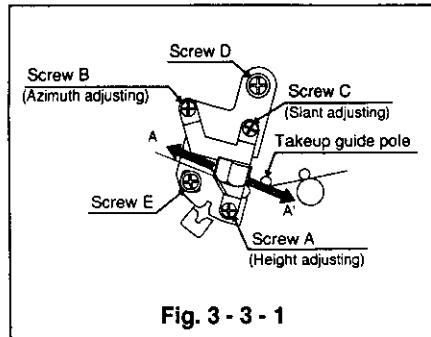

Fig. 3-3-1

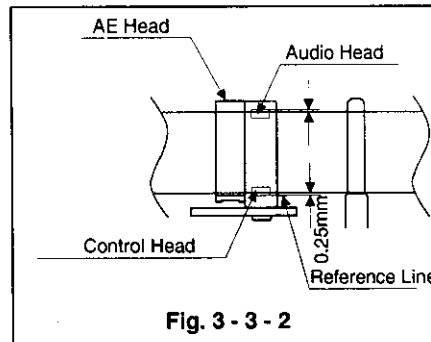

Fig. 3-3-2

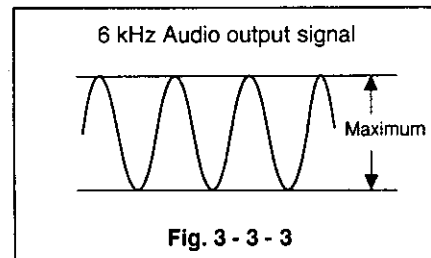

Fig. 3-3-3

#### Identification of Tape Guide Item Number

(Example; Parts No. 635B059010)

Item No. 10

Item No. 1	No marking
Item No. 2	Marked with black magic marker
Item No. 3	Marked with red magic marker

\* The marking point is on the tops of the Takeup and Supply tape guides.  
(Refer to Fig. 3-2-7)

### 3-4 Adjustment of Phase

- ① Set the VCR to the playback mode.  
(Use the alignment tape specified below to perform adjustment ①-④.)  
[PM3KE6 (CH1) 25 : 859C568O50]
- ② Preset tracking. (Refer to NOTE 1 in Para. 3.)
- ③ Loosen the screw E, insert a screw driver into the gap between the Base A/C and the main plate, and shift the Base A/C right and left to adjust the FM waveform to maximum.
- ④ Tighten the screw E.
- ⑤ Play back the alignment tape. (PMX:859C568O70)
- ⑥ Connect TP2A ( the FM waveform output) and the audio output terminal to the oscilloscope, external Trig. to TP2H, and check if the missing portions of the FM waveform and that of the audio waveform are within the specified value (field). (Refer to Fig. 3-4-2.)
- ⑦ If they are not within the specified value, repeat the procedure ③.
- ⑧ Turn the normal tracking control to adjust the FM waveform for maximum and set the oscilloscope so that the waveform is '5' divisions. (Refer to Note in Para. 3-2-5 about tracking adjustment.)
- ⑨ Preset tracking. (Refer to NOTE 1 in Para. 3.)
- ⑩ Check that the FM waveform on the oscilloscope is " 4.8 " or more divisions.
- ⑪ If the FM waveform is below " 4.8 " divisions, perform this adjustment after tracking preset.
- ⑫ Push the A/C head to the right and left (in the direction of A-A' in Fig. 3-4-1) and then release the A/C head. Check that the amplitude of the FM waveform does not change from that before shifting the A/C head.
- ⑬ If the amplitude changes, check if the A/C arm shaft is loose. If it is not loose, replace the A/C arm and repeat the procedure of this adjustment from the beginning, after the adjustment of A/C head in Item 3-3.
- ⑭ Alternately load and unload the tape several times to check that the amplitude of the FM waveform does not change.

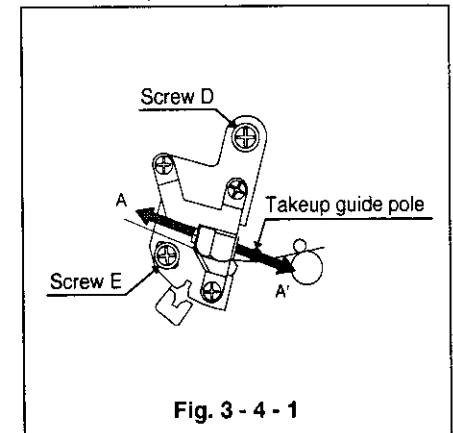

Fig. 3-4-1

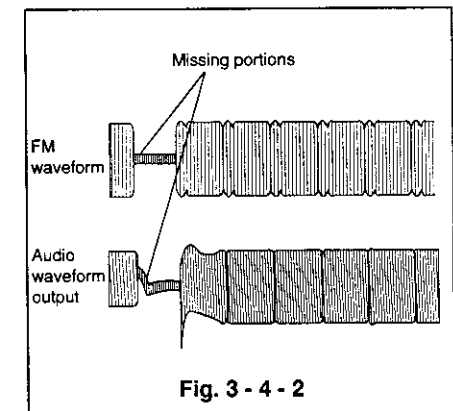

Fig. 3-4-2

### 3-5 Adjustment of Takeup Guide Arm Height

- ① Run a final portion of E-240 blank tape in the reverse search mode.
- ② Tighten the adjusting nut of takeup tape guide until the tape is creased at the lower flange of the takeup guide pole. Then slowly return the nut and stop at the point where the crease is removed. (During adjustment, use an uncovered cassette tape or raise the cover so that the adjustment can be performed.)

**Note:** During adjustment, turn the adjusting nut in the loosening direction. Do not turn the nut more than  $\pm 1/2$  turn.

- ③ Eject the cassette tape, set the VCR to the reverse search mode again, and check that the tape is not creased at the upper or lower flange of the takeup tape guide.
- ④ Set the VCR to the playback mode and check that the tape is not creased at the upper or lower flange of the takeup guide pole.
- ⑤ Run the start portion of E-180 blank tape in the forward search mode and check that the tape is not creased at the takeup guide pole.

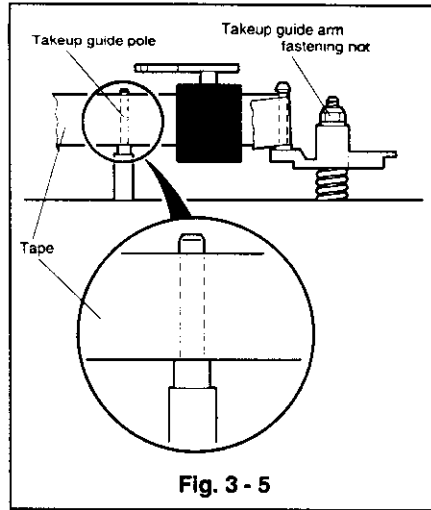

### 4. Servicing for Tape Jamming during the Loading Mode

- ① Remove the upper cover.
- ② Remove the front unit.
- ③ Remove the bottom panel.
- ④ Reverse the deck and turn the pulley worm J in the direction shown by the arrow in Fig.4-1, observe whether the tape guides move to the unloading position. If they do not, follow the procedure (1). If they do, follow the procedure (2).

**(1) If the tape guides do not move (the pulley worm J does not turn);**

- ① Unfasten the clamp holding the leads of the loading motor, which are attached to the side plate of the cassette housing. Unscrew screws (a) and (b) holding the cassette housing as shown in Fig. 4-2.
- ② Hold the cassette door with a screw driver to keep it open. (Take care not to allow the screw driver to touch other parts of the tape transport.)

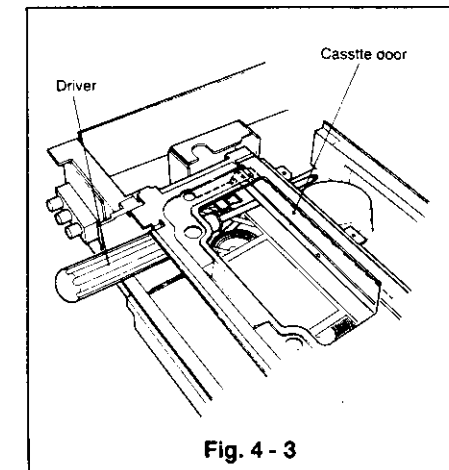
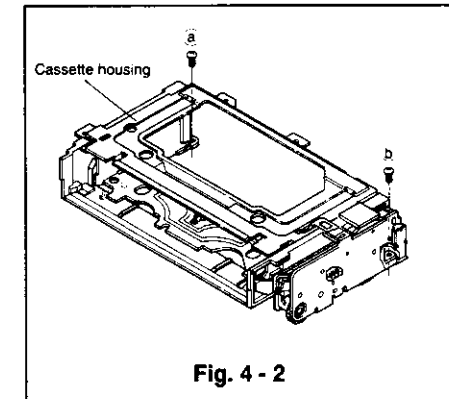
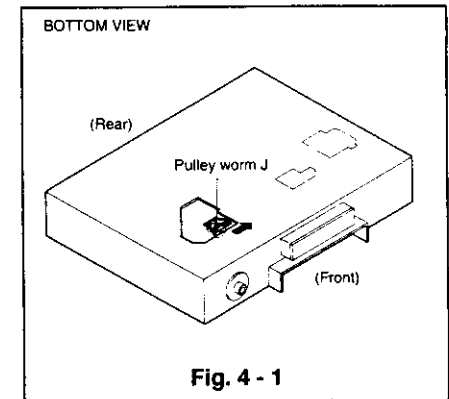

- ③ Open the cassette door fully with your hand. Unfasten the catch to remove the pinch roller arm cap as shown in Fig. 4-4. (Refer to Para. 2-24 for the removal method.)
- ④ Push part A of the pinch roller arm assembly, shown in Fig. 4-5, in the direction shown by the arrow to make a space between the pinch roller arm assembly and the tape. Remove it together with the pinch cam taking care not to damage the tape.
- ⑤ Remove the screw driver (refer to Item ②), while holding the cassette door open with your hand. While pushing the tension arm in the direction shown by the arrow in Fig. 4-6 raise the cassette housing upward to remove it from the tape transport as shown in Fig. 4-7. Take care that the grease, which is applied to the main plate, does not adhere to the tape.

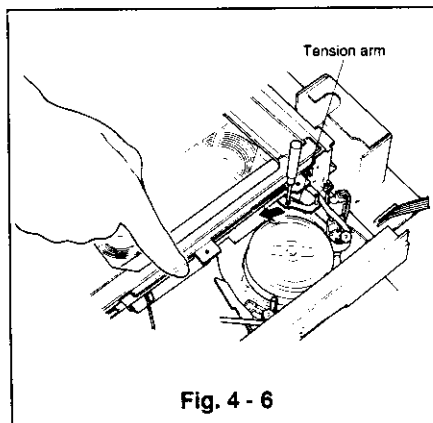
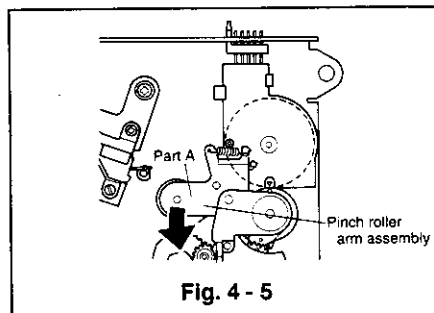
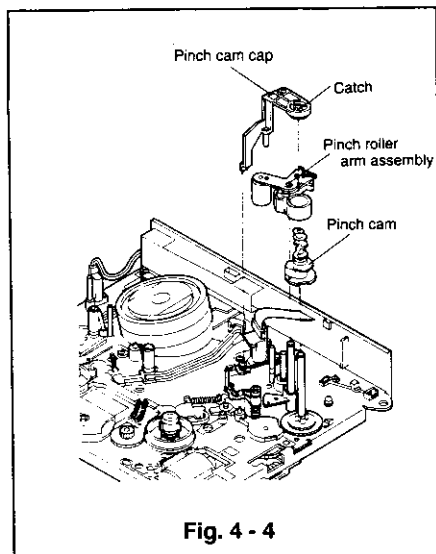

- ⑥ Turn the cassette reel of the cassette tape to wind up the tape as shown in Fig. 4-8.
- ⑦ Turn the wheel gear shown in Fig. 4-9 in the direction shown by the arrow to eject the cassette tape.
- ⑧ Reverse the deck and turn the motor pulley J in the direction, shown by the arrow in Fig. 4-1, so that the matching mark M of the mode switch is in the position shown in Fig. 4-10 (the eject position). Make sure that the matching marks of the mode switch and the gear pinch, and those of the gear pinch and the joint gear, respectively, align as shown in Fig. 4-11. Turn the takeup guide arm clockwise to such a degree that takeup guide gear is not in the way of mounting the pinch roller cam to the shaft. Install the pinch roller cam so that its holes align with the triple catch of the gear pinch. (Refer to Para. 2-24 for the installation method.)
- ⑨ Install the pinch roller arm and the pinch roller arm cap.
- ⑩ Install the cassette housing. (Refer to Para. 2-1 for the installation method.)

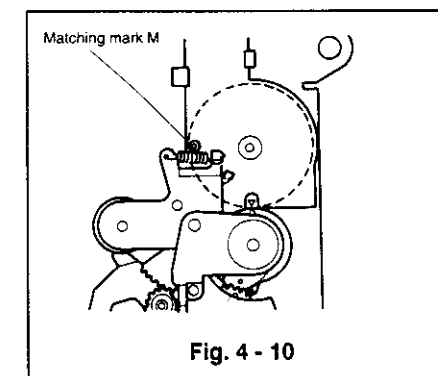
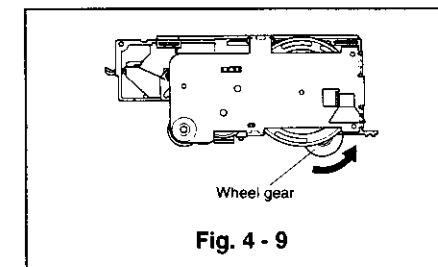
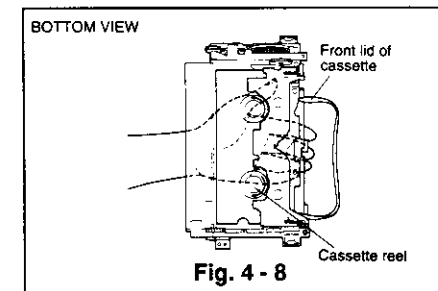
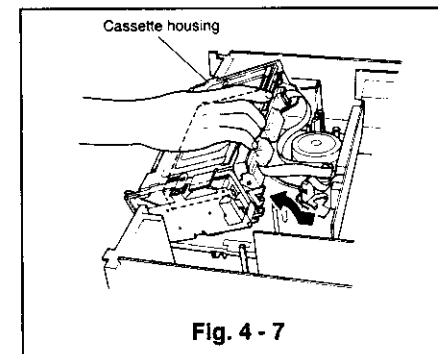

(2) If the tape guides move (the pulley worm J turns);

- ① Reverse the deck and turn the pulley worm J in the direction shown by the arrow in Fig. 4-1 so that the takeup guide arm moves to the end of the unloading cycle.
- ② Turn the capstan shaft, shown in Fig. 4-12, clockwise to turn the reel so that the tape is wound back into the cassette. (Take care not to scar or stain the capstan shaft. After winding up the tape, clean the capstan shaft with alcohol, refer to Para. 1-2.)
- ③ Turn the pulley worm J as in Item ① so that the matching mark of the mode switch is in the position shown in Fig. 4-10 (the eject position). Eject the cassette tape.

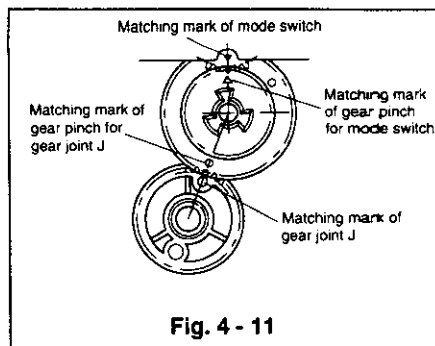

Fig. 4-11

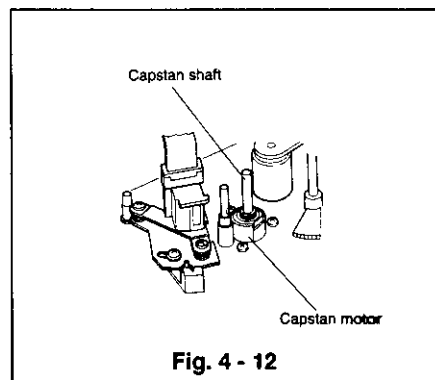

Fig. 4-12

## SPECIFICATION OF VPS RECORDING SYSTEM

[HS-561V(G) only]

### 1. VPS Signal

The VPS signal makes it possible during timer recording of television programs to switch on and off the unit at the correct time by using the preprogrammed recording time. The VPS signal is transmitted in the 16th line of the vertical blanking signal. Refer to Fig. 1. The VPS data signal is shown in Fig. 2. The television stations are responsible for changing of the VPS data. These are included in words 11 to 14.

The normal VPS code includes time data and program data. It is transmitted with the program and recognized by the unit as program identification. A program, which was scheduled for the time from 0:99 to 4:00 and the start of which was changed to the previous day, keeps its original label. If the program is extended, the label is valid until 4:00 of the following day, if the correct sending code is received. The maximum starting time for a delayed program is 4:00 of the following day.

### 2. Expected VPS time and type of VPS recording

- 2-1 At 20:00 on the day before the starting time the recorder is switched on and enters the expected VPS time. During the expected VPS time the unit is switched to the corresponding channel and waits for the VPS signal.
- 2-2 If a VPS signal, which confirms to the preprogrammed signal, is received, the unit switches into the recording mode.
- 2-3 If no VPS signal or status code is transmitted, the original recording time is used.
- 2-4 If an interruption code is transmitted during the VPS recording, the recording is stopped and the unit switches into the VPS stand-by mode. The recording is started, as soon as the regular VPS code is received again.
- 2-5 If the normal VPS code changes after the programmed timer recording into an unnormal code, the recording is finished.

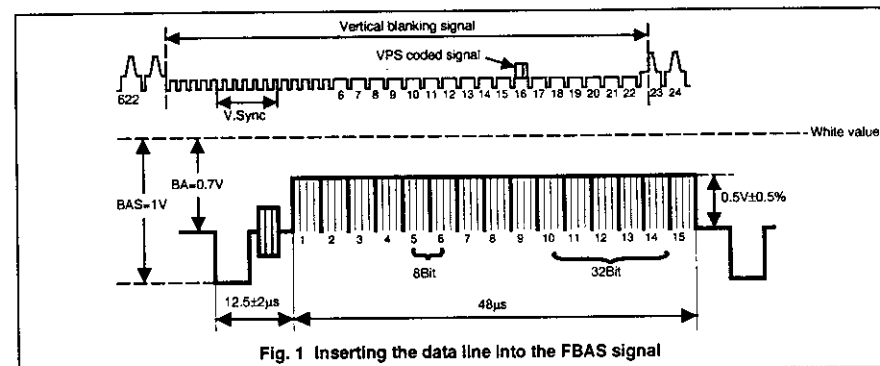

Fig. 1 Inserting the data line into the FBAS signal

Sound data and special designations		Additional VPS information															
5		11				12				13				14			
1 2 3 4 5 6 7 8		DZ 16 Bit No.				DZ 16 Bit No.				DZ 16 Bit No.				DZ 16 Bit No.			
1 2 3 4 5 6 7 8		VPS Bit No.				VPS Bit No.				VPS Bit No.				VPS Bit No.			
0	0	2 channel		Binary code significance		Regular label		System status code		Special system codes		Blank code		Interruption code		The 2-channel-status is coded 11 at the studio side; 00 has to be considered at the receiving side in special cases only.	
0	1	MCHD								A A 0 0 0 0		A A 0 0 0 0		A A 0 0 0 0		M = MSB	
1	0	Stereo								N N 0 0 0 0		N N 0 0 0 0		N N 0 0 0 0		L = LSB	
1	1	2 channel								P P 0 0 0 0		P P 0 0 0 0		P P 0 0 0 0		A = Actual address range code	
0	0	Not rated for youth								0 0 0 0 0 0		0 0 0 0 0 0		0 0 0 0 0 0		N = Actual country code	
1	0	Not rated for youth								1 1 0 0 0 0		1 1 0 0 0 0		1 1 0 0 0 0		P = Actual program source code	
1	1	Not rated for youth								1 1 1 1 0 0		1 1 1 1 0 0		1 1 1 1 0 0			

Fig. 2 Data format of additional information in data line 16



## GLOSSARY OF ABBREVIATIONS

<b>A/C</b>	: Audio/Control	<b>LIM</b>	: Limiter
<b>ACC</b>	: Automatic Colour Control	<b>LPF</b>	: Low-Pass Filter
<b>A.E</b>	: Audio Erase	<b>LM</b>	: Loading Motor
<b>AFC</b>	: Automatic Frequency Control	<b>MDA</b>	: Motor Drive Amplifier
<b>AFT-D</b>	: Automatic Fine Tuning Door Switch	<b>MC</b>	: Mechanical Control
<b>AGC</b>	: Automatic Gain Control	<b>MIC</b>	: Microphone
<b>AL</b>	: After Load	<b>MOD</b>	: Modulator
<b>AMP</b>	: Amplifier	<b>N</b>	: Not Normal
<b>ANT</b>	: Antenna	<b>OPE</b>	: Operation
<b>A-PB</b>	: Audio-Playback	<b>OSC</b>	: Oscillator
<b>A-REC</b>	: Audio-Recording	<b>O-PWV</b>	: ON/OFF Command from Remote Decoder
<b>ALC</b>	: Automatic Level Control	<b>PB</b>	: Play Back
<b>B-FS</b>	: Brake Forward Search	<b>PG</b>	: Pulse Generator
<b>B-RS</b>	: Brake Reverse Search	<b>P/R-SW</b>	: P.B./REC-SW
<b>BPF</b>	: Band-Pass Filter	<b>PCB</b>	: Printed Circuit Board
<b>B/W</b>	: Black and White	<b>PIC</b>	: Picture Control
<b>BS</b>	: Band SW	<b>P/R</b>	: Play/Record
<b>CASS</b>	: Cassette	<b>PSC</b>	: Pulse swallow control
<b>CP</b>	: Capstan	<b>PWT-SET</b>	: Power TV Set
<b>CP-FG</b>	: Capstan-Frequency Generator	<b>PWV</b>	: ON/OFF Command to B + Switching Circuit
<b>CP-F/R</b>	: Capstan-Forward/Reverse	<b>REC</b>	: Recording
<b>CP-M</b>	: Capstan-Motor	<b>REF</b>	: Reference
<b>CONV</b>	: Converter	<b>RIS</b>	: Record Inhibit Switch
<b>CTL</b>	: Control	<b>REW</b>	: Rewind
<b>C-LAMP</b>	: Cassette Lamp	<b>REG</b>	: Regulator
<b>C-ILAMP</b>	: Cassette Indicator Lamp	<b>RS</b>	: Reverse Search
<b>CE</b>	: Chip Enable	<b>REC-2</b>	: Record Command for the Fine Editing Circuit
<b>CE</b>	: Not Chip Enable	<b>R-FS</b>	: Reel Drive Forward Search
<b>CK</b>	: Clock	<b>R-P/R</b>	: Reel Drive Play/Record
<b>CL</b>	: Clear	<b>S/AL</b>	: Stop After Load
<b>CNT</b>	: Counter	<b>SL</b>	: Slow
<b>CP R-R</b>	: Capstan Reverse Rotation	<b>SLOCK</b>	: Slow OK
<b>CS-1</b>	: Cassette Switch 1	<b>S/P</b>	: Still/Pause
<b>CS-2</b>	: Cassette Switch 2	<b>SS</b>	: Start Sensor
<b>DAL</b>	: Delay-After Loading	<b>SRV-REC</b>	: Servo Record
<b>DEMODO</b>	: Demodulator	<b>SS</b>	: Not Speed Search
<b>DET</b>	: Detector	<b>S-STOP</b>	: Stop Command
<b>DL</b>	: Delay Line	<b>STOK</b>	: Still OK
<b>DL-REV</b>	: During Reverse	<b>STW</b>	: Stop Watch
<b>DL-FWD</b>	: During Forward	<b>SENS</b>	: Sensor
<b>DOC</b>	: Drop Out Compensator	<b>STBY</b>	: Stand By
<b>DL-SL</b>	: During Slow	<b>TM</b>	: Take up Motor
<b>DL-SS</b>	: During Not Speed Search	<b>T-REC</b>	: Timer-Record
<b>DOP</b>	: Drop Out Pulse	<b>T.P</b>	: Test Point
<b>EF</b>	: Emitter Follower	<b>TR</b>	: Transistor
<b>EMPHA</b>	: Emphasis	<b>TU-P</b>	: Tuner-Power
<b>EQ</b>	: Equalizer	<b>UL</b>	: Unload
<b>EE</b>	: Electronic-Electronic	<b>VS</b>	: Voltage Synthesizer
<b>ES</b>	: End Sensor	<b>V.SYNC</b>	: Vertical Sync
<b>FE-H</b>	: Full Erase Head	<b>VCO</b>	: Voltage Controlled Oscillator
<b>FF</b>	: Fast Forward	<b>VXO</b>	: Variable Crystal Oscillator
<b>FG</b>	: Frequency Generator	<b>W/D</b>	: White/Dark
<b>FL-SW</b>	: Front Loading SW	<b>X'OSC</b>	: Crystal Oscillator
<b>FLM</b>	: Front Loading Motor	<b>Y/C</b>	: Luminance/Chrominance
<b>F/R-SW</b>	: FF/Rewind Switch		
<b>F/R</b>	: Forward/Reverse		
<b>FS</b>	: Forward Search		
<b>G</b>	: Ground		
<b>HE</b>	: Hall Element		
<b>H-LED</b>	: Humidity-LED		
<b>H-SENS</b>	: Humidity-Sensor		
<b>HPF</b>	: High-Pass Filter		

## CHIP PARTS REPLACEMENT

### CHIP PARTS REPLACEMENT

Some resistors, shorting jumpers (0Ω resistor), ceramic capacitors, transistors and diodes are chip parts which are used for certain circuit elements. When replacing these parts, note the following cautions.

#### Cautions:

- Use fine tipped, well insulated soldering pencil (iron), about 30 watts, and tweezers.
- Melt the solder and remove the Chip Parts carefully not to tear off the copper foil of the printed circuit board.
- Discard removed chips; do not reuse them.
- Do not apply heat for more than 3 seconds to new chip Parts.
- Avoid using a rubbing stroke when soldering.
- Take care not to scratch, or damage the Chip Parts when soldering.
- Supplementary cementing is not required.

### 1 Removal of Chip Parts (Resistors, capacitors, etc.)

- Grasp the part with tweezers. Melt the solder at both sides alternately, remove one side of the part with a twisting motion.
- Melt the solder at the other side and remove the part.

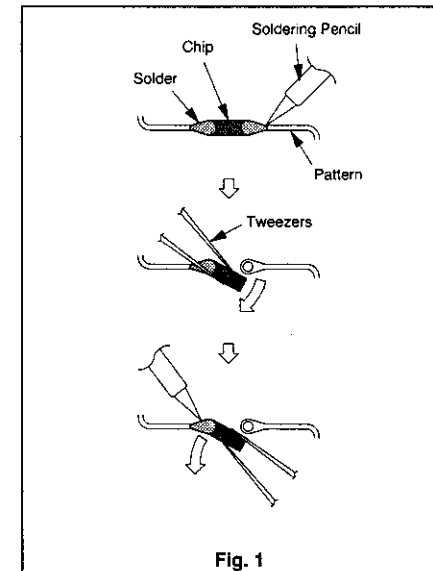

Fig. 1

### 2 Removal of Chip Parts (Transistors)

- Melt the solder of one lead. Lift the side of that lead upward.
- Simultaneously melt the solder of the two remaining leads and lift the part.

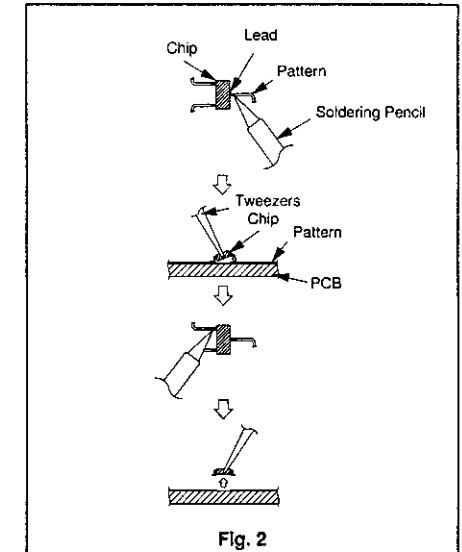

Fig. 2

### 3 Replacement

- Presolder the contact points of the circuit pattern.
- Press the part downward with tweezers and apply the soldering pencil as shown in Fig. 3.

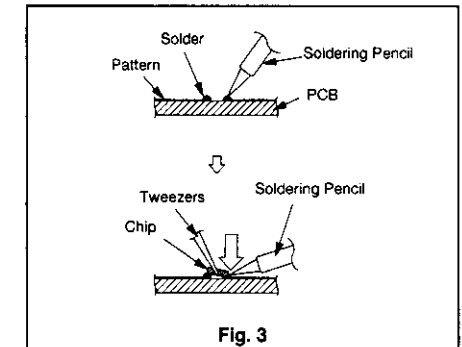
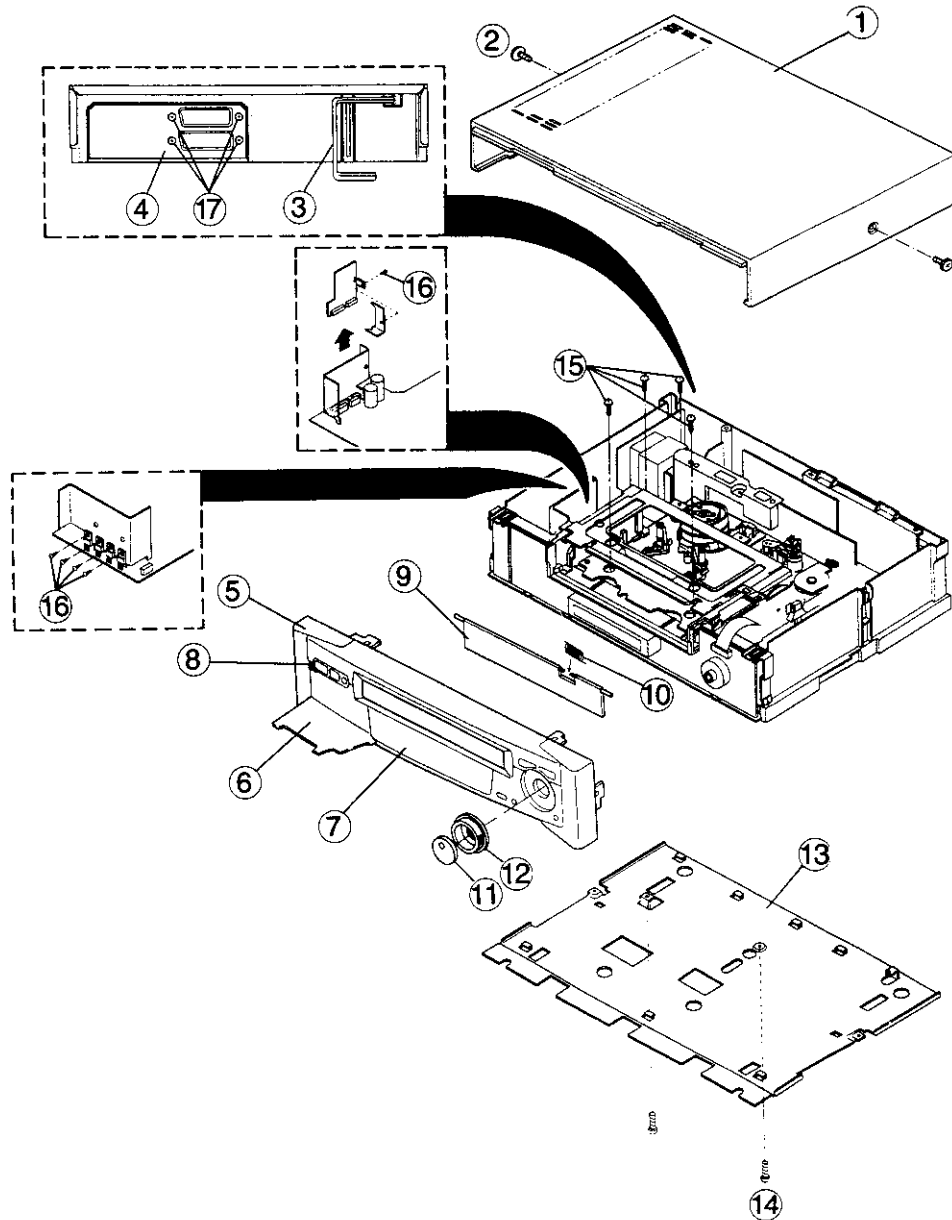

Fig. 3

# PARTS LIST

## 1. CABINET ASSEMBLY



ITEM NO.	PARTS NO.	PARTS NAME	DESCRIPTION
CABINET ASSEMBLY			
1	968C040002	TOP COVER ASSY	
2	669D223080	SCREW	3X10 BLK
3	246C149080	AC POWER CORD	[E, G, Y]
3	246C167040	AC POWER CORD	[B]
3	246C149070	AC POWER CORD	[EE]
4	761B283060	COVER ANTENNA	[B]
4	761B283080	COVER ANTENNA	[E, Y]
4	761B283090	COVER ANTENNA	[EE]
4	761B283070	COVER ANTENNA	[G]
5	968B035011	FRONT PANEL ASSY	[B]
5	968B035013	FRONT PANEL ASSY	[E]
5	968B035012	FRONT PANEL ASSY	[EE, Y]
5	968B035015	FRONT PANEL ASSY	[G]
6	752C163050	DOOR PANEL ASSY	[B]
6	752C163060	DOOR PANEL ASSY	[E]
6	752C163070	DOOR PANEL ASSY	[EE, Y]
6	752C163080	DOOR PANEL ASSY	[G]
7	752C156010	PANEL TIMER	[E, EE, G, Y]
7	752C156020	PANEL TIMER	[B]
8	761C553010	DOOR PUSH	
9	752C162080	CASSETTE DOOR ASSY	[B]
9	752C162020	CASSETTE DOOR ASSY	[E]
9	752C162090	CASSETTE DOOR ASSY	[EE, Y]
9	752C162050	CASSETTE DOOR ASSY	[G]
10	572D385010	SPRING F/L	
11	968D006004	JOG DIAL ASSY	[B, E]
12	754C002010	SHUTTLE RING	[B, E]
13	590A407010	PANEL BOTTOM	
14	669D220030	SCREW	3X10 46LA005
15	669D221040	SCREW	4X12 46LA005
16	669D222090	SCREW	3X10 46LA005
17	669D359040	SCREW	3X12

2. Packing Parts

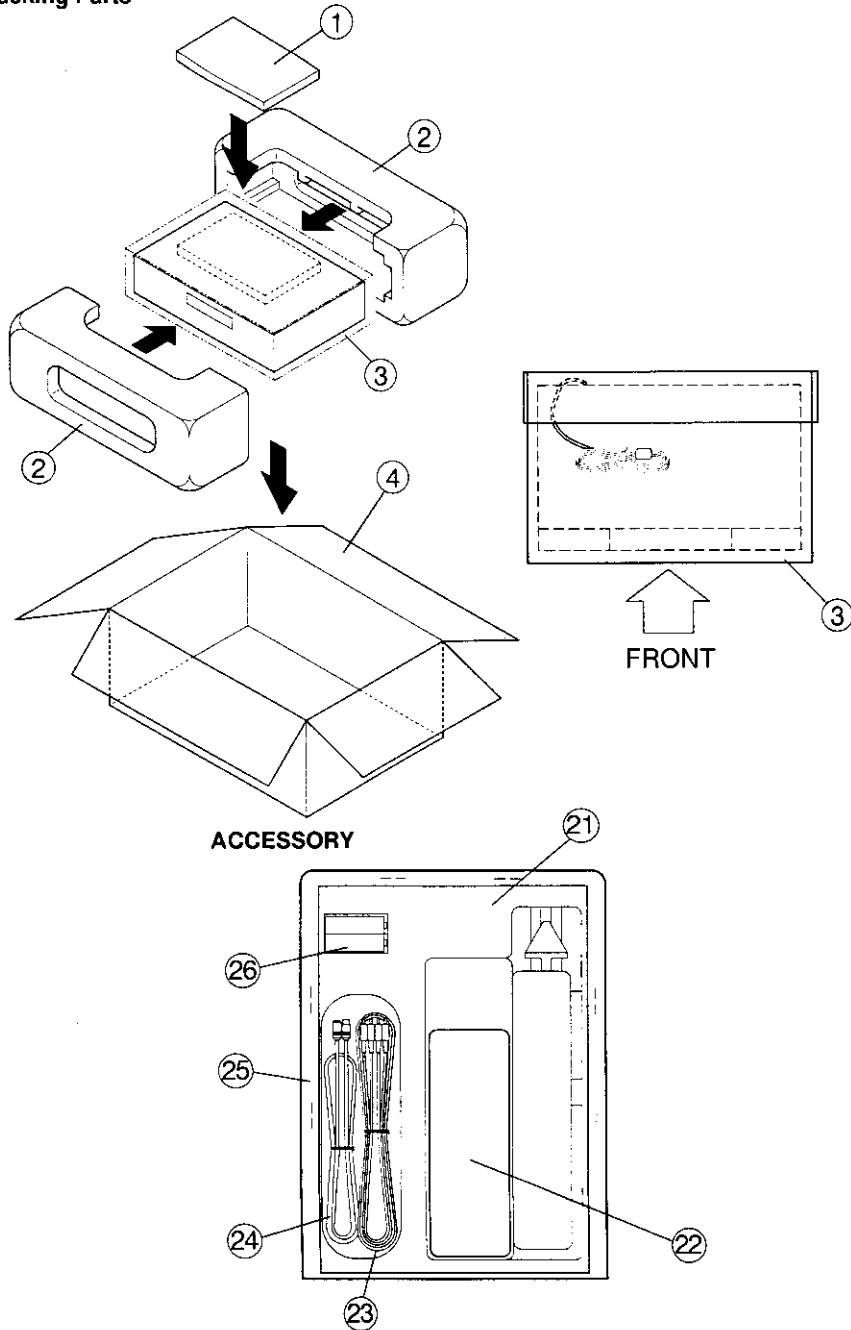

ITEM NO.	PARTS NO.	PARTS NAME	DESCRIPTION
<b>PACKING PARTS</b>			
1	-----	ACCESSORY	
2	803A403010	PACKING CUSHION	
3	-----	POLYETHYLENE SHEET	
4	802B493030	PACKING CASE	
<b>ACCESSORY</b>			
21	872C135060	INSTRUCTION BOOK	[B]
21	872C135040	INSTRUCTION BOOK	[E]
21	872C138060	INSTRUCTION BOOK	[EE]
21	872C135050	INSTRUCTION BOOK	[G]
21	872C135030	INSTRUCTION BOOK	[Y]
22	939P596020	REMOTE HAND UNIT	[B]
22	939P596010	REMOTE HAND UNIT	[E, Y]
22	939P595040	REMOTE HAND UNIT	[EE]
22	939P596030	REMOTE HAND UNIT	[G]
23	242C938010	CABLE PHONO	2P R&W L=1.5m [E, G]
24	242D231030	CABLE	1.5m [B, E, EE, Y]
24	243C120010	CABLE	[G]
25	829B013070	ACCESSORY PACK	[G]
25	829B013030	PACKING PACK	ACCESSORY [B, Y]
25	829B013040	PACKING PACK	ACCESSORY [E, EE]
26	-----	BATTERY	

### 3. ELECTRICAL PARTS

SYMBOL NO.	PARTS NO.	PARTS NAME	DESCRIPTION	SYMBOL NO.	PARTS NO.	PARTS NAME	DESCRIPTION
<b>INTEGRATED CIRCUITS</b>							
IC101	270P184010	IC	M52318SP LA7910 [E, EE, G, Y]	Q 260	260P807010	CHIP TRANSISTOR	UN2212
IC102	266P182010	IC	M51497 [E, G, Y]	Q 261	260P807010	CHIP TRANSISTOR	UN2212
IC103	272P654010	IC	LA7975 [EE]	Q 262	260P807010	CHIP TRANSISTOR	UN2212
IC151	272P862010	IC	BA7184S	Q 2A0	260P805030	CHIP TRANSISTOR	2SC3053-D
IC201	270P183010	IC	LA7449M	Q 2A1	260P804020	CHIP TRANSISTOR	2SC3052-F
IC2A0	270P248010	IC	LC89970M	Q 2A2	260P805030	CHIP TRANSISTOR	2SC3053-D
IC2B01	270P167020	IC	LA7156-S [E, G, Y]	Q 2A3	260P805030	CHIP TRANSISTOR	2SC3053-D
IC2B02	270P867010	IC	BA7645N	Q 2A4	260P805030	CHIP TRANSISTOR	2SC3053-D
IC2B03	270P046010	IC	BA7644AN	Q 2A5	260P805030	CHIP TRANSISTOR	2SC3053-D
IC2B04	270P046010	IC	LA7151 [E, G, Y]	Q 2A7	260P805030	CHIP TRANSISTOR	2SC3053-D
IC2B06	270P201010	IC	LA7151 [E, G, Y]	Q 2A8	260P560040	TRANSISTOR	2SA933S-S
IC301	270P601010	IC	BA7746FS	Q 2A9	260P807010	CHIP TRANSISTOR	UN2212
IC3A0	272P234010	IC	LA7295	Q 2G0	260P806010	CHIP TRANSISTOR	DTA124EK
IC3000	270P271010	IC	AN3967NF80	Q 2G1	260P805030	CHIP TRANSISTOR	2SC3053-D
IC3001	266P419010	IC	M5223P	Q 2G2	260P805030	CHIP TRANSISTOR	2SC3053-D
IC3002	272P583010	IC	NJM22338M	Q 2G4	260P802020	CHIP TRANSISTOR	2SA1235-F
IC4A0	274P802010	IC	MN67492MSB5	Q 2G5	260P807010	CHIP TRANSISTOR	UN2212 [B, EE]
IC4A1	272P237010	IC	LA6324N	Q 2G6	260P806010	CHIP TRANSISTOR	DTA124EK [B, EE]
IC501	274P573010	IC	M35013-050SP	Q 2G7	260P802020	CHIP TRANSISTOR	2SA1235-F
IC551	274P672010	IC	SDA5649 [B, E, G]	Q 2G9	260P807010	CHIP TRANSISTOR	UN2212
IC571	274P677010	IC	M37470M-526SP [B]	Q 2H0	260P807010	CHIP TRANSISTOR	UN2212
IC5A0	274P678030	IC	M38185ME-097FP [B]	Q 2H1	260P806010	CHIP TRANSISTOR	DTA124EK
IC5A0	274P678010	IC	M38185ME-098FP [E]	Q 2R0	260P805030	CHIP TRANSISTOR	2SC3053-D [B, EE]
IC5A0	274P676050	IC		Q 2R1	260P805030	CHIP TRANSISTOR	2SC3053-D [B, EE]
IC5A0	274P676020	IC	M38185ME-096FP [G, Y]	Q 2B01	260P802020	CHIP TRANSISTOR	2SA1235-F
IC5A1	263P593010	IC	CAT35C104P	Q 2B02	260P807010	CHIP TRANSISTOR	UN2212 [E, G, Y]
IC5A2	272P235010	IC	TA7291S	Q 2B03	260P807010	CHIP TRANSISTOR	UN2212 [E, G, Y]
IC5A4	266P010020	IC	μ PC574J-K	Q 2B04	260P804020	CHIP TRANSISTOR	2SC3052-F [E, G, Y]
IC5A5	270P070010	IC	A793C56-10PC [B]	Q 3A0	260P804020	CHIP TRANSISTOR	2SC3052-F
IC5A5	263P593010	IC	CAT35C104P [G]	Q 3A1	260P804020	CHIP TRANSISTOR	2SC3052-F
IC700	270P272010	IC	TDA9821 [E, G, Y]	Q 3A2	260P629060	TRANSISTOR	2SC3331-S
IC701	270P001010	IC	TDA9840 [E, G, Y]	Q 3A3	260P804020	CHIP TRANSISTOR	2SC3052-F
IC7A0	270P273010	IC	SAAT283GP [B, E]	Q 3100	260C676040	TRANSISTOR	2SC3311A-R, S
IC800	274P561010	IC	μ PD16311GC-AB6	Q 3101	260C676040	TRANSISTOR	2SC3311A-R, S
IC9A0	272P237010	IC	LA6324N	Q 3102	260P806010	CHIP TRANSISTOR	DTA124EK
<b>TRANSISTORS</b>				Q 3252	260P804020	CHIP TRANSISTOR	2SC3052-F
Q 101	260P874010	CHIP TRANSISTOR	2SC3082K-P, Q	Q 3400	260P807010	CHIP TRANSISTOR	UN2212
Q 102	260P560040	TRANSISTOR	2SA933S-S	Q 3500	260P804020	CHIP TRANSISTOR	2SC3052-F
Q 103	260P805030	CHIP TRANSISTOR	2SC3053-D	Q 3501	260P804020	CHIP TRANSISTOR	2SC3052-F
Q 106	260P808010	CHIP TRANSISTOR	DTC114EK [E, G, Y]	Q 4A1	260P802020	CHIP TRANSISTOR	2SA1235-F
Q 107	260P807010	CHIP TRANSISTOR	UN2212 [E, G, Y]	Q 4A2	260P804020	CHIP TRANSISTOR	2SC3052-F
Q 108	260P804020	CHIP TRANSISTOR	2SC3052-F	Q 4A3	260P804030	CHIP TRANSISTOR	2SC3052-G
Q 109	260P804020	CHIP TRANSISTOR	2SC3052-F [E, G, Y]	Q 4A4	260P802020	CHIP TRANSISTOR	2SA1235-F
Q 110	260P804020	CHIP TRANSISTOR	2SC3052-F [E, G, Y]	Q 4A5	260P802020	CHIP TRANSISTOR	2SA1235-F
Q 111	260P874010	CHIP TRANSISTOR	2SC3082K-P, Q [E]	Q 4A6	260P804020	CHIP TRANSISTOR	2SC3052-F
Q 201	260P807010	CHIP TRANSISTOR	UN2212	Q 4C8	260P805030	CHIP TRANSISTOR	2SC3053-D [B, E, G, Y]
Q 202	260P807010	CHIP TRANSISTOR	UN2212	Q 501	260P802020	CHIP TRANSISTOR	2SA1235-F
Q 205	260P807010	CHIP TRANSISTOR	UN2212	Q 503	260P802020	CHIP TRANSISTOR	2SA1235-F
Q 207	260P802020	CHIP TRANSISTOR	2SA1235-F	Q 504	260P804020	CHIP TRANSISTOR	2SC3052-F
Q 208	260P805030	CHIP TRANSISTOR	2SC3053-D	Q 505	260P802020	CHIP TRANSISTOR	2SA1235-F [E, EE, G, Y]
				Q 506	260P804030	CHIP TRANSISTOR	2SC3052-G
				Q 507	260P804030	CHIP TRANSISTOR	2SC3052-G
				Q 571	260P562040	TRANSISTOR	2SA952-K [B]
				Q 581	260P562040	TRANSISTOR	2SA952-K [B]
				Q 5A1	260P802020	CHIP TRANSISTOR	2SA1235-F [B]

SYMBOL NO.	PARTS NO.	PARTS NAME	DESCRIPTION	SYMBOL NO.	PARTS NO.	PARTS NAME	DESCRIPTION
Q 5A2	260P802020	CHIP TRANSISTOR	2SA1235-F	CF103	299P051050	CERAMIC RESONATOR	CS8500F9 [E, G, Y]
Q 5A3	260P804020	CHIP TRANSISTOR	2SC3052-F	CF104	296P143020	CERAMIC DISCRIMINATOR	CDSH6, 5ME65 [B, EE]
Q 5A6	260P802020	CHIP TRANSISTOR	2SA1235-F	CF104	296P143010	CERAMIC DISCRIMINATOR	CDSH5, 5ME65 [E, G, Y]
Q 5A7	260P807010	CHIP TRANSISTOR	UN2212	CF151	299P034030	CERAMIC RESONATOR	CS8500E5 [EE]
Q 5A8	260P807010	CHIP TRANSISTOR	UN2212	CF701	296P071010	CERAMIC FILTER	[E, G, Y]
Q 5A9	260P807010	CHIP TRANSISTOR	UN2212	CF702	296P071010	CERAMIC FILTER	[E, G, Y]
Q 5B0	260P806010	CHIP TRANSISTOR	DTA124EK	CF7A0	296P131010	CERAMIC FILTER	-S6R5M5 [E]
Q 5B1	260P802020	CHIP TRANSISTOR	2SA1235-F	CF7A1	296P132010	CERAMIC FILTER	-S6R0M5 [B]
Q 5B2	260P804030	CHIP TRANSISTOR	2SC3052-G	SF101	296P141020	SAW FILTER	SAF38, 9MV80Z [B]
Q 5B3	260P804020	CHIP TRANSISTOR	2SC3052-F [E, Y]	SF101	296P141010	SAW FILTER	SAF38, 9MV88Z [E, EE, G, Y]
Q 5B4	260P807010	CHIP TRANSISTOR	UN2212	SF102	296P134020	SAW FILTER	SAF32, 9MC70Z [B]
Q 5B6	260P807010	CHIP TRANSISTOR	UN2212	SF102	296P134010	SAW FILTER	SAF33, 0MC70Z [E, G, Y]
Q 5B7	260P806010	CHIP TRANSISTOR	DTA124EK	SF102	296P134040	SAW FILTER	SAF32, 9MCA70Z [EE]
Q 5B8	260P806010	CHIP TRANSISTOR	DTA124EK	<b>DELAY LINES</b>			
Q 5C4	260P804020	CHIP TRANSISTOR	2SC3052-F	D 101	264P568010	DIODE	1SS252 [E, G, Y]
Q 5C5	260P802020	CHIP TRANSISTOR	2SA1235-F	D 102	264P568010	DIODE	1SS252 [E, G, Y]
Q 5D6	260P806010	CHIP TRANSISTOR	DTA124EK	D 2A0	264P807010	DIODE	DAP202K HW21C
Q 5E1	268P014030	PHOTO TRANSISTOR	PN205L-(NC), M12	D 2A1	264P568010	DIODE	1SS252
Q 5E2	268P014030	PHOTO TRANSISTOR	PN205L-(NC), M12	D 2A2	264P568010	DIODE	1SS252
Q 5E3	268P059010	PHOTO INTERRUPTER	RP1-244	D 2A3	264P568010	DIODE	1SS252 [B, EE]
Q 5E4	268P059010	PHOTO INTERRUPTER	RP1-244	D 2G0	264P568010	DIODE	1SS252
Q 5F0	260P560040	TRANSISTOR	2SA933S-S	D 2G1	264P568010	DIODE	1SS252
Q 5F1	260P806010	CHIP TRANSISTOR	DTA124EK	D 2G2	264P568010	DIODE	1SS252
Q 701	260P805030	CHIP TRANSISTOR	2SC3053-D [E, G, Y]	D 2G3	264P568010	DIODE	1SS252 [B, EE]
Q 702	260P806010	CHIP TRANSISTOR	DTA124EK [E, G, Y]	D 2G4	264P568010	DIODE	1SS252
Q 703	260P805030	CHIP TRANSISTOR	2SC3053-D [E, G, Y]	D 2G8	264P568010	DIODE	1SS252
Q 704	260P805030	CHIP TRANSISTOR	2SC3053-D [E, G, Y]	D 2B01	264P808010	CHIP DIODE	DAK202K [E, G, Y]
Q 7A0	260P805030	CHIP TRANSISTOR	2SC3053-D [B, E]	D 2B02	264P808010	CHIP DIODE	DAK202K [E, G, Y]
Q 7A2	260P805030	CHIP TRANSISTOR	UN2212 [B, E]	D 2B05	264P568010	DIODE	1SS252 [E, G, Y]
Q 7A3	260P807010	CHIP TRANSISTOR	UN2212	D 2B06	264P568010	DIODE	1SS252
Q 8X1	260C676040	TRANSISTOR	2SC3311A-R, S	D 2B09	264P568010	DIODE	1SS252
Q 901	260C628010	TRANSISTOR	2SA1619A-Q	D 2610	264P568010	DIODE	1SS252
Q 902	260P630010	TRANSISTOR	2SD2012	D 2611	264P568010	DIODE	1SS252
Q 903	260P630010	TRANSISTOR	2SD2012	D 2612	264P568010	DIODE	1SS252
Q 904	260P640030	TRANSISTOR	2SD1762-F	D 2613	264P568010	DIODE	1SS252
Q 907	260P560030	TRANSISTOR	2SA933S-R, F	D 2614	264P826010	CHIP DIODE	DA204K [E, G, Y]
Q 908	260P560040	TRANSISTOR	2SA933S-S	D 2621	264P568010	DIODE	1SS252
Q 910	260P802020	CHIP TRANSISTOR	2SA1235-F	D 2623	264P826010	CHIP DIODE	DA204K
Q 911	260P438010	TRANSISTOR	2SD1273-Q	D 2624	264P826010	CHIP DIODE	DA204K
Q 913	260P804020	CHIP TRANSISTOR	2SC3052-F	D 2625	264P826010	CHIP DIODE	DA204K
Q 9A1	260P438020	TRANSISTOR	2SD1273-P	D 2641	264P568010	DIODE	1SS252 [E, G, Y]
Q 9A5	260P613010	TRANSISTOR	2SC4208A	D 2645	264P568010	DIODE	1SS252 [E, G, Y]
Q 9B2	260P630010	TRANSISTOR	2SD2012 [E, G, Y]	D 2646	264P568010	DIODE	1SS252 [E, G, Y]
<b>DIODES</b>				D 3A0	264P568010	DIODE	1SS252
D 5B1	264P585010	LIGHT EMITTING DIODE	LN59L, M1	D 3A2	264P568010	DIODE	1SS252
D 8F0	264P621010	LIGHT EMITTING DIODE	SEL2210R TP2	D 3A5	264P568010	DIODE	1SS252
D 8P0	264P634010	LIGHT EMITTING DIODE	SLR-932A-7 [B]	D 3400	264P568010	DIODE	1SS252
<b>FILTERS</b>				D 3401	264P568010	DIODE	1SS252
CF101	296P014030	CERAMIC FILTER	SFE-6, 0MHz [B, EE]	D 3402	264P568010	DIODE	1SS252
CF101	296P014090	CERAMIC FILTER	SFE-5, 5MC2 [E, G, Y]	D 3403	264P568010	DIODE	1SS252
CF102	296P024040	CERAMIC TRAP	SFE, 0MB [B]	D 3406	264P483030	DIODE	RD4, 7F81
CF102	296P104010	CERAMIC TRAP	EFC-53F01W3A [E, EE, G, Y]	D 4A0	264P568010	DIODE	1SS252
				D 4A1	264P568010	DIODE	1SS252

SYMBOL NO.	PARTS NO.	PARTS NAME	DESCRIPTION
D 501	264P568010	DIODE	1SS252
D 502	264P568010	DIODE	1SS252
D 5A1	264P342070	DIODE	HZ4C2
D 5A3	264P568010	DIODE	1SS252
D 5A4	264P568010	DIODE	1SS252 [B, E, G, Y]
D 5A5	264P568010	DIODE	1SS252
D 5A7	264P568010	DIODE	1SS252
D 5A8	264P568010	DIODE	1SS252
D 5A9	264P568010	DIODE	1SS252 [B, E, G, Y]
D 5B2	264P568010	DIODE	1SS252
D 5B3	264P568010	DIODE	1SS252
D 5B4	264P568010	DIODE	1SS252
D 7C0	264P675010	DIODE	8B4058 [B, E]
D 7C1	264P568010	DIODE	1SS252 [B, E]
D 7C2	264P568010	DIODE	1SS252 [B, E]
D 8A1	264P568010	DIODE	1SS252
D 8A2	264P568010	DIODE	1SS252
D 8A3	264P568010	DIODE	1SS252
D 8B0	264P568010	DIODE	1SS252
D 8B1	264P568010	DIODE	1SS252
D 8B2	264P568010	DIODE	1SS252
D 8B3	264P568010	DIODE	1SS252
D 8E1	264P568010	DIODE	1SS252
D 8E2	264P568010	DIODE	1SS252
D 8E3	264P568010	DIODE	1SS252
D 8E4	264P568010	DIODE	1SS252
D 8J0	264P568010	DIODE	1SS252 [B, E, G]
D 8J1	264P568010	DIODE	1SS252 [B]
D 8J2	264P568010	DIODE	1SS252 [B, E, G]
D 8K0	264P568010	DIODE	1SS252 [B, E, EE]
D 8K1	264P568010	DIODE	1SS252 [E]
D 8K2	264P568010	DIODE	1SS252 [EE]
D 8K3	264P568010	DIODE	1SS252 [EE]
D 8L1	264P568010	DIODE	1SS252 [E, EE]
D 8L2	264P568010	DIODE	1SS252
D 8M0	264P568010	DIODE	1SS252 [E]
D 8M1	264P568010	DIODE	1SS252 [E]
D 8Z1	264P484080	DIODE	RD6.2FB3
D 901	264P294010	DIODE	EM 1Z
D 902	264P569010	DIODE	G4DL-6140 FORMING
D 903	264P569010	DIODE	G4DL-6140 FORMING
D 904	264P294010	DIODE	EM 1Z
D 905	264P294010	DIODE	EM 1Z
D 906	264P569010	DIODE	G4DL-6140 FORMING
D 907	264P569010	DIODE	G4DL-6140 FORMING
D 908	264P294010	DIODE	EM 1Z
D 909	264P500020	DIODE	EM01Z
D 910	264P500020	DIODE	EM01Z
D 911	264P104040	DIODE	HZ30-2
D 920	264P568010	DIODE	1SS252
D 921	264P568010	DIODE	1SS252
D 922	264P568010	DIODE	1SS252
D 9A1	264P488040	DIODE	RD13FB3
D 9B2	264P484020	DIODE	RD5.6FB1
D 9B3	264P452030	DIODE	HZ5C3

SYMBOL NO.	PARTS NO.	PARTS NAME	DESCRIPTION
D 9C2	264P568010	DIODE	1SS252
D 9C5	264P487080	DIODE	RD12FB2 [E, G, Y]
<b>COILS</b>			
L 01	325C121030	PEAKING COIL	10 $\mu$ H-K
L 101	325C122050	PEAKING COIL	100 $\mu$ H-K
L 102	325C185020	PEAKING COIL	1.2 $\mu$ H-J [B, EE, G, Y]
L 102	325C185050	PEAKING COIL	2.2 $\mu$ H-J [E]
L 103	325C170050	PEAKING COIL	2.2 $\mu$ H-K SHIELD
L 104	325C165040	PEAKING COIL	1.8 $\mu$ H-J
L 105	325C121040	PEAKING COIL	12 $\mu$ H-K
L 106	323P198010	VIF COIL	M7-T1SA-4091-5
L 107	325C167020	PEAKING COIL	56 $\mu$ H-J [B]
L 107	325C167000	PEAKING COIL	39 $\mu$ H-J [E, EE, G, Y]
L 108	323P196020	VIF COIL	M7-T1SA-4092-1
L 109	325C166020	PEAKING COIL	8.2 $\mu$ H-J [B]
L 109	325C168000	PEAKING COIL	5.6 $\mu$ H-J [E, EE, G, Y]
L 112	325C165020	PEAKING COIL	1.2 $\mu$ H-J [E]
L 113	325C167050	PEAKING COIL	100 $\mu$ H-J [E]
L 151	325C121030	PEAKING COIL	10 $\mu$ H-K [EE]
L 201	321C112050	RF COIL	100 $\mu$ H-K
L 202	325C166070	PEAKING COIL	22 $\mu$ H-J
L 203	325C167040	PEAKING COIL	82 $\mu$ H-J
L 204	325C167070	PEAKING COIL	150 $\mu$ H-J
L 205	325C166050	PEAKING COIL	15 $\mu$ H-J
L 2A0	325C166090	PEAKING COIL	33 $\mu$ H-J
L 2A1	325C166050	PEAKING COIL	18 $\mu$ H-J
L 2A2	325C167080	PEAKING COIL	180 $\mu$ H-J
L 2A3	325C166060	PEAKING COIL	18 $\mu$ H-J
L 2A6	325C167050	PEAKING COIL	100 $\mu$ H-J
L 2G0	321C112050	RF COIL	100 $\mu$ H-K
L 2G1	321C112050	RF COIL	100 $\mu$ H-K
L 2G4	325C167050	PEAKING COIL	100 $\mu$ H-J
L 2G5	325C167070	PEAKING COIL	150 $\mu$ H-J
L 2G8	325C166090	PEAKING COIL	33 $\mu$ H-J
L 2G7	325C121090	PEAKING COIL	33 $\mu$ H-K
L 2T0	325C166070	PEAKING COIL	22 $\mu$ H-J
L 2T1	325C167050	PEAKING COIL	100 $\mu$ H-J
L 2301	325C243010	CHIP COIL	330 $\mu$ H-K [E, G, Y]
L 2302	325C243010	CHIP COIL	330 $\mu$ H-K [B, E, G, Y]
L 2303	325C243010	CHIP COIL	330 $\mu$ H-K [B, E, G, Y]
L 2304	325C243010	CHIP COIL	330 $\mu$ H-K [E, G, Y]
L 2601	325C167050	PEAKING COIL	100 $\mu$ H-J
L 2602	325C167050	PEAKING COIL	100 $\mu$ H-J
L 2603	325C112050	PEAKING COIL	100 $\mu$ H-K [E, G, Y]
L 2604	325C112050	PEAKING COIL	100 $\mu$ H-K [B]
L 2605	411P011010	BEADS FERRITE	
L 301	325C102050	PEAKING COIL	100 $\mu$ H-K
L 3A0	321C114080	RF COIL	8200 $\mu$ H-J
L 3A1	321C113070	RF COIL	1000 $\mu$ H-K
L 3A2	325C167080	PEAKING COIL	180 $\mu$ H-J
L 4A7	325C167050	PEAKING COIL	100 $\mu$ H-J [B, E, G, Y]
L 4A8	325C121030	PEAKING COIL	10 $\mu$ H-K [B, E, G, Y]
L 501	325C167050	PEAKING COIL	100 $\mu$ H-J

SYMBOL NO.	PARTS NO.	PARTS NAME	DESCRIPTION
L 502	325C166050	PEAKING COIL	15 $\mu$ H-J
L 503	325C167050	PEAKING COIL	100 $\mu$ H-J
L 504	325C166080	PEAKING COIL	27 $\mu$ H-J [E, EE, G, Y]
L 551	325C122050	PEAKING COIL	100 $\mu$ H-K [B, E, G]
L 571	325C167050	PEAKING COIL	100 $\mu$ H-J [B]
L 702	325C106030	PEAKING COIL	10 $\mu$ H-J [E, G, Y]
L 703	325C106030	PEAKING COIL	10 $\mu$ H-J [E, G, Y]
L 708	321C114050	RF COIL	4700 $\mu$ H-J [E, G, Y]
L 7A0	325C107010	PEAKING COIL	47 $\mu$ H-J [B, E]
L 7A1	325C106050	PEAKING COIL	15 $\mu$ H-J [B]
L 7A3	325C106030	PEAKING COIL	10 $\mu$ H-J [E, G, Y]
L 7C0	325C106060	PEAKING COIL	18 $\mu$ H-J [B, E]
L 7C1	325C107050	PEAKING COIL	100 $\mu$ H-J [B, E]
L 7C2	325C107050	PEAKING COIL	100 $\mu$ H-J [B, E]
L 7C3	325C107050	PEAKING COIL	100 $\mu$ H-J [B, E]
L 7C4	325C107050	PEAKING COIL	100 $\mu$ H-J [B, E]
L 8A0	325C122050	PEAKING COIL	100 $\mu$ H-K [B, E, G, Y]
L 8H0	325C121030	PEAKING COIL	100 $\mu$ H-K [B, E, G, Y]
L 8X1	325C122050	PEAKING COIL	100 $\mu$ H-K
L 901	351P038010	LINE FILTER	ELF-180230CN[B, E, G, Y]
<b>TRANSFORMERS</b>			
T 3A0	409P423030	AUDIO BIAS OSC	409P42301/2
T 901	350P528040	TRANS POWER	PRI
<b>VARIABLE RESISTORS</b>			
VR101	127C381000	VR SEMIFIXED	1/5W B30k $\Omega$ -M
VR310	127C481020	VR SEMIFIXED	1/5W B100k $\Omega$ -25%
VR3000	127C391010	VR SEMIFIXED	1/5W B50k $\Omega$ -M
VR3001	127C391000	VR SEMIFIXED	1/5W B30k $\Omega$ -M
VR3002	127C390090	VR SEMIFIXED	1/5W B20k $\Omega$ -M
VR3003	127C390080	VR SEMIFIXED	1/5W B10k $\Omega$ -M
VR3010	127C381020	VR SEMIFIXED	1/5W B100k $\Omega$ -M [G]
VR3011	127C381020	VR SEMIFIXED	1/5W B100k $\Omega$ -M [G]
VR5A0	127C381020	VR SEMIFIXED	1/5W B100k $\Omega$ -M
VRT56	127C380040	VR SEMIFIXED	1/5W B1k $\Omega$ -M [E, G, Y]
VR8A0	129D157060	VR PCB	1/20W B50k $\Omega$ -177M CS [G]
VR8A1	129D157060	VR PCB	1/20W B50k $\Omega$ -177M CS [G]
<b>RESISTORS</b>			
R 01	103P403070	CHIP RESISTOR	1/10W 10k $\Omega$ -J
R 03	103P404000	CHIP RESISTOR	1/10W 18k $\Omega$ -J
R 04	103P401020	CHIP RESISTOR	1/10W 82 $\Omega$ -J [B]
R 08	103P403070	CHIP RESISTOR	1/10W 10k $\Omega$ -J
R 11	103P403070	CHIP RESISTOR	1/10W 10k $\Omega$ -J
R 12	103P403070	CHIP RESISTOR	1/10W 10k $\Omega$ -J [E, EE, G, Y]
R 16	103P404000	CHIP RESISTOR	1/10W 18k $\Omega$ -J
R 17	103P404080	CHIP RESISTOR	1/10W 82k $\Omega$ -J
R 101	103P403060	CHIP RESISTOR	1/10W 8.2k $\Omega$ -J
R 102	103P402050	CHIP RESISTOR	1/10W 1k $\Omega$ -J [B, EE, G, Y]
R 102	103P402080	CHIP RESISTOR	1/10W 1.8k $\Omega$ -J [E]
R 103	103P402030	CHIP RESISTOR	1/10W 680 $\Omega$ -J

SYMBOL NO.	PARTS NO.	PARTS NAME	DESCRIPTION
R 104	103P401010	CHIP RESISTOR	1/10W 68 $\Omega$ -J [B, EE, G, Y]
R 104	103P401070	CHIP RESISTOR	1/10W 220 $\Omega$ -J [E]
R 105	103P401010	CHIP RESISTOR	1/10W 68 $\Omega$ -J [E]
R 108	103P477010	CHIP RESISTOR	1/10W 82k $\Omega$ -F
R 109	103P478010	CHIP RESISTOR	1/10W 33k $\Omega$ -F
R 110	103P476060	CHIP METAL	1/10W 51k $\Omega$ -F
R 111	103P401030	CHIP RESISTOR	1/10W 100 $\Omega$ -J [E, G, Y]
R 112	103P402040	CHIP RESISTOR	1/10W 820 $\Omega$ -J
R 113	103P402020	CHIP RESISTOR	1/10W 560 $\Omega$ -J [B, E, G, Y]
R 114	103P401030	CHIP RESISTOR	1/10W 100 $\Omega$ -J [B, E]
R 115	103P471090	CHIP RESISTOR	1/10W 560 $\Omega$ -F
R 118	103P471050	CHIP RESISTOR	1/10W 390 $\Omega$ -F [B]
R 118	103P470050	CHIP RESISTOR	1/10W 150 $\Omega$ -F [E, EE, G, Y]
R 119	103P401030	CHIP RESISTOR	1/10W 100 $\Omega$ -J
R 120	103P402050	CHIP RESISTOR	1/10W 1k $\Omega$ -J
R 128	103P409050	CHIP RESISTOR	0.1W 0 $\Omega$ (2125) [E, G, Y]
R 130	103P405090	CHIP RESISTOR	1/10W 680k $\Omega$ -J [E, G, Y]
R 131	103P403050	CHIP RESISTOR	1/10W 6.8k $\Omega$ -J [E, G, Y]
R 132	103P403070	CHIP RESISTOR	1/10W 10k $\Omega$ -J [E, G, Y]
R 133	103P403040	CHIP RESISTOR	1/10W 5.6k $\Omega$ -J [E, G, Y]
R 134	103P401080	CHIP RESISTOR	1/10W 270 $\Omega$ -J [E, G, Y]
R 135	103P402010	CHIP RESISTOR	1/10W 470 $\Omega$ -J [E, G, Y]
R 136	103P405020	CHIP RESISTOR	1/10W 180k $\Omega$ -J [E, G, Y]
R 142	103P404070	CHIP RESISTOR	1/10W 68k $\Omega$ -J [E, G, Y]
R 143	103P404010	CHIP RESISTOR	1/10W 22k $\Omega$ -J [E, G, Y]
R 144	103P402070	CHIP RESISTOR	1/10W 1.5k $\Omega$ -J [E, G, Y]
R 146	103P401030	CHIP RESISTOR	1/10W 100 $\Omega$ -J [E, G, Y]
R 147	103P403010	CHIP RESISTOR	1/10W 3.3k $\Omega$ -J [E, G, Y]
R 151	103P402050	CHIP RESISTOR	1/10W 1k $\Omega$ -J [E]
R 152	103P401010	CHIP RESISTOR	1/10W 68 $\Omega$ -J [E]
R 153	103P401050	CHIP RESISTOR	1/10W 150 $\Omega$ -J [E]
R 154	103P400090	CHIP RESISTOR	1/10W 47 $\Omega$ -J [E]
R 160	103P401030	CHIP RESISTOR	1/10W 100 $\Omega$ -J
R 161	103P402080	CHIP RESISTOR	1/10W 1.8k $\Omega$ -J
R 199	103P406010	CHIP RESISTOR	1/10W 1M $\Omega$ -J [E, G, Y]
R 1S1	103P402000	CHIP RESISTOR	1/10W 390 $\Omega$ -J [EE]
R 1S2	103P409050	CHIP RESISTOR	0.1W 0 $\Omega$ (2125) [EE]
R 202	103P403070	CHIP RESISTOR	1/10W 10k $\Omega$ -J
R 205	103P403070	CHIP RESISTOR	1/10W 10k $\Omega$ -J
R 206	103P476070	CHIP RESISTOR	1/10W 56k $\Omega$ -F
R 207	103P402020	CHIP RESISTOR	1/10W 560 $\Omega$ -J
R 208	103P409050	CHIP RESISTOR	0.1W 0 $\Omega$ (2125)
R 209	103P402050	CHIP RESISTOR	1/10W 1k $\Omega$ -J
R 210	103P402060	CHIP RESISTOR	1/10W 1.2k $\Omega$ -J
R 211	103P404010	CHIP RESISTOR	1/10W 22k $\Omega$ -J
R 212	103P404010	CHIP RESISTOR	1/10W 22k $\Omega$ -J
R 213	103P401030	CHIP RESISTOR	1/10W 100 $\Omega$ -J
R 214	103P402080	CHIP RESISTOR	1/10W 1.8k $\Omega$ -J
R 215	103P473000	CHIP RESISTOR	1/10W 1.6k $\Omega$ -F
R 216	103P472050	CHIP RESISTOR	1/10W 1k $\Omega$ -F
R 217	103P402050	CHIP RESISTOR	1/10W 1k $\Omega$ -J
R 218	103P476000	CHIP RESISTOR	1/10W 30k $\Omega$ -F
R 220	103P474080	CHIP RESISTOR	1/10W 9.1k

SYMBOL NO.	PARTS NO.	PARTS NAME	DESCRIPTION
R 221	103P402050	CHIP RESISTOR	1/10W 1kΩ-J
R 223	103P401080	CHIP RESISTOR	1/10W 270Ω-J
R 224	103P402080	CHIP RESISTOR	1/10W 1.8kΩ-J
R 225	103P402050	CHIP RESISTOR	1/10W 1kΩ-J
R 260	103P473030	CHIP RESISTOR	1/10W 2.2kΩ-F
R 261	103P473070	CHIP RESISTOR	1/10W 3.3kΩ-F
R 262	103P473030	CHIP RESISTOR	1/10W 2.2kΩ-F
R 263	103P473030	CHIP RESISTOR	1/10W 2.2kΩ-F
R 264	103P477050	CHIP RESISTOR	1/10W 120k
R 265	103P475070	CHIP RESISTOR	1/10W 22kΩ-F
R 266	103P476070	CHIP RESISTOR	1/10W 56kΩ-F
R 267	103P474090	CHIP RESISTOR	1/10W 10kΩ-F
R 268	103P474090	CHIP RESISTOR	1/10W 10kΩ-F
R 269	103P474090	CHIP RESISTOR	1/10W 10kΩ-F
R 270	103P403070	CHIP RESISTOR	1/10W 10kΩ-J
R 271	103P403080	CHIP RESISTOR	1/10W 12kΩ-J
R 2A0	103P404040	CHIP RESISTOR	1/10W 39kΩ-J
R 2A1	103P403090	CHIP RESISTOR	1/10W 15kΩ-J
R 2A2	103P473040	CHIP RESISTOR	1/10W 2.4kΩ-F
R 2A3	103P402040	CHIP RESISTOR	1/10W 820Ω-J
R 2A4	103P403010	CHIP RESISTOR	1/10W 3.3kΩ-J
R 2A6	103P401060	CHIP RESISTOR	1/10W 180Ω-J
R 2A8	103P401070	CHIP RESISTOR	1/10W 220Ω-J [B]
R 2A8	103P401090	CHIP RESISTOR	1/10W 330Ω-J [E, EE, G, Y]
R 2A9	103P402000	CHIP RESISTOR	1/10W 390Ω-J [B, EE]
R 2A9	103P401070	CHIP RESISTOR	1/10W 220Ω-J [E, G, Y]
R 2B3	103P402030	CHIP RESISTOR	1/10W 680Ω-J
R 2B4	103P402050	CHIP RESISTOR	1/10W 1kΩ-J
R 2B5	103P403010	CHIP RESISTOR	1/10W 3.3kΩ-J
R 2B6	103P401080	CHIP RESISTOR	1/10W 270Ω-J
R 2B7	103P404030	CHIP RESISTOR	1/10W 33kΩ-J
R 2B8	103P404010	CHIP RESISTOR	1/10W 22kΩ-J
R 2B9	103P402010	CHIP RESISTOR	1/10W 470Ω-J
R 2C0	103P401060	CHIP RESISTOR	1/10W 180Ω-J
R 2C1	103P404030	CHIP RESISTOR	1/10W 33kΩ-J
R 2C2	103P403090	CHIP RESISTOR	1/10W 15kΩ-J
R 2C3	103P404030	CHIP RESISTOR	1/10W 33kΩ-J
R 2C4	103P404030	CHIP RESISTOR	1/10W 33kΩ-J [E, G, Y]
R 2C6	103P401070	CHIP RESISTOR	1/10W 220Ω-J
R 2C7	103P404040	CHIP RESISTOR	1/10W 39kΩ-J
R 2C8	103P404000	CHIP RESISTOR	1/10W 18kΩ-J
R 2D1	103P401080	CHIP RESISTOR	1/10W 270Ω-J
R 2G1	103P402020	CHIP RESISTOR	1/10W 560Ω-J
R 2G2	103P403000	CHIP RESISTOR	1/10W 2.7kΩ-J
R 2G3	103P473040	CHIP RESISTOR	1/10W 2.4kΩ-F
R 2G4	103P403040	CHIP RESISTOR	1/10W 5.6kΩ-J
R 2G6	103P409050	CHIP RESISTOR	0.1W 0Ω (2125)
R 2G8	103P402050	CHIP RESISTOR	1/10W 1kΩ-J
R 2G9	103P402080	CHIP RESISTOR	1/10W 1.8kΩ-J
R 2H0	103P402050	CHIP RESISTOR	1/10W 1kΩ-J
R 2H1	103P401080	CHIP RESISTOR	1/10W 270Ω-J
R 2H3	103P402090	CHIP RESISTOR	1/10W 2.2kΩ-J
R 2H4	103P403000	CHIP RESISTOR	1/10W 2.7kΩ-J
R 2H5	103P403030	CHIP RESISTOR	1/10W 4.7kΩ-J

SYMBOL NO.	PARTS NO.	PARTS NAME	DESCRIPTION
R 2H6	103P402060	CHIP RESISTOR	1/10W 1.2kΩ-J
R 2H7	103P402090	CHIP RESISTOR	1/10W 2.2kΩ-J
R 2J0	103P402050	CHIP RESISTOR	1/10W 1kΩ-J
R 2J1	103P402050	CHIP RESISTOR	1/10W 1kΩ-J
R 2J2	103P401080	CHIP RESISTOR	1/10W 270Ω-J
R 2J3	103P409050	CHIP RESISTOR	0.1W 0Ω (2125)
R 2J4	103P401030	CHIP RESISTOR	1/10W 100Ω-J
R 2K3	103P403070	CHIP RESISTOR	1/10W 10kΩ-J [B, EE]
R 2L0	103P402050	CHIP RESISTOR	1/10W 1kΩ-J
R 2L1	103P404080	CHIP RESISTOR	1/10W 82kΩ-J
R 2L2	103P409050	CHIP RESISTOR	0.1W 0Ω (2125)
R 2M2	103P403060	CHIP RESISTOR	1/10W 8.2kΩ-J
R 2P1	103P402090	CHIP RESISTOR	1/10W 2.2kΩ-J
R 2R1	103P403090	CHIP RESISTOR	1/10W 15kΩ-J [B, EE]
R 2X0	103P401030	CHIP RESISTOR	1/10W 100Ω-J
R 2X1	103P402050	CHIP RESISTOR	1/10W 1kΩ-J
R 2X2	103P402050	CHIP RESISTOR	1/10W 1kΩ-J [B, E, G, Y]
R 2X2	103P409050	CHIP RESISTOR	0.1W 0Ω (2125) [EE]
R 2X3	103P402050	CHIP RESISTOR	1/10W 1kΩ-J [B, E, G, Y]
R 2X3	103P409050	CHIP RESISTOR	0.1W 0Ω (2125) [EE]
R 2301	103P402010	CHIP RESISTOR	1/10W 470Ω-J [E, G, Y]
R 2304	103P402010	CHIP RESISTOR	1/10W 470Ω-J [E, G, Y]
R 2307	103P402050	CHIP RESISTOR	1/10W 1kΩ-J [B, EE]
R 2307	103P402070	CHIP RESISTOR	1/10W 1.5kΩ-J [E, G, Y]
R 2308	103P402050	CHIP RESISTOR	1/10W 1kΩ-J [B, EE]
R 2308	103P402040	CHIP RESISTOR	1/10W 820Ω-J [E, G, Y]
R 2309	103P402010	CHIP RESISTOR	1/10W 470Ω-J
R 2312	103P402010	CHIP RESISTOR	1/10W 470Ω-J
R 2315	103P402050	CHIP RESISTOR	1/10W 1kΩ-J
R 2316	103P402050	CHIP RESISTOR	1/10W 1kΩ-J
R 2605	103P409050	CHIP RESISTOR	0.1W 0Ω (2125) [B, EE]
R 2607	103P403090	CHIP RESISTOR	1/10W 15kΩ-J [E, G, Y]
R 2608	103P403090	CHIP RESISTOR	1/10W 15kΩ-J [E, G, Y]
R 2609	103P403000	CHIP RESISTOR	1/10W 2.7kΩ-J [E, G, Y]
R 2612	103P402050	CHIP RESISTOR	1/10W 1kΩ-J
R 2613	103P401070	CHIP RESISTOR	1/10W 220Ω-J
R 2617	103P409050	CHIP RESISTOR	0.1W 0Ω (2125) [B, E, G, Y]
R 2618	103P403000	CHIP RESISTOR	1/10W 2.7kΩ-J [E, G, Y]
R 2619	103P404080	CHIP RESISTOR	1/10W 82kΩ-J [E, G, Y]
R 2620	103P403070	CHIP RESISTOR	1/10W 10kΩ-J [E, G, Y]
P 2621	103P403070	CHIP RESISTOR	1/10W 10kΩ-J [E, G, Y]
R 2622	103P404050	CHIP RESISTOR	1/10W 47kΩ-J [E, G, Y]
R 2624	103P409050	CHIP RESISTOR	0.1W 0Ω (2125) [B, EE]
R 2624	103P401070	CHIP RESISTOR	1/10W 220Ω-J [E, G, Y]
R 2632	103P409050	CHIP RESISTOR	0.1W 0Ω (2125) [B, EE]
R 2634	103P403090	CHIP RESISTOR	1/10W 15kΩ-J [E, G, Y]
R 2635	103P409050	CHIP RESISTOR	0.1W 0Ω (2125) [B, EE]
R 2635	103P403050	CHIP RESISTOR	1/10W 6.8kΩ-J [E, G, Y]
R 2637	103P404090	CHIP RESISTOR	1/10W 100kΩ-J
R 2636	103P404010	CHIP RESISTOR	1/10W 22kΩ-J [E, G, Y]
R 264C	103P409050	CHIP RESISTOR	0.1W 0Ω (2125) [B, EE]
R 301	103P400010	CHIP RESISTOR	1/10W 10Ω-J
R 302	103P402030	CHIP RESISTOR	1/10W 680Ω-J
R 307	103P402000	CHIP RESISTOR	1/10W 390Ω-J

SYMBOL NO.	PARTS NO.	PARTS NAME	DESCRIPTION
R 308	103P402020	CHIP RESISTOR	1/10W 560Ω-J
R 309	103P402020	CHIP RESISTOR	1/10W 560Ω-J
R 310	103P402000	CHIP RESISTOR	1/10W 390Ω-J
R 311	103P400020	CHIP METAL	1/10W 12Ω-J
R 312	103P405030	CHIP RESISTOR	1/10W 220kΩ-J
R 3A0	103P404030	CHIP RESISTOR	1/10W 33kΩ-J
R 3A1	103P400010	CHIP RESISTOR	1/10W 10Ω-J
R 3A2	103P401080	CHIP RESISTOR	1/10W 270Ω-J
R 3A4	103P403030	CHIP RESISTOR	1/10W 4.7kΩ-J
R 3A5	103P401030	CHIP RESISTOR	1/10W 100Ω-J
R 3A6	103P403000	CHIP RESISTOR	1/10W 2.7kΩ-J
R 3A7	103P403090	CHIP RESISTOR	1/10W 15kΩ-J
R 3A8	103P406010	CHIP RESISTOR	1/10W 1MΩ-J
R 3A9	103P403080	CHIP RESISTOR	1/10W 12kΩ-J
R 3B0	103P404010	CHIP RESISTOR	1/10W 22kΩ-J
R 3B1	103P401090	CHIP RESISTOR	1/10W 330Ω-J
R 3B2	103P403060	CHIP RESISTOR	1/10W 8.2kΩ-J
R 3B3	103P473020	CHIP RESISTOR	1/10W 2kΩ-F
R 3B4	103P401090	CHIP RESISTOR	1/10W 150Ω-J
R 3B6	103P409050	CHIP RESISTOR	0.1W 0Ω (2125)
R 3B7	103P404000	CHIP RESISTOR	1/10W 18kΩ-J
R 3B8	103P404020	CHIP RESISTOR	1/10W 27kΩ-J
R 3B9	103P404000	CHIP RESISTOR	1/10W 18kΩ-J
R 3C0	103P403070	CHIP RESISTOR	1/10W 10kΩ-J
R 3C1	103P403010	CHIP RESISTOR	1/10W 3.3kΩ-J
R 3C4	103P403010	CHIP RESISTOR	1/10W 3.3kΩ-J
R 3C5	103P403070	CHIP RESISTOR	1/10W 10kΩ-J
R 3C6	103P405030	CHIP RESISTOR	1/10W 220kΩ-J
R 3C7	103P403090	CHIP RESISTOR	1/10W 15kΩ-J
R 3C8	103P404000	CHIP RESISTOR	1/10W 18kΩ-J
R 303	103P403030	CHIP RESISTOR	1/10W 4.7kΩ-J
R 304	103P403020	CHIP RESISTOR	1/10W 3.9kΩ-J
R 3000	103P471080	CHIP RESISTOR	1/10W 510Ω-F
R 3001	103P471080	CHIP RESISTOR	1/10W 510Ω-F
R 3002	103P403030	CHIP RESISTOR	1/10W 4.7kΩ-J
R 3003	103P403030	CHIP RESISTOR	1/10W 4.7kΩ-J
R 3004	103P404000	CHIP RESISTOR	1/10W 18kΩ-J
R 3005	103P404000	CHIP RESISTOR	1/10W 18kΩ-J
R 3006	103P403040	CHIP RESISTOR	1/10W 5.8kΩ-J
R 3007	103P403040	CHIP RESISTOR	1/10W 5.6kΩ-J
R 3008	103P405060	CHIP RESISTOR	1/10W 390kΩ-J
R 3009	103P479000	CHIP METAL	1/10W 510kΩ-F
R 3010	103P474090	CHIP RESISTOR	1/10W 10kΩ-F
R 3011	103P475020	CHIP RESISTOR	1/10W 13kΩ-F
R 3102	103P403070	CHIP RESISTOR	1/10W 10kΩ-J
R 3103	103P403070	CHIP RESISTOR	1/10W 10kΩ-J
R 3106	103P404010	CHIP RESISTOR	1/10W 22kΩ-J [B, EE]
R 3106	103P403080	CHIP RESISTOR	1/10W 12kΩ-J [E, G, Y]
R 3107	103P404010	CHIP RESISTOR	1/10W 22kΩ-J [B, EE]
R 3107	103P403080	CHIP RESISTOR	1/10W 12kΩ-J [E, G, Y]
R 3109	103P404000	CHIP RESISTOR	1/10W 18kΩ-J [B, E]
R 3110	103P404010	CHIP RESISTOR	1/10W 22kΩ-J [B, E]
R 3111	103P404010	CHIP RESISTOR	1/10W 22kΩ-J [B, E]
R 3112	103P404020	CHIP RESISTOR	1/10W 27kΩ-J [E, G, Y]
R 3113	103P404020	CHIP RESISTOR	1/10W 27kΩ-J [E, G, Y]

SYMBOL NO.	PARTS NO.	PARTS NAME	DESCRIPTION
R 3114	103P403050	CHIP RESISTOR	1/10W 6.8kΩ-J [E, G, Y]
R 3115	103P403050	CHIP RESISTOR	1/10W 6.8kΩ-J [E, G, Y]
R 3116	103P402030	CHIP RESISTOR	1/10W 680Ω-J
R 3117	103P402030	CHIP RESISTOR	1/10W 680Ω-J [B, EE]
R 3117	103P403020	CHIP RESISTOR	1/10W 3.9kΩ-J [E, G, Y]
R 3118	103P403090	CHIP RESISTOR	1/10W 15kΩ-J
R 3119	103P403090	CHIP RESISTOR	1/10W 15kΩ-J
R 3120	103P403010	CHIP RESISTOR	1/10W 3.3kΩ-J
R 3121	103P403010	CHIP RESISTOR	1/10W 3.3kΩ-J
R 3200	103P403060	CHIP RESISTOR	1/10W 8.2kΩ-J
R 3201	103P402070	CHIP RESISTOR	1/10W 1.5kΩ-J
R 3203	103P404010	CHIP RESISTOR	1/10W 22kΩ-J [B, EE]
R 3203	103P403080	CHIP RESISTOR	1/10W 12kΩ-J [E, G, Y]
R 3258	103P402060	CHIP RESISTOR	1/10W 1.2kΩ-J
R 3259	103P402090	CHIP RESISTOR	1/10W 2.2kΩ-J
R 3400	103P403060	CHIP RESISTOR	1/10W 8.2kΩ-J
R 3401	103P403020	CHIP RESISTOR	1/10W 3.9kΩ-J
R 3402	103P403090	CHIP RESISTOR	1/10W 15kΩ-J
R 3405	103P401090	CHIP RESISTOR	1/10W 330Ω-J
R 3406	103P405030	CHIP RESISTOR	1/10W 220kΩ-J
R 3407	103P405030	CHIP RESISTOR	1/10W 220kΩ-J
R 3408	103P404090	CHIP RESISTOR	1/10W 100kΩ-J
R 3409	103P404090	CHIP RESISTOR	1/10W 100kΩ-J
R 3410	103P404050	CHIP RESISTOR	1/10W 47kΩ-J
R 3411	103P404050	CHIP RESISTOR	1/10W 47kΩ-J
R 3412	103P403080	CHIP RESISTOR	1/10W 12kΩ-J
R 3413	103P403080	CHIP RESISTOR	1/10W 12kΩ-J
R 3421	103P404090	CHIP RESISTOR	1/10W 100kΩ-J
R 3501	103P475020	CHIP RESISTOR	1/10W 13kΩ-F
R 3504	103P402050	CHIP RESISTOR	1/10W 1kΩ-J
R 3505	103P474090	CHIP RESISTOR	1/10W 10kΩ-F [B, E, EE, Y]
R 3506	103P474090	CHIP RESISTOR	1/10W 10kΩ-F [B, E, EE, Y]
R 3561	103P403010	CHIP RESISTOR	1/10W 3.3kΩ-J
R 3562	103P403060	CHIP RESISTOR	1/10W 8.2kΩ-J
R 3900	103P409050	CHIP RESISTOR	0.1W 0Ω (2125) [B, E, EE, Y]
R 4A0	103P404060	CHIP RESISTOR	1/10W 56kΩ-J
R 4A1	103P403030	CHIP RESISTOR	1/10W 4.7kΩ-J
R 4A2	103P404020	CHIP RESISTOR	1/10W 27kΩ-J
R 4A3	103P472070	CHIP RESISTOR	1/10W 1.2kΩ-F
R 4A4	103P472070	CHIP RESISTOR	1/10W 1.2kΩ-F
R 4A5	103P403070	CHIP RESISTOR	1/10W 10kΩ-J
R 4A6	103P404000	CHIP RESISTOR	1/10W 18kΩ-J
R 4A7	103P404010	CHIP RESISTOR	1/10W 22kΩ-J
R 4A9	103P405000	CHIP RESISTOR	1/10W 120kΩ-J
R 4B0	103P402050	CHIP RESISTOR	1/10W 1kΩ-J
R 4B1	103P405000	CHIP RESISTOR	1/10W 120kΩ-J
R 4B2	103P403020	CHIP RESISTOR	1/10W 3.9kΩ-J
R 4B3	103P404060	CHIP RESISTOR	1/10W 56kΩ-J
R 4B4	103P405040	CHIP RESISTOR	1/10W 270kΩ-J
R 4B5	103P403060	CHIP RESISTOR	1/10W 8.2kΩ-J
R 4B6	103P404030	CHIP RESISTOR	1/10W 33kΩ-J
R 4B7	103P4040		

SYMBOL NO.	PARTS NO.	PARTS NAME	DESCRIPTION
R 488	103P405050	CHIP RESISTOR	1/10W 330kΩ-J
R 489	103P403050	CHIP RESISTOR	1/10W 6.8kΩ-J
R 4C0	103P404010	CHIP RESISTOR	1/10W 22kΩ-J
R 4C1	103P402090	CHIP RESISTOR	1/10W 2.2kΩ-J
R 4C2	103P406010	CHIP RESISTOR	1/10W 1MΩ-J
R 4C3	103P404090	CHIP RESISTOR	1/10W 100kΩ-J
R 4C4	103P404050	CHIP RESISTOR	1/10W 47kΩ-J
R 4C5	103P404040	CHIP RESISTOR	1/10W 39kΩ-J
R 4C6	103P405010	CHIP RESISTOR	1/10W 150kΩ-J
R 4C7	103P405010	CHIP RESISTOR	1/10W 150kΩ-J
R 4C8	103P405030	CHIP RESISTOR	1/10W 220kΩ-J
R 4C9	103P403070	CHIP RESISTOR	1/10W 10kΩ-J
R 4D0	103P404090	CHIP RESISTOR	1/10W 100kΩ-J
R 4D1	103P404040	CHIP RESISTOR	1/10W 39kΩ-J
R 4D2	103P405030	CHIP RESISTOR	1/10W 220kΩ-J
R 4D3	103P404060	CHIP RESISTOR	1/10W 56kΩ-J
R 4D4	103P404030	CHIP RESISTOR	1/10W 33kΩ-J
R 4D5	103P405050	CHIP RESISTOR	1/10W 330kΩ-J
R 4D6	103P402050	CHIP RESISTOR	1/10W 1kΩ-J
R 4D7	103P403030	CHIP RESISTOR	1/10W 4.7kΩ-J
R 4D8	103P404000	CHIP RESISTOR	1/10W 18kΩ-J
R 4D9	103P403070	CHIP RESISTOR	1/10W 10kΩ-J
R 4E0	103P402060	CHIP RESISTOR	1/10W 1.2kΩ-J
R 4E1	103P404090	CHIP RESISTOR	1/10W 100kΩ-J
R 4S5	103P403070	CHIP RESISTOR	1/10W 10kΩ-J [B, E, G, Y]
R 4S6	103P404000	CHIP RESISTOR	1/10W 18kΩ-J [B, E, G, Y]
R 4S7	103P409090	CHIP RESISTOR	1/10W 75Ω-J [B, E, G, Y]
R 4S9	103P403000	CHIP RESISTOR	1/10W 2.7kΩ-J [B, E, G, Y]
R 501	103P409050	CHIP RESISTOR	0.1W 0Ω (2125)
R 502	103P401090	CHIP RESISTOR	1/10W 330Ω-J
R 503	103P403080	CHIP RESISTOR	1/10W 12kΩ-J [E, EE, G, Y]
R 504	103P402090	CHIP RESISTOR	1/10W 2.2kΩ-J
R 505	103P404030	CHIP RESISTOR	1/10W 33kΩ-J
R 506	103P403070	CHIP RESISTOR	1/10W 10kΩ-J
R 507	103P404000	CHIP RESISTOR	1/10W 18kΩ-J
R 508	103P403080	CHIP RESISTOR	1/10W 12kΩ-J
R 509	103P403070	CHIP RESISTOR	1/10W 10kΩ-J
R 510	103P409050	CHIP RESISTOR	0.1W 0Ω (2125) [B]
R 510	103P402000	CHIP RESISTOR	1/10W 390Ω-J [E, EE, G, Y]
R 511	103P472070	CHIP RESISTOR	1/10W 1.2kΩ-F
R 512	103P402030	CHIP RESISTOR	1/10W 680Ω-J
R 514	103P402030	CHIP RESISTOR	1/10W 680Ω-J
R 515	103P401070	CHIP RESISTOR	1/10W 220Ω-J
R 516	103P404090	CHIP RESISTOR	1/10W 100kΩ-J
R 518	103P474030	CHIP RESISTOR	1/10W 5.6kΩ-F
R 519	103P473090	CHIP RESISTOR	1/10W 3.9kΩ-F
R 520	103P404010	CHIP RESISTOR	1/10W 22kΩ-J
R 521	103P403020	CHIP RESISTOR	1/10W 3.9kΩ-J
R 522	103P404010	CHIP RESISTOR	1/10W 22kΩ-J
R 551	103P402090	CHIP RESISTOR	1/10W 2.2kΩ-J [B, E, G]
R 552	103P406010	CHIP RESISTOR	1/10W 1MΩ-J [B, E, G]

SYMBOL NO.	PARTS NO.	PARTS NAME	DESCRIPTION
R 553	103P404090	CHIP RESISTOR	1/10W 100kΩ-J [B, E, G]
R 554	103P403050	CHIP RESISTOR	1/10W 6.8kΩ-J [B, E, G]
R 555	103P406020	CHIP METAL	1/10W 1.2MΩ-J [B, E, G]
R 556	103P403050	CHIP RESISTOR	1/10W 6.8kΩ-J [B, E, G]
R 557	103P406020	CHIP METAL	1/10W 1.2MΩ-J [B, E, G]
R 5A0	103P404030	CHIP RESISTOR	1/10W 33kΩ-J
R 5A1	103P402090	CHIP RESISTOR	1/10W 2.2kΩ-J
R 5A2	103P403010	CHIP RESISTOR	1/10W 3.3kΩ-J
R 5A3	103P403010	CHIP RESISTOR	1/10W 3.3kΩ-J
R 5A6	103P403070	CHIP RESISTOR	1/10W 10kΩ-J
R 5A8	103P475010	CHIP RESISTOR	1/10W 12kΩ-F
R 5B1	103P403070	CHIP RESISTOR	1/10W 10kΩ-J
R 5B4	103P404050	CHIP RESISTOR	1/10W 47kΩ-J
R 5B5	103P403070	CHIP RESISTOR	1/10W 10kΩ-J
R 5B7	103P403070	CHIP RESISTOR	1/10W 10kΩ-J
R 5B9	103P404050	CHIP RESISTOR	1/10W 47kΩ-J
R 5C0	103P403070	CHIP RESISTOR	1/10W 10kΩ-J
R 5C1	103P404030	CHIP RESISTOR	1/10W 33kΩ-J
R 5C2	103P402030	CHIP RESISTOR	1/10W 680Ω-J
R 5C3	103P402010	CHIP RESISTOR	1/10W 470Ω-J
R 5C4	103P402050	CHIP RESISTOR	1/10W 1kΩ-J
R 5C5	103P401070	CHIP RESISTOR	1/10W 220Ω-J
R 5C6	103P404030	CHIP RESISTOR	1/10W 33kΩ-J
R 5C8	103P406010	CHIP RESISTOR	1/10W 1MΩ-J
R 5C9	103P405030	CHIP RESISTOR	1/10W 220kΩ-J
R 5D6	103P403000	CHIP RESISTOR	1/10W 2.7kΩ-J
R 5D7	103P403070	CHIP RESISTOR	1/10W 10kΩ-J
R 5E0	103P404080	CHIP RESISTOR	1/10W 82kΩ-J
R 5E1	103P478020	CHIP RESISTOR	1/10W 240kΩ-F
R 5E2	103P477050	CHIP RESISTOR	1/10W 120kΩ
R 5E3	103P476080	CHIP RESISTOR	1/10W 62kΩ-F
R 5E4	103P476000	CHIP RESISTOR	1/10W 30kΩ-F
R 5E5	103P403070	CHIP RESISTOR	1/10W 10kΩ-J
R 5E6	103P475030	CHIP RESISTOR	1/10W 15kΩ-F
R 5E7	103P476070	CHIP RESISTOR	1/10W 56kΩ-F
R 5E8	103P405030	CHIP RESISTOR	1/10W 220kΩ-J
R 5E9	103P406010	CHIP RESISTOR	1/10W 1MΩ-J
R 5F0	103P405070	CHIP RESISTOR	1/10W 470kΩ-J
R 5F1	103P403070	CHIP RESISTOR	1/10W 10kΩ-J
R 5F2	103P403030	CHIP RESISTOR	1/10W 4.7kΩ-J
R 5F3	103P403000	CHIP RESISTOR	1/10W 2.7kΩ-J
R 5F4	103P404060	CHIP RESISTOR	1/10W 56kΩ-J
R 5F5	103P403030	CHIP RESISTOR	1/10W 4.7kΩ-J
R 5F6	103P402050	CHIP RESISTOR	1/10W 1kΩ-J
R 5F7	103P404050	CHIP RESISTOR	1/10W 47kΩ-J
R 5F8	103P402090	CHIP RESISTOR	1/10W 2.2kΩ-J
R 5G2	103P403050	CHIP RESISTOR	1/10W 6.8kΩ-J
R 5G3	103P403050	CHIP RESISTOR	1/10W 6.8kΩ-J
R 5G4	103P403030	CHIP RESISTOR	1/10W 4.7kΩ-J
R 5G5	103P404090	CHIP RESISTOR	1/10W 100kΩ-J
R 5G6	103P404090	CHIP RESISTOR	1/10W 100kΩ-J
R 5G7	103P403090	CHIP RESISTOR	1/10W 15kΩ-J
R 5G8	103P404000	CHIP RESISTOR	1/10W 18kΩ-J
R 5G9	103P403070	CHIP RESISTOR	1/10W 10kΩ-J
R 5H0	103P406090	CHIP METAL	1/10W 4.7MΩ-K

SYMBOL NO.	PARTS NO.	PARTS NAME	DESCRIPTION
R 5H1	103P406090	CHIP METAL	1/10W 4.7MΩ-K
R 5H3	103P403080	CHIP RESISTOR	1/10W 12kΩ-J
R 5H4	103P404000	CHIP RESISTOR	1/10W 1.2MΩ-J [B, E, G]
R 5H6	103P403070	CHIP RESISTOR	1/10W 10kΩ-J
R 5H7	103P403070	CHIP RESISTOR	1/10W 10kΩ-J
R 5J0	103P403070	CHIP RESISTOR	1/10W 10kΩ-J [E, G, Y]
R 5J1	103P403070	CHIP RESISTOR	1/10W 10kΩ-J [E, G, Y]
R 5J2	103P403040	CHIP RESISTOR	1/10W 5.6kΩ-J [E, G, Y]
R 5J3	103P404050	CHIP RESISTOR	1/10W 47kΩ-J [E, Y]
R 5J4	103P403050	CHIP RESISTOR	1/10W 6.8kΩ-J [E, Y]
R 5K0	103P409050	CHIP RESISTOR	0.1W 0Ω (2125) [EE]
R 5K1	103P404030	CHIP RESISTOR	1/10W 33kΩ-J [B, E, G, Y]
R 5K4	103P402050	CHIP RESISTOR	1/10W 1kΩ-J
R 5K5	103P404030	CHIP RESISTOR	1/10W 33kΩ-J [B, G]
R 5K7	103P406010	CHIP RESISTOR	1/10W 1MΩ-J
R 5L1	103P404010	CHIP RESISTOR	1/10W 22kΩ-J
R 5L2	103P403070	CHIP RESISTOR	1/10W 10kΩ-J
R 5L5	103P404090	CHIP RESISTOR	1/10W 100kΩ-J
R 5M0	103P403010	CHIP RESISTOR	1/10W 3.3kΩ-J
R 5M1	103P403010	CHIP RESISTOR	1/10W 3.3kΩ-J
R 701	103P472000	CHIP RESISTOR	1/10W 620Ω-F [E, G, Y]
R 702	103P472000	CHIP RESISTOR	1/10W 620Ω-F [E, G, Y]
R 703	103P401030	CHIP RESISTOR	1/10W 100Ω-J [E, G, Y]
R 704	103P404020	CHIP RESISTOR	1/10W 27kΩ-J [E, G, Y]
R 718	103P404020	CHIP RESISTOR	1/10W 27kΩ-J [E, G, Y]
R 719	103P403090	CHIP RESISTOR	1/10W 15kΩ-J [E, G, Y]
R 720	103P401070	CHIP RESISTOR	1/10W 220Ω-J [E, G, Y]
R 723	103P403010	CHIP RESISTOR	1/10W 3.3kΩ-J [E, G, Y]
R 724	103P403010	CHIP RESISTOR	1/10W 3.3kΩ-J [E, G, Y]
R 725	103P403050	CHIP RESISTOR	1/10W 6.8kΩ-J [E, G, Y]
R 7A1	103P404010	CHIP RESISTOR	1/10W 22kΩ-J [B]
R 7A1	103P403090	CHIP RESISTOR	1/10W 15kΩ-J [E]
R 7A2	103P403010	CHIP RESISTOR	1/10W 3.3kΩ-J [B, E]
R 7A3	103P402000	CHIP RESISTOR	1/10W 390Ω-J [B, E]
R 7A4	103P401050	CHIP RESISTOR	1/10W 150Ω-J [B]
R 7A4	103P402000	CHIP RESISTOR	1/10W 390Ω-J [E]
R 7A5	103P409050	CHIP RESISTOR	0.1W 0Ω (2125) [E]
R 7A9	103P403020	CHIP RESISTOR	1/10W 3.9kΩ-J [B, E]
R 7C0	103P403070	CHIP RESISTOR	1/10W 10kΩ-J [B, E]
R 7C1	103P404010	CHIP RESISTOR	1/10W 22kΩ-J [B, E]
R 7C2	103P406010	CHIP RESISTOR	1/10W 1MΩ-J [B, E]
R 7C5	103P406010	CHIP RESISTOR	1/10W 1MΩ-J [B, E]
R 7C6	103P403070	CHIP RESISTOR	1/10W 10kΩ-J [B, E]
R 7C7	103P406010	CHIP RESISTOR	1/10W 1MΩ-J [B, E]
R 7C8	103P403070	CHIP RESISTOR	1/10W 10kΩ-J [B, E]
R 7C9	103P403010	CHIP RESISTOR	1/10W 3.3kΩ-J [B, E]
R 7D0	103P404090	CHIP RESISTOR	1/10W 100kΩ-J [B, E]
R 7D1	103P401030	CHIP RESISTOR	1/10W 100Ω-J [B, E]
R 7D2	103P402050	CHIP RESISTOR	1/10W 1kΩ-J [B, E]
R 7G2	103P401060	CHIP RESISTOR	1/10W 180Ω-J [B, E]
R 7G5	103P401060	CHIP RESISTOR	1/10W 180Ω-J [B, E]
R 7G6	103P400090	CHIP RESISTOR	1/10W 47Ω-J [B, E]
R 901	109D036040	COMPOSITION	1/2W 8.2MΩ-K
R 903	109P052010	FUSE	1/4W 100Ω-J

SYMBOL NO.	PARTS NO.	PARTS NAME	DESCRIPTION
R 911	103P370040	FUSE	1/4W 18Ω-J
R 917	103P398050	FUSE	1/2W 2.2Ω-J [B]
R 920	103P403070	CHIP RESISTOR	1/10W 10kΩ-J
R 921	103P403070	CHIP RESISTOR	1/10W 10kΩ-J
R 922	103P404010	CHIP RESISTOR	1/10W 22kΩ-J
R 923	103P403030	CHIP RESISTOR	1/10W 4.7kΩ-J
R 924	103P398010	FUSE	1/2W 1.2Ω-J
R 9A4	103P406010	CHIP RESISTOR	1/10W 1MΩ-J
R 9B0	103P475030	CHIP RESISTOR	1/10W 15kΩ-F
R 9C4	103P398020	FUSE	1/2W 1.5Ω-J
R 9C5	103P378080	FUSE	1/4W 4.7Ω-J [E, G, Y]
RJ101	103P409050	CHIP RESISTOR	0.1W 0Ω (2125) [B, EE]
RJ102	103P409050	CHIP RESISTOR	0.1W 0Ω (2125)
RJ104	103P409050	CHIP RESISTOR	0.1W 0Ω (2125)
RJ105	103P409050	CHIP RESISTOR	0.1W 0Ω (2125)
RJ106	103P409050	CHIP RESISTOR	0.1W 0Ω (2125)
RJ107	103P409050	CHIP RESISTOR	0.1W 0Ω (2125) [B, G, Y]
RJ202	103P409050	CHIP RESISTOR	0.1W 0Ω (2125) [B, EE]
RJ203	103P409050	CHIP RESISTOR	0.1W 0Ω (2125)
RJ204	103P409050	CHIP RESISTOR	0.1W 0Ω (2125)
RJ205	103P409050	CHIP RESISTOR	0.1W 0Ω (2125)
RJ206	103P409050	CHIP RESISTOR	0.1W 0Ω (2125)
RJ207	103P409050	CHIP RESISTOR	0.1W 0Ω (2125)
RJ208	103P409050	CHIP RESISTOR	0.1W 0Ω (2125)
RJ209	103P409050	CHIP RESISTOR	0.1W 0Ω (2125)
RJ210	103P409050	CHIP RESISTOR	0.1W 0Ω (2125) [EE]
RJ211	103P409050	CHIP RESISTOR	0.1W 0Ω (2125)
RJ212	103P409050	CHIP RESISTOR	0.1W 0Ω (2125) [B, E]
RJ213	103P409050	CHIP RESISTOR	0.1W 0Ω (2125) [B, E]
RJ214	103P409050	CHIP RESISTOR	0.1W 0Ω (2125)
RJ215	103P409050	CHIP RESISTOR	0.1W 0Ω (2125)
RJ2601	103P409050	CHIP RESISTOR	0.1W 0Ω (2125)
RJ2602	103P409050	CHIP RESISTOR	0.1W 0Ω (2125) [E, G, Y]
RJ2603	103P409050	CHIP RESISTOR	0.1W 0Ω (2125)
RJ2604	103P409050	CHIP RESISTOR	0.1W 0Ω (2125)
RJ2605	103P409050	CHIP RESISTOR	0.1W 0Ω (2125)
RJ2606	103P409050	CHIP RESISTOR	0.1W 0Ω (2125)
RJ2607	103P409050	CHIP RESISTOR	0.1W 0Ω (2125)
RJ2608	103P409050	CHIP RESISTOR	0.1W 0Ω (2125)
RJ2611	103P409050	CHIP RESISTOR	0.1W 0Ω (2125)
RJ2613	103P409050	CHIP RESISTOR	0.1W 0Ω (2125) [E, G, Y]
RJ2614	103P409050	CHIP RESISTOR	0.1W 0Ω (2125)
RJ2616	103P409050	CHIP RESISTOR	0.1W 0Ω (2125) [B, E]
RJ2617	103P409050	CHIP RESISTOR	0.1W 0Ω (2125)
RJ2618	103P409050	CHIP RESISTOR	0.1W 0Ω (2125)
RJ2619	103P409050	CHIP RESISTOR	0.1W 0Ω (2125) [E, G, Y]
RJ2620	103P409050	CHIP RESISTOR	0.1W 0Ω (2125) [EE]
RJ2621	103P409050	CHIP RESISTOR	0.1W 0Ω (2125) [EE]
RJ301	103P409050	CHIP RESISTOR	0.1W 0Ω (2125)
RJ302	103P409050	CHIP RESISTOR	0.1W 0Ω (2125)
RJ303	103P409050	CHIP RESISTOR	0.1W 0Ω (2125)
RJ304	103P409050	CHIP RESISTOR	0.1W 0Ω (2125)
RJ305	103P409050	CHIP RESISTOR	0.1W 0Ω (2125)
RJ307	103P409050	CHIP RESISTOR	0.1W 0Ω (2125)
RJ309	103P409050	CHIP RESISTOR	

SYMBOL NO.	PARTS NO.	PARTS NAME	DESCRIPTION
RJ310	103P409050	CHIP RESISTOR	0.1W 0Ω (2125)
RJ314	103P409050	CHIP RESISTOR	0.1W 0Ω (2125)
RJ315	103P409050	CHIP RESISTOR	0.1W 0Ω (2125)
RJ316	103P409050	CHIP RESISTOR	0.1W 0Ω (2125)
RJ318	103P409050	CHIP RESISTOR	0.1W 0Ω (2125)
RJ319	103P409050	CHIP RESISTOR	0.1W 0Ω (2125)
RJ320	103P409050	CHIP RESISTOR	0.1W 0Ω (2125)
RJ321	103P409050	CHIP RESISTOR	0.1W 0Ω (2125)
RJ322	103P409050	CHIP RESISTOR	0.1W 0Ω (2125)
RJ323	103P409050	CHIP RESISTOR	0.1W 0Ω (2125)
RJ3A1	103P409050	CHIP RESISTOR	0.1W 0Ω (2125)
RJ3A2	103P409050	CHIP RESISTOR	0.1W 0Ω (2125)
RJ3A3	103P409050	CHIP RESISTOR	0.1W 0Ω (2125)
RJ3A5	103P409050	CHIP RESISTOR	0.1W 0Ω (2125)
RJ3A6	103P409050	CHIP RESISTOR	0.1W 0Ω (2125)
RJ3A7	103P409050	CHIP RESISTOR	0.1W 0Ω (2125)
RJ3A8	103P409050	CHIP RESISTOR	0.1W 0Ω (2125)
RJ3A9	103P409050	CHIP RESISTOR	0.1W 0Ω (2125)
RJ3001	103P409050	CHIP RESISTOR	0.1W 0Ω (2125)
RJ3002	103P409050	CHIP RESISTOR	0.1W 0Ω (2125)
RJ3003	103P409050	CHIP RESISTOR	0.1W 0Ω (2125)
RJ3005	103P409050	CHIP RESISTOR	0.1W 0Ω (2125)
RJ3006	103P409050	CHIP RESISTOR	0.1W 0Ω (2125) [E, G, Y]
RJ3007	103P409050	CHIP RESISTOR	0.1W 0Ω (2125) [G]
RJ3008	103P409050	CHIP RESISTOR	0.1W 0Ω (2125)
RJ3009	103P409050	CHIP RESISTOR	0.1W 0Ω (2125)
RJ3010	103P409050	CHIP RESISTOR	0.1W 0Ω (2125)
RJ401	103P409050	CHIP RESISTOR	0.1W 0Ω (2125)
RJ402	103P409050	CHIP RESISTOR	0.1W 0Ω (2125)
RJ403	103P409050	CHIP RESISTOR	0.1W 0Ω (2125)
RJ404	103P409050	CHIP RESISTOR	0.1W 0Ω (2125)
RJ405	103P409050	CHIP RESISTOR	0.1W 0Ω (2125)
RJ406	103P409050	CHIP RESISTOR	0.1W 0Ω (2125)
RJ407	103P409050	CHIP RESISTOR	0.1W 0Ω (2125)
RJ408	103P409050	CHIP RESISTOR	0.1W 0Ω (2125)
RJ501	103P409050	CHIP RESISTOR	0.1W 0Ω (2125)
RJ502	103P409050	CHIP RESISTOR	0.1W 0Ω (2125)
RJ503	103P409050	CHIP RESISTOR	0.1W 0Ω (2125)
RJ504	103P409050	CHIP RESISTOR	0.1W 0Ω (2125)
RJ505	103P409050	CHIP RESISTOR	0.1W 0Ω (2125)
<b>CAPACITORS AND TRIMMERS</b>			
C 101	141P132010	CHIP CAPACITOR	850V 0.01 μF-K
C 102	141P132010	CHIP CAPACITOR	850V 0.01 μF-K
C 103	141P132010	CHIP CAPACITOR	850V 0.01 μF-K [E]
C 104	141P132010	CHIP CAPACITOR	850V 0.01 μF-K
C 105	141P132010	CHIP CAPACITOR	850V 0.01 μF-K
C 106	154P331010	CHIP CAPACITOR	CH50V 100pF-K [B, EE, G, Y]
C 107	141P132010	CHIP CAPACITOR	850V 0.01 μF-K
C 108	141P135000	CHIP CAPACITOR	F25V 0.22 μF-F
C 109	141P132010	CHIP CAPACITOR	850V 0.01 μF-K
C 112	141P132010	CHIP CAPACITOR	850V 0.01 μF-K
C 114	141P132010	CHIP CAPACITOR	850V 0.01 μF-K
C 117	154P331050	CHIP CAPACITOR	CH50V 15pF-J
C 118	141P132010	CHIP CAPACITOR	850V 0.01 μF-K

SYMBOL NO.	PARTS NO.	PARTS NAME	DESCRIPTION
C 119	154P321060	CHIP CAPACITOR	SL50V 15pF-J [B]
C 119	154P321080	CHIP CAPACITOR	SL50V 18pF-J [E, EE, G, Y]
C 122	141P133080	CHIP CAPACITOR	F50V 0.01 μF-F-Z [E, G, Y]
C 124	141P134010	CHIP CAPACITOR	F50V 0.047M [E, G, Y]
C 126	141P131020	CHIP CAPACITOR	B50V 1800pF-K [E, G, Y]
C 127	154P325080	CHIP CAPACITOR	SL50V 820pF [E, G, Y]
C 131	141P130060	CHIP CAPACITOR	850V 560pF-K
C 132	141P137080	CHIP CAPACITOR	B25V 0.047M
C 151	141P132010	CHIP CAPACITOR	B50V 0.01 μF-K [E]
C 152	141P132010	CHIP CAPACITOR	B50V 0.01 μF-K [E]
C 153	141P132010	CHIP CAPACITOR	B50V 0.01 μF-K [E]
C 159	141P130090	CHIP CAPACITOR	B50V 1000pF-K [E, EE, G, Y]
C 151	154P322000	CHIP CAPACITOR	SL50V 22pF-J [EE]
C 152	154P321060	CHIP CAPACITOR	SL50V 15pF-J [EE]
C 153	141P132010	CHIP CAPACITOR	B50V 0.01 μF-K [EE]
C 201	141P139030	CHIP CAPACITOR	B25V 0.1 μF-F-K
C 202	141P136030	CHIP CAPACITOR	F16V 1 μF-F-Z
C 203	141P136030	CHIP CAPACITOR	F16V 1 μF-F-Z
C 204	154P322060	CHIP CAPACITOR	SL50V 39pF-J
C 205	154P322060	CHIP CAPACITOR	SL50V 39pF-J
C 206	141P136030	CHIP CAPACITOR	F16V 1 μF-F-Z
C 207	141P136030	CHIP CAPACITOR	F16V 1 μF-F-Z
C 208	154P322080	CHIP CAPACITOR	SL50V 47pF-J
C 209	154P322080	CHIP CAPACITOR	SL50V 47pF-J
C 210	141P139030	CHIP CAPACITOR	B25V 0.1 μF-F-K
C 212	141P132000	CHIP CAPACITOR	850V 8200pF-K [B, E, G, Y]
C 213	154P333010	CHIP CAPACITOR	CH50V 68pF-J
C 214	141P139030	CHIP CAPACITOR	B25V 0.1 μF-F-K
C 215	154P322040	CHIP CAPACITOR	SL50V 33pF-J
C 216	154P322080	CHIP CAPACITOR	SL50V 47pF-J
C 217	154P323040	CHIP CAPACITOR	SL50V 82pF-J
C 218	154P324020	CHIP CAPACITOR	SL50V 180pF-J
C 219	141P132000	CHIP CAPACITOR	B50V 8200pF-K
C 220	141P137080	CHIP CAPACITOR	B25V 0.047M
C 221	141P130090	CHIP CAPACITOR	B50V 1000pF-K
C 222	141P132000	CHIP CAPACITOR	B50V 8200pF-K
C 224	154P323040	CHIP CAPACITOR	SL50V 82pF-J
C 260	141P130050	CHIP CAPACITOR	B50V 470pF-K
C 261	141P132010	CHIP CAPACITOR	850V 0.01 μF-K
C 2A3	154P325020	CHIP CAPACITOR	SL50V 470pF
C 2A4	154P323020	CHIP CAPACITOR	SL50V 68pF-J
C 2A5	154P325000	CHIP CAPACITOR	SL50V 390pF-J
C 2A6	141P132000	CHIP CAPACITOR	B50V 8200pF-K
C 2A7	154P322060	CHIP CAPACITOR	SL50V 39pF-J
C 2A8	154P322040	CHIP CAPACITOR	SL50V 33pF-J [E, EE, G, Y]
C 2A8	154P321080	CHIP CAPACITOR	SL50V 18pF-J [B]
C 2B0	141P132000	CHIP CAPACITOR	B50V 8200pF-K
C 2B1	141P132000	CHIP CAPACITOR	B50V 8200pF-K
C 260	154P325000	CHIP CAPACITOR	SL50V 390pF-J
C 2G1	154P322000	CHIP CAPACITOR	SL50V 22pF-J
C 2G2	141P137040	CHIP CAPACITOR	B25V 0.022M
C 2G4	141P137040	CHIP CAPACITOR	B25V 0.022M
C 2G6	141P139030	CHIP CAPACITOR	B25V 0.1 μF-K

SYMBOL NO.	PARTS NO.	PARTS NAME	DESCRIPTION
C 2H4	141P137040	CHIP CAPACITOR	B25V 0.022M
C 2H4	141P139030	CHIP CAPACITOR	B25V 0.1 μF-F-K
C 2H9	141P137080	CHIP CAPACITOR	B25V 0.047M
C 2J0	154P321060	CHIP CAPACITOR	SL50V 15pF-J
C 2J1	154P322060	CHIP CAPACITOR	SL50V 39pF-J
C 2J2	154P323020	CHIP CAPACITOR	SL50V 68pF-J
C 2J3	141P132010	CHIP CAPACITOR	B50V 0.01 μF-F-K
C 2J4	154P322020	CHIP CAPACITOR	SL50V 27pF-J [B, E, G, Y]
C 2K0	141P132000	CHIP CAPACITOR	B50V 8200pF-K
C 2K1	141P132000	CHIP CAPACITOR	B50V 8200pF-K
C 2K4	141P132000	CHIP CAPACITOR	B50V 8200pF-K
C 2K5	154P324040	CHIP CAPACITOR	SL50V 220pF-J [B]
C 2K5	154P324020	CHIP CAPACITOR	SL50V 180pF-J [E, EE, G, Y]
C 2L0	141P132000	CHIP CAPACITOR	B50V 8200pF-K
C 2L1	141P132000	CHIP CAPACITOR	B50V 8200pF-K
C 2L3	141P132000	CHIP CAPACITOR	B50V 8200pF-K
C 2L6	141P132000	CHIP CAPACITOR	B50V 8200pF-K
C 2L7	141P132000	CHIP CAPACITOR	B50V 8200pF-K
C 2L8	141P132010	CHIP CAPACITOR	B50V 0.01 μF-F-K
C 2L9	141P132000	CHIP CAPACITOR	B50V 8200pF-K
C 2M3	141P132000	CHIP CAPACITOR	B50V 8200pF-K
C 2M4	141P132000	CHIP CAPACITOR	B50V 8200pF-K
C 2T0	154P324080	CHIP CAPACITOR	SL50V 330pF-J
C 2T1	154P322060	CHIP CAPACITOR	SL50V 39pF-J
C 2X0	141P130010	CHIP CAPACITOR	B50V 220pF-K [B, E, G, Y]
C 2X1	141P130010	CHIP CAPACITOR	B50V 220pF-K [B, E, G, Y]
C 2Y0	141P132000	CHIP CAPACITOR	B50V 8200pF-K
C 2303	141P131090	CHIP CAPACITOR	B50V 6800pF-K [E, G, Y]
C 2306	141P131090	CHIP CAPACITOR	B50V 6800pF-K [E, G, Y]
C 2307	141P130030	CHIP CAPACITOR	B50V 330pF-K [B, EE]
C 2307	141P130040	CHIP CAPACITOR	B50V 390pF-K [E, G, Y]
C 2308	141P130030	CHIP CAPACITOR	B50V 330pF-K [B, EE]
C 2308	141P130050	CHIP CAPACITOR	B50V 470pF-K [E, G, Y]
C 2311	141P131090	CHIP CAPACITOR	B50V 6800pF-K [B, E, G, Y]
C 2314	141P131090	CHIP CAPACITOR	B50V 6800pF-K [B, E, G, Y]
C 2315	154P324080	CHIP CAPACITOR	SL50V 330pF-J
C 2320	141P131020	CHIP CAPACITOR	B50V 1800pF-K [B, E, G, Y]
C 2321	141P131020	CHIP CAPACITOR	B50V 1800pF-K [B, E, G, Y]
C 2322	141P131020	CHIP CAPACITOR	B50V 1800pF-K [E, G, Y]
C 2323	141P131020	CHIP CAPACITOR	B50V 1800pF-K [E, G, Y]
C 2610	141P132010	CHIP CAPACITOR	B50V 0.01 μF-F-K [E, G, Y]
C 2615	141P132010	CHIP CAPACITOR	B50V 0.01 μF-F-K
C 2617	154P324080	CHIP CAPACITOR	SL50V 330pF-J [E, G, Y]
C 2620	154P324080	CHIP CAPACITOR	SL50V 330pF-J [E, G, Y]
C 2642	141P130030	CHIP CAPACITOR	B50V 330pF-K [E, G, Y]
C 2643	141P130030	CHIP CAPACITOR	B50V 330pF-K [E, G, Y]
C 2644	141P130090	CHIP CAPACITOR	F50V 0.022M
C 2645	141P133090	CHIP CAPACITOR	F50V 0.022M
C 2650	141P130030	CHIP CAPACITOR	B50V 330pF-K [B, E, G, Y]
C 2651	141P130030	CHIP CAPACITOR	B50V 330pF-K [B, E, G, Y]

SYMBOL NO.	PARTS NO.	PARTS NAME	DESCRIPTION
C 2652	141P130030	CHIP CAPACITOR	B50V 330pF-K [B, E, G, Y]
C 2653	141P139030	CHIP CAPACITOR	B50V 330pF-K [B, E, G, Y]
C 301	141P139030	CHIP CAPACITOR	B25V 0.1 μF-F-K
C 302	141P135080	CHIP CAPACITOR	F25V 0.1 μF-F-Z
C 304	141P133080	CHIP CAPACITOR	F50V 0.01 μF-F-Z
C 305	141P135080	CHIP CAPACITOR	F25V 0.1 μF-F-Z
C 307	141P132010	CHIP CAPACITOR	B50V 0.01 μF-F-K
C 308	154P324040	CHIP CAPACITOR	SL50V 220pF-J
C 309	141P139030	CHIP CAPACITOR	B25V 0.1 μF-F-K
C 310	141P133080	CHIP CAPACITOR	F50V 0.01 μF-F-Z
C 311	154P323060	CHIP CAPACITOR	SL50V 100pF-J
C 312	154P323060	CHIP CAPACITOR	SL50V 100pF-J
C 313	141P133080	CHIP CAPACITOR	F50V 0.01 μF-F-Z
C 314	141P139030	CHIP CAPACITOR	B25V 0.1 μF-F-K
C 315	141P139030	CHIP CAPACITOR	B25V 0.1 μF-F-K
C 3A0	141P132000	CHIP CAPACITOR	B50V 8200pF-K
C 3A1	141P130080	CHIP CAPACITOR	B50V 820pF-K
C 3A9	141P130090	CHIP CAPACITOR	B50V 1000pF-K
C 3B9	141P135010	CHIP CAPACITOR	F25V 0.33 μF-F-Z
C 3C0	141P132010	CHIP CAPACITOR	B50V 0.01 μF-F-K
C 3C3	141P130060	CHIP CAPACITOR	B50V 560pF-K
C 3010	141P132010	CHIP CAPACITOR	B50V 0.01 μF-F-K
C 3011	141P132010	CHIP CAPACITOR	B50V 0.01 μF-F-K
C 3012	141P132010	CHIP CAPACITOR	B50V 0.01 μF-F-K
C 3013	141P132010	CHIP CAPACITOR	B50V 0.01 μF-F-K
C 3014	141P130020	CHIP CAPACITOR	B50V 270pF-K
C 3252	141P133080	CHIP CAPACITOR	F50V 0.01 μF-F-Z
C 3253	141P133080	CHIP CAPACITOR	F50V 0.01 μF-F-Z
C 3352	141P133080	CHIP CAPACITOR	F50V 0.01 μF-F-Z
C 3354	141P133080	CHIP CAPACITOR	F50V 0.01 μF-F-Z
C 3400	141P133080	CHIP CAPACITOR	F50V 0.01 μF-F-Z
C 3401	141P133080	CHIP CAPACITOR	F50V 0.01 μF-F-Z
C 3415	141P133080	CHIP CAPACITOR	F50V 0.01 μF-F-Z
C 4A2	141P130090	CHIP CAPACITOR	B50V 1000pF-K
C 4A3	154P324020	CHIP CAPACITOR	SL50V 180pF-J
C 4A4	141P130090	CHIP CAPACITOR	B50V 1000pF-K
C 4B0	141P131080	CHIP CAPACITOR	B50V 5600pF-K
C 4B1	141P131080	CHIP CAPACITOR	B50V 5600pF-K
C 4B3	141P132000	CHIP CAPACITOR	B50V 8200pF-K
C 4B5	141P130090	CHIP CAPACITOR	B50V 1000pF-K
C 4B6	141P139030	CHIP CAPACITOR	B25V 0.056 μF-K
C 4B7	154P331030	CHIP CAPACITOR	CH50V 12pF-J [B, E, G, Y]
C 4B8	141P139010	CHIP CAPACITOR	B25V 0.068M
C 4B9	141P139030	CHIP CAPACITOR	B25V 0.1 μF-F-K
C 4C0	141P131050	CHIP CAPACITOR	B50V 3300pF-K
C 4C4	141P133080	CHIP CAPACITOR	F50V 0.01 μF-F-Z
C 4C5	141P 33090	CHIP CAPACITOR	F50V 0.022M
C 4C9	141P131060	CHIP CAPACITOR	B50V 3900pF-K
C 4D0	141P131010	CHIP CAPACITOR	B50V 1500pF
C 4D3	141P137070	CHIP CAPACITOR	B25V 0.039 μF-K
C 4G7	154P333050	CHIP CAPACITOR	CH50V 100pF-J [B, E, G, Y]
C 4G8	154P333050	CHIP CAPACITOR	CH50V 100pF-J [B, E, G, Y]
C 4J0	154P331070	CHIP CAPACITOR	CH50V 18pF-J [B, E, G, Y]



SYMBOL NO.	PARTS NO.	PARTS NAME	DESCRIPTION
C 501	154P330040	CHIP CAPACITOR	CJ50V 3pF-C
C 502	154P330040	CHIP CAPACITOR	CJ50V 3pF-C
C 504	154P331090	CHIP CAPACITOR	CH50V 22pF-J
C 505	154P331090	CHIP CAPACITOR	CH50V 22pF-J
C 507	154P322080	CHIP CAPACITOR	SL50V 47pF-J [E, EE, G, Y]
C 508	141P137080	CHIP CAPACITOR	B25V 0.047M
C 509	141P133080	CHIP CAPACITOR	F50V 0.01 $\mu$ F-Z
C 510	141P133080	CHIP CAPACITOR	F50V 0.01 $\mu$ F-Z
C 511	141P132000	CHIP CAPACITOR	B50V 8200pF-K
C 512	141P132000	CHIP CAPACITOR	B50V 8200pF-K
C 530	141P131010	CHIP CAPACITOR	B50V 1500pF
C 551	154P324000	CHIP CAPACITOR	SL50V 150pF-J [B, E, G]
C 552	141P137080	CHIP CAPACITOR	B50V 0.033 $\mu$ F-K [B, E, G]
C 554	141P131030	CHIP CAPACITOR	B50V 2200pF-K [B, E, G]
C 555	141P137060	CHIP CAPACITOR	B50V 0.033 $\mu$ F-K [B, E, G]
C 556	141P133080	CHIP CAPACITOR	F50V 0.01 $\mu$ F-Z [B, E, G]
C 5A1	141P133080	CHIP CAPACITOR	F50V 0.01 $\mu$ F-Z
C 5A2	141P133080	CHIP CAPACITOR	F50V 0.01 $\mu$ F-Z
C 5A5	189P197020	C-ELE-DOUBLE-LAYER	FMH473Z
C 5A7	141P135080	CHIP CAPACITOR	F25V 0.1 $\mu$ F-Z
C 5A9	141P133080	CHIP CAPACITOR	F50V 0.01 $\mu$ F-Z
C 5B5	141P134010	CHIP CAPACITOR	F50V 0.047M
C 5B7	141P131030	CHIP CAPACITOR	B50V 2200pF-K
C 5C0	154P331010	CHIP CAPACITOR	CH50V 10pF-C
C 5C1	154P331070	CHIP CAPACITOR	CH50V 18pF-J
C 5C2	154P331070	CHIP CAPACITOR	CH50V 18pF-J
C 5C3	154P330090	CHIP CAPACITOR	CH50V 8pF-C
C 5C4	141P130060	CHIP CAPACITOR	B50V 560pF-K
C 5C6	141P132000	CHIP CAPACITOR	B50V 8200pF-K [B, E, G, Y]
C 5C7	141P133080	CHIP CAPACITOR	F50V 0.01 $\mu$ F-Z
C 5L5	141P130090	CHIP CAPACITOR	B50V 1000pF-K
C 701	141P133080	CHIP CAPACITOR	F50V 0.01 $\mu$ F-Z [E, G, Y]
C 703	141P133080	CHIP CAPACITOR	F50V 0.01 $\mu$ F-Z [E, G, Y]
C 704	141P133080	CHIP CAPACITOR	F50V 0.01 $\mu$ F-Z [E, G, Y]
C 705	141P133080	CHIP CAPACITOR	F50V 0.01 $\mu$ F-Z [E, G, Y]
C 706	141P133080	CHIP CAPACITOR	F50V 0.01 $\mu$ F-Z [E, G, Y]
C 707	141P133080	CHIP CAPACITOR	F50V 0.01 $\mu$ F-Z [E, G, Y]
C 709	154P321020	CHIP CAPACITOR	SL50V 10pF-C [E, G, Y]
C 713	141P133080	CHIP CAPACITOR	F50V 0.01 $\mu$ F-Z [E, G, Y]
C 720	154P322080	CHIP CAPACITOR	SL50V 47pF-J [E, G, Y]
C 7A1	141P139030	CHIP CAPACITOR	B25V 0.1 $\mu$ F-K [B, E]
C 7A3	141P133080	CHIP CAPACITOR	F50V 0.01 $\mu$ F-Z [B, E]
C 7A4	141P133080	CHIP CAPACITOR	F50V 0.01 $\mu$ F-Z [B, E]
C 7A5	141P133080	CHIP CAPACITOR	F50V 0.01 $\mu$ F-Z [B, E]
C 7C0	154P324040	CHIP CAPACITOR	SL50V 220pF-J [B, E]
C 7C1	141P139030	CHIP CAPACITOR	B25V 0.1 $\mu$ F-K [B, E]
C 7C3	141P139030	CHIP CAPACITOR	B25V 0.1 $\mu$ F-K [B, E]
C 7C5	141P139030	CHIP CAPACITOR	B25V 0.1 $\mu$ F-K [B, E]
C 7C8	154P322080	CHIP CAPACITOR	SL50V 47pF-J [B, E]
C 7C9	154P322080	CHIP CAPACITOR	SL50V 47pF-J [B, E]
C 7D3	141P139030	CHIP CAPACITOR	B25V 0.1 $\mu$ F-K [B, E]
C 7D4	141P139030	CHIP CAPACITOR	B25V 0.1 $\mu$ F-K [B, E]

SYMBOL NO.	PARTS NO.	PARTS NAME	DESCRIPTION
C 7D6	154P323020	CHIP CAPACITOR	SL50V 68pF-J [B, E]
C 7D9	141P139030	CHIP CAPACITOR	B25V 0.1 $\mu$ F-K [B, E]
C 7E0	154P323020	CHIP CAPACITOR	SL50V 68pF-J [B, E]
C 7E2	141P133080	CHIP CAPACITOR	F50V 0.01 $\mu$ F-Z [B, E]
C 7E5	141P139030	CHIP CAPACITOR	B25V 0.1 $\mu$ F-K [B, E]
C 7E6	154P321020	CHIP CAPACITOR	SL50V 10pF-C [B, E]
C 7E8	141P139030	CHIP CAPACITOR	B25V 0.1 $\mu$ F-K [B, E]
C 7F0	141P130040	CHIP CAPACITOR	B50V 390pF-K [B, E]
C 7F1	141P133090	CHIP CAPACITOR	F50V 0.022M [B, E]
C 9A1	141P133080	CHIP CAPACITOR	F50V 0.01 $\mu$ F-Z
C 9A9	141P139030	CHIP CAPACITOR	B25V 0.1 $\mu$ F-K
C 9C2	141P133080	CHIP CAPACITOR	F50V 0.01 $\mu$ F-Z
<b>SWITCHES</b>			
S 101	431C106010	SLIDE SWITCH	TV/VTR SWITCH
S 5A0	439P033010	SWITCH	RIS MPU10101MM80
S 5A1	432P166010	KEY BOARD SWITCH	RESET
S 8A1	432P089040	KEY BOARD SWITCH	PLAY
S 8A2	432P089020	KEY BOARD SWITCH	POWER
S 8A3	432P089040	KEY BOARD SWITCH	INSERT
S 8B1	432P089040	KEY BOARD SWITCH	STOP
S 8B2	432P089020	KEY BOARD SWITCH	EJECT
S 8B3	432P089040	KEY BOARD SWITCH	AUDIO/DUB
S 8C1	432P089040	KEY BOARD SWITCH	REC/OTR
S 8C2	432P089040	KEY BOARD SWITCH	ONE KEY PROGRAM
S 8D1	432P089040	KEY BOARD SWITCH	PAUSE
S 8D2	432P089020	KEY BOARD SWITCH	RENT PB
S 8D3	432P089040	KEY BOARD SWITCH	AUDIO SET UP
S 8J0	439P034010	SWITCH JG	JOG/SHUTTLE [B, E, G]
<b>MISCELLANEOUS</b>			
CU 01	295P276070	RF CONVERTER	[B]
CU 01	295P276050	RF CONVERTER	[E, G, Y]
CU 01	295P432020	RF CONVERTER	[EE]
F 901	2830046080	FUSE	T630MA
F 902	2830047050	FUSE	T2.5A
F 903	2830047050	FUSE	T2.5A
J 2A0	451C096040	PIN JACK	RED
J 2A1	451C096010	PIN JACK	WHITE
J 2001	451C058020	CONNECTOR	21P
J 2002	451C058020	CONNECTOR	21P
J 5A0	451C096030	PIN JACK	BLACK [B, E, G, Y]
J 5A1	451C129020	JACK MICROPHONE	[B]
J 8A0	440C267050	PIN JACK (3P)	YEL, WHT, RED
J 8A3	451C104010	JACK HEADPHONE	BLACK
K 3A0	287P020010	RELAY	MZ12-B DC12V
M 470	288P126010	MOTOR CAPSTAN	F20K879
M 570	286P088060	MOTOR DRUM	DC12V 3.3W
M 571	288P145010	MOTOR LOADING	M0N13FB12D
MA TA	243C156040	LEAD CARD	11P L140 (MA-0A)
MB HB	243C158020	LEAD CARD	15P L100 (MB-HB)
MC HC	243C163020	LEAD CARD	25P L100 (MC-HC)
MK TK	243C161070	LEAD CARD	21P L200 (MK-TK)
P 5A0	285P010010	BUZZER	PKM22EPT-2001
S 570	439D039010	MODE SELECT SWITCH	(J)

SYMBOL NO.	PARTS NO.	PARTS NAME	DESCRIPTION
T 370	460P060080	A/C HEAD	
T 371	460P153010	FULL ERASE HEAD	FE HEAD
TU 01	295P418010	TUNER	TEKE4-071A [E, EE, G, Y]
TU 01	295P194020	TUNER TV	TERB1-044A [B]
Y 8A0	253P115050	TUBE FLUOR	BJ360K
X 2A0	285P083010	CRYSTAL RESONATOR	4.43362MHz
X 4A0	285P248010	CRYSTAL RESONATOR	4.43MHz [B, E, G, Y]
X 501	285P084010	CRYSTAL RESONATOR	17.7345MHz
X 571	285P029040	CRYSTAL RESONATOR	4.00000MHz [B]
X 5A0	285P054030	CRYSTAL RESONATOR	32.8kHz
X 5A1	285P235010	CRYSTAL RESONATOR	8.3886MHz
X 701	285P204020	CRYSTAL RESONATOR	10MHz [E, G, Y]
X 7A0	285P253010	CRYSTAL RESONATOR	8.192MHz [B, E]
Z 8A0	539P580010	PREAMP UNIT	TFMT 5330
<b>PRINTED CIRCUIT BOARD ASSY'S</b>			
○	928D291004	CONNECTOR PCB ASSY	[B]
○	928D291005	CONNECTOR PCB ASSY	[E, G, Y]
○	928D291006	CONNECTOR PCB ASSY	[EE]
○	928D289004	HA/AUDIO PCB ASSY	[B, E, G, Y]
○	928D289005	HA/AUDIO PCB ASSY	[EE]
○	928D293010	HIFI/NIC/DEC PCB ASSY	[B]
○	928D293012	HIFI/NIC/DEC PCB ASSY	[E]
○	928D293015	HIFI/NIC/DEC PCB ASSY	[EE]
○	928D293011	HIFI/NIC/DEC PCB ASSY	[G]
○	928D293013	HIFI/NIC/DEC PCB ASSY	[Y]
○	927B895010	MAIN PCB ASSY	[B]
○	927B895012	MAIN PCB ASSY	[E]
○	927B895015	MAIN PCB ASSY	[EE]
○	927B895011	MAIN PCB ASSY	[G]
○	927B895013	MAIN PCB ASSY	[Y]
○	928D290004	POWER SUB PCB ASSY	[EE]
○	928D290001	POWER SUB2 PCB ASSY	[B]
○	928D290002	POWER SUB2 PCB ASSY	[E, G, Y]
○	928D321001	TIMER PCB ASSY	[B]
○	928D321003	TIMER PCB ASSY	[E]
○	928D321005	TIMER PCB ASSY	[EE]
○	928D321002	TIMER PCB ASSY	[G]
○	928D321004	TIMER PCB ASSY	[Y]
○	928C322001	SAT LED PCB ASSY	[B]
○	928D292001	SAT PCB ASSY	[B]

ASSEMBLY DECK-2

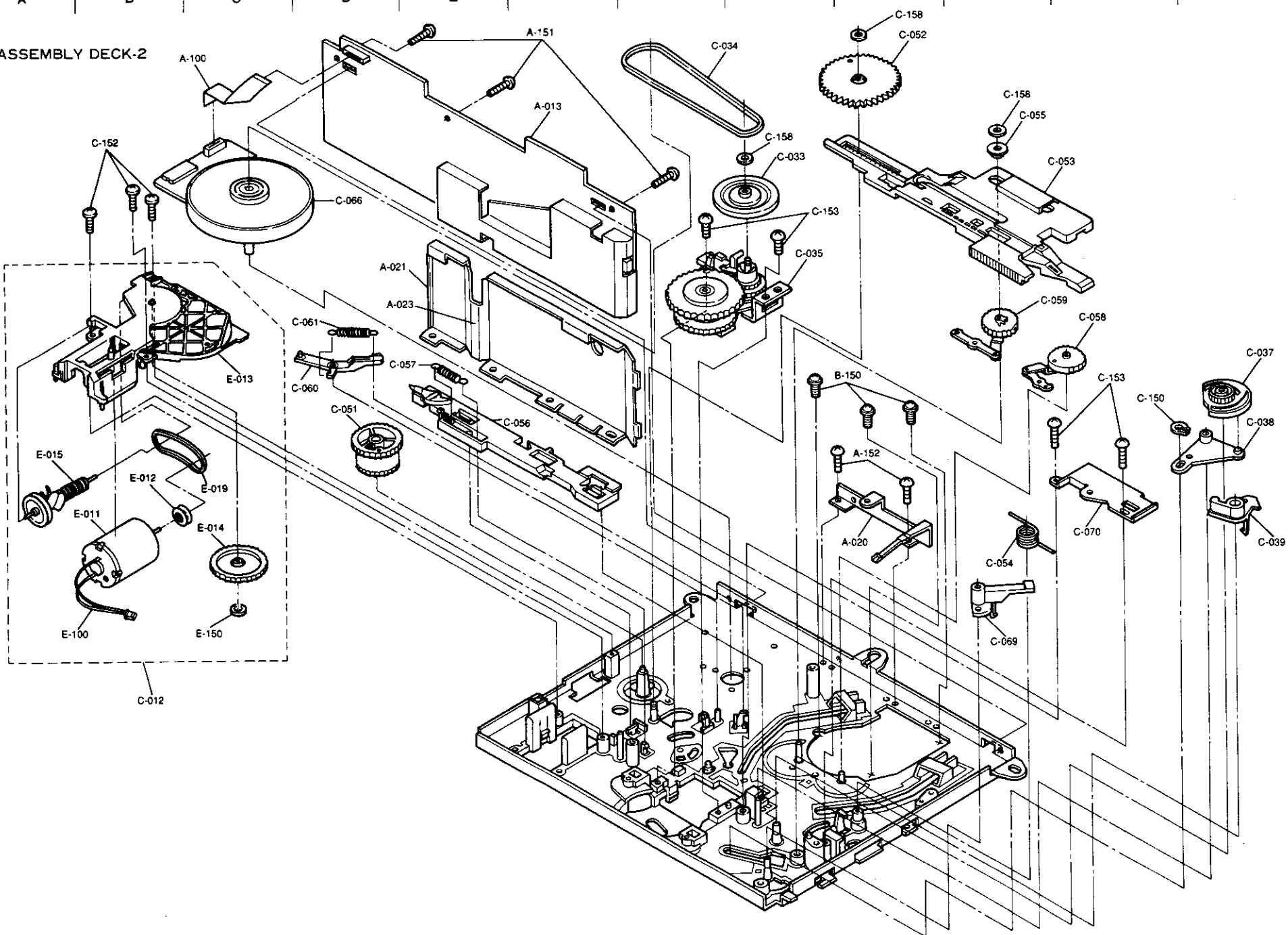

1  
2  
3  
4  
5  
6  
7  
8  
9

1  
2  
3  
4  
5  
6  
7  
8  
9

\* Settled Service Parts

ITEM	PARTS No.	* ADDRESS	PARTS NAME	DESCRIPTION	Qt.
A-013	9280289004	F-2	ASSY-PWB-HA/AUDIO	[B, E, G, Y]	01
A-013	9280289005	F-2	ASSY-PWB-HA/AUDIO	[LEE]	01
C-012	9280105002	B-7	ASSY-L-MOTOR		01
E-011	2880145010	B-5	MOTOR-LOADING		01
E-012	8220220020	B-5	PULLEY-MOTOR		01
E-013	8418727010	C-4	HOLDER-MOTOR-J		01
E-014	621C258010	C-6	GEAR-A		01
E-015	621C259010	A-5	PULLEY-WORM-J		01
E-019	521D088010	C-5	BELT-LM2		01
E-100	2488173020	B-6	LEAD-CONNECTOR-S		01
E-150	552C018020	C-6	CUT-WASHER	2. 5X4. 7X0. 5	01
A-020	299C030010	I-5	BRUSH		01
A-021	292B204010	D-3	SHIELD-PLATE-HAK		01
A-023	2230533010	D-3	BARRIER-HA		01
A-100	243C125010	C-1	LEAD-CARD		01
A-151	669D224020	E-1	SCREW-TB	2. 6X8	03
		G-2			
		I-5	SCREW-TB	2. 6X6	02
B-150	669D200020	I-4	SCREW-SEMS	M2. 6X0. 45-6	03
C-033	621C254010	H-2	PULLEY-BELT		01
C-034	521D081010	G-1	BELT-REEL-J		01
C-035	522B057030	H-3	UNIT-REEL-IDLER		01
C-037	621C235010	L-4	CAM-GEAR-R		01
C-038	622D229010	L-5	LEVER-CHARGE		01
C-039	622D223010	L-5	LEVER-T-OFF		01
C-051	621C257010	D-5	GEAR-JOINT-J		01
C-052	6418637010	I-1	MAIN-GEAR-J		01
C-053	641A311010	J-2	PLATE-CAM-B		01
C-054	572D640010	J-5	SPRING-CAM-B		01
C-055	622D224010	J-2	ROLLER-B		01
C-056	6418636010	E-4	PLATE-CAM-C		01
C-057	572D636010	E-4	SPRING-CAM-C		01
C-058	592B048010	K-4	ARM-LOAD-S		01
C-059	592B047010	J-4	ARM-LOAD-T		01
C-060	621C261010	D-4	BRAKE-CP		01
C-061	572D645010	D-3	SPRING-B-CP		01
C-066	288P126010	C-2	MOTOR-CP	M470	01
C-069	621C308010	J-6	ARM-RIS		01
C-070	593C532010	K-5	PLATE-J		01
C-150	685C090010	K-4	GRIP-RING		01
C-152	669D224020	B-2	SCREW-TB	2. 6X8	03
C-153	669D224010	K-4	SCREW-TB	2. 6X6	04
		G-3			
		J-2	CUT-WASHER	2. 5X6. 0X0. 5	03
C-158	552C018010	H-2			

\* Settled Service Parts

ITEM	PARTS No.	* ADDRESS	PARTS NAME	DESCRIPTION	Qt.
A-012	948A155006	A-4	ASSY-F/L-J		01
A-014	948B349001	K-2	ASSY-CLE		01
N-011	6418680010	K-2	ARM-CLE		01
N-012	6418681010	K-3	LEVER-CLE		01
N-013	572D703010	K-3	SPRING-CLE		01
B-015	948B358002	G-2	ASSY-DRUM		01
K-010	9288984013	G-1	ASSY-UPPR-DRUM		01
K-015	9278681007	G-2	ASSY-LOWER-DRUM		01
K-030	288P088060	H-2	MOTOR-DRUM	M570	01
C-011	928D104002	I-1	ASSY-A/C-HEAD		01
D-011	593C399010	I-2	PLATE-A/C		01
D-015	460P080060	I-1	HEAD	T370	01
D-020	572D639010	I-2	SPRING-A/C		03
D-025	215C730010	J-1	PWB-A/C-JA		01
D-030	452C140080	J-1	CONNECTOR-PC2M(S)		01
D-151	669D483010	I-1	SCREW	M2. 6X8	02
D-152	669D485010	I-1		2. 6X8	01
C-015	948D042001	E-3	ASSY-TAPE-GUIDE-T		01
C-015	948D042002	E-3	ASSY-TAPE-GUIDE-T		01
C-015	948D042003	E-3	ASSY-TAPE-GUIDE-T		01
F-011	635B085010	E-4	TAPE-GUIDE-T		01
F-011	635B085020	E-4	TAPE-GUIDE-T		01
F-011	635B085030	E-4	TAPE-GUIDE-T		01
F-016	522D177020	E-3	GUIDE-ROLLER		01
F-021	669D197020	E-4	SET-SCREW-F	D=M3X0. 5 L=4	01
C-016	948D043001	D-3	ASSY-TAPE-GUIDE-S		01
C-016	948D043002	D-3	ASSY-TAPE-GUIDE-S		01
C-016	948D043003	D-3	ASSY-TAPE-GUIDE-S		01
G-011	635B086010	D-3	TAPE-GUIDE-S		01
G-011	635B086020	D-3	TAPE-GUIDE-S		01
G-011	635B086030	D-3	TAPE-GUIDE-S		01
G-016	522D177020	D-3	GUIDE-ROLLER		01
G-021	669D197020	E-3	SET-SCREW-F	D=M3X0. 5 L=4	01
C-017	948D044001	M-3	ASSY-ARM-PINCH		01
H-011	593C465010	L-2	ARM-PINCH		01
H-015	822D235010	L-3	CAP-ROLLER		01
H-016	621C243010	M-3	LEVER-PINCH		01
H-017	621C241010	M-3	SLIDER-PINCH		01
H-025	522D174010	L-3	ROLLER-PINCH		01
H-035	572D314010	M-2	SPRING-PINCH		01
H-036	572D714010	M-3	SPRING-CAM-PINCH		01
C-018	948C315001	F-4	ASSY-CHARGE		01
J-011	6418629010	F-6	LEVER-SWING-ID		01
J-012	621C238010	F-5	LEVER-REV		01
J-013	572D684010	F-5	SPRING-CHARGE		01
J-014	572D624010	F-5	SPRING-REV		01
C-021	948A159001	I-9	ASSY-MAIN-PLATE		01
C-022	635A038030	G-2	DRUM-BASE		01
C-023	460P153010	C-3	HEAD-FE	T371	01

\* Settled Service Parts

ITEM	PARTS No.	* ADDRESS	PARTS NAME	DESCRIPTION	Qt.
C-024	592B049010	F-3	ARM-TENSION		01
C-025	572D627010	F-2	SPRING-TENS		01
C-026	6418624020	F-2	BELT-TENS-BRAKE		01
C-027	635B084010	K-5	ARM-TU-G		01
C-028	572D647010	K-5	SPRING-TU-G		01
C-029	674D081020	K-5	NUT-NYLON	M3X0. 5	01
C-030	522C092010	I-5	UNIT-REEL-DISK		02
C-031	621C234010	I-5	GEAR-R		02
C-032	6418630010	M-4	CAM-PINCH-J		01
C-042	621C315010	J-4	LEVER-SUB-OFF		01
C-043	6418635020	G-4	BRAKE-MAIN-S		01
C-044	622D219010	K-4	LEVER-RELEASE-M/B		01
C-045	6418634020	J-4	BRAKE-MAIN-T		01
C-046	572D635010	H-4	SPRING-M/B-J		02
C-047	6418633010	G-4	BRAKE-SUB-S		01
C-048	6418632020	I-4	BRAKE-SUB-T		01
C-049	572D623010	H-4	SPRING-SUB-S		01
C-050	572D625010	I-4	SPRING-SUB-T		01
C-062	621C240010	M-5	GEAR-PINCH		01
C-063	635C098010	L-4	GEAR-TU-G		01
C-064	6418628010	M-1	CAP-CAM-PINCH		01
C-065	439P039010	M-6	SW-MODE-J	5570	01
C-067	6418641010	E-7	LEVER-RIS		01
C-068	572D646010	E-6	SPRING-RIS		01
C-071	597D102010	K-5	PLATE-EB		01
C-072	572D12010	H-3	SPRING-DB		01
C-087	572D697010	I-3	SPRING-AC-EARTH		01
C-151	669D285040	L-5	SCREW-TB-PAN	M2. 6X8	03
C-152	669D224020	G-3	SCREW-TB	2. 6X8	03
		I-3			
		I-2	SCREW-TB-SEMS	2. 6X8	02
C-154	669D476020	D-3	SCREW-TB	2. 6X10	01
C-155	669D224030	D-3	SCREW-TB	2. 6X10	01
C-157	552C017030	G-5	WASHER-THRUST	2. 5X6X0. 13	06
A-015	948C322001	C-1	ASSY-IMP-S		01
A-052	621C033010	J-1	UNIT-CLE-ROLLER		01
A-053	6418699010	A-2	HOLDER-TG		01
A-055	572D721010	B-2	SPRING-IMP-J		01
A-056	597D168010	B-1	FLYWHEEL-J		01
A-101	2488173040	C-3	LEAD-CONNECTOR-S		01
A-120	6416895010	E-7	CLAMPER-LEAD-F/L		01
A-151	669D224020	B-4	SCREW-TB	2. 6X8	02



ASSEMBLY DECK-3

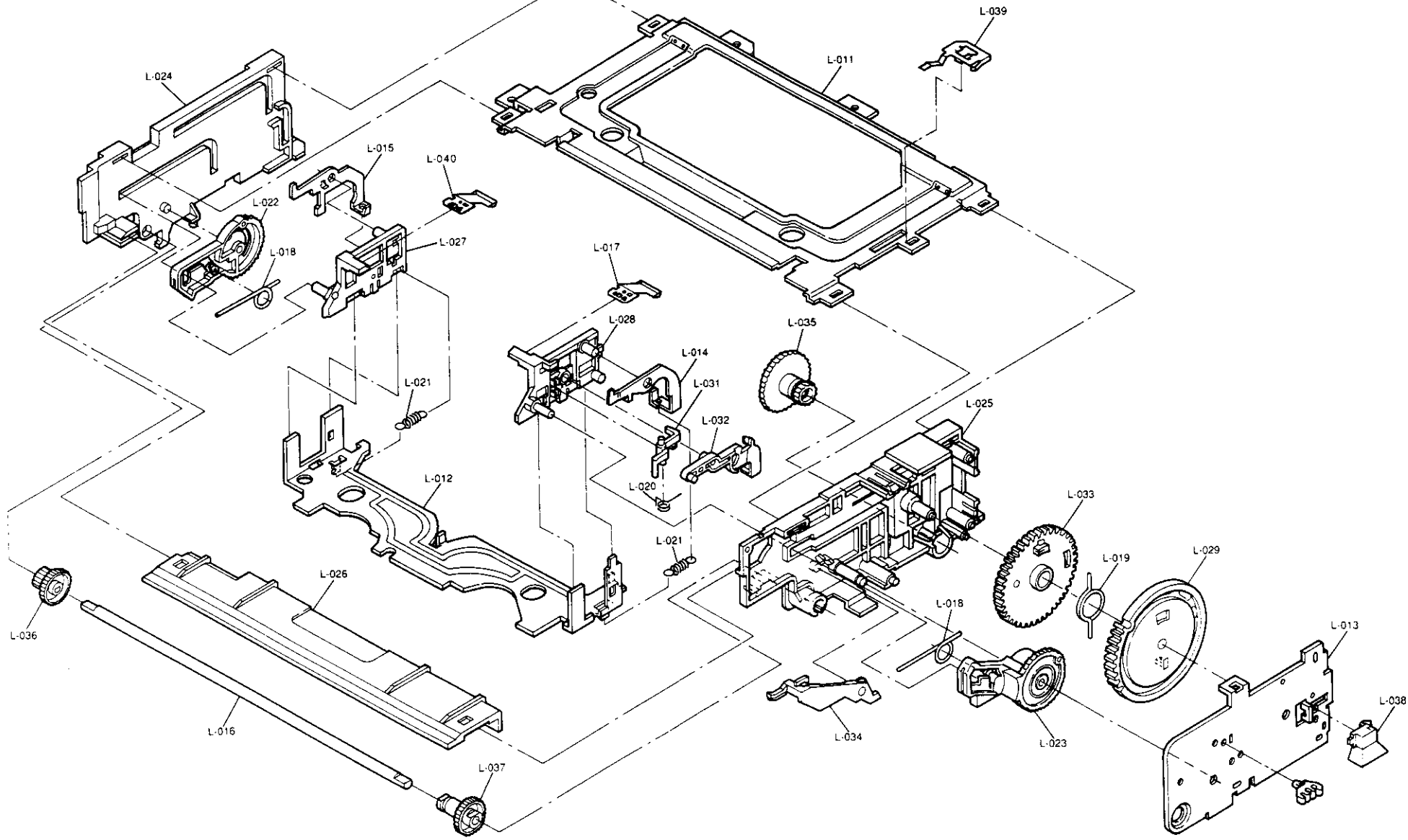

\* Settled Service Parts

ITEM	PARTS No.	* ADDRESS	PARTS NAME	DESCRIPTION	Qt.
L-011	592B156010	H-1	PLATE-ROOF-J		01
L-012	592B150010	D-5	PLATE-BOTTOM-J		01
L-013	592B157010	L-6	PLATE-SIDE-J		01
L-014	596D986010	G-4	LEVER-LOCK-T		01
L-015	596D987010	D-2	LEVER-LOCK-S		01
L-016	631D443010	C-7	SHAFT-FL		01
L-017	572D634010	F-3	PLATE-SPR		01
L-018	572D631010	C-3	SPRING-ARM	I-6	02
L-019	572D632010	J-6	SPRING-CHIP		01
L-020	572D633010	F-5	SPRING-JUT		01
L-021	572D630020	D-4	SPRING-LOCK-T	F-6	02
L-022	621C250010	C-3	ARM-SP		01
L-023	641B719010	J-7	ARM-TU		01
L-024	641A360010	B-2	HOLDER-SIDE-SP		01
L-025	641A718010	I-4	HOLDER-SIDE-TU		01
L-026	621C249010	D-6	GUIDE-INSERT		01
L-027	641B626010	E-3	HOLDER-CAS-SP		01
L-028	641B638010	F-4	HOLDER-CAS-TU		01
L-029	641B625010	K-6	GEAR-SENS		01
L-031	622D231010	G-4	JUT-J		01
L-032	621C245010	G-5	OPENER-LID		01
L-033	622D227010	J-5	GEAR-DRIVE		01
L-034	622D230010	H-7	ARM-DOOR		01
L-035	621C252010	H-4	GEAR-WHEEL		01
L-036	622D225010	A-6	GEAR-S		01
L-037	622D226010	E-8	GEAR-T		01
L-038	622D228010	L-7	COVER-SENS		01
L-039	597D085010	I-1	PLATE-EARTH		01
L-040	572D634020	E-2	PLATE-SPR		01

1

2

3

4

5

6

7

8

038

# PCB-BLOCK DIAGRAM

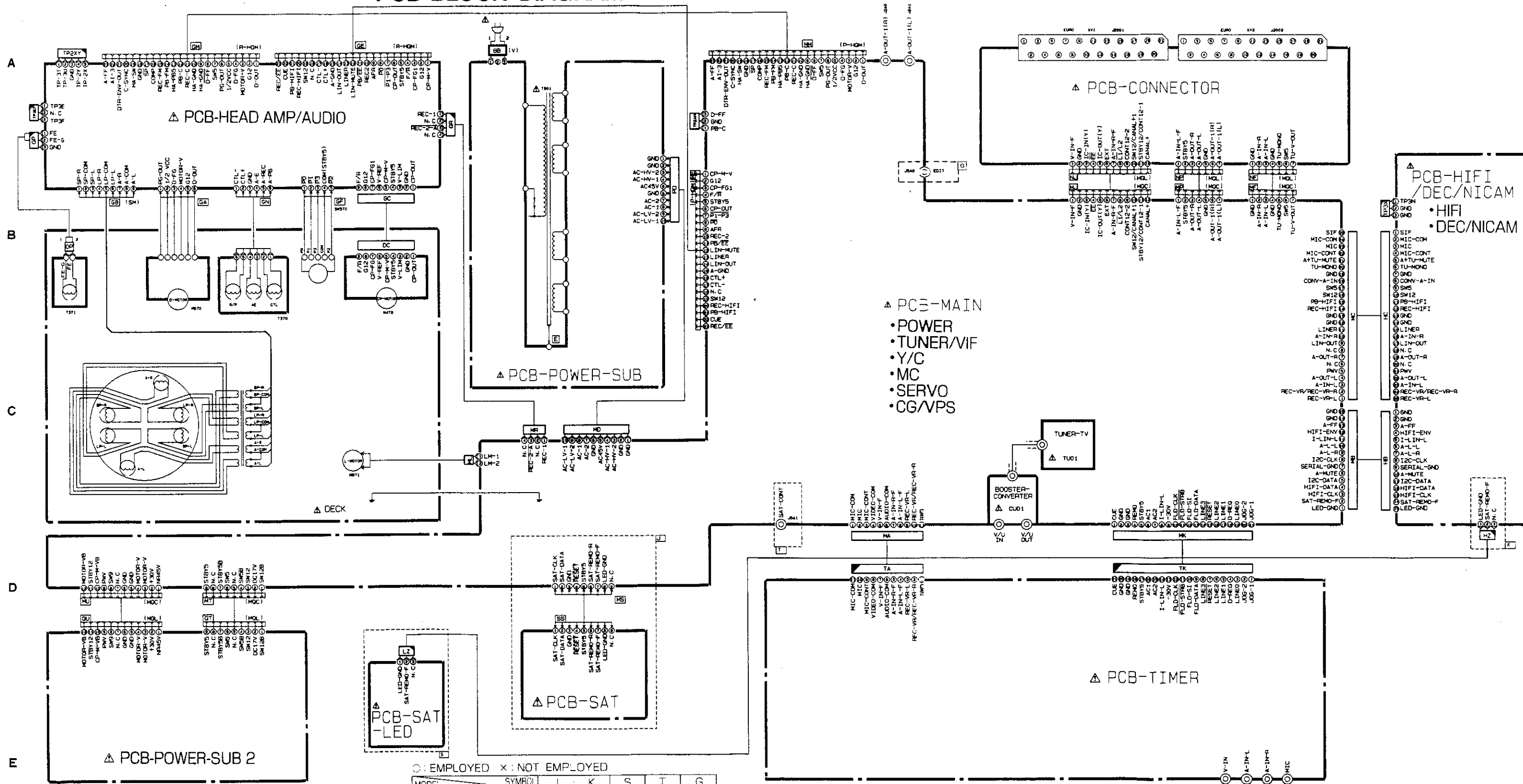

○ : EMPLOYED    × : NOT EMPLOYED

MODEL	SYMBOL	J	K	S	T	G
HS-561V(Y)/V(E)/V(G)		×	×	×	×	○
HS-561V(B)		○	○	○	○	○
HS-561V(E)		×	×	×	×	×

△ PCB-HIFI/DEC/NICAM  
 • HIFI  
 • DEC/NICAM

△ PCB-MAIN  
 • POWER  
 • TUNER/VIF  
 • Y/C  
 • MC  
 • SERVO  
 • CG/VPS

△ PCB-CONNECTOR

△ PCB-POWER-SUB

△ PCB-HEAD AMP/AUDIO

△ PCB-TIMER

△ PCB-SAT

△ PCB-SAT-LED

△ PCB-POWER-SUB 2

BOOSTER-CONVERTER  
 △ CU01

TUNER-TV  
 △ TU01

DECK  
 △

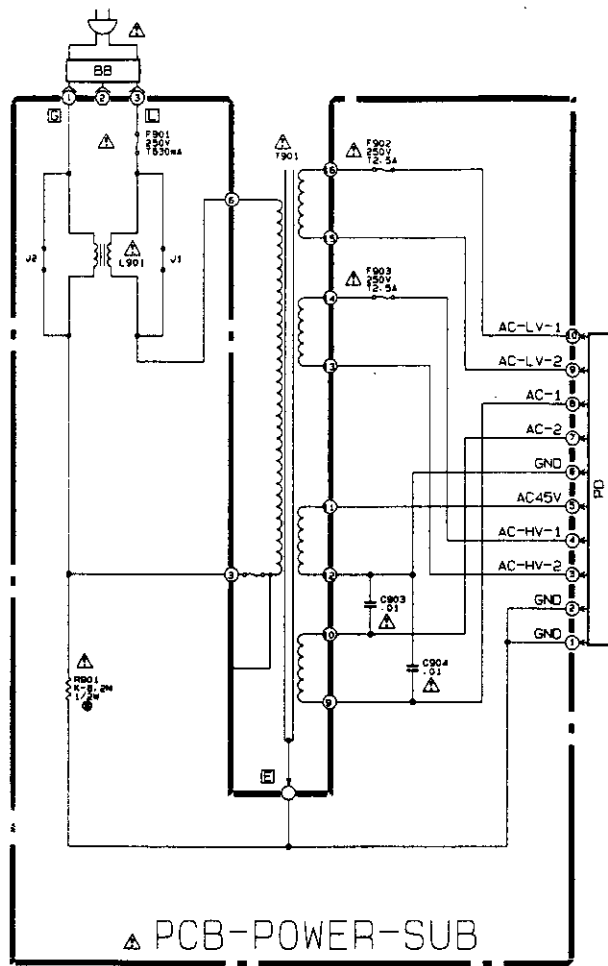

**⚠️ SERVICING PRECAUTION**  
 SYMBOLS INDICATE COMPONENTS HAVING SPECIAL CHARACTERISTICS IMPORTANT TO SAFETY AND PERFORMANCE. THEREFORE REPLACEMENT OF ANY SAFETY PARTS SHOULD BE IDENTICAL IN VALUE AND CHARACTERISTICS.  
 DON'T DEGRADE THE SAFETY OF THE VCR THROUGH IMPROPER SERVICING.

CONTENTS	
① PCB-BLOCK DIAGRAM PCB-MAIN (POWER) PCB-POWER-SUB PCB-POWER-SUB2	⑤ PCB-MAIN (Y/C)
② PCB-MAIN (TUNER/VIF) PCB-HIFI/DEC/NICAM (DEC/NICAM)	⑥ PCB-MAIN (MC)
③ PCB-HIFI/DEC/NICAM (HIFI) PCB-SAT	⑦ PCB-MAIN (SERVO) (CG/VPS)
④ PCB-CONNECTOR PCB-HEAD AMP/AUDIO	⑧ TRANSMITTER REMOTE CONTROL
	⑨ PATTERN

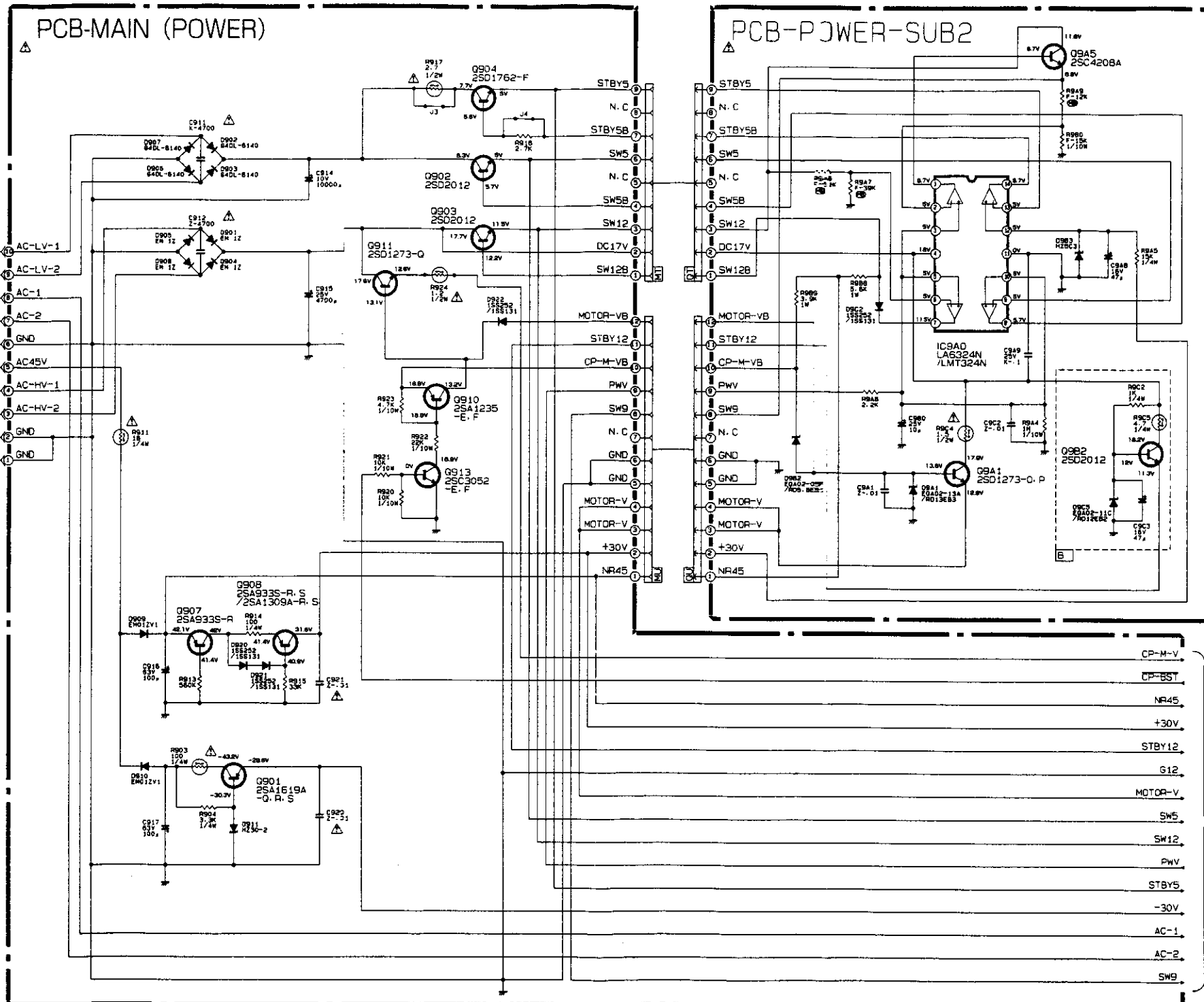

○ : EMPLOYED × : NOT EMPLOYED

MODEL	SYMBOL	J1	R916	J2	R917	J3	B	J4	L901
HS-561V(Y)/V(E)/V(G)		×	○	×	×	○	○	×	○
HS-561V(B)		×	×	×	×	○	×	○	○
HS-561V(A)/V(NZ)/V(EE)		○	○	○	×	×	×	×	×

**SCHEMATIC DIAGRAM**

- NOTE
- Each voltage should be within ±20% of the DC voltages measured with a digital voltmeter.
  - The voltages parenthesised are on SP recording mode. While those without parenthesised are on SP play back mode.
  - Waveforms were taken with standard colour bar signal.
  - TP6A, etc. show Test Points.

**5. CAPACITORS**

Value	Not indicated	PF, for numbers more than 1 μF, for numbers less than 1
Dielectric Strength	Not indicated	:50V
Tolerance	Not indicated	±10% (No Tolerance is indicated for electrolytic capacitors and ±20%)
	G=±2%	P=+100% Q=+30% C=±0.25PF
	J=±5%	-0% -10% D=±0.5PF
	K=±10%	Z=+80% T=+200% F=±1PF
	M=±20%	-20% -0% G=±2PF
Sort	Not indicated	Ceramic capacitor MP: Polyester capacitor PP: Polypropylene film capacitor ALM: Aluminum electrolytic capacitor TF: Twin film capacitor SC: Semiconductor ceramic capacitor Parts except for chips MP: Metalized paper MPP: Metalized plastic film capacitor MMP: Metalized polyester capacitor MF, PP: Polyester polypropylene film capacitor PS: Styrol capacitor TAN or TANT: Tantalum capacitor E: Electrolytic capacitor BP or NP: Non polarized electrolytic capacitor
	II Chips	Not indicated: Ceramic capacitor chip E: Electrolytic capacitor BP or NP: Non polarized electrolytic capacitor chip
Characteristic (only ceramic capacitor)	Not indicated	: F or B (high dielectric percentage) CH, SL, etc.: Temperature compensating types

**6. Resistors**

Value	Not indicated = Ω K = kΩ(1000Ω) M = MΩ(1000kΩ)
Wattage	Parts except for chips: Not indicated = 1/4W or 1/8W
	Chips: Not indicated = 1/10W
Tolerance	Not indicated: ±5%
	D=±0.5% J=±5% F=±1% K=±10%
Short	Not indicated: Carbon resistor S: Fixed composition resistor MB: Metal oxide film resistor(type B) Parts except for chips C: Cemented resistor W: Wire wound resistor M: Metal film resistor MPC: Metal plate cement resistor ML: Metal liner resistor
	II Chip: Not indicated: Chip resistor

7. This is a basic schematic diagram. Some sets may be subject to modification according to engineering improvement.

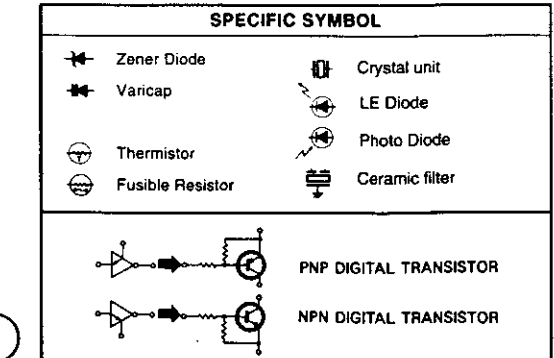



(TUNER/VIF) PCB-MAIN

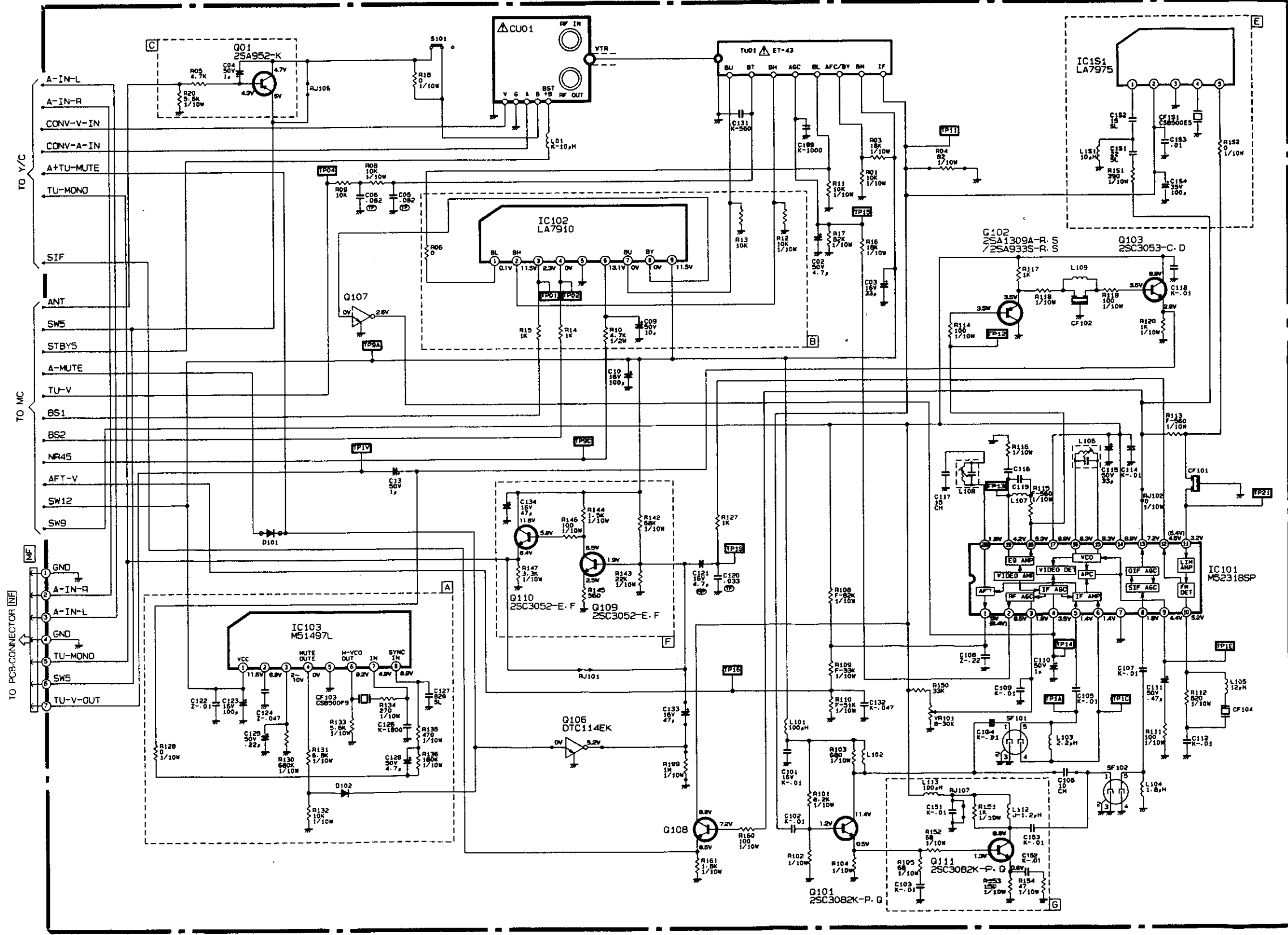

○ : Employed    × : Not employed

SYMBOL	MODEL	(Y)	(B)	(E)	(EE)	(G)	(A)	(NZ)
A	e-5	○	×	○	×	○	×	×
B	c-6	○	×	○	○	○	○	○
C	a-1	×	×	×	×	×	○	○
F	d-5	○	×	○	×	×	×	×
G	g-8	×	×	○	×	×	×	○
C106	f-8	○	○	×	○	○	○	×
C116	d-7	×	×	×	×	×	×	33SL
C119	d-7	18SL	15SL	18SL	18SL	18SL	15SL	12SL
C133	d-3	○	×	○	×	○	×	×
D101	d-2	○	×	○	×	○	×	×
L102	f-7	J-1.2μH	J-1.2μH	J-2.2μH	J-1.2μH	J-1.2μH	J-2.2μH	J-1.2μH
L107	d-7	J-39μH	J-56μH	J-39μH	J-39μH	J-39μH	J-47μH	J-39μH
L109	c-8	J-5.6μH	J-8.2μH	J-5.6μH	J-5.6μH	J-5.6μH	J-5.6μH	J-5.6μH
Q105	e-3	○	×	○	×	○	×	×
Q107	c-3	○	×	○	×	○	×	×
R04	b-7	×	○	×	×	×	○	○
R18	a-4	×	×	×	×	×	○	○
R102	f-6	1K	1K	1.8K	1K	1K	1K	1.8K
R104	f-6	68	68	220	68	68	68	220
R115	d-7	×	×	×	×	×	×	0Ω
R118	c-8	F-150	F-390	F-150	F-150	F-150	F-180	F-220
R199	d-3	○	×	○	×	○	×	×
RJ101	e-5	×	○	×	○	×	○	○
RJ106	a-3	○	○	○	○	○	○	×
RJ107	f-7	○	○	×	×	○	×	×
S101	a-4	○	○	○	○	○	×	×
R113	d-9	○	○	○	×	○	○	○
E	a-9	×	×	×	○	×	×	×

ALL NPN TRANSISTORS ARE 2SC3052-E, F UNLESS OTHERWISE SPECIFIED.  
ALL DIODES ARE 1SS252/1SS131 UNLESS OTHERWISE SPECIFIED.

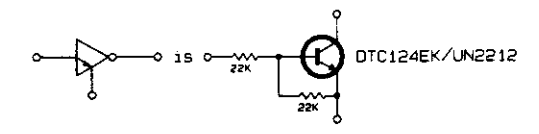

(DEC/NICAM) PCB-HIFI/DEC/NICAM

○ : EMPLOYED    × : UNEMPLOYED

ITEM	A	B	C	CF7A1	CF7A0	L7A1	R7A5	R7A4	R7A1
ADDRESS	a-1	d-1	g-5	b-4	b-4	b-4	b-4	c-3	b-3
(Y)	×	○	○	×	×	×	×	×	×
(B)	○	×	×	×	×	○	×	×	150 22K
(E)	○	○	○	×	○	×	○	390 15K	
(EE)	×	×	×	×	×	×	×	×	×
(G)	×	○	○	×	×	×	×	×	×
(A)	×	○	×	×	×	×	×	×	×
(NZ)	○	×	×	×	○	×	○	390 15K	

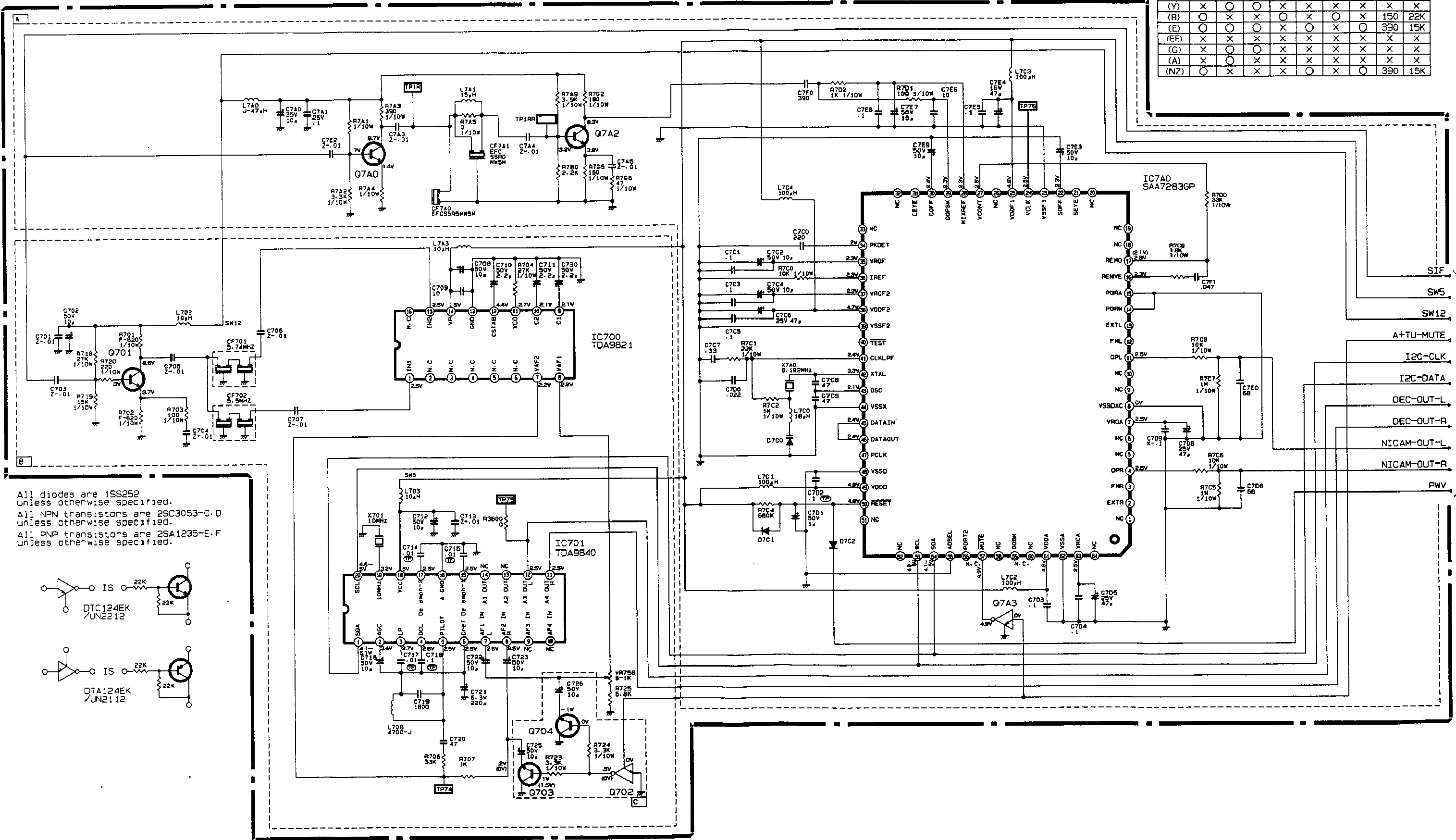

All diodes are 1SS252 unless otherwise specified.  
 All NPN transistors are 2SC3053-C-D unless otherwise specified.  
 All PNP transistors are 2SA1235-E-F unless otherwise specified.

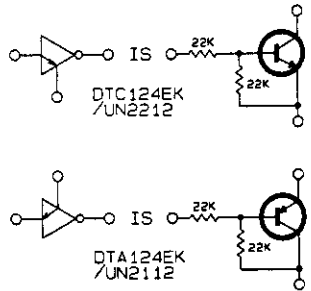

TO HIFI

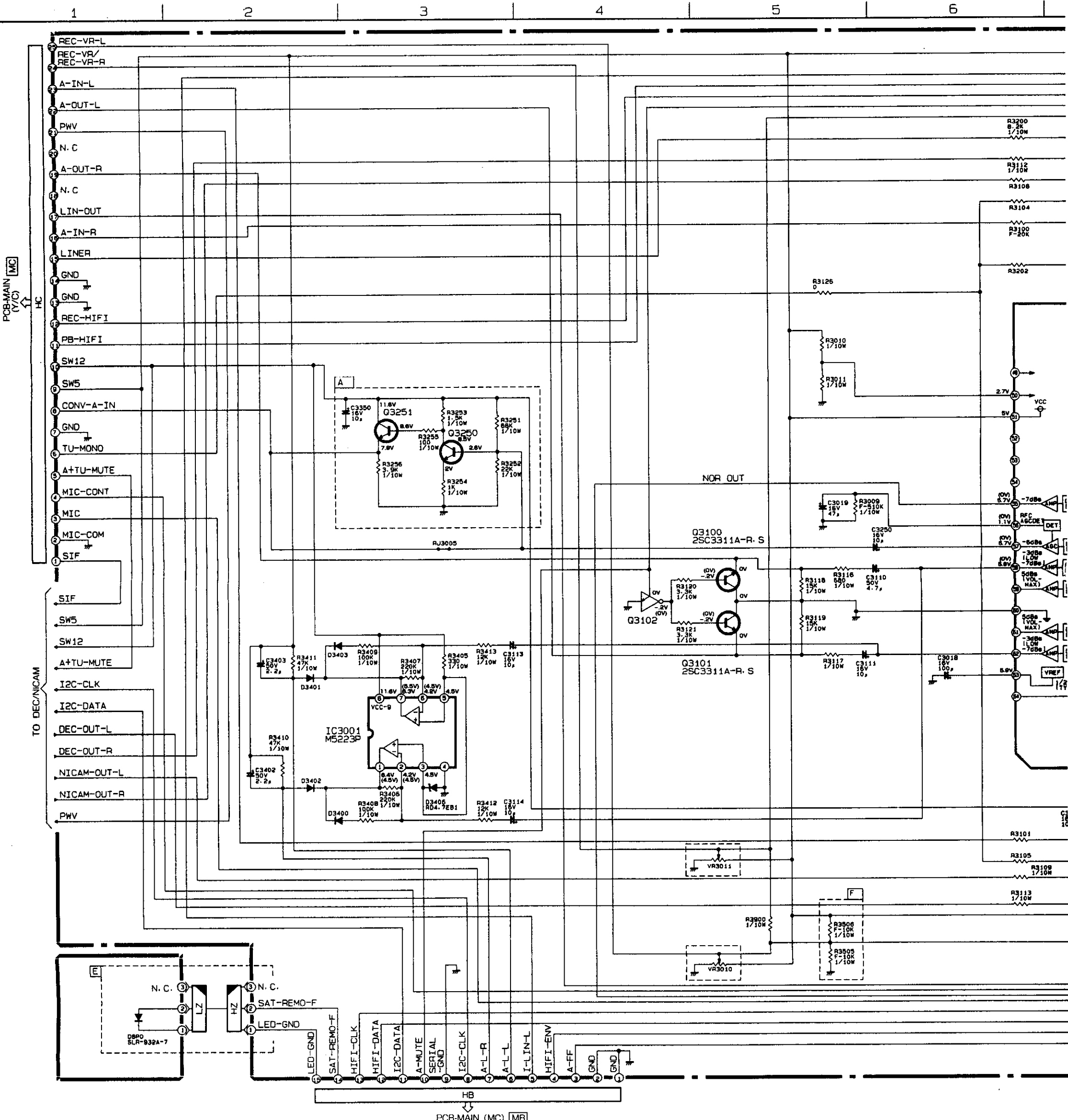

ITEM	A	RJ3005	R3101	R3105	R3202	R3104	R3107	R3203	R3106	R3117	E	R3108	R3109	R3110	R3111	C3104	C3105	R3112	R3113	R3114	R3115	C3106	C3107	R3900	F	VR3010	VR3011	C3100
ADDRESS	c-3	d-3	e-7	e-6	b-6	b-6	e-6	b-7	b-7	d-5	f-1	b-7	e-7	b-7	e-7	b-7	e-7	b-7	e-7	b-7	e-7	b-7	e-7	f-5	f-5	f-4	e-4	b-7
(Y)	X	O	15K	33K	27K	33K	12K	12K	12K	3.9K	X	X	X	X	X	X	X	27K	27K	6.8K	6.8K	50V 1μ	50V 1μ	0Ω	O	X	X	50V 1μ
(B)	X	O	F-20K	4.7K	4.7K	4.7K	22K	22K	22K	680	O	18K	18K	22K	22K	50V 1μ	50V 1μ	X	X	X	X	X	X	0Ω	O	X	X	50V 1μ
(E)	X	O	15K	33K	27K	33K	12K	12K	12K	3.9K	X	18K	18K	22K	22K	50V 1μ	50V 1μ	27K	27K	6.8K	6.8K	50V 1μ	50V 1μ	0Ω	X	X	50V 1μ	
(G)	X	O	15K	33K	27K	33K	12K	12K	12K	3.9K	X	X	X	X	X	X	X	27K	27K	6.8K	6.8K	50V 1μ	50V 1μ	X	X	X	50V 1μ	
(A)	O	X	F-20K	18K	15K	18K	22K	22K	22K	680	X	X	X	X	X	X	X	39K	39K	6.8K	6.8K	50V 1μ	50V 1μ	0Ω	O	X	50V 1μ	
(NZ)	X	O	F-20K	4.7K	2.7K	4.7K	22K	22K	22K	680	X	18K	18K	22K	22K	50V 1μ	50V 1μ	X	X	X	X	X	X	0Ω	O	X	X	50V 1μ
(EF)	X	O	F-20K	4.7K	4.7K	4.7K	22K	22K	22K	680	X	X	X	X	X	X	X	X	X	X	X	X	X	0Ω	O	X	X	50V 1μ





a  
b  
c  
d  
e  
f  
g

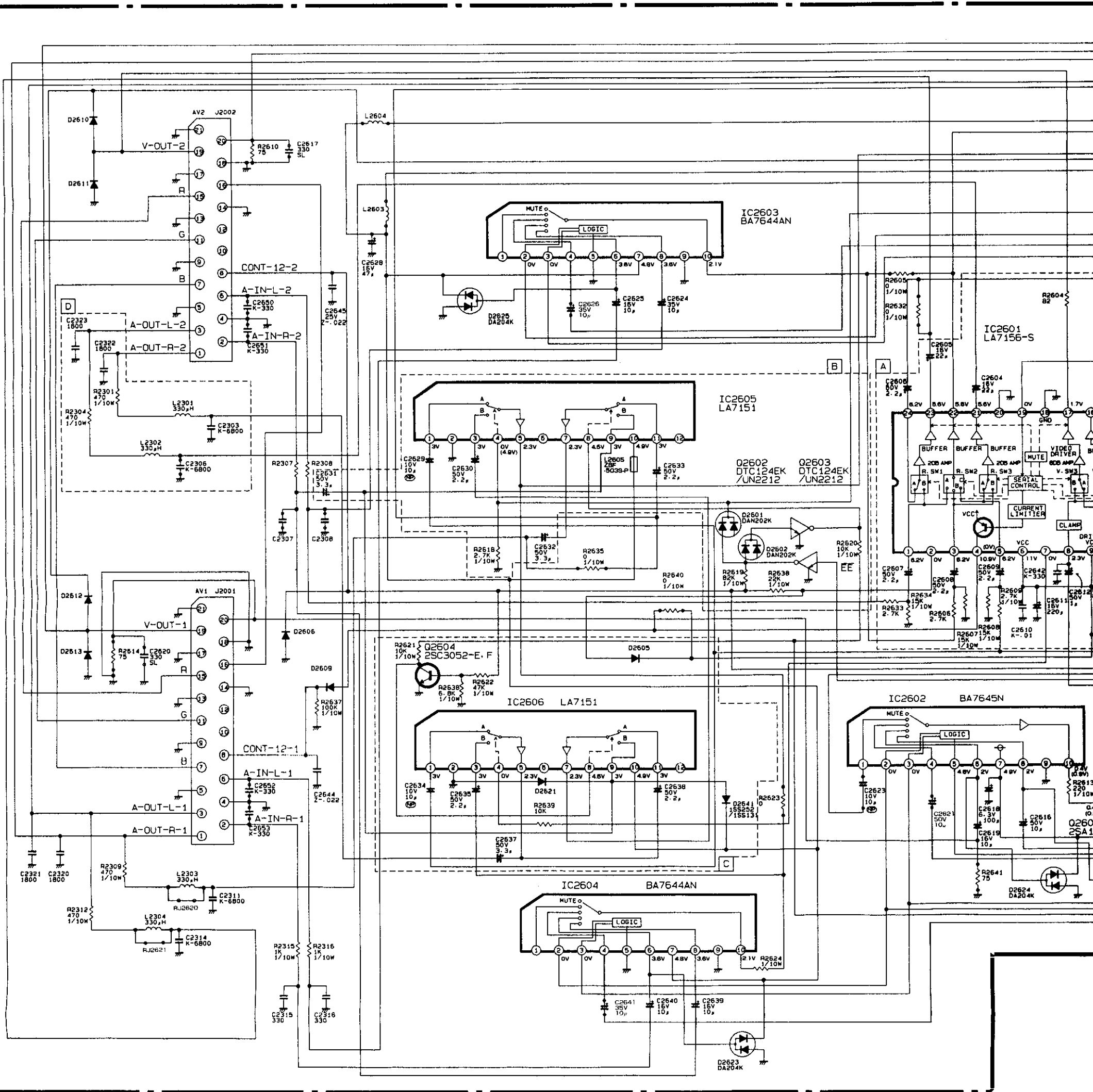

○ : Employed, X : Not Employed

MODEL	ADDRESS	A	B	C	R2603	R2601	R2605	R2632	R2623	C2620	C2617	R2635	R2611	R2307	C2307	R2308	C2308	J2666	R2642	J2650	R2640	R2623	Q	R2614	R2641	D	R2624	D2645	D2646	L2604	L2603	J2661	C2311
HS-561V (Y)(E)(G)	c-6	○	○	○	82	×	×	×	×	○	○	×	×	1.5k 1/10W	K-390	820 1/10W	K-470	×	×	×	×	×	○	×	○	○	220 1/10W	○	○	×	100μ	×	○
HS-561V (B)	c-5	×	×	×	0	○	○	○	○	×	×	○	○	1k 1/10W	K-330	1k 1/10W	K-330	×	○	○	○	○	×	○	×	×	0 1/10W	×	×	100μ	×	○	○
HS-561V (EE)	c-5	×	×	×	0	○	○	○	○	×	×	○	○	1k 1/10W	K-330	1k 1/10W	K-330	○	×	○	○	○	×	○	×	×	0 1/10W	×	×	100μ	×	○	×



# PCB-HEAD AMP/AUDIO

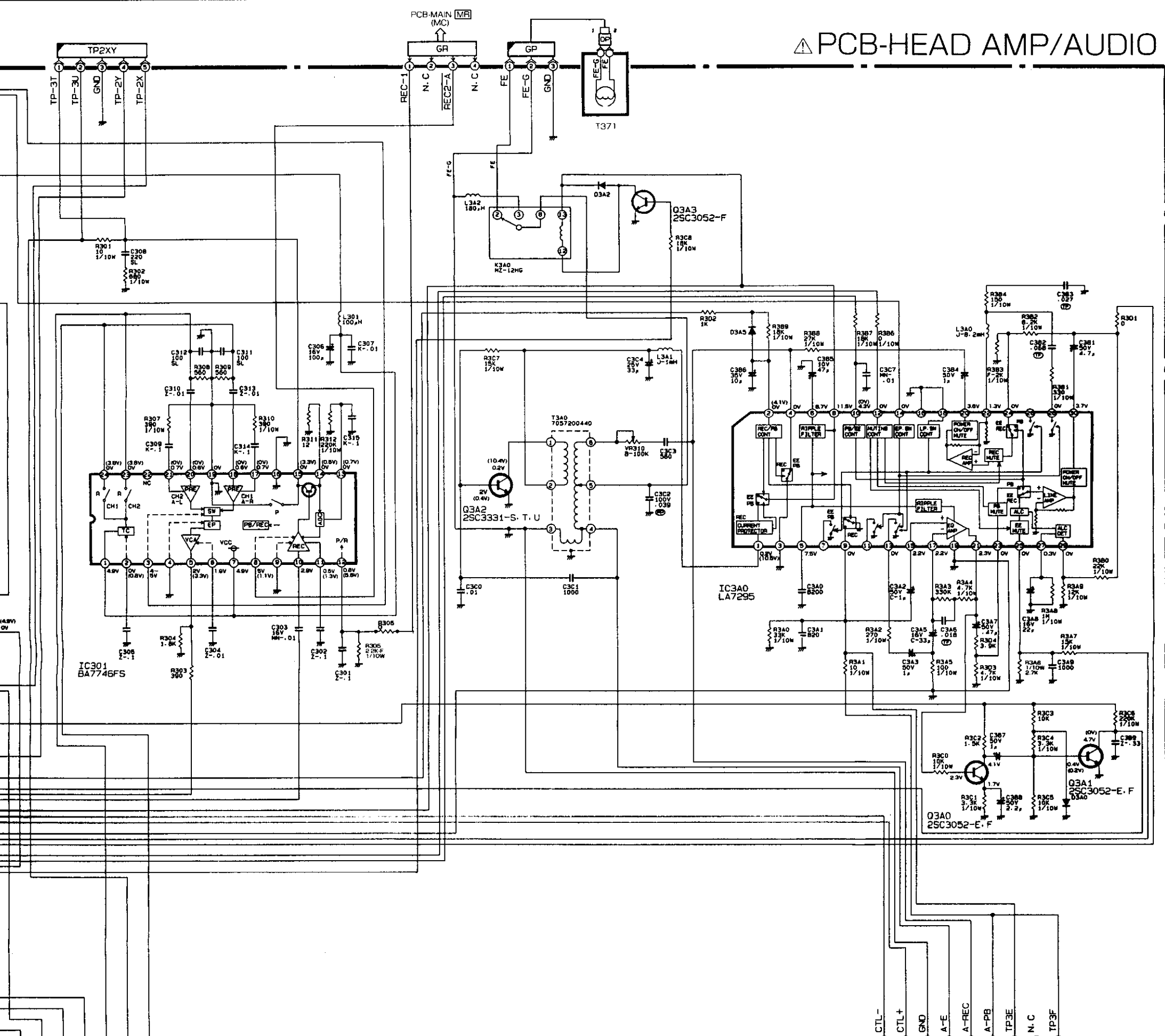

## CAPSTAN MOTOR

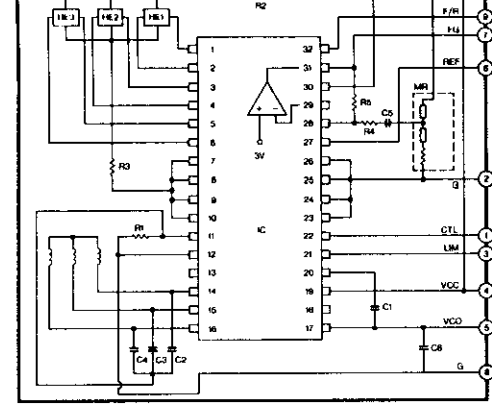

## DRUM MOTOR

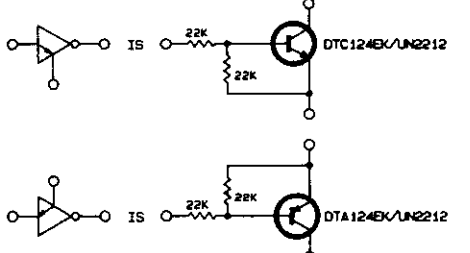
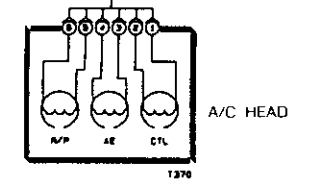
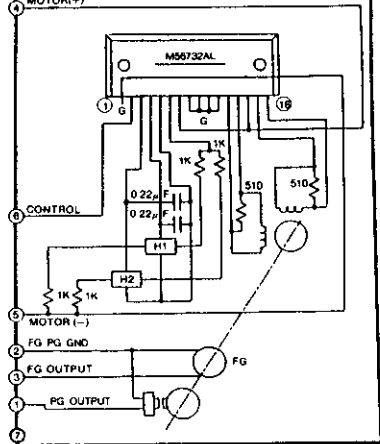

All diodes are 1SS252/1SS131 unless otherwise specified.  
 All NPN transistors are 2SC3053-C.D unless otherwise specified.  
 All PNP transistors are 2SA1235-E.F unless otherwise specified.



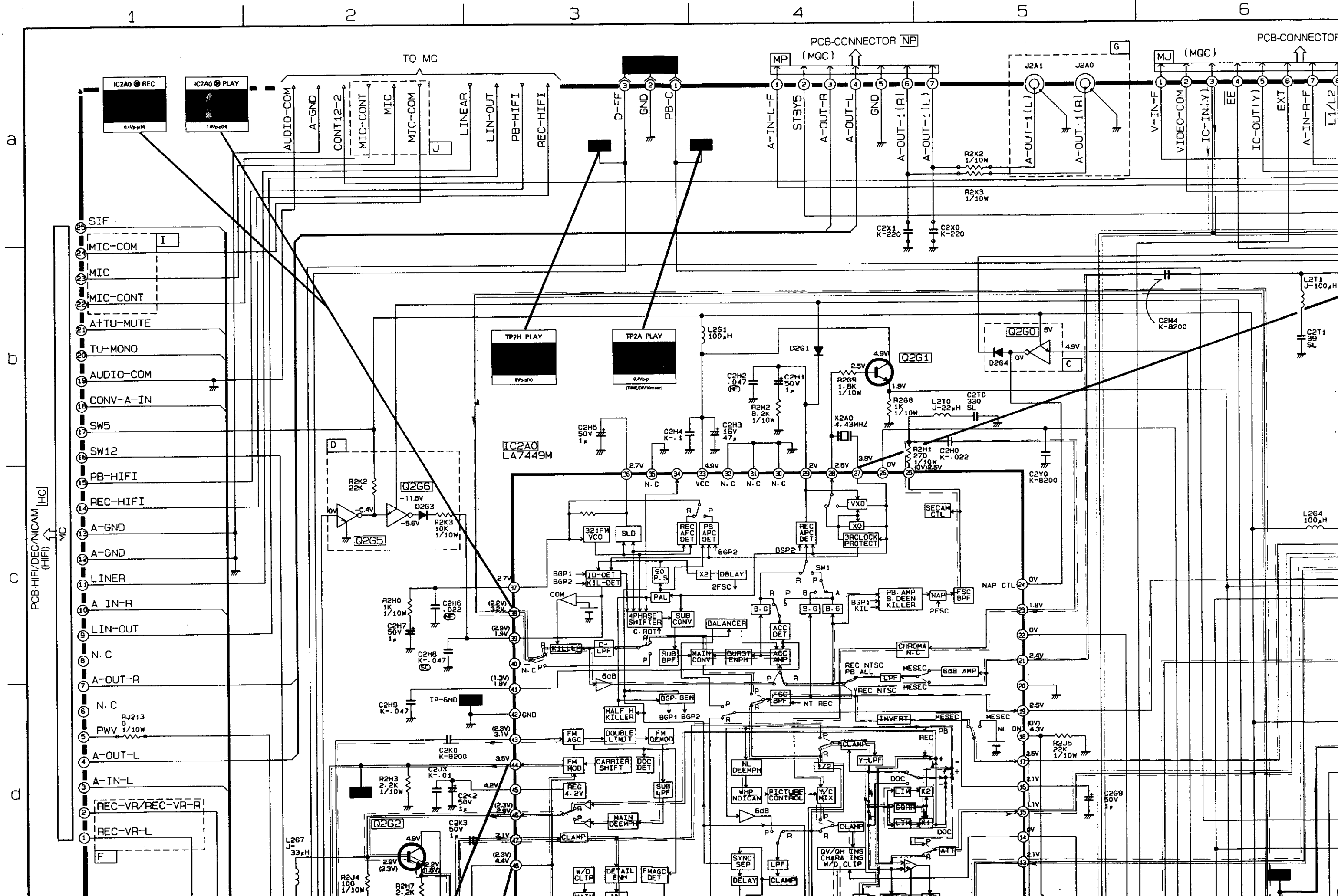

(Y/C) PCB-MAIN

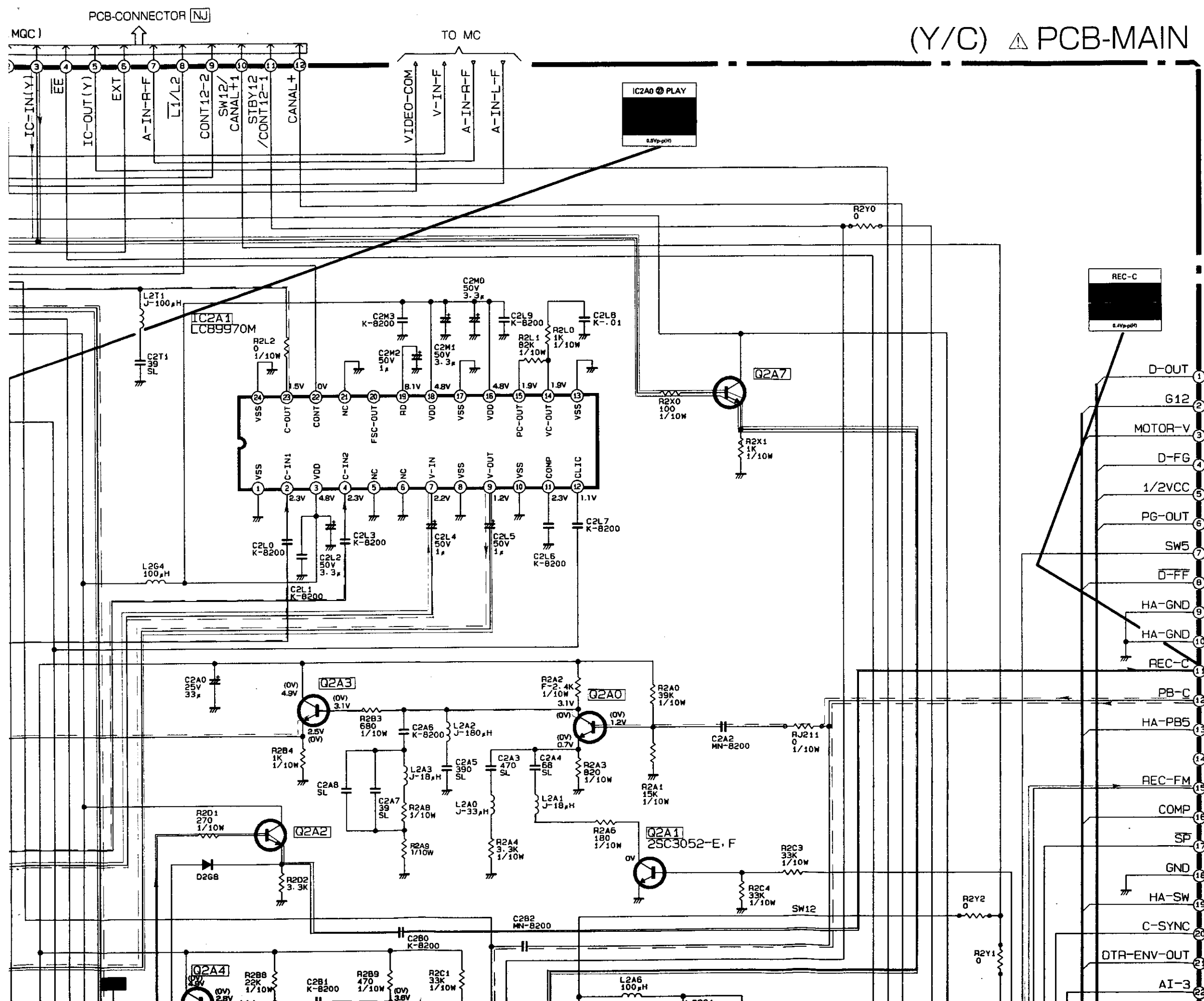

○ : Employed    ✕ : Not Employed

	Y	B	E	G	A	NZ	EE
c (b-4)	○	○	○	○	○	○	○
d (c-2)	✕	○	✕	✕	✕	✕	✕
e (e-7)	✕	○	✕	✕	✕	✕	○
f (d-1)	○	○	○	○	○	○	○
g (a-5)	○	○	○	○	✕	✕	○
h (f-1)	○	○	○	○	○	○	○
i (b-1)	○	○	○	○	○	○	○
j (a-2)	○	○	○	○	○	○	○
R2X2(a-5)	1K	←	←	←	✕	✕	0Ω
R2X3(a-5)	1K	←	←	←	✕	✕	0Ω
C2X0(a-5)	○	○	○	○	✕	✕	✕
C2X1(a-5)	○	○	○	○	✕	✕	✕
C2A8(d-7)	33	18	33	33	←	←	33
C2K5(e-2)	180	220	180	180	←	←	180
R2A8(d-7)	330	300-F	330	330	←	←	330
R2A9(d-7)	220	390	220	220	←	←	220
RJ213(d-1)	✕	○	○	✕	✕	○	✕
R2Y0(b-9)	○	✕	○	○	✕	✕	✕
R2Y1(d-9)	○	✕	○	○	✕	✕	✕
R2Y2(d-9)	✕	○	✕	✕	○	○	○
R2K9(e-9)	○	✕	○	○	✕	✕	✕

PCB-HEAD AMP/AUDIO [GM]

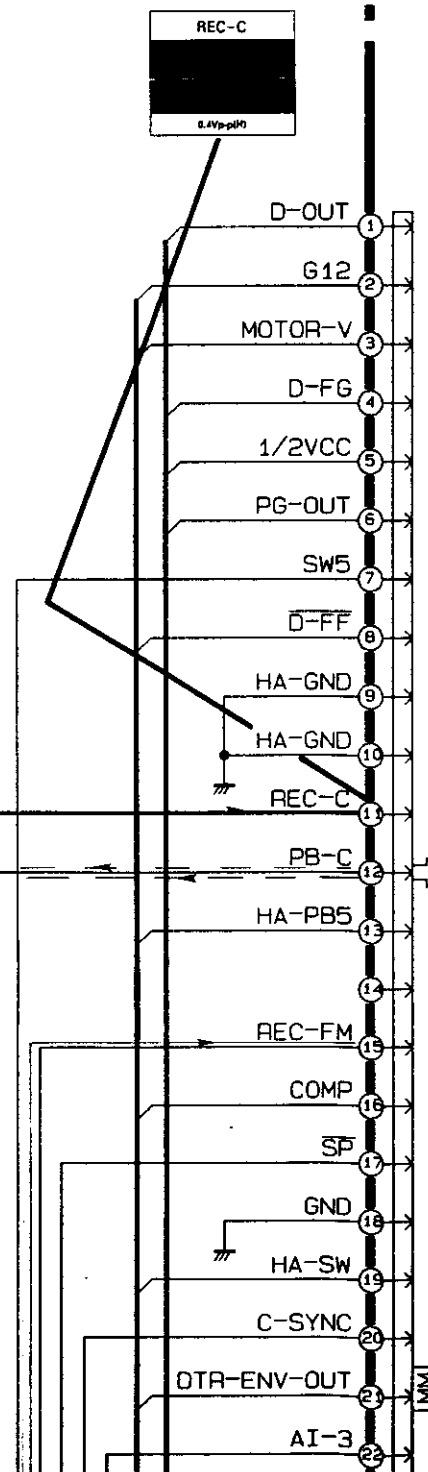



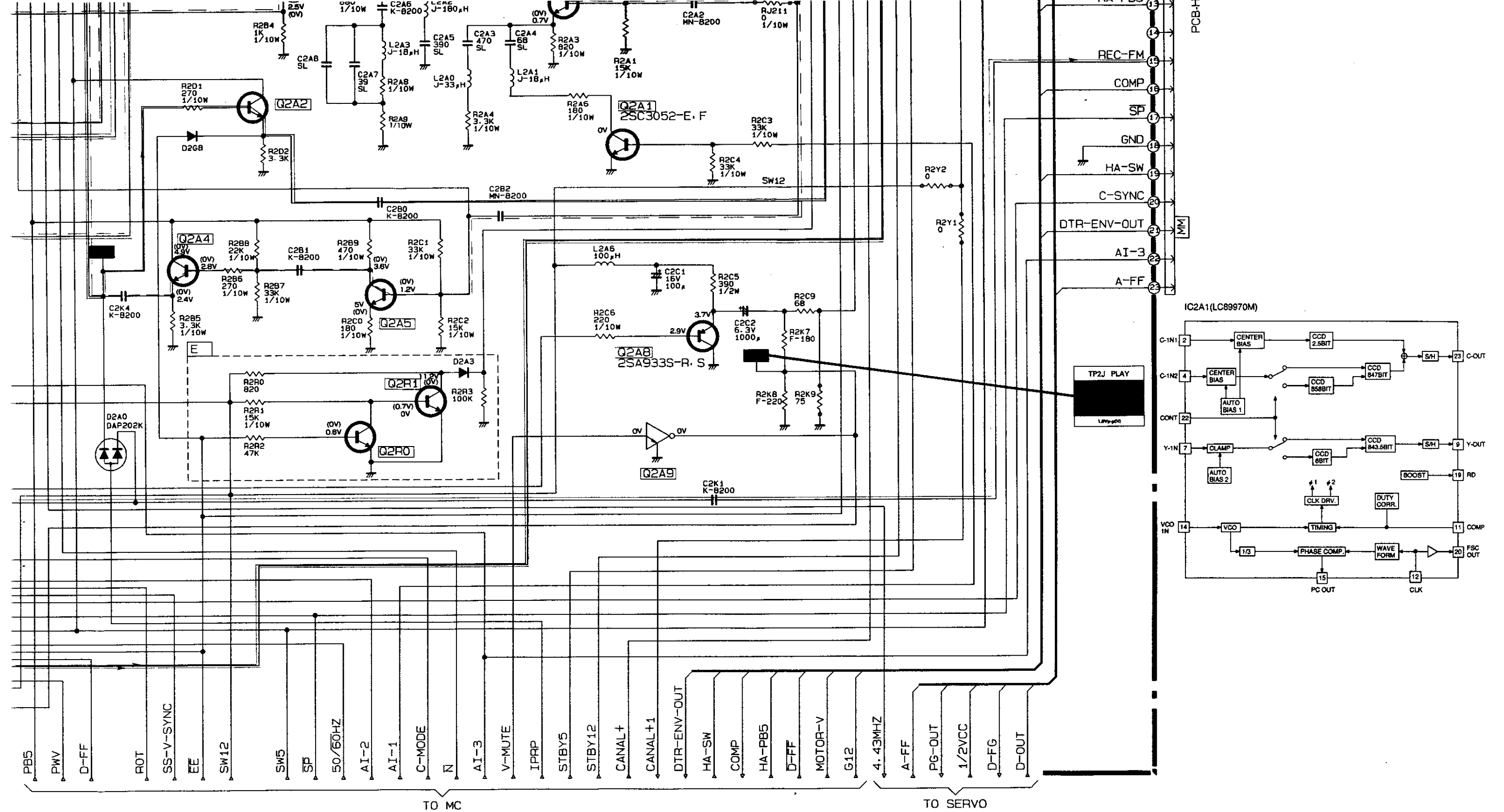

——— Recording of Luminance Signal  
 - - - Playback of Luminance Signal  
 ..... Recording of Color Signal  
 - · - · Playback of Color Signal



PCB-TIMER [TK]

TO POWER

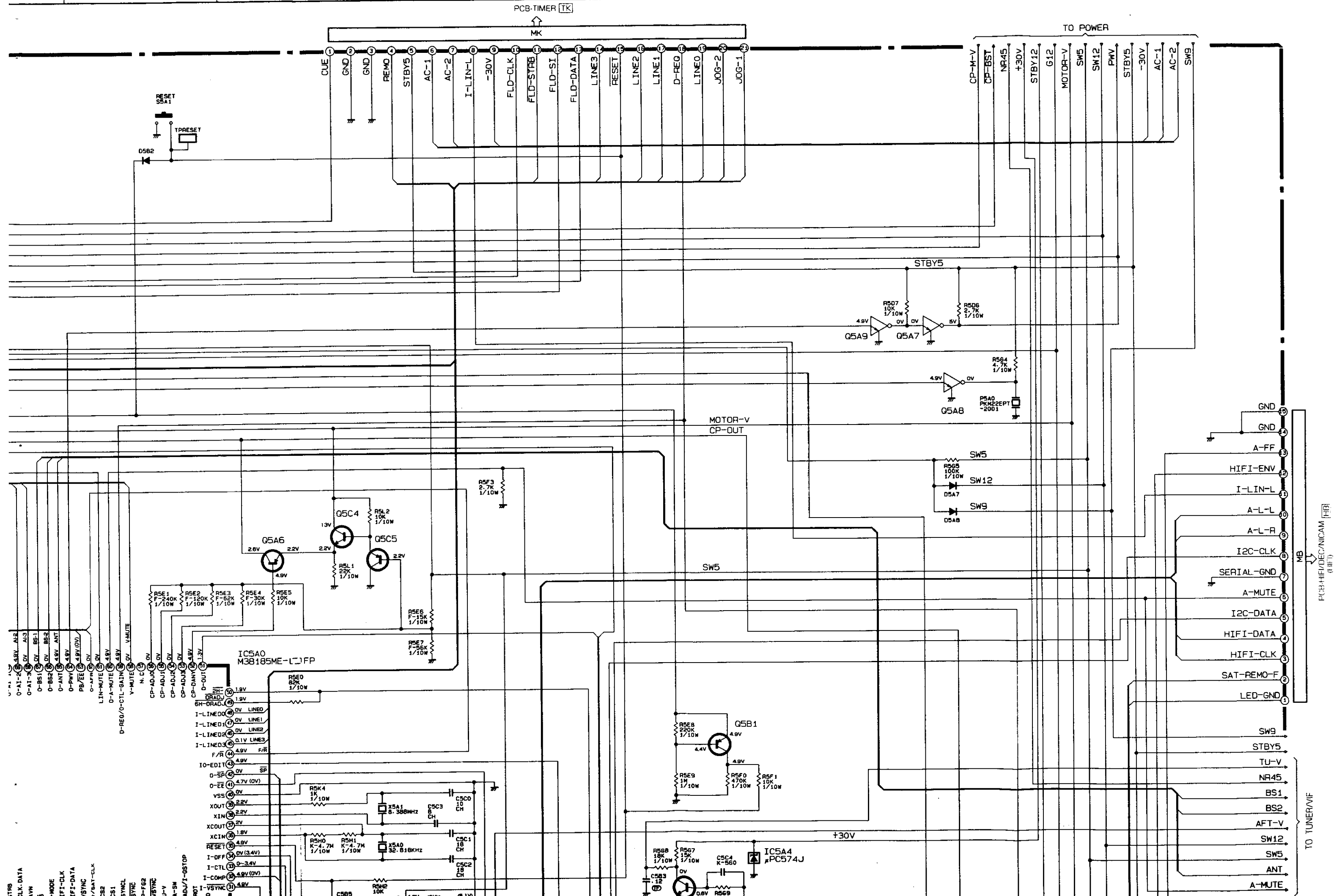

PCB-HIFI/DEC/NICAM [FB]

TO TUNER/VIF

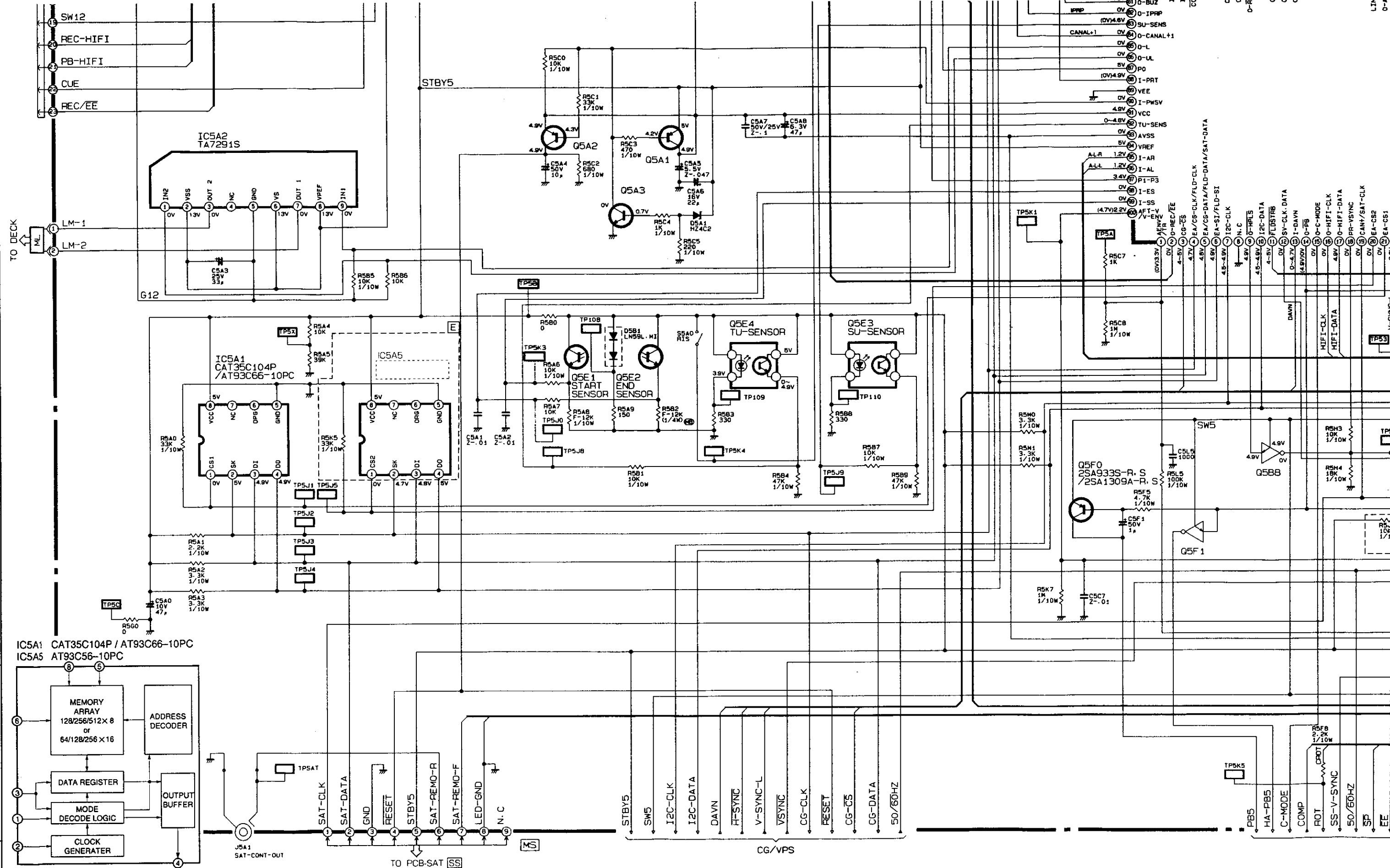

Legend: O: Employed, X: Not employed

SYMBOL	B	E	IC5A5	R5J2	D	IC5A0	G	H	F	R5K0
ADDRESS	n-9	q-3	r-3	d-7	d-7	e-10	a-5	a-8	h-11	i-12
561V(Y)	O	X	---	---	O	096	X	X	O	X
561V(B)	X	X	AT93C56-10PC	X	X	097	X	X	O	X
561V(E)	O	X	---	O	O	098	X	X	O	X
561V(G)	O	O	CAT35C104P/AT93C66-10PC	O	X	096	O	O	O	X
561V(A)	X	X	---	X	X	142	X	X	O	X
561V(NZ)	X	X	---	X	X	119	X	X	O	X
561V(EE)	X	X	---	X	X	110	X	X	X	O

HS-561V(B)/V(G)/V(E)/V(Y)/V(EE)

⑥

All diode  
All NPN t  
All PNP t

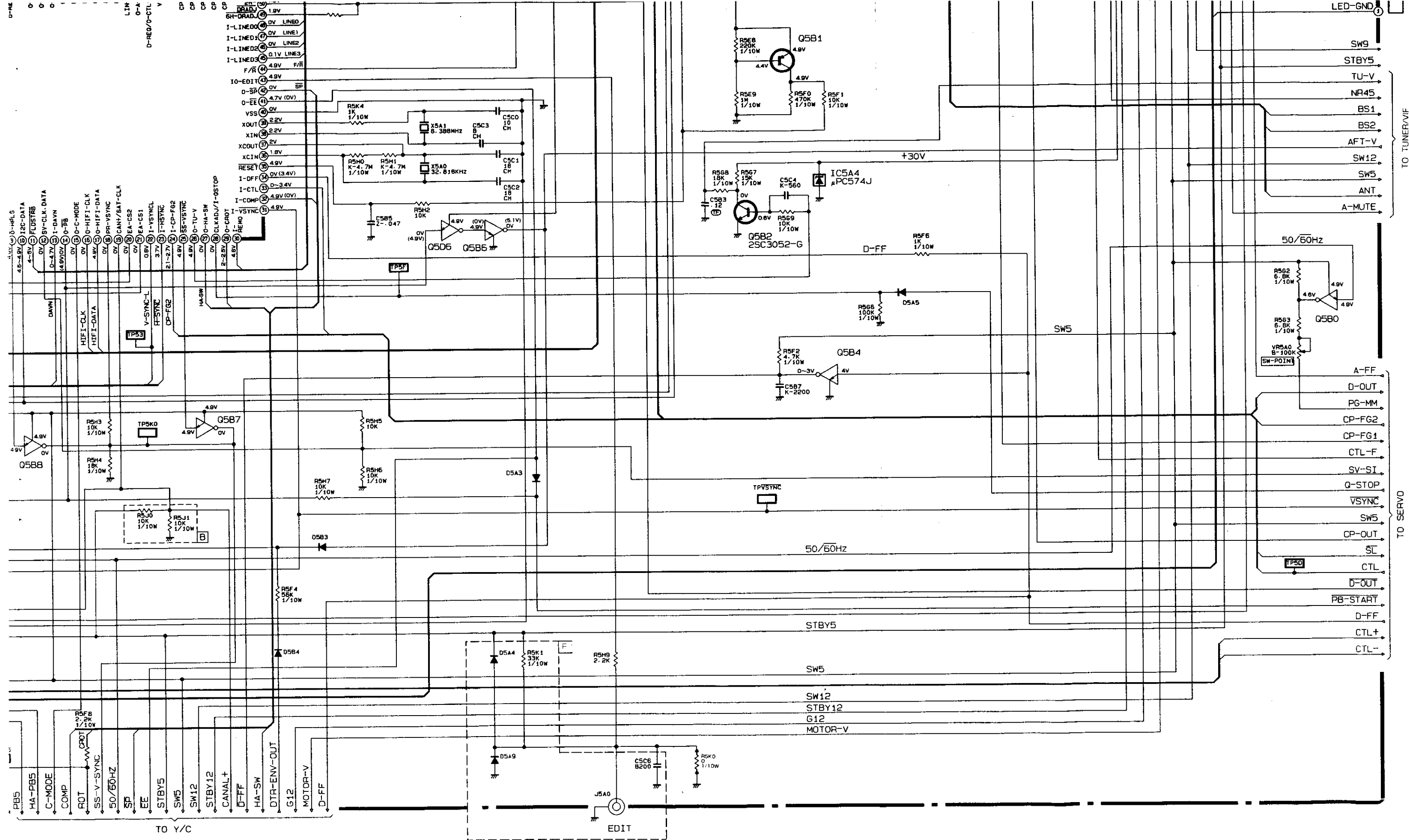

All diodes are 1SS252/1SS131 unless otherwise specified.  
 All NPN transistors are 2SC3052-E.F unless otherwise specified.  
 All PNP transistors are 2SA1235-E.F unless otherwise specified.

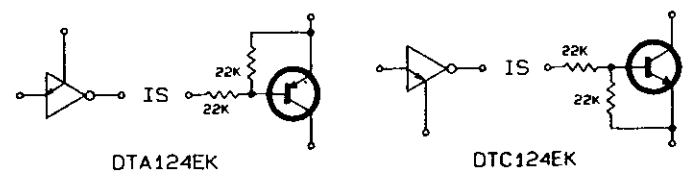

DTA124EK

DTC124EK



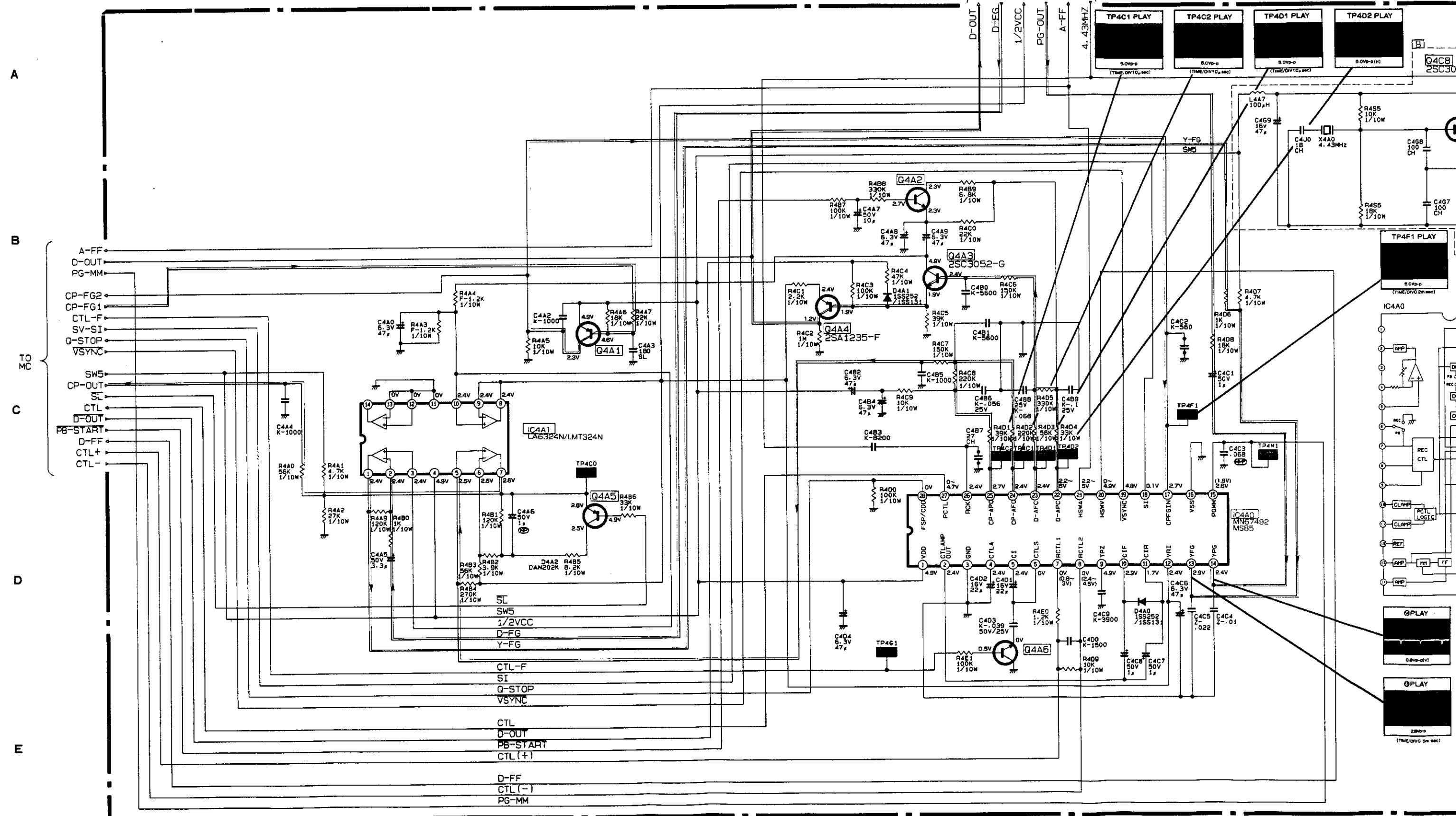

All NPN transistors are 2SC3052-E.F unless otherwise specified.  
 All PNP transistors are 2SA1235-E.F unless otherwise specified.

MODEL	SYMBOL	C4B7	B
HS-561V(Y)(B)(E)(G)	○	○	○
HS-561V(E)	x	x	x

○ Employed  
 x Not Employed

Drum S  
 Capstan

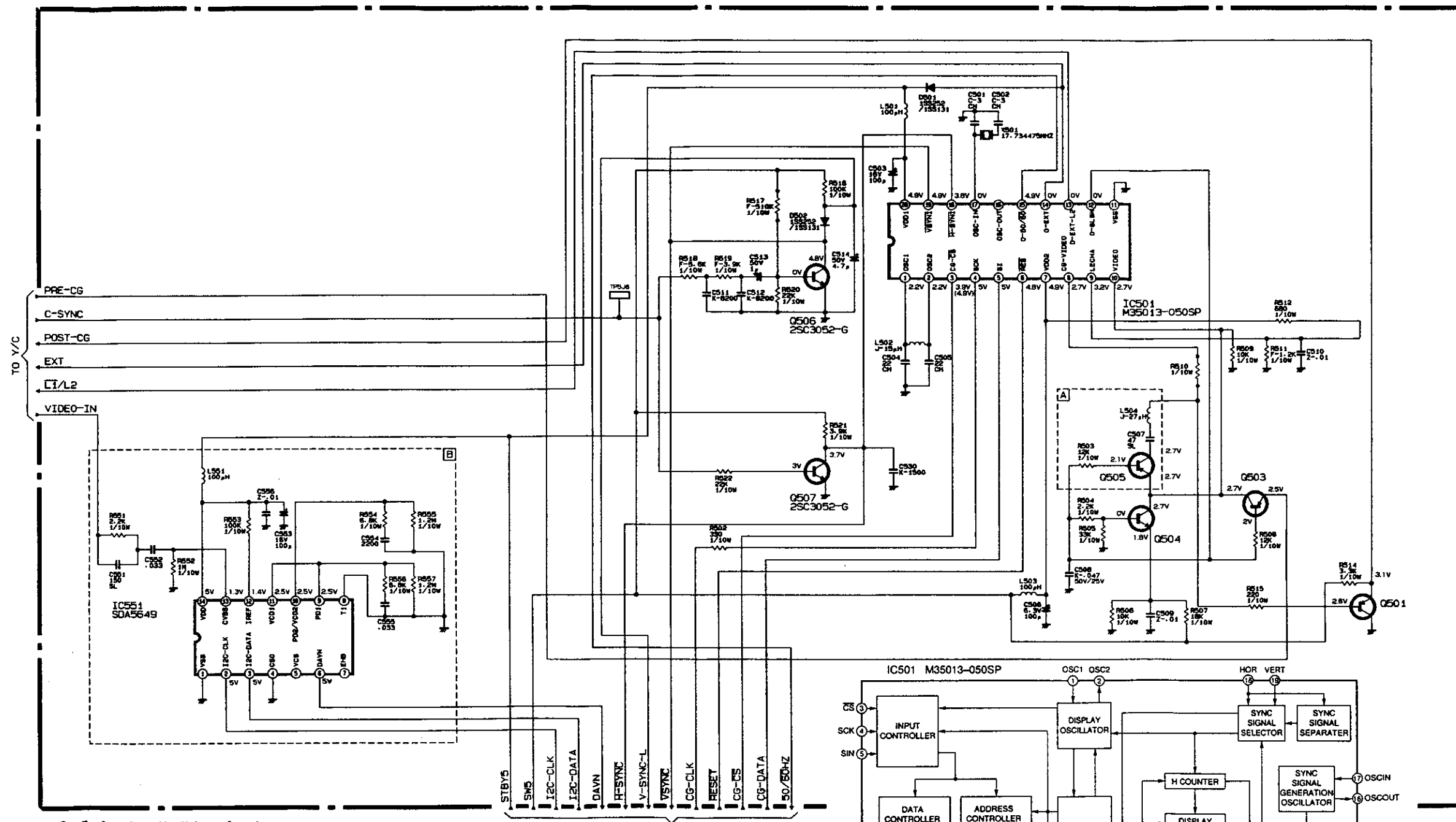
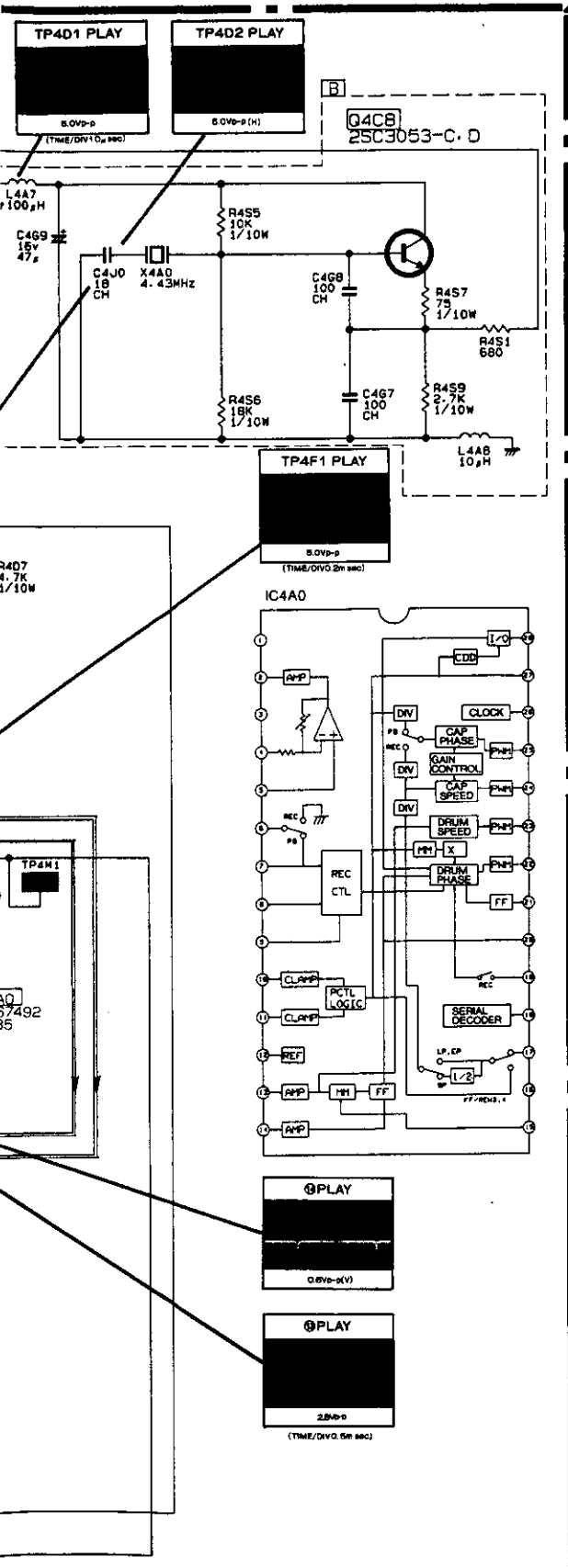

○: Employed X: Not employed

MODE	SYMBOL	A	R517	B	R510
HS-561V(Y)		○	X	X	390
HS-561V(B)		X	X	○	0a
HS-561V(E)		○	X	○	390
HS-561V(G)		○	X	○	390
HS-561V(A)		X	○	X	0a
HS-561V(NZ)		X	X	○	0a
HS-561V(EE)		○	X	X	390

All NPN transistors are 2SC3052-E-F unless otherwise specified.  
 All PNP transistors are 2SA1235-E-F unless otherwise specified.

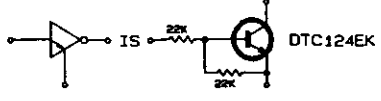

— Drum Servo System  
 — Capstan Servo System







PCB-HIFI/NIC/DEC (SOLDER SIDE)

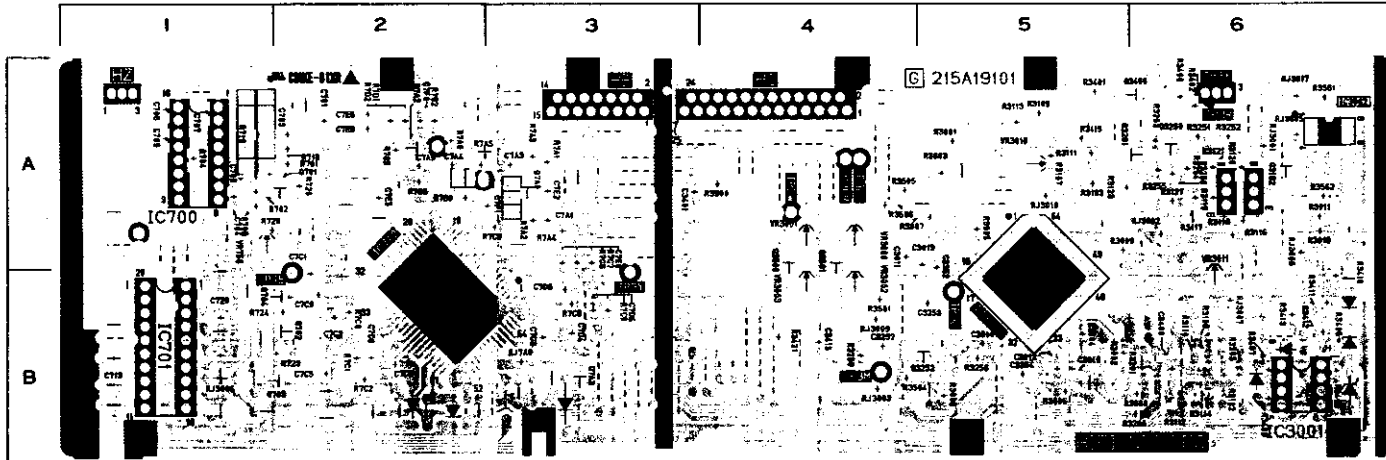

PCB-HIFI/NIC/DEC (SOLDER SIDE)

SYMBOL NO.	ADDRESS	SYMBOL NO.	ADDRESS	SYMBOL NO.	ADDRESS	SYMBOL NO.	ADDRESS
C701	A-2	C7C0	B-2	Q701	A-2	R3000	B-6
C703	A-2	C7C1	A-2	Q702	B-2	R3001	A-5
C704	A-1	C7C3	B-2	Q703	B-2	R3002	B-5
C705	A-1	C7C5	B-2	Q704	B-2	R3003	A-5
C706	A-1	C7C8	B-2	Q3102	A-6	R3004	B-5
C707	A-1	C7C9	B-2	Q3250	A-6	R3005	A-5
C709	A-1	C7D3	B-3	Q3251	A-6	R3006	B-5
C713	B-1	C7D4	B-3	Q3252	B-5	R3007	A-5
C720	B-1	C7D6	B-3	Q3400	A-6	R3008	B-5
C3010	B-5	C7D9	B-3	Q3500	A-4	R3009	A-5
C3011	A-4	C7E0	A-3	Q3501	A-4	R3010	A-6
C3012	B-5	C7E2	A-3	Q7A0	A-3	R3011	A-6
C3013	A-5	C7E5	A-2	Q7A2	A-2	R3102	B-6
C3014	B-5	C7E6	A-2	Q7A3	B-3	R3103	A-5
C3252	B-4	C7E8	A-2			R3106	B-6
C3253	B-5	C7F0	A-2	R701	A-2	R3107	A-5
C3352	A-5	C7F1	A-3	R702	A-1	R3109	A-5
C3354	B-5			R703	A-1	R3110	B-6
C3400	B-6	IC700	A-1	R704	A-1	R3111	A-5
C3401	A-3	IC701	B-1	R718	A-2	R3112	B-6
C3415	B-4	IC3000	B-5	R719	A-1	R3113	A-5
C7A1	A-3	IC3001	B-6	R720	A-2	R3114	B-6
C7A3	A-3	IC3002	A-6	R723	B-2	R3115	A-5
C7A4	A-2	IC7A0	B-2	R724	B-2	R3116	A-6
C7A5	A-2			R725	A-1	R3117	A-6

PCB-HIFI/NIC/DEC (COMPONENT SIDE)

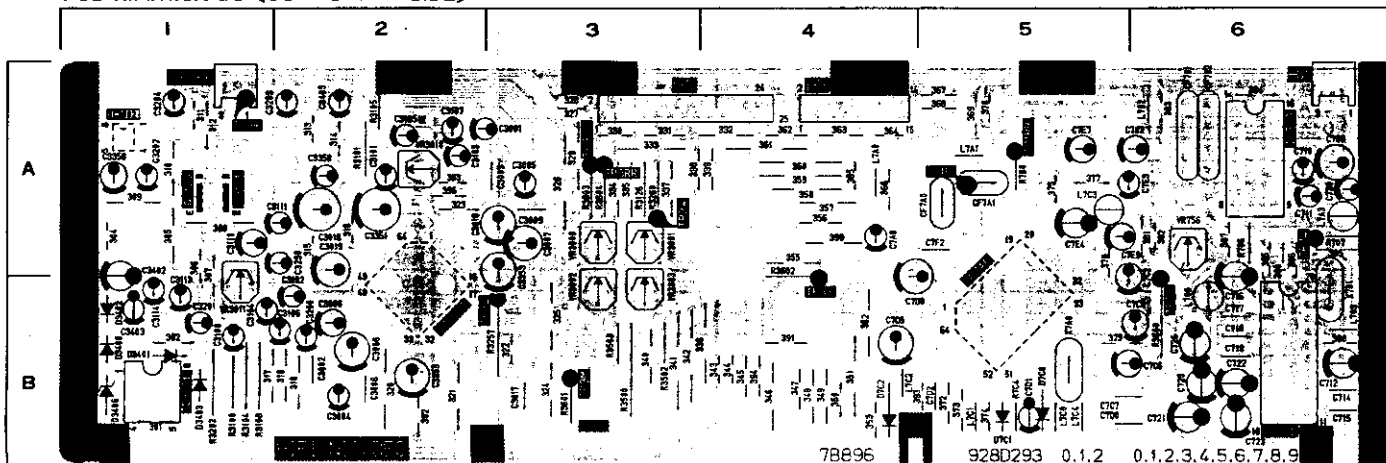

PCB-HIFI/NIC/DEC (COMPONENT SIDE)

SYMBOL NO.	ADDRESS	SYMBOL NO.	ADDRESS	SYMBOL NO.	ADDRESS
CF701	A-6	L7A3	A-6	VR3003	B-3
CF702	A-6	L7C0	B-5	VR3010	A-2
CF7A0	A-5	L7C1	B-5	VR3011	A-1
CF7A1	A-5	L7C2	B-4		
		L7C3	A-5	X701	B-6
D3400	B-1			X7A0	B-5
D3401	B-1	Q3100	A-1		
D3402	B-1	Q3101	A-1		
D3403	B-1				
D3406	B-1	TP74	A-6		
D7C0	B-5	TP75	A-6		
D7C1	B-5	TP1R	A-5		
D7C2	B-4	TP3L	B-3		
IC700	A-6	TP3M	B-3		
IC701	B-6	TP3R	A-1		
IC3000	B-2	TP3W	A-3		
IC3001	B-1	TP3X	A-1		
IC3002	A-1	TP3Y	A-4		
IC7A0	B-5	TP1RR	A-5		
		TP3LL	A-3		
L702	A-6	TP3RR	A-3		
L703	B-6				
L708	B-6	VR756	A-6		
L7A1	A-5	VR3000	A-3		
		VR3001	A-3		

SYMBOL NO.	ADDRESS	SYMBOL NO.	ADDRESS	SYMBOL NO.	ADDRESS	SYMBOL NO.	ADDRESS
R3118	A-6	R3410	B-6	R7C9	A-3	TP3X	A-6
R3119	A-6	R3411	B-6	R7D0	A-2	TP3Y	B-3
R3120	A-6	R3412	B-6	R7D1	A-2	TP3LL	A-4
R3121	A-6	R3413	B-6	R7D2	A-2	TP3RR	A-4
R3127	A-6	R3421	B-4	R7G2	A-2		
R3128	A-5	R3501	B-4	R7G5	A-2	VR756	A-1
R3200	B-6	R3504	B-4	R7G6	A-2	VR3000	A-4
R3201	B-6	R3505	A-4			VR3001	A-4
R3203	B-6	R3506	A-4	RJ3001	A-6	VR3002	B-4
R3251	A-6	R3561	A-6	RJ3002	A-6	VR3003	B-4
R3252	A-6	R3562	A-6	RJ3003	B-4	VR3010	A-5
R3253	A-6	R3900	A-4	RJ3005	A-6	VR3011	A-6
R3254	A-6	R7A1	A-3	RJ3006	B-1		
R3255	A-6	R7A2	A-3	RJ3007	B-6		
R3256	A-6	R7A3	A-3	RJ3008	A-6		
R3258	B-5	R7A4	A-3	RJ3009	B-4		
R3259	B-4	R7A5	A-2	RJ3010	A-5		
R3400	A-6	R7A9	A-2	RJ3017	A-6		
R3401	A-5	R7C0	B-2	RJ7A0	B-3		
R3402	A-6	R7C1	B-2				
R3405	B-6	R7C2	B-2	TP75	B-2		
R3406	B-6	R7C5	B-3	TP3L	B-5		
R3407	B-6	R7C6	B-3	TP3M	B-4		
R3408	B-6	R7C7	A-3	TP3R	A-6		
R3409	B-6	R7C8	A-3	TP3W	A-4		

PCB-POWER-SUB 2 [SOLDER SIDE]

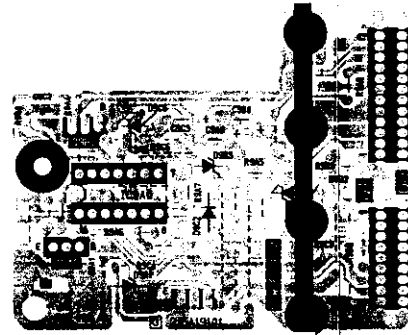

PCB-POWER-SUB 2 [COMPONENT SIDE]

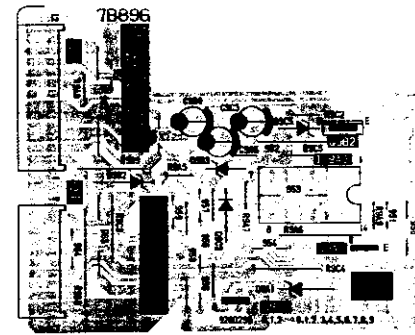

PCB-SAT [SOLDER SIDE] (B) only

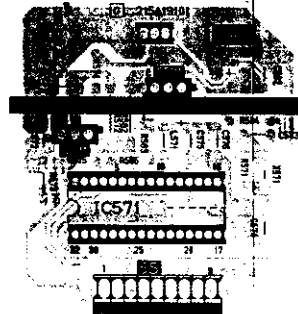

PCB-SAT [COMPONENT SIDE] (B) only

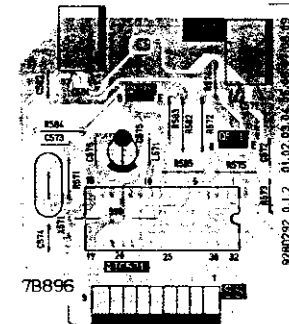

PCB-CONNECTOR (SOLDER SIDE)

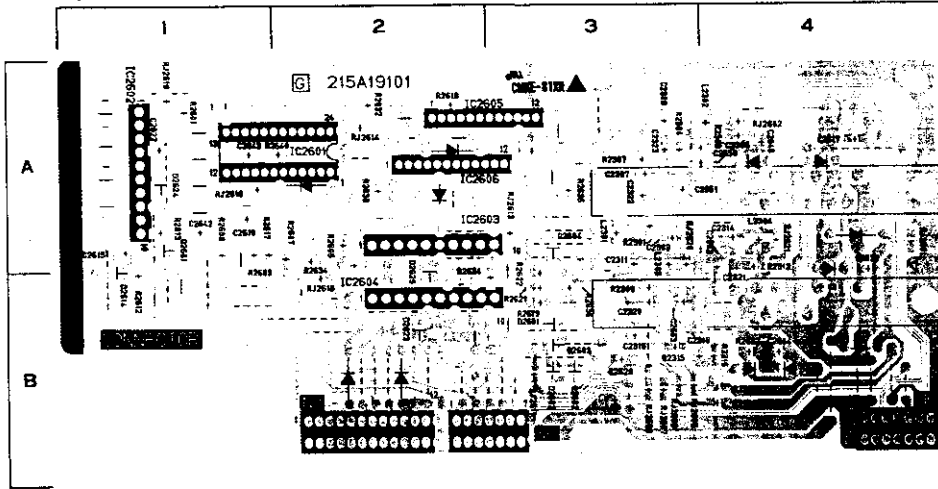

PCB-CONNECTOR (SOLDER SIDE)

SYMBOL NO.	ADDRESS	SYMBOL NO.	ADDRESS	SYMBOL NO.	ADDRESS	SYMBOL NO.	ADDRESS
C2303	A-3	D2601	B-3	R2304	A-3	R2637	B-4
C2306	A-4	D2602	B-3	R2307	A-3	R2638	A-2
C2307	A-3	D2614	B-1	R2308	A-3	R2640	A-1
C2308	A-3	D2623	B-2	R2309	B-3	RJ2601	A-4
C2311	A-3	D2624	A-1	R2312	A-4	RJ2602	A-4
C2314	A-4	D2625	A-2	R2315	B-3	RJ2603	B-4
C2315	B-3			R2316	B-3	RJ2604	B-4
C2316	B-3	IC2601	A-1	R2601	A-1	RJ2605	B-3
C2320	B-3	IC2602	A-1	R2605	A-2	RJ2606	B-3
C2321	B-4	IC2603	A-2	R2607	A-2	RJ2607	B-3
C2322	A-3	IC2604	B-2	R2608	A-1	RJ2608	B-3
C2323	A-3	IC2605	A-2	R2609	A-1	RJ2611	B-3
C2610	A-1	IC2606	A-2	R2612	B-1	RJ2613	A-3
C2615	A-1			R2613	A-1	RJ2614	A-2
C2617	A-4	L2301	A-3	R2617	A-1	RJ2616	B-2
C2620	A-4	L2302	A-3	R2618	A-2	RJ2618	A-1
C2622	A-1	L2303	A-3	R2619	B-3	RJ2619	A-1
C2642	A-1	L2304	A-4	R2620	B-3	RJ2620	A-3
C2643	A-1			R2621	B-3	RJ2621	A-4
C2644	B-4	Q2601	A-1	R2622	B-3		
C2645	A-4	Q2602	B-3	R2624	B-2		
C2650	A-4	Q2603	B-3	R2632	A-2		
C2651	A-3	Q2604	A-3	R2634	A-2		
C2652	A-4			R2635	A-3		
C2653	B-3	R2301	A-3	R2636	B-3		

PCB-CONNECTOR (COMPONENT SIDE)

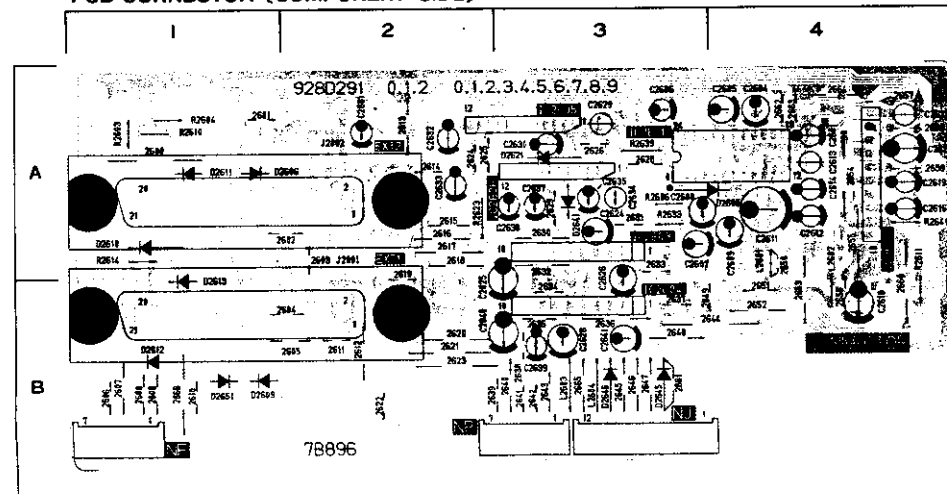

PCB-CONNECTOR (COMPONENT SIDE)

SYMBOL NO.	ADDRESS	SYMBOL NO.	ADDRESS
D2605	A-3		
D2606	A-1	L2603	B-3
D2609	B-1	L2604	B-3
D2610	A-1		
D2611	A-1		
D2612	B-1		
D2613	A-1		
D2621	A-3		
D2641	A-3		
D2645	B-3		
D2646	B-3		
D2651	B-1		
IC2601	A-4		
IC2602	A-4		
IC2603	A-3		
IC2604	B-3		
IC2605	A-3		
IC2606	A-3		
J2001	B-1		
J2002	A-1		
L2601	A-4		
L2602	B-4		



PCB-TIMER

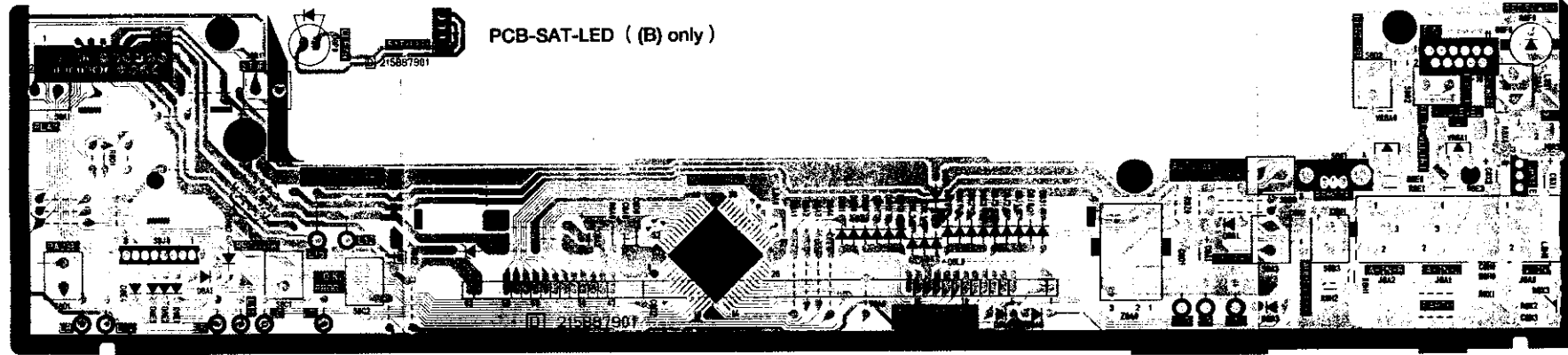

PCB-SAT-LED ( B) only

PCB-TIMER

PCB-HA/AUDIO (SOLDER SIDE)

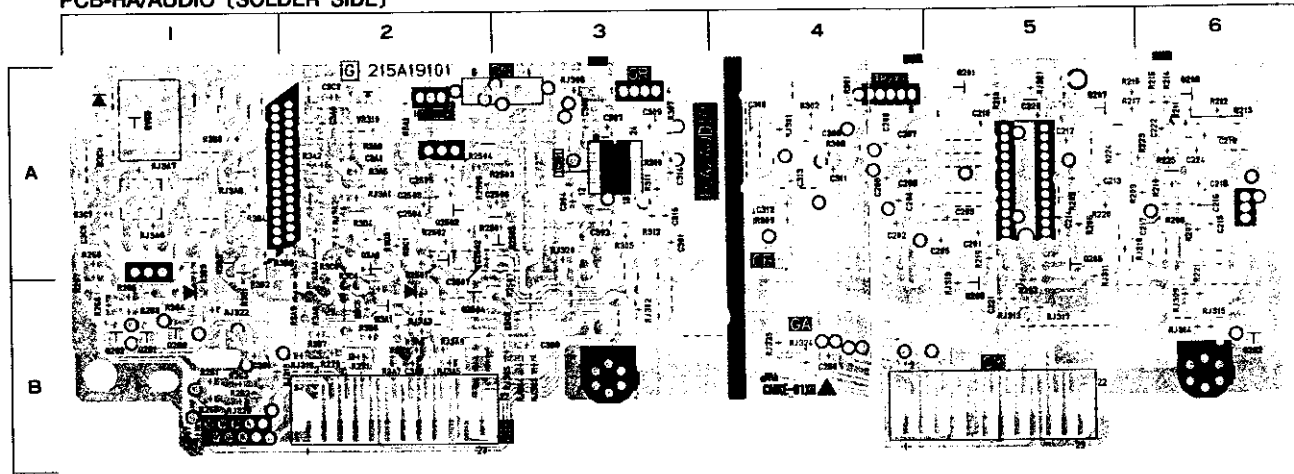

PCB-HA/AUDIO (COMPONENT SIDE)

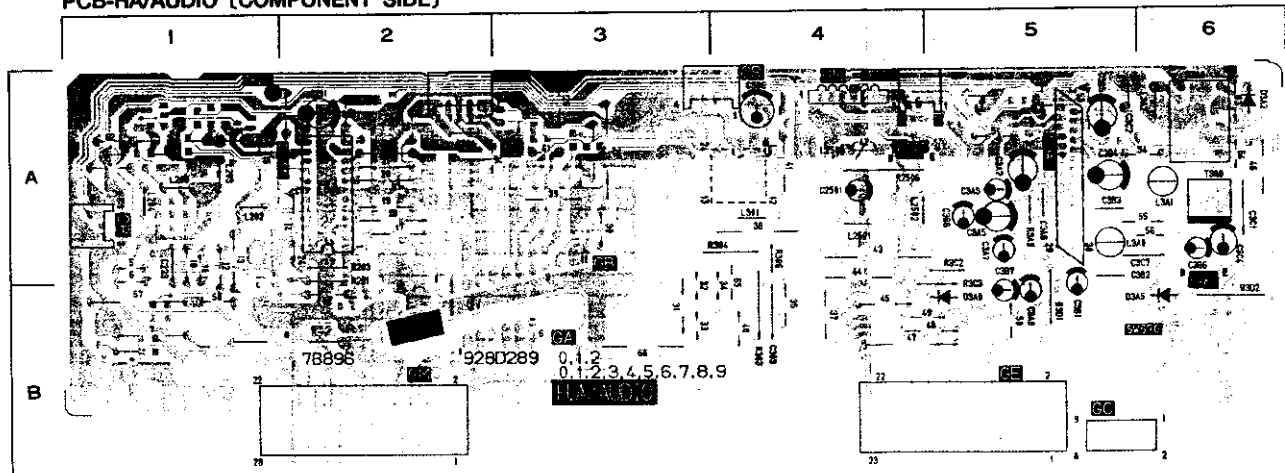

PCB-HA/AUDIO (SOLDER SIDE)

SYMBOL NO.	ADDRESS	SYMBOL NO.	ADDRESS	SYMBOL NO.	ADDRESS	SYMBOL NO.	ADDRESS	SYMBOL NO.	ADDRESS	SYMBOL NO.	ADDRESS	SYMBOL NO.	ADDRESS	SYMBOL NO.	ADDRESS
C201	A-5	C302	A-3	IC301	A-3	R209	A-6	R269	B-1	R3A9	B-2	RJ306	A-3	RJ3A9	B-2
C202	A-4	C304	A-3			R210	A-6	R270	B-2	R3B0	A-2	RJ307	B-1		
C203	A-5	C305	A-3	Q201	A-5	R211	A-6	R271	B-2	R3B1	B-1	RJ309	B-6	TP2XY	A-4
C204	A-4	C307	A-3	Q202	B-6	R212	A-6	R301	A-4	R3B2	A-1	RJ310	A-6	TP3EF	A-2
C205	A-5	C308	A-4	Q205	A-5	R213	A-6	R302	A-4	R3B3	A-1	RJ311	B-5		
C206	A-4	C309	A-3	Q206	B-5	R214	A-6	R305	A-3	R3B4	A-1	RJ313	B-5		
C207	A-4	C310	A-4	Q207	A-5	R215	A-6	R307	A-3	R3B6	B-2	RJ314	B-6		
C208	A-4	C311	A-4	Q208	A-6	R216	A-6	R308	A-4	R3B7	B-2	RJ315	B-6		
C209	A-4	C312	A-4	Q260	B-1	R217	A-6	R309	A-4	R3B8	A-1	RJ316	B-2		
C210	A-5	C313	A-4	Q261	B-1	R218	A-5	R310	A-3	R3B9	A-1	RJ317	B-5		
C212	A-5	C314	A-3	Q262	B-1	R219	A-5	R311	A-3	R3C0	A-2	RJ318	B-2		
C213	A-5	C315	A-3	Q2501	A-2	R220	A-5	R312	A-3	R3C1	A-2	RJ319	B-5		
C214	A-5	C2502	A-2	Q2502	A-2	R221	B-6	R2501	A-2	R3C4	B-2	RJ320	A-3		
C215	A-6	C2503	A-2	Q2504	B-2	R223	A-6	R2502	A-2	R3C5	B-2	RJ321	A-5		
C216	A-6	C2504	A-2	Q2505	A-3	R224	A-5	R2503	A-3	R3C6	B-3	RJ322	B-1		
C217	A-6	C2505	A-2	Q3A0	A-2	R225	A-6	R2504	A-2	R3C7	A-1	RJ323	B-1		
C218	A-6	C2506	A-3	Q3A1	B-2	R260	B-1	R2505	A-2	R3C8	A-1	RJ324	B-4		
C219	A-6	Q2507	A-2	Q3A3	A-1	R261	B-1	R2507	A-3	R3D3	A-2	RJ325	B-4		
C220	A-5	C3A0	A-2	Q3A4	A-2	R262	B-1	R3A0	A-2	R3D4	A-2	RJ3A1	A-2		
C221	B-5	C3A1	A-2			R263	B-1	R3A1	A-2			RJ3A2	A-2		
C222	A-6	C3A9	B-2	R202	B-5	R264	B-1	R3A2	A-2	RJ301	A-4	RJ3A3	B-2		
C224	A-6	C3B9	B-3	R205	A-5	R265	B-1	R3A5	A-2	RJ302	B-3	RJ3A5	B-2		
C260	B-4	C3C0	A-1	R206	A-5	R266	A-1	R3A6	B-2	RJ303	B-3	RJ3A6	A-1		
C261	B-1	C3C3	A-2	R207	A-6	R267	A-1	R3A7	B-2	RJ304	B-3	RJ3A7	A-1		
C301	A-3			R208	A-6	R268	B-1	R3A8	B-2	RJ305	B-3	RJ3A8	A-1		

PCB-HA/AUDIO (COMPONENT SIDE)

SYMBOL NO.	ADDRESS	SYMBOL NO.	ADDRESS
D3A0	B-5	SW570	B-6
D3A2	A-6		
D3A5	B-6	T3A0	A-6
IC201	A-2	TP2N	A-1
IC3A0	A-5	TP2XY	A-2
		TP3EF	A-4
K3A0	A-6	VR310	A-5
L201	A-1		
L202	A-1		
L203	A-1		
L204	A-1		
L205	A-1		
L301	A-4		
L2501	A-4		
L2502	A-5		
L2503	A-4		
L3A0	A-6		
L3A1	A-6		
L3A2	A-6		
Q2503	A-4		
Q3A2	B-6		