

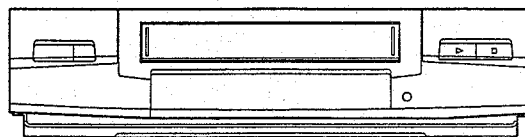

Service Manual

VIDEO CASSETTE RECORDER



HS-550

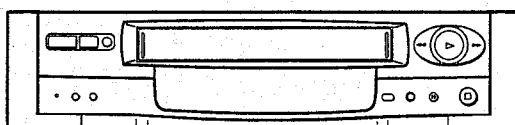

HS-551

MODEL

HS-550V(B)
 HS-551V(B)
 HS-551V(E)
 HS-551V(G)
 HS-551V(IR)
 HS-551V(Y)

Only cassettes marked VHS can be used with this video cassette recorder.

SPECIFICATION

Tape Format	: VHS 1/2" high-density video cassette tape	Video Input	: 0.5 to 2.0Vp-p, 75Ω unbalanced EURO AV socket, RCA pin plug
Power Source	: AC 230V ; 50Hz	Audio Input:Line	: -8dBs, 50kΩ unbalanced EURO AV socket, RCA pin plug
Power Consumption	: Approx. 33W	Video Output	: 1.0Vp-p, 75Ω unbalanced EURO AV socket
Television System	: 625lines, 50fields System CCIR B&G PAL [551V(E)/(Y)/(G)] System CCIR I PAL [550V(B)/551V(B)/(IR)]	Audio Output	: -6dBs, 1kΩ unbalanced EURO AV socket and RCA pin plug
Video Recording System	: Azimuth helical scanning system	TV Tuner	VHF : 47~470MHz [551V(E)/(Y)/(G)] UHF : 44~89MHz, 104~300MHz[551V(IR)]
Luminance	: Frequency modulation recording	Operating Temperature	: 5°C to 40°C
Colour Signal	: Low frequency conversion subcarrier phase shift recording	RF Channel Output	: Set to Channel 36 [550V(B)/551V(B)/(G)/(E)/(Y)] Set to Channel 38 [551V(IR)] (Channel 32~40 selectable)
Hi-Fi Audio Recording System	: Azimuth helical scanning system, Frequency modulation, deep layer recording	Weight	: Approx. 5.4kg
Linear Audio Track	: 1 track	Dimensions	: 380(W)×94(H)×326(D)mm [550] 380(W)×94(H)×335(D)mm [551]
Tape Speed	: 23.39mm/sec (PAL SP mode) 11.70mm/sec (PAL LP mode)	Timer	: 8 programmes for any channels in one month/every day/every week day 24 hour digital synchronized with oscillator frequency.
Record/Playback Time	: 240min. with E-240 cassette (PAL SP mode) 480min. with E-240 cassette (PAL LP mode)	Channel Selection Deck	: 60 position Up/Down + EXT : J Deck
Heads:Video	: 4 rotary heads		
Hi-Fi Audio	: 2 rotary heads		
Audio/Control	: 1 stationary head		
Erase	: 1 full track head		

- Weight and dimensions shown are approximate.
- Design and specifications are subject to change without notice.

CONTENTS

3. Interchangeability Adjustment of the Mechanism	64
3-1 Adjustment of Back-Tension and Tension Pole Position	64
3-2 Check and Adjustment of FM Envelope	65
3-2-1 Guide Roller Adjustment	65
3-2-2 Adjustment of Supply Guide Roller Height	65
3-2-3 Adjustment of Takeup Guide Roller Height	65
3-2-4 Coarse Adjustment of Phase	66
3-2-5 Check of FM Waveform Flatness	66
3-2-6 Check 1: Tape Running Condition at the Guide Rollers	67
3-2-7 Replacement of Tape Guides	67
3-2-8 Check 2: Tape Running Condition on Guide Rollers	67
3-3 Adjustment of A/C Head	68
3-3-1 Adjustment of A/C Head Slant	68
3-3-2 Adjustment of A/C Head Azimuth and Height	68
3-4 Adjustment of Phase	69
3-5 Adjustment of Takeup Guide Arm Height	70
4. Servicing for Tape Jamming during the Loading Mode	71
(1) If the tape guides do not move (the pulley worm J does not turn);	71
(2) If the tape guides move (the pulley worm J turns);	74

SPECIFICATION OF VPS RECORDING

SYSTEM	75
GLOSSARY OF ABBREVIATIONS	76
CHIP PARTS REPLACEMENT	77
Parts List	78
1. CABINET ASSEMBLY	78
2. PACKING PARTS	80
3. ELECTRICAL PARTS	82
4. DECK ASSEMBLY	

DISASSEMBLY

Note: Any screw can be used between silver screw securing the boss of the molded parts and 669D220030 (preferred part) for replacement because they are compatible with each other.

1. Removal of Top Cover

- ① Remove the two Top Cover fastening screws (a and b) shown in Fig. 1 and remove the Top Cover in the direction shown by the arrows.

2. Removal of Front Panel

- ① Remove the Top Cover.
(Refer to Para. 1 of the DISASSEMBLY.)
- ② Unfasten seven catches (c~i), two on the top, two on the side, and three on the bottom, and remove the Front Panel in the direction shown by the arrows.

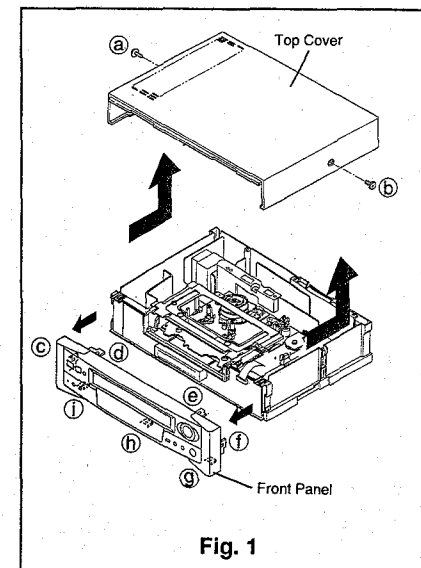

Fig. 1

CONTENTS

DISASSEMBLY	1
HOW TO EXECUTE CIRCUIT BOARD SERVICE	3
MECHANICAL ADJUSTMENT TOOLS	7
ELECTRICAL ADJUSTMENT TOOLS	8
HOW TO INITIALIZE EPROM	9
PROVIDING DUMMY SIGNAL FOR SERVICE POSITION [B] AND [C]	9
SERVICE POSITION	10
ELECTRICAL ADJUSTMENTS	11
Servo Circuit Adjustment	14
Audio Circuit Adjustment	14
Hi-Fi Audio Circuit Adjustments	15
Dual Audio Circuit Adjustment	16
Timer Circuit Adjustment	16
MECHANICAL ADJUSTMENT AND REPLACEMENT	17
1. Cleaning of Deck	17
1-1 Video Head	17
1-2 Tape Transport	17
1-3 Reel Disk Drive System	17
2. Replacement of Major Parts	18
2-1 Cassette Housing	18
2-2 Sense Gear, Driver Gear, Takeup Arm, and Arm Spring (TU)	19
2-3 Door Arm	22
2-4 Gear S and Gear T	22
2-5 Wheel Gear	23
2-6 Supply Arm and Arm Spring (SP)	23
2-7 Jut	26
2-8 PCB-HA/AUDIO	26
2-9 Brush	27
2-10 Drum Assembly	27
2-11 Upper Drum and Drum Motor	29
2-12 Safety Spring and Safety Lever	30
2-13 Safety Arm	31
2-14 Sub Brake (SP) and Sub Spring (SP)	31
2-15 Main Brake (SP) and Main Brake Spring J (SP)	32
2-16 Sub Off Lever, Sub Brake (TU), and Sub Spring (TU)	33
2-17 Main Brake (TU) and Main Brake Spring J (TU)	34
2-18 ID Swing Lever, Revolution Lever, and Revolution Spring	34
2-19 Tension Arm, Tension Brake Belt, and Tension Spring	35
2-20 Takeup Reel Disk and Gear R (takeup side)	37
2-21 Supply Reel Disk	38
2-22 Gear R (supply side)	39
2-23 Main Brake Release Lever	40
2-24 Pinch Cam Cap, Pinch Roller Arm Assembly, Pinch Cam, Takeup Guide Gear, Gear Pinch, Takeup Guide Arm, and Takeup Guide Spring	41
2-25 Pinch Roller, Roller Cap, Pinch Spring, and Pinch Cam Spring	43
2-26 Mode Switch	44
2-27 FE Head	45
2-28 Reel Belt and Belt Pulley	45
2-29 Loading Motor Assembly, Pulley Worm J, Loading Motor Belt, and Gear A	46
2-30 Main Gear J	47
2-31 Gear Joint J	48
2-32 Capstan Brake and Capstan Brake Spring	49
2-33 Plate J, Roller B, and Cam Plate B	50
2-34 Cam Gear R, Change Lever, and Tension Off Lever	51
2-35 Reel Idler Assembly	52
2-36 Cam Plate C and Cam Spring C	53
2-37 Loading Arm (SP, TU)	54
2-38 Capstan Motor and Lead Card	55
2-39 A/C Head Assembly	56
2-40 A/C Head	57
2-41 Supply & Takeup Guide Rollers	58
2-42 Cleaning Roller, Cleaning Arm, Cleaning Lever, and Cleaning Spring	59
2-43 Supply & Takeup Tape Guide Assemblies	60
2-44 Drum base spring	61
2-45 Replacement of ASSY IMPEDANCE ROLLER	62

4. Removal of Bottom Panel

- ① Remove five fastening screws (Ⓐ~Ⓔ) shown in Fig. 3.
- ② Push the two inside hooks (Ⓘ and Ⓢ), holding the Bottom Panel and slide the Bottom Panel toward the rear to remove it.

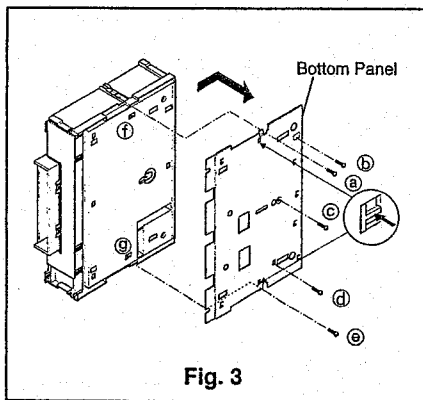

Fig. 3

5. Removal of Assy Deck

- ① Remove the Top Cover.
(Refer to Para. 1 of the DISASSEMBLY.)
- ② Remove the barrier.
(Refer to Para. 3 of the DISASSEMBLY.)
- ③ Remove the three fastening screws (Ⓐ, Ⓑ and Ⓒ) on the bottom of the set shown in Fig. 4.
- ④ Remove the five screws (Ⓘ~Ⓢ) holding the Assy Deck, shown in Fig. 5, and disconnect the connectors **ML**, **MM** and **ME**.
- ⑤ Slowly raise the Assy Deck upward to remove it.

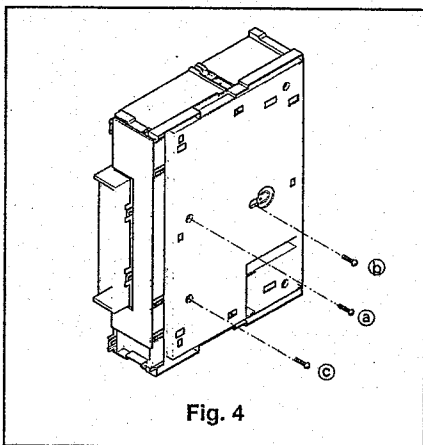

Fig. 4

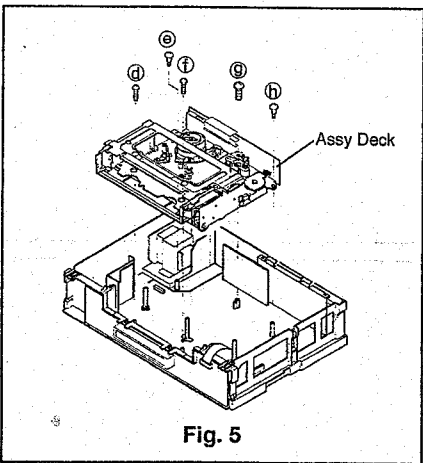

Fig. 5

HOW TO EXECUTE CIRCUIT BOARD SERVICE

CAUTION:

BEFORE ATTEMPTING TO REMOVE OR REPAIR ANY PCB, UNPLUG THE POWER CORD FROM THE A.C. SOURCE.

LOCATION OF PRINT CIRCUIT BOARDS

Note:

- Take caution when removing flat cables to prevent any contact problem.
- Connect and disconnect the flat cables at right angles to the connector and make sure that it is completely secured.
- After servicing the PCB, restore the flat cable and leads to their former state.

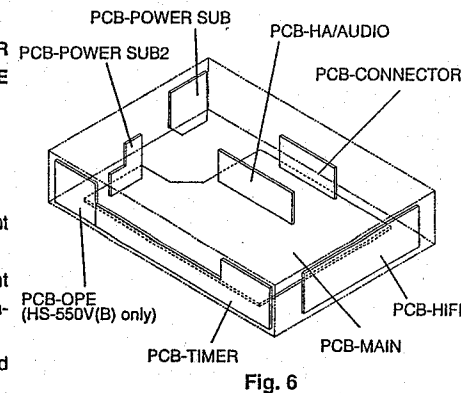

Fig. 6

1. PCB-MAIN

- ① Remove the Top Cover.
(Refer to Para. 1 of the DISASSEMBLY.)
- ② Remove the barrier.
(Refer to Para. 3 of the DISASSEMBLY.)
Servicing on the components side is partially possible.
- ③ Remove the Front Panel.
(Refer to Para. 2 of the DISASSEMBLY.)
Remove eight fastening screws referred to as ③ and ④ in Para. 5 of the DISASSEMBLY. (Do not disconnect the connector **ML**, **MM** and **ME**.)
- ④ Raise the front side of the Assy Deck upward as shown in Fig. 7 and support it with a screw driver, etc. Servicing on the components side of the PCB is now possible.
- ⑤ If necessary to remove PCB-MAIN completely, remove the Assy Deck. (Refer to Para. 5 of the DISASSEMBLY.) Remove all connectors on the PCB-MAIN. Remove one fastening screw (Ⓐ) on the bottom and two fastening screws (Ⓑ and Ⓒ) on the Antenna Cover shown in Fig. 8. Raise the PCB-MAIN upward to remove it.

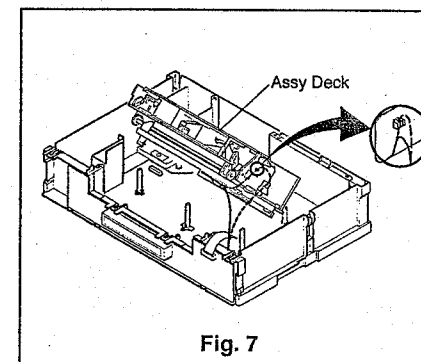

Fig. 7

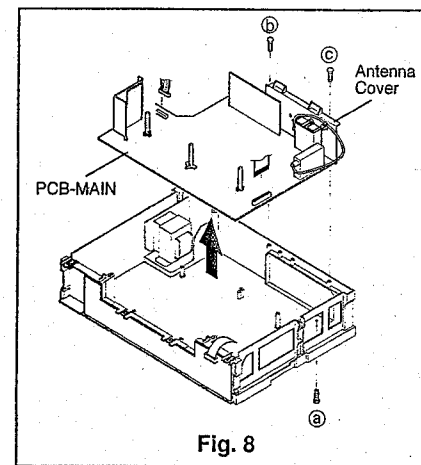

Fig. 8

Service of Transistors (Q902, Q903, Q904 and Q911)

- ▷ Disconnect the power plug.
- ▷ Remove the four screws (a, b, c and d): 669D222090) shown in Fig. 9.

OTE: Check that each transistor (Q902, Q903, Q904 and Q911) is connected to the Heat sink before turning the power on. If the power is turned on without installing the Heat sink, Q902, Q903, Q904 and Q911 are broken.

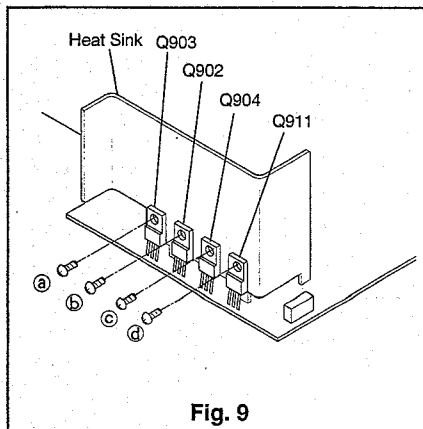

Fig. 9

PCB-CONNECTOR

- ▷ Remove the Top Cover.
(Refer to Para. 1 of the DISASSEMBLY.)
- ▷ If it is necessary to remove the PCB-CONNECTOR comply with the following steps.

- (1) Remove the PCB-MAIN.
(Refer to the preceding paragraph.)
- (2) Remove four screws (a, b, c and d), unfasten five catches (e~i) on the Antenna Cover as shown in Fig.10, and remove the Antenna Cover.
- (3) Raise the PCB-CONNECTOR upward to remove it.

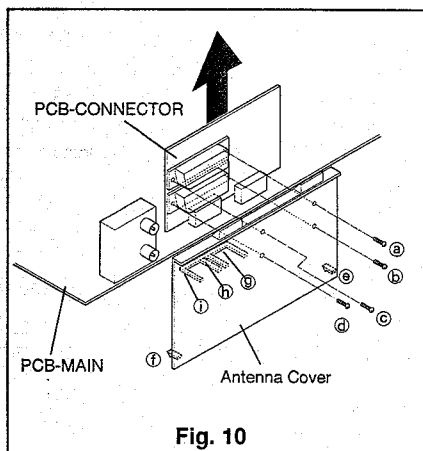

Fig. 10

PCB-HIFI

- ▷ Remove the Top Cover.
(Refer to Para. 1 of the DISASSEMBLY.)
Servicing on the component side is possible.
- ▷ If it is necessary to remove the PCB-HIFI, comply with the following steps.

- (1) Remove a screw (a) and unfasten two snaps (b and c) as shown in Fig.11.
- (2) Disconnect the connectors (HB, HC) and raise the PCB-HIFI upward to remove it.

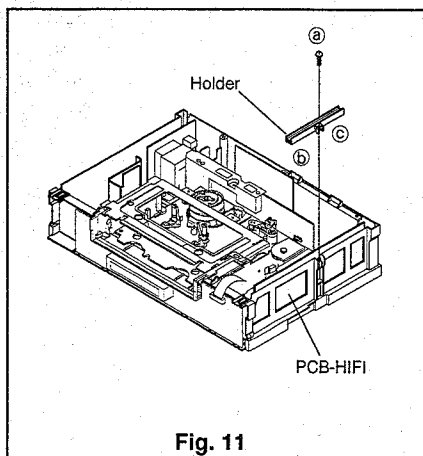

Fig. 11

4. PCB-TIMER/OPE (HS-550V(B) only)

- ① Remove the Top Cover.
(Refer to Para. 1 of the DISASSEMBLY.)
- ② Remove the Front Panel.
(Refer to Para. 2 of the DISASSEMBLY.)
- ③ Remove six catches (a~f), shown in Fig. 12, then remove the PCB-TIMER/OPE.

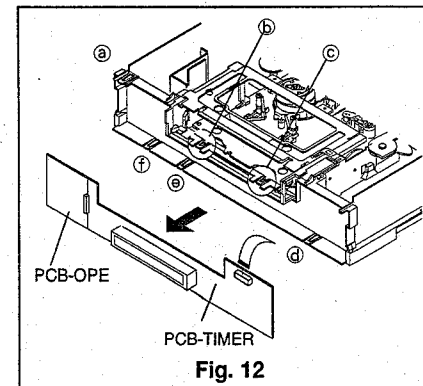

Fig. 12

4. PCB-TIMER (HS-551V only)

- ① Remove the Top Cover.
(Refer to Para. 1 of the DISASSEMBLY.)
- ② Remove the Front Panel.
(Refer to Para. 2 of the DISASSEMBLY.)
- ③ Remove five catches (a~e), shown in Fig. 13, then remove the PCB-TIMER.

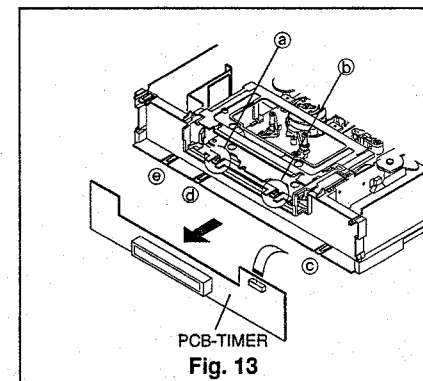

Fig. 13

5. PCB-HA/AUDIO

- ① Remove the Top Cover.
(Refer to Para. 1 of the DISASSEMBLY.)
- ② Remove the barrier.
(Refer to Para. 3 of the DISASSEMBLY.)
Servicing on the copper side is possible.
- ③ If necessary, remove the Assy Deck.
(Refer to Para. 5 of the DISASSEMBLY.)
Raise the Shield Cover upward to remove it. Disconnect three terminals (a, b and c), remove three fastening screws (d, e and f) shown in Fig. 14. Disconnect the connectors of Head FE, A/C Head, and Motor CP then remove the PCB-HA/AUDIO.

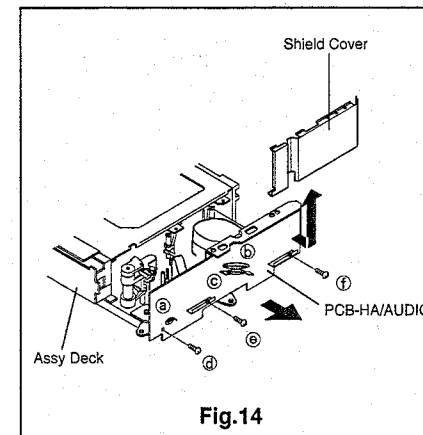
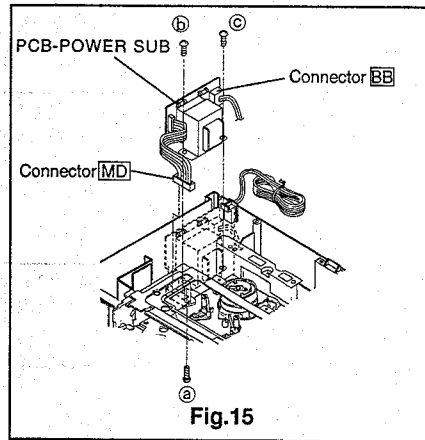

Fig. 14

6. PCB-POWER SUB

- ① Remove the Top Cover.
(Refer to Para. 1 of the DISASSEMBLY.)
- ② Remove the barrier.
(Refer to Para. 3 of the DISASSEMBLY.)
- ③ Remove the holder of AC power cord from the Base Chassis shown in Fig. 15.
- ④ Disconnect connectors **BB** (for the Power receptacle) and **MD** on the PCB-POWER SUB.
- ⑤ Remove one fastening screw (Ⓐ) on the bottom, shown in Fig. 15, and two screws (Ⓑ and Ⓒ : 669D221O40). Hold the transformer, and raise the PCB-POWER SUB to remove it.



7. PCB-POWER SUB2

- ① Remove the Top Cover.
(Refer to Para. 1 of the DISASSEMBLY.)
- ② Remove the barrier.
(Refer to Para. 3 of the DISASSEMBLY.)
- ③ Raise the PCB-POWER SUB2 upward to remove it.

* Service of Transistor (Q9A1)

- (1) Disconnect the power plug.
- (2) Remove a screw (Ⓐ) shown in Fig. 16 to remove the Heat sink 1 in the direction shown by an arrow.

NOTE: Install Q9A1 on the Heat sink 1 and connect the PCB-POWER SUB2 to the PCB-MAIN. Then install the Heat sink 1 and turn the power on. If the power is turned on without installing PCB-POWER SUB2, Heat sink 1, Q9A1, Q902, Q903, Q904 and Q911 are broken.

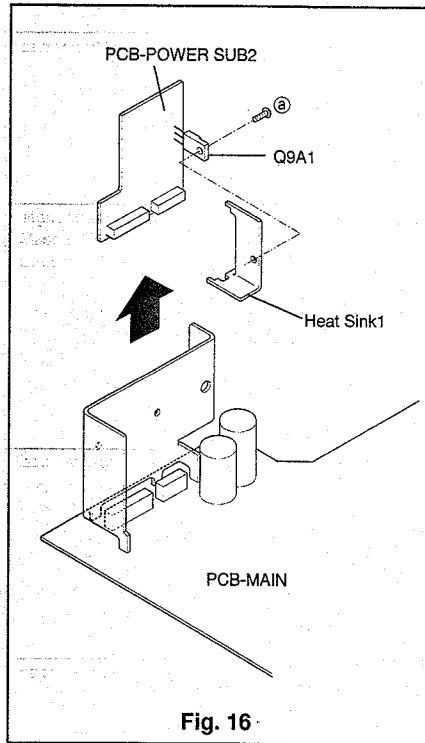

MECHANICAL ADJUSTMENT TOOLS

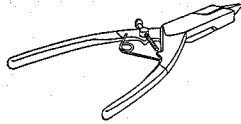
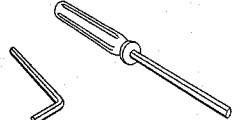
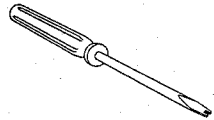
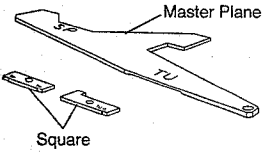
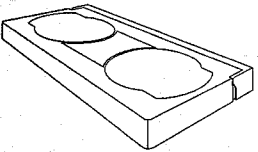
	PURPOSE	METHOD
Grip ring fixer (859C347O50) 	A tool for preventing the grip ring from opening excessively.	Opening the grip ring with the tips of this tool, install the grip ring on to the shaft.
Hex Keys(1.5mm)  (859C259O20) (859C259O50)	The hex keys are used for tightening or removing hexagonal socket head screws which fasten the guide rollers.	Insert the given size(1.5mm) hexagonal socket and turn.
Adjustment Driver (859C259O80) 	For adjustment of guide rollers.	Carefully insert and adjust guide rollers.
Height adjusting Jig •Master Plane (859C342O20) •Square (859C341O70) 	The master plane and the square are used for measuring height and perpendicularity of the reel disk and Takeup guide arm.	The gauge is applied to the part being measured.
Back Tension Gauge (859C345O80) 	The back tension gauge is used for measuring the tension of the tape on the supply side.	Load this gauge in the cassette housing and run in the play mode. Read the gauge indicator.
Cotton gloves	For changing, cleaning and handling of drum, heads and guides.	Use when handling all parts in the tape path.
Grease PG641 (859D055O30) G (859D055O50) MULTEMP SH-M (859D055O60)	Lubrication of various parts.	To be applied as specified.

ELECTRICAL ADJUSTMENT TOOLS

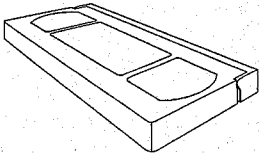
	PURPOSE	METHOD
Adjustment Driver (859C338O00) 767-M 	The adjustment driver is intended to adjust variable resistors, trimmers, transformers etc.in the circuitry.	Select a tip suitable for the particular head of the component concerned and adjust.
Alignment Tape (PS-2 :859C339O10) (PM6KH3 :859C339O30) (PM3KE6(CH1) 25 :859C568O50) (PMX :859C568O70) 	Standard signals(VHS Standard) are recorded on the alignment tape and reproduced when required in the adjustment of Y/C circuit, audio circuit and interchangeability alignment.	Install and run in the play mode, the same as for an ordinary tape.

HOW TO INITIALIZE THE E²PROM

The E²PROM is not initialized before shipping, so the E²PROM must be initialized when replaced.

Initialize the E²PROM by following the steps below.

1. Set the VCR to "CLOCK SET" mode.
2. Push **COUNTER RESET** button on the remote hand unit for 8 seconds.

VCR OPERATION IN SERVICE POSITIONS [B] AND [C]

Refer to page 10 for Service Position Information.

■ To activate PB, REC, FF or REW Mode (Service position [B] only)

- Cover the END SENSOR first then START SENSOR with an infra-red opaque material e.g. black vinyl tape etc..
- The reel sensor must provide input "rotating" signals to the microprocessor. To provide a dummy reel rotating signal, connect TP2H to TP5J8 on PCB-MAIN.

CAUTION:

Because the Start and End sensors are disabled there will be a risk of END of TAPE damage in REW and FF Modes.

■ Ejecting a tape

When TAPE EJECT is necessary, disconnect the main supply and reinstall the DECK ASSY to the Service Position [A], restore power then EJECT the tape.

■ Record Protection Method

- To protect TEST TAPE(s) from accidental Recording (erasure) during testing, connect TP5B (STBY 5V) to TP5K4 on PCB-MAIN .

PCB-MAIN(Component side)

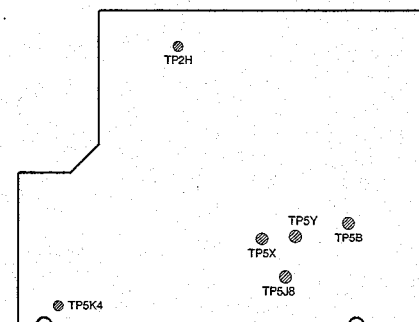

When replacing parts or performing service adjustments, place the unit in the service positions shown below. Refer to page 9 for additional information about Service Positions.

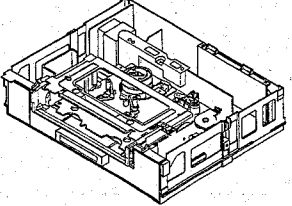
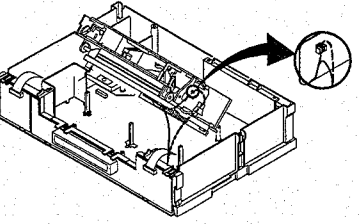
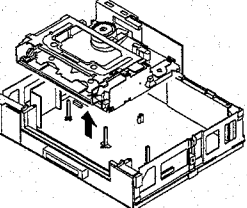
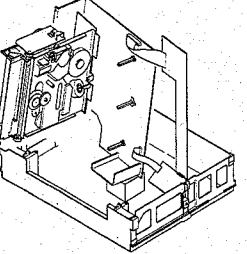
Service Position	Service Item
<p>(A)</p> 	<ul style="list-style-type: none"> Remove the top cover and the front panel. <p>(1) Worn parts on the deck (upper drum, pinch roller assembly, A/C head, and FE head) can be replaced.</p> <p>(2) Checks at test points may be made to isolate a problem to a specific circuit.</p>
<p>(B)</p> 	<ul style="list-style-type: none"> Unfasten the clasper securing ML lead wire on the desk. Remove the screws holding the deck, raise the front of the deck upward, and hold it in place with a screw driver, etc. <p>(1) Worn parts on the deck (reel belt, idler assembly, and capstan motor) can be replaced.</p> <p>(2) The performance of the deck can be checked.</p> <ul style="list-style-type: none"> The REC safety switch does not operate in position (B). Set the deck to service position (A) and load the cassette tape. Then turn the power off and set the deck to service position (B). Cover the start and end sensors, and short-circuit test points TP2H to TP5J8. Turn the power on and play the tape. (Do not use the start or end portion of the tape.) If it is necessary to eject the tape, turn the power off and set the deck to the service position (A). Turn the power on again and eject the tape.
<p>(C)</p> 	<ul style="list-style-type: none"> Remove the screws holding the deck and disconnect the deck from the connector. <p>(1) Parts on the deck (drum assembly, PCB-HA/AUDIO etc.) can be replaced.</p> <p>(2) The EE picture can be displayed with the deck removed by short-circuiting TP5X to TP5Y. (Short-circuit before turning the power on.) (Playback and recording operation can not be checked.)</p>
<p>(D)</p> 	<ul style="list-style-type: none"> Remove the PCB-TIMER/OPE. Remove the deck with the PCB-MAIN attached. Position insulating cushions as, shown in Figure D, supporting the supply side of the Cassette Housing, the Deck Base and the PCB-MAIN. <p>Note Take care that the Deck, PCB-MAIN and inter connecting leads DO NOT touch the Power Transformer or the heat sink.</p> <p>(1) The foil side of the PCB-MAIN can be serviced in this position.</p> <p>* If the bottom cover is removed, IC5A0 and IC4A0 are accessible for service.</p>

Electrical Adjustments

Perform only the alignments required. If proper equipment is not available, do not attempt an alignment.

PRE-ADJUSTMENT SETTING

- Set the "COLOUR SYSTEM" to "PAL" mode in the MENU. (Only HS-551V(Y), (E), (G))
- Set the "STEREO/A2" to "OFF" mode in the MENU. (Only HS-551V(Y))
- Set the "NICAM" to "OFF" mode in the MENU. (Only HS-551V(B), (IR)/HS-550V(B))
- Set the "NICAM/A2" to "OFF" mode in the MENU. (Only HS-551V(E))
- Set the "STEREO/2-TON" to "OFF" mode in the MENU. (Only HS-551V(G))
- Set the "TAPE OPTIMIZER" to "OFF" mode in the INITIAL SET-UP of MENU. (Only HS-551V(Y),(E), (B), (IR)/HS-550V(B))
- Set the "BAND OPTIMIERUNG" to "OFF" mode in the INITIAL SET-UP of MENU. (Only HS-551V(G))
- Set the "RENTAL PB" to "OFF" position.

MEASURING EQUIPMENT AND JIGS

- Oscilloscope (10:1 unless 1:1 specified.)
- Signal generator
- Frequency counter
- Audio tester
- Electrical tools

TEST SIGNAL

Colour bar signal

In this manual, unless otherwise specified in particular, use colour bar signal in specifications below.

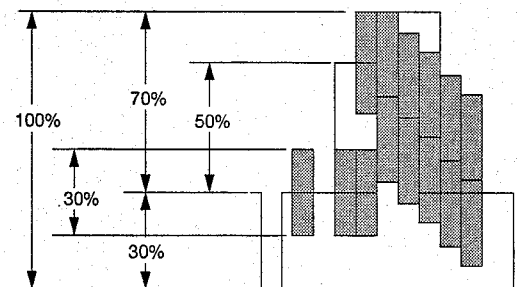

PAL

Split-Field colour bar(with 100% window)

LOCATIONS

PCB-MAIN(Component side)

REAR

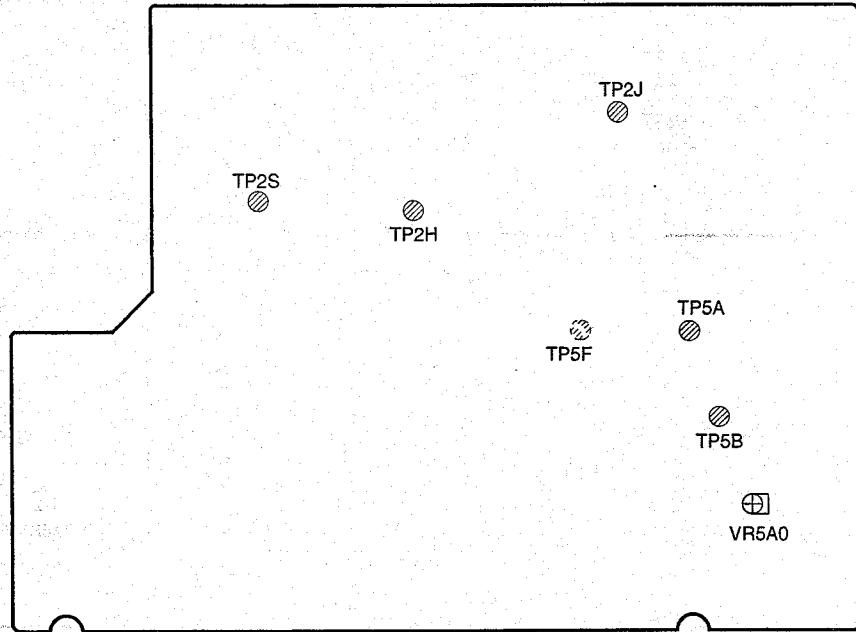

TOP

PCB-HIFI (Solder side)

TOP

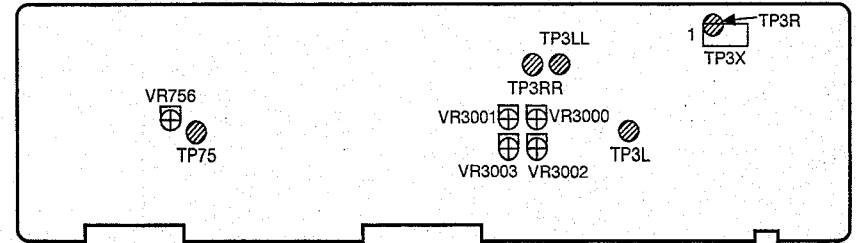

PCB-HA/AUDIO(Component side)

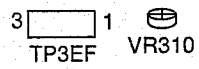

[Servo circuit]		Adjustment purpose Video switch over timing during playback.	
1. Playback Switching Point		Symptom when incorrectly adjusted Switching noise or jitter in the playback picture.	
Measuring instrument and condition		VCR set up condition	
Oscilloscope		Input signal	---
Test point	TP2J	Using tape	Alignment tape (PS2, stair step)
EXT trigger	TP2H	VCR condition	Playback
Measurement range	DIV 20mV TIM 50 μ s	Using Jig	---

1. Playback an alignment tape (PS2, stair step).
 2. Short-circuit TP5A to TP5B. Confirm that the "DTR" displayed in Fluorescent Display flashes fast.
 3. Set the oscilloscope's slope to (-).
 4. Observe the waveform at TP2J.
 5. Adjust VR5A0 so that the trigger point is located at $6.5 \pm 1.0H$ before the vertical synchronizing signal.

PCB-MAIN (Component side)

[Audio circuit]		Adjustment purpose Audio bias level during recording.	
2. Audio Bias Level		Symptom when incorrectly adjusted Poor audio high frequency response or distortion.	
Measuring instrument and condition		VCR set up condition	
Audio tester		Input signal	---
Test point	TP3EF pin ①, pin ③	Using tape	A blank tape
EXT trigger	---	VCR condition	SP REC
Measurement range	---	Using Jig	High pass filter

1. Supply no signal.
 2. Short-circuit EURO AV socket pin ② (AUDIO IN) and pin ④ (GND) using an electrolytic capacitor (16V or more $10\mu F$).
 3. Set the VCR to SP REC mode.
 4. Observe the audio level at TP3EF pin ① and pin ③ with an Audio Tester using a high pass filter.
 5. Confirm that the monitor TV etc. does not affect the indication of the audio tester and then adjust VR310 so that the level is 2.6mVr.m.s.

Note 1:
 Be careful that the audio tester housing does not touch the VCR chassis.

Note 2:
 Never set the VCR to Play mode with the audio tester connected.
 (The audio amplifier will be over loaded.)

PCB-HA/AUDIO (Component side)

[Hi-Fi Audio circuit]		Adjustment purpose Set up of FM carrier frequency for Hi-Fi audio.	
3. VCO (HS-550V(B) / HS-551V(B) only)		Symptom when incorrectly adjusted Buzz only.	
Measuring instrument and condition		VCR set up condition	
Frequency counter		Input signal	---
Test point	TP3L TP3X pin ① (TP3R)	Using tape	---
EXT trigger	---	VCR condition	STOP
Measurement range	---	Using Jig	---

1. Set the CHANNEL position to "L1".
 2. Set the MONITOR button on the remote hand unit to "STEREO" mode.
 3. Short-circuit EURO AV socket pin ② (AUDIO IN) and pin ④ (GND) using an electrolytic capacitor (16V or more $10\mu F$).
 4. Observe the frequency at TP3L.
 5. Adjust VR3002 so that the frequency is $1.400MHz \pm 3kHz$.
 6. Observe the frequency at TP3X pin ① (TP3R).
 7. Adjust VR3003 so that the frequency is $1.800MHz \pm 3kHz$.

PCB-HIFI (Solder side)

[Hi-Fi Audio circuit]		Adjustment purpose Set up of FM carrier frequency for Hi-Fi audio.	
3. VCO (HS-551V(Y)/(E)/(IR)/(G) only)		Symptom when incorrectly adjusted Buzz only.	
Measuring instrument and condition		VCR set up condition	
Frequency counter		Input signal	---
Test point	TP3L TP3X pin ① (TP3R)	Using tape	---
EXT trigger	---	VCR condition	STOP
Measurement range	---	Using Jig	---

1. Set the CHANNEL position to "L1".
 2. Set the MONITOR button on the remote hand unit to "STEREO" mode.
 3. Short-circuit EURO AV socket pin ② (AUDIO IN) and pin ④ (GND) using an electrolytic capacitor (16V or more $10\mu F$).
 4. Short-circuit TP3LL to TP 3X pin ③ (GND).
 5. Observe the frequency at TP3L.
 6. Adjust VR3002 so that the frequency is $1.300MHz \pm 3kHz$.
 7. Open-circuit TP3LL and TP 3X pin ③ (GND).
 8. Short-circuit TP3RR to TP 3X pin ③ (GND).
 9. Observe the frequency at TP 3X pin ① (TP3R).
 10. Adjust VR3003 so that the frequency is $1.700MHz \pm 3kHz$.
 11. Open-circuit TP3RR to TP 3X pin ③ (GND).
 12. Observe the frequency at TP3L.
 13. Adjust VR3000 so that the frequency is $1.400MHz \pm 3kHz$.
 14. Observe the frequency at TP 3X pin ① (TP3R).
 15. Adjust VR3001 so that the frequency is $1.800MHz \pm 3kHz$.

PCB-HIFI (Solder side)

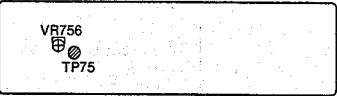
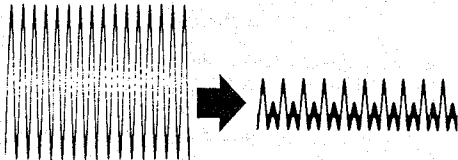
[Dual Audio circuit] 4. Channel Separation (HS-551V(Y)/(E)/(G) only)		Adjustment purpose Positioning of audio separation.	
		Symptom when incorrectly adjusted Mixing audio separation.	
Measuring instrument and condition		VCR set up condition	
Oscilloscope		Input signal	RF signal (Stereo sound)
Test point	TP75	Using tape	---
EXT trigger	---	VCR condition	STOP
Measurement range	DIV 5mV TIM 2ms	Using Jig	---
PCB-HIFI (Sloder side)		<ol style="list-style-type: none"> Supply a Stereo mode RF signal. Observe the waveform at TP75. Adjust VR756 so that the audio output signal at L-CH is minimum. <p>Note: This adjustment should be done precisely because it determines the separation.</p>	
			

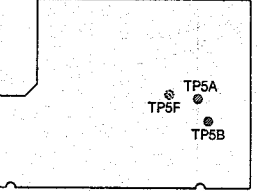
[Timer circuit] 5. Clock Frequency Correction		Adjustment purpose Accuracy of clock.	
		Symptom when incorrectly adjusted Poor clock accuracy.	
Measuring instrument and condition		VCR set up condition	
Frequency Counter		Input signal	---
Test point	TP5F	Using tape	---
EXT trigger	---	VCR condition	Power off
Measurement range	---	Using Jig	---
PCB-MAIN (Component side)		<ol style="list-style-type: none"> Set the VCR to EJECT position (with the tape ejected from the VCR). Short-circuit TP5A to TP5B. Observe the frequency at TP5F. Be certain that the frequency is between 262.1000~262.1882kHz. Use the number buttons on the remote hand unit to enter the last three digits of the frequency counter reading (262.1@b@ckHz). Enter the digits in @b@c sequence. Push the REC button on a remote hand unit. Open circuit TP5A to TP5B. 	
			

MECHANICAL ADJUSTMENT AND REPLACEMENT

1. Cleaning of Deck

The following parts require cleaning whenever serviced to maintain satisfactory performance.

- Takeup guide pole
- Capstan shaft
- Takeup guide arm
- Supply guide roller
- Takeup guide roller
- Pinch roller

1-1 Video Head

A. Clean the video heads by the following method. Dust and other foreign objects on the video heads disturbs the normal playback picture:

Dampen a video head cleaning cloth with alcohol. Hold the cloth against the drum and turn the drum slowly counterclockwise to clean.

NOTE:

Do not directly touch the head attached to the upper drum. The head is very hard but brittle to impact, especially in the vertical direction.

Do not apply force in the vertical direction.

B. Allow residual alcohol to dry thoroughly before running tape. Otherwise, the liquid may stick to and damage the tape.

A. Clean the tape transport using gauze dampened with alcohol, except the supply guide roller, takeup guide roller and pinch roller. If Guide rollers and pinch roller are stained with dust, clean them with dry gauze or replace them with new parts.

B. Allow residual alcohol to dry thoroughly before running a tape. Otherwise the liquid may stick to and damage the tape.

1-3 Reel Disk Drive System

Clean the reel disk braking surfaces and the reel belt.

A. Clean the reel disk braking surfaces with gauze dampened with alcohol.

• After the alcohol dries completely, perform "Adjustment of Back Tension and Tension Pole Position" (Item 3-1).

B. If the Reel belt is stained with dust, clean it with dry gauze or exchange it for a new part.

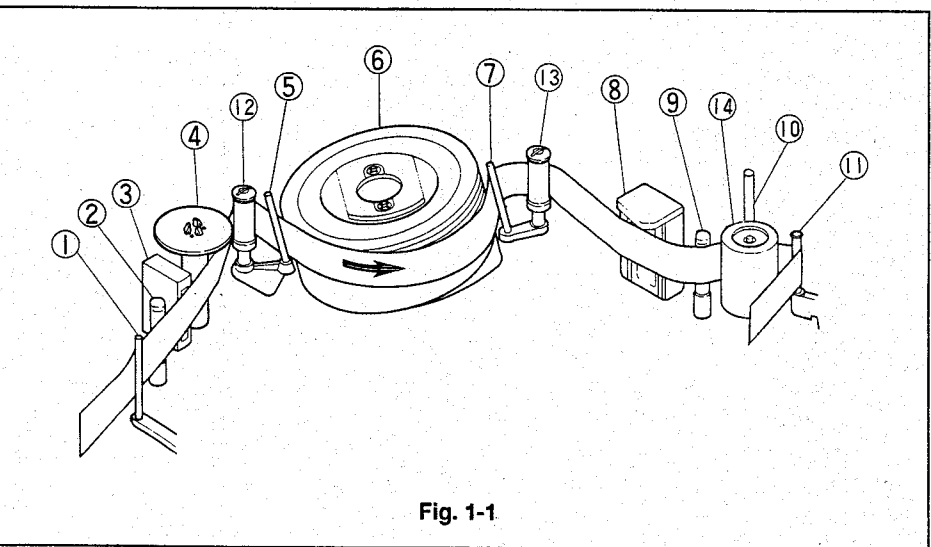

Fig. 1-1

2. Replacement of Major Parts

2-1 Cassette Housing

(Removal)

- ① Set the VCR to the eject mode.
- ② Remove the top cover and the front panel.
- ③ Unfasten the clamp holding the lead of the loading motor, which is attached to the side plate of the cassette housing. Unscrew the two cassette housing fastening screws (a and b). Slowly raise the cassette housing in the direction shown by the arrow. (Refer to Fig. 2-1-1.)

(Installation)

- ① Make sure that the holes (matching mark M) on the body and cogwheel of the mode switch align with each other as shown in Fig. 2-1-2. At the same time confirm that the hole of the gear pinch aligns with the matching marks of the gear joint J and the ▽ mark on the mode switch cogwheel, refer to Fig. 2-19-5. This indicates the J deck is in the EJECT mode.
- ② If the deck is not completely set to the eject position, turn part A of the pulley worm J by hand to set the eject position. (Refer to Fig. 2-1-4)
Turn in the direction a for loading
Turn in the direction b for unloading
- ③ Slowly lower the cassette housing onto the main plate of the deck.
- ④ Make sure the record safety lever enters between the insert guide of the cassette housing and the shaft as shown in Fig. 2-1-3. Align the four points (c, d, e and f), located on the bottom of the housing with the matching holes in the deck. Secure the cassette housing on the deck with the two screws (a and b).
(Refer to Fig. 2-1-1.)

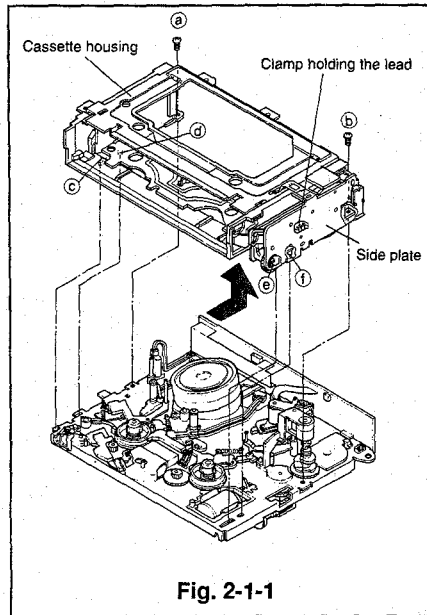

Fig. 2-1-1

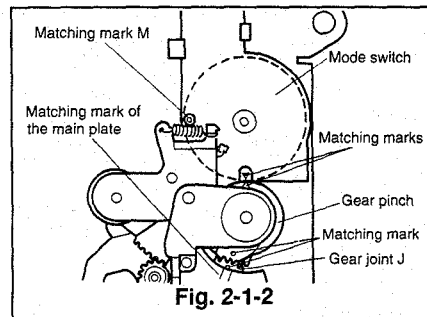

Fig. 2-1-2

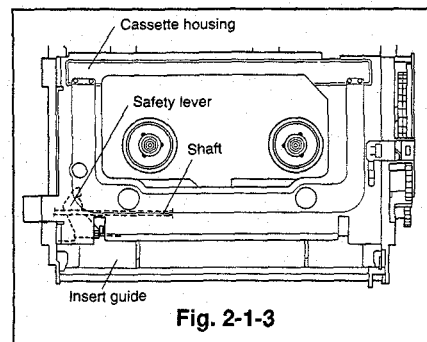

Fig. 2-1-3

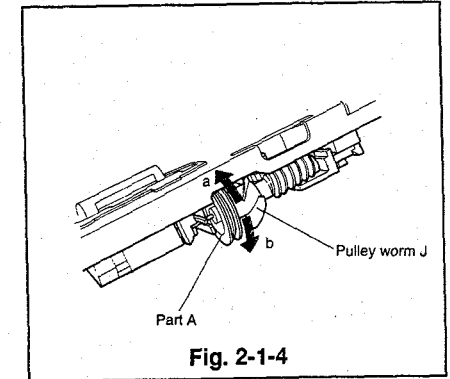

Fig. 2-1-4

2-2 Sens Gear, Drive Gear, Takeup Arm, and Arm Spring (TU)

(Removal)

- ① Remove the cassette housing.
(Refer to Para. 2-1 for the removal method.)
- ② Unfasten the four catches (a, b, c and d) as shown in Fig. 2-2-1 and remove the side plate.
- ③ Remove the sens gear.
- ④ Pull the lock levers on both the supply and takeup sides, shown in Fig. 2-6-1, in the direction shown by the arrow to shift the bottom plate to the position shown in Fig. 2-6-2.
- ⑤ Remove the takeup arm.
- ⑥ To remove the drive gear from the sens gear, turn and pull the drive gear in the direction shown by the arrow shown in Fig. 2-2-3.
- ⑦ Remove the arm spring (TU) from the takeup arm as shown in Fig. 2-2-4.

(Installation)

- ① Apply the grease (MULTEMP SH-M)[859D055O60] to the area of the new takeup arm shown in Fig. 2-2-4.
- ② Apply the grease (MULTEMP SH-M)[859D055O60] to the area shown in Fig. 2-2-5 of the new sens gear.
- ③ Apply the grease (MULTEMP SH-M)[859D055O60] to the area shown in Fig. 2-2-6 of the new sens gear.
- ④ Place the clip spring on the drive gear hooking one end under the catch as shown in Fig. 2-2-5. Install the sens gear on the drive gear so that hole A aligns with hole B. Hold the sens gear while turning the drive gear clockwise, in so doing engage the other end of the clip spring with the catch of the sens gear. The projection A of the sens gear must enter the hole B of the drive gear.

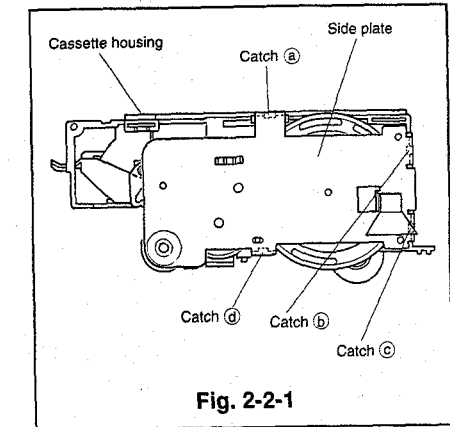

Fig. 2-2-1

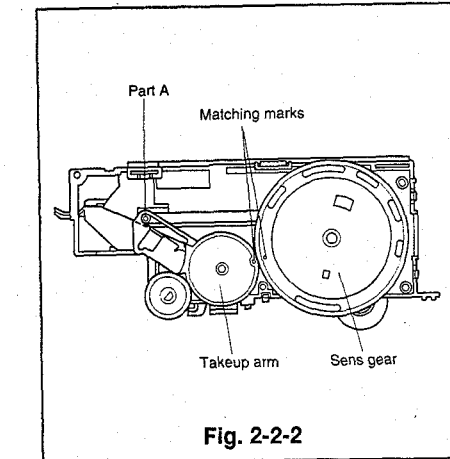

Fig. 2-2-2

- ⑤ Ensure the spring action is effective by holding the sens gear and turning the drive gear slightly clockwise, observing whether the drive gear returns when released.
- ⑥ Apply the grease (MULTEMP SH-M)[859D055O60] to the area of the new takeup arm shown in Fig. 2-2-7.
- ⑦ Install the takeup arm so that the shaft from the bottom plate enters between the takeup arm and takeup spring, after the bottom plate is in the position shown in Fig. 2-6-2.

Note: Install the takeup arm so that the engaging point between the supply arm and gear-S, and that between the takeup arm and gear-T are symmetrical as shown in Fig. 2-4-1.

- ⑧ Shift the bottom plate back to the eject position and install the sens gear so that the matching marks of the sens gear and the takeup arm align as shown in Fig. 2-2-2.
- ⑨ Install the side plate.
- ⑩ Install the cassette housing.
(Refer to Para. 2-1 for the installation method.)

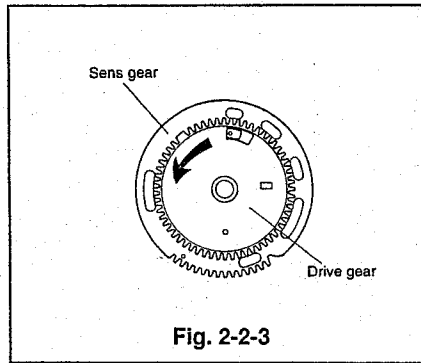

Fig. 2-2-3

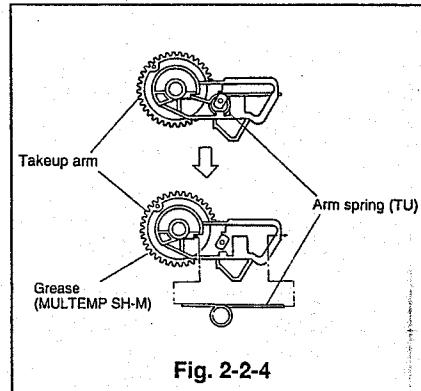

Fig. 2-2-4

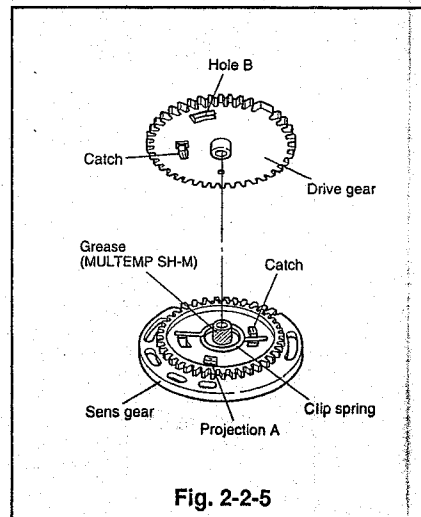

Fig. 2-2-5

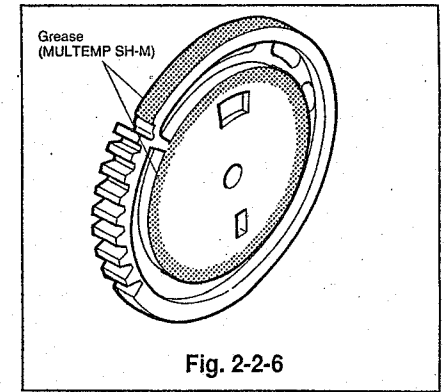

Fig. 2-2-6

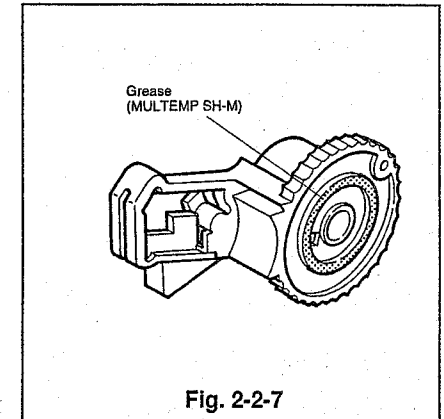

Fig. 2-2-7

2-3 Door Arm

(Removal)

- 1 Remove the cassette housing.
(Refer to Para. 2-1 for the removal method.)
- 2 Remove the side plate, sens gear, and takeup arm.
(Refer to Para. 2-2 for the removal method.)
- 3 Unfasten the catch shown in Fig. 2-3-1 to remove the door arm. (Pull the door arm at the same time as unfastening the catch.)

(Installation)

- 1 Fix the door arm to the shaft A shown in Fig. 2-3-1 and secure it with the catch so that the parts A and B are inside of the cassette housing, as shown in Fig. 2-3-2.
- 2 Install the takeup arm, sens gear, and side plate.
(Refer to Para. 2-2 for the installation method.)
- 3 Install the cassette housing.
(Refer to Para. 2-1 for the installation method.)

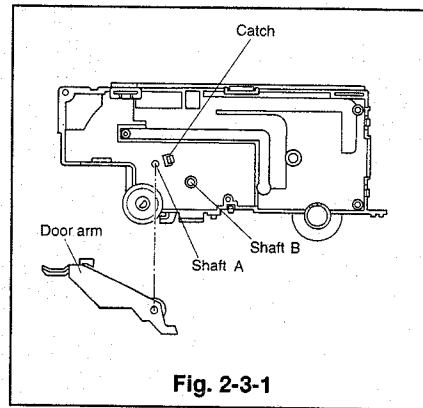

Fig. 2-3-1

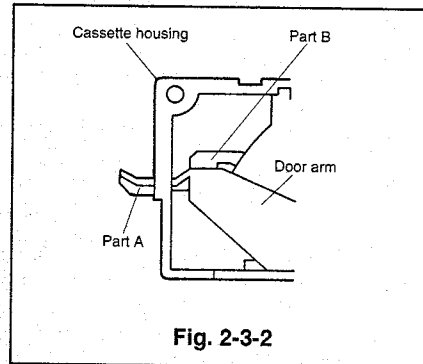

Fig. 2-3-2

2-4 Gear S and Gear T

(Removal)

- 1 Follow the removal method in Items 1 to 5 of Para. 2-2.
- 2 Unfasten the catch holding gear T from the inside of the cassette housing and remove the FL shaft to which the gear S and T are attached. (Refer to Fig. 2-4-2)
- 3 Pull out the gears S and T from the FL shaft.

(Installation)

- 1 Fix the gear' S and T to the FL shaft.
- 2 Install the FL shaft, first the end attached to gear T and then the end with gear S.
- 3 Follow the installation method in Item' 5 to 8 in Para. 2-2.

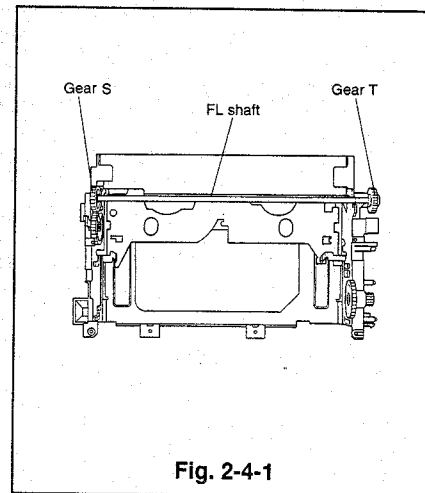

Fig. 2-4-1

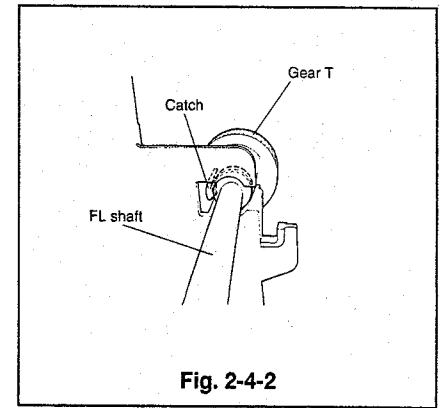

Fig. 2-4-2

2-5 Wheel Gear

(Removal)

- 1 Remove the cassette housing.
(Refer to Para. 2-1 for the removal method.)
- 2 Remove the side plate and sense gear.
(Refer to Para. 2-2 for the removal method.)
- 3 Unfasten the catch shown in Fig. 2-5-1 to remove the wheel gear.

(Installation)

- 1 Install the wheel gear in the position shown in Fig. 2-5-1, from the inside of the cassette housing.
- 2 Install the sens gear and side plate.
(Refer to Para. 2-2 for the installation method.)
- 3 Install the cassette housing.
(Refer to Para. 2-1 for the installation method.)

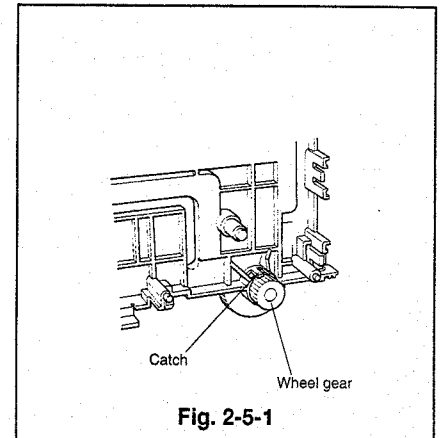

Fig. 2-5-1

2-6 Supply Arm and Arm Spring (SP)

(Removal)

- 1 Remove the cassette housing.
(Refer to Para. 2-1 for the removal method.)
- 2 Remove the side plate.
(Refer to Item 2 of Para. 2-2 for the removal method.)
- 3 Remove the sens gear.
(Refer to Item 3 of Para. 2-2 for the removal method.)
- 4 Pull the lock levers on both the supply and takeup side, shown in Fig. 2-6-1, in the direction shown by the arrow to shift the bottom plate to the position shown in Fig. 2-6-2.
- 5 Remove the takeup arm.
(Refer to Item 5 of Para. 2-2 for the removal method.)
- 6 Pull part A, fixed to the supply arm, in the direction shown by the arrow to remove the bottom plate.
(Refer to Fig. 2-6-3.)

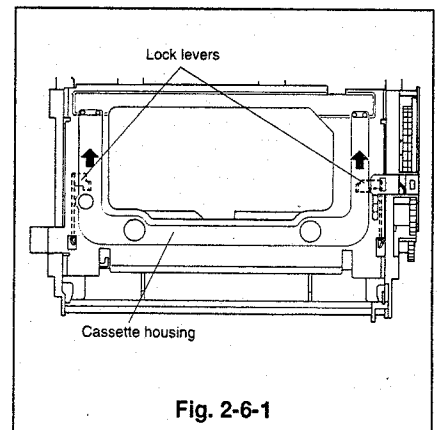

Fig. 2-6-1

- ⑦ Turn the supply arm in the direction shown by the arrow to shift part B, shown in Fig. 2-6-4, so that it aligns with the catch. Unfasten the catch to remove the supply arm.
- ⑧ Detach the arm spring from the supply arm as shown in Fig. 2-6-5.

(Installation)

- ① Attach the arm spring to the supply arm as shown in Fig. 2-6-5.
- ② Install the supply arm in the position shown in Fig. 2-6-4. (Align the catch with the part B of the supply arm.)
- ③ Insert the bottom plate so part A enters between the supply arm and the supply spring as shown in Fig. 2-6-3. Then install the bottom plate so that part C is in the position shown in Fig. 2-6-6.
- ④ Follow the installation method in Item ⑤ to ⑧ in Para. 2-2.

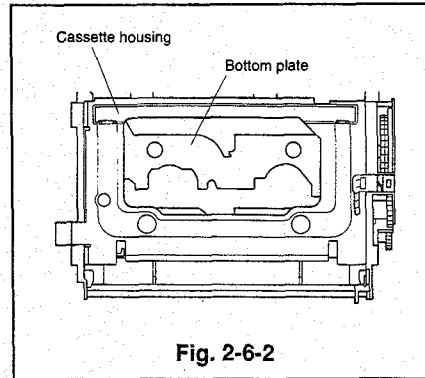

Fig. 2-6-2

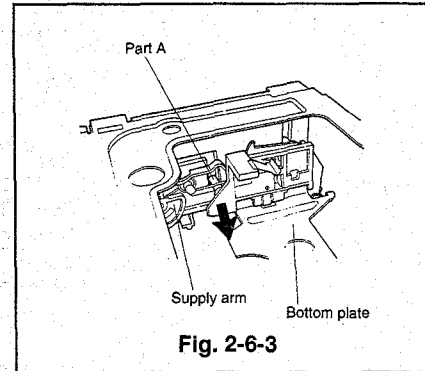

Fig. 2-6-3

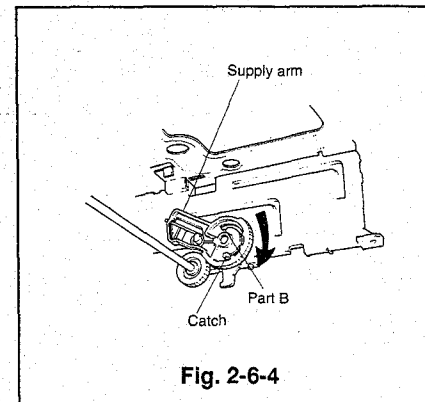

Fig. 2-6-4

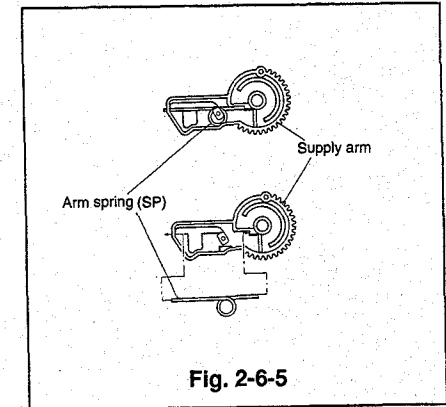

Fig. 2-6-5

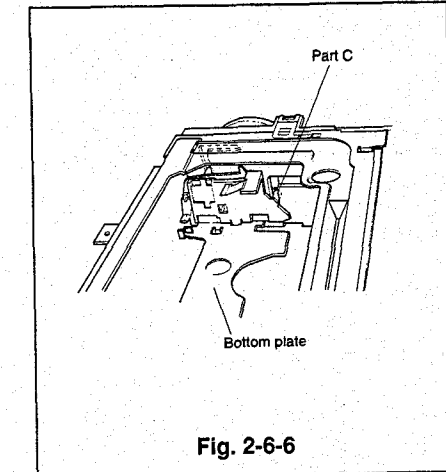

Fig. 2-6-6

2-7 Jut

(Removal)

- 1 Follow the removal method in Items ① to ⑥ of Para. 2-6.
- 2 Unfasten the four catches (Ⓐ, Ⓑ, Ⓒ and Ⓓ) shown in Fig. 2-7-1 to remove the jut and the jut spring.

(Installation)

- 1 Install the jut and the jut spring as shown in Fig. 2-7-1. (Insert the jut spring into the part A of the jut before installing the jut. Hook one end of the jut spring with the outside of the catch (Ⓐ) and the other end with part B of the jut.)
- 2 Install the bottom plate according to the installation method in ③ of Para. 2-6.
- 3 Follow the installation method in Items ⑤ to ⑧ in Para. 2-2.

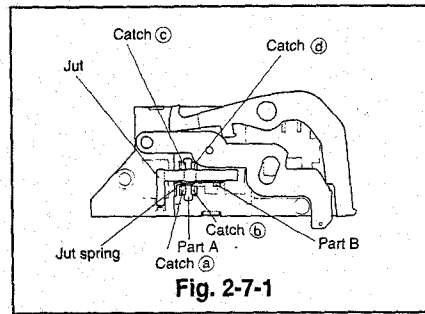

2-8 PCB-HA/AUDIO

(Removal)

- 1 Unfasten the hook and raise the head amp shield cover shown in Fig. 2-8-1 to remove it.
- 2 Unsolder the terminals of the mode switch, the drum motor, and the rotary transformer shown in Fig. 2-8-1.
- 3 Lift the stopper of the A/C head assembly in Fig. 2-8-4 slightly upward and disconnect the lead connector (bare wire), connecting the PCB-HA/AUDIO and the PCB-A/C-HEAD.
- 4 Disconnect the lead connector (point A), connected to the FE head. (Refer to Fig. 2-8-2.)
- 5 Reverse the deck and disconnect the lead card, connecting the PCB of the capstan motor and the PCB-HA/AUDIO. (Refer to Fig. 2-8-3.)
- 6 Remove the three screws (Ⓐ, Ⓑ and Ⓒ) and slowly pull the PCB-HA/AUDIO in the direction shown by the arrows. (Refer to Fig. 2-8-1.)

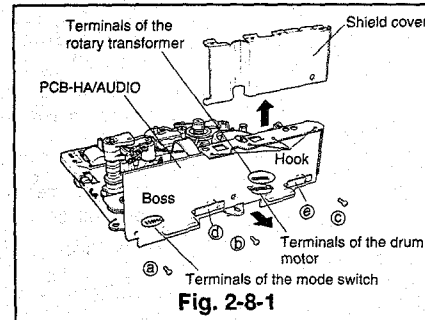

(Installation)

- 1 Insert the terminals of the mode switch, the drum motor, and the rotary transformer, and the boss, adjacent to the mode switch, in the matching holes on the PCB-HA/AUDIO and secure the PCB-HA/AUDIO with the three screws (Ⓐ, Ⓑ and Ⓒ) in the order, Ⓑ→Ⓒ→Ⓐ. (Refer to Fig. 2-8-1)
- 2 Solder the pins mentioned in Item ①.
- 3 Reverse the deck and reconnect the lead card connecting the PCB of the capstan motor and the PCB-HA/AUDIO. (Refer to Fig. 2-8-3) Take care not to fit lead card upside down.
- 4 Connect the lead connector, connected to the FE head, to the point A. (Refer to Fig. 2-8-2.)
- 5 Shift part B of the bare wire lead extended from the head amp slightly downward, lower the stopper, and connect it to the connector on the PCB-A/C-HEAD. (Refer to Fig. 2-8-4)

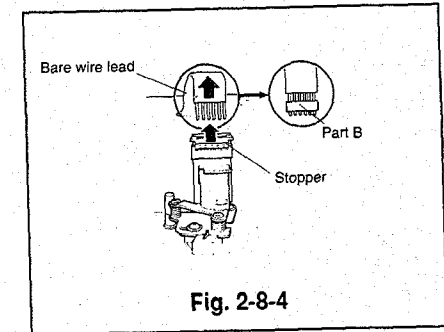
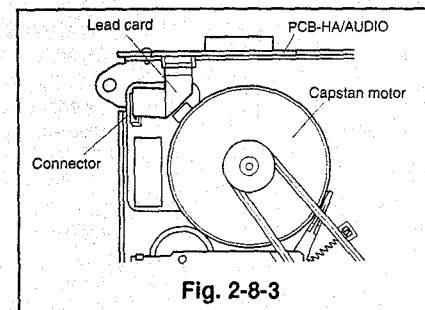
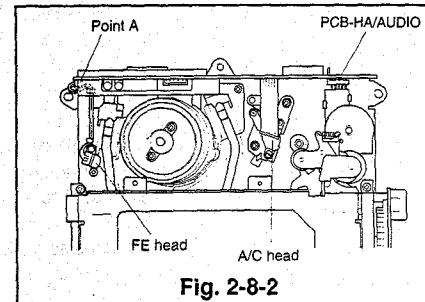

2-9 Brush (Refer to the Fig.2-9-1.)

(Removal)

- 1 Reverse the deck and remove the three screws (Ⓐ, Ⓑ and Ⓒ) to remove the brush.

(Installation)

- 1 Attach the brush on the position shown in Fig. 2-9-1 and secure it with the screws Ⓐ and Ⓑ. Tighten screw Ⓒ.

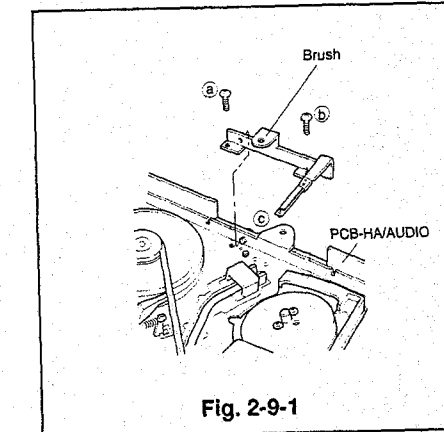

2-10 Drum Assembly

Note: When removing and installing the drum assembly, do not touch the tape running surface with your hands.

Note: Take care not to bend the PCB-HA/AUDIO.

(Removal)

- 1 Remove the cassette housing. (Refer to Para. 2-1 for the removal method.)
 - 2 Remove the PCB-HA/AUDIO. (Refer to Para. 2-8 for the removal method.)
 - 3 Unscrew the three screws (Ⓐ, Ⓑ and Ⓒ) on the reverse side of the deck and remove the drum assembly. (Refer to Fig. 2-10-1.)
 - 4 Slowly raise the drum assembly upward, take care not to touch other parts around it. (Do not touch the tape running surface of the drum with your hand.)
- Note:** During removal, support the drum assembly when it is not secured by fastening screws.

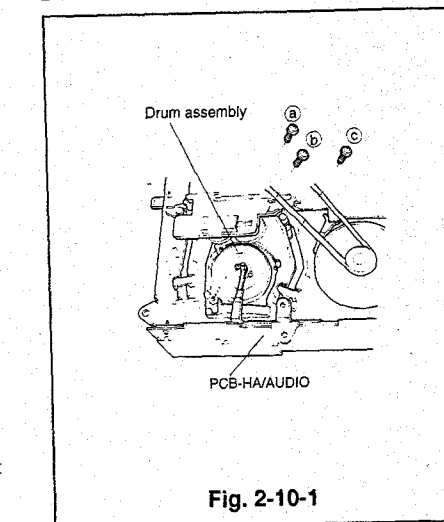

(Installation)

- ① Carefully place the new drum assembly on the main plate of the deck, take care not to touch other parts.
- ② Holding the drum assembly, reverse the deck and secure the drum assembly with the three screws (a, b and c). (Tighten the screws in the order a→b→c and finally tighten again a.) (Refer to Fig. 2-10-1.)
- ③ Install the PCB-HA/AUDIO.
(Refer to Para. 2-8 for the installation method.)
- ④ Install the cassette housing.
(Refer to Para. 2-1 for the installation method.)

[Another Method]

(Removal)

- ① Remove the cassette housing.
(Refer to Para. 2-1 for the removal method.)
- ② Unsolder the soldered pins on the terminal of the drum assembly and the terminal of the rotary transformer. (Refer to Fig. 2-10-2)
- ③ Unscrew the three screws (a, b and c) on the reverse side of the deck and remove the drum assembly.
(Refer to Fig. 2-10-1.)
- ④ Slightly raise the drum assembly in the opposite direction of the pins. Remove the pins of the drum assembly and of the rotary transformer from the PCB-HA/AUDIO. Slowly remove the drum assembly, take care not to touch other parts around it.

(Installation)

- ① Carefully place the drum assembly on the main plate, take care not to touch the other parts around it. The pins of the drum assembly and the rotary transformer must enter the holes of the PCB-HA/AUDIO.
- ② Secure the drum assembly with the three screws (a, b and c) on the reverse side of the deck. (Tighten the screws in the order a→b→c and finally tighten a again.) (Refer to Fig. 2-10-1.)
- ③ Solder the pins of the drum assembly and the rotary transformer. (Refer to Fig. 2-10-2.)
- ④ Install the cassette housing.
(Refer to Para. 2-1 for the installation method.)

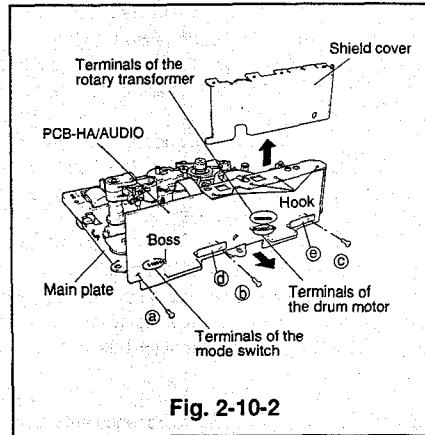

Fig. 2-10-2

2-11 Upper Drum and Drum Motor

Note: When only the upper drum is to be replaced, follow the procedure of Items ②~④ of the removal method and ②~④ of the installation method.

(Removal)

- ① Remove the drum assembly.
(Refer to Para. 2-10 for the removal method.)
- ② Unsolder the terminals of each head on the upper drum.
- ③ Remove the screws holding the upper drum shown in Fig. 2-11-1.
- ④ Remove the upper drum slowly and carefully.
- ⑤ Remove the screws (a and b) shown in Fig. 2-11-1 to remove the rotor case and damper. Remove the screws (c, d and e) to remove the drum motor.

(Installation)

Note: Handle the upper drum carefully as the video heads are fragile.

- ① Attach the rotary transformer and the drum motor so that the terminals of both face in the same direction, and secure them with the screws (c, d and e). Secure the rotor case with the screws (a and b).
- ② Position the white painted (shaded) area of the upper drum so that the area is 90° apart from the hole of the lower drum shaft. Insert the upper drum. Take care not to touch the head terminals. [Fig. 2-11-2]
- ③ Secure the upper drum with the two fastening screws. (Tighten the screws alternately.)
- ④ Solder the terminals of each head.

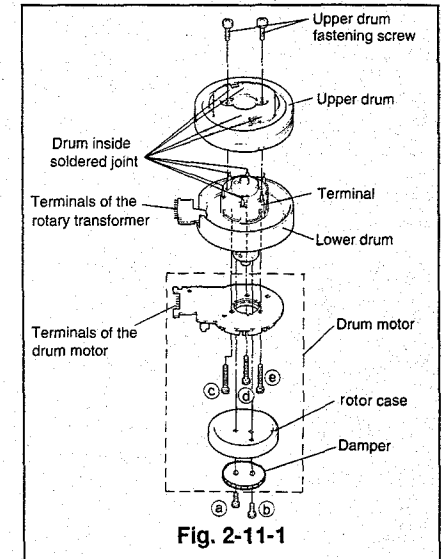

Fig. 2-11-1

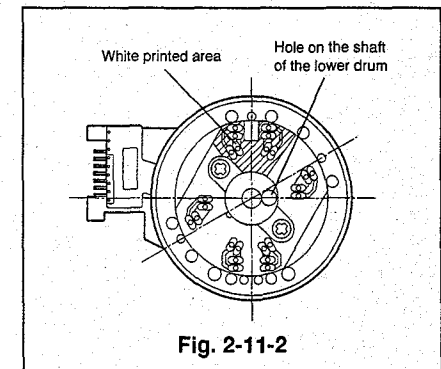

Fig. 2-11-2

2-12 Safety Spring and Safety Lever

(Removal)

- ① Remove the cassette housing. (Refer to Para. 2-1 for the removal method.)
- ② Unhook the safety spring with a tweezers.
- ③ Turn the safety lever clockwise and remove by raising it upward as shown in Fig. 2-12-2.

(Installation)

- ① Install the safety lever so that part A aligns with the hole on the main plate, shown in Fig. 2-12-1, and part B with the hole of the safety arm on the reverse side of the deck.
- ② Fix the safety spring to the shaft of the safety lever and hook it as shown in Fig. 2-12-3.
- ③ Install the cassette housing. (Refer to Para. 2-1 for the installation method.)

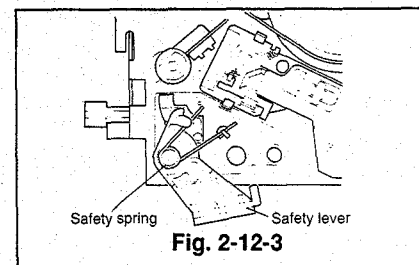
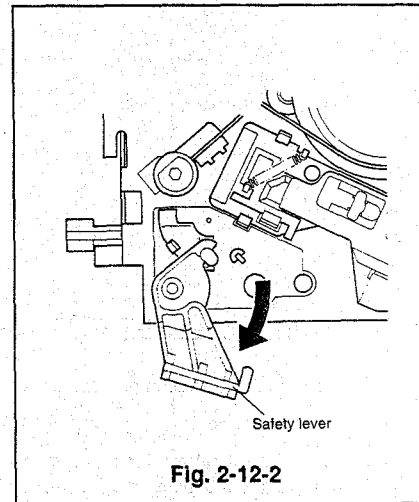
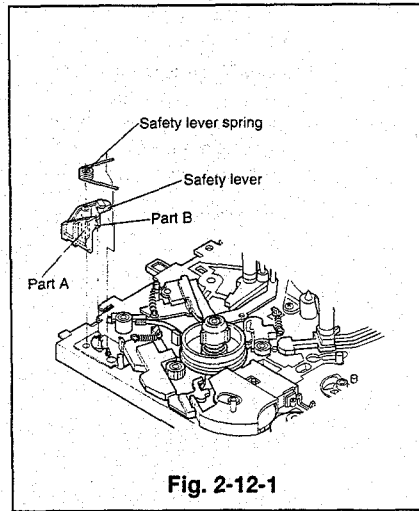

2-13 Safety Arm

(Removal)

- ① Remove the cassette housing. (Refer to Para. 2-1 for the removal method.)
- ② Remove the safety spring and the safety lever. (Refer to Para. 2-12 for the removal method.)
- ③ Unfasten the catch to remove the safety arm. (Refer to Fig. 2-13-1).

(Installation)

- ① Reverse the deck and fix the safety arm to the shaft of the main plate so that its catch is within the range shown in Fig. 2-13-2.
- ② Install the safety spring and the safety lever. (Refer to Para. 2-12 for the installation method.)
- ③ Install the cassette housing. (Refer to Para. 2-1 for the installation method.)

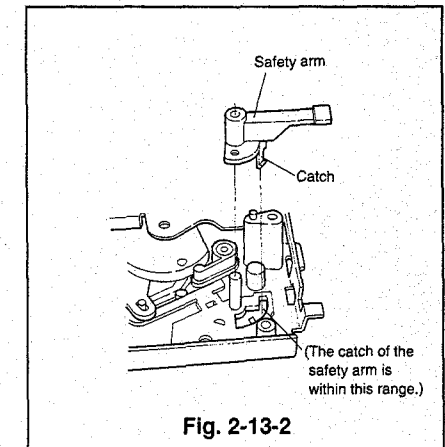
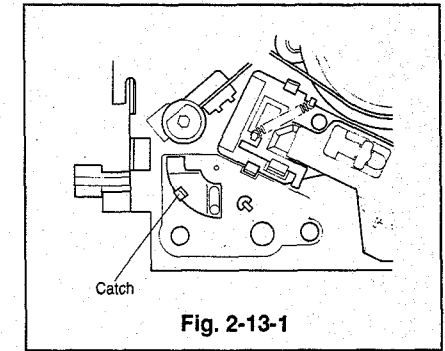

2-14 Sub Brake(SP) and Sub Spring(SP)

(Removal)

- ① Remove the cassette housing. (Refer to Para. 2-1 for the removal method.)
- ② Detach the sub spring(SP).
- ③ Reverse the deck and unfasten the catch with a small screw driver, etc., to remove the sub brake(SP) as shown in Fig. 2-14-2.

(Installation)

- ① Install the sub brake(SP) with care not to score the tension brake belt. (without loosening of the tension brake belt). (Refer to Fig. 2-14-1)
- ② Attach the sub spring(SP).
- ③ Install the cassette housing. (Refer to Para. 2-1 for the installation method.)

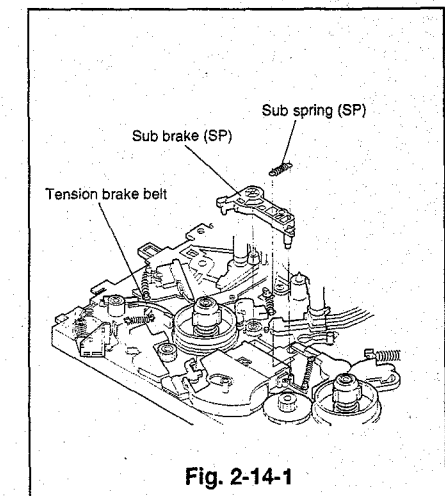

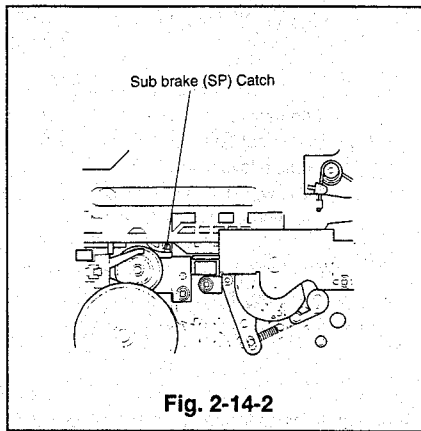

Fig. 2-14-2

**2-15 Main Brake (SP) and Main Brake Spring J(SP)
(Refer to Fig. 2-15-1.)**

(Removal)

- ① Remove the cassette housing. (Refer to Para. 2-1 for the removal method.)
- ② Remove the sub brake(SP) and the sub spring(SP). (Refer to Para. 2-14 for the removal method.)
- ③ Unhook the main brake spring J(SP).
- ④ Raise the main brake(SP) upward to remove it.

(Installation)

- ① Install the main brake(SP) on the main plate and attach the main brake spring J(SP).
- ② Install the sub brake(SP) and the sub spring(SP). (Refer to Para. 2-14 for the installation method.)
- ③ Install the cassette housing. (Refer to Para. 2-1 for the installation method.)

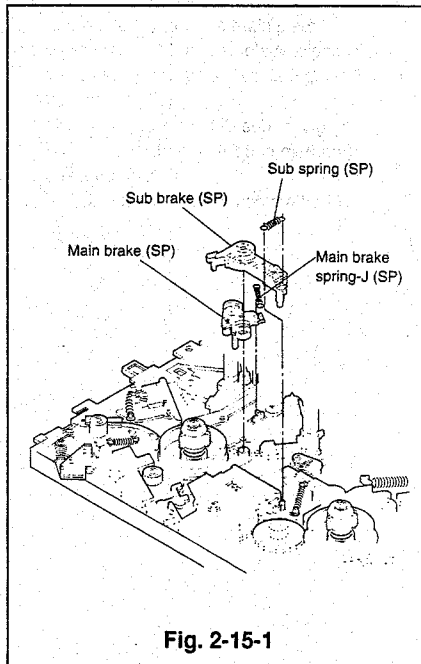

Fig. 2-15-1

2-16 Sub Off Lever, Sub Brake (TU), and Sub Spring (TU)

(Removal)

- ① Remove the cassette housing. (Refer to Para. 2-1 for the removal method.)
- ② Remove the sub brake (SP) and the sub spring (SP). (Refer to Para. 2-14 for the removal method.)
- ③ Unfasten the catch with a small screw driver, etc., and raise the sub off lever upward to remove it. (Refer to Fig. 2-16-2)
- ④ Remove the sub spring (TU). (Refer to Fig. 2-16-1.)
- ⑤ Unfasten the catch with a small screw driver, etc., and raise the sub brake (TU) upward to remove it as shown in Fig. 2-16-2.

(Installation)

- ① Apply the grease (PG-641)[859D055O30] to the area shown in Fig. 2-16-3.
- ② Install the sub brake (TU) on the main plate.
- ③ Install the sub off lever so that the hole A aligns with the boss of the sub brake (TU) as shown in Fig. 2-16-1.
- ④ Install the sub spring (TU).
- ⑤ Install the sub brake (SP) and the sub spring (SP). (Refer to Para. 2-14 for the installation method.)
- ⑥ Install the cassette housing. (Refer to Para. 2-1 for the installation method.)

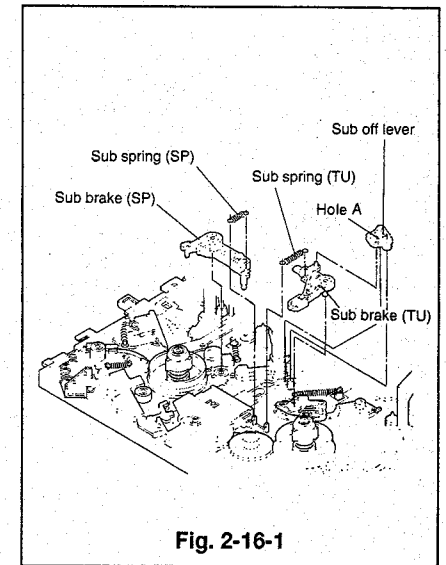

Fig. 2-16-1

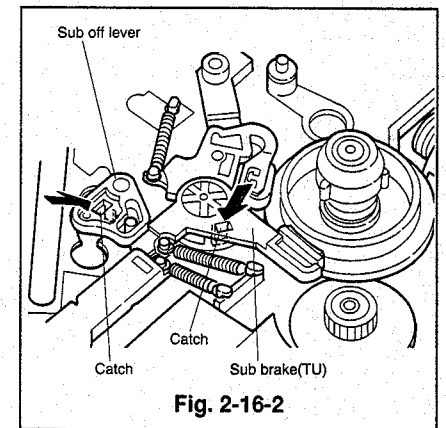

Fig. 2-16-2

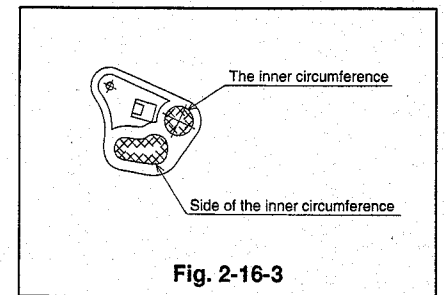

Fig. 2-16-3

2-17 Main Brake(TU) and Main Brake Spring J(TU)

(Removal)

- 1 Remove the cassette housing. (Refer to Para. 2-1 for the removal method.)
- 2 Remove the sub brake(SP) and the sub spring(SP). (Refer to Para. 2-14 for the removal method.)
- 3 Remove the sub off lever, the sub brake(TU), and the sub spring(TU). (Refer to Para. 2-16 for the removal method.)
- 4 Remove the main brake spring J(TU) and raise the main brake(TU) upward to remove it. (Refer to Fig. 2-17-1.)

(Installation)

- 1 Install the main brake(TU) on the main plate assembly so that the coupling portion with the main brake release lever is as shown in Fig. 2-17-2.
- 2 Install the main brake spring J(TU).
- 3 Install the sub brake(TU), the sub off lever, and the sub spring(TU). (Refer to Para. 2-16 for the installation method.)
- 4 Install the sub brake(SP) and the sub spring(SP). (Refer to Para. 2-14 for the installation method.)
- 5 Install the cassette housing. (Refer to Para. 2-1 for the installation method.)

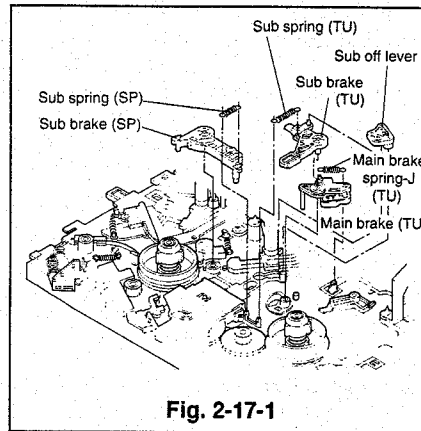

Fig. 2-17-1

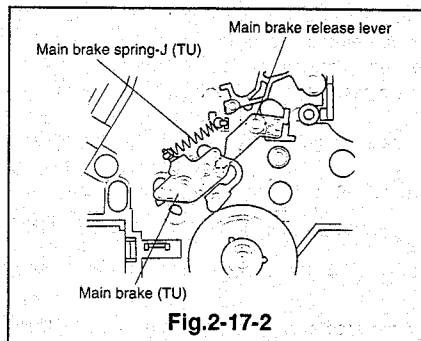

Fig.2-17-2

2-18 ID Swing Lever, Revolution Lever, and Revolution Spring

(Removal)

- 1 Remove the cassette housing. (Refer to Para. 2-1 for the removal method.)
- 2 Reverse the deck and remove the grip ring attached to the shaft G of the charge assembly.
- 3 Unfasten the two catches(A, B) to remove the charge assembly.
- 4 Remove the revolution spring with a tweezers.
- 5 Slide the revolution lever in the direction shown by the arrow and unfasten it from the catch C of the ID swing lever. (Refer to Fig. 2-18-1)
- 6 Detach the charge spring from the ID swing lever.

(Installation)

- 1 Apply the grease(PG-641)[859D055O30] to the areas shown in Fig. 2-18-2 of the new revolution lever and the ID swing lever.

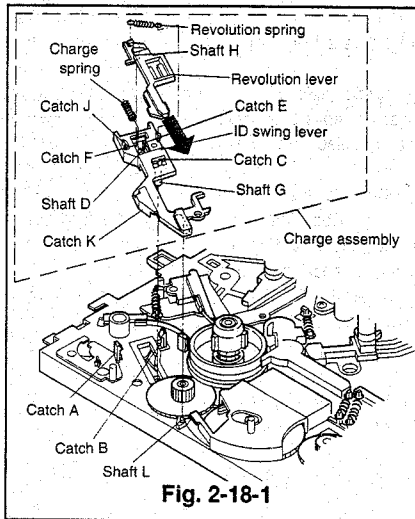

Fig. 2-18-1

- 2 Fix the charge spring to shaft D of the ID swing lever and compress it to hook its ends with the catches E and F. (Refer to Fig. 2-18-1)

Note: The charge spring should be installed in the directions shown below.

(Longitudinal Direction)

The bent tip is attached on the shaft D.

(Traverse Direction)

The wider semicircle is on the left as shown in Fig. 2-18-1.

- 3 Align the shaft H of the revolution lever with the position shown in Fig. 2-18-1. Insert catch C of the ID swing lever into the hole of the revolution lever, pushing the charge spring with a revolution lever in the direction shown by the arrow. At the same time, hook the ends of the revolution lever with the catches J and K.
- 4 Attach the revolution spring with a tweezers.
- 5 Install the charge assembly so that shaft G enters into the oval hole of the charge lever on the reverse side of the deck and the groove of the charge assembly fits the shaft as shown in Fig. 2-18-1. Secure the charge assembly with the catch A and B.
- 6 Reverse the deck and fix the new grip ring to the shaft G of the charge assembly.
- 7 Install the cassette housing. (Refer to Para. 2-1 for the installation method.)

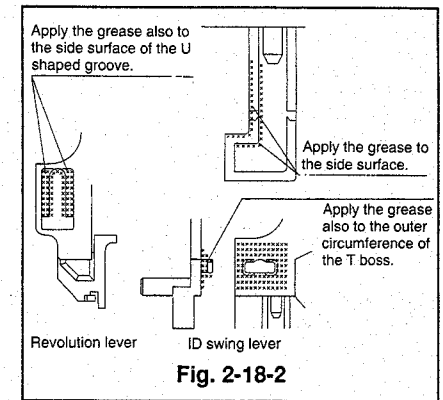

Fig. 2-18-2

2-19 Tension Arm, Tension Brake Belt, and Tension Spring

Note: During removal and installation, take care not to change the shape of the tension brake belt.

(Removal)

- 1 Remove the cassette housing. (Refer to Para. 2-1 for removal method.)
- 2 Supply a voltage(approximately 5V DC plus voltage on the red wire) to the loading motor and slide the tape guide assembly completely to the loaded position, to set it to the loaded position.
- 3 Remove the sub brake(SP) and the sub spring(SP). (Refer to Para. 2-14 for the removal method.)
- 4 Unfasten the catch of the part A on the tension brake belt and raise the part A to unfasten the tension brake belt from the supply reel disk. (Refer to Fig. 2-19-1)
- 5 Remove the tension spring, unfasten the catch shown in Fig. 2-19-2, and raise the tension arm upward to remove it.
- 6 Reverse the tension arm, unfasten the catch with a tweezers as shown in Fig. 2-19-3 to remove the tension brake belt.

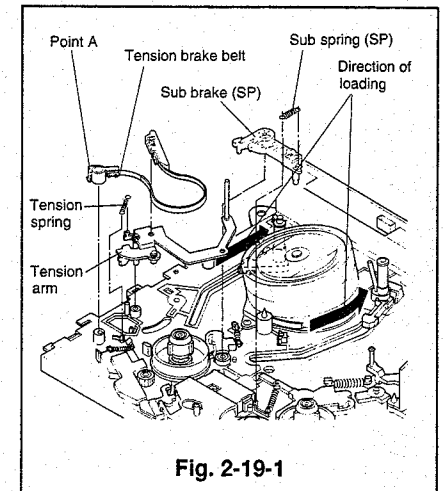

Fig. 2-19-1

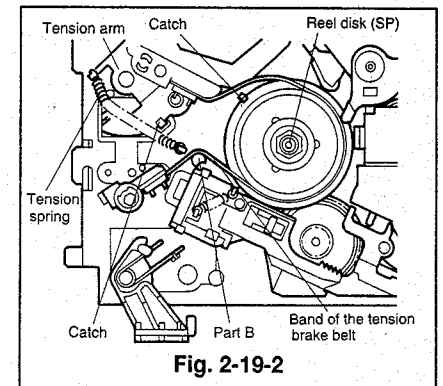

Fig. 2-19-2

(Installation)

- ① Insert the catch in the position of the tension arm as shown in Fig. 2-19-3 to fasten the tension brake belt on the tension arm. (Take care not to let projection C, next to the catch of the tension brake belt touch the tension arm.)
- ② Install the tension arm, where the tension brake belt is fastened, on the main plate.
- ③ Fasten the tension brake belt around the supply reel disk. (The band of the tension brake belt must pass the outside of the catch shown in Fig. 2-19-2 and inside of the part B.)
- ④ Attach the tension spring.
- ⑤ Install the sub brake(SP) and sub spring(SP). (Refer to Para. 2-14 for the installation method.)
- ⑥ Supply voltage (approximately 5V), reversing the polarity used in ② of the Removal method, to set the motor to the unloaded position.
- ⑦ Make sure that the holes (matching mark M) on the body and cogwheel of the mode switch align with each other as shown in Fig. 2-19-4. At the same time confirm that the hole of the gear pinch aligns with the matching marks of the gear joint J and the ∇ mark on the mode switch cogwheel, refer to Fig. 2-19-5. This indicates the J deck is in the EJECT mode.
- ⑧ If the deck is not completely set to the eject mode, turn part D of the pulley worm J by hand to set the eject mode.

Turn in the direction a for loading

Turn in the direction b for unloading

(Refer to Fig. 2-19-6)

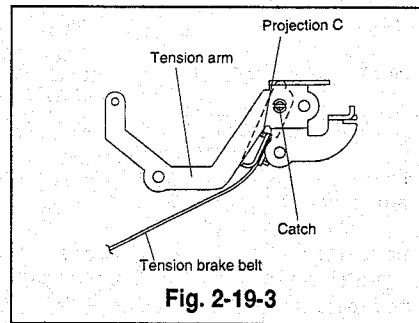

Fig. 2-19-3

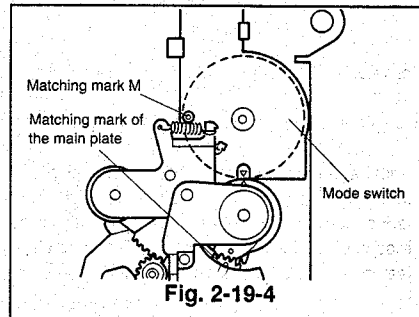

Fig. 2-19-4

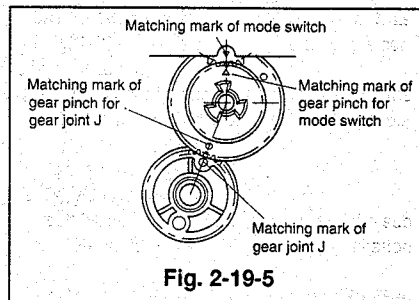

Fig. 2-19-5

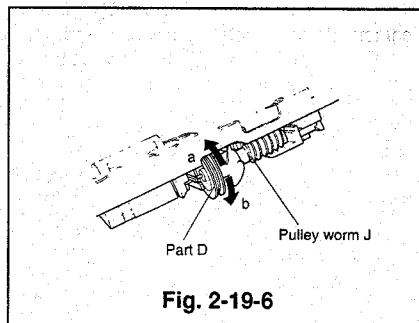

Fig. 2-19-6

2-20 Takeup Reel Disk and Gear R(takeup side)

(Removal)

- ① Remove the cassette housing. (Refer to Para. 2-1 for the removal method.)
- ② Remove the sub brake(SP) and the sub spring(SP). (Refer to Para. 2-14 for the removal method.)
- ③ Remove the sub off lever, the sub brake(TU), and the sub spring(TU). (Refer to Para. 2-16 for the removal method.)
- ④ Unfasten the catch shown in Fig. 2-20-1 and raise the takeup reel disk upward to remove it from the shaft.
- ⑤ Raise the gear R(takeup side) upward to remove it from the shaft. (Refer to Fig. 2-20-2.)

(Installation)

- ① Install the gear R(takeup side) on the shaft. (Refer to Fig. 2-20-2.)
- ② Install the takeup reel disk on the shaft. (Refer to Fig. 2-20-2)
- ③ Install the height adjusting jig [master plane](used for F deck: Part No.859C342020) in the specified position. (Insert the jig into hole A, shown in Fig. 2-20-3, so that the jig sets on part B and the end of part C. Take care that the jig does not touch the supply and takeup reel disks.)
- ④ Place the height adjusting jig [square](used for E deck: Part No.859C341070) on the jig installed in Item ③ as shown in Fig. 2-20-4. Make sure that the height is correct (between A and B).
- ⑤ Adjust the height of the supply reel disk by varying the number of the washers (Part No.552C017020) under the disk.
 - A) If it is high, remove washer(s).
 - B) If it is low, add washer(s).
- ⑥ Install the sub brake(TU), the sub off lever, and the sub spring(TU). (Refer to Para. 2-16 for the installation method.)
- ⑦ Install the sub brake(SP) and the sub spring(SP). (Refer to Para. 2-14 for the installation method.)
- ⑧ Install the cassette housing. (Refer to Para. 2-1 for the installation method.)

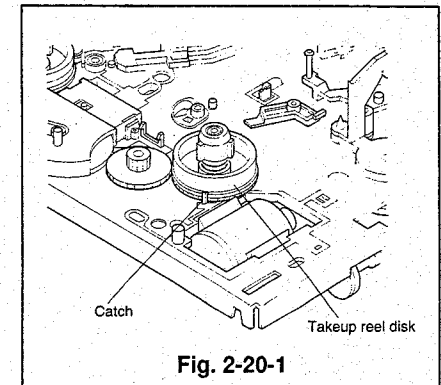

Fig. 2-20-1

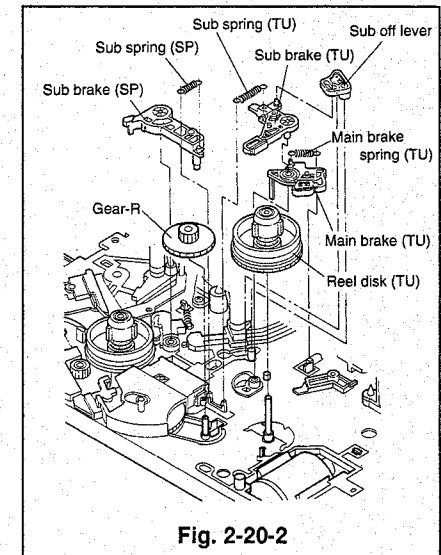

Fig. 2-20-2

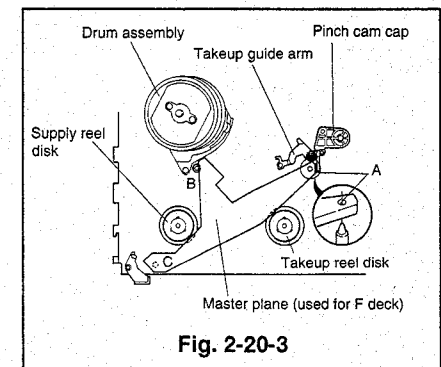

Fig. 2-20-3

2-21 Supply Reel Disk

(Removal)

- 1 Remove the cassette housing. (Refer to Para. 2-1 for the removal method.)
- 2 Remove the sub brake(SP) and the sub spring(SP). (Refer to Para. 2-14 for the removal method.)
- 3 Raise the part B of the tension brake belt upward to unfasten the belt from the supply reel disk as shown in Fig. 2-21-2. (Refer to Para. 2-19 for the removal method.)
- 4 Unfasten the catch shown in Fig. 2-21-1 and raise the supply reel disk upward to remove it from the shaft.

(Installation)

- 1 Install the supply reel disk on the shaft.
- 2 Install the height adjusting jig [master plane](used for F deck: Part No.859C342020) in the specified position. (Insert the jig into the hole A shown in Fig. 2-20-3 so that the jig sets on part B and the end of part C. Take care that the jig does not touch the supply and takeup reel disks.)
- 3 Place the height adjusting jig [square](used for E deck: Part No.859C341070) on the jig, previously installed placed in Item ②, as shown in Fig. 2-21-3. Make sure that the height is correct (between A and B).
- 4 Adjust the height of the supply reel disk by varying the number of the washers(Part No.552C017020) under the disk.
 - A) If it is high, remove washer(s).
 - B) If it is low, add washer(s).

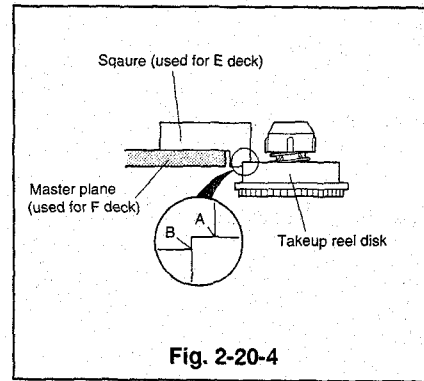

Fig. 2-20-4

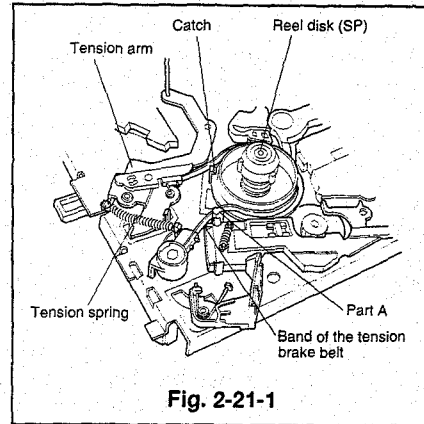

Fig. 2-21-1

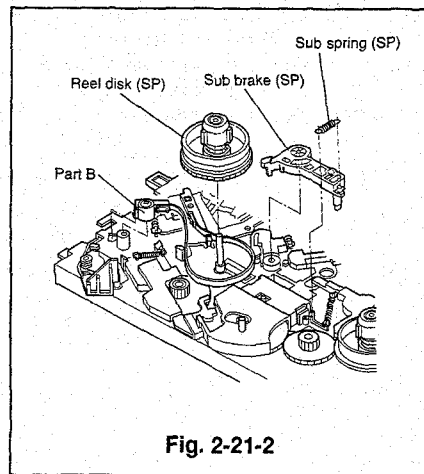

Fig. 2-21-2

- 5 Fasten the tension brake belt round on the supply reel disk, taking care not to score the belt and route part B of the tension brake belt as shown in Fig. 2-21-2. (Refer to Para. 2-19 for the installation method.) (The band of the tension brake belt must pass outside of the catch shown in Fig. 2-21-1 and inside of the part A.)
- 6 Install the sub brake(SP) and the sub spring(SP). (Refer to Para. 2-14 for the installation method.)
- 7 Install the cassette housing. (Refer to Para. 2-1 for the installation method.)

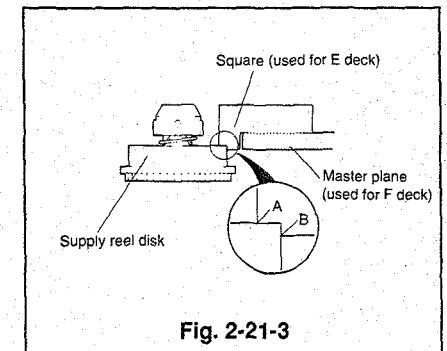

Fig. 2-21-3

2-22 Gear R(supply side) (Refer to Fig. 2-22-1.)

(Removal)

- 1 Remove the cassette housing. (Refer to Para. 2-1 for the removal method.)
- 2 Remove the sub brake(SP) and the sub spring(SP). (Refer to Para. 2-14 for the removal method.)
- 3 Unfasten the tension brake belt from the supply reel disk and remove the supply reel disk. (Refer to Para. 2-21 for the removal method.)
- 4 Remove the charge assembly. (Refer to item ② of Removal in Para. 2-18 for the removal method.)
- 5 Raise the gear R(SP) upward to remove it from the shaft.

(Installation)

- 1 Install the gear R(SP) on the shaft.
- 2 Install the supply reel disk. (Refer to Para. 2-21 for the installation method.)
- 3 Install sub brake(SP) and sub spring(SP). (Refer to Para. 2-14 for the installation method.)
- 4 Install the charge assembly. (Refer to Item ⑤ of Para. 2-18 for the installation method.)
- 5 Install the cassette housing. (Refer to Para. 2-1 for the installation method.)

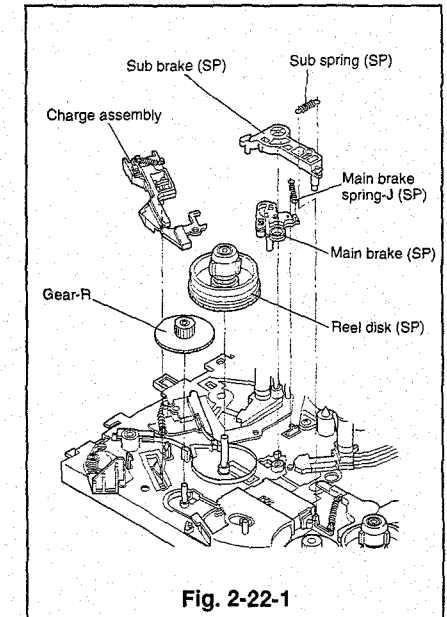

Fig. 2-22-1

2-23 Main Brake Release Lever

(Refer to Fig. 2-23-1.)

(Removal)

- ① Remove the cassette housing. (Refer to Para. 2-1 for the removal method.)
- ② Remove the sub brake(SP), and the sub spring(SP). (Refer to Para. 2-14 for the removal method.)
- ③ Remove the sub off lever, the sub brake(TU), and the sub spring(SP). (Refer to Para. 2-16 for the removal method.)
- ④ Remove the main brake(TU) and the main brake spring J(TU). (Refer to Para. 2-17 for the removal method.)
- ⑤ Shift catch A of the main brake release lever, and push catch B at the same time, in the direction shown by each arrow. Unfasten catch B from the main plate to remove the main brake release lever. (Refer to Fig. 2-23-2.)

(Installation)

- ① Install the main brake release lever so that the shaft enters the inside groove shown in Fig. 2-23-3 of the main gear J.
- ② Install the main brake(TU) and the main brake spring J(TU). (Refer to Para. 2-17 for the installation method.)
- ③ Install the sub brake(TU), the sub off lever, and the sub spring(TU). (Refer to Para. 2-16 for the installation method.)
- ④ Install the sub brake(SP) and the sub spring(SP). (Refer to Para. 2-14 for the installation method.)
- ⑤ Install the cassette housing. (Refer to Para. 2-1 for the installation method.)

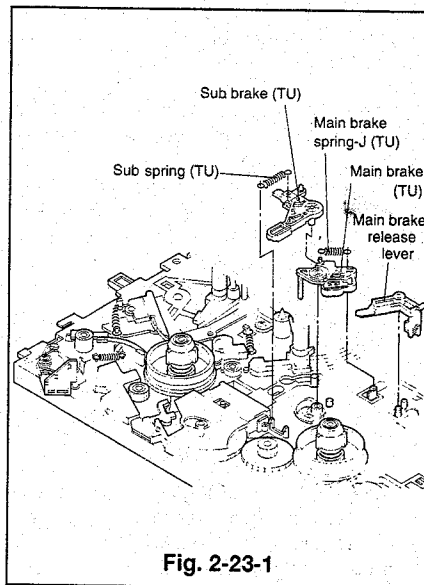

Fig. 2-23-1

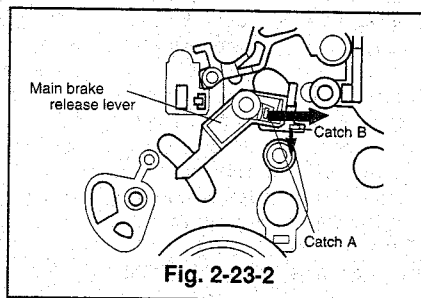

Fig. 2-23-2

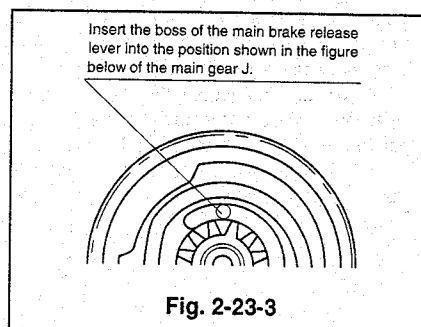

Fig. 2-23-3

2-24 Pinch Cam Cap, Pinch Roller Arm Assembly, Pinch Cam, Takeup Guide Gear, Gear Pinch, Takeup Guide Arm, and Takeup Guide Spring

(Removal)

- ① Unfasten the catch shown in Fig. 2-24-1 and raise the pinch cam cap upward to remove it.
- ② Raise the pinch roller arm assembly upward to remove it.
- ③ Raise the pinch cam and the takeup guide gear upward to remove them from the shaft.
- ④ Unfasten the two catches holding the mode switch and remove the gear pinch from the shaft, lift the mode switch only high enough to remove the gear pinch. (Take care not to break the pins of the mode switch.)
- ⑤ Remove the nut at the top of the takeup guide arm with a (5.5mm) box screw driver.
- ⑥ Raise the takeup guide arm upward to remove it.
- ⑦ Remove the takeup guide spring.

(Installation)

- ① Hook one end of the takeup guide spring with the takeup guide arm, fix the takeup guide spring to the shaft.
- ② Apply grease (PG-641) [859D055O30] around the top of the new takeup guide arm (the surface which touches with the nut). Fix the takeup guide arm to the shaft, and secure it with the nut. (Set the takeup guide arm to the height shown in Fig. 2-24-2 temporarily.)
- ③ Lift the mode switch, only high enough to install the gear pinch and place the gear pinch under the mode switch. Fix the mode switch to the shaft so that the matching marks of the gear pinch align with those of the gear joint J and the mode switch as shown in Fig. 2-24-3.
- ④ Install the takeup guide gear so that the first cog of the takeup guide arm aligns with the matching mark on the takeup guide gear as shown in Fig. 2-24-4.
- ⑤ Apply grease (G) [859D055O50] to the area shown in Fig. 2-24-5 of the new pinch cam.
- ⑥ Turn the takeup guide arm clockwise while inserting the pinch cam into the gear pinch. Install the pinch cam so that it aligns with the triple catch. (Excessive rotation of the takeup guide arm will keep it from returning, since the takeup guide gear is caught on the pinch roller cam.)
- ⑦ Apply the grease (PG-641) [859D055O30] to the new pinch cam cap on the area shown in Fig. 2-24-7.
- ⑧ Install the pinch roller arm assembly and the pinch cam cap.

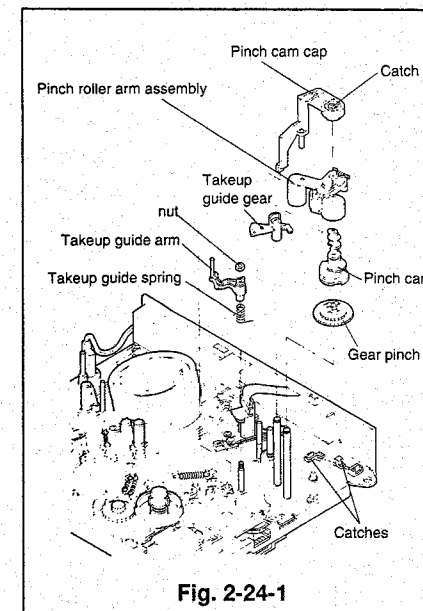

Fig. 2-24-1

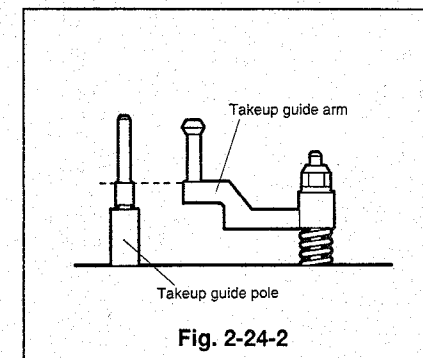

Fig. 2-24-2

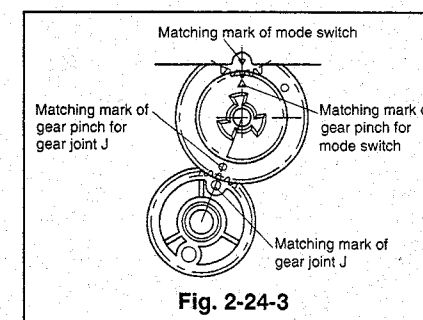

Fig. 2-24-3

[Adjustment of Takeup Guide Arm Height]

Adjust the height of the takeup guide arm according to the following procedure.

- ① Place the height adjusting jig (for the F deck) in the reference position on the main plate (Refer to Fig. 2-20-3). Tighten the takeup guide arm fastening nut so that the lower flange of the takeup guide arm is level with point B of the height adjusting jig (for the E deck). (Refer to Fig. 2-24-6).

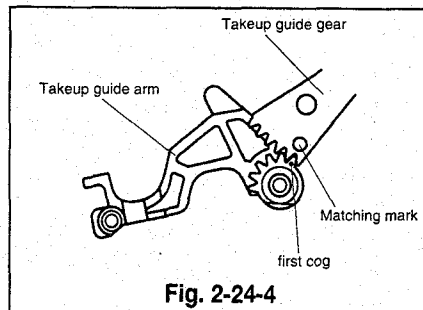

Fig. 2-24-4

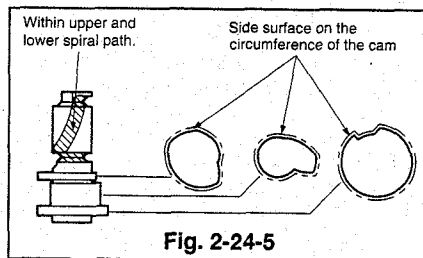

Fig. 2-24-5

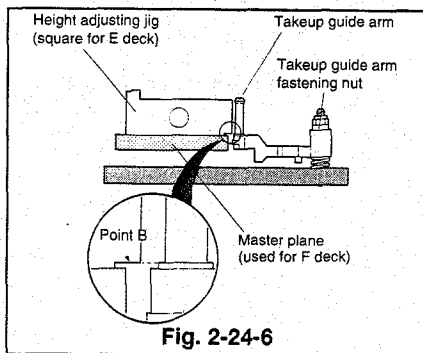

Fig. 2-24-6

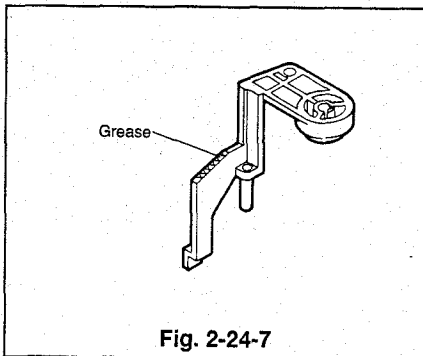

Fig. 2-24-7

2-25 Pinch Roller, Roller Cap, Pinch Spring, and Pinch Cam Spring

Note: During removal and installation, do not expand the pinch spring more than 18mm and the pinch cam spring more than 27mm.

(Removal)

- ① Pry the pinch roller and the roller cap to remove them as shown in Fig. 2-25-1.
- ② Remove the pinch spring and the pinch cam spring.

(Installation)

- ① Install the pinch cam spring and the pinch spring making sure that the pinch arm, the pinch slider, and the pinch lever are composed as shown in Fig. 2-25-2.
- ② Install the pinch roller so that the side, with the widest aluminium bushing, is on the roller cap side. Push the roller cap inside to secure the pinch roller. (Refer to Fig. 2-25-3)

Note: There are two types of pinch rollers as shown in Fig. 2-25-3. Each should be installed in the direction shown below.

(Type A)

The side on which aluminium is wider is attached the roller cap.

(Type B)

The convex portion is attached on the roller cap.

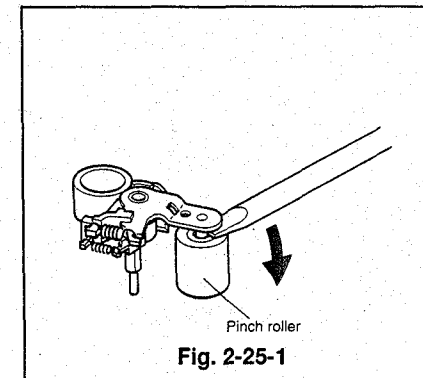

Fig. 2-25-1

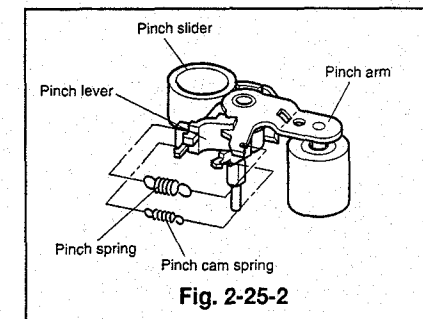

Fig. 2-25-2

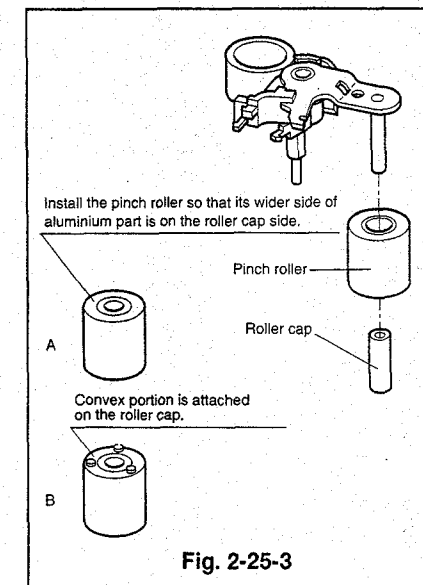
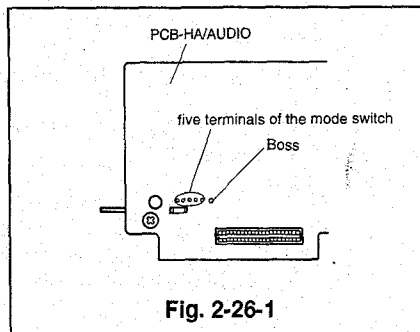

Fig. 2-25-3

2-26 Mode Switch

(Removal)

- 1 Remove the pinch cam cap, the pinch roller arm assembly, the pinch cam, and the takeup guide gear. (Refer to Para. 2-24 for the removal method.)
- 2 Unsolder the five soldered terminals connecting the PCB-HA/AUDIO to the mode switch. (Refer to Fig. 2-26-1).
- 3 Unfasten two catches holding the mode switch. (Refer to Fig. 2-26-2.)
- 4 Slowly remove the mode switch, making sure that it is completely unsoldered.



(Installation)

- 1 Insert the five pins and the boss of the mode switch shown in Fig. 2-26-1 into the matching holes of the PCB-HA/AUDIO. Place the mode switch on the main plate so that the matching mark of the gear pinch aligns with that of the mode switch and fasten it with the catches as shown in Fig. 2-26-3. (Also make sure that the matching mark of the gear joint aligns with that of the gear pinch.)
- 2 Install the takeup guide gear, the pinch cam, the pinch roller arm assembly, and the pinch cam cap. (Refer to Para. 2-24 for the installation method.)

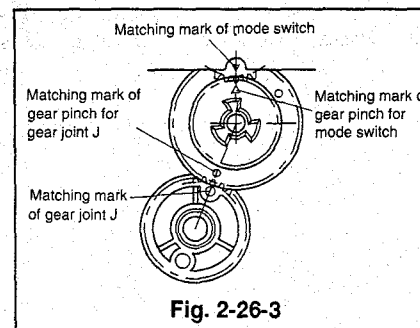
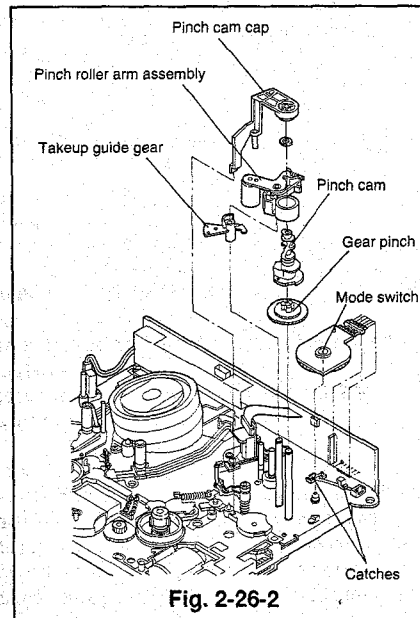

2-27 FE Head (Refer to Fig. 2-27-1.)

(Removal)

- 1 Disconnect the lead connector, connected to the FE head.
- 2 Remove the screw(ⓐ) to remove the FE head.

(Installation)

- 1 Secure the FE head with the screw(ⓐ) and connect the lead connector to the FE head. (Route the lead connector, which is fastened with the catch as shown in Fig. 2-27-1, through the hook of the main plate.)

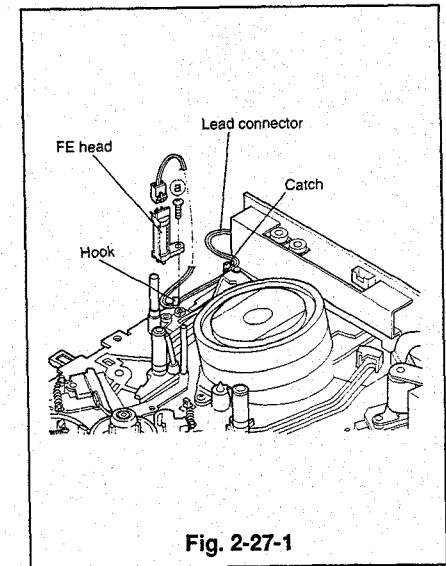

2-28 Reel Belt and Belt Pulley

(Removal)

- 1 Unfasten the reel belt from the capstan motor and the belt pulley.
- 2 Release the belt pulley as shown in Fig. 2-28-1 and raise the belt pulley upward to remove it.

(Installation)

- Note:** When installing the reel belt, make sure it is clean and free of grease. (Clean with dry gauze only)
- 1 Fasten the belt pulley to the shaft. (When fixing the belt pulley to the shaft of the idler assembly, make sure that the three convex parts of the washer fixed to the shaft enter the matching dents.)
 - 2 Secure the belt pulley with the new cut washer.
 - 3 Install the reel belt on the capstan motor and the belt pulley, taking care that the belt is not twisted.

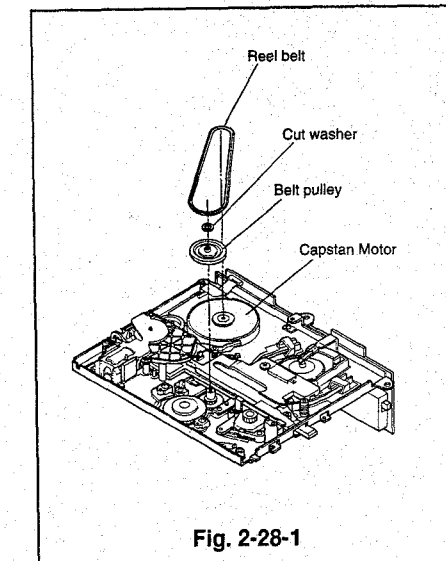

2-29 Loading Motor Assembly, Pulley Worm J, Loading Motor Belt, and Gear A

(Removal)

- 1 Unfasten the reel belt. (Refer to Para. 2-28 for the removal method.)
- 2 Remove the three screws (a, b and c) as shown in Fig. 2-29-2 and unfasten the three catches to remove the loading motor assembly (which holds the motor holder). (Refer to Fig. 2-29-1)
- 3 Remove the loading motor belt from the motor pulley. (Refer to Fig. 2-29-3.)
- 4 Unfasten the catches holding the motor holder to remove the loading motor assembly. (Refer to Fig. 2-29-3.)
- 5 Remove the pulley worm J, first the end attached to the part A shown in Fig. 2-29-3 and then the other end.
- 6 Remove the cut washer and unfasten the catch holding Gear A. Remove Gear A.
- 7 Pull the motor pulley to remove it from the loading motor.
- 8 Disconnect the wires from the loading motor.

(Installation)

- 1 Solder the leads to the loading motor. (Red lead wire to the positive terminal and white lead wire to the negative terminal.)
- 2 Install the motor pulley on the loading motor so that the space between the loading motor and the outer edge of the motor pulley is 8.5 ± 0.1 mm. (Refer to Fig. 2-29-4)
- 3 Install the loading motor assembly so that the label on it faces part B, shown in Fig. 2-29-3.
- 4 Apply grease (G)[859D055O50] to the areas shown in Fig. 2-29-4 of the new pulley worm J. Install the pulley worm J, first the end attached to the part C shown in Fig. 2-29-3 and then the other end.
- 5 Fix the gear A to the shaft of the motor holder J and secure it with new cut washers.
- 6 Lift the end attached to the part A shown in Fig. 2-29-3 of the pulley worm J. Fasten the loading motor belt on the pulley worm J and the motor pulley, taking care not to twist the belt.
- 7 Install the loading motor assembly (which holds the motor holder) in the position shown in Fig. 2-29-2 and secure it with the three screws (a, b and c).
- 8 Install the loading motor belt. (Refer to Para. 2-28 for the installation method.)

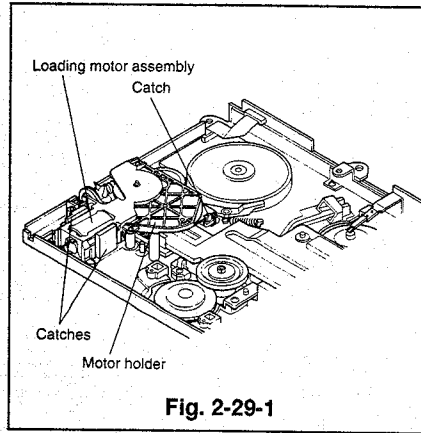

Fig. 2-29-1

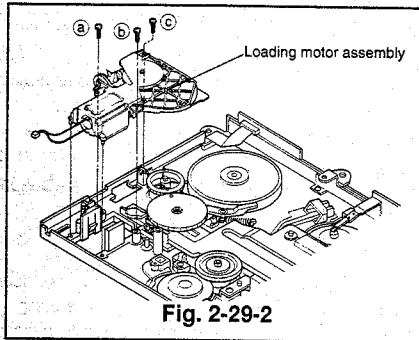

Fig. 2-29-2

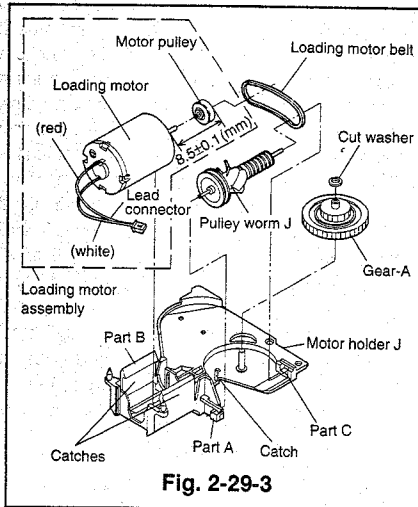

Fig. 2-29-3

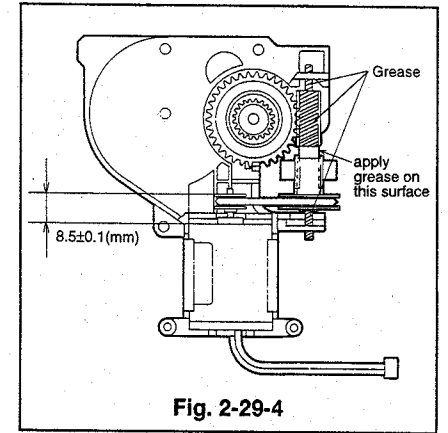

Fig. 2-29-4

2-30 Main Gear J

(Removal)

- 1 Remove the reel belt. (Refer to Para. 2-28 for the removal method.)
- 2 Remove the loading motor assembly (which holds the motor holder). (Refer to Para. 2-29 for the removal method.)
- 3 Remove the cut washer mounted on the main gear J.
- 4 Raise the main gear J upward to remove it.

(Installation)

- 1 Apply grease (G) [859D055O50] to the outside cogs, the groove of the cam and to the inside small cogs of the new main gear J. (Refer to Fig. 2-30-2.)
- 2 Make sure that the cam plate B is set to the right side, viewed from the bottom side of the deck. (Eject mode)
- 3 Push the axis of the main brake (TU) in the direction shown by the arrow until the main brake release lever moves freely. Turn the deck the right side up and shift the axis of the main brake release lever in the direction shown by the arrow. Then fix the main gear J to the shaft, with the axis of the main brake release lever held in place. Secure the main plate J with the cut washer. (Refer to Fig. 2-30-3) (Insert the pin of the capstan brake in the outside groove of the main gear J and align the matching marks of gear joint J and the main gear J.) (Refer to Fig. 2-30-4)
- 4 Install the loading motor assembly (which holds the motor holder) and the reel belt. (Refer to Para. 2-28 for the installation method.)

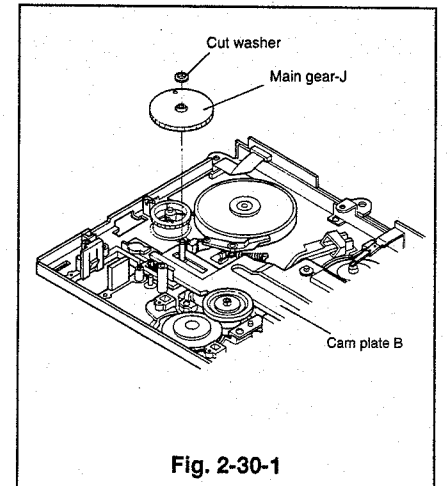

Fig. 2-30-1

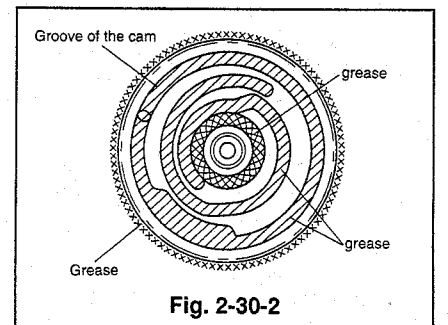

Fig. 2-30-2

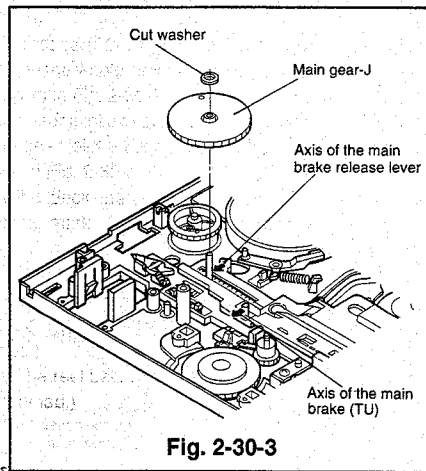

Fig. 2-30-3

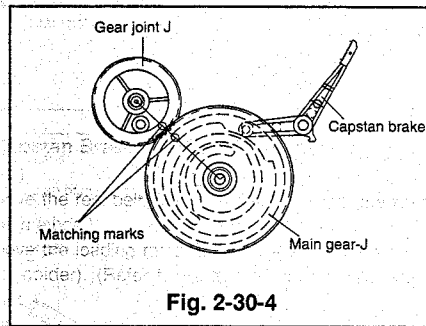

Fig. 2-30-4

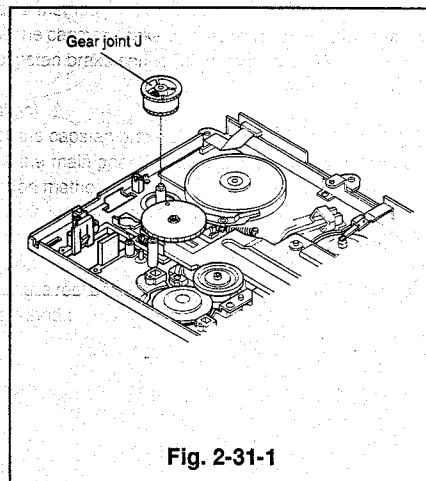

Fig. 2-31-1

2-31 Gear Joint J

(Removal)

- ① Remove the reel belt. (Refer to Para. 2-28 for the removal method.)
- ② Remove the loading motor assembly (which holds the motor holder). (Refer to Para. 2-29 for the removal method.)
- ③ Raise the gear joint J upward to remove it. (Refer to Fig. 2-31-1)

(Installation)

- ① Apply grease (PG-641)[859D055O30] to the new gear joint J on the whole circumference of the small cogwheel as shown in Fig. 2-31-2.
- ② Fix the gear joint J to the shaft so that the matching mark of the gear joint J aligns with that of the main gear as shown in Fig. 2-30-4.
- ③ Turn the deck the right side up, make sure that the matching mark of the gear pinch aligns with that of the gear joint J. (When turning the deck, hold the gear joint J, in place.)(Refer to Fig. 2-31-3)
- ④ Install the loading motor assembly(which holds the motor holder). (Refer to Para. 2-29 for the installation method.)
- ⑤ Install the reel belt. (Refer to Para. 2-28 for the installation method.)

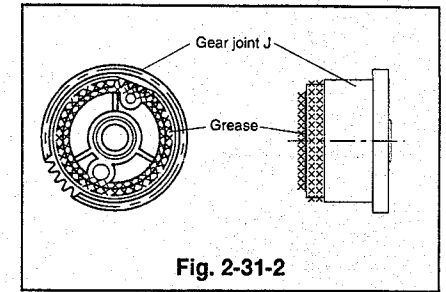

Fig. 2-31-2

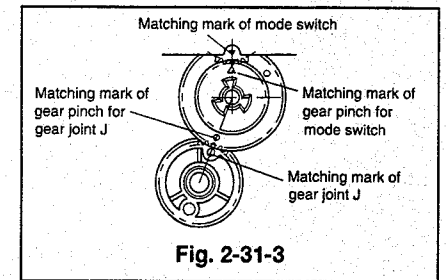

Fig. 2-31-3

2-32 Capstan Brake and Capstan Brake Spring

(Removal)

- ① Remove the reel belt. (Refer to Para. 2-28 for the removal method.)
- ② Remove the loading motor assembly(which holds the motor holder). (Refer to Para. 2-29 for the removal method.)
- ③ Remove the main gear J. (Refer to Para. 2-30 for the removal method.)
- ④ Raise the capstan brake upward to remove it along with the capstan brake spring. (Refer to Fig. 2-32-1.)

(Installation)

- ① Install the capstan brake and the capstan brake spring.
- ② Install the main gear J. (Refer to Para. 2-30 for the installation method.)
- ③ Install the loading motor assembly(which holds the motor holder). (Refer to Para. 2-29 for the installation method.)
- ④ Fasten the reel belt. (Refer to Para. 2-28 for the installation method.)

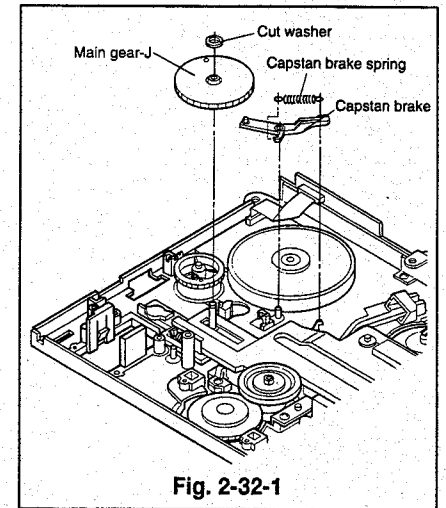

Fig. 2-32-1

2-33 Plate J, Roller B, and Cam Plate B

(Removal)

- ① Remove the two screws (a) and (b) to remove the plate J. (Fig. 2-33-1)
- ② Take off the cut washer fixed to the shaft of the loading arm (TU) to remove the roller B.
- ③ Remove the reel belt.
- ④ Remove the belt pulley. (Refer to Para. 2-28 for the removal method.)
- ⑤ Remove the loading motor assembly (which holds the motor holder). (Refer to Para. 2-29 for the removal method.)
- ⑥ Remove the main gear J. (Refer to Para. 2-30 for the removal method.)
- ⑦ Slide the cam plate B to the left (the direction shown by the arrow) to remove it.

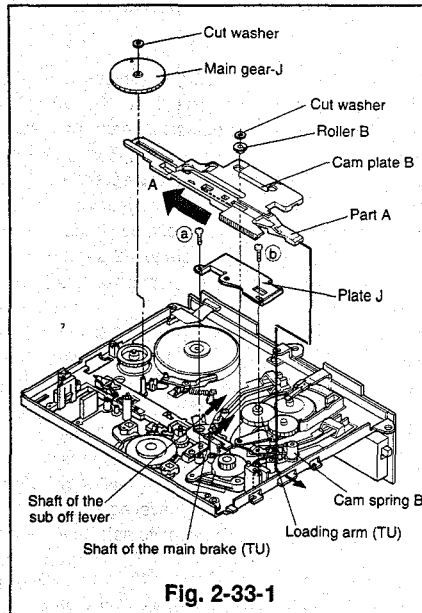

Fig. 2-33-1

(Installation)

- ① Apply grease (G) [859D055O50] to the area shown in Fig. 2-33-2 of the new cam plate B.
- ② Align the loading arms TU and SP so that the matching marks of the cogs align. (Refer to Fig. 2-37-3)
- ③ Passing part A of the cam plate B under cam spring B insert it into the hole on the side of the main plate, as shown by the continuous line. (Refer to Fig. 2-33-1)
- ④ While keeping the rear section of cam plate B raised, align the cam plate B and the cam gear R so that the O mark on the cam plate B aligns with the part A on the cam gear R as shown in Fig. 2-33-3 (Fig. A). Still keeping the rear of cam plate B raised, slide it to the right until the Δ mark on cam plate B and aligns with the part B on the cam gear R, refer Fig. 2-33-3 (Fig. B). From this position lower the rear of the cam plate B unto the already aligned loading gears TU and SP, refer 2 above. Shift the sub off lever and the main brake TU in the directions shown by the arrows to install them. (Refer to Fig. 2-33-1)
- ⑤ Fix the roller B to the shaft of the loading arm (TU) and secure it with the new cut washer.
- ⑥ Install the plate J and secure it with the two screws (a) and (b).
- ⑦ Install the main gear J. (Refer to Para. 2-30 for the installation method.)
- ⑧ Install the loading motor assembly (which holds the motor holder). (Refer to Para. 2-29 for the installation method.)
- ⑨ Install the belt pulley. (Refer to Para. 2-28 for the installation method.)
- ⑩ Fasten the reel belt. (Refer to Para. 2-28 for the installation method.)

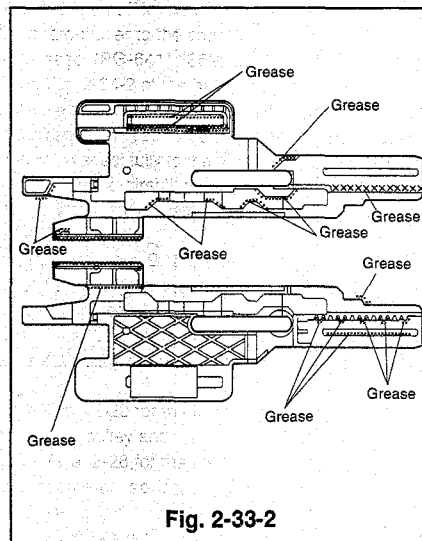

Fig. 2-33-2

2-34 Cam Gear R, Charge Lever, and Tension Off Lever

(Removal)

- ① Remove the cassette housing. (Refer to Para. 2-1 for the installation method.)
- ② Turn the deck the right side up and detach the tension spring. (Refer to Fig. 2-34-4.)
- ③ Remove the charge assembly. (Refer to item ② of Para. 2-18 for the removal method.)
- ④ Remove the reel belt and the pulley belt. (Refer to Para. 2-28 for the removal method.)
- ⑤ Remove the loading motor assembly (which holds the motor holder). (Refer to Para. 2-29 for the removal method.)
- ⑥ Remove the main gear J. (Refer to Para. 2-30 for the removal method.)
- ⑦ Remove the plate J, the roller B, and the cam plate B. (Refer to Para. 2-33 for the removal method.)
- ⑧ Raise the cam gear R upward to remove it. (Refer to Fig. 2-34-1.)
- ⑨ Remove the charge lever. (Refer to Fig. 2-34-1.)
- ⑩ Remove the tension off lever. (Refer to Fig. 2-34-1.)

(Installation)

- ① Let part A pass through part B shown in Fig. 2-34-1 to install the tension off lever.
- ② Fix the charge lever to the shaft.
- ③ Apply grease (PG-641) [859D055O30] to the area shown in Fig. 2-34-2 of the new cam gear R. (The groove and the flank of the outside circumference.)
- ④ Insert the cam gear R so that part A is on the upside, with the charge lever set fully to the right end. Slowly turn the charge lever in the direction shown by the arrow until it enters the groove in the cam gear R. (Refer to Fig. 2-34-3)
- ⑤ Install the cam plate B, the roller B, and the plate J. (Refer to Para. 2-33 for the installation method.)
- ⑥ Install the main gear J. (Refer to Para. 2-30 for the installation method.)
- ⑦ Install the loading motor assembly (which holds the motor holder). (Refer to Para. 2-29 for the installation method.)
- ⑧ Install the belt pulley and the reel belt. (Refer to Para. 2-28 for the installation method.)
- ⑨ Hook the tension spring in the position shown in Fig. 2-34-4.
- ⑩ Install the charge assembly. (Refer to Item ⑤ of Para. 2-18 for the installation method.)
- ⑪ Install the cassette housing. (Refer to Para. 2-1 about the installation method.)

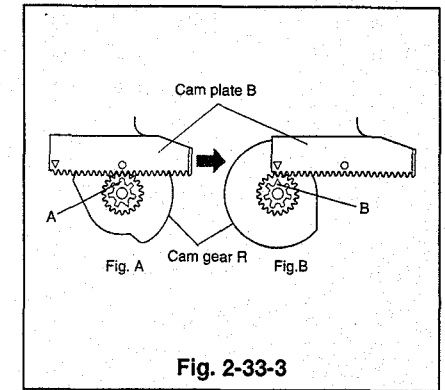

Fig. 2-33-3

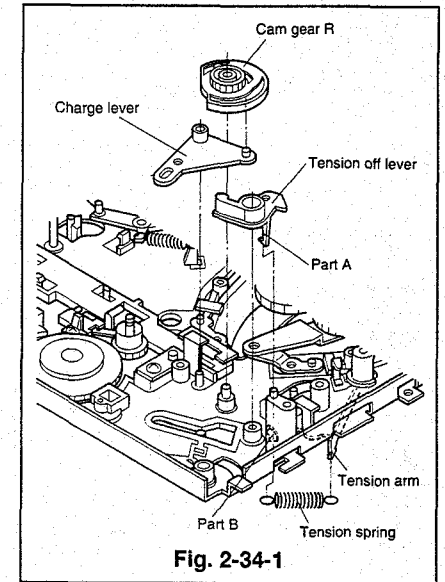

Fig. 2-34-1

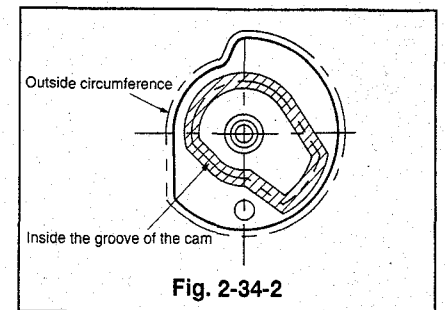

Fig. 2-34-2

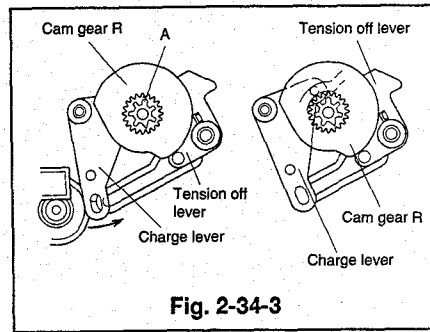

Fig. 2-34-3

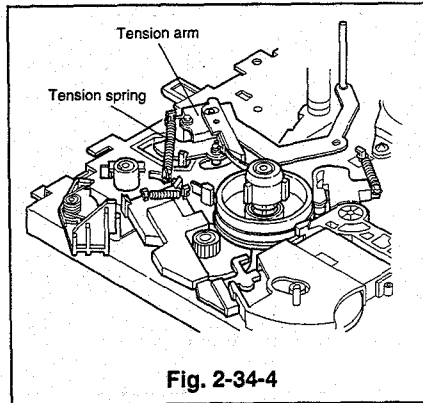

Fig. 2-34-4

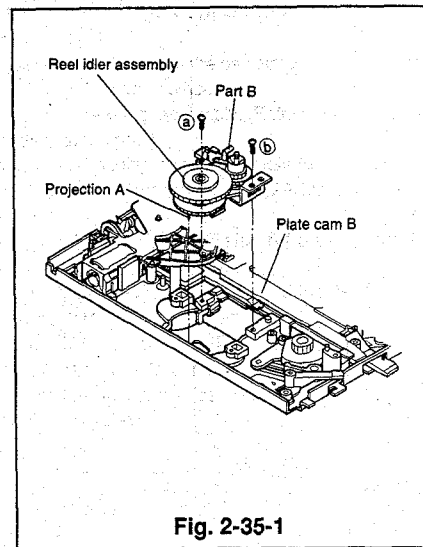

Fig. 2-35-1

2-35 Reel Idler Assembly

(Removal)

- ① Remove the reel belt and the belt pulley.
(Refer to Para. 2-28 for the removal method.)
- ② Remove the two screws (a) and (b) holding the reel idler assembly.
- ③ Unfasten the two catches shown in Fig. 2-35-2 and push the reel idler assembly to remove it, with the deck right side up.

(Installation)

- ① Insert the part B of the reel idler assembly under the plate cam B as shown in Fig. 2-35-1 and ensure projection A enters the hole on the main plate. Position the reel idler assembly so that its screw holes are aligned and secure it with the two screws (a) and (b).
(Fig. 2-35-3 shows its appearance, viewing from the top.)
- ② Install the belt pulley and the reel belt.
(Refer to Para. 2-28 for the installation method.)

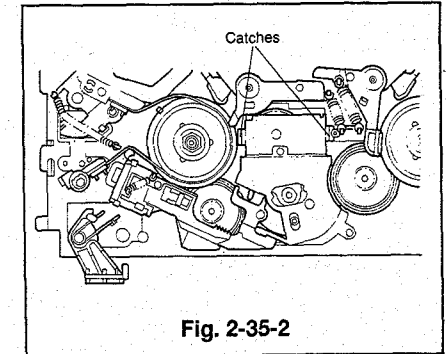

Fig. 2-35-2

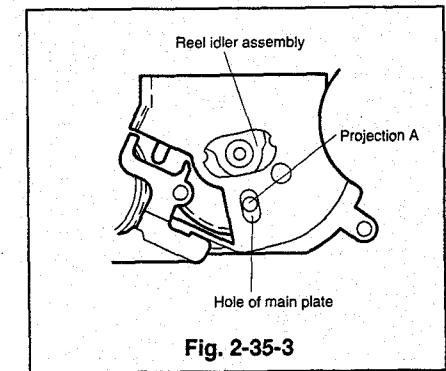

Fig. 2-35-3

2-36 Cam Plate C and Cam Spring C

(Removal)

- ① Remove the reel belt and the belt pulley. (Refer to Para. 2-28 for the removal method.)
- ② Remove the reel idler assembly. (Refer to Para. 2-35 for the removal method.)
- ③ Remove the loading motor assembly (which holds the motor holder). (Refer to Para. 2-29 for the removal method.)
- ④ Remove the main gear-J. (Refer to Para. 2-30 for the removal method.)
- ⑤ Remove the plate-J, the roller-B, and the cam plate-B. (Refer to Para. 2-33 for the removal method.)
- ⑥ Remove the cam spring-C. (Refer to Fig. 2-36-1.)
- ⑦ Slide the cam plate-C to the left end.
- ⑧ Unfasten the catch and raise the cam plate-C to remove it. (refer to Fig. 2-36-1.)

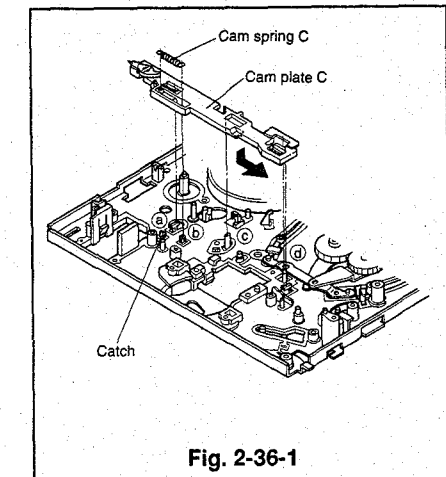

Fig. 2-36-1

(Installation)

- Apply specified grease to the area (A-I) shown in Fig. 2-36-2 of the new cam plate-C.
Area A : (G) [859D055O50]
Area B-I : (PG641) [859D055O30]
- Position the cam plate-C so that the four points (a), (b), (c) and (d) shown in Fig. 2-36-1 enter into the matching holes and slide it to the right end.
- Install the cam spring-C.
- Install the cam plate-B, the roller-B, and the plate-J. (Refer to Para. 2-33 for the installation method.)
- Install the main gear-J. (Refer to Para. 2-30 for the installation method.)
- Install the loading motor assembly (which holds the motor holder). (Refer to Para. 2-35 for the installation method.)
- Install the reel idler assembly. (Refer to Para. 2-35 for the installation method.)
- Install the belt pulley and the reel belt. (Refer to Para. 2-28 for the installation method.)

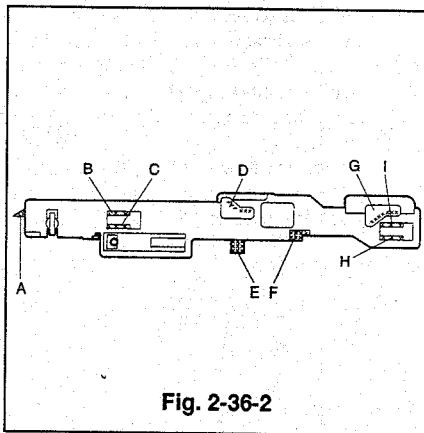

Fig. 2-36-2

2-37 Loading Arm (SP, TU)

(Removal)

- Remove the reel belt and the belt pulley. (Refer to Para. 2-28 for the removal method.)
- Remove the loading motor assembly (which holds the motor holder). (Refer to Para. 2-29 for the removal method.)
- Remove the main gear-J. (Refer to Para. 2-30 for the removal method.)
- Remove the plate-J, the roller-B, and the cam plate-B. (Refer to Para. 2-33 for the removal method.)
- Raise the loading arms upward, first SP and then TU, to remove them. (Refer to Fig. 2-37-1)

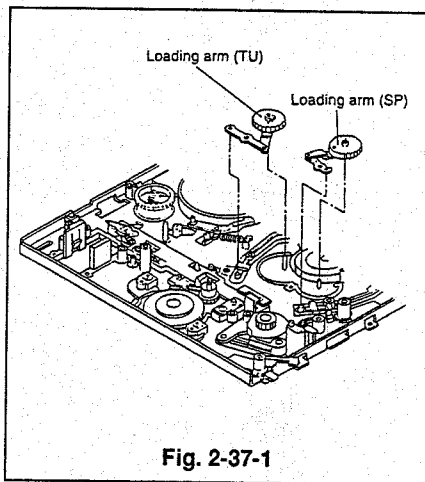

Fig. 2-37-1

(Installation)

- Move the takeup and supply tape guides to the unloaded position. If the supply tape guide is in the loaded position it will be necessary to shift the tension arm in the direction of the arrow in Fig. 2-37-2 at the same time moving the supply tape guide to the unloading position.
- Place the new loading arm (TU) in the position shown in Fig. 2-37-1, then place the loading arm (SP) in the position shown in Fig. 2-37-1 at the same time aligning the marks on the cogs, refer Fig. 2-37-3(shaded area).
- Apply grease (G)[859D055O50] to the area that touches the cogwheel of the loading arm (TU) when the loading arms (SP and TU) are shifted fully to the loading direction. Apply grease (G)[859D055O50] to the gear portion that meshes with the plate cam B. (Refer to Fig.2-37-4.)

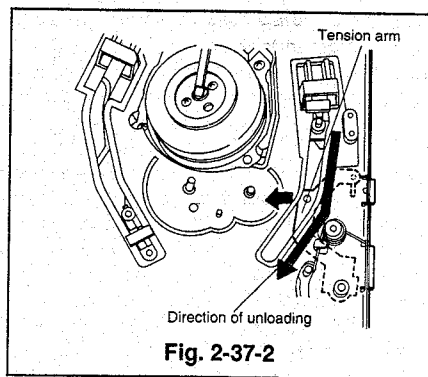

Fig. 2-37-2

- Install the cam plate-B, the roller-B, and the plate-J. (Refer to Para. 2-33 for the installation method.)
- Install the main gear-J. (Refer to Para. 2-30 for the installation method)
- Install the loading motor assembly (which holds the motor holder). (Refer to Para. 2-29 for the installation method.)
- Install the belt pulley and the reel belt. (Refer to Para. 2-28 for the installation method.)

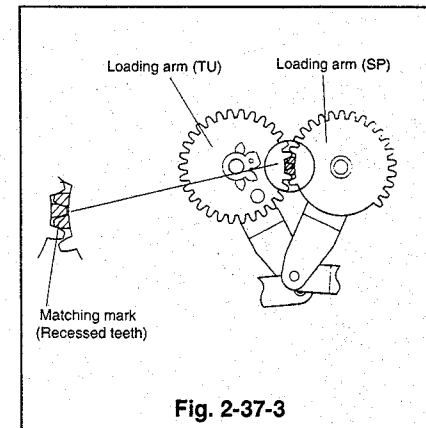

Fig. 2-37-3

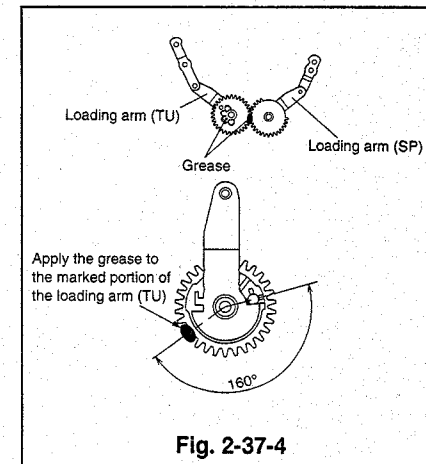

Fig. 2-37-4

2-38 Capstan Motor and Lead Card

Note: During removal and installation of the capstan motor, take care not to touch or score the tape running surface, and ensure there is no grease on the outside of the motor's rim.

(Removal)

- Unfasten the reel belt.
- Disconnect the lead card, connected to the PCB of the capstan motor and the PCB-HA/AUDIO. (Refer to Fig. 2-38-1.)
- Turn the deck the right side up, remove the three screws shown in Fig. 2-38-2 to remove the capstan motor.

Note: During removal, support the capstan motor assembly when it is not secured by its fastening screws. Take care not to touch other parts.

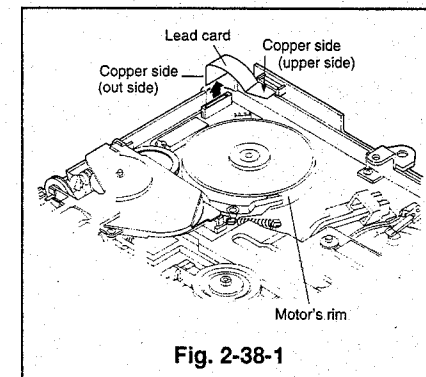
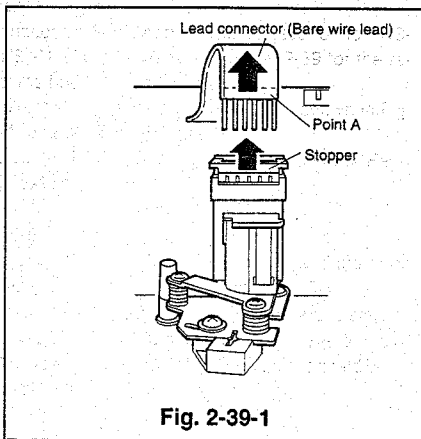
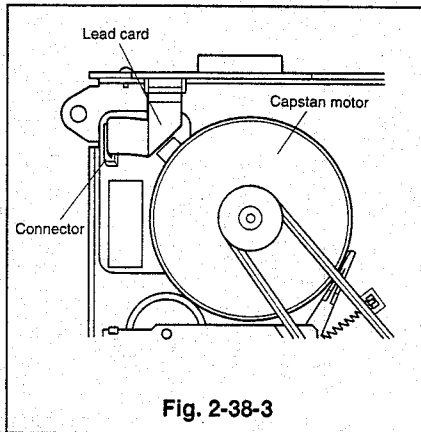
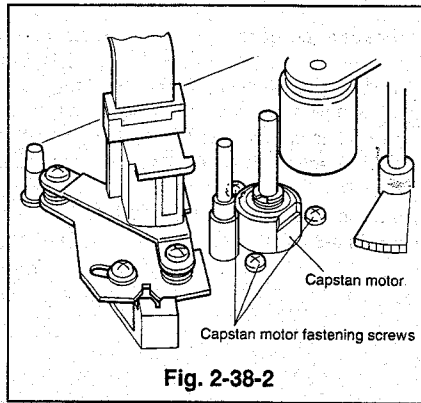

Fig. 2-38-1

(Installation)

- ① Reverse the deck, position the capstan motor so that the capstan brake is on the outside of the capstan motor.
- ② Turn the deck the right side up, secure the capstan motor with the three screws shown in Fig. 2-38-2.
- ③ Bend the new lead card as shown in Fig. 2-38-3 and connect it to the connectors of the PCB of the capstan motor and the PCB-HA/AUDIO so that copper side appears as shown in Fig. 2-38-1. Take care not to touch the rotor of the capstan motor.
- ④ Install the reel belt.
(Refer to Para. 2-28 for the installation method.)



2-39 A/C Head Assembly

(Removal)

Note: During installation of A/C head assembly, take care not to touch or score the tape running surface.

- ① Lift the stopper shown in Fig. 2-39-1 upward and disconnect the lead connector (bare wire), which is connected to the PCB-A/C-HEAD.
- ② Remove the two screws (a) and (b) holding the A/C head assembly to the main plate, and to remove the A/C head assembly. (Refer to Fig. 2-39-2.)

(Installation)

- ① Make sure that the spring (A/C earth spring) is as shown in Fig. 2-39-3.
- ② Place the A/C head assembly in the position shown in Fig. 2-39-2 and secure it with the two screws (a) and (b).
- ③ Shift part A downward and lower the stopper. Connect the lead connector to the connector on the PCB-A/C-HEAD as shown in Fig. 2-39-1.

Note: Conduct the A/C head adjustment and the phase adjustment as outlined in Para. 3-3 and 3-4 after the new A/C head is installed.

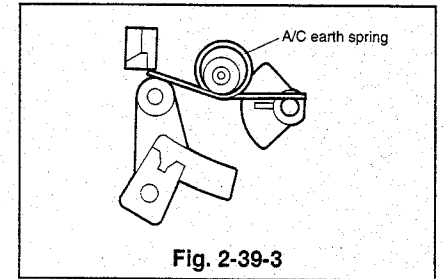
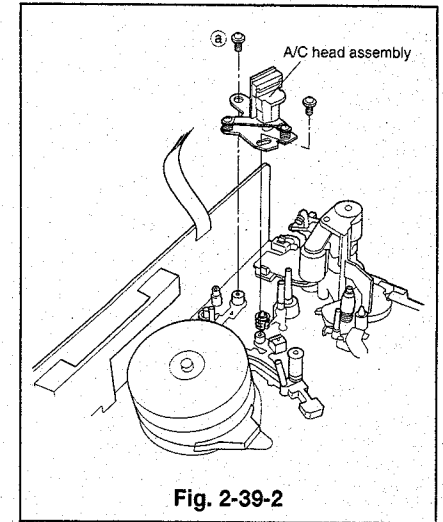

2-40 A/C Head

(Removal)

- ① Disconnect the lead connector connected to the PCB-A/C-HEAD. (Refer to Item ① of Para. 2-39 for the removal method.)
- ② Remove the three screws (a), (b) and (c), shown in Fig. 2-40-1 to remove the A/C head.
- ③ Unsolder the PCB-A/C HEAD from the A/C head. (Refer to Fig. 2-40-1.)

(Installation)

- ① Install the A/C head with the A/C spring and the three screws (a), (b) and (c) as shown in Fig. 2-40-1.

Note: When installing the A/C head on the A/C plate, the base plate of the A/C head must be parallel to the A/C plate and the spacing between them should be as specified in Fig. 2-40-2.

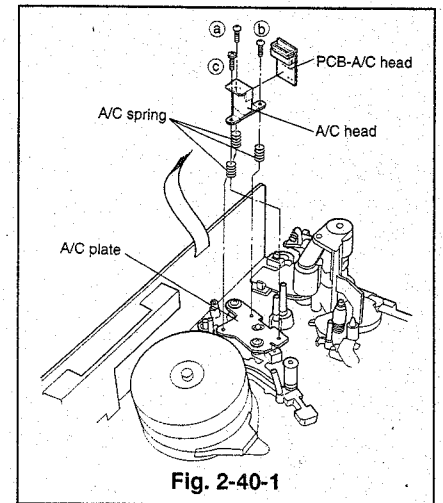

- ② Connect the lead connector to the PCB-A/C-HEAD. (Refer to Item ③ of Para. 2-39 for the installation method.)
- ③ Perform the A/C head adjustment as outlined in Para. 3-3 and the phase adjustment as outlined in Para. 3-4.

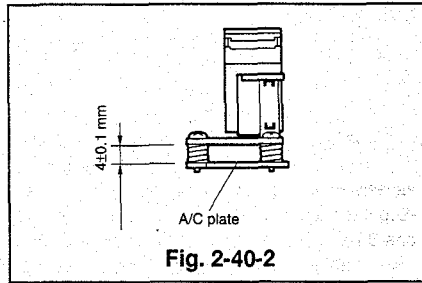

Fig. 2-40-2

2-41 Supply & Takeup Guide Rollers

(Removal)

- ① Loosen the set screws with a hexagon key so that the guide rollers rotate freely.
- ② Turn the height adjustment screws at the top of the guide rollers counterclockwise with a height adjustment screwdriver to loosen them. Lift the guide roller upward to remove them from the tape guides. (Refer to Fig. 2-41-1)

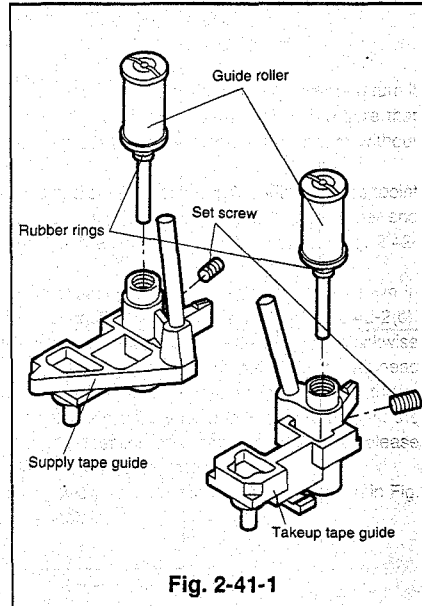

Fig. 2-41-1

(Installation)

- ① Make sure that the rubber rings are fixed to the fastening thread portions of the new guide rollers.
- ② Perform the following steps ③ to ⑤ to seat in the rubber rings.
- ③ Slowly turn the guide rollers clockwise until the rubber rings are firmly seated.
- ④ Turn the guide rollers a further 1/6 of a turn clockwise and then turn them one turn counter-clockwise.
- ⑤ Slowly turn the guide rollers clockwise until they become firmly seated again. Turn the guide rollers a further 1/6 of a turn clockwise.
- ⑥ Secure the guide rollers lightly with the set screws. Perform the mechanism check and adjustment of the FM envelope as outlined in Para. 3-2.

2-42 Cleaning Roller, Cleaning Arm, Cleaning Lever, and Cleaning Spring

(Removal)

- ① Remove the PCB-HA/AUDIO. (Refer to Para. 2-8 for the removal method.)
- ② Unfasten the catch to remove the cleaning roller. (Refer to Fig. 2-42-1)
- ③ Turn part A of the cleaning assembly clockwise as shown in Fig. 2-42-2 to release the catch part B Fig. 2-42-2 and Fig. 2-42-3(c). Release the catch part E and remove the cleaning assembly from the shaft.
- ④ Remove the cleaning spring to detach the cleaning arm and the cleaning lever.

(Installation)

- ① Attach the cleaning arm to the cleaning lever and turn it clockwise as shown in Fig. 2-42-3(c). Make sure that the cleaning arm and the cleaning lever turn without binding.
- ② Hook one end of the cleaning spring with the boss (C), projecting from the cleaning arm, and the other end to point D of the cleaning lever as shown in Fig. 2-42-3(d).
- ③ Place the cleaning assembly in the position shown in Fig. 2-42-1, and in the direction shown in Fig. 2-42-2(b). Turn the part A, shown in Fig. 2-42-2, counterclockwise to set the part B under the A/C plate of the A/C head assembly. Make sure that the spring hooks with the boss of the main plate shown in Fig. 2-42-2. Shift the part A in the direction shown by the arrow and release to make sure that it returns.
- ④ Insert the cleaning roller into the position shown in Fig. 2-42-1 to install it.

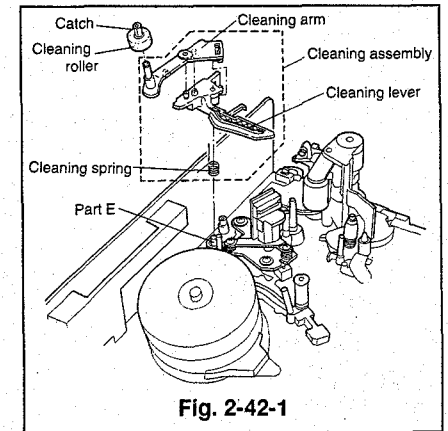

Fig. 2-42-1

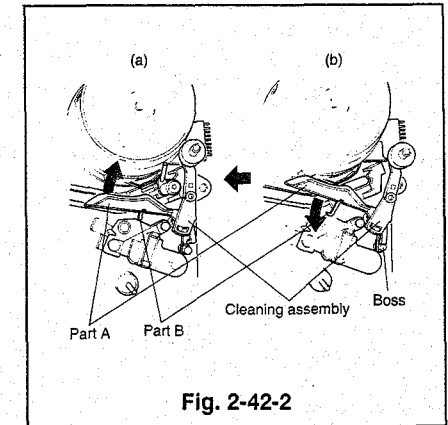

Fig. 2-42-2

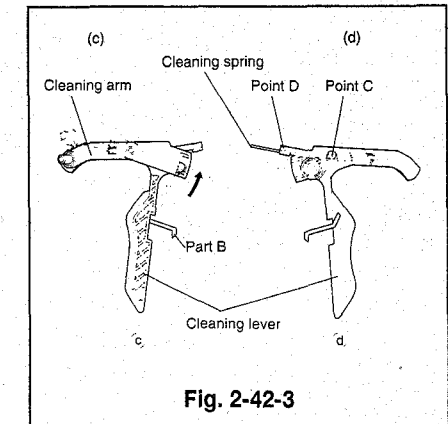

Fig. 2-42-3

2-43 Supply & Takeup Tape Guide Assemblies

(Removal)

- ① Remove the cassette housing.
(Refer to Para. 2-1 for the removal method.)
- ② Remove the PCB-HA/AUDIO.
(Refer to Para. 2-8 for the removal method.)
- ③ Remove the cleaning assembly.
(Refer to item ④ of Para. 2-42 for the removal method.)
- ④ Unscrew the three screws (Ⓐ, Ⓑ and Ⓒ) to remove the drum base together with the drum assembly.
(Refer to Fig. 2-43-1.)
- ⑤ Slide the supply and takeup tape guide assemblies to the end of the loaded position by either of the following methods.
 - Supply voltage (approximately +5V voltage on the red wire) to the loading motor as in ② of the removal method in Para. 2-19.
 - Turn part A of pulley worm J by hand, in the direction shown by the arrow (a) as shown in Fig. 2-43-3. Raise the supply and takeup tape guide assemblies upward to remove them.

(Installation)

- ① Apply grease (PG-641) [859D055O30] to the area shown in Fig. 2-43-2 of the supply tape guide assembly.
- ② Install the supply and takeup tape guide assemblies so that they respectively enter the holes at the ends of the loading arms (SP and TU) attached to the reverse side of the deck as shown in Fig. 2-43-1.
- ③ Slide the supply and takeup tape guide assemblies to the unloaded position, by either of the following methods so that the upper hole of the mode switch aligns with that of the cogwheel as shown in Fig. 2-43-4.
 - Supply voltage (approximately 5V), reversing the polarity used in ④ of the removal method, to the loading motor as ⑤ of the installation method in Para. 2-19.
 - Turn part A of the pulley worm J by hand, in the direction shown by the arrow (b) as shown in Fig. 2-43-3.
- ④ Make sure that the hole of the gear joint J aligns with the matching mark of the main plate, and the matching mark of the gear pinch with that of the mode switch as shown in Fig. 2-43-5.
- ⑤ Install the drum base on which the drum assembly is attached and secure it with the three screws (Ⓐ, Ⓑ and Ⓒ) as shown in Fig. 2-43-1.
(Tighten the screws in the order Ⓐ→Ⓑ→Ⓒ.)
- ⑥ Install the cleaning assembly.
(Refer to Item ③ of Para. 2-42 for the installation method.)
- ⑦ Install the PCB-HA/AUDIO.
(Refer to Para. 2-8 for the installation method.)
- ⑧ Install the cassette housing.
(Refer to Para. 2-1 for the installation method.)

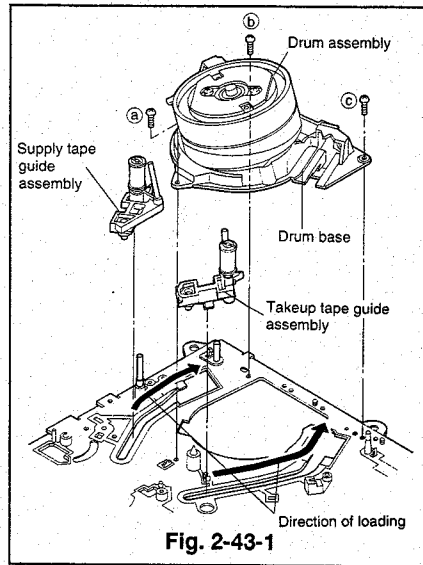

Fig. 2-43-1

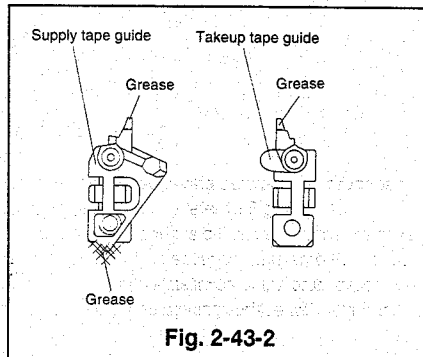

Fig. 2-43-2

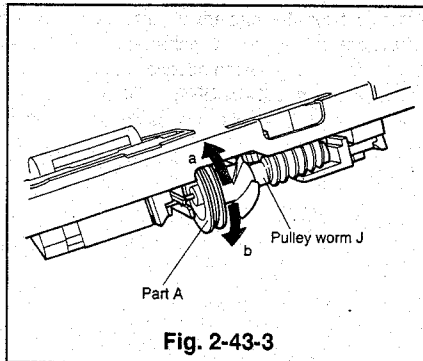

Fig. 2-43-3

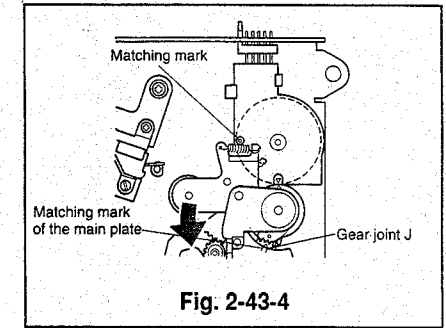

Fig. 2-43-4

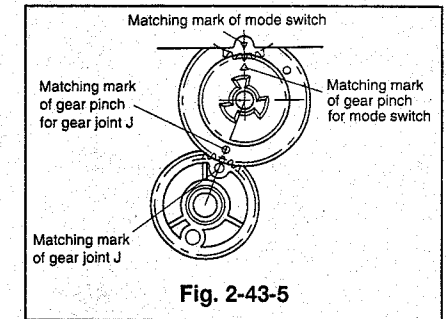

Fig. 2-43-5

2-44 Drum Base Spring

(Removal)

- ① Remove the drum base spring between the drum base and the drum assembly. (Refer to Fig. 2-44-1.)
- Note:** If the drum base spring is difficult to remove, remove the drum assembly in advance. (Refer to Para.2-10)
- Note:** During removal and installation of the drum assembly, do not touch the tape running surface with your hands.

(Installation)

- ① Set the drum base spring in the gap between the drum base and the drum assembly. Make sure that the drum base spring is secure enough not to fall out.
- ② Apply grease (PG-641) [859D055O30] to the area of the drum base spring as shown in Fig. 2-44-1.

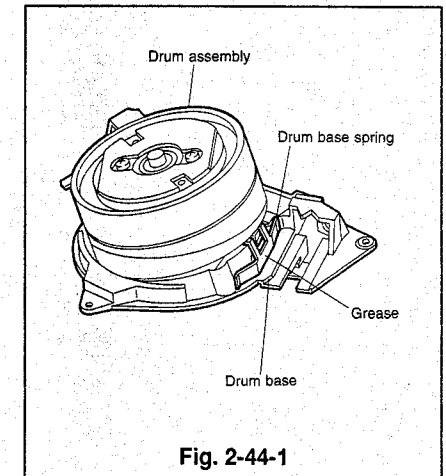

Fig. 2-44-1

2-45. Replacement of ASSY IMPEDANCE ROLLER

(Removal)

- ① Unfasten the catch to remove the FLY WHEEL J.
- ② Remove the IMPEDANCE ROLLER SPRING-J from the catch ㉓ shown in Fig. 2-45-2.
- ③ Shift the ASSY IMPEDANCE ROLLER in the direction shown by the arrow. Unfasten the catch ㉔ and raise the ASSY IMPEDANCE ROLLER to remove it from the HOLDER TG.
- ④ Unfasten two catches of the HOLDER TG on the reverse side to remove the HOLDER TG. [Fig. 2-45-4]

(Installation)

- ① Mount the HOLDER TG on the MAIN PLATE. [Fig. 2-45-4]
- ② Hook the one side of the IMPEDANCE ROLLER SPRING-J to the catch ㉓ and the other side to the catch ㉔ to install the IMPEDANCE ROLLER SPRING-J on the ASSY IMPEDANCE ROLLER. [Fig. 2-45-3]
- ③ Install the ASSY IMPEDANCE ROLLER, to which the IMPEDANCE ROLLER SPRING-J is attached, on the HOLDER TG.

NOTE: Installation of the ASSY IMPEDANCE ROLLER will be easier by pulling the PCB-HA/AUDIO slightly in the direction shown by the arrow in Fig. 2-45-4.

- ④ Make sure that the IMPEDANCE ROLLER SPRING-J is hooked at the catch ㉓ of the HOLDER TG shown in the Fig. 2-45-5.
- ⑤ Install the FLY WHEEL J on the ASSY IMPEDANCE ROLLER so that the side whose hole entrance is cut out diagonally looks up.
- ⑥ Make sure that three catches are tightly hooked on the FLY WHEEL. If they are not, hook them tightly with the tweezers. [Fig. 2-45-1]

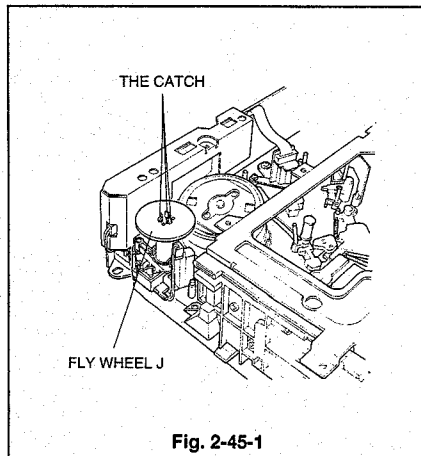

Fig. 2-45-1

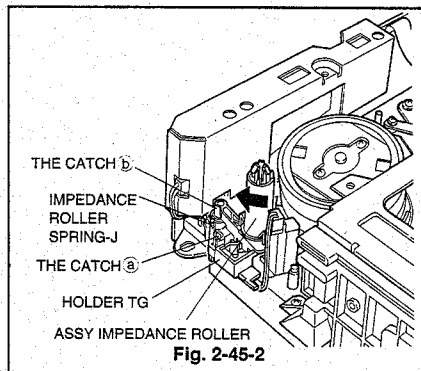

Fig. 2-45-2

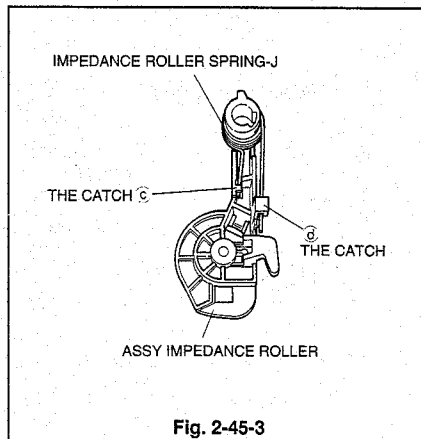

Fig. 2-45-3

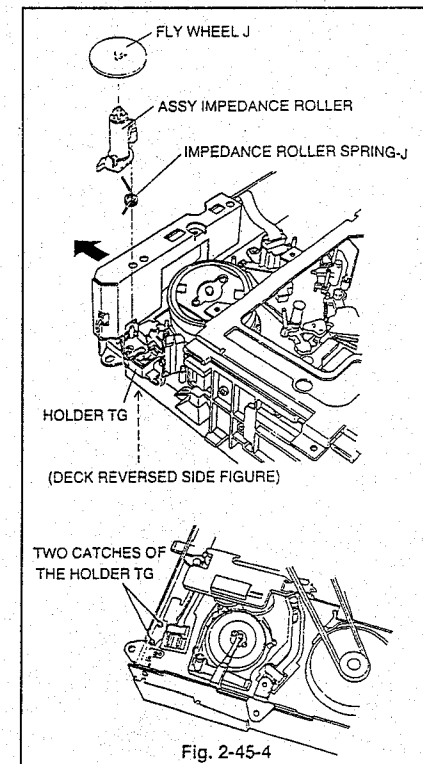
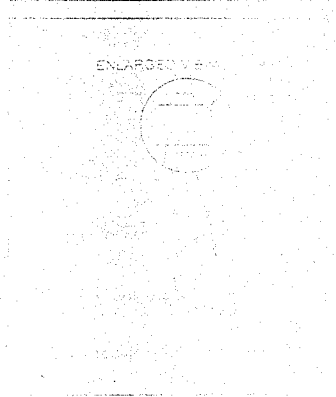

Fig. 2-45-4

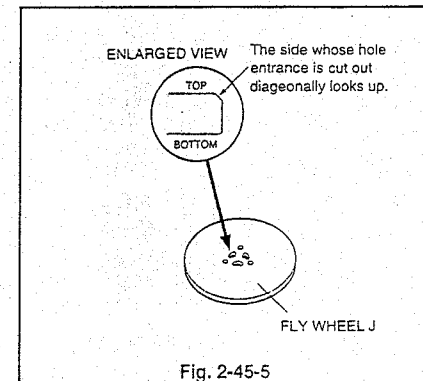

Fig. 2-45-5

3. Interchangeability Adjustment of the Mechanism

Note1: Tracking may need to be preset during interchangeability adjustments of the mechanism. Digital tracking is preset by short circuiting TP5A and TP5B on the PCB-MAIN.

Note2: The adjustments are performed in the playback mode, using the stair step signal of an alignment tape. Connect an oscilloscope to TP2A and external Trig. from TP2H, unless otherwise specified.

3-1 Adjustment of Back-Tension and Tension Pole Position

Run a blank tape for several minutes to break in the reel disks and the transport before making the adjustment.

- ① Cut out the alignment tape [PM6KH3 : 859C339O30] as shown in Fig. 3-1-2. This allows the tape to be adjusted while playing the tape by inserting hexagon wrench through the round hole in the cassette housing shown in Fig. 3-1-1. (Take care not to allow fragments of the cassette case inside the cassette tape.)
- ② Playback an alignment tape which has a cut out.
- ③ Make sure that the tip section A of the tension arm is between the divisions "2" and "2.5" on the main plate. (Fig. 3-1-1) (The divisions are numbered from the right to left.)
- ④ If tip section A of the tension arm is to the right of "2", turn the boss clockwise. If A is to the left of "2.5", turn it counter-clockwise.
- ⑤ Insert a back tension measuring jig (Part No. 859C346060) and set the VCR to the playback mode.
- ⑥ When tape travel becomes steady, make sure that the reading of the Back Tension Measuring Jig is $50 \pm 6g\text{-cm}$.
- ⑦ If the reading is high, replace the tension spring.
- ⑧ When tape travel is steady, check visually to make sure that the runout of the tension pole is 1mm or less. (Fig. 3-1-3)
- ⑨ If the runout is not within the specified value, replace the reel disk.

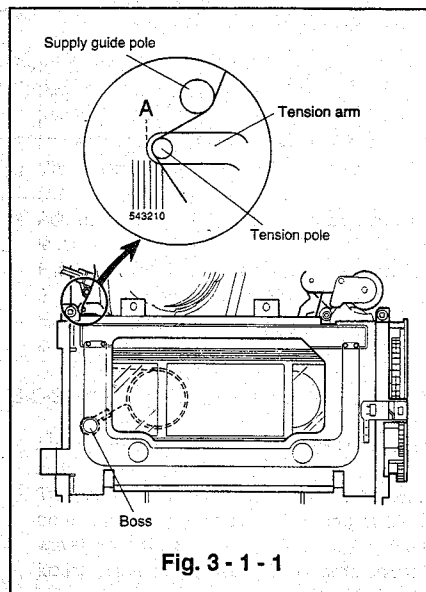

Fig. 3-1-1

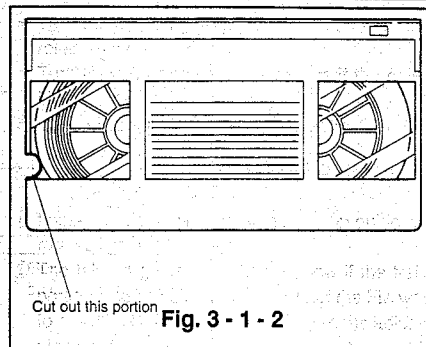

Fig. 3-1-2

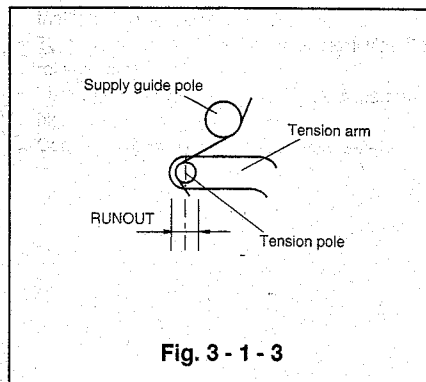

Fig. 3-1-3

3-2 Check and Adjustment of FM Envelope

3-2-1 Guide Roller Adjustment

- ① Play back the alignment tape. [PM6KH3 : 859C339O30]
- ② Preset tracking. (Refer to NOTE 1 in Para. 3.)
- ③ Check if the FM waveform is flat like A. (Refer to Fig. 3-2-1)
- ④ Adjust the height of the supply guide roller if the leading portion (the entry side of the drum) of the FM waveform is not flat, like B or C. (Refer to Fig. 3-2-1) Adjust the height of the takeup guide roller if the trailing portion (the exit side of the drum) is not flat, like D or E.

3-2-2 Adjustment of Supply Guide Roller Height

- ① Loosen the set screw until the supply guide roller is held lightly when rotated.
- ② The supply guide roller may be low if the leading portion (the entry side of the drum) of the FM waveform is like B, and high if like C. Turn the adjusting screw at the top of the roller to adjust the height of it so that the FM waveform is flat like A.
 - Turn the adjusting screw counter-clockwise if the roller is low.
 - Turn the adjusting screw clockwise if the roller is high.
- ③ Coarsely adjust the phase as in Item 3-3-4.

3-2-3 Adjustment of Takeup Guide Roller Height

- ① Loosen the set screw until the takeup guide roller rotates lightly.
- ② The takeup guide roller may be low if the trailing portion (the exit side of the drum) of the FM waveform is like D, and high if like E. Turn the adjusting screw at the top of the roller to adjust the height so that the FM waveform is flat like A.
 - Turn the adjusting screw counter-clockwise if the roller is low.
 - Turn the adjusting screw clockwise if the roller is high.
- ③ Coarsely adjust the phase as in Item 3-2-4.

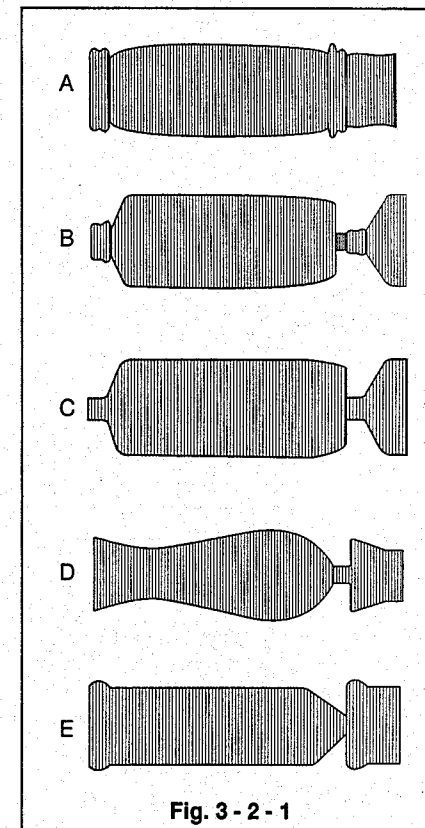

Fig. 3-2-1

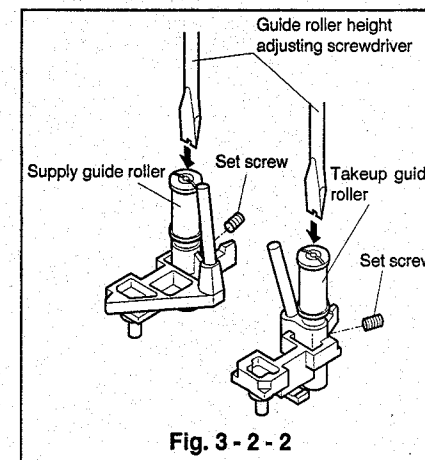

Fig. 3-2-2

3-2-4 Coarse Adjustment of Phase

- 1 Play back the alignment tape.
[PM6KH3 : 859C339O30]
- 2 Preset tracking. (Refer to NOTE 1 in Para. 3.)
- 3 Check the FM waveform after checking and adjusting the guide rollers.
- 4 If the amplitude of the FM waveform is narrow like F because of out of phase, adjust it to maximum like G, as shown in Fig. 3-2-4 by the following procedure. Loosen the screw E, insert a screw driver into the groove at the Base A/C and the main plate, and shift the Base A/C right and left.
- 5 Tighten the screw E to secure the base-A/C in place.

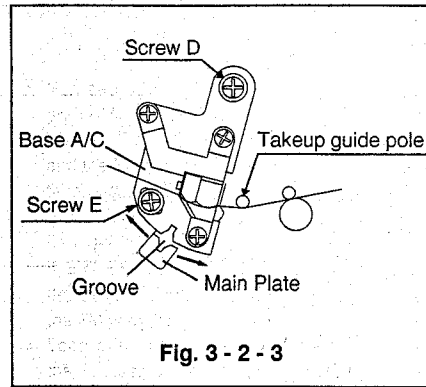

Fig. 3-2-3

3-2-5 Check of FM Waveform Flatness

- 1 Play back the alignment tape.
[PM6KH3 : 859C339O30]
- Note:** In the following adjustment, follow the next procedure for automatic/manual-selection and adjustment of tracking.

- For the manual tracking adjustment, press an up/down button during reproduction.
- To change the adjustment mode from manual to automatic in the tracking adjustment, press the up and down buttons at the same time.

- 2 In the manual tracking mode, change tracking and make sure the amplitude is changeable while the FM signal remains flat.
- 3 Adjust tracking so that the amplitude of the FM waveform is maximum. Set the oscilloscope so the amplitude of the FM waveform is 5 division.
- 4 Adjust tracking so that the peak value of the FM waveform is 4 divisions. Check if the FM waveform B, C, D, and E are within the specified values shown in Fig. 3-2-5.
- 5 If the waveform is not within the specified value, repeat the procedure for checking and adjustment of FM envelope in Item 3-2 from the beginning.

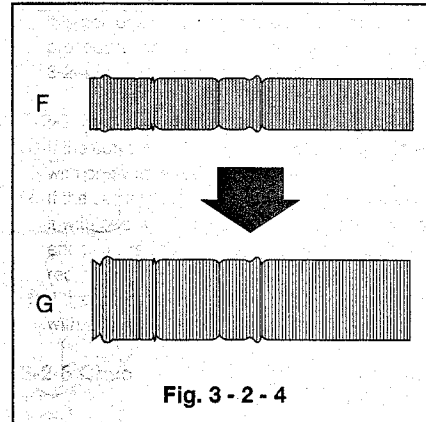

Fig. 3-2-4

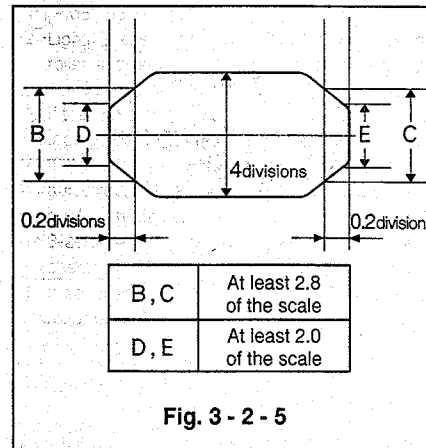

Fig. 3-2-5

3-2-6 Check 1: Tape Running Condition at the Guide Rollers (Refer to Fig. 3-2-6)

- 1 Play back the alignment tape.
[PM6KH3 : 859C339O30]
- 2 Visually check if there is a space between the tape and the lower flange of the supply guide roller and takeup guide roller.
- 3 If there is no space, replace the tape guide as in Item 3-2-7.
- 4 If EITHER GUIDE ROLLER is replaced. Perform the GUIDE ROLLER adjustment in item 3-2-1. And the FM waveform flatness check in item 3-2-5.
- 5 Load and unload the tape several times, check that flatness of the FM waveform does not change.
- 6 If flatness changes, check if the A/C arm is loose. If it is not loose, replace the A/C arm and repeat the procedure for coarse adjustment of phase in Item 3-2-4.

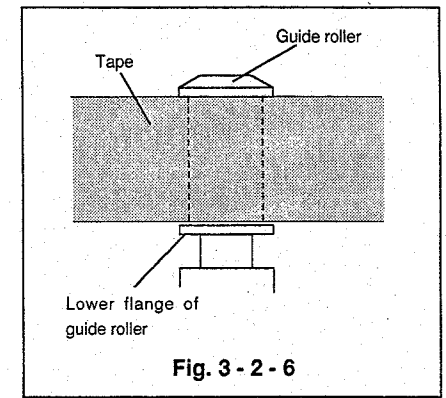

Fig. 3-2-6

3-2-7 Replacement of Tape Guides

- 1 If the current tape guide has no marking, replace it with one with a red mark.
- 2 If the current tape guide has a black mark, replace it with one with no mark. If this replacement is not effective, replace the tape guide with one with a red mark.
- 3 If the current tape guide has a red mark, replace it with another one with red mark.

3-2-8 Check 2: Tape Running Condition on Guide Rollers

- 1 Play back the alignment tape.
[PM6KH3 : 859C339O30]
- 2 Lightly press and release the top of the supply guide roller and takeup guide roller. Check that the FM waveform is quickly restored to the previous level.
- 3 If the waveform is not quickly restored, replace the tape guide as in Item 3-2-7.
- 4 If the supply tape guide is replaced, check the guide roller as in Item 3-2-1, and if the takeup tape guide is replaced, check the guide roller as in Item 3-2-1. Perform the check FM waveform flatness check as in Item 3-2-5.
- 5 If satisfactory, tighten the set screw of the guide roller on the supply side and the takeup side.

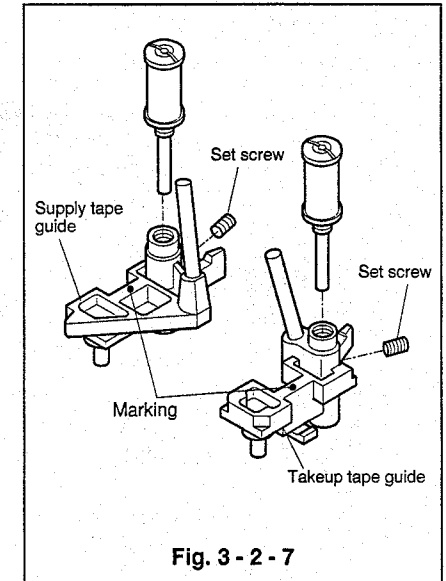

Fig. 3-2-7

Identification of Tape Guide Item Number
(Example; Parts No. 635B059010
Item No. 1)

Item No. 1	No marking
Item No. 2	Marked with black magic marker
Item No. 3	Marked with red magic marker

*The marking point is on the top of the tape guides shown in figure above.

3-3 Adjustment of A/C Head

3-3-1 Adjustment of A/C Head Slant

- ① Playback a blank tape.
- ② Slowly turn the adjusting screw C counter-clockwise to crease the bottom of the tape slightly at the flange portion of the takeup tape guide.
- ③ Return adjusting screw C slowly to remove the crease.
- ④ Slowly turn adjusting screw C counter-clockwise again and stop turning just before the tape is creased.

3-3-2 Adjustment of A/C Head Azimuth and Height

- ① If the height of the CTL head is different from the specified-value in Fig. 3-3-2, adjust the height by the adjusting screw A.
- ② If adjusting screw A is moved, repeat the procedure in Item 3-3-1 to adjust the A/C head Slant.
- ③ Connect the oscilloscope to the audio output terminal and set the VCR to the playback mode.
- ④ Playback the standard tape. [PM6KH3 : 859C339O30]
- ⑤ Turn adjusting screw B to adjust azimuth so that the audio output level is maximum. Set the scope for an amplitude of 5 divisions.
- ⑥ After the adjustment of ⑤, pull out the screw driver and check if the audio output level is 4.6 divisions or more, when the maximum level (audio output) of ⑤ was set for 5 divisions.
- ⑦ If the audio output level is below the specified value, repeat the procedure ①~⑥.
- ⑧ Push the A/C head to the right and left (in the direction of A and A' in Fig. 3-3-1) and then release the A/C head. Check that the audio output level does not change. (Do not push past the point where the audio output level is reduced by 3/4 of its maximum value.)
- ⑨ Set the VCR to the playback mode and check if the change of the audio output level is less than 2dB.
- ⑩ If the change is over 2dB, adjust the A/C head slant again and recheck.
- ⑪ If not satisfactory, replace the takeup tape guide complying with the following procedure and repeat this adjustment.
 - If the original tape guide has no marking, replace it with the one with a black mark.
 - If the original tape guide has a black mark, replace it with one with a black mark.
 - If the original tape guide has a red mark, replace it with the one with a red mark. If this replacement is not effective, replace it with one with a black mark.

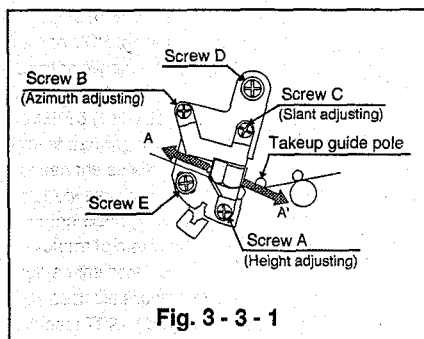

Fig. 3-3-1

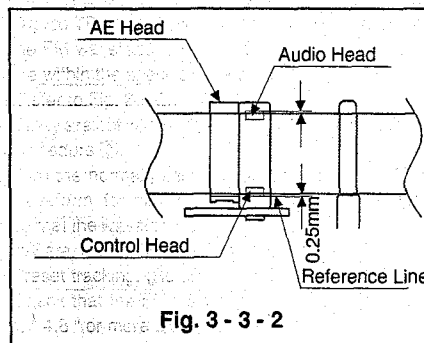

Fig. 3-3-2

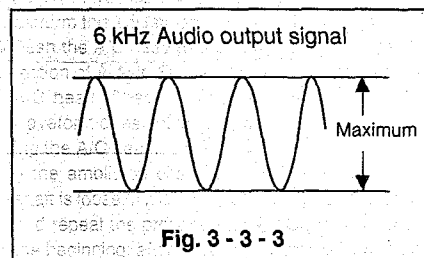

Fig. 3-3-3

Identification of Tape Guide Item Number
(Example; Parts No. 635B059O10)
Item No. _____

Item No. 1	No marking
Item No. 2	Marked with black magic marker
Item No. 3	Marked with red magic marker

* The marking point is on the tops of the Takeup and Supply tape guides.
(Refer to Fig. 3-2-7)

3-4 Adjustment of Phase

- ① Set the VCR to the playback mode.
(Use the alignment tape specified below to perform adjustment ①~④.)
[PM3KE6 (CH1) 25 : 859C568O50]
- ② Preset tracking. (Refer to NOTE 1 in Para. 3.)
- ③ Loosen the screw E, insert a screw driver into the gap between the Base A/C and the main plate, and shift the Base A/C right and left to adjust the FM waveform to maximum.
- ④ Tighten the screw E.
- ⑤ Play back the alignment tape. (PMX:859C568O70)
- ⑥ Connect TP2A (the FM waveform output) and the audio output terminal to the oscilloscope, external Trig. to TP2H, and check if the missing portions of the FM waveform and that of the audio waveform are within the specified value (field).
(Refer to Fig. 3-4-2.)
- ⑦ If they are not within the specified value, repeat the procedure ③.
- ⑧ Turn the normal tracking control to adjust the FM waveform for maximum and set the oscilloscope so that the waveform is '5' divisions. (Refer to Note in Para. 3-2-5 about tracking adjustment.)
- ⑨ Preset tracking. (Refer to NOTE 1 in Para. 3.)
- ⑩ Check that the FM waveform on the oscilloscope is " 4.8 " or more divisions.
- ⑪ If the FM waveform is below " 4.8 " divisions, perform this adjustment after tracking preset.
- ⑫ Push the A/C head to the right and left (in the direction of A-A' in Fig. 3-4-1) and then release the A/C head. Check that the amplitude of the FM waveform does not change from that before shifting the A/C head....
- ⑬ If the amplitude changes, check if the A/C arm shaft is loose. If it is not loose, replace the A/C arm and repeat the procedure of this adjustment from the beginning, after the adjustment of A/C head in Item 3-3.
- ⑭ Alternately load and unload the tape several times to check that the amplitude of the FM waveform does not change.

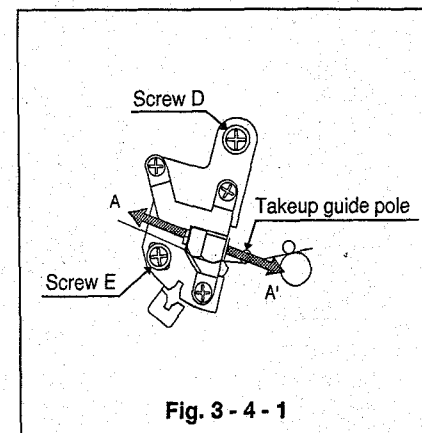

Fig. 3-4-1

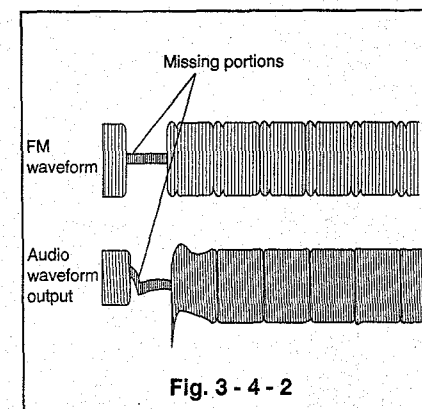

Fig. 3-4-2

3-5 Adjustment of Takeup Guide Arm Height

- ① Run a final portion of E-240 blank tape in the reverse search mode.
- ② Tighten the adjusting nut of takeup tape guide until the tape is creased at the lower flange of the takeup guide pole. Then slowly return the nut and stop at the point where the crease is removed. (During adjustment, use a uncovered cassette tape or raise the cover so that the adjustment can be performed.)

Note: During adjustment, turn the adjusting nut in the loosening direction. Do not turn the nut more than $\pm 1/2$ turn.

- ③ Eject the cassette tape, set the VCR to the reverse search mode again, and check that the tape is not creased at the upper or lower flange of the takeup tape guide.
- ④ Set the VCR to the playback mode and check that the tape is not creased at the upper or lower flange of the takeup guide pole.
- ⑤ Run the start portion of E-180 blank tape in the forward search mode and check that the tape is not creased at the takeup guide pole.

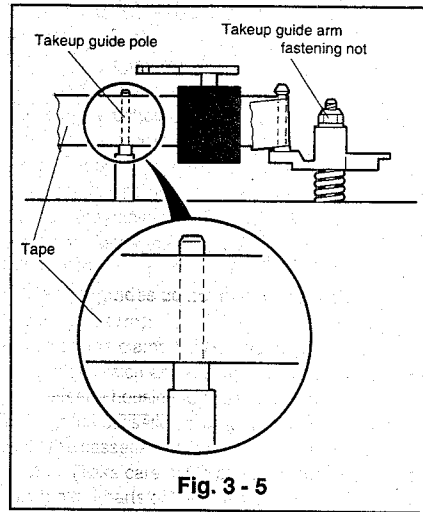

4. Servicing for Tape Jamming during the Loading Mode

- ① Remove the upper cover.
- ② Remove the front unit.
- ③ Remove the bottom panel.
- ④ Reverse the deck and turn the pulley worm J in the direction shown by the arrow in Fig.4-1, observe whether the tape guides move to the unloading position. If they do not, follow the procedure (1). If they do, follow the procedure (2).

(1) If the tape guides do not move (the pulley worm J does not turn);

- ① Unfasten the clamp holding the leads of the loading motor, which are attached to the side plate of the cassette housing. Unscrew screws (a) and (b) holding the cassette housing as shown in Fig. 4-2.
- ② Hold the cassette door with a screw driver to keep it open. (Take care not to allow the screw driver to touch other parts of the tape transport.)

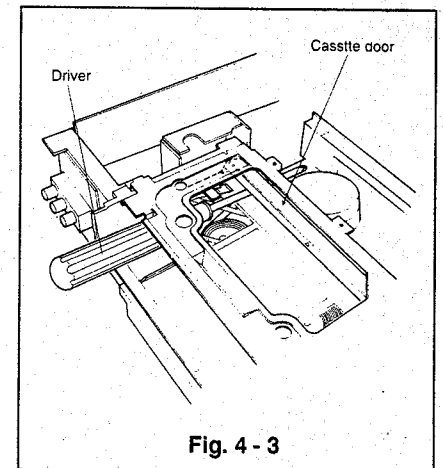
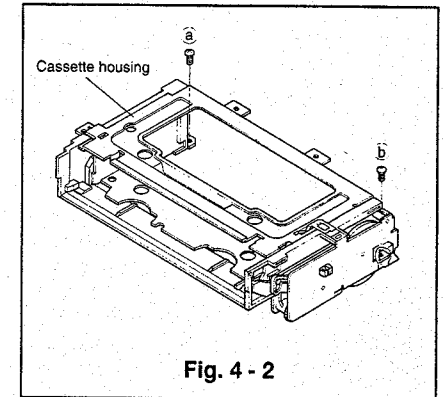
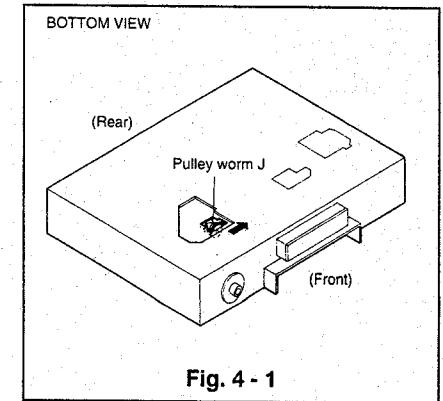

- ③ Open the cassette door fully with your hand. Unfasten the catch to remove the pinch roller arm cap as shown in Fig. 4-4. (Refer to Para. 2-24 for the removal method.)
- ④ Push part A of the pinch roller arm assembly, shown in Fig. 4-5, in the direction shown by the arrow to make a space between the pinch roller arm assembly and the tape. Remove it together with the pinch cam taking care not to damage the tape.
- ⑤ Remove the screw driver (refer to Item ②), while holding the cassette door open with your hand. While pushing the tension arm in the direction shown by the arrow in Fig. 4-6 raise the cassette housing upward to remove it from the tape transport as shown in Fig. 4-7. Take care that the grease, which is applied to the main plate, does not adhere to the tape.

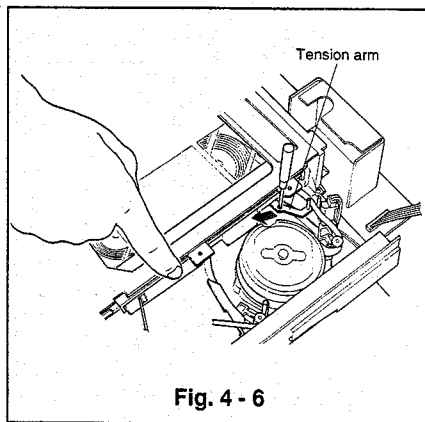
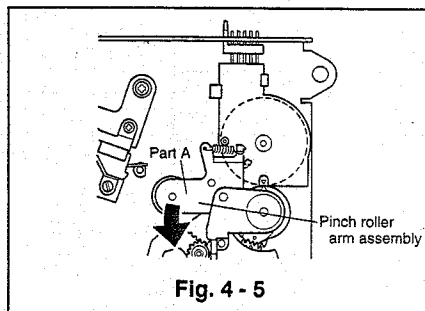
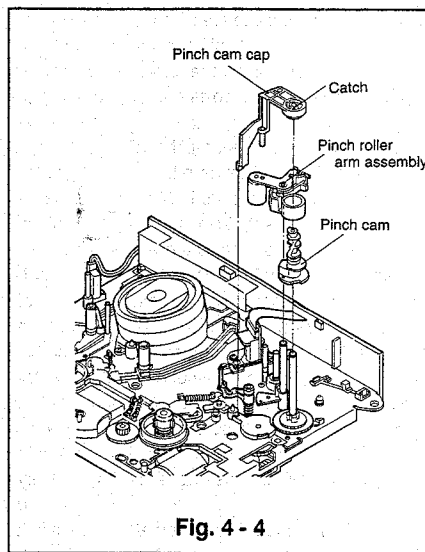

- ⑥ Turn the cassette reel of the cassette tape to wind up the tape as shown in Fig. 4-8.
- ⑦ Turn the wheel gear shown in Fig. 4-9 in the direction shown by the arrow to eject the cassette tape.
- ⑧ Reverse the deck and turn the motor pulley J in the direction, shown by the arrow in Fig. 4-1, so that the matching mark M of the mode switch is in the position shown in Fig. 4-10 (the eject position). Make sure that the matching marks of the mode switch and the gear pinch, and those of the gear pinch and the joint gear, respectively, align as shown in Fig. 4-11. Turn the takeup guide arm clockwise to such a degree that takeup guide gear is not in the way of mounting the pinch roller cam to the shaft. Install the pinch roller cam so that its holes align with the triple catch of the gear pinch. (Refer to Para. 2-24 for the installation method.)
- ⑨ Install the pinch roller arm and the pinch roller arm cap.
- ⑩ Install the cassette housing. (Refer to Para. 2-1 for the installation method.)

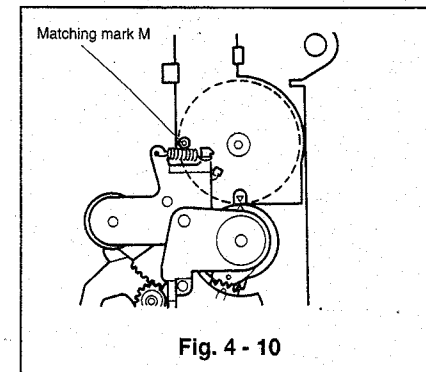
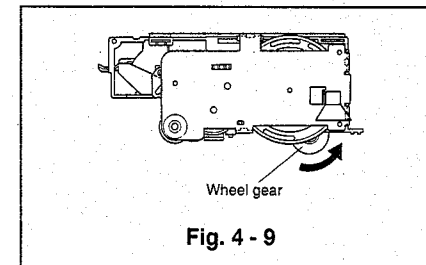
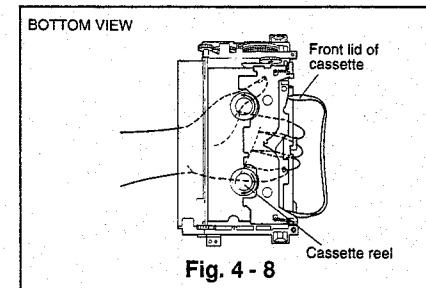
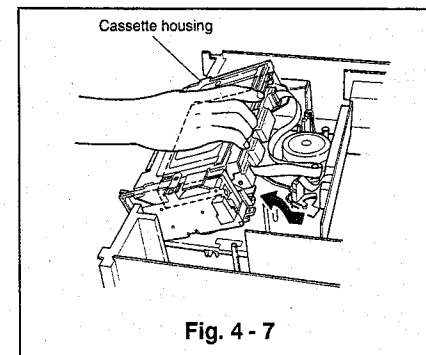

(2) If the tape guides move (the pulley worm J turns);

- ① Reverse the deck and turn the pulley worm J in the direction shown by the arrow in Fig. 4-1 so that the takeup guide arm moves to the end of the unloading cycle.
- ② Turn the capstan shaft, shown in Fig. 4-12, clockwise to turn the reel so that the tape is wound back into the cassette. (Take care not to scar or stain the capstan shaft. After winding up the tape, clean the capstan shaft with alcohol, refer to Para. 1-2.)
- ③ Turn the pulley worm J as in Item ① so that the matching mark of the mode switch is in the position shown in Fig. 4-10 (the eject position). Eject the cassette tape.

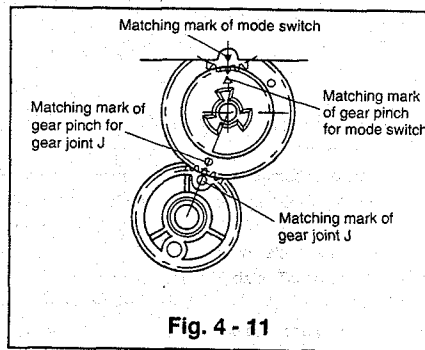

Fig. 4 - 11

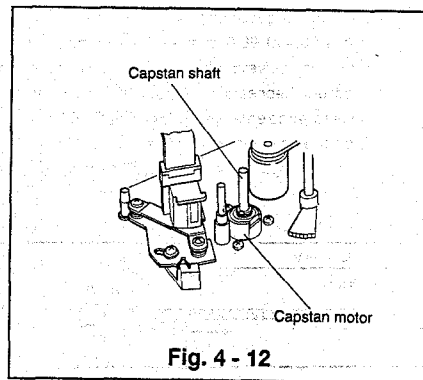

Fig. 4 - 12

SPECIFICATION OF VPS RECORDING SYSTEM

[HS-551V(G) only]

1. VPS Signal

The VPS signal makes it possible during timer recording of television programs to switch on and off the unit at the correct time by using the preprogrammed recording time. The VPS signal is transmitted in the 16th line of the vertical blanking signal. Refer to Fig. 1. The VPS data signal is shown in Fig. 2. The television stations are responsible for changing of the VPS data. These are included in words 11 to 14.

The normal VPS code includes time data and program data. It is transmitted with the program and recognized by the unit as program identification. A program, which was scheduled for the time from 0:99 to 4:00 and the start of which was changed to the previous day, keeps its original label. If the program is extended, the label is valid until 4:00 of the following day, if the correct sending code is received. The maximum starting time for a delayed program is 4:00 of the following day.

2. Expected VPS time and type of VPS recording

- 2-1 At 20:00 on the day before the starting time the recorder is switched on and enters the expected VPS time. During the expected VPS time the unit is switched to the corresponding channel and waits for the VPS signal.
- 2-2 If a VPS signal, which confirms to the preprogrammed signal, is received, the unit switches into the recording mode.
- 2-3 If no VPS signal or status code is transmitted, the original recording time is used.
- 2-4 If an interruption code is transmitted during the VPS recording, the recording is stopped and the unit switches into the VPS stand-by mode. The recording is started, as soon as the regular VPS code is received again.
- 2-5 If the normal VPS code changes after the programmed timer recording into an unnormal code, the recording is finished.

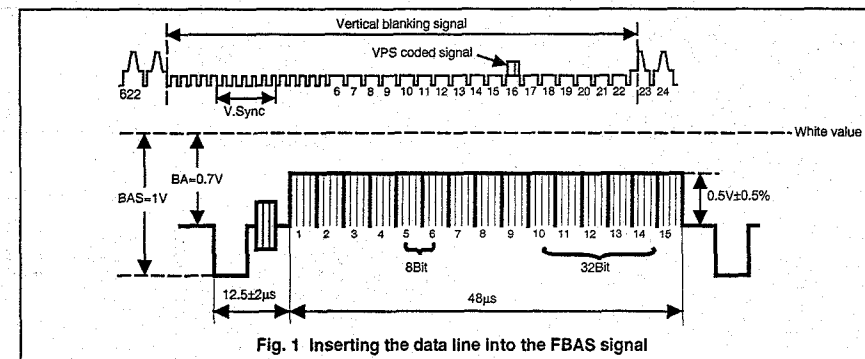

Fig. 1 Inserting the data line into the FBAS signal

Sound data and special designations	Additional VPS Information															
	DZ 16 Word No.								DZ 16 Bit No.							
5	11				12				13				14			
1 2 3 4 5 6 7 8	1		2		3		4		5		6		7		8	
Bit 1 Bit 2 Status	VPS Bit No.		Binary code significance		M		L		M		L		M		L	
0 0 2 channel	Regular label		Day binary		Month binary		Hour binary		Minute binary		Country binary		Program source binary		System status code	
0 1 MONO	Special system codes		Blank code		Interruption code		A		A		A		N		P	
1 0 Stereo																
1 1 2 channel																
Bit 3 Bit 4	0 0		0 0		1 0		1 1		1 1		1 1		1 1		1 1	
0 0	Not used for youth															
1 0																
1 1																

Fig. 2 Data format of additional information in data line 16

The 2-channel status is coded 11 at the studio side; 00 has to be considered at the receiving side in special cases only.

M = MSB
L = LSB

A = Actual address range code
N = Actual country code
P = Actual program source code

GLOSSARY OF ABBREVIATIONS

A/C	: Audio/Control	LIM	: Limiter
ACC	: Automatic Colour Control	LPF	: Low-Pass Filter
A.E	: Audio Erase	LM	: Loading Motor
AFC	: Automatic Frequency Control	MDA	: Motor Drive Amplifier
AFT-D	: Automatic Fine Tuning Door Switch	MC	: Mechanical Control
AGC	: Automatic Gain Control	MIC	: Microphone
AL	: After Load	MOD	: Modulator
AMP	: Amplifier		
ANT	: Antenna	N	: Not Normal
A-PB	: Audio-Playback	OPE	: Operation
A-REC	: Audio-Recording	OSC	: Oscillator
ALC	: Automatic Level Control	O-PWV	: ON/OFF Command from Remote Decoder
B-FS	: Brake Forward Search	PB	: Play Back
B-RS	: Brake Reverse Search	PG	: Pulse Generator
BPF	: Band-Pass Filter	P/R-SW	: P.B/REC-SW
B/W	: Black and White	PCB	: Printed Circuit Board
BS	: Band SW	PIC	: Picture Control
		P/R	: Play/Record
CASS	: Cassette	PSC	: Pulse swallow control
CP	: Capstan	PWT-SET	: Power TV Set
CP-FG	: Capstan-Frequency Generator	PWV	: ON/OFF Command to B + Switching Circuit
CP-F/R	: Capstan-Forward/Reverse		
CP-M	: Capstan-Motor	REC	: Recording
CONV	: Converter	REF	: Reference
CTL	: Control	RIS	: Record Inhibit Switch
C-LAMP	: Cassette Lamp	REW	: Rewind
C-ILAMP	: Cassette Indicator Lamp	REG	: Regulator
CE	: Chip Enable	RS	: Reverse Search
CE	: Not Chip Enable	REC-2	: Record Command for the Fine Editing Circuit
CK	: Clock	R-FS	: Reel Drive Forward Search
CL	: Clear	R-P/R	: Reel Drive Play/Record
CNT	: Counter		
CP R-R	: Capstan Reverse Rotation	S/L	: Stop After Load
CS-1	: Cassette Switch 1	SL	: Slow
CS-2	: Cassette Switch 2	SLOCK	: Slow OK
		S/P	: Still/Pause
DAL	: Delay-After Loading	SS	: Start Sensor
DEMOMD	: Demodulator	SRV-REC	: Servo Record
DET	: Detector	SS	: Not Speed Search
DL	: Delay Line	S-STOP	: Stop Command
DL-REV	: During Reverse	STOK	: Still OK
DL-FWD	: During Forward	STW	: Stop Watch
DOC	: Drop Out Compensator	SENS	: Sensor
DL-SL	: During Slow	STBY	: Stand By
DL-SS	: During Not Speed Search		
DOP	: Drop Out Pulse	TM	: Take up Motor
		T-REC	: Timer-Record
EF	: Emitter Follower	T.P	: Test Point
EMPHA	: Emphasis	TR	: Transistor
EQ	: Equalizer	TU-P	: Tuner-Power
EE	: Electronic-Electronic		
ES	: End Sensor	UL	: Unload
FE-H	: Full Erase Head	VS	: Voltage Synthesizer
FF	: Fast Forward	V.SYNC	: Vertical Sync
FG	: Frequency Generator	VCO	: Voltage Controlled Oscillator
FL-SW	: Front Loading SW	VXO	: Variable Crystal Oscillator
FLM	: Front Loading Motor		
F/R-SW	: FF/Rewind Switch	W/D	: White/Dark
F/R	: Forward/Reverse	X'OSC	: Crystal Oscillator
FS	: Forward Search	Y/C	: Luminance/Chrominance
G	: Ground		
HE	: Hall Element		
H-LED	: Humidity-LED		
H-SENS	: Humidity-Sensor		
HPF	: High-Pass Filter		

CHIP PARTS REPLACEMENT

CHIP PARTS REPLACEMENT

Some resistors, shorting jumpers (0Ω resistor), ceramic capacitors, transistors and diodes are chip parts which are used for certain circuit elements. When replacing these parts, note the following cautions.

Cautions:

- Use fine tipped, well insulated soldering pencil (iron), about 30 watts, and tweezers.
- Melt the solder and remove the Chip Parts carefully not to tear off the copper foil of the printed circuit board.
- Discard removed chips; do not reuse them.
- Do not apply heat for more than 3 seconds to new chip Parts.
- Avoid using a rubbing stroke when soldering.
- Take care not to scratch, or damage the Chip Parts when soldering.
- Supplementary cementing is not required.

1 Removal of Chip Parts (Resistors, capacitors, etc.)

- Grasp the part with tweezers. Melt the solder at both sides alternately, remove one side of the part with a twisting motion.
- Melt the solder at the other side and remove the part.

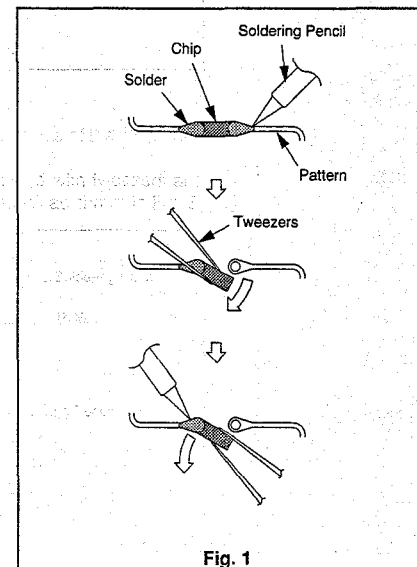

2 Removal of Chip Parts (Transistors)

- Melt the solder of one lead. Lift the side of that lead upward.
- Simultaneously melt the solder of the two remaining leads and lift the part.

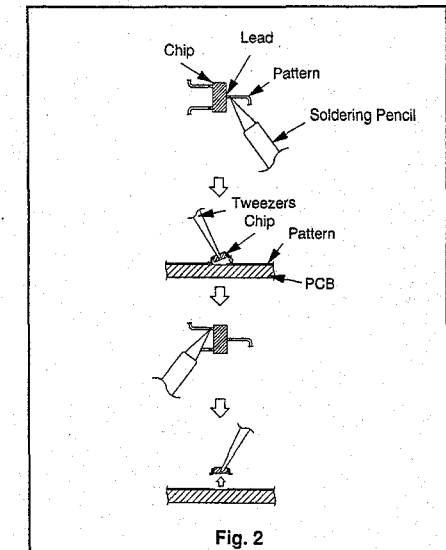

3 Replacement

- Presolder the contact points of the circuit pattern.
- Press the part downward with tweezers and apply the soldering pencil as shown in Fig. 3.

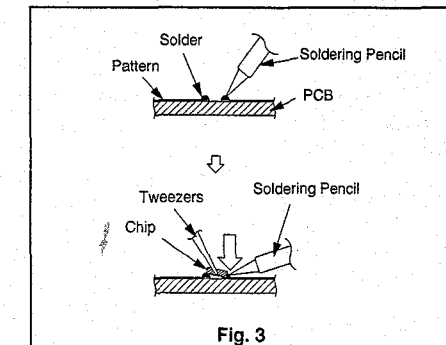

PARTS LIST

1. CABINET ASSEMBLY

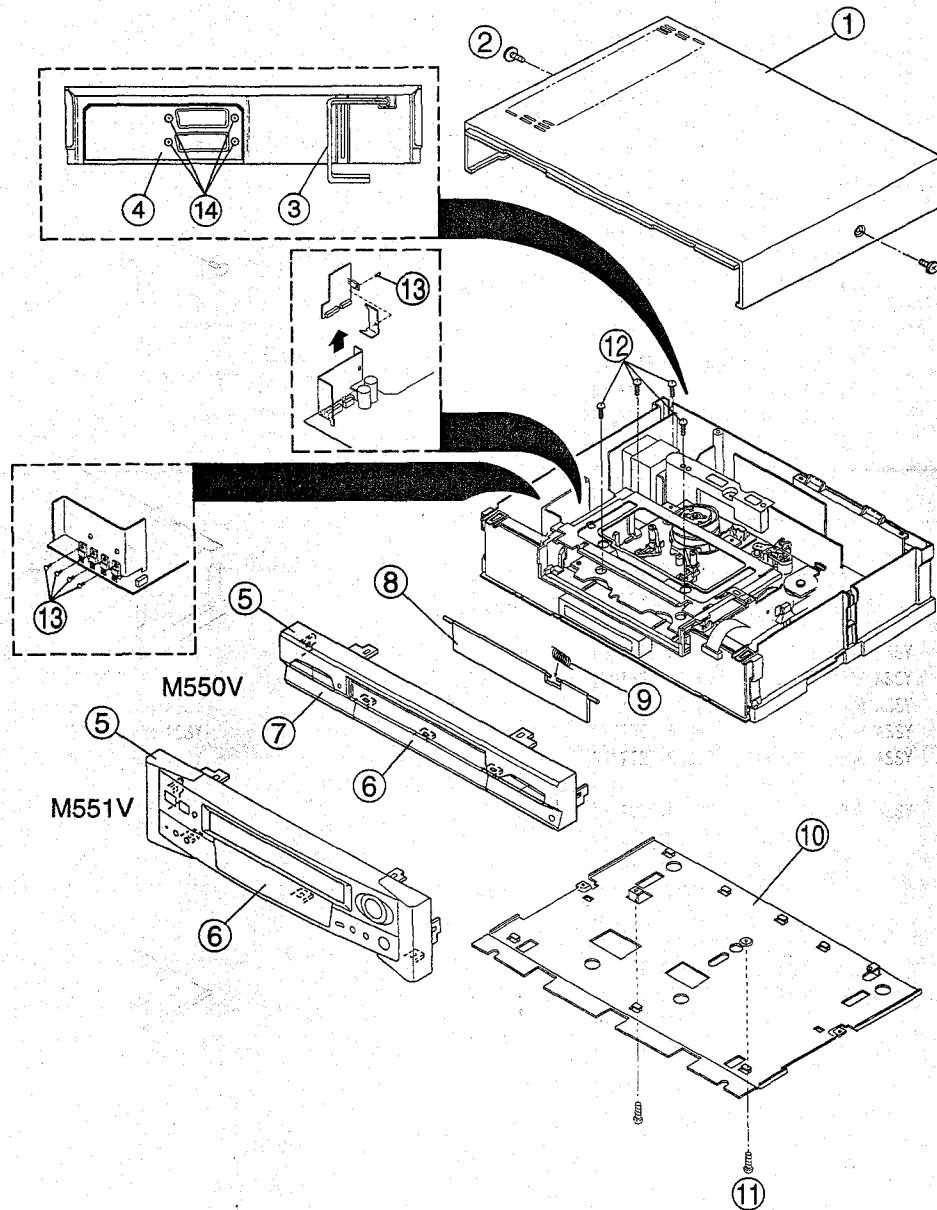

ITEM NO.	PARTS NO.	PARTS NAME	DESCRIPTION
CABINET ASSEMBLY			
1	968C040002	TOP COVER ASSY	
2	669D223080	SCREW	3X10 BLK
3	246C149040	AC POWER CORD	[551VG]
3	246C167030	AC POWER CORD	[550VB]
3	246C167040	AC POWER CORD	[551VB, 551VIR]
3	246C149080	AC POWER CORD	[551VE, 551VG, 551VY]
4	761B283010	COVER ANTENNA	[550VB, 551VIR]
4	761B283020	COVER ANTENNA	[551VB]
4	761B283040	COVER ANTENNA	[551VE, 551VY]
4	761B283030	COVER ANTENNA	[551VG]
5	968B033005	FRONT UNIT	[550VB]
5	968B034015	FRONT UNIT	[551VB]
5	968B034017	FRONT UNIT	[551VE]
5	968B034019	FRONT UNIT	[551VG]
5	968B034018	FRONT UNIT	[551VIR]
5	968B034016	FRONT UNIT	[551VY]
6	702B932010	PANEL TIMER	[550VB]
6	702C156020	PANEL TIMER	[551VB, 551VIR]
6	702C156010	PANEL TIMER	[551VE, 551VG, 551VY]
7	752C163030	DOOR PANEL ASSY	[550VB]
8	752C162040	CASSETTE DOOR ASSY	[550VB]
8	752C162080	CASSETTE DOOR ASSY	[551VB]
8	752C162020	CASSETTE DOOR ASSY	[551VE]
8	752C162050	CASSETTE DOOR ASSY	[551VG]
8	752C164010	CASSETTE DOOR ASSY	[551VIR]
8	752C162090	CASSETTE DOOR ASSY	[551VY]
9	572D385010	SPRING F/L	
10	590A407010	PANEL BOTTOM	
11	669D220030	SCREW	3X10 46LA005
12	669D221040	SCREW	4X12 46LA005
13	669D222090	SCREW	3X10 46LA005
14	669D359040	SCREW	3X12

2. Packing Parts

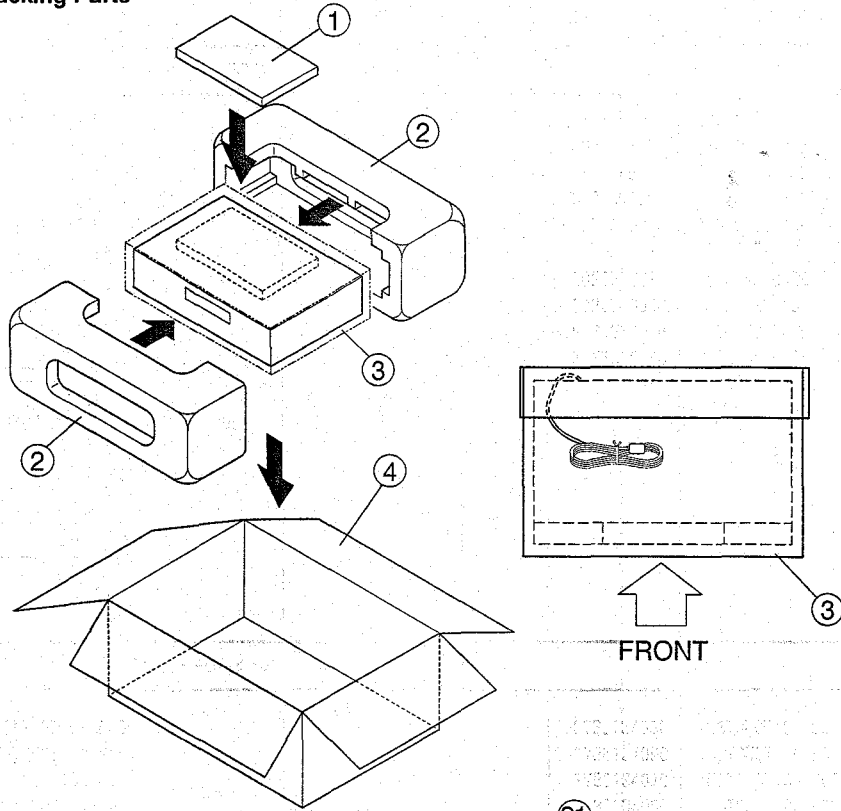

ACCESSORY

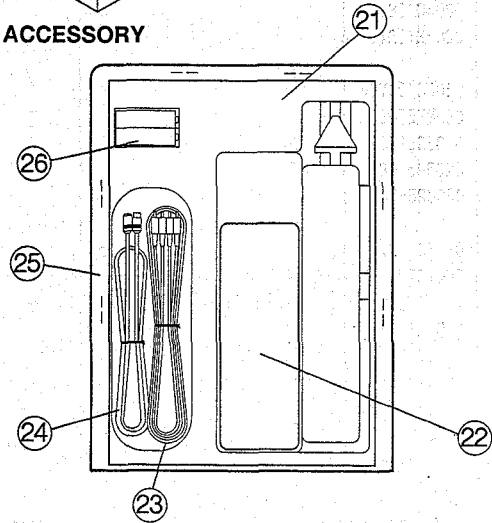

ITEM NO.	PARTS NO.	PARTS NAME	DESCRIPTION
PACKING PARTS			
1	-----	ACCESSORY	
2	803A403010	PACKING CUSHION	
3	-----	POLYETHYLENE SHEET	
4	802B510080	PACKING CASE	[550VB]
4	802B510020	PACKING CASE	[551VB]
4	802B510010	PACKING CASE	[551VE]
4	802B510030	PACKING CASE	[551VG]
4	802B510050	PACKING CASE	[551VIR]
4	802B510040	PACKING CASE	[551VY]
ACCESSORY			
21	872C134050	INSTRUCTION BOOK	[550VB]
21	872C134090	INSTRUCTION BOOK	[551VB]
21	872C134070	INSTRUCTION BOOK	[551VE]
21	872C134080	INSTRUCTION BOOK	[551VG]
21	872C135000	INSTRUCTION BOOK	[551VIR]
21	872C134060	INSTRUCTION BOOK	[551VY]
22	939P578060	REMOTE HAND UNIT	[550VB]
22	939P595010	REMOTE HAND UNIT	[551VB, 551VIR]
22	939P595020	REMOTE HAND UNIT	[551VE, 551VY]
22	939P595030	REMOTE HAND UNIT	[551VG]
23	242C938010	CABLE PHONO	2P R&W L=1.5m [551VE, 551VG]
24	242D231030	CABLE	1.5m [550VB, 551VB, 551VE, 551VIR, 551VY]
24	243C120010	CABLE	[551VG]
25	829B013030	PACKING PACK	ACCESSORY [550VB, 551VB, 551VIR]
25	829B013040	PACKING PACK	ACCESSORY [551VE, 551VY]
25	829B013070	ACCESSORY PACK	[551VG]
26	-----	BATTERY	

SYMBOL NO.	PARTS NO.	PARTS NAME	DESCRIPTION
5C7	141P133080	CHIP CAPACITOR	F50V 0.01 μF-Z
5L5	141P133090	CHIP CAPACITOR	B50V 1000pF-K
701	141P133080	CHIP CAPACITOR	F50V 0.01 μF-Z [3, 4, 6]
703	141P133080	CHIP CAPACITOR	F50V 0.01 μF-Z [3, 4, 6]
704	141P133080	CHIP CAPACITOR	F50V 0.01 μF-Z [3, 4, 6]
705	141P133080	CHIP CAPACITOR	F50V 0.01 μF-Z [3, 4, 6]
706	141P133080	CHIP CAPACITOR	F50V 0.01 μF-Z [3, 4, 6]
707	141P133080	CHIP CAPACITOR	F50V 0.01 μF-Z [3, 4, 6]
709	154P321020	CHIP CAPACITOR	SL50V 10pF-C [3, 4, 6]
713	141P133080	CHIP CAPACITOR	F50V 0.01 μF-Z [3, 4, 6]
720	154P322080	CHIP CAPACITOR	SL50V 47pF-J [3, 4, 6]
7A1	141P139030	CHIP CAPACITOR	B25V 0.1 μF-K [1, 2, 3, 5]
7A3	141P133080	CHIP CAPACITOR	F50V 0.01 μF-Z [1, 2, 3, 5]
7A4	141P133080	CHIP CAPACITOR	F50V 0.01 μF-Z [1, 2, 3, 5]
7A5	141P133080	CHIP CAPACITOR	F50V 0.01 μF-Z [1, 2, 3, 5]
7C0	154P324040	CHIP CAPACITOR	SL50V 220pF-J [1, 2, 3, 5]
7C1	141P139030	CHIP CAPACITOR	B25V 0.1 μF-K [1, 2, 3, 5]
7C3	141P139030	CHIP CAPACITOR	B25V 0.1 μF-K [1, 2, 3, 5]
7C5	141P139030	CHIP CAPACITOR	B25V 0.1 μF-K [1, 2, 3, 5]
7C8	154P322080	CHIP CAPACITOR	SL50V 47pF-J [1, 2, 3, 5]
7C9	154P322080	CHIP CAPACITOR	SL50V 47pF-J [1, 2, 3, 5]
7D3	141P139030	CHIP CAPACITOR	B25V 0.1 μF-K [1, 2, 3, 5]
7D4	141P139030	CHIP CAPACITOR	B25V 0.1 μF-K [1, 2, 3, 5]
7D6	154P323020	CHIP CAPACITOR	SL50V 88pF-J [1, 2, 3, 5]
7D9	141P139030	CHIP CAPACITOR	B25V 0.1 μF-K [1, 2, 3, 5]
7E0	154P323020	CHIP CAPACITOR	SL50V 88pF-J [1, 2, 3, 5]
7E2	141P133080	CHIP CAPACITOR	F50V 0.01 μF-Z [1, 2, 3, 5]
7E5	141P139030	CHIP CAPACITOR	B25V 0.1 μF-K [1, 2, 3, 5]
7E6	154P321020	CHIP CAPACITOR	SL50V 10pF-C [1, 2, 3, 5]
7E8	141P139030	CHIP CAPACITOR	B25V 0.1 μF-K [1, 2, 3, 5]
7F0	141P130040	CHIP CAPACITOR	B50V 390pF-K [1, 2, 3, 5]
7F1	141P133090	CHIP CAPACITOR	F50V 0.022M [1, 2, 3, 5]
901	189P153040	C-METAL-P-FILM	AC250V 0.1 μF-M [1]
902	189P153040	C-METAL-P-FILM	AC250V 0.1 μF-M [1]
9A1	141P133080	CHIP CAPACITOR	F50V 0.01 μF-Z
9A9	141P139030	CHIP CAPACITOR	B25V 0.1 μF-K
9C2	141P133080	CHIP CAPACITOR	F50V 0.01 μF-Z

VITCHES

101	431C106010	SLIDE SWITCH	VTR/TV
5A0	439P033010	SWITCH	RIS MPU1010MMBO
5A1	432P166010	KEY BOARD SWITCH	RESET
8A1	432P089040	KEY BOARD SWITCH	PLAY
8A2	432P089040	KEY BOARD SWITCH	POWER [1]
8A2	432P089020	KEY BOARD SWITCH	POWER [2, 3, 4, 5, 6]
8A3	432P089020	KEY BOARD SWITCH	FF [1]
8A3	432P089040	KEY BOARD SWITCH	FF [2, 3, 4, 5, 6]
8B1	432P089040	KEY BOARD SWITCH	STOP
8B2	432P089040	KEY BOARD SWITCH	EJECT [1]
8B2	432P089020	KEY BOARD SWITCH	EJECT [2, 3, 4, 5, 6]
8B3	432P089020	KEY BOARD SWITCH	REW [1]

SYMBOL NO.	PARTS NO.	PARTS NAME	DESCRIPTION
S 8B3	432P089040	KEY BOARD SWITCH	REW [2, 3, 4, 5, 6]
S 8C1	432P089020	KEY BOARD SWITCH	REC/OTR [1]
S 8C1	432P089040	KEY BOARD SWITCH	REC/OTR [2, 3, 4, 5, 6]
S 8C2	432P089040	KEY BOARD SWITCH	ONE KEY PROGRAM
S 8C3	432P089040	KEY BOARD SWITCH	CH-DOWN
S 8D1	432P089020	KEY BOARD SWITCH	PAUSE [1]
S 8D1	432P089040	KEY BOARD SWITCH	PAUSE [2, 3, 4, 5, 6]
S 8D2	432P089040	KEY BOARD SWITCH	RENT PB [1]
S 8D2	432P089020	KEY BOARD SWITCH	RENT PB [2, 3, 4, 5, 6]
S 8D3	432P089040	KEY BOARD SWITCH	CH-UP
S 8D4	432P089040	KEY BOARD SWITCH	AUTO SET UP/JUST CLOCK [2, 3, 4, 5]
MISCELLANEOUS			
OCU 01	295P276070	RF CONVERTER	[1, 2]
OCU 01	295P276050	RF CONVERTER	[3, 4, 6]
OCU 01	295P276060	RF CONVERTER	[5]
F 901	283D046080	FUSE	T630MA
F 902	283D047050	FUSE	T2.5A
F 903	283D047050	FUSE	T2.5A
J 2A0	451C096040	PIN JACK	RED
J 2A1	451C096010	PIN JACK	WHITE
J 2001	451C058020	CONNECTOR	21P
J 2002	451C058020	CONNECTOR	21P
J 5A1	451C129020	JACK MICROPHONE	[2]
M 470	288P126010	MOTOR CAPSTAN	F20KB79
M 570	288P088060	MOTOR DRUM	DC12V 3.3W
M 571	288P145010	MOTOR LOADING	DC12V 3W
OMB HB	243C158020	LEAD CARD	15P L100(MB-HB)
OMC HC	243C163020	LEAD CARD	25P L100(MC-HC)
OMK TK	243C161070	LEAD CARD	21P L200(MK-TK)
P 5A0	286P010010	BUZZER	PKM22EPT-2001
S 570	439D039010	MODE SELECT SWITCH	(J)
T 370	460P060060	A/C HEAD	
T 371	460P153010	FULL ERASE HEAD	FE HEAD
TU 01	295P418010	TUNER	TEKE4-071A [3, 4, 6]
TU 01	295P194020	TUNER TV	TERB1-044A [1, 2]
TU 01	295P297020	TUNER TV	TERE1-0N3A [5]
OV 8A0	253P115050	TUBE FLUOR	BJ360GK
X 2A0	285P083010	CRYSTAL RESONATOR	4.43362MHz
X 4A0	285P248010	CRYSTAL RESONATOR	4.43MHz
X 501	285P084010	CRYSTAL RESONATOR	17.7345MHz
X 571	285P029040	CRYSTAL RESONATOR	4.00000MHz [2]
X 5A0	285P054030	CRYSTAL RESONATOR	32.8kHz
X 5A1	285P235010	CRYSTAL RESONATOR	8.3886MHz
X 701	285P204020	CRYSTAL RESONATOR	10MHz [3, 4, 6]
OX 7A0	285P253010	CRYSTAL RESONATOR	8.192MHz [1, 2, 3, 5]
Z 8A0	939P580010	PREAMP UNIT	TFMT 5330
PRINTED CIRCUIT BOARD ASSY'S			
○	928D291001	CONNECTOR PCB ASSY	[1, 2, 5]
○	928D291002	CONNECTOR PCB ASSY	[3, 4, 6]
○	928D289001	HA/AUDIO PCB ASSY	
○	928D293006	HIFI/NIC/DEC PCB ASSY	[1]
○	928D293001	HIFI/NIC/DEC PCB ASSY	[2]

SYMBOL NO.	PARTS NO.	PARTS NAME	DESCRIPTION
○	928D293003	HIFI/NIC/DEC PCB ASSY	[3]
○	928D293002	HIFI/NIC/DEC PCB ASSY	[4]
○	928D293005	HIFI/NIC/DEC PCB ASSY	[5]
○	928D293004	HIFI/NIC/DEC PCB ASSY	[6]
○	927B895006	MAIN PCB ASSY	[1]
○	927B895001	MAIN PCB ASSY	[2]
○	927B895003	MAIN PCB ASSY	[3]
○	927B895002	MAIN PCB ASSY	[4]
○	927B895005	MAIN PCB ASSY	[5]
○	927B895004	MAIN PCB ASSY	[6]
○	928D290001	POWER SUB2 PCB ASSY	[1, 2]
○	928D290002	POWER SUB2 PCB ASSY	[3, 4, 6]
○	928D290003	POWER SUB2 PCB ASSY	[5]
○	928D320001	TIMER PCB ASSY	[2]
○	927B791010	TIMER PCB ASSY	[1]
○	928D319001	TIMER PCB ASSY	[2]
○	928D319003	TIMER PCB ASSY	[3]
○	928D319002	TIMER PCB ASSY	[4]
○	928D319005	TIMER PCB ASSY	[5]
○	928D319004	TIMER PCB ASSY	[6]
○	928D292001	SAT PCB ASSY	[2]

ASSEMBLY DECK-2

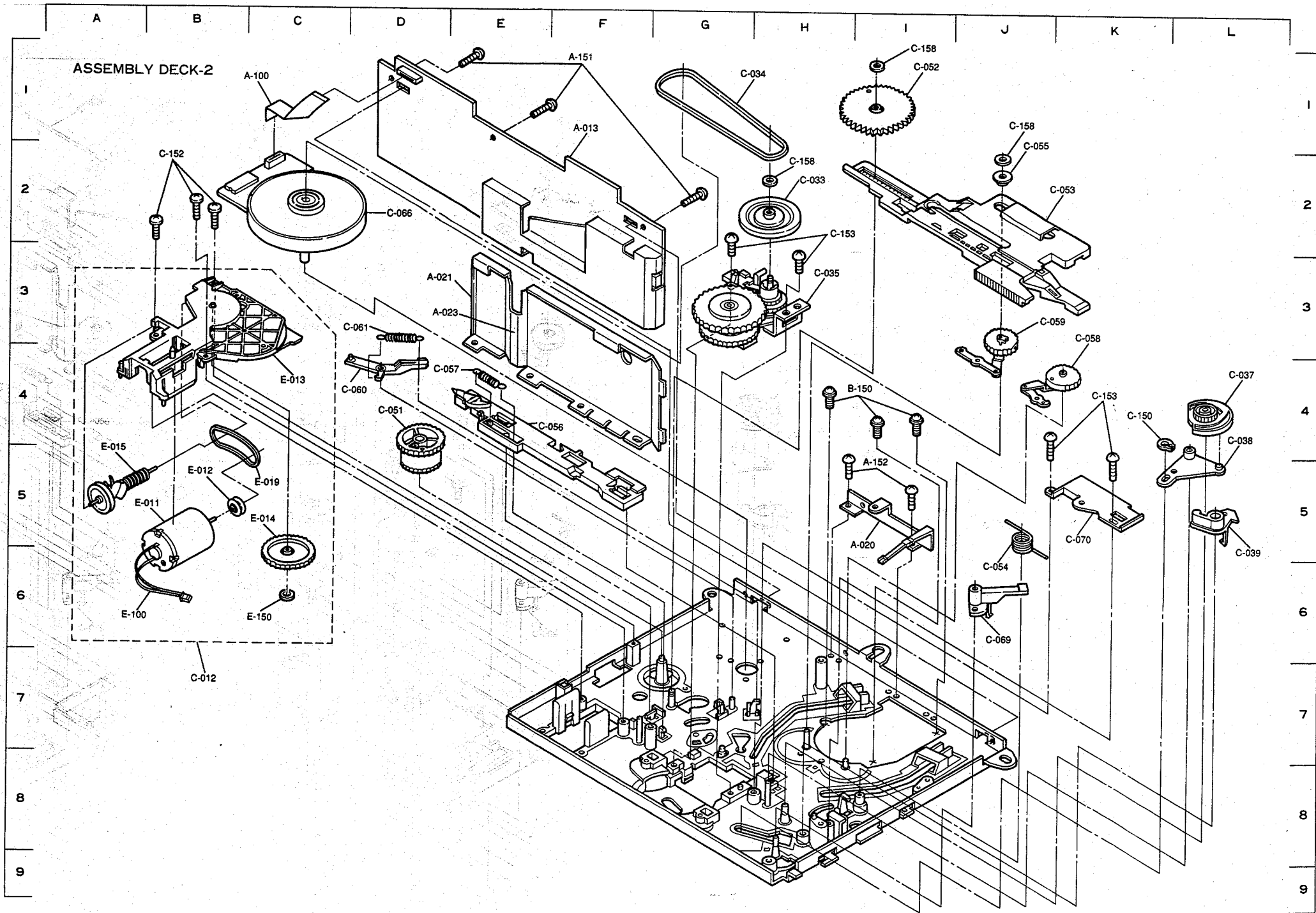

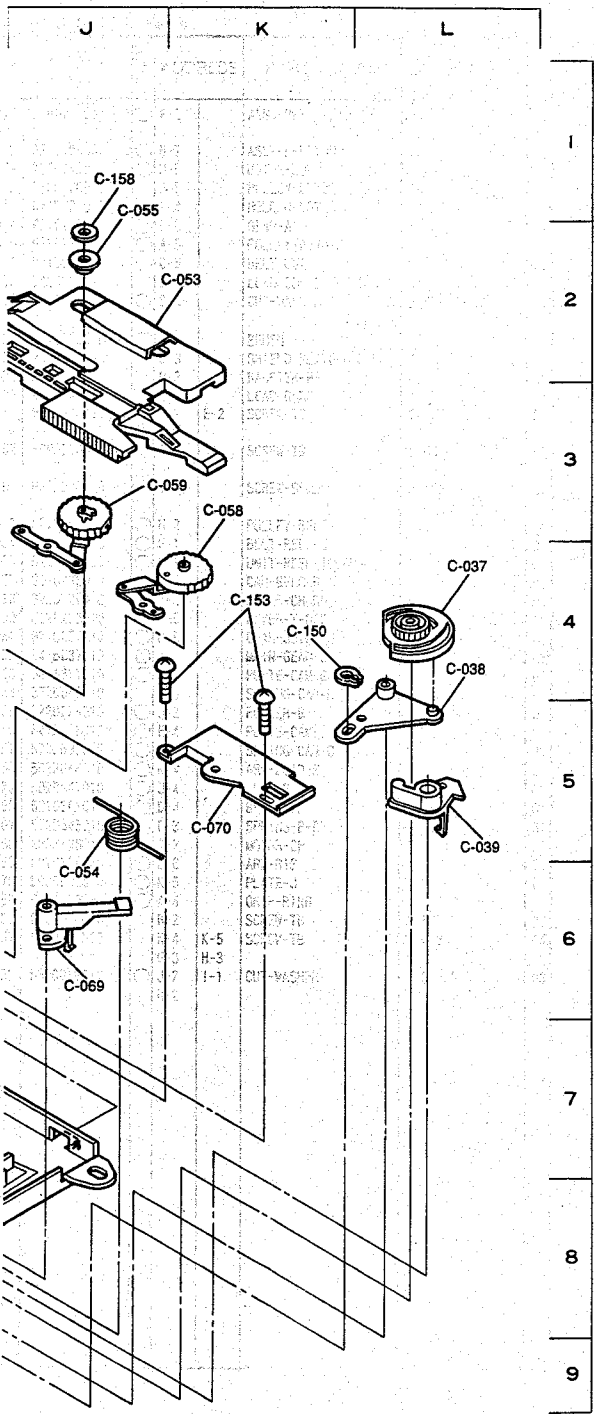

* Settled Service Parts

ITEM	PARTS No.	* ADDRESS	PARTS NAME	DESCRIPTION	Qt.
A-013	928D289001	○ F-2	ASSY-PWB-HA/AUD10		01
C-012	928D105002	○ B-7	ASSY-L-MOTOR		01
E-011	288D145010	○ B-5	MOTOR-LOADING		01
E-012	622D220020	○ B-5	PULLEY-MOTOR		01
E-013	641B727010	○ C-4	HOLDER-MOTOR-J		01
E-014	621C258010	○ C-6	GEAR-A		01
E-015	621C259010	○ A-5	PULLEY-WORM-J		01
E-019	521D088010	○ C-5	BELT-LM2		01
E-100	248B173020	○ B-6	LEAD-CONNECTOR-S		01
E-150	552C018020	○ C-6	CUT-WASHER	2. 5X4. 7X0. 5	01
A-020	299C030010	○ I-5	BRUSH		01
A-021	292B204010	D-3	SHIELD-PLATE-HAK		01
A-023	223D533010	D-3	BARRIER-HA		01
A-100	243C125010	○ C-1	LEAD-CARD		01
A-151	669D224020	E-1	SCREW-TB	2. 6X8	03
		G-2			
A-152	669D224010	I-5	SCREW-TB	2. 6X6	02
B-150	669D200020	I-4	SCREW-SEMS	M2. 6X0. 45-6	03
C-033	621C254010	○ H-2	PULLEY-BELT		01
C-034	521D081010	○ G-1	BELT-REEL-J		01
C-035	522B057030	○ H-3	UNIT-REEL-IDLER		01
C-037	621C235010	○ L-4	CAM-GEAR-R		01
C-038	622D229010	○ L-5	LEVER-CHARGE		01
C-039	622D223010	○ L-5	LEVER-T-OFF		01
C-051	621C257010	○ D-5	GEAR-JOINT-J		01
C-052	641B637010	I-1	MAIN-GEAR-J		01
C-053	641A311010	○ J-2	PLATE-CAM-B		01
C-054	572D640010	○ J-5	SPRING-CAM-B		01
C-055	622D224010	○ J-2	ROLLER-B		01
C-056	641B638010	○ E-4	PLATE-CAM-C		01
C-057	572D636010	○ E-4	SPRING-CAM-C		01
C-058	592B048010	○ K-4	ARM-LOAD-S		01
C-059	592B047010	○ J-4	ARM-LOAD-T		01
C-060	621C261010	○ D-4	BRAKE-CP		01
C-061	572D645010	○ D-3	SPRING-B-CP		01
C-066	288P126010	○ C-2	MOTOR-CP	M470	01
C-069	621C308010	○ J-6	ARM-RIS		01
C-070	593C532010	○ K-5	PLATE-J		01
C-150	685C009010	○ K-4	GRIP-RING		01
C-152	669D224020	○ B-2	SCREW-TB	2. 6X8	03
C-153	669D224010	○ K-4	SCREW-TB	2. 6X6	04
		H-3			
		G-3			
C-158	552C018010	○ J-2	CUT-WASHER	2. 5X6. 0X0. 5	03
		I-1			
		H-2			

4 DECK ASSEMBLY
ASSEMBLY DECK-I

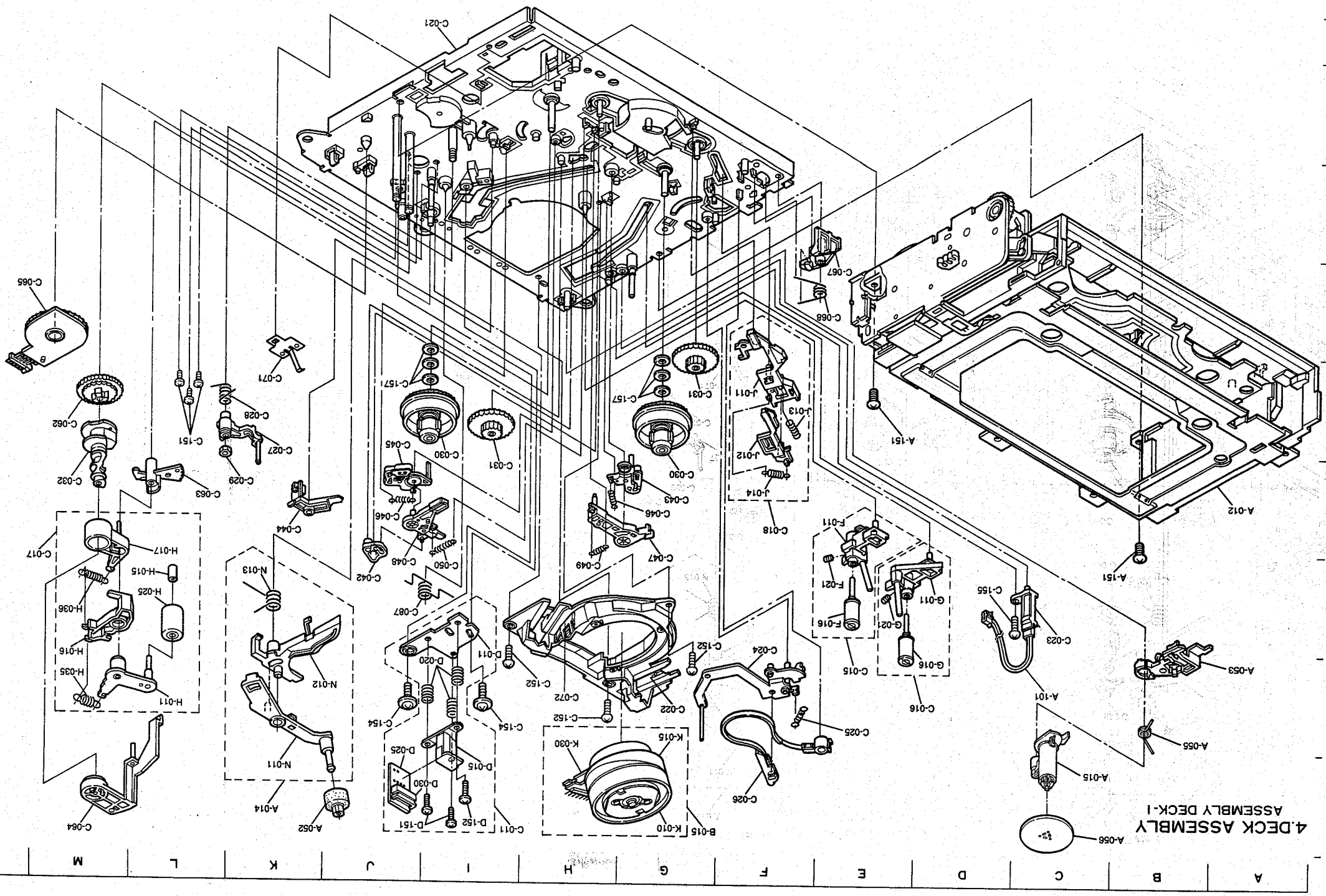

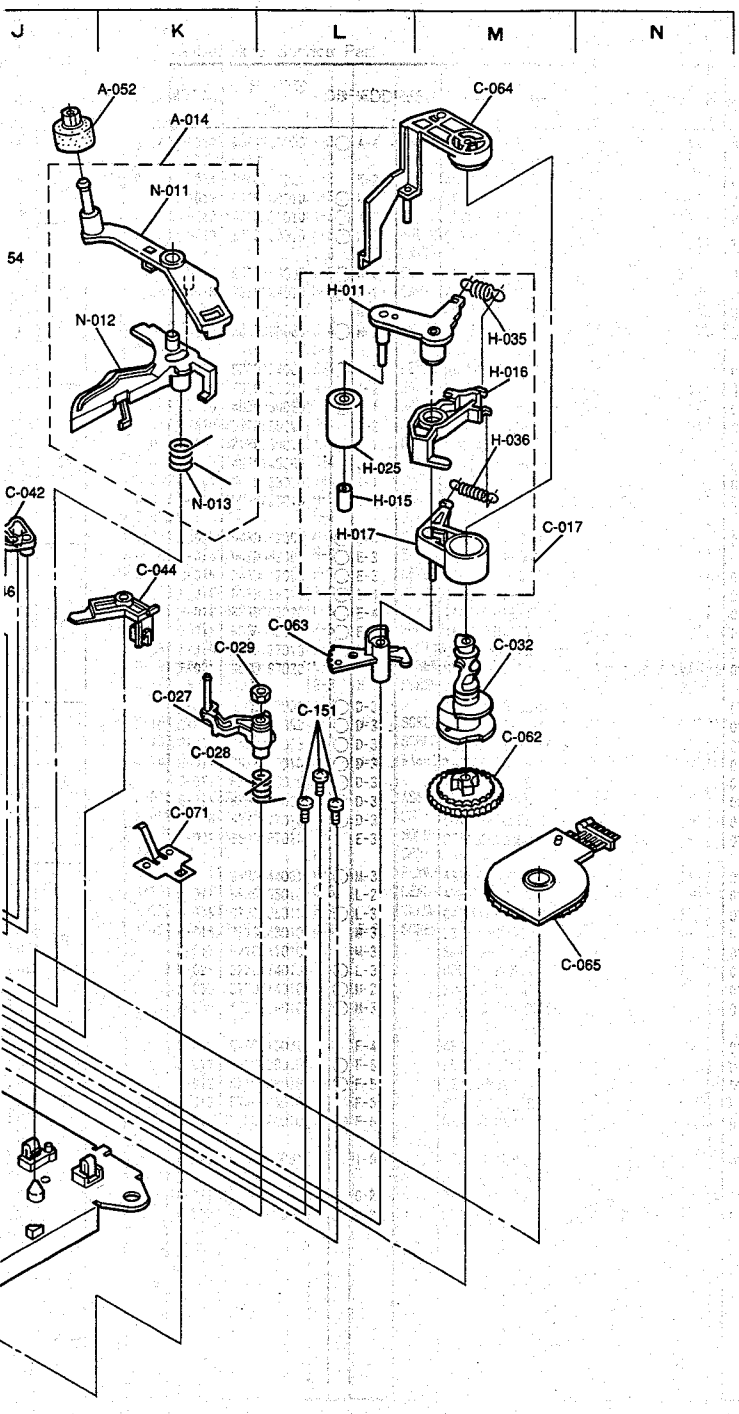

* Settled Service Parts

ITEM	PARTS No.	* ADDRESS	PARTS NAME	DESCRIPTION	Qt.
A-012	948A155006	A-4	ASSY-F/L-J		01
A-014	948B349001	K-2	ASSY-CLE		01
N-011	641B680010	K-2	ARM-CLE		01
N-012	641B681010	K-3	LEVER-CLE		01
N-013	572D703010	K-3	SPRING-CLE		01
B-015	948B358002	G-2	ASSY-DRUM		01
K-010	928B984013	G-1	ASSY-UPPR-DRUM		01
K-015	927B681007	G-2	ASSY-LOWER-DRUM		01
K-030	288P088060	H-2	MOTOR-DRUM	M570	01
C-011	928D104002	I-1	ASSY-A/C-HEAD		01
D-011	593C399010	I-2	PLATE-A/C		01
D-015	460P060060	I-1	HEAD	T370	01
D-020	572D639010	I-2	SPRING-A/C		03
D-025	215C730010	J-1	PWB-A/C-JA		01
D-030	452C140060	J-1	CONNECTOR-PC2M(S)		01
D-151	669D483010	I-1	SCREW	M2. 6X8	02
D-152	669D485010	I-1	SCREW	2. 6X8	01
C-015	948D042001	E-3	ASSY-TAPE-GUIDE-T		01
C-015	948D042002	E-3	ASSY-TAPE-GUIDE-T		01
C-015	948D042003	E-3	ASSY-TAPE-GUIDE-T		01
F-011	6358085010	E-4	TAPE-GUIDE-T		01
F-011	6358085020	E-4	TAPE-GUIDE-T		01
F-011	6358085030	E-4	TAPE-GUIDE-T		01
F-016	522D177010	E-3	GUIDE-ROLLER		01
F-021	669D197020	E-4	SET-SCREW-F	D=M3X0.5 L=4	01
C-016	948D043001	D-3	ASSY-TAPE-GUIDE-S		01
C-016	948D043002	D-3	ASSY-TAPE-GUIDE-S		01
C-016	948D043003	D-3	ASSY-TAPE-GUIDE-S		01
G-011	6358086010	D-3	TAPE-GUIDE-S		01
G-011	6358086020	D-3	TAPE-GUIDE-S		01
G-011	6358086030	D-3	TAPE-GUIDE-S		01
G-016	522D177010	D-3	GUIDE-ROLLER		01
G-021	669D197020	E-3	SET-SCREW-F	D=M3X0.5 L=4	01
C-017	948D044001	M-3	ASSY-ARM-PINCH		01
H-011	593C465010	L-2	ARM-PINCH		01
H-015	622D235010	L-3	CAP-ROLLER		01
H-016	621C243010	M-3	LEVER-PINCH		01
H-017	621C241010	M-3	SLIDER-PINCH		01
H-025	522D174010	L-3	ROLLER-PINCH		01
H-035	572D314010	M-2	SPRING-PINCH		01
H-036	572D714010	M-3	SPRING-CAM-PINCH		01
C-018	948C315001	F-4	ASSY-CHARGE		01
J-011	641B629010	F-6	LEVER-SWING-ID		01
J-012	621C238010	F-5	LEVER-REV		01
J-013	572D684010	F-5	SPRING-CHARGE		01
J-014	572D624010	F-5	SPRING-REV		01
C-021	948A159001	I-9	ASSY-MAIN-PLATE		01
C-022	635A038030	G-2	DRUM-BASE		01
C-023	460P153010	C-3	HEAD-FE	T371	01

* Settled Service Parts

ITEM	PARTS No.	* ADDRESS	PARTS NAME	DESCRIPTION	Qt.
C-024	592B049010	F-3	ARM-TENSION		01
C-025	572D627010	F-2	SPRING-TENS		01
C-026	641B624020	F-2	BELT-TENS-BRAKE		01
C-027	635B084010	K-5	ARM-TU-G		01
C-028	572D647010	K-5	SPRING-TU-G		01
C-029	674D081020	K-5	NUT-NYLON	M3X0.5	01
C-030	522C092010	I-5	UNIT-REEL-DISK		02
C-031	621C234010	I-5	GEAR-R		02
C-032	641B630010	M-4	CAM-PINCH-J		01
C-042	621C315010	J-4	LEVER-SUB-OFF		01
C-043	641B635020	G-4	BRAKE-MAIN-S		01
C-044	622D219010	K-4	LEVER-RELEASE-W/B		01
C-045	641B634020	J-4	BRAKE-MAIN-T		01
C-046	572D635010	H-4	SPRING-M/B-J		02
C-047	641B633010	G-4	BRAKE-SUB-S		01
C-048	641B632020	I-4	BRAKE-SUB-T		01
C-049	572D623010	H-4	SPRING-SUB-S		01
C-050	572D625010	I-4	SPRING-SUB-T		01
C-062	621C240010	M-5	GEAR-PINCH		01
C-063	635C098010	L-4	GEAR-TU-G		01
C-064	641B628010	M-1	CAP-CAM-PINCH		01
C-065	439P039010	N-6	SW-MODE-J	S570	01
C-067	641B641010	E-7	LEVER-RIS		01
C-068	572D646010	E-6	SPRING-RIS		01
C-071	597D102010	K-5	PLATE-EB		01
C-072	572D712010	H-3	SPRING-DB		01
C-087	572D697010	I-3	SPRING-AC-EARTH		01
C-151	669D285040	L-5	SCREW-TB-PAN	M2. 6X8	03
C-152	669D224020	G-3	SCREW-TB	2. 6X8	03
C-154	669D476020	I-3	SCREW-TB-SEMS	2. 6X8	02
C-155	669D224030	D-3	SCREW-TB	2. 6X10	01
C-157	552C017030	G-5	WASHER-THRUST	2. 5X6X0.13	06
A-015	948C322001	C-1	ASSY-IMP-S		01
A-052	621C033010	J-1	UNIT-CLE-ROLLER		01
A-053	641B699010	A-2	HOLDER-TG		01
A-055	572D721010	B-2	SPRING-IMP-J		01
A-056	597D168010	B-1	FLYWHEEL-J		01
A-101	248B173040	C-3	LEAD-CONNECTOR-S		01
A-120	641C685010	E-7	CLAMPER-LEAD-F/L		01
A-151	669D224020	B-4	SCREW-TB	2. 6X8	02

A B C D E F G H I J K L

ASSEMBLY DECK-3

1
2
3
4
5
6
7
8

1
2
3
4
5
6
7
8

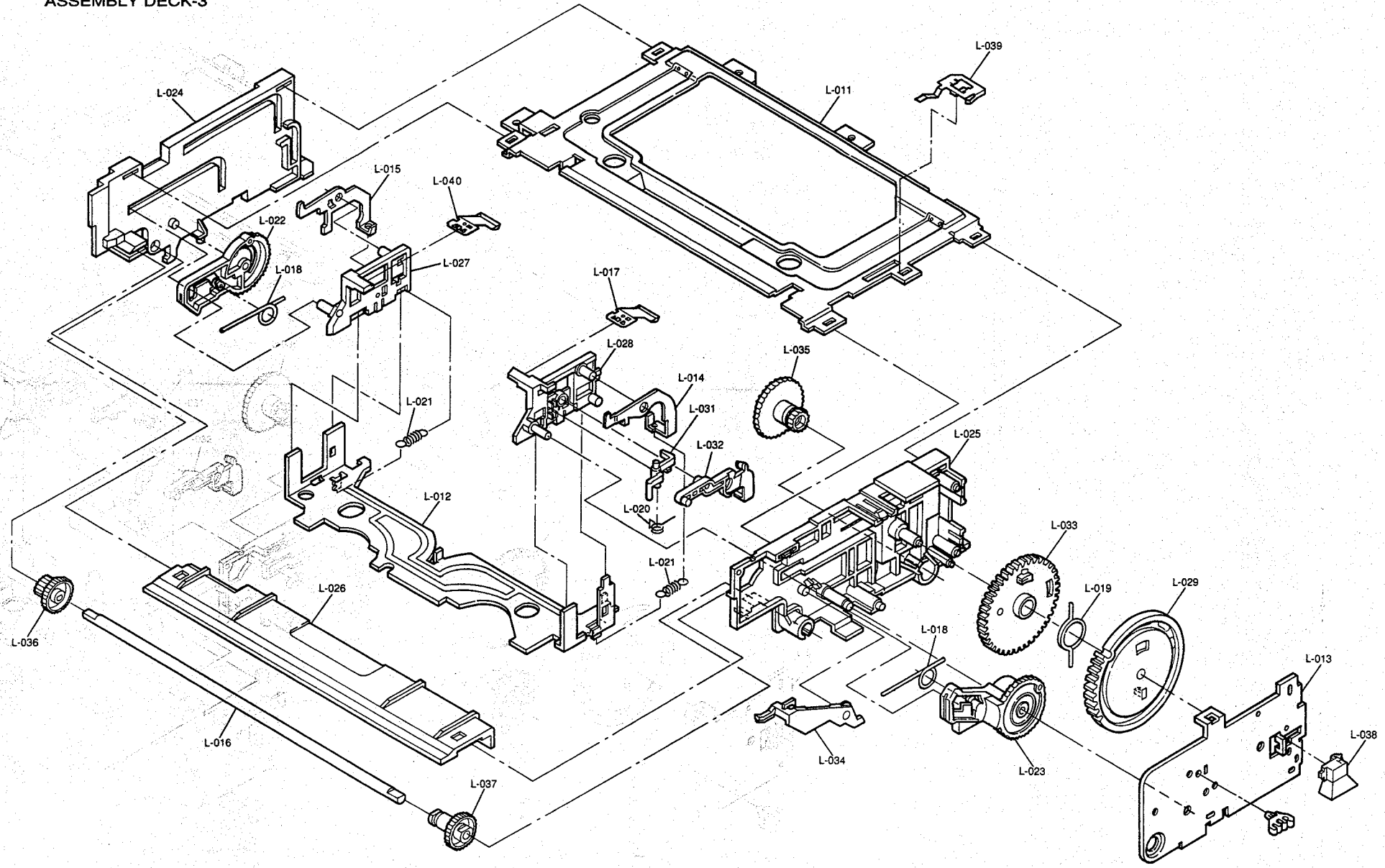

* See

ITEM

L-011
L-012
L-013
L-014
L-015

L-016
L-017
L-018
L-019
L-020

L-021
L-022
L-023
L-024
L-025

L-026
L-027
L-028
L-029
L-030

L-031
L-032
L-033
L-034
L-035

L-036
L-037
L-038
L-039

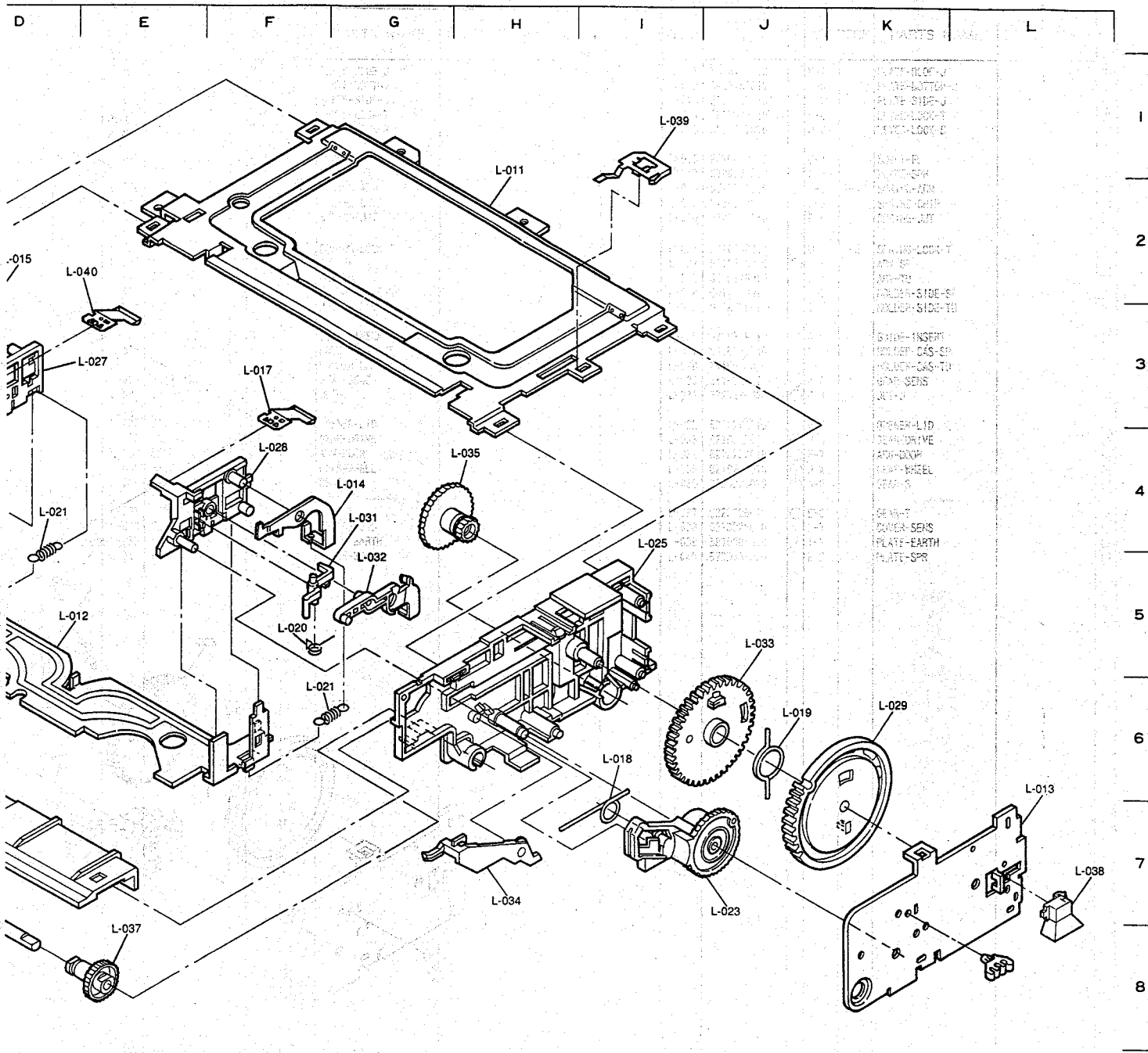

* Settled Service Parts

ITEM	PARTS No.	* ADDRESS	PARTS NAME	DESCRIPTION	Qt.
L-011	5928156010	H-1	PLATE-ROOF-J		01
L-012	5928150010	D-5	PLATE-BOTTOM-J		01
L-013	5928157010	L-6	PLATE-SIDE-J		01
L-014	5960986010	G-4	LEVER-LOCK-T		01
L-015	5960987010	D-2	LEVER-LOCK-S		01
L-016	631D443010	C-7	SHAFT-FL		01
L-017	572D634010	F-3	PLATE-SPR		01
L-018	572D631010	C-3	SPRING-ARM	I-6	02
L-019	572D632010	J-6	SPRING-CHIP		01
L-020	572D633010	F-5	SPRING-JUT		01
L-021	572D630020	D-4	SPRING-LOCK-T	F-6	02
L-022	621C250010	C-3	ARM-SP		01
L-023	641B719010	J-7	ARM-TU		01
L-024	641A360010	B-2	HOLDER-SIDE-SP		01
L-025	641A718010	I-4	HOLDER-SIDE-TU		01
L-026	621C249010	D-6	GUIDE-INSERT		01
L-027	641B626010	E-3	HOLDER-CAS-SP		01
L-028	641B638010	F-4	HOLDER-CAS-TU		01
L-029	641B625010	K-6	GEAR-SENS		01
L-031	622D231010	G-4	JUT-J		01
L-032	621C245010	G-5	OPENER-LID		01
L-033	622D227010	J-5	GEAR-DRIVE		01
L-034	622D230010	H-7	ARM-DOOR		01
L-035	621C252010	H-4	GEAR-WHEEL		01
L-036	622D225010	A-6	GEAR-S		01
L-037	622D226010	E-8	GEAR-T		01
L-038	622D228010	L-7	COVER-SENS		01
L-039	597D085010	I-1	PLATE-EARTH		01
L-040	572D634020	E-2	PLATE-SPR		01

PCB-BLOCK DIAGRAM

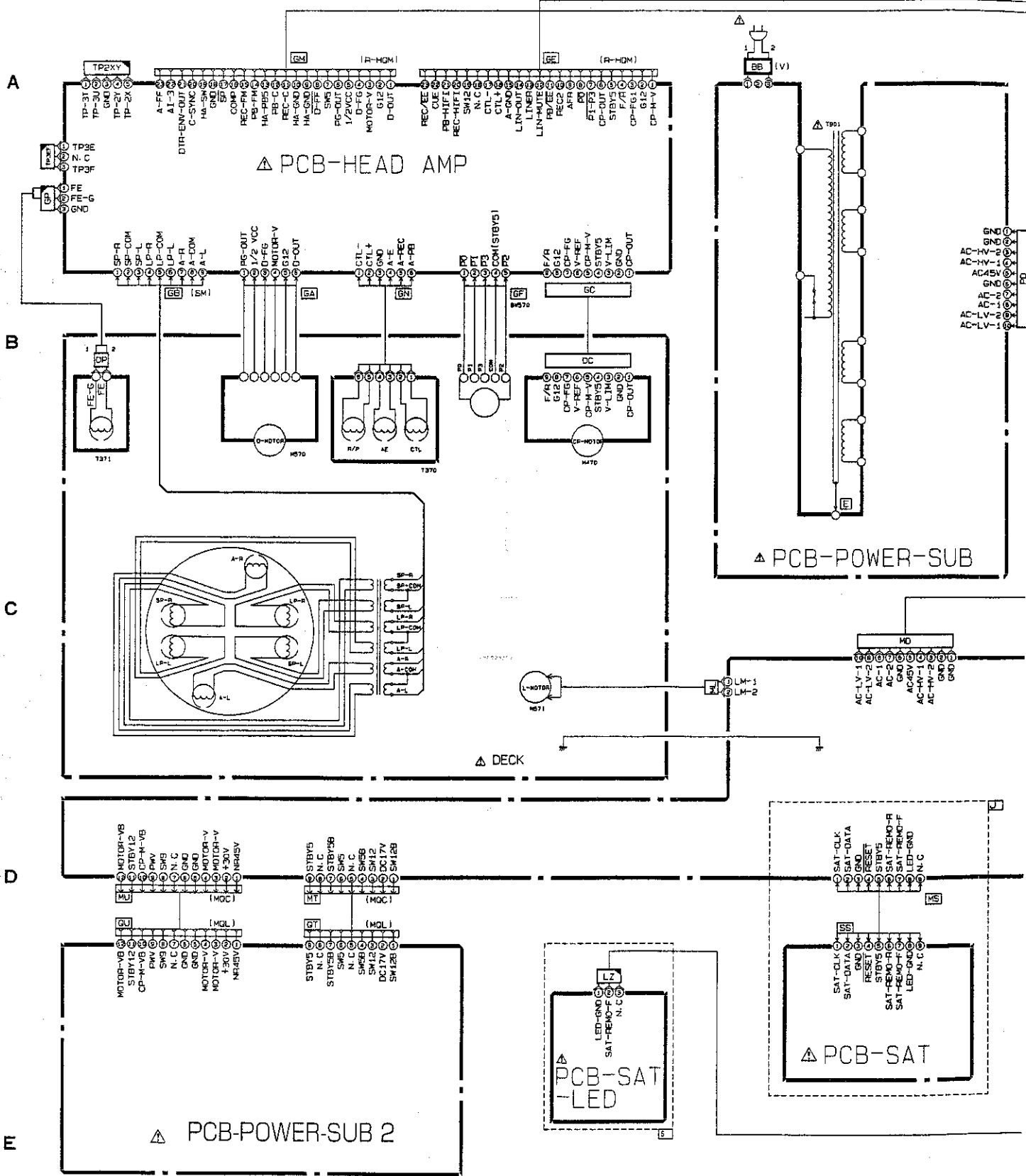

PCB-BLOCK DIAGRAM

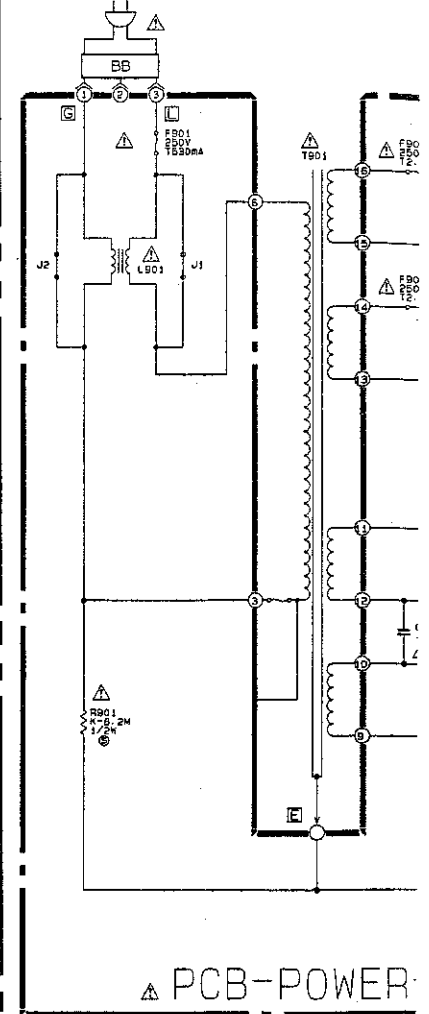
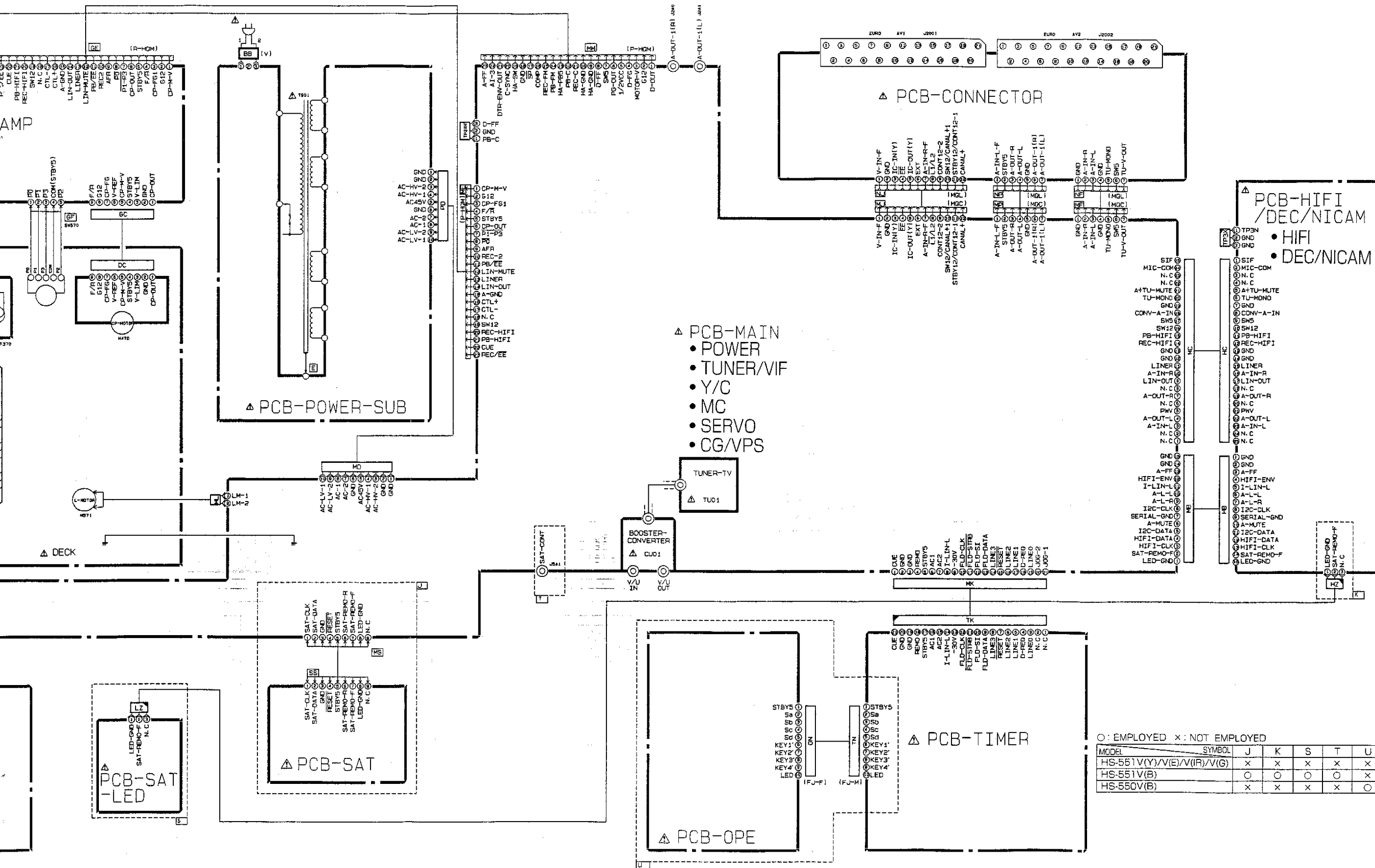

SERVICING PRECAUTION

SYMBOLS INDICATE COMPONENT CHARACTERISTICS IMPORTANT TO PERFORMANCE. THEREFORE REPLACEMENT PARTS SHOULD BE IDENTICAL TO ORIGINAL CHARACTERISTICS. DON'T DEGRADE THE SAFETY OF IMPROPER SERVICING.

CONTENTS

NO.	DESCRIPTION	PC	Y	M	S	C	T	U
1	PCB-BLOCK DIAGRAM	5						
2	PCB-MAIN (POWER)	6						
3	PCB-POWER-SUB	7						
4	PCB-POWER-SUB2	8						
5	PCB-MAIN (TUNER/VIF)	9						
6	PCB-HIFI/DEC/NICAM (DEC/NICAM)							
7	PCB-HIFI/DEC/NICAM (HIFI)							
8	PCB-SAT							
9	PCB-LED							

○ : EMPLOYED x : NOT EMPLOYED

MODEL	SYMBOL	J	K	S	T	U
HS-551V(Y)/V(E)/V(IR)/V(G)		x	x	x	x	x
HS-551V(B)		○	○	○	○	x
HS-550V(B)		x	x	x	x	○

SCHEMATIC DIAGRAM

- NOTE**
- Each voltage should be within $\pm 20\%$ of the DC voltages measured with a digital voltmeter.
 - The voltages parenthesised are on SP recording mode. While those without parenthesised on SP play back mode.
 - Waveforms were taken with standard colour bar signal.
 - TP6A, etc. show Test Points.

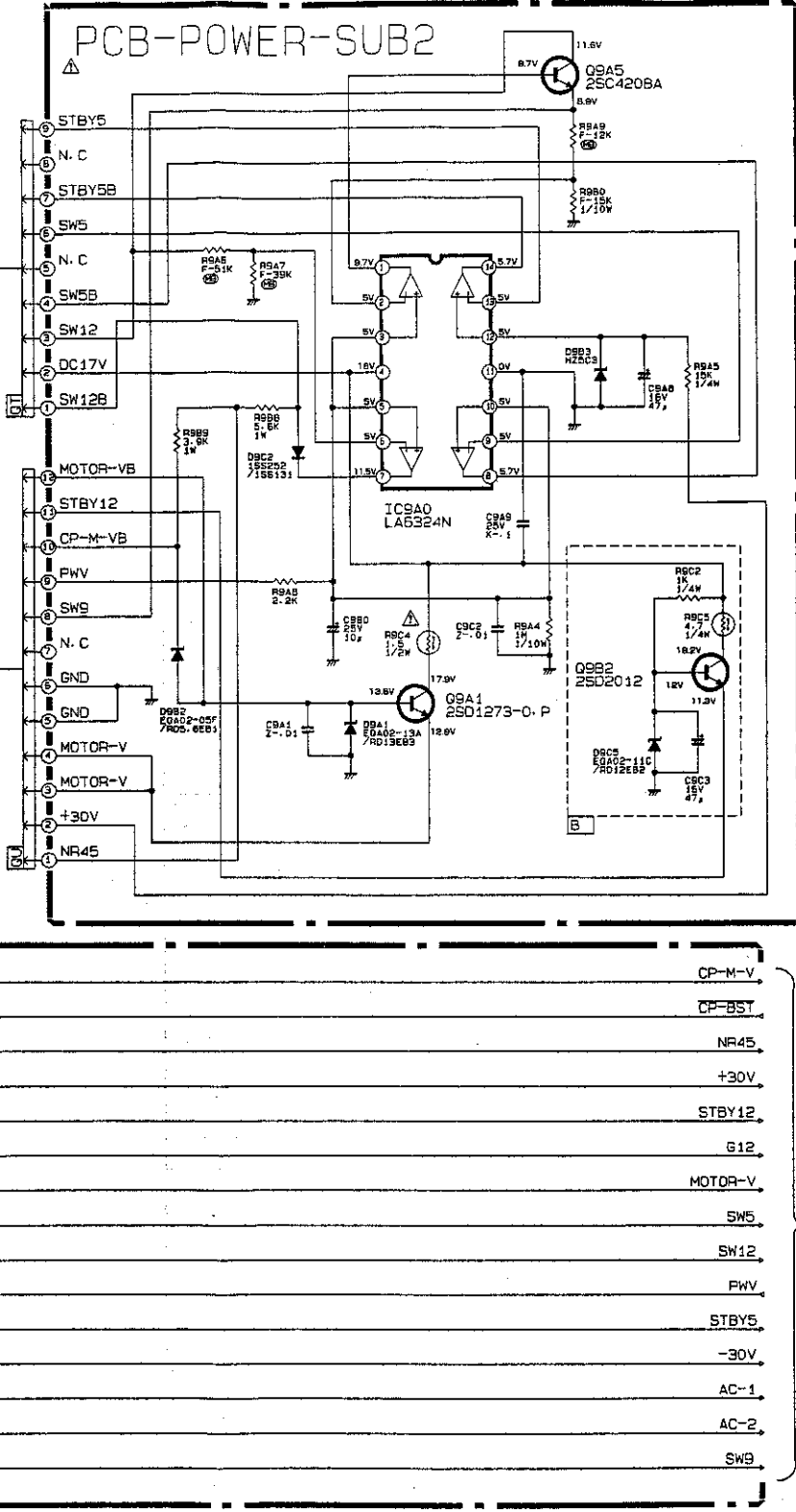
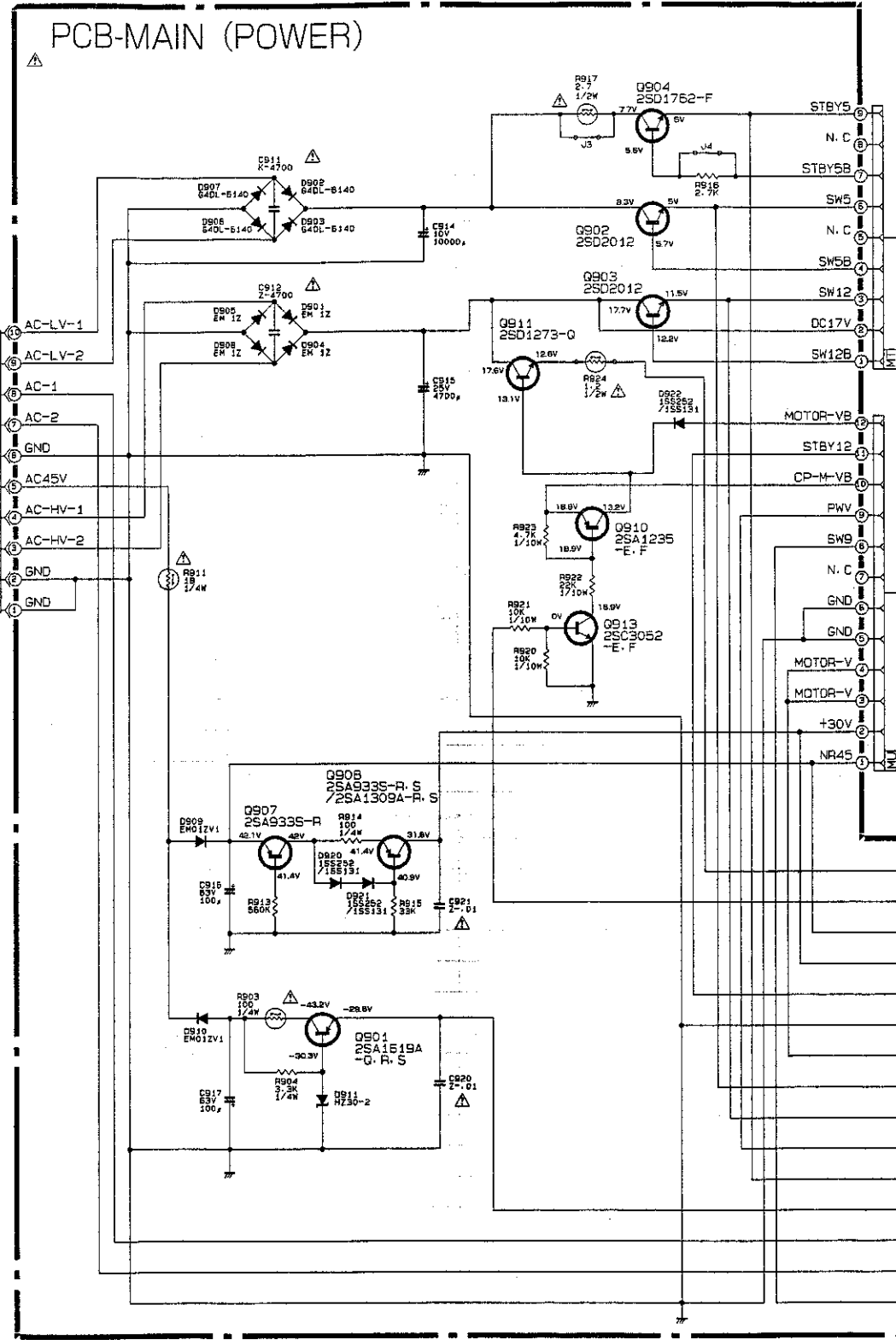
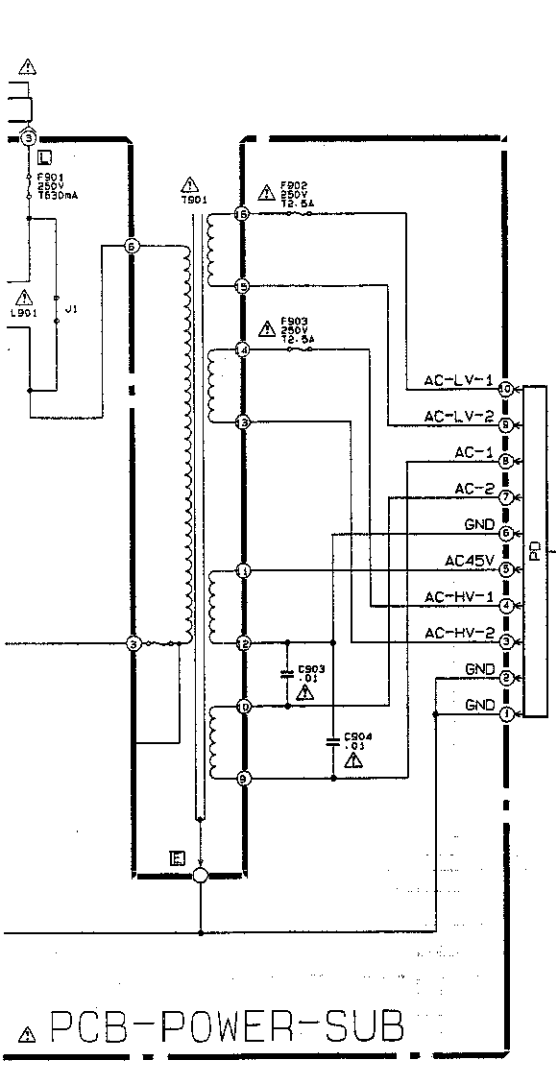

WARNING PRECAUTION

SYMBOLS INDICATE COMPONENTS HAVING SPECIAL CHARACTERISTICS IMPORTANT TO SAFETY AND PERFORMANCE. THEREFOR REPLACEMENT OF ANY PARTS SHOULD BE IDENTICAL IN VALUE AND CHARACTERISTICS.

DO NOT DEGRADE THE SAFETY OF THE VCR THROUGH IMPROPER SERVICING.

CONTENTS

⑤	PCB-MAIN (Y/C)
⑥	PCB-MAIN (MC)
⑦	PCB-MAIN (SERVO) (CG/VPS)
⑧	PCB-TIMER
⑨	TRANSMITTER REMOTE CONTROL

○ : EMPLOYED × : NOT EMPLOYED

MODEL	SYMBOL	J1	R916	J2	R917	J3	B	J4	L901
HS-551V(Y)/V(E)/V(G)		×	○	×	×	○	○	×	○
HS-551V(B)/HS-550V(B)		×	×	×	○	×	×	×	○
HS-551V(IR)		×	○	×	×	○	×	×	○
HS-551V(A)/V(NZ)		○	○	○	×	○	×	×	×

5. CAPACITORS

Value	Not indicated	PF, for numbers more than 1	μF, for numbers less than 1
Dielectric Strength	Not indicated : 50V		
Tolerance	Not indicated $\pm 10\%$	No Tolerance is indicated for electrolytic capacitors and $\pm 20\%$	
Sort	Parts except for chips	Not indicated : Ceramic capacitor	
		(MP) : Polyester capacitor (PP) : Polypropylene film capacitor (ALM) : Aluminum electrolytic capacitor (TF) : Twin film capacitor (SC) : Semiconductor ceramic capacitor (MP) : Metalized paper (MPP) : Metalized plastic film capacitor (MMP) : Metalized polyester capacitor (MF, PP) : Polyester polypropylene film capacitor (PS) : Styrol capacitor (TAN or TANT) : Tantalum capacitor (E) : Electrolytic capacitor (BP or NP) : Non polarized electrolytic capacitor	
Characteristic (only ceramic capacitor)	I	Not indicated : Ceramic capacitor chip	
		(E) : Electrolytic capacitor (BP or NP) : Non polarized electrolytic capacitor chip	
Characteristic (only ceramic capacitor)	II	Not indicated : Ceramic capacitor chip	
		(E) : Electrolytic capacitor (BP or NP) : Non polarized electrolytic capacitor chip	
Characteristic (only ceramic capacitor)	Not indicated : F or B (high dielectric percentage) CH, SL, etc. : Temperature compensating types		

6. Resistors

Value	Not indicated = Ω	
Wattage	Parts except for chips	Not indicated = 1/4W or 1/6W
	Chips	Not indicated = 1/10W
Tolerance	Not indicated	$\pm 5\%$
	D = $\pm 0.5\%$ F = $\pm 1\%$	J = $\pm 5\%$ K = $\pm 10\%$
Short	Parts except for chips	Not indicated : Carbon resistor
		(S) : Fixed composition resistor (MB) : Metal oxide film resistor (type B) (CE) : Cemented resistor (W) : Wire wound resistor (M) : Metal film resistor (MPC) : Metal plate cement resistor (ML) : Metal liner resistor
Short	II	Not indicated : Chip resistor

7. This is a basic schematic diagram. Some sets may be subject to modification according to engineering improvement.

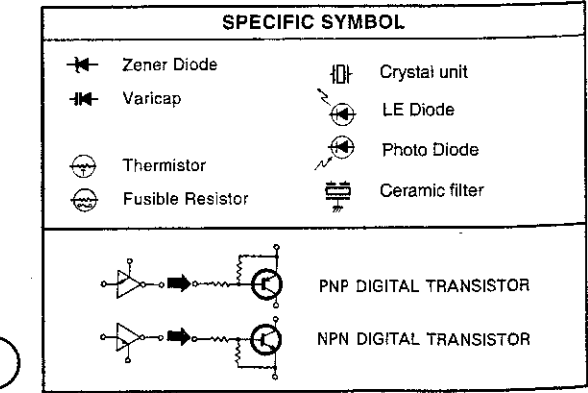

HS-550V(B)
HS-551V(B)/V(G)/V(E)/V(Y)/V(IR)

(TUNER/VIF) PCB-MAIN

○: Employed X: Not employed

SYMBOL	MODEL	(Y)	(B)	(E)	(IR)
A	e-5	○	X	○	X
B	c-5	○	X	○	○
C	a-1	X	X	X	X
F	d-5	○	X	○	X
G	g-8	X	X	○	○
C106	f-8	○	○	X	X
C116	d-7	X	X	X	X
C119	d-7	18SL	15SL	18SL	15SL
C133	d-3	○	X	○	X
D101	d-2	○	X	○	X
L102	f-7	J-1.2μH	J-1.2μH	J-2.2μH	J-1.2μH
L107	d-7	J-39μH	J-56μH	J-39μH	J-47μH
L109	c-8	J-5.6μH	J-8.2μH	J-5.6μH	J-8.2μH
Q106	e-3	○	X	○	X
Q107	c-3	○	X	○	X
R04	b-7	X	○	X	○
R18	a-4	X	X	X	X
R102	f-6	1K	1K	1.8K	1.8K
R104	f-6	68	68	220	220
R116	d-7	X	X	X	X
R118	c-8	F-150	F-390	F-150	F-330
R199	d-3	○	X	○	X
RJ101	e-5	X	○	X	○
RJ106	a-3	○	○	○	○
RJ107	f-7	○	○	X	X
S101	a-4	○	○	○	○

(B): Means HS-551V(B) and HS-550V(B)

ALL NPN TRANSISTORS ARE 2SC3052-E.F UNLESS ALL DIODES ARE 1SS252/1SS131 UNLESS OTH

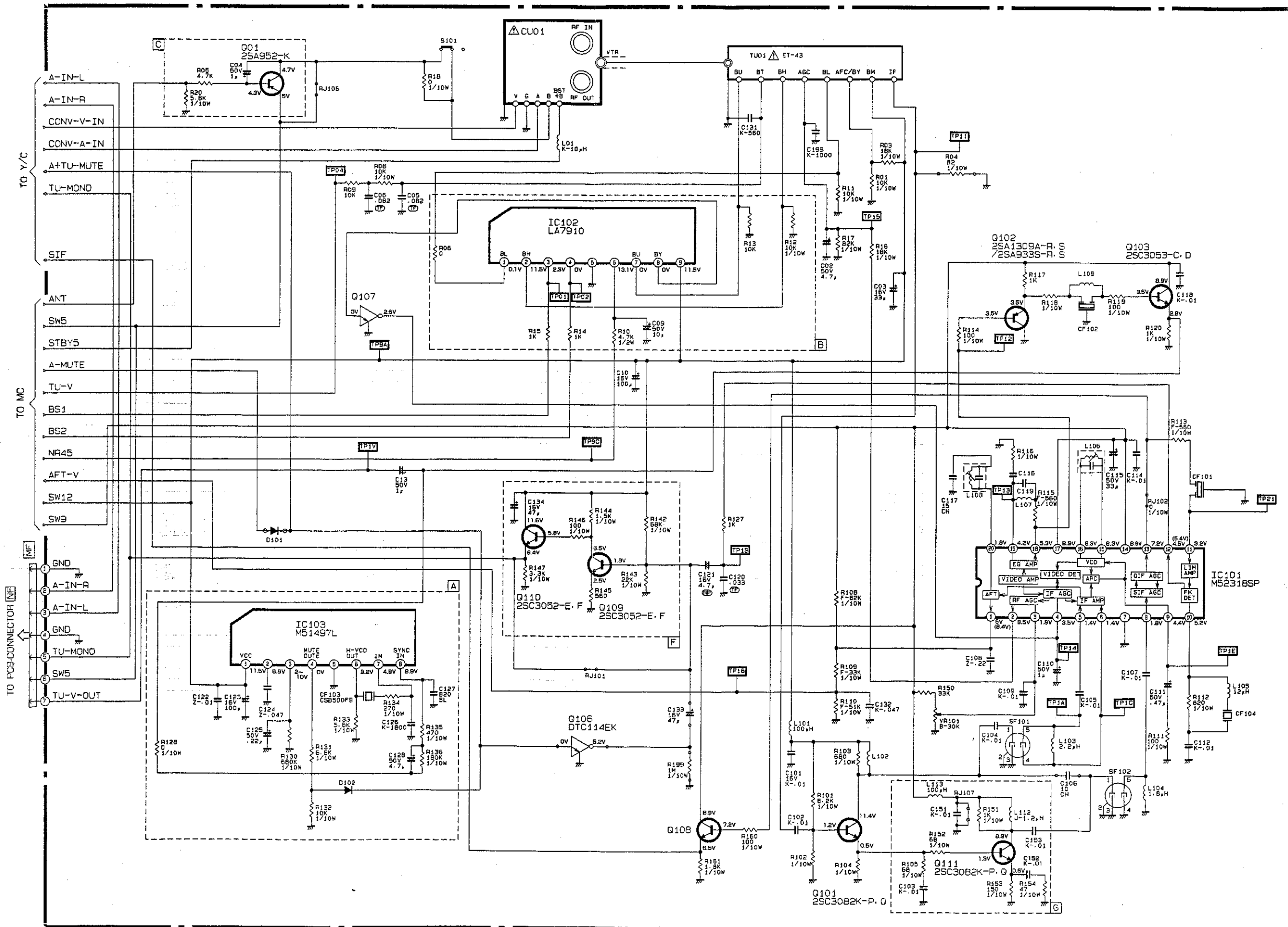
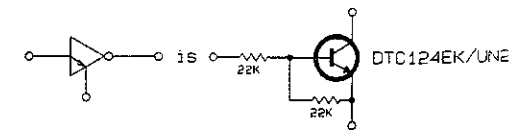

HS-550V(B)
HS-551V(B)/V(G)/V(E)/V(Y)/V(IR)

②

Employed X Not employed

MODEL ADDRESS	(Y)	(B)	(E)	(IR)	(G)	(A)	(NZ)
e-5	○	×	○	×	○	×	×
c-6	○	×	○	○	○	○	○
a-1	×	×	×	×	×	×	×
d-5	○	×	○	×	○	×	×
g-8	○	×	○	○	×	×	○
f-8	○	○	×	×	○	○	×
d-7	×	×	×	×	×	×	33SL
d-7	18SL	15SL	18SL	15SL	18SL	15SL	12SL
d-3	○	×	○	×	○	×	×
d-2	○	×	○	×	○	×	×
f-7	J-1.2μH	J-1.2μH	J-2.2μH	J-1.2μH	J-1.2μH	J-2.2μH	J-1.2μH
d-7	J-39μH	J-56μH	J-39μH	J-47μH	J-39μH	J-47μH	J-39μH
c-B	J-5.6μH	J-8.2μH	J-5.6μH	J-8.2μH	J-5.6μH	J-5.6μH	J-5.6μH
e-3	○	×	○	×	○	×	×
c-3	○	×	○	×	○	×	×
b-7	×	○	×	○	×	○	○
a-4	×	×	×	×	×	○	○
f-6	1K	1K	1.8K	1.8K	1K	1K	1.8K
f-6	68	68	220	220	68	68	220
d-7	×	×	×	×	×	×	0Ω
c-B	F-150	F-390	F-150	F-330	F-150	F-180	F-220
d-3	○	×	○	×	○	×	×
e-5	×	○	×	○	×	○	○
a-3	○	○	○	○	○	×	×
f-7	○	○	×	×	○	×	×
a-4	○	○	○	○	○	×	×

Means HS-551V(B) and HS-550V(B)

ISTORS ARE 2SC3052-E.F UNLESS OTHERWISE SPECIFIED. RE 1SS252/1SS131 UNLESS OTHERWISE SPECIFIED.

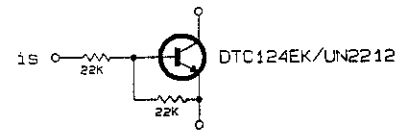

All diodes are 1SS252 unless otherwise specified.
 All NPN transistors are 2SC3053-C.D unless otherwise specified.
 All PNP transistors are 2SA1235-E.F unless otherwise specified.

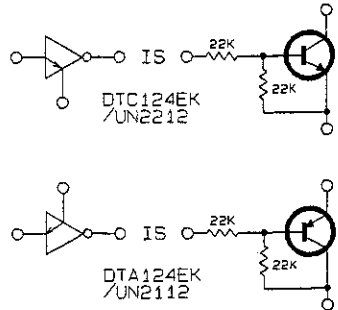

(DEC/NICAM) PCB-HIFI/DEC/NICAM

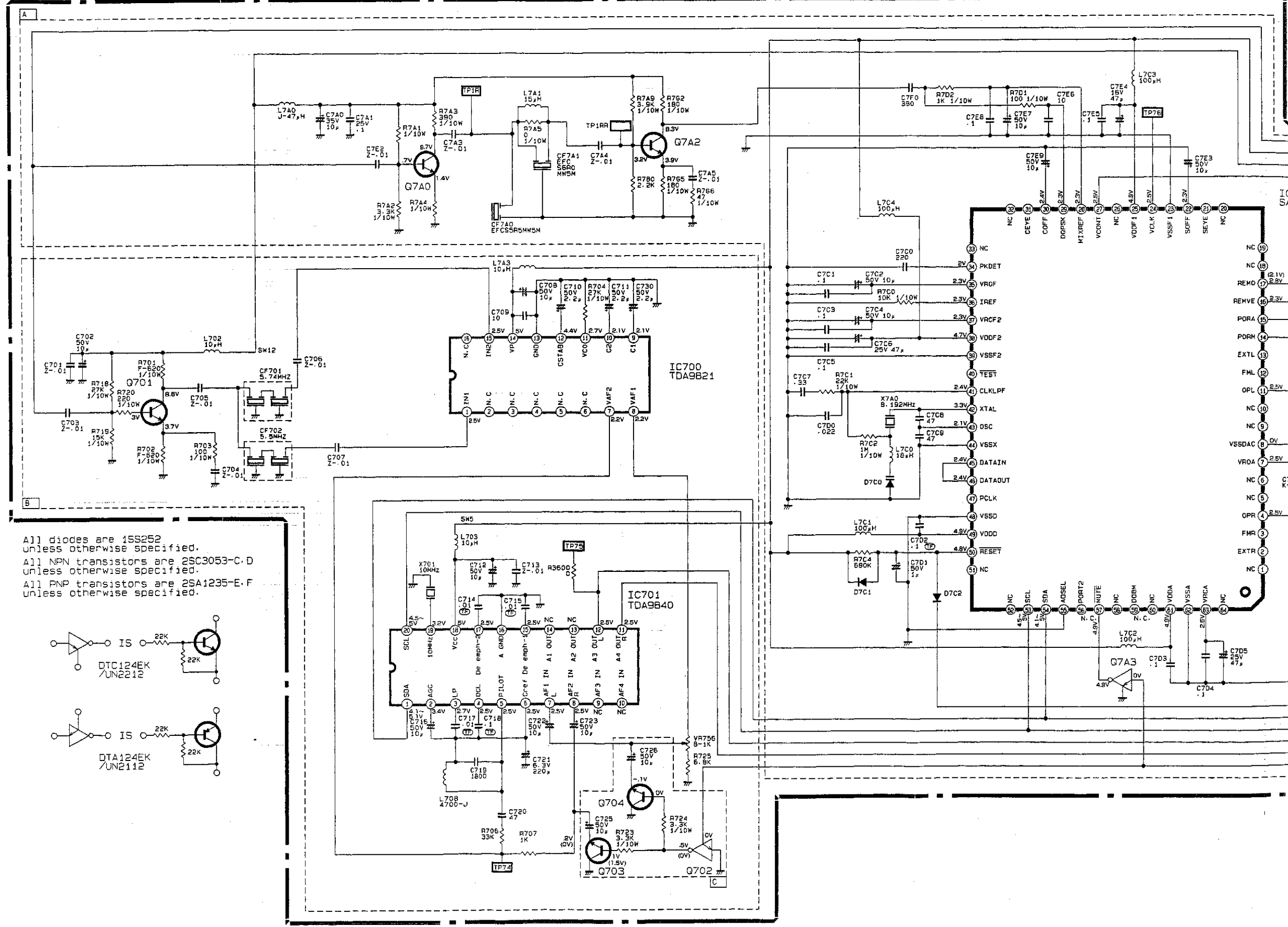

IC: 5A7

A) PCB-HIFI/DEC/NICAM

○ : EMPLOYED × : UNEMPLOYED

ITEM	A	B	C	CF7A1	CF7A0	L7A1	R7A5	R7A4	R7A1
ADDRESS	a-1	d-1	g-5	b-4	b-4	b-4	b-4	c-3	b-3
(Y)	×	○	○	×	×	×	×	×	×
(B)	○	×	×	○	×	○	×	150	22K
(E)	○	○	○	×	○	×	○	390	15K
(IR)	○	×	×	×	×	○	×	150	22K
(G)	×	○	○	×	×	×	×	×	×
(A)	×	○	×	×	×	×	×	×	×
(NZ)	○	×	×	×	○	×	○	390	15K

(B) : Means HS-551V(B) and HS-550V(B)

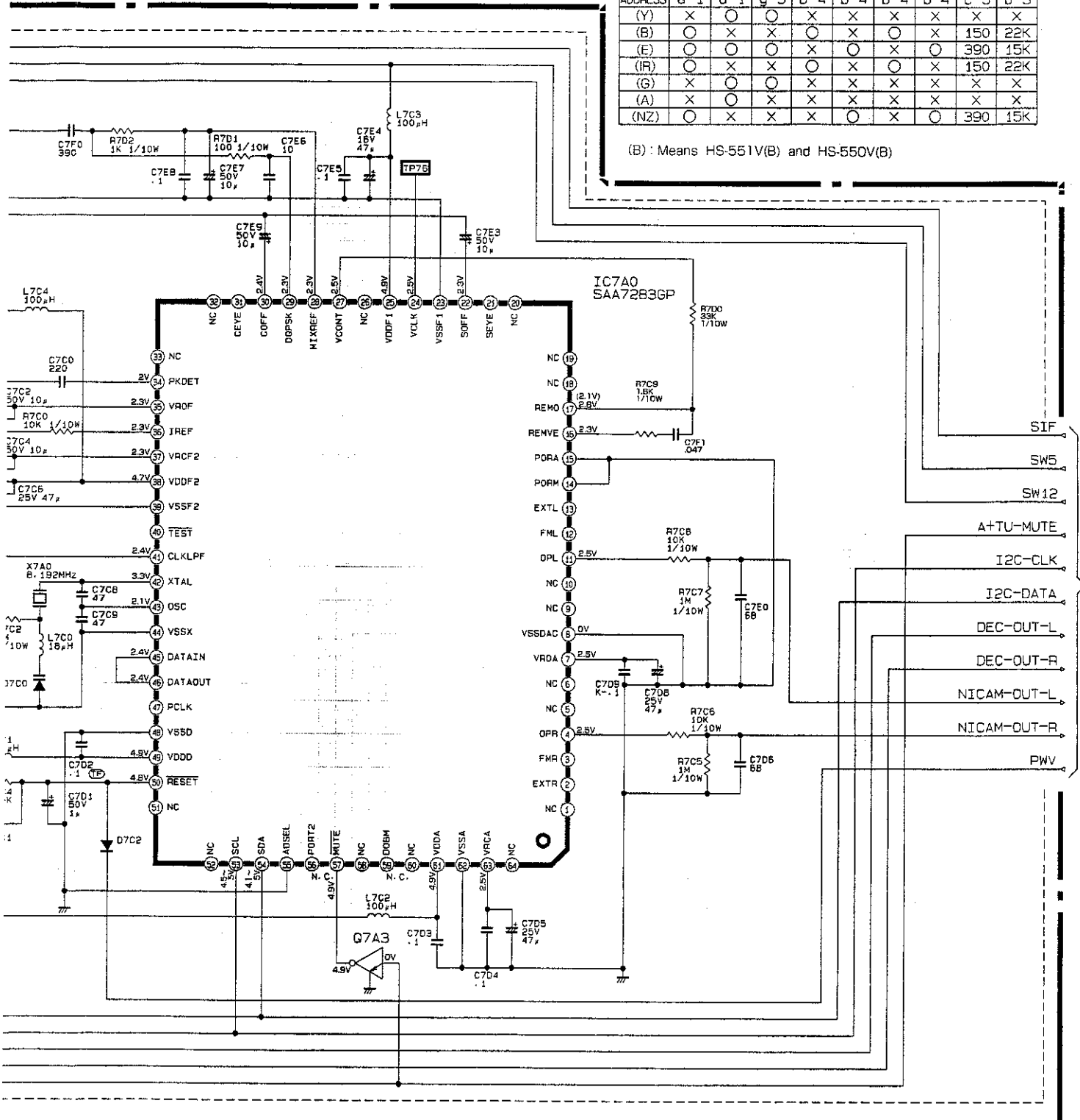

TO HIFI

1 2 3 4 5 6

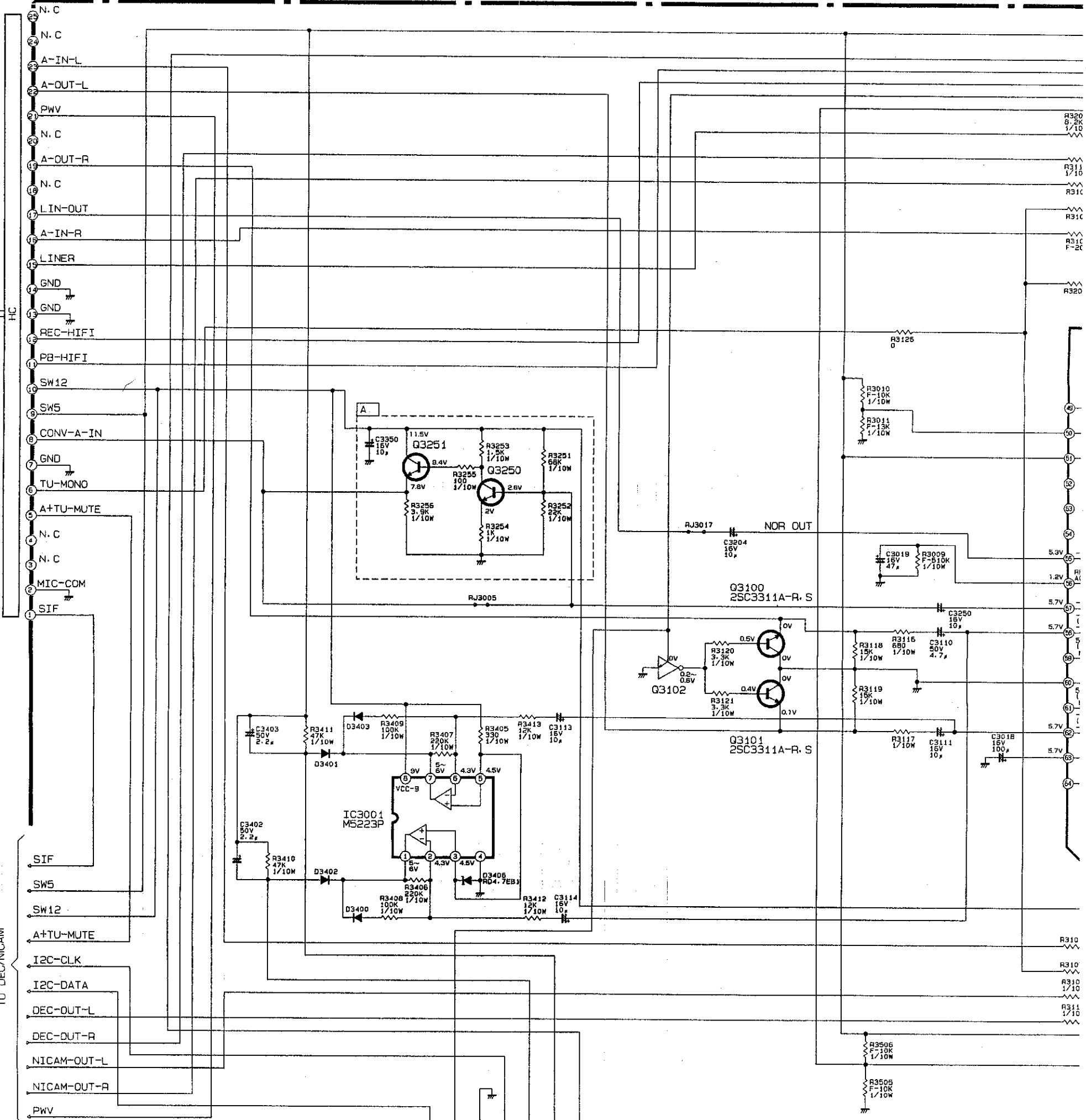

(Y/C) PCB-MAIN [MC]

TO DEC/NICAM

(MC) PCB-MAIN [MB]

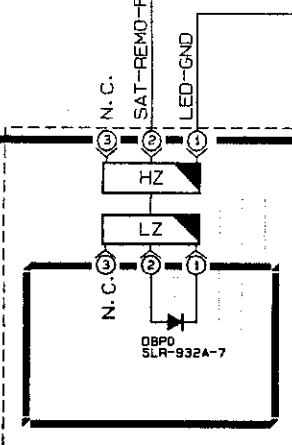

SYMBOL	A	RJ3005	R3101	R3105	R3202	R3104	R3107
ADDRESS	c-3	d-3	e-7	e-6	b-6	b-6	e-6
HS-551V(Y)	X	O	15K	33K	27K	33K	12K
HS-551V(B)	X	O	F-20K	4.7K	2.7K	4.7K	22K
HS-551V(E)	X	O	15K	33K	27K	33K	12K
HS-551V(R)	X	O	F-20K	4.7K	2.7K	4.7K	22K
HS-551V(G)	X	O	15K	33K	27K	33K	12K
HS-551V(A)	O	X	F-20K	18K	15K	18K	22K
HS-551V(NZ)	X	O	F-20K	4.7K	2.7K	4.7K	22K
HS-550V(B)	X	O	F-20K	4.7K	2.7K	4.7K	22K

a
b
c
d
e
f
g

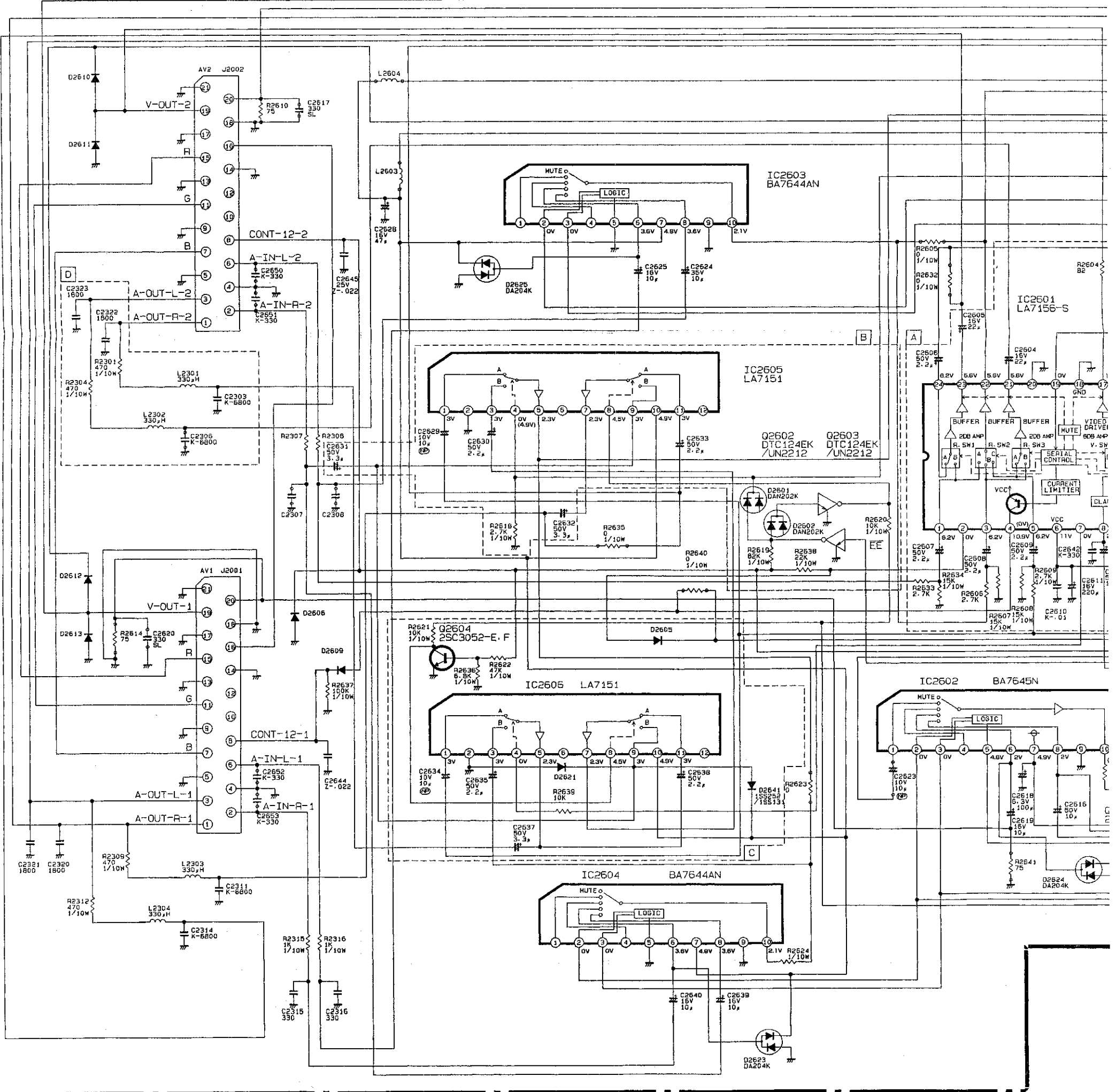

○ : Employed X : Not Employed

SYMBOL	A	B	C	R2603	R2601	R2605	R2632	R2623	C2620	C2617	R2635	R2611	R2307	C2307	R2308	C2308	J2666	J2650	R2640	R2623	Q	R2614	R2641	D
MODEL NAME ADDRESS	c-6	c-5	e-5	b-7	b-8	b-6	c-6	e-6	e-6	b-2	d-4	e-8	d-2	d-2	d-3	d-3	a-7	e-7	d-4	f-5	c-9	e-1	f-6	c-1
HS-551V (Y)/(E)/(G)	○	○	○	82	×	×	×	×	○	○	×	×	1.5k 1/10W	K-390	820 1/10W	K-470	×	×	×	×	○	×	○	○
HS-551V(B)/(IR)	×	×	×	0	○	○	○	○	×	×	○	○	1k 1/10W	K-330	1k 1/10W	K-330	○	○	○	○	×	○	×	×
HS-550V(B)																								

PCB-CONNECTOR

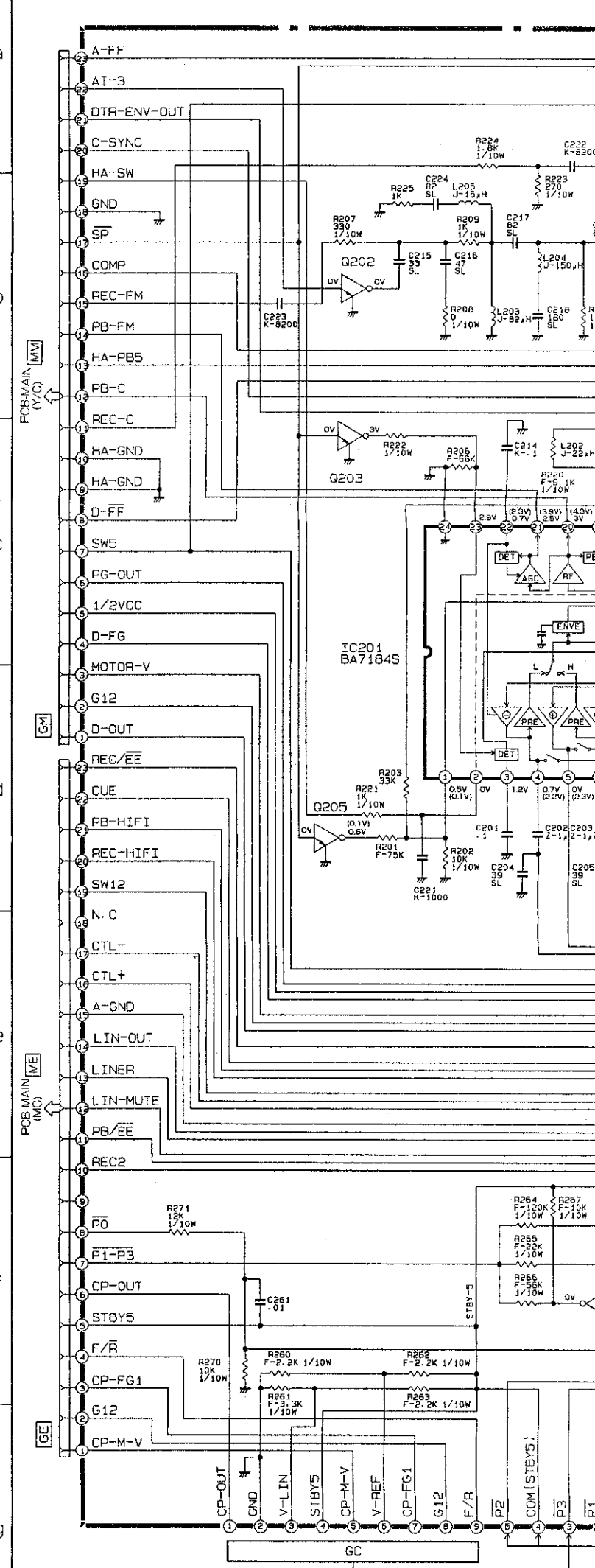
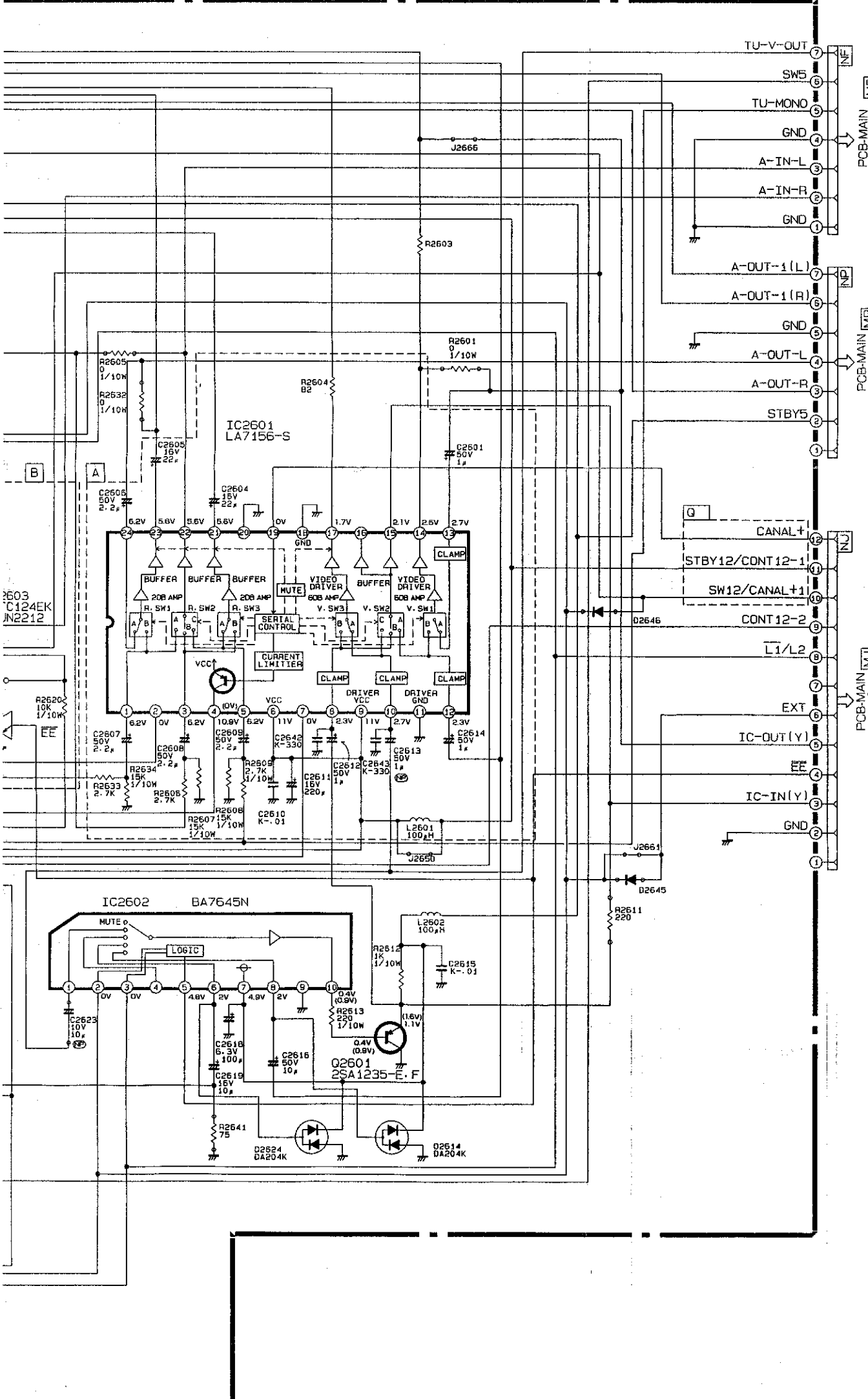

R2650	R2640	R2623	Q	R2614	R2641	D	R2624	D2645	D2646	L2604	L2603	J2661
e-7	d-4	f-5	c-9	e-1	f-6	c-1	f-5	e-8	d-8	b-3	b-3	e-8
×	×	×	○	×	○	○	220 1/10W	○	○	×	100μ	×
○	○	○	×	○	×	×	0 1/10W	×	×	100μ	×	○

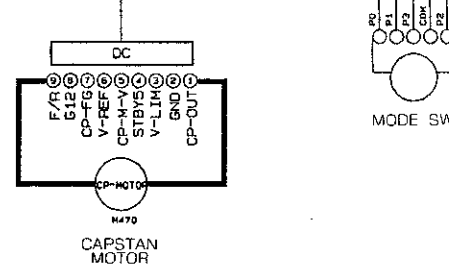

PCB-CONNECTOR

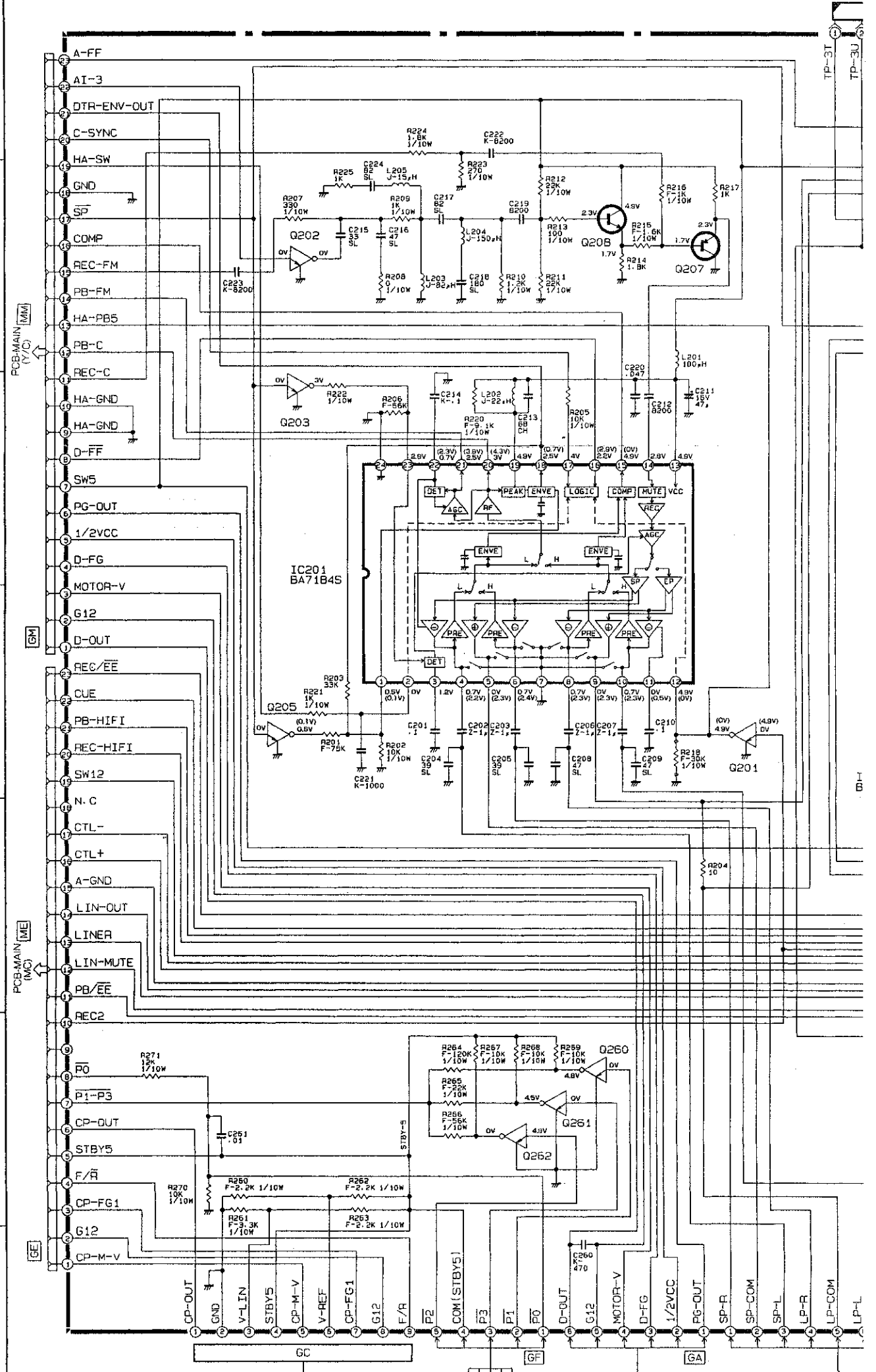
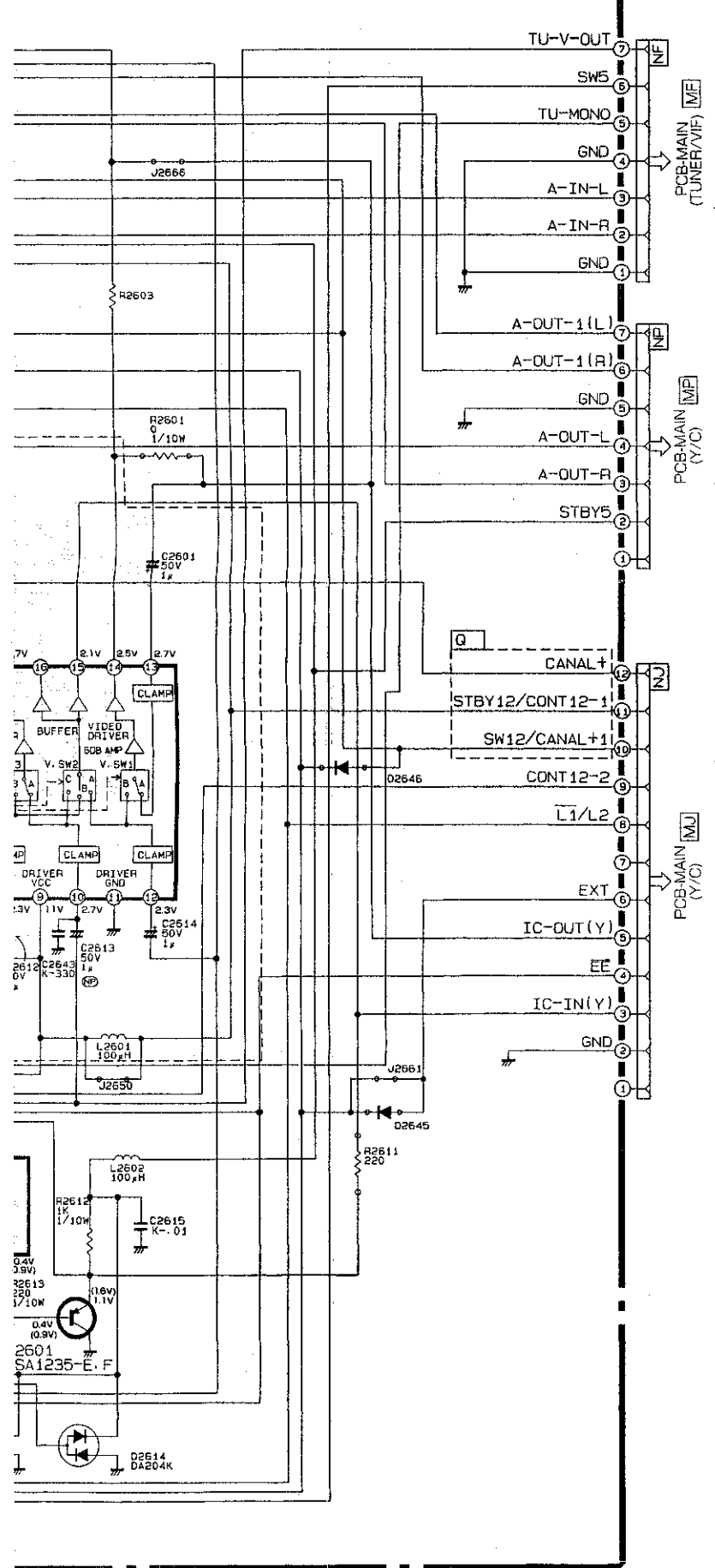

R2624	D2645	D2646	L2604	L2603	J2661
1-5	e-8	d-8	b-3	b-3	e-8
220 1/10W	○	○	×	100μ	×
0 1/10W	×	×	100μ	×	○

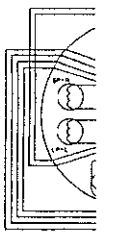
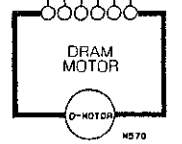
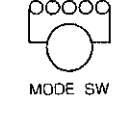
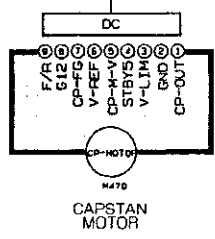

PCB-HEAD AMP/AUDIO

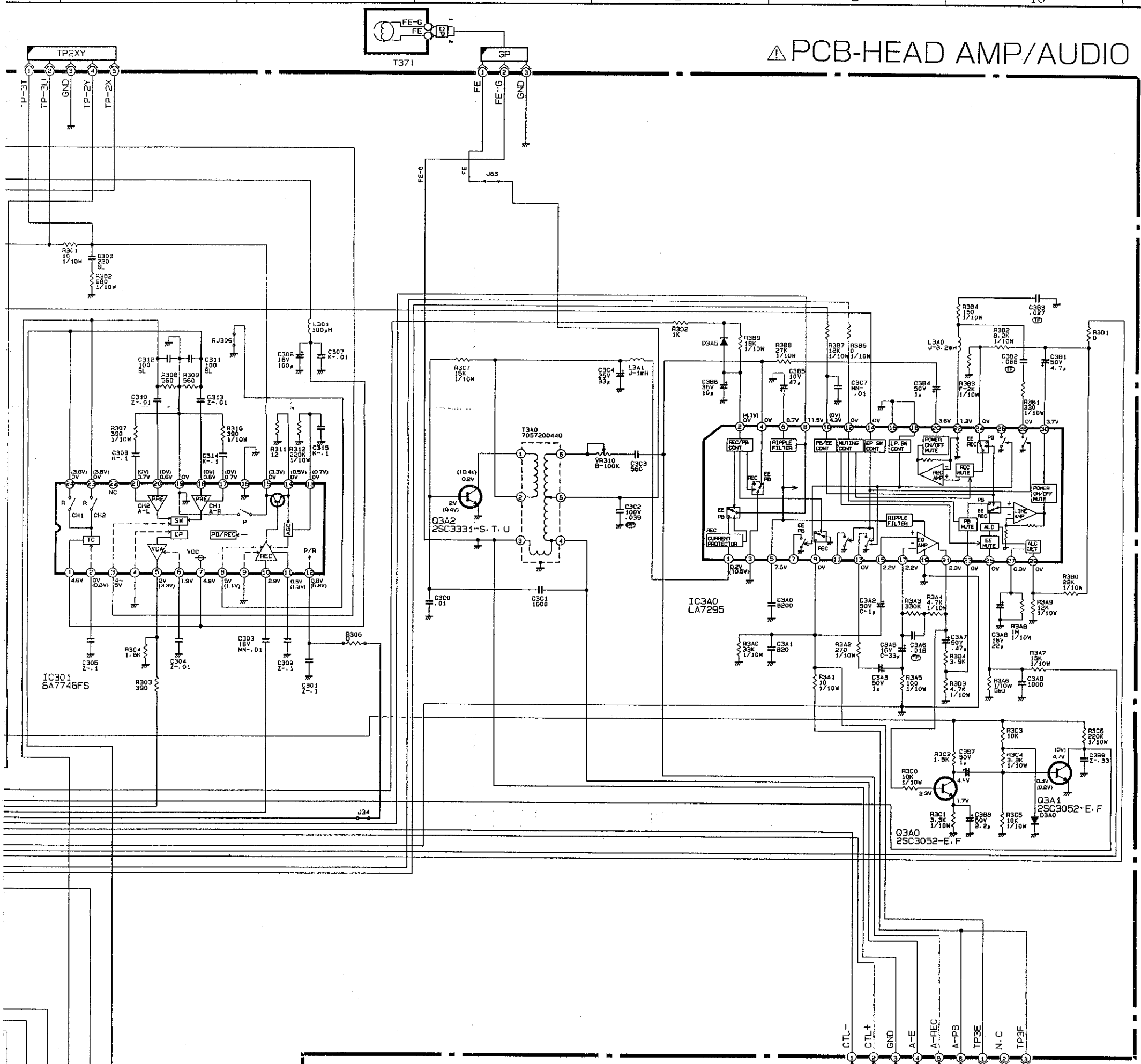

CAPSTAN MOTOR

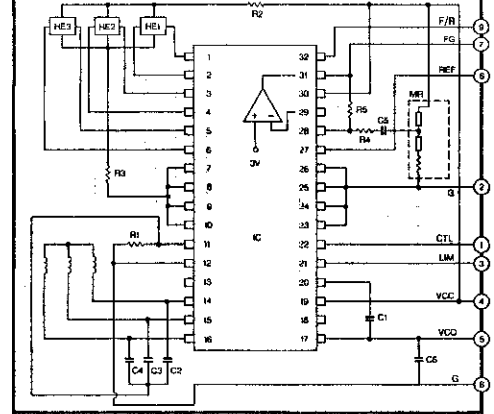

DRUM MOTOR

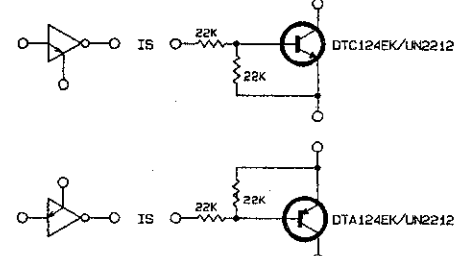
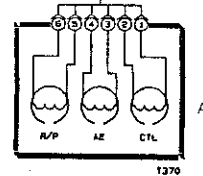
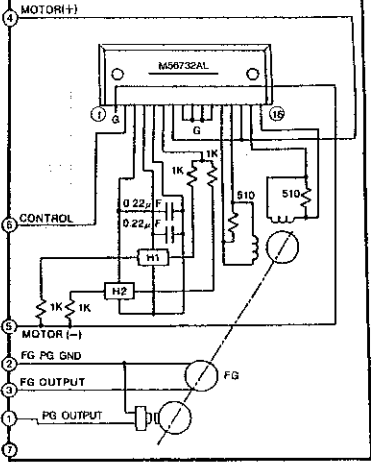

All diodes are 1SS252/1SS131 unless otherwise specified.
 All NPN transistors are 2SC3053-C.D unless otherwise specified.
 All PNP transistors are 2SA1235-E.F unless otherwise specified.

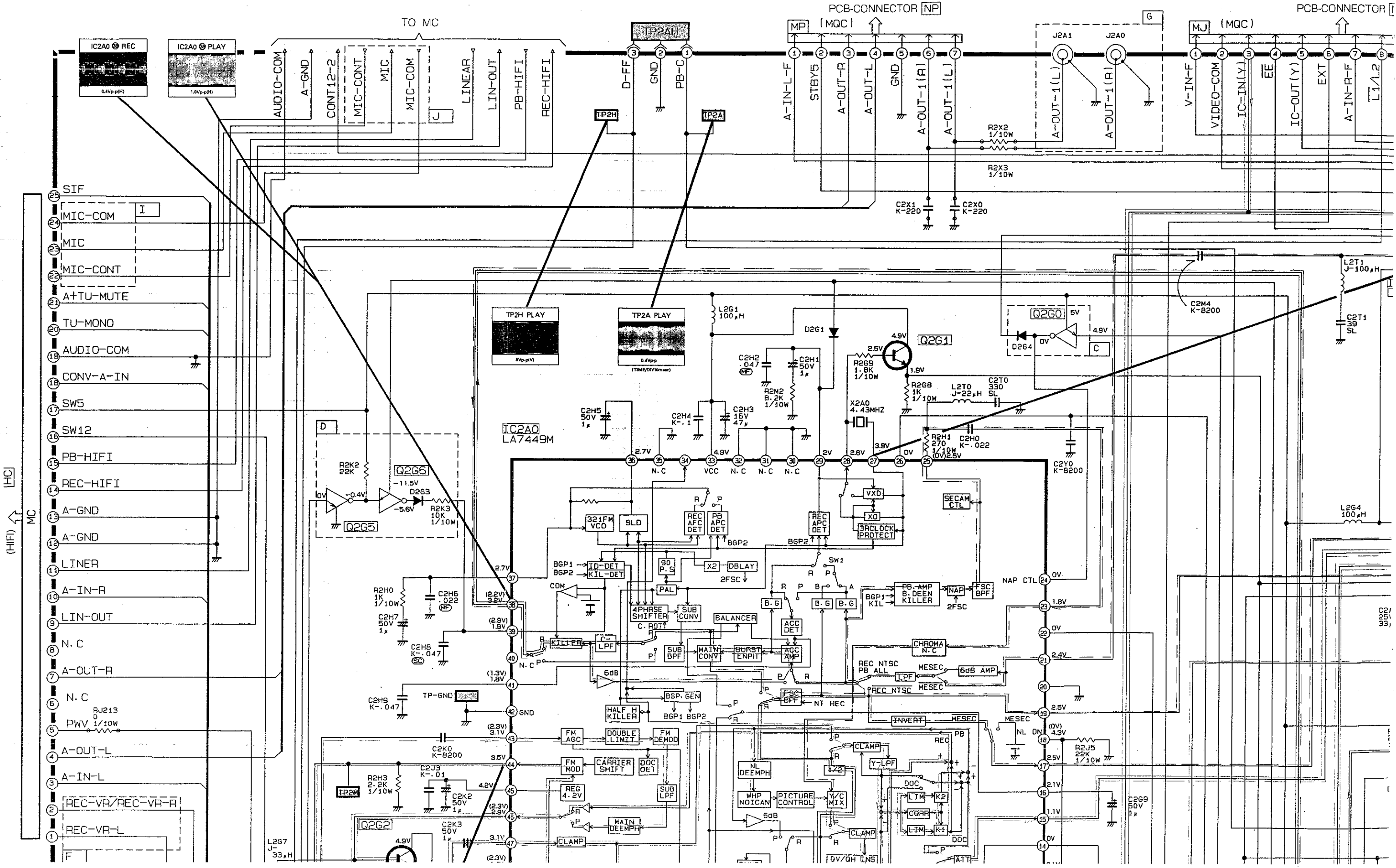

(HIF) ← MC

- 25 SIF
- 24 MIC-COM
- 23 MIC
- 22 MIC-CONT
- 21 A+TU-MUTE
- 20 TU-MONO
- 19 AUDIO-COM
- 18 CONV-A-IN
- 17 SW5
- 16 SW12
- 15 PB-HIFI
- 14 REC-HIFI
- 13 A-GND
- 12 A-GND
- 11 LINER
- 10 A-IN-R
- 9 LIN-OUT
- 8 N. C
- 7 A-OUT-R
- 6 N. C
- 5 PWV
- 4 A-OUT-L
- 3 A-IN-L
- 2 REC-VR/REC-VR-R
- 1 REC-VR-L

L2G7
J-33μH

C2J7
50V
50μF

PCB-CONNECTOR [NJ]

(Y/C) PCB-MAIN

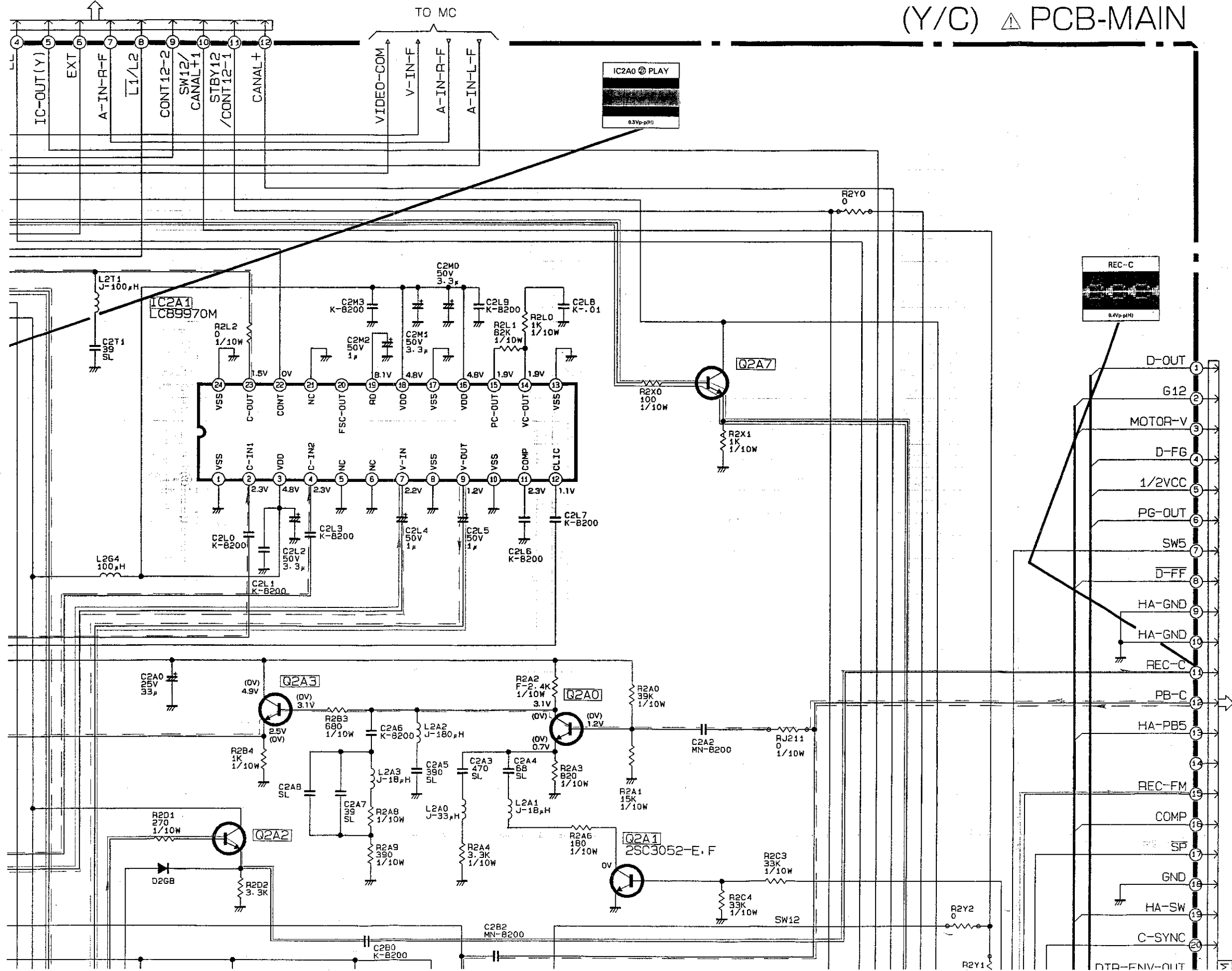

○ : Employed × : Not Employed

	Y	B	E	IR	G	A	NZ
c (b-4)	○	×	○	○	○	○	○
D (c-2)	×	○	×	×	×	×	×
E (e-7)	×	○	×	○	×	×	×
F (d-1)	×	×	×	×	×	×	×
G (a-5)	○	○	○	○	○	×	×
H (f-1)	×	×	×	×	×	×	×
I (b-1)	×	×	×	×	×	×	×
J (a-2)	×	×	×	×	×	×	×
R2X2(a-5)	1K	←	←	←	←	×	×
R2X3(a-5)	1K	←	←	←	←	×	×
C2X0(a-5)	○	○	○	○	○	×	×
C2X1(a-5)	○	○	○	○	○	×	×
C2A8(d-7)	33	18	33	18	33	←	←
R2A5(e-2)	180	220	180	220	180	←	←
R2A8(d-7)	330	300-F	330	300-F	330	←	←
R2A9(d-7)	220	390	220	390	220	←	←
RJ213(d-1)	×	○	○	○	×	×	○
R2Y0(b-9)	○	×	○	×	○	×	×
R2Y1(d-9)	○	×	○	×	○	×	×
R2Y2(d-9)	×	○	×	○	×	○	○
R2K9(e-9)	○	×	○	×	○	×	×

(B) : Means HS-551V(B) and HS-550V(B)

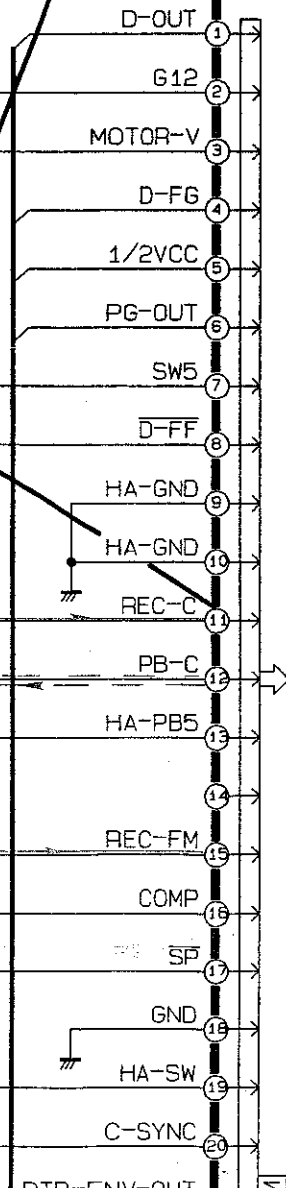
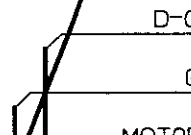
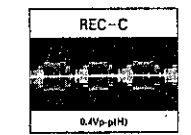

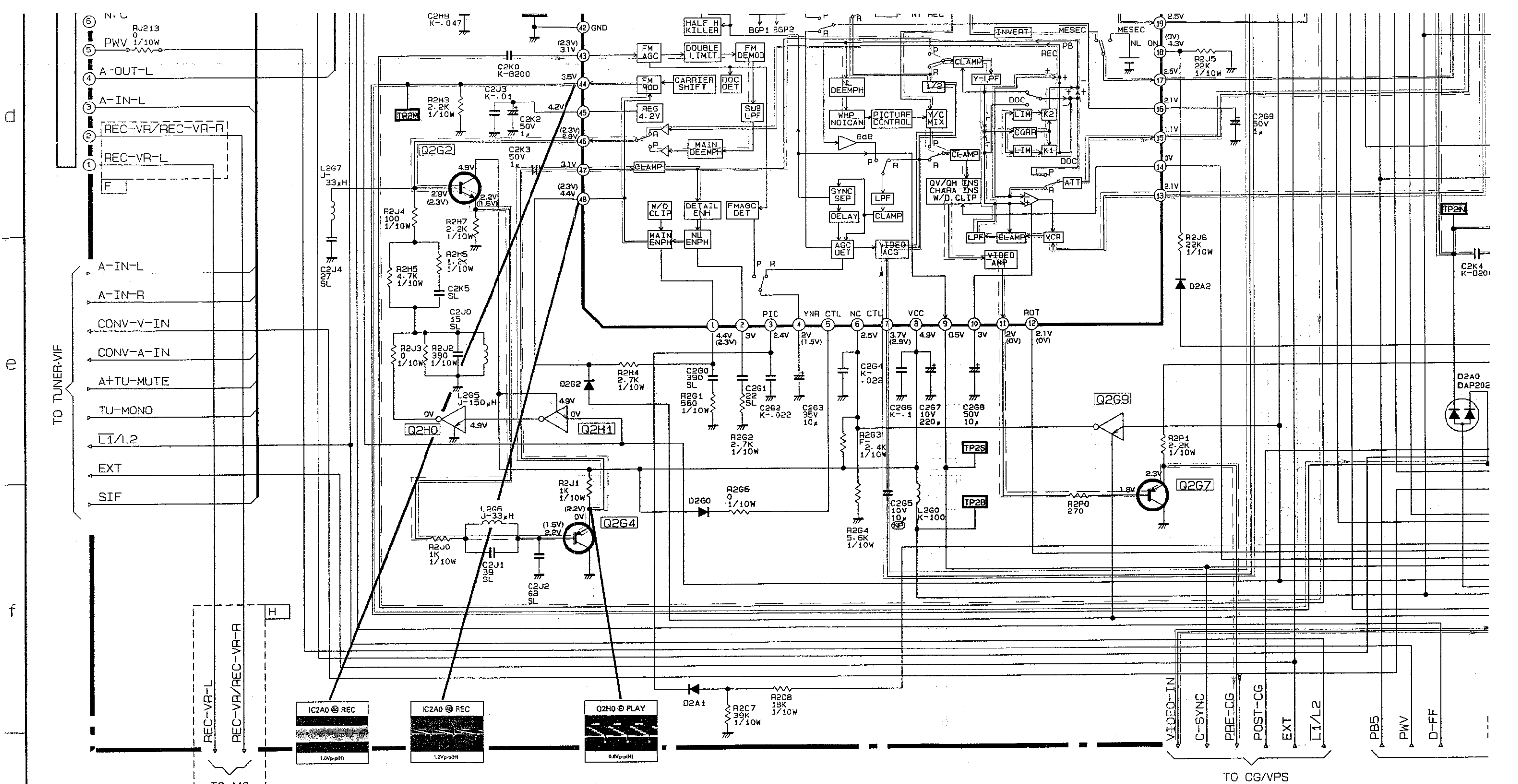

All diodes are 1SS252/1SS1310M unless otherwise specified.
 All NPN transistors are 2SC3053-C,D unless otherwise specified.
 All PNP transistors are 2SA1235-E,F unless otherwise specified.

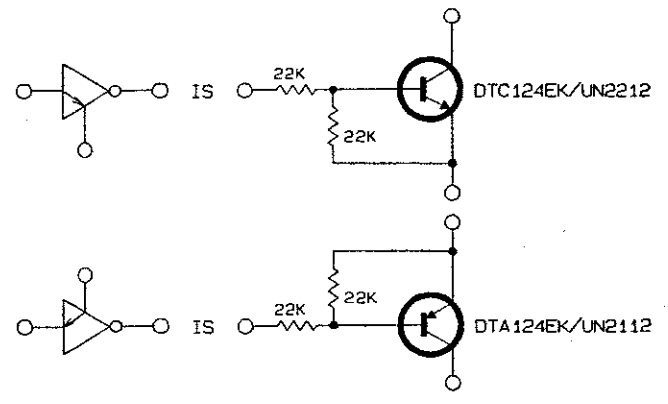

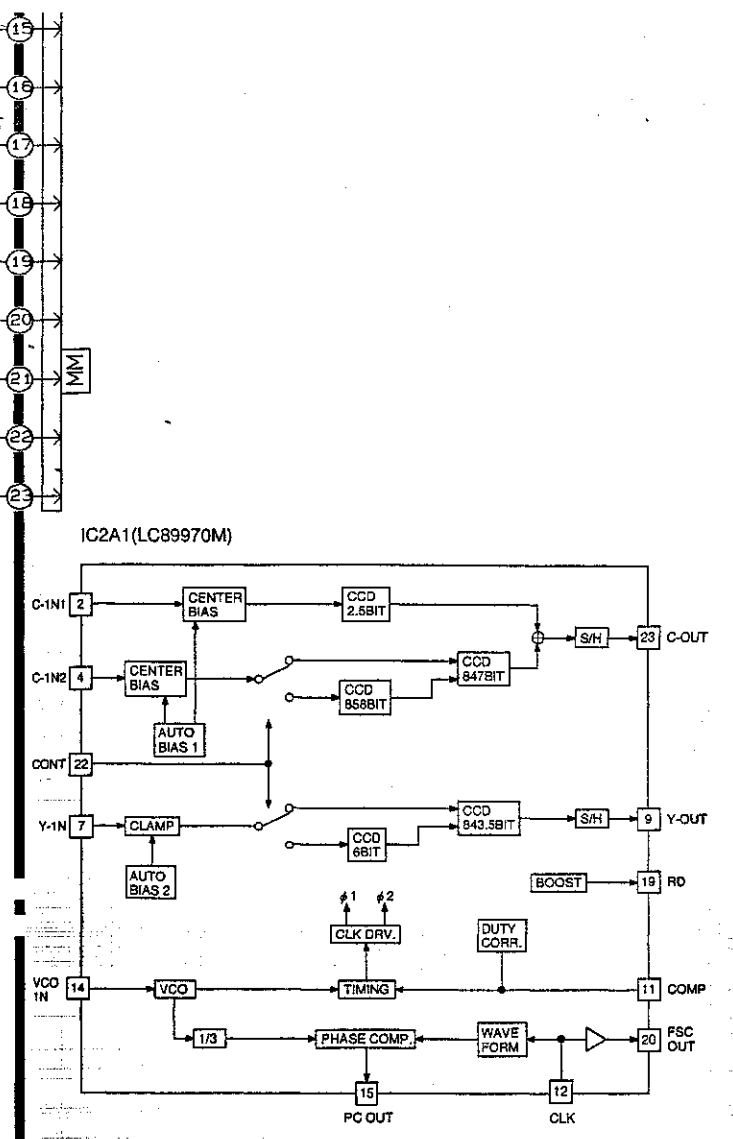
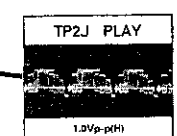
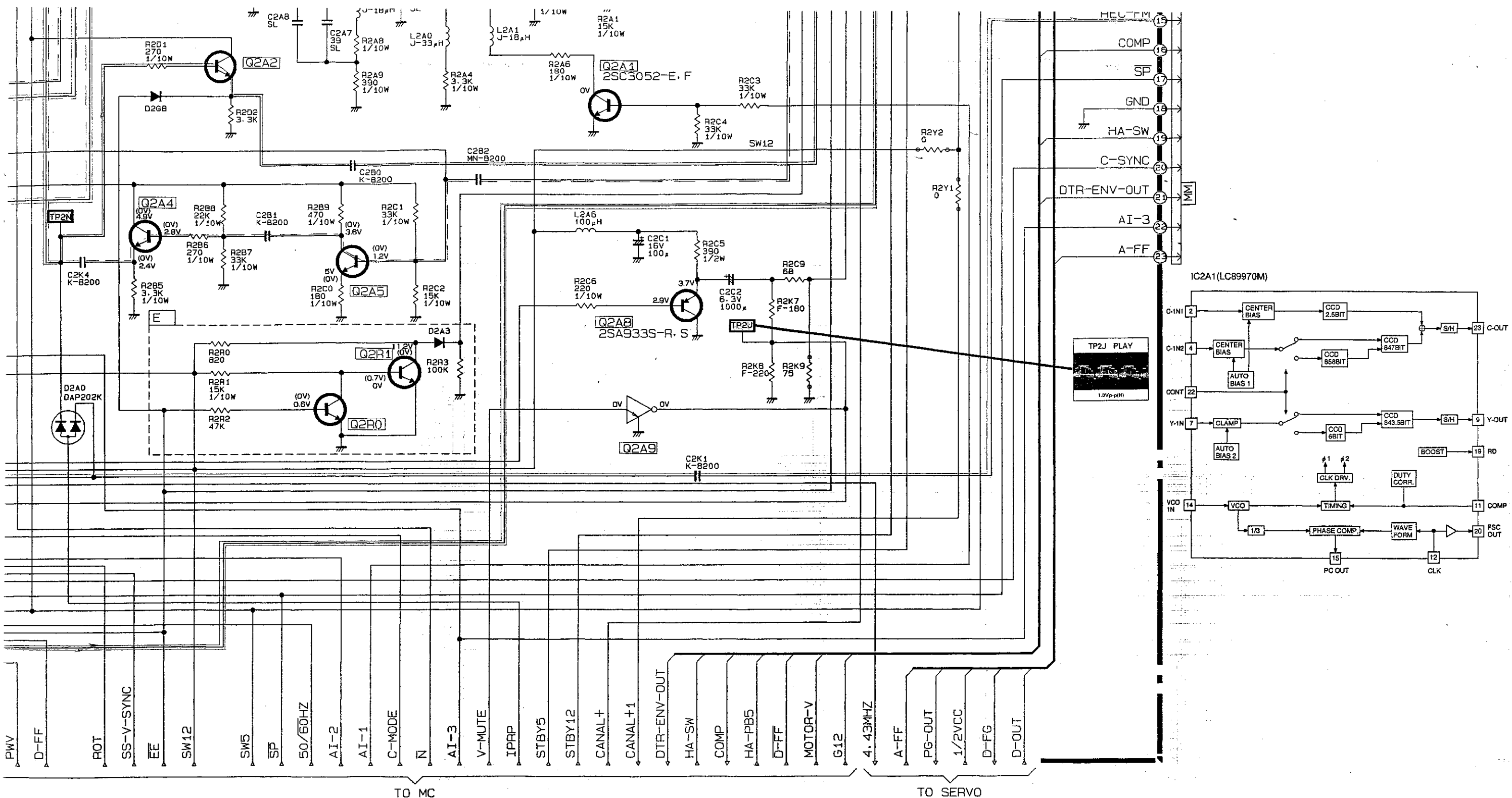

——— Recording of Luminance Signal
 - - - Playback of Luminance Signal
 ——— Recording of Color Signal
 - - - Playback of Color Signal

(MC) PCB-MAIN

TO Y/C

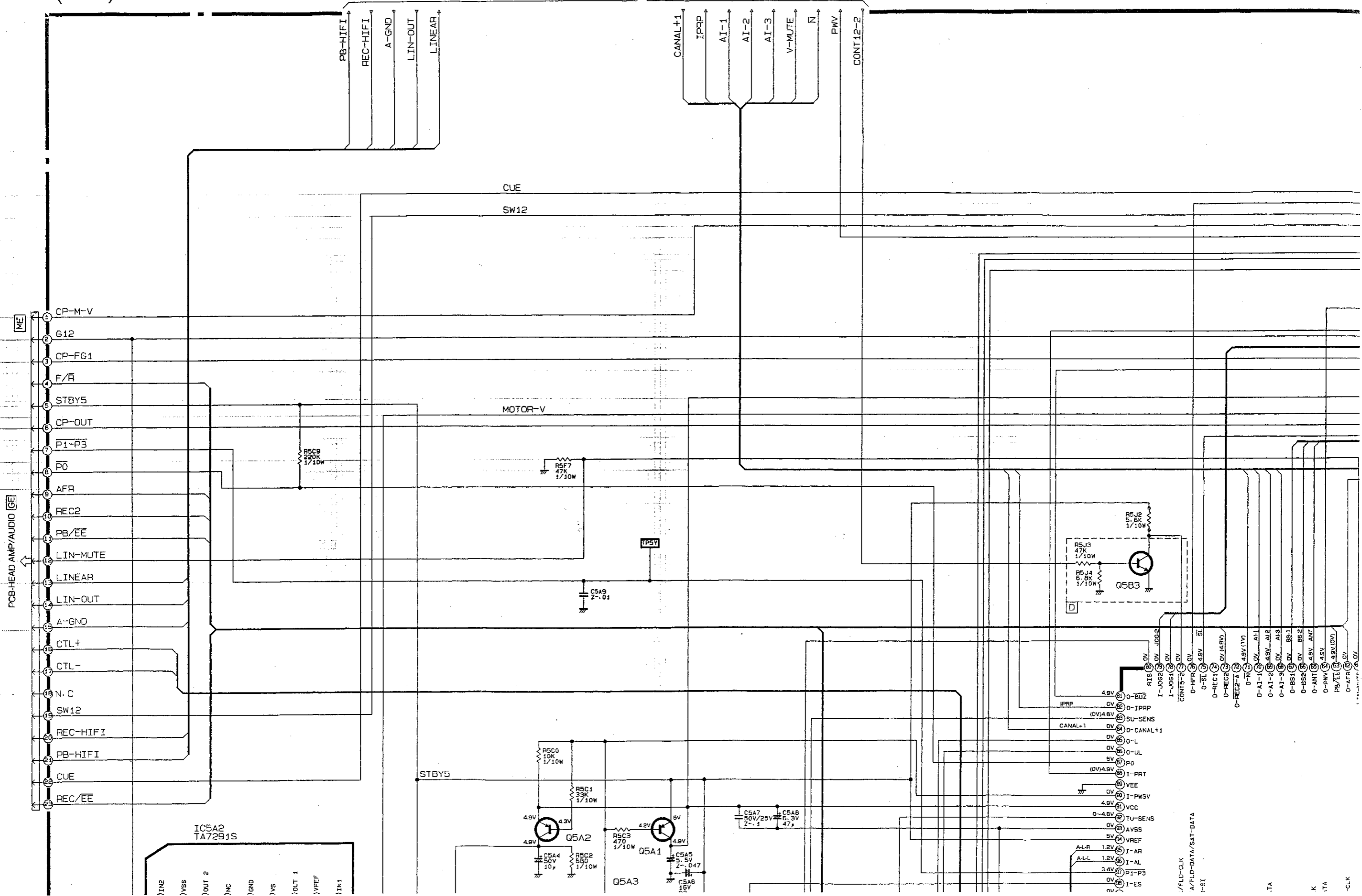

PCB-HEAD AMP/AUDIO

IC5A2 TA7291S

Q5A1

Q5A2

Q5A3

Q5B3

/FLD-CLK
A/FLD-DATA/SAT-DATA
I-SI

.TA

X

.TA

-CLK

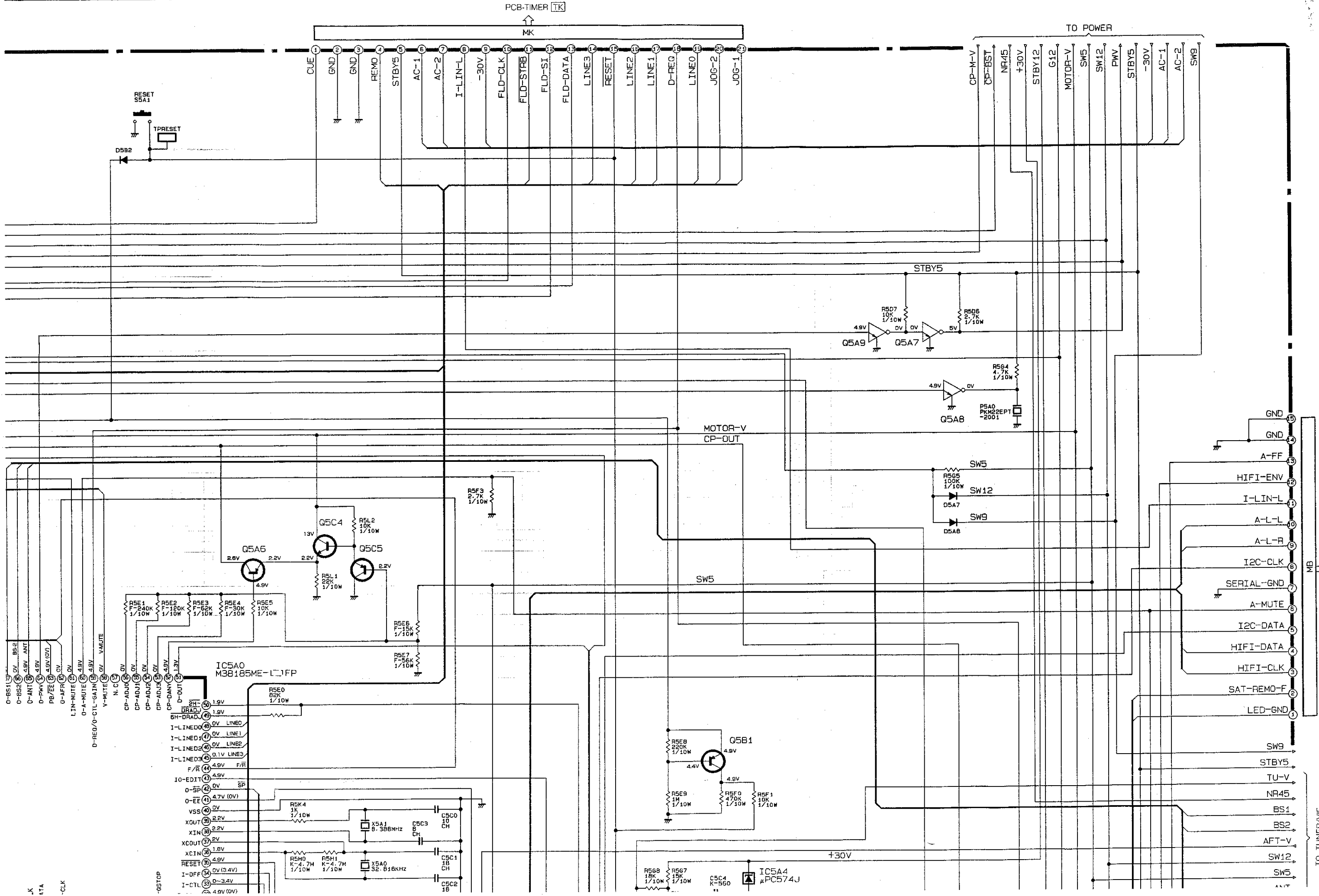

PCB-TIMER TK

TO POWER

MOTOR-V
CP-OUT

IC5A0
M38185ME-LFP

Q5B1

IC5A4
PC574J

TO TUNER/VIF

MB

- ⑤ GND
- ④ GND
- ③ A-FF
- ② HIFI-ENV
- ① I-LIN-L
- ⑩ A-L-L
- ⑨ A-L-R
- ⑧ I2C-CLK
- ⑦ SERIAL-GND
- ⑥ A-MUTE
- ⑤ I2C-DATA
- ④ HIFI-DATA
- ③ HIFI-CLK
- ② SAT-REMO-F
- ① LED-GND

- SW9
- STBY5
- TU-V
- NR45
- BS1
- BS2
- AFT-V
- SW12
- SW5
- ANT

-K
ATA
-CLK

-OSTOP

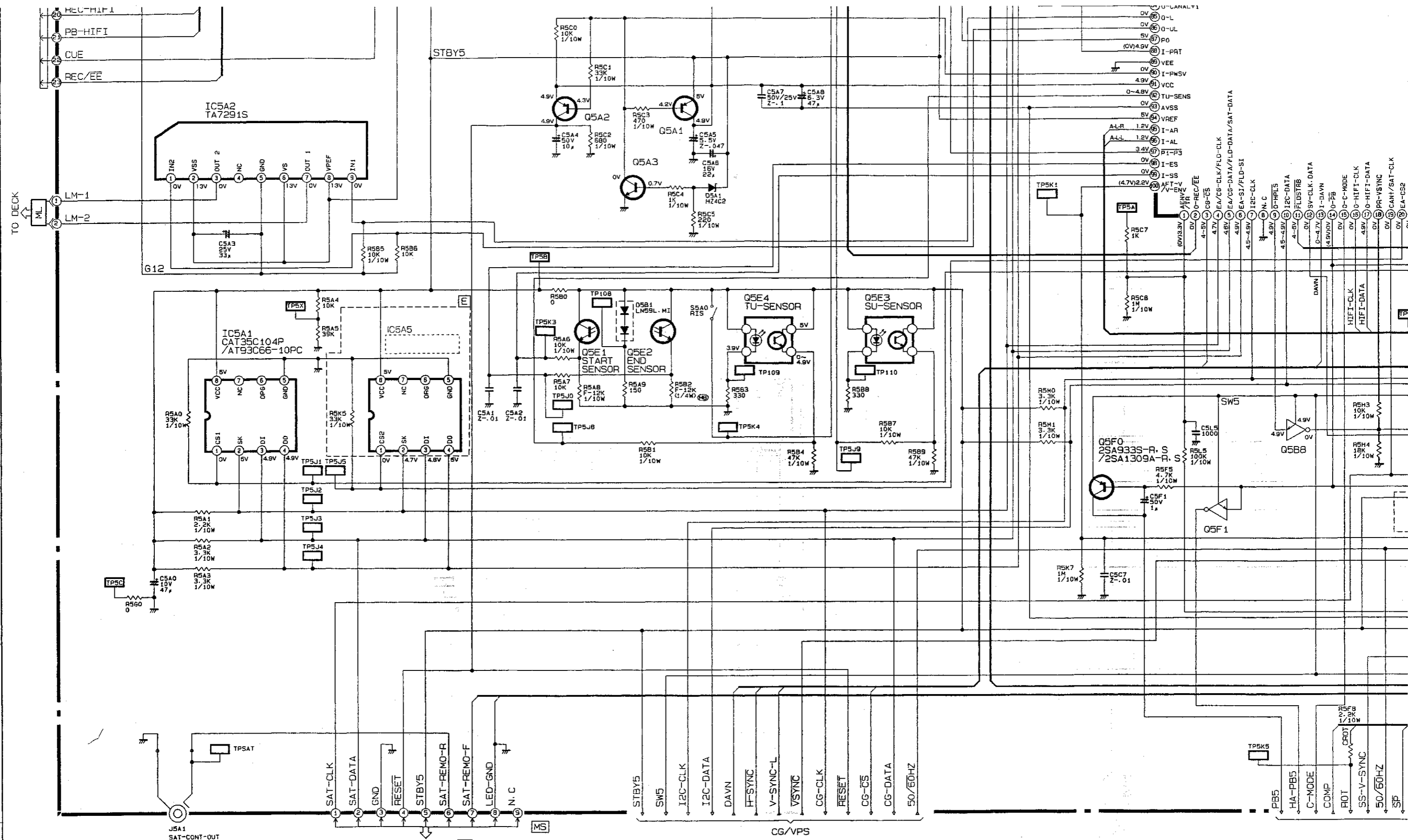

O: Employed X: Not employed

SYMBOL	B	F	IC5A5	D	IC5A0	R5J2
ADDRESS	h-9	g-3	g-3	d-7	e-10	d-7
551V(Y)	O	X	---	O	096	O
551V(B)	X	O	AT93C56-10PC	X	097	X
551V(E)	O	X	---	O	098	O
551V(IR)	X	O	AT93C56-10PC	X	097	X
551V(G)	O	O	CAT35C104P/AT93C66-10PC	X	096	O
551V(A)	X	X	---	X	098	X
551V(NZ)	X	X	---	X	119	X
550V(B)	X	X	---	X	097	X

All diodes
All NPN
All PNP

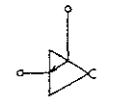

550V(B)
551V(B)/(G)/(E)/(Y)/(IR)

6

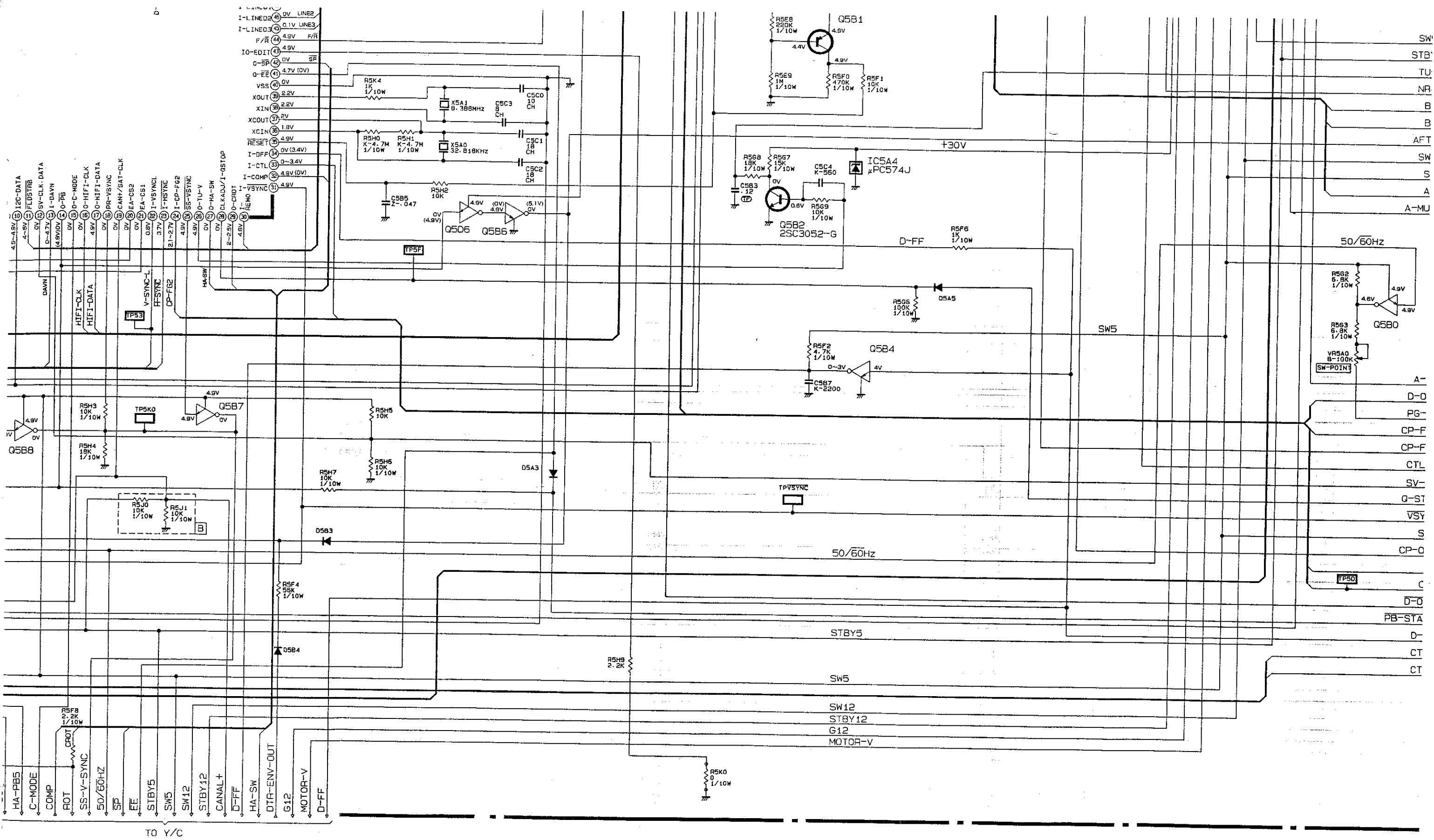

All diodes are 1SS252/1SS131 unless otherwise specified.
 All NPN transistors are 2SC3052-E,F unless otherwise specified.
 All PNP transistors are 2SA1235-E,F unless otherwise specified.

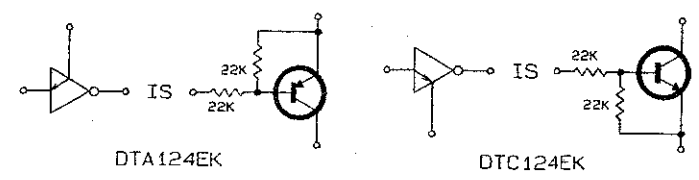

DTA124EK

DTC124EK

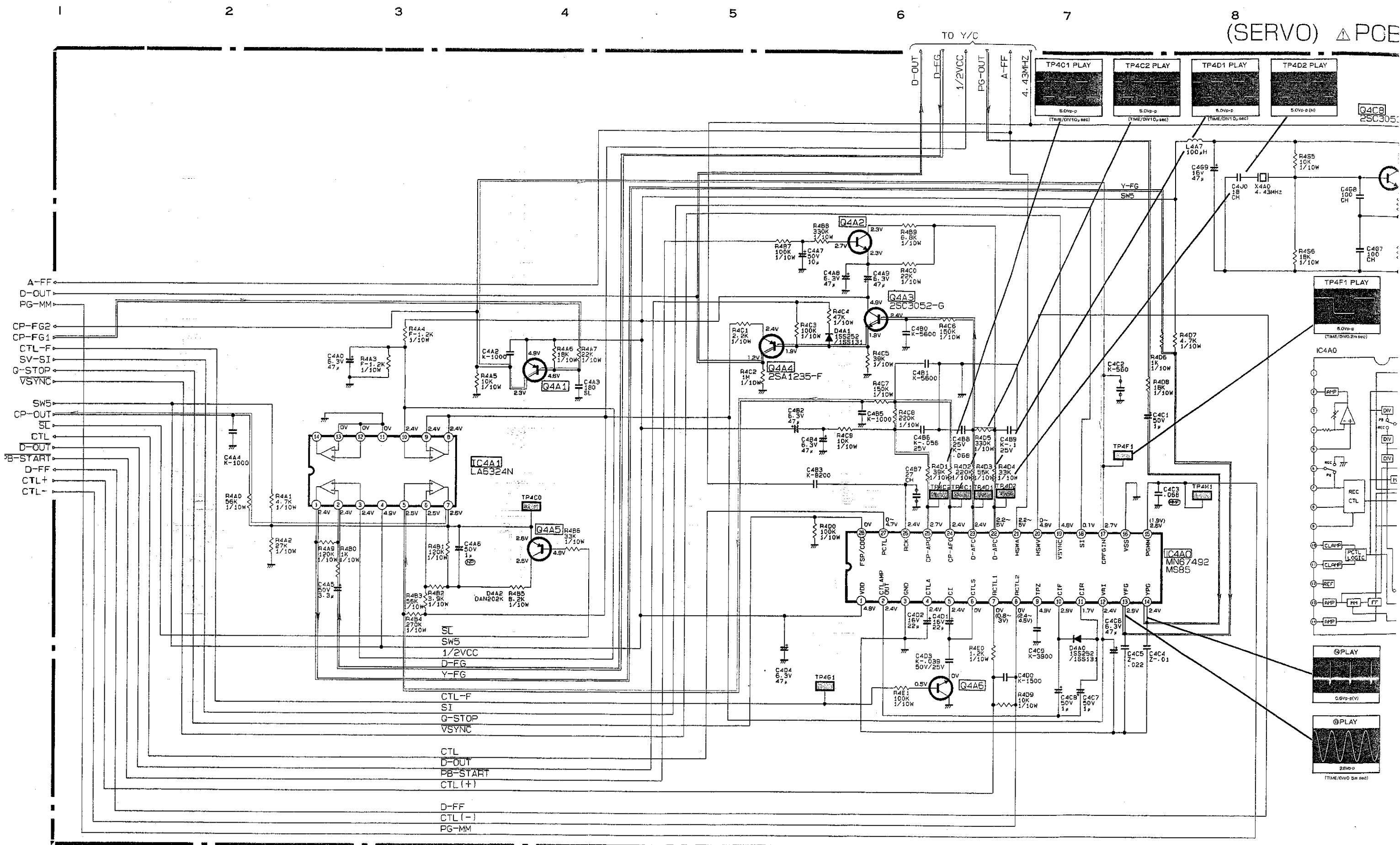

All NPN transistors are 25C3052-E.F unless otherwise specified.
 All PNP transistors are 2SA1235-E.F unless otherwise specified.

— Drum Set
 — Capstan

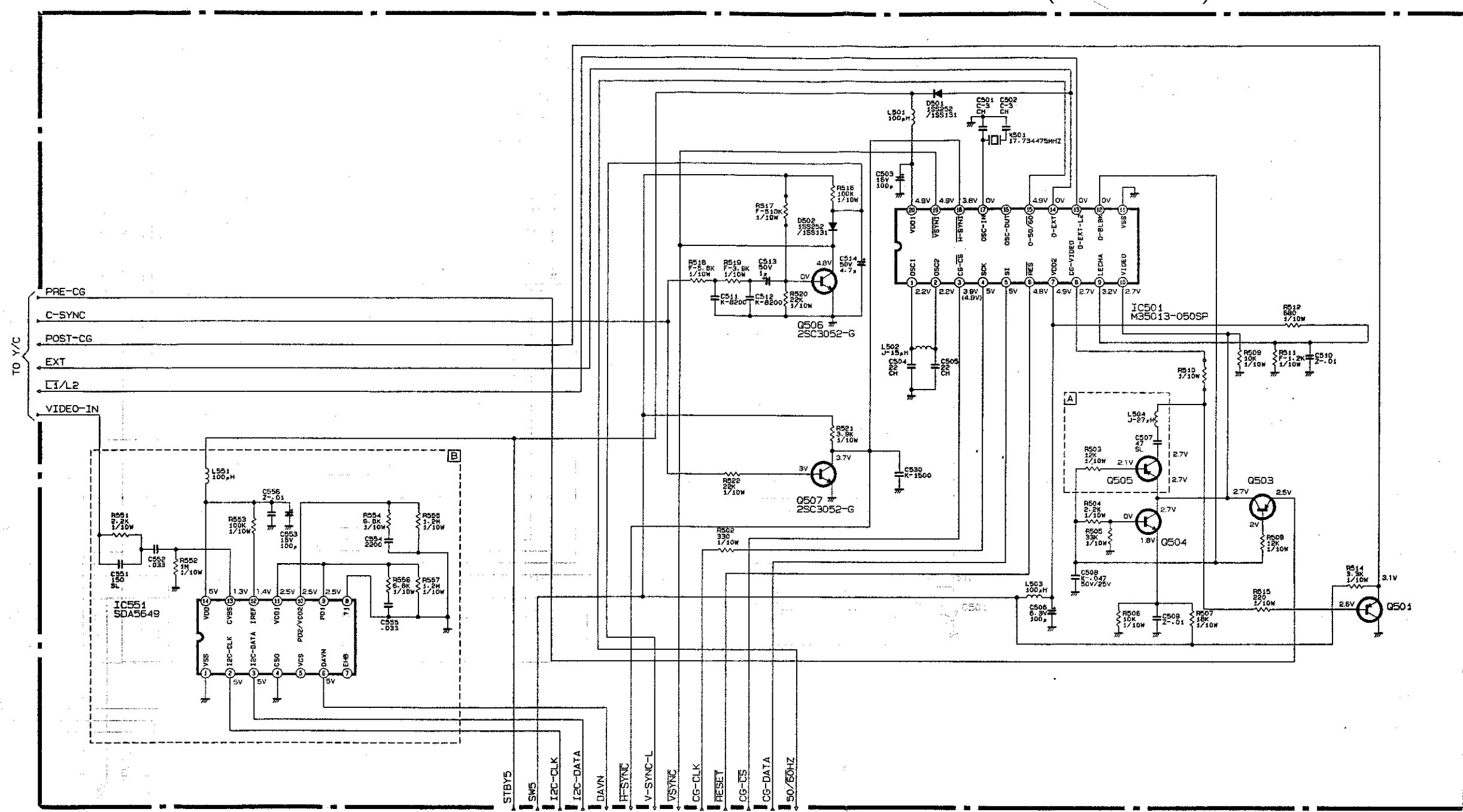
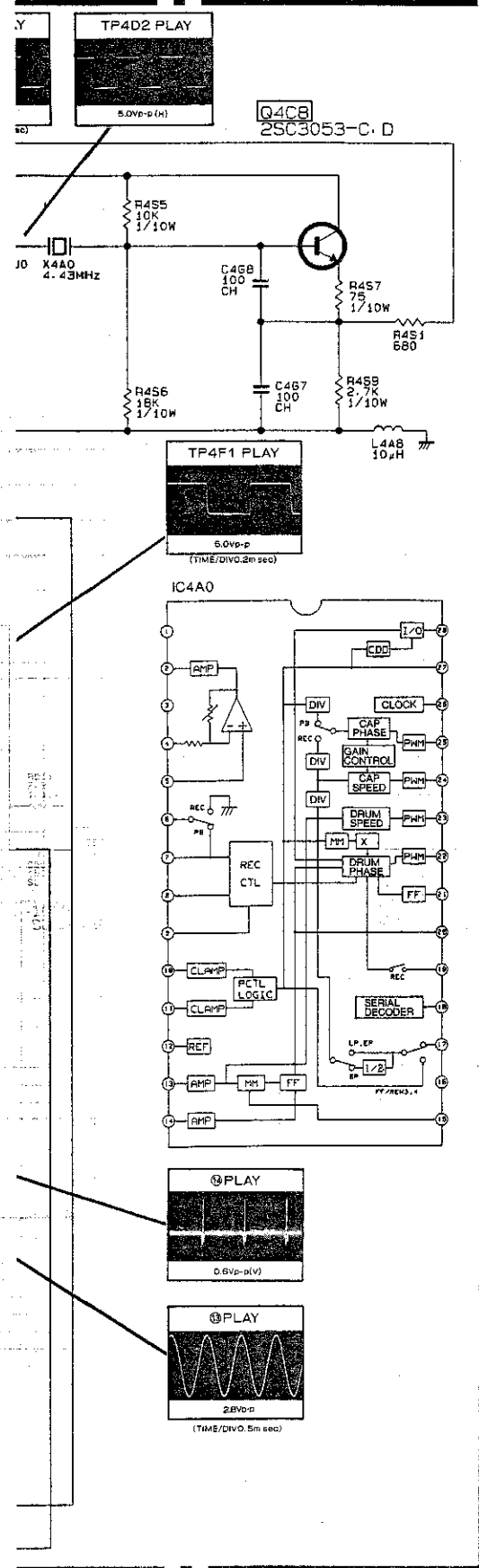

O: Employed X: Not employed

MODEL	SYMBOL	A	R517	B	R510
HS-551V(Y)		O	X	X	390
HS-551V(B)		X	X	O	0Ω
HS-551V(E)		O	X	O	390
HS-551V(IR)		X	X	O	0Ω
HS-551V(G)		O	X	O	390
HS-551V(A)		X	O	X	0Ω
HS-551V(NZ)		X	X	X	0Ω
HS-550V(B)		X	X	X	0Ω

All NPN transistors are 25C3052-E.F unless otherwise specified.
All PNP transistors are 2SA1235-E.F unless otherwise specified.

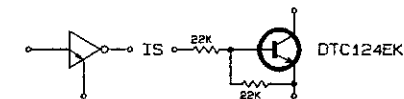

— Drum Servo System
— Capstan Servo System

HS-550V(B)
HS-551V(B)/V(G)/V(E)/V(Y)/V(IR)

HS-551V SERIES PCB

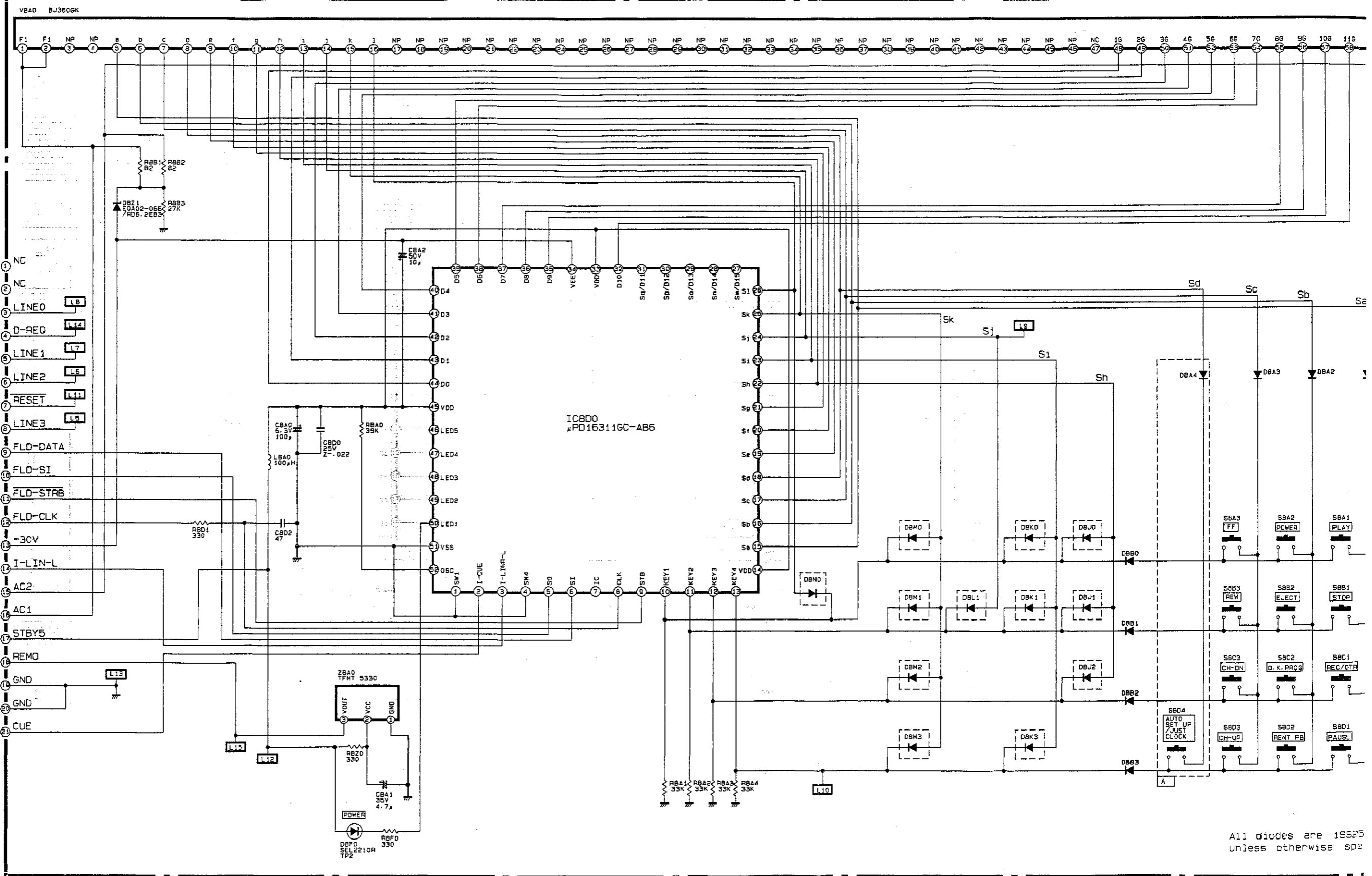

All diodes are 1SS25 unless otherwise spe

HS-551V SERIES PCB-TIMER

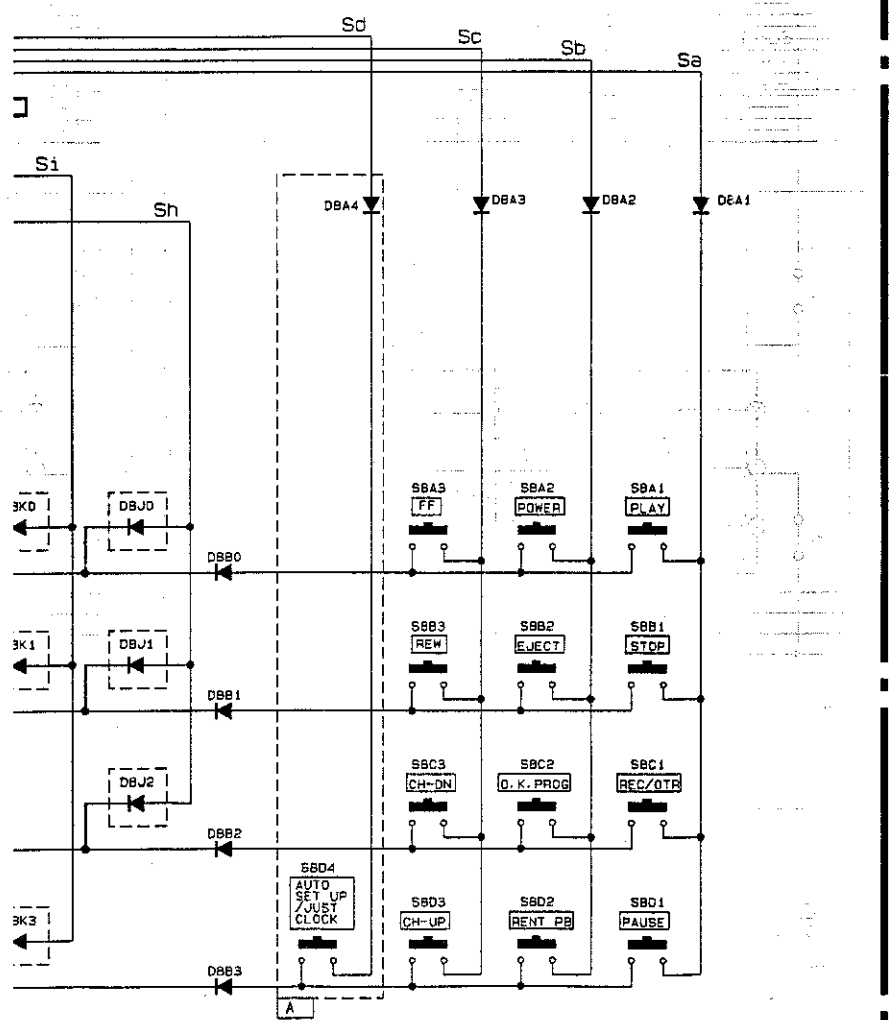
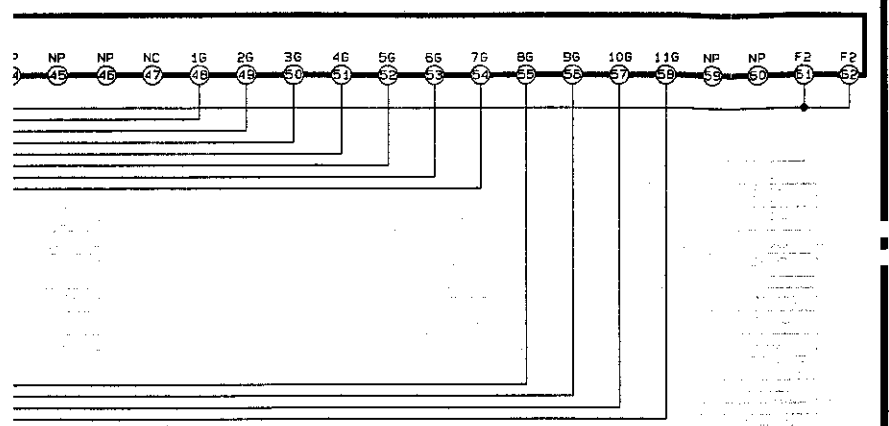

All diodes are 1SS252/1SS131 unless otherwise specified

FUNCTION SELECTOR MAP

	DBN0	DBM0	DBK0	DBJ0
E. A	JOG/REMO	NICAM	MESECAM	PDC
G. Y				VPS
B. IR			U-ONLY	PDC
NZ	JOG/REMO			PDC

	DBN1	DBM1	DBL1	DBK1	DBJ1
E. A		A2	SHOWVIEW	C+ SCRT	CCIR
G. Y					
B. IR					SAT-CONT
NZ					

	DBM2	DBJ2
E. A	ANT	JUST CLK
G. Y		A. S. U
B. IR		A. S. U
NZ		

	DBM3	DBK3	DBJ3
E. A	551	ENGLISH	
G. Y	551		
B. IR	551	3-BAND	
NZ	551		

Z8A0 PREAMAP

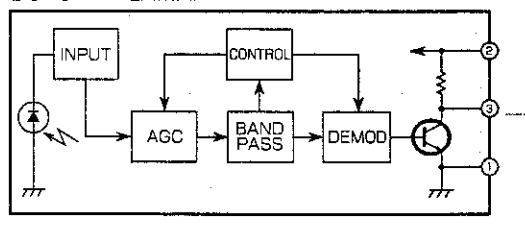

○: Employed
 ×: Not employed

SYMBOL	DBJ0	DBJ1	DBJ2	DBK0	DBK1	DBK3	DBL1	DBM0	DBM1	DBM2	DBN0	A
MODE ADDRESS	d-7	d-7	e-7	d-7	d-7	e-7	d-7	d-6	d-6	e-6	d-6	d-11
HS-551V(Y)	×	×	×	×	×	×	×	×	×	×	×	×
HS-551V(B)	○	○	○	○	×	×	×	×	×	×	×	○
HS-551V(G)	○	×	○	×	×	×	×	×	×	×	×	○
HS-551V(IR)	×	×	○	×	×	×	×	×	×	×	×	○
HS-551V(E)	○	×	○	○	○	×	○	○	○	×	×	○
HS-551V(A)	×	×	×	×	×	○	×	×	○	○	×	×
HS-551V(NZ)	×	×	×	×	×	×	×	×	×	×	○	×

HS-551V(B)/V(E)/V(G)/V(IR)/V(Y)
 TRANSMITTER REMOTE CONTROL

S14: CANCEL
 S15: JOG/CHANNEL -
 S16: JOG/CHANNEL +
 S19: CT-RES/NEXT
 S21: 10-60
 S23: DATA ON SCREEN
 S24: VIDEO Plus +

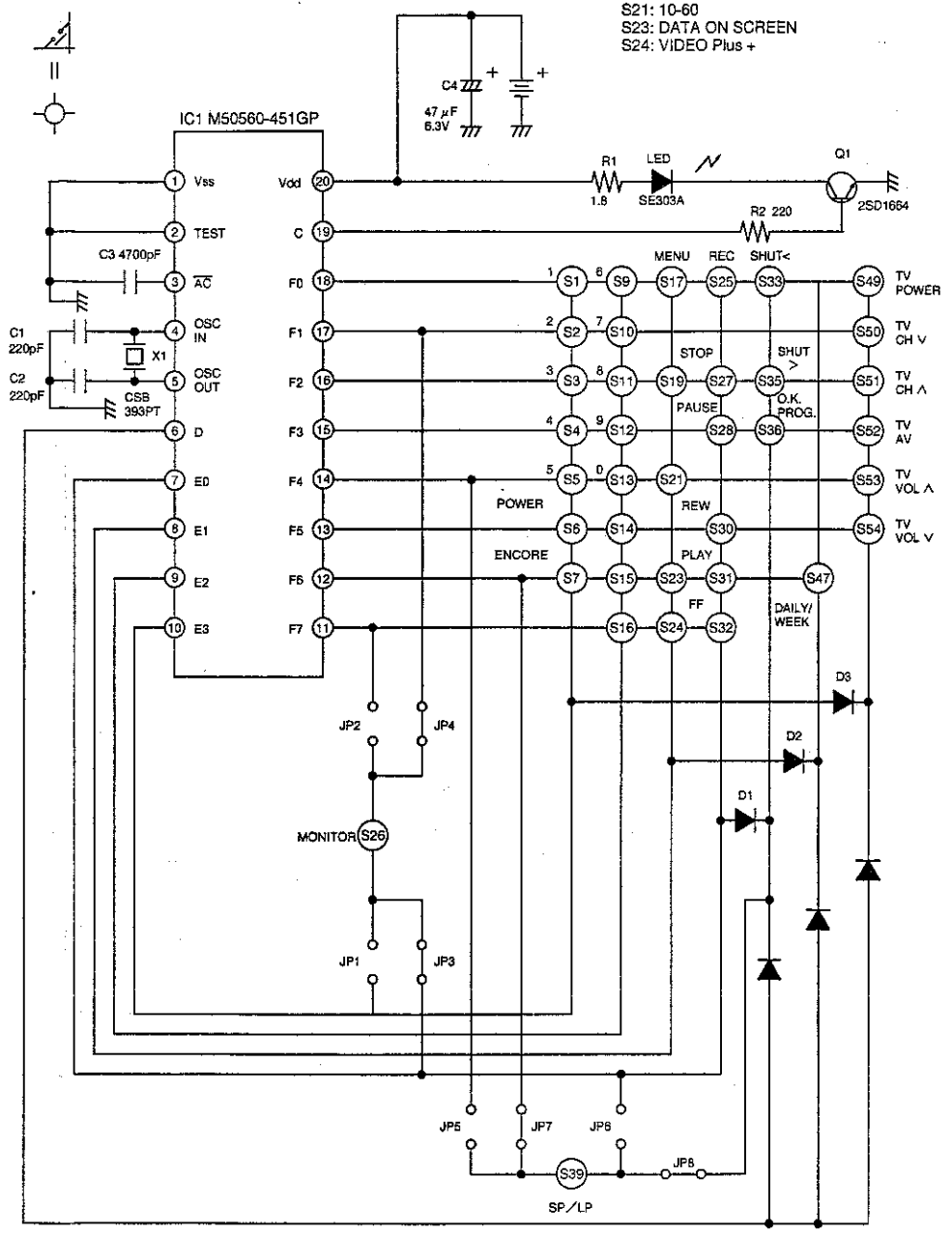

HS-550V(B) PCB-TIMER

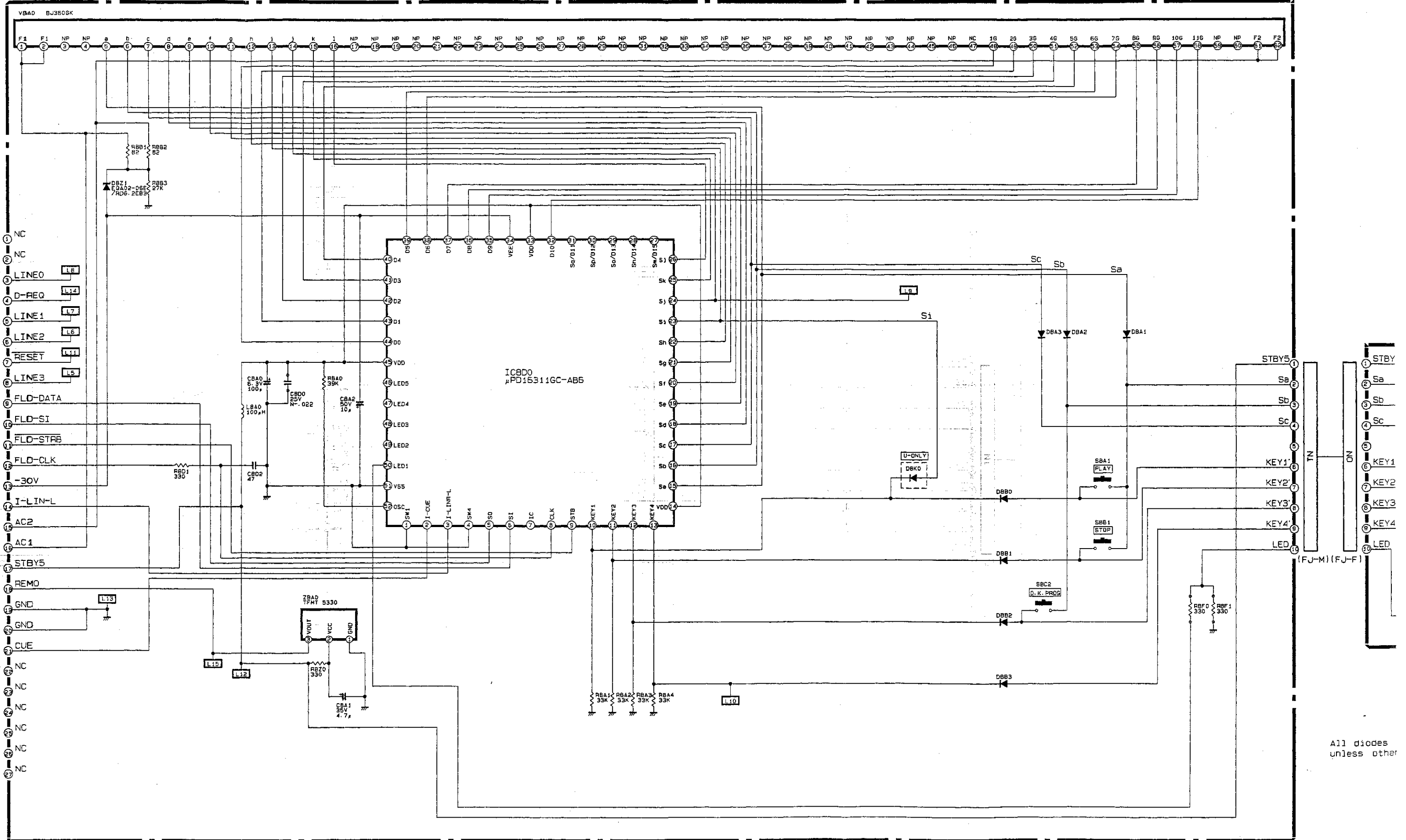

All diodes unless other

HS-550V(B) PCB-TIMER

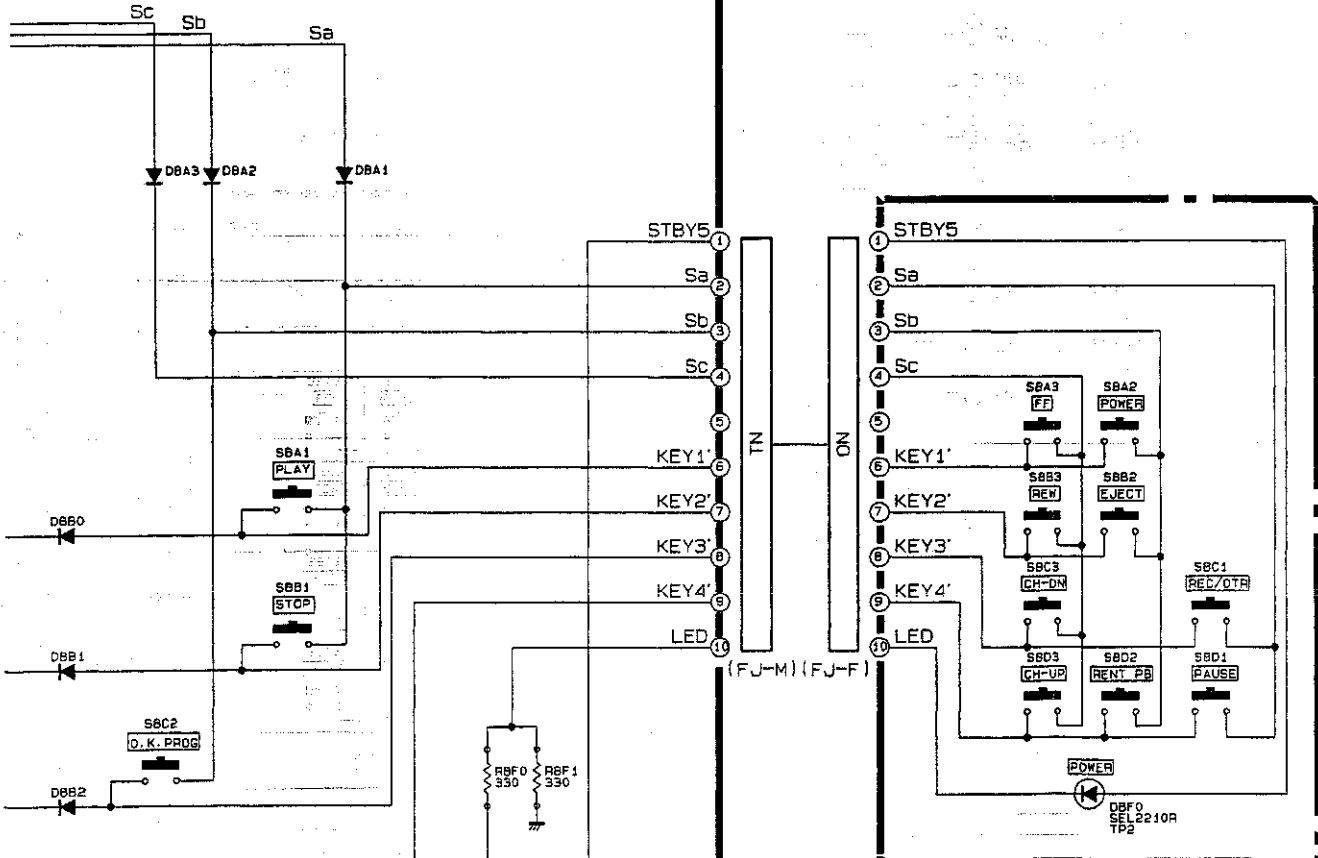
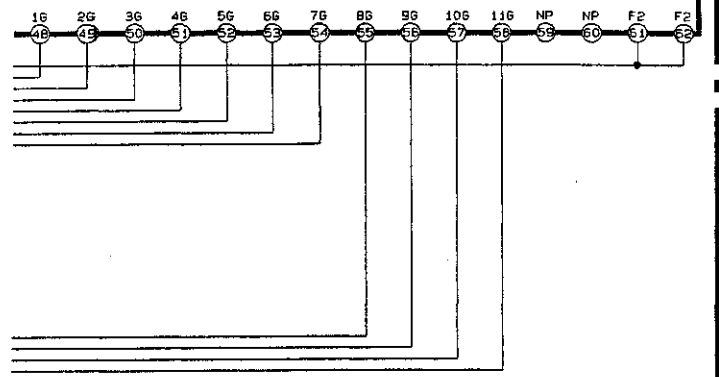

All diodes are 1SS252/1SS131 unless otherwise specified

HS-550V(B)/ HS-F5601V TRANSMITTER REMOTE CONTROL

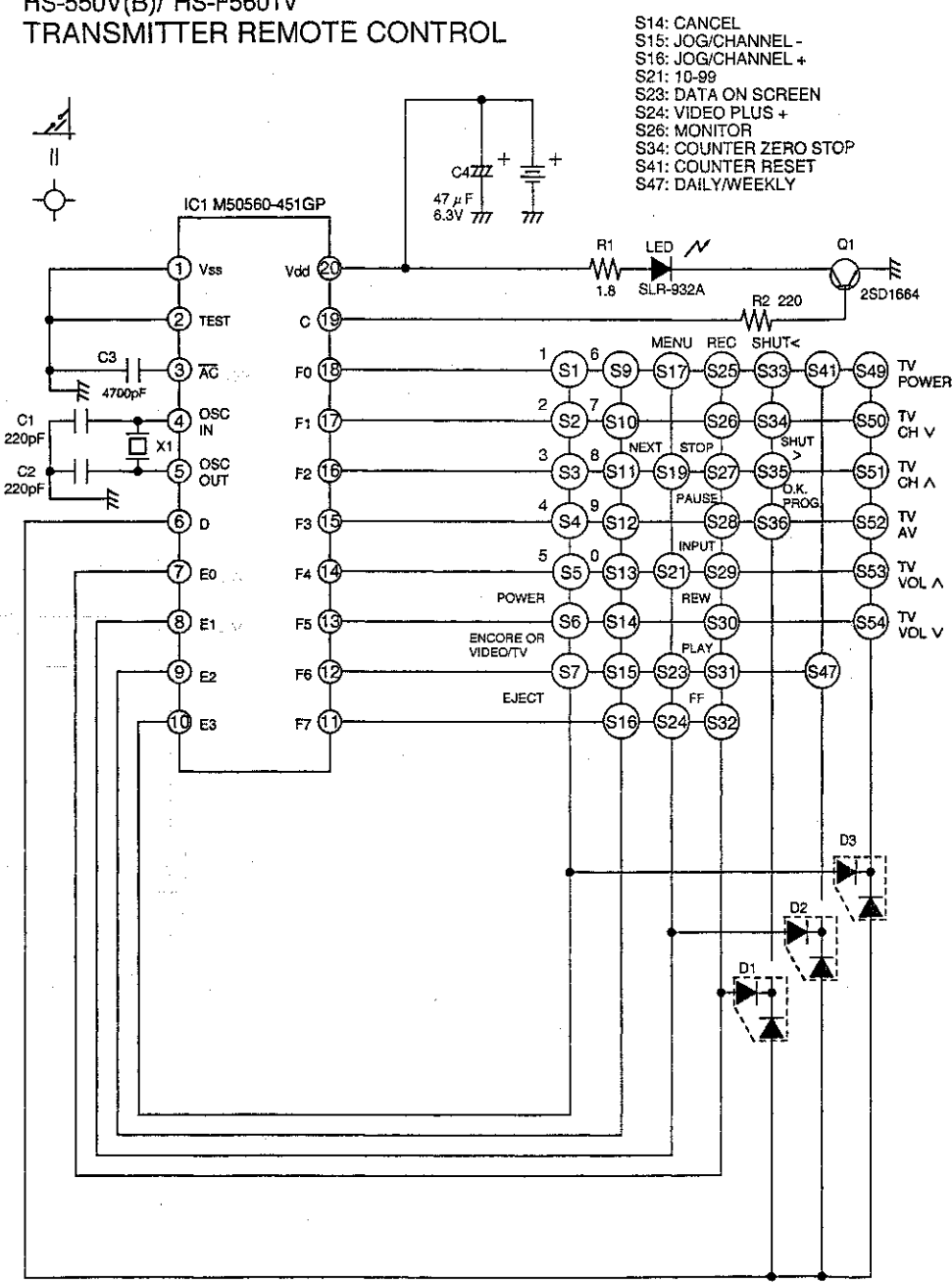

- S14: CANCEL
- S15: JOG/CHANNEL-
- S16: JOG/CHANNEL+
- S21: 10-99
- S23: DATA ON SCREEN
- S24: VIDEO PLUS+
- S26: MONITOR
- S34: COUNTER ZERO STOP
- S41: COUNTER RESET
- S47: DAILY/WEEKLY

SYMBOL NO.	ADDRESS	SYMBOL NO.
C01	A-1	C512
C02	B-1	C513
C03	B-1	C514
C04	C-1	C515
C05	B-1	C530
C06	B-1	C551
C08	B-1	C552
C09	B-1	C553
C10	B-1	C554
C12	B-1	C555
C13	A-2	C556
C101	A-1	C901
C102	A-1	C902
C103	A-1	C903
C104	A-1	C904
C105	A-1	C911
C106	A-1	C912
C107	A-1	C914
C108	B-2	C915
C109	B-2	C916
C110	B-2	C917
C111	A-1	C920
C112	A-1	C921
C113	A-2	C1S1
C114	A-1	C1S2
C115	A-2	C1S3
C116	B-2	C1S4
C117	B-2	C2A0
C118	B-2	C2A2
C119	B-2	C2A3
C120	A-2	C2A4
C121	A-2	C2A5
C122	B-1	C2A6
C123	B-1	C2A7
C124	B-1	C2A8
C125	B-1	C2B0
C126	B-1	C2B1
C127	B-1	C2B2
C128	B-1	C2B3
C129	B-2	C2C1
C130	A-1	C2C2
C131	B-1	C2G0
C132	B-2	C2G1
C133	A-2	C2G2
C134	A-2	C2G3
C151	B-1	C2G4
C152	B-1	C2G5
C153	A-1	C2G6
C199	B-1	C2G7
C501	A-4	C2G8
C502	A-4	C2G9
C503	A-4	C2H0
C504	B-4	C2H1
C505	A-3	C2H2
C506	B-3	C2H3
C507	B-3	C2H4
C508	A-3	C2H5
C509	B-3	C2H6
C510	B-3	C2H7
C511	C-5	C2H8

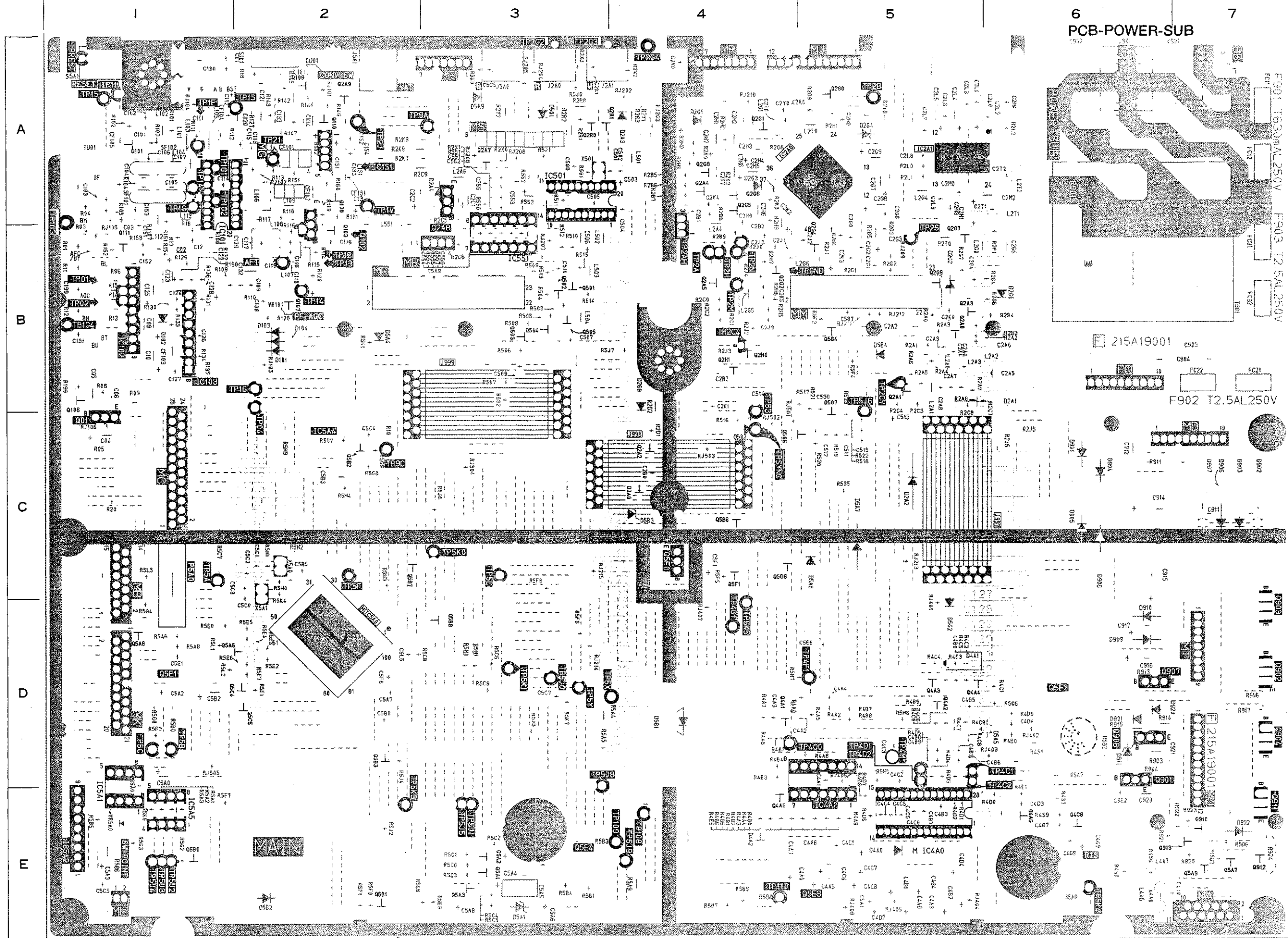

550V(B)
551V(B)/V(G)/V(E)/V(Y)/V(IR)

10

PCB-HIFI/NIC/DEC (SOLDER SIDE)

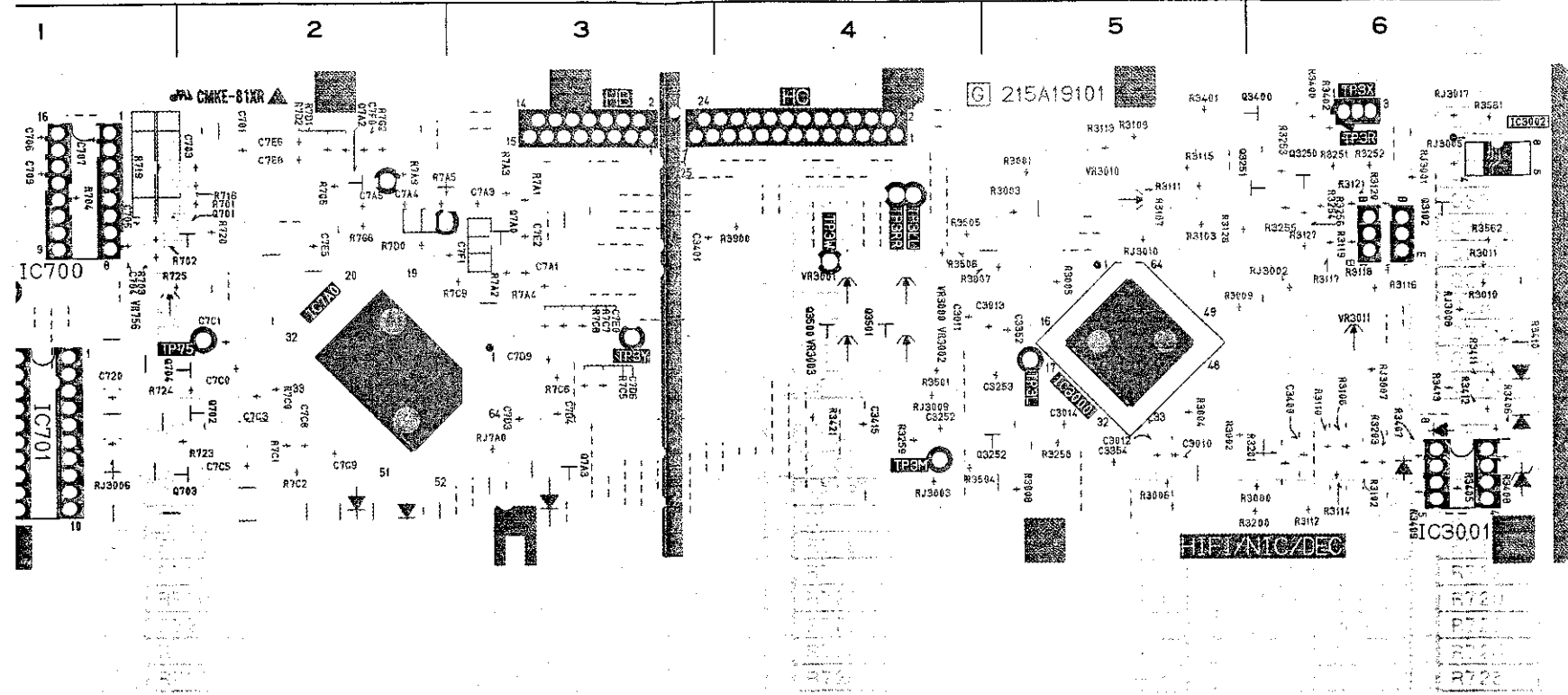

PCB-HIFI/NIC/DEC (SOLDER SIDE)

SYMBOL NO.	ADDRESS	SYMBOL NO.	ADDRESS	SYMBOL NO.	ADDRESS	SYMBOL NO.	ADDRESS	SYMBOL NO.	ADDRESS	S
C701	A-2	C7C0	B-2	Q701	A-2	R3000	B-6	R3118	A-6	R
C703	A-2	C7C1	A-2	Q702	B-2	R3001	A-5	R3119	A-6	R
C704	A-1	C7C3	B-2	Q703	B-2	R3002	B-5	R3120	A-6	R
C705	A-1	C7C5	B-2	Q704	B-2	R3003	A-5	R3121	A-6	R
C706	A-1	C7C8	B-2	Q3102	A-6	R3004	B-5	R3127	A-6	R
C707	A-1	C7C9	B-2	Q3250	A-6	R3005	A-5	R3128	A-5	R
C709	A-1	C7D3	B-3	Q3251	A-6	R3006	B-5	R3200	B-6	F
C713	B-1	C7D4	B-3	Q3252	B-5	R3007	A-5	R3201	B-6	F
C720	B-1	C7D6	B-3	Q3400	A-6	R3008	B-5	R3203	B-6	F
C3010	B-5	C7D9	B-3	Q3500	A-4	R3009	A-5	R3251	A-6	F
C3011	A-4	C7E0	A-3	Q3501	A-4	R3010	A-6	R3252	A-6	F
C3012	B-5	C7E2	A-3	Q7A0	A-3	R3011	A-6	R3253	A-6	F
C3013	A-5	C7E5	A-2	Q7A2	A-2	R3102	B-6	R3254	A-6	F
C3014	B-5	C7E6	A-2	Q7A3	B-3	R3103	A-5	R3255	A-6	F
C3252	B-4	C7E8	A-2			R3106	B-6	R3256	A-6	F
C3253	B-5	C7F0	A-2	R701	A-2	R3107	A-5	R3258	B-5	F
C3352	A-5	C7F1	A-3	R702	A-1	R3109	A-5	R3259	B-4	F
C3354	B-5			R703	A-1	R3110	B-6	R3400	A-6	F
C3400	B-6	IC700	A-1	R704	A-1	R3111	A-5	R3401	A-5	F
C3401	A-3	IC701	B-1	R718	A-2	R3112	B-6	R3402	A-6	F
C3415	B-4	IC3000	B-5	R719	A-1	R3113	A-5	R3405	B-6	F
C7A1	A-3	IC3001	B-6	R720	A-2	R3114	B-6	R3406	B-6	F
C7A3	A-3	IC3002	A-6	R723	B-2	R3115	A-5	R3407	B-6	F
C7A4	A-2	IC7A0	B-2	R724	B-2	R3116	A-6	R3408	B-6	F
C7A5	A-2			R725	A-1	R3117	A-6	R3409	B-6	F

PCB-HIFI/NIC/DEC (COMPONENT SIDE)

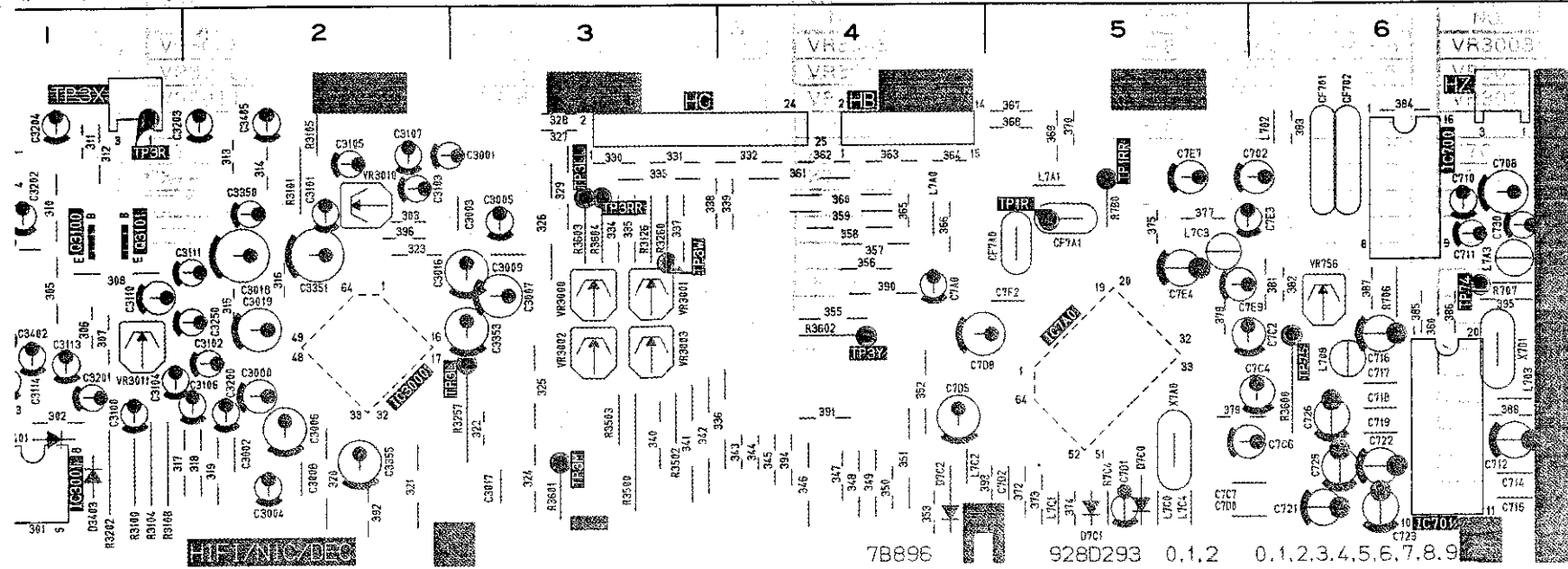

PCB-HIFI/NIC/DEC (COMPONENT SIDE)

SYMBOL NO.	ADDRESS	SYMBOL NO.	ADDRESS	SYMBOL NO.	ADDRESS
CF701	A-6	L7A3	A-6	VR3003	B-3
CF702	A-6	L7C0	B-5	VR3010	A-2
CF7A0	A-5	L7C1	B-5	VR3011	A-1
CF7A1	A-5	L7C2	B-4		
		L7C3	A-5	X701	B-6
				X7A0	B-5
D3400	B-1				
D3401	B-1	Q3100	A-1		
D3402	B-1	Q3101	A-1		
D3403	B-1				
D3406	B-1	TP74	A-6		
D7C0	B-5	TP75	A-6		
D7C1	B-5	TP1R	A-5		
D7C2	B-4	TP3L	B-3		
		TP3M	B-3		
IC700	A-6	TP3R	A-1		
IC701	B-6	TP3W	A-3		
IC3000	B-2	TP3X	A-1		
IC3001	B-1	TP3Y	A-4		
IC3002	A-1	TP1RR	A-5		
IC7A0	B-5	TP3LL	A-3		
		TP3RR	A-3		
L702	A-6				
L703	B-6	VR756	A-6		
L708	B-6	VR3000	A-3		
L7A1	A-5	VR3001	A-3		

DL	ADDRESS	SYMBOL NO.	ADDRESS	SYMBOL NO.	ADDRESS	SYMBOL NO.	ADDRESS
8	A-6	R3410	B-6	R7C9	A-3	TP3X	A-6
9	A-6	R3411	B-6	R7D0	A-2	TP3Y	B-3
0	A-6	R3412	B-6	R7D1	A-2	TP3LL	A-4
1	A-6	R3413	B-6	R7D2	A-2	TP3RR	A-4
7	A-6	R3421	B-4	R7G2	A-2		
8	A-5	R3501	B-4	R7G5	A-2	VR756	A-1
0	B-6	R3504	B-4	R7G6	A-2	VR3000	A-4
1	B-6	R3505	A-4			VR3001	A-4
3	B-6	R3506	A-4	RJ3001	A-6	VR3002	B-4
1	A-6	R3561	A-6	RJ3002	A-6	VR3003	B-4
2	A-6	R3562	A-6	RJ3003	B-4	VR3010	A-5
3	A-6	R3900	A-4	RJ3005	A-6	VR3011	A-6
4	A-6	R7A1	A-3	RJ3006	B-1		
5	A-6	R7A2	A-3	RJ3007	B-6		
6	A-6	R7A3	A-3	RJ3008	A-6		
8	B-5	R7A4	A-3	RJ3009	B-4		
9	B-4	R7A5	A-2	RJ3010	A-5		
0	A-6	R7A9	A-2	RJ3017	A-6		
1	A-5	R7C0	B-2	RJ7A0	B-3		
2	A-6	R7C1	B-2				
5	B-6	R7C2	B-2	TP75	B-2		
6	B-6	R7C5	B-3	TP3L	B-5		
7	B-6	R7C6	B-3	TP3M	B-4		
8	B-6	R7C7	A-3	TP3R	A-6		
9	B-6	R7C8	A-3	TP3W	A-4		

PCB-POWER-SUB 2 [SOLDER SIDE]

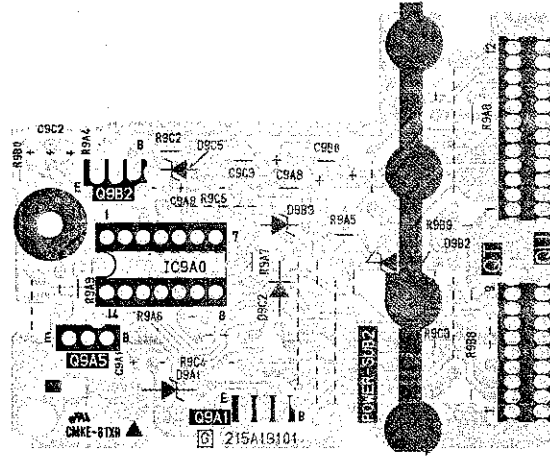

PCB-POWER-SUB 2 [COMPONENT SIDE]

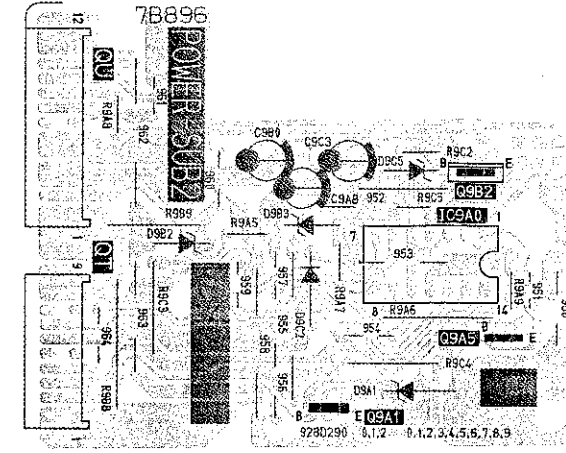

PCB-PCB1

PCB-SAT [SOLDER SIDE] (HS-551V(B) only) PCB-SAT [COMPONENT SIDE] (HS-551V(B) only)

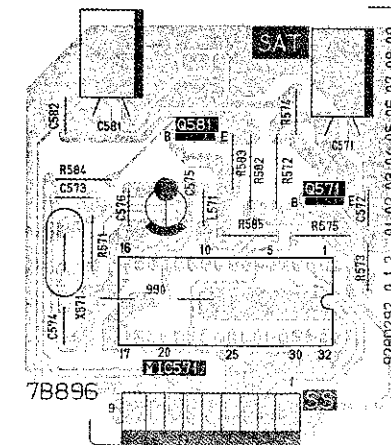
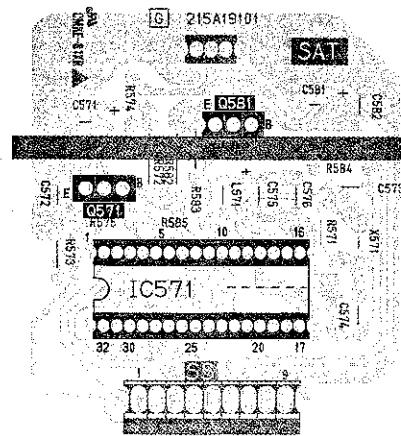

PCB-CONNECTOR [SOLDER SIDE]

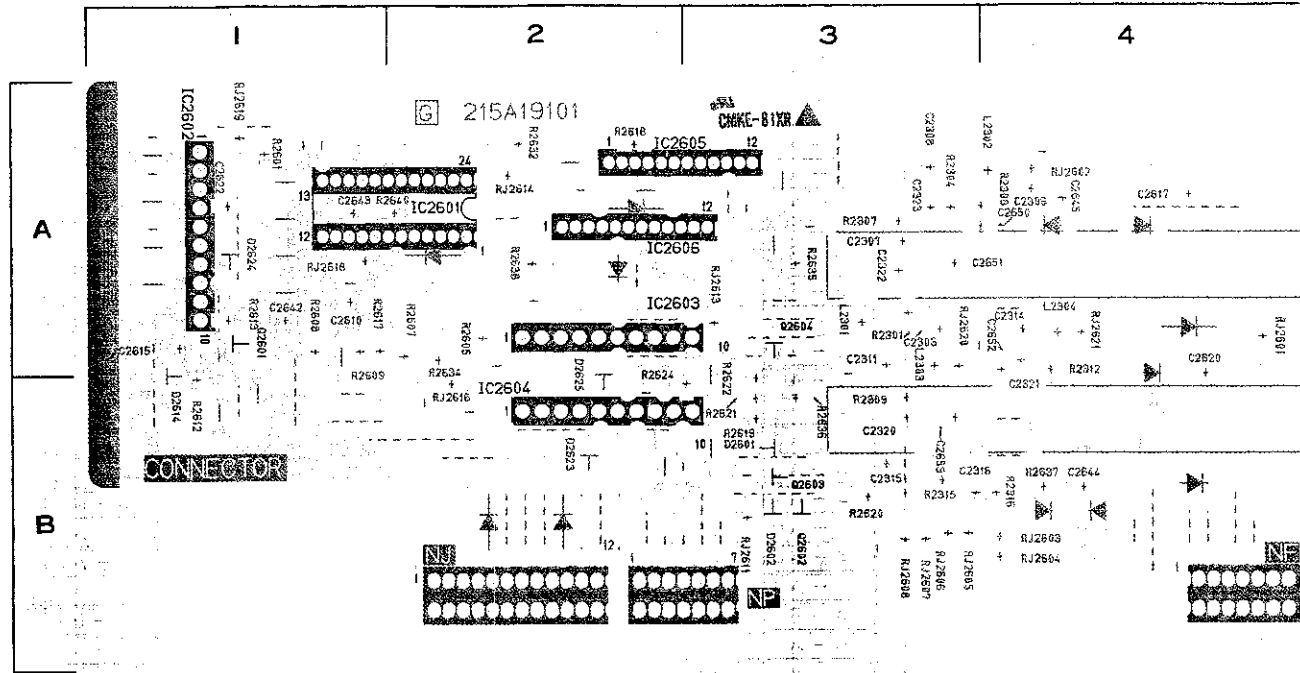

PCB-CONNECTOR [SOLDER SIDE]

SYMBOL NO.	ADDRESS	SYMBOL NO.	ADDRESS	SYMBOL NO.	ADDRESS	SYMBOL NO.	ADDRESS
C2303	A-3	D2601	B-3	R2304	A-3	R2637	B-4
C2306	A-4	D2602	B-3	R2307	A-3	R2638	A-2
C2307	A-3	D2614	B-1	R2308	A-3	R2640	A-1
C2308	A-3	D2623	B-2	R2309	B-3		
C2311	A-3	D2624	A-1	R2312	A-4	RJ2601	A-4
C2314	A-4	D2625	A-2	R2315	B-3	RJ2602	A-4
C2315	B-3			R2316	B-3	RJ2603	B-4
C2316	B-3	IC2601	A-1	R2601	A-1	RJ2604	B-4
C2320	B-3	IC2602	A-1	R2605	A-2	RJ2605	B-3
C2321	B-4	IC2603	A-2	R2607	A-2	RJ2606	B-3
C2322	A-3	IC2604	B-2	R2608	A-1	RJ2607	B-3
C2323	A-3	IC2605	A-2	R2609	A-1	RJ2608	B-3
C2610	A-1	IC2606	A-2	R2612	B-1	RJ2611	B-3
C2615	A-1			R2613	A-1	RJ2613	A-3
C2617	A-4	L2301	A-3	R2617	A-1	RJ2614	A-2
C2620	A-4	L2302	A-3	R2618	A-2	RJ2616	B-2
C2622	A-1	L2303	A-3	R2619	B-3	RJ2618	A-1
C2642	A-1	L2304	A-4	R2620	B-3	RJ2619	A-1
C2643	A-1			R2621	B-3	RJ2620	A-3
C2644	B-4	Q2601	A-1	R2622	B-3	RJ2621	A-4
C2645	A-4	Q2602	B-3	R2624	B-2		
C2650	A-4	Q2603	B-3	R2632	A-2		
C2651	A-3	Q2604	A-3	R2634	A-2		
C2652	A-4			R2635	A-3		
C2653	B-3	R2301	A-3	R2636	B-3		

PCB-TIMER

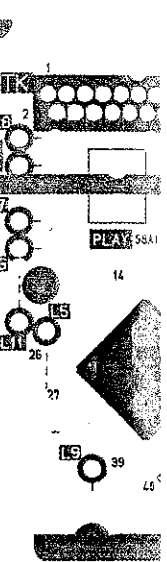

PCB-CONNECTOR [COMPONENT SIDE]

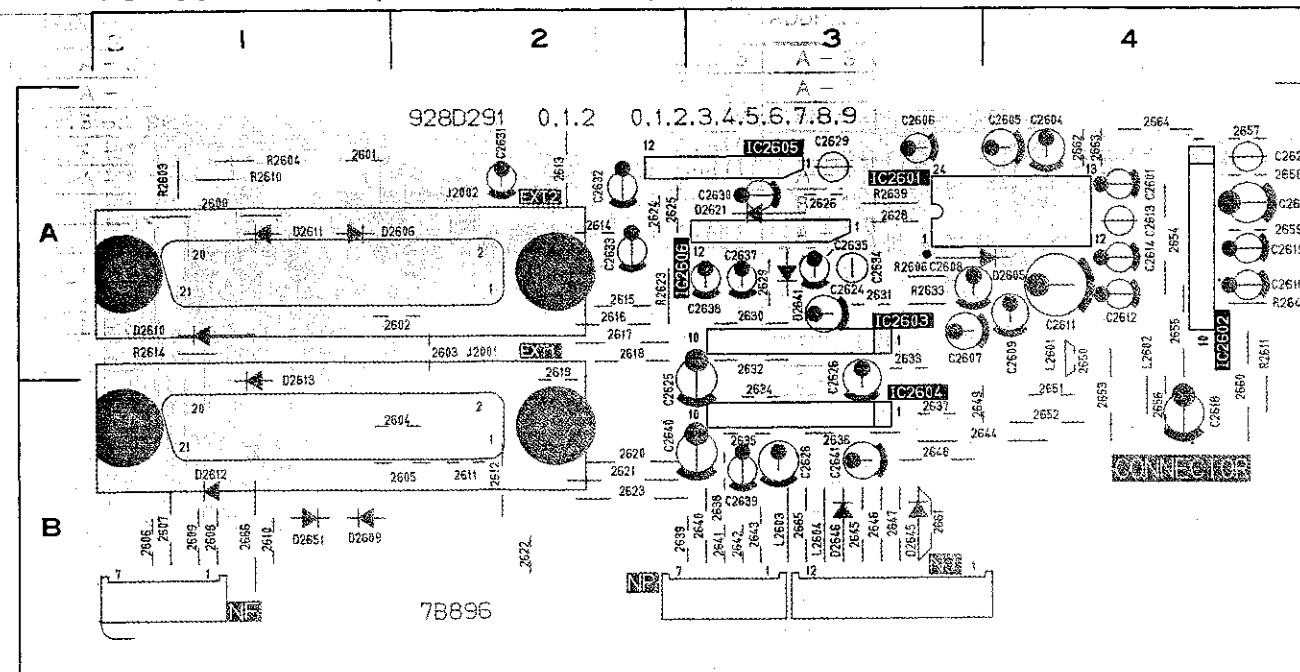

PCB-CONNECTOR [COMPONENT SIDE]

SYMBOL NO.	ADDRESS	SYMBOL NO.	ADDRESS
D2605	A-3	L2603	B-3
D2606	A-1	L2604	B-3
D2609	B-1		
D2610	A-1		
D2611	A-1		
D2612	B-1		
D2613	A-1		
D2621	A-3		
D2641	A-3		
D2645	B-3		
D2646	B-3		
D2651	B-1		
IC2601	A-4		
IC2602	A-4		
IC2603	A-3		
IC2604	B-3		
IC2605	A-3		
IC2606	A-3		
J2001	B-1		
J2002	A-1		
L2601	A-4		
L2602	B-4		

PCB-TIMER (Exce

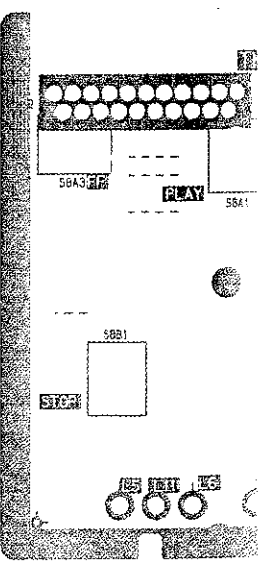

PCB-HA/AUDIO [SOLDER SIDE]

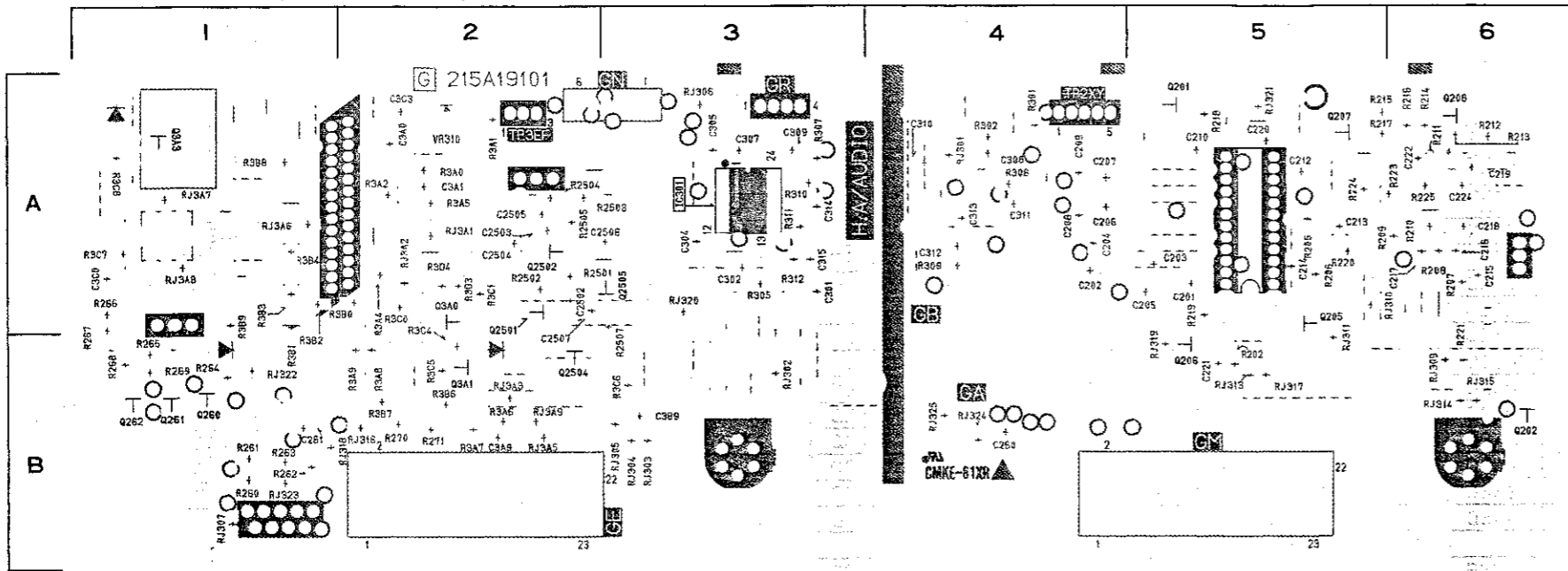

PCB-HA/AUDIO [SOLDER SIDE]

SYMBOL NO.	ADDRESS
C201	A - 5
C202	A - 4
C203	A - 5
C204	A - 4
C205	A - 5
C206	A - 4
C207	A - 4
C208	A - 4
C209	A - 4
C210	A - 5
C212	A - 5
C213	A - 5
C214	A - 5
C215	A - 6
C216	A - 6
C217	A - 6
C218	A - 6
C219	A - 6
C220	A - 5
C221	B - 5
C222	A - 6
C224	A - 6
C260	B - 4
C261	B - 1
C301	A - 3

SYMBOL NO.	ADDRESS
C302	A - 3
C304	A - 3
C305	A - 3
C307	A - 3
C308	A - 4
C309	A - 3
C310	A - 4
C311	A - 4
C312	A - 4
C313	A - 4
C314	A - 3
C315	A - 3
C2502	A - 2
C2503	A - 2
C2504	A - 2
C2505	A - 2
C2506	A - 3
C2507	A - 2
C3A0	A - 2
C3A1	A - 2
C3A9	B - 2
C3B9	B - 3
C3C0	A - 1
C3C3	A - 2

SYMBOL NO.	ADDRESS
IC301	A - 3
Q201	A - 5
Q202	B - 6
Q205	A - 5
Q206	B - 5
Q207	A - 5
Q208	A - 6
Q260	B - 1
Q261	B - 1
Q262	B - 1
Q2501	A - 2
Q2502	A - 2
Q2504	B - 2
Q2505	A - 3
Q3A0	A - 2
Q3A1	B - 2
Q3A3	A - 1
Q3A4	A - 2
R202	B - 5
R205	A - 5
R206	A - 5
R207	A - 6
R208	A - 6

SYMBOL NO.	ADDRESS
R209	A - 6
R210	A - 6
R211	A - 6
R212	A - 6
R213	A - 6
R214	A - 6
R215	A - 6
R216	A - 6
R217	A - 6
R218	A - 5
R219	A - 5
R220	A - 5
R221	B - 6
R223	A - 6
R224	A - 5
R225	A - 6
R260	B - 1
R261	B - 1
R262	B - 1
R263	B - 1
R264	B - 1
R265	B - 1
R266	A - 1
R267	A - 1
R268	B - 1

SYMBOL NO.	AD
R269	
R270	
R271	
R301	
R302	
R305	
R307	
R308	
R309	
R310	
R311	
R312	
R2501	
R2502	
R2503	
R2504	
R2505	
R2507	
R3A0	
R3A1	
R3A2	
R3A5	
R3A6	
R3A7	
R3A8	

PCB-HA/AUDIO [COMPONENT SIDE]

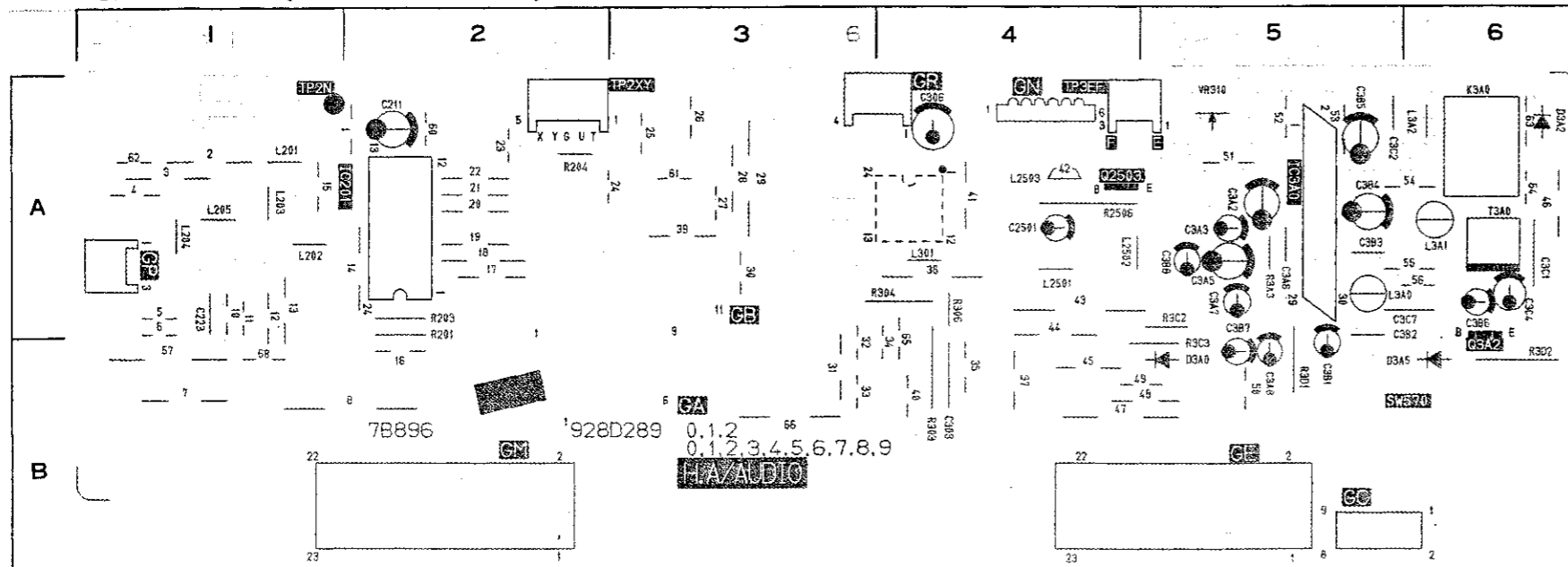

PCB-HA/AUDIO [COMPONENT SIDE]

SYMBOL NO.	ADDRESS
D3A0	B - 5
D3A2	A - 6
D3A5	B - 6
IC201	A - 2
IC3A0	A - 5
K3A0	A - 6
L201	A - 1
L202	A - 1
L203	A - 1
L204	A - 1
L205	A - 1
L301	A - 4
L2501	A - 4
L2502	A - 5
L2503	A - 4
L3A0	A - 6
L3A1	A - 6
L3A2	A - 6
Q2503	A - 4
Q3A2	B - 6

SYMBOL NO.	ADDRESS
SW570	B - 6
T3A0	A - 6
TP2N	A - 1
TP2XY	A - 2
TP3EF	A - 4
VR310	A - 5

PCB-TIMER (HS-550V(B) only)

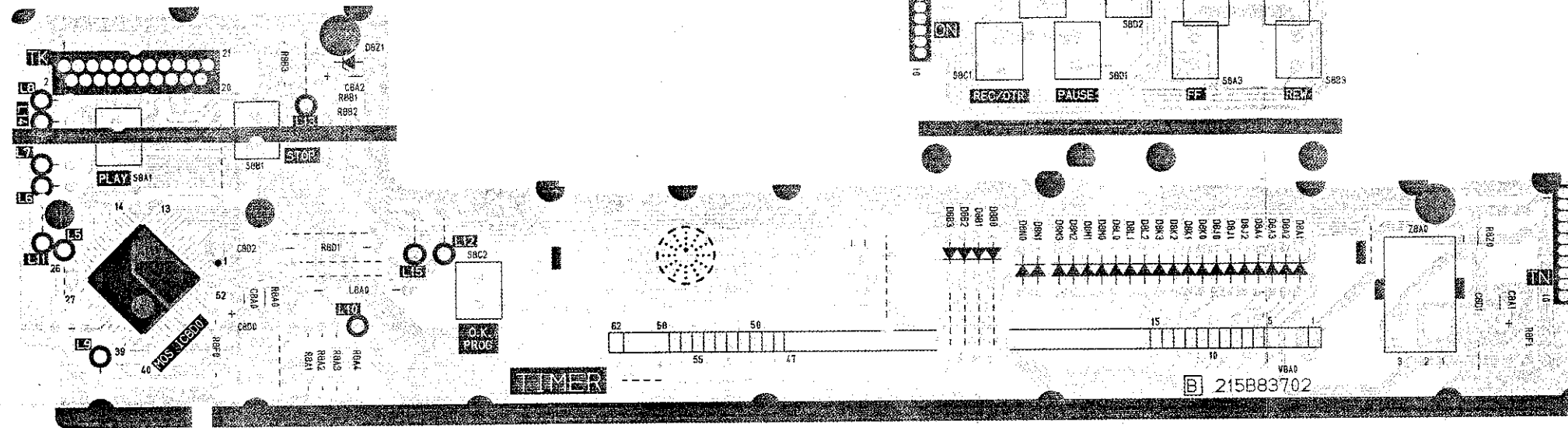

PCB-TIMER

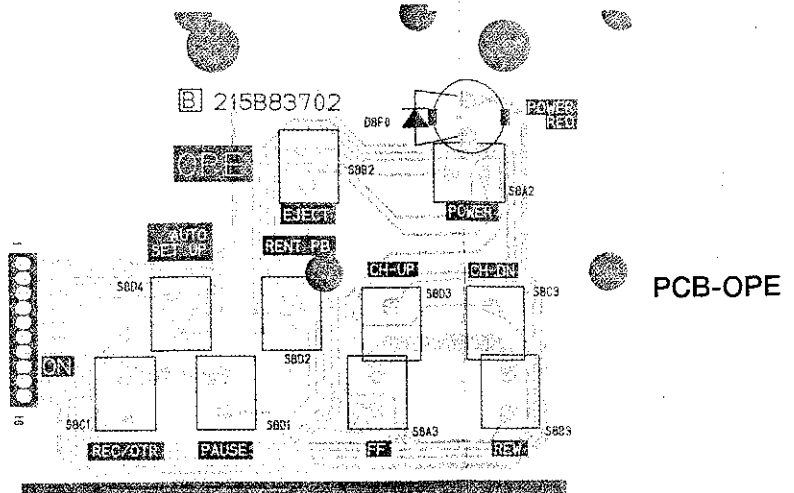

PCB-OPE

PCB-TIMER (Except HS-550V(B))

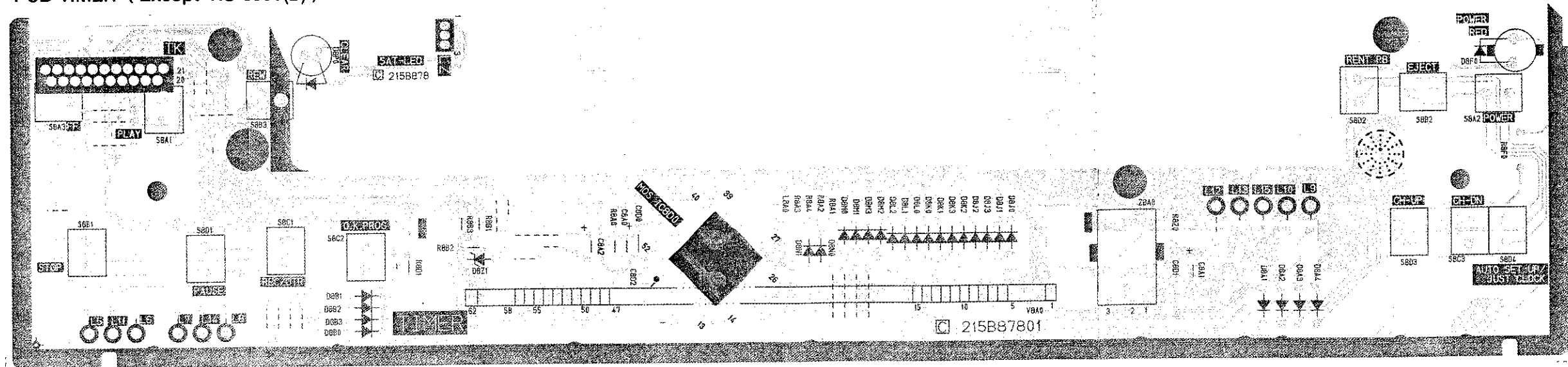

PCB-TIMER

ADDRESS	SYMBOL NO.	ADDRESS	SYMBOL NO.	ADDRESS	SYMBOL NO.	ADDRESS	SYMBOL NO.	ADDRESS	SYMBOL NO.	ADDRESS
A-3	R209	A-6	R269	B-1	R3A9	B-2	RJ306	A-3	RJ3A9	B-2
	R210	A-6	R270	B-2	R3B0	A-2	RJ307	B-1		
A-5	R211	A-6	R271	B-2	R3B1	B-1	RJ309	B-6	TP2XY	A-4
B-6	R212	A-6	R301	A-4	R3B2	A-1	RJ310	A-6	TP3EF	A-2
A-5	R213	A-6	R302	A-4	R3B3	A-1	RJ311	B-5		
B-5	R214	A-6	R305	A-3	R3B4	A-1	RJ313	B-5	VR310	A-2
A-5	R215	A-6	R307	A-3	R3B6	B-2	RJ314	B-6		
A-6	R216	A-6	R308	A-4	R3B7	B-2	RJ315	B-6		
B-1	R217	A-6	R309	A-4	R3B8	A-1	RJ316	B-2		
B-1	R218	A-5	R310	A-3	R3B9	A-1	RJ317	B-5		
B-1	R219	A-5	R311	A-3	R3C0	A-2	RJ318	B-2		
A-2	R220	A-5	R312	A-3	R3C1	A-2	RJ319	B-5		
A-2	R221	B-6	R2501	A-2	R3C4	B-2	RJ320	A-3		
B-2	R223	A-6	R2502	A-2	R3C5	B-2	RJ321	A-5		
A-3	R224	A-5	R2503	A-3	R3C6	B-3	RJ322	B-1		
A-2	R225	A-6	R2504	A-2	R3C7	A-1	RJ323	B-1		
B-2	R260	B-1	R2505	A-2	R3C8	A-1	RJ324	B-4		
A-1	R261	B-1	R2507	A-3	R3D3	A-2	RJ325	B-4		
A-2	R262	B-1	R3A0	A-2	R3D4	A-2	RJ3A1	A-2		
	R263	B-1	R3A1	A-2			RJ3A2	A-2		
B-5	R264	B-1	R3A2	A-2	RJ301	A-4	RJ3A3	B-2		
A-5	R265	B-1	R3A5	A-2	RJ302	B-3	RJ3A5	B-2		
A-5	R266	A-1	R3A6	B-2	RJ303	B-3	RJ3A6	A-1		
A-6	R267	A-1	R3A7	B-2	RJ304	B-3	RJ3A7	A-1		
A-6	R268	B-1	R3A8	B-2	RJ305	B-3	RJ3A8	A-1		