

SERVICE MANUAL
INTELLIGENT AUDIO SYSTEM
MODEL E-63P

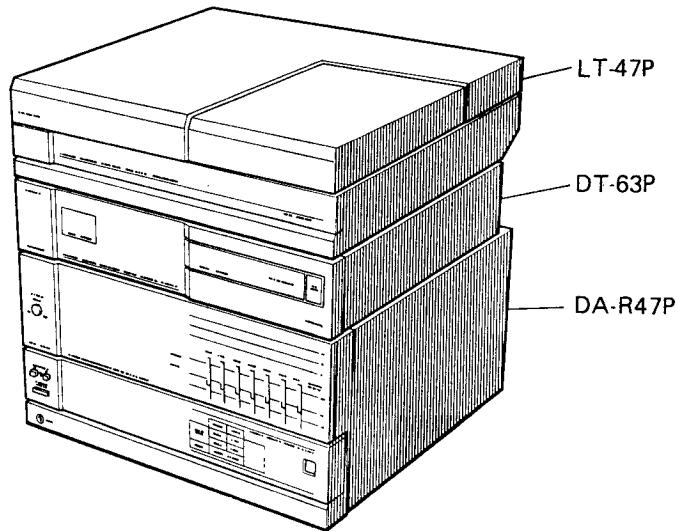

CONTENTS

SPECIFICATIONS	2	ADJUSTMENT PROCEDURE	49
FRONT PANEL TERMINOLOGY AND FUNCTIONS	3	INTERNAL DIAGRAMS AND PINOUT OF INTEGRATED CIRCUITS	55
■ RECEIVER SECTION : MODEL DA-R47P		TIMING CHART	56
DISASSEMBLY PROCEDURE	6	WIRING DIAGRAM	57
ADJUSTMENT PROCEDURE	9	SCHEMATIC DIAGRAM	59
INTERNAL DIAGRAMS AND PINOUT OF INTEGRATED CIRCUIT	12	PRINTED CIRCUIT BOARD	65
BLOCK DIAGRAM	17	EXPLODED VIEW OF CABINET	69
WIRING DIAGRAM	19	CABINET PARTS LIST	70
SCHEMATIC DIAGRAM	21	EXPLODED VIEW OF MECHANISM	71
PRINTED CIRCUIT BOARD	27	MECHANISM PARTE LIST	72
EXPLODED VIEW OF CABINET	33	PARTS LIST	73
CABINET PARTS LIST	34	■ RECORD PLAYER SECTION : MODEL LT-47P	
PARTS LIST	35	DISASSEMBLY PROCEDURE	75
■ SYSTEM COMMANDER		ADJUSTMENT PROCEDURE	77
SCHEMATIC DIAGRAM	38	INTERNAL DIAGRAMS AND PINOUT OF INTEGRATED CIRCUITS	78
PRINTED CIRCUIT BOARD	41	WIRING DIAGRAM	80
EXPLODED VIEW OF CABINET	43	SCHEMATIC DIAGRAM	82
CABINET PARTS LIST	44	PRINTED CIRCUIT BOARD	85
PARTS LIST	44	EXPLODED VIEW OF CABINET	87
■ CASSETTE TAPE DECK SECTION : MODEL DT-63P		CABINET PARTS LIST	88
DISASSEMBLY PROCEDURE	45	EXPLODED VIEW OF TONEARM SECTION	89
DISASSEMBLY OF MECHANISM	46	TONEARM PARTS LIST	90
		PARTS LIST	91
		PACKING INSTRUCTIONS	92

SPECIFICATIONS

DA-R47P RECEIVER AMPLIFIER SECTION

Min. RMS power output . . . 50 watts per channel into 8 ohms load
at 1 kHz with no more than 0.5%
total harmonic distortion

Input sensitivity/Impedance

AUX 150 mV/50 k ohms

TUNER SECTION

FM section

Tuning range 87.5 – 108 MHz (50 kHz step)

Usable sensitivity (IHF) 10.8 dBf (1.9 μ V)

Signal to noise ratio (IHF)

MONO 80 dB

STEREO 73 dB

Total harmonic distortion (75 kHz deviation)

MONO 0.2%

STEREO 0.5%

Capture ratio 1.5 dB

Stereo separation

1 kHz 35 dB

Frequency response 50 – 15,000 Hz \pm 1 dB

MW section

Tuning range 522 – 1,611 kHz (9 kHz step)

Sensitivity (IHF) 300 μ V/m

Selectivity 35 dB

Signal to noise ratio 50 dB

LW section

Tuning range 155 – 353 kHz (9 kHz step)

DT-63P CASSETTE TAPE DECK

Type 4-track, 2-channel stereo

Tape speed 4.76 cm/sec. (1-7/8 ips)

Signal to noise ratio

Dolby NR out 58 dB

Dolby NR in 68 dB

Frequency response

Normal 30 – 16,000 Hz

Special 30 – 17,000 Hz

Metal 30 – 18,000 Hz

LT-47P TURNTABLE

Type Linear tracking

Drive system Belt drive

Wow & flutter 0.04% Wrms

Signal to noise ratio 70 dB (DIN-B)

Tonearm Linear tracking, staight, stratic balance

Cartridge VM type

Tracking force 1.5 gr

ACCESSORIES

T-shaped FM antenna, AM loop antenna

AM loop antenna holder

45 RPM adapter

Batteries

Bus line cable

GENERAL

Power supply 240 V/50 Hz

Power consumption 160 W

Dimensions (W x H x D)

DA-R47P . . . 350 x 183 x 320 mm (13-3/4 x 7-3/16 x 12-5/8")

DT-63P 350 x 70 x 280 mm (13-3/4 x 2-3/4 x 11")

LT-47P 350 x 91 x 320 mm (13-3/4 x 3-5/8 x 11")

Weight

DA-R47P 10.1 kg (22.2 lbs)

DT-63P 3.6 kg (8 lbs)

LT-47P 3.8 kg (8.4 lbs)

- * Noise Reduction System manufactured under license from Dolby Laboratories Licensing Corporation. 'Dolby' and the double-D symbol are trademarks of Dolby Laboratories Licensing Corporation.
- * Specifications of this unit are subject to change without notice for improvement.
- * Under License of staar S.A., Brussels, Belgium.

FRONT PANEL TERMINOLOGY AND FUNCTIONS

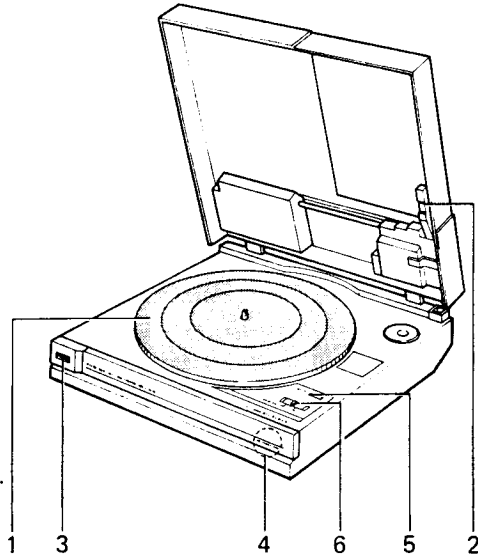
**TURNTABLE LT-47P****1. Turntable Platter****2. Tonearm****3. PHONO Function indicator**

This indicator will light up when the player is operating.

4. SPEED indicator

This indicator shows the rotational speed of the turntable.

5. INVERSE button

Normally the unit will automatically be set 33-1/3 rpm for 30 cm records and 45 rpm for 17 cm records. However, the rotational speed can be selected manually by pressing this button.

6. SENSITIVITY selector**CASSETTE TAPE DECK DT-63P****7. TAPE Function indicator**

This indicator will light up when the tape deck is operating.

8. SYNCHRO Recording indicator**9. TAPE A indicator**

This indicator lights to indicate TAPE A operations.

10. DOLBY NR indicator

This indicator lights when the DOLBY NR switch is set to the "in" position.

11. TAPE B indicator

This indicator lights to indicate TAPE B operations.

12. REW button

TAPE A is rewound by pushing this button.

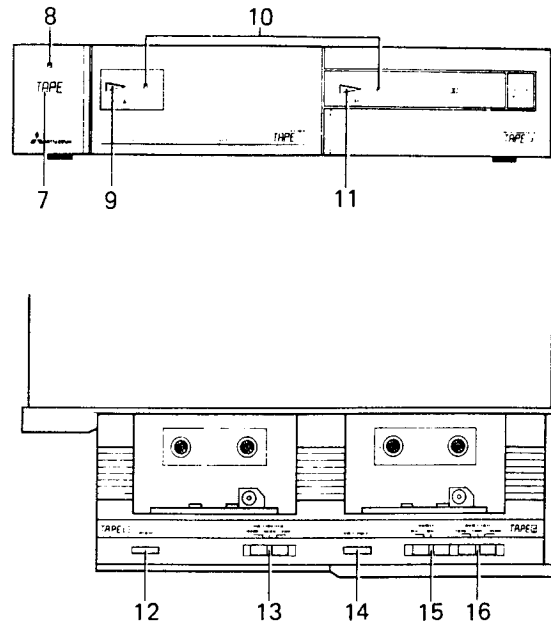
**13. TAPE SELECTOR**

The position of this switch is determined according to the type of tape used in TAPE A.

Special: For special or chrome tape

Normal: For normal tape

Metal: For metal tape

14. REW button

TAPE B is rewound by pushing this button.

15. DOLBY NR switch**16. TAPE SELECTOR**

The position of this switch is determined according to the type of tape used in TAPE B.

Special: For special or chrome tape

Normal: For normal tape

Metal: For metal tape

For Service Manuals Contact
MAURITRON TECHNICAL SERVICES
 8 Cherry Tree Rd, Chinnor
 Oxon OX9 4QY
 Tel:- 01844-351694 Fax:- 01844-352554
 Email:- enquiries@mauritron.co.uk

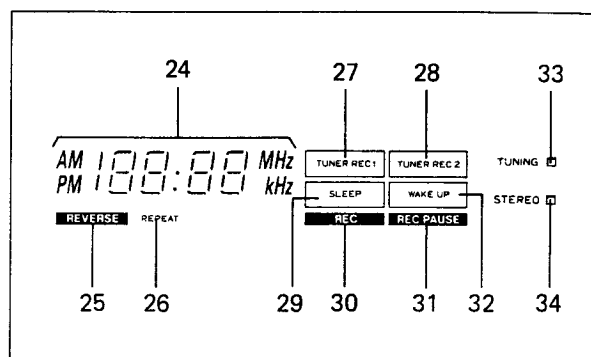
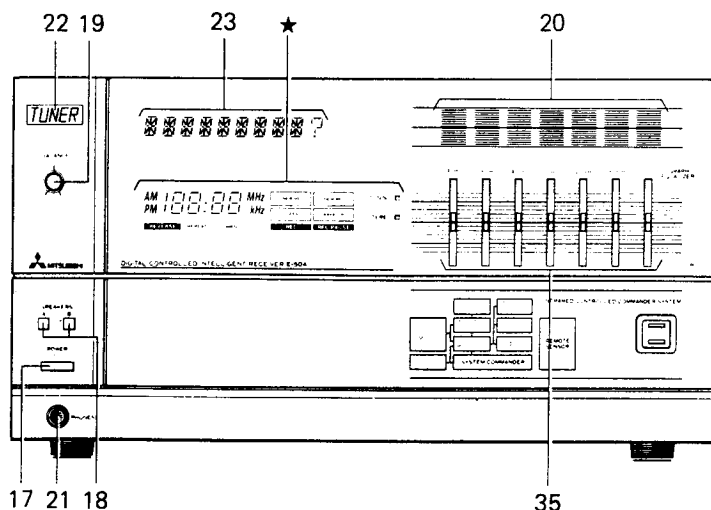

RECEIVER DA-R47P

17. POWER switch







Press this button to ON () position so that this unit can be controlled by the commander.

Note: This unit cannot be controlled by the commander if this switch is set to OFF ().

- To back up the microcomputer circuits, this unit is partly connected to the mains even if the POWER switch is in OFF position. Disconnect the power cord (mains lead) when you do not intend to use for a long period of time.

18. SPEAKERS Selection switch

These switches control speaker selection.

- | | | |
|---|---|---|
| A | B | Outputs are off and no sound will be produced from the speakers. |
|  |  | For listening to the speakers connected to the terminals A. |
|  |  | For listening to the speakers connected to the terminals B. |
|  |  | For listening to the speakers connected to the terminals A and B. |

19. BALANCE control

Left and Right Volume Balance knob.

20. Spectrum Display

21. PHONES jack

22. TUNER Function indicator

This indicator will light up when the tuner is operating.

23. Indicators

These will indicate the FUNCTION currently operating, for the contents of the operation next to be carried out.

24. Indicator

This will indicate the Frequency and the time.

25. REPEAT indicator

This indicator lights when the REPEAT button is pushed for repeat playback operations during the playback of records, CDs, or tapes.

Repeat operations are released when the REPEAT button is pressed once again and this indicator will go out.

26. DUBBING indicator

This indicator lights to indicate dubbing when the dubbing button is pressed.

27. TUNER REC 1 indicator

This indicator will light up when the TUNER REC 1 button is pressed, enabling absentee recordings to be carried out. Pressing the button once again will cancel this function and cause the indicator to go out.

28. TUNER REC 2 indicator

This indicator will light up when the TUNER REC 2 button is pressed, enabling absentee recordings to be carried out. Pressing the button once again will cancel the function and cause the indicator to go out.

29. SLEEP indicator

This indicator will light up when the SLEEP button is pressed, activating the sleep timer. Pressing the SLEEP button once again will cancel this function and cause this indicator to go out.

30. REC indicator

This indicator lights when the REC START button is pressed to indicate the beginning of recording. Recording stops when the STOP button is pressed and this indicator is extinguished.

31. REC PAUSE indicator

This indicator will light up when the AUTO PAUSE button is pressed, automatically creating a five second blank on the tape recording, after which the unit will enter the recording standby mode.

32. WAKE UP indicator

This indicator will light up when the WAKE UP button is pressed, activating the WAKE UP playback function.

Pressing this button once again will cancel the function and cause the indicator to go out.

33. TUNING indicator

This indicator will light up when a station broadcast is being received. However, it will not light up when the signal strength of the broadcast being received is too weak.

34. STEREO indicator

This indicator will light up when FM STEREO broadcasts are being received. It will not light up for non-stereo broadcasts, or when the signal strength of the stereo broadcast is too weak.

35. GRAPHIC EQUALIZER

Use this function to create sound in accordance with your own taste.

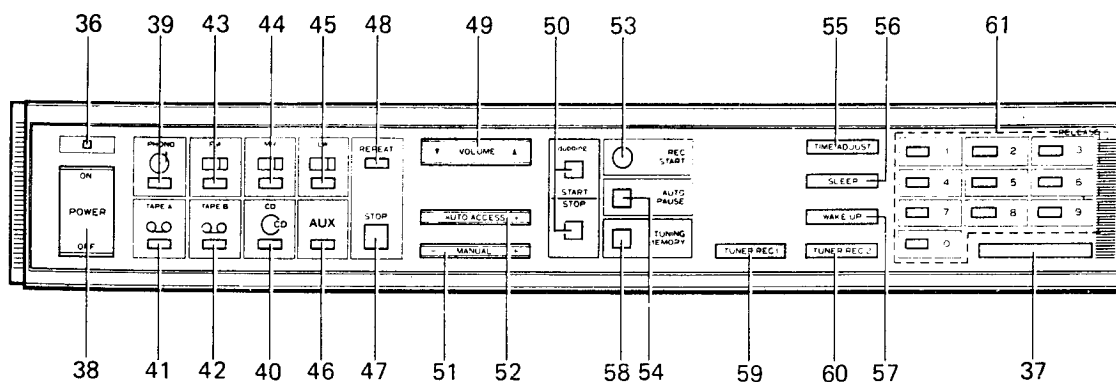

STEM COMMANDER

Indicator

This indicator will light up when any of the system commander buttons are pressed.

Key

When setting the time, press this key before progressing to the next step.

This key is used as a value of ten for the program select functions of RECORD, CD or TAPE functions up to piece number 10 can be selected.

POWER switch

PHONO button

Press this button when you wish to listen to records.

CD button

Press this button when you wish to listen to compact disks.

TAPE A button

Press this button is pressed to listen to the tape in TAPE A.

TAPE B button

Press this button is pressed to listen to the tape in TAPE B.

FM button

Press this button is pressed to listen to FM broadcasts.

MW button

Press this button is pressed to listen to MW broadcasts.

LW button

Press this button is pressed to listen to LW broadcasts.

AUX button

Press this button to listen to the devices connected to the external input terminals (AUX 1, 2, 3) on the rear panel.

STOP button

Press this button to cancel all operations or recording of the device selected by the FUNCTION button.

REPEAT button

Pressing this button will alternate playback between PHONO, TAPE and CD.

VOLUME control button

Pressing this button will cause the volume level to be displayed on the indicator (23). The volume can be adjusted by one level each time the button is pressed.

50. DUBBING button

Press START button to begin dubbing of TAPE A onto TAPE B at twice the normal speed. Dubbing stops when the STOP button is pressed.

51. MANUAL Access button

This button allows the desired selection in the PHONO, CD, or TAPE mode to be selected. It changes the FM, MW or LW reception frequency one step each time is pressed.

52. AUTO ACCESS button

This button allows playback to begin from the beginning of the present selection or the next selection in the PHONO, CD, or TAPE mode. It also allows for automatic selection of FM, MW or LW stations.

53. REC START button

Recording will start when this button is pressed.

54. AUTO PAUSE button

Pressing this button will automatically create a five second blank space on the tape recording, and set the unit to the recording standby mode or the Synchron recording mode.

55. TIME ADJUST button

Pressing this button enables the present time to be adjusted.

56. SLEEP button

Pressing this button enables the time setting of the sleep timer to be made.

57. WAKE UP button

Pressing this button enables the time setting of the WAKE UP timer to be made.

58. TUNING MEMORY button

Pressing this button enables radio broadcast stations to be entered into the presets.

59. TUNER REC 1

Pressing this button enables absentee recordings to be made at the preset time.

60. TUNER REC 2

Pressing this button enables absentee recordings to be made at the preset time.

61. TEN KEYS

Press these keys when setting the time, selecting a tune, selecting a broadcast station, or when selecting devices connected to the auxiliary input terminals.

For Service Manuals Contact
MAURITRON TECHNICAL SERVICES
 8 Cherry Tree Rd, Chinnor
 Oxon OX9 4QY
 Tel:- 01844-351694 Fax:- 01844-352554
 Email:- enquiries@mauritron.co.uk

DISASSEMBLY PROCEDURE FOR DA-R47P

1. Removing the Top Cover

- 1) Remove the thirteen top cover fixing screws (1) as shown in Fig. 1.
- 2) The top cover can be removed by pulling it backward.

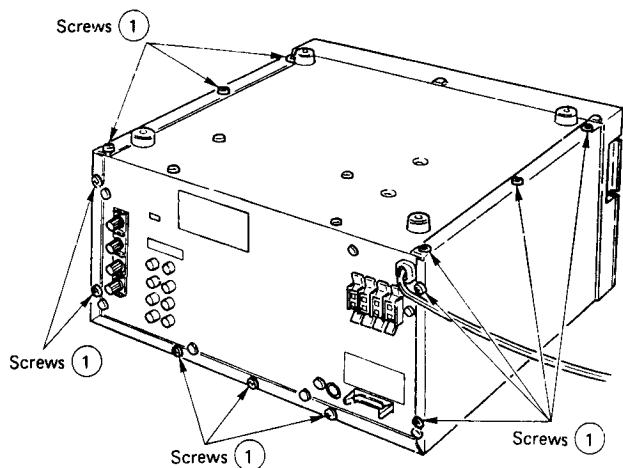

Fig. 1

2. Removing the Front Panel

- 1) After the top cover has been removed, remove the five front panel fixing screws (2) as shown in Fig. 2.
- 2) Remove the "TUNER" indicator P. C. board on the front panel and the connector between the remote control receiver and the main P. C. board, then remove the front panel.

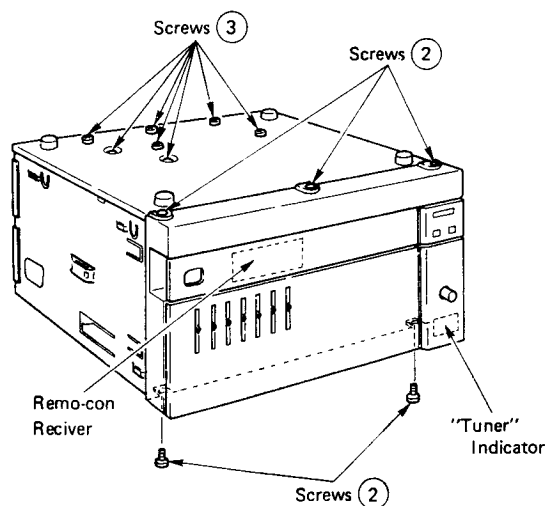

Fig. 2

3. Removing the Bottom Cover

- 1) Remove seven bottom cover fixing screws (3) as shown in Fig. 2.
- 2) The bottom cover then can be removed.

4. Removing the Tuner and Input Terminal P. C. boards

- 1) Remove CN8 connected to the tuner P. C. boards and six screws (4) shown in Fig. 3.
- 2) Remove input terminal P. C. board connectors CN12 and CN13.
- 3) Remove the two plastic rivets and screw (5) shown in Fig. 4.
- 4) First, with the input terminal P. C. board pushed into the set, detach the tuner P. C. board in the interior by lifting up on its back side. Be careful that the P. C. board holder plate does not get caught on the input terminal P. C. board. (Refer to Fig. 5).
- 5) Remove the flat wire (JL70) connected to the bottom of the input terminal P. C. board, then remove the input terminal P. C. board.

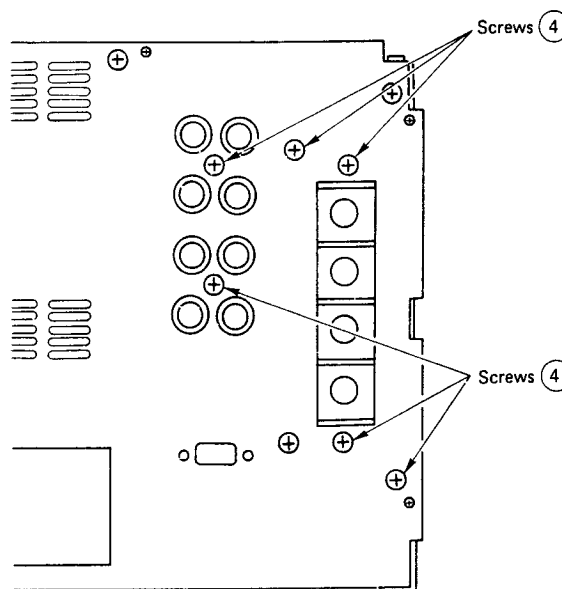

Fig. 3

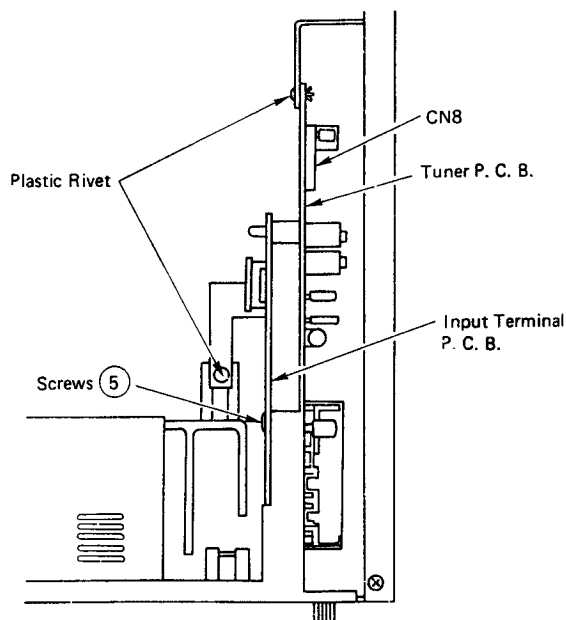

Fig. 4

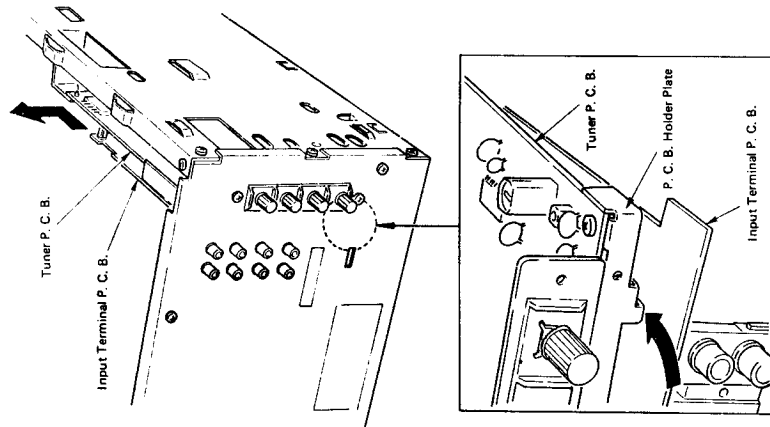

Fig. 5

- 5. Removing the Front Chassis Assembly**
- 1) Remove the connectors between the front chassis assembly and main P. C. board.
 - 2) Remove eleven screws (6) shown in Fig. 6, then remove the front chassis assembly by pulling forward.

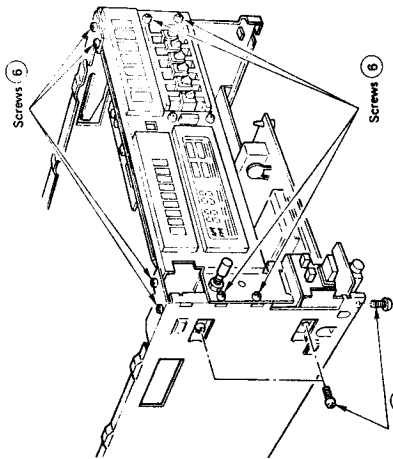

Fig. 6

- 5-1 Removing the Shield Cover**
- 1) Remove two shield cover fixing screws (7) shown in Fig. 7.

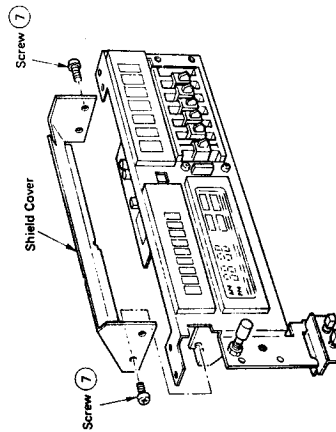

Fig. 7

- 5-2 Removing the Display P. C. board**
- 1) Remove display P. C. board connector CN813.
 - 2) Remove two display P. C. board fixing screws (8) shown in Fig. 8.
 - 3) Remove the display P. C. board by pulling it backward.
 - 4) Display P. C. board parts and function and tuner displays can now be replaced.

These displays are fixed to the front chassis with double-faced tape. Be careful not to break the display glass when removing.

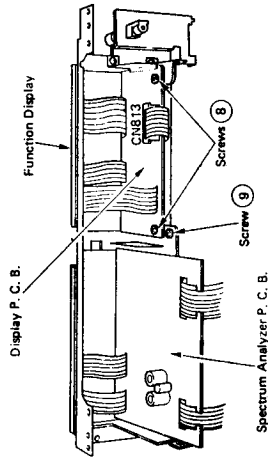

Fig. 8

- 5-3 Removing the Spectrum Analyzer P. C. board**
- 1) Remove screw (9) shown in Fig. 8.
 - 2) Remove two screws (10) shown in Fig. 9, then remove the spectrum analyzer P. C. board by pulling it backward.
 - 3) When the shield plate attached to the spectrum analyzer P. C. board is removed, parts can be replaced.
 - 4) To remove the spectrum display, first remove the graphic equalizer assembly as explained in 5-4. The spectrum display is also fixed to the front chassis with double-faced tape, so be careful not to break the glass when removing.

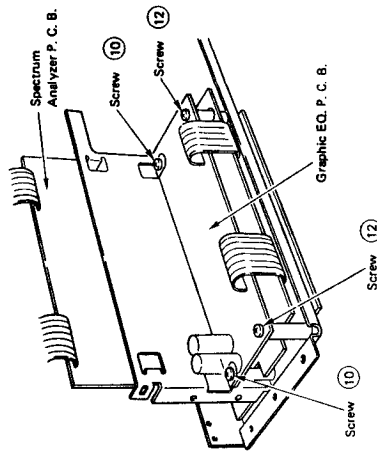
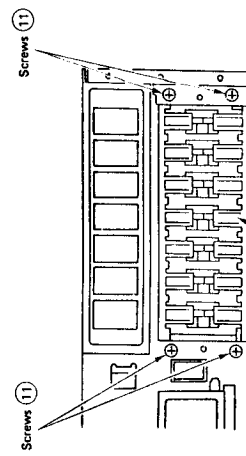

Fig. 9

- 5-4 Removing the Graphic Equalizer Assembly**
- 1) First remove the spectrum analyzer P. C. board then remove four graphic equalizer assembly fixing screws (11) shown in Fig. 10.
 - 2) Remove two screws (12) shown in Fig. 9 to remove the graphic equalizer P. C. board.



Graphic EQ. Ass'y

Fig. 10

For Service Manuals Contact
MAURITRON TECHNICAL SERVICES
 8 Cherry Tree Rd, Chinnor
 Oxon OX9 4QY
 Tel:- 01844-351694 Fax:- 01844-352554
 Email:- enquiries@mauritron.co.uk

Each set cannot be adjusted independently. The sets must be connected with the signal cable. The system commander is necessary for operation.

Before adjustment

- Set the modulation of the AM signal generator to 400Hz, 30%.
- Connect the AM test loop antenna to the AM signal generator.
- Set the modulation of the FM signal generator to 1kHz, 100%.

No.	Measured item	Input/Output and procedure	Point of adjustment	Adjustment for	Remarks
1	AM IF Adjustment	<ul style="list-style-type: none"> ● Set the AM signal generator to 999kHz ± 0.5kHz and radiate to L8 by means of the AM test loop antenna. (signal level 100dB/m) ● Connect the AC voltmeter to W13 (L ch) or W14 (R ch) and TP1 (GND). ● Set the function to the MW position and 999kHz in the state of reception. 	T1 T2	Adjust so that the output is maximized.	
2	FM IF Adjustment	<ul style="list-style-type: none"> ● Set the FM signal generator to 98.00MHz and connect it to the FM antenna terminal through the 300Ω balanced dummy. (signal level 1mV) ● Set the function to the FM position and 98.00MHz in the state of reception. ● Connect the distortion meter to W13 (L ch) or W14 (R ch) and TP1 (GND). ● Connect the DC voltmeter to both side of R16. 	L3 L2	Adjust so that the DC voltage becomes 0V \pm 0.05V. Adjust so that the distortion is minimized.	
3					
4		Adjust by repeating the steps 2 and 3 alternately so that the output voltage becomes within the specified range and the distortion is minimized.			
5	MW Coverage Adjustment	<ul style="list-style-type: none"> ● With the function set to the MW position, set the unit in the reception state whose minimum receiving frequency is 522kHz. ● Connect the DC voltmeter to W22 and TP1 (GND). 	L7	Adjust so that the DC voltage becomes 1.0V \pm 0.05V.	
6		<ul style="list-style-type: none"> ● As in the above step, set the unit in the reception state whose maximum receiving frequency is 1611kHz. 	TC1	Adjust so that the DC voltage becomes 9.0V \pm 0.1V.	
7		Adjust by repeating the steps 5 and 6 alternately so that the output voltage becomes within the specified range.			
8	MW Tracking Adjustment	<ul style="list-style-type: none"> ● Radiate each of the tracking point frequencies given below from the AM test loop antenna to L8. (signal level 56dB/m) ● Receive each of the tracking point frequencies given below by means of the Ten key or Tuning Up/Down Switch. ● Connect the AC voltmeter to W13 (L ch) or W14 (R ch) and TP1 (GND). ● Tracking point frequency 140kHz 999kHz 603kHz 	L8 TC2	Adjust so that the output is maximized at each tracking point.	
9		Repeat adjustment at each tracking point alternately.			

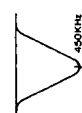
No.	Measured item	Input/Output and procedure	Point of adjustment	Adjustment for	Remarks
10	LW Coverage Adjustment	<ul style="list-style-type: none"> ● Set the function to the LW position and 200kHz in the state of reception. ● Connect the DC voltmeter to W21 and TP1 (GND). 	L99	Adjust so that the DC voltage becomes 1.0V \pm 0.05	
11		<ul style="list-style-type: none"> ● As in the above step, set the unit in the reception state whose maximum receiving frequency is 400kHz. 	TC99	Adjust so that the DC voltage becomes 9.0V \pm 0.1V.	
12		Adjust by repeating the steps 10 and 11 alternately so that the output voltage becomes within the specified range.			
13	LW Tracking Adjustment	<ul style="list-style-type: none"> ● Radiate each of the tracking point frequencies given below from the AM test loop antenna to L98. (signal level 60dB/m) ● Receive each of the tracking point frequencies given below by means of the Ten key or Tuning Up/Down Switch. ● Connect the AC voltmeter to W13 (L ch) or W14 (R ch) and TP1 (GND). ● Tracking point frequency 344kHz 200kHz 161kHz 	L98 TC98	Adjust so that the output is maximized at each tracking point.	
14		Repeat adjustment at each tracking point alternately.			
15	AM IF Wave Form Adjustment	<ul style="list-style-type: none"> ● Set the function to the MW position and 999kHz in the state of reception. ● Connect the AM test loop antenna to the output terminal of the sweep generator and radiate the 450kHz signal to the L8. ● Connect the input terminal of oscilloscope between the R70 and TP1 and check to ensure that the waveform shows a symmetry between the right and left with 450kHz as its center. 	T1 T2	Adjust so that right and left are symmetrical and the trough is maximized. 	If not symmetrical, readjust by varying T1 and T2 within the range of 450kHz \pm 1kHz to move the crest so that a symmetry is obtained between the right and left and the trough and the trough is maximized.
16	FM MPX Free Run Frequency Adjustment	<ul style="list-style-type: none"> ● Set the FM signal generator to 98.00MHz and connect it to the FM antenna terminal through the 300Ω balanced dummy. (signal level 1mV) ● Set the function to the FM position and 98.00MHz in the state of reception. ● Connect the frequency counter to TP2 and TP1 (GND). 	VR1	Adjust so that the frequency becomes 19kHz \pm 50 Hz.	
17	Separation Adjustment	<ul style="list-style-type: none"> ● Connect the stereo signal modulator to the FM signal generator. Connect the 98.00MHz 1mV signal to the FM antenna terminal through the 300Ω balanced dummy. ● Set the function to the FM position and 98.00MHz in the state of reception. ● Connect the AC voltmeter and oscilloscope to W13 (L ch), W14 (R ch) and TP1 (GND). 	VR2	Adjust so that L ch and R ch separation is maximized.	

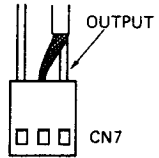
No.	Measured item	Input/Output and procedure	Point of Adjustment	Adjustment for	Remarks
18	19kHz Leakage Adjustment	<ul style="list-style-type: none"> Connect the stereo signal modulator to the FM signal generator. Connect the 98.00MHz 1mV signal to the FM antenna terminal through the 300 balanced dummy with the audio signal modulation cut off (only the pilot signal remains). Set the function to the FM position and 98.00MHz in the state of reception. Connect the AC voltmeter to W13 (L ch) or W14 (R ch) and TP1 (GND). 	L5 L6	Adjust so that the leak at 19kHz of the R ch. and L ch. is less than 0.5mV.	
19	Remote Control unit Adjustment	<ul style="list-style-type: none"> Connect the oscilloscope to the receiver output (CN7). Radiate the signal from the commander transmission unit. Separate the commander transmission unit as far as the output almost ceases. 	L601	Adjust so that the state nearest to the square wave is attained.	

ADJUSTMENT LOCATION DIAGRAM

PHOTO RECEIVE P.C.B

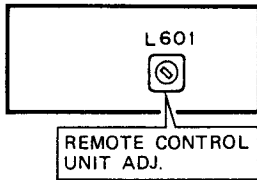

For Service Manuals Contact
MAURITRON TECHNICAL SERVICES
 8 Cherry Tree Rd, Chinnor
 Oxon OX9 4QY
 Tel:- 01844-351694 Fax:- 01844-352554
 Email:- enquiries@mauritron.co.uk

TUNER P.C.B

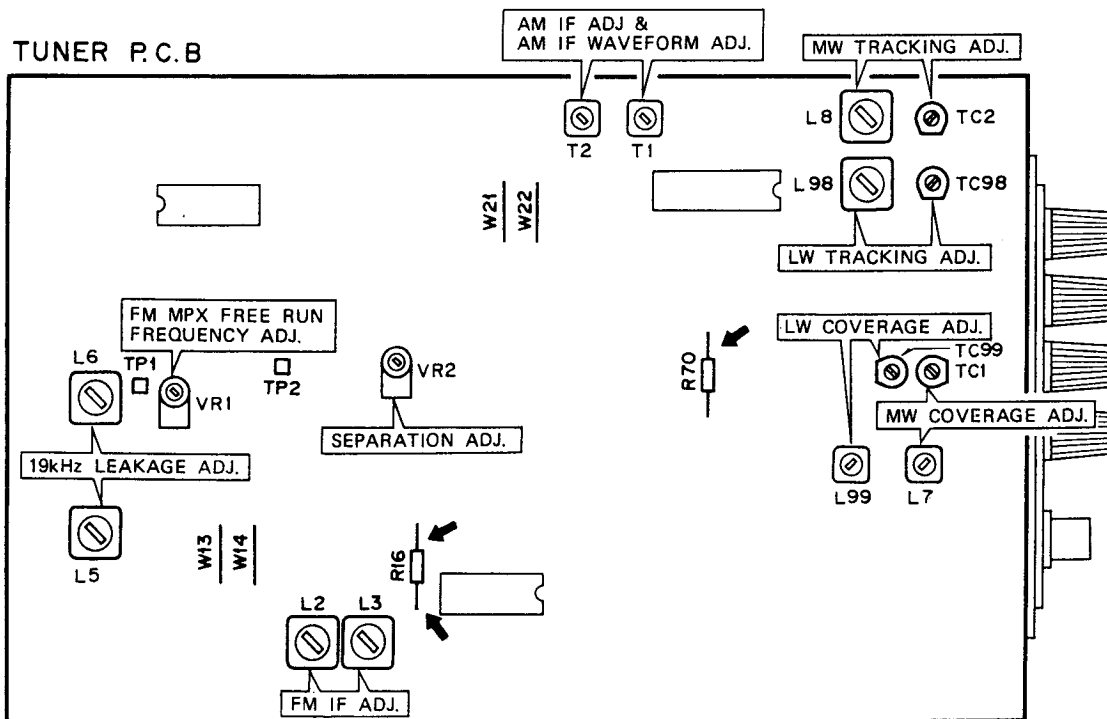

INTERNAL DIAGRAMS AND PINOUT OF INTEGRATED CIRCUIT

IC1: LA1235

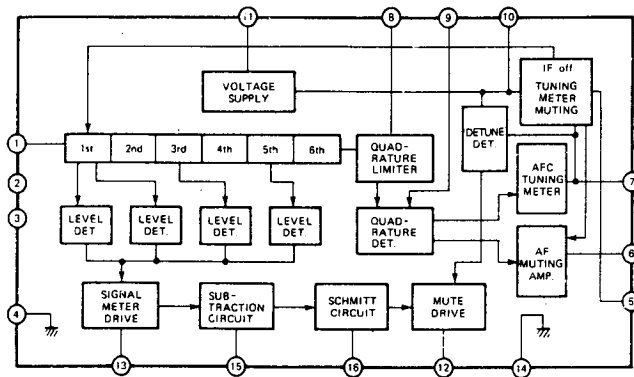

IC3: LA1245

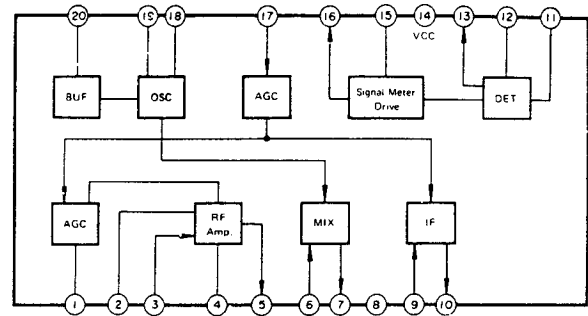

IC2: LA3370

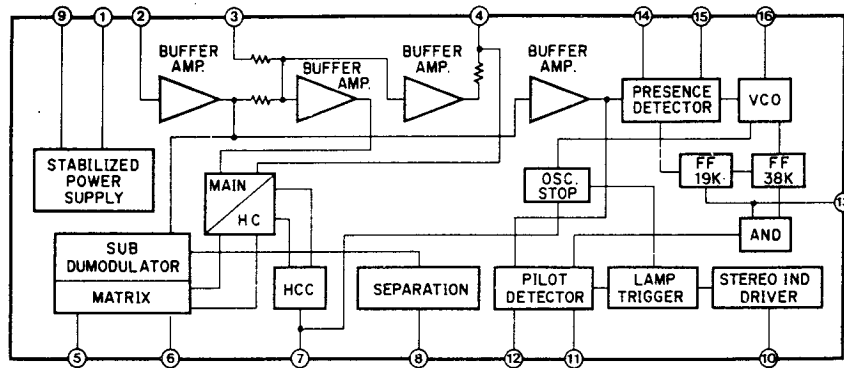

IC4: M54927P

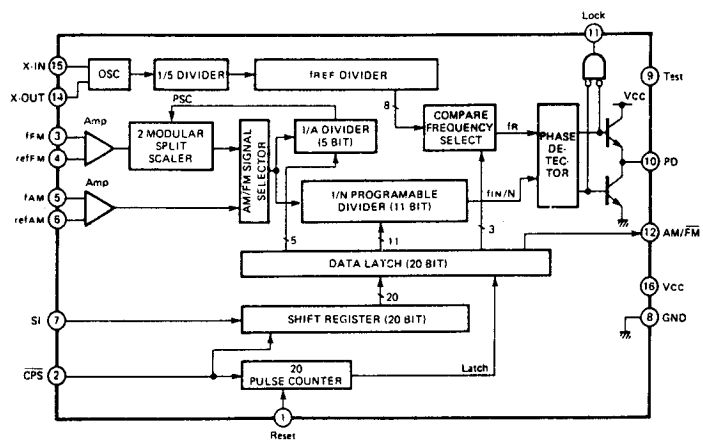
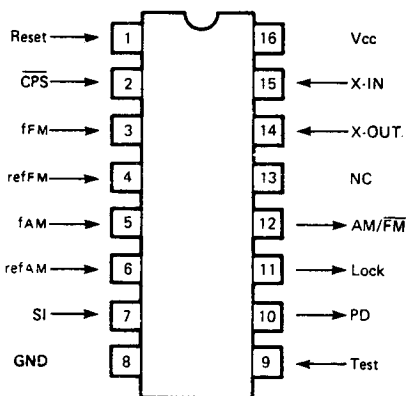

IC 607, 801: μ PD7538

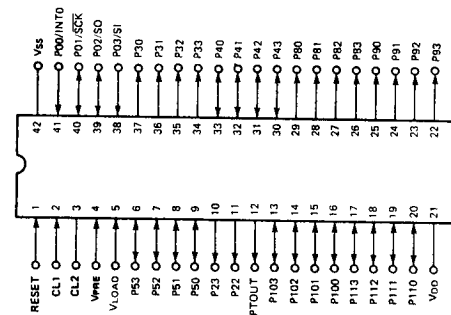

IC802: MSL912RS

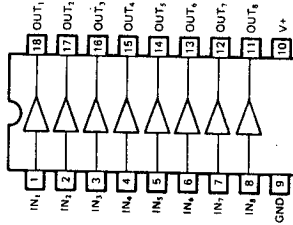

IC619, 620, 803: AN6873

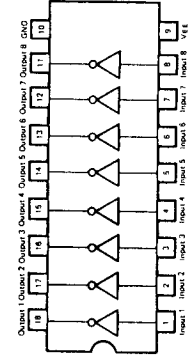

IC603, 610, 611: M5218L

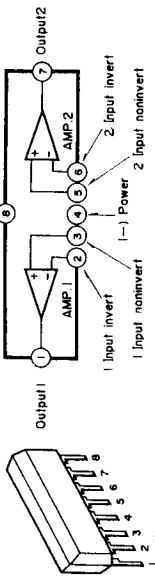

IC604: TC9154P

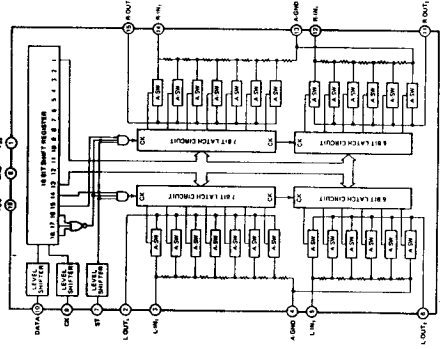

IC605: STK4181A

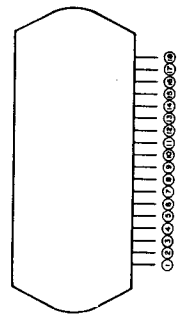

IC606: μ PC1473H

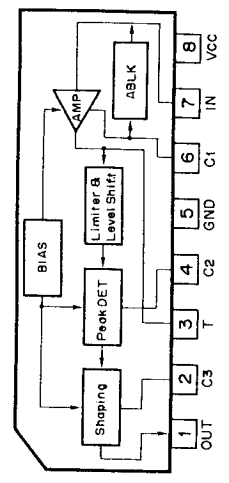

For Service Manuals Contact
MAURITRON TECHNICAL SERVICES
 8 Cherry Tree Rd, Chinnor
 Oxon OX9 4OY
 Tel: 01844-351694 Fax: 01844-352554
 Email: enquiries@mauritron.co.uk

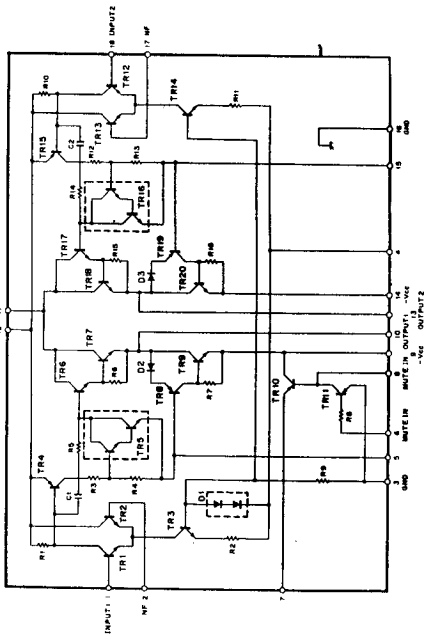

IC608: BA614A

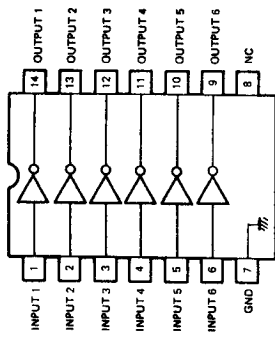

IC609: M74LS145

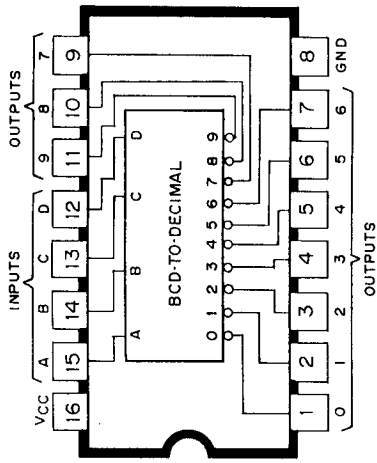

IC615: M74LS193

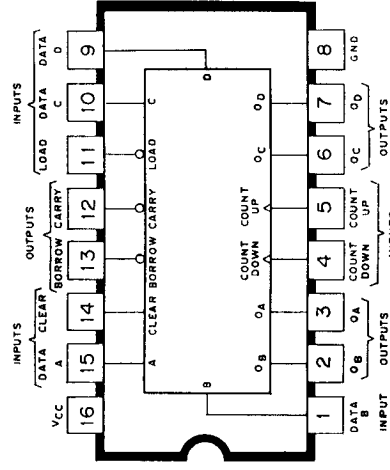

IC617, 618: IR2339

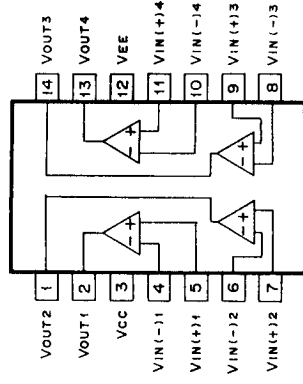

IC610: IR2403

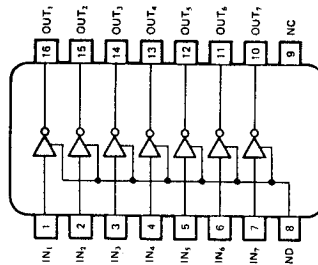

IC614: M74LS04

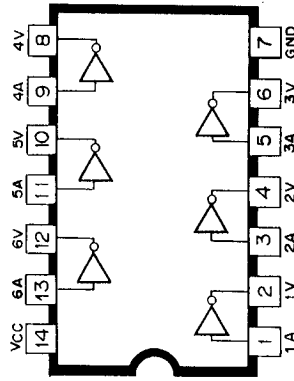

For Service Manuals Contact
MAURITRON TECHNICAL SERVICES
 8 Cherry Tree Rd, Chinnor
 Oxon OX9 4QY
 Tel:- 01844-351694 Fax:- 01844-352554
 Email:- enquiries@mauritron.co.uk

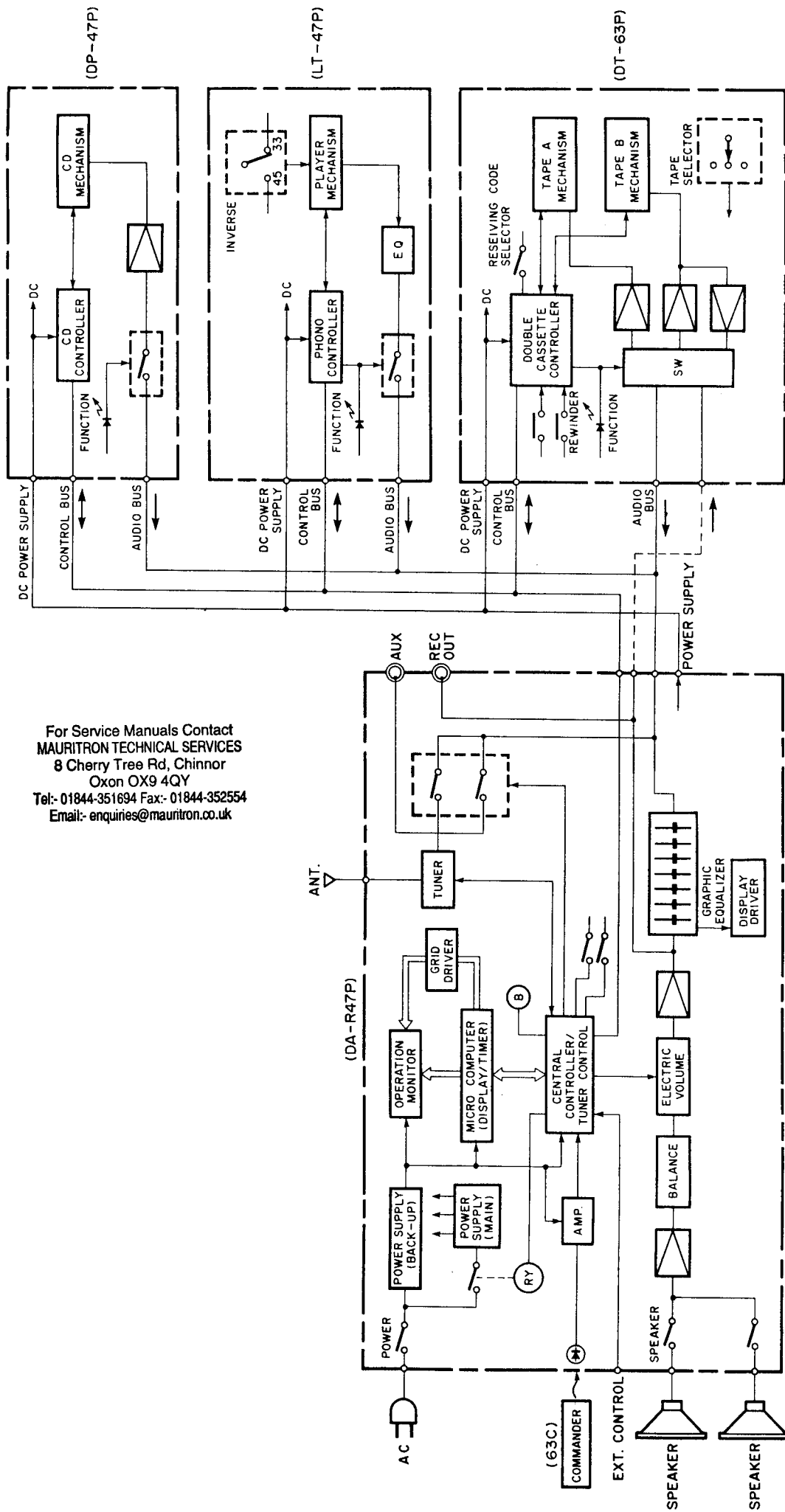

WIRING DIAGRAM

MODEL DA-R47P E-03JF E-03JF MODEL DA-R47P

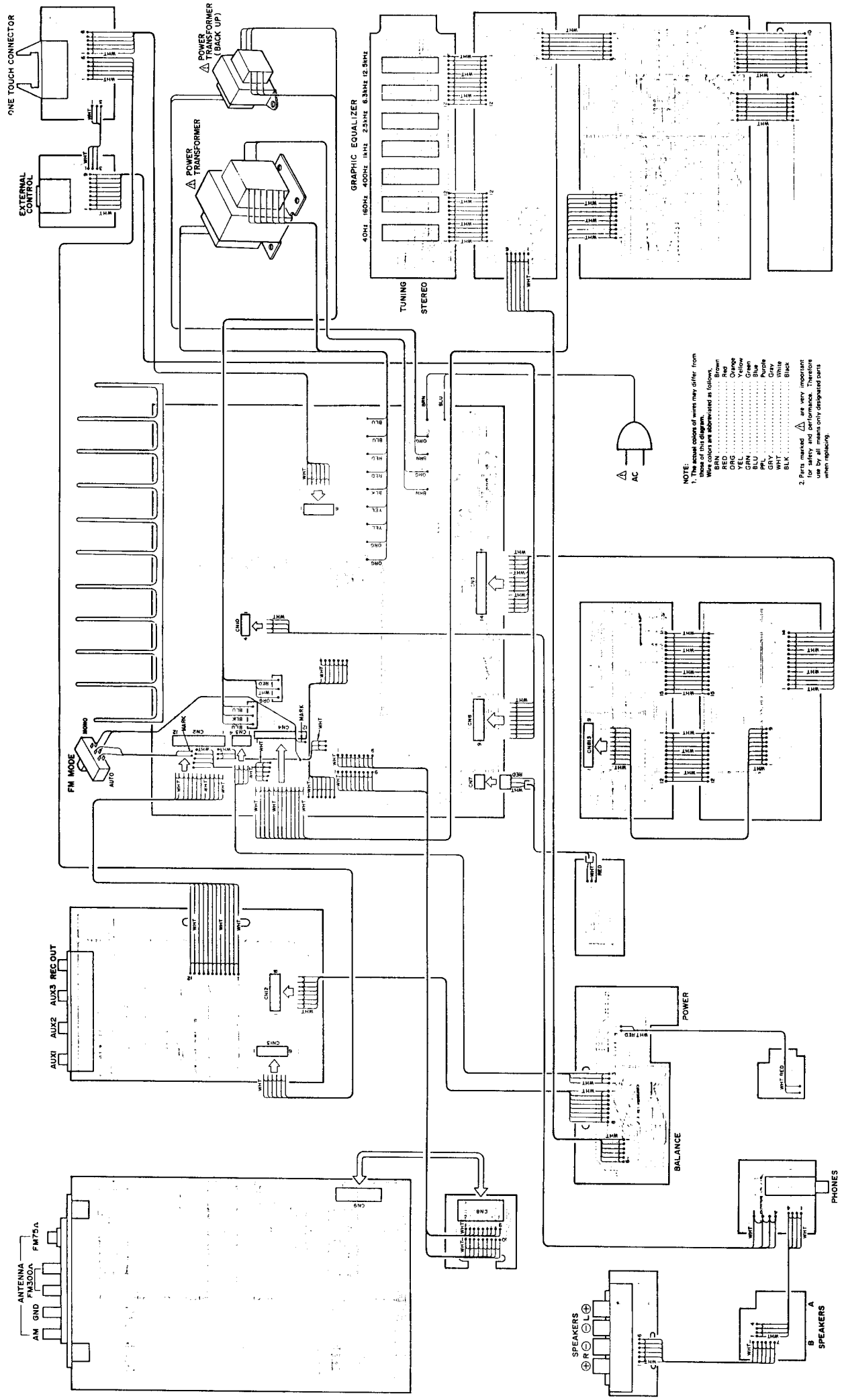

SCHMATIC DIAGRAM

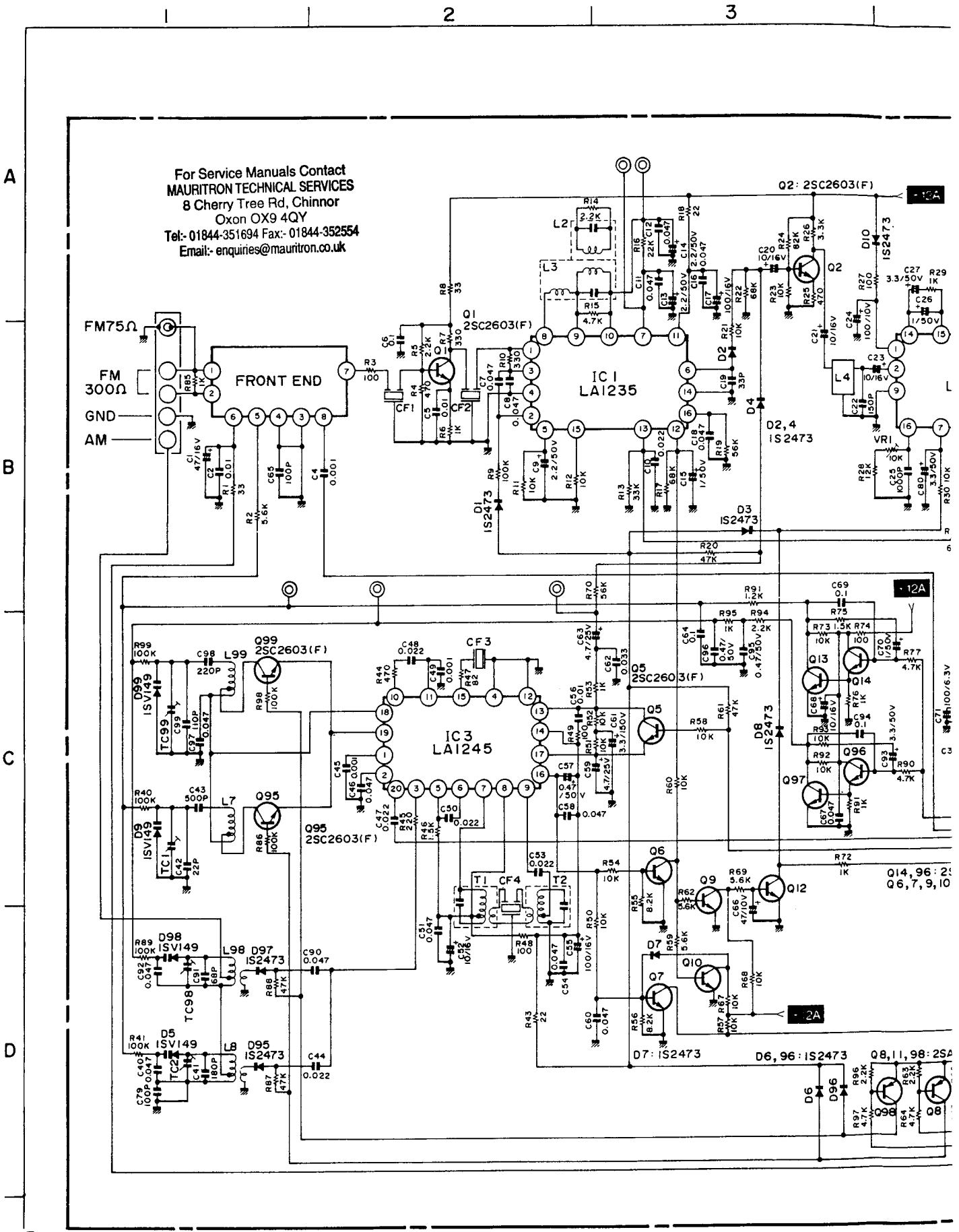

2

3

4

5

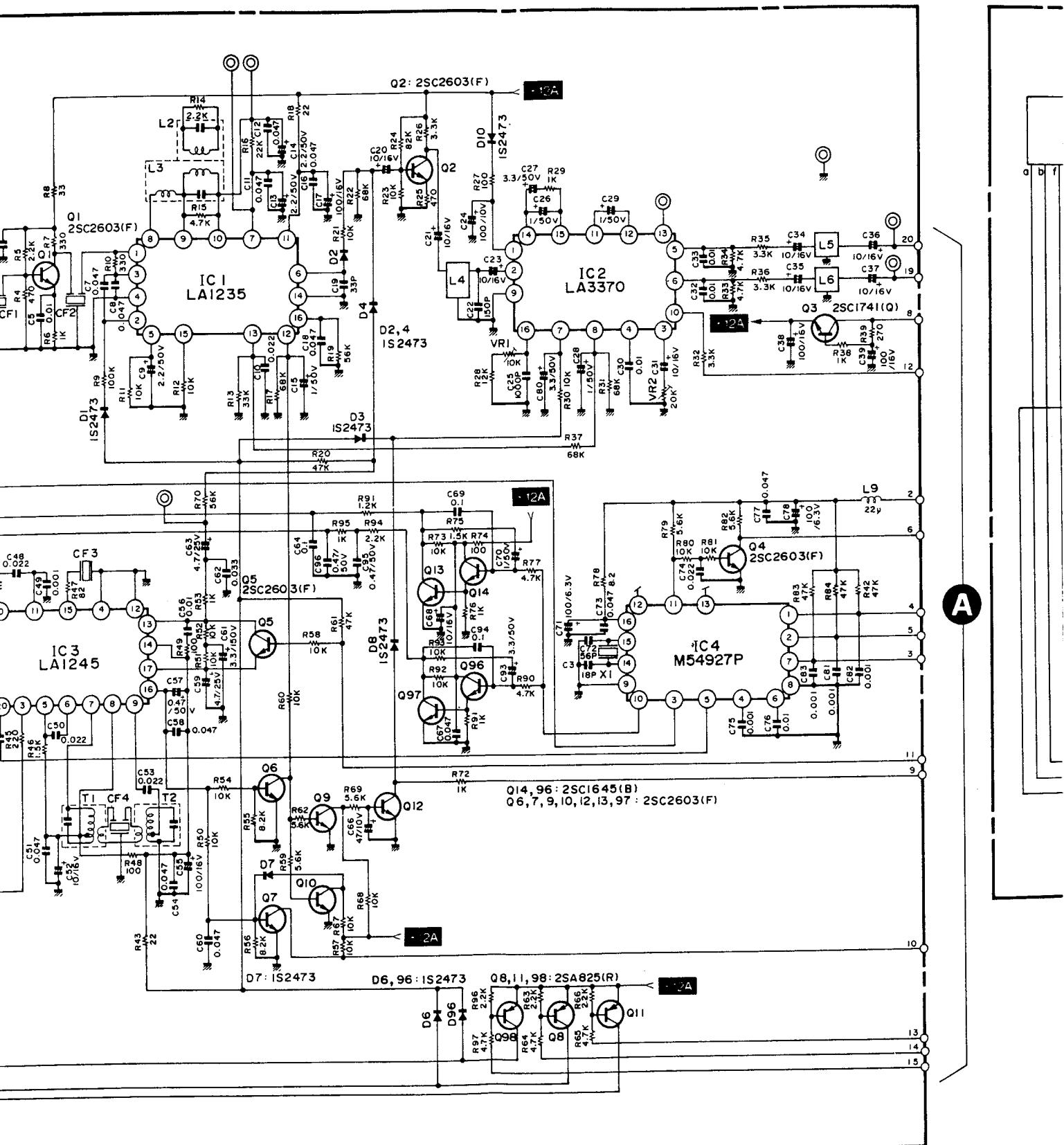

5

6

7

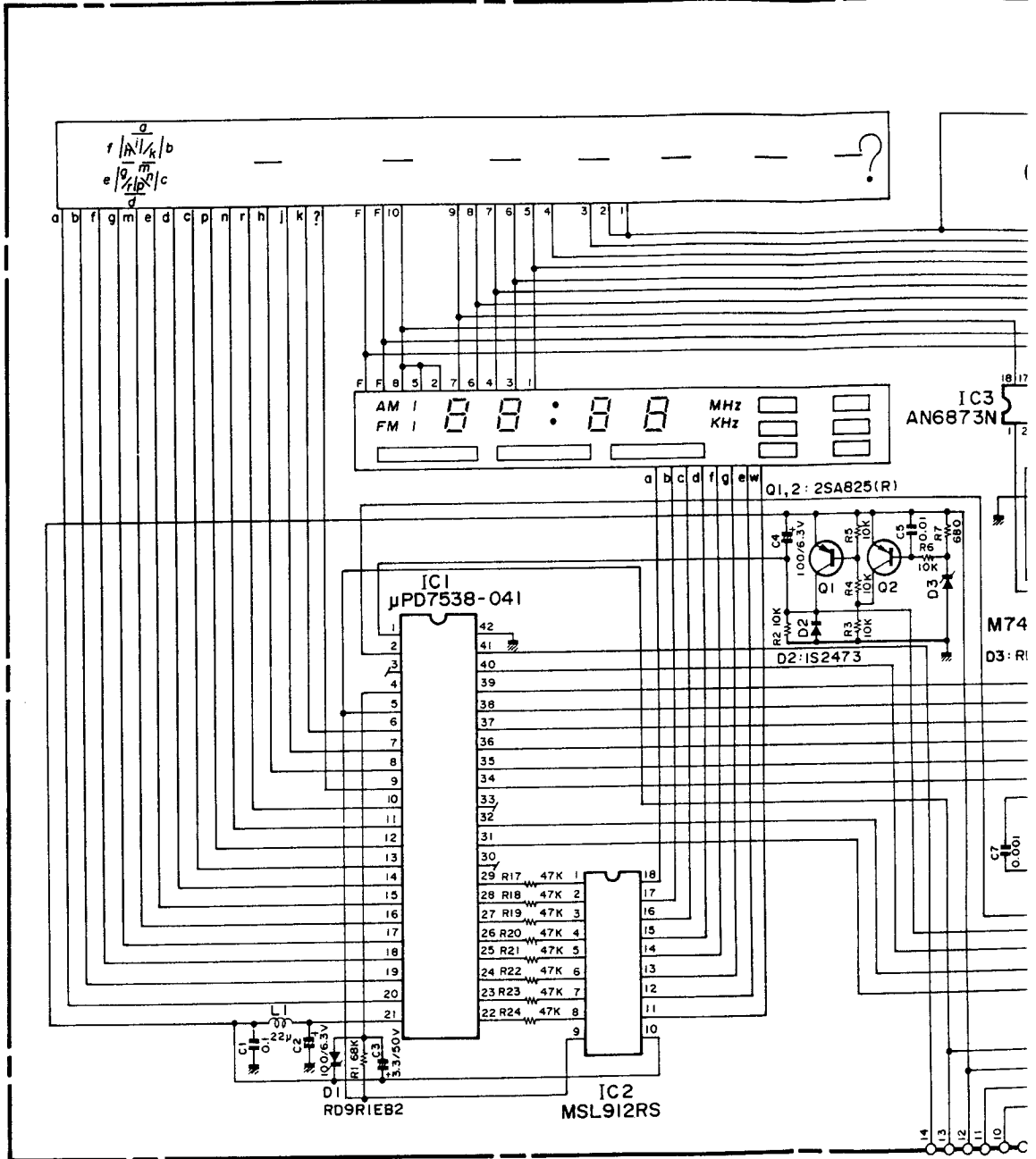
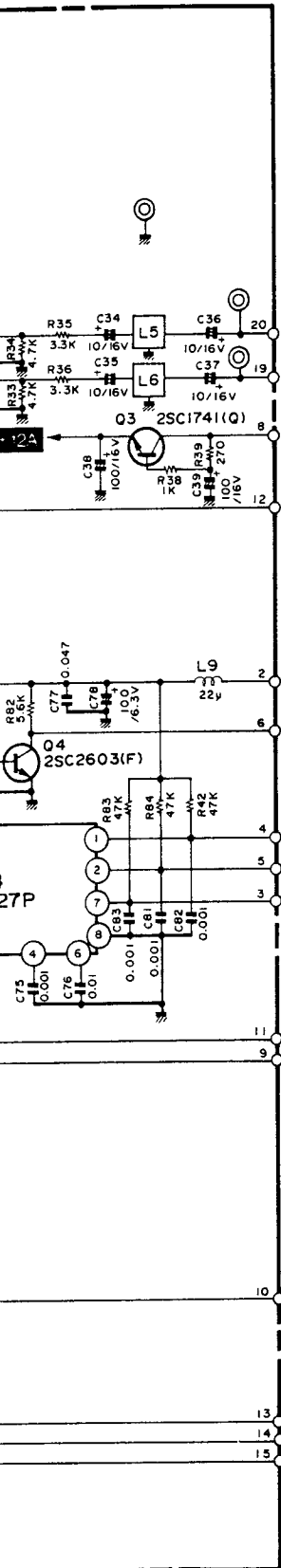

For Service Manuals Contact
 MAURITRON TECHNICAL SERVICES
 8 Cherry Tree Rd, Chinnor
 Oxon OX9 4QY
 Tel:- 01844-351694 Fax:- 01844-352554
 Email:- enquiries@mauritron.co.uk

For Service Manuals Contact
MAURITRON TECHNICAL SERVICES
8 Cherry Tree Rd, Chinnor
Oxon OX9 4QY
Tel:- 01844-351694 Fax:- 01844-352554
Email:- enquiries@mauritron.co.uk

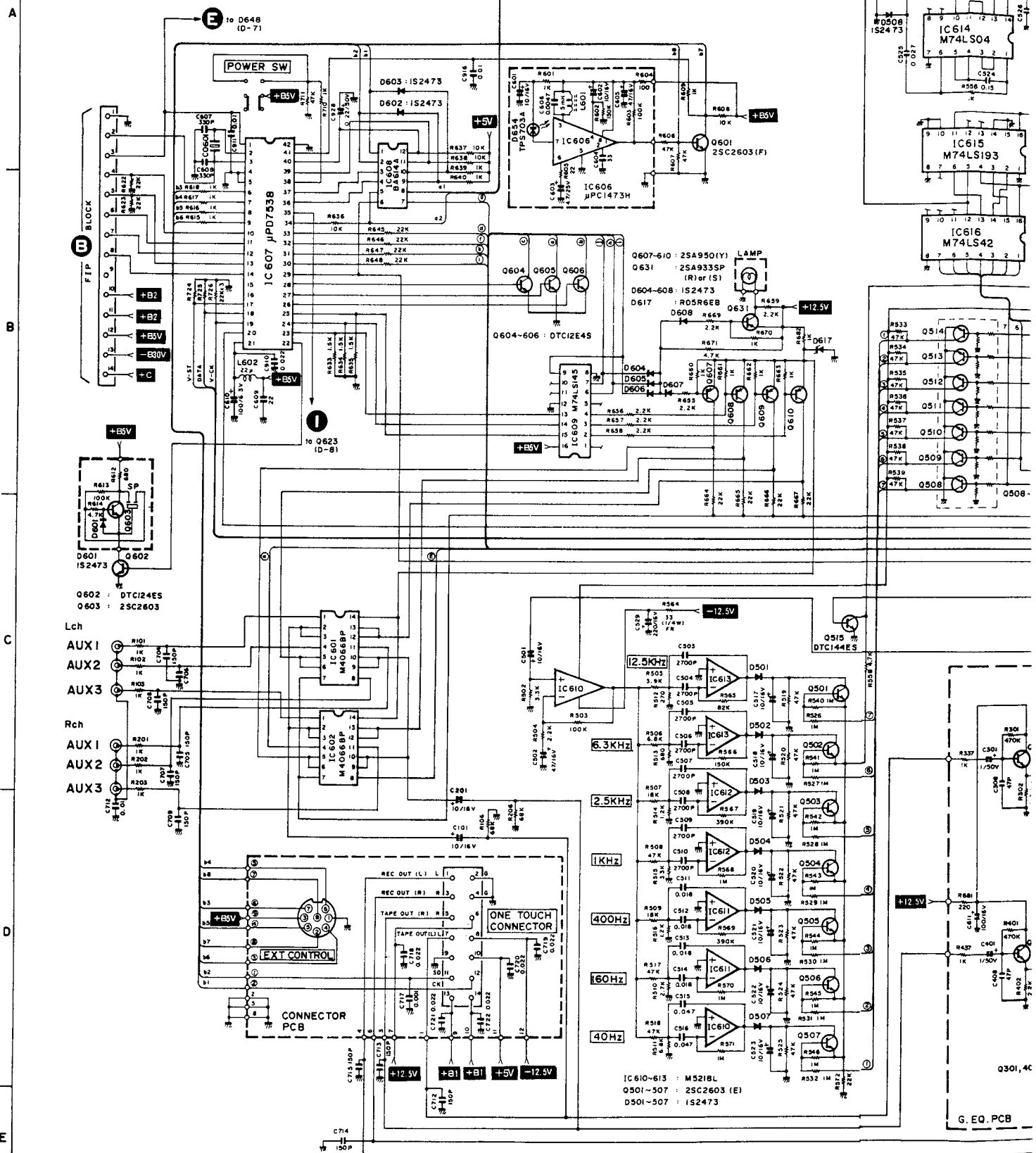

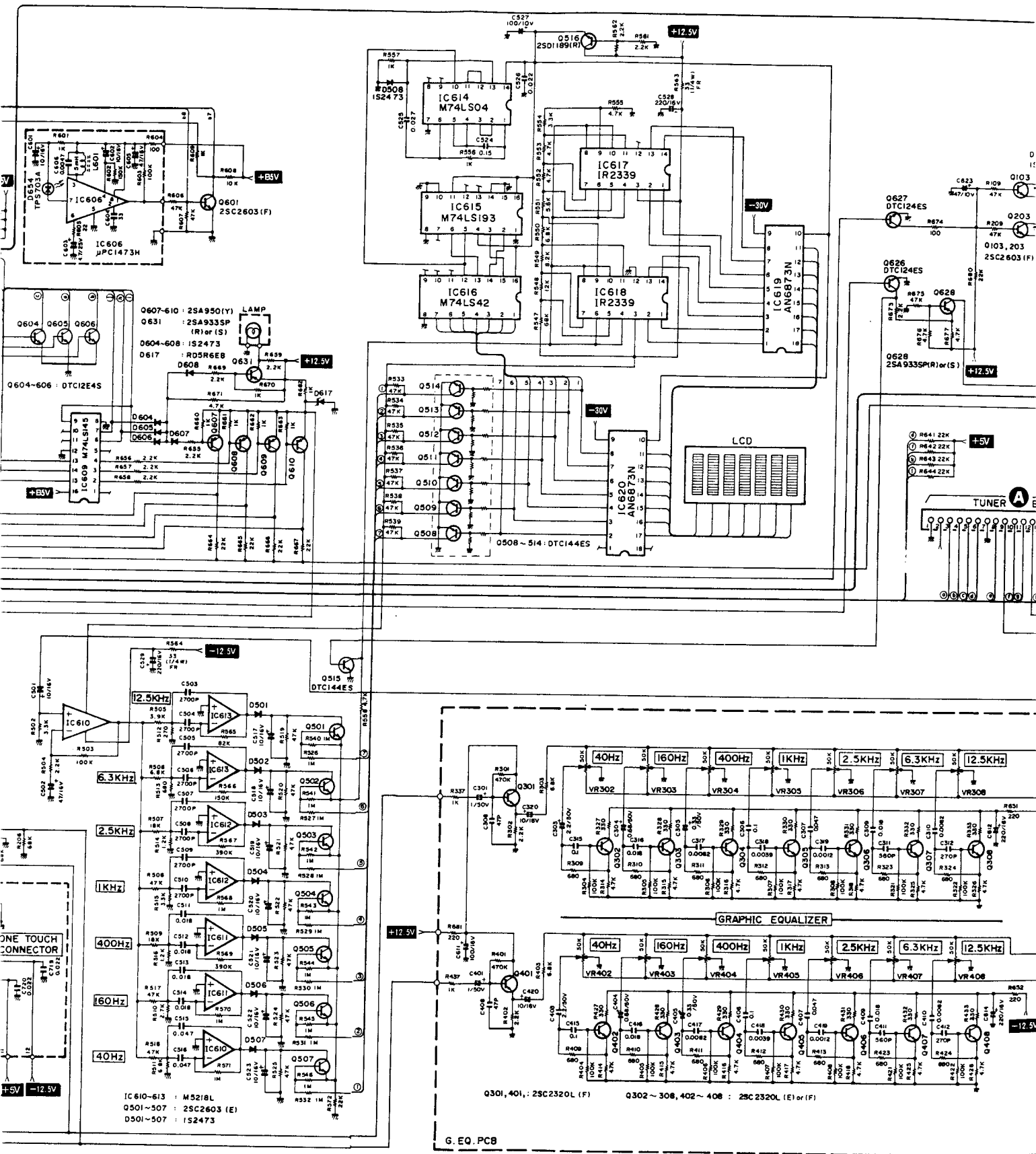

5

6

7

8

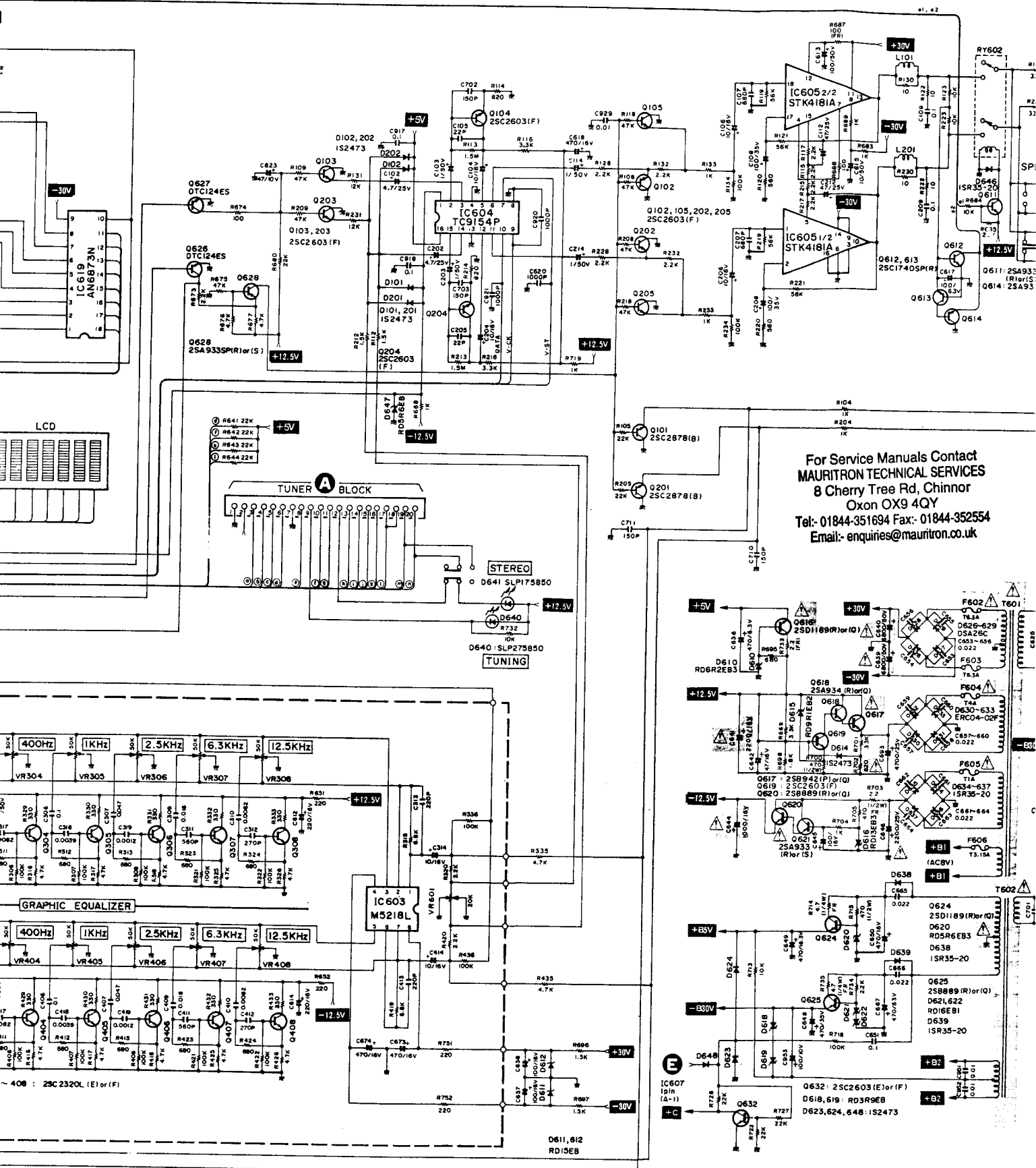

For Service Manuals Contact
MAURITRON TECHNICAL SERVICES
 8 Cherry Tree Rd, Chinnor
 Oxon OX9 4QY
 Tel:- 01844-351894 Fax:- 01844-352554
 Email:- enquiries@mauritron.co.uk

NOTE:

1. Unit of C and R

- C No-symbol; μ F
- P-symbol; PF
- R No-symbol; Ω
- K-symbol; k Ω
- M-symbol; M Ω

Wattage for all unspecified resistor are 1/4W.

2. Voltage are those measured with DC 1M Ω digital voltmeter.

3. ∇ and Δ indicates components which are critical for continued safety and performance of this unit. Replace only with components of the same type as specified.

4. This circuit diagram may be changed due to circuit improvement.

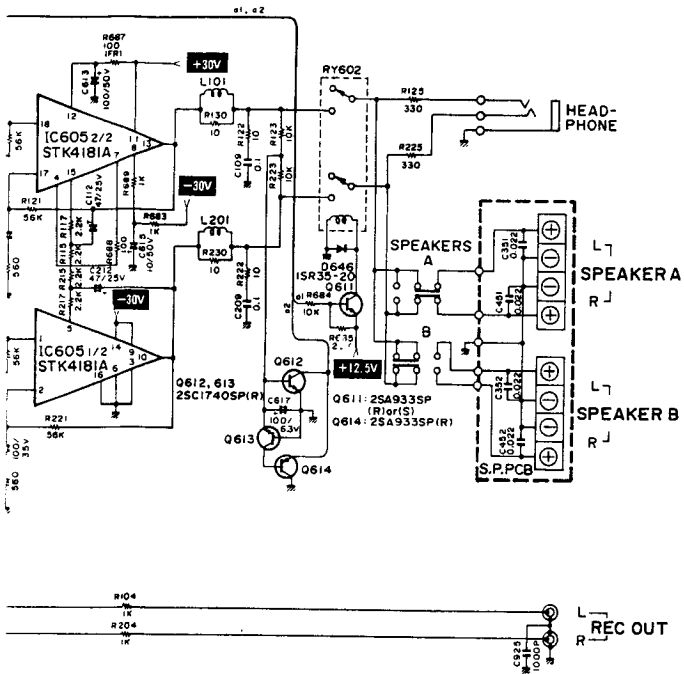

TUNER P.C.B.

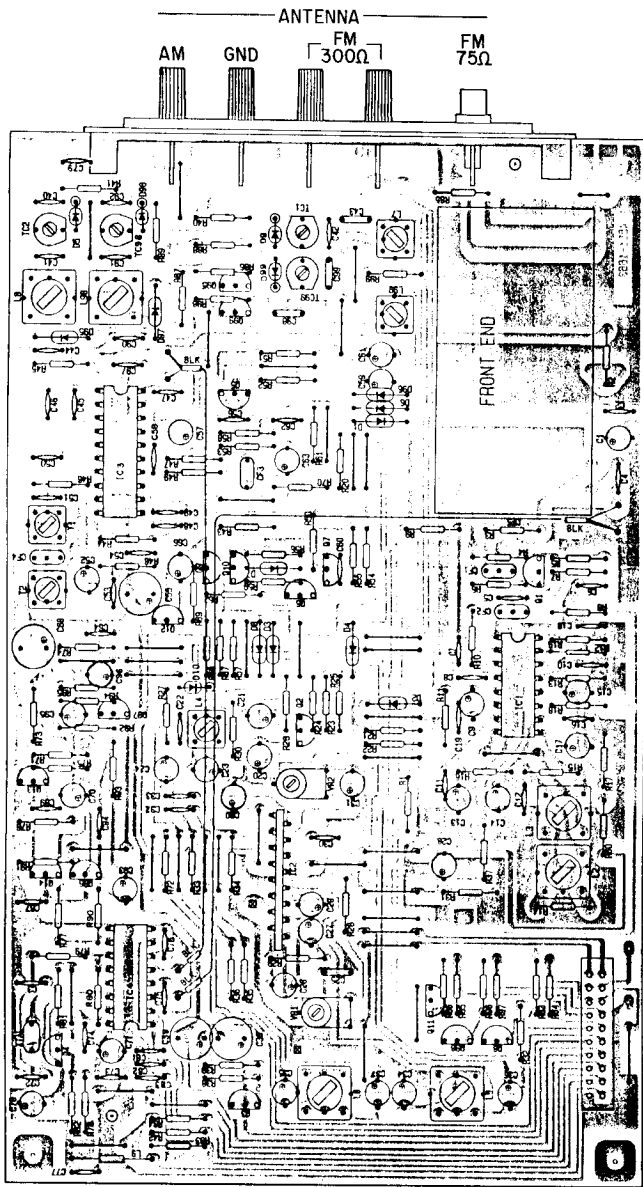

SPEAKER P.C.B.

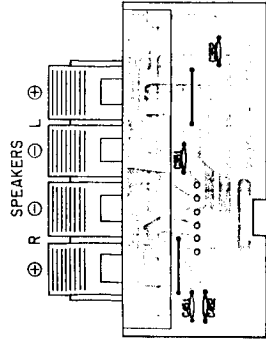
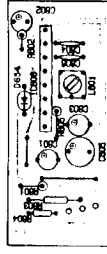
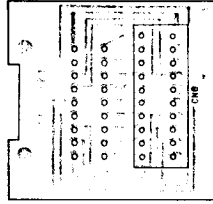

PHOTO RECEIVE P.C.B.



CN8 P.C.B.



PHONES JACK P.C.B.

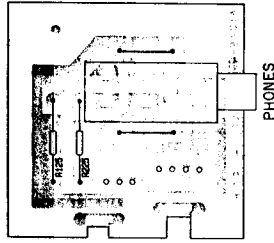

G-EO. P.C.B.

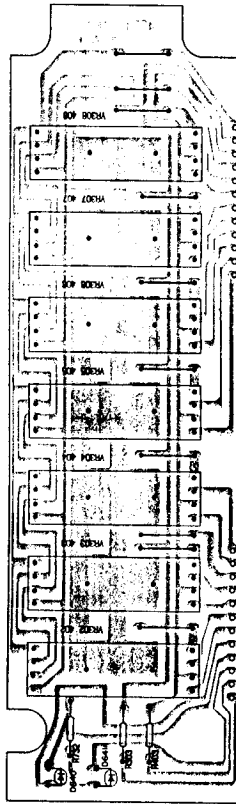

G-EO. SUB P.C.B.

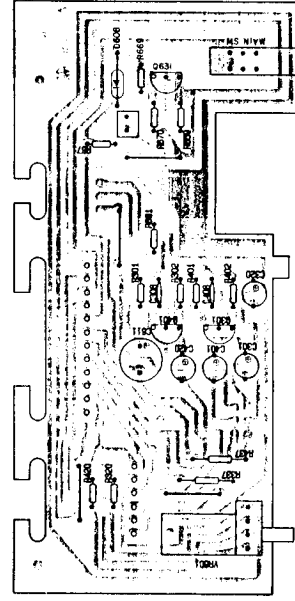

For Service Manuals Contact
MAURITRON TECHNICAL SERVICES
 8 Cherry Tree Rd, Chinnor
 Oxon OX9 4QY
 Tel:- 01844-351694 Fax:- 01844-352554
 Email:- enquiries@mauritron.co.uk

PROGRAM P.C.B.

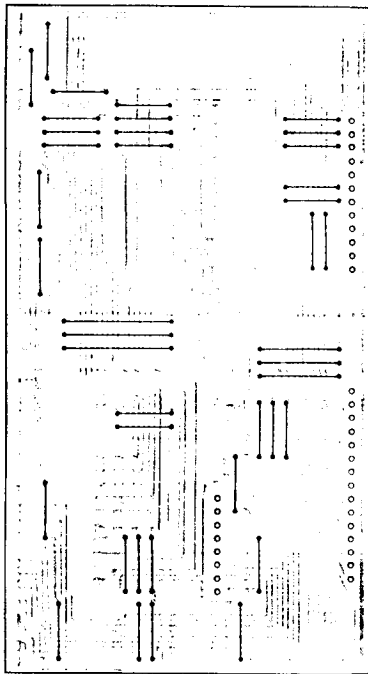

DISPLAY P.C.B.

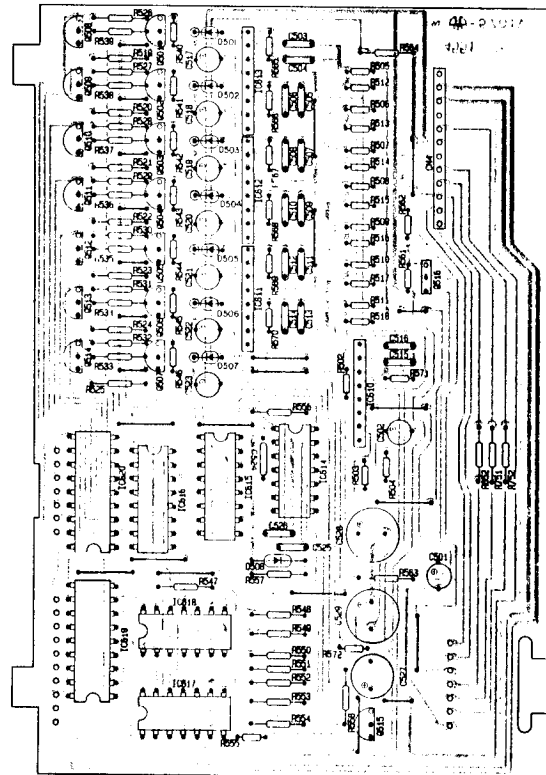
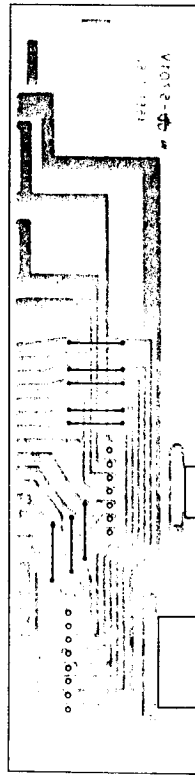

SWITCH P.C.B.

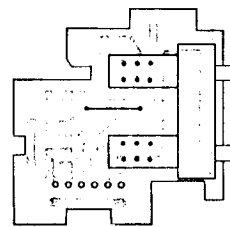

LAMP P.C.B.

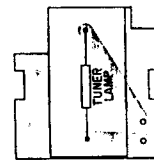

EXPLODED VIEW OF CABINET

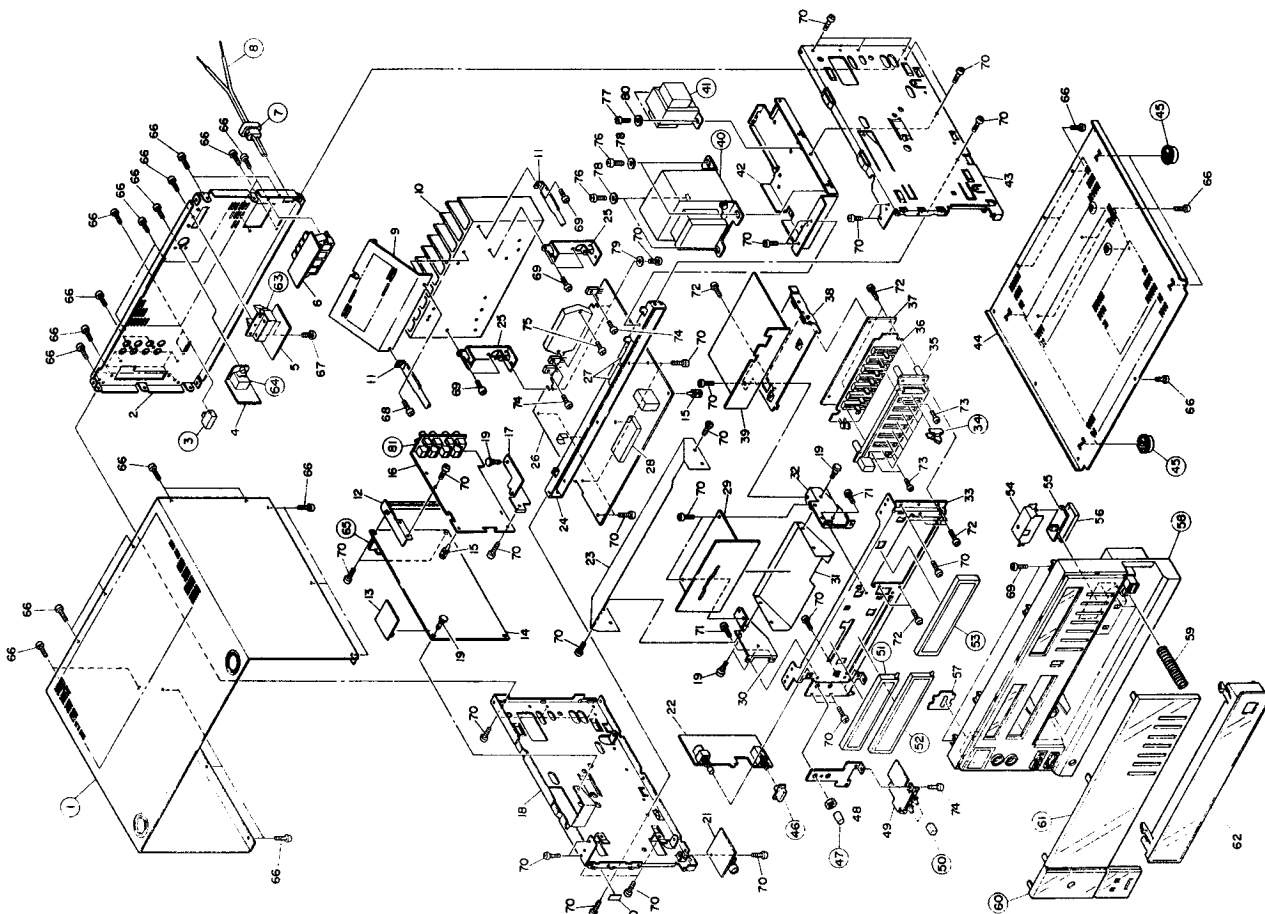



CABINET PARTS LIST

Symbol No.	Parts No.	Description
1	M04A10135	Top Cover
2	M04A10360	Switch Slide (AUTO/MONO)
3		PCB Assy
4		PCB Assy
5		PCB Assy
6		PCB Assy
7	M04207656	Cord Holder
8	M04A01490	AC Cord Holder
9		Heat Sink
10		Holder
11		Holder
12		Metal Fitting
13		PCB Assy (Tuner)
14		PCB Holder
15		PCB Assy (Input)
16		Metal Fitting
17		Slide Chassis (L)
18		Plastic Rivet
19		Insulator
20		PCB Assy (Phones)
21		PCB Assy
22		Shield Plate
23		Metal Fitting
24		Holder
25		PCB Assy (Main)
26		Felt
27		Shield Cover
28		PCB Assy (Display)
29		Metal Fitting
30		Shield Plate
31		Metal Fitting
32		Metal Fitting
33		Front Chassis
34	M04207200	Knob (TONE VR)
35		Holder
36		PCB Assy (Graphic VR)
37		PCB Assy (Graphic EQ)
38		Metal Fitting
39		PCB Assy (Spectrum)
40	M04A13500	Trans-Power (Main)
41	M04A13501	Trans-Power (Back-up)
42		Metal Fitting
43		Side Chassis (R)
44		Bottom Cover
45	M04A10191	Foot
46	M04207202	Knob (Power)
47	M04A10201	Rotary Knob (Balance)
48		Metal Fitting
49		PCB Assy (SP A/B)
50	M04207201	Knob (SP A/B)
51	M04207340	Tube Display (Function)
52	M04207341	Tube Display (Timer)
53	M04A10340	Tube Display (Spectrum)
54		Shield Cover
55		Remote Control Receiver
56		Shield Cover
57	M04A10101	PCB Assy (Lamp)
58		Front Panel
59		Spring
60	M04A10226	Window (Small)

Symbol No.	Parts No.	Description
61	M04A12225	Window Panel
62	M04A10102	One Touch Connector (14P)
63	M04207470	DIN SOCKET
64	M04207465	Terminal Board (Antenna)
65		T-Screw T2.3 x 8
66		Screw M2 x 12
67		T-Screw T2.3 x 6
68		T-Screw T2.3 x 8
69		Screw M3 x 4
70		Screw M3 x 10
71		Screw M2 x 4
72		Screw M3 x 4
73		Screw M3 x 8
74		Screw M3 x 14
75		Screw M4 x 5
76		Screw M3 x 8
77		Washer
78		Washer
79		Washer
80		Washer



For Service Manuals Contact
MAURITRON TECHNICAL SERVICES
 8 Cherry Tree Rd, Chinnor
 Oxon OX9 4QY
 Tel:- 01844-351694 Fax:- 01844-352554
 Email:- enquiries@mauritron.co.uk

PARTS LIST







NOTE:  and  designates components on the Parts list that have special characteristics to maintain the safety performance of this unit. When replacing any of these parts, be sure to use only specified parts.

Symbol No.	Parts No.	Description
Diodes		
D1	M07060320	1S2473
D2	M07060320	1S2473
D3	M07060320	1S2473
D4	M07060320	1S2473
D5	M04A10320	1SV149
D6	M07060320	1S2473
D7	M07060320	1S2473
D8	M07060320	1S2473
D9	M04A10320	1SV149
D10	M07060320	1S2473
D95	M07060320	1S2473
D96	M07060320	1S2473
D97	M07060320	1S2473
D98	M04A10320	1SV149
D99	M04A10320	1SV149
D101	M07060320	1S2473
D102	M07060320	1S2473
D201	M07060320	1S2473
D202	M07060320	1S2473
D501	M07060320	1S2473
D502	M07060320	1S2473
D503	M07060320	1S2473
D504	M07060320	1S2473
D505	M07060320	1S2473
D506	M07060320	1S2473
D507	M07060320	1S2473
D508	M07060320	1S2473
D601	M07060320	1S2473
D602	M07060320	1S2473
D603	M07060320	1S2473
D604	M07060320	1S2473
D605	M07060320	1S2473
D606	M07060320	1S2473
D607	M07060320	1S2473
D608	M07060320	1S2473
D610	M04207328	RD6.2EB3
D611	M04207332	RD15EB
D612	M04207332	RD15EB
D614	M07060320	1S2473
D615	M04207359	RD9.1EB2
D616	M04207331	RD13EB3
D617	M04207334	RD5.6EB
D618	M04207324	RD3.9EB
D619	M04207324	RD3.9EB
D620	M04207327	RD5.6EB3
D621	M04207333	RD16EB1
D622	M04207333	RD16EB1
D623	M07060320	1S2473
D624	M07060320	1S2473
D625	M04207322	1SR35-20
D626	M04A10322	DSA26C
D627	M04A10322	DSA26C
D628	M04A10322	DSA26C
D629	M04A10322	DSA26C
D630	M04207323	ERC0402F
D631	M04207323	ERC0402F
D632	M04207323	ERC0402F
D633	M04207323	ERC0402F

Symbol No.	Parts No.	Description
D634	M04207322	ISR35-20
D635	M04207322	ISR35-20
D636	M04207322	ISR35-20
D637	M04207322	ISR35-20
D638	M04207322	ISR35-20
D639	M04207322	ISR35-20
D640	M04207326	SLP275B5(GRN) : TUNING
D641	M04207325	SLP175B5(RED) : STEREO
D646	M04207322	ISR35-20
D647	M04207334	RD5.6EB
D648	M07060320	1S2473
D649	M07060320	1S2473
D654	M04207338	PHOTO DIODE TPS703A
D801	M04207359	RD9.1EB2
D802	M07060320	1S2473
D803	M04A10321	RD3.9EL2
Transistors		
Q1	M07390303	2SC2603(F)
Q2	M07390303	2SC2603(F)
Q3	M07141303	2SC1741(Q)
Q4	M07390303	2SC2603(F)
Q5	M07390303	2SC2603(F)
Q6	M07390303	2SC2603(F)
Q7	M07390303	2SC2603(F)
Q8	M04207307	2SA825(R)
Q9	M07390303	2SC2603(F)
Q10	M07390303	2SC2603(F)
Q11	M04207307	2SA825(R)
Q12	M07390303	2SC2603(F)
Q13	M07390303	2SC2603(F)
Q14	M05104314	2SC1645(B)
Q95	M07390303	2SC2603(F)
Q96	M05104314	2SC1645(B)
Q97	M07390303	2SC2603(F)
Q98	M04207307	2SA825(R)
Q99	M07390303	2SC2603(F)
Q101	M04207306	2SC2878(B)
Q102	M07390303	2SC2603(F)
Q103	M07390303	2SC2603(F)
Q104	M07390303	2SC2603(F)
Q105	M07390303	2SC2603(F)
Q201	M04207306	2SC2878(B)
Q202	M07390303	2SC2603(F)
Q203	M07390303	2SC2603(F)
Q204	M07390303	2SC2603(F)
Q301	M07587300	2SC2320L(F)
Q302	M07587300	2SC2320L(F)
Q303	M07587300	2SC2320L(F)
Q304	M07587300	2SC2320L(F)
Q305	M07587300	2SC2320L(F)
Q306	M07587300	2SC2320L(F)
Q307	M07587300	2SC2320L(F)
Q308	M07587300	2SC2320L(F)
Q401	M07587300	2SC2320L(F)
Q402	M07587300	2SC2320L(F)

Symbol No.	Parts No.	Description
Q403	M07587300	2SC2320L(F)
Q404	M07587300	2SC2320L(F)
Q405	M07587300	2SC2320L(F)
Q406	M07587300	2SC2320L(F)
Q407	M07587300	2SC2320L(F)
Q408	M07587300	2SC2320L(F)
Q501	M07390303	2SC2603(E)
Q502	M07390303	2SC2603(E)
Q503	M07390303	2SC2603(E)
Q504	M07390303	2SC2603(E)
Q505	M07390303	2SC2603(E)
Q506	M07390303	2SC2603(E)
Q507	M07390303	2SC2603(E)
Q508	M04A10302	DTC144ES
Q509	M04A10302	DTC144ES
Q510	M04A10302	DTC144ES
Q511	M04A10302	DTC144ES
Q512	M04A10302	DTC144ES
Q513	M04A10302	DTC144ES
Q514	M04A10302	DTC144ES
Q515	M04A10302	DTC144ES
Q516	M04207305	2SD1189(R)
Q601	M07390303	2SC2603(F)
Q602	M04200302	DTC124ES
Q603	M07390303	2SC2603(F)
Q604	M04200302	DTC124ES
Q605	M04200302	DTC124ES
Q606	M04200302	DTC124ES
Q607	M04207301	2SA933SP(R)
Q608	M04207301	2SA933SP(R)
Q609	M04207301	2SA933SP(R)
Q610	M04207301	2SA933SP(R)
Q611	M04207301	2SA933SP(R)
Q612	M07387303	2SC1740SP(R)
Q613	M07387303	2SC1740SP(R)
Q614	M04207301	2SA933SP(R)
Q616	M04207305	2SD1189(R,Q) 
Q617	M04A10301	2SB942(P,Q) 
Q618	M04207300	2SA934(R,Q)
Q619	M07390303	2SC2603(F)
Q620	M04207303	2SB889(R,Q)
Q621	M04207301	2SA933(R,S) 
Q622	M07390304	2SA1115(E,F)
Q623	M04200302	DTC124ES
Q624	M04207305	2SD1189(R,Q)
Q625	M04207303	2SB889(R,Q)
Q626	M04200302	DTC124ES
Q627	M04200302	DTC124ES
Q628	M04207301	2SA933SP(R)
Q629	M07290303	2SC2603(F)
Q631	M04A10300	2SA950A(Y)
Q632	M07390303	2SC2603(F)
Q801	M04207307	2SA825(R)
Q802	M04207307	2SA825(R)
Q803	M04207307	2SA825(R)

For Service Manuals Contact
MAURITRON TECHNICAL SERVICES
 8 Cherry Tree Rd, Chinnor
 Oxon OX9 4QY
 Tel:- 01844-351694 Fax:- 01844-352554
 Email:- enquiries@mauritron.co.uk

Symbol No.	Parts No.	Description
ICs		
IC1	M04207310	LA1235
IC2	M04207311	LA3370
IC3	M07556310	LA1245
IC4	M04207312	M54927P
IC601	M04207316	M4066BP
IC602	M04207316	M4066BP
IC603	M05225312	M5218L
IC604	M04207317	TC9154P
IC605	M04A10313	STK4181A
IC606	M04A10315	UPC1473H
IC607	M04207319	MPC7538C-040
IC608	M04207318	BA614A
IC609	M04A10314	M74LS145
IC610	M05225312	M5218L
IC611	M05225312	M5218L
IC612	M05225312	M5218L
IC613	M05225312	M5218L
IC614	M04A10319	M74LS04
IC615	M04A10318	M74LS193
IC616	M04A10312	M74LS42
IC617	M04A10316	IR2339
IC618	M04A10316	IR2339
IC619	M04207314	AN6873N
IC620	M04207314	AN6873N
IC801	M04207315	MPC7538C-041
IC802	M04207313	MSL912RS
IC803	M04207314	AN6873N
IC804	M04A10312	M74LS42
Electrical Parts		
CF1	M04207445	CERAMIC FILTER
CF2	M04207445	CERAMIC FILTER
CF3	M04207447	CERAMIC FILTER
CF4	M04207446	CERAMIC FILTER
CO601	M04207517	CERAMIC OSC (CSB400P)
FU601	M04A01450	FUSE T-2A 
FU602	M04A12451	FUSE T-6.3A 
FU603	M04A12451	FUSE T-6.3A 
FU604	M04207451	FUSE T-4A 
FU605	M04207450	FUSE T-1A 
FU606	M04A12450	FUSE T-3.15A 
G24	M04207548	FM TUNER
L2	M04A10502	FM IFT
L3	M04A10503	FM IFT
L4	M04207441	COIL
L5	M04207440	COIL
L6	M04207440	COIL
L7	M04207513	COIL OSC
L8	M04207511	COIL
L9	M04207515	COIL
L98	M04207512	COIL
L99	M04207514	COIL OSC
L101	M04207516	SPRING COIL
L201	M04207516	SPRING COIL

Symbol No.	Parts No.	Description
L601	M04207339	COIL
L602	M04207515	COIL
L801	M04207515	COIL
R8	M04207456	R-FUSE 33 Δ
R18	M04207455	R-FUSE 22 Δ
R563	M04207456	R-FUSE 33 Δ
R564	M04207456	R-FUSE 33 Δ
R687	M04207459	R-FUSE 100 Δ
R703	M04207457	R-FUSE 2.2 Δ
R714	M04207458	R-FUSE 4.7 Δ
R733	M04207457	R-FUSE 2.2 Δ
R735	M04207458	R-FUSE 4.7 Δ
T1	M04207505	AM IFT
T2	M04207504	AM IFT
T601	M04A13500	TRANS-POWER (MAIN) Δ
T602	M04A13501	TRANS-POWER (BACKUP) Δ
TC1	M04A10425	TRIMMER 1P
TC2	M04A10425	TRIMMER 1P
TC98	M04207426	TRIMMER 1P
TC99	M04207426	TRIMMER 1P
VR1	M04207410	VR-SEMI-10K
VR2	M04207411	VR-SEMI-20K
VR302	M04A10401	VR-SLIDE 50K
VR303	M04A10401	VR-SLIDE 50K
VR304	M04A10401	VR-SLIDE 50K (TONE CONT)
VR305	M04A10401	VR-SLIDE 50K (TONE CONT)
VR306	M04A10401	VR-SLIDE 50K (TONE CONT)
VR307	M04A10401	VR-SLIDE 50K (TONE CONT)
VR308	M04A10401	VR-SLIDE 50K (TONE CONT)
VR402	M04A10401	VR-SLIDE 50K (TONE CONT)
VR403	M04A10401	VR-SLIDE 50K (TONE CONT)
VR404	M04A10401	VR-SLIDE 50K (TONE CONT)
VR405	M04A10401	VR-SLIDE 50K (TONE CONT)
VR406	M04A10401	VR-SLIDE 50K (TONE CONT)
VR407	M04A10401	VR-SLIDE 50K (TONE CONT)
VR408	M04A10401	VR-SLIDE 50K (TONE CONT)
VR601	M04A10400	VR-20KW (BALANCE)
X1	M04207510	X'TAL OSC
	M04207340	TUBE DISPLAY (FUNCTION)
	M04207341	TUBE DISPLAY (TIMER)
	M04207565	LAMP (FUNCTION IND)
	M04207355	SW PUSH (MAIN)
	M04207476	HEADPHONE JACK
	M04A01490	AC CORD Δ
RY601	M04207536	RELAY
	M04207465	DIN SOCKET (EXT. CONT)
	M04207470	14P CONNECTOR (ONE TOUCH)
	M04207477	PIN JACK (AUX)
RY602	M04207537	RELAY
	M04207356	SW-PUSH (SPEAKER A/B)
	M04A10360	SW-SLIDE (MONO/AUTO)
	M04A10340	TUBE DISPLAY (SPECTRAM)
	M04207480	ANTENNA TERMINAL BOARD

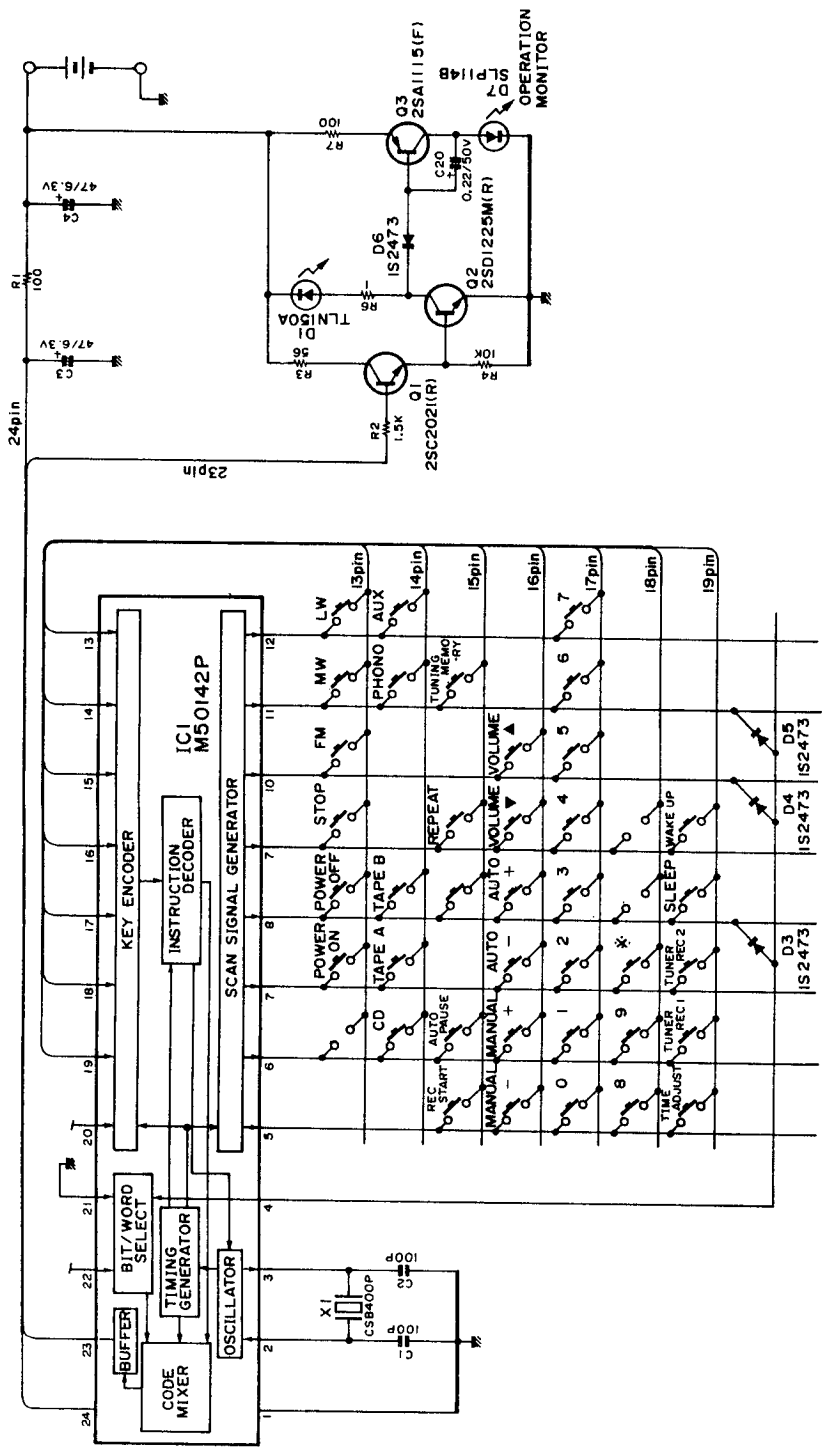

NOTE:
 1. The actual colors of wires may differ from those of this diagram.
 Wire colors are abbreviated as follows,
 BRN Brown
 RED Red
 ORG Orange
 YEL Yellow
 GRN Green
 BLU Blue
 PPL Purple
 GRY Gray
 WHT White
 BLK Black

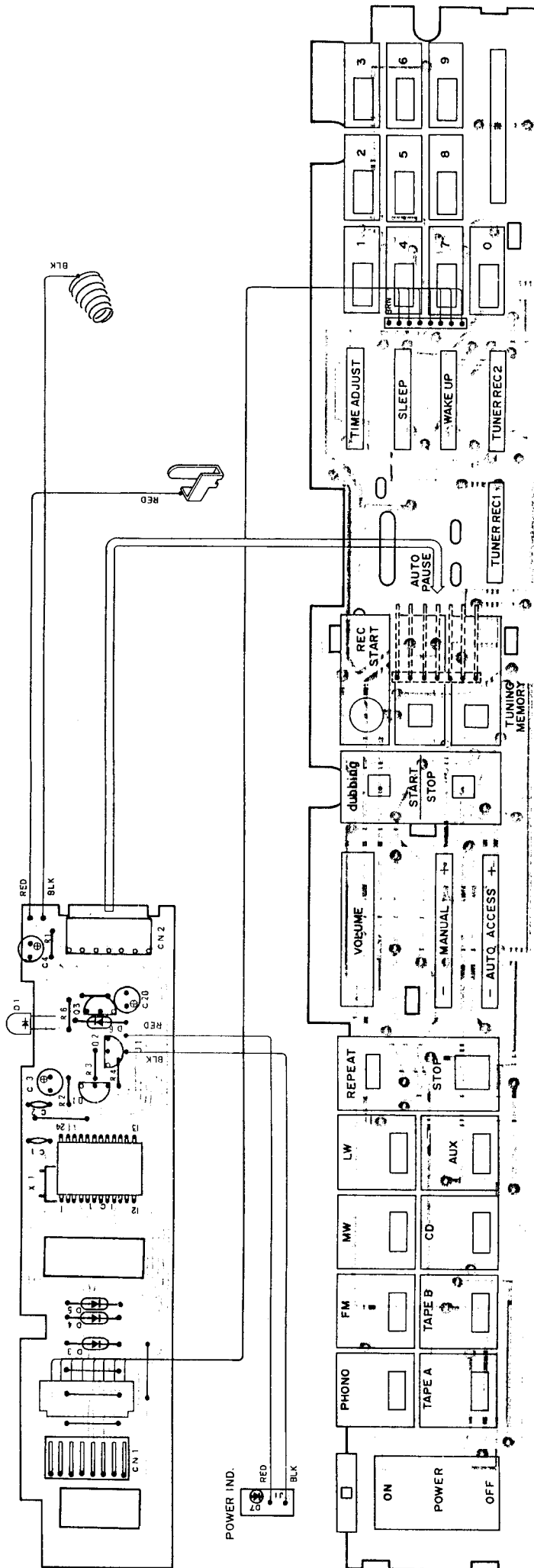

For Service Manuals Contact
MAURITRON TECHNICAL SERVICES
 8 Cherry Tree Rd, Chinnor
 Oxon OX9 4QY
 Tel:- 01844-351694 Fax:- 01844-352554
 Email:- enquiries@mauritron.co.uk

EXPLODED VIEW OF CABINET

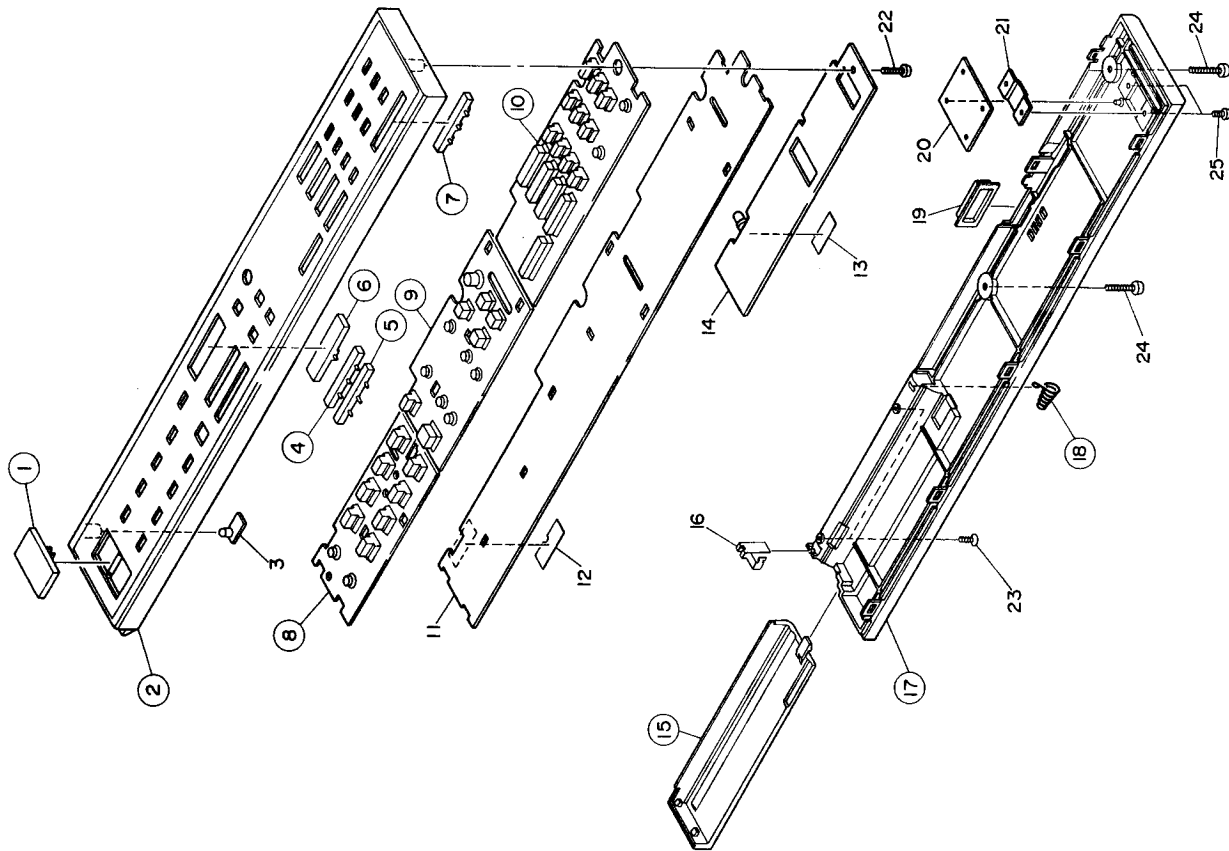

CABINET PARTS LIST

Symbol No.	Parts No.	Description
1	M04A10205	Push Button (Power)
2	M04A10116	Cabinet (Front)
3		PCB Ass'y (LED)
4	M04A10210	Push Button (Auto Access)
5	M04A10209	Push Button (Manual)
6	M04A10204	Push Button (Volume)
7	M04A10206	Push Button (*)
8	M04A10208	Push Button (Power/Function)
9	M04A10203	Push Button (Rec. etc.)
10	M04A10207	Push Button (Ten Key etc.)
11		PCB Ass'y (Switch)
12		Insulator Sheet
13		PCB Ass'y (Main)
14	M04A10134	Battery Lid
15		Battery Terminal (+)
16	M04A10118	Cabinet (Back)
17	M04A10770	Spring (Battery -)
18		Window
19		Rubber Sheet
20		Metal Plate
21		T-Screw T2.7 x 8
22		Flat Head T-Screw T2.2 x 4
23		T-Screw T2.2.6 x 14
24		Screw M2 x 2.5
25		

PART LIST

Symbol No.	Parts No.	Description
		Diodes
D001	M04207378	LED TLN105A
D003	M07060320	1S2473
D004	M07060320	1S2473
D005	M07060320	1S2473
D006	M07060320	1S2473
D007	M05129321	LED SLP114M(RED); MONITOR
		Transistors
Q001	M04207366	2SC2021(R)
Q002	M04207365	2SD1225M(R)
Q003	M07390304	2SA1115(F)
		ICs
IC001	M04207367	M50142P
		Electrical Parts
X001	M04207517	Ceramic OSC

DISASSEMBLY PROCEDURE FOR DT-63P

1. Removing the top cover
 - 1) Remove the six top cover fixing screws (13) as shown in fig. 11.
 - 2) The top cover can be removed by pulling it forward.

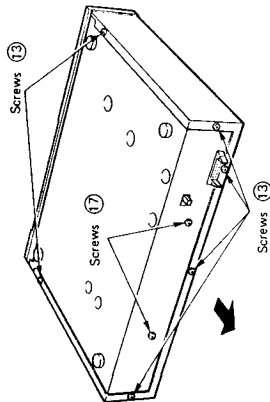

Fig. 11

2. Removing the sub-panel
 - 1) As shown in Fig. 12 remove the sub-panel fixing screw (14) and loosen the screw (15).
 - 2) Remove the sub-panel from the fingers securing it on the right side, and pull the left side slightly forward and raise the sub-panel assembly. The sub-panel should now come free.

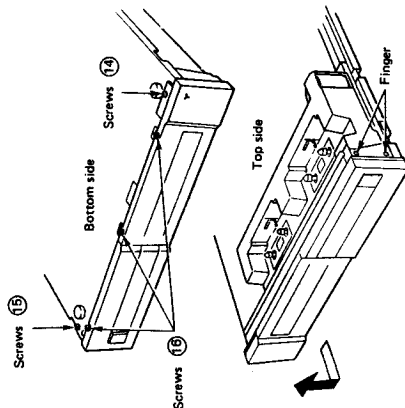

Fig. 12

3. Removing the front panel
 - 1) As shown in Fig. 12 remove the three front panel fixing screws (16).
 - 2) Pull the lower side of the front panel slightly forward, and raise it upward. The front panel should now come free.
4. Removing the mechanism control circuit board
 - 1) As shown in Fig. 11 loosen the two screws (17).
 - 2) As shown in Fig. 13 remove CN904 and CN905 of the mechanism control circuit board, and remove the plastic rivets.
 - 3) The mechanism control circuit board can be removed by pulling it towards the front side until the one-touch connector becomes free from the rear panel.

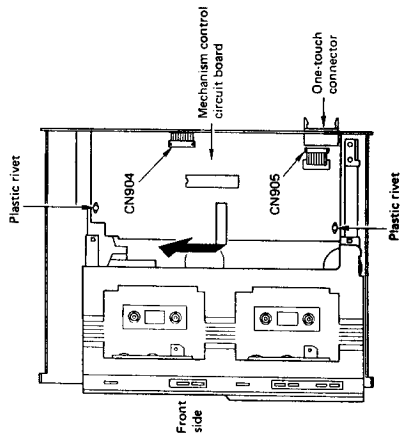

Fig. 13

5. Removing the cassette holder
 - 1) Following steps 1, 2, 3, remove the top cover, sub-panel, front panel.
 - 2) Pushing the cassette holder, pull it forward.
 - 3) As shown in Fig. 14, remove the screw (18), remove the stopper securing the sliding mechanism of the cassette holder, and pull the cassette holder forward.
 - 4) Remove the two screws (19) on the left and right sides of the cassette holder.
 - 5) Turn the set upside down and remove the three screws (20) as shown in Fig. 15.

- 6) Turn the set right-side up, and pull the cassette holder slightly forward. The cassette holder section can be removed by pulling it upwards, while sliding it free from the fingers on the left and right sides. (Be sure not to break the fingers on either side.)

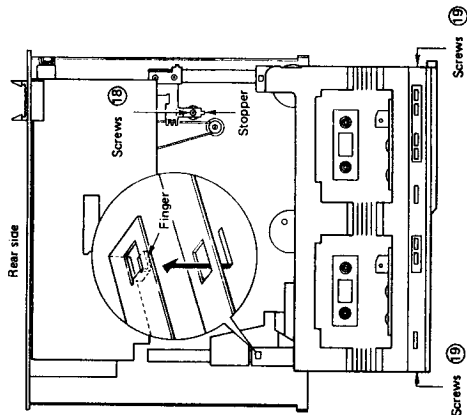

Fig. 14

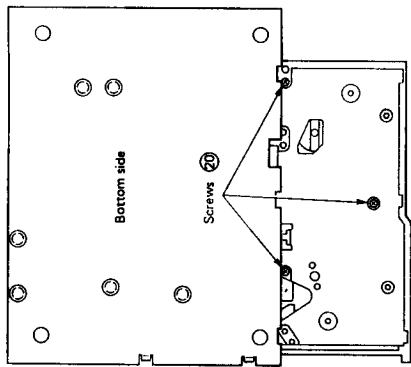
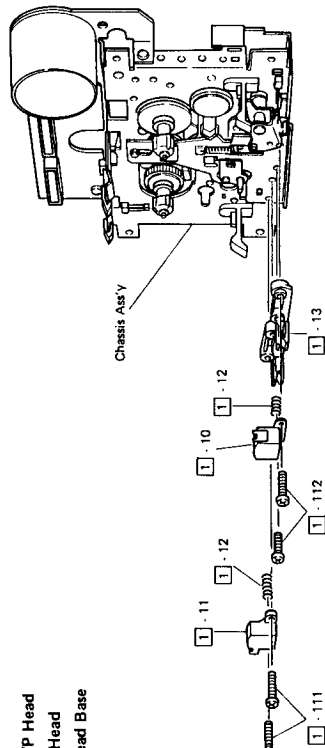

Fig. 15

DISASSEMBLY OF MECHANISM

1. Front Side of Mechanism

- 1) 1 - 10 R/P Head
- 1) 1 - 11 E Head
- 1) 1 - 13 Head Base



For Service Manuals Contact
MAURITRON TECHNICAL SERVICES
 8 Cherry Tree Rd., Chinnor
 Oxon OX9 4QY
 Tel: 01844-351694 Fax: 01844-352554
 Email: enquiries@mauritron.co.uk

- 2) 1 - 7 Head Panel Ass'y
- 1 - 122 Steel Ball
- 1 - 14 Panel Press Plate
- 1 - 15 Pinch Roller Ass'y

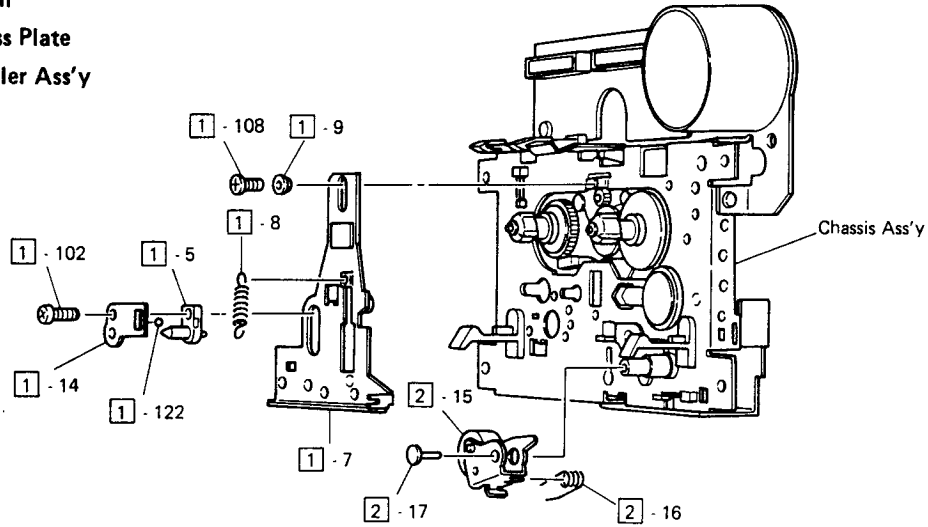

- 3) 2 - 23 T Reel Ass'y
- 2 - 24 S Reel Ass'y

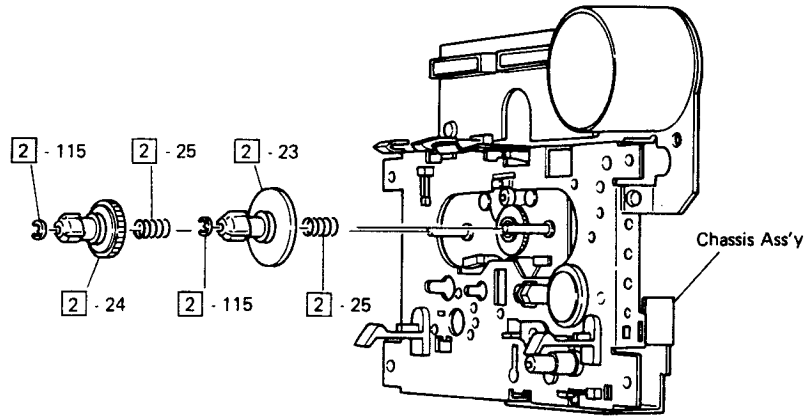

- 4) 4 - 61 Capstan Motor
- 4 - 63 Motor Bracket
- 4 - 82 Connector Base Ass'y

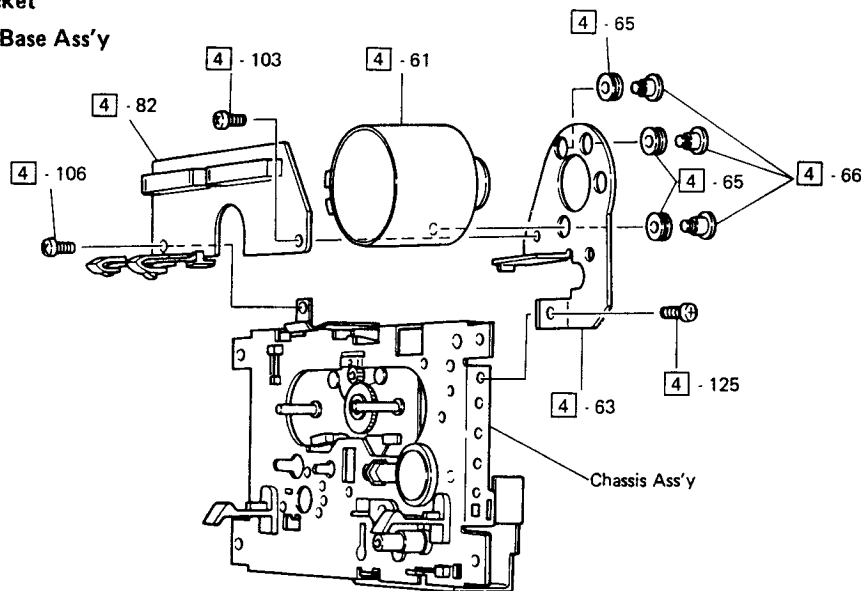

2. Rear Side of Mechanism

- 1) **2** - 45 M Gear
2 - 49 P Gear
2 - 69 FL Bracket
- 3** - 58 Flywheel Capstan
3 - 64 Main Belt

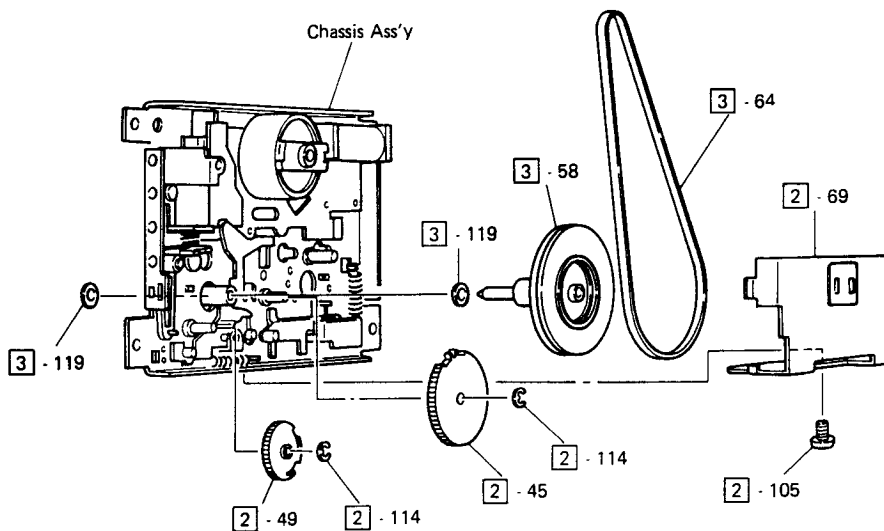

- 2) **2** - 46 M Trigger Arm
2 - 50 P Trigger Arm
2 - 52 Coil Ass'y

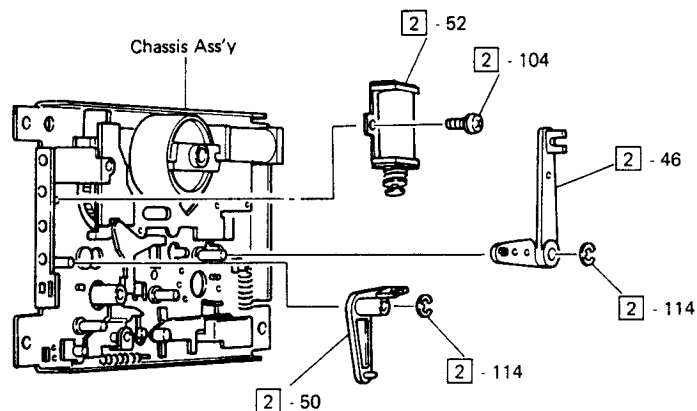

For Service Manuals Contact
MAURITRON TECHNICAL SERVICES
 8 Cherry Tree Rd, Chinnor
 Oxon OX9 4QY
 Tel:- 01844-351694 Fax:- 01844-352554
 Email:- enquiries@mauritron.co.uk

- 3) **3** - 22 Reel Base Ass'y
3 - 26 Reel Motor Ass'y
3 - 32 Sensor Base Ass'y
3 - 51 Coil Ass'y

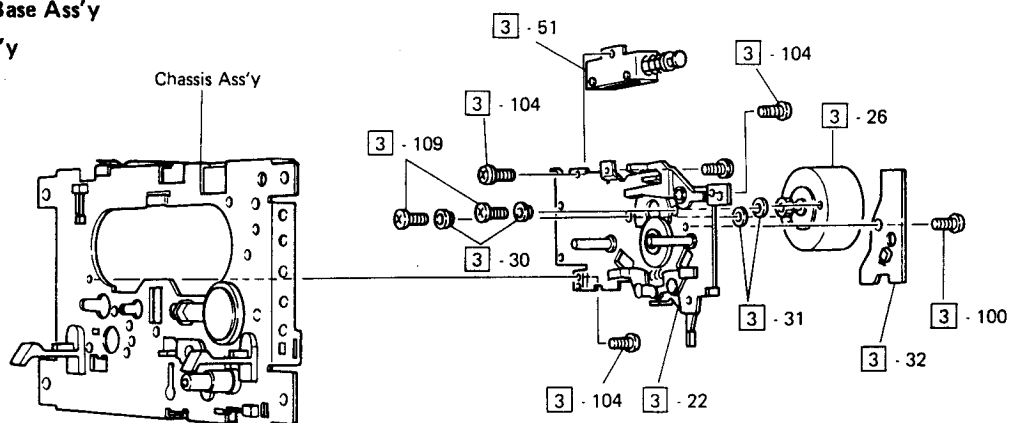

ADJUSTMENT PROCEDURE FOR DT-63P

Before adjustment

- Connect with the receiver DA-R47P by using the signal cable.
- To prevent each measurement error due to magnetization or dirt, be sure to carry out head-erase and head-cleaning.

Switch settings

SWITCH	POSITION
BEAT CANCEL	F II
TAPE SELECTOR	normal
DOLBY NR	out

1. MECHANICAL ADJUSTMENT

Step	Item		Test tape tools used	Output terminal test point	Adjustment point	Adjustment for	Remarks
1	Head azimuth Adjustment		10kHz, -10dB (TCC-173A)	Connect VTVM and the oscilloscope to REC OUT of the receiver.	Head Azimuth Adjustment screw	Adjust so that the output levels of L and R channels are in the same phase at maximum. Adjust on both TAPE A and TAPE B mechanism.	
2	Tape Speed Adjustment	TAPE A standard	3kHz, -10dB (TCC-112)	Connect the Frequency counter to REC OUT of the receiver.	VR901 Playback mode	3000 ± 10 Hz	
	Wow/Flutter confirmation	TAPE A double speed			VR900 Dubbing mode	6000 ± 20 Hz	Load the blank cassette tape in the TAPE B mechanism so that the dubbing mode is obtained.
3	Tape Speed Adjustment	TAPE B standard	3kHz, -10dB (TCC-112)	Connect the Frequency counter to REC OUT of the receiver.	VR903 Playback mode	2990 ± 10 Hz	
	Wow/Flutter confirmation	TAPE B double speed			VR902 Dubbing mode	5980 ± 20 Hz	During the dubbing operation, the TAPE B mechanism is in the REC mode and will therefore erase the test tape. To prevent this, place the unit in the playback operation by shorting the part as shown in figure.

2. PLAYBACK ADJUSTMENT

* Proceed with the playback adjustments after having finished the mechanical adjustments.

Step	Item	Input terminal/ signal	Test tape	Output terminal/ test point	Adjustment point	Adjustment for	Remarks
1	Playback Level Adjustment		400Hz, 200mVb/m (TCC-130)	Connect the VTVM to CN101-5 (L ch), CN101-4 (R ch) and CN101-6 (GND).	TA VR100 (L ch) VR200 (R ch)	30 mV	
				Connect the VTVM to TP1 (L ch), TP4 (R ch) and TP2 (GND).	TB VR150 (L ch) VR250 (R ch)	550 mV	
2	Playback Frequency Characteristic Confirmation		120 μ s+3180 μ s Frequency characteristic check tape (MTT-216U)	Connect the Frequency counter to REC OUT of receiver.		Should be within specification.	

3. RECORD/PLAYBACK ADJUSTMENT

Step	Item	Input terminal/ signal	Test tape	Output terminal/ test point	Adjustment point	Adjustment for	Remarks
1	Bias Frequency Characteristic Adjustment		Load the cassette tape and set for recording.	Connect the frequency counter to the both side of R150, (TP5 and TP6)	OS501 (BIAS OCS)	103kHz	Check the bias frequency with the beat cancel switch set to each position. FI: 98 ~ 101 kHz FIII: 105 ~ 108 kHz
2	Bias Level Adjustment			Connect the VTVM and distortion meter to the both side of R150 (L ch), R250 (R ch)	Metal: VR501 (Lch) VR601 (Rch) Special: VR502 Normal: VR503	Metal: 50mV Special: 30mV Normal: 20mV Temporary adjustment	

For Service Manuals Contact
MAURITRON TECHNICAL SERVICES
 8 Cherry Tree Rd, Chinnor
 Oxon OX9 4QY
 Tel:- 01844-351694 Fax:- 01844-352554
 Email:- enquiries@mauritron.co.uk

Step	Item	Input terminal/ signal	Test tape	Output terminal test point	Adjustment point	Adjustment for	Remarks
3	Bias Trap Adjustment		Load the metal cassette tape (AC-712) and set for recording.	Connect the VTVM to TM303 (L ch), TM301 (R ch) and TM302 (GND).	L501 (Lch) L601 (Rch)	At the Metal position, the bias leak remains the same and minimum even when the beat cancel switch is switched from the FI position to FIII position.	Check that the bias leak is smaller when the beat cancel switch is set to FII position than when set to FI, FIII position.
4	Record Level Adjustment	AUX 1 400Hz, 300mV	Special: AC-512 Metal: AC-712 Normal: TCC-102A	Connect the VTVM and distortion meter to TM303 (L ch), TM301 (R ch) and TM302 (GND).	VR500 (L ch) VR600 (R ch)	<ul style="list-style-type: none"> • Vary the input signal by 550mV ± 1dB so that the output voltage becomes 550mV when the input signal is applied. • Adjust VR500 and 600 so that the K3 distortion is less than 3% when played back. • If the distortion is excessive or if the record/playback frequency response in the step 5,6 or 7 is out of the specification, adjust by increasing or decreasing the bias slightly. 	<p>Check that Normal and Metal are within 550mV ± 1dB.</p> <p>T.H.D reference value Normal: 1.5% Special: 1.3% Metal: 1.3%</p>

Step	Item	Input terminal signal	Test tape	Output terminal/ test point	Adjustment point	Adjustment for	Remarks
5	Record/ Playback Frequency Characteristic Adjustment	AUX I 400Hz, 300mV 40Hz ~ 12.5kHz 300mV (OVU) -25dB	AC-512	Connect the VTVM to REC OUT of the receiver.	L500 (L) L600 (R)	Adjust so that frequency response is within the specification when recording on the test tape and playing it back.	Check the VTVM output for about 315mV. Check also at Dolby IN position. Adjust by repeating steps 5 to 7 so that each specification is obtained.
6	Record/ Playback Frequency Characteristic Adjustment (Normal)		TCC-102A	Connect the VTVM to REC OUT of the receiver.		The frequency response should be within the specifications.	
7	Record/ Playback Frequency Characteristic Adjustment (Metal)		AC-712	Connect the VTVM to REC OUT of the receiver.		The frequency response should be within the specification.	

ADJUSTMENT LOCATION DIAGRAM

For Service Manuals Contact
MAURITRON TECHNICAL SERVICES
 8 Cherry Tree Rd, Chinnor
 Oxon OX9 4QY
 Tel:- 01844-351694 Fax:- 01844-352554
 Email:- enquiries@mauritron.co.uk

PB EQUALIZER AMP. P.C.B

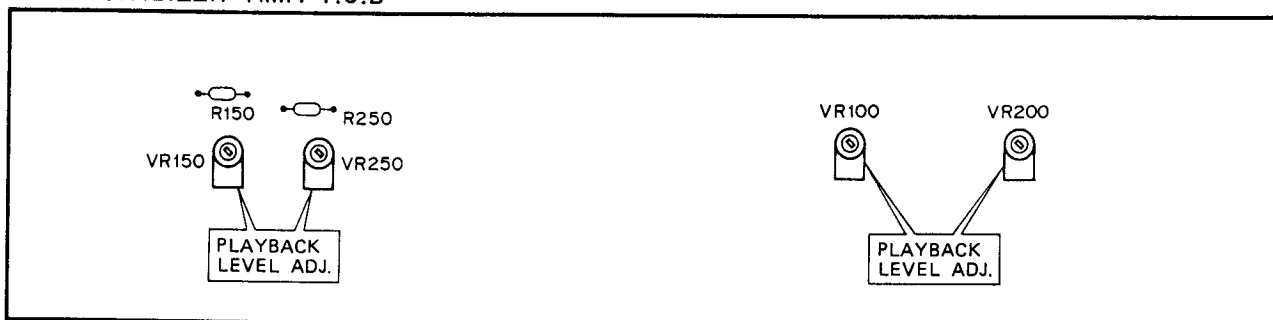

DOLBY AMP. P.C.B

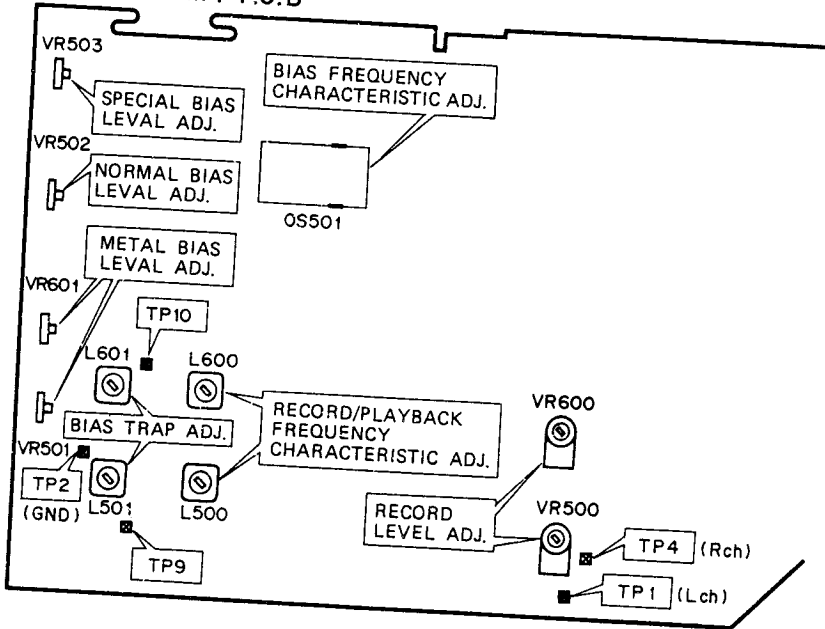

MECHA CONTROL P.C.B

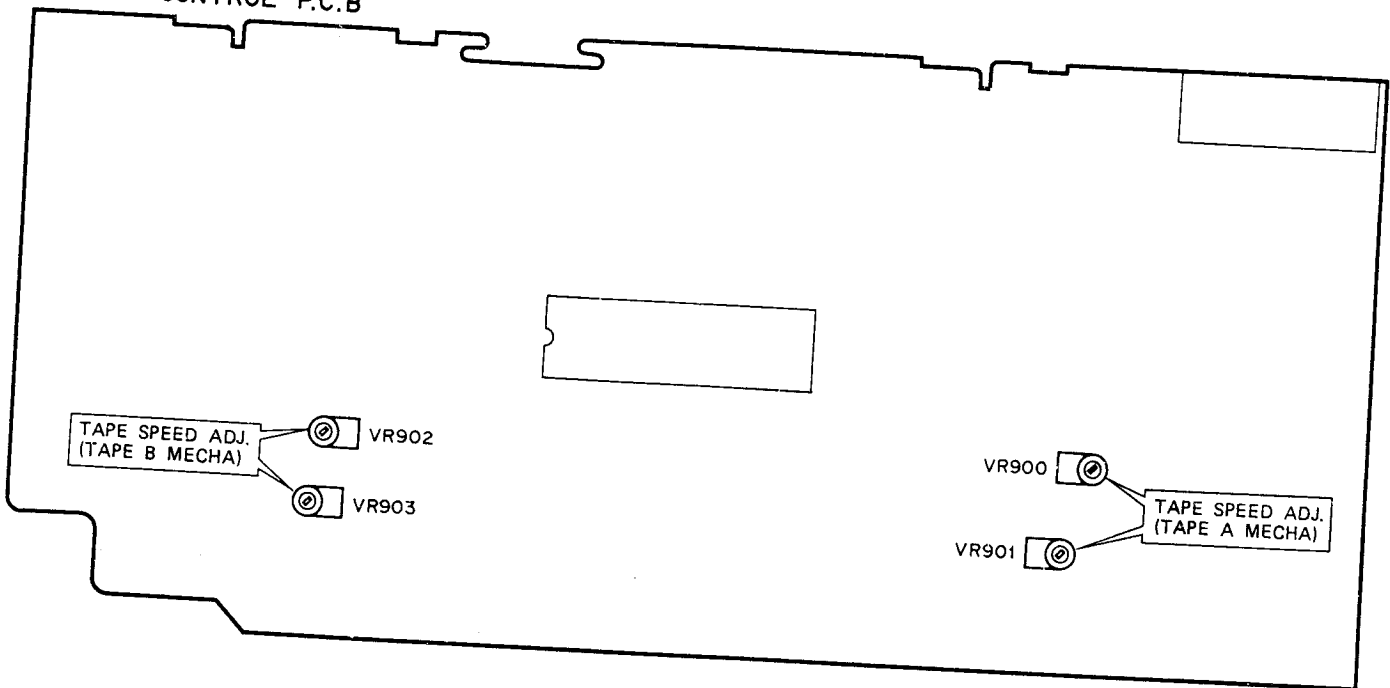

INTERNAL DIAGRAMS AND PINOUT OF INTEGRATED CIRCUIT

IC300, 400: TA7629P

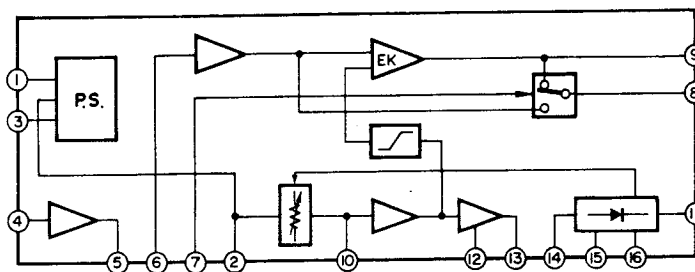

IC505, 903: M5218L

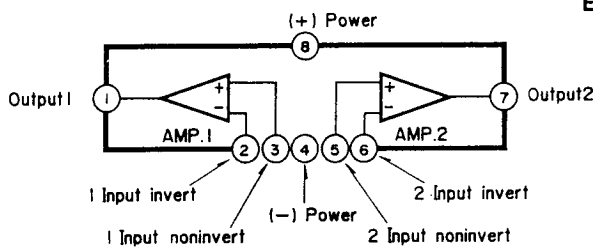
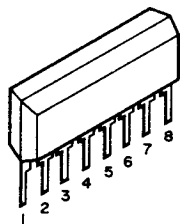

For Service Manuals Contact
MAURITRON TECHNICAL SERVICES
 8 Cherry Tree Rd, Chinnor
 Oxon OX9 4QY
 Tel:- 01844-351694 Fax:- 01844-352554
 Email:- enquiries@mauritron.co.uk

IC701: μ PD4052BC

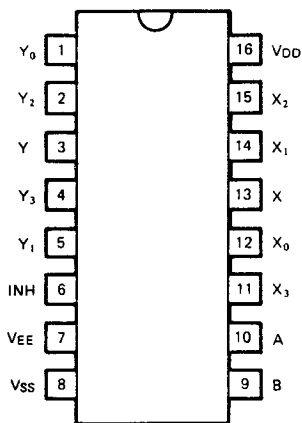

IC702: M4066BP

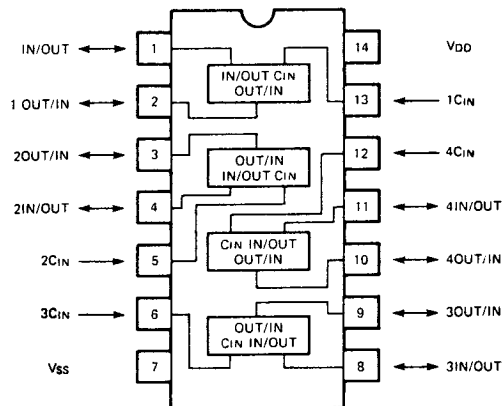

IC703: M51143L

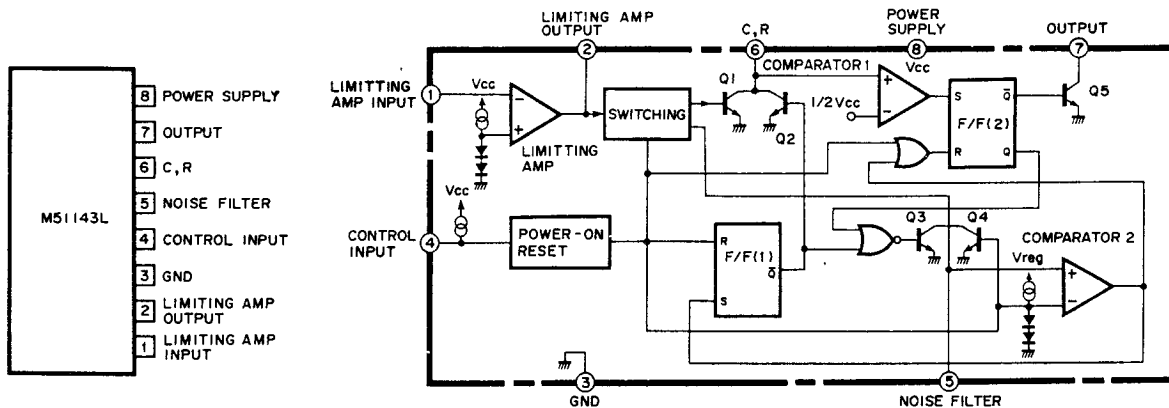

WIRING DIAGRAM

MODEL DT-63P

E-63P

MODEL DT-63P

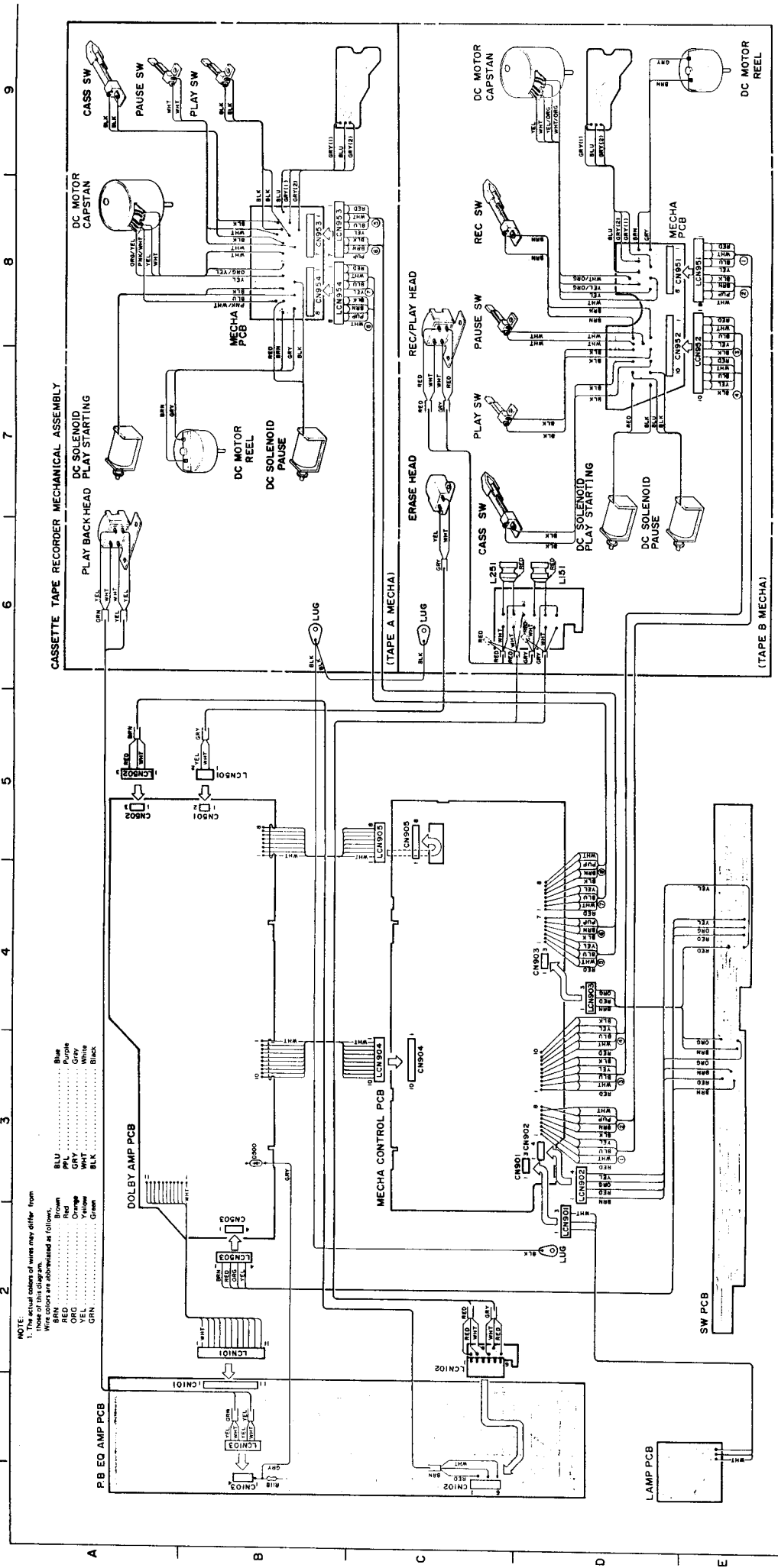

2

3

4

5

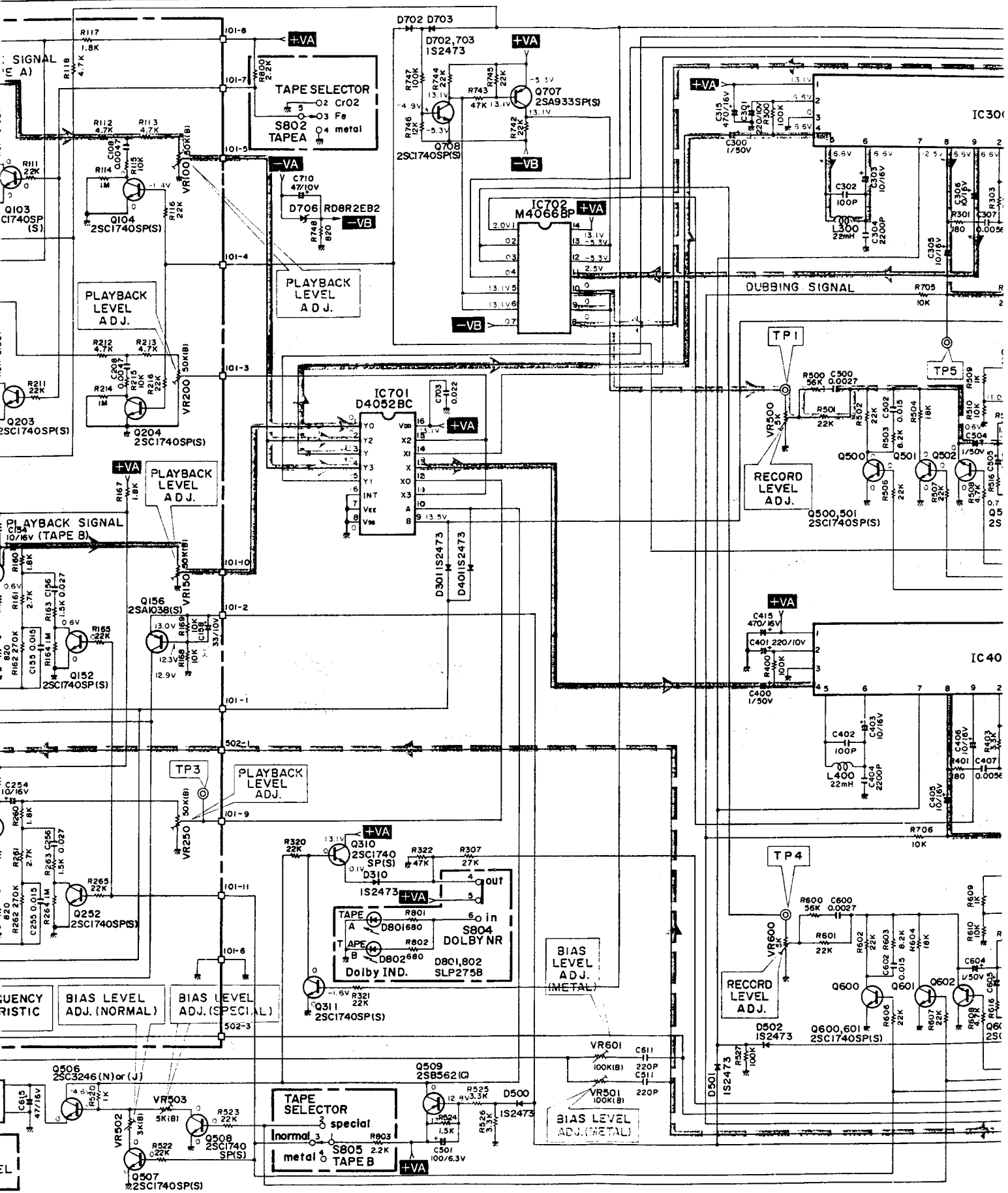

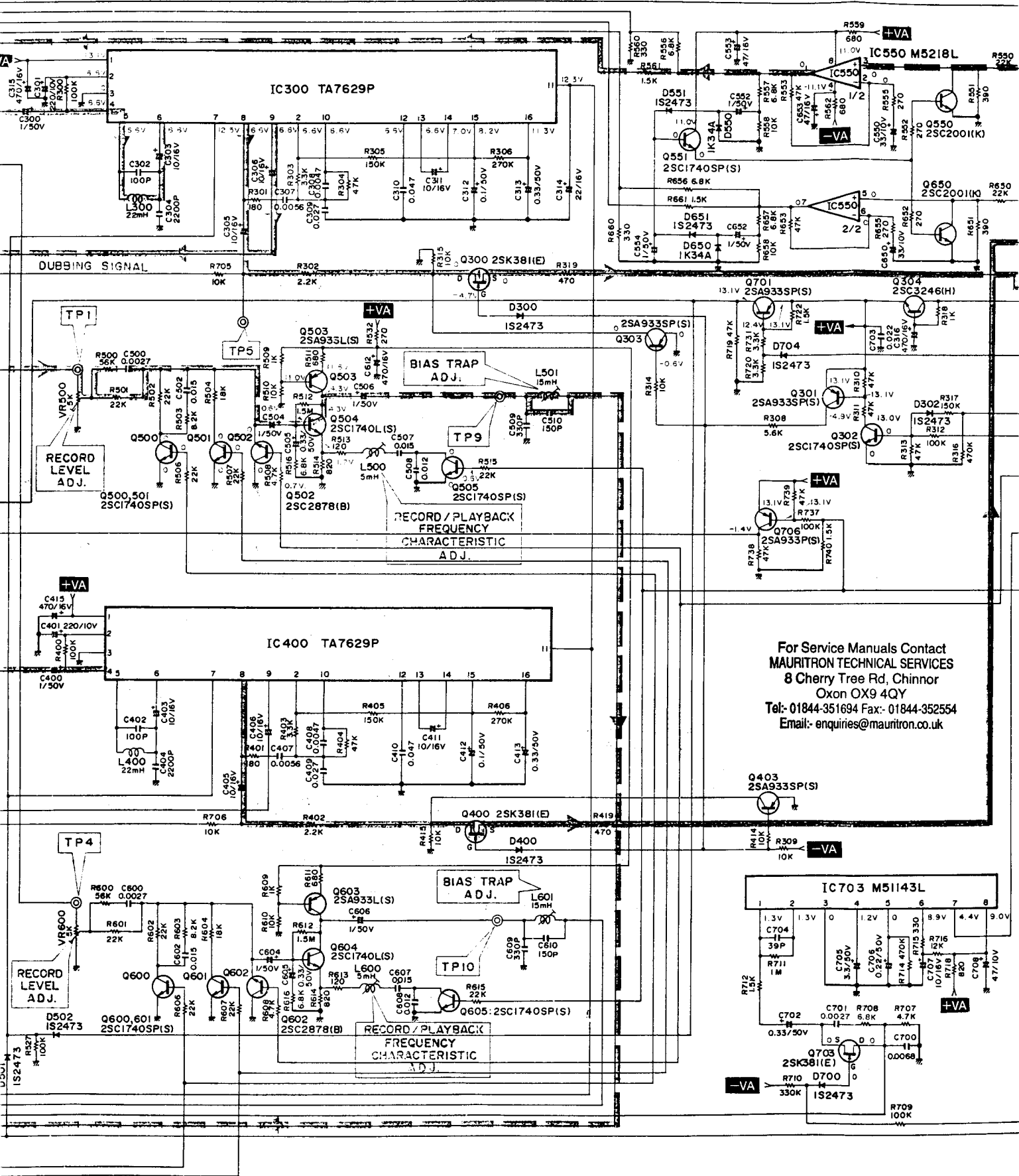

For Service Manuals Contact
MAURITRON TECHNICAL SERVICES
 8 Cherry Tree Rd, Chinnor
 Oxon OX9 4QY
 Tel: 01844-351694 Fax: 01844-352554
 Email: enquiries@mauritron.co.uk

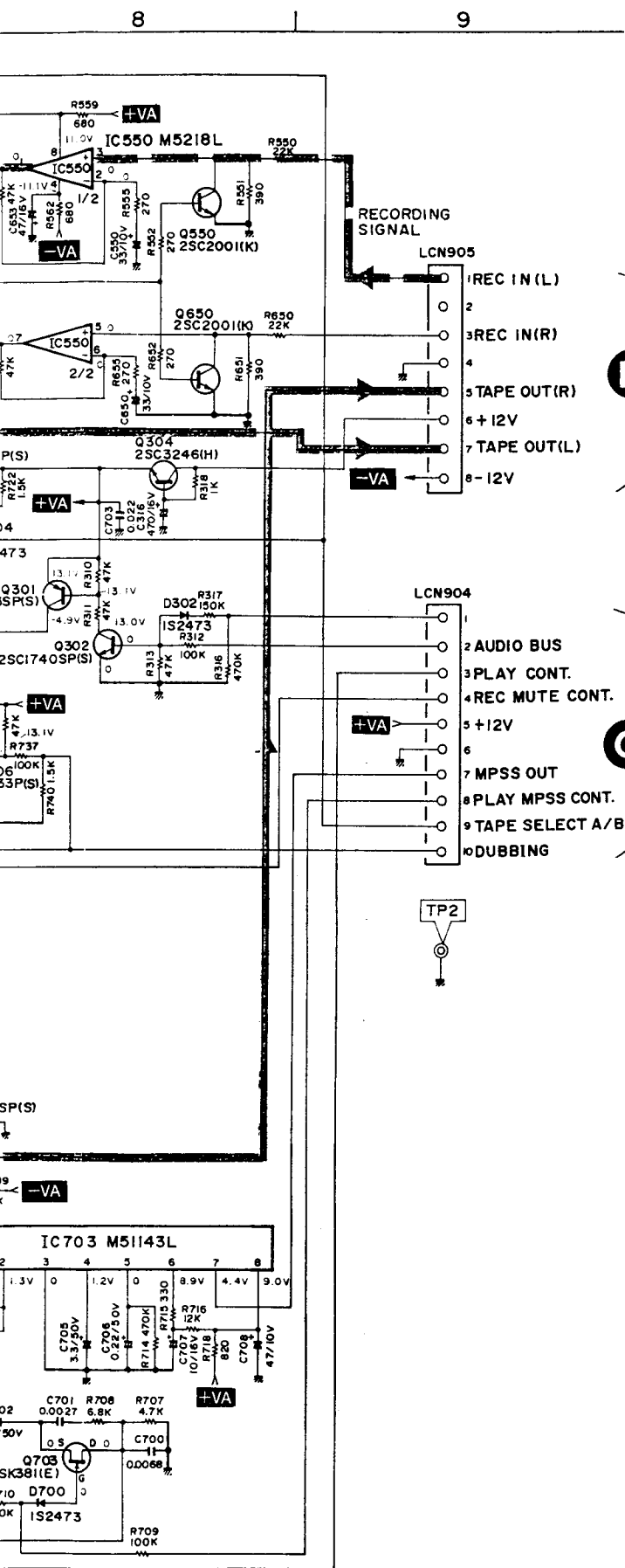

NOTE:

- Unit of C and R
 C No-symbol; μ F
 P-symbol; PF
 R No-symbol; Ω
 K-symbol; k Ω
 M-symbol; M Ω

Wattage for all unspecified resistor are 1/4W.

- Voltage are those measured with DC 1M Ω digital voltmeter.
- This circuit diagram may be changed due to circuit improvement.

TRANSISTORS

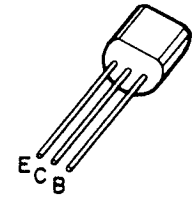
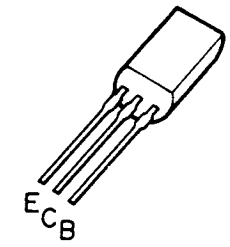
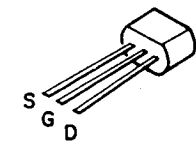
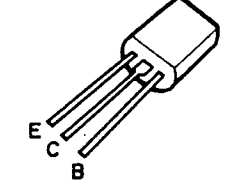
 <p>2SA933L 2SA933SP 2SC1740L 2SC1740SP 2SC2001 2SC2603 2SC2389 2SC2878</p>	 <p>2SB562</p>
 <p>2SK381</p>	 <p>2SC3246</p>

For Service Manuals Contact
MAURITRON TECHNICAL SERVICES
 8 Cherry Tree Rd, Chinnor
 Oxon OX9 4QY
 Tel: 01844-351694 Fax: 01844-352554
 Email: enquiries@mauritron.co.uk

SCHEMATIC DIAGRAM

2

3

4

A

B

C

D

E

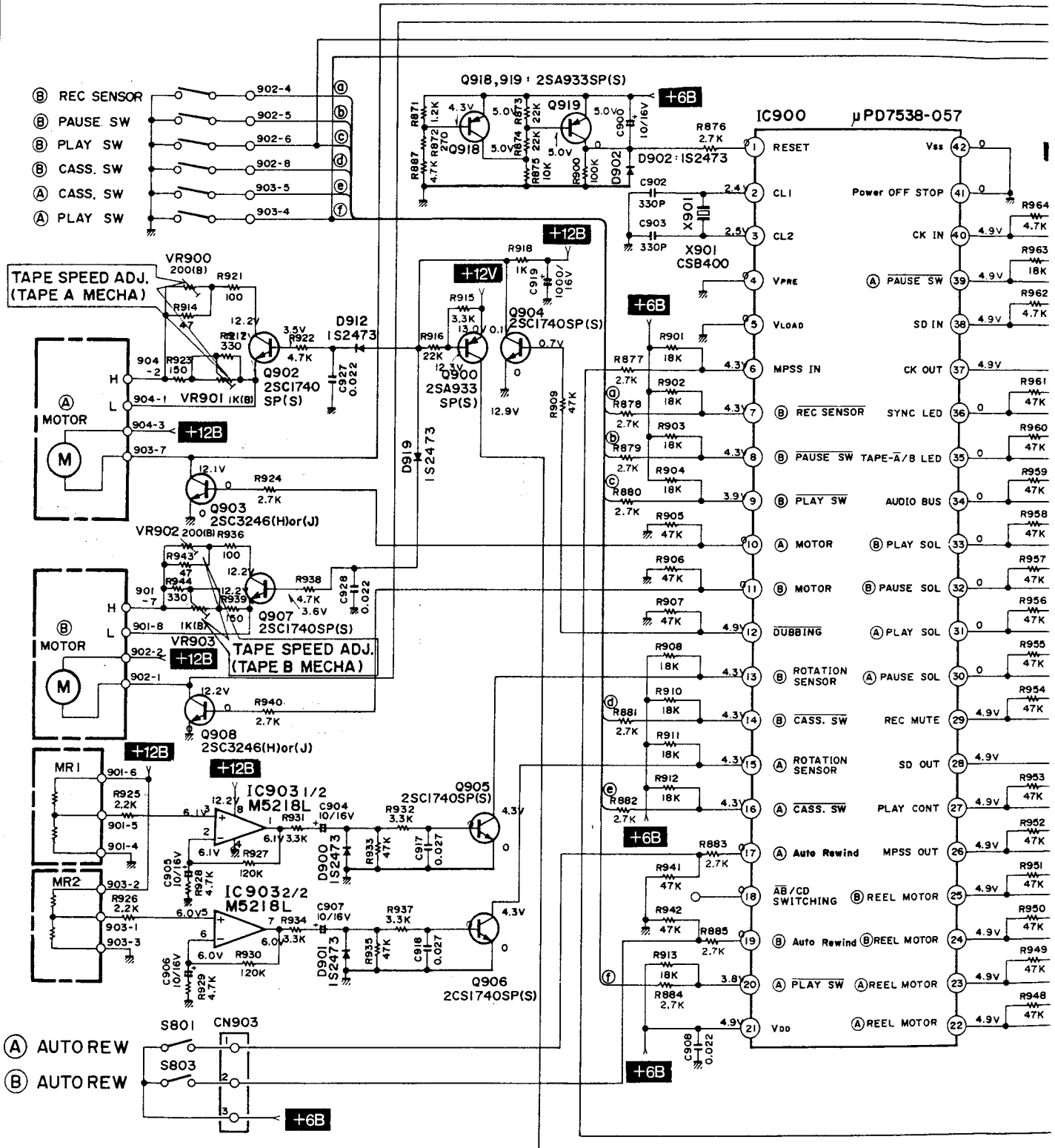

For Service Manuals Contact
MAURITRON TECHNICAL SERVICES
 8 Cherry Tree Rd, Chinnor
 Oxon OX9 4QY
 Tel: 01844-351694 Fax: 01844-352554
 Email: enquiries@mauritron.co.uk

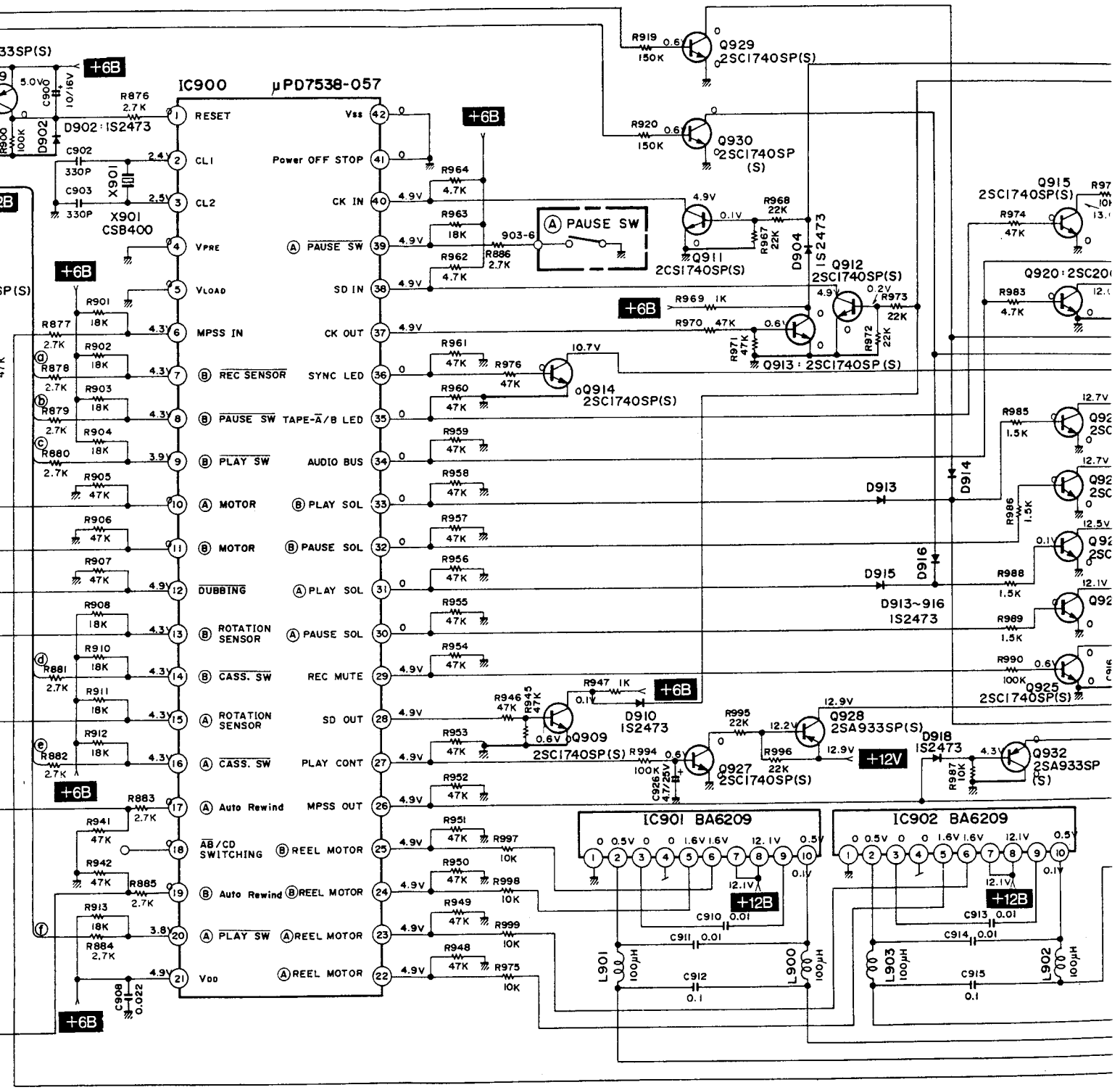

6

7

8

9

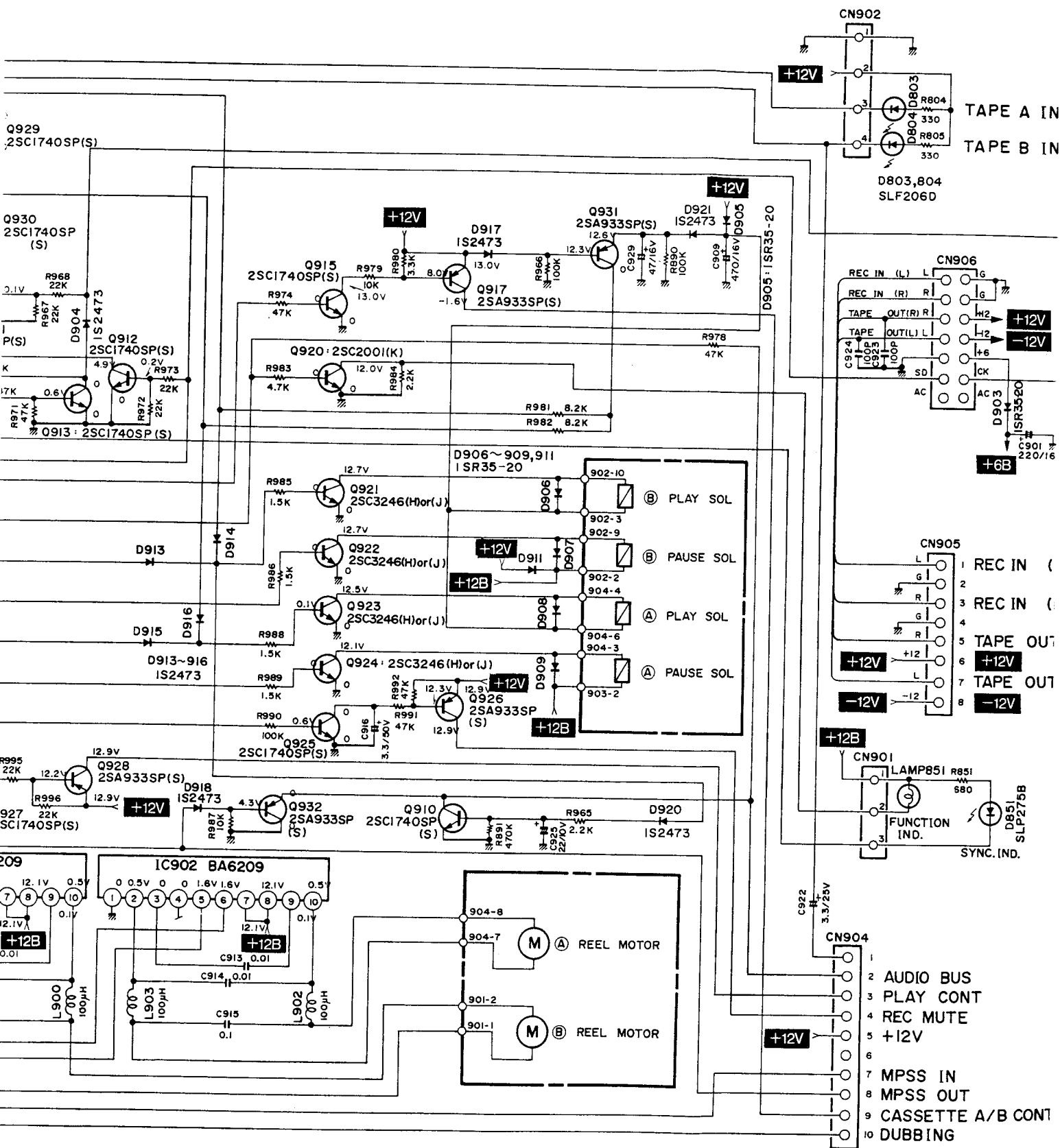

For Service Manuals Contact
MAURITRON TECHNICAL SERVICES
 8 Cherry Tree Rd, Chinnor
 Oxon OX9 4QY
 Tel: 01844-351694 Fax: 01844-352554
 Email: enquiries@mauritron.co.uk

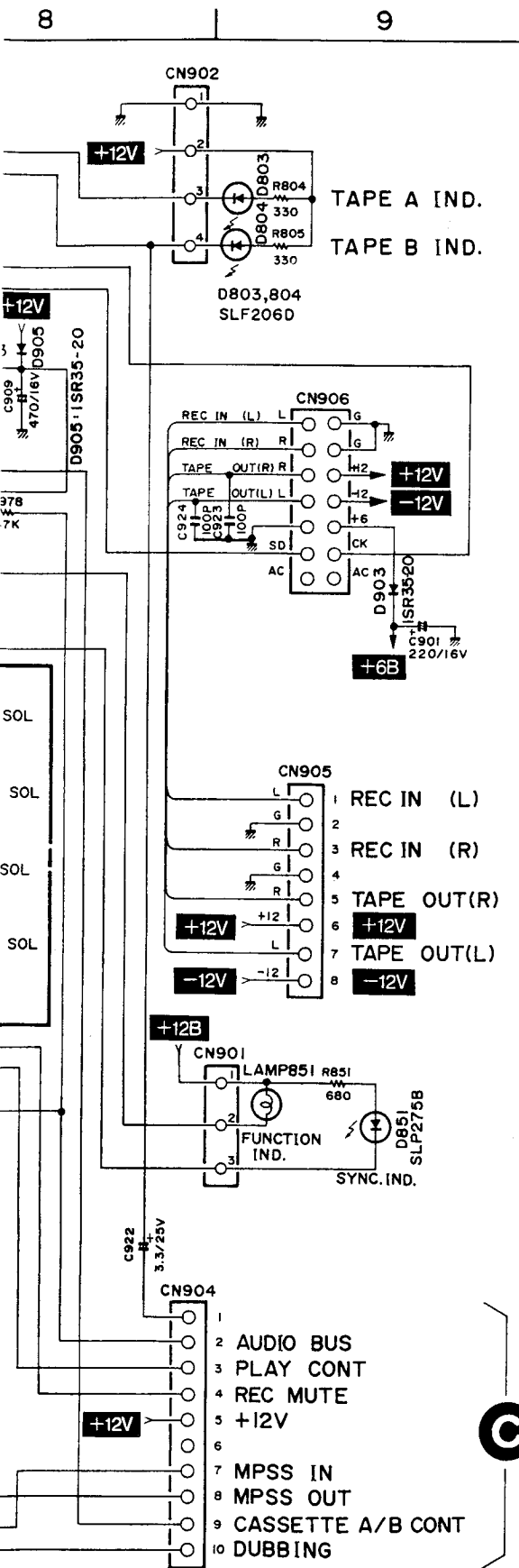

NOTE:

- Unit of C and R
 C No-symbol; μ F
 P-symbol; PF
 R No-symbol; Ω
 K-symbol; k Ω
 M-symbol; M Ω
 Wattage for all unspecified resistor are 1/4W.
- Voltage are those measured with DC 1M Ω digital voltmeter.
- This circuit diagram may be changed due to circuit improvement.

TRANSISTORS

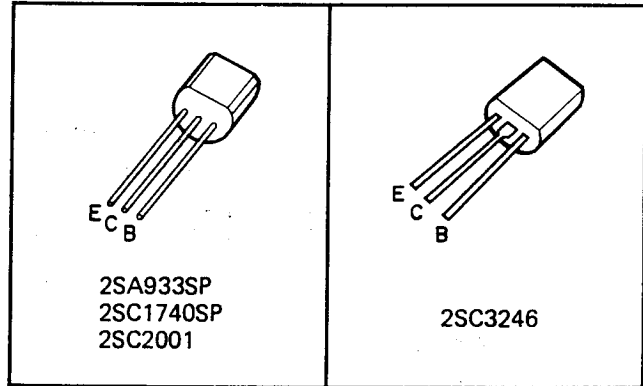

For Service Manuals Contact
MAURITRON TECHNICAL SERVICES
 8 Cherry Tree Rd, Chinnor
 Oxon OX9 4QY
 Tel:- 01844-351694 Fax:- 01844-352554
 Email:- enquiries@mauritron.co.uk

For Service Manuals Contact
MAURITRON TECHNICAL SERVICES
 8 Cherry Tree Rd, Chinnor
 Oxon OX9 4QY
 Tel: 01844-351694 Fax: 01844-352554
 Email: enquiries@mauritron.co.uk

MODEL DT-63P

MODEL DT-63P

MECHA CONTROL P.C.B.

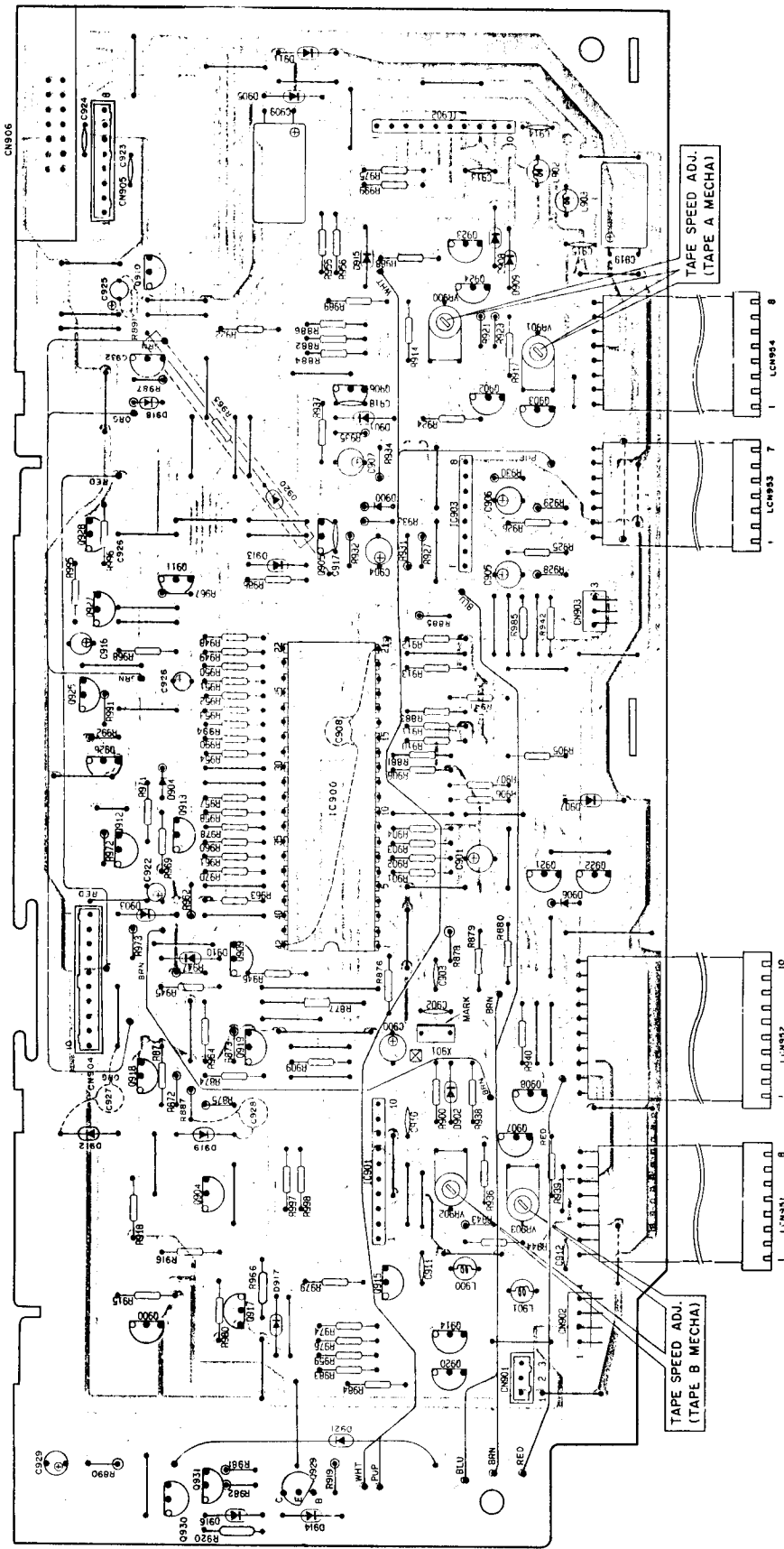

SWITCH P.C.B.

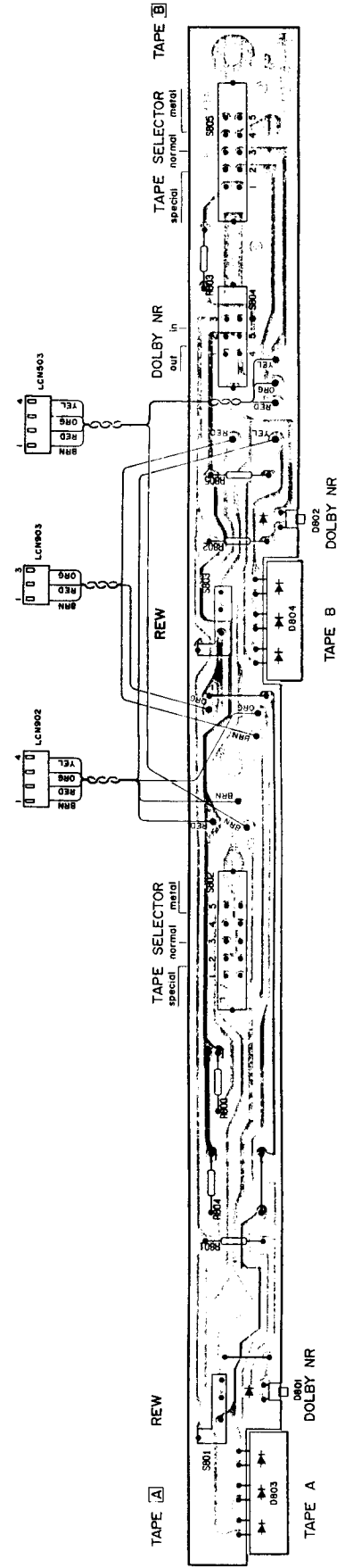

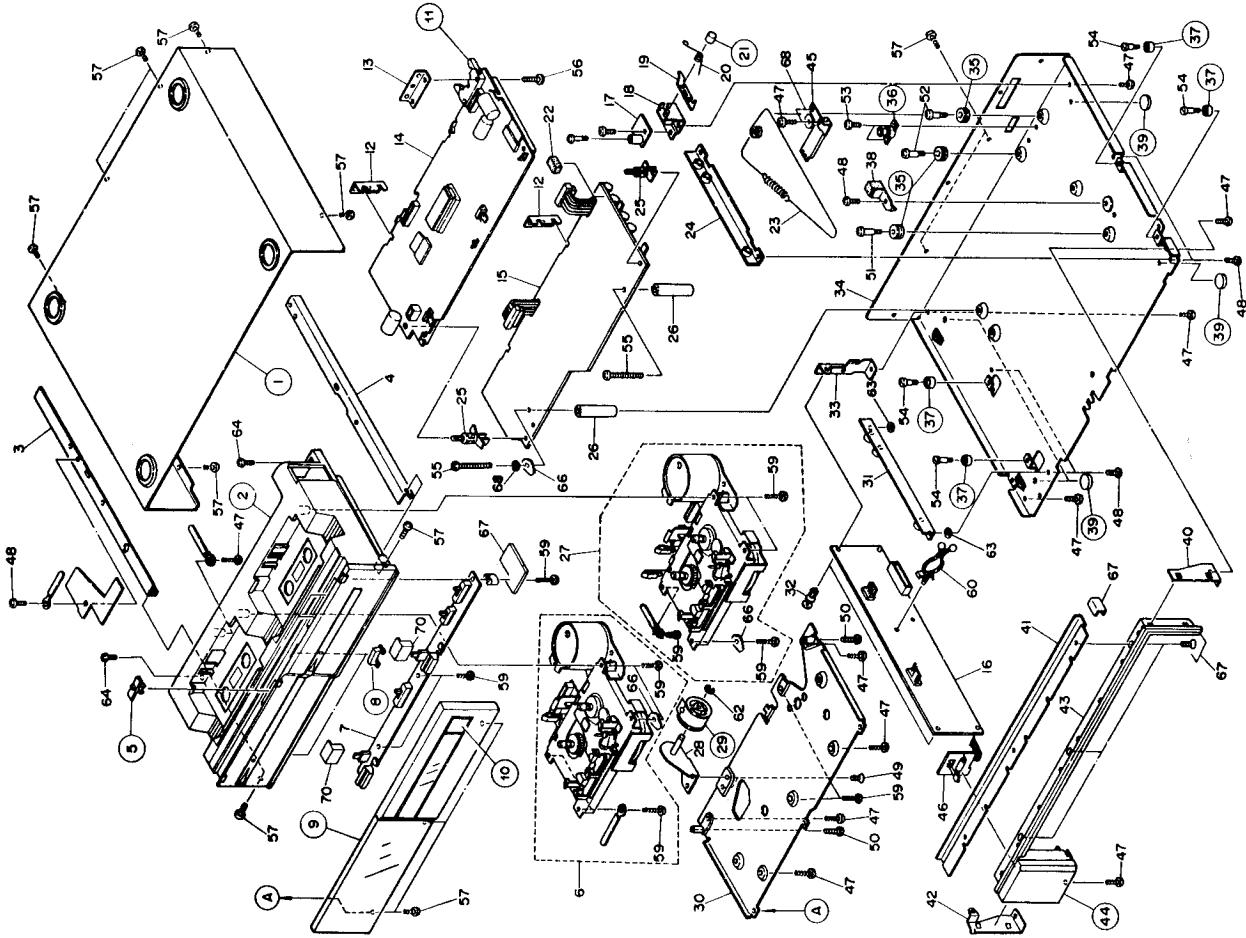

Symbol No.	Parts No.	Description
1	M04A10137	Top Cover
2	M04A10116	Cabinet (Cass Tray)
3		Holder-L (L)
4		Holder-L (R)
5	M04207203	Knob (Dolby/Tape Selection)
6		Mechanism Ass'y (TAPE A)
7		SW P.C. Board
8	M04207204	Push Button (REW)
9	M04A12136	Window
10	M04A10200	Push Button
11	M04207470	One Touch Connector
12		Holder
13		Holder
14		Mecha Control P.C. Board
15		Audio P.C. Board
16		Dolby P.C. Board
17		Pully Ass'y
18		Holder
19		Stopper
20	M04208760	Spring
21	M04208180	Bushing
22		Sponge
23		Dial Cord Ass'y
24		Holder
25		Holder
26		Spacer
27		Mechanism Ass'y (TAPE B)
28	M04208761	Holder
29		Leaf Spring
30		Holder
31		Holder-L
32		Rivet
33		Holder-L
34		Cabinet Back
35	M04208754	Roller
36	M04208750	Damper
37	M04210722	Roller
38		Stopper
39	M04A10190	Foot
40		Holder
41		Holder
42		Holder
43		Pend
44	M04A10138	Window
45		Holder
46		LED P.C. Board
47		Screw 2-3 x 6
48		Screw M3 x 4
49		Screw M3 x 4
50		Screw M2.5 x 12
51		Special Screw M3 x 11
52		Special Screw M3 x 13
53		Screw M2 x 4
54		Special Screw M2.5 x 6
55		Screw M3 x 30
56		Screw M2 x 12
57		Screw 2-3 x 6
58		Screw 3-2 x 6
59		Screw 2-3 x 14
60		Clamper

Symbol No.	Parts No.	Description
61		Screw M2 x 3
62		E-Ring φ4
63		Washer
64		Screw M3 x 6
65		Collar
66		Lug washer
67		Sheet
68		Locking washer
69		P.C.B. Ass'y
70		Holder

EXPLODED VIEW OF MECHANISM

MECHANISM PARTS LIST

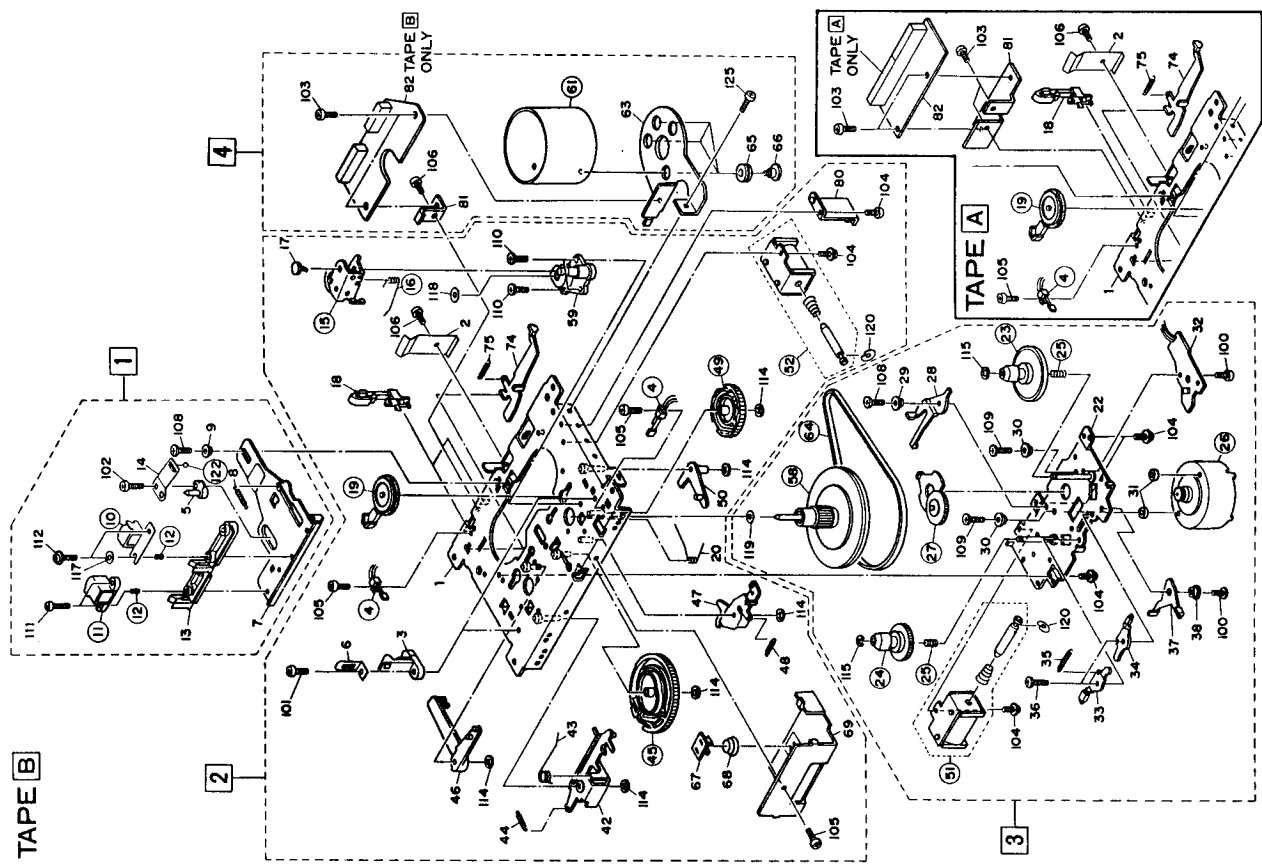



Symbol No.	Part No.	Description
1		Head Panel Ass'y
2		Chassis Ass'y
3		Motor Ass'y
4		Capstan Motor Ass'y
1		Head Panel Ass'y
5		Guide Boss
7		Head Panel Ass'y
8		Panel Spring
9		Coller
10	M04208520	R/P Head
11	M04208524	E Head (TAPE B only)
12	M04210524	Dummy Head (TAPE A only)
13	M04208762	Head Spring
14		Head Base
108		Panel Press Plate
102		Screw M2.6 x 4
111		Camera Screw M2 x 4
112		Screw M2 x 10.5
117		Screw M2 x 10
122		Washer $\phi 2.1 \times 5 \times 0.2$
122	M04208687	Steel Ball $\phi 1.5$
2		Chassis Ass'y
1		Chassis Ass'y
2		Pack Spring
3		Cassette Guide
4	M04208375	Leaf SW (PLAY)
6		Holder Spring
15	M04208720	Pinch Roller Ass'y
16	M04208763	Pinch Roller Spring
17		Stopper
18		Rec SW
19		T Roller Arm Ass'y
20	M04208755	T Roller Arm Spring (R)
42		Lift Arm Ass'y
43		Lift Spring
44		Lift Arm Spring
45		M Gear
46	M04208730	M Trigger Arm
47		Pause Arm Ass'y
48		P Arm Spring
49	M04208731	P Gear
50		P Trigger Arm
52	M04210530	Plunger
59		FL Metal (R)
67		Flywheel Patch Plate
68		Damper Spring
69		FL Bracket
74		E Lever Stopper (A)
75		Spring
80		Bracket (A)
101		Screw M2 x 5
104		Tam's Screw M2 x 5
105		Tapping Screw M2 x 4
106		Tapping Screw M2.6 x 3
110		Camera Screw M2 x 3.5
114		E Ring $\phi 2.0$
118		Nylon Washer $\phi 2.1 \times 7 \times 0.5$
120		Nylon Washer

Symbol No.	Part No.	Description
3		Motor Ass'y
22		Reel Base Ass'y
23		T Reel Ass'y
24	M04208700	S Reel Ass'y
25	M04208764	Back Tension Spring
26	M04208650	Reel Motor Ass'y
27	M04208660	Turn Over Plate Ass'y
28		Center Lever
29		Coller
30		Coller
31		Coller
32		Sensor Base Ass'y
33		Brake Arm (L) Ass'y
34		Brake Arm (R) Ass'y
35		Brake Spring
36		Coller Screw
37		Coller
38		Coller
51	M04208530	Plunger Ass'y
58	M04208756	Flywheel Capstan
64	M04208713	Main Belt
100		Screw M2 x 3
104		Tam's Screw M2 x 4
108		Camera Screw M2 x 4
109		Camera Screw M2.6 x 5
115		E Ring $\phi 2.0$
119		PolySlider Washer $\phi 2.2 \times 3.8 \times 0.5$
120		Nylon Washer
4		Capstan Motor Ass'y
61	M04210550	Main Motor Ass'y
63		M Bracket
65		Motor Rubber
66		Coller Screw
81		P.C.B Angle (TAPE A)
81		P.C.B Angle (TAPE B)
82		Connector Base Ass'y (TAPE A)
82		Connector Base Ass'y (TAPE B)
103		Screw M2.6 x 4
106		Tapping Screw M2.6 x 3

For Service Manuals Contact
MAURITRON TECHNICAL SERVICES
 8 Cherry Tree Rd, Chinnor
 Oxon OX9 4QY
 Tel:- 01844-351694 Fax:- 01844-352554
 Email:- enquiries@mauriron.co.uk

PARTS LIST

NOTE:  and  designates components on the Parts list that have special characteristics to maintain the safety performance of this unit. When replacing any of these parts, be sure to use only specified parts.

Symbol No.	Parts No.	Description
Diodes		
D300	M07060320	1S2473
D301	M07060320	1S2473
D302	M07060320	1S2473
D310	M07060320	1S2473
D400	M07060320	1S2473
D401	M07060320	1S2473
D500	M07060320	1S2473
D501	M07060320	1S2473
D502	M07060320	1S2473
D550	M05241320	1K34A
D551	M07060320	1S2473
D650	M05241320	1K34A
D651	M07060320	1S2473
D700	M07060320	1S2473
D702	M07060320	1S2473
D703	M07060320	1S2473
D704	M07060320	1S2473
D706	M04208320	RD8.2EB2
D801	M04207326	LED SLP275B (DOLBY IND.)
D802	M04207326	LED SLP275B (DOLBY IND.)
D803	M04207368	LED SLF206D (TAPE A/B IND.)
D804	M04207368	LED SLF206D (TAPE A/B IND.)
D851	M04207326	LED SLP275B (SYNC)
D900	M07060320	1S2473
D901	M07060320	1S2473
D902	M07060320	1S2473
D903	M04207322	1SR35-20
D904	M07060320	1S2473
D905	M04207322	1SR35-20
D906	M04207322	1SR35-20
D907	M04207322	1SR35-20
D908	M04207322	1SR35-20
D909	M04207322	1SR35-20
D910	M07060320	1S2473
D911	M04207322	1SR35-20
D912	M07060320	1S2473
D913	M07060320	1S2473
D914	M07060320	1S2473
D915	M07060320	1S2473
D916	M07060320	1S2473
D917	M07060320	1S2473
D918	M07060320	1S2473
D919	M07060320	1S2473
D920	M07060320	1S2473
D921	M07060320	1S2473
Transistors		
Q100	M07387303	2SC1740L(S)
Q101	M07387303	2SC1740L(S)
Q102	M07387303	2SC1740SP(S)
Q103	M07387303	2SC1740SP(S)
Q104	M07387303	2SC1704SP(S)
Q150	M07387303	2SC1704L(S)
Q151	M07387303	2SC1704L(S)
Q152	M07387303	2SC1704SP(S)

Symbol No.	Parts No.	Description
Q153	M07390303	2SC2603
Q154	M04207346	2SC2389(S)
Q155	M04207346	2SC2389(S)
Q156	M04207358	2SA1038(S)
Q200	M07387303	2SC1704L(S)
Q201	M07387303	2SC1740L(S)
Q202	M07387303	2SC1740SP(S)
Q203	M07387303	2SC1740SP(S)
Q204	M07387303	2SC1740SP(S)
Q250	M07387303	2SC1740L(S)
Q251	M07387303	2SC1740L(S)
Q252	M07387303	2SC1740SP(S)
Q253	M07390303	2SC2603
Q254	M04207346	2SC2389(S)
Q255	M04207346	2SC2389(S)
Q300	M05255300	2SK381(E)
Q301	M04207301	2SA933SP(S)
Q302	M07387303	2SC1740SP(S)
Q303	M04207301	2SA933SP(S)
Q304	M04207380	2SC3246(H)
Q310	M07387303	2SC1740SP(S)
Q311	M07387303	2SC1740SP(S)
Q400	M05255300	2SK381(E)
Q403	M04207301	2SA933SP(S)
Q500	M07387303	2SC1740L(S)
Q501	M07387303	2SC1740L(S)
Q502	M04207306	2SC2878(B)
Q503	M04207301	2SA933L(S)
Q504	M07387303	2SC1740L(S)
Q505	M07387303	2SC1740L(S)
Q506	M04207380	2SC3246
Q507	M07387303	2SC1740L(S)
Q508	M07387303	2SC1740L(S)
Q509	M04207369	2SB562C
Q550	M07314303	2SC2001(K)
Q551	M07387303	2SC1740SP(S)
Q600	M07387303	2SC1740L(S)
Q601	M07387303	2SC1740L(S)
Q602	M04207306	2SC2878(B)
Q603	M04207301	2SA933L(S)
Q604	M07387303	2SC1740L(S)
Q605	M07387303	2SC1740L(S)
Q650	M07314303	2SC2001(K)
Q701	M04207301	2SA933SP(S)
Q703	M05255300	2SK381(E)
Q706	M04207301	2SA933SP(S)
Q707	M04207301	2SA933SP(S)
Q708	M07387303	2SC1740SP(S)
Q900	M04207301	2SA933SP(S)
Q902	M07387303	2SC1740SP(S)
Q903	M04207380	2SC3246(H) or (J)
Q904	M07387303	2SC1740SP(S)
Q905	M07387303	2SC1740SP(S)
Q906	M07387303	2SC1740SP(S)
Q907	M07387303	2SC1740SP(S)
Q908	M04207380	2SC3246(H) or (J)
Q909	M07387303	2SC1740SP(S)
Q910	M07387303	2SC1740SP(S)
Q911	M07387303	2SC1740SP(S)
Q912	M07387303	2SC1740SP(S)

Symbol No.	Parts No.	Description
Q913	M07387303	2SC1740SP(S)
Q914	M07387303	2SC1740SP(S)
Q915	M07387303	2SC1740SP(S)
Q917	M04207301	2SA933SP(S)
Q918	M04207301	2SA933SP(S)
Q919	M04207301	2SA933SP(S)
Q920	M07314303	2SC2001(K)
Q921	M04207380	2SC3246(H) or (J)
Q922	M04207380	2SC3246(H) or (J)
Q923	M04207380	2SC3246(H) or (J)
Q924	M04207380	2SC3246(H) or (J)
Q925	M07387303	2SC1740SP(S)
Q926	M04207301	2SA933SP(S)
Q927	M07387303	2SC1740SP(S)
Q928	M04207301	2SA933SP(S)
Q929	M07387303	2SC1740SP(S)
Q930	M07387303	2SC1740SP(S)
Q931	M04207301	2SA933SP(S)
Q932	M04207301	2SA933SP(S)
IC's		
IC300	M04208310	TA7629P
IC400	M04208310	TA7629P
IC550	M05225312	M5218L
IC701	M04208312	μPD4052BC
IC702	M04207316	M4066BP
IC703	M04207342	M51143L
IC900	M04A10310	μPD7538-057
IC901	M04207348	BA6209
IC902	M04207348	BA6209
IC903	M05225312	M5218L
ELECTRICAL PARTS		
CN906	M04207470	ONE TOUCH CONNECTOR (14P)
L151	M04210511	COIL
L201	M04210511	COIL
L251	M04210511	COIL
L300	M04207529	COIL
L400	M04207529	COIL
L500	M04207520	COIL (15mH)
L501	M04207519	COIL (5mH)
L600	M04207520	COIL (15mH)
L601	M04207519	COIL (5mH)
L900	M04208510	COIL (100μH)
L901	M04208510	COIL (100μH)
L902	M04208510	COIL (100μH)
L903	M04208510	COIL (100μH)
LA851	M04207565	LAMP (12V 55mA)
OS501	M04208527	OS BLOCK
S501	M04208360	SW-SLIDE (BEAT CANCEL)
S801	M07207352	SW-PUSH (TAPE A/B REWIND)
S802	M04207361	SW-SLIDE (EQ CONT.)
S803	M07207352	SW-PUSH (TAPE A/B REWIND)
S804	M04208361	SW-SLIDE (DOLBY)

Symbol No.	Parts No.	Description
S805	M04207361	SW-SLIDE (EQ CONT.)
VR100	M04207417	VR-SEMI-50K(B)
VR150	M04207417	VR-SEMI-50K(B)
VR200	M04207417	VR-SEMI-50K(B)
VR250	M04207417	VR-SEMI-50K(B)
VR500	M04207419	VR-SEMI-5K
VR501	M04207420	VR-SEMI-100K(B)
VR502	M04207413	VR-SEMI-3K(B)
VR503	M04207418	VR-SEMI-5K(B)
VR600	M04207419	VR-SEMI-5K
VR601	M04207420	VR-SEMI-100K(B)
VR900	M04208410	VR-SEMI-200(B)
VR901	M04208420	VR-SEMI-1K(B)
VR902	M04208410	VR-SEMI-200(B)
VR903	M04208420	VR-SEMI-1K(B)
X901	M04207517	OSC

For Service Manuals Contact
MAURITRON TECHNICAL SERVICES
 8 Cherry Tree Rd, Chinnor
 Oxon OX9 4QY
 Tel: 01844-351694 Fax: 01844-352554
 Email: enquiries@mauritron.co.uk

RECORD PLAYER SECTION : MODEL LT-47P

DISASSEMBLY PROCEDURE FOR LT-47P

1. Removing the bottom cover

- 1) As shown in Fig. 16, the bottom cover can be removed by removing the five bottom cover screws (21) .

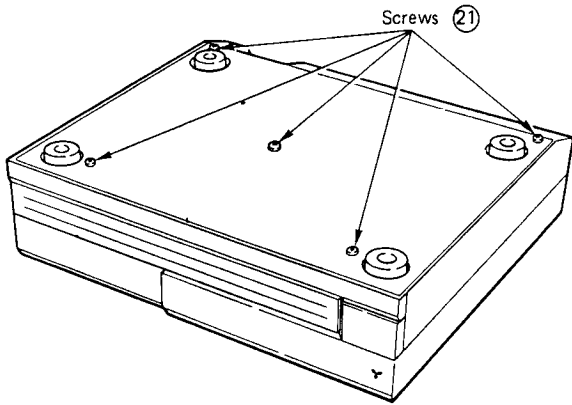

Fig. 16

2. Removing the dust cover

- 1) The dust cover can be removed by removing the four dust cover fixing screws (22) as shown in Fig. 17.

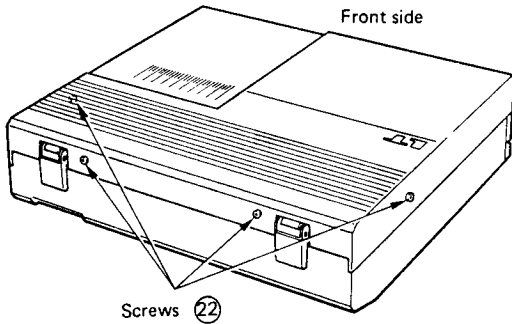

Fig. 17

3. Removing the tonearm chassis

- 1) Following step 2, removing the dust cover.
- 2) As shown in Fig. 18, the tonearm chassis can be removed by first removing the four screws (23) .

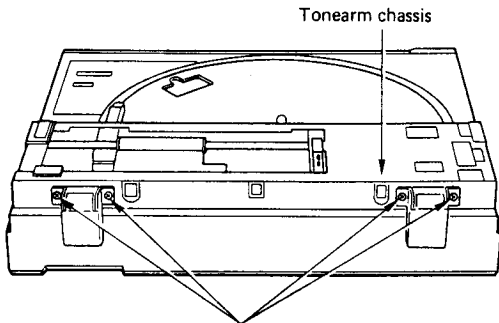

Fig. 18

4. Removing the tonearm base

- 1) Following step 3, remove the tonearm chassis.
- 2) As shown in Fig. 19, remove the two screws (24) , and then remove the cover.
- 3) As shown in Fig. 19, remove the two screws (25) , and then remove the guide shaft.
- 4) Since the tonearm base is attached to the dial cord, remove the E-ring, and then remove the horizontal gear.
- 5) Following the above procedure, the tonearm base can be removed together with the dial cord assembly.

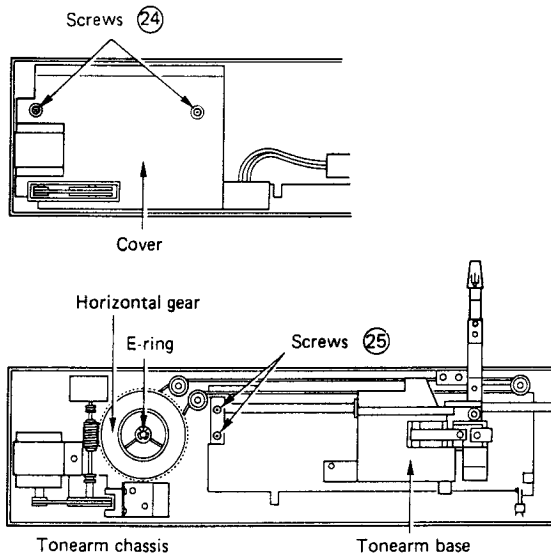

Fig. 19

5. Removing the tonearm

The tonearm can be removed even when the tonearm base is attached to the tonearm chassis.

- 1) As shown in Fig. 20, remove the two screws (26) , and then remove the tonearm from the tonearm base.

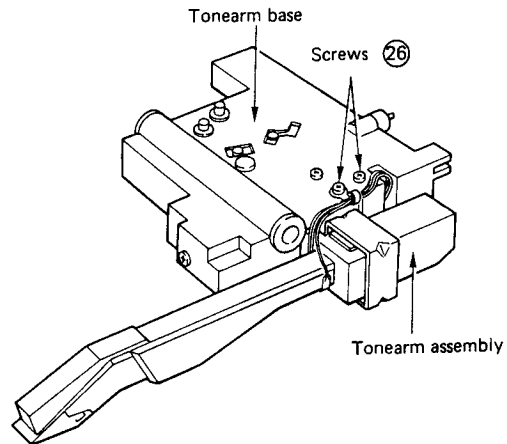

Fig. 20

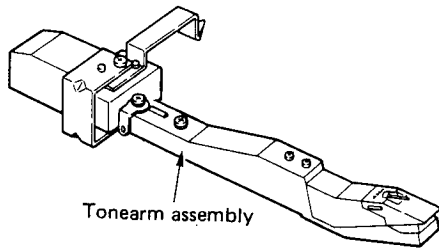

Fig. 21

6. Removing the turntable platter

- 1) Removing the turntable platter sheet, set the turntable platter to the position shown in Fig. 22.
- 2) Remove the drive belt from the motor, and remove the E-ring from the turntable shaft. The turntable platter should now come free.

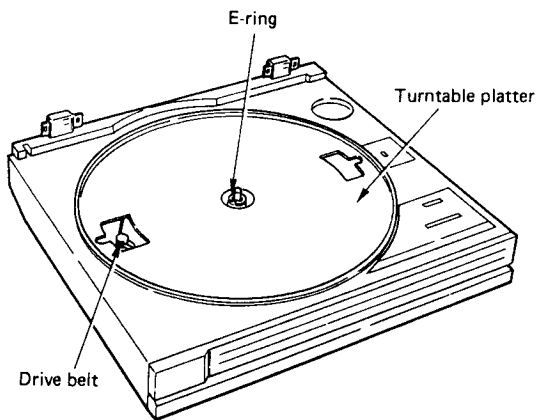

Fig. 22

7. Removing the motor

- 1) As shown in Fig. 23 the motor can be removed by removing the three screws (27)

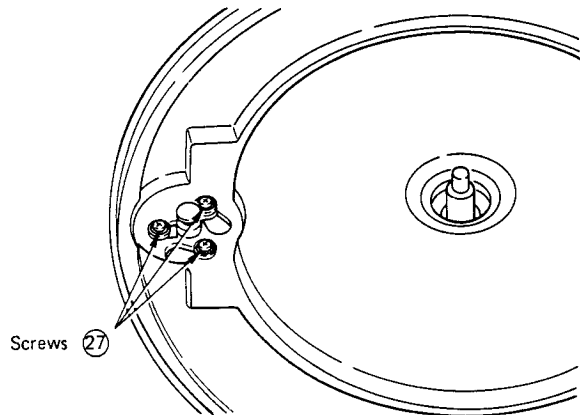

Fig. 23

8. Removing the main circuit board

- 1) Following step 1, remove the bottom cover.
- 2) As shown in Fig. 24, the main circuit board can be removed by removing the four screws (28).

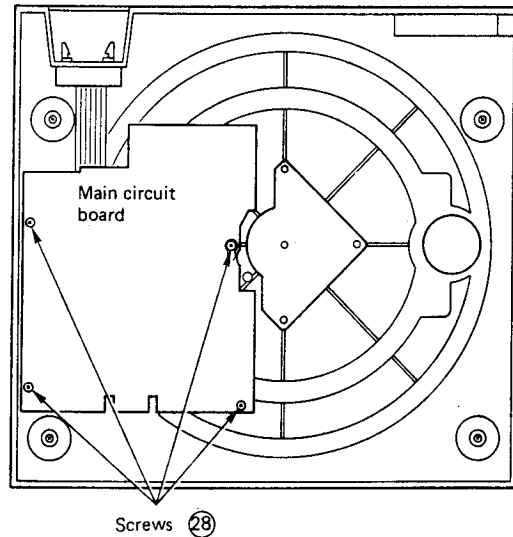

Fig. 24

For Service Manuals Contact
MAURITRON TECHNICAL SERVICES
 8 Cherry Tree Rd, Chinnor
 Oxon OX9 4QY
 Tel:- 01844-351694 Fax:- 01844-352554
 Email:- enquiries@mauritron.co.uk

ADJUSTMENT PROCEDURE FOR LT-47P

- Connect with the receiver DA-R47P by using the signal cable before adjustment.

1. Horizontal motor/arm adjustment

- 1-1 Remove the dust cover by removing the 4 fixing screws and carry out adjustment without the cover.
- 1-2 Set a record on the turntable.
- 1-3 Move the arm over the record by means of the function PHONO > MANUAL key of the commander (speed: 9.5 mm/sec.).
Push the PHONO key again to stop the arm.
- 1-4 By adjusting the stylus height adjusting screw, adjust the distance between the stylus tip and the record surface to 4.0 mm ± 0.5 mm.

2. MRPS/record detection adjustment and tracking adjustment/arm descending position adjustment

- 2-1 Move the arm over the record to the position free of cutting.
- 2-2 With the arm held up, connect the DC voltmeter to TP4 (MRPS·UP) and TP3 (GND) and adjust VR2 so that the output voltage becomes DC2.5V±0.1V.
Note: When adjusting VR2, start from the maximum at the right.
- 2-3 Let down the arm by means of the function keys, MANUAL and PHONO, of the commander and when it starts tracking, adjust the eccentric pin so that the stylus moves up and down smoothly while letting the arm up/down with the MANUAL and PHONO keys.
Tighten the lock screw after adjustment.

- 2-5 Set the test record on the turntable and adjust VR1 so that the arm descending position is within 25 count.
- 2-6 Check to ensure that each lead wire is not pulled.

3. MUTE release sensor sensitivity adjustment

- 3-1 Connect the audio oscillator to PHONO input terminals, apply 1kHz, 35µV (-89dBV) input, connect the DC voltmeter to TP7 (MRPS-DOWN) and TP3 (GND) and adjust VR3 so that the output voltage becomes the GND level.

4. Turntable speed adjustment

- 4-1 Connect the frequency counter to REC OUT of receiver, and play test record at the speed of 33 rpm. speed of 33rpm.
- 4-2 Adjust VR4 so that the frequency becomes 3,000 ± 10 Hz.
- 4-3 Next, adjust VR5 so that the frequency becomes 4,050 ± 10Hz at the speed of 45 rpm.
- 4-4 Again set the speed selector to 33 rpm and check that the frequency is within 3,000 ± 20Hz.

5. Lead-in confirmation

- 5-1 Set the test record on the turntable and by operating the PHONO key, check to ensure that the lead-in takes place within 20 to 40 count.
Also check that the lead-out occurs within 22 to 24 count with the 17 cm record and within 17 to 19 count with the 30 cm record.

ADJUSTMENT LOCATION DIAGRAM

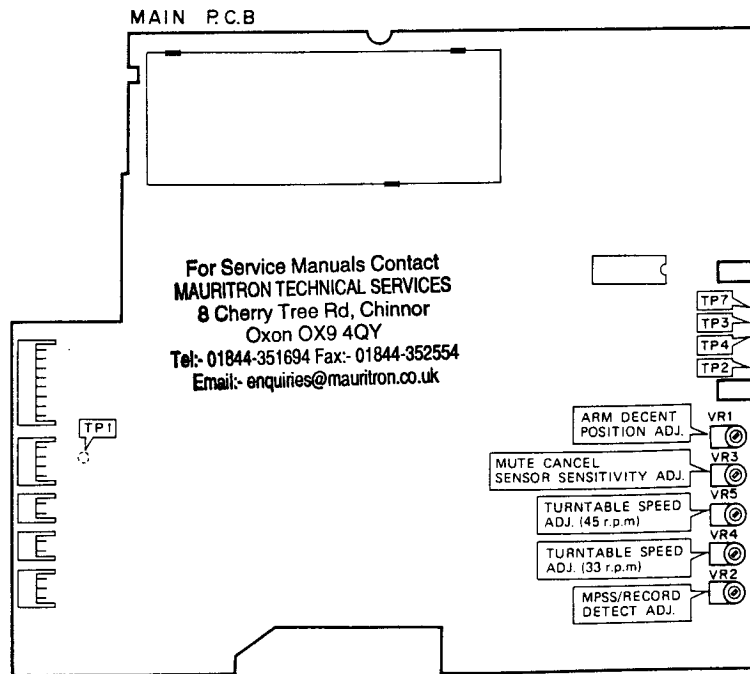

INTERNAL DIAGRAMS AND PINOUT OF INTEGRATED CIRCUIT

IC1: MSM4538B

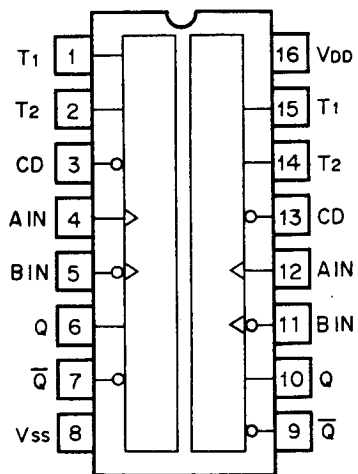

IC2: IR2403

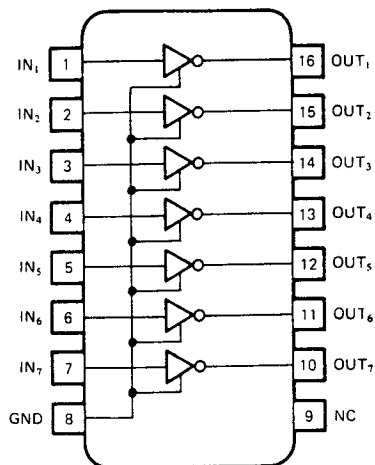

IC3, 6, 7: M5218L

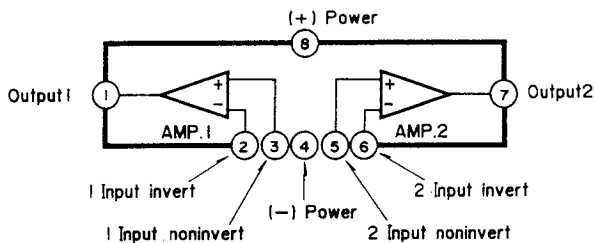
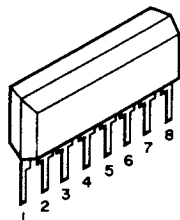

IC4: M51143L

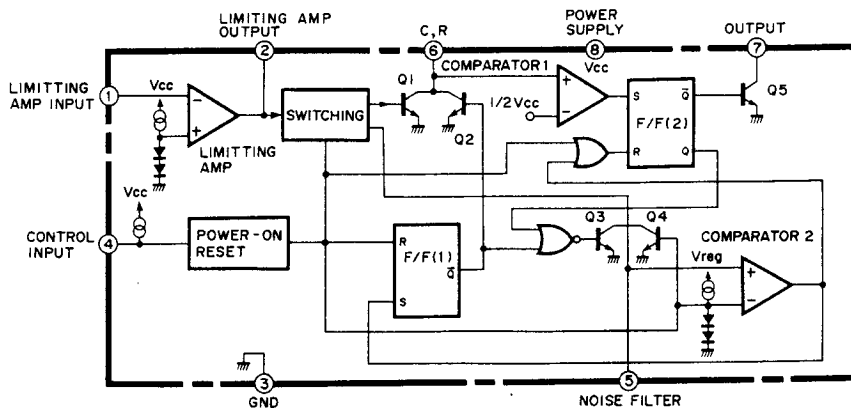
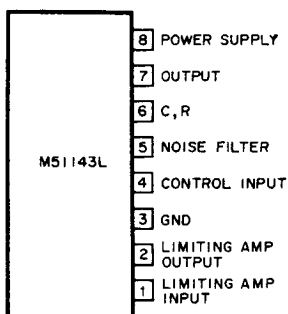

WIRING DIAGRAM

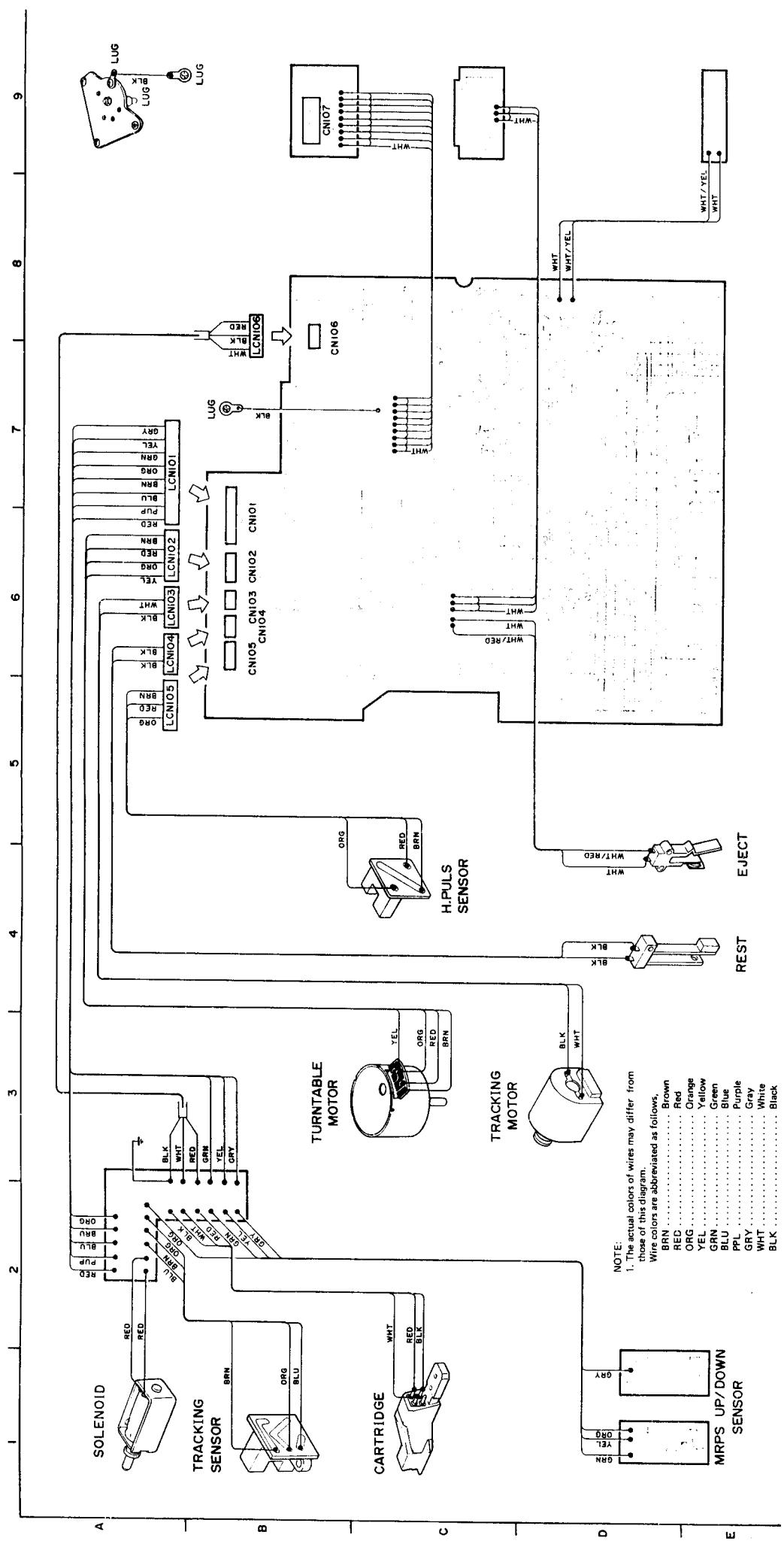

NOTE:
 1. The actual colors of wires may differ from those of this diagram.
 Wire colors are abbreviated as follows.

BRN	Brown
RED	Red
ORG	Orange
YEL	Yellow
GRN	Green
BLU	Blue
PPL	Purple
GRY	Gray
WHT	White
BLK	Black

SCHEMATIC DIAGRAM

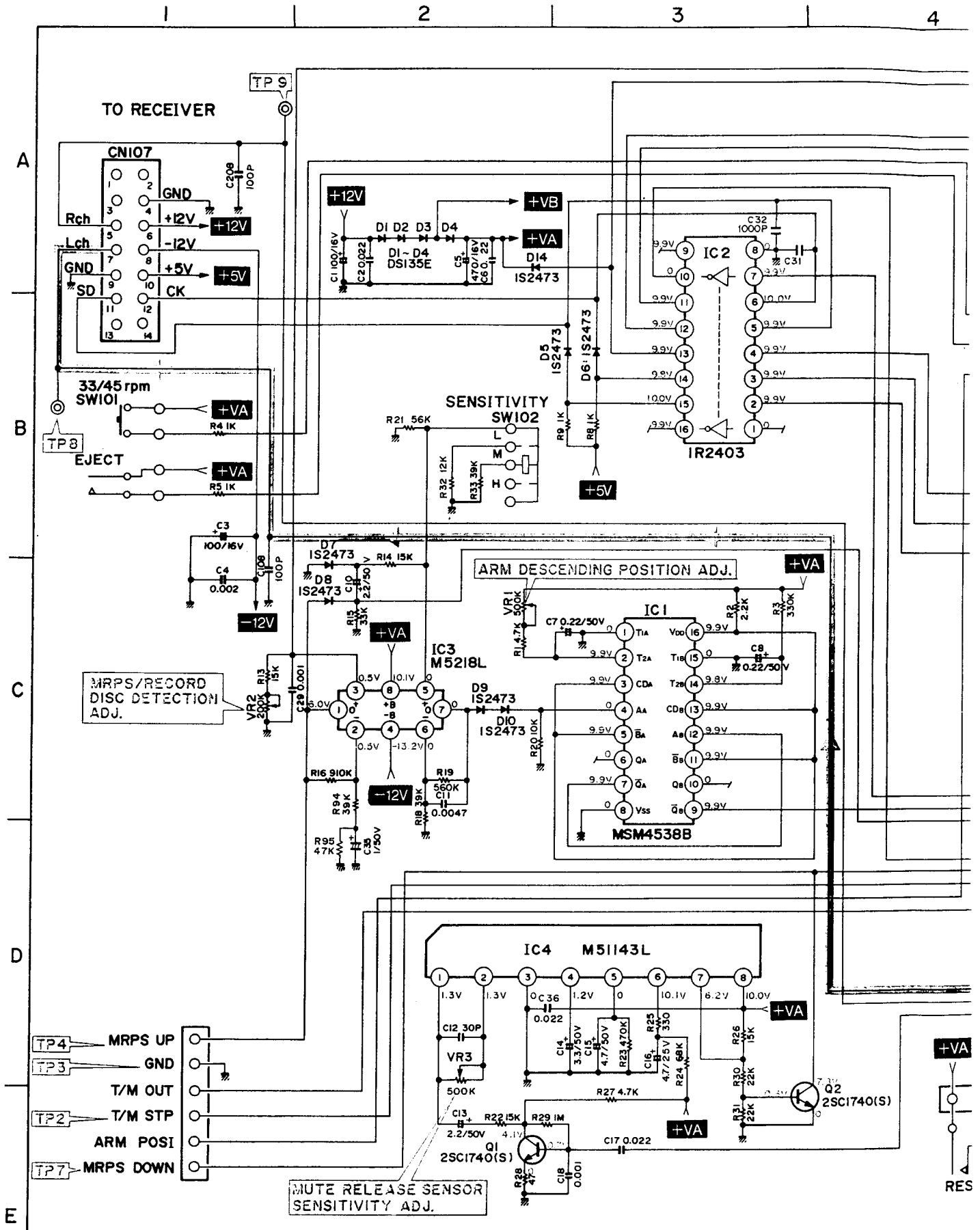

5

6

7

8

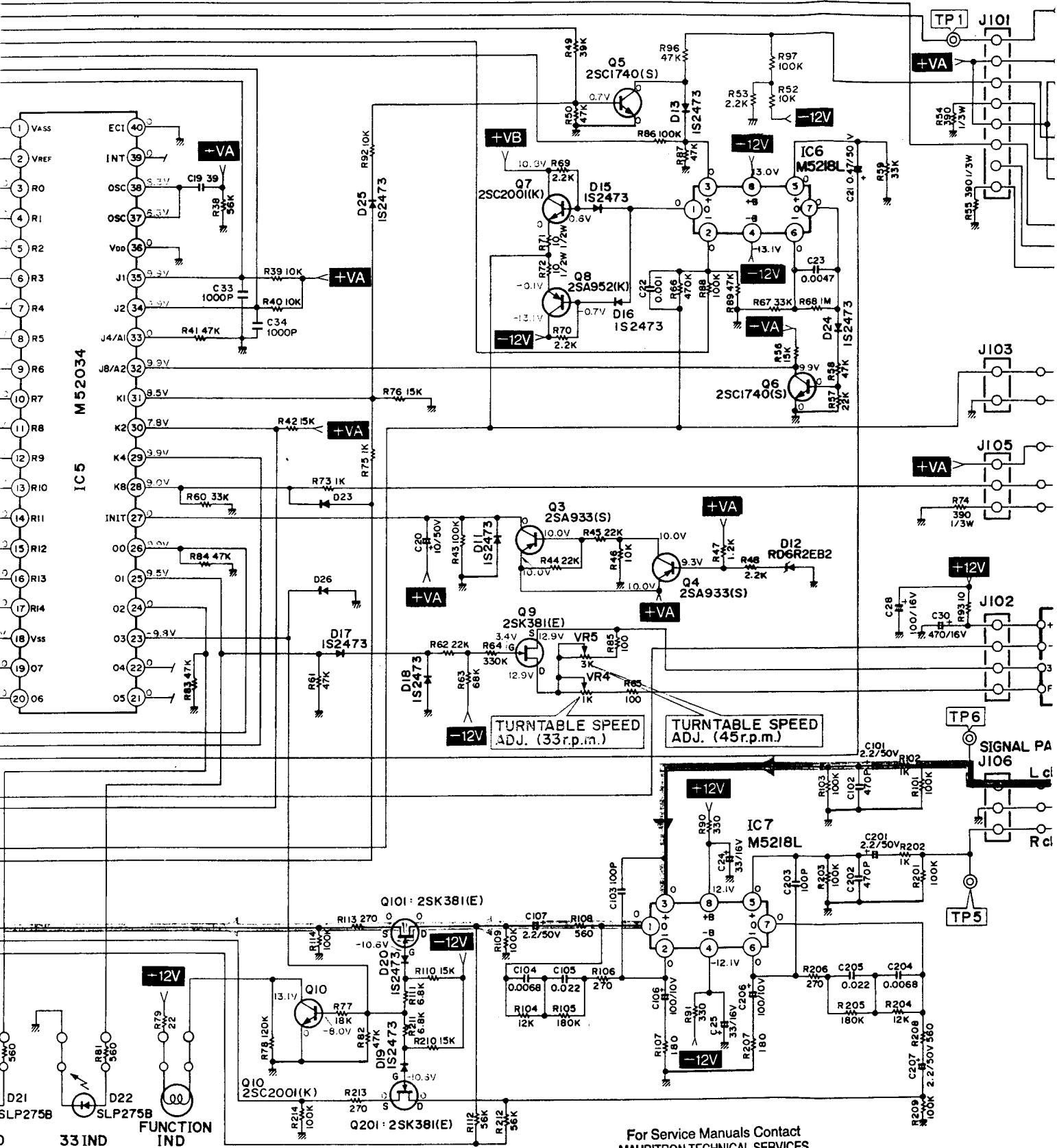

For Service Manuals Contact
MAURITRON TECHNICAL SERVICES
 8 Cherry Tree Rd, Chinnor
 Oxon OX9 4QY
 Tel: 01844-351694 Fax: 01844-352554
 Email: enquiries@mauritron.co.uk

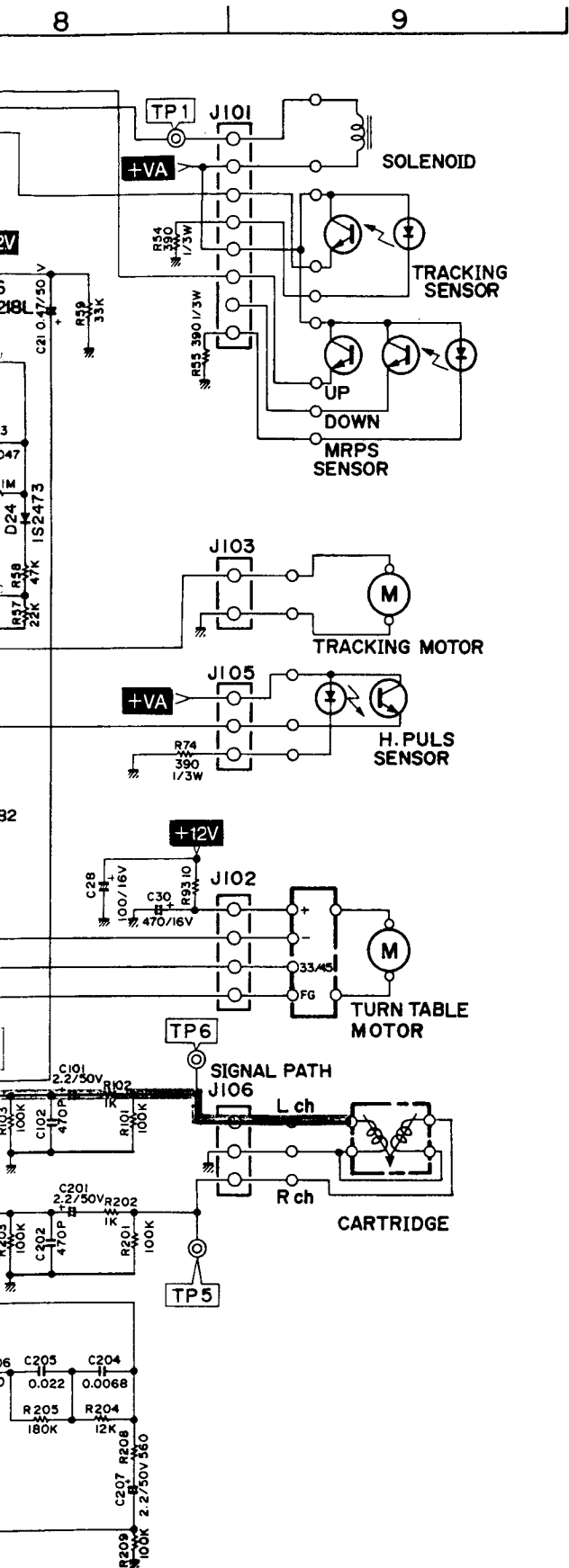

NOTE:

- Unit of C and R
 C No-symbol; μF
 P-symbol; PF
 R No-symbol; Ω
 K-symbol; k Ω
 M-symbol; M Ω
 Wattage for all unspecified resistor are 1/4W.
- Voltage are those measured with DC 1M Ω digital voltmeter.
- This circuit diagram may be changed due to circuit improvement.

TRANSISTORS

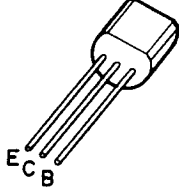
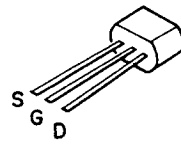
	
2SA993 2SA952 2SC1740 2SC2001	2SK381

For Service Manuals Contact
MAURITRON TECHNICAL SERVICES
 8 Cherry Tree Rd, Chinnor
 Oxon OX9 4QY
 Tel:- 01844-351694 Fax:- 01844-352554
 Email:- enquiries@mauritron.co.uk

For Service Manuals Contact
MAURITRON TECHNICAL SERVICES
 8 Cherry Tree Rd, Chinnor
 Oxon OX9 4QY
 Tel: 01844-351694 Fax: 01844-352554
 Email: enquiries@mauritron.co.uk

LAMP P.C.B.

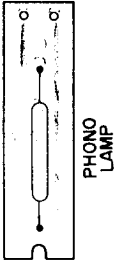

SWITCH P.C.B.

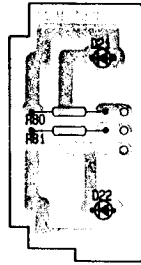

33 SPEED 45

CONNECTOR P.C.B.

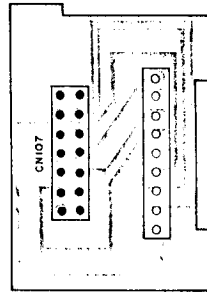

MODEL LT-47P

PRINTED CIRCUIT BOARD

MAIN P.C.B.

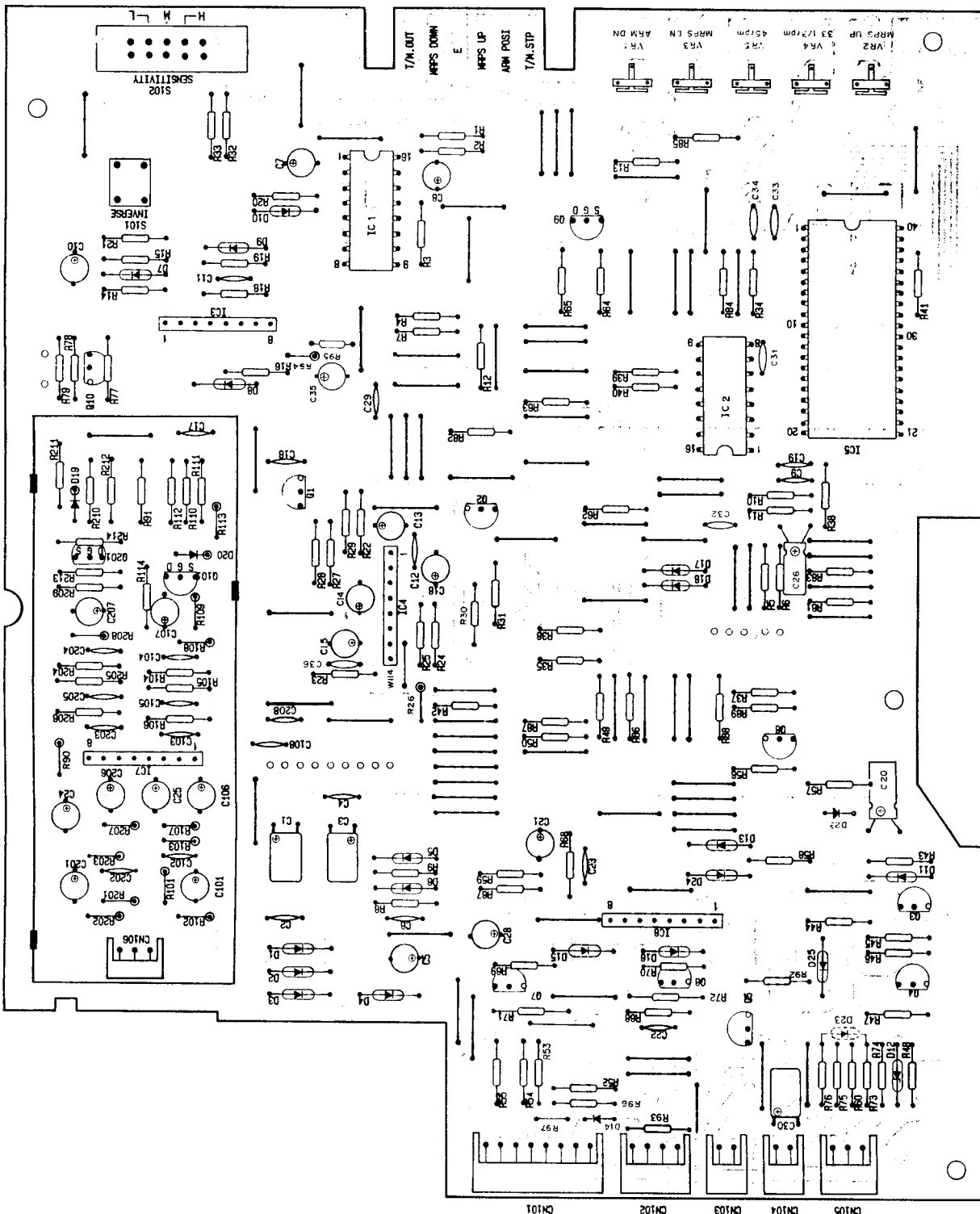

EXPLODED VIEW OF CABINET

CABINET PARTS LIST

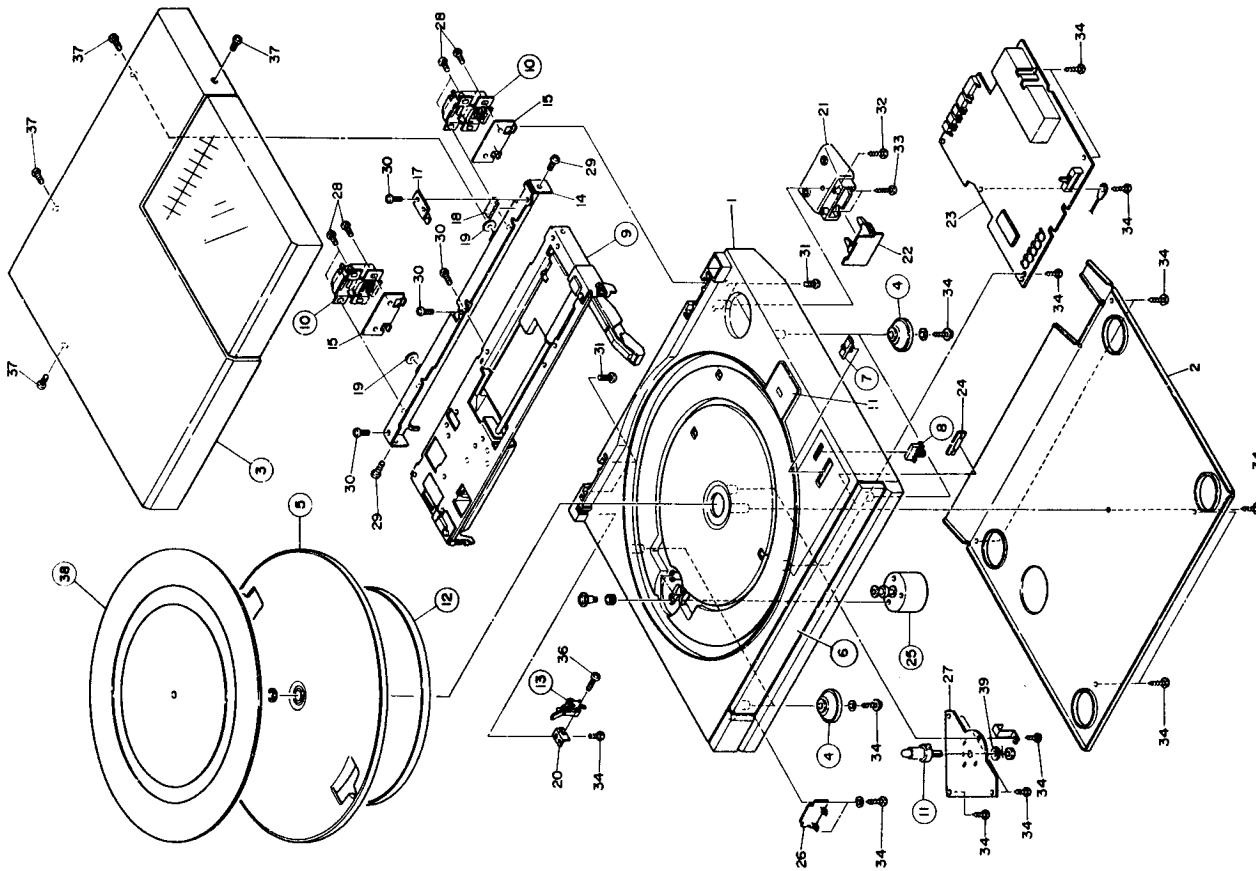

Symbol No.	Parts No.	Description
1		Cabinet Ass'y
2		Cabinet (Back)
3	M04A10130	Dust Cover
4	M04207191	Foot
5	M04207620	Platter
6	M04A12139	Window
7	M04207203	Knob (Sensitivity)
8	M04207204	Knob (Inverse)
9	M04207800	Tonearm Ass'y
10	M04A10140	Hinge Ass'y
11	M04207675	Center Shaft Ass'y
12	M04207713	Belt
13	M04207390	SW Spring (Eject)
14		Holder
15		Holder
16		Holder
17		Holder
18		Sponge
19		Spacer
20		Holder
21		Holder
22		Connector P.C.Board
23		Main P.C.Board
24		Lamp P.C.Board
25	M04A10550	Motor Ass'y
26		LED P.C.Board
27		Holder
28		Screw M3 x 4
29		Screw 2.3 x 6
30		Screw M2.5 x 5
31		Screw M2.6 x 6
32		Screw 1.3 x 20
33		Screw 1.2 x 14
34		Screw 1.3 x 12
35		Screw 1.3 x 14
36		Screw M2 x 8
37		Screw M2.6 x 4
38	M04210622	T-T Sheet
39		Washer

EXPLODED VIEW OF TONEARM SECTION

TONEARM PARTS LIST

For Service Manuals Contact
MAURITRON TECHNICAL SERVICES
 8 Cherry Tree Rd, Chinnor
 Oxon OX9 4QY
 Tel:- 01844-351694 Fax:- 01844-352554
 Email:- enquiries@mauritron.co.uk

Symbol No.	Parts No.	Description
1		Arm Chassis
2		Holder-L
3		Pully (A)
4		Interrupter P.C.Board M
5		Holder-L (B)
6	M04200716	Belt
7	M04200633	Pully (B)
8		Bearing
9	M04200737	Worm Gear
10	M04200553	Motor Ass'y
12		Motor Band
13	M04200678	Guide Shaft
14	M04200738	Horizontal Gear
15		Arm Base
16		Roller Cushion
17		Roller
18		Base Shaft
19		Eccentric Pin
21		Relaying P.C.Board
22		Mold Holder
23		Spring
24		Lever Ass'y
25	M04200650	Mold Bearing
26	M04200679	Unit Cover
27		Interrupter A
28	M04200305	Tonearm Ass'y
30	M04200760	Dial Cord Ass'y
31	M04200630	Solenoid Ass'y
32	M0641C345	Needle (3D-54M)
33		Protector
34	M04207614	Spring
36		Shaft
37	M04200677	Arm Cover
39		Screw 2.2 x 4
41		Screw 3.2 x 6
42		Screw M2.6 x 3
43		Screw M2.6 x 4
44		E-Ring ϕ 1.5
45		Washer
46		Screw M3 x 10
47		Clamp
48		Lug Terminal
49		Reel Switch
50	M04200375	Holder (L)
55		Rubber Cushion
56		Interrupter (B)
57	M04207353	E-Ring ϕ 4
58		E-Ring ϕ 2.5
59		Spring
60		E-Ring ϕ 3
61		Washer
62		E-Ring ϕ 2
63		E-Ring ϕ 2

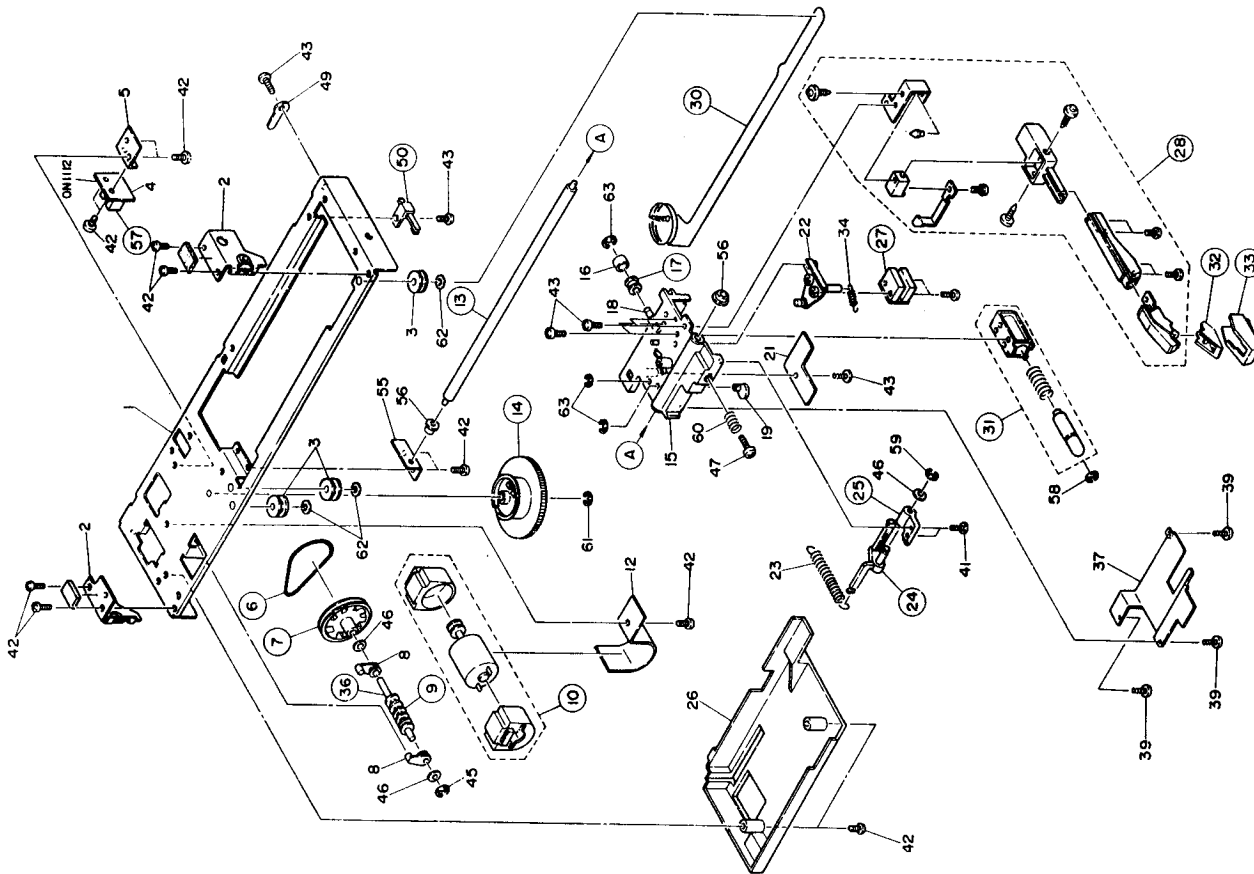

PARTS LIST

NOTE: Δ and ∇ designates components on the Parts list that have special characteristics to maintain the safety performance of this unit. When replacing any of these parts, be sure to use only specified parts.

Symbol No.	Parts No.	Description
Diodes		
D1	M05230322	DS135E
D2	M05230322	DS135E
D3	M05230322	DS135E
D4	M05230322	DS135E
D5	M07060320	1S2473
D6	M07060320	1S2473
D7	M07060320	1S2473
D8	M07060320	1S2473
D9	M07060320	1S2473
D10	M07060320	1S2473
D11	M07060320	1S2473
D12	M04207345	RD6.2E82
D13	M07060320	1S2473
D14	M07060320	1S2473
D15	M07060320	1S2473
D16	M07060320	1S2473
D17	M07060320	1S2473
D18	M07060320	1S2473
D19	M07060320	1S2473
D20	M07060320	1S2473
D21	M04207326	LED SLP275B (45 rpm IND.)
D22	M04207326	LED SLP275B (33 rpm IND.)
D23	M07060320	1S2473
D24	M07060320	1S2473
D25	M07060320	1S2473
D26	M07060320	1S2473
Transistors		
Q1	M07387303	2SC1740SP(S)
Q2	M07387303	2SC1740SP(S)
Q3	M04207301	2SA933SP(S)
Q4	M04207301	2SA933SP(S)
Q5	M07387303	2SC1740SP(S)
Q6	M07387303	2SC1740SP(S)
Q7	M07314303	2SC2001(K)
Q8	M04207309	2SA952(K)
Q9	M05255300	2SK381(E)
Q10	M07314303	2SC2001(K)
Q11	M04200302	DTC124ES
Q12	M04200302	DTC124ES
Q101	M05255300	2SK381(E)
Q201	M05255300	2SK381(E)
IC's		
IC1	M04207343	MSM4538B
IC2	M04207335	IR2403
IC3	M05225312	M5218L
IC4	M04207342	M51143L
IC5	M044A10311	M52036
IC6	M05225312	M5218L
IC7	M05225312	M5218L

PACKING INSTRUCTIONS

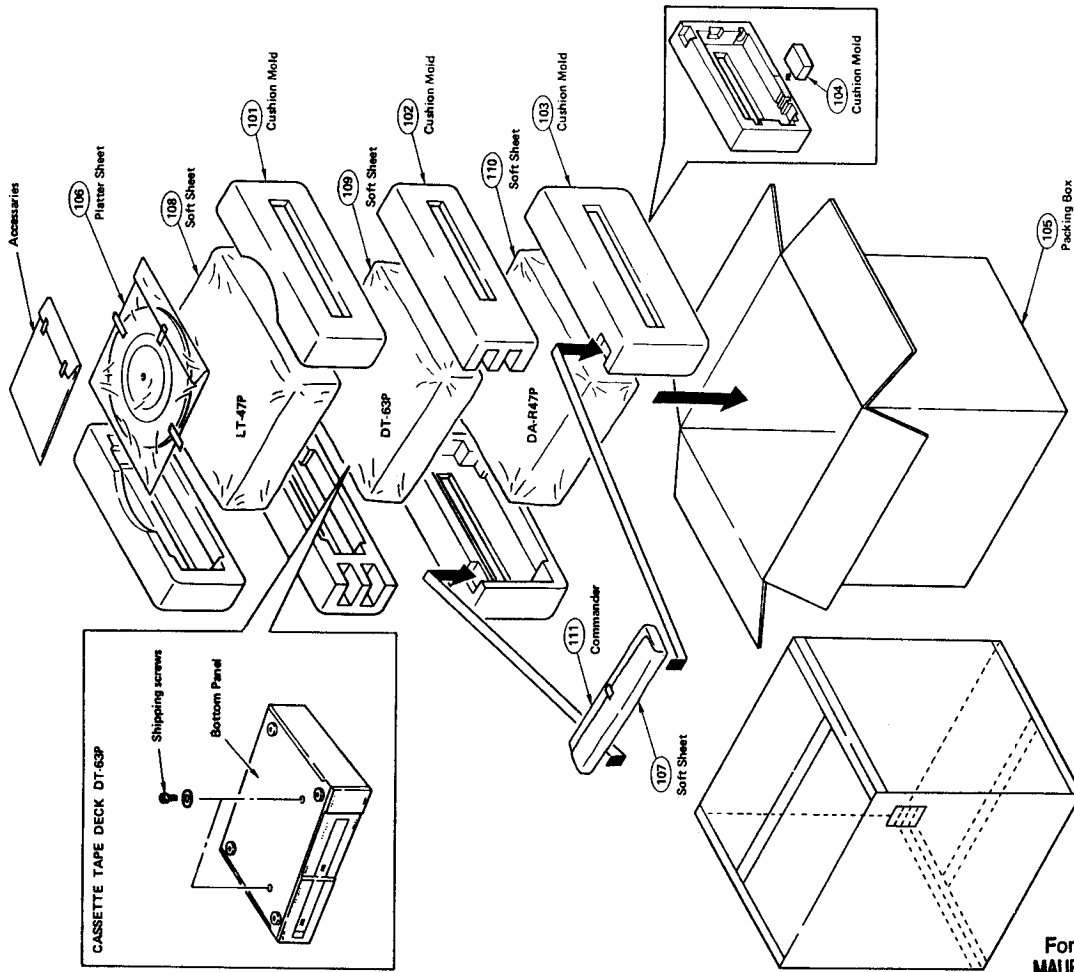

For Service Manuals Contact
MAURITRON TECHNICAL SERVICES
 8 Cherry Tree Rd, Chinnor
 Oxon OX9 4QY
 Tel:- 01844-351694 Fax:- 01844-352554
 Email:- enquiries@mauritron.co.uk

Symbol No.	Parts No.	Description
101	M04207910	Cushion Mold (LT-47P)
102	M04207911	Cushion Mold (DT-63P)
103	M04A10910	Cushion Mold (DA-R47P both side)
104	M04A10911	Cushion Mold (DA-R47P bottom)
105	M04A12900	Packing Box
106	M04210622	Platter Sheet
107	M04A10925	Soft Sheet (Commander)
108	M04207930	Soft Sheet (LT-47P)
109	M04207930	Soft Sheet (DT-63P)
110	M04A10926	Soft Sheet (DA-R47P)
111	M04A12049	Commander
	M04A13940	Instruction Booklet
	M04207655	Holder-ANT.
	M04A01005	45 rpm Adapter
	M04207526	ANT. Coil
	M04A01050	T-feeder ANT.
	M04A01920	Polyethy Bag (Accessories)
	M05230922	Polyethy Bag (AC cord)
	M07705945	Warranty Card
	M04A10470	Connector W/W
	M04A01927	Soft Sheet (Dust Cover)

For Service Manuals Contact
MAURITRON TECHNICAL SERVICES
 8 Cherry Tree Rd, Chinnor
 Oxon OX9 4QY
 Tel:- 01844-351694 Fax:- 01844-352554
 Email:- enquiries@mauritron.co.uk