

SCHEMATIC DIAGRAM

A

B

C

D

1

2

3

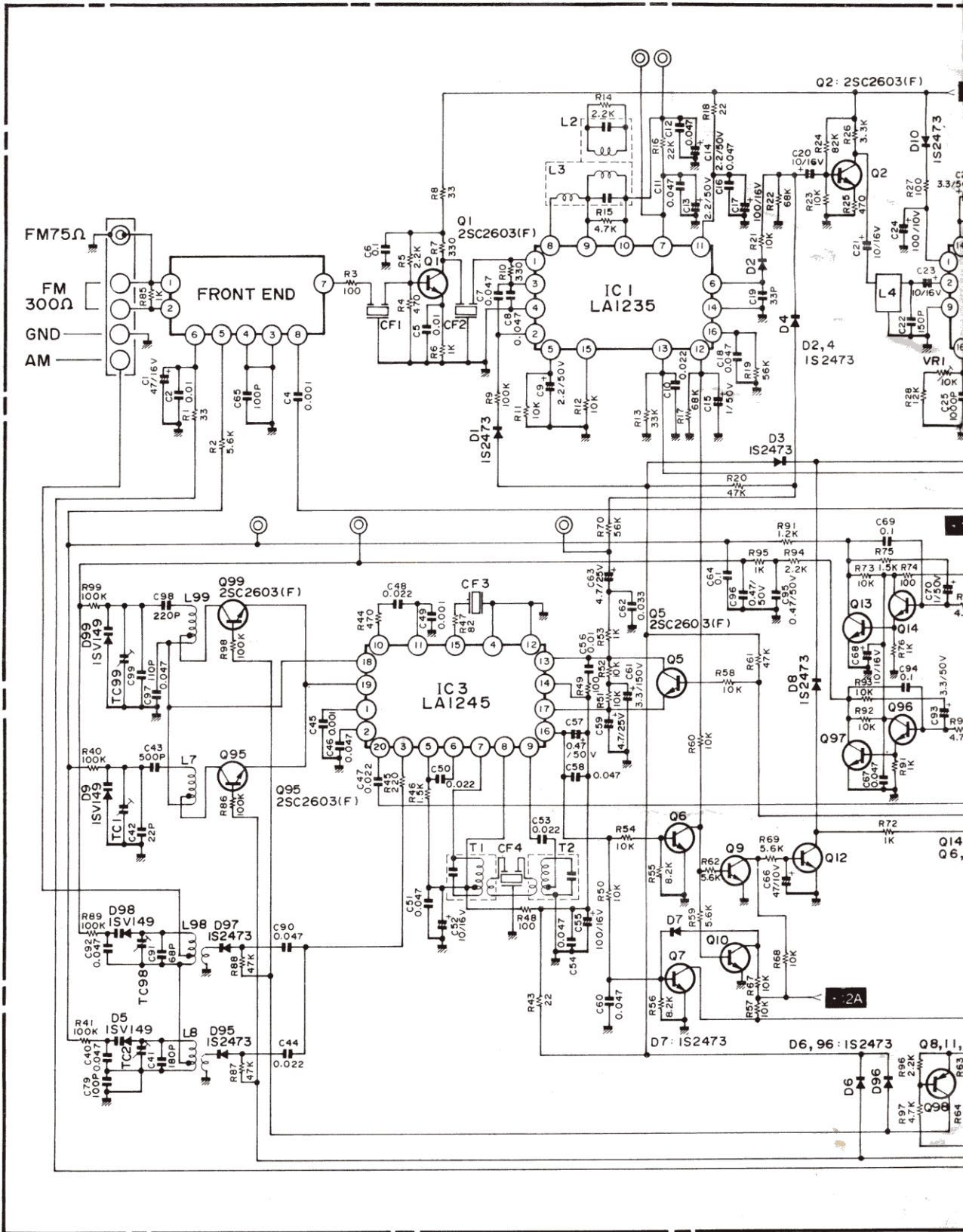

5

6

7

8

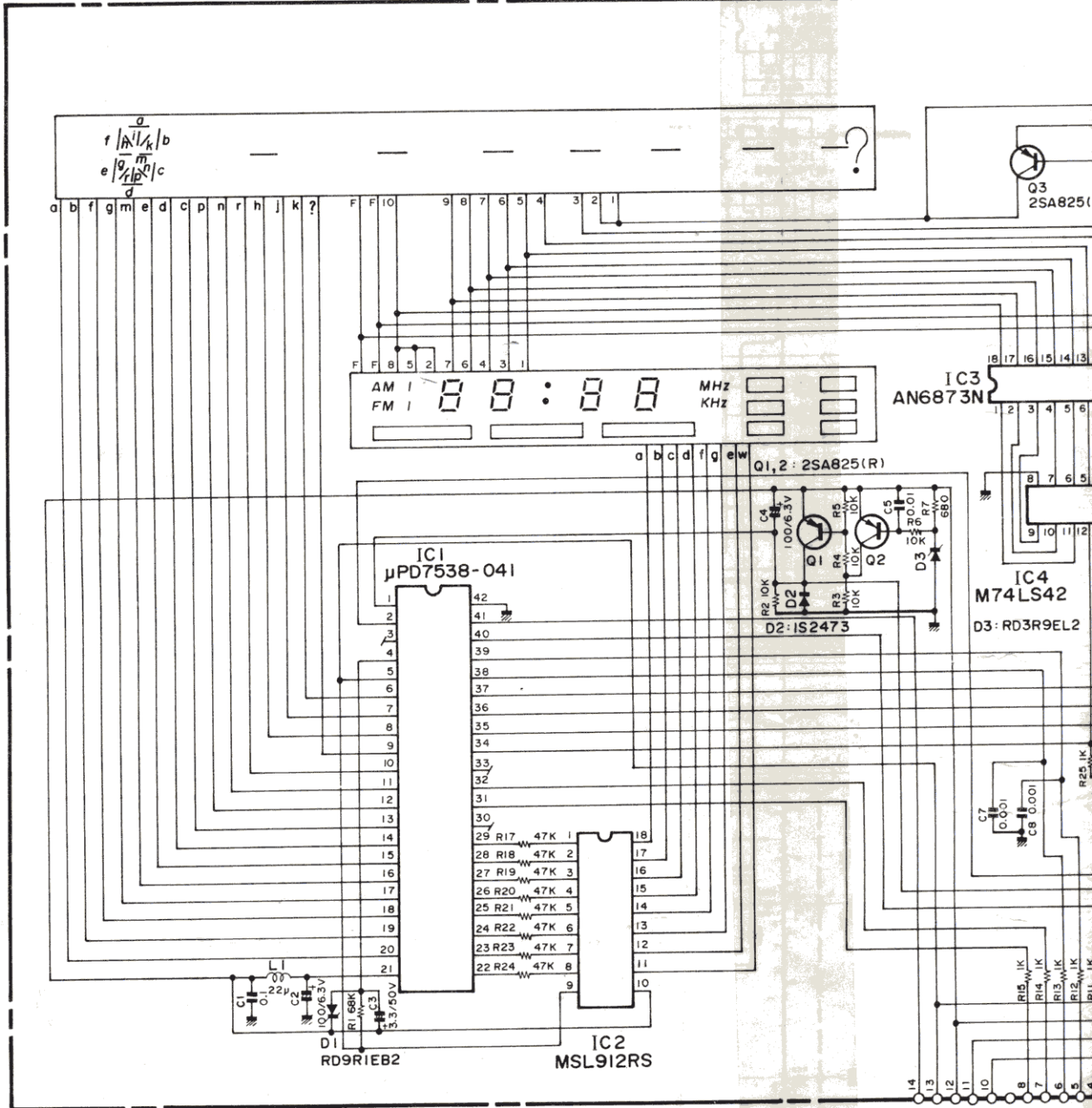
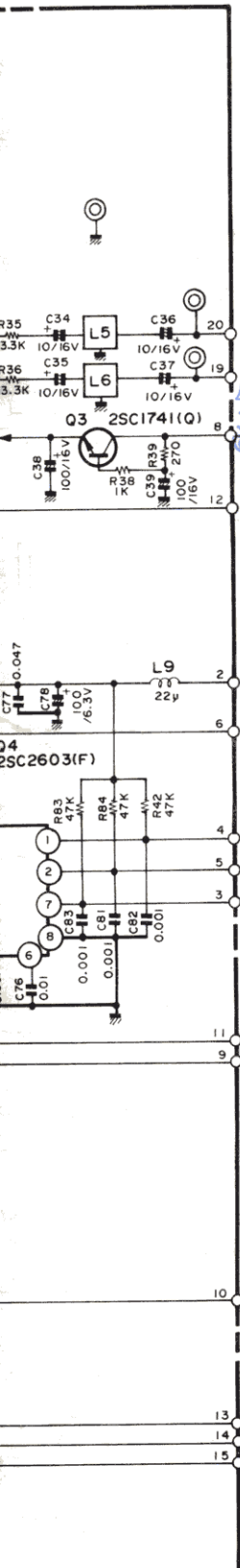

A

B

7

8

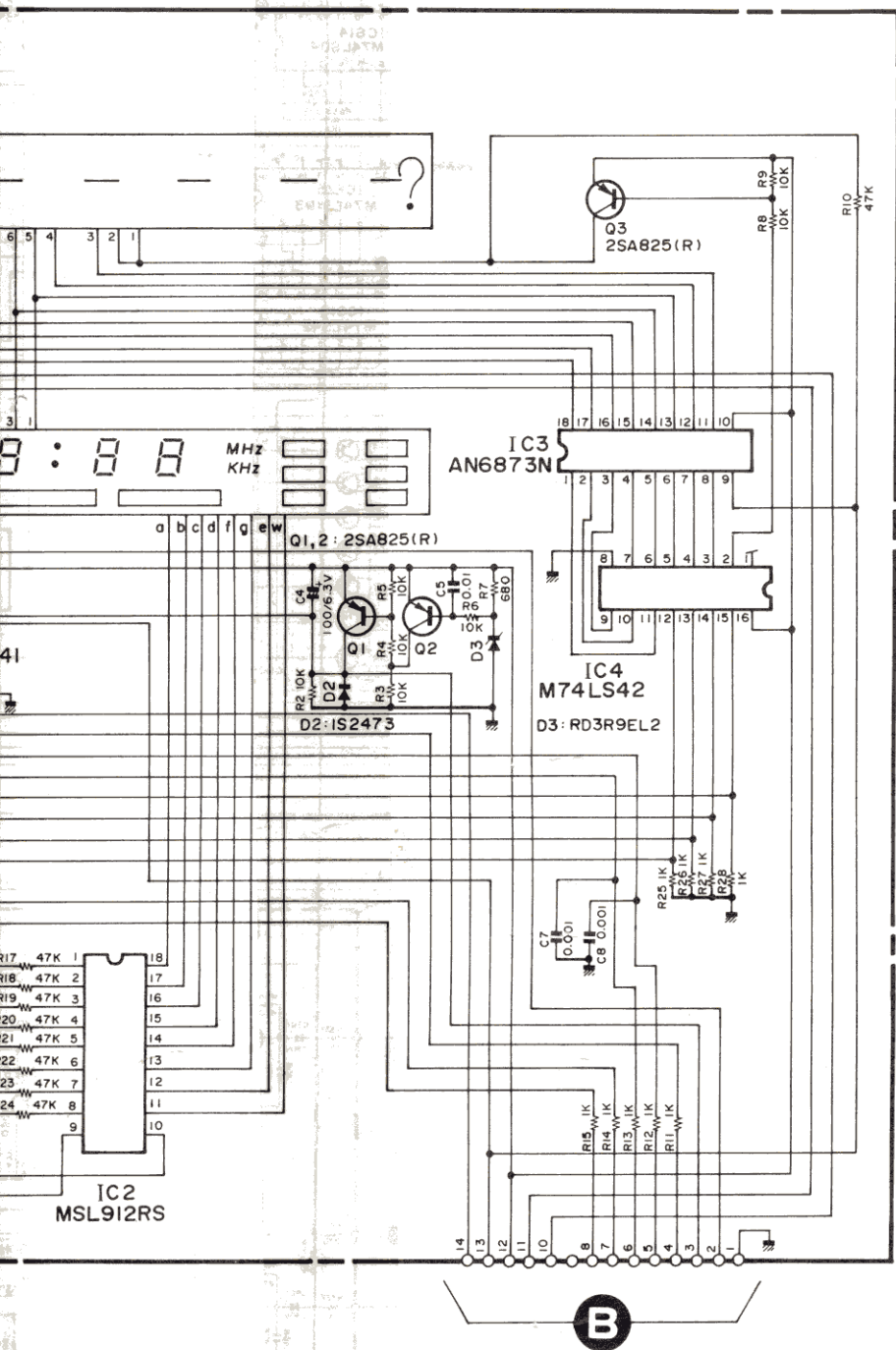

NOTE:

1. Unit of C and R
 C No-symbol; μF
 P-symbol; PF
 R No-symbol; Ω
 K-symbol; k Ω
 M-symbol; M Ω
- Wattage for all unspecified resistor are 1/4W.
2. Voltage are those measured with DC 1M Ω dig voltmeter.
3. This circuit diagram may be changed due to improvement.

TRANSISTOR

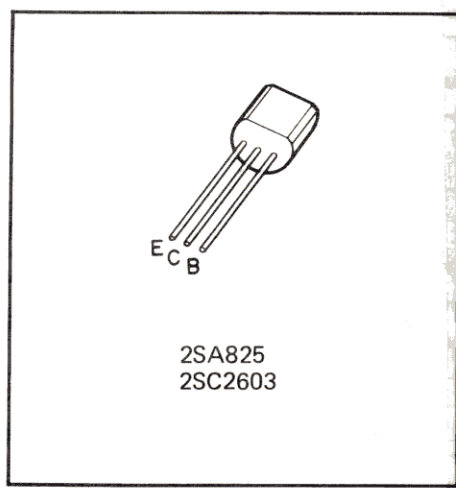

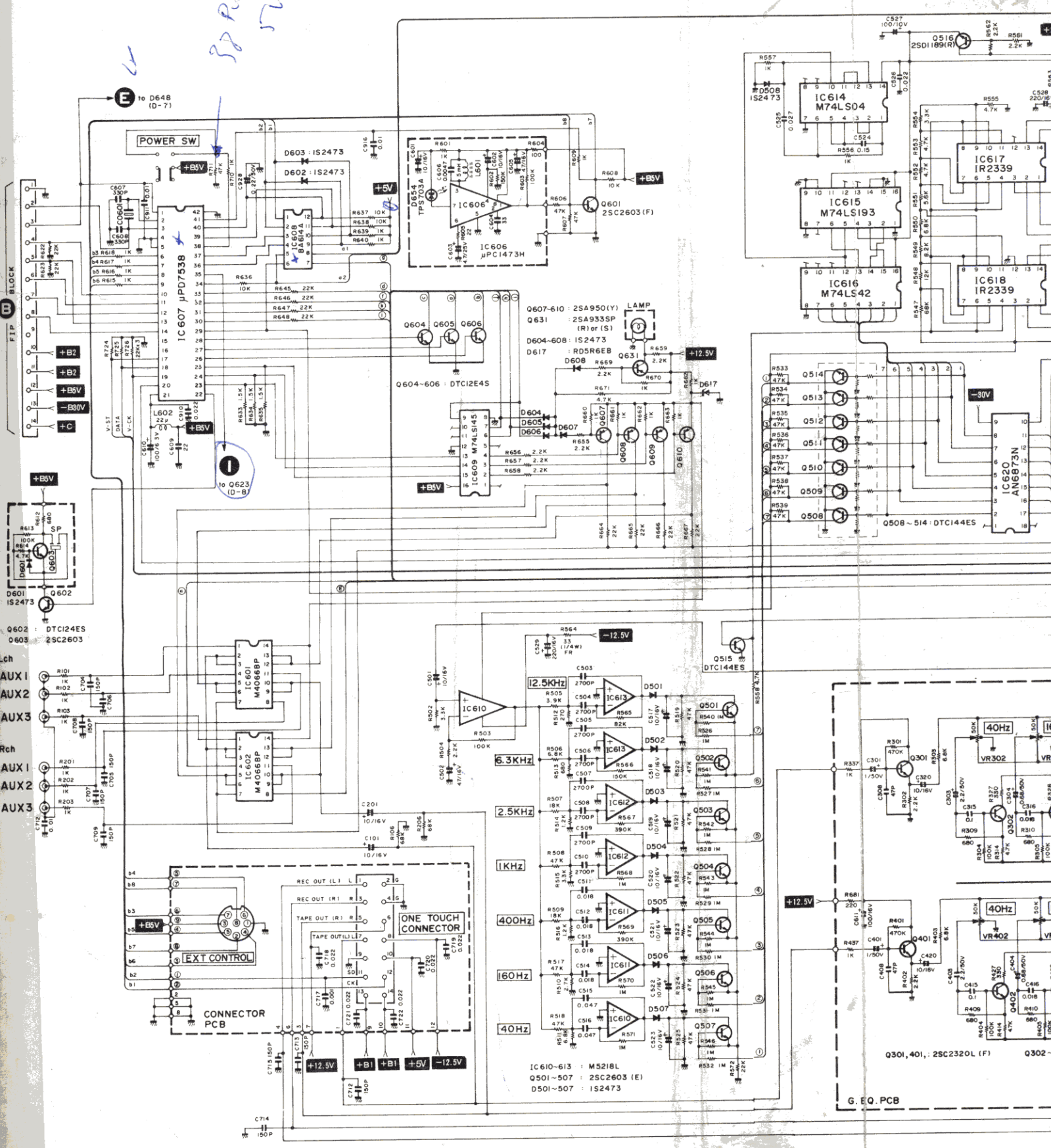

FIP BLOCK

Lch
AUX 1
AUX 2
AUX 3
Rch
AUX 1
AUX 2
AUX 3

CT13 150P
CT14 150P
CT15 150P
CT16 150P
CT17 0.002
CT18 0.002
CT19 0.002
CT20 0.002
CT21 10/18V
CT22 10/18V
CT23 10/18V
CT24 10/18V
CT25 10/18V
CT26 10/18V
CT27 10/18V
CT28 10/18V
CT29 10/18V
CT30 10/18V
CT31 10/18V
CT32 10/18V
CT33 10/18V
CT34 10/18V
CT35 10/18V
CT36 10/18V
CT37 10/18V
CT38 10/18V
CT39 10/18V
CT40 10/18V
CT41 10/18V
CT42 10/18V
CT43 10/18V
CT44 10/18V
CT45 10/18V
CT46 10/18V
CT47 10/18V
CT48 10/18V
CT49 10/18V
CT50 10/18V
CT51 10/18V
CT52 10/18V
CT53 10/18V
CT54 10/18V
CT55 10/18V
CT56 10/18V
CT57 10/18V
CT58 10/18V
CT59 10/18V
CT60 10/18V
CT61 10/18V
CT62 10/18V
CT63 10/18V
CT64 10/18V
CT65 10/18V
CT66 10/18V
CT67 10/18V
CT68 10/18V
CT69 10/18V
CT70 10/18V
CT71 10/18V
CT72 10/18V
CT73 10/18V
CT74 10/18V
CT75 10/18V
CT76 10/18V
CT77 10/18V
CT78 10/18V
CT79 10/18V
CT80 10/18V
CT81 10/18V
CT82 10/18V
CT83 10/18V
CT84 10/18V
CT85 10/18V
CT86 10/18V
CT87 10/18V
CT88 10/18V
CT89 10/18V
CT90 10/18V
CT91 10/18V
CT92 10/18V
CT93 10/18V
CT94 10/18V
CT95 10/18V
CT96 10/18V
CT97 10/18V
CT98 10/18V
CT99 10/18V
CT100 10/18V

IC 610-613 : M5218L
 Q501-507 : 2SC2603 (E)
 D501-507 : 1S2473

Q301, 401 : 2SC2320L (F) Q302-303 : 2SC2320L (F)

G. E. Q. PCB

4

5

6

7

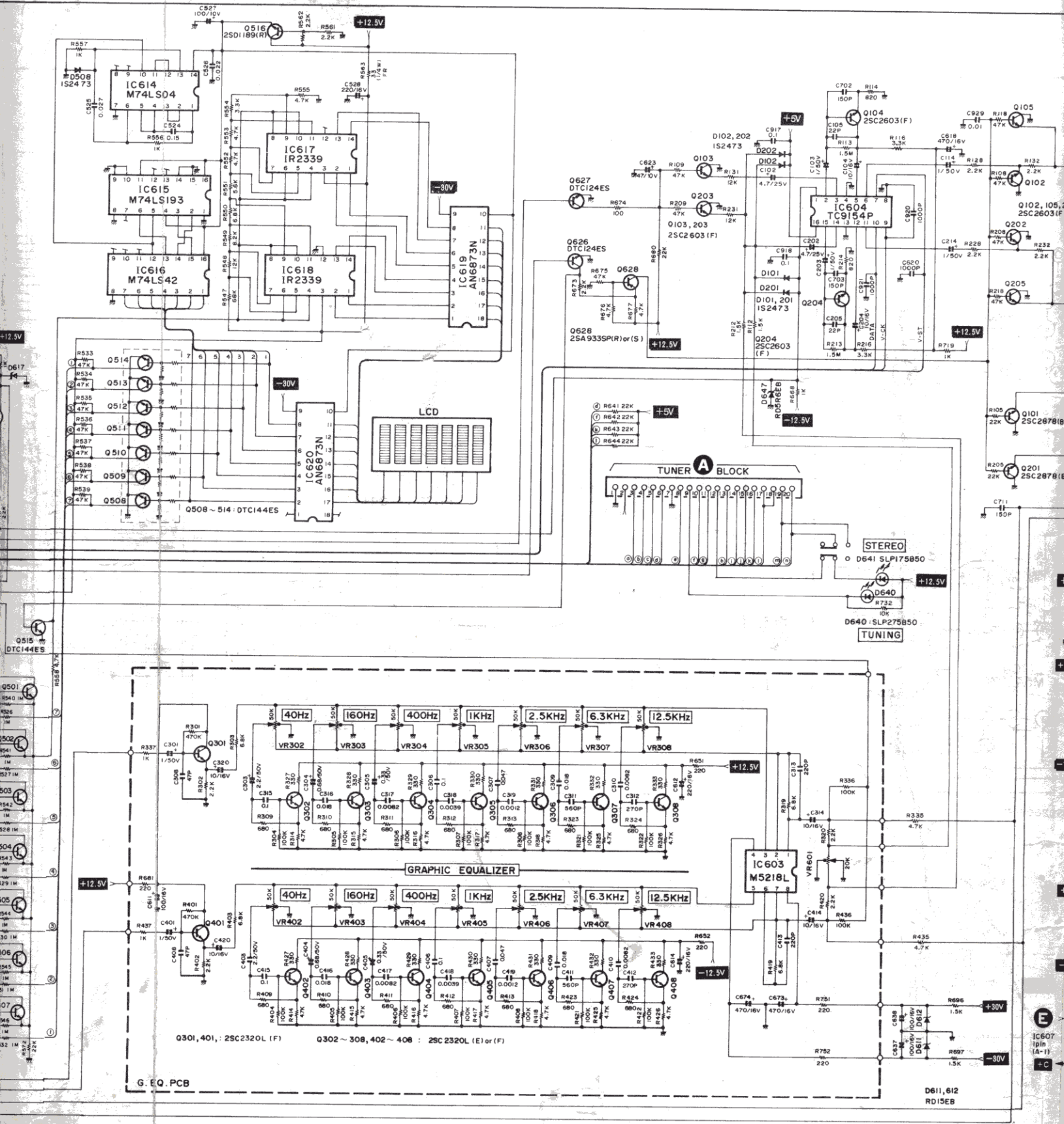

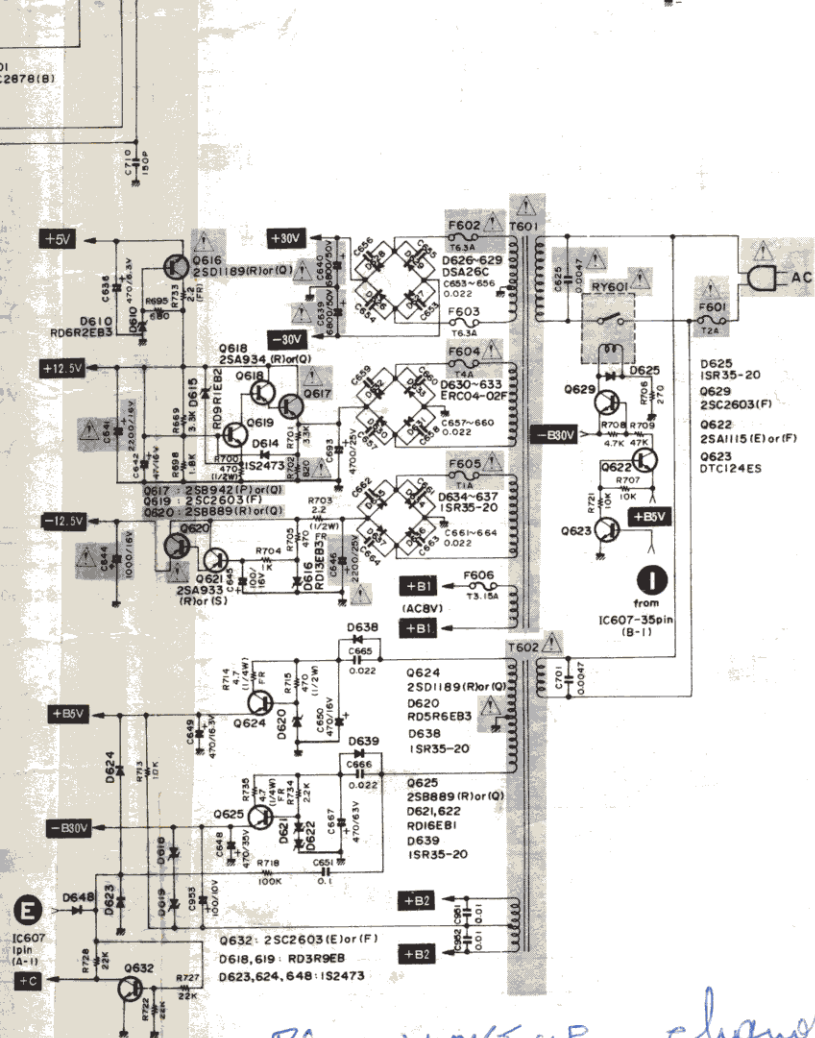
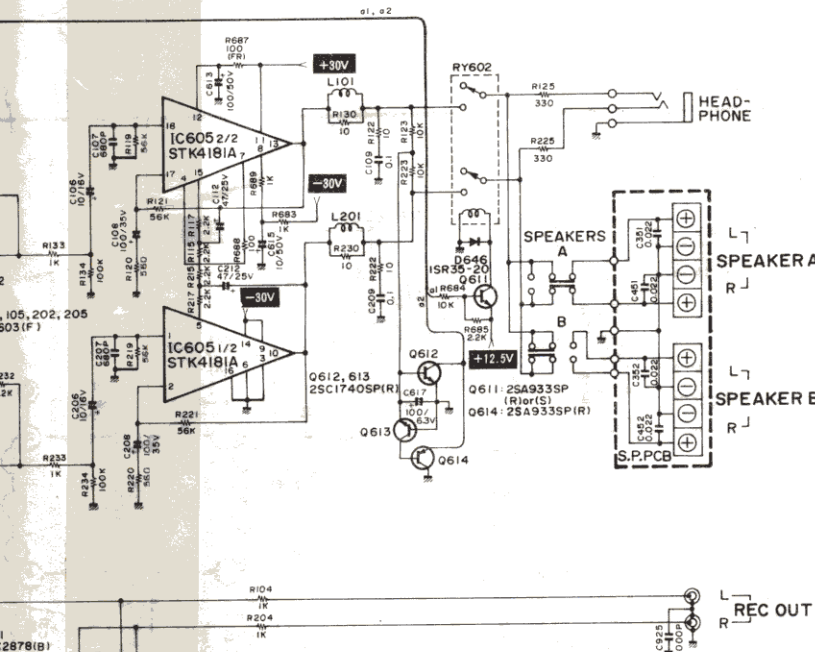

PS: WAKE UP *chiquete*
 et display affiche AM + PM
 apparul en vente

NOTE:

- Unit of C and R
 C No-symbol; μF
 P-symbol; PF
 R No-symbol; Ω
 K-symbol; $k\Omega$
 M-symbol; $M\Omega$
 Wattage for all unspecified resistor are 1/4W.
- Voltage are those measured with DC 1M Ω digital voltmeter.
- ∇ and Δ indicates components which are critical for continued safety and performance of this unit. Replace only with components of the same type as specified.
- This circuit diagram may be changed due to circuit improvement.

TRANSISTORS

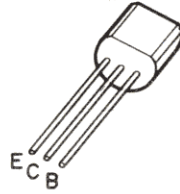
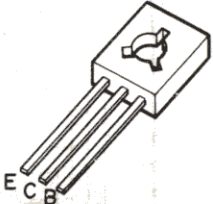
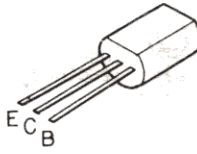
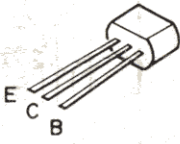
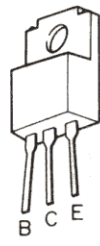
 2SA933 2SA950 2SC1740 2SC2320	 2SC2603 2SC2878 DTC124ES DTC144ES	2SB889 2SD1189
 2SA934	 2SA1115	
 2SB942		

4

5

6

7

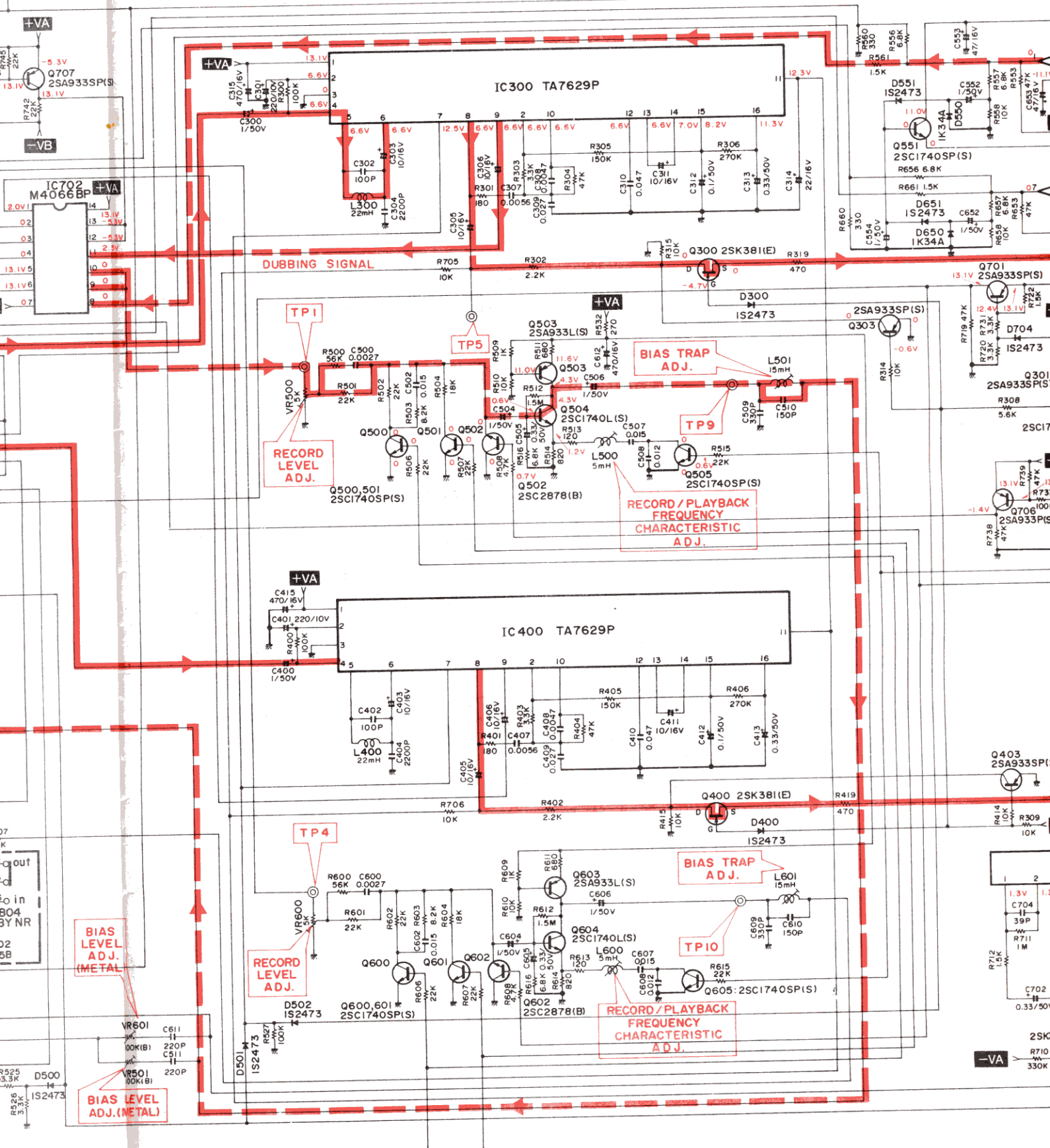

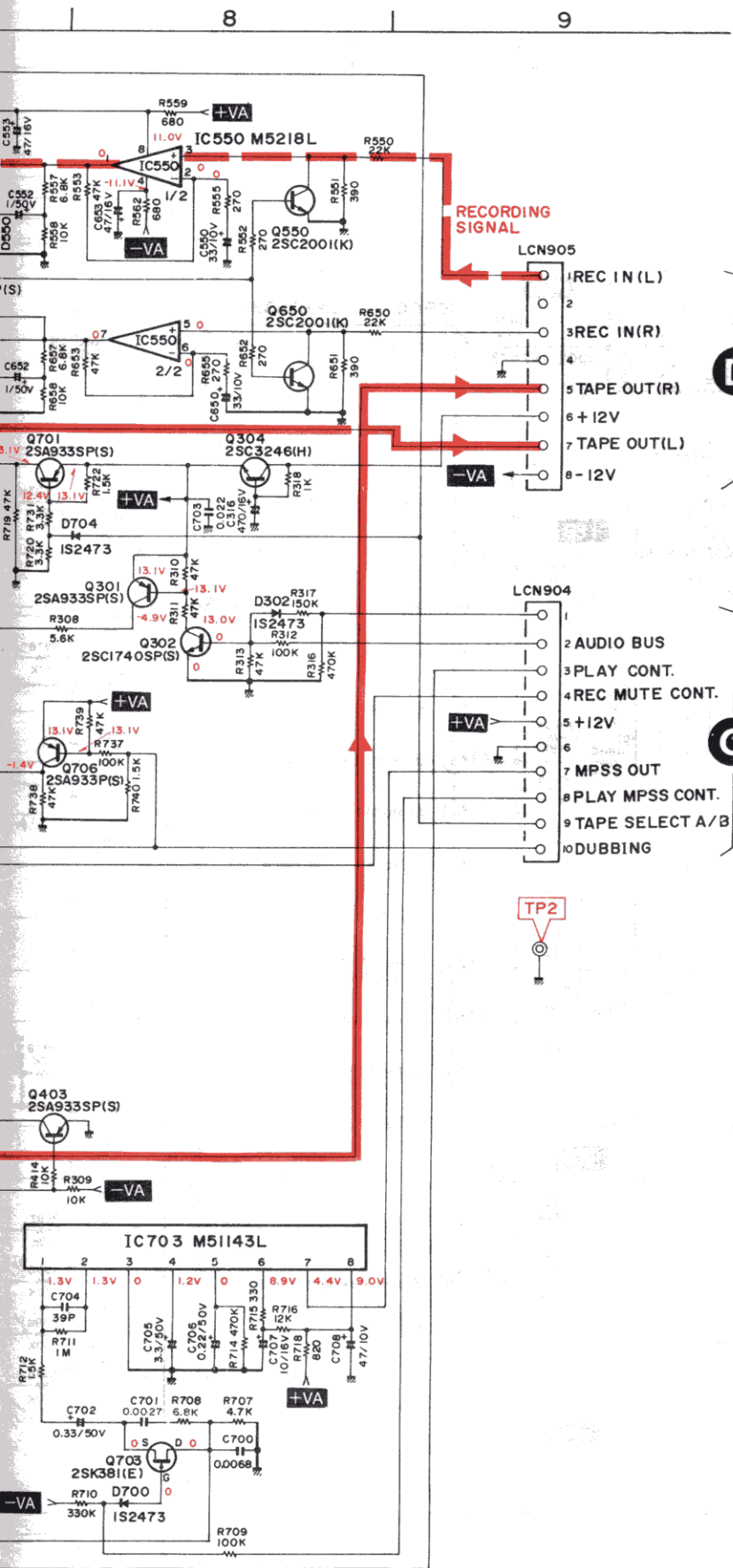

NOTE:

1. Unit of C and R

- C No-symbol; μ F
- P-symbol; PF
- R No-symbol; Ω
- K-symbol; k Ω
- M-symbol; M Ω

Wattage for all unspecified resistor are 1/4W.

2. Voltage are those measured with DC 1M Ω digital voltmeter.

3. This circuit diagram may be changed due to circuit improvement.

TRANSISTORS

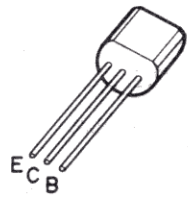
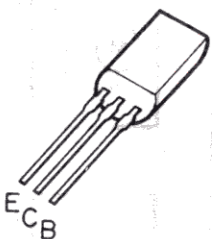
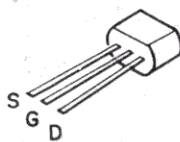
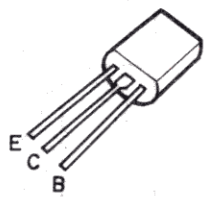
 <p>2SA933L 2SA933SP 2SC1740L 2SC1740SP 2SC2001 2SC2603 2SC2389 2SC2878</p>	 <p>2SB562</p>
 <p>2SK381</p>	 <p>2SC3246</p>

4

5

6

7

8

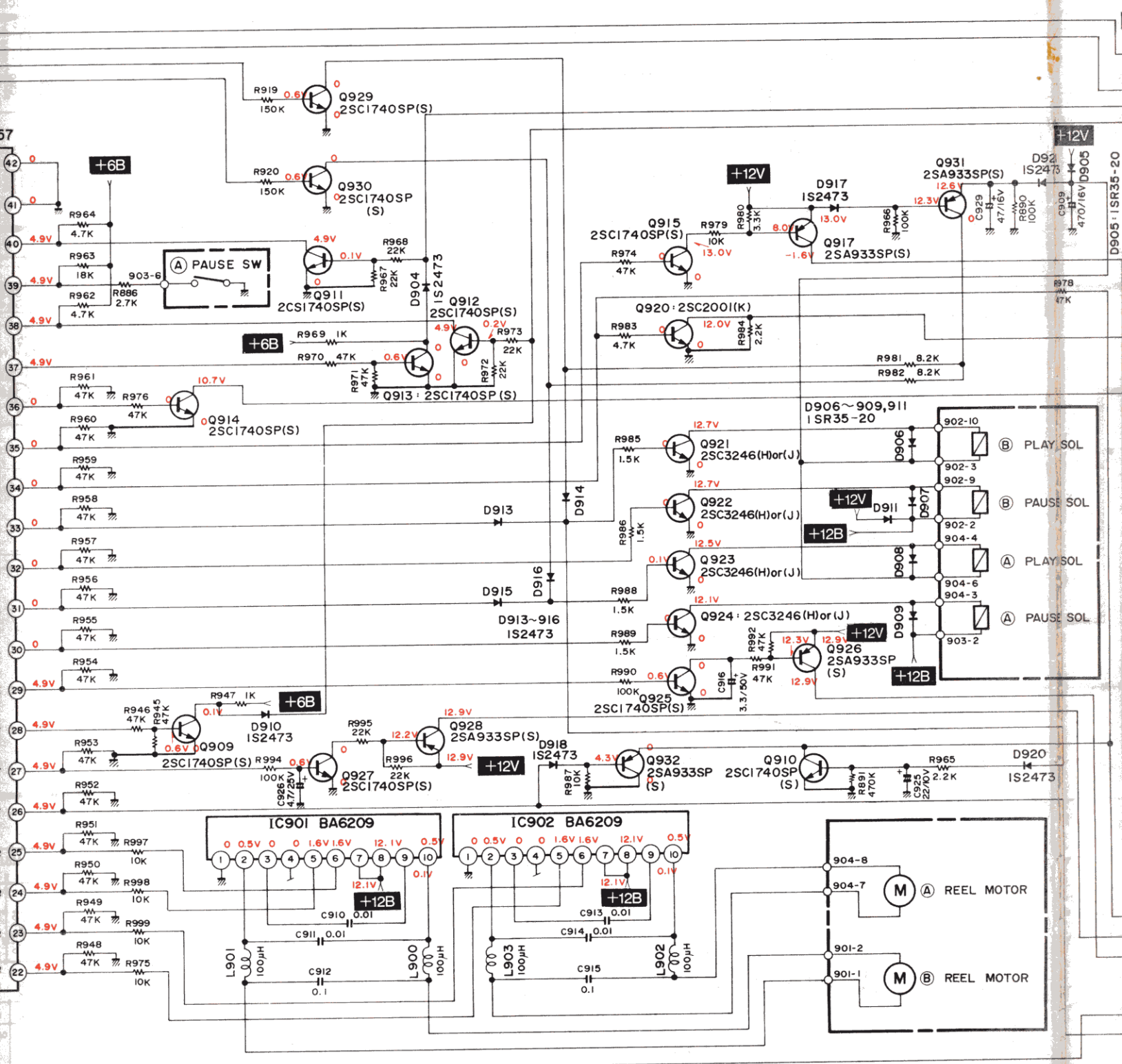

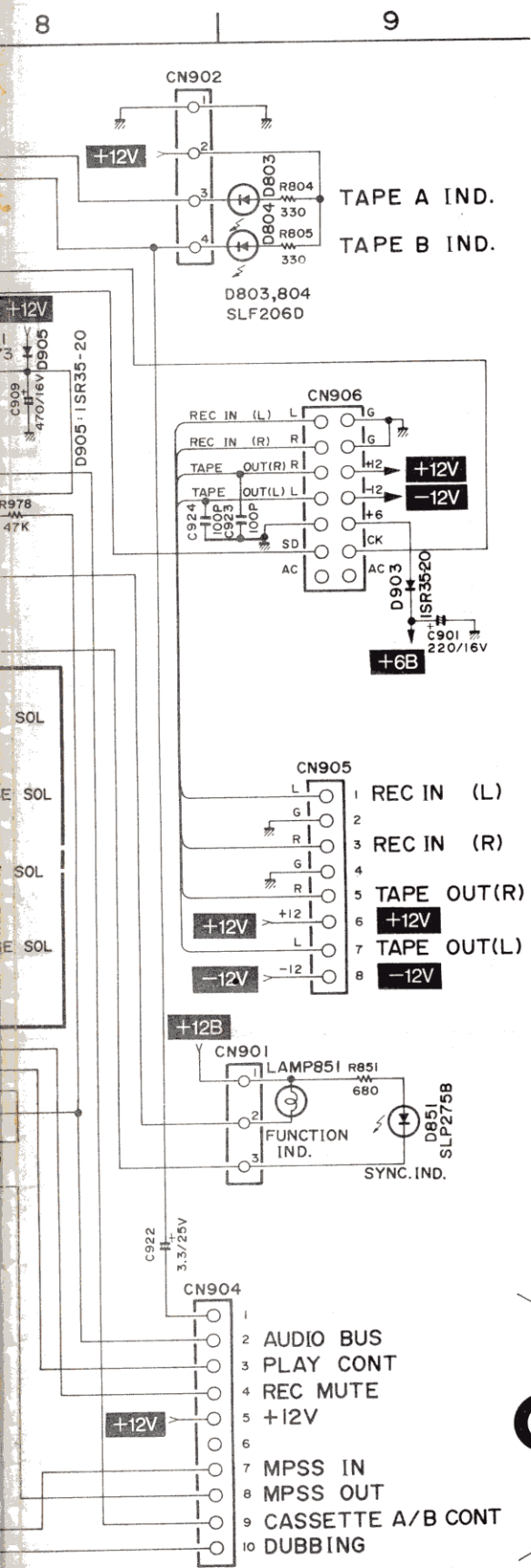

NOTE:

1. Unit of C and R

- C No-symbol; μ F
- P-symbol; PF
- R No-symbol; Ω
- K-symbol; k Ω
- M-symbol; M Ω

Wattage for all unspecified resistor are 1/4W.

2. Voltage are those measured with DC 1M Ω digital voltmeter.

3. This circuit diagram may be changed due to circuit improvement.

TRANSISTORS

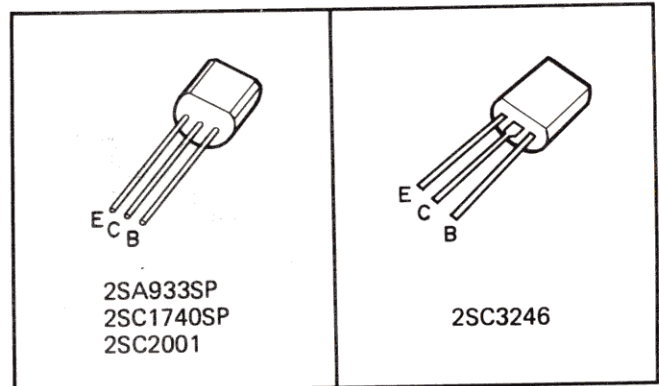

D

C

SCHEMATIC DIAGRAM

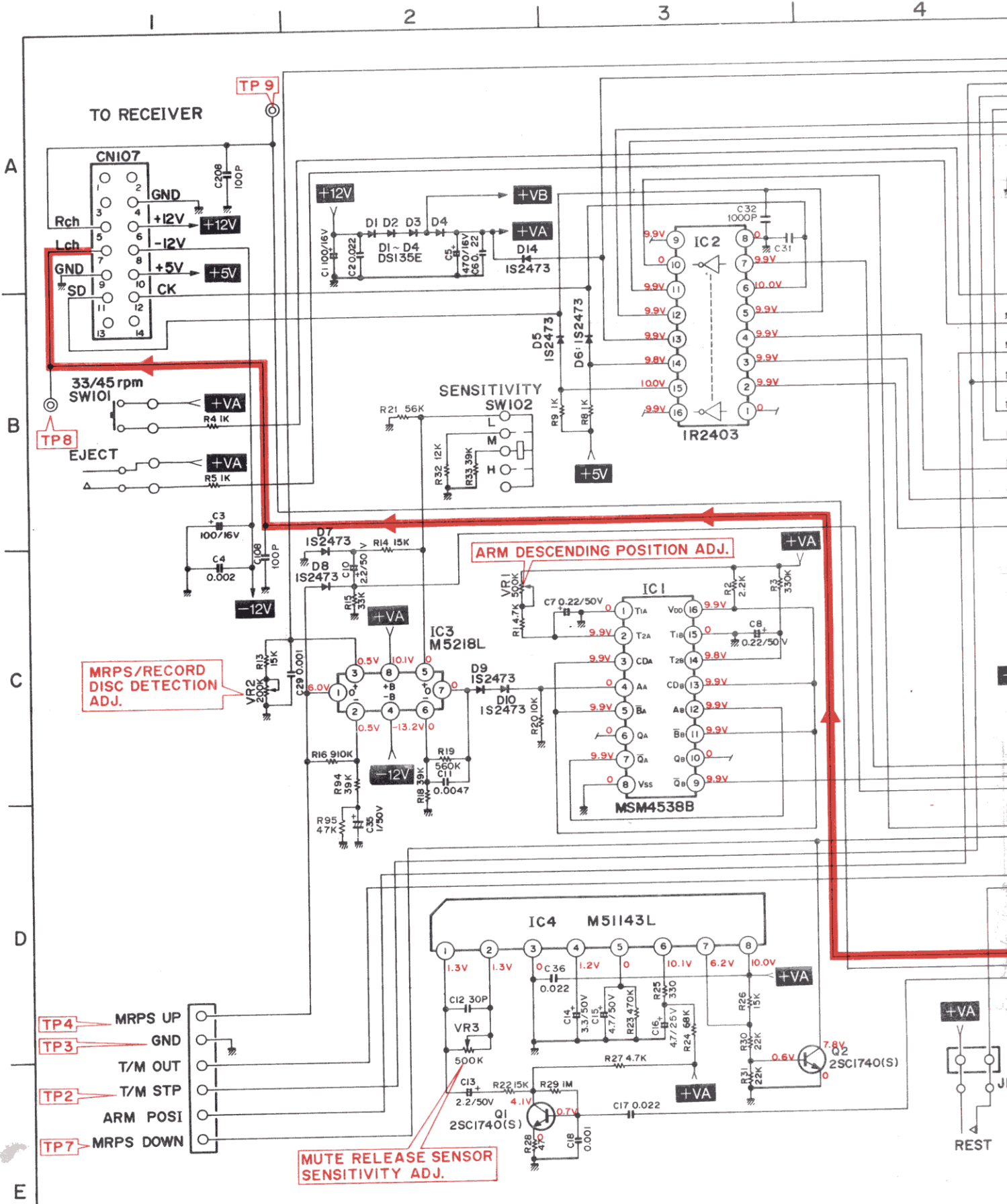

4

5

6

7

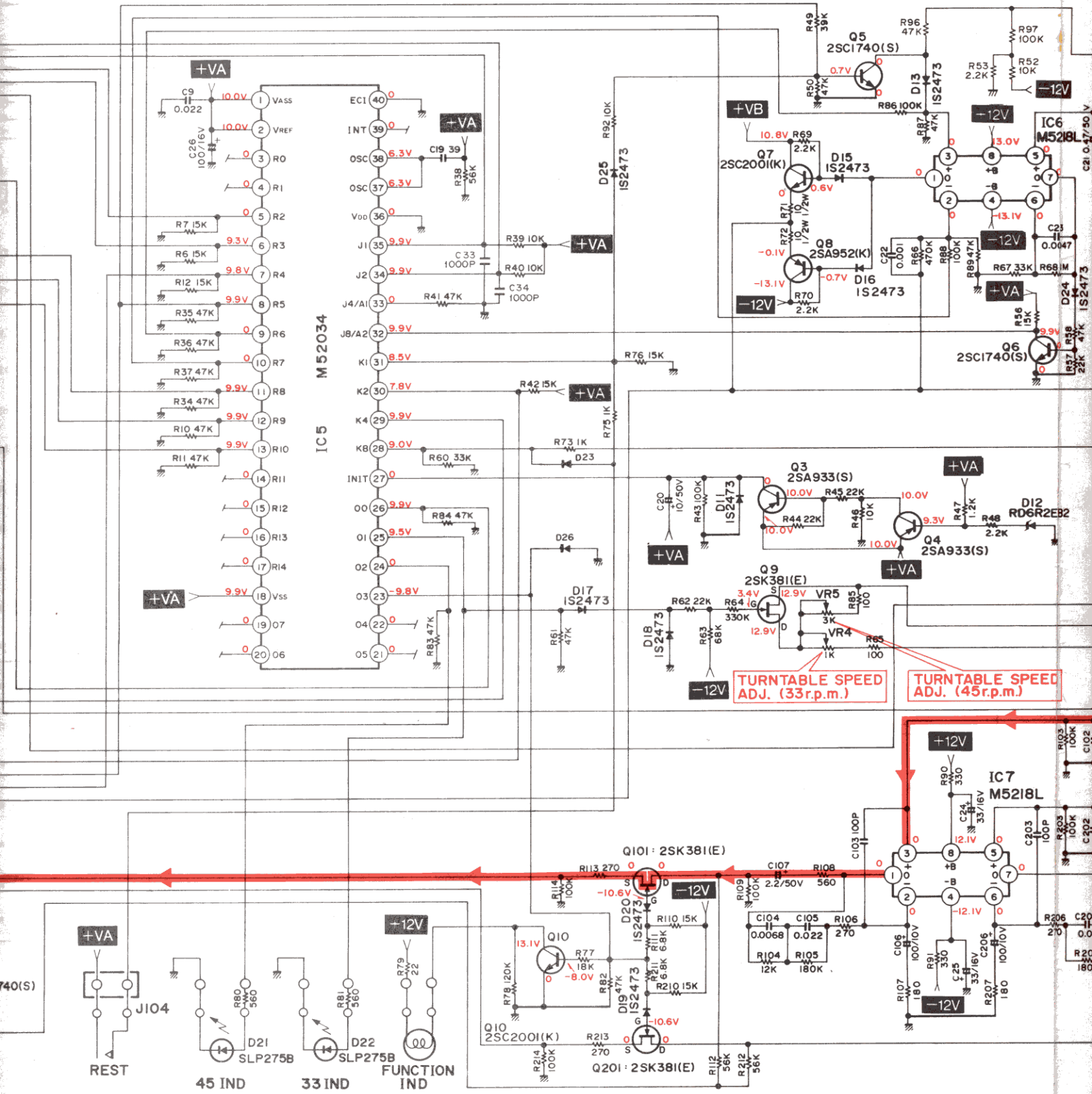

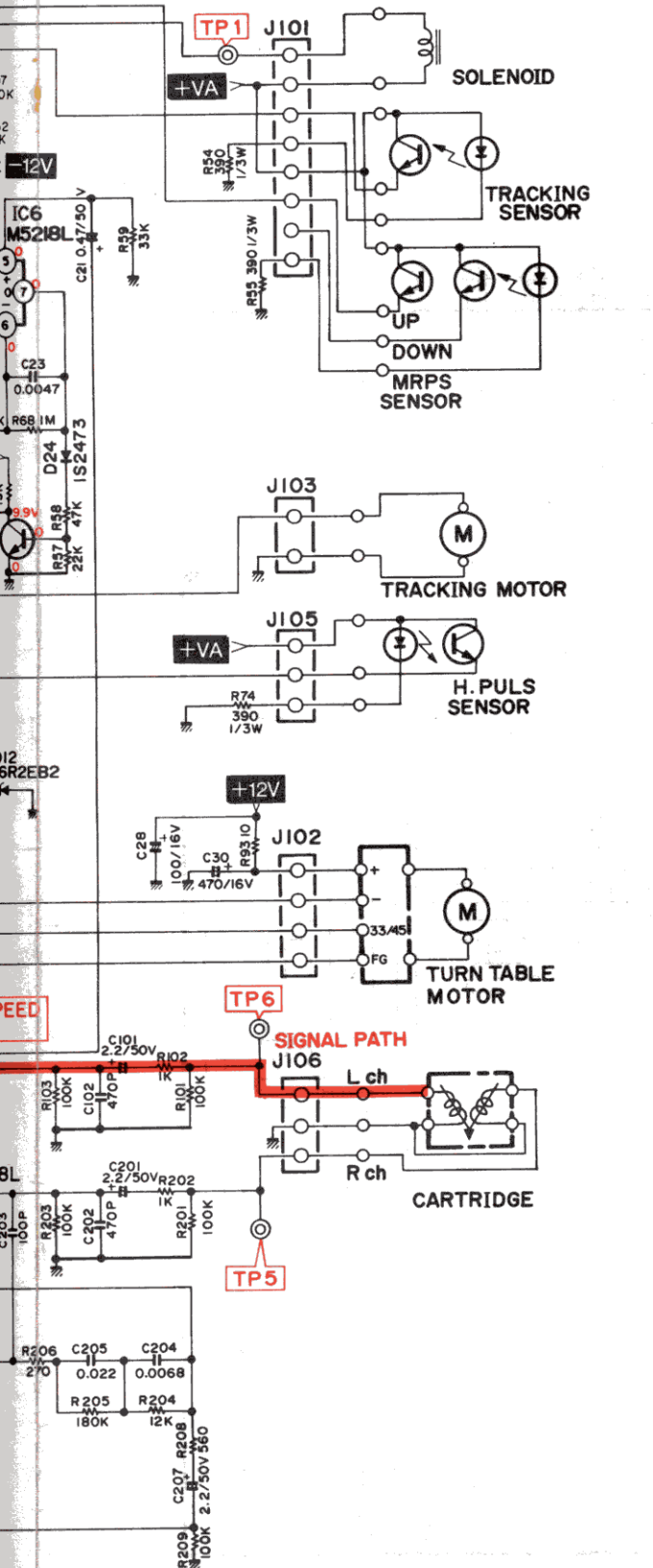

NOTE:

1. Unit of C and R

- C No-symbol; μ F
- P-symbol; PF
- R No-symbol; Ω
- K-symbol; k Ω
- M-symbol; M Ω

Wattage for all unspecified resistor are 1/4W.

2. Voltage are those measured with DC 1M Ω digital voltmeter.

3. This circuit diagram may be changed due to circuit improvement.

TRANSISTORS

