

Service Manual

AUTOMOTIVE ELECTRONICS



<CQ-JB0161A>

MITSUBISHI CQ-JB0161A CQ-JB1161L

AM/FM MPX ELECTRONIC TUNING
RADIO with CD Player

MITSUBISHI PART No. :

CQ-JB0161A : MR587387

CQ-JB1161L : MR587249

ID CODE :

CQ-JB0161A : P004

CQ-JB1161L : P003

VEHICLE :

CQ-JB0161A : DIAMANTE, PAJERO

CQ-JB1161L : GALANT

DESTINATION : North America

PRODUCED AFTER :

CQ-JB0161A : Apr., 2001

CQ-JB1161L : May, 2001

Specification*

General

Power Supply	DC 12V (11V - 16V), Test Voltage 13.2V, Negative Ground
Current Consumption	Less than 1.0A at 100mV
Maximum Power Output	More than 100mV (at 10kΩ)
Output Impedance	10kΩ

AM Radio

Frequency Range	530 - 1,710kHz
Usable Sensitivity	24dB/μV (S/N 20dB)

FM Stereo Radio

Frequency Range	87.7 - 107.9MHz
Usable Sensitivity	7dB/μV (S/N 30dB)

CD Player

Signal to Noise Ratio	More than 66dB
Total Harmonic Distortion	Less than 0.4%
Channel Separation	More than 55dB
Dimension** (W×H×D)	178 × 169 × 150mm
Weight**	1.5kg

* Specifications and the design are subject to possible modification without notice due to improvements.

** Dimensions and Weight shown are approximate.

CONTENTS

	Page		Page
1 FEATUERS	2	9 REPLACEMENT PARTS LIST	12
2 LASER PRODUCTS	2	10 EXPLODED VIEW (Unit)	19
3 REAR VIEW AND CONNECTORS	2	11 CD PLAYER PARTS	20
4 FRONT VIEW AND FUNCTIONS	3	12 EXPLODED VIEW (CD Deck)	21
5 WIRING CONNECTION	4	13 WIRING DIAGRAM	22
6 BLOCK DIAGRAM	5	14 SCHEMATIC DIAGRAM (1)	28
7 TERMINALS DESCRIPTION	7	15 SCHEMATIC DIAGRAM (2)	29
8 PACKAGE AND IC BLOCK DIAGRAM	9		

1 FEATUERS

- PLL (Phase Locked Loop) synthesized tuning.
- 18-station preset (12-FM, 6-AM)
- FM One-tuner diversity.
- Electronic control of power and sound.
- CD random, repeat function.
- CD-CH, MD-CH control.
- Clock function

2 LASER PRODUCTS

Do not take apart this unit or attempt to make any changes yourself.

This unit is very intricate that uses a laser pickup to retrieve information from the surface of compact discs. The laser is carefully shielded so that its rays remain inside the cabinet. Therefore, never try to disassemble the player or alter any of its parts since you may be exposed to laser rays and dangerous voltages.

Laser products :

Wave length	780nm
Laser power	No hazardous radiation is emitted with safety protection.

Caution

This product utilizes a laser. Use of controls or adjustments or performance of procedures other than those specified herein may result in hazardous radiation exposure.

3 REAR VIEW AND CONNECTORS

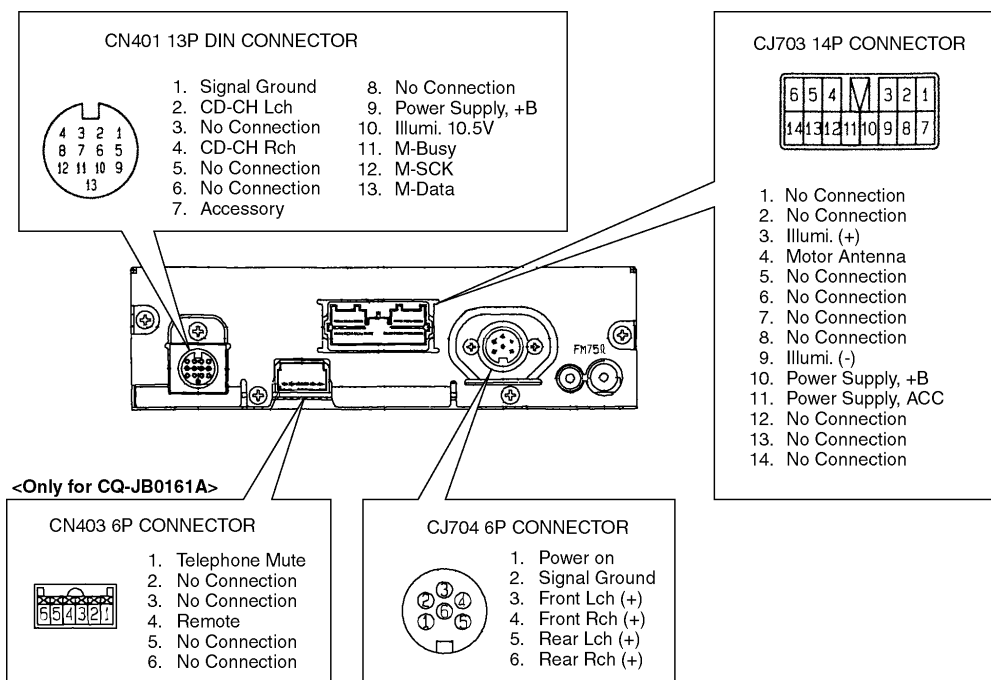

4 FRONT VIEW AND FUNCTIONS

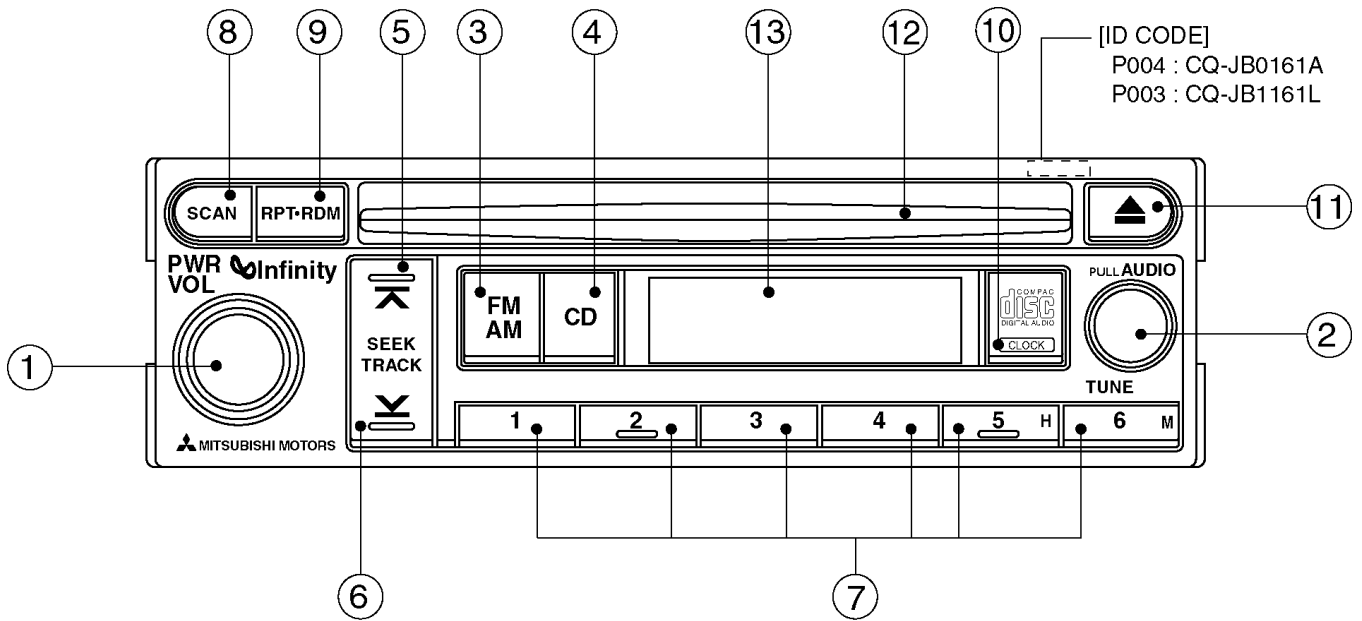

- | | |
|--|--|
| <ul style="list-style-type: none"> ① POW : Power ON/OFF <li style="padding-left: 20px;">VOL : Increase/Decrease/ of volume. ② TUNE : Radio manual tuning. <li style="padding-left: 20px;">AUDIO : Audio adjustment mode selection. ③ FM/AM : Radio band selection. ④ CD : CD mode selection. ⑤ SEEK \wedge : Upward seeking. <li style="padding-left: 20px;">TRACK \wedge : CD track up. ⑥ SEEK \vee : Downward seeking. <li style="padding-left: 20px;">TRACK \vee : CD track down. | <ul style="list-style-type: none"> ⑦ 1-6 : Radio frequency preset/call. <li style="padding-left: 20px;">: CD.CH disc selection. ⑦-5 H (#1) : Time adjustment (Hours). ⑦-6 M (#1) : Time adjustment (Minutes). ⑧ SCAN : Radio scan tuning. ⑨ RPT : CD repeat play. <li style="padding-left: 20px;">RDM : CD random play. ⑩ CLOCK (#1) : Clock mode selection. ⑪ \blacktriangle : CD eject. ⑫ CD slot ⑬ LCD display. |
|--|--|

Note (#1) : Only for CQ-JB1161L.

5 WIRING CONNECTION

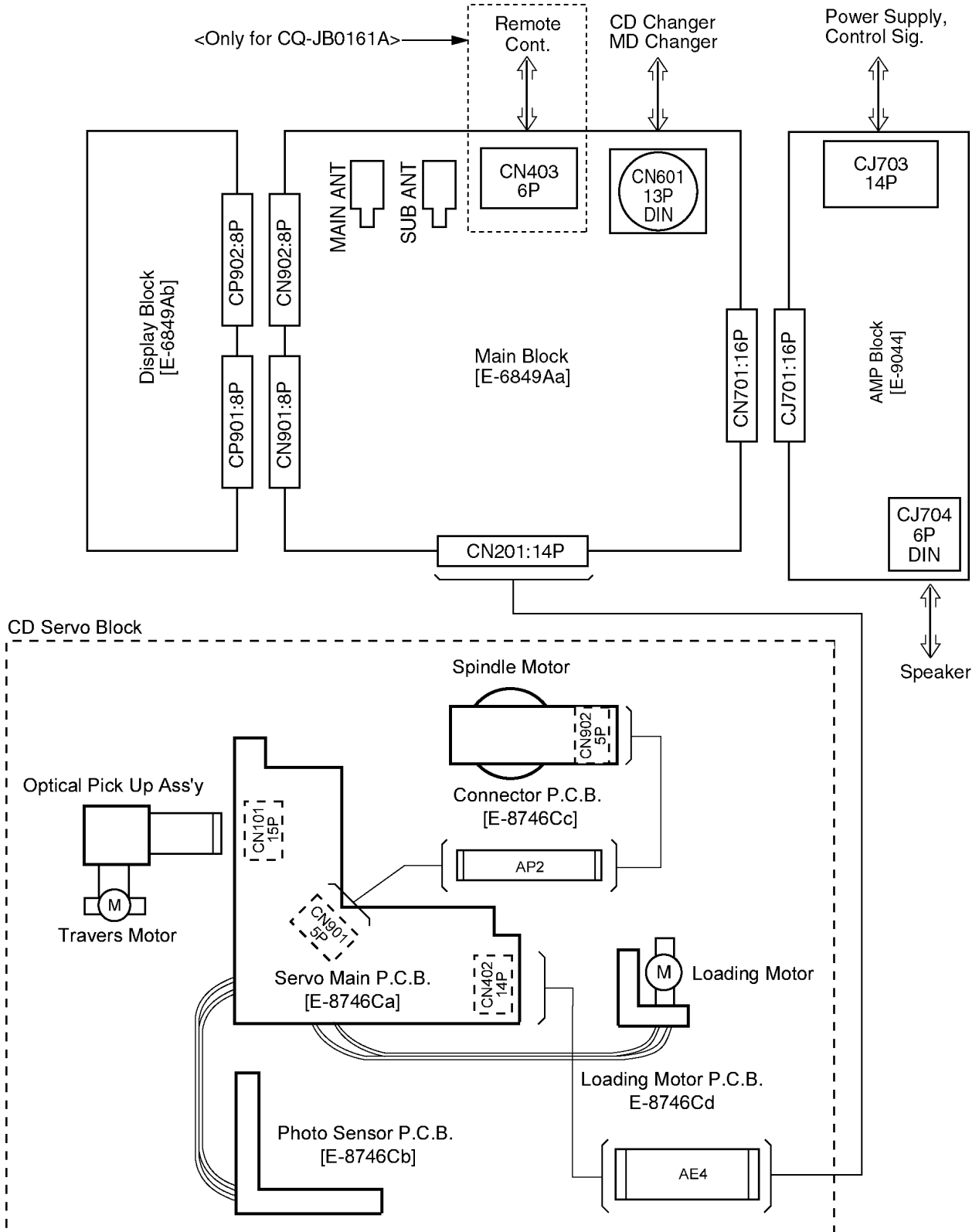

6 BLOCK DIAGRAM

6.1. Main/Display/Amp Block

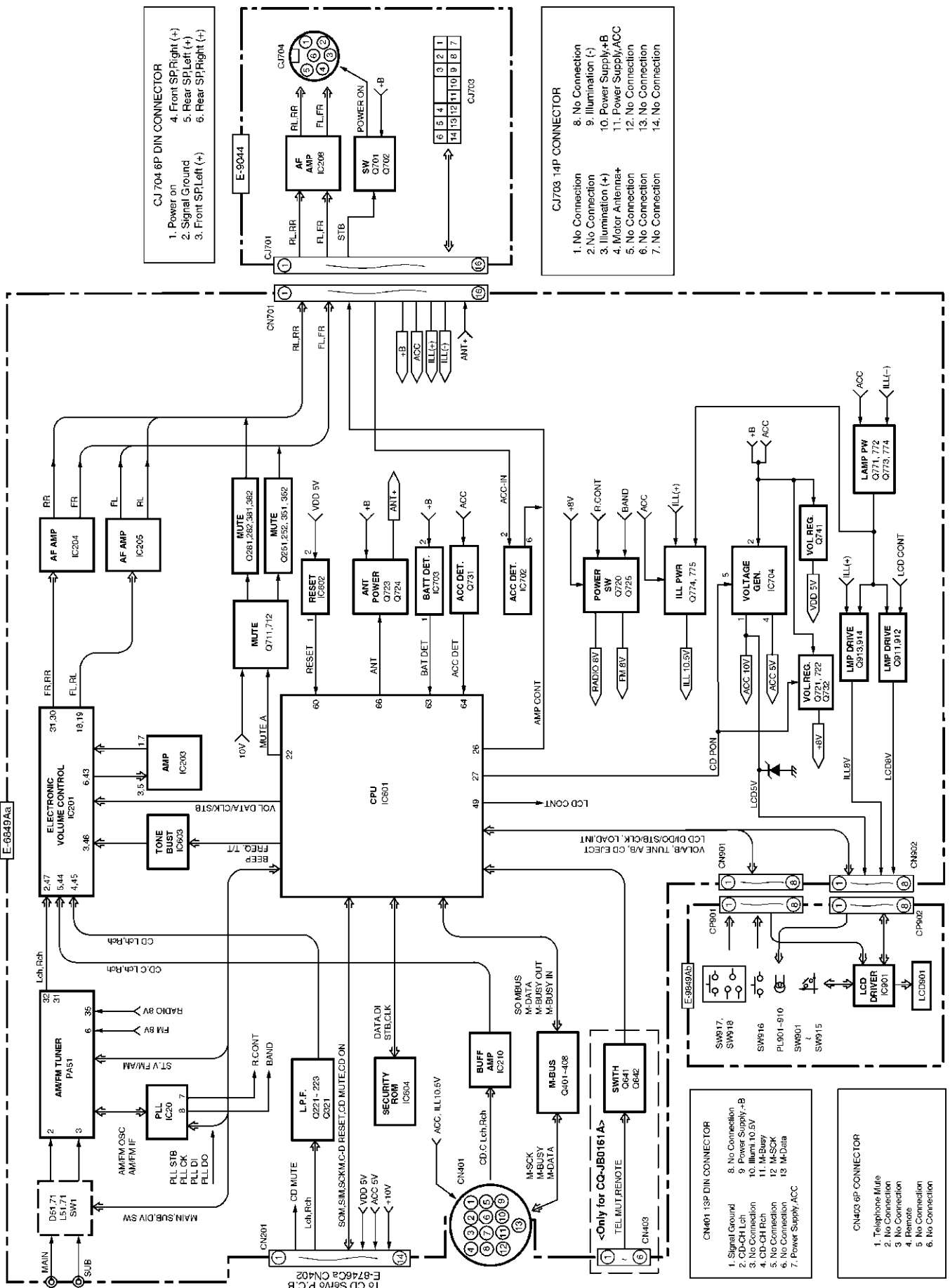

6.2. CD Servo Block

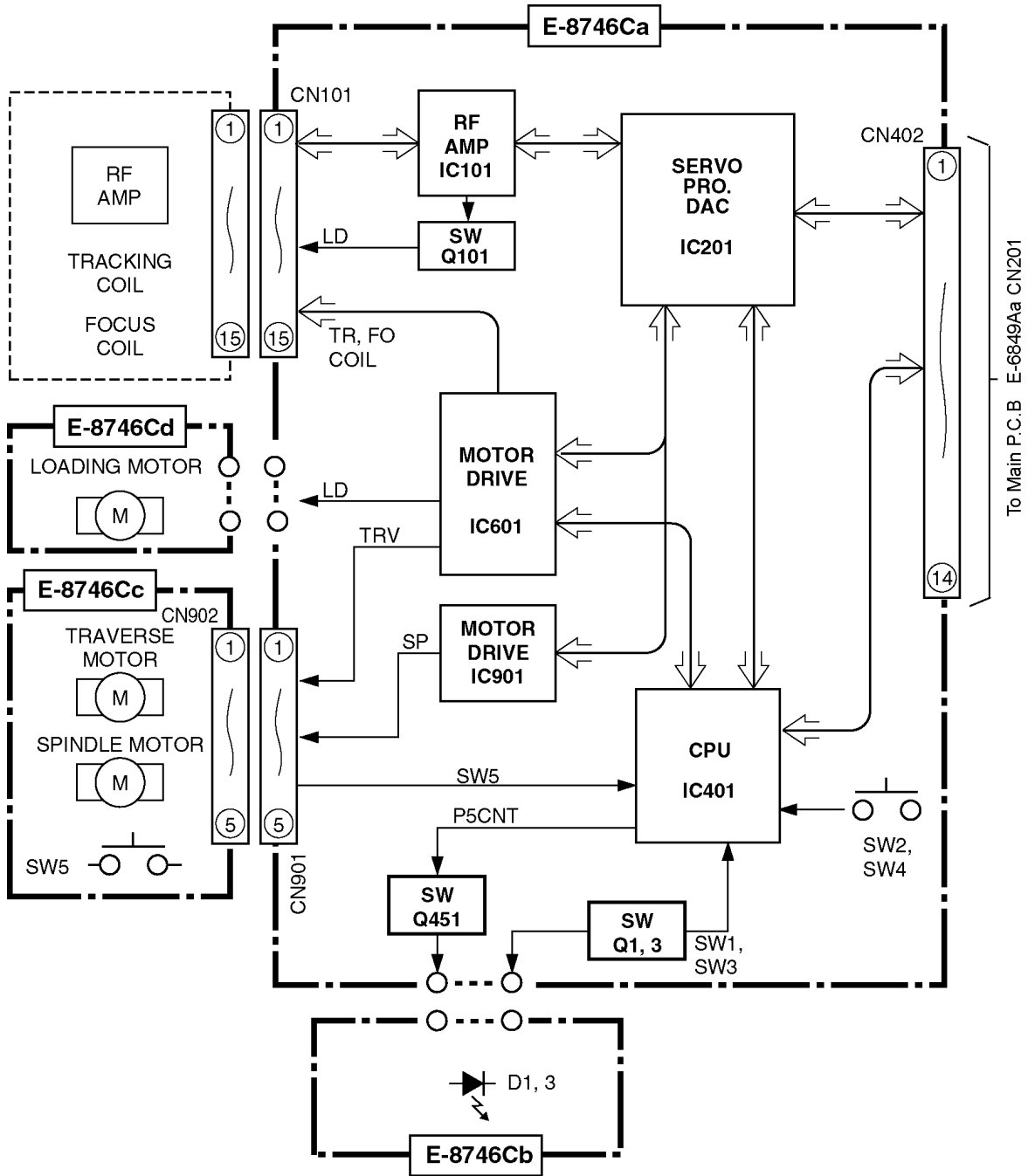

7 TERMINALS DESCRIPTION

7.1. Main Block

IC601 : C2BBGF000256 <CQ-JB1161L>

: C2BBGF000287 <CQ-JB0161A>

Pin No.	Port	Descriptions	I/O	Vol. (V)
1	SUBVOLCLK	(Ground pull-down)	-	0
2	DIV SW	Diversity switch	I	5.1
3	SET S2	System function setting	O	0
4	AVSS	Ground	-	0
5	SET S0	System function setting	O	0
6	SET S1	System function setting	O	0
7	AVREF	+5V power supply	-	5.1
8	SET R0	System function setting	I	0
9	SET R1	System function setting	I	0
10	SET R2	System function setting	I	0
11	CD DI	CD data output	O	2.4
12	CD DO	CD data input	I	1.4
13	CD CLK	Shift clock for CD data	O	4.9
14	PLL DI	PLL data input	I	5.0
15	MBUSY OUT	M-BUS busy	O	0
16	MBUSY IN	M-BUS busy	I	0
17	MDATA	M-BUS data	I/O	4.9
18	MCLK	M-BUS clock	O	4.9
19	PLLDO	PLL data output	O	0
20	PLLSTB	PLL strobe	O	0
21	PLLCLK	PLL clock	O	0
22	MUTE A	Mute signal	O	0
23	VOL STB	Electric volume strobe	O	0
24	VOL CLK	Electric volume clock	O	0
25	VOL DATA	Electric volume data	O	0
26	AMP CONT	Power amp. stand-by	O	4.9
27	CD PON	CD power control	O	4.9
28	CD ON	CD control LSI enable	O	4.9
29	SW1	CD disc-in SW	I	0
30	SW3	CD disc-out SW	I	4.8
31	TUNEA	Tuner switch signal	I	4.7
32	TUNEB	Tuner switch signal	I	0.5
33	GND	Ground	-	0
34	VOLINA	Volume switch signal	I	0
35	VOLINB	Volume switch signal	I	0
36	CD RESET	CD controller reset	O	0
37	MAIN	Main antenna selection	O	4.9
38	SUB	Sub. antenna selection	O	8.3
39	BIBIRI CNT	Rattle noise check control	O	5.0
40	SECDI	Security data input	I	0
41	SECDO	Security data output	O	0
42	SECCLK	Security data read / write clock	O	0
43	SECCS	Security ROM select	O	0
44	FreqOUT	Tone/Burst frequency	O	0
45	TONE/TRG	Tone/Triger control	O	0
46	S.PULSE	Speed pulse input	I	0
47	Ga INPUT	GALA signal input	I	5.0
48	ST	FM stereo detection	I	0.3
49	LCD CONT	LCD back lighth on/off	O	4.8
50	BUZZER	Buzzer output	O	0
51	NC	No connection	-	-
52	KS0	Key strobe	O	0
53	KS1	Key strobe	O	0
54	KS2	Key strobe	O	0
55	KS3	Not used	-	-
56	KR0	Key data	I	0
57	KR1	Key data	I	1.6
58	KR2	(Groung pull-down)	-	0
59	KR3	(Groung pull-down)	-	0
60	RESET	Reset input	I	4.8
61	M-DATA IN	M-BUS data	I	4.9
62	CD EJECT	CD eject SW	I	4.8
63	BATDET	Battery level detection	I	5.0
64	ACCDET	ACC level detection	I	0

Pin No.	Port	Descriptions	I/O	Vol. (V)
65	MUTE_P	Power amp. mute	O	0
66	ANT	Motor antenna power on/off	O	0
67	GND	Ground	-	0
68	VDD	+5V power supply	-	4.9
69	X2	Crystal oscillator	-	0
70	X1	Crystal oscillator	-	2.6
71	GND	Ground	-	0
72	XT2	Crystal oscillator	-	2.7
73	XT1	Crystal oscillator	-	2.5
74	AVDD	+5V power supply	-	4.9
75	AV REF0	+5V power supply	-	5.0
76	VAM/FM	AM/FM vcont	I	0
77	REMOTE_A	(+5V pull-up)	-	5.0
78	BIBIRI.A	(Ground pull-down)	-	0
79	CLIPCONT	Not used	-	-
80	REMOTE_D	(Ground pull-down)	-	0

Note 1 : Voltage measuerments are with respect to ground, with a voltmeter (internal resistance : 10M ohms).

7.2. Display Block

IC901 : YEAMSM6786

Pin No.	Port	Descriptions	I/O	Vol. (V)
1- 6	SEG1 - 6	LCD segment data	O	2.3
7	SEG7	No connection	-	-
8-20	SEG8-20	LCD segment data	O	2.3
21	VDD	+5V power supply	-	5.0
22-29	SEG21 - 28	LCD segment data	O	2.3
30	-	No connection	-	-
31-34	KR0 - 3	Key data input	I	4.4
35,36	-	No connection	-	-
37-40	KS1 - 4	Key scanning	O	3.5
41	KS5	Not used	-	-
42	LOAD	LCD LSI chip enable	I	0
43	CLK	LCD clock	I	0
44	DATA I/O	LCD/Key dat	I/O	0
45	INT	LCD interrupt	O	3.8
46	/RESET	Reset	I	4.0
47	LED	Not used	-	-
48	3/4 SEL	(Connecting to ground)	-	0
49	VDD	+5V power supply	-	5.0
50	OSC	CR oscillator	-	2.2
51	VSS	Ground	-	0
52	TEST	(Connecting to ground)	-	0
53-56	COM4 - 1	LCD common	O	2.3

7.3. CD Servo Block

IC201 : MN662748RPMF

Pin No.	Port	Description	I/O	(V)
1	BCLK	Not used	-	-
2	LRCK	Not used	-	-
3	SRDATA	Not used	-	-
4	DVDD	+5V digital power supply	-	5.0
5	DVSS1	Digital ground	-	0
6	TX	Not used	-	-
7	MCLK	MPU command clock	I	0
8	MDATA	MPU command data	I	0
9	MLD	MPU command load	I	0
10	SENSE	Sense signal	O	0
11	/FLOCK	Focus servo lock	O	0
12	/TLOCK	Tracking servo lock	O	4.9
13	BLKCK	Not used	-	-
14	SQCK	Q code external clock	I	4.9
15	SUBQ	Q code output	O	2.5
16	DMUTE	DSP mute	I	0
17	STAT	DSP Status output	O	3.1
18	/RST	Reset input	I	4.9
19,20		Not used	-	-
21	TRV	Forced traverse output	O	2.5
22	TVD	Traverse drive output	O	2.5
23	PC	Spindle motor control	O	0
24	ECM	Spindle motor drive	O	2.5
25	ECS	Spindle motor drive	O	2.5
26	KICK	Kick pulse output	O	2.5
27	TRD	Tracking motor drive	O	2.5
28	FOD	Focus motor drive	O	2.5
29	VREF	D/A reference voltage	I	2.5
30	FBAL	Focus balance adjust	O	2.5
31	TBAL	Tracking balance adjust	O	2.5
32	FE	Focus error signal	I	2.5
33	TE	Tracking error signal	I	2.5
34	RFENV	RF envelope signal	I	2.5
35	VDET	Vibration detection	I	0
36	OFTR	Off track signal	I	0
37	TRCRS	Track cross signal	I	2.1
38	/RFDET	RF detection signal	I	0
39	BDO	Drop out signal	I	0
40	LDON	Laser on/off control	O	4.5
41	PLL2	Not used	-	-
42	TOFS	TE offset	O	2.5
43	WVEL	Not used	-	-
44	ARE	RF signal	I	1.7
45	IREF	Reference current input	I	1.6
46	DRF	DSL bias	I	0
47	DSL2	DSL loop filter	I/O	2.4
48	PLL2	PLL loop filter	I/O	1.8
49	VCOF	Not used	-	-
50	AVDD2	+5V analog power supply	-	5.0
51	AFSS2	Analog ground	-	0
52	EFM	Not used	-	-
53	PCK/DSL2	DSL bias	I	2.4
54	VCOF2	Tracking offset	O	2.5
55	SUBC	Not used	-	-
56	SBCK	(Connecting to ground)	-	-
57	VSS	Ground	-	0
58	X1	Crystal oscillator	I	1.7
59	X2	Crystal oscillator	O	2.3
60	VDD	+5V power supply	-	5.0
61,62		Not used	-	-
63	FCLK	Not used	-	-

64	IPFLAG	Not used	-	-
65	FLAG	Not used	-	-
66-69		Not used	-	-
70	IOSEL	(Connecting to ground)	I	0
71	/TEST	(Connecting to ground)	I	0
72	AVDD1	+5V analog power supply	-	4.9
73	OUTL	Audio Lch output	O	4.9
74	AVSS1	Analog ground	-	0
75	OUTR	Audio Rch output	O	4.9
76	RSEL	(Connecting to ground)	-	0
77	CSEL	(Connecting to ground)	-	0
78	PSEL	(Connecting to ground)	-	0
79	MSEL	(Connecting to ground)	-	0
80	SSEL	mode select	I	5.0

IC401 : MN101C117AF

Pin No.	Port	Description	I/O	(V)
1	MASHON	Servo IC OSC control	O	5.0
2	P82	No connection	-	-
3	P81	No connection	-	-
4	P80	(Connection to ground)	-	0
5	Q1	Photo sensor signal (DISC IN)	I	4.5
6	Q3	Photo sensor signal (DISC OUT)	I	4.2
7	Q6	Photo sensor signal (Option)	I	5.0
8	SW4	Clamp SW signal	I	0
9	SW5	Inner SW signal	I	5.0
10	SW2	Feeder arm SW	I	5.0
11	PA6	(Connection to ground)	-	0
12	PA7/IFR	(Connecting to ground)	I	0
13	VDD	+5V power supply	-	5.0
14	OSC2	Crystal oscillator	-	5.0
15	OSC1	Crystal oscillator	-	3.3
16	VSS	Ground	-	0
17	NC	No connection	-	-
18	SOM1	CD control data	O	3.2
19	SIMO	CD control data	I	3.8
20	SCLM	Data shift clock	I	5.0
21	P06	Not used	-	-
22	BD0	Drop out signal	I	0
23	PC1	Loading motor driver control	O	5.0
24	PS2	Focus/Tracking driver control	O	0
25	VDET	Vibration detecting signal	I	0
26	P14	No connection	-	-
27	CDON	CD on signal	I	5.0
28	IRQ1.SENSE	(Connecting to ground)	-	0
29	IRQ2	(Connecting to ground)	-	0
30	LOD	Loading motor control	-	2.6
31	TRV	Traverse motor control	-	2.5
32	/PRST	Servo IC reset	O	5.0
33	STAT	Status signal	I	4.0
34	DMUTE	DSP mute	O	0
35	SUBQ	Sub code Q data	I	2.6
36	SQCK	Sub code Q clock	O	5.0
37	/TLOCK	Tracking servo lock	I	0
38	/FLOCK	Focus servo lock	I	0
39	NRST	reset input	I	5.0
40	MMOD	(Connecting to ground)	-	0
41	SENSE	Sense signal	I	0
42	MLD	Command load	O	5.0
43	MDATA	Command data	O	0.9
44	MCLK	Command clock	O	4.6

8 PACKAGE AND IC BLOCK DIAGRAM

8.1. Main Block

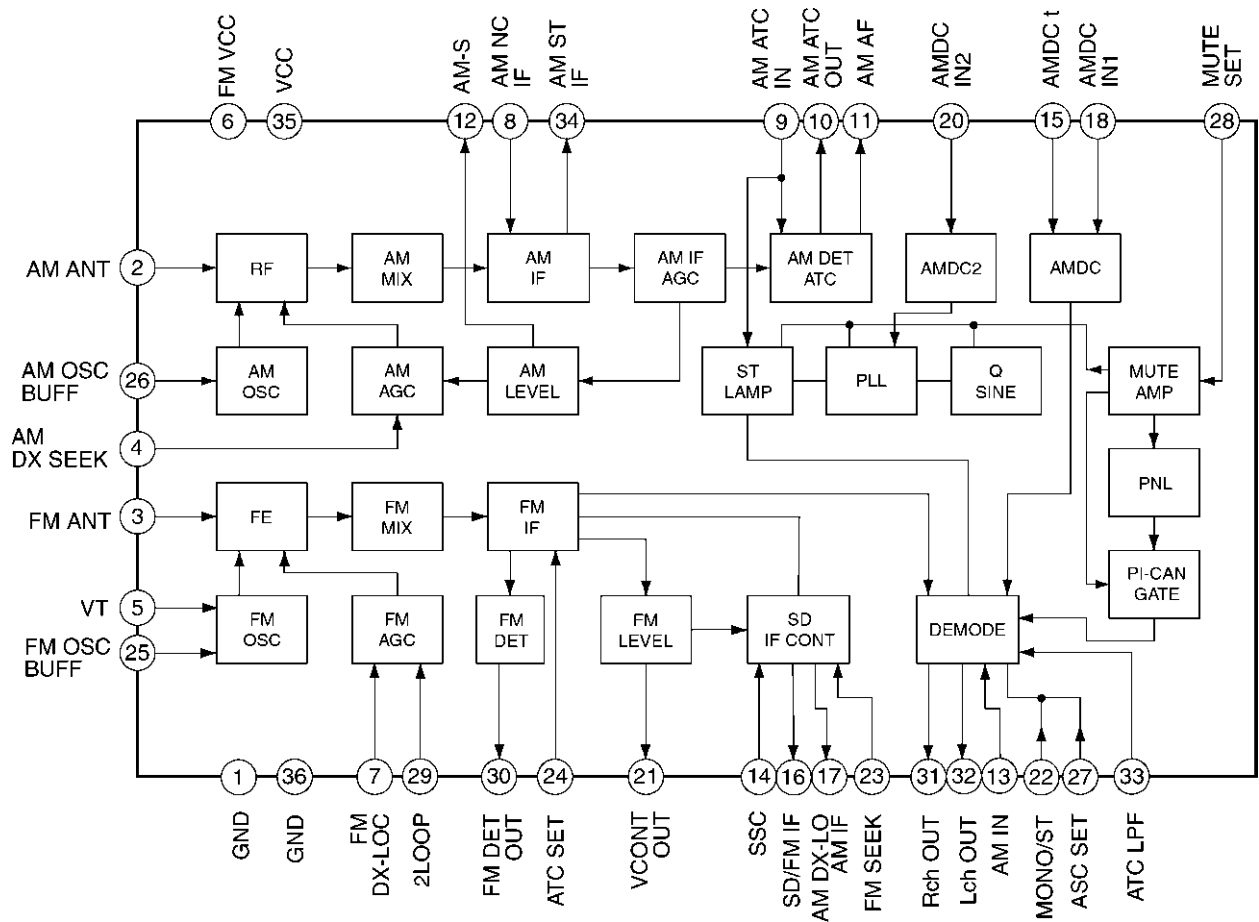

PA51 : YEP0PTA514B0

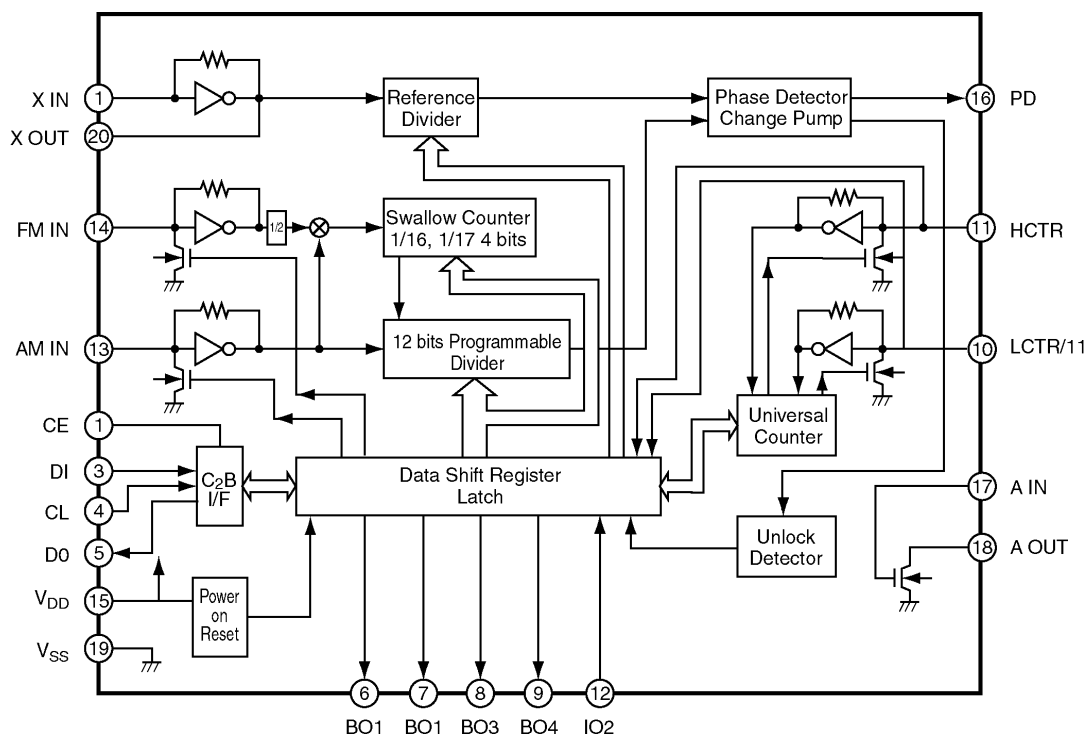

IC20 : YEAMLC72135C

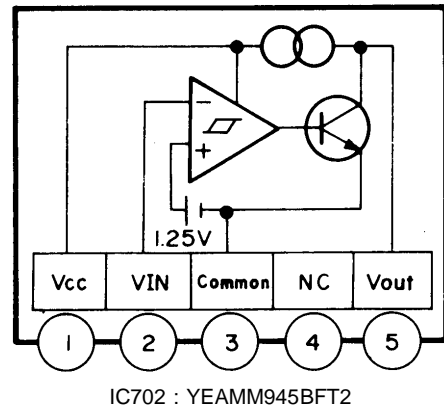
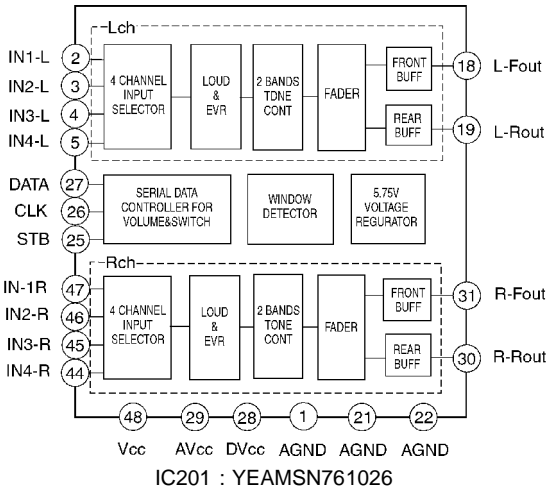

8.2. AMP Block

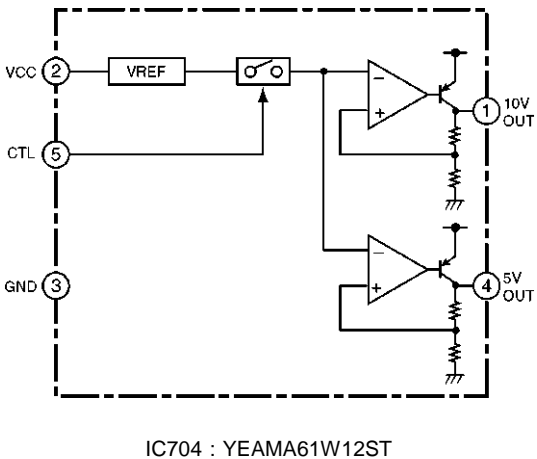
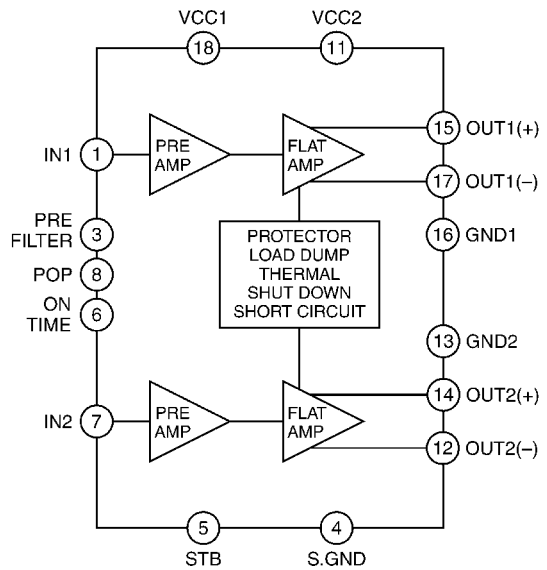
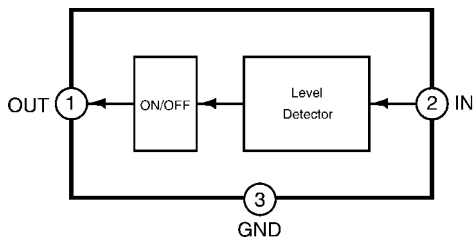
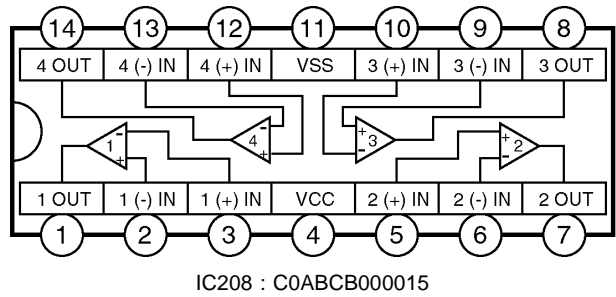
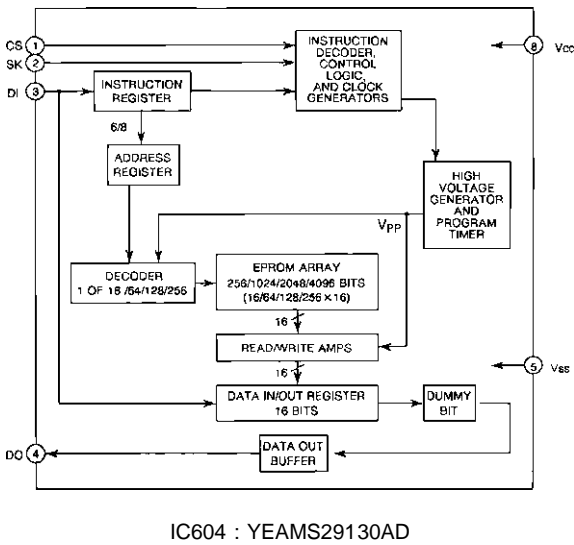

8.3. CD Servo Block

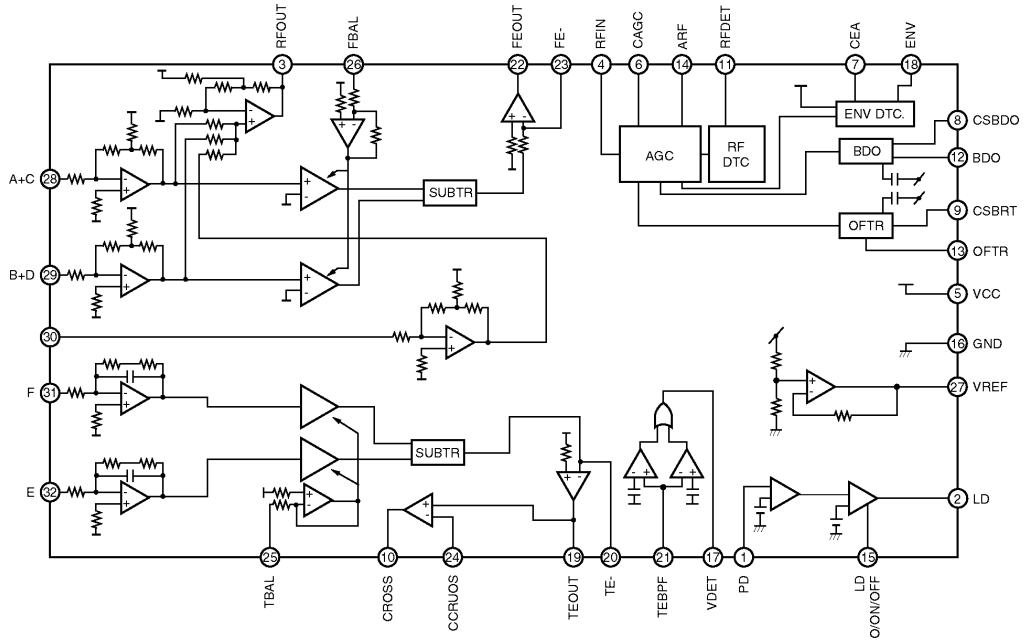

IC101 : YEAMBA6354FS

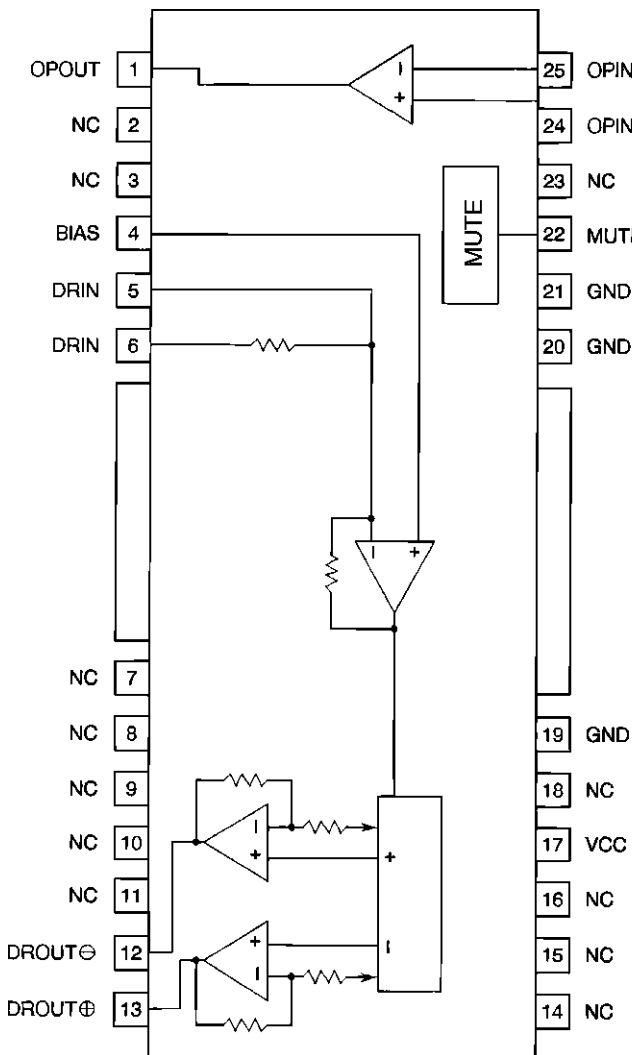

IC901 : C0GBY0000003

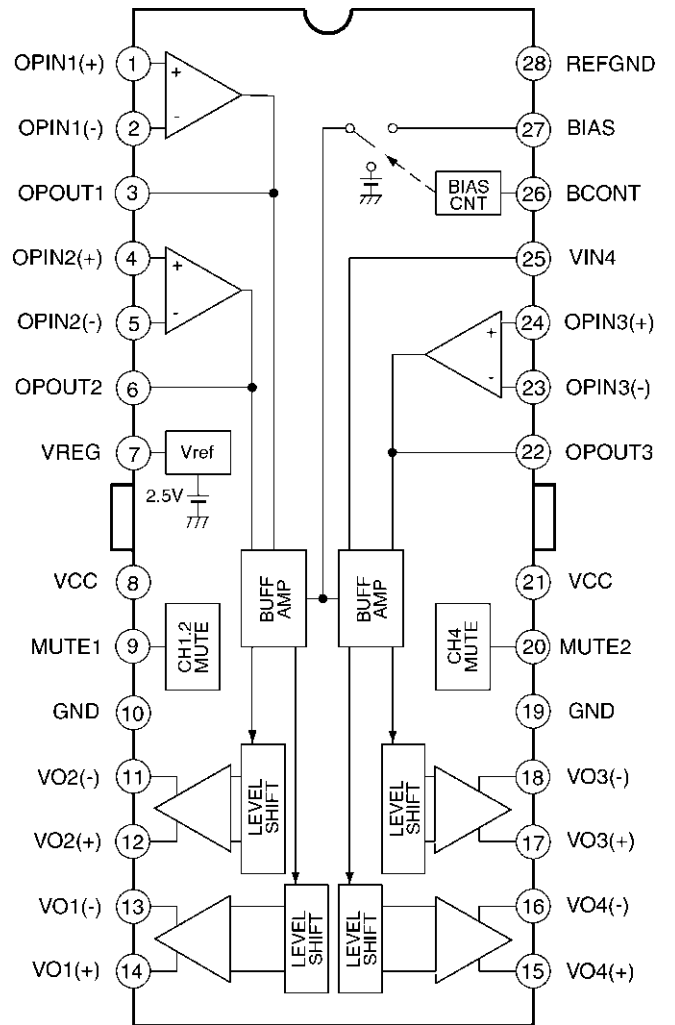

IC601 : C0GBY0000004

9 REPLACEMENT PARTS LIST

Notes :

1. Be sure to make your orders of replacement parts according to this list.
2. Important safety notice: Components, identified by Δ mark have special characteristics important for safety. When replacing any of these components, use only manufacturer's specified parts.
3. Location keys in the remarks column indicates the general location of the parts shown in the exploded drawing, as in a road map.
4. The marking (RTL) indicates that Retention Time is limited for this item. After the discontinuation of assembly in production, the item will continue to be available for a specific period of time. The retention period of availability is dependent on the type of assembly, and in accordance with the laws governing part and product retention. After the end of this period, the assembly will no longer be available.
5. "MCC" marks in remarks column are indicated supply parts of Matsushita Communication Industrial Corp. of America (MCC).
6. "A" or "B" marks in remarks column are indicated as follows :
 - A : CQ-JB0161A
 - B : CQ-JB1161L

Ref. No.	Part No.	Part Name & Description	Remarks
[E6849A] Main/Display Block			
IC's and TRANSISTORS			
IC20	YEAMLC72135C	IC	
IC201	YEAMSN761026	IC	
IC203	C0ABBB000179	IC	
IC204	C0ABBB000179	IC	
IC205	C0ABBB000179	IC	
IC210	C0ABBB000179	IC	
IC601	C2BBGF000287	IC	A
IC601	C2BBGF000256	IC	B
IC602	MN1382KTX	IC	
IC603	C0JBAM000048	IC	
IC604	C3EBCG000037	IC	
IC702	YEAMM945BFT2	IC	
IC703	MN1382QTX	IC	
IC704	YEAMA61W12ST	IC	
IC901	YEAMSM6786	IC	
PA51	YEP0PTA514B0	Electronic Tuner	
Q221	YEANC323TKT	Transistor	
Q222	B1ABCF000042	Transistor	
Q223	YEANA124EKT	Transistor	
Q251	YEANC323TKT	Transistor	
Q252	YEANA114TK	Transistor	
Q281	YEANC323TKT	Transistor	
Q282	YEANA114TK	Transistor	
Q321	YEANC323TKT	Transistor	
Q351	YEANC323TKT	Transistor	
Q352	YEANA114TK	Transistor	
Q381	YEANC323TKT	Transistor	
Q382	YEANA114TK	Transistor	
Q383	B1GBCFJN0005	Transistor	
Q384	B1GBCFJN0005	Transistor	
Q401	YEANA114YKTX	Transistor	
Q402	YEANC143EKT	Transistor	
Q403	B1ABCF000044	Transistor	
Q404	B1ABCF000042	Transistor	
Q405	B1ABCF000044	Transistor	

Ref. No.	Part No.	Part Name & Description	Remarks
Q406	B1ABCF000044	Transistor	
Q407	B1ABCF000042	Transistor	
Q408	B1ABCF000044	Transistor	
Q641	B1GBCFJN0005	Transistor	A
Q642	B1GBCFJN0005	Transistor	A
Q711	YEANA124EKT	Transistor	
Q712	B1GBCFJN0005	Transistor	
Q720	YEANB1F3PT	Transistor	
Q721	2SD245300L	Transistor	
Q722	2SB1398QTA	Transistor	
Q723	2SB1398QTA	Transistor	
Q724	B1GDJEGJ0002	Transistor	
Q725	YEANB1F3PT	Transistor	
Q731	B1ABCF000044	Transistor	
Q732	B1GBCFJN0005	Transistor	
Q741	B1BBAC000007	Transistor	
Q771	2SD245300L	Transistor	
Q772	2SD0601AHR	Transistor	
Q773	YEAN2SD1856	Transistor	
Q774	2SB1398QTA	Transistor	
Q775	2SD0601AHR	Transistor	
Q911	YEANB1F3PT	Transistor	
Q912	B1GDJEGJ0002	Transistor	
Q913	2SB1398QTA	Transistor	
Q914	2SD0601AHR	Transistor	
DIODES			
D51	MA3X55500L	Diode	
D71	MA551TX	Diode	
D401	MA151WKTX	Diode	
D402	MAZ32700ML	Diode	
D403	MAZ32700ML	Diode	
D404	MAZ32700ML	Diode	
D601	MA151KTX	Diode	B
D603	MA151KTX	Diode	
D607	MA151KTX	Diode	
D610	MA151WKTX	Diode	
D621	MA741TX	Diode	
D640	MA174TX	Diode	A
D648	MAZ32700ML	Diode	A
D649	MAZ32700ML	Diode	A
D710	B0BA03300012	Diode	
D711	YEADRD91M1T2	Diode	
D712	MA151KTX	Diode	
D731	YEADRD75M2T1	Diode	
D732	MA741TX	Diode	
D733	YEADRD56M3T1	Diode	
D773	YEADRD12M1T1	Diode	
D774	B0BC5R100014	Diode	
D775	B0EANM000002	Diode	
D776	B0EANM000002	Diode	
D779	YEAD10E2	Diode	
D780	MA151KTX	Diode	
D901	MA151KTX	Diode	
CAPACITORS			
C25	YECUS1H220JM	Ceramic, 22PF 50WV	
C26	YECUS1H150JM	Ceramic, 15PF 50WV	
C51	YECUS1H221JM	Ceramic, 220PF 50WV	
C53	ECEA1AKS221I	Electrolytic, 220µF 10WV	
C55	YECUS1E223KX	Ceramic, 0.022µF 25WV	
C56	YECUS1E223KX	Ceramic, 0.022µF 25WV	
C58	YECUS1H102KX	Ceramic, 0.001µF 50WV	
C59	YECUS1H102KX	Ceramic, 0.001µF 50WV	
C60	YECUS1H103KX	Ceramic, 0.01µF 50WV	
C71	YECUS1H221JM	Ceramic, 220PF 50WV	
C101	YECUS1C154KX	Ceramic, 0.15µF 16WV	
C102	YECUS1H153KX	Ceramic, 0.015µF 50WV	
C103	YECUS1C154KX	Ceramic, 0.15µF 16WV	
C105	FLJ1H2R0A007	Ceramic, 2PF 50WV	
C106	YECUS1H101JM	Ceramic, 100PF 50WV	

Ref. No.	Part No.	Part Name & Description	Remarks
C107	YECUS1H272KX	Ceramic, 0.0027µF 50WV	
C162	YECUS1H103KX	Ceramic, 0.01µF 50WV	
C163	YECUS1H103KX	Ceramic, 0.01µF 50WV	
C166	YECUS1H103KX	Ceramic, 0.01µF 50WV	
C201	ECEA1AKS221I	Electrolytic, 220µF 10WV	
C202	ECEA1HKS2R2I	Electrolytic, 2.2µF 50WV	
C203	ECEA1HKS2R2I	Electrolytic, 2.2µF 50WV	
C204	YECUS1H390JM	Ceramic, 39PF 50WV	
C205	ECEA1EKS4R7I	Electrolytic, 4.7µF 25WV	
C206	YECUS1H390JM	Ceramic, 39PF 50WV	
C207	YECUS1H221JM	Ceramic, 220PF 50WV	
C208	YECUS1H681JM	Ceramic, 680PF 50WV	
C209	FLJ1H393A395	Ceramic, 0.039µF 50WV	
C210	ECEA1HKS010I	Electrolytic, 1µF 50WV	
C212	ECEA1ASN100I	Electrolytic, 10µF 10WV	
C213	YECUS1E223KX	Ceramic, 0.022µF 25WV	
C214	ECEA1EKS4R7I	Electrolytic, 4.7µF 25WV	
C215	ECEA1EKS4R7I	Electrolytic, 4.7µF 25WV	
C216	YECUS1H152KX	Ceramic, 0.0015µF 50WV	
C217	YECUS1H682KX	Ceramic, 0.0068µF 50WV	
C218	YECUS1H821JM	Ceramic, 820PF 50WV	
C219	ECEA1ASN100I	Electrolytic, 10µF 10WV	
C220	YECUS1C683KX	Ceramic, 0.068µF 16WV	
C221	ECEA1VSN2R2I	Electrolytic, 2.2µF 35WV	
C222	YECUS1H101JM	Ceramic, 100PF 50WV	
C223	ECEA1ASN100I	Electrolytic, 10µF 10WV	
C224	ECEA1HKS2R2I	Electrolytic, 2.2µF 50WV	
C225	ECEA1CKS100I	Electrolytic, 10µF 16WV	
C230	YECUS1C104KX	Ceramic, 0.1µF 16WV	
C231	YECUS1C104KX	Ceramic, 0.1µF 16WV	
C250	ECEA1HKS2R2I	Electrolytic, 2.2µF 50WV	
C254	ECEA1HKS2R2I	Electrolytic, 2.2µF 50WV	
C260	YECUS1C104KX	Ceramic, 0.1µF 16WV	
C261	YECUS1C104KX	Ceramic, 0.1µF 16WV	
C280	ECEA1HKS2R2I	Electrolytic, 2.2µF 50WV	
C284	ECEA1HKS2R2I	Electrolytic, 2.2µF 50WV	
C302	ECEA1HKS2R2I	Electrolytic, 2.2µF 50WV	
C303	ECEA1HKS2R2I	Electrolytic, 2.2µF 50WV	
C304	YECUS1H390JM	Ceramic, 39PF 50WV	
C305	ECEA1EKS4R7I	Electrolytic, 4.7µF 25WV	
C306	YECUS1H390JM	Ceramic, 39PF 50WV	
C307	YECUS1H221JM	Ceramic, 220PF 50WV	
C308	YECUS1H681JM	Ceramic, 680PF 50WV	
C309	FLJ1H393A395	Ceramic, 0.039µF 50WV	
C310	ECEA1HKS010I	Electrolytic, 1µF 50WV	
C312	ECEA1ASN100I	Electrolytic, 10µF 10WV	
C313	YECUS1E223KX	Ceramic, 0.022µF 25WV	
C314	ECEA1EKS4R7I	Electrolytic, 4.7µF 25WV	
C315	ECEA1EKS4R7I	Electrolytic, 4.7µF 25WV	
C316	YECUS1H152KX	Ceramic, 0.0015µF 50WV	
C317	YECUS1H682KX	Ceramic, 0.0068µF 50WV	
C318	YECUS1H821JM	Ceramic, 820PF 50WV	
C319	ECEA1ASN100I	Electrolytic, 10µF 10WV	
C320	YECUS1C683KX	Ceramic, 0.068µF 16WV	
C321	ECEA1VSN2R2I	Electrolytic, 2.2µF 35WV	
C322	YECUS1H101JM	Ceramic, 100PF 50WV	
C323	ECEA1ASN100I	Electrolytic, 10µF 10WV	
C324	ECEA1HKS2R2I	Electrolytic, 2.2µF 50WV	
C330	YECUS1C104KX	Ceramic, 0.1µF 16WV	
C331	YECUS1C104KX	Ceramic, 0.1µF 16WV	
C350	ECEA1HKS2R2I	Electrolytic, 2.2µF 50WV	
C354	ECEA1HKS2R2I	Electrolytic, 2.2µF 50WV	
C360	YECUS1C104KX	Ceramic, 0.1µF 16WV	
C361	YECUS1C104KX	Ceramic, 0.1µF 16WV	
C380	ECEA1HKS2R2I	Electrolytic, 2.2µF 50WV	
C384	ECEA1HKS2R2I	Electrolytic, 2.2µF 50WV	
C401	YECUS1H100CC	Ceramic, 10PF 50WV	
C402	YECUS1H100CC	Ceramic, 10PF 50WV	
C501	ECEA1CKS100I	Electrolytic, 10µF 16WV	
C502	YECUS1H151JM	Ceramic, 150PF 50WV	
C503	YECUS1H471JM	Ceramic, 470PF 50WV	
C504	YECUS1H153KX	Ceramic, 0.015µF 50WV	
C505	YECUS1H153KX	Ceramic, 0.015µF 50WV	

Ref. No.	Part No.	Part Name & Description	Remarks
C506	YECUS1H103KX	Ceramic, 0.01µF 50WV	
C507	YECUS1H153KX	Ceramic, 0.015µF 50WV	
C508	YECUS1H153KX	Ceramic, 0.015µF 50WV	
C600	YECUS1H103KX	Ceramic, 0.01µF 50WV	
C602	YECUS1C104KX	Ceramic, 0.1µF 16WV	
C603	ECEA0JKS331I	Electrolytic, 330µF 6.3WV	
C604	YECUS1H103KX	Ceramic, 0.01µF 50WV	
C605	YECUS1C104KX	Ceramic, 0.1µF 16WV	
C606	ECEA0JKS101I	Electrolytic, 100µF 6.3WV	
C607	ECEA1ESN4R7	Electrolytic, 4.7µF 25WV	
C608	YECUS1H103KX	Ceramic, 0.01µF 50WV	
C609	YECUS1C104KX	Ceramic, 0.1µF 16WV	
C610	YECUS1H472KX	Ceramic, 0.0047µF 50WV	
C611	YECUS1H103KX	Ceramic, 0.01µF 50WV	
C612	YECUS1H821JM	Ceramic, 820PF 50WV	
C613	ECEA1AKS221I	Electrolytic, 220µF 10WV	
C614	YECUS1C224KX	Ceramic, 0.22µF 16WV	
C615	ECSOHD473H	Electrolytic, 0.047F 5WV	
C616	YECUS1C104KX	Ceramic, 0.1µF 16WV	
C620	YECUS1H220JM	Ceramic, 22PF 50WV	
C621	YECUS1H220JM	Ceramic, 22PF 50WV	
C622	YECUS1H390JM	Ceramic, 39PF 50WV	
C623	YECUS1H220JM	Ceramic, 22PF 50WV	
C710	ECEA1HKS3R3I	Electrolytic, 3.3µF 50WV	
C711	ECEA1AKS470I	Electrolytic, 47µF 10WV	A
C711	ECEA1AKA470I	Electrolytic, 47µF 10WV	B
C712	YECUS1H103KX	Ceramic, 0.01µF 50WV	
C713	YECUS1C104KX	Ceramic, 0.1µF 16WV	
C715	ECEA1CKS100I	Electrolytic, 10µF 16WV	
C716	YECUS1E473KX	Ceramic, 0.047µF 25WV	
C718	ECEA1AKS221I	Electrolytic, 220µF 10WV	
C720	YECUS1H103KX	Ceramic, 0.01µF 50WV	
C725	ECEA1HKS2R2I	Electrolytic, 2.2µF 50WV	
C726	ECEA1AKS101I	Electrolytic, 100µF 10WV	
C727	ECEA1AKS101I	Electrolytic, 100µF 10WV	
C731	ECEA1HKS2R2I	Electrolytic, 2.2µF 50WV	
C732	FLJ1H333A395	Ceramic, 0.033µF 50WV	
C734	ECEA1CKS470I	Electrolytic, 47µF 16WV	
C735	YECUS1C224KX	Ceramic, 0.22µF 16WV	
C741	ECEA1HKS2R2I	Electrolytic, 2.2µF 50WV	
C742	YECUS1H103KX	Ceramic, 0.01µF 50WV	
C744	ECEA1EKS4R7I	Electrolytic, 4.7µF 25WV	
C747	EEAFCLA820H	Electrolytic, 82µF 10WV	
C750	YECUS1C104KX	Ceramic, 0.1µF 16WV	
C751	ECA1AM221I	Electrolytic, 220µF 10WV	
C752	YECUS1E223KX	Ceramic, 0.022µF 25WV	
C753	YECUS1C104KX	Ceramic, 0.1µF 16WV	
C754	YECUS1C104KX	Ceramic, 0.1µF 16WV	
C755	YECUS1H102KX	Ceramic, 0.001µF 50WV	
C758	ECEA0JKS101I	Electrolytic, 100µF 6.3WV	
C759	YECUS1H103KX	Ceramic, 0.01µF 50WV	
C760	ECA1CM102	Electrolytic, 1000µF 16WV	
C761	YECUS1H101JM	Ceramic, 100PF 50WV	
C782	ECEA1AKS221I	Electrolytic, 220µF 10WV	
C783	YECUS1H103KX	Ceramic, 0.01µF 50WV	
C784	YECUS1C224KX	Ceramic, 0.22µF 16WV	
C785	ECEA1CKS220I	Electrolytic, 22µF 16WV	
C786	YECUS1C334KX	Ceramic, 0.33µF 16WV	
C787	YECUS1C334KX	Ceramic, 0.33µF 16WV	
C788	YECUS1C224KX	Ceramic, 0.22µF 16WV	
C790	EEAFCLA820H	Electrolytic, 82µF 10WV	
C901	YECUS1C105ZF	Ceramic, 1µF 16WV	
C902	YECUS1E223KX	Ceramic, 0.022µF 25WV	
C903	YECUS1E223KX	Ceramic, 0.022µF 25WV	
RESISTORS			
J602	ERJ6GEY0R00	Chip, 0Ω 1/10W	
J701	ERJ6GEY0R00	Chip, 0Ω 1/10W	
R34	ERJ6GEYJ473	Chip, 47kΩ 1/10W	
R35	ERJ6GEYJ103	Chip, 10kΩ 1/10W	
R51	ERJ6GEYJ564	Chip, 560kΩ 1/10W	
R52	ERJ6GEYJ564	Chip, 560kΩ 1/10W	

Ref. No.	Part No.	Part Name & Description	Remarks
R55	ERJ6GEYJ103	Chip, 10kΩ 1/10W	
R56	ERJ6GEYJ563	Chip, 56kΩ 1/10W	
R57	ERJ6GEYJ101	Chip, 100Ω 1/10W	
R58	ERJ6GEYJ272	Chip, 2.7kΩ 1/10W	
R59	ERJ6GEYJ562	Chip, 5.6kΩ 1/10W	
R101	ERJ6GEYJ472	Chip, 4.7kΩ 1/10W	
R102	ERJ6GEYJ153	Chip, 15kΩ 1/10W	
R104	ERJ6GEYJ153	Chip, 15kΩ 1/10W	
R105	ERJ6GEYJ101	Chip, 100Ω 1/10W	
R161	ERJ6GEYJ102	Chip, 1kΩ 1/10W	
R162	ERJ6GEYJ102	Chip, 1kΩ 1/10W	
R164	ERJ6GEYJ473	Chip, 47kΩ 1/10W	
R165	ERJ6GEYJ473	Chip, 47kΩ 1/10W	
R167	ERJ6GEYJ473	Chip, 47kΩ 1/10W	
R201	ERJ6GEYJ103	Chip, 10kΩ 1/10W	
R202	ERJ6GEYJ273	Chip, 27kΩ 1/10W	
R203	ERJ6GEYJ122	Chip, 1.2kΩ 1/10W	
R204	ERJ6GEYJ103	Chip, 10kΩ 1/10W	
R205	ERJ6GEYJ103	Chip, 10kΩ 1/10W	
R207	ERJ8GEYJ273V	Chip, 27kΩ 1/8W	
R208	ERJ6GEYJ121	Chip, 120Ω 1/10W	
R209	ERJ6GEYJ152	Chip, 1.5kΩ 1/10W	
R210	ERJ6GEYJ152	Chip, 1.5kΩ 1/10W	
R211	ERJ6GEYJ101	Chip, 100Ω 1/10W	
R212	ERJ6GEYJ101	Chip, 100Ω 1/10W	
R213	ERJ6GEY0R00	Chip, 0Ω 1/10W	
R215	ERJ6GEYJ103	Chip, 10kΩ 1/10W	
R216	ERJ6GEYJ682	Chip, 6.8kΩ 1/10W	
R217	ERJ6GEYJ103	Chip, 10kΩ 1/10W	
R221	ERJ6GEYJ332	Chip, 3.3kΩ 1/10W	
R222	ERJ6GEYJ103	Chip, 10kΩ 1/10W	
R223	ERJ6GEYJ222	Chip, 2.2kΩ 1/10W	
R224	ERJ6GEYJ222	Chip, 2.2kΩ 1/10W	
R231	ERJ6GEYJ683	Chip, 68kΩ 1/10W	
R232	ERJ6GEYJ274	Chip, 270kΩ 1/10W	
R250	ERJ6GEYJ152	Chip, 1.5kΩ 1/10W	
R252	ERJ6GEYJ272	Chip, 2.7kΩ 1/10W	
R253	ERJ6GEYJ102	Chip, 1kΩ 1/10W	
R261	ERJ6GEYJ683	Chip, 68kΩ 1/10W	
R262	ERJ6GEYJ274	Chip, 270kΩ 1/10W	
R280	ERJ6GEYJ152	Chip, 1.5kΩ 1/10W	
R282	ERJ6GEYJ272	Chip, 2.7kΩ 1/10W	
R283	ERJ6GEYJ102	Chip, 1kΩ 1/10W	
R301	ERJ6GEYJ103	Chip, 10kΩ 1/10W	
R302	ERJ6GEYJ273	Chip, 27kΩ 1/10W	
R303	ERJ6GEYJ102	Chip, 1kΩ 1/10W	
R304	ERJ6GEYJ103	Chip, 10kΩ 1/10W	
R305	ERJ6GEYJ103	Chip, 10kΩ 1/10W	
R307	ERJ8GEYJ273V	Chip, 27kΩ 1/8W	
R308	ERJ6GEYJ121	Chip, 120Ω 1/10W	
R309	ERJ6GEYJ152	Chip, 1.5kΩ 1/10W	
R310	ERJ6GEYJ152	Chip, 1.5kΩ 1/10W	
R311	ERJ6GEYJ101	Chip, 100Ω 1/10W	
R312	ERJ6GEYJ101	Chip, 100Ω 1/10W	
R313	ERJ6GEY0R00	Chip, 0Ω 1/10W	
R315	ERJ6GEYJ103	Chip, 10kΩ 1/10W	
R316	ERJ6GEYJ682	Chip, 6.8kΩ 1/10W	
R317	ERJ6GEYJ103	Chip, 10kΩ 1/10W	
R321	ERJ6GEYJ332	Chip, 3.3kΩ 1/10W	
R331	ERJ6GEYJ683	Chip, 68kΩ 1/10W	
R332	ERJ6GEYJ274	Chip, 270kΩ 1/10W	
R350	ERJ6GEYJ152	Chip, 1.5kΩ 1/10W	
R352	ERJ6GEYJ272	Chip, 2.7kΩ 1/10W	
R353	ERJ6GEYJ102	Chip, 1kΩ 1/10W	
R354	ERJ6GEYJ274	Chip, 270kΩ 1/10W	
R355	ERJ6GEYJ274	Chip, 270kΩ 1/10W	
R356	ERJ6GEYJ472	Chip, 4.7kΩ 1/10W	
R357	ERJ6GEYJ182	Chip, 1.8kΩ 1/10W	
R361	ERJ6GEYJ683	Chip, 68kΩ 1/10W	
R362	ERJ6GEYJ274	Chip, 270kΩ 1/10W	
R380	ERJ6GEYJ152	Chip, 1.5kΩ 1/10W	
R382	ERJ6GEYJ272	Chip, 2.7kΩ 1/10W	
R383	ERJ6GEYJ102	Chip, 1kΩ 1/10W	

Ref. No.	Part No.	Part Name & Description	Remarks
R385	ERJ6GEYJ473	Chip, 47kΩ 1/10W	
R401	ERJ6GEYJ472	Chip, 4.7kΩ 1/10W	
R402	ERJ6GEYJ562	Chip, 5.6kΩ 1/10W	
R403	ERJ6GEYJ272	Chip, 2.7kΩ 1/10W	
R404	ERJ6GEYJ102	Chip, 1kΩ 1/10W	
R405	ERJ6GEYJ392	Chip, 3.9kΩ 1/10W	
R406	ERJ6GEYJ122	Chip, 1.2kΩ 1/10W	
R407	ERJ6GEYJ561	Chip, 560Ω 1/10W	
R409	ERJ6GEY0R00	Chip, 0Ω 1/10W	
R410	ERJ6GEYJ272	Chip, 2.7kΩ 1/10W	
R411	ERJ6GEYJ102	Chip, 1kΩ 1/10W	
R412	ERJ6GEYJ392	Chip, 3.9kΩ 1/10W	
R413	ERJ6GEYJ122	Chip, 1.2kΩ 1/10W	
R414	ERJ6GEYJ561	Chip, 560Ω 1/10W	
R501	ERJ6GEYJ822	Chip, 8.2kΩ 1/10W	
R502	ERJ6GEYJ823	Chip, 82kΩ 1/10W	
R503	ERJ6GEYJ104	Chip, 100kΩ 1/10W	
R504	ERJ6GEYJ103	Chip, 10kΩ 1/10W	
R505	ERJ6GEYJ184	Chip, 180kΩ 1/10W	
R506	ERJ6GEYJ103	Chip, 10kΩ 1/10W	
R507	ERJ6GEYJ222	Chip, 2.2kΩ 1/10W	
R508	ERJ6GEYJ222	Chip, 2.2kΩ 1/10W	
R509	ERJ6GEYJ101	Chip, 100Ω 1/10W	
R601	ERJ6GEYJ473	Chip, 47kΩ 1/10W	
R602	ERJ6GEYJ473	Chip, 47kΩ 1/10W	
R603	ERJ6GEYJ473	Chip, 47kΩ 1/10W	
R604	ERJ6GEYJ102	Chip, 1kΩ 1/10W	
R605	ERJ6GEYJ102	Chip, 1kΩ 1/10W	
R606	ERJ6GEYJ102	Chip, 1kΩ 1/10W	
R607	ERJ6GEYJ102	Chip, 1kΩ 1/10W	
R608	ERJ6GEYJ473	Chip, 47kΩ 1/10W	
R609	ERJ6GEYJ222	Chip, 2.2kΩ 1/10W	
R610	ERJ6GEYJ222	Chip, 2.2kΩ 1/10W	
R611	ERJ6GEYJ473	Chip, 47kΩ 1/10W	
R612	ERJ6GEYJ473	Chip, 47kΩ 1/10W	B
R613	ERJ6GEYJ473	Chip, 47kΩ 1/10W	B
R614	ERJ6GEY0R00	Chip, 0Ω 1/10W	
R615	ERJ6GEYJ473	Chip, 47kΩ 1/10W	
R616	ERJ6GEYJ104	Chip, 100kΩ 1/10W	
R617	ERJ6GEYJ564	Chip, 560kΩ 1/10W	
R619	ERJ6GEYJ221	Chip, 220Ω 1/10W	
R620	ERJ6GEYJ220	Chip, 22Ω 1/10W	
R621	ERJ6GEYJ103	Chip, 10kΩ 1/10W	
R622	ERJ6GEYJ105	Chip, 1M Ω 1/10W	
R623	ERJ6GEYJ103	Chip, 10kΩ 1/10W	
R624	ERJ6GEYJ105	Chip, 1M Ω 1/10W	
R625	ERJ6GEYJ182	Chip, 1.8kΩ 1/10W	
R626	ERJ6GEYJ473	Chip, 47kΩ 1/10W	
R627	ERJ6GEY0R00	Chip, 0Ω 1/10W	
R628	ERJ6GEYJ103	Chip, 10kΩ 1/10W	
R631	ERJ6GEYJ183	Chip, 18kΩ 1/10W	
R632	ERJ6GEYJ432	Chip, 4.3kΩ 1/10W	
R633	ERJ6GEYJ152	Chip, 1.5kΩ 1/10W	
R634	ERJ6GEYJ151	Chip, 150Ω 1/10W	
R635	ERJ6GEYJ152	Chip, 1.5kΩ 1/10W	
R636	ERJ6GEYJ152	Chip, 1.5kΩ 1/10W	
R637	ERJ6GEYJ332	Chip, 3.3kΩ 1/10W	
R638	ERJ6GEYJ103	Chip, 10kΩ 1/10W	
R639	ERJ6GEYJ181	Chip, 180Ω 1/10W	A
R640	ERJ6GEYJ181	Chip, 180Ω 1/10W	A
R641	ERJ6GEYJ472	Chip, 4.7kΩ 1/10W	A
R642	ERJ6GEYJ472	Chip, 4.7kΩ 1/10W	A
R643	ERJ6GEYJ472	Chip, 4.7kΩ 1/10W	A
R644	ERJ6GEYJ103	Chip, 10kΩ 1/10W	A
R645	ERJ6GEYJ103	Chip, 10kΩ 1/10W	A
R646	ERJ6GEYJ822	Chip, 8.2kΩ 1/10W	A
R647	ERJ6GEYJ822	Chip, 8.2kΩ 1/10W	A
R648	ERJ6GEYJ472	Chip, 4.7kΩ 1/10W	A
R649	ERJ6GEY0R00	Chip, 0Ω 1/10W	
R650	ERJ6GEY0R00	Chip, 0Ω 1/10W	
R651	ERJ6GEY0R00	Chip, 0Ω 1/10W	
R653	ERJ6GEYJ473	Chip, 47kΩ 1/10W	
R654	ERJ6GEYJ102	Chip, 1kΩ 1/10W	

Ref. No.	Part No.	Part Name & Description	Remarks
R656	ERJ6GEYJ473	Chip, 47kΩ 1/10W	
R663	ERJ6GEYJ472	Chip, 4.7kΩ 1/10W	
R664	ERJ6GEYJ472	Chip, 4.7kΩ 1/10W	
R665	ERJ6GEYJ472	Chip, 4.7kΩ 1/10W	
R666	ERJ6GEYJ472	Chip, 4.7kΩ 1/10W	
R671	ERJ6GEYJ102	Chip, 1kΩ 1/10W	
R672	ERJ6GEYJ102	Chip, 1kΩ 1/10W	
R673	ERJ6GEYJ102	Chip, 1kΩ 1/10W	
R715	ERX12SJR22V	Metal Film, 0.22Ω 1/2W	
R716	ERJ6GEYJ123	Chip, 12kΩ 1/10W	
R717	ERJ6GEYJ123	Chip, 12kΩ 1/10W	
R718	ERJ6GEYJ222	Chip, 2.2kΩ 1/10W	
R719	ERJ6GEYJ222	Chip, 2.2kΩ 1/10W	
R721	ERJ8GEYJ391V	Chip, 390Ω 1/8W	
R722	ERJ8GEYJ1R0V	Chip, 1.0Ω 1/8W	
R723	ERJ8GEYJ102V	Chip, 1kΩ 1/8W	
R724	ERJ6GEYJ333	Chip, 33kΩ 1/10W	
R728	ERJ6GEYJ222	Chip, 2.2kΩ 1/10W	
R729	ERJ6GEYJ222	Chip, 2.2kΩ 1/10W	
R730	ERJ8GEYJ102V	Chip, 1kΩ 1/8W	
R731	ERJ6GEYJ103	Chip, 10kΩ 1/10W	
R732	ERX1SJR2P	Metal Film, 2.2Ω 1/2W	
R733	ERX1SJR2P	Metal Film, 2.2Ω 1/2W	
R734	ERJ6GEYJ103	Chip, 10kΩ 1/10W	
R735	ERJ6GEYJ334	Chip, 330kΩ 1/10W	
R736	ERJ6GEYJ683	Chip, 68kΩ 1/10W	
R737	ERJ6GEYJ333	Chip, 33kΩ 1/10W	
R738	ERJ6GEYJ333	Chip, 33kΩ 1/10W	
R740	ERJ6GEYJ273	Chip, 27kΩ 1/10W	
R741	ERJ8GEYJ2R2V	Chip, 2.2Ω 1/8W	
R742	ERJ6GEYJ333	Chip, 33kΩ 1/10W	
R743	ERJ6GEYJ333	Chip, 33kΩ 1/10W	
R744	ERJ6GEYJ473	Chip, 47kΩ 1/10W	
R747	ERJ6GEYJ103	Chip, 10kΩ 1/10W	
R748	ERJ6GEYJ123	Chip, 12kΩ 1/10W	
R749	ERJ6GEYJ103	Chip, 10kΩ 1/10W	
R750	ERJ6GEYJ123	Chip, 12kΩ 1/10W	
R751	ERJ6GEYJ222	Chip, 2.2kΩ 1/10W	
R752	ERJ6GEYJ222	Chip, 2.2kΩ 1/10W	
R753	ERJ6GEYJ222	Chip, 2.2kΩ 1/10W	
R754	ERJ6GEYJ222	Chip, 2.2kΩ 1/10W	
R755	ERJ6GEYJ222	Chip, 2.2kΩ 1/10W	
R756	ERJ6GEYJ222	Chip, 2.2kΩ 1/10W	
R757	ERJ8GEYJ561V	Chip, 560Ω 1/8W	
R758	ERJ8GEYJ561V	Chip, 560Ω 1/8W	
R759	ERJ8GEYJ561V	Chip, 560Ω 1/8W	
R760	ERJ8GEYJ561V	Chip, 560Ω 1/8W	
R771	ERJ8GEYJ391V	Chip, 390Ω 1/8W	
R772	ERJ8GEYJ122V	Chip, 1.2kΩ 1/8W	
R773	ERJ6GEYJ182	Chip, 1.8kΩ 1/10W	
R774	ERJ6GEYJ102	Chip, 1kΩ 1/10W	
R775	ERJ6GEYJ473	Chip, 47kΩ 1/10W	
R779	ERJ6GEYJ471	Chip, 470Ω 1/10W	
R780	ERJ6GEYJ103	Chip, 10kΩ 1/10W	
R781	ERJ8GEYJ102V	Chip, 1kΩ 1/8W	
R782	ERJ6GEYJ103	Chip, 10kΩ 1/10W	
R783	ERJ6GEYJ472	Chip, 4.7kΩ 1/10W	
R901	ERJ6GEYJ220	Chip, 22Ω 1/10W	
R902	ERJ6GEYJ473	Chip, 47kΩ 1/10W	
R903	ERJ6GEYJ473	Chip, 47kΩ 1/10W	
R904	ERJ6GEYJ471	Chip, 470Ω 1/10W	
R905	ERJ6GEYJ471	Chip, 470Ω 1/10W	
R906	ERJ6GEYJ471	Chip, 470Ω 1/10W	
R907	ERJ6GEYJ471	Chip, 470Ω 1/10W	
R943	ERJ8GEYJ102V	Chip, 1kΩ 1/8W	
R944	ERJ8GEYJ102V	Chip, 1kΩ 1/8W	
R945	ERJ6GEYJ103	Chip, 10kΩ 1/10W	
R946	ERJ6GEYJ472	Chip, 4.7kΩ 1/10W	
R947	ERJ6GEYJ103	Chip, 10kΩ 1/10W	
R948	ERX1SJ1R0	Metal Film, 1.0Ω 1/2W	
R950	ERJ8GEYJ1R2V	Chip, 1.2Ω 1/8W	
R951	ERJ8GEYJ1R2V	Chip, 1.2Ω 1/8W	
R952	ERJ8GEYJ4R7V	Chip, 4.7Ω 1/8W	

Ref. No.	Part No.	Part Name & Description	Remarks
R953	ERJ8GEYJ4R7V	Chip, 4.7Ω 1/8W	
R954	ERJ8GEYJ4R7V	Chip, 4.7Ω 1/8W	
R955	ERJ8GEYJ4R7V	Chip, 4.7Ω 1/8W	
R956	ERJ8GEYJ3R3V	Chip, 3.3Ω 1/8W	
R957	ERJ8GEYJ4R7V	Chip, 4.7Ω 1/8W	
R958	ERJ8GEYJ3R3V	Chip, 3.3Ω 1/8W	
R959	ERJ8GEYJ4R7V	Chip, 4.7Ω 1/8W	
R960	ERDS1FJ270	Carbon, 27Ω 1/2W	
R961	ERDS1FJ470	Carbon, 47Ω 1/2W	
R962	ERGL1SJ150P	Metal Oxid, 15Ω 1W	
R963	ERGL1SJ150P	Metal Oxid, 15Ω 1W	
R964	ERGL1SJ120P	Metal Oxid, 12Ω 1W	
R965	ERGL1SJ120P	Metal Oxid, 12Ω 1W	
CONNECTORS			
CN1	K9ZZ00000039	Flat Cable, 14P	
CN201	YEAEK623214S	Connector, 14P	
CN401	YEAE012081A	Connector, 8P DIN	
CN403	YEAE06402AL	Connector, 6P	A
CN701	YEAETKCF16QS	Connector, 16P	
CN901	K1KA08B00189	Connector, 8P	
CN902	K1KA08B00189	Connector, 8P	
CP901	YEAETKCF08XY	Connector, 8P	
CP902	YEAETKCF08XY	Connector, 8P	
SWITCHES			
SW1	YEAS08042	Switch	
SW901	KOF111A00336	Switch	
SW902	KOF111A00336	Switch	
SW905	KOF111A00336	Switch	
SW906	KOF111A00336	Switch	
SW907	KOF111A00336	Switch	
SW908	KOF111A00336	Switch	
SW909	KOF111A00336	Switch	
SW910	KOF111A00336	Switch	
SW911	KOF111A00336	Switch	
SW912	KOH1BA000370	Switch	B
SW913	KOF111A00336	Switch	
SW914	KOF111A00336	Switch	
SW915	KOF111A00336	Switch	
SW916	KOF111A00336	Switch	
SW917	EVQBSW00415B	Switch	
SW918	EVQBSW06309B	Switch	
LCD			
LCD901	L5AAAGC00033	LCD	
COILS			
L51	YELT02M1R8KT	Coil	
L52	G1C3R3K00003	Coil	
L71	G1C3R3K00003	Coil	
L101	YELT02MR82KT	Coil	
L163	G1C3R3K00003	Coil	
L501	G1C3R3K00003	Coil	
L502	G1C3R3K00003	Coil	
L601	YELT03N5R6KT	Coil	
L602	G1C3R3K00003	Coil	
L603	G1C3R3K00003	Coil	
L604	G1C3R3K00003	Coil	
L605	G1C3R3K00003	Coil	
L751	JOJCC0000012	Coil	
L752	JOJCC0000012	Coil	
L753	YELTBMHS800T	Coil	
CRYSTALS			
XL20	YEXL49U072TA	Crystal	
XL601	YEXL49U0419S	Crystal	

Ref. No.	Part No.	Part Name & Description	Remarks
XL602	YEXLMC60327	Crystal	
LAMPs			
PL901	YEALHSIB045	Pilot Lamp	
PL902	YEALHSIB045	Pilot Lamp	
PL903	YEALHSIB024	Pilot Lamp	
PL904	YEALHSIB024	Pilot Lamp	
PL905	YEALHSIB024	Pilot Lamp	
PL906	YEALHSIB024	Pilot Lamp	
PL907	YEALHSLB010	Pilot Lamp	
PL908	YEALHSIB024	Pilot Lamp	
PL909	YEALHSLB010	Pilot Lamp	
PL910	YEALSRMB011	Pilot Lamp	
Z51	J0LE00000004	ZNR	
Z71	J0LE00000004	ZNR	
NETWORK RESISTORS			
RA600	EXBV8V471JV	Network Resistor	
RA601	EXBV8V222JV	Network Resistor	
RA602	EXBV8V222JV	Network Resistor	
RA603	EXBV8V222JV	Network Resistor	
RA604	EXBV8V222JV	Network Resistor	
RA605	EXBV8V222JV	Network Resistor	
RA606	EXBV8V222JV	Network Resistor	
RA607	EXBV8V222JV	Network Resistor	
RA608	EXBV8V222JV	Network Resistor	
RA609	EXBV8V222JV	Network Resistor	
RA610	EXBV8V222JV	Network Resistor	
RA611	EXBV8V473JV	Network Resistor	
RA612	EXBV8V222JV	Network Resistor	
RA613	EXBV8V222JV	Network Resistor	
THERMISTERS			
R415	D4ZZ00000015	Thermister	
R739	D4ZZ00000015	Thermister	
[E9044] AMP Block			
IC's and TRANSISTORS			
IC208	C0ABC0000015	IC	
Q701	B1GBCFJN0005	Transistor	
Q702	YEANA124EKT	Transistor	
DIODES			
D250	MA153TX	Diode	
D280	MA153TX	Diode	
D350	MA153TX	Diode	
D380	MA153TX	Diode	
D771	YEADZSA5A27	Diode	
D772	B0EANM000002	Diode	
D773	YEADNSQ03A02	Diode	
D774	YEADSR1544TL	Diode	
CAPACITORS			
C255	YECUS1H330JM	Ceramic, 33PF 50WV	
C256	ECEALEKS4R7B	Electrolytic, 4.7µF 25WV	
C285	YECUS1H330JM	Ceramic, 33PF 50WV	
C286	ECEALEKS4R7B	Electrolytic, 4.7µF 25WV	
C355	YECUS1H330JM	Ceramic, 33PF 50WV	
C356	ECEALEKS4R7B	Electrolytic, 4.7µF 25WV	
C385	YECUS1H330JM	Ceramic, 33PF 50WV	
C386	ECEALEKS4R7B	Electrolytic, 4.7µF 25WV	
C707	YECUS1H472KX	Ceramic, 0.0047µF 50WV	
C723	ECEA0JKS331Q	Electrolytic, 330µF 6.3WV	
C728	ECEA1AKS101	Electrolytic, 100µF 10WV	
C764	YECUS1H103KX	Ceramic, 0.01µF 50WV	
C792	YECUS1H103KX	Ceramic, 0.01µF 50WV	
C793	ECA1CM471	Electrolytic, 470µF 16WV	

Ref. No.	Part No.	Part Name & Description	Remarks
C794	ECA1CM471	Electrolytic, 470µF 16WV	
C795	ECA1CM471	Electrolytic, 470µF 16WV	
C796	YECUV2A103KX	Ceramic, 0.01µF 100WV	
C797	ECA1HM100I	Electrolytic, 10µF 50WV	
C798	YECUV2A103KX	Ceramic, 0.01µF 100WV	
RESISTORS			
J201	ERJ6GEY0R00	Chip, 0Ω 1/10W	
J202	ERJ6GEY0R00	Chip, 0Ω 1/10W	
J204	ERJ6GEY0R00	Chip, 0Ω 1/10W	
J205	ERJ6GEY0R00	Chip, 0Ω 1/10W	
J211	ERJ8GEY0R00V	Chip, 0Ω 1/8W	
J212	ERJ8GEY0R00V	Chip, 0Ω 1/8W	
J213	ERJ8GEY0R00V	Chip, 0Ω 1/8W	
J214	ERJ8GEY0R00V	Chip, 0Ω 1/8W	
J702	ERJ8GEY0R00V	Chip, 0Ω 1/8W	
R249	ERJ6GEYJ181	Chip, 180Ω 1/10W	
R258	ERJ6GEYJ223	Chip, 22kΩ 1/10W	
R259	ERJ6GEYJ333	Chip, 33kΩ 1/10W	
R269	ERJ6GEYJ224	Chip, 220kΩ 1/10W	
R279	ERJ6GEYJ181	Chip, 180Ω 1/10W	
R288	ERJ6GEYJ223	Chip, 22kΩ 1/10W	
R289	ERJ6GEYJ333	Chip, 33kΩ 1/10W	
R299	ERJ6GEYJ224	Chip, 220kΩ 1/10W	
R349	ERJ6GEYJ181	Chip, 180Ω 1/10W	
R358	ERJ6GEYJ223	Chip, 22kΩ 1/10W	
R359	ERJ6GEYJ333	Chip, 33kΩ 1/10W	
R369	ERJ6GEYJ224	Chip, 220kΩ 1/10W	
R379	ERJ6GEYJ181	Chip, 180Ω 1/10W	
R388	ERJ6GEYJ223	Chip, 22kΩ 1/10W	
R389	ERJ6GEYJ333	Chip, 33kΩ 1/10W	
R399	ERJ6GEYJ224	Chip, 220kΩ 1/10W	
R701	ERX12SJR22E	Metal Film, 0.22Ω 1/2W	
R702	ERX12SJR22E	Metal Film, 0.22Ω 1/2W	
R703	ERJ8GEYJ472V	Chip, 4.7kΩ 1/8W	
R707	ERJ6GEYJ102	Chip, 1kΩ 1/10W	
R708	ERJ8GEYJ563V	Chip, 56kΩ 1/8W	
R716	ERJ8GEYJ223V	Chip, 22kΩ 1/8W	
R721	ERJ6GEYJ102	Chip, 1kΩ 1/10W	
R722	ERJ6GEYJ122	Chip, 1.2kΩ 1/10W	
R727	ERJ6GEYJ220	Chip, 22Ω 1/10W	
CONNECTORS			
CJ701	K1K1A16B00077	Connector, 16P	
CJ703	YEAE14SDLYS	Connector, 14P	
CJ704	YEAE012458	Connector, 6P	
COILS			
L701	G0A201E00001	Coil	
L702	G0A201E00001	Coil	
[E8746C] CD Servo Block			
IC's and TRANSISTORS			
IC101	C1BB00000173	IC	
IC201	MN662748RPMF	IC	
IC401	MN101C117AF	IC	
IC601	C0GBY0000004	IC	
IC901	C0GBY0000003	IC	
Q1	YEADPS1101W	Transistor	
Q3	YEADPS1101W	Transistor	
Q6	YEADPS1101W	Transistor	
Q101	2SB766ATX	Transistor	
Q451	YEANCI13ZKTX	Transistor	
DIODES			
D1	YEADAN1102W	Diode	
D3	YEADAN1102W	Diode	
D6	YEADAN1102W	Diode	

Ref. No.	Part No.	Part Name & Description	Remarks
D201	YEAD1SS355T1	Diode	
D401	MA151WKTX	Diode	
D601	YEAD1SS355T1	Diode	
CAPACITORS			
C101	YECUZ1C104KX	Ceramic, 0.1µF 16WV	
C102	YECUZ1C104KX	Ceramic, 0.1µF 16WV	
C103	F3H0J107A001	Ceramic, 100µF 6.3WV	
C104	YECUZ1C104KX	Ceramic, 0.1µF 16WV	
C105	ECSH0JY475CR	Tantalum, 4.7µF 6.3WV	
C106	FIH1E273A011	Ceramic, 0.027µF 25WV	
C107	FIH1H152A201	Ceramic, 0.0015µF 50WV	
C108	YECUZ1H472KX	Ceramic, 0.0047µF 50WV	
C109	YECUZ1H102KX	Ceramic, 0.001µF 50WV	
C110	YECUZ1H102KX	Ceramic, 0.001µF 50WV	
C111	YECUS1A106MA	Tantalum, 10µF 10WV	
C112	YECUZ1C104KX	Ceramic, 0.1µF 16WV	
C113	YECUZ1C104KX	Ceramic, 0.1µF 16WV	
C115	YECUZ1H102KX	Ceramic, 0.001µF 50WV	
C116	YECUZ1H102KX	Ceramic, 0.001µF 50WV	
C117	YECUS1A105KX	Ceramic, 1µF 10WV	
C118	FIH1H681A201	Ceramic, 680PF 50WV	
C119	YECUZ1C104KX	Ceramic, 0.1µF 16WV	
C120	YECUZ1H561KX	Ceramic, 560PF 50WV	
C121	YECUZ1E123KX	Ceramic, 0.012µF 25WV	
C122	YECUZ1C104KX	Ceramic, 0.1µF 16WV	
C133	YECUZ1C104KX	Ceramic, 0.1µF 16WV	
C145	YECUZ1A124KX	Ceramic, 0.12µF 10WV	
C201	YECUZ1E123KX	Ceramic, 0.012µF 25WV	
C203	YECUS1C334KX	Ceramic, 0.33µF 16WV	
C204	YECUZ1C104KX	Ceramic, 0.1µF 16WV	
C205	YECUS1A106MA	Tantalum, 10µF 10WV	
C206	FIH1A4740004	Ceramic, 0.47µF 10WV	
C208	YECUZ1C104KX	Ceramic, 0.1µF 16WV	
C209	YECUZ1C104KX	Ceramic, 0.1µF 16WV	
C210	YECUS1A106MA	Tantalum, 10µF 10WV	
C214	YECUS1C334KX	Ceramic, 0.33µF 16WV	
C451	FIH1A4740004	Ceramic, 0.47µF 50WV	
C453	YECUZ1H103KX	Ceramic, 0.01µF 50WV	
C601	YECUS1C334KX	Ceramic, 0.33µF 16WV	
C602	ECEV1CA470SP	Electrolytic, 47µF 16WV	
C603	YECUZ1C104KX	Ceramic, 0.1µF 16WV	
C605	YECUS1A105KX	Ceramic, 1µF 10WV	
C606	YECUZ1H272KX	Ceramic, 0.0027µF 50WV	
C901	YECUS1C334KX	Ceramic, 0.33µF 16WV	
C903	YECUZ1C333KX	Ceramic, 0.033µF 16WV	
RESISTORS			
J403	ERJ3GEY0R00V	Chip, 0Ω 1/16W	
J423	ERJ3GEY0R00V	Chip, 0Ω 1/16W	
R101	ERJ3GEYJ101V	Chip, 100Ω 1/16W	
R102	ERJ14YJ330H	Chip, 33Ω 1/4W	
R103	ERJ3GEYJ683V	Chip, 68kΩ 1/16W	
R104	ERJ3GEYJ683V	Chip, 68kΩ 1/16W	
R105	ERJ3GEYJ333V	Chip, 33kΩ 1/16W	
R106	ERJ3GEYJ184V	Chip, 180kΩ 1/16W	
R107	ERJ3GEYJ184V	Chip, 180kΩ 1/16W	
R108	ERJ3GEYJ823V	Chip, 82kΩ 1/16W	
R109	ERJ3GEYJ334V	Chip, 330kΩ 1/16W	
R110	ERJ3GEYJ102V	Chip, 1kΩ 1/16W	
R111	ERJ3GEYJ102V	Chip, 1kΩ 1/16W	
R112	ERJ3GEYJ393V	Chip, 39kΩ 1/16W	
R113	ERJ3GEYJ333V	Chip, 33kΩ 1/16W	
R114	ERJ3GEYJ153V	Chip, 15kΩ 1/16W	
R119	ERJ3GEYJ184V	Chip, 180kΩ 1/16W	
R120	ERJ3GEYJ333V	Chip, 33kΩ 1/16W	
R147	ERJ3GEYJ153V	Chip, 15kΩ 1/16W	
R207	ERJ3GEYJ473V	Chip, 47kΩ 1/16W	
R208	ERJ3GEYJ473V	Chip, 47kΩ 1/16W	
R209	ERJ3GEYJ391V	Chip, 390Ω 1/16W	
R210	ERJ3GEYJ334V	Chip, 330kΩ 1/16W	

Ref. No.	Part No.	Part Name & Description	Remarks
R211	ERJ3GEYJ124V	Chip, 120kΩ 1/16W	
R213	ERJ3GEYJ470V	Chip, 47Ω 1/16W	
R214	ERJ3GEYJ272V	Chip, 2.7kΩ 1/16W	
R215	ERJ3GEYJ473V	Chip, 47kΩ 1/16W	
R401	ERJ3GEYJ563V	Chip, 56kΩ 1/16W	
R402	ERJ3GEYJ563V	Chip, 56kΩ 1/16W	
R404	ERJ3GEYJ473V	Chip, 47kΩ 1/16W	
R411	ERJ3GEYJ334V	Chip, 330kΩ 1/16W	
R454	ERJ6GEYJ271	Chip, 270Ω 1/10W	
R456	ERJ3GEYJ472V	Chip, 4.7kΩ 1/16W	
R461	ERJ3GEYJ823V	Chip, 82kΩ 1/16W	
R463	ERJ3GEYJ823V	Chip, 82kΩ 1/16W	
R466	ERJ3GEYJ823V	Chip, 82kΩ 1/16W	
R471	ERJ8GEYJ121V	Chip, 120Ω 1/8W	
R473	ERJ8GEYJ121V	Chip, 120Ω 1/8W	
R476	ERJ8GEYJ121V	Chip, 120Ω 1/8W	
R477	ERJ8GEY0R00V	Chip, 0Ω 1/8W	
R481	ERJ3GEYJ104V	Chip, 100kΩ 1/16W	
R601	ERJ3GEYJ123V	Chip, 12kΩ 1/16W	
R602	ERJ3GEYJ103V	Chip, 10kΩ 1/16W	
R603	ERJ3GEYJ273V	Chip, 27kΩ 1/16W	
R604	ERJ3GEYJ124V	Chip, 120kΩ 1/16W	
R605	ERJ3GEYJ103V	Chip, 10kΩ 1/16W	
R606	ERJ3GEYJ822V	Chip, 8.2kΩ 1/16W	
R607	ERJ3GEYJ103V	Chip, 10kΩ 1/16W	
R608	ERJ3GEYJ103V	Chip, 10kΩ 1/16W	
R609	ERJ3GEYJ472V	Chip, 4.7kΩ 1/16W	
R610	ERJ3GEYJ472V	Chip, 4.7kΩ 1/16W	
R613	ERJ3GEYJ122V	Chip, 1.2kΩ 1/16W	
R901	ERJ3GEYJ103V	Chip, 10kΩ 1/16W	
R902	ERJ3GEYJ333V	Chip, 33kΩ 1/16W	
R903	ERJ3GEYJ122V	Chip, 1.2kΩ 1/16W	
R924	ERJ3GEY0R00V	Chip, 0Ω 1/16W	
R934	ERJ3GEY0R00V	Chip, 0Ω 1/16W	
CONNECTORS			
CN101	YEAESFW15R2E	Connector, 15P	
CN402	K1MN14B00028	Connector, 14P	
CN901	K1MN05B00010	Connector, 5P	
CN902	K1MN05B00009	Connector, 5P	
SWITCHES			
SW2	ESE102MH2	Switch	
SW4	YEAS09275	Switch	
COIL			
L451	YELTBLM21A10	Coil	
CRYSTALS			
XL201	H2D169500005	Crystal	
XL451	YEXLSTCC419T	Crystal	
Mechanical Parts			
MISCELLANEOUS			
AJ1	YEAJ071287	Cord w/Plug	
AJ2	YEAJ071285	Cord w/Plug	
AJ51	YEAA10066	Antenna Receptacle	
AJ71	YEAA10074A	Antenna Receptacle	
AP1	YEAP2711	FPC	
AT1	YEAT05014	Terminal	
TP1	YEAT03346A	Terminal	
1	YEFA031524	Upper Cover	
2	YEF02307	Felt	
3	YEFX0215221	Bracket, Deck	
4	YEP0PT8746B0	PCB w/Component	RTL

Ref. No.	Part No.	Part Name & Description	Remarks
5	YEFA08501	Rear Plate	A
5	YEFA08502	Rear Plate	B
8	YEFLO2592	Spacer	
9	YEOPT9044A0	PCB w/Component	RTL, A
9	YEOPT9044B0	PCB w/Component	RTL, B
11	YEFA09551	Side Plate	
12	YEFA09663	Side Plate	
13	YEFX0213488	Bracket, CN401	
14	YEFX0214202	Bracket, IC704	
15	YEFX0212830	Bracket, Q773	
16	YEFX0214200	Bracket, ANT	
17	YEFX0213232B	Bracket, AJ71	
18	YEFX0213797	Bracket, GND	
19	YEOPT6849B0	PCB w/Component	RTL, A
19	YEOPT6849A0	PCB w/Component	RTL, B
20	YEFE07497	Knob, PWR/VOL.	
21	YEFE07498	Knob, TUNE/AUDIO	
22	YEF027247A	Escucheon Ass'y	A
22	YEF027246A	Escucheon Ass'y	B
23	YEFA131568	Case, LCD	
24	YEFV021785	Optical Shade	
25	YEFX0012129A	Transparent Plate	
26	YEFK06971	Holder, LCD	
27	YEFA07559A	Front Plate	
28	YEFX9991346	Bracket, GND	
29	YEFA05669	Bottom Cover	
41	YEJS06093	Screw, M3x6mm	
42	YEJS06278	Screw,	
43	YEJS06027	Screw, M3x4mm	
45	YEJT03015	Tapping Screw, M3x6mm	
46	YEJT03131	Tapping Screw, M2.6x5mm	
47	YEJT03141	Tapping Screw, M3x8mm	
49	XTB3+6FFX	Tapping Screw, M3x6mm	
50	XTB3+8FFX	Tapping Screw, M3x8mm	
52	YEJT03263	Tapping Screw, M2.8x5mm	
53	XTB2+8GFX	Tapping Screw, M2x8mm	
54	YEJT01089	Tapping Screw,	A
55	XYN2+J4FX	Tapping Screw, M2x4mm	

10 EXPLODED VIEW (Unit)

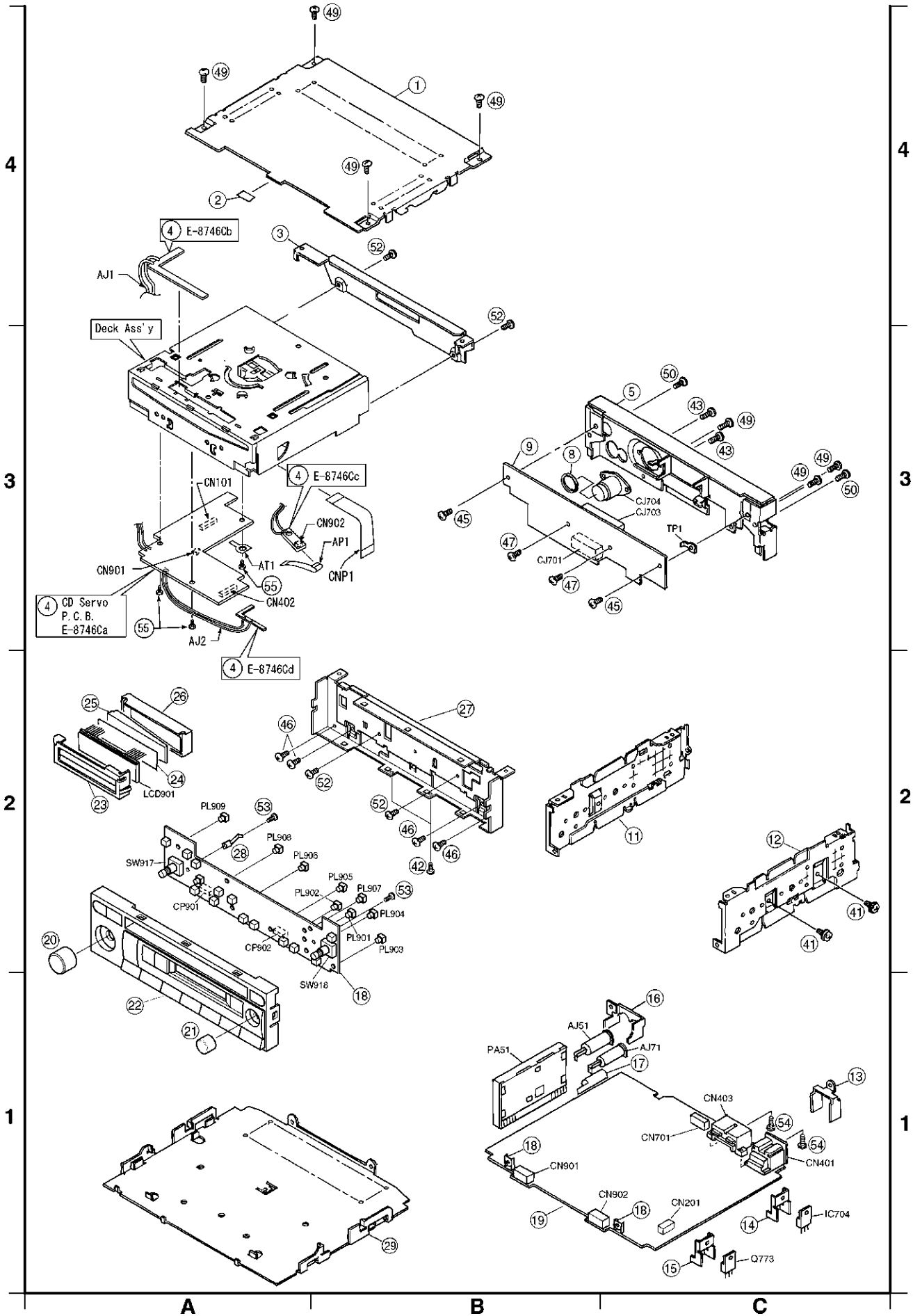

11 CD PLAYER PARTS

MISCELLANEOUS

Ref. No.	Part No.	Part Name & Description	Remarks
1	YGFA011781	Upper Chassis	(4-A)
2	YGFX236153	Disk Guide	(4-A)
3	YGFX0462017	Link Lever	(4-A)
4	YGFX0462018	Detection Lever (2)	(4-B)
5	YGFX0052357	Detection Lever (2) Spring	(4-B)
6	YEJT03131	Tapping Screw, 2.6 mm* 5mm	(2-C) (2-B)
7	YGFX249461	Clamp Arm	(3-A)
8	YGFX007640	Clamper	(3-A)
9	YGFX0052363	Clamper Spring Plate	(3-A)
10	YEFX999957	Ball Bearing	(3-A)
11	YGFX0462013	Detection Lever (1)	(3-A)
12	YGFX0052352	Detection Lever (1) Spring	(3-A)
13	YGFA011795	Suspension Chassis Ass'y	(3-A)
14	YESFD13006	Optical Pick-up Ass'y	(3-B)
15	YEFW04150	Feed Screw Housing A	(2-B)
16	YEFW04137A	Feed Screw Housing B	(2-B)
17	YGFX0052386	Thrust Adjusting Spring	(2-B)
18	YEFX236144B	Traverse Guide	(3-A)
19	YGFX9992027	Feed Screw Carrier	(3-B)
20	YEFX9991458A	FPC Holder	(2-A)
21	YGJT03240	Traverse Gear Ass'y	(2-B)
22	YEJS02037	Screw, (Pick-up)	(3-A) (3-B)
23	XYN2+C5FX	Screw, (FPC) 2mm * 5mm	(2-A)
24	XYN2+J10FX	Screw, (Housing) 2mm * 10m	(2-B)
25	YEFX0051590	Spring Washer	(3-A)
26	XUC15V	Retaining Ring, 1.5mm	(3-A)
27	YEFX9991806A	Sealed Plate	(3-B)
28	YGPOFX3503	Traverse Motor Ass'y	(2-B)
29	YEAS23151A	Inner Switch	(2-B)
30	YEFR03080	Rubber Belt	(2-B)
31	YEFX026124A	Idler Pulley	(2-B)
32	YGFX018611	Motor Bracket Ass'y	(2-B)
33	YEJS02018FZ	Screw, (SW)	(2-B)
34	XQN2+A25FX	Screw, 2mm * 25mm	(2-B)
35	YGPOFX3529	Spindle Motor Ass'y	(2-A)
36	YEFX0051991C	Spring (Motor)	(2-A)
37	YGFX0052353	Clamper Spring	(2-A)
38	YGAJ071286	Motor Cable	(2-A)
39	XQN17+A25FX	Screw, 1.7mm * 25mm	(3-A)
40	YGFX0462019	Feeder Arm Ass'y	(1-A)
41	YGPOFX3507	Roller Gear Ass'y	(2-B)
42	YEFW04144	Roller Shaft Collar (1)	(2-A)
43	YEFW04138	Roller Shaft Collar (2)	(2-A)
44	YEFX218282	Rubber Roller	(2-A)
45	YEJW04128	Washer	(2-A)
46	YGFX0052362	Spring (Feeder Arm)	(1-A)
47	YGFX0462015	Suspension Lock Plate (L)	(1-A)
48	YGPOFX3504	Suspension Lock Plate (R) Ass'y	(1-B)
49	YGFX0052355	Spring (Rack Gear)	(1-A)
50	YGFX0052356	Spring (Rack Lock Lever)	(1-B)
51	YGFX0052360	Spring (Suspension Lock Plate L)	(1-A)
52	YGFX0052361	Spring (Lock Plate)	(3-C)
53	YGFA011779	Bottom Chassis Ass'y	(3-C)
54	YGFX003940	Driving Gear (1)	(3-C)
55	YGFX003941	Driving Gear (2)	(3-C)
56	YGPOFX3506	Loding Motor Ass'y	(3-C)
57	YGFX018605	Loding Motor Bracket Ass'y	(3-C)
58	XQN2+A25FX	Screw, (Motor) 2mm * 25mm	(3-C)
59	YEJS06188	Screw	(2-C)
60	YEF04693	Oil Dumper	(1-C)
61	YGFX0052358	Suspension Spring (A)	(2-C)
62	YGFX0052359	Suspension Spring (B)	(2-C)

12 EXPLODED VIEW (CD Deck)

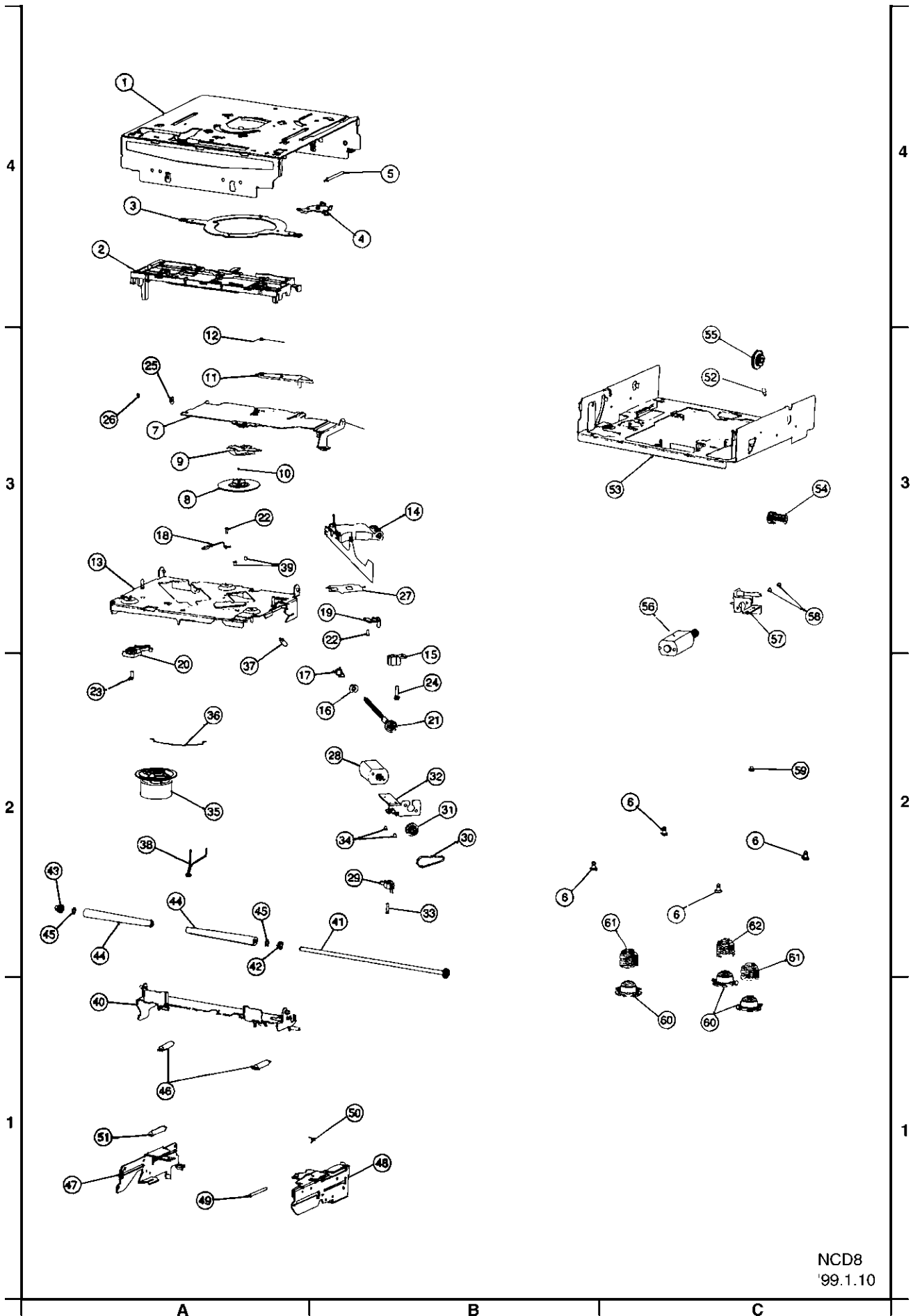

NCD8
'99.1.10

13 WIRING DIAGRAM

13.1. Main Block (Top View)

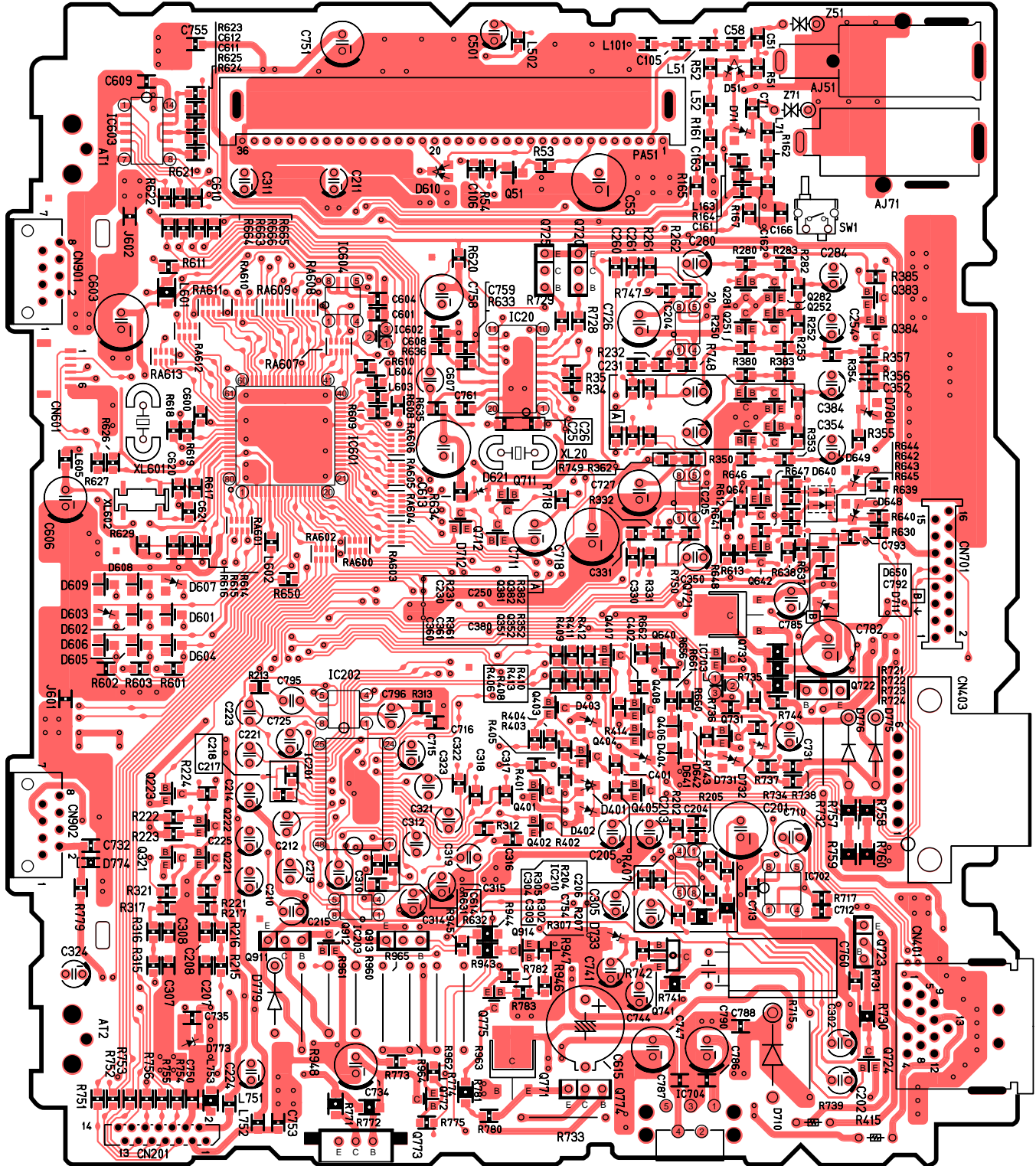

[E-6849Aa][Top View]

13.2. Main Block (Bottom View)

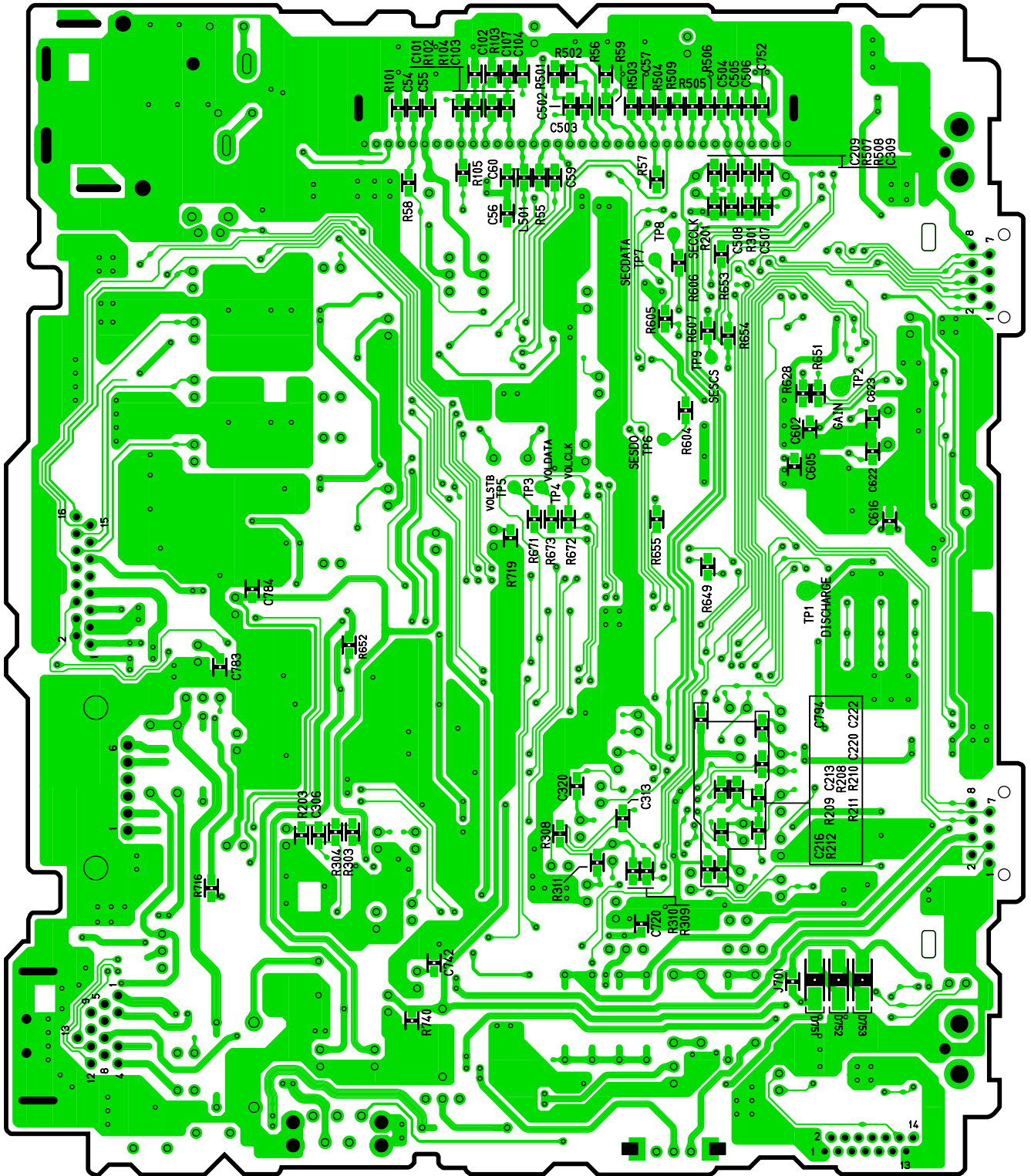

[E-6849Aa][Bottom View]

13.3. Display Block

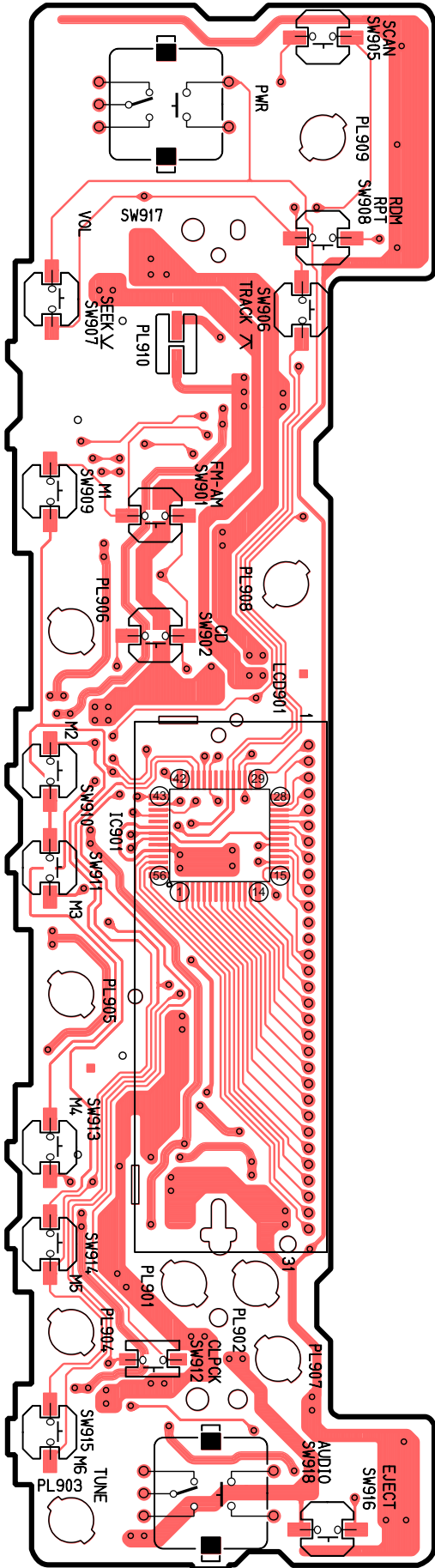

[E-6849Ab][Top View]

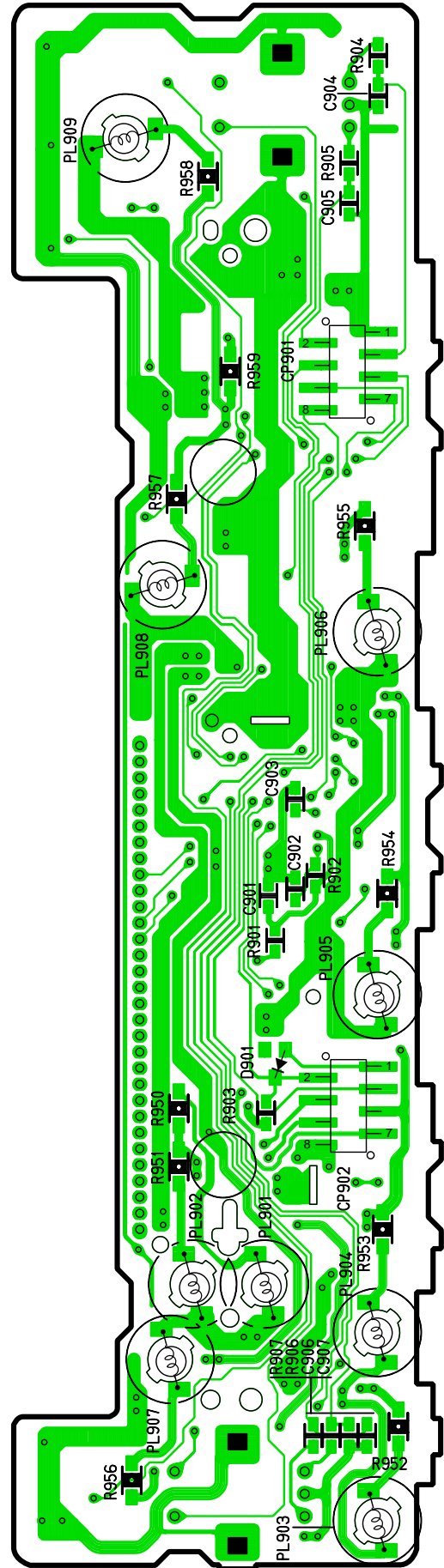

[E-6849Ab][Bottom View]

13.4. Amp. Block

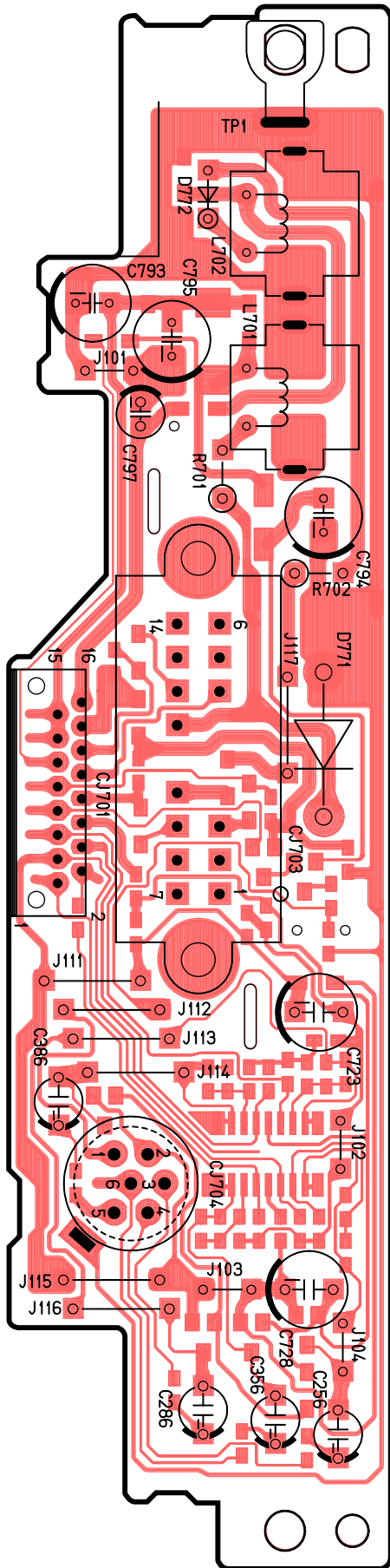

[E-9044][Top View]

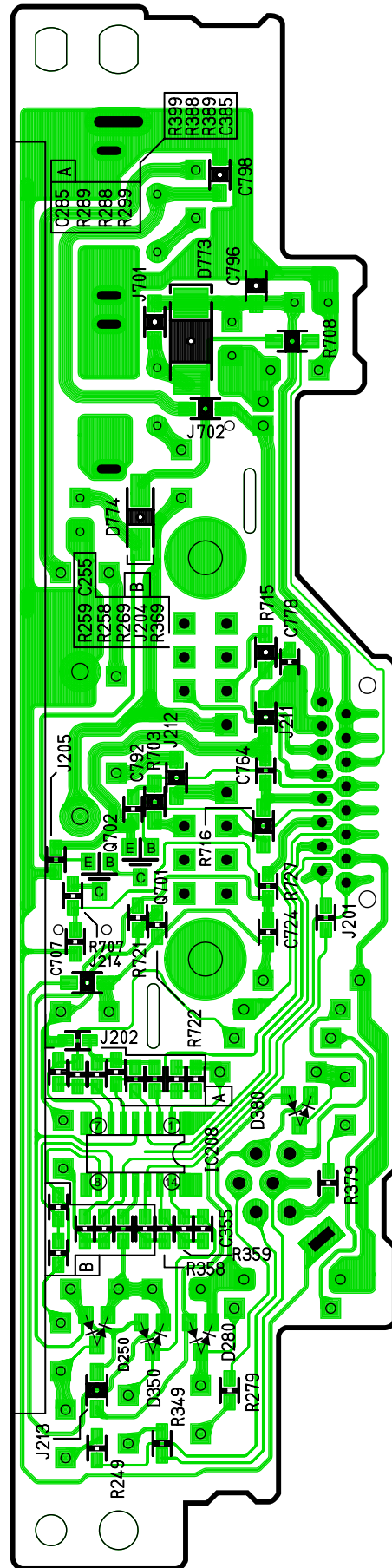

[E-9044][Bottom View]

13.5. CD Servo Block (Top View)

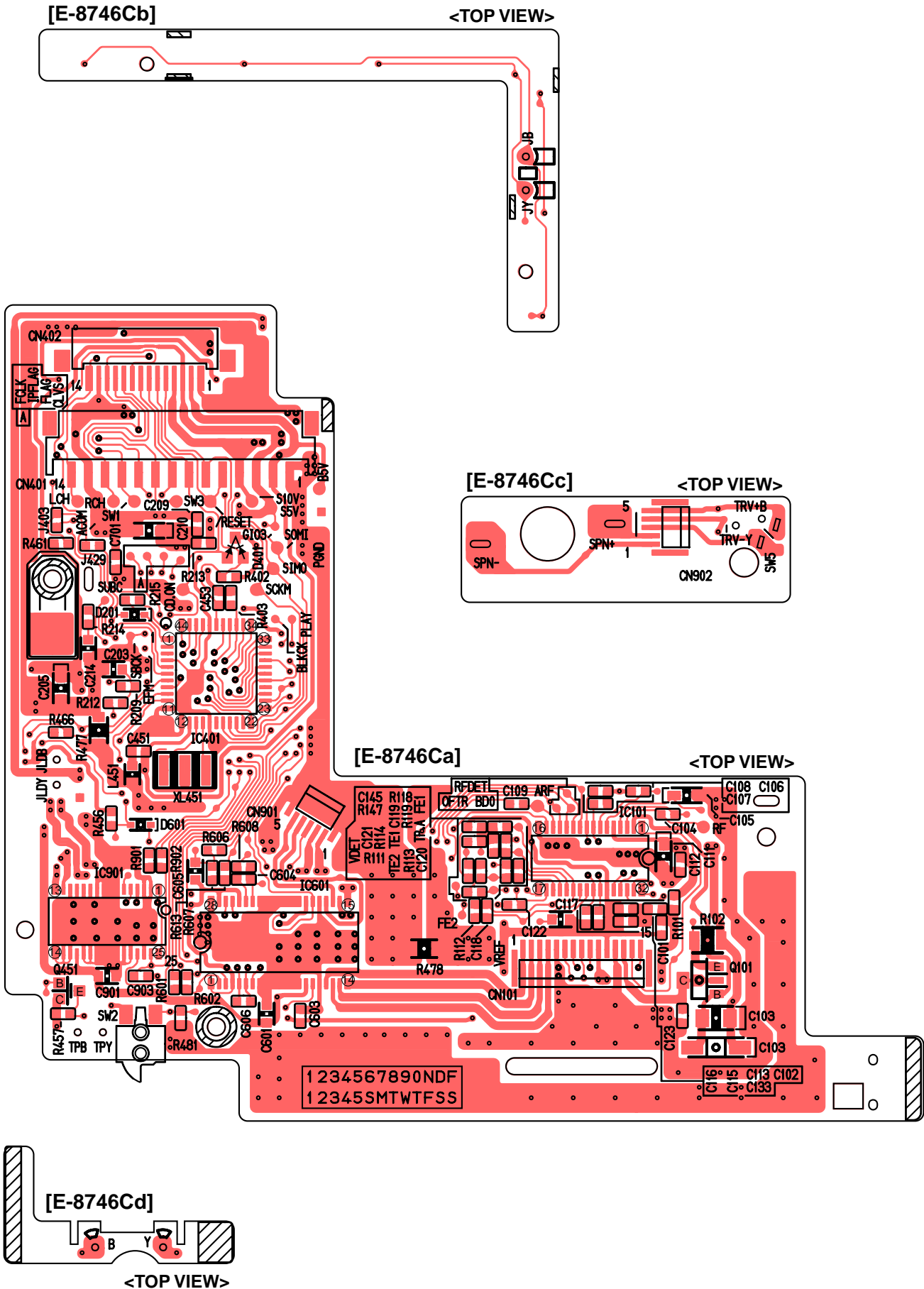

14 SCHEMATIC DIAGRAM (1)

14.1. Display Block

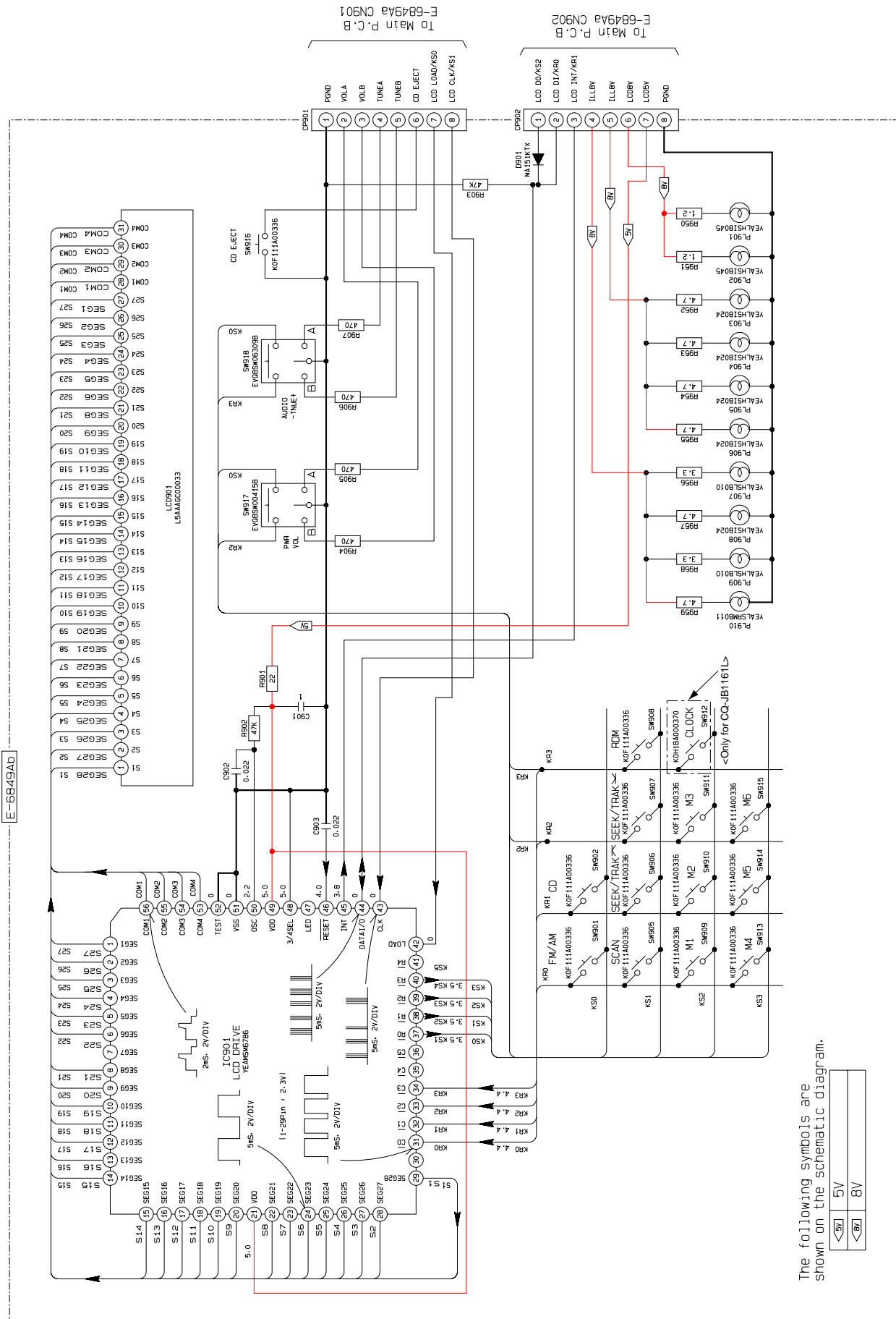

The following symbols are shown on the schematic diagram.

15 SCHEMATIC DIAGRAM (2)

15.1. Amp. Block

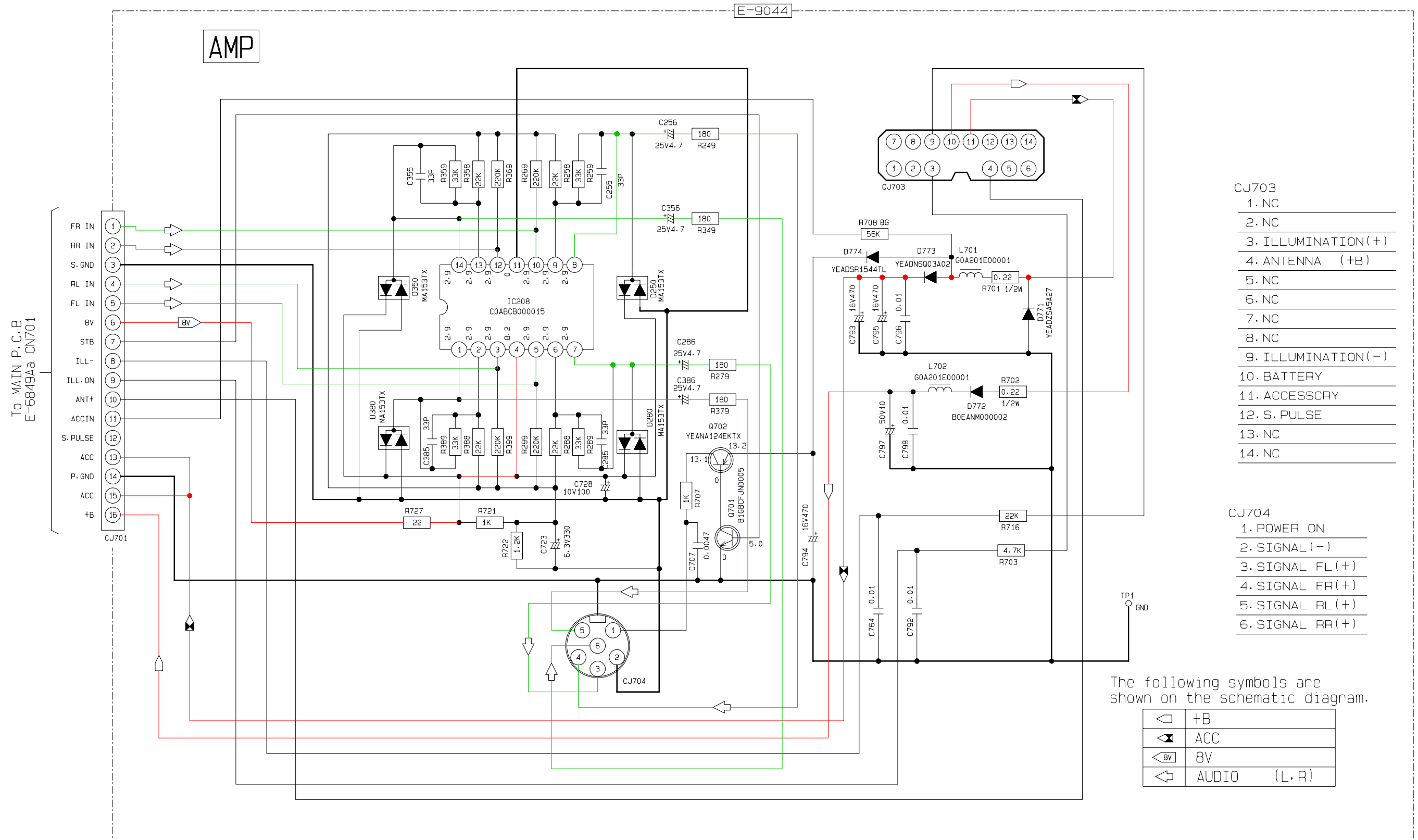

15.2. Main Block

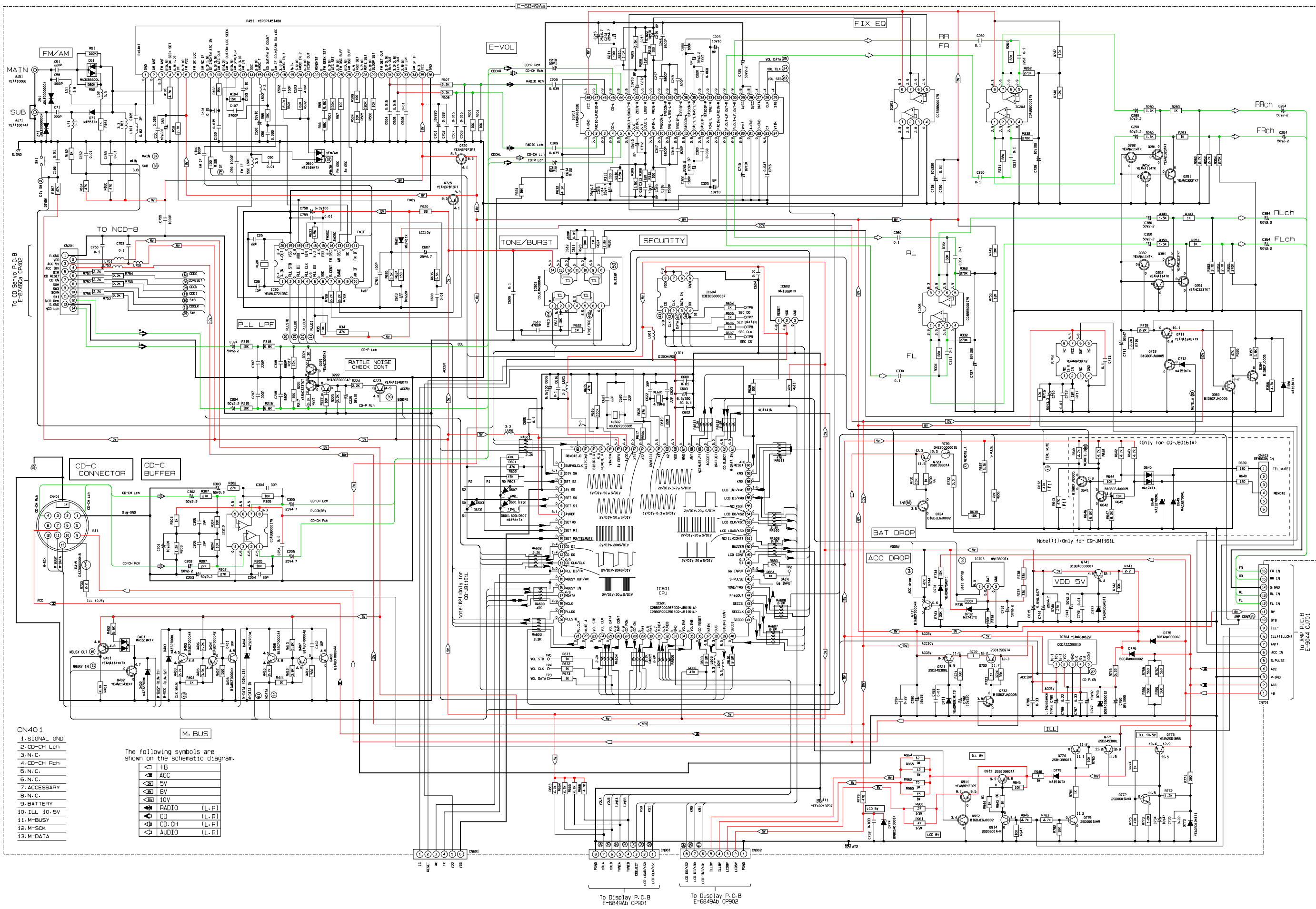

- CN401
1. SIGNAL GND
 2. CD-CH Lch
 3. N.C.
 4. CD-CH Rch
 5. N.C.
 6. N.C.
 7. ACCESSARY
 8. N.C.
 9. BATTERY
 10. ILL 10.5V
 11. M-BUSY
 12. M-SCK
 13. M-DATA
- The following symbols are shown on the schematic diagram.
- | | |
|--|-------------|
| | +B |
| | ACC |
| | 5V |
| | BV |
| | 10V |
| | RADIO (L-R) |
| | CD (L-R) |
| | CD-CH (L-R) |
| | AUDIO (L-R) |

To Display P.C.B E-6849Ab CP901
To Display P.C.B E-6849Ab CP902

To AMP P.C.B E-9044 C/701

15.3. CD Servo Block

