

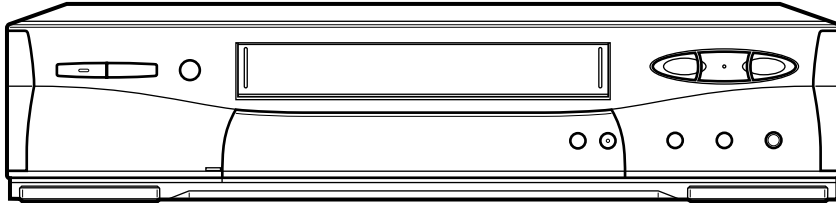

Service Manual

VIDEO CASSETTE RECORDER

S VHS



MODEL
HS-U778

Only cassettes marked S-VHS or VHS can be used with this video cassette recorder.

SPECIFICATIONS

Tape Format	: S-VHS/VHS 1/2" high-density video cassette tape	Video Input	: 0.5 to 2.0 V(p-p), 75Ω unbalanced RCA pin Jack
Power Source	: 120V AC ; 60 Hz	Audio Input	: 346 mV(rms), 47 kΩ unbalanced RCA pin Jack
Power Consumption	: Approx. 25 W	Video Output	: 1.0 V(p-p), 75 Ω unbalanced RCA pin Jack
Video Signal System	: EIA standard ; NTSC color	Audio Output	: 346 mV(rms), 1 kΩ unbalanced RCA pin Jack
Video Recording System	: S-VHS standard	Tuner	VHF : 54~88 MHz, 174~216 MHz
Luminance	: Frequency modulation recording	UHF : 470~806 MHz	
Color Signal	: Low frequency conversion sub-carrier phase shift recording	CATV : 54~88 MHz, 90~804 MHz	
Hi-Fi Audio	: VHS standard	Operating Temperature	: 41 °F to 104 °F
Recording System	: Azimuth helical scanning system	Relative Humidity	: 30 % to 80 %
Linear Audio Track	: 1 track	RF Channel Output	: Channel 3 or 4 switchable
Tape Speed	: 1-5/16 i.p.s (standard play) 7/16 i.p.s (extended play)	Weight	: Approx. 8.4 lbs
Record/Playback Time	: 120min. with T-120 video cassette (SP mode) 360min. with T-120 video cassette (EP mode)	Dimensions	: 16.7"(W) × 3.7"(H) × 11.8"(D)
Heads: Video	: 4 rotary heads	Timer Program Capacity	: 1 month programmable / 8 programs
Hi-Fi Audio	: 2 rotary heads	Deck	: α Deck
Audio/Control	: 1 stationary head		
Erase	: 1 full track head		

- Weight and dimensions shown are approximate.
- Design and specifications are subject to change without notice.

MITSUBISHI DIGITAL ELECTRONICS AMERICA, INC.

9351 Jeronimo Ave. Irvine, California 92618 U.S.A.

Copyright © 2002 Mitsubishi Digital Electronics America, Inc. All Rights Reserved.

CONTENTS

– FILE “COVERPGE” –

SPECIFICATIONS	1
CONTENTS	2
GLOSSARY OF ABBREVIATIONS	4

– FILE “DISASSY” –

SAFETY PRECAUTIONS	1
CONNECTION	3
DISASSEMBLY	4
HOW TO EXECUTE CIRCUIT BOARD SERVICE	7
CHIP PARTS REPLACEMENT	9

– FILE “ELCTADJ” –

HOW TO INITIALIZE THE E²PROM	1
WHEN REPLACING IC5A0	1
ELECTRICAL ADJUSTMENTS	1
Servo circuit Adjustment	2
Y/C signal circuit Adjustment	2

– FILE “MECHAADJ” –

MECHANICAL ADJUSTMENT

AND REPLACEMENT

1. DECK Cleaning	1
1-1 VIDEO HEAD	1
1-2 Tape Running System	1
1-3 REEL DISK Drive System	1
2. Replacement of Major Parts	2
2-1 CLEANING ARM, FELT RING	2
2-2 STAY PLATE	2
2-3 BOTTOM ASSY	3
2-4 INSERT GUIDE (TU)	4
2-5 INSERT GUIDE (SP)	4
2-6 REC HOLDER, REC LEVER, REC SPRING	5
2-7 F/L ARM ASSY, F/L BEARING	5
2-8 A/C HEAD UNIT	6
2-9 F/E HEAD	6
2-10 SENSOR COVER (TU)	7
2-11 SENSOR COVER (SP)	7
2-12 REV UNIT (TU), REV UNIT (SP)	8
2-13 MODE POSITION UNIT	8
2-14 REEL BELT, PULLEY BUSH, THRUST WASHER, BELT PULLEY, SHIFT SLIDER, PULLEY GEAR ASSY, SLIP GEAR,	

SLIP SPRING, SLIP 2 WASHER, THRUST WASHER, SLIP ADJUSTER, IDLER 2 UNIT	9
2-15 CAPSTAN BRAKE SPRING, CAPSTAN BRAKE ASSY	11
2-16 FC HOLDER, MOTOR HOLDER, LOADING WORM, LOADING MOTOR ASSY, WORM WHEEL	12
2-17 PINCH ARM CAP, PINCH ASSY	13
2-18 F/L PLATE, DOOR ARM	13
2-19 BRAKE CAM PLATE	14
2-20 GUIDE LAMP	15
2-21 MAIN CAM, GUIDE ARM (TU), BRAKE LEVER, LB PIN	16
2-22 L/D LOCK LEVER	17
2-23 BRAKE BELT (SP), BELT HOLDER	17
2-24 BELT LEVER, BELT ADJUSTER	18
2-25 TENSION ARM, TENSION LEVER, TENSION SPRING, TENS AXIS HOLDER, REEL DISK (SP side)	18
2-26 BRAKE BELT (TU)	19
2-27 BRAKE (TU), REEL DISK (TU side)	19
2-28 SHIFT LEVER	20
2-29 CHARGE SPRING, SWING LEVER, CHARGE ASSY	21
2-30 LOADING ARM ASSY (SP), LOADING ARM ASSY (TU)	21
2-31 A/L LEVER	22
2-32 TAPE GUIDE ASSY (SP), TAPE GUIDE ASSY (TU)	24
2-33 DRUM CLAMPER, DRUM ASSY	25
2-34 DRUM MOTOR STATOR, BRUSH SPRING, SPACER, ROTOR CASE, END RING, BRUSH, UPPER DRUM ASSY	26
2-35 CAPSTAN MOTOR	27
2-36 IMPEDANCE UNIT (SP), FLYWHEEL (SP)	29
2-37 SSW HOLDER, SSW SLIDER	29
3. Interchangeability Adjustment of the Mechanism	30
3-1 Adjustment of BACK TENSION and TENSION POLE's Position	30
3-2 Check and Adjustment of FM Envelope	31

CONTENTS

3-2-1	GUIDE ROLLER Adjustment Check	31
3-2-2	Height Adjustment of GUIDE ROLLER (SP)	31
3-2-3	Height Adjustment of GUIDE ROLLER (TU)	31
3-2-4	Coarse Adjustment of Phase	32
3-2-5	Flatness Check of FM Waveform.....	32
3-2-6	Tape Running Condition at the GUIDE ROLLERS (Check1)	33
3-2-7	Tape Running Condition at the GUIDE ROLLERS (Check 2)	33
3-3	A/C HEAD Adjustment	34
3-3-1	Slant Adjustment of A/C HEAD	34
3-3-2	Azimuth and Height Adjustment of A/C HEAD	34
3-4	Phase Adjustment	35
3-5	Tape wrinkle check	35
4.	Servicing for Tape Jam during the Loading Process	36
SERVICE CAN BE EXECUTED WITH THE EE PICTURE DISPLAYED.....		37
DECK OPERATION CHECK.....		37
– FILE “PARTSLST” –		
PARTS LIST		1
1.	CABINET ASSEMBLY.....	1
2.	PACKING PARTS.....	3
3.	ELECTRICAL PARTS.....	5
– FILE “DECKASSY” –		
DECK ASSEMBLY-1.....		1
DECK ASSEMBLY-1 P/L		2
DECK ASSEMBLY-2.....		4
DECK ASSEMBLY-2 P/L		5
– FILE “SCHEMATC” –		
BLOCK DIAGRAMS		
SCHEMATIC DIAGRAMS		
PRINTED CIRCUIT BOARDS PARTS LAYOUT		

GLOSSARY OF ABBREVIATIONS

A/C	: Audio/Control	JSTCLK	: Just Clock
A-PB	: Audio Play Back	LIN-IN	: Linear Audio In
A-REC	: Audio Recording	LIN-OUT	: Linear Audio Out
AE	: Audio Erase	LMUTE	: Linear Mute
AENV	: Audio Envelope	LP	: Long Play
AFC	: Automatic Frequency Control	MOD	: Modulator
AFF	: Audio Flip Flop	MOTORV	: Motor Voltage
AFTV	: Auto Fine Tuning Voltage	NL	: Non Linear
ALC	: Automatic Level Control	OSC	: Oscillator
AMODE	: Audio Mode	PB	: Play Back
AMPC	: Amplifier Alternating Current Ground	PC	: Position Control
APC	: Automatic Phase Control	PCB	: Printed Circuit Board
ATFN	: Auto Fine	PG	: Pulse Generator
ATT	: Attenuator	PLL	: Phase Locked Loop
BLMUTE	: Blue Back Mute	PRT	: Protect
C/N	: Carrier/Noise Ratio	PSAVE	: Power Save
CCD	: Charge Coupled Device	PSLED	: Power Save Light Emitting Diode
CG-CS	: Character Generator-Chip Slect	PSYNC	: Pretended Vertical Synchronizing Signal
CHSW	: Channel Switch	PWSV	: Power Save
CLKSEL	: Clock Select	PWV	: ON/OFF Command to supply B + Power
CNTR	: Counter	QH	: Cue Horizontal Signal
COM	: Comparator	QV	: Cue Vertical Signal
CONV SW	: Converter Switch	REC	: Recording
CP-FG	: Capstan-Frequency Generator	REC2	: Record Command for the PB/REC Control Circuit
CP-REV	: Capstan-Reverse	RECPBC	: Record/Play Back Chroma Signal
CPMOTORV	: Capstan Motor Voltage	RES	: Reset
CROT	: Chroma Rotation	RESPCM	: Reset Pulse Code Modulation
CSYNC	: Composite Synchronizing Signal	REW	: Rewind
CTL	: Control	RIS	: Record Inhibit Switch
D.E.	: Detail Enhancer	RMSDET	: Root Mean Square Detector
D-FF	: Drum Flip Flop	RXD	: Read X Data
DEMOD	: Demodulator	SAPIND	: SAP carrier detect Indicator
DET	: Detector	SCLK	: Serial Clock
DLY	: Delay	SCR	: Scramble
DOC	: Drop Out Compensator	SI	: Serial control data Input
DOCSTOP	: Drop Out Control Stop	SLD	: Side Lock Detector
DR-FG	: Drum-Frequency Generator	SP	: Standard Play
DR-OUT	: Drum Control Out	SS	: Start Sensor
DR-PG	: Drum-Phase Generator	SSVSYNC	: Speed Search Vertical Synchronizing Signal
EE	: Electronic-Electronic	STRB	: Strobe
EMPH	: Emphasis	SU-SENS	: Supply Reel Sensor
EP	: Extended Play	TSREC	: Tape Simulate Recording
EQ	: Equalizer	TSSW	: Tape Simulator Switch
ES	: End Sensor	TU-SENS	: Take Up Reel Sensor
FBC	: Feed Back Clamp	V-REF	: Voltage Reference
FE	: Full Erase	VBUSY	: VSET Busy
FF	: Fast Forward	VCA	: Voltage Control Amplifier
FG	: Frequency Generator	VCO	: Voltage Controlled Oscillator
FLDCS	: Fluorescent Tube Driver Chip Slect	VENV	: Video Envelope
FM	: Frequency Modulation	VSETCLK	: VSET Clock
FSC	: Frequency of Color Subcarrier	VSETCS	: VSET Chip Select
G	: Ground	YNR	: Y(Luminance) Signal Noise Reduction
HASW	: Head Amplifier Switch		
HFR400	: Hi-Fast Forward/Rewind 400		
HFRSS	: Hi-Fast Forward/Reverse Speed Search		
HSYNC	: Horizontal Synchronizing Signal		
I-LIMIT	: I(Current)-Limiter		

SAFETY PRECAUTIONS

INTRODUCTION

This manual provides service information for the adjustments of mechanical and electrical operations.

Due to design modifications, the servicing procedures and data given in this manual are subject to possible change without prior notice.

WARNING : Many of the programs broadcast by television stations are protected by copyright and Federal law imposes strict penalties for copyright infringement. Some motion picture companies have taken the position that home recording for noncommercial purposes is an infringement of their copyrights. Until the courts have ruled on the proper interpretation of the law as applied to home video recording, this equipment, if used to record copyrighted material, should be operated at the user's own risk.

WARNING :
TO PREVENT FIRE OR SHOCK HAZARD, DO NOT EXPOSE THIS APPLIANCE TO RAIN OR MOISTURE.
This video cassette recorder should be used with AC 120V, 60Hz only.

SAFETY NOTICE

Before returning VCR to the customer a safety check of the entire VCR should be made. The service technician must be sure that no protective device built into the instrument by the manufacturer has become defective or inadvertently damaged during servicing. Observe all caution and safety related notes located on or inside the VCR cabinet.

WARNING : Alterations of the design or circuitry of this VCR should not be made. Any design alterations or additions, such as circuit modifications, auxiliary speaker jacks, switches, grounding, active or passive circuitry, etc., or use of unauthorized camera, cables, accessories, etc. may alter the safety characteristics of this VCR and potentially create a hazardous situation for the user. Any design alterations or unauthorized additions will invalidate the manufacturer's warranty and will further relieve the manufacturer of responsibility for personal injury or property damage resulting from them. Do not lubricate any motors. When reassembling the VCR, always be certain that all the protective devices are put back in place, such as non-metallic control knobs, shield plates, etc. When service is required, observe the original lead dress. Components that show evidence of overheating or other electrical or mechanical damage should be replaced.



WARNING : Replace with same type 1.6A, 125V FUSE.

LEAKAGE CURRENT CHECK

Before returning the VCR to the customer, it is recommended the leakage current be measured by the following methods.

1. Cold Check

With the AC plug removed from the 120V AC source, place a jumper across the two AC plug prongs. Turn the AC switch on. Using an ohmmeter, connect one lead to the jumpered AC plug and touch the other lead to each exposed metal part (metal cabinet, screwheads, metal overlays, control shafts, etc.), particularly any exposed metal part having a return path to the chassis. Exposed metal parts having a return path to the chassis should have a minimum resistance reading of 1 MΩ. Any resistance below this value indicates an abnormality which requires corrective action. Exposed metal parts not having a return path to the chassis will indicate an open circuit.

2. Hot Check

The test sequence, with reference to the measuring circuit in the figure is as follows:

(1) With switch S1 open, connect the VCR to the measuring circuit. Immediately after connection, measure the leakage current using both positions of switch S2 and with the switching devices in the VCR in all of their operating positions.

(2) Close switch S1, energizing the VCR, and immediately after closing the switch, measure leakage current using both positions of switch S2, and with the switching devices in the VCR in all of their operating positions. Repeat the current measurements of items (1) and (2) after the VCR has reached thermal stabilization. The leakage current should not be more than 0.5 mA.

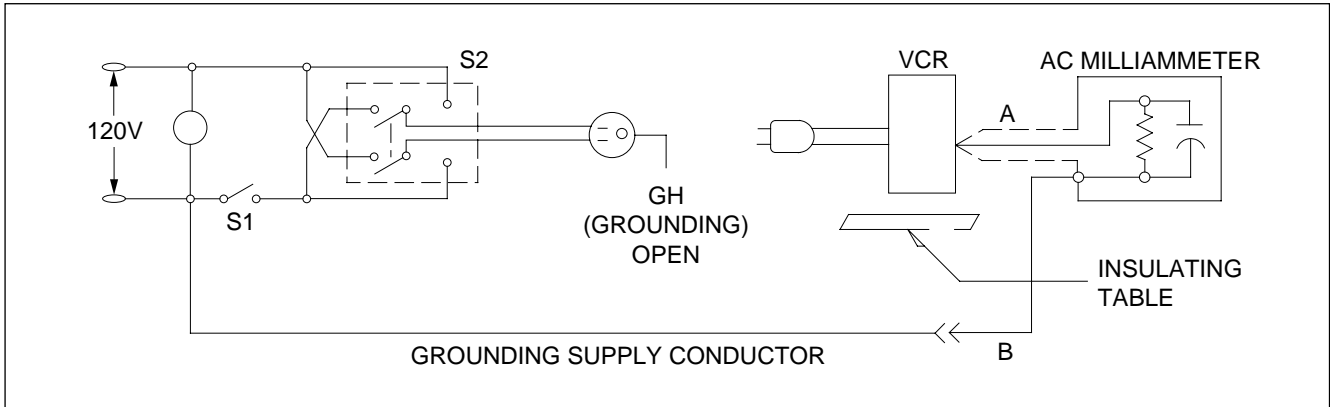

AC Leakage Test

Avoid shock hazards. Do not connect this VCR to a TV antenna, cable or accessory that exhibits excessive leakage currents. If available, the television instrument or cable to which this VCR is connected should have the antenna cold check and leakage current hot check performed.

PRECAUTIONS

Handling and storage

- Avoid using the VCR in the following places:
 - extremely hot, cold or humid places,
 - dusty places,
 - near appliances generating strong magnetic fields,
 - places subject to vibration,
 - poorly ventilated areas.
- Be careful of moisture condensation.
- If you pour a cold liquid into a glass, water vapor in the air will condense on the surface of the glass. This is called moisture condensation.
- Moisture condensation on the head drum, one of the most critical parts of the VCR, will cause damage to the tape.
- The VCR is equipped with a moisture condensation prevention circuit. This circuit operates only when the unit is attached to an AC outlet.
- Handle the VCR carefully.
- Do not block the ventilation openings.
- Do not place anything heavy on the recorder.
- Do not place liquids on the top cover of the recorder.
- Use the Recorder in horizontal (flat) position only.
- Avoid violent shocks to the recorder during packing and transportation.
- Before packing, be sure to remove the cassette from the recorder.

CONNECTION

Connecting separate antennas (UHF/VHF)

Connecting the Television

To connect separate UHF/VHF antennas to the VCR:

1. Disconnect the antennas from the back of your TV.
2. Connect the antenna leads to the combiner.
3. Screw or push the combiner onto the ANTENNA terminal on the VCR labeled ANTENNA IN.
4. When you are finished, refer to "Connecting the Television" to complete your connections.

Now that you've completed the antenna connections to your VCR, you're ready to connect the VCR to the TV.

Because every television is different (especially older model TVs), your VCR may need to be connected in a variety of ways. See the Owner's Manual for Instruction Information ON:

- **Determining if you need a splitter,**
- **Connecting TVs with audio and video inputs.**

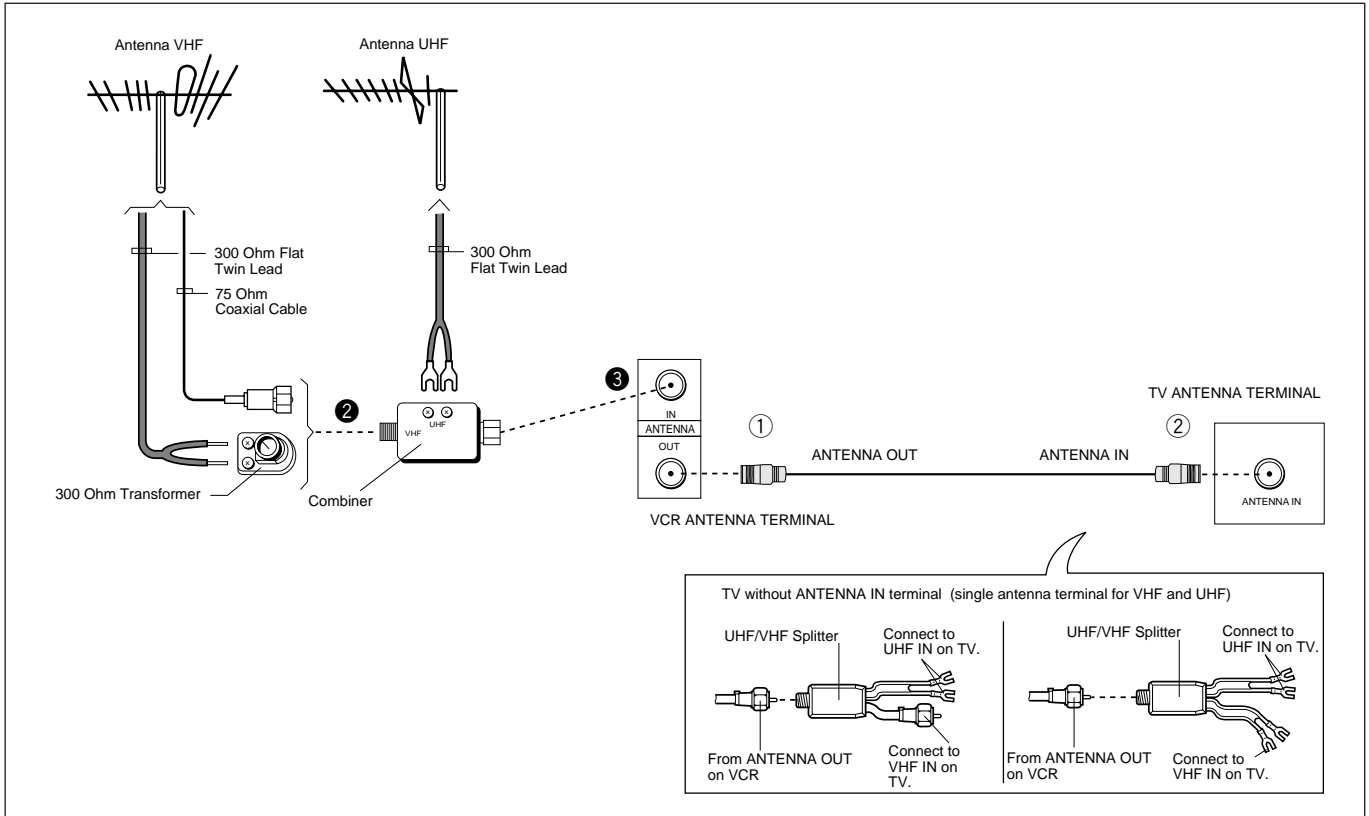

Connecting a regular TV to the VCR

Before connecting the VCR to the TV, complete the cable or antenna connections to the VCR. (If you have not already done so.)

To connect a regular TV to the VCR:

1. Take the black cable that is supplied with your VCR (called a coaxial cable) and connect it to the ANTENNA terminal on the VCR labeled ANTENNA OUT.
2. Connect the other end of this cable to the terminal on your TV labeled ANTENNA IN. (This terminal may also be labeled VHF IN.) If you have an older TV without this kind of terminal, you will have to use a splitter and then connect the splitter to the television.

DISASSEMBLY

1. Removal of Top Cover

1. Remove the two Top Cover fastening screws (a) shown in Fig. 1 and remove the Top Cover in the direction shown by arrow.

2. Removal of Front Panel

1. Remove the Top Cover.
(Refer to Para. 1 of the DISASSEMBLY.)
2. Unfasten the seven catches (b) shown in Fig. 1 and remove the Front Panel in the direction shown by arrows.

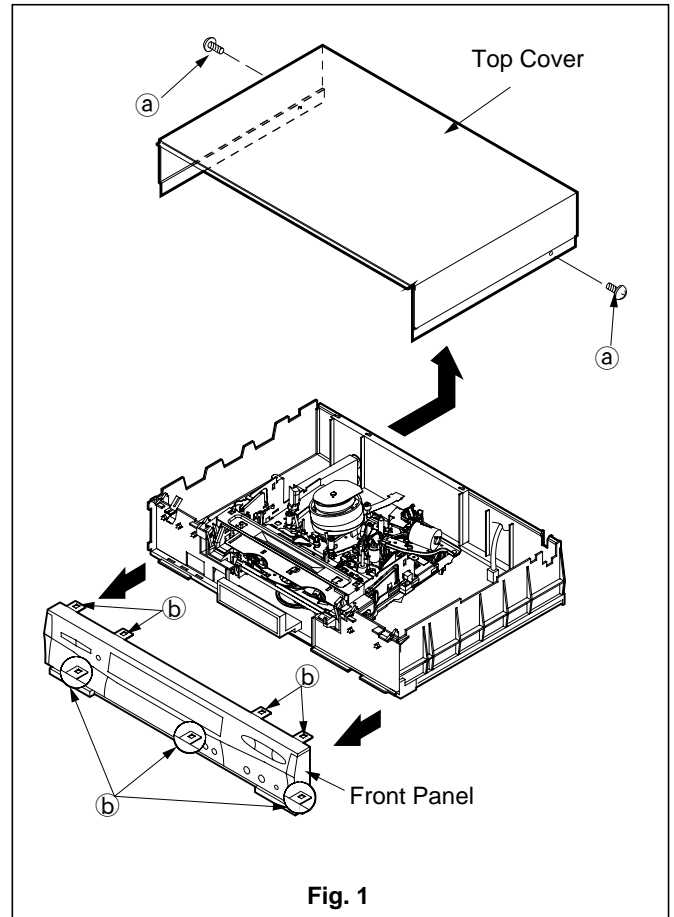
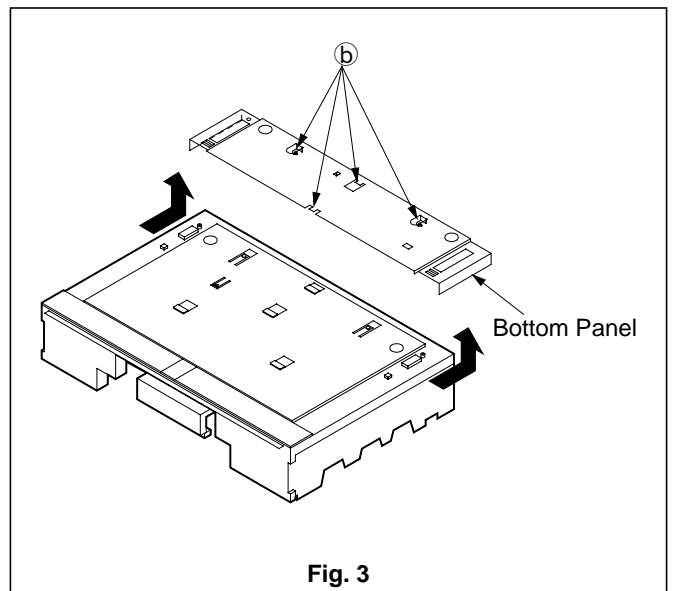
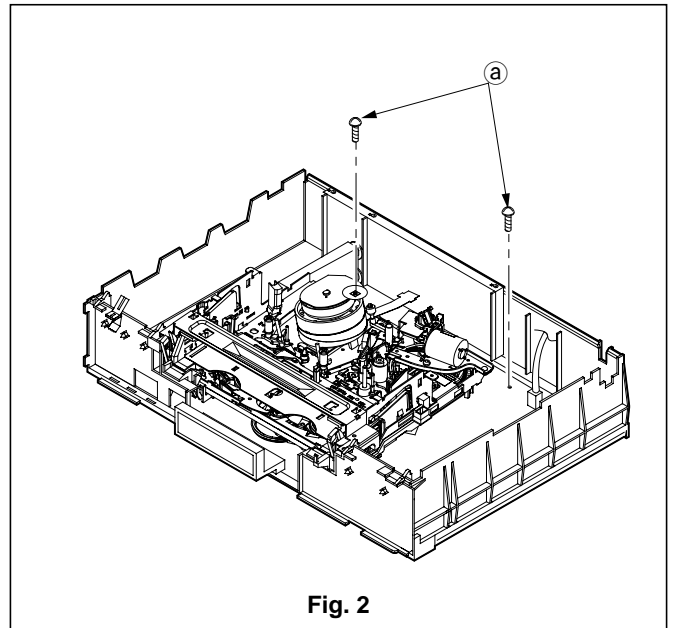

Fig. 1

3. Removal of Bottom Panel

1. Remove the two fastening screws (a) shown in Fig. 2.
2. Turn the set upside down as shown in Fig. 3.
3. Slide the Bottom Panel backward to remove it, taking care of the four catches (b).



4. Removal of DECK ASSY

1. Remove the Top Cover.
(Refer to Para. 1 of the DISASSEMBLY.)
2. Remove the Front Panel.
(Refer to Para. 2 of the DISASSEMBLY.)
3. Short-circuit the cathode side of D927 and the GND of the DECK ASSY using the jig shown below.

Note: The CAPSTAN MOTOR may be damaged without above short circuit.

4. Remove the two screws (a) shown in Fig. 4 and raise the Shield Cover to remove it.
5. Remove the four screws (b) shown in Fig. 5.
6. Disconnect the Connectors MA, MD, MH and ML.
7. Release the two catches (c) shown in Fig.5 and raise the DECK ASSY to remove it.

Note1: Remove the DECK ASSY paying attention to the Connectors MC and MF under it.

Note2: Short-circuit the cathode side of D927 and the Shield Case using the jig shown below before attaching the DECK ASSY.

Jig (Part No. : 859C548O10)

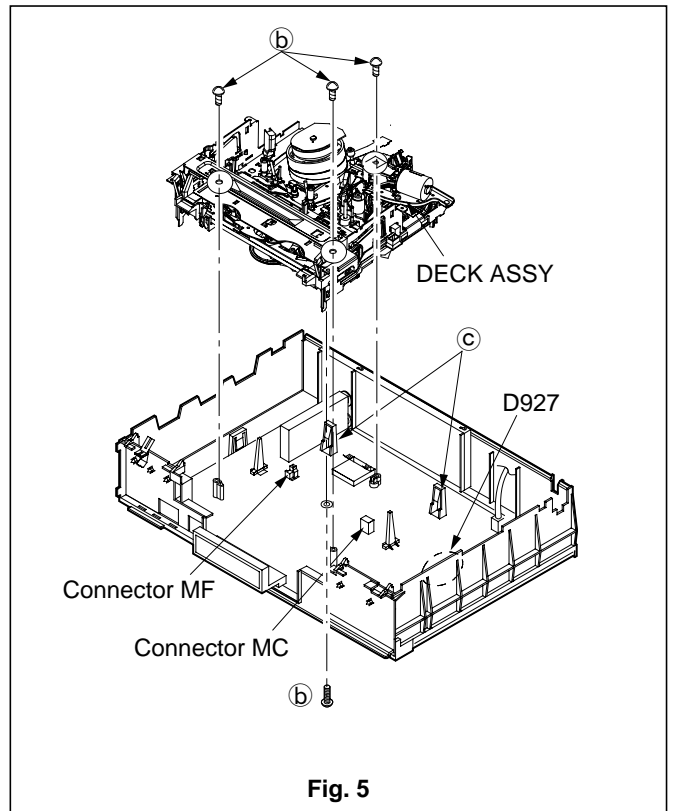
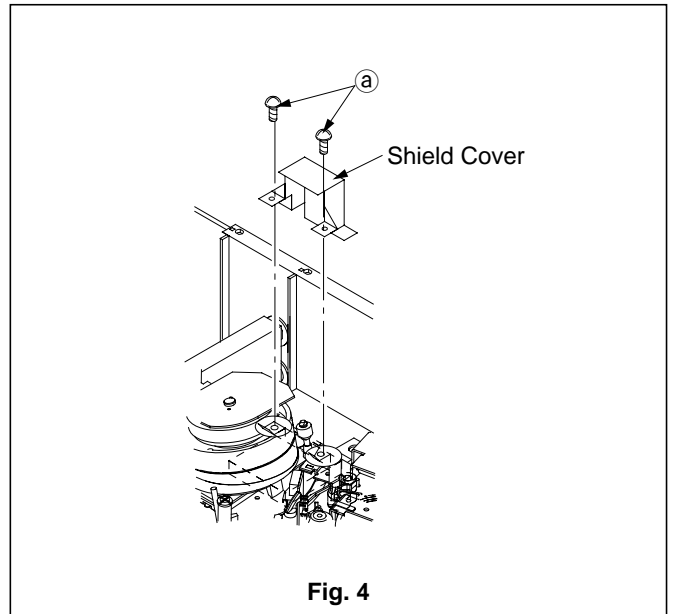
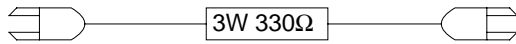

HOW TO EXECUTE CIRCUIT BOARD SERVICE

CAUTION: BEFORE ATTEMPTING TO REMOVE OR REPAIR ANY PCB, UNPLUG THE POWER CORD FROM THE A.C. SOURCE.

LOCATION OF PRINTED CIRCUIT BOARDS

Note :

- Take caution when removing flat cables to prevent any contact problem.
- Connect and disconnect the flat cables at right angles to the connector and make sure that it is completely secured.
- After servicing the PCB, restore the flat cable and leads to their former state.

1. PCB-OPE

1. Remove the Top Cover.
(Refer to Para. 1 of the DISASSEMBLY.)
2. Remove the Front Panel.
(Refer to Para. 2 of the DISASSEMBLY.)
3. Unfasten the one catch (a) shown in Fig. 7 and rotate the PCB-OPE in the direction shown by arrow (b) and remove it in the direction shown by arrow (c).

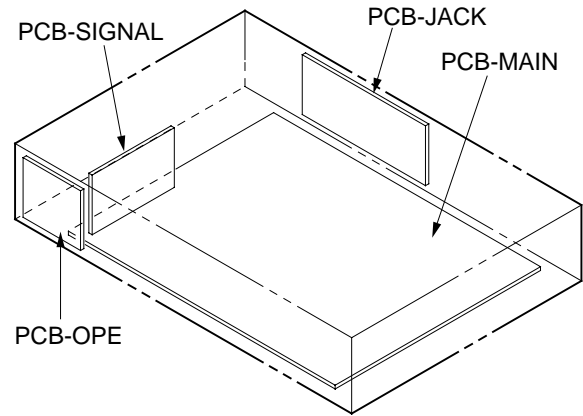

Fig. 6

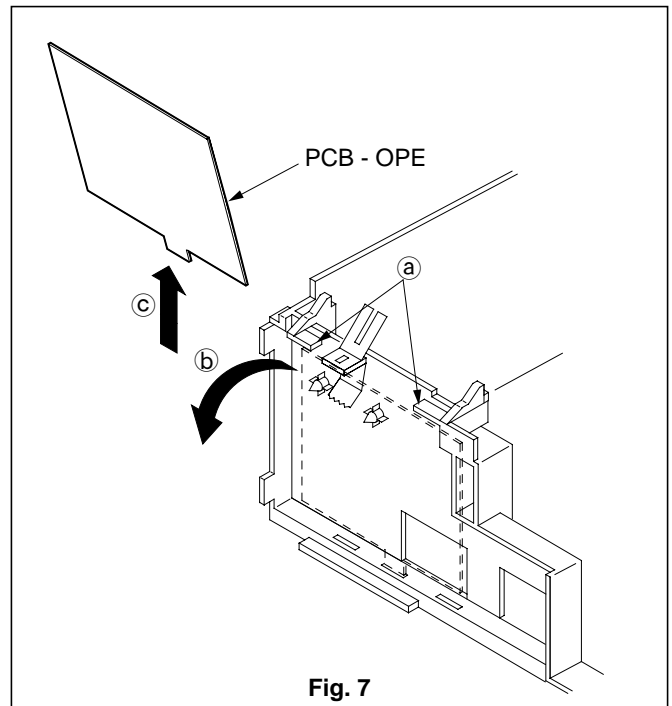

Fig. 7

2. PCB-SIGNAL

1. Remove the Top Cover.
(Refer to Para. 1 of the DISASSEMBLY.)
2. Remove the one PCB Holder fastening screw (a) shown in Fig. 8 and remove the PCB Holder.
3. Raise the PCB-SIGNAL upward to remove it as shown in Fig. 8.

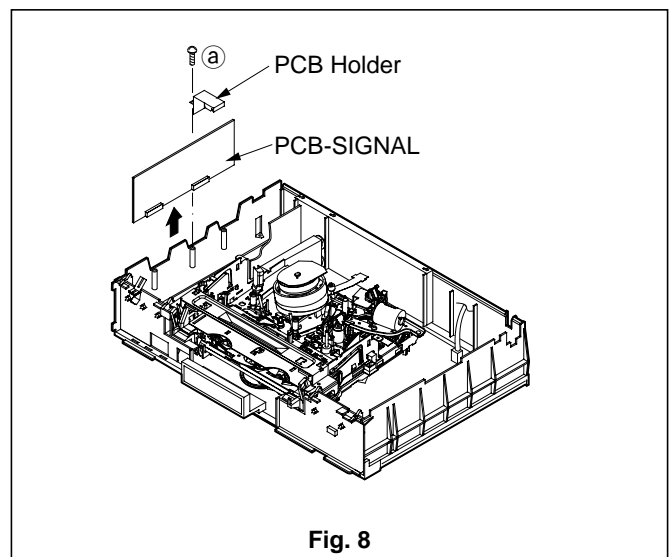
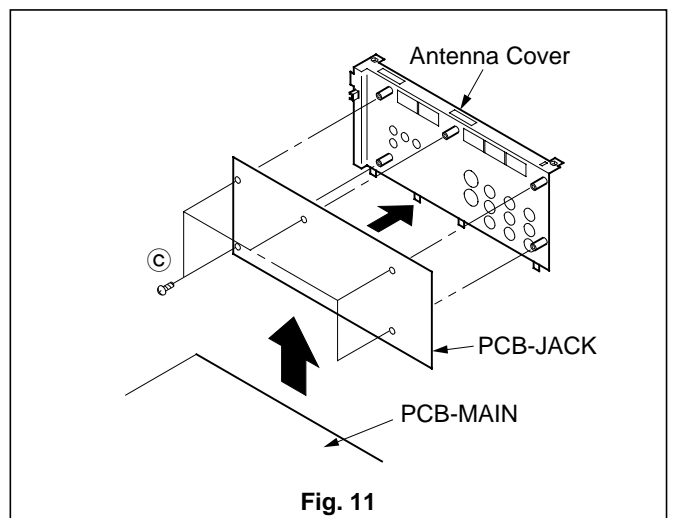
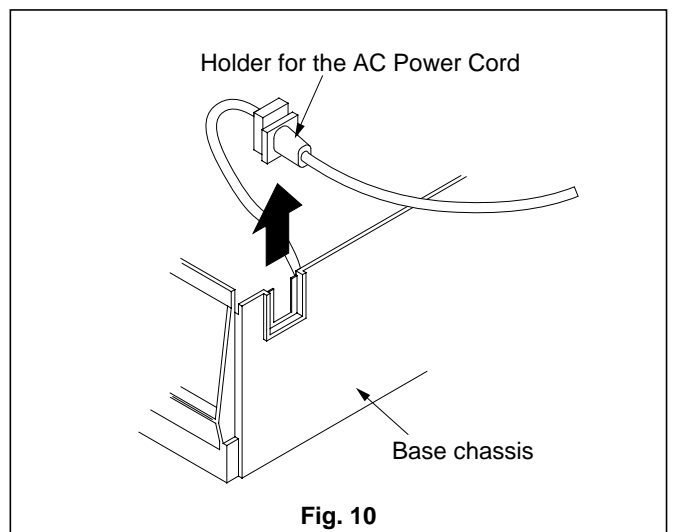
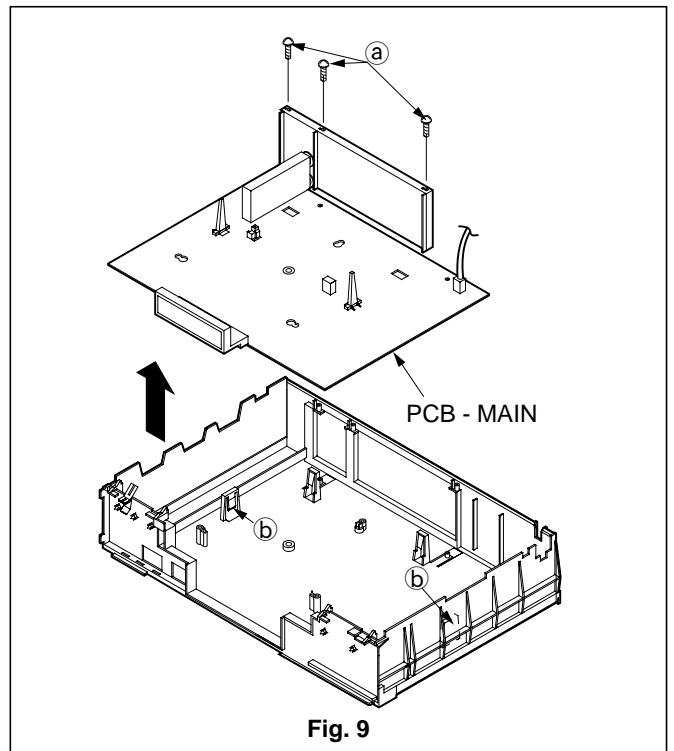

Fig. 8

3. PCB-MAIN

1. Remove the Bottom Panel.
(Refer to Para. 3 of the DISASSEMBLY.)
2. Remove the DECK ASSY.
(Refer to Para. 4 of the DISASSEMBLY.)
3. Remove the three screws (a) shown in Fig. 9.
4. Remove the Holder for the AC Power Cord from the Base Chassis shown in Fig. 10.
5. Release the two fastening catches (b) shown in Fig. 9. Raise the PCB-MAIN to remove it.
6. Unfasten the fastening five screws (c) shown in Fig.11 and remove the Antenna Cover.
7. Raise the PCB-JACK upward to remove it as shown in Fig.11.



CHIP PARTS REPLACEMENT

CHIP PARTS REPLACEMENT

Some resistors, shorting jumpers (0Ω resistor), ceramic capacitors, transistors and diodes are chip parts. When replacing these parts, note the following cautions.

Cautions :

- Use fine tipped, well insulated soldering pencil (iron), about 30 watts, and tweezers.
- Melt the solder and remove the Chip Parts carefully not to tear off the copper foil of the printed circuit board.
- Discard removed chips ; do not reuse them.
- Do not apply heat for more than 3 seconds to new Chip Parts.
- Avoid using a rubbing stroke when soldering.
- Take care not to scratch, or damage the Chip Parts when soldering.
- Supplementary cementing is not required.

1. Removal of Chip Parts (Resistors, capacitors, etc.)

- Grasp the part with tweezers. Melt the solder at both sides alternately, remove one side of the part with a twisting motion.
- Melt the solder at the other side and remove the part.

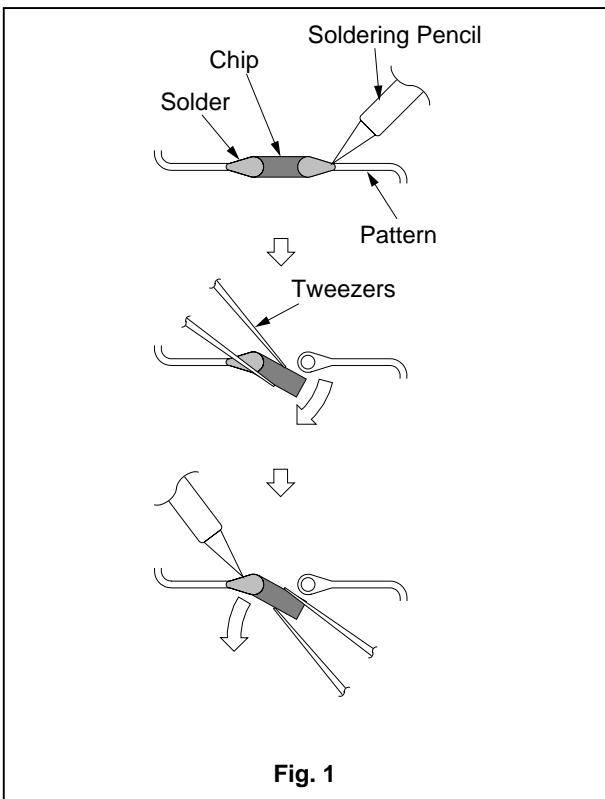

2. Removal of Chip Parts (Transistors)

- Melt the solder of one lead. Lift the side of that lead upward.
- Simultaneously melt the solder of the two remaining leads and lift the part from the PCB.

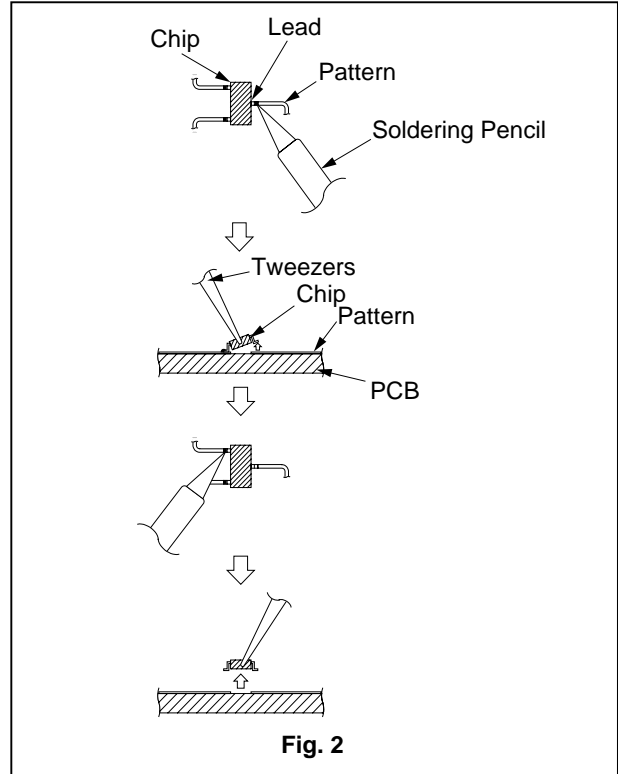

3. Replacement

- Presolder the contact points of the circuit pattern.
- Press the part downward with tweezers and apply the soldering pencil as shown in Fig. 3.

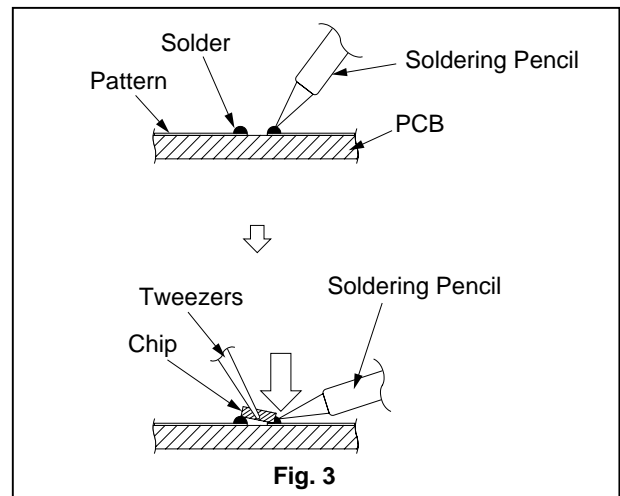

MECHANICAL ADJUSTMENT AND REPLACEMENT

1. DECK Cleaning

The following Parts require cleaning whenever serviced in order to maintain satisfactory performance.

1-1. VIDEO HEAD

1. Clean the VIDEO HEAD according to the following method. Dust and other foreign objects on the VIDEO HEAD disturb the normal PLAYBACK picture. To clean the VIDEO HEAD, hold a VIDEO HEAD cleaning cloth dampened with alcohol against the DRUM and slowly turn the DRUM counter-clockwise.

Note : Do not directly touch the HEADS installed to the UPPER DRUM ASSY. The HEADS are very hard but brittle to shock (especially to shock in the vertical direction) and easily breakable.

Never apply force to it in the vertical direction.

2. Allow the residual alcohol to dry thoroughly before running a tape. The residual alcohol on the HEADS may damage the tape if not dried completely.

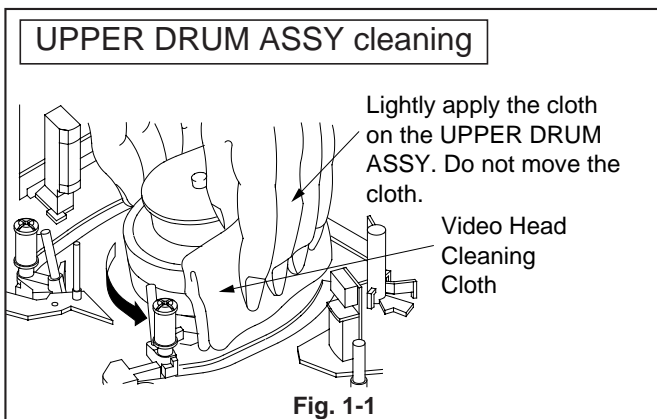

1-2. Tape Running System

Clean the following Parts of the Tape Running System.

1. TENSION PIN
 2. F/E HEAD
 3. SLANT POLE (SP)
 4. SLANT POLE (TU)
 5. A/C HEAD
 6. GUIDE POLE (TU)
 7. PINCH ROLLER
 8. GUIDE PIN (TU)
 9. GUIDE ROLLER (SP)
 10. UPPER / LOWER DRUM ASSY
 11. GUIDE ROLLER (TU)
 12. CAPSTAN SHAFT
 13. IMPEDANCE UNIT (SP)
1. Clean the Tape Running System, using a piece of gauze dampened with alcohol, except for the GUIDE ROLLER (SP), GUIDE ROLLER (TU), and PINCH ROLLER which require to be cleaned with a piece of dry gauze.
 2. Allow the residual alcohol to dry thoroughly before running the tape. The residual alcohol on the SYSTEM may damage the tape if not dried completely.

1-3. REEL DISK Drive System

1. Clean the BRAKE side and REEL BELT of the REEL DISK Drive System.
2. Clean the REEL DISK Drive System, using a piece of gauze dampened with alcohol, except for the REEL BELT which requires cleaning with a piece of dry gauze.
3. Allow the residual alcohol to dry thoroughly before operation.

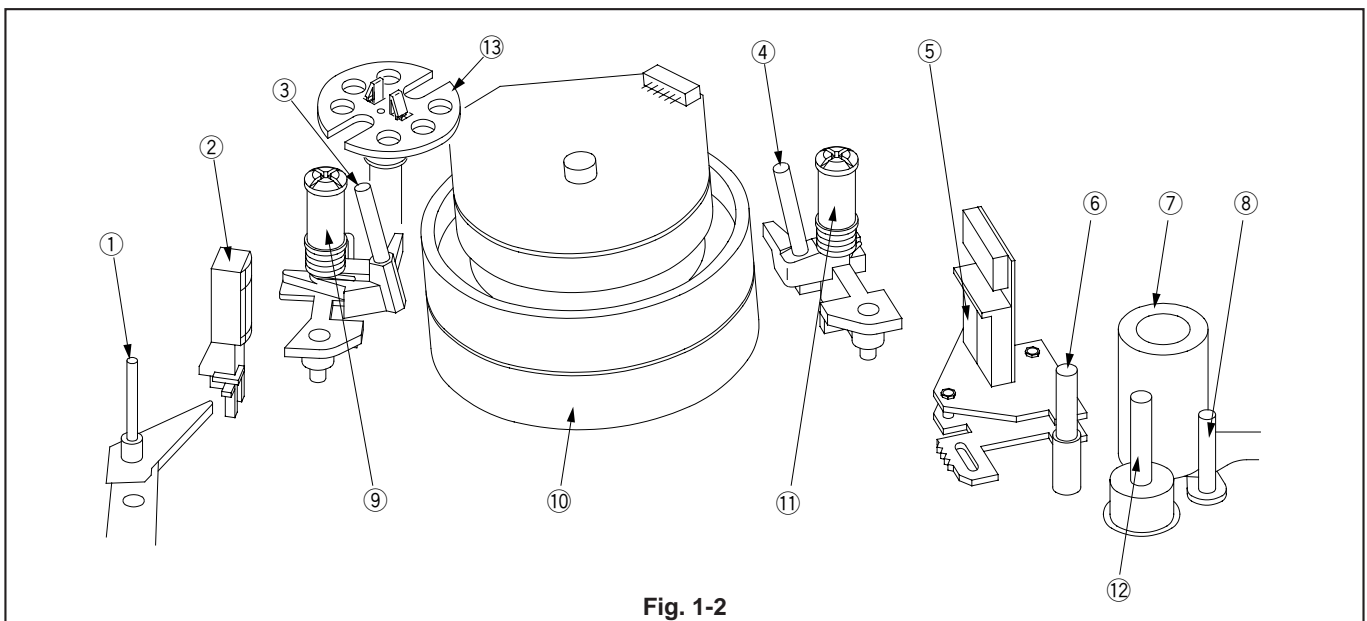

2. Replacement of Major Parts

2-1. CLEANING ARM, FELT RING

SET POSITION : Normal

(Removal)

1. Release the two catches (a) of the CLEANING ARM shown in the Fig. 2-1 to remove the CLEANING ARM.
2. Release the two catches (b) of the CLEANING ARM shown in the Fig. 2-1 to remove the FELT RING.

(Installation)

1. Install the FELT RING shown in the Fig. 2-1 to the CLEANING ARM.
2. Install the CLEANING ARM shown in the Fig. 2-1.

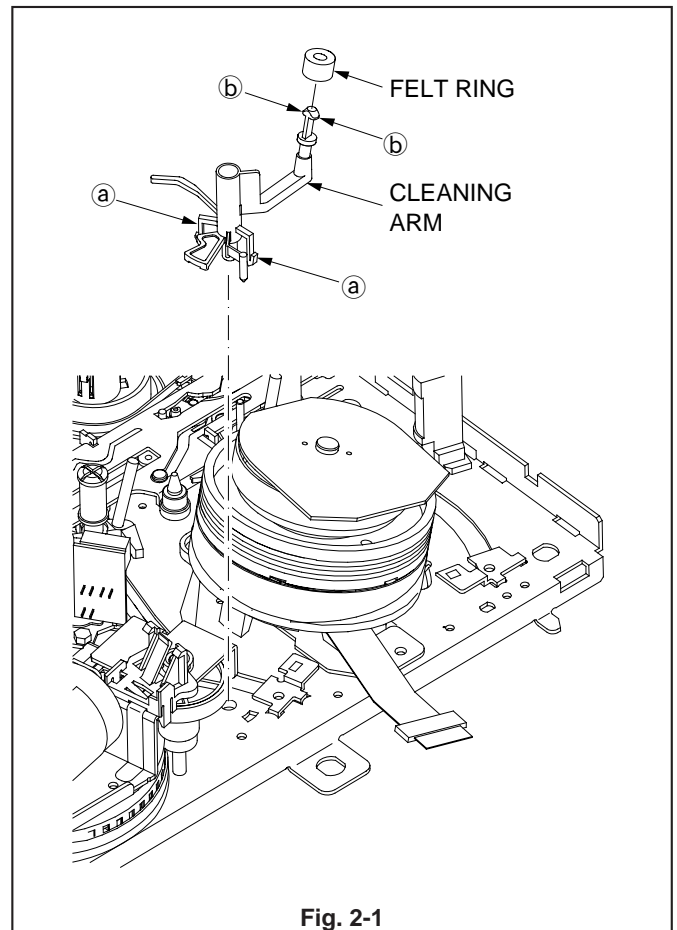

2-2. STAY PLATE

SET POSITION : Normal

(Removal)

1. Remove the two screws (a) fastening the STAY PLATE shown in the Fig. 2-2 to remove the STAY PLATE.

(Installation)

1. Install the STAY PLATE shown in the Fig. 2-2.

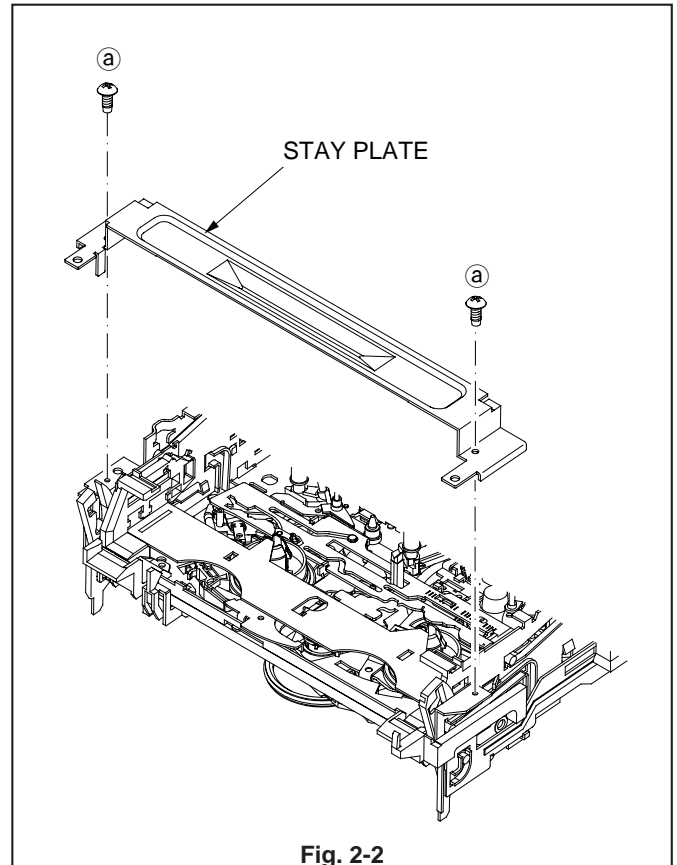

2-3. BOTTOM ASSY

SET POSITION : Normal

Remove the following part before replacing the BOTTOM ASSY. Refer to the corresponding item to install it.

- STAY PLATE (Item 2-2)

(Removal)

1. Move the WORM WHEEL in the Fig. 2-3-1 in the direction shown by the arrow (A). And match the Boss (a) of the BOTTOM ASSY with the Hole in the MAIN PLATE ASSY.
2. Lift the BOTTOM ASSY in the Fig. 2-3-1 in the direction shown by the arrow (B) and pull it out in the direction shown by the arrow (C).

(Installation)

1. Apply GREASE (MULTEMP AC-DM)[859D055O90] to the Grooves of the MAIN PLATE ASSY shown in the Fig. 2-3-2.
2. Apply GREASE (MULTEMP AC-DM)[859D055O90] to the Bosses of the BOTTOM ASSY shown in the Fig. 2-3-2.
3. Rotate the WORM WHEEL shown in the Fig. 2-3-1 so that the ARM (SP) stands vertically.
4. Insert the Boss (b) of the BOTTOM ASSY shown in the Fig. 2-3-2 in the Upper Groove of the MAIN PLATE and the Boss (c) in the Lower Groove.
5. Insert the Boss (d) of the BOTTOM ASSY to the Upper Groove through the Hole in the MAIN PLATE ASSY shown in the Fig. 2-3-1 and the Boss (e) to the Lower Groove through the slot in the ARM (SP).

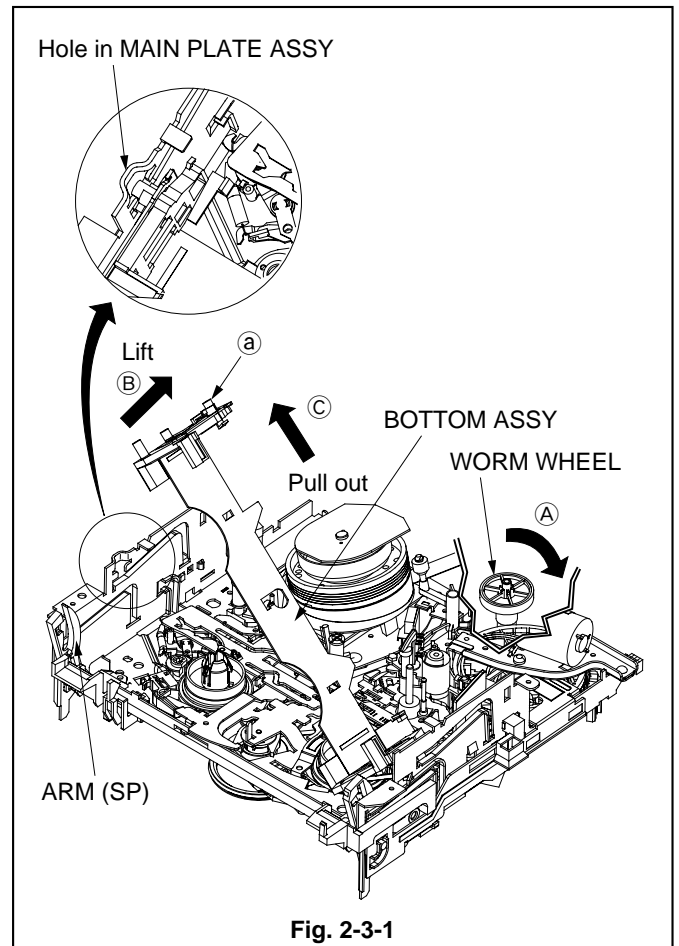

Fig. 2-3-1

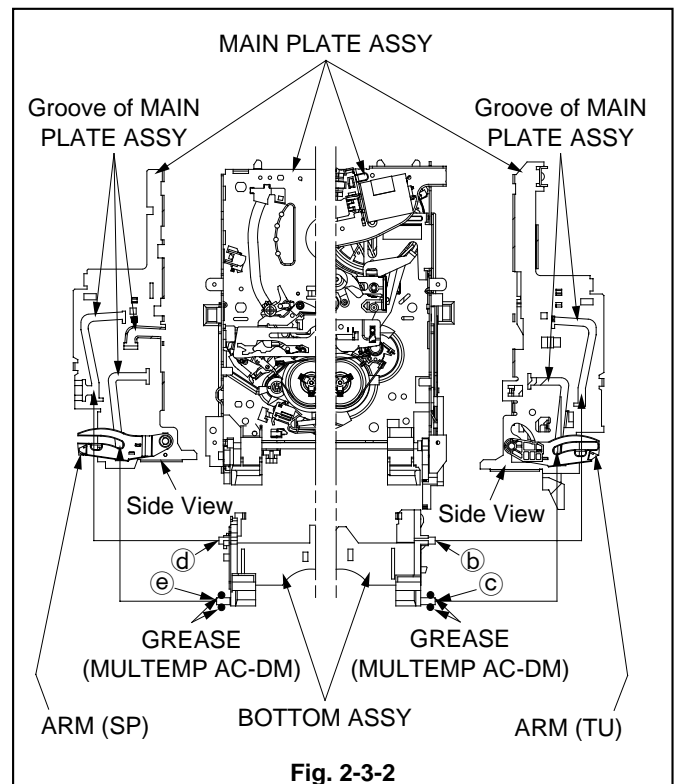

Fig. 2-3-2

2-4. INSERT GUIDE (TU)

SET POSITION : Normal

Remove the following parts before replacing the INSERT GUIDE (TU). Refer to the corresponding items to install them.

- STAY PLATE (Item 2-2)
- BOTTOM ASSY (Item 2-3)

(Removal)

1. Remove the screw (a) fastening the INSERT GUIDE (TU) shown in the Fig. 2-4 to remove the INSERT GUIDE (TU).

(Installation)

1. Install the INSERT GUIDE (TU) shown in the Fig. 2-4.

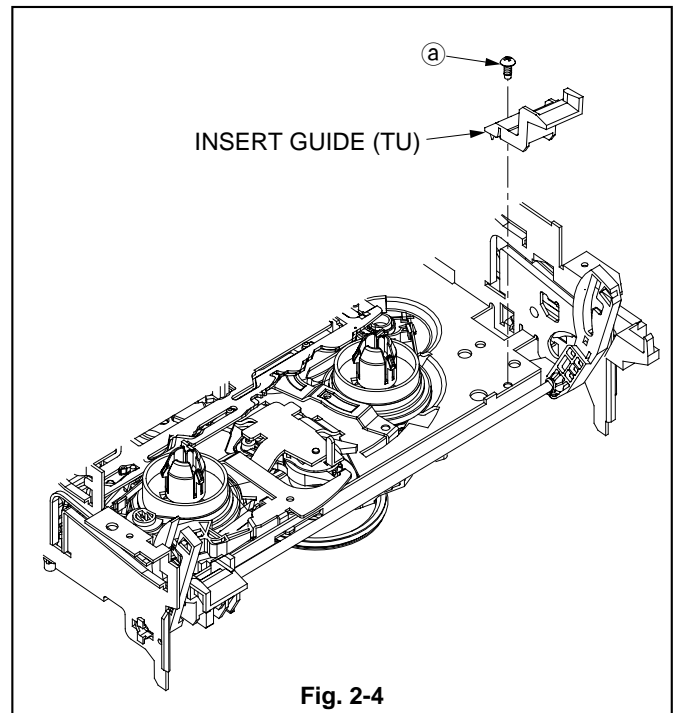

Fig. 2-4

2-5. INSERT GUIDE (SP)

SET POSITION : Normal

Remove the following parts before replacing the INSERT GUIDE (SP). Refer to the corresponding items to install them.

- STAY PLATE (Item 2-2)
- BOTTOM ASSY (Item 2-3)

(Removal)

1. Remove the screw (a) fastening the INSERT GUIDE (SP) shown in the Fig. 2-5 to remove the INSERT GUIDE (SP).

(Installation)

1. Install the INSERT GUIDE (SP) shown in the Fig. 2-5.

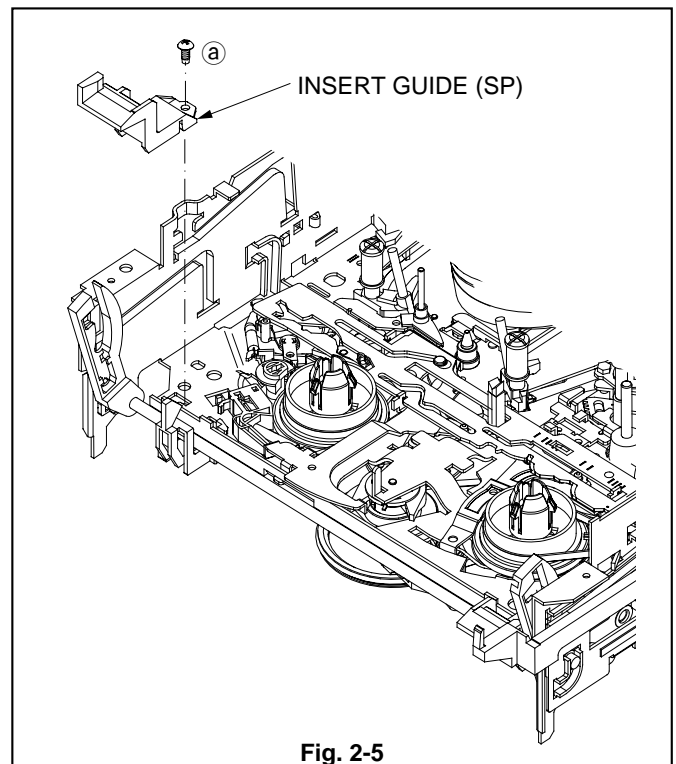

Fig. 2-5

2-6. REC HOLDER, REC LEVER, REC SPRING

SET POSITION : Upside down

(Removal)

1. Remove the screw (a) fastening the REC HOLDER shown in the Fig. 2-6 to remove the REC HOLDER.
2. Release the REC SPRING shown in the Fig. 2-6 from the catch (b) of the REC HOLDER to remove the REC LEVER.
3. Release the two catches (c) of the REC LEVER shown in the Fig. 2-6 to remove the REC SPRING.

(Installation)

1. Install the REC SPRING shown in the Fig. 2-6 to the REC LEVER and hook the REC SPRING to the catches (c).
2. Install the REC LEVER shown in the Fig. 2-6 to the REC HOLDER.
3. Hook the REC SPRING shown in the Fig. 2-6 to the catch (b).
4. Install the REC HOLDER shown in the Fig. 2-6.

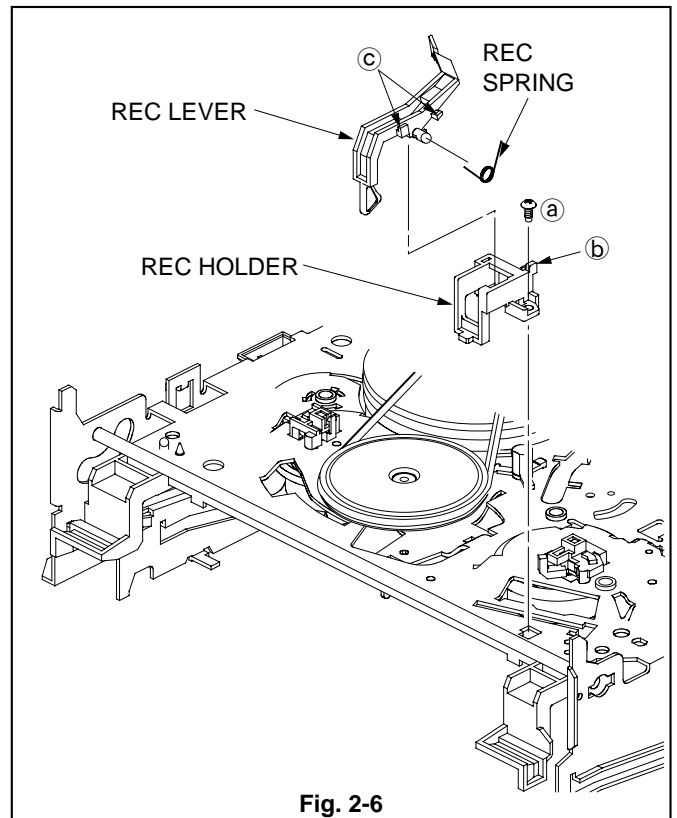

Fig. 2-6

2-7. F/L ARM ASSY, F/L BEARING

SET POSITION : Normal

Remove the following parts before replacing the F/L ARM ASSY, F/L BEARING. Refer to the corresponding items to install them.

- STAY PLATE (Item 2-2)
- BOTTOM ASSY (Item 2-3)
- INSERT GUIDE (TU) (Item 2-4)
- INSERT GUIDE (SP) (Item 2-5)
- REC HOLDER (Item 2-5)

(Removal)

1. Release the catch (a) of the F/L BEARING shown in the Fig. 2-7 and pull out the F/L ARM ASSY in the direction shown by the arrow (A).

Note : Do not pull the F/L ARM by force because it may break the catch (a) of the F/L BEARING.

2. Release the catch (b) of the F/L BEARING shown in the Fig. 2-7 and rotate the F/L BEARING by 90 degrees to remove it.

(Installation)

1. Apply GREASE (MULTEMP AC-DM)[859D055O90] to the Groove of the MAIN PLATE ASSY shown in the Fig. 2-7.
2. Apply GREASE (MULTEMP AC-DM)[859D055O90] to the Boss of the ARM (SP) shown in the Fig. 2-7.
3. Apply GREASE (MULTEMP AC-DM)[859D055O90] to the Bosses of the ARM (TU) shown in the Fig. 2-7.
4. Install the F/L BEARING shown in the Fig. 2-7.
5. Insert the Boss (c) of the F/L ARM ASSY shown in the Fig. 2-7 into the Groove (d) of the MAIN PLATE ASSY to install the F/L ARM ASSY.

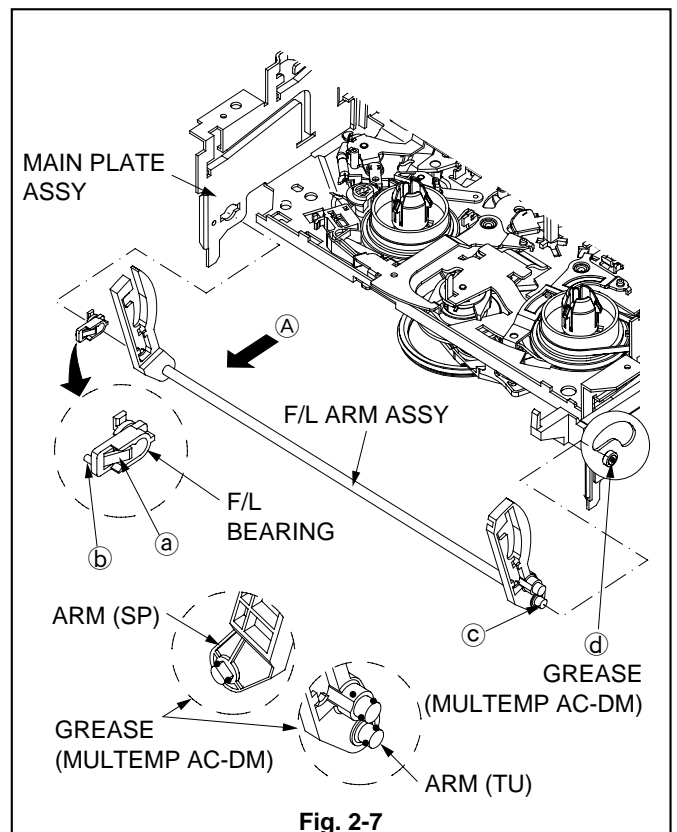

Fig. 2-7

2-8. A/C HEAD UNIT

SET POSITION : Normal

(Removal)

1. Remove the LEAD CONNECTOR of the A/C HEAD UNIT shown in the Fig. 2-8.
2. Remove the two screws (a) fastening the A/C HEAD UNIT shown in the Fig. 2-8 to remove the A/C HEAD UNIT.

(Installation)

1. Install the A/C HEAD UNIT shown in the Fig. 2-8.

Note : Never touch the Head of the A/C HEAD UNIT shown in the Fig. 2-8. Clean the dirt on the Head with alcohol if necessary.

2. Install the LEAD CONNECTOR of the A/C HEAD UNIT shown in the Fig. 2-8.
3. Perform the Item 3-3. "A/C HEAD Adjustment" and Item 3-4. "Phase Adjustment" of the "Interchangeability Adjustment of the Mechanism".

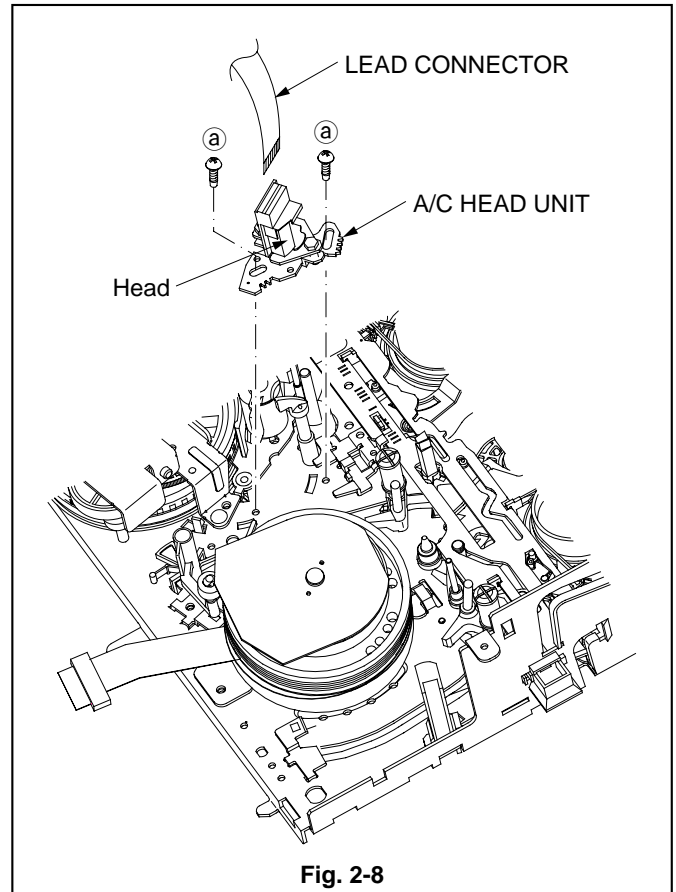

Fig. 2-8

2-9. F/E HEAD

SET POSITION : Normal

(Removal)

1. Lift the F/E HEAD shown in the Fig. 2-9-1 in the direction by the arrow (A) to remove it.

Note : Be sure to replace the removed F/E HEAD with a new one.

(Installation)

1. Install the F/E HEAD shown in the Fig. 2-9-1.

Note : Never touch the Head shown in the Fig. 2-9-2. Clean it with alcohol if necessary.

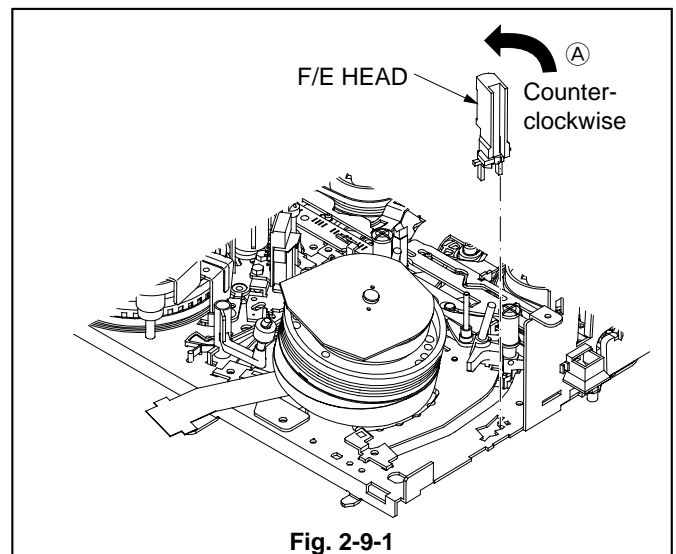

Fig. 2-9-1

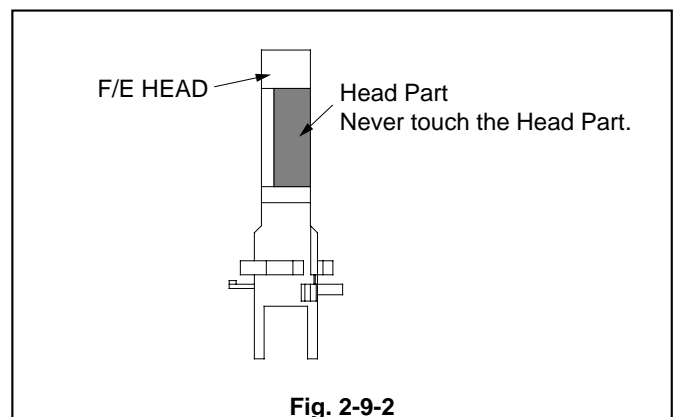

Fig. 2-9-2

2-10. SENSOR COVER (TU)

SET POSITION : Normal

(Removal)

1. Release the catch (a) of the SENSOR COVER (TU) shown in the Fig. 2-10 to remove the SENSOR COVER (TU).

(Installation)

1. Install the SENSOR COVER (TU) shown in the Fig. 2-10.

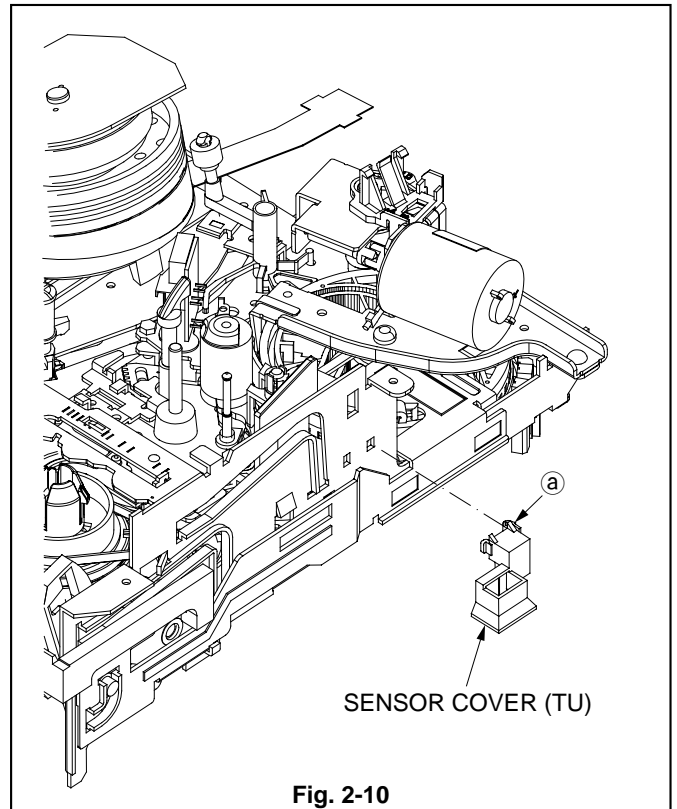

Fig. 2-10

2-11. SENSOR COVER (SP)

SET POSITION : Normal

(Removal)

1. Remove the catch (a) of the SENSOR COVER (SP) shown in the Fig. 2-11 to remove the SENSOR COVER (SP).

(Installation)

1. Install the SENSOR COVER (SP) shown in the Fig. 2-11.

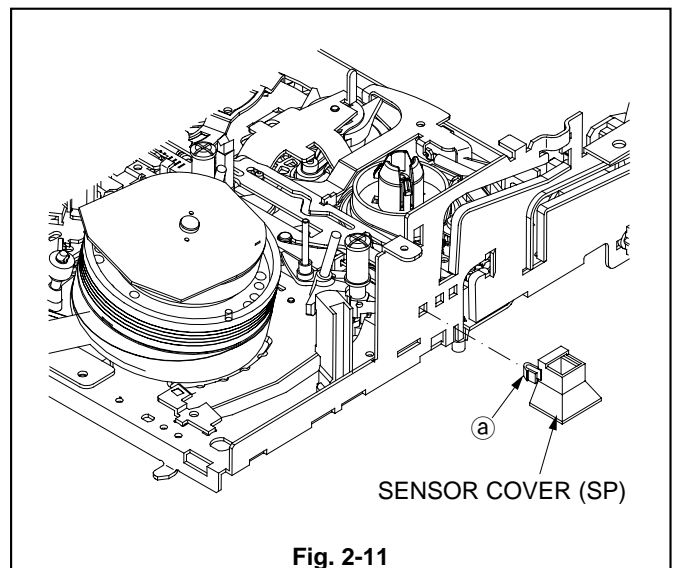

Fig. 2-11

2-12.REV UNIT (TU), REV UNIT (SP)

SET POSITION : Upside down

(Removal)

1. Release the two catches (a) of the REV UNIT (TU) shown in the Fig. 2-12 to remove the REV UNIT (TU).
2. Release the two catches (b) of the REV UNIT (SP) shown in the Fig. 2-12 to remove the REV UNIT (SP).

(Installation)

1. Clean the dirt on the transparent part of the REV UNIT (TU) with a VIDEO HEAD cleaning cloth.

Note : Never use solvent such as alcohol to clean the REV UNIT (TU).

2. Install the REV UNIT (TU) shown in the Fig. 2-12.
3. Clean the dirt on the transparent part of the REV UNIT (SP) with a VIDEO HEAD cleaning cloth.

Note : Never use solvent such as alcohol to clean the REV UNIT (SP).

4. Install the REV UNIT (SP) shown in the Fig. 2-12.

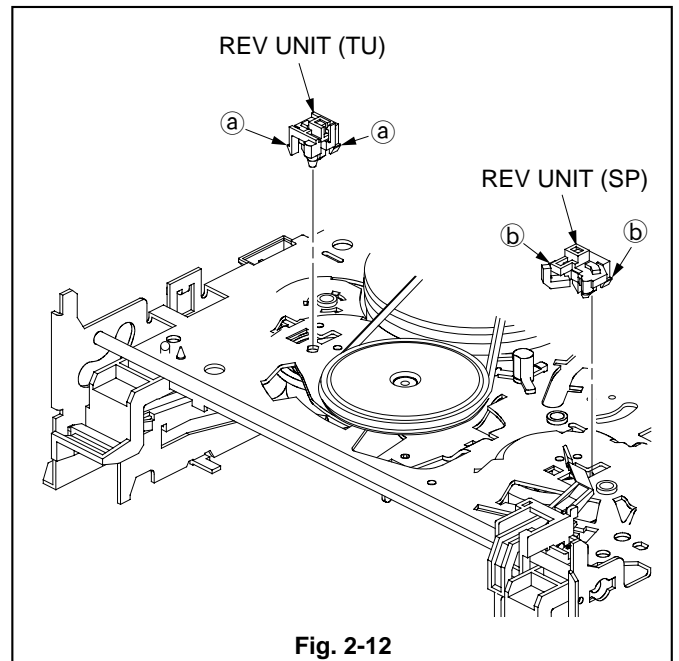

2-13.MODE POSITION UNIT

SET POSITION: Upside down

(Removal)

1. Release the two catches (a, b) of the MODE POSITION UNIT shown in the Fig. 2-13 to remove the MODE POSITION UNIT.

(Installation)

1. Install the catch (b) of the MODE POSITION UNIT shown in the Fig. 2-13.
2. Install the catch (a) of the MODE POSITION UNIT shown in the Fig. 2-13.

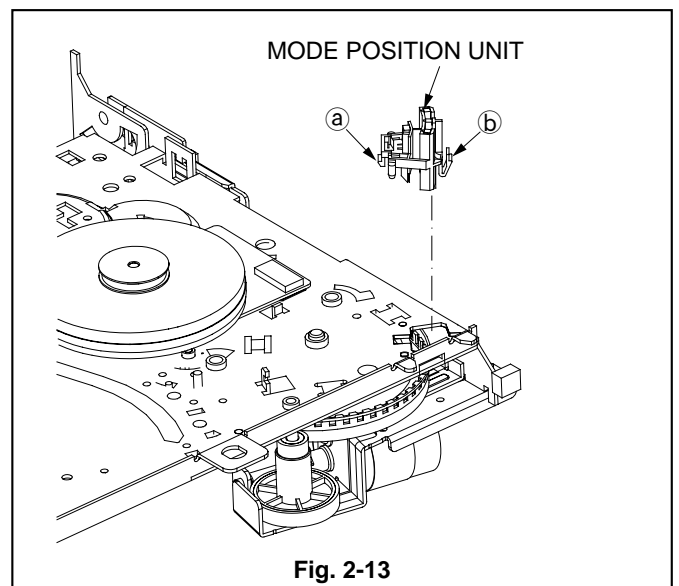

2-14. REEL BELT, PULLEY BUSH, THRUST WASHER, BELT PULLEY, SHIFT SLIDER, PULLEY GEAR ASSY, SLIP GEAR, SLIP SPRING, SLIP 2 WASHER, THRUST WASHER, SLIP ADJUSTER, IDLER 2 UNIT

SET POSITION : Upside down

(Removal)

1. Remove the REEL BELT shown in the Fig. 2-14-1.
2. Move the SHIFT SLIDER in the Fig. 2-14-1 in the direction shown of the arrow (A) to remove the SHIFT SLIDER from the SHIFT LEVER.
3. Release the two catches (a) of the PULLEY BUSH shown in the Fig. 2-14-1 to remove the PULLEY BUSH.

Note : Be sure to replace the removed PULLEY BUSH with a new one.

4. Remove the units from the THRUST WASHER to IDLER 2 UNIT shown in the Fig. 2-14-1.

(Installation)

Note : Be careful so that GREASE and OIL does not adhere on the Felt Side of the PULLEY GEAR ASSY or the Grooved Side of the SLIP GEAR shown in the Fig. 2-14-4.

1. Apply OIL (FLOIL 948P) [859D154O20] to the SHAFT for the IDLER 2 UNIT shown in the Fig. 2-14-1.
2. Apply GREASE (PG-641) [859D055O30] to the parts on the IDLER 2 UNIT specified in the Fig. 2-14-1.
3. Apply GREASE (MULTEMP AC-DM) [859D055O90] to the parts on the MAIN PLATE ASSY specified in the Fig. 2-14-1.
4. Apply GREASE (PG-641) [859D055O30] to the parts on the new SHIFT SLIDER specified in the Fig. 2-14-2.
5. Apply GREASE (PG-641) [859D055O30] to the parts on the new SLIP ADJUSTER specified in the Fig. 2-14-2.
6. Apply GREASE (PG-641) [859D055O30] to the parts on the new BELT PULLEY specified in the Fig. 2-14-3.
7. Install the IDLER 2 UNIT shown in the Fig. 2-14-1.
8. Install the SLIP ADJUSTER shown in the Fig. 2-14-3, matching the Lug of the SLIP ADJUSTER with the Center Notch of the IDLER 2 UNIT.

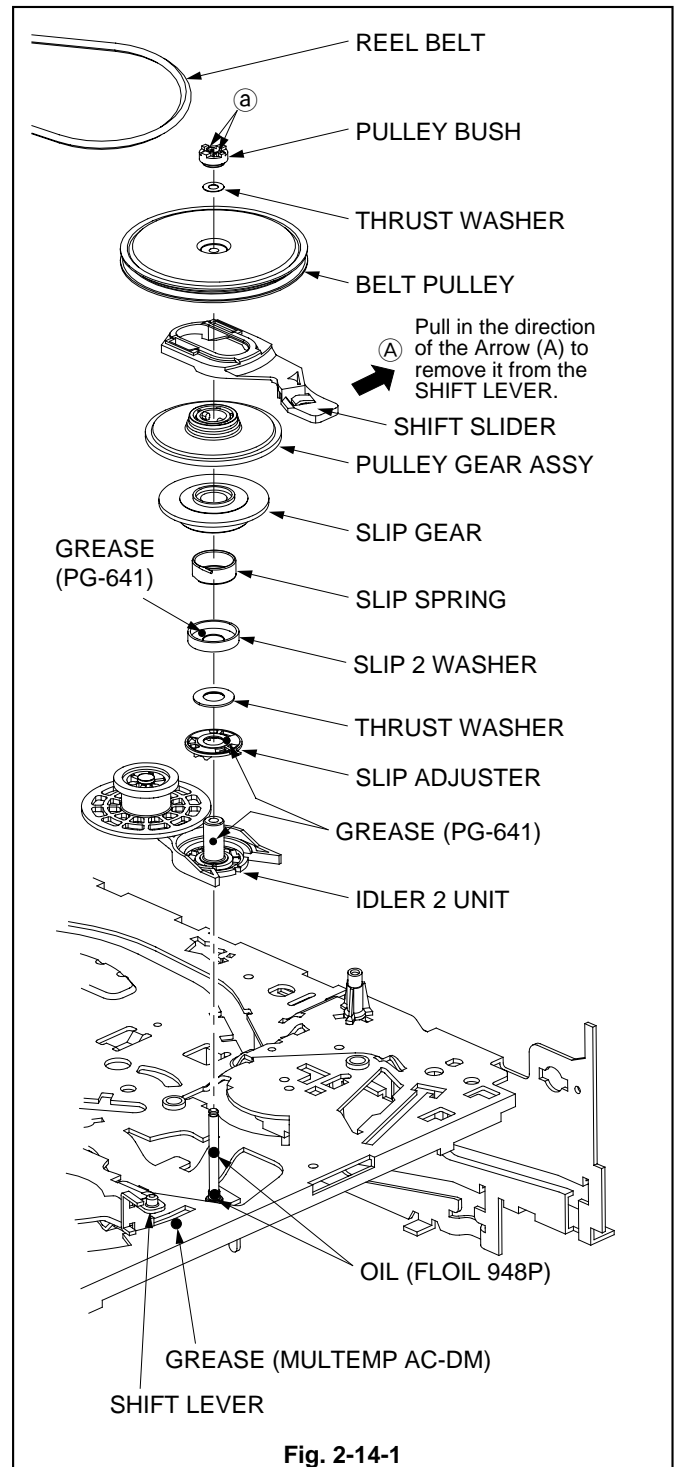

Fig. 2-14-1

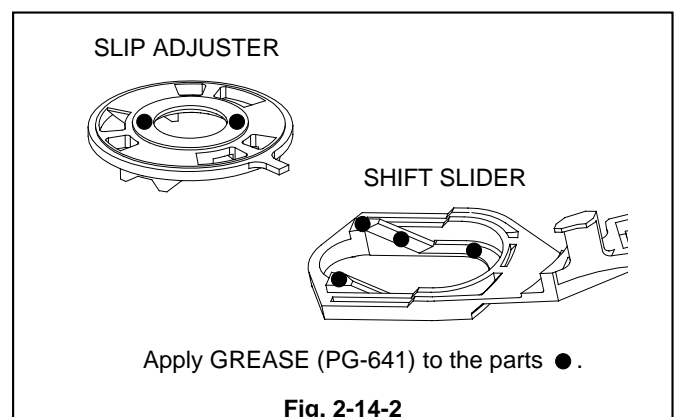

Fig. 2-14-2

9. Install the units from the SLIP 2 WASHER to REEL BELT shown in the Fig. 2-14-1.

Note1 : Be sure to replace the removed PULLEY BUSH with a new one.

Note2 : Attach the SLIP SPRING with its straight end facing the SLIP GEAR side.

Note3 : Attach the SLIP 2 WASHER with its position set as shown in the Fig. 2-14-5.

Note4 : Apply GREASE (PG-641) [859D055O30] to the part on the SLIP 2 WASHER specified in the Fig. 2-14-5.

10. Install the SHIFT SLIDER to the SHIFT LEVER shown in the Fig. 2-14-1.

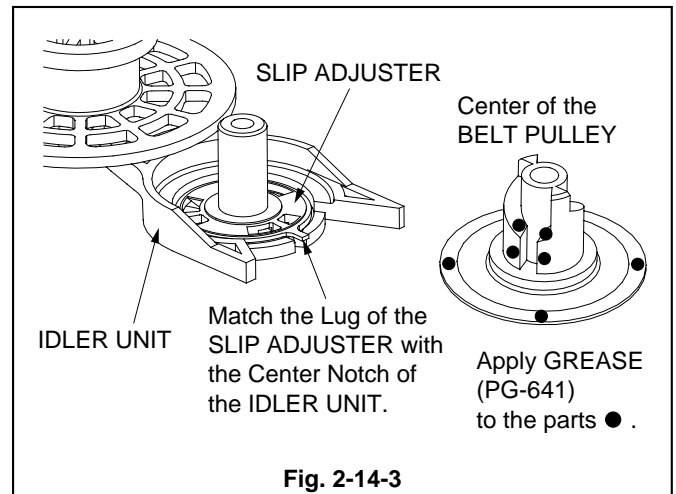

Fig. 2-14-3

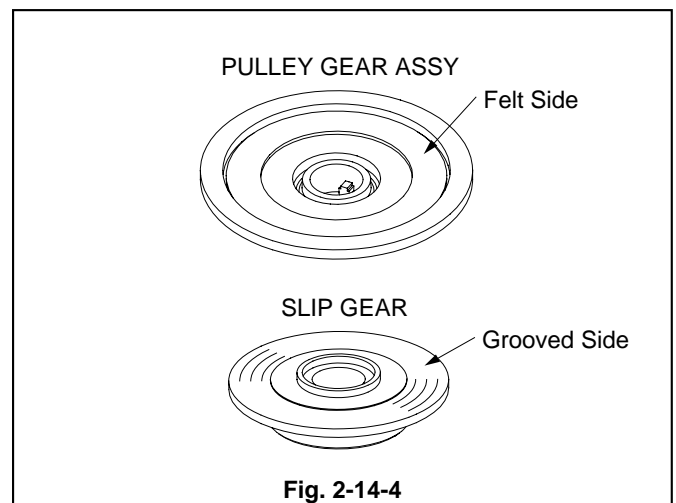

Fig. 2-14-4

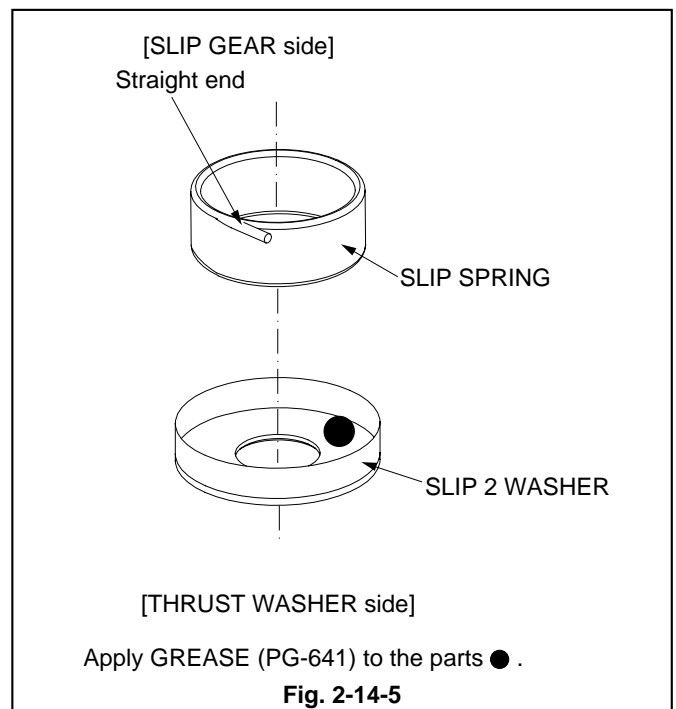

Fig. 2-14-5

2-15. CAPSTAN BRAKE SPRING, CAPSTAN BRAKE ASSY

SET POSITION : Upside down

(Removal)

1. Remove the CAPSTAN BRAKE SPRING shown in the Fig. 2-15.
2. Remove the catch (a) of the CAPSTAN BRAKE ASSY shown in the Fig. 2-15 to remove the CAPSTAN BRAKE ASSY.

(Installation)

1. Install the CAPSTAN BRAKE ASSY shown in the Fig. 2-15.
2. Install the CAPSTAN BRAKE SPRING shown in the Fig. 2-15.

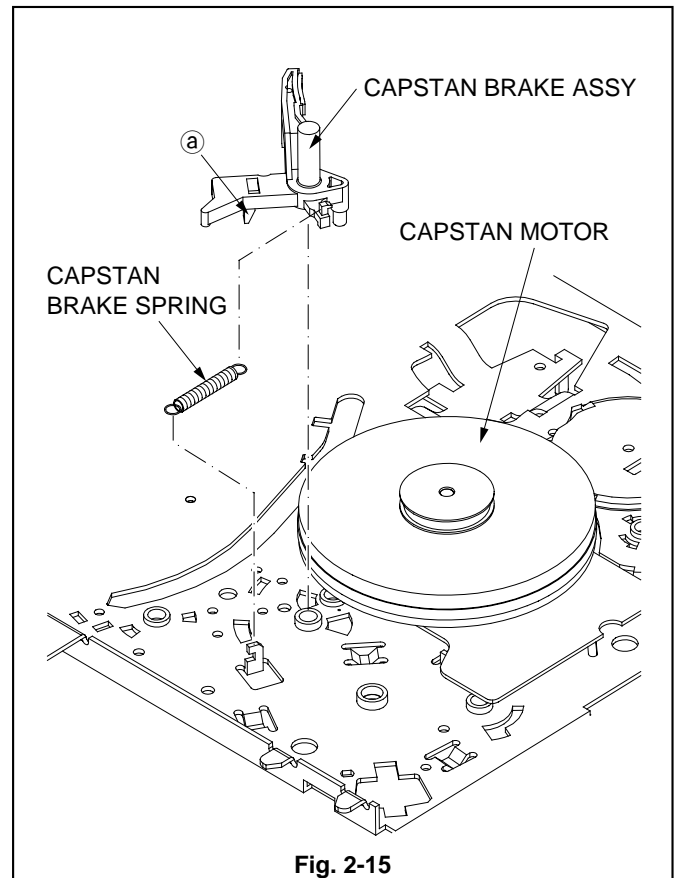

Fig. 2-15

2-16.FC HOLDER, MOTOR HOLDER, LOADING WORM, LOADING MOTOR ASSY, WORM WHEEL

SET POSITION : Normal

(Removal)

1. Release the two catches (a) of the FC HOLDER shown in the Fig. 2-16-1 to remove the FC HOLDER.
2. Remove the two screws (b) fastening the MOTOR HOLDER shown in the Fig. 2-16-1 to remove the MOTOR HOLDER.
3. Remove the two screws (c) fastening the LOADING MOTOR ASSY shown in the Fig. 2-16-1 to remove the LOADING MOTOR ASSY and LOADING WORM.
4. Remove the WORM WHEEL.

(Installation)

1. Apply GREASE (MULTEMP AC-DM)[859D055O90] to the LOADING WORM shown in the Fig. 2-16-2.
2. Apply GREASE (MULTEMP AC-DM)[859D055O90] to the WORM WHEEL shown in the Fig. 2-16-2.
3. Install the WORM WHEEL.
4. Install the LOADING WORM, LOADING MOTOR ASSY to the MOTOR HOLDER.

Note : Tighten the screw (c) shown in the Fig. 2-16-1 after putting the LUG TERMINAL on the screw.

5. Install the MOTOR HOLDER.
6. Install the FC HOLDER.

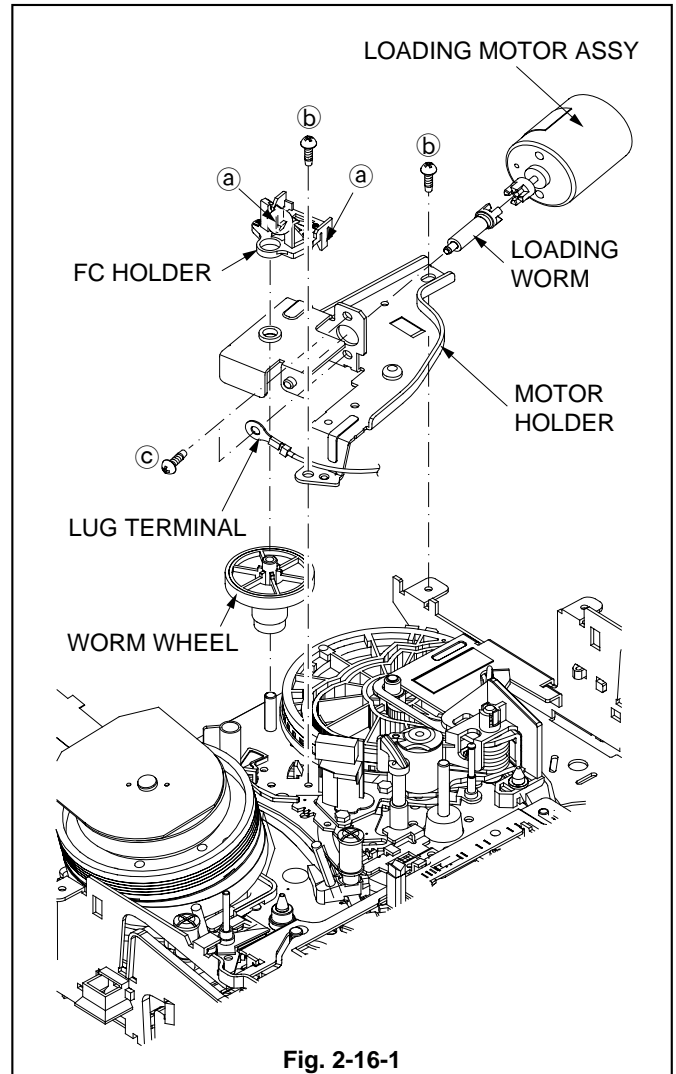

Fig. 2-16-1

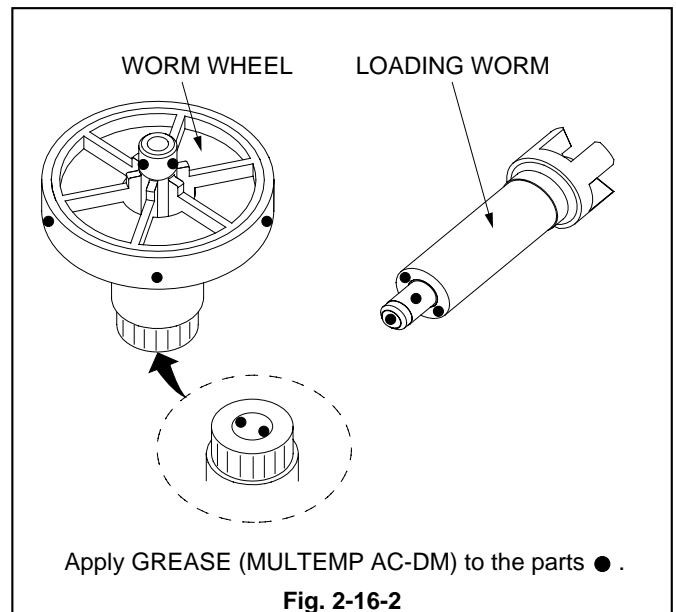

Fig. 2-16-2

2-17. PINCH ARM CAP, PINCH ASSY

SET POSITION : Normal

(Removal)

1. Release the two catches (Ⓐ) of the PINCH ARM CAP shown in the Fig. 2-17 to remove the PINCH ARM CAP.
2. Remove the PINCH ASSY shown in the Fig. 2-17.

(Installation)

1. Insert Part Ⓐ of the PINCH ASSY shown in the Fig. 2-17 in the most external groove of the MAIN CAM.
2. Install the PINCH ARM CAP matching the Part Ⓑ of the PINCH ARM CAP with the Rib of the MAIN PLATE ASSY.

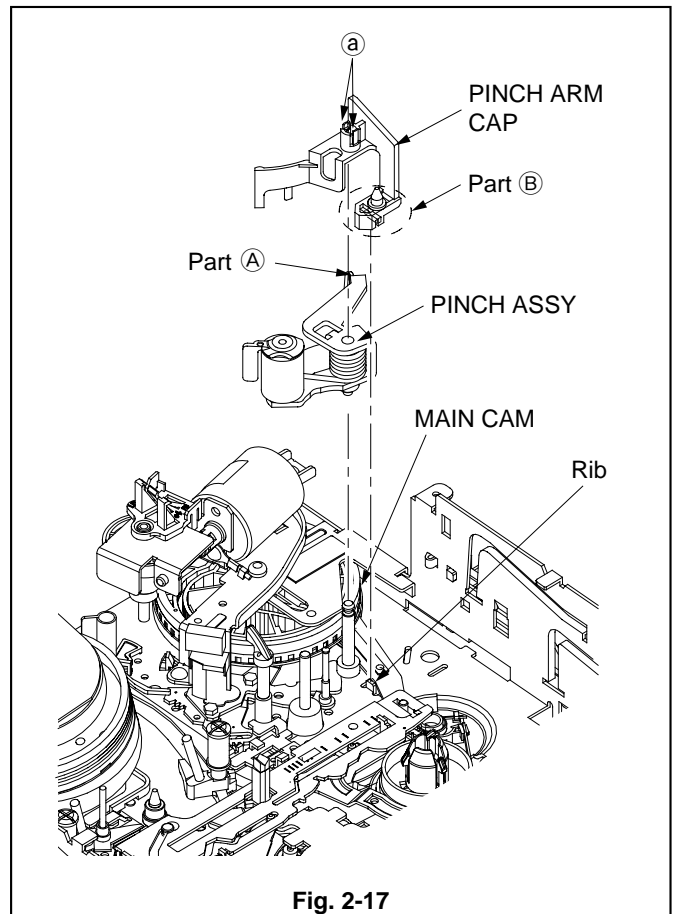

Fig. 2-17

2-18. F/L PLATE, DOOR ARM

SET POSITION : Normal

Remove the following parts before replacing the F/L PLATE, DOOR ARM. Refer to the corresponding items to install them.

- STAY PLATE (Item 2-2)
- BOTTOM ASSY (Item 2-3)
- SENSOR COVER (TU) (Item 2-10)
- MOTOR HOLDER (Item 2-16)
- PINCH ARM CAP (Item 2-17)
- PINCH ASSY (Item 2-17)

(Removal)

1. Slightly lift the back of the F/L PLATE (MAIN CAM side) shown in the Fig. 2-18-1 to remove the F/L PLATE.
2. Remove the DOOR ARM.

(Installation)

1. Apply GREASE (MULTEMP AC-DM)[859D055O90] to the points on the new F/L PLATE specified in the Fig. 2-18-1.
2. Apply GREASE (MOLYKOTE G PASTE) [859D055O50] to the points on the new F/L PLATE specified in the Fig. 2-18-1.

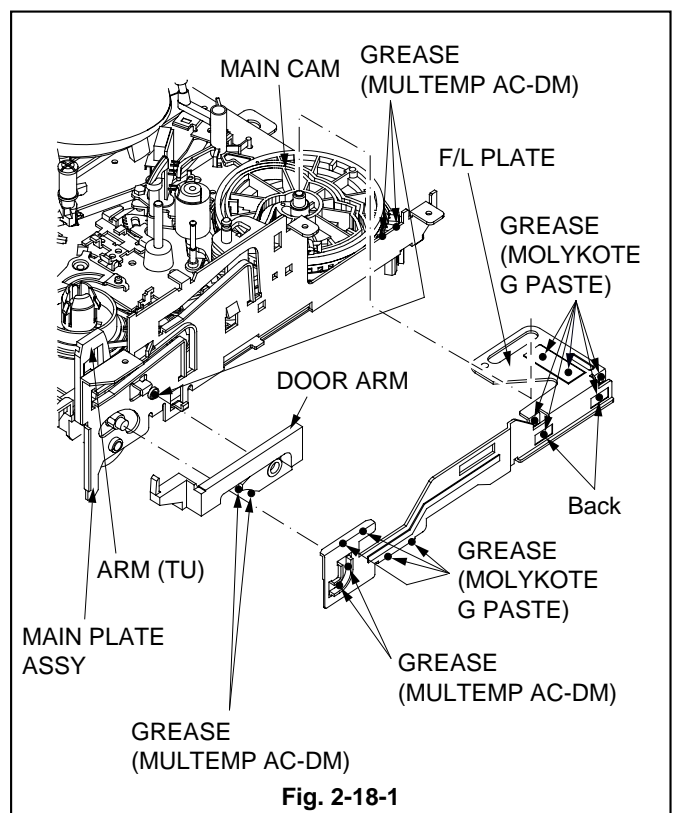

Fig. 2-18-1

3. Apply GREASE (MULTEMP AC-DM)[859D055O90] to the points on the MAIN PLATE ASSY specified in the Fig. 2-18-1.
4. Apply GREASE (MULTEMP AC-DM)[859D055O90] to the points on the DOOR ARM specified in the Fig. 2-18-1.
5. Install the DOOR ARM.
6. Match the Hole in the MAIN CAM with the Hole in the MAIN PLATE ASSY shown in the Fig. 2-18-2.
7. Install the F/L PLATE shown in the Fig. 2-18-1 from the front side (ARM (TU) side).
8. Insert the Boss of the F/L PLATE shown in the Fig. 2-18-2 into the Groove of the MAIN CAM.

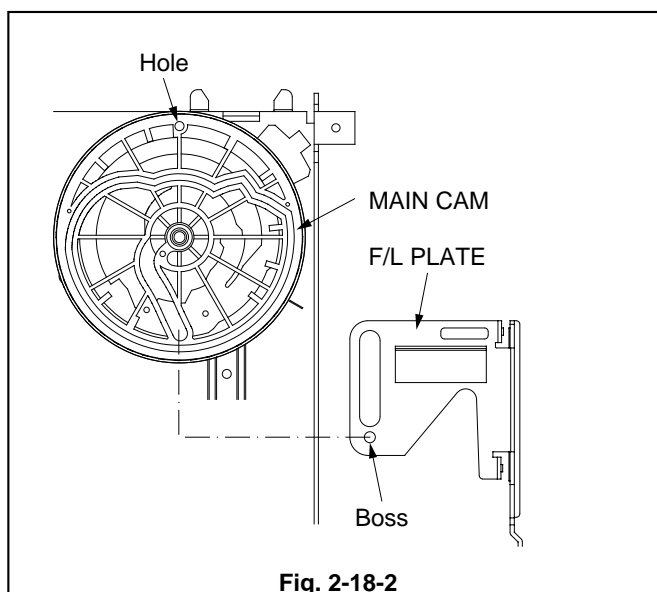

Fig. 2-18-2

2-19. BRAKE CAM PLATE

SET POSITION : Normal

Remove the following parts before replacing the BRAKE CAM PLATE. Refer to the corresponding items to install them.

- STAY PLATE (Item 2-2)
- BOTTOM ASSY (Item 2-3)
- MOTOR HOLDER (Item 2-16)
- PINCH ARM CAP (Item 2-17)
- PINCH ASSY (Item 2-17)

(Removal)

1. Rotate the MAIN CAM in the Fig. 2-19-1 in the direction shown by the arrow (A). And move the BRAKE CAM PLATE so that the three catches (a) of the MAIN PLATE ASSY can be released.
2. Remove the BRAKE CAM PLATE.

(Installation)

1. Apply GREASE (MOLYKOTE G PASTE) [859D055O50] to the points on the BRAKE CAM PLATE specified in the Fig. 2-19-2.
2. Hook the BRAKE SPRING shown in the Fig. 2-19-3 to the catch of the BRAKE (TU).
3. Install the BRAKE CAM PLATE, inserting the six Guide Pins (b) shown in the Fig. 2-19-1 into the slits of the BRAKE CAM PLATE.
4. Move the BRAKE SPRING in the Fig. 2-19-3 in the direction of the arrow (C) to release the Catch of the BRAKE (TU) and insert the BRAKE SPRING under the Catch.
5. Rotate the MAIN CAM shown in the Fig. 2-19-1 in the direction shown of the arrow (B). And move the BRAKE CAM PLATE to hook it to the three catches (a) of the MAIN PLATE ASSY.

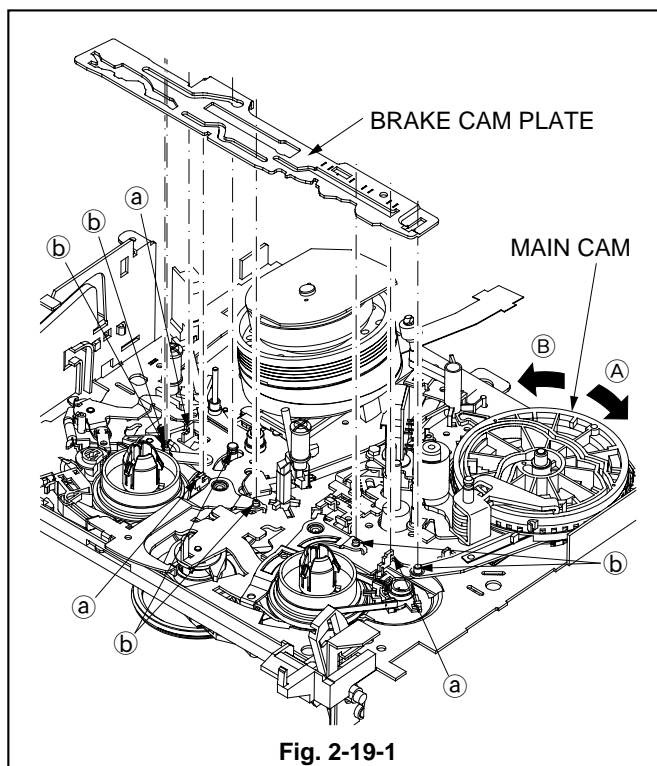

Fig. 2-19-1

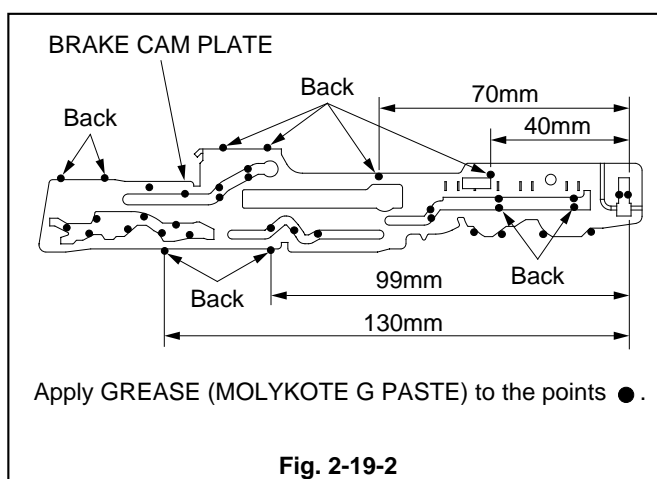

Fig. 2-19-2

2-20. GUIDE LAMP

SET POSITION : Normal

Remove the following parts before replacing the GUIDE LAMP. Refer to the corresponding items to install them.

- STAY PLATE (Item 2-2)
- BOTTOM ASSY (Item 2-3)
- MOTOR HOLDER (Item 2-16)
- PINCH ARM CAP (Item 2-17)
- PINCH ASSY (Item 2-17)
- BRAKE CAM PLATE (Item 2-19)

(Removal)

1. Release the catch (Ⓐ) of the GUIDE LAMP shown in the Fig. 2-20.
2. Rotate the GUIDE LAMP in the direction shown by the arrow Ⓐ (counterclockwise, when viewed from the bottom) to match the longest slit (Ⓒ) of the MAIN PLATE ASSY with the longest arm (Ⓑ) of the GUIDE LAMP shown in the Fig. 2-20. Pull it out downward to remove it.

(Installation)

1. Clean the dirt on the GUIDE LAMP with a VIDEO HEAD cleaning cloth.
- Note:** Never use solvent such as alcohol to clean the GUIDE LAMP.
2. Insert the GUIDE LAMP in the Fig. 2-20, matching the longest arm (Ⓑ) of the GUIDE LAMP with the longest slit (Ⓒ) of the MAIN PLATE ASSY.
 3. Rotate the GUIDE LAMP in the direction shown by the arrow Ⓑ (clockwise, when viewed from the bottom) to match the arm (Ⓐ) of the GUIDE LAMP shown in the Fig. 2-20 with the longest slit (Ⓒ) of the MAIN PLATE ASSY.

Note : Clean the dirt on the GUIDE LAMP with a VIDEO HEAD cleaning cloth if necessary.

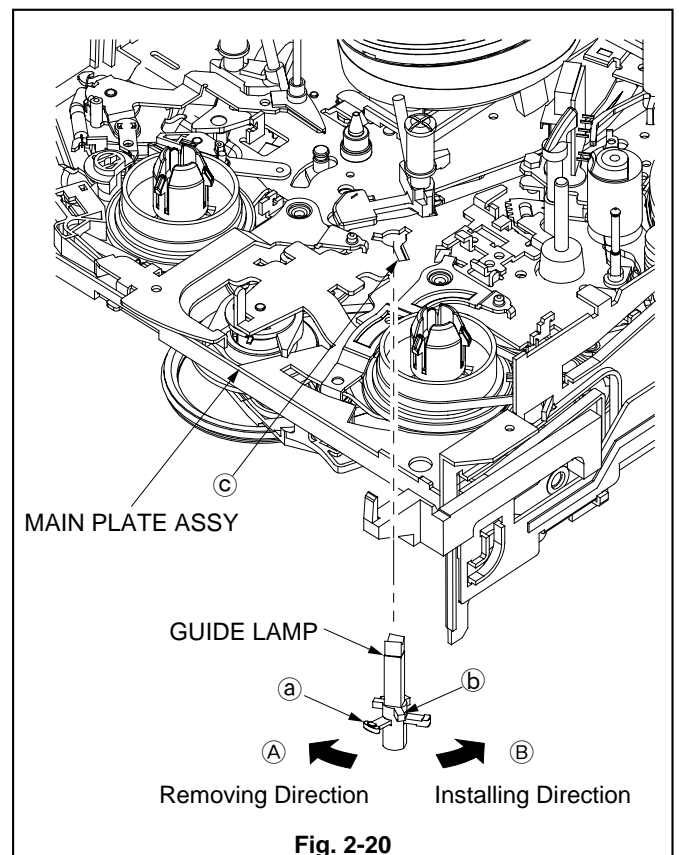
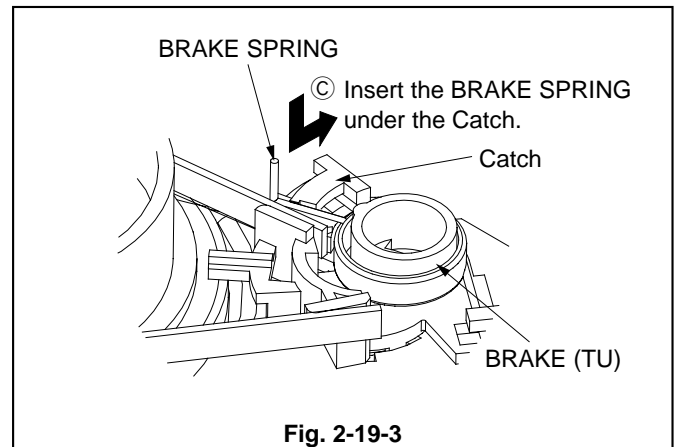

2-21.MAIN CAM, GUIDE ARM (TU), BRAKE LEVER, LB PIN

SET POSITION : Normal

Remove the following parts before replacing the MAIN CAM, GUIDE ARM (TU), BRAKE LEVER. Refer to the corresponding items to install them.

- STAY PLATE (Item 2-2)
- BOTTOM ASSY (Item 2-3)
- SENSOR COVER (TU) (Item 2-10)
- MOTOR HOLDER (Item 2-16)
- WORM WHEEL (Item 2-16)
- PINCH ARM CAP (Item 2-17)
- PINCH ASSY (Item 2-17)
- F/L PLATE (Item 2-18)

(Removal)

1. Remove the MAIN CAM shown in the Fig. 2-21-1.
2. Remove the GUIDE ARM (TU) shown in the Fig. 2-21-1.
3. Move the BRAKE LEVER in the Fig. 2-21-1 in the direction shown by the arrow (A) and release the catch (a) to remove the BRAKE LEVER.
4. Remove the LB PIN shown in the Fig. 2-21-1.

(Installation)

1. Apply GREASE (MULTEMP AC-DM)[859D055O90] to the points on the new GUIDE ARM (TU) specified in the Fig. 2-21-1.
2. Apply GREASE (MULTEMP AC-DM)[859D055O90] to the points on the MAIN PLATE ASSY specified in the Fig. 2-21-1.
3. Install the GUIDE ARM (TU), matching the Hole in the GUIDE ARM (TU) shown in the Fig. 2-21-2 with the Hole in the MAIN PLATE ASSY.

Note : Install the GUIDE ARM (TU) so that the Part specified with the Oblique Lines of the GUIDE ARM (TU) will be under the SHAFT FLANGE of the PINCH ASSY.

4. Install the BRAKE LEVER shown in the Fig. 2-21-2 so that the Hole in the BRAKE LEVER overlaps the Hole in the MAIN PLATE ASSY.
5. Apply GREASE (MULTEMP AC-DM)[859D055O90] to the points on the new MAIN CAM specified in the Fig. 2-21-3.
6. Install the MAIN CAM so that the Hole in the MAIN CAM shown in the Fig. 2-21-2 overlaps with the Hole in the MAIN PLATE ASSY.

Note : Install the MAIN CAM inserting the Pins of the CAPSTAN BRAKE ASSY, GUIDE ARM (TU), BRAKE LEVER into the Grooves on the back of the MAIN CAM for sure.
Be careful that GREASE does not adhere on the Wall when applying GREASE to the most external circle on the back of the MAIN CAM (4 parts) shown in the Fig. 2-21-3.

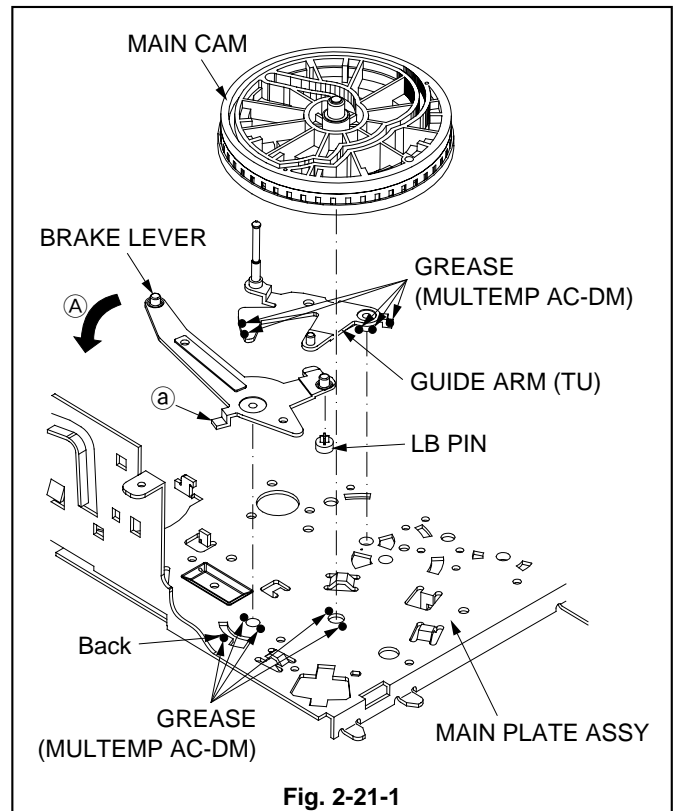

Fig. 2-21-1

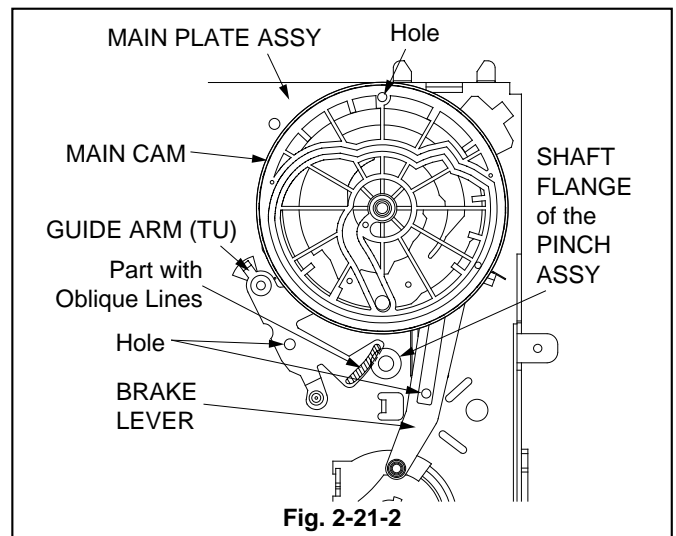

Fig. 2-21-2

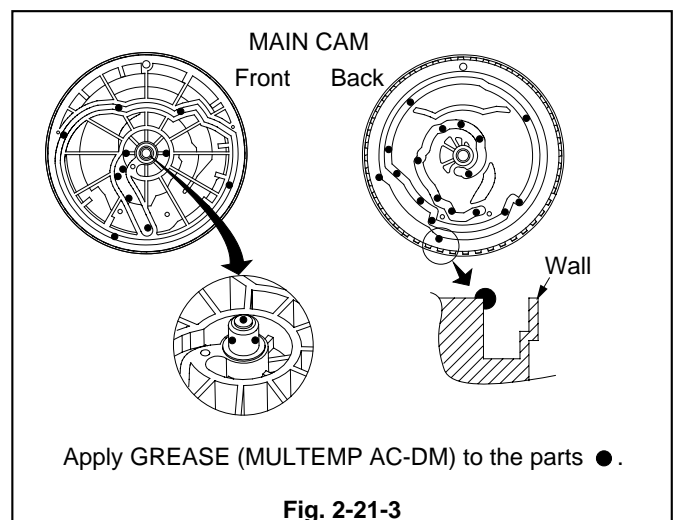

Fig. 2-21-3

2-22. L/D LOCK LEVER

SET POSITION : Normal

Remove the following parts before replacing the L/D LOCK LEVER. Refer to the corresponding items to install them.

- STAY PLATE (Item 2-2)
- BOTTOM ASSY (Item 2-3)
- MOTOR HOLDER (Item 2-16)
- PINCH ARM CAP (Item 2-17)
- PINCH ASSY (Item 2-17)
- BRAKE CAM PLATE (Item 2-19)

(Removal)

1. Remove the L/D LOCK LEVER shown in the Fig. 2-22.

(Installation)

1. Install the L/D LOCK LEVER shown in Fig. 2-22.

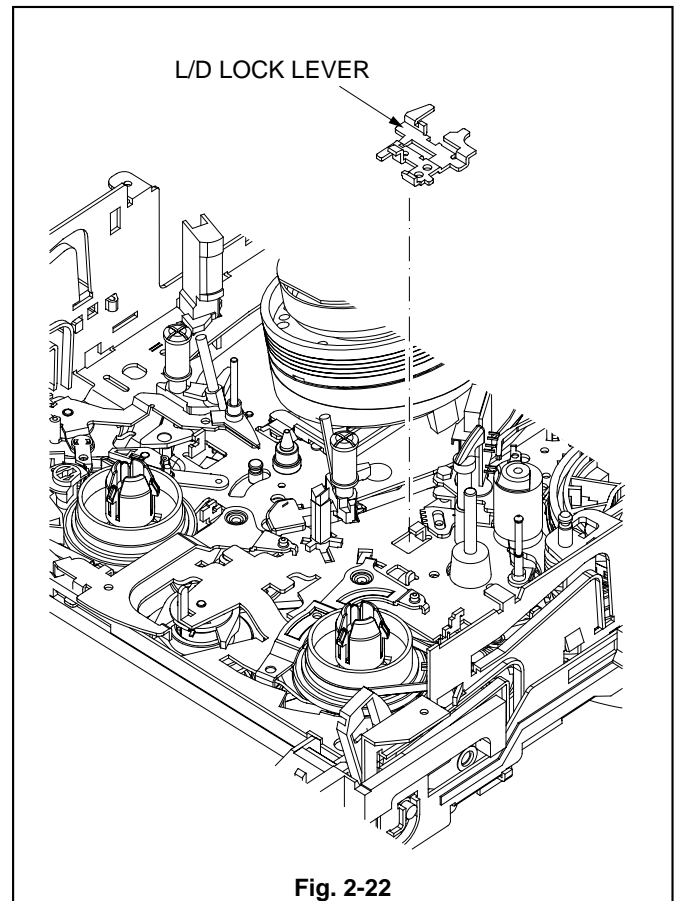

Fig. 2-22

2-23. BRAKE BELT (SP), BELT HOLDER

SET POSITION : Normal

Remove the following parts before replacing the BRAKE BELT (SP), BELT HOLDER. Refer to the corresponding items to install them.

- STAY PLATE (Item 2-2)
- BOTTOM ASSY (Item 2-3)

(Removal)

1. Lift the BRAKE BELT (SP) shown in the Fig. 2-23 to remove it from the REEL DISK (SP side).
2. Release the BRAKE BELT (SP) from the catch (a) of the BELT LEVER shown in the Fig. 2-23.
3. Release the two catches (b) of the BELT HOLDER shown in the Fig. 2-23 and separate the BELT HOLDER from the BRAKE BELT (SP).
4. Release the catch (c) of the BELT HOLDER shown in the Fig. 2-23 to remove the BRAKE BELT (SP).

(Installation)

Note : Install the BRAKE BELT (SP) so that its Felt Side touches the REEL DISK (SP side). GREASE applied to the BRAKE CAM PLATE and MAIN PLATE ASSY should not adhere on the Felt Side of the BRAKE BELT (SP).

1. Install the BRAKE BELT (SP) shown in the Fig. 2-23 to the catch (c) of the BELT HOLDER.
2. Install the BELT HOLDER shown in the Fig. 2-23.
3. Install the BRAKE BELT (SP) shown in the Fig. 2-23 to the catch (a) of the BELT LEVER.
4. Hook the BRAKE BELT (SP) shown in the Fig. 2-23 to the REEL DISK (SP side).

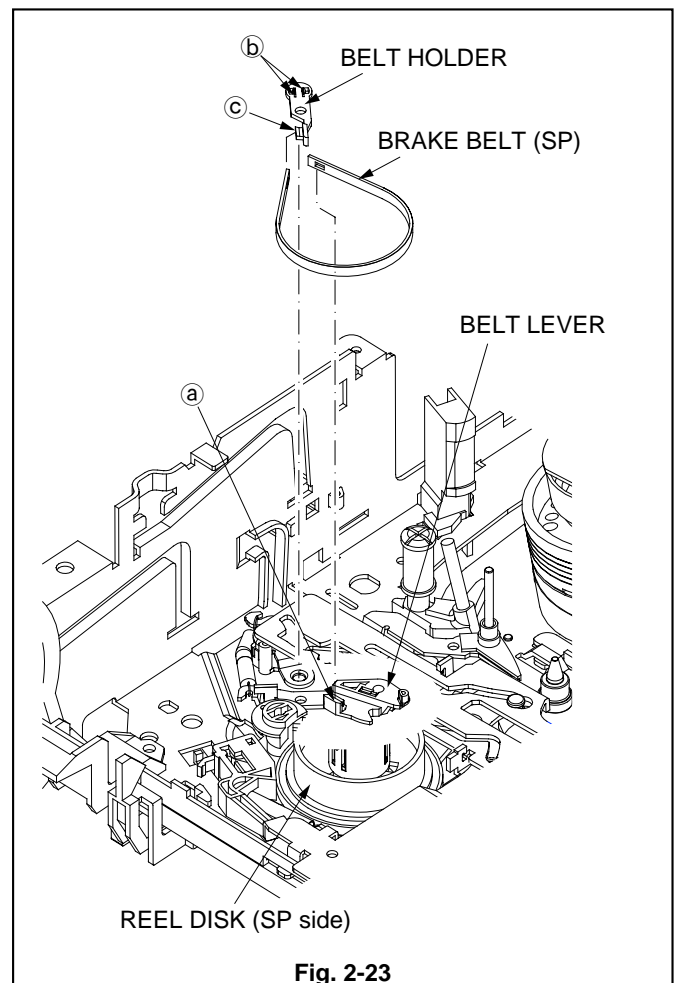

Fig. 2-23

2-24. BELT LEVER, BELT ADJUSTER

SET POSITION : Normal

Remove the following parts before replacing the BELT LEVER, BELT ADJUSTER. Refer to the corresponding items to install them.

- STAY PLATE (Item 2-2)
- BOTTOM ASSY (Item 2-3)
- MOTOR HOLDER (Item 2-16)
- PINCH ARM CAP (Item 2-17)
- PINCH ASSY (Item 2-17)
- BRAKE CAM PLATE (Item 2-19)
- BRAKE BELT (SP) (Item 2-23)
- BELT HOLDER (Item 2-23)

(Removal)

1. Release the catch (a) of the BELT LEVER shown in the Fig. 2-24 to remove the BELT LEVER.
2. Remove the BELT ADJUSTER shown in the Fig. 2-24.

(Installation)

1. Install the BELT ADJUSTER shown in the Fig. 2-24.
2. Install the BELT LEVER shown in the Fig. 2-24.

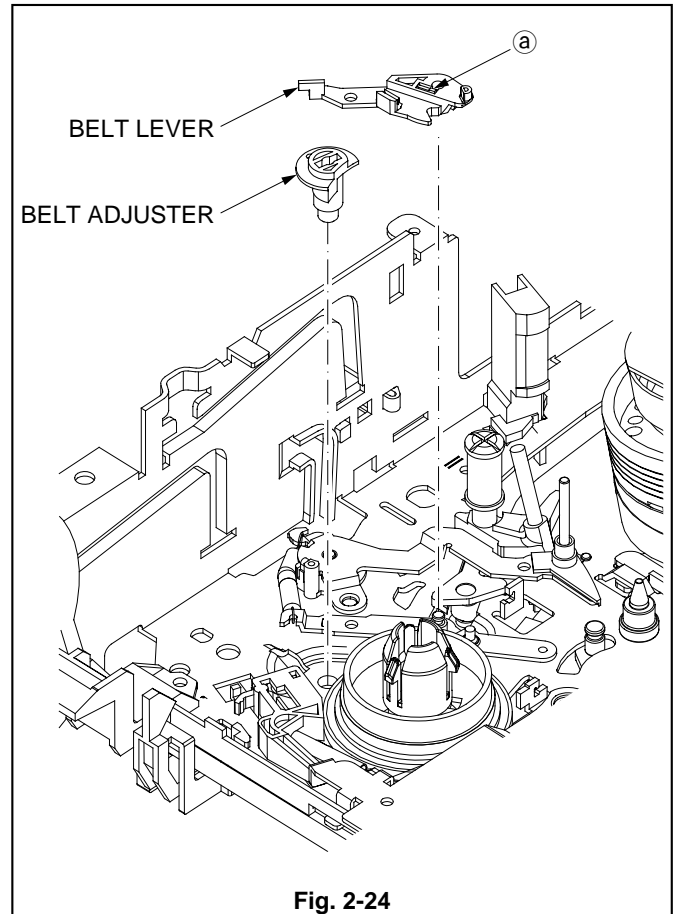

Fig. 2-24

2-25 TENSION ARM, TENSION LEVER, TENSION SPRING, TENS AXIS HOLDER, REEL DISK (SP side)

SET POSITION : Normal

Remove the following parts before performing this item. Refer to the corresponding items to install them.

- STAY PLATE (Item 2-2)
- BOTTOM ASSY (Item 2-3)
- MOTOR HOLDER (Item 2-16)
- PINCH ARM CAP (Item 2-17)
- PINCH ASSY (Item 2-17)
- BRAKE CAM PLATE (Item 2-19)
- BRAKE BELT (SP) (Item 2-23)
- BELT HOLDER (Item 2-23)
- BELT LEVER (Item 2-24)

(Removal)

1. Remove the TENSION SPRING shown in the Fig. 2-25.
2. Release the catch (a) of the TENS AXIS HOLDER shown in the Fig. 2-25 to remove the TENSION ARM.
3. Remove the TENSION LEVER shown in the Fig. 2-25.
4. Release the catch (b) of the TENS AXIS HOLDER shown in the Fig. 2-25. Move the TENS AXIS HOLDER in the direction shown by the arrow A to remove it.
5. Remove the REEL DISK (SP side).

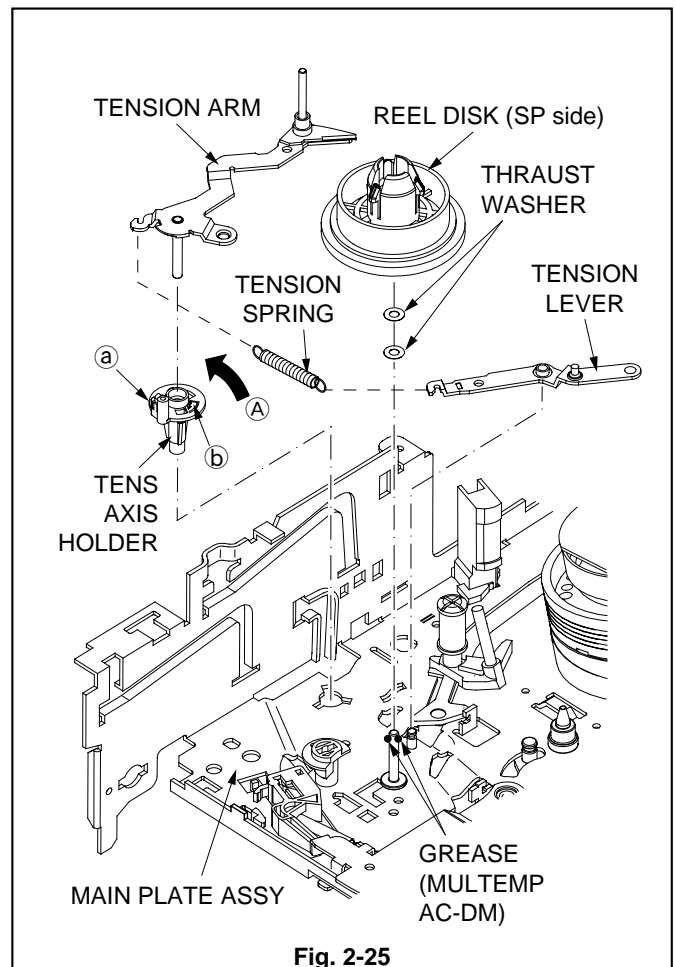

Fig. 2-25

(Installation)

1. Apply OIL (FLOIL 948P) [859D154O20] to the parts on the MAIN PLATE ASSY specified in the Fig. 2-25.
2. Install the REEL DISK (SP side).
3. Install the TENS AXIS HOLDER.

Note : Install the TENS AXIS HOLDER so that the catch (a) for the TENSION ARM will be positioned on the front (F/L ARM ASSY side).

4. Install the TENSION LEVER.
5. Install the TENSION ARM.
6. Install the TENSION SPRING.

Note : Install the longer hook of the TENSION SPRING to the TENSION ARM.

2-26. BRAKE BELT (TU)

SET POSITION : Normal

Remove the following parts before replacing the BRAKE BELT. Refer to the corresponding items to install them.

- STAY PLATE (Item 2-2)
- BOTTOM ASSY (Item 2-3)

(Removal)

1. Lift the BRAKE BELT (TU) shown in the Fig. 2-26 to remove it from the REEL DISK (TU side).
2. Release the two catches (a) of the BRAKE (TU) shown in the Fig. 2-26 to remove the BRAKE BELT (TU).

(Installation)

1. Install the BRAKE BELT (TU) shown in the Fig. 2-26 to the BRAKE (TU).
2. Hook the BRAKE BELT (TU) shown in the Fig. 2-26 to the REEL DISK (TU side).

Note : Install the BRAKE BELT (TU) so that its Felt Side touches the REEL DISK (TU side).

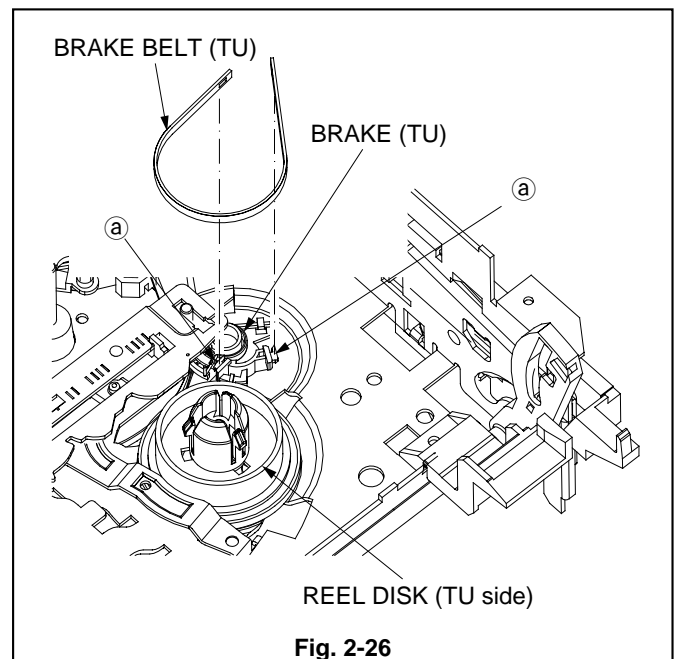

2-27. BRAKE (TU), REEL DISK (TU side)

SET POSITION : Normal

Remove the following parts before replacing the BRAKE (TU), REEL DISK (TU side). Refer to the corresponding items to install them.

- STAY PLATE (Item 2-2)
- BOTTOM ASSY (Item 2-3)
- MOTOR HOLDER (Item 2-16)
- PINCH ARM CAP (Item 2-17)
- PINCH ASSY (Item 2-17)
- BRAKE CAM PLATE (Item 2-19)

(Removal)

1. Move the BRAKE (TU) in the Fig. 2-27 in the direction shown by the arrow (A) to remove it.
2. Remove the BRAKE BELT (TU) from the BRAKE (TU).
3. Remove the REEL DISK (TU).

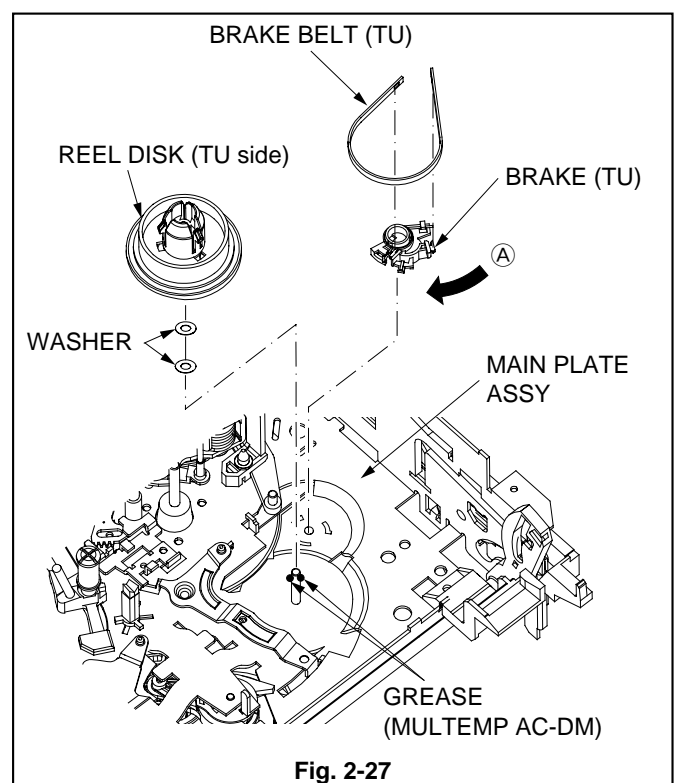

(Installation)

Note : Install the BRAKE BELT (TU) so that its Felt Side touches the REEL DISK (TU side).

The GREASE applied to the BRAKE CAM PLATE and the MAIN PLATE ASSY should not adhere on the Felt Side of the BRAKE BELT (SP).

1. Apply GREASE (MULTEMP AC-DM)[859D055O90] to the parts on the MAIN PLATE ASSY specified in the Fig. 2-27.
2. Install the REEL DISK (TU side).
3. Install the BRAKE BELT (TU) to the BRAKE (TU).
4. Install the BRAKE (TU).
5. Hook the BRAKE BELT (TU) to the REEL DISK (TU side).

2-28. SHIFT LEVER

SET POSITION : Normal

Remove the following parts before replacing the SHIFT LEVER. Refer to the corresponding items to install them.

- STAY PLATE (Item 2-2)
- BOTTOM ASSY (Item 2-3)
- MOTOR HOLDER (Item 2-16)
- PINCH ARM CAP (Item 2-17)
- PINCH ASSY (Item 2-17)
- BRAKE CAM PLATE (Item 2-19)
- BRAKE (TU) (Item 2-27)
- REEL DISK (TU side) (Item 2-27)

(Removal)

1. Move the SHIFT SLIDER in the Fig. 2-28 in the direction shown by the arrow (A) to release it from the SHIFT LEVER.
2. Move the SHIFT LEVER in the Fig. 2-28 in the direction shown by the arrow (B) to remove it.

(Installation)

1. Apply GREASE (MULTEMP AC-DM)[859D055O90] to the parts on the new SHIFT LEVER specified in the Fig. 2-28.
2. Apply GREASE (MULTEMP AC-DM)[859D055O90] to the parts on the MAIN PLATE ASSY specified in the Fig. 2-28.
3. Install the SHIFT LEVER so that its Part (a) shown in the Fig. 2-28 will be positioned under the MAIN PLATE ASSY.
4. Install the SHIFT SLIDER to the SHIFT LEVER.

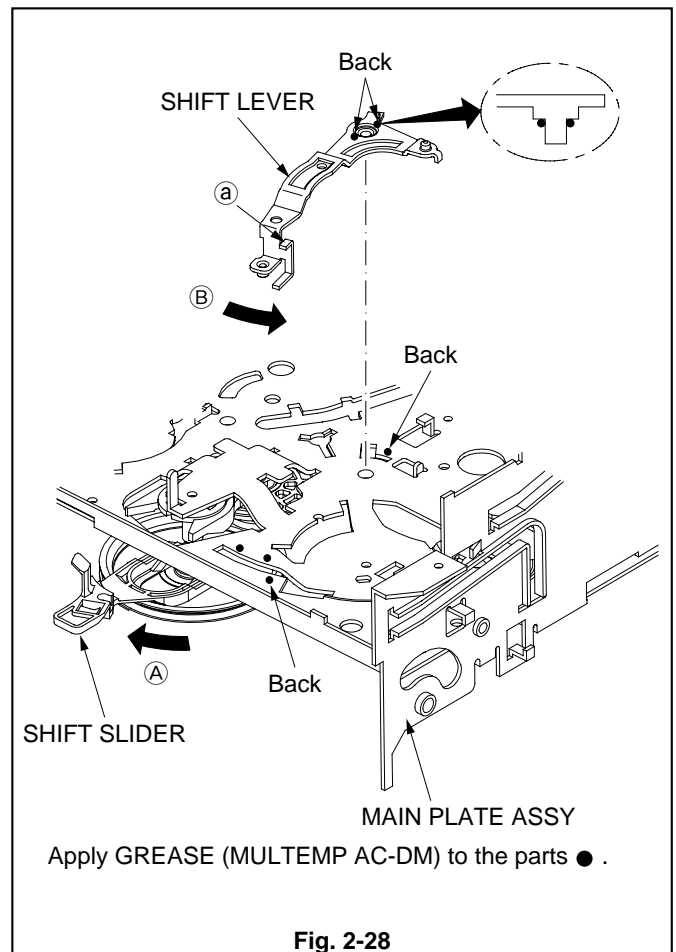

2-29. CHARGE SPRING, SWING LEVER, CHARGE ASSY

SET POSITION : Normal

Remove the following parts before replacing the CHARGE SPRING, SWING LEVER, CHARGE ASSY. Refer to the corresponding items to install them.

- STAY PLATE (Item 2-2)
- BOTTOM ASSY (Item 2-3)
- MOTOR HOLDER (Item 2-16)
- PINCH ARM CAP (Item 2-17)
- PINCH ASSY (Item 2-17)
- BRAKE CAM PLATE (Item 2-19)

(Removal)

1. Remove the CHARGE SPRING shown in the Fig. 2-29 from the SWING LEVER.
2. Remove the SWING LEVER shown in the Fig. 2-29.
3. Release the Part ① of the CHARGE ASSY shown in the Fig. 2-29 from the Part ② of the MAIN PLATE ASSY to remove the CHARGE ASSY.

(Installation)

1. Apply GREASE (MULTEMP AC-DM)[859D055O90] to the parts on the MAIN PLATE ASSY specified in the Fig. 2-29.
2. Install the CHARGE ASSY.
3. Install the SWING LEVER inserting the Part ③ of the SWING LEVER in the Fig. 2-29 into the groove in the MAIN PLATE ASSY.
4. Install the CHARGE SPRING to the SWING LEVER.

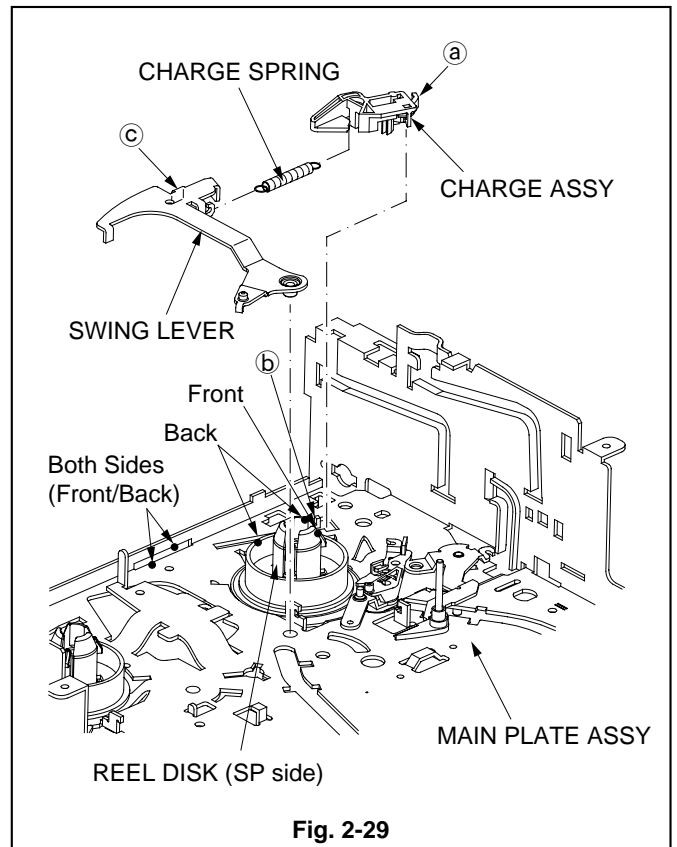

Fig. 2-29

2-30. LOADING ARM ASSY (SP), LOADING ARM ASSY (TU)

SET POSITION : Upside down

(Removal)

1. Release the catch (①) of the LOADING ARM ASSY (SP) shown in the Fig. 2-30-1 to remove the LOADING ARM ASSY (SP).

Note : Be sure to replace the removed LOADING ARM ASSY (SP) with a new one.

2. Remove the screw (②) fastening the SPACER PLATE shown in the Fig. 2-30-1 to remove the SPACER PLATE.
3. Remove the LOADING ARM ASSY (TU) shown in the Fig. 2-30-1.

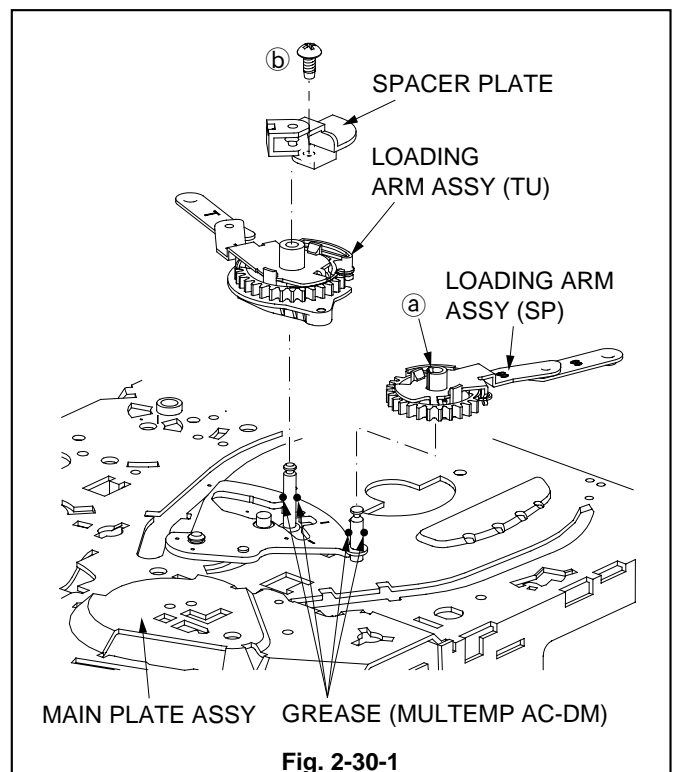
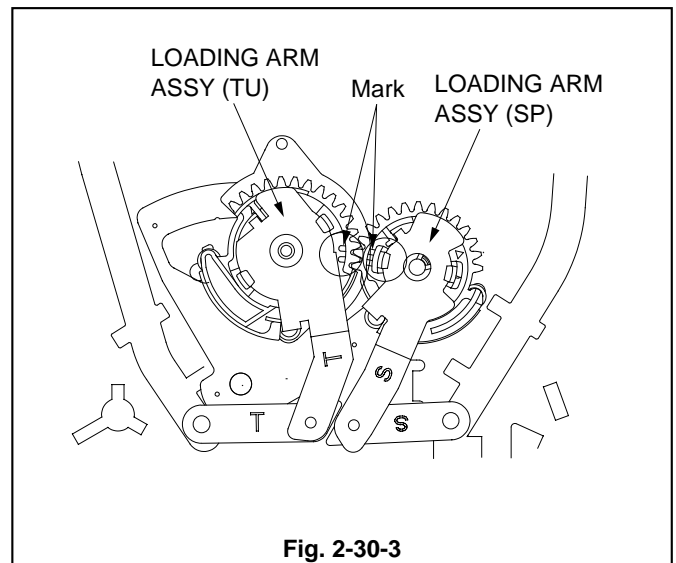
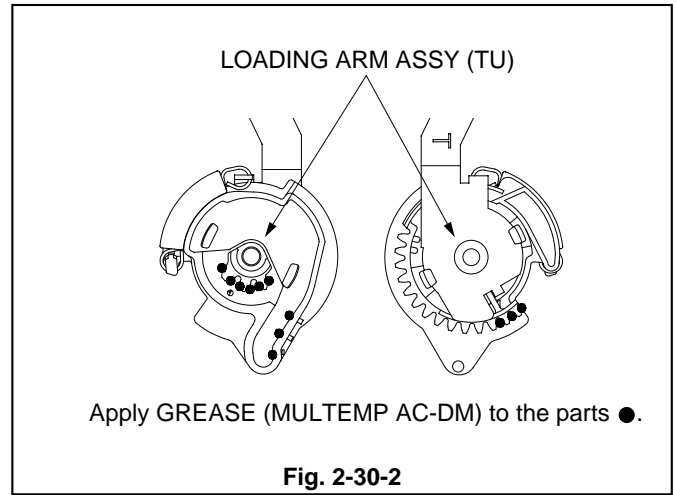

Fig. 2-30-1

(Installation)

1. Apply GREASE (MULTEMP AC-DM)[859D055O90] to the parts on the MAIN PLATE ASSY specified in the Fig. 2-30-1.
2. Apply GREASE (MULTEMP AC-DM)[859D055O90] to the parts on the LOADING ARM ASSY (TU) specified in the Fig. 2-30-2.
3. Install the LOADING ARM ASSY (SP) and LOADING ARM ASSY (TU) so that the Marks on the both UNITs face each other, as shown in the Fig. 2-30-3.

Note : Be sure to replace the removed LOADING ARM ASSY (SP) with a new one.



2-31. A/L LEVER

SET POSITION: Upside down

Remove the following parts before replacing the A/L LEVER. Refer to the corresponding items to install them.

- STAY PLATE (Item 2-2)
- BOTTOM ASSY (Item 2-3)
- MOTOR HOLDER (Item 2-16)
- PINCH ARM CAP (Item 2-17)
- PINCH ASSY (Item 2-17)
- BRAKE CAM PLATE (Item 2-19)
- LOADING ARM ASSY (SP) (Item 2-30)
- LOADING ARM ASSY (TU) (Item 2-30)

(Removal)

1. Remove the CUT WASHER and WASHER shown in the Fig. 2-31-1. Then, remove the A/L LEVER.

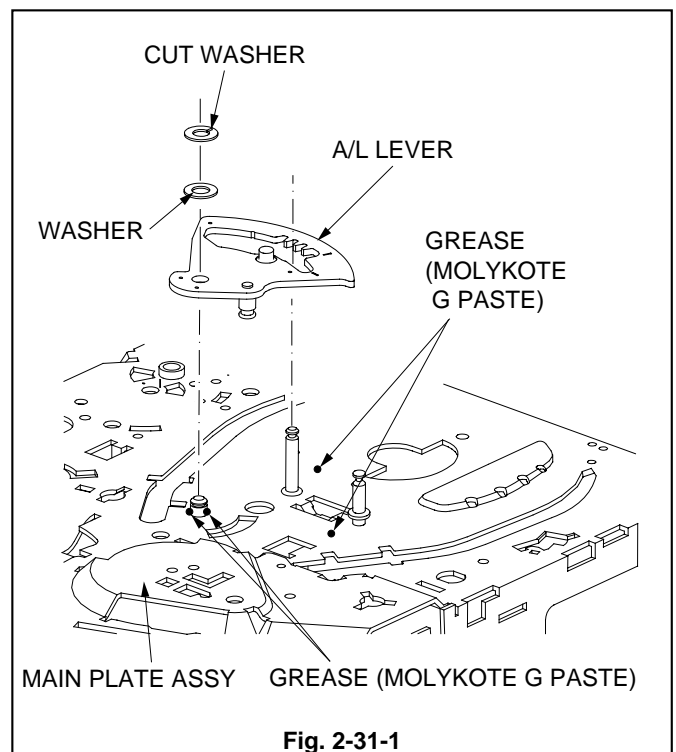

(Installation)

Note : Install the LOADING ARM ASSY (TU) and LOADING ARM ASSY (SP), according to the following procedure, after installing the A/L LEVER.

1. Apply GREASE (MOLYKOTE G PASTE) [859D055O50] to the parts on the MAIN PLATE ASSY specified in the Fig. 2-31-1.
2. Apply GREASE (MOLYKOTE G PASTE) [859D055O50] to the parts on the A/L LEVER specified in the Fig. 2-31-2.
3. Install the A/L LEVER so that the Mark on the A/L LEVER faces to the FLANGE of the LOADING ARM ASSY (SP), as shown in the Fig. 2-31-3.

Note : The Part specified with Oblique Lines on the A/L LEVER should be under the FLANGE of the LOADING ARM ASSY (SP).

4. Install the LOADING ARM ASSY (TU) so that the Marks on the LOADING ARM ASSY (TU) and on the A/L LEVER will face each other, as shown in the Fig. 2-31-4.
5. Install the LOADING ARM ASSY (SP) so that the ▲ mark on the LOADING ARM ASSY (SP) and the Reinforcement Rib of the LOADING ARM ASSY (TU) will face each other, as shown in the Fig. 2-31-4.

Note : Be sure to replace the removed LOADING ARM ASSY (SP) with a new one.

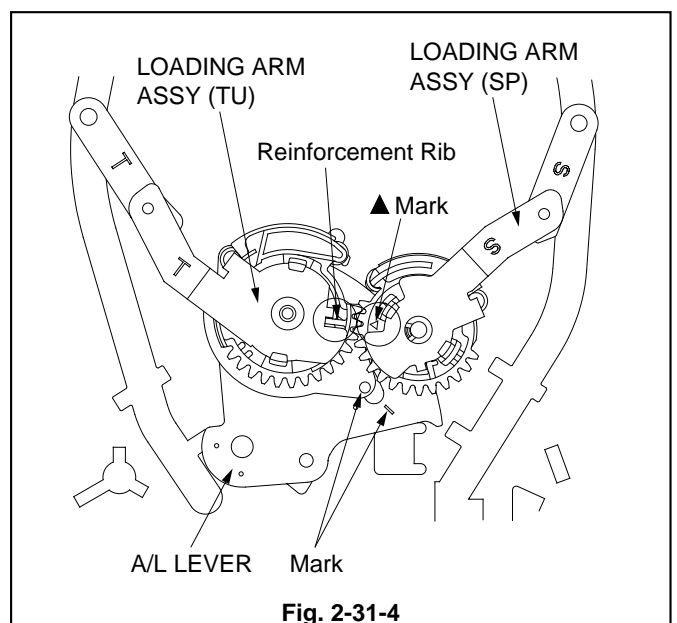
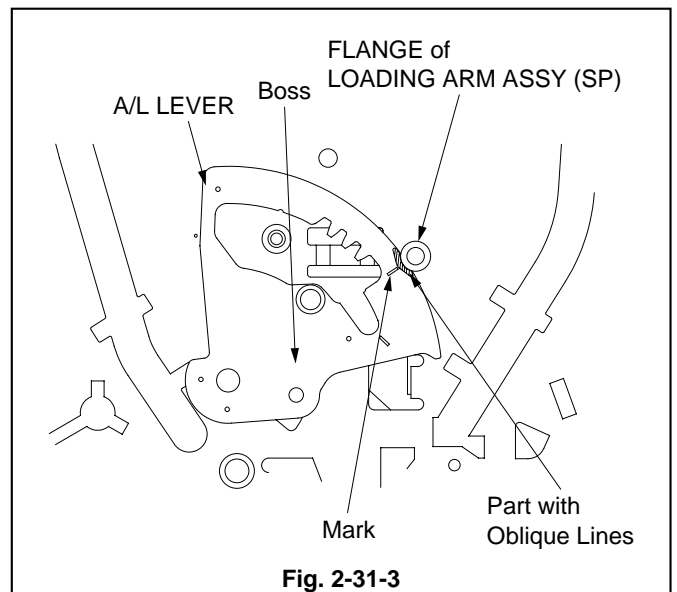
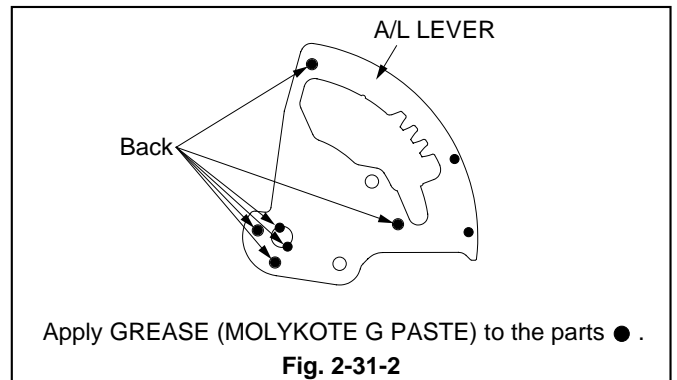

2-32. TAPE GUIDE ASSY (SP), TAPE GUIDE ASSY (TU)

SET POSITION : Normal

Remove the following parts before replacing the TAPE GUIDE ASSY (SP), (TU). Refer to the corresponding items to install them.

- STAY PLATE (Item 2-2)
- BOTTOM ASSY (Item 2-3)
- MOTOR HOLDER (Item 2-16)
- PINCH ARM CAP (Item 2-17)
- PINCH ASSY (Item 2-17)
- BRAKE CAM PLATE (Item 2-19)
- BRAKE BELT (SP) (Item 2-23)
- BELT HOLDER (Item 2-23)
- BELT LEVER (Item 2-24)
- TENSION ARM (Item 2-25)

(Removal)

1. Loosen the TAPE GUIDE ASSY (SP) shown in the Fig. 2-32-1 (turn it fully in the Unloading direction) to remove it.
2. Loosen the TAPE GUIDE ASSY (TU) shown in the Fig. 2-32-1 (turn it fully in the Unloading direction) to remove it.

(Installation)

1. Apply GREASE (MULTEMP AC-DM)[859D055O90] to the parts on the MAIN PLATE ASSY specified in the Fig. 2-32-2.
2. Install the TAPE GUIDE ASSY (SP) shown in the Fig. 2-32-1.
3. Install the TAPE GUIDE ASSY (TU) shown in the Fig. 2-32-1.
4. Perform the Item 3-2-1. "GUIDE ROLLER Check" to the Item 3-2-5. "Flatness Check of FM Waveform" of the "Interchangeability Adjustment of the Mechanism".

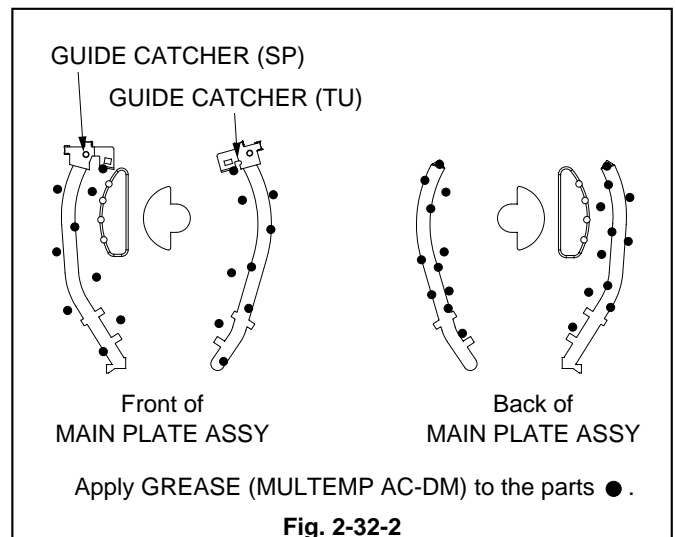
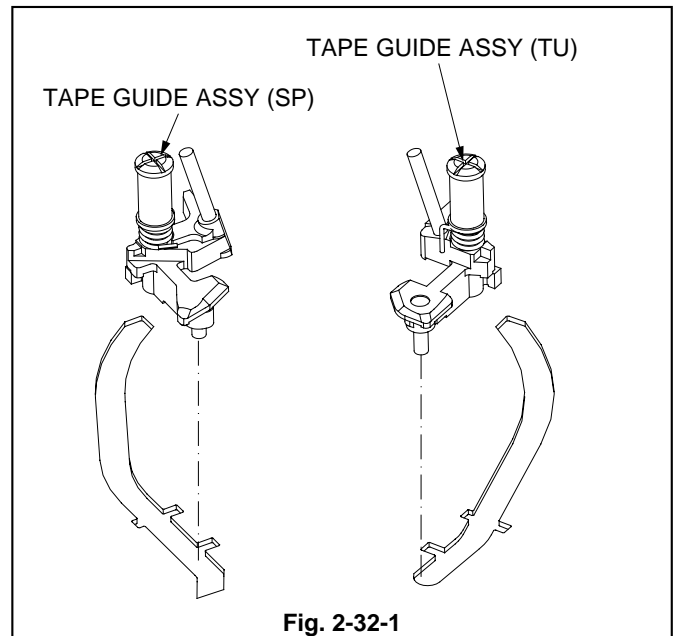

2-33.DRUM CLAMPER, DRUM ASSY

SET POSITION : Normal

(Removal)

1. Disconnect the LEAD CONNECTOR of the DRUM ASSY shown in the Fig. 2-33-1.
2. Remove the two screws (a, b) fastening the DRUM CLAMPER shown in the Fig. 2-33-1 to remove the DRUM ASSY with the DRUM CLAMPER.
3. Rotate the DRUM CLAMPER in the Fig. 2-33-2 in the direction shown by the arrow (A) to remove it from the DRUM ASSY.

(Installation)

1. Install the DRUM CLAMPER in the Fig. 2-33-2 to the DRUM ASSY by rotating it in the direction shown of the arrow (B).
2. Hook the Catch of the DRUM CLAMPER shown in the Fig. 2-33-3 to the Reference Pin.
3. Fasten the screw (b) while pushing the Part (A) in the direction shown by the arrow (C) (clockwise when viewed from the top) as shown in the Fig. 2-33-3.

Note : Confirm at this time that the Catch of the DRUM CLAMPER touches the side of the Reference Pin.

4. Fasten the screw (a) shown in the Fig. 2-33-3.

Note : Confirm at this time that the Catch of the DRUM CLAMPER touches the side of the Reference Pin.

5. Connect the LEAD CONNECTOR of the DRUM ASSY with the DRUM CLAMPER shown in the Fig. 2-33-1.
6. Connect the LEAD CONNECTOR of the DRUM ASSY shown in the Fig. 2-33-1.
7. Perform the Item "PLAYBACK Switching Point" of the "Circuit Adjustment" in this service manual.
8. Perform the Item "Interchangeability Adjustment of the Mechanism".
9. Clean the DRUM ASSY shown in the Fig. 2-33-1 with alcohol.

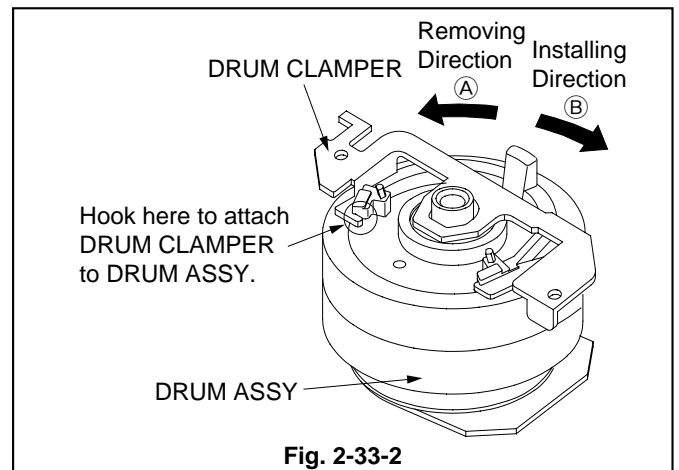
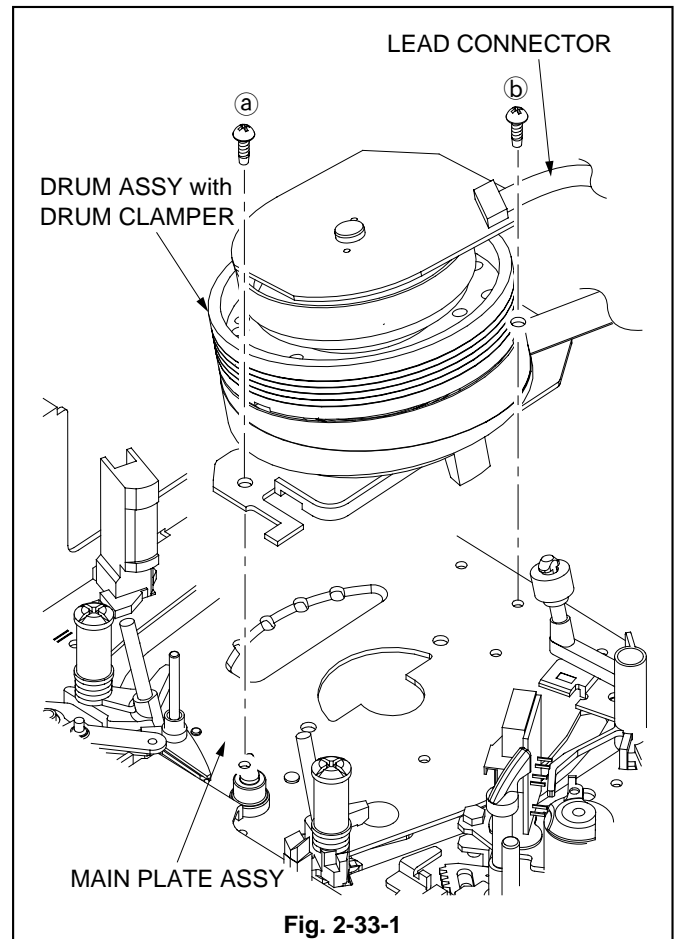

2-34.DRUM MOTOR STATOR, BRUSH SPRING, SPACER, ROTOR CASE, END RING, BRUSH, UPPER DRUM ASSY

SET POSITION : Normal

(Removal)

1. Disconnect the LEAD CONNECTOR of the DRUM ASSY shown in the Fig. 2-34-1.
2. Remove the two screws (a) fastening the DRUM MOTOR STATOR shown in the Fig. 2-34-1 to remove the DRUM MOTOR STATOR.
3. Remove the two screws (b) fastening the ROTOR CASE shown in the Fig. 2-34-1 to remove the ROTOR CASE.

Note : Mark on the END RING and UPPER DRUM ASSY shown in the Fig. 2-34-1 using a pen, etc. for convenience in installing them.

4. Loosen the hexagon screw (c) fastening the END RING shown in the Fig. 2-34-1 to remove the END RING.
5. Remove the BRUSH SPRING shown in the Fig. 2-34-1.
6. Remove the BRUSH shown in the Fig. 2-34-1.
7. Remove the UPPER DRUM ASSY shown in the Fig. 2-34-1.
8. Remove the SPACER shown in the Fig. 2-34-1.

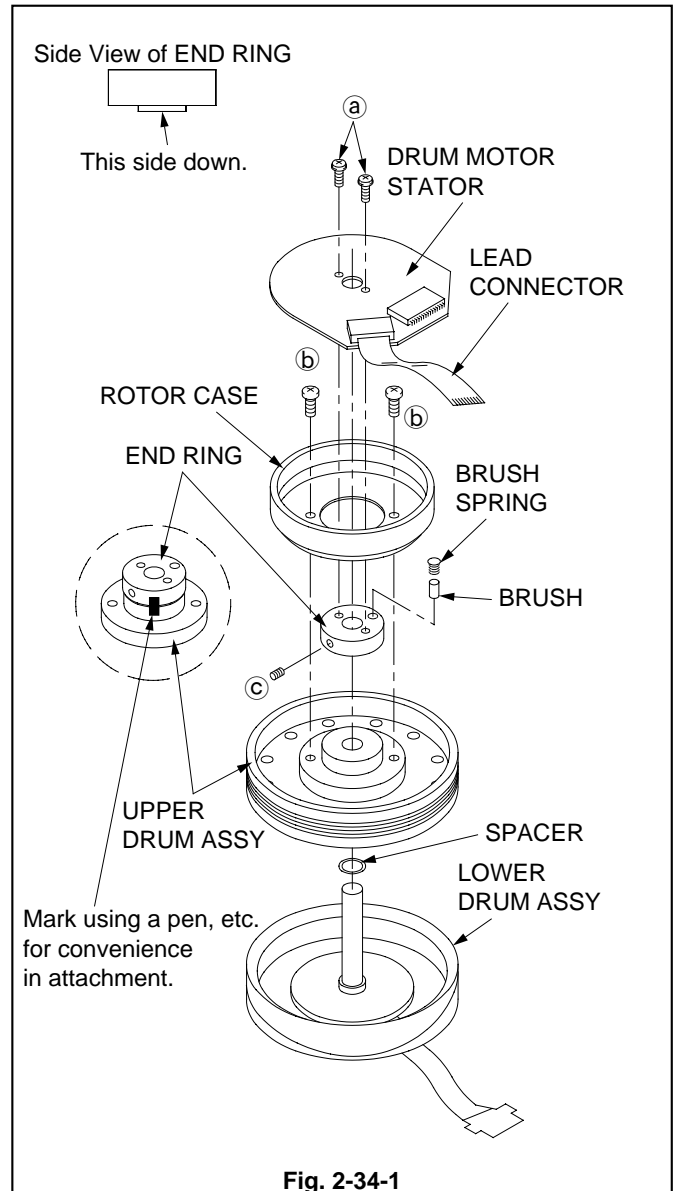
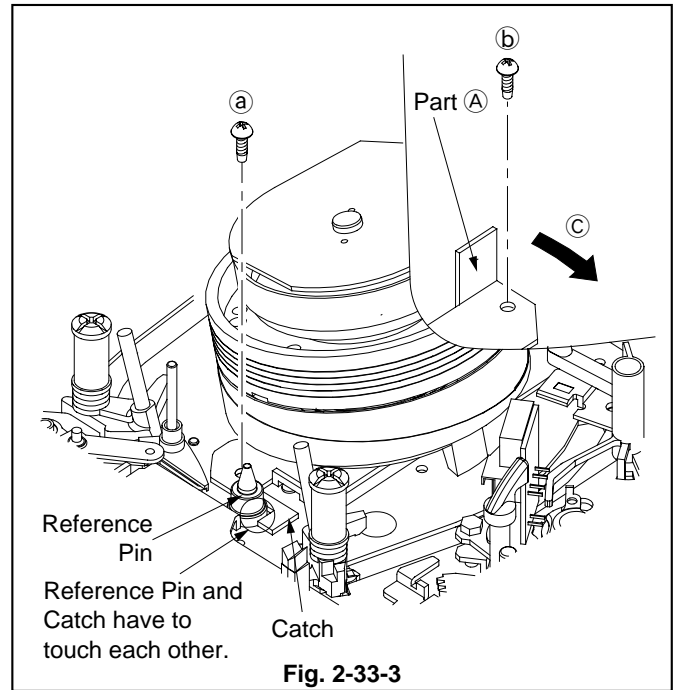

(Installation)

1. Install the SPACER shown in the Fig. 2-34-1.
- Note :** Be sure to use the new SPACER packed with the new UPPER DRUM ASSY.
2. Install the UPPER DRUM ASSY shown in the Fig. 2-34-1.
3. Install the END RING so that the reference hole (A) of the END RING shown in the Fig. 2-34-2 will be placed in parallel with the Rear Line of the MAIN PLATE ASSY. (The reference hole (A) should be on the right when viewed from the bottom.)
4. Apply the screw-sealing agent to the hexagon screw (C) fastening the END RING shown in the Fig. 2-34-1.
5. Install the ROTOR CASE shown in the Fig. 2-34-3, matching its Holes with the three reference holes (B) of the UPPER DRUM ASSY.
6. Install the BRUSH shown in the Fig. 2-34-1.
7. Install the BRUSH SPRING shown in the Fig. 2-34-1.
8. Install the DRUM MOTOR STATOR shown in the Fig. 2-34-1.
9. Connect the LEAD CONNECTOR of the DRUM ASSY shown in the Fig. 2-34-1.
10. Perform the Item "PLAYBACK Switching Point" adjustment.
11. Perform the Item "Interchangeability Adjustment of the Mechanism".
12. Clean the DRUM ASSY with alcohol.

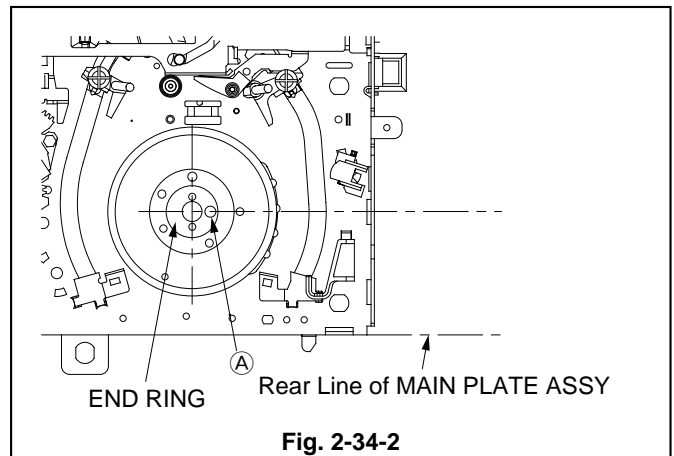

Fig. 2-34-2

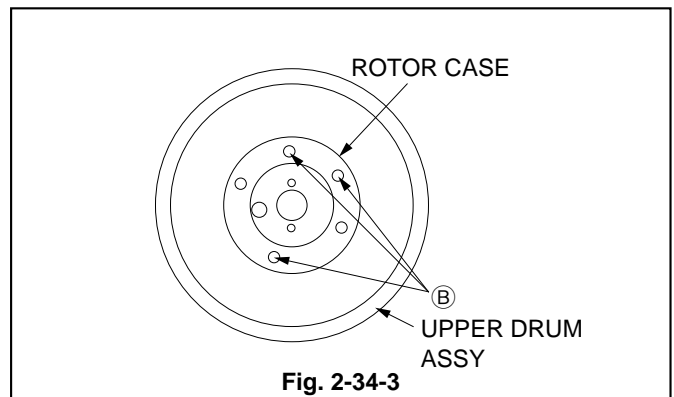

Fig. 2-34-3

2-35. CAPSTAN MOTOR

SET POSITION : Normal

Remove the following part before replacing the CAPSTAN MOTOR. Refer to the corresponding item to install it.

- REEL BELT (Item 2-14.)

(Removal)

1. Rotate the WORM WHEEL in the Fig. 2-35-1 in the direction shown by the arrow (A) to release the Hooks of the BOTTOM ASSY from the Locks of the STAY PLATE.
2. Rotate the WORM WHEEL in the Fig. 2-35-2 in the direction shown by the arrow (A) so that the GUIDE ARM (TU) moves in the direction of arrow (B) and expose the three screws (a) fastening the CAPSTAN MOTOR.
3. Remove the three screws (a) fastening the CAPSTAN MOTOR shown in the Fig. 2-35-2 to remove the CAPSTAN MOTOR.

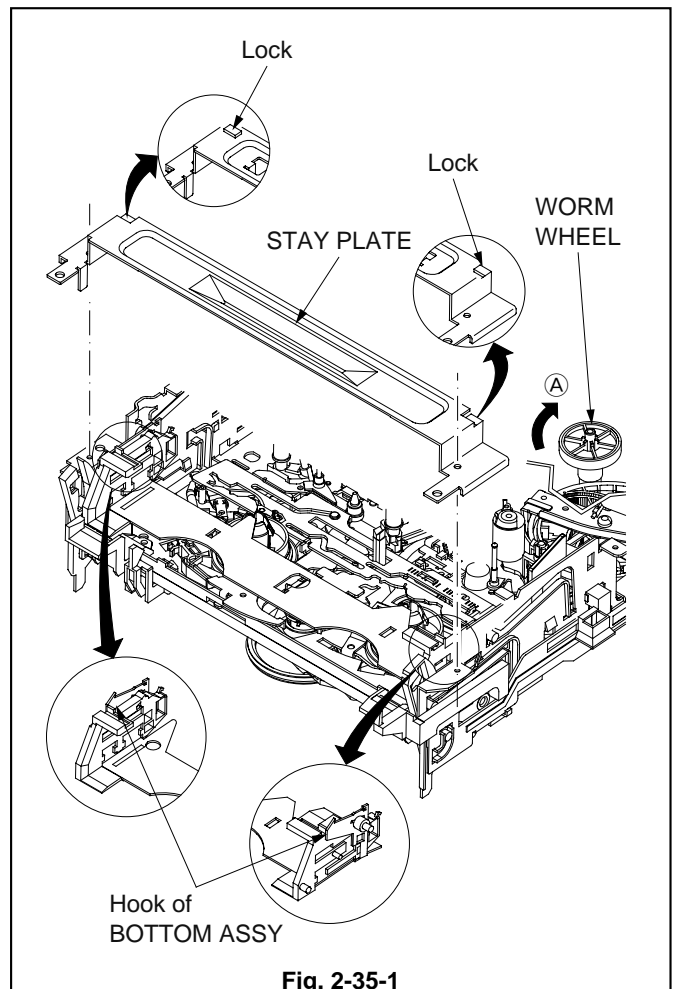
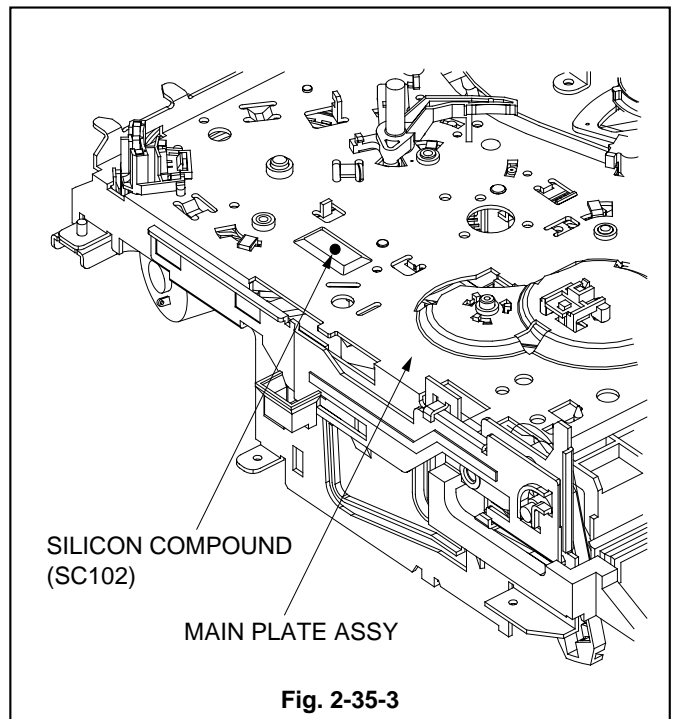
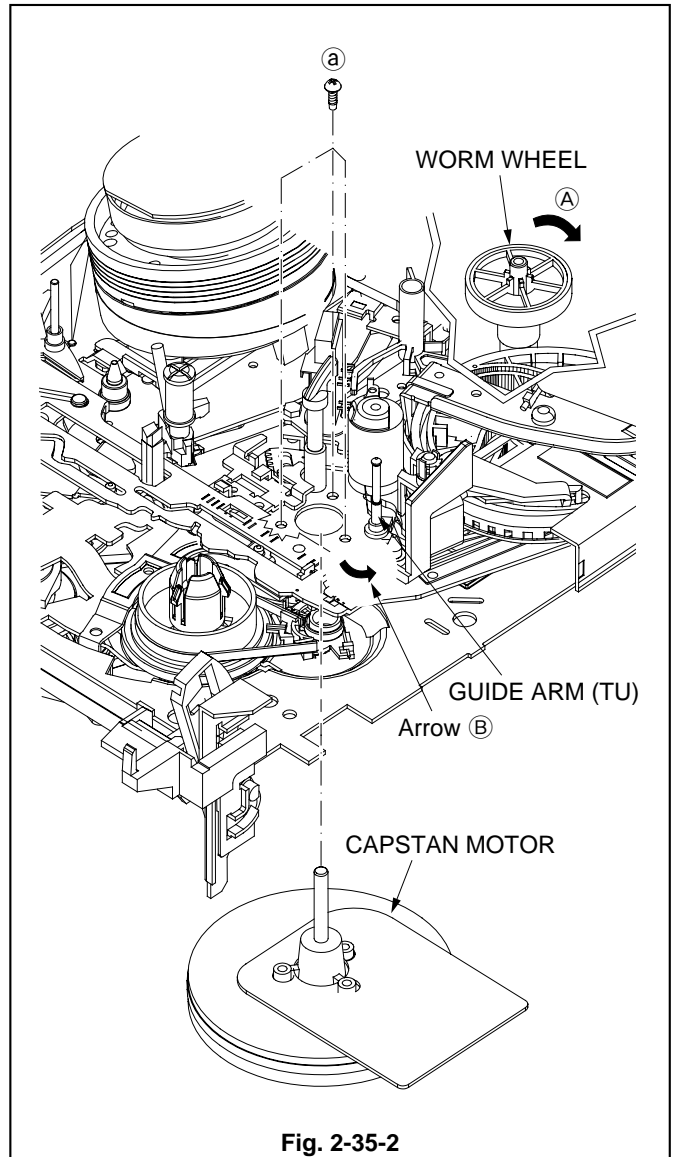

Fig. 2-35-1

(Installation)

1. Apply SILICON COMPOUND (SC102) [859D164O10] to the parts on the MAIN PLATE ASSY specified in the Fig. 2-35-3.
2. Install the CAPSTAN MOTOR.



2-36.IMPEDANCE UNIT (SP), FLYWHEEL (SP)

SET POSITION : Normal

(Removal)

1. Unfasten the two catches (a) on the IMPEDANCE UNIT (SP) shown in Fig. 2-36, and remove the FLYWHEEL (SP).
2. Remove the screw (b) on the IMPEDANCE UNIT (SP) shown in Fig. 2-36, and remove the IMPEDANCE UNIT (SP).

(Installation)

1. Install the IMPEDANCE UNIT (SP) shown in Fig. 2-36.
2. Install the FLYWHEEL (SP) shown in Fig. 2-36.

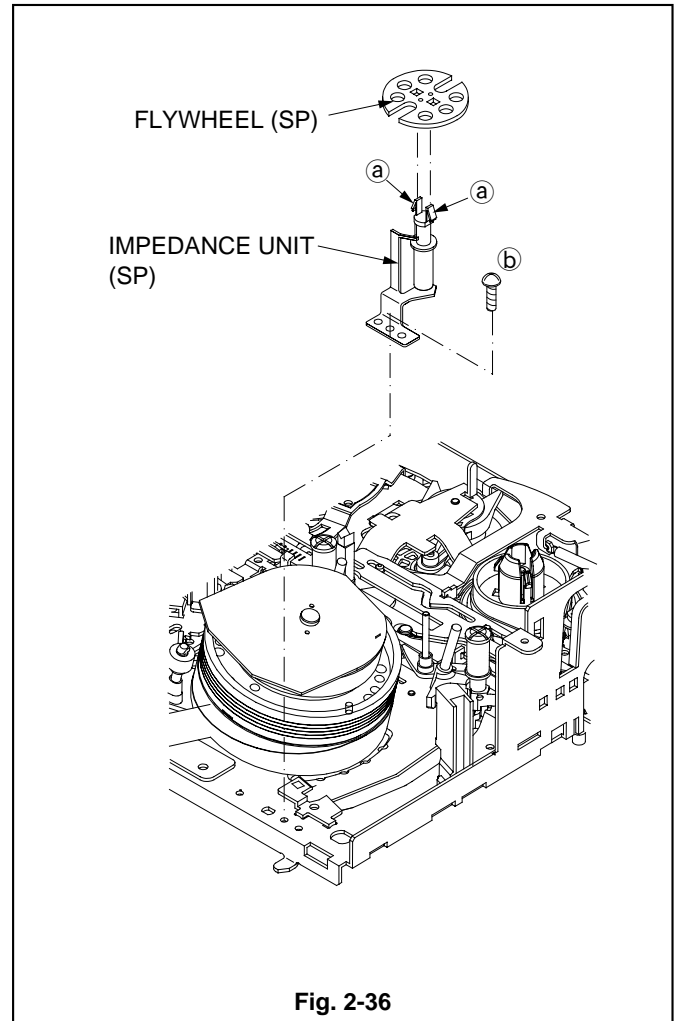

Fig. 2-36

2-37.SSW HOLDER, SSW SLIDER

SET POSITION : Upside down

To access the SSW UNIT, remove the following parts :

- STAY PLATE (Para. 2-2)
- BOTTOM ASSY (Para. 2-3)

(Removal)

1. Remove the SSW SLIDER shown in the Fig. 2-37 .
2. Unfasten the two catches (a) shown in Fig. 2-37, and remove the SSW HOLDER.

(Installation)

1. Install the SSW HOLDER shown in Fig. 2-37.
2. Install the SSW SLIDER shown in Fig. 2-37.

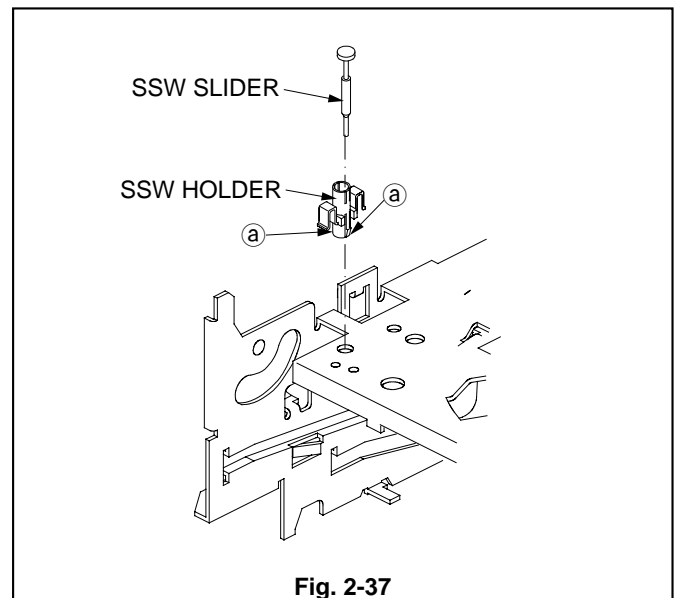

Fig. 2-37

3. Interchangeability Adjustment of the Mechanism

Note 1 : Tracking may need to be preset during interchangeability adjustment of the mechanism. Digital tracking is preset by short circuiting TP5A and TP5B on the PCB-MAIN.

Note 2 : The adjustments are performed in the PLAYBACK mode, using the staircase signal of an alignment tape, unless otherwise specified. Connect an oscilloscope to TP2A and externally trigger from TP2H.

3-1. Adjustment of BACK TENSION and TENSION POLE's Position

Run a Blank Tape for several minutes to break in the REEL DISKS and the Tape Running System before the adjustment.

1. Play back a dummy Tape.
2. Confirm that "A", the distance between the Holes in the TENSION ARM and the MAIN PLATE ASSY shown in the Fig. 3-1-1, is $0.6 \pm 0.5\text{mm}$.
3. If "A" is not $0.6 \pm 0.5\text{mm}$, move the Hole in the BELT ADJUSTER in the Fig. 3-1-2 within the range shown by the arrow (A) to set "A" at $0.6 \pm 0.5\text{mm}$.
4. Set the BACK TENSION measuring jig (Code: 859C345O80) and play-back the tape.
5. Confirm that "A" shown in the Fig. 3-1-1 is $0.0 \pm 0.5\text{mm}$.
6. If "A" is not $0.0 \pm 0.5\text{mm}$ at step 5, repeat the adjustment from step 1.
7. Confirm that the indicated value of the BACK TENSION measuring jig is within $55 \pm 6\text{g/cm}$.

Note 1 : Check the indicated value of the BACK TENSION measuring jig when the tape running condition becomes steady.

Note 2 : Replace the TENSION SPRING if the indicated value exceeds the specified value.

8. While the tape is running steadily, check visually that the vibration range of the TENSION POLE is 1mm or less. If the vibration range exceeds 1mm, replace the REEL DISK.

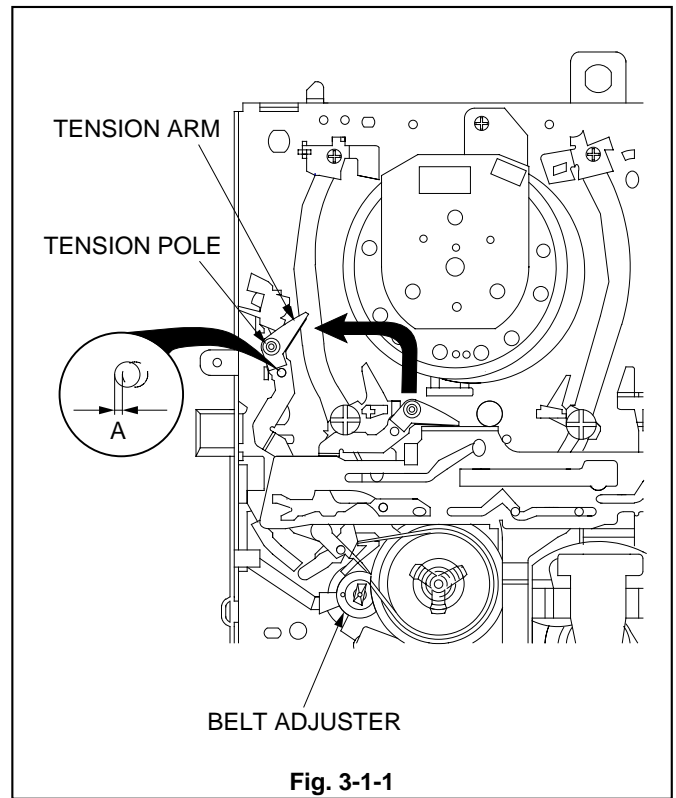

Fig. 3-1-1

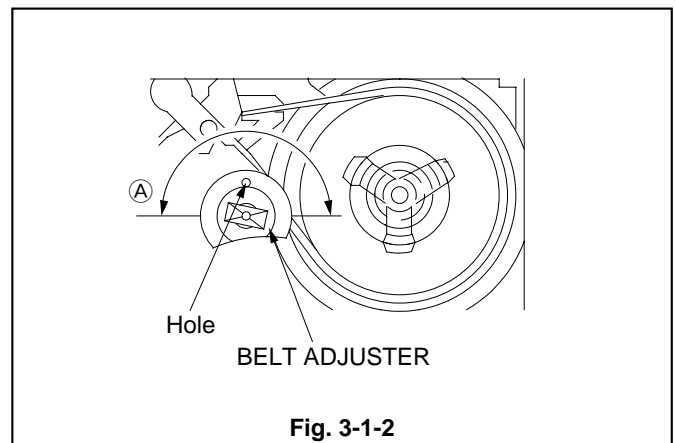

Fig. 3-1-2

3-2. Check and Adjustment of the FM Envelope

3-2-1. GUIDE ROLLER Adjustment check

1. Play back an alignment tape (NM6KE2 : 859C339O90).
2. Preset the tracking.
3. Confirm that the FM Waveform is flat such as in (A).
4. Perform the Item 3-2-2. "Height Adjustment of GUIDE ROLLER (SP)" if the leading edge (the DRUM entry side) of the FM Waveform is not flat (Waveform (B) or (C)). Perform the Item 3-2-3. "Height Adjustment of GUIDE ROLLER (TU)" if the trailing edge (the DRUM exit side) is not flat (Waveform (D) or (E)).

3-2-2. Height Adjustment of GUIDE ROLLER (SP)

1. Loosen the height adjustment screw at the top of the GUIDE ROLLER (SP) so that the GUIDE ROLLER (SP) will rotate smoothly.
2. Observe the leading edge (DRUM entry side) of the FM Waveform. If it looks like (B), the GUIDE ROLLER may be set too low. If it looks like (C), the GUIDE ROLLER may be set too high. To adjust it, turn the height adjustment screw at the top of the GUIDE ROLLER (SP) so that the FM Waveform becomes flat such as in (A).
 - Turn the screw counter-clockwise if the position of the GUIDE ROLLER is lower than specified.
 - Turn the screw clockwise if the position of the GUIDE ROLLER is higher than specified.
3. Perform the Item 3-2-4. "Coarse Adjustment of Phase".

3-2-3. Height Adjustment of GUIDE ROLLER (TU)

1. Loosen the height adjustment screw at the top of the GUIDE ROLLER (TU) so that the GUIDE ROLLER (TU) will rotate smoothly.
2. Observe the trailing edge (DRUM exit side) of the FM Waveform. If it looks like (D), the GUIDE ROLLER may be set too low. If it looks like (E), the GUIDE ROLLER may be set too high. To adjust it, turn the height adjustment screw at the top of the GUIDE ROLLER (TU) so that the FM Waveform becomes flat as in (A).
 - Turn the screw counter-clockwise if the position of the GUIDE ROLLER is too low.
 - Turn the screw clockwise if the position of the GUIDE ROLLER is too high.
3. Perform the Item 3-2-4. "Coarse Adjustment of Phase".

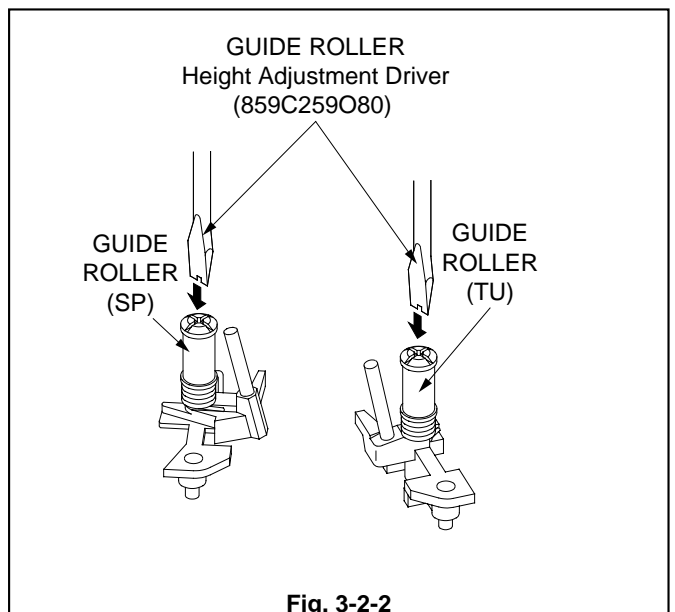
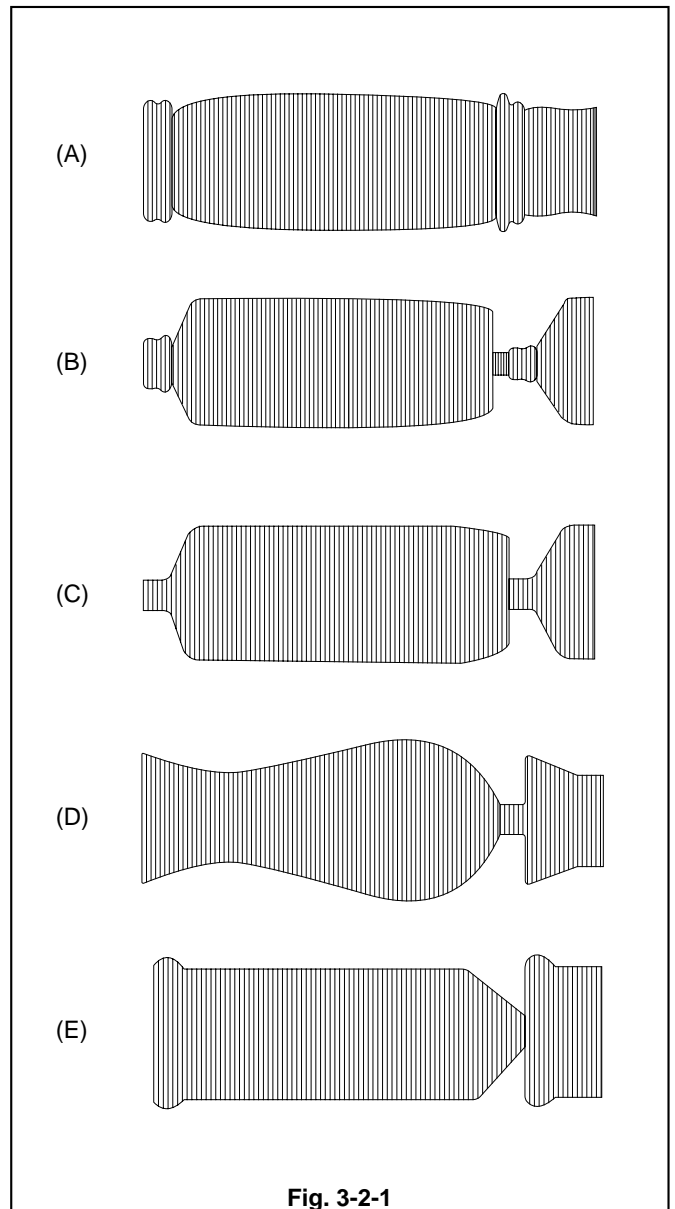

3-2-4. Coarse Adjustment of Phase

1. Play back an alignment tape (NM6KE2 : 859C339O90).
2. Preset the tracking.
3. Observe the FM Waveform after performing Item 3-2-1. "GUIDE ROLLER Check".
4. If the amplitude level of the FM Waveform is low as in (F) in Fig. 3-2-4, set it at the maximum level as in (G), according to the following procedure. Loosen the Screws D and E and insert a screw driver (+) into the Hole in the MAIN PLATE ASSY (Part A). Then, move the A/C PLATE to the right and left to set the amplitude level to maximum.
5. Tighten the Screws D and E.

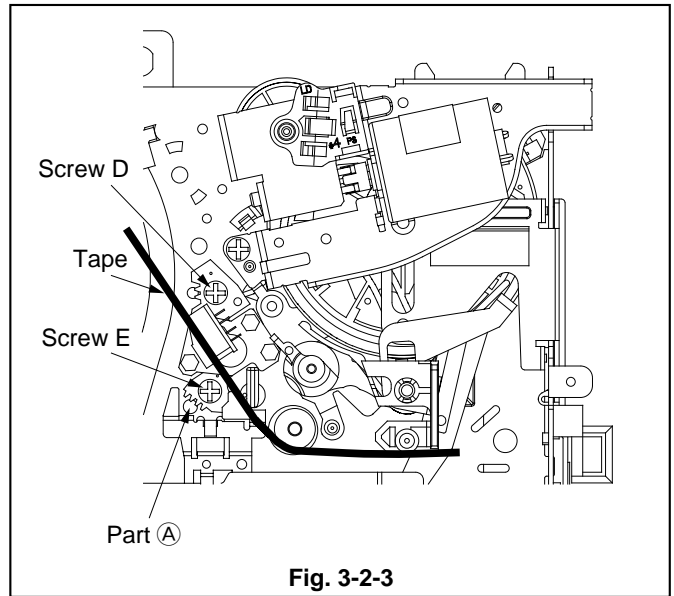

Fig. 3-2-3

3-2-5. Flatness Check of FM Waveform

1. Play back an alignment tape (NM6KE2 : 859C339O90).
2. Adjust the tracking and confirm that the amplitude of the FM signal remains flat.

Note : Adjust the tracking manually, according to the following procedure.

- Turn the Shuttle Ring of the product during PLAYBACK for manual tracking adjustment.
- Press the 3DSP button to switch the tracking adjustment from "Manual" to "Auto".

3. Adjust the tracking so that the amplitude level of the FM Waveform will be at the maximum. Set the oscilloscope so that the amplitude level of the FM Waveform is 5 divisions on the oscilloscope.
4. Adjust the tracking so that the peak of the FM Output Waveform is 4 divisions. Confirm that the FM Waveforms (B), (C), (D) and (E) are within the range of the specified values in the Fig. 3-2-5.
5. If the Waveforms are out of the specified values in step 4, repeat the Item 3-2. "Check and Adjustment of FM Envelope" from the beginning.

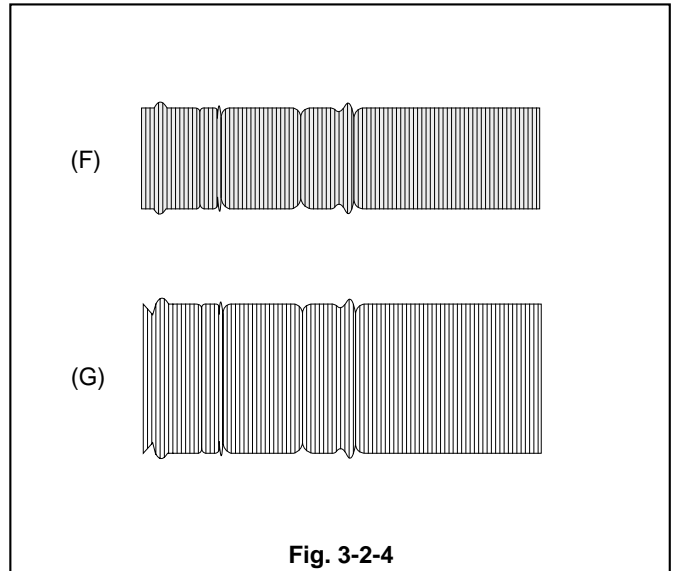

Fig. 3-2-4

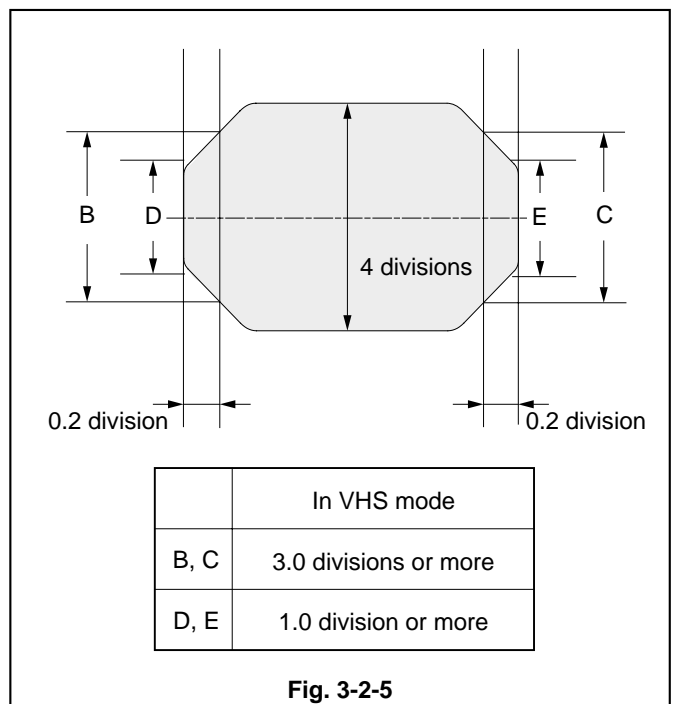
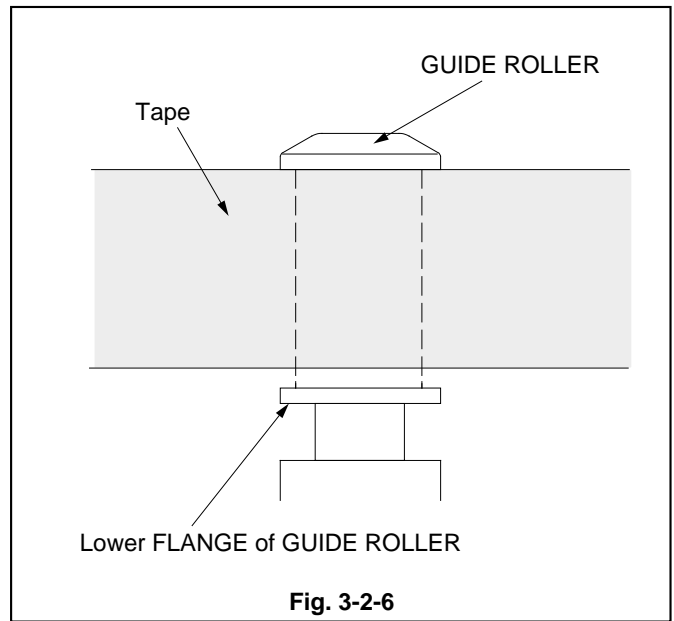

Fig. 3-2-5

3-2-6. Tape Running Condition at the GUIDE ROLLERS (Check 1)

1. Play back an Alignment Tape.
[NM6KE2: 859C339O90]
2. Confirm visually that there is a space between the Tape and the Lower FLANGE of the GUIDE ROLLER (SP) and the GUIDE ROLLER (TU).
3. If there is no space in step 2, replace the TAPE GUIDE ASSY (SP) and TAPE GUIDE ASSY (TU), according to the Item 2-32. "TAPE GUIDE ASSY (SP), TAPE GUIDE ASSY (TU)".
4. Alternately load and unload the tape several times and confirm that the FM Waveform remains flat.
5. If the flatness is affected, check the position of the A/C HEAD. If it is installed incorrectly, correct it according to the Item 2-8. "A/C HEAD UNIT" and repeat Item 3-2-4. "Coarse Adjustment of Phase".



3-2-7. Tape Running Condition at the GUIDE ROLLERS (Check 2)

1. Play back an alignment tape (NM6KE2 : 859C339O90).
2. Check that the FM Waveform is quickly restored to the previous level, after lightly pressing and releasing the tops of the GUIDE ROLLER (SP) and GUIDE ROLLER (TU).
3. If the FM Waveform is not restored immediately, replace the TAPE GUIDE ASSY (SP) and TAPE GUIDE ASSY (TU) according to the Item 2-32. "TAPE GUIDE ASSY (SP), TAPE GUIDE ASSY (TU)".

3-3. A/C HEAD Adjustment

3-3-1. Slant Adjustment of A/C HEAD

1. Play back a blank tape.
2. Slowly turn the slant adjustment Screw C shown in the Fig. 3-3-1 counter-clockwise to slightly crease the bottom of the tape at the Lower FLANGE of the GUIDE POLE (TU).
3. Slowly return the slant adjustment Screw C to remove the crease.
4. Slowly turn the slant adjustment Screw C counter-clockwise again and stop just before the tape is creased.

3-3-2. Azimuth and Height Adjustment of A/C HEAD

1. If the height of the CONTROL HEAD is shifted from the specified value in the Fig. 3-3-2, adjust it with the Height Adjustment Screws A, B and C shown in the Fig. 3-3-1.
2. After adjustment with the Screws A, B or C, repeat the Item 3-3-1. "Slant Adjustment of A/C HEAD".
3. Connect the oscilloscope to the audio output terminal.
4. Play back an alignment tape (NM6KE2 : 859C339O90).
5. Turn the Azimuth Adjustment Screw B in the Fig. 3-3-1 to set the audio output level in the Fig. 3-3-1 at the maximum. After the adjustment, remove the screw driver and confirm that the audio output level is 4.6 divisions or more when the maximum audio output level is set to 5. If the audio output level is less than 4.6, repeat steps 1 ~ 5.
6. Push the A/C HEAD to the right and left (in the direction of A-A' in the Fig. 3-3-1) and release it. And confirm that the audio output level does not change. (Do not push the A/C HEAD until the audio output level is reduced to 3/4 or less of its maximum level.)
7. Confirm that changes in the audio output level are 2dB or less in the PLAYBACK mode.
8. If the change in the audio output level exceeds 2dB, repeat the Item 3-3-1. "Slant Adjustment of A/C HEAD".
9. If the above procedure steps 1 ~ 8 proves to be unsatisfactory, replace the TAPE GUIDE ASSY (SP) and the TAPE GUIDE ASSY (TU), according to the Item 2-32. "TAPE GUIDE ASSY (SP), TAPE GUIDE ASSY (TU)".

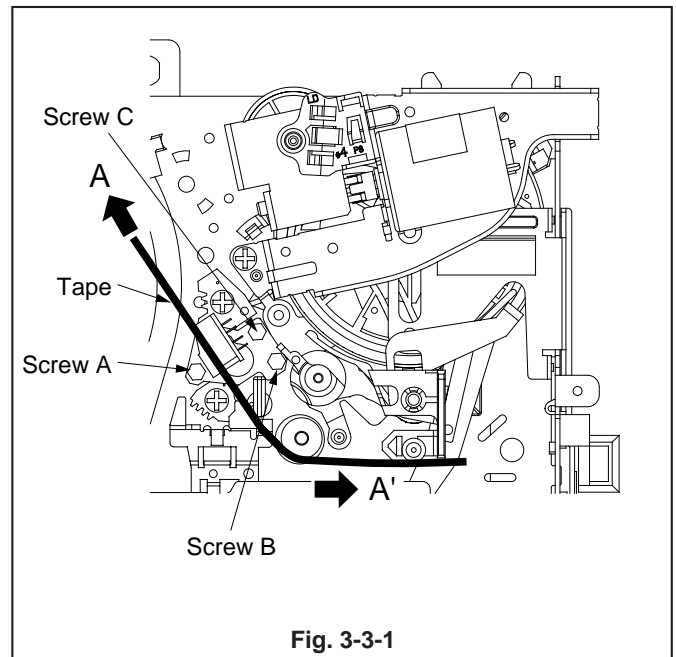

Fig. 3-3-1

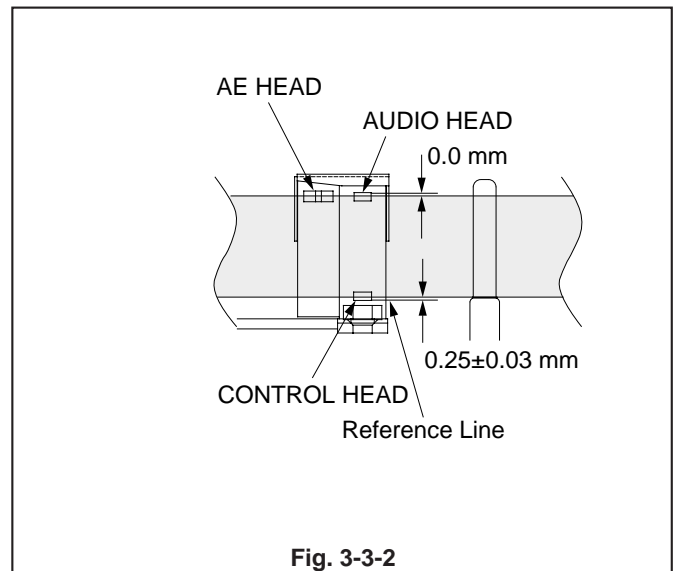

Fig. 3-3-2

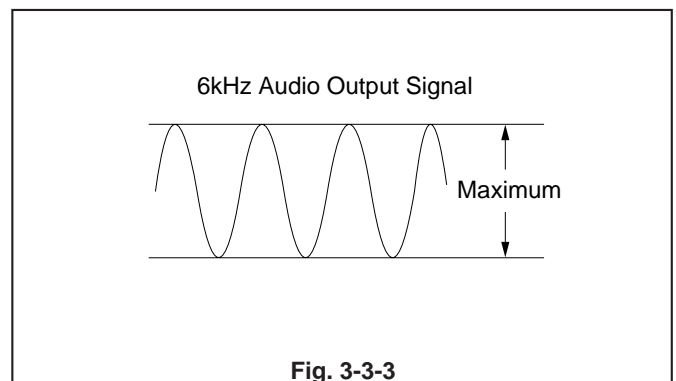

Fig. 3-3-3

3-4. Phase Adjustment

1. Play back an alignment tape (NM3KE6 : 859C339O50).
2. Preset the tracking.
3. Loosen the Screws D and E shown in the Fig. 3-4-1. Insert a screw driver (+) into the Hole in the MAIN PLATE ASSY (Part A) and move the A/C PLATE to the right and left to set the amplitude level of the FM Waveform to maximum.
4. Tighten the Screws D and E.
5. Play back an alignment tape [NMX : 859C568O60].
6. Confirm the Missing Portions of the FM Waveform and Audio Waveform are as shown in the Fig. 3-4-2.
7. If the Missing Portions differ from the Fig. 3-4-2, repeat the procedure 3.
8. Adjust the tracking so that the amplitude level of the FM Waveform will be at the maximum. And set the oscilloscope so that the Waveform will be 5 divisions of the oscilloscope.
9. Preset the tracking.
10. Confirm that the FM Waveform on the oscilloscope is 4.8 divisions or more.
11. If the FM Waveform is below 4.8 divisions, preset the tracking and repeat steps 3~10.
12. Push the A/C HEAD to the right and left (in the direction of A-A' in the Fig. 3-4-1) and release it. Confirm that the amplitude of the FM Waveform does not change, compared to before the A/C HEAD was shifted.
13. If the amplitude level of the FM Waveform changes, check the set position of the A/C HEAD. If the A/C HEAD is installed incorrectly, correct the position according to the Item 2-8. "A/C HEAD UNIT" and 3-3. "A/C HEAD Adjustment", and then repeat this item from the beginning.
14. Alternately load and unload the tape several times. Confirm that the amplitude of the FM Waveform does not change.

3-5. Tape wrinkle check

1. Confirm that there is no wrinkle at the lower edge of GUIDE POLE(TU) in PB/FS mode with T-160 tape beginning and ending.
2. Confirm that there is no wrinkle at the upper edge of GUIDE POLE(TU) in RS mode with T-160 tape beginning and ending.

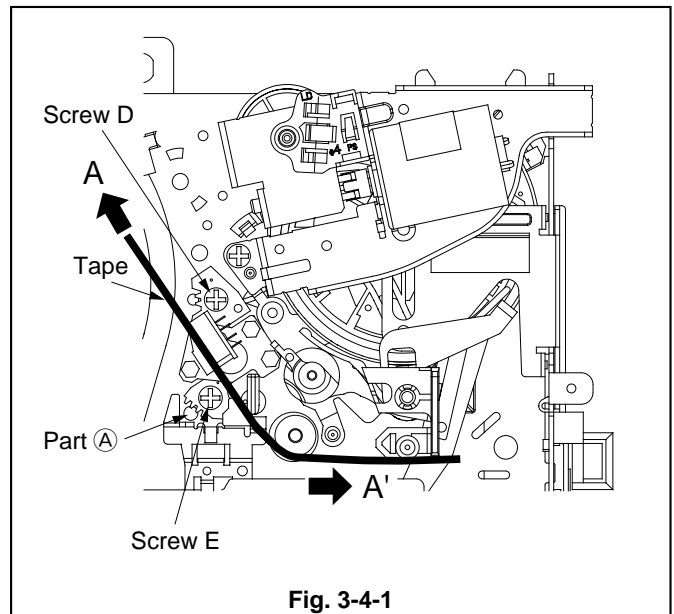

Fig. 3-4-1

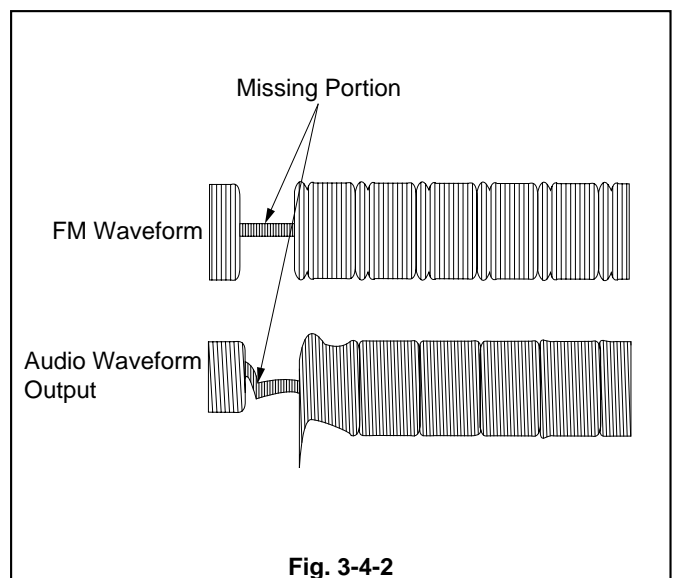

Fig. 3-4-2

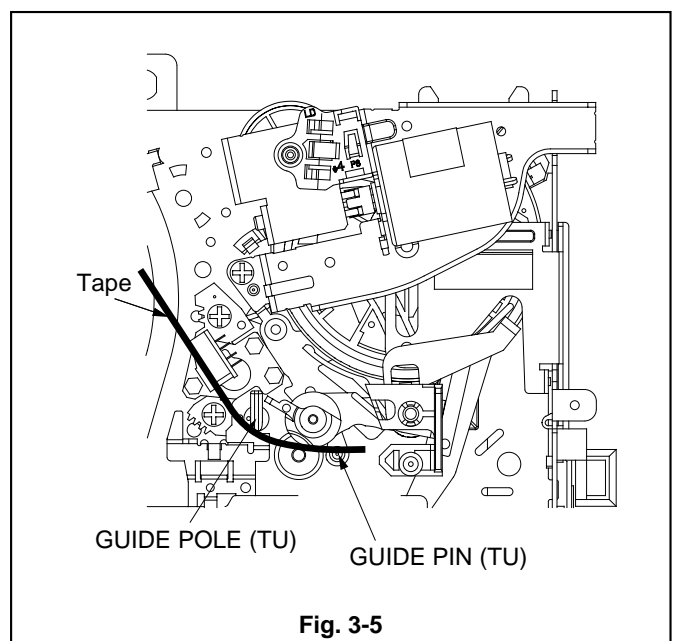
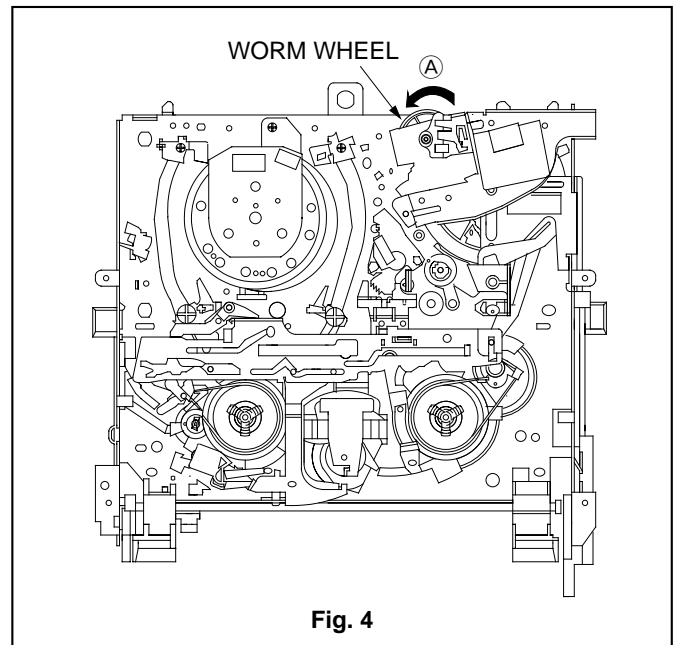

Fig. 3-5

4. Servicing for Tape Jam during the Loading Process

1. Remove the tape if the mechanism part is locked due tangled tape.
2. Rotate the WORM WHEEL of the LOADING MOTOR ASSY shown in the Fig. 4 in the direction of the arrow **A** to eject the cassette tape.



SERVICE CAN BE EXECUTED WITH THE EE PICTURE DISPLAYED

1. Short-circuit the cathode side of D927 and the GND of the DECK ASSY using the jig shown in Fig. 2.
2. Remove the DECK ASSY.
3. Connect TP5X and TP5Y with a jumper

Note1: Short-circuit the test points before turning on the power.

Note2: Short-circuit the Shield Case and the cathode side of D927 using the jig shown in Fig. 2 before attaching the DECK ASSY.

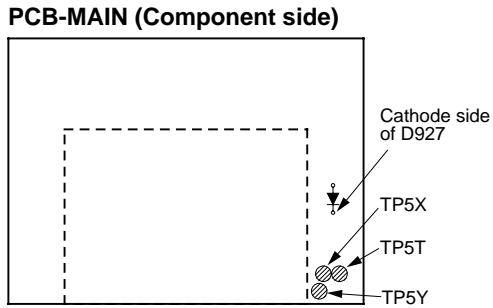

Fig. 1

Jig (Part No. : 859C548010)

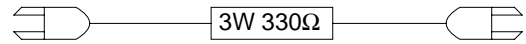

Fig. 2

DECK OPERATION CHECK

Check the DECK position and the operation of the Tape Running System, according to the following procedure.

1. Short-circuit TP5T and TP5Y shown in the Fig. 1.
2. Initialize the E²PROM.
3. Check the operation of the Tape Running System by pressing the FF button, REW button on the PCB-MAIN.
FF button : For forward rotation of the CAPSTAN MOTOR
REW button : For reverse rotation of the CAPSTAN MOTOR
4. Check the DECK position by pressing the CH-UP button, CH-DOWN button on the PCB-MAIN.
CH-UP button : DECK operation in the Loading direction
CH-DOWN button : DECK operation in the Unloading direction

HOW TO INITIALIZE THE E²PROM

A replacement E²PROM is not initialized before shipping, so the E²PROM must be initialized when replaced.

Initialize the E²PROM by following the steps below.

1. Press and hold the POWER button on the set for 8 seconds.
2. E²PROM initial setting is completed.

WHEN REPLACING IC5A0

When replacing IC5A0, be sure to press the RESET button after turning on the power.

ELECTRICAL ADJUSTMENTS

Perform only the alignments required. If proper equipment is not available, do not attempt an alignment.

PRE-ADJUSTMENT SETTINGS

- Set the PerfectTape™ to "MANUAL" mode.

TEST EQUIPMENT

- Oscilloscope (10:1 probe unless 1:1 specified.)
- Signal generator
- Miscellaneous electrical tools

ALIGNMENT TAPES

- NS1.....Part No.859C339O00
Stair step, Color Bars, RF, 1kHz audio (SP)
- NM6KE2.....Part No.859C339O90
Monoscope, 6kHz audio (SP)
- NC1KS.....Part No.859C339O80
Color Bars, 1kHz audio (SP)
- NM3KE6.....Part No.859C339O50
Monoscope, 3kHz audio (EP)
- NMX.....Part No.859C568O60
Monoscope, 3kHz audio (SP)

LOCATIONS

PCB-MAIN (Component side) REAR

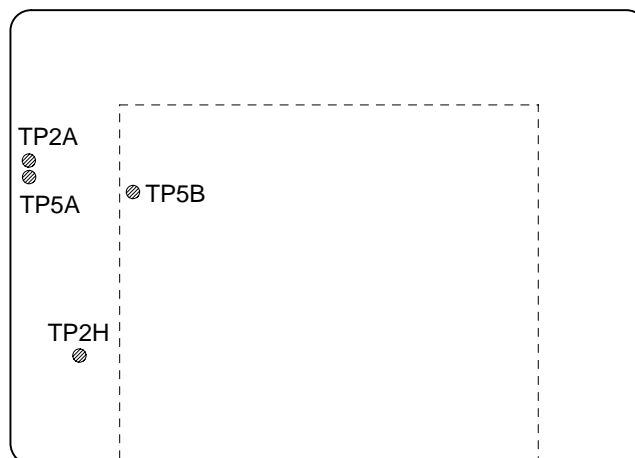

[Servo circuit] 1. Playback Switching Point	Adjustment purpose Video switch over timing during playback.
	Symptom when incorrectly adjusted Switching noise or jitter in the playback picture.

Measuring instrument and condition		VCR set up condition	
	---	Input signal	---
Test point	---	Using tape	Alignment Tape (NS1, stair step)
EXT trigger	---	VCR condition	Playback
Measurement range	---	Using Jig	---

1. Play back an Alignment Tape. (NS1, stair step)
2. Short-circuit TP5A to TP5B.
3. Push the CHANNEL-UP, DOWN buttons at the same time.
4. Confirm that the values 55 ~ 75 are displayed on the fluorescent display after approx 6 seconds.
5. Open-circuit TP5A to TP5B.

PCB-MAIN (Component side)

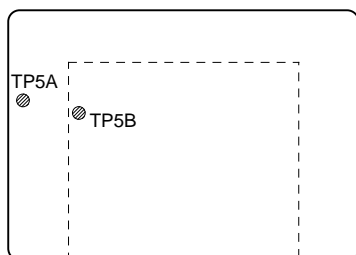

PARTS LIST

1. CABINET ASSEMBLY

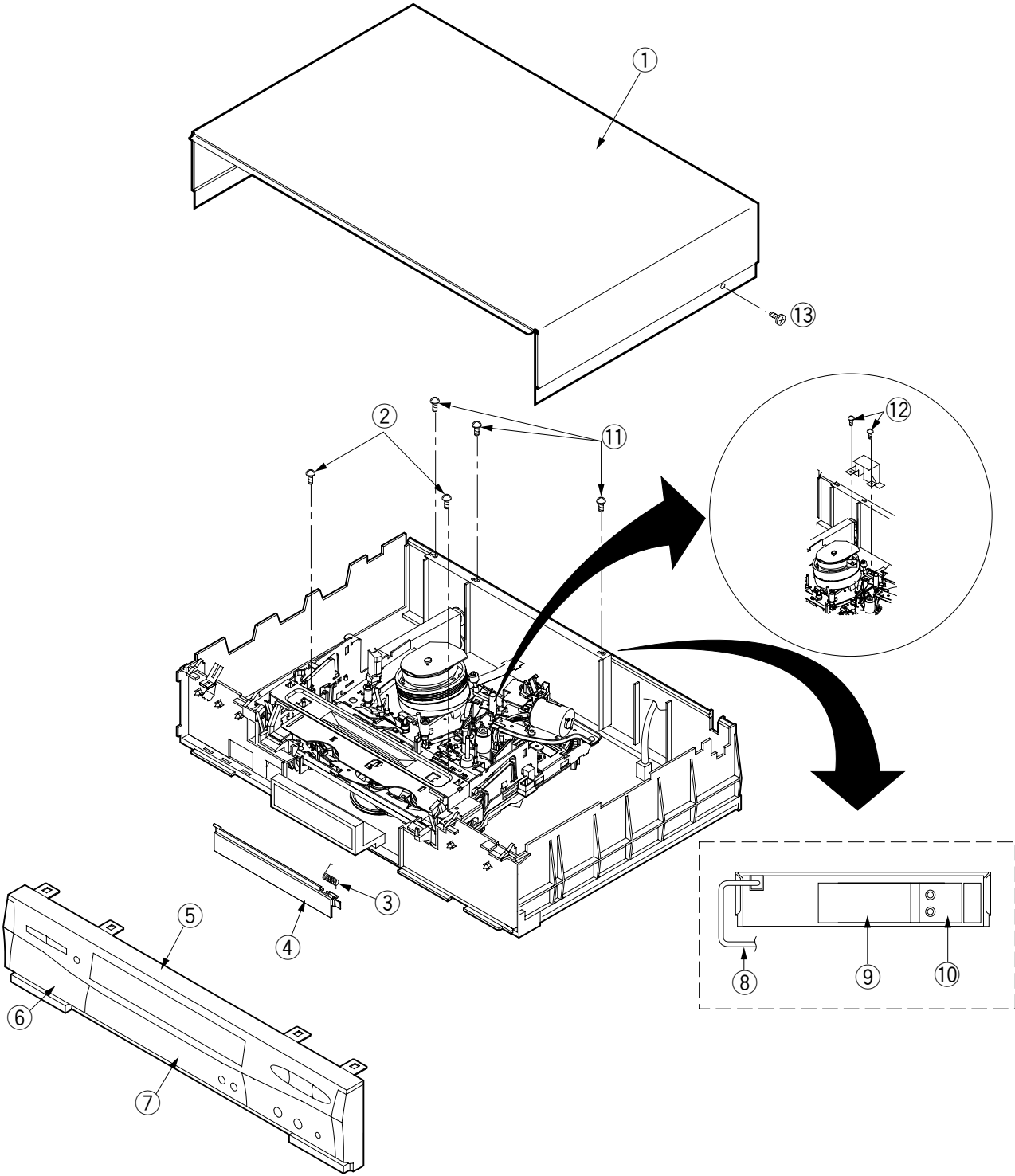

ITEM NO.	PARTS NO.	PARTS NAME	DESCRIPTION
1	968C049O03	TOP COVER ASSY	
2	669D221O40	SCREW	4 × 12 46LA005
3	572D385O10	F/L SPRING	
4	752C673O70	CASSETTE DOOR ASSY	
5	701B433O20	FRONT UNIT	
6	752C664O40	DOOR PANEL ASSY	
7	752C674O60	TIMER PANEL	
8	246C324O10	AC POWER CORD	
9	761B366O10	TERMINAL COVER	
10	761C645O20	ANTENNA COVER	
11	669D500O30	SCREW	3 × 10
12	669D229O90	SCREW	M3.0 × 4 46LA005
13	669D501O30	SCREW	3 × 10

2. PACKING PARTS

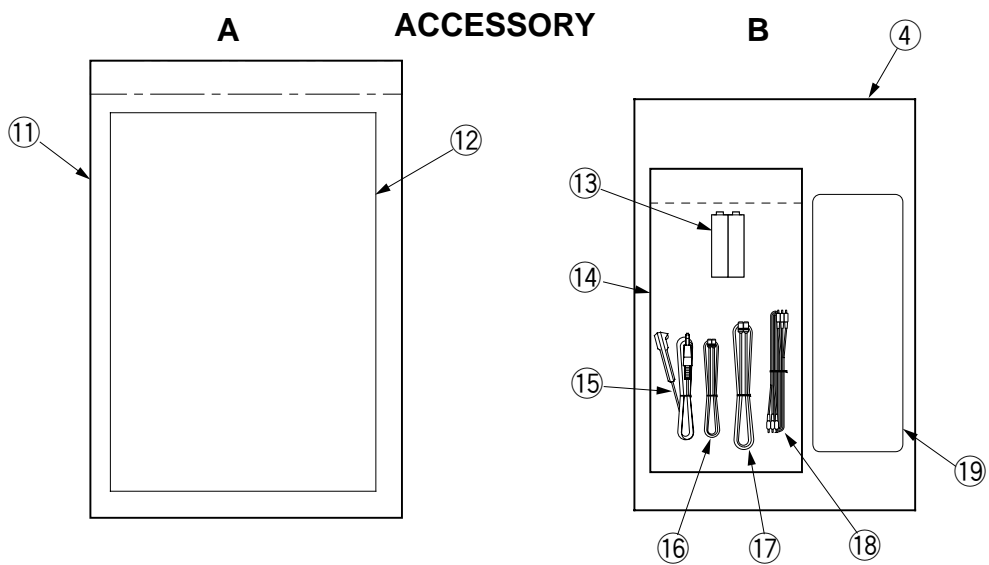
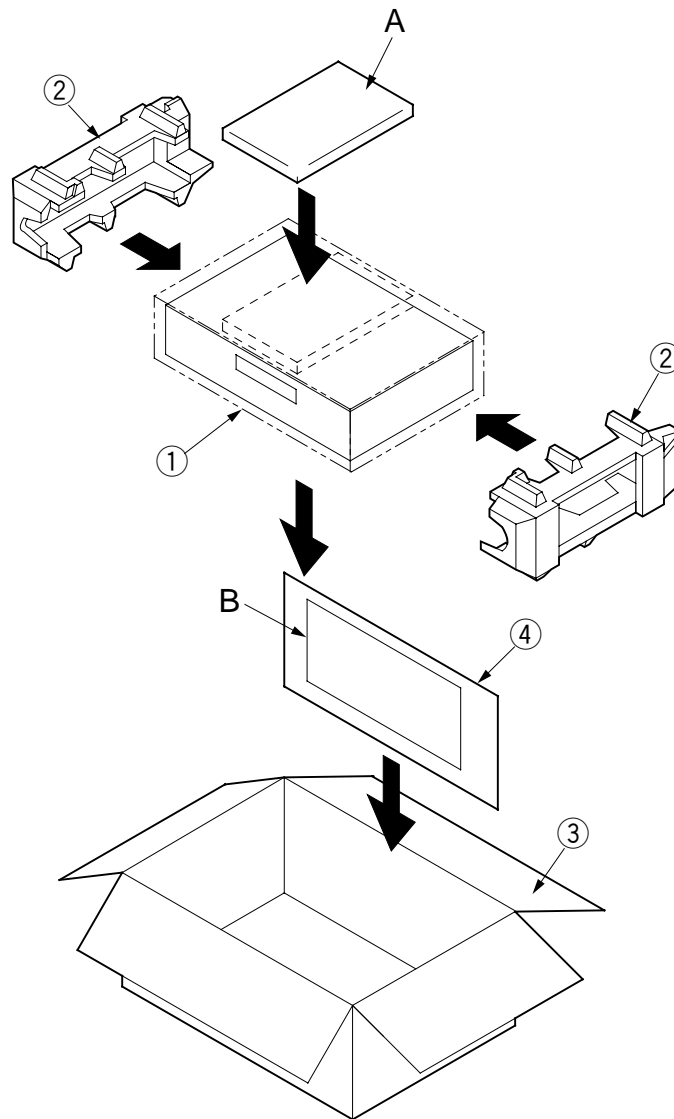

ITEM NO.	PARTS NO.	PARTS NAME	DESCRIPTION
PACKING PARTS			
1	831D190O30	PACKING SHEET	800X800
2	803A570O10	CUSHION	
3	802B827O30	PACKING CASE	
4	-----	ACCESSORY BOARD	
ACCESSORY			
11	831D337O10	PACKING BAG	(FOR ACCESSORY A)
12	872C246O70	INSTRUCTION BOOK	
13	-----	BATTERY	
14	-----	PACKING BAG	(FOR PARTS)
15	939P724O10	IR BLASTER	
16	243C273O10	CABLE	RF
17	243C274O10	Y/C CABLE	S-S 1.5m
18	243C247O10	CABLE	3P
19	939P755O10	REMOTE HAND UNIT	

DECK ASSEMBLY

DECK ASSEMBLY-1

* Settled Service Parts

ITEM	PARTS NO.	*	ADDRESS	PARTS NAME	DESCRIPTION	Qt.
A-019	669D224O90	○	G-3	SCREW	2.6 × 5	1
A-021	597D568O10	○	G-2	FLYWHEEL (SP)		1
A-022	948B404O09	○	G-1	DRUM ASSY		1
A-023	592B552O10	○	F-2	DRUM CLAMPER		1
A-024	594C306O10	○	F-3	IMPEDANCE UNIT (SP)		1
A-025	927D027O01	○	H-2	CLEANING ASSY		1
A-026	669D556O10	○	F-2	SCREW	2.6 × 4	1
A-027	669D556O10	○	F-2	SCREW	2.6 × 4	1
B-010	925B115O15	○	G-1	UPPER DRUM ASSY		1
B-015	927B955O05	○	G-1	LOWER DRUM ASSY		1
B-025	288P158O30	○	G-1	DRUM MOTOR		1
C-010	641B903O10	○	G-2	CLEANING ARM		1
C-011	554D104O20	○	H-2	FELT RING		1
G-012	928D472O11	○	K-2	LOADING MOTOR ASSY		1
G-015	948D088O03	○	D-8	F/L ARM ASSY		1
G-016	948B406O03	○	B-8	F/L BOTTOM ASSY		1
G-022	948D095O01	○	F-1	TENSION BELT ASSY		1
G-023	948D096O01	○	F-8	BRAKE ASSY (TU)		1
G-024	948D097O02	○	A-5	CHARGE ASSY		1
G-032	594C260O40	○	K-4	PINCH ASSY		1
G-033	460C007O10	○	E-7	A/C HEAD UNIT		1
G-045	621C769O20	○	I-4	MAIN CAM		1
G-047	621C783O10	○	E-4	SENER COVER (SP)	SUPPLY	1
G-048	621C784O10	○	G-6	SENER COVER (TU)	TAKE UP	1
G-049	621C794O10	○	J-3	WROM WHEEL		1
G-054	640C181O20	○	D-4	D-7 REEL DISK		2
G-062	621C789O10	○	C-6	INSERT GUIDE (SP)	SUPPLY	1
G-063	621C790O10	○	D-7	INSERT GUIDE (TU)	TAKE UP	1
G-064	641B902O10	○	K-3	PINCH ARM CAP		1
G-065	641B908O10	○	H-6	DOOR ARM		1
G-067	621C804O10	○	J-1	FC HOLDER		1
G-071	592B549O10	○	B-3	STAY PLATE		1
G-072	640D852O20	○	B-1	B-2 SPACER		2
G-074	594C217O10	○	E-2	TENSION LEVER		1
G-075	594C218O10	○	D-1	TENSION ARM		1
G-077	594C222O10	○	I-3	BRAKE LEVER		1
G-078	594C223O10	○	I-6	F/L PLATE		1
G-079	594C224O20	○	H-2	GUIDE ARM (TU)		1
G-080	594C225O30	○	D-4	BRAKE CAM PLATE		1
G-082	594C229O10	○	E-7	SHIFT LEVER		1
G-083	594C230O10	○	C-5	SWING LEVER		1
G-084	597D866O10	○	G-7	L/D LOCK LEVER		1
G-089	622D829O10	○	I-4	LB PIN		1
G-091	572D974O10	○	D-2	TENSION SPRING		1
G-104	460D018O10	○	C-4	F/E HEAD		1
G-201	669D224O90	○	A-1	C-2 SCREW	2.6×5	6
			D-7	I-1		
			J-2			
G-203	669D476O30	○	E-7	SCREW	2.6×6	2
G-212	552C017O30	○	C-5	E-8 THRUST WASHER	2.5×6×0.13	4
H-011	621C758O10	○	J-2	LOADING WORM		1
H-012	622D788O10	○	J-2	COUPLING WORM		1
H-021	594C216O10	○	J-2	MOTOR HOLDER		1
H-031	288P090O10	○	J-2	LOADING MOTOR		1
H-051	669D173O80	○	H-2	SCREW	M3×0.5-4	2

DECK ASSEMBLY-1

* Settled Service Parts

ITEM	PARTS NO.	*	ADDRESS	PARTS NAME	DESCRIPTION	Qt.
I-011	641B913O10	○	B-7	ARM (SP)		1
I-012	641B911O20	○	C-8	ARM (TU)		1
I-021	631D823O10	○	C-7	F/L SHAFT		1
I-031	573D004O10	○	B-7	D-8 ARM SPRING		2
M-011	948B403O01	○	G-5	MAIN PLATE ASSY		1
M-012	948D084O01	○	A-3	TAPE GUIDE ASSY (SP)	SUPPLY	1
M-013	948D086O01	○	B-3	TAPE GUIDE ASSY (TU)	TAKE UP	1
M-021	594C258O01	○	F-3	GUIDE CATCHER (SP)	SUPPLY	1
M-022	594C259O01	○	H-3	GUIDE CATCHER (TU)	TAKE UP	1
M-023	622D799O10	○	B-7	F/L BEARING		1
M-025	622D820O10	○	G-3	GUIDE PIN COVER		1
M-026	621C944O10	○	G-3	GUIDE PIN COVER 2		1
M-032	622D791O10	○	D-6	BELT ADJUSTER		1
M-033	669D224O90	○	F-3	H-2 SCREW	M2.6×5	2
M-037	622D792O10	○	C-2	TENS AXIS HOLDER		1
S-011	522B061O10	○	A-3	GUIDE ROLLER (SP)	SUPPLY	1
T-011	522B061O10	○	B-3	GUIDE ROLLER (TU)	TAKE UP	1
N-011	621C759O10	○	E-1	BELT LEVER		1
N-012	622D790O10	○	D-1	BELT HOLDER		1
N-013	554D103O10	○	E-1	BRAKE BELT (SP)		1
O-011	621C760O10	○	F-8	BRAKE (TU)		1
O-021	572D975O10	○	F-8	BRAKE SPRING		1
O-031	554D103O10	○	F-8	BRAKE BELT (TU)		1
P-011	640C187O10	○	B-5	CHARGE BASE		1
P-012	640C188O20	○	B-5	CHARGE TIP		1
P-021	572D983O20	○	B-5	CHARGE SPRING		1

A B C D E F G H I

DECK ASSEMBLY
DECK ASSEMBLY-2

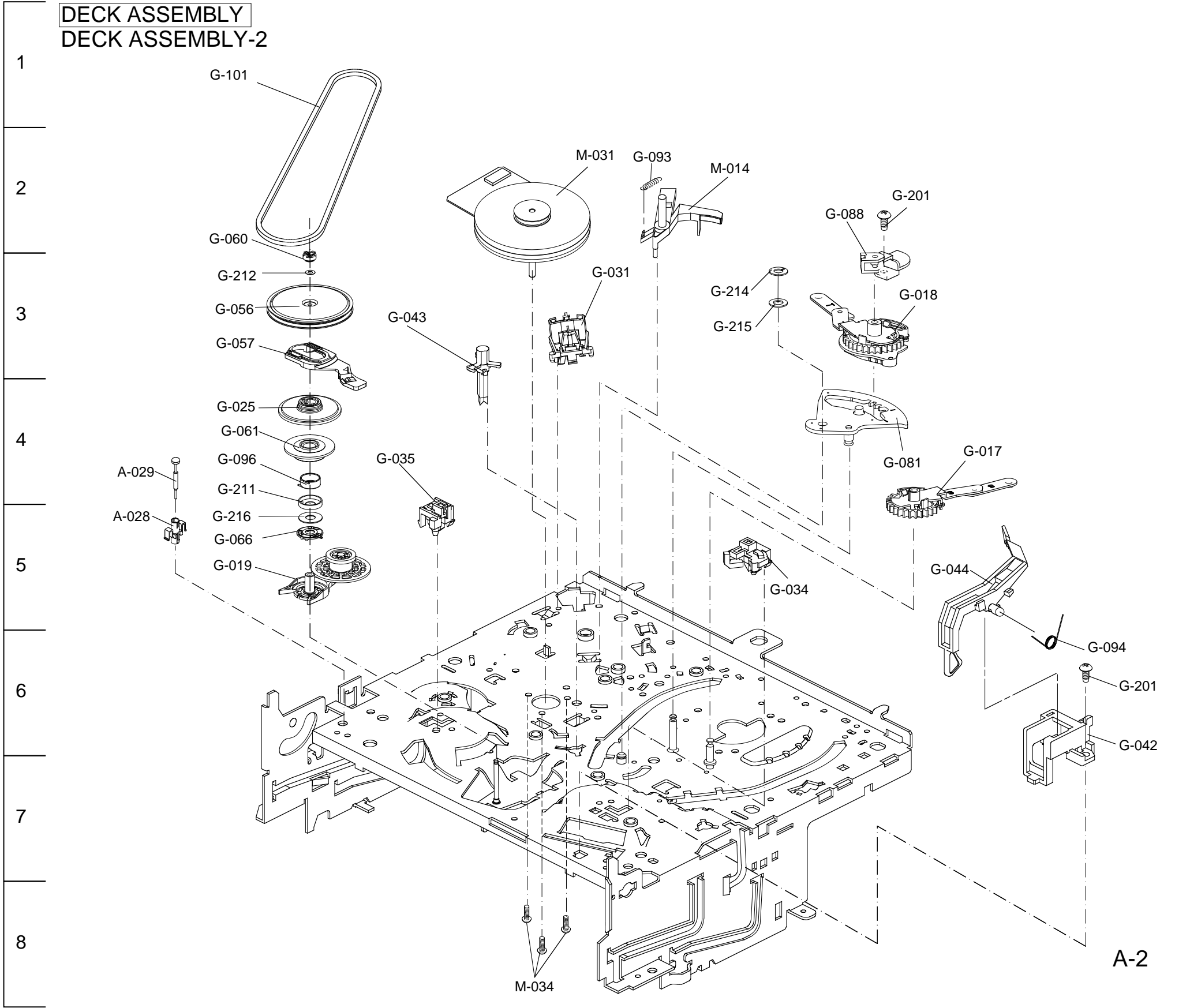

DECK ASSEMBLY-2

* Settled Service Parts

ITEM	PARTS NO.	*	ADDRESS	PARTS NAME	DESCRIPTION	Qt.
A-028	621C810O10		A-5	SSW HOLDER		1
A-029	622D837O10		A-4	SSW SLIDER		1
G-017	948D089O01	○	H-4	LOADING ARM ASSY (SP)	SUPPLY	1
G-018	948D090O01	○	G-3	LOADING ARM ASSY (TU)	TAKE UP	1
G-019	622D916O10	○	B-5	IDLER2 UNIT		1
G-025	948D098O03	○	B-4	PULLEY GEAR ASSY		1
G-031	622D800O10	○	E-3	MODE POSITION UNIT		1
G-034	622D801O10	○	F-5	REV UNIT (SP)	SUPPLY	1
G-035	622D802O10	○	C-4	REV UNIT (TU)	TAKE UP	1
G-042	621C807O10		I-6	REC HOLDER		1
G-043	621C765O10	○	C-3	LAMP GUIDE		1
G-044	621C766O20	○	H-5	REC LEVER		1
G-056	640C185O30	○	B-3	BELT PULLEY		1
G-057	640C186O10	○	B-3	SHIFT SLIDER		1
G-060	640D948O10	○	B-2	PULLEY BUSH		1
G-061	640D949O10	○	B-4	SLIP GEAR		1
G-066	640C189O20	○	B-5	SLIP ADJUSTER		1
G-081	594C228O10	○	G-4	A/L LEVER		1
G-088	594C304O10	○	G-2	SPACER PLATE		1
G-093	572D976O10	○	E-2	CAPSTAN BRAKE SPRING		1
G-094	572D977O10	○	I-6	REC SPRING		1
G-096	573D073O10	○	B-4	SLIP2 SPRING		1
G-101	521D102O10	○	B-1	REEL BELT		1
G-201	669D224O90	○	G-2	I-6 SCREW	2.6×5	2
G-211	597D997O10	○	B-4	SLIP WASHER		1
G-212	552C017O30	○	B-3	THRUST WASHER	2.5×6×0.13	1
G-214	552C022O10		F-3	CUT WASHER	4.0×8.0×0.5	1
G-215	680P140O10		F-3	WASHER		1
G-216	552C012O50		B-5	THRUST WASHER	5.6×9.5×0.2	1
M-014	948D094O01	○	F-2	CAPSTAN BRAKE ASSY		1
M-031	288P213O30	○	E-2	CAPSTAN MOTOR	F2QSB34	1
M-034	669D285O10		D-8	SCREW	M2.6×6	3

3. ELECTRICAL PARTS

: Critical Components

SYMBOL No.	PARTS No.	PARTS NAME	DESCRIPTION	SYMBOL No.	PARTS No.	PARTS NAME	DESCRIPTION
INTEGRATED CIRCUITS				Q2008	261P066O10	CHIP TRANSISTOR	2SA1037AK
IC120	275P344O30	MOS IC	M35053-051FP	Q2009	260P818O30	CHIP TRANSISTOR	2SC2412K-S
IC150	272P583O20	IC	NJM2533M	Q2010	260P818O30	CHIP TRANSISTOR	2SC2412K-S
IC151	272P325O40	IC	NJM2535M	Q2011	260P818O30	CHIP TRANSISTOR	2SC2412K-S
IC2A0	270P827O10	IC	JCP8017-NSA	Q2012	260P818O30	CHIP TRANSISTOR	2SC2412K-S
IC2A1	270P787O10	IC	NJM2534M	Q2013	261P066O10	CHIP TRANSISTOR	2SA1037AK
IC2000	270P826O10	IC	JCP8013	Q351	261P056O10	TRANSISTOR	2SD734F
IC3A0	275P410O10	IC	AN3662FBP	Q352	260P629O60	TRANSISTOR	2SC3331-T
IC5A0	275P565O20	MOS IC	M3777MAH4C1GP	Q353	260P629O60	TRANSISTOR	2SC3331-T
IC5A1	274D103O30	MOS IC	BR24C16F-E2/CAT24WC16J-TE13	Q354	261P065O30	CHIP TRANSISTOR	DTA124EKA
IC5A4	272P235O10	IC	TA7291S	Q355	260P562O40	TRANSISTOR	2SA952-K
IC6A0	270P825O10	IC	JCP8008	Q356	261P067O30	CHIP TRANSISTOR	DTC124EKA
IC6A1	272P765O10	IC	M52052FP	Q3A0	261P065O30	CHIP TRANSISTOR	DTA124EKA
IC6B0	272P278O10	IC	LA7213	Q3A2	260P818O30	CHIP TRANSISTOR	2SC2412K-S
IC6001	270P838O10	IC	NJM2520M	Q3L0	261P067O30	CHIP TRANSISTOR	DTC124EKA
IC6002	270P838O10	IC	NJM2520M	Q5A3	260P802O20	CHIP TRANSISTOR	2SA1235-F
IC6003	270P828O10	IC	MM1506XNRE	Q5A4	261P066O10	CHIP TRANSISTOR	2SA1037AK
IC6004	270P829O10	IC	MM1508XNRE	Q5A5	260P818O30	CHIP TRANSISTOR	2SC2412K-S
IC6005	272P583O20	IC	NJM2533M	Q5B1	261P066O10	CHIP TRANSISTOR	2SA1037AK
IC6301	275P360O20	MOS IC	M38503M4-294FP	Q5B4	260P804O30	CHIP TRANSISTOR	2SC3052-G
IC8A0	275P345O20	IC	PT6312LQ/UPD16312GB	Q5B5	260P818O30	CHIP TRANSISTOR	2SC2412K-S
IC901	272P500O20	IC	HA17431PA	Q5B6	260P818O30	CHIP TRANSISTOR	2SC2412K-S
TRANSISTORS				Q5L0	260P818O30	CHIP TRANSISTOR	2SC2412K-S
Q100	260P818O30	CHIP TRANSISTOR	2SC2412K-S	Q6A1	260P818O30	CHIP TRANSISTOR	2SC2412K-S
Q102	261P066O10	CHIP TRANSISTOR	2SA1037AK	Q6A2	261P065O30	CHIP TRANSISTOR	DTA124EKA
Q122	261P066O10	CHIP TRANSISTOR	2SA1037AK	Q6A3	261P066O10	CHIP TRANSISTOR	2SA1037AK
Q123	260P818O30	CHIP TRANSISTOR	2SC2412K-S	Q6A4	261P066O10	CHIP TRANSISTOR	2SA1037AK
Q124	261P067O30	CHIP TRANSISTOR	DTC124EKA	Q6A5	261P066O10	CHIP TRANSISTOR	2SA1037AK
Q150	260P818O30	CHIP TRANSISTOR	2SC2412K-S	Q6A6	261P066O10	CHIP TRANSISTOR	2SA1037AK
Q153	261P067O30	CHIP TRANSISTOR	DTC124EKA	Q6C6	261P066O10	CHIP TRANSISTOR	2SA1037AK
Q154	261P067O30	CHIP TRANSISTOR	DTC124EKA	Q6C7	260P818O30	CHIP TRANSISTOR	2SC2412K-S
Q155	261P067O30	CHIP TRANSISTOR	DTC124EKA	Q6C8	260P586O20	TRANSISTOR	2SB892-T
Q156	261P065O30	CHIP TRANSISTOR	DTA124EKA	Q6D1	260P818O30	CHIP TRANSISTOR	2SC2412K-S
Q157	261P067O30	CHIP TRANSISTOR	DTC124EKA	Q6D2	260P818O30	CHIP TRANSISTOR	2SC2412K-S
Q2A0	261P067O30	CHIP TRANSISTOR	DTC124EKA	Q6D3	261P066O10	CHIP TRANSISTOR	2SA1037AK
Q2A2	261P067O30	CHIP TRANSISTOR	DTC124EKA	Q6002	261P066O10	CHIP TRANSISTOR	2SA1037AK
Q2A3	261P067O30	CHIP TRANSISTOR	DTC124EKA	Q6003	261P066O10	CHIP TRANSISTOR	2SA1037AK
Q2A5	261P066O10	CHIP TRANSISTOR	2SA1037AK	Q6004	261P066O10	CHIP TRANSISTOR	2SA1037AK
Q2A6	260P818O30	CHIP TRANSISTOR	2SC2412K-S	Q6005	261P067O30	CHIP TRANSISTOR	DTC124EKA
Q2B0	261P066O10	CHIP TRANSISTOR	2SA1037AK	Q6009	261P065O30	CHIP TRANSISTOR	DTA124EKA
Q2B1	261P066O10	CHIP TRANSISTOR	2SA1037AK	Q6010	260P818O30	CHIP TRANSISTOR	2SC2412K-S
Q2B2	260P818O30	CHIP TRANSISTOR	2SC2412K-S	Q6011	260P818O30	CHIP TRANSISTOR	2SC2412K-S
Q2B3	261P066O10	CHIP TRANSISTOR	2SA1037AK	Q6301	260P562O40	TRANSISTOR	2SA952-K
Q2B9	261P067O30	CHIP TRANSISTOR	DTC124EKA	Q6302	260P818O30	CHIP TRANSISTOR	2SC2412K-S
Q2D0	261P065O30	CHIP TRANSISTOR	DTA124EKA	Q6303	261P067O30	CHIP TRANSISTOR	DTC124EKA
Q2E0	261P067O30	CHIP TRANSISTOR	DTC124EKA	Q6304	261P065O30	CHIP TRANSISTOR	DTA124EKA
Q2000	260P818O30	CHIP TRANSISTOR	2SC2412K-S	Q6305	261P067O30	CHIP TRANSISTOR	DTC124EKA
Q2001	260P818O30	CHIP TRANSISTOR	2SC2412K-S	Q6306	261P067O30	CHIP TRANSISTOR	DTC124EKA
Q2002	261P066O10	CHIP TRANSISTOR	2SA1037AK	Q901	261P035O20	TRANSISTOR	2SC5130
Q2003	260P818O30	CHIP TRANSISTOR	2SC2412K-S	Q903	260P629O60	TRANSISTOR	2SC3331-T
Q2004	260P818O30	CHIP TRANSISTOR	2SC2412K-S	Q905	260P559O40	TRANSISTOR	2SC1740S-R,S
Q2005	260P818O30	CHIP TRANSISTOR	2SC2412K-S	Q906	260P559O40	TRANSISTOR	2SC1740S-R,S
Q2006	261P066O10	CHIP TRANSISTOR	2SA1037AK	Q907	260P559O40	TRANSISTOR	2SC1740S-R,S
Q2007	261P066O10	CHIP TRANSISTOR	2SA1037AK	Q908	260C628O10	TRANSISTOR	2SA1619A-Q
				Q910	260C560O10	TRANSISTOR	2SA933S-R,S
				Q918	260P559O40	TRANSISTOR	2SC1740S-R,S
				Q919	261P067O30	CHIP TRANSISTOR	DTC124EKA

SYMBOL No.	PARTS No.	PARTS NAME	DESCRIPTION	SYMBOL No.	PARTS No.	PARTS NAME	DESCRIPTION
Q922	260P562040	TRANSISTOR	2SA952-K				
Q927	260P586020	TRANSISTOR	2SB892-T				
Q928	260P559040	TRANSISTOR	2SC1740S-R,S				
Q929	261P036010	TRANSISTOR	2SB1548				
Q930	260P559040	TRANSISTOR	2SC1740S-R,S				
DIODES							
D120	264P568030	DIODE	1SS254				
D3A0	264P568030	DIODE	1SS254				
D3A1	264P568030	DIODE	1SS254				
D3A2	264P568030	DIODE	1SS254				
D5A0	264P568030	DIODE	1SS254				
D5A9	264P795020	LIGHT EMITTING DIODE	SID1050CMMTP5				
D5B4	264P795020	LIGHT EMITTING DIODE	SID1050CMMTP5				
D5B5	264P795020	LIGHT EMITTING DIODE	SID1050CMMTP5				
D5C0	264P795020	LIGHT EMITTING DIODE	SID1050CMMTP5				
D5D0	264P342070	DIODE	HZ4C2				
D5D2	264P500020	DIODE	EM01Z				
D6A3	264P808010	CHIP DIODE	DAN202K				
D6A4	264P808010	CHIP DIODE	DAN202K				
D6A5	264P807010	CHIP DIODE	DAP202K				
D6002	264P568030	DIODE	1SS254				
D811	264P568030	DIODE	1SS254				
D812	264P568030	DIODE	1SS254				
D813	264P568030	DIODE	1SS254				
D8A0	264P568030	DIODE	1SS254				
D8A1	264P568030	DIODE	1SS254				
D8A2	264P568030	DIODE	1SS254				
D8A3	264P568030	DIODE	1SS254				
D8A4	264P568030	DIODE	1SS254				
D8A5	264P568030	DIODE	1SS254				
D8A6	264P568030	DIODE	1SS254				
D8A7	264P568030	DIODE	1SS254				
D8A8	264P568030	DIODE	1SS254				
D8A9	264P568030	DIODE	1SS254				
D8G5	264P568030	DIODE	1SS254				
D8GE	264P568030	DIODE	1SS254				
D901	264P508070	DIODE	S1WB(A)60F4072				
D902	264P687020	DIODE	AG01				
D905	264P628010	DIODE	FMB-G14L				
D907	264P628010	DIODE	FMB-G14L				
D908	264P750010	DIODE	FMB-G16L				
D909	264P663010	DIODE	D1NL20U				
D910	264P663010	DIODE	D1NL20U				
D911	264P527030	DIODE	D1NS4/AK04				
D912	264P771080	DIODE	MTZJ2.4A				
D913	264P783060	DIODE	MTZJ30D				
D914	264P783010	DIODE	MTZJ27D				
D917	264P452030	DIODE	HZ5C3				
D918	264P568030	DIODE	1SS254				
D920	264P500020	DIODE	EM01Z				
D926	264P488090	DIODE	RD16FB				
D927	264P695070	DIODE	RK39				
D931	264P568030	DIODE	1SS254				
D943	264P568030	DIODE	1SS254				
D960	264P568030	DIODE	1SS254				
D961	264P772050	DIODE	MTZJ3.0A				
D970	264P568030	DIODE	1SS254				
D971	264P568030	DIODE	1SS254				
D972	264P568030	DIODE	1SS254				
D973	264P568030	DIODE	1SS254				
FILTERS							
L901	351P172010	LINE FILTER	SS11V-10062				
LC2000	409P402030	EMI FILTER	FZ103N100				
COILS							
L02	325C472020	PEAKING COIL	56μH-J				
L03	325C472050	PEAKING COIL	100μH-J				
L04	325C472050	PEAKING COIL	100μH-J				
L100	325C473070	PEAKING COIL	1000μH-J				
L120	325C472050	PEAKING COIL	100μH-J				
L121	325C473010	PEAKING COIL	330μH-J				
L122	325C472010	PEAKING COIL	47μH-J				
L150	325C472050	PEAKING COIL	100μH-J				
L2A1	325C472030	PEAKING COIL	68μH-J				
L2A3	325C472050	PEAKING COIL	100μH-J				
L2A4	325C472050	PEAKING COIL	100μH-J				
L2A6	325C472050	PEAKING COIL	100μH-J				
L2A7	325C166040	PEAKING COIL	12μH-J				
L2A9	325C471030	PEAKING COIL	10μH-J				
L2B0	325C472050	PEAKING COIL	100μH-J				
L2B1	325C472050	PEAKING COIL	100μH-J				
L2B2	325C166080	PEAKING COIL	27μH-J				
L2000	325C472050	PEAKING COIL	100μH-J				
L2001	325C472050	PEAKING COIL	100μH-J				
L2002	325C472050	PEAKING COIL	100μH-J				
L2003	325C471090	PEAKING COIL	33μH-J				
L2004	325C471030	PEAKING COIL	10μH-J				
L2005	325C471050	PEAKING COIL	15μH-J				
L2006	325C471030	PEAKING COIL	10μH-J				
L300	325C472050	PEAKING COIL	100μH-J				
L350	325C472050	PEAKING COIL	100μH-J				
L3A0	325C471030	PEAKING COIL	10μH-J				
L3A1	325C471030	PEAKING COIL	10μH-J				
L3A2	325C472050	PEAKING COIL	100μH-J				
L6A2	325C472020	PEAKING COIL	56μH-J				
L6A3	325C472050	PEAKING COIL	100μH-J				
L6A4	325C472050	PEAKING COIL	100μH-J				
L6A5	325C472050	PEAKING COIL	100μH-J				
L6008	325C472050	PEAKING COIL	100μH-J				
L6009	325C472050	PEAKING COIL	100μH-J				
L6150	325C472050	PEAKING COIL	100μH-J				
L6300	325C472050	PEAKING COIL	100μH-J				
L8A0	325C472050	PEAKING COIL	100μH-J				
L902	321C141090	RF COIL	33μH-K				
L903	321C141030	RF COIL	10μH-K				
L904	321C141090	RF COIL	33μH-K				
L906	321C141090	RF COIL	33μH-K				
L907	321C141030	RF COIL	10μH-K				
T350	409P880030	BIAS OSCILLATOR COIL					

SYMBOL No.	PARTS No.	PARTS NAME	DESCRIPTION	SYMBOL No.	PARTS No.	PARTS NAME	DESCRIPTION
TRANSFORMERS				R2E5	103P404080	CHIP RESISTOR	1/10W 82kΩ-J
				R2E6	103P405030	CHIP RESISTOR	1/10W 220kΩ-J
T901	350P717060	POWER TRANSFORMER		R2F0	103P405080	CHIP RESISTOR	1/10W 560kΩ-J
VARIABLE RESISTORS				R2000	103P404010	CHIP RESISTOR	1/10W 22kΩ-J
				R2001	103P403080	CHIP RESISTOR	1/10W 12kΩ-J
				R2002	103P472050	CHIP RESISTOR	1/10W 1kΩ-F
				R2003	103P471050	CHIP RESISTOR	1/10W 390Ω-F
R901	127C510080	SEMIFIXED RESISTOR	1/5W B10kΩ ±25%	R2004	103P471070	CHIP RESISTOR	1/10W 470Ω-F
	109C010050	SOLID RESISTOR	1W 2.2MΩ-K (UL)	R2005	103P473030	CHIP RESISTOR	1/10W 2.2kΩ-F
RESISTORS				R2006	103P402030	CHIP RESISTOR	1/10W 680Ω-J
C2G8	103P409050	CHIP RESISTOR	0.1W 0Ω (2125)	R2007	103P470030	CHIP RESISTOR	1/10W 120Ω-F
R100	103P401030	CHIP RESISTOR	1/10W 100Ω-J	R2008	103P473050	CHIP RESISTOR	1/10W 2.7kΩ-F
R101	103P402060	CHIP RESISTOR	1/10W 1.2kΩ-J	R2009	103P402010	CHIP RESISTOR	1/10W 470Ω-J
R102	103P403090	CHIP RESISTOR	1/10W 15kΩ-J	R2010	103P470010	CHIP RESISTOR	1/10W 100Ω-F
R103	103P403070	CHIP RESISTOR	1/10W 10kΩ-J	R2011	103P471090	CHIP RESISTOR	1/10W 560Ω-F
R105	103P403070	CHIP RESISTOR	1/10W 10kΩ-J	R2012	103P403010	CHIP RESISTOR	1/10W 3.3kΩ-J
R106	103P402050	CHIP RESISTOR	1/10W 1kΩ-J	R2013	103P400090	CHIP RESISTOR	1/10W 47Ω-J
R107	103P403070	CHIP RESISTOR	1/10W 10kΩ-J	R2014	103P400090	CHIP RESISTOR	1/10W 47Ω-J
R108	103P401030	CHIP RESISTOR	1/10W 100Ω-J	R2015	103P403000	CHIP RESISTOR	1/10W 2.7kΩ-J
R120	103P472090	CHIP RESISTOR	1/10W 1.5kΩ-F	R2016	103P470090	CHIP RESISTOR	1/10W 220Ω-F
R121	103P472000	CHIP RESISTOR	1/10W 620Ω-F	R2017	103P473070	CHIP RESISTOR	1/10W 3.3kΩ-F
R122	103P402050	CHIP RESISTOR	1/10W 1kΩ-J	R2018	103P470010	CHIP RESISTOR	1/10W 100Ω-F
R125	103P401070	CHIP RESISTOR	1/10W 220Ω-J	R2019	103P470010	CHIP RESISTOR	1/10W 100Ω-F
R127	103P403070	CHIP RESISTOR	1/10W 10kΩ-J	R2020	103P472010	CHIP RESISTOR	1/10W 680Ω-F
R128	103P472060	CHIP RESISTOR	1/10W 1.1kΩ-F	R2021	103P473050	CHIP RESISTOR	1/10W 2.7kΩ-F
R129	103P473040	CHIP RESISTOR	1/10W 2.4kΩ-F	R2022	103P401030	CHIP RESISTOR	1/10W 100Ω-J
R130	103P402050	CHIP RESISTOR	1/10W 1kΩ-J	R2023	103P473010	CHIP RESISTOR	1/10W 1.8kΩ-F
R131	103P402010	CHIP RESISTOR	1/10W 470Ω-J	R2024	103P402070	CHIP RESISTOR	1/10W 1.5kΩ-J
R134	103P474070	CHIP RESISTOR	1/10W 8.2kΩ-F	R2025	103P402040	CHIP RESISTOR	1/10W 820Ω-J
R135	103P475030	CHIP RESISTOR	1/10W 15kΩ-F	R2026	103P402050	CHIP RESISTOR	1/10W 1kΩ-J
R136	103P475010	CHIP RESISTOR	1/10W 12kΩ-F	R2027	103P470050	CHIP RESISTOR	1/10W 150Ω-F
R150	103P402050	CHIP RESISTOR	1/10W 1kΩ-J	R2028	103P471030	CHIP RESISTOR	1/10W 330Ω-F
R151	103P472050	CHIP RESISTOR	1/10W 1kΩ-F	R2029	103P471070	CHIP RESISTOR	1/10W 470Ω-F
R152	103P472050	CHIP RESISTOR	1/10W 1kΩ-F	R2030	103P471070	CHIP RESISTOR	1/10W 470Ω-F
R2A0	103P409050	CHIP RESISTOR	0.1W 0Ω (2125)	R2031	103P402040	CHIP RESISTOR	1/10W 820Ω-J
R2A1	103P409050	CHIP RESISTOR	0.1W 0Ω (2125)	R2032	103P403080	CHIP RESISTOR	1/10W 12kΩ-J
R2A2	103P474040	CHIP RESISTOR	1/10W 6.2kΩ-F	R2033	103P404010	CHIP RESISTOR	1/10W 22kΩ-J
R2A3	103P472090	CHIP RESISTOR	1/10W 1.5kΩ-F	R2034	103P404010	CHIP RESISTOR	1/10W 22kΩ-J
R2A4	103P475030	CHIP RESISTOR	1/10W 15kΩ-F	R2035	103P403040	CHIP RESISTOR	1/10W 5.6kΩ-J
R2A5	103P409050	CHIP RESISTOR	0.1W 0Ω (2125)	R2036	103P402040	CHIP RESISTOR	1/10W 820Ω-J
R2B0	103P476030	CHIP RESISTOR	1/10W 39kΩ-F	R2037	103P409050	CHIP RESISTOR	0.1W 0Ω (2125)
R2B2	103P473090	CHIP RESISTOR	1/10W 3.9kΩ-F	R2038	103P409050	CHIP RESISTOR	0.1W 0Ω (2125)
R2B3	103P473070	CHIP RESISTOR	1/10W 3.3kΩ-F	R2039	103P409050	CHIP RESISTOR	0.1W 0Ω (2125)
R2B8	103P401070	CHIP RESISTOR	1/10W 220Ω-J	R2040	103P409050	CHIP RESISTOR	0.1W 0Ω (2125)
R2C0	103P406020	CHIP METAL RESISTOR	1/10W 1.2MΩ-J	R2041	103P409050	CHIP RESISTOR	0.1W 0Ω (2125)
R2C1	103P409050	CHIP RESISTOR	0.1W 0Ω (2125)	R2043	103P409050	CHIP RESISTOR	0.1W 0Ω (2125)
R2C4	103P402060	CHIP RESISTOR	1/10W 1.2kΩ-J	R2045	103P409050	CHIP RESISTOR	0.1W 0Ω (2125)
R2C7	103P474010	CHIP RESISTOR	1/10W 4.7kΩ-F	R2047	103P409050	CHIP RESISTOR	0.1W 0Ω (2125)
R2D2	103P472050	CHIP RESISTOR	1/10W 1kΩ-F	R2048	103P409050	CHIP RESISTOR	0.1W 0Ω (2125)
R2D3	103P402060	CHIP RESISTOR	1/10W 1.2kΩ-J	R2049	103P409050	CHIP RESISTOR	0.1W 0Ω (2125)
R2D4	103P402070	CHIP RESISTOR	1/10W 1.5kΩ-J	R2051	103P409050	CHIP RESISTOR	0.1W 0Ω (2125)
R2D6	103P402090	CHIP RESISTOR	1/10W 2.2kΩ-J	R2054	103P409050	CHIP RESISTOR	0.1W 0Ω (2125)
R2D7	103P472070	CHIP RESISTOR	1/10W 1.2kΩ-F	R2055	103P409050	CHIP RESISTOR	0.1W 0Ω (2125)
R2D8	103P409050	CHIP RESISTOR	0.1W 0Ω (2125)	R2057	103P409050	CHIP RESISTOR	0.1W 0Ω (2125)
R2D9	103P473030	CHIP RESISTOR	1/10W 2.2kΩ-F	R2058	103P475010	CHIP RESISTOR	1/10W 12kΩ-F
R2E0	103P472050	CHIP RESISTOR	1/10W 1kΩ-F	R2059	103P783010	CHIP METAL RESISTOR	1/10W 18Ω-F
R2E1	103P472050	CHIP RESISTOR	1/10W 1kΩ-F	R2060	103P403060	CHIP RESISTOR	1/10W 8.2kΩ-J

SYMBOL No.	PARTS No.	PARTS NAME	DESCRIPTION	SYMBOL No.	PARTS No.	PARTS NAME	DESCRIPTION
R2061	103P409050	CHIP RESISTOR	0.1W 0Ω (2125)	R5C4	103P403070	CHIP RESISTOR	1/10W 10kΩ-J
R2062	103P409050	CHIP RESISTOR	0.1W 0Ω (2125)	R5C5	103P403070	CHIP RESISTOR	1/10W 10kΩ-J
R2063	103P409050	CHIP RESISTOR	0.1W 0Ω (2125)	R5C6	103P401070	CHIP RESISTOR	1/10W 220Ω-J
R2064	103P409050	CHIP RESISTOR	0.1W 0Ω (2125)	R5D4	103P405030	CHIP RESISTOR	1/10W 220kΩ-J
R2065	103P409050	CHIP RESISTOR	0.1W 0Ω (2125)	R5D5	103P406010	CHIP RESISTOR	1/10W 1MΩ-J
R2066	103P409050	CHIP RESISTOR	0.1W 0Ω (2125)	R5D6	103P405070	CHIP RESISTOR	1/10W 470kΩ-J
R2070	103P409050	CHIP RESISTOR	0.1W 0Ω (2125)	R5D7	103P403070	CHIP RESISTOR	1/10W 10kΩ-J
R2071	103P409050	CHIP RESISTOR	0.1W 0Ω (2125)	R5D9	103P403040	CHIP RESISTOR	1/10W 5.6kΩ-J
R301	103P405050	CHIP RESISTOR	1/10W 330kΩ-J	R5E0	103P403020	CHIP RESISTOR	1/10W 3.9kΩ-J
R302	103P403080	CHIP RESISTOR	1/10W 12kΩ-J	R5E1	103P403060	CHIP RESISTOR	1/10W 8.2kΩ-J
R303	103P470080	CHIP RESISTOR	1/10W 200Ω-F	R5E2	103P404090	CHIP RESISTOR	1/10W 100kΩ-J
R304	103P404010	CHIP RESISTOR	1/10W 22kΩ-J	R5E3	103P406090	CHIP METAL RESISTOR	1/10W 4.7MΩ-K
R351	103P403070	CHIP RESISTOR	1/10W 10kΩ-J	R5E4	103P406090	CHIP METAL RESISTOR	1/10W 4.7MΩ-K
R352	103P403030	CHIP RESISTOR	1/10W 4.7kΩ-J	R5E5	103P402040	CHIP RESISTOR	1/10W 820Ω-J
R357	103P403030	CHIP RESISTOR	1/10W 4.7kΩ-J	R5E6	103P406010	CHIP RESISTOR	1/10W 1MΩ-J
R358	103P403030	CHIP RESISTOR	1/10W 4.7kΩ-J	R5E7	103P403070	CHIP RESISTOR	1/10W 10kΩ-J
R365	103P400090	CHIP RESISTOR	1/10W 47Ω-J	R5F7	103P402090	CHIP RESISTOR	1/10W 2.2kΩ-J
R366	103P403030	CHIP RESISTOR	1/10W 4.7kΩ-J	R5F8	103P402090	CHIP RESISTOR	1/10W 2.2kΩ-J
R367	103P408040	CHIP RESISTOR	1/10W 2.2Ω-J	R5G5	103P402050	CHIP RESISTOR	1/10W 1kΩ-J
R368	103P403020	CHIP RESISTOR	1/10W 3.9kΩ-J	R5L0	103P404090	CHIP RESISTOR	1/10W 100kΩ-J
R3A0	103P409050	CHIP RESISTOR	0.1W 0Ω (2125)	R5R2	103P402060	CHIP RESISTOR	1/10W 1.2kΩ-J
R3A2	103P403010	CHIP RESISTOR	1/10W 3.3kΩ-J	R5R3	103P403090	CHIP RESISTOR	1/10W 15kΩ-J
R3A3	103P402030	CHIP RESISTOR	1/10W 680Ω-J	R5R4	103P404020	CHIP RESISTOR	1/10W 27kΩ-J
R3A4	103P403050	CHIP RESISTOR	1/10W 6.8kΩ-J	R5R5	103P404000	CHIP RESISTOR	1/10W 18kΩ-J
R3A8	103P405060	CHIP RESISTOR	1/10W 390kΩ-J	R5S0	103P404030	CHIP RESISTOR	1/10W 33kΩ-J
R3A9	103P474040	CHIP RESISTOR	1/10W 6.2kΩ-F	R5S3	103P403090	CHIP RESISTOR	1/10W 15kΩ-J
R3B0	103P404050	CHIP RESISTOR	1/10W 47kΩ-J	R5S4	103P404040	CHIP RESISTOR	1/10W 39kΩ-J
R3B1	103P474040	CHIP RESISTOR	1/10W 6.2kΩ-F	R5S8	103P473070	CHIP RESISTOR	1/10W 3.3kΩ-F
R3B2	103P404050	CHIP RESISTOR	1/10W 47kΩ-J	R5S9	103P405050	CHIP RESISTOR	1/10W 330kΩ-J
R3B3	103P474070	CHIP RESISTOR	1/10W 8.2kΩ-F	R5T3	103P403070	CHIP RESISTOR	1/10W 10kΩ-J
R3B4	103P476010	CHIP RESISTOR	1/10W 33kΩ-F	R5T4	103P403070	CHIP RESISTOR	1/10W 10kΩ-J
R3B5	103P409050	CHIP RESISTOR	0.1W 0Ω (2125)	R5T5	103P404030	CHIP RESISTOR	1/10W 33kΩ-J
R3B9	103P409050	CHIP RESISTOR	0.1W 0Ω (2125)	R5T6	103P404030	CHIP RESISTOR	1/10W 33kΩ-J
R3C1	103P404050	CHIP RESISTOR	1/10W 47kΩ-J	R5V2	103P404090	CHIP RESISTOR	1/10W 100kΩ-J
R3C2	103P404050	CHIP RESISTOR	1/10W 47kΩ-J	R5W0	103P402050	CHIP RESISTOR	1/10W 1kΩ-J
R3C3	103P474040	CHIP RESISTOR	1/10W 6.2kΩ-F	R5W1	103P404030	CHIP RESISTOR	1/10W 33kΩ-J
R3C4	103P404050	CHIP RESISTOR	1/10W 47kΩ-J	R6A0	103P403040	CHIP RESISTOR	1/10W 5.6kΩ-J
R3C5	103P474040	CHIP RESISTOR	1/10W 6.2kΩ-F	R6A1	103P406090	CHIP METAL RESISTOR	1/10W 4.7MΩ-K
R3C6	103P404050	CHIP RESISTOR	1/10W 47kΩ-J	R6A2	103P403020	CHIP RESISTOR	1/10W 3.9kΩ-J
R3F0	103P403010	CHIP RESISTOR	1/10W 3.3kΩ-J	R6A4	103P405060	CHIP RESISTOR	1/10W 390kΩ-J
R3F6	103P476010	CHIP RESISTOR	1/10W 33kΩ-F	R6A6	103P405020	CHIP RESISTOR	1/10W 180kΩ-J
R3L0	103P473050	CHIP RESISTOR	1/10W 2.7kΩ-F	R6A8	103P403010	CHIP RESISTOR	1/10W 3.3kΩ-J
R3Y0	103P402050	CHIP RESISTOR	1/10W 1kΩ-J	R6A9	103P402070	CHIP RESISTOR	1/10W 1.5kΩ-J
R5A1	103P404000	CHIP RESISTOR	1/10W 18kΩ-J	R6B0	103P409050	CHIP RESISTOR	0.1W 0Ω (2125)
R5A3	103P404000	CHIP RESISTOR	1/10W 18kΩ-J	R6B1	103P401030	CHIP RESISTOR	1/10W 100Ω-J
R5A7	103P403020	CHIP RESISTOR	1/10W 3.9kΩ-J	R6B2	103P401030	CHIP RESISTOR	1/10W 100Ω-J
R5A8	103P401070	CHIP RESISTOR	1/10W 220Ω-J	R6B3	103P472050	CHIP RESISTOR	1/10W 1kΩ-F
R5A9	103P402050	CHIP RESISTOR	1/10W 1kΩ-J	R6B4	103P402000	CHIP RESISTOR	1/10W 390Ω-J
R5B0	103P402080	CHIP RESISTOR	1/10W 1.8kΩ-J	R6B5	103P402000	CHIP RESISTOR	1/10W 390Ω-J
R5B2	103P402020	CHIP RESISTOR	1/10W 560Ω-J	R6B6	103P402000	CHIP RESISTOR	1/10W 390Ω-J
R5B3	103P403070	CHIP RESISTOR	1/10W 10kΩ-J	R6B7	103P409050	CHIP RESISTOR	0.1W 0Ω (2125)
R5B6	103P405030	CHIP RESISTOR	1/10W 220kΩ-J	R6B8	103P402000	CHIP RESISTOR	1/10W 390Ω-J
R5B8	103P405000	CHIP RESISTOR	1/10W 120kΩ-J	R6B9	103P403070	CHIP RESISTOR	1/10W 10kΩ-J
R5B9	103P405000	CHIP RESISTOR	1/10W 120kΩ-J	R6D7	103P402020	CHIP RESISTOR	1/10W 560Ω-J
R5C0	103P405000	CHIP RESISTOR	1/10W 120kΩ-J	R6E2	103P471070	CHIP RESISTOR	1/10W 470Ω-F
R5C2	103P404020	CHIP RESISTOR	1/10W 27kΩ-J	R6E3	103P473070	CHIP RESISTOR	1/10W 3.3kΩ-F
				R6E4	103P473070	CHIP RESISTOR	1/10W 3.3kΩ-F

SYMBOL No.	PARTS No.	PARTS NAME	DESCRIPTION	SYMBOL No.	PARTS No.	PARTS NAME	DESCRIPTION
R6E5	103P472090	CHIP RESISTOR	1/10W 1.5kΩ-F	R6112	103P401030	CHIP RESISTOR	1/10W 100Ω-J
R6E6	103P472050	CHIP RESISTOR	1/10W 1kΩ-F	R6115	103P404050	CHIP RESISTOR	1/10W 47kΩ-J
R6E7	103P472050	CHIP RESISTOR	1/10W 1kΩ-F	R6118	103P404050	CHIP RESISTOR	1/10W 47kΩ-J
R6E8	103P472050	CHIP RESISTOR	1/10W 1kΩ-F	R6122	103P404010	CHIP RESISTOR	1/10W 22kΩ-J
R6E9	103P471070	CHIP RESISTOR	1/10W 470Ω-F	R6126	103P403020	CHIP RESISTOR	1/10W 3.9kΩ-J
R6F0	103P473070	CHIP RESISTOR	1/10W 3.3kΩ-F	R6301	103P404090	CHIP RESISTOR	1/10W 100kΩ-J
R6F1	103P472050	CHIP RESISTOR	1/10W 1kΩ-F	R6303	103P403070	CHIP RESISTOR	1/10W 10kΩ-J
R6F2	103P472050	CHIP RESISTOR	1/10W 1kΩ-F	R6304	103P402000	CHIP RESISTOR	1/10W 390Ω-J
R6F3	103P472090	CHIP RESISTOR	1/10W 1.5kΩ-F	R6306	103P404090	CHIP RESISTOR	1/10W 100kΩ-J
R6F4	103P473070	CHIP RESISTOR	1/10W 3.3kΩ-F	R6307	103P404090	CHIP RESISTOR	1/10W 100kΩ-J
R6F5	103P473030	CHIP RESISTOR	1/10W 2.2kΩ-F	R6308	103P402040	CHIP RESISTOR	1/10W 820Ω-J
R6F6	103P472050	CHIP RESISTOR	1/10W 1kΩ-F	R6309	103P402090	CHIP RESISTOR	1/10W 2.2kΩ-J
R6F7	103P402080	CHIP RESISTOR	1/10W 1.8kΩ-J	R6310	103P402090	CHIP RESISTOR	1/10W 2.2kΩ-J
R6F8	103P403070	CHIP RESISTOR	1/10W 10kΩ-J	R6311	103P401030	CHIP RESISTOR	1/10W 100Ω-J
R6F9	103P402050	CHIP RESISTOR	1/10W 1kΩ-J	R6312	103P403070	CHIP RESISTOR	1/10W 10kΩ-J
R6G0	103P409050	CHIP RESISTOR	0.1W 0Ω (2125)	R6313	103P402000	CHIP RESISTOR	1/10W 390Ω-J
R6G2	103P409050	CHIP RESISTOR	0.1W 0Ω (2125)	R6314	103P403010	CHIP RESISTOR	1/10W 3.3kΩ-J
R6G3	103P409050	CHIP RESISTOR	0.1W 0Ω (2125)	R8A0	103P404030	CHIP RESISTOR	1/10W 33kΩ-J
R6G4	103P472050	CHIP RESISTOR	1/10W 1kΩ-F	R8A1	103P404030	CHIP RESISTOR	1/10W 33kΩ-J
R6G7	103P409050	CHIP RESISTOR	0.1W 0Ω (2125)	R8A2	103P404030	CHIP RESISTOR	1/10W 33kΩ-J
R6H0	103P472030	CHIP RESISTOR	1/10W 820Ω-F	R8A3	103P404030	CHIP RESISTOR	1/10W 33kΩ-J
R6H2	103P401090	CHIP RESISTOR	1/10W 330Ω-J	R8A4	103P403070	CHIP RESISTOR	1/10W 10kΩ-J
R6H3	103P405030	CHIP RESISTOR	1/10W 220kΩ-J	R8A5	103P404050	CHIP RESISTOR	1/10W 47kΩ-J
R6H4	103P409050	CHIP RESISTOR	0.1W 0Ω (2125)	R902	102P108050	WIRE RESISTOR	2W 2.7Ω-J
R6H5	103P403070	CHIP RESISTOR	1/10W 10kΩ-J	R905	103P402090	CHIP RESISTOR	1/10W 2.2kΩ-J
R6H6	103P402050	CHIP RESISTOR	1/10W 1kΩ-J	R911	103P472070	CHIP RESISTOR	1/10W 1.2kΩ-F
R6H7	103P402050	CHIP RESISTOR	1/10W 1kΩ-J	R912	103P472070	CHIP RESISTOR	1/10W 1.2kΩ-F
R6H8	103P472050	CHIP RESISTOR	1/10W 1kΩ-F	R917	103P472020	CHIP RESISTOR	1/10W 750Ω-F
R6H9	103P471090	CHIP RESISTOR	1/10W 560Ω-F	R918	103P403070	CHIP RESISTOR	1/10W 10kΩ-J
R6J0	103P404060	CHIP RESISTOR	1/10W 56kΩ-J	R919	103P404080	CHIP RESISTOR	1/10W 82kΩ-J
R6J1	103P403090	CHIP RESISTOR	1/10W 15kΩ-J	R920	103P403020	CHIP RESISTOR	1/10W 3.9kΩ-J
R6K0	103P406050	CHIP RESISTOR	1/10W 2.2MΩ-J	R921	103P751030	FUSE RESISTOR	1/4W 100Ω-J
R6K1	103P404050	CHIP RESISTOR	1/10W 47kΩ-J	R925	103P758070	FUSE RESISTOR	1/4W 3.9Ω-J
R6K2	103P404010	CHIP RESISTOR	1/10W 22kΩ-J	R926	103P470010	CHIP RESISTOR	1/10W 100Ω-F
R6001	103P409090	CHIP RESISTOR	1/10W 75Ω-J	R927	103P403040	CHIP RESISTOR	1/10W 5.6kΩ-J
R6002	103P409090	CHIP RESISTOR	1/10W 75Ω-J	R955	103P472030	CHIP RESISTOR	1/10W 820Ω-F
R6003	103P409090	CHIP RESISTOR	1/10W 75Ω-J	R956	103P472070	CHIP RESISTOR	1/10W 1.2kΩ-F
R6004	103P402040	CHIP RESISTOR	1/10W 820Ω-J	R963	103P403070	CHIP RESISTOR	1/10W 10kΩ-J
R6006	103P402040	CHIP RESISTOR	1/10W 820Ω-J	R964	103P478020	CHIP RESISTOR	1/10W 240kΩ-F
R6010	103P403010	CHIP RESISTOR	1/10W 3.3kΩ-J	R971	103P403070	CHIP RESISTOR	1/10W 10kΩ-J
R6011	103P403010	CHIP RESISTOR	1/10W 3.3kΩ-J	R973	103P403070	CHIP RESISTOR	1/10W 10kΩ-J
R6012	103P402030	CHIP RESISTOR	1/10W 680Ω-J	RJ01	103P409050	CHIP RESISTOR	0.1W 0Ω (2125)
R6013	103P402030	CHIP RESISTOR	1/10W 680Ω-J	RJ02	103P409050	CHIP RESISTOR	0.1W 0Ω (2125)
R6025	103P401090	CHIP RESISTOR	1/10W 330Ω-J	RJ03	103P409050	CHIP RESISTOR	0.1W 0Ω (2125)
R6026	103P401090	CHIP RESISTOR	1/10W 330Ω-J	RJ151	103P409050	CHIP RESISTOR	0.1W 0Ω (2125)
R6029	103P409090	CHIP RESISTOR	1/10W 75Ω-J	RJ153	103P409050	CHIP RESISTOR	0.1W 0Ω (2125)
R6031	103P409090	CHIP RESISTOR	1/10W 75Ω-J	RJ154	103P409050	CHIP RESISTOR	0.1W 0Ω (2125)
R6032	103P409090	CHIP RESISTOR	1/10W 75Ω-J				
R6039	103P402050	CHIP RESISTOR	1/10W 1kΩ-J	CAPACITORS AND TRIMMERS			
R6040	103P402050	CHIP RESISTOR	1/10W 1kΩ-J	C100	141P132010	CHIP CAPACITOR	B50V 0.01μF-K
R6041	103P402040	CHIP RESISTOR	1/10W 820Ω-J	C101	141P132010	CHIP CAPACITOR	B50V 0.01μF-K
R6042	103P401030	CHIP RESISTOR	1/10W 100Ω-J	C103	141P137040	CHIP CAPACITOR	B25V 0.022μF-K
R6056	103P400080	CHIP METAL RESISTOR	1/10W 39Ω-J	C120	154P325020	CHIP CAPACITOR	SL50V 470pF-J
R6086	103P404020	CHIP RESISTOR	1/10W 27kΩ-J	C121	141P139070	CHIP CAPACITOR	B16V 0.22μF-K
R6087	103P404020	CHIP RESISTOR	1/10W 27kΩ-J	C123	141P132010	CHIP CAPACITOR	B50V 0.01μF-K
R6110	103P400080	CHIP METAL RESISTOR	1/10W 39Ω-J	C124	181P350050	ELECTROLYTIC CAPACITOR	04W 6.3V 470μF-M
R6111	103P400080	CHIP METAL RESISTOR	1/10W 39Ω-J				

SYMBOL No.	PARTS No.	PARTS NAME	DESCRIPTION	SYMBOL No.	PARTS No.	PARTS NAME	DESCRIPTION
C126	141P132010	CHIP CAPACITOR	B50V 0.01 μ F-K	C2H7	141P137060	CHIP CAPACITOR	B50V 0.033 μ F-K
C127	141P132010	CHIP CAPACITOR	B50V 0.01 μ F-K	C2H9	154P331050	CHIP CAPACITOR	CH50V 15pF-J
C128	154P332070	CHIP CAPACITOR	CH50V 47pF-J	C2J0	141P132010	CHIP CAPACITOR	B50V 0.01 μ F-K
C130	141P130030	CHIP CAPACITOR	B50V 330pF-K	C2J4	141P139030	CHIP CAPACITOR	B25V 0.1 μ F-K
C132	141P132010	CHIP CAPACITOR	B50V 0.01 μ F-K	C2J5	154P333090	CHIP CAPACITOR	CH50V 150pF-J
C133	154P332050	CHIP CAPACITOR	CH50V 39pF-J	C2000	141P139030	CHIP CAPACITOR	B25V 0.1 μ F-K
C150	141P132010	CHIP CAPACITOR	B50V 0.01 μ F-K	C2001	141P132010	CHIP CAPACITOR	B50V 0.01 μ F-K
C151	141P132010	CHIP CAPACITOR	B50V 0.01 μ F-K	C2002	154P331090	CHIP CAPACITOR	CH50V 22pF-J
C152	141P132010	CHIP CAPACITOR	B50V 0.01 μ F-K	C2003	154P330070	CHIP CAPACITOR	CH50V 6pF-C
C156	141P132010	CHIP CAPACITOR	B50V 0.01 μ F-K	C2004	154P332050	CHIP CAPACITOR	CH50V 39pF-J
C163	141P132010	CHIP CAPACITOR	B50V 0.01 μ F-K	C2005	141P135080	CHIP CAPACITOR	F25V 0.1 μ F-Z
C2A0	141P132010	CHIP CAPACITOR	B50V 0.01 μ F-K	C2006	141P139030	CHIP CAPACITOR	B25V 0.1 μ F-K
C2A1	141P132010	CHIP CAPACITOR	B50V 0.01 μ F-K	C2007	141P135080	CHIP CAPACITOR	F25V 0.1 μ F-Z
C2A2	141P132010	CHIP CAPACITOR	B50V 0.01 μ F-K	C2008	141P135080	CHIP CAPACITOR	F25V 0.1 μ F-Z
C2A3	141P132010	CHIP CAPACITOR	B50V 0.01 μ F-K	C2009	141P132010	CHIP CAPACITOR	B50V 0.01 μ F-K
C2A4	141P132010	CHIP CAPACITOR	B50V 0.01 μ F-K	C2010	141P135080	CHIP CAPACITOR	F25V 0.1 μ F-Z
C2A5	141P132010	CHIP CAPACITOR	B50V 0.01 μ F-K	C2011	141P135080	CHIP CAPACITOR	F25V 0.1 μ F-Z
C2A6	141P132010	CHIP CAPACITOR	B50V 0.01 μ F-K	C2012	141P135080	CHIP CAPACITOR	F25V 0.1 μ F-Z
C2A7	141P132010	CHIP CAPACITOR	B50V 0.01 μ F-K	C2013	154P324040	CHIP CAPACITOR	SL50V 220pF-J
C2A8	141P132010	CHIP CAPACITOR	B50V 0.01 μ F-K	C2014	154P325000	CHIP CAPACITOR	SL50V 390pF-J
C2B4	141P139070	CHIP CAPACITOR	B16V 0.22 μ F-K	C2015	154P330070	CHIP CAPACITOR	CH50V 6pF-C
C2C0	154P330060	CHIP CAPACITOR	CH50V 5pF-C	C2016	154P333010	CHIP CAPACITOR	CH50V 68pF-J
C2C1	154P333090	CHIP CAPACITOR	CH50V 150pF-J	C2017	154P332070	CHIP CAPACITOR	CH50V 47pF-J
C2C2	154P331090	CHIP CAPACITOR	CH50V 22pF-J	C2018	154P330090	CHIP CAPACITOR	CH50V 8pF-C
C2C3	141P135080	CHIP CAPACITOR	F25V 0.1 μ F-Z	C2019	141P135080	CHIP CAPACITOR	F25V 0.1 μ F-Z
C2C5	141P139030	CHIP CAPACITOR	B25V 0.1 μ F-K	C2020	141P139030	CHIP CAPACITOR	B25V 0.1 μ F-K
C2C7	154P331030	CHIP CAPACITOR	CH50V 12pF-J	C2021	141P139030	CHIP CAPACITOR	B25V 0.1 μ F-K
C2C8	154P331090	CHIP CAPACITOR	CH50V 22pF-J	C2022	141P135080	CHIP CAPACITOR	F25V 0.1 μ F-Z
C2C9	141P139030	CHIP CAPACITOR	B25V 0.1 μ F-K	C2023	141P135080	CHIP CAPACITOR	F25V 0.1 μ F-Z
C2D0	141P139030	CHIP CAPACITOR	B25V 0.1 μ F-K	C2024	141P135080	CHIP CAPACITOR	F25V 0.1 μ F-Z
C2D3	141P139030	CHIP CAPACITOR	B25V 0.1 μ F-K	C2025	141P135080	CHIP CAPACITOR	F25V 0.1 μ F-Z
C2D4	141P139030	CHIP CAPACITOR	B25V 0.1 μ F-K	C2026	141P139030	CHIP CAPACITOR	B25V 0.1 μ F-K
C2D5	141P139030	CHIP CAPACITOR	B25V 0.1 μ F-K	C2028	141P135080	CHIP CAPACITOR	F25V 0.1 μ F-Z
C2D9	141P132010	CHIP CAPACITOR	B50V 0.01 μ F-K	C2029	141P135080	CHIP CAPACITOR	F25V 0.1 μ F-Z
C2E2	141P132010	CHIP CAPACITOR	B50V 0.01 μ F-K	C2030	141P135080	CHIP CAPACITOR	F25V 0.1 μ F-Z
C2E3	141P130030	CHIP CAPACITOR	B50V 330pF-K	C2031	141P139030	CHIP CAPACITOR	B25V 0.1 μ F-K
C2E5	141P132010	CHIP CAPACITOR	B50V 0.01 μ F-K	C2032	141P130090	CHIP CAPACITOR	B50V 1000pF-K
C2E6	141P132010	CHIP CAPACITOR	B50V 0.01 μ F-K	C2034	141P135080	CHIP CAPACITOR	F25V 0.1 μ F-Z
C2E7	141P132010	CHIP CAPACITOR	B50V 0.01 μ F-K	C2035	181P210040	ELECTROLYTIC CAPACITOR	6.3V 100 μ F-M
C2E8	141P139030	CHIP CAPACITOR	B25V 0.1 μ F-K	C2036	141P135080	CHIP CAPACITOR	F25V 0.1 μ F-Z
C2E9	141P139030	CHIP CAPACITOR	B25V 0.1 μ F-K	C2037	181P210060	ELECTROLYTIC CAPACITOR	04W 6.3V 330 μ F-M
C2F1	141P132010	CHIP CAPACITOR	B50V 0.01 μ F-K	C2038	141P135080	CHIP CAPACITOR	F25V 0.1 μ F-Z
C2F2	141P132010	CHIP CAPACITOR	B50V 0.01 μ F-K	C2040	181P219020	ELECTROLYTIC CAPACITOR	04W 35V 4.7 μ F-M
C2F5	154P330050	CHIP CAPACITOR	CH50V 4pF-C	C2041	141P132010	CHIP CAPACITOR	B50V 0.01 μ F-K
C2F6	141P135080	CHIP CAPACITOR	F25V 0.1 μ F-Z	C2042	181P210040	ELECTROLYTIC CAPACITOR	6.3V 100 μ F-M
C2F7	141P139010	CHIP CAPACITOR	B25V 0.068 μ F-K	C2048	181P219070	ELECTROLYTIC CAPACITOR	50V 1 μ F-M
C2G0	141P137040	CHIP CAPACITOR	B25V 0.022 μ F-K	C2049	181P219070	ELECTROLYTIC CAPACITOR	50V 1 μ F-M
C2G1	141P131070	CHIP CAPACITOR	B50V 4700pF-K	C2050	181P210040	ELECTROLYTIC CAPACITOR	6.3V 100 μ F-M
C2G4	141P139030	CHIP CAPACITOR	B25V 0.1 μ F-K	C300	141P132010	CHIP CAPACITOR	B50V 0.01 μ F-K
C2G5	154P331050	CHIP CAPACITOR	CH50V 15pF-J	C301	141P132010	CHIP CAPACITOR	B50V 0.01 μ F-K
C2G7	141P139030	CHIP CAPACITOR	B25V 0.1 μ F-K	C302	141P130060	CHIP CAPACITOR	B50V 560pF-K
C2G9	141P139030	CHIP CAPACITOR	B25V 0.1 μ F-K	C303	141P131060	CHIP CAPACITOR	B50V 3900pF-K
C2H0	154P331050	CHIP CAPACITOR	CH50V 15pF-J	C304	141P132010	CHIP CAPACITOR	B50V 0.01 μ F-K
C2H1	154P332070	CHIP CAPACITOR	CH50V 47pF-J	C305	141P139030	CHIP CAPACITOR	B25V 0.1 μ F-K
C2H3	141P135080	CHIP CAPACITOR	F25V 0.1 μ F-Z	C350	141P130010	CHIP CAPACITOR	B50V 220pF-K
C2H5	141P132010	CHIP CAPACITOR	B50V 0.01 μ F-K	C357	141P137040	CHIP CAPACITOR	B25V 0.022 μ F-K
C2H6	141P139030	CHIP CAPACITOR	B25V 0.1 μ F-K				

SYMBOL No.	PARTS No.	PARTS NAME	DESCRIPTION	SYMBOL No.	PARTS No.	PARTS NAME	DESCRIPTION
C358	141P131070	CHIP CAPACITOR	B50V 4700pF-K	C6A6	141P139030	CHIP CAPACITOR	B25V 0.1μF-K
C379	181P212060	ELECTROLYTIC CAPACITOR	04W 16V 47μF-M	C6A7	141P139030	CHIP CAPACITOR	B25V 0.1μF-K
C3A7	141P139030	CHIP CAPACITOR	B25V 0.1μF-K	C6A8	141P132010	CHIP CAPACITOR	B50V 0.01μF-K
C3A9	141P139070	CHIP CAPACITOR	B16V 0.22μF-K	C6A9	141P139030	CHIP CAPACITOR	B25V 0.1μF-K
C3B0	141P139070	CHIP CAPACITOR	B16V 0.22μF-K	C6B0	154P332030	CHIP CAPACITOR	CH50V 33pF-J
C3B6	141P139030	CHIP CAPACITOR	B25V 0.1μF-K	C6B1	181P219080	ELECTROLYTIC CAPACITOR	50V 2.2μF-M
C3B8	141P139030	CHIP CAPACITOR	B25V 0.1μF-K	C6B2	181P219020	ELECTROLYTIC CAPACITOR	04W 35V 4.7μF-M
C3B9	141P139030	CHIP CAPACITOR	B25V 0.1μF-K	C6B3	181P219080	ELECTROLYTIC CAPACITOR	50V 2.2μF-M
C3C0	141P139030	CHIP CAPACITOR	B25V 0.1μF-K	C6B4	141P135080	CHIP CAPACITOR	F25V 0.1μF-Z
C3C8	141P139030	CHIP CAPACITOR	B25V 0.1μF-K	C6B5	181P352040	ELECTROLYTIC CAPACITOR	04W 16V 100μF-M
C3E4	141P133080	CHIP CAPACITOR	F50V 0.01μF-Z	C6B6	141P132010	CHIP CAPACITOR	B50V 0.01μF-K
C3F2	141P137040	CHIP CAPACITOR	B25V 0.022μF-K	C6B7	141P132010	CHIP CAPACITOR	B50V 0.01μF-K
C3F4	141P139030	CHIP CAPACITOR	B25V 0.1μF-K	C6B8	141P139030	CHIP CAPACITOR	B25V 0.1μF-K
C3F5	141P132010	CHIP CAPACITOR	B50V 0.01μF-K	C6B9	141P139030	CHIP CAPACITOR	B25V 0.1μF-K
C3G1	141P132010	CHIP CAPACITOR	B50V 0.01μF-K	C6C0	141P139030	CHIP CAPACITOR	B25V 0.1μF-K
C3G3	141P132010	CHIP CAPACITOR	B50V 0.01μF-K	C6C1	181P219070	ELECTROLYTIC CAPACITOR	50V 1μF-M
C3J0	141P139030	CHIP CAPACITOR	B25V 0.1μF-K	C6C2	141P132010	CHIP CAPACITOR	B50V 0.01μF-K
C3J1	141P139030	CHIP CAPACITOR	B25V 0.1μF-K	C6C3	181P219080	ELECTROLYTIC CAPACITOR	50V 2.2μF-M
C3J2	141P139030	CHIP CAPACITOR	B25V 0.1μF-K	C6C4	141P132010	CHIP CAPACITOR	B50V 0.01μF-K
C3J3	141P132010	CHIP CAPACITOR	B50V 0.01μF-K	C6C5	141P132010	CHIP CAPACITOR	B50V 0.01μF-K
C3J4	141P132010	CHIP CAPACITOR	B50V 0.01μF-K	C6C6	181P352040	ELECTROLYTIC CAPACITOR	04W 16V 100μF-M
C3J6	141P132030	CHIP CAPACITOR	B50V 0.015μF-K	C6C7	141P135080	CHIP CAPACITOR	F25V 0.1μF-Z
C3J7	141P132030	CHIP CAPACITOR	B50V 0.015μF-K	C6C8	141P139030	CHIP CAPACITOR	B25V 0.1μF-K
C3L0	141P134050	CHIP CAPACITOR	B50V 0.047μF-K	C6C9	181P219070	ELECTROLYTIC CAPACITOR	50V 1μF-M
C5A0	189P197020	ELE DOUBLE LAYER CAPACITOR	FM0H473Z	C6D0	181P219080	ELECTROLYTIC CAPACITOR	50V 2.2μF-M
C5A3	141P133090	CHIP CAPACITOR	F50V 0.022μF-Z	C6D1	181P219070	ELECTROLYTIC CAPACITOR	50V 1μF-M
C5A6	141P132010	CHIP CAPACITOR	B50V 0.01μF-K	C6D2	181P219070	ELECTROLYTIC CAPACITOR	50V 1μF-M
C5A7	141P132010	CHIP CAPACITOR	B50V 0.01μF-K	C6D4	181P219020	ELECTROLYTIC CAPACITOR	04W 35V 4.7μF-M
C5B1	141P131090	CHIP CAPACITOR	B50V 6800pF-K	C6D5	141P132010	CHIP CAPACITOR	B50V 0.01μF-K
C5B2	141P131090	CHIP CAPACITOR	B50V 6800pF-K	C6E0	141P132010	CHIP CAPACITOR	B50V 0.01μF-K
C5B3	141P131090	CHIP CAPACITOR	B50V 6800pF-K	C6E7	181P219020	ELECTROLYTIC CAPACITOR	04W 35V 4.7μF-M
C5B5	141P132010	CHIP CAPACITOR	B50V 0.01μF-K	C6E8	181P219020	ELECTROLYTIC CAPACITOR	04W 35V 4.7μF-M
C5B6	154P331090	CHIP CAPACITOR	CH50V 22pF-J	C6E9	181P219020	ELECTROLYTIC CAPACITOR	04W 35V 4.7μF-M
C5B7	154P331070	CHIP CAPACITOR	CH50V 18pF-J	C6F0	181P219000	ELECTROLYTIC CAPACITOR	6.3V 22μF-M
C5B8	154P331070	CHIP CAPACITOR	CH50V 18pF-J	C6F1	141P135080	CHIP CAPACITOR	F25V 0.1μF-Z
C5B9	154P331070	CHIP CAPACITOR	CH50V 18pF-J	C6F2	181P351060	ELECTROLYTIC CAPACITOR	CE04W 10V 330μF-M
C5C0	141P132010	CHIP CAPACITOR	B50V 0.01μF-K	C6F3	154P334050	CHIP CAPACITOR	CH50V 270pF-J
C5C6	141P130050	CHIP CAPACITOR	B50V 470pF-K	C6F4	154P334050	CHIP CAPACITOR	CH50V 270pF-J
C5C9	141P132010	CHIP CAPACITOR	B50V 0.01μF-K	C6F5	154P333090	CHIP CAPACITOR	CH50V 150pF-J
C5J9	141P133090	CHIP CAPACITOR	F50V 0.022μF-Z	C6F6	154P333030	CHIP CAPACITOR	CH50V 82pF-J
C5L0	141P139030	CHIP CAPACITOR	B25V 0.1μF-K	C6F7	154P334050	CHIP CAPACITOR	CH50V 270pF-J
C5R1	141P130080	CHIP CAPACITOR	B50V 820pF-K	C6F8	154P333030	CHIP CAPACITOR	CH50V 82pF-J
C5S0	141P131070	CHIP CAPACITOR	B50V 4700pF-K	C6F9	154P334050	CHIP CAPACITOR	CH50V 270pF-J
C5S1	141P132020	CHIP CAPACITOR	B50V 0.012μF-K	C6G0	154P334030	CHIP CAPACITOR	CH50V 220pF-J
C5S3	141P139000	CHIP CAPACITOR	B25V 0.056μF-K	C6G1	154P334050	CHIP CAPACITOR	CH50V 270pF-J
C5S4	141P139000	CHIP CAPACITOR	B25V 0.056μF-K	C6G2	181P352040	ELECTROLYTIC CAPACITOR	04W 16V 100μF-M
C5S5	141P130090	CHIP CAPACITOR	B50V 1000pF-K	C6G5	141P139030	CHIP CAPACITOR	B25V 0.1μF-K
C5S6	141P131030	CHIP CAPACITOR	B50V 2200pF-K	C6H0	141P132010	CHIP CAPACITOR	B50V 0.01μF-K
C5T5	141P130090	CHIP CAPACITOR	B50V 1000pF-K	C6J0	141P135080	CHIP CAPACITOR	F25V 0.1μF-Z
C5T6	141P130090	CHIP CAPACITOR	B50V 1000pF-K	C6J1	154P334010	CHIP CAPACITOR	CH50V 180pF-J
C5T9	141P134050	CHIP CAPACITOR	B50V 0.047μF-K	C6J2	181P219090	ELECTROLYTIC CAPACITOR	04W 50V 3.3μF-M
C5V2	154P334030	CHIP CAPACITOR	CH50V 220pF-J	C6J3	154P333050	CHIP CAPACITOR	CH50V 100pF-J
C6A0	181P219030	ELECTROLYTIC CAPACITOR	04W 50V 0.1μF-M	C6005	141P132010	CHIP CAPACITOR	B50V 0.01μF-K
C6A1	141P139030	CHIP CAPACITOR	B25V 0.1μF-K	C6028	141P132010	CHIP CAPACITOR	B50V 0.01μF-K
C6A2	181P219060	ELECTROLYTIC CAPACITOR	50V 0.47μF-M	C6030	141P132010	CHIP CAPACITOR	B50V 0.01μF-K
C6A3	181P219010	ELECTROLYTIC CAPACITOR	16V 10μF-M	C6032	181P219090	ELECTROLYTIC CAPACITOR	04W 50V 3.3μF-M
C6A5	181P219020	ELECTROLYTIC CAPACITOR	04W 35V 4.7μF-M	C6033	181P219090	ELECTROLYTIC CAPACITOR	04W 50V 3.3μF-M

SYMBOL No.	PARTS No.	PARTS NAME	DESCRIPTION	SYMBOL No.	PARTS No.	PARTS NAME	DESCRIPTION
C6034	181P219090	ELECTROLYTIC CAPACITOR	04W 50V 3.3μF-M	CF6301	299P116010	CERAMIC RESONATOR	KBR-4.0KES
C6035	181P219090	ELECTROLYTIC CAPACITOR	04W 50V 3.3μF-M	F901	283D130030	FUSE	S1.6A 125V
C6036	141P132010	CHIP CAPACITOR	B50V 0.01μF-K	J6003	449C100010	DIN SOCKET(4P)	
C6037	141P132010	CHIP CAPACITOR	B50V 0.01μF-K	J6004	451C207030	RCA PIN JACK	
C6040	181P219090	ELECTROLYTIC CAPACITOR	04W 50V 3.3μF-M	J6005	449C100010	DIN SOCKET(4P)	
C6041	181P219090	ELECTROLYTIC CAPACITOR	04W 50V 3.3μF-M	J6006	451C207010	RCA PIN JACK	3P
C6072	141P132010	CHIP CAPACITOR	B50V 0.01μF-K	J6012	451C117010	HEADPHONE JACK	BLACK
C6116	141P132010	CHIP CAPACITOR	B50V 0.01μF-K	J6014	451C117010	HEADPHONE JACK	BLACK
C6117	181P350060	ELECTROLYTIC CAPACITOR	CE04W 6.3V 1000μF-M	J6015	451C117010	HEADPHONE JACK	BLACK
C6151	141P132010	CHIP CAPACITOR	B50V 0.01μF-K	J801	451C207030	RCA PIN JACK	
C6303	154P331090	CHIP CAPACITOR	CH50V 22pF-J	J804	449C100010	DIN SOCKET(4P)	
C8A1	141P132010	CHIP CAPACITOR	B50V 0.01μF-K	MA DA	243C193050	CARD LEAD WIRE	7PIN L=160
C901	189P193030	C-M-P-AC	AC125V 0.068μF-M	MD DD	243C193030	CARD LEAD WIRE	7PIN L=120
C907	181P355050	ELECTROLYTIC CAPACITOR	04W 50V 10μF-M	MS OS	243C158020	CARD LEAD WIRE	15P L100(MB-HB)
C908	189P186010	AC CERAMIC CAPACITOR	AC250V E3300pF-M	PC901	268P058010	PHOTO COUPLER	ON3131-R
C911	141P132010	CHIP CAPACITOR	B50V 0.01μF-K	Q5A0	268P076020	PHOTO TRANSISTOR	SPS-1119C-BC-T
C912	181P351090	ELECTROLYTIC CAPACITOR	10V 2200μF-M	Q5A1	268P076020	PHOTO TRANSISTOR	SPS-1119C-BC-T
C913	181P351090	ELECTROLYTIC CAPACITOR	10V 2200μF-M	Q5A2	268P076020	PHOTO TRANSISTOR	SPS-1119C-BC-T
C914	141P139090	CHIP CAPACITOR	B16V 0.47μF-K	Q5A6	268P092010	PHOTO TRANSISTOR	PT492FK1
C915	181P355010	ELECTROLYTIC CAPACITOR	04W 50V 1μF-M	Q5A7	268P092010	PHOTO TRANSISTOR	PT492FK1
C916	181P352090	ELECTROLYTIC CAPACITOR	16V 2200μF-M	Q5A8	268P076020	PHOTO TRANSISTOR	SPS-1119C-BC-T
C917	181P355060	ELECTROLYTIC CAPACITOR	04W 50V 22μF-M	Q5A9	268P076020	PHOTO TRANSISTOR	SPS-1119C-BC-T
C918	181P355060	ELECTROLYTIC CAPACITOR	04W 50V 22μF-M	Q5B0	268P076020	PHOTO TRANSISTOR	SPS-1119C-BC-T
C920	181P351070	ELECTROLYTIC CAPACITOR	10V 470μF-M	RV901	265P100020	VARISTOR	ERZV10D271CS
C921	181P351050	ELECTROLYTIC CAPACITOR	10V 220μF-M	TU01	295P510010	TUNER	VD025AR
C926	181P352050	ELECTROLYTIC CAPACITOR	04W 16V 220μF-M	V8A0	253D045020	FLUOR DISPLAY TUBE	
C927	141P130060	CHIP CAPACITOR	B50V 560pF-K	X2A0	285P147060	CRYSTAL RESONATOR	3.579545MHz
C929	181P352060	ELECTROLYTIC CAPACITOR	16V 330μF-M	X5A0	285P054010	CRYSTAL RESONATOR	32.768kHz
C930	181P358000	ELECTROLYTIC CAPACITOR	CE04W 35V 1000μF-M	X5A1	285P368040	CRYSTAL RESONATOR	12.000MHz
C933	181P352050	ELECTROLYTIC CAPACITOR	04W 16V 220μF-M	Z5A0	939P713030	PREAMP UNIT	TSOP1833XG1
C936	181P351050	ELECTROLYTIC CAPACITOR	10V 220μF-M				
C937	181P351050	ELECTROLYTIC CAPACITOR	10V 220μF-M				
C944	181P352040	ELECTROLYTIC CAPACITOR	04W 16V 100μF-M				
C945	181P351040	ELECTROLYTIC CAPACITOR	CE04W 10V 100μF-M				
C946	181P351040	ELECTROLYTIC CAPACITOR	CE04W 10V 100μF-M				
C9Y1	189P185090	AC CERAMIC CAPACITOR	AC250V E2200pF-M				
		SWITCHES					
S5B1	432P166010	KEY BOARD SWITCH	RESET 1-1 L=4.75				
S5S0	439P045010	SWITCH	S/SW MPU10184MLBO				
S811	432P203030	KEY BOARD SWITCH	EJECT				
S812	432P203030	KEY BOARD SWITCH	POWER				
S813	432P203030	KEY BOARD SWITCH	SP/EP				
S8A0	432P203030	KEY BOARD SWITCH	CH-DOWN				
S8A1	432P203030	KEY BOARD SWITCH	STOP				
S8A2	432P203030	KEY BOARD SWITCH	CH-UP				
S8A3	432P203030	KEY BOARD SWITCH	PLAY				
S8A4	432P203030	KEY BOARD SWITCH	FF				
S8A5	432P203030	KEY BOARD SWITCH	PAUSE				
S8A6	432P203030	KEY BOARD SWITCH	REW				
S8A7	432P203030	KEY BOARD SWITCH	REC				
		MISCELLANEOUS					
621C525010	LED HOLDER		(D5B4)				
621C564010	LED HOLDER R		(Q5A0)				
621C564010	LED HOLDER R		(Q5A1)				
621C527010	PHOTO HOLDER		(Q5A2)				
						PRINTED CIRCUIT BOARD ASSY'S	
						928D506003	JACK PCB ASSY
						925B131003	MAIN PCB ASSY
						928D507002	OPE PCB ASSY
						928D503003	SIGNAL PCB ASSY

Luminance Record, Chroma Record HS-U778

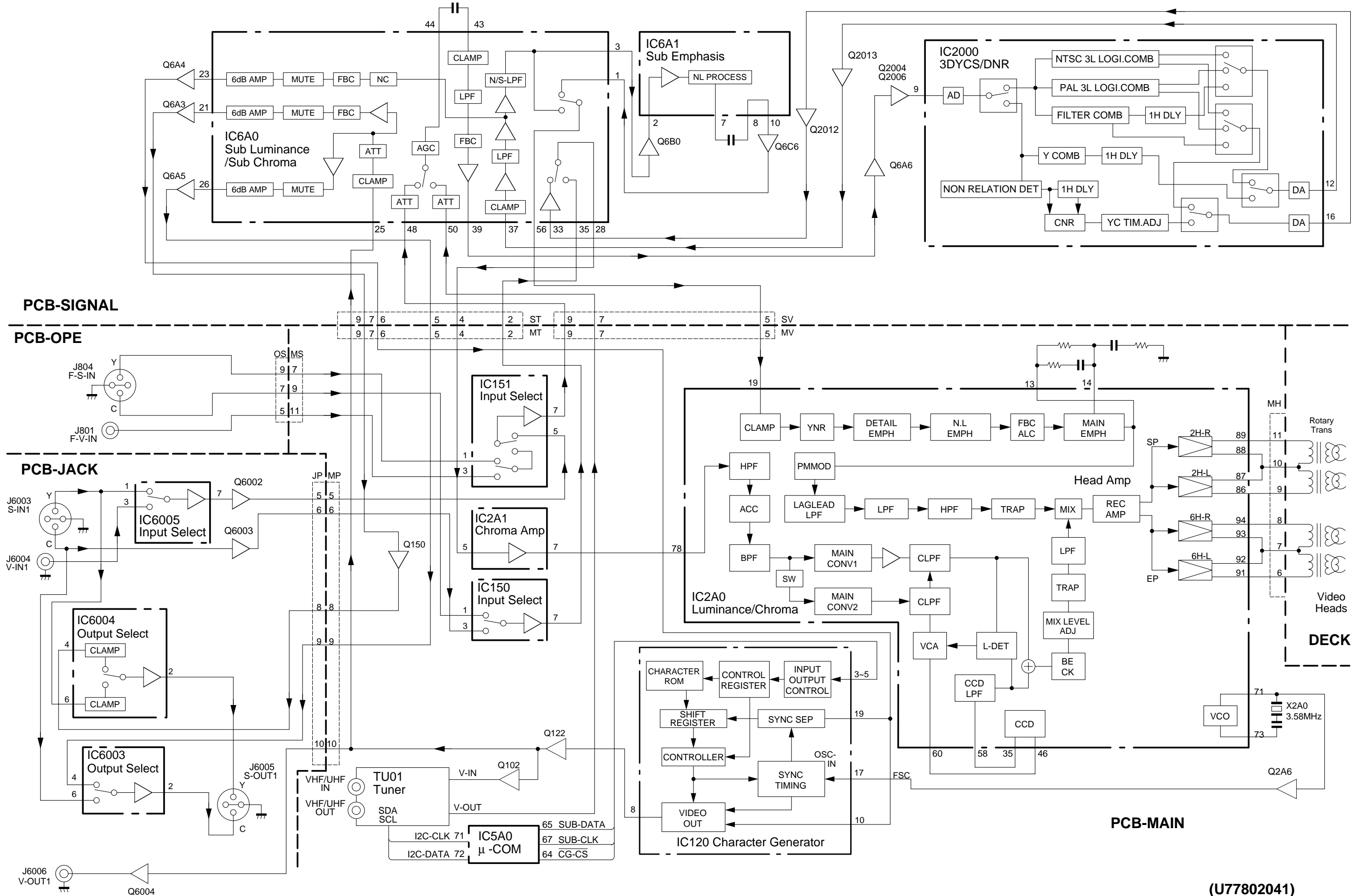

(U77802041)

Luminance Playback, Chroma Playback HS-U778

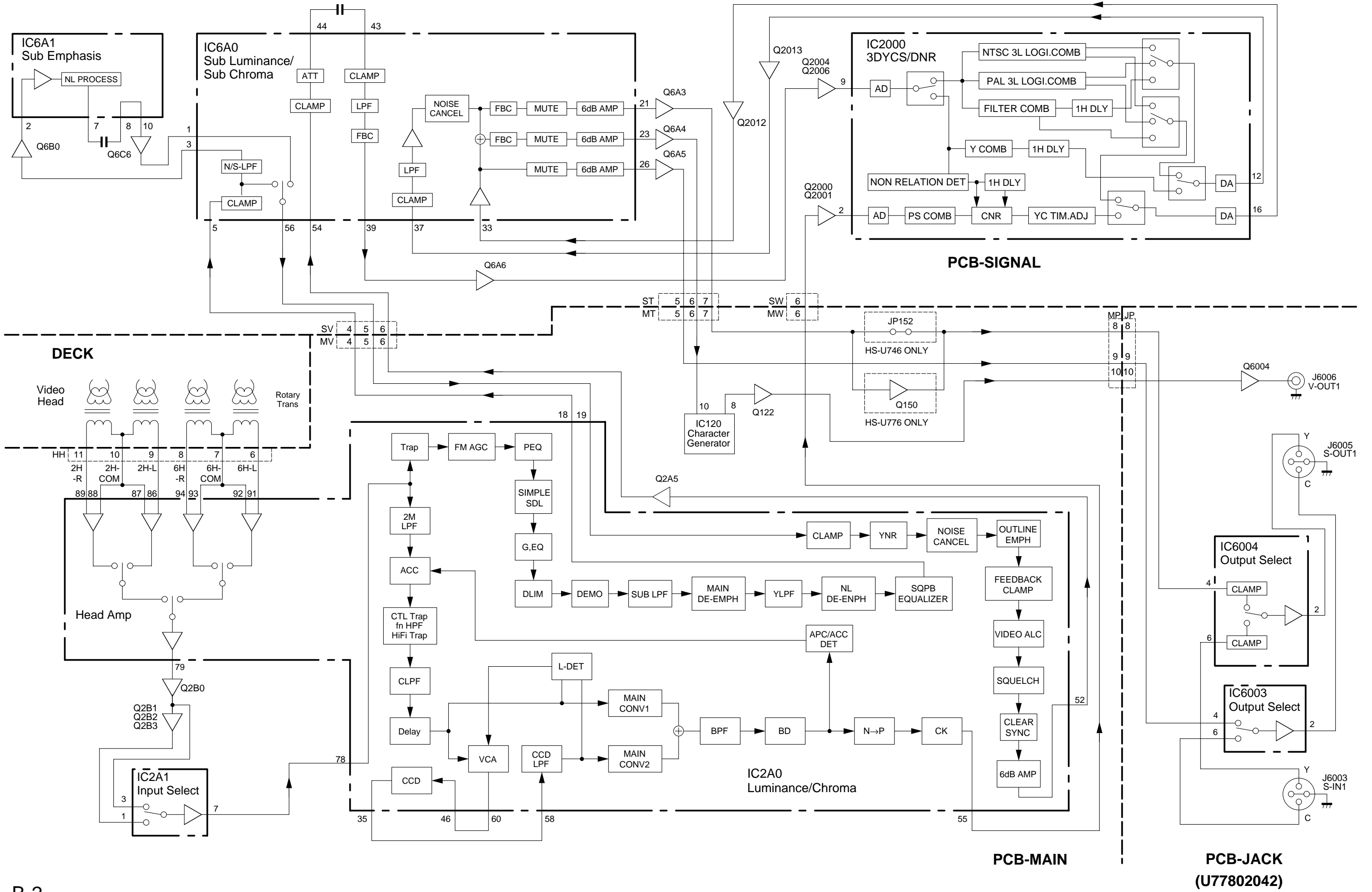

Hi-Fi , Linear Sound and MCS Decoder HS-U778

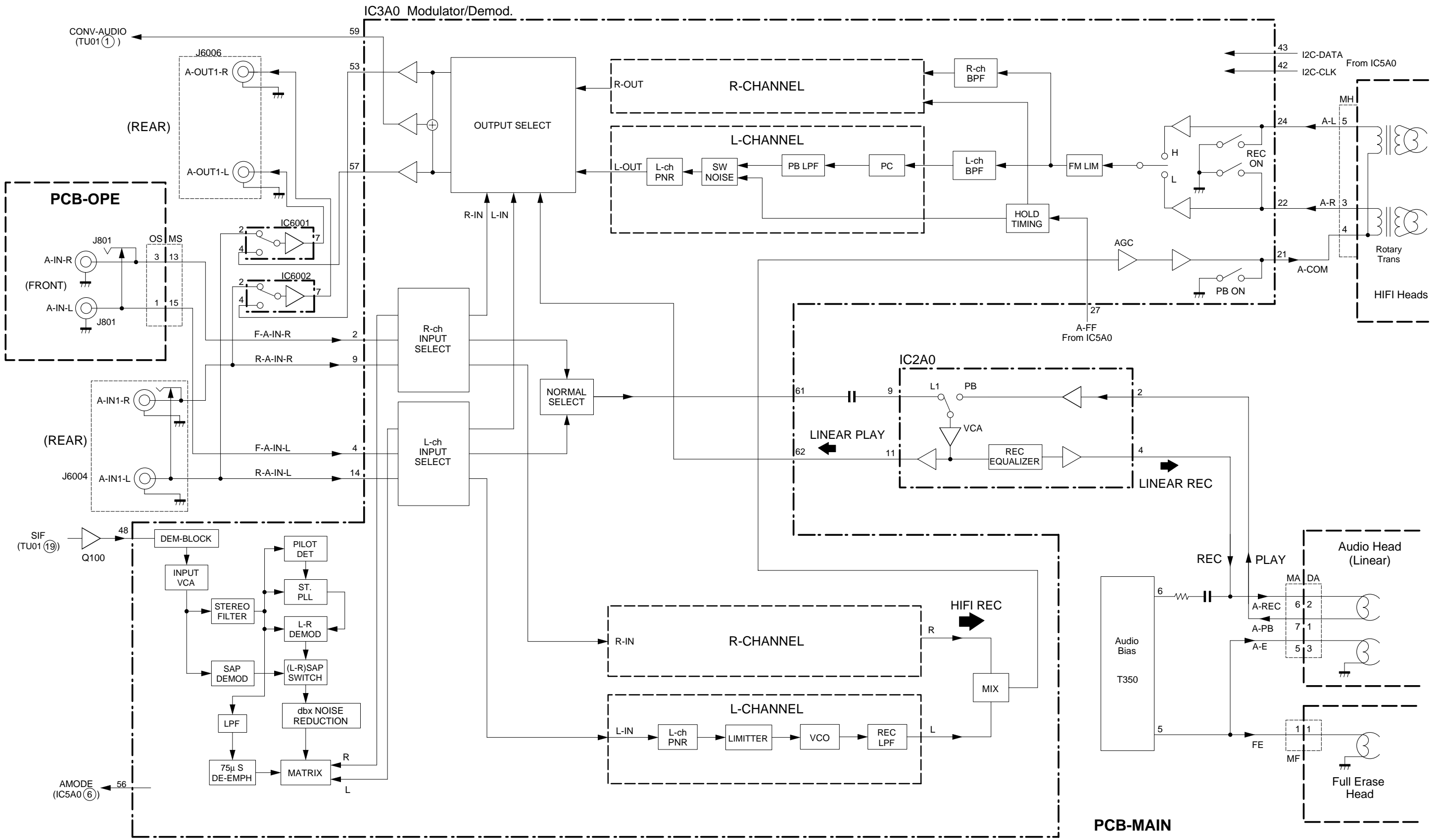

Power, Timer, Mechanical Control HS-U778

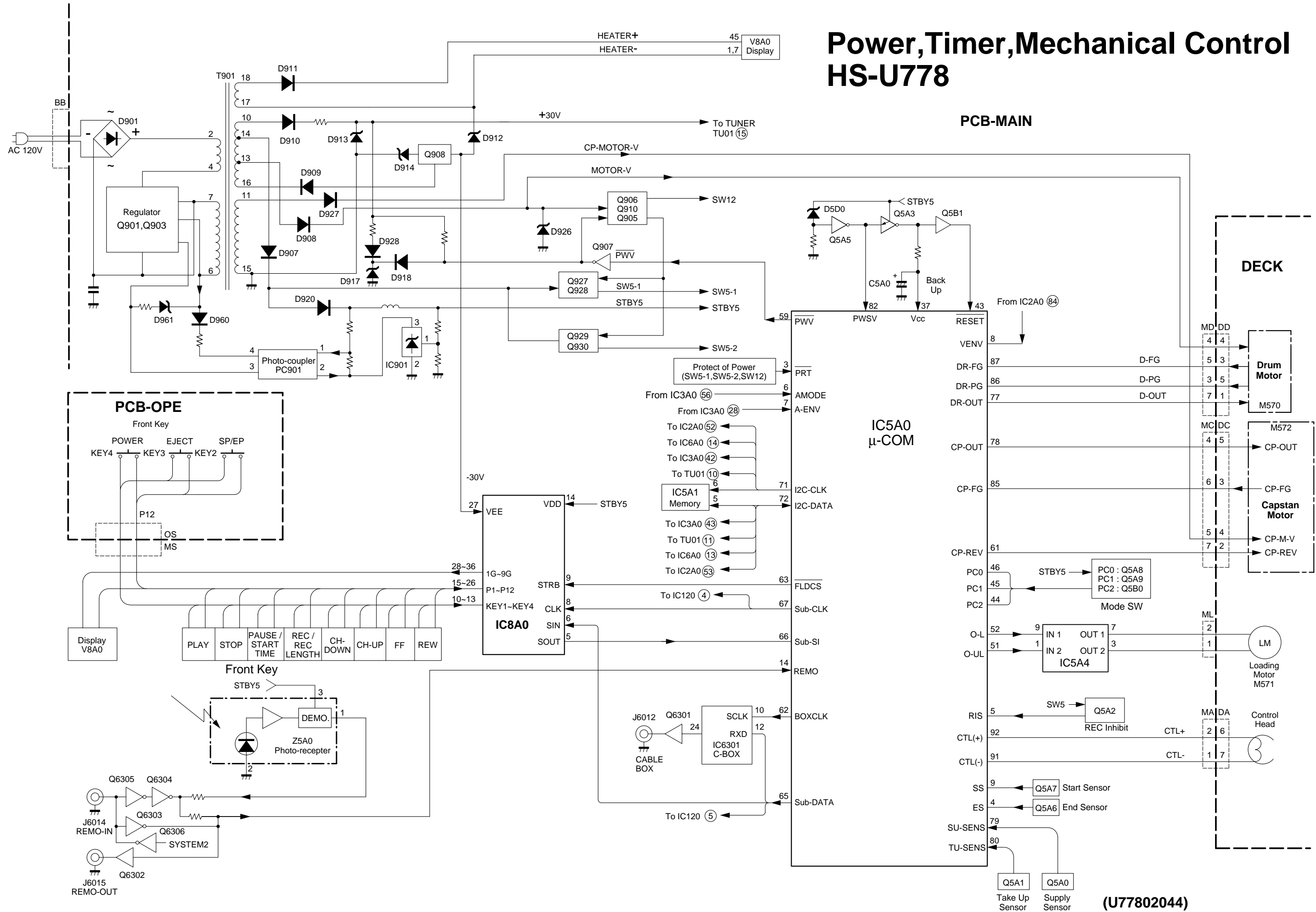

(U77802044)

PCB-INTERCONNECT

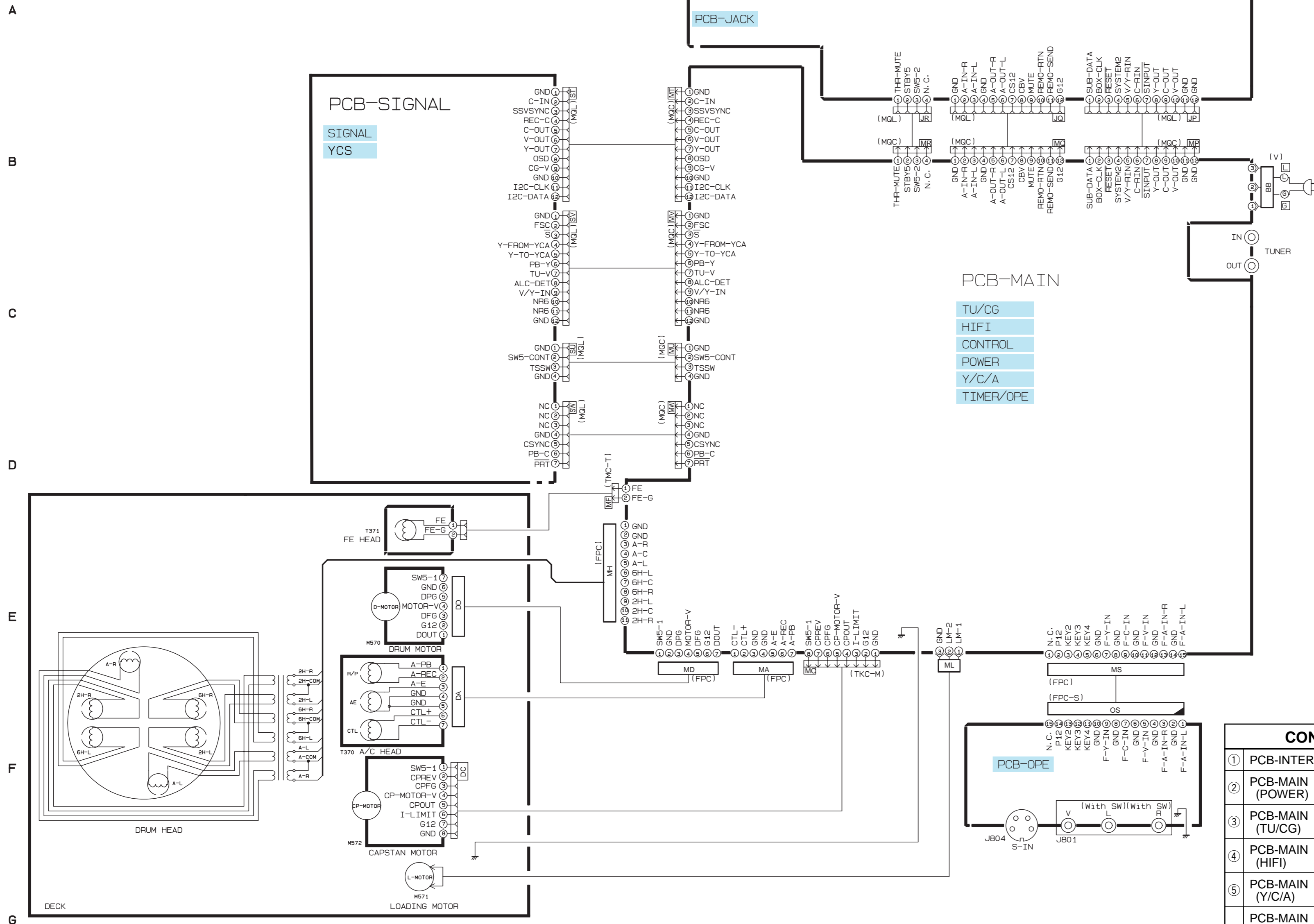

SCHEMATIC DIAGRAMS

- NOTE
- Each voltage should be within $\pm 20\%$ of the DC voltages measured with a digital voltmeter.
 - The voltages parenthesised on SP recording mode. While those without parenthesised on SP play back mode.
 - Waveforms were taken with standard color bar signal.
 - TP6A, etc. show Test Points.
 - Capacitors

Value	Not indicated	μF for numbers more than 1 μF for numbers less than 1
Dielectric Strength	Not indicated : 50V	
Tolerance	Not indicated = $\pm 10\%$ (No Tolerance is indicated for electrolytic capacitors and $\pm 20\%$) $G = \pm 2\%$ $N = \pm 30\%$ $Q = +30\%$ $C = \pm 0.25\mu\text{F}$ $J = \pm 5\%$ $K = \pm 10\%$ $P = +100\%$ $Z = -10\%$ $D = \pm 0.5\mu\text{F}$ $M = \pm 20\%$ -0% -20% $G = \pm 2\mu\text{F}$	
Sort	Not indicated : Ceramic capacitor (MP) : Polyester capacitor (PP) : Polypropylene film capacitor (ALM) : Aluminum electrolytic capacitor (TF) : Twin film capacitor (SC) : Semiconductor ceramic capacitor (MC) : Metallized paper capacitor (MPP) : Metallized plastic film capacitor (MMF) : Metallized polyester capacitor (MFP) : Polyester polypropylene film capacitor (PS) : Styrol capacitor (TAN) or (TANT) : Tantalum capacitor (E) : Electrolytic capacitor (BP) or (NP) : Non polarized electrolytic capacitor	
II Chips	Not indicated : Ceramic capacitor chip (E) : Electrolytic capacitor chip (BP) or (NP) : Non polarized electrolytic capacitor chip	
Characteristic (only ceramic capacitor)	Not indicated : F or B (high dielectric percentage) CH, SL, etc. : Temperature compensating types	

6 Resistors

Value	Not indicated = Ω $K = k\Omega$ (1000 Ω) $M = M\Omega$ (1000k Ω)	
Wattage	Parts except for chips	Not indicated = 1/4W or 1/6W
	Chips	Not indicated = 1/10W
Tolerance	Not indicated = $\pm 5\%$ $J = \pm 5\%$ $D = \pm 0.5\%$ $F = \pm 1\%$ $K = \pm 10\%$	
Sort	Not indicated : Carbon resistor (S) : Fixed composition resistor (MB) : Metal oxide film resistor (type B) (CE) : Cemented resistor (W) : Wire wound resistor (MPC) : Metal plate cement resistor (ML) : Metal liner resistor	
II Chips	Not indicated : Chip resistor	

7. This is basic schematic diagram. Some sets may be subject to modification according to engineering improvement.

SPECIFIC SYMBOL

	Zener Diode		Fusible Resistor
	Varicap		Crystal unit
	Positive Thermistor		Air Gap
	Thermistor		Part (resistor) attached on the copper-foil side of PCB
	Photo Diode		Ceramic filter
	LED		

8. Correspondence of the units in the Schematic Diagrams to the SI units.

	Schematic Diagram	SI
Kilo	K	k
Hertz	HZ	Hz
Pico	P	p

SHADED COMPONENTS HAVE SPECIAL CHARACTERISTICS IMPORTANT TO SAFETY. BEFORE REPLACING ANY OF THESE COMPONENTS READ CAREFULLY THE PRODUCT SAFETY NOTICE IN THE SERVICE MANUAL. DON'T DEGRADE THE SAFETY OF THE RECEIVERS THROUGH IMPROPER SERVICING.

CONTENTS

①	PCB-INTERCONNECT
②	PCB-MAIN (POWER)
③	PCB-MAIN (TU/CG)
④	PCB-MAIN (HIFI)
⑤	PCB-MAIN (Y/C/A)
⑥	PCB-MAIN (CONTROL) REMOTE HAND UNIT
⑦	PCB-MAIN (TIMER/OPE) PCB-OPE
⑧	PCB-JACK
⑨	PCB-SIGNAL (SIGNAL)
⑩	PCB-SIGNAL (YCS)
⑪	PRINTED CIRCUIT BOARD PARTS LAYOUT

(POWER) PCB-MAIN

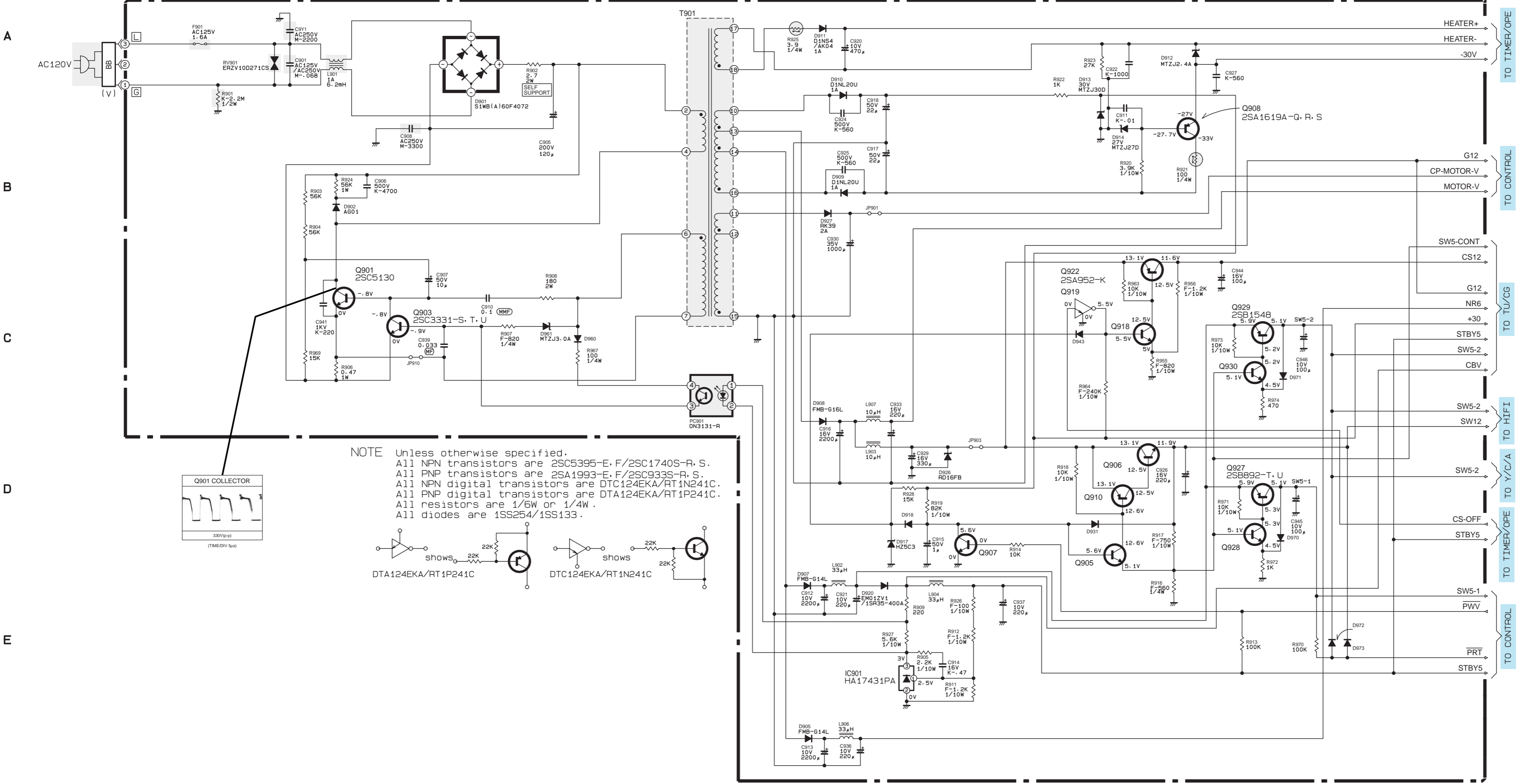

NOTE Unless otherwise specified.
 All NPN transistors are 2SC5395-E, F/2SC1740S-R, S.
 All PNP transistors are 2SA1993-E, F/2SC933S-R, S.
 All NPN digital transistors are DTC124EKA/RT1N241C.
 All PNP digital transistors are DTA124EKA/RT1P241C.
 All resistors are 1/8W or 1/4W.
 All diodes are 1SS254/1SS133.

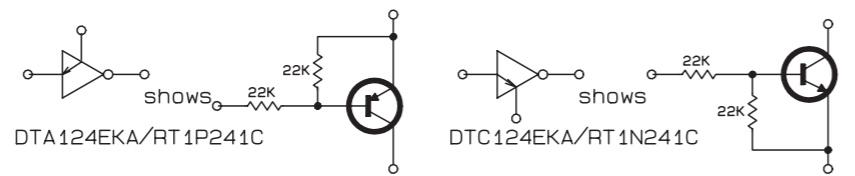
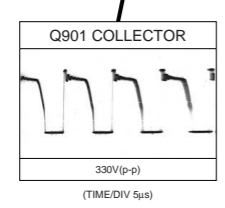

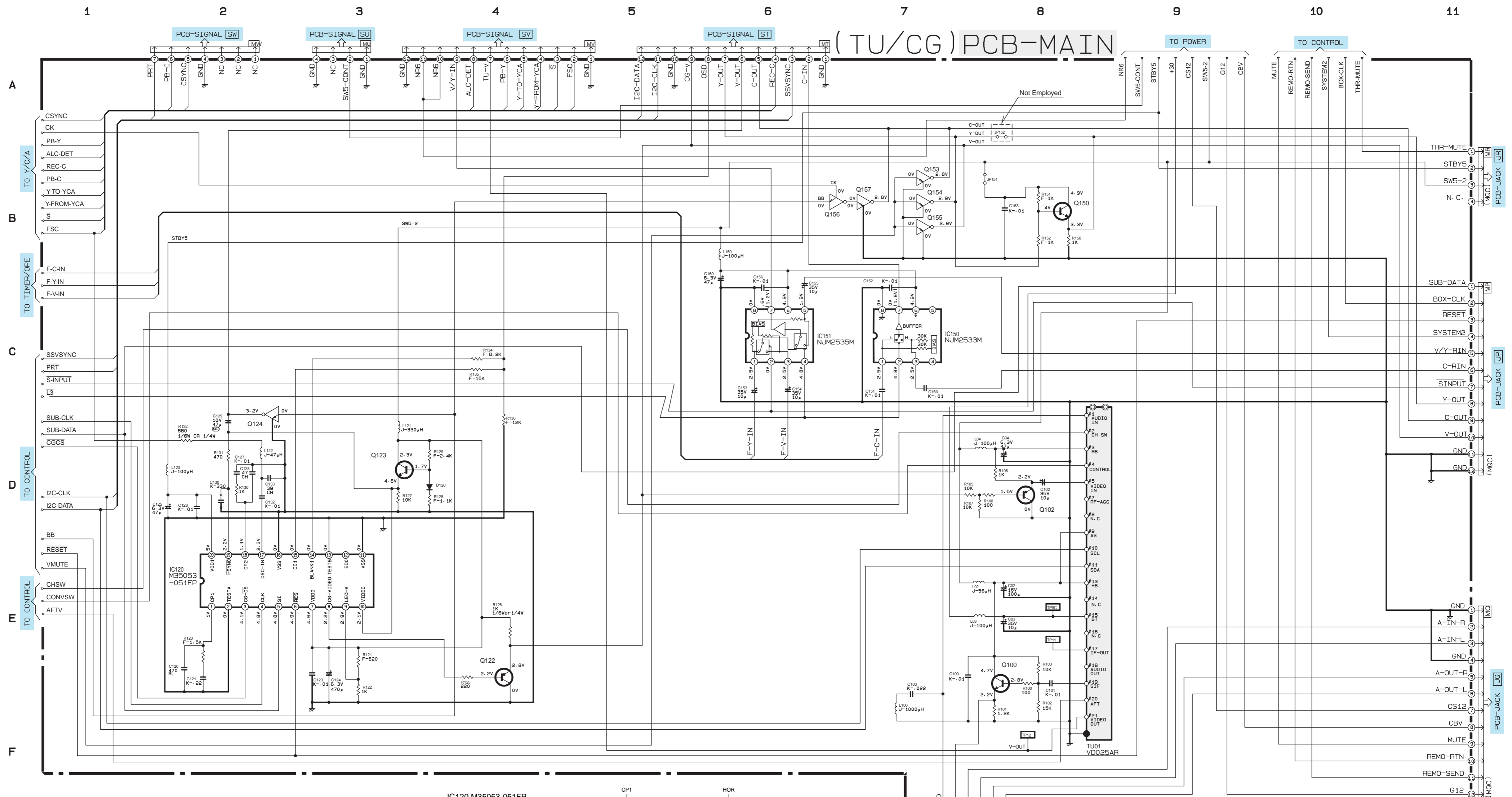

Note:
 Unless otherwise specified,
 All R-M-CHIP are 1/10W.
 PNP transistors are 2SA1037AK-R-S.
 NPN transistors are 2SC2412K-R-S/2SD601AI-R-S.
 All diodes are 1SS254/1SS133.
 PNP digital transistors are DTA124EKA/RT1P241C.
 NPN digital transistors are DTC124EKA/RT1N241C.

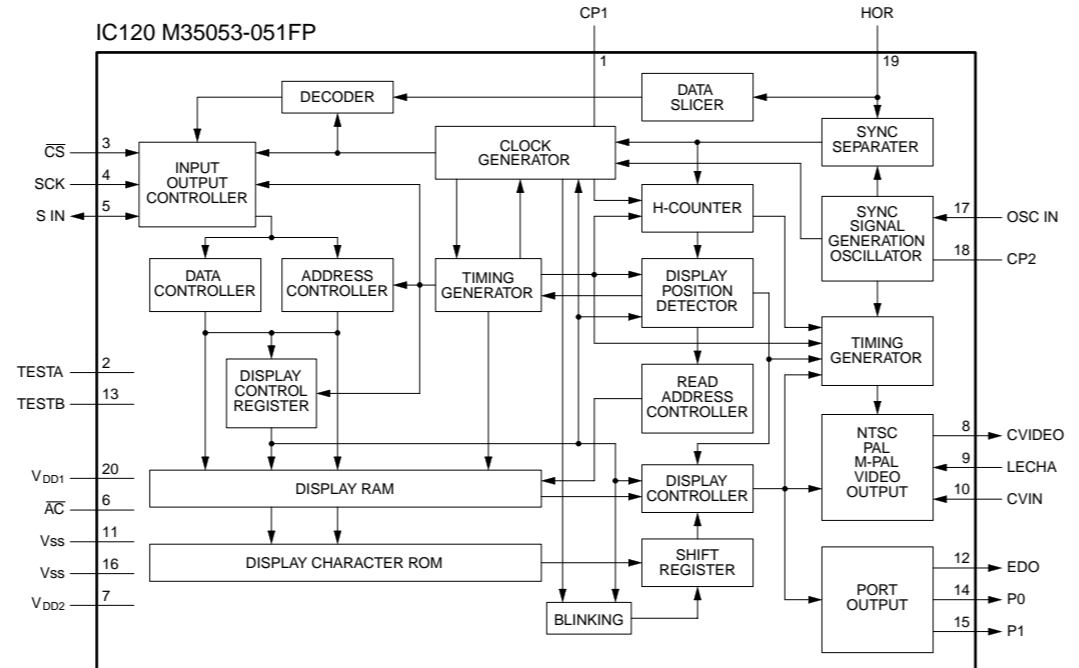

(HIFI) PCB-MAIN

A
B
C
D
E
F

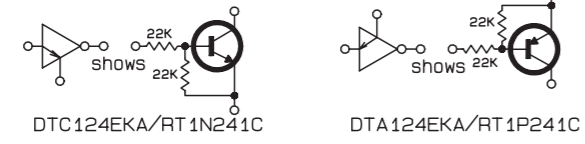
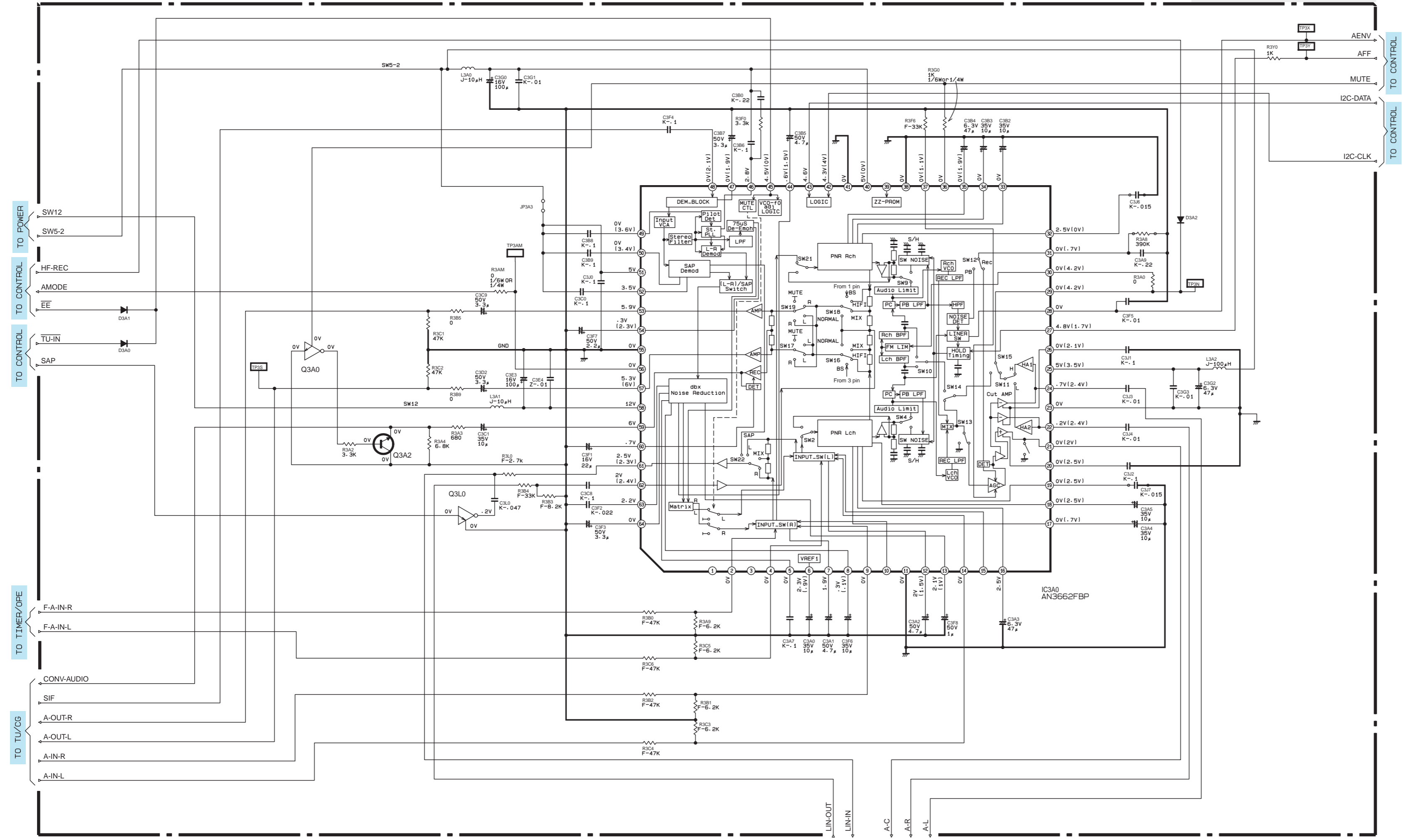

Note:
 Unless otherwise specified:
 All PNP transistors are 2SA1037AK-R.S.
 All NPN transistors are 2SC2412K-R.S/2SD601AI-R.S.
 All diodes are 1SS254/1SS133.
 All resistors are 1/10W.
 All PNP digital transistors are DTA124EKA/RT1P241C.
 All NPN digital transistors are DTC124EKA/RT1N241C.

TO Y/C/A

TO Y/C/A

G

A
B
C
D
E
F
G
H
I
J

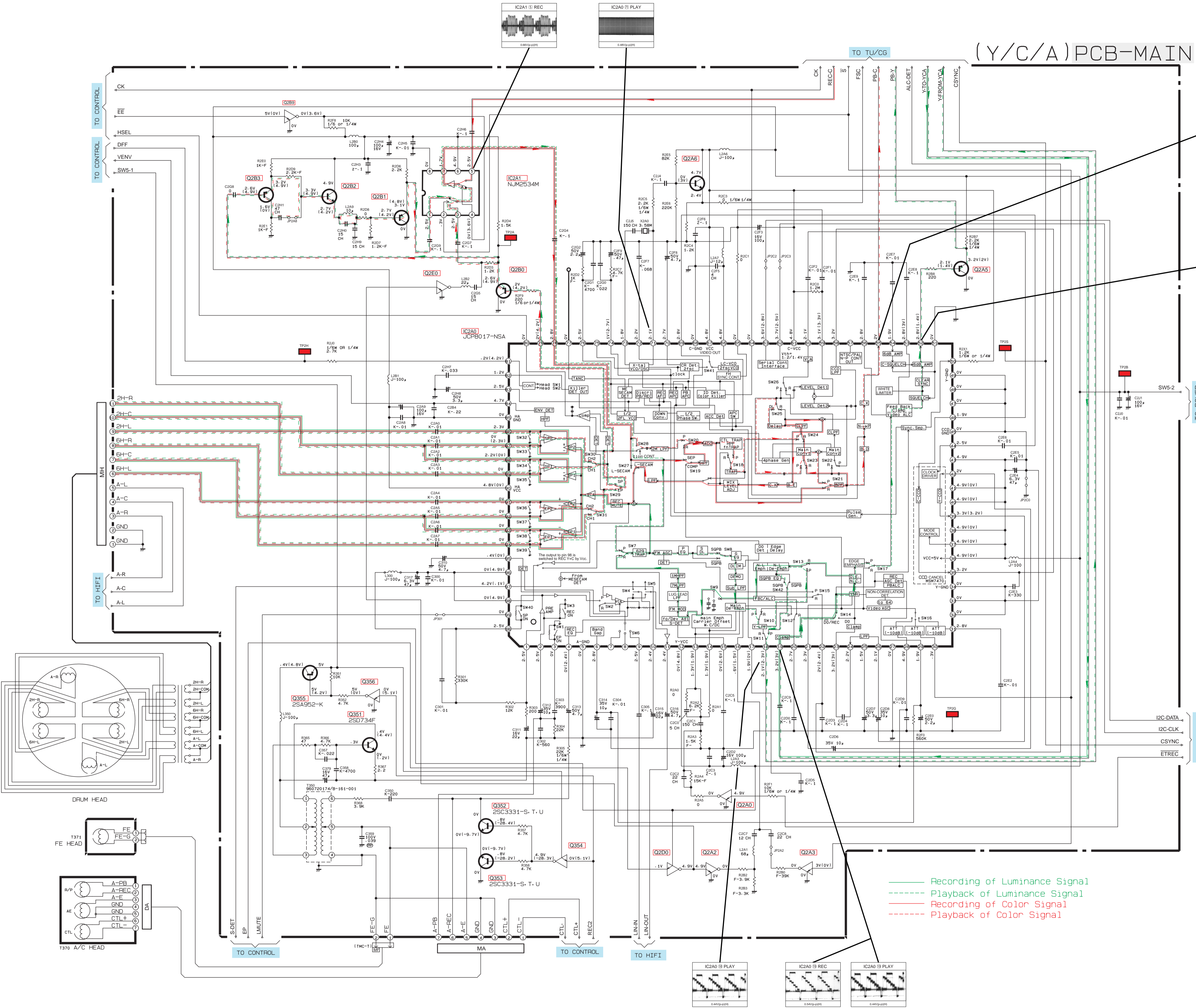

NOTE:
 UNLESS OTHERWISE SPECIFIED
 ALL RESISTORS ARE 1/10W.
 ALL DIODES ARE 1SS254.
 ALL PNP TRANSISTORS ARE 2SA1037AK-R-S.
 ALL NPN TRANSISTORS ARE 2SC2412K-R-S/2SD601A1-R-S.
 PNP digital transistors are DTA124EKA/RT1P241C.
 NPN digital transistors are DTC124EKA/RT1N241C.

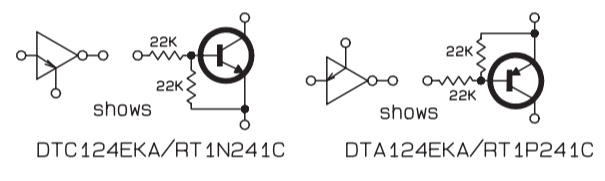

— Recording of Luminance Signal
 - - - Playback of Luminance Signal
 - - - Recording of Color Signal
 - - - Playback of Color Signal

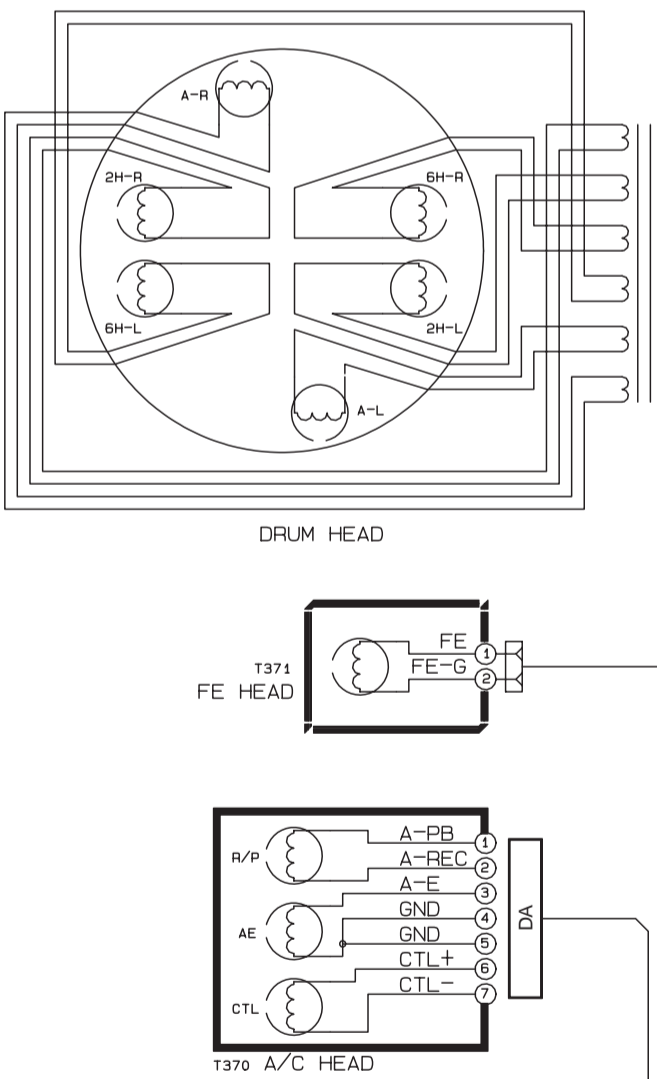

(CONTROL) PCB-MAIN

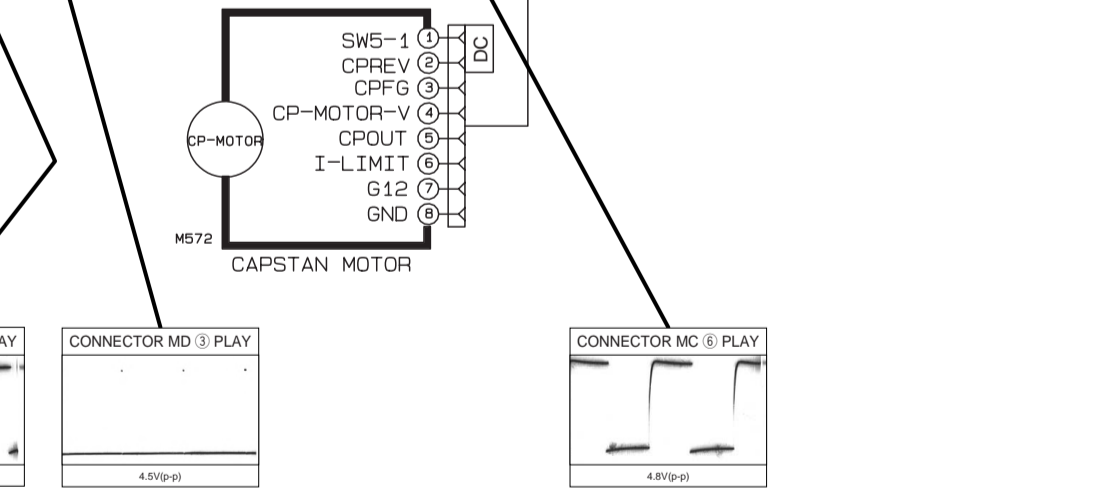
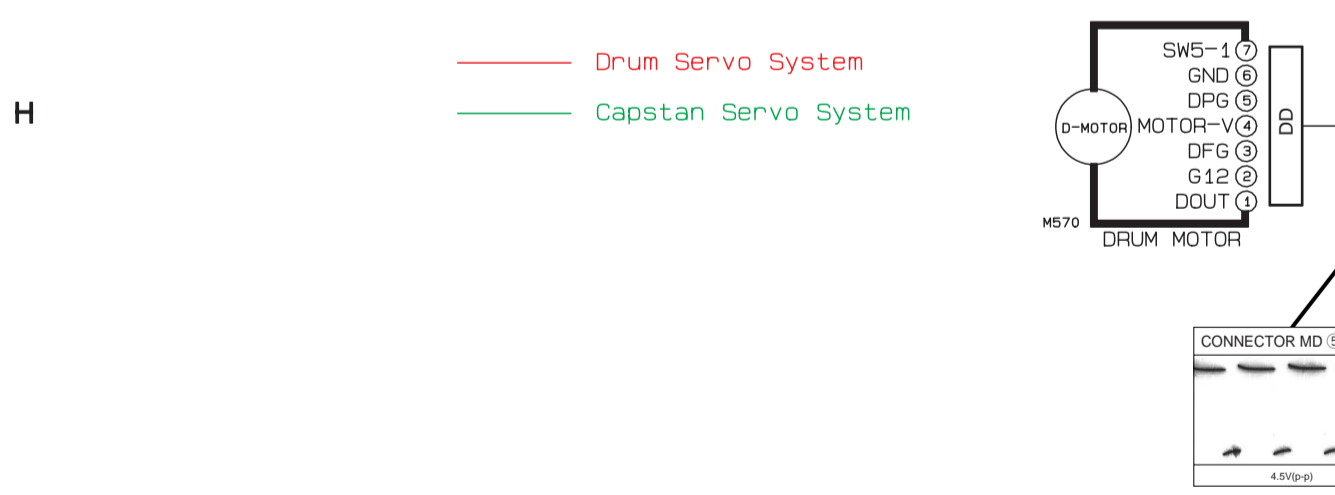
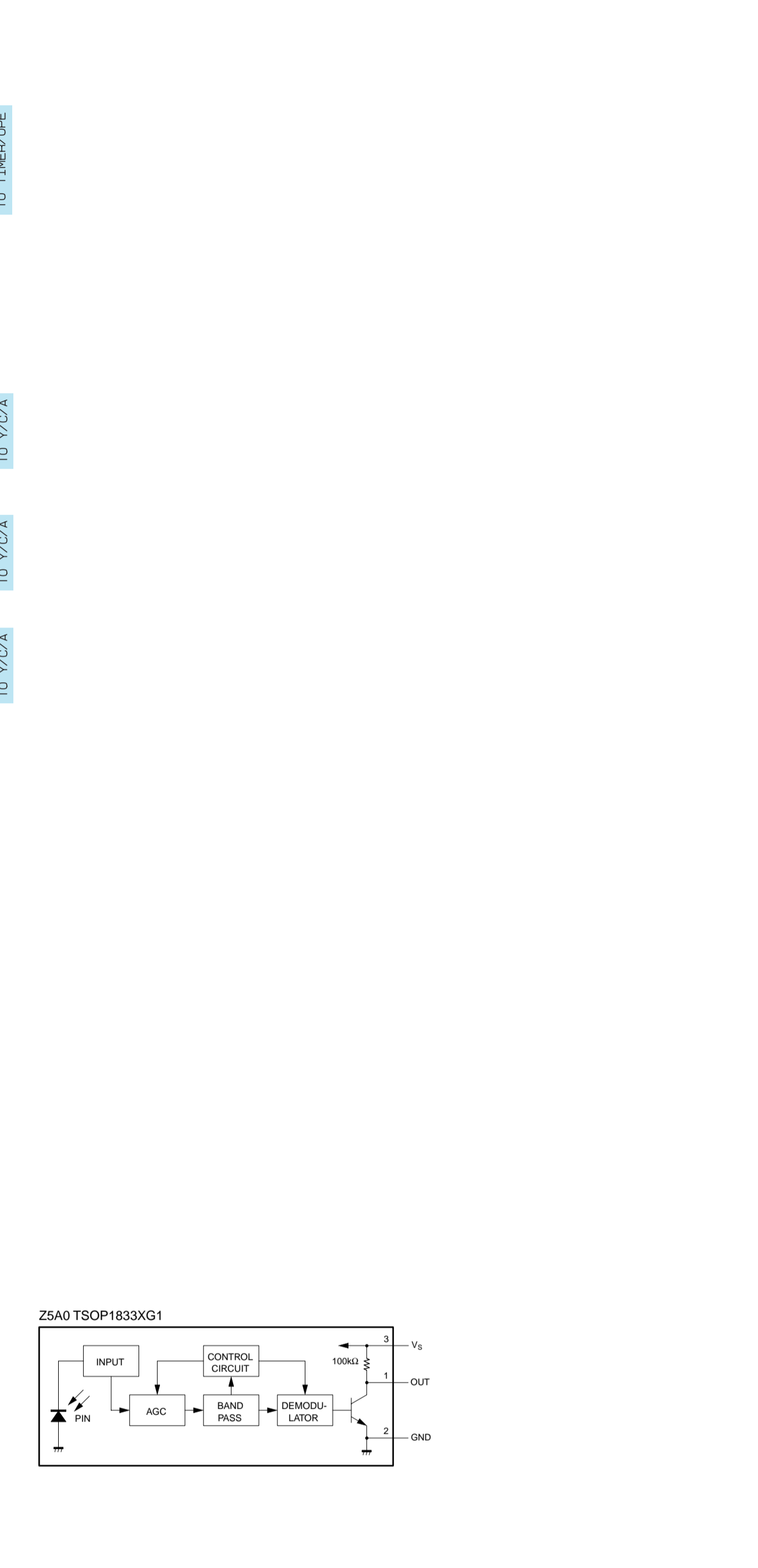
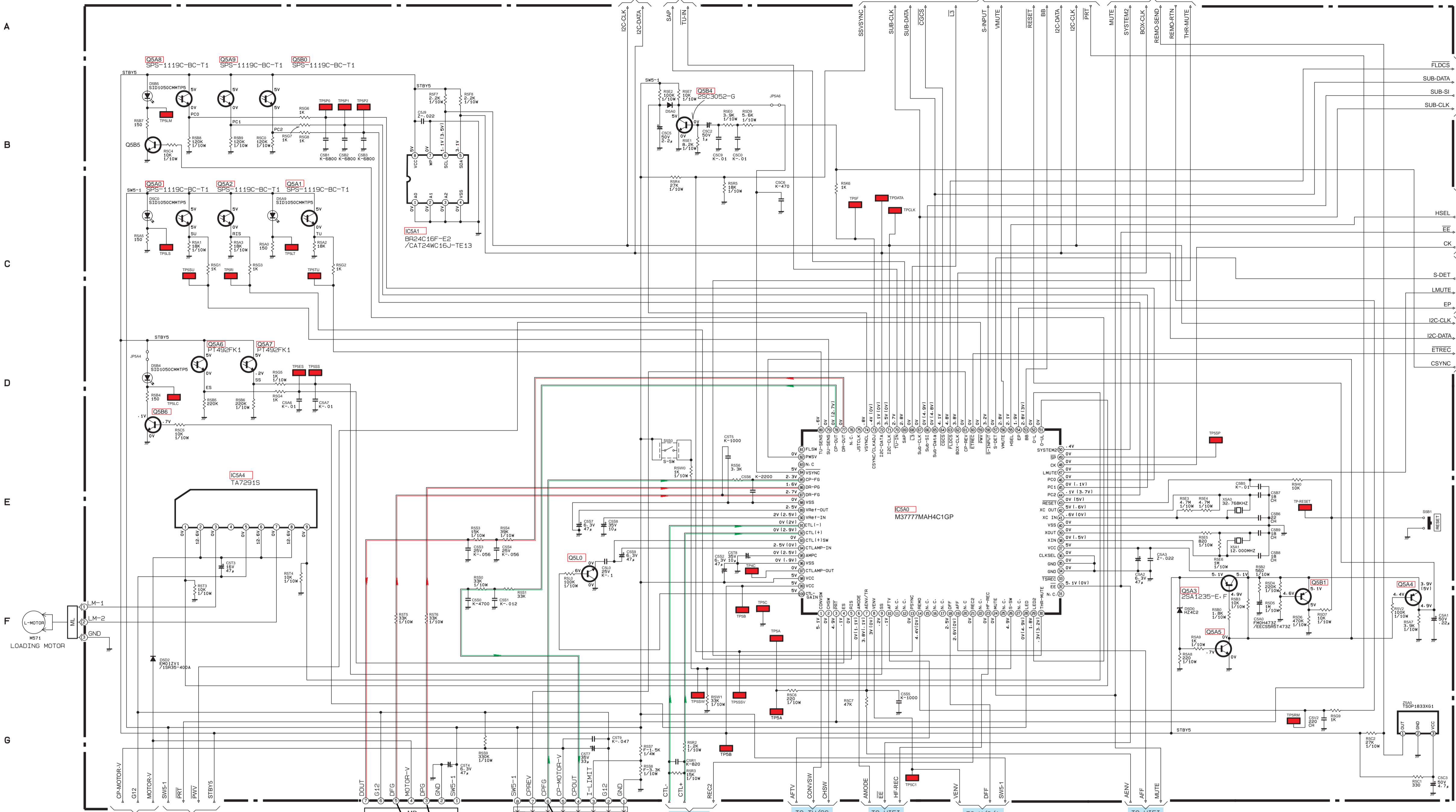

INPUT	OUTPUT	MODE
0 0 0 0	0 0 0 0	STOP
1 0 H L	0 0 0 0	CCWCV
0 1 L H	0 0 0 0	CCWCV
1 1 L L	0 0 0 0	BRAKE

NOTE:
 All resistors are 1/8 or 1/4W unless otherwise specified.
 All diodes are 1SS254/1SS133 unless otherwise specified.
 All NPN transistors are 2SC2412K-R/S/2SD601A1-R/S unless otherwise specified.
 All PNP transistors are 2SA1037M-R/S unless otherwise specified.
 All PNP digital transistors are DTAS1604A/DT1604C.
 All NPN digital transistors are DT1126KA/DT11264C.

REMOTE HAND UNIT

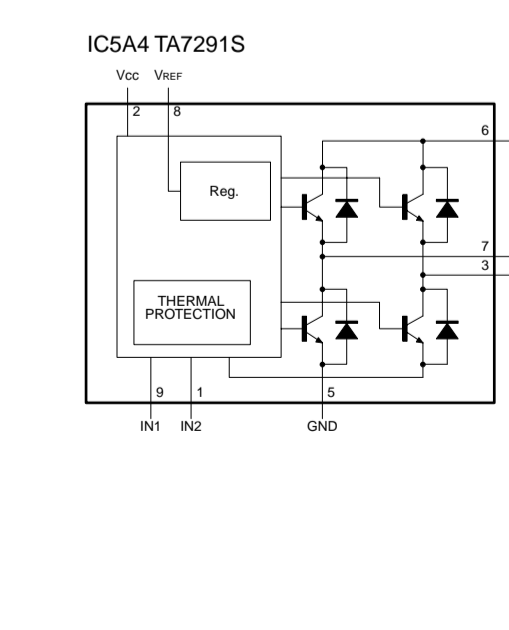
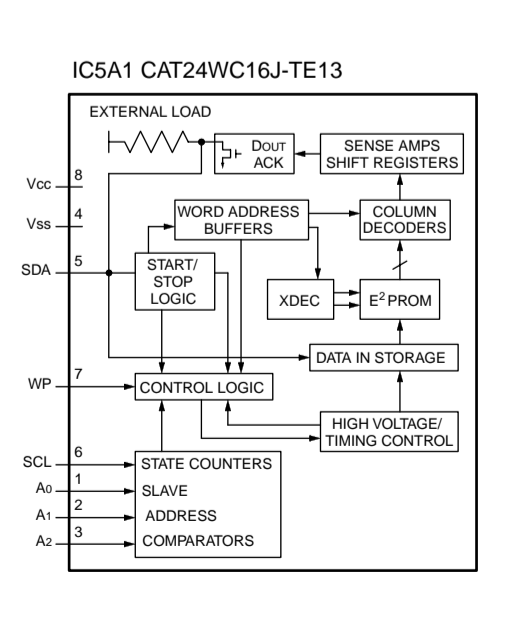
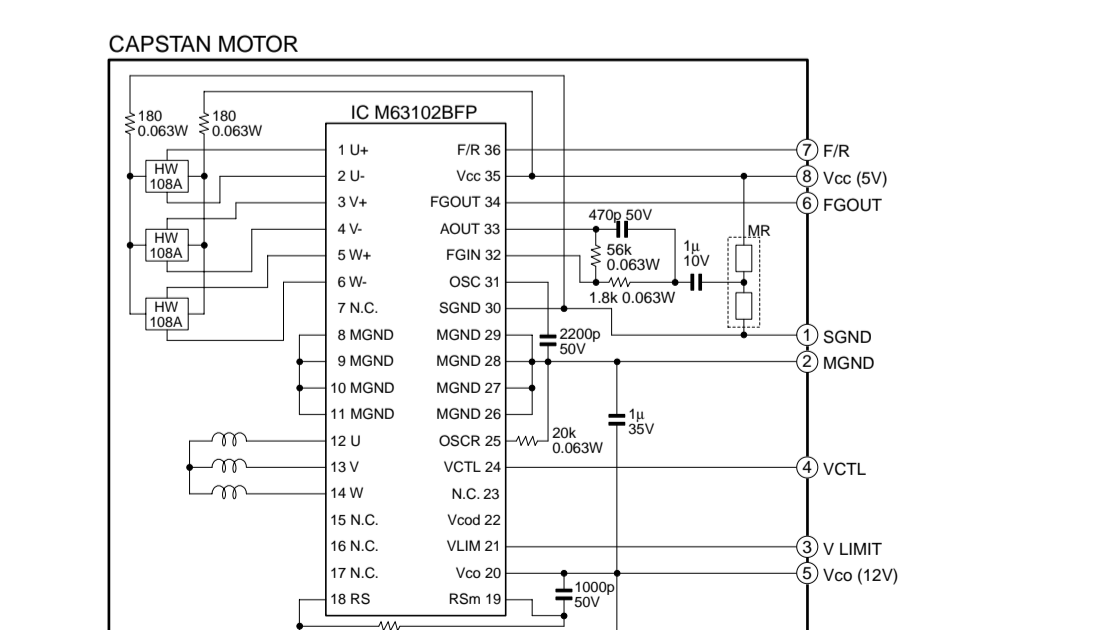
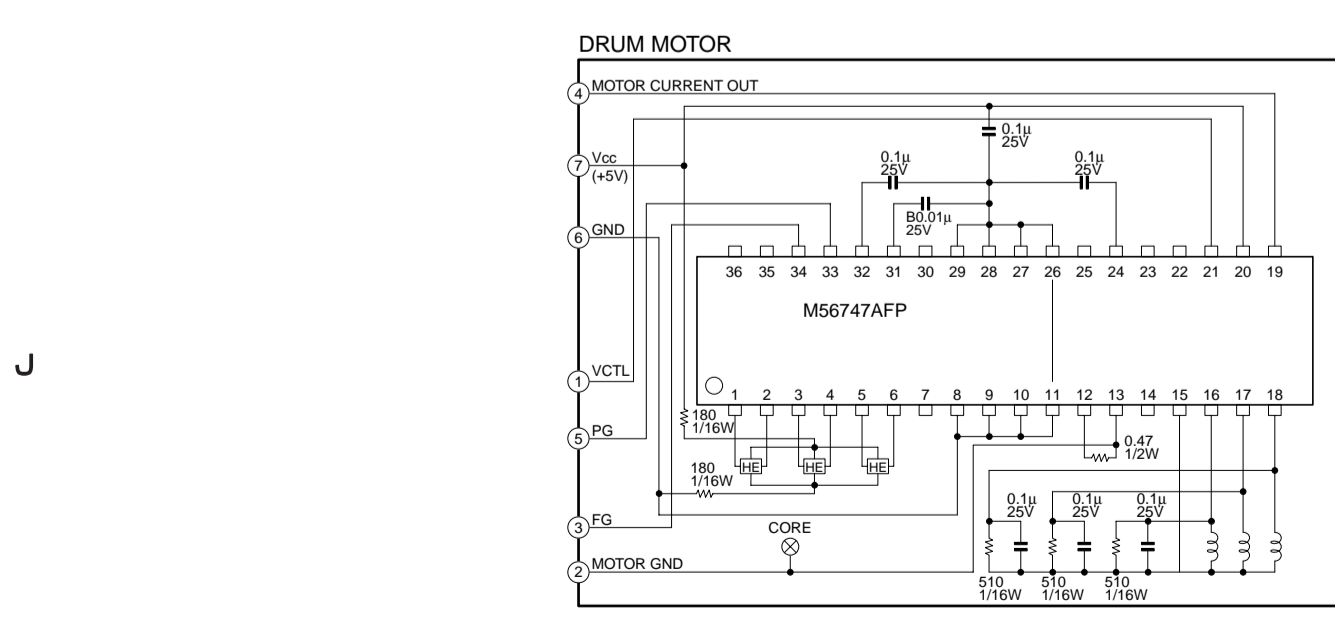
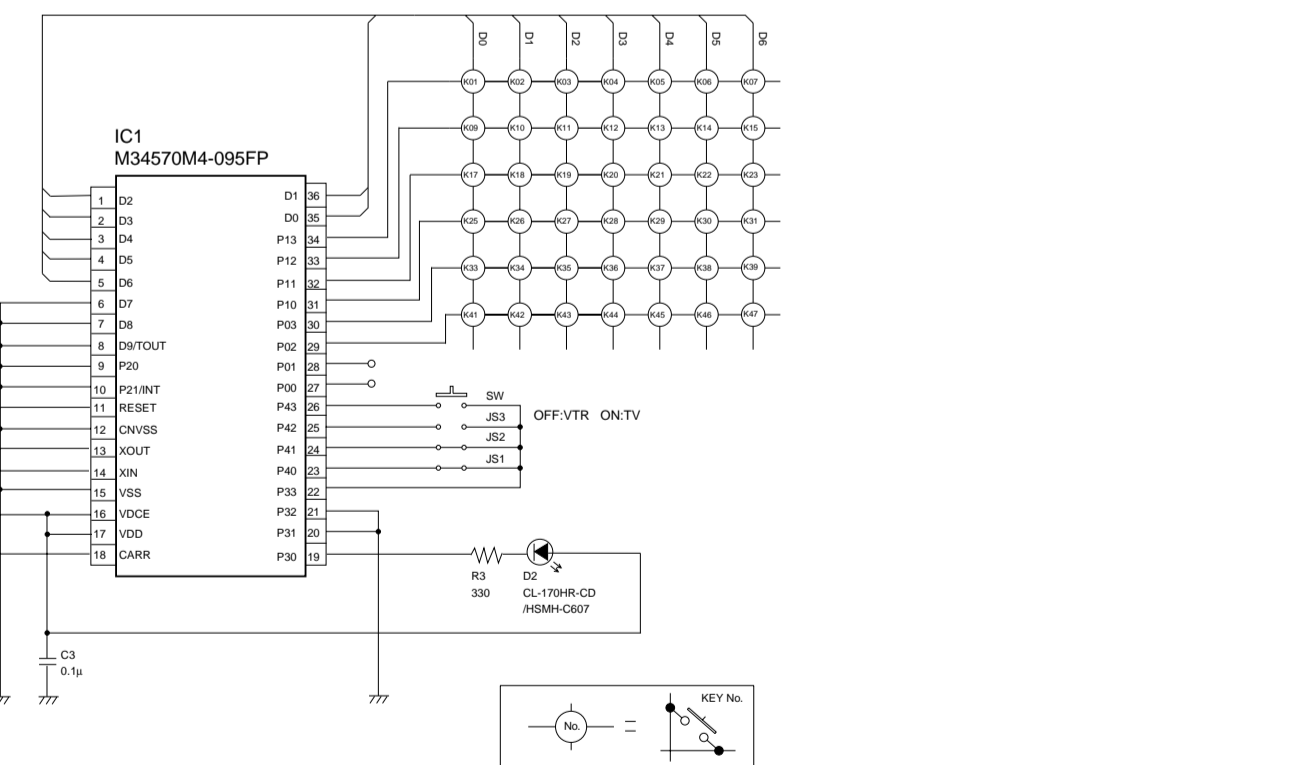

KEY NO.	FUNCTION	KEY NO.	FUNCTION
K01	VCR POWER	K25	REC
K02	EJECT	K26	REW
K03	CH Δ	K27	PAUSE
K04	CH V	K28	STOP
K05	VOL V	K29	DISPLAY
K06	VOL Δ	K30	FF
K07	TV POWER	K31	LIGHTING
K08		K32	
K09	1	K33	AUDIO/VIDEO
K10	4	K34	CANCEL ←
K11	5	K35	INDEX -
K12	2	K36	ADJ Δ
K13	6	K37	INDEX +
K14	3	K38	ENTER →
K15	MUTE	K39	MENU
K16		K40	
K17	7	K41	VCR/TV
K18	QUICK PROGRAM	K42	
K19	PLAY	K43	
K20	8	K44	ADJ -
K21	10	K45	
K22	9	K46	
K23	INPUT X2	K47	SP/EP
K24		K48	

(TIMER/OPE) PCB-MAIN

A

B

C

D

E

F

G

PCB-OPE

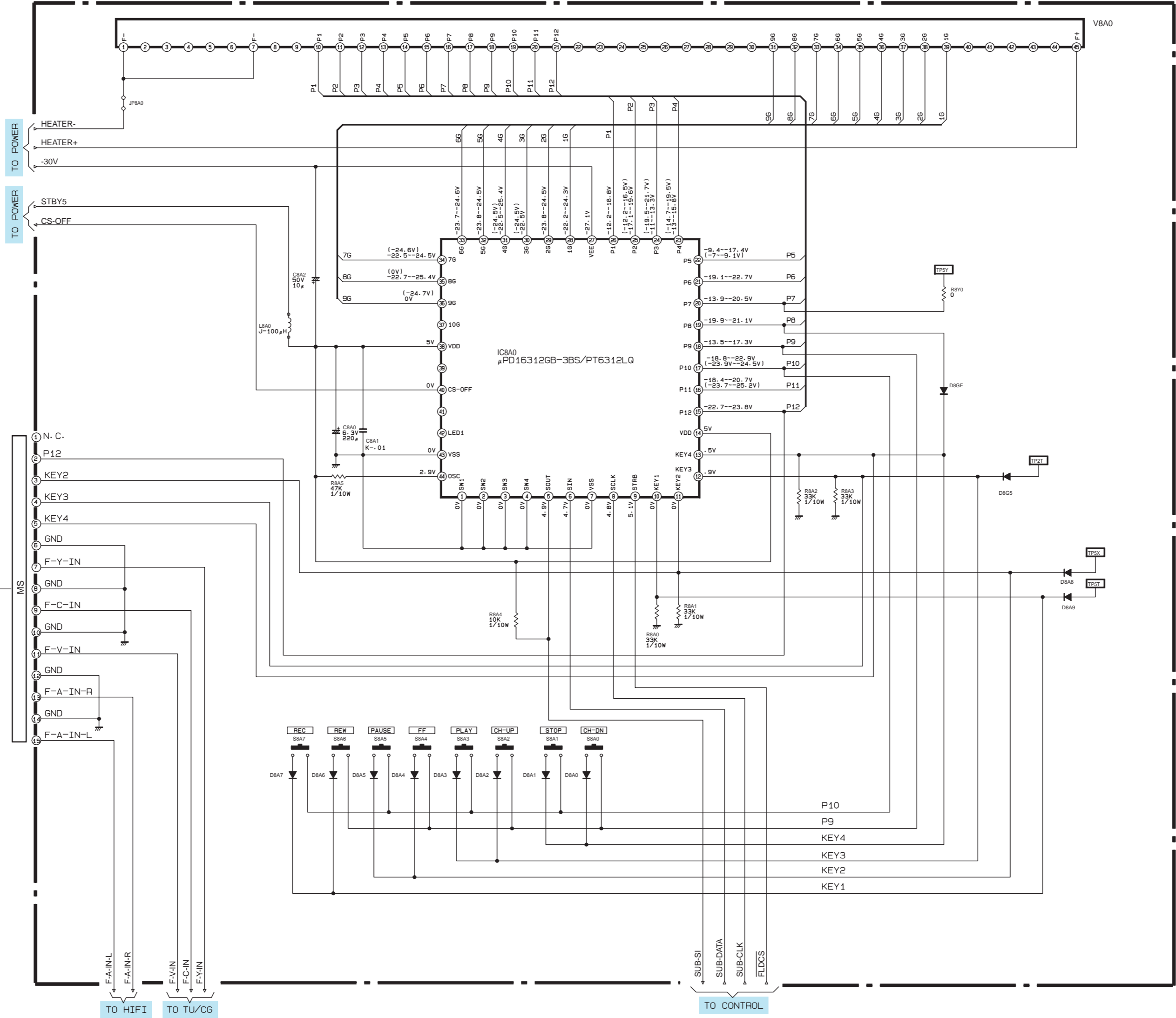
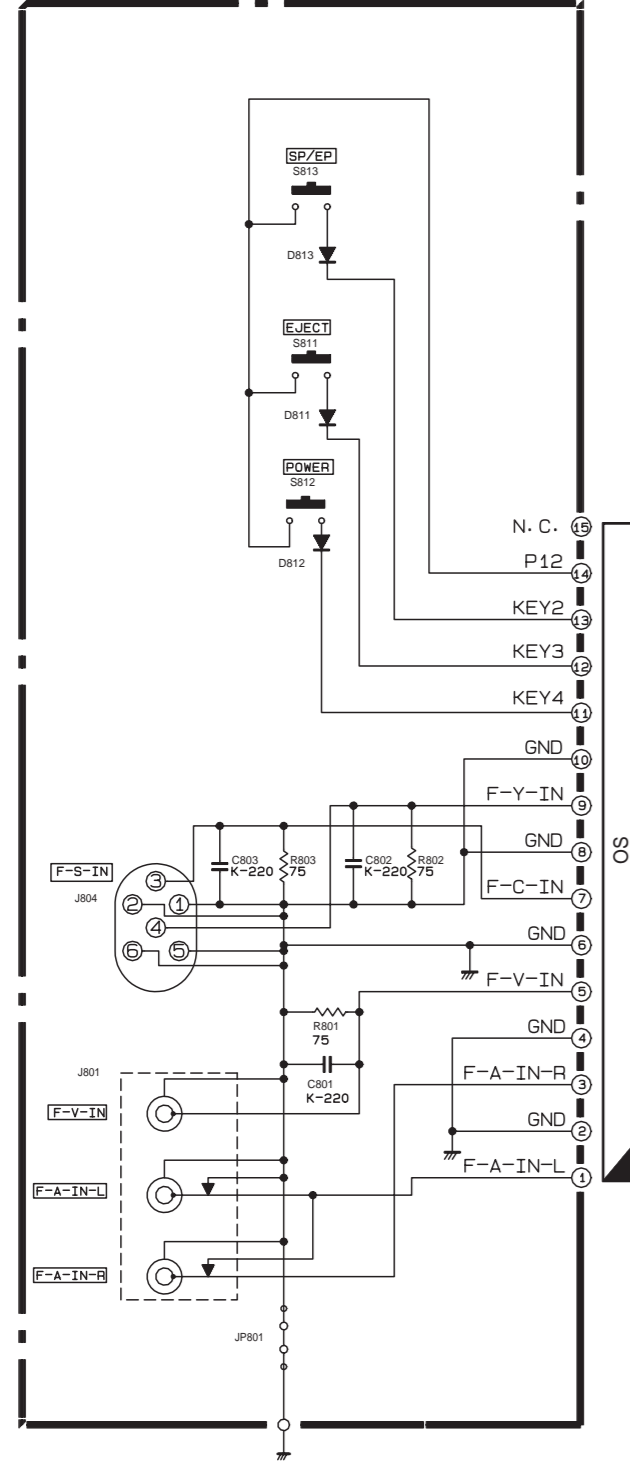

All resistors are 1/6 or 1/4W unless otherwise specified.
 All diodes are 1SS254/1SS133 unless otherwise specified.

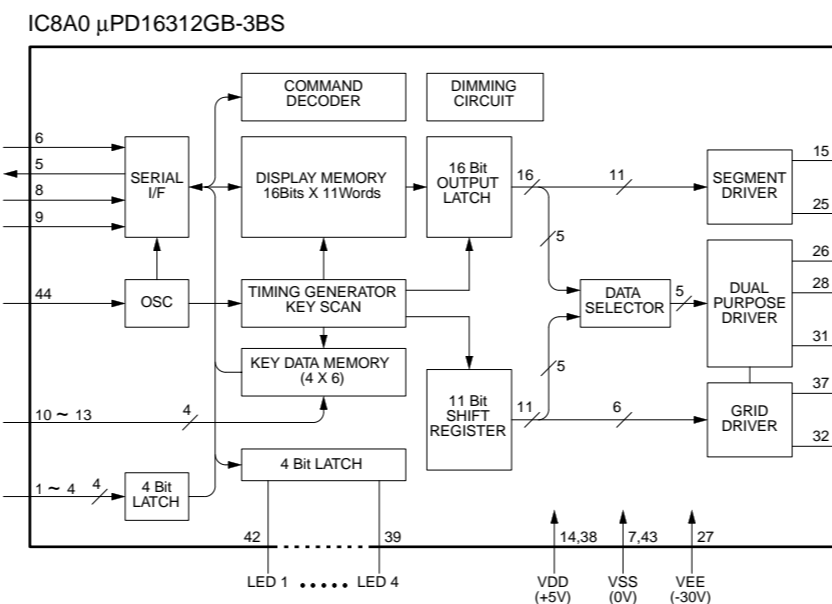

A
B
C
D
E
F
G

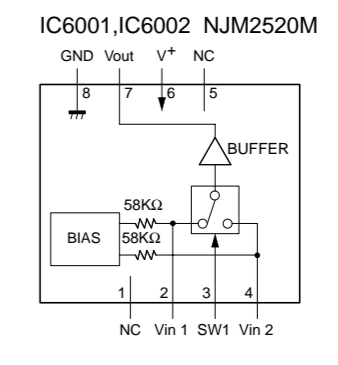
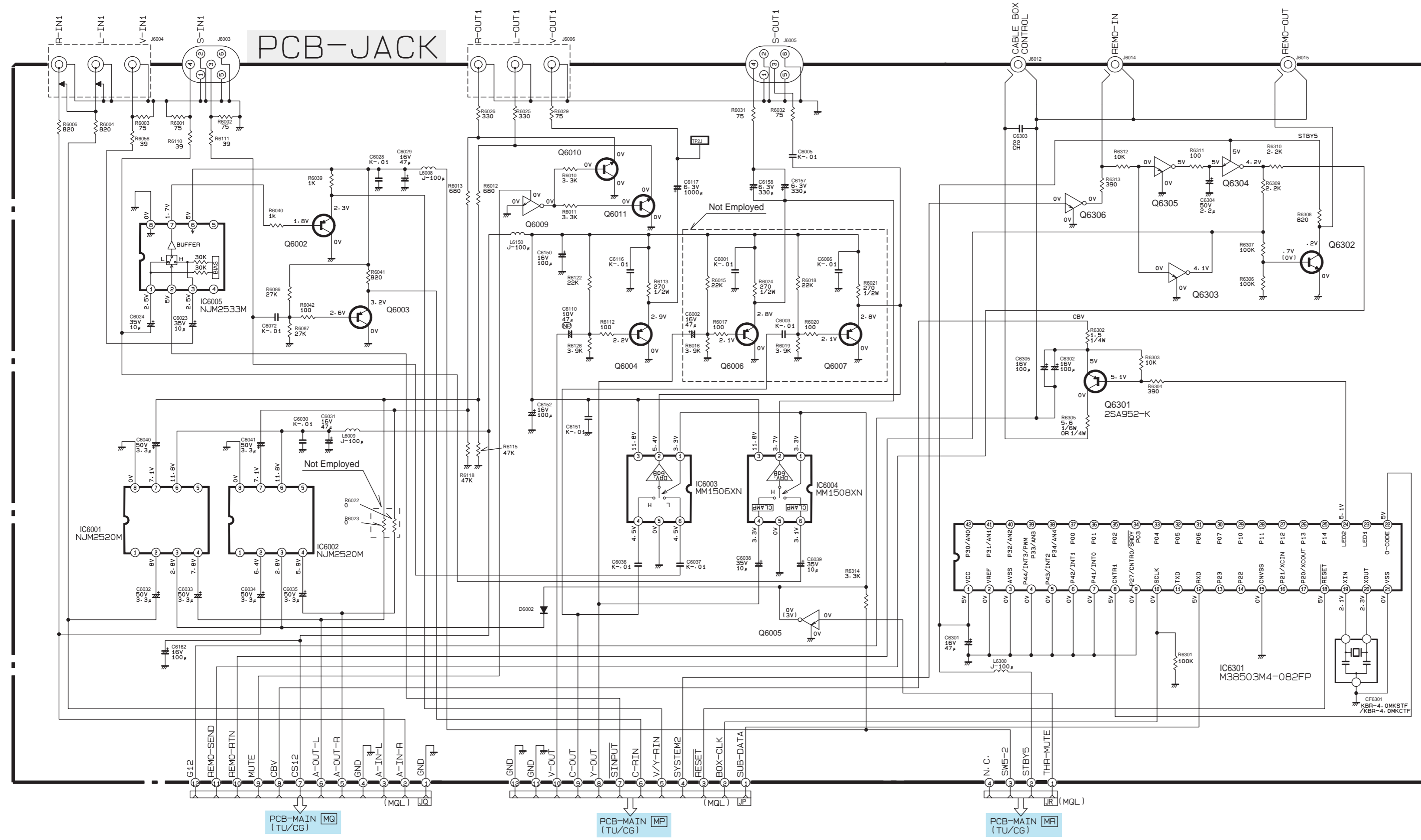

Note:
Unless otherwise specified.
PNP transistors are 2SA1037AK-R.S.
NPN transistors are 2SC2412K-R.S/2SD601AI-R.S.
All diodes are 1SS254.
PNP digital transistors are DTA124EKA/RT1P241C.
NPN digital transistors are DTC124EKA/RT1N241C.
All resistors are 1/10W.

A (SIGNAL) PCB-SIGNAL

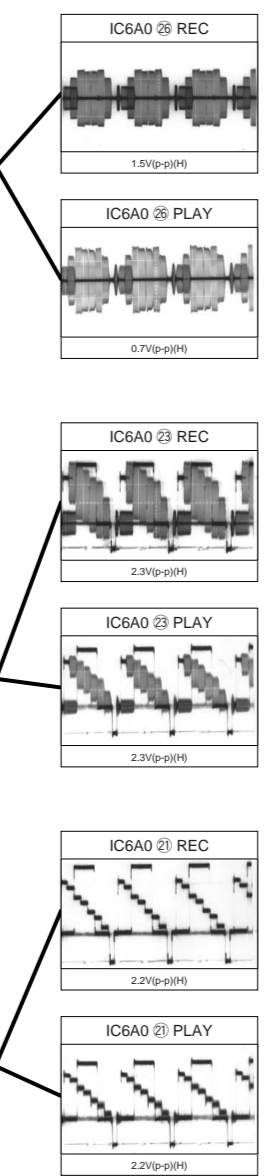
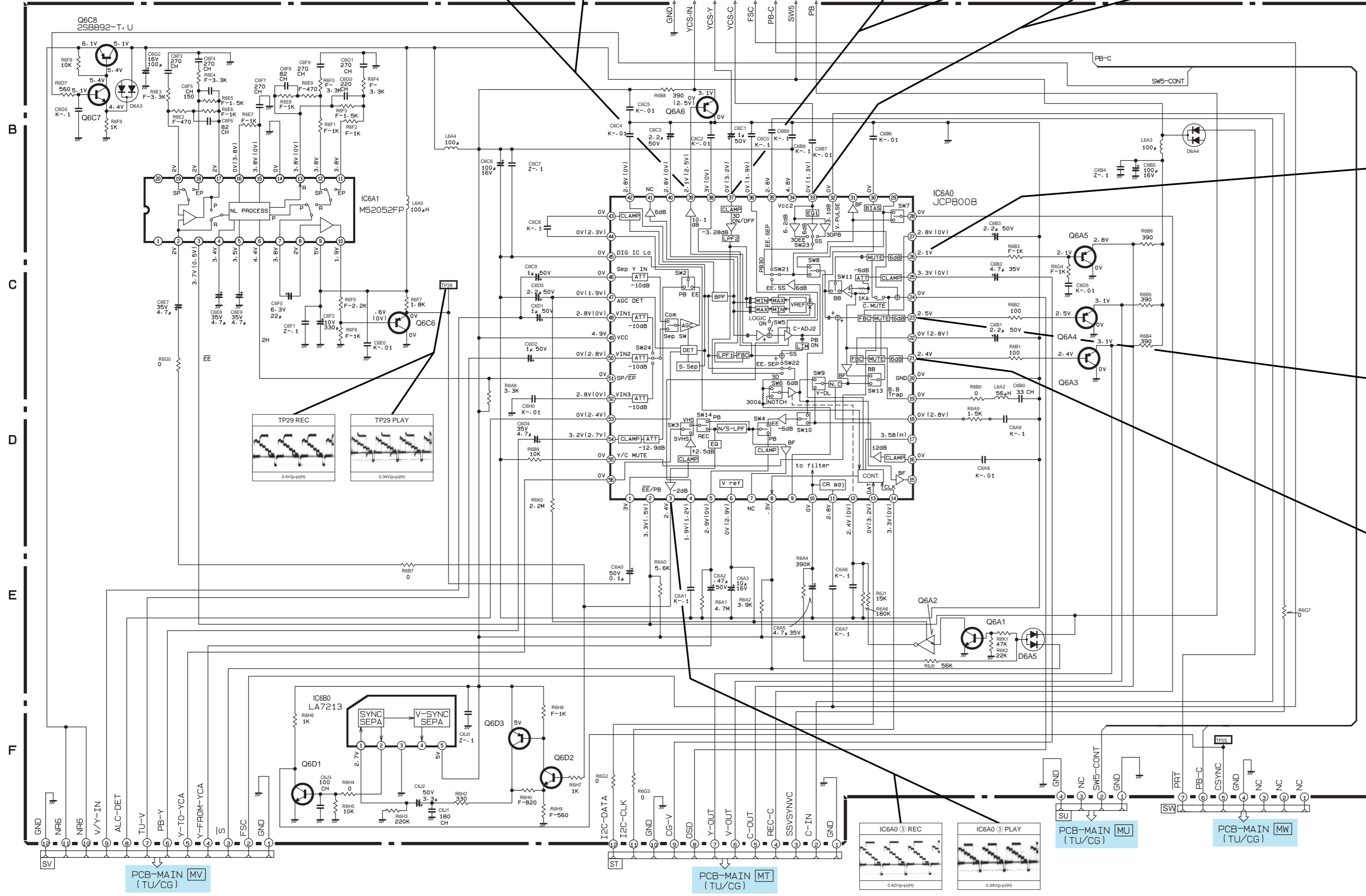

Note:
 Unless otherwise specified.
 All PNP transistors are 2SA1037AK-R-S.
 All NPN transistors are 2SC2412K-R-S/2SD601AI-R-S.
 All diodes are DAP202K.
 All resistors are 1/10W.
 All PNP digital transistors are DTA124EKA/RT1P241C.
 All NPN digital transistors are DTC124EKA/RT1N241C.

(YCS) PCB-SIGNAL

A
B
C
D
E
F

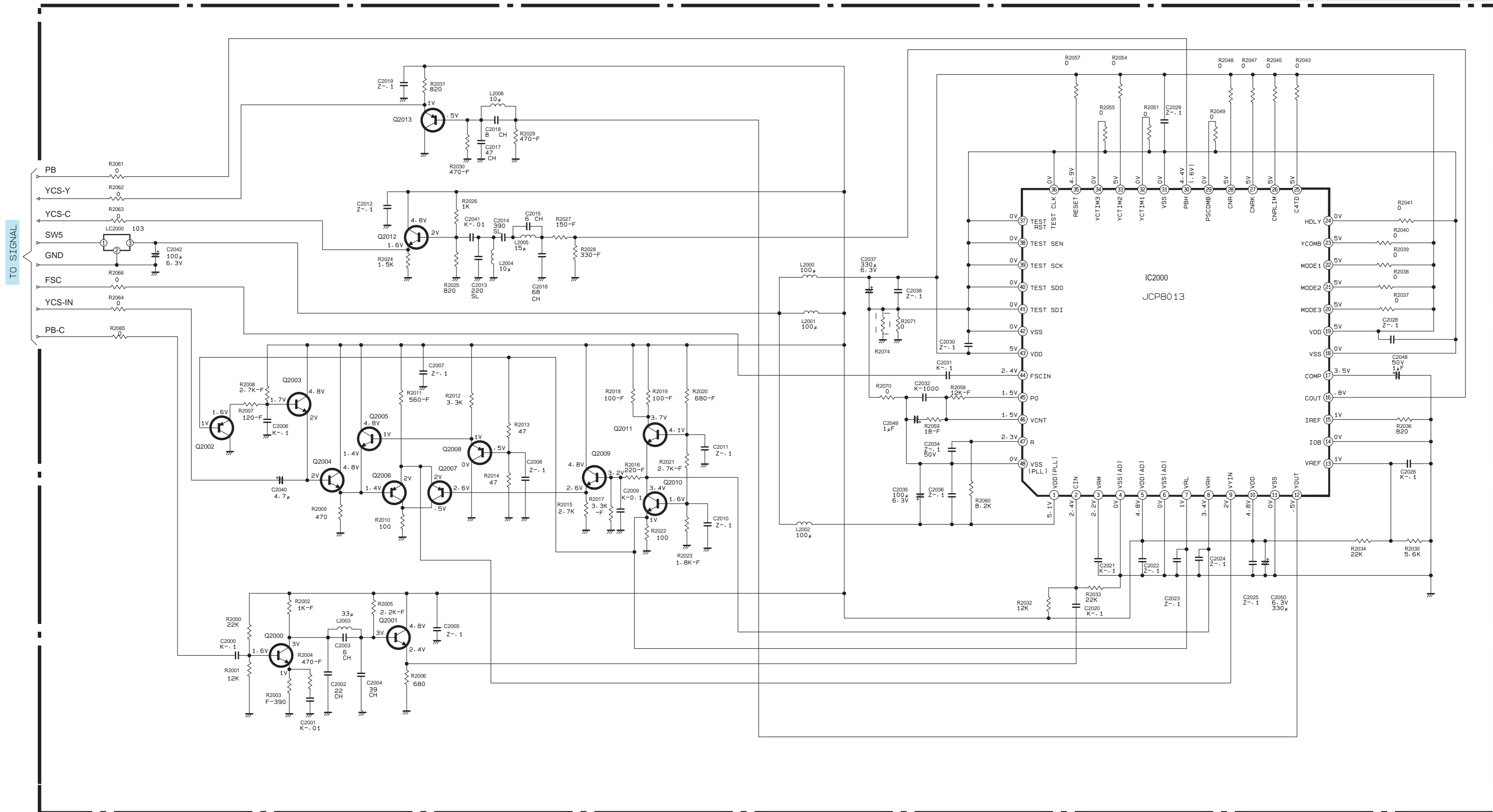

G

Note : Unless otherwise specified
 All PNP transistors are 2SA1037AK-R.S.
 All NPN transistors are 2SC2412K-R.S/2SD601AI-R.S.
 All PNP digital transistors are DTA124EKA/RT1P241C.
 All NPN digital transistors are DTC124EKA/RT1N241C.
 All diodes are 1SS254.
 All R-M-CHIP are 1/10W.

