

Service Manual

for

Thorens Model TD 224 Transcription Turntable and Record Changer

Parts List ----- Group Repertory

<u>Group</u>		<u>Service Manual Chapter</u>	<u>Service Manual Figures</u>	<u>Prod. drawing</u>
<u>A</u>	Tone arm	1	1 to 8	PUE 1085 CB 1501
<u>B</u>	Pick-up lift mechanism	1.2	1 to 8	CB 1501
<u>C</u>	Pick-up lateral control	1.3 to 1.5	1 to 8	CB 1501
<u>D</u>	Pick-up muting switch	2	9 to 12	CB 1501 CB 1814
<u>E</u>	Record Support	4.7	16 and 22	CB 1501 CBE 1508
<u>F</u>	Feed-in arm and record grippers	4	16,19,20,23 DE 375,376,377	CB 1501 CBE 1506
<u>G</u>	Feed-in arm lift mechanism	4.2, 4.3	18,24bis,38	CB 1501 CB 1530
<u>H</u>	Feed-in arm lateral control	4.4	25,26,38	CB 1501 CB 1524
<u>I</u>	Record gripper control	4.5	24	CB 1501
<u>J</u>	Cams		31,38	CB 1501 CBE 1510
<u>K</u>	Auto-trip mechanism	5	27,36	CBE 1502
<u>L</u>	Clutch mechanism	3	13,38	CB 1502 CB 1511
<u>M</u>	Start, stop and manual controls	5.6, 6	32,36	CB 1501 CB 1502
<u>N</u>	Switch	6.2	34,35	CB 1501 CB 1815
<u>O</u>	Last record stop	7	31	CB 1501
<u>P</u>	Turntable platter drive system	8		CBE 1502 CBE 1505 CB 1042
<u>Q</u>	Speed change mechanism			CB 1501 CBE 1502
<u>R</u>	Speed adjustment mechanism			CBE 1502
<u>S</u>	Stroboscope			CBE 1502 CBE 1502

Service Manual

for

Thorens Model TD-224 Transcription Turntable and Record Changer

1. Tone arm adjustment

1.1. Pick-up height

Normal adjustment: This adjustment may be checked when the turntable is "off" in the normal last record stop position:

- lift the turntable platter rubber cover slightly from the rim (see Fig. 4),
- bring the pick-up near the edge of the platter with the needle tip outside,
- verify that the lower end of the lateral abutment of the plug-in head is from 1/32" to 1/16" (1 and 2 mm) above the platter surface (Distance h),
- check that the stylus is protruding between 3/32" and 7/32" (2 and 5 mm) out of the shell. (See "Cartridge installation" instructions on page 13 and 14 of Instruction Manual).

New adjustment: turn screw PU 1007 (see Fig. 5):

- clockwise to increase pick-up height
- counterclockwise to decrease pick-up height

Notice. When the pick-up is playing a record, normal distance between the head of screw PU 1007 and abutment PU 1021 is about 1/8" (3 mm) and the arm lifting ear PU 942 should be approximately in the middle.

1.2. Pick-up lift

Symptom: Failure of pick-up arm to lift out of rest position during automatic operation.

Normal adjustment: The tone arm should be lifted by about 1/16" (1 mm) above the arm rest post.

Cause No. 1: Improper adjustment of pick-up height

Remedy: See 1.1. above

Cause No. 2: Clearance between arm lifting lever CB 1065 (see Fig. 6) and extremity D of lifting spindle PU 1019 is excessive when the unit is in the normal stop position.

Normal clearance: For units with serial number above 1500 this clearance, as checked with a wedge C, should be 1/16" (1,3 +

For units with serial number underneath 1400 , this clearance should be  $1/32"$  (0,8 + 1 mm).

For units with serial number inbetween, first try with a  $1/16"$  (1,3 + 1,5 mm) clearance, then if necessary adjust to  $1/32"$  (0,8 + 1 mm). (Proceed in the same way for units No. 3601 to 4000).

Remedy: adjust with retaining collar CB 1824 on link rod CB 1777. Loosen set screw and re-set retaining collar to obtain the proper clearance.

### 1.3. Pick-up landing position

#### Symptom No. 1

The pick-up does not land properly at approximately  $1/8"$  from the edge of a 10" or 12" record.

Cause No 1: Improper adjustment of pick-up height or pick-up lift

Remedy: Check normal adjustment according to 1.1. and 1.2. and adjust if necessary.

Cause No 2: The lateral abutment PU 953 of the plug-in shell is out of adjustment (see Fig. 1 to 3)

Remedy: Loosen slightly black screw M2x3F37 on top of plug-in shell:

- for a more outer landing position pull the lateral abutment out of the head slightly,
- for a more inner landing position, push the lateral abutment slightly into the head,
- tighten the black screw

Notice. For PU 953 Mo lateral abutment as delivered until the end of 1964 (Fig. 1) it may be necessary to stop the nut M2 VSM 12699 when tightening black screw M2x3F37.

Cause No 3: Excessive space between clutch plate CBE 1542 and friction pad E on bolt CBE 1827 (Fig. 6) due to:

a) Improper adjustment of bolt CBE 1827

Remedy: This adjustment is made when the changer is "off" in the normal stop position and the tone arm locked in the arm rest clamp:

- loosen nut 24012
- turn bolt CBE 1827 until a space of  $1/64"$  (0,3 mm) as checked with a wedge A, is obtained.
- tighten nut 24012

b) Plastic pad E does not protrude from the bolt ( $0,02"$  (0,5 mm)

Remedy: Bolt CBE 1827 should be replaced

Important Notice. Before proceeding to adjustments a) and b), check that the space between the collar of clutch plate CBE 1542 and the unit plate is about 1/16" (1,5 mm) (wedge B).

Cause No 4: Oil or grease on clutch plate CBE 1542

Remedy: Clean with a clean rag impregnated with denatured alcohol.

Cause No 5: Clutch plate CBE 1542 is not perfectly flat. It should then be replaced by a new one.

#### Symptom No 2

The pick-up lands correctly on 10" and 12" records but lands too much inside on certain 7" records.

Remedy: It is sometimes difficult to find a compromise position for the lateral abutment PU 953 Mo of the plug-in shell for all types of records. A new type of lateral abutment PU 953 (see Fig. 2 and 3), available from the fall of 1964 on, will make this adjustment more easy. These two lateral abutments are readily interchangeable.

#### Symptom No 3

The pick-up lands properly on the edge of a record and enters the groove, but upon disengagement of the cycle control mechanism, it jumps out of the groove.

Cause: (See Fig. 6 and 8). The vertical spindle PU 1020 of the tone arm does not glide down completely when the pick-up is lowered on the record, but remains slightly jammed by the balls at the 2/3 of its course down. The slight shock produced by the disengagement of the cycle control mechanism liberates the vertical spindle from its jammed position and, when it drops down, the pick-up is shaken.

Remedy:

- Check the freedom of the vertical spindle according to "Cause No 6" below.
- Check all the adjustments mentioned under "Cause No 3" above and particularly under "Important Notice".
- Strengthening lower coil spring CB 1392 by reducing space B (see Fig. 6) may help; but if the clutch plate CBE 1542 is displaced on the spindle, all the adjustments mentioned under "Cause No 3" should be set again.

### 1.4. Pick-up tracking

Symptom: Tone arm does not track properly

Cause No 1: Improper setting of pick-up stylus force.

- Remedy:
- Check the balance of tone arm according to the Instruction Manual, page 15;
  - for stylus forces underneath 2 grams, control the scale indications on the tone arm with a precision gauge for tracking force.

Stylus force spring calibration. For a new calibration of PU 1061 spring proceed as follows (see Fig. 7):

- Remove escutcheon plate PU 1060;
- Bring stylus force adjustment knob to the 1 1/2 gram position (between the 1 and 2 gram scale indications);
- Turn the calibrating screw PU 1009 with the provided key (2 VSM 35920) until the precision gauge indicates 1 1/2 gram. Turn counterclockwise to increase weight.

Cause No 2: Excessive wire drag

Remedy: Make certain that the three leads from the pick-up arm are secured to clutch plate CBE 1542, as illustrated on Fig. 9, and that the loop between clutch plate and ring CD 1638 does not touch any other part of the changer or the mounting board.

The three leads should go through the semi-circular aperture of the unit plate, underneath tone arm base, without rubbing this unit plate.

Cause No 3: Not enough clearance between clutch plate CBE 1542 and plastic pad E (see Fig. 6).

Remedy: See 1.3., cause No. 3 above.

Cause No 4: Improper adjustment of pick-up height.

Remedy: See 1.1. above.

Cause No 5: Auto-trip mechanism out of adjustment

Notice. To be certain that the auto-trip mechanism is the cause of the defect, first play a record manually, following exactly the "Manual operation" instructions on page 20 and 21 of the Instruction Manual. If tracking remains unsatisfactorily, the cause is not in the auto-trip mechanism.

Remedy: Auto-trip control lever CB 1078 should have a slight axial play and be very free on pin CB 1667 (see Fig. 27)

The auto-trip lever CB 1077 should contact the control lever CB 1078 on the two ribs only. These ribs should not present a burr which could mark the auto-trip lever. Lever CB 1077 should not contact the unit plate.

Cause No 6: Grit or rust in tone arm pivots.

Remedy: An extra-light special lubricant (for example Kontakt 61 made by SOLOGRA SARL, Forbach/Moselle, B.P. 41, France. should be applied on both ball bearings of the vertical spindle with a pressure can. See Fig. 8 for pivots design.

### 1.5. Pick-up arm rest position

When the changer is "off" after the last record stop, the normal pick-up arm rest position is on top of the arm rest post. If the arm has been forced by accident and does not come to the above described position, try to gently force it in the suitable direction. If an effort is necessary, first loosen slightly the two set screws of the clutch plate CBE 1542 (Fig. 6 and 8).

#### Caution.

Make sure that space B has not been modified (see 1.3., cause No 3, "Important Notice").

## 2. Muting Switch adjustment

Both channels of the pick-up are short-circuited during the record changing operations. They are not short-circuited in the rest position of the pick-up arm to allow the immediate manual play.

Symptoms: - One channel mute during play,  
- No muting action during record changing operations.

Remedy: - Check the adjustment mentioned under 1.2. "Cause No 2"  
- Check bracket CBE 1814 (Fig. 12) for square angle at A.  
- When changer is in the normal "off" position, adjust clearance between both muting switch fixed contacts and the corresponding mobile contacts, according to Fig. 11, by slightly displacing the bracket CBE 1814 (elongated slot).  
- If the contacts are out of shape, the whole CBE 1814 assembly (comprising the muting switch) should be replaced.  
- Normal force to open switch, measured according to Fig. 12, is comprised between 12 and 18 grams.

## 3. Clutch of the cycle control mechanism

### 3.1. How it works (See Fig. 13 and 14)

After the end of a record, the auto-trip lever CB 1077, driven by the steel wire of the striker, pushes the clutch stop lever CBE 1528

CB 1764 is then disengaged from notch C and the clutch control cam CBE ~~1830~~ is free to rotate clockwise, allowing clutch plate CBE 1512 to pivot clockwise under the action of spring CB 1769 until the rubber tire of wheel CBE 1513 comes into driving engagement with the stepped pulley CBE 1351 (Fig. 13).

At the end of the automatic record changing operations, pin E on cam assembly rotates arm B of clutch control lever CBE 1531 clockwise. Arm A of the same lever takes the clutch stop lever CBE 1528 back until steel wire D may enter notch C.

As soon as arm B of control lever CBE 1531 is disengaged from pin E, it turns rapidly counterclockwise. The clutch control cam CBE ~~1551~~ <sup>1830</sup> is driven counterclockwise through steel wire CB 1764 and notch C, urging clutch plate CBE 1512 counterclockwise and interrupting the contact between the rubber tire of wheel CBE 1513 and the stepped pulley.

Symptom: Continuous cycle. The pick-up is lifted immediately after having landed and will not play the record.

Cause No 1: Insufficient tension of coil spring 910.35.54. The vertical end D of steel wire CB 1764 does not remain in notch C of clutch stop lever CBE 1528.

Remedy: Increase slightly the tension of coil spring 910.35.54 at retaining screw F.

Cause No 2: Vertical end D of steel wire CB 1764 is broken.

Remedy:

- Remove the complete clutch plate assembly according to the Instruction Manual, page 27, last paragraph.
- Remove the clutch control cam CBE ~~1551~~ <sup>1830</sup> from the unit plate after loosening its pivot screw (CB 1693)
- Check the clutch control cam for a black sleeve underneath point D. If it is not present, replace the whole clutch control cam CBE **1830** by a new one and the broken steel wire CB 1764.

Notice: When reassembling the clutch control cam on the unit plate, make sure that it is perfectly free on its pivot screw and that vertical end D of steel wire clears the side edge of lever CBE 1528.

Cause No 3: Pin CB 1671 on which control lever CBE 1531 pivots is loose on the unit plate.

Remedy: Tighten the corresponding nut on top of unit plate

## 4. Feed-in arm adjustment

=====

Important preliminary notices

A. Each operation in the record handling cycle is closely related to the others. For this reason, it is strongly recommended to go through the complete serie of tests listed below, in the prescribed order, whatever may be the particular defect experimented.

B. The record support is NOT interchangeable from one unit to the other without a complete readjustment of the feed-in arm mechanism.

C. When adjusting the feed-in arm mechanism, it will be necessary to stop the changer at a precise moment of the automatic record changing operation:

- before reaching the particular point of the cycle, brake slightly the turntable platter;
- stop the changer by moving the Speed Selector knob to a "0" position.

To start again the changer:

- move the Speed Selector knob to the desired speed;
- gently lift the record feed-in arm by hand while helping the turntable platter to start;
- if necessary, turn slightly the turntable platter counterclockwise and then clockwise.

D. The record changing cycle may be hand operated for checking successive operation:

- remove the turntable platter;
- turn with the hand the large toothed wheel of cam shaft in counterclockwise direction.

Caution: Important damage will be caused to the mechanism if the cams are turned in the other direction.

4.1. Caution: Accidental misadjustment due to improper handling by packing or unpacking.

Symptom: Erratic or abrupt moves of the feed-in arm during cycle.

Cause: Cam follower roller CB 1716 (Fig. 19) is jammed over control cam CB 1593. (See also Fig. DE 377/412).

Remedy: Action from underside, with the hand, control link CBE 1550/ CBE 1548, inside feed-in arm CBE 1807, in the direction of arrow  $f_1$ . This will disengage the roller from the cam (see Fig. 23).



4.2. Feed-in arm height above the upper record support.

- Start the changer without records on the upper record support.
- Stop the changer by moving the Speed Selector knob to a "0" position as soon as the feed-in arm has reached the position illustrated on Fig. 16. Make sure that the feed-in arm has not already begun to go down towards the record support.
- Check vertical distance "b" between the upper extremity of centering post CB 1568 and the lower extremity of the longest record gripper CB 1599. This distance should be at least 5/64" (2 mm).

Notice. If the feed-in arm goes down towards the upper support when hole A is not aligned with the centering post, see 4.4.1 below.

Symptoms: The record gripper CB 1598 (See Fig. 16 and 23) is retained by the upper end of centering post CB 1568. The record rubs on top of centering post CB 1568 when being transported to the right.

Cause No. 1: Misadjustment of the feed-in arm lifting mechanism: feed-in arm is not lifted to its upper abutment, distance "b" is too small.

Remedy: Adjust the length of link CB 1694/CB 1695 between lifting lever CBE 1525 and cam lever CBE 1518 (see Fig. 17, 18 and 24 bis). First remove one circlip 362.15.11 and pin CB 1653. Then turn sleeve CB 1694: one revolution counterclockwise to increase lifting height of feed-in arm. Replace the pin and test for proper clearance by running the changer through one complete cycle. If properly adjusted, replace circlip 362.15.11. If distance "b" is still too small, repeat operation.

Caution: Make sure that the feed-in arm is not forced against its upper abutment by the lifting mechanism, but that a small play is still present in its upper position.

Cause No. 2: - Improper positioning of the records on the upper record support.

When stacking the records, make sure to push the whole stack forwards against the centering post in the direction of the front of the unit.

- Badly warped or twisted record.
- Non standard record.
- The dimensions of the central hole is non conform to the following standards:  
 Diameter : 0,280" to 0,290" or 7,15 to 7,4 mm.  
 Thickness: 0.06" to 0.12" or 1,5 to 3 mm.

Records whose warpage is beyond 5/64" (2 mm) should be played manually only.

Cause No. 3: The feed-in arm has been bent due to shipping or improper handling damage.

Remedy: As the feed-in arm has been hardened by heat treatment, it is fairly difficult to make it straight again. Repair or replacement should be done at a Master Service Station only.

Cause No. 4: Misadjustment of the record grippers.

Remedy: See 4.8 below.

Feed-in arm height above the turntable platter.

- Start the changer without records on the upper record support;
- Maintain the tone arm above the arm rest post;
- When the cycle mechanism is disengaged in the "play" position, handle the Reject lever;
- Stop immediately the changer by moving the Speed Change knob to a "0" position, as soon as the feed-in arm reaches its lowest position over the turntable platter. Make sure that it is the lowest position and that the feed-in arm is not already going up again.

The feed-in arm should rest on the unit plate at G. A vertical clearance "a" of about 1/64" (0,4 mm) should be present between the circular plate CB 1787 (see Fig. 15), at the free extremity of the feed-in arm, and 45 rpm. adaptor CBE 1822. This play may be checked when pressing on the extremity of the feed-in arm.

Symptom: The feed-in arm does not remove a record from turntable platter.

Misadjustment No.1: The feed-in arm does not go completely down to its abutment G on unit plate.

Cause No. 1: Lifting lever CBE 1525 prevents the feed-in arm column CBE 1507 to go down to its lowermost position. (See Fig. 24 bis).

Remedy: Check that a slight bent of arm CBE 1535 or of link CB 259 does not prevent lifting lever CBE 1525 to reach its lowermost position.

**Cause No 2:** Support bracket CB 1562 (see Fig. 24) has been bent. Column CBE 1507 of feed-in arm is slightly jamming on spindle CBE 1538 in its lowermost position.

**Remedy:** Straighten support bracket as indicated on Fig. 24 until spindle CBE 1538 is correctly centered inside column CBE 1507 (clearance d).

### Important Notice

To check freedom of column CBE 1507 and of ball sleeve CBE 1806 when gliding up and down in the bearing of the unit plate, proceed in the following way:

- Remove the turntable platter;
- Start the changer without records on the upper record support;
- Maintain the tone arm above the arm rest post;
- When the cycle mechanism is disengaged in the "Play" position, stop the changer by moving the Speed Change knob to a "0" position;
- Turn large toothed wheel of cam shaft very slowly and smoothly in counterclockwise direction. the feed-in arm should go down regularly and smoothly to its abutment on the unit plate at G. If the feed-in arm does not go completely down, the column CBE 1507 is not free enough. (See Fig. 15)

Caution Grease, thick oil or dirt on the column or in its bearing should be removed with denatured alcohol and a proper lubrication applied with our ROB oil exclusively.

Cause No 3: The centering sleeve CB 1698 on turntable platter spindle is not gliding freely on this spindle (see Fig. DE 376/412).

**Remedy:** Clean and lubricate slightly sleeve CB 1698.

Cause No 4: Misadjustment of the record gripper control cam.

**Remedy:** See 4.5. below.

Misadjustment No 2: The feed-in arm rests on abutment G of the unit plate, but the clearance "a" is substantially larger than 1/64" (0,4 mm), or the feed-in arm does not reach its abutment G while pressing on the 45 rpm adaptor.

Cause: The feed-in arm is not perfectly parallel to the turntable

platter. Bent due to shipping or improper handling damage.

Remedy: See 4.2., Symptom 1, cause No 3 above.

Misadjustment No 3: Incorrect adjustment of the lateral end position of feed-in arm or of feed-in arm length.

Remedy: See 4.4.2. and 4.6. below.

Misadjustment No 4: Incorrect adjustment of the record grippers.

Remedy: See 4.8. below.

#### 4.4. End positions of the feed-in arm for lateral displacement

##### 4.4.1. Left end position on the upper record support

(Fig. DE 375/411 illustrates the functioning of the record grippers for two thin adjacent records, one thick record and 45 rpm large hole records).

- Start the changer without records on the upper record support,
- Stop the changer by moving the Speed Selector knob to a "0" position as soon as the feed-in arm has gone down on the upper record support;
- Check, when looking from above, through hole A (see Fig. 16) that equal clearance or play be present on both sides of the centering post CB 1568;
- Lift manually the feed-in arm to check that the clearance is the same on top of centering post as on bottom.

Misadjustment No 1: Clearance or play is correct on bottom but not on top of centering post, or the contrary.

Cause: Centering post CB 1568 has been bent.

Remedy: Straighten both halves of the centering post so that they are tight from the bottom to the upper end and perfectly perpendicular to the record support.

Misadjustment No 2: Hole A is not centered on the centering post.

Cause: Left side lateral abutment out of adjustment.

- Remedy:
- Determine the sense of the necessary adjustment: to the left or to the right;
  - Start the changer and stop it again when the feed-in arm is mid-way between the record support and the turntable platter;
  - Turn screw B by a few degrees only.

clockwise to bring the feed-in arm more to the left,

counterclockwise to bring the feed-in arm more to the right.

Misadjustment No 3: Incorrect adjustment of lateral displacement control link CBE 1803 (See Fig. 25 and 26).

Symptom No 1: The feed-in arm goes down towards the upper support before hole A (see Fig. 16) has been aligned with the centering post CB 1568.

Cause: Spring abutment CB 1556 is not under tension when the feed-in arm is in the position illustrated on Fig. 16. No clearance at point E. (See Fig. 25).

- Remedy:
- Introduce a small plate of cardboard or metal the thickness of which is about 1/64" (0,3 mm) at E between spring abutment CB 1556 and lateral displacement control lever CB 1554;
  - Untighten nut 200.41.11.
  - Push link CBE 1803 in direction of arrow f<sub>1</sub> while maintaining post against spring abutment CB 1556 (arrow f<sub>2</sub>);
  - Tighten nut 200.40.11 and remove the wedge.

Symptom No 2: Feed-in arm strikes the edge of records stacked on the upper record support while elevating from lower record support.

Cause. Incorrect adjustment to Symptom No 1 above.

Remedy: Readjust according to Remedy above making use of a thinner wedge.

Notice: Striking slightly the edge of the records can do no harm whatsoever to these records or to the feed-in arm.

#### 4.4.2. Right end position of the feed-in arm over turntable platter (See Fig. 20).

- a) Start the changer without records on the upper record support.

- b) Maintain the tone arm above the arm rest post.
- c) When the changer is in the playing position, check when looking from above through hole A that it is well centered with the turntable platter centering post.

If it is not the case, determine the sense of the necessary adjustment: to the right or to the left.

- d) Start the cycle mechanism with the "Reject" knob and stop it again with the Speed Selector knob when the feed-in arm is midway between the upper record support and the turntable platter.

- e) Turn screw C by a few degrees only:

counterclockwise to bring the feed-in arm more to the right,

clockwise to bring the feed-in arm more to the left.

Remark: Precise adjustment may be checked as follows:

- Proceed as a), b) and c) above;
- Action the "Reject" knob while braking slightly the turntable platter;
- Observe very closely the feed-in arm when the record grippers contact the centering sleeve CB 1698: a well adjusted arm will not be displaced to the left or to the right at that very moment, but goes down vertically. (It will receive a slight lateral impulse as the record grippers open, when the feed-in arm reaches the turntable platter).

#### 4.5. Adjustment of the record gripper control cam

Symptoms: a) The feed-in arm CBE 1807 drops records in improper position on the lower record support: the records strike the turntable platter.

- b) The feed-in arm column CBE 1507 is not free despite all the adjustments made under 4.3. above.

Cause: The record gripper control cam CB 1593 is out of adjustment (See Fig. 19 and DE 377/413).

- Remedy:
- Start the changer without records on the upper record support.
  - Maintain the tone arm above the arm rest post.
  - When the changer is in the playing position, with the feed-in arm above the turntable platter, move the Speed Selector knob to a "0" position.

Observe the position of cam follower roller CB 1716 on cam CB 1593: it should be just engaged on top a) of the cam slope (see Fig. DE 377/413).

If necessary, adjust as follows (See Fig. 24):

- Check that arm CBE 1535 or link CB 259/CB 1563 have not been bent accidentally.

If necessary, straighten. The link should be free on its two end articulations and not twisted.

- Loosen set screws M 3x4 VSM 12156 and modify slightly the length of link CB 259/CB 1563 until proper position of cam CB 1593 is obtained. Re-set the two screws.

Important  
Notice:

Check that arm CBE 1535 is securely fastened on spindle CBE 1538. When the two screws M 3x4 VSM 12156 are not approximately in the middle of the slots of link CB 259 for proper adjustment this means that arm CB 1535 has turned on spindle CBE 1538. Re-position arm on spindle.

4.6. Adjustment of the length of the feed-in arm

Notice: This adjustment may be necessary only when a unit has been badly damaged in transit or elsewhere.

Symptom: Records are not securely removed from turntable platter despite all the adjustments made under 4.3, 4.4.2. and 4.5. above, and 4.8. below.

Remedy: Loosen large chrome screw CB 1718 (see Fig. 20) with special key OG 1721 and small chrome screw M 3x6 F-31 on top of feed-in arm. The feed-in arm may now be shifted on column CBE 1507.

For precise adjustment proceed as follows:

- Put special gauge OG 1719 on the turntable platter centering post, 7,2 mm diameter hole upside.
- Bring the feed-in arm to the turntable platter by the normal cycle operation and stop the changer before the record grippers open.
- Position the feed-in arm so that the closed record grippers may penetrate into the 7,2 mm diameter hole of gauge OG 1719.
- Tighten the two chrome screws CB 1718 and M 3x6 F 31 again.

#### 4.7. Adjustment of the position of the upper record support on the record support itself.

See Notice under 4.6.

Symptom: Records are not securely removed from the upper record support despite all the adjustments made under 4.2., 4.4.1., 4.5. above and 4.8. below.

Cause: Damaged or exchanged record support.

Remedy: See Fig. 22. When the two screws M 3,5x10 VSM 12140 and the corresponding nuts are loosened, the upper record support circular plate CB 1509 may be slightly shifted in the direction of arrows on the record support. Proceed as follows:

- Put special gauge OG 1720 on the centering post of the upper record support, the circular hole upside. (See Fig. 21).
- Bring the feed-in arm to the upper record support by the normal cycle operation and stop the changer before the record grippers open.
- Position the upper record support CB 1509 so that the closed record grippers may penetrate into the hole of gauge OG 1719.
- Tighten the two screws M 3,5x10 VSM 12140 and the corresponding nuts again.

#### 4.8. Adjustment of the record grippers.

Symptom: Feed-in arm does not remove records securely from upper record support or from turntable platter.

Important notice: All the adjustments mentioned above in chapter 4 should first be checked in the prescribed order.

Cause No 1: Non standard records. For optimum results, the dimensions of the central hole of each record should be the following:

Diameter : 0,280" to 0,290" or 7,15 to 7,4 mm  
Thickness: 0,06 " to 0,12 " or 1,5 to 3 mm.

A burr around the central hole should be carefully smoothed.

Cause No 2: The record grippers (See Fig. 23) are not spreading



sufficiently to grasp a record, or, when closed, they are too far apart and will not enter the record center hole.

Remedy:

a) To check the adjustment of the opened grippers:

- Start the changer without records on the upper record support and stop it when the feed-in arm is mid-way between the record support and the turntable platter.
- Take special gauge OG 1718.
- Push its forked extremity in direction of arrow  $f_2$ , applying simultaneously its flat upper side against CB 1787 collar until reaching the upper extremity of the grippers.
- When properly adjusted, the record grippers will be spread sufficiently not to enter the fork. Do not force the fork against the grippers or permanent damage to the grippers surface will occur.

If the grippers are not spreading sufficiently and may enter the fork easily, proceed as follows:

- Loosen the two set screws M 3x3 VSM 12156 on the underside of the feed-in arm and shorten very slightly link CBE 1595/CBE 1548.
- Tighten again the two screws.

b) To check the adjustment of the closed grippers:

- Start the changer again and, maintaining the tone arm above the arm rest post, stop it in the normal playing position.
- Take special gauge OG 1718 and try gently to introduce the closed record grippers into the circular hole of the gauge. When properly adjusted, the grippers should freely enter the hole.

If the grippers are not sufficiently closed, link CBE 1595/CBE 1548 should be very slightly lengthened.

Caution: When the grippers are closed, check that a small additional longitudinal move of link CBE 1595/CBE 1548 is still possible when pulling with the hand on screws M 3x3 VSM 12156 in direction of arrow  $f_1$ . If this slight play is not present, the cycle mechanism will stall.

## 5. Auto-trip mechanism

=====

How it works and how to adjust it

- 5.1. The changer being "off" in the normal last record stop position, remove the turntable platter.

The auto-trip lever CB 1077 and the auto-trip friction lever CB 1078 (see Fig. 27 and 36) should be in their extreme left position (when viewed from above) against the abutment on the unit plate.

A clearance of about 1/8" (3. mm) should be present between the edge of these levers and the vertical part of steel wire CB 1766.

Adjust by bending slightly the horizontal part of the steel wire.

- 5.2. Start the changer without records on the upper record support by moving the Speed Selector knob to the proper speed, pushing the Control knob to the start position and pushing the auto-trip lever CB 1077 to its extreme right position.

Maintain the tone arm above the record support.

Observe how steel wire CB 1766 drives levers CB 1077 and CB 1078 to their left abutment.

Notice: if steel wire CB 1766 does not push the levers to their abutment, adjust according to 5.1 above.

- 5.3. When the cycle mechanism is disengaged in the "play" position, move the tone arm very slowly towards the turntable platter bearing.

If properly adjusted, the auto-trip friction lever CB 1078 begins to be driven by pin CB 1665 on clutch plate CBE 1542 (see Fig. 27) when the needle tip is approximately aligned with the right edge of the collar of the large toothed wheel CBE 1517.

Adjust by slightly bending finger H of the auto-trip friction lever:

- in the direction of pin CB 1665 if the auto-trip action begins too late;
- in the opposite direction if the auto-trip action begins too early.

- 5.4. From that moment, when the tone arm is further driven towards the platter bearing, the steel wire CB 1219 of the striker, mounted on the turntable spindle underneath the platter, would normally push

back the auto-trip lever CB 1077 at each revolution of the platter.

Symptom  
No 1: An abnormally loud impulse is heard in the loudspeakers at each revolution of the platter towards the end of a record modulated at a low level.

Cause No 1: The auto-trip action begins too early.

Remedy: See 5.3. above.

Cause No 2: The auto-trip and auto-trip friction levers CB 1077 and CB 1078 are not free enough on pin CB 1667 (see Fig. 27).

Remedy: Check for a small axial play of the two levers on the pin. Clean pin and levers.

Cause No 3: Too much friction on auto-trip lever CB 1077.

Remedy. The auto-trip lever should contact the control lever CB 1078 on its two ribs only. These ribs should not present a burr which could mark the auto-trip lever.

Clean and polish both levers on their surfaces in contact.

Lever CB 1077 should not contact the unit plate when driven by lever CB 1078.

Symptom  
No 2: Tone arm does not track properly at the end of a record.

Remedy: See chapter 1.4. "Pick-up tracking" above and chapter 5 above and 7.1. below.

### 5.5. Auto-trip action and clutch mechanism

See chapter 3.1. above.

### 5.6. Manual control knob

Symptom The Control knob does not remain in the "Manual" position.

Cause: Roller CB 562 does not come out of the v-shaped notch of cam CB 1578.

Remedy: Adjust by slightly bending ear K of lever CB 1604 towards coil spring. roller CB 562 should be just out of the notch of cam CB 1578 while arm J of lever CB 1604 is applying the auto-trip lever CB 1077 against the unit plate.

#### Important:

Check that the auto-trip lever is not pushed by arm J of lever CB 1604 when the Control knob is moved back to its rest position. The free extremity of arm J should be at

about 1/32" (1 mm) back from the edge of the rectangular opening on unit plate when the Control knob is in its normal rest position. Adjust by bending slightly ear K towards end collar CD 1606.

## 6. Start and Stop

=====

### 6.1. Initial check and adjustments to the control links

Before proceeding to any further controls, check the following adjustments:

- The changer being "off" in the normal last record stop, disconnect the power cord and move the Speed Selector knob to the 16 2/3 rpm. position and the Control knob to the "Start" position.

6.1.1. A clearance of 1/32" to 3/32" (1 to 2 mm) should be present between spindle CB 1234, lower extremity of the idler wheel spindle (see Fig. 32) and the bottom of the v-shaped notch of disengagement lever CB 1061 (with the turntable platter in position).

#### 6.1.2. Adjustment:

To adjust the proper clearance if necessary, proceed as follows:

- a) Check that switch control lever CBE 1523 is in the "on" position by moving the Control knob to the "Start" position.
- b) Loosen retaining collar CBE 1824 a on link CB 1776 and CBE 1824 c on link CB 1789.
- c) Check that disengagement lever CB 1061, when applied against inner retaining collar CBE 1824 b, gives the prescribed clearance of 1/32" to 3/32" (1 to 2 mm) to spindle CB 1234 (see 6.1.1. above).
- d) If necessary, adjust by moving slightly retaining collar CBE 1824 b (inside of lever CB 1061) along link CB 1789.
- e) Push retaining collar CBE 1824 c against lever CB 1061 and fasten it on link CB 1789.
- f) Push retaining collar CBE 1824 a against lever CB 1061 and fasten it on link CB 1776.
- g) Check that switch control lever CBE 1523 has just a very slight play between the two retaining collars CBE 1824 d and e.
- h) Move the Speed Selector knob to a "0" position. Check that there is a small clearance between retaining collar CBE 1824 e and the switch cover plate. Be sure that this cover plate is aligned with the bottom plate of the switch and has not been replaced previously up-side down.

If necessary, re-position retaining collars e and d on link

- i) Maintain the Control lever to the "Start" position and check that the retaining collar CBE 1824 f on switch actuating link CB 1775 is pushing the switch actuating lever CB 1546 into the "on" position illustrated on Fig. 34: there should be no clearance between collar f and arm g of the actuating lever.

Adjust by displacing retaining collar f.

### 6.1.3. Final check of the control links

- a) Move Speed Selector knob to a "0" position.
- b) Move it to the 33 1/3 rpm position.
- c) Push very slowly the Control knob towards the "Start" position: disengagement lever CB 1061 should tumble from its "off" to its "on" position without hesitation under the action of v-shaped spring CB 1765 (see Fig. 32).

If disengagement lever does not tumble normally, remove spring CB 1765 from lever CB 1061 and from ear l. When free, the two arms of this spring should be opened of slightly more than 90°.

If necessary give it the proper shape and mount it again according to Fig. 32.

### 6.2. Switch

To check the proper adjustment of the switch proceed as follows:

- Be sure that all the adjustments mentioned under 6.1. above are correct.
- Move the Speed Selector knob to 33 1/3 rpm.
- Move very slowly with the hand the disengagement lever CB 1061 (see Fig. 32) between its two end positions in both directions.
- Observe ear A of switch control lever CB 1546 (see Fig. 34 and 35): it should come energetically to its abutments before disengagement lever reaches its end positions.

#### Adjustment:

If switch control lever CB 1546 does not tumble energetically in both directions, remove the switch cover plate CB 509 according to Fig. 34. Check the switch contact plate CBE 652:

- if fairly flat, adjust by slightly bending ear A
- if substantially bent, replace by a new one, observing precisely the position in which the original contact plate and the coil spring were mounted.

### 7. Last record stop

=====

- Start the changer without records on the upper record support and without turntable platter.
- Maintain the tone arm above the arm rest post.
- When the cycle mechanism is disengaged in the "play" position, move the Speed Selector knob to a "0" position.
- Move the tone arm until the lateral abutment PU 953 of the plug-in shell comes into contact with the feed-in arm.
- Check the proper adjustment of vertical arm B of last record feeler lever CBE 1532 with regard to the extremity A of auto-trip friction lever CB 1078 (see Fig. 27 and 31). Observe through rectangular hole on unit plate:
  - a) <sup>Vertical</sup> clearance of about 1/64" (0,4 mm) should be present between the extremity A and step D on arm B. Adjust by slightly bending the feeler lever at F.
  - b) Extremity A should just contact the extremity E, or the <sup>horizontal</sup> clearance should not be more than 1/64" (0,4 mm) between these parts. Adjust by slightly twisting the feeler lever at F.
  - c) Check that adjustment a) has not been modified.

## 7.2. Last record feeler lever CBE 1532 in the last record stop position

- Start the changer without records on the upper record support and without turntable platter.
- Leave the tone arm free to move. As soon as the lateral abutment PU 953 of the plug-in shell comes into contact with the feed-in arm, move the Speed Selector knob to a "0" position.

Check the proper adjustment of the last record feeler lever CBE 1532:

- a) The extremity A of the auto-trip friction lever CB 1078 should be engaged on step D of the extremity B of the last record feeler lever CBE 1532 (see Fig. 29). Adjustment should be made according to 7.1. above.
- b) Bent extremity C of the last record feeler lever should be lifted by about 1/16" (1,5 mm) above the lower cam CBE 1544.
- c) Edge G of the last record feeler should come to the height of the top of cam CB 1570. Adjust by slightly bending and twisting the feeler lever at H.

## 7.3. How it works

### 7.3.1. When a record is to be played.

- The feed-in arm brings a record above the turntable platter.

- The tone arm moves inside until it is stopped by the lateral abutment of the plug-in shell coming into contact with the edge of the record.
  - The extremity A of the auto-trip friction lever CB 1078 is consequently stopped before taking contact with the extremity B of the last record feeler lever CBE 1532.
  - The extremity C of the last record feeler lever remains on lower cam CBE 1544 and the edge G engages between cam CB 1570 and upper cam CBE 1545.
  - The upper cam CBE 1545 is lifted above cam CB 1570 (see Fig. 27 and 31) in such a way that its control pin CB 1673 (see Fig. 32) cannot action the switch control lever CBE 1523, and its second control pin CBE 1674 cannot action the clutch control lever CBE 1531 (see Fig. 13): the cycle operations will not be interrupted after the record has been dropped to the lower record support.
- Check that the two control pins CB 1673 and CB 1674 are just passing above lever CBE 1523 with a slight clearance (maximum 1/64", 0,3 mm).

## 6.2. When there is not record on the feed-in arm.

- The feed-in arm moves to a position above the turntable platter.
- The tone arm moves inside until the lateral abutment of the plug-in shell contacts the feed-in arm (see Fig. 28 and 29).
- The extremity A of the auto-trip friction lever CB 1078 engages the 45° slope on extremity B of the last record feeler lever CBE 1532 and pushes it down.
- The extremity C of the last record feeler lever is consequently lifted above the lower cam CBE 1544 and the edge G engages the top of upper cam CBE 1545.
- The upper cam is not lifted above cam CB 1570 with the following consequences:
  - a) The notch on cam CB 1570 controlling the lifting of the tone arm is concealed and the pick-up is not lowered on the turntable platter.
  - b) Control pin CB 1673 engages the switch control lever CBE 1523 (see Fig. 32) which, acting on link CB 1789, opens the switch and stops the motor, and disengages the idler wheel from the turntable platter through disengagement lever CB 1061. (For the co-ordination of these operations, see 6.1. above).
  - c) Control pin CB 1674 engages the clutch control lever CBE 1531 interrupting the contact between the rubber tire of wheel CBE 1513 and the stepped pulley (see 3.1. above).

#### 7.4. Coordination of the last record stop operations

Observe the last record stop operations after having removed the turntable platter:

If the mechanism is properly adjusted, the idler wheel should be disengaged and the motor stopped when the feed-in arm is just moving from the lower record support and the clutch wheel CBE 1513 should be disengaged when the feed-in arm is approximately parallel to the left side of the unit plate.

Important. (See Fig. 37)

From the moment where the motor has been switched off, the energy for the completion of the cycle operations is furnished by coil spring CB 1790 through compensation lever CBE 1541 and cam CB 1608. Therefore the motor should not be switched off before the cam follower roller of compensation lever CBE 1541 engages the slope on the cam.

#### 7.5. Misadjustments to the last record stop mechanism

- |                                |  |
|--------------------------------|--|
| <u>Symptom</u><br><u>No 1:</u> | The pick-up does not set down on the record after it has indexed this record and the changer shuts off after each cycle.   |
| <u>Cause.</u>                  | The upper cam CBE 1545 is not lifted above cam CB 1570 by the last record feeler lever CBE 1532 (see Fig. 27 and 31).  |
| Remedy:                        | Adjust according to 7.1. above.  |
| <u>Symptom</u><br><u>No 2:</u> | The pick-up sets down on the rubber mat of the turntable platter when there is no record on the feed-in arm, and the changer continues to cycle.   |
| <u>Cause:</u>                  | The upper cam CBE 1545 is lifted above cam CB 1570 by the last record feeler lever CBE 1532 (see Fig. 27 and 31).  |
| Remedy:                        | Adjust according to 7.1. and 7.2. above.   |
| <u>Symptom</u><br><u>No 3:</u> | The cycle mechanism disengages at the last record stop but the motor and the platter continue to run.  |
| <u>Cause No 1:</u>             | Misadjustment of the switch control lever CBE 1523 (see Fig. 32)   |
| Remedy:                        | a) bent slightly the vertical extremity of lever CBE 1523 in the direction of retaining collar e.<br><br>b) if it does not give the proper result, check the complete adjustment of the start and stop links according to chapter 6 above. |
| <u>Cause No 2:</u>             | The extremity i of the switch control lever CBE 1523 (see Fig. 32) has been bent and does not cooperate with control pin CB 1673.  |
| Remedy:                        | Carefully bent the switch control lever until its extremity i comes to the level of pin CB 1673. This operation should be performed when the changer is in the normal last record stop   |



Symptom  
No 4. When Control knob is set at Manual, the unit will only operate in automatic cycle.

Symptom  
No 5. Both channels are mute during play.

Cause No 1: Misadjustment of the clutch control lever CBE 1531. The arm B of this lever is released too early by pin E (CB 1674), before the cam follower roller of compensation lever CBE 1541 engages the slope of cam CB 1608 (see 7.4. above).

Remedy:

- Check that post CB 1671 on which control lever CBE 1531 pivots (see Fig. 13) is tight on unit plate. If necessary tighten the corresponding nut on top of unit plate.
- If the proper result is not attained, post CB 1671 should be bent slightly closer to cam plate CB 1757.

Cause No 2: The clutch control lever CBE 1531 has been twisted.

Remedy: The arms A and B of the clutch control lever should be perfectly parallel to one another when viewed from underneath. If the lever has been twisted, it should be carefully straightened.

## 8. Turntable platter drive system

=====

### Important Notice.

For the perfect functioning of the drive system of the TD 224 turntable the following parts should be entirely free from any trace of oil or grease on their external working surfaces: the motor pulley, the stepped pulley, the two idler wheels, the rubber belt and the inner skirt of the turntable. Therefore any excess of lubricant may interfere with proper operation. If the presence of oil or grease on the mentioned parts is suspected, they should be thoroughly cleaned with a clean rag impregnated with denatured alcohol.

The rubber belt, the motor pulley and the stepped pulley may be cleaned without removing the clutch plate assembly CBE 1512 (see Fig. 13). A fragment of clean rag or absorbent cotton fixed on a small stick and impregnated with denatured alcohol may be applied against these parts, underneath the clutch rubber wheel CBE 1513, when the drive mechanism is running in the Manual position.

Symptom  
No 1: Wow or flutter when playing a record.

Cause No 1: Grease on the drive system friction surfaces.

Remedy: See Important Notice above.

Cause No 2: Improper adjustment of the idler wheel height.

Remedy: See Fig. 19, page 28 of the Instruction Manual for normal height of the idler wheel with regard to the steps of the

stepped pulley. If the proper adjustment cannot be obtained by means of F 1028 fibre washers, the retaining collar at the extremity of the link controlled through the Speed Selector knob should be slightly displaced.

Symptom Noisy drive system (as heard directly near the unit).  
No 2:

Cause No 1: The rubber belt CB 965 is slightly sticking on the pulleys.

Remedy: A slight application of talcum powder on the belt with absorbent cotton will provide a silencing effect.

Caution: too much talcum powder will lead to a slipping of the belt.

Cause No 2: The stepped pulley needs lubrication.

Remedy: See Instruction manual page 27 and 28.

## 9. Cycle mechanism drive system

=====

Symptom The changer stalls during the automatic cycle.  
No 1:

Cause No 1: Grease on the drive system friction surfaces.

Remedy: See Important notice under chapter 8 above.

Cause No 2: Slipping rubber belt through an excess of talcum powder.

Remedy: Clean the belt.

Cause No 3: Improper height of the motor pulley on the motor spindle, the belt rubs on the motor cover plate.

Remedy: Re-set the motor pulley according to the Instruction Manual, page 12.

Cause No 4: Improper adjustment of the feed-in arm lifting mechanism: the feed-in arm is forced against its upper abutment.

Remedy: Adjust according to chapter 4.2., cause No 1, above.

Cause No 5: Improper adjustment of the record gripper control mechanism: when the grippers are closed, the link CBE 1595/CBE 1548 has not the prescribed longitudinal play.

Remedy: Adjust according to chapter 4.8. b) above.

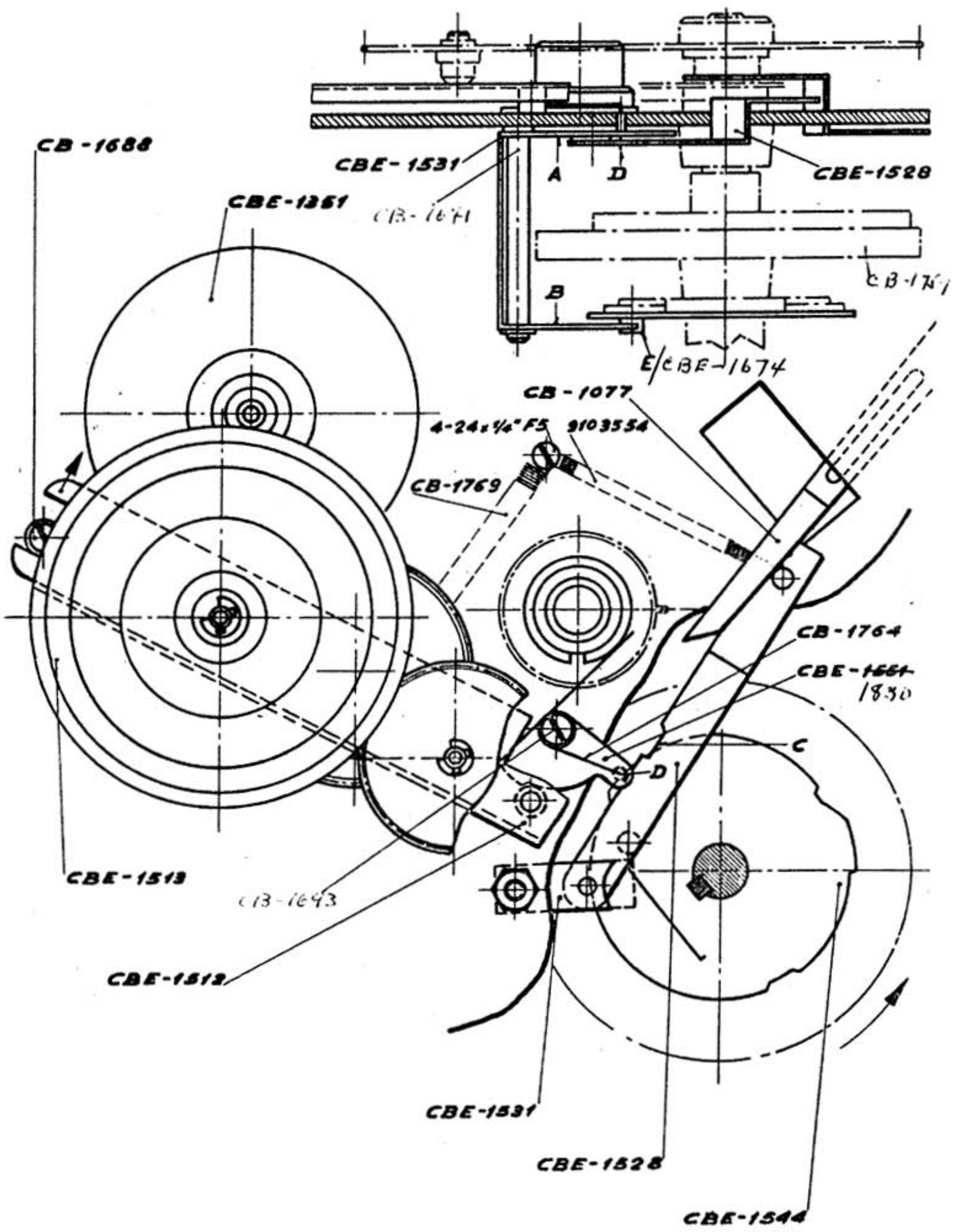

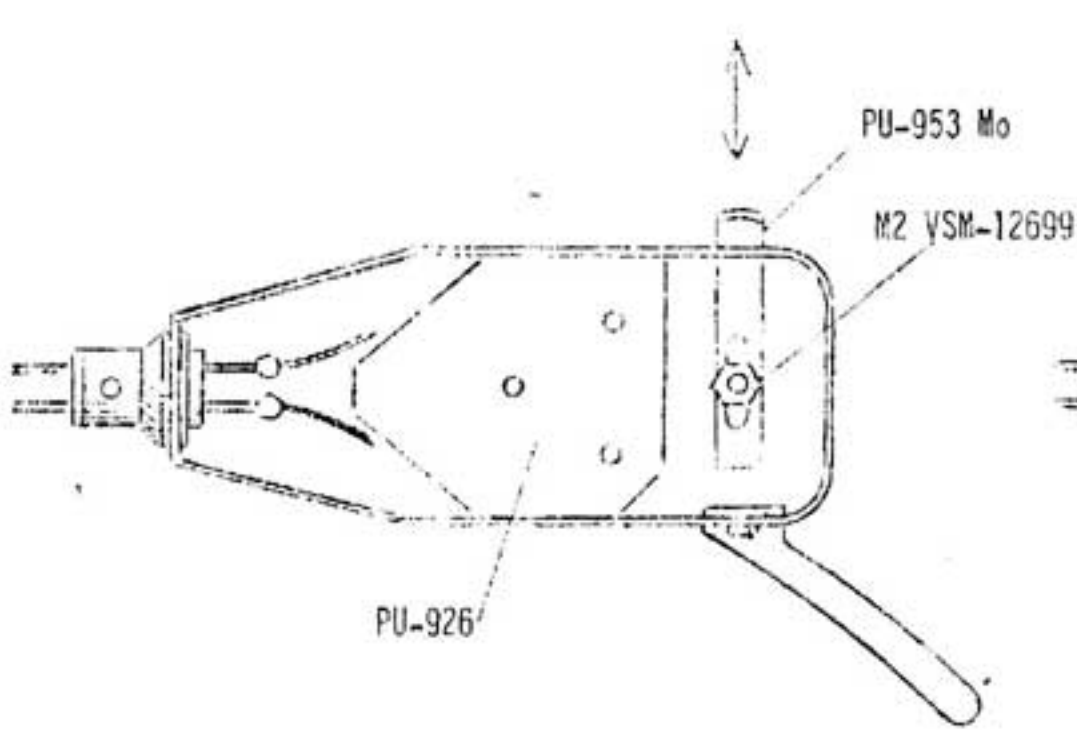

Fig. 1

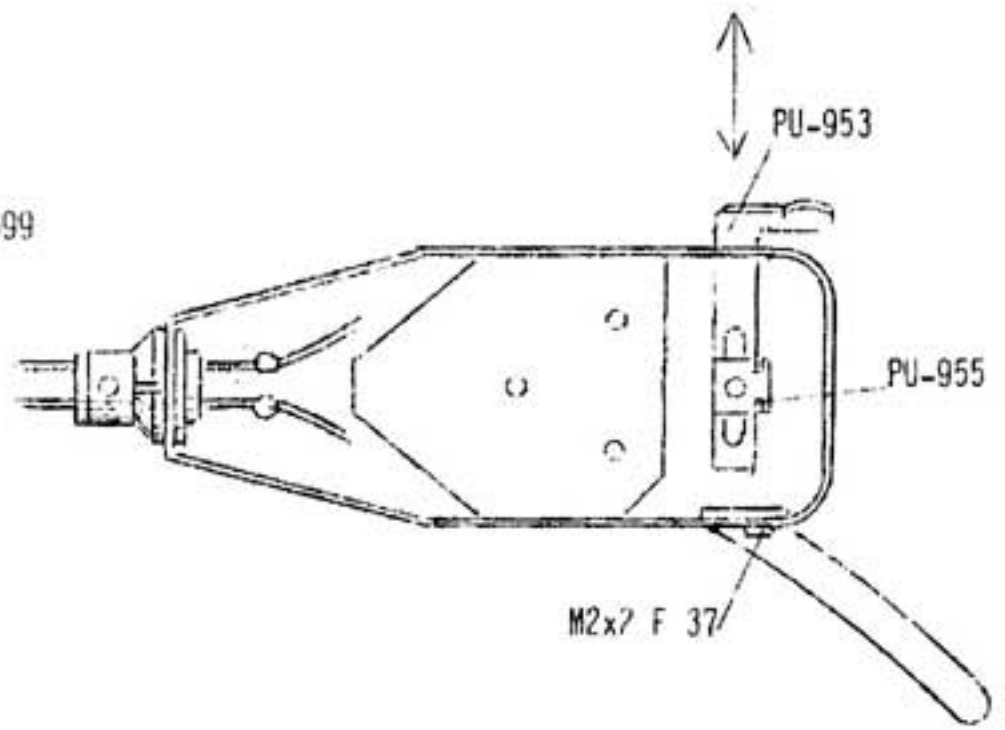

Fig. 2

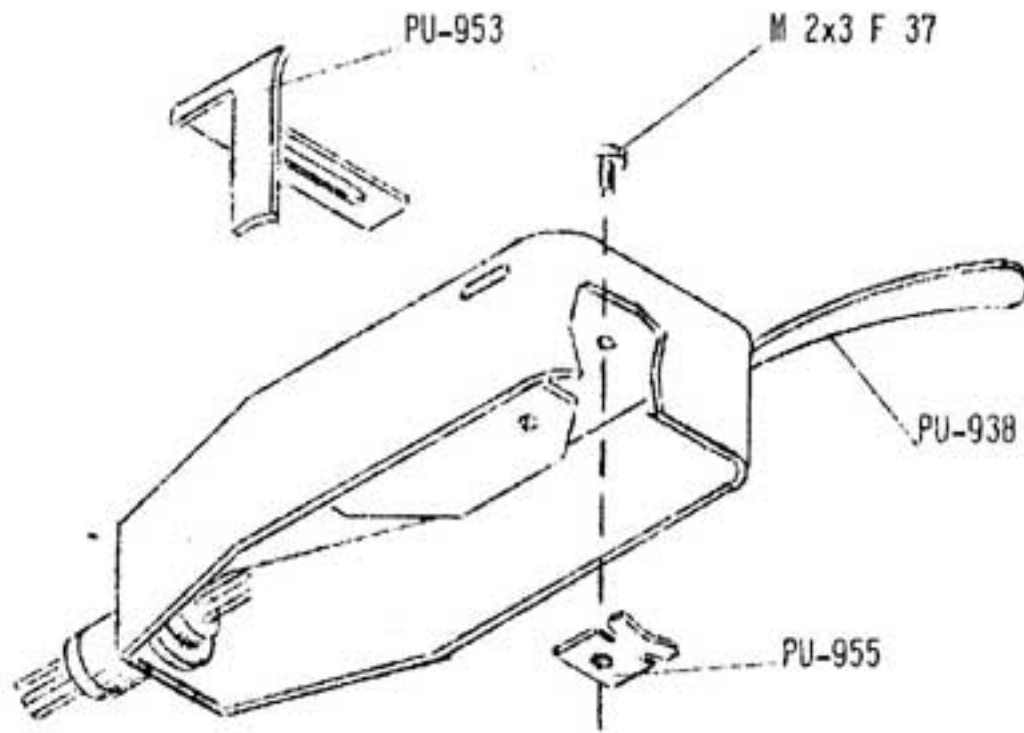
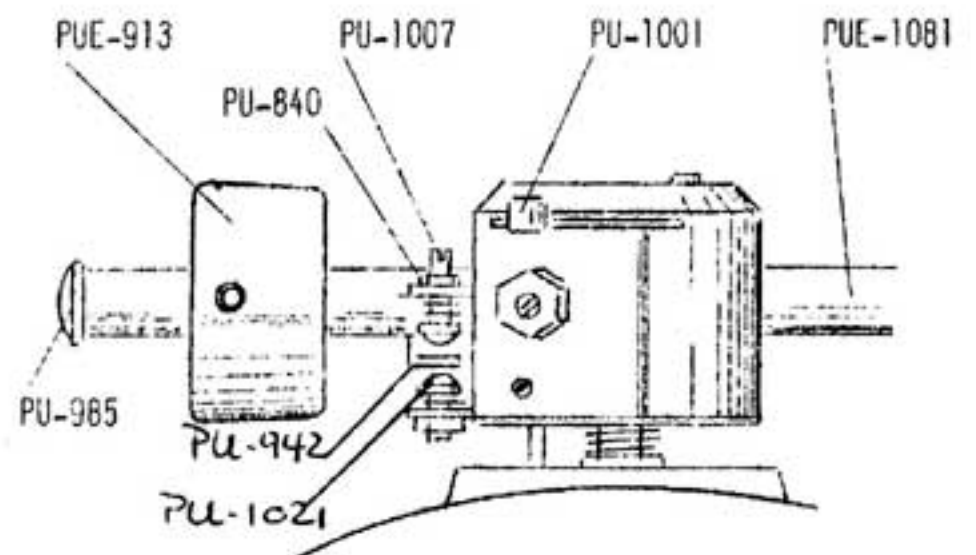
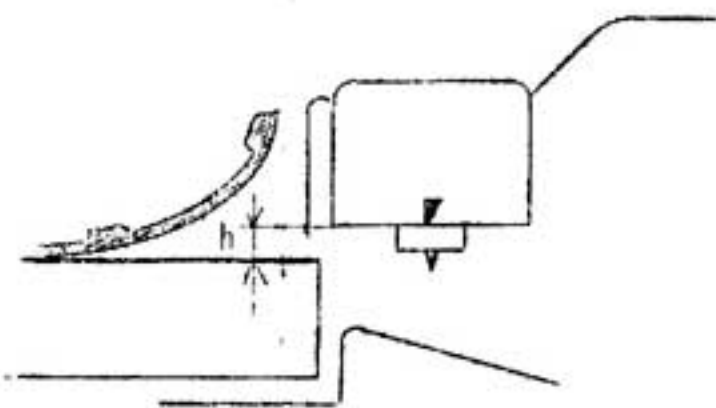
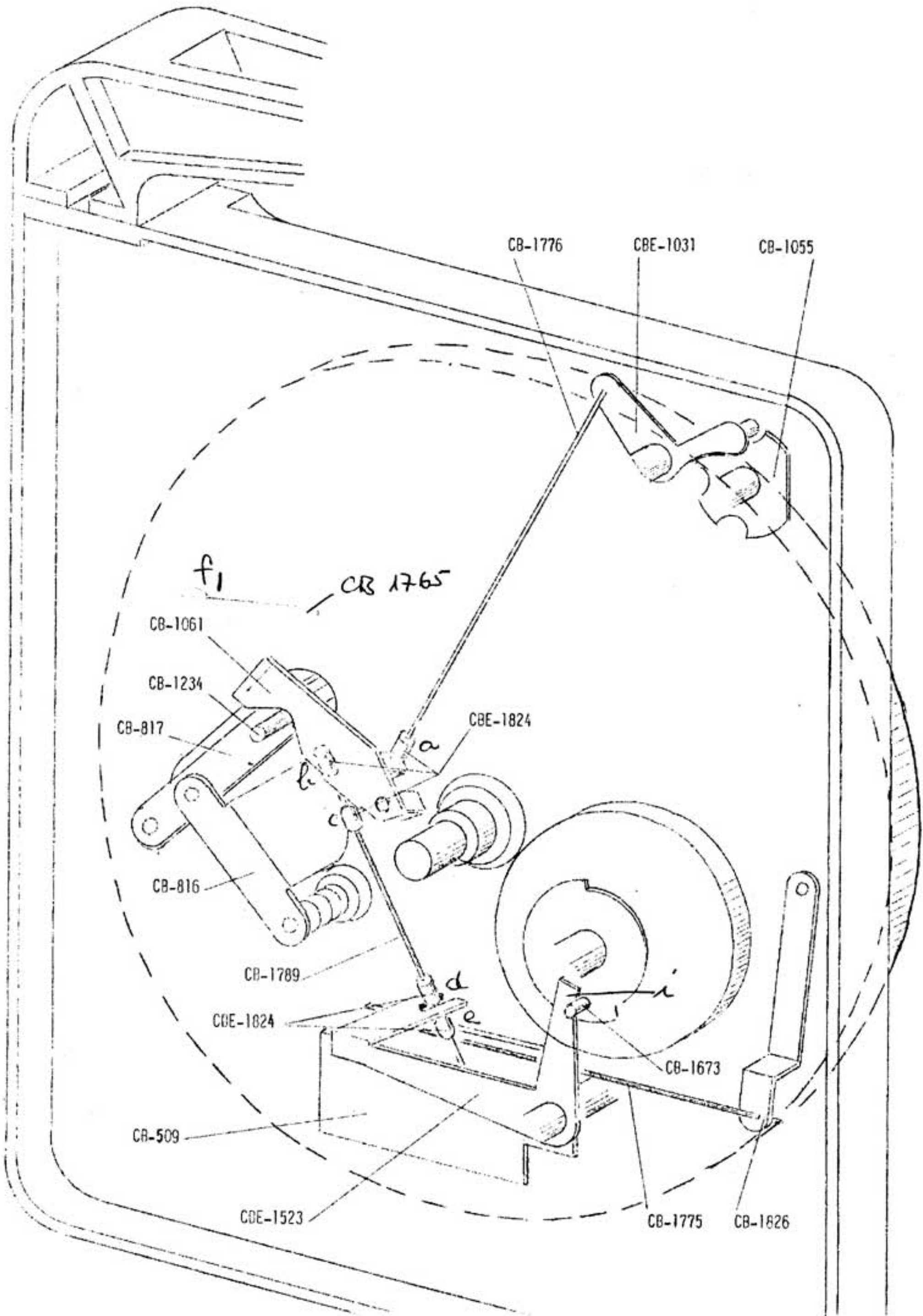

Fig. 3





MA VSM 12639

CBE-1827

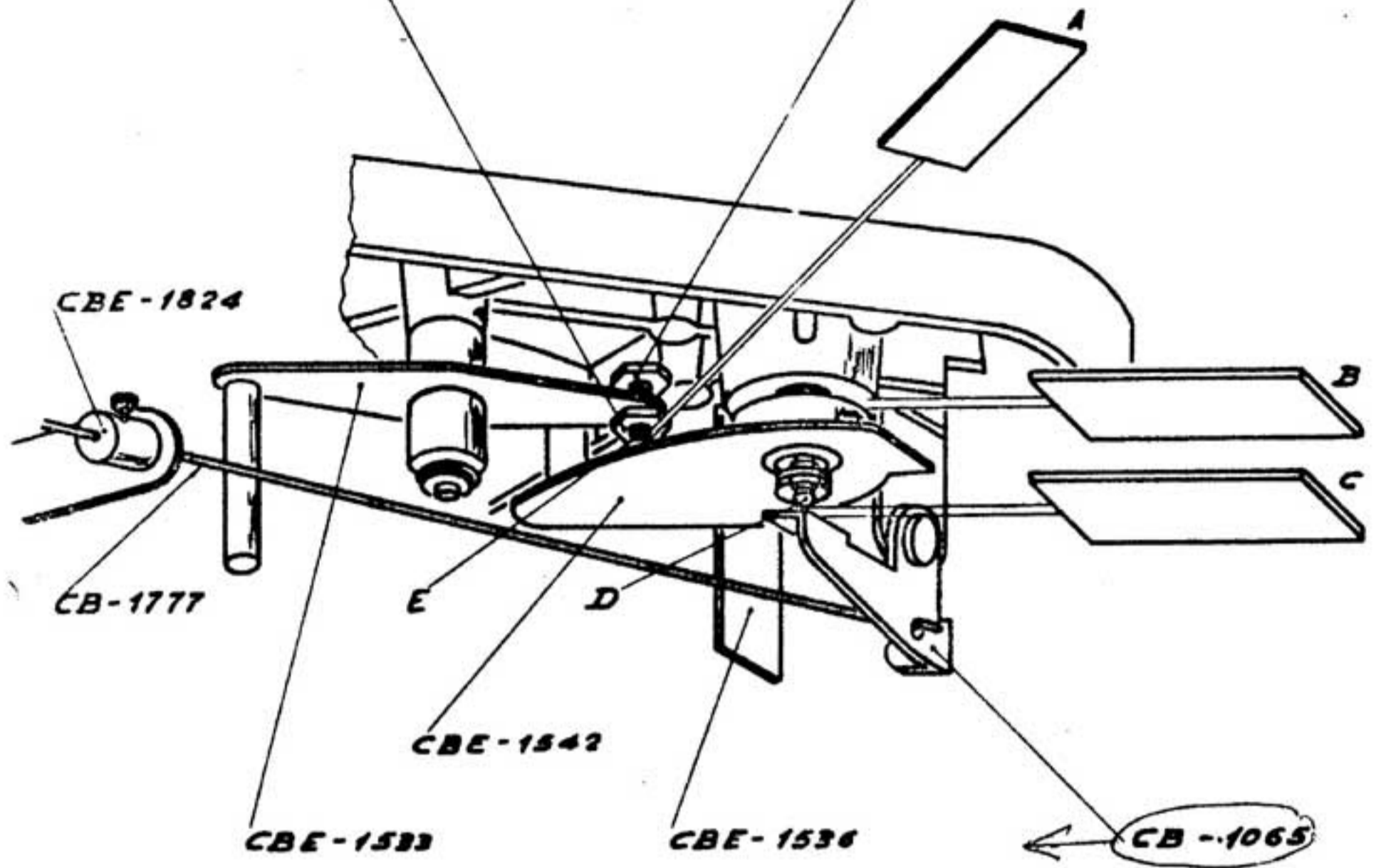

Fig. 6

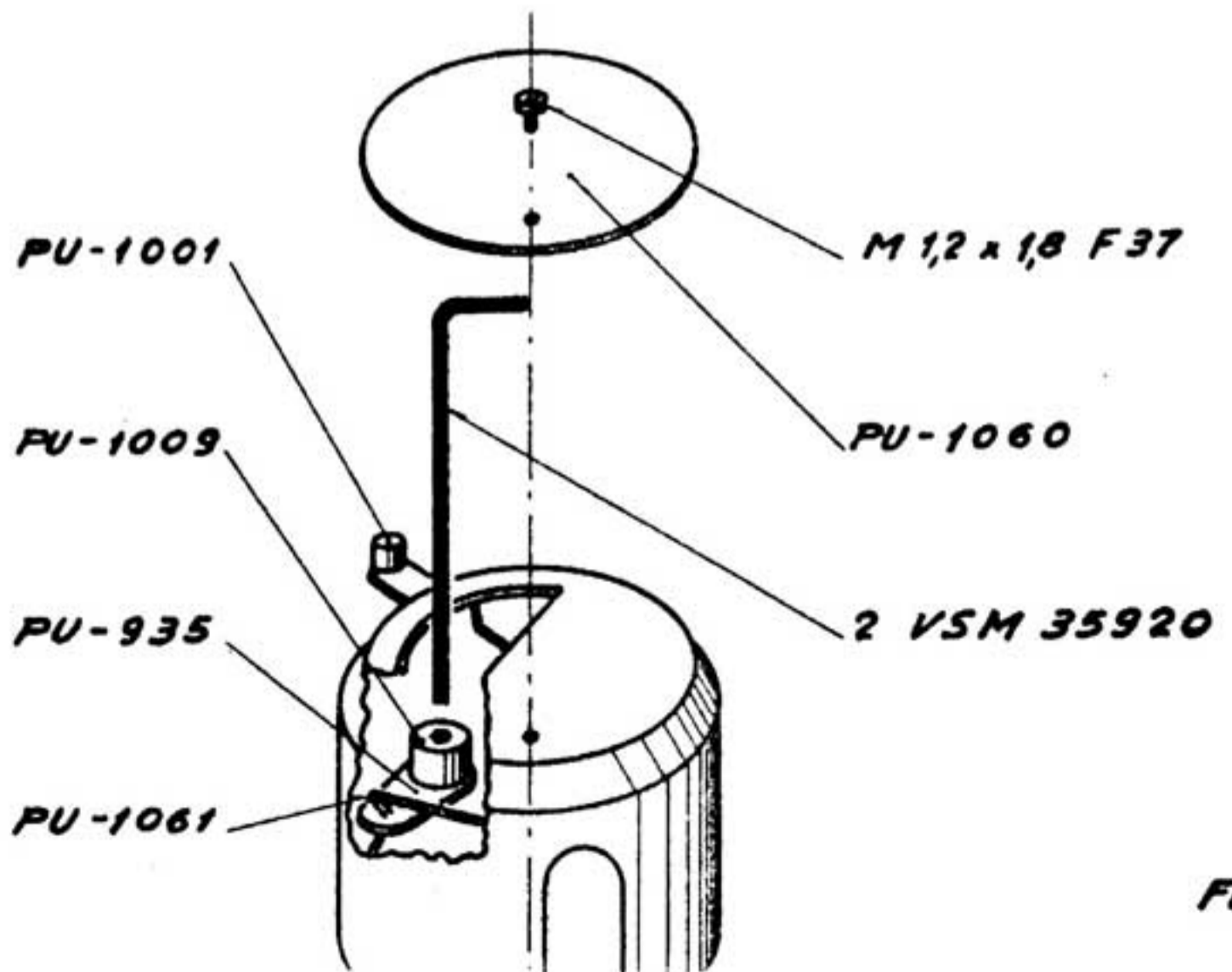

Fig. 7

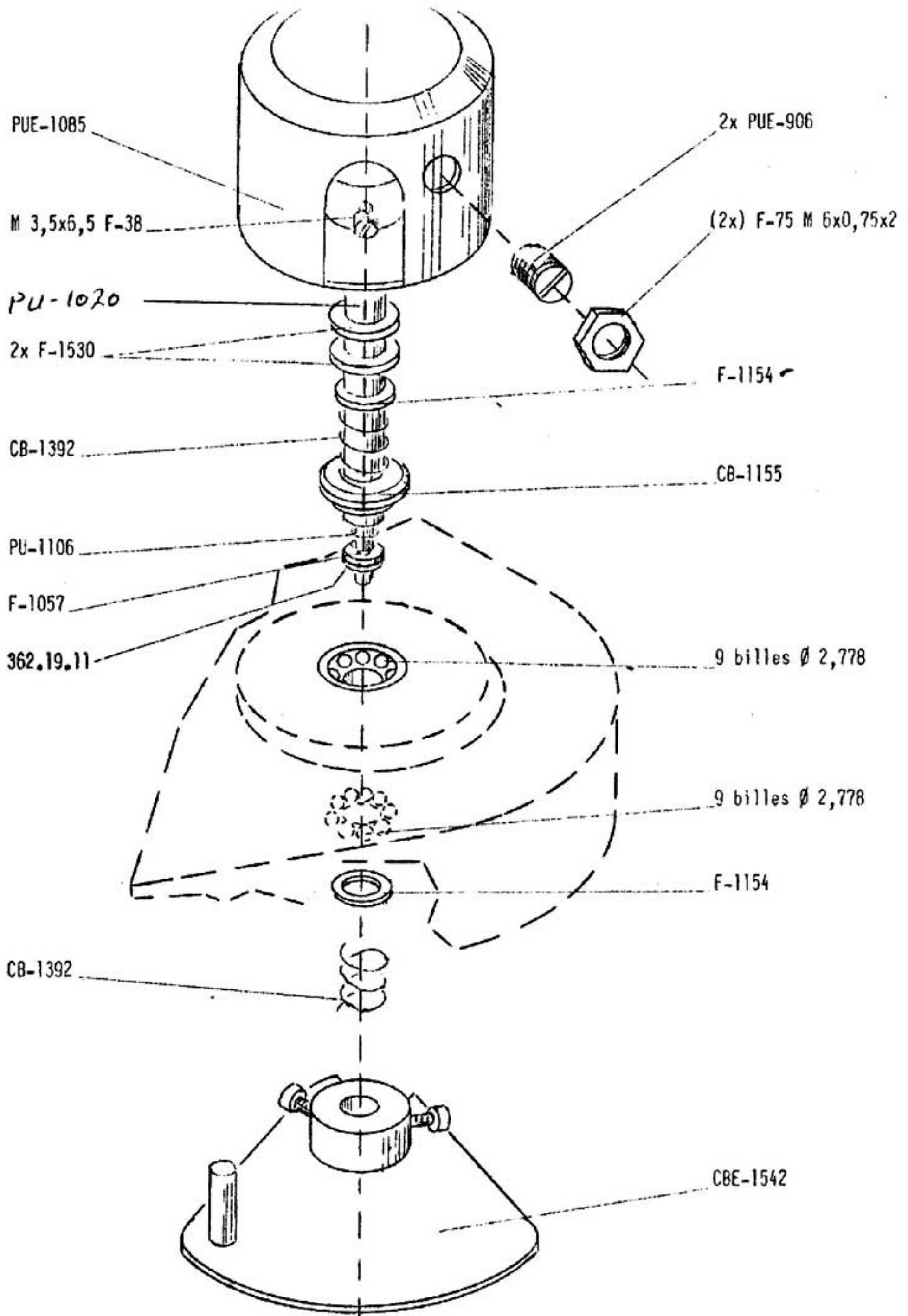

Fig. 8

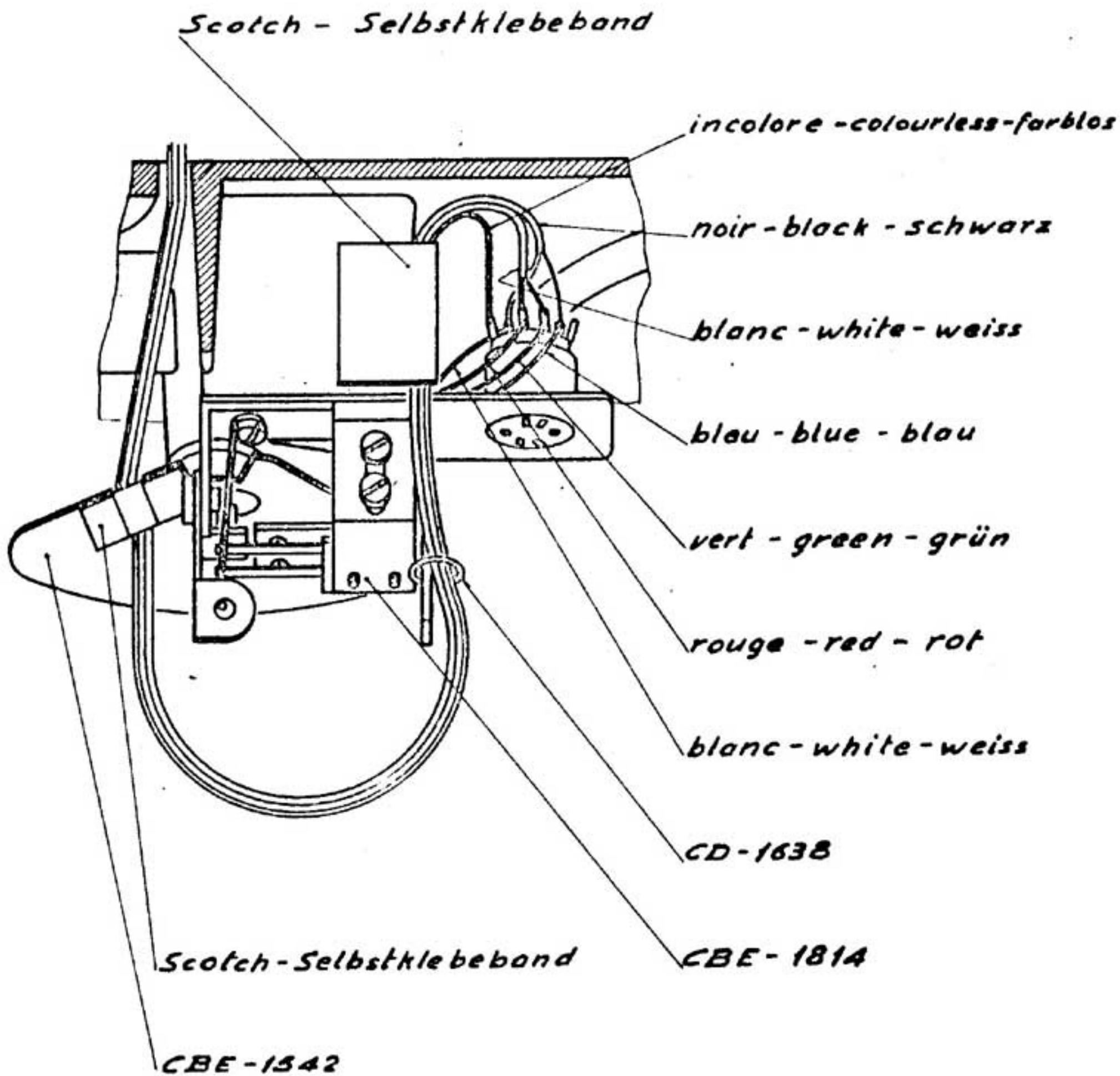

Fig. 9



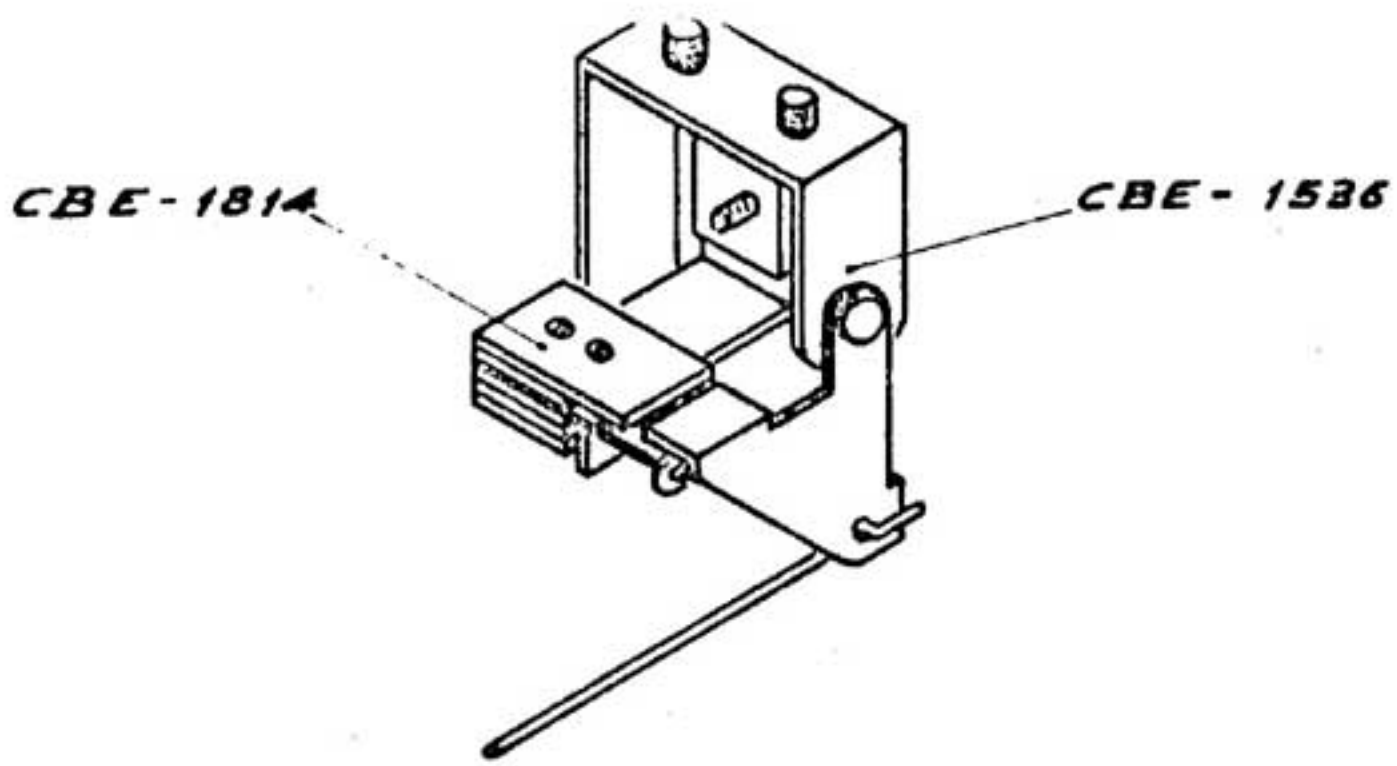

Fig. 10

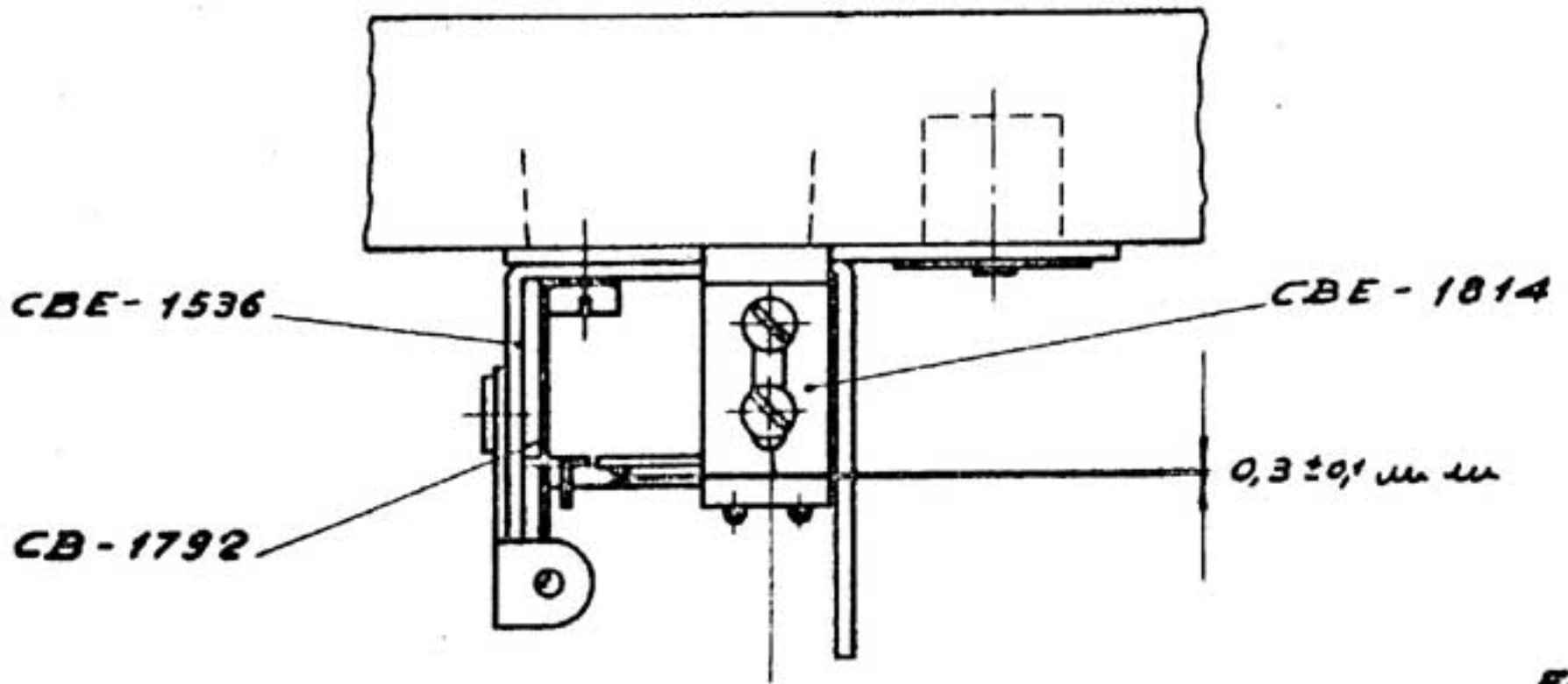

Fig. 11

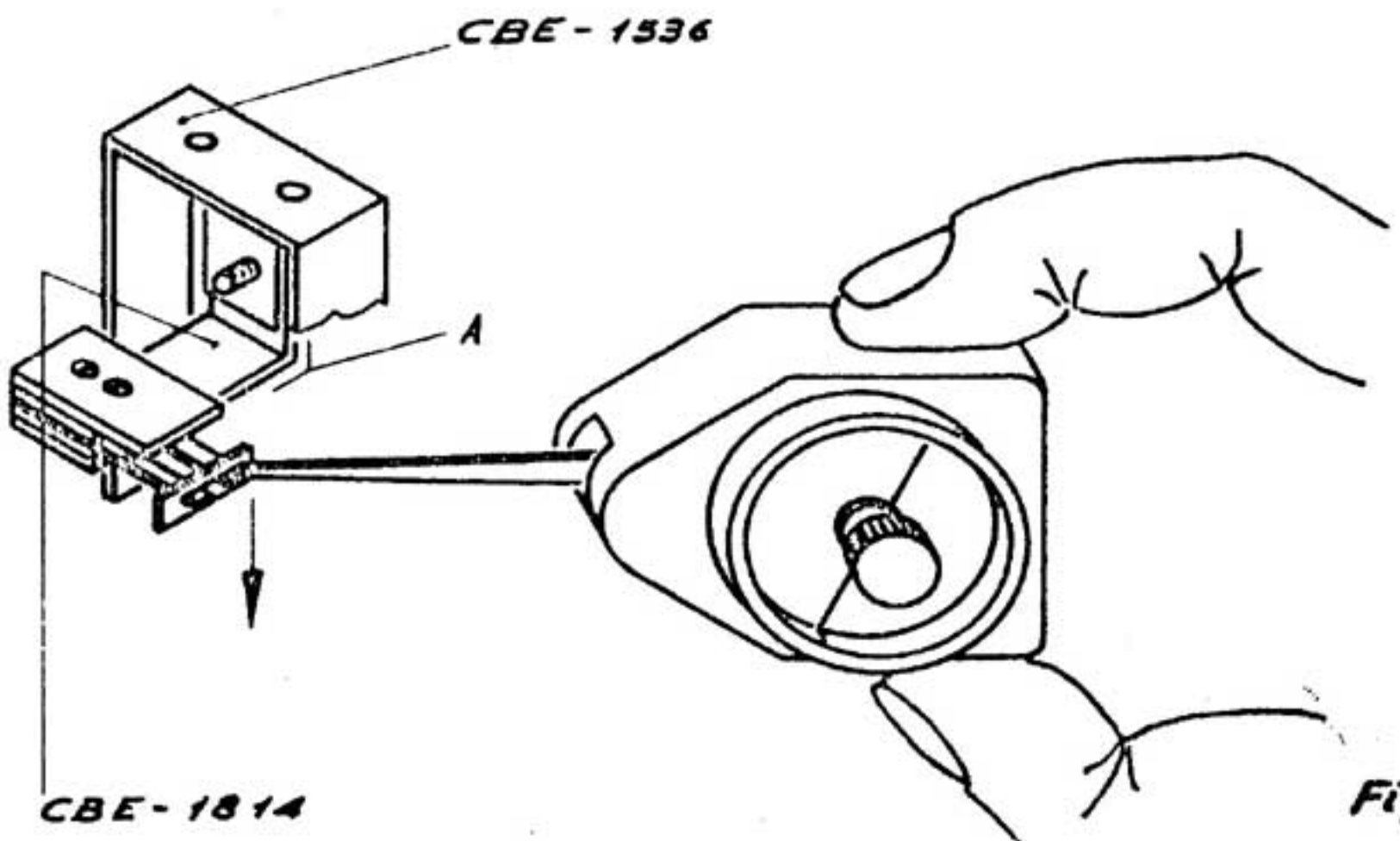

Fig. 12

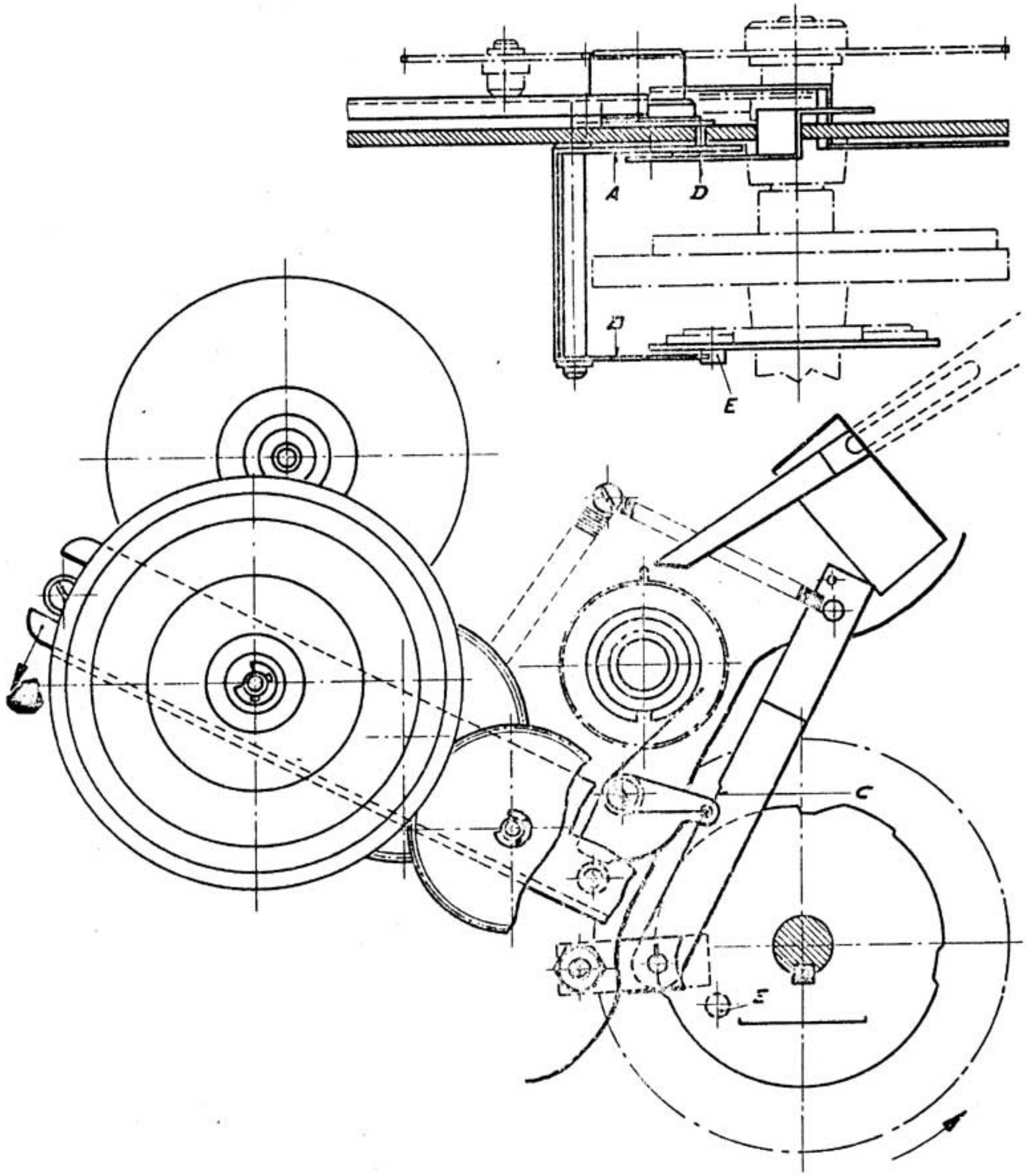

Fig. 14

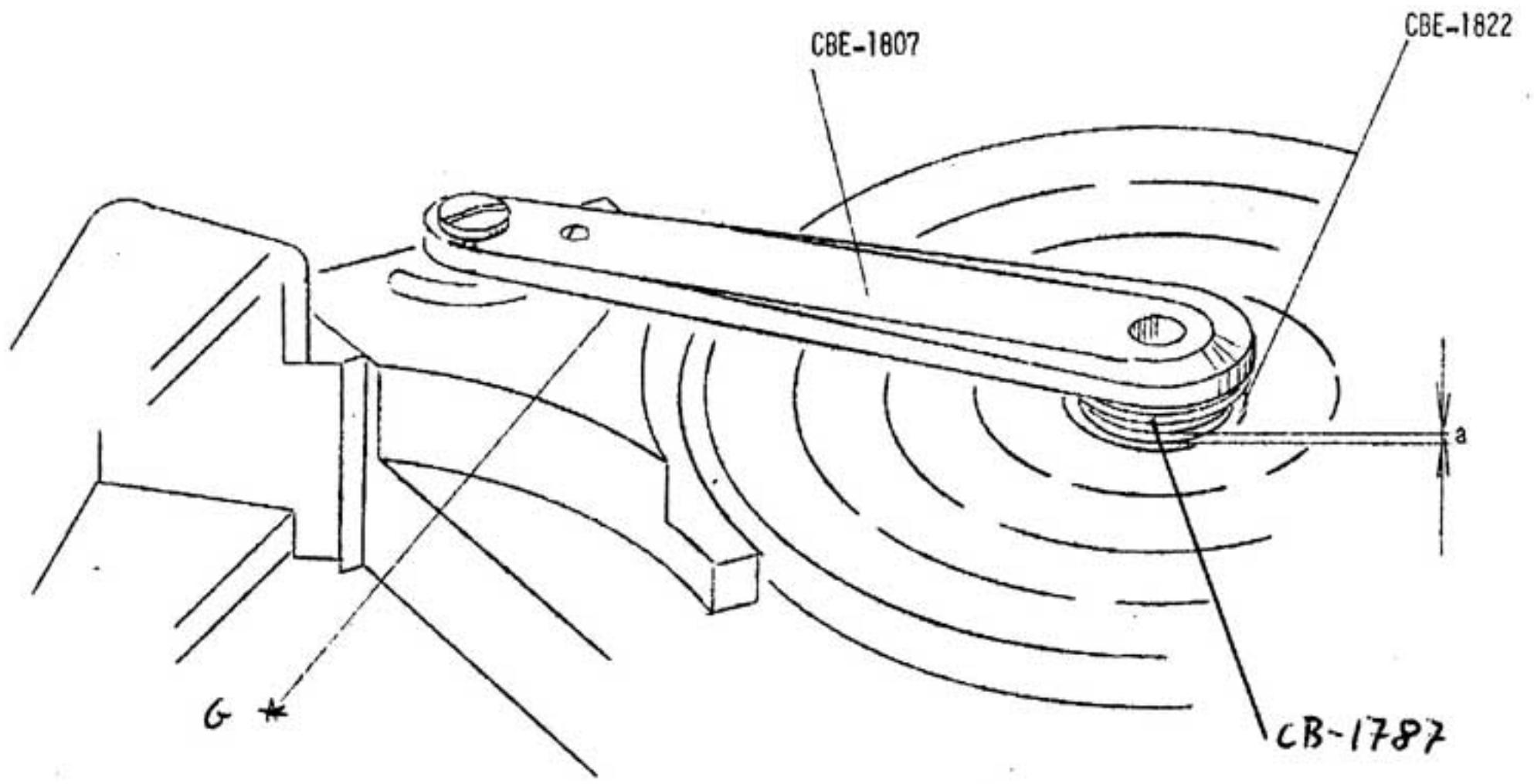

Fig. 15

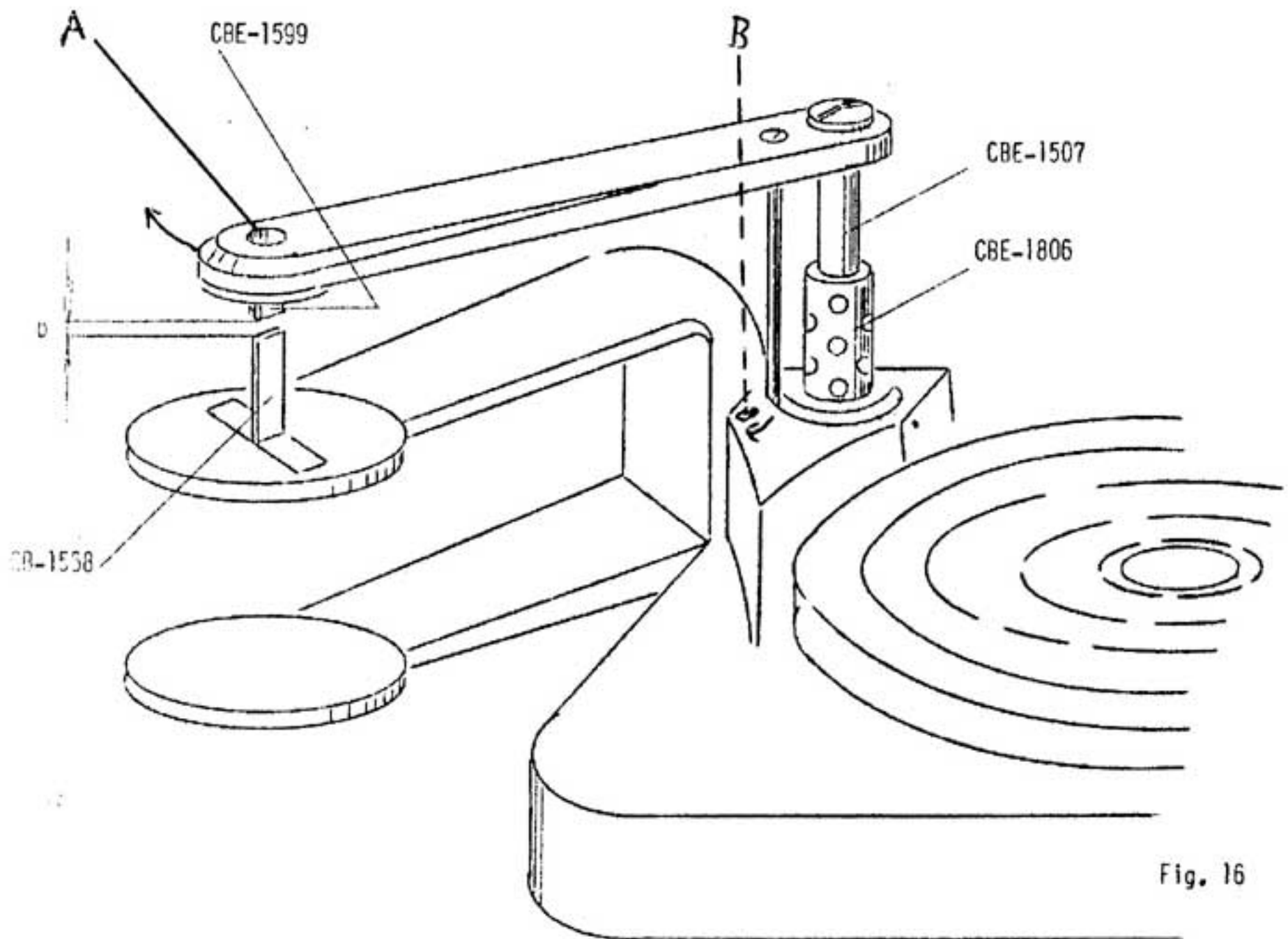

Fig. 16

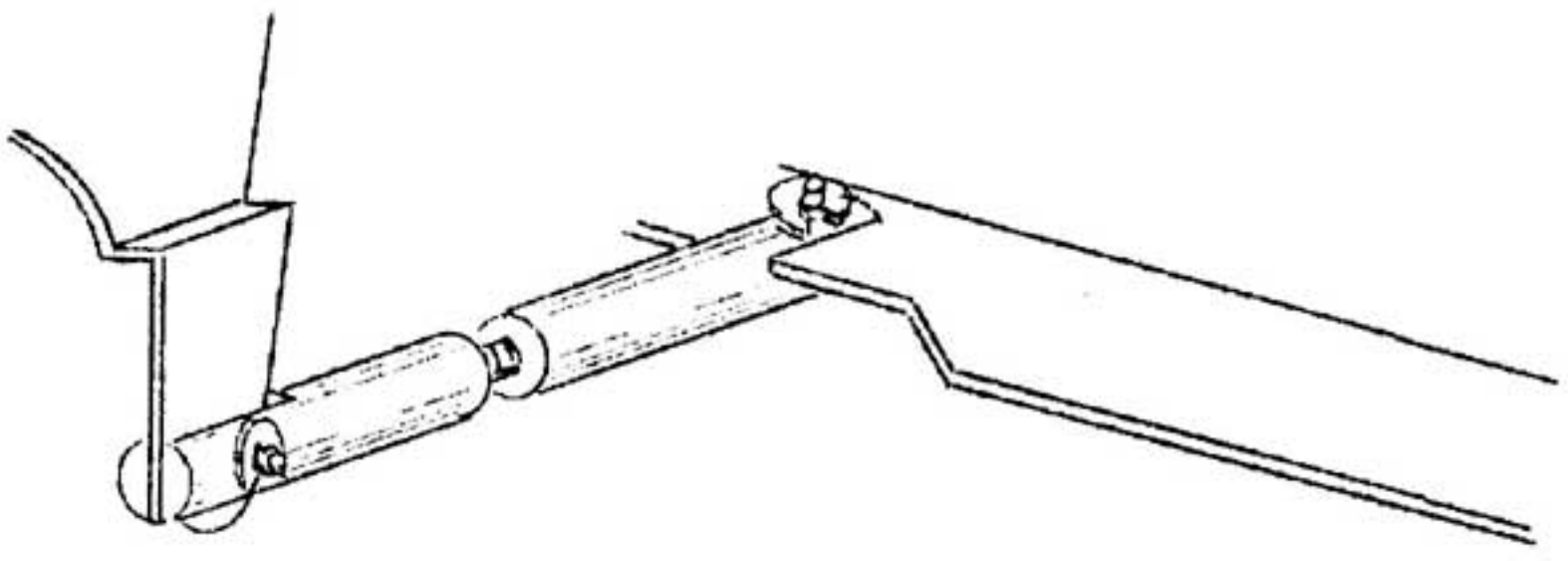

Fig. 17

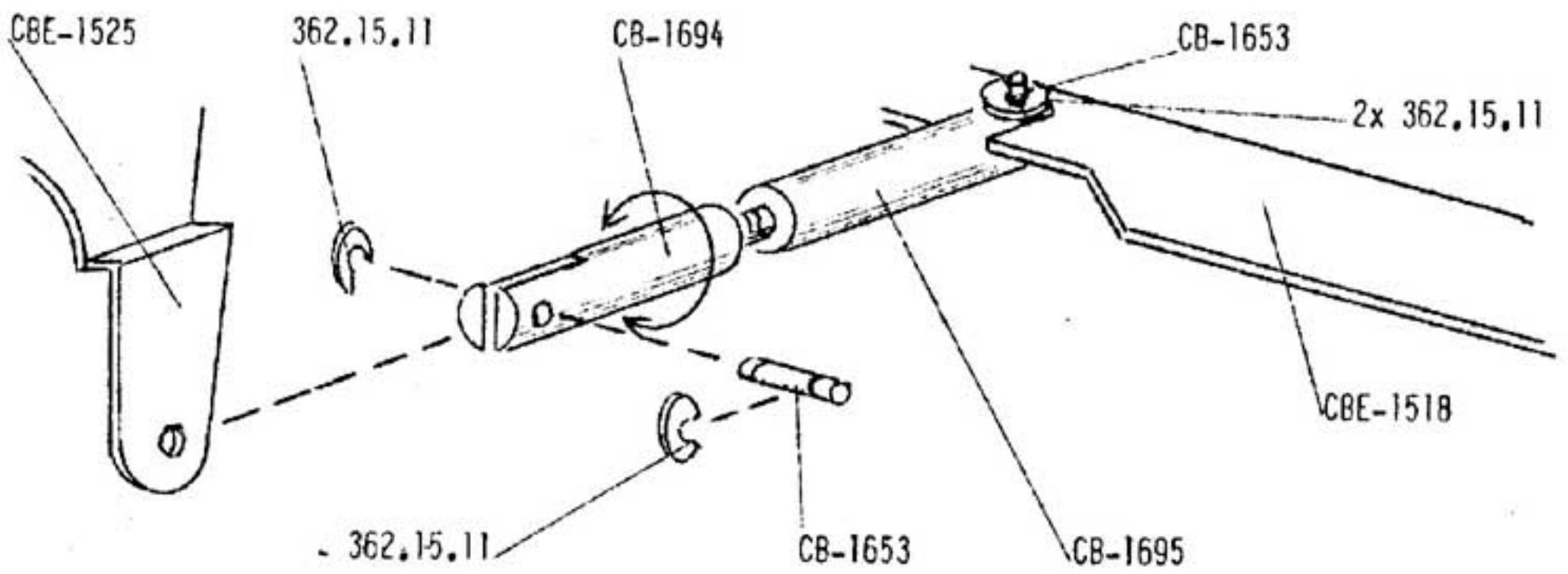

Fig. 18

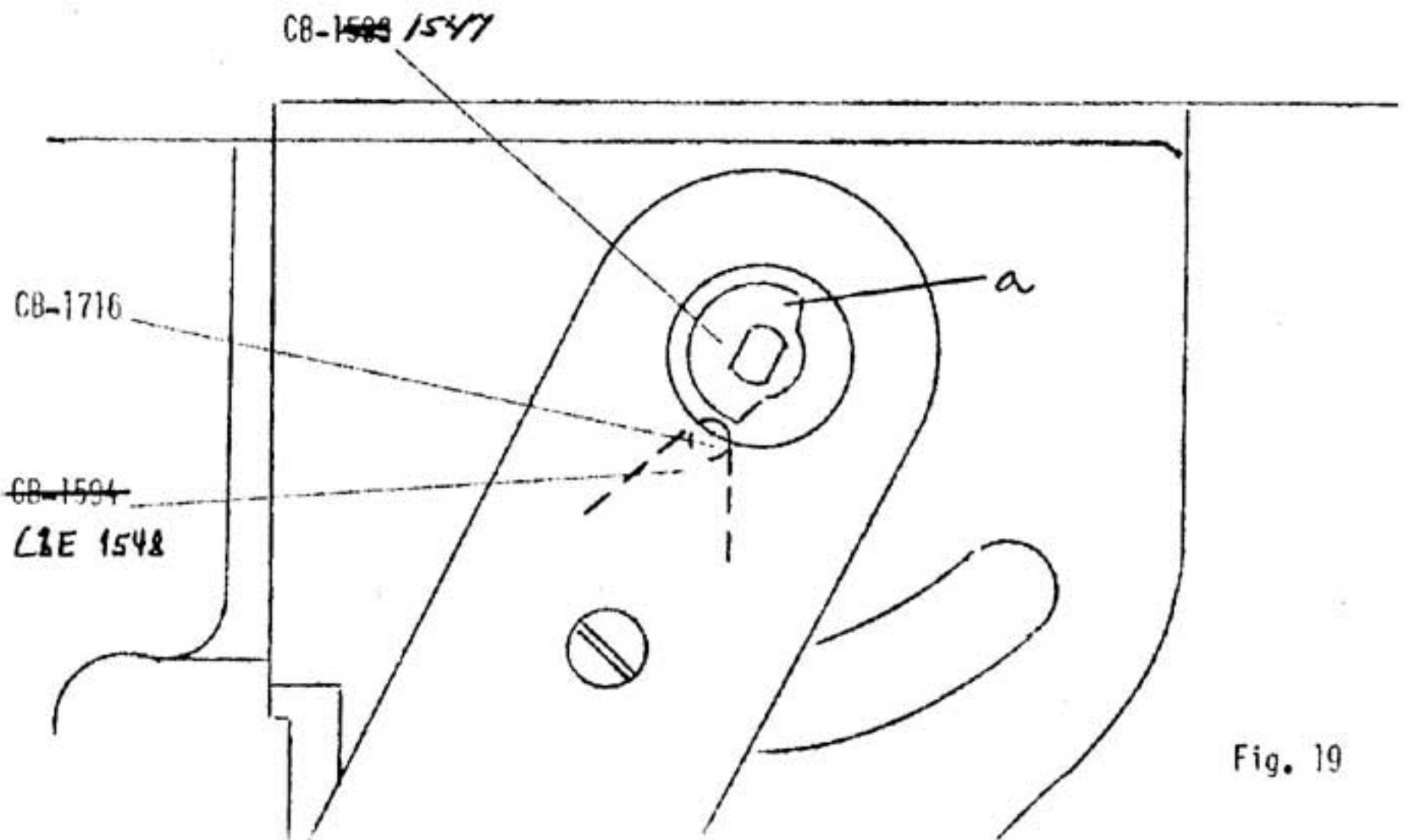

Fig. 19

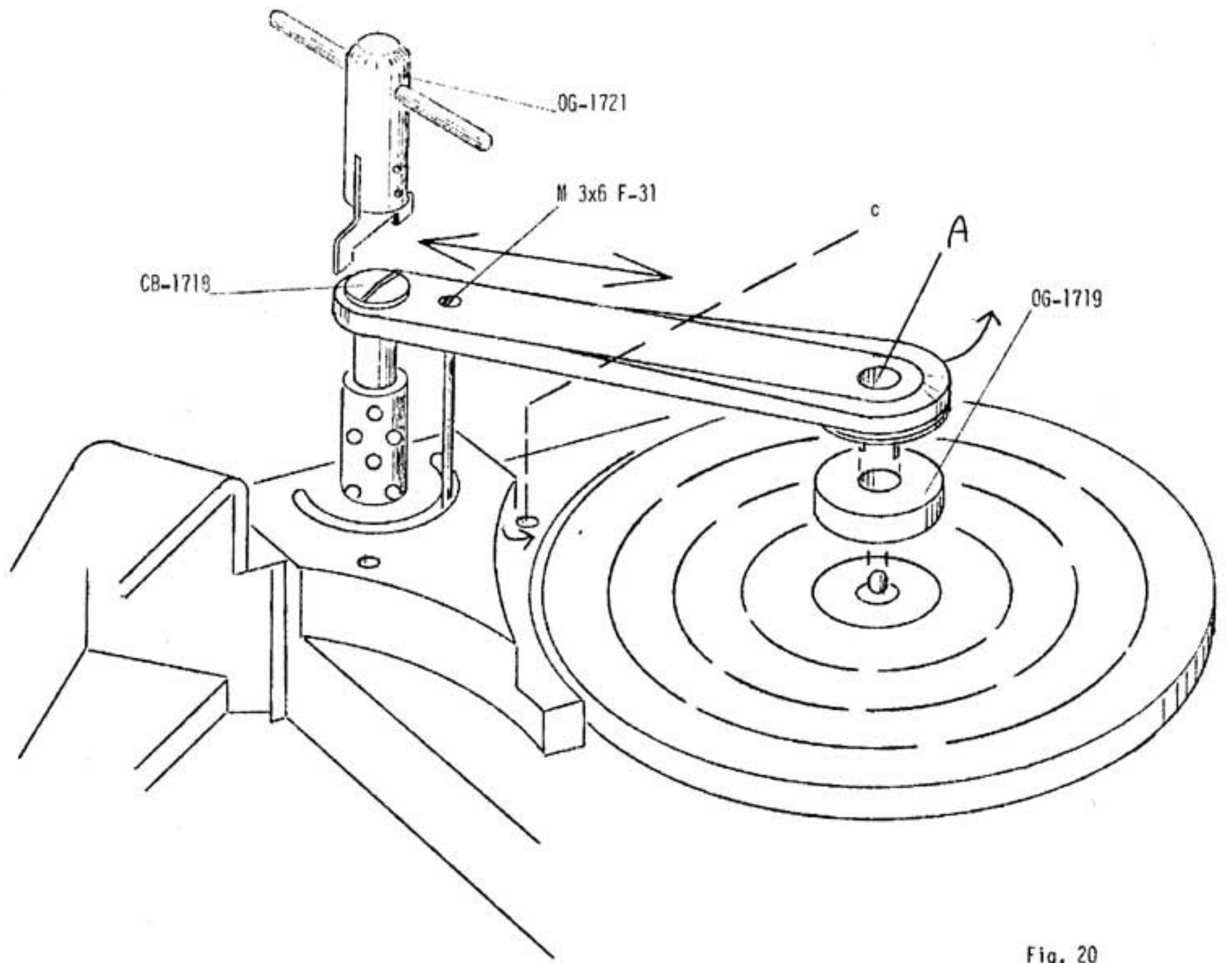
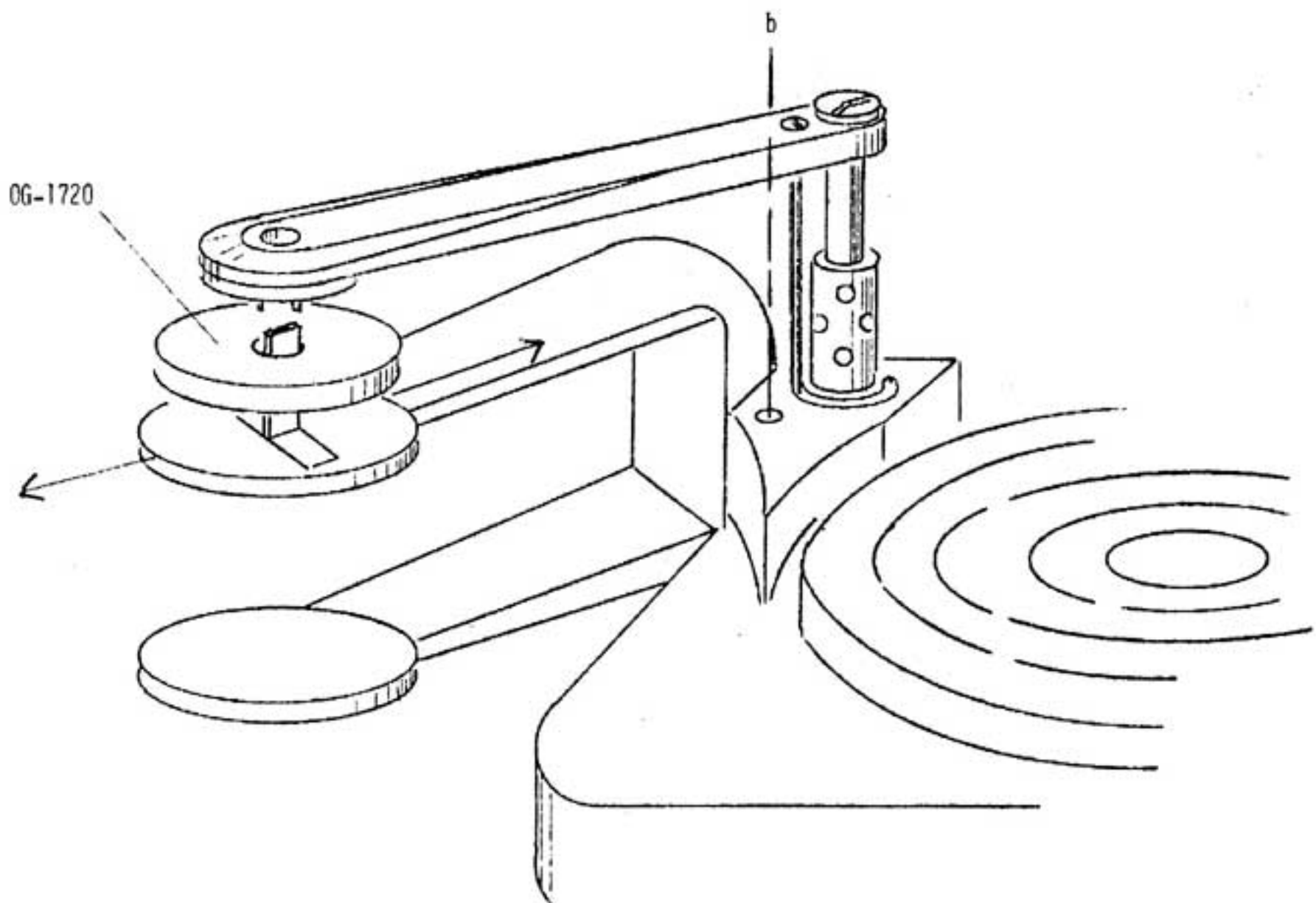

Fig. 20



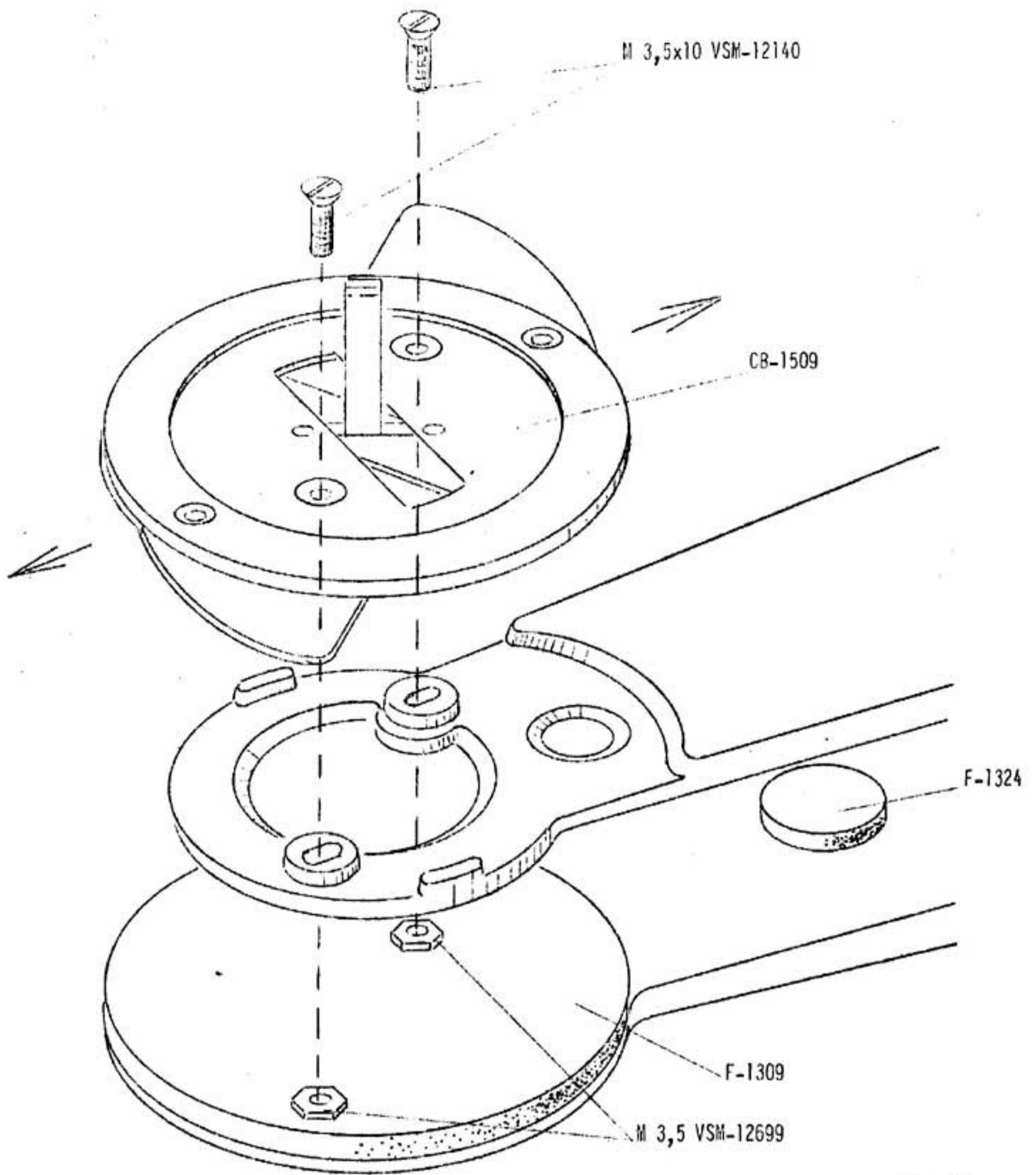

Fig. 22

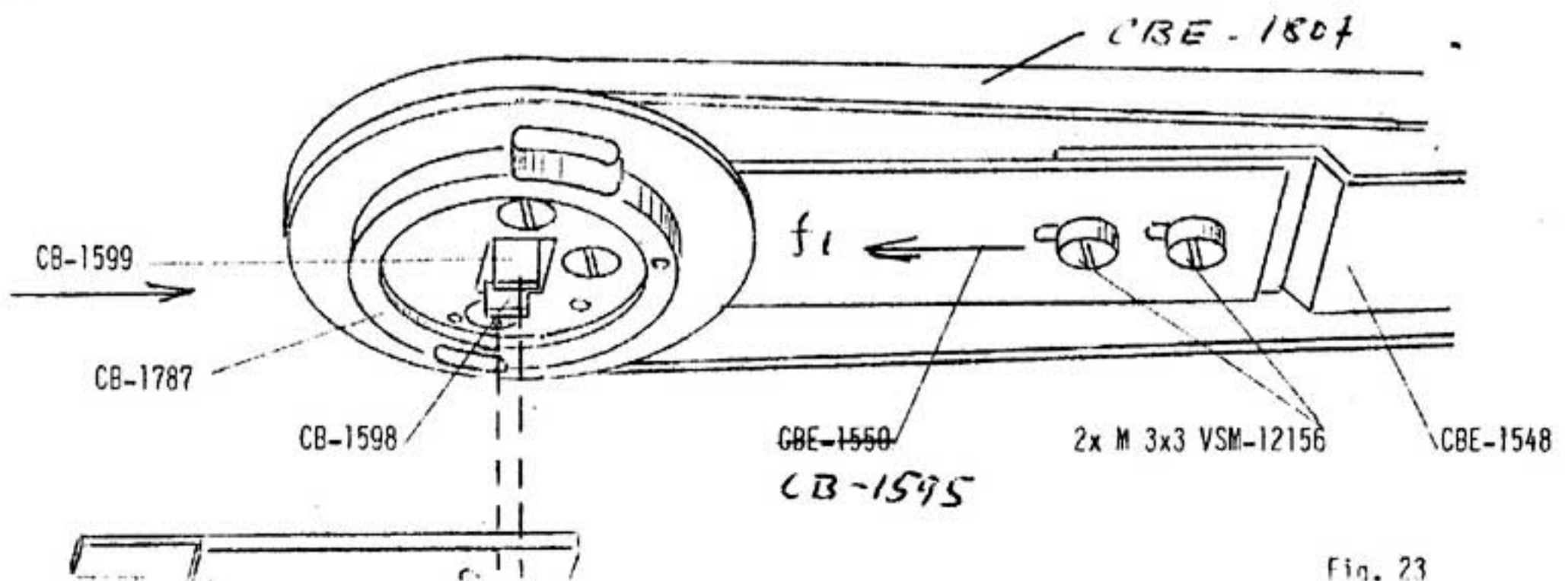
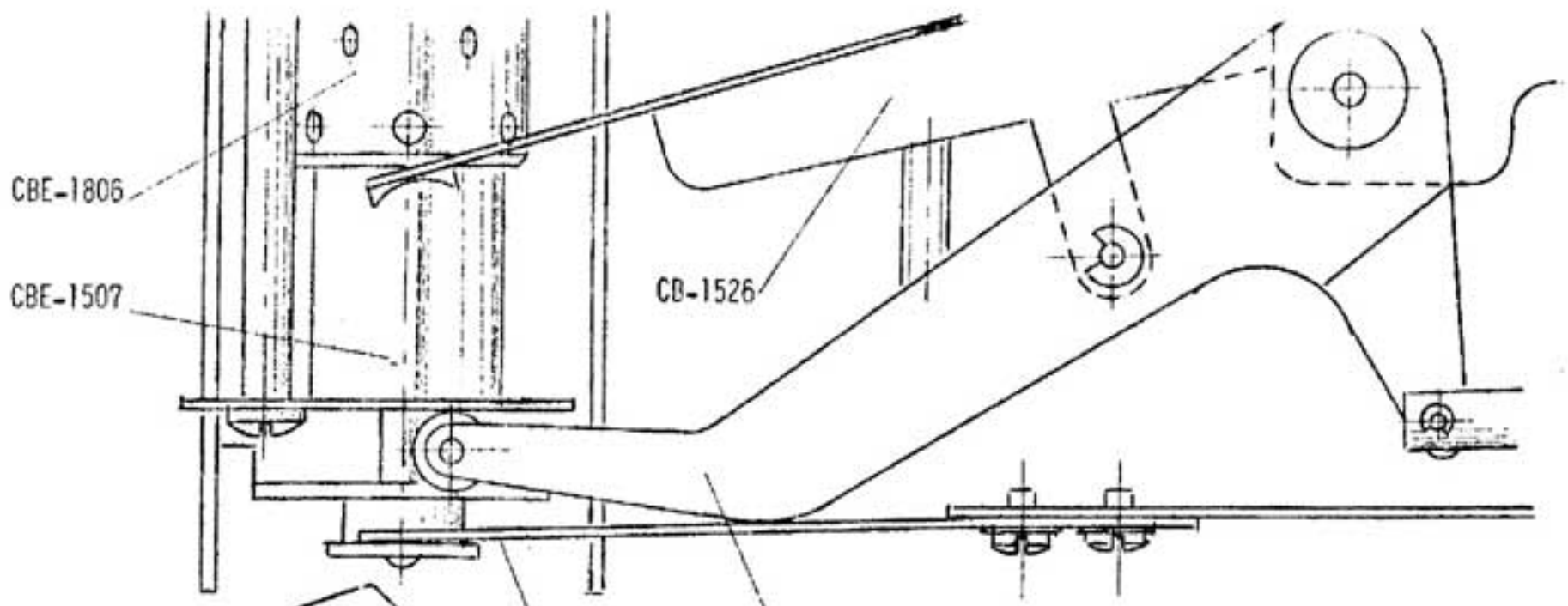
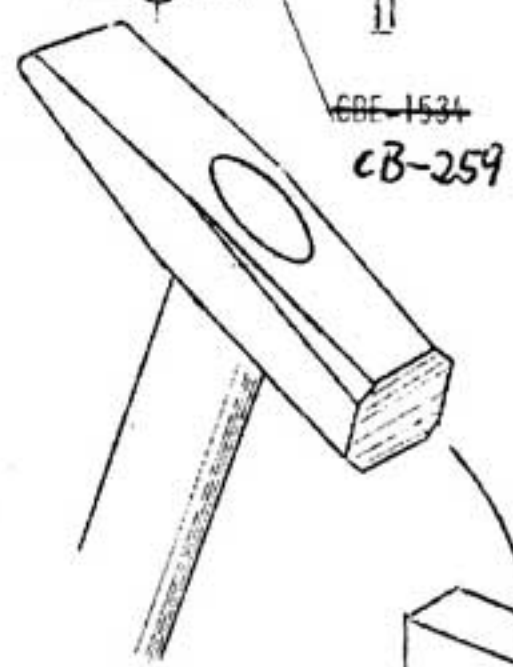

Fig. 23



24  
Fig. 24 bis



$d \neq$

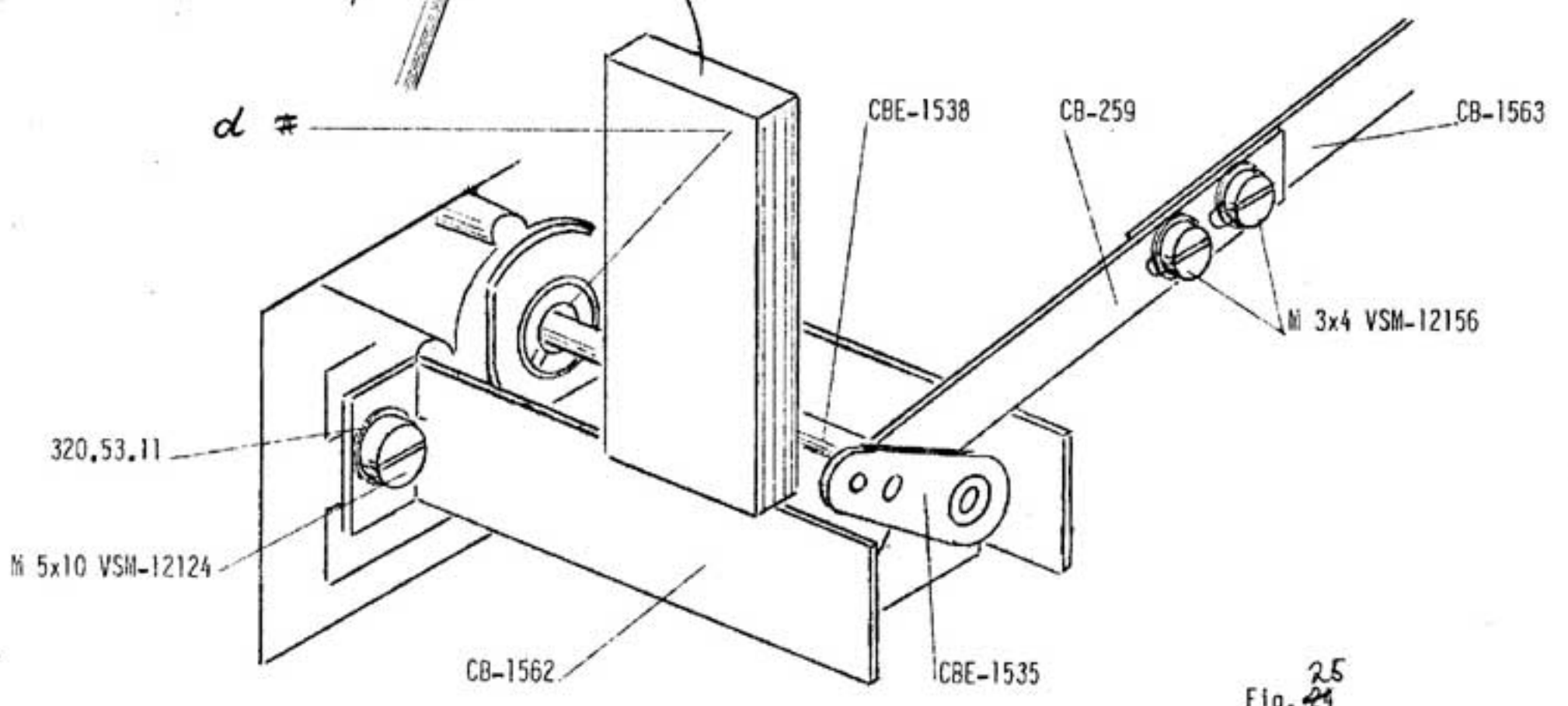

25  
Fig. 25

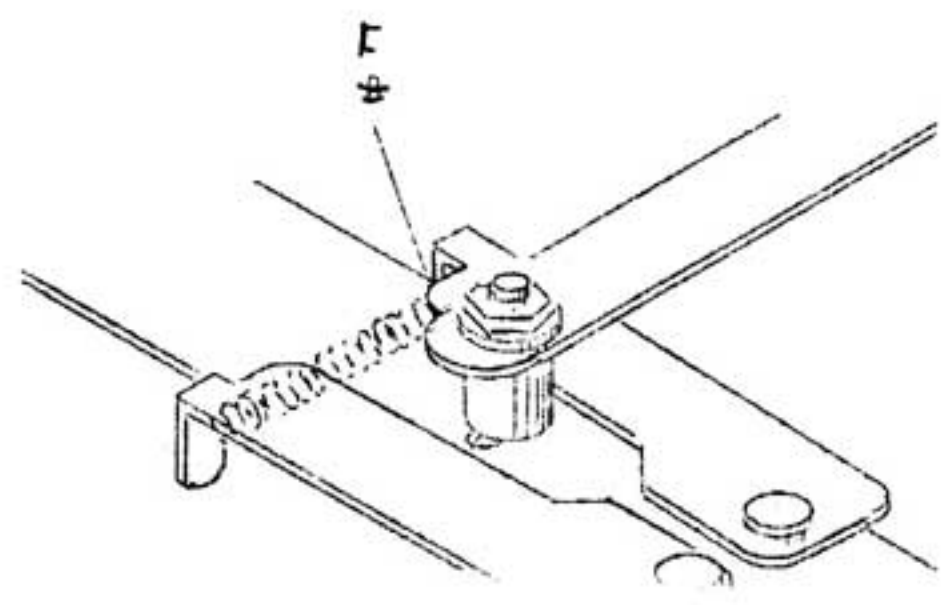
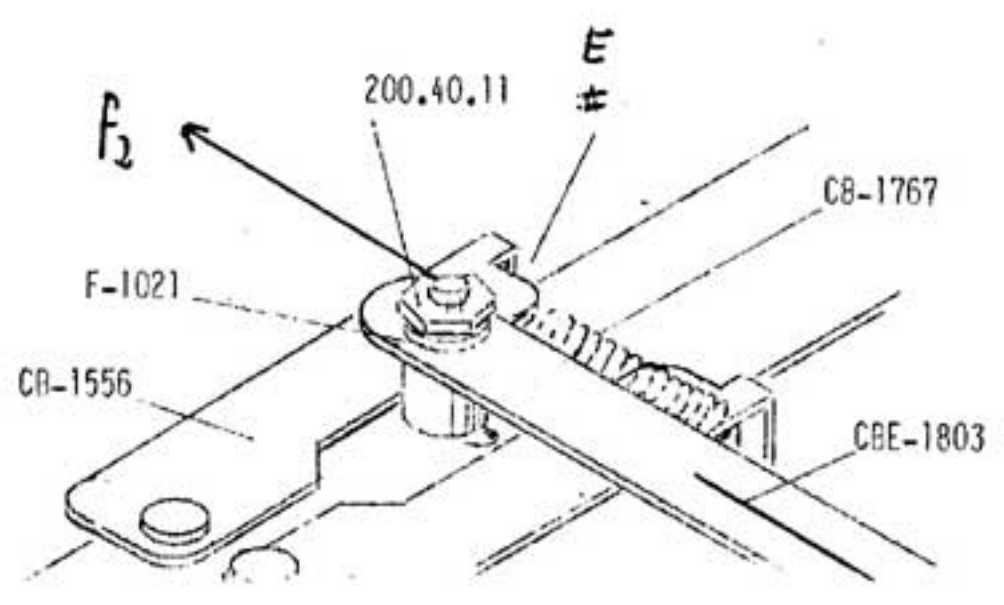

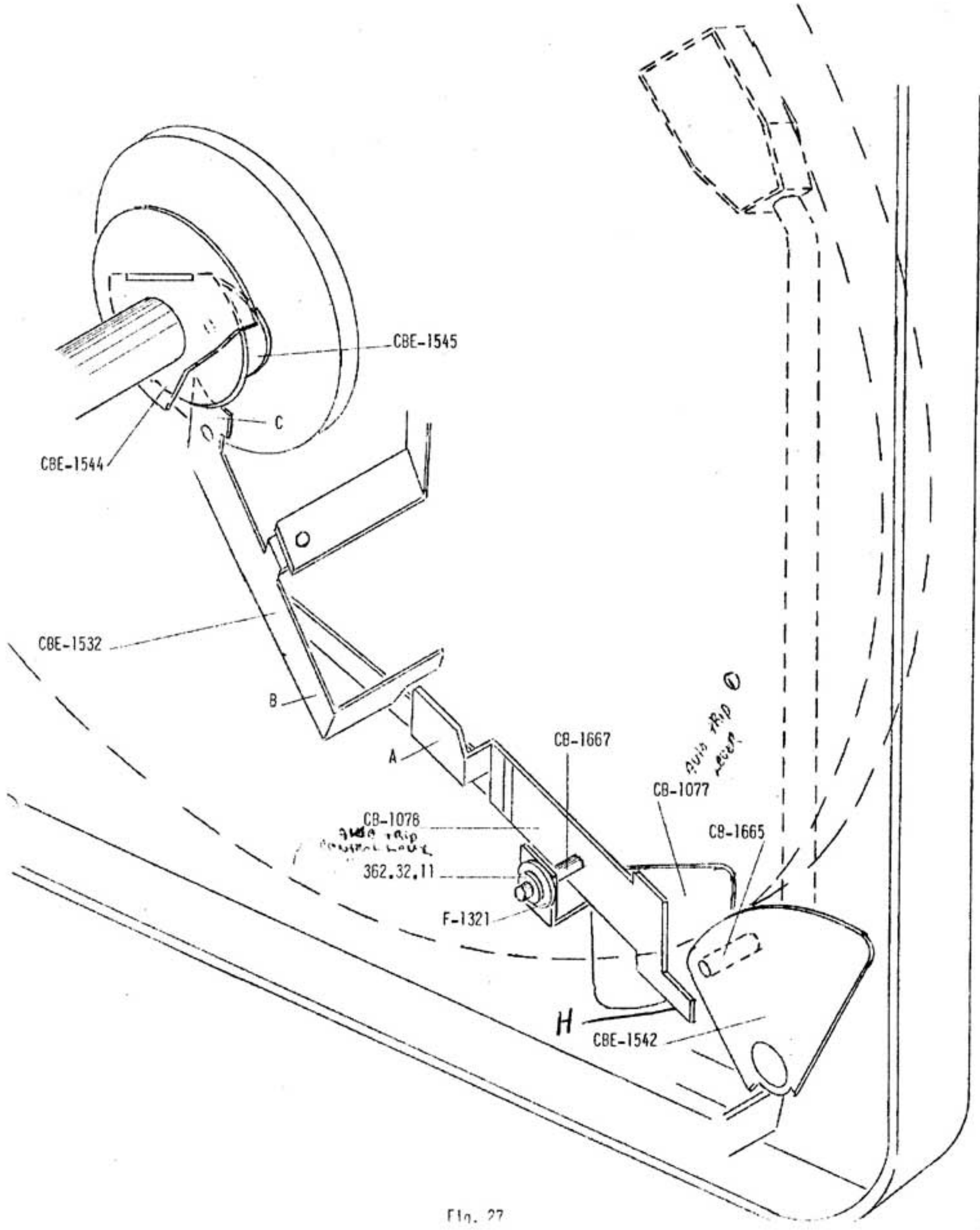

Fig. 27



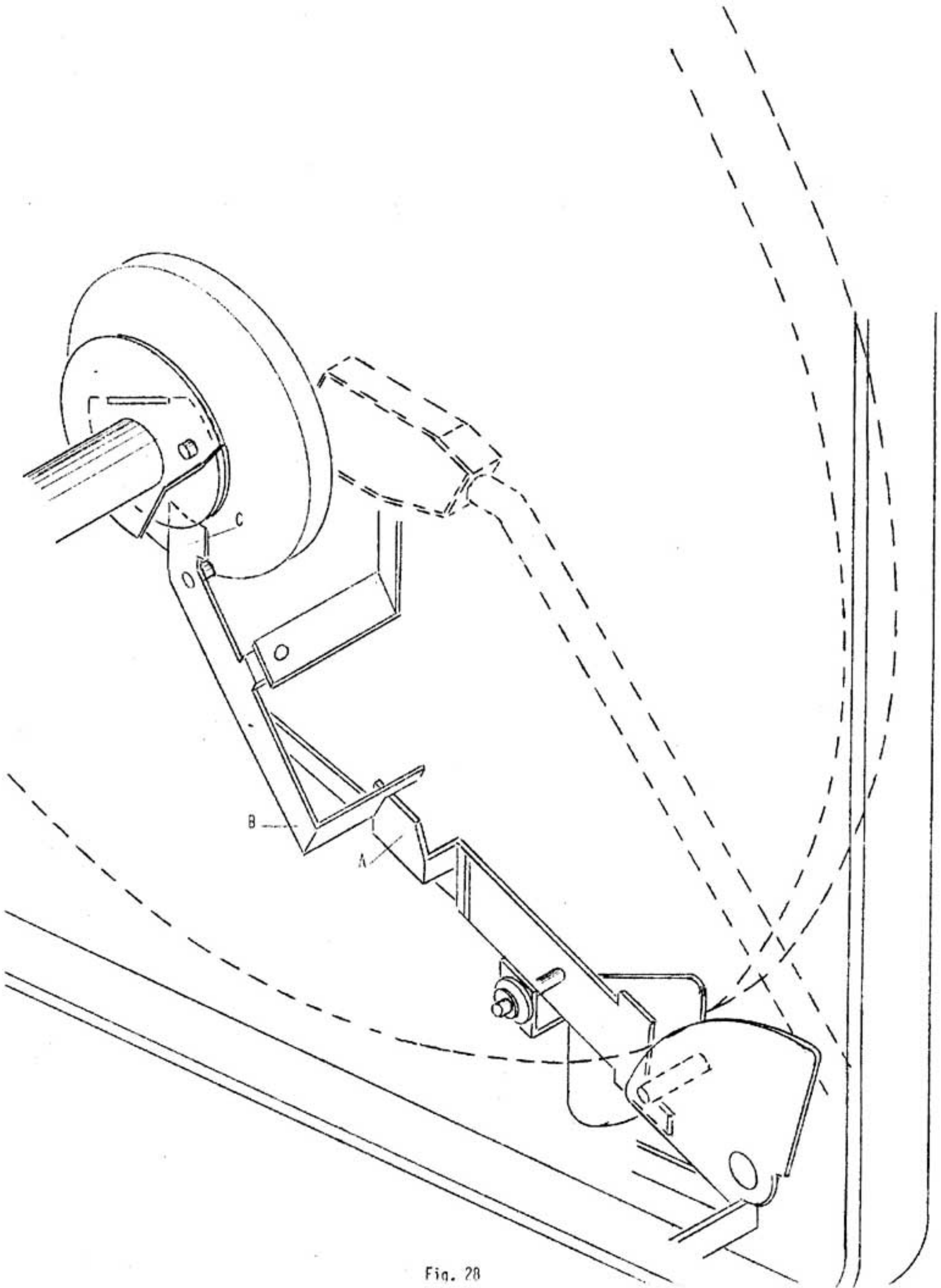

Fig. 28

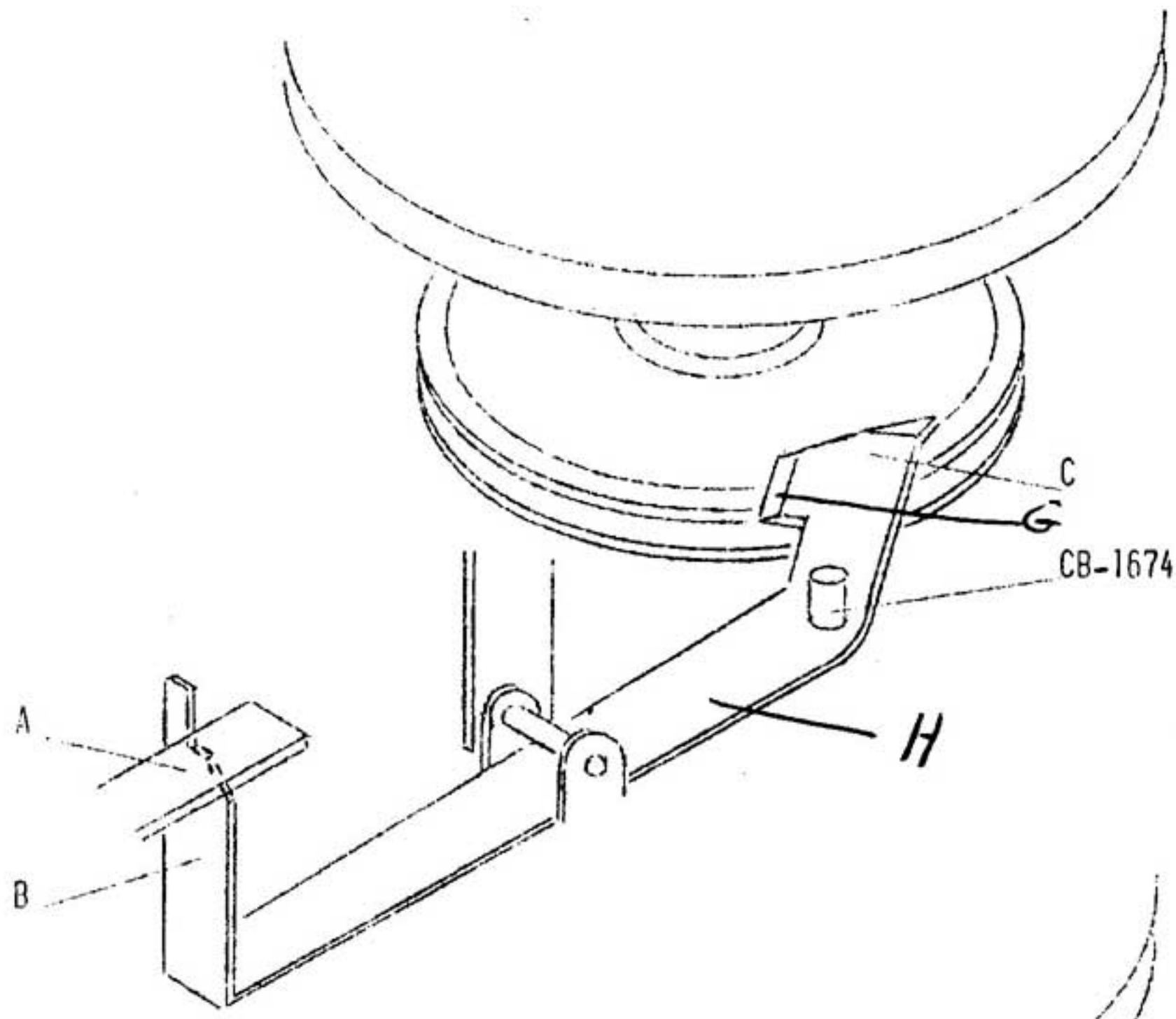

Fig. 29

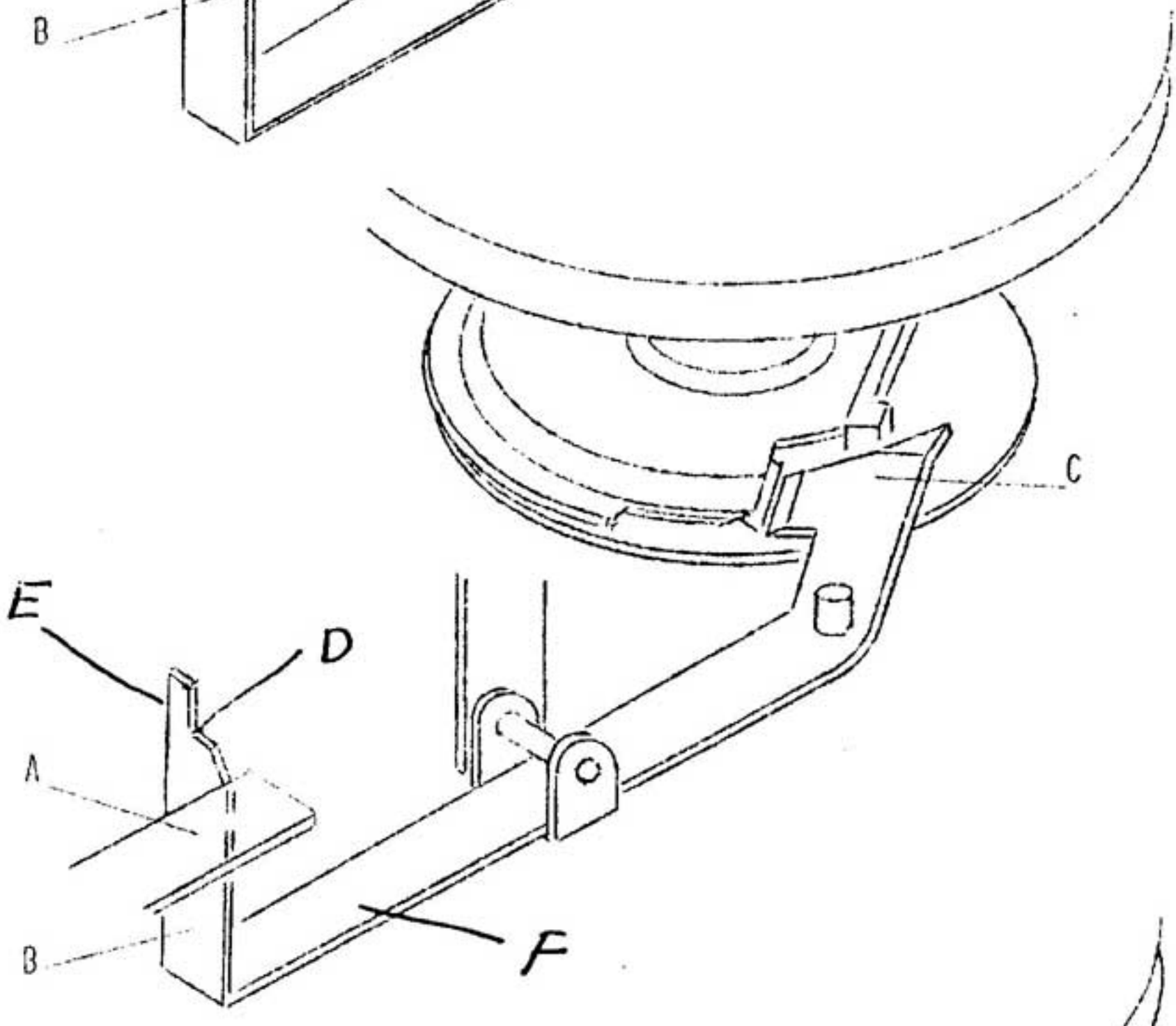

Fig. 30

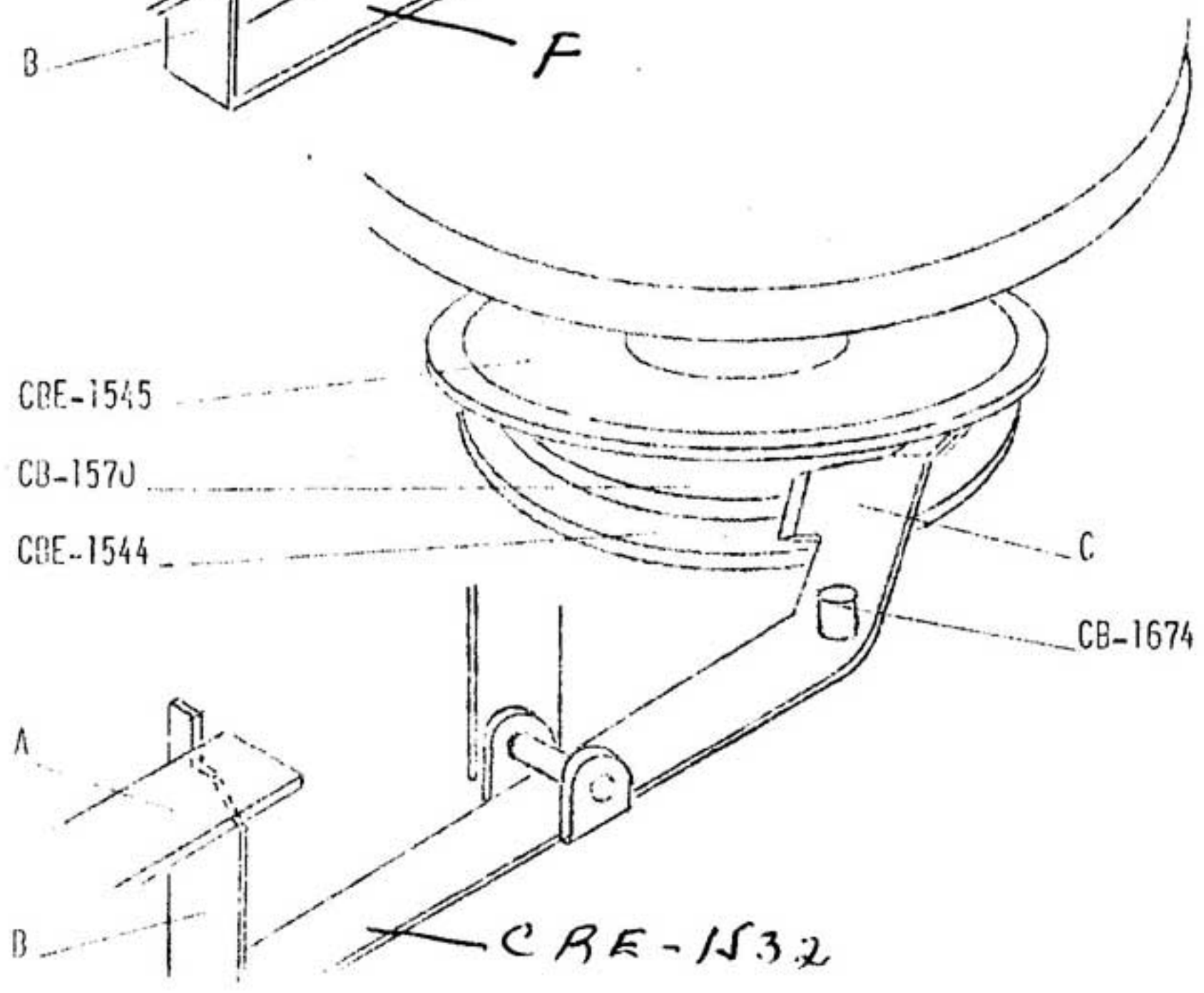

Fig. 31

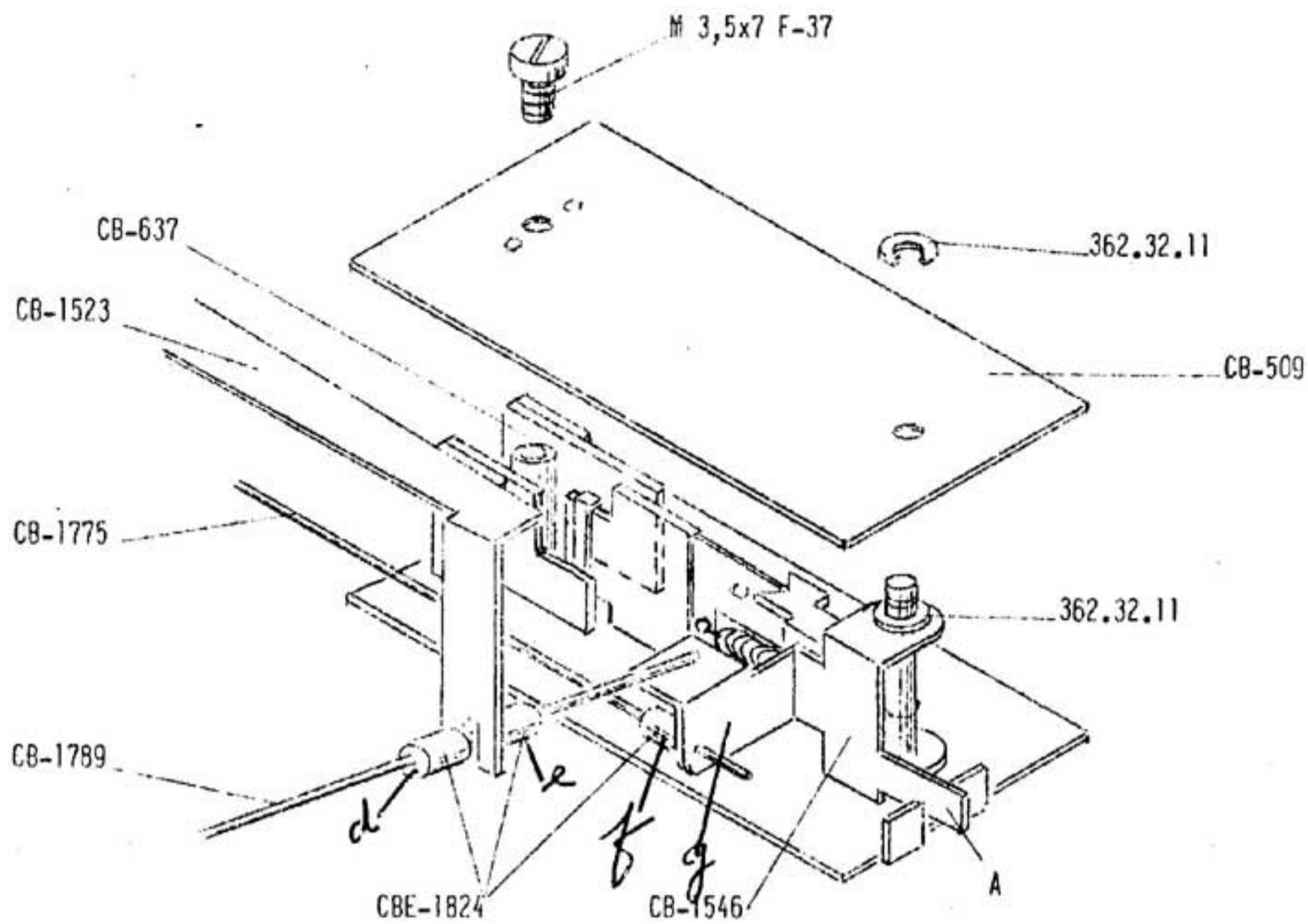

Fig. 34

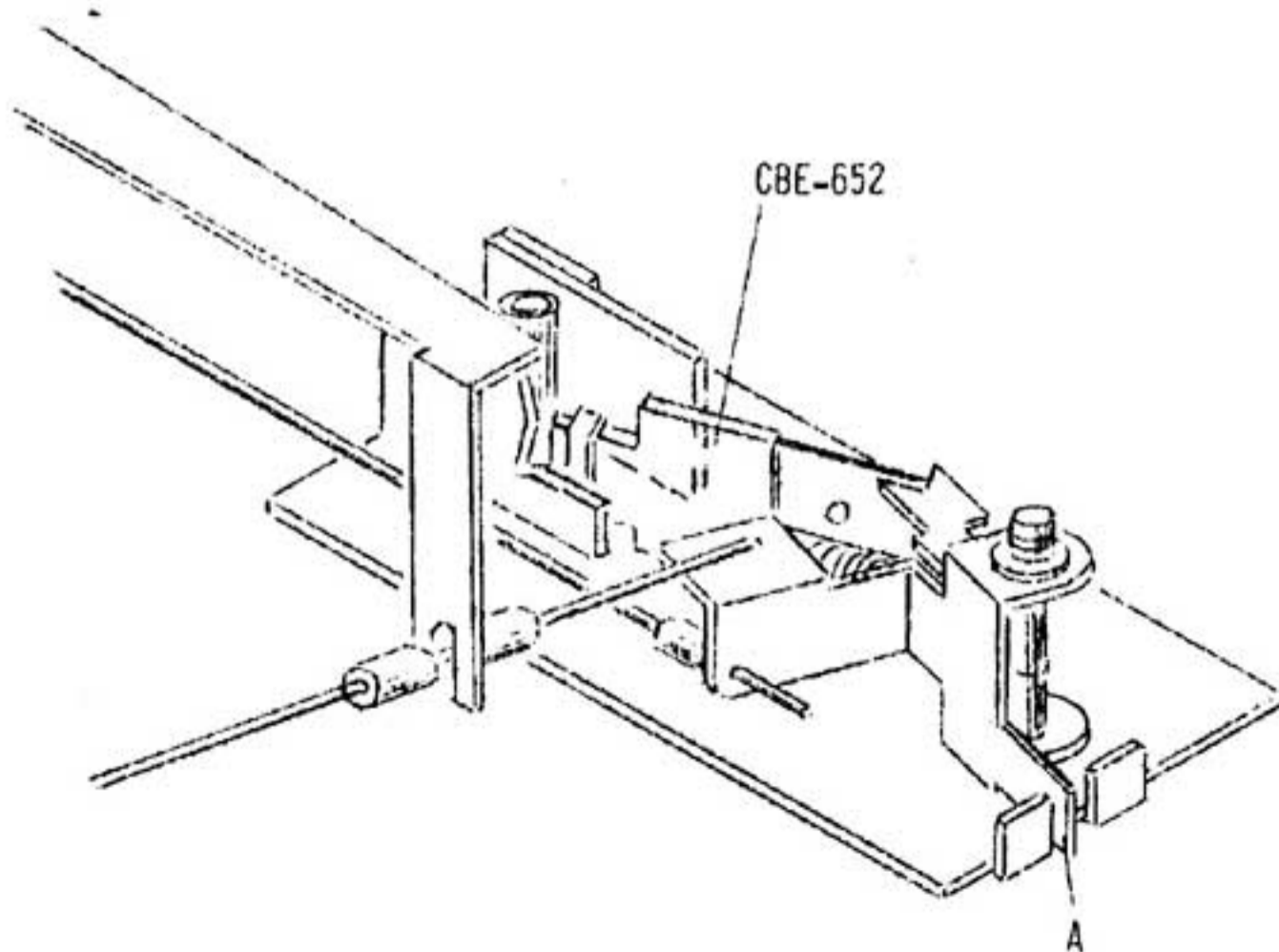

Fig. 35

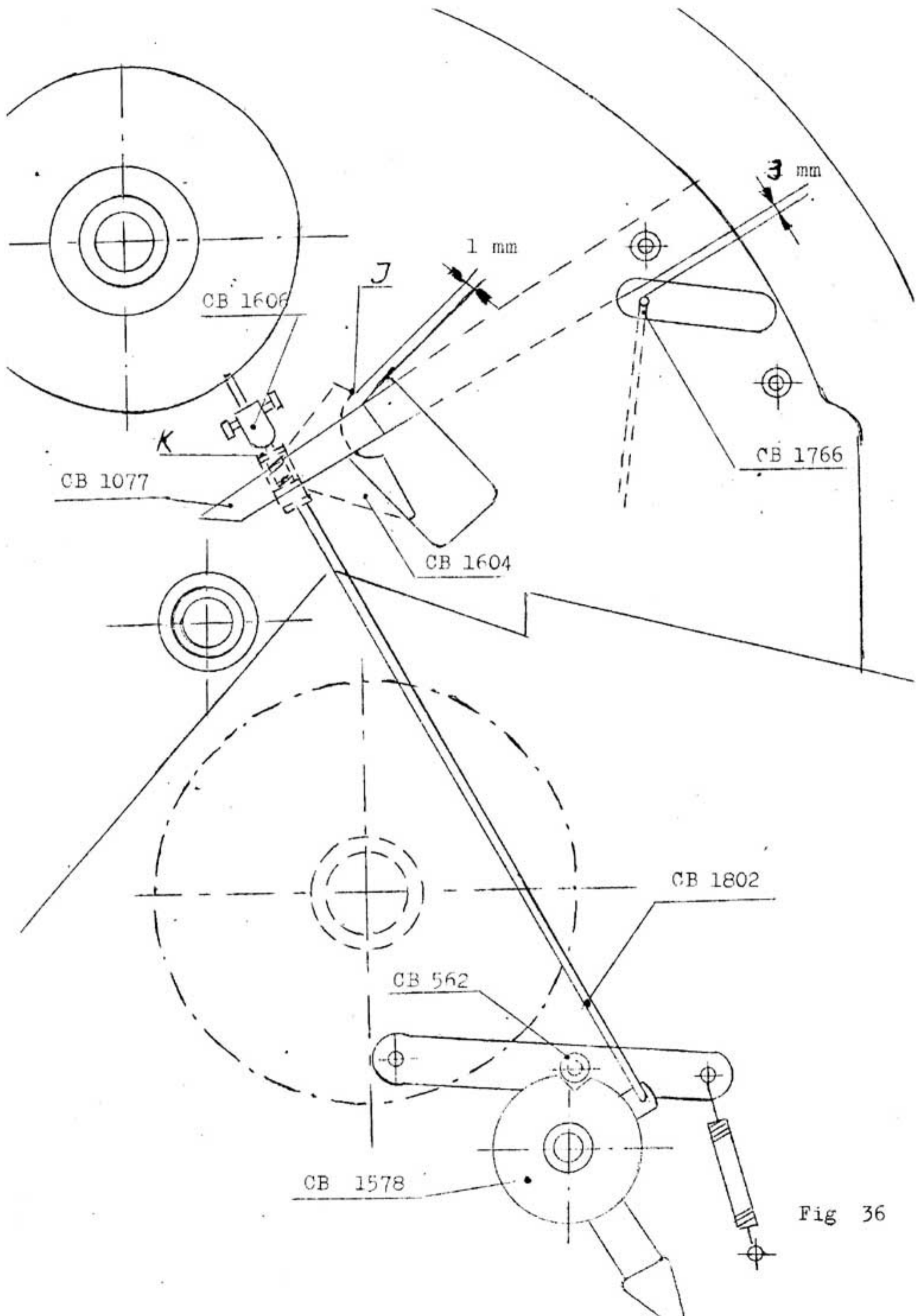

Fig 36

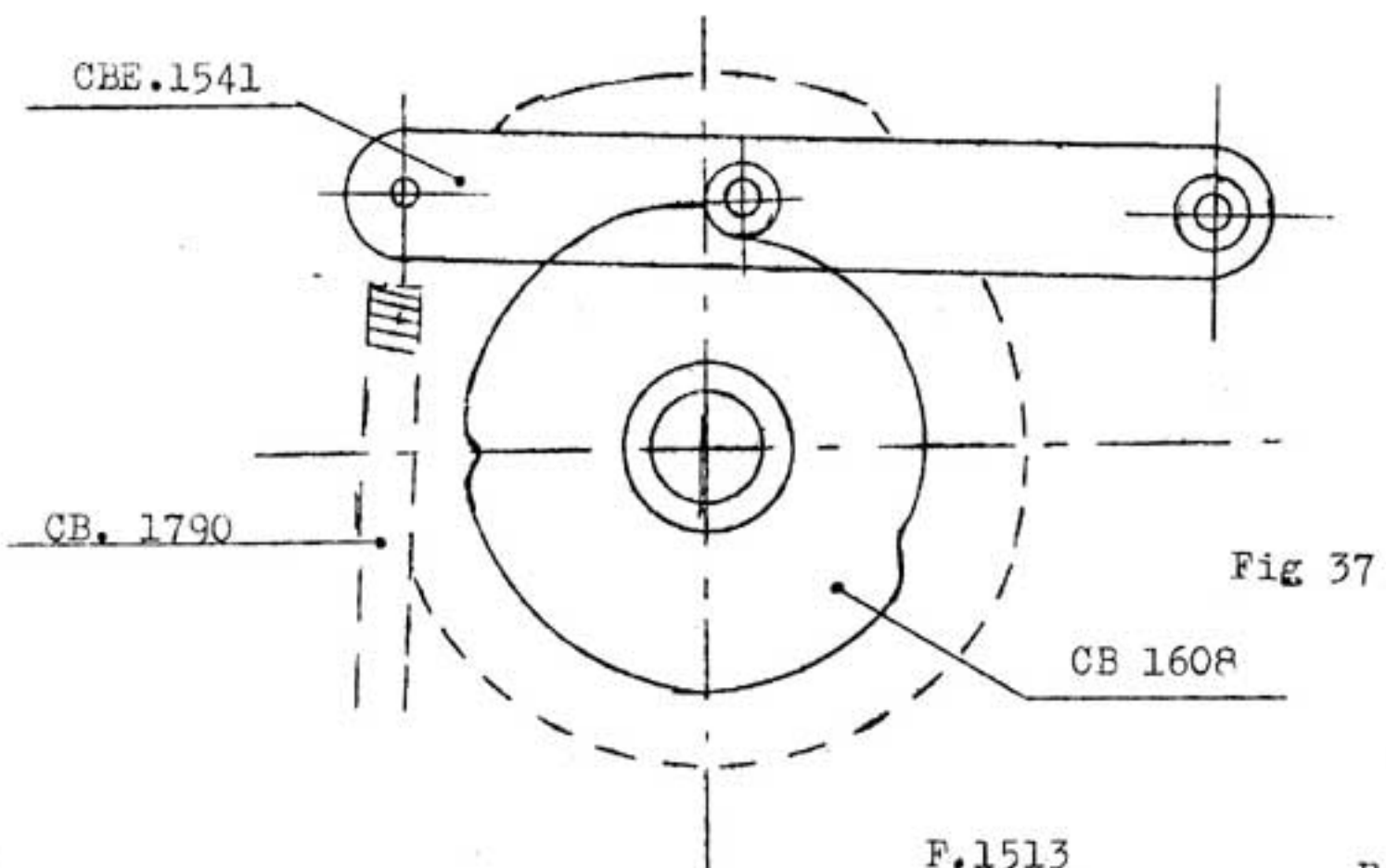

Fig 37

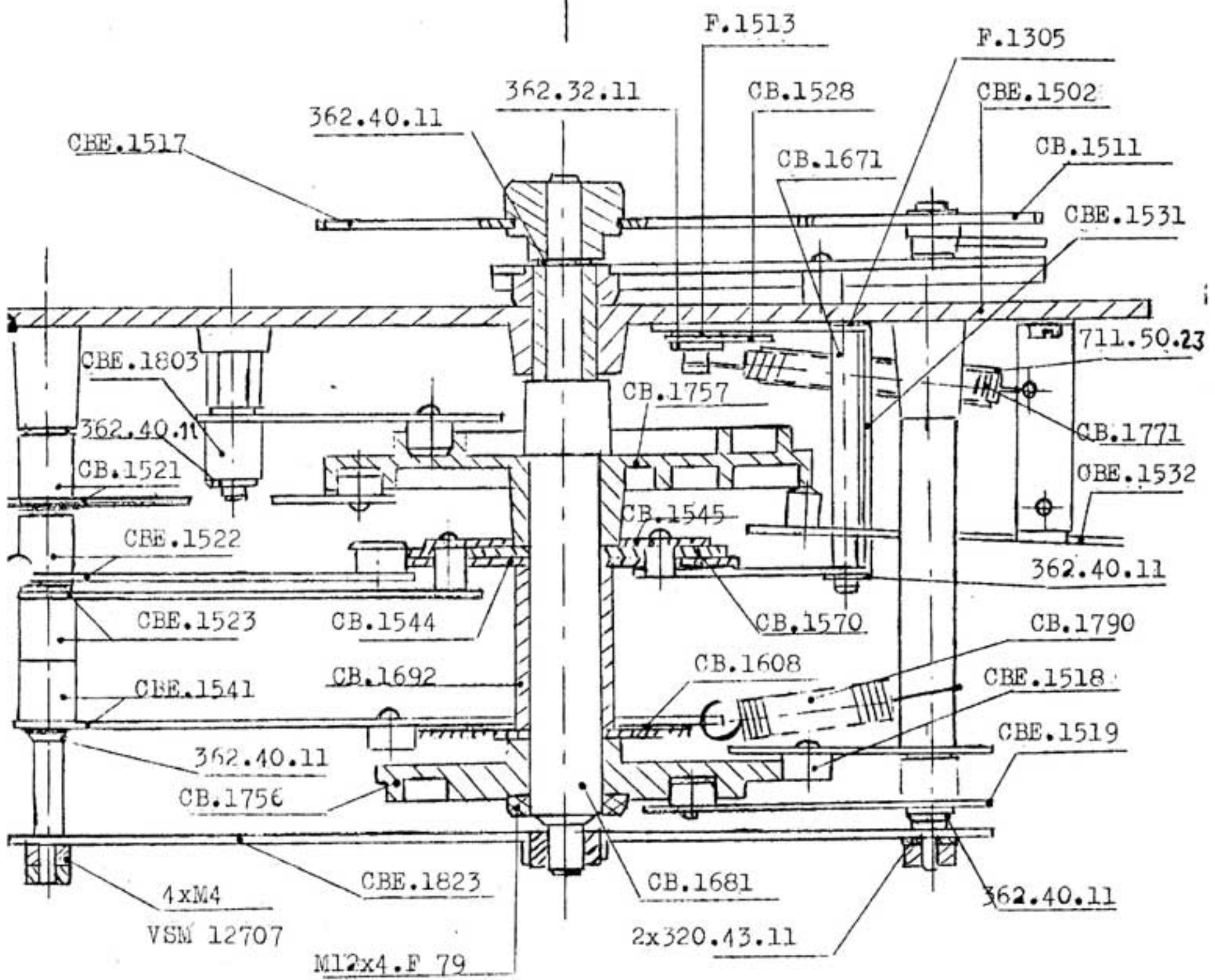

Fig 38

Liste de prix - Price List - Preisliste

Pièces de rechange TD 224 - Spare Parts TD 224 - Ersatzteile TD 224

Pièce Part Teil	Prix Price (2n) Preis	Pièce Part Teil	Prix Price (2n) Preis	Pièce Part Teil	Prix Price (2n) Preis
CB 117	8.40 \$	CB 1513	8.60	CB 1681	5.—
CB 508	0.30	CB 1515	1.20	CB 1688	-.30
CB 509	0.40	CB 1516	3.10	CB 1692	2.20
CB 560	0.60	CB 1517	4.—	CB 1693	-.20
CB 571	0.20	CB 1518	1.80	CB 1694	-.60
CB 621	0.40	CB 1519	3.—	CB 1695	-.70
CB 637	2.10	CB 1521	2.10	CB 1698	1.10
CB 652	1.—	CB 1522	2.30	CB 1709	-.20
CB 763	7.20	CB 1523	1.40	CB 1710	-.20
CB 818	0.20	CB 1524	5.70	CB 1718	3.—
CB 822	0.20	CB 1527	1.20	CB 1719	1.—
CB 823	0.30	CB 1528	-.90	CB 1720	-.20
CB 828	0.70	CB 1530	5.90	CB 1754	40.—
CB 855	0.50	CB 1531	-.80	CB 1755/1	20.—
CB 856	1.—	CB 1532	-.90	CB 1756	5.90
CB 857	0.20	CB 1533	1.30	CB 1757	5.90
CB 873	1.—	CB 1534	2.80	CB 1763	1.20
CB 874	14.20	CB 1536	1.20	CB 1764	2.—
CB 912	1.80	CB 1537	1.—	CB 1765	-.60
CB 913	1.30	CB 1538	-.80	CB 1766	-.40
CB 916	0.40	CB 1539	3.—	CB 1768	-.40
CB 921	8.—	CB 1540	-.50	CB 1769	-.40
CB 922	0.50	CB 1541	1.70	CB 1770	-.30
CB 926	0.20	CB 1542	2.80	CB 1771	-.60
CB 928	0.20	CB 1543	3.30	CB 1775	-.40
CB 941	6.—	CB 1544	-.60	CB 1776	-.40
CB 948	0.30	CB 1545	-.50	CB 1778	-.50
CB 961	1.20	CB 1546	-.80	CB 1781	-.20
CB 965	2.—	CB 1547	3.20	CB 1784	-.30
CB 967	0.20	CB 1548	1.20	CB 1788	8.—
CB 975	0.20	CB 1550	8.80	CB 1789	-.40
CB 1031	0.70	CB 1562	1.50	CB 1790	-.80
CB 1032	0.80	CB 1570	-.90	CB 1792	-.40
CB 1042	17.60	CB 1583	1.60	CB 1795	4.10
CB 1061	0.70	CB 1587	-.40	CB 1801	4.—
CB 1077	2.50	CB 1602	-.30	CB 1802	2.40
CB 1078	0.60	CB 1603	-.20	CB 1803	3.90
CB 1139	0.20	CB 1608	-.30	CB 1806	17.40
CB 1148	0.20	CB 1617	-.70	CB 1807	9.50
CB 1155	0.50	CB 1653	-.10	CB 1813	4.40
CB 1211	0.20	CB 1657	1.90	CB 1814	9.50
CB 1219	0.60	CB 1662	-.20	CB 1815	8.40
CB 1351	21.60	CB 1667	-.20	CB 1816	1.90
CB 1392	0.30	CB 1668	1.60	CB 1819	11.—
CB 1505	72.—	CB 1669	-.70	CB 1821	16.40
CB 1507	25.—	CB 1670	1.10	CB 1822	4.—

Pièces Part Teil	Prix Price (2n) Preis	Pièce Part Teil	Prix Price (2n) Preis	Pièce Part Teil	Prix Price (2n) Preis
CB 1826	1.10	F 1321	8.80 ₣	Phillips Bulb E 50.13	4.40
CB 1827	1.40	F 1323	8.80 ₣		75.60
CB 1829	2.80	F 1324	-.30		
CB 1830	-.60	F 1347	8.80 ₣		
CB 1854	-.10	F 1417	8.80 ₣		
CD 464	-.10	F 1479	8.80 ₣		
CD 638	-.10	F 1513	8.80 ₣		
CD 1638	-.10	F 1526	13.20 ₣		
CD 1882	-.10	F 1529	8.80 ₣		
PU 840	-.30	F 1530	17.20 ₣		
PU 873	-.30	FD 75	2.80		
PU 906	3.10	FD 81	-.30		
PU 911	-.60	FL 104	3.40		
PU 912	-.20	ME 283	-.20		
PU 913	8.60	ME 331	5.-		
PU 926	-.40	ME 333	3.50		
PU 938	-.80	ME 578	8.80 ₣		
PU 953 M0	-.50	VSM 12124	-.30		
PU 953 M1	-.50	VSM 12126	-.30		
PU 955	-.10	VSM 12140	13.20 ₣		
PU 1007	-.60	VSM 12156	17.20 ₣		
PU 1013	-.20	VSM 12251 M3x4	8.80 ₣		
PU 1021	-.50	VSM 12252 M8x12	-.50		
PU 1060	-.50	VSM 12364	-.90		
PU 1074	-.70	VSM 12699	-.50		
PU 1081	34.20	VSM 12707	8.80 ₣		
PUE 1085	90.50	VSM 12771	-.80		
PUE 1087	15.10	101.30.161	8.80 ₣		
PU 1105	-.20	105.35.21	-.30		
F 37 M2x2	8.80 ₣	109.30.1012	-.50		
F 37 M3x3	-.40	120.30.24	-.30		
F 37 M2x3	17.20 ₣	130/2	-.90		
F 37 M1,2x1,8	8.80 ₣	189.50.106	1.40		
F 37	13.20 ₣	236	1.60		
F 38	-.30	320.32.11	8.80 ₣		
F 48	17.20 ₣	320.43.11	8.80 ₣		
F 75 M6x0,75x2	-.60	320.53.11	8.80 ₣		
F 79 M12x4	105.20 ₣	362.15.11	8.80 ₣		
F 1016	8.80 ₣	362.19.11	8.80 ₣		
F 1017	8.80 ₣	362.32.11	8.80 ₣		
F 1018	8.80 ₣	362.40.11	8.80 ₣		
F 1021	8.80 ₣	362.50.11	8.80 ₣		
F 1023	-.30	362.90.11	17.20 ₣		
F 1028	8.80 ₣	600.27.11	8.80 ₣		
F 1033	8.80 ₣	600.50.11	8.80 ₣		
F 1054	8.80 ₣	900.48.13	-.30		