

LW/AM/SW₁/SW₂/SW₃/SW₄/SW₅/FM
SOLID STATE 8 BAND RADIO

MODEL TF-182 & TF-182FB

SERVICE MANUAL

CONTENTS

SPECIFICATIONS 1

CHASSIS REMOVAL 2

DIAL STRINGING..... 2

VOLTAGE CHART 3

ALIGNMENT INSTRUCTIONS 6

PRINTED CIRCUIT BOARD(TOP VIEW) 17

PRINTED CIRCUIT BOARD(BOTTOM VIEW) 19

REPLACEMENT PARTS LIST 21

CIRCUIT DIAGRAM 43

SPECIFICATIONS

Circuit	:	19 AF and RF Transistors 1 Transistor Voltage Stabilizer 14 Diodes
Frequency	:	LW 150 - 400 KHz AM 535 - 1605 KHz SW1 1.6 - 4 MHz SW2 4 - 12 MHz SW3 12 - 22 MHz SW4 22 - 30 MHz SW5 5.7 - 6.6 MHz FM 88 - 108 MHz
Intermediate Freq.	:	LW, AM, SW1, SW2, SW3, SW4, SW5, - 455 KHz FM - 10.7 MHz
Power output	:	Maximum output 1.5 W Undistorted output 1 W
Batteries	:	"D" X 6 pcs. Flashlight batteries
AC source	:	115 V and 230 V, 60 Hz 7 W
Speaker	:	5" Permanent Dynamic Wide Range
Antenna	:	Two ferrite rods for LW, AM, SW1, SW2, SW3, SW4, SW5 Telescopic rod antenna for FM, SW1, SW2
Dimensions	:	19 1/2" (W) X 10 1/2" (H) X 5 1/2" (D)
Weight	:	15.6 lbs with batteries
Accessories	:	Earphone Batteries External antenna plug

CHASSIS REMOVAL

1. Remove the Tuning knob, Tone control knob, Volume control knob and squelch knob.
2. Remove the four screws of the cabinet back cover.
3. Remove the earphone jack, EP/SP jack and Antenna jack from the cabinet back cover.
4. Remove the six (Deck mounting) screw and remove the 3 wire from BFO AFC switch and take out the deck from cabinet.
5. Remove the four (Audio P. C. B. mounting) screw and lift up the Audio P. C. B.

DIAL STRINGING

SMALL PULLEY $2\frac{3}{4}$ TURN
 LARGE PULLEY $1\frac{1}{3}$ TURN

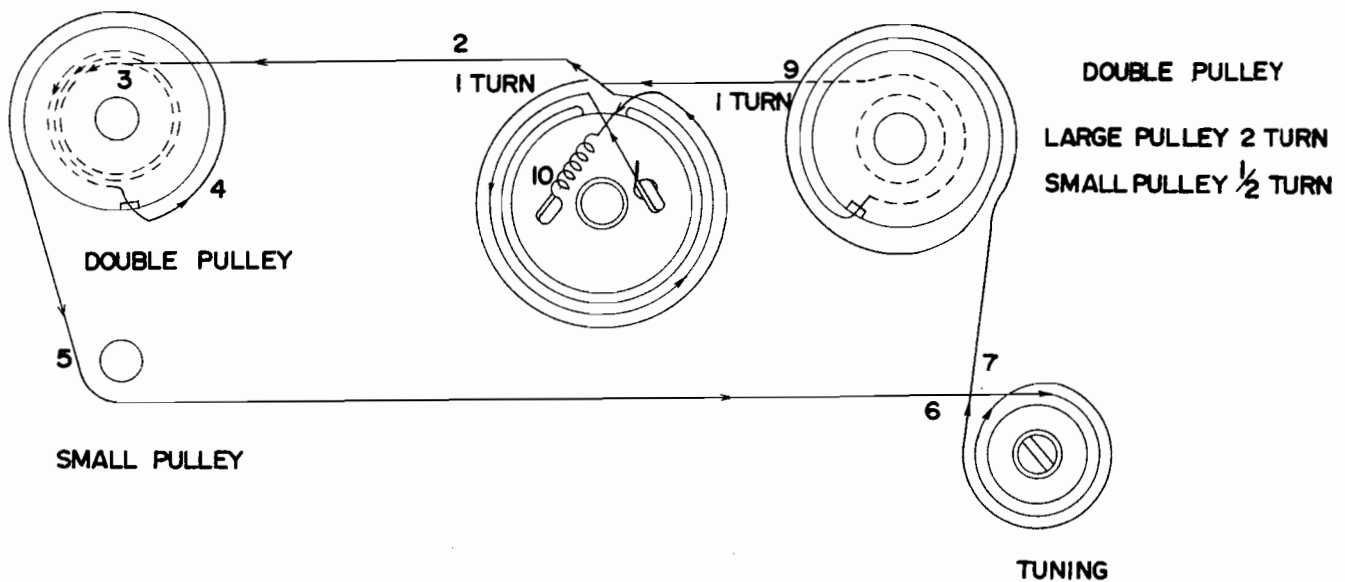

VOLTAGE CHART

NOTE: The below values are the voltages between the earth pattern and the corresponding points.
The values are measured with V. T. V. M and all negative signs are omitted.

Tuning Range	Q1 SE5006			Q2 SE3001			Q3 SE3001			Q4 SE3001			Q5 SE3001			Q6 SE3001			Q7 SE3001		
	Vb	Ve	Vc	Vb	Ve	Vc	Vb	Ve	Vc	Vb	Ve	Vc	Vb	Ve	Vc	Vb	Ve	Vc	Vb	Ve	Vc
L W	-	-	-	-	-	-	5.5	6.8	0.8	-	-	-	-	-	-	-	-	-	-	-	-
A M	-	-	-	-	-	-	5.5	6.8	0.8	-	-	-	-	-	-	-	-	-	-	-	-
S W1	-	-	-	-	-	-	5.5	6.8	0.8	-	-	-	-	-	-	-	-	-	-	-	-
S W2	-	-	-	-	-	-	5.5	6.8	0.8	-	-	-	-	-	-	-	-	-	-	-	-
S W3	-	-	-	-	-	-	5.5	6.8	0.8	-	-	-	-	-	-	-	-	-	-	-	-
S W4	-	-	-	-	-	-	5.5	6.8	0.8	-	-	-	-	-	-	-	-	-	-	-	-
S W5	-	-	-	-	-	-	5.5	6.8	0.8	-	-	-	-	-	-	-	-	-	-	-	-
F M	5.4	6.6	0.7	4.0	0.1	5.0	-	-	-	5.2	6.0	0.4	5.5	6.2	0.4	5.4	6.2	0.43	5.0	5.8	2.5

NOTE: The below values are the voltages between the earth pattern and the corresponding points.
The values are measured with V. T. V. M and all negative signs are omitted.

Tuning Range	Q8 CS1254			Q9 CS1254			Q10 SE5001			Q11 SE1001			Q12 SE1001			Q13 SE5006			Q14 SE4010		
	Vb	Ve	Vc	Vb	Ve	Vc	Vb	Ve	Vc	Vb	Ve	Vc	Vb	Ve	Vc	Vb	Ve	Vc	Vb	Ve	Vc
L W	-	-	-	-	-	-	5.6	6.6	0.01	5.5	6.8	0	6.0	6.8	0	4.0	5.0	0	4.0	3.1	0
A M	-	-	-	-	-	-	5.6	6.6	0.01	5.5	6.8	0	6.0	6.8	0	4.2	4.8	0	4.0	3.1	0
S W1	-	-	-	-	-	-	6.0	6.7	0.01	5.4	6.7	0	6.0	6.8	0	4.2	4.8	0	4.0	3.1	0
S W2	-	-	-	-	-	-	6.0	6.7	0.01	5.4	6.7	0	6.0	6.8	0	4.2	4.8	0	4.0	3.1	0
S W3	-	-	-	-	-	-	6.0	6.7	0.01	5.4	6.7	0	6.0	6.8	0	4.2	4.8	0	4.0	3.1	0
S W4	-	-	-	-	-	-	6.0	6.7	0.01	5.4	6.7	0	6.0	6.8	0	4.2	4.8	0	4.0	3.1	0
S W5	-	-	-	-	-	-	6.0	6.7	0.01	5.4	6.7	0	6.0	6.8	0	4.2	4.8	0	4.0	3.1	0
F M	5.9	6.6	6.5	6.7	6.6	5.9	-	-	-	-	-	-	-	-	-	-	-	-	-	-	-

NOTE: The below values are the voltages between the earth pattern and the corresponding points.
 The values are measured with V. T. V. M and all negative signs are omitted.

Tuning Range	Q15 SE4010			Q16 2SB186			Q17 2SB187			Q18 2SB405			Q19 2SB405			Q20 2SB185		
	Vb	Ve	Vc	Vb	Ve	Vc	Vb	Ve	Vc	Vb	Ve	Vc	Vb	Ve	Vc	Vb	Ve	Vc
L W	2.0	3.5	5.8	2.5	2.5	5.0	1.3	1.1	7.3	4.4	4.4	8.4	0.16	0	4.4	8.2	8.4	8.4
A M	2.0	3.5	5.8	2.5	2.5	5.0	1.3	1.1	7.3	4.4	4.4	8.4	0.16	0	4.4	8.2	8.4	8.4
S W1	2.0	3.5	5.8	2.5	2.5	5.0	1.3	1.1	7.3	4.4	4.4	8.4	0.16	0	4.4	8.2	8.4	8.4
S W2	2.0	3.5	5.8	2.5	2.5	5.0	1.3	1.1	7.3	4.4	4.4	8.4	0.16	0	4.4	8.2	8.4	8.4
S W3	2.0	3.5	5.8	2.5	2.5	5.0	1.3	1.1	7.3	4.4	4.4	8.4	0.16	0	4.4	8.2	8.4	8.4
S W4	2.0	3.5	5.8	2.5	2.5	5.0	1.3	1.1	7.3	4.4	4.4	8.4	0.16	0	4.4	8.2	8.4	8.4
S W5	2.0	3.5	5.8	2.5	2.5	5.0	1.3	1.1	7.3	4.4	4.4	8.4	0.16	0	4.4	8.2	8.4	8.4
F M	2.0	3.5	5.8	2.5	2.5	5.0	1.3	1.1	7.3	4.4	4.4	8.4	0.16	0	4.4	8.2	8.4	8.4

ALIGNMENT INSTRUCTIONS

INSTRUMENT REQUIRED

Signal Source

1. RF signal generator (AM, FM).
2. IF sweep generator (Centered 455 KHz for AM and 10.7 MHz for FM).

Output Indicator

1. V. T. V. M
2. Oscilloscope.

General Preparation

1. Check source voltage.
2. Set function switch to band being aligned.
3. Tone control should be kept "treble". Squelch control should be kept "OFF".
4. Telescopic antenna should be closed.
5. Connect low side of signal source and output indicator to chassis ground unless otherwise specified.
6. Signal input should be kept as low possible to avoid A. V. C and AFC action. (Set output indicator to high sensitivity.)
7. Standard modulation is 400 Hz 30% mod. for AM.
(400 Hz 22.5 KHz dev. for FM.)

REGULAR ADJUSTING STEP

For Band	For Stages on each band
(1) FM	1st : IF (and detector on FM). 2nd : RF Frequency range. 3rd : RF Tracking.
(2) AM	1st : IF. 2nd : RF Frequency range. 3rd : RF Tracking.

FM IF ALIGNMENT

Step	Signal source	Set signal to	Alignment indicator	Set radio dial to	Adjust	Adjust for
	connect to		connect to			
(IF and detector stage)						
1	FM IF sweep gene. TR2 Emit. (IF input term.)	Sweep centered 10.7 MHz	Oscilloscope C74 (AF input term.)	Max. Freq.	T1 (1st IFT)	Max. symmetrical response equal heights.
2	"	"	"	"	T2, T3 (2nd IFT)	"
3	"	"	"	"	T4, T5 (3rd IFT)	"
4	"	"	"	"	T6 (4th IFT)	"
5	"	"	"	"	T7 (Det. coil)	Symmetrical response centered 10.7 MHz
6	(Repeat steps 1 to 5 to obtain a balanced "S" curve linearity)					

AM IF ALIGNMENT

Step	Signal source	Set signal to	Alignment indicator	Set radio dial to	Adjust	Adjust for
	connect to		connect to			
1	AM IF sweep gene.	Sweep centered 455 KHz	Oscilloscope	Min. Freq.	T8, T9 (1st IFT)	Maximum.
			(AF input term.)			
2	"	"	"	"	T10 (2nd IFT)	"
3	"	"	"	"	T11 (3rd IFT)	"
4	(Repeat steps 1 to 3)					

AM ALIGNMENT

Step	Signal source	Set signal to	Alignment indicator	Set radio dial to	Adjust	Adjust for
	connect to		connect to			
1	AM signal gene.	AM 510 KHz (modulated)	V. T. V. M	510 KHz (low end)	L20 (OSC. coil)	Maximum
	a standard radiating loop		across speaker voice coil (Using earphone plug w/8 ohm resistive load is recommended)			
2	"	1650 KHz (modulated)	"	1650 KHz (high end)	TC15 (OSC. trim)	"
3	(Repeat steps 1 and 2 as necessary to obtain frequency range)					
4	"	610 KHz (modulated)	"	610 KHz	L8 (ANT. coil)	"
5	"	1400 KHz (modulated)	"	1400 KHz	TC4 (ANT. trim)	"
6	(Repeat steps 4 and 5 to minimize tracking error, and also step 3 if necessary.)					

LW ALIGNMENT

Step	Signal source	Set signal to	Alignment indicator	Set radio dial to	Adjust	Adjust for
	connect to		connect to			
1	AM signal gene.	140 KHz (modulated)	across speaker voice coil (Using earphone plug w/8 ohm resistive load is recommended.)	140 KHz (low end)	L21 (OSC. coil)	Maximum
	a standard radiating loop					
2	"	420 KHz (modulated)	"	420 KHz (high end)	TC16 (OSC. trim)	"
3	(Repeat steps 1 and 2 to obtain frequency range)					
4	"	200 KHz (modulated)	"	200 KHz	L8 (ANT. coil)	"
5	"	350 KHz (modulated)	"	350 KHz	TC3 (ANT. trim)	"
6	(Repeat steps 4 and 5 to minimize tracking error, and also step 3 if necessary.)					

SW₁ ALIGNMENT

Step	Signal source	Set signal to	Alignment indicator	Set radio dial to	Adjust	Adjust for
	connect to		connect to			
1	AM signal gene. ----- a standard radiating loop	1.58 MHz (modulated)	across speaker voice coil (Using earphone plug w/8 ohm resistive load is recommended)	1.58 MHz (low end)	L19 (OSC. coil)	Maximum
2	"	4.2 MHz (modulated)	"	4.2 MHz (high end)	TC14 (OSC. trim)	"
3	(Repeat steps 1 and 2 to obtain frequency range)					
4	"	1.9 MHz (modulated)	"	1.9 MHz	L10 (ANT. coil)	"
5	"	3.8 MHz (modulated)	"	3.8 MHz	TC5 (ANT. trim)	"
6	(Repeat steps 4 and 5 to minimize tracking error, and also step 3 if necessary)					

SW₂ ALIGNMENT

Step	Signal source	Set signal to	Alignment indicator	Set radio dial to	Adjust	Adjust for
	connect to		connect to			
1	AM signal gene.	3.8 MHz (modulated)		3.8 MHz (low end)	L18 (OSC. coil)	Maximum
	a standard radiating loop		across speaker voice coil (Using earphone plug w/8 ohm resistive load is recommended)			
2	"	12.5 MHz (modulated)	"	12.5 MHz (high end)	TC13 (OSC. trim)	"
3	(Repeat steps 1 and 2 to obtain frequency range)					
4	"	4.2 MHz (modulated)	"	4.2 MHz	L11 (ANT. coil)	"
5	"	9 MHz (modulated)	"	9 MHz	TC6 (ANT. trim)	"
6	(Repeat steps 4 and 5 to minimize tracking error, and also step 3 if necessary.)					

SW₃ ALIGNMENT

Step	Signal source	Set signal to	Alignment indicator	Set radio dial to	Adjust	Adjust for
	connect to		connect to			
1	AM signal gene.	11.5 MHz (modulated)	across speaker voice coil (Using earphone plug w/8 ohm resistive load is recommended)	11.5 MHz (low end)	L17 (OSC. coil)	Maximum
	a standard radiating loop					
2		22.5 MHz (modulated)		22.5 MHz (high end)	TC12 (OSC. trim)	
3	(Repeat steps 1 and 2 to obtain frequency range.)					
4	"	13 MHz (modulated)	"	13 MHz	L12 (ANT. coil)	"
5	"	21 MHz (modulated)	"	21 MHz	TC7 (ANT. trim)	"
6	(Repeat steps 4 and 5 to minimize tracking error, and also step 3 if necessary.)					

SW₄ ALIGNMENT

Step	Signal source	Set signal to	Alignment indicator	Set radio dial to	Adjust	Adjust for
	connect to		connect to			
1	AM signal gene.	21.5 MHz (modulated)		21.5 MHz (low end)	L16 (OSC. coil)	Maximum
	a standard radiating loop		across speaker voice coil (Using earphone plug w/8 ohm resistive load is recommended)			
2	"	30.5 MHz (modulated)	"	30.5 MHz (high end)	TC11 (OSC. trim)	"
3	(Repeat steps 1 and 2 to obtain frequency range.)					
4	"	23 MHz (modulated)	"	23 MHz	L13 (ANT. coil)	"
5	"	29 MHz (modulated)	"	29 MHz	TC8 (ANT. trim)	"
6	(Repeat steps 4 and 5 to minimize tracking error, and also step 3 if necessary.)					

SW₅ ALIGNMENT

Step	Signal source	Set signal to	Alignment indicator	Set radio dial to	Adjust	Adjust for
	connect to		connect to			
1	AM signal gene.	5.6 MHz (modulated)		5.6 MHz (low end)	L15 (OSC. coil)	Maximum
	a standard radiating loop		across speaker voice coil (Using earphone plug w/8 ohm resistive load is recommended)			
2	"	6.7 MHz (modulated)	"	6.7 MHz (high end)	TC10 (OSC. trim)	"
3	(Repeat steps 1 and 2 to obtain frequency range.)					
4	"	5.8 MHz (modulated)	"	5.8 MHz	L14 (ANT. coil)	"
5	"	5.8 MHz (modulated)	"	6.5 MHz	TC9 (ANT. trim)	"
6	(Repeat steps 4 and 5 to minimize tracking error, and also step 3 if necessary.)					

FM ALIGNMENT

Step	Signal source	Set signal to	Alignment indicator	Set radio dial to	Adjust	Adjust for
	connect to		connect to			
(RF stage)						
1	FM signal gene.	88 MHz (modulated)	V. T. V. M	88 MHz	L6 (OSC. coil)	Maximum
	EXT ANT jack Used matching network		across speaker voice coil (Using earphone plug w/8 ohm resistor is recommended)			
2	"	108 MHz (modulated)	"	108 MHz	TC2 (OSC. trim)	"
3	(Repeat steps 1 and 2 to obtain frequency range.)					
4	"	90 MHz (modulated)	"	90 MHz	L4 (RF coil)	"
5	"	106 MHz (modulated)	"	106 MHz	TC1 (RF trim)	"
6	(Repeat steps 4 and 5 to minimize tracking error, and also step 3 if necessary.)					

PRINTED CIRCUIT BOARD-TOP VIEW MODEL ; TF-182 & TF-182 FB

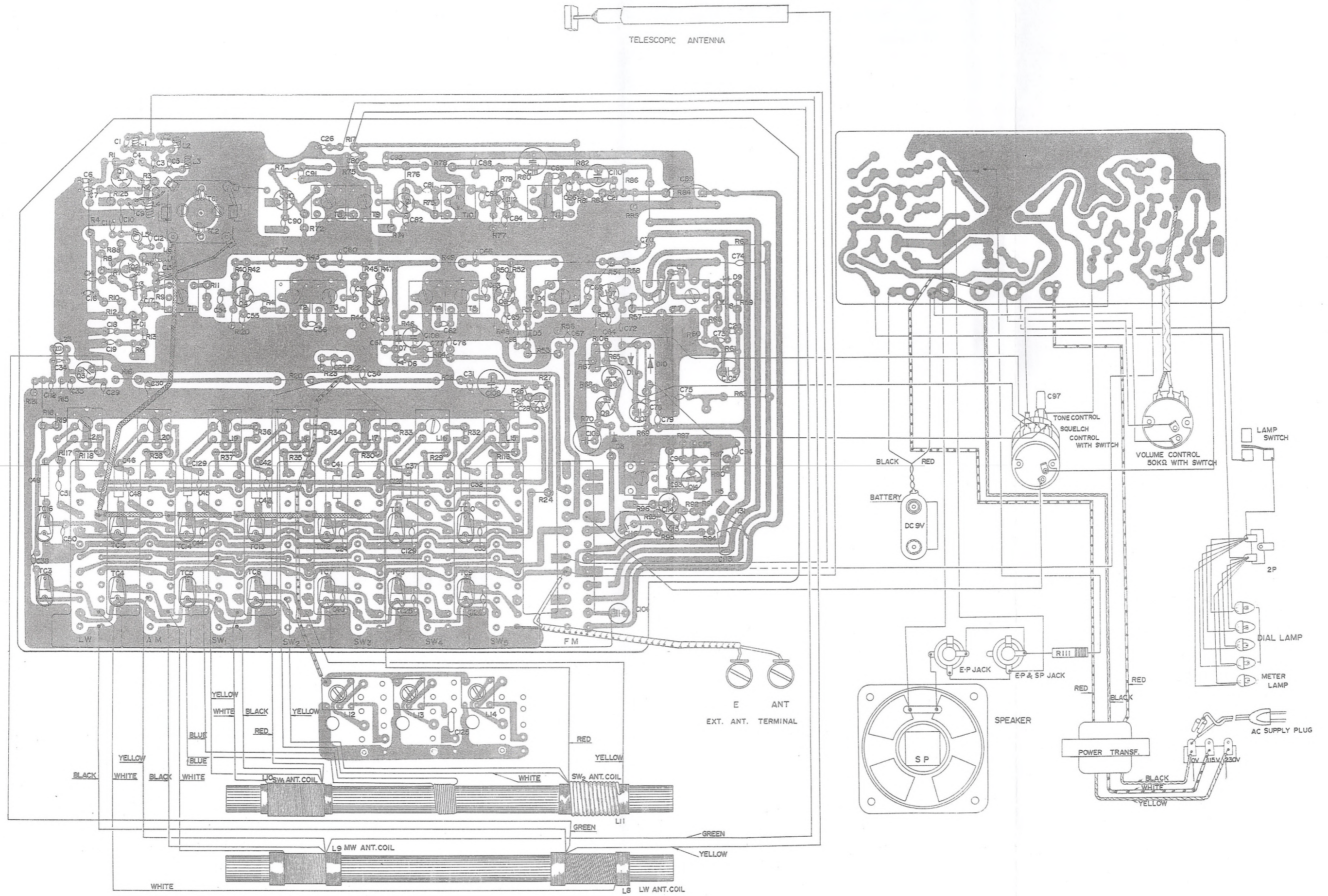

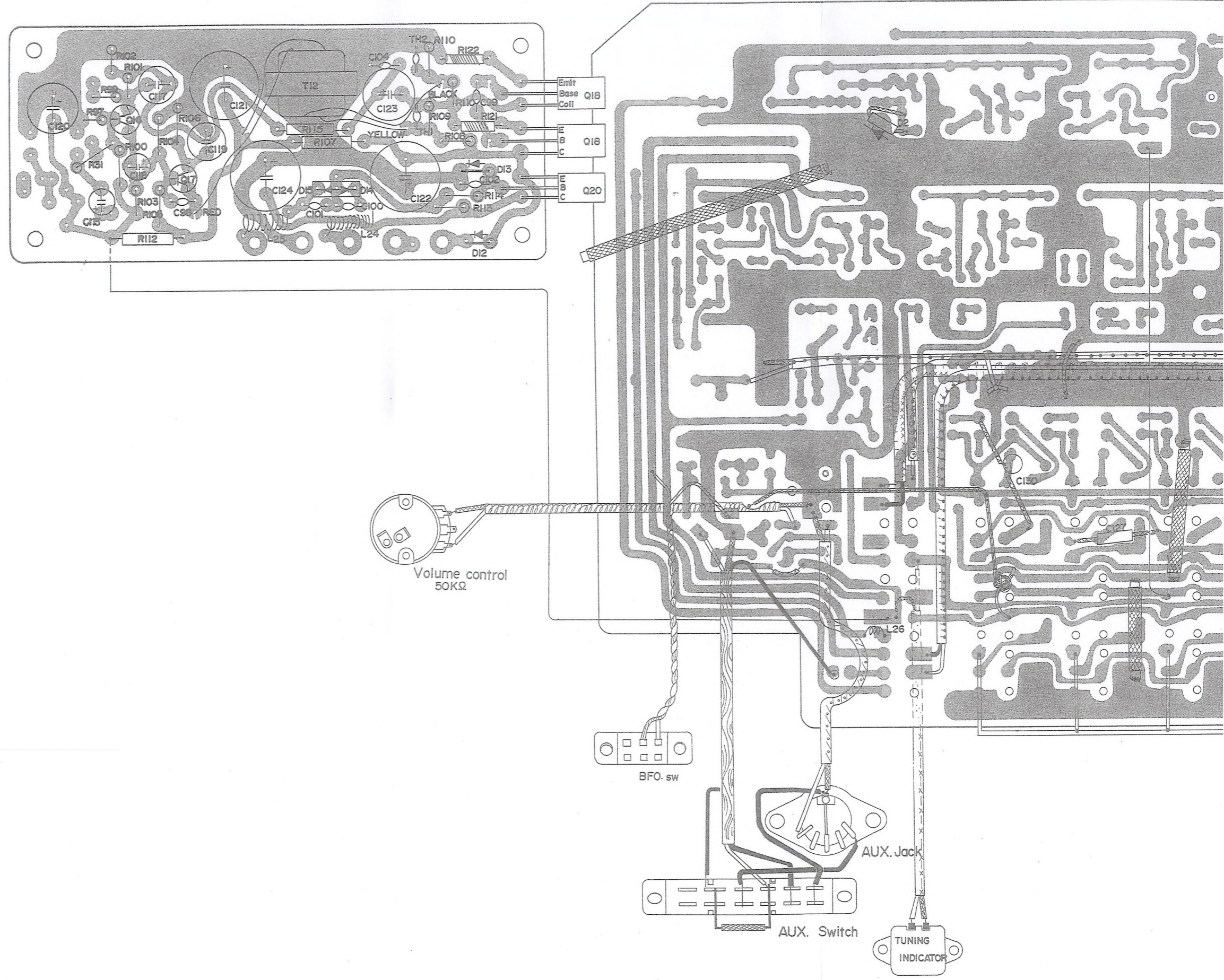

PRINTED CIRCUIT BOARD-BOTTOM VIEW MODEL ; TF-182 & TF-182 FB

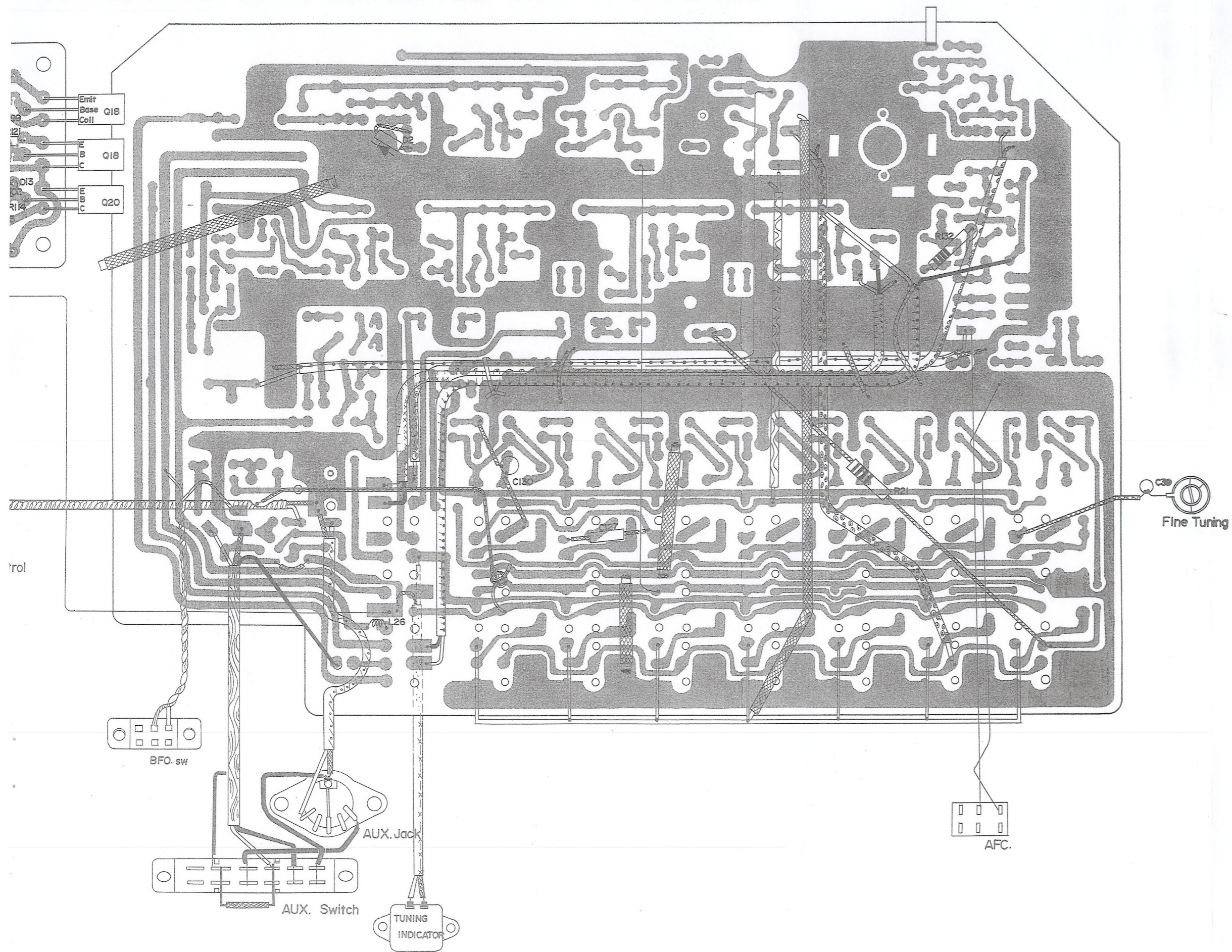

REPLACEMENT PARTS LIST

MODEL ; TF-182 & TF-182 FB

<u>Symbol Location</u>	<u>Description</u>		<u>Remarks</u>	<u>Part No.</u>
C1	Cap. 50 pF	FM Filter	Ceramic cap. $\pm 5\%$	
C2	" 40 pF	"	" "	
C3	" 10 pF	"	" "	
C4	" 20 pF	TR1 Emit.	" "	
C5	" "	FM ANT	" "	
C6	" 0.02 μ F	FM - B line	" $+80\%$ -20%	
C7	" "	TR1 Base	" "	
C8				
C9	" 20 pF	FM RF	" $\pm 5\%$	
C10	" 3 pF	TR2 Emit.	" ± 0.5 pF	
C11	" 33 pF	10.7 MHz Trap	" $\pm 5\%$	
C12	" 330 pF	"	" $+80\%$ -20%	
C13	" 4 pF	TR2 Emit.	" ± 0.5 pF	
C14	" 0.02 μ F	TR2 Base	" $+80\%$ -20%	
C15	" 15 pF	AFC	" $\pm 5\%$	
C16	" 0.02 μ F	AFC	" $+80\%$ -20%	
C17	" 5 pF	FM OSC	" ± 0.5 pF	
C18	" 0.01 μ F	AFC	" $+80\%$ -20%	
C19	" 0.01 μ F	"	" "	
C20	" 0.001 μ F	FM Det.	" $\pm 20\%$	
C21	" 0.001 μ F	AM Det.	Mylar cap. $\pm 20\%$	
C22				
C23	" 33 pF	SW4 OSC	Ceramic cap. $\pm 5\%$	
C24	" 75 pF	SW3 ANT	Ceramic cap. $\pm 5\%$	
C25	" 500 μ F	- B line	Electrolytic tubular cap. 10wV	
C26	" 0.04 μ F	AM ANT	Ceramic cap. $+80\%$ -20%	
C27	" 0.04 μ F	SW4 ANT	Ceramic cap. "	
C28	" "	TR13 Base	" "	
C29	" 0.04 μ F	TR3 Emit.	" "	
C30	" "	"	" "	

<u>Symbol</u> <u>Location</u>	<u>Description</u>		<u>Remarks</u>	<u>Part No.</u>
C31	Cap.	0.04 μ F AM OSC	Ceramic cap. $\begin{matrix} +80\% \\ -20\% \end{matrix}$	
C32	"	1500 pF SW5 OSC	Polystyrol cap. $\pm 10\%$	
C33	"	0-470 pF "	" $\pm 5\%$	
C34	"	50 pF LW RF	Ceramic cap. "	
C35	"	150 pF "	" $\pm 10\%$	
C36	"	0.04 μ F SW4 ANT	" $\begin{matrix} +80\% \\ -20\% \end{matrix}$	
C37	"	280 p SW4 DSC	Polystyrol cap. $\pm 5\%$	
C38	"	0.02 μ F LW RF	Mylar cap. $\pm 20\%$	
C39	"	3 pF Fine tuning	Ceramic cap. ± 0.5 pF	
C40	"	92 pF SW3 OSC	" $\pm 5\%$	
C41	"	330 pF "	Polystyrol cap. $\pm 5\%$	
C42	"	2200 pF SW2 OSC	" $\pm 10\%$	
C43	"	680 pF "	" $\pm 5\%$	
C44	"	5 pF SW1 OSC	Ceramic cap. ± 0.5 pF	
C45	"	0.0033 "	Mylar cap. $\pm 20\%$	
C46	"	280 pF AM OSC	Polystyrol cap. $\pm 5\%$	
C47				
C48	"	0.0047 AM OSC	Mylar cap. $\pm 20\%$	
C49	"	120 pF LW OSC	Mylar cap. $\pm 5\%$	
C50	"	12 pF "	Ceramic cap. "	
C51	"	0.01 μ F "	Mylar cap. $\pm 20\%$	
C52				
C53				
C54	"	0.01 μ F TR4 Base	Ceramic cap. $\begin{matrix} +80\% \\ -20\% \end{matrix}$	
C55	"	0.02 μ F TR4 Emit.	" "	
C56	"	40 pF FM 2nd IF	" $\pm 5\%$	
C57	"	0.02 μ F	" $\begin{matrix} +80\% \\ -20\% \end{matrix}$	
C58	"	0.01 μ F TR5 Base	" "	
C59	"	0.01 μ F TR5 Emit.	" "	
C60	"	0.02 μ F	" "	
C61	"	15 pF TR5 Coll.	" $\pm 5\%$	

<u>Symbol</u> <u>Location</u>	<u>Description</u>		<u>Remarks</u>	<u>Part No.</u>
C62	Cap.	40 pF FM 3rd IF	Ceramic cap.	+5%
C63	"	0.01 μ F TR6 Base	"	+80% -20%
C64	"	0.02 μ F	"	"
C65	"	0.01 μ F TR6 Emit.	"	"
C66	"	20 pF TR6 Coll.	"	+5%
C67	"	0.02	"	+80% -20%
C68	"	0.01 μ F TR7 Base	"	"
C69	"	" TR7 Emit.	"	"
C70	"	0.02 μ F	"	"
C71	"	30 pF FM Det.	"	+5%
C72	"	8 pF TR7 Coll.	"	+0.5pF
C73	"	0.001 μ F FM Det.	"	+20%
C74	"	"	Mylar cap.	"
C75	"	0.02 μ F	Ceramic cap.	+80% -20%
C76	"	"	"	"
C77	"	"	"	"
C78	"	" Squelch	"	"
C79	"	"	"	"
C80	"	0.04 μ F	"	"
C81	"	2 pF TR11 Base	"	+0.5pF
C82	"	0.04 μ F TR11 Emit.	"	+80% -20%
C83	"	0.02 μ F TR12 Base	"	"
C84	"	0.04 μ F TR12 Emit.	"	"
C85	"	0.04 μ F AM Det.	"	"
C86	"	0.001 μ F	Mylar cap.	+20%
C87				
C88	"	0.004 μ F - B line	Ceramic cap.	+80% -20%
C89	"	0.0047 μ F AM Det.	Mylar cap.	+20%
C90	"	0.04 μ F TR10 Emit.	Ceramic cap.	+80% -20%
C91	"	" - B line	"	"
C92	"	"	"	"
C93	"	680 pF TR14 Coll.	Polystyrol cap.	+5%
C94	"	0.04 μ F B. F. O.	Ceramic cap.	+80% -20%

<u>Symbol Location</u>		<u>Description</u>	<u>Remarks</u>	<u>Part No.</u>
C95	Cap.	370 pF	TR14 Base	Polystyrol cap. +5%
C96	"	280 pF	TR14 Emit.	" "
C97	"	0.02 μ F	Tone volume	Mylar cap. +20%
C98	"	680 pF	TR17 Base - Coll.	Ceramic cap. "
C99				
C100	"	0.01 μ F	Rectifier	Ceramic cap. +80% -20%
C101	"	"	"	" "
C102	"	0.04 μ F	Voltage stabilizer	" "
C103	"	100 μ F	TR13 Emit.	Electrolytic tubular cap. 10 wV
C104	"	0.04 μ F	Audio Power	Ceramic cap. +80% -20%
C105	"	10 μ F	FM Det.	Electrolytic tubular cap. 10 wV
C106				
C107	"	0.47 μ F	B. F. O.	Electrolytic tubular cap. 10 wV
C108	"	10 μ F	- B line	" "
C109	"	50 μ F	TR9 Coll.	" "
C110	"	30 μ F	AM Det.	" "
C111	"	50 μ F	-B line	" "
C112	"	150 μ F	LW RF	Ceramic cap. +10%
C113	"	3 μ F	TR15 Base	Electrolytic tubular cap. 10 wV
C114	"	"	TR15 Coll.	" "
C115	"	"	Aux. switch	" "
C116	"	50 μ F	TR15 Emit.	" "
C117	"	"	TR16 Emit.	" "
C118	"	5 μ F	TR17 Base	" "
C119	"	50 μ F	TR17 Emit.	" "
C120	"	200 μ F	-B line	" "
C121	"	500 μ F	"	" "
C122	"	"	"	" "
C123	"	200 μ F	TR19 Coll.	" "
C124	"	500 μ F	TR20 Coll.	" "

<u>Symbol</u>	<u>Location</u>	<u>Description</u>	<u>Remarks</u>	<u>Part No.</u>
C125	Cap.	100 pF SW4 ANT.	Polystyrol cap. ±5%	
C126	"	680 pF SW5 ANT.	" "	
C127	"	100 pF SW4 DSC	" "	
C128				
C129	"	1000 pF SW1 OSC	" "	

<u>Symbol</u> <u>Location</u>		<u>Description</u>	<u>Remarks</u>	<u>Part No.</u>
R1	Res.	330 ohm TR1 Emit.	1/4W <u>+10%</u>	
R2	"	100K ohm TR1 Base	" "	
R3	"	680 ohm TR1 Coll.	" "	
R4	"	22 ohm - B line	" "	
R5	"	2.7K ohm B. F. O.		
R6	"	47K ohm TR2 Base	1/4W <u>+10%</u>	
R7	"	22 ohm TR2 Emit.	" "	
R8	"	33K ohm TR2 Base	" "	
R9	"	10K ohm FM OSC	" "	
R10	"	1M ohm A. F. C.	" "	
R11	"	330 ohm FM 1st IF	" "	
R12	"	220K ohm A. F. C.	" "	
R13	"	68K ohm "	" "	
R14	"	6.8K ohm "	" "	
R15	"	1K ohm TR3 Coll.	" "	
R16	"	2.2K ohm TR3 Emit.	" "	
R17	"	3.3K ohm AM ANT.	" "	
R18	"	330 ohm LW RF	" "	
R19	"	680 ohm "	" "	
R20	"	1K ohm TR3 Emit.	" "	
R21	"	10K ohm SW3 ANT.	" "	
R22	"	6.8K ohm SW4 ANT.	" "	
R23	"	27K ohm SW2 ANT.	" "	
R24	"	22 ohm TR13 Emit.	" "	
R25	"	8.2K ohm TR13 Base	" "	
R26	"	6K ohm "	" "	
R27	"	2.2K ohm TR13 Emit.	" "	
R28	"	1K ohm -B line	" "	
R29	"	10 ohm SW3, OSC	" "	
R30	"	" SW3, OSC	" "	
R31	"	4.7K ohm TR16 Base		
R32	"	22 ohm SW4 OSC	1/4W <u>+10%</u>	
R33	"	56 ohm SW3 OSC	" "	
R34	"	150 ohm SW2 OSC	" "	

<u>Symbol</u>	<u>Location</u>	<u>Description</u>	<u>Remarks</u>	<u>Part No.</u>
R35	Res.	10 ohm SW2 OSC	1/4W	<u>+10%</u>
R36	"	220 ohm SW1 OSC	"	"
R37	"	10 ohm SW1 OSC	"	"
R38	"	22 ohm AM OSC	"	"
R39				
R40	Res.	6.8K ohm TR4 Base	1/4W	<u>+10%</u>
R41	"	330 ohm TR4 Coll.	"	"
R42	"	680 ohm TR4 Emit.	"	"
R43	"	22 ohm -B line	"	"
R44	"	10K ohm TR5 Base	"	"
R45	"	2.7K ohm "	"	"
R46	"	330 ohm TR5 Coll.	"	"
R47	"	680 ohm TR5 Emit.	"	"
R48	"	10K ohm TR6 Base	"	"
R49	"	22 ohm - B line	"	"
R50	"	3.3K ohm TR6 Base	"	"
R51	"	330 ohm TR6 Coll.	"	"
R52	"	680 ohm TR6 Emit.	"	"
R53	"	"	"	"
R54	"	4.7K ohm TR7 Base	"	"
R55	"	10K ohm "	"	"
R56	"	33K ohm	"	"
R57	"	1.5K ohm TR7 Coll.	"	"
R58	"	680 ohm TR7 Emit.	"	"
R59	"	1K ohm FM Det.	"	"
R60	"	10K ohm "	"	"
R61	"	10K ohm FM Det.	"	"
R62	"	100 ohm "	"	"
R63	"	1M ohm	"	"
R64	"	33K ohm	"	"
R65	"	1K ohm TR8 Base	"	"
R66	"			
R67	"	47K ohm TR8 Base	1/4W	<u>+10%</u>
R68	"	6.8K ohm TR9 Base	"	"

<u>Symbol</u> <u>Location</u>		<u>Description</u>	<u>Remarks</u>	<u>Part No.</u>
R69	Res.	47 ohm TR8 Emit.	1/4W +10%	
R70	"	4.7K ohm TR9 Coll.	" "	
R71	"	2.2K ohm TR10 Emit.	" "	
R72	"	15K ohm TR10 Coll.	" "	
R73	"	22 ohm -B line	" "	
R74	"	3.3K ohm TR11 Emit.	" "	
R75	"	270K ohm TR11 Coll.	" "	
R76	"	680 ohm TR11 Emit.	" "	
R77	"	18K ohm TR12 Base	" "	
R78	"	22 ohm -B line	" "	
R79	"	4.7K ohm TR12 Base	" "	
R80	"	680 ohm TR12 Emit.	" "	
R81	"	10K ohm AM Det.	" "	
R82	"	4.7K ohm "	" "	
R83	"	1.5K ohm "	" "	
R84	"	22K ohm "	" "	
R85	"	82K ohm "	" "	
R86	"	33K ohm "	" "	
R87	"	22K ohm TR14 Base	" "	
R88	"			
R89	"	56K ohm TR14 Base	1/4W +10%	
R90	"	4.7K ohm TR14 Emit.	" "	
R91	"	330K ohm TR15 Base	" "	
R92	"	10K ohm TR15 Coll.	" "	
R93	"	6.8K ohm TR15 Emit.	" "	
R94	"	180K ohm TR15 Base	" "	
R95	"	2.2K ohm TR15 Emit.	" "	
R96	"	100K ohm	" "	
R97	"	15K ohm TR16 Base	" "	
R98				
R99	Res.	220 ohm Audio Power	1/4W +10%	
R100	"	27K ohm TR16 Base	" "	
R101	"	3.3K ohm TR16 Emit.	" "	
R102	"	22 ohm TR16 Emit.	" "	

<u>Symbol</u> <u>Location</u>	<u>Description</u>		<u>Remarks</u>	<u>Part No.</u>
R103	Res.	3.3K ohm TR16 Coll.	1/4W	+10%
R104	"	5.6K ohm TR17 Base	"	"
R105	"	47K ohm "	"	"
R106	"	330 ohm TR17 Emit.	"	"
R107	"	68 ohm -B line	"	"
R108	"	2.2K ohm TR18 Coll.	"	"
R109	"	220 ohm Audio power	"	"
R110	"	2.2K ohm "	"	"
R111	"	15 ohm EP/SP	1/2W	"
R112	"	22 ohm -B line	1/4W	"
R113	"	2.2 ohm Voltage stabilizer	1/2W	"
R114	"	330 ohm "	"	"
R115	"	2.2K ohm	1/4W	"
R116	"	10 ohm SW5 OSC	"	"
R117	"	220 ohm LW OSC	"	"
R118	"	100 ohm "	"	"
R119	"	3.3K ohm	"	"
R120	"	22K ohm TR4 Base	"	"
R131	"	1K ohm LW RF	"	"
R132	"	150 ohm TR2 Coll.	"	"
R133	"	47K ohm TR15 Base	"	"
		Volume control with switch	5K ohm	
		Tone/squelch control with switch	50K ohm/10K ohm	
TR1	SE-5006	FM RF amp.	Transistor NPN type	
TR2	SE-3001	FM MIX	"	"
TR3	"	LW RF amp.	"	"
TR4	"	FM IF amp.	"	"
TR5	"	"	"	"
TR6	"	"	"	"
TR7	"	"	"	"
TR8	CS-1254	Squelch	"	"
TR9	"	"	"	"
TR10	SE-5001	AM IF amp.	"	"

<u>Symbol</u> <u>Location</u>		<u>Description</u>	<u>Remarks</u>	<u>Part No.</u>
TR11	SE-1001	AM IF amp.	Transistor NPN type	
TR12	"	"	" "	
TR13	SE-5006	AM OSC	" "	
TR14	CS-1254	B. F. O.	" "	
TR15	SE-4010	AF amp.	" "	
TR16	2SB 185	"	" PNP type	
TR17	2SB 187	Audio driver	" "	
TR18	2SB 405	Audio Power	" "	
TR19	"	"	" "	
TR20	"	Voltage stabilizer	" "	
D1	1S351	A. F. C.	Germanium diode	
D2	1N60	AM Det.	"	
D3	"	Squelch	"	
D4	"	Limiter	"	
D5	"	Tuning indicator	"	
D6	"	A. G. C.	"	
D7	"	"	"	
D8	1N60 (P)	FM Det.	"	
D9	"	"	"	
D10	1N60	Squelch	"	
D11	"	"	"	
D12	10D-1	Rectifier	Silicon diode	
D13	1S334	"	Zener diode	
D14	DS-18	"	Silicon diode	
TH1	5D-170	Thermistor	Temperature Compensator	
TH2	"	"	"	
L1	Filter coil for FM			R170047
L2	"			R170048
L3	FM ANT coil			"
L4	FM RF coil			R160131
L5	Trap coil			R170050

<u>Symbol</u> <u>Location</u>	<u>Description</u>	<u>Remarks</u>	<u>Part No.</u>
L6	FM OSC coil		R165001
L7			
L8	AM ANT coil (AM-178)		R180178
L9	LW " "		"
L10	SW1 " (AM-177)		R180177
L11	SW2 " "		"
L12	SW3 " (AM-184)		R180184
L13	SW4 " (AM-183)		R180183
L14	SW5 " (AM-159)		R180159
L15	SW5 OSC coil (OMO-165)		R160165
L16	SW4 " (OMO-149)		R160149
L17	SW3 " "		"
L18	SW2 " (OMO-148)		R160148
L19	SW1 " (OMO-147)		R160147
L20	AM " (OMO-146)		R160146
L21	LW " (OMO-155)		R160155
L22	BFO OSC coil (OMO-168)		R160168
L23	Filter coil		R151001
L24	" for power		R130014
L25	" "		"
T1	Transformer K-102	FM 1st IFT	R15093
T2	" K-112	FM 2nd IFT	R15124
T3	" K-113	"	R15125
T4	" K-112	FM 3rd IFT	R15124
T5	" K-113	"	R15125
T6	" K-102	FM 4th IFT	R15093
T7	" WK-104	FM Det.	R15094
T8	" A-16	AM 1st IFT	R15120
T9	" A-18	"	R15126
T10	" B-13	AM 2nd IFT	R15086
T11	" C-24	AM 3rd IFT	R151031
T12	Transformer for driver		G12324
T13	Power transformer		R110056

<u>Symbol</u> <u>Location</u>	<u>Description</u>	<u>Remarks</u>	<u>Part No.</u>
TC1	Trimmer	FM ANT.	
TC2	"	FM RF.	
TC3	"	LW ANT.	Capacitor max. 8pF R213012
TC4	"	AM ANT.	" " "
TC5	"	SW1 ANT.	" " "
TC6	"	SW2 ANT.	" " "
TC7	"	SW3 ANT.	" 16pF R213013
TC8	"	SW4 ANT.	" " "
TC9	"	SW5 ANT.	" " "
TC10	"	SW5 OSC.	" " "
TC11	"	SW4 OSC.	" " "
TC12	"	SW3 OSC.	" " "
TC13	"	SW2 OSC.	" 8pF R213012
TC14	"	SW1 OSC.	" " "
TC15	"	AM OSC.	" " "
TC16	"	LW OSC.	" " "

VC1	} Variable Capacitor Tuning four section with trimmers
VC2	
VC3	
VC4	

TF-182

Screw for Variable Capacitor	2 pcs. BB + 2604	
Deck		R610285
Screw for main P. C. board ass'y	3 pcs. BB + 3006	
"	BN + 3006	
Washer for main P. C. board ass'y	4 pcs.	
Holder(A) for ferrite antenna		R633060
Spring Washer for holder (A)	2 pcs. VB 301	
Screw for holder (A)	2 pcs. BB + 3006	
Holder(B) for ferrite antenna		R633061
Spring washer for holder (B)	2 pcs. VB 301	
Screw for holder(B)	2 pcs. BB + 3006	
Hook up terminal board		G43057
Spring washer for hook up	VB 301	
Nut for hook up	NMB 301	

<u>Symbol Location</u>	<u>Description</u>	<u>Remarks</u>	<u>Part No.</u>
	Fixture for pair transistor		R66051
	Fixture for rectifier transistor		R651038
	Screw for fixture	2 pcs. BB + 3008	
	Spring washer for fixture	2 pcs. VB 301	
	Nut for fixture	2 pcs. NMB 301	
	Power transformer		R110056
	Cord for Power Transformer	Grey 6 feet	R440033
	Connector	2 pcs.	R437004
	Fixture for Cord		
	Washer for Fixture	ZB 301	
	Screw for Fixture	BB + 3010	
	Cord Stopper	Black	R81707
	Earphone Jack	2 pcs.	G43959
	Antenna Jack	1 pcs.	G43959
	Main P. C. board		R530194
	Audio P. C. board		R530195
	B. F. O. P. C. board		R530196
	Cabinet		R840554
	Front cover		R810959
	Tapping Screw for Stopper	4 pcs. B type + 2006	
	Magnet A for front cover	2 pcs.	R636261
	Tapping Screw for Magnet	2 pcs. B type + 2606	
	Time indicator plate		R636319
	The base of time indicator		R810918
	Shaft for time indicator		R680068
	Cushion for time indicator		R810925
	Stopper for shaft		
	Washer for shaft	ZB 301	
	A map of world		R636274
	Time indicator		R636267
	Name plate of front cover		R636318
	Handle		R810915
	Screw for handle	5 pcs. BS + 3015	
	Metal assembly for handle		
	Washer for metal assembly	8 pcs. ZB 301	
	Screw for metal assembly	4 pcs. BB + 3006	
	"	4 pcs. BB + 3016	
	Spring washer for metal ass'y	8 pcs. VB 301	
	Bolt for metal assembly	MBO 310	
	"	4 pcs. MBO 316	
	"	MBO 314	

<u>Symbol Location</u>	<u>Description</u>	<u>Remarks</u>	<u>Part No.</u>
	Antenna core holder	4 pcs.	R81725
	Screw for antenna core holder	4 pcs. BB + 3018	
	Nut for "	4 pcs. NMB 301	
	Tuning shaft		R97663
	Special washer		R93014
	Fine tuning		R261005
	Holder for band selector		R633062
	Tapping screw for holder	2 pcs.	
	Screw for holder	4 pcs. BB + 3005	
	Fixture for push buttons	(Shaft) 5 ϕ	R680070
	Special washer for shaft	2 pcs.	
	E type lag	2 pcs. 3 ϕ	
	Washer for shaft	2 pcs.	
	Push buttons	8 pcs. White	R810916
	Spring for push buttons	8 pcs.	R700244
	Double Pulley	2 pcs. Black	R644017
	Shaft for Double Pulley	2 pcs.	R680071
	Spring washer for shaft	2 pcs. VB 301	
	Nut for shaft	2 pcs. NMB 301	
	E type lag	2 pcs. 3 ϕ	
	Pulley	2 pcs.	R64409
	Small Pulley	White	R67272
	Shaft for small pulley		R680072
	Screw for Shaft	BB + 2005	
	Spring washer for Shaft	VB 301	
	Nut for Shaft	NMB 301	
	Dial String	0.5 ϕ 1500 m/m	R70002
	Spring for dial string		
	Eyelet	2 ϕ x 3	
	Fixture for Dial Backing	(Shaft A) 2 pcs.	R676065
	Spring washer for Shaft	2 pcs. VB 301	
	Nut for Shaft	2 pcs. NMB 301	
	Fixture for Dial Backing	(Shaft B) 2 pcs.	
	Spring washer for shaft	2 pcs. VB 301	
	Nut for shaft	2 pcs. NMB 301	
	Dial Backing (Metal)		R620219
	Sticker (Dial Backing)		R851142
	Screw for dial backing	4 pcs. BB + 3006	
	Small lamp	5 pcs. 9V/30mA	R411003
	Pointer	Red	R877027
	Felt ring for pointer	2 pcs. 1.2 ϕ x 4.5 ϕ	
	Heat sink		R651178
	Screw for heat sink	BB + 3006	
	Spring washer for heat sink	VB 301	

<u>Symbol</u> <u>Location</u>	<u>Description</u>	<u>Remarks</u>	<u>Part No.</u>
	Telescopic rod antenna		R180085
	Screw for rod antenna	BB + 4012	
	Spring washer for rod antenna	VB 401	
	Washer for rod antenna	ZB 401	
	Net for speaker		R851152
	Decoration panel A		R636268
	" B		R636269
	" C		R636270
	Indicator panel for band selector		R636321
	Reflector paper	2 pcs.	R810941
	Dial		R860476
	Name plate for expression transistor		R636272
	Name plate for expression switch on-off		R636320
	Decoration panel	Grain printing	R636277
	Tuning meter	200 μ A	R590024
	Cover for tuning meter	Green	R820120
	Badge		R636322
	Side piece board	Left side	R810908
	Bolt for side piece board	5 pcs. MBO 316	
	Nut for side piece board	2 pcs. U type	
	Washer for "	5 pcs. ZB 301	
	Nut for "	5 pcs. NMB 303	
	Decoration panel for Left side board	(small)	R636262
	"	(big)	R636265
	Screw for rear cabinet	2 pcs. BB + 3020	
	"	2 pcs. BB + 3026	
	Battery snap		R440027
	Battery case		R810922
	Cushion for Battery	2 pcs.	R830358
	Knob-spring for battery door	2 pcs.	R810917
	Knob for battery door	2 pcs.	R700243
	Washer for Knob	2 pcs. ZB 231	
	Tapping Screw for battery door	B Type + 2006	
	Spacer for main P. C. board	L=12mm	R676070
	Stud for Audio P. C. board	L=25mm	R676069
	Tapping Screw for P. C. board assembly	8 pcs. B type + 3012	
	Screw for P. C. board assembly	BB + 3008	
	Washer for "	9 pcs. Fiber	R93031

<u>Symbol Location</u>	<u>Description</u>	<u>Remarks</u>	<u>Part No.</u>
	Leather for side piece board	2 pcs. Grain printing	R810923
	Net for rear cabinet		R851140
	Crush washer for chassis		
	Fixture metal for front cover	4 pcs.	
	Battery	6 pcs. "D" cell MAXELL brand	R470028
	Polyethylene bag for battery		R810808
	Earphone		G45211
	Polyethylene bag for earphone		R81612
	Supporter for ferrite core Antenna	Rubber block	R830379
	Polyethylene bag for set		R810921
	Packing paper		
	Polyethylene bag for power cord		R810807
	Individual packing box		R885263
	Master packing box	1/2 pcs.	R885264
	Operating instruction booklet		R890227
	Squelch tag		R890229
	Voltage card		R890198
	Instruction for Battery case		R890217
	Spacer for rear cabinet		R810960
	AUX. Jack		R438012
	Screw for AUX. Jack	2 pcs. BB + 2610	
	Spring washer for AUX. Jack	2 pcs. VB 261	
	Nut for AUX. Jack	2 pcs. NMB 261	
	Slide switch		G42324
	Screw for slide switch	2 pcs. SS + 2106	
	Spacer for Badge		R851182

[For TF-182FB only use]

	Screw for Variable Capacitor	2 pcs. BB + 2604	
	Deck		R610285
	Screw for main P. C. board ass'y	3 pcs. BB + 3006 BN + 3006	
	Washer for main P. C. board ass'y	4 pcs.	

<u>Symbol Location</u>	<u>Description</u>	<u>Remarks</u>	<u>Part No.</u>
	Nut for power transf.	2 pcs. NMB 301	
	Washer for power transf.	2 pcs.	
	Screw for P. C board assembly	2 pcs. BB + 3010	
	Screw for Fixture cord	BB + 3010	
	Washer for power transf.	ZB 301	
	Special washer for power transf.	2 pcs.	R93015
	Name plate for rear cabinet		R636317
	Bolt for P. C board assembly	2 pcs. MBO 314	
	Tuning Knob		R871059
	Felt for tuning Knob		R851138
	Squelch Knob		R871063
	Tone Knob		R871062
	Felt for tone Knob		R851139
	Fine tuning Knob		R871058
	Volume control Knob		"
	Felt for VR Knob	2 pcs.	R851139
	B. F. O. Switch	Seasaw switch	R429003A
	A. F. C. Switch	Seasaw switch	R429003A
	Tapping screw for B. F. O Switch	4 pcs. B type + 3008	
	Spring washer for A. F. C switch	4 pcs. VB 301	
	Cover for B. F. O and A. F. C. Switch	2 pcs.	R851136
	Knob for dial lamp	White	R951089A
	Washer for knob	ZB 201	
	Screw for knob	BC + 2005	
	Dial lamp switch		
	Tapping screw for dial lamp switch	2 pcs.	
	Speaker	5"	R450064
	Washer for speaker	4 pcs. ZB 301	
	Spring washer for speaker	4 pcs. VB 301	
	Nut for speaker	4 pcs. NMB 303	
	Egg type lag	2 pcs.	
	Side piece board	Right side	R810905
	Bolt for side piece board	5 pcs. MBO 316	
	Nut for "	2 pcs. U type	
	Washer for "	5 pcs. ZB 301	
	Nut for "	5 pcs. NMB 303	
	Washer for "	7 pcs. Fiber	R93031
	Decoration panel for right side board	(small)	R636263
	"	(big)	R636264

<u>Symbol</u> <u>Location</u>	<u>Description</u>	<u>Remarks</u>	<u>Part No.</u>
	Holder (A) for ferrite antenna		R633060
	Spring Washer for holder(A)	2 pcs. VB 301	
	Screw for holder(A)	2 pcs. BB + 3006	
	Holder (B) for ferrite antenna		R633061
	Spring washer for holder(B)	2 pcs. VB 301	
	Screw for holder(B)	2 pcs. BB + 3006	
	Hook up terminal board		G43057
	Spring washer for hook up	VB 301	
	Nut for hook up	NMB 301	
	Antenna core holder	4 pcs.	R81725
	Screw for antenna core holder	4 pcs. BB + 3018	
	Nut for "	4 pcs. NMB 301	
	Tuning shaft		R97663
	Special washer		R93014
	Fine tuning		R261005
	Holder for band selector		R633062
	Tapping screw for holder	2 pcs.	
	Screw for holder	4 pcs. BB + 3005	
	Fixture for push buttons	(Shaft) 5 ϕ	R680070
	Special washer for shaft	2 pcs.	
	E type lag	2 pcs. 3 ϕ	
	Washer for shaft	2 pcs.	
	Push buttons	8 pcs. White	R810916
	Spring for push buttons	8 pcs.	R700244
	Double Pulley	2 pcs. Black	R644017
	Shaft for Double Pulley	2 pcs.	R680071
	Spring washer for shaft	2 pcs. VB 301	
	Nut for shaft	2 pcs. NMB 301	
	E type lag	2 pcs. 3 ϕ	
	Pulley	2 pcs.	R64409
	Small Pulley	White	R67272
	Shaft for small pulley		R680072
	Screw for Shaft	BB + 2005	
	Spring washer for Shaft	VB 301	
	Nut for Shaft	NMB 301	
	Dial String	0.5 ϕ 1500 m/m	R70002
	Spring for dial string		
	Eyelet	2 ϕ x 3	
	Fixture for Dial Backing	(Shaft A) 2 pcs.	R676065
	Spring washer for Shaft	2 pcs. VB 301	
	Nut for Shaft	2 pcs. NMB 301	
	Fixture for Dial Backing	(Shaft B) 2 pcs.	
	Spring washer for shaft	2 pcs. VB 301	
	Nut for shaft	2 pcs. NMB 301	

<u>Symbol Location</u>	<u>Description</u>	<u>Remarks</u>	<u>Part No.</u>
	Dial Backing (Metal)		R620219
	Sticker (Dial Backing)		R851142
	Screw for dial backing	4 pcs. BB + 3006	
	Small lamp	5 pcs. 9V/30mA	R411003
	Pointer	Red	R877027
	Felt ring for pointer	2 pcs. 1.2ϕ x 4.5ϕ	
	Heat sink		R651178
	Screw for heat sink	BB + 3006	
	Spring washer for heat sink	VB 301	
	Fixture for pair transistor		R66051
	Fixture for rectifier transistor		R651038
	Screw for fixture	2 pcs. BB + 3008	
	Spring washer for fixture	2 pcs. VB 301	
	Nut for fixture	2 pcs. NMB 301	
	Power transformer		R110056
	Cord for Power Transformer	Grey 6 feet	R440033
	Connector	2 pcs.	R437004
	Fixture for Cord		
	Washer for Fixture	ZB 301	
	Screw for Fixture	BB + 3010	
	Cord Stopper	Black	R81707
	Earphone Jack	2 pcs.	G43959
	Antenna Jack	1 pc.	G43959
	Main P. C. board		R530194
	Audio P. C. board		R530195
	B. F. O. P. C. board		R530196
	Cabinet		R840554A
	Front cover		R810959A
	Tapping Screw for Stopper	4 pcs. B type + 2006	
	Magnet A for front cover	2 pcs.	R636261
	Tapping Screw for Magnet	2 pcs. B type + 2606	
	Time indicator plate		R636319A
	The base of time indicator		R810918
	Shaft for time indicator		R680068
	Cushion for time indicator		R810925
	Stopper for shaft		
	Washer for shaft	ZB 301	
	A map of world		R636274A
	Time indicator		R636267A
	Name plate of front cover		R636373

<u>Symbol Location</u>	<u>Description</u>	<u>Remarks</u>	<u>Part No.</u>
	Handle		R810915A
	Screw for handle	5 pcs. BS + 3015	
	Metal assembly for handle		
	Washer for metal assembly	8 pcs. ZB 301	
	Screw for metal assembly	4 pcs. BB + 3006	
	"	4 pcs. BB + 3016	
	Spring washer for metal assembly	8 pcs. VB 301	
	Bolt for metal assembly	MBO 310	
	"	4 pcs. MBO 316	
	"	MBO 314	
	Telescopic rod antenna		R180085A
	Screw for rod antenna	BB + 4012	
	Spring washer for rod antenna	VB 401	
	Washer for rod antenna	ZB 401	
	Net for speaker		R851152
	Decoration panel A		R636268
	" B		R636269
	" C		R636270
	Indicator panel for band selector		R636321
	Reflector paper	2 pcs.	R810941
	Dial		R860481
	Name plate for expression transistor		R63272A
	Name plate for expression switch on-off		R636371
	Decoration panel	Grain printing	R636372
	Tuning meter	200 μ A	R590024
	Cover for tuning meter	Green	R820120
	Badge		R636322
	Side piece board	Left side	R810908
	Bolt for side piece board	5 pcs. MBO 316	
	Nut for side piece board	2 pcs. U type	
	Washer for "	5 pcs. ZB 301	
	Nut for "	5 pcs. NMB 303	
	Decoration panel for Left side board	(small)	R636262
	"	(big)	R636265
	Screw for rear cabinet	2 pcs. BB + 3020	
	"	2 pcs. BB + 3026	
	Battery snap		R440027
	Battery case		R810922

<u>Symbol Location</u>	<u>Description</u>	<u>Remarks</u>	<u>Part No.</u>
	Cushion for Battery	2 pcs.	R830358
	Knob-spring for battery door	2 pcs.	R810971
	Knob for battery door	2 pcs.	R810917A
	Washer for Knob	2 pcs. ZB 231	
	Tapping Screw for battery door	B Type + 2006	
	Spacer for main P. C board	L=12mm	R676070
	Stud for Audio P. C board	L=25mm	R676069
	Tapping Screw for P. C board assembly	8 pcs. B type + 3012	
	Screw for P. C board assembly	BB + 3008	
	Washer for "	9 pcs. Fiber	R93031
	Nut for power transf.	2 pcs. NMB 301	
	Washer for power transf.	2 pcs.	
	Screw for P. C board assembly	2 pcs. BB + 3010	
	Screw for Fixture cord	BB + 3010	
	Washer for power transf.	ZB 301	
	Special washer for power transf.	2 pcs.	R93015
	Name plate for rear cabinet		R636374
	Bolt for P. C. board assembly	2 pcs. MBO 314	
	Tuning Knob		R871057
	Felt for tuning Knob		R851186
	Squelch Knob		R871053
	Tone Knob		R871054
	Felt for tone Knob		R851185
	Fine tuning Knob		R871057
	Volume control Knob		R871080
	Felt for VR Knob	2 pcs.	R851185
	B. F. O. Switch	Seesaw switch	R429003A
	A. F. C. Switch	Seesaw switch	R429003A
	Tapping screw for B. F. O. Switch	4 pcs. B type + 3008	
	Spring washer for A. F. C. Switch	4 pcs. VB 301	
	Cover for B. F. O and A. F. C. Switch	2 pcs.	R851136
	Knob for dial lamp	White	R95065
	Washer for knob	ZB 201	
	Screw for knob	BC + 2005	
	Dial lamp switch		
	Tapping screw for dial lamp switch	2 pcs.	
	Speaker	5"	R450064
	Washer for speaker	4 pcs. ZB 301	

<u>Symbol Location</u>	<u>Description</u>	<u>Remarks</u>	<u>Part No.</u>
	Spring washer for speaker	4 pcs. VB 301	
	Nut for speaker	4 pcs. NMB 303	
	Egg type lag	2 pcs.	
	Side piece board	Right side	R810905
	Bolt for side piece board	5 pcs. MBO 316	
	Nut for "	2 pcs. U type	
	Washer for "	5 pcs. ZB 301	
	Nut for "	5 pcs. NMB 303	
	Washer for "	7 pcs. Fiber	R93031
	Decoration panel for right side board	(small)	R636263
	"	(big)	R636264
	Leather for side piece board	2 pcs. Black	R810923A
	Net for rear cabinet		R851140
	Crush washer for chassis		
	Fixture metal for front cover	4 pcs.	
	Battery	6 pcs. "D" cell MAXWELL Brand	R470028
	Polyethylene bag for battery		R810808
	Earphone		G45211
	Polyethylene bag for earphone		R81612
	Supporter for ferrite core Antenna	Rubber block	R830379
	Polyethylene bag for set		R810921
	Packing paper		
	Polyethylene bag for power cord		R810807
	Individual packing box		R885287
	Master packing box	1/2 pcs.	R885264
	Operating instruction booklet		R890244
	Squelch tag		R890225A
	Voltage card		R890198
	Instruction for Battery case		R890217
	Spacer for rear cabinet		R810960
	AUX. Jack		R438012
	Screw for AUX. Jack	2 pcs. BB + 2610	
	Spring washer for AUX. Jack	2 pcs. VB 261	
	Nut for AUX. Jack	2 pcs. NMB 261	
	Slide switch		G42324
	Screw for slide switch	2 pcs. SS + 2606	
	Spacer for Badge		R851182

CIRCUIT DIAGRAM MODEL : TF-182 & TF-182 FB

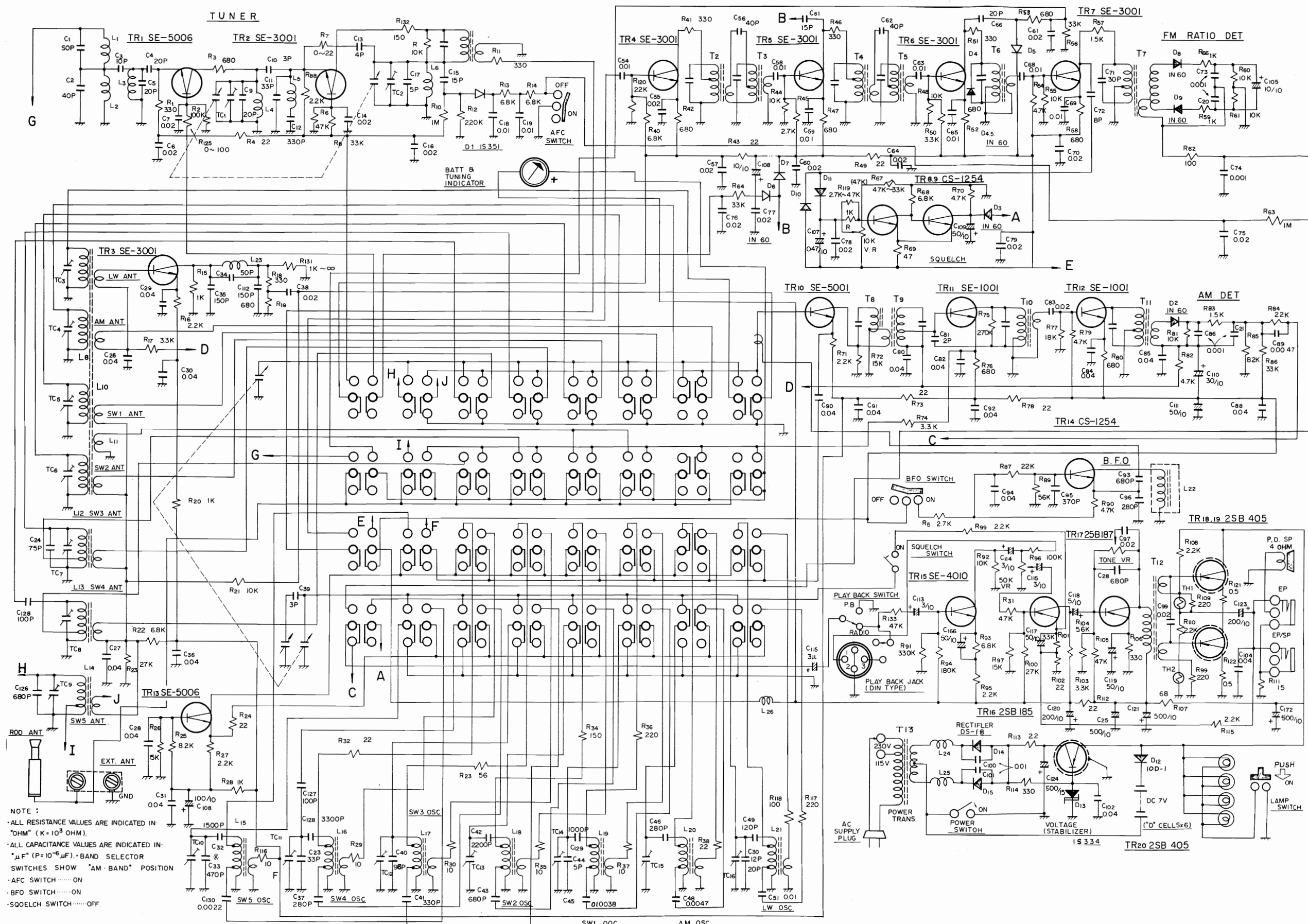

NOTE :

- ALL RESISTANCE VALUES ARE INDICATED IN "OHM" (K = 10^3 OHM).
- ALL CAPACITANCE VALUES ARE INDICATED IN "μF" ($P = 10^{-6}$ μF). BAND SELECTOR SWITCHES SHOW "AM-BAND" POSITION.
- AFC SWITCH ON
- BFO SWITCH ON
- SQUELCH SWITCH OFF.