

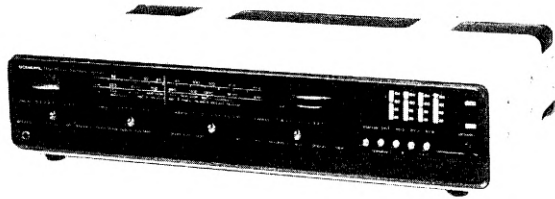

SERVICE MANUAL

Hi-Fi MW/LW/SW/FM Stereo Receiver MODEL TFS-70



Germany: TELETON Elektro GmbH.
4000 Düsseldorf-Rath Oberhausener Str. 17
Tel. (0211) 65 30 81 TX 858 6768

United Kingdom: TELETON Electro (UK) Co., Ltd.
Teleton House, Waterhouse Lane,
Chelmsford/Essex
Tel. Chelmsford 62 442 TX 99 338

Technical Service Organization
Waterhouse Lane, Chelmsford, Essex.
Tel. 0245-54621 TX 99338

Belgium: TELETON N.V.
2200 Borgerhout Belgium
Prins-Leopold-Straat 28
Tel. 03/361045 TX32508
03/357670

Netherlands: TELETON NEDERLAND B.V.
Marconiweg 10. Vianen
Tel. 03473-3744 TX 40581

France: TELETON Electro (France) S.à.r.l.
21 rue Paul Lafargue
94270 Le Kremlin-Bicêtre
Tel. 677 6934 TX24 468

Switzerland: TRANSACO AG
Kanzleistrasse 126 8004 Zürich
Tel. 39 45 60/23 50 40 TX 52 362

CABINET EXPLODED VIEW

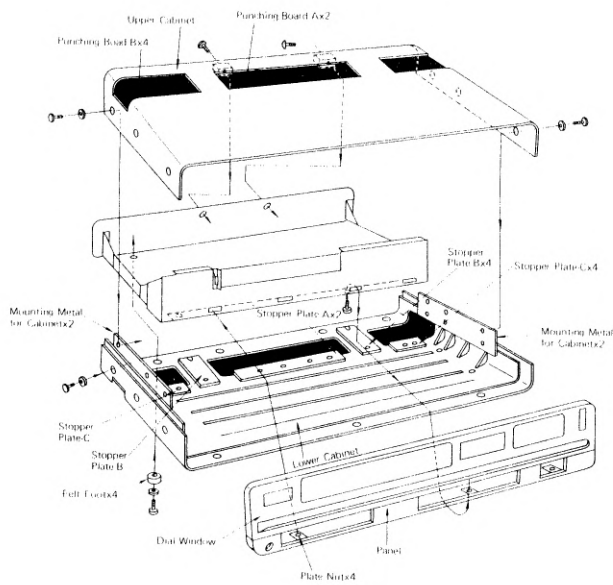

Figure 1

CABINET REMOVAL

1. Remove six screws on the cabinet sides.
2. Remove two screws on the cabinet rear.
3. Pull backward the upper cabinet, then this will be removed.
4. Remove all screws (includes foot screws), then the lower cabinet will be removed.

ADJUSTMENT INSTRUCTIONS

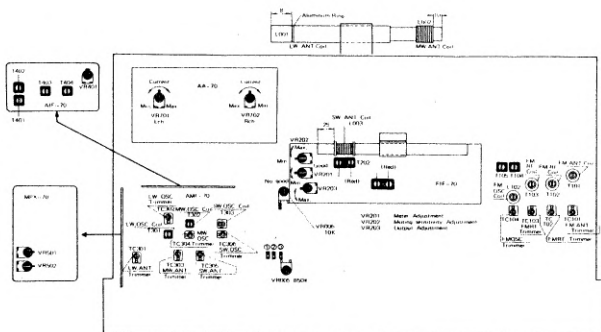

Figure 2

1. Adjustment of Main Amp.

When transistors Q711, 712, 713, 714 are exchanged, the following adjustment is necessary:

- 1-1 Measuring Equipment
 - (a) Current Meter
- 1-2 Condition of the Set
 - (a) Treble Middle Position
 - (b) Bass Middle Position
 - (c) Volume Minimum
 - (d) Balance Middle Position
 - (e) Muting, AFC, Loudness, Tape, Low, High OFF Position
 - (f) ST/MONO ST
 - (g) Mode AUX
 - (h) Speaker A
 - (i) Quad ST
- 1-3 Adjustment
 - (a) Adjust VR701, VR702 to middle position.
 - (b) Connect the Current Meter ⊕ Side to Terminal 3(Rch.) or 4(Lch.) on the Fuse Board A, and the Current Meter ⊖ Side to Terminal 1(Rch) or 2(Lch).
 - (c) Adjust VR702 to 40 mA ± 3 mA.
 - (d) Set the Current Meter to L Channel.
 - (e) Adjust VR701 to 40 mA ± 3 mA.
 - (f) Repeat Procedure a - d several times.

2. AM IF Adjustment

- 2-1 Measuring Equipments
 - (a) AM Standard Signal Generator
 - (b) Audio Oscillator
 - (c) Output Meter (V.T.V.M)
 - (d) Oscilloscope
 - (e) Dummy Load 8Ω 50W
- 2-2 Preparation of Adjustment
 - (a) Volume: Max., Mode: MW, Others: same as procedure 1-2
 - (b) Measuring Connection is as follows:

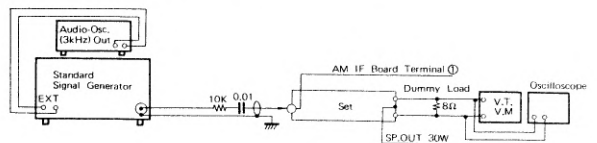

Figure 3

- 2-3 Adjustment
 - (a) Set S.G. to 465 KHz (Mod. 400 Hz 30%) 80 dB, and adjust IF cores of T401, T402, T403 and T404 for maximum output reading.
Adjust the Attenuator of S.G. according to increase the output, and put the output reading to 500 mW (2V) approx.

(b) Set S.G. to 465 KHz (Mod. 3000 Hz 30%), and adjust cores of T401 and T402 for maximum output reading.

3. AM Tracking Adjustment (Adjusting procedure for LW, MW, and SW)

3-1 Measuring Equipments

- (a) AM Standard S.G. (including loop antenna)
- (b) Output Meter (V.T.V.M.)
- (c) Oscilloscope
- (d) Dummy Load 8Ω 50W

3-2 Preparation of Adjustment

- (a) Volume: Max., Mode: LW, Others: Same as procedure 1-2
- (b) Measuring connection is as follows:

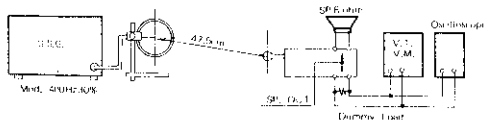

Figure 4



Figure 5

- (c) TC301, TC302, TC304, TC305 and TC306 Position are as shown in Figure 5.
- (d) Set the Aluminium ring of L001 (Ant. coil) as shown in Figure 2.
- (e) Set L002 (Ant. coil) as shown in Figure 2.
- (f) Set L003 (Ant. coil) as shown in Figure 2.

Note: All adjustments for max. Output.

3-3 LW Tracking Adjustment

3-3-1 Adjustment of Local Osc. circuit

Adjustment Step	1	2
Frequency (S.G.)	145 KHz	350 KHz
V.C. Position	Max. Capacitance	Min. Capacitance
Adjust Point	T301	TC302

Repeat Step 1 and 2 several times. When step 1 and 2 match, adjustment of the Local Osc. Circuit is finished.

3-3-2 Adjustment of Tuning Circuit

Adjustment Step	1	2
Frequency (S.G.)	160 KHz	320 KHz
V.C. Position	160 KHz Tuning Position	320 KHz Tuning Position
Adjust Position	Aluminium Ring	TC301

Repeat step 1 and 2 several times. When step 1 and 2 match, adjustment of tuning circuit is finished. Fix the Aluminium ring with wax, and adjust finely the Local Osc. Circuit (because the coverage drag by the Tracking adjustment.)

3-4 MW Tracking Adjustment (Mode: MW)

3-4-1 Adjustment of Local Osc. Circuit

Adjustment Step	1	2
Frequency	515 KHz	1710 KHz
V.C. Position	Max. Capacitance	Min. Capacitance
Adjust Position	T302	TC304

3-4-2 Adjustment of Tuning Circuit

Adjustment Step	1	2
Frequency	600 KHz	1400 KHz
V.C. Position	600 KHz Tuning Position	1400 KHz Tuning Position
Adjust Position	L002	TC303

3-5 SW Tracking Adjustment (Mode: SW)

3-5-1 Adjustment of Local Osc. Circuit

Adjustment Step	1	2
Frequency (S.G.)	5.8 MHz	12.5 MHz
V.C. Position	Max. Capacitance	Min. Capacitance
Adjust Position	T303	TC306

3-5-2 Adjustment of Tuning Circuit

Adjustment Step	1	2
Frequency (S.G.)	7 MHz	11 MHz
V.C. Position	7 MHz Tuning Position	11 MHz Tuning Position
Adjust Position	L003	TC305

4. FM, IF Adjustment (FM, IF Adjustment is adjusted with S Curve.)

4-1 Measuring Equipment

- (a) 10.7 MHz Interscope (Sweep generator and scope)

4-2 Preparation of Adjustment

- (a) Mode-FM, Others --- same as procedure 1-2
- (b) Measuring connection is as follows:

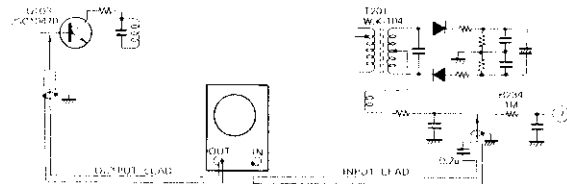

Figure 6

1. Keep output lead and input lead at a distance.
2. Ground of the output & input lead should be done near point of hot side.

4-3 Adjustment

- (a) In condition of Figure 6, adjust vertical gain (80 dB ATT.) for approx. 1/3 height output wave form. Output wave form on the Interscope is as shown in Figure 7.

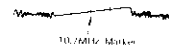

Figure 7

- (b) Adjust black core and red core of T201 to obtain the wave form as shown in Figure 8.

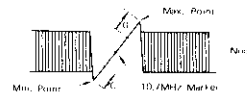

Figure 8

Note: See Figure 9.

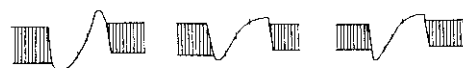

Figure 9

(c) Adjust cores of T105 & T104 to obtain Figure 10.

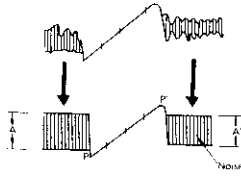

Figure 10

Note: 1. Take the height of A & A' as long as possible.
2. Inequality of noise (See figure 11) is no good.



Figure 11

5. FM Tracking Adjustment (do not remove the tuner cover.)

5-1 Measuring Equipment

- FM Standard Signal Generator (include the pad)
- Output Meter (V.T.V.M.)
- Oscilloscope
- Distortion Meter
- Dummy Load 8Ω 50W

5-2 Preparation of Adjustment

- Volume ----- Max. Mode ----- FM
- Measuring connection is as follows.

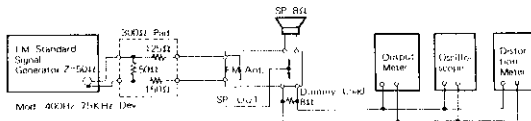

Figure 12

(c) TC101, TC102, TC103 and TC104 position are as follows.



Figure 13

- Set VR201, VR202, VR203, VR005 and VR006 to mechanical center position.
- Set Pre-Setter to MANUAL.

5-3 Adjustment

5-3-1 Adjustment of Local Osc. Circuit

- Connect \oplus terminal of Voltmeter to VR007 2 terminal, and \ominus terminal of Voltmeter to chassis.
- Set tuning to max. and adjust VR005 for 8V Voltmeter scale.
- Set tuning to min. frequency and adjust VR006 for 1.5V Voltmeter scale.
- Repeat step (b) and (c) several times. When step (b) and (c) match, voltage adjustment is finished.
- Adjustment of tuning circuit

Adjustment Step	1	2
Frequency (S.G.)	87.5 MHz	104.5 MHz
Freq. Position	Min. frequency	Max. frequency
Adjust point	L102	TC104

Adjust for max. output.

Repeat step 1 and 2 several times. When step 1 and 2 match, adjustment of the Local Osc. Circuit is ending.

5-3-2 Adjustment of Tuning Circuit

Adjustment Procedure	1	2
Frequency (S.G.)	90 MHz	102 MHz
V.C. Position	90 MHz Tuning Position	102 MHz Tuning Position
Adjust Point	T101, T102, T103	TC101, TC102, TC103

6. Adjustment of Meter, Muting, Tape Output Circuit

Note: Adjustment of Tape Output Circuit should be done after MPX adjustment.

6-1 Adjustment of Meter

- Input 90 MHz (Mod. 400 Hz, 22.5 kHz Dev.) 32dB (Att. scale), and adjust red and black cores of T202 for max. Meter scale.
- Set S.G. Att. scale to 112dB, and adjust VR202 for 8 meter scale.

6-2 Adjustment of Muting Circuit

- Input 90 MHz (Mod. 400 Hz, 22.5 kHz Dev.) 32dB (Att. scale), and set Muting Switch "ON". Turn VR201 counterclockwise to end (mute the output), and turn clockwise to the point of which the output wave appears, then set the point of which turn clockwise slightly.

6-3 Adjustment of Tape Output Circuit

- Input 90 MHz (Mod. 400 Hz, 22.5 kHz Dev.) 72dB (Att. scale), and adjust VR203 for 45 mV output of TAPE OUT.

Note: Insert 47k ohm resistor to TAPE OUT as suspected load.

7. MPX Adjustment

7-1 Measuring Equipment

- FM Standard Signal Generator (S.G.)
- STEREO Signal Generator (MPX S.G.)
- V.T.V.M.
- Oscilloscope
- Counter
- Dummy Load 8Ω 50W

7-2 Preparation of Adjustment

- Volume, Balance ---- Adjust output of L ch. and R ch. for 500mW (2V).
Mode ---- FM Others ---- Same as procedure 1-2.
- Measuring connection is as follows:

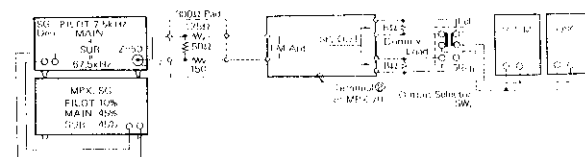

Figure 14

(c) Adjust VR501 & VR502 to middle position.

7-3 Adjustment

- Set S.G. to 90 MHz (L+R) + PILOT 32 dB.
- Tune set to 90 MHz.
- Adjust Volume & Balance for 500mW SP. output of both channel.
- Select (L+R) of MPX S.G. to "SUB". (ST. lamp not light.)
- Adjust VR501 for max. and no-distortion "SUB" waveform.
- Set MPX S.G. to R signal, and Output Selector SW. to L ch. (leakage of R signal appears on V.T.V.M.) Then, adjust VR502 for min. leakage of R signal.
- Set MPX S.G. to L signal, and Output Selector SW. to R ch. (leakage of L signal appears on V.T.V.M.) Then, confirm that the leakage is within 2 dB for R-L.

CIRCUIT DIAGRAM

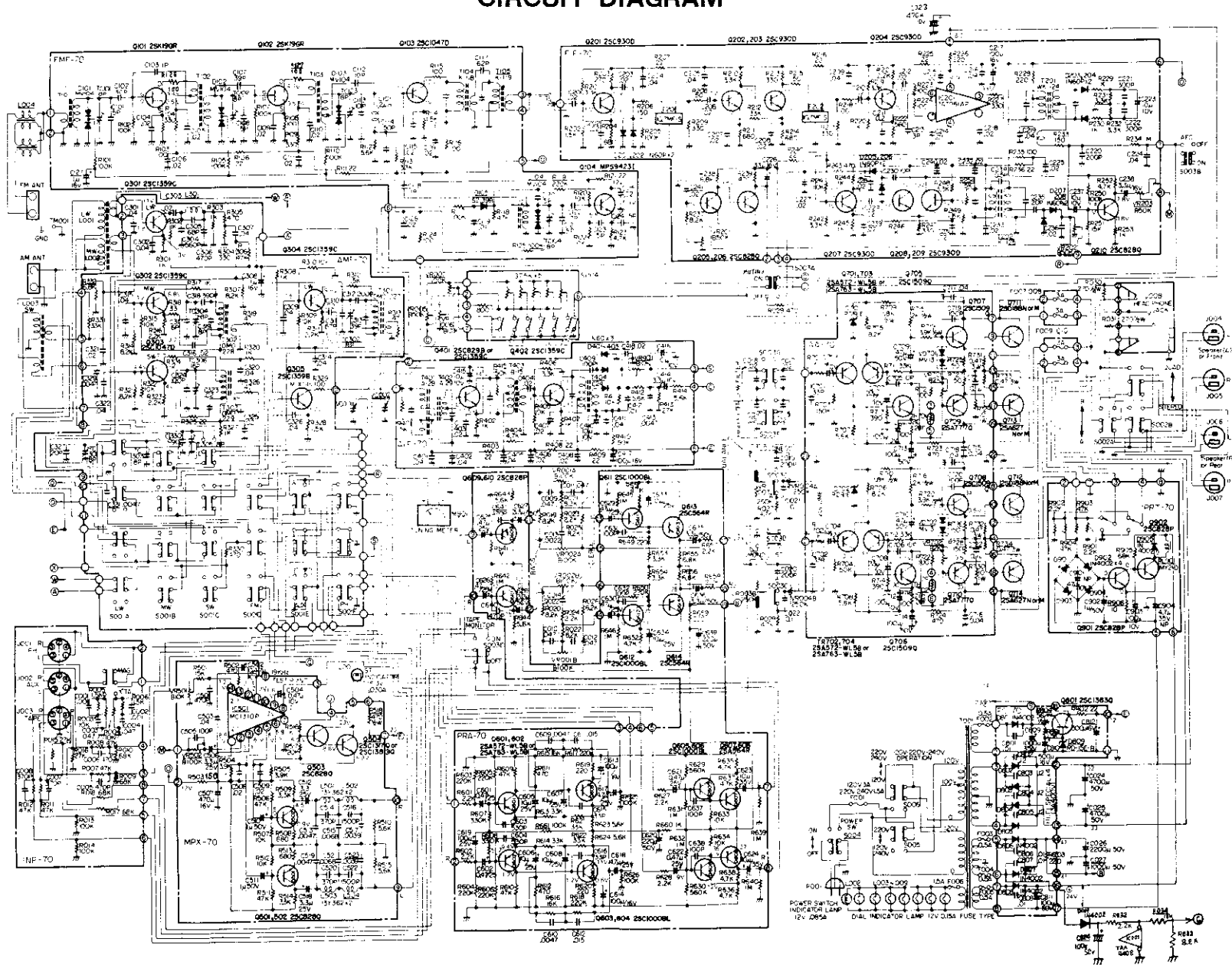

NOTE 1) FUNCTION SWITCH SHOWS IN LW POSITION

- 2) ALL RESISTANCES VALUE ARE INDICATED IN "OHM" (K=10³ OHM)
- 3) ALL CAPACITANCES VALUE ARE INDICATED IN "PF" (P=10⁻⁹ μF)
- 4) Q301, Q302, Q402, 25C1359C or 25C829C

PARTS LIST

(Standard Parts Resistors, Capacitors are not listed here)

Ref. No.	Part No.	Description	Ref. No.	Part No.	Description
A. Front Deck Parts (See PARTS LOCATION)					
	R610363B	Front Deck		R633210	MPX P.C Board Holder
VR004A VR004B	R361111	Slide Variable Resistor	C024, 025		Electrolytic Capacitor 50V 4700μF
VR003A VR003B	R361112	Slide Variable Resistor	C026		Electrolytic Capacitor 50V 2200μF
VR002A VR002B VR001A VR001B	R361113	Slide Variable Resistor	C027		Electrolytic Capacitor 50V 1000μF
S001A~F S003A~G S002A~B S004	R429060 R429061 R429062 R429063	Push Switch Push Switch Push Switch Preset Mechanism	VR007		Variable Resistor with V.C.
J008	R860612	Preset Dial	VC001, 002	R261023	(Variable Capacitance with VR)
S004	R439000	Head Phone Jack		R811263	Pulley
L002	R633203	Head Phone Jack Holder		R633211	VC. Holder
L003	R429064	Power Switch	VR005	R382024	Semi Fixed Resistor B50K
L001	R830507	Indicator Cover	VR006	R382026	Semi Fixed Resistor B10K
M901	R411045	Meter Lamp	S004, 005	H425020	AC Line Voltage Selector Switch
	R411046	Stereo Indicator Lamp		H850211	Switch Mask
	R590059	Tuning Meter		H430028	Fuse Holder
	R633226	Meter Lamp Holder	L003	R180267	SW Antenna Coil
	R671073A	Fly Wheel Ass'y		R62653	Core Holder-B
	R871299A	Fly Wheel Knob		R633212	Antenna Holder-C
	R871300	Fly Wheel Decoration Cover		R633213	Lamp Holder-B
	R820121	Bearing		R633058	Fuse Holder-B
		E. Type Ring		R633214	Lamp Holder-A
	R651728	Bearing Holder		H667051	Small Pulley-E
	R633204	Pulley Holder-B		R633215	Pulley Holder-A
	H667052	Small Pulley-F		H667053	Small Pulley-G
	R860613	Dial		R633216	Fly Wheel Guide
B. Rear Deck Parts (See PARTS LOCATION)				G43057	P.C.B. Terminal
	R610364	Rear Deck	T001	R110135	Power Transformer
	R422036	Phono Selector Switch (Slide Switch)		R633217	Transformer Holder-A
	R439021	FM Antenna Socket		R633218	Transformer Holder-B
	R439022	AM Antenna Socket		R811213	Spacer
	R811071	Cord Stopper		R700301	Pulley Spring 3.5φ x 12t
	H920011	G.N.D Terminal Screw		R877091	Dial Pointer
	R434003	Fuse Holder		H850105	Dial Pointer Felt
	R633205	Protector Circuit P.C Board Holder	D802, 803 804, 805	R411025	Lamp of Fuse Type
	R633206	Antenna Holder-A	RL901	R421048	MY2-D DC 24V Relay
	R633207	Antenna Holder-B		R651727A	Heat Sink
	R811262	Core Holder-A		R651726A	Heat Sink Holder
	R180266	LW. MW. Ant Coil	D. Cabinet Parts (See Figure 1.)		
	R651339	Antenna Ring		R840651	Upper Cabinet
	R830551	Ring Stopper-A		R840676	Lower Cabinet
	R820215	Antenna Cord Bushing		R851387	Punching board-A
				R851388	Punching board-B
				R820200	Stopper Plate-A
				R820201	Stopper Plate-B
				R820202A	Stopper Plate-C
				R811264	Panel
				R811265	Dial Window
				R811210	Felt foot
				R651656	Mounting Metal for Cabinet
				R871301	Push Switch Knob
				R871303	Slide Knob
				R871302	Power Switch Knob
C. Center Deck Parts					
	R610364	Center Deck			
	R651729	Tuner Case			
	R651731	Tuner Case Cover			
	R651732	Lock Pin			
	R633209	AM, IF P.C Board Holder			

AM TUNER P. C. BOARD

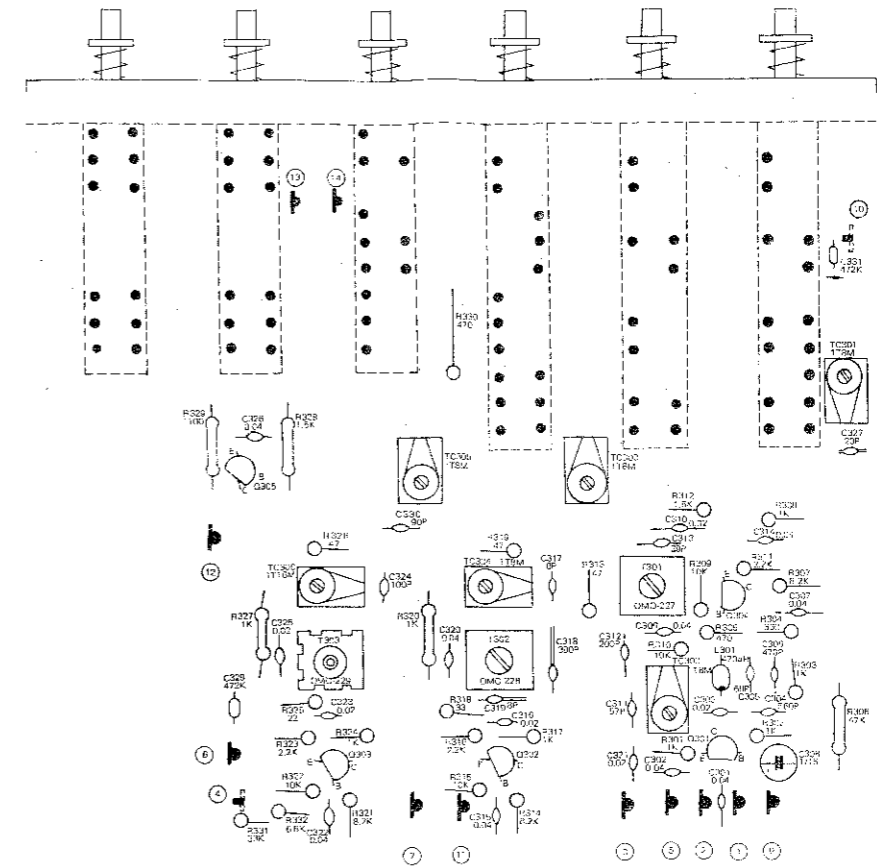

FM TUNER P. C. BOARD

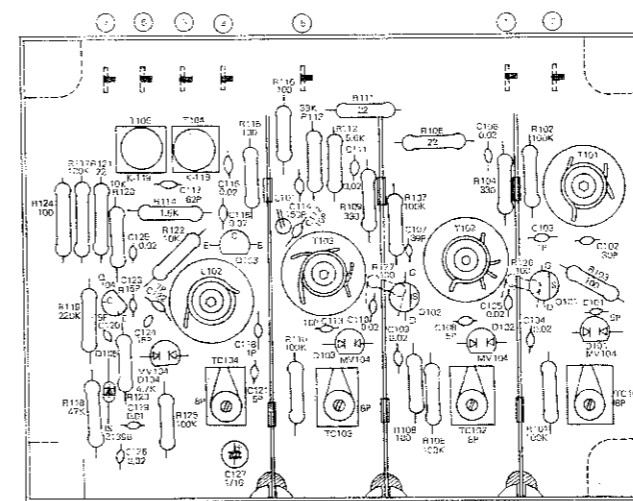

AM IF P. C. BOARD

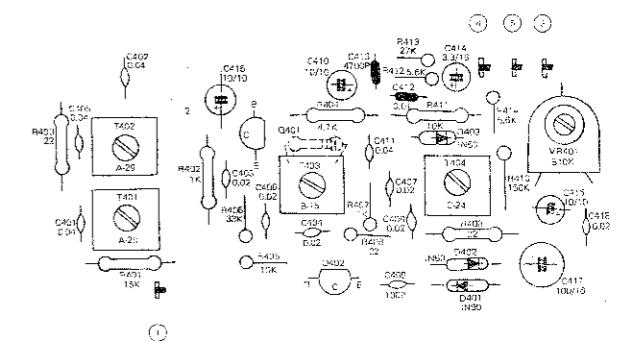

FM IF P. C. BOARD

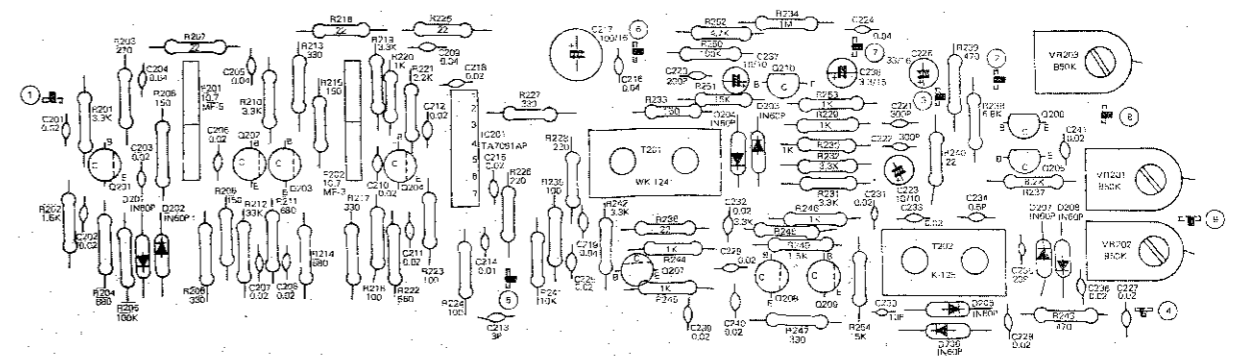

PRE AMP P. C. BOARD

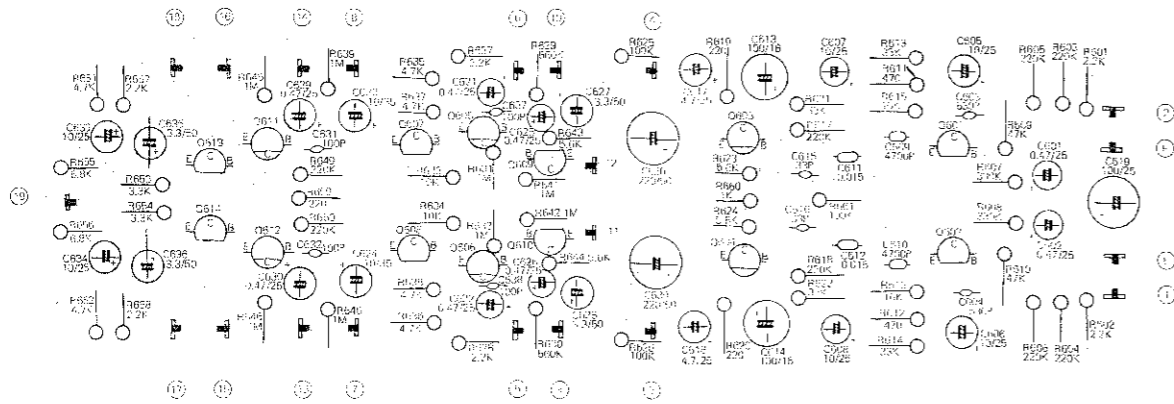

INPUT P. C. BOARD

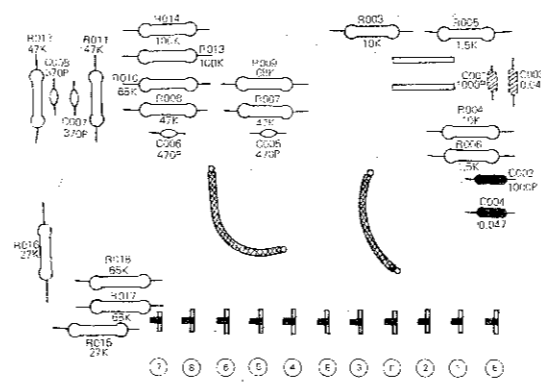

PROTECTOR CIRCUIT P. C. BOARD

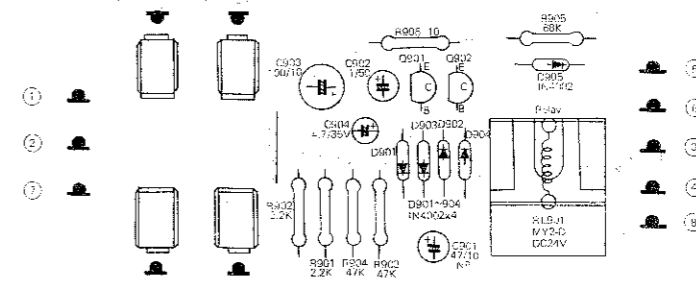

MAIN AMP P. C. BOARD

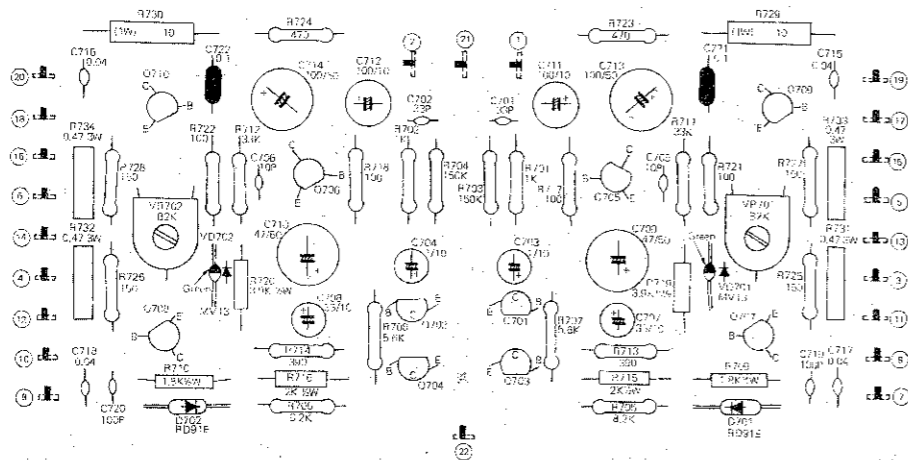

POWER SUPPLY P. C. BOARD

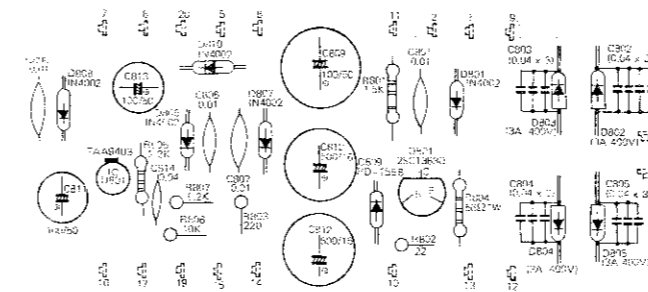

FUSE P. C. BOARD-A

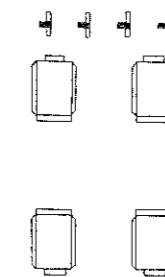

FUSE P. C. BOARD-B

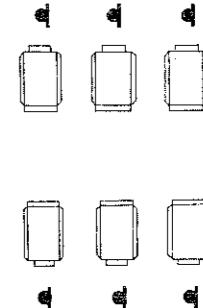

PARTS LOCATION

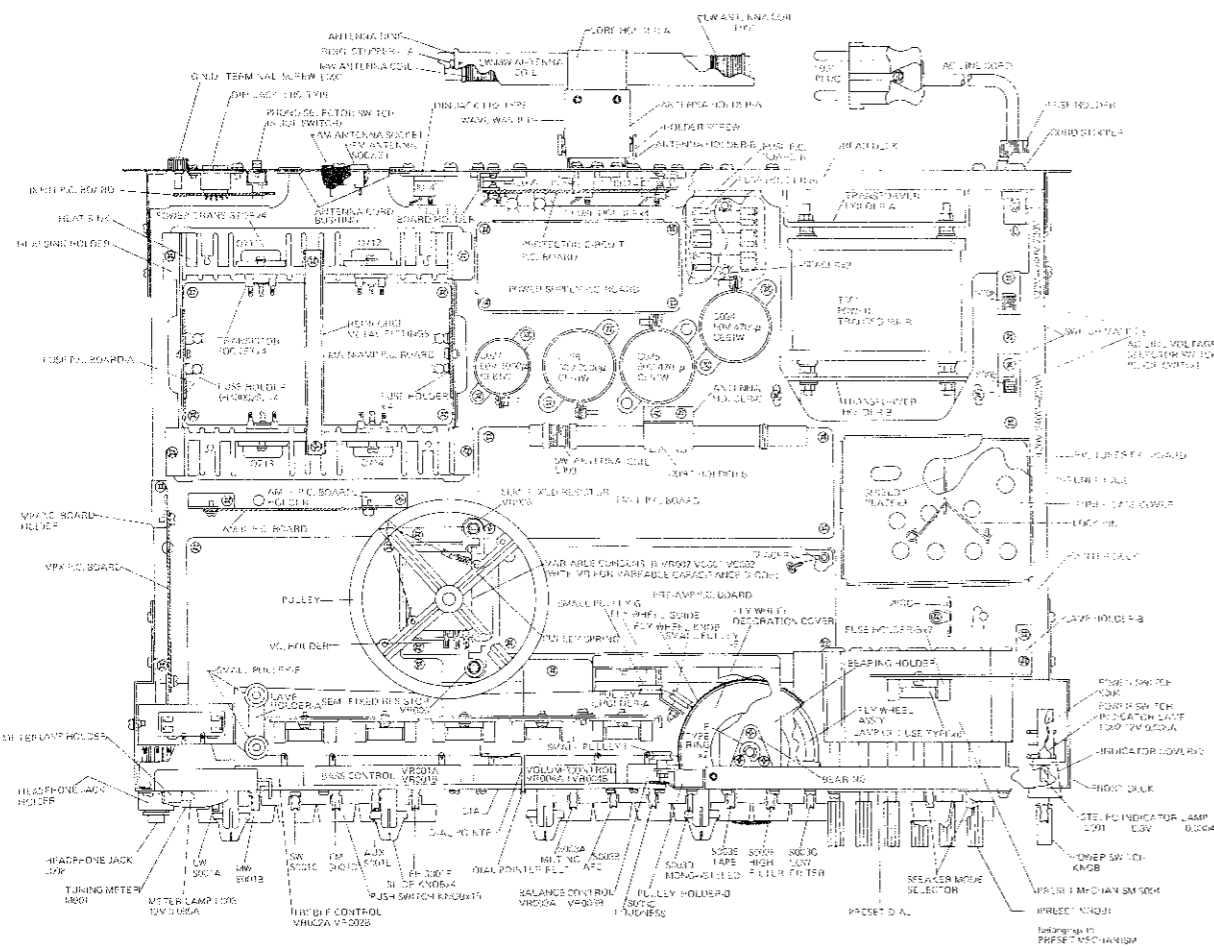

DIAL CORD STRINGING

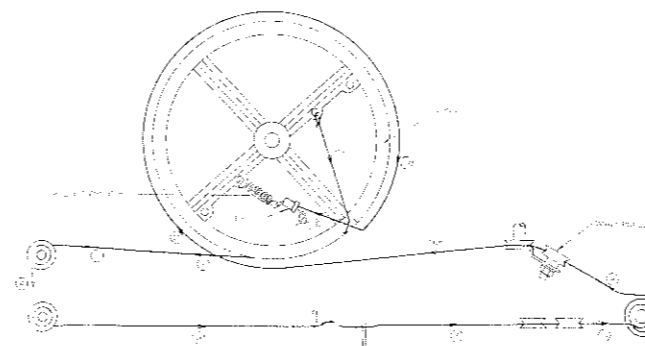

MPX P. C. BOARD

