

ARCHIVE COPY
DO NOT REMOVE

Schematics

SAQ 408

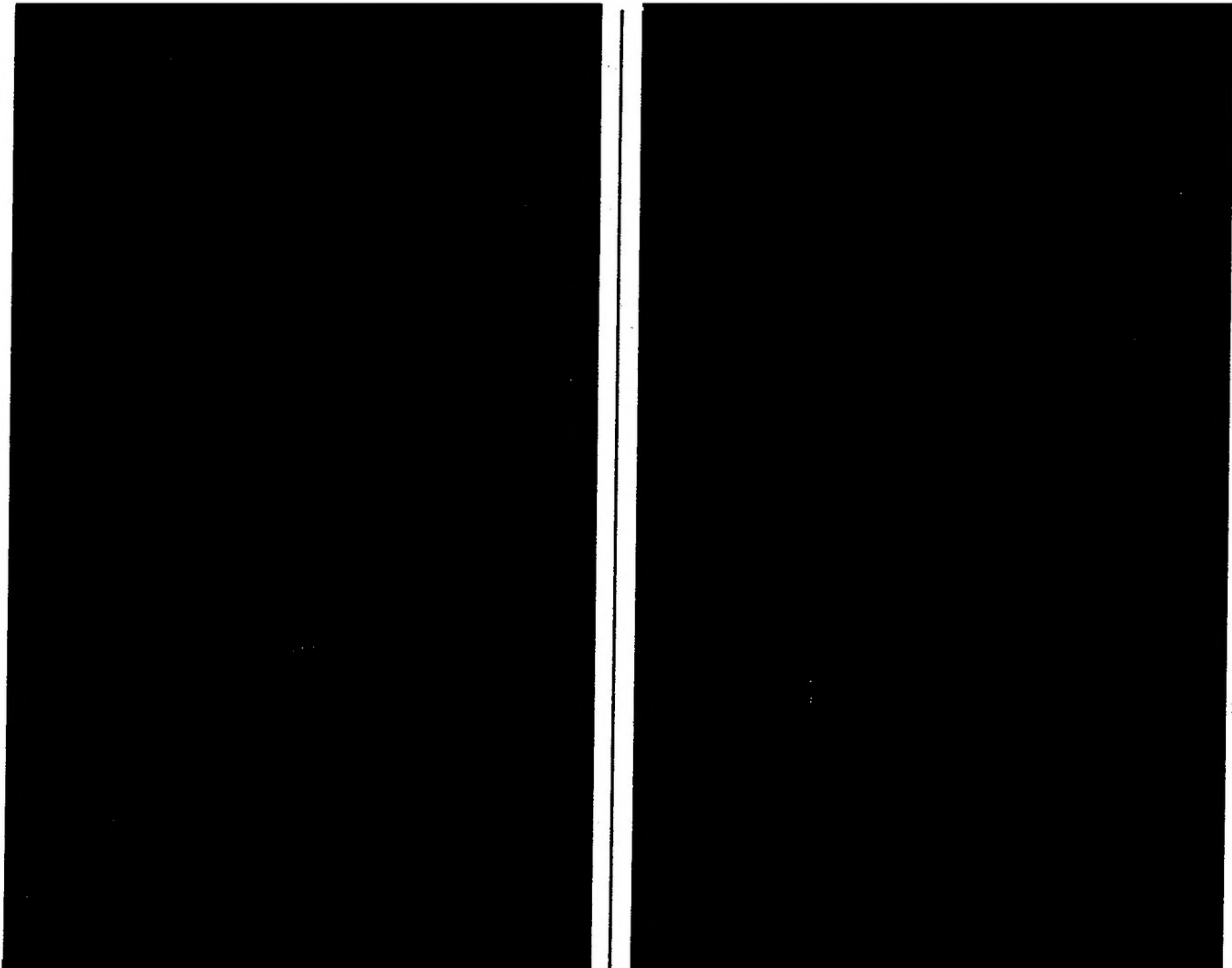

SCHEMATIC DIAGRAM

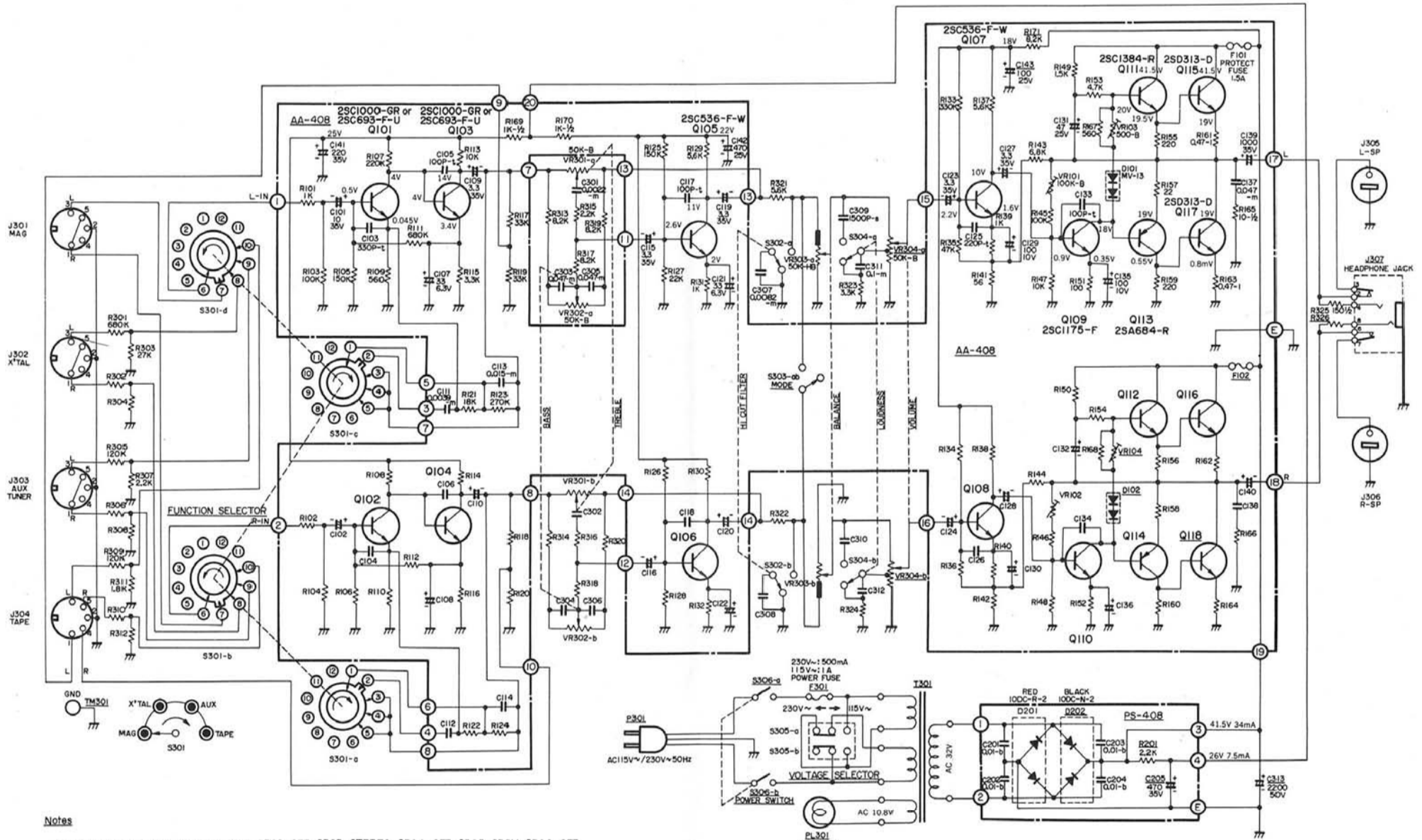

Notes

- 1) Switch shown in position S301-MAG S302-OFF S303-STEREO S304-OFF S305-230V S306-OFF
- 2) This schematic diagram is subject to partial change without notice
- 3) All resistor values are indicated in Ω ($K=10^3$) ($\pm 10\%$) (): Tolerance
- 4) All capacitor values are indicated in μF ($P=10^9$)
 - t - Ceramic capacitor ($\pm 10\%$) $\frac{1}{2}$ - Chemical capacitor ($\pm 150\%$)
 - b - Ceramic capacitor ($\pm 100\%$) s - Polyethylene capacitor ($\pm 10\%$)
 - m - Mylar capacitor ($\pm 10\%$)

Voltage Values : at Volume Minimum