

DENON

Hi-Fi Component

SERVICE MANUAL

MODEL TU-680NAB

2-BAND (AM-FM STEREO) TUNER

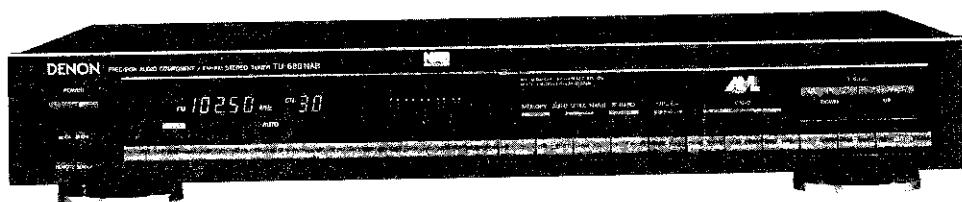

— TABLE OF CONTENTS —

OPERATING INSTRUCTIONS	2 ~ 8
BLOCK DIAGRAM	9
REMOVAL OF EACH SECTION	10 ~ 11
METHOD OF ADJUSTMENTS	12 ~ 13
SEMICONDUCTORS	14 ~ 15
NOTE FOR PARTS LIST	16
PARTS LIST OF P.W.BOARD (1U-1950H)	16
PARTS LIST OF P.W.BOARD (KU-9265)	16 ~ 17
PRINTED WIRING BOARD OF TUNER UNIT (1U-1950H)	18
PRINTED WIRING BOARD OF TUNER UNIT (KU-9265)	19
EXPLODED VIEW	20
PARTS LIST OF EXPLODED VIEW	21
PARTS LIST OF PACKING & ACCESSORIES	21
WIRING DIAGRAM	22
SCHEMATIC DIAGRAM	23

NIPPON COLUMBIA CO., LTD.



CAUTION

**RISK OF ELECTRIC SHOCK
DO NOT OPEN**



CAUTION: TO REDUCE THE RISK OF ELECTRIC SHOCK, DO NOT REMOVE COVER (OR BACK). NO USER SERVICE-ABLE PARTS INSIDE. REFER SERVICING TO QUALIFIED SERVICE PERSONNEL.



The lightning flash with arrowhead symbol, within an equilateral triangle, is intended to alert the user to the presence of uninsulated "dangerous voltage" within the product's enclosure that may be of sufficient magnitude to constitute a risk of electric shock to persons.



The exclamation point within an equilateral triangle is intended to alert the user to the presence of important operating and maintenance (servicing) instructions in the literature accompanying the appliance.

WARNING: TO REDUCE THE RISK OF FIRE OR ELECTRIC SHOCK, DO NOT EXPOSE THIS APPLIANCE TO RAIN OR MOISTURE.

SAFETY INSTRUCTIONS

1. Read Instructions – All the safety and operating instructions should be read before the appliance is operated.
2. Retain Instructions – The safety and operating instructions should be retained for future reference.
3. Heed Warnings – All warnings on the appliance and in the operating instructions should be adhered to.
4. Follow Instructions – All operating and use instructions should be followed.
5. Water and Moisture – The appliance should not be used near water – for example, near a bathtub, washbowl, kitchen sink, laundry tub, in a wet basement, or near a swimming pool, and the like.
6. Carts and Stands – The appliance should be used only with a cart or stand that is recommended by the manufacturer.
- 6A. An appliance and cart combination should be moved with care. Quick stops, excessive force, and uneven surfaces may cause the appliance and cart combination to overturn.
7. Wall or Ceiling Mounting – The appliance should be mounted to a wall or ceiling only as recommended by the manufacturer.
8. Ventilation – The appliance should be situated so that its location or position does not interfere with its proper ventilation. For example, the appliance should not be situated on a bed, sofa, rug, or similar surface that may block the ventilation openings; or, placed in a built-in installation, such as a bookcase or cabinet that may impede the flow of air through the ventilation openings.
9. Heat – The appliance should be situated away from heat sources such as radiators, heat registers, stoves, or other appliances (including amplifiers) that produce heat.
10. Power Sources – The appliance should be connected to a power supply only of the type described in the operating instructions or as marked on the appliance.
11. Grounding or Polarization – Precautions should be taken so that the grounding or polarization means of an appliance is not defeated.
12. Power-Cord Protection – Power-supply cords should be routed so that they are not likely to be walked on or pinched by items placed upon or against them, paying particular attention to cords at plugs, convenience receptacles, and the point where they exit from the appliance.
14. Cleaning – The appliance should be cleaned only as recommended by the manufacturer.
15. Power Lines – An outdoor antenna should be located away from power lines.



- 16. Outdoor Antenna Grounding – If an outside antenna is connected to the receiver, be sure the antenna system is grounded so as to provide some protection against voltage surges and built-up static charges. Article 810 of the National Electrical Code, ANSI/NFPA 70, provides information with regard to proper grounding of the mast and supporting structure, grounding of the lead-in wire to an antenna-discharge unit, size of grounding conductors, location of antenna-discharge unit, connection to grounding electrodes, and requirements for the grounding electrode. See Figure A.
- 17. Nonuse Periods – The power cord of the appliance should be unplugged from the outlet when left unused for a long period of time.
- 18. Object and Liquid Entry – Care should be taken so that objects do not fall and liquids are not spilled into the enclosure through openings.
- 19. Damage Requiring Service – The appliance should be serviced by qualified service personnel when:
 - A. The power-supply cord or the plug has been damaged; or

- B. Objects have fallen, or liquid has been spilled into the appliance; or
 - C. The appliance has been exposed to rain; or
 - D. The appliance does not appear to operate normally or exhibits a marked change in performance; or
 - E. The appliance has been dropped, or the enclosure damaged.
20. Servicing – The user should not attempt to service the appliance beyond that described in the operating instructions. All other servicing should be referred to qualified service personnel.

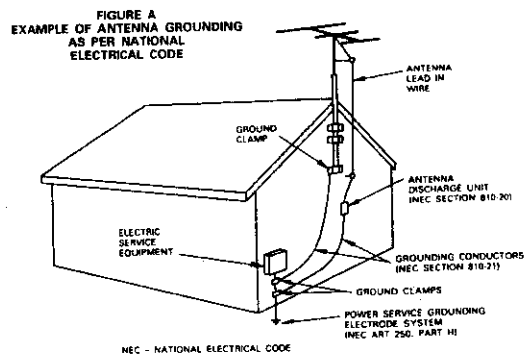

NOTE ON USE

<ul style="list-style-type: none"> • Avoid high temperatures Allow for sufficient heat dispersion when installed on a rack. 	<ul style="list-style-type: none"> • Keep the set free from moisture, water, and dust. 	<ul style="list-style-type: none"> • Do not let foreign objects in the set.
<ul style="list-style-type: none"> • Handle the power cord carefully. Hold the plug when unplugging the cord. 	<ul style="list-style-type: none"> • Unplug the power cord when not using the set for long periods of time. 	<ul style="list-style-type: none"> • Do not let insecticides, benzene, and thinner come in contact with the set.
	<p>*(For sets with ventilation holes)</p> <ul style="list-style-type: none"> • Do not obstruct the ventilation holes. 	<ul style="list-style-type: none"> • Never disassemble or modify the set in any way.

CAUTION

TO PREVENT ELECTRIC SHOCK DO NOT USE THIS (POLARIZED) PLUG WITH AN EXTENSION CORD, RECEPTACLE OR OTHER OUTLET UNLESS THE BLADES CAN BE FULLY INSERTED TO PREVENT BLADE EXPOSURE.

Please check to make sure the following items are included with the main unit in the carton:

- ① Operating Instructions 1
- ② Audio 2-Pin plug cord 1
- ③ FM Indoor Antenna 1
- ④ AM Loop Antenna 1
- ⑤ Remote Control unit RC-126 1
- ⑥ R03 ("AAA") Dry cell batteries 2

FRONT PANEL

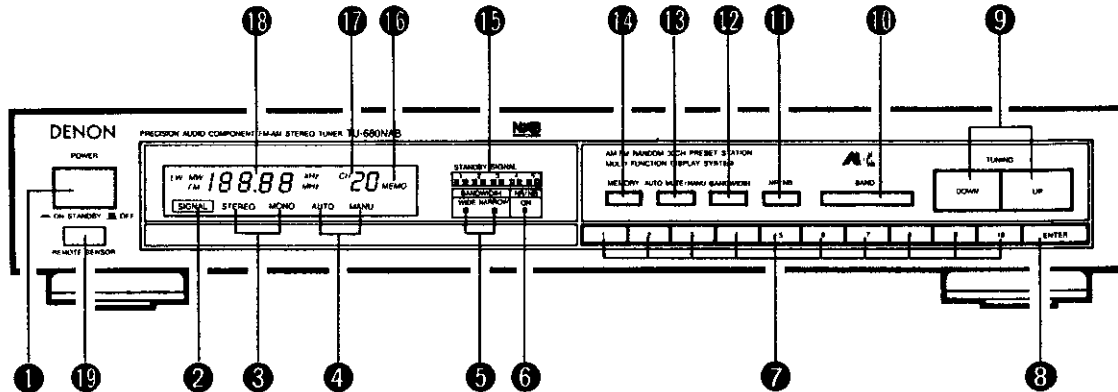

FOLLOW THE PROCEDURES IN THE INDICATED ORDER.

FM AM (MW)

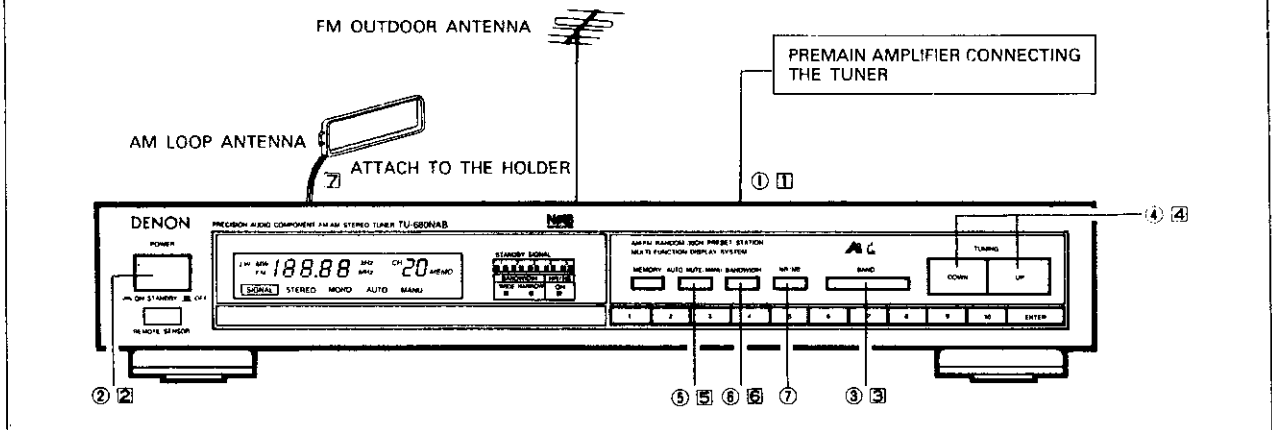

CAUTION

1. Noise may be generated if a near-by television set is on during AM broadcasting reception. The tuner should be used as far away from a television as possible.
2. Effective period of memory back-up is about a month under normal temperature. If the memorized stations cannot be called back, preset the stations again.

DESIGNATIONS AND FUNCTIONS OF PANEL CONTROLS

- 1 POWER (Power ON-STANDBY/OFF Switch)**
The unit works 2 to 3 seconds after this switch is turned on.
- 2 SIGNAL (Signal Indicator)**
This lights when a station can be received.
- 3 STEREO/MONO (Stereo/Mono Indicator)**
"STEREO" lights automatically when receiving a stereo broadcast.
"MONO" lights when receiving a monaural broadcast or no broadcast at all.
- 4 TUNING MODE (AUTO/MANUAL)**
Pressing MODE **16** causes "AUTO" and "MANUAL" to light up alternately.
- 5 WIDE/NARROW (Bandwidth LED Indicator)**
Pressing "BANDWIDTH" **12** causes WIDE or NARROW to light up alternately.
- 6 NR/NB (MPX NR/NB Indicator)**
This LED lights up when the NR/NB button **11** is pressed, and indicates that MPX NR in FM, NB (Noise Blanking) in AM is operating.
- 7 TEN KEYS (Ten Key Buttons)**
Used to specify numbers for Memory and Preset Call. Channels 1-30 can be specified using these buttons. Preset Call Setting Method
A station that has already been preset can be fetched by the following method.
Pressing **1**, **2**, **ENTER** in order fetches the station present in memory for channel 12.
- 8 ENTER (Enter Button)**
Used for setting Memory, and Preset Call.
- 9 TUNING (Tuning Buttons)**
Used to change the received frequency to a higher frequency (UP) or a lower frequency (DOWN).
- 10 BAND (Band Button)**
Selects between FM or AM.
- 11 NR/NB (MPX NR/NB Button)**
Switches NR/NB "ON" or "OFF". Lights "ON" LED **6**.
ON: In FM, Suppresses noise when a stereo broadcast with weak signal is being received.
In AM, Suppresses impulse noise from cars, power lines and so on.
OFF: Does not carry out the above operation.
- 12 BANDWIDTH (Bandwidth Selector Button)**
Selects the IF bandwidth in FM, "WIDE" or "NARROW", and the audio bandwidth in AM. In AM "NARROW", Audiobandwidth is automatically controlled according to the strength of input signal. Weak signal makes the audiobandwidth narrow.
Bandwidth indicator **5** shows either state.
- 13 AUTO MUTE/MANU (Tuning Mode Button)**
This switches between auto and manual tuning.
Auto tuning: When the UP button is pressed, the radio is tuned automatically to a higher frequency. Press the DOWN button to tune to a lower frequency. Use this position to eliminate noise when no signals or weak signals are being received.
Manual tuning: In this position, the radio can be tuned manually.
- 14 MEMORY (Memory Button)**
Used to store the frequency of the station currently received.
Pressing **MEMORY**, **1**, **2**, **ENTER** in order stores the station on channel 12 in memory. Up to 30 channels of either FM or AM can be stored in memory.
- 15 SIGNAL (Signal-Strength Indicators)**
The number of LEDs that light increases in correspondence with the strength of the signal being picked up by the antenna.
- 16 MEMORY (Memory Indicator)**
This indicator lights when the MEMORY button **14** is pressed.
- 17 CHANNEL (Channel Indicator)**
This displays the number of the channel at which the station is stored.
- 18 DIGITAL FREQUENCY INDICATOR**
Reception frequencies are digitally indicated with numbers. The FM frequency unit is MHz; the AM (MW) frequency unit is kHz.
- 19 REMOTE SENSOR (Remote Control Photosensitive Window)**
This sensor receives the infrared light transmitted from the wireless remote control unit.
When operating the wireless remote control unit, point it towards this sensor.

OPERATION INSTRUCTIONS

PREPARATION

CHECKING CONNECTIONS

- Check all the connections by referring to connection diagram (Fig. 1).
- Check that the right (R) and left (L) channels of the speakers are connected to the corresponding right (R) and left (L) plugs, and check that polarities (positive and negative) are correctly matched.
- Check that the right (R) and left (L) pins are correctly inserted to the corresponding jacks.
- Check that all the cords are firmly connected.
* Turn on the power with the POWER switch after checking all the connections.

CHECKING ANTENNA

1. Do not incorrectly connect the loop antenna. If you are not sure how to connect the loop antenna, refer to Fig. 1.
2. Use of loop antenna: Keep the loop antenna away from the main body. If the antenna contacts a metal body, reception sensitivity is degraded, thus resulting in unclear reproduction.

Using the AM Noise Blanking System

The AM Noise Blanking (NB) circuit provided in this tuner uses digital technology which is very effective in eliminating the random pops and pulse noises caused by power lines, automobile ignitions, and certain weather conditions. However, under some conditions, the NB circuit may not be effective. This is not a defect.
When you select an AM station, listen to the broadcast with the NB switch On then Off. Leave the NB switch in the position that offers you the best results.

CONNECTIONS

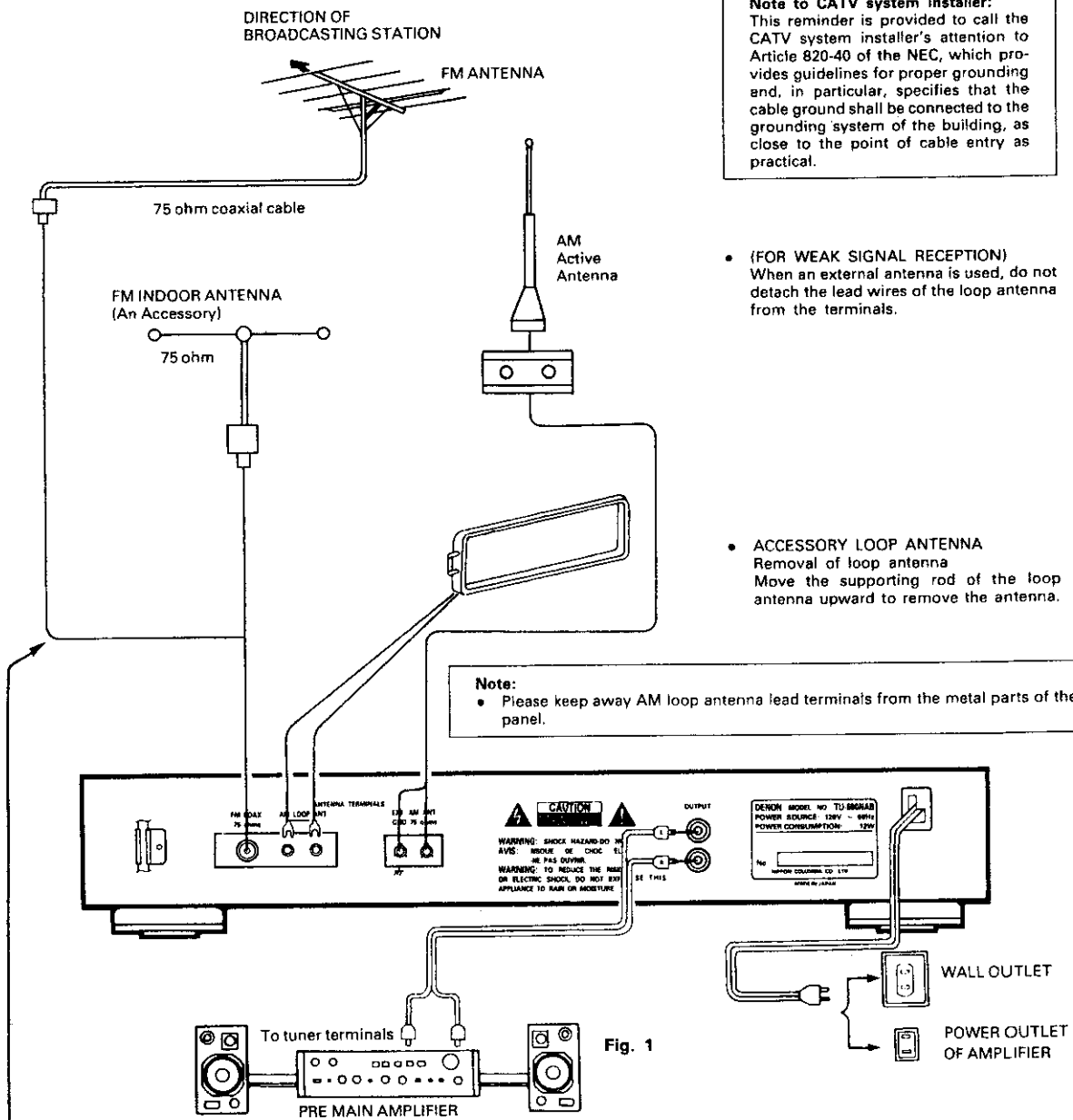

Note to CATV system installer:
This reminder is provided to call the CATV system installer's attention to Article 820-40 of the NEC, which provides guidelines for proper grounding and, in particular, specifies that the cable ground shall be connected to the grounding system of the building, as close to the point of cable entry as practical.

- (FOR WEAK SIGNAL RECEPTION)
When an external antenna is used, do not detach the lead wires of the loop antenna from the terminals.

- ACCESSORY LOOP ANTENNA
Removal of loop antenna
Move the supporting rod of the loop antenna upward to remove the antenna.

Note:

- Please keep away AM loop antenna lead terminals from the metal parts of the back panel.

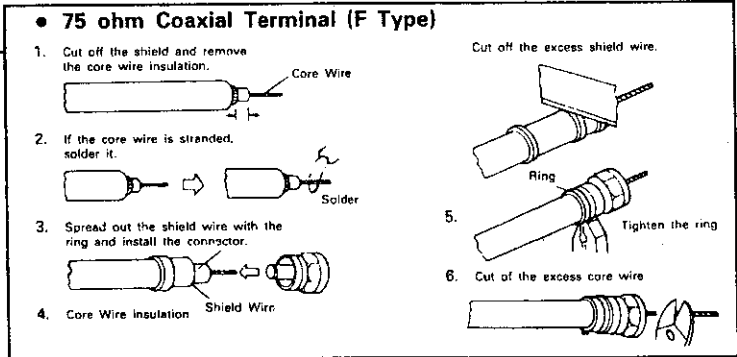

REMOTE CONTROL UNIT

The accessory RC-126 remote control unit is used to control the tuner from a distance.

● Inserting the dry cell batteries

- 1 Remove the rear cover on the remote control unit.

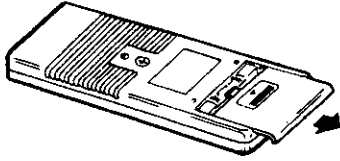

- 2 Insert two size R03 ("AAA") dry cell batteries as shown in the diagram on the battery supply unit.

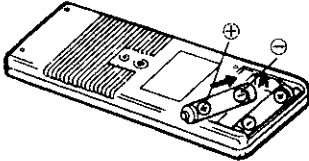

- 3 Replace the rear cover.

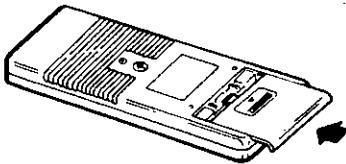

Notes on Use of the Batteries

- The remote control unit uses size R03 ("AAA") dry cell batteries.
- The batteries will need to be replaced approximately once a year. This will depend upon how often the remote control unit is used.
- If, in less than a year from the time new batteries were inserted, the remote control fails to operate this unit from a near-by position, it is time to replace the batteries.
- Insert the batteries properly, following the diagram on the remote control battery supply unit, and making sure to align the plus and minus sides of each battery.
- Batteries are prone to damage and leakage. Therefore:
 - Do not combine new batteries with used ones.
 - Do not combine different types of batteries.
 - Do not jumper the opposite poles of the batteries, expose them to heat or break them open, or put them into open fire.
- When the remote control unit is not to be used for a long period of time, remove the batteries from the unit.
- If the batteries have leaked, remove any battery fluid from the inside of the battery supply unit by wiping it out thoroughly, and insert new batteries.

● Using the remote control unit

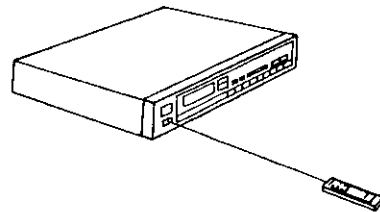
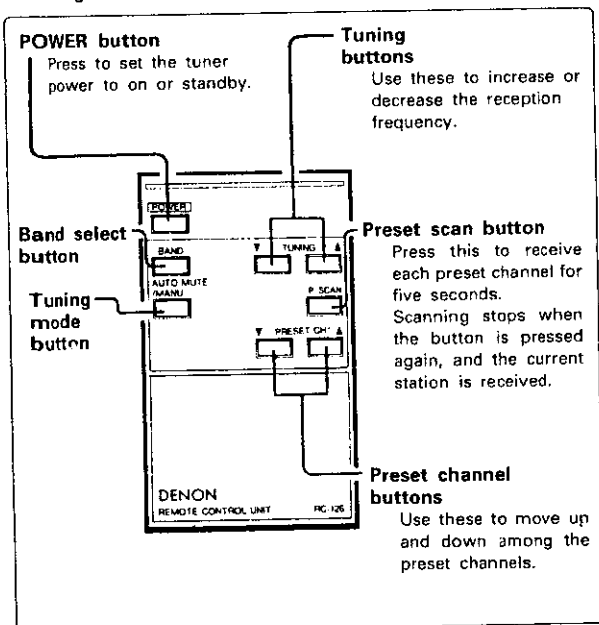

- Set the POWER switch on the tuner to OFF (■) when not using for long periods of time.
- Point the remote control unit towards the remote control sensor on the tuner when pressing keys.
- The remote control unit can be used at a distance of about 8 meters directly in front of the tuner. The remote control unit uses infrared rays, so it will not work if there are obstacles between it and the tuner. Also, if used at an angle, the distance from which operation is possible will be shortened.
- Do not press keys on the tuner and the remote control unit simultaneously, as this may result in malfunction.
- The remote control unit may not function if intense light is shining on the tuner's remote control sensor.
- Do not operate two remote control units simultaneously, as this may result in malfunction.

ADVICE FOR USE

- Do not place the set in direct sunlight, in hot areas such as near heating equipment, with high humidity or dust levels. This may cause damage to the unit.
- Check that all parts are connected correctly before turning on the power source.
- When user is absent for long periods, be sure to remove plug from wall socket.
- Do not use insecticide, benzene or thinner near the unit, or the cabinet color will fade. Avoid using polish: use a soft cloth (e.g. silicon cloth).
- It is not recommended to place players, decks and other objects on the this appliance so that the ventilation openings are blocked.
This will cause internal temperature rise and equipment failure. Do not use this appliance in a closed cabinet or container. This will cause internal temperature rise abnormally.

SPECIFICATIONS

• FM SECTION

Frequency Range:	87.5 MHz ~ 108.0 MHz
Antenna Terminal:	75 ohm Unbalanced
Usable Sensitivity:	1.0 μ V (11.2 dBf)
S/N 50 dB Sensitivity:	Monaural 1.6 μ V (15.3 dBf) Stereo 20 μ V (37.2 dBf) (μ V at 75 ohms, 0 dBf= 10^{-15} W)
Image Interference Ratio:	80 dB
IF Interference Ratio:	100 dB
AM Suppression Ratio:	60 dB
Effectiva Selectivity:	NARROW 75 dB (\pm 400 kHz) WIDE 50 dB (\pm 400 kHz)
Capture Ratio:	1.3 dB
Frequency Characteristics:	20 Hz ~ 15 kHz +0.5 dB, -1.0 dB
Signal-to-noise Ratio:	Monaural 88 dB Stereo 82 dB
Total Harmonic Distortion:	Mono 1 kHz (at 75 kHz dev.) 0.06% Stereo 1 kHz (at 67.5 kHz dev.) 0.1%
Stereo Separation 1 kHz:	50 dB

• AM (MW) SECTION

MEDIUM WAVE

Frequency Range:	520 kHz ~ 1710 kHz
Frequency characteristics	50 Hz ~ 7.5 kHz +1.5 -3.0 dB (wide position, refer to NRSC)
Signal-to-noise Ratio:	53 dB (Monaural)
Stereo Separation:	32 dB (1 kHz, 50% modulation)
Total Harmonic Distortion:	Mono 0.3% 1 kHz 50% modulation Stereo 0.5% 1 kHz 50% modulation

• OTHERS

Power Supply:	AC 120 V/60 Hz
Power Consumption:	12W
Dimensions:	434(17-3/32")(W) \times 74(2-29/32")(H) \times 287(11-19/64")(D)mm
Net Weight:	3.1 kg (6 lbs 13 oz)

• REMOTE CONTROL UNIT

RC-126	
Remote control system:	Infrared pulse
Power Supply:	DC 3V with two R03 (AAA) batteries
External dimensions:	58 (W) \times 125 (H) \times 19.5 (D) mm
Weight:	80 g (including batteries)

Design and Specifications are subject to change without prior notice.

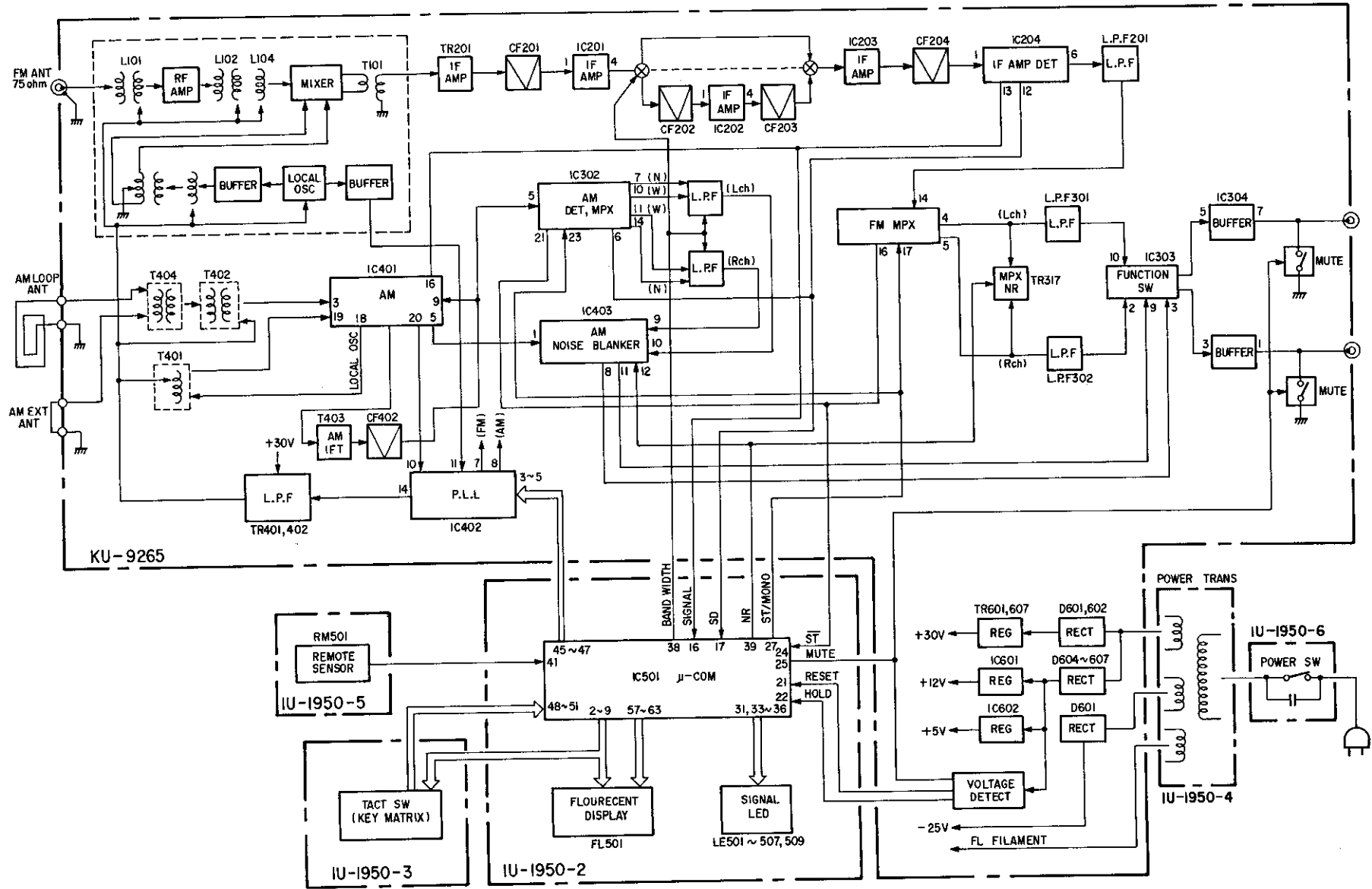

REMOVAL OF EACH SECTION

● Removing the Top Cover

1. Remove the five top cover installation screws (four on the sides, one on the rear).
2. Slip the top cover slightly to the rear in the direction of the arrow, then lift it off.

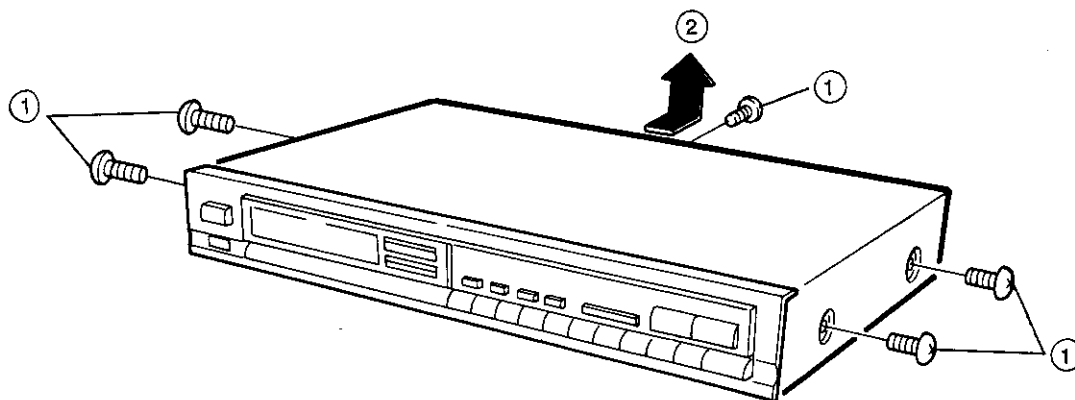

● Removing the Front Panel Ass'y

1. Remove the six front panel assembly installation screws (two on the sides, four on the bottom).
2. Pull the front panel assembly forward and off in the direction of the arrow.

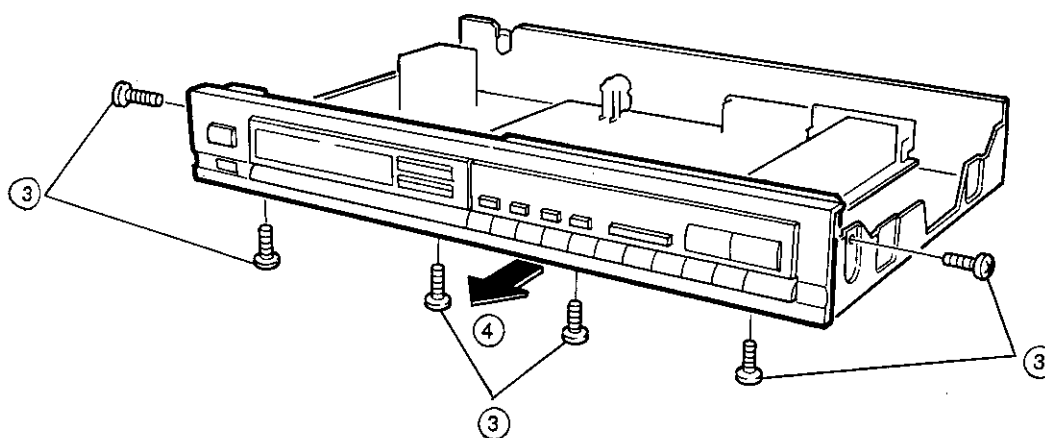

● Removing each Circuit Board

1. Remove the five installation screws securing the terminals of the KU-9265 board.
2. Use radio pliers to grasp the P.W.B. holder (shown by the arrow) securing the KU-9265 board, then remove the KU-9265 board.
3. Remove the two installation screws from the 1U-1950H-2 board, lift slightly up in the direction of the arrow, then pull forward and remove the 1U-1950H-2 board.
4. Remove the two installation screws from the 1U-1950H-3 board.
5. Unclasp the two installation hooks from the 1U-1950H-3 board, lift the 1U-1950H-3 board slightly up, then pull forward and remove.
6. Remove the installation screw from the 1U-1950H-5 board, then pull forward and remove the 1U-1950H-5 board.

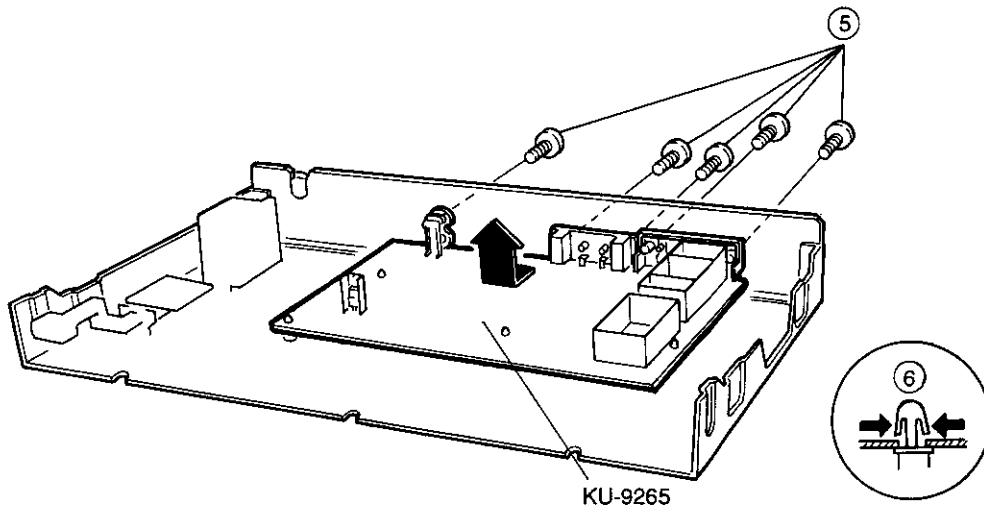

● Removing the Front Panel

Use a screwdriver to press the four hooks on the front panel (shown by arrows), then pull the front panel forward and remove.

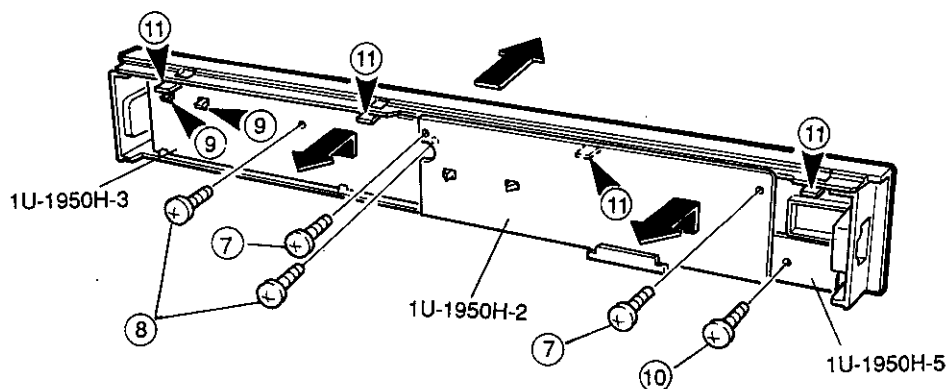

METHOD OF ADJUSTMENT

CONNECTION DIAGRAM OF MEASURING INSTRUMENTS

When making adjustments, be sure the power supply is at the rated voltage and the room air is on normal conditions with respect to temperature and humidity.

● FM

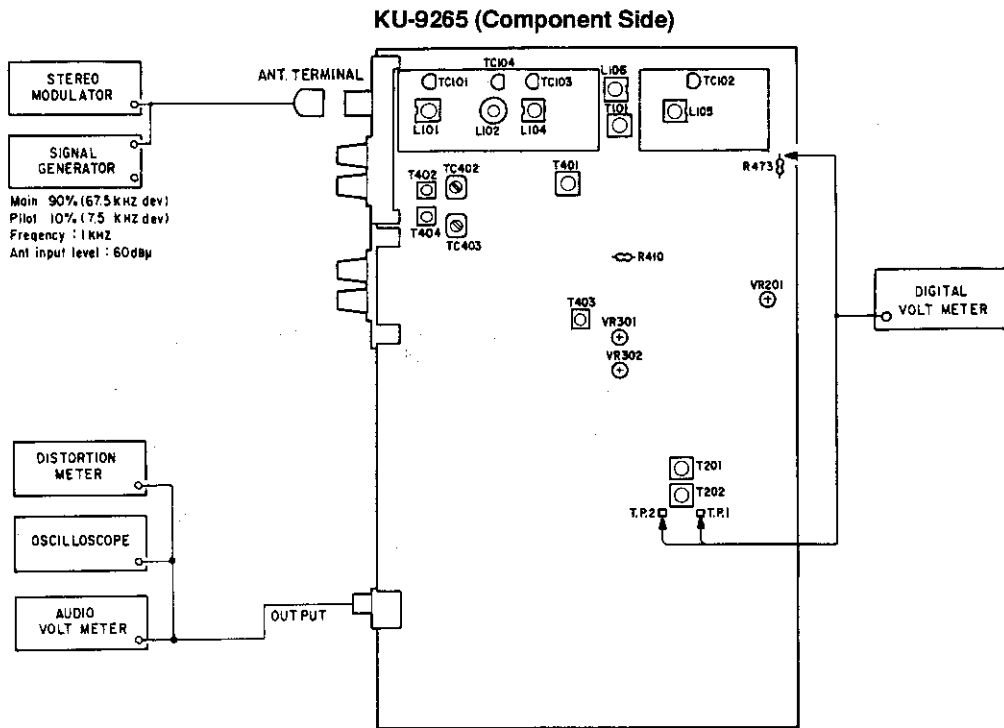

● AM

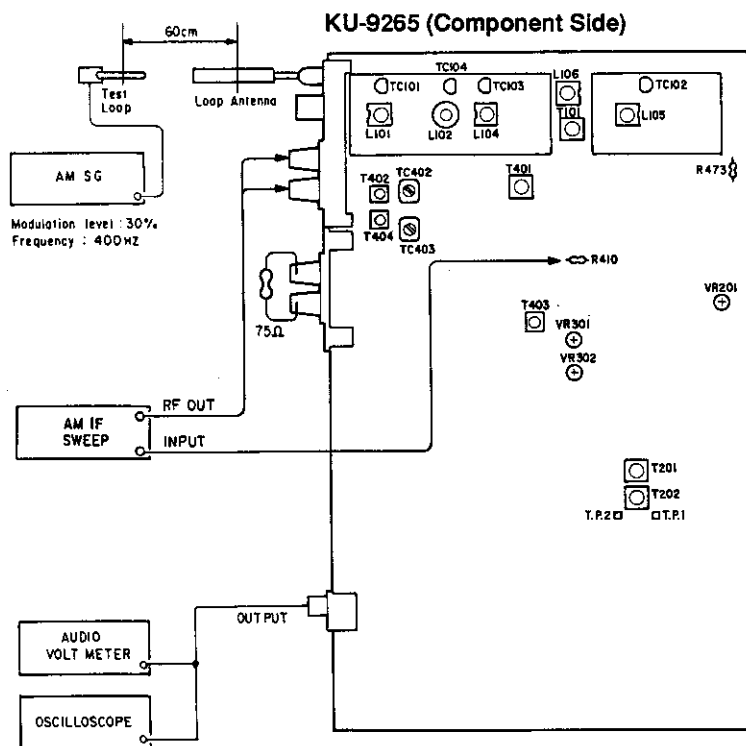

KU-9265 TUNER UNIT FM Alignment Points (Component Side)

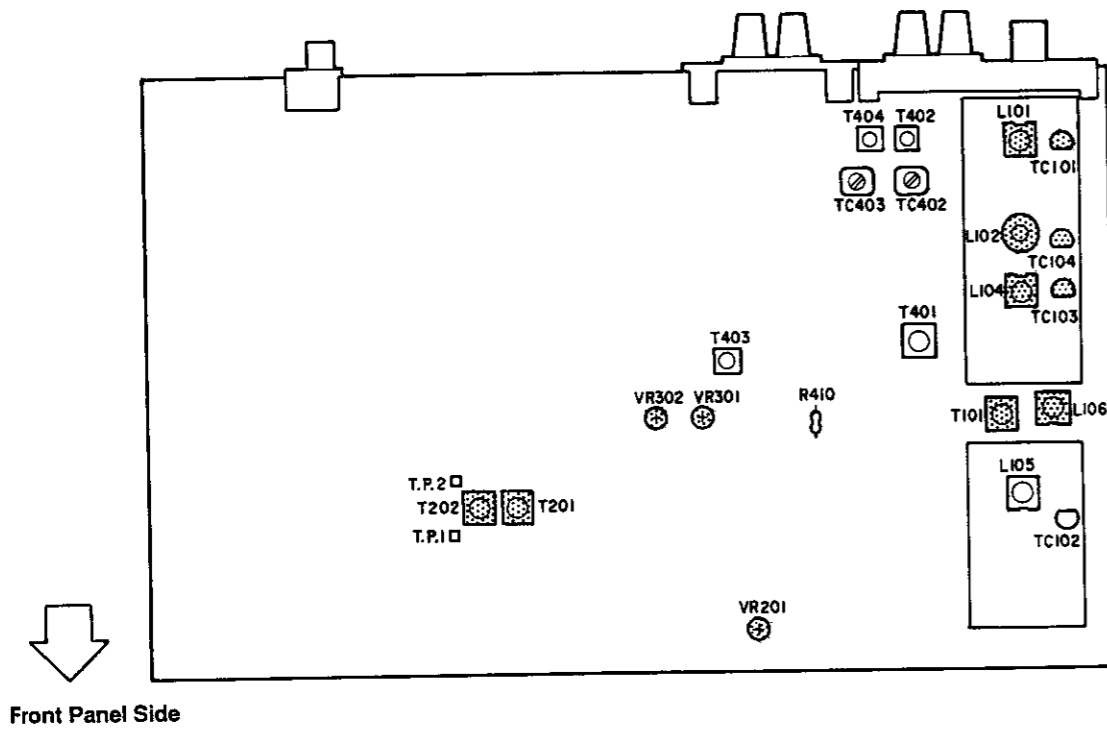

FRONTEND ALIGNMENT

Item	Alignment Item	Tuning Frequency Setting	Input					Output		Adjustment		Remarks
			Type	Frequency	Input Level	Modulation	Coupling	Type	Connect to	Points	Adjust to	
1	Tuning Voltage	108 MHz	FMSSG	108 MHz	0 dBμ	Mono 1 kHz 100%	Antenna Terminal	DC Voltmeter	R473	TC102	25.0V	BANDWIDTH : WIDE MUTE : off (MANUAL)
2		87.5 MHz	FMSSG	87.5 MHz	0 dBμ	Mono 1 kHz 100%	Antenna Terminal	DC Voltmeter	R473	L105	5.0V	
3	Repeat several times from 1 to 2 to obtain accurate tuning voltage.											
4	Tracking Alignment	108 MHz	FMSSG	108 MHz	60 dBμ	Mono 1 kHz 100%	Antenna Terminal	Audio Voltmeter	Output Terminal (L)	TC101, 103, 104	Maximum Output	
5		87.5 MHz	FMSSG	87.5 MHz	60 dBμ	Mono 1 kHz 100%	Antenna Terminal	Audio Voltmeter	Output Terminal (L)	L101, 102, 104, 106	Maximum Output	
6	Repeat several times from 4 to 5 to obtain maximum output level.											

FM ALIGNMENT

1	Center Adjustment	98 MHz	FMSSG	98 MHz	60 dBμ	Mono 1 kHz 100%	Antenna Terminal	Digital Voltmeter	TP. 1,2	T201	±50mV	BANDWIDTH : WIDE
2	Distortion	98 MHz	FMSSG	98 MHz	60 dBμ	Mono 1 kHz 100%	Antenna Terminal	Distortion Meter	Output Terminal (L)	T202	Minimum Distortion	BANDWIDTH : WIDE
3	Distortion	98 MHz	FMSSG	98 MHz	60 dBμ	Stereo (L) 1 kHz 100%	Antenna Terminal	Distortion Meter	Output Terminal (L)	T101	Minimum Distortion	BANDWIDTH : WIDE
4	Separation	98 MHz	FMSSG	98 MHz	60 dBμ	Stereo (L) 1 kHz 100%	Antenna Terminal	AC Voltmeter	Output Terminal (R)	VR301	Maximum Separation	BANDWIDTH : WIDE
5	Separation	98 MHz	FMSSG	98 MHz	60 dBμ	Stereo (L) 1 kHz 100%	Antenna Terminal	AC Voltmeter	Output Terminal (R)	VR302	Maximum Separation	BANDWIDTH : NARROW
6	Signal Level	98 MHz	FMSSG	98 MHz	15 dBμ	off	Antenna Terminal			VR201	Light 1st Signal LED	BANDWIDTH : WIDE

KU-9265 TUNER UNIT AM Alignment Points (Component Side)

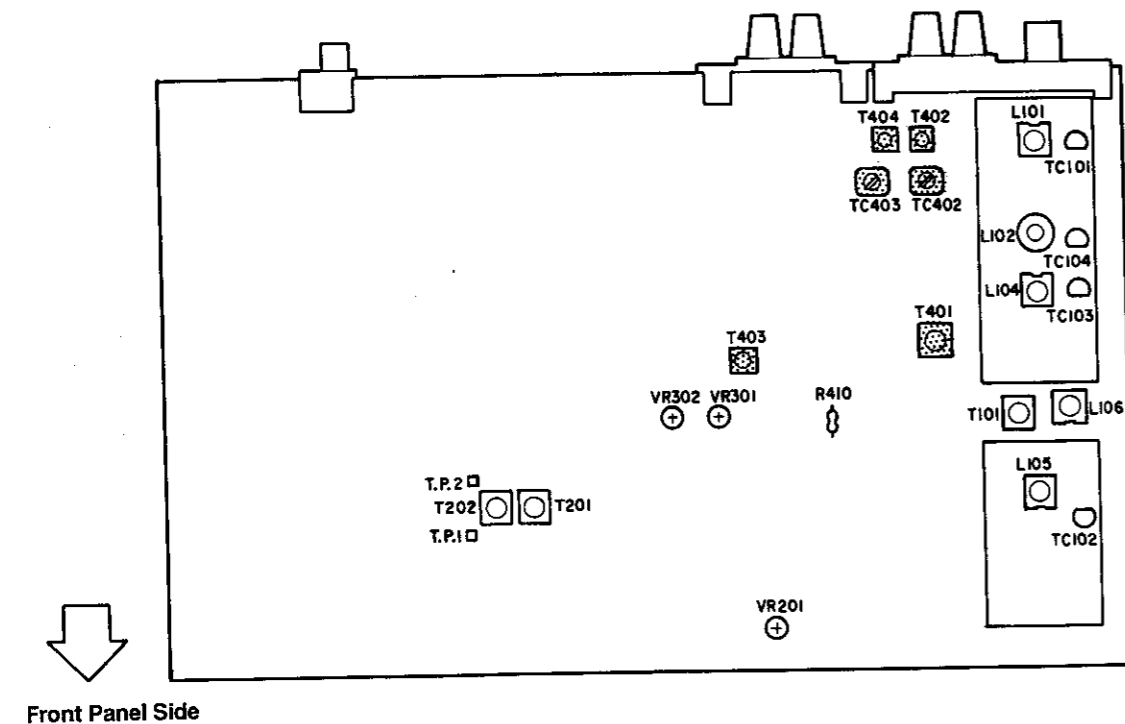

AM ALIGNMENT

1	Tuning Voltage	520 kHz	—	—	—	—	—	DC Voltmeter	R473	T401	2.0V	
		1710 kHz	—	—	—	—	—	DC Voltmeter	R473	—	27V >	Check the Voltage
2	IF	—	IF Sweep	—	Input level is not over to work A.G.C.	—	Antenna Terminal	AM IF Sweep	R410	T403	Maximum Height and Best Symmetry Curve	Center of Wave Form: 450 kHz BAND WIDTH: WIDE
3	Tracking Alignment	600 kHz	AM SSG	600 kHz	Input level is not over to work A.G.C.	400 Hz 30%	Loop Antenna	Audio V.T.V.M	Output Terminal (L)	T402 T404	Maximum Distortion	
		1400 kHz	AM SSG	1400 kHz	Input level is not over to work A.G.C.	400 Hz 30%	Loop Antenna	Audio V.T.V.M	Output Terminal (L)	TC402 TC403	Maximum Distortion	

* AM adjustment must be performed by shortcircuit of external ANT terminal with 75 ohm resistor.

SEMICONDUCTORS

IC's

NJM78M06FA (S)
NJM78M12FA (S)

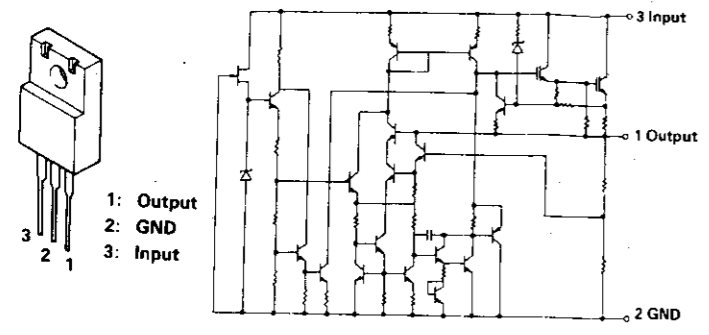

TA-7060AP

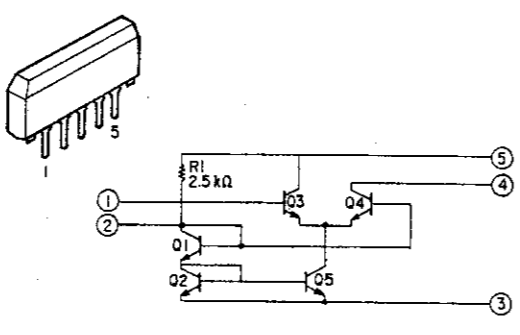

LA1247

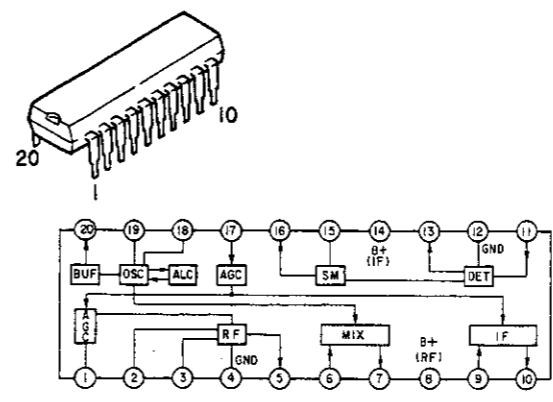

ULH3827A

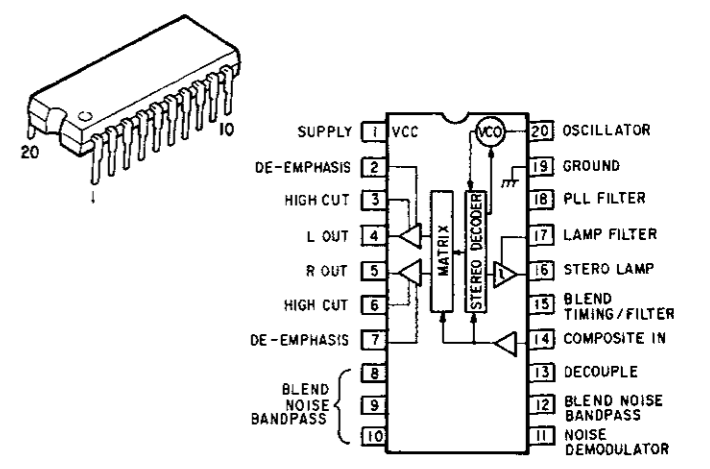

LA6358

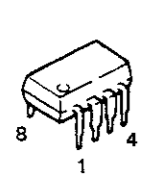

NJM4558D-D

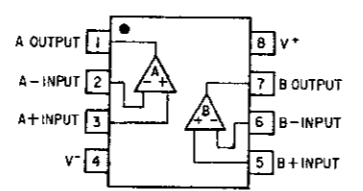
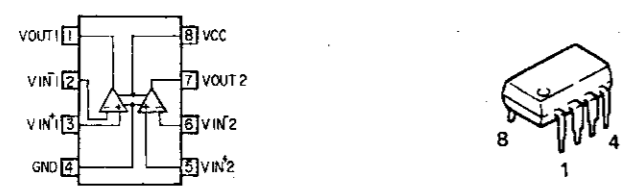

MC13022

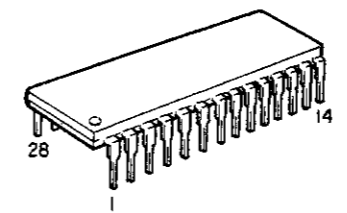

TMP47P870N

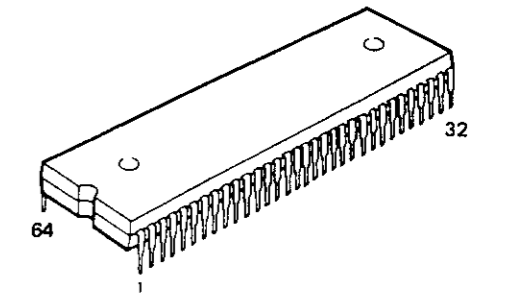

HD14066BP

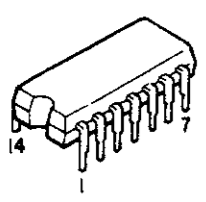

LM7001

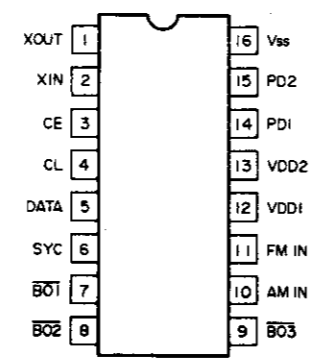
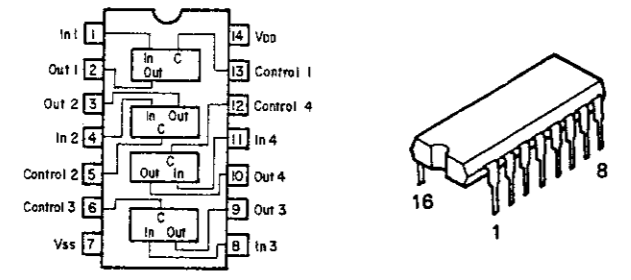

LA1235

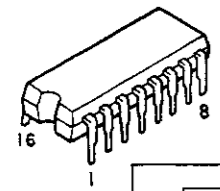

ULN3845A

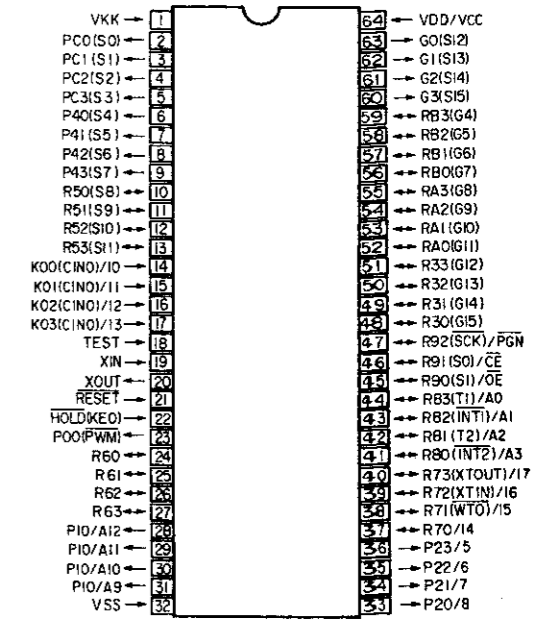
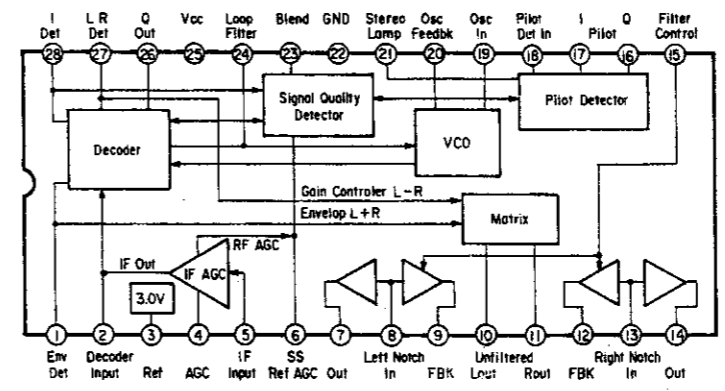
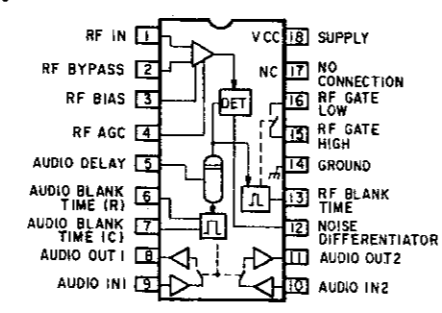
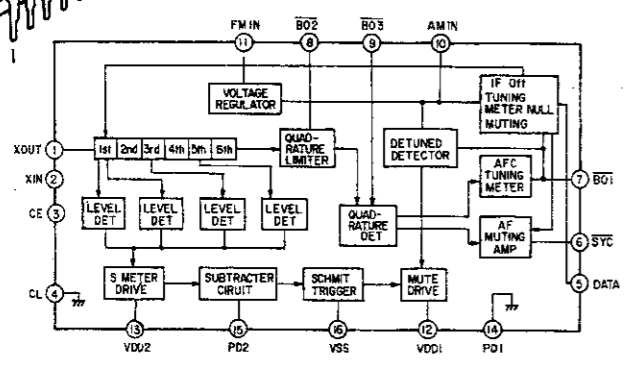
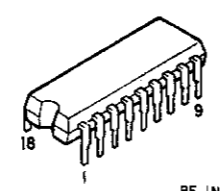

● QH3031H0
(Remote Control Receiver)

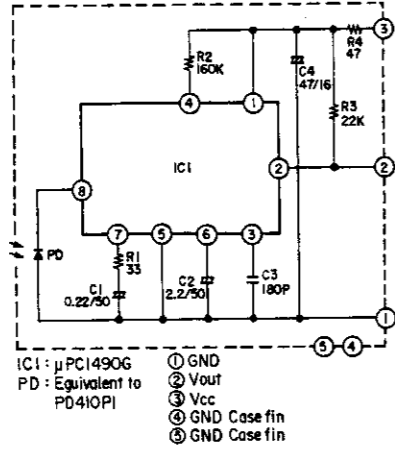
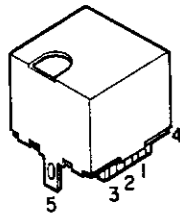

● TRANSISTORS
2SA1015 (Y/GR)
2SC2878 (A/B)
2SC1815

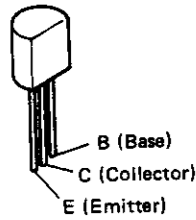

2SK161 (GR)

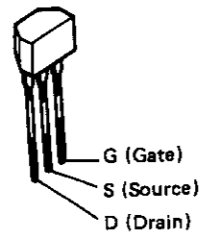

2SK365 (BL/GR)

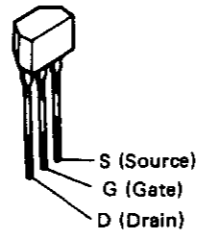

- 2SC2839 (E)
- 2SA1048 (Y/GR)
- 2SC2458 (Y/GR)
- RN1204
- RN2202
- DTA143TS
- DTA144ES
- DTC144TS
- DTC144ES

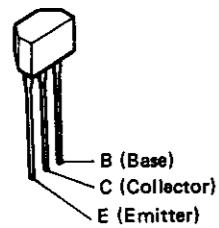

RN1204 (47k-47k)
DTC144ES (47k-47k)

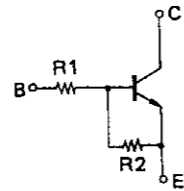

	R1	R2
RN1204	47kohm	47kohm
DTC144ES	47kohm	47kohm

RN2202 (10k-10k)
DTA144ES (47k-47k)

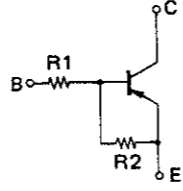

	R1	R2
RN2202	10Kohm	10Kohm
DTA144ES	47kohm	47kohm

DTC144TS (47k)

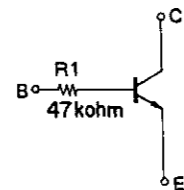

DTA143TS

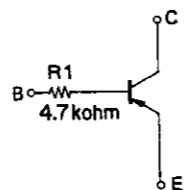

● DIODES (LED)
1SS270A



HZS6B-1
HZS9A-1

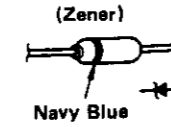

1SR35-200A

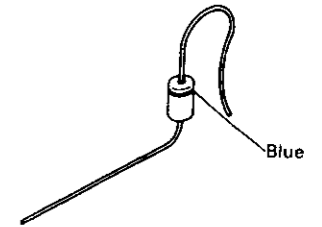

● SVC333SPA-3 (Varactor)

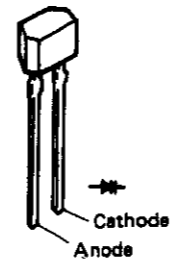

(LED)
SEL1321G (Green)

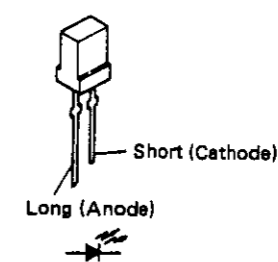

KV1320-5 (Varactor)

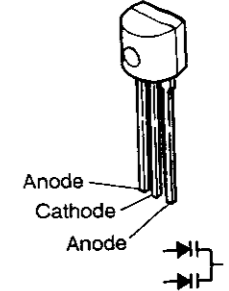

● FLD (FIP10TM7)

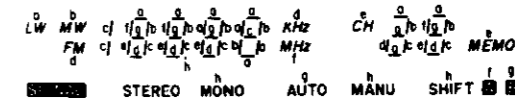
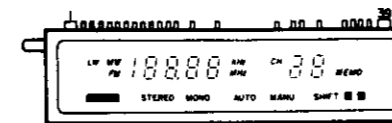

TERMINAL No.	1	2	3	4	5	6	7	8	9	10	11	12	13	14	15	16	17	18	19	20
ELECTRODE	F	F	BG	P(h)	P(g)	P(f)	P(e)	P(d)	BG	P(c)	7G	P(b)	P(a)	6G	NP	5G	NP	NP	4G	NP
TERMINAL No.		21	22	23	24	25	26	27	28	29	30	31	32	33	34	35	36	37	38	39
ELECTRODE		NP	NP	NP	NP	NP	4G	NP	P(Z)	3G	NP	2G	NP	NP	P(Z)	1G	P(Stere)	P(Signal)	F	F

Notes F: Filament NP: No-Pin
G: Grid
P: Anode

NOTE FOR PARTS LIST

- Part indicated with the mark "◎" are not always in stock and possibly to take a long period of time for supplying, or in some case supplying of part may be refused.
- When ordering of part, clearly indicate "1" and "I" (i) to avoid mis-supplying.
- Ordering part without stating its part number can not be supplied.
- Part indicated with the mark "★" is not illustrated in the exploded view.
- Not including Carbon Film ±5%, 1/4W Type in the P.W.Board parts list. (Refer to the Schematic Diagram for those parts.)

WARNING:

Parts marked with this symbol  have critical characteristics. Use ONLY replacement parts recommended by the manufacturer.

● Resistors

Ex: RN 14K 2E 182 G FR

RN	14K	2E	182	G	FR
Type	Shape and performance	Power	Resistance	Allowable error	Others

RD : Carbon	2B : 1/8W	F : ±1%	P : Pulse-resistant type
RC : Composition	2E : 1/4W	G : ±2%	NL : Low noise type
RS : Metal oxide film	2H : 1/2W	J : ±5%	NB : Non-burning type
RW : Winding	3A : 1W	K : ±10%	FR : Fuse-resistor
RN : Metal film	3D : 2W	M : ±20%	F : Lead wire forming
RK : Metal mixture	3F : 3W		
	3H : 5W		

• Resistance

1 8 2 ⇒ 1800 ohm = 1.8 kohm
 Indicates number of zeros after effective number.
 2-digit effective number.
 • Units: ohm

1 R 2 ⇒ 1.2 ohm
 1-digit effective number.
 2-digit effective number, decimal point indicated by R.
 • Units: ohm

• Capacity (electrolyte only)

2 2 2 ⇒ 2200µF
 Indicates number of zeros after effective number.
 2-digit effective number.
 • Units: µF.

2 R 2 ⇒ 2.2µF
 1-digit effective number.
 2-digit effective number, decimal point indicated by R.
 • Units: µF.

● Capacitors

Ex: CE 04W 1H 2R2 M BP

CE	04W	1H	2R2	M	BP
Type	Shape and performance	Dielectric strength	Capacity	Allowable error	Others

CE : Aluminum foil electrolytic	0J : 6.3V	F : ±1%	HS : High stability type
CA : Aluminum solid electrolytic	1A : 10V	G : ±2%	BP : Non-polar type
CS : Tantalum electrolytic	1C : 16V	J : ±5%	HR : Ripple-resistant type
CQ : Film	1E : 25V	K : ±10%	DL : For charge and discharge
CK : Ceramic	1V : 35V	M : ±20%	HF : For assuring high frequency
CC : Ceramic	1H : 50V	Z : +80%	U : UL part
CP : Oil	2A : 100V	-20%	C : CSA part
CM : Mica	2B : 125V	P : +100%	W : UL CSA type
CF : Metalized	2C : 160V	-0%	F : Lead wire forming
CH : Metalized	2D : 200V	C : ±0.25pF	
	2E : 250V	D : ±0.5pF	
	2H : 500V		
	2J : 630V		

• Capacity (except electrolyte)

2 2 2 ⇒ 2200µF = 0.0022µF
 (More than 2) — Indicates number of zeros after effective number.
 2-digit effective number.
 • Units: µF.

2 2 1 ⇒ 220PF
 (0 or 1) — Indicates number of zeros after effective number.
 2-digit effective number.
 • Units: PF.

• When the dielectric strength is indicated in AC, "AC" is included after the dielectric strength value.

**PARTS LIST OF P.W. BOARD
1U-1950H TUNER UNIT**

Ref. No.	Part No.	Part Name	Remarks
SEMICONDUCTORS GROUP			
IC501	262 1795 103	IC TMP47P870N	
TR501	269 0026 007	Transistor RN2202(10K-10K)	Built-in Resistor
TR502	273 0322 001	Transistor 2SC2458(Y/GR)	
D501-505	276 0432 903	Diode 1SS270A	
LE501-508	393 9261 027	LED SEL1321G(D2/3)	
RESISTORS GROUP			
(Not included Carbon Film ±5% 1/4W type)			
R608	242 0073 000	Composition 2.2M ohm 1/2W	RC05GF2H225K
RA501	246 2053 004	Resistor Array 10k ohm x 5	RK99=103JP5
CAPACITORS GROUP			
C501	254 4195 932	Electrolytic 22µF/35V	CE04W1V220MT(SRA)
C502	254 4250 055	Electrolytic 470µF/6.3V	CE04W0J471M
C503	254 4260 045	Electrolytic 1µF/50V	CE04W1H010M
C608	253 8014 702	Ceramic 0.01µF/400V AC	CK45F2GAC103MC
OTHER PARTS			
XL501	399 9018 003	Ceramic Oscillator	CST 4.00 MGW
SW501-518	212 4388 907	TACT Switch	
★S501	219 0266 003	Power Switch	
★T601	233 5781 005	Power Trans	
RM501	499 0088 002	Remote Sensor	QH3031H0
FL501	393 4043 004	FL Tube	FIP10TM7
	203 4633 014	3P KR-DA Conn. Cord(RED)	
	204 0265 078	6P KR-DA Conn. Cord	
	203 4456 068	3P KR-DA Conn. Cord	
	204 2244 071	8P KR-DA Conn. Cord	
	204 2340 027	10P KR-DA Conn. Cord	
	204 2341 000	10P SAN-SAN Conn. Cord	

KU-9265 TUNER UNIT

Ref. No.	Part No.	Part Name	Remarks
SEMICONDUCTORS GROUP			
IC201-203	263 0099 007	IC TA-7060AP	
IC204	263 0520 000	IC LA1235	
IC205	263 0237 005	IC LA6358	
IC301	263 0853 007	IC ULN3827A	
IC302	263 0852 008	IC MC13022	
IC303	262 0276 005	IC HD14066BP	
IC304	263 0081 002	IC NJM4558D	
IC401	263 0356 009	IC LA1247	
IC402	262 0719 009	IC LM7001	
IC403	263 0854 006	IC ULN3845A	
IC601	263 0794 001	IC NJM78M12FA(S)	
IC602	263 0792 003	IC NJM78M06FA(S)	
TR101-103	275 0063 007	Transistor 3SK73 GR	
TR104	275 0051 909	Transistor 2SK161(GR)	
TR105	273 0357 908	Transistor 2SC2839(E)	
TR106	275 0051 909	Transistor 2SK161(GR)	
TR201	275 0051 909	Transistor 2SK161(GR)	
TR203	269 0100 907	Transistor DTA143TS(4.7K)	Built-in Resistor
TR204	269 0029 907	Transistor RN1204(47K-47K)	Built-in Resistor
TR205	269 0100 907	Transistor DTA143TS(4.7K)	Built-in Resistor
TR206	269 0029 907	Transistor RN1204(47K-47K)	Built-in Resistor
TR207,208	273 0222 907	Transistor 2SC2458(Y/GR)	
TR301,302	275 0053 907	Transistor 2SK365(BL/GR)	
TR303	269 0079 902	Transistor DTC144TS(47K)	Built-in Resistor
TR305	269 0093 904	Transistor DTA144ES(47K-47K)	Built-in Resistor
TR306,307	269 0079 902	Transistor DTC144TS(47K)	Built-in Resistor
TR308	269 0029 907	Transistor RN1204(47K-47K)	Built-in Resistor
TR309	273 0222 907	Transistor 2SC2458(Y/GR)	
TR310	269 0040 902	Transistor DTC144ES(47K-47K)	Built-in Resistor
TR311	273 0222 907	Transistor 2SC2458(Y/GR)	
TR312	271 0102 937	Transistor 2SA1015(Y/GR)	
TR313-316	273 0253 918	Transistor 2SC2878(A/B)	
TR317	275 0053 907	Transistor 2SK365(BL/GR)	
TR401	275 0053 907	Transistor 2SK365(BL/GR)	
TR402,403	273 0222 907	Transistor 2SC2458(Y/GR)	
TR405-408	271 0102 937	Transistor 2SA1015(Y/GR)	
TR409-412	273 0222 907	Transistor 2SC2458(Y/GR)	
TR413	269 0100 907	Transistor DTA143TS(4.7K)	Built-in Resistor
TR414	271 0194 903	Transistor 2SA1048(Y/GR)	
TR415	269 0100 907	Transistor DTA143TS(4.7K)	Built-in Resistor
TR601	273 0198 947	Transistor 2SC1815(Y/GR)	
TR602	271 0102 937	Transistor 2SA1015(Y/GR)	
TR603	269 0029 907	Transistor RN1204(47K-47K)	Built-in Resistor
TR604	271 0194 903	Transistor 2SA1048(Y/GR)	
TR605-607	273 0222 907	Transistor 2SC2458(Y/GR)	
D201-207	276 0432 903	Diode 1SS270A	
D209-212	276 0432 903	Diode 1SS270A	
D301,302	276 0432 903	Diode 1SS270A	
D304-307	276 0432 903	Diode 1SS270A	
D401	276 0432 903	Diode 1SS270A	
D601-607	276 0553 905	Diode 1SR35-200A(T93X)	
D608	276 0432 903	Diode 1SS270A	
D609,610	276 0553 905	Diode 1SR35-200A(T93X)	
D611,612	276 0432 903	Diode 1SS270A	

Ref. No.	Part No.	Part Name	Remarks
ZD401	276 0467 004	Zener Diode HZS9A-1TD	
ZD402,403	276 0462 902	Zener Diode HZS6B-1TD	
ZD601	276 0462 902	Zener Diode HZS6B-1TD	
ZD602,603	276 0467 907	Zener Diode HZS9A-1TD	
CD101-105	276 0556 009	Varactor	KV1320-5
CD401-403	276 0606 001	Varactor	SVC333SPA-3
RESISTORS GROUP			
(Not included Carbon Film ±5% 1/4W type)			
VR201	211 6077 938	Adjust 100k ohm	VO6PB104
VR301,302	211 6077 925	Adjust 10k ohm	VO6PB103
CAPASITORS GROUP			
C101	253 4536 996	Ceramic 24pF/50V	CC45SL1H240JT DD-3
C102	253 4538 907	Ceramic 68pF/50V	CC45SL1H680JT DD-3
C103	253 4536 909	Ceramic 10pF/50V	CC45SL1H100DT DD-3
C104,105	253 4535 955	Ceramic 5pF/50V	CC45SL1H050CT DD-3
C106,107	253 1146 907	Ceramic 0.01µF/50V	CK45F1H103ZT
C108	253 4538 907	Ceramic 68pF/50V	CC45SL1H680JT DD-3
C109	253 3141 900	Ceramic 68pF/50V	CC45CH1H680JT
C110	253 4535 997	Ceramic 9pF/50V	CC45SL1H090DT DD-3
C111	253 4538 907	Ceramic 68pF/50V	CC45SL1H680JT DD-3
C112,113	253 4535 926	Ceramic 2pF/50V	CC45SL1H020CT DD-3
C114	253 4535 968	Ceramic 6pF/50V	CC45SL1H060DT DD-3
C115,116	253 4539 906	Ceramic 100pF/50V	CC45CH1H101JT
C117	253 1148 905	Ceramic 0.022µF/50V	CK45F1H223ZT
C119	253 1146 907	Ceramic 0.01µF/50V	CK45F1H103ZT
C120	253 1180 921	Ceramic 0.001µF/50V	CK45B1H102KT DD-3
C121	253 4536 909	Ceramic 10pF/50V	CC45SL1H100DT DD-3
C122	254 4254 909	Electrolytic 10µF/16V	CE04W1C100MT
C123	253 1146 907	Ceramic 0.01µF/50V	CK45F1H103ZT
C124	253 3535 901	Ceramic 15pF/50V	CC45UJ1H150JT
C125	253 3137 901	Ceramic 47pF/50V	CC45CH1H470JT
C126	253 3531 905	Ceramic 10pF/50V	CC45UJ1H100DT
C127	253 4540 908	Ceramic 2pF/50V	CC45CK1H020CT
C128	253 4536 909	Ceramic 10pF/50V	CC45SL1H100DT DD-3
C129	254 4254 938	Electrolytic 47µF/16V	CE04W1C470MT
C130	253 4535 984	Ceramic 8pF/50V	CC45SL1H080DT DD-3
C131	253 4538 907	Ceramic 68pF/50V	CC45SL1H680JT DD-3
C132	253 1146 907	Ceramic 0.01µF/50V	CK45F1H103ZT
C201-210	253 1146 907	Ceramic 0.01µF/50V	CK45F1H103ZT
C212-215	253 1146 907	Ceramic 0.01µF/50V	CK45F1H103ZT
C216	254 4260 948	Electrolytic 1µF/50V	CE04W1H010MT
C217	253 1146 907	Ceramic 0.01µF/50V	CK45F1H103ZT
C219	253 1148 907	Ceramic 0.01µF/50V	CK45F1H103ZT
C220	254 4260 948	Electrolytic 1µF/50V	CE04W1H010MT
C221	253 1146 907	Ceramic 0.01µF/50V	CK45F1H103ZT
C222	254 4252 943	Electrolytic 220µF/10V	CE04W1A221MT
C223	254 4260 935	Electrolytic 0.47µF/50V	CE04W1HR47MT
C224	253 1146 907	Ceramic 0.01µF/50V	CK45F1H103ZT

Ref. No.	Part No.	Part Name	Remarks
C225	254 4260 945	Electrolytic 1µF/50V	CE04W1H010M
C301	254 4254 912	Electrolytic 22µF/16V	CE04W1C220M
C302,303	255 1206 908	Film 0.0033µF/50V	CQ93M1H332JT
C304	254 4254 909	Electrolytic 10µF/16V	CE04W1C100MT
C305	254 4254 938	Electrolytic 47µF/16V	CE04W1C470MT
C307,308	255 1206 908	Film 0.0033µF/50V	CQ93M1H332JT
C309	255 1205 909	Film 0.0027µF/50V	CQ93M1H272JT
C310,311	255 1204 900	Film 0.0022µF/50V	CQ93M1H222JT
C312	255 1205 909	Film 0.0027µF/50V	CQ93M1H272JT
C313	253 1146 907	Ceramic 0.01µF/50V	CK45F1H103ZT
C315	253 1180 918	Ceramic 820pF/50V	CK45B1H821KT DD-3
C316	255 1206 908	Film 0.0033µF/50V	CQ93M1H332JT
C317	254 4254 909	Electrolytic 10µF/16V	CE04W1C100MT
C318	254 4260 948	Electrolytic 1µF/50V	CE04W1H010MT
C319	255 1218 909	Film 0.033µF/50V	CQ93M1H333JT
C320	256 1035 978	Metallized 0.68µF/50V	CF93A1H684JT
C321,322	255 1204 900	Film 0.0022µF/50V	CQ93M1H222JT
C323,324	254 4258 905	Electrolytic 4.7µF/35V	CE04W1V4R7MT
C325	253 1180 921	Ceramic 0.001µF/50V	CK45B1H102KT DD-3
C326,327	253 1146 907	Ceramic 0.01µF/50V	CK45F1H103ZT
C328,329	254 4254 909	Electrolytic 10µF/16V	CE04W1C100MT
C330	253 1146 907	Ceramic 0.01µF/50V	CK45F1H103ZT
C331-333	253 1180 921	Ceramic 0.001µF/50V	CK45B1H102KT DD-3
C334	254 4254 941	Electrolytic 100µF/16V	CE04W1C101MT
C335	254 4254 938	Electrolytic 47µF/16V	CE04W1C470MT
C336	254 9012 722	Electrolytic 47µF/16V	CE04W1C470MLRC
C337	255 1212 905	Electrolytic 33µF/16V	CE04W1C330MT
C338	253 4537 982	Film 0.01µF/50V	CQ93M1H103JT
C339	254 4260 948	Ceramic 56pF/50V	CC45SL1H560JT DD-3
C340	254 4254 909	Electrolytic 1µF/50V	CE04W1H010MT
C341	254 4260 935	Electrolytic 0.47µF/50V	CE04W1C100MT
C342	256 1035 910	Metallized 0.22µF/50V	CE04W1HR47MT
C344,345	254 4260 948	Electrolytic 1µF/50V	CF93A1H224JT
C346	254 4252 930	Electrolytic 100µF/10V	CE04W1H010MT
C347,348	254 4260 948	Electrolytic 1µF/50V	CE04W1A101MT
C349	254 4254 941	Electrolytic 100µF/16V	CE04W1H010MT
C350	253 1146 907	Ceramic 0.01µF/50V	CK45F1H103ZT
C351	255 1212 905	Film 0.01µF/50V	CQ93M1H103JT
C352	254 4258 905	Electrolytic 4.7µF/35V	CE04W1V4R7MT
C353	254 4254 006	Electrolytic 10µF/16V	CE04W1C100MT
C354	254 4260 945	Electrolytic 1µF/50V	CE04W1H010M
C355	256 1035 075	Metallized 0.68µF/50V	CF93A1H684J
C356,357	253 4456 908	Ceramic 680pF/50V	CC45SL1H681JT
C401	253 4537 966	Ceramic 47pF/50V	CC45SL1H470JT DD-3
C402	255 4201 942	Film 390pF/50V	CQ93P1H391JT
C403	253 4536 967	Ceramic 18pF/50V	CC45SL1H180JT DD-3
C404	253 1146 907	Ceramic 0.01µF/50V	CK45F1H103ZT
C406	254 4254 925	Electrolytic 33µF/16V	CE04W1C330MT
C407,408	253 1146 907	Ceramic 0.01µF/50V	CK45F1H103ZT
C409	253 4536 941	Ceramic 15pF/50V	CC45SL1H150JT DD-3
C410	253 1180 921	Ceramic 0.001µF/50V	CK45B1H102KT DD-3
C411	253 1182 903	Ceramic 0.047µF/50V	CK45F1H473ZT DD-3
C412	253 1146 907	Ceramic 0.01µF/50V	CK45F1H103ZT
C413	254 4254 909	Electrolytic 10µF/16V	CE04W1C100MT
C414	253 1148 905	Ceramic 0.022µF/50V	CK45F1H223ZT
C415	253 1146 907	Ceramic 0.01µF/50V	CK45F1H103ZT

Ref. No.	Part No.	Part Name	Remarks
C416	254 4258 905	Electrolytic 4.7µF/65V	CE04W1V4R7MT
C417	253 1146 907	Ceramic 0.01µF/50V	CK45F1H103ZT
C418	254 4254 938	Electrolytic 47µF/16V	CE04W1C470MT
C419	253 1180 921	Ceramic 0.001µF/50V	CK45B1H102KT DD-3
C420	253 1146 907	Ceramic 0.01µF/50V	CK45F1H103ZT
C422	253 1024 003	Ceramic 0.01µF/50V	CK45F1H103Z
C423	254 3056 917	Electrolytic 1µF/50V (Bipolar)	CE04D1H010MBPT
C424	253 1148 905	Ceramic 0.022µF/50V	CK45F1H223ZT
C425	254 4258 947	Electrolytic 47µF/65V	CE04W1V470MT
C426,427	253 4536 954	Ceramic 16pF/50V	CC45SL1H160JT DD-3
C428,429	253 1146 907	Ceramic 0.01µF/50V	CK45F1H103ZT
C430	254 4260 948	Electrolytic 1µF/50V	CE04W1H010MT
C432	253 1180 921	Ceramic 0.001µF/50V	CK45B1H102KT DD-3
C433,434	253 9039 906	Ceramic 0.1µF/25V	CK45=1E104ZT DD-3
C435	254 4254 925	Electrolytic 33µF/16V	CE04W1C330MT
C436	253 1180 921	Ceramic 0.001µF/50V	CK45B1H102KT DD-3
C437,438	254 4260 919	Electrolytic 0.22µF/50V	CE04W1HR22MT
C439,440	254 4252 914	Electrolytic 33µF/10V	CE04W1A330MT
C441,442	254 4260 948	Electrolytic 1µF/50V	CE04W1H010MT
C443,444	256 1035 910	Metallized 0.22µF/50V	CF93A1H224JT
C445,446	256 1035 936	Metallized 0.33µF/50V	CF93A1H334JT
C447,448	256 1035 910	Metallized 0.22µF/50V	CF93A1H224JT
C449,450	255 1213 904	Film 0.012µF/50V	CQ93M1H123JT
C451-454	253 1179 990	Ceramic 560pF/50V	CK45B1H561KT DD-3
C455,456	253 4538 949	Ceramic 100pF/50V	CC45SL1H101JT DD-3
C457-459	254 4260 948	Electrolytic 1µF/50V	CE04W1H010MT
C460	254 4254 909	Electrolytic 10µF/16V	CE04W1C100MT
C461	253 1146 907	Ceramic 0.01µF/50V	CK45F1H103ZT
C463,464	253 1146 907	Ceramic 0.01µF/50V	CK45F1H103ZT
C465	253 4537 908	Ceramic 27pF/50V	CC45SL1H270JT DD-3
C466	256 1035 075	Metallized 0.68µF/50V	CF93A1H684J
C601	254 4258 918	Electrolytic 10µF/35V	CE04W1V100MT
C602	254 4261 918	Electrolytic 47µF/50V	CE04W1H470MT
C603	254 4254 909	Electrolytic 10µF/16V	CE04W1C100MT
C604	253 1146 907	Ceramic 0.01µF/50V	CK45F1H103ZT
C605	254 4261 921	Electrolytic 100µF/50V	CE04W1H101MT
C606	254 4258 950	Electrolytic 100µF/35V	CE04W1V101MT
C609	254 4254 909	Electrolytic 10µF/16V	CE04W1C100MT
C610	254 4315 709	Electrolytic 3300µF/25V	CE04W1E332MC
C611	254 4260 948	Electrolytic 1µF/50V	CE04W1H010MT
C612,613	253 1146 907	Ceramic 0.01µF/50V	CK45F1H103ZT
C614	259 0007 702	Super Capacitor 8200µF/5.5V	SB CAP=822=C
C615	254 4254 909	Electrolytic 10µF/16V	CE04W1C100MT
C616	254 4258 950	Electrolytic 100µF/35V	CE04W1V101MT
C617	256 1034 979	Metallized 0.1µF/50V	CF93A1H104JT
C618	254 4260 948	Electrolytic 1µF/50V	CE04W1H010MT
C619	253 1146 907	Ceramic 0.01µF/50V	CK45F1H103ZT
C620	254 4260 948	Electrolytic 1µF/50V	CE04W1H010MT
TC101-104	213 0041 021	Trimmer Capacitor	
TC402,403	213 0046 000	Trimmer Capacitor	GT-15AU

Ref. No.	Part No.	Part Name	Remarks
OTHER PARTS			
X401	399 0075 003	Crystal Oscillator	Crystal (7.2MHz)
CF201	261 0085 002	Ceramic Filter	SFE10.7MXH-A
CF202,203	261 0067 004	Ceramic Filter	SFE10.7MS3G-A
CF204	261 0078 006	Ceramic Filter	SFE10.7MM(25KHz)
CF301	261 0131 008	Ceramic Filter	CSB608F4
CF302	399 0190 001	Ceramic Oscillator	CSA3.60MGF103
CF401	261 0031 001	Ceramic Filter	BFU450C4
CF402	261 0130 009	Ceramic Filter	SFH450D
LPF201	232 0132 009	Anti Birdie Filter	
CPF301,302	232 0148 006	MPX Filter	
NF301	261 0129 007	Notch Filter	TWIN T 10KHz
T101	231 2080 004	FM IF Trans (F/E)	
T201	231 2072 009	IF DET Trans (P)	
T202	231 2073 008	IF DET Trans (S)	
T301,302	231 3031 007	AM IF Trans	
T401	231 4901 000	MW OSC Coil	
T402	231 1143 104	AM Antenna Coil(S)	
T403	231 0076 007	AM IF Trans	
T404	231 1142 008	AM Antenna Coil(P)	
L101	231 2063 005	FM Antenna Coil	
L102	231 2081 003	FM RF Coil	
L103	231 2083 001	Input Trans	
L104	231 2063 005	FM Antenna Coil	
L105,106	231 2064 004	FM OSC Coil	
L107,108	235 0081 023	Inductor	SPT02

PRINTED WIRING BOARD (Pattern Side) 1U-1950H TUNER UNIT

1 2 3 4 5 6 7 8

A

B

C

D

E

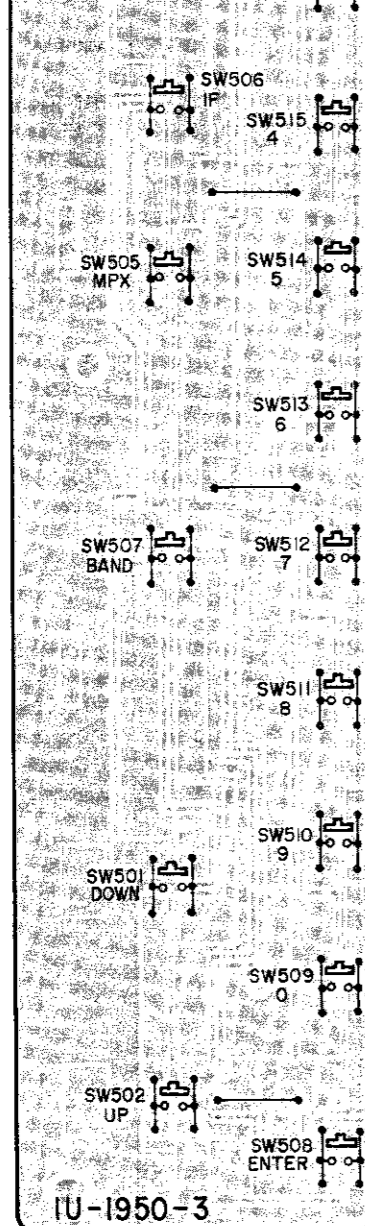
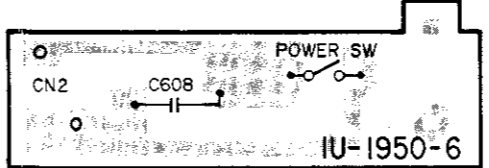
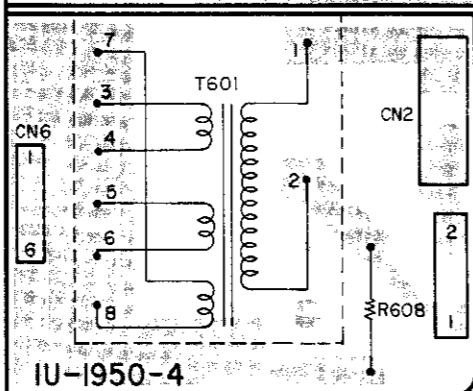
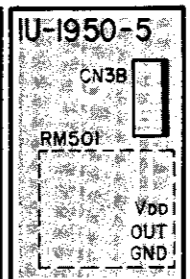
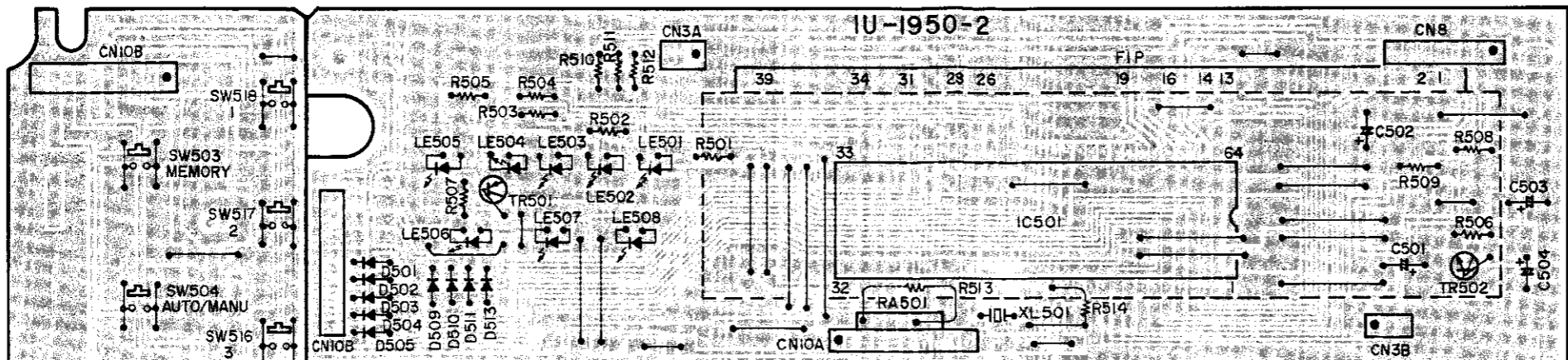

KU-9265 TUNER UNIT

1 2 3 4 5 6 7 8

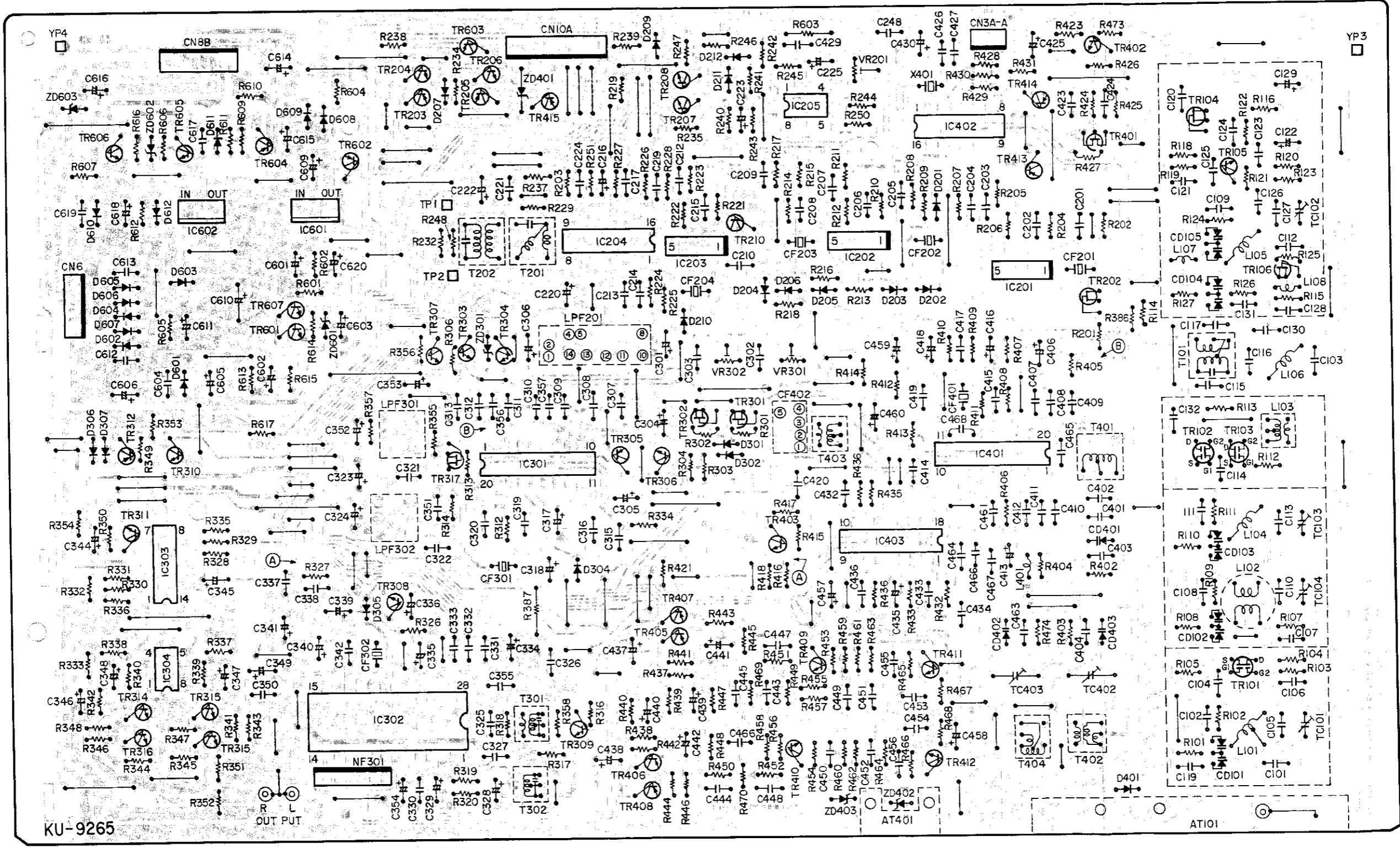

KU-9265

A
B
C
D
E

EXPLODED VIEW

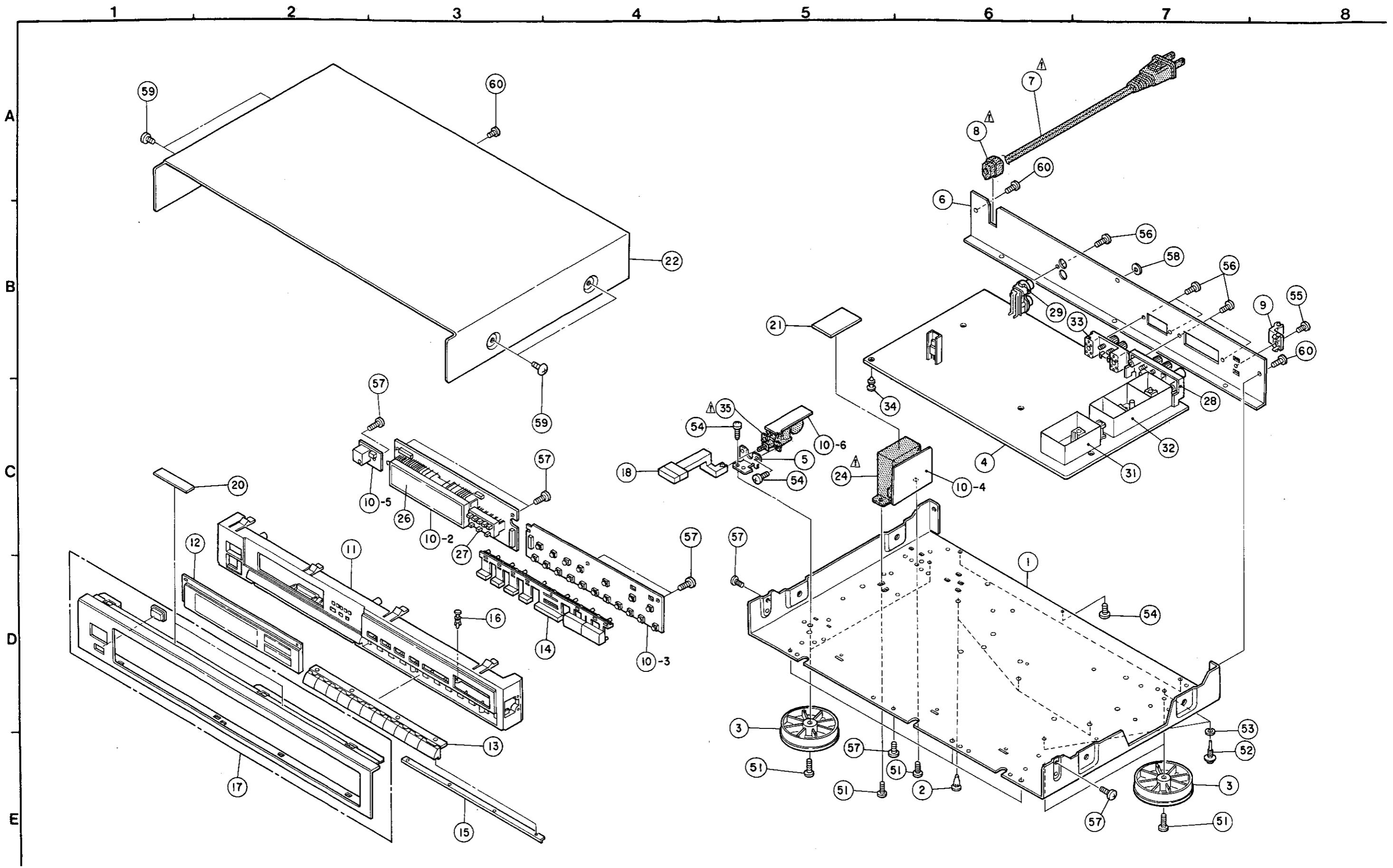

PARTS LIST OF EXPLODED VIEW

PACKING & ACCESSORIES

Ref. No.	Part No.	Part Name	Remarks
● 1	411 0752 600	Main Chassis	
● 2	412 1979 003	P.W.B. Holder	
3	104 0208 201	Foot Ass'y	
● 4	KU-9265	Tuner Unit	Main
● 5	441 0658 116	Switch Bracket	
● 6	105 1069 002	Rear Panel	
▲ 7	146 0925 009	Antenna Holder	
● 9	146 0925 009	Antenna Holder	
● 10	1U-1950 H	Tuner Unit	Display Unit etc.
10-2	—	Display Unit	
10-3	—	Tact Switch Unit	
10-4	—	Power Trans Unit	
10-5	—	Remote Sensor Unit	
10-6	—	Power Switch Unit	
● 11	146 1440 004	Inner Panel	
● 12	143 0835 006	Window	
13	113 1164 209	Push Button (Preset)	
14	113 1277 002	Push Button (Tuning)	
● 15	412 2880 104	Push Button Bracket	
16	477 0096 007	Push Rivet	
● 17	144,2270 002	Front Panel Ass'y	
18	113 1278 001	Power Button Ass'y	
19	445 8004 007	Wire Clamper	
● 20	122 0146 028	Himeron Sheet	
● 21	461 0551 000	Rubber Sheet	
● 22	102 0122 378	Top Cover	
23	—	—	
▲ 24	238 4791 005	FL Tube	
26	393 4043 004	FL Tube (FIP10TM7)	
● 27	146,1087 001	LED Holder	
28	205 0433 010	Antenna Terminal	For FM/AM
29	205 0274 004	2P Connector Base	
● 31	414 0429 000	Shield Case(A)	
● 32	414 0543 009	Shield Case(B)	
● 33	205 0510 001	2P Antenna Terminal	For AM EXIT
● 34	412 2814 002	Card Spacer(L=8)	
▲ 35	212 0286 003	Power Switch	
SCREWS & WASHER			
51	473 7002 021	Screw 3x8 CBTS(S)-B	
52	477 0276 018	Earth Screw	
53	475 2003 005	3φ Spring Washer	
54	473 7002 034	Screw 3x6 CBTS(S)-B	
55	473 7006 027	Screw 3x10 CBTS(S)-B	
56	477 0064 107	Fixing Screw	
57	473 7508 017	Screw 3x10 CBTS(P)-B	
58	415 0501 002	Washer	
59	477 0263 005	φP. Swelling Screw	
60	473 7015 018	Screw 3x8 CBTS(S)-B	

Ref. No.	Part No.	Part Name	Remarks	Q'ty
●	504 0090 017	Cabinet Cover		1
●	503 0762 106	Cushion		2
●	501 1664 003	Carton Case		1
●	505 8006 019	Envelope		1
●	511 2436 101	Instruction Manual		1
●	203 2223 002	2P Pin Cord		1
	231 1129 005	Loop Antenna		1
	395 0020 027	FM Antenna Ass'y		1
	499 0147 008	Remote Control Unit(RC-126)		1

WARNING:

- Parts marked with "▲" and/shading have special characteristics important to safety.
Be sure to use the specified parts for replacement.
- Part indicated with the mark "●" are not always in stock and possibly to take a long period of time for supplying, or in some case supplying of part may be refused.

WIRING DIAGRAM

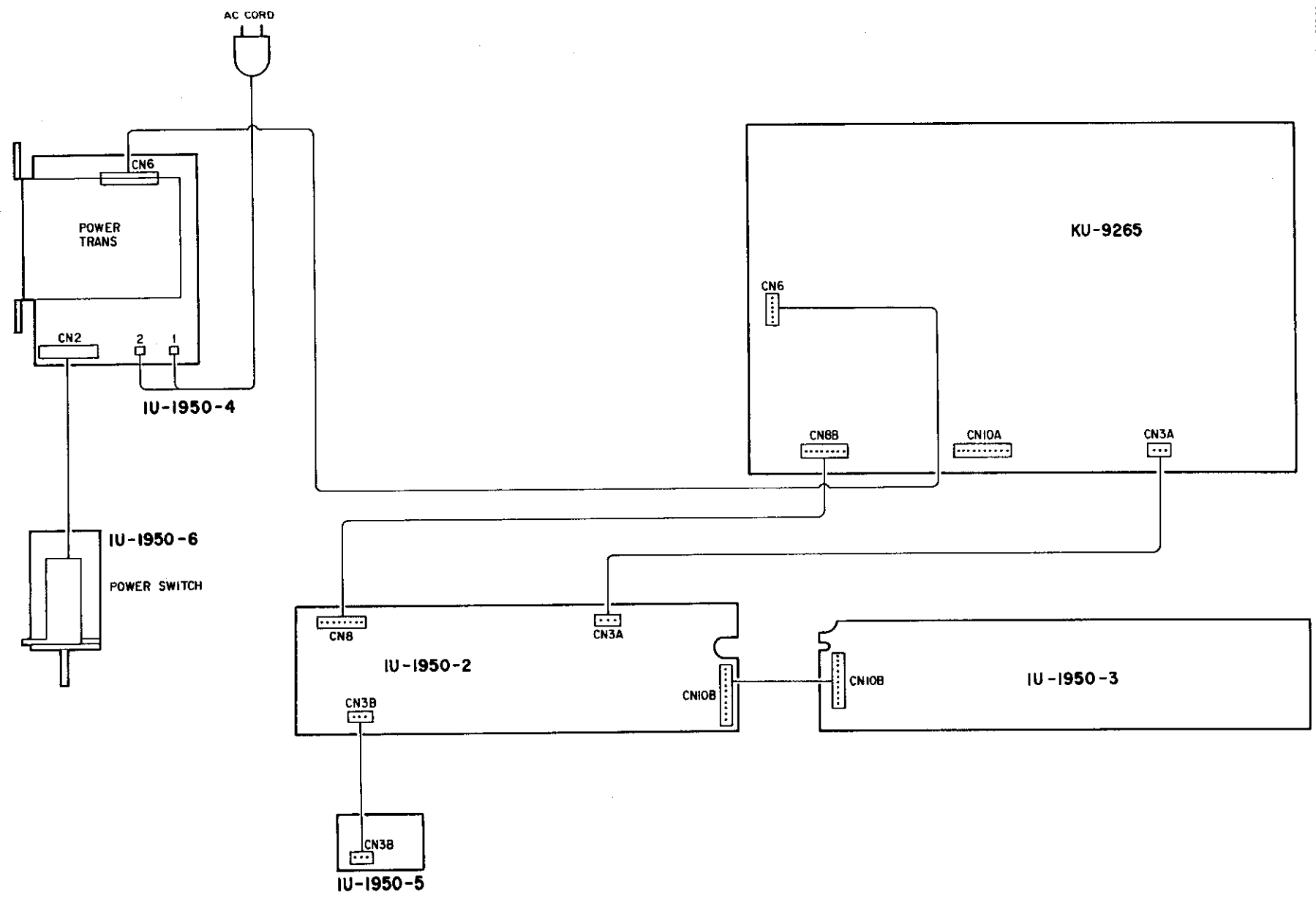

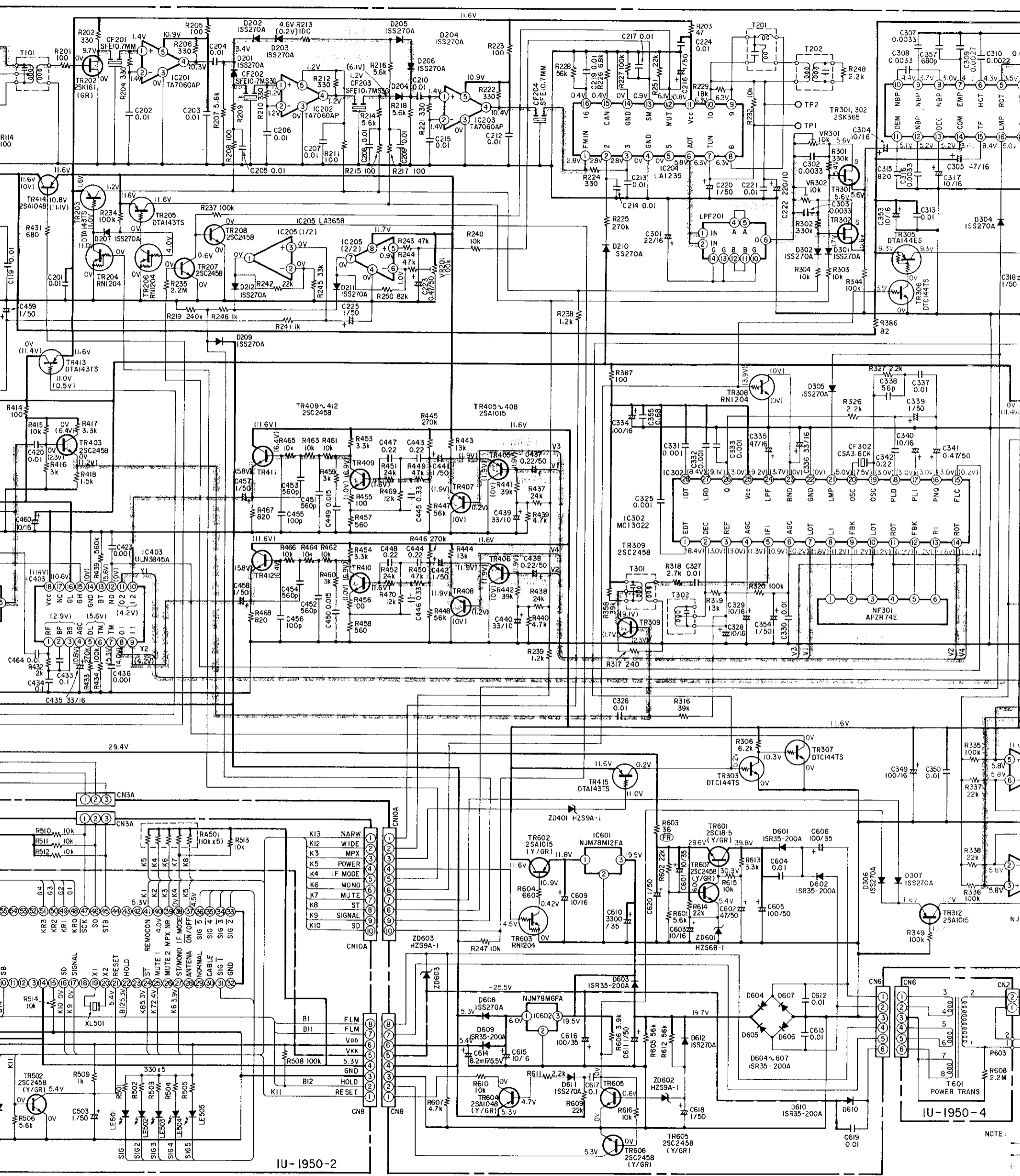

NOTES
 ALL RESISTANCE VALUES IN OHM. k=1,000 OHM, M=1,000,000 OHM
 ALL CAPACITANCE VALUES IN MICRO FARAD. P=MICRO-MICRO FARAD
 EACH VOLTAGE AND CURRENT ARE MEASURED AT NO SIGNAL INPUT CONDITION.
 CIRCUIT AND PARTS ARE SUBJECT TO CHANGE WITHOUT PRIOR NOTICE.

WARNING:
 Parts marked with this symbol  have critical characteristics. Use ONLY replacement parts recommended by the manufacturer.

CAUTION:
 Before returning the unit to the customer, make sure you make either (1) a leakage current check leakage current exceeds 0.5 milliamps, or if the resistance from chassis to either side of the power transformer is less than 100,000 ohms.

WARNING:
 DO NOT return the unit to the customer until the problem is located and corrected.

