

# DENON

Hi-Fi Stereo Tuner

## SERVICE MANUAL MODEL TU-450/450L

EUROPEAN MODEL

TU450  
2-BAND (AM-FM) STEREO TUNER  
TU450L  
3-BAND (LW-MW-FM) STEREO TUNER



### TABLE OF CONTENTS

SPECIFICATIONS .....	2
FUNCTIONS OF PANEL CONTROLS .....	2
CONNECTIONS .....	3
BLOCK DIAGRAM .....	4
REMOVAL EACH SECTION .....	5
METHOD OF ADJUSTMENTS .....	6
SEMICONDUCTORS .....	8~9
PRINTED WIRING BOARD PATTERNS AND PARTS LIST	
ETC0852 TUNER UNIT (for 3 Band) .....	10, 2
ETC0861D TUNER UNIT (for 2 Band) .....	11, 3
WIRING DIAGRAM .....	4
SCHEMATIC DIAGRAM .....	5
EXPLODED VIEW OF CHASSIS AND CABINET & PARTS LIST .....	6

**NIPPON COLUMBIA CO., LTD.**



**SPECIFICATIONS**

**FM SECTION**

Frequency Range:	87.50 ~ 108.00 MHz
Antenna:	75 ohm unbalanced/300 ohm balanced
Usable Sensitivity:	1.0 μV (11.2 dBf)
S/N 50 dB Sensitivity:	Stereo: 23 μV (38.5 dBf) Monaural: 3.1 μV (21.2 dBf)
Image Rejection:	70 dB
IF Rejection:	85 dB
Spurious Response Rejection:	80 dB
AM Suppression:	50 dB
Effective Selectivity:	75 dB (±400 kHz)
Capture Ratio:	1.5 dB
Frequency Response:	20 Hz to 15 kHz +0.2 -1.5 dB
Signal-to-noise Ratio:	Monaural: 80 dB Stereo: 76 dB
Total Harmonic Distortion:	
Monaural	1 kHz 0.3% (at 100% modulation)
Stereo	1 kHz 0.7% (at 90% modulation)
Stereo Separation:	1 kHz 40 dB
Muting Level:	10 μV
Output Level (at 100% modulation):	0.6 V (75 kHz deviation)

**AM SECTION**

**MEDIUM WAVE**

Frequency Range:	522 ~ 1611 kHz
Antenna Terminal:	Terminal Type, with Loop Antenna
Usable Sensitivity:	18 μV
Selectivity:	33 dB (9 kHz)
Image Rejection:	35 dB
Signal-to-noise Ratio:	53 dB
Total Harmonic Distortion:	0.6%
Output Level (at 30% modulation):	0.18 V
<b>LONG WAVE (For TU-450L only)</b>	
Frequency Range:	153 ~ 360 kHz
Usable Sensitivity:	30 μV
Selectivity:	35 dB (±9 kHz)
Image Rejection:	50 dB
Signal-to-noise Ratio:	50 dB
<b>OTHERS</b>	
Power Supply:	AC 220 V/50 Hz (for Europe) AC 240 V/50 Hz (for England for EK Version only)
Power Consumption:	AC 7 W
Dimensions:	434 mm (17-3/32") W x 70 mm (2-3/4") H x 238 mm (9-3/8") D
Net Weight:	3.0 kg (6 lbs. 10 oz)

Design and specifications are subject to change without prior notice.

NOTE: The following codes correspond to the appropriate models.  
E2 for Europe, EK for U.K.  
This Service Manual is prepared based on E2 BLACK Version.

**FUNCTIONS OF PANEL CONTROLS**

• TU-450

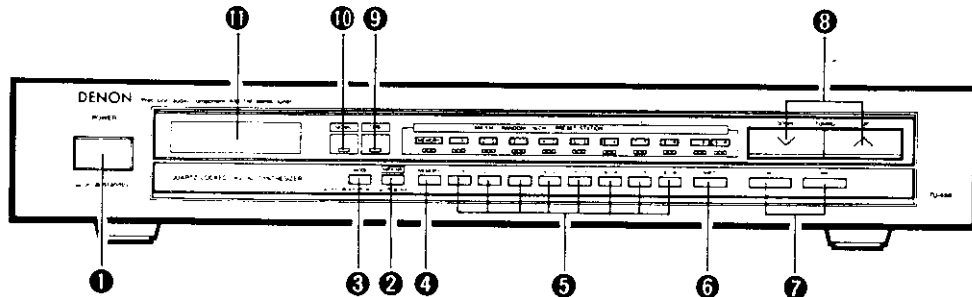

• TU-450L

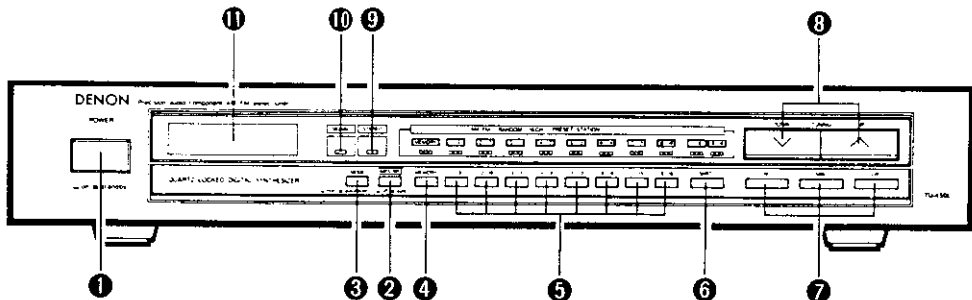

- |  |  |
|--|--|
| ① POWER (Power On/Standby Switch)                      | ⑦ SELECT (Selector Buttons)<br>FM, AM: TU-450, FM, MW, LW: TU-450L |
| ② MPX NR (MPX Noise Reduction Switch)<br>■ auto, ■ off | ⑧ TUNING (Tuning Buttons)<br>∇ down, ▲ up                          |
| ③ MODE (Mode Switch)<br>■ auto/mute, ■ mono            | ⑨ STEREO (Stereo Indicator)  |
| ④ MEMORY (Memory Button)                               | ⑩ SIGNAL (Signal-Strength Indicators)                              |
| ⑤ PRESET CHANNEL 1 to 8 (Preset Channel Buttons)       | ⑪ DIGITAL FREQUENCY INDICATOR                                      |
| ⑥ SHIFT (Change Memory)<br>1-8 ↔ 9-16                  |  |

Fig. 1

## CONNECTIONS

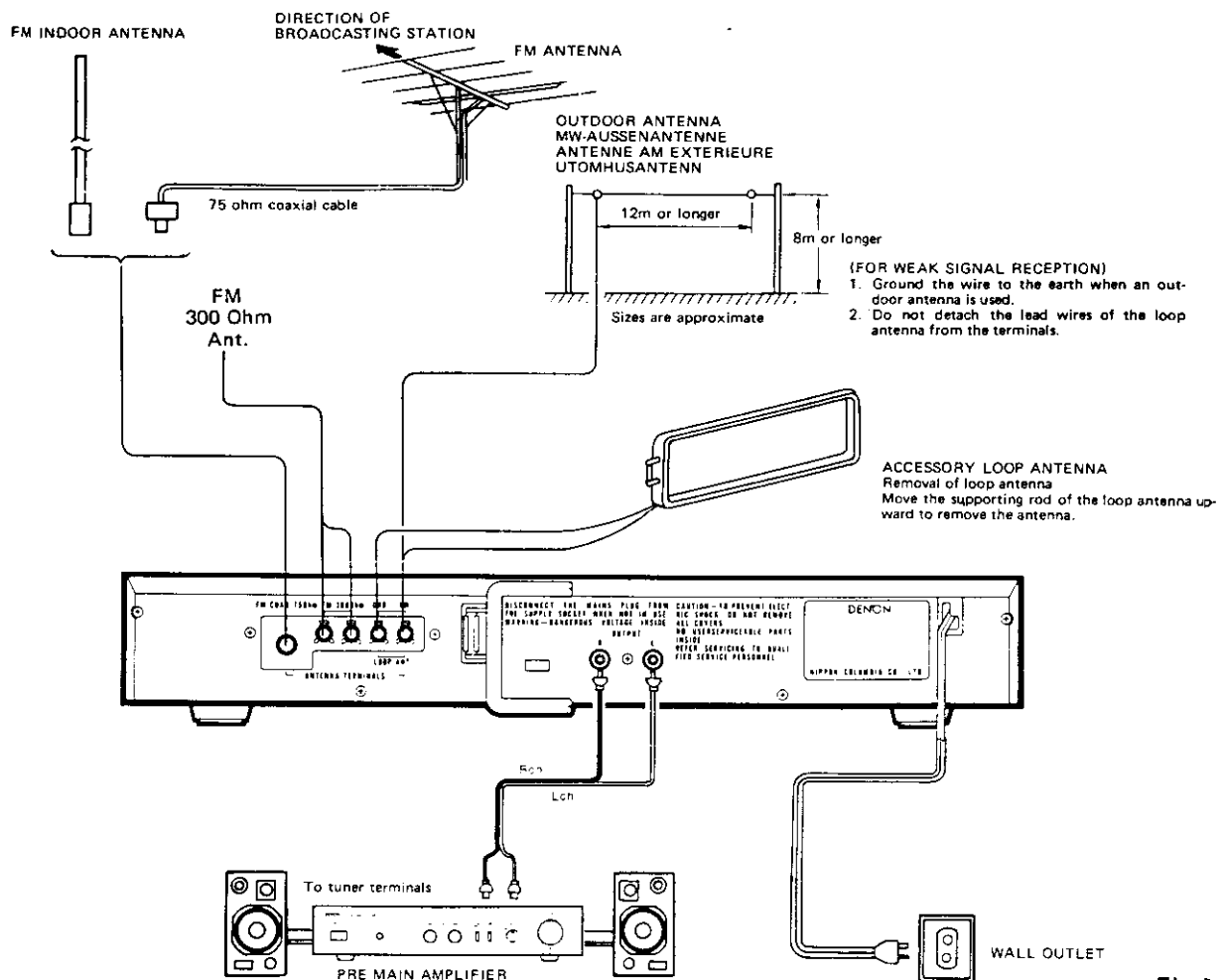

Fig. 2

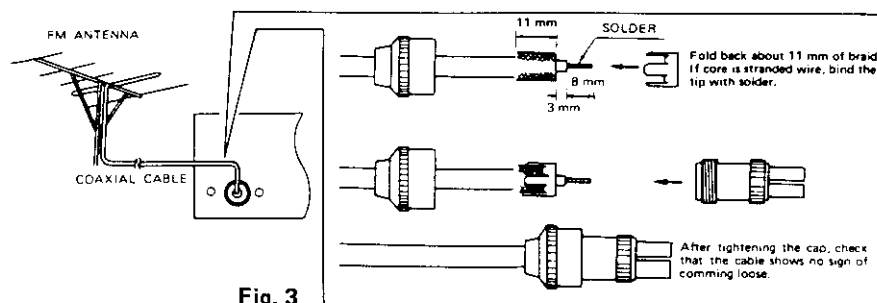

Fig. 3

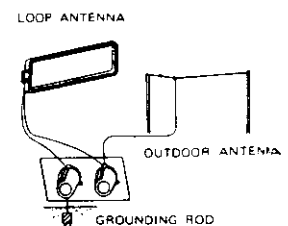

Fig. 4

## ANTENNA INSTALLATION

## ● LEAD WIRE FM INDOOR ANTENNA

A lead wire indoor antenna can be used in a wood-frame house where broadcasting stations are located nearby and strong signals can be received. While receiving an FM program, extend the antenna. Orient for optimal reception and mount the antenna on the wall or ceiling.

\* In general, FM indoor antenna might not consistently assure stable reception, due to environmental changes. In such case use an FM indoor antenna temporarily until an outdoor antenna is installed.

## ● FM OUTDOOR ANTENNA CONNECTION (Fig. 3)

Use 75-ohm coaxial cable or 300 ohm ribbon feeder, to connect the outdoor antenna and the tuner. The 75-ohm coaxial cable (3C-2V, 5C-2V) is preferable to obtain better performance of the tuner.

\* Contact your local dealer for details on selection and installation of the FM outdoor antenna.

When connecting the coaxial cable to the antenna terminal using the DIN connector, please refer to the procedures in Fig. 3.

• MW and LW ANTENNA CONNECTION (Fig. 4)

Since this model is provided with a high-performance loop antenna at the back panel, this accessory antenna can effectively be used for optimal reception in places where broadcasting stations are located nearby and relatively strong signals are received with low noise.

Orient the loop antenna horizontally for obtaining optimal reception.

In places where strong, clear signals are not received due to the particular location and/or environmental conditions, connect a vinyl lead wire to the MW/LW antenna terminals and hold it to the wall or lintel.

In places where broadcasting stations are too far away and only weak signals are received, or where signals are blocked by obstacles, install an outdoor antenna for MW/LW.

\* Even if an outdoor antenna is installed, do not detach the loop antenna.

**GROUNDING**

If there is much noise during reception of a radio program, it is recommended that a grounding wire be used to ground the unit.

Connect a thick vinyl lead wire to the "GND" terminal, and wind the unconnected bare end around a metal water pipe, a grounding rod, or a grounded copper plate.

\* Do not connect a grounding wire to a gas pipe in order to prevent explosion of fire.

**BLOCK DIAGRAM**

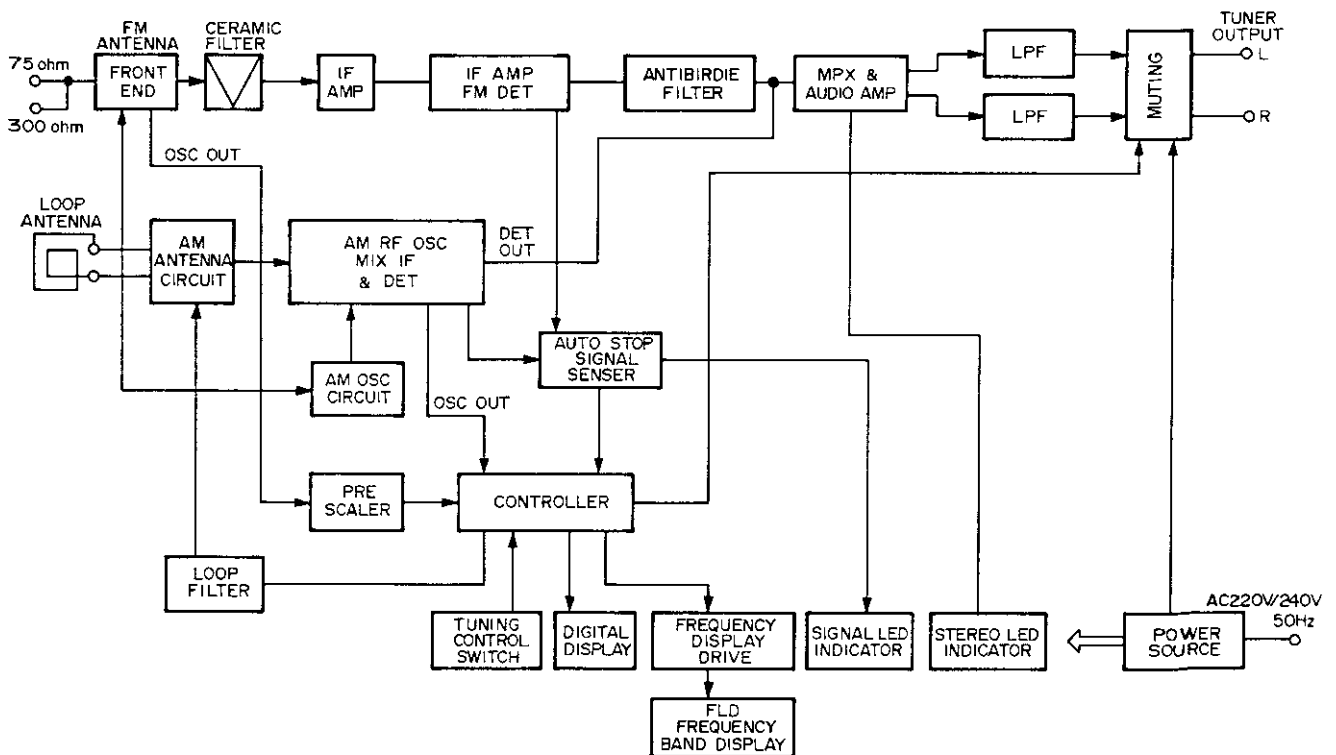

Fig. 5

## REMOVE OF EACH SECTION

### 1. How to remove the top cover (Fig. 6)

- (1) Remove the four screws on both sides.
- (2) Raise the back of the top cover and remove it.

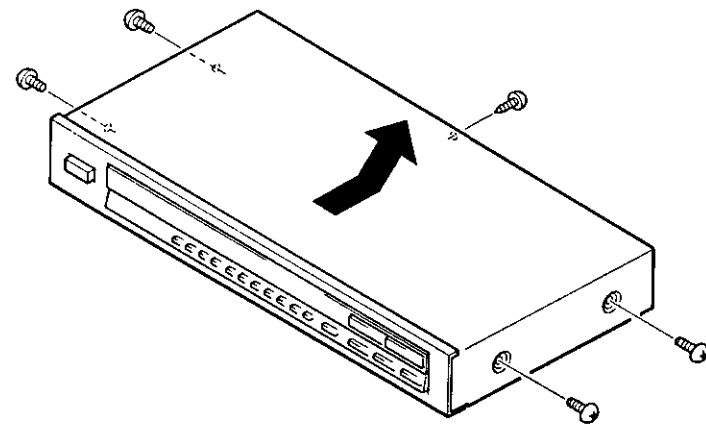

Fig. 6

### 2. How to remove the Front Panel Ass'y (Fig. 7)

- (1) Remove the five screws.
- (2) Remove the nail in the center of the Front Panel.
- (3) Pull out the F/Panel forwardly.

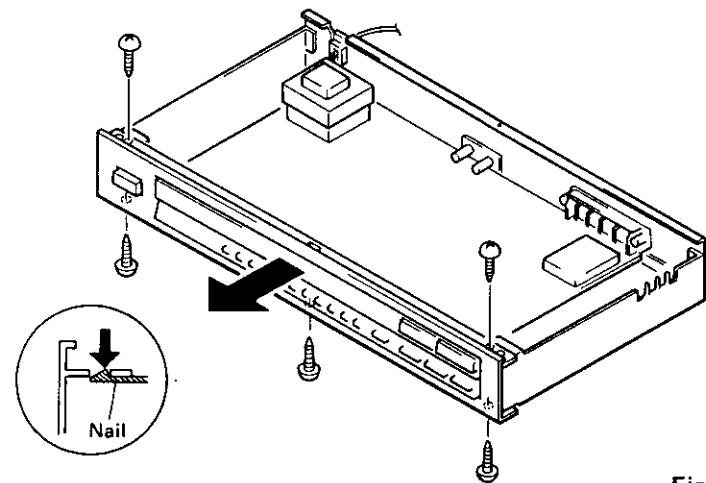

Fig. 7

### 3. How to remove the Inner Panel (Fig. 8)

- (1) Detach the four connectors.
- (2) Remove the two screws.

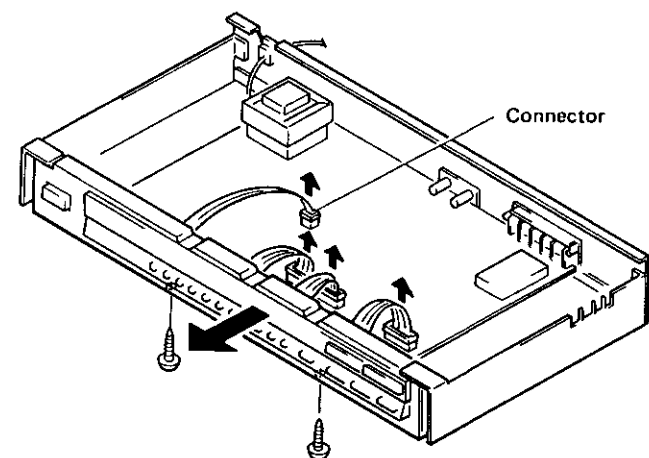

Fig. 8

### 4. How to remove the Switch Unit P.W.B. (Fig. 9)

- A. Switch (A) Unit P.W.B.  
(1) Remove the four nails.
- B. Switch (B) Unit P.W.B.  
(1) Remove the six nails.

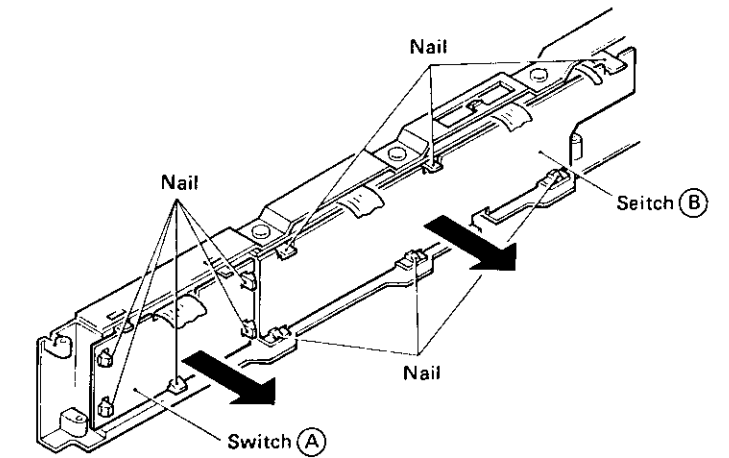

Fig. 9

### 5. How to remove the Main Unit P.W.B. (Fig. 10)

- Tuner Unit P.W.B.  
(1) Remove the three screws of the Unit and the two screws for connecting the transformer.
- (2) Detach the cord bush of the AC cord.
- (3) Remove the three screws of the Back Panel.

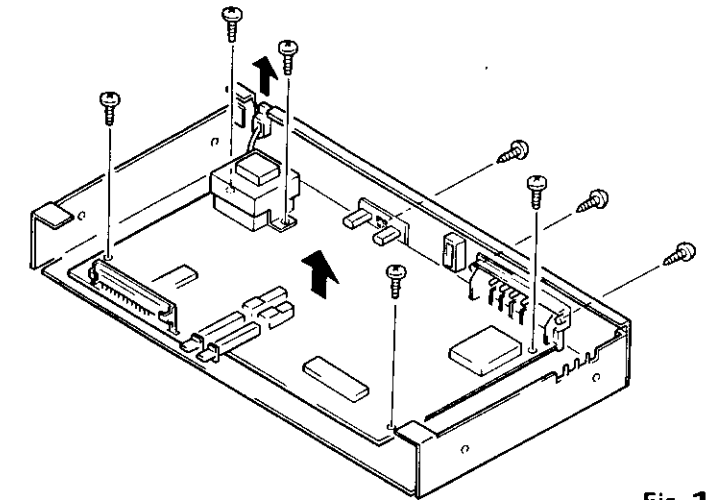

Fig. 10

METHOD OF ADJUSTMENTS

When making adjustments, be sure the power supply is at the rated voltage and the room air is on normal conditions with respect to temperature and humidity.

INSTRUMENT HOOK-UP DIAGRAM

FM

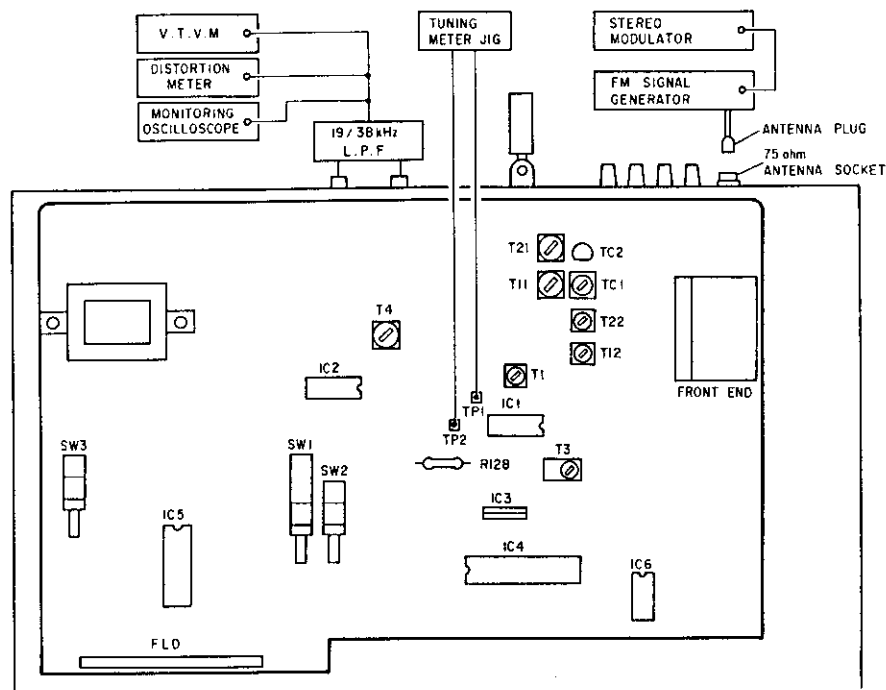

Fig. 11

AM

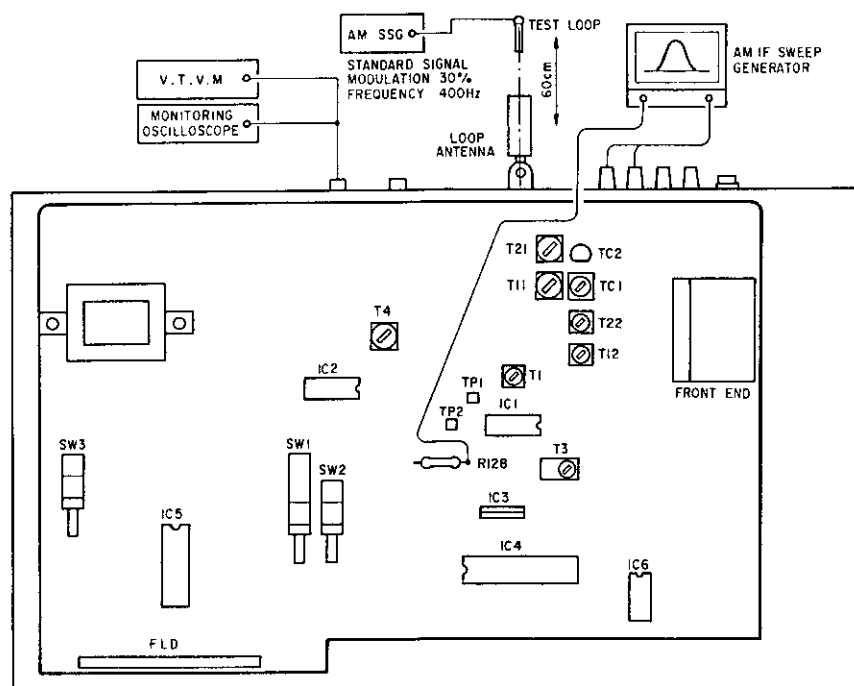

Fig. 12

INSTRUMENT CONNECTIONS AND SETTING

● Preparation

1. Connection of Measuring Equipment

FM

(1) The modulated output of the stereo modulator is supplied to an FM signal generator. Connect the output end of the FM signal generator to the antenna terminal (75 ohm) of the unit. Set the stereo modulator to the following conditions:

- L + R: 67.5 kHz deviation 1 kHz (internal modulation frequency)
- Pilot: 7.5 kHz deviation

(2) Connect a filter jig of 19 kHz to the output terminal L of the unit. Then, connect the output of the filter jig to a distortion meter, the output of which is in turn connected to an oscilloscope for monitoring.

(3) Connect tuning jigs to TP. 1 and 2.

LW or MW

(1) The AM signal generator should be set as follows:

- Modulation: 30%, modulation frequency: 400 Hz
- (Antenna input signal level: about 60 dB/m).

Tuning Meter Jig

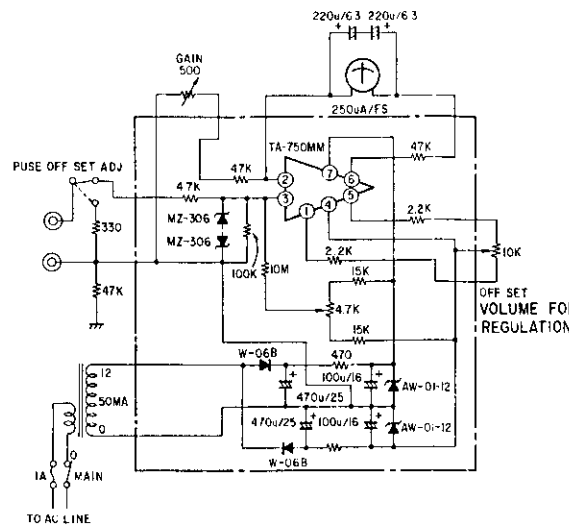

Fig. 13

FM/MPX ALIGNMENT (Fig. 11)

Step	Alignment Item	Tuning Frequency Setting	Input					Output		Adjustment		
			Type	Frequency	Input Level	Modulation	Coupling	Type	Connect to	Points	Adjust to	
1	Tuning Center	98 MHz	FM SSG, Mono	98 MHz	60 dBμ	None	Antenna Terminal	Center Meter	T.P. 1, 2	T-1	Center of Tuning Meter	Function: FM Mode: Auto
2	Distortion (Stereo)	98 MHz	FM SSG Stereo (L)	98 MHz	60 dBμ	Main: 1 kHz L-ch 67.5 kHz Dev. Pilot: 7.5 kHz Dev.	Antenna Terminal	Distortion Meter	Output Terminal (L)	IFT on Front End	Minimum Distortion	Function: FM Mode: Auto
3	Noise Center & Distortion		Repeat 1, 2 to obtain minimum distortion and same time indicating of center meter at center condition.									

LW AND MW ALIGNMENT (Fig. 12)

1	IF	-	IF Sweep	-	Input Level is not over to work A.G.C.	-	Antenna Terminal	Oscilloscope	R128	T-3	Maximum Height and Best Symmetry Curve	Function: MW Center of Wave Form: 450 kHz
2	Tracking Alignment MW	603 kHz	AM SSG	603 kHz	Input Level is not over to work A.G.C.	400 Hz 30%	Loop Antenna	Audio V.T.V.M.	Output Terminal (L)	T-11	Maximum Output	Function: MW
		1404 kHz	AM SSG	1404 kHz	Input Level is not over to work A.G.C.	400 Hz 30%	Loop Antenna	Audio V.T.V.M.	Output Terminal (L)	TC-1	Maximum Output	Function: MW
3	Tracking Alignment LW	163 kHz	AM SSG	163 kHz	Input Level is not over to work A.G.C.	400 Hz 30%	Loop Antenna	Audio V.T.V.M.	Output Terminal (L)	T-21	Maximum Output	Function: LW
		330 kHz	AM SSG	330 kHz	Input Level is not over to work A.G.C.	400 Hz 30%	Loop Antenna	Audio V.T.V.M.	Output Terminal (L)	TC-2	Maximum Output	Function: LW

TUNING UNIT Alignment Points (Component Side)  
 ETC0852B TUNER UNIT (for 3 Band)

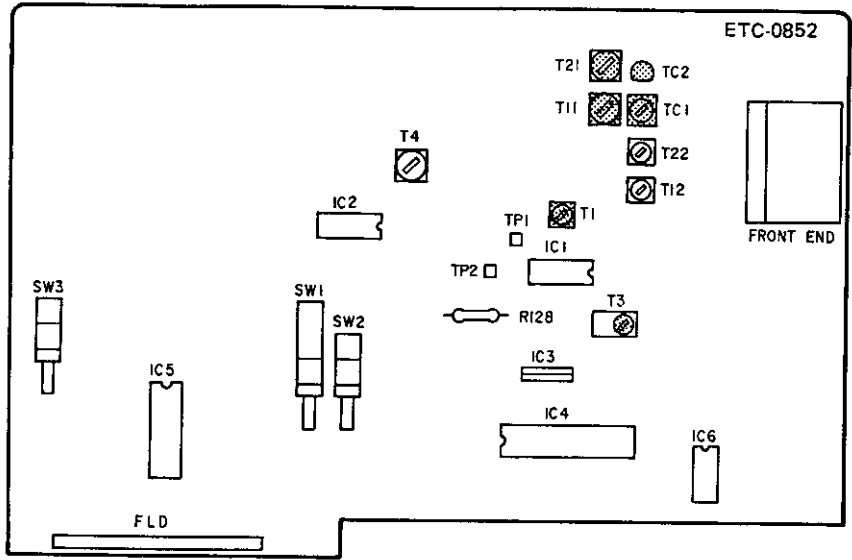

Fig. 14

ETC0861D TUNER UNIT (for 2 Band)

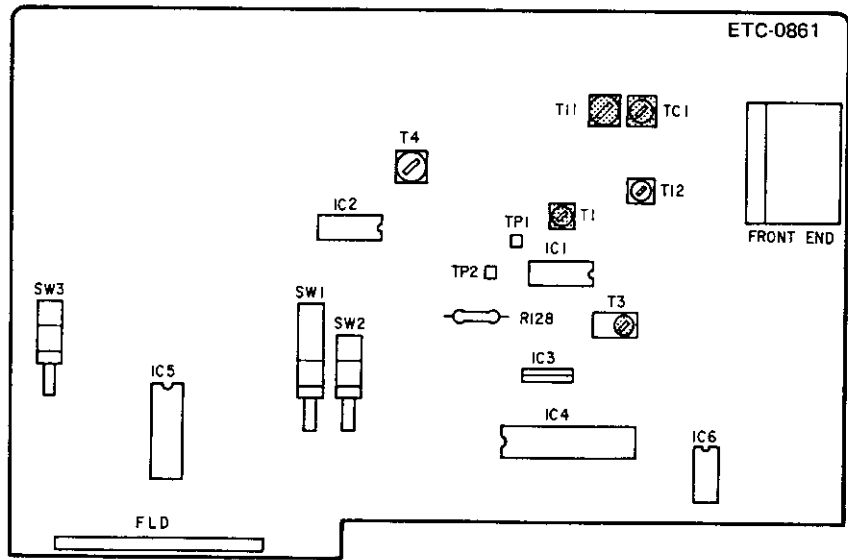
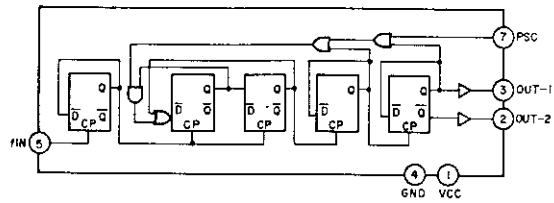
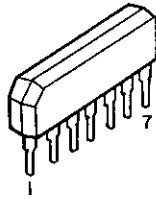

Fig. 15

SEMICONDUCTORS

• IC's

TD6104P (Toshiba)



HD14011BP (Hitachi)

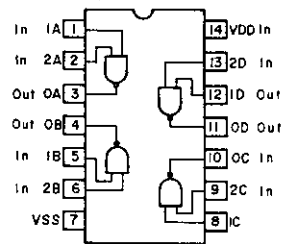
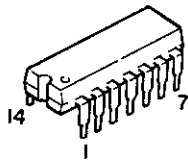

LA3401 (Sanyo)

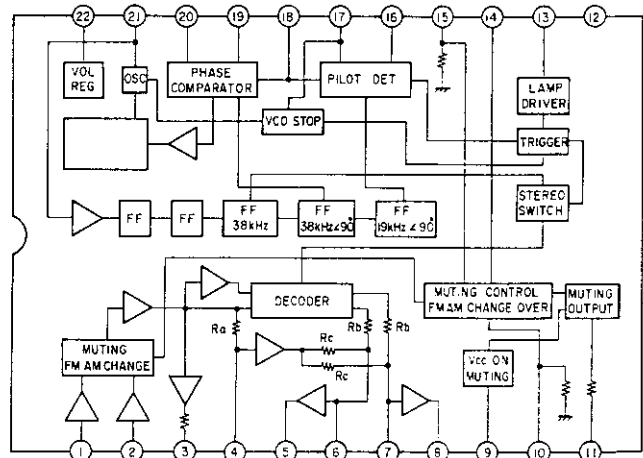
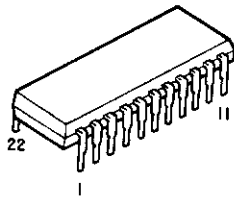

LA1266 (Sanyo)

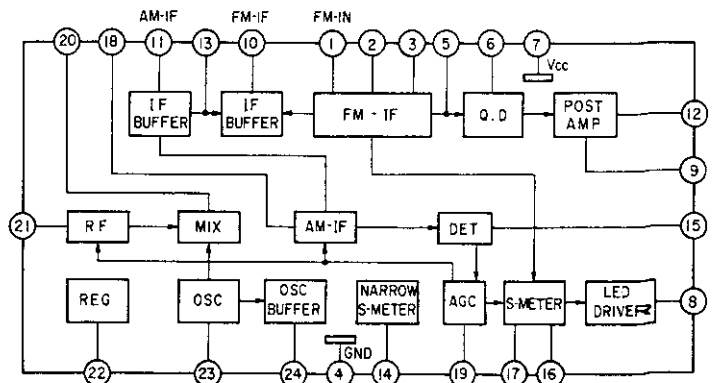
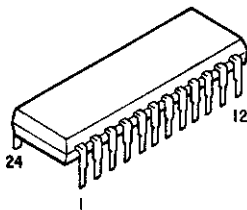



TD6301AP (Toshiba)

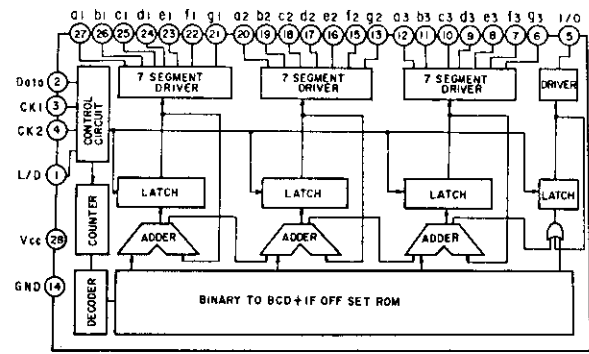
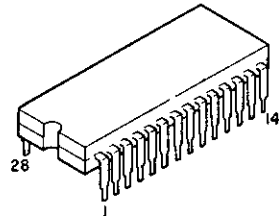

TD9147P (Toshiba)

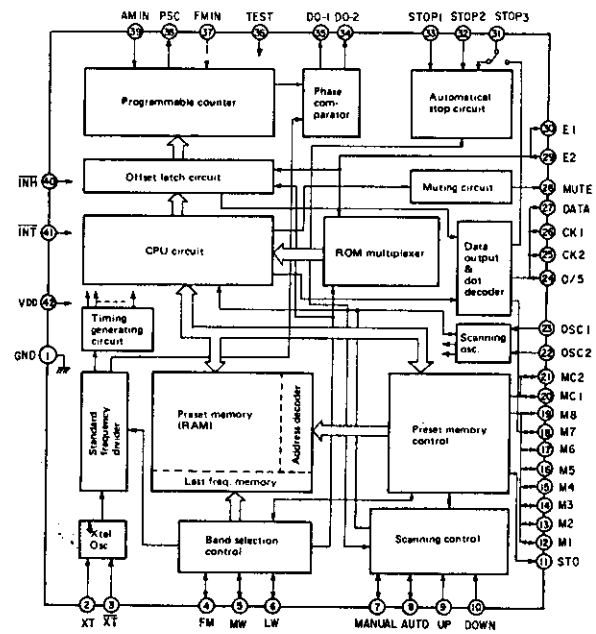
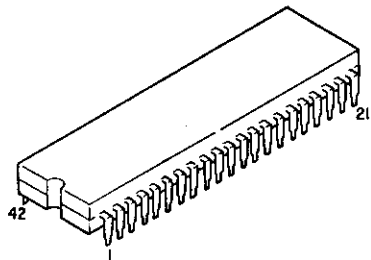

• TRANSISTORS (including FET)

2SC461(C)  
2SC1815(BL)

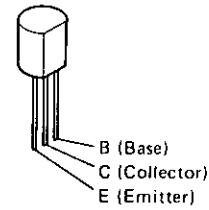

2SA1048(Y/GR)  
2SC2458(Y/GR)

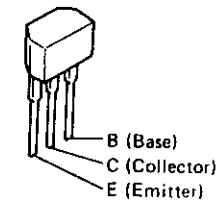

2SD880(Y)

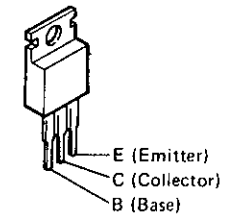

(FET)  
2SK365(BL/GR)

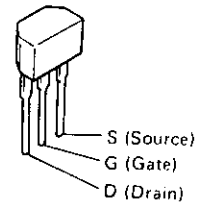

• DIODES, LEDS

HZ7A-1  
HZ12C-2

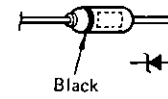

1S2076

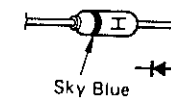

SVC321SP-D2

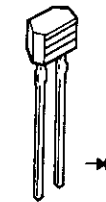

PB103M



(LED)  
LT9233 (Green)  
LT9213R (Red)

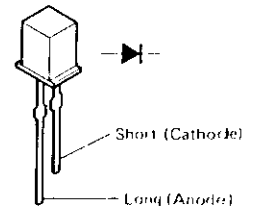

7BT168A (Futaba)

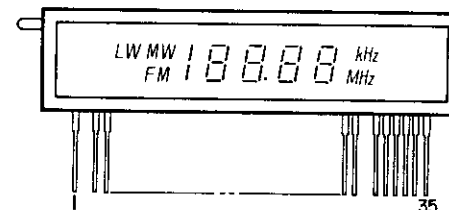

LW MW 188.88 kHz  
FM 105.000 MHz

PIN NO	1	2	3	4	5	6	7	8	9	10	11	12	13	14	15	16	17	18	19	20	21	22	23	24	25	26	27	28	29	30	31	32	33	34	35		
ELECTRODE	F	NP	LW	MW	KHz	0	FM	b5	c5	04	F4	04	04	04	04	04	04	04	04	04	04	04	04	04	04	04	04	04	04	04	04	04	04	04	04	04	04

ETC0852B TUNER UNIT (for 3 Band)

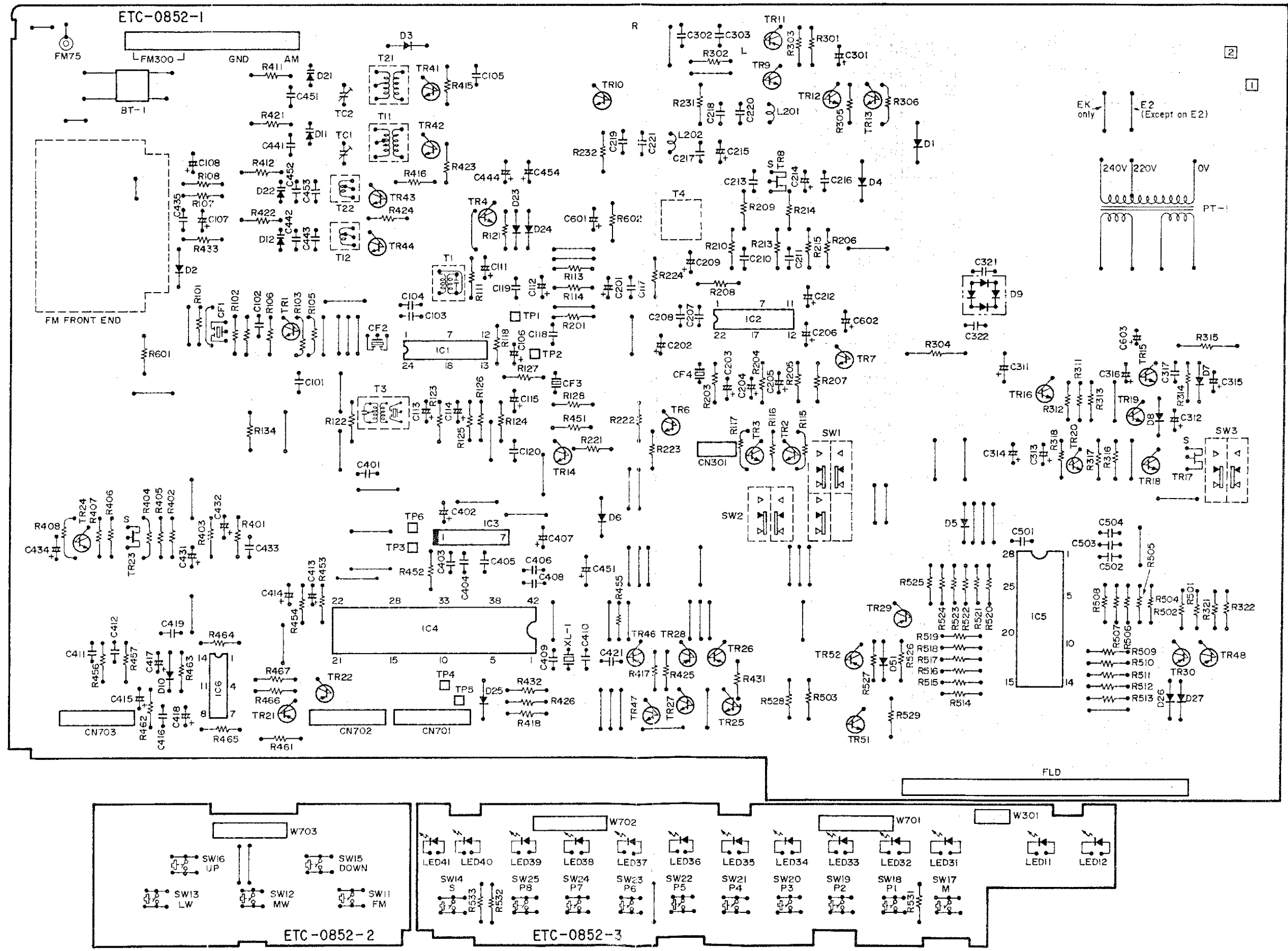

ETC0861D TUNER UNIT (for 2 Band)

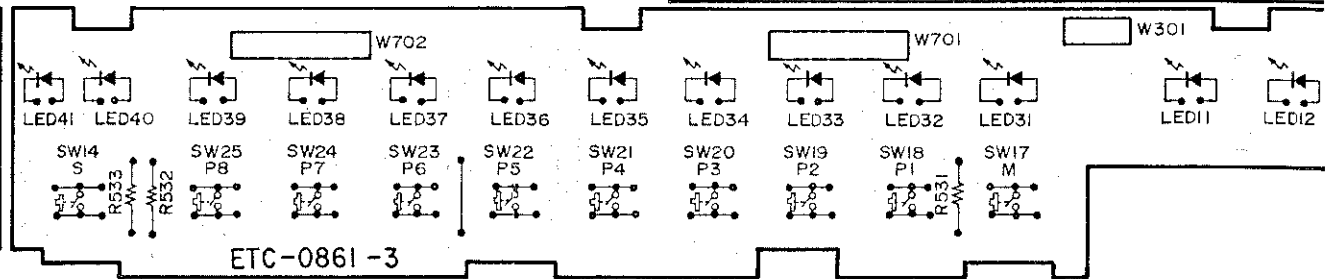
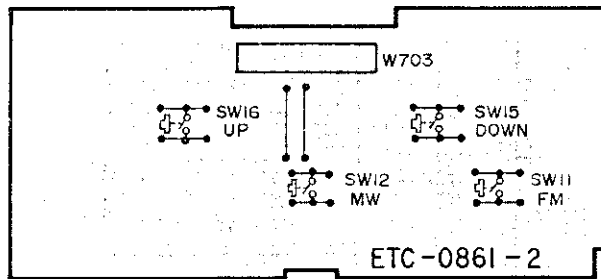
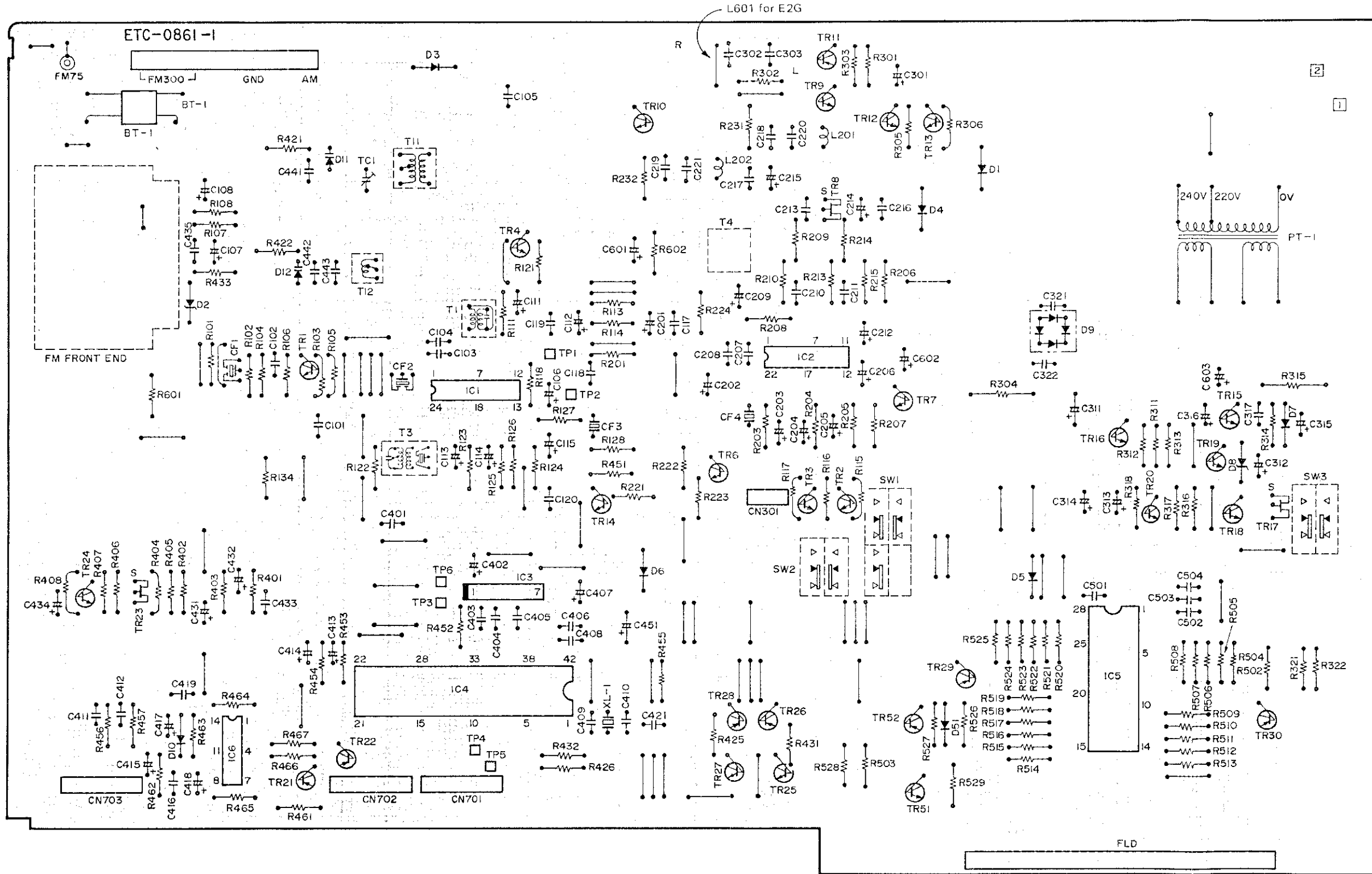

ETC0852B TUNER UNIT PARTS LIST (for 3 Band)

Ref. No.	Part No.	Part Name & Descriptions
<b>SEMICONDUCTORS</b>		
IC001	2630438008	LA1266 (Sanyo) IC •
IC002	2630439007	LA3401 (Sanyo) IC •
IC003	2630232000	TD6104P (Toshiba) IC
IC004	2620452104	TC9147BP (Toshiba) IC
IC005	2620453006	TD6301AP (Toshiba) IC
IC006	2620300007	HD14011BP (Hitachi) IC
TR001	2730025023	2SC461(C) Transistor
TR002 ~004	2730322001	2SC2458(Y/GR) Transistor
TR006, 007	2730322001	2SC2458(Y/GR) Transistor
TR008	2750053004	2SK365(BL/GR) FET
TR009, 010	2730322001	2SC2458(Y/GR) Transistor
TR011	2710194000	2SA1048(Y/GR) Transistor
TR012 ~014	2730322001	2SC2458(Y/GR) Transistor
TR015	2730198015	2SC1815(BL) Transistor
TR016	2730322001	2SC2458(Y/GR) Transistor
TR017	2750053004	2SK365(BL/GR) FET
TR018	2740065002	2SD880(Y) Transistor
TR019	2730322001	2SC2458(Y/GR) Transistor
TR020	2730198015	2SC1815(BL) Transistor
TR021, 022	2710194000	2SA1048(Y/GR) Transistor
TR023	2750053004	2SK365(BL/GR) FET
TR024, 025	2730322001	2SC2458(Y/GR) Transistor
TR026	2710194000	2SA1048(Y/GR) Transistor
TR027	2730322001	2SC2458(Y/GR) Transistor
TR028 ~030	2710194000	2SA1048(Y/GR) Transistor
TR041 ~044	2730322001	2SC2458(Y/GR) Transistor
TR046	2710194000	2SA1048(Y/GR) Transistor
TR047	2730322001	2SC2458(Y/GR) Transistor
TR048	2710194000	2SA1048(Y/GR) Transistor
TR051	2730322001	2SC2458(Y/GR) Transistor
TR052	2710194000	2SA1048(Y/GR) Transistor
D001	2760049008	1S2076 Diode
D002	2760185014	HZ4B-3 Zener
D003~006	2760049008	1S2076 Diode
D007	2760051054	HZ7A-1 Zener
D008	2760255038	HZ12C-2 Zener
D009	2760446009	PB103M Diode
D010	2760049008	1S2076 Diode
D011,012	2760302004	SVC321SP-D2 Varactor
D021,022	2760302004	SVC321SP-D2 Varactor
D023~027	2760049008	1S2076 Diode
D051	2760049008	1S2076 Diode
LE011	3939173005	LT9213R (Red) LED
LE012	3939356000	LT9233 (Green) LED
LE031	3939356000	LT9233 (Green) LED
LE032 ~039	3939173005	LT9213R (Red) LED
LE040, 041	3939356000	LT9233 (Green) LED
<b>RESISTORS (not included Carbon Film ±5%, 1/4W Type)</b>		
R304	2410193000	2.2k ohm ±5% 1/2W Carbon Film
R315	2440033020	220 ohm ±5% 1W Metal Oxide (NBF)
<b>CAPACITORS</b>		
C001	2538014003	0.01µF ±20% 400V(AC) Ceramic
C101	2531024003	0.01µF +80,-20% 50V Ceramic
C102~104	2531026001	0.047µF +80,-20% 50V Ceramic
C105	2531024003	0.01µF +80,-20% 50V Ceramic
C106,107	2544237036	47µF 16V Electrolytic

Ref. No.	Part No.	Part Name & Descriptions
C108	2544237007	10µF 16V Electrolytic
C111	2544237036	47µF 16V Electrolytic
C112	2544243017	1µF 50V Electrolytic
C113	2544241006	4.7µF 35V Electrolytic
C114	2544237007	10µF 16V Electrolytic
C115	2544243033	3.3µF 50V Electrolytic
C117	2531026001	0.047µF +80,-20% 50V Ceramic
C118	2533627000	100pF ±5% 50V Ceramic
C119	2531024003	0.01µF +80,-20% 50V Ceramic
C120	2531026001	0.047µF +80,-20% 50V Ceramic
C201	2544237001	10µF 16V Electrolytic
C202	2544237049	100µF 16V Electrolytic
C203	2544243017	1µF 50V Electrolytic
C204	2544243004	0.47µF 50V Electrolytic
C205,206	2544243017	1µF 50V Electrolytic
C207	2531026001	0.047µF +80,-20% 50V Ceramic
C208	2533639001	330pF ±5% 50V Ceramic
C209	2544237007	10µF 16V Electrolytic
C210,211	2534350004	680pF ±5% 50V Ceramic
C212	2544243033	3.3µF 50V Electrolytic
C213	2531024003	0.01µF +80,-20% 50V Ceramic
C214,215	2544243033	3.3µF 50V Electrolytic
C216,217	2539031069	2700pF ±10% 25V Ceramic
C218,219	2539030002	1000pF ±10% 25V Ceramic
C220,221	2539031056	1800pF ±10% 25V Ceramic
C301	2544243004	0.47µF 50V Electrolytic
C302,303	2533635005	220pF ±5% 50V Ceramic
C311	2544239092	1000µF 25V Electrolytic
C312	2544237007	10µF 16V Electrolytic
C313	2544237049	100µF 16V Electrolytic
C314~316	2544237007	10µF 16V Electrolytic
C317	2531024003	0.01µF +80,-20% 50V Ceramic
C321,322	2531024003	0.01µF +80,-20% 50V Ceramic
C351	2590004006	22000µF Backup Capacitor
C401	2531024003	0.01µF +80,-20% 50V Ceramic
C402	2544235025	47µF 10V Electrolytic
C403~406	2531024003	0.01µF +80,-20% 50V Ceramic
C407	2544235038	100µF 10V Electrolytic
C408	2531024003	0.01µF +80,-20% 50V Ceramic
C409,410	2533618006	43pF ±5% 50V Ceramic
C411,412	2531024003	0.01µF +80,-20% 50V Ceramic
C413,414	2544243020	2.2µF 50V Electrolytic
C415	2544243004	0.47µF 50V Electrolytic
C416	2531024003	0.01µF +80,-20% 50V Ceramic
C417,418	2544241006	4.7µF 35V Electrolytic
C419	2531024003	0.01µF +80,-20% 50V Ceramic
C421	2531024003	0.01µF +80,-20% 50V Ceramic
C431	2544237049	100µF 16V Electrolytic
C432	2543016009	1µF 50V Electrolytic (By Pole)
C433	2531025002	0.022µF +80,-20% 50V Ceramic
C434	2549011008	1µF 50V Electrolytic (Low Leak)
C435	2531024003	0.01µF +80,-20% 50V Ceramic
C441	2531026001	0.047µF +80,-20% 50V Ceramic
C442	2533125007	15pF ±5% 50V Ceramic (Temp.)
C443	2554201049	390pF ±5% 50V Plastic Film
C444	2544243020	2.2µF 50V Electrolytic
C451	2531026001	0.047µF +80,-20% 50V Ceramic
C452	2533143005	82pF ±5% 50V Ceramic (Temp.)
C453	2554127000	180pF ±5% 50V Plastic Film
C454	2544243020	2.2µF 50V Electrolytic
C501	2531024003	0.01µF +80,-20% 50V Ceramic
C502~504	2539030028	2200pF ±10% 25V Ceramic
C601	2544243033	3.3µF ±20% 50V Electrolytic
C602	2544243033	0.47µF ±20% 50V Electrolytic
C603	2544237052	220µF ±20% 16V Electrolytic
TC001	2130022008	Trimmer Condenser 1
TC002	2130037006	Trimmer Condenser 1

Ref. No.	Part No.	Part Name & Descriptions
<b>COIL, TRANS</b>		
L201,202	2350032014	Inductor 39mH
T001	2312060008	FM IF Det. Trans •
T003	2313028007	AM IFT •
T004	2320106006	Anti Birdie Filter •
T011	2311122002	MW Ant. Trans •
T012	2311123001	MW OSC Coil •
T021	2311124000	LW Ant. Trans •
T022	2311125009	LW OSC Coil •
BT1	2310074009	Balun Trans •
CF001, 002	2610064007	FM Ceramic Filter (SFT10.7MS2)
CF003	2610031001	AM Ceramic Filter (BFU450C4)
CF004	2610079005	Ceramic Filter (CSB456F11) •
XL001	3990031005	X-tal (7.2MHz)
<b>SWITCHES</b>		
SW001	2129543006	1P Push Switch (Mode) •
SW002	2124630008	1P Push Switch (MPX) •
SW003	2124629006	1P Push Switch (Power) •
SW011 ~025	2124407008	Tact Switch
<b>E.U.P</b>		
PT001	2335565001	Power Trans •
FL001	3934030004	7BT16ZA (FLD) •
	2050350009	Antenna Terminal •
	2160039003	Front End •
	2048224008	2P Pin Jack •
<b>OTHER PARTS</b>		
	2221371105	(P.W. Board) •
	2090008146	Jumper Wire P=5mm •
	2090008120	Jumper Wire P=10mm •
	EP-5667H1	Terminal Pin •
	1460858008	LED Holder •
	1460857009	FLD Holder •
CN301	2034362000	3P Connector Cord •
CN701	2042197018	7P Connector Cord •
CN702, 703	2042197005	7P Connector Cord •
	2050190036	3P NH Connector Base •
	2050190078	7P NH Connector Base •

ETC0852 TUNER UNIT PARTS LIST for U.K (J220 or J240) means only difference of jumper for selecting power voltage between 220V and 240V.

• indicates the parts newly used in this unit.

ETC0861D TUNER UNIT PARTS LIST (for 2 Band)

Ref. No.	Part No.	Part Name & Descriptions
<b>SEMICONDUCTORS</b>		
IC001	2630438008	LA1266 (Sanyo) IC •
IC002	2630439007	LA3401 (Sanyo) IC •
IC003	2630232000	TD6104P (Toshiba) IC
IC004	2620452104	TC9147BP (Toshiba) IC
IC005	2620453006	TD6301AP (Toshiba) IC
IC006	2620300007	HD14011BP (Hitachi) IC
TR001	2730025023	2SC461(C) Transistor
TR002	2730322001	2SC2458(Y/GR) Transistor
TR006, 007	2730322001	2SC2458(Y/GR) Transistor
TR008	2750053004	2SK365(BL/GR) FET
TR009, 010	2730322001	2SC2458(Y/GR) Transistor
TR011	2710194000	2SA1048(Y/GR) Transistor
TR012	2730322001	2SC2458(Y/GR) Transistor
TR014	2730198015	2SC1815(BL) Transistor
TR015	2730322001	2SC2458(Y/GR) Transistor
TR016	2750053004	2SK365(BL/GR) FET
TR017	2740065002	2SD880(Y) Transistor
TR018	2730322001	2SC2458(Y/GR) Transistor
TR019	2730198015	2SC1815(BL) Transistor
TR020	2710194000	2SA1048(Y/GR) Transistor
TR021, 022	2750053004	2SK365(BL/GR) FET
TR023	2730322001	2SC2458(Y/GR) Transistor
TR024, 025	2710194000	2SA1048(Y/GR) Transistor
TR026	2730322001	2SC2458(Y/GR) Transistor
TR027	2710194000	2SA1048(Y/GR) Transistor
TR028	2730322001	2SC2458(Y/GR) Transistor
TR051	2710194000	2SA1048(Y/GR) Transistor
TR052	2710194000	2SA1048(Y/GR) Transistor
D001	2760049008	1S2076 Diode
D002	2760185014	HZ4B-3 Zener
D003~006	2760049008	1S2076 Diode
D007	2760051054	HZ7A-1 Zener
D008	2760255038	HZ12C-2 Zener
D009	2760446009	PB103M Diode
D010	2760049008	1S2076 Diode
D011,012	2760302004	SVC321SP-D2 Varactor
D051	2760049008	1S2076 Diode
LE011	3939173005	LT9213R (Red) LED
LE012	3939356000	LT9233 (Green) LED
LE031	3939356000	LT9233 (Green) LED
LE032	3939173005	LT9213R (Red) LED
LE040, ~039	3939356000	LT9233 (Green) LED
LE041	3939356000	LT9233 (Green) LED
<b>RESISTORS (not included Carbon Film ±5%, 1/4W Type)</b>		
R304	2410193000	2.2k ohm ±5% 1/2W Carbon Film
R315	2440033020	220 ohm ±5% 1W Metal Oxide (NBF)
<b>CAPACITORS</b>		
C001	2538014003	0.01µF ±20% 400V(A.C.) Ceramic
C101	2531024003	0.01µF +80,-20% 50V Ceramic
C102~104	2531026001	0.047µF +80,-20% 50V Ceramic
C105	2531024003	0.01µF +80,-20% 50V Ceramic
C106,107	2544237036	47µF 16V Electrolytic
C108	2544237007	10µF 16V Electrolytic
C111	2544237036	47µF 16V Electrolytic
C112	2544243017	1µF 50V Electrolytic
C113	2544241006	4.7µF 35V Electrolytic
C114	2544237007	10µF 16V Electrolytic
C115	2544243033	3.3µF 50V Electrolytic
C117	2531026001	0.047µF +80,-20% 50V Ceramic

Ref. No.	Part No.	Part Name & Descriptions
C118	2533627000	100pF ±5% 50V Ceramic
C119	2531024003	0.01µF +80,-20% 50V Ceramic
C120	2531026001	0.047µF +80,-20% 50V Ceramic
C201	2544237001	10µF 16V Electrolytic
C202	2544237049	100µF 16V Electrolytic
C203	2544243017	1µF 50V Electrolytic
C204	2544243004	0.47µF 50V Electrolytic
C205,206	2544243017	1µF 50V Electrolytic
C207	2531026001	0.047µF +80,-20% 50V Ceramic
C208	2533639001	330pF ±5% 50V Ceramic
C209	2544237007	10µF 16V Electrolytic
C210,211	2534350004	680pF ±5% 50V Ceramic
C212	2544243033	3.3µF 50V Electrolytic
C213	2531024003	0.01µF +80,-20% 50V Ceramic
C214,215	2544243033	3.3µF 50V Electrolytic
C216,217	2539031069	2700pF ±10% 25V Ceramic
C218,219	2539035036	0.039µF ±10% 25V Ceramic
C220,221	2539031056	1800pF ±10% 25V Ceramic
C301	2544243004	0.47µF 50V Electrolytic
C302,303	2533635005	220pF ±5% 50V Ceramic
C311	2544239092	1000µF 25V Electrolytic
C312	2544237007	10µF 16V Electrolytic
C313	2544237049	100µF 16V Electrolytic
C314	2544237007	10µF 16V Electrolytic
C317	2531024003	0.01µF +80,-20% 50V Ceramic
C321,322	2531024003	0.01µF +80,-20% 50V Ceramic
C351	2590004006	22000µF Backup Capacitor
C401	2531024003	0.01µF +80,-20% 50V Ceramic
C402	2544235025	47µF 10V Electrolytic
C403~406	2531024003	0.01µF +80,-20% 50V Ceramic
C407	2544235038	100µF 10V Electrolytic
C408	2531024003	0.01µF +80,-20% 50V Ceramic
C409,410	2533618006	43pF ±5% 50V Ceramic
C411,412	2531024003	0.01µF +80,-20% 50V Ceramic
C413,414	2544243020	2.2µF 50V Electrolytic
C415	2544243004	0.47µF 50V Electrolytic
C416	2531024003	0.01µF +80,-20% 50V Ceramic
C417,418	2544241006	4.7µF 35V Electrolytic
C419	2531024003	0.01µF +80,-20% 50V Ceramic
C421	2531024003	0.01µF +80,-20% 50V Ceramic
C431	2544237049	100µF 16V Electrolytic
C432	2543016009	1µF 50V Electrolytic (By Pole)
C433	2531025002	0.022µF +80,-20% 50V Ceramic
C434	2549011008	1µF 50V Electrolytic (Low Leak)
C435	2531024003	0.01µF +80,-20% 50V Ceramic
C441	2531026001	0.047µF +80,-20% 50V Ceramic
C442	2533125007	15pF ±5% Ceramic (Temp.)
C443	2554201049	390pF ±5% 50V Plastic Film
C501	2531024003	0.01µF +80,-20% 50V Ceramic
C502~504	2539030028	2200pF ±10% 25V Ceramic
C601	2544243033	3.3µF ±20% 50V Electrolytic
C602	2544243004	0.47µF ±20% 50V Electrolytic
C603	2544237052	220µF ±20% 16V Electrolytic
TC001	2130022008	Trimmer Condenser 1
<b>COIL, TRANS</b>		
L201,202	2350032014	Inductor 39mH
T001	2312060008	FM IF Det. Trans
T003	2313028007	AM IFT
T004	2320106006	Anti Birdie Filter
T011	2311122002	MW Ant. Trans
T012	2311123001	MW OSC Coil
BT1	2310074009	Balun Trans

Ref. No.	Part No.	Part Name & Descriptions
CF001, 002	2610064007	FM Ceramic Filter (SFT10.7MS2) 2
CF003	2610031001	AM Ceramic Filter (BFU450C4) 1
CF004	2610079005	Ceramic Filter (CSB456F11) 1
XL001	3990031005	X-tal (7.2MHz) 1
<b>SWITCHES</b>		
SW001	2129543006	1P Push Switch (Mode) 1
SW002	2124630008	1P Push Switch (MPX) 1
SW003	2124629006	1P Push Switch (Power) 1
SW011, 012	2124407008	Tact Switch 2
SW014 ~025	2124407008	Tact Switch 12
<b>E.U.P</b>		
PT001	2335565001	Power Trans 1
FL001	3934030004	7BT16ZA (FLD) 1
	2050350009	Antenna Terminal 1
	2160039003	Front End 1
	2048224008	2P Pin Jack 1
<b>OTHER PARTS</b>		
	2221396009	(P.W. Board) 1
	2090008146	Jumper Wire P=5mm 3
	2090008120	Jumper Wire P=10mm 66
	BP-5667H1	Terminal Pin 8
	1460858008	LED Holder 1
	1460857009	FLD Holder 1
CN301	2034362000	3P Connector Cord 1
CN702, 703	2042197005	7P Connector Cord 2
	2050190036	3P NH Connector Base 1
CN701	2050190078	7P NH Connector Base 3
	2042197018	7P Connector Cord 1

ETC0861 TUNER UNIT PARTS LIST for GERMANY (Same as ETC0861D TUNER UNIT P/LIST except the followings.)

Ref. No.	Part No.	Part Name & Descriptions
<b>RESISTOR</b>		
R108	2412120000	15k ohm ±5% 1/4W Carbon Film (Change)
<b>CAPACITORS</b>		
C302,303	2533635005	220pF ±5% 50V Carbon (Delete)
<b>COILS</b>		
L601	2350016014	18µH Inductor (Add.)

• indicates the parts newly used in this unit.

WIRING DIAGRAM

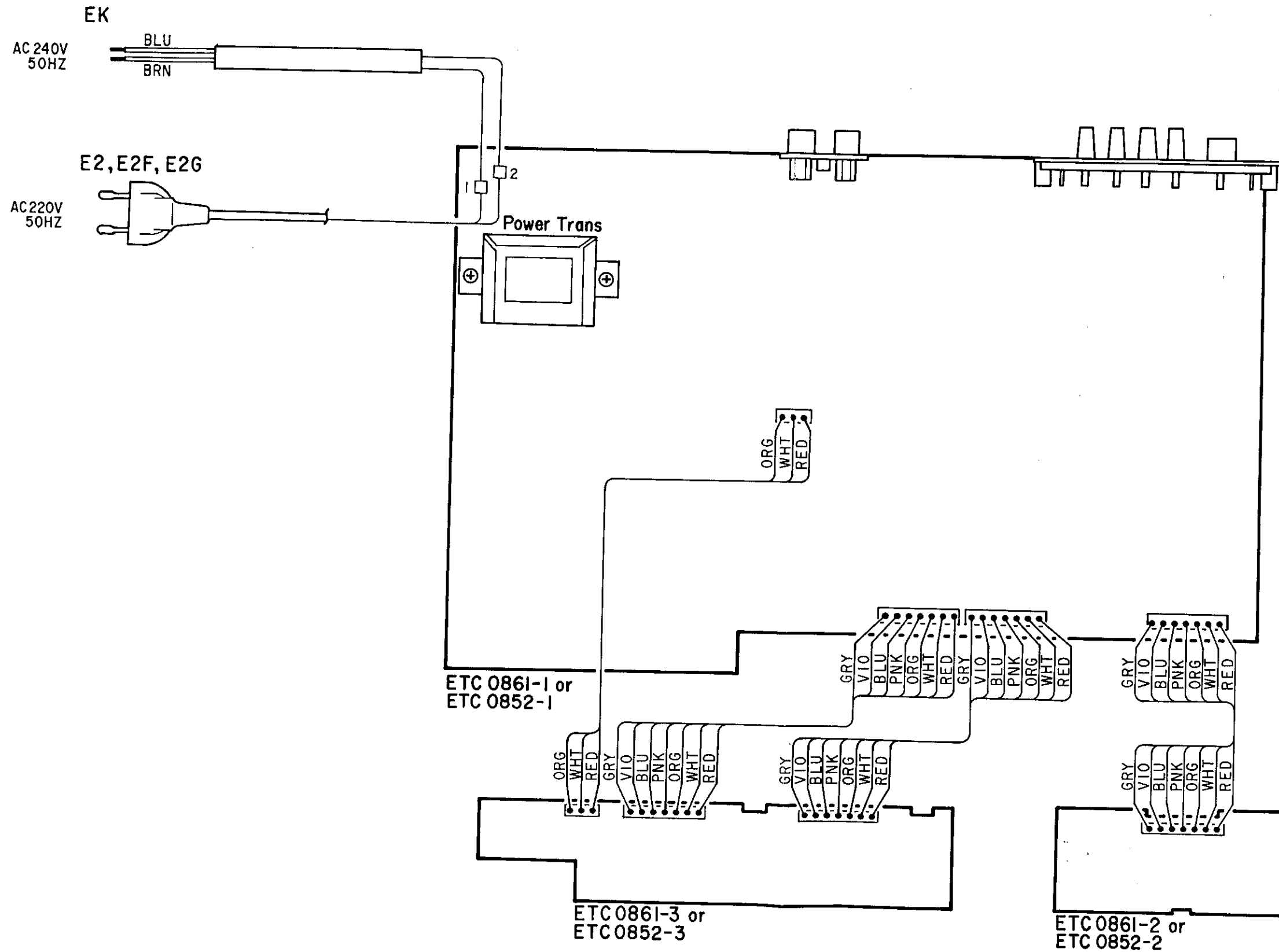

	Model Name	Unit No.
2 Band	Black for European	ETC0861D
2 Band	Black for Germany	ETC0861
2 Band	Gold for Germany	ETC0861
3 Band	Black for European	ETC0852B
3 Band	Black for U.K.	ETC0852
3 Band	Black for France	ETC0852

CAUTION - With the power switch in "Stand by" mode, mains is still connected.  
 WICHTIGER HINWEIS - Auch bei auf "Betriebsbereitschaft" gestelltem Netzschalter wird das Gerät noch mit Strom versorgt.  
 PRECAUTION - L'interrupteur d'alimentation sur "stand by" (attente), l'alimentation n'est pas coupée.  
 OBS! - Nätströmtillförseln kopplas inte ur när strömbrytaren står i beredskapsläget (Stand by).

for 3 Band

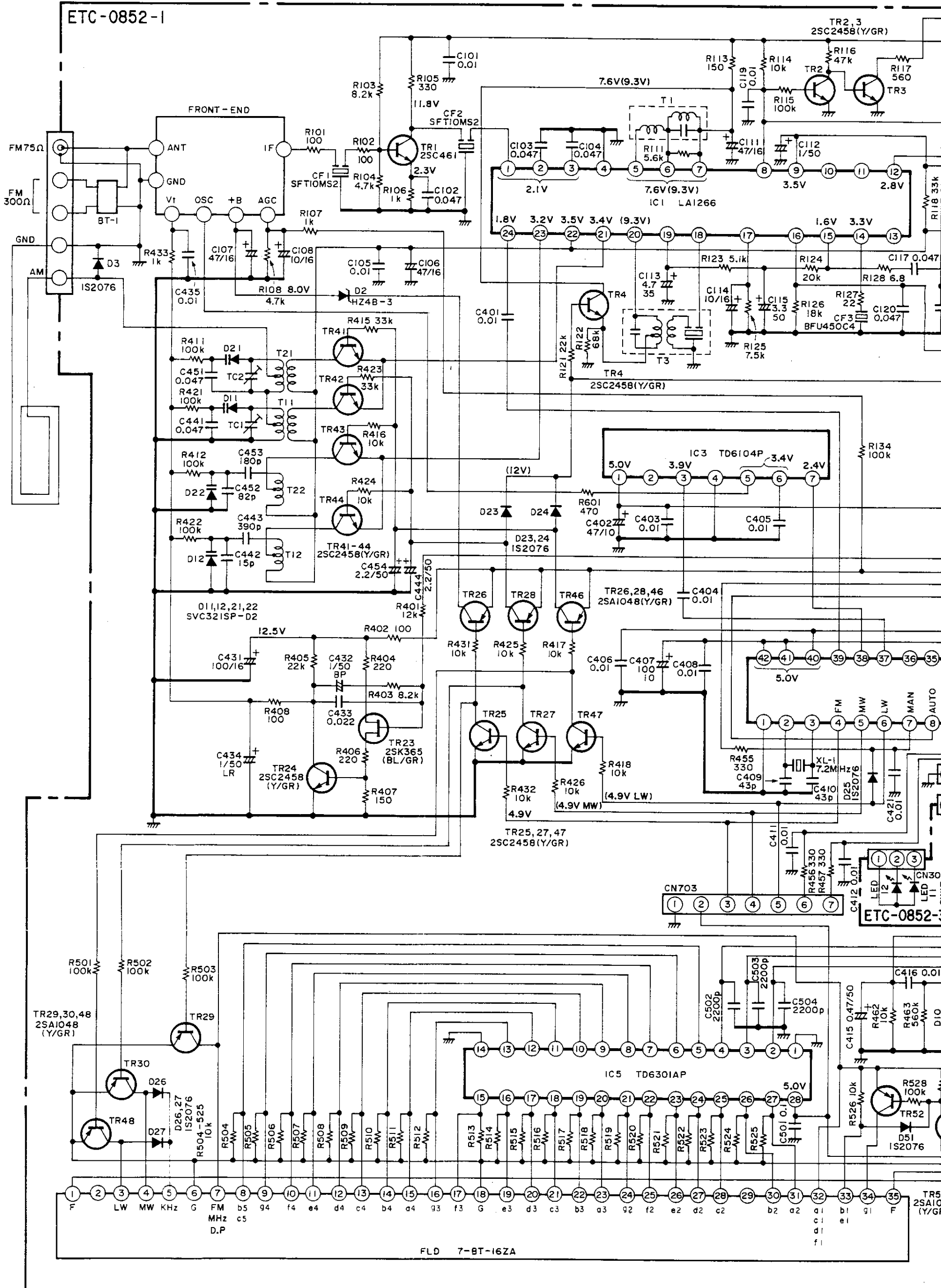

M when necessary by the manufacturer

for 3 Band

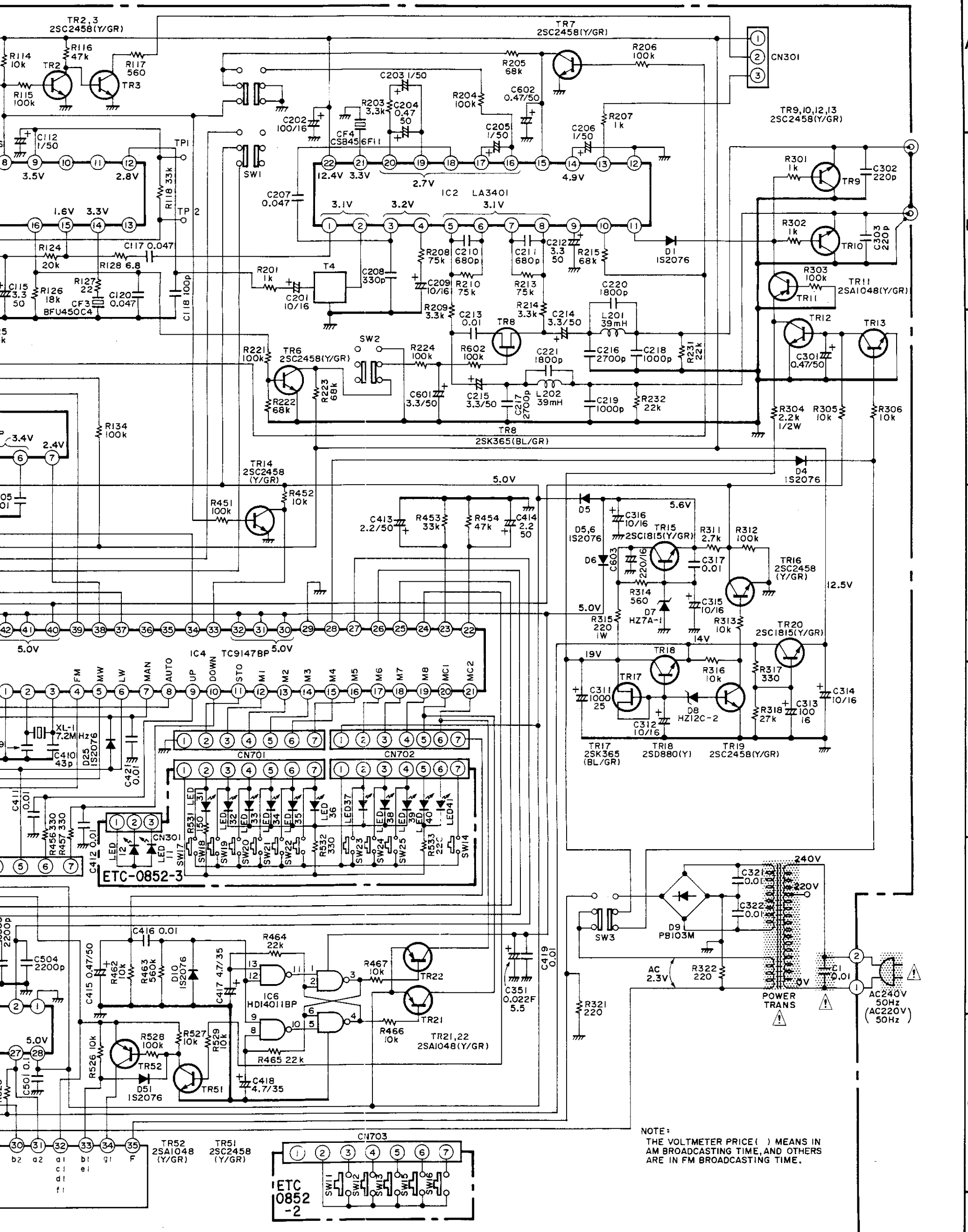

⚠ Means important safety item, which must be replaced, when necessary, by a part specified or meeting the specification by the manufacturer.

NOTES:  
 ALL RESISTANCE VALUES IN OHM, K = 1,000 OHM, M = 1,000,000 OHM.  
 ALL CAPACITANCE VALUES IN MICROFARAD, P = MICRO-MICRO FARAD.  
 EVERY VOLTAGES AND CURRENTS IS MEASURED AT NO SIGNAL INPUT CONDITION.  
 CIRCUIT AND PARTS ARE SUBJECT TO CHANGE WITHOUT PRIOR NOTICE.



EXPLODED VIEW OF CHASSIS AND CABINET

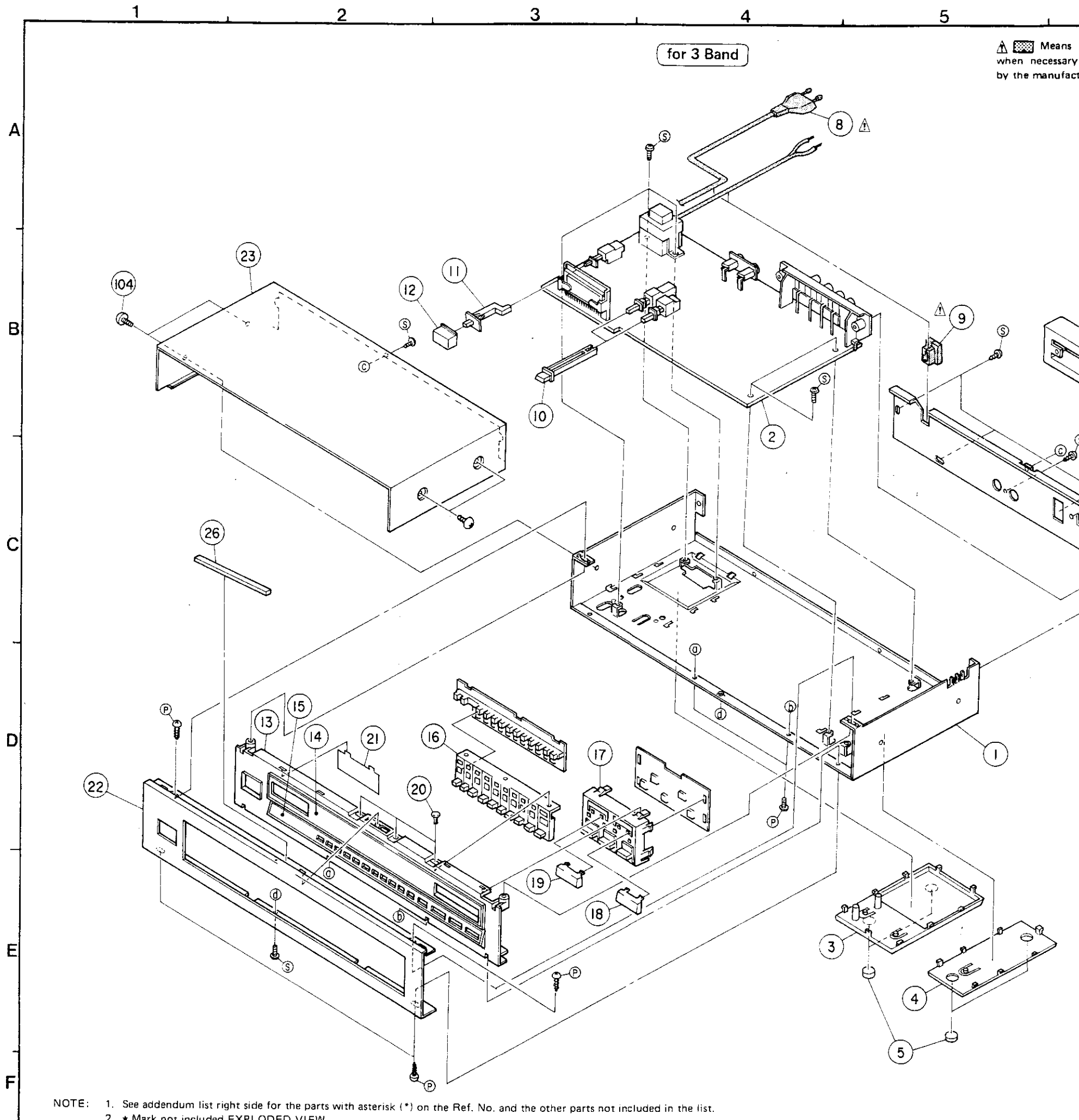

NOTE: 1. See addendum list right side for the parts with asterisk (\*) on the Ref. No. and the other parts not included in the list.  
 2. \* Mark not included EXPLODED VIEW.  
 3. The list is prepared based on E2 for Black Version.  
 4. • indicates the parts newly used in this unit.

EXPLODED VIEW OF CHASSIS AND CABINET

Ref. No.	Part No.	Part Name & Descriptions	Q'ty
1	4110595016	CHASSIS	1
*2	ETC0852B	TUNER UNIT	1s
3	1030948005	BOTTOM COVER (A)	1
4	1030949004	BOTTOM COVER (B)	1
5	4610162004	FELT PAD	4
*6	1050715001	BACK PANEL	1
7	1460859007	ANT. HOLDER	1
Δ *8	2062047009	AC CORD	1
Δ *9	4450056008	CORD BUSH	1
**10	1130866003	PUSH KNOB (C)	2
11	1190057001	KNOB JOINT	1
**12	1130854002	PUSH KNOB (P) (POWER)	1
**13	1460851005	INNER PANEL	1
**14	1430491000	WINDOW PLATE	1
*15	1430492009	ESC PLATE	1
**16	1130860009	PUSH KNOB (A)	1
**17	1130861008	PUSH KNOB (B) (TUNING)	1
**18	1130862007	KNOB CAP (D) (TUNING)	1
**19	1130862010	KNOB CAP (D) (TUNING)	1
20	4770096007	PUSH RIVET	3
21	1430493008	FILTER	1
**22	1441541004	FRONT PANEL	1
23	1020262005	TOP COVER	1
24	5138253009	APPROVAL MARK	1
*25	4450033005	WIRE CLAMP BAND	1
26			
27			

Ref. No.	Part No.	Part Name & Descriptions	Q'ty
<b>SCREWS</b>			
101	4737002021	TAPPING SCREW (S) 3x8 BLACK	12
102	4737508017	TAPPING SCREW (P) 3x10	8
103			
104	4734454038	TRUSS TAPPING SCREW (2) 4x8	4
105			
106			
<b>PACKING &amp; ACCESSORIES (not included EXPLODED VIEW)</b>			
201	5050133003	CABINET COVER	1
202	5030576004	CUSHION	• 2
*203	5011141005	CARTON CASE	• 1
204			
205	PC-3244	ENVELOPE	1
206	2311126008	LOOP ANTENNA	• 1
207	2032101001	2P CONNECTOR CORD	• 1
208	5111476007	INST. MANUAL	• 1
*209	5139111014	COLOR LABEL (BLACK)	• 2
210	5131167008	CONTROL CARD	• 1
211			
212			

⚠  Means important safety item, which must be replaced, when necessary, by a part specified or meeting the specification by the manufacturer.

## ADDENDUM LIST

Ref. No.	Part Name & Descriptions	Part No.			
		EK for U.K.	E2F for France		
2	TUNER UNIT	ETC0852	ETC0852		
6	BACK PANEL	1050693000	1050702001		
8	AC CORD	2062051008	2062047009		
9	CORD BUSH	4450056008	4450056008		
15	ESC. PLATE	1430492009	1430492009		
104	TAPPING SCREW (4x8)	4734454038	4734454038		
203	CARTON CASE	5011141005	5011141018		
209	COLOR LABEL	5139111014	5139111014		

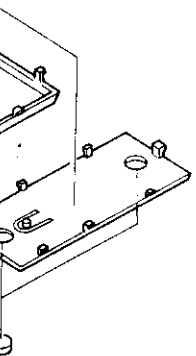
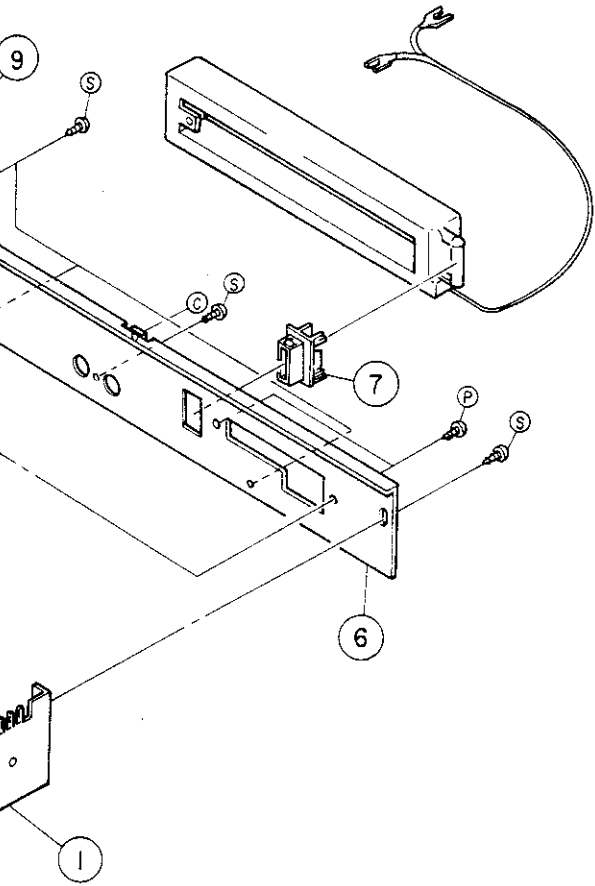

For United Kingdom model only.

**WARNING:**

As the colours of the wires in the mains lead of this appliance may not correspond with the coloured markings identifying the terminals in your plug proceed as follows.

The wire which is coloured blue must be connected to the terminal which is marked with the letter N or coloured black.  
The wire which is coloured brown must be connected to the terminal which is marked with the letter L or coloured red.

The wire which is coloured BROWN must be connected to the terminal which is marked with the letter L or coloured RED.

**IMPORTANT**

The wires in this mains lead are coloured in accordance with the following code:

Blue Neutral  
Brown Live

SCHEMATIC DIAGRAM

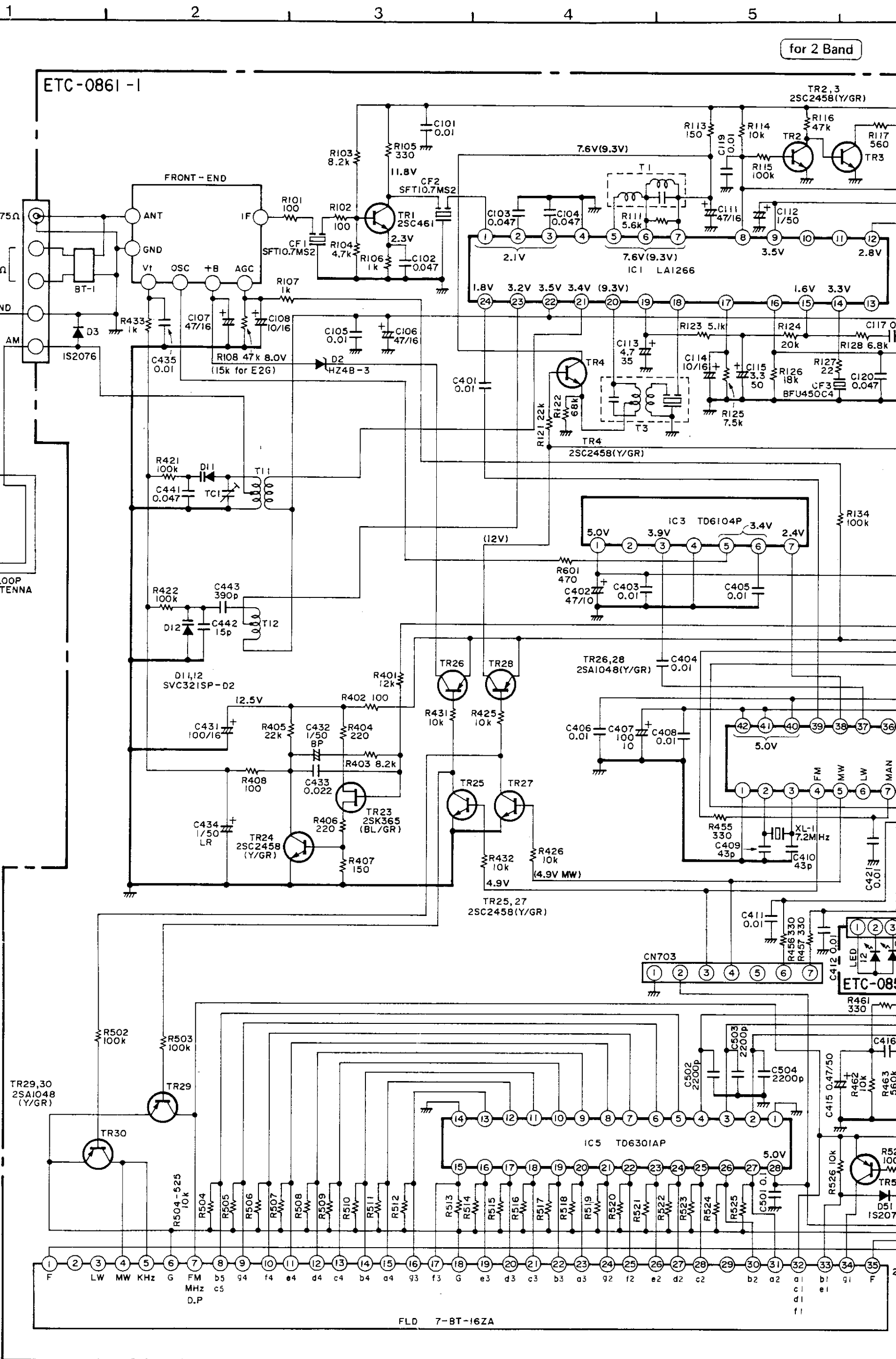

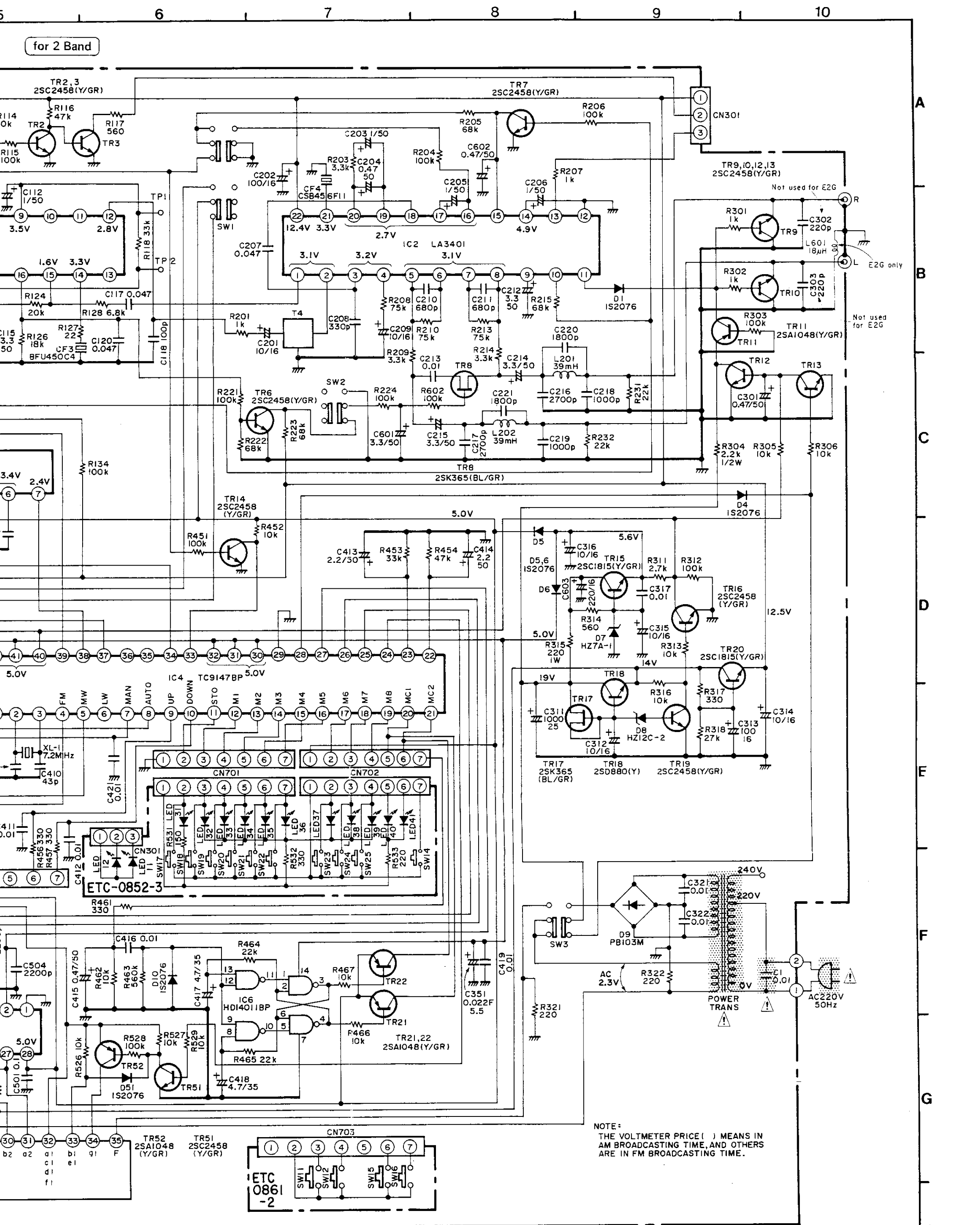

for 2 Band

NOTE:  
 THE VOLTMETER PRICE ( ) MEANS IN  
 AM BROADCASTING TIME, AND OTHERS  
 ARE IN FM BROADCASTING TIME.

⚠ Means important safety item, which must be replaced, when necessary, by a part specified or meeting the specification by the manufacturer.

NOTES:  
 ALL RESISTANCE VALUES IN OHM, K = 1,000 OHM, M = 1,000,000 OHM.  
 ALL CAPACITANCE VALUES IN MICROFARAD, P = MICRO-MICRO FARAD.  
 EVERY VOLTAGE AND CURRENT IS MICRO AT NO SIGNAL INPUT CONDITION.  
 CIRCUIT AND PARTS ARE SUBJECT TO CHANGE WITHOUT PRIOR NOTICE.

EXPLODED VIEW OF CHASSIS AND CABINET

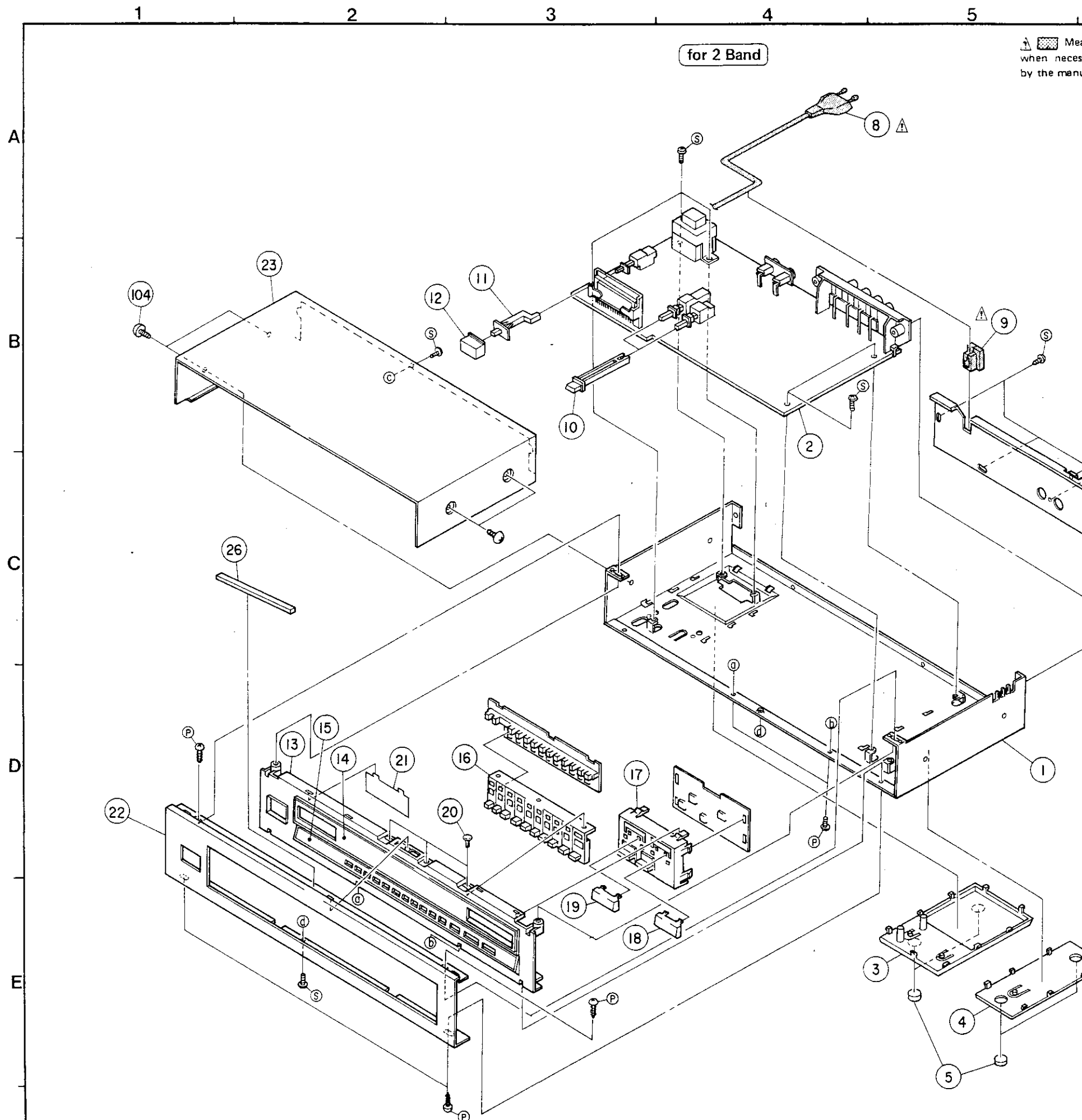

NOTE: 1. See addendum list right side for the parts with asterisk (\*) on the Ref. No. and the other parts not included in the list.  
 2. \* Mark not included EXPLODED VIEW.  
 3. The list is prepared based on E2 for Black Version.  
 4. ● indicates the parts newly used in this unit.

EXPLODED VIEW OF CHASSIS AND CABINET PARTS LIST

Ref. No.	Part No.	Part Name & Descriptions	Q'ty
1	4110595016	CHASSIS	1
*2	ETC0861D	TUNER UNIT	1s
3	1030948005	BOTTOM COVER (A)	1
4	1030949004	BOTTOM COVER (B)	1
5	4610162004	FELT PAD	4
*6	1050693000	BACK PANEL	1
7	1460859007	ANT. HOLDER	1
Δ *8	2062047009	AC CORD	1
Δ *9	4450056008	CORD BUSH	1
**10	1130866003	PUSH KNOB (C)	2
11	1190057001	KNOB JOINT	1
**12	1130854002	PUSH KNOB (P) (POWER)	1
**13	1460851005	INNER PANEL	● 1
**14	1430491000	WINDOW PLATE	1
*15	1430492012	ESC PLATE	1
**16	1130860009	PUSH KNOB (A)	1
**17	1130861008	PUSH KNOB (B) (TUNING)	1
**18	1130862007	KNOB CAP (D) (TUNING)	1
**19	1130862010	KNOB CAP (D) (TUNING)	1
20	4770096007	PUSH RIVET	3
21	1430493008	FILTER	1
**22	1441541017	FRONT PANEL	● 1
23	1020262005	TOP COVER	1
24	5138253009	APPROVAL MARK	1
*25	4450033005	WIRE CLAMP BAND	1
26	4610319006	SPACER	1
27			
28			

Ref. No.	Part No.	Part Name & Descriptions	Q'ty
<b>SCREWS</b>			
101	4737002021	TAPPING SCREW (S) 3x8 BLACK	12
102	4737508017	TAPPING SCREW (P) 3x10 BLACK	8
103	-	-	-
*104	4734454038	TRUSS TAPPING SCREW (2) 4x8	4
105			
106			
<b>PACKING &amp; ACCESSORIES (not included EXPLODED VIEW)</b>			
201	5050133003	CABINET COVER	1
202	5030576004	CUSHION	2
*203	5011141034	CARTON CASE	● 1
204	-	-	-
205	PC-3244	ENVELOPE	1
206	2311126008	LOOP ANTENNA	● 1
207	2032101001	2P CONNECTOR CORD	1
208	5111476007	INST. MANUAL	● 1
*209	5139111014	COLOR LABEL (BLACK)	2
210	5131167008	CONTROL CARD	1
211			
212			

E2 Gold Version PARTS LIST (Same as E2 BLACK VERSION except the followings.)

Ref. No.	Part No.	Part Name & Descriptions
12	1130854015	PUSH KNOB (C)
22	1441541020	FRONT PANEL
23	1020262018	TOP COVER
104	4734801005	TRUSS TAPPING SCREW (2) 4x8
203	5011141063	CARTON CASE
209	5139111001	COLOR LABEL (BLACK)

⚠ Means important safety item, which must be replaced, when necessary, by a part specified or meeting the specification by the manufacturer.

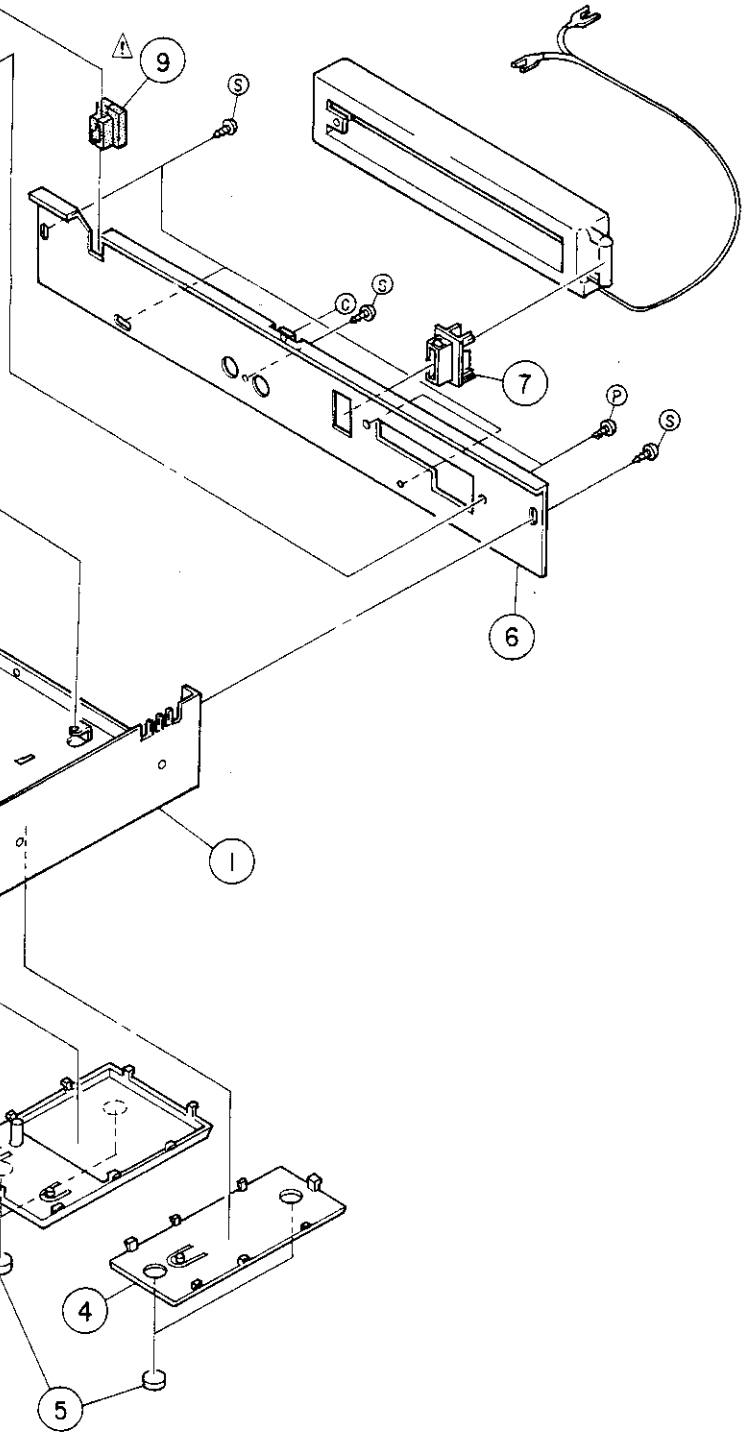

ADDENDUM LIST

Ref. No.	Part Name & Descriptions	Part No.			
		E2G for Germany			
2	TUNER UNIT	ETC0861			
6	BACK PANEL	1050703000			
⚠ 8	AC CORD	2062047009			
⚠ 9	CORD BUSH	4450056008			
15	ESC. PLATE	1430492012			
104	TAPPING SCREW (4x8)	4734454038			
203	CARTON CASE	5011141021			
209	COLOR LABEL	5139111014			

Old Version PARTS LIST  
as E2 BLACK VERSION (Left P/List)  
(the followings.)

Part No.	Part Name & Descriptions	Q'ty
1130854015	PUSH KNOB (P)	1
1441541020	FRONT PANEL	1
1020262018	TOP COVER	1
4734801005	TRUSS TAPPING SCREW 4x8	4
5011141063	CARTON CASE	1
5139111001	COLOR LABEL (GOLD)	2