

# DENON

Hi-Fi AM-FM Stereo Tuner

## SERVICE MANUAL

# MODEL TU-235RD

# MODEL TU-260LII

### AM-FM STEREO TUNER

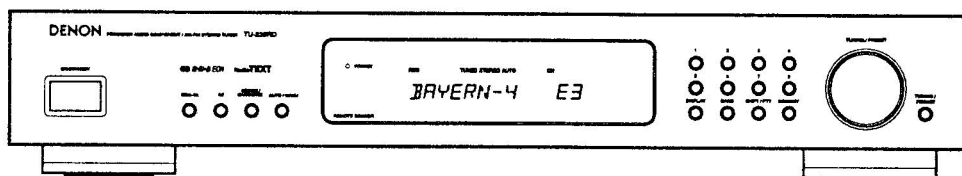

The illustration shows the TU-235RD.

#### — TABLE OF CONTENTS —

SAFETY PRECAUTIONS .....	2
SPECIFICATIONS .....	2
DISASSEMBLY .....	3,4
BLOCK DIAGRAM .....	5
ADJUSTMENT .....	6,7
SEMICONDUCTORS .....	8~13
PRINTED WIRING BOARD .....	14
NOTE FOR PARTS LIST .....	15
PARTS LIST OF P.W.B. UNIT .....	16,17
EXPLODED VIEW .....	18
PARTS LIST OF EXPLODED VIEW .....	19
SCHEMATIC DIAGRAM .....	21

● Some illustrations using in this service manual are slightly different from the actual set.

## NIPPON COLUMBIA CO., LTD.

## SAFETY PRECAUTIONS

The following check should be performed for the continued protection of the customer and service technician.

### LEAKAGE CURRENT CHECK

Before returning the unit to the customer, make sure you make either (1) a leakage current check or (2) a line to chassis resistance check. If the leakage current exceeds 0.5 milliamps, or if the resistance from chassis to either side of the power cord is less than 460 kohms, the unit is defective.

## SPECIFICATIONS

### ● FM SECTION

Frequency Range	87.5 MHz – 108.0 MHz
Antenna Terminals	75 Ω / ohms Unbalanced
Usable Sensitivity	0.9 μV (10.3 dBf) 1.2 μV (IHF)
S/N 50 dB Sensitivity	
Monaural	1.6 μV (15.3 dBf)
stereo	20 μV (37.2 dBf)
(μV is at 75 Ω / ohms 0 dBf = 10 <sup>-15</sup> W)	
Image Interference Ratio	80 dB
IF Interference Ratio	100 dB
AM Suppression Ratio	50 dB
Effective Selectivity	70 dB (± 400 kHz)
Capture Ratio	1.5 dB
Frequency Characteristics	20 Hz – 15 kHz <sup>+0.5</sup> <sub>-1.0</sub> dB
Signal-to-noise Ratio	
Monaural	82 dB (IHF) 78 dB (DIN)
stereo	76 dB (IHF) 72 dB (DIN)
Total Harmonic Distortion	
Mono 1 kHz (at 75 kHz dev.)	0.5 %
Stereo 1 kHz (at 67.5 kHz dev.)	0.8 %
Stereo Separation 1 kHz	40 dB

### ● AM SECTION (MW and LW)

MEDIUM WAVE	
Frequency Range	522 kHz - 1611 kHz
Antenna Terminals	Terminal Type with Loop Ant.
Usable Sensitivity	18 μV
Signal-to-noise Ratio	53 dB
LONG WAVE	
Frequency Range	153 kHz - 279 kHz
Usable Sensitivity	30 μV
Signal-to-noise Ratio	50 dB

### ● OTHERS

Power Supply	AC230 V 50Hz
Power Consumption	9 W
Dimensions (W) x (H) x (D)	434 x 75 x 239 mm
Net weight	2.5 kg

## DISASSEMBLY

(Follow the procedure below in reverse order when reassembling)

### Top Cover

1. Remove 6 screws ① fixing the Top Cover.  
(4 on both sides, 2 on the rear)
2. Detach the Top Cover, moving backwards a little and lifting it as shown in the arrow direction.

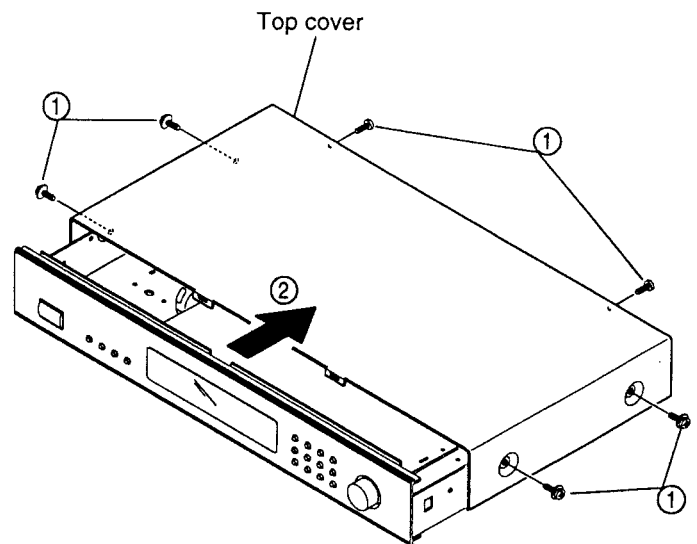

### Tuner P.W.B.

1. Remove 3 screws ③ fixing the Tuner P.W.B.
2. Remove 3 screws ④ on the rear.
3. Disconnect 2 connectors ⑤.
4. Release the Tuner P.W.B. from P.W.B. holder ⑥.

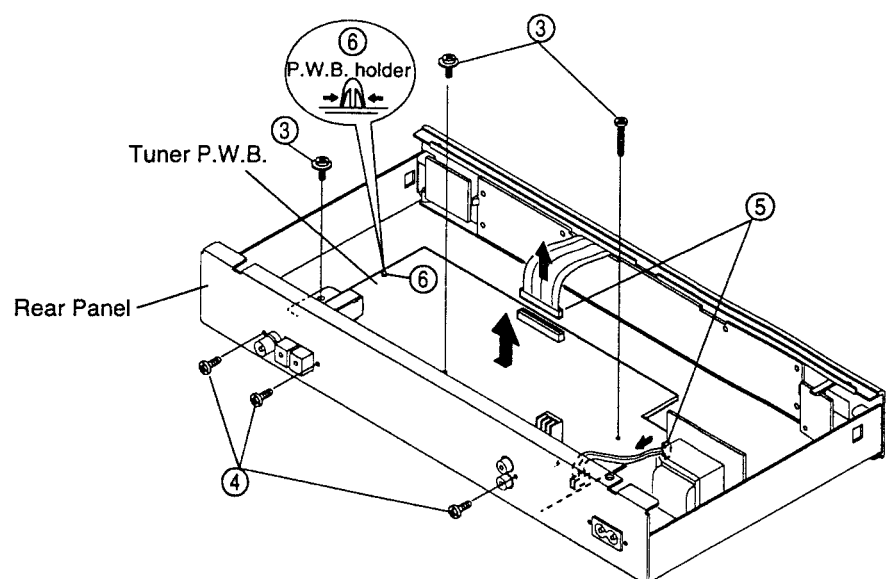

## Front Panel

1. Remove 7 screws ⑧ fixing the Front Panel.  
(2 on both sides, 5 on the bottom)

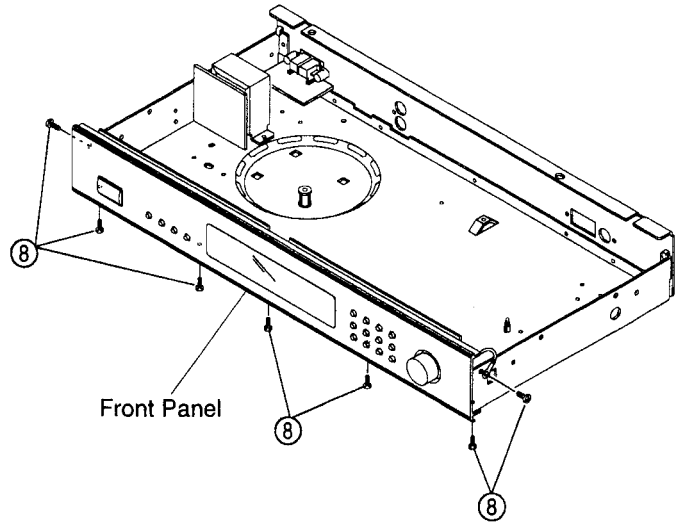

2. Remove 8 screws ⑨ fixing each P.W.B.
3. Detach the 1U-3139-2 P.W.B. from the Front Panel as shown in the arrow by releasing 2 hooks ⑩.
4. Detach the 1U-3139-3 and 1U-3139-4 P.W.B.s from the Front Panel as shown in the arrow, after pulling out tuning knob ⑪ and removing nut ⑫.

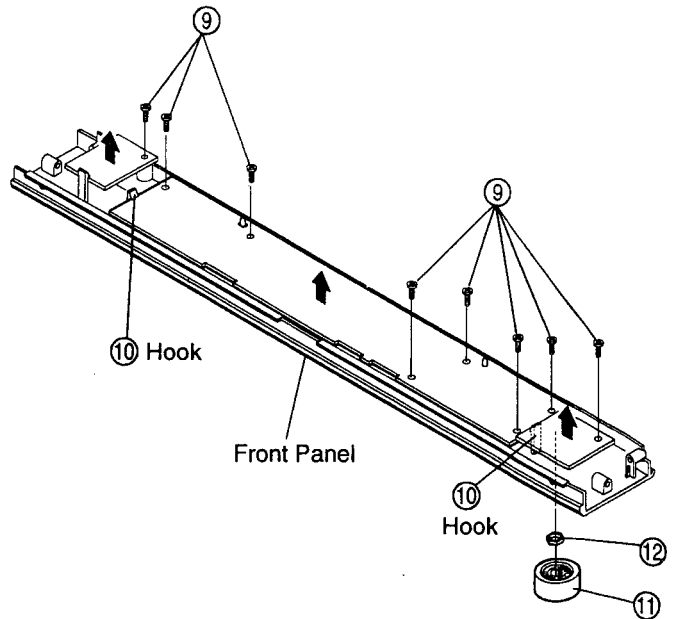

BLOCK DIAGRAM

4

3

2

1

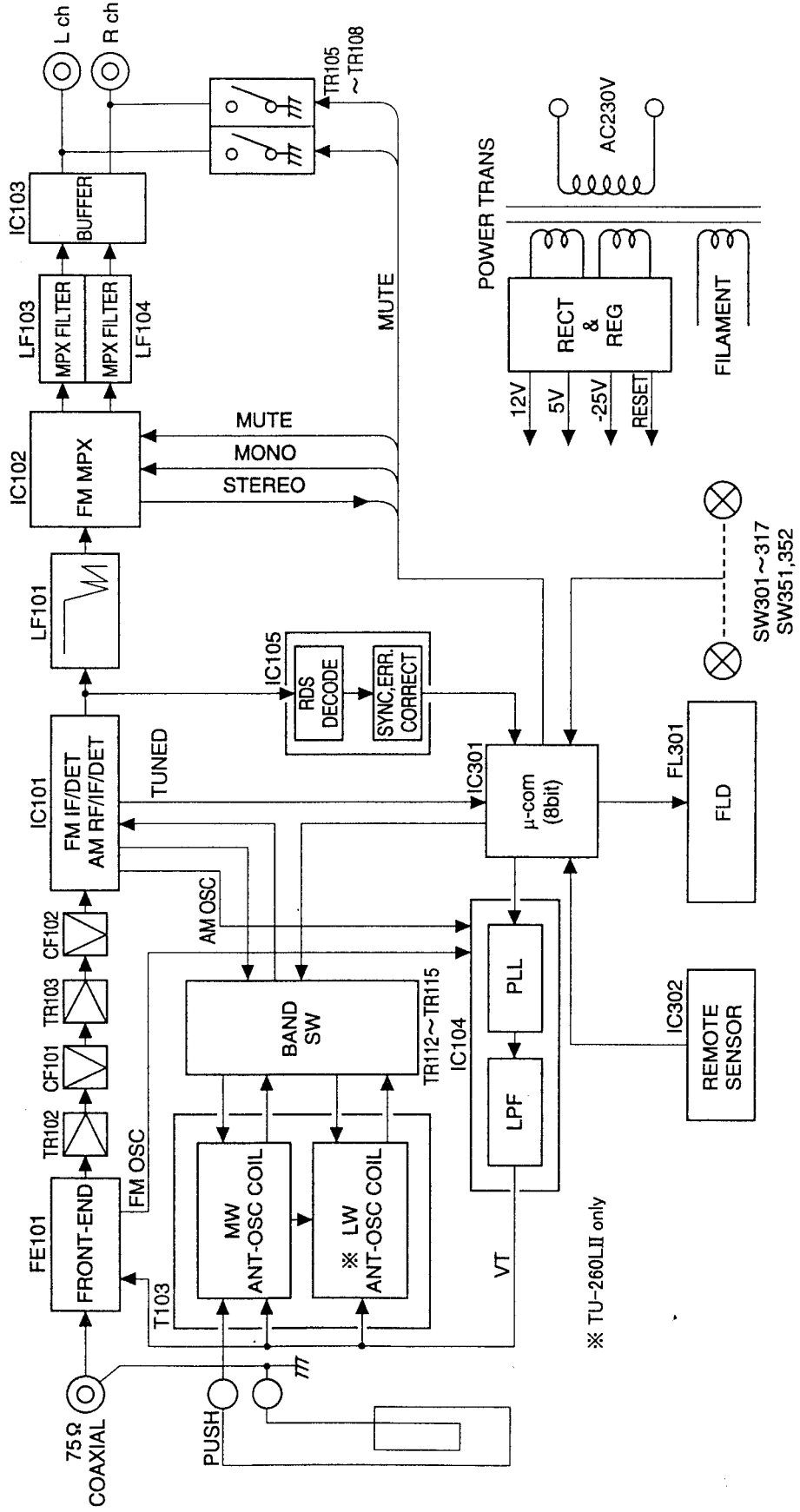

A

B

C

D

E

## METHOD OF ADJUSTMENT

### CONNECTION DIAGRAM OF MEASURING INSTRUMENTS

When making adjustments, be sure the power supply is at the rated voltage and the room air is on normal conditions with respect to temperature and humidity.

● FM

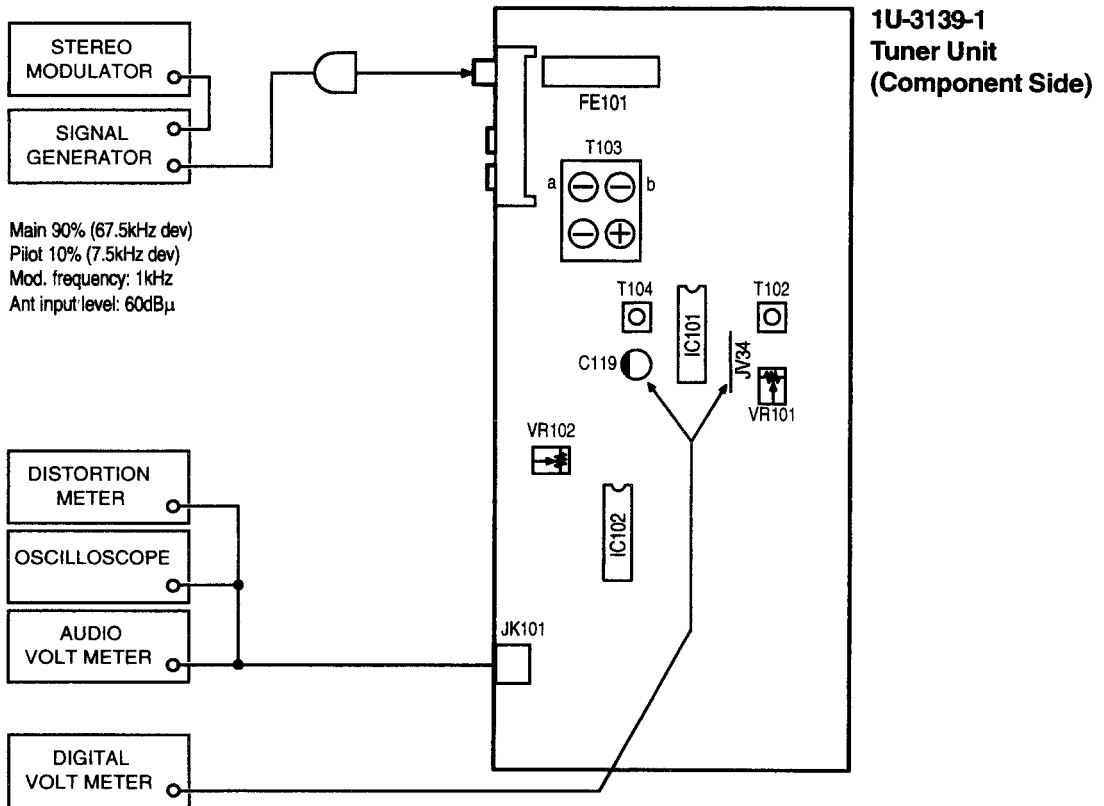

### 1U-3139-1 TUNER UNIT FM Alignment Points (Component Side)

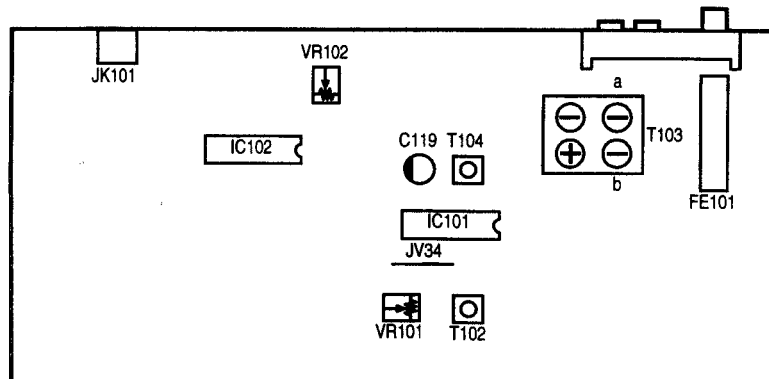

↓  
Front Panel Side

### FM ALIGNMENT

Item	Alignment Item	Tuning Frequency Setting	Input					Output		Adjustment		Remarks
			Type	Frequency	Input Level	Modulation	Coupling	Type	Connect to	Points	Adjust to	
1	Center Adjustment	98 MHz	FMSSG	98 MHz	60 dBμ	Mono 1 kHz 100%	Antenna Terminal	Digital Voltmeter	C119 PLUS And JV34	T104	±10 mV	
2	Separation	98 MHz	FMSSG	98 MHz	60 dBμ	Stereo (L) 1 kHz 100%	Antenna Terminal	AC Voltmeter	Output Terminal (R)	VR102	Maximum Separation	
3	Signal Level	98 MHz	FMSSG	98 MHz	20 dBμ	off	Antenna Terminal			VR101	Light TUNED on FL Display	

### AM ALIGNMENT

Item	Alignment Item	Tuning Frequency Setting	Input					Output		Adjustment		Remarks
			Type	Frequency	Input Level	Modulation	Coupling	Type	Connect to	Points	Adjust to	
1	IF Adjustment	603 kHz	AM SSG	603 kHz	*	400 Hz 30%	AM Loop Antenna	AC Voltmeter	Output Terminal (L)	T102	Maximum Output	
2	RF Adjustment	1404 kHz	AM SSG	1404 kHz	*	400 Hz 30%	AM Loop Antenna	AC Voltmeter	Output Terminal (L)	T103-a	Maximum Output	
3	RF Adjustment	270 kHz	AM SSG	270 kHz	*	400 Hz 30%	AM Loop Antenna	AC Voltmeter	Output Terminal (L)	T103-b	Maximum Output	TU-260LI Only

\* The level at AGC is not activated.

### Initializing (Memory clearing) Method

To clear memory contents of microcomputer and restore to the state of shipment at the factory, take the following step.

- While pressing the Keys 1 and 7 of the front panel, insert power cord into the AC outlet.

### FRONT END Parts No.: 216 9013 004

No.	Name	No.	Name
1	ANT	5	Vt
2	GND	6	+B
3	GND	7	IF OUT
4	GND	8	OSC OUT

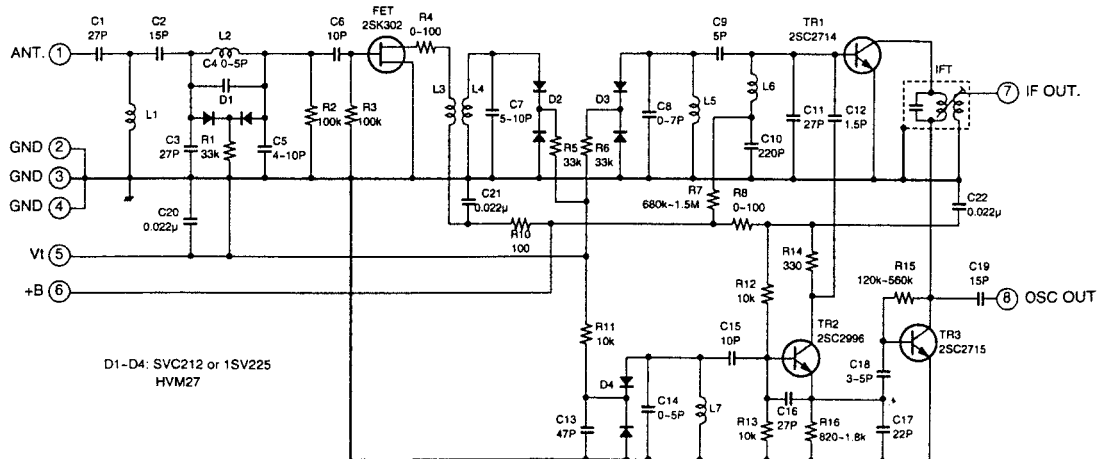
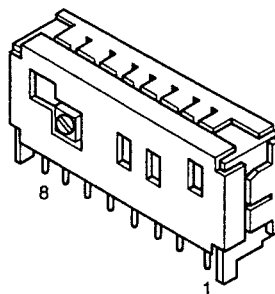

- NOTES
1. TERMINAL NUMBER REFER TO OVERALL APPEARANCE.
  2. RECEIVING FREQUENCY. 87.5-108 MHz.
  3. INPUT IMPEDANCE. 75 ohm.
  4. OUTPUT IMPEDANCE. 300 ohm.
  5. SUPPLY VOLTAGE. +B 12 V.
  6. TUNING VOLTAGE. Vt 1.2 min-9.0 max V.

# SEMICONDUCTORS

● IC's

TMP87CM71F-6754 (IC301)

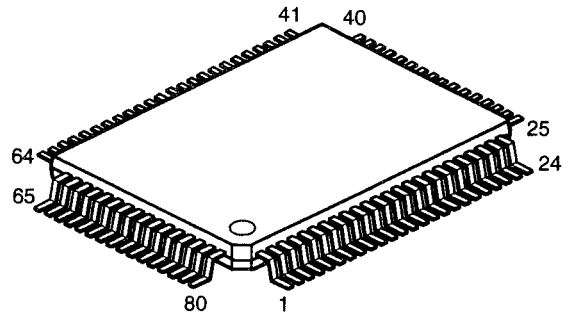

TMP87CM71F-6754 Terminal Function

Pin No.	Port Name	Symbol	I/O	Typ	Op	Det	Res	Ini	Function
1	P10/INT 0	STOP	I	—	Eu	Lv	Z	—	Power down detection
2	P11/INT 1	Not Used	I	—	GND	—	Z	—	Connected to GND
3	P12/INT 2	Not Used	I	—	GND	—	Z	—	Connected to GND
4	P13/DVO	Not Used	I	—	GND	—	Z	—	Connected to GND
5	P14	SELA	I	—	Eu	—	Z	—	Rot. Encoder input
6	P15/TC2	SELB	I	—	Eu	—	Z	—	Rot. Encoder input
7	P16	Not Used	I	—	GND	—	Z	—	Connected to GND
8	P17	Not Used	I	—	GND	—	Z	—	Connected to GND
9	TEST		I	—	GND	—	—	—	Connected to GND
10	P21/XTIN	TUNED	I	—	Eu	Lv	Z	—	Tuning detection (L: Tuned)
11	P22/XTO	Not Used	I	—	GND	—	Z	—	Connected to GND
12	RESET_		I	—	Eu	Lv	Z	—	Reset input
13	XIN		—	—	—	—	—	—	Oscillation circuit (4MHz)
14	XOUT		—	—	—	—	—	—	Oscillation circuit (4MHz)
15	Vss	GND	—	—	GND	—	—	—	Connected to GND
16	P20/INT 5	Not Used	I	—	GND	—	Z	—	Connected to GND
17	P30/INT 3	REMOTE	I	—	Eu	E&L	Z	—	Remote control signal input
18	P31/TC4	STEREO	I	—	Eu	Lv	Z	—	When stereo receiving "L"
19	P32/SCK	Not Used	I	—	GND	—	Z	—	Connected to GND
20	P33/SI	Do	I	—	Eu	S	Z	—	RDS data input (data)
21	P34/SO	Not Used	I	—	GND	—	Z	—	Connected to GND
22	P35/HACK	Not Used	I	—	GND	—	Z	—	Connected to GND
23	P36	Not Used	I	N	GND	—	Z	—	Connected to GND
24	P37/HSO	STB	O	N	Eu	—	Z	H	LC72131/LC72720NM control output (latch)
25	P00	DATA	O	C	—	—	Z	H	LC72131/ LC72720NM control output (serial data)
26	P01	CLK	O	C	—	—	Z	H	LC72131/ LC72720NM control output (serial clock)
27	P02	AUTO /MANU	O	C	—	—	Z	L	Auto/Manu control signal (L: Auto)
28	P03	Not Used	I	—	GND	—	Z	—	Connected to GND
29	P04	POWER ON/OFF	O	C	—	—	Z	H	Power relay control output (H: ON)
30	P05	Not Used	O	C	—	—	Z	—	Connected to GND
31	P06	Not Used	O	C	—	—	Z	—	Connected to GND
32	P07	Not Used	O	C	—	—	Z	—	Connected to GND
33	VDD	VDD	—	—	—	—	—	—	Connected to +5V
34	P60	Not Used	I	—	GND	—	Z	—	Connected to GND
35	P61	Not Used	I	—	GND	—	Z	—	Connected to GND
36	P62	G1	O	P	Id	—	Z	—	FLD Grid control output
37	P63	G2	O	P	Id	—	Z	—	FLD Grid control output
38	P64	G3	O	P	Id	—	Z	—	FLD Grid control output
39	P65	G4	O	P	Id	—	Z	—	FLD Grid control output
40	P66	G5	O	P	Id	—	Z	—	FLD Grid control output
41	P67	G6	O	P	Id	—	Z	—	FLD Grid control output
42	P70	G7	O	P	Id	—	Z	—	FLD Grid control output
43	P71	G8	O	P	Id	—	Z	—	FLD Grid control output
44	P72	G9	O	P	Id	—	Z	—	FLD Grid control output
45	P73	G10	O	P	Id	—	Z	—	FLD Grid control output
46	P74	G11	O	P	Id	—	Z	—	FLD Grid control output
47	P75	G12	O	P	Id	—	Z	—	FLD Grid control output
48	P76	G13	O	P	Id	—	Z	—	FLD Grid control output



Pin No.	Port Name	Symbol	I/O	Typ	Op	Det	Res	Ini	Function
49	P77	G14	I	—	ld	—	Z	—	FLD Grid control output
50	P80	a1	O	P	ld	—	Z	—	FLD Anode control output
51	P81	a2	O	P	ld	—	Z	—	FLD Anode control output
52	P82	b	O	P	ld	—	Z	—	FLD Anode control output
53	P83	c	O	P	ld	—	Z	—	FLD Anode control output
54	P84	d2	O	P	ld	—	Z	—	FLD Anode control output
55	P85	d1	O	P	ld	—	Z	—	FLD Anode control output
56	P66	e	O	P	ld	—	Z	—	FLD Anode control output
57	P87	f	O	P	ld	—	Z	—	FLD Anode control output
58	P90	j	O	P	ld	—	Z	—	FLD Anode control output
59	P91	k	O	P	ld	—	Z	—	FLD Anode control output
60	P92	m	O	P	ld	—	Z	—	FLD Anode control output
61	P93	n	O	P	ld	—	Z	—	FLD Anode control output
62	P94	p	O	P	ld	—	Z	—	FLD Anode control output
63	P95	r	O	P	ld	—	Z	—	FLD Anode control output
64	P96	q	O	P	ld	—	Z	—	FLD Anode control output
65	P97	h	O	P	ld	—	Z	—	FLD Anode control output
66	VKK	Vkk	—	—	—	—	—	—	FLD Drive battery
67	P40/KEY0	Not Used	I	—	GND	—	Z	—	Connected to GND
68	P41/KEY1	Not Used	I	—	GND	—	Z	—	Connected to GND
69	P42/KEY2	Not Used	I	—	GND	—	Z	—	Connected to GND
70	P43/KEY3	LW	I	—	—	Lv	Z	—	LW band setting (H: yes)
71	P44/KEY4	Not Used	I	—	Eu	—	Z	—	Connected to GND
72	P45/KEY5	Not Used	I	—	Eu	—	Z	—	Connected to GND
73	P46/CIN5	KEY1	I	—	Eu	Lv	Z	—	Key input
74	P47/CIN4	KEY2	I	—	Eu	Lv	Z	—	Key input
75	P50/CIN3	KEY3	I	—	Eu	Lv	Z	—	Key input
76	P51/CIN2	KEY3	I	—	Eu	Lv	Z	—	Key input
77	P52/CIN1	VER.	I	—	Eu	Lv	Z	—	Destination setting
78	P53/CIN0	VER.	I	—	Eu	Lv	Z	—	Specifications setting
79	P54	MUTE	O	N	Eu	—	Z	H	Mute output (H: Mute)
80	P55/PMW	PRESET	O	—	Eu	—	Z	—	LED Drive output

**NOTE:** Pin No. : Terminal number of microcomputer.  
Port Name : The name entered on the data sheet of microcomputer.  
Symbol : Symbolized interface function.  
I/O : Input or out of port.  
    "I" = Input port  
    "O" = Output port  
Type : Composition of port in case of output port.  
    "C" = CMOS output  
    "N" = NMOS open drain output  
    "P" = PMOS open drain output  
OP : Pull up/Pull down selection information.  
    "lu" = Inner microcomputer pull up  
    "ld" = Inner microcomputer pull down  
    "Eu" = External microcomputer pull up  
    "Ed" = External microcomputer pull down  
Det : Indicates judging state of input port. Level detection is "LV"; Edge detection is "Ed"; Detection by both shifting is "E&L"; Serial data detection is "S" (Serial data output is also "S").  
Res : State at reset.  
    "H" = Outputs High Level at reset  
    "L" = Output Low Level at reset  
    "Z" = Becomes High impedance mode at reset  
Ini : Initial output state.  
Function : Function and logical level explanation of signals to be interface.

LC72720NM

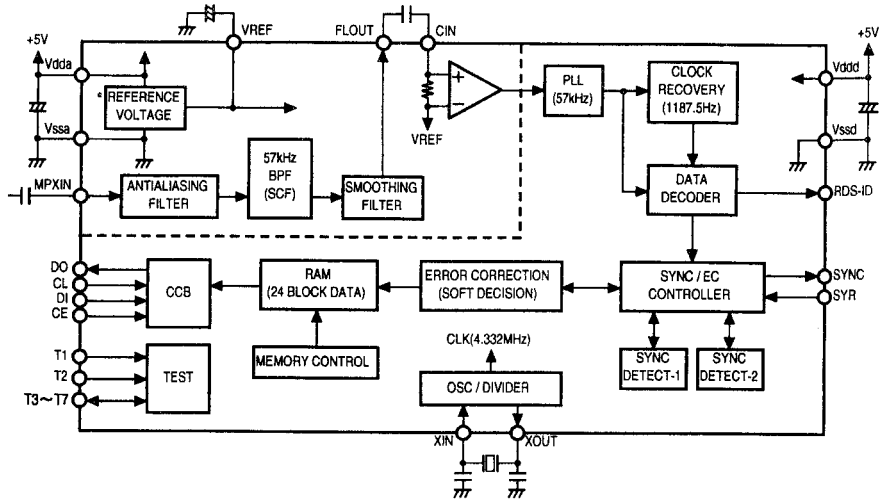
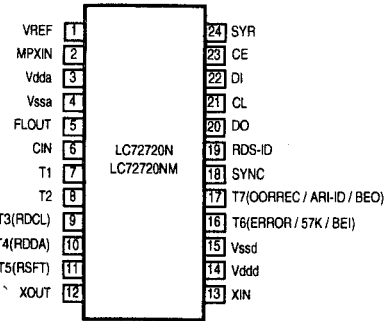
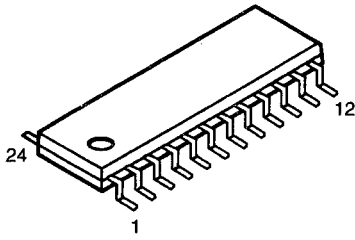

LC72720NM Terminal Function

Pin No.	Terminal	I/O	Function
1	VREF	O	Ref. voltage output (Vdda/2).
2	MPXIN	I	Base band (multiplex) signal input.
3	Vdda	—	Analog part power (+5V).
4	Vssa	—	Analog part GND.
5	FLOUT	O	Sub-carrier output (filter output).
6	CIN	I	Sub-carrier input (comparator input).
7	T1	I	Test input (connect to GND).
8	T2	I	Test input (standby cont.) 0: normal, 1: standby
9	T3 (RDCL)	I	Test I/O (RDS clock output).
10	T4 (RDDA)	I/O*	Test I/O (RDS data output).
11	T5 (RSFT)	I/O*	Test I/O (judge data output).
12	XOUT	O	X'tal osc, output (4.332/8.664 MHz).
13	XIN	I	X'tal osc. input (external ref. signal input).
14	Vddd	—	Digital part power (+5V).
15	Vssd	—	Digital GND.
16	T6 (ERROR/57K/BE1)	I/O*	Test I/O (error, play carrier, error block output).
17	T7 (CORREC/ARI-ID/BE0)	I/O*	Test I/O (error correct, SK detect, error block output).
18	SYNC	I/O*	Block sync. detect output.
19	RDS-ID	O	RDS detect output.
20	DO	O	Data output.
21	CL	I	Clock input.
22	DI	I	Data input.
23	CE	I	Chip enable.
24	SYR	I	sync. & RAM address reset (positive logic).

\* Normal output terminal, used in/out terminal at test (user setting impossible).

LA1265 (S) (IC101)  
LA3401 (IC102)

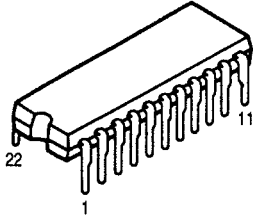

LA1265 (S)

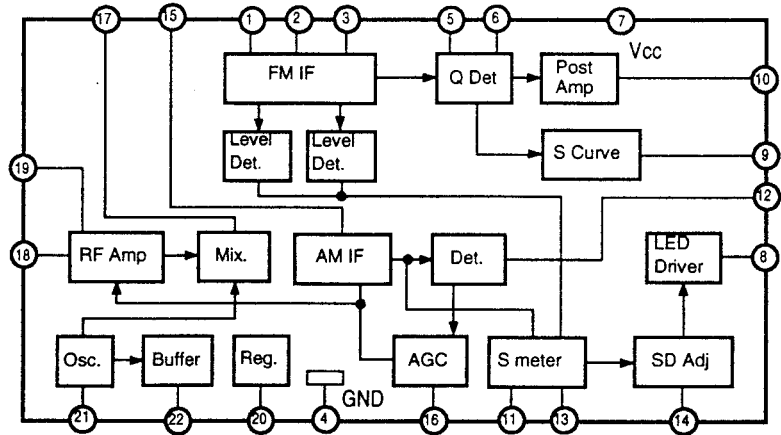

LA3401

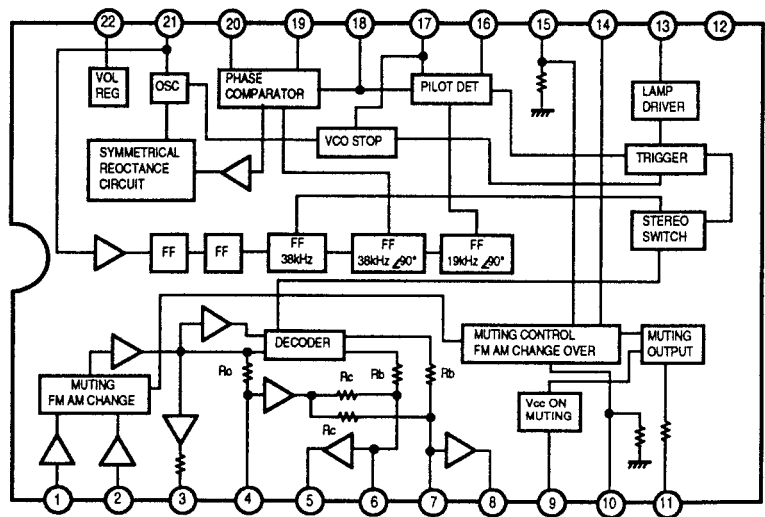

LC72131M (IC104)

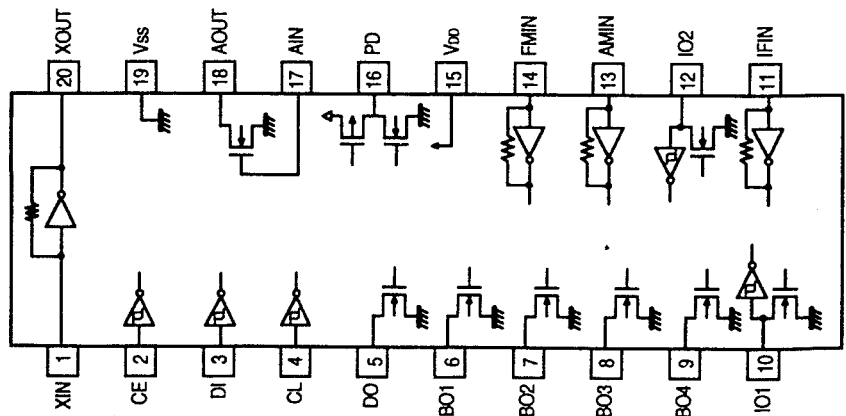
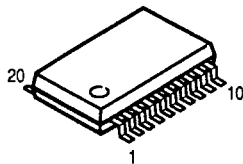

BA178M12 (IC106)  
BA178M06 (IC107)

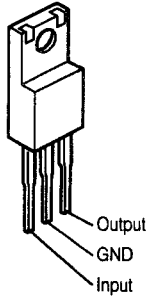

1: Output  
2: GND  
3: Input

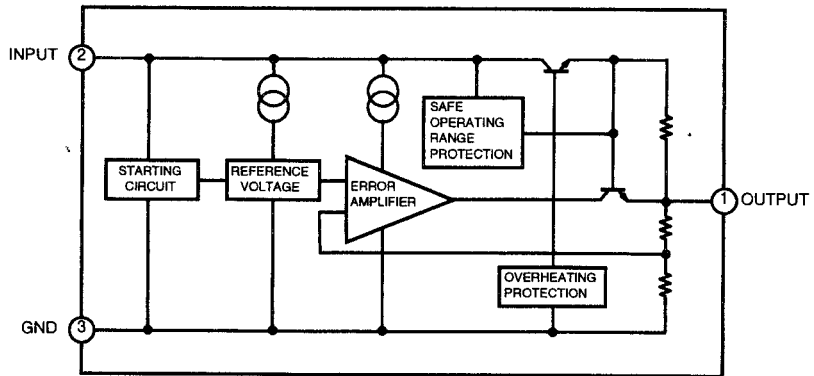

● TRANSISTORS

DTA114EK  
DTC144EK  
DTC323TK

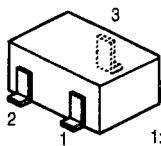

1: GND/Emitter  
2: Input/Base  
3: Output/Collector

DTA114EK

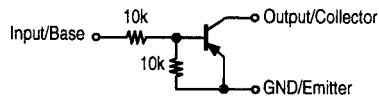

DTC144EK

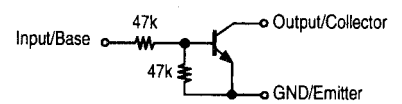

DTC323TK

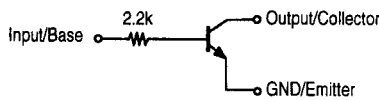

2SK211 (Y/GR)

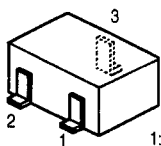

1: Gate  
2: Drain  
3: Source

2SB1197 (Q/R)  
2SC2412 (S)  
2SC2413 (Q)

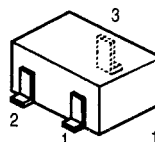

1: Emitter  
2: Base  
3: Collector

● DIODES

1SR35-200A

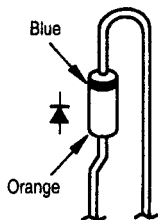

MA151A

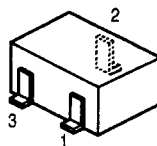

1: Cathode  
2: Cathode  
3: Anode

UDZ3.3B  
UDZ6.8B  
UDZ12B

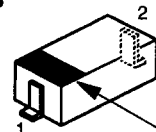

1: Cathode  
2: Anode

● REMOTE CONTROL SENSOR

GP1U271X (IC302)

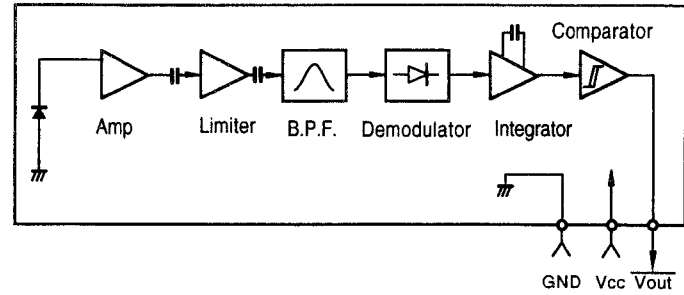
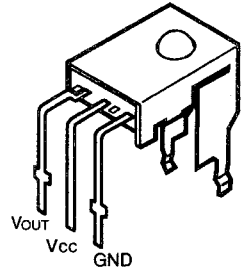

● FLD (14-BF39GK)

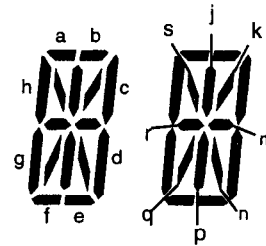
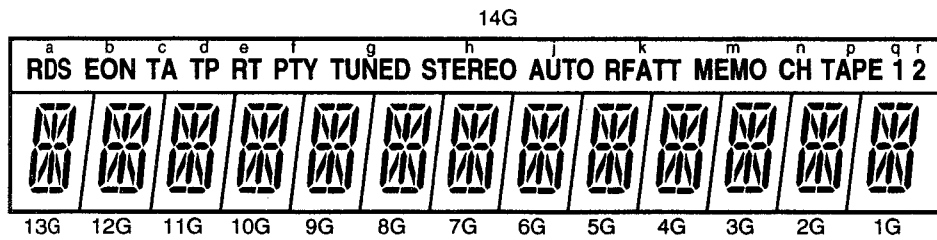
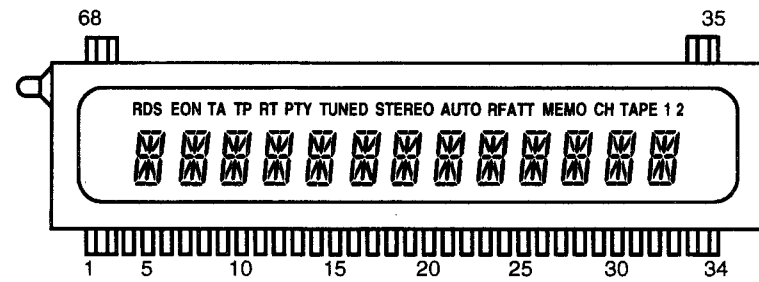

TERMINAL CONNECTION

(UPPER)

TERMINAL NO.	68	67	66	65	64	63	62	61	60	59	58	57	56	55	54	53	52			
ELECTRODE	F1	F1	NP	NP	NP	NP	NP	NP	NP	NP	NP	NP	NP	NP	NP	NP	NP			
TERMINAL NO.				51	50	49	48	47	46	45	44	43	42	41	40	39	38	37	36	35
ELECTRODE				F1	F1	NP	NP	NP	NP	NP	NP	NP	NP	NP	NP	NP	NP	NP	NP	NP

(LOWER)

TERMINAL NO.				18	19	20	21	22	23	24	25	26	27	28	29	30	31	32	33	34	
ELECTRODE				F1		14G	13G	12G	11G	10G	9G	8G	7G	6G	5G	4G	3G	2G	1G	F2	F2
TERMINAL NO.	1	2	3	4	5	6	7	8	9	10	11	12	13	14	15	16	17				
ELECTRODE	F1	F1	P	P	P	P	P	P	P	P	P	P	P	P	P	P	P				
			s	r	q	p	n	m	k	j	h	g	f	e	d	c	b				

Notes: F: Filament  
G: Grid  
P: Anode  
NP: NO. Pin



## NOTE FOR PARTS LIST

- Part indicated with the mark "⊙" are not always in stock and possibly to take a long period of time for supplying, or in some case supplying of part may be refused.
  - When ordering of part, clearly indicate "1" and "I" (i) to avoid mis-supplying.
  - Ordering part without stating its part number can not be supplied.
  - Part indicated with the mark "★" is not illustrated in the exploded view.
  - Not including Carbon Film ±5%, 1/4W Type in the P.W.Board parts list. (Refer to the Schematic Diagram for those parts.)
- WARNING:**  
 Parts marked with this symbol have critical characteristics.  
 Use ONLY replacement parts recommended by the manufacturer.

### ● Resistors

Ex.: **RN 14K 2E 182 G FR**

Type	Shape and performance	Power	Resistance	Allowable error	Others
RD : Carbon	2B : 1/8W	F : ±1%	P : Pulse-resistant type		
RC : Composition	2E : 1/4W	G : ±2%	NL : Low noise type		
RS : Metal oxide film	2H : 1/2W	J : ±5%	NB : Non-burning type		
RW : Winding	3A : 1W	K : ±10%	FR : Fuse-resistor		
RN : Metal film	3D : 2W	M : ±20%	F : Lead wire forming		
RK : Metal mixture	3F : 3W				
	3H : 5W				

**\* Resistance**

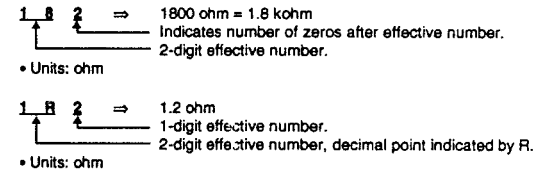

### ● Capacitors

Ex.: **CE 04W 1H 2R2 M BP**

Type	Shape and performance	Dielectric strength	Capacity	Allowable error	Others
CE : Aluminum foil electrolytic	0J : 6.3V	F : ±1%	HS : High stability type		
CA : Aluminum solid electrolytic	1A : 10V	G : ±2%	BP : Non-polar type		
CS : Tantalum electrolytic	1C : 16V	J : ±5%	HR : Ripple-resistant type		
CQ : Film	1E : 25V	K : ±10%	DL : For charge and discharge		
CK : Ceramic	1V : 35V	M : ±20%	HF : For assuring high frequency		
CC : Ceramic	1H : 50V	Z : +80%	U : UL part		
CP : Oil	2A : 100V	-20%	C : CSA part		
CM : Mica	2B : 125V	P : +100%	W : UL-CSA type		
CF : Metallized	2C : 160V	-0%	F : Lead wire forming		
CH : Metallized	2D : 200V	C : ±0.25pF			
	2E : 250V	D : ±0.5pF			
	2H : 500V	= : Others			
	2J : 630V				

**\* Capacity (electrolyte only)**

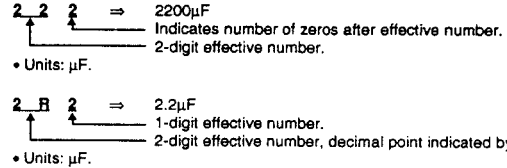

**\* Capacity (except electrolyte)**

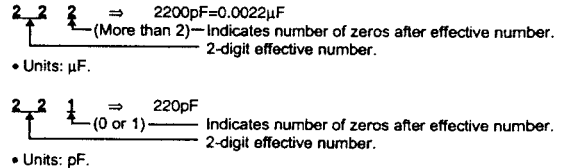

• When the dielectric strength is indicated in AC, "AC" is included after the dielectric strength value.

## PARTS LIST OF P.W.B. UNIT

### 1U-3139 MAIN P.W.B. UNIT

Ref. No.	Part No.	Part Name	Remarks	Ref. No.	Part No.	Part Name	Remarks
<b>SEMICONDUCTORS GROUP</b>				R107	247 0009 985	Carbon chip 10 kohm 1/10W	RM73B--103J
IC101	263 0891 001	IC LA1265(S)		R108	247 0005 905	Carbon chip 100 ohm 1/10W	RM73B--101J
IC102	263 0439 007	IC LA3401		R111,112	247 0018 905	Carbon chip 0 ohm 1/10W	RM73B--0R0K TU-235RD only
IC103	263 0672 903	IC BA4558F		R113	247 0008 944	Carbon chip 2.7 kohm 1/10W	RM73B--272J
IC104	262 2450 900	IC LC72131M-TLM		R114	247 0006 945	Carbon chip 1 kohm 1/10W	RM73B--102J
IC105	262 2547 907	IC LC72720NM		R115	247 0006 920	Carbon chip 330 ohm 1/10W	RM73B--331J
IC106	263 1004 004	IC BA178M12		R117	247 0005 989	Carbon chip 220 ohm 1/10W	RM73B--221J
IC107	263 1010 001	IC BA178M06		R118	247 0006 920	Carbon chip 330 kohm 1/10W	RM73B--331J
IC301	262 2527 008	IC TMP87CM71F-6754		R119	247 0006 962	Carbon chip 470 ohm 1/10W	RM73B--471J
IC302	499 0290 007	Remocon sensor GP1U271X		R120	247 0011 902	Carbon chip 33 kohm 1/10W	RM73B--333J TU-260LII only
TR101	269 0083 901	Transistor DTA114EK		R122	247 0011 902	Carbon chip 33 kohm 1/10W	RM73B--333J TU-260LII only
TR102	275 0074 902	FET 2SK211-Y/GR		R124	247 0010 929	Carbon chip 15 kohm 1/10W	RM73B--153J TU-260LII only
TR120,121	269 0054 901	Transistor DTC144EK		R126	247 0010 929	Carbon chip 15 kohm 1/10W	RM73B--153J TU-260LII only
TR103	273 0438 908	Transistor 2SC2413K(Q)		R129	247	Carbon chip 2.4 kohm 1/10W	RM73B--242J
TR104	269 0054 901	Transistor DTC144EK		R130	247 0006 920	Carbon chip 330 ohm 1/10W	RM73B--331J
TR105~108	269 0066 902	Transistor DTC323TK		R131	247	Carbon chip 750 kohm 1/10W	RM73B--751J
TR109	269 0083 901	Transistor DTA114EK		R132	247 0010 929	Carbon chip 15 kohm 1/10W	RM73B--153J
TR110,111	269 0054 901	Transistor DTC144EK		R133~135	247 0009 927	Carbon chip 5.6 kohm 1/10W	RM73B--562J
TR112-115	273 0384 900	Transistor 2SC2412K(S)	TU-260LII only	R136	247 0005 905	Carbon chip 100 ohm 1/10W	RM73B--101J
TR116,117	269 0083 901	Transistor DTA114EK		R137	247 0011 928	Carbon chip 39 kohm 1/10W	RM73B--393J
TR118	272 0153 905	Transistor 2SB1197K(Q/R)		R138	247 0009 985	Carbon chip 10 kohm 1/10W	RM73B--103J
TR119	269 0054 901	Transistor DTC144EK		R139	247 0009 901	Carbon chip 4.7 kohm 1/10W	RM73B--472J
TR122	273 0384 900	Transistor 2SC2412K(S)		R140	247 0011 986	Carbon chip 68 kohm 1/10W	RM73B--683J
TR301	269 0083 901	Transistor DTA114EK		R141	247 0009 985	Carbon chip 10 kohm 1/10W	RM73B--103J
TR302	269 0054 901	Transistor DTC144EK		R143	247 0008 944	Carbon chip 2.7 kohm 1/10W	RM73B--272J
TR303	269 0083 901	Transistor DTA114EK		R144	247 0009 985	Carbon chip 10 kohm 1/10W	RM73B--103J
D101	276 0438 910	Diode MA151A		R145	247 0008 960	Carbon chip 3.3 kohm 1/10W	RM73B--332J
D104,105	276 0553 905	Diode 1SR35-200A		R146	247 0009 985	Carbon chip 10 kohm 1/10W	RM73B--103J
D106	276 0438 910	Diode MA151A		R147	247 0009 927	Carbon chip 5.6 kohm 1/10W	RM73B--562J
D107-112	276 0553 905	Diode 1SR35-200A		R149	247 0012 927	Carbon chip 100 kohm 1/10W	RM73B--104J
D114,115	276 0438 910	Diode MA151A		R150	247 0011 915	Carbon chip 36 kohm 1/10W	RM73B--363J
D152	276 0438 910	Diode MA151A		R151,152	247 0012 927	Carbon chip 100 kohm 1/10W	RM73B--104J
D301	276 0438 910	Diode MA151A		R153,154	247 0012 998	Carbon chip 200 kohm 1/10W	RM73B--204J
ZD101	276 0686 908	Zener diode UDZ3.3B	3.3V	R155	247 0007 987	Carbon chip 1.5 kohm 1/10W	RM73B--152J
ZD102,103	276 0694 932	Zener diode UDZ6.8B	6.8V	R156	247 0009 927	Carbon chip 5.6 kohm 1/10W	RM73B--562J
LD301	393 9502 906	LED SEL4214R		R157	247 0013 900	Carbon chip 220 kohm 1/10W	RM73B--224J
FL301	393 8020 007	VFD (14-BT-39GK)		R158,159	247 0008 928	Carbon chip 2.2 kohm 1/10W	RM73B--222J
<b>RESISTORS GROUP</b>				R160,161	244 2055 970	Metal oxide 56 ohm 1W	RS14B3A560JNBS(S)
R101	247 0002 966	Carbon chip 10 ohm 1/10W	RM73B--101J	R162	244 2055 938	Metal oxide 6.8 ohm 1W	RS14B3A6R8JNBS(S)
R102,103	247 0007 945	Carbon chip 1 kohm 1/10W	RM73B--102J	R163	247 0009 985	Carbon chip 10 kohm 1/10W	RM73B--103J
R104	247 0012 927	Carbon chip 100 kohm 1/10W	RM73B--104J	R164	247 0010 916	Carbon chip 13 kohm 1/10W	RM73B--133J
R105	247 0007 945	Carbon chip 1 kohm 1/10W	RM73B--102J	R165	247 0009 901	Carbon chip 4.7 kohm 1/10W	RM73B--472J
R106	247 0009 927	Carbon chip 5.6 kohm 1/10W	RM73B--562J	R166	247 0009 985	Carbon chip 10 kohm 1/10W	RM73B--103J
				R168	247 0009 901	Carbon chip 4.7 kohm 1/10W	RM73B--472J
				R169	247 0012 927	Carbon chip 100 kohm 1/10W	RM73B--104J
				R170	247 0007 945	Carbon chip 1 kohm 1/10W	RM73B--102J
				R171	247 0009 901	Carbon chip 4.7 kohm 1/10W	RM73B--472J
				R172	247 0007 945	Carbon chip 1 kohm 1/10W	RM73B--102J





# EXPLODED VIEW

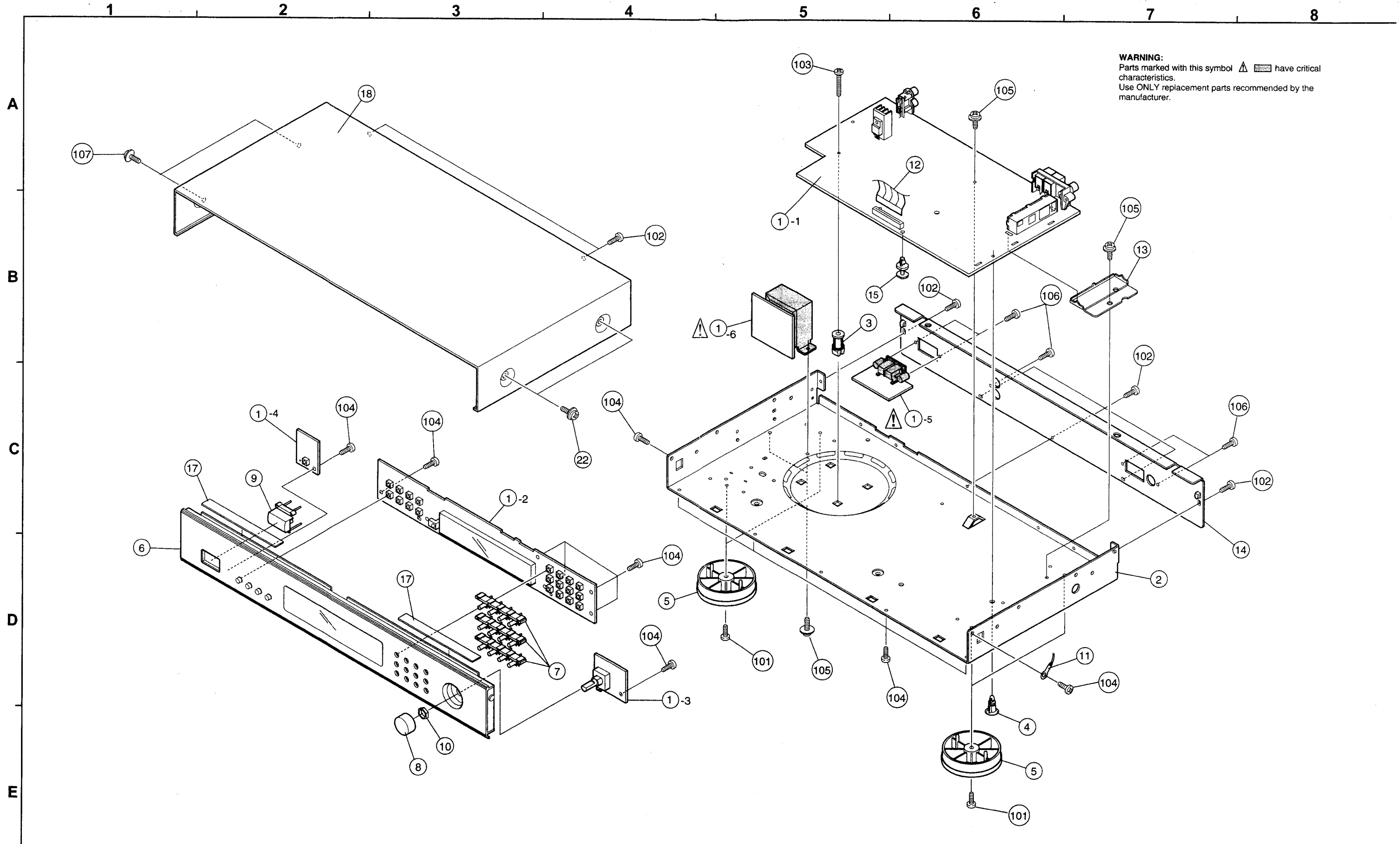

## PARTS LIST OF EXPLODED VIEW

Ref. No.	Part No.	Part Name	Remarks	Q'ty	Ref. No.	Part No.	Part Name	Remarks	Q'ty
1	1U-3139	Main P.W.B. unit ass'y		1	207	515 0671 627	Service station list (EX)		1
1-1	—	Tuner unit			208	505 0131 050	Cabinet cover		1
1-2	—	Display unit			209	503 1284 007	Cushion		2
1-3	—	Rotary encoder. unit			210	501 2031 004	Carton case		1
1-4	—	Power switch unit			501 2031 017	Carton case	TU-260LII only	1	
1-5	—	Inlet unit			211	513 1389 006	Control card base		1
1-6	—	Power trans unit			212	513 1349 004	Thermal carbon film		1
2	411 0942 902	Chassis		1	213	517 1378 006	E2 POS label	Black Model	1
3	412 2762 002	P.W.B. holder		1	517 1378 019	E2 POS label	Gold Model	1	
4	412 2741 007	P.W.B. holder (H=8)		1	517 1338 088	EK POS label	Black Model (TU-260LII)	2	
5	104 0208 308	Foot ass'y		4	214	513 9111 001	Color label	Gold Model only	1
6	144 2620 209	Front panel ass'y	Black Model (TU-235RD)	1	215	502 0898 022	PAD	TU-260LII only	2
	144 2620 212	Front panel ass'y	Gold Model (TU-235RD)	1					
	144 2620 322	Front panel ass'y	Black Model (TU-260LII)	1					
7	113 1838 111	Tact knob (4)	Black Model	3					
	113 1838 108	Tact knob (4)	Gold Model	3					
8	112 0806 002	Knob ass'y	Black Model	1					
	112 0806 015	Knob ass'y	Gold Model	1					
9	113 1292 207	Push knob (P)	Black Model	1					
	113 1292 210	Push knob (P)	Gold Model	1					
10	—	9 nut							
11	203 0458 015	1P contact ass'y		1					
12	009 0113 004	21P FFC cable		1					
13	414 0839 001	Shield cover		1					
14	105 1293 001	Back panel	TU-235RD	1					
	105 1293 014	Back panel	TU-260LII	1					
15	412 2814 002	Card spacer (L=8)		1					
16	—	—							
17	461 0577 000	Rubber sheet		2					
18	102 0413 207	Top cover	Black Model	1					
	102 0413 210	Top cover	Gold Model	1					
<b>SCREWS</b>									
101	473 7002 018	Screw 3 x 8 CBTS(S)-Z		4					
102	473 7015 018	Screw 3 x 8 CBTS(S)-B		7					
103	473 7501 030	Screw 3 x 20 CBTS (P)-Z		1					
104	473 7508 017	Screw 3 x 10 CBTS(P)-B		15					
105	473 8007 025	Cup screw 3 x 8		4					
106	477 0064 107	Fixing screw		5					
107	477 0263 005	3P. swelling screw	Black Model	4					
	477 0263 018	3P. swelling screw	Gold Model	4					
<b>PACKING &amp; ACCESSORIES</b>									
201	505 0283 018	Poly. cover		1					
202	511 3329 000	Instruction manual		1					
203	203 2310 009	2P pin cord		1					
204	231 0922 009	Loop antenna		1					
205	395 0023 008	FM antenna ass'y		1					
Δ	206 2108 003	AC cord with plug		1					
Δ	206 2113 001	AC cord with plug	(TU-260LII)	1					

MEMO

# SCHEMATIC DIAGRAM

1 2 3 4 5

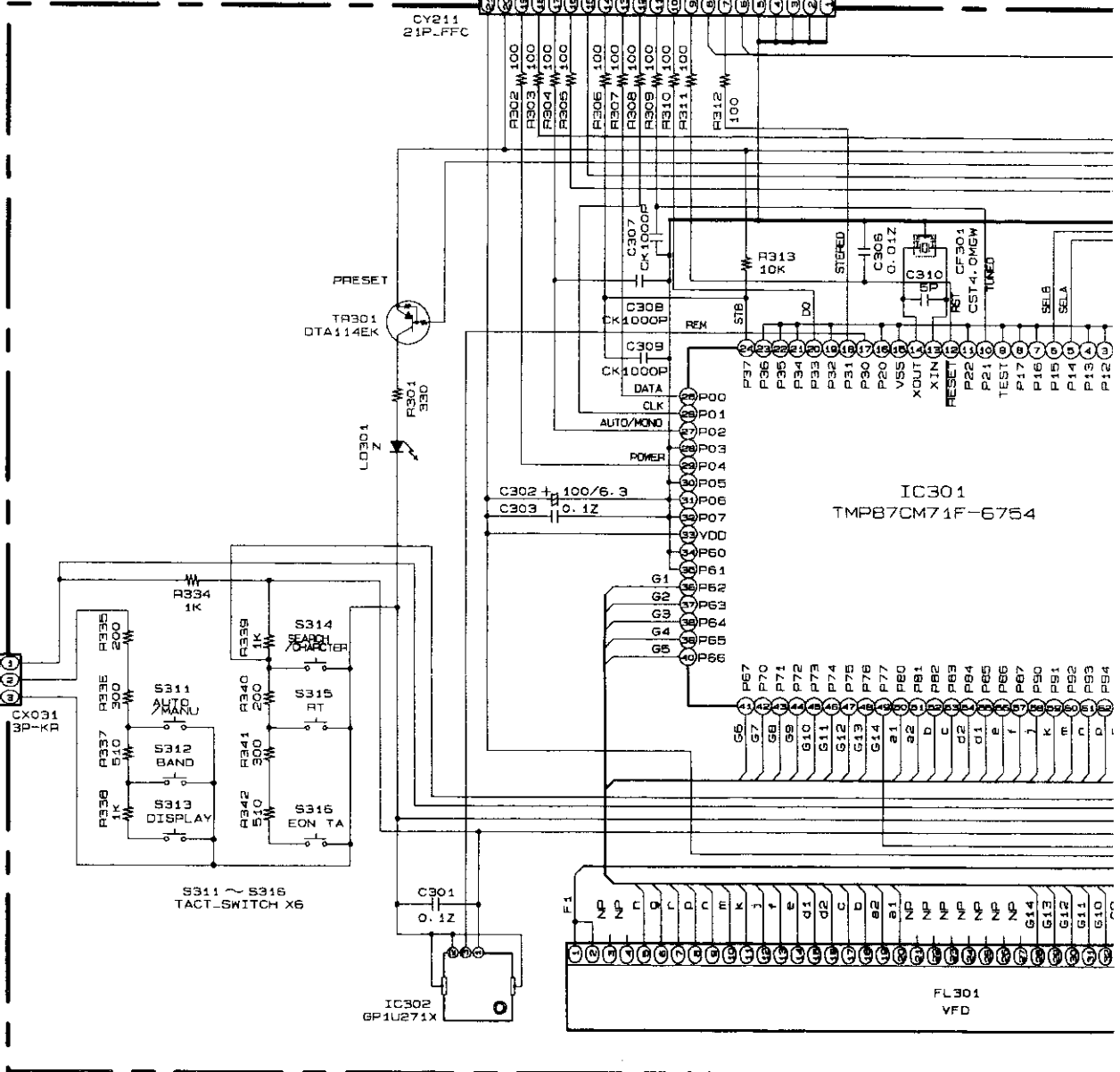
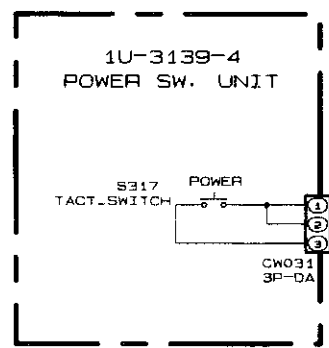
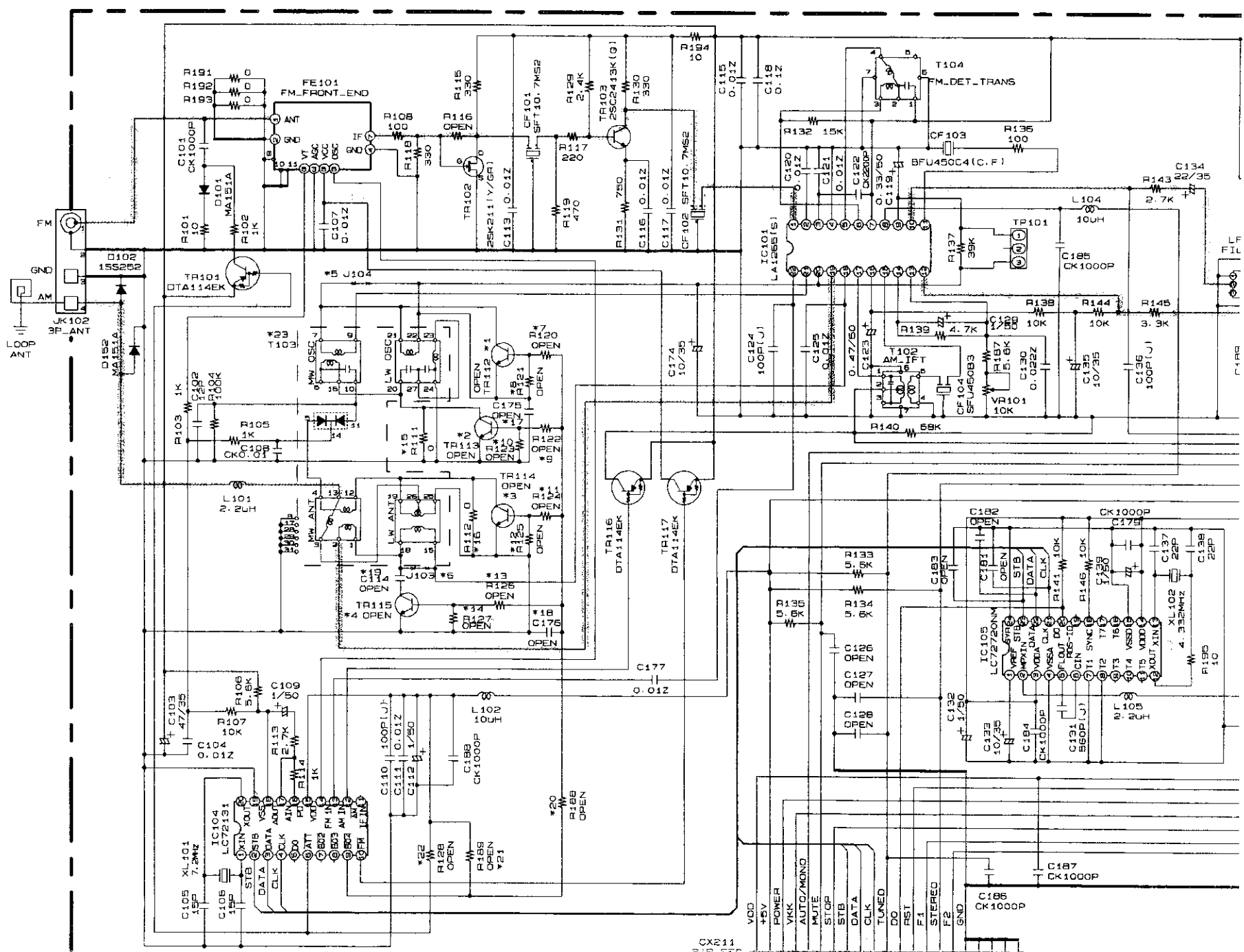

7

8

9

10

11

A

B

C

D

E

F

G

H

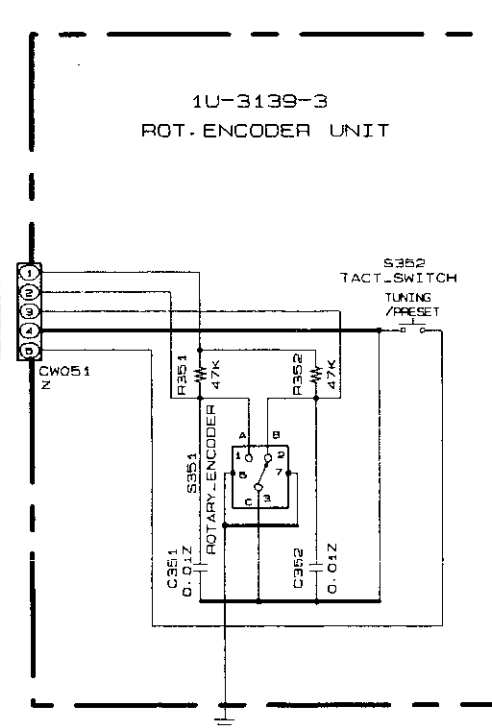
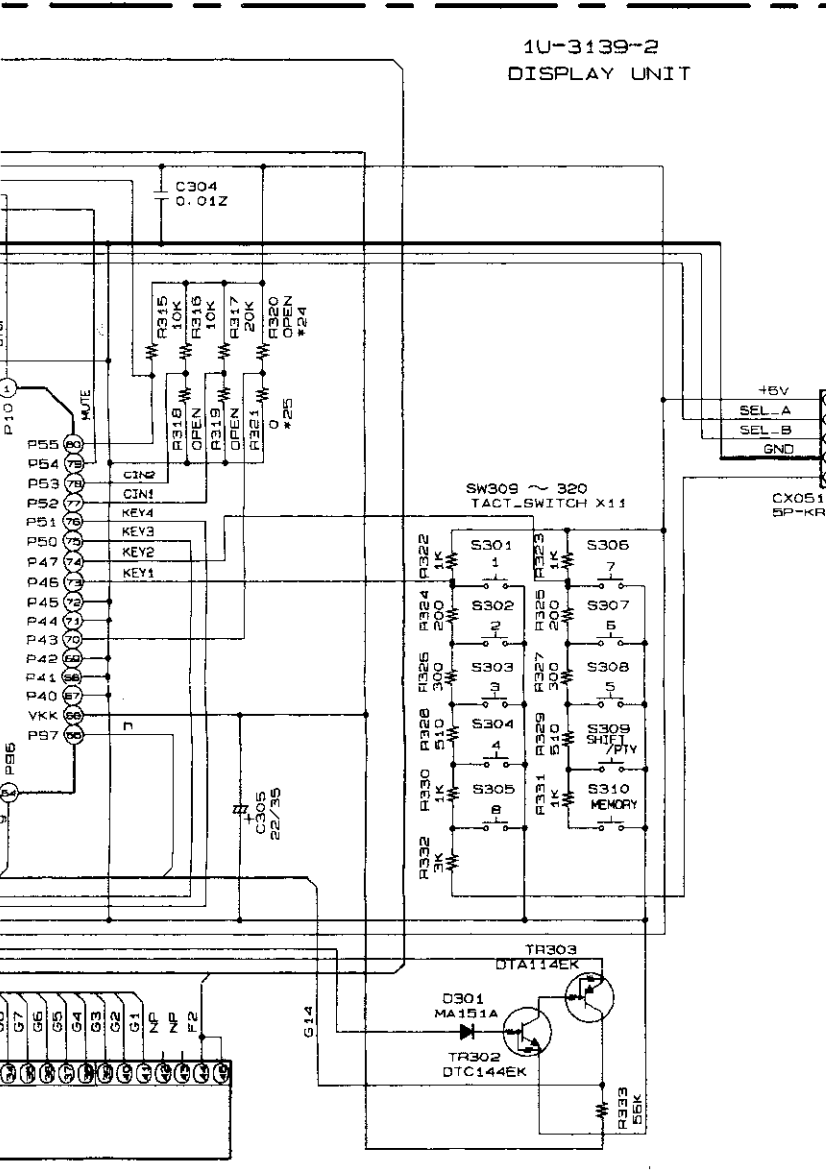
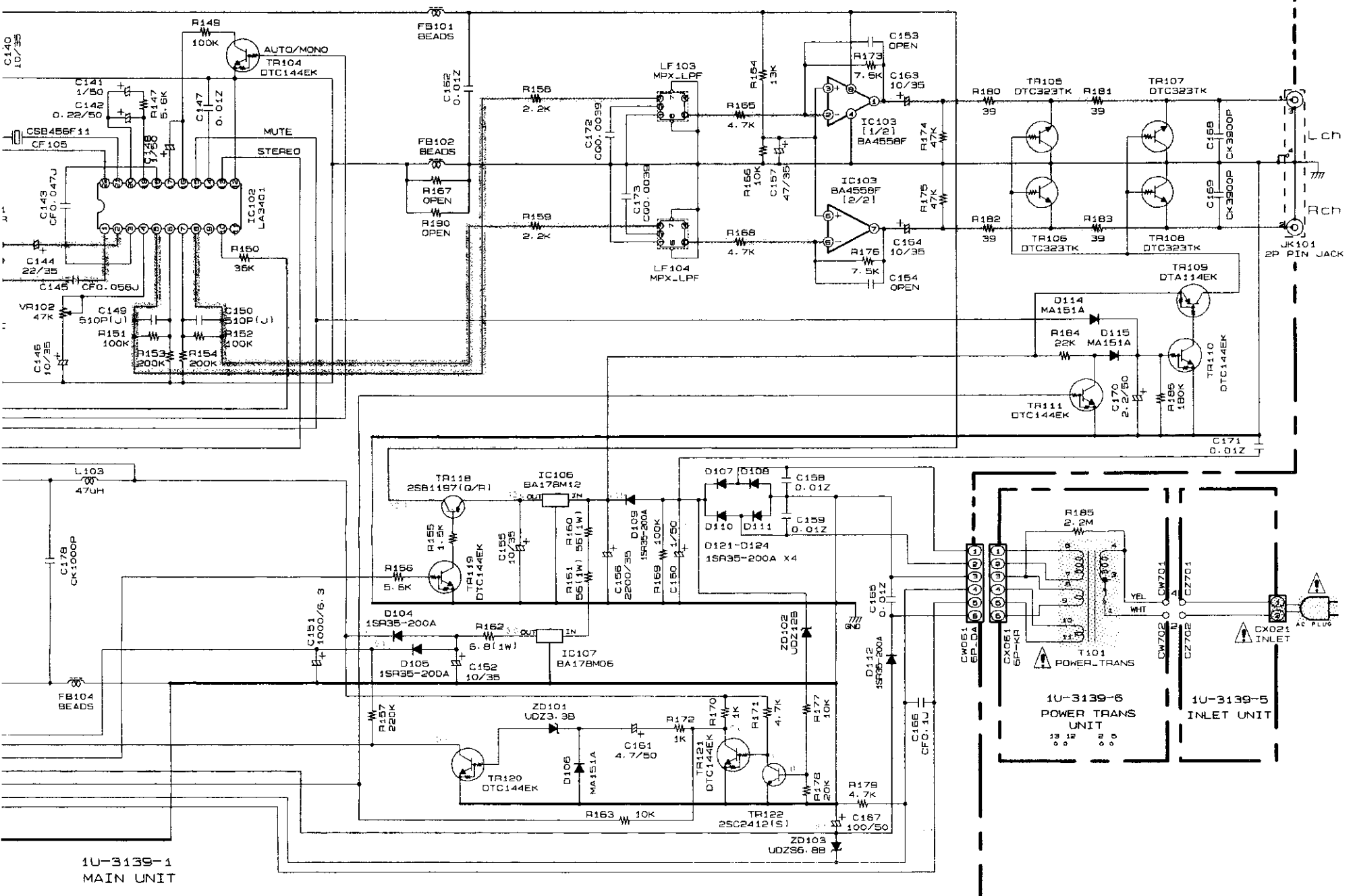

	TU-235RD	TU-260LI
*1	TR112	25C2412(S)
*2	TR113	25C2412(S)
*3	TR114	25C2412(S)
*4	TR115	25C2412(S)
*5	J104	JUMPER
*6	J103	JUMPER
*7	R120	33K
*8	R121	---
*9	R122	33K
*10	R123	---
*11	R124	15K
*12	R125	---
*13	R126	15K
*14	R127	---
*15	R111	0
*16	R112	0
*17	C175	0.047
*18	C176	---
*19	C114	0.047
*20	R188	0
*21	R189	1K
*22	R128	---
*23	T103	MW/LN ANT -OSC COIL
*24	R320	0
*25	R321	0

+B LINE  
-B LINE  
SIGNAL LINE