

DENON

Hi-Fi AM-FM Stereo Tuner

SERVICE MANUAL MODEL TU-255 AM-FM STEREO TUNER

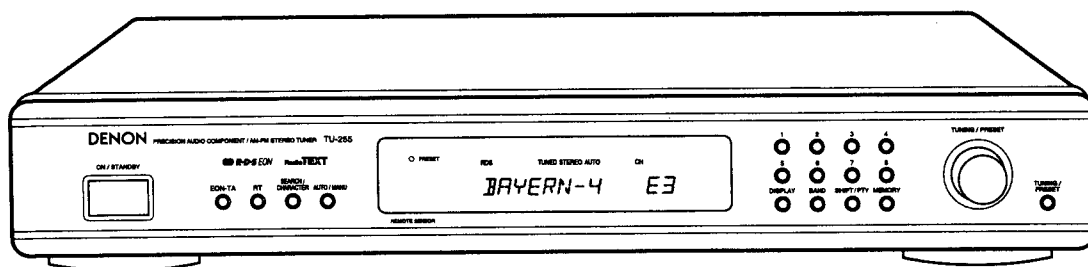

— TABLE OF CONTENTS —

SPECIFICATIONS	2
DISASSEMBLY	3,4
BLOCK DIAGRAM	5
ADJUSTMENT	6,7
SEMICONDUCTORS	8~13
PRINTED WIRING BOARD	14,15
NOTE FOR PARTS LIST	16
PARTS LIST OF P.W.B. UNIT ASS'Y	16,17
EXPLODED VIEW	18
PARTS LIST OF EXPLODED VIEW	19
PACKING VIEW	20
PARTS LIST OF PACKING & ACCESSORIES	20
SCHEMATIC DIAGRAM	21

• Some illustrations using in this service manual are slightly different from the actual set.

SAFETY PRECAUTIONS

The following check should be performed for the continued protection of the customer and service technician.

LEAKAGE CURRENT CHECK

Before returning the unit to the customer, make sure you make either (1) a leakage current check or (2) a line to chassis resistance check. If the leakage current exceeds 0.5 milliamps, or if the resistance from chassis to either side of the power cord is less than 460 kohms, the unit is defective.

SPECIFICATIONS

■ FM SECTION

Frequency Range:	87.5 MHz ~ 108.0 MHz
Antenna Terminals:	75 Ω /ohms Unbalanced
Usable Sensitivity:	0.9 μ V (10.3 dBf)
S/N 50 dB Sdsitivity:	1.2 μ V (IHF)
Monaural:	1.6 μ V (15.3 dBf)
Stereo:	20 μ V (37.2 dBf)
(μ V is at 78 Ω /ohms 0 dBf= 10^{-15} W)	
Image Interference Ratio:	80 dB
IF Interference Ratio:	100 dB
AM Suppression Ratio:	50 dB
Effective Selectivity:	70 dB (\pm 400 kHz)
Capture Ratio:	1.5 dB
Frequency characteristics:	20 Hz - 15 kHz $^{+0.5}_{-1.0}$ dB
Signal-to-noise Ratio:	
Monaural:	82 dB (IHF) 78 dB (DIN)
Stereo:	76 dB (IHF) 72 dB (DIN)
Total Harmonic Distortion:	
Mono 1 kHz (at 75 kHz dev.):	0.5 %
Stereo 1 kHz (at 67.5 kHz dev.):	0.8 %
Stereo Separation 1 kHz:	40 dB

■ AM SECTION

Frequency Range:	522 kHz ~ 1611 kHz
Antenna Terminals:	Terminal Type with Loop Ant.
Usable Sensitivity:	18 μ V
Signal-to-noise Ratio:	53 dB

■ OTHERS

Power Supply:	AC230 V 50 Hz
Power Consumption:	
Operating:	9W
Standby:	2.4 W
Dimensions (W) \times (H) \times (D):	434 \times 75 \times 242 mm
Mass:	2.5 kg

DISASSEMBLY

(Follow the procedure below in reverse order when reassembling)

Top Cover

1. Remove 6 screws ① fixing the Top Cover.
(4 on both sides, 2 on the rear)
2. Detach the Top Cover, moving backwards a little and lifting it as shown in the arrow direction.

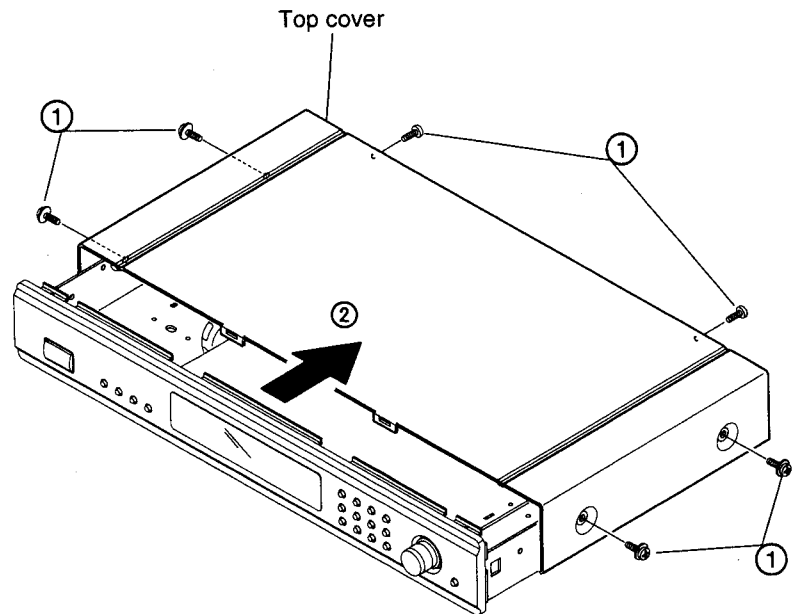

Tuner P.W.B.

1. Remove 3 screws ③ fixing the Tuner P.W.B.
2. Remove 3 screws ④ on the rear.
3. Disconnect 2 connectors ⑤.
4. Release the Tuner P.W.B. from P.W.B. holder ⑥.

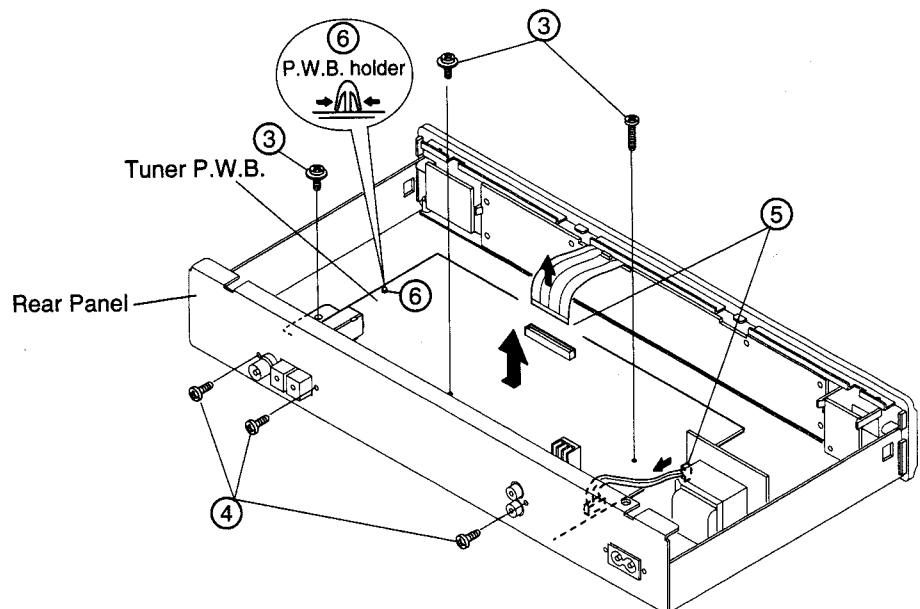

Front Panel

1. Remove 6 screws (8) fixing the Front Panel.
(2 on both sides, 4 on the bottom)

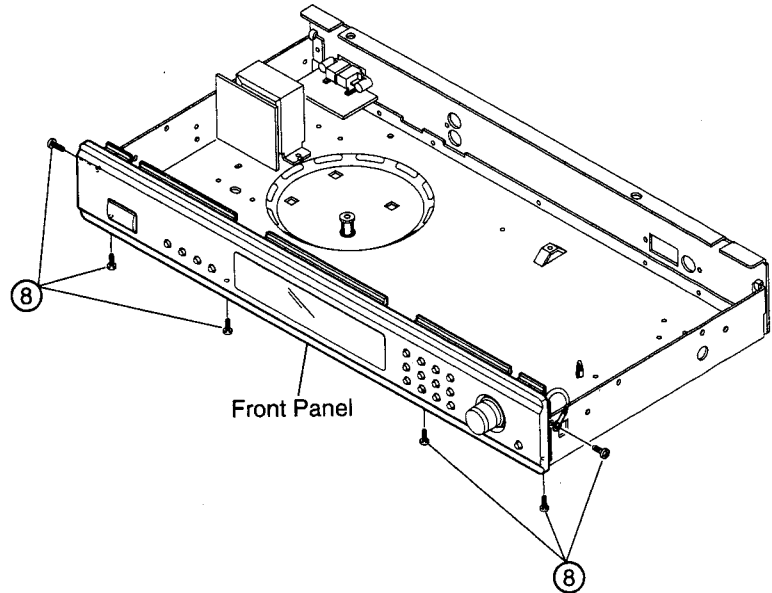

2. Remove 10 screws (9) fixing each P.W.B.
3. Detach the 1U-3299-2 P.W.B. from the Front Panel as shown in the arrow by releasing 2 hooks (10).
4. Detach the 1U-3299-3 and 1U-3299-4 P.W.B.s from the Front Panel as shown in the arrow, after pulling out tuning knob (11) and removing nut (12).

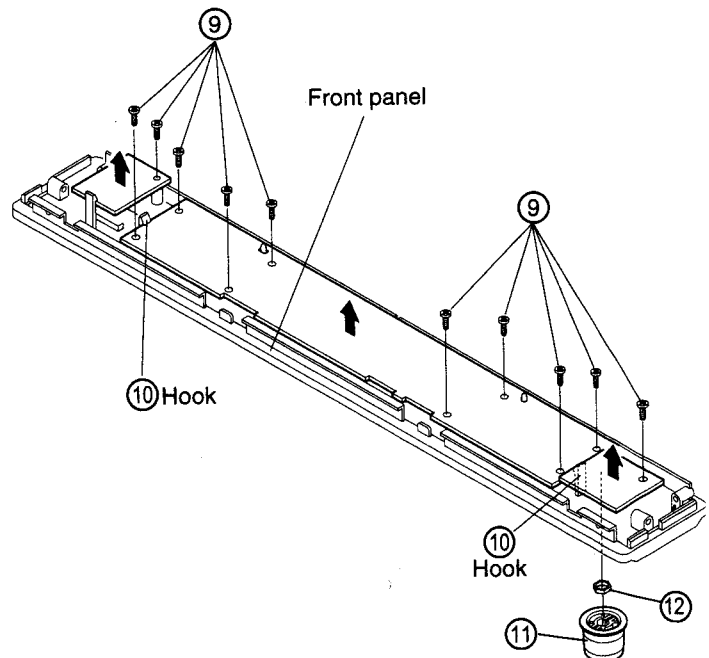

BLOCK DIAGRAM

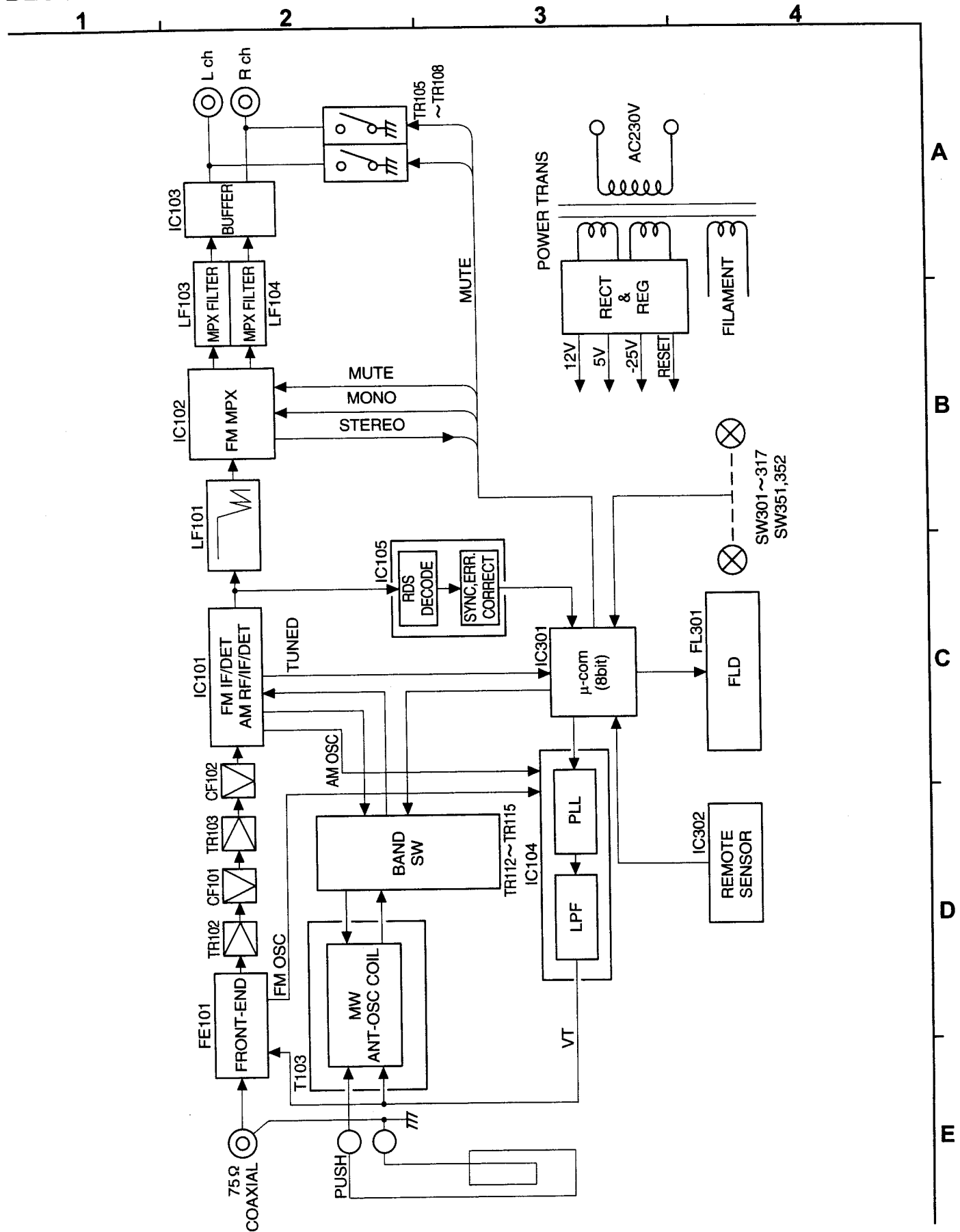

METHOD OF ADJUSTMENT

CONNECTION DIAGRAM OF MEASURING INSTRUMENTS

When making adjustments, be sure the power supply is at the rated voltage and the room air is on normal conditions with respect to temperature and humidity.

● FM

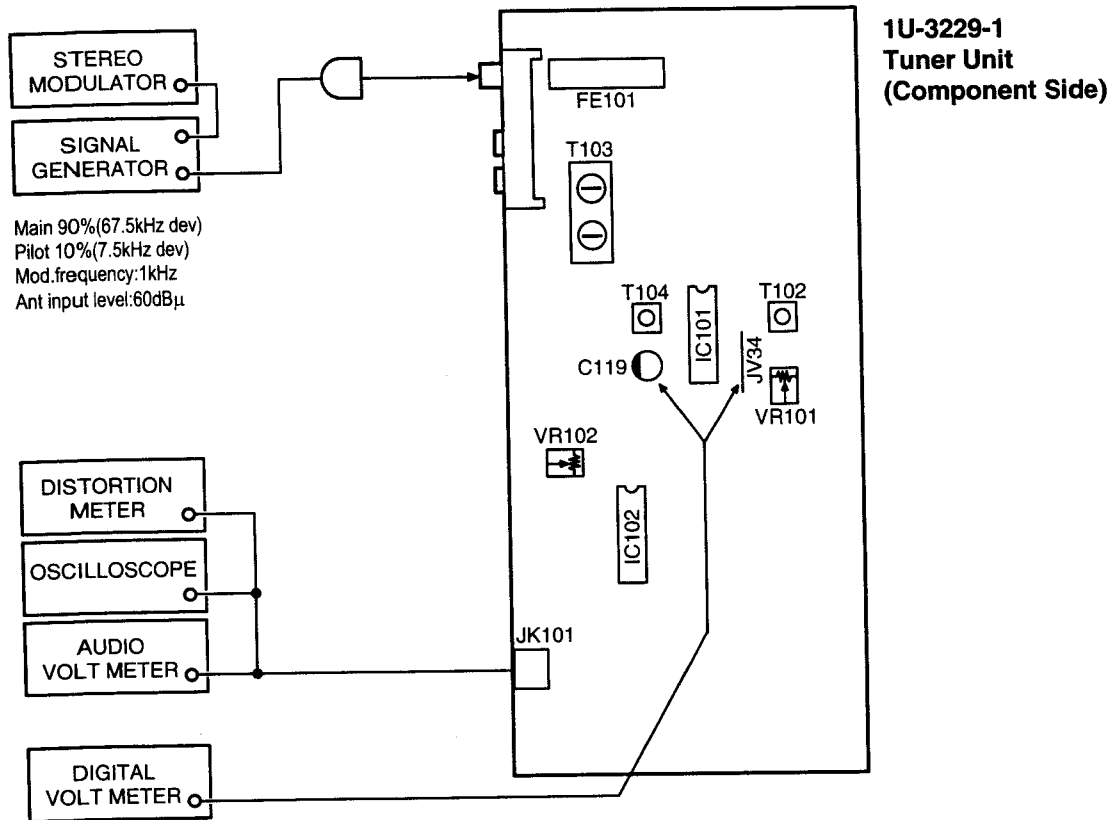

1U-3299-1 TUNER UNIT Alignment Points (Component Side)

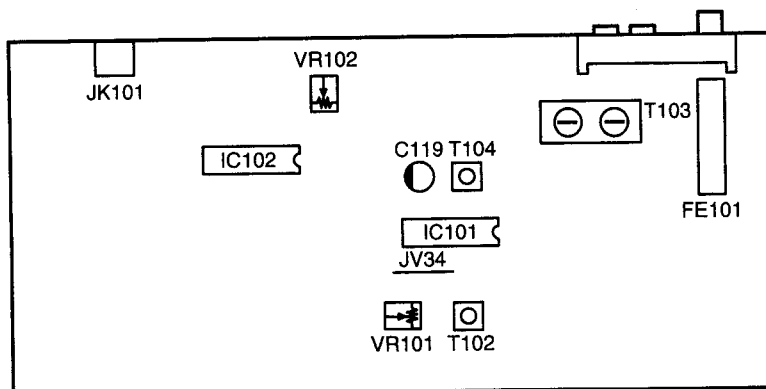

↓
Front Panel Side

FM ALIGNMENT

No.	Alignment Item	Tuning Frequency Setting	Input					Output		Adjustment		Remarks
			Type	Frequency	Input Level	Modulation	Coupling	Type	Connect to	Points	Adjust to	
1	Center Adjustment	98 MHz	FMSSG	98 MHz	60 dBμ	Mono 1 kHz 100%	Antenna Terminal	Digital Voltmeter	C119 PLUS And JV34	T104	±50 mV	
2	Separation	98 MHz	FMSSG	98 MHz	60 dBμ	Stereo (L) 1 kHz 100%	Antenna Terminal	AC Voltmeter	Output Terminal (R)	VR102	Maximum Separation	
3	Signal Level	98 MHz	FMSSG	98 MHz	20 dBμ	off	Antenna Terminal			VR101	Light TUNED on FL Display	

AM ALIGNMENT

No.	Alignment Item	Tuning Frequency Setting	Input					Output		Adjustment		Remarks
			Type	Frequency	Input Level	Modulation	Coupling	Type	Connect to	Points	Adjust to	
1	IF Adjustment	603 kHz	AM SSG	603 kHz	*	400 Hz 30%	AM Loop Antenna	AC Voltmeter	Output Terminal (L)	T102	Maximum Output	
2	RF Adjustment	1404 kHz	AM SSG	1404 kHz	*	400 Hz 30%	AM Loop Antenna	AC Voltmeter	Output Terminal (L)	T103	Maximum Output	

* The level at AGC is not activated.

Initializing (Memory clearing) Method

To clear memory contents of microcomputer and restore to the state of shipment at the factory, take the following step.

- While pressing the Keys 1 and 7 of the front panel, insert power cord into the AC outlet.

FRONT END Parts No.: 216 9013 004

No.	Name	No.	Name
1	ANT	5	Vt
2	GND	6	+B
3	GND	7	IF OUT
4	GND	8	OSC OUT

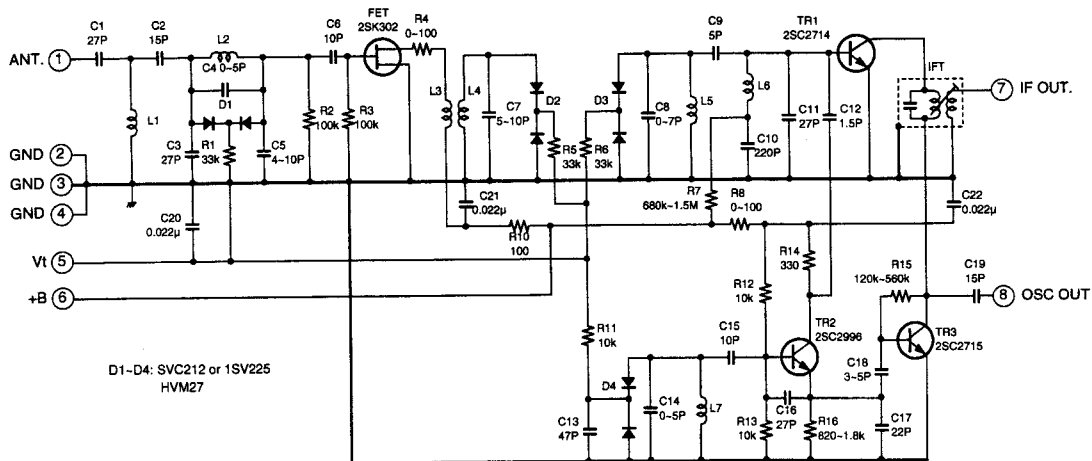
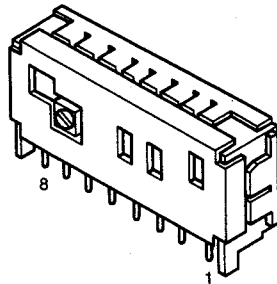

- NOTES
1. TERMINAL NUMBER REFFER TO OVERALL APPEARANCE.
 2. RECEIVING FREQUENCY. 87.5-108 MHz.
 3. INPUT IMPEDANCE. 75 ohm.
 4. OUTPUT IMPEDANCE. 300 ohm.
 5. SUPPLY VOLTAGE. +B 12 V.
 6. TUNING VOLTAGE. Vt 1.2 min-9.0 max V.

SEMICONDUCTORS

● IC's

TMP87CM71F-6754 (IC301)

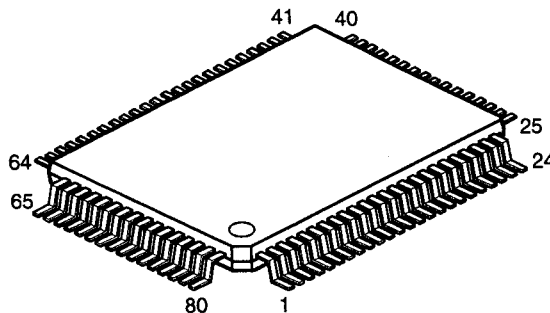

TMP87CM71F-6754 Terminal Function

Pin No.	Port Name	Symbol	I/O	Typ	Op	Det	Res	Ini	Function
1	P10/INT 0	STOP	I	—	Eu	Lv	Z	—	Power down detection
2	P11/INT 1	Not Used	I	—	GND	—	Z	—	Connected to GND
3	P12/INT 2	Not Used	I	—	GND	—	Z	—	Connected to GND
4	P13/DVO	Not Used	I	—	GND	—	Z	—	Connected to GND
5	P14	SELA	I	—	Eu	—	Z	—	Rot. Encoder input
6	P15/TC2	SELB	I	—	Eu	—	Z	—	Rot. Encoder input
7	P16	Not Used	I	—	GND	—	Z	—	Connected to GND
8	P17	Not Used	I	—	GND	—	Z	—	Connected to GND
9	TEST		I	—	GND	—	—	—	Connected to GND
10	P21/XTIN	TUNED	I	—	Eu	Lv	Z	—	Tuning detection (L: Tuned)
11	P22/XTO	Not Used	I	—	GND	—	Z	—	Connected to GND
12	RESET_		I	—	Eu	Lv	Z	—	Reset input
13	XIN		—	—	—	—	—	—	Oscillation circuit (4MHz)
14	XOUT		—	—	—	—	—	—	Oscillation circuit (4MHz)
15	Vss	GND	—	—	GND	—	—	—	Connected to GND
16	P20/INT 5	Not Used	I	—	GND	—	Z	—	Connected to GND
17	P30/INT 3	REMOTE	I	—	Eu	E&L	Z	—	Remote control signal input
18	P31/TC4	STEREO	I	—	Eu	Lv	Z	—	When stereo receiving "L"
19	P32/SCK	Not Used	I	—	GND	—	Z	—	Connected to GND
20	P33/SI	Do	I	—	Eu	S	Z	—	RDS data input (data)
21	P34/SO	Not Used	I	—	GND	—	Z	—	Connected to GND
22	P35/HACK	Not Used	I	—	GND	—	Z	—	Connected to GND
23	P36	Not Used	I	N	GND	—	Z	—	Connected to GND
24	P37/HSO	STB	O	N	Eu	—	Z	H	LC72131/LC72720NM control output (latch)
25	P00	DATA	O	C	—	—	Z	H	LC72131/ LC72720NM control output (serial data)
26	P01	CLK	O	C	—	—	Z	H	LC72131/ LC72720NM control output (serial clock)
27	P02	AUTO /MANU	O	C	—	—	Z	L	Auto/Manu control signal (L: Auto)
28	P03	Not Used	I	—	GND	—	Z	—	Connected to GND
29	P04	POWER ON/OFF	O	C	—	—	Z	H	Power relay control output (H: ON)
30	P05	Not Used	O	C	—	—	Z	—	Connected to GND
31	P06	Not Used	O	C	—	—	Z	—	Connected to GND
32	P07	Not Used	O	C	—	—	Z	—	Connected to GND
33	VDD	VDD	—	—	—	—	—	—	Connected to +5V
34	P60	Not Used	I	—	GND	—	Z	—	Connected to GND
35	P61	Not Used	I	—	GND	—	Z	—	Connected to GND
36	P62	G1	O	P	Id	—	Z	—	FLD Grid control output
37	P63	G2	O	P	Id	—	Z	—	FLD Grid control output
38	P64	G3	O	P	Id	—	Z	—	FLD Grid control output
39	P65	G4	O	P	Id	—	Z	—	FLD Grid control output
40	P66	G5	O	P	Id	—	Z	—	FLD Grid control output
41	P67	G6	O	P	Id	—	Z	—	FLD Grid control output
42	P70	G7	O	P	Id	—	Z	—	FLD Grid control output
43	P71	G8	O	P	Id	—	Z	—	FLD Grid control output
44	P72	G9	O	P	Id	—	Z	—	FLD Grid control output
45	P73	G10	O	P	Id	—	Z	—	FLD Grid control output
46	P74	G11	O	P	Id	—	Z	—	FLD Grid control output
47	P75	G12	O	P	Id	—	Z	—	FLD Grid control output
48	P76	G13	O	P	Id	—	Z	—	FLD Grid control output

Pin No.	Port Name	Symbol	I/O	Typ	Op	Det	Res	Ini	Function
49	P77	G14	I	—	Id	—	Z	—	FLD Grid control output
50	P80	a1	O	P	Id	—	Z	—	FLD Anode control output
51	P81	a2	O	P	Id	—	Z	—	FLD Anode control output
52	P82	b	O	P	Id	—	Z	—	FLD Anode control output
53	P83	c	O	P	Id	—	Z	—	FLD Anode control output
54	P84	d2	O	P	Id	—	Z	—	FLD Anode control output
55	P85	d1	O	P	Id	—	Z	—	FLD Anode control output
56	P66	e	O	P	Id	—	Z	—	FLD Anode control output
57	P87	f	O	P	Id	—	Z	—	FLD Anode control output
58	P90	j	O	P	Id	—	Z	—	FLD Anode control output
59	P91	k	O	P	Id	—	Z	—	FLD Anode control output
60	P92	m	O	P	Id	—	Z	—	FLD Anode control output
61	P93	n	O	P	Id	—	Z	—	FLD Anode control output
62	P94	p	O	P	Id	—	Z	—	FLD Anode control output
63	P95	r	O	P	Id	—	Z	—	FLD Anode control output
64	P96	q	O	P	Id	—	Z	—	FLD Anode control output
65	P97	h	O	P	Id	—	Z	—	FLD Anode control output
66	VKK	Vkk	—	—	—	—	—	—	FLD Drive battery
67	P40/KEY0	Not Used	I	—	GND	—	Z	—	Connected to GND
68	P41/KEY1	Not Used	I	—	GND	—	Z	—	Connected to GND
69	P42/KEY2	Not Used	I	—	GND	—	Z	—	Connected to GND
70	P43/KEY3	LW	I	—	—	Lv	Z	—	LW band setting (H: yes)
71	P44/KEY4	Not Used	I	—	Eu	—	Z	—	Connected to GND
72	P45/KEY5	Not Used	I	—	Eu	—	Z	—	Connected to GND
73	P46/CIN5	KEY1	I	—	Eu	Lv	Z	—	Key input
74	P47/CIN4	KEY2	I	—	Eu	Lv	Z	—	Key input
75	P50/CIN3	KEY3	I	—	Eu	Lv	Z	—	Key input
76	P51/CIN2	KEY3	I	—	Eu	Lv	Z	—	Key input
77	P52/CIN1	VER.	I	—	Eu	Lv	Z	—	Destination setting
78	P53/CIN0	VER.	I	—	Eu	Lv	Z	—	Specifications setting
79	P54	MUTE	O	N	Eu	—	Z	H	Mute output (H: Mute)
80	P55/PMW	PRESET	O	—	Eu	—	Z	—	LED Drive output

- NOTE:** Pin No. : Terminal number of microcomputer.
Port Name : The name entered on the data sheet of microcomputer.
Symbol : Symbolized interface function.
I/O : Input or out of port.
 "I" = Input port
 "O" = Output port
Type : Composition of port in case of output port.
 "C" = CMOS output
 "N" = NMOS open drain output
 "P" = PMOS open drain output
OP : Pull up/Pull down selection information.
 "Iu" = Inner microcomputer pull up
 "Id" = Inner microcomputer pull down
 "Eu" = External microcomputer pull up
 "Ed" = External microcomputer pull down
Det : Indicates judging state of input port. Level detection is "LV"; Edge detection is "Ed"; Detection by both shifting is "E&L"; Serial data detection is "S" (Serial data output is also "S").
Res : State at reset.
 "H" = Outputs High Level at reset
 "L" = Output Low Level at reset
 "Z" = Becomes High impedance mode at reset
Ini : Initial output state.
Function : Function and logical level explanation of signals to be interface.

LC72720NM

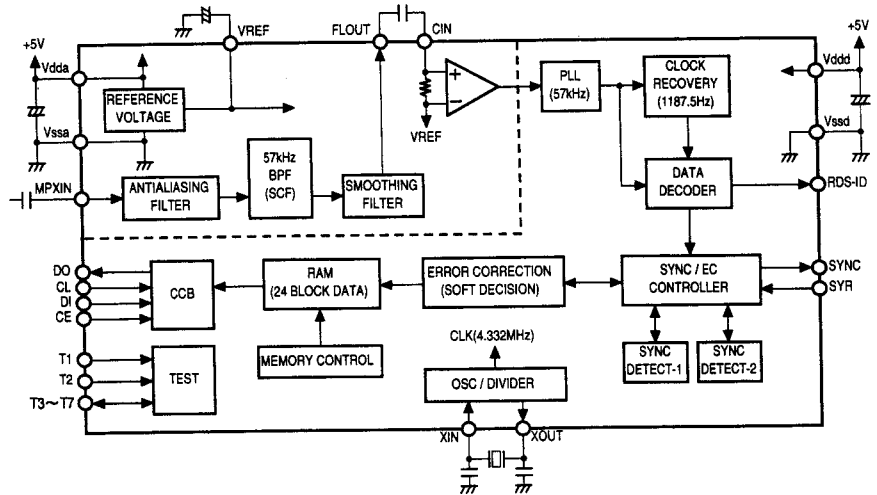
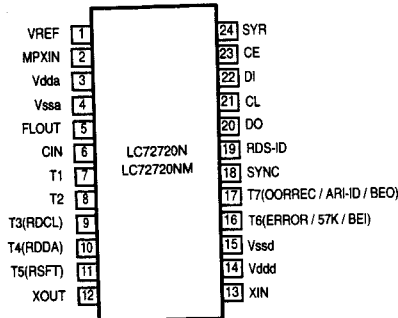
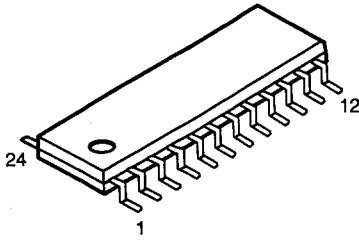

LC72720NM Terminal Function

Pin No.	Terminal	I/O	Function
1	VREF	O	Ref. voltage output ($V_{dda}/2$).
2	MPXIN	I	Base band (multiplex) signal input.
3	Vdda	—	Analog part power (+5V).
4	Vssa	—	Analog part GND.
5	FLOUT	O	Sub-carrier output (filter output).
6	CIN	I	Sub-carrier input (comparator input).
7	T1	I	Test input (connect to GND).
8	T2	I	Test input (standby cont.) 0: normal, 1: standby
9	T3 (RDCL)	I	Test I/O (RDS clock output).
10	T4 (RDDA)	I/O*	Test I/O (RDS data output).
11	T5 (RSFT)	I/O*	Test I/O (judge data output).
12	XOUT	O	X'tal osc, output (4.332/8.664 MHz).
13	XIN	I	X'tal osc. input (external ref. signal input).
14	Vddd	—	Digital part power (+5V).
15	Vssd	—	Digital GND.
16	T6 (ERROR/57K/BE1)	I/O*	Test I/O (error, play carrier, error block output).
17	T7 (CORREC/ARI-ID/BE0)	I/O*	Test I/O (error correct, SK detect, error block output).
18	SYNC	I/O*	Block sync. detect output.
19	RDS-ID	O	RDS detect output.
20	DO	O	Data output.
21	CL	I	Clock input.
22	DI	I	Data input.
23	CE	I	Chip enable.
24	SYR	I	sync. & RAM address reset (positive logic).

* Normal output terminal, used in/out terminal at test (user setting impossible).

LA1265 (S) (IC101)
LA3401 (IC102)

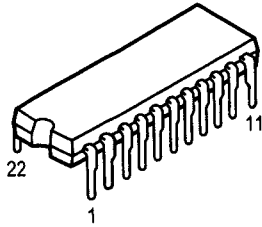

LA1265 (S)

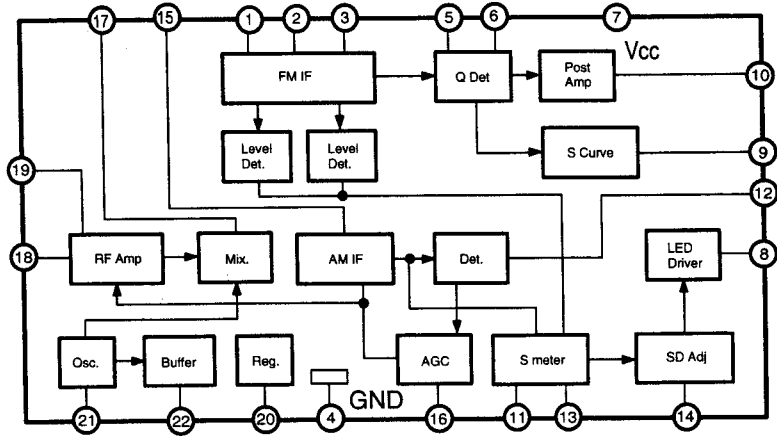

LA3401

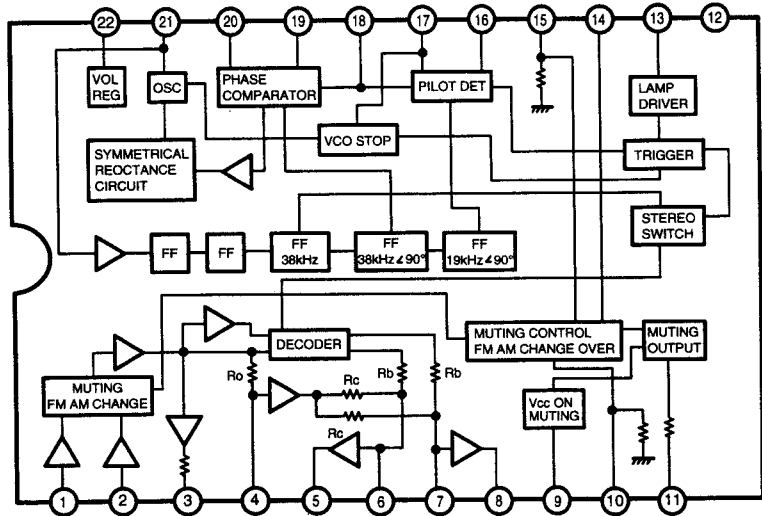

LC72131M (IC104)

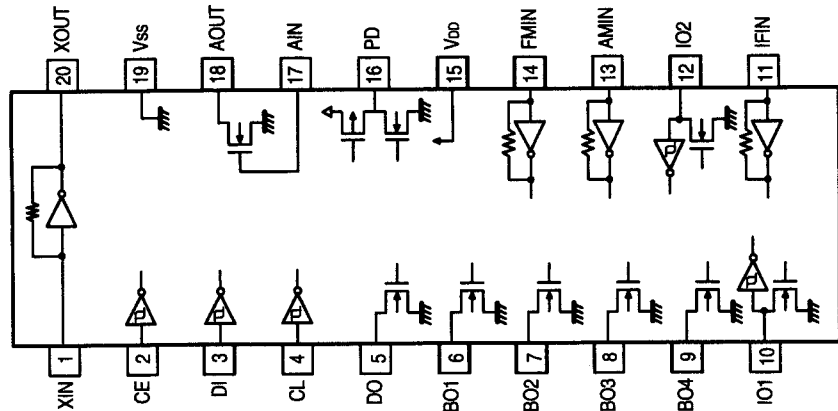
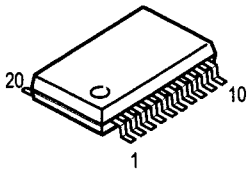

BA178M12 (IC106)
BA178M06 (IC107)

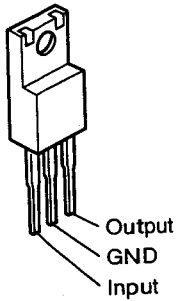

1: Output
2: GND
3: Input

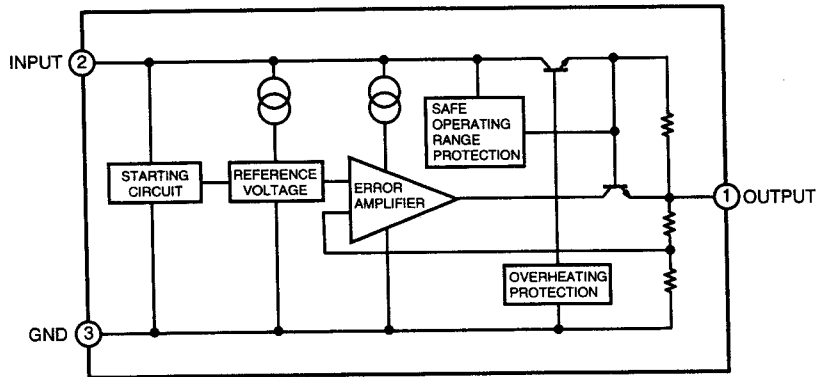

● TRANSISTORS

DTA114EK
DTC144EK
DTC323TK

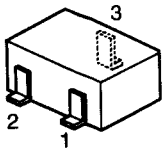

1: GND/Emitter
2: Input/Base
3: Output/Collector

DTA114EK

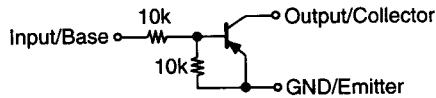

DTC144EK

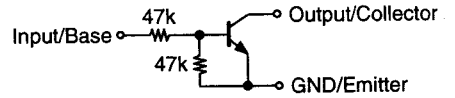

DTC323TK

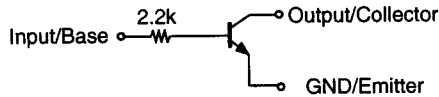

2SK211 (Y/GR)

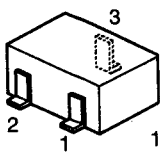

1: Gate
2: Drain
3: Source

2SA1037K(S/R)
2SB1197 (Q/R)
2SC2412 (S)
2SC2413 (Q)
2SC3326(A/B)

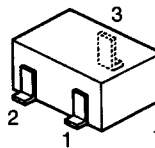

1: Emitter
2: Base
3: Collector

● DIODES

1SR35-200A

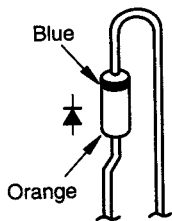

MA151A

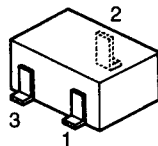

1: Cathode
2: Cathode
3: Anode

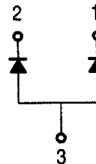

UDZ3.3B
UDZ6.8B
UDZ12B
UDZ30B

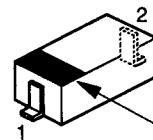

1: Cathode
2: Anode



● REMOTE CONTROL SENSOR

GP1U271X (IC302)

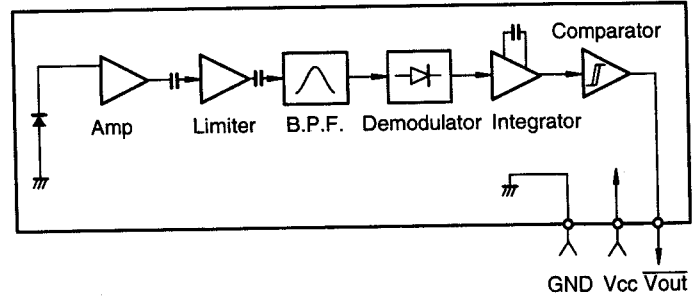
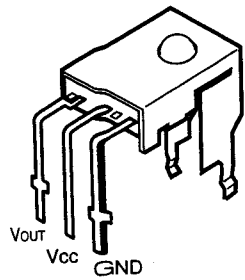

● FLD (14-B F39GK)

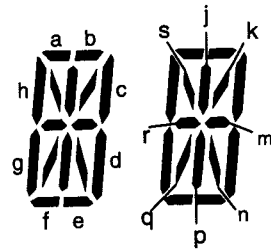
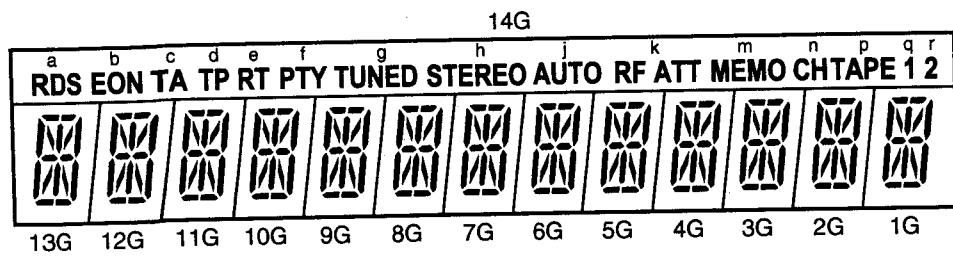
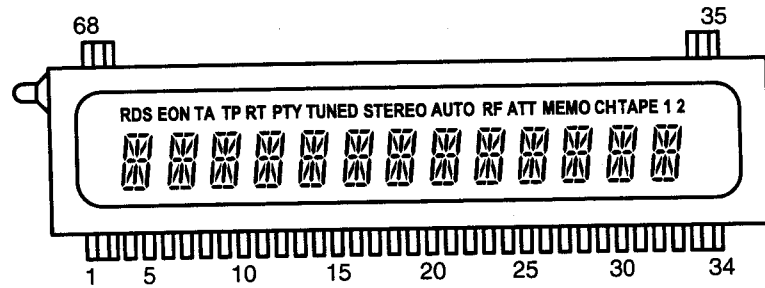

TERMINAL CONNECTION

(UPPER)

TERMINAL NO.	68	67	66	65	64	63	62	61	60	59	58	57	56	55	54	53	52			
ELECTRODE	F1	F1	NP	NP	NP	NP	NP	NP	NP	NP	NP	NP	NP	NP	NP	NP	NP			
TERMINAL NO.				51	50	49	48	47	46	45	44	43	42	41	40	39	38	37	36	35
ELECTRODE				F1	F1	NP	NP	NP	NP	NP	NP	NP	NP	NP	NP	NP	NP	NP	NP	NP

(LOWER)

TERMINAL NO.				18	19	20	21	22	23	24	25	26	27	28	29	30	31	32	33	34	
ELECTRODE				F1		14G	13G	12G	11G	10G	9G	8G	7G	6G	5G	4G	3G	2G	1G	F2	F2
TERMINAL NO.	1	2	3	4	5	6	7	8	9	10	11	12	13	14	15	16	17				
ELECTRODE	F1	F1	P	P	P	P	P	P	P	P	P	P	P	P	P	P	P				
			s	r	q	p	n	m	k	j	h	g	f	e	d	c	b				

Notes: F: Filament
G: Grid
P: Anode
NP: NO. Pin

PRINTED WIRING BOARD

1U-3299-1 TUNER UNIT / 1U-3299-2 DISPLAY UNIT

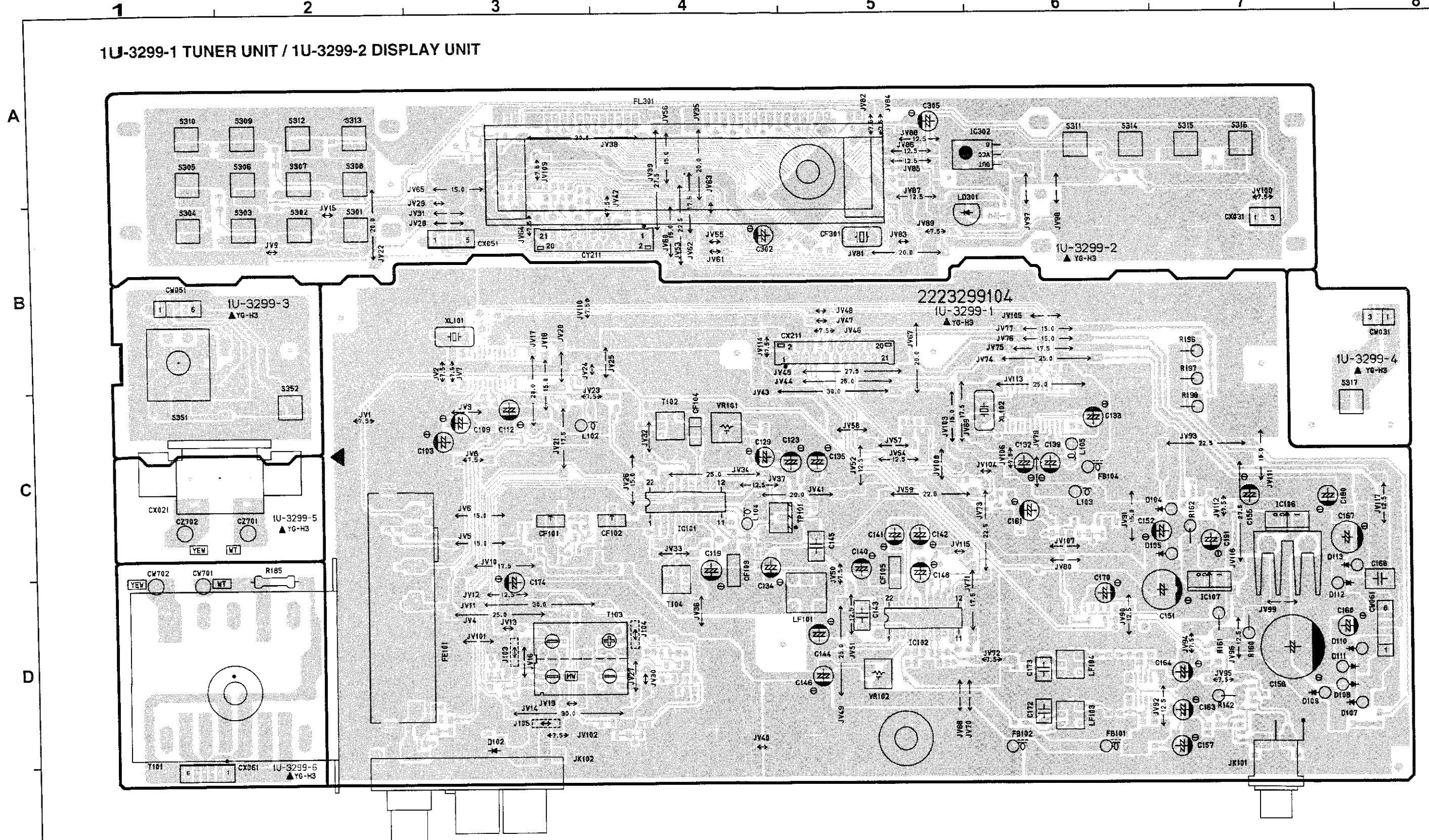

COMPONENT SIDE

1 2 3 4 5 6 7 8

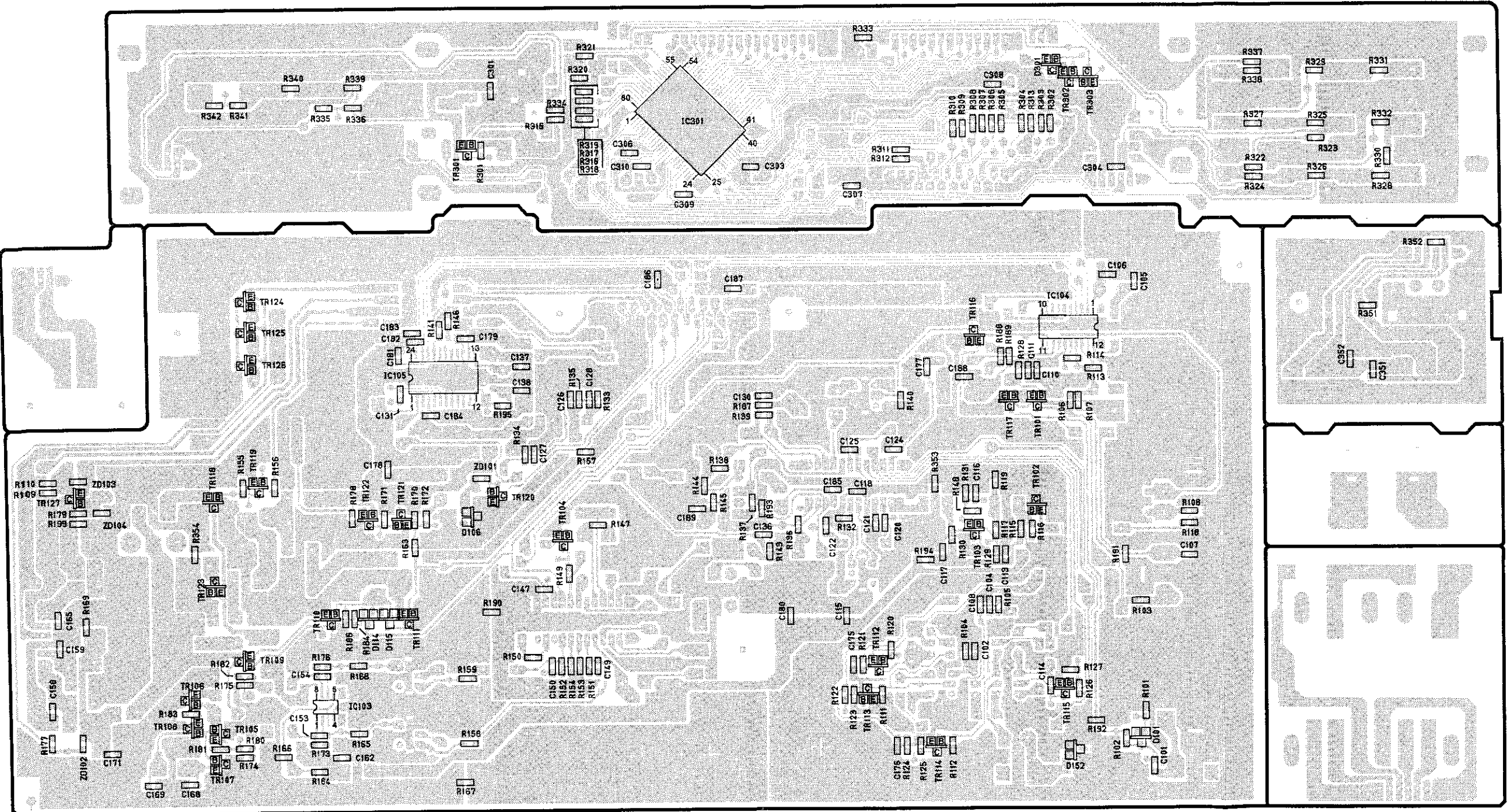

A

B

C

D

E

FOIL SIDE

NOTE FOR PARTS LIST

- Part indicated with the mark "⊙" are not always in stock and possibly to take a long period of time for supplying, or in some case supplying of part may be refused.
- When ordering of part, clearly indicate "1" and "I" (i) to avoid mis-supplying.
- Ordering part without stating its part number can not be supplied.
- Part indicated with the mark "★" is not illustrated in the exploded view.
- Not including Carbon Film ±5%, 1/4W Type in the P.W.Board parts list. (Refer to the Schematic Diagram for those parts.)

WARNING:
Parts marked with this symbol  have critical characteristics.
Use ONLY replacement parts recommended by the manufacturer.

● Resistors

Ex.: **RN** **14K** **2E** **182** **G** **FR**
Type Shape Power Resist- Allowable Others
 and per- ance error
 formance

RD : Carbon	2B : 1/8W	F : ±1%	P : Pulse-resistant type
RC : Composition	2E : 1/4W	G : ±2%	NL : Low noise type
RS : Metal oxide film	2H : 1/2W	J : ±5%	NB : Non-burning type
RW : Winding	3A : 1W	K : ±10%	FR : Fuse-resistor
RN : Metal film	3D : 2W	M : ±20%	F : Lead wire forming
RK : Metal mixture	3F : 3W		
	3H : 5W		

* Resistance
1 8 2 ⇒ 1800 ohm = 1.8 kohm
 ↑ ↑ ↑
 1-digit effective number. 2-digit effective number.
Indicates number of zeros after effective number.
• Units: ohm

1 R 2 ⇒ 1.2 ohm
 ↑ ↑ ↑
 1-digit effective number. 2-digit effective number, decimal point indicated by R.
• Units: ohm

● Capacitors

Ex.: **CE** **04W** **1H** **2R2** **M** **BP**
Type Shape Dielectric Capacity Allowable Others
 and per- strength error
 formance

CE : Aluminum foil electrolytic	0J : 6.3V	F : ±1%	HS : High stability type
CA : Aluminum solid electrolytic	1A : 10V	G : ±2%	BP : Non-polar type
CS : Tantalum electrolytic	1C : 16V	J : ±5%	HR : Ripple-resistant type
CQ : Film	1E : 25V	K : ±10%	DL : For change and discharge
CK : Ceramic	1V : 35V	M : ±20%	HF : For assuring high frequency
CC : Ceramic	1H : 50V	Z : +80%	U : UL part
CP : Oil	2A : 100V	-20%	C : CSA part
CM : Mica	2B : 125V	P : +100%	W : UL-CSA type
CF : Metallized	2C : 160V	-0%	F : Lead wire forming
CH : Metallized	2D : 200V	C : ±0.25pF	
	2E : 250V	D : ±0.5pF	
	2H : 500V	= : Others	
	2J : 630V		

* Capacity (electrolyte only)
2 2 2 ⇒ 2200µF
 ↑ ↑ ↑
 1-digit effective number. 2-digit effective number.
Indicates number of zeros after effective number.
• Units: µF.

2 R 2 ⇒ 2.2µF
 ↑ ↑ ↑
 1-digit effective number. 2-digit effective number, decimal point indicated by R.
• Units: µF.

* Capacity (except electrolyte)
2 2 2 ⇒ 2200pF=0.0022µF
 ↑ ↑ ↑
 1-digit effective number. 2-digit effective number.
(More than 2) — Indicates number of zeros after effective number.
• Units: pF.

2 2 1 ⇒ 220pF
 ↑ ↑ ↑
 1-digit effective number. 2-digit effective number.
(0 or 1) — Indicates number of zeros after effective number.
• Units: pF.

• When the dielectric strength is indicated in AC, "AC" is included after the dielectric strength value.

PARTS LIST OF P.W.B. UNIT ASS'Y 1U-3299 MAIN P.W.B. UNIT

Ref. No.	Part No.	Part Name	Remarks	Ref. No.	Part No.	Part Name	Remarks
SEMICONDUCTORS GROUP				RESISTORS GROUP			
IC101	263 0891 001	IC LA1265(S)		R101	247 0002 966	Carbon chip 10 ohm 1/10W	RM73B-101J
IC102	263 0439 007	IC LA3401		R102,103	247 0007 945	Carbon chip 1 kohm 1/10W	RM73B-102J
IC103	263 0672 903	IC BA4558F		R104	247 0012 927	Carbon chip 100 kohm 1/10W	RM73B-104J
IC104	262 2450 900	IC LC72131M-TLM		R105	247 0007 945	Carbon chip 1 kohm 1/10W	RM73B-102J
IC105	262 2547 907	IC LC72720NM		R106	247 0009 927	Carbon chip 5.6 kohm 1/10W	RM73B-562J
IC106	263 1004 004	IC BA178M12		R107	247 0009 985	Carbon chip 10 kohm 1/10W	RM73B-103J
IC107	263 1010 001	IC BA178M06		R108	247 0005 905	Carbon chip 100 ohm 1/10W	RM73B-101J
IC301	262 2527 008	IC TMP87CM71F-6754		R110-112	247 0018 905	Carbon chip 0 ohm 1/10W	RM73B-0R0K TU-235RD only
IC302	499 0290 007	Remocon sensor GP1U271X		R113	247 0008 944	Carbon chip 2.7 kohm 1/10W	RM73B-272J
TR101	269 0083 901	Transistor DTA114EK		R114	247 0007 945	Carbon chip 1 kohm 1/10W	RM73B-102J
TR102	275 0074 902	FET 2SK211-Y/GR		R115	247 0006 920	Carbon chip 330 ohm 1/10W	RM73B-331J
TR103	273 0438 908	Transistor 2SC2413K(Q)		R117	247 0005 989	Carbon chip 220 ohm 1/10W	RM73B-221J
TR104	269 0054 901	Transistor DTC144EK		R118	247 0006 920	Carbon chip 330 kohm 1/10W	RM73B-331J
TR105-108	269 0066 902	Transistor DTC323TK		R119	247 0006 962	Carbon chip 470 ohm 1/10W	RM73B-471J
TR109	269 0083 901	Transistor DTA114EK		R129	247 0008 931	Carbon chip 2.4 kohm 1/10W	RM73B-242J
TR110,111	269 0054 901	Transistor DTC144EK		R130	247 0006 920	Carbon chip 330 ohm 1/10W	RM73B-331J
TR116,117	269 0083 901	Transistor DTA114EK		R131	247 0008 902	Carbon chip 1.8 kohm 1/10W	RM73B-182J
TR118	272 0153 905	Transistor 2SB1197K(Q/R)		R132	247 0010 929	Carbon chip 15 kohm 1/10W	RM73B-153J
TR119-121	269 0054 901	Transistor DTC144EK		R133-135	247 0009 927	Carbon chip 5.6 kohm 1/10W	RM73B-562J
TR122	273 0384 900	Transistor 2SC2412K(S)		R136	247 0005 905	Carbon chip 100 ohm 1/10W	RM73B-101J
TR123	269 0083 901	Transistor DTA114EK		R137	247 0011 928	Carbon chip 39 kohm 1/10W	RM73B-393J
TR124-126	273 0414 906	Transistor 2SC3326 (A/B)		R138	247 0009 985	Carbon chip 10 kohm 1/10W	RM73B-103J
TR127	271 0238 908	Transistor 2SA1037K (S/R)		R139	247 0009 901	Carbon chip 4.7 kohm 1/10W	RM73B-472J
TR301	269 0083 901	Transistor DTA114EK		R140	247 0011 986	Carbon chip 68 kohm 1/10W	RM73B-683J
TR302	269 0054 901	Transistor DTC144EK		R141	247 0009 985	Carbon chip 10 kohm 1/10W	RM73B-103J
TR303	269 0083 901	Transistor DTA114EK		R142	244 2064 932	Metal oxide 3.9 kohm 1W (NB)	RS14B3A392JNBS (S)
D101	276 0438 910	Diode MA151A		R143	247 0008 944	Carbon chip 2.7 kohm 1/10W	RM73B-272J
D104,105	276 0553 905	Diode 1SR35-200A		R144	247 0009 985	Carbon chip 10 kohm 1/10W	RM73B-103J
D106	276 0438 910	Diode MA151A		R145	247 0008 960	Carbon chip 3.3 kohm 1/10W	RM73B-332J
D107-113	276 0553 905	Diode 1SR35-200A		R146	247 0009 985	Carbon chip 10 kohm 1/10W	RM73B-103J
D114,115	276 0438 910	Diode MA151A		R147	247 0009 927	Carbon chip 5.6 kohm 1/10W	RM73B-562J
D152	276 0438 910	Diode MA151A		R148	247 0005 905	Carbon chip 100 ohm 1/10W	RM73B-101J
D301	276 0438 910	Diode MA151A		R149	247 0012 927	Carbon chip 100 kohm 1/10W	RM73B-104J
ZD101	276 0686 908	Zener diode UDZ3.3B	3.3V	R150	247 0011 915	Carbon chip 36 kohm 1/10W	RM73B-363J
ZD102,103	276 0694 932	Zener diode UDZ6.8B	6.8V	R151,152	247 0012 927	Carbon chip 100 kohm 1/10W	RM73B-104J
ZD104	276 0686 911	Zener diode UDZ30B	30V	R153,154	247 0012 998	Carbon chip 200 kohm 1/10W	RM73B-204J
LD301	393 9502 906	LED SEL4214R		R155	247 0007 987	Carbon chip 1.5 kohm 1/10W	RM73B-152J
FL301	393 8020 007	VFD (14-BT-39GK)		R156	247 0009 927	Carbon chip 5.6 kohm 1/10W	RM73B-562J
				R157	247 0013 900	Carbon chip 220 kohm 1/10W	RM73B-224J
				R158,159	247 0008 928	Carbon chip 2.2 kohm 1/10W	RM73B-222J
				R160,161	244 2055 970	Metal oxide 56 ohm 1W	RS14B3A560JNBS(S)
				R162	244 2055 938	Metal oxide 6.8 ohm 1W	RS14B3A6R8JNBS(S)
				R163	247 0009 985	Carbon chip 10 kohm 1/10W	RM73B-103J
				R164	247 0010 916	Carbon chip 13 kohm 1/10W	RM73B-133J
				R165	247 0009 901	Carbon chip 4.7 kohm 1/10W	RM73B-472J
				R166	247 0009 985	Carbon chip 10 kohm 1/10W	RM73B-103J
				R168	247 0009 901	Carbon chip 4.7 kohm 1/10W	RM73B-472J
				R169	247 0012 927	Carbon chip 100 kohm 1/10W	RM73B-104J
				R170	247 0007 945	Carbon chip 1 kohm 1/10W	RM73B-102J
				R171	247 0009 901	Carbon chip 4.7 kohm 1/10W	RM73B-472J

Ref. No.	Part No.	Part Name	Remarks	Ref. No.	Part No.	Part Name	Remarks
R172	247 0007 945	Carbon chip 1 kohm 1/10W	RM73B--102J	C107	257 0012 966	Ceramic chip 0.01 μF/50V	CK73F1H103Z
R173	247 0009 956	Carbon chip 7.5 kohm 1/10W	RM73B--752J	C108	257 0010 900	Ceramic chip 0.01 μF/50V	CK73B1H103K
R174,175	247 00 11 944	Carbon chip 47 kohm 1/10W	RM73B--473J	C109	254 4524 943	Electrolytic 1 μF/50V	CE04W1H010M SMG/RE3
R176	247 0009 956	Carbon chip 7.5 kohm 1/10W	RM73B--752J	C110	257 0004 961	Ceramic chip 100 pF/50V	CC73SL1H101J
R177	247 0009 985	Carbon chip 10 kohm 1/10W	RM73B--103J	C111	257 0012 966	Ceramic chip 0.01 μF/50V	CK73F1H103Z
R178	247 00 10 958	Carbon chip 20 kohm 1/10W	RM73B--203J	C112	254 4524 943	Electrolytic 1 μF/50V	CE04W1H010M SMG/RE3
R179	247 0009 901	Carbon chip 4.7 kohm 1/10W	RM73B--472J	C113	257 0012 966	Ceramic chip 0.01 μF/50V	CK73F1H103Z
R180-183	247 0004 906	Carbon chip 39 ohm 1/10W	RM73B--390J	C115	257 0010 984	Ceramic chip 0.047mF/50V	CK73B1H473K
R184	247 00 10 961	Carbon chip 22 kohm 1/10W	RM73B--223J	C116,117	257 0012 966	Ceramic chip 0.01 mF/50V	CK73F1H103Z
R186	247 00 12 985	Carbon chip 180 kohm 1/10W	RM73B--184J	C119	254 4524 927	Electrolytic 0.33 μF/50V	CE04W1HR33M SMG/RE3
R187	247 0009 927	Carbon chip 5.6 kohm 1/10W	RM73B--562J	C120,121	257 0012 966	Ceramic chip 0.01 μF/50V	CK73F1H103Z
R191-193	247 0018 905	Carbon chip 0 ohm 1/10W	RM73B--0R0K	C123	254 4524 930	Electrolytic 0.47 μF/50V	CE04W1HR47M SMG/RE3
R194,195	247 0002 966	Carbon chip 10 ohm 1/10W	RM73B--100J	C124	257 0004 961	Ceramic chip 100 pF/50V	CC73SL1H101J
R196-198	244 2050 991	Metal oxide 6.8 kohm 1W (NB)	RS14B3A682JNBS (S)	C125	257 0012 966	Ceramic chip 0.01 μF/50V	CK73F1H103Z
R199	247 0012 927	Carbon chip 100 kohm 1/10W	RM73B--104J	C129	254 4524 943	Electrolytic 1 μF/50V	CE04W1H010M SMG/RE3
R301	247 0006 920	Carbon chip 330 ohm 1/10W	RM73B--331J	C130	257 0012 982	Ceramic chip 0.022 μF/50V	CK73F1H223Z
R302	247 0005 905	Carbon chip 100 ohm 1/10W	RM73B--101J	C131	257 0006 943	Ceramic chip 560 pF/50V	CC73SL1H561J
R303	247 0018 905	Carbon chip 0 ohm 1/10W	RM73B--0R0K	C132	254 4524 943	Electrolytic 1 μF/50V	CE04W1H010M SMG/RE3
R304-312	247 0005 905	Carbon chip 100 ohm 1/10W	RM73B--101J	C133	254 4522 916	Electrolytic 10 μF/35V	CE04W1V100M SMG/RE3
R313	247 0009 985	Carbon chip 10 kohm 1/10W	RM73B--103J	C134	254 4522 929	Electrolytic 22 μF/35V	CE04W1V220M SMG/RE3
R315,316	247 0009 985	Carbon chip 10 kohm 1/10W	RM73B--103J	C135	254 4522 916	Electrolytic 10 μF/35V	CE04W1V100M SMG/RE3
R317	247 0010 958	Carbon chip 20 kohm 1/10W	RM73B--203J	C136	257 0004 961	Ceramic chip 100 pF/50V	CC73SL1H101J
R321	247 0018 905	Carbon chip 0 ohm 1/10W	RM73B--0R0K	C137,138	257 0003 904	Ceramic chip 22 pF/50V	CC73SL1H220J
R322,323	247 0007 945	Carbon chip 1 kohm 1/10W	RM73B--102J	C139	254 4524 943	Electrolytic 1 μF/50V	CE04W1H010M SMG/RE3
R324,325	247 0005 976	Carbon chip 200 ohm 1/10W	RM73B--201J	C140	254 4522 916	Electrolytic 10 μF/35V	CE04W1H100M SMG/RE3
R326,327	247 0006 917	Carbon chip 300 ohm 1/10W	RM73B--301J	C141	254 4524 943	Electrolytic 1 μF/50V	CE04W1H010M SMG/RE3
R328,329	247 0006 975	Carbon chip 510 ohm 1/10W	RM73B--511J	C142	254 4524 914	Electrolytic 2.2 μF/50V	CE04W1HR22M SMG/RE3
R330,331	247 0007 945	Carbon chip 1 kohm 1/10W	RM73B--102J	C143	256 1058 939	Metalized 0.047 μF/50V	CF93A1H473J (JL)
R332	247 0008 957	Carbon chip 3 kohm 1/10W	RM73B--302J	C144	254 4522 929	Electrolytic 22 μF/35V	CE04W1V220M SMG/RE3
R333	247 0011 960	Carbon chip 56 kohm 1/10W	RM73B--563J	C145	256 1058 942	Metalized 0.056 μF/50V	CF93A1H563J (JL)
R334	247 0007 945	Carbon chip 1 kohm 1/10W	RM73B--102J	C146	254 4522 916	Electrolytic 10 μF/35V	CE04W1V100M SMG/RE3
R335	247 0005 976	Carbon chip 200 ohm 1/10W	RM73B--201J	C147	257 0012 966	Ceramic chip 0.01 μF/50V	CK73F1H103Z
R336	247 0006 917	Carbon chip 300 ohm 1/10W	RM73B--301J	C148	254 4524 943	Electrolytic 1 μF/50V	CE04W1H010M SMG/RE3
R337	247 0006 975	Carbon chip 510 ohm 1/10W	RM73B--511J	C149,150	257 0006 930	Ceramic chip 510 pF/50V	CC73SL1H511J
R338,339	247 0007 945	Carbon chip 1 kohm 1/10W	RM73B--102J	C151	254 4327 904	Electrolytic 1000 μF/6.3V	CE04W0J102M(SMG)
R340	247 0005 976	Carbon chip 200 ohm 1/10W	RM73B--201J	C152	254 4522 916	Electrolytic 10 μF/35V	CE04W1V100M SMG/RE3
R341	247 0006 917	Carbon chip 300 ohm 1/10W	RM73B--301J	C155	254 4522 916	Electrolytic 10 μF/35V	CE04W1V100M SMG/RE3
R342	247 0006 975	Carbon chip 510 ohm 1/10W	RM73B--511J	C156	254 4428 706	Electrolytic 2200 μF/35V	CE04W1V222M(SMG)
R351,352	247 0011 944	Carbon chip 47 kohm 1/10W	RM73B--473J	C157	254 4522 945	Electrolytic 47 μF/35V	CE04W1V470M SMG/RE3
R354	247 0018 905	Carbon chip 0 ohm 1/10W	RM73B--0R0K	C158,159	257 0012 966	Ceramic chip 0.01 μF/50V	CK73F1H103Z
VR101	211 6093 941	Semi fixed resistor 10 kohm	V06PB103	C160	254 4524 943	Electrolytic 1 μF/50V	CE04W1H010M SMG/RE3
VR102	211 6093 967	Semi fixed resistor 47 kohm	V06PB473	C161	254 4524 972	Electrolytic 4.7 μF/50V	CE04W1HR7M SMG/RE3
C101	257 0008 983	Ceramic chip 1000 pF/50V	CK73B1H102K	C162	257 0012 966	Ceramic chip 0.01 μF/50V	CK73F1H103Z
C102	257 0002 947	Ceramic chip 12 pF/50V	CC73SL1H120J	C163,164	254 4522 916	Electrolytic 10 μF/35V	CE04W1V100M SMG/RE3
C103	254 4522 945	Electrolytic 47 μF/35V	CE04W1V470M SMG/RE3	C165	257 0012 966	Ceramic chip 0.01 μF/50V	CK73F1H103Z
C104	257 0012 966	Ceramic chip 0.01 μF/50V	CK73F1H103Z	C166	256 1058 971	Metalized 0.1 μF/50V	CF93A1H104J (JL)
C105,106	257 0002 963	Ceramic chip 15 pF/50V	CC73SL1H150J	C167	254 4525 926	Electrolytic 100 μF/50V	CE04W1H101M SMG/RE3
C170	254 4524 956	Electrolytic 2.2 μF/50V	CE04W1H2R2M SMG/RE3	C168,169	257 0009 953	Ceramic chip 3900 pF/50V	CK73B1H392K
C171	257 0012 966	Ceramic chip 0.01 μF/50V	CK73F1H103Z	C170	254 4524 956	Electrolytic 2.2 μF/50V	CE04W1H2R2M SMG/RE3
C172,173	255 1264 979	Mylar film 3900 pF/50V	CQ93M1H392J(B)	C171	257 0012 966	Ceramic chip 0.01 μF/50V	CK73F1H103Z
C174	254 4522 916	Electrolytic 10 μF/35V	CE04W1V100M SMG/RE3	C172,173	255 1264 979	Mylar film 3900 pF/50V	CQ93M1H392J(B)
C174	254 4522 916	Electrolytic 10 μF/35V	CE04W1V100M SMG/RE3	C174	254 4522 916	Electrolytic 10 μF/35V	CE04W1V100M SMG/RE3

Ref. No.	Part No.	Part Name	Remarks	Q'ty
C177	257 0012 966	Ceramic chip 0.01 μF/50V	CK73F1H103Z	1
C178,179	257 0008 983	Ceramic chip 1000 pF/50V	CK73B1H102K	1
C182	257 0008 983	Ceramic chip 1000 pF/50V	CK73B1H102K	1
C184-188	257 0008 983	Ceramic chip 1000 pF/50V	CK73B1H102K	1
C190	254 4522 916	Electrolytic 10 μF/35V	CE04W1V100M SMG/RE3	1
C301	257 0014 935	Ceramic chip 0.1 μF/25V	CK73F1E104Z	1
C302	254 4299 906	Electrolytic 10 μF/16V	CE04W1C100M(SRE)	1
C303	257 0014 935	Ceramic chip 0.1 μF/25V	CK73F1E104Z	1
C304	257 0012 966	Ceramic chip 0.01 μF/50V	CK73F1H103Z	1
C305	254 4304 969	Electrolytic 22 μF/35V	CE04W1V220M(SRE)	1
C306	257 0012 966	Ceramic chip 0.01 μF/50V	CK73F1H103Z	1
C307-309	257 0008 983	Ceramic chip 1000 pF/50V	CK73B1H102K	1
C351,352	257 0012 966	Ceramic chip 0.01 μF/50V	CK73F1H103Z	2
OTHER PARTS				Q'ty
CF101,102	261 0064 007	Ceramic filter SFT10.7MS2		2
CF103	261 0031 001	Ceramic filter BFU450C4		1
CF104	261 0116 007	Ceramic filter SFU450B3		1
CF105	261 0079 005	Ceramic resonator CSB456F11		1
CF301	399 0191 903	Ceramic 4.00 MHz	CST4.00MGW-TF01	1
CW031	203 4834 004	3P KR-DA connector cord		1
CW051	203 8280 010	5P KR-DA connector cord		1
CW061	204 0247 012	6P KR-DA connector cord		1
CW701	203 0598 001	1P SIN cord Ass'y		1
CW702	203 0598 014	1P SIN cord Ass'y		1
Δ CX021	203 2349 009	2P Inlet		1
CX031	205 0343 032	3P connector base (KR-PH)		1
CX051	205 0343 058	5P connector base (KR-PH)		1
CX061	205 0343 061	6P connector base (KR-PH)		1
CX211	205 0549 056	21P FFC connector base		1
CY211	205 0549 056	21P FFC connector base		1
FB101,102	235 0049 900	Beads inductor		2
FB104	235 0049 900	Beads inductor		1
FE101	216 9013 004	FM front end (U) S		1
JK101	205 0274 004	2P connector base		1
JK102	205 0847 004	3P antenna terminal (PAL/F)		1
L102	235 0060 950	Inductor 10 μH		1
L103	235 0060 934	Inductor 47 μH		1
L104	235 0060 950	Inductor 10 μH		1
L105	235 0060 905	Inductor 2.2 μH		1
LF101	232 0159 008	Anti birdie filter		1
LF103,104	232 0191 008	MPX LPF		2
S301-317	212 5604 910	Tact switch -TA (ALPS)		17

Ref. No.	Part No.	Part Name	Remarks	Q'ty
S351	212 0399 000	Rotary encoder		1
S352	212 5604 910	Tact switch -TA (ALPS)		1
Δ T101	233 6329 000	Power trans.		1
T102	231 1138 009	AM IFT		1
T103	231 2096 001	MW ant.-osc. coil		1
T104	231 2099 008	FM DET trans.		1
XL101	399 0075 003	Crystal 7.2 MHz		1
XL102	399 0178 007	Crystal 4.332 MHz		1
	417 0476 007	Radiator		1
	471 3304 015	Screw 3 x 8 CBS-Z		1
	461 0877 014	Rubber sheet		2

EXPLODED VIEW

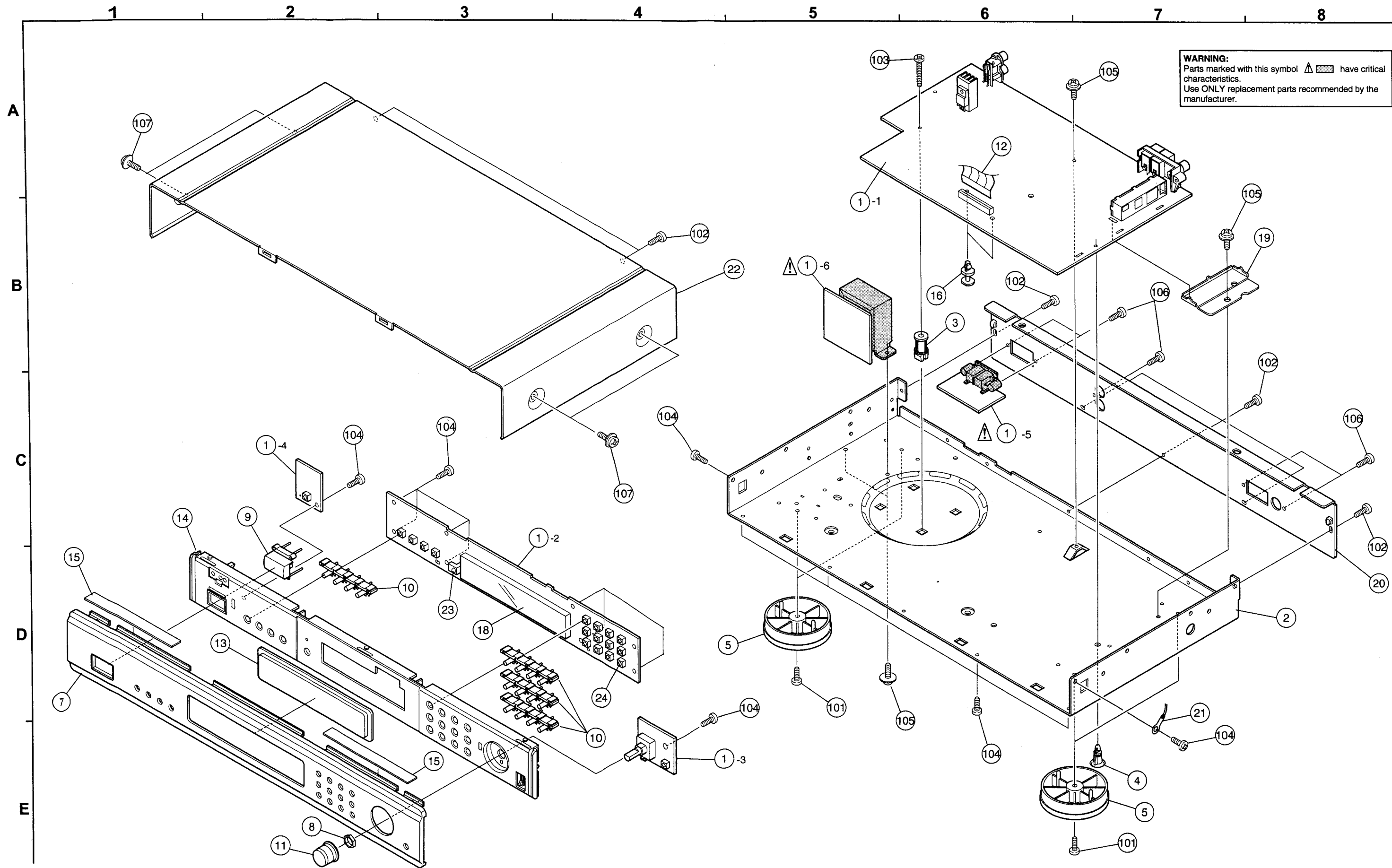

PARTS LIST OF EXPLODED VIEW

Ref. No.	Part No.	Part Name	Remarks	Q'ty
1	1U-3299	Main unit		1
1-1		Tuner unit		
1-2		Display unit		
1-3		Rot. encoder unit		
1-4		Power sw unit		
1-5		Inlet unit		
1-6		Power trans unit		
2	411 0942 902	Chassis		1
3	412 2762 002	P.W.B. holder		1
4	412 2741 007	P.W.B. holder (H=8)		1
5	104 0208 308	Foot ass'y		4
6	—	—		
7	144 2592 065	Front panel	Black model only	1
	144 2592 078	Front panel	Gold model only	1
8	—	9 nut		
9	113 1292 207	Push knob (P)	Black model only	1
	113 1292 210	Push knob (P)	Gold model only	1
10	113 1838 111	Tact knob(4)	Black model only	4
	113 1838 108	Tact knob(4)	Gold model only	4
11	112 0813 011	Tuning knob ass'y	Black model only	1
	112 0813 008	Tuning knob ass'y	Gold model only	1
12	009 0113 004	21P FFC cable		1
13	143 1081 008	Window		1
14	146 2190 104	Inner panel	Black model only	1
	146 2190 117	Inner panel	Gold model only	1
15	461 0577 000	Rubber sheet		2
16	412 2814 002	Card spacer (L=8)		1
17	—	—		
18	393 8020 007	VFD (14-BT-39GK)	FL301	
19	414 0839 001	Shield cover		1
20	105 1293 027	Back panel		1
21	203 0458 015	1P contact ass'y		1
22	102 0592 115	Top cover	Black model only	1
	102 0592 102	Top cover	Gold model only	1
23	499 0290 007	Remocon sensor GP1U271X	IC302	1
24	212 5604 910	Tact switch	S301-317,352	18
★	513 1642 002	No. sheet		1
SCREWS				
101	473 7002 018	Screw 3×8 CBTS(S)-Z		4
102	473 7015 018	Screw 3×8 CBTS(S)-B		7
103	473 7501 030	Screw 3×20 CBTS (P)-Z		1
104	473 7508 017	Screw 3×10 CBTS(P)-B		18
105	473 8007 025	Cup screw 3×8		4
106	477 0064 107	Fixing screw		5
107	477 0263 005	3P. swelling screw	Black model only	4
	477 0263 018	3P. swelling screw	Gold model only	4

PACKING VIEW

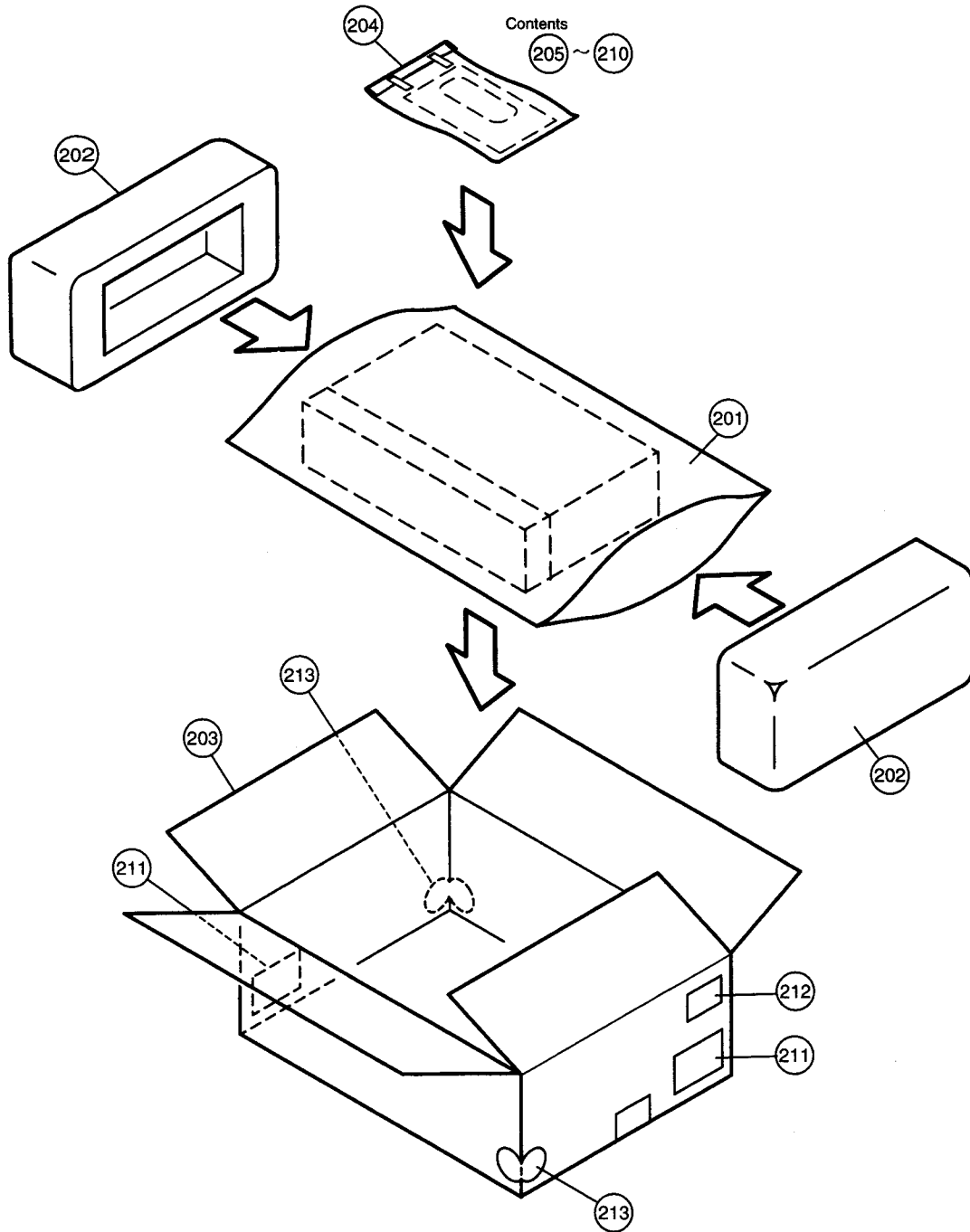

PARTS LIST OF PACKING & ACCESSORIES

Ref. No.	Part No.	Part Name	Remarks	Q'ty	Ref. No.	Part No.	Part Name	Remarks	Q'ty
201	505 0131 050	Cabinet cover		1	208	231 0922 009	Loop antenna		1
202	503 1284 007	Cushion ass'y		2	209	395 0023 008	FM ant ass'y		1
203	501 2071 006	Carton case		1	210	206 2106 003	AC cord with plug		1
204	505 9125 009	Poly cover		1	211	—	Control card		2
205	511 3616 001	Inst. manual		1	212	517 1426 000	E2 pos label	Black model only	1
206	515 0867 004	S.S.list (EX)		1		517 1426 013	E2 pos label	Gold model only	1
207	203 2310 009	2P pin cord		1	213	513 9111 001	Color label (Gold)	Gold model only	2

SCHEMATIC DIAGRAM

1

2

3

4

5

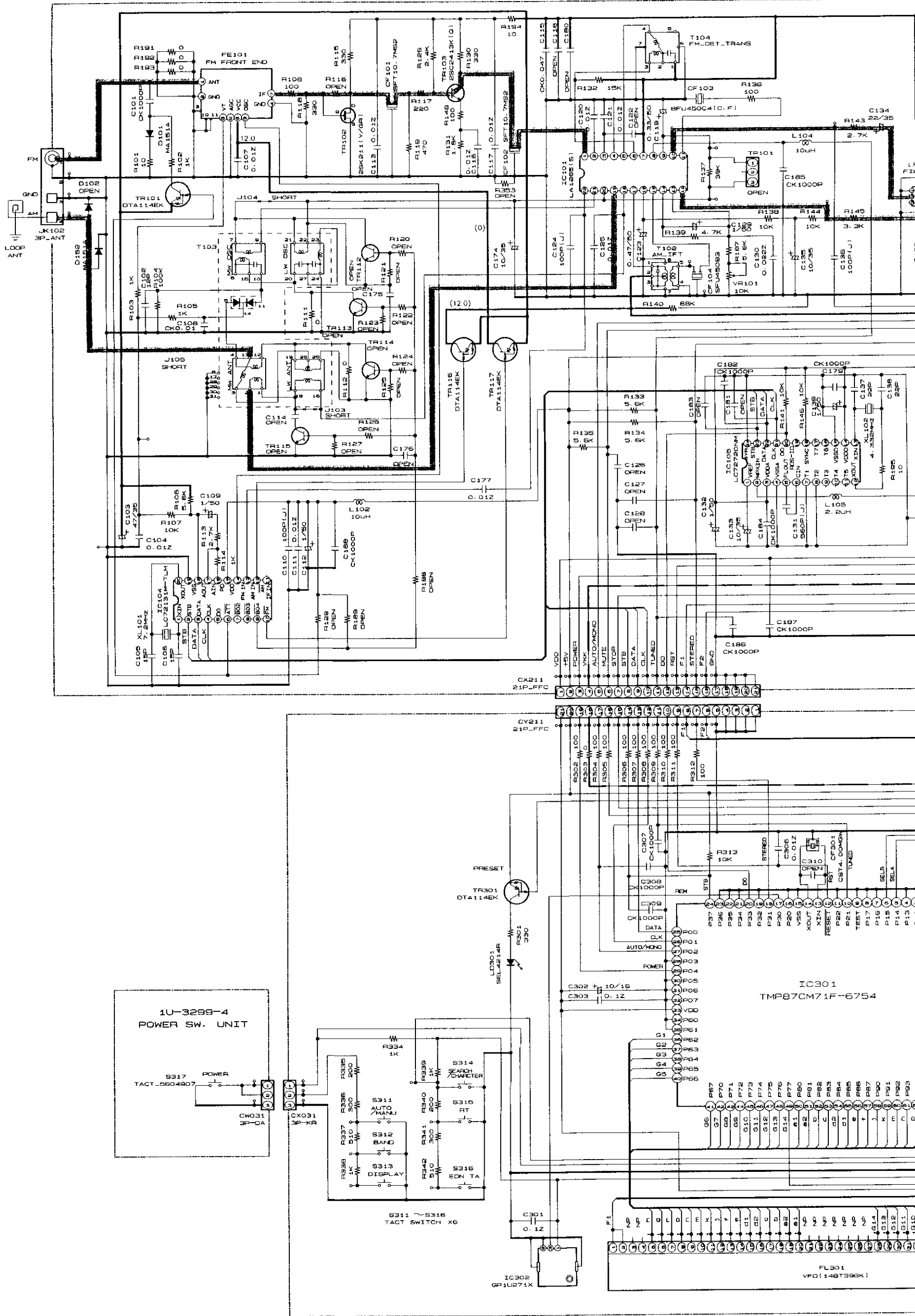

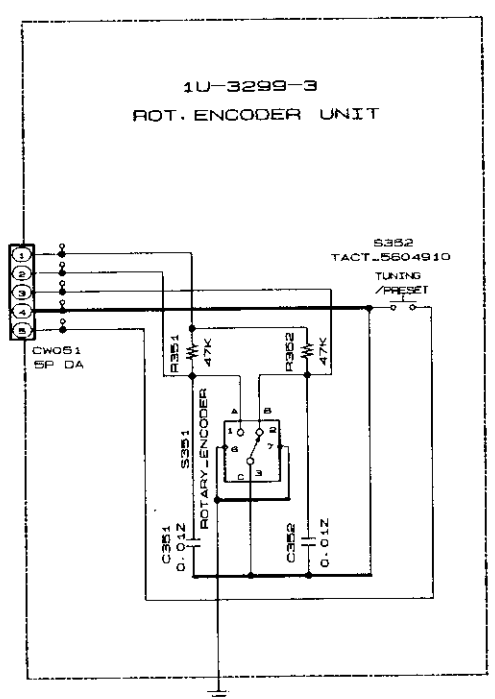
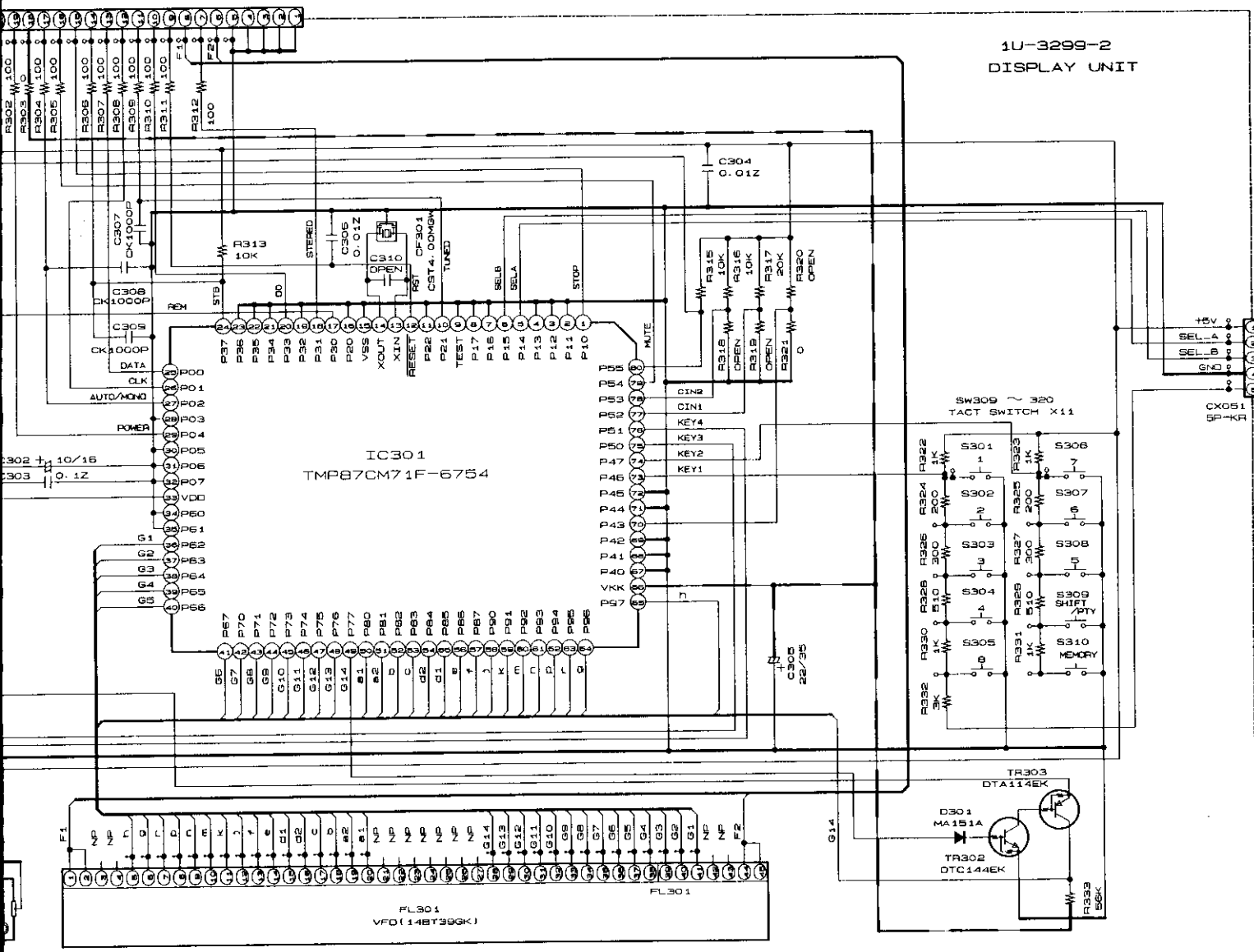
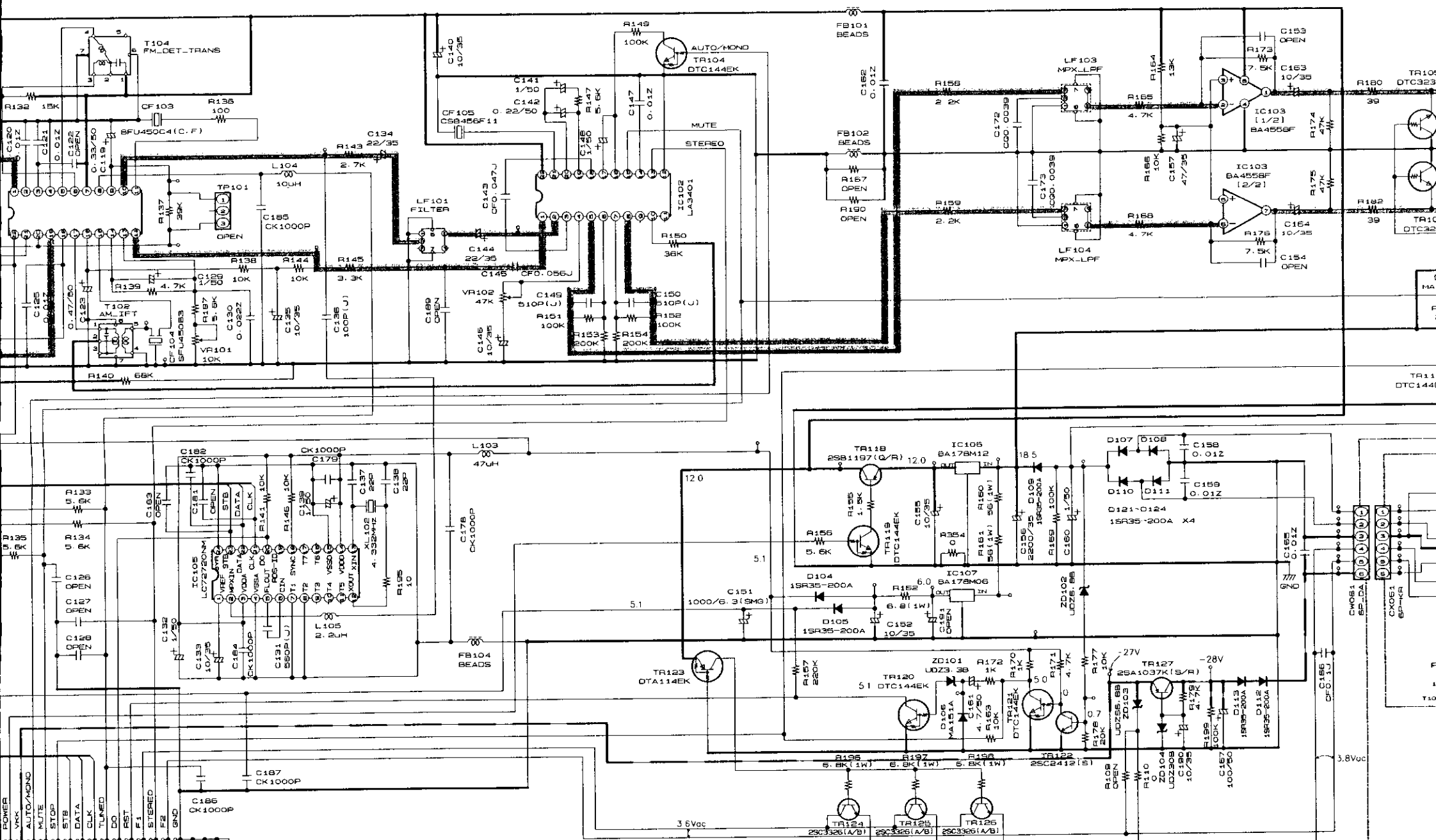

NOTICE
 ALL RESISTANCE VALUES
 ALL CAPACITANCE VALUE
 EACH VOLTAGE AND CURR
 CONDITION.
 CIRCUIT AND PARTS ARE
 NOTICE.

WARNING:
 Parts marked with this s
 Use ONLY replacement p

CAUTION:
 Before returning the unit
 leakage current check or
 current exceeds 0.5 milli
 of the power cord is less

WARNING:
 DO NOT return the unit
 corrected.

SCHEMATIC DIA
 1U-3299-1 TUNER UNIT
 1U-3299-3 ROT. ENCOD
 1U-3299-5 INLET UNIT

7

8

9

10

11

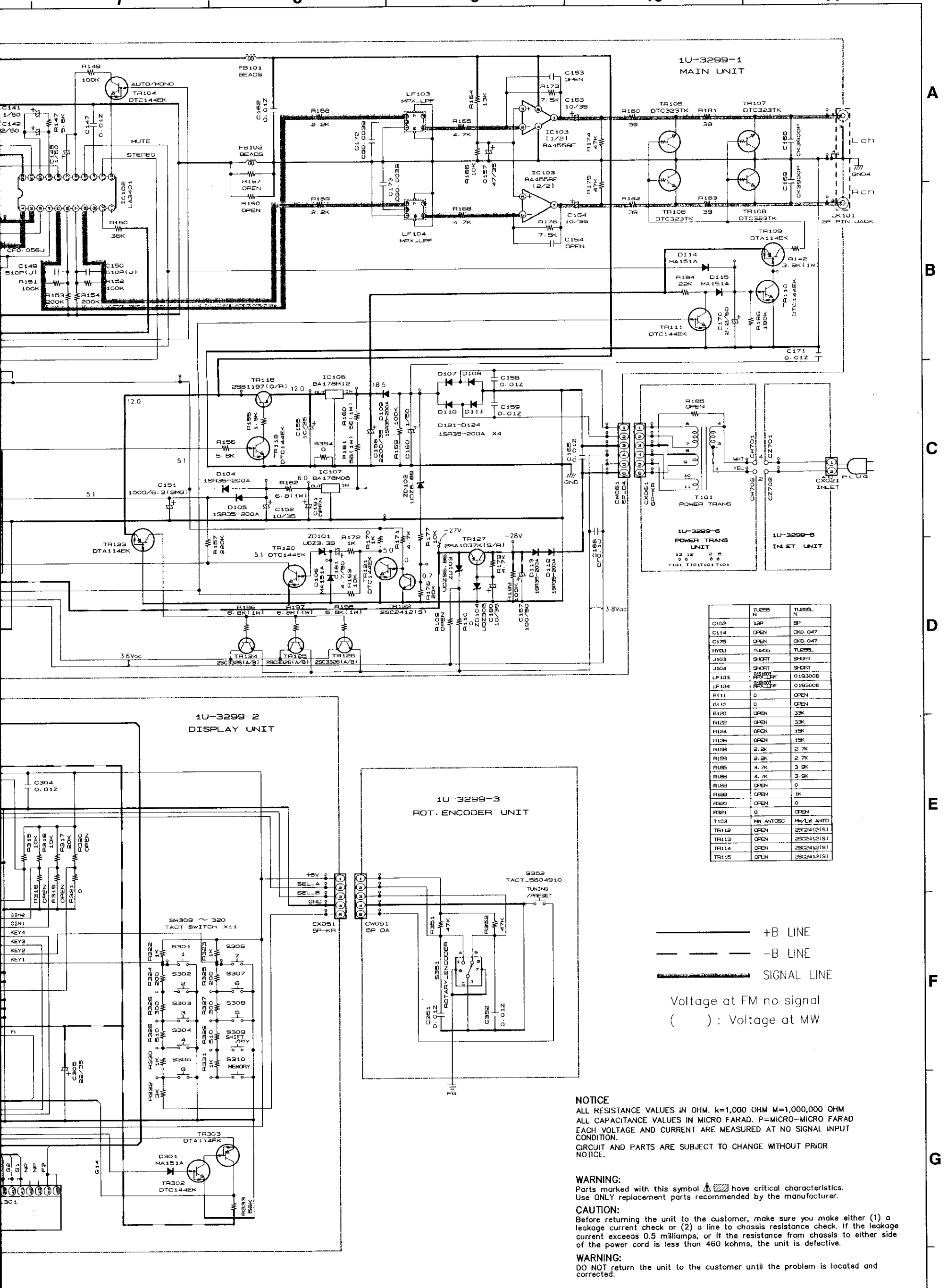

Part No.	Value	Value
C102	12P	BP
C114	OPEN	CK0.047
C175	OPEN	CK0.047
JW01	TU255	TU255L
J103	SHORT	SHORT
J104	SHORT	SHORT
LF103	MPX-LPF	0193006
LF104	MPX-LPF	0193006
R111	0	OPEN
R112	0	OPEN
R120	OPEN	33K
R122	OPEN	33K
R124	OPEN	15K
R126	OPEN	15K
R155	2.2K	2.7K
R159	2.2K	2.7K
R165	4.7K	3.9K
R168	4.7K	3.9K
R188	OPEN	0
R189	OPEN	1K
R200	OPEN	0
R201	0	OPEN
R202	MM ANTOSC	MM/LM ANT0
TR102	OPEN	25C2412(S)
TR112	OPEN	25C2412(S)
TR113	OPEN	25C2412(S)
TR114	OPEN	25C2412(S)
TR115	OPEN	25C2412(S)

——— +B LINE
 - - - -B LINE
 [] SIGNAL LINE
 Voltage at FM no signal
 () : Voltage at MW

NOTICE
 ALL RESISTANCE VALUES IN OHM. k=1,000 OHM M=1,000,000 OHM
 ALL CAPACITANCE VALUES IN MICRO FARAD. P=MICRO-MICRO FARAD
 EACH VOLTAGE AND CURRENT ARE MEASURED AT NO SIGNAL INPUT
 CONDITION.
 CIRCUIT AND PARTS ARE SUBJECT TO CHANGE WITHOUT PRIOR
 NOTICE.

WARNING:
 Parts marked with this symbol have critical characteristics.
 Use ONLY replacement parts recommended by the manufacturer.

CAUTION:
 Before returning the unit to the customer, make sure you make either (1) a
 leakage current check or (2) a chassis resistance check. If the leakage
 current exceeds 0.5 milliamps, or if the resistance from chassis to either side
 of the power cord is less than 460 kohms, the unit is defective.

WARNING:
 DO NOT return the unit to the customer until the problem is located and
 corrected.

SCHEMATIC DIAGRAM
 1U-3299-1 TUNER UNIT / 1U-3299-2 DISPLAY UNIT
 1U-3299-3 ROT. ENCODER UNIT / 1U-3299-4 POWER SW UNIT
 1U-3299-5 INLET UNIT / 1U-3299-6 POWER TRANS UNIT