

Service Manual

VHS TWO DECK VIDEO RECORDER



ORION

TT-112

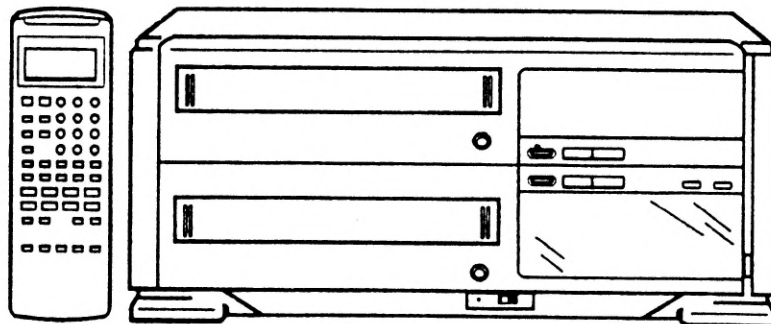

Chassis Code:

B

Bestell-Nr.:

4822

SCART 2 CONTROL/IN/OUT SCHEMATIC DIAGRAM

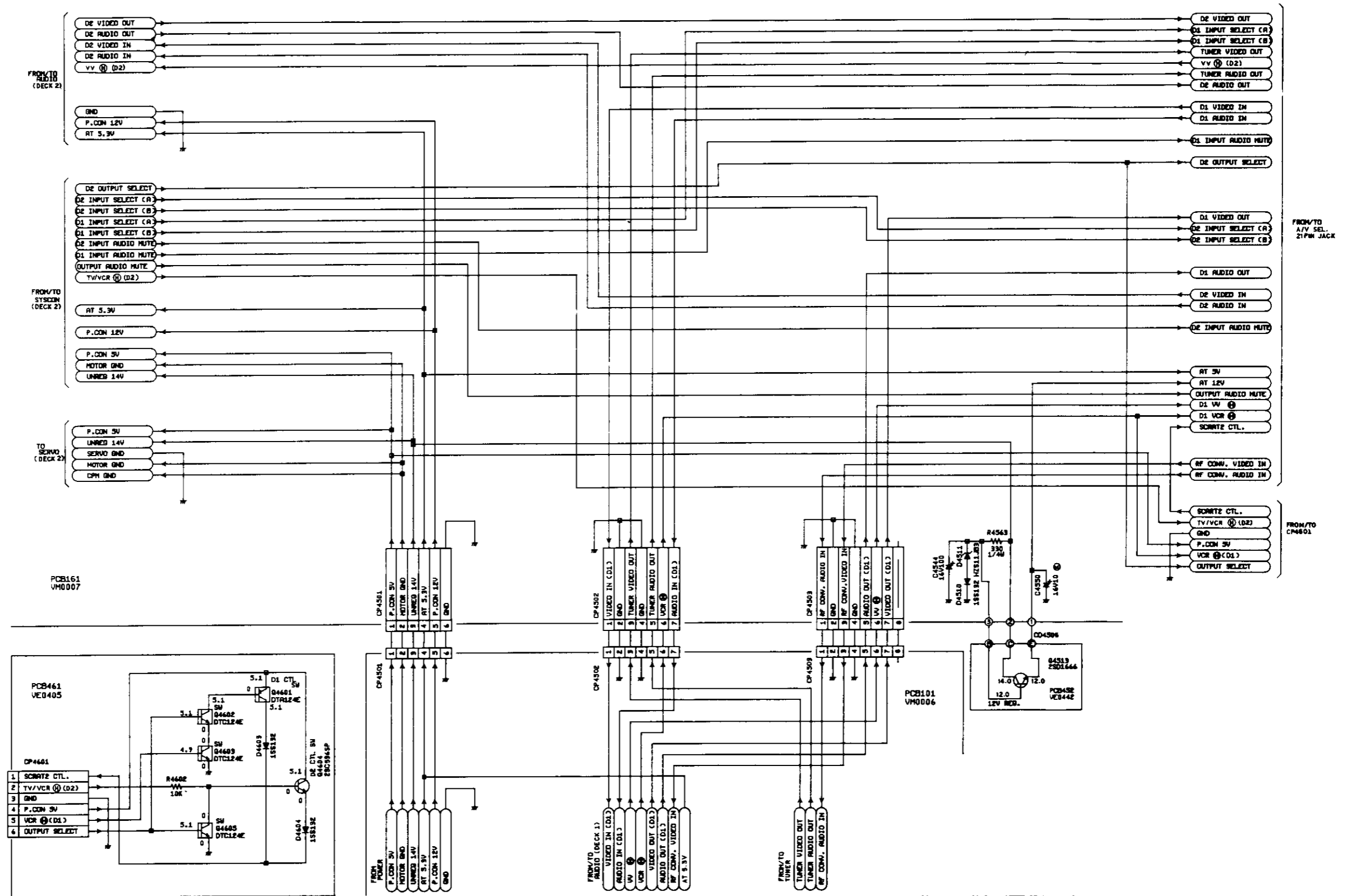

NOTE: THIS SCHEMATIC DIAGRAM IS THE LATEST AT THE TIME OF PRINTING AND SUBJECT TO CHANGE WITHOUT NOTICE.
 D1: DECK 1
 D2: DECK 2

SCART 2 CONTROL/IN/OUT SCHEMATIC DIAGRAM

DIFFERENCES

Electrical improvement

REF.NO	CHASSIS CODE A		CHASSIS CODE B	
	Part No.	Description	Part No.	Description
R646			R001T6562J	RC 5.6K OHM 1/6W
R4566	R802R8242J	RC 2.4K OHM 1/8W	R802R8681J	RC 680 OHM 1/8W
C1001	E01IT0471M	CE 470 UF 6.3V	E01IT0102M	CE 1000 UF 16V
C1601	E01IT0471M	CE 470 UF 6.3V	E01IT0102M	CE 1000 UF 16V
C4045	E01IT0101M	CE 100 UF 6.3V	E01IT0331M	CE 330 UF 6.3V
C8045	E01IT0101M	CE 100 UF 6.3V	E01IT0331M	CE 330U UF 6.3V
D4512			D940A130J0	DIODE,ZENER HZS13JB
D4513			D940A130J0	DIODE,ZENER HZS13JB
IC601	I56KI7014A	IC 0EC7014A	I56KI7014B	IC 0EC7014B

OPERATION SCHEMATIC DIAGRAM

(CHASSIS CODE A)

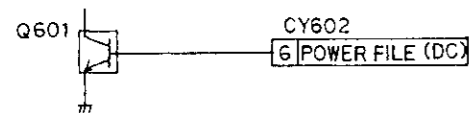

(CHASSIS CODE B)

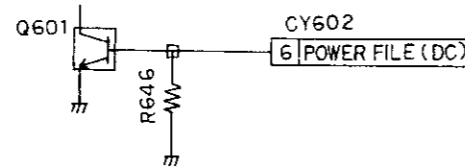

ADD R646

A/V SELECT/21PIN JACK SCHEMATIC DIAGRAM

(CHASSIS CODE A)

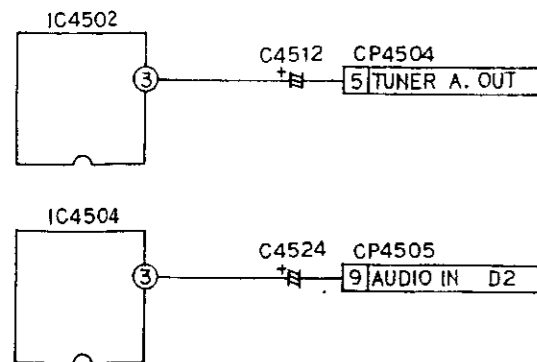

(CHASSIS CODE B)

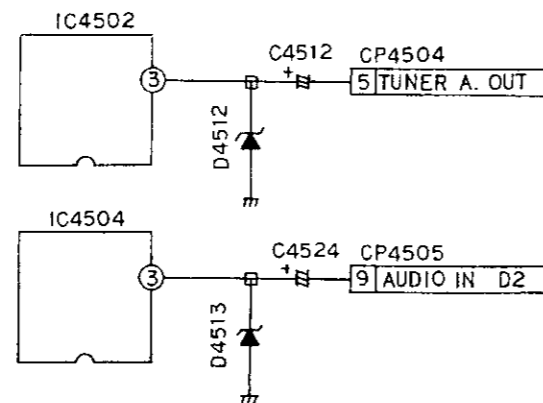

ADD D4512
D4513

PRINTED CIRCUIT BOARDS

OPERATION
(CHASSIS CODE B)

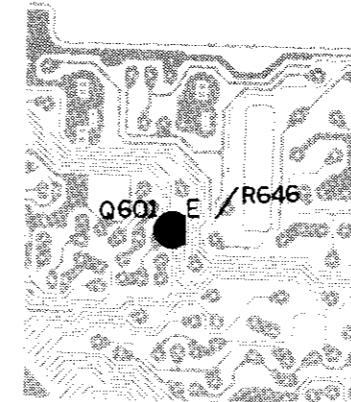

MAIN 2/A/V SELECT
/TRANSISTOR 2

COMPONENT SIDE
(CHASSIS CODE B)

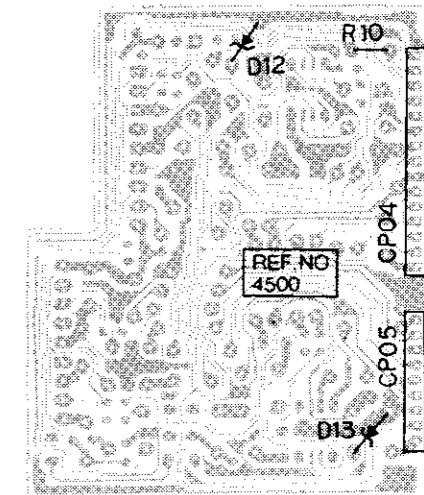

ADD R646

ADD D4512
D4513

INTERCHANGEABLE PARTS LIST

NOTE: THE FOLLOWING PART(S) MAY BE SUBSTITUTED FOR PARTS INDICATED IN THE BASIC PART(S) LIST (WITH THE SAME REF.NO.). THESE PARTS SHARE THE SAME ELECTRICAL CHARACTERISTICS AND OTHER ELEMENTS FOR COMMON USAGE. EITHER PART NUMBER MAY BE USED IN THIS UNIT.

REF. NO	DESCRIPTION (PART NO)	DESCRIPTION (PART NO)
SW601	SKHVB005 (0504201T22)	EVQ-11405K (0504101T20)
SW602	SKHVB005 (0504201T22)	EVQ-11405K (0504101T20)
SW603	SKHVB005 (0504201T22)	EVQ-11405K (0504101T20)
SW604	SKHVB005 (0504201T22)	EVQ-11405K (0504101T20)
SW605	SKHVB005 (0504201T22)	EVQ-11405K (0504101T20)
SW606	SKHVB005 (0504201T22)	EVQ-11405K (0504101T20)
SW607	SKHVB005 (0504201T22)	EVQ-11405K (0504101T20)
SW608	SKHVB005 (0504201T22)	EVQ-11405K (0504101T20)
SW610	SKHVB005 (0504201T22)	EVQ-11405K (0504101T20)
ΔTU6001	TERE1-006A (0145601018)	TERE-078A (0145M01018)
ΔTU6002	MDLK6D533A (0151601017)	MDLK6D553A (0151M01017)

DIFFERENCES

Spec. change of deck 2 pin 8 (PERI.CONTROL) of J4501(21PIN JACK)

REF.NO	CHASSIS CODE A		CHASSIS CODE B	
	Part No.	Description	Part No.	Description
R1090	R00104103J	RC 10K OHM 1/4W	R00104472J	RC 4.7K OHM 1/4W
R4602			R001T6103J	RC 10K OHM 1/6W
C4208			CH4TF0314Z	CC 10000PF 25V
D4603			D1VT001320	DIODE GMA-01-BT
D4604			D1VT001320	DIODE GMA-01-BT
Q4601			TPYTC03001	TR 2SA1346-AC
Q4602			TNYTC03001	TR 2SC3400-AC
Q4603			TNYTC03001	TR 2SC3400-AC
Q4604			TCQT1740S0	TR 2SC536(F,G)
Q4605			TNYTC03001	TR 2SC3400-AC
PCB461			A47101A12A	SCART 2 CONTROL PCB ASS'Y
CD4601			068116084A	CONNECTOR 8116084A
CP4601			0694160019	CONNECTOR 171825-6

SCHEMATIC DIAGRAM

(CHASSIS CODE A)

A/V SELECT/21PIN JACK

IN/OUT

SYSTEM CONTROL

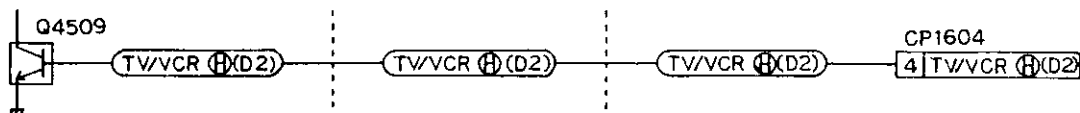

(CHASSIS CODE B)

**A/V SELECT/
21PIN JACK**

**SCART 2 CONTROL/
IN/OUT**

SYSTEM CONTROL

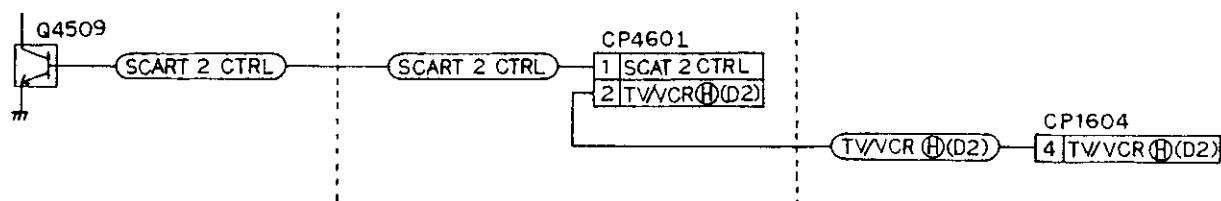

PRINTED CIRCUIT BOARD

SCART 2 CONTROL

(CHASSIS CODE B)

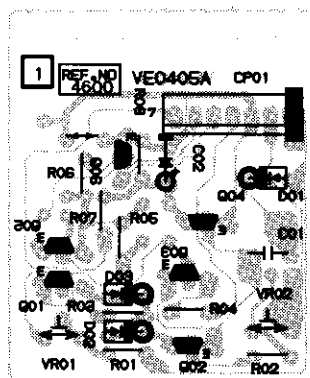

DIFFERENCES

Spec. change of deck 2 pin 8 (PERI.CONTROL) of J4501(21PIN JACK)

REF. NO	Description	Part No.	
		CHASSIS CODE A	CHASSIS CODE B
705	SCREW, TAP TITE(P) BRAZIER 3*8	_____	8110630804

MECHANICAL EXPLODED VIEW (DECK 2)

(CHASSIS CODE B)

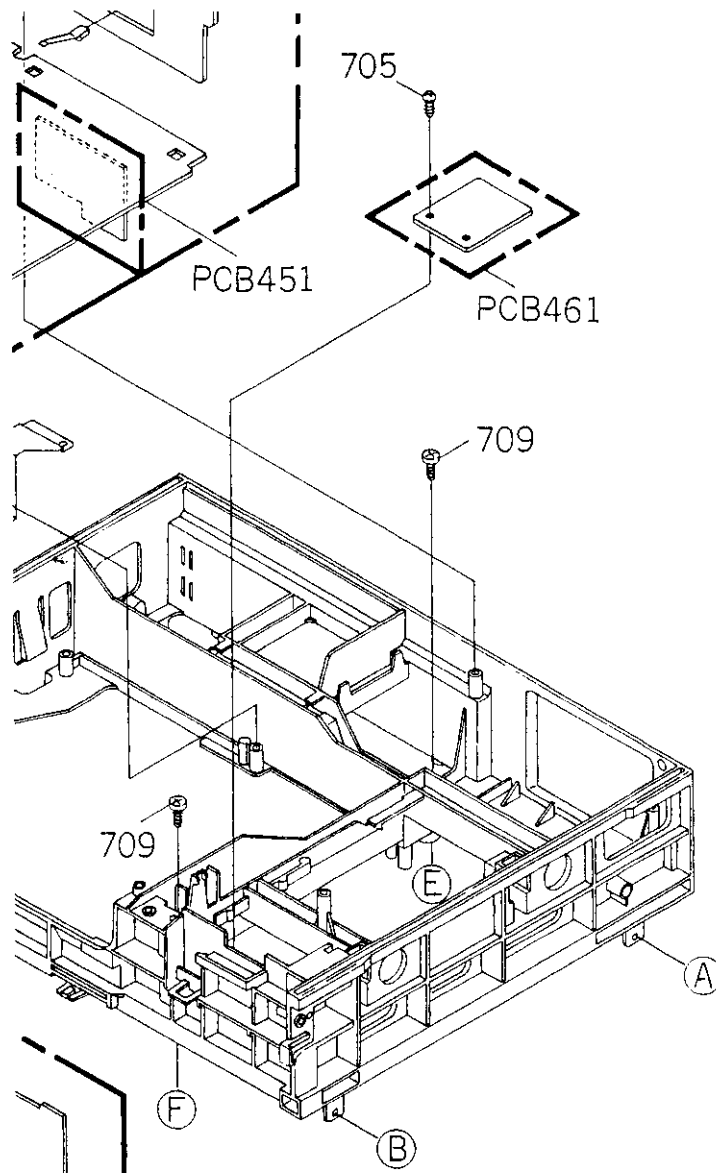

Zentralwerkstatt und
Ersatzteildepot
für ORION-Produkte

**Schwalbe**

Service & Versand GmbH

Auvico Elektronik
Service 6200 Dreieich
Hans-Brate-Rastick-Str. 20
28306 Dreieich
Tel: 0421 40 40 02
FAX 42 39 60



☎ Ersatzteil-Bestellung: (0 61 03) 39 99-95
Tech. Auskunft (tägl. 9 - 12 Uhr):
☎ Video / Camcorder: (0 61 03) 39 99-62
☎ TV / Audio: (0 61 03) 39 99-66
Fax: (0 61 03) 39 99-88/63

Telefax: (0 61 03) 39 99-79
Telex: d 4 185 274 ssv
BTX: Leitseite Nr. *20 797 #

Service Manual

Nachdruck bzw. Kopieren dieser Unterlagen ist grundsätzlich verboten!

VHS TWO DECK VIDEO RECORDER



ORION

MODEL TT-119 HY

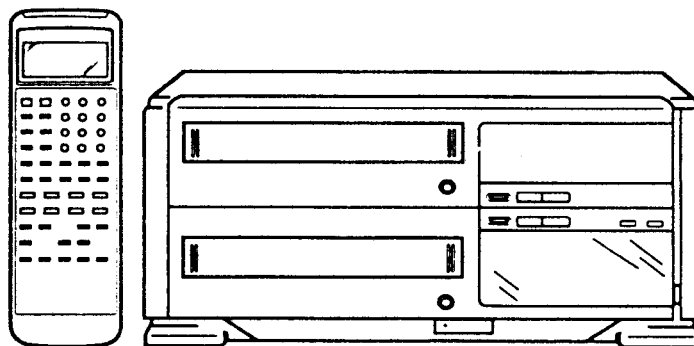

Änderungen vorbehalten!

Printed in Germany

Chassis Code:

B

Bestell-Nr.

5571

HOW TO ORDER PARTS

Please include the following informations when you order parts. (Particularly the CHASSIS CODE.)

A. MODEL NUMBER and CHASSIS CODE

You can find it in the back of your unit.

B. PART NO. and DESCRIPTION

You can find it in your SERVICE MANUAL.

SPECIFICATIONS

Power Source :	230V 50Hz	Heads :	Video : 2 rotary heads×2
Power Consumption :	Approx. 48W		Audio/Control : 1 stationary head×2
Operating Temperature :	5°C to 40°C		Erase : 1 full track erase ×2
Television System :	CCIR : 625 lines, 50 fields	Input Level :	Video : VIDEO IN socket 1.0Vp-p, 75 ohm unbalanced
	PAL colour signal PAL B.G.		Audio : AUDIO IN socket -3.8dB, 50K ohm unbalanced
Video Recording System :	2 rotary heads, helical scanning system	Output Level :	Video : VIDEO OUT socket 1.0Vp-p, 75 ohm unbalanced
	Luminance : FM azimuth recording		Audio : AUDIO OUT socket -3.8dB, 1K ohm unbalanced
	Color signal : Converted subcarrier phase shift recording	Weight :	8.6kg
Audio Track :	1 track ×2	Dimension :	385(W)x163.5(H)x328.5(D)mm
Tape Format :	12.7mm high density tape		
RF Output Channel :	36(±4) channel		
Tape Speed :	23.39 mm/s		

CONTENTS

	PAGE		PAGE
SPECIFICATIONS	1	2-9: CLOCK	20
DISASSEMBLY INSTRUCTIONS	2~4	2-10-A: VCO	20
KEY TO ABBREVIATIONS	5	2-10-B: TRAP	20
SERVICING FIXTURES & TOOLS	6	2-10-C: CHECKING VIDEO IF OVERALL	21
PREVENTIVE CHECKS AND SERVICE INTERVALS	6	2-11: AFT	21
DECK PARTS LOCATION (DECK 1/2)	7, 8	2-12: DISTORTION FACTOR	21
MECHANICAL ADJUSTMENTS		2-13: RF AGC	21
1. BEFORE MAKING MECHANICAL ADJUSTMENTS (DECK 1/2)		2-14: COLOR LEVEL	22
1-1: HOW TO REMOVE AND INSTALL STAGE	9	MAJOR COMPONENTS LOCATION GUIDE	23, 24
2. REPLACEMENT OF MAIN PARTS (DECK 1/2)		HOW TO RESET MICROCOMPUTER	25
2-1: REEL DISK	9	BLOCK DIAGRAMS	
2-2: A/C HEAD	10	Y.C./HEAD AMP (DECK 1)	26
2-3: CYLINDER UNIT	10	SYSTEM CONTROL (DECK 1)	27
2-4: TENSION BAND	11	SERVO (DECK 1)	28
2-5: LOADING MOTOR/LOADING MOTOR BELT	11	Y.C./HEAD AMP (DECK 2)	29
2-6: PINCH ROLLER	12	SYSTEM CONTROL (DECK 2)	30
2-7: CAPSTAN DD UNIT	12, 13	SERVO (DECK 2)	31
2-8: TRANSISTOR PCB	14	TUNER	32
3. CONFIRMATION AND ADJUSTMENT (DECK 1/2)		A/V SELECT/21PIN JACK	33
3-1: CONFIRMATION OF FAST FORWARD TORQUE	14	AUDIO (DECK 1/2)	34
3-2: CONFIRMATION OF REWIND TORQUE	14	OPERATION / POWER SUPPLY	35
3-3: CONFIRMATION OF PLAYBACK TAKE-UP TORQUE	15	PRINTED CIRCUIT BOARDS	
3-4: CONFIRMATION OF REEL BRAKE TORQUE	15	MAIN 1 / POWER SUPPLY/TRANSISTOR 1 / HEAD AMP	36
3-5: CONFIRMATION AND ADJUSTMENT OF REEL DISK HEIGHT	15	Y.C. / OPERATION / SUB MAIN / DECK	37
3-6: CONFIRMATION AND ADJUSTMENT OF TENSION POST POSITION	16	MAIN 2/A/V SELECT/TRANSISTOR 2	38, 39
3-7: CONFIRMATION AND ADJUSTMENT OF BACK TENSION ON PLAYBACK	16	SCHEMATIC DIAGRAMS	
4. TAPE RUNNING CONFIRMATION AND ADJUSTMENT (DECK 1/2)		TUNER	40
4-1: GUIDE ROLLER	16	Y.C./HEAD AMP (DECK 1)	41
4-2: CONFIRMATION AND ADJUSTMENT OF A/C HEAD TILT	17	AUDIO (DECK 1)	42
4-3: ADJUSTMENT OF A/C HEAD HEIGHT AND AZIMUTH	17	SYSTEM CONTROL (DECK 1)	43
4-4: TAPE RUNNING ADJUSTMENT	17	SERVO (DECK 1)	44
ELECTRICAL ADJUSTMENTS		Y.C./HEAD AMP (DECK 2)	45
1. BEFORE MAKING ELECTRICAL ADJUSTMENTS	18	AUDIO (DECK 2)	46
2. ADJUSTMENT PROCEDURE (DECK 1/2)		SYSTEM CONTROL (DECK 2)	47
2-1: PB. SWITCHING POSITION	18	SERVO (DECK 2)	48
2-2: TRACKING FIX	18	POWER SUPPLY	49
2-3: PLAYBACK LUMINANCE LEVEL	18	IN/OUT	50
2-4: E-E LEVEL	19	A/V SELECT/21PIN JACK	51
2-5: CARRIER AND DEVIATION	19	OPERATION	52
2-6: RECORD CURRENT	19	INTERCONNECTION DIAGRAM (DECK 1)	53
2-7: AUDIO BIAS CURRENT	20	INTERCONNECTION DIAGRAM (DECK 2)	54
2-8: PLAYBACK AUDIO LEVEL	20	MECHANICAL EXPLODED VIEW (DECK 1)	55
		MECHANICAL EXPLODED VIEW (DECK 2)	56
		DECK EXPLODED VIEW (DECK 1/2)	57, 58
		MECHANICAL REPLACEMENT PARTS LIST (DECK 1/2)	59
		DECK REPLACEMENT PARTS LIST (DECK 1/2)	60
		ELECTRICAL REPLACEMENT PARTS LIST (DECK 1/2)	61~63
		INTERCHANGEABLE PARTS LIST (DECK 1/2)	64

HQ FEATURE

This video recorder is equipped with HQ (High Quality) recording capability. A built-in detail enhancer is used to boost the recorded signal for cleaner, sharper images and maximum picture quality in playback.

DISASSEMBLY INSTRUCTIONS

REMOVAL OF MECHANICAL PARTS AND P. C. BOARDS.

1. TOP CABINET AND FRONT CABINET (Refer to Fig. 1-1)

1. Remove the 4 screws ①.
2. Remove the TOP CABINET in the direction of arrow (A).
3. Unlock the 7 supports ②.
4. Remove the FRONT CABINET in the direction of arrow (B).

NOTE: When re-installing the FRONT CABINET to the unit, hold the unit steady, and with hand, push the DOOR FLAP of the both decks open to an angle of 90°.

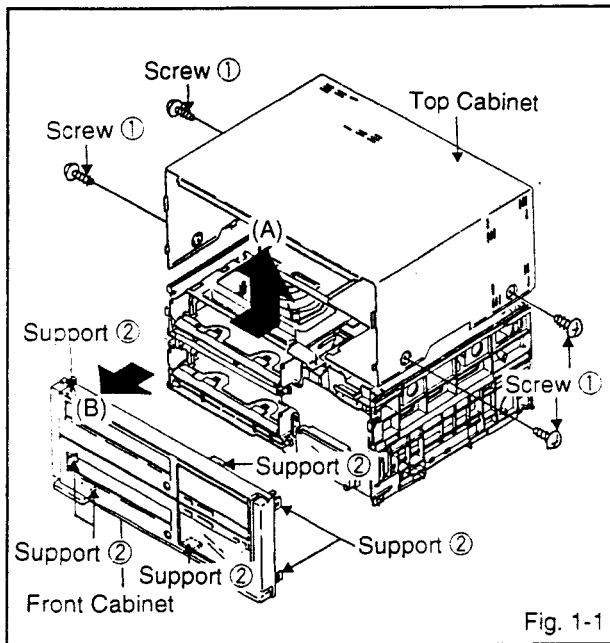

2. OPERATION PCB (Refer to Fig. 1-2)

1. Disconnect the following connectors. (CP603 7 pins, CP604 10 pins)
2. Unlock the 4 supports ①, then lay the OPERATION PCB in the direction of arrow (A).
3. Remove the OPERATION PCB in the direction of arrow (B).

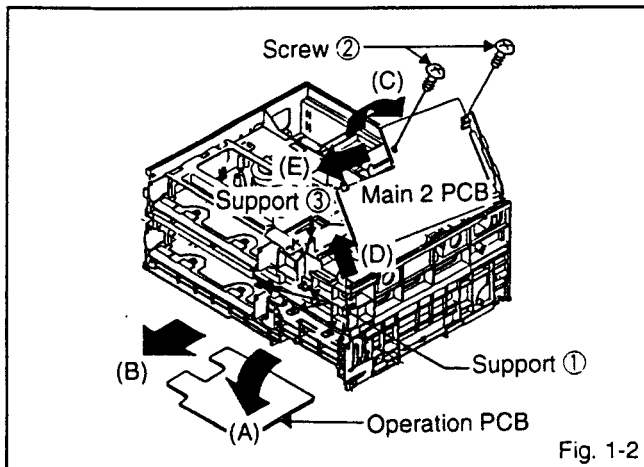

3. DECK 1/2 AND MAIN 2 PCB (Refer to Fig. 1-2 and 1-3)

1. Remove the 2 screws ②. (Refer to Fig. 1-2)
2. Open the MAIN 2 PCB in the direction of arrow (C). (Refer to Fig. 1-2)
3. Disconnect the following connectors. (CP4501 6 pins, CP4502 7 pins, CP4503 8 pins)
4. Remove the 6 screws ①.
5. Remove the DECK 2 in the direction of arrow.
6. Disconnect the following connectors. (CP2501 2 pins, CP2503 17 pins, CP4102 8 pins, CP5501 5 pins, 9 pins of capstan DD motor and 6 pins of cylinder unit)
7. Remove the TRANSISTOR PCB. (Refer to item 2-9 of the MECHANICAL ADJUSTMENT.)
8. Remove (a) part of the MAIN 2 PCB in the direction of arrow (D).
9. Remove the MAIN 2 PCB in the direction of arrow (E). (Refer to Fig. 1-2)

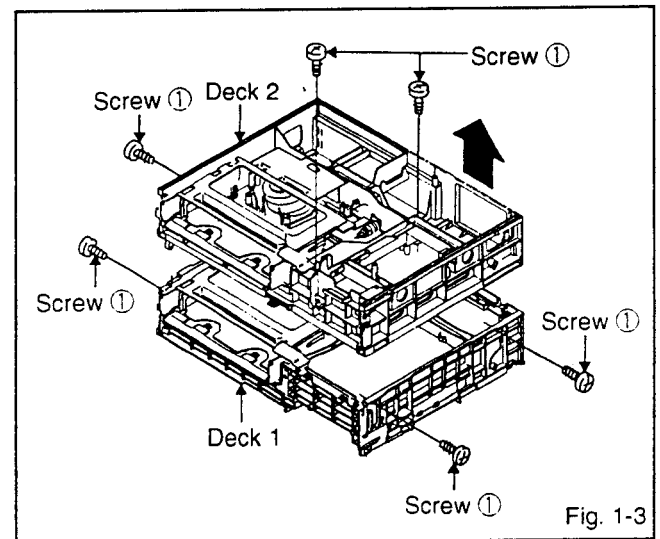

4. FLAP (Refer to Fig. 1-4)

1. When opening the FLAP at an angle of 90°, remove the FLAP HOLDER in the direction of arrow (A).
2. Remove the FLAP in the direction of arrow (B).

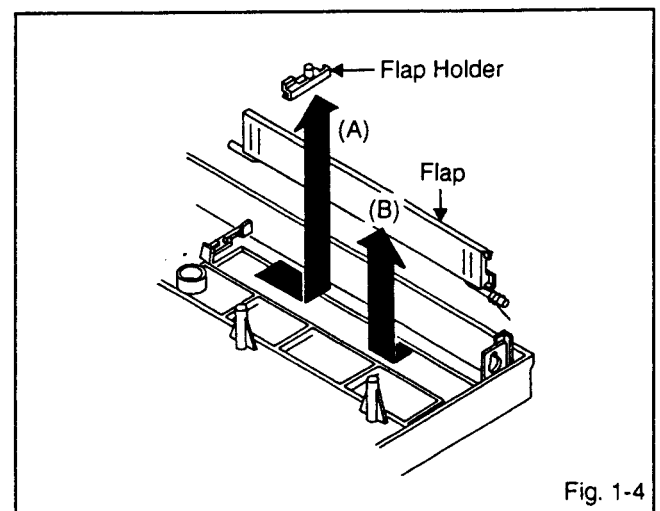

DISASSEMBLY INSTRUCTIONS

5. BOTTOM CABINET (Refer to Fig. 1-5)

1. Remove the 6 screws ①.
2. Remove the BOTTOM CABINET in the direction of arrow.

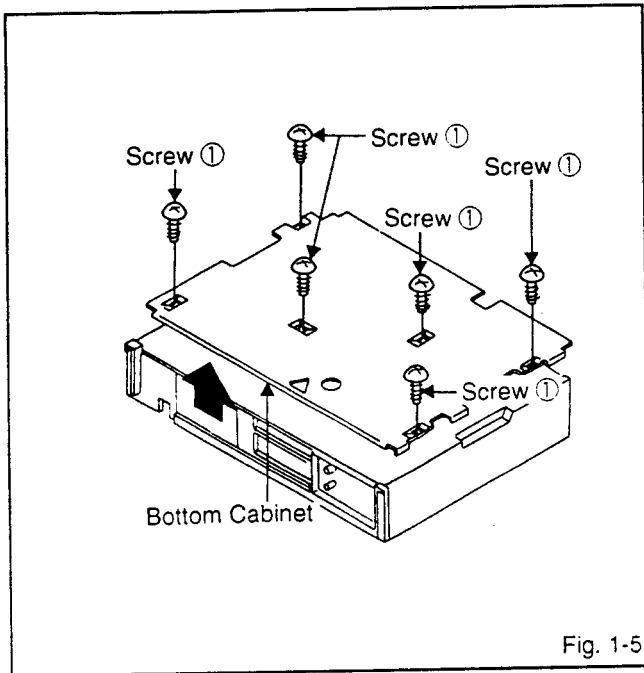

6. CAUTION; BEFORE ATTEMPTING TO REMOVE OR REPAIR ANY PCB, UNPLUG THE POWER CORD FROM THE AC SOURCE.

LOCATION OF P. C. BOARDS (Refer to Fig. 1-6)

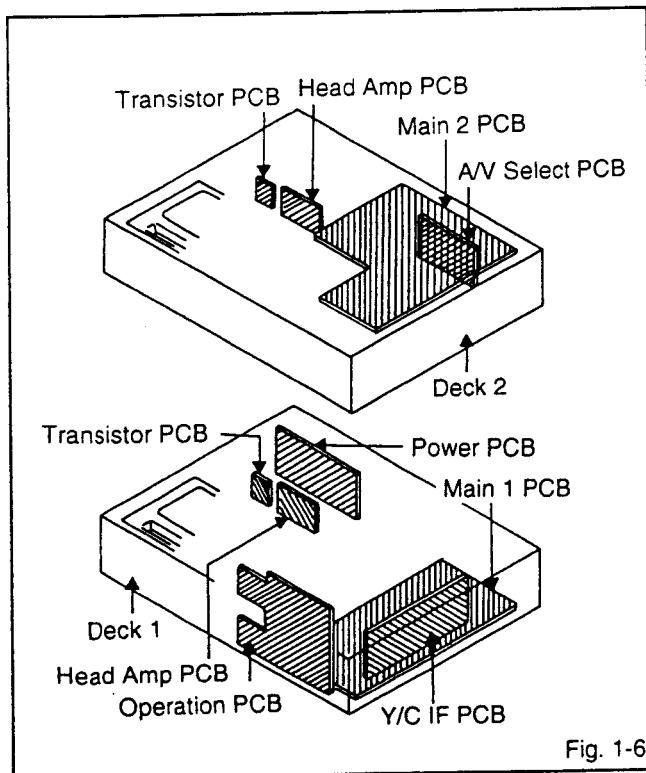

7. MAIN 1 PCB (Refer to Fig. 1-7)

1. Remove the screw ①.
2. Disconnect the following connectors. (CP2001 2 pins, CP2003 17 pins, CP4102 8 pins, CP5001 5 pins, CP7501 6 pins, CP7502 8 pins, 9 pins of capstan DD motor and 6 pins of cylinder unit.)
3. Unlock the 3 supports ②, then remove the SYSCON1 PCB by while lifting it in the direction of arrow.

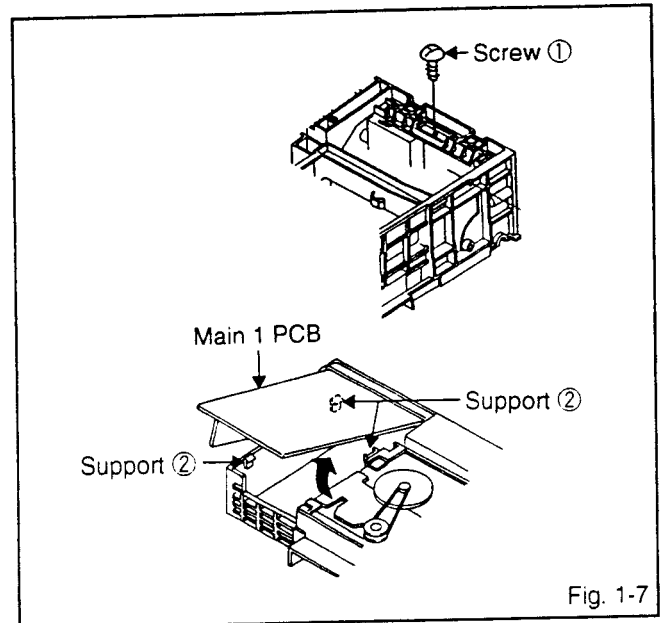

8. POWER PCB (Refer to Fig. 1-8)

1. Remove the 3 screws ①.
2. Remove the TRANSISTOR PCB. (Refer to item 2-9 of the MECHANICAL ADJUSTMENT.)
3. Remove the POWER PCB ASS'Y in the direction of arrow.

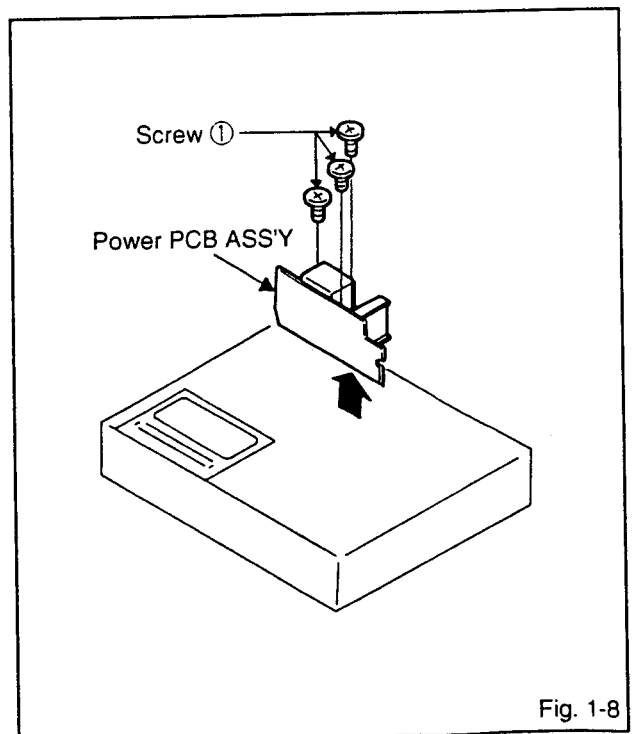

DISASSEMBLY INSTRUCTIONS

9. FRONT LOADING UNIT AND CHASSIS SECTION (Refer to Fig. 1-9)

1. Remove the 3 screw ①.
2. Remove the Plate Head Shield.
3. Remove the screws ②.
4. Remove the 2 screws ③.
5. Remove the FRONT LOADING BELT 2.
6. Remove the FRONT LOADING UNIT in the direction of arrow (A).
7. Remove the 3 screws ④.
8. Unlock the 2 supports ⑤, then remove the CHASSIS SECTION in the direction of arrow (B).

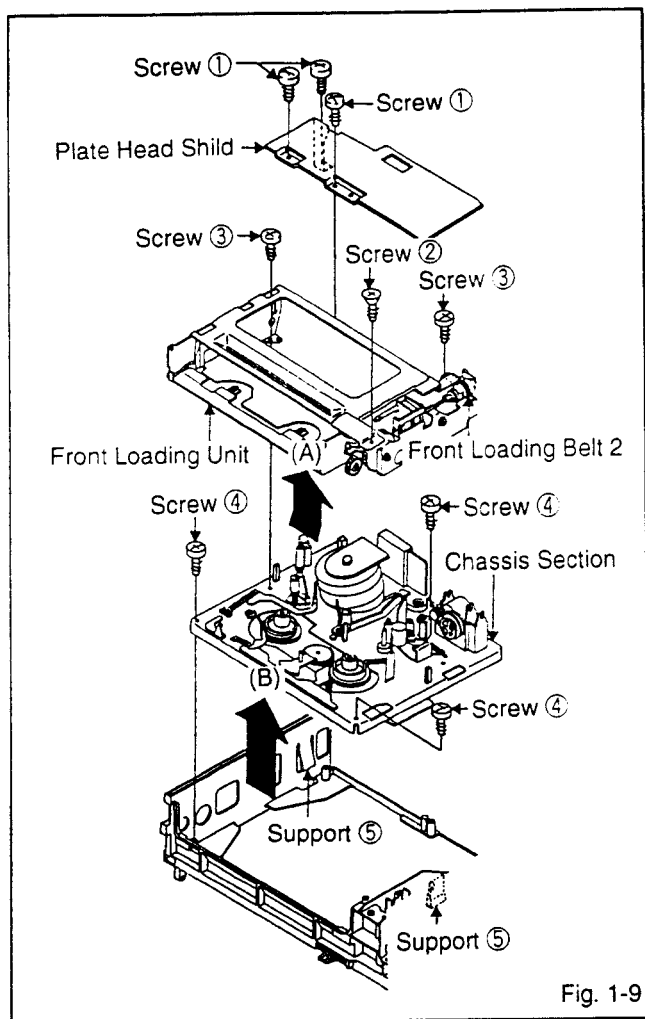

KEY TO ABBREVIATIONS

A	AC	: Alternating Current	L	LED	: Light Emitting Diode
	A/C	: Audio/Control		LIMIT AMP	: Limiter Amplifier
	ACC	: Automatic Color Control		LH	: Loading Motor
	AE	: Audio Erase		LOAD	: Loading
	AFC	: Automatic Frequency Control		L.P.F	: Low Pass Filter
	AFT	: Automatic Fine Tuning		LUMI	: Luminance
	AFT DEF	: Automatic Fine Tuning Defeat	M	MM	: Monostable Multivibrator
	AGC	: Automatic Gain Control		MOD	: Modulator, Modulation
	AMP	: Amplifier		MS SW	: Mech State Switch
	ANT	: Antenna	N	NC	: Non Connection
	APC	: Automatic Phase Control	O	OSC	: Oscillator
	ASB	: Assemble Mode		OR EQ	: Or Equivalent
	AT	: All Time	P	PB	: Playback
B	BGP	: Burst Gate Pulse		PB CTL	: Playback Control
	BOT	: Beginning of Tape		P.CON	: Power Control
	B.P.F	: Band Pass Filter		PD	: Phase Detector
	B/W	: Black & White		PG	: Phase Generator
C	CASE	: Cassette		PWM	: Pulse Width Modulation
	CAP	: Capstan		PWM TV	: Pulse Width Modulated Tuning Voltage
	CARR	: Carrier	R	REC	: Recording
	CCD	: Charged Coupled Device		REC ST	: Recording Start
	CH	: Channel		REEL BRK	: Reel Brake
	CLK	: Clock		REEL S	: Reel Sensor
	CLOCK(SY-SE)	: Clock(Syscon to Servo)		REG	: Regulator, Regulated
	CONV	: Converter		REW	: Rewind
	CPM	: Capstan Motor		RF	: Radio Frequency
	CTL	: Control	S	S.CLK	: Serial Clock
	CYL	: Cylinder		S.COM	: Sensor Common
	CYL-M	: Cylinder Motor		S.DATE IN	: Serial Date Input
	CYL SENS	: Cylinder Sensor		S.DATE OUI	: Serial Date Output
D	DATA(SY-SE)	: Data(Syscon to Servo)		SEG	: Segment
	DC	: Direct Current		SER	: Search Mode
	DD UNIT	: Direct Drive Motor Unit		SI	: Serial Input
	DET	: Detection, Detector		SIF	: Sound Intermediate Frequency
	DEV	: Deviation		SO	: Serial Output
E	EE	: Electric to Electric		SP	: Standard Play
	EF	: Emitter Follower		STB	: Serial Strobe
	EOT	: Ending of Tape		SW	: Switch
	EQ	: Equalizer		SYNC SEP	: Sync Separator, Separation
	EXT	: External	T	TR	: Transistor
F	FBC	: Feed Back Clamp		TRACK VR	: Tracking Variable Resistor
	FE	: Full Erase		TRIC PB	: Trick Playback
	FG	: Frequency Generator		TP	: Test Point
	FL SW	: Front Loading Switch	U	UNREG	: Unregulated
	FH	: Frequency Modulation	V	VCO	: Voltage Controlled Oscillator
	FSC	: Frequency Sub Carrier		VIF	: Video Intermediate Frequency
	FWD	: Forward		VP	: Vertical Pulse, Voltage Display
G	GND	: Ground		VR	: Variable Resistor
H	H.P.F	: High Pass Filter		V-SYNC	: Vertical-Synchronization
I	IF	: Intermediate Frequency		VI	: Voltage Tuning
	INST	: Insert Mode	Y	Y/C	: Luminance/Chrominance
	INT	: Interrupt			
	INV	: Inverter			

PREVENTIVE CHECKS AND SERVICE INTERVALS

The following standard table depends on environmental conditions and usage. Unless maintenance is properly carried out, the following service intervals may be quite shortened as harmful effects may be had on other parts. Also, long term storage or disuse may cause transformation and aging of rubber parts.

Parts Name	Time					Notes
	500 hours	1,000 hours	1,500 hours	2,000 hours	3,000 hours	
Audio Control Head	■	■	■	■	■	Clean those parts in contact with the tape.
Full Erase Head	■	■	■	■	■	
Reel Belt		■		●		Clean the rubber, and parts which the rubber touches.
Front Loading Belt		■		●		
Pinch Roller	■	■	■	■	■●	
Capstan DD Unit					●	
Loading Motor					●	
Tension Band Ass'y					●	
Capstan Shaft	■	■	■	■	■	
Tape Running Guide Post	■	■	■	■	■	Replace when rolling becomes abnormal.
Cylinder Unit	■	■●	■	■●	■●	※

● : Replace
 ■ : Clean

※ Clean the upper drum (especially the video heads) in the direction or drum rotation using a thick, textured cloth with a high quality methyl alcohol. Avoid wiping vertically as this may cause damage to the video heads.

HOW TO REMOVE AND INSTALL RIBBON WIRE IN CASE OF DISCONNECTION.

1. To remove the wire, simultaneously press both parts indicated by arrow (A).
2. To install the wire, do not press the parts indicated by arrow (A), but insert the wire into the connector.

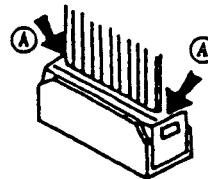

DECK PART LOCATIONS

(TOP VIEW)

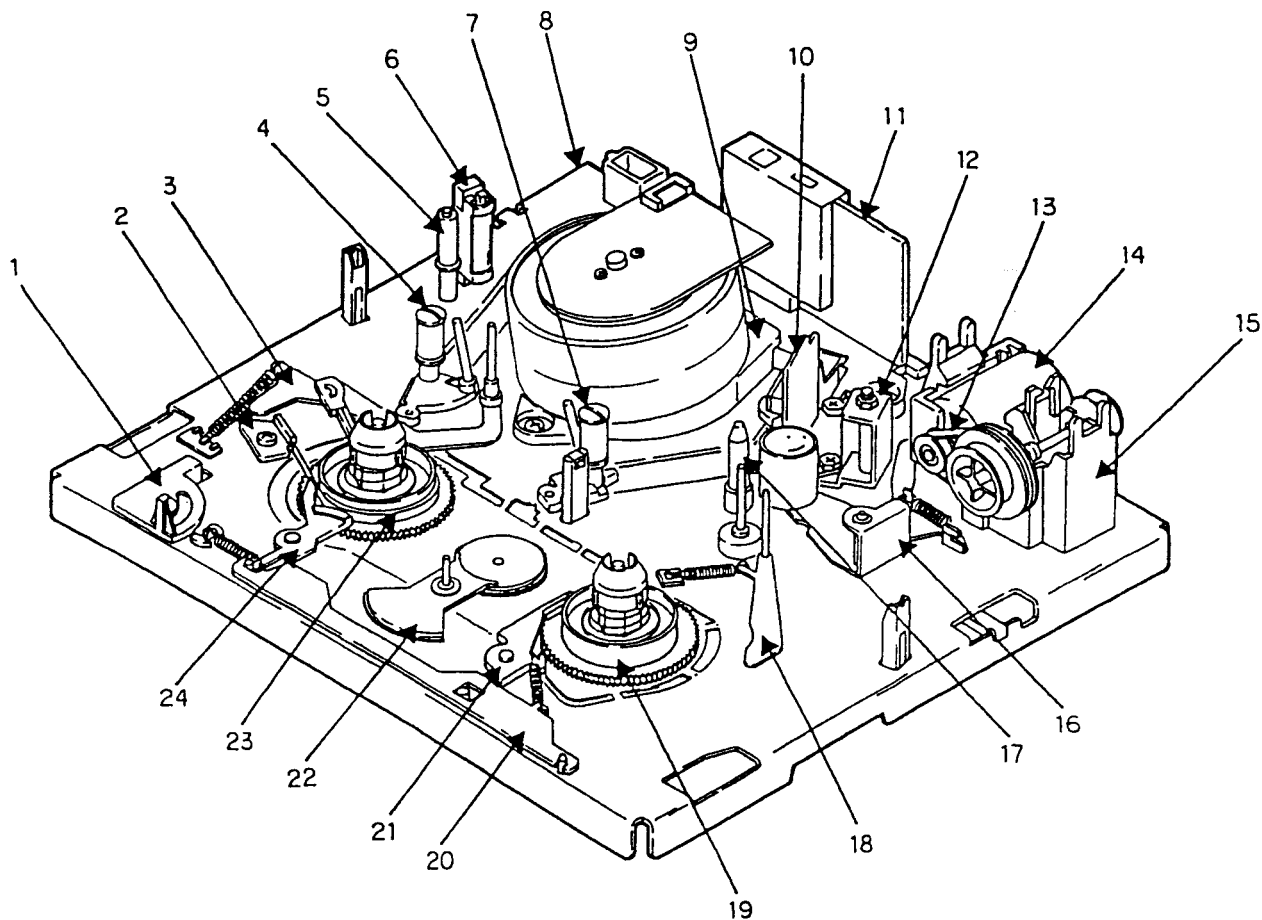

- | | |
|-----------------------|-----------------------------|
| 1. REC SW Lever | 13. Front Loading Belt |
| 2. Tension Band Ass'y | 14. Loading Motor |
| 3. Tension Arm Ass'y | 15. Loading Motor Box Ass'y |
| 4. Guide Roller Ass'y | 16. Pinch Roller Arm Ass'y |
| 5. P1 Post | 17. P4 Post |
| 6. Full Erase Head | 18. Limiter Post Arm Ass'y |
| 7. Guide Roller Ass'y | 19. Reel Disk I Ass'y |
| 8. Main Chassis | 20. Actuator Sub Brake |
| 9. Cylinder Unit | 21. IS Brake 2 Ass'y |
| 10. A/C Head | 22. Idler Ass'y |
| 11. Head Amp PCB | 23. Reel Disk S Ass'y |
| 12. A/C Head Base | 24. SS Brake Arm |

DECK PARTS LOCATIONS

(BOTTOM VIEW)

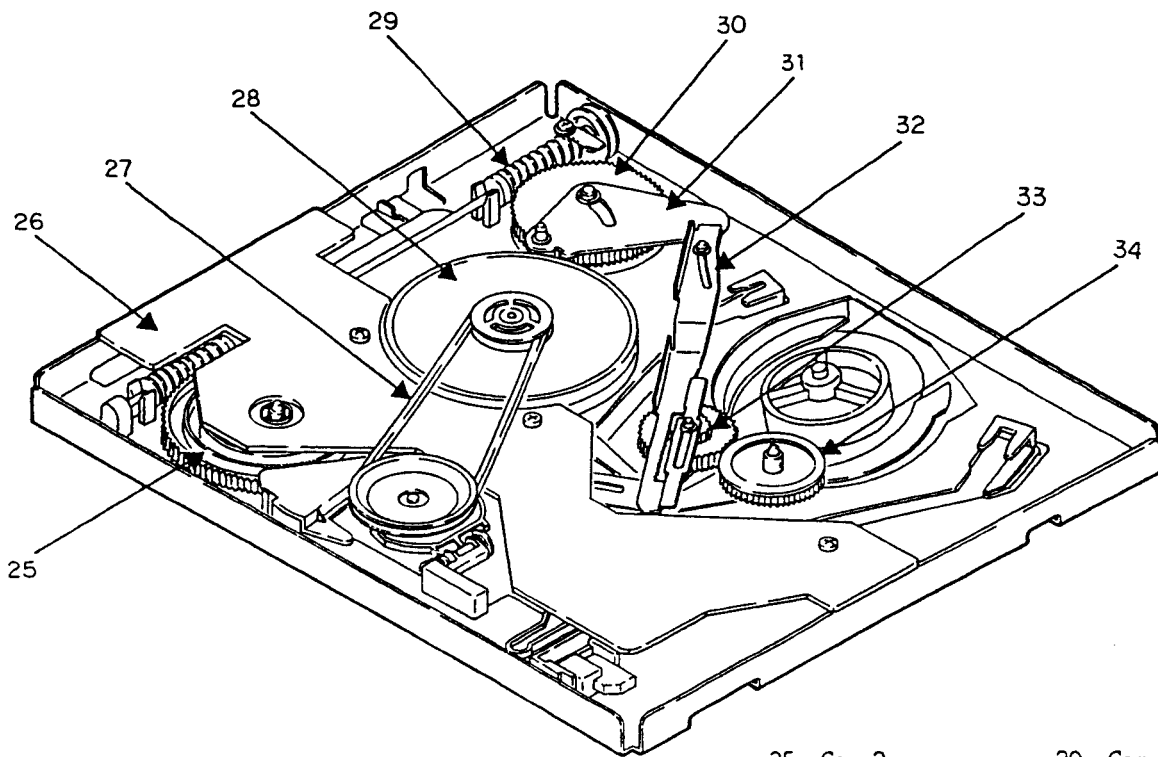

- | | |
|---------------------|---------------------------|
| 25. Cam 2 | 30. Cam 1 |
| 26. Deck PCB | 31. Loading Lever 2 Ass'y |
| 27. Reel Belt | 32. Slide Loading 2 |
| 28. Capstan DD Unit | 33. Loading Gear T Ass'y |
| 29. Worm Ass'y | 34. Loading Gear S Ass'y |

(FRONT LOADING UNIT)

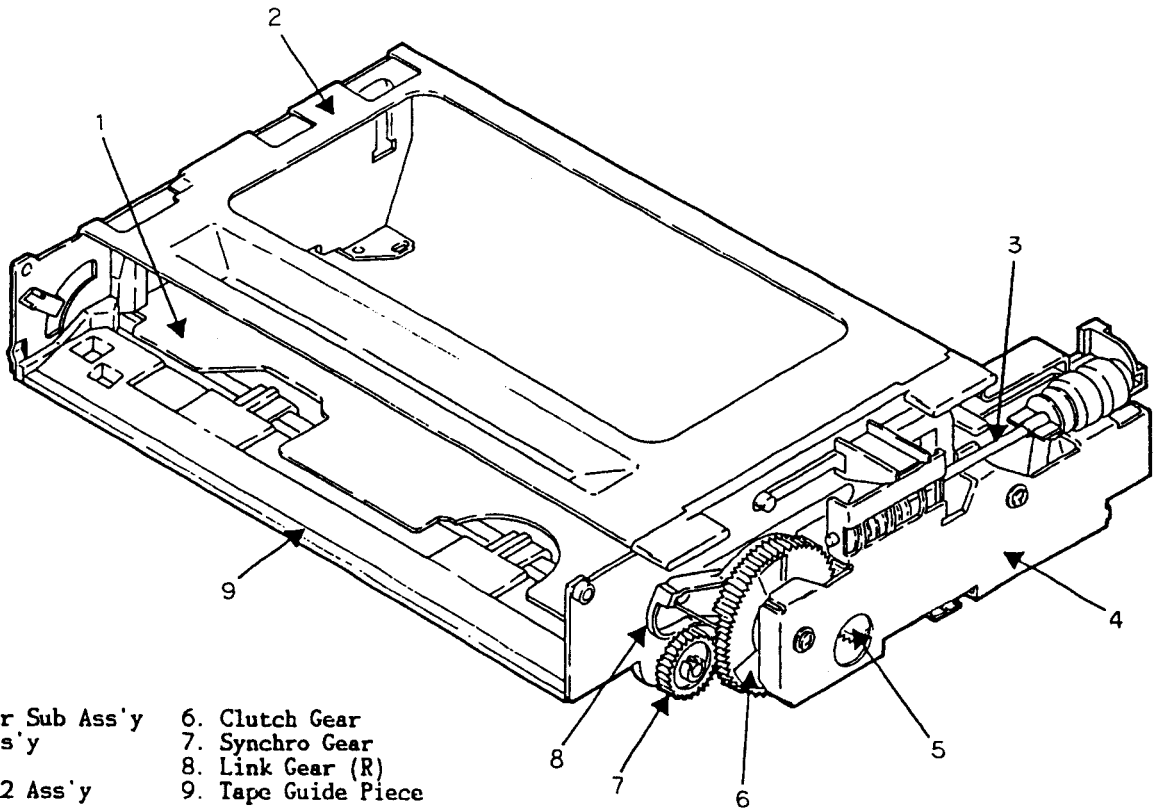

- | | |
|------------------------------|---------------------|
| 1. Cassette Holder Sub Ass'y | 6. Clutch Gear |
| 2. Top Bracket Ass'y | 7. Synchro Gear |
| 3. Worm Ass'y | 8. Link Gear (R) |
| 4. Side Bracket R2 Ass'y | 9. Tape Guide Piece |
| 5. Wheel | |

MECHANICAL ADJUSTMENTS

1. BEFORE MAKING MECHANICAL ADJUSTMENTS (DECK 1/2)

CAUTION

Inferior silicon grease can damage IC's and transistors.
When replacing IC's or transistors, use only specified silicon grease (YG6260M).
Remove all old silicon before applying new silicon.

PRECAUTION

Remove the following items before adjusting the deck and starting work.

1. Remove 4 screws and remove the TOP CABINET.
2. Remove 6 screws and remove the BOTTOM CABINET.
3. Remove the FRONT CABINET.
(Refer to DISASSEMBLY INSTRUCTIONS)
4. Remove the STAGE. (Refer to Item 1-1)

Read the following NOTED items before starting work.

- * Remove the stage when replacing the deck parts.
- * Place an object which weighs between 350g and 500g on the Cassette Tape to keep it steady when you want to make the tape run without the stage. (Do not place an object which weighs over 500g.)
- * When you activate the deck without the stage, place a black sleeve over Q1101 (BOT) and Q1102 (EOT). EOT/BOT sensor will not function in this condition. Be sure to return the deck to its original condition after repairs are completed.

1-1: HOW TO REMOVE AND INSTALL STAGE

(DECK 1)

REMOVAL (Refer to Fig. 1-1)

1. Remove the pulley of loading motor box and the front loading belt hooked on the stage worm.
2. Remove the screws ① and ② in the EJECT mode.
3. Push the stage in the direction of the arrow and lift up to remove it.

(DECK 2)

REMOVAL (Refer to Fig. 1-2)

1. Remove 2 screws ① from the main PCB.
2. Remove the screws ② and ③ in the EJECT mode.
3. Push the stage in the direction of the arrow and lift up to remove it.

NOTE

When you remove and install the stage, be careful not to touch the guide post or cylinder head.

INSTALLATION

Install new stage in the reverse steps of REMOVAL.

NOTE

When you re-install the stage, it should be in the EJECT mode.

CONFIRMATION

1. The front loading operation works well when turning on the power and when inserting a cassette tape into the stage.
2. Each function works well when pressing the PLAY, EJECT and REC buttons.

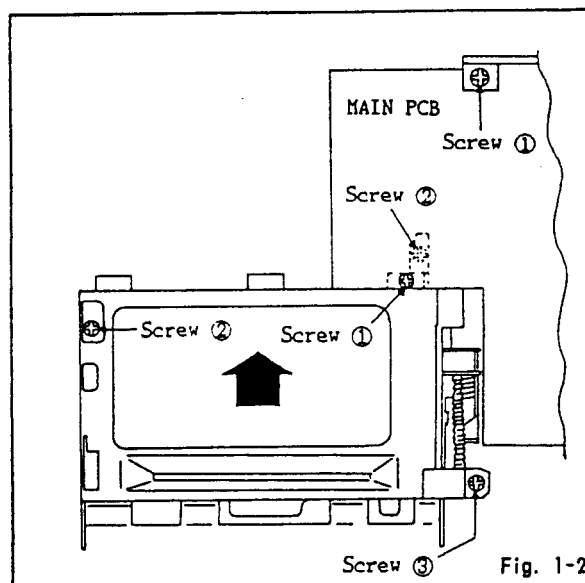
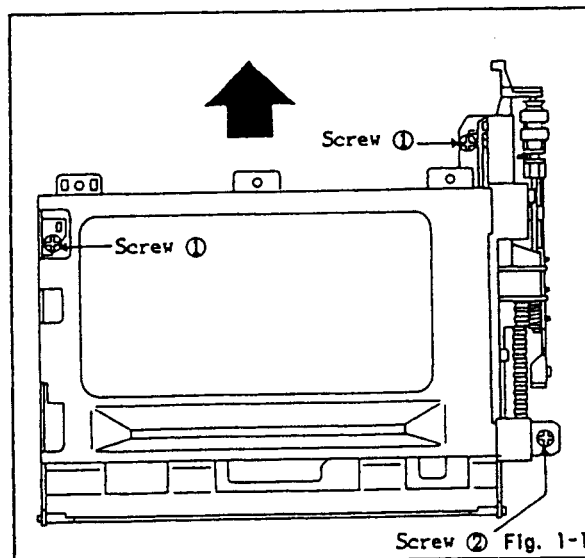

2. REPLACEMENT OF MAIN PARTS (DECK 1/2)

2-1: REEL DISK

REMOVAL (Refer to Fig. 2-1)

(Supply Reel Disk)

1. Remove the actuator sub brake.
2. Remove the SS brake spring, then remove the SS brake arm.
3. Remove the tension band from the main chassis.
4. Remove the polyslider washer ①.
5. Pull the supply reel disk ③ upward and replace it.

(Take-Up Reel Disk)

1. Remove the actuator sub brake.
2. Remove the IS brake spring, then remove the TS brake.
3. Remove the polyslider washer ④.
4. Pull the take-up reel disk ⑤ upward and replace it.

NOTE

The height adjustment washers ② and ⑥ are sometimes attached to the back of the reel disk.

MECHANICAL ADJUSTMENTS

INSTALLATION

(Supply/Take-Up Reel Disk)

1. Clean the reel disk shaft and put in height adjusting washers ② and ⑥.
2. Install new reel disk.
3. Adjust the height of the reel disk. (Refer to item 3-5)
4. Pull out the new supply/take-up reel disk. After oiling (Cosmo Oil Hydro HV100) the reel disk shaft, install the new supply/take-up reel disk again.
5. Install the supply/take-up reel disk in the reverse steps of REMOVAL.

NOTE

1. Be careful not to damage the tension band at the time of removal and installation.
2. Be careful not to scratch the reel disk shaft with the polyslider washer or the tool at the time of removal and installation.
3. After installation, adjust and confirm the tension post position. (Refer to item 3-6)

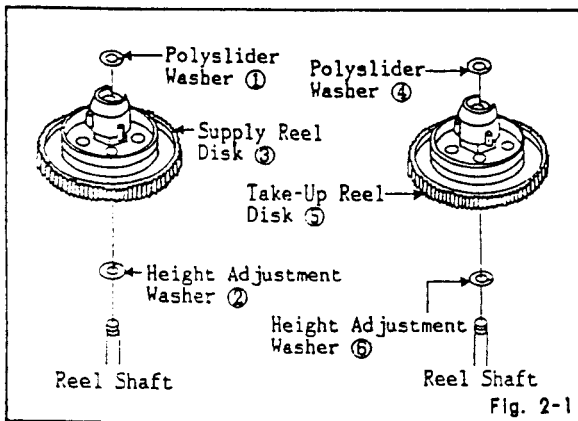

Fig. 2-1

2-2: A/C HEAD

REMOVAL (Refer to Fig. 2-2)

Remove the screws ①, ② and ③.

INSTALLATION

Install new A/C head in reverse steps of REMOVAL.

NOTE

Do not touch the heads by any means when replacing the A/C head.

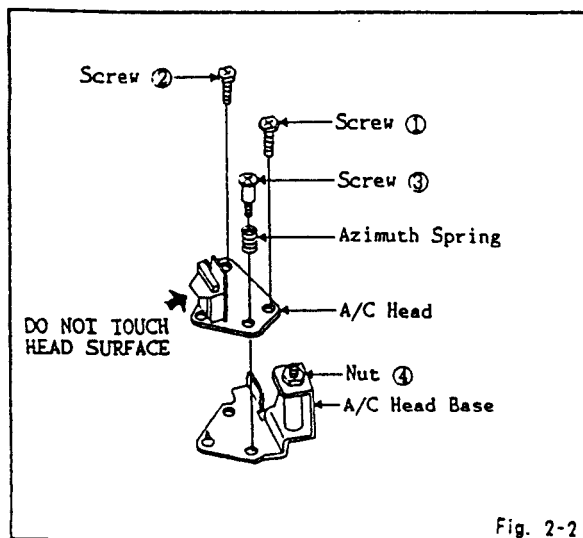

Fig. 2-2

2-3: CYLINDER UNIT

(DECK 1)

REMOVAL (Refer to Fig. 2-3)

1. Remove the transistor PCB. (Refer to item 2-9)
2. Disconnect the connector (CP4102, 8 pin) from the head amp PCB.
3. Remove the 3 screws ③, then remove the cylinder unit from the main chassis.
4. Disconnect the connector of the cylinder motor.

(DECK 2)

REMOVAL (Refer to Fig. 2-3)

1. Remove the transistor PCB. (Refer to item 2-9)
2. Disconnect the connector (CP4102, 8 pin) from the head amp PCB.
3. Remove the 3 screws ③, then remove the cylinder unit from the main chassis.
4. Disconnect the connector of the cylinder motor.

INSTALLATION

Install new cylinder unit in reverse steps of REMOVAL.

NOTE

1. Do not touch the surface of the cylinder head.
2. After replacement confirm the following adjustments.

- a. ELECTRICAL ADJUSTMENTS : ITEM 2-1
- b. ELECTRICAL ADJUSTMENTS : ITEM 2-2
- c. ELECTRICAL ADJUSTMENTS : ITEM 2-3
- d. MECHANICAL ADJUSTMENTS : ITEM 4-3

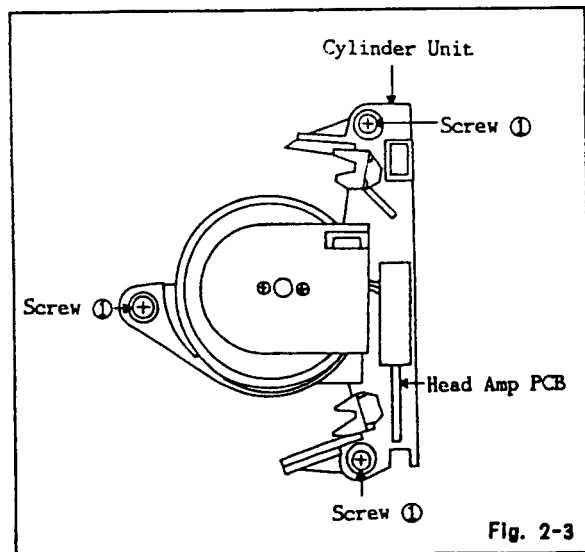

Fig. 2-3

MECHANICAL ADJUSTMENTS

2-4: TENSION BAND

REMOVAL (Refer to Fig. 2-4)

1. Remove the actuator sub brake.
2. Remove the SS brake spring, then remove the SS brake arm.
3. Remove the screw ①.
4. Remove the tension band from the tension arm.

INSTALLATION

Install new tension band in reverse steps of REMOVAL.

NOTE

1. Install the tension band without twisting it.
2. Adjust the placement of the tension post. (Refer to item 3-6)
3. Adjust and confirm the back tension during playback. (Refer to item 3-7)

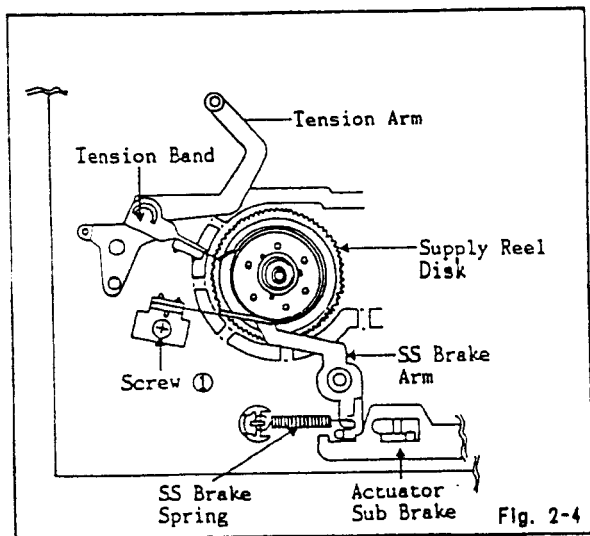

2-5: LOADING MOTOR / LOADING MOTOR BELT

REMOVAL (Refer to Fig. 2-5)

1. Remove the 2 wires soldered to the loading motor.
2. Remove the lead wire in the hook of the loading motor box.
3. Remove the loading motor belt ②.
4. Remove the 2 screws ①, then remove the loading motor box.
5. Remove the front loading belt ③.
6. Remove the 2 screws ④, then lift the loading motor upward.

INSTALLATION

Install new loading belt in reverse steps of REMOVAL.

NOTE

1. Clean the pulley when replacing loading belt.
2. Replace it while in the EJECT mode.
3. Avoid getting grease on the loading belt.

CHECK AFTER INSTALLATION

1. Check if strange sound is heard in PLAY mode.
2. Check if P2 post and P3 post are fitted to the post stopper.
3. Check if P2 post and P3 post are completely returned in EJECT mode.

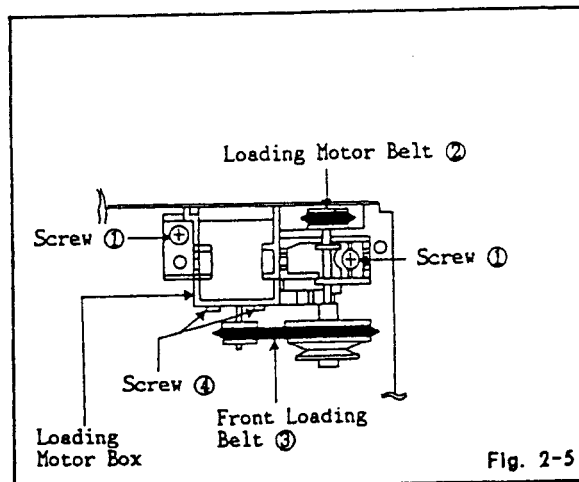

MECHANICAL ADJUSTMENTS

2-6: PINCH ROLLER

REMOVAL (Refer to Fig. 2-6)

1. Remove the pinch roller arm spring.
2. Remove the polyslider washer ①.
3. Remove the pinch roller.

INSTALLATION

Install new pinch roller in reverse steps of REMOVAL.

NOTE

1. Be careful not to bend the pinch roller arm in removal and installation.
2. Do not touch the pinch roller. (Use gloves.)

CHECK AFTER INSTALLATION

Check if the tape is running normally in PLAY mode.

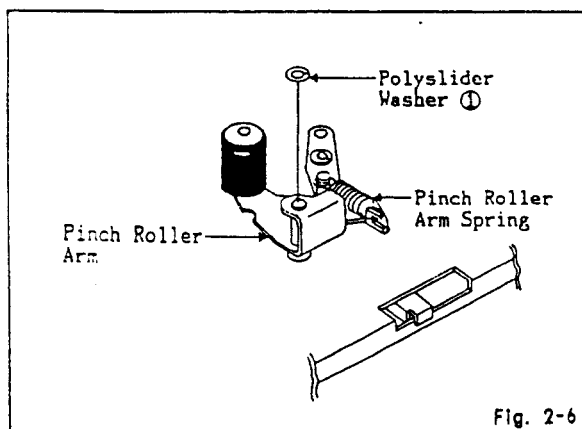

2-7: CAPSTAN DD UNIT

(DECK 1)

REMOVAL (REFER TO FIG. 2-7-A)

1. Disconnect the connector (CP2003 17 pin) from the main PCB.
2. Disconnect the connector (CP4102 8 pin) of the head amp PCB and the connector (CP5001 5 pin, CP2001 2 pin) of the main PCB.
3. Remove the screw ①, unlock the hooks (3 positions) which have been connected to the main PCB.
4. Disconnect the connector (9 pin) of the capstan DD unit.
5. Disconnect the connector (6 pin) of the cylinder unit back side.
6. Remove the reel belt.
7. Remove the solder "A" positions, remove the screws ① and then remove the deck bottom PCB.
8. Remove the loading motor belt ②.
9. Remove the screw ④, then remove the bracket worm 3.
10. Pull the hook ③ in the direction of arrow, then remove the worm. (Refer to Fig. 2-7-B)
11. Remove the screws ①, then remove the capstan DD unit. (Refer to Fig. 2-7-C)
(Be sure to support the capstan DD unit with your hand.)

(DECK 2)

REMOVAL

1. Remove the reel belt.
2. Remove the solder "A" positions, remove the screws ① and then remove the deck bottom PCB.
3. Remove the loading motor belt ②.
4. Remove the screw ④, then remove the bracket worm 3.
5. Pull the hook ③ in the direction of arrow, then remove the worm. (Refer to Fig. 2-7-B)
6. Remove the screws ①, then remove the capstan DD unit. (Refer to Fig. 2-7-C)
(Be sure to support the capstan DD unit with your hand.)

INSTALLATION

Install new capstan DD unit in reverse steps of REMOVAL.

MECHANICAL ADJUSTMENTS

NOTE

1. Do not bend the limiter post.
2. Use the specified screw held to the DD unit.
3. Avoid getting grease on the reel belt.
4. Be sure to install in the EJECT position.
(Refer to Fig. 2-7-E, F)
5. Install in the position where the capstan DD unit PCB reaches to the "B" position.
(Refer to Fig. 2-7-B)
6. When installing the worm, be sure to unlock the hook ③ in the direction of arrow, and the cam 1 and cam 2 must be meshed smoothly.
(Refer to Fig. 2-7-B)
7. When installing the deck bottom PCB, be sure to install the rotary switch in the EJECT position.
The EJECT position is the point where the "A" tooth is aligned to "B".
(Refer to Fig. 2-7-D)

CHECK AFTER INSTALLATION

1. Check if tape running is normal in PLAY mode.
2. Check if FF/REW mode works normally.

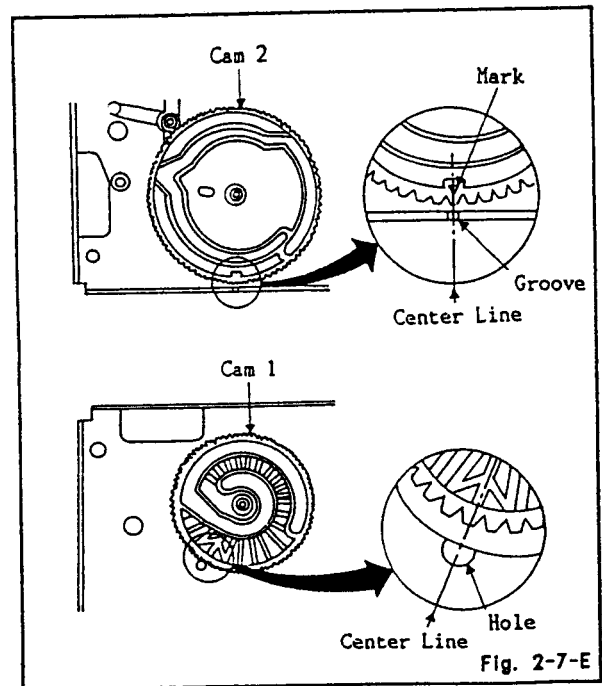
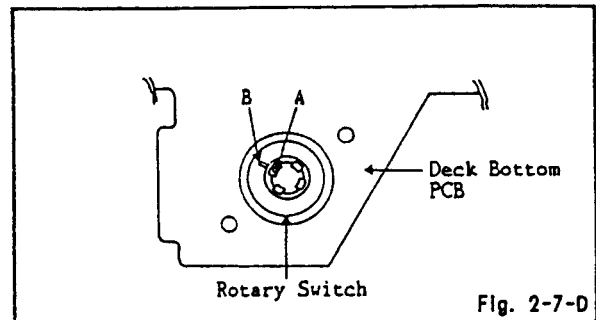
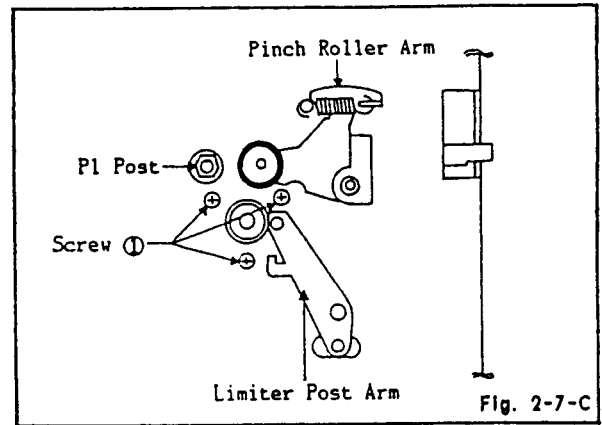
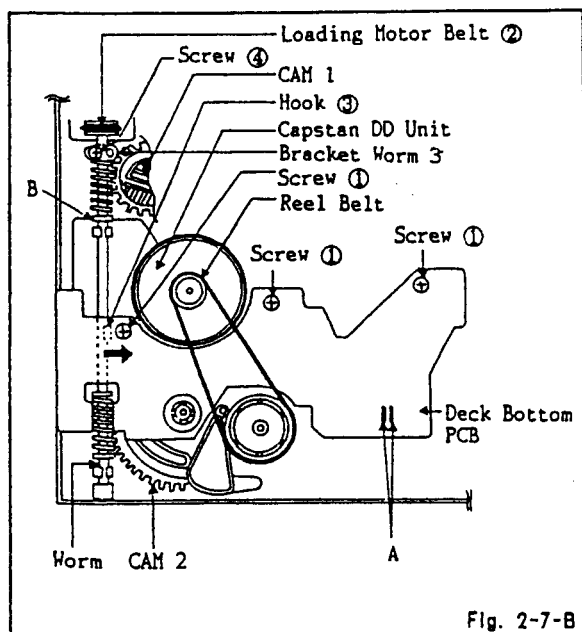
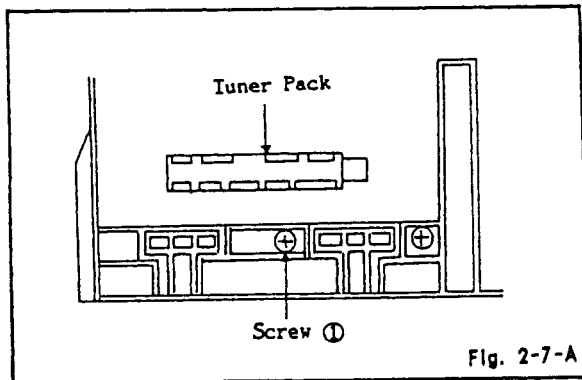

MECHANICAL ADJUSTMENTS

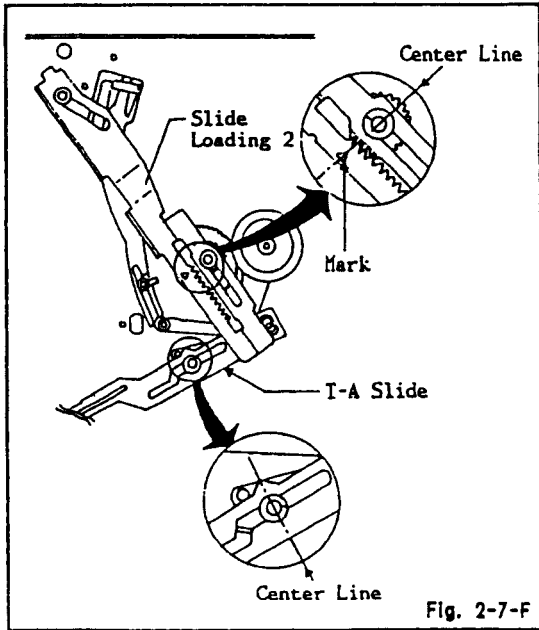

Fig. 2-7-F

2-8: TRANSISTOR PCB

REMOVAL

1. Insert a small flat-blade screwdriver into the transistor spring as shown in Fig. 2-8.
2. Hold both edges of the transistor PCB ("A" part) with your fingers and pull out the transistor PCB while turning the driver.

INSTALLATION

Install new transistor PCB in reverse steps of REMOVAL.

NOTE

1. The unit should be unplugged from the AC outlet.
2. Do not scratch or mar the cylinder.
3. Be careful not to split the transistor PCB.
4. If the transistor spring is broken when holding or removing the transistor PCB, replace with a new one.

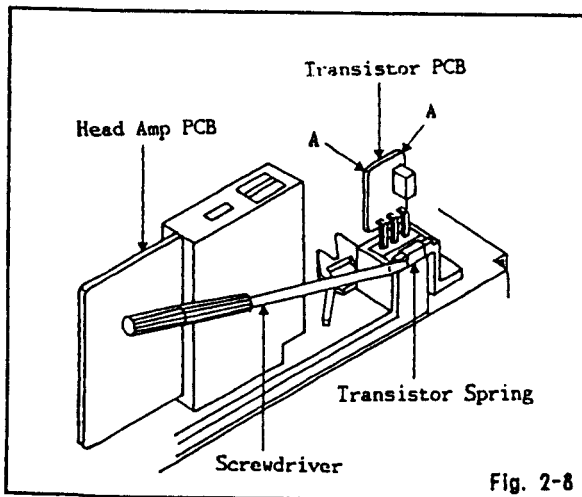

Fig. 2-8

3. CONFIRMATION AND ADJUSTMENT (DECK 1/2)

3-1: CONFIRMATION OF FAST FORWARD TORQUE

CONFIRMATION

1. Set torque gauge (JG002G) on take-up reel disk, and place unit in FAST FORWARD mode. (Refer to Fig. 3-1)
2. Confirm that torque is more than 800g/cm.

NOTE

After setting the torque gauge on the reel disk, hold the gauge in place. Push the FAST FORWARD button and the reel disk will begin to turn.

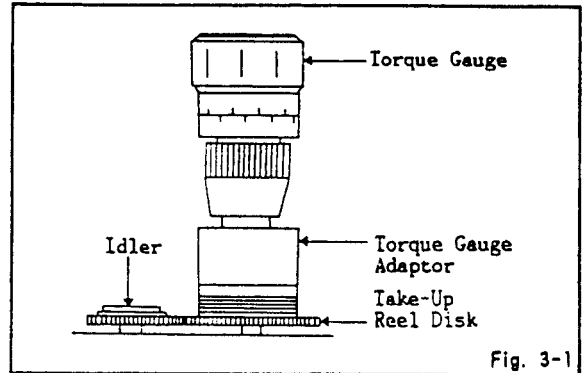

Fig. 3-1

3-2: CONFIRMATION OF REWIND TORQUE

CONFIRMATION

1. Operate within 4 or 5 seconds after the reel disk begins to turn.
2. Set torque gauge (JG002G) on supply reel Disk, and place the unit in REWIND mode. (Refer to Fig. 3-2)
3. Confirm that torque is more than 800g/cm.

NOTE

After setting the torque gauge on the reel disk, hold the gauge in place. Push the REWIND button and the reel disk will begin to turn.

MECHANICAL ADJUSTMENTS

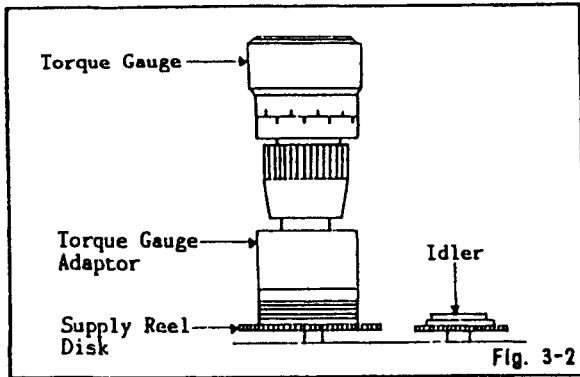

Fig. 3-2

3-3: CONFIRMATION OF PLAYBACK TAKE-UP TORQUE

CONFIRMATION

1. Set the torque gauge (JG002F) on the rewind reel disk, then check PB mode.
2. Make sure that the torque covers the range, 60~150g/cm.

3-4: CONFIRMATION OF REEL BRAKE TORQUE

CONFIRMATION (Refer to Fig. 3-3-A)

(Take-Up Reel Brake)

1. Set to STOP mode.
2. Set the torque gauge (JG002G) to the take-up reel and turn it counterclockwise.
3. Confirm that it is more than 200g/cm at that time.

CONFIRMATION (Refer to Fig. 3-3-B)

(Supply Reel Brake)

1. Set to STOP mode.
2. Set the torque gauge (JG002G) to the supply reel and turn it clockwise.
3. Confirm that it is more than 200g/cm at that time.

NOTE

Separate the idler from the reel and confirm the brake torque.

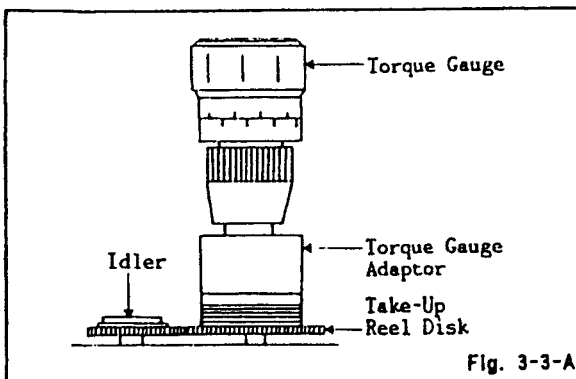

Fig. 3-3-A

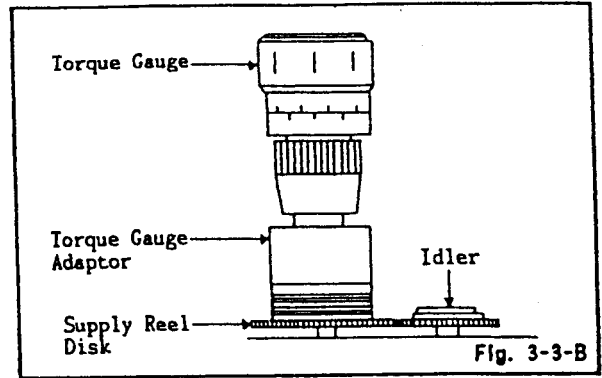

Fig. 3-3-B

NOTE

Refer to the table below for possible cause of problems when confirmation cannot be made for indicated items.

CONFIRMATION ITEM	CHECK POINT (REPLACEMENT)
3-1 3-2 3-3	Capstan belt may be stretched. Clutch may be worn out (if so, change reel disk). Idler ass'y may be worn out.
3-4	Main brake belt may be worn out.

3-5: CONFIRMATION AND ADJUSTMENT OF REEL DISK HEIGHT

ADJUSTMENT

1. Set the master plane (JG022) on mechanism framework, taking care not to scratch the drum, as shown in Fig. 3-4-A.
2. Confirm that the reel disk is lower than "A" of the reel disk height adjustment jig, (JG024) on the master plane and higher than "B" as shown in Fig. 3-4-B.
3. When it does not satisfy above items, adjust to less than 0.1mm~0.5mm with the height adjustment washer.

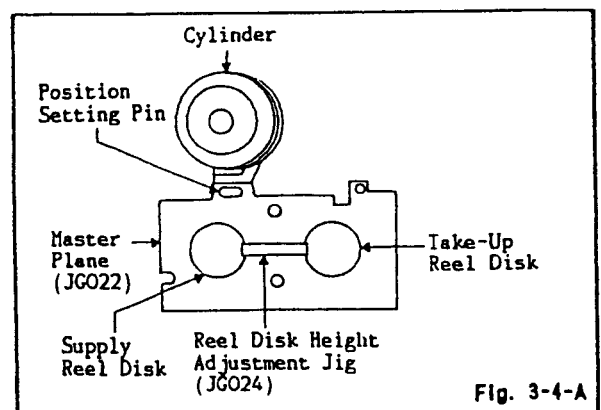

Fig. 3-4-A

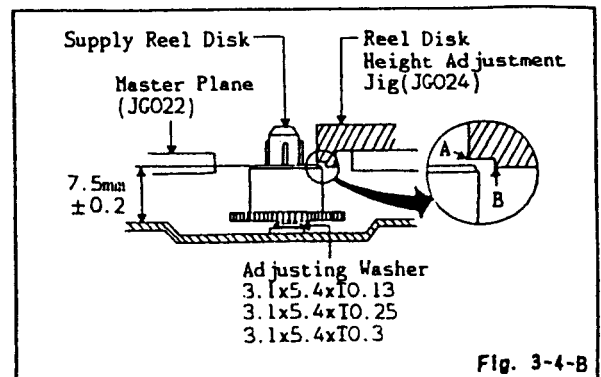

Fig. 3-4-B

MECHANICAL ADJUSTMENTS

3-6: CONFIRMATION AND ADJUSTMENT OF TENSION POST POSITION

CONFIRMATION

1. Turn on the power and set to the PLAY mode by using the tension post adjustment jig (JG036).
2. As soon as the guide rollers, L, R begin to draw the tape from the cassette, the tension post shall move to the left, thus loading will start.
3. Move the tension band adjuster to the "A" or the "B" direction to set tension post adjusting jig red line to the round edge of the tension post. (Refer to Fig. 3-5)
4. Confirm that the video tape is not curling at the flange of PI post or is not running on flanges.

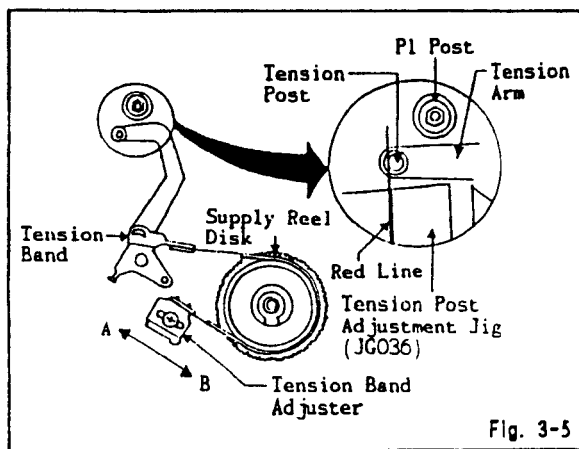

3-7: CONFIRMATION AND ADJUSTMENT OF BACK TENSION ON PLAYBACK

CONFIRMATION

1. After adjustment, confirm and adjust of tension post position (Refer to item 3-6) for the tension arm, install the cassette type torque meter (JG100) and set to the PLAY mode.
2. Confirm that the left hand side tension value of the torque meter is 45~60g/cm at the standard mode tape.
Set the tension arm spring to "A" direction when the torque meter indicates more than 60g/cm. (Refer to Fig. 3-6)
Set the tension arm spring to "B" direction when the torque meter indicates less than 45g/cm. (Refer to Fig. 3-6)

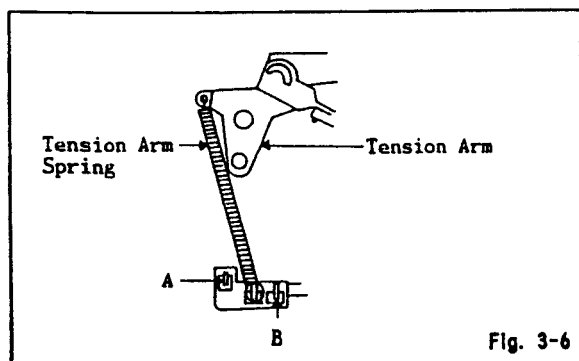

4. TAPE RUNNING CONFIRMATION AND ADJUSTMENT

Tape running is adjusted precisely at the factory. Normally, it is not necessary to make adjustments. It is necessary to confirm and make adjustments when the parts of the tape running mechanism are replaced because of extensive usage or failure.

4-1: GUIDE ROLLER

ADJUSTMENT

1. Switch on main power and then connect monitor output cord and video input cord to proper positions.
2. Insert the VHS adjustment tape (JG001) into the unit.
3. Connect CH-1 and CH-2 of oscilloscope to envelope output and to the test point of switching pulse, respectively.
4. Carry out this adjustment in PLAY mode.
5. Trigger with SW pulse and observe the envelope. (Refer to Fig. 4-1-A)
6. Adjust the guide roller height while observing the envelope, and make the envelope flat. Adjust the envelope so that the flatness will not be affected even when the tracking control button is pressed. (Use the adjustment screwdriver JG005).
7. When the tracking control button is pressed. (the point that the envelope waveform starts to reduce), adjust the envelope so that its A:B ratio is better than 3:2. (Refer to Fig. 4-1-B)
8. Adjust the PB switching position (ELECTRICAL ADJUSTMENTS : ITEM 2-1) in the PLAY mode.

NOTE

After adjustment, confirm and adjust A/C head tilt. (Refer to item 4-2)

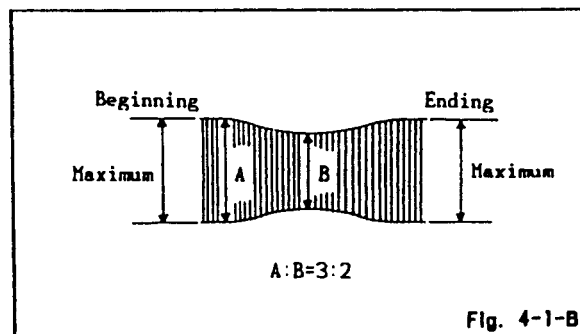
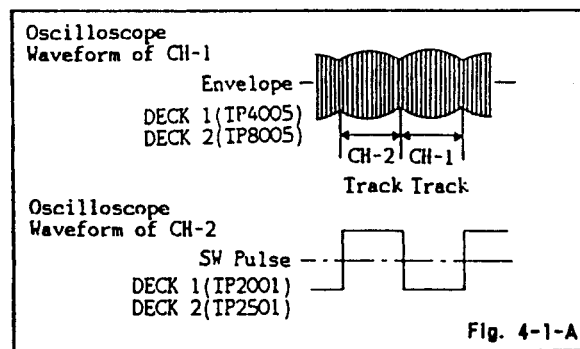

MECHANICAL ADJUSTMENTS

4-2: CONFIRMATION AND ADJUSTMENT OF A/C HEAD TILT

ADJUSTMENT

When the tape is running abnormally, perform the following adjustments.

1. Check the tape running condition with the unit in the PLAY mode using the E-60 tape.
2. Confirm that there is no crease on the tape between the guide post and guide roller(R) and the tape is running smoothly. (It is absolutely impossible to get satisfactory sound if the tape is distorted between the A/C head and guide post.)
3. If the tape still does not run smoothly, turn the screw ① and adjust the tilt of the A/C head. Do not move the guide post. (Refer to Fig. 2-2)

4-3: ADJUSTMENT OF A/C HEAD HEIGHT AND AZIMUTH

ADJUSTMENT

1. Play back a VHS adjustment tape (JG001) and observe the waveform at the audio output terminal.
2. Turn the screw ② slowly to change the height of the A/C head. Adjust the height so that the audio output becomes maximum. (Refer to Fig. 2-2)
3. Adjust the nut ④. (Refer to Fig. 2-2) until the height of the A/C head reaches the position against the tape as shown in Fig. 4-2.

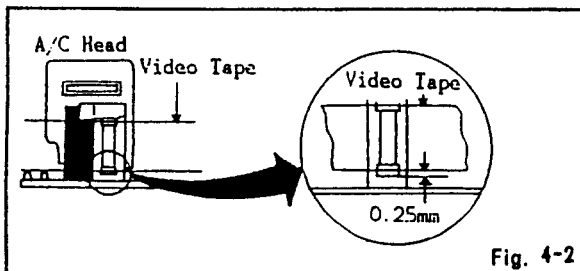

4-4: TAPE RUNNING ADJUSTMENT

1. Adjust the height of reel disk. (Refer to Item 3-5)
2. Confirm and adjust tension post position. (Refer to Item 3-6)
3. Adjust the guide roller. (Refer to Item 4-1)
4. Adjust the A/C head height and azimuth. (Refer to Item 4-3)
5. Adjust the A/C head tilt. (Refer to Item 4-2)
6. Set the tracking control to the center position. Turn X-nut adjustment screwdriver (JG021) until the envelope appears maximum.

ELECTRICAL ADJUSTMENTS

1. BEFORE MAKING ELECTRICAL ADJUSTMENTS

Read and perform these adjustments when repairing the circuits or replacing electrical parts or PCB assemblies.

1-1: Prepare the following measurement tools for the electrical adjustment.

1. Oscilloscope (2 channel type)
2. AC Voltmeter
3. Sweepmarker Generator
4. AFT Adjustment Oscillator
5. VIF Unit
6. Audio Oscillator
7. Frequency Counter
8. DC Voltmeter
9. Spectrum Analyzer
10. Distortion Meter

2. ADJUSTMENT PROCEDURE

2-1: PB. SWITCHING POSITION

CONDITIONS

MODE - PLAYBACK

Input Signal - Standard Test Tape

NOTE

Tracking control should be set at click point.

INSTRUCTIONS

(DECK 1)

1. Connect CH-1 on the oscilloscope to TP2001 and CH-2 to pin 19 of J4501.
2. Playback the tape.
3. Adjust VR2001 so that the waveform of the oscilloscope measures $6.5 \pm 0.5(H)$ at both leading and trailing edges. (Refer to Fig. 2-1-A, B)

(DECK 2)

1. Connect CH-1 on the oscilloscope to TP2501 and CH-2 to pin 19 of J4501.
2. Playback the tape.
3. Adjust VR2501 so that the waveform of the oscilloscope measures $6.5 \pm 0.5(H)$ at both leading and trailing edges. (Refer to Fig. 2-1-A, B)

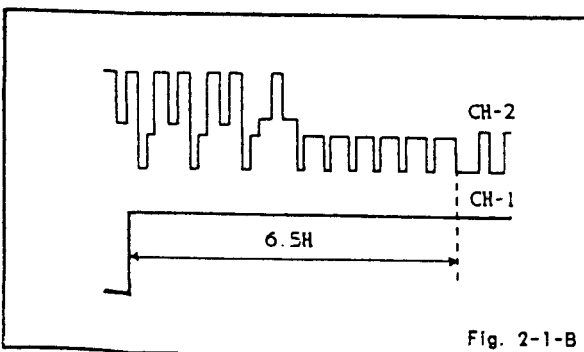
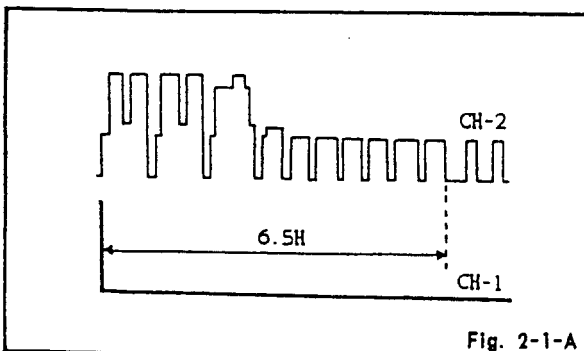

2-2: TRACKING FIX

CONDITIONS

MODE - PLAYBACK

Input Signal - Standard Test Tape

NOTE

1. Tracking control should be set at click point.
2. Before adjusting, set DC level of both switching pulse and sampling pulse.

INSTRUCTIONS

(DECK 1)

1. Connect CH-1 on the oscilloscope to TP2001 and CH-2 to TP2003.
2. Playback the tape.
3. Adjust VR2002 so that the "T" portion measures $-1.0 \pm 0.3msec$. (Refer to Fig. 2-2)

(DECK 2)

1. Connect CH-1 on the oscilloscope to TP2501 and CH-2 to TP2503.
2. Playback the tape.
3. Adjust VR2502 so that the "T" portion measures $-1.0 \pm 0.3msec$. (Refer to Fig. 2-2)

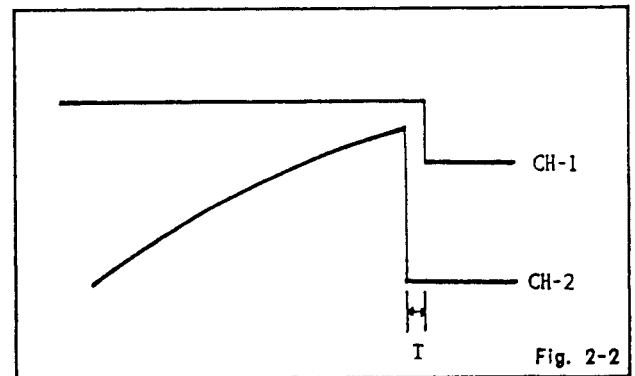

2-3: PLAYBACK LUMINANCE LEVEL

CONDITIONS

MODE - PLAYBACK

Input Signal - Color Bar Test Tape

NOTE

Video out (pin 19 of J4501) of the unit should be terminated with 75 ohm load.

INSTRUCTIONS

(DECK 1)

1. Connect the oscilloscope to pin 19 of J4501.
2. Playback the tape.
3. Adjust VR4001 so that the signal becomes $1.0 \pm 0.05Vp-p$ as shown in Fig. 2-3.

(DECK 2)

1. Connect the oscilloscope to pin 19 of J4501.
2. Playback the tape.
3. Adjust VR8001 so that the signal becomes $1.0 \pm 0.05Vp-p$ as shown in Fig. 2-3.

ELECTRICAL ADJUSTMENTS

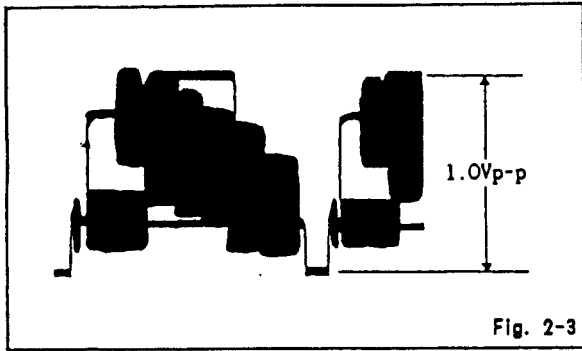

2-4: E-E LEVEL

CONDITIONS

MODE - STOP

Input Signal - PAL Color Bar

NOTE

Video out (pin 19 of J4501) of the unit should be terminated with 75 ohm load.

INSTRUCTIONS

(DECK 1)

1. Input the color bar signal to the pin 20 of J4501.
2. Connect the oscilloscope to TP4001.
3. Adjust VR4004 so that the waveform measures $0.5 \pm 0.025V_{p-p}$. (Refer to Fig. 2-4)

(DECK 2)

1. Input the color bar signal to the pin 20 of J4501.
2. Connect the oscilloscope to TP8001.
3. Adjust VR8004 so that the waveform measures $0.5 \pm 0.025V_{p-p}$. (Refer to Fig. 2-4)



2-5: CARRIER AND DEVIATION

CONDITIONS

MODE - RECORD

Input Signal - PAL Color Bar

INSTRUCTIONS

(DECK 1)

1. Input the color bar signal to the pin 20 of J4501.
2. Connect TP4003 to the input terminal on the spectrum analyzer, then adjust 3.8MHz and 4.8MHz as shown in Fig. 2-5 with VR4005 and VR4006.

VR4005 (CARRIER)
VR4006 (DEVIATION)

(DECK 2)

1. Input the color bar signal to the pin 20 of J4501.
2. Connect TP8003 to the input terminal on the spectrum analyzer, then adjust 3.8MHz and 4.8MHz as shown in Fig. 2-5 with VR8005 and VR8006.

VR8005 (CARRIER)
VR8006 (DEVIATION)

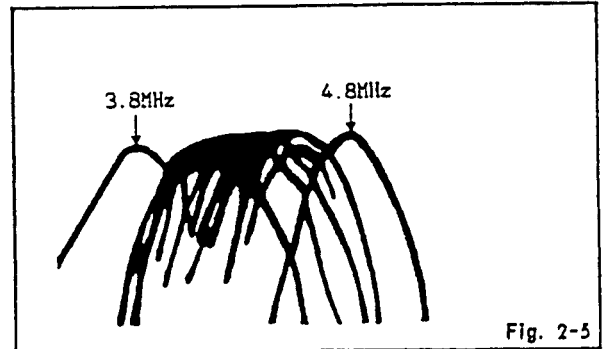

2-6: RECORD CURRENT

CONDITIONS

MODE - RECORD

Input Signal - PAL Color Bar

INSTRUCTIONS

(DECK 1)

1. Input the color bar signal to the pin 20 of J4501.
2. Connect CH-1 on the oscilloscope to TP4101 and connect the GND side to TP4102. Connect CH-2 on the oscilloscope to TP4201. Reduce REC.-Luminance signal factors by turning VR4007 fully counterclockwise.
3. Adjust VR4301 so that the cyan level becomes $140 \pm 10mV_{p-p}$ as shown in Fig. 2-6-A.
4. Adjust VR4007 so that the horizontal sync level becomes $480 \pm 20mV_{p-p}$ as shown in Fig. 2-6-B.

(DECK 2)

1. Input the color bar signal to the pin 20 of J4501.
2. Connect CH-1 on the oscilloscope to TP4101 and connect the GND side to TP4102. Connect CH-2 on the oscilloscope to TP4201. Reduce REC.-Luminance signal factors by turning VR8007 fully counterclockwise.
3. Adjust VR8301 so that the cyan level becomes $140 \pm 10mV_{p-p}$ as shown in Fig. 2-6-A.
4. Adjust VR8007 so that the horizontal sync level becomes $480 \pm 20mV_{p-p}$ as shown in Fig. 2-6-B.

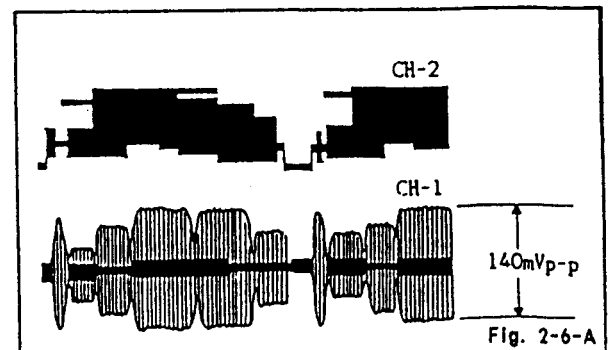

ELECTRICAL ADJUSTMENTS

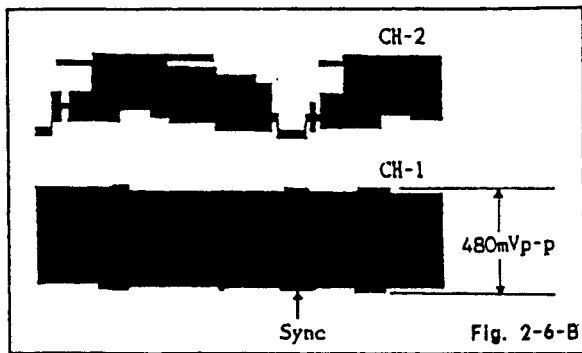

2-7: AUDIO BIAS CURRENT

CONDITIONS

MODE - RECORD
Input Signal - No Signal

INSTRUCTIONS

(DECK 1)

Connect the AC voltmeter as shown then adjust the voltage to $3.3 \pm 0.1 \text{mVrms}$ with VR5002. (Refer to Fig. 2-7)

(DECK 2)

Connect the AC voltmeter as shown then adjust the voltage to $3.3 \pm 0.1 \text{mVrms}$ with VR5502. (Refer to Fig. 2-7)

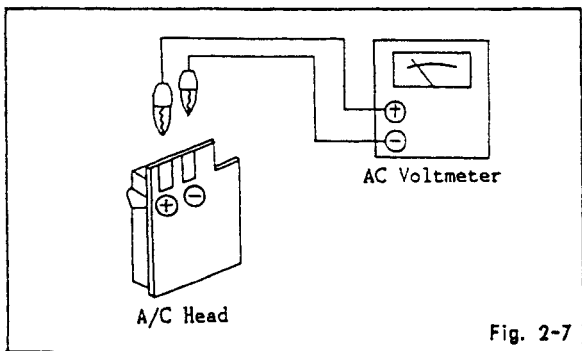

2-8: PLAYBACK AUDIO LEVEL

CONDITIONS

MODE - Self (RECORD and PLAYBACK) (SP MODE)
Input Signal - Audio Signal : 1KHz 500mVrms
Video Signal : PAL Color Bar

INSTRUCTIONS

(DECK 1)

1. Connect the AC voltmeter to pin 19 of J4501, which is terminated with 47K ohm resistor.
2. Record and then playback the audio signal as specified.
3. Adjust VR5001 so that the playback output will become $500 \pm 10 \text{mVrms}$.

(DECK 2)

1. Connect the AC voltmeter to pin 19 of J4501, which is terminated with 47K ohm resistor.
2. Record and then playback the audio signal as specified.
3. Adjust VR5501 so that the playback output will become $500 \pm 10 \text{mVrms}$.

2-9: CLOCK

CONDITIONS

MODE - STOP
POWER ON
CLOCK SET

INSTRUCTIONS

1. Connect the frequency counter to TP601.
2. Adjust TC601 so that the value of frequency counter is 4096Hz.

2-10-A: VCO

CONDITION

MODE - STOP

INSTRUCTIONS

1. Connect the output of sweepmarker generator to pin 5 side on IC6001 of resistor R6009.

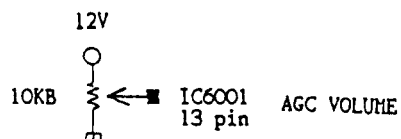

2. Adjust L6010 so that output waveform of pin 17 on IC6001 may become as shown in Fig. 2-8-A.

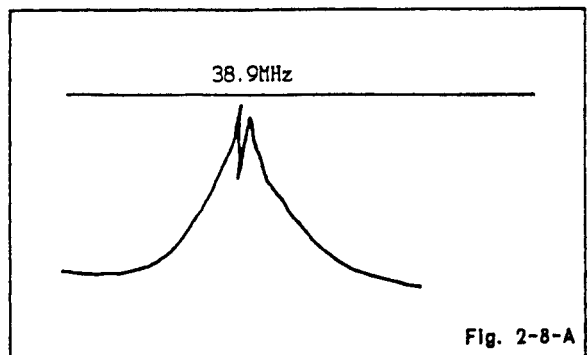

2-10-B: TRAP

CONDITION

MODE - TUNER MODE

INSTRUCTIONS

1. Connect the pin 1 of CP6001 to the output of the sweepmarker generator.
2. Connect the saw filter (CF6001) side of the condenser (C6025), to the oscilloscope. (Use the detector as prob.) (Refer to Fig. 2-8-B)
3. Adjust L6014 until the marker of 32.4MHz will be same as shown in Fig. 2-8-C.

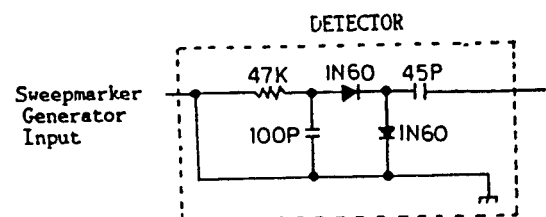

Fig. 2-8-B

ELECTRICAL ADJUSTMENTS

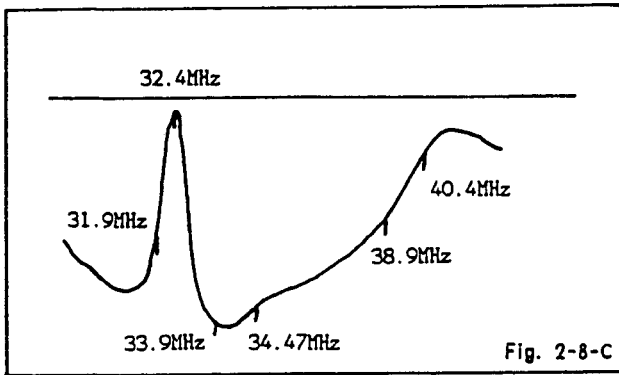

Fig. 2-8-C

2-10-C: CHECKING VIDEO IF OVERALL

CONDITIONS

MODE - STOP
BAND - UHF POSITION

INSTRUCTIONS

1. Connect the output of sweepmarker generator to the tuner pack TP.

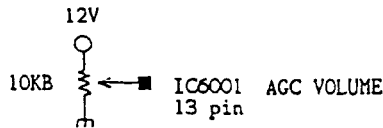

2. Connect the condenser (50V, 47 μ F) between the pins 18 on IC6001 and ground.
3. Make sure that the output of waveform of pin 17 on IC6001 may become as shown in Fig. 2-8-D.

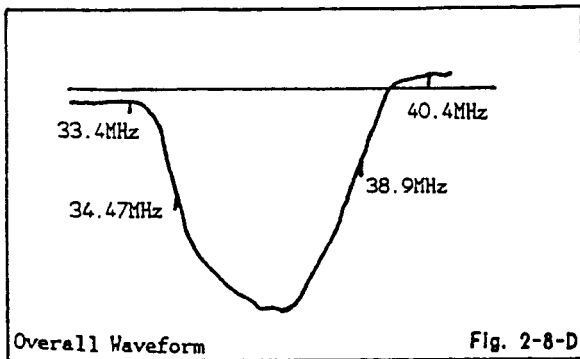

Fig. 2-8-D

2-11: AFT

CONDITION

MODE - STOP
BAND - UHF POSITION

NOTE

Disconnect the condenser C6022 in the adjustment.

INSTRUCTIONS

1. Connect output of the sweepmarker generator to tuner pack TP and adjust L6011 so that output waveform for TP6001 is as shown in Fig. 2-9.
2. Disconnect the sweepmarker generator and the oscilloscope from tuner pack TP and connect the condenser C6022.
3. Connect the AFT adjustment oscillator (38.9MHz) to the tuner pack TP through 2.2K ohm and connect the DC voltmeter to TP6001.
4. Adjust L6011 so that voltage at AFT switch ON is as much as one at AFT switch OFF.

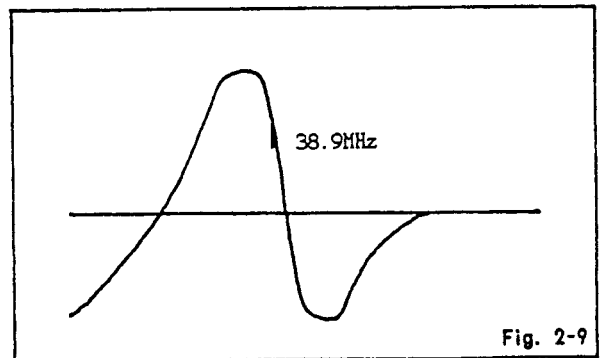

Fig. 2-9

2-12: DISTORTION FACTOR

CONDITIONS

MODE - STOP
AFT SW : ON MODE

INSTRUCTIONS

1. Receive the monochrome pattern signal. (Receive the CH11)
2. Connect the distortion meter to pin 19 of J4501.
3. Adjust L6005 until the distortion ratio of the distortion meter is minimum and the level meter indicator is maximum.

2-13: RF AGC

CONDITION

MODE - STOP

INSTRUCTIONS

1. Receive the monochrome pattern signal. (Receive the CH11)
2. Connect the DC voltmeter to TP6008.
3. Set input field strength to 80dB μ .
4. Adjust VR6001 so that the voltage is equal to $4.5 \pm 0.1V$.

ELECTRICAL ADJUSTMENTS

2-14: COLOR LEVEL

CONDITIONS

MODE - STOP
AFT SW : ON MODE

NOTE

Video out of the unit should be terminated with 75 ohm load.

INSTRUCTIONS

1. Obtain a color bar signal.
(Receive the CH48)
2. Connect the oscilloscope to pin 19 of J4501.
3. Adjust VR6002 so that the magenta level is $45 \pm 5\%$ when Y-level is 100%.
(Refer to Fig. 2-10)

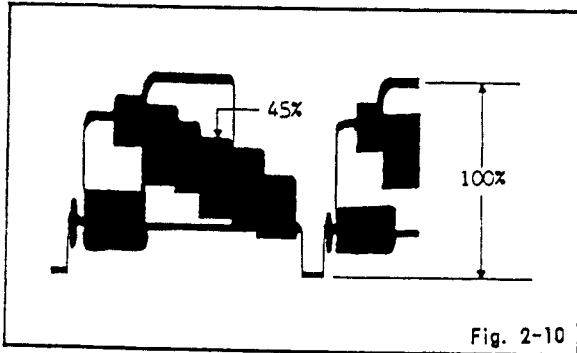

MAJOR COMPONENTS LOCATION GUIDE

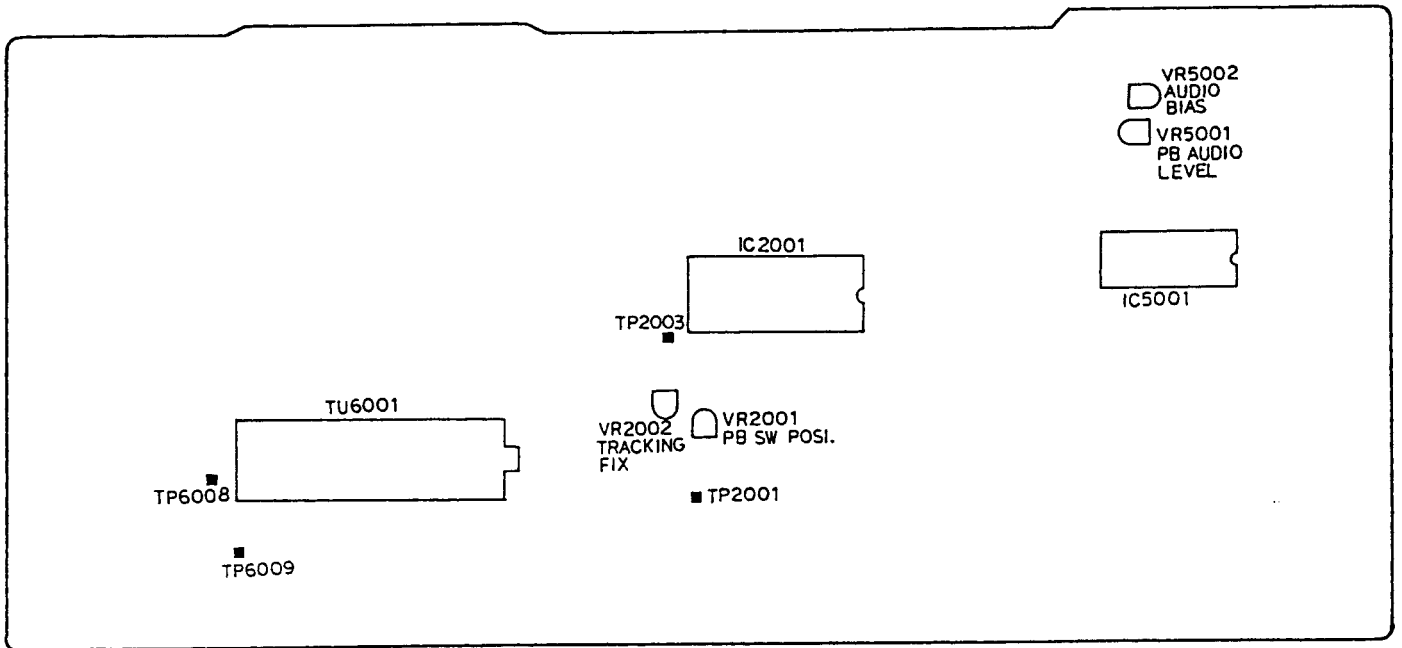

MAIN 1

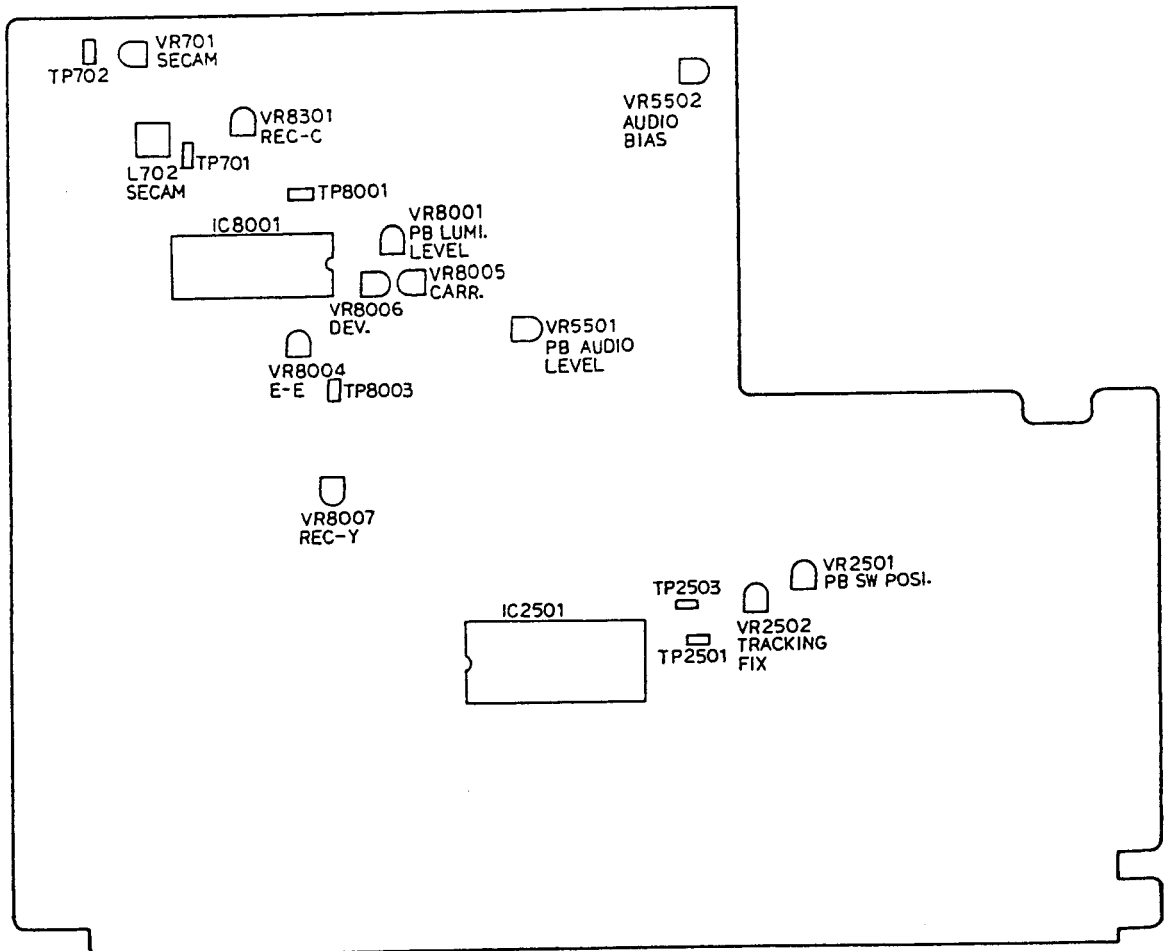

MAIN 2

MAJOR COMPONENTS LOCATION GUIDE

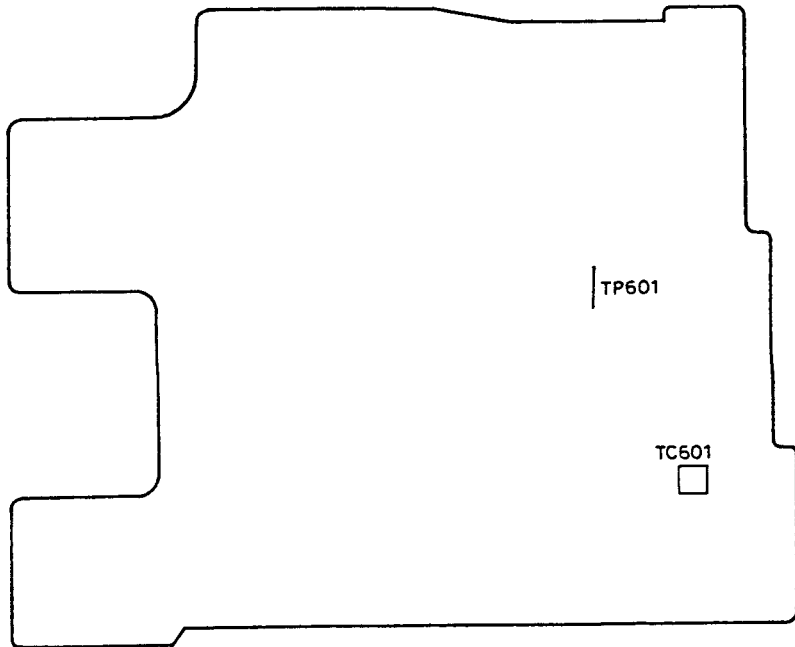

OPERATION

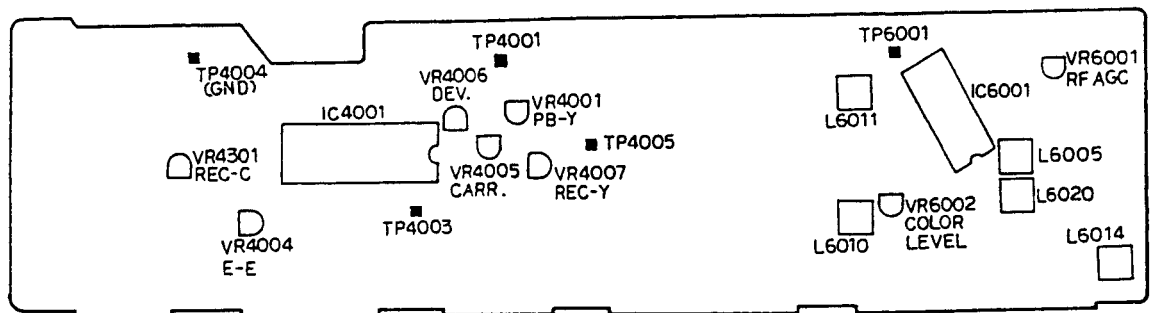

Y.C.

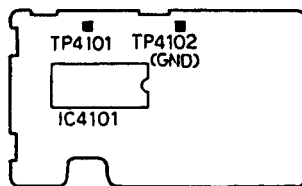

HEAD AMP

HOW TO RESET MICROCOMPUTER

When either or both of the following conditions occur, follow the procedure below:

CONDITIONS

- * The digitron display does not light up.
- * The unit does not stop, even when the "STOP" button is pressed.

PROCEDURE

1. The reset switch is accessed through an unmarked hole, which is pointed to by an arrow in the illustration.
2. The unit is reset when a long, narrow probe (eg, the end of a paper clip) is inserted into the hole.

* After resetting the microcomputer, set the clock to the preset time according to the owner's manual.

* A back-up circuit protects the unit from entering reset mode, even if the AC cord is unplugged from its AC outlet.

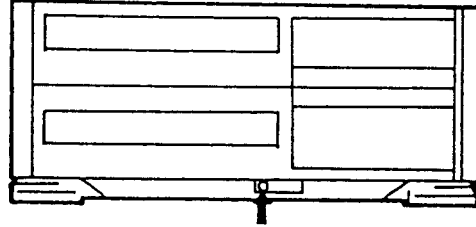

Y.C./HEAD AMP BLOCK DIAGRAM (DECK 1)

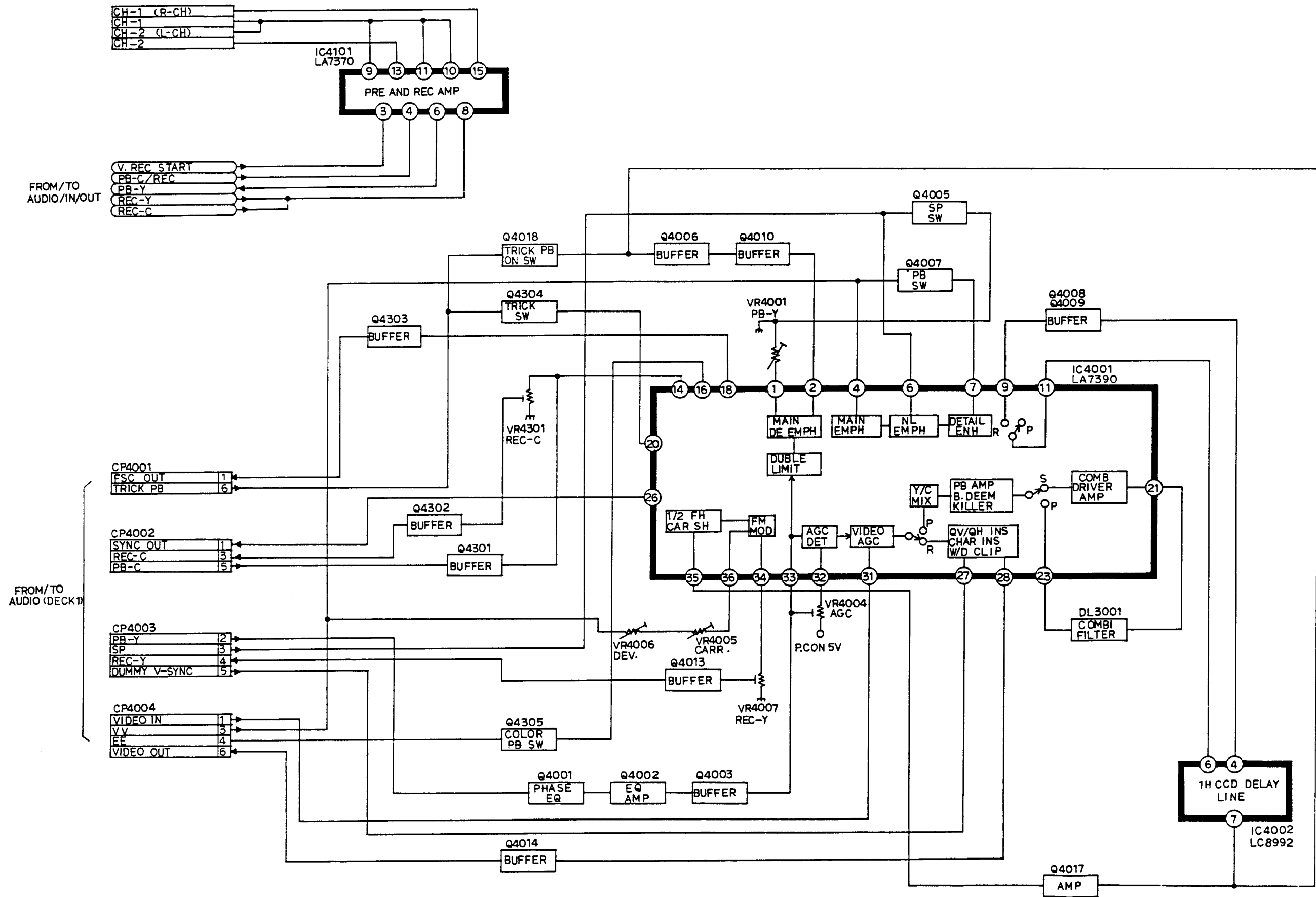

SYSTEM CONTROL BLOCK DIAGRAM (DECK 1)

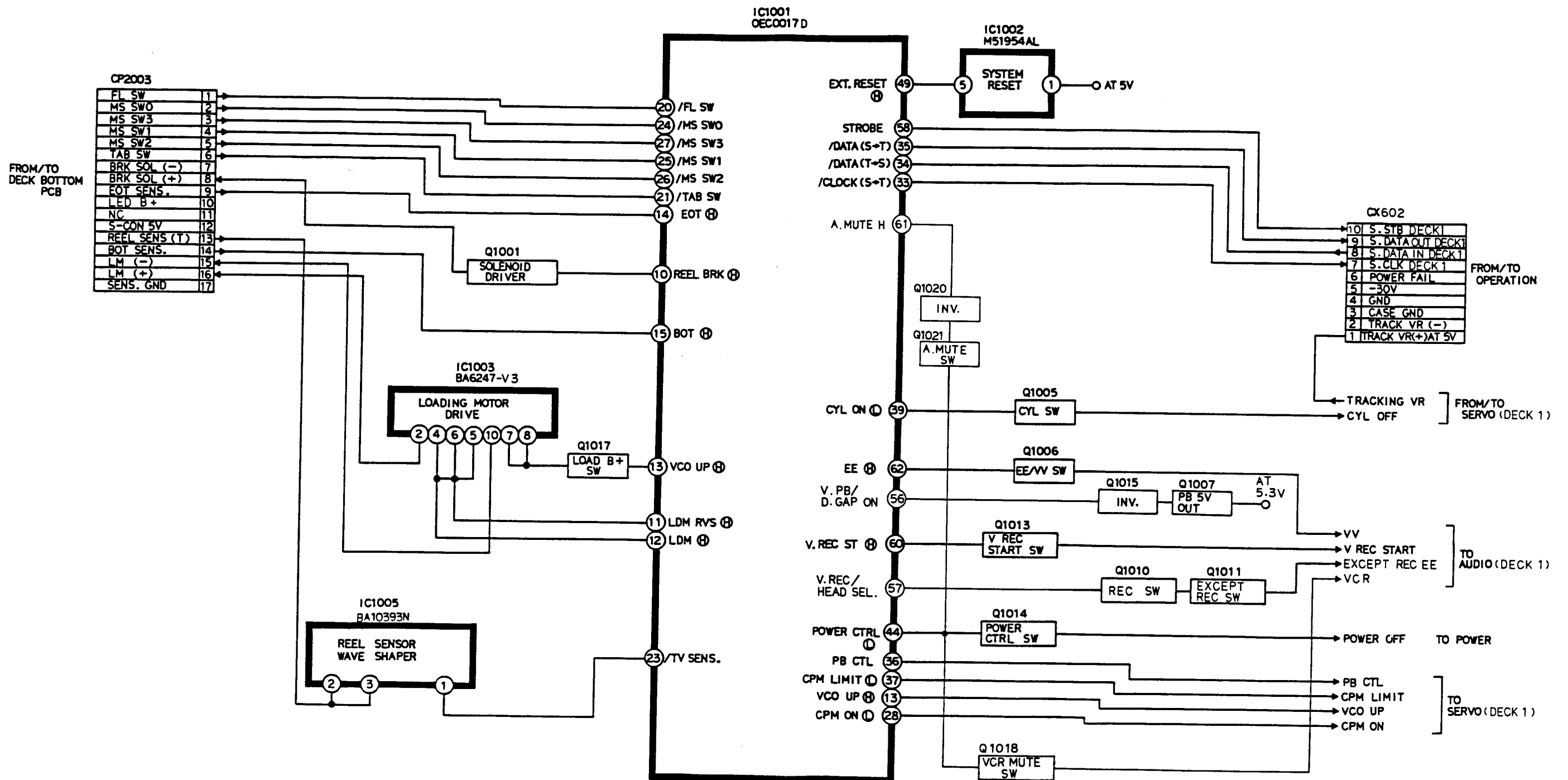

SERVO BLOCK DIAGRAM (DECK 1)

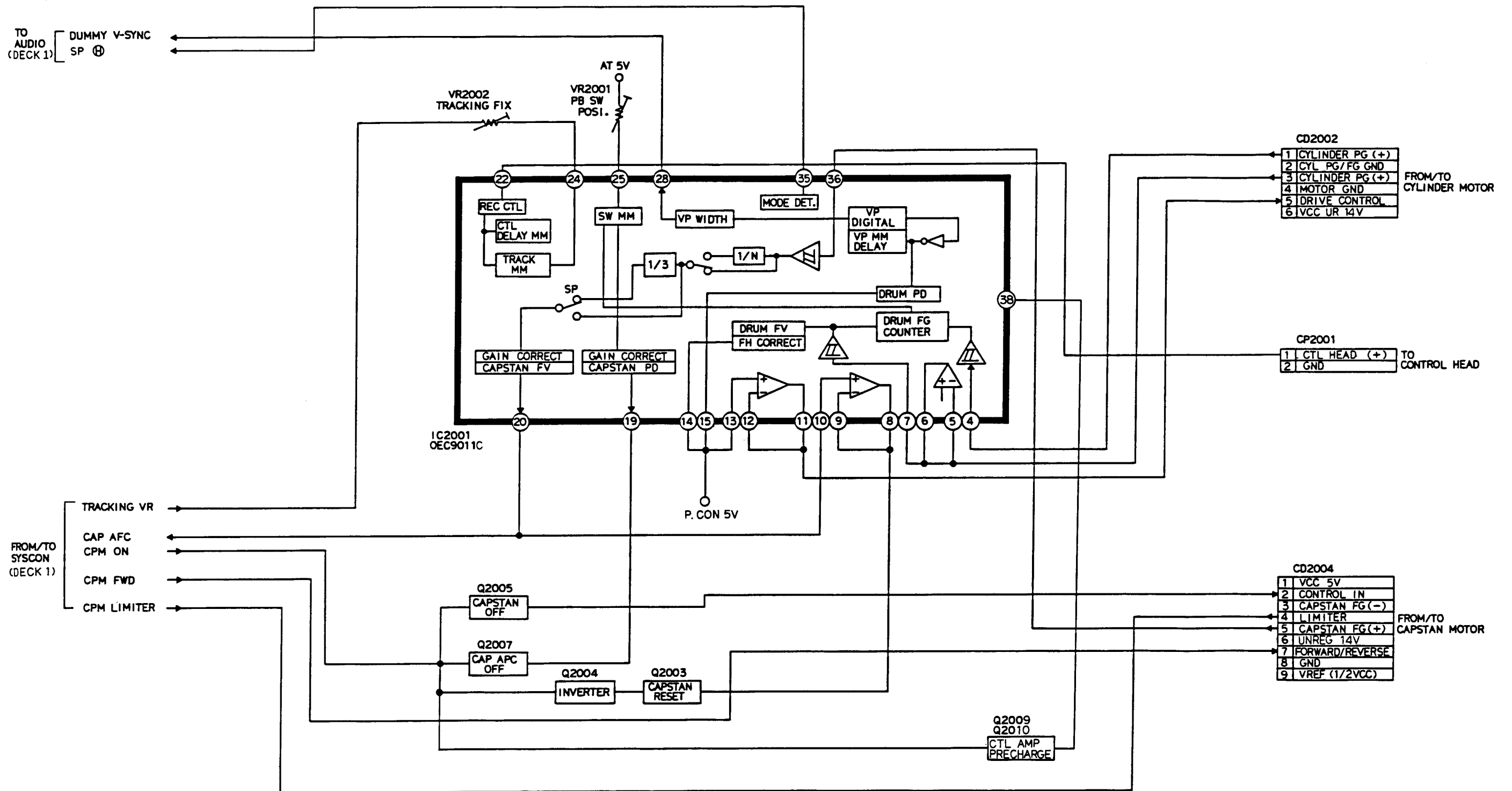

Y.C./HEAD AMP BLOCK DIAGRAM (DECK 2)

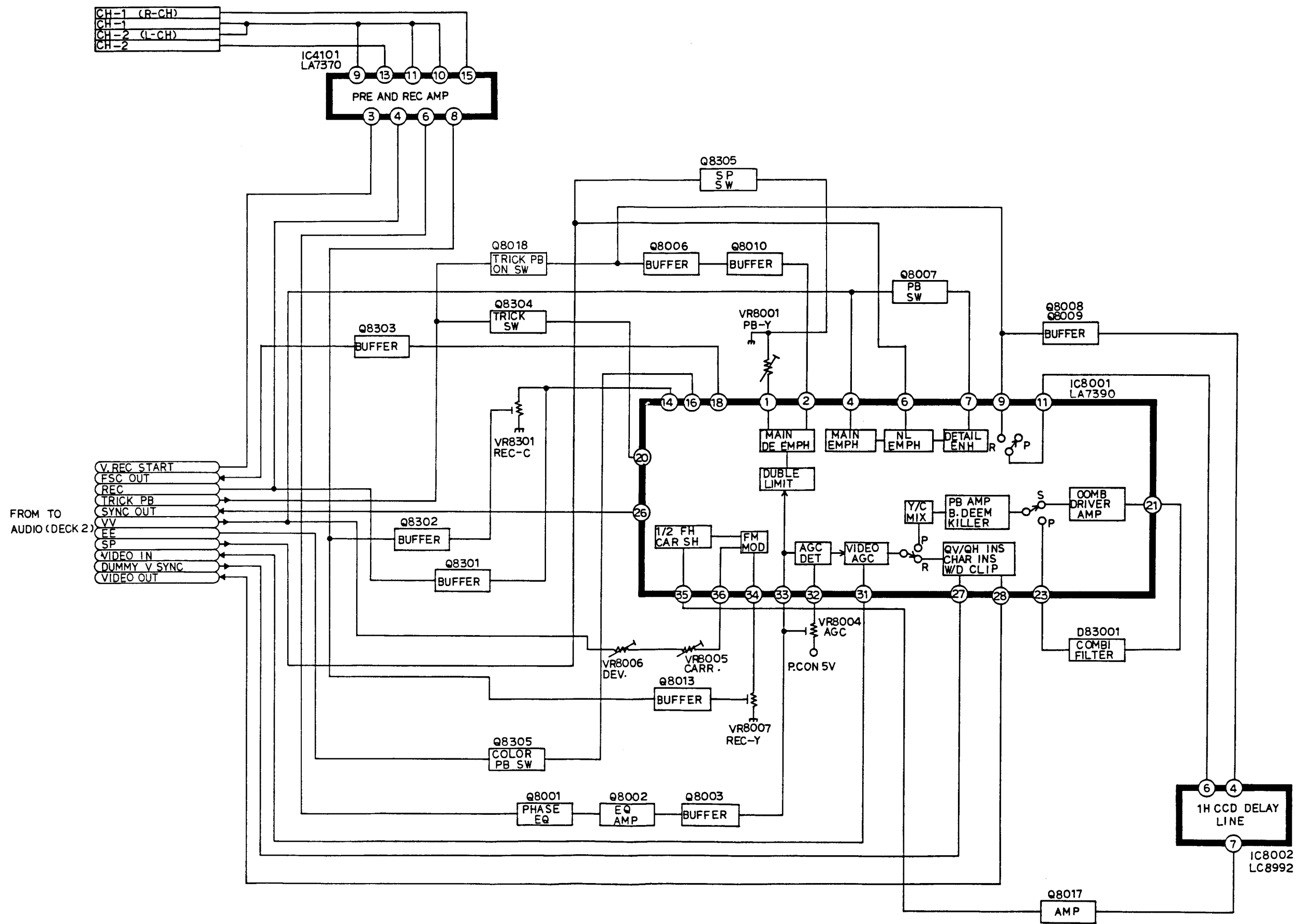

SYSTEM CONTROL BLOCK DIAGRAM (DECK 2)

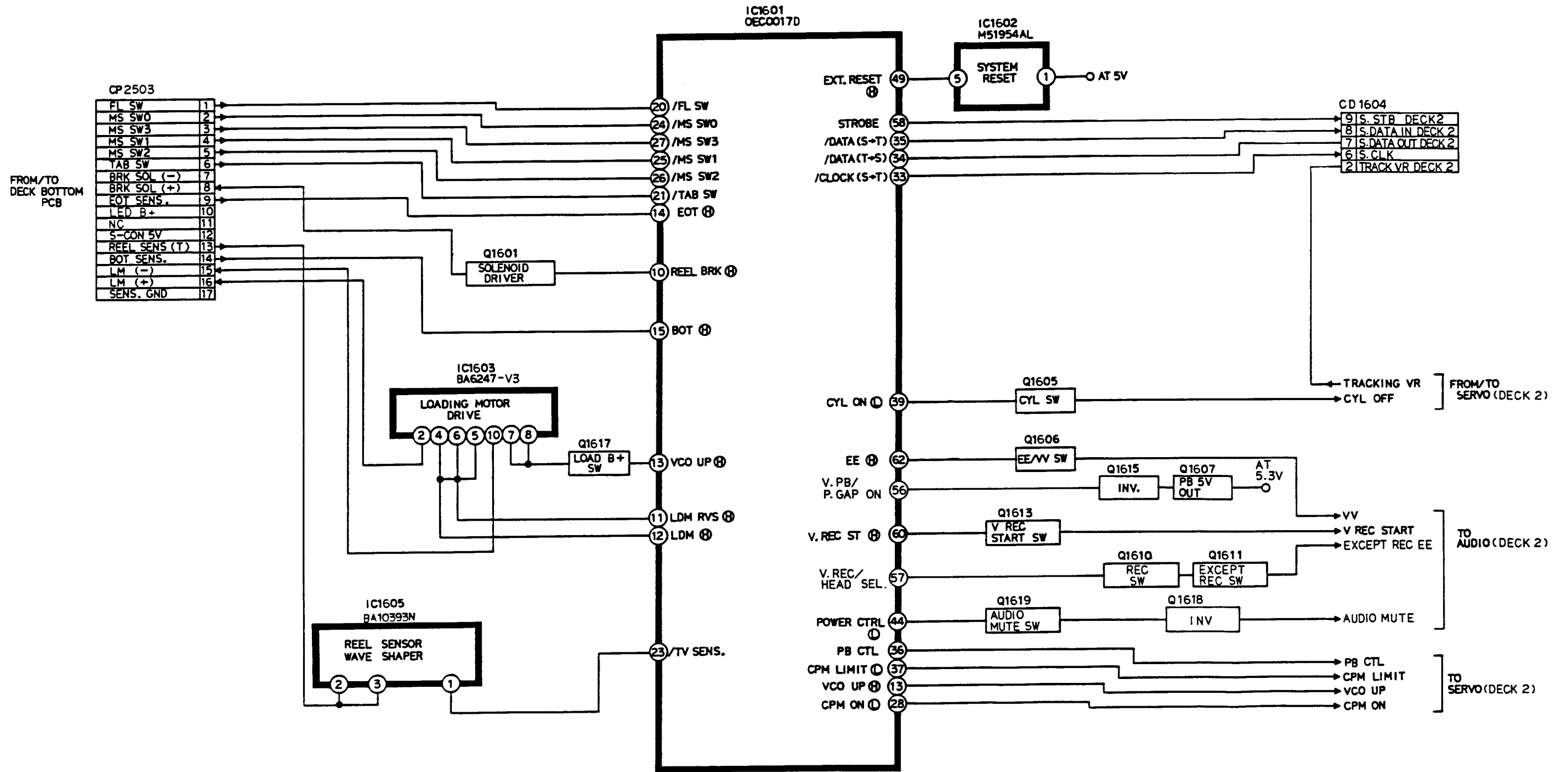

SERVO BLOCK DIAGRAM (DECK 2)

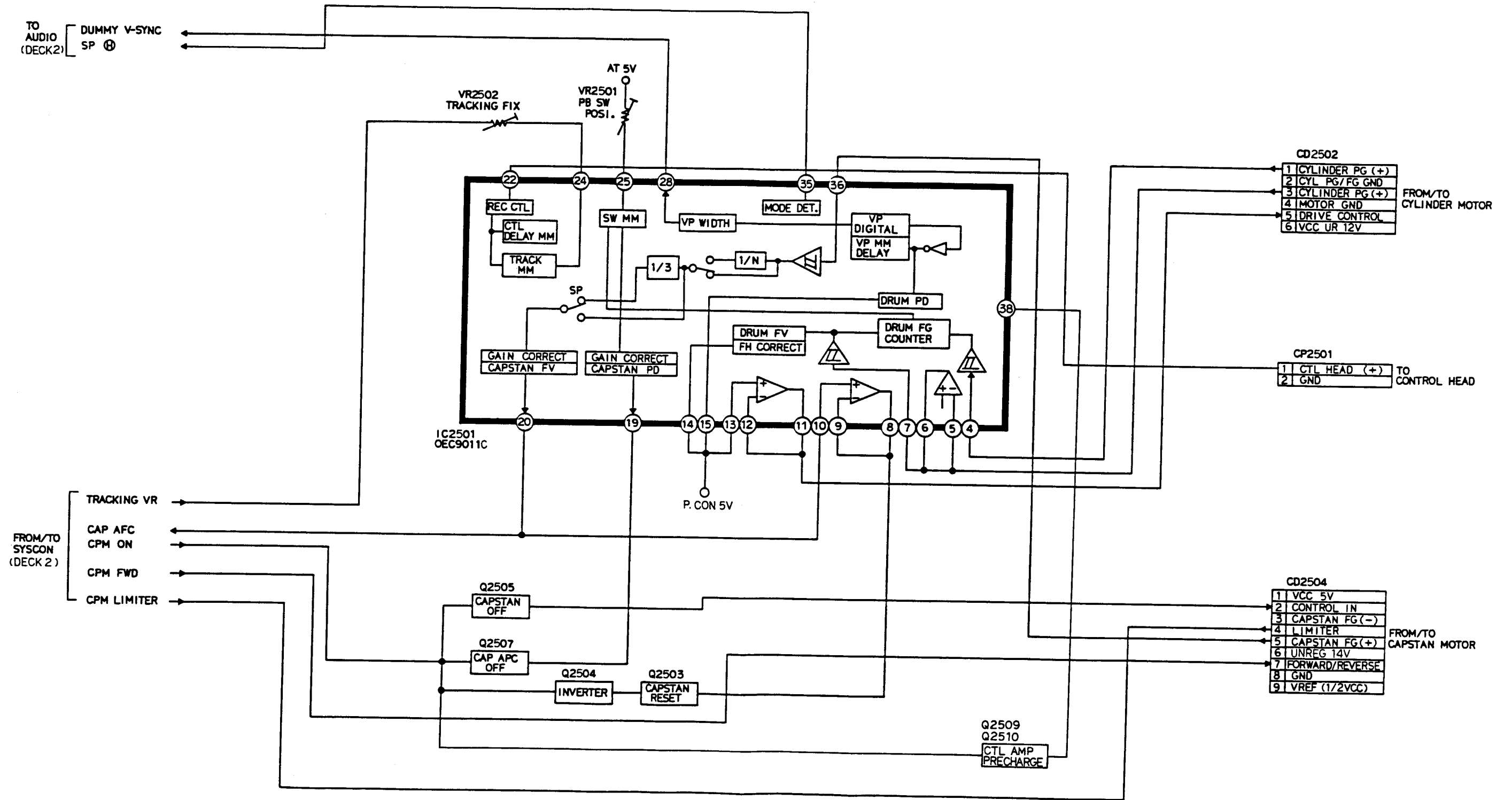

TUNER BLOCK DIAGRAM

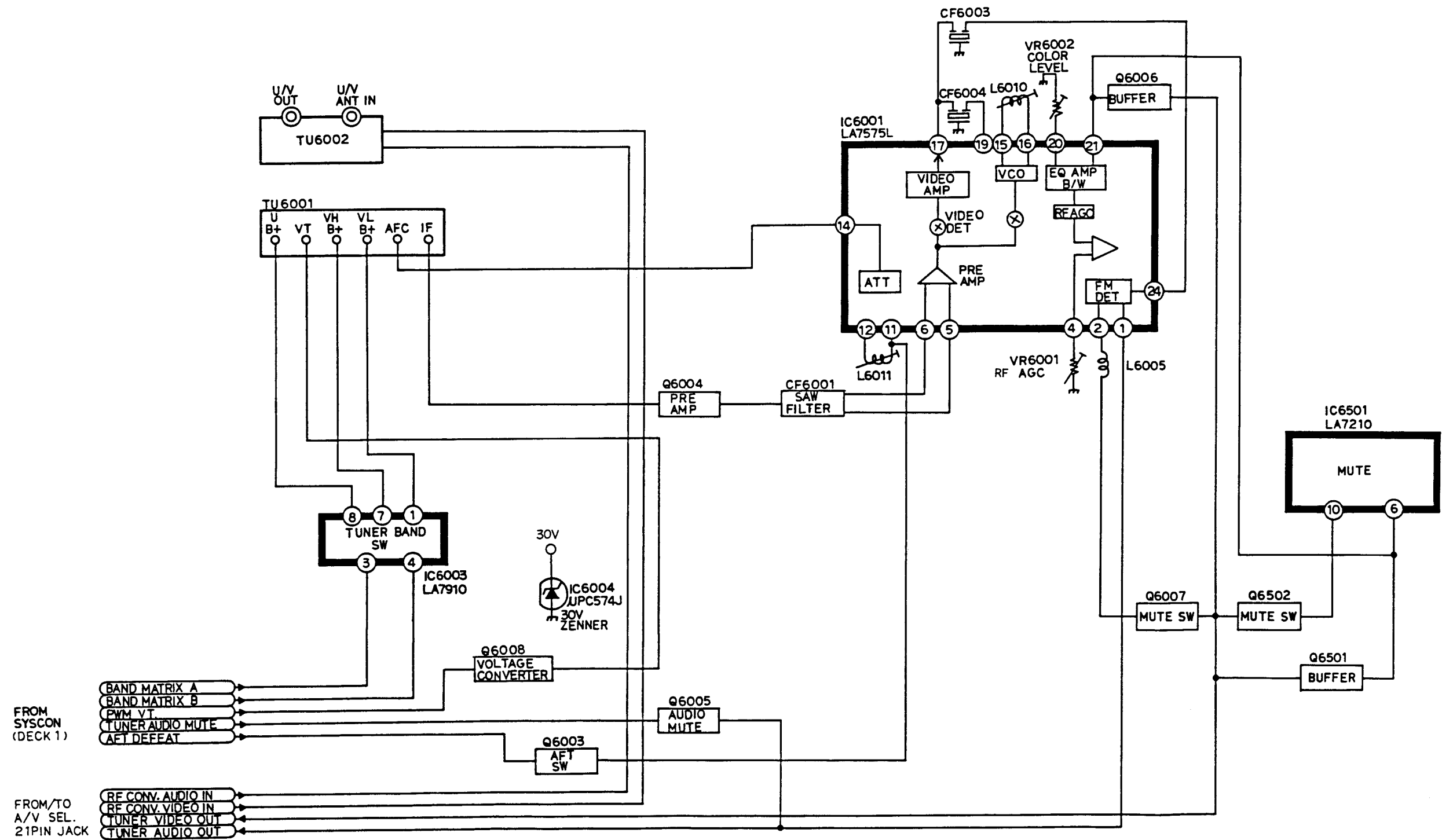

A/V SELECT/21PIN JACK BLOCK DIAGRAM

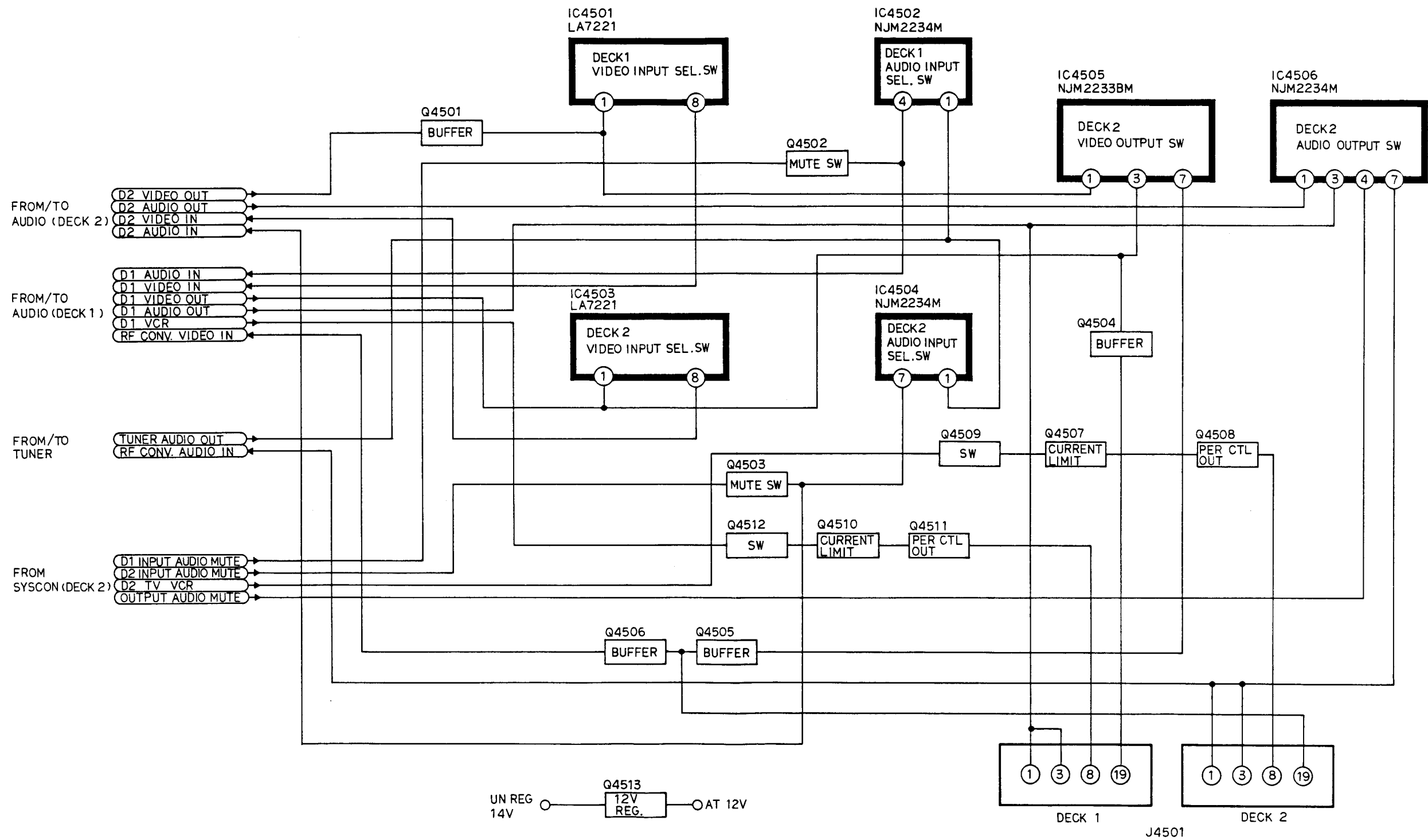

AUDIO BLOCK DIAGRAM (DECK 1)

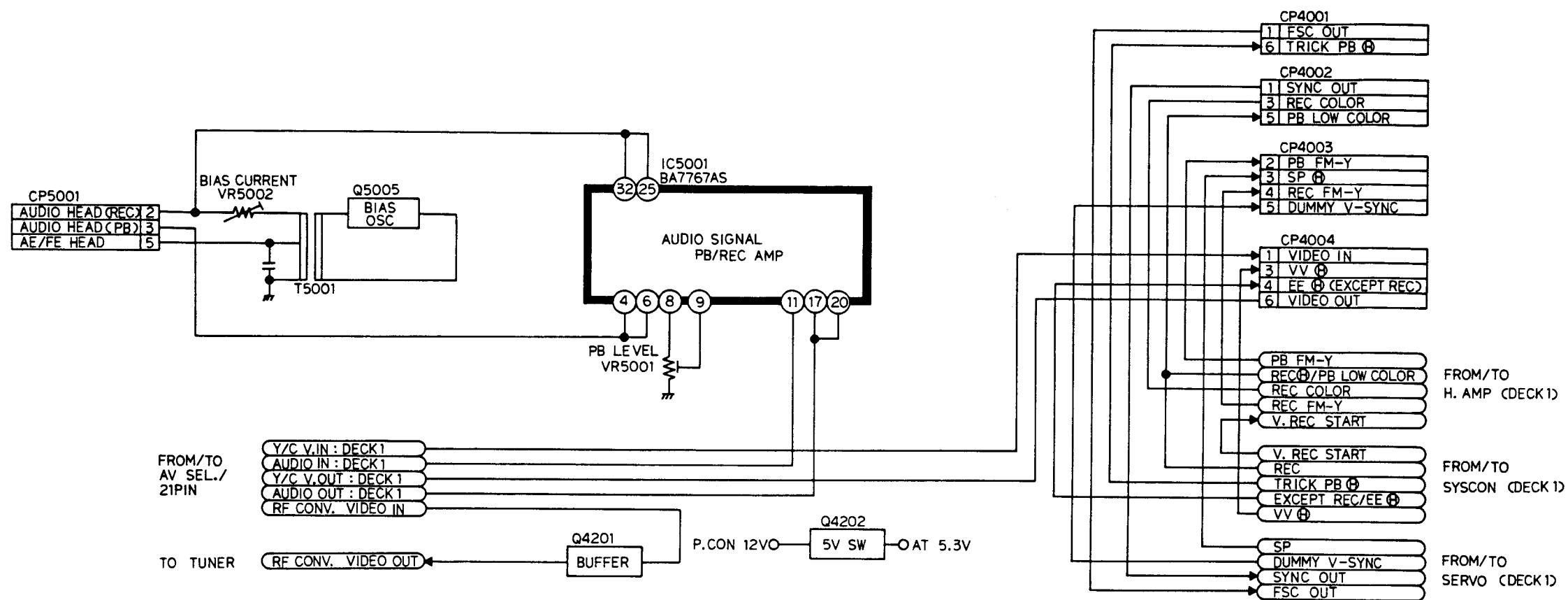

AUDIO BLOCK DIAGRAM (DECK 2)

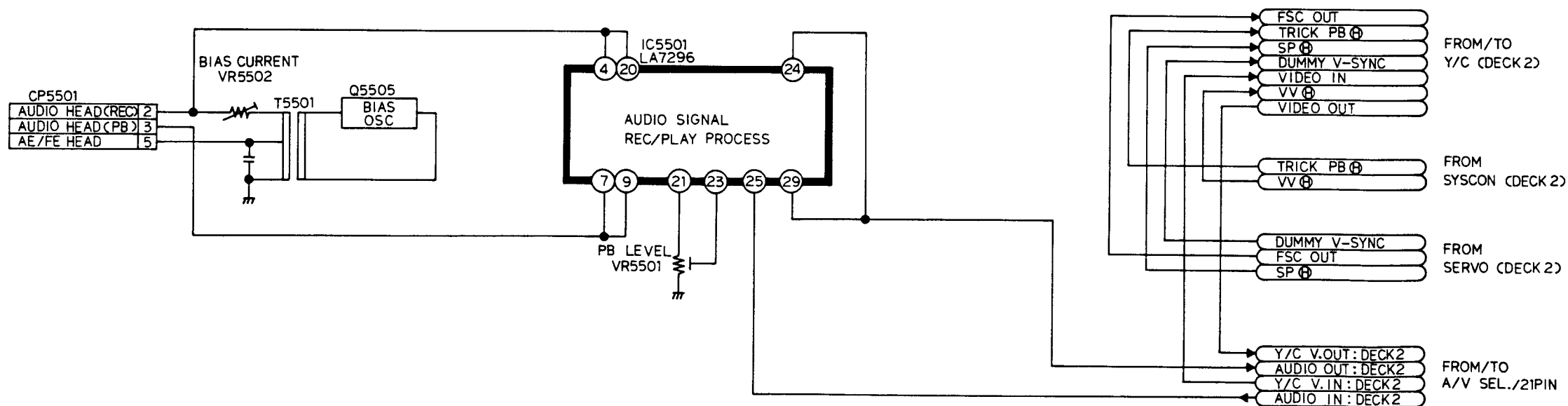

OPERATION BLOCK DIAGRAM

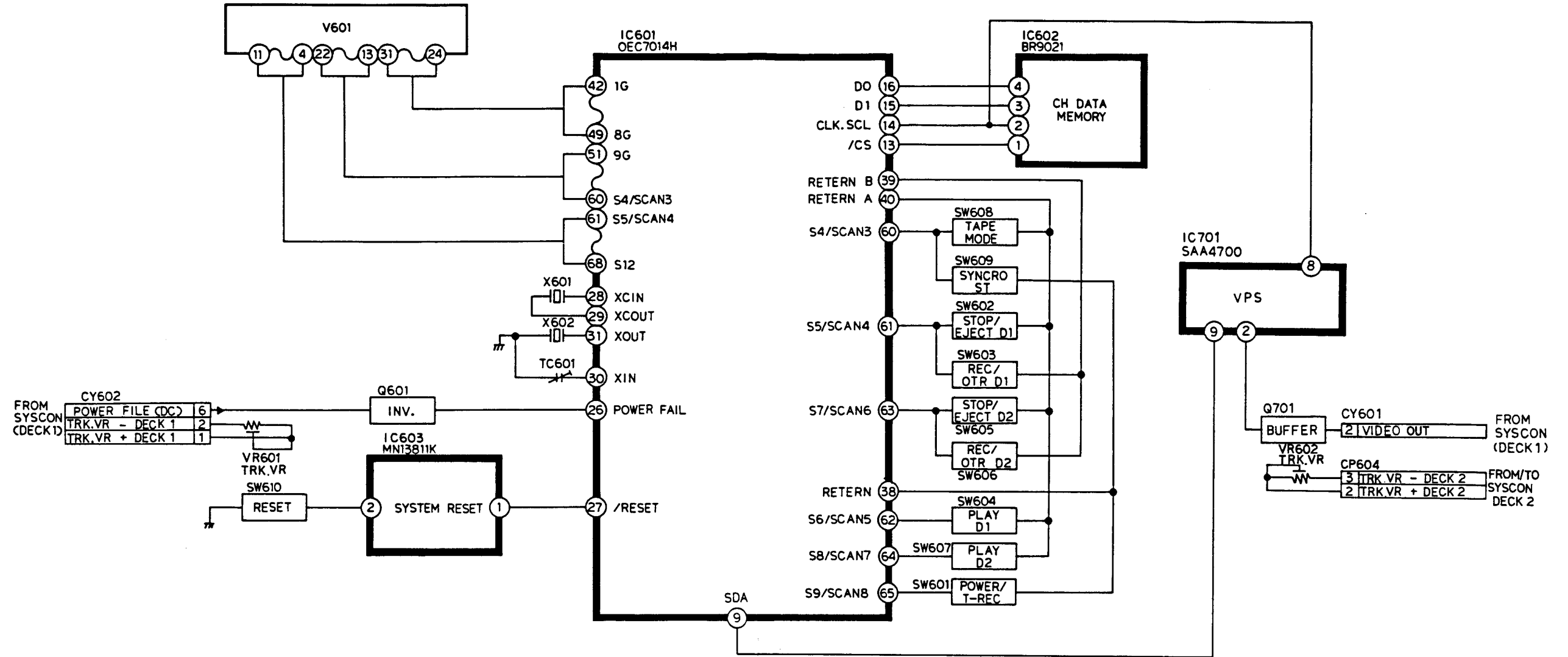

POWER SUPPLY BLOCK DIAGRAM

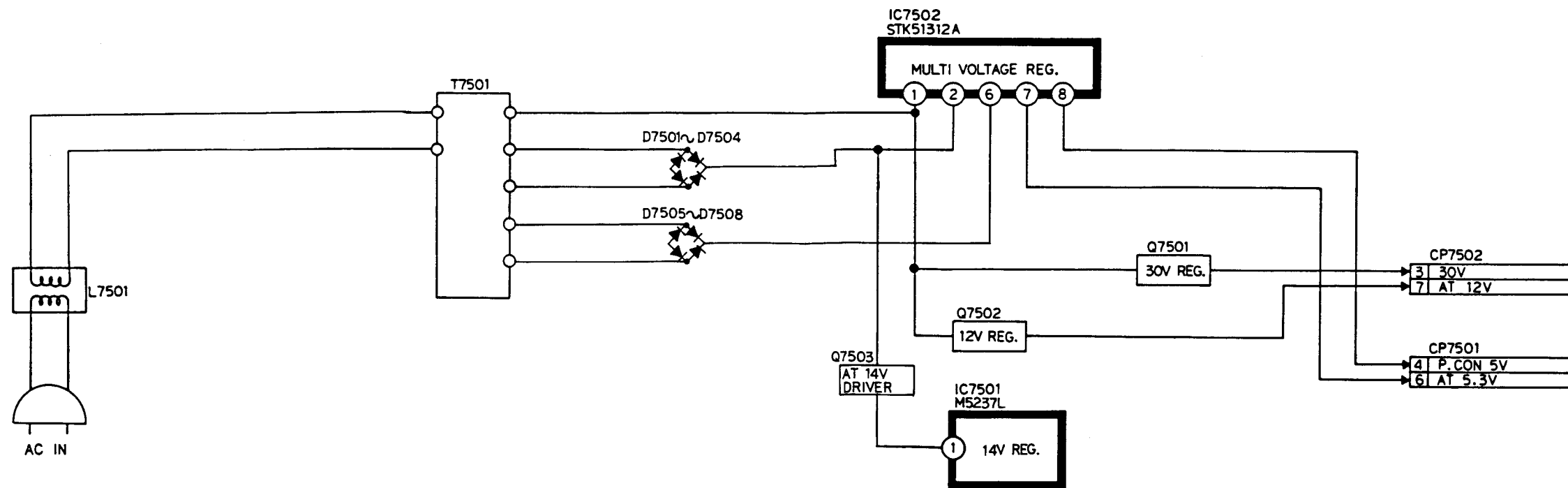

**PRINTED CIRCUIT BOARDS
MAIN 1**

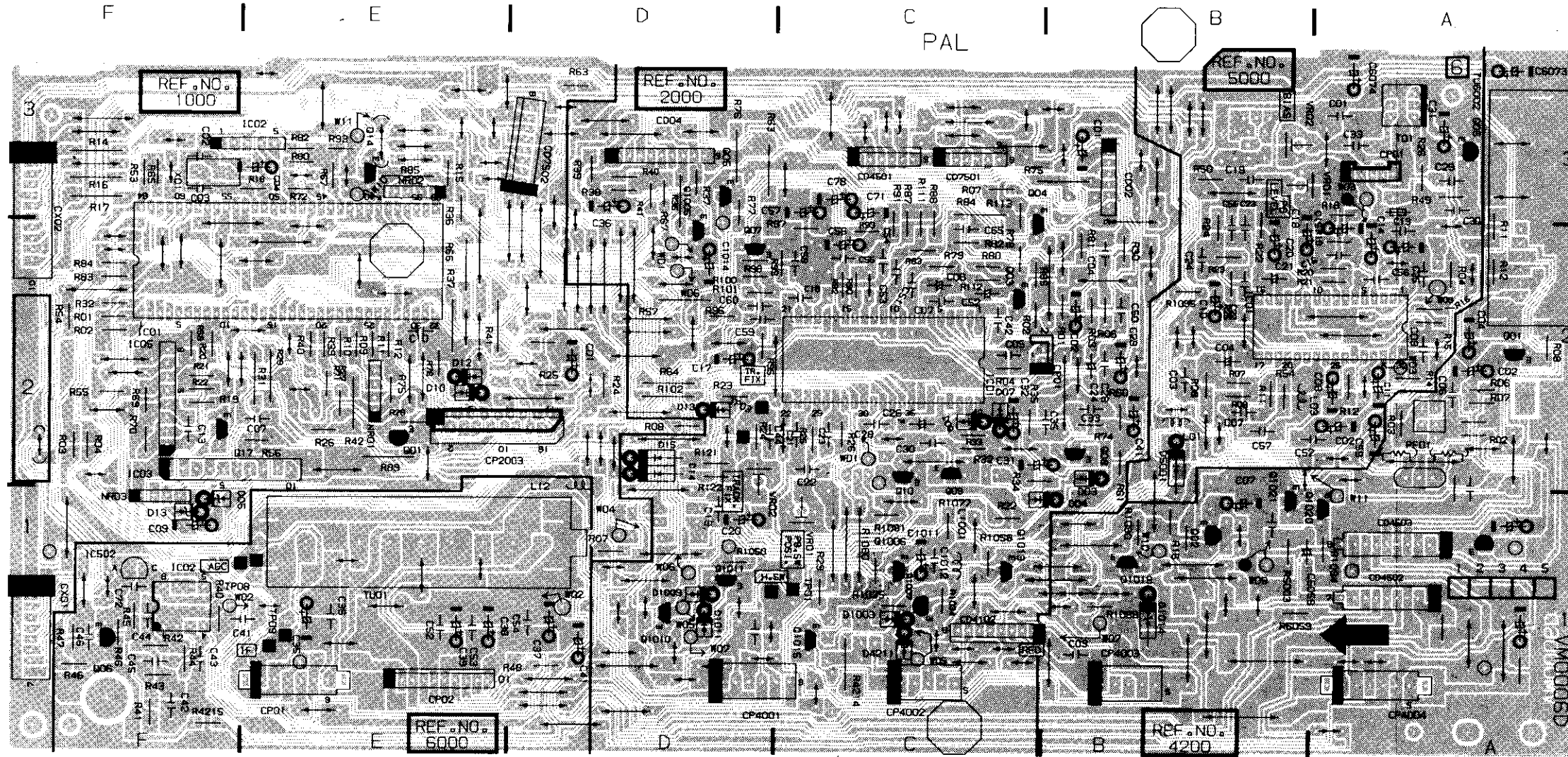

POWER SUPPLY/TRANSISTOR 1

**HEAD AMP
(DECK 1/2)**

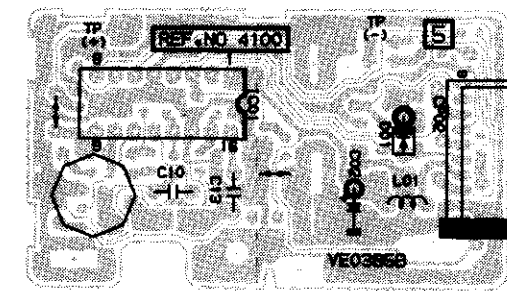
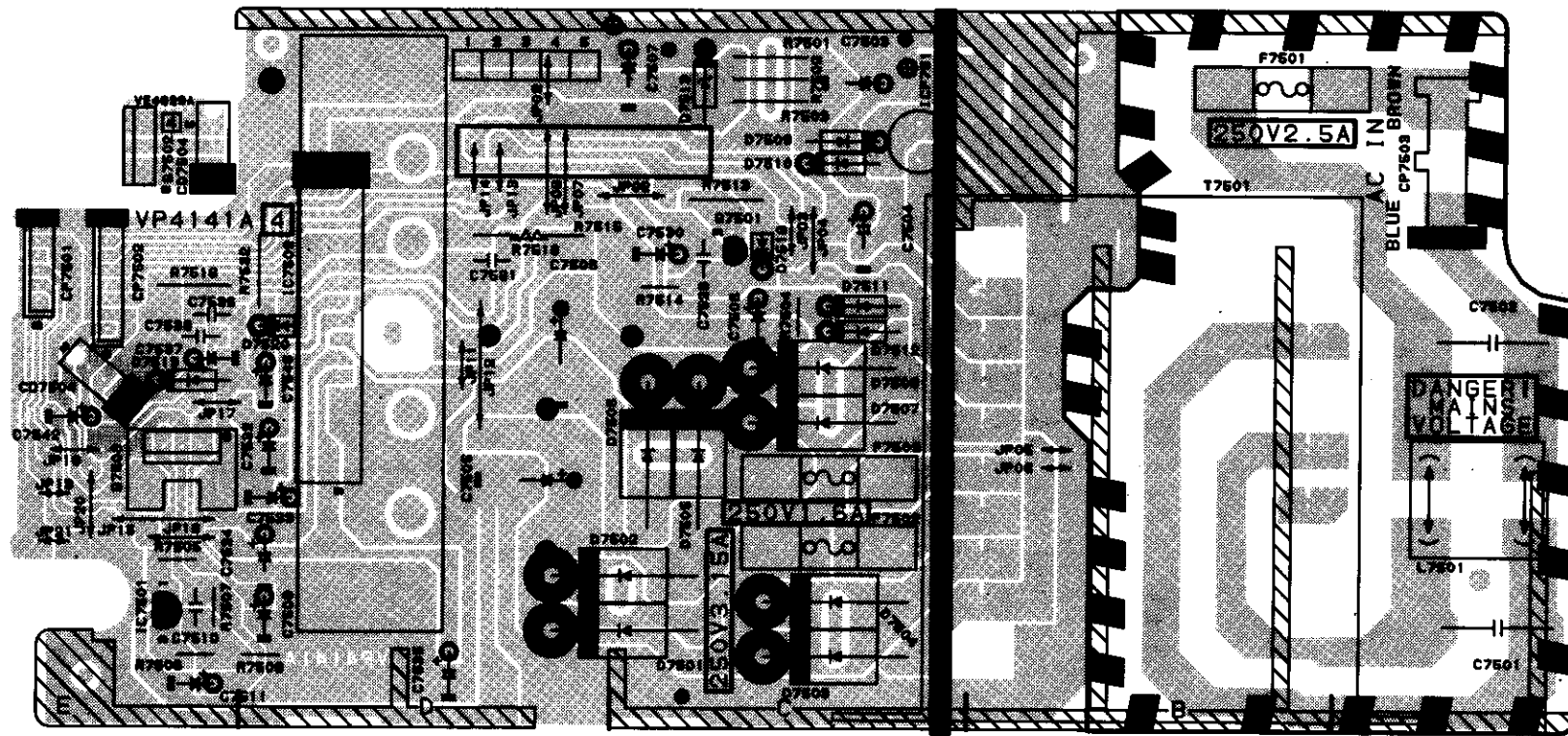

COMPONENT SIDE

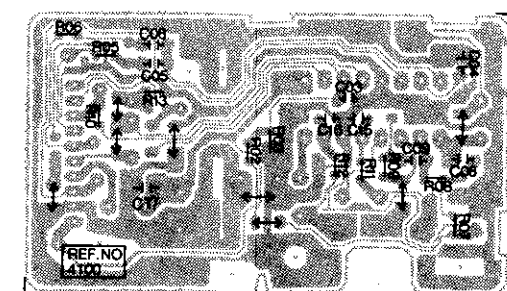

SOLDER SIDE

PRINTED CIRCUIT BOARDS

**Y.C.
COMPONENT SIDE**

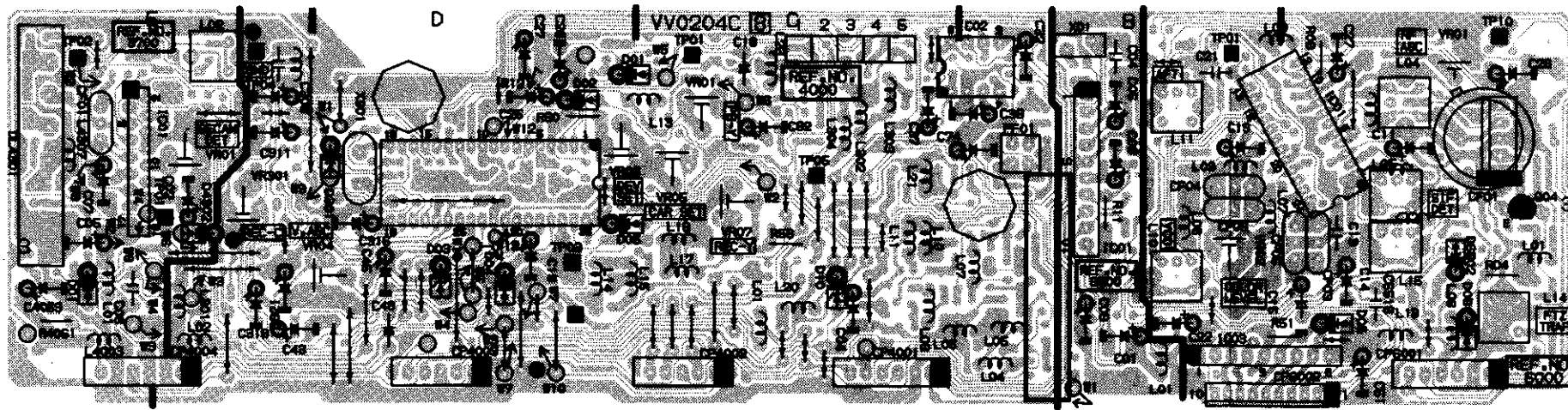

SOLDER SIDE

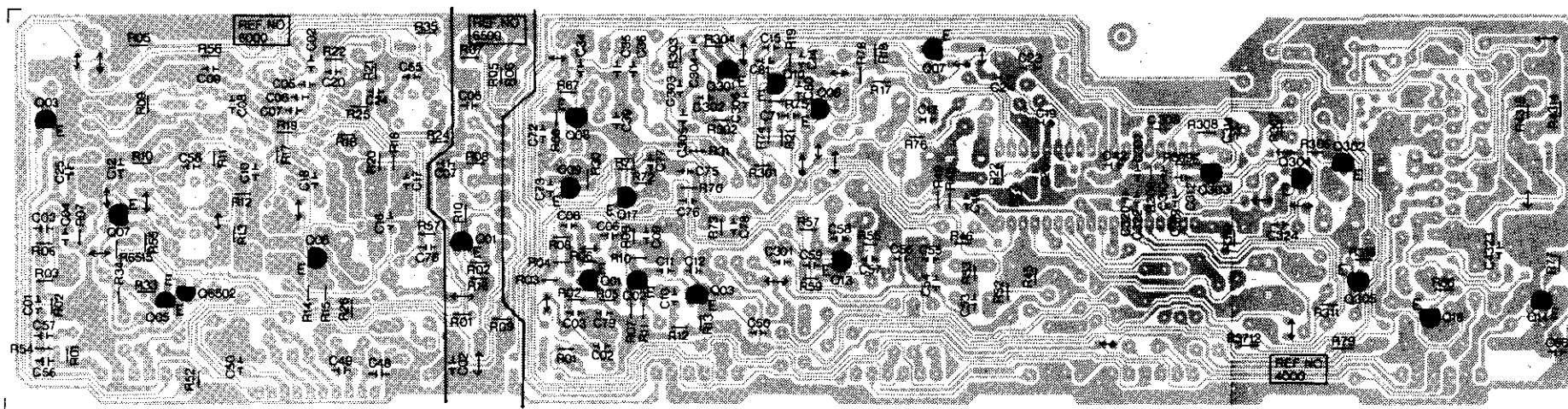

**DECK
(DECK 1/2)**

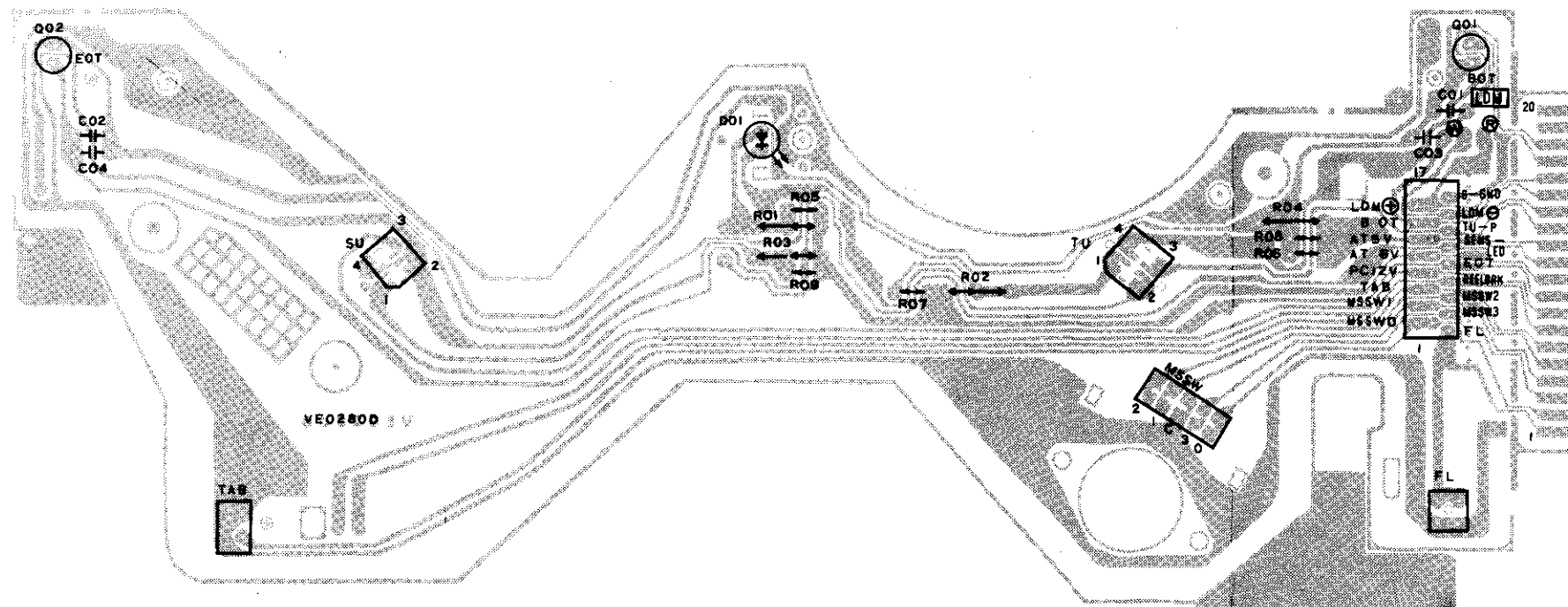

OPERATION

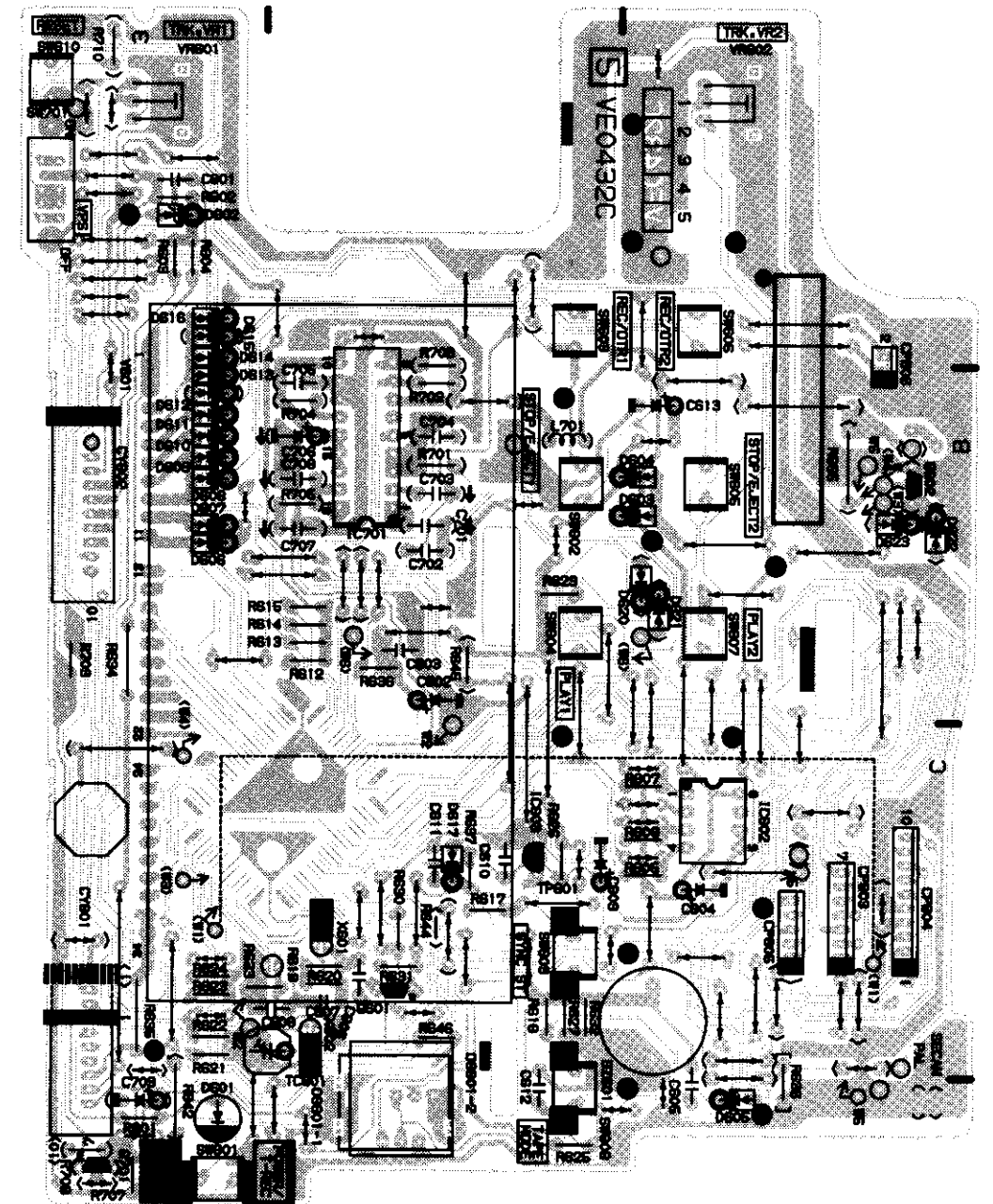

**SUB MAIN
(DECK 1/2)**

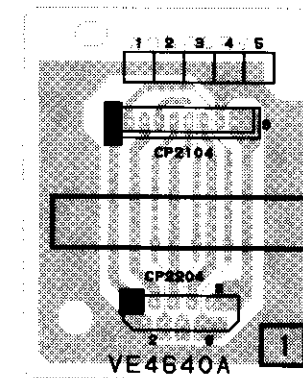

PRINTED CIRCUIT BOARD
MAIN 2/A/V SELECT/TRANSISTOR 2
COMPONENT SIDE

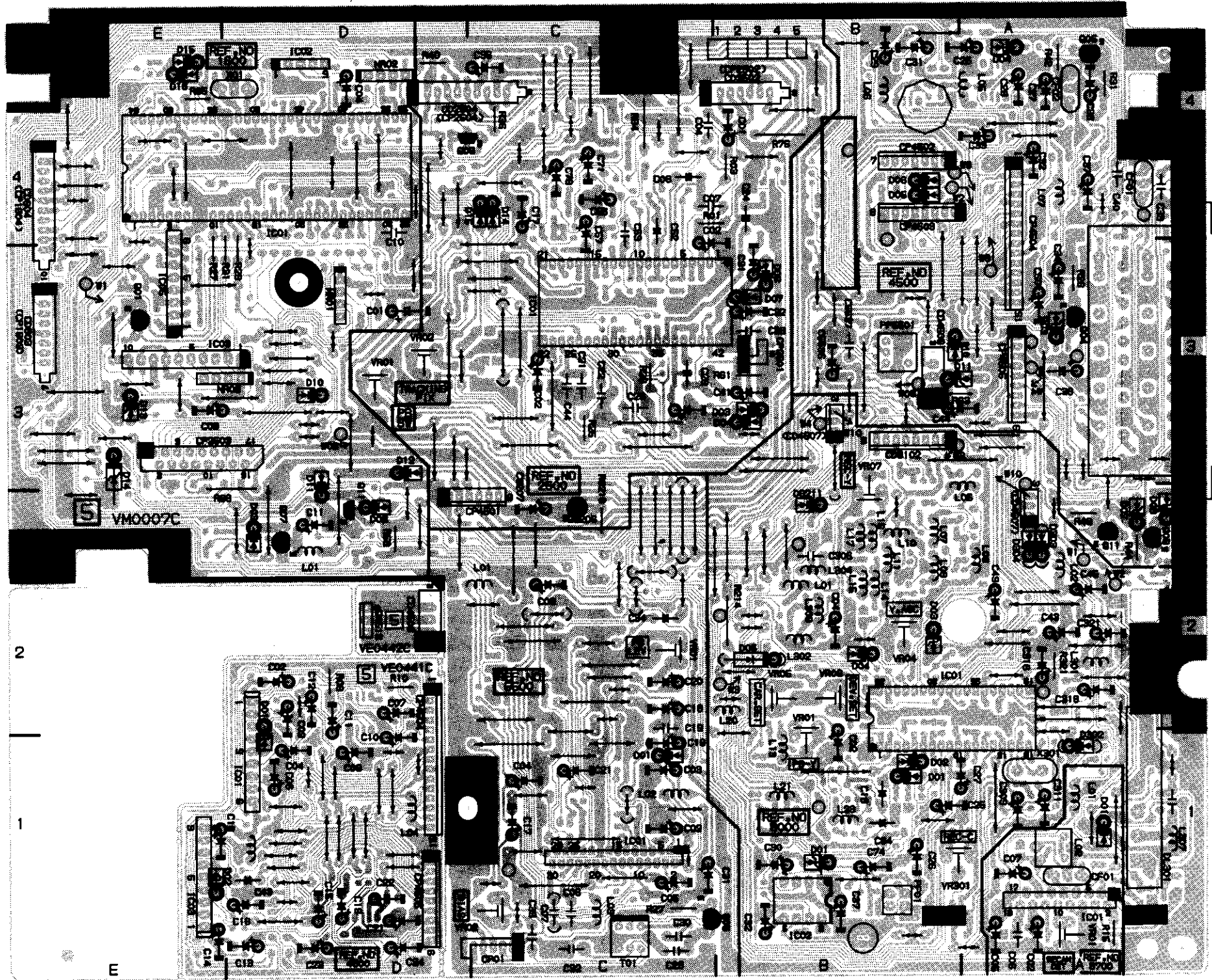

PRINTED CIRCUIT BOARD
MAIN 2/A/V SELECT/TRANSISTOR 2
SOLDER SIDE

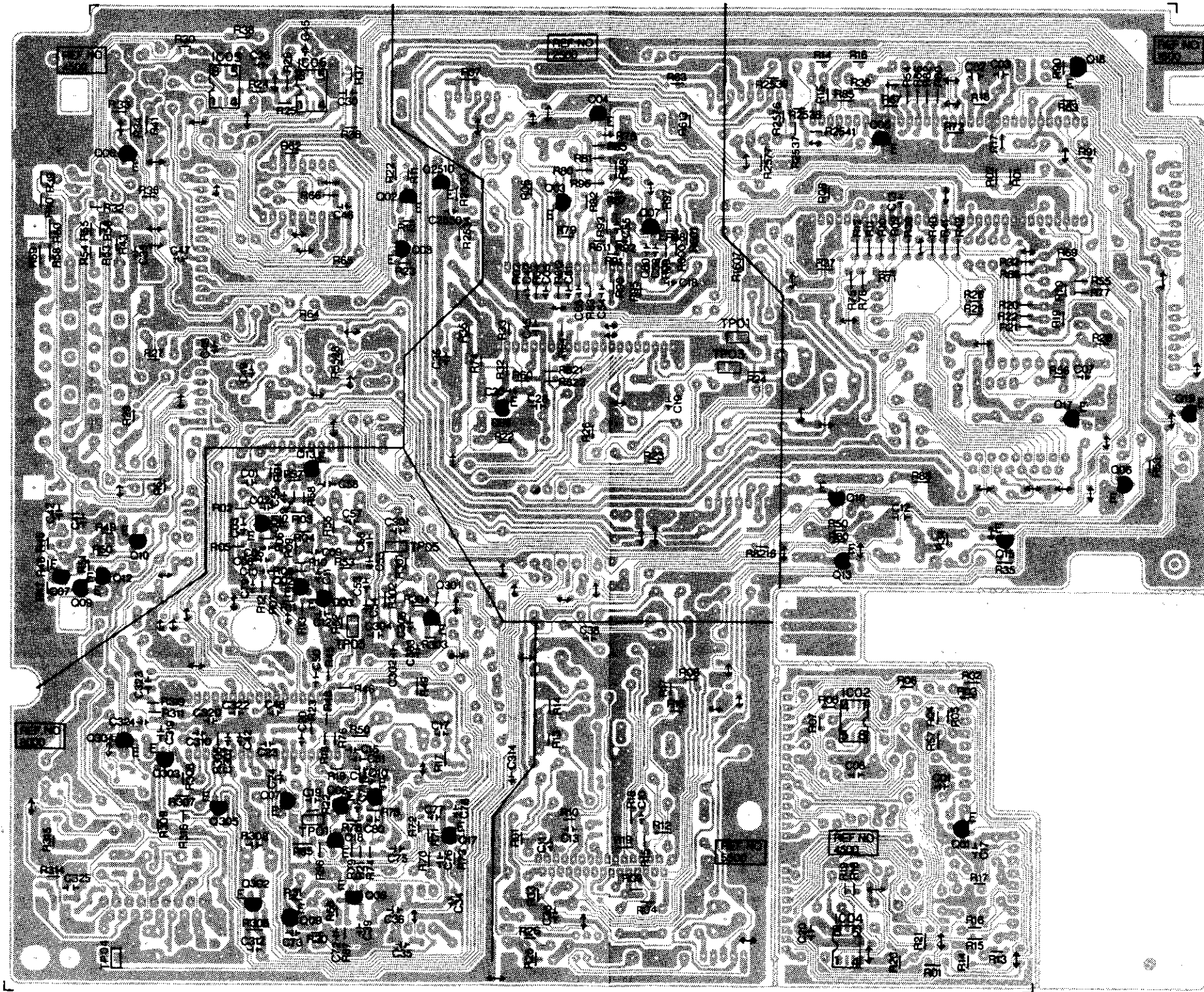

TUNER SCHEMATIC DIAGRAM

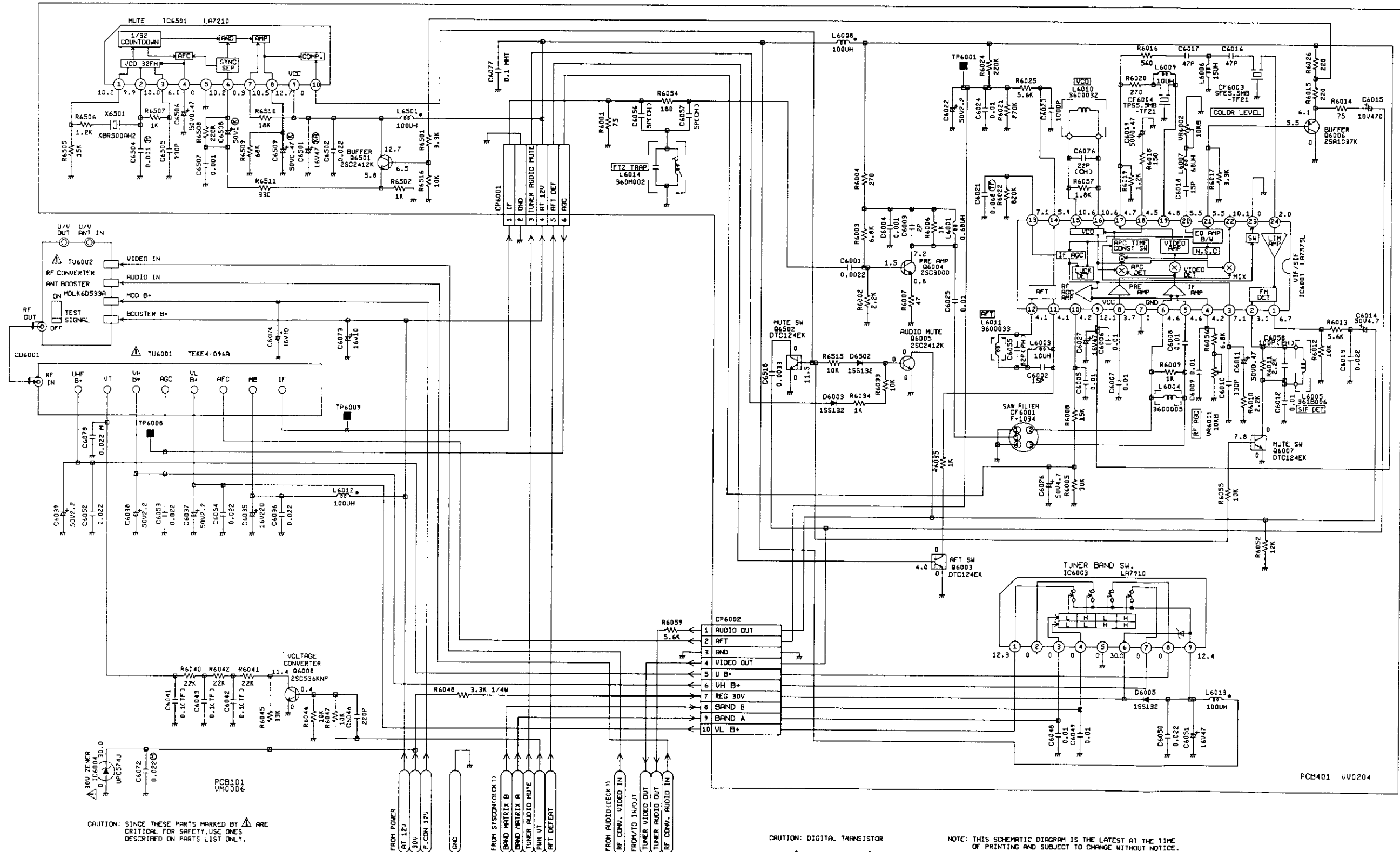

CAUTION: SINCE THESE PARTS MARKED BY Δ ARE CRITICAL FOR SAFETY, USE ONES DESCRIBED ON PARTS LIST ONLY.

ATTENTION: LES PIÈCES REPARÉES PAR UN Δ ÉTANT DANGEREUSES AU POINT DE VUE SÉCURITÉ N'UTILISER QUE CELLES DÉCRITES DANS LA NOMENCLATURE DES PIÈCES.

CAUTION: DIGITAL TRANSISTOR

NOTE: THIS SCHEMATIC DIAGRAM IS THE LATEST AT THE TIME OF PRINTING AND SUBJECT TO CHANGE WITHOUT NOTICE.

Y.C./HEAD AMP SCHEMATIC DIAGRAM (DECK 1)

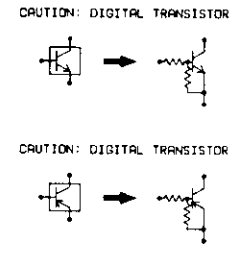
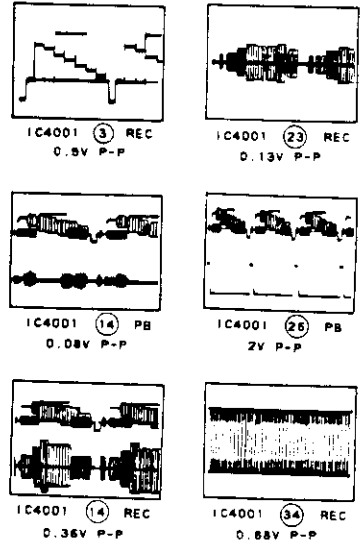
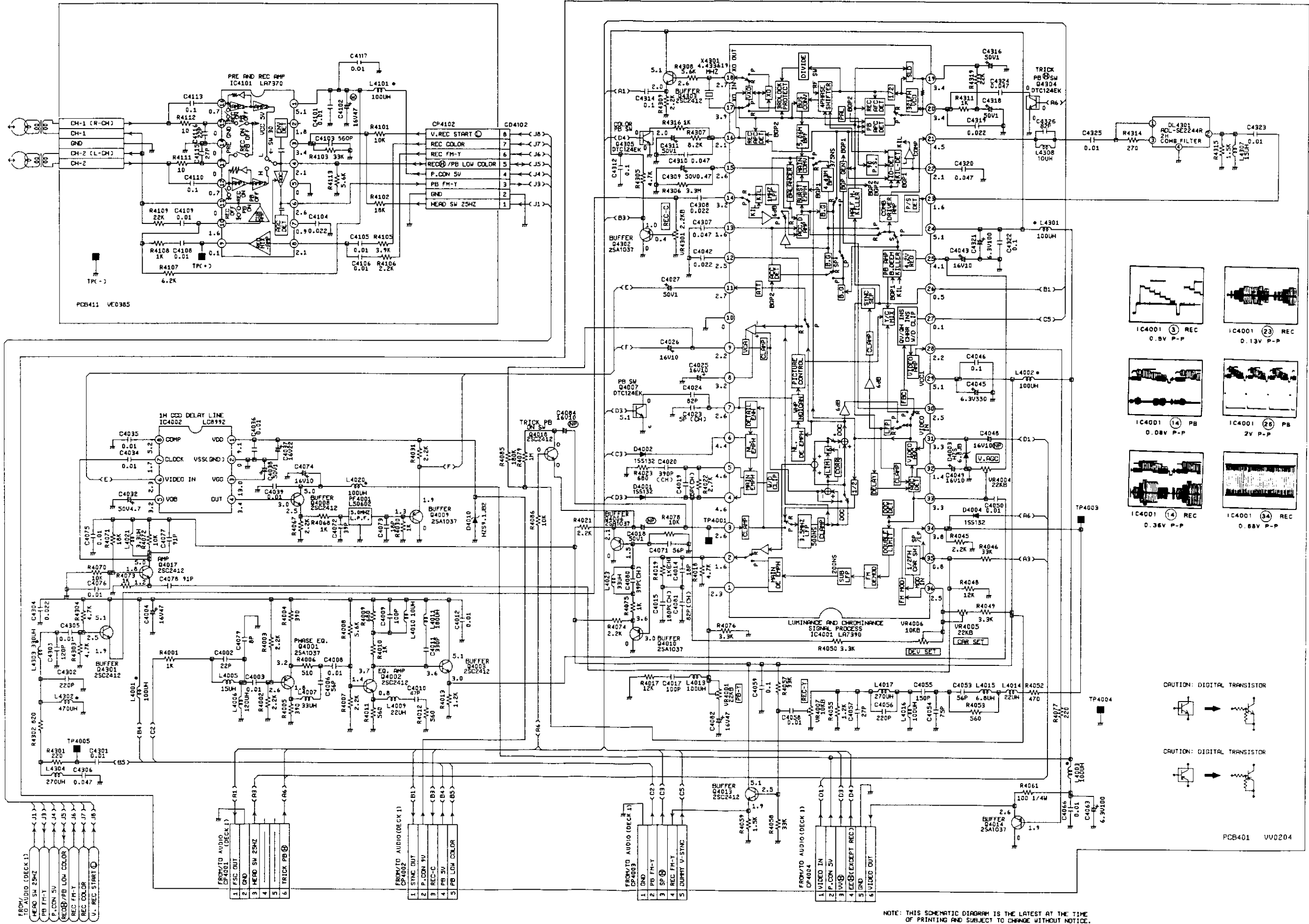

NOTE: THIS SCHEMATIC DIAGRAM IS THE LATEST AT THE TIME OF PRINTING AND SUBJECT TO CHANGE WITHOUT NOTICE.

AUDIO SCHEMATIC DIAGRAM (DECK 1)

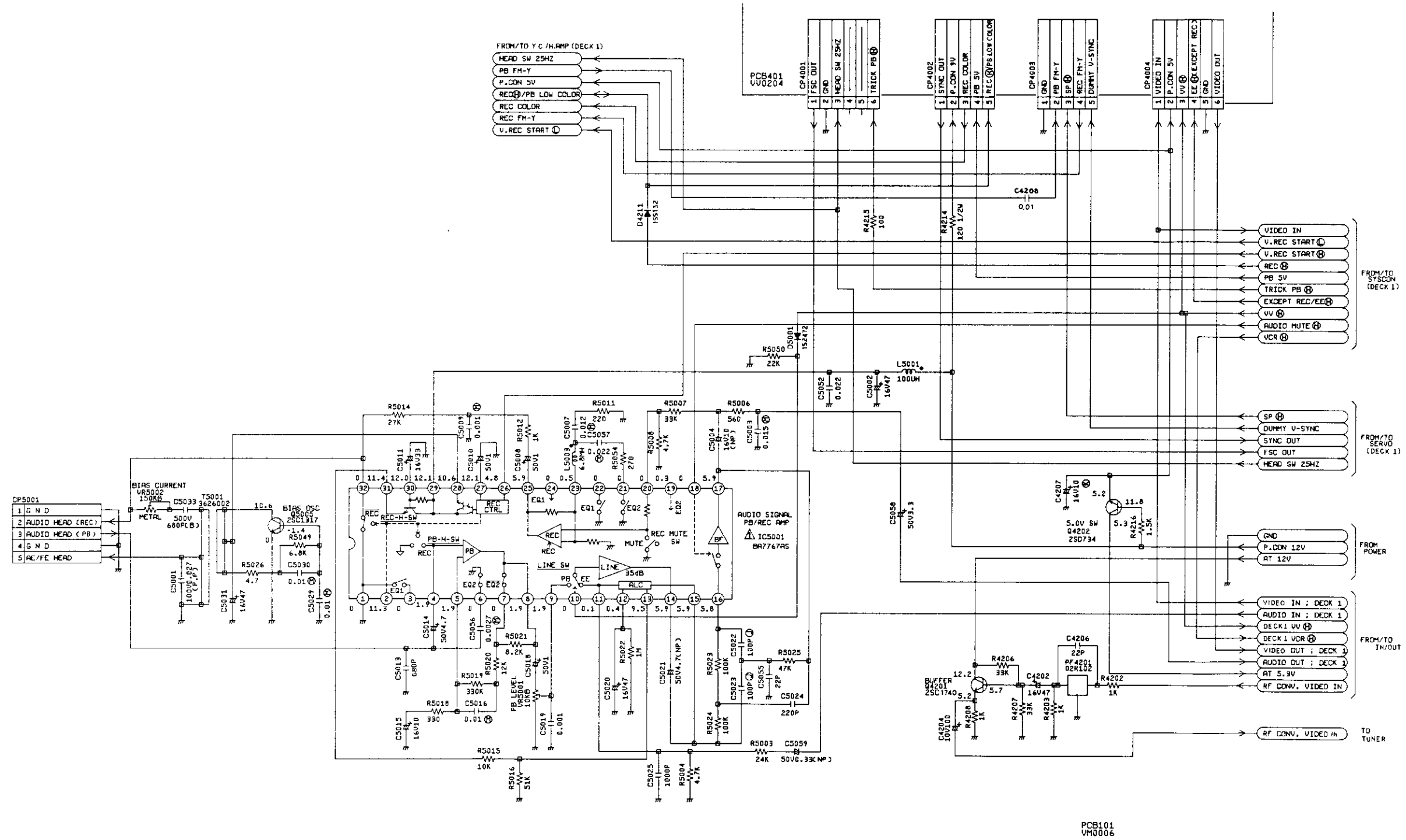

CAUTION: SINCE THESE PARTS MARKED BY Δ ARE CRITICAL FOR SAFETY, USE ONES DESCRIBED ON PARTS LIST ONLY.

ATTENTION: LES PIÈCES MARQUÉES PAR UN Δ ÉTAIENT DANGEREUSES AU POINT DE VUE SÉCURITÉ. N'UTILISER QUE DES PIÈCES DÉCRITES DANS LA NOMENCLATURE DES PIÈCES.

NOTE: THIS SCHEMATIC DIAGRAM IS THE LATEST AT THE TIME OF PRINTING AND SUBJECT TO CHANGE WITHOUT NOTICE.

SYSTEM CONTROL SCHEMATIC DIAGRAM (DECK 1)

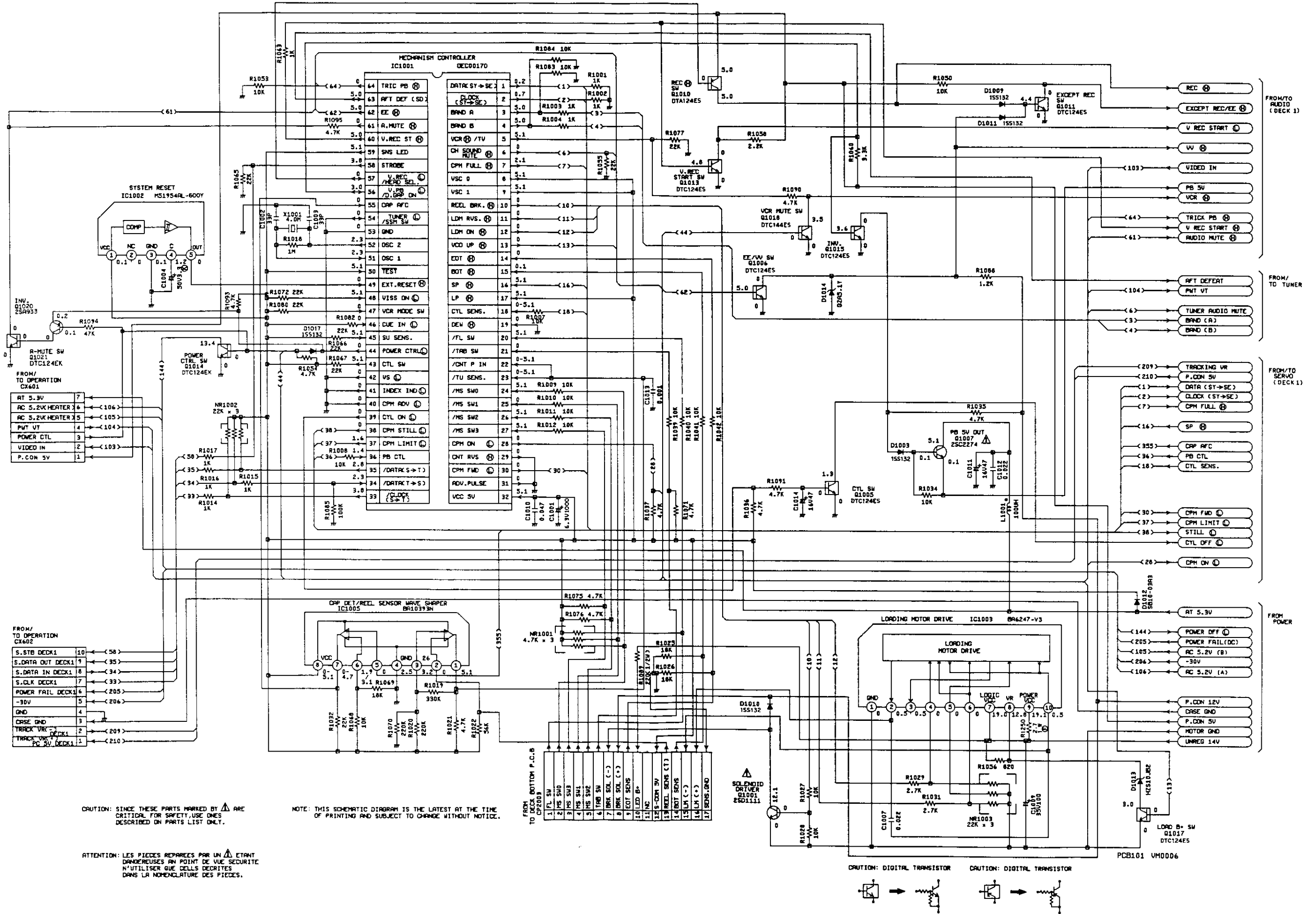

SERVO SCHEMATIC DIAGRAM (DECK 1)

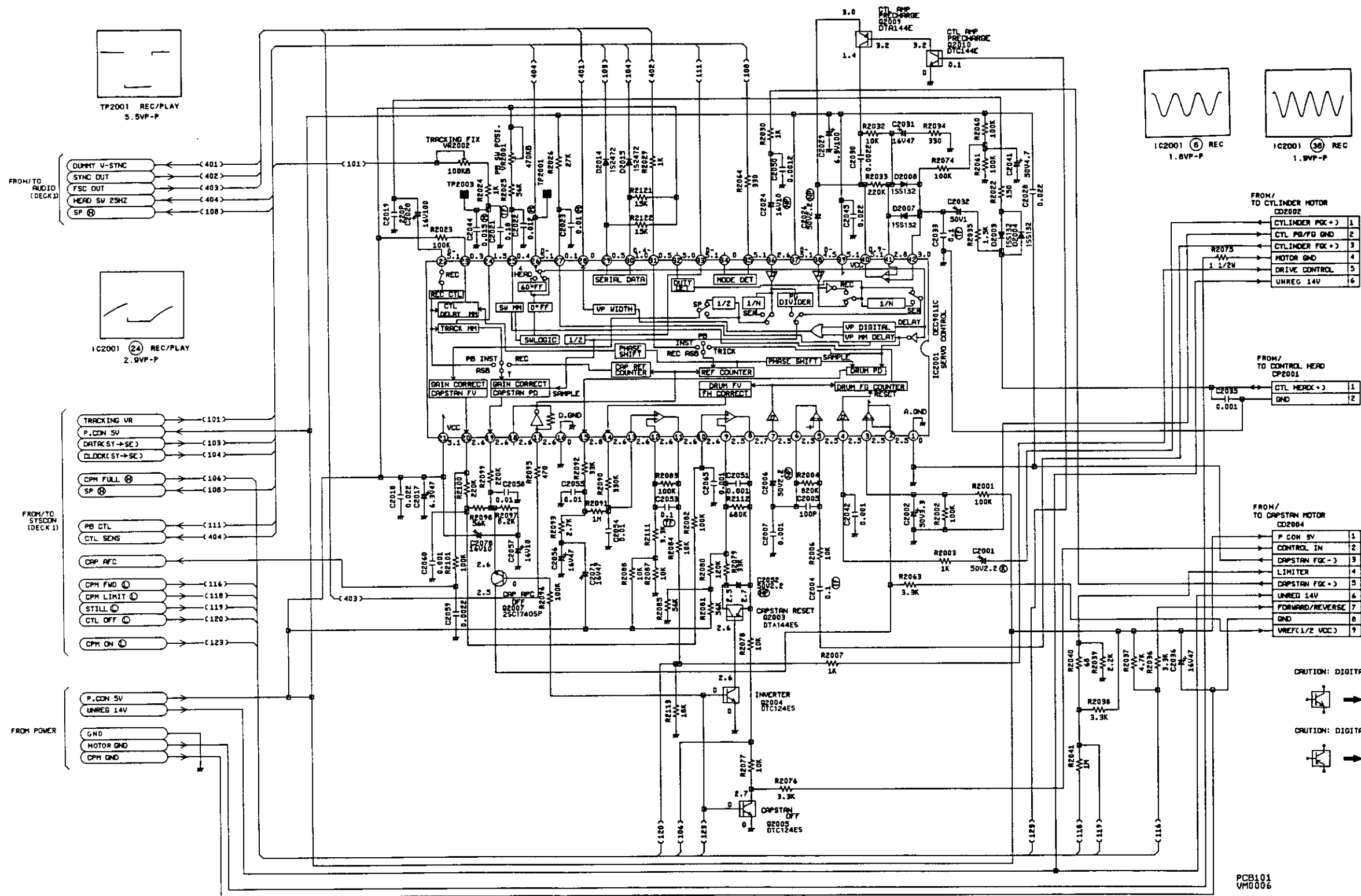

NOTE: THIS SCHEMATIC DIAGRAM IS THE LATEST AT THE TIME OF PRINTING AND SUBJECT TO CHANGE WITHOUT NOTICE.

Y.C./HEAD AMP SCHEMATIC DIAGRAM (DECK 2)

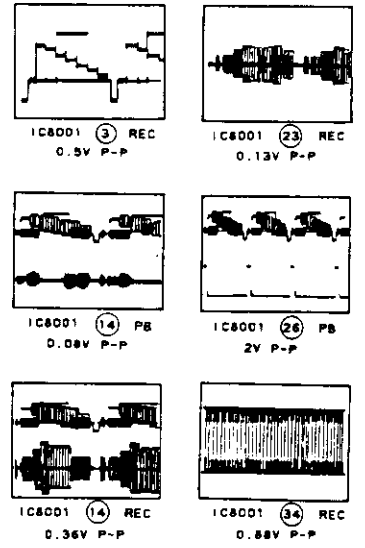
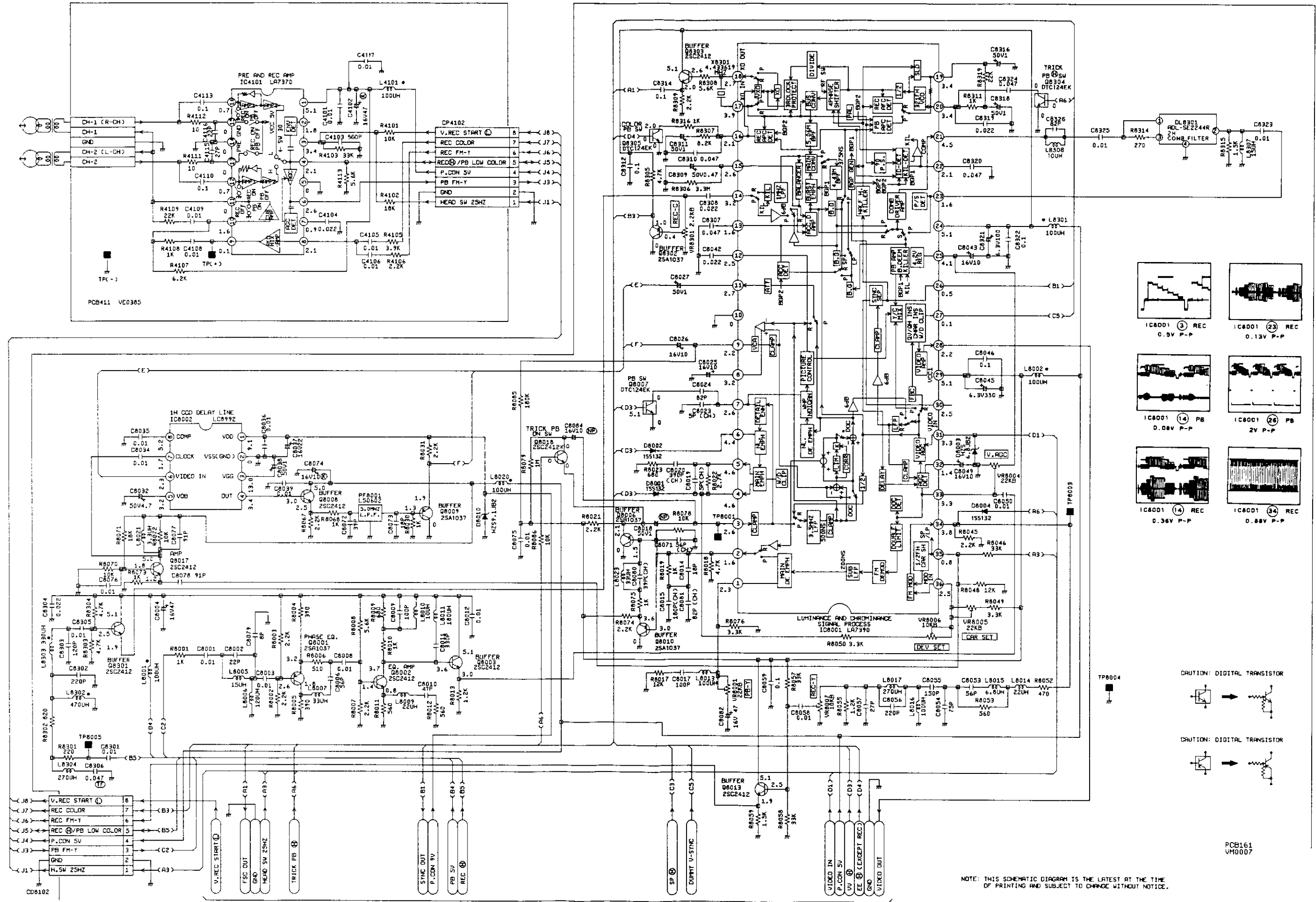

CAUTION: DIGITAL TRANSISTOR

CAUTION: DIGITAL TRANSISTOR

PCB161
VM0007

NOTE: THIS SCHEMATIC DIAGRAM IS THE LATEST AT THE TIME OF PRINTING AND SUBJECT TO CHANGE WITHOUT NOTICE.

AUDIO SCHEMATIC DIAGRAM (DECK 2)

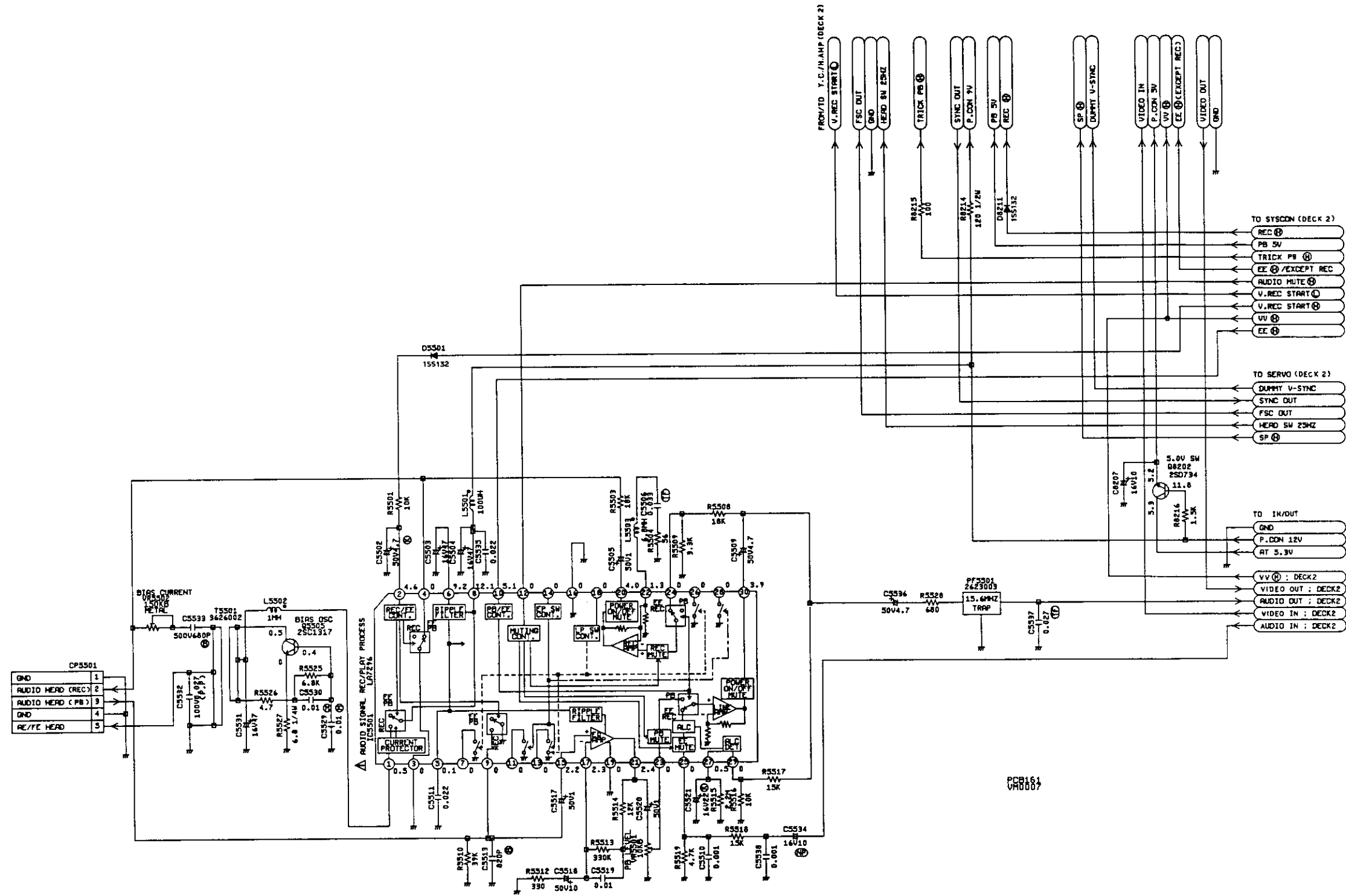

CAUTION: SINCE THESE PARTS MARKED BY Δ ARE CRITICAL FOR SAFETY, USE ONES DESCRIBED ON PARTS LIST ONLY.

ATTENTION: LES PIÈCES MARQUÉES PAR UN Δ ÉTANT DANGEREUSES AU POINT DE VUE SÉCURITÉ, N'UTILISER QUE CELLES DÉCRITES DANS LA NOMÉCLATURE DES PIÈCES.

NOTE: THIS SCHEMATIC DIAGRAM IS THE LATEST AT THE TIME OF PRINTING AND SUBJECT TO CHANGE WITHOUT NOTICE.

SYSTEM CONTROL SCHEMATIC DIAGRAM (DECK 2)

CAUTION: SINCE THESE PARTS MARKED BY Δ ARE CRITICAL FOR SAFETY, USE ONES DESCRIBED ON PARTS LIST ONLY.

ATTENTION: LES PIÈCES MARQUÉES PAR UN Δ ÉTAIENT DANGEREUSES AU POINT DE VUE SÉCURITÉ. N'UTILISER QUE CELLES DÉCRITES DANS LA NOMÉNCLATURE DES PIÈCES.

NOTE: THIS SCHEMATIC DIAGRAM IS THE LATEST AT THE TIME OF PRINTING AND SUBJECT TO CHANGE WITHOUT NOTICE.

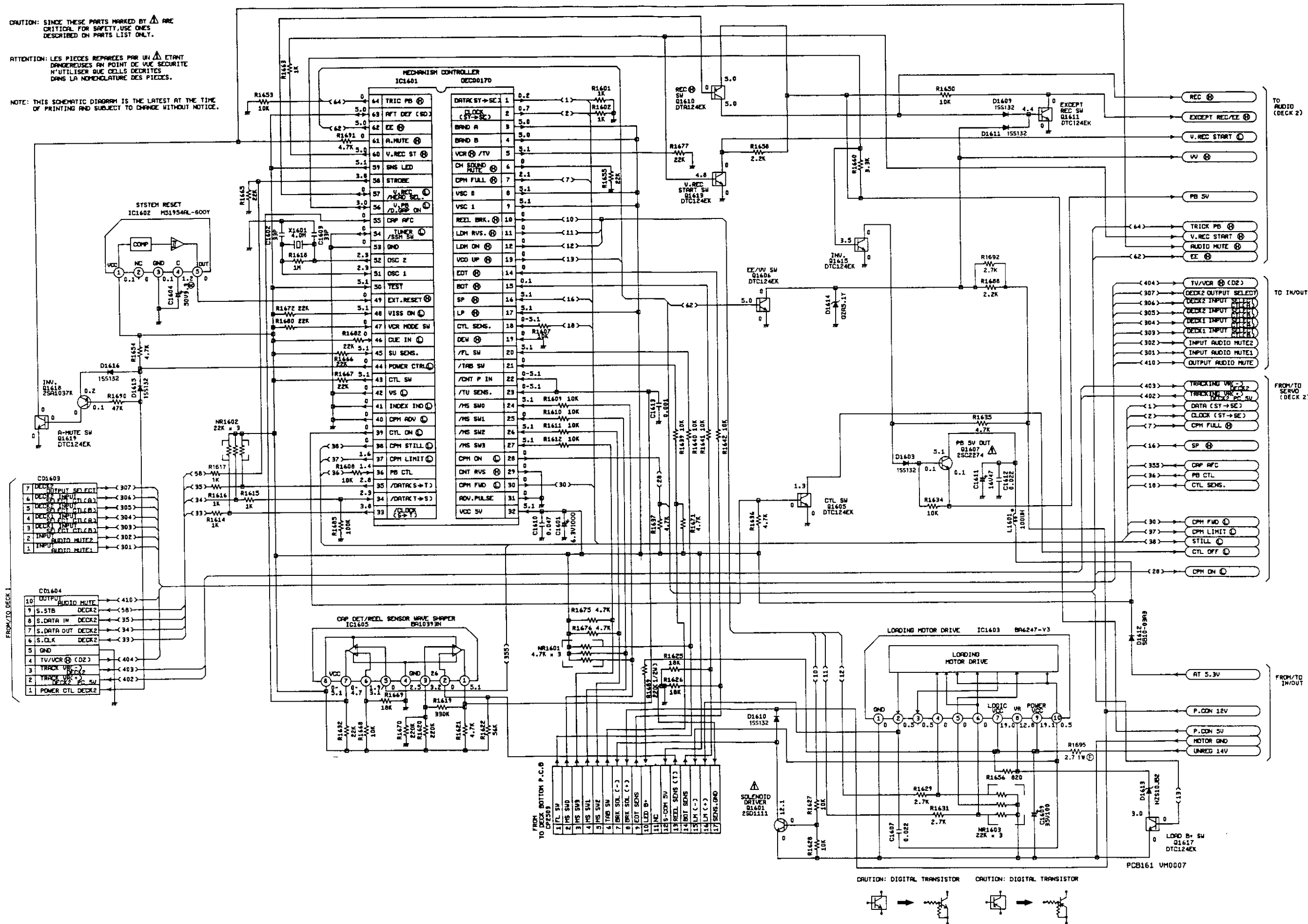

SERVO SCHEMATIC DIAGRAM (DECK 2)

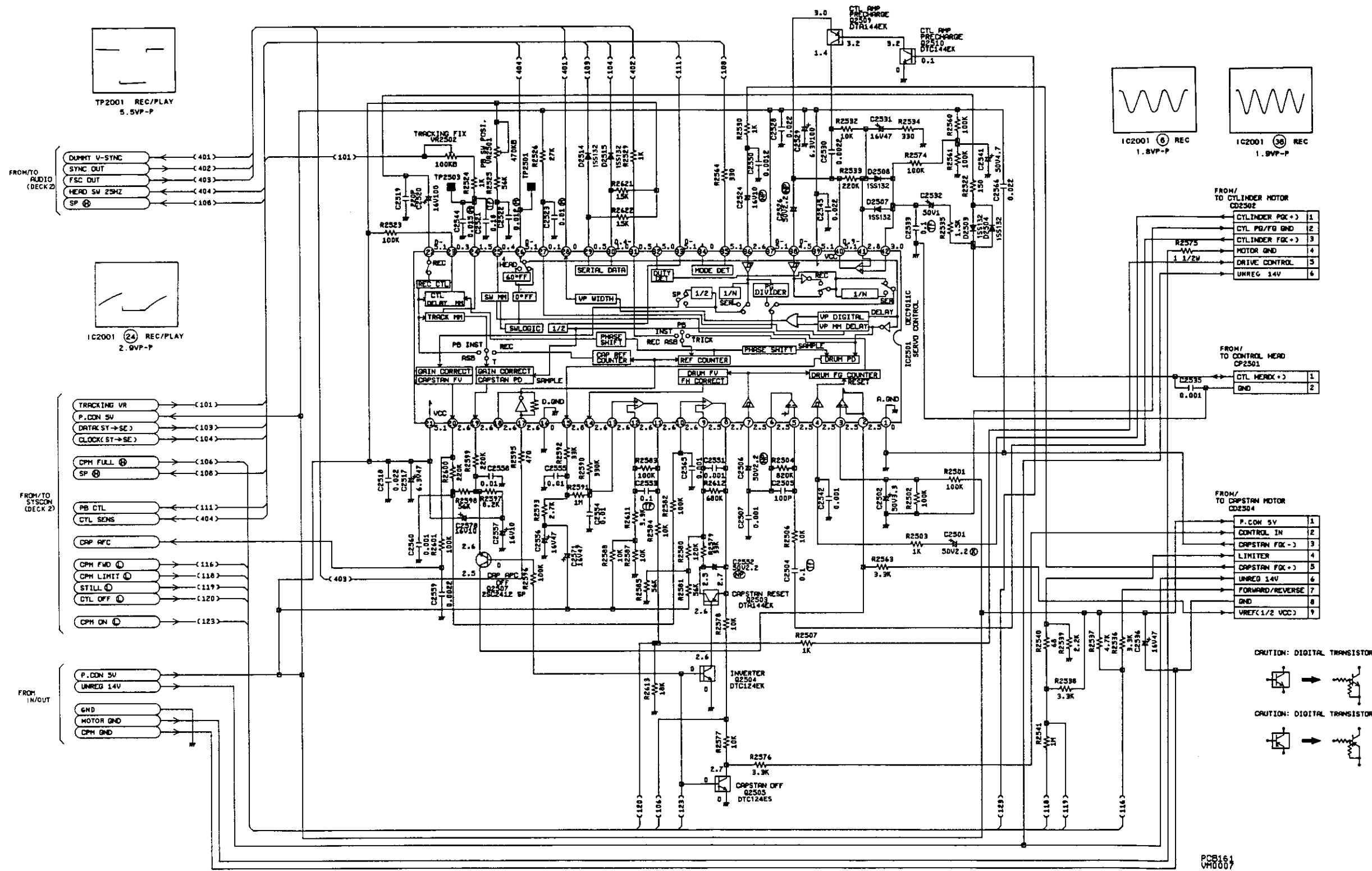

NOTE: THIS SCHEMATIC DIAGRAM IS THE LATEST AT THE TIME OF PRINTING AND SUBJECT TO CHANGE WITHOUT NOTICE.

PCB161
VH0007

POWER SUPPLY SCHEMATIC DIAGRAM

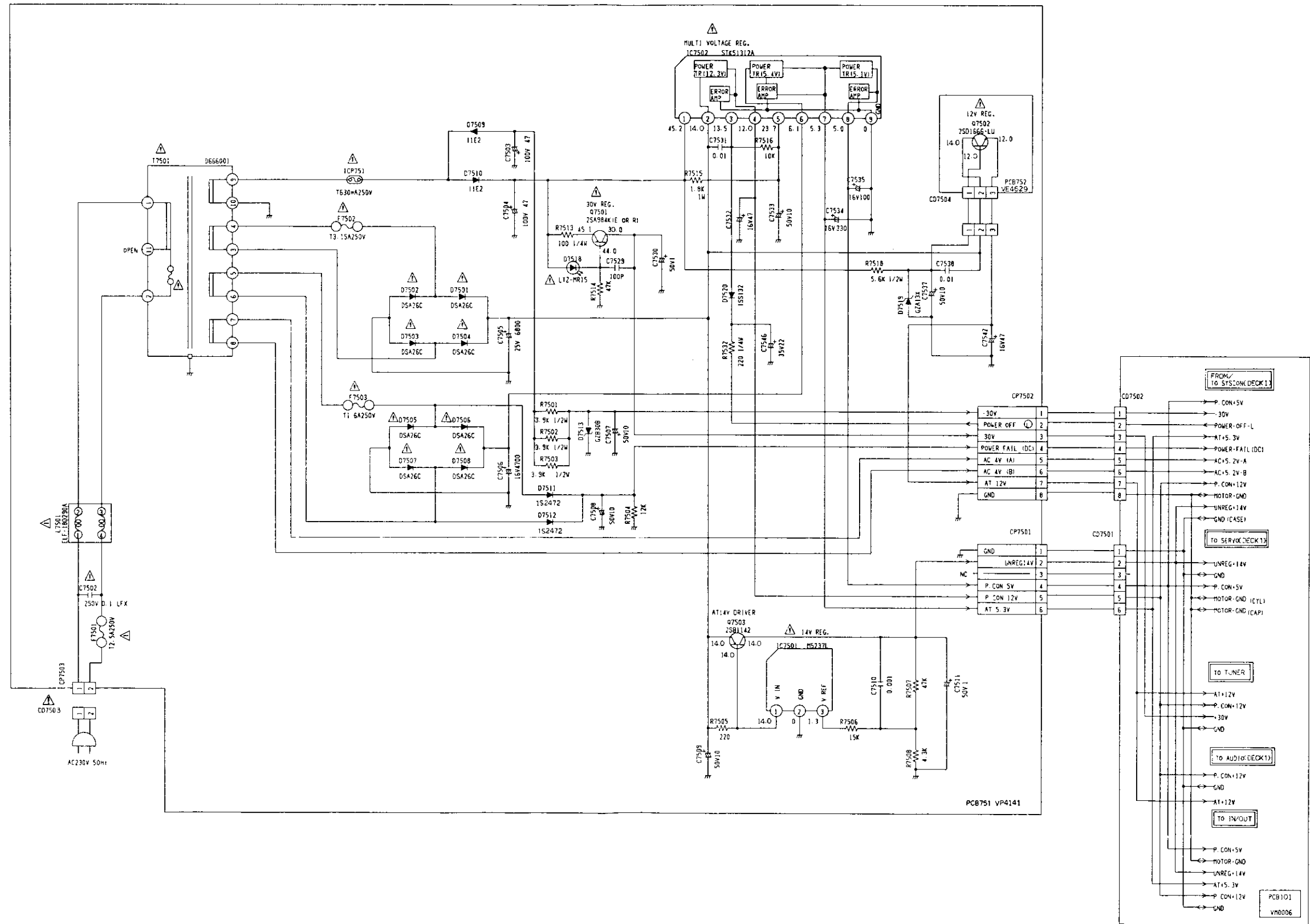

NOTE: THE DC VOLTAGE AT EACH PART WAS MEASURED WITH THE DIGITAL TESTER DURING PLAYBACK.

NOTE: THIS SCHEMATIC DIAGRAM IS THE LATEST AT THE TIME OF PRINTING AND SUBJECT TO CHANGE WITHOUT NOTICE.

ATTENTION: LES PIÈCES MARQUÉES PAR UN Δ ÉTAIENT DANGEREUSES AU POINT DE VUE SÉCURITÉ. N'UTILISER QUE CELLES DÉCRITES DANS LA NOMENCLATURE DES PIÈCES.

CAUTION: SINCE THESE PARTS MARKED BY Δ ARE CRITICAL FOR SAFETY, USE ONES DESCRIBED ON PARTS LIST ONLY.

IN/OUT SCHEMATIC DIAGRAM

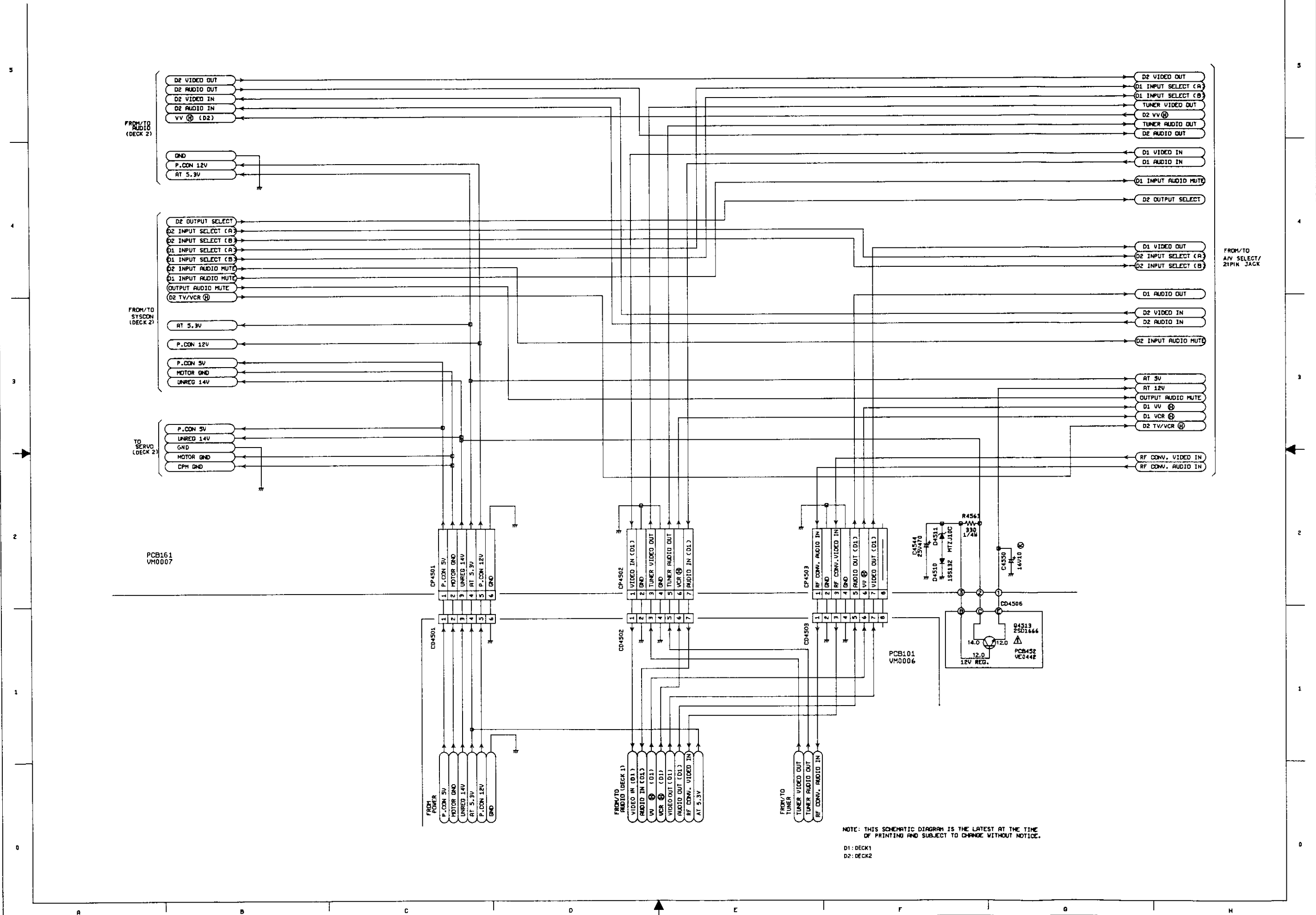

NOTE: THIS SCHEMATIC DIAGRAM IS THE LATEST AT THE TIME OF PRINTING AND SUBJECT TO CHANGE WITHOUT NOTICE.

D1: DECK1
D2: DECK2

A/V SELECT/21PIN JACK SCHEMATIC DIAGRAM

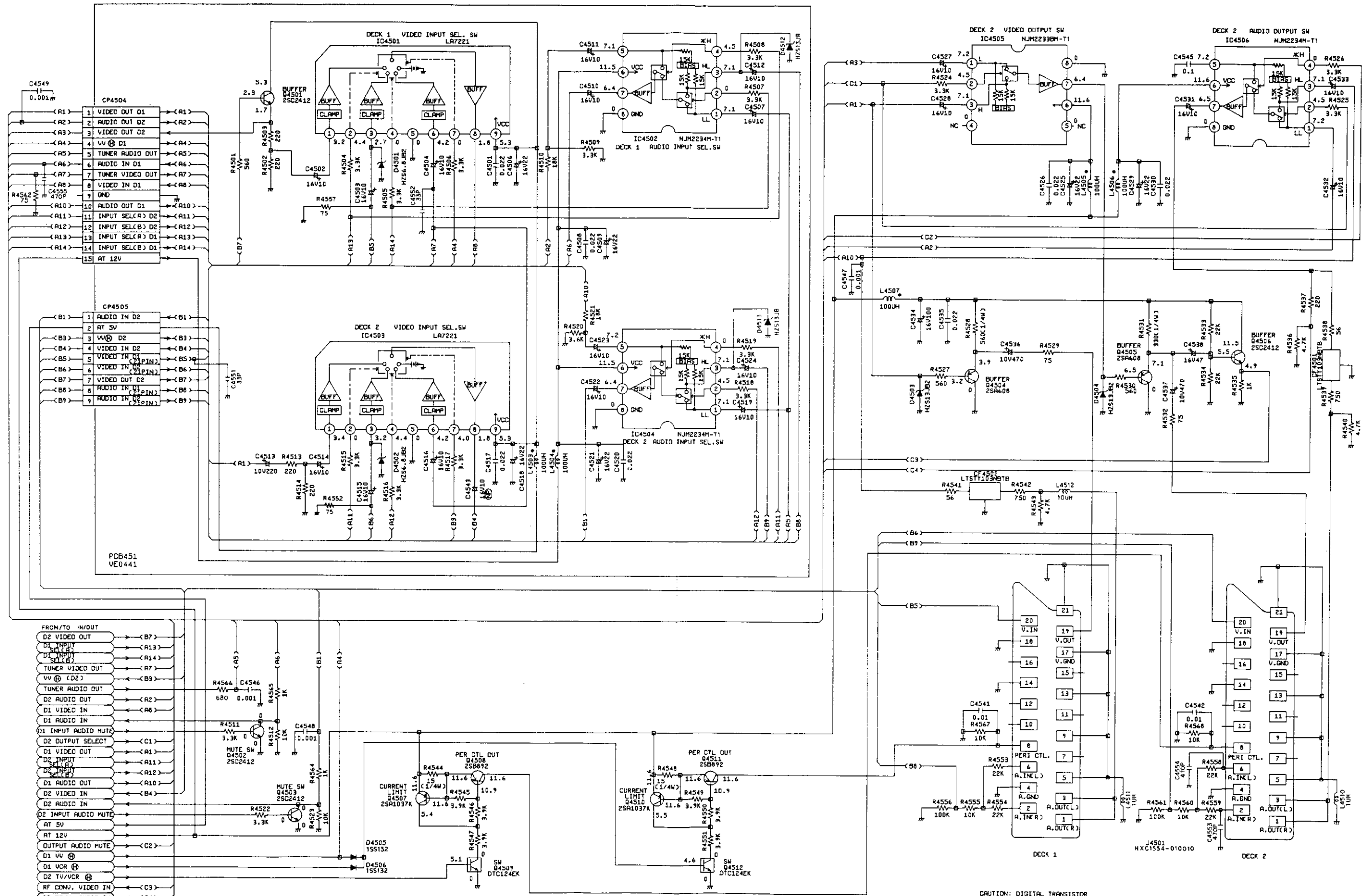

PCB151 VM0007

NOTE: THIS SCHEMATIC DIAGRAM IS THE LATEST AT THE TIME OF PRINTING AND SUBJECT TO CHANGE WITHOUT NOTICE.
 D1: DECK 1
 D2: DECK 2

OPERATION SCHEMATIC DIAGRAM

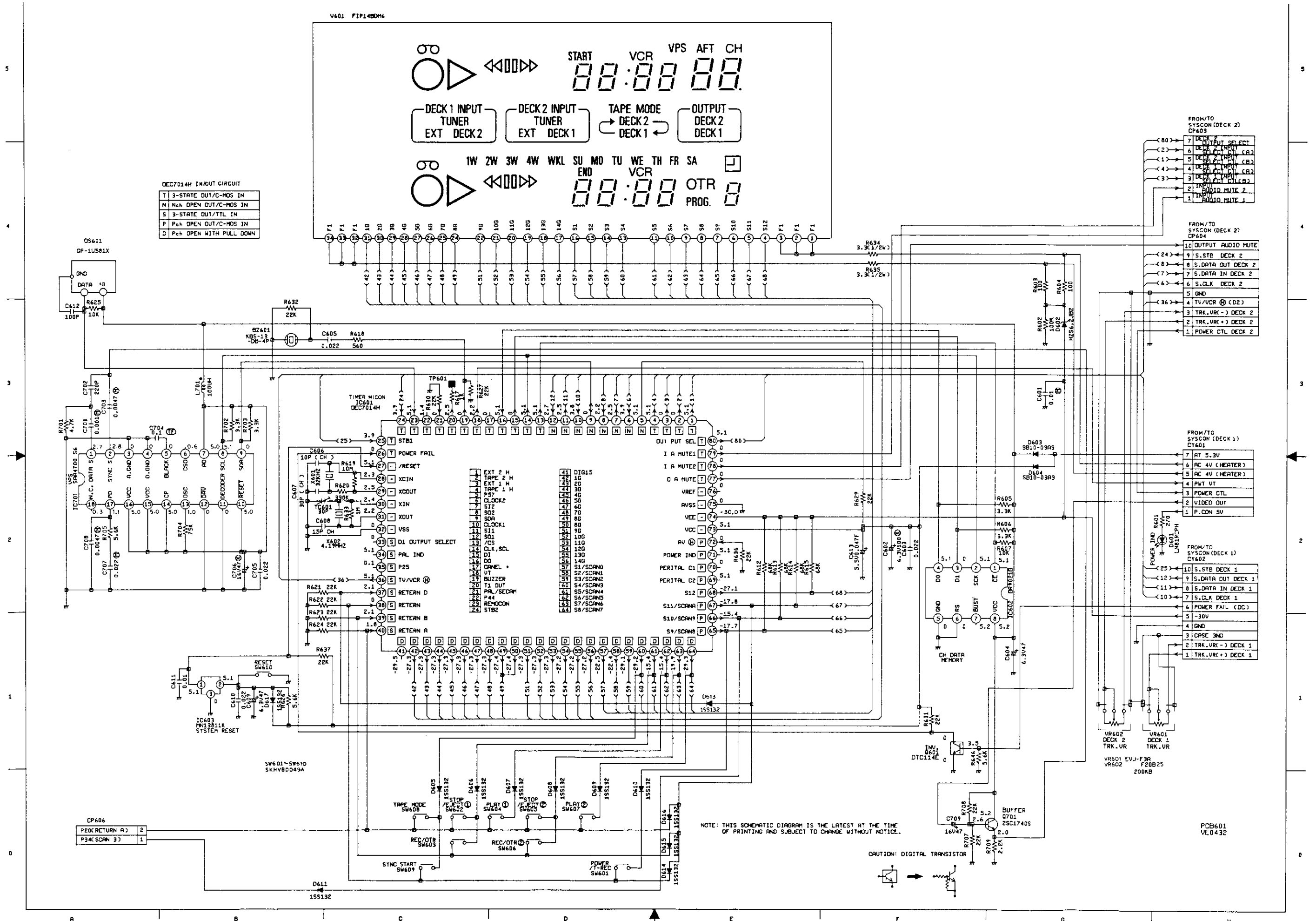

DEC7014H IN/OUT CIRCUIT

T	3-STATE OUT/C-MOS IN
N	Non OPEN OUT/C-MOS IN
S	3-STATE OUT/TTL IN
P	Open OUT/C-MOS IN
D	Open WITH PULL DOWN

NOTE: THIS SCHEMATIC DIAGRAM IS THE LATEST AT THE TIME OF PRINTING AND SUBJECT TO CHANGE WITHOUT NOTICE.

CAUTION: DIGITAL TRANSISTOR

INTERCONNECTION DIAGRAM (DECK 1)

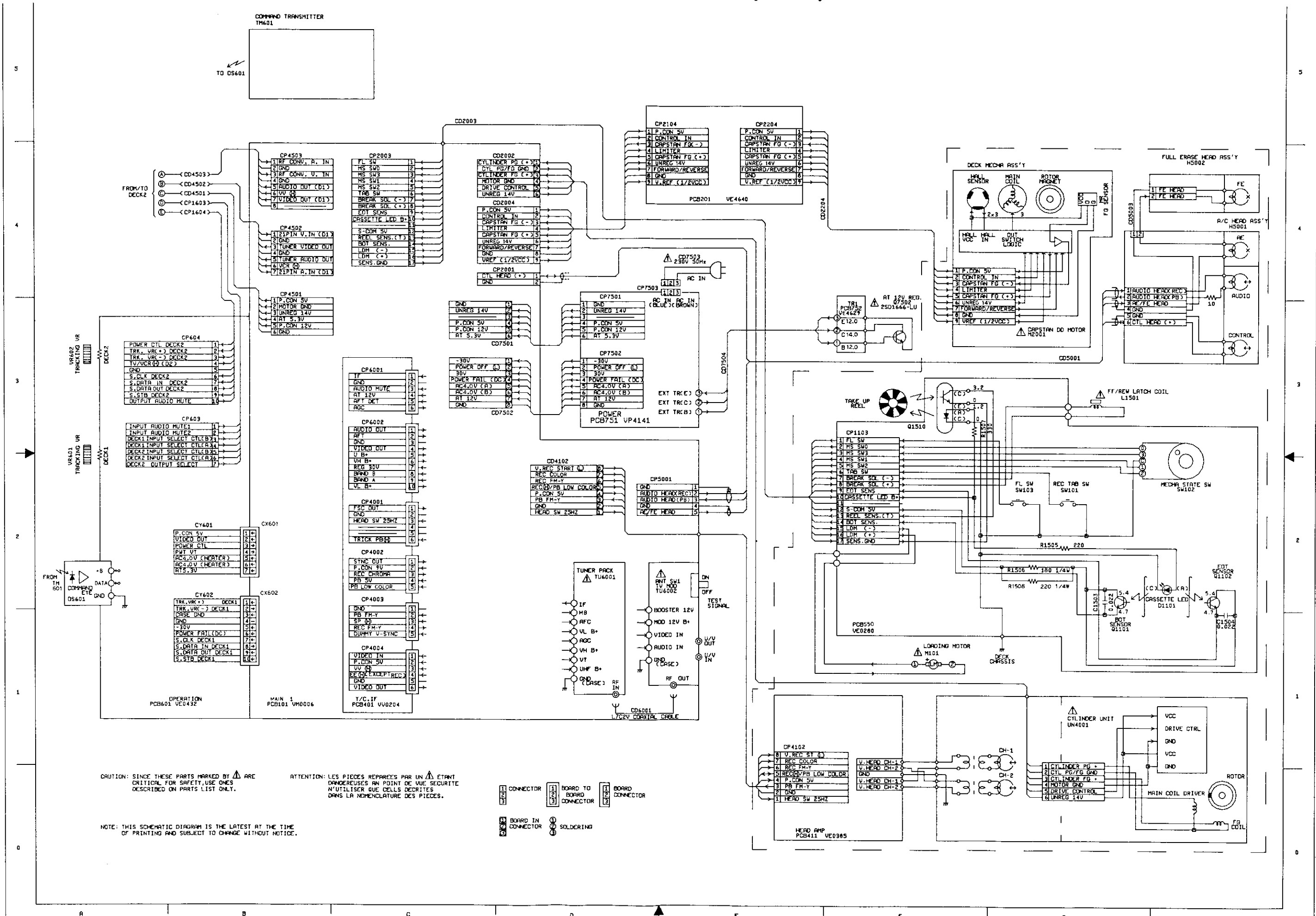

INTERCONNECTION DIAGRAM (DECK 2)

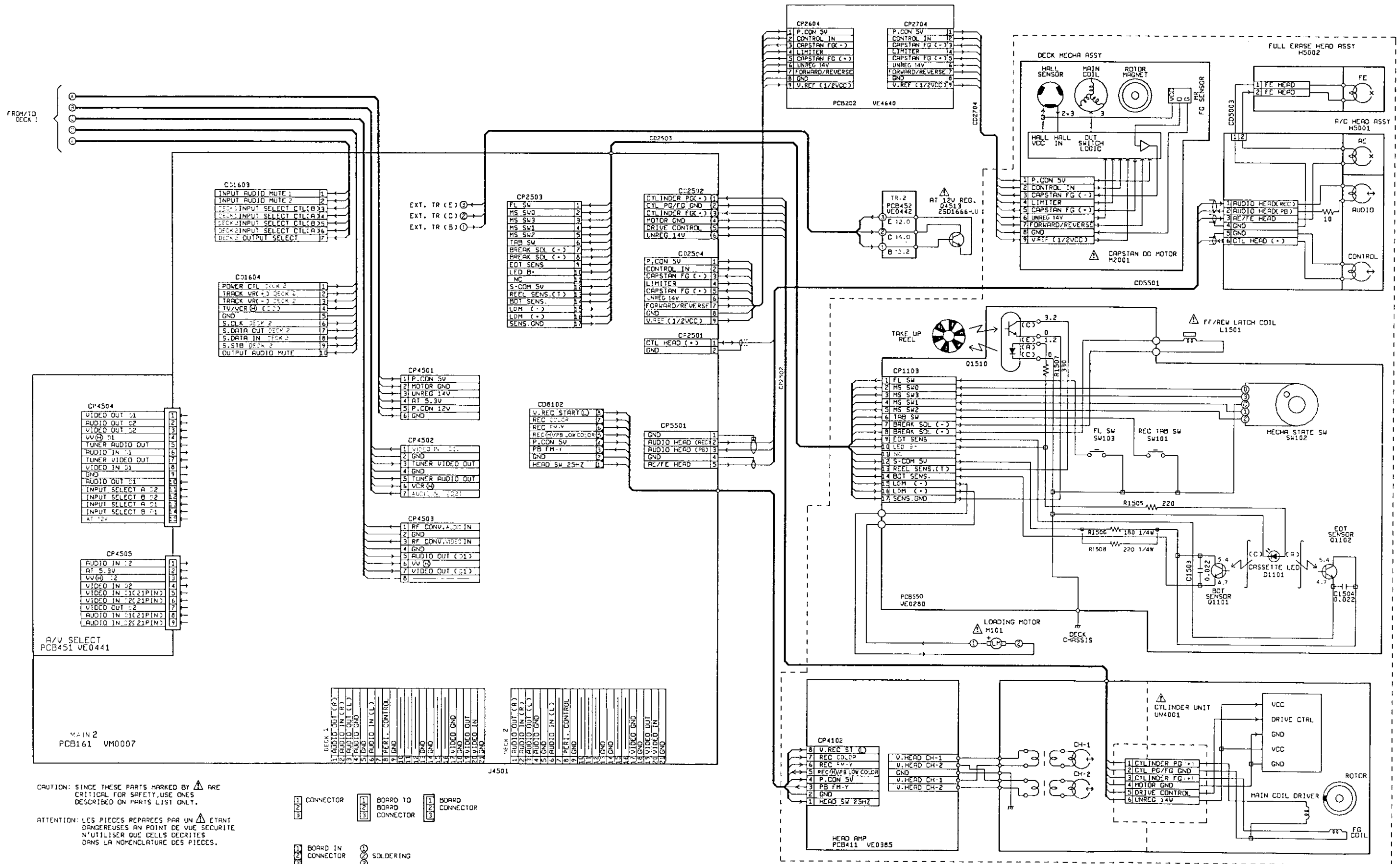

CAUTION: SINCE THESE PARTS MARKED BY ARE CRITICAL FOR SAFETY, USE ONES DESCRIBED ON PARTS LIST ONLY.

ATTENTION: LES PIÈCES RÉPARÉES PAR UN ÉTAIENT DANGEREUSES EN POINT DE VUE SÉCURITÉ N'UTILISER QUE CELLES DÉCRITES DANS LA NOMÉNCLATURE DES PIÈCES.

NOTE: THIS SCHEMATIC DIAGRAM IS THE LATEST AT THE TIME OF PRINTING AND SUBJECT TO CHANGE WITHOUT NOTICE.

D1: DECK 1
D2: DECK 2

- CONNECTOR
- BOARD TO BOARD CONNECTOR
- BOARD CONNECTOR
- BOARD IN CONNECTOR
- SOLDERING

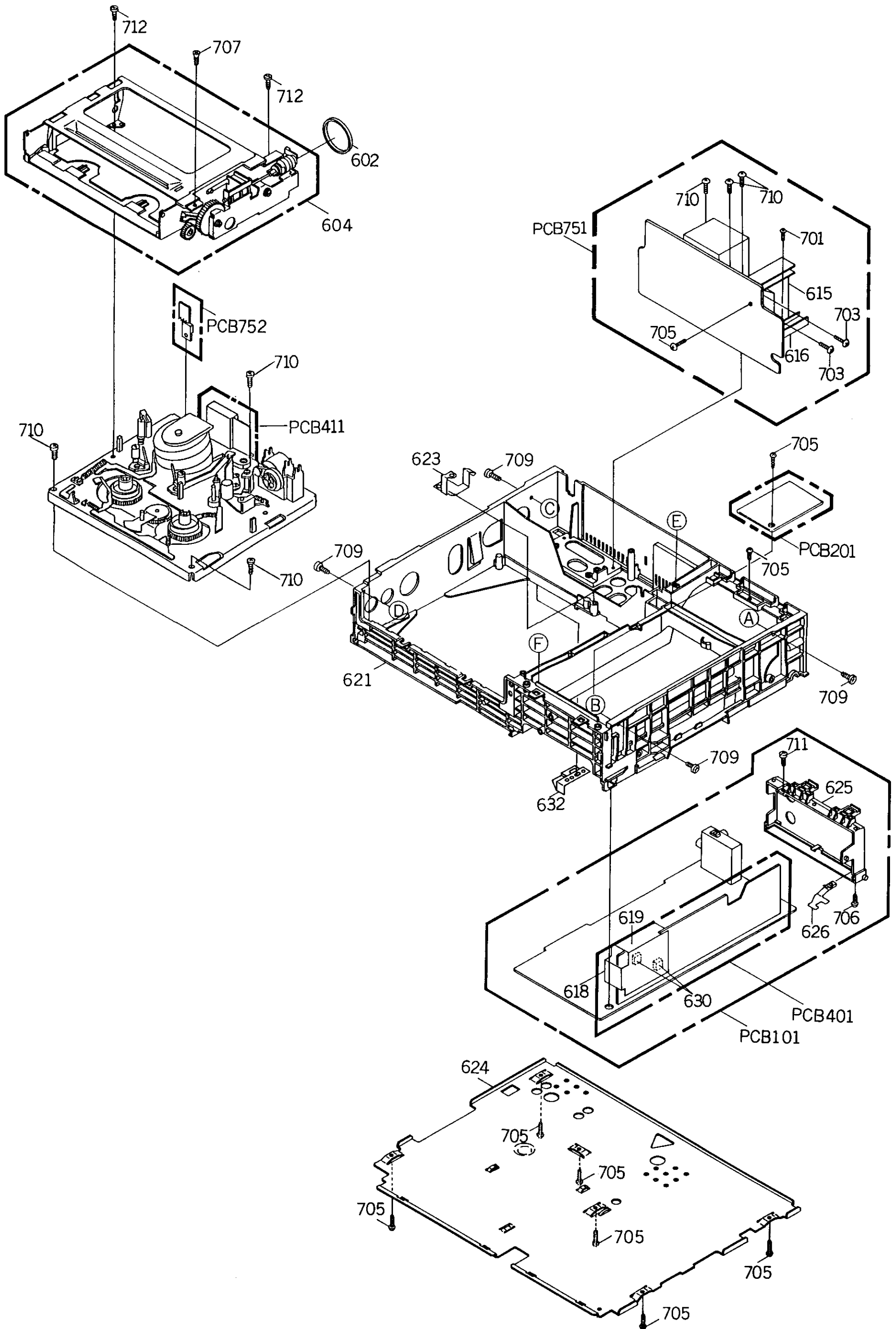

MECHANICAL EXPLODED VIEW (DECK 1)

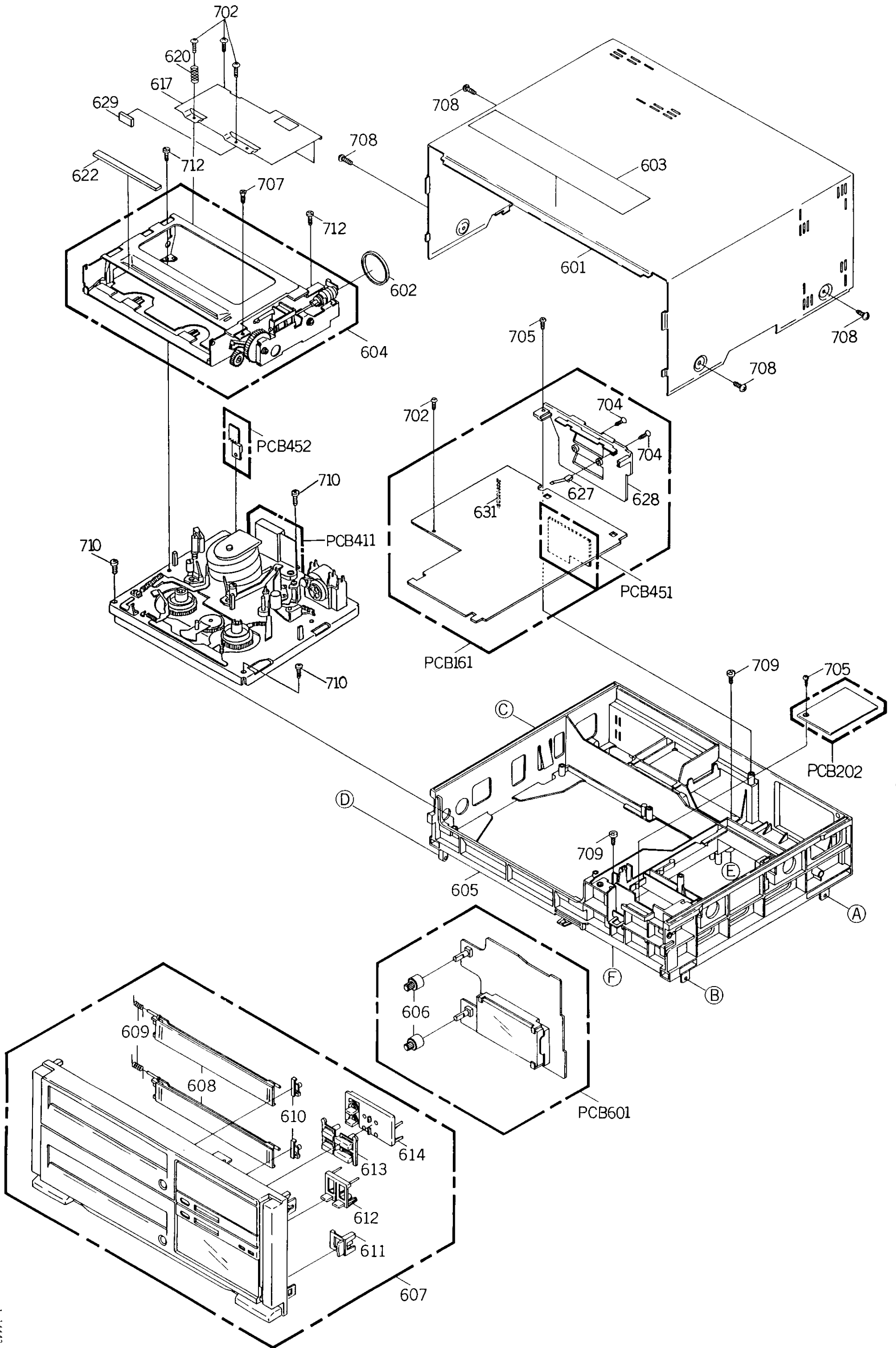

MECHANICAL EXPLODED VIEW (DECK 2)

DECK EXPLODED VIEW

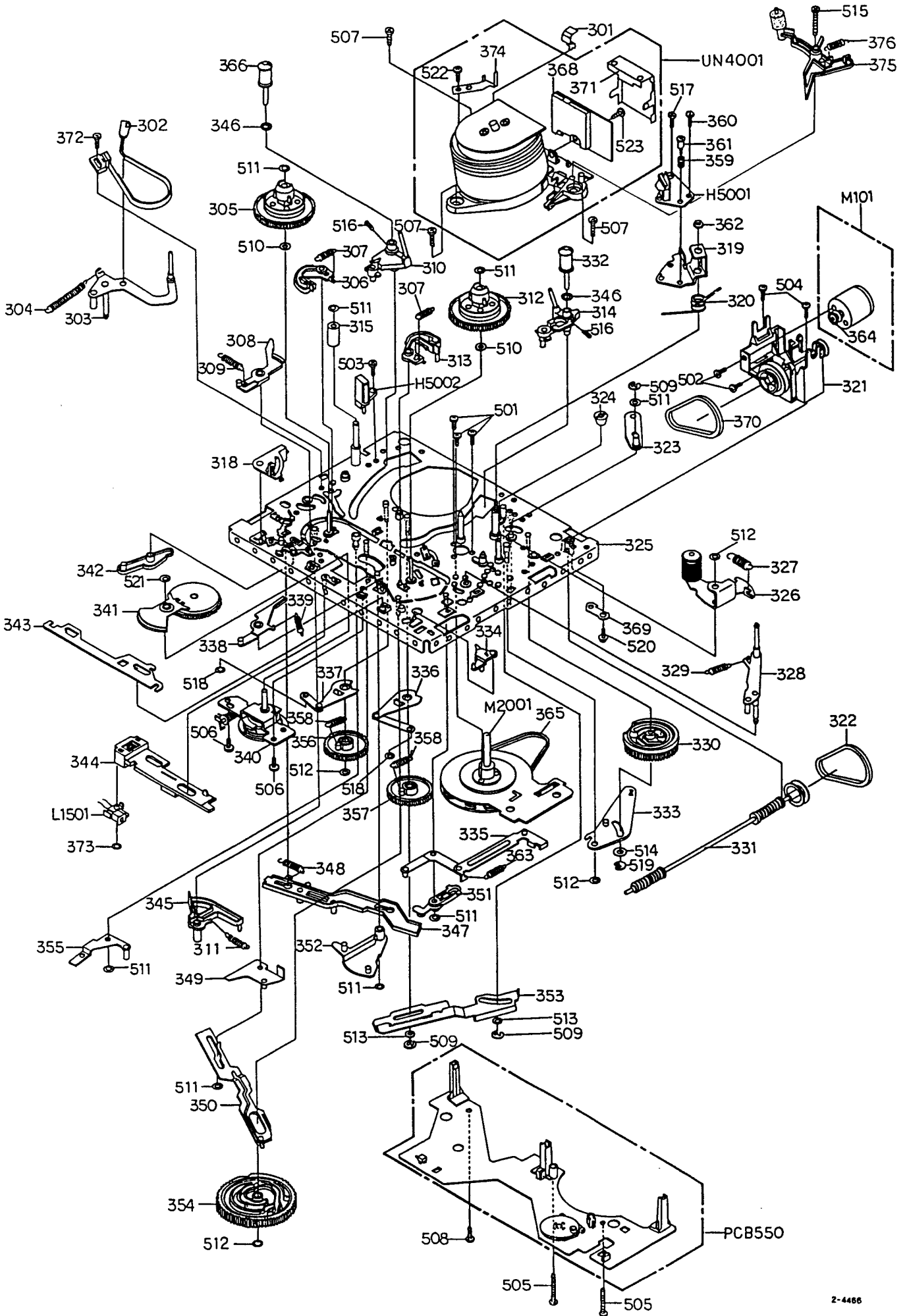

DECK EXPLODED VIEW

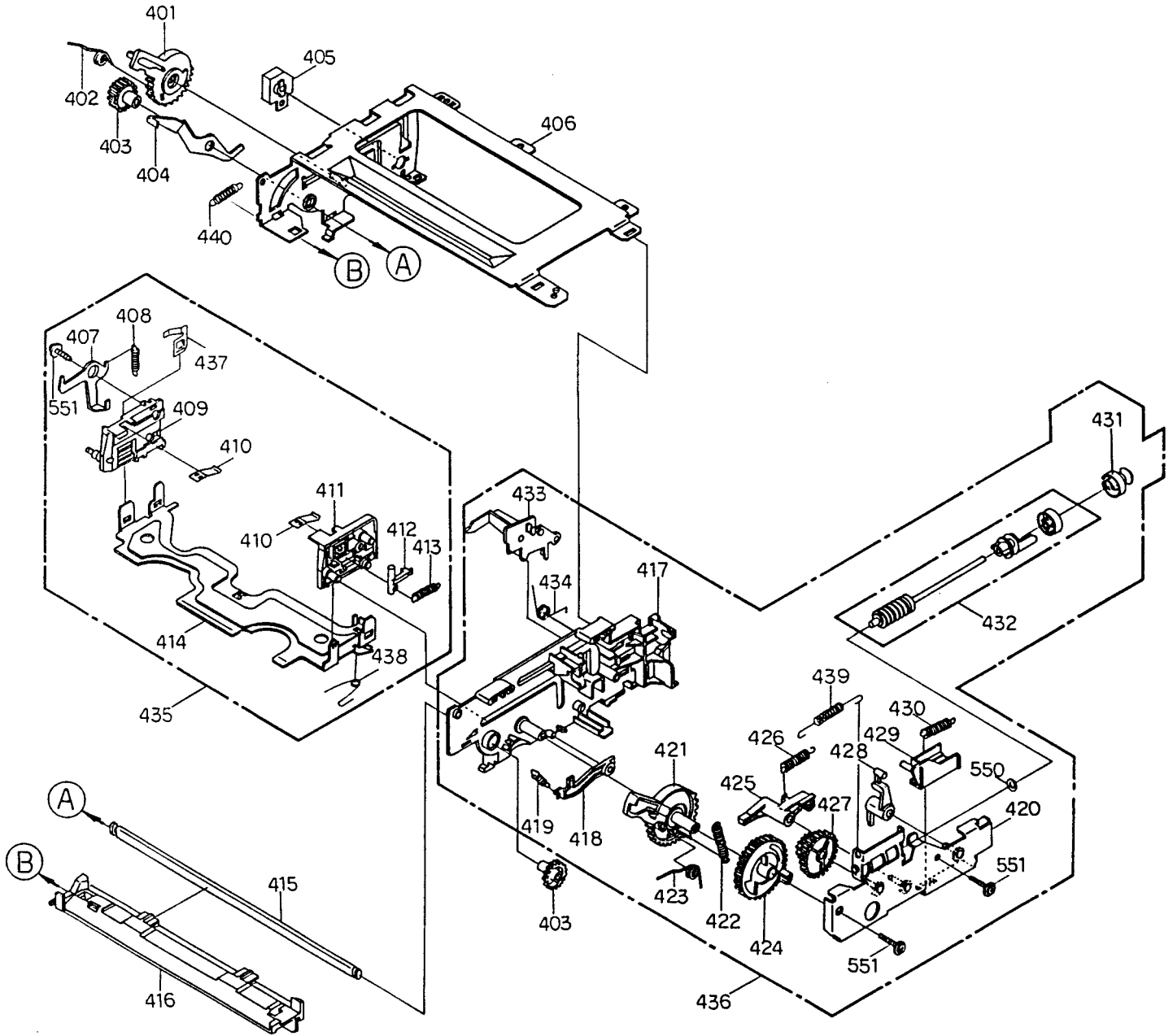

MECHANICAL REPLACEMENT PARTS LIST

REF.NO.	PART NO.	DESCRIPTION	
601	702USS0017	CABINET.TOP	
602	850P600438	BELT.FRONT LOADING 2	
603	7230005174	FILM.DECORATION	
604	A48901A650	FRONT LOADING UNIT (FL-6B)	
605	702UPA0072	CABINET.INSIDE UPPER	
606	732WPA0005	KNOB.TRACKING	
607	A47116A720	CABINET.FRONT ASS'Y	
	701UPJ0196	CABINET.FRONT	
	7230005310	PLATE.DISPLAY	
	7232020223	BADGE.BRAND	
608	712UPJ0149	FLAP	
609	743JKA0003	SPRING.FLAP	
610	756WPA0010	HOLDER.FLAP	
611	735UPA0071	BUTTON.POWER	
612	735UPA0070	BUTTON.FUNCTION	
613	735UPD0130	BUTTON.DECK	
614	735UPA0068	BUTTON.REC	
615	----	HEAT SINK.POWER IC	
616	----	HEAT SINK	
617	752TSA0070	PLATE.HEAD SHILD.	
618	752WSA0008	COVER.IF SHIELD	
619	752WSA0009	FRAME.IF SHIELD	
620	753WUA0008	SPRING.EARTH P-TOP	
621	702UPA0092	CABINET.INSIDE	
	7222021858	SHEET.RATING	
	800JF00161	CUSHION.LEG	
622	800JF00182	FC SHEET	100*5*T2
623	753JUA0021	SPRING.DECK EARTH	
624	702USA0016	CABINET.BOTTOM	
625	771WPA0022	PLATE.JACK	
626	753JUA0024	PLATE EARTH M-PCB	
627	753WUA0001	SPRING.EARTH M-PCB	
628	771WPA0031	PLATE.JACK	
629	800JF00179	FC SHEET	20*10*T1
630	800WF00002	FC SHEET	10*10*T5
631	----	COATING CLIP CP-2S	
632	753WUA0020	PLATE BOTTOM EARTH	
701	810A130804	SCREW/WASHER(A)	M3*8
702	8107230604	SCREW.TAP TITE(S) BIND	3*6
703	8110630A44	SCREW.TAP TITE(P) BRAZIER	3*14
704	8117430A22	SCREW.TAPPING(BO) OVAL	3*12
705	8110630804	SCREW.TAP TITE(P) BRAZIER	3*8
706	8110630A24	SCREW.TAP TITE(P) BRAZIER	3*12
707	8117330A04	SCREW.TAPPING(BO) FLAT	3*10
708	8117548002	SCREW.TAPPING(BO) TRUSS	4*8
709	8117240A04	SCREW.TAPPING(BO) BIND	4*10
710	8117140A24	SCREW.TAPPING(BO) PAN	4*12
711	8102230604	SCREW.BIND	M3*6
712	8107230804	SCREW.TAP TITE(S) BIND	3*8
---	J85X0500	POLYBAG + ACCEMBLY CHARGE	
---	J4710139	VPS CAUTION SHEET	
---	J4711601	INSTRUCTION BOOK	
---	J4802020	DEW CAUTION SHEET	
---	715WPA0006	HOLDER.CLOCK	
---	791UHA0010	PACKAGE (L)	
---	792UHA0069	PACKAGE (R)	
---	793UCD0705	GIFT BOX	

DECK REPLACEMENT PARTS LIST (DECK 1/2)

REF. NO.	PART NO.	DESCRIPTION	REF. NO.	PART NO.	DESCRIPTION
301	850P500023	SPRING,TR.	410	850P900354	SPRING.PACK
302	850A600139	TENSION.BAND ASS'Y	411	850P900536	CASS.SIDE RA
303	850A400077	TENSION.ARM ASS'Y	412	850P900474	REMOVING 2
304	850P800141	SPRING.TENSION ARM	413	850P800198	SPRING.REMOVING 2
305	850A200036	S REEL ASS'Y	414	850A900122	CASS.HOLDER SUB ASS'Y
306	850A600136	MAIN BRAKE S ASS'Y	415	850P900267	SHAFT,SYNCHRO
307	850P800187	SPRING,MAIN BRAKE	416	850P900529	TAPE GUIDE PIECE
308	850P600446	ARM.S-S BRAKE 1	417	850P900532	BRACKET.SIDE RIA
309	850P800164	SPRING.SS BRAKE	418	850P900416	LEVER.FRONT LOADING SW.
			419	850P800158	SPRING.FRONT LOADING SW.LEVER
310	850A400108	BASE.S INCLINED ASS'Y	420	850A900129	SIDE BRACKET R2 ASS'Y
311	850P800190	SPRING.M-B 3	421	850P900431	GEAR.LINK R
312	850A200035	T REEL ASS'Y	422	850P800153	SPRING.CLUTCH GEAR
313	850A600135	MAIN BRAKE T ASS'Y	423	850P800181	SPRING.LINK GEAR R2
314	850A400109	BASE.T INCLINED ASS'Y	424	850P900432	GEAR.CLUTCH
315	850P600432	ROLLER IMPEDANCE	425	850P900417	LEVER.LOCK
316	850A400112	ARM.AHC UNIT	426	850P800159	SPRING.LOCK LEVER
317	850P800236	SPRING AHC 1	427	850P900438	WHEEL
318	850P600306	LEVER.REC.SW	428	850P900435	LEVER.CLUTCH
319	850P500042	BASE.AC HEAD 2	429	850P900434	LEVER.SLIDE
320	850P800233	SPRING.AC HEAD BASE 2	430	850P800180	SPRING.SLIDE LEVER 2
321	850A600148	LOADING MOTOR BOX A ASS'Y	431	850P900531	JOINT,PULLEY 2
322	850P600317	BELT,LOADING MOTOR	432	850A900089	WORM ASS'Y
323	850A500008	P-R.LEVER ASS'Y	433	850P900450	OPENER A
324	850P600459	NUT.ADJUST X2	434	850P800172	SPRING.OPENER A
325	850A000090	MAIN CHASSIS ASS'Y Z2	435	A45101A690	CASSETTE HOLDER ASS'Y
326	850A400073	PINCH ROLLER ARM ASS'Y	436	A44802A640	SIDE BRACET R ASS'Y
327	850P800149	SPRING,P-R ARM	437	850P900523	SPRING.FRONT LOADING EARTH
328	850A400105	LIMITER POST ARM 2 ASS'Y	438	850P800230	SPRING.LOCKER R
329	850P800148	SPRING.L-P ARM	439	850P800243	SPRING.EARTH
330	850P600305	CAM 1	440	850P800157	SPRING.FLAP FRONT LOADING
331	850A600114	WORM ASS'Y	501	8107126604	SCREW,TAP TITE(S) PAN 2.6*6
332	850A400102	G-ROLLER ASS'Y	502	8102130404	SCREW,PAN M3*4
333	850A300031	LOADING,LEVER 2 ASS'Y	503	8107226804	SCREW,TAP TITE(S) BIND 2.6*8
334	850P600311	LEVER.SUB BRAKE	504	8107230A44	SCREW,TAP TITE(S) BIND 3*14
335	850A900083	LEVER.FRONT LOADING ASS'YT	505	8107230A64	SCREW,TAP TITE(S) BIND 3*16
336	850A300052	LOADING.ARM T ASS'Y	506	8107230604	SCREW,TAP TITE(S) BIND 3*6
337	850A300051	LOADING.ARM S ASS'Y	507	8107230804	SCREW,TAP TITE(S) BIND 3*8
338	850A600137	T-S BRAKE 2 ASS'Y	508	8110230804	SCREW,TAP TITE(P) BIND 3*8
339	850P800165	SPRING.TS BRAKE	509	83ETW25000	E-RING 2.5
340	850A200043	CLUTCH ASS'Y	510	82Q315483N	POLYSLIDER WASHER 3.1*5.4*TO.13
341	850A200038	IDLER JS ASS'Y		82Q315403N	POLYSLIDER WASHER 3.1*5.4*TO.3
342	850P600445	LEVER MAIN BRAKE 1	511	82P255504N	POLYSLIDER WASHER(CUT) 2.5*5.5*TO.4
343	850P600310	ACTUATOR.SUB BRAKE	512	82P306005N	POLYSLIDER WASHER(CUT) 3.1*6.0*TO.5
344	850A600129	CLUTCH ACTUATOR JS ASS'Y	513	82A3270054	WASHER 3.1*7.0*TO.5
345	850P600303	LEVER.TENSION	514	82A4080054	WASHER 4.3*8.0*TO.5
346	850P400326	O-RING	515	8107126144	SCREW TAP TITE(S) PAN 2.6*14
347	850P600381	SLIDE MAIN BRAKE	516	815DJ20302	SET SCREW 6 CUP POINT M2*3
348	850P800188	SPRING.M-B SLIDE	517	8145J30601	SCREW,+UPSET M3*6
349	850A600109	M-B 2 LEVER ASS'Y	518	83CST35050	CS-RING 3.5
			519	83ETW30060	E-RING 3.0
350	850A600108	T-A SLIDE ASS'Y	520	8117B26804	SCREW,TAPPING(BO) WH6 2.6*8
351	850P600416	LEVER,LIMITER POST	521	82P2660C5N	POLYSLIDER WASHER(CUT) 2.6*6.0*TO.25
352	850P600409	LEVER,CLUTCH ACTUATOR	522	810A130604	SCREW/WASHER(A) M3*6
353	850P300112	SLIDE,LOADING 2	523	810W126801	SCREW/WASHER(W) M2.6*8 W6
354	850P600304	CAM 2	551	82Q315405N	POLYSLIDER WASHER 3.1*5.4*TO.5
355	850A600099	M-B 3 LEVER ASS'Y	551	86817CGA04	TAPPING(BO) BIND WH6.5 2.6*10
356	850A300049	GEAR LOADING S ASS'Y	552	8107220504	SCREW,TAP TITE(S) BIND 2*5
357	850A300050	GEAR LOADING T ASS'Y			
358	850P800191	SPRING,LOADING GEAR			
359	850P800245	SPRING.AZIMUTH 2			
360	8144J30604	CONEHEAD SCREW M3*6			
361	8146130A31	JOINT SCREW PAN M3*13	CD5001	068T26017A	CORD EIS CONNECTOR 8726017A
362	850P500010	ADJUST NUT			(DECK 1 ONLY)
363	850P800189	SPRING,FRONT LOADING LEVER	CD5003	06CT23027A	CORD EIS CONNECTOR C723027A
364	850P600319	PULLEY,LOADING MOTOR	CD5501	068126053A	CORD EIS CONNECTOR 8126053A
365	850P600316	BELT,REEL			(DECK 2 ONLY)
366	850A400088	G-ROLLER ASS'Y	CP1103	069R7H0069	CONNECTOR PCB SIDE 52044-1710
367	850PAA0134	SHEET,EARTH			
368	850PAA0118	CASE.AMP SHIELD	D1101	0010100300	INFRARED LED LN59L
369	850P000262	BRACKET.WORM 3			
370	850P600315	BELT,FRONT LOADING	H5001	1523J91003	HEAD AUDIO CONTROL MH-150RM
371	850PAA0117	LID.AMP SHIELD	H5002	1543J02002	HEAD FULL ERASE MH-131R
372	868501H804	SCREW,TAP TITE(S) PAN W6 3*8			
373	850P000285	CS-RING 2.6*5.4*TO.1	△ L1501	02BH000005	ELECTRO MAGNET JTM1002-01-0100
374	850P800251	SPRING.LEVER REC	△ M101	1596P58008	MOTOR,LOADING MXN-13FB12F
401	850P900430	GEAR.LINK L	△ M2001	1510S98024	CAPSTAN DD UNIT F20TB02
402	850P800175	SPRING.LINK GEAR L			
403	850P900525	GEAR,SYNCHRO	PCB550	A44802A550	DECK PCB ASS'Y VE0280
404	850P900451	LEVER,FLAP 2			
405	850P900537	COVER SENSOR 2	SW101	0500211001	PUSH SWITCH SPPB61023A
406	850A900142	TOP,BRACKET ASS'Y	SW102	0520U44002	SWITCH,ROTARY SRZZ08047A
407	850P900458	LOCKER	SW103	0501211001	PUSH SWITCH SPPB51096A
408	850P800154	SPRING,LOCKER			
409	850A900138	CASS.SIDE L ASS'Y	△ UN4001	A47101B500	CYLINDER UNIT ASS'Y A47101B500

THIS ELECTRICAL PARTS LIST IS STANDARD PART LIST. BUT INTERCHANGEABLE PARTS MAY BE USED IN THE UNIT. SEE THE INTERCHANGEABLE PARTS LIST AFTER THE STANDARD PARTS LIST.

ELECTRICAL REPLACEMENT PARTS LIST

REF. NO.	PART NO.	DESCRIPTION	REF. NO.	PART NO.	DESCRIPTION
RESISTORS			SEMICONDUCTORS (CONT.)		
R634	R002023R3J	RC 3.3 OHM 1/2W	D4513	D940A130J0	DIODE. ZENER HZS13JB
R635	R002023R3J	RC 3.3 OHM 1/2W	D5001	D1VT024720	DIODE. SILICON 1S2472T-77
R1250	R614812R7J	R.FUSE 2.7 OHM 1 W	D5501	D1VT001320	DIODE. SILICON 1SS132T-77
R1695	R614812R7J	R.FUSE 2.7 OHM 1 W	D6003	D1VT001320	DIODE. SILICON 1SS132T-77
R4085	R00106184J	RC 180K OHM 1/6W	D6005	D1VT001320	DIODE. SILICON 1SS132T-77
R7515	R3U181182J	R.METAL OXIDE 1.8K OHM 1 W	D6502	D1VT001320	DIODE. SILICON 1SS132T-77
CAPACITORS			△ D7501	D23J0A26C0	DIODE. RECTIFIER DSA26C-KD2
C2028	CHG0F03H4Z	CC 0.022 UF 25V	△ D7502	D23J0A26C0	DIODE. RECTIFIER DSA26C-KD2
C2566	CHG0F03H4Z	CC 0.022 UF 25V	△ D7503	D23J0A26C0	DIODE. RECTIFIER DSA26C-KD2
C4084	E0EE02100M	CE 10 UF 16V	△ D7504	D23J0A26C0	DIODE. RECTIFIER DSA26C-KD2
C4512	E001T2100M	CE 10 UF 16V	△ D7505	D23J0A26C0	DIODE. RECTIFIER DSA26C-KD2
C4516	E001T2100M	CE 10 UF 16V	△ D7506	D23J0A26C0	DIODE. RECTIFIER DSA26C-KD2
C4544	E0E7F3471M	CE 470 UF 25V	△ D7507	D23J0A26C0	DIODE. RECTIFIER DSA26C-KD2
△ C7502	P2420A104M	CCMP 0.1 UFAC125V/250V	△ D7508	D23J0A26C0	DIODE. RECTIFIER DSA26C-KD2
C7505	E53JF3682M	CE 6800 UF 25V	D7509	D28T011E20	DIODE. SILICON 11E2TA1
C7506	E001F2472M	CE 4700 UF 16V	D7510	D28T011E20	DIODE. SILICON 11E2TA1
C8326	CHG0B04W1J	CC 82 PF 50V	D7511	D1VT024720	DIODE. SILICON 1S2472T-77
SEMI CONDUCTORS			D7512	D1VT024720	DIODE. SILICON 1S2472T-77
D601	002112Q050	LED LN81RCPH-(TA2)	D7513	D93013001B	DIODE. ZENER GZB30B
D602	D94TA6R2J2	DIODE. ZENER HZS6R8J82-TE	△ D7518	DB7T2MR150	SEALED LED LTZ-MR15-T77
D603	D23U1003A3	DIODE. SCHOTTKY SB10-03A3	D7519	D93T01300X	DIODE. ZENER GZA13 X BT
D604	D23U1003A3	DIODE. SCHOTTKY SB10-03A3	D7520	D1VT001320	DIODE. SILICON 1SS132T-77
D605	D1VT001320	DIODE. SILICON 1SS132T-77	D8001	D1VT001320	DIODE. SILICON 1SS132T-77
D606	D1VT001320	DIODE. SILICON 1SS132T-77	D8002	D1VT001320	DIODE. SILICON 1SS132T-77
D607	D1VT001320	DIODE. SILICON 1SS132T-77	D8003	D94TA6R8J2	DIODE. ZENER HZS6R8J82-TE
D608	D1VT001320	DIODE. SILICON 1SS132T-77	D8004	D1VT001320	DIODE. SILICON 1SS132T-77
D609	D1VT001320	DIODE. SILICON 1SS132T-77	D8010	D94TA9R1J2	DIODE. ZENER HZS9R1J82-TE
D610	D1VT001320	DIODE. SILICON 1SS132T-77	D8211	D1VT001320	DIODE. SILICON 1SS132T-77
D611	D1VT001320	DIODE. SILICON 1SS132T-77	IC601	I56KT7014H	IC OEC7014H
D613	D1VT001320	DIODE. SILICON 1SS132T-77	IC602	I57D09021B	IC BR9021B
D614	D1VT001320	DIODE. SILICON 1SS132T-77	IC603	I51J03811K	IC MN13811-K-(TA)
D615	D1VT001320	DIODE. SILICON 1SS132T-77	IC701	I9KD647002	IC SAA4700 S6
D616	D1VT001320	DIODE. SILICON 1SS132T-77	IC1001	I54D50017D	IC OEC0017D
D617	D1VT001320	DIODE. SILICON 1SS132T-77	IC1002	I06S51954A	IC M51954AL-600Y
D1003	D1VT001320	DIODE. SILICON 1SS132T-77	IC1003	I07S06247Y	IC BA6247-V3
D1009	D1VT001320	DIODE. SILICON 1SS132T-77	IC1005	I07S003930	IC BA10393N
D1010	D1VT001320	DIODE. SILICON 1SS132T-77	IC1601	I54D50017D	IC OEC0017D
D1011	D1VT001320	DIODE. SILICON 1SS132T-77	IC1602	I06S51954A	IC M51954AL-600Y
D1012	D23U1003A3	DIODE. SCHOTTKY SB10-03A3	IC1603	I07S06247Y	IC BA6247-V3
D1013	D94TA100J2	DIODE. ZENER HZS10JB2-TE	IC1605	I07S003930	IC BA10393N
D1014	D93T05R10Y	DIODE. ZENER GZA5.1 Y BT	IC2001	I97D49011C	IC OEC9011C
D1017	D1VT001320	DIODE. SILICON 1SS132T-77	IC2501	I97D49011C	IC OEC9011C
D1603	D1VT001320	DIODE. SILICON 1SS132T-77	IC4001	I03D373900	IC LAT390
D1609	D1VT001320	DIODE. SILICON 1SS132T-77	IC4002	I03D389920	IC LC8992
D1610	D1VT001320	DIODE. SILICON 1SS132T-77	IC4101	I03DG73700	IC (DECK 1/2) LAT370
D1611	D1VT001320	DIODE. SILICON 1SS132T-77	IC4501	I03S072210	IC LAT721
D1612	D23U1003A3	DIODE. SCHOTTKY SB10-03A3	IC4502	I00F022340	IC NJM2234M-T1
D1613	D94TA100J2	DIODE. ZENER HZS10JB2-TE	IC4503	I03S072210	IC LAT721
D1614	D93T05R10Y	DIODE. ZENER GZA5.1 Y BT	IC4504	I00F022340	IC NJM2234M-T1
D1615	D1VT001320	DIODE. SILICON 1SS132T-77	IC4505	I00F022340	IC NJM2234M-T1
D1616	D1VT001320	DIODE. SILICON 1SS132T-77	△ IC4506	I00F022340	IC NJM2234M-T1
D2003	D1VT001320	DIODE. SILICON 1SS132T-77	△ IC5001	I07D767AS0	IC BAT767AS
D2004	D1VT001320	DIODE. SILICON 1SS132T-77	△ IC5501	I03T772960	IC LAT296
D2007	D1VT001320	DIODE. SILICON 1SS132T-77	IC6001	I03DA7575L	IC LAT7575L
D2008	D1VT001320	DIODE. SILICON 1SS132T-77	IC6003	I03S079100	IC LAT910
D2014	D1VT024720	DIODE. SILICON 1S2472T-77	△ IC6004	I0M190574J	IC UPC6574J-T
D2015	D1VT024720	DIODE. SILICON 1S2472T-77	△ IC6501	I03S072100	IC LAT7210
D2503	D1VT001320	DIODE. SILICON 1SS132T-77	△ IC7501	I06I95237L	IC M5237L
D2504	D1VT001320	DIODE. SILICON 1SS132T-77	△ IC7502	I23S51312A	IC STK51312A
D2507	D1VT001320	DIODE. SILICON 1SS132T-77	IC8001	I03D373900	IC LAT390
D2508	D1VT001320	DIODE. SILICON 1SS132T-77	IC8002	I03D389920	IC LC8992
D2514	D1VT001320	DIODE. SILICON 1SS132T-77	Q601	TNYTB03001	COMPOUND TRANSISTOR DTC114ESTP
D2515	D1VT001320	DIODE. SILICON 1SS132T-77	Q701	TCYT1740S0	TRANSISTOR. SILICON 2SC1740SP (R.S)
D4001	D1VT001320	DIODE. SILICON 1SS132T-77	△ Q1001	TDWTO11110	TRANSISTOR. SILICON 2SD1111-AA
D4002	D1VT001320	DIODE. SILICON 1SS132T-77	Q1005	TNYTC03001	COMPOUND TRANSISTOR DTC124ESTP
D4003	D94TA6R8J2	DIODE. ZENER HZS6R8J82-TE	Q1006	TNYTC03001	COMPOUND TRANSISTOR DTC124ESTP
D4004	D1VT001320	DIODE. SILICON 1SS132T-77	△ Q1007	TCWT022740	TRANSISTOR. SILICON 2SC2274 (E.F)
D4010	D94TA9R1J2	DIODE. ZENER HZS9R1J82-TE	Q1010	TPYTC03001	COMPOUND TRANSISTOR DTA124ESTP
D4211	D1VT001320	DIODE. SILICON 1SS132T-77	Q1011	TNYTC03001	COMPOUND TRANSISTOR DTC124ESTP
D4501	D94TA6R8J2	DIODE. ZENER HZS6R8J82-TE	Q1013	TNYTC03001	COMPOUND TRANSISTOR DTC124ESTP
D4502	D94TA6R8J2	DIODE. ZENER HZS6R8J82-TE	Q1014	TN3TC03001	COMPOUND TRANSISTOR 2SC3400-AC
D4503	D94TA130J2	DIODE. ZENER HZS13JB2-TE	Q1015	TNYTC03001	COMPOUND TRANSISTOR DTC124ESTP
D4504	D94TA130J2	DIODE. ZENER HZS13JB2-TE	Q1017	TNYTC03001	COMPOUND TRANSISTOR DTC124ESTP
D4505	D1VT001320	DIODE. SILICON 1SS132T-77	Q1018	TNYTD03001	COMPOUND TRANSISTOR DTC144ESTP
D4506	D1VT001320	DIODE. SILICON 1SS132T-77	Q1020	TAYTO933S0	TRANSISTOR. SILICON 2SA933STP (R.S)
D4510	D1VT001320	DIODE. SILICON 1SS132T-77	Q1021	TNYTC03001	COMPOUND TRANSISTOR DTC124ESTP
D4511	D97U01001C	DIODE. ZENER MT2J10C T-77	△ Q1601	TDWTO11110	TRANSISTOR. SILICON 2SD1111-AA
D4512	D940A130J0	DIODE. ZENER HZS13JB	Q1605	TNYTC05001	COMPOUND TRANSISTOR DTC124EKT147
			Q1606	TNYTC05001	COMPOUND TRANSISTOR DTC124EKT147
			△ Q1607	TCWT022740	TRANSISTOR. SILICON 2SC2274 (E.F)
			Q1610	TPYTC05001	COMPOUND TRANSISTOR DTA124EKT147

ELECTRICAL REPLACEMENT PARTS LIST

REF. NO.	PART NO.	DESCRIPTION	REF. NO.	PART NO.	DESCRIPTION
SEMI CONDUCTORS (CONT.)			COILS & TRANSFORMERS (CONT.)		
Q1611	TNYTC03001	COMPOUND TRANSISTOR DTC124ESTP	L1601	021B73101K	COIL 100 UH
Q1613	TNYTC05001	COMPOUND TRANSISTOR DTC124EKT147	L4001	021B73101K	COIL 100 UH
Q1615	TNYTC05001	COMPOUND TRANSISTOR DTC124EKT147	L4002	021B73101K	COIL 100 UH
Q1617	TNYTC05001	COMPOUND TRANSISTOR DTC124EKT147	L4003	021B73101K	COIL 100 UH
Q1618	T6YA1037K0	TRANSISTOR, SILICON 2SA1037KT147	L4005	021LA6150K	COIL 15 UH
Q1619	TNYTC05001	COMPOUND TRANSISTOR DTC124EKT147	L4006	021LA6121K	COIL 120 UH
Q2003	TPYTD03001	COMPOUND TRANSISTOR DTA144ESTP	L4007	021LA6330K	COIL 33 UH
Q2004	TNYTC03001	COMPOUND TRANSISTOR DTC124ESTP	L4009	021LA6220K	COIL 22 UH
Q2005	TNYTC03001	COMPOUND TRANSISTOR DTC124ESTP	L4010	021LA6100K	COIL 10 UH
Q2007	TCYT1740S0	TRANSISTOR, SILICON 2SC1740SP(R.S)	L4011	021LA6181K	COIL 180 UH
Q2009	TPYTD03001	COMPOUND TRANSISTOR DTA144ESTP	L4013	021LA6101K	COIL 100 UH
Q2010	TNYTD03001	COMPOUND TRANSISTOR DTC144ESTP	L4014	021LA6220K	COIL 22 UH
Q2503	TPYTD05001	COMPOUND TRANSISTOR DTA144EKT147	L4015	021LA66R8K	COIL 6.8 UH
Q2504	TNYTC05001	COMPOUND TRANSISTOR DTC124EKT147	L4016	021LA6101K	COIL 100 UH
Q2505	TNYTC03001	COMPOUND TRANSISTOR DTC124ESTP	L4017	021LA6271K	COIL 270 UH
Q2507	T8YA2412K0	TRANSISTOR, SILICON 2SC2412KT147	L4020	021B73101K	COIL 100 UH
Q2509	TPYTD05001	COMPOUND TRANSISTOR DTA144EKT147	L4021	021LA63R3K	COIL 3.3 UH
Q2510	TNYTD05001	COMPOUND TRANSISTOR DTC144EKT147	L4023	021LA6330K	COIL 33 UH
Q4001	T6YA1037K0	TRANSISTOR, SILICON 2SA1037KT147	L4101	021B7B101K	COIL (DECK 1/2) 100 UH
Q4002	T8YA2412K0	TRANSISTOR, SILICON 2SC2412KT147	L4301	021B73101K	COIL 100 UH
Q4003	T8YA2412K0	TRANSISTOR, SILICON 2SC2412KT147	L4302	021J79471J	COIL 470 UH
Q4006	T6YA1037K0	TRANSISTOR, SILICON 2SA1037KT147	L4303	021J79331J	COIL 330 UH
Q4007	TNYTC05001	COMPOUND TRANSISTOR DTC124EKT147	L4304	021LA6271K	COIL 270 UH
Q4008	T8YA2412K0	TRANSISTOR, SILICON 2SC2412KT147	L4307	021LA6150K	COIL 15 UH
Q4009	T6YA1037K0	TRANSISTOR, SILICON 2SA1037KT147	L4308	021LA6100K	COIL 10 UH
Q4010	T6YA1037K0	TRANSISTOR, SILICON 2SA1037KT147	L4503	021B73101K	COIL 100 UH
Q4013	T8YA2412K0	TRANSISTOR, SILICON 2SC2412KT147	L4504	021B73101K	COIL 100 UH
Q4014	T6YA1037K0	TRANSISTOR, SILICON 2SA1037KT147	L4505	021B73101K	COIL 100 UH
Q4017	T8YA2412K0	TRANSISTOR, SILICON 2SC2412KT147	L4506	021B73101K	COIL 100 UH
Q4018	T8YA2412K0	TRANSISTOR, SILICON 2SC2412KT147	L4507	021B73101K	COIL 100 UH
Q4201	TCYT1740S0	TRANSISTOR, SILICON 2SC1740SP(R.S)	L4510	021L961ROM	COIL 1.0 UH
Q4202	TD3T007340	TRANSISTOR, SILICON 2SD734(E.F.G)	L4511	021L961ROM	COIL 1.0 UH
Q4301	T8YA2412K0	TRANSISTOR, SILICON 2SC2412KT147	L4512	021LA6100K	COIL 10 UH
Q4302	T6YA1037K0	TRANSISTOR, SILICON 2SA1037KT147	L5001	021B73101K	COIL 100 UH
Q4303	T8YA2412K0	TRANSISTOR, SILICON 2SC2412KT147	L5003	021J74682J	COIL 6.8 MH
Q4304	TNYTC05001	COMPOUND TRANSISTOR DTC124EKT147	L5501	021B73101K	COIL 100 UH
Q4305	TNYTC05001	COMPOUND TRANSISTOR DTC124EKT147	L5502	021B73102K	COIL 1 MH
Q4501	T8YA2412K0	TRANSISTOR, SILICON 2SC2412KT147	L5503	021J74682J	COIL 6.8 MH
Q4502	T8YA2412K0	TRANSISTOR, SILICON 2SC2412KT147	L6001	021LA6R68M	COIL 0.68 UH
Q4503	T8YA2412K0	TRANSISTOR, SILICON 2SC2412KT147	L6003	021LA6100K	COIL 10 UH
Q4504	TA3T0608K0	TRANSISTOR, SILICON 2SA608K(F.G)	L6004	0336000057	COIL, VIDEO IFT 3600005(E693X)
Q4505	TA3T0608K0	TRANSISTOR, SILICON 2SA608K(F.G)	L6005	033618006N	COIL, SOUND IFT 361B006
Q4506	T8YA2412K0	TRANSISTOR, SILICON 2SC2412KT147	L6006	021LA6150K	COIL 15 UH
Q4507	T6YA1037K0	TRANSISTOR, SILICON 2SA1037KT147	L6007	021LA6680K	COIL 68 UH
Q4508	TB3T008920	TRANSISTOR, SILICON 2SB892(S.T)-AE	L6008	021B73101K	COIL 100 UH
Q4509	TNYTC05001	COMPOUND TRANSISTOR DTC124EKT147	L6009	021LA6100K	COIL 10 UH
Q4510	T6YA1037K0	TRANSISTOR, SILICON 2SA1037KT147	L6010	033600032N	COIL, VIDEO IFT 3600032
Q4511	TB3T008920	TRANSISTOR, SILICON 2SB892(S.T)-AE	L6011	033600033N	COIL, VIDEO IFT 3600033
Q4512	TNYTC05001	COMPOUND TRANSISTOR DTC124EKT147	L6012	021B73101K	COIL 100 UH
Q4513	TD3H016660	TRANSISTOR, SILICON 2SD1666-LU	L6013	021B73101K	COIL 100 UH
Q5005	TCKT013170	TRANSISTOR, SILICON 2SC1317(Q.R.S)	L6014	03360M0021	COIL, VIDEO IFT 360M002
Q5505	TCKT013170	TRANSISTOR, SILICON 2SC1317(Q.R.S)	L6501	021B73101K	COIL 100 UH
Q6003	TNYTC05001	COMPOUND TRANSISTOR DTC124EKT147	L7501	0291000053	COIL, LINE FILTER ELF-18D290A
Q6004	TC3T030000	TRANSISTOR, SILICON 2SC3000-AA	L8001	021B73101K	COIL 100 UH
Q6005	T8YA2412K0	TRANSISTOR, SILICON 2SC2412KT147	L8002	021B73101K	COIL 100 UH
Q6006	T6YA1037K0	TRANSISTOR, SILICON 2SA1037KT147	L8005	021LA6150K	COIL 15 UH
Q6007	TNYTC05001	COMPOUND TRANSISTOR DTC124EKT147	L8006	021LA6121K	COIL 120 UH
Q6008	TC3T0536K0	TRANSISTOR, SILICON 2SC536K(F.G)	L8007	021LA6330K	COIL 33 UH
Q6501	T8YA2412K0	TRANSISTOR, SILICON 2SC2412KT147	L8009	021LA6220K	COIL 22 UH
Q6502	TNYTC05001	COMPOUND TRANSISTOR DTC124EKT147	L8010	021LA6100K	COIL 10 UH
Q7501	TAWT0984K0	TRANSISTOR, SILICON 2SA984K(E.F)	L8011	021LA6181K	COIL 180 UH
Q7502	TD3H016660	TRANSISTOR, SILICON 2SD1666-LU	L8013	021LA6101K	COIL 100 UH
Q7503	TB30011420	TRANSISTOR, SILICON 2SB1142S/T	L8014	021LA6220K	COIL 22 UH
Q8001	T6YA1037K0	TRANSISTOR, SILICON 2SA1037KT147	L8015	021LA66R8K	COIL 6.8 UH
Q8002	T8YA2412K0	TRANSISTOR, SILICON 2SC2412KT147	L8016	021LA6101K	COIL 100 UH
Q8003	T8YA2412K0	TRANSISTOR, SILICON 2SC2412KT147	L8017	021LA6271K	COIL 270 UH
Q8006	T6YA1037K0	TRANSISTOR, SILICON 2SA1037KT147	L8020	021LA6101K	COIL 100 UH
Q8007	TNYTC05001	COMPOUND TRANSISTOR DTC124EKT147	L8021	021LA63R3K	COIL 3.3 UH
Q8008	T8YA2412K0	TRANSISTOR, SILICON 2SC2412KT147	L8023	021LA6330K	COIL 33 UH
Q8009	T6YA1037K0	TRANSISTOR, SILICON 2SA1037KT147	L8301	021B73101K	COIL 100 UH
Q8010	T6YA1037K0	TRANSISTOR, SILICON 2SA1037KT147	L8302	021J79471J	COIL 470 UH
Q8013	T8YA2412K0	TRANSISTOR, SILICON 2SC2412KT147	L8303	021J79331J	COIL 330 UH
Q8017	T8YA2412K0	TRANSISTOR, SILICON 2SC2412KT147	L8304	021LA6271K	COIL 270 UH
Q8018	T8YA2412K0	TRANSISTOR, SILICON 2SC2412KT147	L8307	021LA6150K	COIL 15 UH
Q8202	TD3T007340	TRANSISTOR, SILICON 2SD734(E.F.G)	L8308	021L96100K	COIL 10 UH
Q8301	T8YA2412K0	TRANSISTOR, SILICON 2SC2412KT147	T5001	0336260026	COIL, BIAS OSC 3626002
Q8302	T6YA1037K0	TRANSISTOR, SILICON 2SA1037KT147	T5501	0336260026	COIL, BIAS OSC 3626002
Q8303	T8YA2412K0	TRANSISTOR, SILICON 2SC2412KT147	T7501	0406660015	TRANSFORMER, POWER AC 0666001
Q8304	TNYTC05001	COMPOUND TRANSISTOR DTC124EKT147			
Q8305	TNYTC05001	COMPOUND TRANSISTOR DTC124EKT147			
COILS & TRANSFORMERS			JACKS		
L701	021B73101K	COIL 100 UH	J4501	0632100027	SOCKET, 21PIN HXC1554-010010
L1001	021B73101K	COIL 100 UH			

ELECTRICAL REPLACEMENT PARTS LIST

REF. NO.	PART NO.	DESCRIPTION	REF. NO.	PART NO.	DESCRIPTION
SWITCHES			MISCELLANEOUS (CONT.)		
SW601	0504201T22	SWITCH, TACT SKHVBD049A	CD4503	068128043B	CORD, EIS CONNECTOR 8128043B
SW602	0504201T22	SWITCH, TACT SKHVBD049A	CD4506	122U034601	CORD, JUMPER 2U034601
SW603	0504201T22	SWITCH, TACT SKHVBD049A	CD6001	06C6H27003	CORD, COAXIAL C6H27003
SW604	0504201T22	SWITCH, TACT SKHVBD049A	CD6002	06CZL05015	RF CABLE PAL FTZ D-2070
SW605	0504201T22	SWITCH, TACT SKHVBD049A	CD6101	068101362A	CORD, EIS CONNECTOR 8101362A
SW606	0504201T22	SWITCH, TACT SKHVBD049A	CD7501	068126051A	CORD, EIS CONNECTOR 8126051A
SW607	0504201T22	SWITCH, TACT SKHVBD049A	CD7502	068128042A	CORD, EIS CONNECTOR 8128042A
SW608	0504201T22	SWITCH, TACT SKHVBD049A	CD7503	1206655806	CORD, AC E2N
SW609	0504201T22	SWITCH, TACT SKHVBD049A	CD7504	122U032601	CORD, JUMPER 2U032601
SW610	0504201T22	SWITCH, TACT SKHVBD049A	CD7506	068101405A	CORD, EIS CONNECTOR 8101405A
VARIABLE RESISTORS			MISCELLANEOUS (CONT.)		
VR601	V014025B05	VR, ROTARY EVU-F3A F20 B25	CD8102	068128044A	CORD, EIS CONNECTOR 8128044A
VR602	V014025B05	VR, ROTARY EVU-F3A F20 B25	CF4501	116F2T14N1	FILTER, EMI LTSTY103NBTB
VR2001	V1M63Q5BT6	VR, SEMIFIXED RH0638CS5R0TA	CF4502	116F2T14N1	FILTER, EMI LTSTY103NBTB
VR2002	V1M6315BT6	VR, SEMIFIXED RH0638CS5R0TA	CF6001	102T038R91	FILTER, SAW F1034
VR2501	V1M63Q5BT6	VR, SEMIFIXED RH0638CS5R0TA	CF6003	1012T5R502	FILTER, CERAMIC SFE5.5MB-TF21
VR2502	V1M6315BT6	VR, SEMIFIXED RH0638C15R0TA	CF6004	1012T5R503	FILTER, CERAMIC TRAP TPS5.5MB-TF21
VR4001	V1M63H4BT6	VR, SEMIFIXED RH0638CJ4R0TA	CP1603	067R007019	WIRE HOLDER 51048-0700
VR4004	V1M63H4BT6	VR, SEMIFIXED RH0638CJ4R0TA	CP1604	067R010019	WIRE HOLDER 51048-1000
VR4005	V1M63H4BT6	VR, SEMIFIXED RH0638CJ4R0TA	CP2001	069H220329	CONNECTOR PCB SIDE IL-S-2P-S2T2-EF
VR4006	V1M6314BT6	VR, SEMIFIXED RH0638C14R0TA	CP2003	069J7H0059	CONNECTOR PCB SIDE IMSA-9602S-17C
VR4007	V1M6314BT6	VR, SEMIFIXED RH0638C14R0TA	CP2104	0694290129	CONNECTOR PCB SIDE 173981-9
VR4301	V1M63H3BT6	VR, SEMIFIXED RH0638CJ3R0TA	CP2204	069J790109	CONNECTOR PCB SIDE IMSA-9603S-09C
VR5001	V1M6314BT6	VR, SEMIFIXED RH0638C14R0TA	CP2501	069H220329	CONNECTOR PCB SIDE IL-S-2P-S2T2-EF
VR5002	V1263E5B03	VR, SEMIFIXED RH0624CE5J	CP2502	067R006019	WIRE HOLDER 51048-0600
VR5003	V1M6314BT6	VR, SEMIFIXED RH0638C14R0TA	CP2503	069J7H0059	CONNECTOR PCB SIDE IMSA-9602S-17C
VR5004	V1263E5B03	VR, SEMIFIXED RH0624CE5J	CP2504	067R009019	WIRE HOLDER 51048-0900
VR5005	V1263E5B03	VR, SEMIFIXED RH0624CE5J	CP2604	0694290129	CONNECTOR PCB SIDE 173981-9
VR6001	V126214BT1	VR, SEMIFIXED RH0632C14R01	CP2704	069J790109	CONNECTOR PCB SIDE IMSA-9603S-09C
VR6002	V1M6314BT6	VR, SEMIFIXED RH0638C14R0TA	CP4001	069J160260	CONNECTOR PCB SIDE 6035B-062002-T
VR8001	V1M63H4BT6	VR, SEMIFIXED RH0638CJ4R0TA	CP4002	069J150260	CONNECTOR PCB SIDE 6035B-052002-T
VR8004	V1M63H4BT6	VR, SEMIFIXED RH0638CJ4R0TA	CP4003	069J150260	CONNECTOR PCB SIDE 6035B-052002-T
VR8005	V1M63H4BT6	VR, SEMIFIXED RH0638CJ4R0TA	CP4004	069Q160179	CONNECTOR PCB SIDE CPB1806-0101
VR8006	V1M6314BT6	VR, SEMIFIXED RH0638C14R0TA	CP4102	0694280139	CONNECTOR PCB SIDE 173979-8
VR8007	V1M6314BT6	VR, SEMIFIXED RH0638C14R0TA	CP4501	0694260124	CONNECTOR PCB SIDE 4-173981-6
VR8301	V1M63H3BT6	VR, SEMIFIXED RH0638CJ3R0TA	CP4502	0694270129	CONNECTOR PCB SIDE 173981-7
P.C. BOARD ASSEMBLIES			CP4503	0694280129	CONNECTOR PCB SIDE 173981-8
PCB101	A47116A01A	PCB ASS'Y VM0006D	CP4504	069R2F0359	CONNECTOR PCB SIDE 5550-15E
PCB161	A47116A05A	PCB ASS'Y VM0007C	CP4505	069R290359	CONNECTOR PCB SIDE 5550-09E
PCB201	A47116A811	PCB ASS'Y VE4640A	CP5001	069H250329	CONNECTOR PCB SIDE IL-S-5P-S2T2-EF
PCB202	A47116A821	PCB ASS'Y VE4640A	CP5501	069H250329	CONNECTOR PCB SIDE IL-S-5P-S2T2-EF
PCB401	A47116A30A	PCB ASS'Y VV0204C	CP6001	0690160179	CONNECTOR PCB SIDE CPB1806-0101
PCB411	A45801A33A	PCB ASS'Y (DECK 1/2) VE0385B	CP6002	069R2A0349	CONNECTOR PCB SIDE 5550-10D
PCB451	A47116A11A	PCB ASS'Y VE0441C	CP7501	0694260129	CONNECTOR PCB SIDE 173981-6
PCB452	A47116A10A	PCB ASS'Y VE0442C	CP7502	0694280129	CONNECTOR PCB SIDE 173981-8
PCB550	A44802A550	SEE DECK REPLACEMENT PARTS LIST (DECK 1/2)	CP7503	0694430106	CORD, UX CONNECTOR 2-173270-3
PCB601	A47116A27A	PCB ASS'Y VE0432C	DL4301	104W24R436	DELAY LINE ADL-SE2244R
PCB751	A47116A02A	PCB ASS'Y VP4141A	DL8301	104W24R436	DELAY LINE ADL-SE2244R
PCB752	A47116A09A	PCB ASS'Y VE4629A	FH501	06710T0006	HOLDER, FUSE EYF-52BC
MISCELLANEOUS			FH502	06710T0006	HOLDER, FUSE EYF-52BC
BT601	1412004004	BATTERY, MANGAN UM-4 (GR)	F7501	080ET2R501	FUSE BET 2.5A(T)250V
BZ601	0717000003	BUZZER, PIEZOELECTRIC KBS-13DB-4P-2	F7502	080ET3R101	FUSE BET 3.15A(T)250V
CF603	0694270129	CONNECTOR PCB SIDE 173981-7	F7503	080PT1R602	FUSE BET 1.6A(T)250V
CP604	06942A0129	CONNECTOR PCB SIDE 1-173981-0	ICP751	0842S0R601	IC PROTECTOR TR5-T19372K630MA
CP606	0694220124	CONNECTOR PCB SIDE 4-173981-2	NR1001	11023472T1	R, NETWORK RGLD3X472J-T21
CUS01	800WF00004	CUSHION-A	NR1002	11023223T1	R, NETWORK RGLD3X223J-T21
CUS02	800WF00004	CUSHION-A	NR1003	11023223T1	R, NETWORK RGLD3X223J-T21
CUS03	800WF00004	CUSHION-A	NR1601	11023472T1	R, NETWORK RGLD3X472J-T21
CUS04	800WF00004	CUSHION-A	NR1602	11023223T1	R, NETWORK RGLD3X223J-T21
CUS05	800WF00004	CUSHION-A	NR1603	11023223T1	R, NETWORK RGLD3X223J-T21
CUS06	800WF00004	CUSHION-A	OS601	0779010004	REMOTE RECEIVER GP-1U581X
CUS07	800WF00004	CUSHION-A	PF4001	114JL50602	FILTER, LOW PASS 4JL50602
CUS08	800WF00004	CUSHION-A	PF4201	103L02R102	DELAY 3L02R102
CX601	0694270070	CONNECTOR PCB SIDE 173992-7	PF5501	0326230038	COIL, TRAP 2623003
CX602	06942A0070	CONNECTOR PCB SIDE 1-173992-0	PF8001	114JL50602	FILTER, LOW PASS 4JL50602
CY601	0694270060	CONNECTOR PCB SIDE 173991-7	TC601	0100614T08	C, CERAMIC TRIMMER VCT51F522A
CY602	06942A0060	CONNECTOR PCB SIDE 1-173991-0	TM601	076G0A0G10	TRANSMITTER EUR-531610
CD1603	068127041A	CORD, EIS CONNECTOR 8127041A	TU6001	0145601024	TUNER, UHF-VHF TEKE4-096A
CD1604	06812A010A	CORD, EIS CONNECTOR 812A010A	TU6002	0151601017	RF-CONVERTER MDLK6D533A
CD2002	06C726074A	CORD, EIS CONNECTOR C726074A	V601	097JB0R301	TUBE, FLUORESCENT DISPLAY FIP148DM6
CD2003	122B0H1001	CORD, JUMPER 280H1001	X601	100D32R801	CRYSTAL DT-26S 32.768KHZ
CD2004	06C729017A	CORD, EIS CONNECTOR C729017A	X602	10064R1906	CRYSTAL DS-MAT 4.194304MHZ
CD2204	122B091602	CORD, JUMPER 28091602	X1001	1002T4R001	CERAMIC OSCILLATOR CSA4.00MG-TF01
CD2502	06C726071A	CORD, EIS CONNECTOR C726071A	X1601	1002T4R001	CERAMIC OSCILLATOR CSA4.00MG-TF01
CD2503	122B0H2501	CORD, JUMPER 280H2501	X4301	100WA4R303	CRYSTAL HC-49/U 4.433619MHZ
CD2504	068129040A	CORD, EIS CONNECTOR 8129040A	X6501	1003R50001	CERAMIC OSCILLATOR KBR-500AHZ
CD2704	122B091602	CORD, JUMPER 28091602	X8301	100WA4R303	CRYSTAL HC-49/U 4.433619MHZ
CD4102	068128036A	CORD, EIS CONNECTOR 8128036A	RESISTOR		
CD4501	068126052A	CORD, EIS CONNECTOR 8126052A	RC.....CARBON RESISTOR		
CD4502	068127040B	CORD, EIS CONNECTOR 8127040B	CAPACITORS		
			CC.....CERAMIC CAPACITOR		
			CE.....ALUMI ELECTROLYTIC CAPACITOR		
			CP.....POLYESTER CAPACITOR		
			CPP.....POLYPROPYLENE CAPACITOR		
			CPL.....PLASTIC CAPACITOR		
			CMP.....METAL POLYESTER CAPACITOR		
			CML.....METAL PLASTIC CAPACITOR		
			CMLP.....METAL POLYPROPYLENE CAPACITOR		
			CST.....STYROL CAPACITOR		

INTERCHANGEABLE PARTS LIST

NOTE: THE FOLLOWING PART(S) MAY BE SUBSTITUTED FOR PARTS INDICATED IN THE ELECTRICAL REPLACEMENT PARTS LIST (WITH THE SAME REF.NO.). THESE PARTS SHARE THE SAME ELECTRICAL CHARACTERISTICS AND OTHER ELEMENTS FOR COMMON USAGE. EITHER PART NUMBER MAY BE USED IN THIS UNIT.

REF. NO.	BASE		REPLACEMENT	
	PART NO.	DESCRIPTION	PART NO.	DESCRIPTION
1C4101	103DG73700	LA7370	103DG7376S	LA7376ST