

# DENON

Hi-Fi AV Surround Amplifier

## SERVICE MANUAL

# MODEL AVC-1530/1530G

## AV SURROUND AMPLIFIER

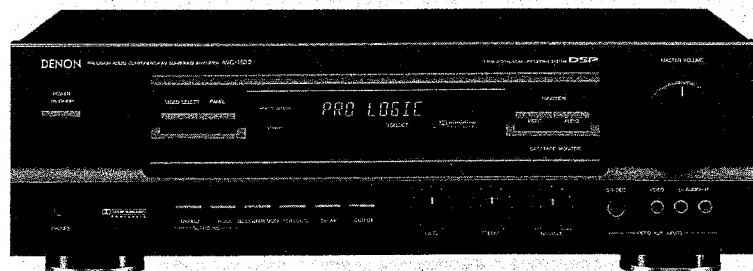

(Photo: AVC-1530)

### CONTENTS

OPERATING INSTRUCTIONS .....	2 ~ 16
WIRE ARRANGEMENT .....	18
DISASSEMBLY .....	19
ADJUSTMENT .....	20, 21
SEMICONDUCTORS .....	22 ~ 27
PRINTED WIRING BOARD .....	28 ~ 30
PRINTED WIRING BOARD PARTS LIST .....	31 ~ 36
BLOCK DIAGRAM .....	37
WIRING DIAGRAM .....	38
SCHEMATIC DIAGRAM (1/3),(2/3),(3/3) .....	39 ~ 41
EXPLODED VIEW OF CHASSIS AND CABINET .....	42
PARTS LIST OF EXPLODED VIEW .....	43
REMOTE CONTROL UNIT .....	44

# NIPPON COLUMBIA CO., LTD.

**SPECIFICATIONS**

<ul style="list-style-type: none"> <li>• <b>Audio Section</b> (Power amplifier) <b>Rated output:</b></li> </ul>	<p><b>for U.K. model</b> Front (main 2ch driven) 70 W + 70 W (8 ohms, 20 Hz – 20 kHz with 0.1% THD)</p>	<p><b>for multi voltage model</b> Front 90 W + 90 W (6 ohms, EIAJ)</p>
	<p>(All properties shown are only for the power amplifier stage.)</p> <p>Center (center 1ch driven) 70 W (8 ohms, 20 Hz – 20 kHz with 0.1% THD)</p> <p>Rear (rear 2ch driven) 20 W + 20 W (8 ohms, 1 kHz with 0.5% THD)</p>	<p>Center 90 W (6 ohms, EIAJ)</p> <p>Rear 25 W + 25 W (6 ohms, EIAJ)</p>
<p><b>Output terminals:</b></p>	<p>Front: 6 to 16 ohms Center: 6 to 16 ohms Rear: 6 to 16 ohms</p>	
<p><b>Line input (Each line input – FRONT SP OUT)</b></p>		
<p><b>Input sensitivity / impedance:</b></p>	<p>150 mV / 47 k ohms</p>	<p>PHONO (MM): 2.5 mV / 47 kohms</p>
<p><b>Frequency response:</b></p>	<p>10 Hz to 50 kHz: ±3 dB</p>	
<p><b>Tone control range:</b></p>	<p>BASS: ±10 dB at 100 Hz TREBLE: ±10 dB at 10 kHz</p>	
<p><b>Signal-to-noise ratio</b></p>	<p>92 dB</p>	
<p><b>Phono equalizer (PHONO input – REC OUT)</b></p>		
<p><b>RIAA deviation:</b></p>	<p>±1 dB (20 Hz to 20 kHz)</p>	
<p><b>Signal-to-noise ratio:</b></p>	<p>74 dB (A weighting, with 5 mV input)</p>	
<p><b>Rated output / Maximum output:</b></p>	<p>150 mV / 8 V</p>	
<p><b>Distortion factor:</b></p>	<p>0.03% (1 kHz, 1 V)</p>	
<ul style="list-style-type: none"> <li>• <b>Video Section</b></li> </ul>	<p><b>Standard video jacks</b></p>	
	<p><b>Input and output level / impedance:</b> 1 Vp-p / 75 ohms</p> <p><b>Frequency response:</b> 3 Hz to 8 MHz ±3 dB</p>	
<ul style="list-style-type: none"> <li>• <b>S-Video output jacks</b></li> </ul>	<p><b>Input and output level / impedance:</b></p>	
	<p><b>Y (brightness) signal:</b> 1Vp-p / 75 ohms</p> <p><b>C (color) signal:</b> 0.286 Vp-p / 75 ohms</p> <p><b>Frequency response:</b> 3 Hz to 8 MHz ±3 dB</p>	
<ul style="list-style-type: none"> <li>• <b>General</b></li> </ul>	<p><b>Power supply:</b> AC 240 V, 50 Hz (for U.K. model) AC 110/220 V, 50/60 Hz (for multi-voltage model)</p>	
	<p><b>Power consumption:</b> 230 W (for U.K. model) 210 W (for multi-voltage model)</p>	
<p><b>Maximum external dimensions:</b></p>	<p>434 (W) × 142 (H) × 337 (D) mm (17-3/32" × 5-19/32" × 13-17/64") (AVC-1530)</p> <p>470 (W) × 143 (H) × 337 (D) mm (18-1/2" × 5-5/8" × 13-17/64") (AVC-1530G)</p>	
<p><b>Weight:</b></p>	<p>9.6 kg (21 lbs 3 oz) (AVC-1530) 10.4 kg (22 lbs 15 oz) (AVC-1530G)</p>	
<ul style="list-style-type: none"> <li>• <b>Remote control unit</b></li> </ul>	<p><b>System remote control</b></p>	
	<p><b>RC-167:</b></p>	<p>Total buttons: 41</p> <p>DENON system code</p> <p>Tuner: 2 buttons</p> <p>CD player: 6 buttons</p> <p>Cassette deck: 6 buttons</p> <p>AVC-1530/1530G fixed codes: 27 buttons</p> <p>Batteries: R6P/AA Type (two batteries)</p> <p>External dimensions: 60 (W) × 175 (H) × 18 (D) mm</p> <p>Weight: 120 g (Approx. 4 oz) (including batteries)</p>

\* For purposes of improvement, specifications and design are subject to change without notice.

# 1 INTRODUCTION

## SAFETY PRECAUTIONS



**CAUTION**

**RISK OF ELECTRIC SHOCK**

**DO NOT OPEN**



**CAUTION: TO REDUCE THE RISK OF ELECTRIC SHOCK, DO NOT REMOVE COVER (OR BACK). NO USER SERVICEABLE PARTS INSIDE. REFER SERVICING TO QUALIFIED SERVICE PERSONNEL.**



The lightning flash with arrowhead symbol, within an equilateral triangle, is intended to alert the user to the presence of uninsulated "dangerous voltage" within the product's enclosure that may be of sufficient magnitude to constitute a risk of electric shock to persons.



The exclamation point within an equilateral triangle is intended to alert the user to the presence of important operating and maintenance (servicing) instructions in the literature accompanying the appliance.

**WARNING: TO REDUCE THE RISK OF FIRE OR ELECTRIC SHOCK, DO NOT EXPOSE THIS APPLIANCE TO RAIN OR MOISTURE.**

**CAUTION**

TO PREVENT ELECTRIC SHOCK DO NOT USE THIS (POLARIZED) PLUG WITH AN EXTENSION CORD, RECEPTACLE OR OTHER OUTLET UNLESS THE BLADES CAN BE FULLY INSERTED TO PREVENT BLADE EXPOSURE.

**ATTENTION**

POUR PREVENIR LES CHOCS ELECTRIQUES NE PAS UTILISER CETTE FICHE POLARISEE AVEC UN PROLONGATEUR UNE PRISE DE COURANT OU UNE AUTRE SORTIE DE COURANT, SAUF SI LES LAMES PEUVENT ETRE INSEREES A FOND SANS EN LAISSER AUCUNE PARTIE A DECOUVERT.

**• FOR UNITED KINGDOM MODEL ONLY**

**CONNECTING THE MAINS PLUG:**

This unit operates from a 240V ac 50 Hz mains supply.

Fit a proper mains plug to the mains lead of this equipment. If a 13 amp (BS1363) plug is used, a 5 amp fuse must be fitted. The 13 amp fuse supplied in a new plug must NOT be used. If any other type of plug is used, a 5 amp fuse must be fitted either in the plug or adaptor or at the distribution board.

**IMPORTANT**

The wires in the mains lead are coloured in accordance with the following code:  
 Blue: Neutral  
 Brown: Live

As the colours of the wires in the mains lead of this apparatus may not correspond with the coloured markings identifying the terminals in your plug, proceed as follows:

The wire which is coloured **BLUE** must be connected to the terminal which is marked with the letter **N** or coloured black.  
 The wire which is coloured **BROWN** must be connected to the terminal which is marked with the letter **L** or coloured red.

**DO NOT MAKE ANY CONNECTION TO THE LARGER PIN MARKED WITH THE LETTER E OR BY THE SYMBOL  $\perp$  OR COLOURED GREEN OR GREEN-AND-YELLOW.**



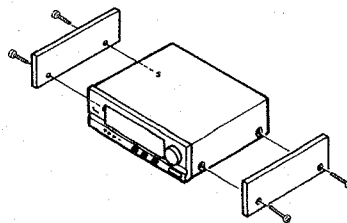

Disconnect the mains plug from the supply socket when not in use.

**For models with wood sides: (AVC-1530G ONLY)**

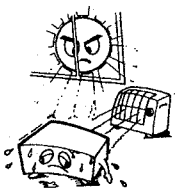

If the wood sides are removed, the top cabinet cannot be reinstalled using the same screws. Consult your store of purchase or a DENON Overseas Service Center.

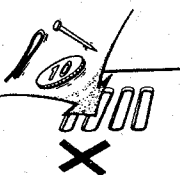
## NOTE ON USE

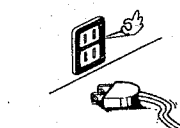
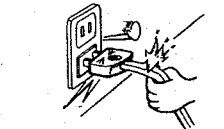
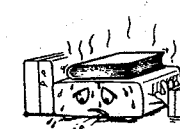
 <p><b>Be careful of high temperatures</b></p> <ul style="list-style-type: none"> <li>Do not place the set in a location where it will be exposed to direct sunlight or near a heating appliance.</li> </ul> <p><b>Caution on rack/cabinet installation</b></p> <ul style="list-style-type: none"> <li>Avoid installing the set in a closed-type rack.</li> <li>When installing in a rack or cabinet, provide a sufficiently large ventilation opening to promote heat radiation.</li> </ul>	 <p><b>Caution on humidity, water, and dust</b></p> <ul style="list-style-type: none"> <li>Do not place the set in a location where there is high humidity or a lot of dust.</li> </ul> <p>Flower vases or other items containing water should not be placed on top of the set.</p>	 <p><b>Do not open the case</b></p> <ul style="list-style-type: none"> <li>Opening the top cover or the bottom plate of the case and inserting your hand is dangerous. Do not open the case.</li> </ul> <p>If some trouble arises with the performance of the set, remove the power plug soon and contact the store where the set was purchased or a nearby dealer.</p>
 <p><b>Do not allow foreign matter into the equipment</b></p> <ul style="list-style-type: none"> <li>Be especially careful of needles, hair pins, and coins getting into the set.</li> </ul>	 <p><b>Care of the case</b></p> <ul style="list-style-type: none"> <li>Avoid the use of pesticides near the set as well as wiping the case with benzine, thinner or other solvents since they may cause a change in quality or color. Use a soft cloth when wiping away dirt and follow the instructions carefully when using chemically treated cloths.</li> </ul>	 <p><b>During your absence</b></p> <ul style="list-style-type: none"> <li>When not using the set for an extended period such as when taking a trip, be sure to disconnect the plug from the receptacle.</li> </ul>
 <p><b>Care with the power cord</b></p> <ul style="list-style-type: none"> <li>When removing the plug from the receptacle, do not pull the power cord; be sure to hold the plug when removing it.</li> </ul>	 <p><b>Do not block the ventilation holes of the set</b></p> <ul style="list-style-type: none"> <li>Blocking of the ventilation holes will lead to damage of the set.</li> <li>The ventilation holes are very important for heat radiation from within the set. Care must be taken since placing an object against the holes will result in an extreme rise of temperature within the set.</li> </ul>	<p>For sets with ventilation holes</p>

■ We greatly appreciate your purchase of the AVC-1530/1530G.  
 ■ To be sure you take maximum advantage of all the features the AVC-1530/1530G has to offer, read these instructions carefully and use the set properly. Be sure to keep this manual for future reference should any questions or problems arise.

● ACCESSORIES

Check that the following parts are included in addition to the main unit:

- ① Operating instructions ..... 1
- ② AC Plug Adapter (for multi voltage model only) ..... 1
- ③ Remote control unit (RC-167) ..... 1
- ④ R6P/AA batteries ..... 2

● INSTALLATION PRECAUTIONS

Using this amplifier or other electronic equipment containing microprocessors simultaneously with a tuner or TV may result in noise in the sound or picture.  
 If this should happen, take the following steps:  
 • Install the amplifier as far as possible from the tuner or TV set.  
 • Keep the antenna lines of the tuner or TV as far as possible from the amplifier's power cord and connection cables.  
 • This problem is especially frequent when using indoor antennas or 300 ohm feeder lines. We recommend using outdoor antennas and 75 ohm coaxial cables.

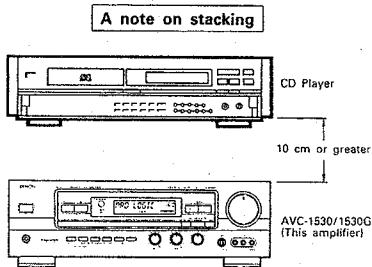

For cooling purposes, do not place another AV component directly on top of the amplifier. Be sure to leave a space of at least 10 cm.

● TABLE OF CONTENTS

① Introduction ..... 2, 3  
 • Safety Precautions ..... 2  
 • Note on Use ..... 3  
 ② Names of Parts - 1 (Front Panel and Remote Control Unit) ..... 5  
 ③ Remote Control Unit ..... 6  
 ④ Multi Function Display (MFD) ..... 7  
 ⑤ Names of Parts - 2 (Rear Panel) ..... 8  
 ⑥ Connections ..... 9~13  
 ⑦ Playback ..... 14, 15  
 • Preparations for Playback ..... 14  
 • Playing the Program Source ..... 14  
 • Simulcast Playback ..... 15  
 • Using the Muting Function ..... 15  
 ⑧ Recording ..... 16  
 ⑨ Tape Monitor Function ..... 16, 17

⑩ Using Headphones ..... 17  
 ⑪ Surround Playback ..... 18~25  
 • DSP Modes ..... 18  
 • Using Dolby Pro Logic Surround ..... 19~22  
 • Other DSP Surround Modes ..... 23  
 • Using the Personal Memory ..... 24  
 • Operations Possible in the Various Surround Modes ..... 25  
 ⑫ Last Function Memory ..... 25  
 ⑬ Troubleshooting ..... 26  
 ⑭ Initialization of the Microprocessor ..... 27  
 • Initialization of the Individual Modes ..... 27  
 ⑮ Specifications ..... 28  
 DENON SERVICE NETWORK ..... 29

② NAMES OF PARTS - 1 (Front Panel and Remote Control Unit)

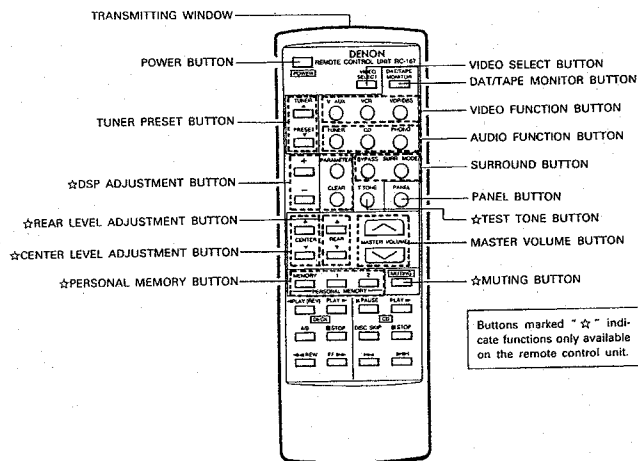
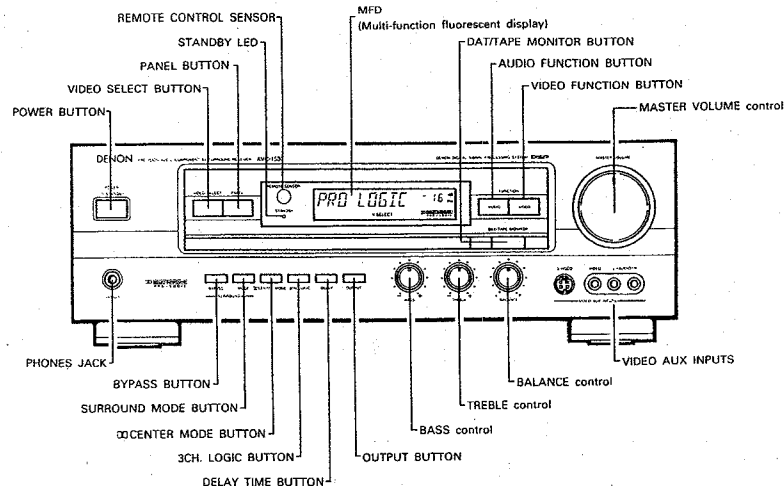

Buttons marked "☆" indicate functions only available on the remote control unit.

### 3 REMOTE CONTROL UNIT

Following the procedure outlined below, insert the batteries before using the remote control unit.

#### Range of operation of the remote control unit

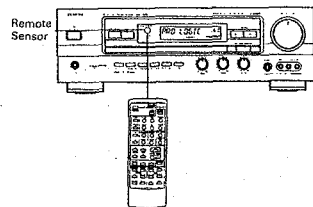

Point the remote control unit at the remote control sensor as shown on the diagram at the left.

#### NOTES:

- The remote control unit can be used from a straight distance of approximately 7 meters, but this distance will shorten or operation will become difficult if there are obstacles between the remote control unit and the remote control sensor, if the remote control sensor is exposed to direct sunlight or other strong light, or if operated from an angle.
- Neon signs or other devices emitting pulse-type noise nearby may result in malfunction, so keep the set as far away from such devices as possible.

#### Inserting the batteries

- Open the bottom cover of the remote control unit and remove the battery cover.

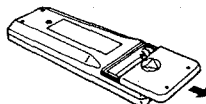

- Insert the two R6P/AA or UM-3 batteries, matching the ⊕ and ⊖ marks on the batteries with those in the case. Close the bottom cover until it clicks shut.

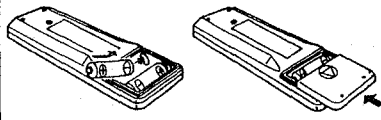

#### System codes

The system codes for DENON tape decks, CD players and tuners are set in this remote control unit.

##### Tuner system buttons

- ▲: Preset channel up
- ▼: Preset channel down

##### Tape deck system buttons

These buttons can be used to operate DENON remote controllable components. For details, refer to the component's operating instructions. Note that operation may not be possible for some models.

- ▶: Forward play
- ◀: Reverse play
- : Stop
- ◀◀: Rewind
- ▶▶: Fast-forward
- A/B: Switching between decks A and B for double decks

##### CD system buttons

These buttons can be used to operate DENON remote controllable components. For details, refer to the component's operating instructions. Note that operation may not be possible for some models.

- ▶: Play
- : Pause
- : Stop
- ◀◀ and ▶▶: Auto search (reverse and forward)
- ⏏: CD changer, disc skip

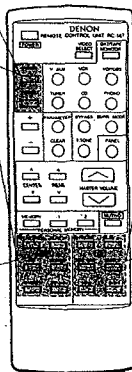

### 4 MULTI FUNCTION DISPLAY (MFD)

The MFD indicates the operating modes when operations are performed and when PANEL button is pressed.

#### FLD (Fluorescent Light Display)

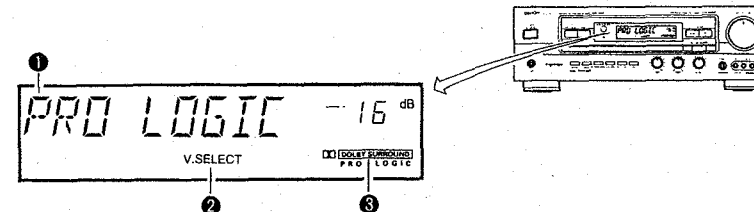

#### MULTI FUNCTION DISPLAY

This displays a maximum of 9 characters. Normally the reception frequency is displayed when the function is set to tuner, and the surround mode is displayed when the function is set to other positions. The display also indicates various other information according to the buttons pressed.

#### V. SELECT (VIDEO INPUT SELECT Indicator)

This indicator lights when the video monitor output is fixed in the video input select mode.

#### DOLBY SURROUND Indicator

This indicator lights when DOLBY PRO LOGIC is selected by pressing the SURROUND MODE button.

#### To check the settings of the different modes:

- Press the PANEL button.



Either hold the PANEL button in or press it repeatedly to display the settings for the different modes.

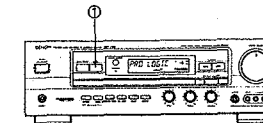

#### FLD OFF

Turning the FLD off:

- Press and hold in the PANEL button.

The FLD display changes continuously and finally turns off. Now when a button is pressed, the related display appears for a few seconds then turns off automatically.

- Turning the FLD back on:

Press the PANEL button once again.

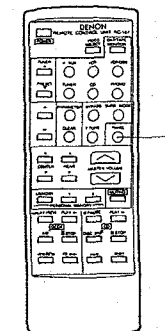

**5 NAMES OF PARTS – 2 (Rear Panel)**

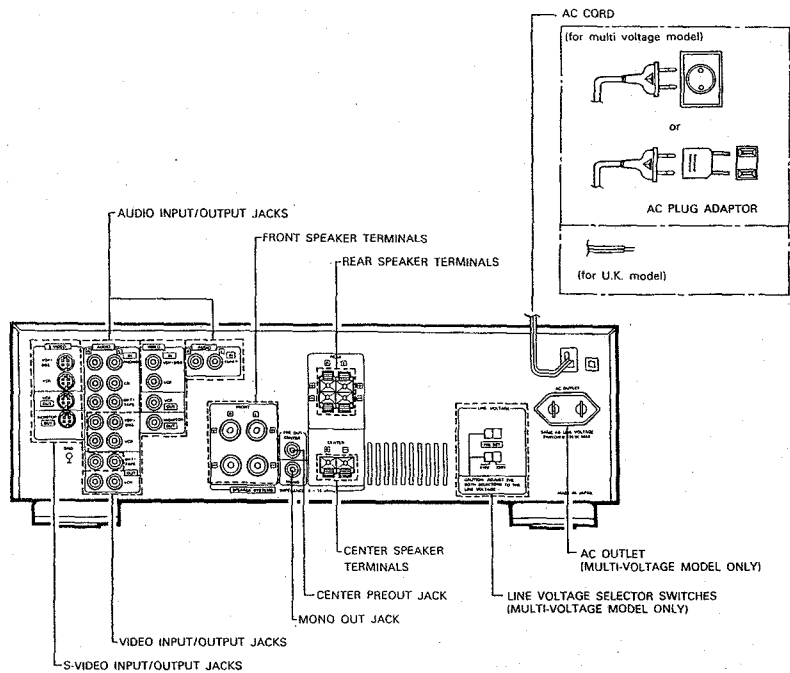

**6 CONNECTIONS**

→ Continued

- Always turn off the power of the various components when making connections. Also refer to the operating instructions for the other components.
- Do not plug in the power cord until all connections are completed.

**■ MULTI-VOLTAGE MODEL ONLY**

Make the following settings before connecting the components.

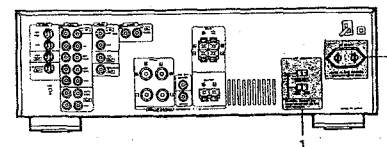

**1. Setting the line voltage**

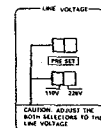

- The customer can set the VOLTAGE SELECTORS on the back panel for appropriate line voltage by using a screwdriver.
- Do not use excessive force in setting the VOLTAGE SELECTOR KNOB – you may damage it.
- If the VOLTAGE SELECTOR KNOB does not turn smoothly, contact your store of purchase.
- Be sure to set both voltage selectors to same position.

**2. AC OUTLET**

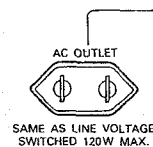

**Connecting the AC OUTLET**

**AC OUTLET**  
• SWITCHED  
This AC outlet is controlled by the power switch and Remote Control Unit.  
Maximum capacity is 120 W.

**NOTE:**

Only use the AC outlet for audio equipment. Never use them for hair driers, TVs or other electrical appliances.

### Speaker System Connections

- This amplifier can accommodate connections of a total of five speakers including one set of front speakers, one set of rear speakers, and one center speaker.
- Connect the speaker terminals with the speakers making sure that like polarities are matched (⊕ with ⊕, ⊖ with ⊖). Mismatching of polarities will result in weak central sound, unclear orientation of the various instruments, and the sense of direction of the stereo being impaired.

#### Preparing the cord

1. Peel off the sheath.



2. Twist the wires.

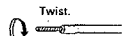

#### Connecting the front speaker terminals

1. Loosen by turning counterclockwise.



2. Insert the cord and tighten by turning clockwise.

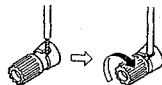

#### Connecting banana plugs

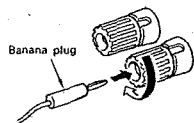

Turn clockwise to tighten, then insert the banana plug.

- When making connections, take care that none of the individual conductors of the speaker cord come in contact with adjacent terminals, with other speaker cord conductors, or with the rear panel.
- **Speaker Impedance**
  - Speakers with an impedance of 6 to 16 ohms can be connected for use as front, center and rear speakers.
  - Using speakers with an impedance other than the specified one may result in damage. Be sure to use speakers of the specified impedance.

#### Connecting the center and rear speaker terminals

1. Press the lever.

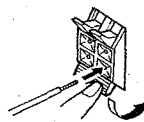

2. Insert the cord and release the lever.

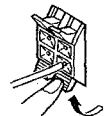

→ Continued

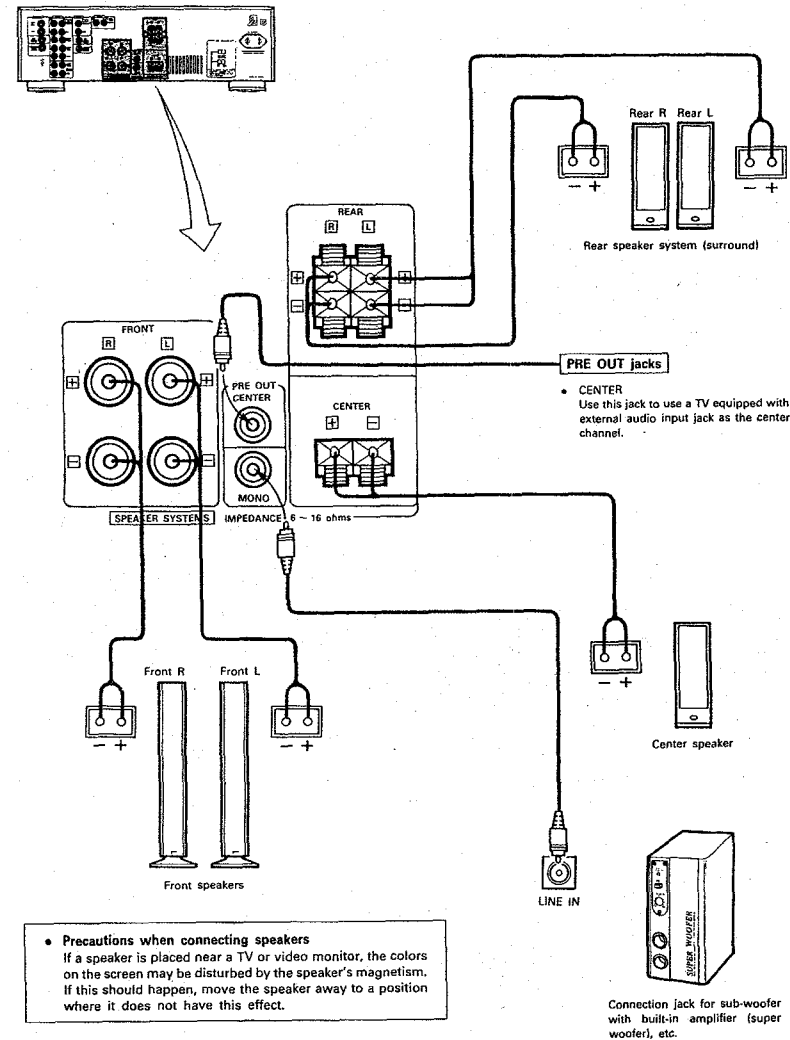

**Audio Section**

- Do not plug in the power cord until all connections have been completed.
- Be sure to connect the left and right channels properly (left with left, right with right).
- Insert the plugs securely. Incomplete connections will result in the generation of noise.
- Note that binding pin plug cords together with power cords or placing them near a power transformer will result in the introduction of hum or other noise.

- If hum or other noise is produced when the ground wire is connected, disconnect it.
- Noise or humming may be generated if a connected component is used independently without turning the power of the AVC-1530/1530G on. If this happens, turn on the power of the AVC-1530/1530G.

**NOTE:**  
The amplifier cannot be used with MC cartridges directly. Use a separate head amplifier or step-up transformer.

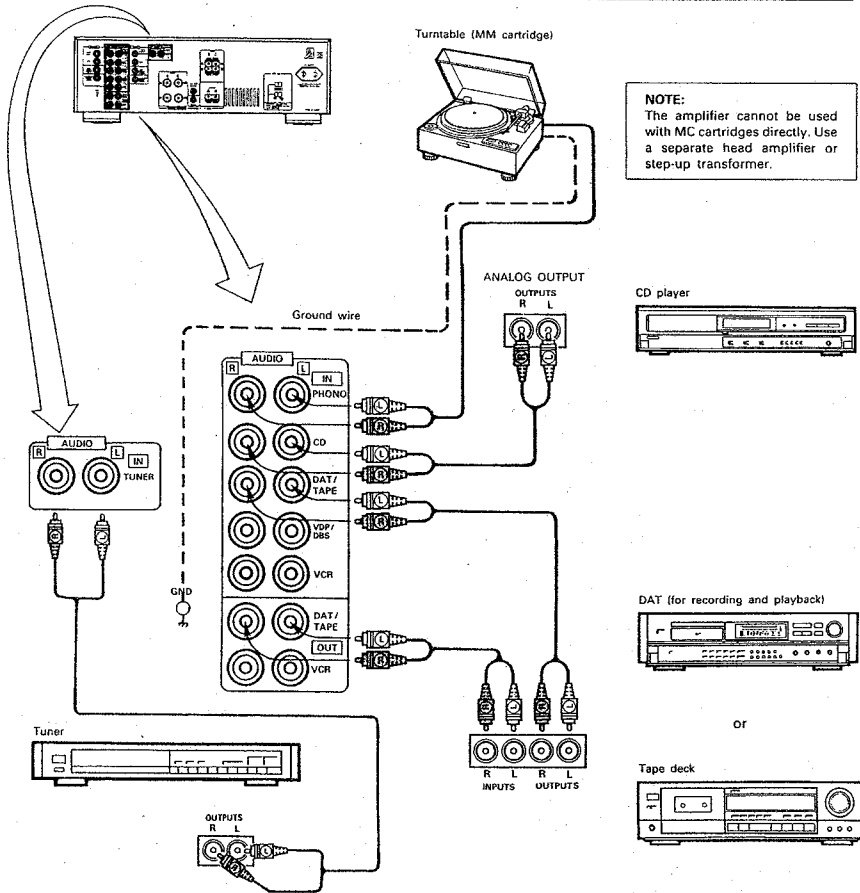

**Video Section**

→ Continued

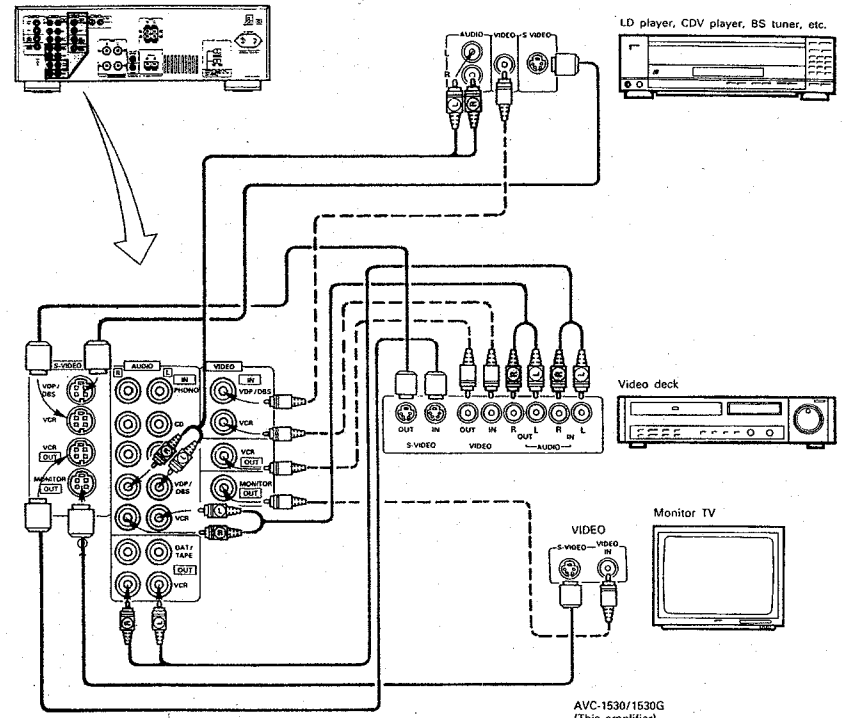

The AVC-1530/1530G is equipped with VIDEO AUX jacks on the front panel for playback of video equipment. This permits video cam-corders with playback functions as well as other equipment to be connected.

- A note on the jacks**
- The input selector for the S inputs and that for the pin jack inputs work in conjunction with each other. But the S input and output jacks and the pin-jack input and output jacks on the AVC1530/1530G have independent circuits, so the signals input to the S input jacks are only output from the S output jacks, and the signals input to the pin-jack input jacks are only output from the pin-jack output jacks. Remember this when connecting the AVC-1530/1530G to a component equipped with S jacks, and refer to the manuals of the different components.

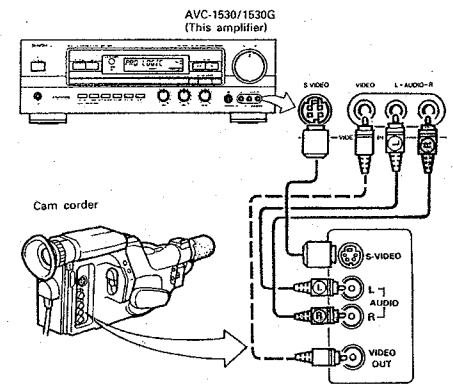



## 7 PLAYBACK

### ■ Preparations for Playback

Check the connections

- Check that all connections are proper, referring to the connections diagrams (pages 9 to 13).

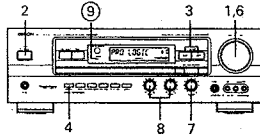

### ■ Playing the program source (normal stereo playback)

<p>1. Set the MASTER VOLUME control to the minimum.</p> <p>Main unit</p>	<p>4. Press the BYPASS button.</p> <p>Main unit Remote control unit</p>	
<p>2. Press the POWER button to turn the power on.</p> <p>The muting mode is set for several seconds, after which the STANDBY LED ② flashes for several seconds.</p> <p>Main unit Remote control unit</p>	<p>5. Start playback of the program source.</p> <p>For instructions, refer to the source's operating instructions.</p>	
<p>3. Select the source to be played.</p> <p><b>Audio function button</b></p> <p>Example:</p> <p>Main unit Remote control unit</p> <p>PHONO, CD or TUNER can be selected directly.</p> <p>The source switches as shown above MFD.</p>	<p>6. Adjust the volume.</p> <p>Main unit Remote control unit</p> <p>Turn the control clockwise to increase the volume, counterclockwise to decrease it.</p> <p>Press the  button to increase the volume, the  button to decrease it.</p>	
<p><b>Video function button</b></p> <p>Example:</p> <p>Main unit Remote control unit</p> <p>VDP/DBS, VCR and V-AUX can be selected directly.</p> <p>The source switches as shown above MFD.</p>	<p>7. Adjust the left/right balance.</p> <p>Main unit</p> <p>Turn the control counterclockwise to reduce the volume of the right channel, clockwise to reduce the volume of the left channel.</p>	
<p>8. Adjust the tone.</p> <p>Main unit Main unit</p> <p>Turn the control clockwise to increase the bass, counterclockwise to decrease it.</p> <p>Turn the control clockwise to increase the treble, counterclockwise to decrease it.</p>	<p><b>NOTE:</b></p> <p>The sound may be interrupted if switches are operated during playback. This is because the muting circuit is activated to prevent switching noise.</p>	

### ■ Simulcast playback (playing different video and audio sources simultaneously)

<p>1. Follow steps 1 to 3 under "Playing the program source".</p>	<p>2. Select the desired video program source.</p> <p>Main unit Remote control unit</p> <p>The source switches as shown above.</p>	
<p>3. Follow steps 4 to 8 under "Playing the program source".</p>	<p><b>■ Cancelling simulcast playback</b></p> <ul style="list-style-type: none"> <li>• Press the VIDEO SELECT button again.</li> <li>• Press the video function button on the main unit or remote control unit.</li> </ul>	

### ■ Using the muting function

Use this to turn off the audio output temporarily.

<p>1. Press the MUTING button.</p> <p>Remote control unit</p> <p>The STANDBY LED ② flashes when the muting function is set.</p>	<p>This function can only be set from the remote control unit.</p>	
<p>2. Press the MUTING button again.</p> <p>The muting function is cancelled.</p>		

## 8 RECORDING

### ■ Recording the program source (recording the source currently being monitored)

- Follow steps 1 to 3 under "Playing the program source".
- Start recording on the tape or video deck.  
For instructions, refer to the component's operating instructions.

#### NOTES:

- The audio signals selected with the audio or video function button are output from the DAT/TAPE REC OUT jacks.
- The recording source switches if the audio function, video function, personal memory "1" or "2" buttons are pressed during recording. Do not press these buttons during recording.

#### Simultaneous recording

The signals of the source selected with the function selector button are output simultaneously to the DAT/TAPE and VCR REC OUT jacks. If a total of two tape and/or video decks are connected and set to the recording mode, the same source can be recorded simultaneously on both decks. In addition, if the TAPE MONITOR (DAT/TAPE) button is pressed, the audio signals from the tape deck are output to the VCR AUDIO REC OUT jacks.

## 9 TAPE MONITOR FUNCTION

### ■ When playing a DAT or tape deck

Use this function to switch between the DAT or tape deck and the input (source) selected with the audio or video function buttons.

- Follow steps 1 and 2 under "Playing the program source".

- Select the deck to be played.

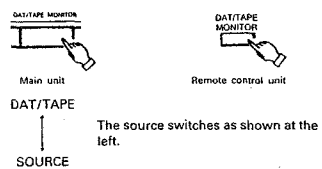

- Follow steps 5 to 8 under "Playing the program source".

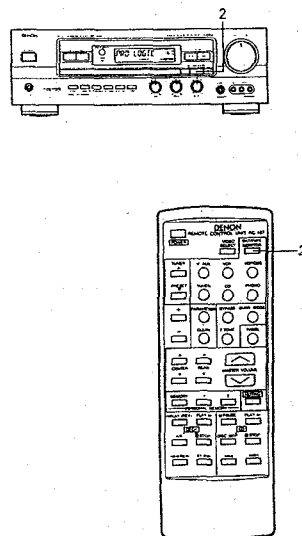

### ■ Monitoring the recording on a three-headed tape deck

The sound actually being recorded can be monitored during recording when a three-headed tape deck is used.

- Select the deck to be monitored.

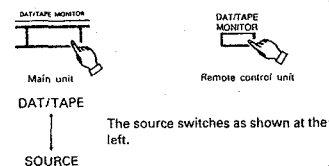

- Follow steps 1 to 3 under "Playing the program source".

- Start recording on the tape deck. For instructions, refer to the component's operating instructions.

- Press the three-headed tape deck's source/tape button to monitor the recording.

#### NOTE:

- Also refer to the three-headed tape deck's operating instructions.

## 10 USING HEADPHONES

The sound from the speakers can be turned off using the OUTPUT button to listen to the sound over the headphones only, for example at night.

- Press the OUTPUT button.



"H/P ONLY" appears on the MFD.

- Insert the headphones' plug into the PHONES jack.

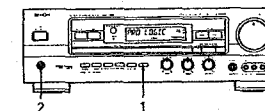

#### Cancelling

Either press the OUTPUT button again or press the POWER button to turn the power off.

## 11 SURROUND PLAYBACK

### ■ DSP modes

The AVC-1530/1530G is equipped with a DSP (Digital Signal Processor) for the surround processing of digital signals. The DSP lets you enjoy surround sound with a greater sense of reality to match the listening room or software.

#### • Surround playback using the DSP:

In these mode, signals are output to the center and rear speakers as well for four- or five-channel playback.

The surround modes are as follows:

1	Dolby Pro Logic	Use this when playing program sources recorded in Dolby Surround.
2	Wide Screen	Use this to enjoy program sources with the atmosphere of a movie theater, recorded in Dolby Surround.
3	Live	Use this to enjoy program sources with the atmosphere of a live performance, recorded in Dolby Surround.
4	Mono movie	In this mode, a sense of expansion is added to monaural audio sources. This mode is best suited for playing old movies or movie tapes recorded in monaural.
5	Classic concert	This mode simulates the sound of a large concert hall. It is suited for classical music, etc.
6	Rock concert	This mode is best for playing rock, popular music, etc.
7	Stadium	This mode simulates the sound field of an outdoor stadium.

\* These effects may not be very pronounced for some sources.

If this is the case, try other modes, not relying too much on their names, and find the mode you like best.

\* To adjust the speaker balance for the different surround modes, first adjust for the Dolby Pro Logic Surround mode as explained on page 22, then use the position of the center level and rear level controls at this time as a guide to adjust the balance for that surround mode.

Manufactured under license from Dolby Laboratories Licensing Corporation. Additionally licensed under one or more of the following patents: U.S. number 3,959,590; Canadian numbers 1,004,603 and 1,037,877. "Dolby," "Pro Logic," and the double-D symbol are trademarks of Dolby Laboratories Licensing Corporation.

→ Continued

### ■ Using Dolby Pro Logic Surround

#### • Speaker disposition and the Dolby Pro Logic Center mode

Ideally, center speakers should be used when playing sources in Dolby Pro Logic Surround. Select the center mode according to your speaker system.

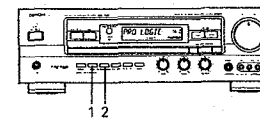
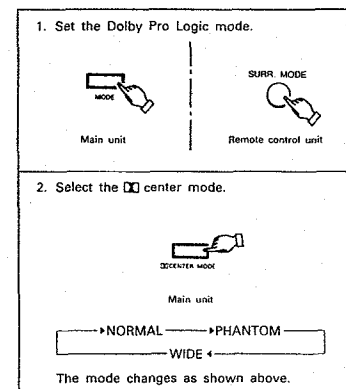

Also select the center mode according to your speaker system when using the Wide Screen and Live modes.

Once the center mode is set, there is no need to readjust it unless you change the speaker system or the listening room. However, when the CLEAR button (3) is pressed, the mode changes as shown on the table on Page 27. In this case, reset the center mode.

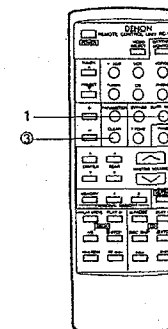

#### Center Mode

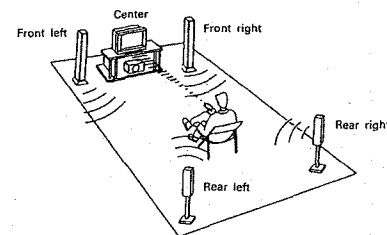

#### NORMAL mode

**Normal mode:** This mode is suited for an arrangement in which the center channel speaker is smaller than the left and right speakers. Signals below 100 Hz which have almost no effect on directional orientation are distributed to the left and right channels, whereas the center channel outputs signals greater than 100 Hz. As a result, the bass of the left and right channels increases the apparent deepness of the sound.

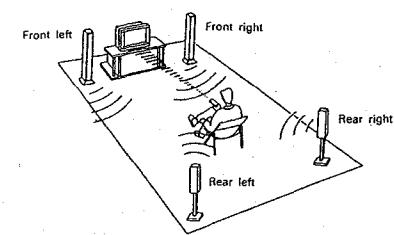

#### PHANTOM mode

**Phantom mode:** Use this mode when center channel speaker is not used. A directional emphasis circuit provides signal reproduction which is electrically oriented to the center and this provides an exciting sound field for your enjoyment.

**Center Mode**

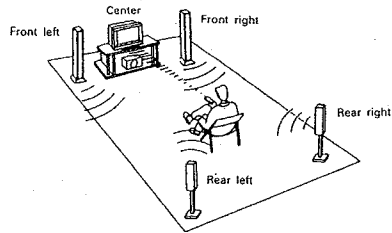

**WIDE mode**

**Wide mode:** This mode is suited for an arrangement in which the center channel speaker is of the same grade as the left and right speakers. The entire sound band from low region to high is output to the center channel to provide an exciting sound field for your enjoyment.

**• Dolby 3CH. Logic (three-channel logic mode)**

Select this mode when not using rear speakers.

1. Set the Dolby Pro Logic mode.
 

Main unit

Remote control unit
2. Press the 3CH. LOGIC button.
 

Main unit

3CH. LOGIC  
↓  
PRO LOGIC

The mode changes as shown at the left.
3. Select the center mode according to your speaker system.
 

Main unit

NORMAL ↔ WIDE

The mode changes as shown above.

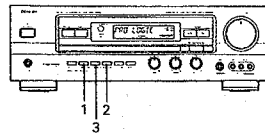

**NOTE:**  
The center mode cannot be set to the Phantom mode when the 3CH Logic mode is set.

**3CH. LOGIC MODE**

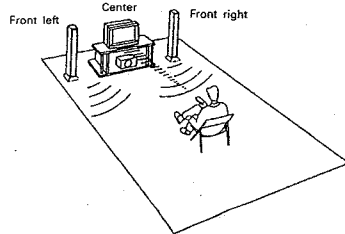

**3CH. LOGIC MODE**

**Three-channel logic mode:** Use this mode when rear channel speakers are not used. The rear channel information is reproduced by the front speakers.

**• Setting the delay time**

The optimum delay time will differ depending on the listening position. Referring to the chart at right, set the optimum delay time for your room's space and seating position. For example, when the distance from the front speakers to the listening position is 6 m and that from the rear speakers to the listening position is 4 m, the optimum delay time will be 21 ms. The variable range of the delay time differs depending on the mode. For details about the variable range, see Page 25.

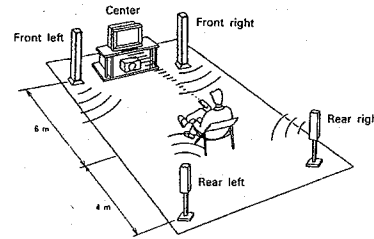

→ Continued

Listening position and optimum delay time for playback with Dolby Pro Logic surround

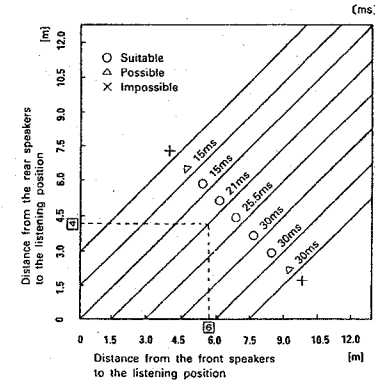

1. To increase the delay time:
 

Remote control unit

Main unit
2. To decrease the delay time:
 



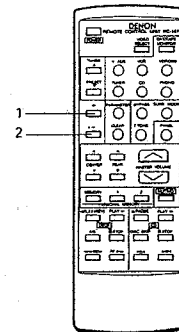
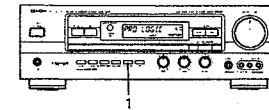





Remote control unit



- The delay time can be set between the range of 15.0ms to 30ms in steps of 1.5ms.
- Once the delay time is set, there is no need to readjust it unless you change the speaker system or the listening room. However, when the CLEAR button is pressed, the mode changes as shown on the table on Page 27. In this case, reset the center mode.

### • Speaker volume adjustment and Dolby Pro Logic mode

To obtain the maximum surround effect, use the test tones to adjust the volume and balance of the speakers for the best balance for the listening position and so that the sound from all the speakers is heard at the same level.

Auto mode	Manual mode
<p>1. Press the T.TONE button.</p>  <p>Remote control unit</p> <p>Test tones are produced from the speakers in the order shown below, at 4 second intervals for the first two cycles, 2 second intervals after that.</p> <p>→ [FL] → [C] → [FR] → [S]</p> <p>For the Dolby 3CH Logic mode:</p> <p>→ [FL] → [C] → [FR]</p>	<p>6. Switch to the manual mode.</p>  <p>Remote control unit</p> <p>Auto mode → manual mode The mode switches as shown above.</p>
<p>2. To increase the level of the center speakers:</p>  <p>Remote control unit</p>	<p>7. To emit the test tones in the clockwise direction.</p>  <p>Remote control unit</p> <p>→ [FL] → [C] → [FR] → [S]</p>
<p>3. To decrease the level of the center speakers:</p>  <p>Remote control unit</p>	<p>8. To emit the test tones in the counterclockwise direction.</p>  <p>Remote control unit</p> <p>← [FL] ← [C] ← [FR] ← [S]</p>
<p>4. To increase the level of the rear speakers:</p>  <p>Remote control unit</p>	<p>9. Follow steps 2 to 5 for the auto mode to adjust the level of the different speakers.</p>
<p>5. To decrease the level of the rear speakers:</p>  <p>Remote control unit</p>	<p><b>Cancelling</b></p> <p>10. Press the T.TONE button again.</p>  <p>Remote control unit</p>

#### NOTES:

- When the T.TONE button is pressed, the auto mode is set and test tones are produced starting from the front left channel.
- In the auto mode, the test tone will not move on to the next channel when it is being emitted from the center channel and the level of the center speakers is being adjusted, or when it is being emitted from the rear channel and the level of the rear speakers is being adjusted. It only moves on to the next channel approximately two seconds after the level key has been released.
- When the mode is switched from the auto mode to the manual mode, the test tone is emitted starting from the channel from which it was last being emitted in the auto mode.

The level of the center and rear channels can be adjusted from 0dB to -24dB in steps of 2dB.

Once the level of the center and rear channels is set, there is no need to readjust it unless you change the speaker system or the listening room. However, when the CLEAR button is pressed, the mode changes as shown on the table on Page 27. In this case, reset the center mode.



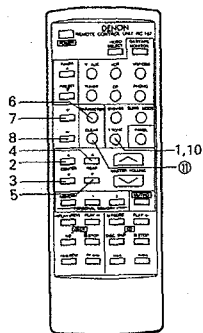



In other surround modes, adjust the balance based on the adjustment made in the Dolby Pro Logic mode. The balance may not be optimum for some sources, so readjust it as necessary.

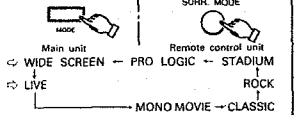
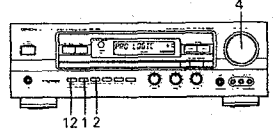
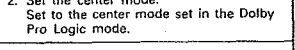
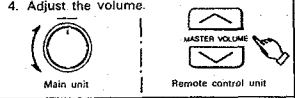

### ■ Other DSP Surround Modes

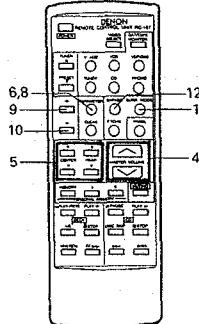
#### • Using the directivity emphasis circuit and DSP surround

Use this to play sources recorded in Dolby Stereo and Dolby Surround with even greater power. (The directivity emphasis circuit detects the signals with the dominant direction from the level and phase of the left and right channels and produces a sharp acoustic image and sense of direction.)

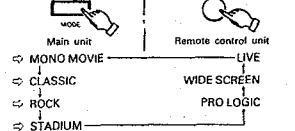
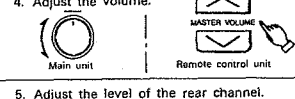
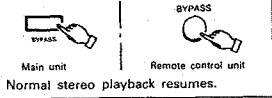
<p>1. When playing movies, set the Wide Screen mode. When playing music, set the Live mode.</p>  <p>Main unit: WIDE SCREEN — PRO LOGIC — STADIUM Remote control unit: LIVE — MONO MOVIE — CLASSIC</p>	
<p>2. Set the center mode. Set to the center mode set in the Dolby Pro Logic mode.</p> 	
<p>3. Start playing the movie or music.</p>	
<p>4. Adjust the volume.</p> 	
<p>5. Adjust the level of the center and rear channels. Adjust the levels according to the source, using the Dolby Pro Logic settings as reference.</p>	
<p><b>Adjusting the effect level</b></p> <p>8. Select the effect level mode.</p>  <p>Remote control unit: DELAY — EFFECT LEVEL The parameter switches as shown above.</p>	
<p>9. To increase the effect level.</p>  <p>Remote control unit</p>	
<p>10. To decrease the effect level.</p>  <p>Remote control unit</p>	
<p><b>Adjusting the delay time</b></p> <p>6. Select the delay time mode.</p>  <p>Remote control unit: DELAY — EFFECT LEVEL The parameter switches as shown above.</p>	
<p>7. Set the delay time following the procedure on Page 21.</p>	
<p><b>DSP surround playback</b></p> <p>1. Select the desired surround mode.</p>  <p>Main unit: MONO MOVIE — CLASSIC — ROCK — STADIUM Remote control unit: LIVE — WIDE SCREEN — PRO LOGIC</p>	<p>6. Adjust the effect level. Adjust the level in the same way as for the Wide Screen mode above.</p> <p>7. Follow steps 6 to 8 under "Playing the program source". on Page 14.</p>
<p>3. Play the desired program source.</p>	
<p>4. Adjust the volume.</p> 	
<p>5. Adjust the level of the rear channel. Adjust the level according to the source, using the Dolby Pro Logic settings as reference.</p>	
<p><b>To turn off the surround mode</b></p> <p>12. Press the BYPASS button.</p>  <p>Main unit: BYPASS Remote control unit: BYPASS Normal stereo playback resumes.</p>	

→ Continued

■ Using the Personal Memory

Surround mode settings and the input function can be stored at personal memory buttons "1" and "2", then recalled directly from any surround mode simply by pressing button "1" or "2".

1 Storing the setting in the personal memory

- Set the desired surround mode and input function.
- Press the personal memory button.
 



Remote control unit

(The memory setting mode is set and the indicator on the MFD flashes.)
- Press the desired personal memory button ("1" or "2").
 

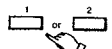

Remote control unit
- "M 1 (2) SET" appears on the MFD indicating that the setting has been stored.

NOTE:

- The memory setting mode is set for 6 seconds. If any button other than personal memory button "1" or "2" is pressed, the memory setting mode is cancelled.

2 Recalling the personal memory

- Press the personal memory button ("1" or "2") at which the desired setting was stored.
 

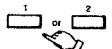

Remote control unit
- The surround mode and input function switch automatically.

NOTES:

- Personal memory buttons "1" and "2" will not function during the tape monitor mode.
- The surround mode recalled with the PERSONAL MEMORY "1" or "2" button is the same as the mode selected with the surround mode button. Thus, if the parameters of the surround mode which was stored in the memory are cleared, when the mode is recalled it is set to the initial values.
- Upon shipment from the factory, the "WIDE SCREEN" mode is stored at personal memory "1", the "LIVE" mode at personal memory "2". The input function is set to VDP/DBS for both "1" and "2".
- Do not to press personal memory buttons "1" or "2" buttons during recording on the cassette deck.

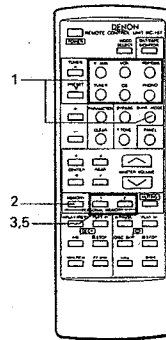
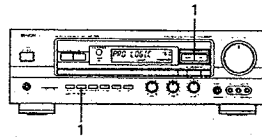

■ Operations Possible in the Various Surround Modes

The following is a list of the buttons and functions which can be operated during the different surround modes. Figures in parentheses indicate adjustment ranges.

		OUTPUT	CENTER LEVEL	REAR LEVEL	CENTER MODE	3CH LOGIC	TEST TONE	DELAY TIME
BYPASS		○	×	×	△ <sup>1</sup>	×	×	×
DOLBY PRO LOGIC	NORMAL	○	○ (0~24dB)	○ (0~24dB)	○	○	○	○ (15~30ms)
	PHANTOM	○	×	○ (0~24dB)	○	×	○	○ (15~30ms)
	WIDE	○	○ (0~24dB)	○ (0~24dB)	○	○	○	○ (15~30ms)
DOLBY 3CH LOGIC	NORMAL	○	○ (0~24dB)	×	○	○	○	×
	WIDE	○	○ (0~24dB)	×	○	○	○	×
WIDE SCREEN &	NORMAL	○	○ (0~24dB)	○ (0~24dB)	○	×	×	○ (6~30ms)
	PHANTOM	○	×	○ (0~24dB)	○	×	×	○ (6~30ms)
LIVE	WIDE	○	○ (0~24dB)	○ (0~24dB)	○	×	×	○ (6~30ms)
MONO MOVIE		○	×	○ (0~24dB)	△ <sup>1</sup>	×	×	×
CLASSIC CONCERT		○	×	○ (0~24dB)	△ <sup>1</sup>	×	×	×
ROCK CONCERT		○	×	○ (0~24dB)	△ <sup>1</sup>	×	×	×
STADIUM		○	×	○ (0~24dB)	△ <sup>1</sup>	×	×	×

		EFFECT LEVEL	CLEAR	PERSONAL <sup>2</sup>		DAT/TAPE MONITOR
				"MEMORY"	"1" & "2"	
BYPASS		×	○	×	○	○
DOLBY PRO LOGIC	NORMAL	×	○	○	○	○
	PHANTOM	×	○	○	○	○
	WIDE	×	○	○	○	○
DOLBY 3CH LOGIC	NORMAL	×	○	○	○	○
	WIDE	×	○	○	○	○
WIDE SCREEN &	NORMAL	○ (5~15)	○	○	○	○
	PHANTOM	○ (5~15)	○	○	○	○
LIVE	WIDE	○ (5~15)	○	○	○	○
MONO MOVIE		○ (5~15)	○	○	○	○
CLASSIC CONCERT		○ (5~15)	○	○	○	○
ROCK CONCERT		○ (5~15)	○	○	○	○
STADIUM		○ (5~15)	○	○	○	○

○: Operation possible  
 ×: Operation not possible

<sup>1</sup> Switches to the Dolby Pro (3CH) Logic mode for any modes other than Dolby Pro (3CH) Logic, Wide Screen and LIVE.  
<sup>2</sup> Personal memory buttons MEMORY "1" and "2" will not function during the DAT/tape monitor mode.

- The sound may be distorted for some sources if the rear level or effect level is raised during surround playback. If this happens, lower the rear level and effect level.

12 LAST FUNCTION MEMORY

- This amplifier is equipped with a last function memory which stores the input and output setting conditions as they were immediately before the power is switched off. This function eliminates the need to perform complicated resettings when the power is switched on.
- This amplifier is also equipped with a back-up memory. This function provides approximately one week of memory storage with the power cord disconnected.

### 13 TROUBLESHOOTING

If a problem should arise, first check the following:

1. Are the connections correct?
2. Have you operated the amplifier according to the Operating Instructions?
3. Are the speakers, turntable, and other components operating properly?

If the amplifier is not operating properly, check the items listed in the table below. Should the problem persist, there may be a malfunction. Disconnect the power immediately and contact your store of purchase.

Symptom	Cause	Measures	Page	
Common problems arising when listening to the CD, records, tapes, etc.	MFD not lit and sound not produced when power switch set to on.	• Power cord not plugged in securely.	• Check the insertion of the power cord plug.	8
	MFD lit but sound not produced.	• Speaker cords not securely connected. • OUTPUT button is off. • Improper position of the audio function button. • Volume control set to minimum. • MUTING is on.	• Connect securely. • Press the OUTPUT button. • Set to a suitable position. • Turn volume up to suitable level. • Switch off MUTING.	10, 11 17 14 14 15
	-PROTECT- display appears multi-function display.	• Speaker terminals are short-circuited.	• Switch power off, connect speakers properly, then switch power back on.	10, 11
		• Block the ventilation holes of the set.	• Turn off the set's power, then ventilate it well to cool it down. Once the set is cooled down, turn the power back on.	3, 4
	• The unit is operating at continuous high power conditions and/or inadequate ventilation.		• Turn off the set's power, then ventilate it well to cool it down. Once the set is cooled down, turn the power back on.	3, 4
		• Incomplete connection of speaker cords. • Incomplete connection of input/output cords. • Left/right balance is off.	• Connect securely. • Connect securely. • Adjust balance knob properly.	10, 11 12, 13 14
	Positions of instruments reversed during stereo playback.	• Reverse connections of left and right speakers or left and right input/output cords.	• Check left and right connections.	12, 13
	Sound seems distorted.	• Effect level parameter is high.	• Set the effect level parameter to lower level.	22, 23
		• Rear level is too high.	• Set the rear level to lower level.	22, 23
	Sound seems strange.	• DSP parameter settings are poor.	• Press the CLEAR button then adjust the DSP parameters.	22,23,27
Personal memory function does not work.	• DAT/tape monitor mode set.	• Press the DAT/TAPE button to set the source.	16	
When playing records	Humming noise produced when record is playing.	• Ground wire of turntable not connected properly. • Incomplete PHONO jack connection. • TV or radio transmission antenna nearby.	• Connect securely. • Connect securely. • Contact your store of purchase.	12 12 -
	Howling noise produced when volume is high.	• Turntable and speaker systems too close together. • Floor is unstable and vibrates easily.	• Separate as much as possible.	-
			• Use cushions to absorb speaker vibrations transmitted by floor. If turntable is not equipped with insulators, use audio insulators (commonly available).	-
	Sound is distorted.	• Stylus pressure too weak. • Dust or dirt on stylus. • Cartridge defective.	• Apply proper stylus pressure.	-
			• Check stylus. • Replace cartridge.	-
Volume is weak.	• MC cartridge being used.	• Replace with MM cartridge or use a head amplifier or step-up transformer.	12	
Remote control unit	Amplifier does not operate properly when remote control unit is used.	• Batteries dead.	• Replace with new batteries.	6
		• Remote control unit too far from amplifier.	• Move closer.	6
		• Obstacle between amplifier and remote control unit.	• Remove obstacle.	6
		• Different button is being pressed.	• Press the proper button.	6
		• (+) and (-) ends of battery inserted in reverse.	• Insert batteries properly.	6

### 14 INITIALIZATION OF THE MICROPROCESSOR

When the indication of the MFD display is not normal or when the operation of the unit does not show the reasonable result, the initialization of the microprocessor is required by the following procedure.

1. Switch off the unit and remove the AC power cord from the wall outlet.
2. Hold the following 2 buttons of the main unit at the same time (as illustrated in the diagram below, ① AUDIO FUNCTION button, ② VIDEO FUNCTION button, and plug the power cord into the outlet.

3. Check that the entire MFD display is flashing with an interval of about 1 second, and release your fingers from the 2 buttons.
4. Switch on the unit and the microprocessor will be initialized. The input function is set to tuner with the bypass mode automatically.

**NOTE:**

- When the unit does not show the result of above 3 and 4, repeat the procedure from 1 again.
- When the microprocessor is initialized, all settings you have made are reset to the factory presettings.

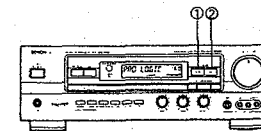

Initial parameter values for the different modes

	OUTPUT	FRONT SP	CENTER SP/PRE	REAR SP	CENTER LEVEL	REAR LEVEL	CENTER MODE	3CH LOGIC	TEST TONE	DELAY TIME	EFFECT LEVEL
BYPASS	ON	ON	OFF	OFF	—	—	—	—	—	—	—
DOLBY PRO LOGIC	ON	ON	ON	ON	-12dB	-12dB	NORMAL	OFF	OFF	21msec	—
WIDE SCREEN	ON	ON	ON	ON	-12dB	-12dB	NORMAL	—	—	21msec	10
LIVE	ON	ON	ON	ON	-12dB	-12dB	NORMAL	—	—	21msec	10
MONO MOVIE	ON	ON	OFF	ON	—	-12dB	—	—	—	—	10
CLASSIC	ON	ON	OFF	ON	—	-12dB	—	—	—	—	10
ROCK	ON	ON	OFF	ON	—	-12dB	—	—	—	—	10
STADIUM	ON	ON	OFF	ON	—	-12dB	—	—	—	—	10

SP: SPEAKER OUT  
PRE: PRE OUT

- INPUT FUNCTION : TUNER
- PERSONAL MEMORY 1 INPUT : VDP/DBS
- SURROUND MODE : WIDE SCREEN
- PERSONAL MEMORY 2 INPUT : VDP/DBS
- SURROUND MODE : LIVE

#### Initialization of the Individual Modes

Use this to set the adjusted values back to the factory preset values.

1. Press the CLEAR button.



The values for the currently selected mode only are reset to the values shown on the above table.

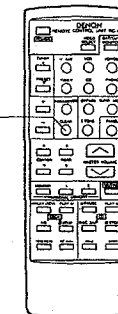

### WIRE ARRANGEMENT

In case of wires require unclasping or loosening to move the location to perform adjustment or part replacement, be sure to rearrange them neatly to restore properly in the same location as they were originally placed, or causing to produce a noise may occasionally occur.

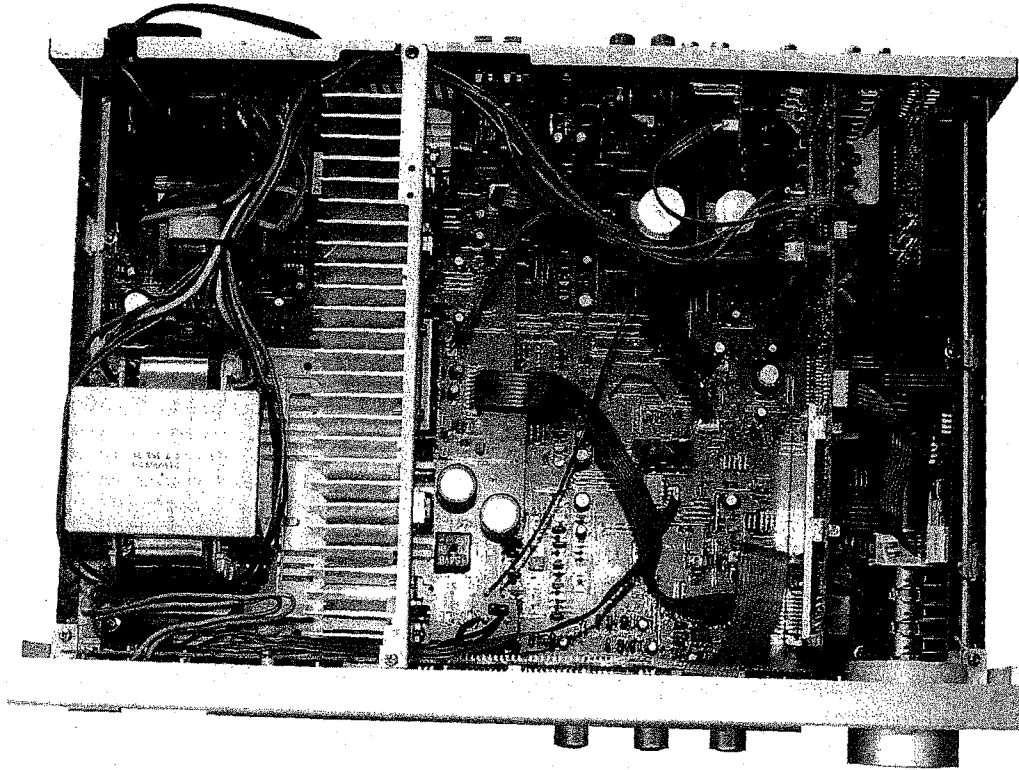



**DISASSEMBLY**

(To reassemble reverse disassembly)

**1. Wood Boards (AVC-1530G only)**

Remove 4 screws ①.

**2. Top Cover**

Remove 2 screws ②.

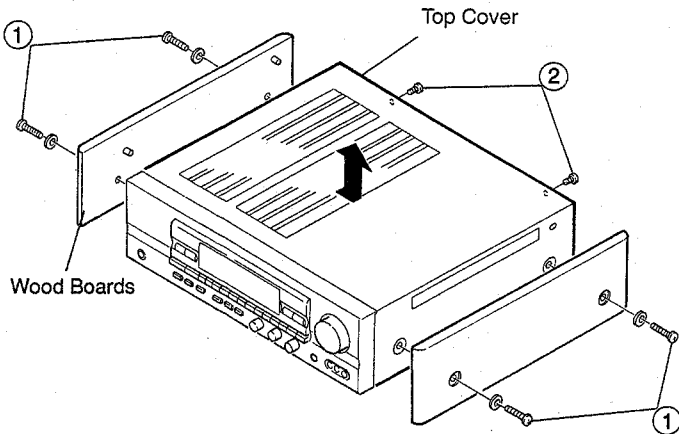

**4. Front Mold Panel**

(1) Pull out Master Volume knob ④ and 3 round knobs ⑤.

(2) Remove 4 nut ⑥ and nut ⑦ and remove bracket ⑧.

(3) Remove 3 screws ⑨.

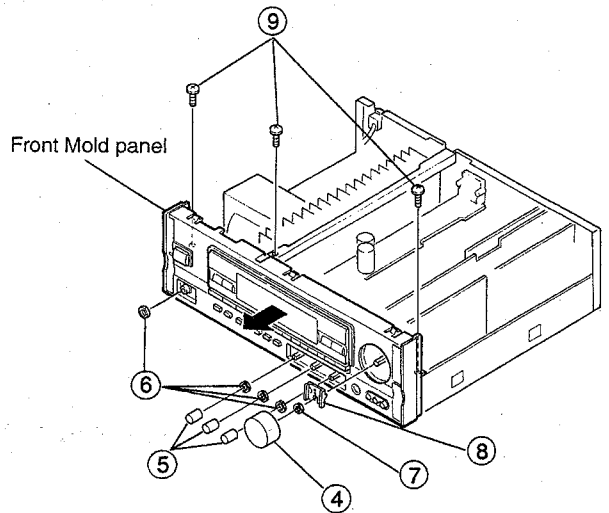

**3. Front Aluminium Panel**

Remove 4 screws ③ and undo hooks at 3 places.

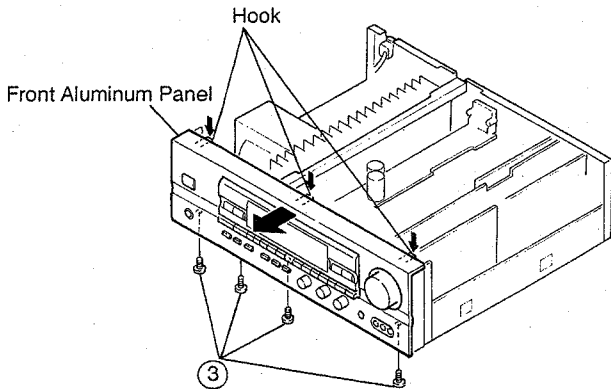

**5. Rear Panel**

(1) Disconnect cord bush ⑩

(2) Remove 18 screws ⑪ and 5 screws ⑫

(3) Remove hooks at 2 places in arrow direction.

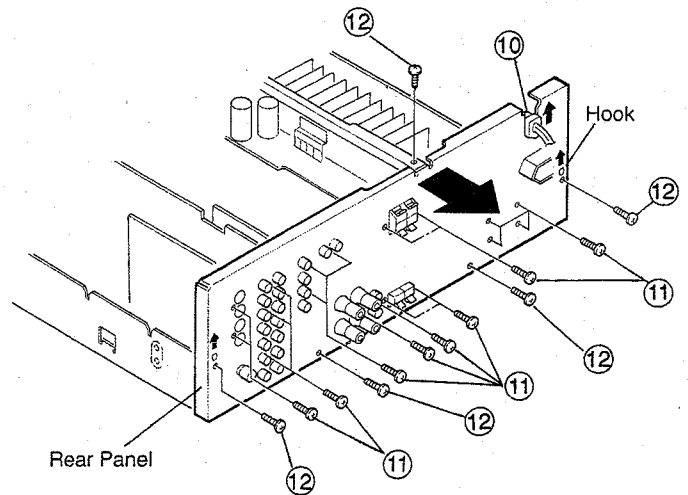

## ADJUSTMENT

### ● Initiating (Memory clearing) Method

To clear memory contents of microcomputer and restore to the initial state, take the following steps;

1. Press power switch, turn off power of the unit, and set to standby mode.
2. Pull out power cord from wall outlet temporarily.
3. Insert power cord into outlet while simultaneously pressing two keys of AUDIO and VIDEO.
4. Press power switch to confirm that memory contents are cleared.

By completion of the above, the initial state is restored. In case the memory can not be cleared due to some reasons, repeat steps 1 through 3.

## ● AUDIO SECTION

### Idling Current (1U-2615-1)

Required measurement equipment: DC Voltmeter

#### Arrangement

(1) Avoid direct blow from an air conditioner or an electric fan, and adjust the unit at normal room temperature 15°C ~ 30°C. (59°F ~ 86°F).

#### (2) Presetting

- |   |  |
|---|--|
| ● POWER (Power source switch)           | → OFF  |
| ● MODE (Mode button)                    | → BY PASS  |
| ● FUNCTION (Function button)            | → CD   |
| ● VOLUME (Volume control)               | → 0: fully counterclockwise ( ⤴ min.)                    |
| ● CENTER VOLUME (Center volume control) | → -12dB  |
| ● BASS, TREBLE (Tone control)           | → 0: (Controls to center)                                |
| ● SPEAKERS (Speaker terminal)           | → No load (Do not connect speaker, dummy resistor, etc.) |

#### Adjustment

- (1) Remove top cover and set VR401, VR301 and VR302 of 1U-2615-1 (Main Unit) at counterclockwise fully.
- (2) Connect DC Voltmeter to test points (Lch T.P.302, Rch T.P.301, CENTER ch T.P.401).
- (3) Connect power cord to AC Line, and turn power switch "ON".
- (4) Allow 15 minutes, and turn VR301, VR302 and VR401 clockwise ( ⤵ ) and adjust the TEST POINTS voltage to 1.5 mV ± 0.5 mV DC.
- (5) After 2 minutes from preset, turn VR301, VR302 and VR401 to set the voltage to 3 mV ± 0.5mV DC.

#### 1U-2615-1 Main Unit (Component Side)

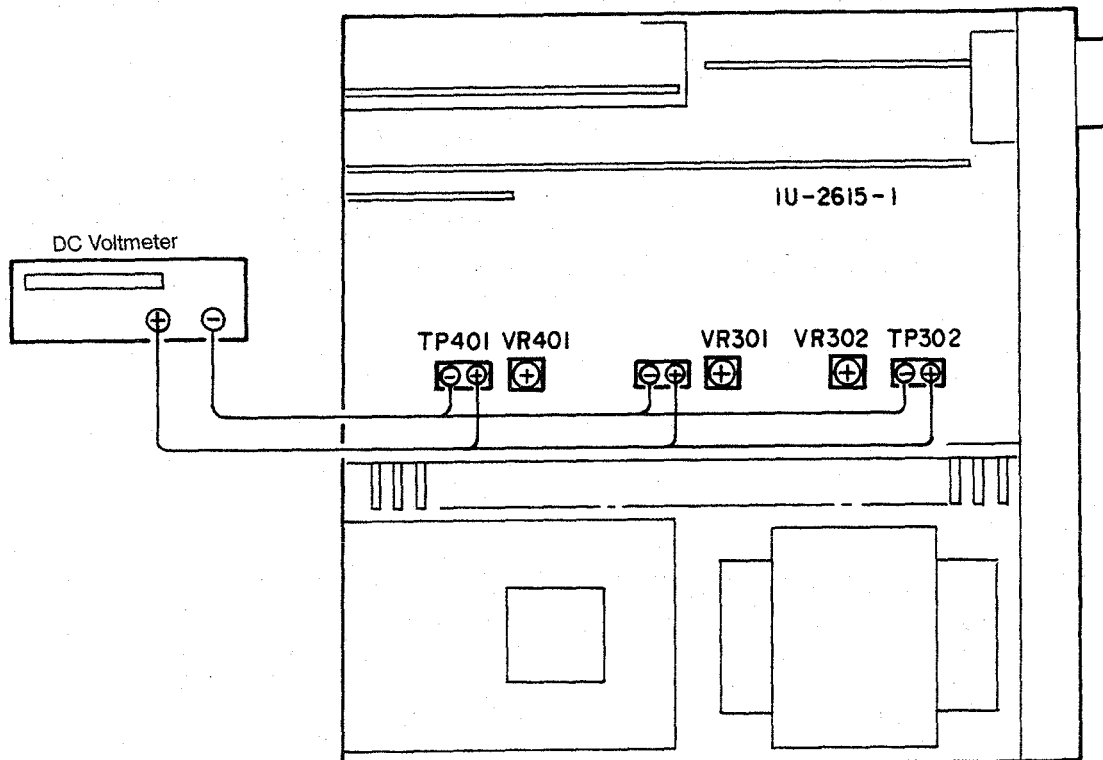

SEMICONDUCTORS

IC's

Note)  
 Indications before IC numbers denote P.W.B. Name.  
 MA : Main Amp P.W.B. Unit  
 RE : Rear Amp P.W.B. Unit  
 SU : Surround P.W.B. Unit

F71002B  
 (SU: IC106)

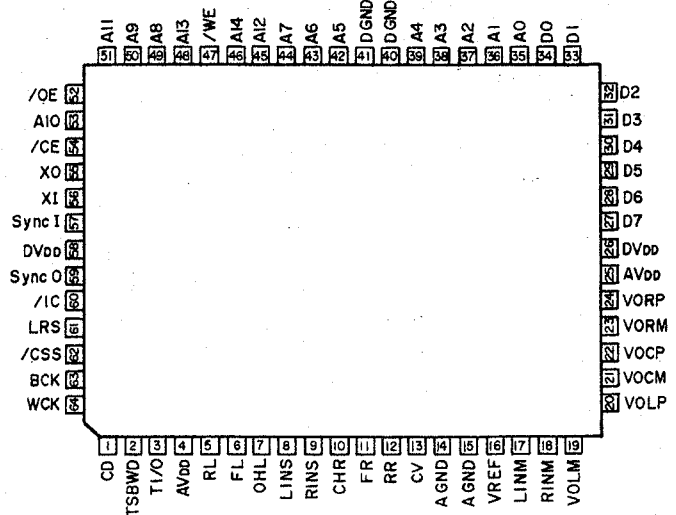
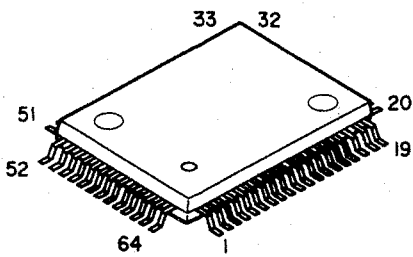

BLOCK DIAGRAM

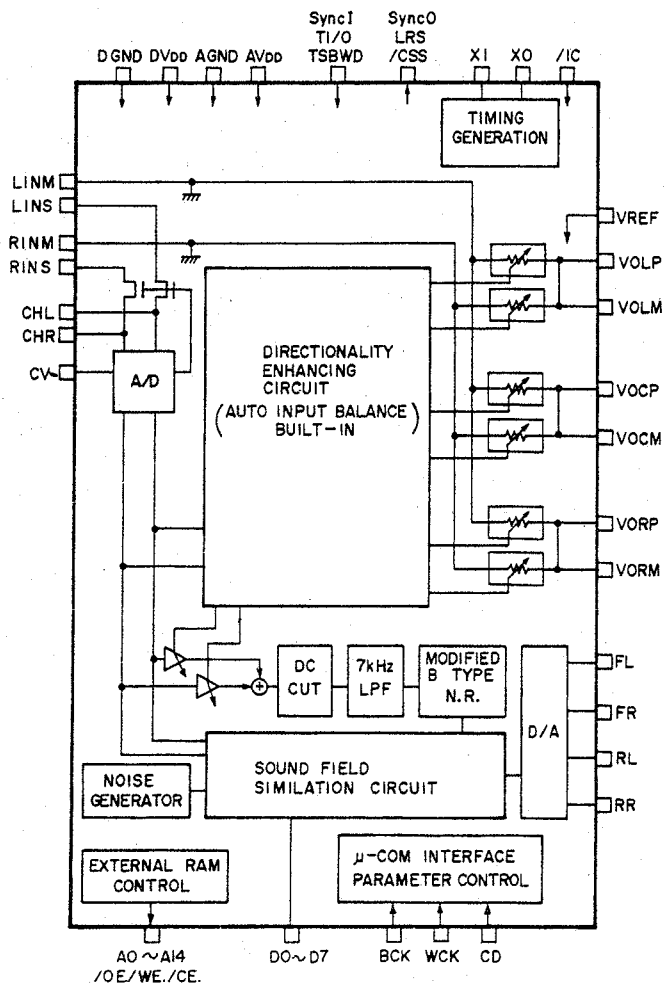

LC4966  
(SU: IC103)

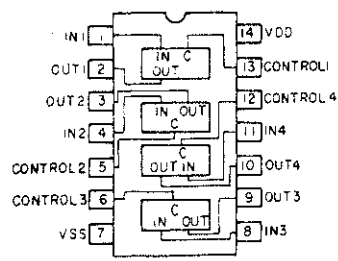
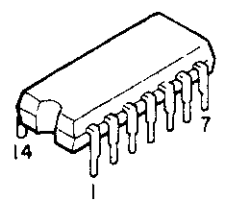

BA4558  
(MA: IC451)

BA4558F (SU: IC101, 104, 105, 115 ~ 117, 253, 255, 257)  
NJM2082M (SU: IC109, 110, 113, 114)  
NJM5532MD (SU: IC111, 112)

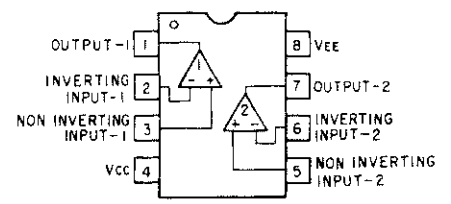
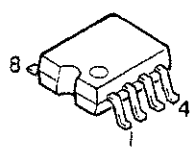
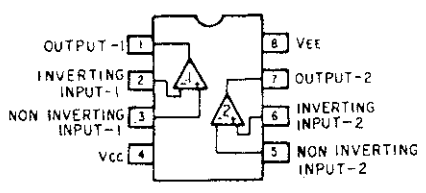
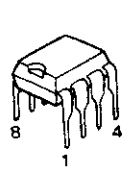

LB1639 (SU: IC255)

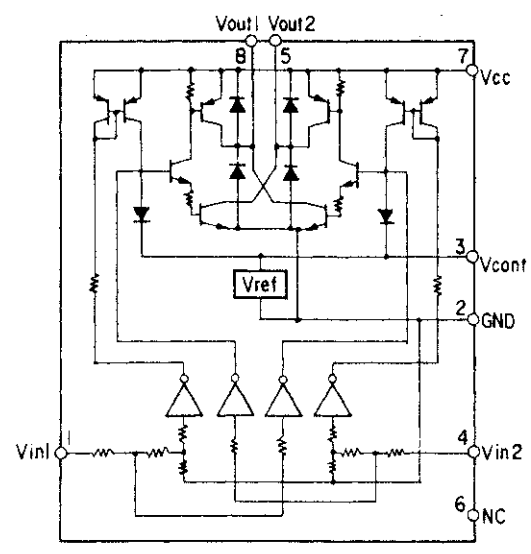
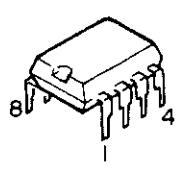

SI-18752 (RE: IC501, 502)

● IC PROTECTORS

ICP-N15 (RE: IC552, 603)  
ICP-N20 (RE: IC505, 506)

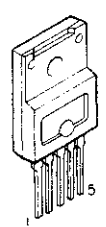

- 1. +IN
- 2. -IN
- 3. -VEE
- 4. Output
- 5. +Vcc

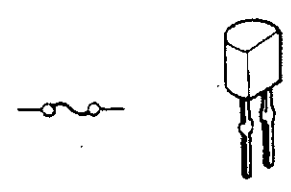

**HM65256BLFP-10T**  
(SU: IC107)

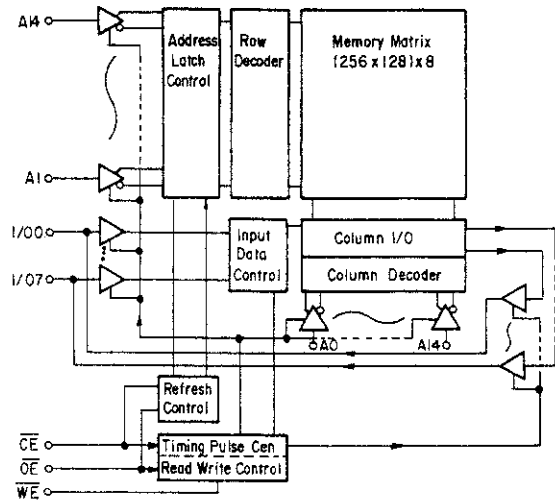
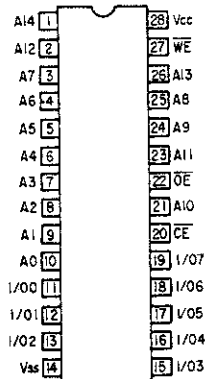
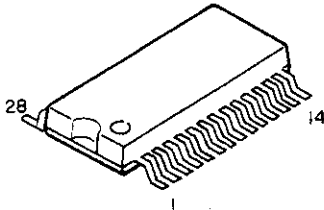

**NJM7805FA(S)** (RE: IC507, 602)  
**NJM7815FA(S)** (RE: IC503)  
**NJM7806FA(S)** (RE: IC551)

**NJM7915FA** (RE: IC504)

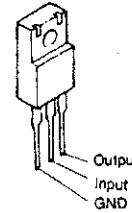
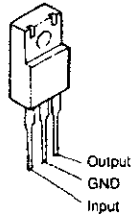

● **OTHERS**

**SBX1610-52 (Remote Control Receiver)**  
(RE: IC701)

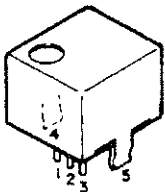

- 1. Vcc
- 2. Output
- 3. GND
- 4. Case fin
- 5. Case fin

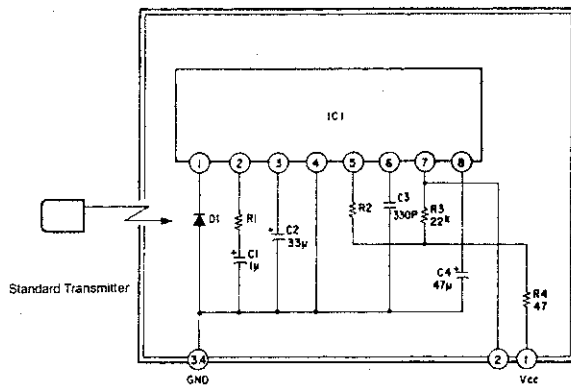

- IC1 : CX20106A chip
- D1 : Pin photodiode chip
- C1, C2, C4 : Aluminum electrolytic capacitor
- C3 : SL characteristic ± 5%
- R1 : Gain control resistor
- R2 : fo control resistor (using ± 1%)
- R (Other than above items) : ± 5%

TMP87CK70AF (MA:IC801)

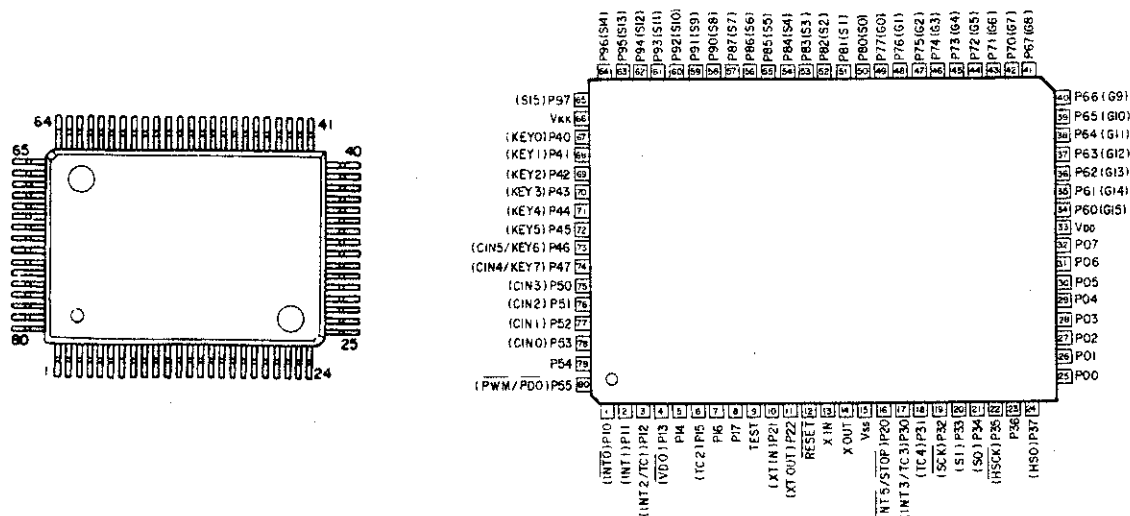

TMP87CK70AF Port Allocation Table Table 1 (1/4)

Pin	Terminal Name	I/O	Logic	Initial Setting	Usage
1	P10(INT0)	I	L*	—	Power breakdown; Breakdown detect input (*L at Breakdown)
2	P11(INT1)	I	L*	—	PROTECTION: PROTECTION INPUT (*H at detect mode)
3	P12(INT2/TC1)	O	Serial	L	ST TUNER PLL Control (LM7001)
4	P13(DV0)	O	H*	L	TUNER MUTE (*H at MUTE mode)
5	P14	I	L*	—	TUNED SIGNAL input (*L at reception mode)
6	P15(TC2)	I	L*	—	STEREO SIGNAL input (*L at stereo reception mode)
7	P16	O	L*	L	(ST / MONO ; STEREO / MONO SHIFT (*L at stereo mode)
8	P17	O	—	L	Not used
9	TEST	I	—	—	Connect to GND
10	P21(XTIN)	O	—	L	Not used
11	P22(XTOUT)	O	—	L	Not used
12	RESET	I	L	—	RESET; Microcomputer reset input
13	XIN	I	—	—	Oscillator connection (8MHz)
14	XOUT	I	—	—	—
15	Vss	PW	—	—	0V (GND)
16	P20 (INT5/STOP)	O	—	L	Not used
17	P30 (INT3/TC3)	I	L	—	REMOTE: REMOTE controller optical signal input (*H at reset mode)
18	P31(TC4)	O	H	L	FL-RS
19	P32(SCK)	O	H	H	FL-DATA
20	P33(SI)	O	H	H	FL-CLK

\* In AVR mode, ports within frame takes setting contents of Table 1-1. In each mode, unused ports are set to output ports depending on contents of initial setting. (P. ON state)

Table 1 (2/4)

Pin	Terminal Name	I/O	Logic	Initial Setting	Usage
21	P34(SO)	O	L	L/H	IC : DSP Initial clear (*L at reset mode)
22	P35(HSCK)	O	H	L/H	BCK
23	P36	O	H	L	WCK
24	P37(HSO)	O	H	L/H	CD
25	P00	O	H	L	CK
26	P01	O	H	L	CE
27	P02	O	H	L	DATA
28	P03	O	H	L	CK
29	P04	O	H	H	DATA
30	P05	O	H	L	ST1
31	P06	O	—	L	Not used
32	P07	O	L*	L/H	DSP POWER : DSP POWER ON/OFF (*H at ON)
33	VDD	PW	—	—	+5V
34	P60(G15)	O	H	L	VOL.UP
35	P61(G14)	O	H	L	VOL.DOWN
36	P62(G13)	O	H*	H	LED : STANDBY LED (*H at lit time)
37	P63(G12)	O	L*	H	VCR-1 1NH (*H at inhibit mode)
38	P64(G11)	O	—	L	Not used
39	P65(G10)	O	—	L	Not used
40	P66(G9)	O	—	L	Not used

\* In AVR mode, ports within frame are set to output ports and set to "L". In each mode, unused ports are set to output ports depending on contents of initial setting. (P. ON state)

Table 1 (3/4)

Pin	Terminal Name	I/O	Logic	Initial Setting	Usage
41	P67(G8)	O	—	L	Not used
42	P70(G7)	O	—	L	Not used
43	P71(G6)	O	—	L	Not used
44	P72(G5)	O	H	L	FRONT : Speaker relay control
45	P73(G4)	O	—	L	Not used
46	P74(G3)	O	H	L	SP-REAR : Speaker relay control
47	P75(G2)	O	H	L	SP-CENTER : Seaker relay control
48	P76(G1)	O	H	L	H/P, PRE MUTE : Premute control
49	P77(G0)	O	L*	H	H/P, PRE MUTE : (*L at Mute mode)
50	P80(S0)	O	H	L	POWER : Power relay control
51	P81(S1)	O	—	L	Not used
52	P82(S2)	O	—	L	Not used
53	P83(S3)	O	—	L	Not used
54	P84(S4)	O	—	L	Not used
55	P85(S5)	O	—	L	Not used
56	P86(S6)	O	—	L	Not used
57	P87(S7)	O	—	L	Not used
58	P90(S8)	O	—	L	Not used
59	P91(S9)	O	—	L	Not used
60	P92(S10)	O	—	L	Not used

\* In each mode, unused ports are set to output ports depending on contents of initial setting. (P.ON State)

Table 1 (4/4)

Pin	Terminal Name	I/O	Logic	Initial Setting	Usage
61	P93(S11)	O	—	L	Not used
62	P94(S12)	O	—	L	Not used
63	P95(S13)	O	—	L	Not used
64	P96(S14)	O	—	L	Not used
65	P97(S15)	O	—	L	Not Used
66	V <sub>CC</sub>	PW	—	—	V <sub>CC</sub> -15V
67	P40(KEY0)	O	L	H	A } VIDEO INPUT CONTROL
68	P41(KEY1)	O	L	H	B } (BA7625, 7626)
69	P42(KEY2)	O	L	H	C } VIDEO REC OUT CONTROL
70	P43(KEY3)	O	L	H	D } (BA7625, 7626)
71	P44(KEY4)	O	L	H	E } VIDEO INPUT/REC CONTROL
72	P45(KEY5)	O	—	L	Not Used
73	P46(CIN5/KEY6)	O	—	L	Not Used
74	P47(CIN4/KEY7)	I	—	—	MODE : AVC/AVR shift (A/D conversion input)
75	P50(CIN3)	I	—	—	Key 4
76	P51(CIN2)	I	—	—	Key 3
77	P52(CIN1)	I	—	—	Key 2
78	P53(CIN0)	I	—	L	Key 1
79	P54	O	Serial	L	CK : TUNER PLL CONTROL (LM7001)
80	P55(PWM/PD0)	O	Serial	—	DATA : TUNER PLL Control (LM7001)

\* In AVR mode, ports within frame takes setting contents of Table 1-1. In each mode, unused ports are set to outputs ports depending on contents of initial setting. (P. ON state)

TC9176P (SU: IC251)

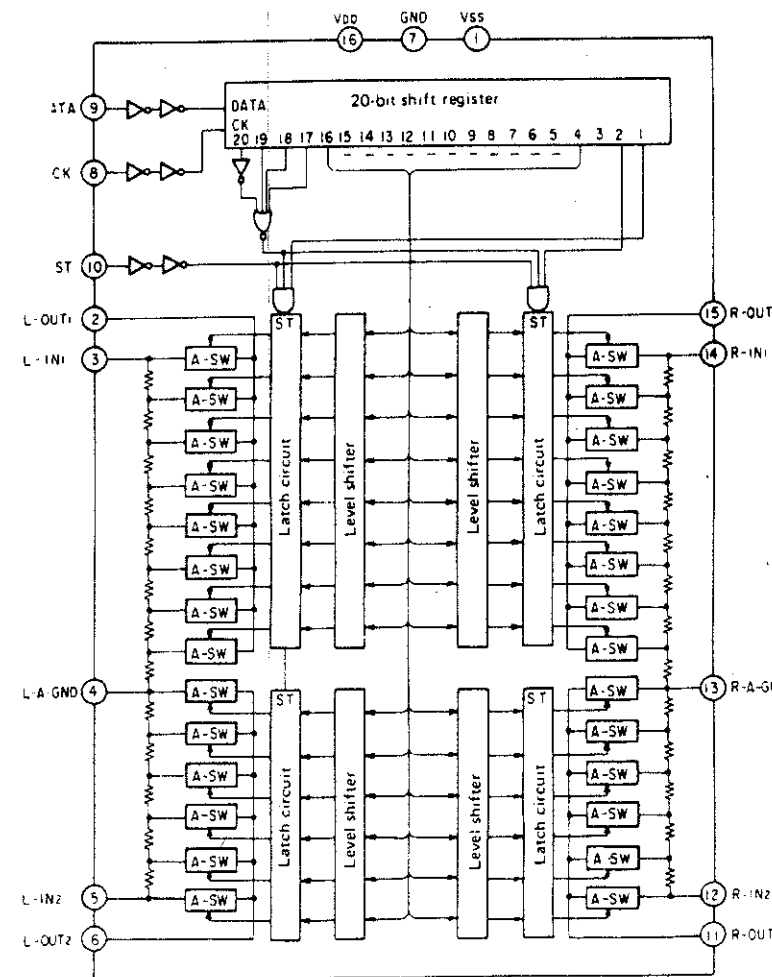
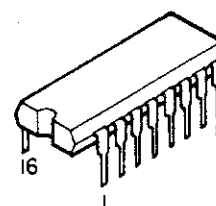

LC7821 (SU: IC102)  
LC7823 (SU: IC108)

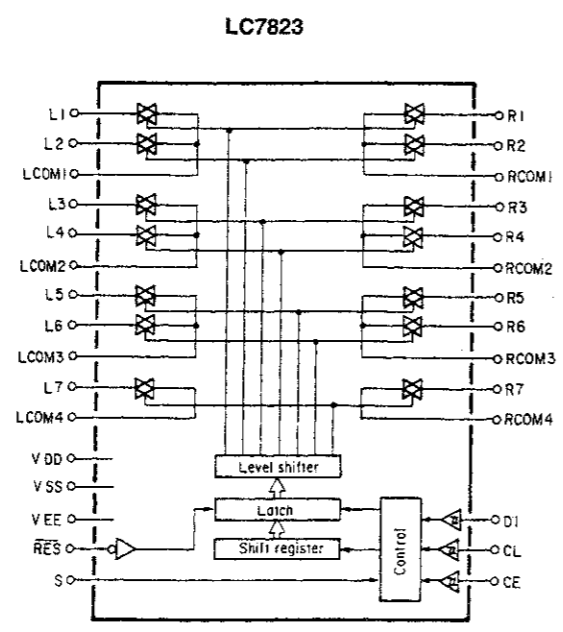
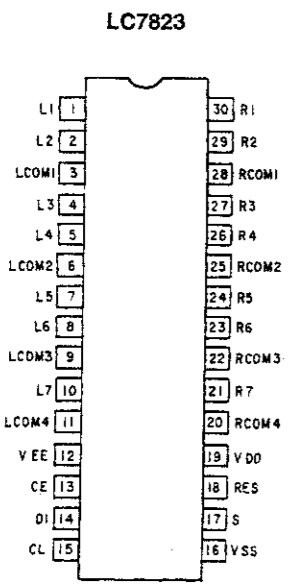
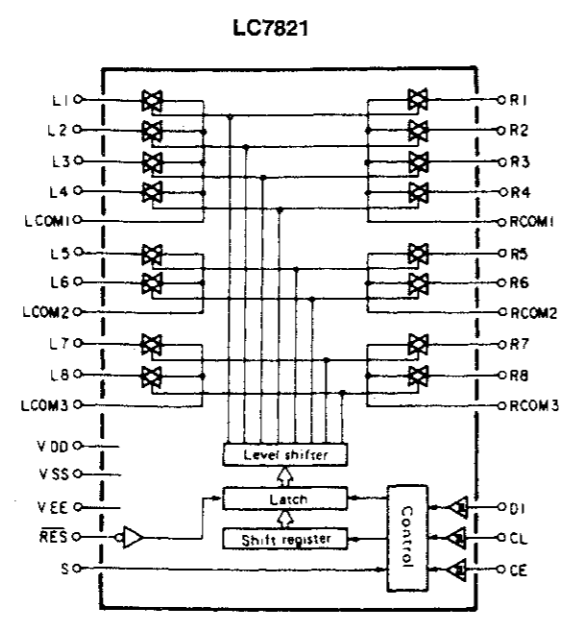
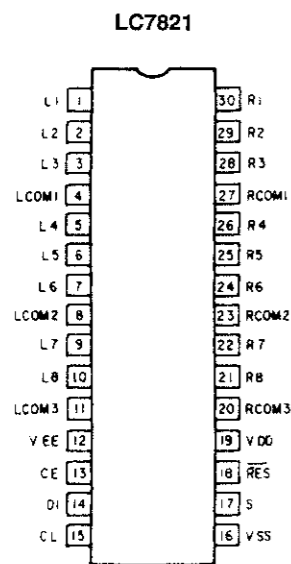
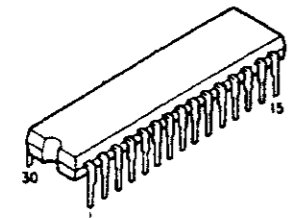
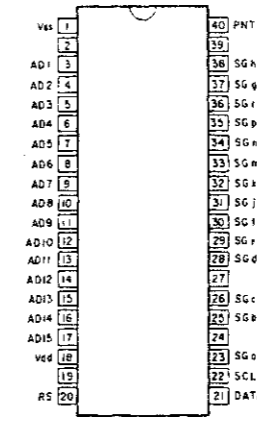
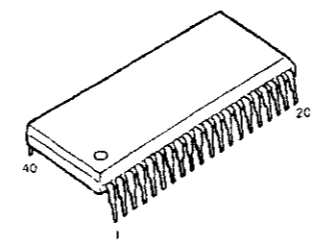

Table of LC7821, LC7823 Terminal Function

Name of Terminal	I/O	Equivalent Internal Circuit	Function of Terminal																																
VDD, VSS, VEE			Power terminal.																																
L1 ~ L8, R1 ~ R8 LCOM1 ~ LCOM4, BCOM1 ~ BCOM4		Refer to block diagram	In/Out terminal of analog switch.																																
CL, DI, CE	I		Serial data input terminal (Schmidt buffer). CL = Clock input terminal. DI = Data input terminal. CE = Chip enable terminal.																																
S	I		Selection terminal for using of two. Address will be shifted as per below table when switching S terminal to L or H. <table border="1" style="margin: 10px auto;"> <thead> <tr> <th rowspan="2">Name of Item</th> <th rowspan="2">S Terminal</th> <th colspan="4">Address</th> </tr> <tr> <th>A0</th> <th>A1</th> <th>A2</th> <th>A3</th> </tr> </thead> <tbody> <tr> <td rowspan="2">LC7821</td> <td>L</td> <td>0</td> <td>1</td> <td>0</td> <td>1</td> </tr> <tr> <td>H</td> <td>1</td> <td>1</td> <td>0</td> <td>1</td> </tr> <tr> <td rowspan="2">LC7823</td> <td>L</td> <td>0</td> <td>1</td> <td>1</td> <td>1</td> </tr> <tr> <td>H</td> <td>1</td> <td>1</td> <td>1</td> <td>1</td> </tr> </tbody> </table>	Name of Item	S Terminal	Address				A0	A1	A2	A3	LC7821	L	0	1	0	1	H	1	1	0	1	LC7823	L	0	1	1	1	H	1	1	1	1
Name of Item	S Terminal	Address																																	
		A0	A1	A2	A3																														
LC7821	L	0	1	0	1																														
	H	1	1	0	1																														
LC7823	L	0	1	1	1																														
	H	1	1	1	1																														
RES	I		Reset terminal. Condition of analog switch is not fixed at the time of turning on the power. When shift this terminal to L, all analog switches become OFF.																																

MSC1937-01 (RE:IC702)



Pin No.	Terminal Function
1	Power Supply (+5V)
3	Digit 1 Output
7	Digit 17 Output
17	Digit 17 Output
18	GND
19	---
20	POWER-ON-RESET
21	Data Input
22	Shift Clock Input
23	Segment a Output
38	Segment h Output
39	---
40	POINT Output

BA7625 (RE: IC601, 651)  
BA7626 (RE: IC652)

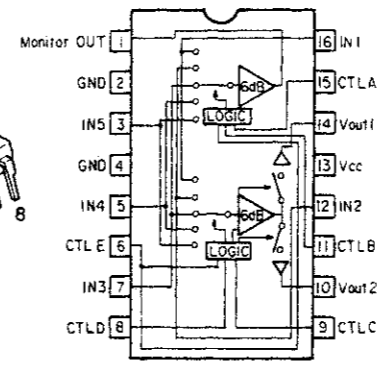
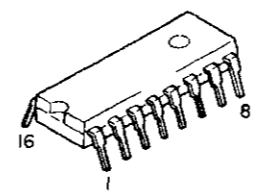

A	B	E	MONITOR OUT
L	L	*	IN 1
H	L	*	IN 2
L	H	*	IN 3
H	H	L	IN 4
H	H	H	IN 5

C	D	E	V OUT 1
L	L	*	---
H	L	*	IN 2
L	H	*	IN 3
H	H	L	IN 4
H	H	H	IN 5

C	D	E	V OUT 2
L	L	*	IN 1
H	L	*	---
L	H	*	IN 3
H	H	L	IN 4
H	H	H	IN 5

Note 1: \* mark means that feasible for either H or L.  
Note 2: Each input terminal is provided with sink chip clamp. (BA7625)  
Each input terminal takes 20kohm at the end. (BA7626)

Truth value table





PRINTED WIRING BOARD (Pattern side)

1 2 3 4 5 6 7 8

1U-2615C, D MAIN AMP. UNIT ASS'Y

1U-2615C, D	
1	Main Amp Unit
2	Head Phone Unit

A  
B  
C  
D  
E

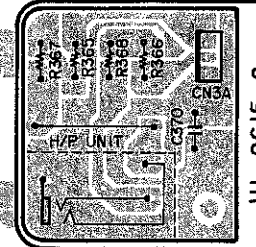
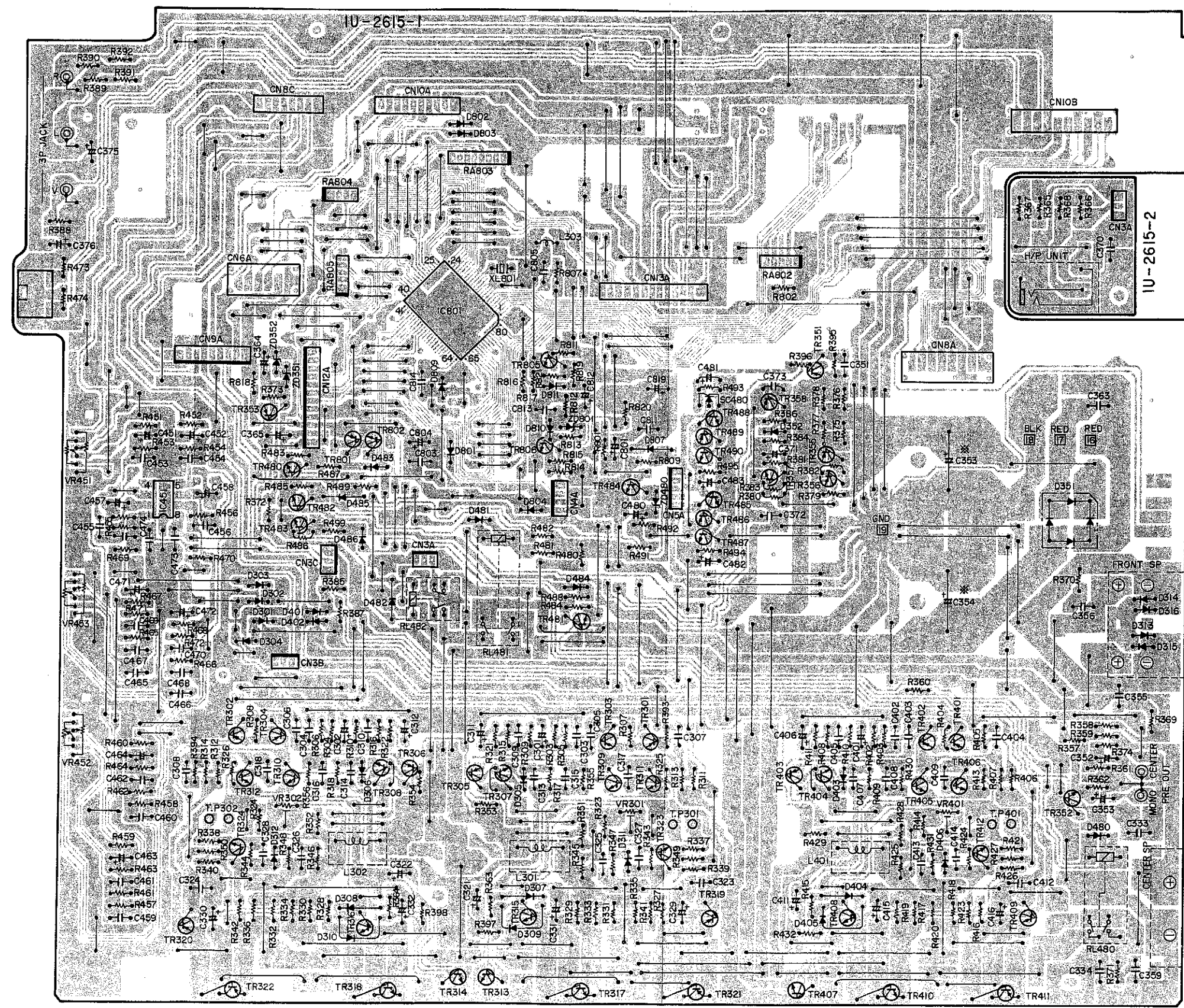

	Unit No.	C353, 354
Multi-Voltage	1U-2615C	6800µF/50V 2544365717
U.K.	1U-2615D	8200µF/56V 2544374708

1 2 3 4 5 6 7 8

1U-2616C, D REAR AMP. UNIT ASS'Y

1U-2616C, D	
1	Rear Amp. Unit
2	MFD Unit
3	Power Supply Unit
4	Video Unit
5	S-Video Unit
6	Voltage Sel. Unit

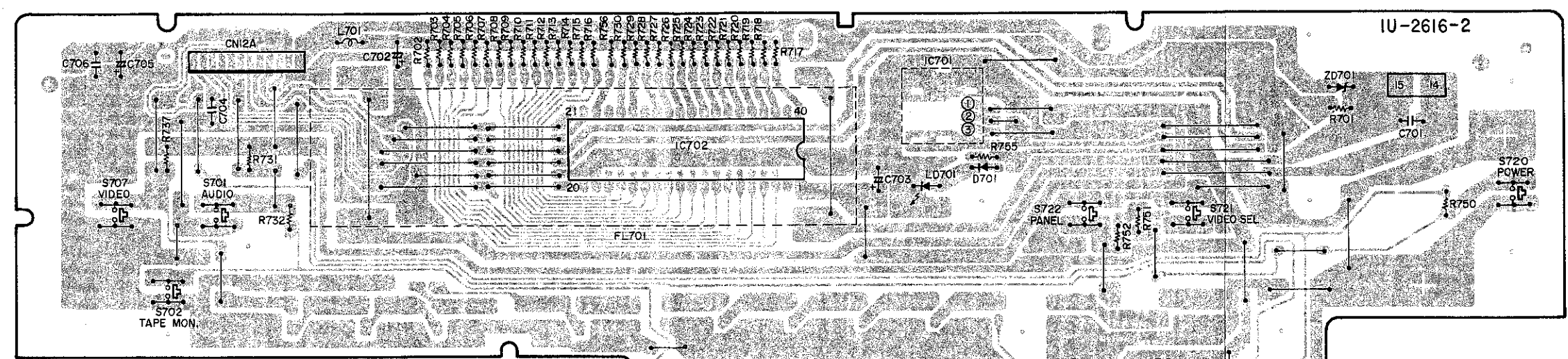

	Unit No.	Power Trans	Fuse	
			F001	F002
Multi-Voltage	1U-2616C	233 6068 002	206 1015 087 4A, 125V	206 1015 061 2 A, 250V
U.K.	1U-2616D	233 6071 002	206 1015 032 2.5 A	-

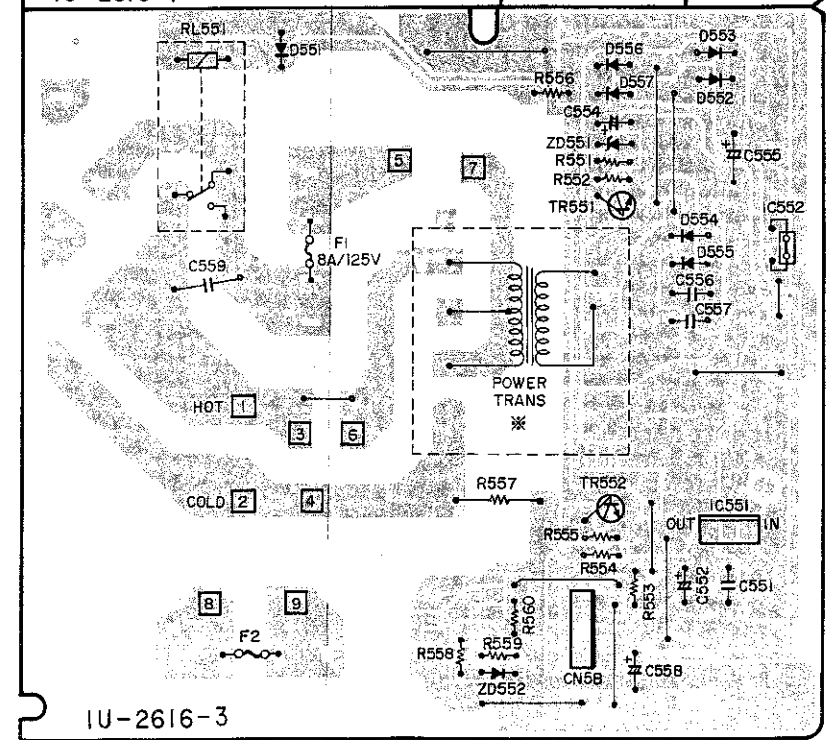
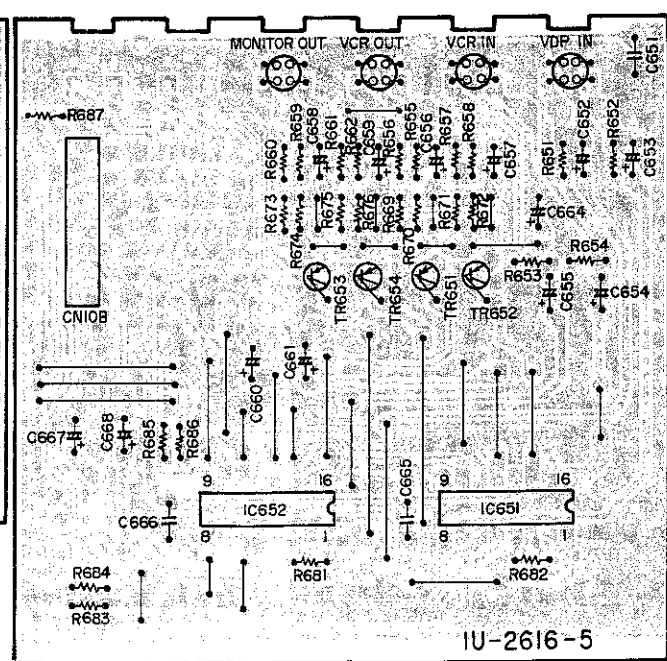
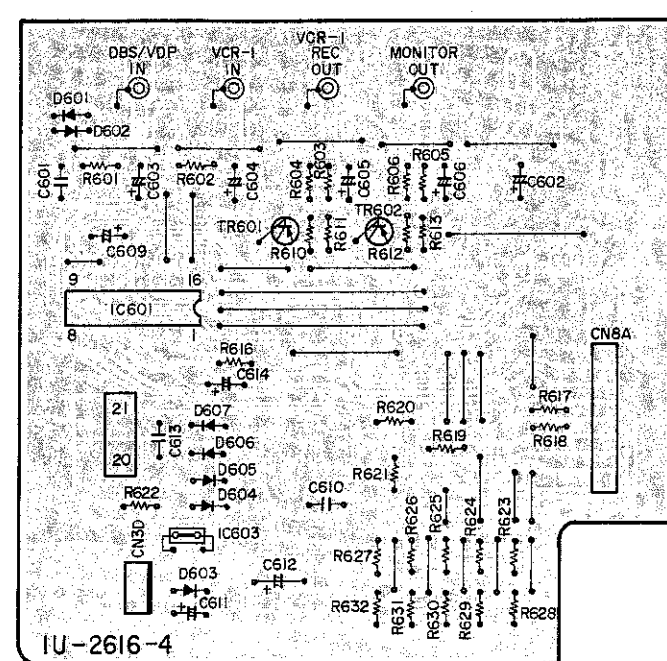
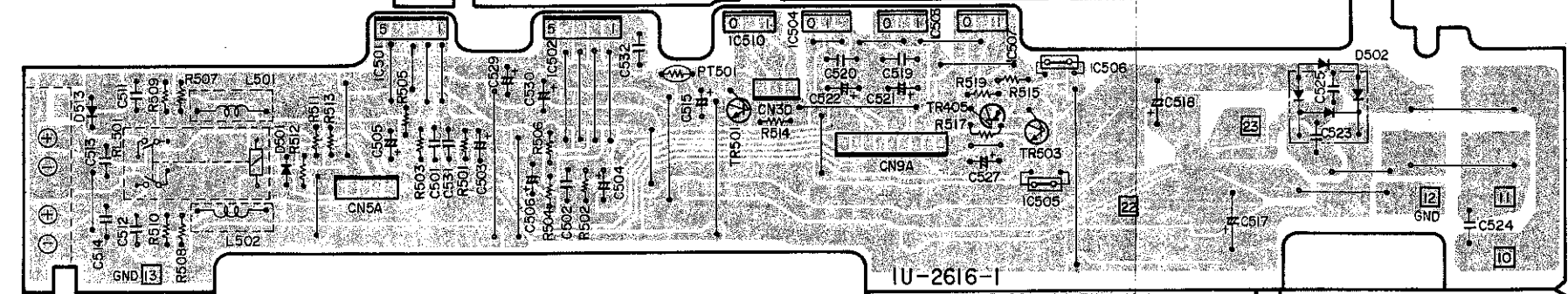

A  
B  
C  
D  
E



**NOTE FOR PARTS LIST**

- Part indicated with the mark "●" are not always in stock and possibly to take a long period of time for supplying, or in some case supplying of part may be refused.
- When ordering of part, clearly indicate "1" and "I" (i) to avoid mis-supplying.
- Ordering part without stating its part number can not be supplied.
- Part indicated with the mark "★" is not illustrated in the exploded view.
- Not including Carbon Film ±5%, 1/4W Type in the P.W.Board parts list. (Refer to the Schematic Diagram for those parts.)

**WARNING:**

Parts marked with this symbol  have critical characteristics.  
Use ONLY replacement parts recommended by the manufacturer.

**● Resistors**

Ex.: RN 14K 2E 182 G FR  
 Type Shape and performance Power Resistance Allowable error Others

RD : Carbon	2B : 1/8W	F : ±1%	P : Pulse-resistant type
RC : Composition	2E : 1/4W	G : ±2%	NL : Low noise type
RS : Metal oxide film	2H : 1/2W	J : ±5%	NB : Non-burning type
RW : Winding	3A : 1W	K : ±10%	FR : Fuse-resistor
RN : Metal film	3D : 2W	M : ±20%	F : Lead wire forming
RK : Metal mixture	3H : 5W		

**\* Resistance**

1 8 2 ⇒ 1800 ohm = 1.8 kohm  
 Indicates number of zeros after effective number.  
 2-digit effective number.

• Units: ohm

1 R 2 ⇒ 1.2 ohm  
 1-digit effective number.  
 2-digit effective number, decimal point indicated by R.

• Units: ohm

**● Capacitors**

Ex.: CE 04W 1H 2R2 M BP  
 Type Shape and performance Dielectric strength Capacity Allowable error Others

CE : Aluminum foil electrolytic	0J : 6.3V	F : ±1%	HS : High stability type
CA : Aluminum solid electrolytic	1A : 10V	G : ±2%	BP : Non-polar type
CS : Tantalum electrolytic	1C : 16V	J : ±5%	HR : Ripple-resistant type
CQ : Film	1E : 25V	K : ±10%	DL : For charge and discharge
CK : Ceramic	1V : 35V	M : ±20%	HF : For assuring high frequency
CC : Ceramic	1H : 50V	Z : ±80%	U : UL part
CP : Oil	2A : 100V	-20%	C : CSA part
CM : Mica	2B : 125V	P : ±100%	W : UL-CSA type
CF : Metallized	2C : 160V	-0%	F : Lead wire forming
CH : Metallized	2D : 200V	C : ±0.25pF	
	2E : 250V	D : ±0.5pF	
	2H : 500V	= : Others	
	2J : 630V		

**\* Capacity (electrolyte only)**

2 2 2 ⇒ 2200µF  
 Indicates number of zeros after effective number.  
 2-digit effective number.

• Units: µF.

2 R 2 ⇒ 2.2µF  
 1-digit effective number.  
 2-digit effective number, decimal point indicated by R.

• Units: µF.

**\* Capacity (except electrolyte)**

2 2 2 ⇒ 2200pF = 0.0022µF  
 (More than 2) — Indicates number of zeros after effective number.  
 2-digit effective number.

• Units: µF.

2 2 1 ⇒ 220pF  
 (0 or 1) — Indicates number of zeros after effective number.  
 2-digit effective number.

• Units: pF.

• When the dielectric strength is indicated in AC, "AC" is included after the dielectric strength value.

**P.W.B. ASS'Y PARTS LIST**  
**1U-2615C, D MAIN UNIT ASS'Y (C : Multi-Voltage, D : U.K.)**

Ref. No.	Part No.	Part Name	Remarks	Ref. No.	Part No.	Part Name	Remarks
<b>SEMICONDUCTORS</b>				<b>RESISTORS GROUP</b>			
IC451	263 0322 004	IC BA4558		<b>(Not included Carbon Film ±5% 1/4 W Type. Refer to the Schematic Diagram for those parts.)</b>			
IC801	262 1839 108	IC TMP87CK70AF-****	μ-com	△ R311-314	241 2380 963	Carbon Film 2.2kohm 1/4W(NB)	RD14B2E222JNBS
TR301-304	271 0094 919	Transistor 2SA970(BL)		△ R317 318	241 2377 976	Carbon Film 130ohm 1/4W(NB)	RD14B2E131JNBS
TR305,306	271 0131 924	Transistor 2SA988(E/F)		△ R325 326	241 2315 967	Fusible 68ohm 1/4W(NB)	RD14B2E680GFRRS
TR307-312	273 0235 923	Transistor 2SC1841(E/F)		△ R327 328	241 2378 920	Carbon Film 220ohm 1/4W(NB)	RD14B2E221JNBS
TR313,314	273 0198 002	Transistor 2SC1815(Y)		△ R329-336	244 2043 982	Metal Oxide 0.22ohm 1W(NB)	RS14B3AR22JNBS(S)
TR315,316	274 0060 900	Transistor 2SD667A(C)		△ R341-344	241 2380 950	Carbon Film 2kohm 1/4W(NB)	RD14B2E202JNBS
TR319,320	272 0053 908	Transistor 2SB647A(C)		△ R345 346	244 2051 987	Metal Oxide 4.7ohm 1W(NB)	RS14B3A4R7JNBS(S)
TR323,324	273 0235 923	Transistor 2SC1841(E/F)		△ R355 356	241 2377 976	Carbon Film 130ohm 1/4W(NB)	RD14B2E131JNBS
TR351	271 0131 924	Transistor 2SA988(E/F)		△ R365-368	244 2051 958	Metal Oxide 220ohm 1W(NB)	RS14B3A221JNBS(S)
TR352	273 0253 918	Transistor 2SC2878(A/B)		△ R369-371	244 2051 987	Metal Oxide 4.7ohm 1W(NB)	RS14B3A4R7JNBS(S)
TR353	272 0053 908	Transistor 2SA647A(C)		△ R372	241 2376 964	Carbon Film 47ohm 1/4W(NB)	RD14B2E470JNBS
TR355,356	271 0131 924	Transistor 2SA988(E/F)		△ R375-378	244 2043 982	Metal Oxide 0.22ohm 1W(NB)	RS14B3AR22JNBS(S)
TR357	273 0235 923	Transistor 2SC1841(E/F)		△ R406 407	241 2380 963	Carbon Film 2.2kohm 1/4W(NB)	RD14B2E222JNBS
TR358	271 0131 924	Transistor 2SA988(E/F)		△ R409	241 2377 976	Carbon Film 130ohm 1/4W(NB)	RD14B2E131JNBS
TR401,402	271 0094 919	Transistor 2SA970(BL)		△ R413	241 2315 967	Fusible 68ohm 1/4W(NB)	RD14B2E680GFRRS
TR403	271 0131 924	Transistor 2SA988(E/F)		△ R416	241 2378 920	Carbon Film 220ohm 1/4W(NB)	RD14B2E221JNBS
TR404-406	273 0235 923	Transistor 2SC1841(E/F)		△ R417-420	244 2043 982	Metal Oxide 0.22ohm 1W(NB)	RS14B3AR22JNBS(S)
TR407	273 0198 002	Transistor 2SC1815(Y)		△ R423 424	241 2380 950	Carbon Film 2kohm 1/4W(NB)	RD14B2E202JNBS
TR408	274 0060 900	Transistor 2SD667A(C)		△ R425	244 2051 987	Metal Oxide 4.7ohm 1W(NB)	RS14B3A4R7JNBS(S)
TR409	272 0053 908	Transistor 2SB647A(C)		△ R430	241 2377 976	Carbon Film 130ohm 1/4W(NB)	RD14B2E131JNBS
TR412	273 0235 923	Transistor 2SC1841(E/F)		△ R480,481	241 2376 964	Carbon Film 47ohm 1/4W(NB)	RD14B2E470JNBS
TR480-485	273 0317 906	Transistor 2SC2458(BL)		△ R482	244 2051 974	Metal Oxide 1kohm 1W(NB)	RS14B3A102JNBS(S)
TR486	271 0191 906	Transistor 2SA1048(GR)		△ R491	244 2050 988	Metal Oxide 2kohm 1W(NB)	RS14B3A202JNBS(S)
TR487,488	273 0317 906	Transistor 2SC2458(BL)		△ R809	241 2387 940	Carbon Film 4.7ohm 1/4W(NB)	RD14B2E4R7JNBS
TR489	271 0191 906	Transistor 2SA1048(GR)		VR301,302	211 6093 912	Semi Fixed VR 4.7kohm	V06PB472
TR490	273 0317 906	Transistor 2SC2458(BL)		VR401	211 6093 912	Semi Fixed VR 4.7kohm	V06PB472
TR801	269 0024 902	Transistor RN2201	Built in Resistor	VR451	211 0798 103	Variable Resistor 100kohm	Balance
TR802	269 0029 907	Transistor RN1204	Built in Resistor	VR452	211 0797 117	Variable Resistor 30kohm	Bass
TR805	273 0198 918	Transistor 2SC1815(BL)		VR453	211 0797 104	Variable Resistor 5kohm	Treble
TR806	269 0023 903	Transistor RN1201	Built in Resistor	RA802	246 2052 005	Resistor Array 10kohm x4	RK99==103JP4
D301-306	276 0432 903	Diode 1SS270A		RA803	246 2054 003	Resistor Array 10kohm x7	RK99==103JP7
D307-310	276 0049 914	Diode 1S2076A		RA804	246 2076 023	Resistor Array 1.5kohm x3	RK99==152JP3
D311-316	276 0432 903	Diode 1SS270A		RA805	246 2052 018	Resistor Array 4.7kohm x4	RK99==472JP4
△ D351	276 0424 005	Diode 4D4B42(LC1)	Bridge	<b>CAPACITORS GROUP</b>			
D352	276 0432 903	Diode 1SS270A		C301,302	254 4254 909	Electrolytic 10μF/16V	CE04W1C100M
D401-403	276 0432 903	Diode 1SS270A		C303,304	253 1179 903	Ceramic 100pF/50V	CK45B1H101K
D404,405	276 0049 914	Diode 1S2076A		C305,306	253 1179 945	Ceramic 220pF/50V	CK45B1H221K
D406	276 0432 903	Diode 1SS270A		C307,308	255 1264 966	Plastic Film 0.0033μF/50V	CQ93M1H332J(B)
D480,481	276 0432 903	Diode 1SS270A		C309,310	253 4536 983	Ceramic 22pF/50V	CC45SL1H220J
D482	276 0049 914	Diode 1S2076A		C311,312	254 4256 952	Electrolytic 220μF/25V	CE04W1E221M
D483,484	276 0432 903	Diode 1SS270A		C313-316	255 1264 908	Plastic Film 0.001μF/50V	CQ93M1H102J(B)
D485	276 0049 914	Diode 1S2076A		C317,318	253 4470 900	Ceramic 10pF/500V	CC45SL2H100D
D486	276 0432 903	Diode 1SS270A		C321,322	254 4260 948	Electrolytic 1μF/50V	CE04W1H010M
D801-804	276 0432 903	Diode 1SS270A		C323,324	253 1128 909	Ceramic 220pF/500V	CK45B2H221K
D807	276 0049 914	Diode 1S2076A		C325,326	256 1034 979	Metalized 0.1μF/50V	CF93A1H104J
D809-811	276 0432 903	Diode 1SS270A		C327,328	255 1265 936	Plastic Film 0.01μF/50V	CQ93M1H103J(B)
ZD351,352	276 0473 904	Zener Diode HZS12A-1	12V	C329-332	254 4262 904	Electrolytic 4.7μF/63V	CE04W1J4R7M
ZD480	276 0466 908	Zener Diode HZS7C-1	7V	C333-335	253 1146 907	Ceramic 0.01μF/50V	CK45F1H103Z
ZD801	276 0454 907	Zener Diode HZS3C-1	3V	C351	255 1265 936	Plastic Film 0.01μF/50V	CQ93M1H103J(B)
SC480	279 0016 904	Thyristor SF0R1A42		C352,353	254 4254 941	Electrolytic 100μF/16V	CE04W1C101M
				C353,354	254 4365 717	Electrolytic 6800μF/56V	CE04W==682MC(DL)
				C353,354	254 4374 708	Electrolytic 8200μF/56V	CE04W==822MC(DL)
							U.K. model

Ref. No.	Part No.	Part Name	Remarks	Ref. No.	Part No.	Part Name	Remarks	Q'ty
C355,356	256 1034 979	Metalized 0.1μF/50V	CF93A1H104J		204 8404 006	3P Pin Jack	V-AUX	1
C359	256 1034 979	Metalized 0.1μF/50V	CF93A1H104J		205 0315 002	2P Connector Base	Pre- Out	1
C363	256 1042 903	Metalized 0.1μF/250V	CF93A2E104K		205 0578 001	S-Terminal		1
C364,365	254 4260 948	Electrolytic 1μF/50V	CE04W1H010M					
C370	253 1182 903	Ceramic 0.047μF/12V	CK45F==473Z		415 0309 071	PVC Tube(L=10)		6
C371	254 4258 918	Electrolytic 10μF/35V	CE04W1V100M	CN3A	205 0343 032	3P Conn. Base(KR-PH)		2
C372,373	256 1034 979	Metalized 0.1μF/50V	CF93A1H104J	CN4A	205 0343 045	4P Conn. Base(KR-PH)		1
C375,376	254 4260 948	Electrolytic 1μF/50V	CE04W1H010M	CN5A	205 0343 058	5P Conn. Base(KR-PH)		1
				CN6A	205 0696 064	JL Connector(BT-E)		1
C401	254 4254 909	Electrolytic 10μF/16V	CE04W1C100M		205 0696 006	JL Connector(BT-E)-10P		1
C402	253 1179 903	Ceramic 100pF/50V	CK45B1H101K	CN8A	205 0696 080	JL Connector(BT-E)		1
C403	253 1179 945	Ceramic 220pF/50V	CK45B1H221K	CN8C	205 0535 002	8P Conn. Base		1
C404	255 1264 966	Plastic Film 0.0033μF/50V	CQ93M1H332J(B)	CN9A	205 0343 090	9P Conn. Base(KR-PH)		1
C405	253 4536 983	Ceramic 22pF/50V	CC45SL1H220J	CN10A	205 0535 057	10P Conn. Base		1
C406	254 4256 952	Electrolytic 220μF/25V	CE04W1E221M	CN12A	205 0375 026	12P Conn. Base(KR-PH)		1
C407,408	255 1264 908	Plastic Film 0.001μF/50V	CQ93M1H102J(B)	CN13A	205 0707 005	13P Conn. Base		1
C409	253 4470 900	Ceramic 10pF/500V	CC45SL2H100D					
C411	254 4260 948	Electrolytic 1μF/50V	CE04W1H010M					
C412	253 1128 909	Ceramic 220pF/500V	CK45B2H221K					
C413	256 1034 979	Metalized 0.1μF/50V	CF93A1H104J					
C414	255 1265 936	Plastic Film 0.01μF/50V	CQ93M1H103J(B)					
C415,416	254 4262 904	Electrolytic 4.7μF/63V	CE04W1J4R7M					
C451,452	254 4254 909	Electrolytic 10μF/16V	CE04W1C100M					
C453-456	253 1179 903	Ceramic 100pF/50V	CK45B1H101K					
C457,458	254 4254 938	Electrolytic 47μF/16V	CE04W1C470M					
C459,460	255 1264 908	Plastic Film 0.001μF/50V	CQ93M1H102J(B)					
C461,462	256 1034 995	Metalized 0.15μF/50V	CF93A1H154J					
C463,464	254 4260 948	Electrolytic 1μF/50V	CE04W1H010M					
C465,466	255 1264 937	Plastic Film 0.0018μF/50V	CQ93M1H182J(B)					
C467,468	255 1265 949	Plastic Film 0.012μF/50V	CQ93M1H123J(B)					
C469,470	256 1034 953	Metalized 0.068μF/50V	CF93A1H683J					
C471,472	254 4260 935	Electrolytic 0.47μF/50V	CE04W1HR47M					
C473	256 1034 937	Metalized 0.047μF/50V	CF93A1H473J					
C474	253 1181 917	Ceramic 0.022μF/50V	CK45F1H223Z					
C480	254 4260 980	Electrolytic 10μF/50V	CE04W1H100M					
C481	254 4260 993	Electrolytic 22μF/50V	CE04W1H220M					
C482,483	254 4250 945	Electrolytic 330μF/6.3V	CE04W0J331M					
C803	253 1181 904	Ceramic 0.01μF/50V	CK45F1H103Z					
C804	254 4250 932	Electrolytic 220μF/6.3V	CE04W0J221M					
C805	256 1034 982	Metalized 0.12μF/50V	CF93A1H124J					
C811	253 1181 904	Ceramic 0.01μF/50V	CK45F1H103Z					
C812	254 4258 905	Electrolytic 4.7μF/35V	CE04W1V4R7M					
C813	255 1265 936	Plastic Film 0.01μF/50V	CQ93M1H103J(B)					
C814	253 1181 904	Ceramic 0.01μF/50V	CK45F1H103Z					
C819	254 4250 783	Electrolytic 3300μF/6.3V	CE04W0J332MC					
<b>OTHER GROUP</b>								<b>Q'ty</b>
	—	(P.W.Board)						1
L301,302	235 0068 004	Inductor 1μH						2
L303	235 0060 989	Inductor 120μH						1
L401	235 0068 004	Inductor 1 μH						1
RL480	214 0167 005	Relay(G5Z-2A)						1
RL481	214 9003 005	Relay						1
RL482	214 0162 000	Relay(A12W-K)						1
XL801	399 0191 903	Ceramic Resonator	CST 4.00MGW19MGW					1
	204 8354 004	Headphone Jack						
	205 0550 003	4P Terminal	Front					1
	205 0695 007	2P Push Terminal(V-1)	Center					1

1U-2616C, D REAR AMP. UNIT ASS'Y  
(C : Multi-Voltage, D : U.K.)

Ref. No.	Part No.	Part Name	Remarks
<b>SEMICONDUCTORS</b>			
IC501,502	263 0855 005	IC SI-18752	
IC503	263 0812 006	IC NJM7815FA(S)	Regulator +15V
IC504	263 0561 001	IC NJM7915FA	Regulator -15V
IC505,506	268 0074 904	IC ICP-N20	IC Protector 20V
IC507	263 0809 006	IC NJM7805FA(S)	Regulator +5V
IC510	263 0809 006	IC NJM7805FA(S)	Regulator +5V
IC551	263 0793 002	IC NJM7806FA(S)	Regulator +6V
IC552	268 0073 905	IC ICP-N15	IC Protector 15V
IC601	263 0856 004	IC BA7625	
IC603	268 0073 905	IC ICP-N15	IC Protector 15V
IC651	263 0856 004	IC BA7625	
IC652	263 0857 003	IC BA7626	
IC701	499 0150 008	IC SBX1610-52	Remocon Receiver
IC702	262 1564 004	IC MSC1937-01	μ-com
TR501	273 0198 918	Transistor 2SC1815(BL)	
TR503	269 0023 903	Transistor RN1201	Built in Resistor
TR504	272 0053 908	Transistor 2SB647A(C)	
TR551,552	273 0317 906	Transistor 2SC2458(BL)	
TR601,602	271 0102 924	Transistor 2SA1015(GR)	
TR651-654	271 0102 924	Transistor 2SA1015(GR)	
D501	276 0432 903	Diode 1SS270A	
▲ D502	276 0305 001	Diode S4VB20	Bridge
D551	276 0432 903	Diode 1SS270A	
D552-557	276 0553 905	Diode 1SR35-200A	
D601-603	276 0432 903	Diode 1SS270A	
D604-607	276 0548 910	Diode DSM1D2(Type-3)	
D701	276 0432 903	Diode 1SS270A	
ZD551	276 0465 909	Zener Diode HZS7B-1	7V
ZD701	276 0467 907	Zener Diode HZS9A-1	9V
PT501	279 0034 067	Thermistor PTH9M04BB222TS2F333	
LD701	393 9434 906	LED SEL1210S	Red
FL701	393 4131 000	FLD (FIP14PM8) Ass'y	

<b>RESISTORS GROUP</b>			
(Not included Carbon Film ±5% 1/4 W Type. Refer to the Schematic Diagram for those parts.)			
▲ R509,510	244 2051 987	Metal Oxide 4.7ohm 1W(NB)	RS14B3A4R7JNBS(S)
▲ R513	241 2376 964	Carbon Film 47ohm 1/4W(NB)	RD14B2E470JNBS
▲ R515	241 2387 940	Carbon Film 4.7ohm 1/4W(NB)	RD14B2E4R7JNBS
▲ R556	241 2375 978	Carbon Film 20ohm 1/4W(NB)	RD14B2E200JNBS
▲ R622	241 2387 908	Carbon Film 1ohm 1/4W(NB)	RD14B2E010JNBS

<b>CAPACITORS GROUP</b>			
C501,502	253 1179 903	Ceramic 100pF/50V	CK45B1H101K
C503,504	254 4260 951	Electrolytic 2.2μF/50V	CE04W1H2R2M
C505,506	254 4254 938	Electrolytic 47μF/16V	CE04W1C470M
C511,512	256 1034 979	Metalized 0.1μF/50V	CF93A1H104J
C513,514	253 1181 904	Ceramic 0.01μF/50V	CK45F1H103Z
C515	254 4254 909	Electrolytic 10μF/16V	CE04W1C100M

Ref. No.	Part No.	Part Name	Remarks
C517,518	254 4259 014	Electrolytic 3300μF/35V	CE04W1V332M
C519,520	253 1181 904	Ceramic 0.01μF/50V	CK45F1H103Z
C521,522	254 4258 918	Electrolytic 10μF/35V	CE04W1V100M
C524	256 1042 903	Metalized 0.1μF/250V	CF93A2E104K
C526	254 4254 909	Electrolytic 10μF/16V	CE04W1C100M
C529,530	254 4260 948	Electrolytic 1μF/50V	CE04W1H010M
C533	253 1146 907	Ceramic 0.01μF/50V	CK45F1H103Z
C534	254 4260 948	Electrolytic 1μF/50V	CE04W1H010M
C551	253 1181 904	Ceramic 0.01μF/50V	CK45F1H103Z
C552	254 4254 909	Electrolytic 10μF/16V	CE04W1C100M
C554	254 4260 948	Electrolytic 1μF/50V	CE04W1H010M
C555	254 4256 790	Electrolytic 2200μF/25V	CE04W1E222MC
C556,557	253 1181 904	Ceramic 0.01μF/50V	CK45F1H103Z
C558	254 4260 948	Electrolytic 1μF/50V	CE04W1H010M
▲ C559	253 8014 702	Ceramic 0.01μF/400V(AG)	CK45F2GAC103MC
C601	253 9039 906	BC Ceramic 0.1μF/25V	CK45=1E104Z
C602	254 4260 948	Electrolytic 1μF/50V	CE04W1H010M
C603,604	254 4258 905	Electrolytic 4.7μF/35V	CE04W1V4R7M
C605,606	254 4250 958	Electrolytic 470μF/6.3V	CE04W0J471M
C609	254 4252 930	Electrolytic 100μF/10V	CE04W1A101M
C610	253 1181 904	Ceramic 0.01μF/50V	CK45F1H103Z
C611	254 4254 909	Electrolytic 10μF/16V	CE04W1C100M
C612	254 4254 792	Electrolytic 2200μF/16V	CE04W1C222MC
C613	253 1181 904	Ceramic 0.01μF/50V	CK45F1H103Z
C614	254 4258 905	Electrolytic 4.7μF/35V	CE04W1V4R7M
C651	253 1146 907	Ceramic 0.01μF/50V	CK45F1H103Z
C652-655	254 4258 905	Electrolytic 4.7μF/35V	CE04W1V4R7M
C656	254 4250 932	Electrolytic 220μF/6.3V	CE04W0J221M
C657	254 4250 958	Electrolytic 470μF/6.3V	CE04W0J471M
C658	254 4250 932	Electrolytic 220μF/6.3V	CE04W0J221M
C659	254 4250 958	Electrolytic 470μF/6.3V	CE04W0J471M
C664	254 4252 930	Electrolytic 100μF/10V	CE04W1A101M
C665,666	253 1181 917	Ceramic 0.022μF/50V	CK45F1H223Z
C667,668	254 4258 905	Electrolytic 4.7μF/35V	CE04W1V4R7M
C669	253 1146 907	Ceramic 0.01μF/50V	CK45F1H103Z
C701	256 1034 979	Metalized 0.1μF/50V	CF93A1H104J
C702	254 4261 921	Electrolytic 100μF/50V	CE04W1H101M
C703	254 4250 945	Electrolytic 330μF/6.3V	CE04W0J331M
C704	253 1146 907	Ceramic 0.01μF/50V	CK45F1H103Z

<b>OTHER GROUP</b>				Qty
		(P.W.Board)		1
L501,502	235 0068 004	Inductor 1μH		2
L701	235 0060 989	Inductor 120μH		1
RL501	214 0167 005	Relay(G5Z-2A)	Rear	1
▲ RL551	214 0120 013	Relay(TV-8)	Pr.	1
S701-707	212 4388 907	Tact Switch		7
S718-722	212 4388 907	Tact Switch		5
▲	212 2611 003	Slide Switch(Vol.Sel.SW)	Multi-Voltage model only	2
▲	233 6068 002	Power Trans(Mini)	Multi-Voltage model	1
▲	233 6067 003	Power Trans(Mini)	U.K. model	1
	202 0022 008	Fuse Holder	Multi-Voltage model	4
	202 0022 008	Fuse Holder	U.K. model	2
▲ F001	206 1015 087	Fuse 4.0A(T) 125V	Multi-Voltage model	1
▲ F002	206 1015 061	Fuse 2A(T) 250V	Multi-Voltage model	1
▲ F001	206 1015 032	Fuse 2.5A(T)	U.K. model	1



1U-2617C SURROUND UNIT ASS'Y

Ref. No.	Part No.	Part Name	Remarks	Q'ty	Ref. No.	Part No.	Part Name	Remarks
	513 2049 031	Fuse Label	Multi-Voltage model	1	<b>SEMICONDUCTORS</b>			
	513 2049 044	Fuse Label	Multi-Voltage model	1	IC101	263 0672 903	IC BA4558F	
	513 2018 062	Fuse Label	U.K. model	1	IC102	262 1227 008	IC LC7821	
	204 8309 004	4P Pin Jack(C-GND)	Video	1	IC103	263 0359 006	IC LC4966	
	205 0592 003	4P Push Terminal	Rear	1	IC104,105	263 0672 903	IC BA4558F	
	205 0075 025	2P Terminal		2	IC106	262 1609 105	IC F71002B	μ-com
	204 8414 012	2P S-Terminal		2	IC107	262 1610 000	IC HM65256BLFP-10T	
CN3D	205 0343 032	3P Conn. Base(KR-PH)		2	IC108	262 1229 006	IC LC7823	
CN4A	205 0343 045	4P Conn. Base(KR-PH)		1	IC109,110	263 0892 903	IC NJM2082M	
CN5A	205 0343 058	5P Conn. Base(KR-PH)		1	IC111,112	263 0898 907	IC NJM5532MD	
CN8A	205 0748 080	JL Connector(R)-8 P		1	IC113,114	263 0892 903	IC NJM2082M	
CN9A	205 0343 090	9P Conn. Base(KR-PH)		1	IC115-117	263 0672 903	IC BA4558F	
CN12A	205 0375 026	12P Conn. Base(KR-PH)		1	IC251	262 0625 009	IC TC9176P	
	203 0418 000	1P SIN Cord Ass'y		1	IC253	263 0672 903	IC BA4558F	
	205 0748 006	JL Connector(R)-10 P		1	IC255	263 0476 002	IC LB1639	
	415 0309 000	P.V.C. Tube(L=15)		2	IC256,257	263 0672 903	IC BA4558F	
	415 0299 000	Condenser Cover		1	TR101	269 0054 901	Transistor DTC144EK	Built in Resistor
					D101-109	276 0432 903	Diode 1SS270A	
					D251,252	276 0432 903	Diode 1SS270A	
					<b>RESISTORS GROUP</b>			
					<b>(Not included Carbon Film ±5% 1/4 W Type. Refer to the Schematic Diagram for those parts.)</b>			
					R076-078	241 2400 995	Carbon Film 10kohm 1/4W	RD14B2E103J(5)
					R101,102	247 0006 946	Chip Carbon 390ohm 1/10W	RM73B-391J
					R103,104	247 0011 986	Chip Carbon 68kohm 1/10W	RM73B-683J
					R105,106	247 0012 969	Chip Carbon 150kohm 1/10W	RM73B-154J
					R107,108	247 0004 922	Chip Carbon 47ohm 1/10W	RM73B-470J
					R109,110	247 0007 945	Chip Carbon 1kohm 1/10W	RM73B-102J
					R111,112	247 0014 909	Chip Carbon 560kohm 1/10W	RM73B-564J
					R113,114	247 0011 944	Chip Carbon 47kohm 1/10W	RM73B-473J
					R115,116	247 0003 949	Chip Carbon 22ohm 1/10W	RM73B-220J
					R117,118	247 0005 905	Chip Carbon 100ohm 1/10W	RM73B-101J
					R119,120	247 0013 984	Chip Carbon 470kohm 1/10W	RM73B-474J
					R121-132	247 0015 966	Chip Carbon 2.7Mohm 1/10W	RM73B-275J
					R133-144	247 0006 962	Chip Carbon 470ohm 1/10W	RM73B-471J
					R145,146	247 0014 925	Chip Carbon 680kohm 1/10W	RM73B-684J
					R147,148	247 0009 985	Chip Carbon 10kohm 1/10W	RM73B-103J
					R149,150	247 0009 927	Chip Carbon 5.6kohm 1/10W	RM73B-562J
					R151,152	247 0006 962	Chip Carbon 470ohm 1/10W	RM73B-471J
					R153,154	247 0011 973	Chip Carbon 62kohm 1/10W	RM73B-623J
					R155,156	247 0013 984	Chip Carbon 470kohm 1/10W	RM73B-474J
					R157-160	247 0005 905	Chip Carbon 100ohm 1/10W	RM73B-101J
					R161-164	247 0004 922	Chip Carbon 47ohm 1/10W	RM73B-470J
					R165,166	247 0009 985	Chip Carbon 10kohm 1/10W	RM73B-103J
					R167-170	247 0009 901	Chip Carbon 4.7kohm 1/10W	RM73B-472J
					R171-174	247 0005 905	Chip Carbon 100ohm 1/10W	RM73B-101J
					R175,176	247 0009 985	Chip Carbon 10kohm 1/10W	RM73B-103J
					R177	247 0005 989	Chip Carbon 220ohm 1/10W	RM73B-221J
					R178	247 0014 967	Chip Carbon 1 Mohm 1/10W	RM73B-105J
					R179-182	247 0009 985	Chip Carbon 10kohm 1/10W	RM73B-103J
					R183,184	247 0009 927	Chip Carbon 5.6kohm 1/10W	RM73B-562J
					R185,186	247 0009 985	Chip Carbon 10kohm 1/10W	RM73B-103J
					R187	247 0009 927	Chip Carbon 5.6kohm 1/10W	RM73B-562J
					R188	247 0014 967	Chip Carbon 1 Mohm 1/10W	RM73B-105J
					R189	247 0009 927	Chip Carbon 5.6kohm 1/10W	RM73B-562J
					R190,191	247 0009 943	Chip Carbon 6.8kohm 1/10W	RM73B-682J
					R192	247 0009 943	Chip Carbon 6.8kohm 1/10W	RM73B-682J

Ref. No.	Part No.	Part Name	Remarks
R194,195	247 0009 930	Chip Carbon 6.2kohm 1/10W	RM73B-622J
R196,197	247 0009 943	Chip Carbon 6.8kohm 1/10W	RM73B-682J
R198	247 0009 943	Chip Carbon 6.8kohm 1/10W	RM73B-682J
R199	247 0005 905	Chip Carbon 100ohm 1/10W	RM73B-101J
R201,202	247 0009 943	Chip Carbon 6.8kohm 1/10W	RM73B-682J
R203,204	247 0005 905	Chip Carbon 100ohm 1/10W	RM73B-101J
R205,206	247 0007 945	Chip Carbon 1kohm 1/10W	RM73B-102J
R207-210	247 0009 985	Chip Carbon 10kohm 1/10W	RM73B-103J
R211,212	247 0005 905	Chip Carbon 100ohm 1/10W	RM73B-101J
R213,214	247 0007 945	Chip Carbon 1kohm 1/10W	RM73B-102J
R215,216	247 0008 960	Chip Carbon 3.3kohm 1/10W	RM73B-332J
R217-222	247 0009 985	Chip Carbon 10kohm 1/10W	RM73B-103J
R223,224	247 0005 905	Chip Carbon 100ohm 1/10W	RM73B-101J
R225,226	247 0011 944	Chip Carbon 47kohm 1/10W	RM73B-473J
R227,228	247 0005 905	Chip Carbon 100ohm 1/10W	RM73B-101J
R229,230	247 0011 944	Chip Carbon 47kohm 1/10W	RM73B-473J
R231-236	247 0009 985	Chip Carbon 10kohm 1/10W	RM73B-103J
R237,238	247 0005 905	Chip Carbon 100ohm 1/10W	RM73B-101J
R251	247 0012 927	Chip Carbon 100kohm 1/10W	RM73B-104J
R252	247 0013 900	Chip Carbon 220kohm 1/10W	RM73B-224J
R253	247 0008 960	Chip Carbon 3.3kohm 1/10W	RM73B-332J
R254	247 0007 945	Chip Carbon 1kohm 1/10W	RM73B-102J
R255	247 0005 905	Chip Carbon 100ohm 1/10W	RM73B-101J
R267,268	247 0009 985	Chip Carbon 10kohm 1/10W	RM73B-103J
R269	247 0013 984	Chip Carbon 470kohm 1/10W	RM73B-474J
R270	247 0005 905	Chip Carbon 100ohm 1/10W	RM73B-101J
R271	247 0009 927	Chip Carbon 5.6kohm 1/10W	RM73B-562J
R272	247 0007 945	Chip Carbon 1kohm 1/10W	RM73B-102J
R273	247 0005 905	Chip Carbon 100ohm 1/10W	RM73B-101J
R275,276	247 0013 984	Chip Carbon 470kohm 1/10W	RM73B-474J
R277,278	247 0005 905	Chip Carbon 100ohm 1/10W	RM73B-101J
R279,280	247 0009 969	Chip Carbon 8.2kohm 1/10W	RM73B-822J
R281,282	247 0007 945	Chip Carbon 1kohm 1/10W	RM73B-102J
R283,284	247 0005 905	Chip Carbon 100ohm 1/10W	RM73B-101J
R295,296	247 0006 962	Chip Carbon 470ohm 1/10W	RM73B-471J
R297,298	247 0015 966	Chip Carbon 2.7Mohm 1/10W	RM73B-275J
VR251	211 0637 002	Variable Resister100kohm	
<b>CAPACITORS GROUP</b>			
C101,102	257 0005 944	Chip Ceramic 220pF/50V	CC73SL1H221J
C103,104	254 4254 909	Electrolytic 10μF/16V	CE04W1C100M
C105,106	257 0004 961	Chip Ceramic 100pF/50V	CC73SL1H101J
C107,108	254 4254 925	Electrolytic 33μF/16V	CE04W1C330M
C109,110	255 1264 995	Plastic Film 0.0056μF/50V	CQ93M1H562J(B)
C111,112	257 0009 908	Chip Ceramic 1500pF/50V	CK73F1H152K
C113,114	257 0012 982	Chip Ceramic 0.022μF/50V	CK73F1H223Z
C115,116	254 4260 951	Electrolytic 2.2μF/50V	CE04W1H2R2M
C133-135	254 4260 948	Electrolytic 1μF/50V	CE04W1H010M
C136-138	257 0012 982	Chip Ceramic 0.022μF/50V	CK73F1H223Z
C139	257 0009 924	Chip Ceramic 2200pF/50V	CK73B1H222K
C140,141	257 0012 966	Chip Ceramic 0.01μF/50V	CK73F1H103Z
C142-144	257 0012 982	Chip Ceramic 0.022μF/50V	CK73F1H223Z
C145,146	254 4261 918	Electrolytic 47μF/50V	CE04W1H470M
C151,152	254 4254 909	Electrolytic 10μF/16V	CE04W1C100M
C153,154	257 0004 961	Chip Ceramic 100pF/50V	CC73SL1H101J
C157,158	254 4260 951	Electrolytic 2.2μF/50V	CE04W1H2R2M
C159,160	254 4260 948	Electrolytic 1μF/50V	CE04W1H010M
C161	254 4254 941	Electrolytic 100μF/16V	CE04W1C101M
C162	257 0012 966	Chip Ceramic 0.01μF/50V	CK73F1H103Z
C163	254 4252 930	Electrolytic 100μF/10V	CE04W1A101M
C164	257 0012 966	Chip Ceramic 0.01μF/50V	CK73F1H103Z

Ref. No.	Part No.	Part Name	Remarks	Q'ty
C164	257 0006 927	Chip Ceramic 470pF/50V	CC73SL1H471J	
C165	254 4254 938	Electrolytic 47μF/16V	CE04W1C470M	
C166	257 0006 927	Chip Ceramic 470pF/50V	CC73SL1H471J	
C167	254 4254 909	Electrolytic 10μF/16V	CE04W1C100M	
C168	257 0012 966	Chip Ceramic 0.01μF/50V	CK73F1H103Z	
C169,170	255 1264 966	Plastic Film 0.0033μF/50V	CQ93M1H332J(B)	
C171	254 4250 932	Electrolytic 220μF/6.3V	CE04W0J221M	
C172	257 0014 935	Chip Ceramic 0.1μF/25V	CK73F1E104Z	
C173	257 0008 983	Chip Ceramic 100pF/50V	CK73B1H102K	
C175,176	254 4254 909	Electrolytic 10μF/16V	CE04W1C100M	
C177,178	257 0004 961	Chip Ceramic 100pF/50V	CC73SL1H101J	
C179,180	254 4258 905	Electrolytic 4.7μF/35V	CE04W1V4R7M	
C181	254 4254 909	Electrolytic 10μF/16V	CE04W1C100M	
C182	257 0004 961	Chip Ceramic 100pF/50V	CC73SL1H101J	
C183	254 4258 905	Electrolytic 4.7μF/35V	CE04W1V4R7M	
C184	256 1035 936	Metalized 0.33μF/50V	CF93A1H334J	
C185,186	257 0004 961	Chip Ceramic 100pF/50V	CC73SL1H101J	
C187,188	254 4254 909	Electrolytic 10μF/16V	CE04W1C100M	
C189	257 0004 961	Chip Ceramic 100pF/50V	CC73SL1H101J	
C191-194	257 0004 961	Chip Ceramic 100pF/50V	CC73SL1H101J	
C196	257 0004 961	Chip Ceramic 100pF/50V	CC73SL1H101J	
C198	254 4260 948	Electrolytic 1μF/50V	CE04W1H010M	
C203,204	253 1126 901	Ceramic 150pF/500V	CK45B2H151K	
C205,206	257 0009 908	Chip Ceramic 1500pF/50V	CK73B1H152K	
C207,208	257 0005 944	Chip Ceramic 220pF/50V	CC73SL1H221J	
C209,210	257 0009 953	Chip Ceramic 3900pF/50V	CK73B1H392K	
C211,212	254 4260 966	Electrolytic 0.1μF/50V	CE04W1H0R1M	
C215,216	253 4488 905	Ceramic 56pF/500V	CC45SL2H560J	
C217,218	254 4260 966	Electrolytic 0.1μF/50V	CE04W1H0R1M	
C219,220	257 0009 908	Chip Ceramic 100pF/50V	CK73B1H152K	
C221,222	2			

Ref. No.	Part No.	Part Name	Remarks	Qty
CN8C	205 0536 001	8P Conn. Socket		1
CN7B	205 0343 074	7P Conn. Base(KR-PH)		2
CN10A	205 0536 056	10P Conn. Socket		1
CN13A	205 0708 004	13P Conn. Socket		1
	203 0426 005	1P Conn. Cord Ass'y		1
	414 0695 009	Shield Plate		1

BLOCK DIAGRAM

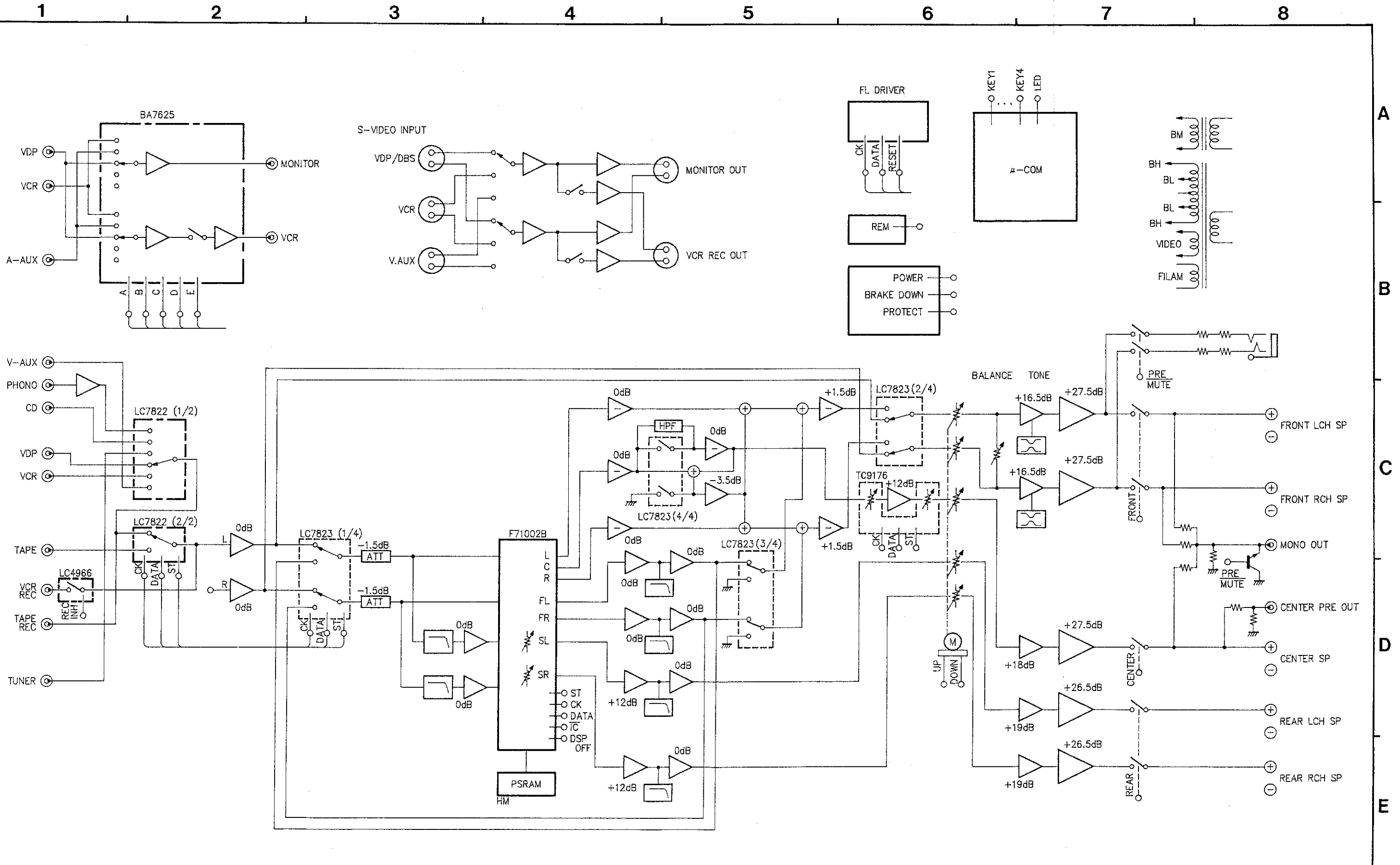

WIRING DIAGRAM

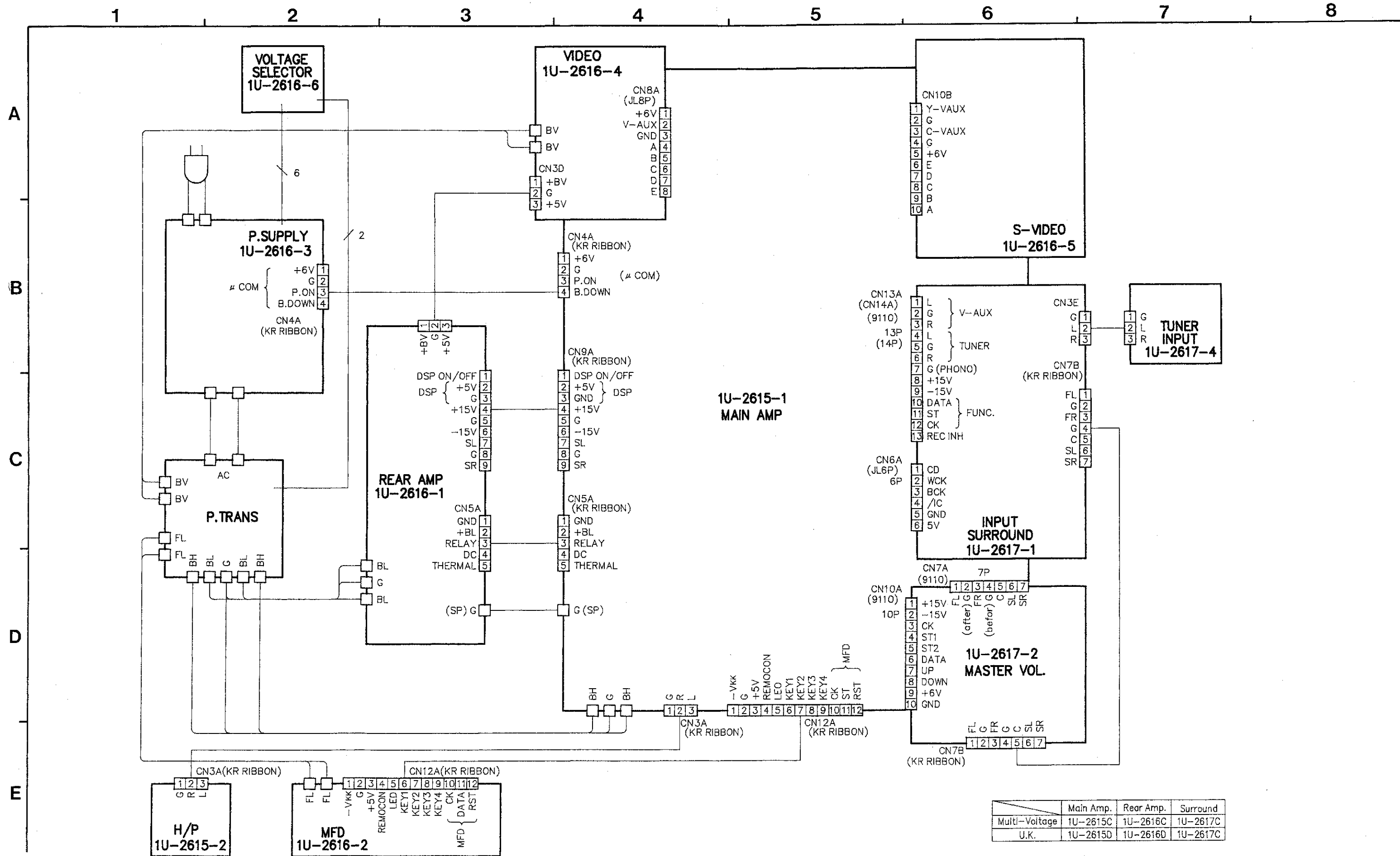

	Main Amp.	Rear Amp.	Surround
Multi-Voltage	1U-2615C	1U-2616C	1U-2617C
U.K.	1U-2615D	1U-2616D	1U-2617C

SCHEMATIC DIAGRAM-1/3

1 2 3 4 5 6 7 8

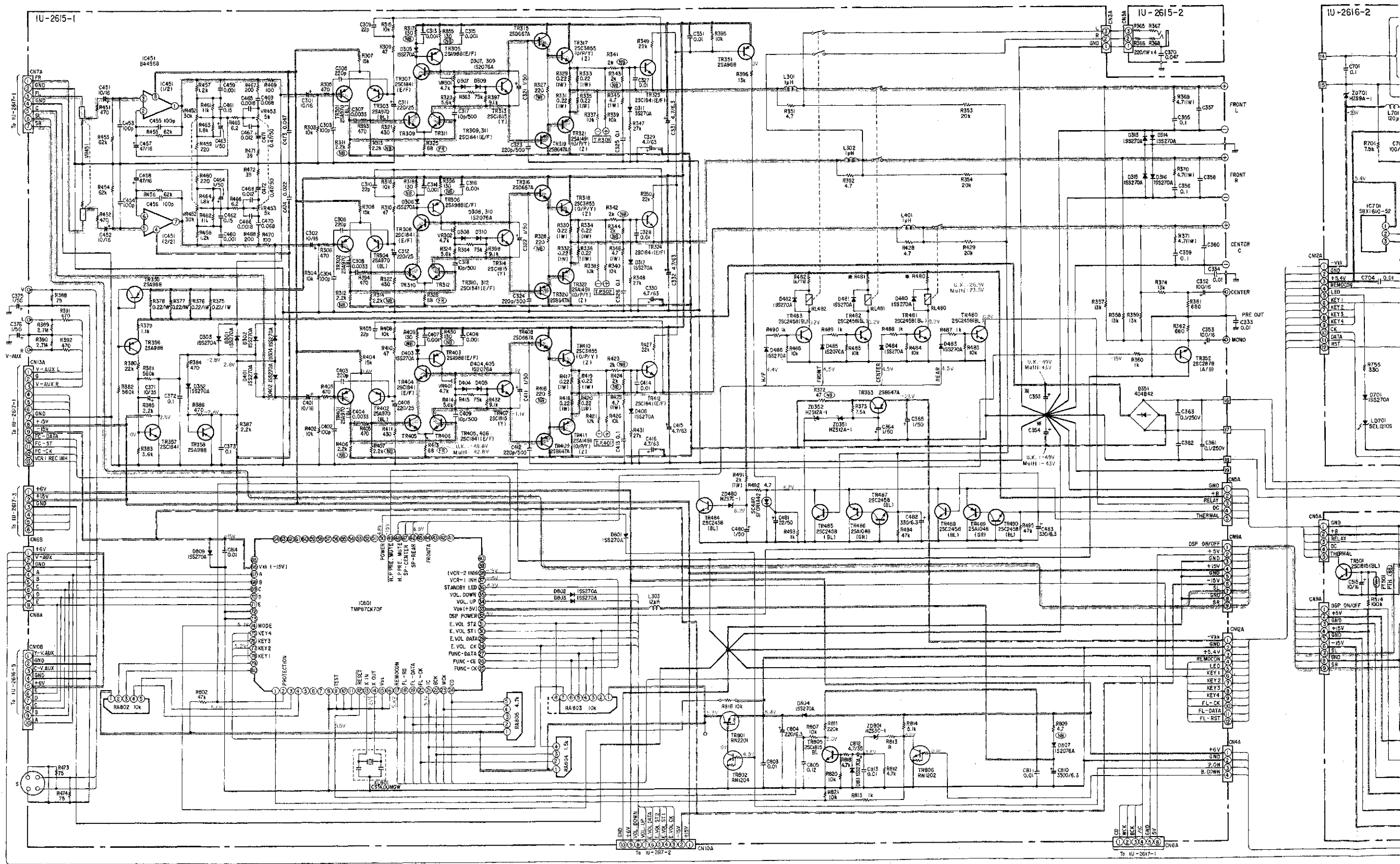

8 9 10 11 12 13 14 15

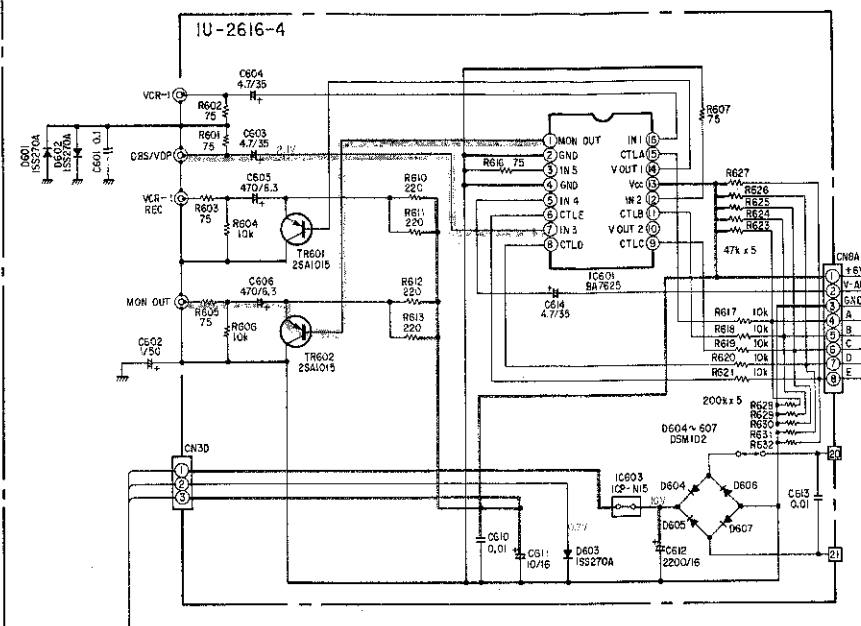
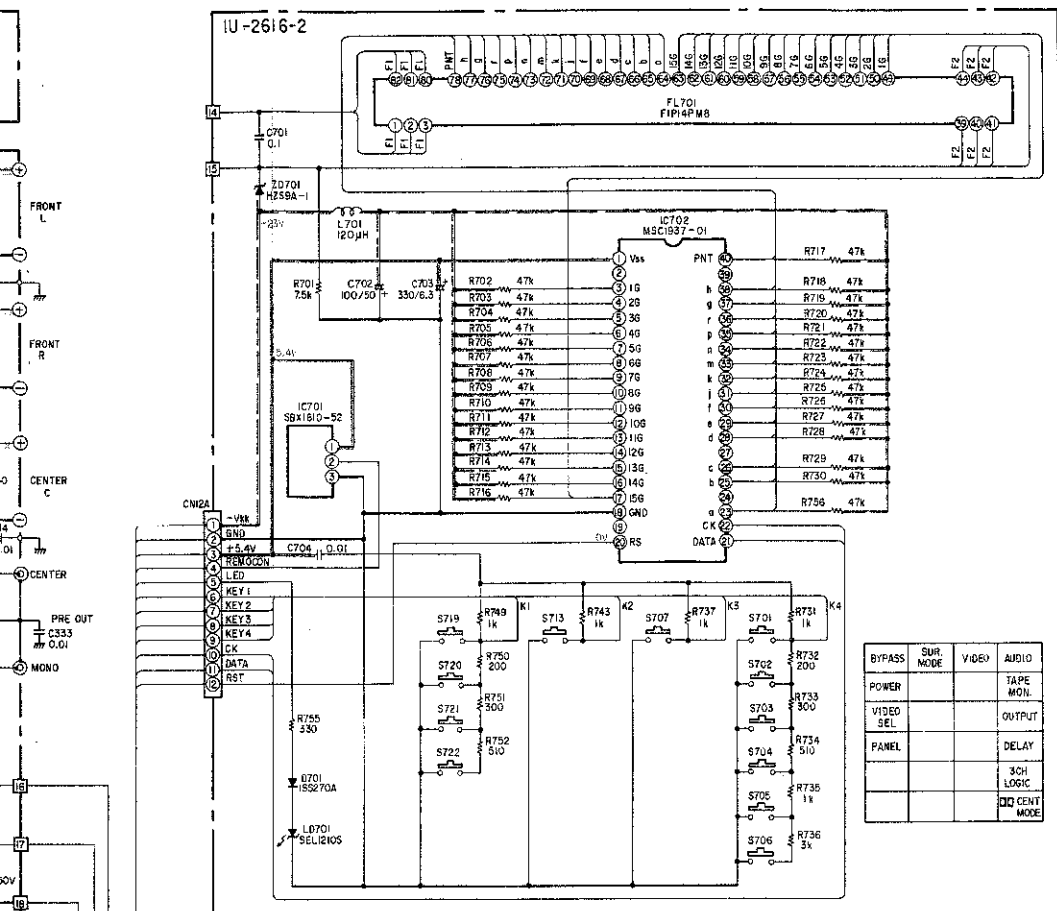

BYPASS	SUR. MODE	VIDEO	AUDIO
POWER		TAPE MON.	
VIDEO SEL.		OUTPUT	
PANEL		DELAY	
		SOH LOGIC	
		CENT. MODE	

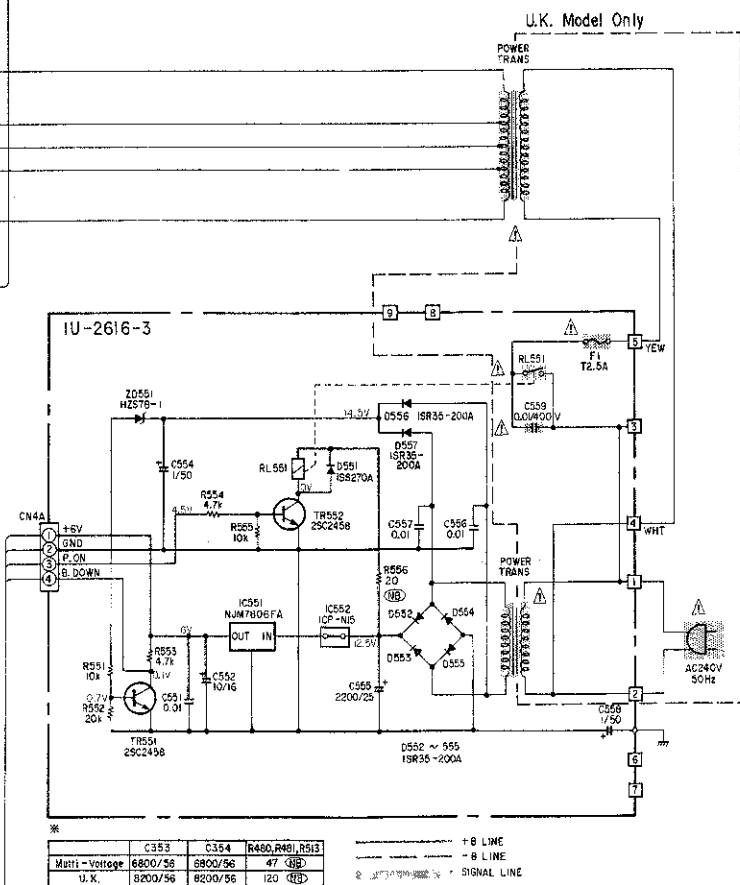
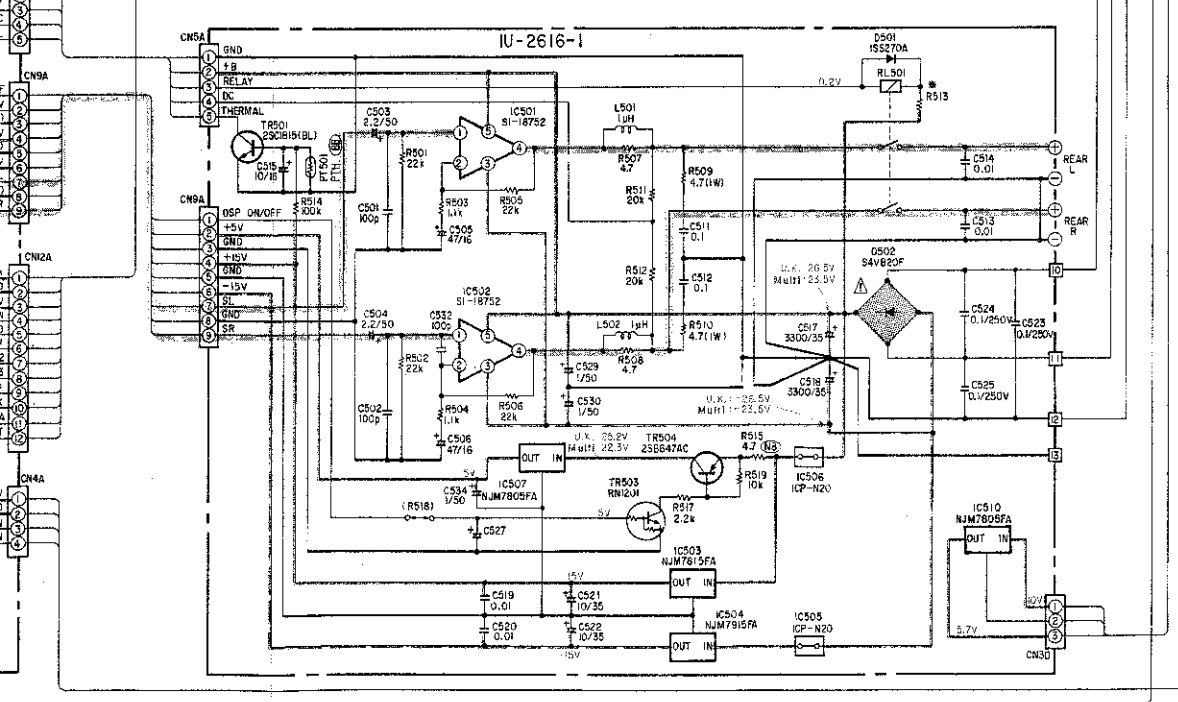

	C353	C354	R400, R401, R513
Multi-Voltage	8200/58	8200/56	47 Ω
U.K.	8200/56	8200/56	120 Ω

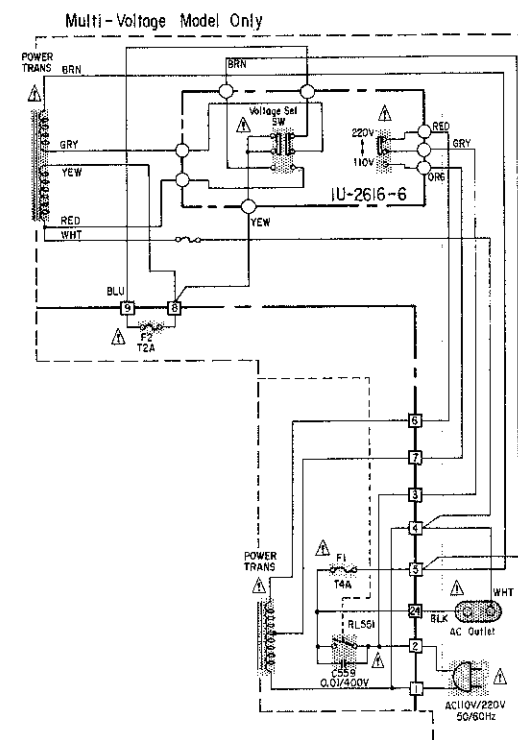

**NOTES**  
 ALL RESISTANCE VALUES IN OHM. k=1,000 OHM, M=1,000,000 OHM  
 ALL CAPACITANCE VALUES IN MICRO FARAD. P=MICRO-MICRO FARAD  
 EACH VOLTAGE AND CURRENT ARE MEASURED AT NO SIGNAL INPUT CONDITION.  
 CIRCUIT AND PARTS ARE SUBJECT TO CHANGE WITHOUT PRIOR NOTICE.

**WARNING:**  
 Parts marked with this symbol have critical characteristics. Use ONLY replacement parts recommended by the manufacturer.

**CAUTION:**  
 Before returning the unit to the customer, make sure you make either (1) a leakage current check or (2) a line to chassis resistance check. If the leakage current exceeds 0.5 milliamps, or if the resistance from chassis to either side of the power cord is less than 240 kohms, the unit is defective.

**WARNING:**  
 DO NOT return the unit to the customer until the problem is located and corrected.

A  
B  
C  
D  
E

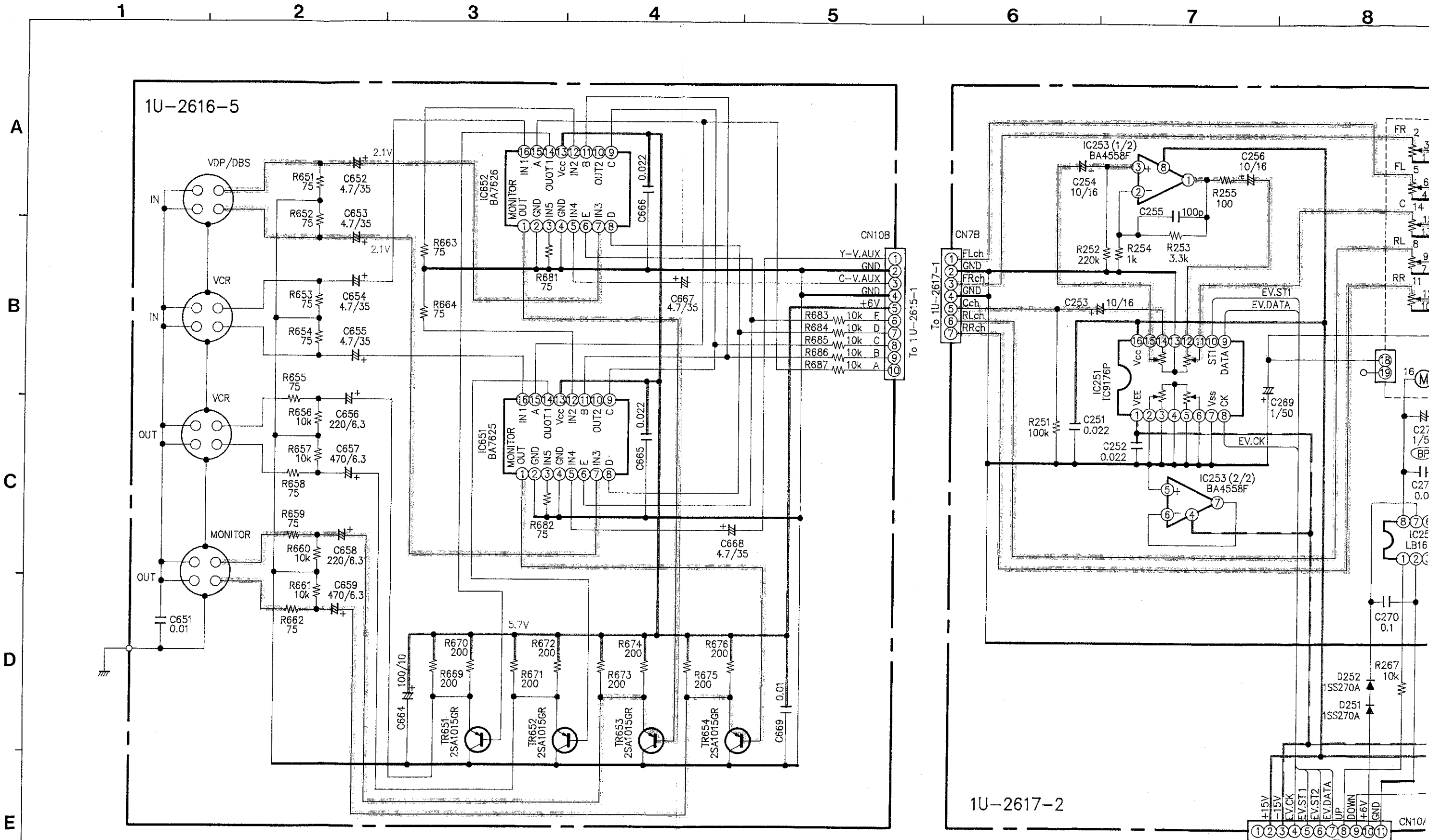

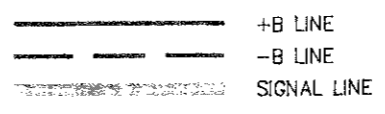
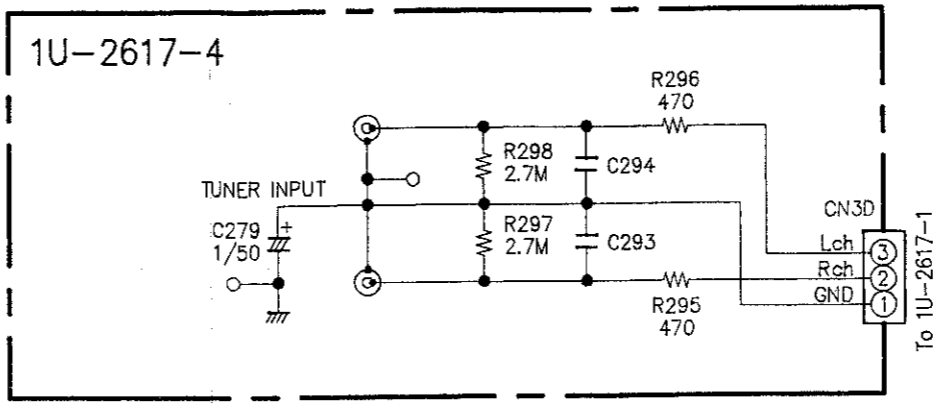
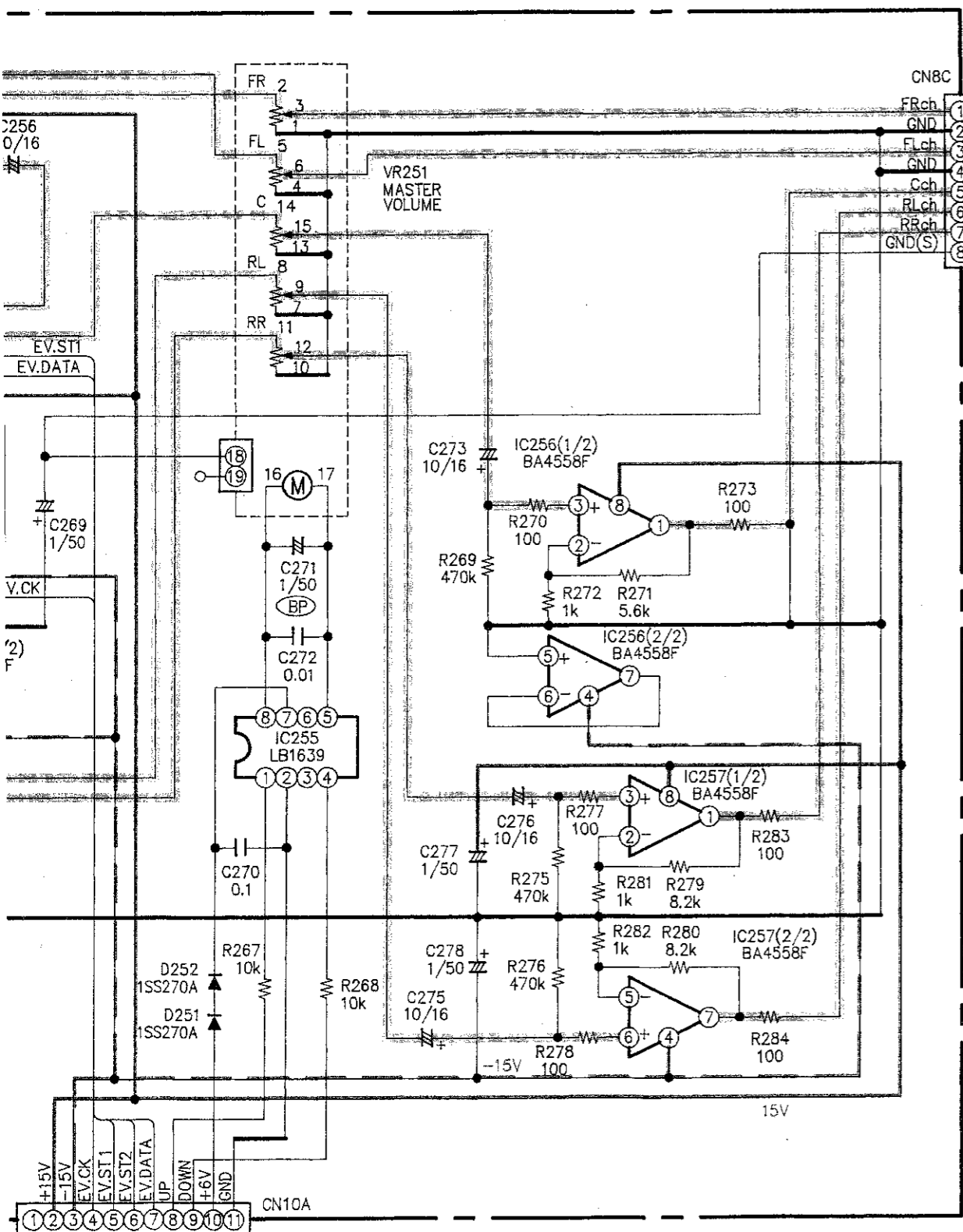

**NOTES**  
 ALL RESISTANCE VALUES IN OHM. k=1,000 OHM, M=1,000,000 OHM  
 ALL CAPACITANCE VALUES IN MICRO FARAD. P=MICRO-MICRO FARAD  
 EACH VOLTAGE AND CURRENT ARE MEASURED AT NO SIGNAL INPUT CONDITION.  
 CIRCUIT AND PARTS ARE SUBJECT TO CHANGE WITHOUT PRIOR NOTICE.

**WARNING:**  
 Parts marked with this symbol  have critical characteristics. Use ONLY replacement parts recommended by the manufacturer.

**CAUTION:**  
 Before returning the unit to the customer, make sure you make either (1) a leakage current check or (2) a line to chassis resistance check. If the leakage current exceeds 0.5 milliamps, or if the resistance from chassis to either side of the power cord is less than 240 kohms, the unit is defective.

**WARNING:**  
 DO NOT return the unit to the customer until the problem is located and corrected.



SCHEMATIC DIAGRAM-3/3

1 2 3 4 5 6 7 8

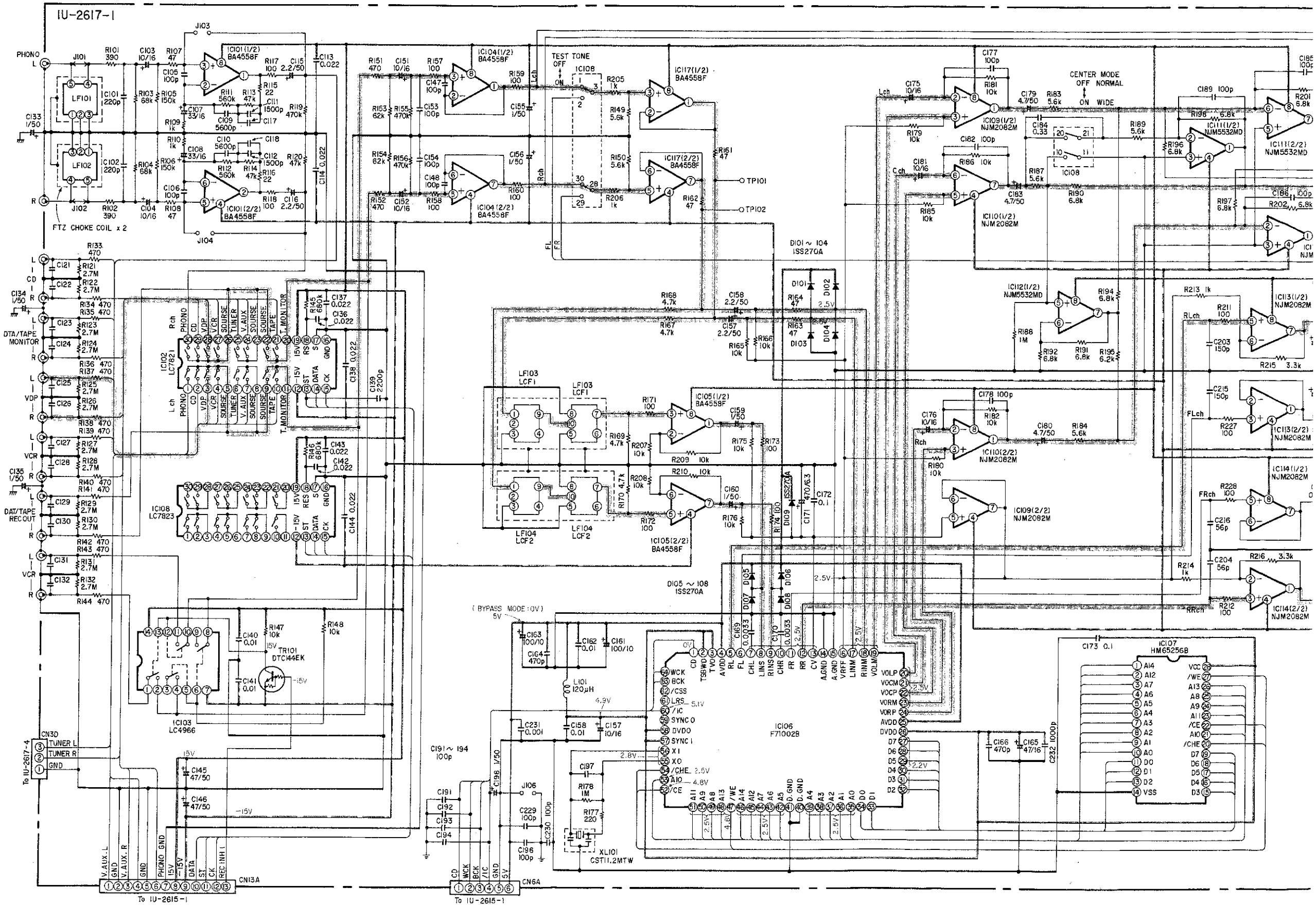

4 5 6 7 8 9 10 11

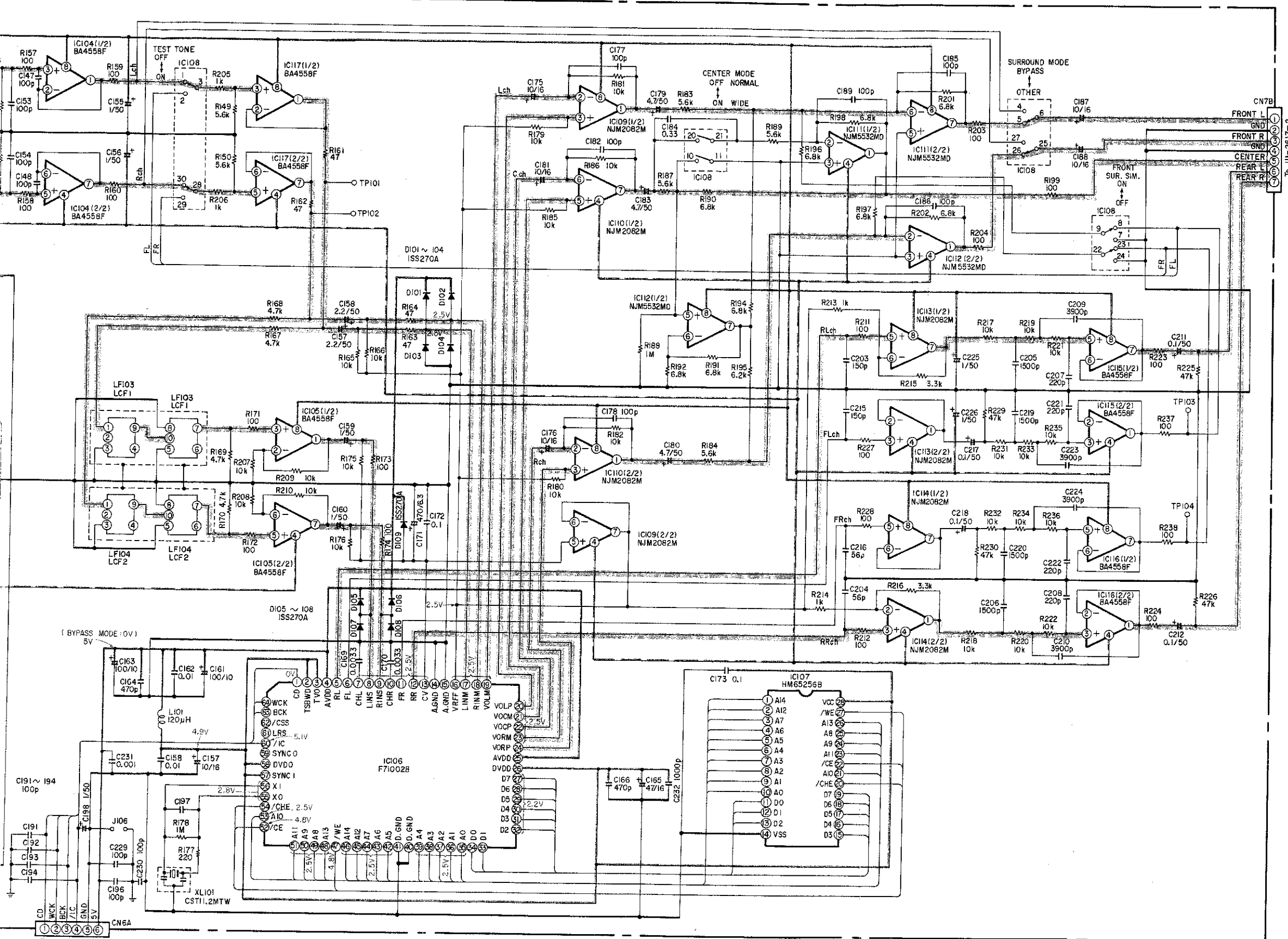

**NOTES**  
 ALL RESISTANCE VALUES IN OHM. k=1,000 OHM, M=1,000,000 OHM  
 ALL CAPACITANCE VALUES IN MICRO FARAD. P=MICRO-MICRO FARAD  
 EACH VOLTAGE AND CURRENT ARE MEASURED AT NO SIGNAL INPUT CONDITION.  
 CIRCUIT AND PARTS ARE SUBJECT TO CHANGE WITHOUT PRIOR NOTICE.

**WARNING:**  
 Parts marked with this symbol  have critical characteristics. Use ONLY replacement parts recommended by the manufacturer.

**CAUTION:**  
 Before returning the unit to the customer, make sure you make either (1) a leakage current check or (2) a line to chassis resistance check. If the leakage current exceeds 0.5 milliamps, or if the resistance from chassis to either side of the power cord is less than 240 kohms, the unit is defective.

**WARNING:**  
 DO NOT return the unit to the customer until the problem is located and corrected.

— +B LINE  
 - - - -B LINE  
 --- SIGNAL LINE

A  
B  
C  
D  
E

EXPLODED VIEW OF CHASSIS AND CABINET

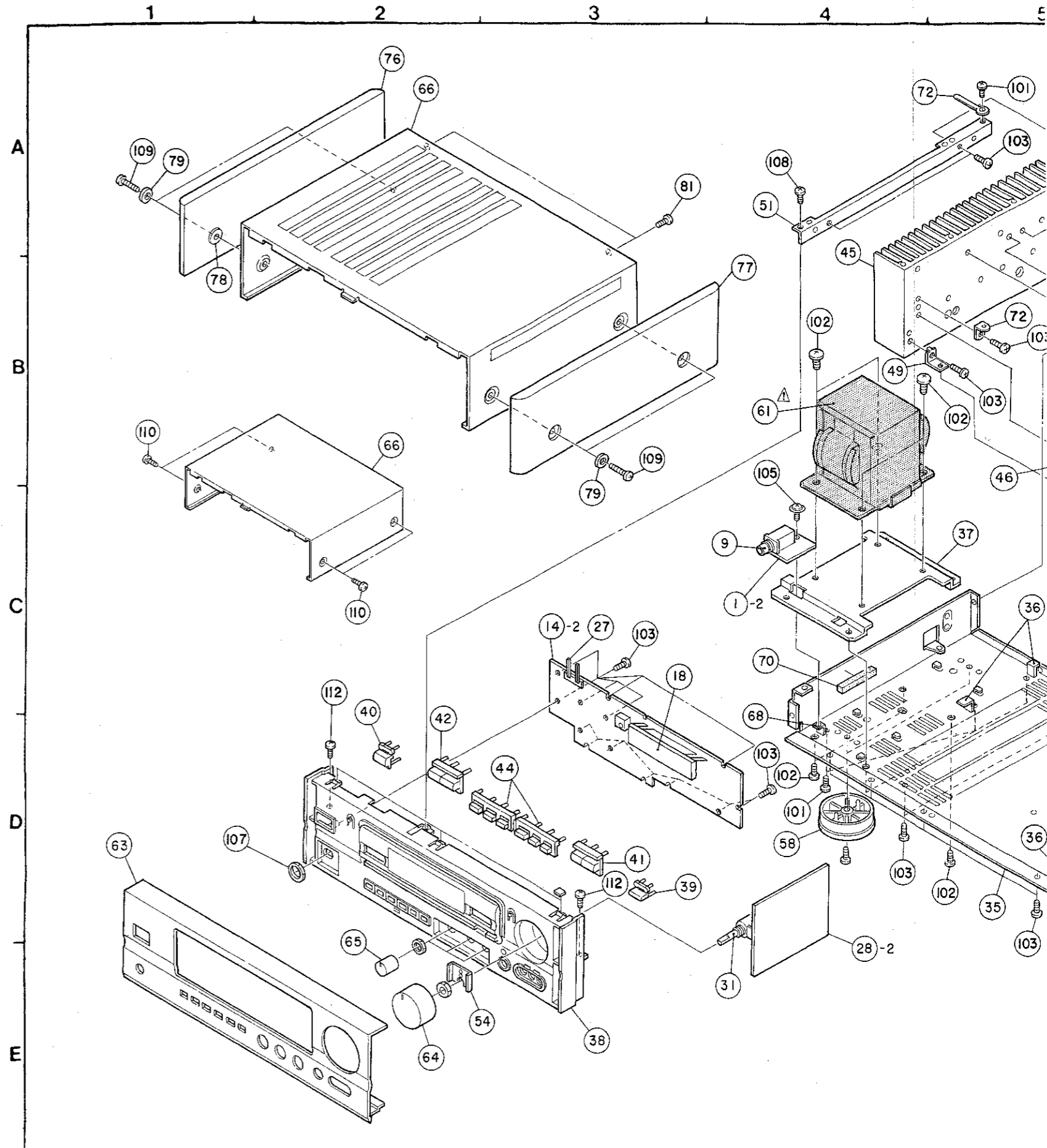

EXPLODED VIEW OF CHASSIS AND CABINET

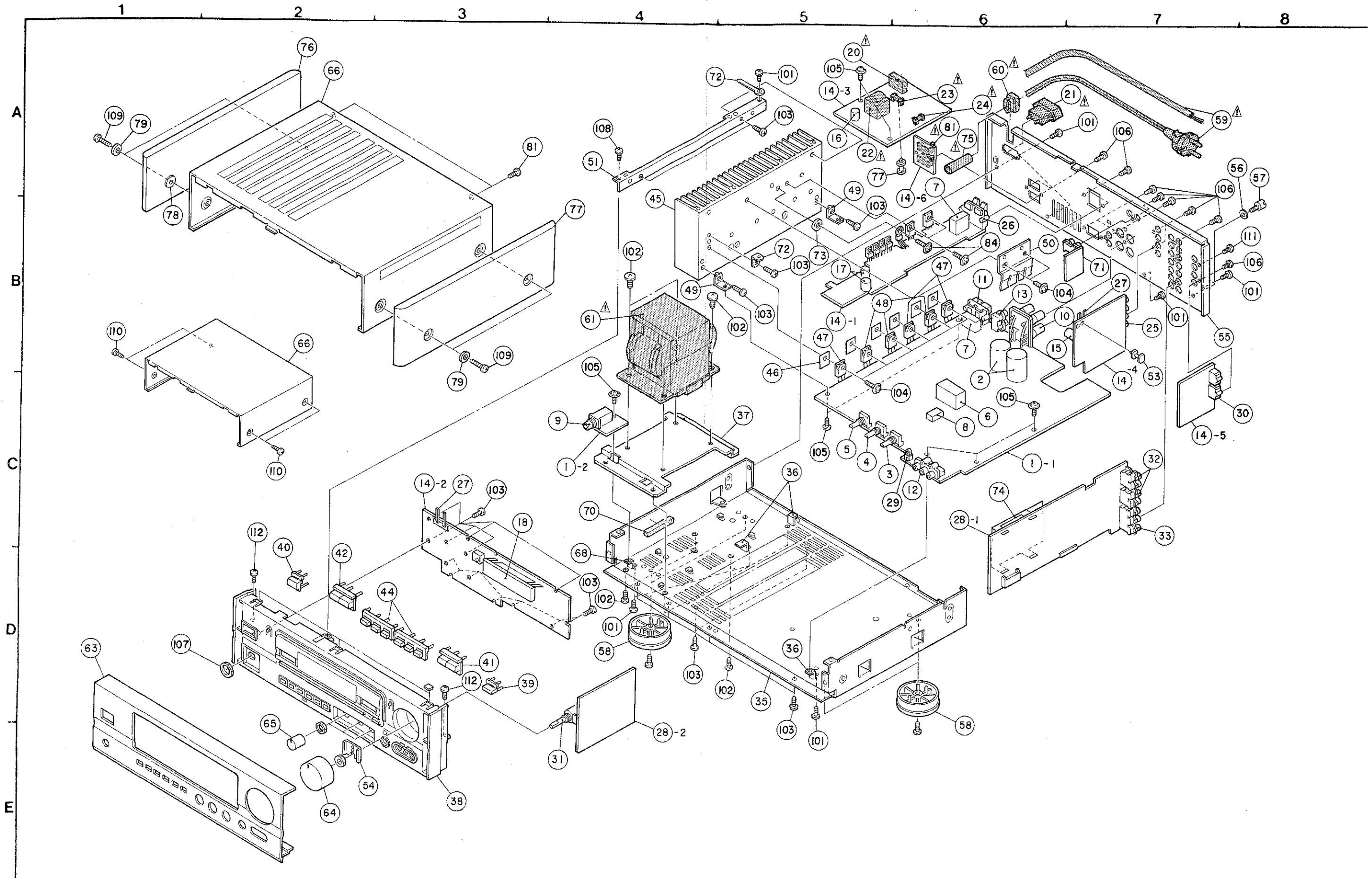

EXPLODED VIEW OF PARTS LIST

Ref. No.	Part No.	Part Name	Remarks	Q'ty	Ref. No.	Part No.	Part Name	Remarks	Q'ty
1	Note	Main Amp. Unit Ass'y		1 <sup>S</sup>	54	412 2897 100	VR. Bracket		1
1-1	—	Main Amp. Unit		(1)	55	Note	Rear Panel		1
1-2	—	Headphone Unit		(1)	56	477 0018 001	Washer(P-87)		1
2	Note	Chemicon	C-353,354	2	57	205 0071 016	Terminal Ass'y		1
3	211 0798 006	Variable Resistor 100kohm	Balance	1	58	104 0194 108	Foot Ass'y		4
4	211 0797 117	Variable Resistor 30kohm	Bass	1	59	Note	AC Cord with Plug		1
5	211 0797 104	Variable Resistor 5kohm	Treble	1	60	445 0056 008	Cord Bush		1
6	214 9003 005	Relay		1	61	Note	Power Trans		1
7	214 0167 005	Relay(G5Z-2A)		2	62	445 8004 007	Wire Clamper		10
8	214 0162 000	Relay(A12W-K)		1	63	Note	Front Panel		1
9	204 8354 004	Headphone Jack		1	64	Note	VR. Knob Ass'y		1
10	205 0550 003	4P Terminal		1	65	Note	Knob(Round)		3
11	205 0695 007	2P Push Terminal		1	66	Note	Top Cover		1
12	204 8404 006	3P Pin Jack		1	67	461 0818 002	Rubber Sheet	T10 x 10 x 60	1
13	205 0315 002	2P Connector Base		1	68	412 3705 000	Earth Bracket		1
14	Note	Rear Amp. Unit Ass'y		1 <sup>S</sup>	69	254 4250 783	Chemicon 3300µF/6.3V	C-819	1
14-1	—	Rear Amp. Unit		(1)	70	232 0188 002	LC Filter		1
14-2	—	MFD Unit		(1)	71	205 0274 004	2 P Connector Base		1
14-3	—	Power Supply Unit		(1)	72	412 3724 007	L Bracket		1
14-4	—	Video Unit		(1)	73	415 0505 008	F.S. Washer		1
14-5	—	S-Video Unit		(1)	74	412 2814 057	Card Spacer(L=12)		1
14-6	—	Voltage Sel. Unit		(1)	75	415 0546 096	UL Tube(8.3)	Black	1
15	254 4254 792	Chemicon 2200µF/16V	C-612	1	76	Note	Wood Board(L)		1
16	254 4256 790	Chemicon 2200µF/25V	C-555	1	77	Note	Wood Board(R)		1
17	254 4259 014	Chemicon 3300µF/35V	C-517,518	2	78	Note	Felt Sheet		4
18	393 4131 000	FLD(FIP14PM8) Ass'y	FL701	1	79	Note	Washer φ 5	Black	4
19	—	—		—	80	504 0159 039	Side Pad		2
20	214 0120 013	Relay(TV-8)	RL551	1	81	Note	Slide Switch	Voltage Sel. Switch	2
21	Note	AC Outlet		1	82	—	—		—
22	Note	Power Trans(Mini)		1	83	—	—		—
23	Note	Fuse A	F-001	1	84	—	—		—
24	Note	Fuse A	F-002	1	85	—	—		—
25	204 8309 004	4P Pin Jack(C-GND)		1	86	—	—		—
26	205 0592 003	4P Push Terminal		1	87	—	—		—
27	205 0075 025	2P Terminal		2	88	—	—		—
28	1U-2617 C	Surround Unit Ass'y		1 <sup>S</sup>	89	—	—		—
28-1	—	Surround Unit		(1)	90	—	—		—
28-2	—	Volume Unit		(1)	<b>SCREW</b>				
28-3	—	—		—	101	473 7015 018	Tapping Screw(S) 3 x 8	Black	17
28-4	—	Tuner Input Unit		(1)	102	473 7007 000	Tapping Screw(S) 4 x 8	Black	8
29	205 0578 001	S-Terminal		1	103	473 7501 001	Tapping Screw(P) 3 x 10		26
30	204 8414 012	2P S-Terminal		1	104	473 8007 009	Cup Screw 3 x 12		12
31	211 0637 002	Variable Resistor 100kohm	VR251	1	105	473 8007 025	Cup Screw 3 x 8		8
32	204 8313 003	4 P Pin Jack(S-GND)		2	106	477 0064 107	Fixing Screw		14
33	204 8346 009	6 P Pin Jack(S-GND)		1	108	473 7500 015	Tapping Screw(S)3x8	Black	1
34	—	—		—	109	Note	Tapping Screw(S)4x20	Black	4
35	411 1256 503	Main Chassis		1	110	Note	3P Swelling Screw		4
36	412 3702 003	P.W.B Bracket		3	111	477 0276 018	Earth Screw		1
37	412 3715 003	Trans Bracket		1	112	477 7002 018	Tapping Screw(S)3x8		2
38	Note	Inner Panel Ass'y		1	<b>PACKING &amp; ACCESORIES</b>				
39	Note	Push Knob(P)		1	<b>(Not included EXPLODED VIEW.)</b>				
40	Note	Push Knob(P)		1	201	504 0092 060	Stylen Paper	for AC cord	1
41	Note	Function Knob(B)		1	202	504 9102 029	Stylen Paper	for Set	1
42	Note	Function Knob(B)		1	203	505 9102 019	Poly Cover		1
43	—	—		—	204	503 1096 004	Cushion		2
44	Note	Tact Knob		2	205	GEN 2487	Envelope Sub Ass'y		1 <sup>S</sup>
45	417 0479 208	Power Radiator		1	205-1	505 8006 019	Envelope		(1)
46	415 0234 007	Insulating Sheet		6	205-2	511 2541 009	Inst. Manual		(1)
47	271 0240 006	Transistor 2SA1491(O/P/Y)(Z)	TR321, 322, 411	3	205-3	Note	Inst. Manual		(1)
48	273 0389 002	Transistor 2SC3855(O/P/Y)(Z)	TR317, 318, 410	3	205-4	399 0210 004	Remote Control	RC-167	(1)
49	412 3225 108	P.W.B Bracket(A)		2	205-5	—	Battery		(2)
50	412 3314 200	Spring Plate(A)		1	206	Note	Carton Case		1
51	412 3526 302	Radiator Bracket		1	207	502 0741 043	Pad	185 x 45 x T45	1
52	445 0048 003	Cord Holder(L=76)		1	208	Note	AC Adaptor (4.8)		1
53	412 2814 028	Card Spacer(L=10)		1	209	—	—		—

ADDENDUM PARTS LIST

Ref.No.	Part Name		Part No.		
			Multiple Gold	Multiple Black	U.K. Black
1	Main Amp. Unit Ass'y	(1s)	1U-2615 C	1U-2615 C	1U-2615 D
2	Chemicon C-353,354	(2)	254 4365 717 6800µF/56V	254 4365 717 6800µF/56V	254 4374 708 8200µF/56V
14	Rear Amp. Unit Ass'y	(1s)	1U-2616 C	1U-2616 C	1U-2616 D
21	AC Outlet	(1)	203 3942 007	203 3942 007	—
22	Power Trans(Mini)	(1)	233 6068 002	233 6068 002	233 6071 002
23	Fuse (F-001)	(1)	206 1015 087	206 1015 087	206 1015 032
24	Fuse (F-002)	(1)	4A, 125V 206 1015 061	4A, 125V 206 1015 061	2.5A —
38	Inner Panel Ass'y	(1)	146 1464 420	146 1464 433	146 1464 433
39	Push Knob(P)	(1)	113 1465 050	113 1465 047	113 1465 047
40	Push Knob(P)	(1)	113 1292 210	113 1292 207	113 1292 207
41	Function Knob(B)	(1)	113 1631 004	113 1535 087	113 1535 087
42	Function Knob(B)	(1)	113 1535 003	113 1535 016	113 1535 016
44	Tact Knob	(2)	113 1454 210	113 1454 207	113 1454 207
55	Rear Panel	(1)	105 1093 120	105 1093 133	105 1093 146
59	AC Cord with Plug	(1)	206 2070 005 (250V,6A C2)	206 2070 005 (250V,6A C2)	206 2024 103
61	Power Trans	(1)	233 6069 001	233 6069 001	233 6070 003
63	Front Panel	(1)	144 2321 113	144 2321 126	144 2321 126
64	VR. Knob Ass'y	(1)	112 0726 124	112 0569 242	112 0569 242
65	Knob(Round)	(3)	112 0685 113	112 0685 100	112 0685 100
66	Top Cover	(1)	102 0314 131	102 0314 128	102 0314 128
76	Wood Board(L)	(1)	101 2500 005	—	—
77	Wood Board(R)	(1)	101 2501 004	—	—
78	Felt Sheet	(4)	124 0032 002	—	—
79	Washer φ 5	(4)	475 1006 016	—	—
81	Slide Switch	(2)	212 2611 003	212 2611 003	—
82	AC Adaptor (4.8)	(1)	202 0043 003	202 0043 003	—
83	—	—	—	—	—
84	—	—	—	—	—
<b>SCREWS</b>					
109	Tapping Screw(S)4 x 20	(4)	473 7007 039	—	—
110	3P Swelling Screw	(4)	—	477 0263 005	477 0263 005
111	—	—	—	—	—
<b>PACKING &amp; ACCESORIES</b>					
<b>(Not included EXPLODED VIEW)</b>					
205-3	Inst. Manuul	(1)	511 2542 008	511 2542 008	—
206	Carton Case	(1)	501 1709 036	501 1709 049	501 1709 052
208	AC Adaptor	(1)	202 0043 003	202 0043 003	—
209	—	—	—	—	—
210	—	—	—	—	—

NOTE FOR PARTS LIST

- Part indicated with the mark "●" are not always in stock and possibly to take a long period of time for supplying, or in some case supplying of part may be refused.
- When ordering of part, clearly indicate "1" and "I" (i) to avoid mis-supplying.
- Ordering part without stating its part number can not be supplied.
- Part indicated with the mark "★" is not illustrated in the exploded view.
- Not including Carbon Film ±5%, 1/6W, 1/4W Type in the P.W.Board parts list. (Refer to the Schematic Diagram for those parts.)

WARNING:

Parts marked with this symbol  have critical characteristics. Use ONLY replacement parts recommended by the manufacturer.

SCHEMATIC DIAGRAM (RC-167)

1 2 3 4

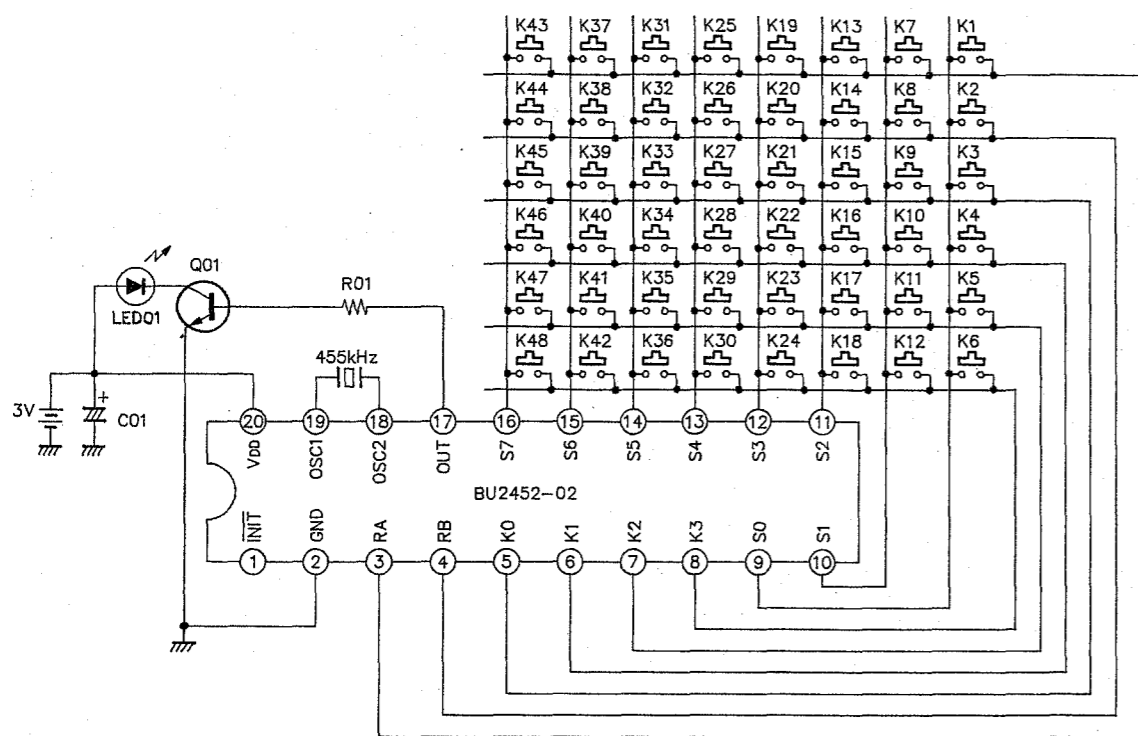

SPECIFICATIONS

- When each Key is pressed double transmission is not performed. When one side is released from double pressed state, transmit code on unreleased side.

NOTES

ALL RESISTANCE VALUES IN OHM. k=1,000 OHM, M=1,000,000 OHM  
 ALL CAPACITANCE VALUES IN MICRO FARAD. P=MICRO-MICRO FARAD  
 EACH VOLTAGE AND CURRENT ARE MEASURED AT NO SIGNAL INPUT CONDITION.  
 CIRCUIT AND PARTS ARE SUBJECT TO CHANGE WITHOUT PRIOR NOTICE.

CORDS TABLE

KEY No.	System address					Custom code					Extension	Mask	Judgment K	Remarks	Item No.1 RC-167	Item No.2	Item No.3	
	C1	C2	C3	C4	C5	C6	C7	C8	C9	C10								C11
K1	0	1	0	0	0	0	1	1	0	1	1	1	1	0	0			CENTER ▼
K2	0	1	0	0	0	0	0	1	0	1	1	1	1	0	0			REAR ▼
K3	0	0	1	1	0	1	0	0	1	0	1	0	1	0	0			MEMOLY
K4	0	0	1	1	0	0	1	0	1	0	1	0	1	0	0			1
K5	0	0	0	1	0	1	1	0	1	0	1	1	0	0	0			DISC SKIP
K6	0	1	0	0	0	0	1	0	1	0	0	1	1	0	0			VDP/DBS
K7	0	1	0	0	0	1	0	1	0	1	1	1	1	0	0			CENTER ▲
K8	0	1	0	0	0	1	1	0	0	1	1	1	1	0	0			REAR ▲
K9	0	1	0	0	0	0	1	0	0	1	1	1	1	0	0			MASTER VOLUME ▼
K10	0	0	0	1	0	0	0	1	1	1	0	1	0	0	0			CD PLAY (▶)
K11	0	0	1	0	0	0	1	1	1	1	0	1	0	0	0			DECK STOP (■)
K12	0	1	0	0	0	1	1	0	0	0	0	1	1	0	0			PHONO
K13	0	0	1	1	0	0	1	0	0	0	1	0	1	0	0			SET - (DELAY -)
K14	0	0	1	1	0	0	1	0	0	0	1	0	1	0	0			CLEAR
K15	0	1	0	0	0	1	0	0	0	1	1	1	1	0	0			MASTER VOLUME ▲
K16	0	0	0	1	0	0	1	1	1	1	0	1	0	0	0			CD STOP (■)
K17	0	0	1	0	0	1	1	0	0	1	0	1	0	0	0			DECK A/B
K18	0	1	0	0	0	0	1	0	0	1	0	1	1	0	0			DAT/TAPE MONITOR
K19	0	0	1	1	0	1	1	0	0	0	1	0	1	0	0			SET + (DELAY +)
K20	0	0	1	1	0	0	0	0	0	0	1	0	1	0	0			PARAMETER
K21	0	1	0	0	0	1	1	1	0	0	1	1	1	0	0			BYPASS
K22	0	0	1	1	0	1	1	0	1	0	1	0	1	0	0			2
K23	0	0	0	1	0	0	0	0	1	1	0	1	0	0	0			AUTO SERCH + (▶▶)
K24	0	1	0	0	0	0	1	1	0	0	1	1	1	0	0			SURROUND MODE
K25	0	0	1	1	0	1	0	1	0	1	0	1	1	0	0			PRESET ▼
K26	0	1	0	0	0	1	0	1	0	0	0	1	1	0	0			TUNER
K27	0	1	0	0	0	0	1	0	1	0	0	1	1	0	0			T. TONE
K28	0	0	0	1	0	1	0	1	1	1	0	1	0	0	0			CD PAUSE (  )
K29	0	0	0	1	0	1	0	0	1	1	0	1	0	0	0			AUTO SERCH - (◀◀)
K30	0	1	0	0	0	0	1	1	1	1	0	1	1	0	0			PANEL
K31	0	0	1	1	0	0	1	1	0	1	0	1	1	0	0			PRESET ▲
K32	0	1	0	0	0	0	0	0	1	1	0	1	1	0	0			VIDEO SELECT
K33	0	1	0	0	0	0	0	1	0	0	0	1	1	0	0			CD
K34	0	0	1	0	0	0	0	1	1	1	0	1	0	0	0			DECK PLAY (▶)
K35	0	0	1	0	0	0	1	0	1	1	0	1	0	0	0			DECK FF (▶▶)
K36	0	1	0	0	0	0	0	0	0	1	1	1	1	0	0			MUTING
K37	0	1	0	0	0	1	0	0	0	0	0	1	1	0	0			POWER
K38	0	1	0	0	0	0	0	1	1	0	0	1	1	0	0			V. AUX
K39	0	1	0	0	0	1	0	1	1	0	0	1	1	0	0			VCR
K40	0	0	1	0	0	1	1	1	0	1	0	1	0	0	0			DECK PLAY (REV ◀)
K41	0	0	1	0	0	1	1	0	1	1	0	1	0	0	0			DECK REW (◀◀)
K42	0	1	0	0	0	0	1	1	1	1	0	0	1	0	0			VCR-2
K43	0	1	0	0	0	1	1	0	0	1	0	1	1	0	0			DAT/TAPE-2
K44	0	0	1	1	0	0	0	1	1	0	0	0	1	0	0			CD-DIRECT
K45	0	1	0	0	0	0	0	1	0	0	1	1	1	0	0			◀◀ CENTER MODE
K46	0	0	1	1	0	0	1	1	0	0	1	0	1	0	0			EFFECT
K47	0	1	0	0	0	1	0	0	1	1	0	1	1	0	0			A.V.S.E
K48	0	1	0	0	0	1	0	1	0	1	0	1	1	0	0			CINEMA

REMOTE CONTROL UNIT ASS'Y

Ref. No.	Part No.	Part Name	Remarks	Q'ty
<b>SEMICONDUCTORS GROUP</b>				
IC1	—	IC BU2462-02	μ-Com	
Q1	—	Transistor 2SC3377 (Q/R)		
or	273 0195 908	Transistor 2SC2060 (Q/R)		
LED1	—	LED SE303ARF-CX/Y	Infrared	
or	—	LED SID1K10CXM	Infrared	
<b>RESISTORS GROUP</b>				
R1	241 2397 901	Carbon Resistor 220ohm, 1/10W	RD14B2E221J(S)	
<b>CAPACITORS GROUP</b>				
C1	254 4213 021	Electrolytic 47μF/6.3V	CE04W0J470M	
<b>OTHER GROUP</b>				
X1	—	(P.W. Boardd) Ceramic Resonator	CSB455EB	(1) 1

PARTS LIST OF EXPLODED VIEW

Ref. No.	Part No.	Part Name	Remarks	Q'ty
1		Case Top Ass'y		1
2		Panel		1
3		Switch Rubber		1
4	9H3 1000 146	Case Bottom Ass'y		1
5	9H3 1000 147	Cover Battery		1
6	—	Tapping Screw 2.6 × 12		1
7	—	Filter		1
8	9H3 1000 151	Spring Coil		1
9	9H3 1000 152	Spring Coil		1
10	9H3 1000 125	Poly Cover	85 × 250	1
11	9H3 1000 156	P.W.B. Unit Ass'y		1 <sup>8</sup>

NOTE FOR PARTS LIST

- Part indicated with the mark "◎" are not always in stock and possibly to take a long period of time for supplying, or in some case supplying of part may be refused.
- When ordering part, clearly indicate "1" and "1" (i) to avoid mis-supplying.
- Ordering part without stating its part number can not be supplied.
- Part indicated with the mark "★" is not illustrated in the exploded view.

WARNING:

Parts marked with this symbol have critical characteristics. Use ONLY replacement parts recommended by the manufacturer.