

DENON

For U.S.A., Canada, Europe, U.K.,
Asia, China, Taiwan R.O.C., Korea
& Japan model

Ver. 1

SERVICE MANUAL

MODEL **AVR-2105/885** **AVC-1890**

AV SURROUND RECEIVER / AMPLIFIER

注 意

サービスをおこなう前に、このサービスマニュアルを必ずお読みください。本機は、火災、感電、けがなどに対する安全性を確保するために、さまざまな配慮をおこなっており、また法的には「電気用品安全法」にもとづき、所定の許可を得て製造されております。従ってサービスをおこなう際は、これらの安全性が維持されるよう、このサービスマニュアルに記載されている注意事項を必ずお守りください。

● For purposes of improvement, specifications and design are subject to change without notice.

● Please use this service manual with referring to the operating instructions without fail.

● Some illustrations using in this service manual are slightly different from the actual set.

● 本機の仕様は性能改良のため、予告なく変更することがあります。
● 補修用性能部品の保有期間は、製造打切後8年です。

● 修理の際は、必ず取扱説明書を参照の上、作業を行ってください。

● 本文中に使用しているイラストは、説明の都合上現物と多少異なる場合があります。

DENON, Ltd.

Tokyo, Japan

SAFETY PRECAUTIONS

The following check should be performed for the continued protection of the customer and service technician.

LEAKAGE CURRENT CHECK

Before returning the unit to the customer, make sure you make either (1) a leakage current check or (2) a line to chassis resistance check. If the leakage current exceeds 0.5 milliamps, or if the resistance from chassis to either side of the power cord is less than 460 kohms, the unit is defective.

注意 サービス、点検時には次のことにご注意願います。

●注意事項をお守りください！

サービスのとき特に注意を必要とする個所については、キャビネット、部品、シャーシなどにラベルや捺印で、注意事項を表示しています。これらの注意書きおよび取扱説明書などの注意事項を必ずお守りください。

●感電に注意！

- (1) このセットは、交流電圧が印加されていますので、通電時に内部金属部に触れると感電することがあります。従って通電サービス時には、絶縁トランスの使用や手袋の着用、部品交換には、電源プラグを抜くなどして、感電にご注意ください。
- (2) 内部には、高電圧の部分がありますので、通電時の取扱には、十分ご注意ください。

●指定部品の使用！

セットの部品は難燃性や耐電圧など安全上の特性を持ったものとなっています。従って交換部品は、使用されていたものと同じ特性の部品を使用してください。特に配線図、部品表に△印で指定されている安全上重要な部品は必ず指定のものをご使用ください。

●部品の取付けや配線の引きまわしは、元どおりに！安全上、テープやチューブなどの絶縁材料を使用したり、プリント基板から浮かして取付けた部品があります。また内部配線は引きまわしやクランプによって発熱部品や高圧部品に接近しないように配慮されていますので、これらは必ず元どおりにしてください。

●サービス後は安全点検を！

サービスのために取り外したねじ、部品、配線などが元どおりになっているか、またサービスした個所の周辺を劣化させてしまったところがないかなどを点検し、外部金属端子部と、電源プラグの刃の間の絶縁チェックをおこなうなど、安全性が確保されていることを確認してください。

(絶縁チェックの方法)

電源コンセントから電源プラグを抜き、アンテナや、プラグなどを外し、電源スイッチを入れます。500V絶縁抵抗計を用いて、電源プラグのそれぞれの端子と、外部露出金属部〔アンテナ端子、ヘッドホン端子、マイク端子、入力端子など〕との間で、絶縁抵抗値が1MΩ以上であること、この値以下のときは、セットの点検修理が必要です。

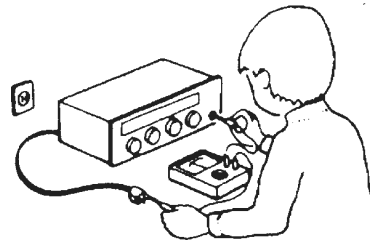

注意 安全上重要な部品について

本機に使用している多くの電気部品、および機構部品は安全上、特別な特性を持っています。この特性はほとんどの場合、外観では判別つきにくく、また、もとの部品より高い定格（定格電力、耐圧）を持ったものを使用しても安全性が維持されるとは、限りません。安全上の特性を持った部品は、このサービスマニュアルの配線図、部品表につぎのように表示していますので、必ず指定されている部品番号のものを使用願います。

(1)配線図… △マークで表示しています。

(2)部品表… △マークで表示しています。

指定された部品と異なるものを使用した場合には、感電、火災などの危険を生じる恐れがあります。

LEVEL DIAGRAMS
FRONT/CENTR/SURROUND/SURROUND BACK

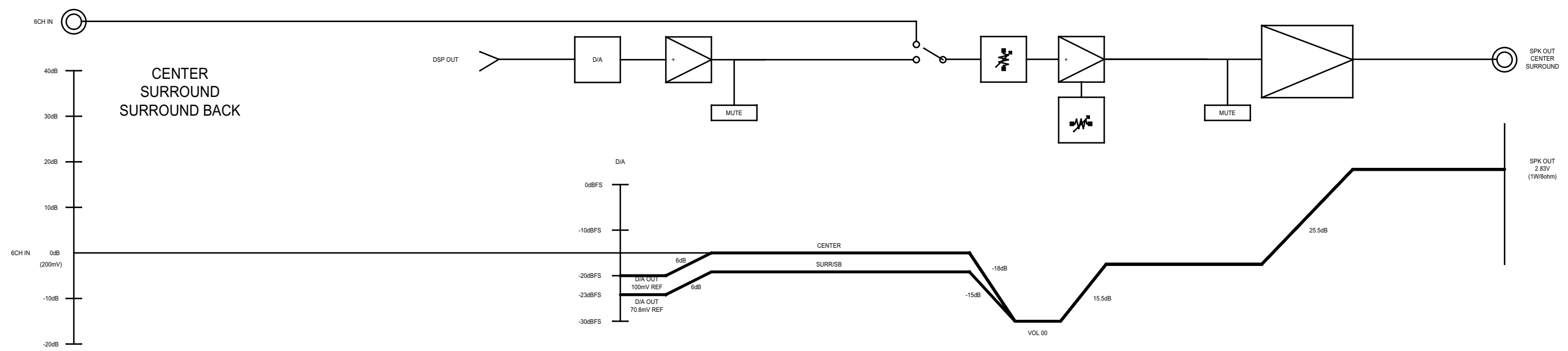
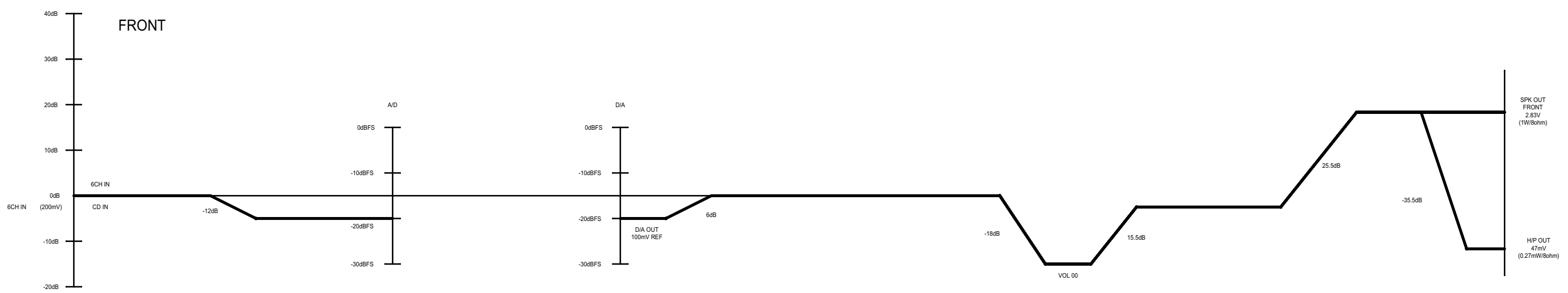
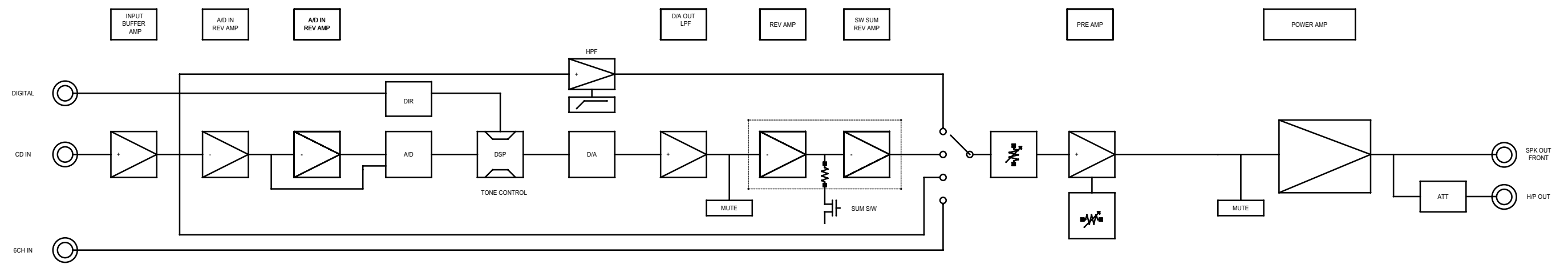

SUB WOOFER

SUB_WOOFER

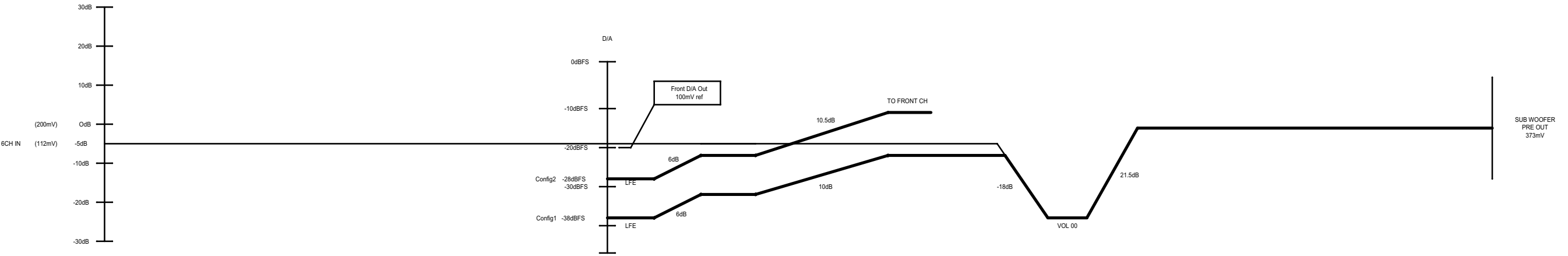
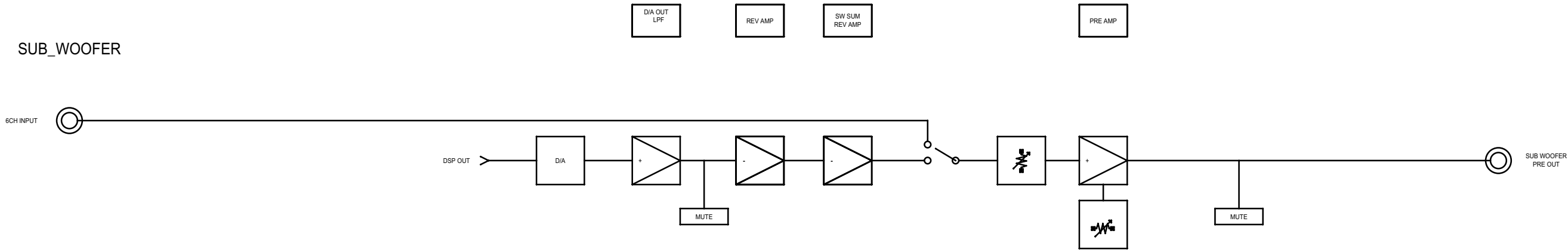

FRONT VS SW

FRONT VS SW

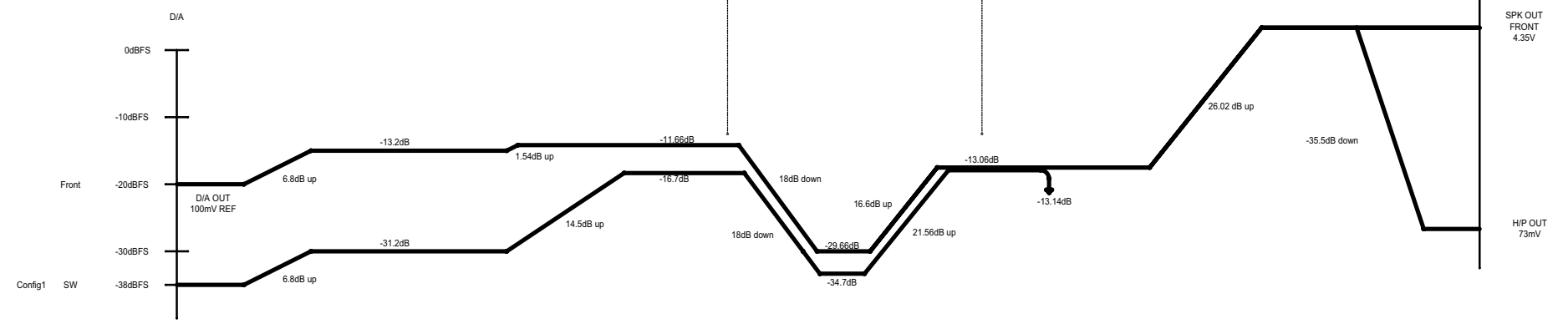
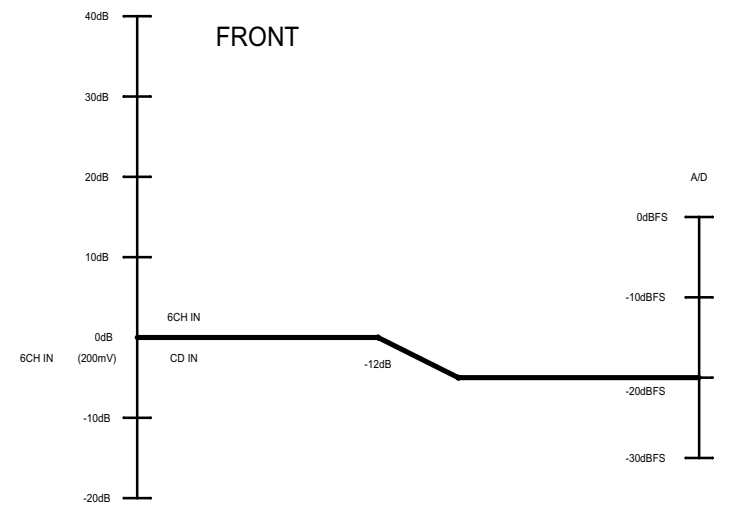
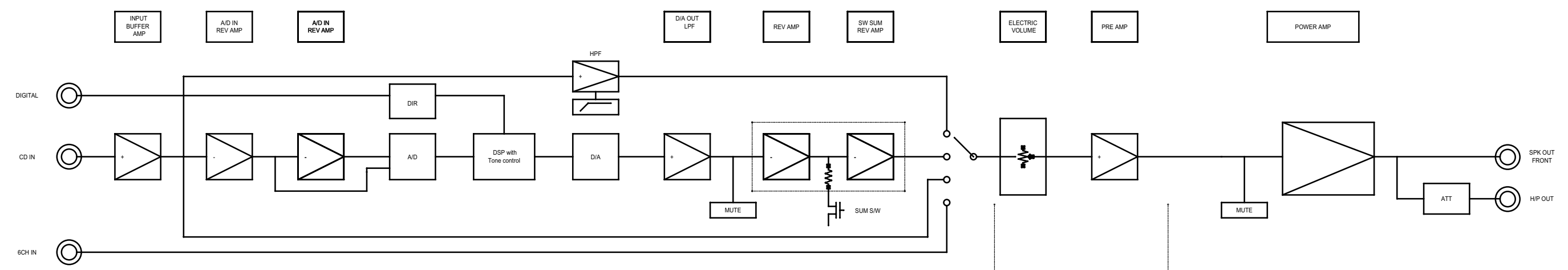

BLOCK DIAGRAM

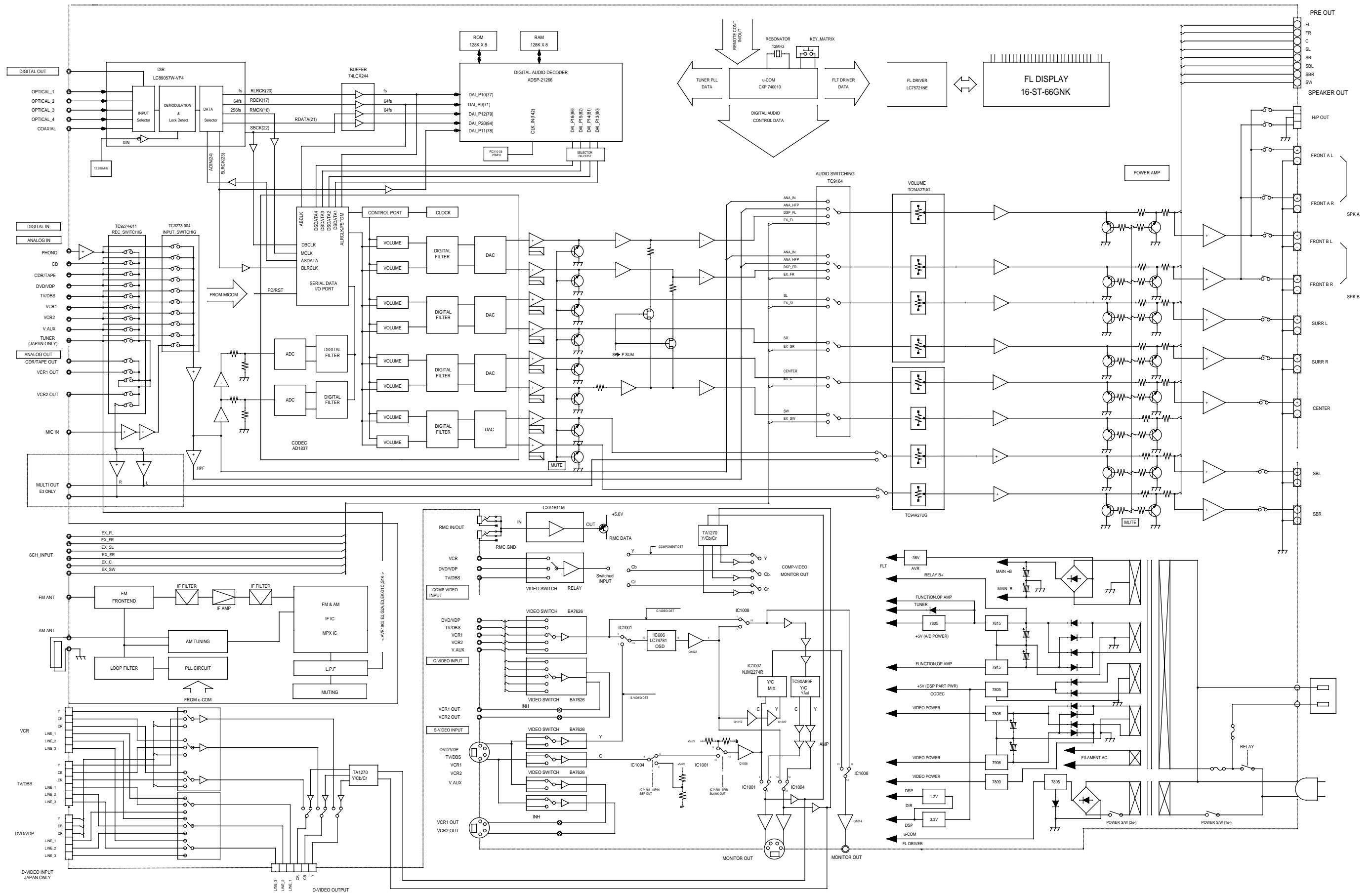

CAUTION IN SERVICING

● Initializing AV SURROUND RECEIVER

AV SURROUND RECEIVER initialization should be performed when the mcom, peripheral parts of mcom, and DSP P.W.B. are replaced.

1. Switch off the unit .
2. Hold the following SPEAKERS-A button and SPEAKERS-B button, and switch on the unit.
3. Check that the entire display is flashing with an interval of about 1 second, and release your fingers from the 2 buttons and the microprocessor will be initialized

Note: • If step 3 does not work, start over from step 1.
 • All user settings will be lost and this factory setting will be recovered when this initialization mode. So make sure to memorize your setting for restoring after the initialization.

サービス時の注意事項

● AV サラウンドアンプの初期化について

マイコンやマイコン周辺部品、DSP 基板等を交換した場合は、AV サラウンドアンプの初期化を行って下さい。

1. オン/オフボタンを OFF にします。
2. SPEAKERS-A ボタンと SPEAKERS-B ボタンを同時に押しながら、オン/オフボタンを押して ON にします。
3. ディスプレイ表示が約 1 秒間隔で点滅するのを確認後、2つのボタンから指を離します。
 ●マイコンが初期化されます。

注意: • 上記 3 の状態にならない場合は、もう一度操作 1 からやり直してください。
 • 初期化を行うとお客様が設定した内容が工場出荷状態に戻りますので、あらかじめ設定内容を控えておき初期化後再設定してください。

ADJUSTMENT

Audio Section

Idling Current

Required measurement equipment : DC Voltmeter





調整に必要な測定器 : 直流電圧計

Preparation

- (1) Avoid direct blow from an air conditioner or an electric fan, and adjust the unit at normal room temperature 15 °C ~ 30 °C (59 °F ~ 86 °F).
- (2) Presetting
 - POWER (Power source switch) → OFF
 - SPEAKER (Speaker terminal) → No load (Do not connect speaker, dummy resistor, etc.)
- (1) セットをクーラ、扇風機のそばなど風通しの良い場所を避け、通常の使用状態に置きます。セットの周囲温度は 15 ~ 30℃、湿度は常湿とします。

Adjustment

- (1) Remove top cover and set VR101, VR102, VR103, VR104, VR105 on Amp. Unit, VR106,107 on SURR.-BACK ch Amp. Unit at full counterclockwise () position.
- (2) Connect DC Voltmeter to test points (FRONT-Lch: TP104, FRONT-Rch: TP105, CENTER ch: TP103, SURROUND-Lch:TP101, SURROUND-Rch:TP102, SURROUND-BACK Lch:TP106, SURROUND-BACK Rch:TP107).
- (3) Connect power cord to AC Line, and turn power switch "ON".
- (4) Presetting.

MASTER VOLUME	: "---" counterclockwise ( min.)
MODE	: 7CH STEREO
FUNCTION	: CD
- (5) Within 2 minutes after the power on, turn VR101 clockwise () to adjust the TEST POINT voltage to 1.5 mV ±0.5 mV DC.
- (6) After 10 minutes from the preset above, turn VR101 to set the voltage to 2.5 mV ±0.5 mV DC.
- (7) Adjust the Variable Resistors of other channels in the same way.
- (1) 上カバーをはずし、パワーアンプ基板のVR101, VR102, VR103, VR104, VR105及びSurr. Backアンプ基板のVR106, 107を反時計方向()に回し切った状態にセットします。
- (2) テストポイント(FRONT-Lch: TP104, FRONT-Rch: TP105, CENTER ch: TP103, SURROUND-Lch: TP101, SURROUND-Rch: TP102, SURROUND-BACK Lch: TP106, SURROUND-BACK Rch: TP107)に直流電圧計を接続します。
- (3) 電源コードをAC100V (95 ~ 105V の範囲でも可) に接続し、電源スイッチを"ON"にします。
- (4) ON後、次のようにセットします。
 - VOLUME (音量調節つまみ) →反時計方向 ()に回す、最小の状態にする。
 - SPEAKER-A (スピーカ端子) →無負荷 (スピーカ、ダミー抵抗器などを接続しない。)

MODE	: 7CH STEREO
FUNCTION	: CD
- (5) 2分以内にVR101を時計方向()に回しテストポイントの電圧を次のように調整します。
 1. 5mV ±0.5mV DC
- (6) 予備調整から10分後VR101を回し、次のように電圧を設定します。
 2. 5mV ±0.5mV DC
- (7) 同じ方法で各チャンネルの可変抵抗を調整します。

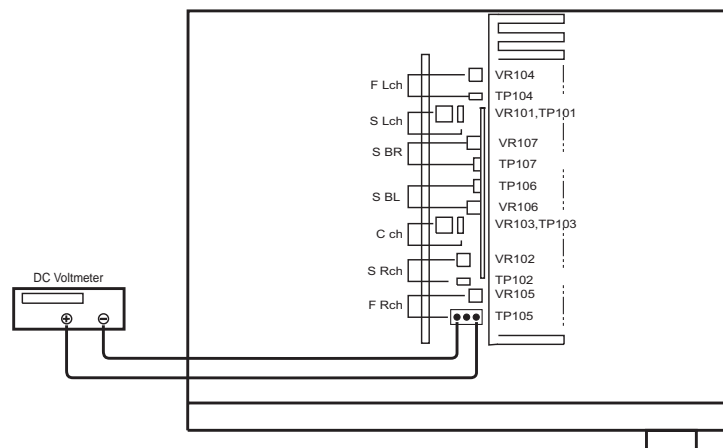

Video Section (For U.S.A., Canada & Japan) ビデオセクション

Component Video Level Adjustment

Required measurement equipment etc: Oscilloscope, DVD VIDEO PLAYER (ex: DVD-1500)



Test Disc: DVD T-S01

Preparation

- (1) Avoid direct blow from an air conditioner or an electric fan, and adjust the unit at normal room temperature 15 °C ~ 30 °C (59 °F ~ 86 °F).
- (2) Playback the color-bar 75% of the Test Disc (Title 12) using the DVD Video Player, and check that Y and C levels of the S terminal output are within the specified output levels.
If they are out of the specified levels, adjust with the variable resistor inside of the unit.
- (3) Presetting

● POWER (Power source switch)	OFF
● SPEAKER (Speaker terminal)	No load (Do not connect speaker, dummy resistor, etc.)
● DVD (Video terminal)	No input

Adjustment

- (1) Remove top cover and set VR608, VR609, VR610 on C-S VIDEO2 Unit at fully counterclockwise ().
- (2) Connect a pin-plug terminated with 75-ohms to Y(Cb, Cr) of the Component Video Monitor Output, and hook up the Oscilloscope's probe to both ends of the pin-plug.
- (3) Connect S terminal output of the DVD Player with the DVD input terminal of the Receiver.
- (4) Connect power cord to AC Line, and turn power switch "ON".
- (5) Presetting
 - FUNCTION: DVD
 - Playback the color-bar 75% of the Test Disc (Title 12)
- (6) Turn VR610 clockwise () to adjust the COMPONENT VideoY voltage (except H.Sync) to 714 ±50 mVp-p. (Refer to Fig.1)
- (7) Adjust the Variable Resistors of Cr: VR609 and Cb: VR608 in the same way. (Refer to Fig. 2, 3)
Cb,Cr: 486±50 mVp-p. (U.S.A. & Canada model)
525±50 mVp-p. (Others)

コンポーネントビデオレベルの調整

調整に必要な測定器: Oscilloscope, DVD VIDEO PLAYER
(例: DVD-1500)



テストディスク: DVD T-S01

準備

- (1) セットをクーラ、扇風機のそばなど風通しの良い場所を避け、通常の使用状態に置きます。セットの周囲温度は15～30℃、湿度は常湿とします。
- (2) DVD VIDEO PLAYER でテストディスクのカラーバー75%(Title12)を再生し、S端子出力Y、Cレベルが正規の出力レベルであることを確認する。正規の出力レベルではない場合は、セット内部の可変抵抗器で調整してください。
- (3) プリセット

● 電源スイッチ	OFF
● スピーカ端子 (スピーカ・ダミー抵抗器などを接続しない。)	無負荷
● DVD入力端子	無入力

調整

- (1) 上カバーをはずし、C-S VIDEO2 ユニットのVR608, VR609, VR610を反時計方向()に回し切った状態にセットします。
- (2) コンポーネントビデオモニターアウトのY(Cb, Cr)に75Ωで終端したピンプラグをを接続し、その両端をOscilloscopeのプロープでつまみます。
- (3) DVD VIDEO PLAYERのS端子出力を本機のDVD入力端子に接続します。
- (4) 電源コードを電源コンセントに接続し、電源スイッチを"ON"にします。
- (5) ON後、次のようにセットします。
 - 本機のFUNCTIONをDVDにする。
 - テスクディスクのカラーバー75%(Title12)を再生する。
- (6) VR610を時計方向()に回しコンポーネントビデオY(H.Syncを除く)の電圧を調整します。(Fig.1参照)
714mV ±50mVp-p
- (7) 同じ方法でCr: VR609、Cb: VR608の可変抵抗器を調整します。(Fig.2、3参照)
Cb,Cr: 525±50 mVp-p.

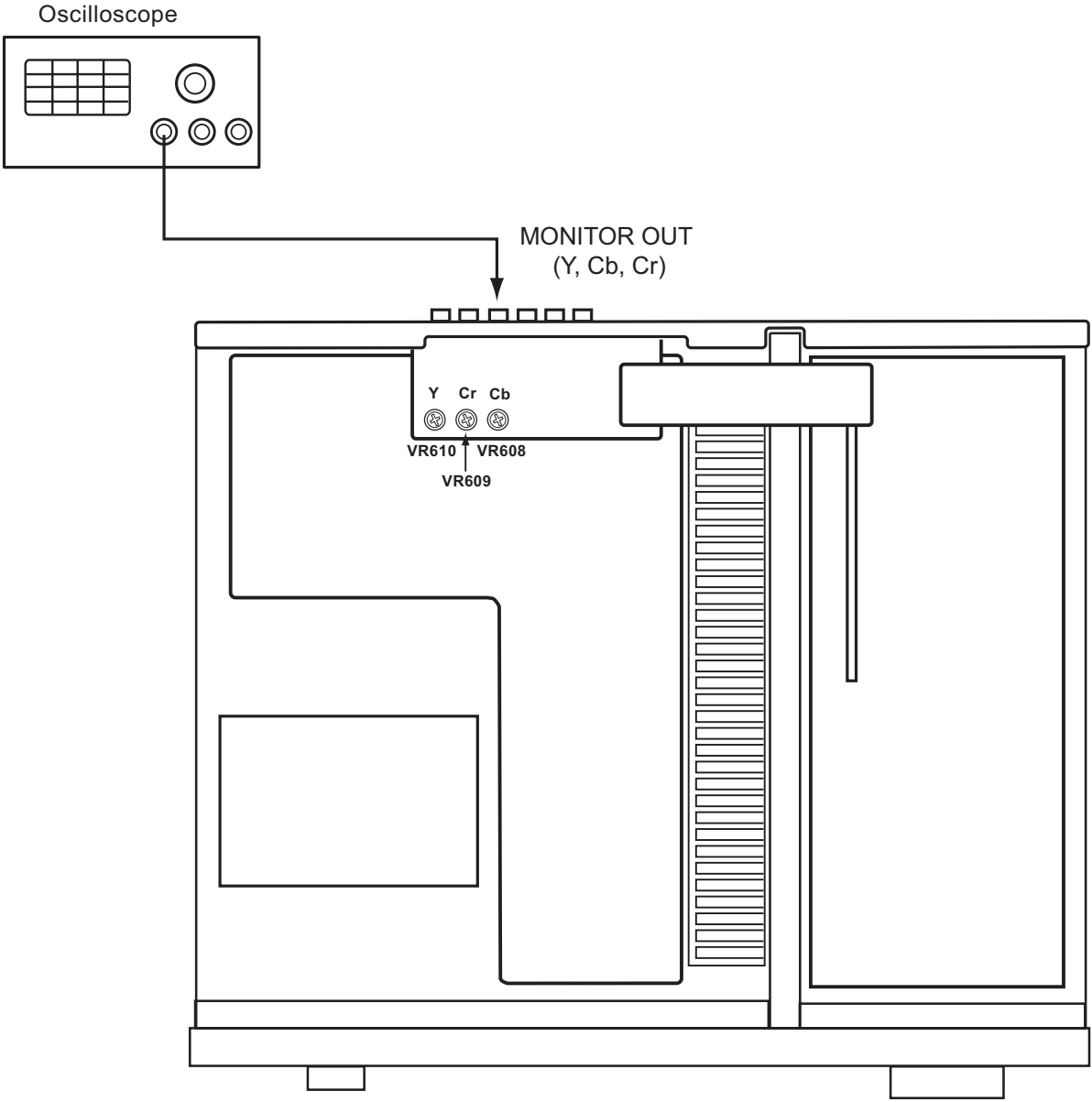

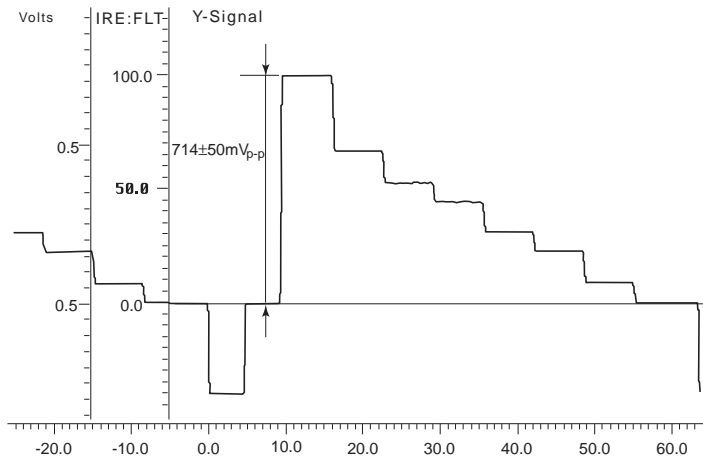

Fig.1 Component Video Y signal

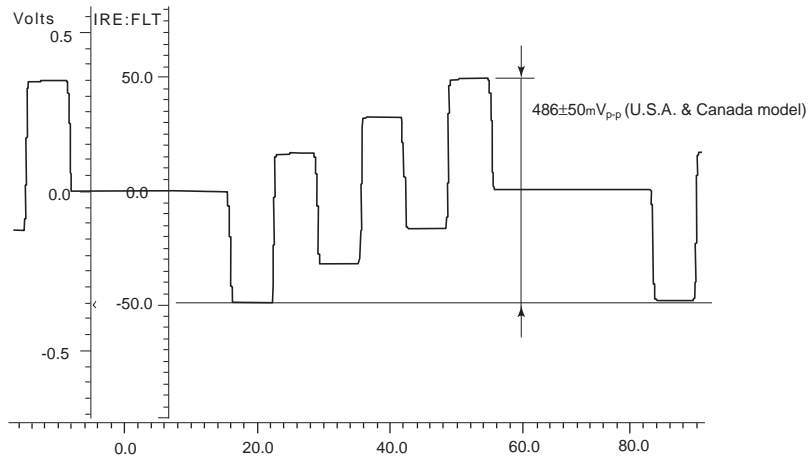

Fig.2 Cb signal

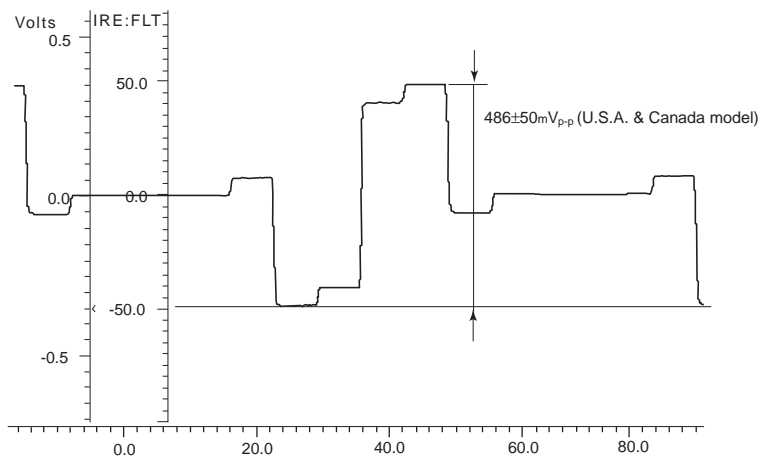

Fig.3 Cr signal

SEMICONDUCTORS

Only major semiconductors are shown, general semiconductors etc. are omitted to list.
 主な半導体を記載しています。汎用の半導体は記載を省略しています。

● IC's

CXP740010 (IC201)

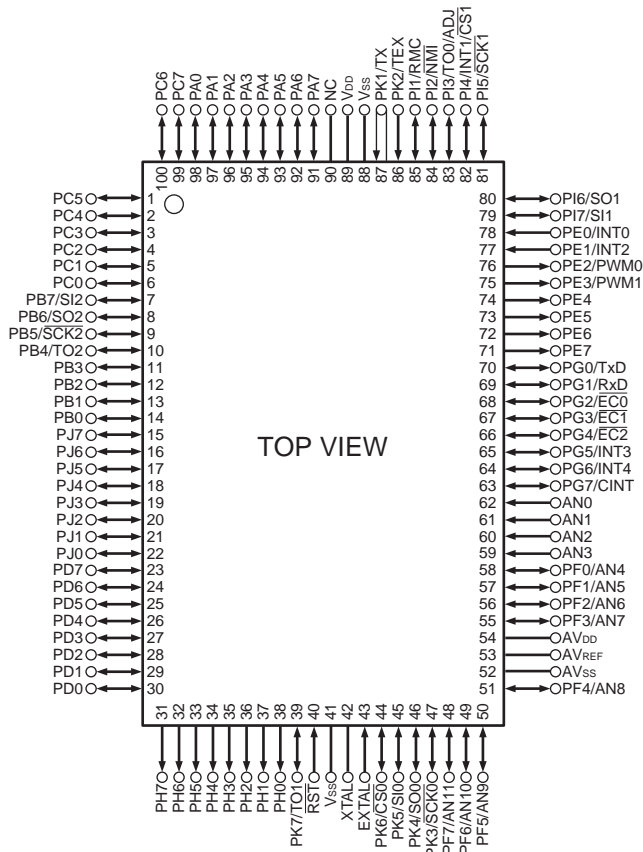

CXP740096 Terminal Function

PIN No.	PIN NAME	I/O	FUNCTION
1	9274 STB	O	TC9274 CONTROL
2	9274 73 9164 CLK	O	TC9274/TC9273/TC9164 CLOCK
3	9274 73 9164 DATA	O	TC9274/TC9273/TC9164 DATA
4	FRONT MUTE	O	FRONT MUTE
5	9273 CE	O	TC9273 CONTROL
6	ERR_MUTE	O	ERR MUTE
7	ERR_MUTE_OFF	O	ERR MUTE OFF
8	BSE	O	DIGITAL SIGNAL MUTE
9	89057_EMPHA	I	LC89057 CONTROL
10	SW_SUM	O	SW SUMMING CONTROL
11	SHARC_SDIN	I	SHARC EX(DSP) DATA INPUT
12	89057_SDIN	I	LC89057 CONTROL
13	EPROM_RESET	O	EPROM RESET
14	89057_RESET	O	LC89057 RESET
15	SHARC_CS	O	SHARC EX(DSP) CS
16	SHARC_SDOUT	O	SHARC EX(DSP) DATA OUTPUT
17	89057_CE	O	LC89057 CONTROL
18	89057/1837_SDOUT	O	CONTROL DATA
19	89057/1837_SCLK	O	CONTROL CLOCK
20	1837_RESET	O	CODEC RESET
21	9164_STB	O	TC9164 CONTROL
22	SW_MUTE	O	SW MUTE
23	RELAY_SURR_B	O	SURROUND BACK RELAY
24	RELAY_FRONT_A	O	FRONT A RELAY
25	RELAY_SURR	O	SURROUND RELAY
26	RELAY_CNT	O	CENTER RELAY

PIN No.	PIN NAME	I/O	FUNCTION
27	RELAY_H/P	O	RELAY H/P
28	FUNC_UP	O	ENCODER INPUT (FUNCTION)
29	H/P_DETECT	I	DETECT H/P
30	FUNC_DOWN	O	ENCODER INPUT (FUNCTION)
31	SURR_SB_MUTE	O	SURROUND BACK MUTE
32	CNT_MUTE	O	CENTER MUTE
33	TA1270_TC90A69F_CLK	O	TA1270/TC90A69F CONTROL
34	SURR_MUTE	O	SURROUND MUTE
35	NC	-	-
36	MULTI SB RLY	O	ZONE2/SURROUND BACK : SELECTION RELAY
37	RELAY_FRONT_B	O	FRONT B RELAY
38	FL_DRV_RST	O	LC75721 RESET
39	RELAY_POWER	O	POWER RELAY
40	RESET	I	RESET
41	GND	-	GND
42	XTAL	-	OSILATOR CONECTION
43	EXTAL	-	OSILATOR CONECTION
44	FL_DRV_CE	O	LC75721 CE
45	FL_DRV_DATA	O	LC75721 DATA
46	FL_DRV/2090_CLK	O	LC75721/BU2090 CLOCK
47	2090_DATA	O	BU2090 DATA
48	VOL_DOWN	I	ENCODER INPUT (VOLUME)
49	VOL_UP	I	ENCODER INPUT (VOLUME)
50	SEL_DOWN	I	ENCODER INPUT (SELECTOR)
51	SEL_UP	I	ENCODER INPUT (SELECTOR)
52	AVSS	-	AVSS
53	VREF	-	VREF
54	AVDD	-	AVDD
55	89057_INT	-	LC89057 INT
56	TA1270_TC90A69 DATA	O	TA1270/TC90A69 DATA
57	GREEN_LED	O	GREEN LED
58	SET_OPT	I	MODEL SELECT
59	STEP_OPT	I	AREA SELECT
60	KEY_IN3	I	KEY INPUT
61	KEY_IN2	I	KEY INPUT
62	KEY_IN1	I	KEY INPUT
63	PWR_DOWN	I	POWER DOWN DETECT
64	PROTECT	I	PROTECTION
65	C-VIDEO_DET	I	Composit Signal Detect input
66	SHARC_SCLK	O	SHARC EX(DSP) SCLK
67	1837_CE	O	CODEC CE
68	SHARC_RESET	O	SHARC EX(DSP) RESET
69	FRONT_MUTE	O	FRONT MUTE
70	STBY_LED	O	STANDBY LED
71	NC	-	-
72	NC	-	-
73	74781 CS	-	LC74781 CONTROL ENABLE
74	74781 SCLK	O	LC74781 CONTROL CLOCK
75	SURR_BACK_MUTE	O	SURROUND BACK MUTE
76	2090 CLK2	O	BU2090 CLOCK2(VIDEO)
77	RDS_DATA	I	TDA7330 CONTROL DATA
78	RDS_CLK	I	TDA7330 CLOCK DATA
79	FLAG3	I	Special flag for ROM updata
80	FLAG2	I	DSP operation check flag
81	FLAG1	I	NON USE
82	FLAG0	I	EPROM chip select control for DSP
83	MULTI MUTE	O	MULTI MUTE
84	S-VIDEO_DET	I	S Signal Detect input
85	REMOCON	I	REMOTE CONTROL SIGNAL INPUT
86	COPM_DET	I	Compornent Signal input

PIN No.	PIN NAME	I/O	FUNCTION
87	OVERLOAD	I	OVERLOAD DETECT
88	VSS	-	VSS
89	VDD(BACK UP)	-	VDD FOR BACK UP
90	NC	-	-
91	TC94A27UG_STB	-	TC94A27UG CONTROL
92	TC94A27UG_PLL_DATA	O	PLL CONTROL (LC72131),DATA (TC94A27UG)
93	TC94A27UG_PLL_CLK	O	PLL CONTROL (LC72131),CLOCK (TC94A27UG)
94	PLL_DT_IN	I	PLL CONTROL (LC72131)
95	TU_MUTE	O	TUNER MUTE
96	ST	I	STEREO DETECT
97	TUNED	I	TUNE DETECT
98	PLL_CE	O	PLL CONTROL (LC72131)
99	2090_CLK1	O	BU2090 CLOCK(VIDEO)
100	2090_74781_DATA	O	BU2090/LC74781 CONTROL DATA(VIDEO)

ADSP-21266SKSTZ-2B (IC804)

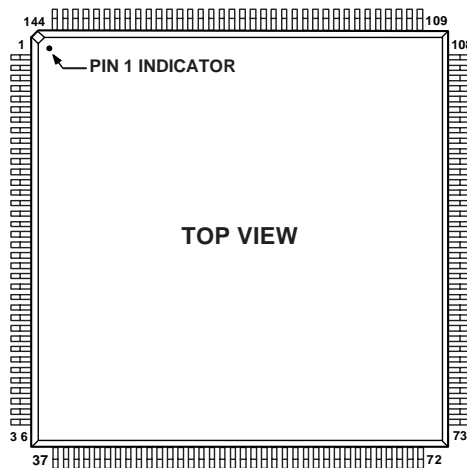

ADSP-21266SKSTZ-2B Terminal Function

Pin Name	LQFP Pin #	Pin Name	LQFP Pin #	Pin Name	LQFP Pin #	Pin Name	LQFP Pin #
V _{DDINT}	1	V _{DDINT}	37	V _{DDEXT}	73	GND	109
CLKCFG0	2	GND	38	GND	74	V _{DDINT}	110
CLKCFG1	3	RD	39	V _{DDINT}	75	GND	111
BOOTCFG0	4	ALE	40	GND	76	V _{DDINT}	112
BOOTCFG1	5	AD15	41	DAI_P10 (SD2B)	77	GND	113
GND	6	AD14	42	DAI_P11 (SD3A)	78	V _{DDINT}	114
V _{DDEXT}	7	AD13	43	DAI_P12 (SD3B)	79	GND	115
GND	8	GND	44	DAI_P13 (SCLK23)	80	V _{DDEXT}	116
V _{DDINT}	9	V _{DDEXT}	45	DAI_P14 (SFS23)	81	GND	117
GND	10	AD12	46	DAI_P15 (SD4A)	82	V _{DDINT}	118
V _{DDINT}	11	V _{DDINT}	47	V _{DDINT}	83	GND	119
GND	12	GND	48	GND	84	V _{DDINT}	120
V _{DDINT}	13	AD11	49	GND	85	RESET	121
GND	14	AD10	50	DAI_P16 (SD4B)	86	SPIDS	122
FLAG0	15	AD9	51	DAI_P17 (SD5A)	87	GND	123
FLAG1	16	AD8	52	DAI_P18 (SD5B)	88	V _{DDINT}	124
AD7	17	DAI_P1 (SD0A)	53	DAI_P19 (SCLK45)	89	SPICLK	125
GND	18	V _{DDINT}	54	V _{DDINT}	90	MISO	126
V _{DDINT}	19	GND	55	GND	91	MOSI	127
GND	20	DAI_P2 (SD0B)	56	GND	92	GND	128
V _{DDEXT}	21	DAI_P3 (SCLK0)	57	V _{DDEXT}	93	V _{DDINT}	129
GND	22	GND	58	DAI_P20 (SFS45)	94	V _{DDEXT}	130
V _{DDINT}	23	V _{DDEXT}	59	GND	95	A _{VDD}	131
AD6	24	V _{DDINT}	60	V _{DDINT}	96	A _{VSS}	132
AD5	25	GND	61	FLAG2	97	GND	133
AD4	26	DAI_P4 (SFS0)	62	FLAG3	98	CLKOUT	134
V _{DDINT}	27	DAI_P5 (SD1A)	63	V _{DDINT}	99	EMU	135
GND	28	DAI_P6 (SD1B)	64	GND	100	TDO	136
AD3	29	DAI_P7 (SCLK1)	65	V _{DDINT}	101	TDI	137
AD2	30	V _{DDINT}	66	GND	102	TRST	138
V _{DDEXT}	31	GND	67	V _{DDINT}	103	TCK	139
GND	32	V _{DDINT}	68	GND	104	TMS	140
AD1	33	GND	69	V _{DDINT}	105	GND	141
AD0	34	DAI_P8 (SFS1)	70	GND	106	CLKIN	142
WR	35	DAI_P9 (SD2A)	71	V _{DDINT}	107	XTAL	143
V _{DDINT}	36	V _{DDINT}	72	V _{DDINT}	108	V _{DDEXT}	144

AD1837 (IC808)

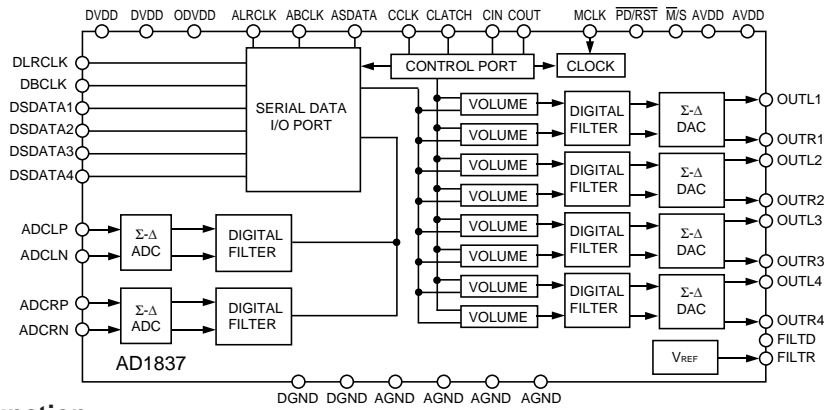
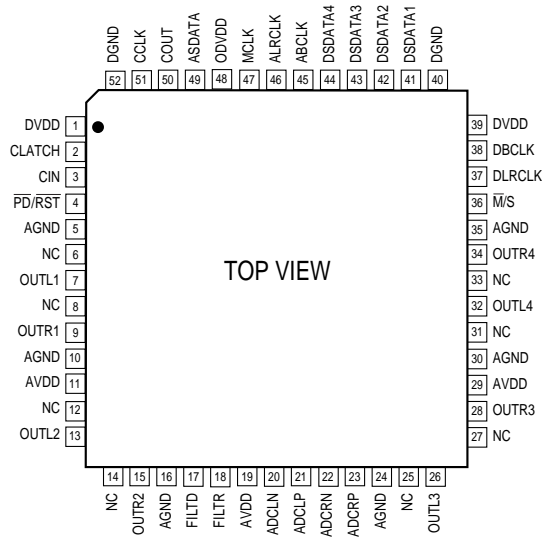

AD1837 Terminal Function

Pin No.	Pin Name	Input/Output	Description
1,39	DVDD		Digital Power Supply. Connect to digital 5V supply.
2	CLATCH	I	Latch Input for Control Data
33	CIN	I	Serial Control Input
4	PD/RST	I	Power-Down/Reset
5,10,16,24,30,35	AGND		Analog Ground
6,12,25,31	NC		Not connected
7,13,26,32	OUTLx	O	DACx Left Channel Output
8,14,27,33	NC		Not connected
9,15,28,34	OUTRx	O	DACx Right Channel Output
11,19,29	AVDD		Analog Power Supply. Connect to analog 5V supply.
17	FILTD		Filter Capacitor Connection. Recommend 10μF/100nF.
18	FILTR		Reference Filter Capacitor Connection. Recommended 10μF/100nF.
20	ADCLN	I	ADC Left Channel Negative Input
21	ADCLP	I	ADC Left Channel Positive Input
22	ADCRN	I	ADC Right Channel Negative Input
23	ADCRP	I	ADC Right Channel Positive Input
36	M/S	I	ADC Master/Slave Select
37	DLCLK	I/O	DAC LR Clock
38	DBCLK	I/O	DAC Bit Clock
40,52	DGND		Digital Ground
41-44	DSDATAx	I	DACx Input Data (Left and Right Supply)
45	ABCLK	I/O	ADC Bit Clock
46	ALRCLK	I/O	ADC LR Clock
47	MCLK	I	Master Clock Input
48	ADVDD		Digital Output Driver Power Supply
49	ASDATA	O	ADC Serial Data Output
50	COUT	O	Output for Control Data
51	CCLK	I	Control Clock Input for Control Data

LC89057W (IC807)

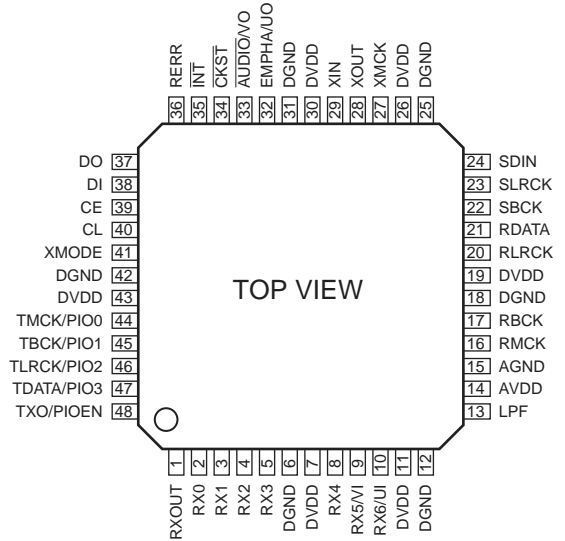
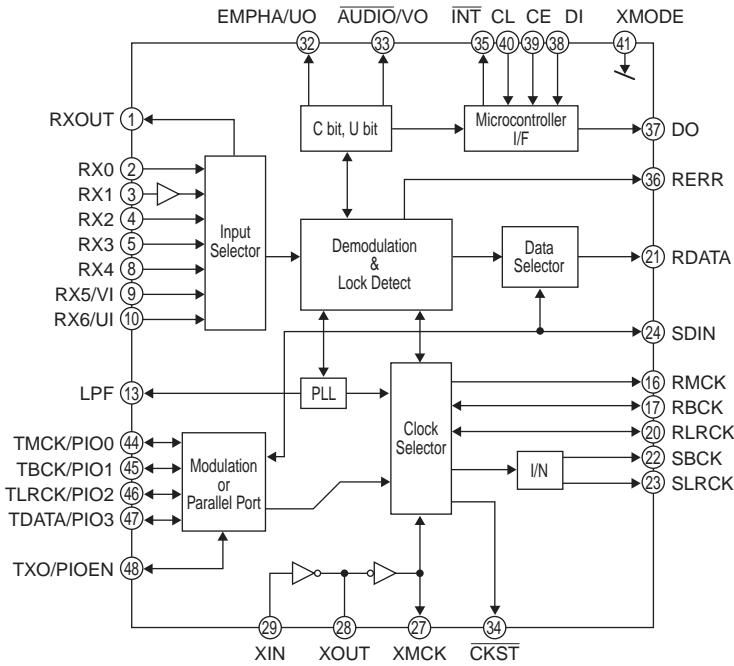

LC89057W Terminal Function

Pin No.	Pin Name	I/O	Function
1	RXOUT	O	Input bi-phase select data output terminal
2	RX0	I	TTL compatible digital data input terminal
3	RX1	I	Coaxial compatible amp built-in digital data input terminal
4	RX2	I	TTL compatible digital data input terminal
5	RX3	I	TTL compatible digital data input terminal
6	DGND	—	Digital GND
7	DVDD	—	Digital power
8	RX4	I	TTL compatible digital data input terminal
9	RX5/VI	I	TTL compatible digital data/Validity flag input terminal for modulation
10	RX6/UI	I	TTL compatible digital data/User data input terminal for modulation
11	DVDD	—	Digital power for PLL
12	DGND	—	Digital GND for PLL
13	LPF	O	PLL loop filter connecting terminal
14	AVDD	—	Analog power for PLL
15	AGND	—	Analog GND for PLL
16	RMCK	O	RMCK clock output terminal (256fs, 512fs, XIN, VCO)
17	RBCK	O/I	RBCK clock in/output terminal (64fs)
18	DGND	—	Digital GND
19	DVDD	—	Digital power
20	RLRCK	O/I	RLRCK clock in/output terminal (fs)
21	RDATA	O	Serial audio data output terminal
22	SBCK	O	SBCK clock output terminal (32fs, 64fs, 128fs)
23	SLRCK	O	SLRCK clock output terminal (fs/2, fs, 2fs)
24	SDIN	I	Serial audio data input terminal
25	DGND	—	Digital GND
26	DVDD	—	Digital power
27	XMCK	O	Osc. amp output terminal

Pin No.	Pin Name	I/O	Function
28	XOUT	O	X'tal osc. connecting output terminal
29	XIN	I	X'tal osc. connection, external clock input terminal (24.576MHz or 12.288MHz)
30	DVDD	—	Digital power
31	DGND	—	Digital GND
32	EMPHA/UO	I/O	Emphasis information/U-data output/Chip address setting terminal
33	AUDIO/VO	I/O	Non-PCM detect/V-flag output/ Chip address setting terminal
34	CKST	I/O	Clock switch transition period output/Demodulation master or slave function switching terminal
35	INT	I/O	Interrupt output for μ com (Interrupt factor selectable)/Modulation or general I/O switching terminal
36	RERR	O	PLL lock error, data error flag output
37	DO	O	μ com I/F, read out data output terminal (3-state)
38	DI	I	μ com I/F, write data input terminal
39	CE	I	μ com I/F, chip enable input terminal
40	CL	I	μ com I/F, clock input terminal
41	XMODE	I	System reset input terminal
42	DGND	—	Digital GND
43	DVDD	—	Digital power
44	TMCK/PIO0	I/O	256fs system clock input for modulation/General I/O in/output terminal
45	TBCK/PIO1	I/O	64fs bit clock input for modulation/General I/O in/output terminal
46	TLRCK/PIO2	I/O	fs clock input for modulation/General I/O in/output terminal
47	TDATA/PIO3	I/O	Serial audio data input for modulation/General I/O in/output terminal
48	TXO/PIOEN	O/I	Modulation data output/ General I/O enable input terminal

* For latch-up countermeasure, perform each power supply ON/OFF in the same timing.

TC94A27UG (IC201T, 202T)

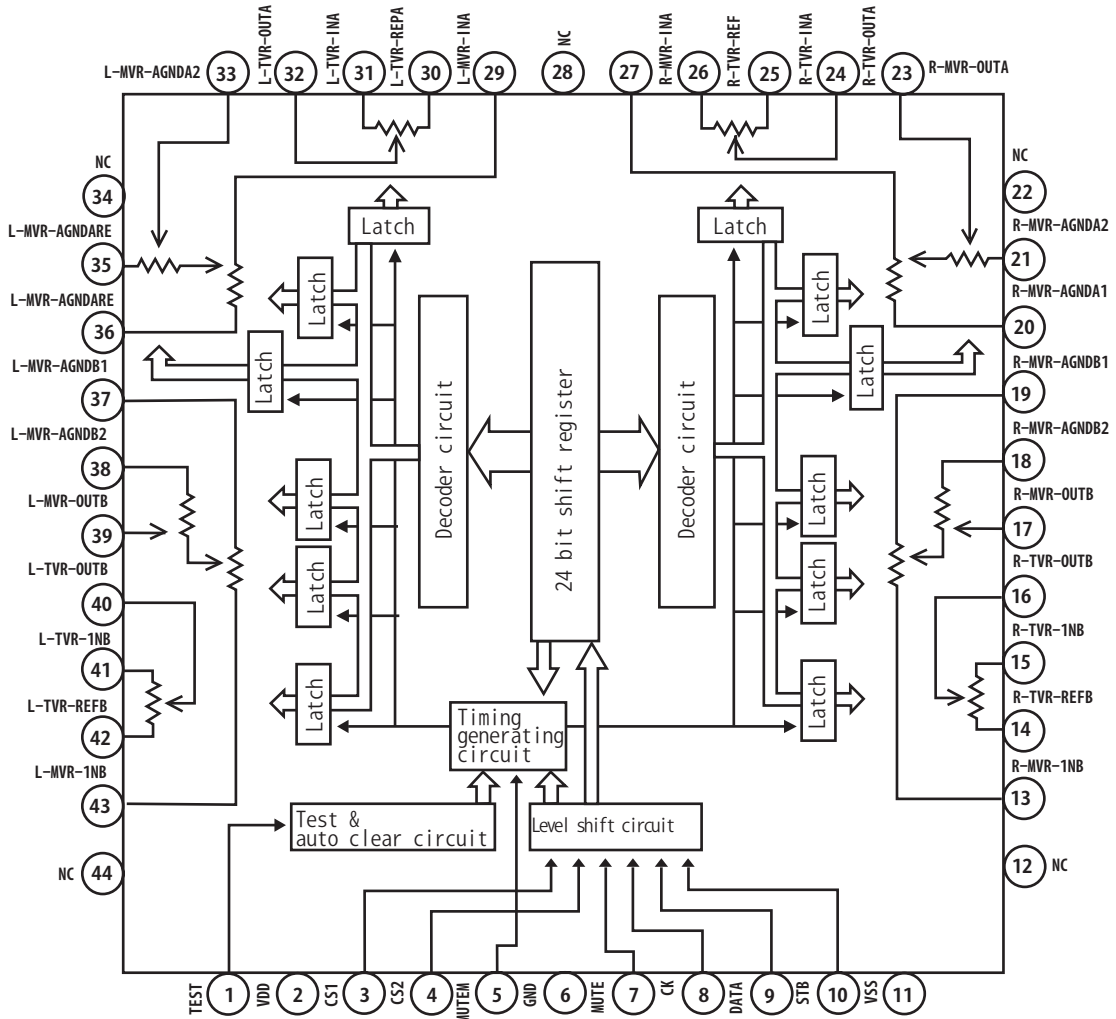

AS7C34096A-10TC (IC806, 817)

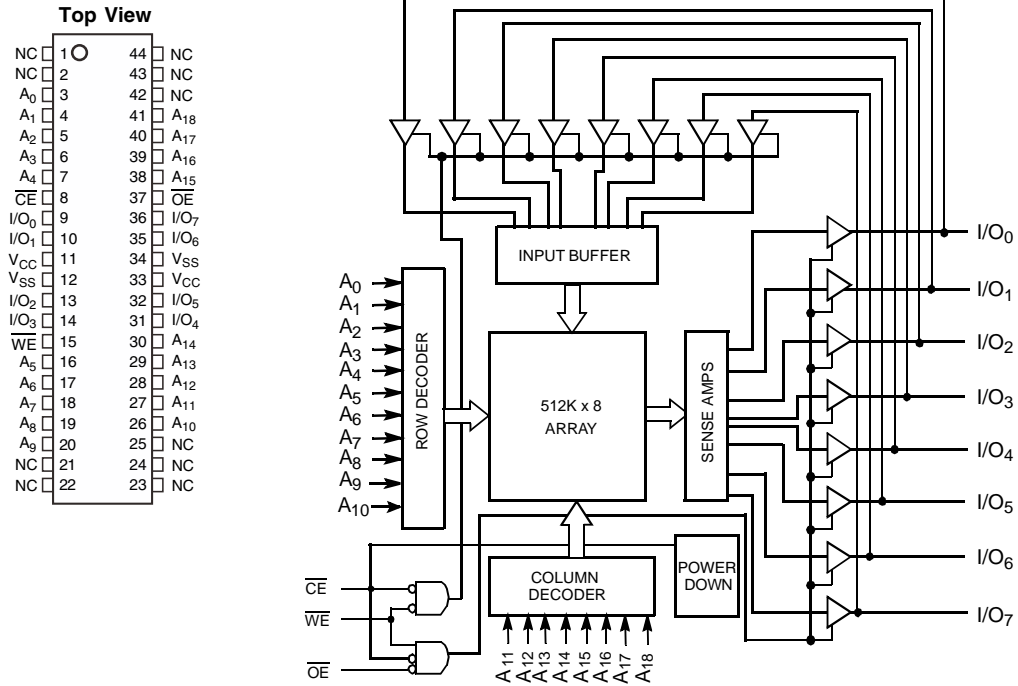

TC90A69F (IC1009)

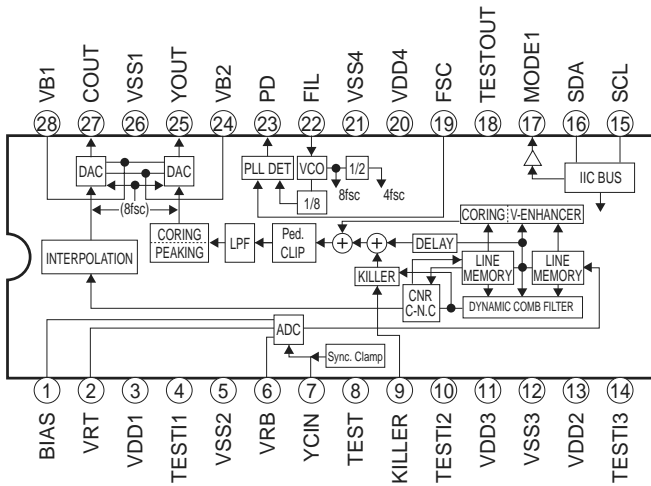

NJM2274R (IC1007)

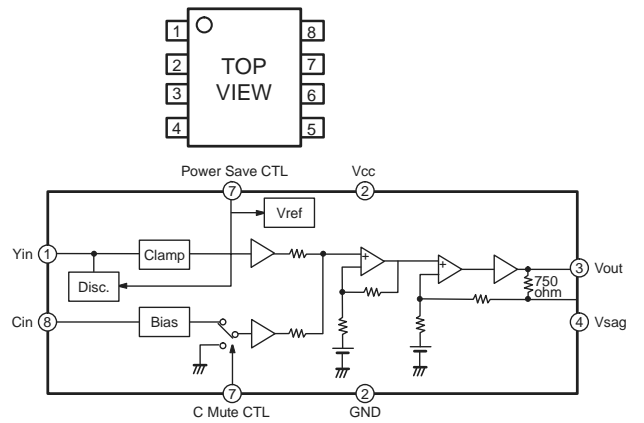

TA1270BF (IC1154)

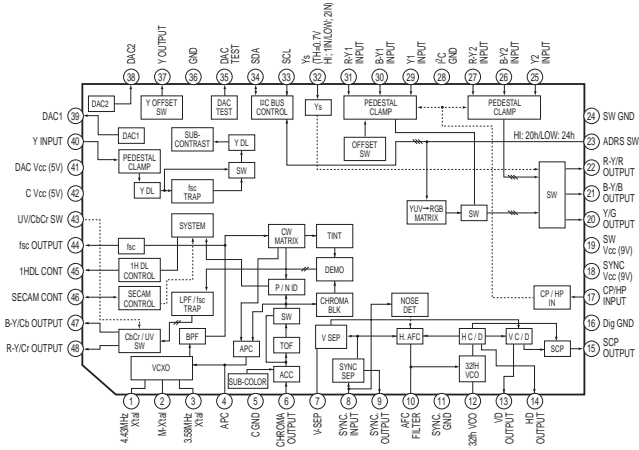

TC9274N-011 (IC701)

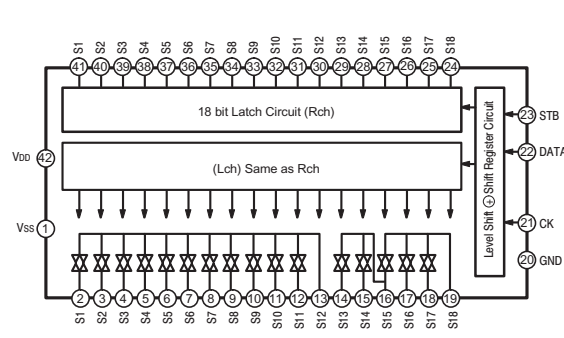

BU2090F (IC302, 1003, 1005)

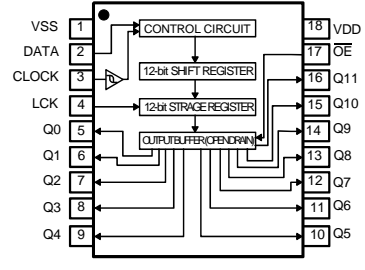

TC9273N-004 (IC705)

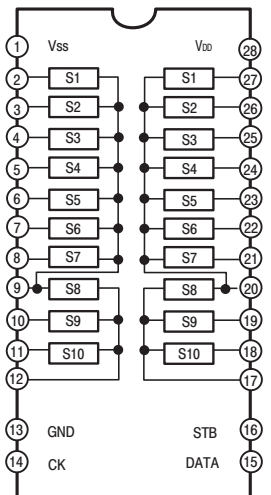

TC9273N Terminal Function

Pin No	Symbol	Name	Function	
1	VSS	+Power Terminal	Dual Power Use: VDD = 8.0~17 V Single Power Use: VDD = 8.0~18V	
13	GND	Digital Ground	GND=0V	
28	VDD	+Power Terminal	VSS=-8.0~-17V	
2~12 12~27	S1~S10	I/O Terminal	Input terminal of analog switch.	
14	CK	Clock Input	Clock input for data transfer.	Low level Border Input Terminal
15	DATA	Data Input	Serial input for switch setting.	
16	STB	Strobe Input	Strobe Input Strobe input for data writing.	

**BU4052BCF
(IC601D,602D)**

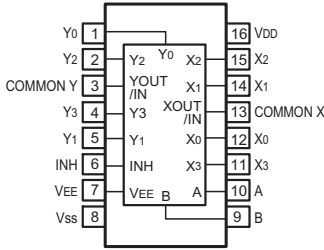

Truth Table

INH	A	B	ON Switches
L	L	L	X ₀ Y ₀
L	H	L	X ₁ Y ₁
L	L	H	X ₂ Y ₂
L	H	H	X ₃ Y ₃
H	X	X	NONE

X = Don't Care

MM74HC4053MX (IC1001, 1004, 1008)

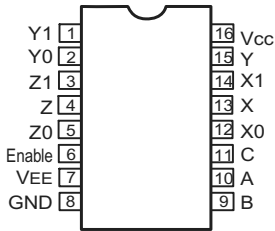

Truth Table

Enable	Control Inputs			ONSwitches
	Select			
	C	B	A	
L	L	L	L	Z0 Y0 X0
L	L	L	H	Z0 Y0 X1
L	L	H	L	Z0 Y1 X0
L	L	H	H	Z0 Y1 X1
L	H	L	L	Z1 Y0 X0
L	H	L	H	Z1 Y0 X1
L	H	H	L	Z1 Y1 X0
L	H	H	H	Z1 Y1 X1
H	X	X	X	None

X = Don't Care

BA7626 (IC1000, 1002, 1150-1153)

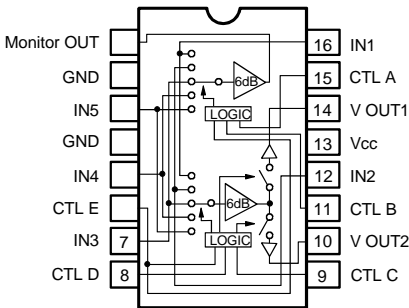

A	B	E	MONITOR OUT
L	L	*	IN 1
H	L	*	IN 2
L	H	*	IN 3
H	H	L	IN 4
H	H	H	IN 5

C	D	E	V OUT 1
L	L	*	—
H	L	*	IN 2
L	H	*	IN 3
H	H	L	IN 4
H	H	H	IN 5

Note 1: * mark means that feasible for either H or L.

Note 2: Each input terminal is provided with sink chip clamp (BA7625). Each input terminal takes 20kohm at the end (BA7626).

C	D	E	V OUT 2
L	L	*	IN 1
H	L	*	—
L	H	*	IN 3
H	H	L	IN 4
H	H	H	IN 5

LC74781 (IC1006)

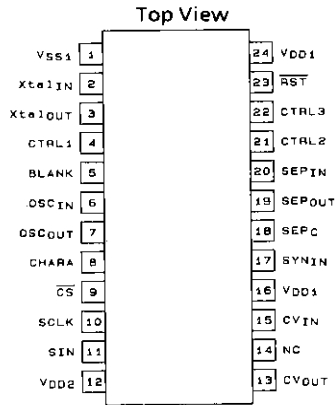

Pin No.	Symbol	Name
1	VSS1	GND
2	Xtal IN	Xtal oscillation
3	Xtal OUT	Xtal oscillation
4	CTRL1	Xtal oscillation input switching
5	BLANK	Blank output
6	OSC IN	LC oscillation
7	OSC OUT	LC oscillation
8	CHARA	Character output
9	CS	Enable input
10	SCLK	Clock input
11	SIN	Data input
12	VDD2	Power
13	CV OUT	VIDEO signal output
14	NC	
15	CV IN	VIDEO signal input
16	VDD1	Power
17	SYN IN	Sync. separate circuit input
18	SEP C	Sync. separate circuit bias voltage
19	SEP OUT	Complex sync. signal output
20	SEP IN	Vertical sync. signal input
21	CTRL2	NTSC/PAL-M switching input
22	CTRL3	SEP IN input control
23	RST	Reset input
24	VDD1	Power (+5V)

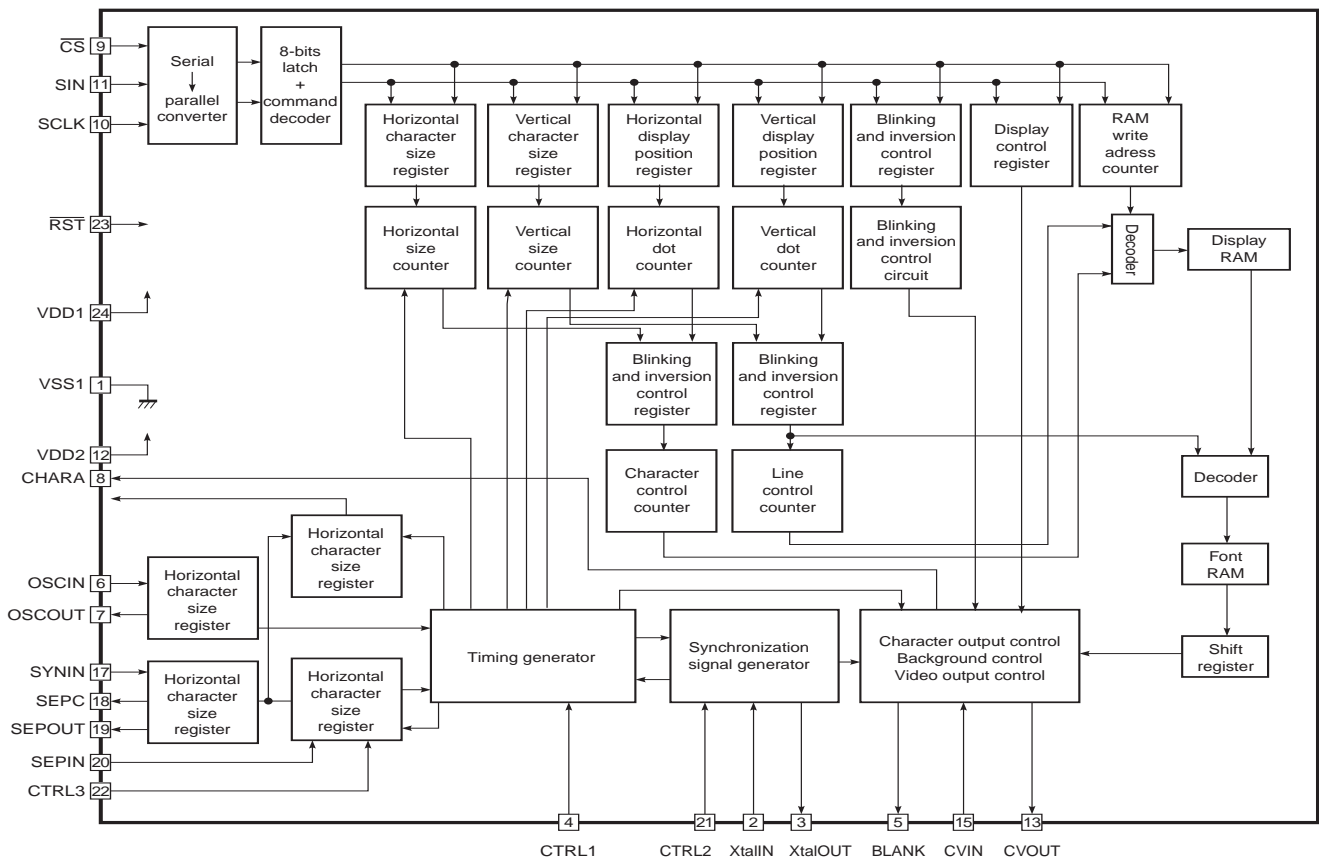

**74LVX157
(IC810)**

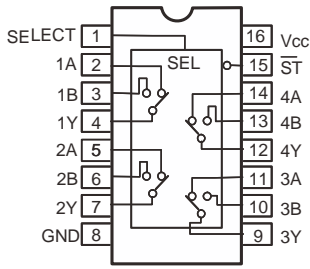

~ ~

SN74LVC139APWR (IC820)

FUNCTION TABLE
(each decoder/demultiplexer)

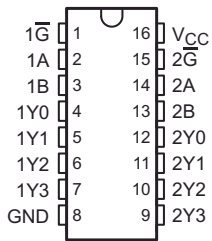

\overline{G}	INPUTS		OUTPUTS			
	SELECT		Y3	Y2	Y1	Y0
	B	A				
L	L	L	H	H	H	L
L	L	H	H	H	L	H
L	H	L	H	L	H	H
L	H	H	L	H	H	H
H	X	X	H	H	H	H

● **LED**

SML1216W (LED901)

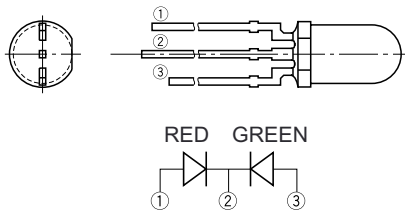

● FL DISPLAY

16-ST-66GNK

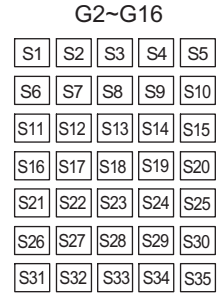
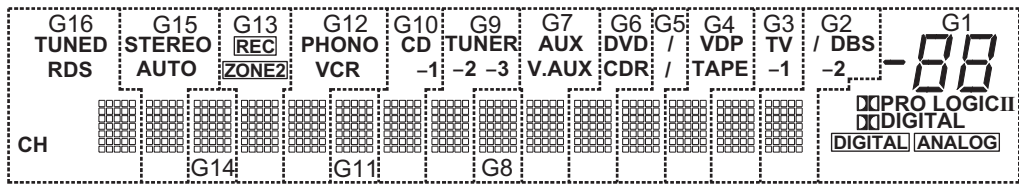
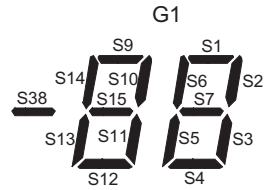
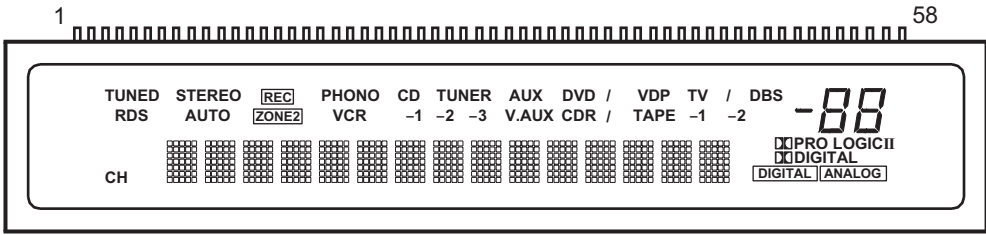

Pin Assignment

PIN NO.	1	2	3	4	5	6	7	8	9	10	11	12	13	14	15	16	17	18	19	20
CONNECTION	F1	F1	S1	S2	S3	S4	S5	S6	S7	S8	S9	S10	S11	S12	S13	S14	S15	S16	S17	S18
PIN NO.	21	22	23	24	25	26	27	28	29	30	31	32	33	34	35	36	37	38	39	40
CONNECTION	S19	S20	S21	S22	S23	S24	S25	S26	S27	S28	S29	S30	S31	S32	S33	S34	S35	S36	S37	S38
PIN NO.	41	42	43	44	45	46	47	48	49	50	51	52	53	54	55	56	57	58		
CONNECTION	G16	G15	G14	G13	G12	G11	G10	G9	G8	G7	G6	G5	G4	G3	G2	G1	F2	F2		

F1, F2 : Filament
 G1-G16: Grid
 S1-S38 : Anode

Anode & Grid Assignment

	G1	G2-G16		G1	G2-G16		G1	G2-G16		G1	G2-G16
S1	S1	S1	S10	S10	S10	S19	—	S19	S28	—	S28
S2	S2	S2	S11	S11	S11	S20	—	S20	S29	—	S29
S3	S3	S3	S12	S12	S12	S21	—	S21	S30	—	S30
S4	S4	S4	S13	S13	S13	S22	—	S22	S31	—	S31
S5	S5	S5	S14	S14	S14	S23	—	S23	S32	—	S32
S6	S6	S6	S15	S15	S15	S24	—	S24	S33	—	S33
S7	S7	S7	S16	—	S16	S25	—	S25	S34	—	S34
S8	—	S8	S17	DIGITAL	S17	S26	—	S26	S35	—	S35
S9	S9	S9	S18	PRO LOGIC II	S18	S27	—	S27			

	G1	G2	G3	G4	G5	G6	G7	G8	G9	G10	G11	G12	G13	G14	G15	G16
S36	DIGITAL	/	TV	VDP	/(DVD)	DVD	AUX	—	TUNER	CD	—	PHONO	REC	—	STEREO	TUNED
S37	ANALOG	-2	-1	TAPE	/(MD)	CDR	V.AUX	—	-2	-1	—	VCR	ZONE2	—	AUTO	RDS
S38	S38	DBS	—	—	—	—	—	—	-3	—	—	—	—	—	—	CH

PRINTED WIRING BOARDS

MAIN P.W.B. UNIT

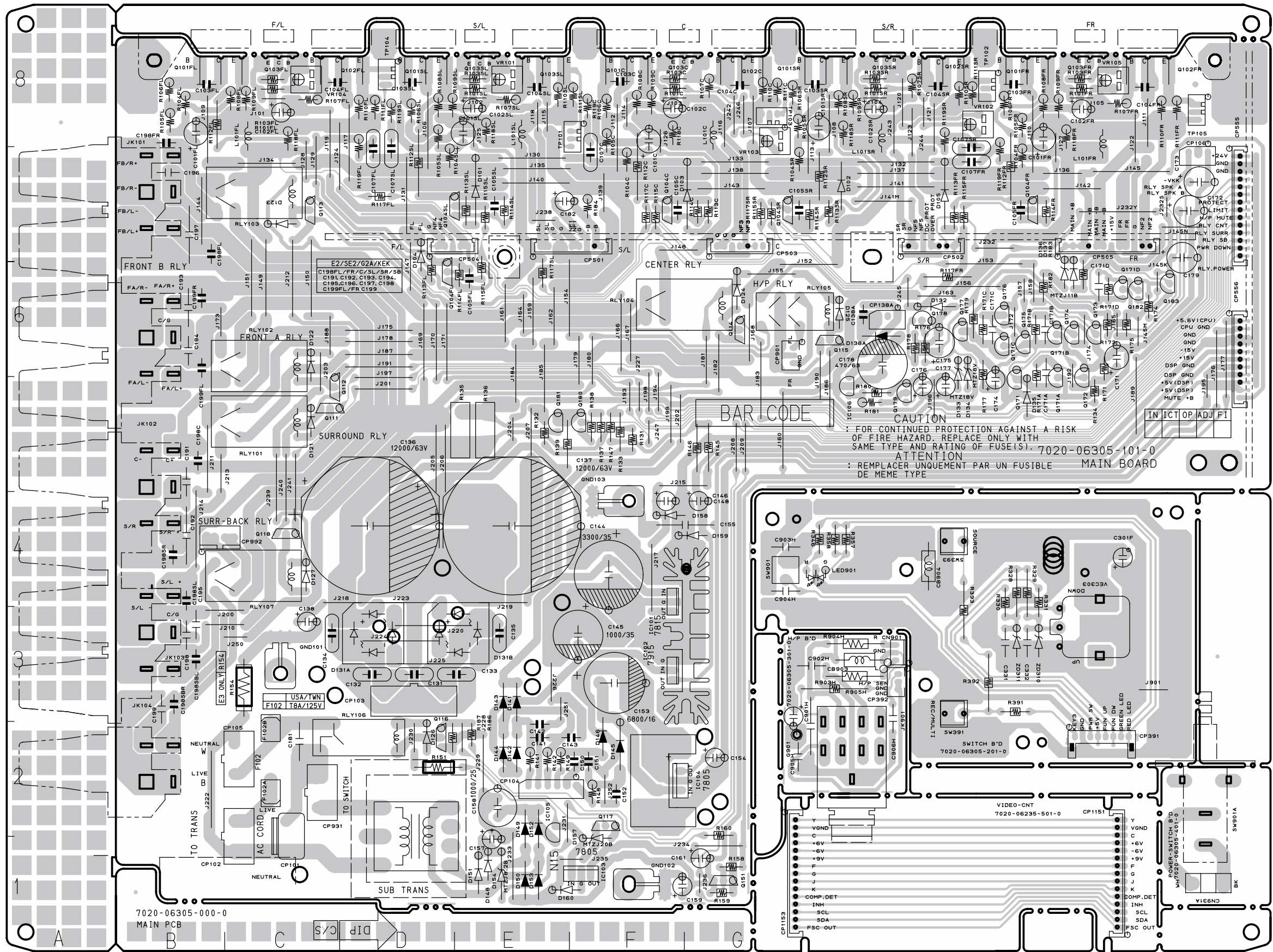

COMPONENT SIDE

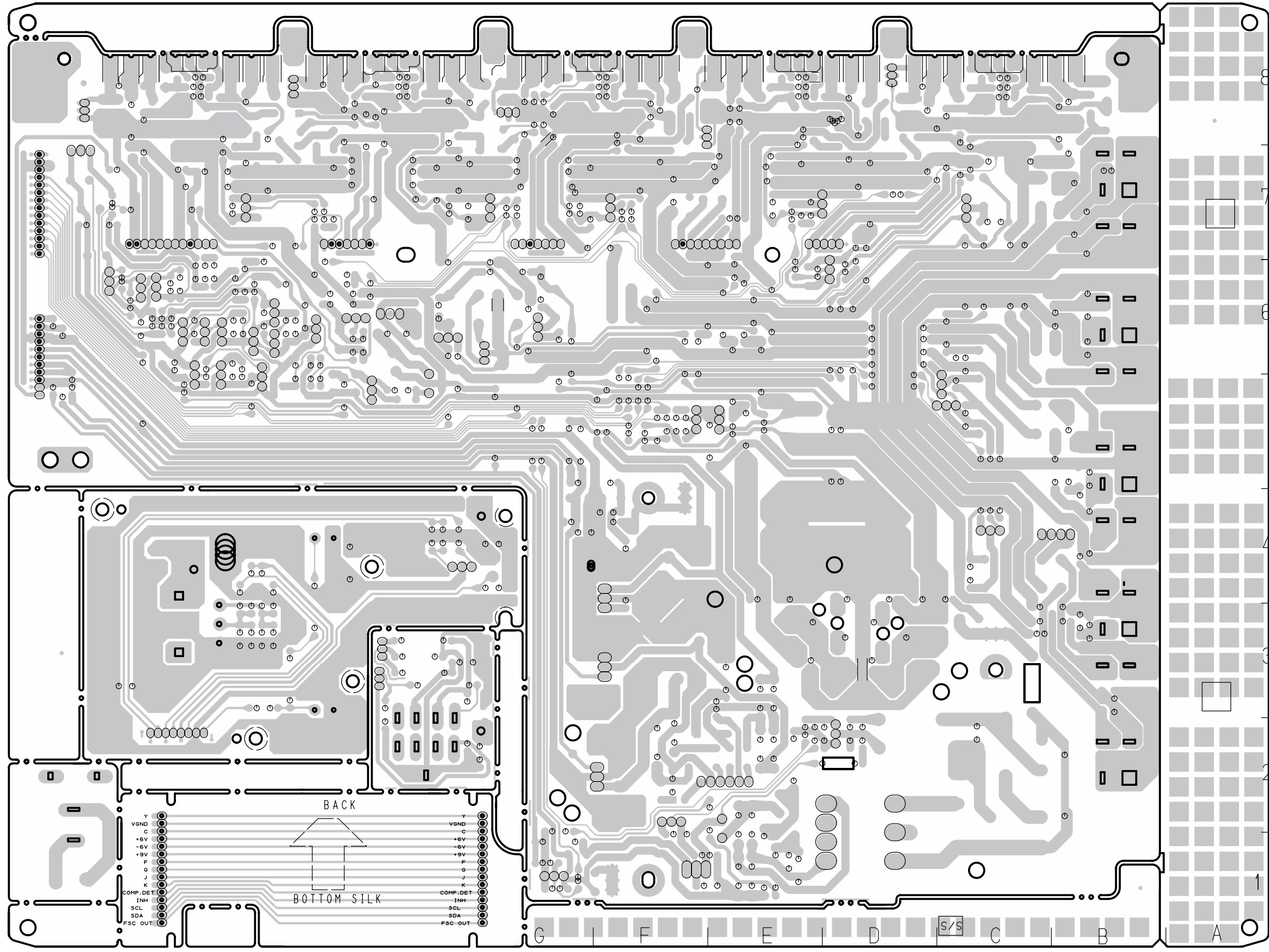

FOIL SIDE

CPU, FRONT P.W.B. UNIT

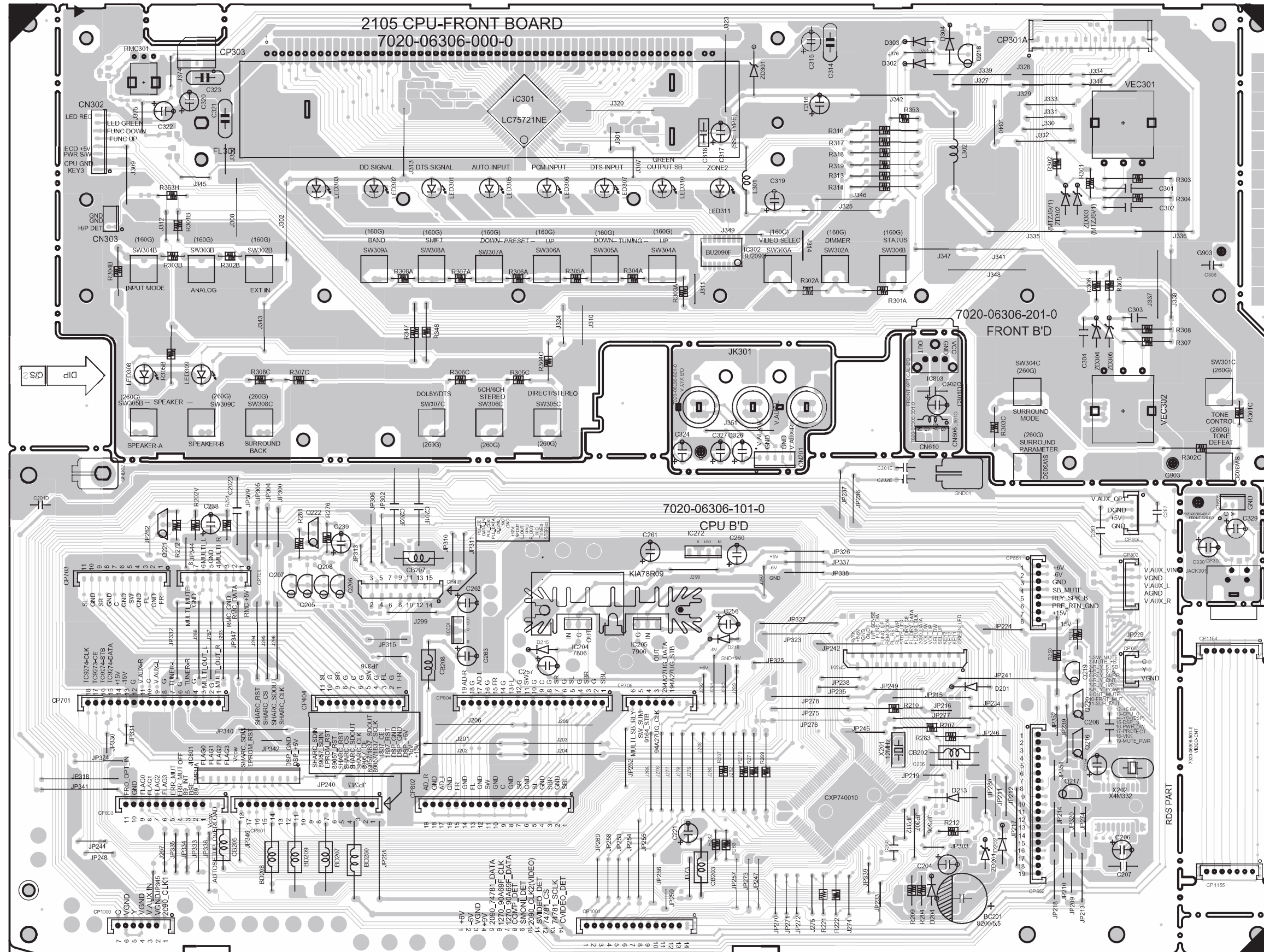

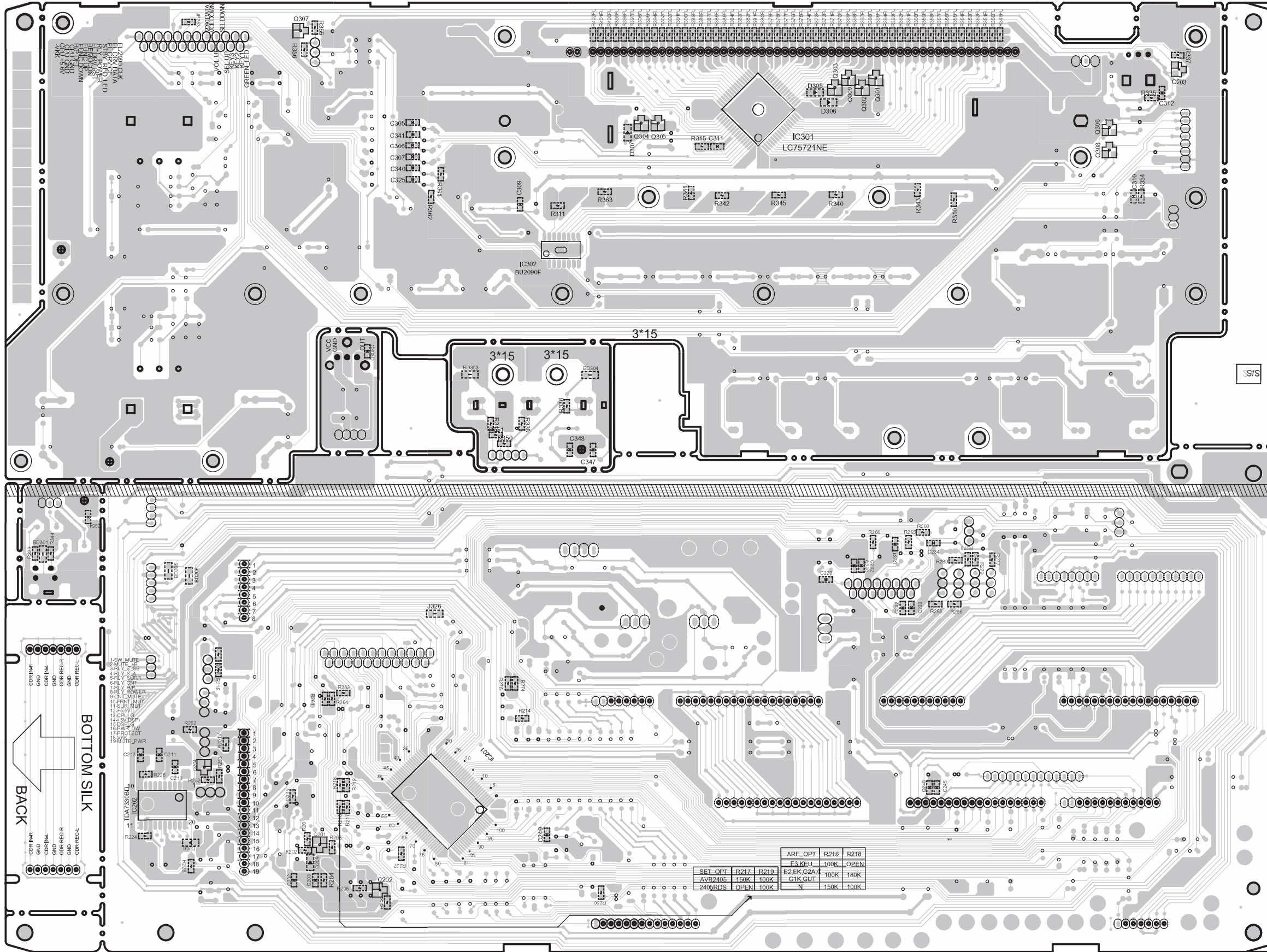

FOIL SIDE

CNT, PRE-AMP P.W.B. UNIT

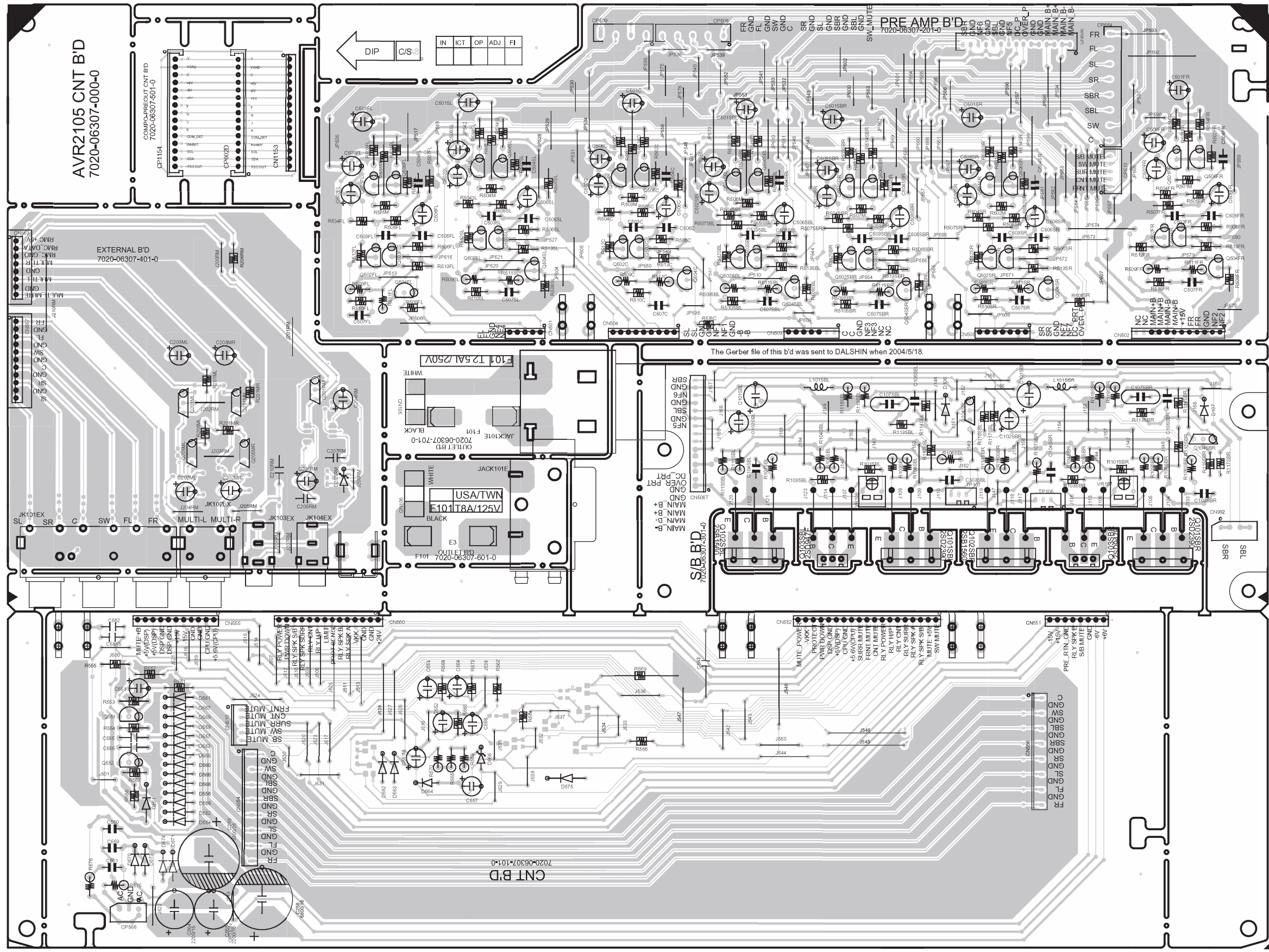

COMPONENT SIDE

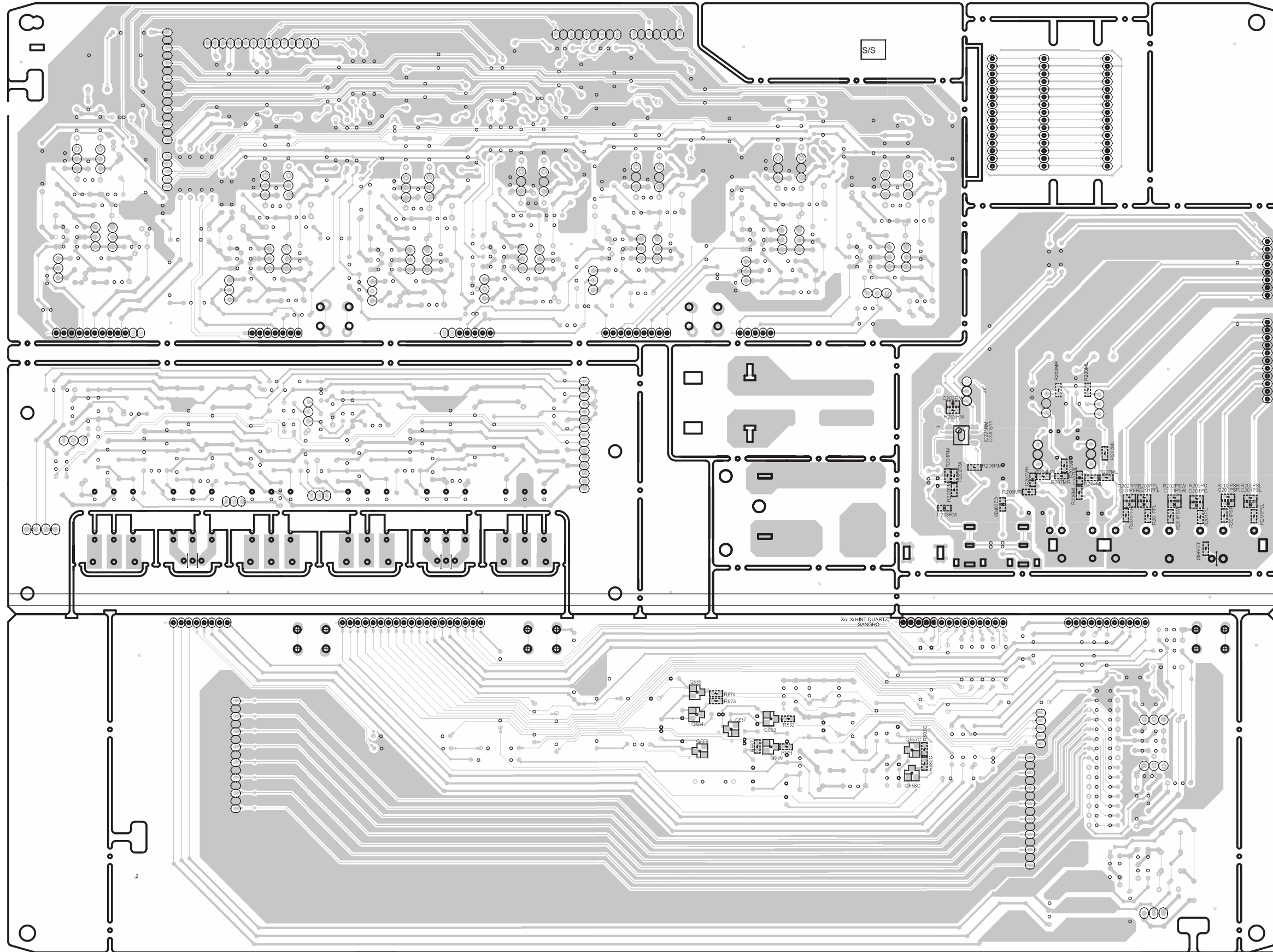

FOIL SIDE

INPUT, VIDEO P.W.B. UNIT (FOR U.S.A., CANADA & JAPAN MODELS)

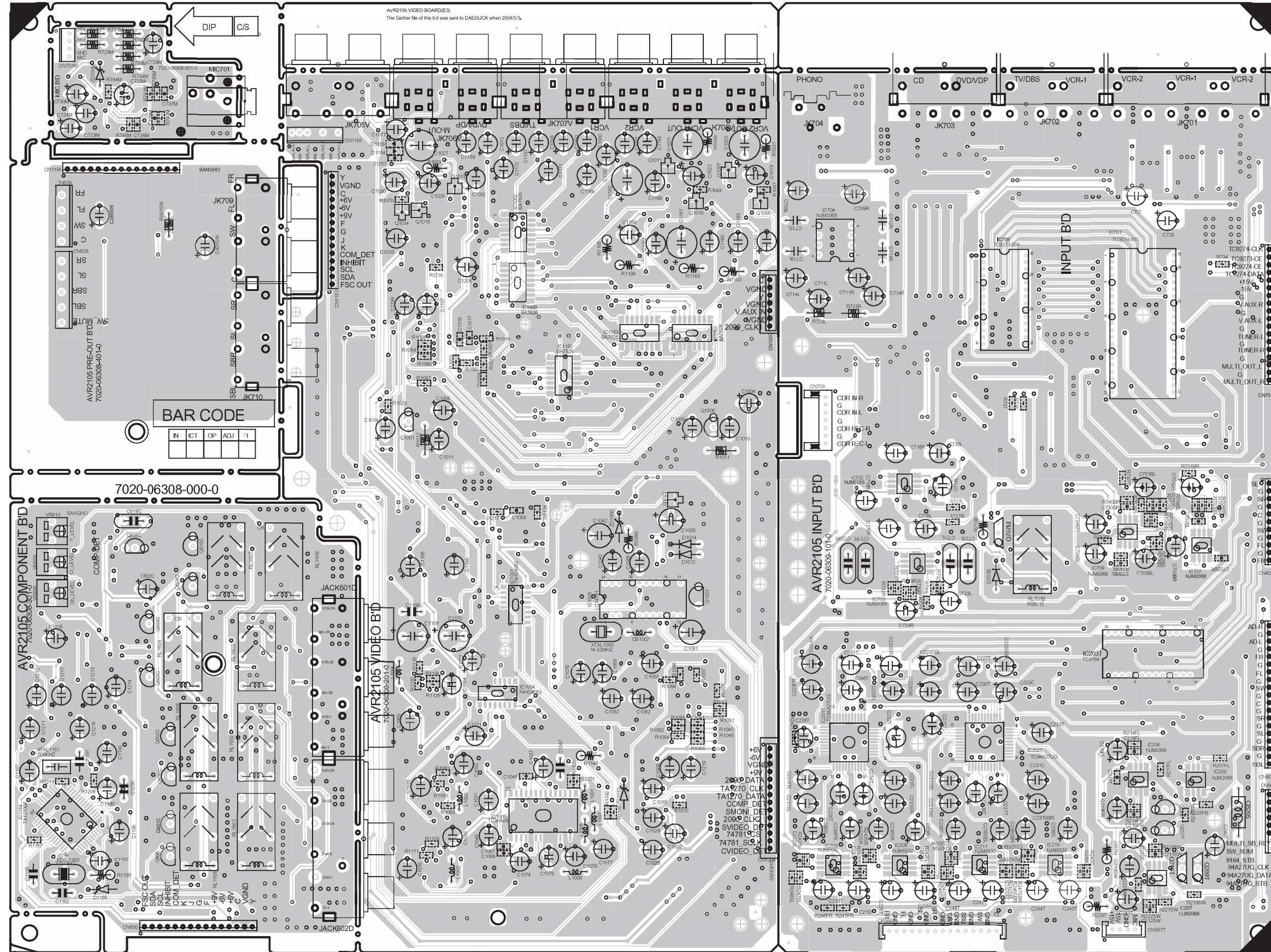

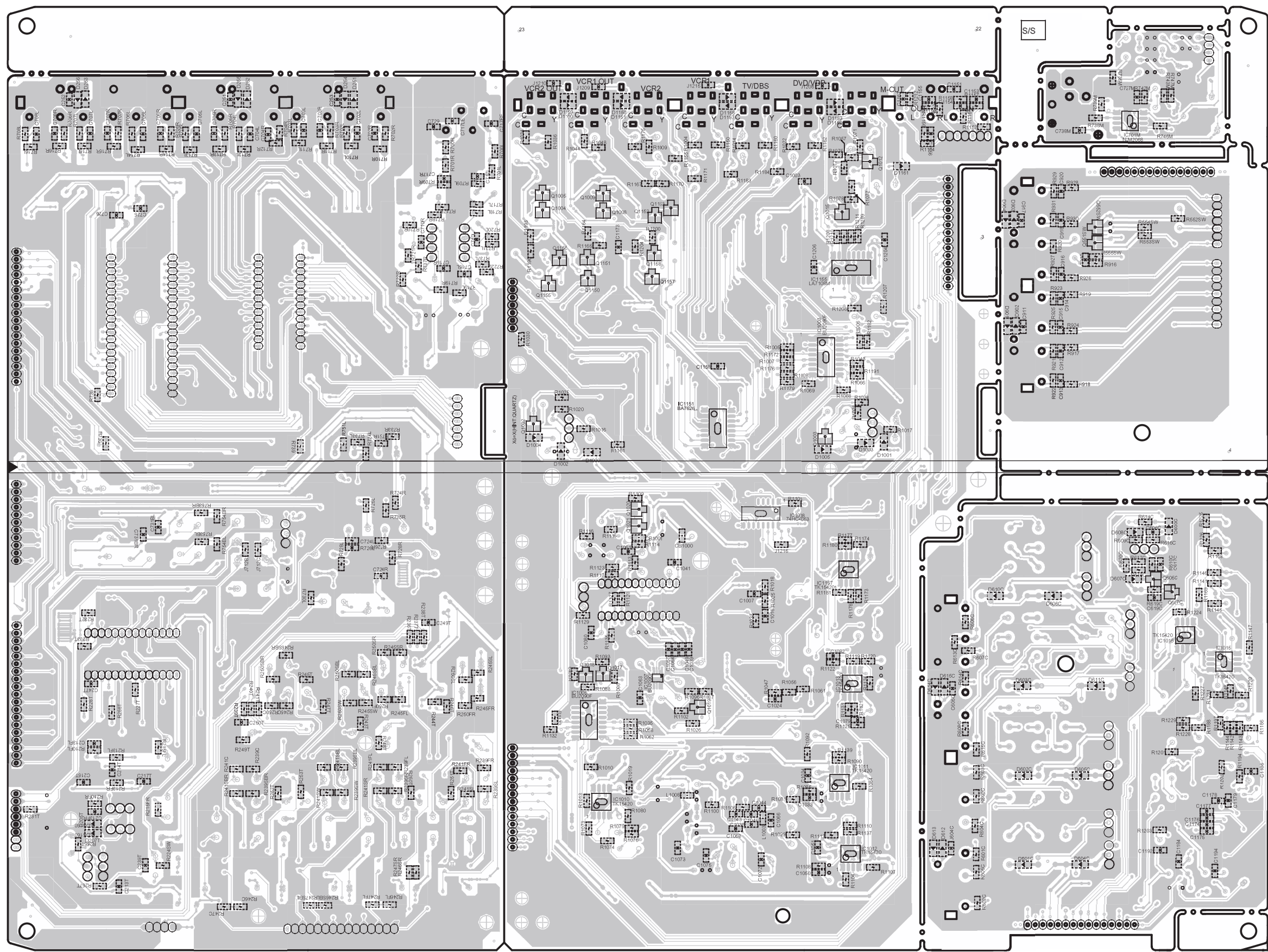

FOIL SIDE

INPUT, VIDEO P.W.B. UNIT (FOR EUROPE, U.K., ASIA, CHINA, TAIWAN R.O.C. & KOREA MODELS)

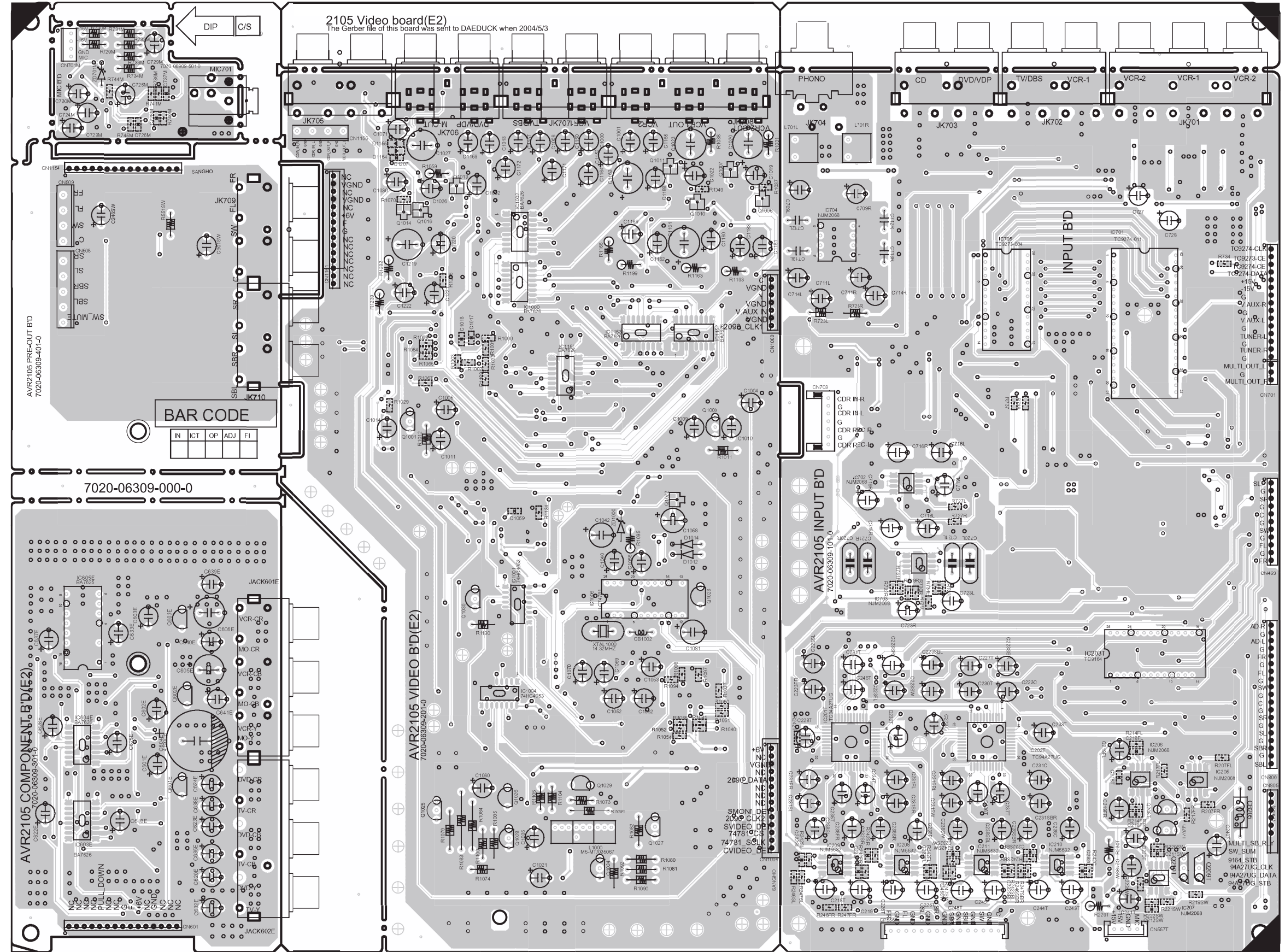

COMPONENT SIDE

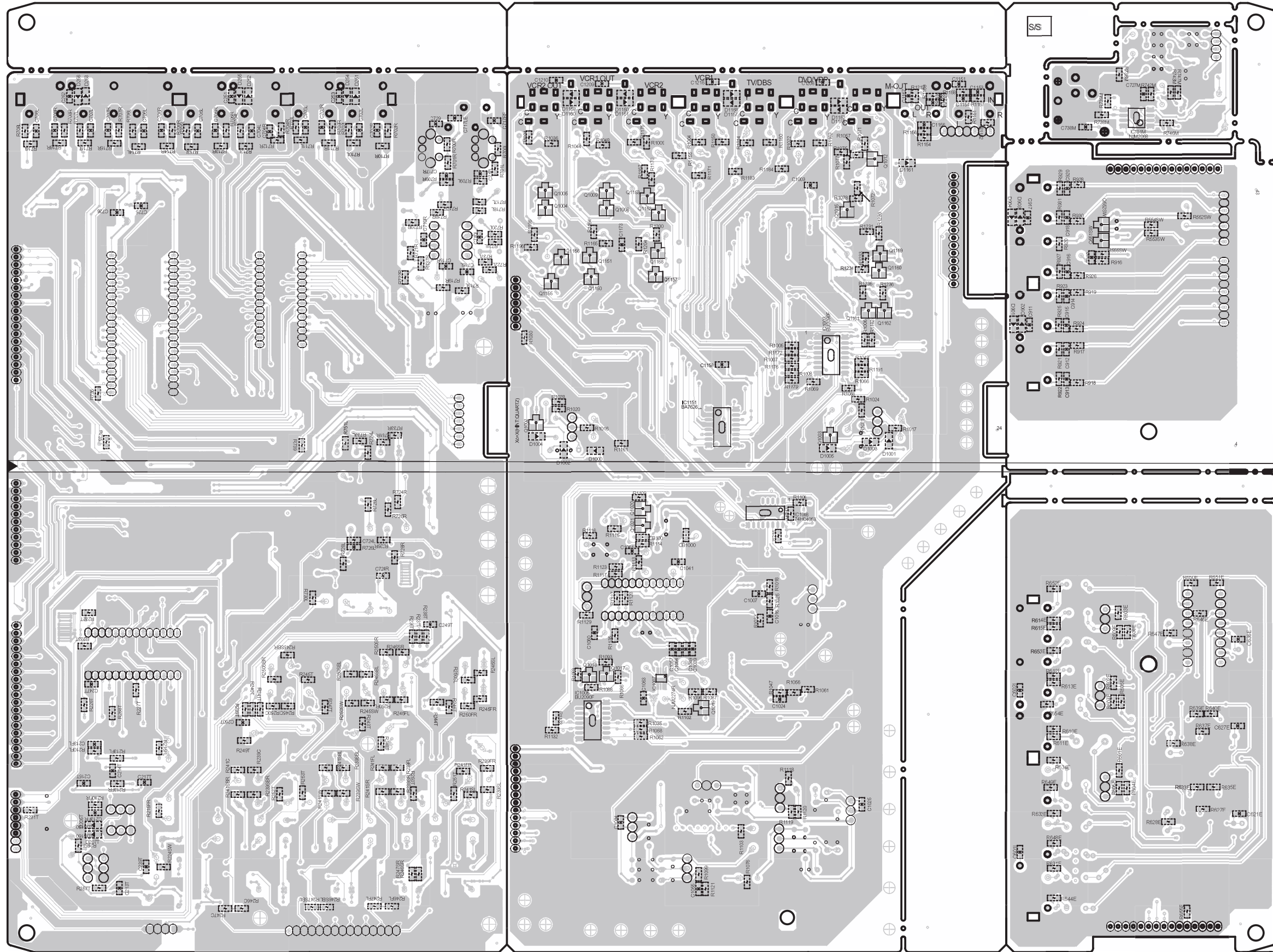

FOIL SIDE

D-VIDEO P.W.B. UNIT (FOR JAPAN MODEL)

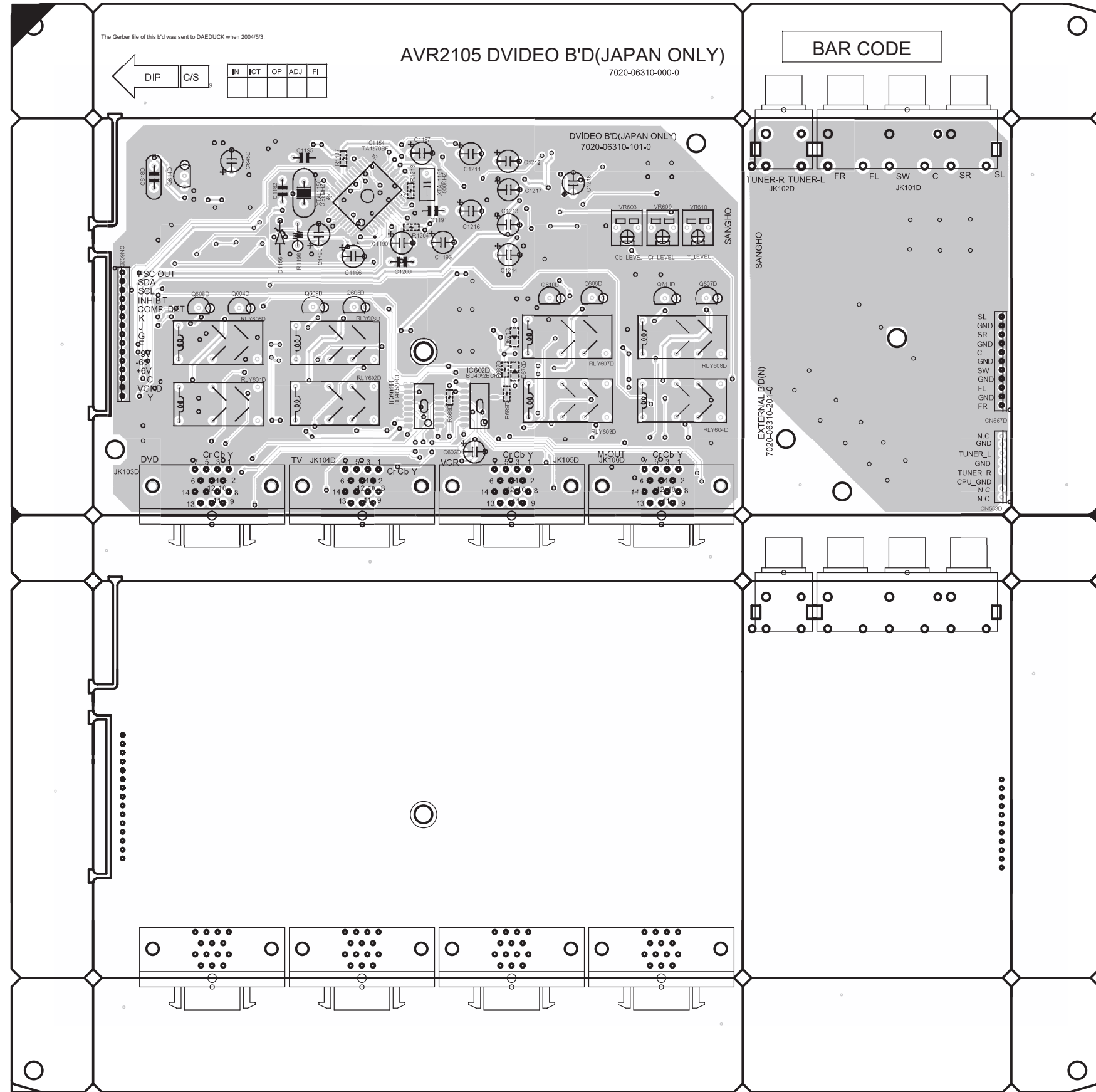

COMPONENT SIDE

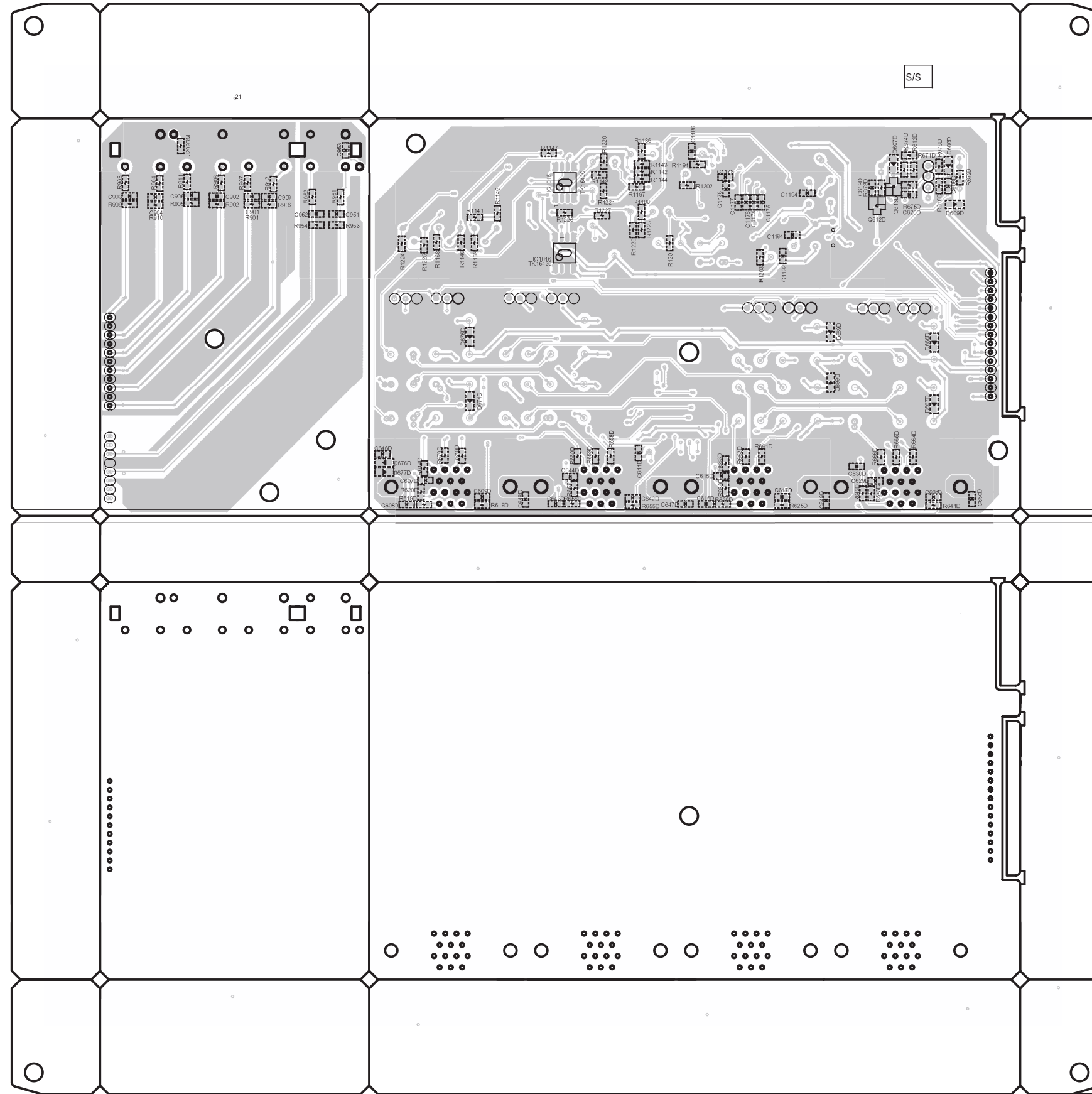

FOIL SIDE

NOTE FOR PARTS LIST

- Part indicated with the mark "◎" are not always in stock and possibly to take a long period of time for supplying, or in some case supplying of part may be refused.
- When ordering of part, clearly indicate "1" and "I" (i) to avoid mis-supplying.
- Ordering part without stating its part number can not be supplied.
- Part indicated with the mark "★" is not illustrated in the exploded view.
- Not including Carbon Film Resister ±5%, 1/4W Type in the P.W.Board parts list. (Refer to the Schematic Diagram for those parts.)
- Not including Carbon Chip Resister 1/16W Type in the P.W.Board parts list. (Refer to the Schematic Diagram for those parts.)

WARNING:

Parts marked with this symbol  have critical characteristics.
Use ONLY replacement parts recommended by the manufacturer.

● Resistors

Ex.: RN 14K 2E 182 G FR
Type Shape and performance Power Resist-ance Allowable error Others

RD : Carbon RC : Composition RS : Metal oxide film RW : Winding RN : Metal film RK : Metal mixture	2B : 1/8W 2E : 1/4W 2H : 1/2W 3A : 1W 3D : 2W 3F : 3W 3H : 5W	F : ±1% G : ±2% J : ±5% K : ±10% M : ±20%	P : Pulse-resistant type NL : Low noise type NB : Non-burning type FR : Fuse-resistor F : Lead wire forming
---	---	---	---

* Resistance

1 8 2 ⇒ 1800 ohm = 1.8 kohm
Indicates number of zeros after effective number.
2-digit effective number.

● Units: ohm

1 R 2 ⇒ 1.2 ohm
1-digit effective number.
2-digit effective number, decimal point indicated by R.

● Units: ohm

● Capacitors

Ex.: CE 04W 1H 2R2 M BP
Type Shape and performance Dielectric strength Capacity Allowable error Others

CE : Aluminum foil electrolytic CA : Aluminum solid electrolytic CS : Tantalum electrolytic CQ : Film CK : Ceramic CC : Ceramic CP : Oil CM : Mica CF : Metallized CH : Metallized	0J : 6.3V 1A : 10V 1C : 16V 1E : 25V 1V : 35V 1H : 50V 2A : 100V 2B : 125V 2C : 160V 2D : 200V 2E : 250V 2H : 500V 2J : 630V	F : ±1% G : ±2% J : ±5% K : ±10% M : ±20% Z : +80% -20% P : +100% -0% C : ±0.25pF D : ±0.5pF = : Others	HS : High stability type BP : Non-polar type HR : Ripple-resistant type DL : For change and discharge HF : For assuring high frequency U : UL part C : CSA part W : UL-CSA type F : Lead wire forming
---	--	--	---

* Capacity (electrolyte only)

2 2 2 ⇒ 2200μF
Indicates number of zeros after effective number.
2-digit effective number.

● Units: μF.

2 R 2 ⇒ 2.2μF
1-digit effective number.
2-digit effective number, decimal point indicated by R.

● Units: μF.

* Capacity (except electrolyte)

2 2 2 ⇒ 2200pF=0.0022μF
(More than 2) Indicates number of zeros after effective number.
2-digit effective number.

● Units: pF.

2 2 1 ⇒ 220pF
(0 or 1) Indicates number of zeros after effective number.
2-digit effective number.

● Units: pF.

● When the dielectric strength is indicated in AC, "AC" is included after the dielectric strength value.

部品表について

- 印の部品は常時在庫していませんので供給に長時間を要することがあります。
場合によっては、供給をお断りすることがあります。
- 部品を発注する際は特に数字の“1”と英字の“I”との区別をはっきり記入してください。
- 部品番号を表示していない部品は供給できません。
- △印の部品は安全上重要な部品です。交換するときは、安全および性能維持のため必ず指定の部品をご使用ください。
- ★印のついている部品は分解図中には記載していません。
- カーボン抵抗器±5%、1/4W型は記載していません。定数は回路図を参照願います。
- カーボンチップ抵抗器1/16W型は記載していません。定数は回路図を参照願います。
- 部品表の抵抗器、コンデンサの品名記号の読み方は表を参照してください。

●抵抗器

例) RN 14K 2E 182 G FR
種類 形状特性 電力 抵抗値 許容差 その他

RD : カーボン RC : 固定体 RS : 金属系皮膜 RW : 巻線 RN : 金属皮膜 RK : 金属混合体	2B : 1/8 W 2E : 1/4 W 2H : 1/2 W 3A : 1 W 3D : 2 W 3F : 3 W 3H : 5 W	F : ±1% G : ±2% J : ±5% K : ±10% M : ±20%	P : 耐パルス形 NL : 低雑音形 NB : 不燃形 FR : ヒューズ抵抗 F : リード線成形
---	--	---	---

* 抵抗値

18 2 ⇒ 1800Ω=1.8kΩ
有効数字につづく0の数を表わす。
2桁の有効数字を表わす。

1R 2 ⇒ 1.2Ω
1桁の有効数字を表わす。
2桁の有効数字で小数点はRで表わす。
: 単位はΩ

●コンデンサ

例) CE 04W 1H 2R2 M BP
種類 形状特性 耐圧 容量 許容差 その他

CE : アルミ 溶電解 CA : アルミ 固体電解 CS : タンタル電解 CQ : フィルム CK : セラミック CC : セラミック CP : オイル CM : マイカ CF : メタライズド CH : メタライズド	0J : 6.3 V 1A : 10 V 1C : 16 V 1E : 25 V 1V : 35 V 1H : 50 V 2A : 100 V 2B : 125 V 2C : 160 V 2D : 200 V 2E : 250 V 2H : 500 V 2J : 630 V	F : ±1% G : ±2% J : ±5% K : ±10% M : ±20% Z : +80% -20% C : ±0.25pF D : ±0.5pF = : その他	HS : 高安定形 BP : 無極性形 HR : 耐リップル形 DL : 充放電対策用 HF : 高周波保証用 U : UL 部品 C : CSA 部品 W : UL-CSA 部品 F : リード線成形
---	---	---	---

* 容量値

● 電解コンデンサの場合

22 2 ⇒ 2200μF
有効数字につづく0の数を表わす。
2桁の有効数字を表わす。
: 単位はμF

2R 2 ⇒ 2.2μF
1桁の有効数字を表わす。
2桁の有効数字で小数点はRで表わす。
: 単位はμF

● 電解コンデンサ以外の場合

22 2 ⇒ 2200pF=0.0022μF
有効数字につづく0の数を表わす。
(0の数が2以上の場合)
2桁の有効数字を表わす。
: 単位はpF

22 1 ⇒ 220pF
有効数字につづく0の数を表わす。
(0の数が0または1の場合)
2桁の有効数字を表わす。
: 単位はpF

● 耐圧を交流で表示する場合は、耐圧表示の次に「AC」を表示します。

PARTS LIST OF P.W.B. UNIT ASS'Y (FOR U.S.A. & CANADA)**MAIN P.W.B. UNIT**

	Ref. No.	Part No.	Part Name	Remarks	New
SEMICONDUCTORS GROUP					
	IC101	00D 963 0110 507	IC MC7815CT		
	IC102	00D 960 0179 905	IC KIA7915		
	IC103	00D 960 0159 501	IC KIA7805API		
	IC104	00D 963 0110 604	IC MC7805CT		
	IC105	00D 960 0195 808	IC protector ICP-N15		
	IC106	00D 960 0195 808	IC protector ICP-N15		
	Q104C	00D 960 0196 506	Transistor KSC1845F		
	Q104FL	00D 960 0196 506	Transistor KSC1845F		
	Q104FR	00D 960 0196 506	Transistor KSC1845F		
	Q104SL	00D 960 0196 506	Transistor KSC1845F		
	Q104SR	00D 960 0196 506	Transistor KSC1845F		
	Q111	00D 963 0121 208	Transistor KRC107M		
	Q112	00D 960 0097 508	Transistor KRC111M		
	Q113	00D 963 0121 208	Transistor KRC107M		
	Q114	00D 963 0121 208	Transistor KRC107M		
	Q115	00D 963 0121 208	Transistor KRC107M		
	Q116	00D 960 0196 409	Transistor 2SC1740SR		
	Q117	00D 963 0121 208	Transistor KRC107M		
	Q118	00D 963 0121 208	Transistor KRC107M		
	Q151	00D 960 0196 409	Transistor 2SC1740SR		
	Q171	00D 960 0005 202	Transistor KTC3198Y		
	Q171A	00D 960 0196 302	Transistor KTA1268BL		
	Q171B	00D 960 0196 302	Transistor KTA1268BL		
	Q171C	00D 960 0196 302	Transistor KTA1268BL		
	Q171D	00D 960 0196 302	Transistor KTA1268BL		
	Q172	00D 960 0005 202	Transistor KTC3198Y		
	Q173	00D 960 0005 202	Transistor KTC3198Y		
	Q174	00D 960 0005 202	Transistor KTC3198Y		
	Q175	00D 960 0005 202	Transistor KTC3198Y		
	Q176	00D 960 0005 202	Transistor KTC3198Y		
	Q177	00D 960 0005 202	Transistor KTC3198Y		
	Q178	00D 960 0005 105	Transistor KTA1266Y		
	Q179	00D 960 0189 005	Transistor KSA916Y		
	Q180	00D 960 0196 302	Transistor KTA1268BL		
	Q181	00D 960 0196 302	Transistor KTA1268BL		
	Q182	00D 960 0005 202	Transistor KTC3198Y		
	Q183	00D 960 0005 202	Transistor KTC3198Y		
	D101	00D 963 0020 309	Diode 1SS133T		
	D102	00D 963 0020 309	Diode 1SS133T		
	D103	00D 963 0020 309	Diode 1SS133T		
	D104	00D 963 0020 309	Diode 1SS133T		
	D105	00D 963 0020 309	Diode 1SS133T		
	D121	00D 963 0020 309	Diode 1SS133T		
	D122	00D 963 0020 309	Diode 1SS133T		
	D123	00D 963 0020 309	Diode 1SS133T		
	D124	00D 963 0020 309	Diode 1SS133T		
	D125	00D 963 0020 309	Diode 1SS133T		
	D126	00D 963 0020 309	Diode 1SS133T		
	D127	00D 963 0020 309	Diode 1SS133T		
	D131A	00D 960 0197 107	Diode KBPC604		
	D131B	00D 960 0197 107	Diode KBPC604		
	D133	00D 963 0046 202	Zener diode MTZJ18B		
	D134	00D 963 0046 202	Zener diode MTZJ18B		

Ref. No.	Part No.	Part Name	Remarks	New
D136	00D 963 0058 504	Zener diode MTZJ11B		
D138A	00D 963 0058 407	Diode IN4007		
D141	00D 963 0058 407	Diode IN4007		
D142	00D 963 0058 407	Diode IN4007		
D143	00D 963 0058 407	Diode IN4007		
D144	00D 963 0058 407	Diode IN4007		
D145	00D 963 0058 407	Diode IN4007		
D146	00D 963 0058 407	Diode IN4007		
D149	00D 963 0058 407	Diode IN4007		
D150	00D 963 0058 407	Diode IN4007		
D152	00D 963 0058 407	Diode IN4007		
D153	00D 963 0058 407	Diode IN4007		
D154	00D 960 0095 908	Zener diode MTZJ8.2B		
D157	00D 960 0014 905	Zener diode MTZJ20B		
ZD310	00D 960 0095 500	Zener diode MTZJ5.1B		
ZD311	00D 960 0095 500	Zener diode MTZJ5.1B		
LED901	00D 963 0148 605	LED SML1216W 5PI R/G		
RESISTORS GROUP				
R104C	00D 963 9006 285	Metal oxide 5.6 kohm 1W		
R104FL	00D 963 9006 285	Metal oxide 5.6 kohm 1W		
R104FR	00D 963 9006 285	Metal oxide 5.6 kohm 1W		
R104SL	00D 963 9006 285	Metal oxide 5.6 kohm 1W		
R104SR	00D 963 9006 285	Metal oxide 5.6 kohm 1W		
R105C	00D 963 9006 285	Metal oxide 5.6 kohm 1W		
R105FL	00D 963 9006 285	Metal oxide 5.6 kohm 1W		
R105FR	00D 963 9006 285	Metal oxide 5.6 kohm 1W		
R105SL	00D 963 9006 285	Metal oxide 5.6 kohm 1W		
R105SR	00D 963 9006 285	Metal oxide 5.6 kohm 1W		
R106C	00D 963 0047 900	Metal film 4.7 kohm 1W		
R106FL	00D 963 0047 900	Metal film 4.7 kohm 1W		
R106FR	00D 963 0047 900	Metal film 4.7 kohm 1W		
R106SL	00D 963 0047 900	Metal film 4.7 kohm 1W		
R106SR	00D 963 0047 900	Metal film 4.7 kohm 1W		
R107C	00D 963 0047 900	Metal film 4.7 kohm 1W		
R107FL	00D 963 0047 900	Metal film 4.7 kohm 1W		
R107FR	00D 963 0047 900	Metal film 4.7 kohm 1W		
R107SL	00D 963 0047 900	Metal film 4.7 kohm 1W		
R107SR	00D 963 0047 900	Metal film 4.7 kohm 1W		
R108C	00D 963 9006 269	Metal oxide 0.22 ohm 1W		
R108FL	00D 963 9006 269	Metal oxide 0.22 ohm 1W		
R108FR	00D 963 9006 269	Metal oxide 0.22 ohm 1W		
R108SL	00D 963 9006 269	Metal oxide 0.22 ohm 1W		
R108SR	00D 963 9006 269	Metal oxide 0.22 ohm 1W		
R109C	00D 963 9006 269	Metal oxide 0.22 ohm 1W		
R109FL	00D 963 9006 269	Metal oxide 0.22 ohm 1W		
R109FR	00D 963 9006 269	Metal oxide 0.22 ohm 1W		
R109SL	00D 963 9006 269	Metal oxide 0.22 ohm 1W		
R118C	00D 963 9006 256	Metal oxide 10 ohm 1W		
R118FL	00D 963 9006 256	Metal oxide 10 ohm 1W		
R118FR	00D 963 9006 256	Metal oxide 10 ohm 1W		
R118SL	00D 963 9006 256	Metal oxide 10 ohm 1W		
R118SR	00D 963 9006 256	Metal oxide 10 ohm 1W		
R119C	00D 963 9006 256	Metal oxide 10 ohm 1W		
R119FL	00D 963 9006 256	Metal oxide 10 ohm 1W		
R119FR	00D 963 9006 256	Metal oxide 10 ohm 1W		

Ref. No.	Part No.	Part Name	Remarks	New
R119SL	00D 963 9006 256	Metal oxide 10 ohm 1W		
R119SR	00D 963 9006 256	Metal oxide 10 ohm 1W		
R135	00D 963 0144 502	Cement resistor 0.1 ohm 5W		
R136	00D 963 0144 502	Cement resistor 0.1 ohm 5W		
R141	00D 960 0180 606	Metal oxide 0.22 ohm 1W		
R142	00D 960 0180 606	Metal oxide 0.22 ohm 1W		
R148	00D 960 0180 606	Metal oxide 0.22 ohm 1W		
R149	00D 960 0180 606	Metal oxide 0.22 ohm 1W		
R151	00D 963 9003 343	Metal film 68ohm 1/4W		
R154	00D 963 0043 108	Metal film 2.2 Mohm 1/2W		
R179	00D 963 9003 055	Metal film 47 kohm 1/4W (NB)		
R181	00D 963 0047 900	Metal film 4.7 kohm 1W		
R184	00D 963 9006 256	Metal oxide 10 ohm 1W		
R903H	00D 960 9009 270	Metal film 470ohm 2W		
R904H	00D 960 9009 270	Metal film 470ohm 2W		
VR101	00D 960 0091 601	Semi fixed resistor 1 kohm		
VR102	00D 960 0091 601	Semi fixed resistor 1 kohm		
VR103	00D 960 0091 601	Semi fixed resistor 1 kohm		
VR104	00D 960 0091 601	Semi fixed resistor 1 kohm		
VR105	00D 960 0091 601	Semi fixed resistor 1 kohm		
CAPACITORS GROUP				
C101C	00D 963 9006 450	Electrolytic 47uF/50V		
C101FL	00D 963 9006 450	Electrolytic 47uF/50V		
C101FR	00D 963 9006 450	Electrolytic 47uF/50V		
C101SL	00D 963 9006 450	Electrolytic 47uF/50V		
C101SR	00D 963 9006 450	Electrolytic 47uF/50V		
C102C	00D 963 9006 308	Electrolytic 10uF/50V		
C102FL	00D 963 9006 308	Electrolytic 10uF/50V		
C102FR	00D 963 9006 308	Electrolytic 10uF/50V		
C102SL	00D 963 9006 308	Electrolytic 10uF/50V		
C102SR	00D 963 9006 308	Electrolytic 10uF/50V		
C103C	00D 963 9003 084	Ceramic 100pF/500V		
C103FL	00D 963 9003 084	Ceramic 100pF/500V		
C103FR	00D 963 9003 084	Ceramic 100pF/500V		
C103SL	00D 963 9003 084	Ceramic 100pF/500V		
C103SR	00D 963 9003 084	Ceramic 100pF/500V		
C104C	00D 963 9003 084	Ceramic 100pF/500V		
C104FL	00D 963 9003 084	Ceramic 100pF/500V		
C104FR	00D 963 9003 084	Ceramic 100pF/500V		
C104SL	00D 963 9003 084	Ceramic 100pF/500V		
C104SR	00D 963 9003 084	Ceramic 100pF/500V		
C105C	00D 963 9008 640	Mylar film 0.022uF/100V		
C105FL	00D 963 9008 640	Mylar film 0.022uF/100V		
C105FR	00D 963 9008 640	Mylar film 0.022uF/100V		
C105SL	00D 963 9008 640	Mylar film 0.022uF/100V		
C105SR	00D 963 9008 640	Mylar film 0.022uF/100V		
C107C	00D 963 9003 097	Mylar film 0.1uF/250V		
C107FL	00D 963 9003 097	Mylar film 0.1uF/250V		
C107FR	00D 963 9003 097	Mylar film 0.1uF/250V		
C107SL	00D 963 9003 097	Mylar film 0.1uF/250V		
C107SR	00D 963 9003 097	Mylar film 0.1uF/250V		
C131	00D 963 9003 097	Mylar film 0.1uF/250V		
C132	00D 963 9003 097	Mylar film 0.1uF/250V		
C133	00D 963 9003 097	Mylar film 0.1uF/250V		
C134	00D 963 9003 097	Mylar film 0.1uF/250V		
C135	00D 963 9003 097	Mylar film 0.1uF/250V		

	Ref. No.	Part No.	Part Name	Remarks	New
	C136	00D 963 0161 307	Electrolytic 12000uF/63V		*
	C137	00D 963 0161 307	Electrolytic 12000uF/63V		*
	C138	00D 963 9006 379	Electrolytic 1uF/50V		
	C138A	00D 963 9003 097	Mylar film 0.1uF/250V		
	C141	00D 963 0021 900	Mylar film 0.047uF/100V		
	C142	00D 963 0021 900	Mylar film 0.047uF/100V		
	C143	00D 963 0021 900	Mylar film 0.047uF/100V		
	C144	00D 960 9007 201	Electrolytic 3300uF/35V		
	C145	00D 963 9003 123	Electrolytic 1000uF/35V		
	C146	00D 963 9006 379	Electrolytic 1uF/50V		
	C148	00D 963 9006 379	Electrolytic 1uF/50V		
	C150	00D 963 0021 900	Mylar film 0.047uF/100V		
	C151	00D 963 0021 900	Mylar film 0.047uF/100V		
	C152	00D 963 0021 900	Mylar film 0.047uF/100V		
	C153	00D 963 0021 104	Electrolytic 6800uF/16V		
	C154	00D 963 9006 308	Electrolytic 10uF/50V		
	C155	00D 963 0020 202	Ceramic 0.1uF/50V		
	C157	00D 963 9006 379	Electrolytic 1uF/50V		
	C158	00D 963 9003 136	Electrolytic 1000uF/25V		
	C159	00D 963 9006 379	Electrolytic 1uF/50V		
	C161	00D 963 9006 308	Electrolytic 10uF/50V		
	C171	00D 963 9005 312	Electrolytic 100uF/10V		
	C171A	00D 963 0020 202	Ceramic 0.1uF/50V		
	C171B	00D 963 0020 202	Ceramic 0.1uF/50V		
	C171C	00D 963 0020 202	Ceramic 0.1uF/50V		
	C171D	00D 963 0020 202	Ceramic 0.1uF/50V		
	C172	00D 963 9005 833	Electrolytic 220uF/6.3V		
	C173	00D 963 9005 833	Electrolytic 220uF/6.3V		
	C174	00D 963 9006 308	Electrolytic 10uF/50V		
	C175	00D 963 0149 507	Electrolytic 220uF/16V		
	C176	00D 963 9006 379	Electrolytic 1uF/50V		
	C177	00D 963 9006 379	Electrolytic 1uF/50V		
	C178	00D 963 0157 900	Electrolytic 470uF/63V		*
	C179	00D 963 9005 833	Electrolytic 220uF/6.3V		
⚠	C181	00D 963 9006 191	Ceramic 4700pF/250V(AC)		
	C182	00D 963 9006 311	Electrolytic 10uF/100V		
	C331	00D 963 9004 546	Ceramic 0.01uF/16V		
	C332	00D 963 9004 546	Ceramic 0.01uF/16V		
	C901H	00D 963 9004 533	Ceramic 0.001uF/50V		
	C902H	00D 963 9004 533	Ceramic 0.001uF/50V		
	C903H	00D 963 0020 202	Ceramic 0.1uF/50V		
	C904H	00D 960 9003 108	Ceramic 0.022uF/25V		
	C905H	00D 963 0020 202	Ceramic 0.1uF/50V		
	C906H	00D 963 9004 546	Ceramic 0.01uF/16V		
OTHER PARTS GROUP					
	CB903	00D 963 0154 602	Beads inductor		*
	CB904	00D 963 0154 602	Beads inductor		*
	CN901	00D 963 0160 201	3P connector cord		*
	CN931A	00D 963 0148 809	2P connector cord		
	CN992	00D 963 0160 007	4P connector cord		*
⚠	CP101	00D 960 0118 908	AC cord connector base		
	CP102	00D 960 0123 304	2P connector base		
	CP103	00D 960 0128 901	3P connector base		
	CP104	00D 960 0128 804	6P connector base		
	CP105	00D 963 0149 109	2P connector base(BLACK)		

	Ref. No.	Part No.	Part Name	Remarks	New
	CP106	00D 960 0123 207	3P connector base		
	CP1151	00D 963 0097 507	15P connector base (TUC-P)		
	CP1153	00D 963 0097 507	15P connector base (TUC-P)		
	CP138A	00D 960 0123 207	3P connector base		
	CP3911	00D 963 0160 900	8P connector base		*
	CP392	00D 963 0048 909	3P connector base		
	CP501	00D 963 0086 806	9P connector base (TUC-P)		
	CP502	00D 963 0085 807	7P connector base (TUC-P)		
	CP503	00D 963 0085 807	7P connector base (TUC-P)		
	CP504	00D 963 0086 903	5P connector base (TUC-P)		
	CP505	00D 963 0087 708	12P connector base (TUC-P)		
	CP555	00D 963 0111 108	14P connector base (TUC-P)		
	CP556	00D 963 0087 805	11P connector base (TUC-P)		
	CP901	00D 963 0048 909	3P connector base		
	CP931	00D 963 0149 206	2P connector base(BLUE)		
⚠	F102	00D 960 0188 705	Fuse 8A		
	F102A	00D 960 0005 804	Fuse clip		
	F102B	00D 960 0005 804	Fuse clip		
	GND101	00D 960 9006 600	Terminal		
	GND102	00D 960 9006 600	Terminal		
	GND103	00D 960 9006 600	Terminal		
	JK901	00D 963 0095 402	Head phone jack		
	L101C	00D 963 0049 005	Inductor 0.5uH		
	L101FL	00D 963 0049 005	Inductor 0.5uH		
	L101FR	00D 963 0049 005	Inductor 0.5uH		
	L101SL	00D 963 0049 005	Inductor 0.5uH		
	L101SR	00D 963 0049 005	Inductor 0.5uH		
	RLY101	00D 960 0181 702	Relay (G5PA-28 24V)		
	RLY102	00D 960 0181 702	Relay (G5PA-28 24V)		
	RLY103	00D 960 0181 702	Relay (G5PA-28 24V)		
⚠	RLY104	00D 960 0181 702	Relay (G5PA-28 24V)		
	RLY105	00D 963 0071 303	Relay (RSB24S 24V)		
	RLY106	00D 960 0181 605	Relay (G5PA-1-8 12V)		
	RLY107	00D 960 0181 702	Relay (G5PA-28 24V)		
	SW391	00D 963 0045 708	Tact switch		
	SW393	00D 963 0045 708	Tact switch		
	SW901	00D 963 0045 708	Tact switch		
	SW901A	00D 963 0145 802	Push switch		
	TP101	00D 960 0161 405	3P connector base		
	TP102	00D 960 0161 405	3P connector base		
	TP103	00D 960 0161 405	3P connector base		
	TP104	00D 960 0161 405	3P connector base		
	TP105	00D 960 0161 405	3P connector base		
	VEC303	00D 963 0095 208	ENCODER SW		
	-	-	Heat sink	1	
	-	-	Heat sink	1	
⚠	-	00D 963 0094 924	Power trans. (Mini)	1	
	-	00D 963 0018 007	Screw (2S 3Å~8 ZNY/BH)	3	
	-	00D 963 0158 608	2P speaker terminal	1	*
	-	00D 963 0119 906	8P speaker terminal	2	

CPU, FRONT P.W.B. UNIT

	Ref. No.	Part No.	Part Name	Remarks	New
SEMICONDUCTORS GROUP					
	IC201	00D 963 0161 705	IC CXP740010		
	IC203	00D 960 0100 301	IC KIA7812		
	IC204	00D 963 0114 600	IC MC7806CT		
	IC205	00D 963 0147 703	IC KIA7906		
	IC272	00D 963 0147 606	IC KIA78R09API		
	IC301	00D 960 0180 004	IC LC75721E		
	IC302	00D 963 0074 504	IC BU2090F		
	IC803	00D 963 0113 106	IC GP1FA513RZ		
	RMC301	00D 960 0181 100	IC NJL64H380A		
	Q201	00D 960 0285 006	Transistor KRC104S		
	Q202	00D 963 0121 509	Transistor KTC3875S		
	Q203	00D 963 0121 402	Transistor KRA104S		
	Q204	00D 963 0121 606	Transistor KRC107S		
	Q205	00D 960 0196 603	Transistor KTC2874B		
	Q206	00D 960 0196 603	Transistor KTC2874B		
	Q207	00D 960 0196 603	Transistor KTC2874B		
	Q208	00D 960 0196 603	Transistor KTC2874B		
	Q216	00D 960 0097 207	Transistor KRA102M		
	Q217	00D 963 0102 803	Transistor 2SA933S		
	Q218	00D 963 0102 803	Transistor 2SA933S		
	Q219	00D 963 0102 803	Transistor 2SA933S		
	Q220	00D 963 0121 208	Transistor KRC107M		
	Q221	00D 960 0097 207	Transistor KRA102M		
	Q222	00D 960 0097 207	Transistor KRA102M		
	Q300	00D 963 0121 402	Transistor KRA104S		
	Q301	00D 963 0121 402	Transistor KRA104S		
	Q302	00D 960 0285 006	Transistor KRC104S		
	Q303	00D 960 0285 006	Transistor KRC104S		
	Q304	00D 960 0285 006	Transistor KRC104S		
	Q305	00D 963 0121 402	Transistor KRA104S		
	Q306	00D 963 0120 704	Transistor KRA102S		
	Q307	00D 963 0121 606	Transistor KRC107S		
	Q308	00D 963 0120 704	Transistor KRA102S		
	D201	00D 963 0020 309	Diode 1SS133T		
	D202	00D 963 0058 407	Diode IN4007		
	D204	00D 963 0020 309	Diode 1SS133T		
	D209	00D 960 0197 000	Diode KDS160		
	D213	00D 963 0020 309	Diode 1SS133T		
	D215	00D 963 0020 309	Diode 1SS133T		
	D218	00D 963 0020 309	Diode 1SS133T		
	D302	00D 963 0020 309	Diode 1SS133T		
	D303	00D 963 0020 309	Diode 1SS133T		
	D304	00D 963 0020 309	Diode 1SS133T		
	D305	00D 960 0197 000	Diode KDS160		
	D306	00D 960 0197 000	Diode KDS160		
	D307	00D 960 0197 000	Diode KDS160		
	ZD201	00D 963 0047 502	Zener diode MTZJ3.3B		
	ZD301	00D 960 0095 801	Zener diode MTZJ6.8B		
	ZD302	00D 960 0095 500	Zener diode MTZJ5.1B		
	ZD303	00D 960 0095 500	Zener diode MTZJ5.1B		
	ZD304	00D 960 0095 500	Zener diode MTZJ5.1B		
	ZD305	00D 960 0095 500	Zener diode MTZJ5.1B		

Ref. No.	Part No.	Part Name	Remarks	New
LED301	00D 960 0197 204	LED P15-RD/HL50RDRF4T		
LED302	00D 960 0197 204	LED P15-RD/HL50RDRF4T		
LED305	00D 960 0197 204	LED P15-RD/HL50RDRF4T		
LED306	00D 960 0197 204	LED P15-RD/HL50RDRF4T		
LED307	00D 960 0197 204	LED P15-RD/HL50RDRF4T		
LED308	00D 960 0197 204	LED P15-RD/HL50RDRF4T		
LED309	00D 960 0197 204	LED P15-RD/HL50RDRF4T		
LED310	00D 960 0197 204	LED P15-RD/HL50RDRF4T		
LED311	00D 960 0197 204	LED P15-RD/HL50RDRF4T		
CAPACITORS GROUP				
BC201	00D 963 0061 504	Electrolytic 8200uF/5.5V		
C201D	00D 960 9010 816	Ceramic 0.1uF/50V		
C201E	00D 963 9004 517	Ceramic 0.022uF/50V		
C201F	00D 963 9004 546	Ceramic 0.01uF/16V		
C202	00D 963 9004 698	Ceramic chip 0.01uF/50V		
C202D	00D 963 9004 546	Ceramic 0.01uF/16V		
C202E	00D 963 9004 517	Ceramic 0.022uF/50V		
C202F	00D 963 9004 546	Ceramic 0.01uF/16V		
C203	00D 963 9004 698	Ceramic chip 0.01uF/50V		
C204	00D 963 9006 476	Electrolytic 4.7uF/50V		
C205	00D 963 9004 562	Ceramic 0.047uF/50V		
C221	00D 963 9005 312	Electrolytic 100uF/10V		
C228	00D 963 9004 575	Ceramic chip 100pF/50V		
C230	00D 963 9004 575	Ceramic chip 100pF/50V		
C231	00D 963 9004 575	Ceramic chip 100pF/50V		
C232	00D 963 9004 575	Ceramic chip 100pF/50V		
C233	00D 963 9004 575	Ceramic chip 100pF/50V		
C234	00D 963 9004 575	Ceramic chip 100pF/50V		
C238	00D 963 9006 366	Electrolytic 0.1uF/50V		
C239	00D 963 9006 366	Electrolytic 0.1uF/50V		
C242	00D 963 9004 685	Ceramic chip 1000pF/50V		
C245	00D 963 9004 575	Ceramic chip 100pF/50V		
C248	00D 963 9004 685	Ceramic chip 1000pF/50V		
C249	00D 963 9004 737	Ceramic chip 0.022uF/25V		
C251	00D 963 0020 202	Ceramic 0.1uF/50V		
C252	00D 960 9010 816	Ceramic 0.1uF/50V		
C256	00D 963 9006 308	Electrolytic 10uF/50V		
C257	00D 963 9006 308	Electrolytic 10uF/50V		
C260	00D 963 9006 379	Electrolytic 1uF/50V		
C261	00D 963 9006 379	Electrolytic 1uF/50V		
C262	00D 963 9006 379	Electrolytic 1uF/50V		
C263	00D 963 9006 379	Electrolytic 1uF/50V		
C301	00D 963 9004 546	Ceramic 0.01uF/16V		
C3010	00D 963 9006 421	Electrolytic 47uF/10V		
C302	00D 963 9004 546	Ceramic 0.01uF/16V		
C3020	00D 963 0020 202	Ceramic 0.1uF/50V		
C303	00D 963 9004 546	Ceramic 0.01uF/16V		
C303O	00D 963 9004 591	Ceramic chip 22pF/50V		
C304	00D 963 9004 546	Ceramic 0.01uF/16V		
C305	00D 963 9004 685	Ceramic chip 1000pF/50V		
C306	00D 963 9004 575	Ceramic chip 100pF/50V		
C307	00D 963 9004 575	Ceramic chip 100pF/50V		
C309	00D 963 9004 737	Ceramic chip 0.022uF/25V		
C310	00D 963 9004 753	Ceramic chip 0.047uF/50V		
C311	00D 963 9005 406	Ceramic chip 30pF/50V		

Ref. No.	Part No.	Part Name	Remarks	New
C312	00D 963 9004 753	Ceramic chip 0.047uF/50V		
C314	00D 963 0021 900	Mylar film 0.047uF/100V		
C315	00D 963 9006 379	Electrolytic 1uF/50V		
C316	00D 963 9006 308	Electrolytic 10uF/50V		
C317	00D963 9005 859	Electrolytic 47uF/16V		
C318	00D 963 9005 419	Mylar film 0.047uF/63V		
C319	00D 963 9006 434	Electrolytic 47uF/16V		
C320	00D 963 9006 379	Electrolytic 1uF/50V		
C321	00D 963 0021 900	Mylar film 0.047uF/100V		
C322	00D 963 9006 434	Electrolytic 47uF/16V		
C323	00D 963 9004 766	Mylar film 0.1uF/100V		
C324	00D 963 9006 476	Electrolytic 4.7uF/50V		
C325	00D 963 9004 575	Ceramic chip 100pF/50V		
C326	00D 963 9006 382	Electrolytic 22uF/25V		
C327	00D 963 9006 476	Electrolytic 4.7uF/50V		
C329	00D 963 9006 531	Electrolytic 22uF/16V		
C330	00D 963 9006 531	Electrolytic 22uF/16V		
C340	00D 963 9004 575	Ceramic chip 100pF/50V		
C341	00D 963 9004 575	Ceramic chip 100pF/50V		
C347	00D 963 9004 708	Ceramic chip 0.1uF/50V		
C348	00D 963 9004 708	Ceramic chip 0.1uF/50V		
C354	00D 963 9004 708	Ceramic chip 0.1uF/50V		
OTHER PARTS GROUP				
BD205	00D 963 0050 502	Chip emifil		
BD206	00D 963 0050 502	Chip emifil		
BD207	00D 963 0154 602	Beads inductor		*
BD208	00D 963 0154 602	Beads inductor		*
BD209	00D 963 0154 602	Beads inductor		*
BD301	00D 963 0050 502	Chip emifil		
BD303	00D 963 0050 502	Chip emifil		
BD304	00D 963 0050 502	Chip emifil		
CB202	00D 963 0154 602	Beads inductor		*
CB203	00D 963 0154 602	Beads inductor		*
CB205	00D 963 0154 602	Beads inductor		*
CB207	00D 963 0154 602	Beads inductor		*
CB208	00D 963 0154 602	Beads inductor		*
CN201	00D 963 0159 801	5P SHIELD WIRE		*
CN302	00D 963 0160 502	8P connector cord		*
CN303	00D 963 0160 308	3P connector cord		*
CN605	00D 963 0159 908	3P connector cord		*
CN606	00D 963 0159 607	4P connector cord		*
CP1000	00D 963 0085 807	7P connector base (TUC-P)		
CP1001	00D 963 0111 108	14P connector base (TUC-P)		
CP1154	00D 963 0085 807	7P connector base (TUC-P)		
CP1155	00D 963 0085 807	7P connector base (TUC-P)		
CP301	00D 963 0161 103	23P FFC connector base		*
CP301A	00D 963 0161 006	23P FFC connector base		*
CP302	00D 963 0066 101	5P connector base		
CP303	00D 963 0049 102	3P connector base		
CP401	00D 963 0149 303	15P FFC connector base		
CP404	00D 963 0087 805	11P connector base (TUC-P)		
CP551	00D 963 0087 601	8P connector base (TUC-P)		
CP552	00D 963 0087 504	19P connector base (TUC-P)		
CP605	00D 963 0048 909	3P connector base		

Ref. No.	Part No.	Part Name	Remarks	New
CP606	00D 963 0050 104	4P connector base		
CP701	00D 963 0087 601	18P connector base (TUC-P)		
CP703	00D 963 0087 805	11P connector base (TUC-P)		
CP705	00D 963 0087 601	8P connector base (TUC-P)		
CP706	00D 963 0087 601	8P connector base (TUC-P)		
CP801	00D 963 0087 601	18P connector base (TUC-P)		
CP802	00D 963 0087 504	19P connector base (TUC-P)		
CP803	00D 960 0239 609	13P connector base (TUC-P)		
CP804	00D 963 0087 504	19P connector base (TUC-P)		
GND01	00D 960 9006 600	Terminal		
GND02	00D 960 9006 600	Terminal		
GP301	-	1P contact Ass'y		
GP301	-	1P contact Ass'y		
J326	00D 963 9003 372	Carbon chip 0 ohm 1/16W		
JP353	00D 963 9003 372	Carbon chip 0 ohm 1/16W		
L301	00D 960 0010 307	Inductor 10uH		
L3010	00D 960 0215 908	Inductor 4.7uH		
L302	00D 960 0128 008	Inductor 100uH		
SW301C	00D 963 0045 708	Tact switch		
SW302A	00D 963 0095 305	Tact switch		
SW302B	00D 963 0095 305	Tact switch		
SW302C	00D 963 0045 708	Tact switch		
SW303A	00D 963 0095 305	Tact switch		
SW303B	00D 963 0095 305	Tact switch		
SW303C	00D 963 0045 708	Tact switch		
SW304A	00D 963 0095 305	Tact switch		
SW304B	00D 963 0095 305	Tact switch		
SW304C	00D 963 0045 708	Tact switch		
SW305A	00D 963 0095 305	Tact switch		
SW305B	00D 963 0045 708	Tact switch		
SW305C	00D 963 0045 708	Tact switch		
SW306C	00D 963 0045 708	Tact switch		
SW306C	00D 963 0095 305	Tact switch		
SW307C	00D 963 0045 708	Tact switch		
SW307C	00D 963 0095 305	Tact switch		
SW308C	00D 963 0045 708	Tact switch		
SW308C	00D 963 0095 305	Tact switch		
SW309C	00D 963 0045 708	Tact switch		
SW309C	00D 963 0095 305	Tact switch		
VEC301	00D 963 0095 208	ENCODER SW		
VEC302	00D 963 0095 208	ENCODER SW		
X201	00D 960 0181 003	Resonator CST12.0MTW-TF01		
-	-	Heat sink	1	
-	00D 963 0018 007	Screw (2S 3X8 ZNY/BH)	2	
-	00D 960 0184 408	FLT holder	1	
-	00D 963 0109 505	FLT (16-ST-66GNK)	1	
-	00D 963 0158 307	DIN SOCKET DIN-416G	1	*
-	00D 963 0146 403	3P pin jack	1	

CNT,PRE-AMP P.W.B. UNIT

	Ref. No.	Part No.	Part Name	Remarks	New
SEMICONDUCTORS GROUP					
	IC201RM	00D 960 0174 104	IC CXA1511M		
	Q101SBL	00D 963 0044 204	Transistor 2SD2390-Y		
	Q101SBR	00D 963 0044 204	Transistor 2SD2390-Y		
	Q102SBL	00D 963 0044 107	Transistor 2SB1560-Y		
	Q102SBR	00D 963 0044 107	Transistor 2SB1560-Y		
	Q103SBL	00D 963 0058 106	Transistor 2SD947F		
	Q103SBR	00D 963 0058 106	Transistor 2SD947F		
	Q104SBL	00D 960 0196 506	Transistor KSC1845F		
	Q104SBR	00D 960 0196 506	Transistor KSC1845F		
	Q201ML	00D 960 0196 603	Transistor KTC2874B		
	Q201MR	00D 960 0196 603	Transistor KTC2874B		
	Q201RM	00D 960 0097 003	Transistor KRA104M		
	Q205ML	00D 960 0196 603	Transistor KTC2874B		
	Q205MR	00D 960 0196 603	Transistor KTC2874B		
	Q501C	00D 960 0196 603	Transistor KTC2874B		
	Q501FL	00D 960 0196 603	Transistor KTC2874B		
	Q501FR	00D 960 0196 603	Transistor KTC2874B		
	Q501SBL	00D 960 0196 603	Transistor KTC2874B		
	Q501SBR	00D 960 0196 603	Transistor KTC2874B		
	Q501SL	00D 960 0196 603	Transistor KTC2874B		
	Q501SR	00D 960 0196 603	Transistor KTC2874B		
	Q502C	00D 960 0196 205	Transistor KSA992F		
	Q502FL	00D 960 0196 205	Transistor KSA992F		
	Q502FR	00D 960 0196 205	Transistor KSA992F		
	Q502SBL	00D 960 0196 205	Transistor KSA992F		
	Q502SBR	00D 960 0196 205	Transistor KSA992F		
	Q502SL	00D 960 0196 205	Transistor KSA992F		
	Q502SR	00D 960 0196 205	Transistor KSA992F		
	Q503C	00D 960 0196 205	Transistor KSA992F		
	Q503FL	00D 960 0196 205	Transistor KSA992F		
	Q503FR	00D 960 0196 205	Transistor KSA992F		
	Q503SBL	00D 960 0196 205	Transistor KSA992F		
	Q503SBR	00D 960 0196 205	Transistor KSA992F		
	Q503SL	00D 960 0196 205	Transistor KSA992F		
	Q503SR	00D 960 0196 205	Transistor KSA992F		
	Q504C	00D 960 0196 506	Transistor KSC1845F		
	Q504FL	00D 960 0196 506	Transistor KSC1845F		
	Q504FR	00D 960 0196 506	Transistor KSC1845F		
	Q504SBL	00D 960 0196 506	Transistor KSC1845F		
	Q504SBR	00D 960 0196 506	Transistor KSC1845F		
	Q504SL	00D 960 0196 506	Transistor KSC1845F		
	Q504SR	00D 960 0196 506	Transistor KSC1845F		
	Q506C	00D 960 0196 603	Transistor KTC2874B		
	Q506FL	00D 960 0196 603	Transistor KTC2874B		
	Q506FR	00D 960 0196 603	Transistor KTC2874B		
	Q506SBL	00D 960 0196 603	Transistor KTC2874B		
	Q506SBR	00D 960 0196 603	Transistor KTC2874B		
	Q506SL	00D 960 0196 603	Transistor KTC2874B		
	Q506SR	00D 960 0196 603	Transistor KTC2874B		
	Q551	00D 960 0196 700	Transistor KTC3200BL		
	Q552	00D 960 0196 302	Transistor KTA1268BL		
	Q553	00D 963 0120 704	Transistor KRA102S		

	Ref. No.	Part No.	Part Name	Remarks	New
	Q554	00D 963 0120 704	Transistor KRA102S		
	Q555	00D 963 0120 704	Transistor KRA102S		
	Q556	00D 963 0120 704	Transistor KRA102S		
	Q557C	00D 963 0148 508	Transistor KTA1504S		
	Q558C	00D 963 0121 606	Transistor KRC107S		
	D106	00D 963 0020 309	Diode 1SS133T		
	D107	00D 963 0020 309	Diode 1SS133T		
	D201RM	00D 960 0095 704	Zener diode MTZJ6.2B		
	D551	00D 963 0020 309	Diode 1SS133T		
	D552	00D 963 0020 309	Diode 1SS133T		
	D553	00D 963 0020 309	Diode 1SS133T		
	D554	00D 963 0020 309	Diode 1SS133T		
	D555	00D 963 0020 309	Diode 1SS133T		
	D556	00D 963 0020 309	Diode 1SS133T		
	D557	00D 963 0020 309	Diode 1SS133T		
	D558	00D 963 0020 309	Diode 1SS133T		
	D559	00D 963 0020 309	Diode 1SS133T		
	D560	00D 963 0020 309	Diode 1SS133T		
	D561	00D 963 0020 309	Diode 1SS133T		
	D562	00D 963 0058 407	Diode IN4007		
	D563	00D 963 0058 407	Diode IN4007		
	D564	00D 963 0020 309	Diode 1SS133T		
	D565	00D 960 0095 500	Zener diode MTZJ5.1B		
	D566	00D 963 0020 309	Diode 1SS133T		
	D567	00D 963 0020 309	Diode 1SS133T		
	D568	00D 963 0020 309	Diode 1SS133T		
	D568C	00D 960 0197 000	Diode KDS160		
	D569	00D 963 0020 309	Diode 1SS133T		
	D569C	00D 960 0197 000	Diode KDS160		
	D570	00D 963 0058 407	Diode IN4007		
	D570C	00D 960 0197 000	Diode KDS160		
	D571	00D 963 0058 407	Diode IN4007		
	D573	00D 963 0058 407	Diode IN4007		
	D574	00D 963 0058 407	Diode IN4007		
	D575	00D 963 0058 407	Diode IN4007		
RESISTORS GROUP					
	R104SBL	00D 963 9006 285	Metal oxide 5.6 kohm 1W		
	R104SBR	00D 963 9006 285	Metal oxide 5.6 kohm 1W		
	R105SBL	00D 963 9006 285	Metal oxide 5.6 kohm 1W		
	R105SBR	00D 963 9006 285	Metal oxide 5.6 kohm 1W		
	R106SBL	00D 963 0047 900	Metal film 4.7 kohm 1W		
	R106SBR	00D 963 0047 900	Metal film 4.7 kohm 1W		
	R107SBL	00D 963 0047 900	Metal film 4.7 kohm 1W		
	R107SBR	00D 963 0047 900	Metal film 4.7 kohm 1W		
	R108SBL	00D 963 9006 269	Metal oxide 0.22 ohm 1W		
	R108SBR	00D 963 9006 269	Metal oxide 0.22 ohm 1W		
	R109SBL	00D 963 9006 269	Metal oxide 0.22 ohm 1W		
	R109SBR	00D 963 9006 269	Metal oxide 0.22 ohm 1W		
	R110SBL	00D 963 9006 269	Metal oxide 0.22 ohm 1W		
	R110SBR	00D 963 9006 269	Metal oxide 0.22 ohm 1W		
	R111SBL	00D 963 9006 269	Metal oxide 0.22 ohm 1W		
	R111SBR	00D 963 9006 269	Metal oxide 0.22 ohm 1W		
	R118SBL	00D 963 9006 256	Metal oxide 10 ohm 1W		
	R118SBR	00D 963 9006 256	Metal oxide 10 ohm 1W		
	R119SBL	00D 963 9006 256	Metal oxide 10 ohm 1W		
	R119SBR	00D 963 9006 256	Metal oxide 10 ohm 1W		

Ref. No.	Part No.	Part Name	Remarks	New
R509C	00D 960 9005 902	Metal film 1.2 kohm 1/4W		
R509FL	00D 960 9005 902	Metal film 1.2 kohm 1/4W		
R509FR	00D 960 9005 902	Metal film 1.2 kohm 1/4W		
R509SBL	00D 960 9005 902	Metal film 1.2 kohm 1/4W		
R509SBR	00D 960 9005 902	Metal film 1.2 kohm 1/4W		
R509SL	00D 960 9005 902	Metal film 1.2 kohm 1/4W		
R509SR	00D 960 9005 902	Metal film 1.2 kohm 1/4W		
R511C	00D 960 9004 301	Metal film 47 ohm 1/4W		
R511FL	00D 960 9004 301	Metal film 47 ohm 1/4W		
R511FR	00D 960 9004 301	Metal film 47 ohm 1/4W		
R511SBL	00D 960 9004 301	Metal film 47 ohm 1/4W		
R511SBR	00D 960 9004 301	Metal film 47 ohm 1/4W		
R511SL	00D 960 9004 301	Metal film 47 ohm 1/4W		
R511SR	00D 960 9004 301	Metal film 47 ohm 1/4W		
R559	00D 963 9005 642	Metal film 1.2 kohm 1W		
R565	00D 963 9005 642	Metal film 1.2 kohm 1W		
R570	00D 963 9005 642	Metal film 1.2 kohm 1W		
R575	00D 963 9006 269	Metal oxide 0.22 ohm 1W		
R576	00D 963 9006 269	Metal oxide 0.22 ohm 1W		
VR106	00D 963 0105 208	Semi fixed resistor 1 kohm		
VR107	00D 963 0105 208	Semi fixed resistor 1 kohm		
CAPACITORS GROUP				
C101SBL	00D 963 9006 450	Electrolytic 47uF/50V		
C101SBR	00D 963 9006 450	Electrolytic 47uF/50V		
C102SBL	00D 963 9006 308	Electrolytic 10uF/50V		
C102SBR	00D 963 9006 308	Electrolytic 10uF/50V		
C103SBL	00D 963 9003 084	Ceramic 100pF/500V		
C103SBR	00D 963 9003 084	Ceramic 100pF/500V		
C104SBL	00D 963 9003 084	Ceramic 100pF/500V		
C104SBR	00D 963 9003 084	Ceramic 100pF/500V		
C105SBL	00D 963 9008 640	Mylar film 0.022uF/100V		
C105SBR	00D 963 9008 640	Mylar film 0.022uF/100V		
C107SBL	00D 963 9003 097	Mylar film 0.1uF/250V		
C107SBR	00D 963 9003 097	Mylar film 0.1uF/250V		
C201ML	00D 963 9004 575	Ceramic chip 100pF/50V		
C201MR	00D 963 9004 575	Ceramic chip 100pF/50V		
C201PC	00D 963 9004 575	Ceramic chip 100pF/50V		
C201PFL	00D 963 9004 575	Ceramic chip 100pF/50V		
C201PFR	00D 963 9004 575	Ceramic chip 100pF/50V		
C201PSL	00D 963 9004 575	Ceramic chip 100pF/50V		
C201PSR	00D 963 9004 575	Ceramic chip 100pF/50V		
C201PSW	00D 963 9004 575	Ceramic chip 100pF/50V		
C202ML	00D 963 9006 476	Electrolytic 4.7uF/50V		
C202MR	00D 963 9006 476	Electrolytic 4.7uF/50V		
C203ML	00D 963 9006 476	Electrolytic 4.7uF/50V		
C203MR	00D 963 9006 476	Electrolytic 4.7uF/50V		
C203RM	00D 963 9004 575	Ceramic chip 100pF/50V		
C204RM	00D 963 9006 379	Electrolytic 1uF/50V		
C205RM	00D 960 9008 653	Mylar film 0.012uF/100V		
C206RM	00D 963 9006 421	Electrolytic 47uF/10V		
C207RM	00D 960 9008 653	Mylar film 0.012uF/100V		
C208RM	00D 960 9010 094	Ceramic chip 0.01uF/50V		
C209RM	00D 963 9004 711	Ceramic chip 0.1uF/50V		
C210RM	00D 963 9004 546	Ceramic 0.01uF/16V		
C258	00D 963 0021 104	Electrolytic 6800uF/16V		
C259	00D 960 0133 501	Electrolytic 2200uF/16V		

Ref. No.	Part No.	Part Name	Remarks	New
C501C	00D 963 9006 382	Electrolytic 22uF/25V		
C501FL	00D 963 9006 382	Electrolytic 22uF/25V		
C501FR	00D 963 9006 382	Electrolytic 22uF/25V		
C501SBL	00D 963 9006 382	Electrolytic 22uF/25V		
C501SBR	00D 963 9006 382	Electrolytic 22uF/25V		
C501SL	00D 963 9006 382	Electrolytic 22uF/25V		
C501SR	00D 963 9006 382	Electrolytic 22uF/25V		
C502C	00D 963 9006 308	Electrolytic 10uF/50V		
C502FL	00D 963 9006 308	Electrolytic 10uF/50V		
C502FR	00D 963 9006 308	Electrolytic 10uF/50V		
C502SBL	00D 963 9006 308	Electrolytic 10uF/50V		
C502SBR	00D 963 9006 308	Electrolytic 10uF/50V		
C502SL	00D 963 9006 308	Electrolytic 10uF/50V		
C502SR	00D 963 9006 308	Electrolytic 10uF/50V		
C503C	00D 963 9003 165	Ceramic 220pF/500V		
C503FL	00D 963 9003 165	Ceramic 220pF/500V		
C503FR	00D 963 9003 165	Ceramic 220pF/500V		
C503SBL	00D 963 9003 165	Ceramic 220pF/500V		
C503SBR	00D 963 9003 165	Ceramic 220pF/500V		
C503SL	00D 963 9003 165	Ceramic 220pF/500V		
C503SR	00D 963 9003 165	Ceramic 220pF/500V		
C504C	00D 96 30157 502	Ceramic 220pF/50V		*
C504FL	00D 96 30157 502	Ceramic 220pF/50V		*
C504FR	00D 96 30157 502	Ceramic 220pF/50V		*
C504SBL	00D 96 30157 502	Ceramic 220pF/50V		*
C504SBR	00D 96 30157 502	Ceramic 220pF/50V		*
C504SL	00D 96 30157 502	Ceramic 220pF/50V		*
C504SR	00D 96 30157 502	Ceramic 220pF/50V		*
C505C	00D 963 9003 181	Ceramic 33pF/500V		
C505FL	00D 963 9003 181	Ceramic 33pF/500V		
C505FR	00D 963 9003 181	Ceramic 33pF/500V		
C505SBL	00D 963 9003 181	Ceramic 33pF/500V		
C505SBR	00D 963 9003 181	Ceramic 33pF/500V		
C505SL	00D 963 9003 181	Ceramic 33pF/500V		
C505SR	00D 963 9003 181	Ceramic 33pF/500V		
C506C	00D 963 9005 312	Electrolytic 100uF/10V		
C506FL	00D 963 9005 312	Electrolytic 100uF/10V		
C506FR	00D 963 9005 312	Electrolytic 100uF/10V		
C506SBL	00D 963 9005 312	Electrolytic 100uF/10V		
C506SBR	00D 963 9005 312	Electrolytic 100uF/10V		
C506SL	00D 963 9005 312	Electrolytic 100uF/10V		
C506SR	00D 963 9005 312	Electrolytic 100uF/10V		
C507C	00D 963 9003 194	Mylar film 0.0022uF/100V		
C507FL	00D 963 9003 194	Mylar film 0.0022uF/100V		
C507FR	00D 963 9003 194	Mylar film 0.0022uF/100V		
C507SBL	00D 963 9003 194	Mylar film 0.0022uF/100V		
C507SBR	00D 963 9003 194	Mylar film 0.0022uF/100V		
C507SL	00D 963 9003 194	Mylar film 0.0022uF/100V		
C507SR	00D 963 9003 194	Mylar film 0.0022uF/100V		
C508C	00D 963 9006 382	Electrolytic 22uF/25V		
C508FL	00D 963 9006 382	Electrolytic 22uF/25V		
C508FR	00D 963 9006 382	Electrolytic 22uF/25V		
C508SBL	00D 963 9006 382	Electrolytic 22uF/25V		
C508SBR	00D 963 9006 382	Electrolytic 22uF/25V		
C508SL	00D 963 9006 382	Electrolytic 22uF/25V		
C508SR	00D 963 9006 382	Electrolytic 22uF/25V		
C551	00D 963 9006 405	Electrolytic 2.2uF/50V		
C551M	00D 963 9005 804	Electrolytic 100uF/25V		
C551S	00D 963 9004 562	Ceramic 0.047uF/50V		
C552	00D 963 9006 366	Electrolytic 0.1uF/50V		
C553	00D 963 9006 366	Electrolytic 0.1uF/50V		

	Ref. No.	Part No.	Part Name	Remarks	New
	C554	00D 963 9006 366	Electrolytic 0.1uF/50V		
	C555	00D 963 9004 546	Ceramic 0.01uF/16V		
	C556	00D 963 9004 546	Ceramic 0.01uF/16V		
	C557	00D 963 9006 308	Electrolytic 10uF/50V		
	C558	00D 963 9006 366	Electrolytic 0.1uF/50V		
	C559	00D 963 0145 006	Mylar film 0.047uF/50V		
	C560	00D 963 0145 006	Mylar film 0.047uF/50V		
	C561	00D 963 0145 006	Mylar film 0.047uF/50V		
	C562	00D 963 9004 546	Ceramic 0.01uF/16V		
	C563	00D 963 9004 546	Ceramic 0.01uF/16V		
	C564	00D 960 0133 501	Electrolytic 2200uF/16V		
	C565	00D 960 0133 501	Electrolytic 2200uF/16V		
OTHER PARTS GROUP					
	CN106	00D 963 0159 500	2P connector cord		*
	CN1153	00D 963 0097 303	15P connector socket (TUC-P)		
	CN501	00D 963 0085 603	5P connector socket (TUC-P)		
	CN502	00D 963 0086 602	12P connector socket (TUC-P)		
	CN503	00D 963 0086 505	7P connector socket (TUC-P)		
	CN504	00D 963 0085 506	9P connector socket (TUC-P)		
	CN505	00D 963 0086 505	7P connector socket (TUC-P)		
	CN506	00D 963 0060 903	15P connector base		*
	CN506T	00D 963 0159 704	15P connector cord		*
	CN510	00D 963 0160 405	5P connector cord		*
	CN551	00D 963 0097 206	8P connector socket (TUC-P)		
	CN552	00D 963 0086 204	19P connector socket (TUC-P)		
	CN553	00D 963 0097 206	8P connector socket (TUC-P)		*
	CN554	00D 963 0160 609	15P connector cord		*
	CN555	00D 963 0086 709	11P connector socket (TUC-P)		
	CN556	00D 963 0159 403	15P connector cord		*
	CN557	00D 963 0086 709	11P connector socket (TUC-P)		
	CN560	00D 963 0110 701	14P connector socket (TUC-P)		
	CN992	00D 960 0217 553	4P connector base		
	CP1154	00D 963 0097 507	15P connector base (TUC-P)		
	CP508	00D 963 0068 303	9P connector base		
	CP509	00D 963 0060 505	7P connector base		
	CP510	00D 963 0066 101	5P connector base		
	CP554	00D 963 0060 903	15P connector base		
	CP568	00D 963 0049 102	3P connector base		
	CP602D	00D 963 0097 507	15P connector base (TUC-P)		
⚠	F101	00D 960 0188 705	Fuse 8A		
	F101A	00D 960 0005 804	Fuse clip		
	F101B	00D 960 0005 804	Fuse clip		
	J209RM	00D 963 9003 372	Carbon chip 0 ohm 1/16W		
	L101SBL	00D 963 0049 005	Inductor 0.5uH		
	L101SBR	00D 963 0049 005	Inductor 0.5uH		
	TP106	00D 960 0161 418	3P connector base		
	TP107	00D 960 0161 418	3P connector base		
	-	00D 960 0184 000	Screw bracket	2	
	-	00D 960 0184 000	Screw bracket	2	
	-	00D 960 0236 602	Shield plate	1	
	-	00D 960 0187 007	Mini jack	2	

	Ref. No.	Part No.	Part Name	Remarks	New
	-	00D 963 0158 501	2P pin jack	1	*
	-	00D 960 0268 803	6P pin jack	1	
	-	00D 960 0187 803	AC outlet(2P)	1	

INPUT, VIDEO P.W.B. UNIT

	Ref. No.	Part No.	Part Name	Remarks	New
SEMICONDUCTORS GROUP					
	IC1000		IC BA7626F	J171762600010	
	IC1001	00D 963 0116 103	IC MM74HC4053MX		
	IC1002		IC BA7626F	J171762600010	
	IC1003	00D 963 0074 504	IC BU2090F		
	IC1004	00D 963 0116 103	IC MM74HC4053MX		
	IC1005	00D 963 0074 504	IC BU2090F		
	IC1006	00D 963 0116 307	IC LC7478		
	IC1007	00D 963 0116 200	IC NJM2274R		
	IC1008	00D 963 0116 103	IC MM74HC4053MX		
	IC1010	00D 963 0147 907	IC TK15420MTL		
	IC1011	00D 963 0147 907	IC TK15420MTL		
	IC1012	00D 963 0147 907	IC TK15420MTL		
	IC1013	00D 963 0147 907	IC TK15420MTL		
	IC1015	00D 963 0147 907	IC TK15420MTL		
	IC1016	00D 963 0147 907	IC TK15420MTL		
	IC1109	00D 963 0148 100	IC TC90A69F		
	IC1150		IC BA7626F	J171762600010	
	IC1151		IC BA7626F	J171762600010	
	IC1152		IC BA7626F	J171762600010	
	IC1153		IC BA7626F	J171762600010	
	IC1154	00D 963 0148 003	IC TA1270BF		
	IC1155	00D 963 0148 207	IC LA7108M		
	IC1157	00D 963 0147 907	IC TK15420MTL		
	IC201T	00D 963 0158 909	IC TC94A27UG		*
	IC202T	00D 963 0158 909	IC TC94A27UG		*
	IC203T	00D 960 0080 201	IC KIC9164AN		
	IC205	00D 963 0024 004	IC NJM2068M		
	IC206	00D 963 0024 004	IC NJM2068M		
	IC207	00D 963 0024 004	IC NJM2068M		
	IC208	00D 963 0159 005	IC NJM5532M		*
	IC209	00D 963 0159 005	IC NJM5532M		*
	IC210	00D 963 0159 005	IC NJM5532M		*
	IC211	00D 963 0159 005	IC NJM5532M		*
	IC701	00D 963 0083 207	IC TC9274N-011		
	IC701M	00D 963 0024 004	IC NJM2068M		
	IC702	00D 963 0024 004	IC NJM2068M		
	IC703	00D 963 0024 004	IC NJM2068M		
	IC704	00D 960 0174 502	IC NJM2068DD		
	IC705	00D 960 0174 201	IC TC9273N-004		
	IC707	00D 963 0024 004	IC NJM2068M		
	IC708	00D 963 0024 004	IC NJM2068M		
	Q1000	00D 963 0102 803	Transistor 2SA933S		
	Q1001	00D 963 0102 803	Transistor 2SA933S		
	Q1002	00D 963 0121 703	Transistor KRA107S		
	Q1003	00D 963 0121 703	Transistor KRA107S		
	Q1004	00D 963 0120 704	Transistor KRA102S		
	Q1005	00D 963 0159 102	Transistor KRC111S		*
	Q1006	00D 963 0120 801	Transistor KRC102S		
	Q1007	00D 960 0068 207	Transistor KTA1504Y		
	Q1008	00D 963 0120 704	Transistor KRA102S		
	Q1009	00D 963 0159 102	Transistor KRC111S		*
	Q1010	00D 963 0120 801	Transistor KRC102S		
	Q1011	00D 960 0068 207	Transistor KTA1504Y		
	Q1012	00D 963 0044 301	Transistor KTC2875B		
	Q1013	00D 963 0120 704	Transistor KRA102S		

	Ref. No.	Part No.	Part Name	Remarks	New
	Q1014	00D 960 0068 207	Transistor KTA1504Y		
	Q1015	00D 963 0120 801	Transistor KRC102S		
	Q1016	00D 960 0068 207	Transistor KTA1504Y		
	Q1017	00D 960 0068 207	Transistor KTA1504Y		
	Q1018	00D 960 0068 207	Transistor KTA1504Y		
	Q1019	00D 960 0068 207	Transistor KTA1504Y		
	Q1020	00D 963 0066 606	Transistor KTC3875Y		
	Q1021	00D 963 0066 606	Transistor KTC3875Y		
	Q1022	00D 960 0068 207	Transistor KTA1504Y		
	Q1023	00D 963 0102 803	Transistor 2SA933S		
	Q1150	00D 963 0159 102	Transistor KRC111S		*
	Q1151	00D 960 0068 207	Transistor KTA1504Y		
	Q1152	00D 963 0159 102	Transistor KRC111S		*
	Q1153	00D 960 0068 207	Transistor KTA1504Y		
	Q1155	00D 963 0159 102	Transistor KRC111S		*
	Q1156	00D 960 0068 207	Transistor KTA1504Y		
	Q1157	00D 963 0159 102	Transistor KRC111S		*
	Q1158	00D 960 0068 207	Transistor KTA1504Y		
	Q207T	00D 960 0196 807	Transistor 2SK117Y		
	Q208T	00D 960 0196 807	Transistor 2SK117Y		
	Q209T	00D 960 0097 003	Transistor KRA104M		
	Q210T	00D 963 0121 004	Transistor KRC104M		
	Q551SW	00D 963 0044 301	Transistor KTC2875B		
	Q552SW	00D 963 0044 301	Transistor KTC2875B		
	Q601C	00D 963 0121 208	Transistor KRC107M		
	Q602C	00D 963 0121 208	Transistor KRC107M		
	Q603C	00D 963 0121 208	Transistor KRC107M		
	Q604C	00D 963 0121 208	Transistor KRC107M		
	Q605C	00D 960 0111 808	Transistor KRC107S		
	Q606	00D 963 0121 208	Transistor KRC107M		
	Q606C	00D 963 0102 803	Transistor 2SA933S		
	Q607C	00D 963 0120 801	Transistor KRC102S		
	Q608C	00D 963 0121 208	Transistor KRC107M		
	Q609C	00D 963 0121 208	Transistor KRC107M		
	Q610C	00D 963 0121 208	Transistor KRC107M		
	Q707M	00D 960 0097 508	Transistor KRC111M		
	D1000	00D 960 0197 000	Diode KDS160		
	D1001	00D 960 0197 000	Diode KDS160		
	D1002	00D 960 0197 000	Diode KDS160		
	D1003	00D 960 0197 000	Diode KDS160		
	D1004	00D 960 0197 000	Diode KDS160		
	D1005	00D 960 0197 000	Diode KDS160		
	D1012	00D 963 0020 309	Diode 1SS133T		
	D1014	00D 963 0020 309	Diode 1SS133T		
	D1150	00D 960 0197 000	Diode KDS160		
	D1151	00D 960 0197 000	Diode KDS160		
	D1152	00D 960 0197 000	Diode KDS160		
	D1153	00D 960 0197 000	Diode KDS160		
	D1154	00D 960 0197 000	Diode KDS160		
	D1155	00D 960 0197 000	Diode KDS160		
	D1156	00D 960 0095 500	Zener diode MTZJ5.1B		
	D205T	00D 960 0197 000	Diode KDS160		
	D207T	00D 960 0197 000	Diode KDS160		
	D251	00D 960 0197 000	Diode KDS160		
	D252	00D 960 0197 000	Diode KDS160		
	D253	00D 960 0197 000	Diode KDS160		
	D254	00D 960 0197 000	Diode KDS160		
	D255	00D 960 0197 000	Diode KDS160		
	D256	00D 960 0197 000	Diode KDS160		
	D601C	00D 960 0197 000	Diode KDS160		

Ref. No.	Part No.	Part Name	Remarks	New
D602C	00D 960 0197 000	Diode KDS160		
D603C	00D 960 0197 000	Diode KDS160		
D604C	00D 960 0197 000	Diode KDS160		
D605C	00D 960 0197 000	Diode KDS160		
D606C	00D 960 0197 000	Diode KDS160		
D607C	00D 960 0197 000	Diode KDS160		
D608C	00D 960 0197 000	Diode KDS160		
D609C	00D 960 0197 000	Diode KDS160		
D610C	00D 960 0197 000	Diode KDS160		
D611C	00D 960 0197 000	Diode KDS160		
D612	00D 960 0197 000	Diode KDS160		
D701B	00D 963 0020 309	Diode 1SS133T		
D901	00D 960 0197 000	Diode KDS160		
D902	00D 960 0197 000	Diode KDS160		
D903	00D 960 0197 000	Diode KDS160		
D904	00D 960 0197 000	Diode KDS160		
ZD1000	00D 960 0095 500	Zener diode MTZJ5.1B		
ZD1013	00D 960 0095 500	Zener diode MTZJ5.1B		
ZD701M	00D 960 0095 500	Zener diode MTZJ5.1B		
RESISTORS GROUP				
R1031	00D 963 9005 639	Metal film 100 ohm 1W		
R1038	00D 963 9005 639	Metal film 100 ohm 1W		
R1059	00D 963 9005 639	Metal film 100 ohm 1W		
R1095	00D 963 0018 007	Metal film 100 ohm 1/4W		
R1140	00D 963 9003 068	Metal film 4.7 ohm 1/4W (NB)		
R1163	00D 963 9005 639	Metal film 100 ohm 1W		
R1166	00D 963 9005 639	Metal film 100 ohm 1W		
R1193	00D 963 9005 639	Metal film 100 ohm 1W		
R1198	00D 963 9003 068	Metal film 4.7 ohm 1/4W (NB)		
R1199	00D 963 9005 639	Metal film 100 ohm 1W		
R229T	00D 963 9005 639	Metal film 100 ohm 1W		
R230T	00D 963 9005 639	Metal film 100 ohm 1W		
R713B	00D 960 9004 301	Metal film 47 ohm 1/4W		
R738M	00D 963 9005 338	Carbon chip 1.6 kohm 1/10W		
VR608	00D 960 0091 601	Semi fixed resistor 1 kohm		
VR609	00D 960 0091 601	Semi fixed resistor 1 kohm		
VR610	00D 960 0091 601	Semi fixed resistor 1 kohm		
CAPACITORS GROUP				
C1000	00D 963 9006 382	Electrolytic 22uF/25V		
C1001	00D 963 9006 382	Electrolytic 22uF/25V		
C1002	00D 963 9005 312	Electrolytic 100uF/10V		
C1003	00D 963 9004 753	Ceramic chip 0.047uF/50V		
C1004	00D 963 9006 308	Electrolytic 10uF/50V		
C1005	00D 963 9006 308	Electrolytic 10uF/50V		
C1006	00D 963 9006 382	Electrolytic 22uF/25V		
C1007	00D 963 9004 753	Ceramic chip 0.047uF/50V		
C1008	00D 963 9006 382	Electrolytic 22uF/25V		
C1009	00D 963 9006 308	Electrolytic 10uF/50V		
C1010	00D 963 9006 405	Electrolytic 2.2uF/50V		
C1011	00D 963 9006 405	Electrolytic 2.2uF/50V		
C1013	00D 963 9006 382	Electrolytic 22uF/25V		

Ref. No.	Part No.	Part Name	Remarks	New
C1014	00D 963 9006 308	Electrolytic 10uF/50V		
C1015	00D 963 9005 312	Electrolytic 100uF/10V		
C1016	00D 963 9006 146	Ceramic chip 560pF/50V		
C1017	00D 963 9004 575	Ceramic chip 100pF/50V		
C1018	00D 963 9004 575	Ceramic chip 100pF/50V		
C1019	00D 963 9006 308	Electrolytic 10uF/50V		
C1020	00D 963 9006 463	Electrolytic 470uF/6.3V		
C1022	00D 963 9006 308	Electrolytic 10uF/50V		
C1023	00D 963 9006 463	Electrolytic 470uF/6.3V		
C1024	00D 963 9004 753	Ceramic chip 0.047uF/50V		
C1026	00D 963 9006 308	Electrolytic 10uF/50V		
C1027	00D 963 9006 463	Electrolytic 470uF/6.3V		
C1028	00D 963 9005 312	Electrolytic 100uF/10V		
C1029	00D 963 9006 382	Electrolytic 22uF/25V		
C1030	00D 963 9006 434	Electrolytic 47uF/16V		
C1031	00D 963 9005 312	Electrolytic 100uF/10V		
C1032	00D 963 9006 382	Electrolytic 22uF/25V		
C1033	00D 963 0144 609	Ceramic chip 12pF/50V		
C1034	00D 963 9004 591	Ceramic chip 22pF/50V		
C1035	00D 963 9006 382	Electrolytic 22uF/25V		
C1036	00D 960 9010 094	Ceramic chip 0.01uF/50V		
C1037	00D 963 9006 382	Electrolytic 22uF/25V		
C1038	00D 963 9006 382	Electrolytic 22uF/25V		
C1039	00D 963 9006 528	Ceramic chip 20pF/50V		
C1040	00D 963 9006 379	Electrolytic 1uF/50V		
C1041	00D 963 0157 706	Ceramic chip 0.022uF/50V		*
C1042	00D 963 9006 434	Electrolytic 47uF/16V		
C1043	00D 963 9004 711	Ceramic chip 0.1uF/50V		
C1044	00D 960 9010 094	Ceramic chip 0.01uF/50V		
C1045	00D 960 9010 094	Ceramic chip 0.01uF/50V		
C1046	00D 963 9004 672	Ceramic chip 680pF/50V		
C1047	00D 960 9003 409	Mylar film 0.01uF/50V		
C1048	00D 963 9005 312	Electrolytic 100uF/10V		
C1049	00D 963 9006 528	Ceramic chip 20pF/50V		
C1050	00D 963 0144 609	Ceramic chip 12pF/50V		
C1051	00D 963 9004 591	Ceramic chip 22pF/50V		
C1052	00D 963 9006 308	Electrolytic 10uF/50V		
C1053	00D 963 9006 308	Electrolytic 10uF/50V		
C1054	00D 963 9005 998	Ceramic chip 24pF/50V		
C1055	00D 963 9006 382	Electrolytic 22uF/25V		
C1056	00D 963 9006 379	Electrolytic 1uF/50V		
C1057	00D 963 9005 998	Ceramic chip 24pF/50V		
C1058	00D 963 9006 434	Electrolytic 47uF/16V		
C1059	00D 963 9004 753	Ceramic chip 0.047uF/50V		
C1060	00D 963 9006 382	Electrolytic 22uF/25V		
C1061	00D 963 0129 909	Ceramic chip 1200pF/50V		
C1062	00D 963 9005 312	Electrolytic 100uF/10V		
C1063	00D 960 9010 094	Ceramic chip 0.01uF/50V		
C1065	00D 960 9010 094	Ceramic chip 0.01uF/50V		
C1066	00D 960 9010 094	Ceramic chip 0.01uF/50V		
C1067	00D 960 9010 094	Ceramic chip 0.01uF/50V		
C1068	00D 960 9010 094	Ceramic chip 0.01uF/50V		
C1069	00D 963 9006 382	Electrolytic 22uF/25V		
C1070	00D 963 9005 312	Electrolytic 100uF/10V		
C1071	00D 963 9006 379	Electrolytic 1uF/50V		
C1072	00D 960 9010 094	Ceramic chip 0.01uF/50V		
C1073	00D 960 9010 094	Ceramic chip 0.01uF/50V		
C1074	00D 963 9005 312	Electrolytic 100uF/10V		
C1075	00D 960 9010 094	Ceramic chip 0.01uF/50V		
C1076	00D 963 9006 382	Electrolytic 22uF/25V		
C1077	00D 963 9006 382	Electrolytic 22uF/25V		

Ref. No.	Part No.	Part Name	Remarks	New
C1078	00D 960 9010 515	Electrolytic 0.47uF/50V		
C1079	00D 963 0144 609	Ceramic chip 12pF/50V		
C1080	00D 963 0157 706	Ceramic chip 0.022uF/50V		*
C1081	00D 963 9006 434	Electrolytic 47uF/16V		
C1082	00D 963 9004 591	Ceramic chip 22pF/50V		
C1150	00D 963 9006 382	Electrolytic 22uF/25V		
C1151	00D 960 9010 094	Ceramic chip 0.01uF/50V		
C1152	00D 963 9006 382	Electrolytic 22uF/25V		
C1153	00D 963 9004 575	Ceramic chip 100pF/50V		
C1154	00D 963 9004 575	Ceramic chip 100pF/50V		
C1155	00D 963 9004 575	Ceramic chip 100pF/50V		
C1156	00D 963 9004 575	Ceramic chip 100pF/50V		
C1157	00D 963 9006 382	Electrolytic 22uF/25V		
C1158	00D 963 9004 753	Ceramic chip 0.047uF/50V		
C1159	00D 963 9006 382	Electrolytic 22uF/25V		
C1160	00D 963 9006 308	Electrolytic 10uF/50V		
C1161	00D 963 9006 463	Electrolytic 470uF/6.3V		
C1162	00D 963 9006 308	Electrolytic 10uF/50V		
C1163	00D 963 9006 463	Electrolytic 470uF/6.3V		
C1164	00D 963 9006 382	Electrolytic 22uF/25V		
C1165	00D 963 9006 382	Electrolytic 22uF/25V		
C1166	00D 963 9006 382	Electrolytic 22uF/25V		
C1167	00D 963 9004 753	Ceramic chip 0.047uF/50V		
C1168	00D 963 9006 382	Electrolytic 22uF/25V		
C1169	00D 963 9006 463	Electrolytic 470uF/6.3V		
C1170	00D 963 9006 463	Electrolytic 470uF/6.3V		
C1171	00D 963 9006 382	Electrolytic 22uF/25V		
C1172	00D 963 9006 382	Electrolytic 22uF/25V		
C1173	00D 963 9004 753	Ceramic chip 0.047uF/50V		
C1174	00D 963 9004 711	Ceramic chip 0.1uF/50V		
C1175	00D 963 9004 711	Ceramic chip 0.1uF/50V		
C1176	00D 963 9004 711	Ceramic chip 0.1uF/50V		
C1177	00D 963 9004 711	Ceramic chip 0.1uF/50V		
C1178	00D 963 9004 711	Ceramic chip 0.1uF/50V		
C1179	00D 963 9004 711	Ceramic chip 0.1uF/50V		
C1181	00D 963 9006 308	Electrolytic 10uF/50V		
C1182	00D 963 9005 202	Mylar film 0.1uF/50V		
C1183	00D 960 9010 515	Electrolytic 0.47uF/50V		
C1184	00D 960 9010 094	Ceramic chip 0.01uF/50V		
C1185	00D 963 9005 312	Electrolytic 100uF/10V		
C1186	00D 960 9010 094	Ceramic chip 0.01uF/50V		
C1187	00D 963 9006 434	Electrolytic 47uF/16V		
C1188	00D 963 9006 308	Electrolytic 10uF/50V		
C1189	00D 960 9010 515	Electrolytic 0.47uF/50V		
C1190	00D 963 9006 405	Electrolytic 2.2uF/50V		
C1191	00D 963 9005 257	Mylar film 0.022uF/50V		
C1192	00D 960 9010 094	Ceramic chip 0.01uF/50V		
C1193	00D 963 9006 405	Electrolytic 2.2uF/50V		
C1194	00D 963 0144 609	Ceramic chip 12pF/50V		
C1195	00D 963 0144 900	Mylar film 0.0022uF/50V		
C1196	00D 963 9005 972	Electrolytic 0.22uF/50V		
C1197	00D 963 9006 434	Electrolytic 47uF/16V		
C1198	00D 960 9003 409	Mylar film 0.01uF/50V		
C1199	00D 963 9006 434	Electrolytic 47uF/16V		
C1200	00D 963 9005 202	Mylar film 0.1uF/50V		
C1203	00D 963 9006 434	Electrolytic 47uF/16V		
C1204	00D 963 9004 711	Ceramic chip 0.1uF/50V		
C1205	00D 963 9006 434	Electrolytic 47uF/16V		
C1206	00D 963 9004 711	Ceramic chip 0.1uF/50V		
C1211	00D 963 9005 312	Electrolytic 100uF/10V		
C1212	00D 963 9005 312	Electrolytic 100uF/10V		

Ref. No.	Part No.	Part Name	Remarks	New
C1213	00D 963 9006 382	Electrolytic 22uF/25V		
C1214	00D 963 9006 382	Electrolytic 22uF/25V		
C1216	00D 963 9005 312	Electrolytic 100uF/10V		
C1217	00D 963 9006 382	Electrolytic 22uF/25V		
C1218	00D 963 9006 382	Electrolytic 22uF/25V		
C1219	00D 963 9006 434	Electrolytic 47uF/16V		
C1220	00D 963 9006 434	Electrolytic 47uF/16V		
C1221	00D 963 9005 312	Electrolytic 100uF/10V		
C1222	00D 963 9005 312	Electrolytic 100uF/10V		
C211SW	00D 963 9004 575	Ceramic chip 100pF/50V		
C212SW	00D 963 9004 643	Ceramic chip 47pF/50V		
C213FL	00D 963 9004 575	Ceramic chip 100pF/50V		
C213FR	00D 963 9004 575	Ceramic chip 100pF/50V		
C213T	00D 963 9004 753	Ceramic chip 0.047uF/50V		
C214T	00D 963 9004 753	Ceramic chip 0.047uF/50V		
C215T	00D 963 9004 753	Ceramic chip 0.047uF/50V		
C216T	00D 963 9004 753	Ceramic chip 0.047uF/50V		
C217T	00D 963 9004 753	Ceramic chip 0.047uF/50V		
C218FL	00D 963 9004 627	Ceramic chip 33pF/50V		
C218FR	00D 963 9004 627	Ceramic chip 33pF/50V		
C218T	00D 963 9006 379	Electrolytic 1uF/50V		
C219FL	00D 963 9006 308	Electrolytic 10uF/50V		
C219FR	00D 963 9006 308	Electrolytic 10uF/50V		
C219SW	00D 963 9006 308	Electrolytic 10uF/50V		
C219T	00D 963 9006 379	Electrolytic 1uF/50V		
C220T	00D 963 9006 308	Electrolytic 10uF/50V		
C223C	00D 963 9006 382	Electrolytic 22uF/25V		
C223FL	00D 963 9006 382	Electrolytic 22uF/25V		
C223FR	00D 963 9006 382	Electrolytic 22uF/25V		
C223SBL	00D 963 9006 382	Electrolytic 22uF/25V		
C223SBR	00D 963 9006 382	Electrolytic 22uF/25V		
C223SL	00D 963 9006 382	Electrolytic 22uF/25V		
C223SR	00D 963 9006 382	Electrolytic 22uF/25V		
C223SW	00D 963 9006 382	Electrolytic 22uF/25V		
C225T	00D 963 9006 379	Electrolytic 1uF/50V		
C226T	00D 963 9006 379	Electrolytic 1uF/50V		
C227T	00D 963 9006 308	Electrolytic 10uF/50V		
C228T	00D 963 9006 434	Electrolytic 47uF/16V		
C229T	00D 963 9006 434	Electrolytic 47uF/16V		
C230T	00D 963 9006 308	Electrolytic 10uF/50V		
C231C	00D 963 9006 418	Electrolytic 3.3uF/50V		
C231FL	00D 963 9006 418	Electrolytic 3.3uF/50V		
C231FR	00D 963 9006 418	Electrolytic 3.3uF/50V		
C231SBL	00D 963 9006 418	Electrolytic 3.3uF/50V		
C231SBR	00D 963 9006 418	Electrolytic 3.3uF/50V		
C231SL	00D 963 9006 418	Electrolytic 3.3uF/50V		
C231SR	00D 963 9006 418	Electrolytic 3.3uF/50V		
C231SW	00D 963 9006 418	Electrolytic 3.3uF/50V		
C231T	00D 963 9006 308	Electrolytic 10uF/50V		
C232C	00D 960 9010 104	Ceramic 5pF/50V		
C232FL	00D 960 9010 104	Ceramic 5pF/50V		
C232FR	00D 960 9010 104	Ceramic 5pF/50V		
C232SBL	00D 960 9010 104	Ceramic 5pF/50V		
C232SBR	00D 960 9010 104	Ceramic 5pF/50V		
C232SL	00D 960 9010 104	Ceramic 5pF/50V		
C232SR	00D 960 9010 104	Ceramic 5pF/50V		
C232SW	00D 960 9010 104	Ceramic 5pF/50V		
C232T	00D 963 9006 434	Electrolytic 47uF/16V		
C233T	00D 963 9006 434	Electrolytic 47uF/16V		
C234T	00D 963 9006 434	Electrolytic 47uF/16V		
C235T	00D 963 9006 434	Electrolytic 47uF/16V		

	Ref. No.	Part No.	Part Name	Remarks	New
	C236T	00D 963 9006 434	Electrolytic 47uF/16V		
	C237T	00D 963 9006 434	Electrolytic 47uF/16V		
	C238C	00D 963 9006 418	Electrolytic 3.3uF/50V		
	C238FL	00D 963 9006 418	Electrolytic 3.3uF/50V		
	C238FR	00D 963 9006 418	Electrolytic 3.3uF/50V		
	C238SBL	00D 963 9006 418	Electrolytic 3.3uF/50V		
	C238SBR	00D 963 9006 418	Electrolytic 3.3uF/50V		
	C238SL	00D 963 9006 418	Electrolytic 3.3uF/50V		
	C238SR	00D 963 9006 418	Electrolytic 3.3uF/50V		
	C238SW	00D 963 9006 418	Electrolytic 3.3uF/50V		
	C239T	00D 963 9004 753	Ceramic chip 0.047uF/50V		
	C240T	00D 963 9006 379	Electrolytic 1uF/50V		
	C241T	00D 963 9006 308	Electrolytic 10uF/50V		
	C243T	00D 963 9006 379	Electrolytic 1uF/50V		
	C244T	00D 963 9006 379	Electrolytic 1uF/50V		
	C245T	00D 963 9006 379	Electrolytic 1uF/50V		
	C246SW	00D 963 9006 476	Electrolytic 4.7uF/50V		
	C246T	00D 963 9006 308	Electrolytic 10uF/50V		
	C247T	00D 963 9004 575	Ceramic chip 100pF/50V		
	C248T	00D 963 9006 379	Electrolytic 1uF/50V		
	C251	00D 963 9004 708	Ceramic chip 0.1uF/50V		
	C252	00D 963 9004 708	Ceramic chip 0.1uF/50V		
	C253	00D 963 9004 708	Ceramic chip 0.1uF/50V		
	C602C	00D 963 9006 379	Electrolytic 1uF/50V		
	C605C	00D 960 9010 094	Ceramic chip 0.01uF/50V		
	C606C	00D 963 9004 753	Ceramic chip 0.047uF/50V		
	C617C	00D 960 9010 094	Ceramic chip 0.01uF/50V		
	C618C	00D 963 0130 105	Mylar film 1uF/63V		
	C619C	00D 963 9004 753	Ceramic chip 0.047uF/50V		
	C701BL	00D 963 9006 476	Electrolytic 4.7uF/50V		
	C701BR	00D 963 9006 476	Electrolytic 4.7uF/50V		
	C702	00D 963 9004 575	Ceramic chip 100pF/50V		
	C702BL	00D 963 9004 698	Ceramic chip 0.01uF/50V		
	C702BR	00D 963 9004 698	Ceramic chip 0.01uF/50V		
	C702R	00D 963 9004 575	Ceramic chip 100pF/50V		
	C703BL	00D 963 9006 308	Electrolytic 10uF/50V		
	C703BR	00D 963 9006 308	Electrolytic 10uF/50V		
	C703L	00D 963 9004 575	Ceramic chip 100pF/50V		
	C703R	00D 963 9004 575	Ceramic chip 100pF/50V		
	C704BL	00D 963 9006 308	Electrolytic 10uF/50V		
	C704BR	00D 963 9006 308	Electrolytic 10uF/50V		
	C704L	00D 963 9004 575	Ceramic chip 100pF/50V		
	C704R	00D 963 9004 575	Ceramic chip 100pF/50V		
	C705L	00D 963 9004 575	Ceramic chip 100pF/50V		
	C705R	00D 963 9004 575	Ceramic chip 100pF/50V		
	C706L	00D 963 9004 575	Ceramic chip 100pF/50V		
	C706R	00D 963 9004 575	Ceramic chip 100pF/50V		
	C707L	00D 963 9004 575	Ceramic chip 100pF/50V		
	C707R	00D 963 9004 575	Ceramic chip 100pF/50V		
	C708L	00D 963 9004 575	Ceramic chip 100pF/50V		
	C708R	00D 963 9004 575	Ceramic chip 100pF/50V		
	C709L	00D 963 9006 308	Electrolytic 10uF/50V		
	C709R	00D 963 9006 308	Electrolytic 10uF/50V		
	C710L	00D 963 9004 575	Ceramic chip 100pF/50V		
	C710R	00D 963 9004 575	Ceramic chip 100pF/50V		
	C711L	00D 963 9006 557	Electrolytic 220uF/6.3V		
	C711R	00D 963 9006 557	Electrolytic 220uF/6.3V		
	C712L	00D 963 9004 779	Mylar film 0.024uF/50V		
	C712R	00D 963 9004 779	Mylar film 0.024uF/50V		
	C713L	00D 960 9008 695	Mylar film 0.0068uF/100V		
	C713R	00D 960 9008 695	Mylar film 0.0068uF/100V		

Ref. No.	Part No.	Part Name	Remarks	New
C714L	00D 963 9006 476	Electrolytic 4.7uF/50V		
C714R	00D 963 9006 476	Electrolytic 4.7uF/50V		
C715L	00D 963 9004 737	Ceramic chip 0.022uF/25V		
C715R	00D 963 9004 737	Ceramic chip 0.022uF/25V		
C716L	00D 963 9006 308	Electrolytic 10uF/50V		
C716R	00D 963 9006 308	Electrolytic 10uF/50V		
C717L	00D 963 9004 601	Ceramic chip 220pF/50V		
C717R	00D 963 9004 601	Ceramic chip 220pF/50V		
C718L	00D 963 9006 421	Electrolytic 47uF/10V		
C718R	00D 963 9006 421	Electrolytic 47uF/10V		
C719L	00D 963 9006 379	Electrolytic 1uF/50V		
C719R	00D 963 9006 379	Electrolytic 1uF/50V		
C720L	00D 963 9003 152	Mylar film 0.068uF/100V		
C720R	00D 963 9003 152	Mylar film 0.068uF/100V		
C721L	00D 963 9003 152	Mylar film 0.068uF/100V		
C721R	00D 963 9003 152	Mylar film 0.068uF/100V		
C723L	00D 963 9006 308	Electrolytic 10uF/50V		
C723M	00D 963 9006 379	Electrolytic 1uF/50V		
C723R	00D 963 9006 308	Electrolytic 10uF/50V		
C724L	00D 963 9004 698	Ceramic chip 0.01uF/50V		
C724M	00D 963 9006 379	Electrolytic 1uF/50V		
C724R	00D 963 9004 698	Ceramic chip 0.01uF/50V		
C725	00D 963 9004 698	Ceramic chip 0.01uF/50V		
C725M	00D 963 9006 379	Electrolytic 1uF/50V		
C726	00D 963 9004 698	Ceramic chip 0.01uF/50V		
C726M	00D9630157609	Ceramic chip 150pF/50V		*
C727	00D 963 9006 308	Electrolytic 10uF/50V		
C727M	00D 963 9004 575	Ceramic chip 100pF/50V		
C728	00D 963 9006 308	Electrolytic 10uF/50V		
C728M	00D9630157609	Ceramic chip 150pF/50V		*
C729	00D 963 9004 708	Ceramic chip 0.1uF/50V		
C729M	00D 963 9006 379	Electrolytic 1uF/50V		
C730BL	00D 963 9004 575	Ceramic chip 100pF/50V		
C730BR	00D 963 9004 575	Ceramic chip 100pF/50V		
C730M	00D 963 9006 308	Electrolytic 10uF/50V		
C731BL	00D 963 9004 698	Ceramic chip 0.01uF/50V		
C731BR	00D 963 9004 698	Ceramic chip 0.01uF/50V		
C737M	00D 963 9004 575	Ceramic chip 100pF/50V		
C738M	00D 963 9004 698	Ceramic chip 0.01uF/50V		
C901SW	00D 963 9006 476	Electrolytic 4.7uF/50V		
C910	00D 963 9004 575	Ceramic chip 100pF/50V		
C911	00D 960 9010 094	Ceramic chip 0.01uF/50V		
C912	00D 963 9004 575	Ceramic chip 100pF/50V		
C913	00D 963 9004 575	Ceramic chip 100pF/50V		
C914	00D 963 9004 575	Ceramic chip 100pF/50V		
C915	00D 963 9004 575	Ceramic chip 100pF/50V		
C916	00D 963 9004 575	Ceramic chip 100pF/50V		
C917	00D 960 9010 094	Ceramic chip 0.01uF/50V		
C918	00D 963 9004 575	Ceramic chip 100pF/50V		
C920	00D 963 9004 575	Ceramic chip 100pF/50V		
OTHER PARTS GROUP				
CB1000	00D 963 0120 908	Beads inductor		
CB1001	00D 963 0120 908	Beads inductor		
CB1002	00D 963 0115 609	Inductor 33uH		
CB205	00D 963 0154 602	Beads inductor		*
CN1000	00D 963 0086 505	7P connector socket (TUC-P)		

Ref. No.	Part No.	Part Name	Remarks	New
CN1004	00D 963 0110 701	14P connector socket (TUC-P)		
CN1150	00D 963 0086 505	7P connector socket (TUC-P)		
CN1151	00D 963 0097 303	15P connector socket (TUC-P)		
CN1154	00D 963 0097 303	15P connector socket (TUC-P)		
CN403	00D 963 0086 709	11P connector socket (TUC-P)		
CN508	00D 963 0159 306	9P connector cord		*
CN509	00D 963 0159 209	7P connector cord		*
CN557T	00D 963 0050 104	4P connector base		
CN600	00D 963 0097 303	15P connector socket (TUC-P)		
CN701	00D 963 0086 301	18P connector socket (TUC-P)		
CN701M	00D 963 0160 104	4P connector cord		*
CN703	00D 963 0086 505	7P connector socket (TUC-P)		
CN805	00D 963 0097 206	8P connector socket (TUC-P)		
CN806	00D 963 0086 204	19P connector socket (TUC-P)		
CP556	00D 963 0060 903	15P connector base		
JK704	00D 960 0188 103	2P pin jack		
L1000	00D 963 0145 200	Inductor 27uH		
L1001	00D 960 0128 008	Inductor 100uH		
L1002	00D 963 0145 200	Inductor 27uH		
L1003	00D 963 0120 908	Beads inductor		
L1004	00D 963 0145 200	Inductor 27uH		
L1005	00D 963 0145 103	Inductor 22uH		
L1006	00D 960 0128 008	Inductor 100uH		
L1007	00D 960 0128 008	Inductor 100uH		
L1008	00D 963 0120 908	Beads inductor		
RL701B	00D 963 0083 100	Relay (RSB12S DC12V)		
RLY601	00D 963 0146 704	Relay (RSB6S DC6V)		
RLY602	00D 963 0146 704	Relay (RSB6S DC6V)		
RLY603	00D 963 0146 704	Relay (RSB6S DC6V)		
RLY604	00D 963 0146 704	Relay (RSB6S DC6V)		
RLY605	00D 963 0146 704	Relay (RSB6S DC6V)		
RLY606	00D 963 0146 704	Relay (RSB6S DC6V)		
RLY607	00D 963 0146 704	Relay (RSB6S DC6V)		
RLY608	00D 963 0146 704	Relay (RSB6S DC6V)		
XTAL1000	00D 963 0131 405	Crystal 14.318180MHZ		
XTAL1150	00D 963 0145 404	Crystal 3.579545MHZ		
XTAL1151	00D 963 0145 501	Resonator CSB503F2		
-	00D 963 0101 707	Input cushion	1	
-	00D 963 0094 102	PLATE INPUT	1	
-	00D 963 0146 209	4P pin jack	2	
-	00D 960 0268 803	6P pin jack	1	
-	00D 963 0146 102	2P pin jack	2	
-	00D 963 0146 209	4P pin jack	1	
-	00D 963 0146 500	3P pin jack	1	
-	00D 963 0146 306	6P pin jack	2	
-	00D 963 0146 209	4P pin jack	2	
-	00D 963 0158 200	Mini jack	1	*

DSP P.W.B. UNIT

	Ref. No.	Part No.	Part Name	Remarks	New
SEMICONDUCTORS GROUP					
	IC801	00D 963 0113 106	IC GP1FA513RZ		
	IC802	00D 963 0113 106	IC GP1FA513RZ		
	IC803	00D 963 0113 106	IC GP1FA513RZ		
	IC804	00D 963 0147 402	IC ADSP-21266		
	IC805	00D 963 0146 908	IC LH28F800BJE		
	IC806	00D 963 0158 705	IC CY7C1049CV33		*
	IC807	00D 963 0096 100	IC LC89057W		
	IC808	00D 963 0158 802	IC AD1837AAS		*
	IC809	00D 960 0266 805	IC MM74LCX244		
	IC810	00D 960 0266 805	IC MM74LCX244		
	IC811	00D 960 0266 805	IC MM74LCX244		
	IC812	00D 960 0266 902	IC MM74HCT244		
	IC814	00D 963 0102 308	IC MM74HC00MTCX		
	IC815	00D 963 0102 308	IC MM74HC00MTCX		
	IC815A	00D 963 0043 807	IC BA4510F		
	IC816	00D 963 0147 208	IC 74LVX157		
	IC816A	00D 963 0043 807	IC BA4510F		
	IC817	00D 963 0158 705	IC CY7C1049CV33		*
	IC817A	00D 963 0024 004	IC NJM2068M		
	IC818	00D 963 0147 305	IC 74LCX573		
	IC818A	00D 963 0024 004	IC NJM2068M		
	IC819	00D 963 0147 305	IC 74LCX573		
	IC819A	00D 963 0024 004	IC NJM2068M		
	IC820	00D 963 0147 101	IC SN74LVC139A		
	IC820A	00D 963 0024 004	IC NJM2068M		
	IC821	00D 963 0096 003	IC 74LCX74MTC		
	IC822	00D 960 0159 501	IC KIA7805API		
	IC823	00D 963 0111 603	IC RC1117-3.3		
	IC824	00D 963 0147 509	IC RC1117-1.2		
	IC825	00D 963 0096 003	IC 74LCX74MTC		
	IC826	00D 963 0113 009	IC GP1FA513TZ		
	Q804C	00D 960 0196 603	Transistor KTC2874B		
	Q804FL	00D 960 0196 603	Transistor KTC2874B		
	Q804FR	00D 960 0196 603	Transistor KTC2874B		
	Q804SBL	00D 960 0196 603	Transistor KTC2874B		
	Q804SBR	00D 960 0196 603	Transistor KTC2874B		
	Q804SL	00D 960 0196 603	Transistor KTC2874B		
	Q804SR	00D 960 0196 603	Transistor KTC2874B		
	Q804SW	00D 960 0196 603	Transistor KTC2874B		
	Q808	00D 963 0120 801	Transistor KRC102S		
	Q809	00D 963 0120 704	Transistor KRA102S		
	D801	00D 960 0197 000	Diode KDS160		
	D803	00D 960 0197 000	Diode KDS160		
CAPACITORS GROUP					
	C801	00D 963 9004 708	Ceramic chip 0.1uF/50V		
	C802	00D 963 9004 591	Ceramic chip 22pF/50V		
	C803	00D 963 9004 591	Ceramic chip 22pF/50V		
	C804	00D 963 9004 591	Ceramic chip 22pF/50V		
	C805	00D 963 9004 591	Ceramic chip 22pF/50V		
	C806	00D 963 9004 708	Ceramic chip 0.1uF/50V		

Ref. No.	Part No.	Part Name	Remarks	New
C807	00D 963 9004 708	Ceramic chip 0.1uF/50V		
C808	00D 963 9005 862	Electrolytic 47uF/16V		
C809	00D 963 9004 708	Ceramic chip 0.1uF/50V		
C810	00D 963 9005 862	Electrolytic 47uF/16V		
C811	00D 963 9004 591	Ceramic chip 22pF/50V		
C812	00D 963 9005 927	Electrolytic 0.1uF/50V		
C813	00D 963 9004 698	Ceramic chip 0.01uF/50V		
C814	00D 963 9005 862	Electrolytic 47uF/16V		
C815	00D 963 9005 312	Electrolytic 100uF/10V		
C817	00D 963 9005 778	Electrolytic 10uF/50V		
C818	00D 963 9005 749	Electrolytic 1uF/50V		
C819	00D 963 9005 901	Electrolytic 470uF/10V		
C820	00D 963 9005 862	Electrolytic 47uF/16V		
C821	00D 963 9005 901	Electrolytic 470uF/10V		
C830	00D 963 9005 901	Electrolytic 470uF/10V		
C831	00D 963 9004 708	Ceramic chip 0.1uF/50V		
C832	00D 963 9004 708	Ceramic chip 0.1uF/50V		
C833	00D 963 9004 698	Ceramic chip 0.01uF/50V		
C835	00D 963 9004 708	Ceramic chip 0.1uF/50V		
C836	00D 963 9004 685	Ceramic chip 1000pF/50V		
C837	00D 963 9004 685	Ceramic chip 1000pF/50V		
C838	00D 963 9004 708	Ceramic chip 0.1uF/50V		
C839	00D 963 9004 708	Ceramic chip 0.1uF/50V		
C840	00D 963 9004 708	Ceramic chip 0.1uF/50V		
C841	00D 963 9004 708	Ceramic chip 0.1uF/50V		
C842	00D 963 9004 591	Ceramic chip 22pF/50V		
C843	00D 963 9004 698	Ceramic chip 0.01uF/50V		
C844	00D 963 9004 708	Ceramic chip 0.1uF/50V		
C845	00D 963 9004 708	Ceramic chip 0.1uF/50V		
C846	00D 963 9004 708	Ceramic chip 0.1uF/50V		
C847	00D 963 9004 591	Ceramic chip 22pF/50V		
C858	00D 960 9009 856	Ceramic chip 0.022uF/50V		
C861	00D 963 9005 998	Ceramic chip 24pF/50V		
C862	00D 963 9005 998	Ceramic chip 24pF/50V		
C863	00D 963 9004 698	Ceramic chip 0.01uF/50V		
C864L	00D 963 9005 862	Electrolytic 47uF/16V		
C864R	00D 963 9005 862	Electrolytic 47uF/16V		
C865L	00D 963 9005 723	Ceramic chip 120pF/50V		
C865R	00D 963 9005 723	Ceramic chip 120pF/50V		
C866	00D 963 9004 698	Ceramic chip 0.01uF/50V		
C867	00D 963 9004 698	Ceramic chip 0.01uF/50V		
C868	00D 963 9004 698	Ceramic chip 0.01uF/50V		
C869L	00D 963 9004 575	Ceramic chip 100pF/50V		
C869R	00D 963 9004 575	Ceramic chip 100pF/50V		
C871L	00D 963 9009 500	Mylar film 0.001uF/100V		
C871R	00D 963 9009 500	Mylar film 0.001uF/100V		
C873	00D 963 9006 340	Electrolytic 100uF/25V		
C873C	00D 963 9004 672	Ceramic chip 680pF/50V		
C873FL	00D 963 9004 672	Ceramic chip 680pF/50V		
C873FR	00D 963 9004 672	Ceramic chip 680pF/50V		
C873SBL	00D 963 9004 672	Ceramic chip 680pF/50V		
C873SBR	00D 963 9004 672	Ceramic chip 680pF/50V		
C873SL	00D 963 9004 672	Ceramic chip 680pF/50V		
C873SR	00D 963 9004 672	Ceramic chip 680pF/50V		
C873SW	00D 963 9004 672	Ceramic chip 680pF/50V		
C874	00D 963 9006 340	Electrolytic 100uF/25V		
C874C	00D 963 9006 146	Ceramic chip 560pF/50V		
C874FL	00D 963 9006 146	Ceramic chip 560pF/50V		
C874FR	00D 963 9006 146	Ceramic chip 560pF/50V		
C874SBL	00D 963 9006 146	Ceramic chip 560pF/50V		
C874SBR	00D 963 9006 146	Ceramic chip 560pF/50V		

	Ref. No.	Part No.	Part Name	Remarks	New
	C874SL	00D 963 9006 146	Ceramic chip 560pF/50V		
	C874SR	00D 963 9006 146	Ceramic chip 560pF/50V		
	C874SW	00D 963 9006 146	Ceramic chip 560pF/50V		
	C875C	00D 963 9005 778	Electrolytic 10uF/50V		
	C875FL	00D 963 9005 778	Electrolytic 10uF/50V		
	C875FR	00D 963 9005 778	Electrolytic 10uF/50V		
	C875SBL	00D 963 9005 778	Electrolytic 10uF/50V		
	C875SBR	00D 963 9005 778	Electrolytic 10uF/50V		
	C875SL	00D 963 9005 778	Electrolytic 10uF/50V		
	C875SR	00D 963 9005 778	Electrolytic 10uF/50V		
	C875SW	00D 963 9005 778	Electrolytic 10uF/50V		
	C876C	00D 960 9008 611	Mylar film 0.0033uF/100V		
	C876FL	00D 960 9008 611	Mylar film 0.0033uF/100V		
	C876FR	00D 960 9008 611	Mylar film 0.0033uF/100V		
	C876SBL	00D 960 9008 611	Mylar film 0.0033uF/100V		
	C876SBR	00D 960 9008 611	Mylar film 0.0033uF/100V		
	C876SL	00D 960 9008 611	Mylar film 0.0033uF/100V		
	C876SR	00D 960 9008 611	Mylar film 0.0033uF/100V		
	C876SW	00D 960 9008 611	Mylar film 0.0033uF/100V		
	C880C	00D 963 9005 778	Electrolytic 10uF/50V		
	C889	00D 963 9004 698	Ceramic chip 0.01uF/50V		
	C890	00D 963 9004 698	Ceramic chip 0.01uF/50V		
	C891	00D 963 9004 698	Ceramic chip 0.01uF/50V		
	C893	00D 963 9005 749	Electrolytic 1uF/50V		
	C894	00D 963 9004 698	Ceramic chip 0.01uF/50V		
	C896	00D 963 9005 927	Electrolytic 0.1uF/50V		
	C902	00D 963 9005 901	Electrolytic 470uF/10V		
	C907	00D 963 9005 312	Electrolytic 100uF/10V		
	C912	00D 963 9004 698	Ceramic chip 0.01uF/50V		
	C913	00D 963 9004 698	Ceramic chip 0.01uF/50V		
	C920	00D 963 9004 902	Ceramic chip 18pF/50V		
OTHER PARTS GROUP					
	CB801	00D 963 0050 502	Chip emifil		
	CB802	00D 963 0050 502	Chip emifil		
	CB803	00D 963 0050 502	Chip emifil		
	CB804	00D 963 0050 502	Chip emifil		
	CB805	00D 963 0050 502	Chip emifil		
	CB806	00D 963 0050 502	Chip emifil		
	CB808	00D 963 0050 502	Chip emifil		
	CB810	00D 963 0050 502	Chip emifil		
	CN801	00D 963 0086 301	18P connector socket (TUC-P)		
	CN802	00D 963 0086 204	19P connector socket (TUC-P)		
	CN803	00D 960 0239 900	13P connector socket (TUC-P)		
	JACK801	00D 963 0052 500	1P pin jack		
	L801	00D 963 0050 803	Inductor 4.7uH		
	L802	00D 963 0050 803	Inductor 4.7uH		
	L803	00D 963 0050 803	Inductor 4.7uH		
	L804	00D 963 0050 803	Inductor 4.7uH		
	L805	00D 963 0050 900	Inductor 2.2uH		
	R831	00D 963 0120 908	Beads inductor		
	R832	00D 963 0120 908	Beads inductor		
	R833	00D 963 0120 908	Beads inductor		

	Ref. No.	Part No.	Part Name	Remarks	New
	XTAL1	00D 963 0095 101	Crystal 12.288MHz		
	XTAL2	00D 963 0158 103	Crystal 18.75MHZ		*

PARTS LIST OF P.W.B. UNIT ASS'Y (FOR U.K.)

MAIN P.W.B. UNIT

	Ref. No.	Part No.	Part Name	Remarks	New
SEMICONDUCTORS GROUP					
	IC101	00D 963 0110 507	IC MC7815CT		
	IC102	00D 960 0179 905	IC KIA7915		
	IC103	00D 960 0159 501	IC KIA7805API		
	IC104	00D 963 0110 604	IC MC7805CT		
	IC105	00D 960 0195 808	IC protector ICP-N15		
	IC106	00D 960 0195 808	IC protector ICP-N15		
	Q104C	00D 960 0196 506	Transistor KSC1845F		
	Q104FL	00D 960 0196 506	Transistor KSC1845F		
	Q104FR	00D 960 0196 506	Transistor KSC1845F		
	Q104SL	00D 960 0196 506	Transistor KSC1845F		
	Q104SR	00D 960 0196 506	Transistor KSC1845F		
	Q111	00D 963 0121 208	Transistor KRC107M		
	Q112	00D 960 0097 508	Transistor KRC111M		
	Q113	00D 963 0121 208	Transistor KRC107M		
	Q114	00D 963 0121 208	Transistor KRC107M		
	Q115	00D 963 0121 208	Transistor KRC107M		
	Q116	00D 960 0196 409	Transistor 2SC1740SR		
	Q117	00D 963 0121 208	Transistor KRC107M		
	Q118	00D 963 0121 208	Transistor KRC107M		
	Q151	00D 960 0196 409	Transistor 2SC1740SR		
	Q171	00D 960 0005 202	Transistor KTC3198Y		
	Q171A	00D 960 0196 302	Transistor KTA1268BL		
	Q171B	00D 960 0196 302	Transistor KTA1268BL		
	Q171C	00D 960 0196 302	Transistor KTA1268BL		
	Q171D	00D 960 0196 302	Transistor KTA1268BL		
	Q172	00D 960 0005 202	Transistor KTC3198Y		
	Q173	00D 960 0005 202	Transistor KTC3198Y		
	Q174	00D 960 0005 202	Transistor KTC3198Y		
	Q175	00D 960 0005 202	Transistor KTC3198Y		
	Q176	00D 960 0005 202	Transistor KTC3198Y		
	Q177	00D 960 0005 202	Transistor KTC3198Y		
	Q178	00D 960 0005 105	Transistor KTA1266Y		
	Q179	00D 960 0189 005	Transistor KSA916Y		
	Q180	00D 960 0196 302	Transistor KTA1268BL		
	Q181	00D 960 0196 302	Transistor KTA1268BL		
	Q182	00D 960 0005 202	Transistor KTC3198Y		
	Q183	00D 960 0005 202	Transistor KTC3198Y		
	D101	00D 963 0020 309	Diode 1SS133T		
	D102	00D 963 0020 309	Diode 1SS133T		
	D103	00D 963 0020 309	Diode 1SS133T		
	D104	00D 963 0020 309	Diode 1SS133T		
	D105	00D 963 0020 309	Diode 1SS133T		
	D121	00D 963 0020 309	Diode 1SS133T		
	D122	00D 963 0020 309	Diode 1SS133T		
	D123	00D 963 0020 309	Diode 1SS133T		
	D124	00D 963 0020 309	Diode 1SS133T		
	D125	00D 963 0020 309	Diode 1SS133T		
	D126	00D 963 0020 309	Diode 1SS133T		
	D127	00D 963 0020 309	Diode 1SS133T		
	D131A	00D 960 0197 107	Diode KBPC604		
	D131B	00D 960 0197 107	Diode KBPC604		
	D132	00D 963 0020 309	Diode 1SS133T		
	D133	00D 963 0046 202	Zener diode MTZJ18B		

	Ref. No.	Part No.	Part Name	Remarks	New
	D134	00D 963 0046 202	Zener diode MTZJ18B		
	D135	00D 963 0020 309	Diode 1SS133T		
	D136	00D 963 0058 504	Zener diode MTZJ11B		
	D137	00D 963 0020 309	Diode 1SS133T		
	D138A	00D 963 0058 407	Diode IN4007		
	D141	00D 963 0058 407	Diode IN4007		
	D142	00D 963 0058 407	Diode IN4007		
	D143	00D 963 0058 407	Diode IN4007		
	D144	00D 963 0058 407	Diode IN4007		
	D145	00D 963 0058 407	Diode IN4007		
	D146	00D 963 0058 407	Diode IN4007		
	D149	00D 963 0058 407	Diode IN4007		
	D150	00D 963 0058 407	Diode IN4007		
	D152	00D 963 0058 407	Diode IN4007		
	D153	00D 963 0058 407	Diode IN4007		
	D154	00D 960 0095 908	Zener diode MTZJ8.2B		
	D157	00D 960 0014 905	Zener diode MTZJ20B		
	ZD310	00D 960 0095 500	Zener diode MTZJ5.1B		
	ZD311	00D 960 0095 500	Zener diode MTZJ5.1B		
	LED901	00D 963 0148 605	LED SML1216W 5PI R/G		
RESISTORS GROUP					
	R104C	00D 963 9006 285	Metal oxide 5.6 kohm 1W		
	R104FL	00D 963 9006 285	Metal oxide 5.6 kohm 1W		
	R104FR	00D 963 9006 285	Metal oxide 5.6 kohm 1W		
	R104SL	00D 963 9006 285	Metal oxide 5.6 kohm 1W		
	R104SR	00D 963 9006 285	Metal oxide 5.6 kohm 1W		
	R105C	00D 963 9006 285	Metal oxide 5.6 kohm 1W		
	R105FL	00D 963 9006 285	Metal oxide 5.6 kohm 1W		
	R105FR	00D 963 9006 285	Metal oxide 5.6 kohm 1W		
	R105SL	00D 963 9006 285	Metal oxide 5.6 kohm 1W		
	R105SR	00D 963 9006 285	Metal oxide 5.6 kohm 1W		
	R106C	00D 963 0047 900	Metal film 4.7 kohm 1W		
	R106FL	00D 963 0047 900	Metal film 4.7 kohm 1W		
	R106FR	00D 963 0047 900	Metal film 4.7 kohm 1W		
	R106SL	00D 963 0047 900	Metal film 4.7 kohm 1W		
	R106SR	00D 963 0047 900	Metal film 4.7 kohm 1W		
	R107C	00D 963 0047 900	Metal film 4.7 kohm 1W		
	R107FL	00D 963 0047 900	Metal film 4.7 kohm 1W		
	R107FR	00D 963 0047 900	Metal film 4.7 kohm 1W		
	R107SL	00D 963 0047 900	Metal film 4.7 kohm 1W		
	R107SR	00D 963 0047 900	Metal film 4.7 kohm 1W		
	R108C	00D 963 9006 269	Metal oxide 0.22 ohm 1W		
	R108FL	00D 963 9006 269	Metal oxide 0.22 ohm 1W		
	R108FR	00D 963 9006 269	Metal oxide 0.22 ohm 1W		
	R108SL	00D 963 9006 269	Metal oxide 0.22 ohm 1W		
	R108SR	00D 963 9006 269	Metal oxide 0.22 ohm 1W		
	R109C	00D 963 9006 269	Metal oxide 0.22 ohm 1W		
	R109FL	00D 963 9006 269	Metal oxide 0.22 ohm 1W		
	R109FR	00D 963 9006 269	Metal oxide 0.22 ohm 1W		
	R109SL	00D 963 9006 269	Metal oxide 0.22 ohm 1W		
	R109SR	00D 963 9006 269	Metal oxide 0.22 ohm 1W		
	R110C	00D 963 9006 269	Metal oxide 0.22 ohm 1W		
	R110FL	00D 963 9006 269	Metal oxide 0.22 ohm 1W		
	R118C	00D 963 9006 256	Metal oxide 10 ohm 1W		
	R118FL	00D 963 9006 256	Metal oxide 10 ohm 1W		

Ref. No.	Part No.	Part Name	Remarks	New
R118FR	00D 963 9006 256	Metal oxide 10 ohm 1W		
R118SL	00D 963 9006 256	Metal oxide 10 ohm 1W		
R118SR	00D 963 9006 256	Metal oxide 10 ohm 1W		
R119C	00D 963 9006 256	Metal oxide 10 ohm 1W		
R119FL	00D 963 9006 256	Metal oxide 10 ohm 1W		
R119FR	00D 963 9006 256	Metal oxide 10 ohm 1W		
R119SL	00D 963 9006 256	Metal oxide 10 ohm 1W		
R119SR	00D 963 9006 256	Metal oxide 10 ohm 1W		
R135	00D 963 0144 502	Cement resistor 0.1 ohm 5W		
R136	00D 963 0144 502	Cement resistor 0.1 ohm 5W		
R141	00D 960 0180 606	Metal oxide 0.22 ohm 1W		
R142	00D 960 0180 606	Metal oxide 0.22 ohm 1W		
R148	00D 960 0180 606	Metal oxide 0.22 ohm 1W		
R149	00D 960 0180 606	Metal oxide 0.22 ohm 1W		
R151	00D 963 9003 343	Metal film 68ohm 1/4W		
R179	00D 963 9003 055	Metal film 47 kohm 1/4W (NB)		
R181	00D 963 0047 900	Metal film 4.7 kohm 1W		
R184	00D 963 9006 256	Metal oxide 10 ohm 1W		
R903H	00D 960 9009 270	Metal film 470ohm 2W		
R904H	00D 960 9009 270	Metal film 470ohm 2W		
VR101	00D 960 0091 601	Semi fixed resistor 1 kohm		
VR102	00D 960 0091 601	Semi fixed resistor 1 kohm		
VR103	00D 960 0091 601	Semi fixed resistor 1 kohm		
VR104	00D 960 0091 601	Semi fixed resistor 1 kohm		
VR105	00D 960 0091 601	Semi fixed resistor 1 kohm		
CAPACITORS GROUP				
C101C	00D 963 9006 450	Electrolytic 47uF/50V		
C101FL	00D 963 9006 450	Electrolytic 47uF/50V		
C101FR	00D 963 9006 450	Electrolytic 47uF/50V		
C101SL	00D 963 9006 450	Electrolytic 47uF/50V		
C101SR	00D 963 9006 450	Electrolytic 47uF/50V		
C102C	00D 963 9006 308	Electrolytic 10uF/50V		
C102FL	00D 963 9006 308	Electrolytic 10uF/50V		
C102FR	00D 963 9006 308	Electrolytic 10uF/50V		
C102SL	00D 963 9006 308	Electrolytic 10uF/50V		
C102SR	00D 963 9006 308	Electrolytic 10uF/50V		
C103C	00D 963 9003 084	Ceramic 100pF/500V		
C103FL	00D 963 9003 084	Ceramic 100pF/500V		
C103FR	00D 963 9003 084	Ceramic 100pF/500V		
C103SL	00D 963 9003 084	Ceramic 100pF/500V		
C103SR	00D 963 9003 084	Ceramic 100pF/500V		
C104C	00D 963 9003 084	Ceramic 100pF/500V		
C104FL	00D 963 9003 084	Ceramic 100pF/500V		
C104FR	00D 963 9003 084	Ceramic 100pF/500V		
C104SL	00D 963 9003 084	Ceramic 100pF/500V		
C104SR	00D 963 9003 084	Ceramic 100pF/500V		
C105C	00D 963 9008 640	Mylar film 0.022uF/100V		
C105FL	00D 963 9008 640	Mylar film 0.022uF/100V		
C105FR	00D 963 9008 640	Mylar film 0.022uF/100V		
C105SL	00D 963 9008 640	Mylar film 0.022uF/100V		
C105SR	00D 963 9008 640	Mylar film 0.022uF/100V		
C107C	00D 963 9003 097	Mylar film 0.1uF/250V		
C107FL	00D 963 9003 097	Mylar film 0.1uF/250V		
C107FR	00D 963 9003 097	Mylar film 0.1uF/250V		
C107SL	00D 963 9003 097	Mylar film 0.1uF/250V		
C107SR	00D 963 9003 097	Mylar film 0.1uF/250V		

	Ref. No.	Part No.	Part Name	Remarks	New
	C131	00D 963 9003 097	Mylar film 0.1uF/250V		
	C132	00D 963 9003 097	Mylar film 0.1uF/250V		
	C133	00D 963 9003 097	Mylar film 0.1uF/250V		
	C134	00D 963 9003 097	Mylar film 0.1uF/250V		
	C135	00D 963 9003 097	Mylar film 0.1uF/250V		
	C136	00D 963 0157 803	Electrolytic 12000uF/63V		*
	C137	00D 963 0157 803	Electrolytic 12000uF/63V		*
	C138	00D 963 9006 379	Electrolytic 1uF/50V		
	C138A	00D 963 9003 097	Mylar film 0.1uF/250V		
	C141	00D 963 0021 900	Mylar film 0.047uF/100V		
	C142	00D 963 0021 900	Mylar film 0.047uF/100V		
	C143	00D 963 0021 900	Mylar film 0.047uF/100V		
	C144	00D 960 9007 201	Electrolytic 3300uF/35V		
	C145	00D 963 9003 123	Electrolytic 1000uF/35V		
	C146	00D 963 9006 379	Electrolytic 1uF/50V		
	C148	00D 963 9006 379	Electrolytic 1uF/50V		
	C150	00D 963 0021 900	Mylar film 0.047uF/100V		
	C151	00D 963 0021 900	Mylar film 0.047uF/100V		
	C152	00D 963 0021 900	Mylar film 0.047uF/100V		
	C153	00D 963 0021 104	Electrolytic 6800uF/16V		
	C154	00D 963 9006 308	Electrolytic 10uF/50V		
	C155	00D 963 0020 202	Ceramic 0.1uF/50V		
	C157	00D 963 9006 379	Electrolytic 1uF/50V		
	C158	00D 963 9003 136	Electrolytic 1000uF/25V		
	C159	00D 963 9006 379	Electrolytic 1uF/50V		
	C161	00D 963 9006 308	Electrolytic 10uF/50V		
	C171	00D 963 9005 312	Electrolytic 100uF/10V		
	C171A	00D 963 0020 202	Ceramic 0.1uF/50V		
	C171B	00D 963 0020 202	Ceramic 0.1uF/50V		
	C171C	00D 963 0020 202	Ceramic 0.1uF/50V		
	C171D	00D 963 0020 202	Ceramic 0.1uF/50V		
	C172	00D 963 9005 833	Electrolytic 220uF/6.3V		
	C173	00D 963 9005 833	Electrolytic 220uF/6.3V		
	C174	00D 963 9006 308	Electrolytic 10uF/50V		
	C175	00D 963 0149 507	Electrolytic 220uF/16V		
	C176	00D 963 9006 379	Electrolytic 1uF/50V		
	C177	00D 963 9006 379	Electrolytic 1uF/50V		
	C178	00D 963 0157 900	Electrolytic 470uF/63V		*
	C179	00D 963 9005 833	Electrolytic 220uF/6.3V		
⚠	C181	00D 963 9006 191	Ceramic 4700pF/250V(AC)		
	C182	00D 963 9006 311	Electrolytic 10uF/100V		
	C191	00D 963 9006 007	Ceramic 2200pF/16V		
	C192	00D 963 9006 007	Ceramic 2200pF/16V		
	C193	00D 963 9006 007	Ceramic 2200pF/16V		
	C194	00D 963 9006 007	Ceramic 2200pF/16V		
	C195	00D 963 9006 007	Ceramic 2200pF/16V		
	C196	00D 963 9006 007	Ceramic 2200pF/16V		
	C197	00D 963 9006 007	Ceramic 2200pF/16V		
	C198	00D 963 9006 007	Ceramic 2200pF/16V		
	C198C	00D 963 0024 703	Mylar film 0.01uF/100V		
	C198FL	00D 963 0024 703	Mylar film 0.01uF/100V		
	C198FR	00D 963 0024 703	Mylar film 0.01uF/100V		
	C198SBL	00D 963 0024 703	Mylar film 0.01uF/100V		
	C198SBR	00D 963 0024 703	Mylar film 0.01uF/100V		
	C198SL	00D 963 0024 703	Mylar film 0.01uF/100V		
	C198SR	00D 963 0024 703	Mylar film 0.01uF/100V		
	C199	00D 963 9006 007	Ceramic 2200pF/16V		
	C199FL	00D 963 0024 703	Mylar film 0.01uF/100V		
	C199FR	00D 963 0024 703	Mylar film 0.01uF/100V		
	C331	00D 963 9004 546	Ceramic 0.01uF/16V		
	C332	00D 963 9004 546	Ceramic 0.01uF/16V		

	Ref. No.	Part No.	Part Name	Remarks	New
	C901H	00D 963 9004 533	Ceramic 0.001uF/50V		
	C902H	00D 963 9004 533	Ceramic 0.001uF/50V		
	C903H	00D 963 0020 202	Ceramic 0.1uF/50V		
	C904H	00D 960 9003 108	Ceramic 0.022uF/25V		
	C905H	00D 963 0020 202	Ceramic 0.1uF/50V		
	C906H	00D 963 9004 546	Ceramic 0.01uF/16V		
	C907H	00D 960 9006 202	Ceramic 0.01uF/50V		
OTHER PARTS GROUP					
	CB903	00D 963 0154 602	Beads inductor		*
	CB904	00D 963 0154 602	Beads inductor		*
	CN901	00D 963 0160 201	3P connector cord		*
	CN931A	00D 963 0148 809	2P connector cord		
	CN992	00D 963 0160 007	4P connector cord		*
⚠	CP101	00D 960 0118 908	AC cord connector base		
	CP102	00D 960 0123 304	2P connector base		
	CP103	00D 960 0128 901	3P connector base		
	CP104	00D 960 0128 804	6P connector base		
	CP106	00D 960 0123 207	3P connector base		
	CP1151	00D 963 0097 507	15P connector base (TUC-P)		
	CP1153	00D 963 0097 507	15P connector base (TUC-P)		
	CP138A	00D 960 0123 207	3P connector base		
	CP3911	00D 963 0160 900	8P connector base		*
	CP392	00D 963 0048 909	3P connector base		
	CP501	00D 963 0086 806	9P connector base (TUC-P)		
	CP502	00D 963 0085 807	7P connector base (TUC-P)		
	CP503	00D 963 0085 807	7P connector base (TUC-P)		
	CP504	00D 963 0086 903	5P connector base (TUC-P)		
	CP505	00D 963 0087 708	12P connector base (TUC-P)		
	CP555	00D 963 0111 108	14P connector base (TUC-P)		
	CP556	00D 963 0087 805	11P connector base (TUC-P)		
	CP901	00D 963 0048 909	3P connector base		
	CP931	00D 963 0149 206	2P connector base(BLUE)		
⚠	F102	00D 963 0104 801	Fuse 3.15A		
	F102A	00D 960 0005 804	Fuse clip		
	F102B	00D 960 0005 804	Fuse clip		
	G901	-	1P contact Ass'y		
	GND101	00D 960 9006 600	Terminal		
	GND102	00D 960 9006 600	Terminal		
	GND103	00D 960 9006 600	Terminal		
	JK901	00D 963 0095 402	Head phone jack		
	L101C	00D 963 0049 005	Inductor 0.5uH		
	L101FL	00D 963 0049 005	Inductor 0.5uH		
	L101FR	00D 963 0049 005	Inductor 0.5uH		
	L101SL	00D 963 0049 005	Inductor 0.5uH		
	L101SR	00D 963 0049 005	Inductor 0.5uH		
	RLY101	00D 960 0181 702	Relay (G5PA-28 24V)		
	RLY102	00D 960 0181 702	Relay (G5PA-28 24V)		
	RLY103	00D 960 0181 702	Relay (G5PA-28 24V)		
	RLY104	00D 960 0181 702	Relay (G5PA-28 24V)		

	Ref. No.	Part No.	Part Name	Remarks	New
⚠	RLY105	00D 963 0071 303	Relay (RSB24S 24V)		
	RLY106	00D 960 0181 605	Relay (G5PA-1-8 12V)		
	RLY107	00D 960 0181 702	Relay (G5PA-28 24V)		
	SW391	00D 963 0045 708	Tact switch		
	SW393	00D 963 0045 708	Tact switch		
	SW901	00D 963 0045 708	Tact switch		
	SW901A	00D 963 0145 802	Push switch		
	TP101	00D 960 0161 405	3P connector base		
	TP102	00D 960 0161 405	3P connector base		
	TP103	00D 960 0161 405	3P connector base		
	TP104	00D 960 0161 405	3P connector base		
	TP105	00D 960 0161 405	3P connector base		
	VEC303	00D 963 0095 208	ENCODER SW		
	-	-	Heat sink	1	
	-	-	Heat sink	1	
⚠	-	00D 963 0068 400	Capacitor cover	1	
	-	00D 963 0120 500	Fuse label	1	
	-	00D 963 0094 937	Power trans. (Mini)	1	
	-	00D 963 0018 007	Screw (2S 3X8 ZNY/BH)	3	
	-	00D 963 0158 608	2P speaker terminal	1	*
	-	00D 963 0119 906	8P speaker terminal	2	

CPU, FRONT P.W.B. UNIT

Ref. No.	Part No.	Part Name	Remarks	New
SEMICONDUCTORS GROUP				
IC201	00D 963 0161 705	IC CXP740010		
IC202	00D 963 0057 602	IC TDA7330BD		
IC203	00D 960 0100 301	IC KIA7812		
IC204	00D 963 0114 600	IC MC7806CT		
IC301	00D 960 0180 004	IC LC75721E		
IC302	00D 963 0074 504	IC BU2090F		
IC803	00D 963 0113 106	IC GP1FA513RZ		
RMC301	00D 960 0181 100	IC NJL64H380A		
Q201	00D 960 0285 006	Transistor KRC104S		
Q202	00D 963 0121 509	Transistor KTC3875S		
Q203	00D 963 0121 402	Transistor KRA104S		
Q204	00D 963 0121 606	Transistor KRC107S		
Q205	00D 960 0196 603	Transistor KTC2874B		
Q206	00D 960 0196 603	Transistor KTC2874B		
Q207	00D 960 0196 603	Transistor KTC2874B		
Q208	00D 960 0196 603	Transistor KTC2874B		
Q216	00D 960 0097 207	Transistor KRA102M		
Q217	00D 963 0102 803	Transistor 2SA933S		
Q218	00D 963 0102 803	Transistor 2SA933S		
Q219	00D 963 0102 803	Transistor 2SA933S		
Q220	00D 963 0121 208	Transistor KRC107M		
Q221	00D 960 0097 207	Transistor KRA102M		
Q222	00D 960 0097 207	Transistor KRA102M		
Q300	00D 963 0121 402	Transistor KRA104S		
Q301	00D 963 0121 402	Transistor KRA104S		
Q302	00D 960 0285 006	Transistor KRC104S		
Q303	00D 960 0285 006	Transistor KRC104S		
Q304	00D 960 0285 006	Transistor KRC104S		
Q305	00D 963 0121 402	Transistor KRA104S		
Q306	00D 963 0120 704	Transistor KRA102S		
Q307	00D 963 0121 606	Transistor KRC107S		
Q308	00D 963 0120 704	Transistor KRA102S		
D201	00D 963 0020 309	Diode 1SS133T		
D202	00D 963 0058 407	Diode IN4007		
D204	00D 963 0020 309	Diode 1SS133T		
D206	00D 960 0197 000	Diode KDS160		
D209	00D 960 0197 000	Diode KDS160		
D213	00D 963 0020 309	Diode 1SS133T		
D302	00D 963 0020 309	Diode 1SS133T		
D303	00D 963 0020 309	Diode 1SS133T		
D304	00D 963 0020 309	Diode 1SS133T		
D305	00D 960 0197 000	Diode KDS160		
D306	00D 960 0197 000	Diode KDS160		
D307	00D 960 0197 000	Diode KDS160		
ZD201	00D 963 0047 502	Zener diode MTZJ3.3B		
ZD301	00D 960 0095 801	Zener diode MTZJ6.8B		
ZD302	00D 960 0095 500	Zener diode MTZJ5.1B		
ZD303	00D 960 0095 500	Zener diode MTZJ5.1B		
ZD304	00D 960 0095 500	Zener diode MTZJ5.1B		
ZD305	00D 960 0095 500	Zener diode MTZJ5.1B		
LED301	00D 960 0197 204	LED PI5-RD/HL50RDRF4T		

	Ref. No.	Part No.	Part Name	Remarks	New
	LED302	00D 960 0197 204	LED P15-RD/HL50RDRF4T		
	LED305	00D 960 0197 204	LED P15-RD/HL50RDRF4T		
	LED306	00D 960 0197 204	LED P15-RD/HL50RDRF4T		
	LED307	00D 960 0197 204	LED P15-RD/HL50RDRF4T		
	LED308	00D 960 0197 204	LED P15-RD/HL50RDRF4T		
	LED309	00D 960 0197 204	LED P15-RD/HL50RDRF4T		
	LED310	00D 960 0197 204	LED P15-RD/HL50RDRF4T		
CAPACITORS GROUP					
	BC201	00D 963 0061 504	Electrolytic 8200uF/5.5V		
	C201D	00D 960 9010 816	Ceramic 0.1uF/50V		
	C201E	00D 963 9004 517	Ceramic 0.022uF/50V		
	C201F	00D 963 9004 546	Ceramic 0.01uF/16V		
	C202	00D 963 9004 698	Ceramic chip 0.01uF/50V		
	C202D	00D 963 9004 546	Ceramic 0.01uF/16V		
	C202E	00D 963 9004 517	Ceramic 0.022uF/50V		
	C202F	00D 963 9004 546	Ceramic 0.01uF/16V		
	C203	00D 963 9004 698	Ceramic chip 0.01uF/50V		
	C204	00D 963 9006 476	Electrolytic 4.7uF/50V		
	C205	00D 963 9004 562	Ceramic 0.047uF/50V		
	C206	00D 963 9006 421	Electrolytic 47uF/10V		
	C207	00D 963 9004 546	Ceramic 0.01uF/16V		
	C208	00D 963 9004 805	Ceramic 270pF/50V		
	C209	00D 963 9006 308	Electrolytic 10uF/50V		
	C210	00D 963 9004 698	Ceramic chip 0.01uF/50V		
	C211	00D 963 9004 614	Ceramic chip 27pF/50V		
	C212	00D 963 9004 614	Ceramic chip 27pF/50V		
	C221	00D 963 9005 312	Electrolytic 100uF/10V		
	C228	00D 963 9004 575	Ceramic chip 100pF/50V		
	C230	00D 963 9004 575	Ceramic chip 100pF/50V		
	C231	00D 963 9004 575	Ceramic chip 100pF/50V		
	C232	00D 963 9004 575	Ceramic chip 100pF/50V		
	C233	00D 963 9004 575	Ceramic chip 100pF/50V		
	C234	00D 963 9004 575	Ceramic chip 100pF/50V		
	C238	00D 963 9006 366	Electrolytic 0.1uF/50V		
	C239	00D 963 9006 366	Electrolytic 0.1uF/50V		
	C242	00D 963 9004 685	Ceramic chip 1000pF/50V		
	C245	00D 963 9004 575	Ceramic chip 100pF/50V		
	C248	00D 963 9004 685	Ceramic chip 1000pF/50V		
	C249	00D 963 9004 737	Ceramic chip 0.022uF/25V		
	C251	00D 963 0020 202	Ceramic 0.1uF/50V		
	C252	00D 960 9010 816	Ceramic 0.1uF/50V		
	C257	00D 963 9006 308	Electrolytic 10uF/50V		
	C262	00D 963 9006 379	Electrolytic 1uF/50V		
	C263	00D 963 9006 379	Electrolytic 1uF/50V		
	C301	00D 963 9004 546	Ceramic 0.01uF/16V		
	C3010	00D 963 9006 421	Electrolytic 47uF/10V		
	C302	00D 963 9004 546	Ceramic 0.01uF/16V		
	C3020	00D 963 0020 202	Ceramic 0.1uF/50V		
	C303	00D 963 9004 546	Ceramic 0.01uF/16V		
	C303O	00D 963 9004 591	Ceramic chip 22pF/50V		
	C304	00D 963 9004 546	Ceramic 0.01uF/16V		
	C305	00D 963 9004 685	Ceramic chip 1000pF/50V		
	C306	00D 963 9004 575	Ceramic chip 100pF/50V		
	C307	00D 963 9004 575	Ceramic chip 100pF/50V		
	C308	00D 960 9010 816	Ceramic 0.1uF/50V		
	C309	00D 963 9004 737	Ceramic chip 0.022uF/25V		
	C310	00D 963 9004 753	Ceramic chip 0.047uF/50V		
	C311	00D 963 9005 406	Ceramic chip 30pF/50V		

Ref. No.	Part No.	Part Name	Remarks	New
C312	00D 963 9004 753	Ceramic chip 0.047uF/50V		
C314	00D 963 0021 900	Mylar film 0.047uF/100V		
C315	00D 963 9006 379	Electrolytic 1uF/50V		
C316	00D 963 9006 308	Electrolytic 10uF/50V		
C317	00D963 9005 859	Electrolytic 47uF/16V		
C318	00D 963 9005 419	Mylar film 0.047uF/63V		
C319	00D 963 9006 434	Electrolytic 47uF/16V		
C320	00D 963 9006 379	Electrolytic 1uF/50V		
C321	00D 963 0021 900	Mylar film 0.047uF/100V		
C322	00D 963 9006 434	Electrolytic 47uF/16V		
C323	00D 963 9004 766	Mylar film 0.1uF/100V		
C324	00D 963 9006 476	Electrolytic 4.7uF/50V		
C325	00D 963 9004 575	Ceramic chip 100pF/50V		
C326	00D 963 9006 382	Electrolytic 22uF/25V		
C327	00D 963 9006 476	Electrolytic 4.7uF/50V		
C329	00D 963 9006 531	Electrolytic 22uF/16V		
C330	00D 963 9006 531	Electrolytic 22uF/16V		
C340	00D 963 9004 575	Ceramic chip 100pF/50V		
C341	00D 963 9004 575	Ceramic chip 100pF/50V		
C347	00D 963 9004 708	Ceramic chip 0.1uF/50V		
C348	00D 963 9004 708	Ceramic chip 0.1uF/50V		
C354	00D 963 9004 708	Ceramic chip 0.1uF/50V		
OTHER PARTS GROUP				
BD205	00D 963 0050 502	Chip emifil		
BD206	00D 963 0050 502	Chip emifil		
BD207	00D 963 0154 602	Beads inductor		*
BD208	00D 963 0154 602	Beads inductor		*
BD209	00D 963 0154 602	Beads inductor		*
BD250	00D 963 0154 602	Beads inductor		*
BD301	00D 963 0050 502	Chip emifil		
BD303	00D 963 0050 502	Chip emifil		
BD304	00D 963 0050 502	Chip emifil		
CB202	00D 963 0154 602	Beads inductor		*
CB203	00D 963 0154 602	Beads inductor		*
CB205	00D 963 0154 602	Beads inductor		*
CB207	00D 963 0154 602	Beads inductor		*
CB208	00D 963 0154 602	Beads inductor		*
CN201	00D 963 0159 801	5P SHIELD WIRE		*
CN302	00D 963 0160 502	8P connector cord		*
CN303	00D 963 0160 308	3P connector cord		*
CN605	00D 963 0159 908	3P connector cord		*
CN606	00D 963 0159 607	4P connector cord		*
CP1000	00D 963 0085 807	7P connector base (TUC-P)		
CP1001	00D 963 0111 108	14P connector base (TUC-P)		
CP1154	00D 963 0085 807	7P connector base (TUC-P)		
CP1155	00D 963 0085 807	7P connector base (TUC-P)		
CP301	00D 963 0161 103	23P FFC connector base		*
CP301A	00D 963 0161 006	23P FFC connector base		*
CP302	00D 963 0066 101	5P connector base		
CP303	00D 963 0049 102	3P connector base		
CP401	00D 963 0149 303	15P FFC connector base		
CP404	00D 963 0087 805	11P connector base (TUC-P)		
CP551	00D 963 0087 601	8P connector base (TUC-P)		
CP552	00D 963 0087 504	19P connector base (TUC-P)		

Ref. No.	Part No.	Part Name	Remarks	New
CP605	00D 963 0048 909	3P connector base		
CP606	00D 963 0050 104	4P connector base		
CP701	00D 963 0087 601	18P connector base (TUC-P)		
CP703	00D 963 0087 805	11P connector base (TUC-P)		
CP705	00D 963 0087 601	8P connector base (TUC-P)		
CP706	00D 963 0087 601	8P connector base (TUC-P)		
CP801	00D 963 0087 601	18P connector base (TUC-P)		
CP802	00D 963 0087 504	19P connector base (TUC-P)		
CP803	00D 960 0239 609	13P connector base (TUC-P)		
CP804	00D 963 0087 504	19P connector base (TUC-P)		
G903	-	1P contact Ass'y		
GND01	00D 960 9006 600	Terminal		
GND02	00D 960 9006 600	Terminal		
GP301	-	1P contact Ass'y		
GP301	-	1P contact Ass'y		
J326	00D 963 9003 372	Carbon chip 0 ohm 1/16W		
JIG601	00D 960 0123 605	13P connector base		
JP353	00D 963 9003 372	Carbon chip 0 ohm 1/16W		
L301	00D 960 0010 307	Inductor 10uH		
L3010	00D 960 0215 908	Inductor 4.7uH		
L302	00D 960 0128 008	Inductor 100uH		
SW301C	00D 963 0045 708	Tact switch		
SW302A	00D 963 0095 305	Tact switch		
SW302B	00D 963 0095 305	Tact switch		
SW302C	00D 963 0045 708	Tact switch		
SW303A	00D 963 0095 305	Tact switch		
SW303B	00D 963 0095 305	Tact switch		
SW303C	00D 963 0045 708	Tact switch		
SW304A	00D 963 0095 305	Tact switch		
SW304B	00D 963 0095 305	Tact switch		
SW304C	00D 963 0045 708	Tact switch		
SW305A	00D 963 0095 305	Tact switch		
SW305B	00D 963 0045 708	Tact switch		
SW305C	00D 963 0045 708	Tact switch		
SW306A	00D 963 0095 305	Tact switch		
SW306B	00D 963 0095 305	Tact switch		
SW306C	00D 963 0045 708	Tact switch		
SW307A	00D 963 0095 305	Tact switch		
SW307C	00D 963 0045 708	Tact switch		
SW308A	00D 963 0095 305	Tact switch		
SW308C	00D 963 0045 708	Tact switch		
SW309A	00D 963 0095 305	Tact switch		
SW309C	00D 963 0045 708	Tact switch		
VEC301	00D 963 0095 208	ENCODER SW		
VEC302	00D 963 0095 208	ENCODER SW		
X201	00D 960 0181 003	Resonator CST12.0MTW-TF01		
X202	00D 963 0099 505	Crystal 4.332MHz		
-	-	Heat sink	1	
-	00D 963 0018 007	Screw (2S 3X8 ZNY/BH)	1	
-	00D 960 0184 408	FLT holder	1	

	Ref. No.	Part No.	Part Name	Remarks	New
	-	00D 963 0109 505	FLT (16-ST-66GNK)	1	
	-	00D 963 0158 307	DIN SOCKET DIN-416G	1	*
	-	00D 963 0146 403	3P pin jack	1	

CNT,PRE-AMP P.W.B. UNIT

	Ref. No.	Part No.	Part Name	Remarks	New
SEMICONDUCTORS GROUP					
	Q101SBL	00D 963 0044 204	Transistor 2SD2390-Y		
	Q101SBR	00D 963 0044 204	Transistor 2SD2390-Y		
	Q102SBL	00D 963 0044 107	Transistor 2SB1560-Y		
	Q102SBR	00D 963 0044 107	Transistor 2SB1560-Y		
	Q103SBL	00D 963 0058 106	Transistor 2SD947F		
	Q103SBR	00D 963 0058 106	Transistor 2SD947F		
	Q104SBL	00D 960 0196 506	Transistor KSC1845F		
	Q104SBR	00D 960 0196 506	Transistor KSC1845F		
	Q501C	00D 960 0196 603	Transistor KTC2874B		
	Q501FL	00D 960 0196 603	Transistor KTC2874B		
	Q501FR	00D 960 0196 603	Transistor KTC2874B		
	Q501SBL	00D 960 0196 603	Transistor KTC2874B		
	Q501SBR	00D 960 0196 603	Transistor KTC2874B		
	Q501SL	00D 960 0196 603	Transistor KTC2874B		
	Q501SR	00D 960 0196 603	Transistor KTC2874B		
	Q502C	00D 960 0196 205	Transistor KSA992F		
	Q502FL	00D 960 0196 205	Transistor KSA992F		
	Q502FR	00D 960 0196 205	Transistor KSA992F		
	Q502SBL	00D 960 0196 205	Transistor KSA992F		
	Q502SBR	00D 960 0196 205	Transistor KSA992F		
	Q502SL	00D 960 0196 205	Transistor KSA992F		
	Q502SR	00D 960 0196 205	Transistor KSA992F		
	Q503C	00D 960 0196 205	Transistor KSA992F		
	Q503FL	00D 960 0196 205	Transistor KSA992F		
	Q503FR	00D 960 0196 205	Transistor KSA992F		
	Q503SBL	00D 960 0196 205	Transistor KSA992F		
	Q504C	00D 960 0196 506	Transistor KSC1845F		
	Q504FL	00D 960 0196 506	Transistor KSC1845F		
	Q504FR	00D 960 0196 506	Transistor KSC1845F		
	Q504SBL	00D 960 0196 506	Transistor KSC1845F		
	Q504SBR	00D 960 0196 506	Transistor KSC1845F		
	Q504SL	00D 960 0196 506	Transistor KSC1845F		
	Q504SR	00D 960 0196 506	Transistor KSC1845F		
	Q506C	00D 960 0196 603	Transistor KTC2874B		
	Q506FL	00D 960 0196 603	Transistor KTC2874B		
	Q506FR	00D 960 0196 603	Transistor KTC2874B		
	Q506SBL	00D 960 0196 603	Transistor KTC2874B		
	Q551	00D 960 0196 700	Transistor KTC3200BL		
	Q552	00D 960 0196 302	Transistor KTA1268BL		
	Q553	00D 963 0120 704	Transistor KRA102S		
	Q554	00D 963 0120 704	Transistor KRA102S		
	Q555	00D 963 0120 704	Transistor KRA102S		
	Q556	00D 963 0120 704	Transistor KRA102S		
	Q557C	00D 963 0148 508	Transistor KTA1504S		
	Q558C	00D 963 0121 606	Transistor KRC107S		
	D106	00D 963 0020 309	Diode 1SS133T		
	D107	00D 963 0020 309	Diode 1SS133T		
	D551	00D 963 0020 309	Diode 1SS133T		
	D552	00D 963 0020 309	Diode 1SS133T		
	D553	00D 963 0020 309	Diode 1SS133T		
	D554	00D 963 0020 309	Diode 1SS133T		
	D555	00D 963 0020 309	Diode 1SS133T		
	D556	00D 963 0020 309	Diode 1SS133T		
	D557	00D 963 0020 309	Diode 1SS133T		
	D558	00D 963 0020 309	Diode 1SS133T		

	Ref. No.	Part No.	Part Name	Remarks	New
	D559	00D 963 0020 309	Diode 1SS133T		
	D560	00D 963 0020 309	Diode 1SS133T		
	D561	00D 963 0020 309	Diode 1SS133T		
	D562	00D 963 0058 407	Diode IN4007		
	D563	00D 963 0058 407	Diode IN4007		
	D564	00D 963 0020 309	Diode 1SS133T		
	D565	00D 960 0095 500	Zener diode MTZJ5.1B		
	D566	00D 963 0020 309	Diode 1SS133T		
	D567	00D 963 0020 309	Diode 1SS133T		
	D568	00D 963 0020 309	Diode 1SS133T		
	D568C	00D 960 0197 000	Diode KDS160		
	D569	00D 963 0020 309	Diode 1SS133T		
	D569C	00D 960 0197 000	Diode KDS160		
	D570C	00D 960 0197 000	Diode KDS160		
	D573	00D 963 0058 407	Diode IN4007		
	D574	00D 963 0058 407	Diode IN4007		
	D575	00D 963 0058 407	Diode IN4007		
RESISTORS GROUP					
	R104SBL	00D 963 9006 285	Metal oxide 5.6 kohm 1W		
	R104SBR	00D 963 9006 285	Metal oxide 5.6 kohm 1W		
	R105SBL	00D 963 9006 285	Metal oxide 5.6 kohm 1W		
	R105SBR	00D 963 9006 285	Metal oxide 5.6 kohm 1W		
	R106SBL	00D 963 0047 900	Metal film 4.7 kohm 1W		
	R106SBR	00D 963 0047 900	Metal film 4.7 kohm 1W		
	R107SBL	00D 963 0047 900	Metal film 4.7 kohm 1W		
	R107SBR	00D 963 0047 900	Metal film 4.7 kohm 1W		
	R108SBL	00D 963 9006 269	Metal oxide 0.22 ohm 1W		
	R108SBR	00D 963 9006 269	Metal oxide 0.22 ohm 1W		
	R109SBL	00D 963 9006 269	Metal oxide 0.22 ohm 1W		
	R109SBR	00D 963 9006 269	Metal oxide 0.22 ohm 1W		
	R110SBL	00D 963 9006 269	Metal oxide 0.22 ohm 1W		
	R110SBR	00D 963 9006 269	Metal oxide 0.22 ohm 1W		
	R111SBL	00D 963 9006 269	Metal oxide 0.22 ohm 1W		
	R111SBR	00D 963 9006 269	Metal oxide 0.22 ohm 1W		
	R118SBL	00D 963 9006 256	Metal oxide 10 ohm 1W		
	R118SBR	00D 963 9006 256	Metal oxide 10 ohm 1W		
	R119SBL	00D 963 9006 256	Metal oxide 10 ohm 1W		
	R119SBR	00D 963 9006 256	Metal oxide 10 ohm 1W		
	R509C	00D 960 9005 902	Metal film 1.2 kohm 1/4W		
	R509FL	00D 960 9005 902	Metal film 1.2 kohm 1/4W		
	R509FR	00D 960 9005 902	Metal film 1.2 kohm 1/4W		
	R509SBL	00D 960 9005 902	Metal film 1.2 kohm 1/4W		
	R509SBR	00D 960 9005 902	Metal film 1.2 kohm 1/4W		
	R509SL	00D 960 9005 902	Metal film 1.2 kohm 1/4W		
	R509SR	00D 960 9005 902	Metal film 1.2 kohm 1/4W		
	R511C	00D 960 9004 301	Metal film 47 ohm 1/4W		
	R511FL	00D 960 9004 301	Metal film 47 ohm 1/4W		
	R511FR	00D 960 9004 301	Metal film 47 ohm 1/4W		
	R511SBL	00D 960 9004 301	Metal film 47 ohm 1/4W		
	R511SBR	00D 960 9004 301	Metal film 47 ohm 1/4W		
	R511SL	00D 960 9004 301	Metal film 47 ohm 1/4W		
	R511SR	00D 960 9004 301	Metal film 47 ohm 1/4W		
	R559	00D 963 9005 642	Metal film 1.2 kohm 1W		
	R565	00D 963 9005 642	Metal film 1.2 kohm 1W		
	R570	00D 963 9005 642	Metal film 1.2 kohm 1W		
	R575	00D 963 9006 269	Metal oxide 0.22 ohm 1W		

Ref. No.	Part No.	Part Name	Remarks	New
VR106	00D 963 0105 208	Semi fixed resistor 1 kohm		
VR107	00D 963 0105 208	Semi fixed resistor 1 kohm		
CAPACITORS GROUP				
C101SBL	00D 963 9006 450	Electrolytic 47uF/50V		
C101SBR	00D 963 9006 450	Electrolytic 47uF/50V		
C102SBL	00D 963 9006 308	Electrolytic 10uF/50V		
C102SBR	00D 963 9006 308	Electrolytic 10uF/50V		
C103SBL	00D 963 9003 084	Ceramic 100pF/500V		
C103SBR	00D 963 9003 084	Ceramic 100pF/500V		
C104SBL	00D 963 9003 084	Ceramic 100pF/500V		
C104SBR	00D 963 9003 084	Ceramic 100pF/500V		
C105SBL	00D 963 9008 640	Mylar film 0.022uF/100V		
C105SBR	00D 963 9008 640	Mylar film 0.022uF/100V		
C107SBL	00D 963 9003 097	Mylar film 0.1uF/250V		
C107SBR	00D 963 9003 097	Mylar film 0.1uF/250V		
C201PC	00D 963 9004 575	Ceramic chip 100pF/50V		
C201PFL	00D 963 9004 575	Ceramic chip 100pF/50V		
C201PFR	00D 963 9004 575	Ceramic chip 100pF/50V		
C201PSL	00D 963 9004 575	Ceramic chip 100pF/50V		
C201PSR	00D 963 9004 575	Ceramic chip 100pF/50V		
C201PSW	00D 963 9004 575	Ceramic chip 100pF/50V		
C258	00D 963 0021 104	Electrolytic 6800uF/16V		
C501C	00D 963 9006 382	Electrolytic 22uF/25V		
C501FL	00D 963 9006 382	Electrolytic 22uF/25V		
C501FR	00D 963 9006 382	Electrolytic 22uF/25V		
C501SBL	00D 963 9006 382	Electrolytic 22uF/25V		
C501SBR	00D 963 9006 382	Electrolytic 22uF/25V		
C501SL	00D 963 9006 382	Electrolytic 22uF/25V		
C501SR	00D 963 9006 382	Electrolytic 22uF/25V		
C502C	00D 963 9006 308	Electrolytic 10uF/50V		
C502FL	00D 963 9006 308	Electrolytic 10uF/50V		
C502FR	00D 963 9006 308	Electrolytic 10uF/50V		
C502SBL	00D 963 9006 308	Electrolytic 10uF/50V		
C502SBR	00D 963 9006 308	Electrolytic 10uF/50V		
C502SL	00D 963 9006 308	Electrolytic 10uF/50V		
C502SR	00D 963 9006 308	Electrolytic 10uF/50V		
C503C	00D 963 9003 165	Ceramic 220pF/500V		
C503FL	00D 963 9003 165	Ceramic 220pF/500V		
C503FR	00D 963 9003 165	Ceramic 220pF/500V		
C503SBL	00D 963 9003 165	Ceramic 220pF/500V		
C503SBR	00D 963 9003 165	Ceramic 220pF/500V		
C503SL	00D 963 9003 165	Ceramic 220pF/500V		
C503SR	00D 963 9003 165	Ceramic 220pF/500V		
C504C	00D 963 0157 502	Ceramic 220pF/50V		*
C504FL	00D 963 0157 502	Ceramic 220pF/50V		*
C504FR	00D 963 0157 502	Ceramic 220pF/50V		*
C504SBL	00D 963 0157 502	Ceramic 220pF/50V		*
C504SBR	00D 963 0157 502	Ceramic 220pF/50V		*
C504SL	00D 963 0157 502	Ceramic 220pF/50V		*
C504SR	00D 963 0157 502	Ceramic 220pF/50V		*
C505C	00D 963 9003 181	Ceramic 33pF/500V		
C505FL	00D 963 9003 181	Ceramic 33pF/500V		
C505FR	00D 963 9003 181	Ceramic 33pF/500V		
C505SBL	00D 963 9003 181	Ceramic 33pF/500V		
C505SBR	00D 963 9003 181	Ceramic 33pF/500V		
C505SL	00D 963 9003 181	Ceramic 33pF/500V		
C505SR	00D 963 9003 181	Ceramic 33pF/500V		

Ref. No.	Part No.	Part Name	Remarks	New
C506C	00D 963 9005 312	Electrolytic 100uF/10V		
C506FL	00D 963 9005 312	Electrolytic 100uF/10V		
C506FR	00D 963 9005 312	Electrolytic 100uF/10V		
C506SBL	00D 963 9005 312	Electrolytic 100uF/10V		
C506SBR	00D 963 9005 312	Electrolytic 100uF/10V		
C506SL	00D 963 9005 312	Electrolytic 100uF/10V		
C506SR	00D 963 9005 312	Electrolytic 100uF/10V		
C507C	00D 963 9003 194	Mylar film 0.0022uF/100V		
C507FL	00D 963 9003 194	Mylar film 0.0022uF/100V		
C507FR	00D 963 9003 194	Mylar film 0.0022uF/100V		
C507SBL	00D 963 9003 194	Mylar film 0.0022uF/100V		
C507SBR	00D 963 9003 194	Mylar film 0.0022uF/100V		
C507SL	00D 963 9003 194	Mylar film 0.0022uF/100V		
C507SR	00D 963 9003 194	Mylar film 0.0022uF/100V		
C508C	00D 963 9006 382	Electrolytic 22uF/25V		
C508FL	00D 963 9006 382	Electrolytic 22uF/25V		
C508FR	00D 963 9006 382	Electrolytic 22uF/25V		
C508SBL	00D 963 9006 382	Electrolytic 22uF/25V		
C551	00D 963 9006 405	Electrolytic 2.2uF/50V		
C551M	00D 963 0161 200	Electrolytic 10uF/25V		*
C551S	00D 963 9004 562	Ceramic 0.047uF/50V		
C552	00D 963 9006 366	Electrolytic 0.1uF/50V		
C553	00D 963 9006 366	Electrolytic 0.1uF/50V		
C554	00D 963 9006 366	Electrolytic 0.1uF/50V		
C555	00D 963 9004 546	Ceramic 0.01uF/16V		
C556	00D 963 9004 546	Ceramic 0.01uF/16V		
C557	00D 963 9006 308	Electrolytic 10uF/50V		
C558	00D 963 9006 366	Electrolytic 0.1uF/50V		
C559	00D 963 0145 006	Mylar film 0.047uF/50V		
C561	00D 963 0145 006	Mylar film 0.047uF/50V		
C562	00D 963 9004 546	Ceramic 0.01uF/16V		
C563	00D 963 9004 546	Ceramic 0.01uF/16V		
C564	00D 960 0133 501	Electrolytic 2200uF/16V		
OTHER PARTS GROUP				
CN1153	00D 963 0097 303	15P connector socket (TUC-P)		
CN501	00D 963 0085 603	5P connector socket (TUC-P)		
CN502	00D 963 0086 602	12P connector socket (TUC-P)		
CN503	00D 963 0086 505	7P connector socket (TUC-P)		
CN504	00D 963 0085 506	9P connector socket (TUC-P)		
CN505	00D 963 0086 505	7P connector socket (TUC-P)		
CN506	00D 963 0060 903	15P connector base		
CN506T	00D 963 0159 704	15P connector cord		*
CN510	00D 963 0160 405	5P connector cord		*
CN551	00D 963 0097 206	8P connector socket (TUC-P)		
CN552	00D 963 0086 204	19P connector socket (TUC-P)		
CN553	00D 963 0097 206	8P connector socket (TUC-P)		
CN554	00D 963 0160 609	15P connector cord		*
CN555	00D 963 0086 709	11P connector socket (TUC-P)		
CN556	00D 963 0159 403	15P connector cord		*
CN557	00D 963 0086 709	11P connector socket (TUC-P)		
CN560	00D 963 0110 701	14P connector socket (TUC-P)		
CN992	00D 960 0217 553	4P connector base		
CP1154	00D 963 0097 507	15P connector base (TUC-P)		
CP508	00D 963 0068 303	9P connector base		
CP509	00D 963 0060 505	7P connector base		
CP510	00D 963 0066 101	5P connector base		

	Ref. No.	Part No.	Part Name	Remarks	New
	CP554	00D 963 0060 903	15P connector base		
	CP568	00D 963 0049 102	3P connector base		
	CP602D	00D 963 0097 507	15P connector base (TUC-P)		
	J209RM	00D 963 9003 372	Carbon chip 0 ohm 1/16W		
	L101SBL	00D 963 0049 005	Inductor 0.5uH		
	L101SBR	00D 963 0049 005	Inductor 0.5uH		
	TP106	00D 960 0161 418	3P connector base		
	TP107	00D 960 0161 418	3P connector base		
	-	00D 960 0184 000	Screw bracket	2	
	-	00D 960 0184 000	Screw bracket	2	
	-	00D 960 0236 602	Shield plate	1	
	-	00D 960 0268 803	6P pin jack	1	

INPUT, VIDEO P.W.B. UNIT

	Ref. No.	Part No.	Part Name	Remarks	New
SEMICONDUCTORS GROUP					
	IC1000		IC BA7626F	J171762600010	
	IC1001	00D 963 0116 103	IC MM74HC4053MX		
	IC1002		IC BA7626F	J171762600010	
	IC1003	00D 963 0074 504	IC BU2090F		
	IC1004	00D 963 0116 103	IC MM74HC4053MX		
	IC1005	00D 963 0074 504	IC BU2090F		
	IC1006	00D 963 0116 307	IC LC7478		
	IC1007	00D 963 0116 200	IC NJM2274R		
	IC1008	00D 963 0116 103	IC MM74HC4053MX		
	IC1150		IC BA7626F	J171762600010	
	IC1151		IC BA7626F	J171762600010	
	IC1152		IC BA7626F	J171762600010	
	IC1153		IC BA7626F	J171762600010	
	IC201T	00D 963 0158 909	IC TC94A27UG		*
	IC202T	00D 963 0158 909	IC TC94A27UG		*
	IC203T	00D 960 0080 201	IC KIC9164AN		
	IC205	00D 963 0024 004	IC NJM2068M		
	IC206	00D 963 0024 004	IC NJM2068M		
	IC207	00D 963 0024 004	IC NJM2068M		
	IC208	00D 963 0159 005	IC NJM5532M		*
	IC209	00D 963 0159 005	IC NJM5532M		*
	IC210	00D 963 0159 005	IC NJM5532M		*
	IC211	00D 963 0159 005	IC NJM5532M		*
	IC603E		IC BA7626F	J171762600010	
	IC604E		IC BA7626F	J171762600010	
	IC605E	00D 960 0175 200	IC BA7625		
	IC701	00D 963 0083 207	IC TC9274N-011		
	IC701M	00D 963 0024 004	IC NJM2068M		
	IC702	00D 963 0024 004	IC NJM2068M		
	IC703	00D 963 0024 004	IC NJM2068M		
	IC704	00D 960 0174 502	IC NJM2068DD		
	IC705	00D 960 0174 201	IC TC9273N-004		
	Q1000	00D 963 0102 803	Transistor 2SA933S		
	Q1001	00D 963 0102 803	Transistor 2SA933S		
	Q1002	00D 963 0121 703	Transistor KRA107S		
	Q1003	00D 963 0121 703	Transistor KRA107S		
	Q1004	00D 963 0120 704	Transistor KRA102S		
	Q1005	00D 963 0159 102	Transistor KRC111S		*
	Q1006	00D 963 0120 801	Transistor KRC102S		
	Q1007	00D 960 0068 207	Transistor KTA1504Y		
	Q1008	00D 963 0120 704	Transistor KRA102S		
	Q1009	00D 963 0159 102	Transistor KRC111S		*
	Q1010	00D 963 0120 801	Transistor KRC102S		
	Q1011	00D 960 0068 207	Transistor KTA1504Y		
	Q1012	00D 963 0044 301	Transistor KTC2875B		
	Q1013	00D 963 0120 704	Transistor KRA102S		
	Q1014	00D 960 0068 207	Transistor KTA1504Y		
	Q1015	00D 963 0120 801	Transistor KRC102S		
	Q1016	00D 960 0068 207	Transistor KTA1504Y		
	Q1017	00D 960 0068 207	Transistor KTA1504Y		
	Q1018	00D 960 0068 207	Transistor KTA1504Y		
	Q1019	00D 960 0068 207	Transistor KTA1504Y		
	Q1020	00D 963 0066 606	Transistor KTC3875Y		
	Q1021	00D 963 0066 606	Transistor KTC3875Y		
	Q1022	00D 960 0068 207	Transistor KTA1504Y		

Ref. No.	Part No.	Part Name	Remarks	New
Q1023	00D 963 0102 803	Transistor 2SA933S		
Q1024	00D 960 0005 202	Transistor KTC3198Y		
Q1025	00D 960 0005 105	Transistor KTA1266Y		
Q1026	00D 960 0005 105	Transistor KTA1266Y		
Q1027	00D 960 0005 105	Transistor KTA1266Y		
Q1028	00D 960 0005 202	Transistor KTC3198Y		
Q1029	00D 960 0005 105	Transistor KTA1266Y		
Q1030	00D 960 0005 202	Transistor KTC3198Y		
Q1150	00D 963 0159 102	Transistor KRC111S		*
Q1151	00D 960 0068 207	Transistor KTA1504Y		
Q1152	00D 963 0159 102	Transistor KRC111S		*
Q1153	00D 960 0068 207	Transistor KTA1504Y		
Q1155	00D 963 0159 102	Transistor KRC111S		*
Q1156	00D 960 0068 207	Transistor KTA1504Y		
Q1157	00D 963 0159 102	Transistor KRC111S		*
Q1158	00D 960 0068 207	Transistor KTA1504Y		
Q1159	00D 960 0068 207	Transistor KTA1504Y		
Q1160	00D 963 0159 102	Transistor KRC111S		*
Q1161	00D 963 0159 102	Transistor KRC111S		*
Q1162	00D 960 0068 207	Transistor KTA1504Y		
Q207T	00D 960 0196 807	Transistor 2SK117Y		
Q208T	00D 960 0196 807	Transistor 2SK117Y		
Q209T	00D 960 0097 003	Transistor KRA104M		
Q210T	00D 963 0121 004	Transistor KRC104M		
Q551SW	00D 963 0044 301	Transistor KTC2875B		
Q552SW	00D 963 0044 301	Transistor KTC2875B		
Q601E	00D 960 0005 105	Transistor KTA1266Y		
Q602E	00D 960 0005 105	Transistor KTA1266Y		
Q603E	00D 960 0005 105	Transistor KTA1266Y		
D1000	00D 960 0197 000	Diode KDS160		
D1001	00D 960 0197 000	Diode KDS160		
D1002	00D 960 0197 000	Diode KDS160		
D1003	00D 960 0197 000	Diode KDS160		
D1004	00D 960 0197 000	Diode KDS160		
D1005	00D 960 0197 000	Diode KDS160		
D1012	00D 963 0020 309	Diode 1SS133T		
D1014	00D 963 0020 309	Diode 1SS133T		
D1150	00D 960 0197 000	Diode KDS160		
D1151	00D 960 0197 000	Diode KDS160		
D1152	00D 960 0197 000	Diode KDS160		
D1153	00D 960 0197 000	Diode KDS160		
D1154	00D 960 0197 000	Diode KDS160		
D1155	00D 960 0197 000	Diode KDS160		
D1157	00D 960 0197 000	Diode KDS160		
D1158	00D 960 0197 000	Diode KDS160		
D205T	00D 960 0197 000	Diode KDS160		
D207T	00D 960 0197 000	Diode KDS160		
D251	00D 960 0197 000	Diode KDS160		
D252	00D 960 0197 000	Diode KDS160		
D253	00D 960 0197 000	Diode KDS160		
D254	00D 960 0197 000	Diode KDS160		
D255	00D 960 0197 000	Diode KDS160		
D256	00D 960 0197 000	Diode KDS160		
D901	00D 960 0197 000	Diode KDS160		
D902	00D 960 0197 000	Diode KDS160		
D903	00D 960 0197 000	Diode KDS160		
D904	00D 960 0197 000	Diode KDS160		
ZD1000	00D 960 0095 500	Zener diode MTZJ5.1B		
ZD701M	00D 960 0095 500	Zener diode MTZJ5.1B		

Ref. No.	Part No.	Part Name	Remarks	New
RESISTORS GROUP				
R1031	00D 963 9005 639	Metal film 100 ohm 1W		
R1038	00D 963 9005 639	Metal film 100 ohm 1W		
R1059	00D 963 9005 639	Metal film 100 ohm 1W		
R1095	00D 963 0018 007	Metal film 100 ohm 1/4W		
R1163	00D 963 9005 639	Metal film 100 ohm 1W		
R1166	00D 963 9005 639	Metal film 100 ohm 1W		
R1193	00D 963 9005 639	Metal film 100 ohm 1W		
R1199	00D 963 9005 639	Metal film 100 ohm 1W		
R1232	00D 963 9005 639	Metal film 100 ohm 1W		
R1239	00D 963 9005 639	Metal film 100 ohm 1W		
R229T	00D 963 9005 639	Metal film 100 ohm 1W		
R230T	00D 963 9005 639	Metal film 100 ohm 1W		
R738M	00D 963 9005 338	Carbon chip 1.6 kohm 1/10W		
CAPACITORS GROUP				
C1000	00D 963 9006 382	Electrolytic 22uF/25V		
C1001	00D 963 9006 382	Electrolytic 22uF/25V		
C1002	00D 963 9005 312	Electrolytic 100uF/10V		
C1003	00D 963 9004 753	Ceramic chip 0.047uF/50V		
C1004	00D 963 9006 308	Electrolytic 10uF/50V		
C1005	00D 963 9006 308	Electrolytic 10uF/50V		
C1006	00D 963 9006 382	Electrolytic 22uF/25V		
C1007	00D 963 9004 753	Ceramic chip 0.047uF/50V		
C1009	00D 963 9006 308	Electrolytic 10uF/50V		
C1010	00D 963 9006 405	Electrolytic 2.2uF/50V		
C1011	00D 963 9006 405	Electrolytic 2.2uF/50V		
C1013	00D 963 9006 382	Electrolytic 22uF/25V		
C1014	00D 963 9006 308	Electrolytic 10uF/50V		
C1016	00D 963 9006 146	Ceramic chip 560pF/50V		
C1017	00D 963 9004 575	Ceramic chip 100pF/50V		
C1018	00D 963 9004 575	Ceramic chip 100pF/50V		
C1019	00D 963 9006 308	Electrolytic 10uF/50V		
C1020	00D 963 9006 463	Electrolytic 470uF/6.3V		
C1021	00D 963 9006 560	Electrolytic 47uF/35V		
C1022	00D 963 9006 308	Electrolytic 10uF/50V		
C1023	00D 963 9006 463	Electrolytic 470uF/6.3V		
C1024	00D 963 9004 753	Ceramic chip 0.047uF/50V		
C1025	00D 963 9006 515	Ceramic 1pF/50V		
C1026	00D 963 9006 308	Electrolytic 10uF/50V		
C1027	00D 963 9006 463	Electrolytic 470uF/6.3V		
C1030	00D 963 9006 434	Electrolytic 47uF/16V		
C1034	00D 963 9006 515	Ceramic 1pF/50V		
C1035	00D 963 9006 560	Electrolytic 47uF/35V		
C1039	00D 963 9006 528	Ceramic chip 20pF/50V		
C1040	00D 963 9006 379	Electrolytic 1uF/50V		
C1041	00D 963 0157 706	Ceramic chip 0.022uF/50V		*
C1042	00D 963 9006 434	Electrolytic 47uF/16V		
C1049	00D 963 9006 528	Ceramic chip 20pF/50V		
C1052	00D 963 9006 308	Electrolytic 10uF/50V		
C1053	00D 963 9006 308	Electrolytic 10uF/50V		
C1054	00D 963 9005 998	Ceramic chip 24pF/50V		
C1055	00D 963 9004 753	Ceramic chip 0.047uF/50V		
C1056	00D 963 9006 379	Electrolytic 1uF/50V		

Ref. No.	Part No.	Part Name	Remarks	New
C1057	00D 963 9005 998	Ceramic chip 24pF/50V		
C1058	00D 963 9006 434	Electrolytic 47uF/16V		
C1059	00D 963 9004 753	Ceramic chip 0.047uF/50V		
C1060	00D 963 9006 434	Electrolytic 47uF/16V		
C1061	00D 963 0129 909	Ceramic chip 1200pF/50V		
C1062	00D 963 9005 312	Electrolytic 100uF/10V		
C1063	00D 960 9010 094	Ceramic chip 0.01uF/50V		
C1069	00D 963 9006 382	Electrolytic 22uF/25V		
C1070	00D 963 9005 312	Electrolytic 100uF/10V		
C1071	00D 963 9006 379	Electrolytic 1uF/50V		
C1080	00D 963 0157 706	Ceramic chip 0.022uF/50V		*
C1081	00D 963 9006 434	Electrolytic 47uF/16V		
C1150	00D 963 9006 382	Electrolytic 22uF/25V		
C1151	00D 960 9010 094	Ceramic chip 0.01uF/50V		
C1152	00D 963 9006 382	Electrolytic 22uF/25V		
C1153	00D 963 9004 575	Ceramic chip 100pF/50V		
C1154	00D 963 9004 575	Ceramic chip 100pF/50V		
C1155	00D 963 9004 575	Ceramic chip 100pF/50V		
C1156	00D 963 9004 575	Ceramic chip 100pF/50V		
C1157	00D 963 9006 382	Electrolytic 22uF/25V		
C1158	00D 963 9004 753	Ceramic chip 0.047uF/50V		
C1159	00D 963 9006 382	Electrolytic 22uF/25V		
C1160	00D 963 9006 308	Electrolytic 10uF/50V		
C1161	00D 963 9006 463	Electrolytic 470uF/6.3V		
C1162	00D 963 9006 308	Electrolytic 10uF/50V		
C1163	00D 963 9006 463	Electrolytic 470uF/6.3V		
C1164	00D 963 9006 382	Electrolytic 22uF/25V		
C1165	00D 963 9006 382	Electrolytic 22uF/25V		
C1167	00D 963 9004 753	Ceramic chip 0.047uF/50V		
C1171	00D 963 9006 382	Electrolytic 22uF/25V		
C1172	00D 963 9006 382	Electrolytic 22uF/25V		
C1173	00D 963 9004 753	Ceramic chip 0.047uF/50V		
C1181	00D 963 9006 308	Electrolytic 10uF/50V		
C1183	00D 960 9010 515	Electrolytic 0.47uF/50V		
C1188	00D 963 9006 308	Electrolytic 10uF/50V		
C1189	00D 960 9010 515	Electrolytic 0.47uF/50V		
C1207	00D 963 9003 372	Carbon chip 0 ohm 1/16W		
C1208	00D 963 9003 372	Carbon chip 0 ohm 1/16W		
C1209	00D 963 9003 372	Carbon chip 0 ohm 1/16W		
C1210	00D 963 9003 372	Carbon chip 0 ohm 1/16W		
C1215	00D 963 9003 372	Carbon chip 0 ohm 1/16W		
C1219	00D 963 9006 463	Electrolytic 470uF/6.3V		
C1220	00D 963 9006 308	Electrolytic 10uF/50V		
C1222	00D 960 9010 515	Electrolytic 0.47uF/50V		
C211SW	00D 963 9004 575	Ceramic chip 100pF/50V		
C212SW	00D 963 9004 643	Ceramic chip 47pF/50V		
C213FL	00D 963 9004 575	Ceramic chip 100pF/50V		
C213FR	00D 963 9004 575	Ceramic chip 100pF/50V		
C213T	00D 963 9004 753	Ceramic chip 0.047uF/50V		
C214T	00D 963 9004 753	Ceramic chip 0.047uF/50V		
C215T	00D 963 9004 753	Ceramic chip 0.047uF/50V		
C216T	00D 963 9004 753	Ceramic chip 0.047uF/50V		
C217T	00D 963 9004 753	Ceramic chip 0.047uF/50V		
C218FL	00D 963 9004 627	Ceramic chip 33pF/50V		
C218FR	00D 963 9004 627	Ceramic chip 33pF/50V		
C218T	00D 963 9006 379	Electrolytic 1uF/50V		
C219FL	00D 963 9006 308	Electrolytic 10uF/50V		
C219FR	00D 963 9006 308	Electrolytic 10uF/50V		
C219SW	00D 963 9006 308	Electrolytic 10uF/50V		
C219T	00D 963 9006 379	Electrolytic 1uF/50V		
C220T	00D 963 9006 308	Electrolytic 10uF/50V		

Ref. No.	Part No.	Part Name	Remarks	New
C223C	00D 963 9006 382	Electrolytic 22uF/25V		
C223FL	00D 963 9006 382	Electrolytic 22uF/25V		
C223FR	00D 963 9006 382	Electrolytic 22uF/25V		
C223SBL	00D 963 9006 382	Electrolytic 22uF/25V		
C223SBR	00D 963 9006 382	Electrolytic 22uF/25V		
C223SL	00D 963 9006 382	Electrolytic 22uF/25V		
C223SR	00D 963 9006 382	Electrolytic 22uF/25V		
C223SW	00D 963 9006 382	Electrolytic 22uF/25V		
C225T	00D 963 9006 379	Electrolytic 1uF/50V		
C226T	00D 963 9006 379	Electrolytic 1uF/50V		
C227T	00D 963 9006 308	Electrolytic 10uF/50V		
C228T	00D 963 9006 434	Electrolytic 47uF/16V		
C229T	00D 963 9006 434	Electrolytic 47uF/16V		
C230T	00D 963 9006 308	Electrolytic 10uF/50V		
C231C	00D 963 9006 418	Electrolytic 3.3uF/50V		
C231FL	00D 963 9006 418	Electrolytic 3.3uF/50V		
C231FR	00D 963 9006 418	Electrolytic 3.3uF/50V		
C231SBL	00D 963 9006 418	Electrolytic 3.3uF/50V		
C231SBR	00D 963 9006 418	Electrolytic 3.3uF/50V		
C231SL	00D 963 9006 418	Electrolytic 3.3uF/50V		
C231SR	00D 963 9006 418	Electrolytic 3.3uF/50V		
C231SW	00D 963 9006 418	Electrolytic 3.3uF/50V		
C231T	00D 963 9006 308	Electrolytic 10uF/50V		
C232C	00D 960 9010 104	Ceramic 5pF/50V		
C232FL	00D 960 9010 104	Ceramic 5pF/50V		
C232FR	00D 960 9010 104	Ceramic 5pF/50V		
C232SBL	00D 960 9010 104	Ceramic 5pF/50V		
C232SBR	00D 960 9010 104	Ceramic 5pF/50V		
C232SL	00D 960 9010 104	Ceramic 5pF/50V		
C232SR	00D 960 9010 104	Ceramic 5pF/50V		
C232SW	00D 960 9010 104	Ceramic 5pF/50V		
C232T	00D 963 9006 434	Electrolytic 47uF/16V		
C233T	00D 963 9006 434	Electrolytic 47uF/16V		
C234T	00D 963 9006 434	Electrolytic 47uF/16V		
C235T	00D 963 9006 434	Electrolytic 47uF/16V		
C236T	00D 963 9006 434	Electrolytic 47uF/16V		
C237T	00D 963 9006 434	Electrolytic 47uF/16V		
C238C	00D 963 9006 418	Electrolytic 3.3uF/50V		
C238FL	00D 963 9006 418	Electrolytic 3.3uF/50V		
C238FR	00D 963 9006 418	Electrolytic 3.3uF/50V		
C239T	00D 963 9004 753	Ceramic chip 0.047uF/50V		
C240T	00D 963 9006 379	Electrolytic 1uF/50V		
C241T	00D 963 9006 308	Electrolytic 10uF/50V		
C243T	00D 963 9006 379	Electrolytic 1uF/50V		
C244T	00D 963 9006 379	Electrolytic 1uF/50V		
C245T	00D 963 9006 379	Electrolytic 1uF/50V		
C246SW	00D 963 9006 476	Electrolytic 4.7uF/50V		
C246T	00D 963 9006 308	Electrolytic 10uF/50V		
C247T	00D 963 9004 575	Ceramic chip 100pF/50V		
C248T	00D 963 9006 379	Electrolytic 1uF/50V		
C251	00D 963 9004 708	Ceramic chip 0.1uF/50V		
C252	00D 963 9004 708	Ceramic chip 0.1uF/50V		
C253	00D 963 9004 708	Ceramic chip 0.1uF/50V		
C601E	00D 963 9005 312	Electrolytic 100uF/10V		
C601I	00D 963 9003 372	Carbon chip 0 ohm 1/16W		
C602E	00D 963 9005 312	Electrolytic 100uF/10V		
C602I	00D 963 9003 372	Carbon chip 0 ohm 1/16W		
C603E	00D 963 9005 312	Electrolytic 100uF/10V		
C604E	00D 963 9006 159	Electrolytic 4700uF/16V		
C605E	00D 963 9006 463	Electrolytic 470uF/6.3V		
C606E	00D 963 9006 463	Electrolytic 470uF/6.3V		

Ref. No.	Part No.	Part Name	Remarks	New
C618E	00D 963 9006 379	Electrolytic 1uF/50V		
C620E	00D 963 9006 476	Electrolytic 4.7uF/50V		
C621E	00D 963 0157 706	Ceramic chip 0.022uF/50V		*
C622E	00D 963 9005 312	Electrolytic 100uF/10V		
C623E	00D 963 9006 476	Electrolytic 4.7uF/50V		
C624E	00D 963 9006 476	Electrolytic 4.7uF/50V		
C625E	00D 963 9006 379	Electrolytic 1uF/50V		
C627E	00D 963 0157 706	Ceramic chip 0.022uF/50V		*
C628E	00D 963 9005 312	Electrolytic 100uF/10V		
C632E	00D 963 9006 476	Electrolytic 4.7uF/50V		
C633E	00D 963 9006 379	Electrolytic 1uF/50V		
C635E	00D 963 9006 476	Electrolytic 4.7uF/50V		
C636E	00D 963 0157 706	Ceramic chip 0.022uF/50V		*
C637E	00D 963 9005 312	Electrolytic 100uF/10V		
C638E	00D 963 9006 476	Electrolytic 4.7uF/50V		
C639E	00D 963 9006 476	Electrolytic 4.7uF/50V		
C640E	00D 963 9006 476	Electrolytic 4.7uF/50V		
C641E	00D 963 9006 476	Electrolytic 4.7uF/50V		
C702L	00D 963 9004 575	Ceramic chip 100pF/50V		
C702R	00D 963 9004 575	Ceramic chip 100pF/50V		
C703L	00D 963 9004 575	Ceramic chip 100pF/50V		
C703R	00D 963 9004 575	Ceramic chip 100pF/50V		
C704L	00D 963 9004 575	Ceramic chip 100pF/50V		
C704R	00D 963 9004 575	Ceramic chip 100pF/50V		
C705L	00D 963 9004 575	Ceramic chip 100pF/50V		
C705R	00D 963 9004 575	Ceramic chip 100pF/50V		
C709L	00D 963 9006 308	Electrolytic 10uF/50V		
C709R	00D 963 9006 308	Electrolytic 10uF/50V		
C711L	00D 963 9006 557	Electrolytic 220uF/6.3V		
C711R	00D 963 9006 557	Electrolytic 220uF/6.3V		
C712L	00D 963 9004 779	Mylar film 0.024uF/50V		
C712R	00D 963 9004 779	Mylar film 0.024uF/50V		
C713L	00D 960 9008 695	Mylar film 0.0068uF/100V		
C713R	00D 960 9008 695	Mylar film 0.0068uF/100V		
C714L	00D 963 9006 476	Electrolytic 4.7uF/50V		
C714R	00D 963 9006 476	Electrolytic 4.7uF/50V		
C715L	00D 963 9004 737	Ceramic chip 0.022uF/25V		
C715R	00D 963 9004 737	Ceramic chip 0.022uF/25V		
C716L	00D 963 9006 308	Electrolytic 10uF/50V		
C717L	00D 963 9004 601	Ceramic chip 220pF/50V		
C717R	00D 963 9004 601	Ceramic chip 220pF/50V		
C718L	00D 963 9006 421	Electrolytic 47uF/10V		
C718R	00D 963 9006 421	Electrolytic 47uF/10V		
C719L	00D 963 9006 379	Electrolytic 1uF/50V		
C719R	00D 963 9006 379	Electrolytic 1uF/50V		
C720L	00D 963 9003 152	Mylar film 0.068uF/100V		
C720R	00D 963 9003 152	Mylar film 0.068uF/100V		
C721L	00D 963 9003 152	Mylar film 0.068uF/100V		
C721R	00D 963 9003 152	Mylar film 0.068uF/100V		
C723M	00D 963 9006 379	Electrolytic 1uF/50V		
C724L	00D 963 9004 698	Ceramic chip 0.01uF/50V		
C724M	00D 963 9006 379	Electrolytic 1uF/50V		
C724R	00D 963 9004 698	Ceramic chip 0.01uF/50V		
C725	00D 963 9004 698	Ceramic chip 0.01uF/50V		
C725M	00D 963 9006 379	Electrolytic 1uF/50V		
C726	00D 963 9004 698	Ceramic chip 0.01uF/50V		
C726M	00D 963 0157 609	Ceramic chip 150pF/50V		*
C727M	00D 963 9004 575	Ceramic chip 100pF/50V		
C728M	00D 963 0157 609	Ceramic chip 150pF/50V		*
C729	00D 963 9004 708	Ceramic chip 0.1uF/50V		
C729M	00D 963 9006 379	Electrolytic 1uF/50V		

	Ref. No.	Part No.	Part Name	Remarks	New
	C730M	00D 963 9006 308	Electrolytic 10uF/50V		
	C737M	00D 963 9004 575	Ceramic chip 100pF/50V		
	C738M	00D 963 9004 698	Ceramic chip 0.01uF/50V		
	C901SW	00D 963 9006 476	Electrolytic 4.7uF/50V		
	C910	00D 963 9004 575	Ceramic chip 100pF/50V		
	C911	00D 960 9010 094	Ceramic chip 0.01uF/50V		
	C912	00D 963 9004 575	Ceramic chip 100pF/50V		
	C913	00D 963 9004 575	Ceramic chip 100pF/50V		
	C914	00D 963 9004 575	Ceramic chip 100pF/50V		
	C915	00D 963 9004 575	Ceramic chip 100pF/50V		
	C916	00D 963 9004 575	Ceramic chip 100pF/50V		
	C917	00D 960 9010 094	Ceramic chip 0.01uF/50V		
	C918	00D 963 9004 575	Ceramic chip 100pF/50V		
	C920	00D 963 9004 575	Ceramic chip 100pF/50V		
OTHER PARTS GROUP					
	CB1000	00D 963 0120 908	Beads inductor		
	CB1001	00D 963 0120 908	Beads inductor		
	CB1002	00D 963 0115 609	Inductor 33uH		
	CB205	00D 963 0154 602	Beads inductor		*
	CN1000	00D 963 0086 505	7P connector socket (TUC-P)		
	CN1004	00D 963 0110 701	14P connector socket (TUC-P)		
	CN1150	00D 963 0086 505	7P connector socket (TUC-P)		
	CN1151	00D 963 0097 303	15P connector socket (TUC-P)		
	CN1154	00D 963 0097 303	15P connector socket (TUC-P)		
	CN403	00D 963 0086 709	11P connector socket (TUC-P)		
	CN508	00D 963 0159 306	9P connector cord		*
	CN509	00D 963 0159 209	7P connector cord		*
	CN557T	00D 963 0050 104	4P connector base		
	CN601	00D 963 0097 303	15P connector socket (TUC-P)		
	CN701	00D 963 0086 301	18P connector socket (TUC-P)		
	CN701M	00D 963 0160 104	4P connector cord		*
	CN703	00D 963 0086 505	7P connector socket (TUC-P)		
	CN805	00D 963 0097 206	8P connector socket (TUC-P)		
	CN806	00D 963 0086 204	19P connector socket (TUC-P)		
	CP556	00D 963 0060 903	15P connector base		
	G902	-	1P contact Ass'y		
	J712B	00D 963 9003 372	Carbon chip 0 ohm 1/16W		
	J712C	00D 963 9003 372	Carbon chip 0 ohm 1/16W		
	JK704	00D 960 0188 103	2P pin jack		
	L1000	00D 963 0131 007	Y/C SEPARATE FILTER		
	L701L	00D 963 0056 302	FTZ CHOKE COIL		
	L701R	00D 963 0056 302	FTZ CHOKE COIL		
	XTAL1000	00D 963 0131 405	Crystal 14.318180MHZ		
	-	00D 963 0101 707	Input cushion	1	
	-	00D 963 0094 102	PLATE INPUT	1	
	-	00D 963 0146 209	4P pin jack	2	
	-	00D 960 0268 803	6P pin jack	1	
	-	00D 963 0146 102	2P pin jack	2	
	-	00D 963 0146 209	4P pin jack	1	

	Ref. No.	Part No.	Part Name	Remarks	New
	-	00D 963 0146 500	3P pin jack	1	
	-	00D 963 0146 306	6P pin jack	2	
	-	00D 963 0146 209	4P pin jack	2	
	-	00D 963 0158 200	Mini jack	1	*

DSP P.W.B. UNIT

	Ref. No.	Part No.	Part Name	Remarks	New
SEMICONDUCTORS GROUP					
	IC801	00D 963 0113 106	IC GP1FA513RZ		
	IC802	00D 963 0113 106	IC GP1FA513RZ		
	IC803	00D 963 0113 106	IC GP1FA513RZ		
	IC804	00D 963 0147 402	IC ADSP-21266		
	IC805	00D 963 0146 908	IC LH28F800BJE		
	IC806	00D 963 0158 705	IC CY7C1049CV33		*
	IC807	00D 963 0096 100	IC LC89057W		
	IC808	00D 963 0158 802	IC AD1837AAS		*
	IC809	00D 960 0266 805	IC MM74LCX244		
	IC810	00D 960 0266 805	IC MM74LCX244		
	IC811	00D 960 0266 805	IC MM74LCX244		
	IC812	00D 960 0266 902	IC MM74HCT244		
	IC814	00D 963 0102 308	IC MM74HC00MTCX		
	IC815	00D 963 0102 308	IC MM74HC00MTCX		
	IC815A	00D 963 0043 807	IC BA4510F		
	IC816	00D 963 0147 208	IC 74LVX157		
	IC816A	00D 963 0043 807	IC BA4510F		
	IC817	00D 963 0158 705	IC CY7C1049CV33		*
	IC817A	00D 963 0024 004	IC NJM2068M		
	IC818	00D 963 0147 305	IC 74LCX573		
	IC818A	00D 963 0024 004	IC NJM2068M		
	IC819	00D 963 0147 305	IC 74LCX573		
	IC819A	00D 963 0024 004	IC NJM2068M		
	IC820	00D 963 0147 101	IC SN74LVC139A		
	IC820A	00D 963 0024 004	IC NJM2068M		
	IC821	00D 963 0096 003	IC 74LCX74MTC		
	IC822	00D 960 0159 501	IC KIA7805API		
	IC823	00D 963 0111 603	IC RC1117-3.3		
	IC824	00D 963 0147 509	IC RC1117-1.2		
	IC825	00D 963 0096 003	IC 74LCX74MTC		
	IC826	00D 963 0113 009	IC GP1FA513TZ		
	Q804C	00D 960 0196 603	Transistor KTC2874B		
	Q804FL	00D 960 0196 603	Transistor KTC2874B		
	Q804FR	00D 960 0196 603	Transistor KTC2874B		
	Q804SBL	00D 960 0196 603	Transistor KTC2874B		
	Q804SBR	00D 960 0196 603	Transistor KTC2874B		
	Q804SL	00D 960 0196 603	Transistor KTC2874B		
	Q804SR	00D 960 0196 603	Transistor KTC2874B		
	Q804SW	00D 960 0196 603	Transistor KTC2874B		
	Q808	00D 963 0120 801	Transistor KRC102S		
	Q809	00D 963 0120 704	Transistor KRA102S		
	D801	00D 960 0197 000	Diode KDS160		
	D803	00D 960 0197 000	Diode KDS160		
CAPACITORS GROUP					
	C801	00D 963 9004 708	Ceramic chip 0.1uF/50V		
	C802	00D 963 9004 591	Ceramic chip 22pF/50V		
	C803	00D 963 9004 591	Ceramic chip 22pF/50V		
	C804	00D 963 9004 591	Ceramic chip 22pF/50V		
	C805	00D 963 9004 591	Ceramic chip 22pF/50V		
	C806	00D 963 9004 708	Ceramic chip 0.1uF/50V		

Ref. No.	Part No.	Part Name	Remarks	New
C807	00D 963 9004 708	Ceramic chip 0.1uF/50V		
C808	00D 963 9005 862	Electrolytic 47uF/16V		
C809	00D 963 9004 708	Ceramic chip 0.1uF/50V		
C810	00D 963 9005 862	Electrolytic 47uF/16V		
C811	00D 963 9004 591	Ceramic chip 22pF/50V		
C812	00D 963 9005 927	Electrolytic 0.1uF/50V		
C813	00D 963 9004 698	Ceramic chip 0.01uF/50V		
C814	00D 963 9005 862	Electrolytic 47uF/16V		
C815	00D 963 9005 312	Electrolytic 100uF/10V		
C817	00D 963 9005 778	Electrolytic 10uF/50V		
C818	00D 963 9005 749	Electrolytic 1uF/50V		
C819	00D 963 9005 901	Electrolytic 470uF/10V		
C820	00D 963 9005 862	Electrolytic 47uF/16V		
C821	00D 963 9005 901	Electrolytic 470uF/10V		
C830	00D 963 9005 901	Electrolytic 470uF/10V		
C831	00D 963 9004 708	Ceramic chip 0.1uF/50V		
C832	00D 963 9004 708	Ceramic chip 0.1uF/50V		
C833	00D 963 9004 698	Ceramic chip 0.01uF/50V		
C835	00D 963 9004 708	Ceramic chip 0.1uF/50V		
C836	00D 963 9004 685	Ceramic chip 1000pF/50V		
C837	00D 963 9004 685	Ceramic chip 1000pF/50V		
C838	00D 963 9004 708	Ceramic chip 0.1uF/50V		
C839	00D 963 9004 708	Ceramic chip 0.1uF/50V		
C840	00D 963 9004 708	Ceramic chip 0.1uF/50V		
C841	00D 963 9004 708	Ceramic chip 0.1uF/50V		
C842	00D 963 9004 591	Ceramic chip 22pF/50V		
C843	00D 963 9004 698	Ceramic chip 0.01uF/50V		
C844	00D 963 9004 708	Ceramic chip 0.1uF/50V		
C845	00D 963 9004 708	Ceramic chip 0.1uF/50V		
C846	00D 963 9004 708	Ceramic chip 0.1uF/50V		
C847	00D 963 9004 591	Ceramic chip 22pF/50V		
C858	00D 960 9009 856	Ceramic chip 0.022uF/50V		
C861	00D 963 9005 998	Ceramic chip 24pF/50V		
C862	00D 963 9005 998	Ceramic chip 24pF/50V		
C863	00D 963 9004 698	Ceramic chip 0.01uF/50V		
C864L	00D 963 9005 862	Electrolytic 47uF/16V		
C864R	00D 963 9005 862	Electrolytic 47uF/16V		
C865L	00D 963 9005 723	Ceramic chip 120pF/50V		
C865R	00D 963 9005 723	Ceramic chip 120pF/50V		
C866	00D 963 9004 698	Ceramic chip 0.01uF/50V		
C867	00D 963 9004 698	Ceramic chip 0.01uF/50V		
C868	00D 963 9004 698	Ceramic chip 0.01uF/50V		
C869L	00D 963 9004 575	Ceramic chip 100pF/50V		
C869R	00D 963 9004 575	Ceramic chip 100pF/50V		
C871L	00D 963 9009 500	Mylar film 0.001uF/100V		
C871R	00D 963 9009 500	Mylar film 0.001uF/100V		
C873	00D 963 9006 340	Electrolytic 100uF/25V		
C873C	00D 963 9004 672	Ceramic chip 680pF/50V		
C873FL	00D 963 9004 672	Ceramic chip 680pF/50V		
C873FR	00D 963 9004 672	Ceramic chip 680pF/50V		
C873SBL	00D 963 9004 672	Ceramic chip 680pF/50V		
C873SBR	00D 963 9004 672	Ceramic chip 680pF/50V		
C873SL	00D 963 9004 672	Ceramic chip 680pF/50V		
C873SR	00D 963 9004 672	Ceramic chip 680pF/50V		
C873SW	00D 963 9004 672	Ceramic chip 680pF/50V		
C874	00D 963 9006 340	Electrolytic 100uF/25V		
C874C	00D 963 9006 146	Ceramic chip 560pF/50V		
C874FL	00D 963 9006 146	Ceramic chip 560pF/50V		
C874FR	00D 963 9006 146	Ceramic chip 560pF/50V		
C874SBL	00D 963 9006 146	Ceramic chip 560pF/50V		
C874SBR	00D 963 9006 146	Ceramic chip 560pF/50V		

	Ref. No.	Part No.	Part Name	Remarks	New
	C874SL	00D 963 9006 146	Ceramic chip 560pF/50V		
	C874SR	00D 963 9006 146	Ceramic chip 560pF/50V		
	C874SW	00D 963 9006 146	Ceramic chip 560pF/50V		
	C875C	00D 963 9005 778	Electrolytic 10uF/50V		
	C875FL	00D 963 9005 778	Electrolytic 10uF/50V		
	C875FR	00D 963 9005 778	Electrolytic 10uF/50V		
	C875SBL	00D 963 9005 778	Electrolytic 10uF/50V		
	C875SBR	00D 963 9005 778	Electrolytic 10uF/50V		
	C875SL	00D 963 9005 778	Electrolytic 10uF/50V		
	C875SR	00D 963 9005 778	Electrolytic 10uF/50V		
	C875SW	00D 963 9005 778	Electrolytic 10uF/50V		
	C876C	00D 960 9008 611	Mylar film 0.0033uF/100V		
	C876FL	00D 960 9008 611	Mylar film 0.0033uF/100V		
	C876FR	00D 960 9008 611	Mylar film 0.0033uF/100V		
	C876SBL	00D 960 9008 611	Mylar film 0.0033uF/100V		
	C876SBR	00D 960 9008 611	Mylar film 0.0033uF/100V		
	C876SL	00D 960 9008 611	Mylar film 0.0033uF/100V		
	C876SR	00D 960 9008 611	Mylar film 0.0033uF/100V		
	C876SW	00D 960 9008 611	Mylar film 0.0033uF/100V		
	C880C	00D 963 9005 778	Electrolytic 10uF/50V		
	C889	00D 963 9004 698	Ceramic chip 0.01uF/50V		
	C890	00D 963 9004 698	Ceramic chip 0.01uF/50V		
	C891	00D 963 9004 698	Ceramic chip 0.01uF/50V		
	C893	00D 963 9005 749	Electrolytic 1uF/50V		
	C894	00D 963 9004 698	Ceramic chip 0.01uF/50V		
	C896	00D 963 9005 927	Electrolytic 0.1uF/50V		
	C902	00D 963 9005 901	Electrolytic 470uF/10V		
	C907	00D 963 9005 312	Electrolytic 100uF/10V		
	C912	00D 963 9004 698	Ceramic chip 0.01uF/50V		
	C913	00D 963 9004 698	Ceramic chip 0.01uF/50V		
	C920	00D 963 9004 902	Ceramic chip 18pF/50V		
OTHER PARTS GROUP					
	CB801	00D 963 0050 502	Chip emifil		
	CB802	00D 963 0050 502	Chip emifil		
	CB803	00D 963 0050 502	Chip emifil		
	CB804	00D 963 0050 502	Chip emifil		
	CB805	00D 963 0050 502	Chip emifil		
	CB806	00D 963 0050 502	Chip emifil		
	CB808	00D 963 0050 502	Chip emifil		
	CB810	00D 963 0050 502	Chip emifil		
	CN801	00D 963 0086 301	18P connector socket (TUC-P)		
	CN802	00D 963 0086 204	19P connector socket (TUC-P)		
	CN803	00D 960 0239 900	13P connector socket (TUC-P)		
	JACK801	00D 963 0052 500	1P pin jack		
	L801	00D 963 0050 803	Inductor 4.7uH		
	L802	00D 963 0050 803	Inductor 4.7uH		
	L803	00D 963 0050 803	Inductor 4.7uH		
	L804	00D 963 0050 803	Inductor 4.7uH		
	L805	00D 963 0050 900	Inductor 2.2uH		
	R831	00D 963 0120 908	Beads inductor		
	R832	00D 963 0120 908	Beads inductor		
	R833	00D 963 0120 908	Beads inductor		

	Ref. No.	Part No.	Part Name	Remarks	New
	XTAL1	00D 963 0095 101	Crystal 12.288MHz		
	XTAL2	00D 963 0158 103	Crystal 18.75MHZ		*

PARTS LIST OF P.W.B. UNIT ASS'Y (FOR EUROPE & ASIA)**MAIN P.W.B. UNIT**

	Ref. No.	Part No.	Part Name	Remarks	New
SEMICONDUCTORS GROUP					
	IC101	00D 963 0110 507	IC MC7815CT		
	IC102	00D 960 0179 905	IC KIA7915		
	IC103	00D 960 0159 501	IC KIA7805API		
	IC104	00D 963 0110 604	IC MC7805CT		
	IC105	00D 960 0195 808	IC protector ICP-N15		
	IC106	00D 960 0195 808	IC protector ICP-N15		
	Q104C	00D 960 0196 506	Transistor KSC1845F		
	Q104FL	00D 960 0196 506	Transistor KSC1845F		
	Q104FR	00D 960 0196 506	Transistor KSC1845F		
	Q104SL	00D 960 0196 506	Transistor KSC1845F		
	Q104SR	00D 960 0196 506	Transistor KSC1845F		
	Q111	00D 963 0121 208	Transistor KRC107M		
	Q112	00D 960 0097 508	Transistor KRC111M		
	Q113	00D 963 0121 208	Transistor KRC107M		
	Q114	00D 963 0121 208	Transistor KRC107M		
	Q115	00D 963 0121 208	Transistor KRC107M		
	Q116	00D 960 0196 409	Transistor 2SC1740SR		
	Q117	00D 963 0121 208	Transistor KRC107M		
	Q118	00D 963 0121 208	Transistor KRC107M		
	Q151	00D 960 0196 409	Transistor 2SC1740SR		
	Q171	00D 960 0005 202	Transistor KTC3198Y		
	Q171A	00D 960 0196 302	Transistor KTA1268BL		
	Q171B	00D 960 0196 302	Transistor KTA1268BL		
	Q171C	00D 960 0196 302	Transistor KTA1268BL		
	Q171D	00D 960 0196 302	Transistor KTA1268BL		
	Q172	00D 960 0005 202	Transistor KTC3198Y		
	Q173	00D 960 0005 202	Transistor KTC3198Y		
	Q174	00D 960 0005 202	Transistor KTC3198Y		
	Q175	00D 960 0005 202	Transistor KTC3198Y		
	Q176	00D 960 0005 202	Transistor KTC3198Y		
	Q177	00D 960 0005 202	Transistor KTC3198Y		
	Q178	00D 960 0005 105	Transistor KTA1266Y		
	Q179	00D 960 0189 005	Transistor KSA916Y		
	Q180	00D 960 0196 302	Transistor KTA1268BL		
	Q181	00D 960 0196 302	Transistor KTA1268BL		
	Q182	00D 960 0005 202	Transistor KTC3198Y		
	Q183	00D 960 0005 202	Transistor KTC3198Y		
	D101	00D 963 0020 309	Diode 1SS133T		
	D102	00D 963 0020 309	Diode 1SS133T		
	D103	00D 963 0020 309	Diode 1SS133T		
	D104	00D 963 0020 309	Diode 1SS133T		
	D105	00D 963 0020 309	Diode 1SS133T		
	D121	00D 963 0020 309	Diode 1SS133T		
	D122	00D 963 0020 309	Diode 1SS133T		
	D123	00D 963 0020 309	Diode 1SS133T		
	D124	00D 963 0020 309	Diode 1SS133T		
	D125	00D 963 0020 309	Diode 1SS133T		
	D126	00D 963 0020 309	Diode 1SS133T		
	D127	00D 963 0020 309	Diode 1SS133T		
	D131A	00D 960 0197 107	Diode KBPC604		
	D131B	00D 960 0197 107	Diode KBPC604		
	D132	00D 963 0020 309	Diode 1SS133T		
	D133	00D 963 0046 202	Zener diode MTZJ18B		

Ref. No.	Part No.	Part Name	Remarks	New
D134	00D 963 0046 202	Zener diode MTZJ18B		
D135	00D 963 0020 309	Diode 1SS133T		
D136	00D 963 0058 504	Zener diode MTZJ11B		
D137	00D 963 0020 309	Diode 1SS133T		
D138A	00D 963 0058 407	Diode IN4007		
D141	00D 963 0058 407	Diode IN4007		
D142	00D 963 0058 407	Diode IN4007		
D143	00D 963 0058 407	Diode IN4007		
D144	00D 963 0058 407	Diode IN4007		
D145	00D 963 0058 407	Diode IN4007		
D146	00D 963 0058 407	Diode IN4007		
D149	00D 963 0058 407	Diode IN4007		
D150	00D 963 0058 407	Diode IN4007		
D152	00D 963 0058 407	Diode IN4007		
D153	00D 963 0058 407	Diode IN4007		
D154	00D 960 0095 908	Zener diode MTZJ8.2B		
D157	00D 960 0014 905	Zener diode MTZJ20B		
ZD310	00D 960 0095 500	Zener diode MTZJ5.1B		
ZD311	00D 960 0095 500	Zener diode MTZJ5.1B		
LED901	00D 963 0148 605	LED SML1216W 5PI R/G		
RESISTORS GROUP				
R104C	00D 963 9006 285	Metal oxide 5.6 kohm 1W		
R104FL	00D 963 9006 285	Metal oxide 5.6 kohm 1W		
R104FR	00D 963 9006 285	Metal oxide 5.6 kohm 1W		
R104SL	00D 963 9006 285	Metal oxide 5.6 kohm 1W		
R104SR	00D 963 9006 285	Metal oxide 5.6 kohm 1W		
R105C	00D 963 9006 285	Metal oxide 5.6 kohm 1W		
R105FL	00D 963 9006 285	Metal oxide 5.6 kohm 1W		
R105FR	00D 963 9006 285	Metal oxide 5.6 kohm 1W		
R105SL	00D 963 9006 285	Metal oxide 5.6 kohm 1W		
R105SR	00D 963 9006 285	Metal oxide 5.6 kohm 1W		
R106C	00D 963 0047 900	Metal film 4.7 kohm 1W		
R106FL	00D 963 0047 900	Metal film 4.7 kohm 1W		
R106FR	00D 963 0047 900	Metal film 4.7 kohm 1W		
R106SL	00D 963 0047 900	Metal film 4.7 kohm 1W		
R106SR	00D 963 0047 900	Metal film 4.7 kohm 1W		
R107C	00D 963 0047 900	Metal film 4.7 kohm 1W		
R107FL	00D 963 0047 900	Metal film 4.7 kohm 1W		
R107FR	00D 963 0047 900	Metal film 4.7 kohm 1W		
R107SL	00D 963 0047 900	Metal film 4.7 kohm 1W		
R107SR	00D 963 0047 900	Metal film 4.7 kohm 1W		
R108C	00D 963 9006 269	Metal oxide 0.22 ohm 1W		
R108FL	00D 963 9006 269	Metal oxide 0.22 ohm 1W		
R108FR	00D 963 9006 269	Metal oxide 0.22 ohm 1W		
R108SL	00D 963 9006 269	Metal oxide 0.22 ohm 1W		
R108SR	00D 963 9006 269	Metal oxide 0.22 ohm 1W		
R109C	00D 963 9006 269	Metal oxide 0.22 ohm 1W		
R109FL	00D 963 9006 269	Metal oxide 0.22 ohm 1W		
R109FR	00D 963 9006 269	Metal oxide 0.22 ohm 1W		
R109SL	00D 963 9006 269	Metal oxide 0.22 ohm 1W		
R109SR	00D 963 9006 269	Metal oxide 0.22 ohm 1W		
R118C	00D 963 9006 256	Metal oxide 10 ohm 1W		
R118FL	00D 963 9006 256	Metal oxide 10 ohm 1W		
R118FR	00D 963 9006 256	Metal oxide 10 ohm 1W		
R118SL	00D 963 9006 256	Metal oxide 10 ohm 1W		

Ref. No.	Part No.	Part Name	Remarks	New
R118SR	00D 963 9006 256	Metal oxide 10 ohm 1W		
R119C	00D 963 9006 256	Metal oxide 10 ohm 1W		
R119FL	00D 963 9006 256	Metal oxide 10 ohm 1W		
R119FR	00D 963 9006 256	Metal oxide 10 ohm 1W		
R119SL	00D 963 9006 256	Metal oxide 10 ohm 1W		
R119SR	00D 963 9006 256	Metal oxide 10 ohm 1W		
R135	00D 963 0144 502	Cement resistor 0.1 ohm 5W		
R136	00D 963 0144 502	Cement resistor 0.1 ohm 5W		
R141	00D 960 0180 606	Metal oxide 0.22 ohm 1W		
R142	00D 960 0180 606	Metal oxide 0.22 ohm 1W		
R148	00D 960 0180 606	Metal oxide 0.22 ohm 1W		
R149	00D 960 0180 606	Metal oxide 0.22 ohm 1W		
R151	00D 963 9003 343	Metal film 68ohm 1/4W		
R179	00D 963 9003 055	Metal film 47 kohm 1/4W (NB)		
R181	00D 963 0047 900	Metal film 4.7 kohm 1W		
R184	00D 963 9006 256	Metal oxide 10 ohm 1W		
R903H	00D 960 9009 270	Metal film 470ohm 2W		
R904H	00D 960 9009 270	Metal film 470ohm 2W		
VR101	00D 960 0091 601	Semi fixed resistor 1 kohm		
VR102	00D 960 0091 601	Semi fixed resistor 1 kohm		
VR103	00D 960 0091 601	Semi fixed resistor 1 kohm		
VR104	00D 960 0091 601	Semi fixed resistor 1 kohm		
VR105	00D 960 0091 601	Semi fixed resistor 1 kohm		
CAPACITORS GROUP				
C101C	00D 963 9006 450	Electrolytic 47uF/50V		
C101FL	00D 963 9006 450	Electrolytic 47uF/50V		
C101FR	00D 963 9006 450	Electrolytic 47uF/50V		
C101SL	00D 963 9006 450	Electrolytic 47uF/50V		
C101SR	00D 963 9006 450	Electrolytic 47uF/50V		
C102C	00D 963 9006 308	Electrolytic 10uF/50V		
C102FL	00D 963 9006 308	Electrolytic 10uF/50V		
C102FR	00D 963 9006 308	Electrolytic 10uF/50V		
C102SL	00D 963 9006 308	Electrolytic 10uF/50V		
C102SR	00D 963 9006 308	Electrolytic 10uF/50V		
C103C	00D 963 9003 084	Ceramic 100pF/500V		
C103FL	00D 963 9003 084	Ceramic 100pF/500V		
C103FR	00D 963 9003 084	Ceramic 100pF/500V		
C103SL	00D 963 9003 084	Ceramic 100pF/500V		
C103SR	00D 963 9003 084	Ceramic 100pF/500V		
C104C	00D 963 9003 084	Ceramic 100pF/500V		
C104FL	00D 963 9003 084	Ceramic 100pF/500V		
C104FR	00D 963 9003 084	Ceramic 100pF/500V		
C104SL	00D 963 9003 084	Ceramic 100pF/500V		
C104SR	00D 963 9003 084	Ceramic 100pF/500V		
C105C	00D 963 9008 640	Mylar film 0.022uF/100V		
C105FL	00D 963 9008 640	Mylar film 0.022uF/100V		
C105FR	00D 963 9008 640	Mylar film 0.022uF/100V		
C105SL	00D 963 9008 640	Mylar film 0.022uF/100V		
C105SR	00D 963 9008 640	Mylar film 0.022uF/100V		
C107C	00D 963 9003 097	Mylar film 0.1uF/250V		
C107FL	00D 963 9003 097	Mylar film 0.1uF/250V		
C107FR	00D 963 9003 097	Mylar film 0.1uF/250V		
C107SL	00D 963 9003 097	Mylar film 0.1uF/250V		
C107SR	00D 963 9003 097	Mylar film 0.1uF/250V		
C131	00D 963 9003 097	Mylar film 0.1uF/250V		
C132	00D 963 9003 097	Mylar film 0.1uF/250V		

	Ref. No.	Part No.	Part Name	Remarks	New
	C133	00D 963 9003 097	Mylar film 0.1uF/250V		
	C134	00D 963 9003 097	Mylar film 0.1uF/250V		
	C135	00D 963 9003 097	Mylar film 0.1uF/250V		
	C136	00D 963 0157 803	Electrolytic 12000uF/63V		*
	C137	00D 963 0157 803	Electrolytic 12000uF/63V		*
	C138	00D 963 9006 379	Electrolytic 1uF/50V		
	C138A	00D 963 9003 097	Mylar film 0.1uF/250V		
	C141	00D 963 0021 900	Mylar film 0.047uF/100V		
	C142	00D 963 0021 900	Mylar film 0.047uF/100V		
	C143	00D 963 0021 900	Mylar film 0.047uF/100V		
	C144	00D 960 9007 201	Electrolytic 3300uF/35V		
	C145	00D 963 9003 123	Electrolytic 1000uF/35V		
	C146	00D 963 9006 379	Electrolytic 1uF/50V		
	C148	00D 963 9006 379	Electrolytic 1uF/50V		
	C150	00D 963 0021 900	Mylar film 0.047uF/100V		
	C151	00D 963 0021 900	Mylar film 0.047uF/100V		
	C152	00D 963 0021 900	Mylar film 0.047uF/100V		
	C153	00D 963 0021 104	Electrolytic 6800uF/16V		
	C154	00D 963 9006 308	Electrolytic 10uF/50V		
	C155	00D 963 0020 202	Ceramic 0.1uF/50V		
	C157	00D 963 9006 379	Electrolytic 1uF/50V		
	C158	00D 963 9003 136	Electrolytic 1000uF/25V		
	C159	00D 963 9006 379	Electrolytic 1uF/50V		
	C161	00D 963 9006 308	Electrolytic 10uF/50V		
	C171	00D 963 9005 312	Electrolytic 100uF/10V		
	C171A	00D 963 0020 202	Ceramic 0.1uF/50V		
	C171B	00D 963 0020 202	Ceramic 0.1uF/50V		
	C171C	00D 963 0020 202	Ceramic 0.1uF/50V		
	C171D	00D 963 0020 202	Ceramic 0.1uF/50V		
	C172	00D 963 9005 833	Electrolytic 220uF/6.3V		
	C173	00D 963 9005 833	Electrolytic 220uF/6.3V		
	C174	00D 963 9006 308	Electrolytic 10uF/50V		
	C175	00D 963 0149 507	Electrolytic 220uF/16V		
	C176	00D 963 9006 379	Electrolytic 1uF/50V		
	C177	00D 963 9006 379	Electrolytic 1uF/50V		
	C178	00D 963 0157 900	Electrolytic 470uF/63V		*
	C179	00D 963 9005 833	Electrolytic 220uF/6.3V		
⚠	C181	00D 963 9006 191	Ceramic 4700pF/250V(AC)		
	C182	00D 963 9006 311	Electrolytic 10uF/100V		
	C191	00D 963 9006 007	Ceramic 2200pF/16V		
	C192	00D 963 9006 007	Ceramic 2200pF/16V		
	C193	00D 963 9006 007	Ceramic 2200pF/16V		
	C194	00D 963 9006 007	Ceramic 2200pF/16V		
	C195	00D 963 9006 007	Ceramic 2200pF/16V		
	C196	00D 963 9006 007	Ceramic 2200pF/16V		
	C197	00D 963 9006 007	Ceramic 2200pF/16V		
	C198	00D 963 9006 007	Ceramic 2200pF/16V		
	C198C	00D 963 0024 703	Mylar film 0.01uF/100V		
	C198FL	00D 963 0024 703	Mylar film 0.01uF/100V		
	C198FR	00D 963 0024 703	Mylar film 0.01uF/100V		
	C198SBL	00D 963 0024 703	Mylar film 0.01uF/100V		
	C198SBR	00D 963 0024 703	Mylar film 0.01uF/100V		
	C198SL	00D 963 0024 703	Mylar film 0.01uF/100V		
	C198SR	00D 963 0024 703	Mylar film 0.01uF/100V		
	C199	00D 963 9006 007	Ceramic 2200pF/16V		
	C199FL	00D 963 0024 703	Mylar film 0.01uF/100V		
	C199FR	00D 963 0024 703	Mylar film 0.01uF/100V		
	C331	00D 963 9004 546	Ceramic 0.01uF/16V		
	C332	00D 963 9004 546	Ceramic 0.01uF/16V		
	C901H	00D 963 9004 533	Ceramic 0.001uF/50V		
	C902H	00D 963 9004 533	Ceramic 0.001uF/50V		

	Ref. No.	Part No.	Part Name	Remarks	New
	C903H	00D 963 0020 202	Ceramic 0.1uF/50V		
	C904H	00D 960 9003 108	Ceramic 0.022uF/25V		
	C905H	00D 963 0020 202	Ceramic 0.1uF/50V		
	C906H	00D 963 9004 546	Ceramic 0.01uF/16V		
	C907H	00D 960 9006 202	Ceramic 0.01uF/50V		
OTHER PARTS GROUP					
	CB903	00D 963 0154 602	Beads inductor		*
	CB904	00D 963 0154 602	Beads inductor		*
	CN901	00D 963 0160 201	3P connector cord		*
	CN931A	00D 963 0148 809	2P connector cord		
	CN992	00D 963 0160 007	4P connector cord		*
⚠	CP101	00D 960 0118 908	AC cord connector base		
	CP102	00D 960 0123 304	2P connector base		
	CP103	00D 960 0128 901	3P connector base		
	CP104	00D 960 0128 804	6P connector base		
	CP105	00D 963 0149 109	2P connector base(BLACK)		
	CP106	00D 960 0123 207	3P connector base		
	CP1151	00D 963 0097 507	15P connector base (TUC-P)		
	CP1153	00D 963 0097 507	15P connector base (TUC-P)		
	CP138A	00D 960 0123 207	3P connector base		
	CP3911	00D 963 0160 900	8P connector base		*
	CP392	00D 963 0048 909	3P connector base		
	CP501	00D 963 0086 806	9P connector base (TUC-P)		
	CP502	00D 963 0085 807	7P connector base (TUC-P)		
	CP503	00D 963 0085 807	7P connector base (TUC-P)		
	CP504	00D 963 0086 903	5P connector base (TUC-P)		
	CP505	00D 963 0087 708	12P connector base (TUC-P)		
	CP555	00D 963 0111 108	14P connector base (TUC-P)		
	CP556	00D 963 0087 805	11P connector base (TUC-P)		
	CP901	00D 963 0048 909	3P connector base		
	CP931	00D 963 0149 206	2P connector base(BLUE)		
⚠	F102	00D 963 0104 801	Fuse 3.15A		
	F102A	00D 960 0005 804	Fuse clip		
	F102B	00D 960 0005 804	Fuse clip		
	G901	-	1P contact Ass'y		
	GND101	00D 960 9006 600	Terminal		
	GND102	00D 960 9006 600	Terminal		
	GND103	00D 960 9006 600	Terminal		
	JK901	00D 963 0095 402	Head phone jack		
	L101C	00D 963 0049 005	Inductor 0.5uH		
	L101FL	00D 963 0049 005	Inductor 0.5uH		
	L101FR	00D 963 0049 005	Inductor 0.5uH		
	L101SL	00D 963 0049 005	Inductor 0.5uH		
	L101SR	00D 963 0049 005	Inductor 0.5uH		
	RLY101	00D 960 0181 702	Relay (G5PA-28 24V)		
	RLY102	00D 960 0181 702	Relay (G5PA-28 24V)		
	RLY103	00D 960 0181 702	Relay (G5PA-28 24V)		
	RLY104	00D 960 0181 702	Relay (G5PA-28 24V)		
	RLY105	00D 963 0071 303	Relay (RSB24S 24V)		

	Ref. No.	Part No.	Part Name	Remarks	New
⚠	RLY106	00D 960 0181 605	Relay (G5PA-1-8 12V)		
	RLY107	00D 960 0181 702	Relay (G5PA-28 24V)		
	SW391	00D 963 0045 708	Tact switch		
	SW393	00D 963 0045 708	Tact switch		
	SW901	00D 963 0045 708	Tact switch		
	SW901A	00D 963 0145 802	Push switch		
	TP101	00D 960 0161 405	3P connector base		
	TP102	00D 960 0161 405	3P connector base		
	TP103	00D 960 0161 405	3P connector base		
	TP104	00D 960 0161 405	3P connector base		
	TP105	00D 960 0161 405	3P connector base		
	VEC303	00D 963 0095 208	ENCODER SW		
	-	-	Heat sink	1	
	-	-	Heat sink	1	
⚠	-	00D 963 0068 400	Capacitor cover	1	
	-	00D 963 0120 500	Fuse label	1	
	-	00D 963 0094 937	Power trans. (Mini)	1	
	-	00D 963 0018 007	Screw (2S 3X8 ZNY/BH)	3	
	-	00D 963 0158 608	2P speaker terminal	1	*
	-	00D 963 0119 906	8P speaker terminal	2	

CPU, FRONT P.W.B. UNIT

Ref. No.	Part No.	Part Name	Remarks	New
SEMICONDUCTORS GROUP				
IC201	00D 963 0161 705	IC CXP740010		
IC202	00D 963 0057 602	IC TDA7330BD		
IC203	00D 960 0100 301	IC KIA7812		
IC204	00D 963 0114 600	IC MC7806CT		
IC301	00D 960 0180 004	IC LC75721E		
IC302	00D 963 0074 504	IC BU2090F		
IC803	00D 963 0113 106	IC GP1FA513RZ		
RMC301	00D 960 0181 100	IC NJL64H380A		
Q201	00D 960 0285 006	Transistor KRC104S		
Q202	00D 963 0121 509	Transistor KTC3875S		
Q203	00D 963 0121 402	Transistor KRA104S		
Q204	00D 963 0121 606	Transistor KRC107S		
Q205	00D 960 0196 603	Transistor KTC2874B		
Q206	00D 960 0196 603	Transistor KTC2874B		
Q207	00D 960 0196 603	Transistor KTC2874B		
Q208	00D 960 0196 603	Transistor KTC2874B		
Q216	00D 960 0097 207	Transistor KRA102M		
Q217	00D 963 0102 803	Transistor 2SA933S		
Q218	00D 963 0102 803	Transistor 2SA933S		
Q219	00D 963 0102 803	Transistor 2SA933S		
Q220	00D 963 0121 208	Transistor KRC107M		
Q221	00D 960 0097 207	Transistor KRA102M		
Q222	00D 960 0097 207	Transistor KRA102M		
Q300	00D 963 0121 402	Transistor KRA104S		
Q301	00D 963 0121 402	Transistor KRA104S		
Q302	00D 960 0285 006	Transistor KRC104S		
Q303	00D 960 0285 006	Transistor KRC104S		
Q304	00D 960 0285 006	Transistor KRC104S		
Q305	00D 963 0121 402	Transistor KRA104S		
Q306	00D 963 0120 704	Transistor KRA102S		
Q307	00D 963 0121 606	Transistor KRC107S		
Q308	00D 963 0120 704	Transistor KRA102S		
D201	00D 963 0020 309	Diode 1SS133T		
D202	00D 963 0058 407	Diode IN4007		
D204	00D 963 0020 309	Diode 1SS133T		
D206	00D 960 0197 000	Diode KDS160		
D209	00D 960 0197 000	Diode KDS160		
D213	00D 963 0020 309	Diode 1SS133T		
D302	00D 963 0020 309	Diode 1SS133T		
D303	00D 963 0020 309	Diode 1SS133T		
D304	00D 963 0020 309	Diode 1SS133T		
D305	00D 960 0197 000	Diode KDS160		
D306	00D 960 0197 000	Diode KDS160		
D307	00D 960 0197 000	Diode KDS160		
ZD201	00D 963 0047 502	Zener diode MTZJ3.3B		
ZD301	00D 960 0095 801	Zener diode MTZJ6.8B		
ZD302	00D 960 0095 500	Zener diode MTZJ5.1B		
ZD303	00D 960 0095 500	Zener diode MTZJ5.1B		
ZD304	00D 960 0095 500	Zener diode MTZJ5.1B		
ZD305	00D 960 0095 500	Zener diode MTZJ5.1B		
LED301	00D 960 0197 204	LED PI5-RD/HL50RDRF4T		

	Ref. No.	Part No.	Part Name	Remarks	New
	LED302	00D 960 0197 204	LED P15-RD/HL50RDRF4T		
	LED305	00D 960 0197 204	LED P15-RD/HL50RDRF4T		
	LED306	00D 960 0197 204	LED P15-RD/HL50RDRF4T		
	LED307	00D 960 0197 204	LED P15-RD/HL50RDRF4T		
	LED308	00D 960 0197 204	LED P15-RD/HL50RDRF4T		
	LED309	00D 960 0197 204	LED P15-RD/HL50RDRF4T		
	LED310	00D 960 0197 204	LED P15-RD/HL50RDRF4T		
CAPACITORS GROUP					
	BC201	00D 963 0061 504	Electrolytic 8200uF/5.5V		
	C201D	00D 960 9010 816	Ceramic 0.1uF/50V		
	C201E	00D 963 9004 517	Ceramic 0.022uF/50V		
	C201F	00D 963 9004 546	Ceramic 0.01uF/16V		
	C202	00D 963 9004 698	Ceramic chip 0.01uF/50V		
	C202D	00D 963 9004 546	Ceramic 0.01uF/16V		
	C202E	00D 963 9004 517	Ceramic 0.022uF/50V		
	C202F	00D 963 9004 546	Ceramic 0.01uF/16V		
	C203	00D 963 9004 698	Ceramic chip 0.01uF/50V		
	C204	00D 963 9006 476	Electrolytic 4.7uF/50V		
	C205	00D 963 9004 562	Ceramic 0.047uF/50V		
	C206	00D 963 9006 421	Electrolytic 47uF/10V		
	C207	00D 963 9004 546	Ceramic 0.01uF/16V		
	C208	00D 963 9004 805	Ceramic 270pF/50V		
	C209	00D 963 9006 308	Electrolytic 10uF/50V		
	C210	00D 963 9004 698	Ceramic chip 0.01uF/50V		
	C211	00D 963 9004 614	Ceramic chip 27pF/50V		
	C212	00D 963 9004 614	Ceramic chip 27pF/50V		
	C221	00D 963 9005 312	Electrolytic 100uF/10V		
	C228	00D 963 9004 575	Ceramic chip 100pF/50V		
	C230	00D 963 9004 575	Ceramic chip 100pF/50V		
	C231	00D 963 9004 575	Ceramic chip 100pF/50V		
	C232	00D 963 9004 575	Ceramic chip 100pF/50V		
	C233	00D 963 9004 575	Ceramic chip 100pF/50V		
	C234	00D 963 9004 575	Ceramic chip 100pF/50V		
	C238	00D 963 9006 366	Electrolytic 0.1uF/50V		
	C239	00D 963 9006 366	Electrolytic 0.1uF/50V		
	C242	00D 963 9004 685	Ceramic chip 1000pF/50V		
	C245	00D 963 9004 575	Ceramic chip 100pF/50V		
	C248	00D 963 9004 685	Ceramic chip 1000pF/50V		
	C249	00D 963 9004 737	Ceramic chip 0.022uF/25V		
	C251	00D 963 0020 202	Ceramic 0.1uF/50V		
	C252	00D 960 9010 816	Ceramic 0.1uF/50V		
	C257	00D 963 9006 308	Electrolytic 10uF/50V		
	C262	00D 963 9006 379	Electrolytic 1uF/50V		
	C263	00D 963 9006 379	Electrolytic 1uF/50V		
	C301	00D 963 9004 546	Ceramic 0.01uF/16V		
	C3010	00D 963 9006 421	Electrolytic 47uF/10V		
	C302	00D 963 9004 546	Ceramic 0.01uF/16V		
	C3020	00D 963 0020 202	Ceramic 0.1uF/50V		
	C303	00D 963 9004 546	Ceramic 0.01uF/16V		
	C303O	00D 963 9004 591	Ceramic chip 22pF/50V		
	C304	00D 963 9004 546	Ceramic 0.01uF/16V		
	C305	00D 963 9004 685	Ceramic chip 1000pF/50V		
	C306	00D 963 9004 575	Ceramic chip 100pF/50V		
	C307	00D 963 9004 575	Ceramic chip 100pF/50V		
	C308	00D 960 9010 816	Ceramic 0.1uF/50V		
	C309	00D 963 9004 737	Ceramic chip 0.022uF/25V		
	C310	00D 963 9004 753	Ceramic chip 0.047uF/50V		
	C311	00D 963 9005 406	Ceramic chip 30pF/50V		

Ref. No.	Part No.	Part Name	Remarks	New
C312	00D 963 9004 753	Ceramic chip 0.047uF/50V		
C314	00D 963 0021 900	Mylar film 0.047uF/100V		
C315	00D 963 9006 379	Electrolytic 1uF/50V		
C316	00D 963 9006 308	Electrolytic 10uF/50V		
C317	00D963 9005 859	Electrolytic 47uF/16V		
C318	00D 963 9005 419	Mylar film 0.047uF/63V		
C319	00D 963 9006 434	Electrolytic 47uF/16V		
C320	00D 963 9006 379	Electrolytic 1uF/50V		
C321	00D 963 0021 900	Mylar film 0.047uF/100V		
C322	00D 963 9006 434	Electrolytic 47uF/16V		
C323	00D 963 9004 766	Mylar film 0.1uF/100V		
C324	00D 963 9006 476	Electrolytic 4.7uF/50V		
C325	00D 963 9004 575	Ceramic chip 100pF/50V		
C326	00D 963 9006 382	Electrolytic 22uF/25V		
C327	00D 963 9006 476	Electrolytic 4.7uF/50V		
C329	00D 963 9006 531	Electrolytic 22uF/16V		
C330	00D 963 9006 531	Electrolytic 22uF/16V		
C340	00D 963 9004 575	Ceramic chip 100pF/50V		
C341	00D 963 9004 575	Ceramic chip 100pF/50V		
C347	00D 963 9004 708	Ceramic chip 0.1uF/50V		
C348	00D 963 9004 708	Ceramic chip 0.1uF/50V		
C354	00D 963 9004 708	Ceramic chip 0.1uF/50V		
OTHER PARTS GROUP				
BD205	00D 963 0050 502	Chip emifil		
BD206	00D 963 0050 502	Chip emifil		
BD207	00D 963 0154 602	Beads inductor		*
BD208	00D 963 0154 602	Beads inductor		*
BD209	00D 963 0154 602	Beads inductor		*
BD250	00D 963 0154 602	Beads inductor		*
BD301	00D 963 0050 502	Chip emifil		
BD303	00D 963 0050 502	Chip emifil		
BD304	00D 963 0050 502	Chip emifil		
CB202	00D 963 0154 602	Beads inductor		*
CB203	00D 963 0154 602	Beads inductor		*
CB205	00D 963 0154 602	Beads inductor		*
CB207	00D 963 0154 602	Beads inductor		*
CB208	00D 963 0154 602	Beads inductor		*
CN201	00D 963 0159 801	5P SHIELD WIRE		*
CN302	00D 963 0160 502	8P connector cord		*
CN303	00D 963 0160 308	3P connector cord		*
CN605	00D 963 0159 908	3P connector cord		*
CN606	00D 963 0159 607	4P connector cord		*
CP1000	00D 963 0085 807	7P connector base (TUC-P)		
CP1001	00D 963 0111 108	14P connector base (TUC-P)		
CP1154	00D 963 0085 807	7P connector base (TUC-P)		
CP1155	00D 963 0085 807	7P connector base (TUC-P)		
CP301	00D 963 0161 103	23P FFC connector base		*
CP301A	00D 963 0161 006	23P FFC connector base		*
CP302	00D 963 0066 101	5P connector base		
CP303	00D 963 0049 102	3P connector base		
CP401	00D 963 0149 303	15P FFC connector base		
CP404	00D 963 0087 805	11P connector base (TUC-P)		
CP551	00D 963 0087 601	8P connector base (TUC-P)		
CP552	00D 963 0087 504	19P connector base (TUC-P)		

Ref. No.	Part No.	Part Name	Remarks	New
CP605	00D 963 0048 909	3P connector base		
CP606	00D 963 0050 104	4P connector base		
CP701	00D 963 0087 601	18P connector base (TUC-P)		
CP703	00D 963 0087 805	11P connector base (TUC-P)		
CP705	00D 963 0087 601	8P connector base (TUC-P)		
CP706	00D 963 0087 601	8P connector base (TUC-P)		
CP801	00D 963 0087 601	18P connector base (TUC-P)		
CP802	00D 963 0087 504	19P connector base (TUC-P)		
CP803	00D 960 0239 609	13P connector base (TUC-P)		
CP804	00D 963 0087 504	19P connector base (TUC-P)		
G903	-	1P contact Ass'y		
GND01	00D 960 9006 600	Terminal		
GND02	00D 960 9006 600	Terminal		
GP301	-	1P contact Ass'y		
GP301	-	1P contact Ass'y		
J326	00D 963 9003 372	Carbon chip 0 ohm 1/16W		
JIG601	00D 960 0123 605	13P connector base		
JP353	00D 963 9003 372	Carbon chip 0 ohm 1/16W		
L301	00D 960 0010 307	Inductor 10uH		
L3010	00D 960 0215 908	Inductor 4.7uH		
L302	00D 960 0128 008	Inductor 100uH		
SW301C	00D 963 0045 708	Tact switch		
SW302A	00D 963 0095 305	Tact switch		
SW302B	00D 963 0095 305	Tact switch		
SW302C	00D 963 0045 708	Tact switch		
SW303A	00D 963 0095 305	Tact switch		
SW303B	00D 963 0095 305	Tact switch		
SW303C	00D 963 0045 708	Tact switch		
SW304A	00D 963 0095 305	Tact switch		
SW304B	00D 963 0095 305	Tact switch		
SW304C	00D 963 0045 708	Tact switch		
SW305A	00D 963 0095 305	Tact switch		
SW305B	00D 963 0045 708	Tact switch		
SW305C	00D 963 0045 708	Tact switch		
SW306A	00D 963 0095 305	Tact switch		
SW306B	00D 963 0095 305	Tact switch		
SW306C	00D 963 0045 708	Tact switch		
SW307A	00D 963 0095 305	Tact switch		
SW307C	00D 963 0045 708	Tact switch		
SW308A	00D 963 0095 305	Tact switch		
SW308C	00D 963 0045 708	Tact switch		
SW309A	00D 963 0095 305	Tact switch		
SW309C	00D 963 0045 708	Tact switch		
VEC301	00D 963 0095 208	ENCODER SW		
VEC302	00D 963 0095 208	ENCODER SW		
X201	00D 960 0181 003	Resonator CST12.0MTW-TF01		
X202	00D 963 0099 505	Crystal 4.332MHz		
-	-	Heat sink	1	
-	00D 963 0018 007	Screw (2S 3X8 ZNY/BH)	1	
-	00D 960 0184 408	FLT holder	1	

	Ref. No.	Part No.	Part Name	Remarks	New
	-	00D 963 0109 505	FLT (16-ST-66GNK)	1	
	-	00D 963 0158 307	DIN SOCKET DIN-416G	1	*
	-	00D 963 0146 403	3P pin jack	1	

CNT,PRE-AMP P.W.B. UNIT

	Ref. No.	Part No.	Part Name	Remarks	New
SEMICONDUCTORS GROUP					
	Q101SBL	00D 963 0044 204	Transistor 2SD2390-Y		
	Q101SBR	00D 963 0044 204	Transistor 2SD2390-Y		
	Q102SBL	00D 963 0044 107	Transistor 2SB1560-Y		
	Q102SBR	00D 963 0044 107	Transistor 2SB1560-Y		
	Q103SBL	00D 963 0058 106	Transistor 2SD947F		
	Q103SBR	00D 963 0058 106	Transistor 2SD947F		
	Q104SBL	00D 960 0196 506	Transistor KSC1845F		
	Q104SBR	00D 960 0196 506	Transistor KSC1845F		
	Q501C	00D 960 0196 603	Transistor KTC2874B		
	Q501FL	00D 960 0196 603	Transistor KTC2874B		
	Q501FR	00D 960 0196 603	Transistor KTC2874B		
	Q501SBL	00D 960 0196 603	Transistor KTC2874B		
	Q501SBR	00D 960 0196 603	Transistor KTC2874B		
	Q501SL	00D 960 0196 603	Transistor KTC2874B		
	Q501SR	00D 960 0196 603	Transistor KTC2874B		
	Q502C	00D 960 0196 205	Transistor KSA992F		
	Q502FL	00D 960 0196 205	Transistor KSA992F		
	Q502FR	00D 960 0196 205	Transistor KSA992F		
	Q502SBL	00D 960 0196 205	Transistor KSA992F		
	Q502SBR	00D 960 0196 205	Transistor KSA992F		
	Q502SL	00D 960 0196 205	Transistor KSA992F		
	Q502SR	00D 960 0196 205	Transistor KSA992F		
	Q503C	00D 960 0196 205	Transistor KSA992F		
	Q503FL	00D 960 0196 205	Transistor KSA992F		
	Q503FR	00D 960 0196 205	Transistor KSA992F		
	Q504C	00D 960 0196 506	Transistor KSC1845F		
	Q504FL	00D 960 0196 506	Transistor KSC1845F		
	Q504FR	00D 960 0196 506	Transistor KSC1845F		
	Q504SBL	00D 960 0196 506	Transistor KSC1845F		
	Q504SBR	00D 960 0196 506	Transistor KSC1845F		
	Q504SL	00D 960 0196 506	Transistor KSC1845F		
	Q504SR	00D 960 0196 506	Transistor KSC1845F		
	Q506C	00D 960 0196 603	Transistor KTC2874B		
	Q506FL	00D 960 0196 603	Transistor KTC2874B		
	Q506FR	00D 960 0196 603	Transistor KTC2874B		
	Q506SBL	00D 960 0196 603	Transistor KTC2874B		
	Q551	00D 960 0196 700	Transistor KTC3200BL		
	Q552	00D 960 0196 302	Transistor KTA1268BL		
	Q553	00D 963 0120 704	Transistor KRA102S		
	Q554	00D 963 0120 704	Transistor KRA102S		
	Q555	00D 963 0120 704	Transistor KRA102S		
	Q556	00D 963 0120 704	Transistor KRA102S		
	Q557C	00D 963 0148 508	Transistor KTA1504S		
	Q558C	00D 963 0121 606	Transistor KRC107S		
	D106	00D 963 0020 309	Diode 1SS133T		
	D107	00D 963 0020 309	Diode 1SS133T		
	D551	00D 963 0020 309	Diode 1SS133T		
	D552	00D 963 0020 309	Diode 1SS133T		
	D553	00D 963 0020 309	Diode 1SS133T		
	D554	00D 963 0020 309	Diode 1SS133T		
	D555	00D 963 0020 309	Diode 1SS133T		
	D556	00D 963 0020 309	Diode 1SS133T		
	D557	00D 963 0020 309	Diode 1SS133T		
	D558	00D 963 0020 309	Diode 1SS133T		
	D559	00D 963 0020 309	Diode 1SS133T		

Ref. No.	Part No.	Part Name	Remarks	New
D560	00D 963 0020 309	Diode 1SS133T		
D561	00D 963 0020 309	Diode 1SS133T		
D562	00D 963 0058 407	Diode IN4007		
D563	00D 963 0058 407	Diode IN4007		
D564	00D 963 0020 309	Diode 1SS133T		
D565	00D 960 0095 500	Zener diode MTZJ5.1B		
D566	00D 963 0020 309	Diode 1SS133T		
D567	00D 963 0020 309	Diode 1SS133T		
D568	00D 963 0020 309	Diode 1SS133T		
D568C	00D 960 0197 000	Diode KDS160		
D569	00D 963 0020 309	Diode 1SS133T		
D569C	00D 960 0197 000	Diode KDS160		
D570C	00D 960 0197 000	Diode KDS160		
D573	00D 963 0058 407	Diode IN4007		
D574	00D 963 0058 407	Diode IN4007		
D575	00D 963 0058 407	Diode IN4007		
RESISTORS GROUP				
R104SBL	00D 963 9006 285	Metal oxide 5.6 kohm 1W		
R104SBR	00D 963 9006 285	Metal oxide 5.6 kohm 1W		
R105SBL	00D 963 9006 285	Metal oxide 5.6 kohm 1W		
R105SBR	00D 963 9006 285	Metal oxide 5.6 kohm 1W		
R106SBL	00D 963 0047 900	Metal film 4.7 kohm 1W		
R106SBR	00D 963 0047 900	Metal film 4.7 kohm 1W		
R107SBL	00D 963 0047 900	Metal film 4.7 kohm 1W		
R107SBR	00D 963 0047 900	Metal film 4.7 kohm 1W		
R108SBL	00D 963 9006 269	Metal oxide 0.22 ohm 1W		
R108SBR	00D 963 9006 269	Metal oxide 0.22 ohm 1W		
R109SBL	00D 963 9006 269	Metal oxide 0.22 ohm 1W		
R109SBR	00D 963 9006 269	Metal oxide 0.22 ohm 1W		
R110SBL	00D 963 9006 269	Metal oxide 0.22 ohm 1W		
R110SBR	00D 963 9006 269	Metal oxide 0.22 ohm 1W		
R111SBL	00D 963 9006 269	Metal oxide 0.22 ohm 1W		
R111SBR	00D 963 9006 269	Metal oxide 0.22 ohm 1W		
R118SBL	00D 963 9006 256	Metal oxide 10 ohm 1W		
R118SBR	00D 963 9006 256	Metal oxide 10 ohm 1W		
R119SBL	00D 963 9006 256	Metal oxide 10 ohm 1W		
R119SBR	00D 963 9006 256	Metal oxide 10 ohm 1W		
R509C	00D 960 9005 902	Metal film 1.2 kohm 1/4W		
R509FL	00D 960 9005 902	Metal film 1.2 kohm 1/4W		
R509FR	00D 960 9005 902	Metal film 1.2 kohm 1/4W		
R509SBL	00D 960 9005 902	Metal film 1.2 kohm 1/4W		
R509SBR	00D 960 9005 902	Metal film 1.2 kohm 1/4W		
R509SL	00D 960 9005 902	Metal film 1.2 kohm 1/4W		
R509SR	00D 960 9005 902	Metal film 1.2 kohm 1/4W		
R511C	00D 960 9004 301	Metal film 47 ohm 1/4W		
R511FL	00D 960 9004 301	Metal film 47 ohm 1/4W		
R511FR	00D 960 9004 301	Metal film 47 ohm 1/4W		
R511SBL	00D 960 9004 301	Metal film 47 ohm 1/4W		
R511SBR	00D 960 9004 301	Metal film 47 ohm 1/4W		
R511SL	00D 960 9004 301	Metal film 47 ohm 1/4W		
R511SR	00D 960 9004 301	Metal film 47 ohm 1/4W		
R559	00D 963 9005 642	Metal film 1.2 kohm 1W		
R565	00D 963 9005 642	Metal film 1.2 kohm 1W		
R570	00D 963 9005 642	Metal film 1.2 kohm 1W		
R575	00D 963 9006 269	Metal oxide 0.22 ohm 1W		
VR106	00D 963 0105 208	Semi fixed resistor 1 kohm		

Ref. No.	Part No.	Part Name	Remarks	New
VR107	00D 963 0105 208	Semi fixed resistor 1 kohm		
CAPACITORS GROUP				
C101SBL	00D 963 9006 450	Electrolytic 47uF/50V		
C101SBR	00D 963 9006 450	Electrolytic 47uF/50V		
C102SBL	00D 963 9006 308	Electrolytic 10uF/50V		
C102SBR	00D 963 9006 308	Electrolytic 10uF/50V		
C103SBL	00D 963 9003 084	Ceramic 100pF/500V		
C103SBR	00D 963 9003 084	Ceramic 100pF/500V		
C104SBL	00D 963 9003 084	Ceramic 100pF/500V		
C104SBR	00D 963 9003 084	Ceramic 100pF/500V		
C105SBL	00D 963 9008 640	Mylar film 0.022uF/100V		
C105SBR	00D 963 9008 640	Mylar film 0.022uF/100V		
C107SBL	00D 963 9003 097	Mylar film 0.1uF/250V		
C107SBR	00D 963 9003 097	Mylar film 0.1uF/250V		
C201PC	00D 963 9004 575	Ceramic chip 100pF/50V		
C201PFL	00D 963 9004 575	Ceramic chip 100pF/50V		
C201PFR	00D 963 9004 575	Ceramic chip 100pF/50V		
C201PSL	00D 963 9004 575	Ceramic chip 100pF/50V		
C201PSR	00D 963 9004 575	Ceramic chip 100pF/50V		
C201PSW	00D 963 9004 575	Ceramic chip 100pF/50V		
C258	00D 963 0021 104	Electrolytic 6800uF/16V		
C501C	00D 963 9006 382	Electrolytic 22uF/25V		
C501FL	00D 963 9006 382	Electrolytic 22uF/25V		
C501FR	00D 963 9006 382	Electrolytic 22uF/25V		
C501SBL	00D 963 9006 382	Electrolytic 22uF/25V		
C501SBR	00D 963 9006 382	Electrolytic 22uF/25V		
C501SL	00D 963 9006 382	Electrolytic 22uF/25V		
C501SR	00D 963 9006 382	Electrolytic 22uF/25V		
C502C	00D 963 9006 308	Electrolytic 10uF/50V		
C502FL	00D 963 9006 308	Electrolytic 10uF/50V		
C502FR	00D 963 9006 308	Electrolytic 10uF/50V		
C502SBL	00D 963 9006 308	Electrolytic 10uF/50V		
C502SBR	00D 963 9006 308	Electrolytic 10uF/50V		
C502SL	00D 963 9006 308	Electrolytic 10uF/50V		
C502SR	00D 963 9006 308	Electrolytic 10uF/50V		
C503C	00D 963 9003 165	Ceramic 220pF/500V		
C503FL	00D 963 9003 165	Ceramic 220pF/500V		
C503FR	00D 963 9003 165	Ceramic 220pF/500V		
C503SBL	00D 963 9003 165	Ceramic 220pF/500V		
C503SBR	00D 963 9003 165	Ceramic 220pF/500V		
C503SL	00D 963 9003 165	Ceramic 220pF/500V		
C503SR	00D 963 9003 165	Ceramic 220pF/500V		
C504C	00D 963 0157 502	Ceramic 220pF/50V		*
C504FL	00D 963 0157 502	Ceramic 220pF/50V		*
C504FR	00D 963 0157 502	Ceramic 220pF/50V		*
C504SBL	00D 963 0157 502	Ceramic 220pF/50V		*
C504SBR	00D 963 0157 502	Ceramic 220pF/50V		*
C504SL	00D 963 0157 502	Ceramic 220pF/50V		*
C504SR	00D 963 0157 502	Ceramic 220pF/50V		*
C505C	00D 963 9003 181	Ceramic 33pF/500V		
C505FL	00D 963 9003 181	Ceramic 33pF/500V		
C505FR	00D 963 9003 181	Ceramic 33pF/500V		
C505SBL	00D 963 9003 181	Ceramic 33pF/500V		
C505SBR	00D 963 9003 181	Ceramic 33pF/500V		
C505SL	00D 963 9003 181	Ceramic 33pF/500V		
C505SR	00D 963 9003 181	Ceramic 33pF/500V		
C506C	00D 963 9005 312	Electrolytic 100uF/10V		

Ref. No.	Part No.	Part Name	Remarks	New
C506FL	00D 963 9005 312	Electrolytic 100uF/10V		
C506FR	00D 963 9005 312	Electrolytic 100uF/10V		
C506SBL	00D 963 9005 312	Electrolytic 100uF/10V		
C506SBR	00D 963 9005 312	Electrolytic 100uF/10V		
C506SL	00D 963 9005 312	Electrolytic 100uF/10V		
C506SR	00D 963 9005 312	Electrolytic 100uF/10V		
C507C	00D 963 9003 194	Mylar film 0.0022uF/100V		
C507FL	00D 963 9003 194	Mylar film 0.0022uF/100V		
C507FR	00D 963 9003 194	Mylar film 0.0022uF/100V		
C507SBL	00D 963 9003 194	Mylar film 0.0022uF/100V		
C507SBR	00D 963 9003 194	Mylar film 0.0022uF/100V		
C507SL	00D 963 9003 194	Mylar film 0.0022uF/100V		
C507SR	00D 963 9003 194	Mylar film 0.0022uF/100V		
C508C	00D 963 9006 382	Electrolytic 22uF/25V		
C508FL	00D 963 9006 382	Electrolytic 22uF/25V		
C508FR	00D 963 9006 382	Electrolytic 22uF/25V		
C551	00D 963 9006 405	Electrolytic 2.2uF/50V		*
C551M	00D 963 0161 200	Electrolytic 10uF/25V		
C551S	00D 963 9004 562	Ceramic 0.047uF/50V		
C552	00D 963 9006 366	Electrolytic 0.1uF/50V		
C553	00D 963 9006 366	Electrolytic 0.1uF/50V		
C554	00D 963 9006 366	Electrolytic 0.1uF/50V		
C555	00D 963 9004 546	Ceramic 0.01uF/16V		
C556	00D 963 9004 546	Ceramic 0.01uF/16V		
C557	00D 963 9006 308	Electrolytic 10uF/50V		
C558	00D 963 9006 366	Electrolytic 0.1uF/50V		
C559	00D 963 0145 006	Mylar film 0.047uF/50V		
C561	00D 963 0145 006	Mylar film 0.047uF/50V		
C562	00D 963 9004 546	Ceramic 0.01uF/16V		
C563	00D 963 9004 546	Ceramic 0.01uF/16V		
C564	00D 960 0133 501	Electrolytic 2200uF/16V		
OTHER PARTS GROUP				
CN105	00D 963 0148 702	2P connector cord		
CN1153	00D 963 0097 303	15P connector socket (TUC-P)		
CN501	00D 963 0085 603	5P connector socket (TUC-P)		
CN502	00D 963 0086 602	12P connector socket (TUC-P)		
CN503	00D 963 0086 505	7P connector socket (TUC-P)		
CN504	00D 963 0085 506	9P connector socket (TUC-P)		
CN505	00D 963 0086 505	7P connector socket (TUC-P)		
CN506	00D 963 0060 903	15P connector base		*
CN506T	00D 963 0159 704	15P connector cord		
CN510	00D 963 0160 405	5P connector cord		*
CN551	00D 963 0097 206	8P connector socket (TUC-P)		
CN552	00D 963 0086 204	19P connector socket (TUC-P)		
CN553	00D 963 0097 206	8P connector socket (TUC-P)		
CN554	00D 963 0160 609	15P connector cord		*
CN555	00D 963 0086 709	11P connector socket (TUC-P)		
CN556	00D 963 0159 403	15P connector cord		*
CN557	00D 963 0086 709	11P connector socket (TUC-P)		
CN560	00D 963 0110 701	14P connector socket (TUC-P)		
CN992	00D 960 0217 553	4P connector base		
CP1154	00D 963 0097 507	15P connector base (TUC-P)		
CP508	00D 963 0068 303	9P connector base		
CP509	00D 963 0060 505	7P connector base		
CP510	00D 963 0066 101	5P connector base		
CP554	00D 963 0060 903	15P connector base		

	Ref. No.	Part No.	Part Name	Remarks	New
	CP568	00D 963 0049 102	3P connector base		
	CP602D	00D 963 0097 507	15P connector base (TUC-P)		
	F101	00D 963 0104 704	Fuse 2.5A		
	F101A	00D 960 0005 804	Fuse clip		
	F101B	00D 960 0005 804	Fuse clip		
	J209RM	00D 963 9003 372	Carbon chip 0 ohm 1/16W		
	L101SBL	00D 963 0049 005	Inductor 0.5uH		
	L101SBR	00D 963 0049 005	Inductor 0.5uH		
	TP106	00D 960 0161 418	3P connector base		
	TP107	00D 960 0161 418	3P connector base		
	-	00D 960 0184 000	Screw bracket	2	
	-	00D 960 0184 000	Screw bracket	2	
	-	00D 960 0236 602	Shield plate	1	
	-	00D 960 0268 803	6P pin jack	1	
	-	00D 960 0143 203	AC outlet	1	

INPUT, VIDEO P.W.B. UNIT

	Ref. No.	Part No.	Part Name	Remarks	New
SEMICONDUCTORS GROUP					
	IC1000		IC BA7626F	J171762600010	
	IC1001	00D 963 0116 103	IC MM74HC4053MX		
	IC1002		IC BA7626F	J171762600010	
	IC1003	00D 963 0074 504	IC BU2090F		
	IC1004	00D 963 0116 103	IC MM74HC4053MX		
	IC1005	00D 963 0074 504	IC BU2090F		
	IC1006	00D 963 0116 307	IC LC7478		
	IC1007	00D 963 0116 200	IC NJM2274R		
	IC1008	00D 963 0116 103	IC MM74HC4053MX		
	IC1150		IC BA7626F	J171762600010	
	IC1151		IC BA7626F	J171762600010	
	IC1152		IC BA7626F	J171762600010	
	IC1153		IC BA7626F	J171762600010	
	IC201T	00D 963 0158 909	IC TC94A27UG		*
	IC202T	00D 963 0158 909	IC TC94A27UG		*
	IC203T	00D 960 0080 201	IC KIC9164AN		
	IC205	00D 963 0024 004	IC NJM2068M		
	IC206	00D 963 0024 004	IC NJM2068M		
	IC207	00D 963 0024 004	IC NJM2068M		
	IC208	00D 963 0159 005	IC NJM5532M		*
	IC209	00D 963 0159 005	IC NJM5532M		*
	IC210	00D 963 0159 005	IC NJM5532M		*
	IC211	00D 963 0159 005	IC NJM5532M		*
	IC603E		IC BA7626F	J171762600010	
	IC604E		IC BA7626F	J171762600010	
	IC605E	00D 960 0175 200	IC BA7625		
	IC701	00D 963 0083 207	IC TC9274N-011		
	IC701M	00D 963 0024 004	IC NJM2068M		
	IC702	00D 963 0024 004	IC NJM2068M		
	IC703	00D 963 0024 004	IC NJM2068M		
	IC704	00D 960 0174 502	IC NJM2068DD		
	IC705	00D 960 0174 201	IC TC9273N-004		
	Q1000	00D 963 0102 803	Transistor 2SA933S		
	Q1001	00D 963 0102 803	Transistor 2SA933S		
	Q1002	00D 963 0121 703	Transistor KRA107S		
	Q1003	00D 963 0121 703	Transistor KRA107S		
	Q1004	00D 963 0120 704	Transistor KRA102S		
	Q1005	00D 963 0159 102	Transistor KRC111S		*
	Q1006	00D 963 0120 801	Transistor KRC102S		
	Q1007	00D 960 0068 207	Transistor KTA1504Y		
	Q1008	00D 963 0120 704	Transistor KRA102S		
	Q1009	00D 963 0159 102	Transistor KRC111S		*
	Q1010	00D 963 0120 801	Transistor KRC102S		
	Q1011	00D 960 0068 207	Transistor KTA1504Y		
	Q1012	00D 963 0044 301	Transistor KTC2875B		
	Q1013	00D 963 0120 704	Transistor KRA102S		
	Q1014	00D 960 0068 207	Transistor KTA1504Y		
	Q1015	00D 963 0120 801	Transistor KRC102S		
	Q1016	00D 960 0068 207	Transistor KTA1504Y		
	Q1017	00D 960 0068 207	Transistor KTA1504Y		
	Q1018	00D 960 0068 207	Transistor KTA1504Y		
	Q1019	00D 960 0068 207	Transistor KTA1504Y		
	Q1020	00D 963 0066 606	Transistor KTC3875Y		
	Q1021	00D 963 0066 606	Transistor KTC3875Y		
	Q1022	00D 960 0068 207	Transistor KTA1504Y		

	Ref. No.	Part No.	Part Name	Remarks	New
	Q1023	00D 963 0102 803	Transistor 2SA933S		
	Q1024	00D 960 0005 202	Transistor KTC3198Y		
	Q1025	00D 960 0005 105	Transistor KTA1266Y		
	Q1026	00D 960 0005 105	Transistor KTA1266Y		
	Q1027	00D 960 0005 105	Transistor KTA1266Y		
	Q1028	00D 960 0005 202	Transistor KTC3198Y		
	Q1029	00D 960 0005 105	Transistor KTA1266Y		
	Q1030	00D 960 0005 202	Transistor KTC3198Y		
	Q1150	00D 963 0159 102	Transistor KRC111S		*
	Q1151	00D 960 0068 207	Transistor KTA1504Y		
	Q1152	00D 963 0159 102	Transistor KRC111S		*
	Q1153	00D 960 0068 207	Transistor KTA1504Y		
	Q1155	00D 963 0159 102	Transistor KRC111S		*
	Q1156	00D 960 0068 207	Transistor KTA1504Y		
	Q1157	00D 963 0159 102	Transistor KRC111S		*
	Q1158	00D 960 0068 207	Transistor KTA1504Y		
	Q1159	00D 960 0068 207	Transistor KTA1504Y		
	Q1160	00D 963 0159 102	Transistor KRC111S		*
	Q1161	00D 963 0159 102	Transistor KRC111S		*
	Q1162	00D 960 0068 207	Transistor KTA1504Y		
	Q207T	00D 960 0196 807	Transistor 2SK117Y		
	Q208T	00D 960 0196 807	Transistor 2SK117Y		
	Q209T	00D 960 0097 003	Transistor KRA104M		
	Q210T	00D 963 0121 004	Transistor KRC104M		
	Q551SW	00D 963 0044 301	Transistor KTC2875B		
	Q552SW	00D 963 0044 301	Transistor KTC2875B		
	Q601E	00D 960 0005 105	Transistor KTA1266Y		
	Q602E	00D 960 0005 105	Transistor KTA1266Y		
	Q603E	00D 960 0005 105	Transistor KTA1266Y		
	D1000	00D 960 0197 000	Diode KDS160		
	D1001	00D 960 0197 000	Diode KDS160		
	D1002	00D 960 0197 000	Diode KDS160		
	D1003	00D 960 0197 000	Diode KDS160		
	D1004	00D 960 0197 000	Diode KDS160		
	D1005	00D 960 0197 000	Diode KDS160		
	D1012	00D 963 0020 309	Diode 1SS133T		
	D1014	00D 963 0020 309	Diode 1SS133T		
	D1150	00D 960 0197 000	Diode KDS160		
	D1151	00D 960 0197 000	Diode KDS160		
	D1152	00D 960 0197 000	Diode KDS160		
	D1153	00D 960 0197 000	Diode KDS160		
	D1154	00D 960 0197 000	Diode KDS160		
	D1155	00D 960 0197 000	Diode KDS160		
	D1157	00D 960 0197 000	Diode KDS160		
	D1158	00D 960 0197 000	Diode KDS160		
	D205T	00D 960 0197 000	Diode KDS160		
	D207T	00D 960 0197 000	Diode KDS160		
	D251	00D 960 0197 000	Diode KDS160		
	D252	00D 960 0197 000	Diode KDS160		
	D253	00D 960 0197 000	Diode KDS160		
	D254	00D 960 0197 000	Diode KDS160		
	D255	00D 960 0197 000	Diode KDS160		
	D256	00D 960 0197 000	Diode KDS160		
	D901	00D 960 0197 000	Diode KDS160		
	D902	00D 960 0197 000	Diode KDS160		
	D903	00D 960 0197 000	Diode KDS160		
	D904	00D 960 0197 000	Diode KDS160		
	ZD1000	00D 960 0095 500	Zener diode MTZJ5.1B		
	ZD701M	00D 960 0095 500	Zener diode MTZJ5.1B		

Ref. No.	Part No.	Part Name	Remarks	New
RESISTORS GROUP				
R1031	00D 963 9005 639	Metal film 100 ohm 1W		
R1038	00D 963 9005 639	Metal film 100 ohm 1W		
R1059	00D 963 9005 639	Metal film 100 ohm 1W		
R1095	00D 963 0018 007	Metal film 100 ohm 1/4W		
R1163	00D 963 9005 639	Metal film 100 ohm 1W		
R1166	00D 963 9005 639	Metal film 100 ohm 1W		
R1193	00D 963 9005 639	Metal film 100 ohm 1W		
R1199	00D 963 9005 639	Metal film 100 ohm 1W		
R1232	00D 963 9005 639	Metal film 100 ohm 1W		
R1239	00D 963 9005 639	Metal film 100 ohm 1W		
R229T	00D 963 9005 639	Metal film 100 ohm 1W		
R230T	00D 963 9005 639	Metal film 100 ohm 1W		
R738M	00D 963 9005 338	Carbon chip 1.6 kohm 1/10W		
CAPACITORS GROUP				
C1000	00D 963 9006 382	Electrolytic 22uF/25V		
C1001	00D 963 9006 382	Electrolytic 22uF/25V		
C1002	00D 963 9005 312	Electrolytic 100uF/10V		
C1003	00D 963 9004 753	Ceramic chip 0.047uF/50V		
C1004	00D 963 9006 308	Electrolytic 10uF/50V		
C1005	00D 963 9006 308	Electrolytic 10uF/50V		
C1006	00D 963 9006 382	Electrolytic 22uF/25V		
C1007	00D 963 9004 753	Ceramic chip 0.047uF/50V		
C1009	00D 963 9006 308	Electrolytic 10uF/50V		
C1010	00D 963 9006 405	Electrolytic 2.2uF/50V		
C1011	00D 963 9006 405	Electrolytic 2.2uF/50V		
C1013	00D 963 9006 382	Electrolytic 22uF/25V		
C1014	00D 963 9006 308	Electrolytic 10uF/50V		
C1016	00D 963 9006 146	Ceramic chip 560pF/50V		
C1017	00D 963 9004 575	Ceramic chip 100pF/50V		
C1018	00D 963 9004 575	Ceramic chip 100pF/50V		
C1019	00D 963 9006 308	Electrolytic 10uF/50V		
C1020	00D 963 9006 463	Electrolytic 470uF/6.3V		
C1021	00D 963 9006 560	Electrolytic 47uF/35V		
C1022	00D 963 9006 308	Electrolytic 10uF/50V		
C1023	00D 963 9006 463	Electrolytic 470uF/6.3V		
C1024	00D 963 9004 753	Ceramic chip 0.047uF/50V		
C1025	00D 963 9006 515	Ceramic 1pF/50V		
C1026	00D 963 9006 308	Electrolytic 10uF/50V		
C1027	00D 963 9006 463	Electrolytic 470uF/6.3V		
C1030	00D 963 9006 434	Electrolytic 47uF/16V		
C1034	00D 963 9006 515	Ceramic 1pF/50V		
C1035	00D 963 9006 560	Electrolytic 47uF/35V		
C1039	00D 963 9006 528	Ceramic chip 20pF/50V		
C1040	00D 963 9006 379	Electrolytic 1uF/50V		
C1041	00D 963 0157 706	Ceramic chip 0.022uF/50V		*
C1042	00D 963 9006 434	Electrolytic 47uF/16V		
C1049	00D 963 9006 528	Ceramic chip 20pF/50V		
C1052	00D 963 9006 308	Electrolytic 10uF/50V		
C1053	00D 963 9006 308	Electrolytic 10uF/50V		
C1054	00D 963 9005 998	Ceramic chip 24pF/50V		
C1055	00D 963 9004 753	Ceramic chip 0.047uF/50V		
C1056	00D 963 9006 379	Electrolytic 1uF/50V		

Ref. No.	Part No.	Part Name	Remarks	New
C1057	00D 963 9005 998	Ceramic chip 24pF/50V		
C1058	00D 963 9006 434	Electrolytic 47uF/16V		
C1059	00D 963 9004 753	Ceramic chip 0.047uF/50V		
C1060	00D 963 9006 434	Electrolytic 47uF/16V		
C1061	00D 963 0129 909	Ceramic chip 1200pF/50V		
C1062	00D 963 9005 312	Electrolytic 100uF/10V		
C1063	00D 960 9010 094	Ceramic chip 0.01uF/50V		
C1069	00D 963 9006 382	Electrolytic 22uF/25V		
C1070	00D 963 9005 312	Electrolytic 100uF/10V		
C1071	00D 963 9006 379	Electrolytic 1uF/50V		
C1080	00D 963 0157 706	Ceramic chip 0.022uF/50V		*
C1081	00D 963 9006 434	Electrolytic 47uF/16V		
C1150	00D 963 9006 382	Electrolytic 22uF/25V		
C1151	00D 960 9010 094	Ceramic chip 0.01uF/50V		
C1152	00D 963 9006 382	Electrolytic 22uF/25V		
C1153	00D 963 9004 575	Ceramic chip 100pF/50V		
C1154	00D 963 9004 575	Ceramic chip 100pF/50V		
C1155	00D 963 9004 575	Ceramic chip 100pF/50V		
C1156	00D 963 9004 575	Ceramic chip 100pF/50V		
C1157	00D 963 9006 382	Electrolytic 22uF/25V		
C1158	00D 963 9004 753	Ceramic chip 0.047uF/50V		
C1159	00D 963 9006 382	Electrolytic 22uF/25V		
C1160	00D 963 9006 308	Electrolytic 10uF/50V		
C1161	00D 963 9006 463	Electrolytic 470uF/6.3V		
C1162	00D 963 9006 308	Electrolytic 10uF/50V		
C1163	00D 963 9006 463	Electrolytic 470uF/6.3V		
C1164	00D 963 9006 382	Electrolytic 22uF/25V		
C1165	00D 963 9006 382	Electrolytic 22uF/25V		
C1167	00D 963 9004 753	Ceramic chip 0.047uF/50V		
C1171	00D 963 9006 382	Electrolytic 22uF/25V		
C1172	00D 963 9006 382	Electrolytic 22uF/25V		
C1173	00D 963 9004 753	Ceramic chip 0.047uF/50V		
C1181	00D 963 9006 308	Electrolytic 10uF/50V		
C1183	00D 960 9010 515	Electrolytic 0.47uF/50V		
C1188	00D 963 9006 308	Electrolytic 10uF/50V		
C1189	00D 960 9010 515	Electrolytic 0.47uF/50V		
C1207	00D 963 9003 372	Carbon chip 0 ohm 1/16W		
C1208	00D 963 9003 372	Carbon chip 0 ohm 1/16W		
C1209	00D 963 9003 372	Carbon chip 0 ohm 1/16W		
C1210	00D 963 9003 372	Carbon chip 0 ohm 1/16W		
C1215	00D 963 9003 372	Carbon chip 0 ohm 1/16W		
C1219	00D 963 9006 463	Electrolytic 470uF/6.3V		
C1220	00D 963 9006 308	Electrolytic 10uF/50V		
C1222	00D 960 9010 515	Electrolytic 0.47uF/50V		
C211SW	00D 963 9004 575	Ceramic chip 100pF/50V		
C212SW	00D 963 9004 643	Ceramic chip 47pF/50V		
C213FL	00D 963 9004 575	Ceramic chip 100pF/50V		
C213FR	00D 963 9004 575	Ceramic chip 100pF/50V		
C213T	00D 963 9004 753	Ceramic chip 0.047uF/50V		
C214T	00D 963 9004 753	Ceramic chip 0.047uF/50V		
C215T	00D 963 9004 753	Ceramic chip 0.047uF/50V		
C216T	00D 963 9004 753	Ceramic chip 0.047uF/50V		
C217T	00D 963 9004 753	Ceramic chip 0.047uF/50V		
C218FL	00D 963 9004 627	Ceramic chip 33pF/50V		
C218FR	00D 963 9004 627	Ceramic chip 33pF/50V		
C218T	00D 963 9006 379	Electrolytic 1uF/50V		
C219FL	00D 963 9006 308	Electrolytic 10uF/50V		
C219FR	00D 963 9006 308	Electrolytic 10uF/50V		
C219SW	00D 963 9006 308	Electrolytic 10uF/50V		
C219T	00D 963 9006 379	Electrolytic 1uF/50V		
C220T	00D 963 9006 308	Electrolytic 10uF/50V		

	Ref. No.	Part No.	Part Name	Remarks	New
	C223C	00D 963 9006 382	Electrolytic 22uF/25V		
	C223FL	00D 963 9006 382	Electrolytic 22uF/25V		
	C223FR	00D 963 9006 382	Electrolytic 22uF/25V		
	C223SBL	00D 963 9006 382	Electrolytic 22uF/25V		
	C223SBR	00D 963 9006 382	Electrolytic 22uF/25V		
	C223SL	00D 963 9006 382	Electrolytic 22uF/25V		
	C223SR	00D 963 9006 382	Electrolytic 22uF/25V		
	C223SW	00D 963 9006 382	Electrolytic 22uF/25V		
	C225T	00D 963 9006 379	Electrolytic 1uF/50V		
	C226T	00D 963 9006 379	Electrolytic 1uF/50V		
	C227T	00D 963 9006 308	Electrolytic 10uF/50V		
	C228T	00D 963 9006 434	Electrolytic 47uF/16V		
	C229T	00D 963 9006 434	Electrolytic 47uF/16V		
	C230T	00D 963 9006 308	Electrolytic 10uF/50V		
	C231C	00D 963 9006 418	Electrolytic 3.3uF/50V		
	C231FL	00D 963 9006 418	Electrolytic 3.3uF/50V		
	C231FR	00D 963 9006 418	Electrolytic 3.3uF/50V		
	C231SBL	00D 963 9006 418	Electrolytic 3.3uF/50V		
	C231SBR	00D 963 9006 418	Electrolytic 3.3uF/50V		
	C231SL	00D 963 9006 418	Electrolytic 3.3uF/50V		
	C231SR	00D 963 9006 418	Electrolytic 3.3uF/50V		
	C231SW	00D 963 9006 418	Electrolytic 3.3uF/50V		
	C231T	00D 963 9006 308	Electrolytic 10uF/50V		
	C232C	00D 960 9010 104	Ceramic 5pF/50V		
	C232FL	00D 960 9010 104	Ceramic 5pF/50V		
	C232FR	00D 960 9010 104	Ceramic 5pF/50V		
	C232SBL	00D 960 9010 104	Ceramic 5pF/50V		
	C232SBR	00D 960 9010 104	Ceramic 5pF/50V		
	C232SL	00D 960 9010 104	Ceramic 5pF/50V		
	C232SR	00D 960 9010 104	Ceramic 5pF/50V		
	C232SW	00D 960 9010 104	Ceramic 5pF/50V		
	C232T	00D 963 9006 434	Electrolytic 47uF/16V		
	C233T	00D 963 9006 434	Electrolytic 47uF/16V		
	C234T	00D 963 9006 434	Electrolytic 47uF/16V		
	C235T	00D 963 9006 434	Electrolytic 47uF/16V		
	C236T	00D 963 9006 434	Electrolytic 47uF/16V		
	C237T	00D 963 9006 434	Electrolytic 47uF/16V		
	C238C	00D 963 9006 418	Electrolytic 3.3uF/50V		
	C238FL	00D 963 9006 418	Electrolytic 3.3uF/50V		
	C238FR	00D 963 9006 418	Electrolytic 3.3uF/50V		
	C239T	00D 963 9004 753	Ceramic chip 0.047uF/50V		
	C240T	00D 963 9006 379	Electrolytic 1uF/50V		
	C241T	00D 963 9006 308	Electrolytic 10uF/50V		
	C243T	00D 963 9006 379	Electrolytic 1uF/50V		
	C244T	00D 963 9006 379	Electrolytic 1uF/50V		
	C245T	00D 963 9006 379	Electrolytic 1uF/50V		
	C246SW	00D 963 9006 476	Electrolytic 4.7uF/50V		
	C246T	00D 963 9006 308	Electrolytic 10uF/50V		
	C247T	00D 963 9004 575	Ceramic chip 100pF/50V		
	C248T	00D 963 9006 379	Electrolytic 1uF/50V		
	C251	00D 963 9004 708	Ceramic chip 0.1uF/50V		
	C252	00D 963 9004 708	Ceramic chip 0.1uF/50V		
	C253	00D 963 9004 708	Ceramic chip 0.1uF/50V		
	C601E	00D 963 9005 312	Electrolytic 100uF/10V		
	C601I	00D 963 9003 372	Carbon chip 0 ohm 1/16W		
	C602E	00D 963 9005 312	Electrolytic 100uF/10V		
	C602I	00D 963 9003 372	Carbon chip 0 ohm 1/16W		
	C603E	00D 963 9005 312	Electrolytic 100uF/10V		
	C604E	00D 963 9006 159	Electrolytic 4700uF/16V		
	C605E	00D 963 9006 463	Electrolytic 470uF/6.3V		
	C606E	00D 963 9006 463	Electrolytic 470uF/6.3V		

Ref. No.	Part No.	Part Name	Remarks	New
C618E	00D 963 9006 379	Electrolytic 1uF/50V		
C620E	00D 963 9006 476	Electrolytic 4.7uF/50V		
C621E	00D 963 0157 706	Ceramic chip 0.022uF/50V		*
C622E	00D 963 9005 312	Electrolytic 100uF/10V		
C623E	00D 963 9006 476	Electrolytic 4.7uF/50V		
C624E	00D 963 9006 476	Electrolytic 4.7uF/50V		
C625E	00D 963 9006 379	Electrolytic 1uF/50V		
C627E	00D 963 0157 706	Ceramic chip 0.022uF/50V		*
C628E	00D 963 9005 312	Electrolytic 100uF/10V		
C632E	00D 963 9006 476	Electrolytic 4.7uF/50V		
C633E	00D 963 9006 379	Electrolytic 1uF/50V		
C635E	00D 963 9006 476	Electrolytic 4.7uF/50V		
C636E	00D 963 0157 706	Ceramic chip 0.022uF/50V		*
C637E	00D 963 9005 312	Electrolytic 100uF/10V		
C638E	00D 963 9006 476	Electrolytic 4.7uF/50V		
C639E	00D 963 9006 476	Electrolytic 4.7uF/50V		
C640E	00D 963 9006 476	Electrolytic 4.7uF/50V		
C641E	00D 963 9006 476	Electrolytic 4.7uF/50V		
C702L	00D 963 9004 575	Ceramic chip 100pF/50V		
C702R	00D 963 9004 575	Ceramic chip 100pF/50V		
C703L	00D 963 9004 575	Ceramic chip 100pF/50V		
C703R	00D 963 9004 575	Ceramic chip 100pF/50V		
C704L	00D 963 9004 575	Ceramic chip 100pF/50V		
C704R	00D 963 9004 575	Ceramic chip 100pF/50V		
C705L	00D 963 9004 575	Ceramic chip 100pF/50V		
C705R	00D 963 9004 575	Ceramic chip 100pF/50V		
C709L	00D 963 9006 308	Electrolytic 10uF/50V		
C709R	00D 963 9006 308	Electrolytic 10uF/50V		
C711L	00D 963 9006 557	Electrolytic 220uF/6.3V		
C711R	00D 963 9006 557	Electrolytic 220uF/6.3V		
C712L	00D 963 9004 779	Mylar film 0.024uF/50V		
C712R	00D 963 9004 779	Mylar film 0.024uF/50V		
C713L	00D 960 9008 695	Mylar film 0.0068uF/100V		
C713R	00D 960 9008 695	Mylar film 0.0068uF/100V		
C714L	00D 963 9006 476	Electrolytic 4.7uF/50V		
C714R	00D 963 9006 476	Electrolytic 4.7uF/50V		
C715L	00D 963 9004 737	Ceramic chip 0.022uF/25V		
C715R	00D 963 9004 737	Ceramic chip 0.022uF/25V		
C716L	00D 963 9006 308	Electrolytic 10uF/50V		
C717L	00D 963 9004 601	Ceramic chip 220pF/50V		
C717R	00D 963 9004 601	Ceramic chip 220pF/50V		
C718L	00D 963 9006 421	Electrolytic 47uF/10V		
C718R	00D 963 9006 421	Electrolytic 47uF/10V		
C719L	00D 963 9006 379	Electrolytic 1uF/50V		
C719R	00D 963 9006 379	Electrolytic 1uF/50V		
C720L	00D 963 9003 152	Mylar film 0.068uF/100V		
C720R	00D 963 9003 152	Mylar film 0.068uF/100V		
C721L	00D 963 9003 152	Mylar film 0.068uF/100V		
C721R	00D 963 9003 152	Mylar film 0.068uF/100V		
C723M	00D 963 9006 379	Electrolytic 1uF/50V		
C724L	00D 963 9004 698	Ceramic chip 0.01uF/50V		
C724M	00D 963 9006 379	Electrolytic 1uF/50V		
C724R	00D 963 9004 698	Ceramic chip 0.01uF/50V		
C725	00D 963 9004 698	Ceramic chip 0.01uF/50V		
C725M	00D 963 9006 379	Electrolytic 1uF/50V		
C726	00D 963 9004 698	Ceramic chip 0.01uF/50V		
C726M	00D 963 0157 609	Ceramic chip 150pF/50V		*
C727M	00D 963 9004 575	Ceramic chip 100pF/50V		
C728M	00D 963 0157 609	Ceramic chip 150pF/50V		*
C729	00D 963 9004 708	Ceramic chip 0.1uF/50V		
C729M	00D 963 9006 379	Electrolytic 1uF/50V		

	Ref. No.	Part No.	Part Name	Remarks	New
	C730M	00D 963 9006 308	Electrolytic 10uF/50V		
	C737M	00D 963 9004 575	Ceramic chip 100pF/50V		
	C738M	00D 963 9004 698	Ceramic chip 0.01uF/50V		
	C901SW	00D 963 9006 476	Electrolytic 4.7uF/50V		
	C910	00D 963 9004 575	Ceramic chip 100pF/50V		
	C911	00D 960 9010 094	Ceramic chip 0.01uF/50V		
	C912	00D 963 9004 575	Ceramic chip 100pF/50V		
	C913	00D 963 9004 575	Ceramic chip 100pF/50V		
	C914	00D 963 9004 575	Ceramic chip 100pF/50V		
	C915	00D 963 9004 575	Ceramic chip 100pF/50V		
	C916	00D 963 9004 575	Ceramic chip 100pF/50V		
	C917	00D 960 9010 094	Ceramic chip 0.01uF/50V		
	C918	00D 963 9004 575	Ceramic chip 100pF/50V		
	C920	00D 963 9004 575	Ceramic chip 100pF/50V		
OTHER PARTS GROUP					
	CB1000	00D 963 0120 908	Beads inductor		
	CB1001	00D 963 0120 908	Beads inductor		
	CB1002	00D 963 0115 609	Inductor 33uH		
	CB205	00D 963 0154 602	Beads inductor		*
	CN1000	00D 963 0086 505	7P connector socket (TUC-P)		
	CN1004	00D 963 0110 701	14P connector socket (TUC-P)		
	CN1150	00D 963 0086 505	7P connector socket (TUC-P)		
	CN1151	00D 963 0097 303	15P connector socket (TUC-P)		
	CN1154	00D 963 0097 303	15P connector socket (TUC-P)		
	CN403	00D 963 0086 709	11P connector socket (TUC-P)		
	CN508	00D 963 0159 306	9P connector cord		*
	CN509	00D 963 0159 209	7P connector cord		*
	CN557T	00D 963 0050 104	4P connector base		
	CN601	00D 963 0097 303	15P connector socket (TUC-P)		
	CN701	00D 963 0086 301	18P connector socket (TUC-P)		
	CN701M	00D 963 0160 104	4P connector cord		*
	CN703	00D 963 0086 505	7P connector socket (TUC-P)		
	CN805	00D 963 0097 206	8P connector socket (TUC-P)		
	CN806	00D 963 0086 204	19P connector socket (TUC-P)		
	CP556	00D 963 0060 903	15P connector base		
	G902	-	1P contact Ass'y		
	J712B	00D 963 9003 372	Carbon chip 0 ohm 1/16W		
	J712C	00D 963 9003 372	Carbon chip 0 ohm 1/16W		
	JK704	00D 960 0188 103	2P pin jack		
	L1000	00D 963 0131 007	Y/C SEPARATE FILTER		
	L701L	00D 963 0056 302	FTZ CHOKE COIL		
	L701R	00D 963 0056 302	FTZ CHOKE COIL		
	XTAL1000	00D 963 0131 405	Crystal 14.318180MHZ		
	-	00D 963 0101 707	Input cushion	1	
	-	00D 963 0094 102	PLATE INPUT	1	
	-	00D 963 0146 209	4P pin jack	2	
	-	00D 960 0268 803	6P pin jack	1	
	-	00D 963 0146 102	2P pin jack	2	
	-	00D 963 0146 209	4P pin jack	1	

	Ref. No.	Part No.	Part Name	Remarks	New
	-	00D 963 0146 500	3P pin jack	1	
	-	00D 963 0146 306	6P pin jack	2	
	-	00D 963 0146 209	4P pin jack	2	
	-	00D 963 0158 200	Mini jack	1	*

DSP P.W.B. UNIT

	Ref. No.	Part No.	Part Name	Remarks	New
SEMICONDUCTORS GROUP					
	IC801	00D 963 0113 106	IC GP1FA513RZ		
	IC802	00D 963 0113 106	IC GP1FA513RZ		
	IC803	00D 963 0113 106	IC GP1FA513RZ		
	IC804	00D 963 0147 402	IC ADSP-21266		
	IC805	00D 963 0146 908	IC LH28F800BJE		
	IC806	00D 963 0158 705	IC CY7C1049CV33		*
	IC807	00D 963 0096 100	IC LC89057W		
	IC808	00D 963 0158 802	IC AD1837AAS		*
	IC809	00D 960 0266 805	IC MM74LCX244		
	IC810	00D 960 0266 805	IC MM74LCX244		
	IC811	00D 960 0266 805	IC MM74LCX244		
	IC812	00D 960 0266 902	IC MM74HCT244		
	IC814	00D 963 0102 308	IC MM74HC00MTCX		
	IC815	00D 963 0102 308	IC MM74HC00MTCX		
	IC815A	00D 963 0043 807	IC BA4510F		
	IC816	00D 963 0147 208	IC 74LVX157		
	IC816A	00D 963 0043 807	IC BA4510F		
	IC817	00D 963 0158 705	IC CY7C1049CV33		*
	IC817A	00D 963 0024 004	IC NJM2068M		
	IC818	00D 963 0147 305	IC 74LCX573		
	IC818A	00D 963 0024 004	IC NJM2068M		
	IC819	00D 963 0147 305	IC 74LCX573		
	IC819A	00D 963 0024 004	IC NJM2068M		
	IC820	00D 963 0147 101	IC SN74LVC139A		
	IC820A	00D 963 0024 004	IC NJM2068M		
	IC821	00D 963 0096 003	IC 74LCX74MTC		
	IC822	00D 960 0159 501	IC KIA7805API		
	IC823	00D 963 0111 603	IC RC1117-3.3		
	IC824	00D 963 0147 509	IC RC1117-1.2		
	IC825	00D 963 0096 003	IC 74LCX74MTC		
	IC826	00D 963 0113 009	IC GP1FA513TZ		
	Q804C	00D 960 0196 603	Transistor KTC2874B		
	Q804FL	00D 960 0196 603	Transistor KTC2874B		
	Q804FR	00D 960 0196 603	Transistor KTC2874B		
	Q804SBL	00D 960 0196 603	Transistor KTC2874B		
	Q804SBR	00D 960 0196 603	Transistor KTC2874B		
	Q804SL	00D 960 0196 603	Transistor KTC2874B		
	Q804SR	00D 960 0196 603	Transistor KTC2874B		
	Q804SW	00D 960 0196 603	Transistor KTC2874B		
	Q808	00D 963 0120 801	Transistor KRC102S		
	Q809	00D 963 0120 704	Transistor KRA102S		
	D801	00D 960 0197 000	Diode KDS160		
	D803	00D 960 0197 000	Diode KDS160		
CAPACITORS GROUP					
	C801	00D 963 9004 708	Ceramic chip 0.1uF/50V		
	C802	00D 963 9004 591	Ceramic chip 22pF/50V		
	C803	00D 963 9004 591	Ceramic chip 22pF/50V		
	C804	00D 963 9004 591	Ceramic chip 22pF/50V		
	C805	00D 963 9004 591	Ceramic chip 22pF/50V		
	C806	00D 963 9004 708	Ceramic chip 0.1uF/50V		

Ref. No.	Part No.	Part Name	Remarks	New
C807	00D 963 9004 708	Ceramic chip 0.1uF/50V		
C808	00D 963 9005 862	Electrolytic 47uF/16V		
C809	00D 963 9004 708	Ceramic chip 0.1uF/50V		
C810	00D 963 9005 862	Electrolytic 47uF/16V		
C811	00D 963 9004 591	Ceramic chip 22pF/50V		
C812	00D 963 9005 927	Electrolytic 0.1uF/50V		
C813	00D 963 9004 698	Ceramic chip 0.01uF/50V		
C814	00D 963 9005 862	Electrolytic 47uF/16V		
C815	00D 963 9005 312	Electrolytic 100uF/10V		
C817	00D 963 9005 778	Electrolytic 10uF/50V		
C818	00D 963 9005 749	Electrolytic 1uF/50V		
C819	00D 963 9005 901	Electrolytic 470uF/10V		
C820	00D 963 9005 862	Electrolytic 47uF/16V		
C821	00D 963 9005 901	Electrolytic 470uF/10V		
C830	00D 963 9005 901	Electrolytic 470uF/10V		
C831	00D 963 9004 708	Ceramic chip 0.1uF/50V		
C832	00D 963 9004 708	Ceramic chip 0.1uF/50V		
C833	00D 963 9004 698	Ceramic chip 0.01uF/50V		
C835	00D 963 9004 708	Ceramic chip 0.1uF/50V		
C836	00D 963 9004 685	Ceramic chip 1000pF/50V		
C837	00D 963 9004 685	Ceramic chip 1000pF/50V		
C838	00D 963 9004 708	Ceramic chip 0.1uF/50V		
C839	00D 963 9004 708	Ceramic chip 0.1uF/50V		
C840	00D 963 9004 708	Ceramic chip 0.1uF/50V		
C841	00D 963 9004 708	Ceramic chip 0.1uF/50V		
C842	00D 963 9004 591	Ceramic chip 22pF/50V		
C843	00D 963 9004 698	Ceramic chip 0.01uF/50V		
C844	00D 963 9004 708	Ceramic chip 0.1uF/50V		
C845	00D 963 9004 708	Ceramic chip 0.1uF/50V		
C846	00D 963 9004 708	Ceramic chip 0.1uF/50V		
C847	00D 963 9004 591	Ceramic chip 22pF/50V		
C858	00D 960 9009 856	Ceramic chip 0.022uF/50V		
C861	00D 963 9005 998	Ceramic chip 24pF/50V		
C862	00D 963 9005 998	Ceramic chip 24pF/50V		
C863	00D 963 9004 698	Ceramic chip 0.01uF/50V		
C864L	00D 963 9005 862	Electrolytic 47uF/16V		
C864R	00D 963 9005 862	Electrolytic 47uF/16V		
C865L	00D 963 9005 723	Ceramic chip 120pF/50V		
C865R	00D 963 9005 723	Ceramic chip 120pF/50V		
C866	00D 963 9004 698	Ceramic chip 0.01uF/50V		
C867	00D 963 9004 698	Ceramic chip 0.01uF/50V		
C868	00D 963 9004 698	Ceramic chip 0.01uF/50V		
C869L	00D 963 9004 575	Ceramic chip 100pF/50V		
C869R	00D 963 9004 575	Ceramic chip 100pF/50V		
C871L	00D 963 9009 500	Mylar film 0.001uF/100V		
C871R	00D 963 9009 500	Mylar film 0.001uF/100V		
C873	00D 963 9006 340	Electrolytic 100uF/25V		
C873C	00D 963 9004 672	Ceramic chip 680pF/50V		
C873FL	00D 963 9004 672	Ceramic chip 680pF/50V		
C873FR	00D 963 9004 672	Ceramic chip 680pF/50V		
C873SBL	00D 963 9004 672	Ceramic chip 680pF/50V		
C873SBR	00D 963 9004 672	Ceramic chip 680pF/50V		
C873SL	00D 963 9004 672	Ceramic chip 680pF/50V		
C873SR	00D 963 9004 672	Ceramic chip 680pF/50V		
C873SW	00D 963 9004 672	Ceramic chip 680pF/50V		
C874	00D 963 9006 340	Electrolytic 100uF/25V		
C874C	00D 963 9006 146	Ceramic chip 560pF/50V		
C874FL	00D 963 9006 146	Ceramic chip 560pF/50V		
C874FR	00D 963 9006 146	Ceramic chip 560pF/50V		
C874SBL	00D 963 9006 146	Ceramic chip 560pF/50V		
C874SBR	00D 963 9006 146	Ceramic chip 560pF/50V		

	Ref. No.	Part No.	Part Name	Remarks	New
	C874SL	00D 963 9006 146	Ceramic chip 560pF/50V		
	C874SR	00D 963 9006 146	Ceramic chip 560pF/50V		
	C874SW	00D 963 9006 146	Ceramic chip 560pF/50V		
	C875C	00D 963 9005 778	Electrolytic 10uF/50V		
	C875FL	00D 963 9005 778	Electrolytic 10uF/50V		
	C875FR	00D 963 9005 778	Electrolytic 10uF/50V		
	C875SBL	00D 963 9005 778	Electrolytic 10uF/50V		
	C875SBR	00D 963 9005 778	Electrolytic 10uF/50V		
	C875SL	00D 963 9005 778	Electrolytic 10uF/50V		
	C875SR	00D 963 9005 778	Electrolytic 10uF/50V		
	C875SW	00D 963 9005 778	Electrolytic 10uF/50V		
	C876C	00D 960 9008 611	Mylar film 0.0033uF/100V		
	C876FL	00D 960 9008 611	Mylar film 0.0033uF/100V		
	C876FR	00D 960 9008 611	Mylar film 0.0033uF/100V		
	C876SBL	00D 960 9008 611	Mylar film 0.0033uF/100V		
	C876SBR	00D 960 9008 611	Mylar film 0.0033uF/100V		
	C876SL	00D 960 9008 611	Mylar film 0.0033uF/100V		
	C876SR	00D 960 9008 611	Mylar film 0.0033uF/100V		
	C876SW	00D 960 9008 611	Mylar film 0.0033uF/100V		
	C880C	00D 963 9005 778	Electrolytic 10uF/50V		
	C889	00D 963 9004 698	Ceramic chip 0.01uF/50V		
	C890	00D 963 9004 698	Ceramic chip 0.01uF/50V		
	C891	00D 963 9004 698	Ceramic chip 0.01uF/50V		
	C893	00D 963 9005 749	Electrolytic 1uF/50V		
	C894	00D 963 9004 698	Ceramic chip 0.01uF/50V		
	C896	00D 963 9005 927	Electrolytic 0.1uF/50V		
	C902	00D 963 9005 901	Electrolytic 470uF/10V		
	C907	00D 963 9005 312	Electrolytic 100uF/10V		
	C912	00D 963 9004 698	Ceramic chip 0.01uF/50V		
	C913	00D 963 9004 698	Ceramic chip 0.01uF/50V		
	C920	00D 963 9004 902	Ceramic chip 18pF/50V		
OTHER PARTS GROUP					
	CB801	00D 963 0050 502	Chip emifil		
	CB802	00D 963 0050 502	Chip emifil		
	CB803	00D 963 0050 502	Chip emifil		
	CB804	00D 963 0050 502	Chip emifil		
	CB805	00D 963 0050 502	Chip emifil		
	CB806	00D 963 0050 502	Chip emifil		
	CB808	00D 963 0050 502	Chip emifil		
	CB810	00D 963 0050 502	Chip emifil		
	CN801	00D 963 0086 301	18P connector socket (TUC-P)		
	CN802	00D 963 0086 204	19P connector socket (TUC-P)		
	CN803	00D 960 0239 900	13P connector socket (TUC-P)		
	JACK801	00D 963 0052 500	1P pin jack		
	L801	00D 963 0050 803	Inductor 4.7uH		
	L802	00D 963 0050 803	Inductor 4.7uH		
	L803	00D 963 0050 803	Inductor 4.7uH		
	L804	00D 963 0050 803	Inductor 4.7uH		
	L805	00D 963 0050 900	Inductor 2.2uH		
	R831	00D 963 0120 908	Beads inductor		
	R832	00D 963 0120 908	Beads inductor		
	R833	00D 963 0120 908	Beads inductor		

	Ref. No.	Part No.	Part Name	Remarks	New
	XTAL1	00D 963 0095 101	Crystal 12.288MHz		
	XTAL2	00D 963 0158 103	Crystal 18.75MHZ		*

PARTS LIST OF P.W.B. UNIT ASS'Y (FOR CHINA)

MAIN P.W.B. UNIT

	Ref. No.	Part No.	Part Name	Remarks	New
SEMICONDUCTORS GROUP					
	IC101	00D 963 0110 507	IC MC7815CT		
	IC102	00D 960 0179 905	IC KIA7915		
	IC103	00D 960 0159 501	IC KIA7805API		
	IC104	00D 963 0110 604	IC MC7805CT		
	IC105	00D 960 0195 808	IC protector ICP-N15		
	IC106	00D 960 0195 808	IC protector ICP-N15		
	Q104C	00D 960 0196 506	Transistor KSC1845F		
	Q104FL	00D 960 0196 506	Transistor KSC1845F		
	Q104FR	00D 960 0196 506	Transistor KSC1845F		
	Q104SL	00D 960 0196 506	Transistor KSC1845F		
	Q104SR	00D 960 0196 506	Transistor KSC1845F		
	Q111	00D 963 0121 208	Transistor KRC107M		
	Q112	00D 960 0097 508	Transistor KRC111M		
	Q113	00D 963 0121 208	Transistor KRC107M		
	Q114	00D 963 0121 208	Transistor KRC107M		
	Q115	00D 963 0121 208	Transistor KRC107M		
	Q116	00D 960 0196 409	Transistor 2SC1740SR		
	Q117	00D 963 0121 208	Transistor KRC107M		
	Q118	00D 963 0121 208	Transistor KRC107M		
	Q151	00D 960 0196 409	Transistor 2SC1740SR		
	Q171	00D 960 0005 202	Transistor KTC3198Y		
	Q171A	00D 960 0196 302	Transistor KTA1268BL		
	Q171B	00D 960 0196 302	Transistor KTA1268BL		
	Q171C	00D 960 0196 302	Transistor KTA1268BL		
	Q171D	00D 960 0196 302	Transistor KTA1268BL		
	Q172	00D 960 0005 202	Transistor KTC3198Y		
	Q173	00D 960 0005 202	Transistor KTC3198Y		
	Q174	00D 960 0005 202	Transistor KTC3198Y		
	Q175	00D 960 0005 202	Transistor KTC3198Y		
	Q176	00D 960 0005 202	Transistor KTC3198Y		
	Q177	00D 960 0005 202	Transistor KTC3198Y		
	Q178	00D 960 0005 105	Transistor KTA1266Y		
	Q179	00D 960 0189 005	Transistor KSA916Y		
	Q180	00D 960 0196 302	Transistor KTA1268BL		
	Q181	00D 960 0196 302	Transistor KTA1268BL		
	Q182	00D 960 0005 202	Transistor KTC3198Y		
	Q183	00D 960 0005 202	Transistor KTC3198Y		
	D101	00D 963 0020 309	Diode 1SS133T		
	D102	00D 963 0020 309	Diode 1SS133T		
	D103	00D 963 0020 309	Diode 1SS133T		
	D104	00D 963 0020 309	Diode 1SS133T		
	D105	00D 963 0020 309	Diode 1SS133T		
	D121	00D 963 0020 309	Diode 1SS133T		
	D122	00D 963 0020 309	Diode 1SS133T		
	D123	00D 963 0020 309	Diode 1SS133T		
	D124	00D 963 0020 309	Diode 1SS133T		
	D125	00D 963 0020 309	Diode 1SS133T		
	D126	00D 963 0020 309	Diode 1SS133T		
	D127	00D 963 0020 309	Diode 1SS133T		
	D131A	00D 960 0197 107	Diode KBPC604		
	D131B	00D 960 0197 107	Diode KBPC604		
	D132	00D 963 0020 309	Diode 1SS133T		
	D133	00D 963 0046 202	Zener diode MTZJ18B		

Ref. No.	Part No.	Part Name	Remarks	New
D134	00D 963 0046 202	Zener diode MTZJ18B		
D135	00D 963 0020 309	Diode 1SS133T		
D136	00D 963 0058 504	Zener diode MTZJ11B		
D137	00D 963 0020 309	Diode 1SS133T		
D138A	00D 963 0058 407	Diode IN4007		
D141	00D 963 0058 407	Diode IN4007		
D142	00D 963 0058 407	Diode IN4007		
D143	00D 963 0058 407	Diode IN4007		
D144	00D 963 0058 407	Diode IN4007		
D145	00D 963 0058 407	Diode IN4007		
D146	00D 963 0058 407	Diode IN4007		
D149	00D 963 0058 407	Diode IN4007		
D150	00D 963 0058 407	Diode IN4007		
D152	00D 963 0058 407	Diode IN4007		
D153	00D 963 0058 407	Diode IN4007		
D154	00D 960 0095 908	Zener diode MTZJ8.2B		
D157	00D 960 0014 905	Zener diode MTZJ20B		
ZD310	00D 960 0095 500	Zener diode MTZJ5.1B		
ZD311	00D 960 0095 500	Zener diode MTZJ5.1B		
LED901	00D 963 0148 605	LED SML1216W 5PI R/G		
RESISTORS GROUP				
R104C	00D 963 9006 285	Metal oxide 5.6 kohm 1W		
R104FL	00D 963 9006 285	Metal oxide 5.6 kohm 1W		
R104FR	00D 963 9006 285	Metal oxide 5.6 kohm 1W		
R104SL	00D 963 9006 285	Metal oxide 5.6 kohm 1W		
R104SR	00D 963 9006 285	Metal oxide 5.6 kohm 1W		
R105C	00D 963 9006 285	Metal oxide 5.6 kohm 1W		
R105FL	00D 963 9006 285	Metal oxide 5.6 kohm 1W		
R105FR	00D 963 9006 285	Metal oxide 5.6 kohm 1W		
R105SL	00D 963 9006 285	Metal oxide 5.6 kohm 1W		
R105SR	00D 963 9006 285	Metal oxide 5.6 kohm 1W		
R106C	00D 963 0047 900	Metal film 4.7 kohm 1W		
R106FL	00D 963 0047 900	Metal film 4.7 kohm 1W		
R106FR	00D 963 0047 900	Metal film 4.7 kohm 1W		
R106SL	00D 963 0047 900	Metal film 4.7 kohm 1W		
R106SR	00D 963 0047 900	Metal film 4.7 kohm 1W		
R107C	00D 963 0047 900	Metal film 4.7 kohm 1W		
R107FL	00D 963 0047 900	Metal film 4.7 kohm 1W		
R107FR	00D 963 0047 900	Metal film 4.7 kohm 1W		
R107SL	00D 963 0047 900	Metal film 4.7 kohm 1W		
R107SR	00D 963 0047 900	Metal film 4.7 kohm 1W		
R108C	00D 963 9006 269	Metal oxide 0.22 ohm 1W		
R108FL	00D 963 9006 269	Metal oxide 0.22 ohm 1W		
R108FR	00D 963 9006 269	Metal oxide 0.22 ohm 1W		
R108SL	00D 963 9006 269	Metal oxide 0.22 ohm 1W		
R108SR	00D 963 9006 269	Metal oxide 0.22 ohm 1W		
R109C	00D 963 9006 269	Metal oxide 0.22 ohm 1W		
R109FL	00D 963 9006 269	Metal oxide 0.22 ohm 1W		
R109FR	00D 963 9006 269	Metal oxide 0.22 ohm 1W		
R109SL	00D 963 9006 269	Metal oxide 0.22 ohm 1W		
R109SR	00D 963 9006 269	Metal oxide 0.22 ohm 1W		
R110C	00D 963 9006 269	Metal oxide 0.22 ohm 1W		
R118C	00D 963 9006 256	Metal oxide 10 ohm 1W		
R118FL	00D 963 9006 256	Metal oxide 10 ohm 1W		
R118FR	00D 963 9006 256	Metal oxide 10 ohm 1W		

Ref. No.	Part No.	Part Name	Remarks	New
R118SL	00D 963 9006 256	Metal oxide 10 ohm 1W		
R118SR	00D 963 9006 256	Metal oxide 10 ohm 1W		
R119C	00D 963 9006 256	Metal oxide 10 ohm 1W		
R119FL	00D 963 9006 256	Metal oxide 10 ohm 1W		
R119FR	00D 963 9006 256	Metal oxide 10 ohm 1W		
R119SL	00D 963 9006 256	Metal oxide 10 ohm 1W		
R119SR	00D 963 9006 256	Metal oxide 10 ohm 1W		
R135	00D 963 0144 502	Cement resistor 0.1 ohm 5W		
R136	00D 963 0144 502	Cement resistor 0.1 ohm 5W		
R141	00D 960 0180 606	Metal oxide 0.22 ohm 1W		
R142	00D 960 0180 606	Metal oxide 0.22 ohm 1W		
R148	00D 960 0180 606	Metal oxide 0.22 ohm 1W		
R149	00D 960 0180 606	Metal oxide 0.22 ohm 1W		
R151	00D 963 9003 343	Metal film 68ohm 1/4W		
R179	00D 963 9003 055	Metal film 47 kohm 1/4W (NB)		
R181	00D 963 0047 900	Metal film 4.7 kohm 1W		
R184	00D 963 9006 256	Metal oxide 10 ohm 1W		
R903H	00D 960 9009 270	Metal film 470ohm 2W		
R904H	00D 960 9009 270	Metal film 470ohm 2W		
VR101	00D 960 0091 601	Semi fixed resistor 1 kohm		
VR102	00D 960 0091 601	Semi fixed resistor 1 kohm		
VR103	00D 960 0091 601	Semi fixed resistor 1 kohm		
VR104	00D 960 0091 601	Semi fixed resistor 1 kohm		
VR105	00D 960 0091 601	Semi fixed resistor 1 kohm		
CAPACITORS GROUP				
C101C	00D 963 9006 450	Electrolytic 47uF/50V		
C101FL	00D 963 9006 450	Electrolytic 47uF/50V		
C101FR	00D 963 9006 450	Electrolytic 47uF/50V		
C101SL	00D 963 9006 450	Electrolytic 47uF/50V		
C101SR	00D 963 9006 450	Electrolytic 47uF/50V		
C102C	00D 963 9006 308	Electrolytic 10uF/50V		
C102FL	00D 963 9006 308	Electrolytic 10uF/50V		
C102FR	00D 963 9006 308	Electrolytic 10uF/50V		
C102SL	00D 963 9006 308	Electrolytic 10uF/50V		
C102SR	00D 963 9006 308	Electrolytic 10uF/50V		
C103C	00D 963 9003 084	Ceramic 100pF/500V		
C103FL	00D 963 9003 084	Ceramic 100pF/500V		
C103FR	00D 963 9003 084	Ceramic 100pF/500V		
C103SL	00D 963 9003 084	Ceramic 100pF/500V		
C103SR	00D 963 9003 084	Ceramic 100pF/500V		
C104C	00D 963 9003 084	Ceramic 100pF/500V		
C104FL	00D 963 9003 084	Ceramic 100pF/500V		
C104FR	00D 963 9003 084	Ceramic 100pF/500V		
C104SL	00D 963 9003 084	Ceramic 100pF/500V		
C104SR	00D 963 9003 084	Ceramic 100pF/500V		
C105C	00D 963 9008 640	Mylar film 0.022uF/100V		
C105FL	00D 963 9008 640	Mylar film 0.022uF/100V		
C105FR	00D 963 9008 640	Mylar film 0.022uF/100V		
C105SL	00D 963 9008 640	Mylar film 0.022uF/100V		
C105SR	00D 963 9008 640	Mylar film 0.022uF/100V		
C107C	00D 963 9003 097	Mylar film 0.1uF/250V		
C107FL	00D 963 9003 097	Mylar film 0.1uF/250V		
C107FR	00D 963 9003 097	Mylar film 0.1uF/250V		
C107SL	00D 963 9003 097	Mylar film 0.1uF/250V		
C107SR	00D 963 9003 097	Mylar film 0.1uF/250V		
C131	00D 963 9003 097	Mylar film 0.1uF/250V		

	Ref. No.	Part No.	Part Name	Remarks	New
	C132	00D 963 9003 097	Mylar film 0.1uF/250V		
	C133	00D 963 9003 097	Mylar film 0.1uF/250V		
	C134	00D 963 9003 097	Mylar film 0.1uF/250V		
	C135	00D 963 9003 097	Mylar film 0.1uF/250V		
	C136	00D 963 0157 803	Electrolytic 12000uF/63V		*
	C137	00D 963 0157 803	Electrolytic 12000uF/63V		*
	C138	00D 963 9006 379	Electrolytic 1uF/50V		
	C138A	00D 963 9003 097	Mylar film 0.1uF/250V		
	C141	00D 963 0021 900	Mylar film 0.047uF/100V		
	C142	00D 963 0021 900	Mylar film 0.047uF/100V		
	C143	00D 963 0021 900	Mylar film 0.047uF/100V		
	C144	00D 960 9007 201	Electrolytic 3300uF/35V		
	C145	00D 963 9003 123	Electrolytic 1000uF/35V		
	C146	00D 963 9006 379	Electrolytic 1uF/50V		
	C148	00D 963 9006 379	Electrolytic 1uF/50V		
	C150	00D 963 0021 900	Mylar film 0.047uF/100V		
	C151	00D 963 0021 900	Mylar film 0.047uF/100V		
	C152	00D 963 0021 900	Mylar film 0.047uF/100V		
	C153	00D 963 0021 104	Electrolytic 6800uF/16V		
	C154	00D 963 9006 308	Electrolytic 10uF/50V		
	C155	00D 963 0020 202	Ceramic 0.1uF/50V		
	C157	00D 963 9006 379	Electrolytic 1uF/50V		
	C158	00D 963 9003 136	Electrolytic 1000uF/25V		
	C159	00D 963 9006 379	Electrolytic 1uF/50V		
	C161	00D 963 9006 308	Electrolytic 10uF/50V		
	C171	00D 963 9005 312	Electrolytic 100uF/10V		
	C171A	00D 963 0020 202	Ceramic 0.1uF/50V		
	C171B	00D 963 0020 202	Ceramic 0.1uF/50V		
	C171C	00D 963 0020 202	Ceramic 0.1uF/50V		
	C171D	00D 963 0020 202	Ceramic 0.1uF/50V		
	C172	00D 963 9005 833	Electrolytic 220uF/6.3V		
	C173	00D 963 9005 833	Electrolytic 220uF/6.3V		
	C174	00D 963 9006 308	Electrolytic 10uF/50V		
	C175	00D 963 0149 507	Electrolytic 220uF/16V		
	C176	00D 963 9006 379	Electrolytic 1uF/50V		
	C177	00D 963 9006 379	Electrolytic 1uF/50V		
	C178	00D 963 0157 900	Electrolytic 470uF/63V		*
	C179	00D 963 9005 833	Electrolytic 220uF/6.3V		
⚠	C181	00D 963 9006 191	Ceramic 4700pF/250V(AC)		
	C182	00D 963 9006 311	Electrolytic 10uF/100V		
	C331	00D 963 9004 546	Ceramic 0.01uF/16V		
	C332	00D 963 9004 546	Ceramic 0.01uF/16V		
	C901H	00D 963 9004 533	Ceramic 0.001uF/50V		
	C902H	00D 963 9004 533	Ceramic 0.001uF/50V		
	C903H	00D 963 0020 202	Ceramic 0.1uF/50V		
	C904H	00D 960 9003 108	Ceramic 0.022uF/25V		
	C905H	00D 963 0020 202	Ceramic 0.1uF/50V		
	C906H	00D 963 9004 546	Ceramic 0.01uF/16V		
	C907H	00D 960 9006 202	Ceramic 0.01uF/50V		
OTHER PARTS GROUP					
	CB903	00D 963 0154 602	Beads inductor		*
	CB904	00D 963 0154 602	Beads inductor		*
	CN901	00D 963 0160 201	3P connector cord		*
	CN931A	00D 963 0148 809	2P connector cord		
	CN992	00D 963 0160 007	4P connector cord		*

	Ref. No.	Part No.	Part Name	Remarks	New
⚠	CP101	00D 960 0118 908	AC cord connector base		
	CP102	00D 960 0123 304	2P connector base		
	CP103	00D 960 0128 901	3P connector base		
	CP104	00D 960 0128 804	6P connector base		
	CP106	00D 960 0123 207	3P connector base		
	CP1151	00D 963 0097 507	15P connector base (TUC-P)		
	CP1153	00D 963 0097 507	15P connector base (TUC-P)		
	CP138A	00D 960 0123 207	3P connector base		*
	CP3911	00D 963 0160 900	8P connector base		
	CP392	00D 963 0048 909	3P connector base		
	CP501	00D 963 0086 806	9P connector base (TUC-P)		
	CP502	00D 963 0085 807	7P connector base (TUC-P)		
	CP503	00D 963 0085 807	7P connector base (TUC-P)		
	CP504	00D 963 0086 903	5P connector base (TUC-P)		
	CP505	00D 963 0087 708	12P connector base (TUC-P)		
	CP555	00D 963 0111 108	14P connector base (TUC-P)		
	CP556	00D 963 0087 805	11P connector base (TUC-P)		
	CP901	00D 963 0048 909	3P connector base		
	CP931	00D 963 0149 206	2P connector base(BLUE)		
⚠	F102	00D 963 0104 801	Fuse 3.15A		
	F102A	00D 960 0005 804	Fuse clip		
	F102B	00D 960 0005 804	Fuse clip		
	G901	-	1P contact Ass'y		
	GND101	00D 960 9006 600	Terminal		
	GND102	00D 960 9006 600	Terminal		
	GND103	00D 960 9006 600	Terminal		
	JK901	00D 963 0095 402	Head phone jack		
	L101C	00D 963 0049 005	Inductor 0.5uH		
	L101FL	00D 963 0049 005	Inductor 0.5uH		
	L101FR	00D 963 0049 005	Inductor 0.5uH		
	L101SL	00D 963 0049 005	Inductor 0.5uH		
	L101SR	00D 963 0049 005	Inductor 0.5uH		
	RLY101	00D 960 0181 702	Relay (G5PA-28 24V)		
	RLY102	00D 960 0181 702	Relay (G5PA-28 24V)		
⚠	RLY103	00D 960 0181 702	Relay (G5PA-28 24V)		
	RLY104	00D 960 0181 702	Relay (G5PA-28 24V)		
	RLY105	00D 963 0071 303	Relay (RSB24S 24V)		
	RLY106	00D 960 0181 605	Relay (G5PA-1-8 12V)		
	RLY107	00D 960 0181 702	Relay (G5PA-28 24V)		
	SW391	00D 963 0045 708	Tact switch		
	SW393	00D 963 0045 708	Tact switch		
	SW901	00D 963 0045 708	Tact switch		
	SW901A	00D 963 0145 802	Push switch		
	TP101	00D 960 0161 405	3P connector base		
	TP102	00D 960 0161 405	3P connector base		
	TP103	00D 960 0161 405	3P connector base		
	TP104	00D 960 0161 405	3P connector base		
	TP105	00D 960 0161 405	3P connector base		
	VEC303	00D 963 0095 208	ENCODER SW		
	-	-	Heat sink	1	
	-	-	Heat sink	1	

	Ref. No.	Part No.	Part Name	Remarks	New
⚠	-	00D 963 0068 400	Capacitor cover	1	
	-	00D 963 0120 500	Fuse label	1	
	-	00D 963 0094 911	Power trans. (Mini)	1	
	-	00D 963 0018 007	Screw (2S 3X8 ZNY/BH)	3	
	-	00D 963 0158 608	2P speaker terminal	1	*
	-	00D 963 0119 906	8P speaker terminal	2	

CPU, FRONT P.W.B. UNIT

	Ref. No.	Part No.	Part Name	Remarks	New
SEMICONDUCTORS GROUP					
	IC201	00D 963 0161 705	IC CXP740010		
	IC203	00D 960 0100 301	IC KIA7812		
	IC204	00D 963 0114 600	IC MC7806CT		
	IC301	00D 960 0180 004	IC LC75721E		
	IC302	00D 963 0074 504	IC BU2090F		
	IC803	00D 963 0113 106	IC GP1FA513RZ		
	RMC301	00D 960 0181 100	IC NJL64H380A		
	Q201	00D 960 0285 006	Transistor KRC104S		
	Q202	00D 963 0121 509	Transistor KTC3875S		
	Q203	00D 963 0121 402	Transistor KRA104S		
	Q204	00D 963 0121 606	Transistor KRC107S		
	Q205	00D 960 0196 603	Transistor KTC2874B		
	Q206	00D 960 0196 603	Transistor KTC2874B		
	Q207	00D 960 0196 603	Transistor KTC2874B		
	Q208	00D 960 0196 603	Transistor KTC2874B		
	Q216	00D 960 0097 207	Transistor KRA102M		
	Q217	00D 963 0102 803	Transistor 2SA933S		
	Q218	00D 963 0102 803	Transistor 2SA933S		
	Q219	00D 963 0102 803	Transistor 2SA933S		
	Q220	00D 963 0121 208	Transistor KRC107M		
	Q221	00D 960 0097 207	Transistor KRA102M		
	Q222	00D 960 0097 207	Transistor KRA102M		
	Q300	00D 963 0121 402	Transistor KRA104S		
	Q301	00D 963 0121 402	Transistor KRA104S		
	Q302	00D 960 0285 006	Transistor KRC104S		
	Q303	00D 960 0285 006	Transistor KRC104S		
	Q304	00D 960 0285 006	Transistor KRC104S		
	Q305	00D 963 0121 402	Transistor KRA104S		
	Q306	00D 963 0120 704	Transistor KRA102S		
	Q307	00D 963 0121 606	Transistor KRC107S		
	Q308	00D 963 0120 704	Transistor KRA102S		
	D201	00D 963 0020 309	Diode 1SS133T		
	D202	00D 963 0058 407	Diode IN4007		
	D204	00D 963 0020 309	Diode 1SS133T		
	D209	00D 960 0197 000	Diode KDS160		
	D213	00D 963 0020 309	Diode 1SS133T		
	D302	00D 963 0020 309	Diode 1SS133T		
	D303	00D 963 0020 309	Diode 1SS133T		
	D304	00D 963 0020 309	Diode 1SS133T		
	D305	00D 960 0197 000	Diode KDS160		
	D306	00D 960 0197 000	Diode KDS160		
	D307	00D 960 0197 000	Diode KDS160		
	ZD201	00D 963 0047 502	Zener diode MTZJ3.3B		
	ZD301	00D 960 0095 801	Zener diode MTZJ6.8B		
	ZD302	00D 960 0095 500	Zener diode MTZJ5.1B		
	ZD303	00D 960 0095 500	Zener diode MTZJ5.1B		
	ZD304	00D 960 0095 500	Zener diode MTZJ5.1B		
	ZD305	00D 960 0095 500	Zener diode MTZJ5.1B		
	LED301	00D 960 0197 204	LED PI5-RD/HL50RDRF4T		
	LED302	00D 960 0197 204	LED PI5-RD/HL50RDRF4T		
	LED305	00D 960 0197 204	LED PI5-RD/HL50RDRF4T		

Ref. No.	Part No.	Part Name	Remarks	New
LED306	00D 960 0197 204	LED P15-RD/HL50RDRF4T		
LED307	00D 960 0197 204	LED P15-RD/HL50RDRF4T		
LED308	00D 960 0197 204	LED P15-RD/HL50RDRF4T		
LED309	00D 960 0197 204	LED P15-RD/HL50RDRF4T		
LED310	00D 960 0197 204	LED P15-RD/HL50RDRF4T		
CAPACITORS GROUP				
BC201	00D 963 0061 504	Electrolytic 8200uF/5.5V		
C201D	00D 960 9010 816	Ceramic 0.1uF/50V		
C201E	00D 963 9004 517	Ceramic 0.022uF/50V		
C201F	00D 963 9004 546	Ceramic 0.01uF/16V		
C202	00D 963 9004 698	Ceramic chip 0.01uF/50V		
C202D	00D 963 9004 546	Ceramic 0.01uF/16V		
C202E	00D 963 9004 517	Ceramic 0.022uF/50V		
C202F	00D 963 9004 546	Ceramic 0.01uF/16V		
C203	00D 963 9004 698	Ceramic chip 0.01uF/50V		
C204	00D 963 9006 476	Electrolytic 4.7uF/50V		
C205	00D 963 9004 562	Ceramic 0.047uF/50V		
C221	00D 963 9005 312	Electrolytic 100uF/10V		
C228	00D 963 9004 575	Ceramic chip 100pF/50V		
C230	00D 963 9004 575	Ceramic chip 100pF/50V		
C231	00D 963 9004 575	Ceramic chip 100pF/50V		
C232	00D 963 9004 575	Ceramic chip 100pF/50V		
C233	00D 963 9004 575	Ceramic chip 100pF/50V		
C234	00D 963 9004 575	Ceramic chip 100pF/50V		
C238	00D 963 9006 366	Electrolytic 0.1uF/50V		
C239	00D 963 9006 366	Electrolytic 0.1uF/50V		
C242	00D 963 9004 685	Ceramic chip 1000pF/50V		
C245	00D 963 9004 575	Ceramic chip 100pF/50V		
C248	00D 963 9004 685	Ceramic chip 1000pF/50V		
C249	00D 963 9004 737	Ceramic chip 0.022uF/25V		
C251	00D 963 0020 202	Ceramic 0.1uF/50V		
C252	00D 960 9010 816	Ceramic 0.1uF/50V		
C257	00D 963 9006 308	Electrolytic 10uF/50V		
C262	00D 963 9006 379	Electrolytic 1uF/50V		
C263	00D 963 9006 379	Electrolytic 1uF/50V		
C301	00D 963 9004 546	Ceramic 0.01uF/16V		
C3010	00D 963 9006 421	Electrolytic 47uF/10V		
C302	00D 963 9004 546	Ceramic 0.01uF/16V		
C3020	00D 963 0020 202	Ceramic 0.1uF/50V		
C303	00D 963 9004 546	Ceramic 0.01uF/16V		
C3030	00D 963 9004 591	Ceramic chip 22pF/50V		
C304	00D 963 9004 546	Ceramic 0.01uF/16V		
C305	00D 963 9004 685	Ceramic chip 1000pF/50V		
C306	00D 963 9004 575	Ceramic chip 100pF/50V		
C307	00D 963 9004 575	Ceramic chip 100pF/50V		
C308	00D 960 9010 816	Ceramic 0.1uF/50V		
C309	00D 963 9004 737	Ceramic chip 0.022uF/25V		
C310	00D 963 9004 753	Ceramic chip 0.047uF/50V		
C311	00D 963 9005 406	Ceramic chip 30pF/50V		
C312	00D 963 9004 753	Ceramic chip 0.047uF/50V		
C314	00D 963 0021 900	Mylar film 0.047uF/100V		
C315	00D 963 9006 379	Electrolytic 1uF/50V		
C316	00D 963 9006 308	Electrolytic 10uF/50V		
C317	00D963 9005 859	Electrolytic 47uF/16V		
C318	00D 963 9005 419	Mylar film 0.047uF/63V		
C319	00D 963 9006 434	Electrolytic 47uF/16V		

Ref. No.	Part No.	Part Name	Remarks	New
C320	00D 963 9006 379	Electrolytic 1uF/50V		
C321	00D 963 0021 900	Mylar film 0.047uF/100V		
C322	00D 963 9006 434	Electrolytic 47uF/16V		
C323	00D 963 9004 766	Mylar film 0.1uF/100V		
C324	00D 963 9006 476	Electrolytic 4.7uF/50V		
C325	00D 963 9004 575	Ceramic chip 100pF/50V		
C326	00D 963 9006 382	Electrolytic 22uF/25V		
C327	00D 963 9006 476	Electrolytic 4.7uF/50V		
C329	00D 963 9006 531	Electrolytic 22uF/16V		
C330	00D 963 9006 531	Electrolytic 22uF/16V		
C340	00D 963 9004 575	Ceramic chip 100pF/50V		
C341	00D 963 9004 575	Ceramic chip 100pF/50V		
C347	00D 963 9004 708	Ceramic chip 0.1uF/50V		
C348	00D 963 9004 708	Ceramic chip 0.1uF/50V		
C354	00D 963 9004 708	Ceramic chip 0.1uF/50V		
OTHER PARTS GROUP				
BD205	00D 963 0050 502	Chip emifil		
BD206	00D 963 0050 502	Chip emifil		
BD207	00D 963 0154 602	Beads inductor		*
BD208	00D 963 0154 602	Beads inductor		*
BD209	00D 963 0154 602	Beads inductor		*
BD250	00D 963 0154 602	Beads inductor		*
BD301	00D 963 0050 502	Chip emifil		
BD303	00D 963 0050 502	Chip emifil		
BD304	00D 963 0050 502	Chip emifil		
CB202	00D 963 0154 602	Beads inductor		*
CB203	00D 963 0154 602	Beads inductor		*
CB207	00D 963 0154 602	Beads inductor		*
CB208	00D 963 0154 602	Beads inductor		*
CN201	00D 963 0159 801	5P SHIELD WIRE		*
CN302	00D 963 0160 502	8P connector cord		*
CN303	00D 963 0160 308	3P connector cord		*
CN605	00D 963 0159 908	3P connector cord		*
CN606	00D 96 30159 607	4P connector cord		*
CP1000	00D 963 0085 807	7P connector base (TUC-P)		
CP1001	00D 963 0111 108	14P connector base (TUC-P)		
CP1154	00D 963 0085 807	7P connector base (TUC-P)		
CP1155	00D 963 0085 807	7P connector base (TUC-P)		
CP301	00D 963 0161 103	23P FFC connector base		*
CP301A	00D 963 0161 006	23P FFC connector base		*
CP302	00D 963 0066 101	5P connector base		
CP303	00D 963 0049 102	3P connector base		
CP401	00D 963 0149 303	15P FFC connector base		
CP404	00D 963 0087 805	11P connector base (TUC-P)		
CP551	00D 963 0087 601	8P connector base (TUC-P)		
CP552	00D 963 0087 504	19P connector base (TUC-P)		
CP605	00D 963 0048 909	3P connector base		
CP606	00D 963 0050 104	4P connector base		
CP701	00D 963 0087 601	18P connector base (TUC-P)		
CP703	00D 963 0087 805	11P connector base (TUC-P)		
CP705	00D 963 0087 601	8P connector base (TUC-P)		
CP706	00D 963 0087 601	8P connector base (TUC-P)		
CP801	00D 963 0087 601	18P connector base (TUC-P)		
CP802	00D 963 0087 504	19P connector base (TUC-P)		

	Ref. No.	Part No.	Part Name	Remarks	New
	CP803	00D 960 0239 609	13P connector base (TUC-P)		
	CP804	00D 963 0087 504	19P connector base (TUC-P)		
	G903	-	1P contact Ass'y		
	GND01	00D 960 9006 600	Terminal		
	GND02	00D 960 9006 600	Terminal		
	GP301	-	1P contact Ass'y		
	GP301	-	1P contact Ass'y		
	J326	00D 963 9003 372	Carbon chip 0 ohm 1/16W		
	JIG601	00D 960 0123 605	13P connector base		
	JP353	00D 963 9003 372	Carbon chip 0 ohm 1/16W		
	L301	00D 960 0010 307	Inductor 10uH		
	L3010	00D 960 0215 908	Inductor 4.7uH		
	L302	00D 960 0128 008	Inductor 100uH		
	SW301C	00D 963 0045 708	Tact switch		
	SW302A	00D 963 0095 305	Tact switch		
	SW302B	00D 963 0095 305	Tact switch		
	SW302C	00D 963 0045 708	Tact switch		
	SW303A	00D 963 0095 305	Tact switch		
	SW303B	00D 963 0095 305	Tact switch		
	SW303C	00D 963 0045 708	Tact switch		
	SW304A	00D 963 0095 305	Tact switch		
	SW304B	00D 963 0095 305	Tact switch		
	SW304C	00D 963 0045 708	Tact switch		
	SW305A	00D 963 0095 305	Tact switch		
	SW305B	00D 963 0045 708	Tact switch		
	SW305C	00D 963 0045 708	Tact switch		
	SW306A	00D 963 0095 305	Tact switch		
	SW306B	00D 963 0095 305	Tact switch		
	SW306C	00D 963 0045 708	Tact switch		
	SW307A	00D 963 0095 305	Tact switch		
	SW307C	00D 963 0045 708	Tact switch		
	SW308C	00D 963 0045 708	Tact switch		
	SW309C	00D 963 0045 708	Tact switch		
	VEC301	00D 963 0095 208	ENCODER SW		
	VEC302	00D 963 0095 208	ENCODER SW		
	X201	00D 960 0181 003	Resonator CST12.0MTW-TF01		
	-	-	Heat sink	1	
	-	00D 963 0018 007	Screw (2S 3X8 ZNY/BH)	1	
	-	00D 960 0184 408	FLT holder	1	
	-	00D 963 0109 505	FLT (16-ST-66GNK)	1	
	-	00D 963 0158 307	DIN SOCKET DIN-416G	1	*
	-	00D 963 0146 403	3P pin jack	1	

CNT,PRE-AMP P.W.B. UNIT

	Ref. No.	Part No.	Part Name	Remarks	New
SEMICONDUCTORS GROUP					
	Q101SBL	00D 963 0044 204	Transistor 2SD2390-Y		
	Q101SBR	00D 963 0044 204	Transistor 2SD2390-Y		
	Q102SBL	00D 963 0044 107	Transistor 2SB1560-Y		
	Q102SBR	00D 963 0044 107	Transistor 2SB1560-Y		
	Q103SBL	00D 963 0058 106	Transistor 2SD947F		
	Q103SBR	00D 963 0058 106	Transistor 2SD947F		
	Q104SBL	00D 960 0196 506	Transistor KSC1845F		
	Q104SBR	00D 960 0196 506	Transistor KSC1845F		
	Q501C	00D 960 0196 603	Transistor KTC2874B		
	Q501FL	00D 960 0196 603	Transistor KTC2874B		
	Q501FR	00D 960 0196 603	Transistor KTC2874B		
	Q501SBL	00D 960 0196 603	Transistor KTC2874B		
	Q501SBR	00D 960 0196 603	Transistor KTC2874B		
	Q501SL	00D 960 0196 603	Transistor KTC2874B		
	Q501SR	00D 960 0196 603	Transistor KTC2874B		
	Q502C	00D 960 0196 205	Transistor KSA992F		
	Q502FL	00D 960 0196 205	Transistor KSA992F		
	Q502FR	00D 960 0196 205	Transistor KSA992F		
	Q502SBL	00D 960 0196 205	Transistor KSA992F		
	Q502SBR	00D 960 0196 205	Transistor KSA992F		
	Q502SL	00D 960 0196 205	Transistor KSA992F		
	Q502SR	00D 960 0196 205	Transistor KSA992F		
	Q503C	00D 960 0196 205	Transistor KSA992F		
	Q503FL	00D 960 0196 205	Transistor KSA992F		
	Q503FR	00D 960 0196 205	Transistor KSA992F		
	Q503SBL	00D 960 0196 205	Transistor KSA992F		
	Q504C	00D 960 0196 506	Transistor KSC1845F		
	Q504FL	00D 960 0196 506	Transistor KSC1845F		
	Q504FR	00D 960 0196 506	Transistor KSC1845F		
	Q504SBL	00D 960 0196 506	Transistor KSC1845F		
	Q504SBR	00D 960 0196 506	Transistor KSC1845F		
	Q504SL	00D 960 0196 506	Transistor KSC1845F		
	Q504SR	00D 960 0196 506	Transistor KSC1845F		
	Q506C	00D 960 0196 603	Transistor KTC2874B		
	Q506FL	00D 960 0196 603	Transistor KTC2874B		
	Q506FR	00D 960 0196 603	Transistor KTC2874B		
	Q506SBL	00D 960 0196 603	Transistor KTC2874B		
	Q551	00D 960 0196 700	Transistor KTC3200BL		
	Q552	00D 960 0196 302	Transistor KTA1268BL		
	Q553	00D 963 0120 704	Transistor KRA102S		
	Q554	00D 963 0120 704	Transistor KRA102S		
	Q555	00D 963 0120 704	Transistor KRA102S		
	Q556	00D 963 0120 704	Transistor KRA102S		
	Q557C	00D 963 0148 508	Transistor KTA1504S		
	Q558C	00D 963 0121 606	Transistor KRC107S		
	D106	00D 963 0020 309	Diode 1SS133T		
	D107	00D 963 0020 309	Diode 1SS133T		
	D551	00D 963 0020 309	Diode 1SS133T		
	D552	00D 963 0020 309	Diode 1SS133T		
	D553	00D 963 0020 309	Diode 1SS133T		
	D554	00D 963 0020 309	Diode 1SS133T		
	D555	00D 963 0020 309	Diode 1SS133T		
	D556	00D 963 0020 309	Diode 1SS133T		
	D557	00D 963 0020 309	Diode 1SS133T		
	D558	00D 963 0020 309	Diode 1SS133T		

Ref. No.	Part No.	Part Name	Remarks	New
D559	00D 963 0020 309	Diode 1SS133T		
D560	00D 963 0020 309	Diode 1SS133T		
D561	00D 963 0020 309	Diode 1SS133T		
D562	00D 963 0058 407	Diode IN4007		
D563	00D 963 0058 407	Diode IN4007		
D564	00D 963 0020 309	Diode 1SS133T		
D565	00D 960 0095 500	Zener diode MTZJ5.1B		
D566	00D 963 0020 309	Diode 1SS133T		
D567	00D 963 0020 309	Diode 1SS133T		
D568	00D 963 0020 309	Diode 1SS133T		
D568C	00D 960 0197 000	Diode KDS160		
D569	00D 963 0020 309	Diode 1SS133T		
D569C	00D 960 0197 000	Diode KDS160		
D570C	00D 960 0197 000	Diode KDS160		
D573	00D 963 0058 407	Diode IN4007		
D574	00D 963 0058 407	Diode IN4007		
D575	00D 963 0058 407	Diode IN4007		
RESISTORS GROUP				
R104SBL	00D 963 9006 285	Metal oxide 5.6 kohm 1W		
R104SBR	00D 963 9006 285	Metal oxide 5.6 kohm 1W		
R105SBL	00D 963 9006 285	Metal oxide 5.6 kohm 1W		
R105SBR	00D 963 9006 285	Metal oxide 5.6 kohm 1W		
R106SBL	00D 963 0047 900	Metal film 4.7 kohm 1W		
R106SBR	00D 963 0047 900	Metal film 4.7 kohm 1W		
R107SBL	00D 963 0047 900	Metal film 4.7 kohm 1W		
R107SBR	00D 963 0047 900	Metal film 4.7 kohm 1W		
R108SBL	00D 963 9006 269	Metal oxide 0.22 ohm 1W		
R108SBR	00D 963 9006 269	Metal oxide 0.22 ohm 1W		
R109SBL	00D 963 9006 269	Metal oxide 0.22 ohm 1W		
R109SBR	00D 963 9006 269	Metal oxide 0.22 ohm 1W		
R110SBL	00D 963 9006 269	Metal oxide 0.22 ohm 1W		
R110SBR	00D 963 9006 269	Metal oxide 0.22 ohm 1W		
R111SBL	00D 963 9006 269	Metal oxide 0.22 ohm 1W		
R111SBR	00D 963 9006 269	Metal oxide 0.22 ohm 1W		
R118SBL	00D 963 9006 256	Metal oxide 10 ohm 1W		
R118SBR	00D 963 9006 256	Metal oxide 10 ohm 1W		
R119SBL	00D 963 9006 256	Metal oxide 10 ohm 1W		
R119SBR	00D 963 9006 256	Metal oxide 10 ohm 1W		
R509C	00D 960 9005 902	Metal film 1.2 kohm 1/4W		
R509FL	00D 960 9005 902	Metal film 1.2 kohm 1/4W		
R509FR	00D 960 9005 902	Metal film 1.2 kohm 1/4W		
R509SBL	00D 960 9005 902	Metal film 1.2 kohm 1/4W		
R509SBR	00D 960 9005 902	Metal film 1.2 kohm 1/4W		
R509SL	00D 960 9005 902	Metal film 1.2 kohm 1/4W		
R509SR	00D 960 9005 902	Metal film 1.2 kohm 1/4W		
R511C	00D 960 9004 301	Metal film 47 ohm 1/4W		
R511FL	00D 960 9004 301	Metal film 47 ohm 1/4W		
R511FR	00D 960 9004 301	Metal film 47 ohm 1/4W		
R511SBL	00D 960 9004 301	Metal film 47 ohm 1/4W		
R511SBR	00D 960 9004 301	Metal film 47 ohm 1/4W		
R511SL	00D 960 9004 301	Metal film 47 ohm 1/4W		
R511SR	00D 960 9004 301	Metal film 47 ohm 1/4W		
R559	00D 963 9005 642	Metal film 1.2 kohm 1W		
R565	00D 963 9005 642	Metal film 1.2 kohm 1W		
R570	00D 963 9005 642	Metal film 1.2 kohm 1W		
R575	00D 963 9006 269	Metal oxide 0.22 ohm 1W		

Ref. No.	Part No.	Part Name	Remarks	New
VR106	00D 963 0105 208	Semi fixed resistor 1 kohm		
VR107	00D 963 0105 208	Semi fixed resistor 1 kohm		
CAPACITORS GROUP				
C101SBL	00D 963 9006 450	Electrolytic 47uF/50V		
C101SBR	00D 963 9006 450	Electrolytic 47uF/50V		
C102SBL	00D 963 9006 308	Electrolytic 10uF/50V		
C102SBR	00D 963 9006 308	Electrolytic 10uF/50V		
C103SBL	00D 963 9003 084	Ceramic 100pF/500V		
C103SBR	00D 963 9003 084	Ceramic 100pF/500V		
C104SBL	00D 963 9003 084	Ceramic 100pF/500V		
C104SBR	00D 963 9003 084	Ceramic 100pF/500V		
C105SBL	00D 963 9008 640	Mylar film 0.022uF/100V		
C105SBR	00D 963 9008 640	Mylar film 0.022uF/100V		
C107SBL	00D 963 9003 097	Mylar film 0.1uF/250V		
C107SBR	00D 963 9003 097	Mylar film 0.1uF/250V		
C201PC	00D 963 9004 575	Ceramic chip 100pF/50V		
C201PFL	00D 963 9004 575	Ceramic chip 100pF/50V		
C201PFR	00D 963 9004 575	Ceramic chip 100pF/50V		
C201PSL	00D 963 9004 575	Ceramic chip 100pF/50V		
C201PSR	00D 963 9004 575	Ceramic chip 100pF/50V		
C201PSW	00D 963 9004 575	Ceramic chip 100pF/50V		
C258	00D 963 0021 104	Electrolytic 6800uF/16V		
C501C	00D 963 9006 382	Electrolytic 22uF/25V		
C501FL	00D 963 9006 382	Electrolytic 22uF/25V		
C501FR	00D 963 9006 382	Electrolytic 22uF/25V		
C501SBL	00D 963 9006 382	Electrolytic 22uF/25V		
C501SBR	00D 963 9006 382	Electrolytic 22uF/25V		
C501SL	00D 963 9006 382	Electrolytic 22uF/25V		
C501SR	00D 963 9006 382	Electrolytic 22uF/25V		
C502C	00D 963 9006 308	Electrolytic 10uF/50V		
C502FL	00D 963 9006 308	Electrolytic 10uF/50V		
C502FR	00D 963 9006 308	Electrolytic 10uF/50V		
C502SBL	00D 963 9006 308	Electrolytic 10uF/50V		
C502SBR	00D 963 9006 308	Electrolytic 10uF/50V		
C502SL	00D 963 9006 308	Electrolytic 10uF/50V		
C502SR	00D 963 9006 308	Electrolytic 10uF/50V		
C503C	00D 963 9003 165	Ceramic 220pF/500V		
C503FL	00D 963 9003 165	Ceramic 220pF/500V		
C503FR	00D 963 9003 165	Ceramic 220pF/500V		
C503SBL	00D 963 9003 165	Ceramic 220pF/500V		
C503SBR	00D 963 9003 165	Ceramic 220pF/500V		
C503SL	00D 963 9003 165	Ceramic 220pF/500V		
C503SR	00D 963 9003 165	Ceramic 220pF/500V		
C504C	00D 963 0157 502	Ceramic 220pF/50V		*
C504FL	00D 963 0157 502	Ceramic 220pF/50V		*
C504FR	00D 963 0157 502	Ceramic 220pF/50V		*
C504SBL	00D 963 0157 502	Ceramic 220pF/50V		*
C504SBR	00D 963 0157 502	Ceramic 220pF/50V		*
C504SL	00D 963 0157 502	Ceramic 220pF/50V		*
C504SR	00D 963 0157 502	Ceramic 220pF/50V		*
C505C	00D 963 9003 181	Ceramic 33pF/500V		
C505FL	00D 963 9003 181	Ceramic 33pF/500V		
C505FR	00D 963 9003 181	Ceramic 33pF/500V		
C505SBL	00D 963 9003 181	Ceramic 33pF/500V		
C505SBR	00D 963 9003 181	Ceramic 33pF/500V		
C505SL	00D 963 9003 181	Ceramic 33pF/500V		
C505SR	00D 963 9003 181	Ceramic 33pF/500V		

Ref. No.	Part No.	Part Name	Remarks	New
C506C	00D 963 9005 312	Electrolytic 100uF/10V		
C506FL	00D 963 9005 312	Electrolytic 100uF/10V		
C506FR	00D 963 9005 312	Electrolytic 100uF/10V		
C506SBL	00D 963 9005 312	Electrolytic 100uF/10V		
C506SBR	00D 963 9005 312	Electrolytic 100uF/10V		
C506SL	00D 963 9005 312	Electrolytic 100uF/10V		
C506SR	00D 963 9005 312	Electrolytic 100uF/10V		
C507C	00D 963 9003 194	Mylar film 0.0022uF/100V		
C507FL	00D 963 9003 194	Mylar film 0.0022uF/100V		
C507FR	00D 963 9003 194	Mylar film 0.0022uF/100V		
C507SBL	00D 963 9003 194	Mylar film 0.0022uF/100V		
C507SBR	00D 963 9003 194	Mylar film 0.0022uF/100V		
C507SL	00D 963 9003 194	Mylar film 0.0022uF/100V		
C507SR	00D 963 9003 194	Mylar film 0.0022uF/100V		
C508C	00D 963 9006 382	Electrolytic 22uF/25V		
C508FL	00D 963 9006 382	Electrolytic 22uF/25V		
C508FR	00D 963 9006 382	Electrolytic 22uF/25V		
C508SBL	00D 963 9006 382	Electrolytic 22uF/25V		
C551	00D 963 9006 405	Electrolytic 2.2uF/50V		
C551M	00D 963 0161 200	Electrolytic 10uF/25V		*
C551S	00D 963 9004 562	Ceramic 0.047uF/50V		
C552	00D 963 9006 366	Electrolytic 0.1uF/50V		
C553	00D 963 9006 366	Electrolytic 0.1uF/50V		
C554	00D 963 9006 366	Electrolytic 0.1uF/50V		
C555	00D 963 9004 546	Ceramic 0.01uF/16V		
C556	00D 963 9004 546	Ceramic 0.01uF/16V		
C557	00D 963 9006 308	Electrolytic 10uF/50V		
C558	00D 963 9006 366	Electrolytic 0.1uF/50V		
C559	00D 963 0145 006	Mylar film 0.047uF/50V		
C561	00D 963 0145 006	Mylar film 0.047uF/50V		
C562	00D 963 9004 546	Ceramic 0.01uF/16V		
C563	00D 963 9004 546	Ceramic 0.01uF/16V		
C564	00D 960 0133 501	Electrolytic 2200uF/16V		
OTHER PARTS GROUP				
CN1153	00D 963 0097 303	15P connector socket (TUC-P)		
CN501	00D 963 0085 603	5P connector socket (TUC-P)		
CN502	00D 963 0086 602	12P connector socket (TUC-P)		
CN503	00D 963 0086 505	7P connector socket (TUC-P)		
CN504	00D 963 0085 506	9P connector socket (TUC-P)		
CN505	00D 963 0086 505	7P connector socket (TUC-P)		
CN506	00D 963 0060 903	15P connector base		
CN506T	00D 963 0159 704	15P connector cord		*
CN510	00D 963 0160 405	5P connector cord		*
CN551	00D 963 0097 206	8P connector socket (TUC-P)		
CN552	00D 963 0086 204	19P connector socket (TUC-P)		
CN553	00D 963 0097 206	8P connector socket (TUC-P)		
CN554	00D 963 0160 609	15P connector cord		*
CN555	00D 963 0086 709	11P connector socket (TUC-P)		
CN556	00D 963 0159 403	15P connector cord		*
CN557	00D 963 0086 709	11P connector socket (TUC-P)		
CN560	00D 963 0110 701	14P connector socket (TUC-P)		
CN992	00D 960 0217 553	4P connector base		
CP1154	00D 963 0097 507	15P connector base (TUC-P)		
CP508	00D 963 0068 303	9P connector base		
CP509	00D 963 0060 505	7P connector base		
CP510	00D 963 0066 101	5P connector base		

	Ref. No.	Part No.	Part Name	Remarks	New
	CP554	00D 963 0060 903	15P connector base		
	CP568	00D 963 0049 102	3P connector base		
	CP602D	00D 963 0097 507	15P connector base (TUC-P)		
	J209RM	00D 963 9003 372	Carbon chip 0 ohm 1/16W		
	L101SBL	00D 963 0049 005	Inductor 0.5uH		
	L101SBR	00D 963 0049 005	Inductor 0.5uH		
	TP106	00D 960 0161 418	3P connector base		
	TP107	00D 960 0161 418	3P connector base		
	-	00D 960 0184 000	Screw bracket	2	
	-	00D 960 0184 000	Screw bracket	2	
	-	00D 960 0236 602	Shield plate	1	
	-	00D 960 0268 803	6P pin jack	1	

INPUT, VIDEO P.W.B. UNIT

	Ref. No.	Part No.	Part Name	Remarks	New
SEMICONDUCTORS GROUP					
	IC1000		IC BA7626F	J171762600010	
	IC1001	00D 963 0116 103	IC MM74HC4053MX		
	IC1002		IC BA7626F	J171762600010	
	IC1003	00D 963 0074 504	IC BU2090F		
	IC1004	00D 963 0116 103	IC MM74HC4053MX		
	IC1005	00D 963 0074 504	IC BU2090F		
	IC1006	00D 963 0116 307	IC LC7478		
	IC1007	00D 963 0116 200	IC NJM2274R		
	IC1008	00D 963 0116 103	IC MM74HC4053MX		
	IC1150		IC BA7626F	J171762600010	
	IC1151		IC BA7626F	J171762600010	
	IC1152		IC BA7626F	J171762600010	
	IC1153		IC BA7626F	J171762600010	
	IC201T	00D 963 0158 909	IC TC94A27UG		*
	IC202T	00D 963 0158 909	IC TC94A27UG		*
	IC203T	00D 960 0080 201	IC KIC9164AN		
	IC205	00D 963 0024 004	IC NJM2068M		
	IC206	00D 963 0024 004	IC NJM2068M		
	IC207	00D 963 0024 004	IC NJM2068M		
	IC208	00D 963 0159 005	IC NJM5532M		*
	IC209	00D 963 0159 005	IC NJM5532M		*
	IC210	00D 963 0159 005	IC NJM5532M		*
	IC211	00D 963 0159 005	IC NJM5532M		*
	IC603E		IC BA7626F	J171762600010	
	IC604E		IC BA7626F	J171762600010	
	IC605E	00D 960 0175 200	IC BA7625		
	IC701	00D 963 0083 207	IC TC9274N-011		
	IC701M	00D 963 0024 004	IC NJM2068M		
	IC702	00D 963 0024 004	IC NJM2068M		
	IC703	00D 963 0024 004	IC NJM2068M		
	IC704	00D 960 0174 502	IC NJM2068DD		
	IC705	00D 960 0174 201	IC TC9273N-004		
	Q1000	00D 963 0102 803	Transistor 2SA933S		
	Q1001	00D 963 0102 803	Transistor 2SA933S		
	Q1002	00D 963 0121 703	Transistor KRA107S		
	Q1003	00D 963 0121 703	Transistor KRA107S		
	Q1004	00D 963 0120 704	Transistor KRA102S		
	Q1005	00D 963 0159 102	Transistor KRC111S		*
	Q1006	00D 963 0120 801	Transistor KRC102S		
	Q1007	00D 960 0068 207	Transistor KTA1504Y		
	Q1008	00D 963 0120 704	Transistor KRA102S		
	Q1009	00D 963 0159 102	Transistor KRC111S		*
	Q1010	00D 963 0120 801	Transistor KRC102S		
	Q1011	00D 960 0068 207	Transistor KTA1504Y		
	Q1012	00D 963 0044 301	Transistor KTC2875B		
	Q1013	00D 963 0120 704	Transistor KRA102S		
	Q1014	00D 960 0068 207	Transistor KTA1504Y		
	Q1015	00D 963 0120 801	Transistor KRC102S		
	Q1016	00D 960 0068 207	Transistor KTA1504Y		
	Q1017	00D 960 0068 207	Transistor KTA1504Y		
	Q1018	00D 960 0068 207	Transistor KTA1504Y		
	Q1019	00D 960 0068 207	Transistor KTA1504Y		
	Q1020	00D 963 0066 606	Transistor KTC3875Y		
	Q1021	00D 963 0066 606	Transistor KTC3875Y		
	Q1022	00D 960 0068 207	Transistor KTA1504Y		

	Ref. No.	Part No.	Part Name	Remarks	New
	Q1023	00D 963 0102 803	Transistor 2SA933S		
	Q1024	00D 960 0005 202	Transistor KTC3198Y		
	Q1025	00D 960 0005 105	Transistor KTA1266Y		
	Q1026	00D 960 0005 105	Transistor KTA1266Y		
	Q1027	00D 960 0005 105	Transistor KTA1266Y		
	Q1028	00D 960 0005 202	Transistor KTC3198Y		
	Q1029	00D 960 0005 105	Transistor KTA1266Y		
	Q1030	00D 960 0005 202	Transistor KTC3198Y		
	Q1150	00D 963 0159 102	Transistor KRC111S		*
	Q1151	00D 960 0068 207	Transistor KTA1504Y		
	Q1152	00D 963 0159 102	Transistor KRC111S		*
	Q1153	00D 960 0068 207	Transistor KTA1504Y		
	Q1155	00D 963 0159 102	Transistor KRC111S		*
	Q1156	00D 960 0068 207	Transistor KTA1504Y		
	Q1157	00D 963 0159 102	Transistor KRC111S		*
	Q1158	00D 960 0068 207	Transistor KTA1504Y		
	Q1159	00D 960 0068 207	Transistor KTA1504Y		
	Q1160	00D 963 0159 102	Transistor KRC111S		*
	Q1161	00D 963 0159 102	Transistor KRC111S		*
	Q207T	00D 960 0196 807	Transistor 2SK117Y		
	Q208T	00D 960 0196 807	Transistor 2SK117Y		
	Q209T	00D 960 0097 003	Transistor KRA104M		
	Q210T	00D 963 0121 004	Transistor KRC104M		
	Q551SW	00D 963 0044 301	Transistor KTC2875B		
	Q552SW	00D 963 0044 301	Transistor KTC2875B		
	Q601E	00D 960 0005 105	Transistor KTA1266Y		
	Q602E	00D 960 0005 105	Transistor KTA1266Y		
	Q603E	00D 960 0005 105	Transistor KTA1266Y		
	D1000	00D 960 0197 000	Diode KDS160		
	D1001	00D 960 0197 000	Diode KDS160		
	D1002	00D 960 0197 000	Diode KDS160		
	D1003	00D 960 0197 000	Diode KDS160		
	D1004	00D 960 0197 000	Diode KDS160		
	D1005	00D 960 0197 000	Diode KDS160		
	D1012	00D 963 0020 309	Diode 1SS133T		
	D1014	00D 963 0020 309	Diode 1SS133T		
	D1150	00D 960 0197 000	Diode KDS160		
	D1151	00D 960 0197 000	Diode KDS160		
	D1152	00D 960 0197 000	Diode KDS160		
	D1153	00D 960 0197 000	Diode KDS160		
	D1154	00D 960 0197 000	Diode KDS160		
	D1155	00D 960 0197 000	Diode KDS160		
	D1157	00D 960 0197 000	Diode KDS160		
	D205T	00D 960 0197 000	Diode KDS160		
	D207T	00D 960 0197 000	Diode KDS160		
	D251	00D 960 0197 000	Diode KDS160		
	D252	00D 960 0197 000	Diode KDS160		
	D253	00D 960 0197 000	Diode KDS160		
	D254	00D 960 0197 000	Diode KDS160		
	D255	00D 960 0197 000	Diode KDS160		
	D256	00D 960 0197 000	Diode KDS160		
	D901	00D 960 0197 000	Diode KDS160		
	D902	00D 960 0197 000	Diode KDS160		
	D903	00D 960 0197 000	Diode KDS160		
	D904	00D 960 0197 000	Diode KDS160		
	ZD1000	00D 960 0095 500	Zener diode MTZJ5.1B		
	ZD701M	00D 960 0095 500	Zener diode MTZJ5.1B		

Ref. No.	Part No.	Part Name	Remarks	New
RESISTORS GROUP				
R1031	00D 963 9005 639	Metal film 100 ohm 1W		
R1038	00D 963 9005 639	Metal film 100 ohm 1W		
R1059	00D 963 9005 639	Metal film 100 ohm 1W		
R1095	00D 963 0018 007	Metal film 100 ohm 1/4W		
R1163	00D 963 9005 639	Metal film 100 ohm 1W		
R1166	00D 963 9005 639	Metal film 100 ohm 1W		
R1193	00D 963 9005 639	Metal film 100 ohm 1W		
R1199	00D 963 9005 639	Metal film 100 ohm 1W		
R1232	00D 963 9005 639	Metal film 100 ohm 1W		
R1239	00D 963 9005 639	Metal film 100 ohm 1W		
R229T	00D 963 9005 639	Metal film 100 ohm 1W		
R230T	00D 963 9005 639	Metal film 100 ohm 1W		
R738M	00D 963 9005 338	Carbon chip 1.6 kohm 1/10W		
CAPACITORS GROUP				
C1000	00D 963 9006 382	Electrolytic 22uF/25V		
C1001	00D 963 9006 382	Electrolytic 22uF/25V		
C1002	00D 963 9005 312	Electrolytic 100uF/10V		
C1003	00D 963 9004 753	Ceramic chip 0.047uF/50V		
C1004	00D 963 9006 308	Electrolytic 10uF/50V		
C1005	00D 963 9006 308	Electrolytic 10uF/50V		
C1006	00D 963 9006 382	Electrolytic 22uF/25V		
C1007	00D 963 9004 753	Ceramic chip 0.047uF/50V		
C1009	00D 963 9006 308	Electrolytic 10uF/50V		
C1010	00D 963 9006 405	Electrolytic 2.2uF/50V		
C1011	00D 963 9006 405	Electrolytic 2.2uF/50V		
C1013	00D 963 9006 382	Electrolytic 22uF/25V		
C1014	00D 963 9006 308	Electrolytic 10uF/50V		
C1016	00D 963 9006 146	Ceramic chip 560pF/50V		
C1017	00D 963 9004 575	Ceramic chip 100pF/50V		
C1018	00D 963 9004 575	Ceramic chip 100pF/50V		
C1019	00D 963 9006 308	Electrolytic 10uF/50V		
C1020	00D 963 9006 463	Electrolytic 470uF/6.3V		
C1021	00D 963 9006 560	Electrolytic 47uF/35V		
C1022	00D 963 9006 308	Electrolytic 10uF/50V		
C1023	00D 963 9006 463	Electrolytic 470uF/6.3V		
C1024	00D 963 9004 753	Ceramic chip 0.047uF/50V		
C1025	00D 963 9006 515	Ceramic 1pF/50V		
C1026	00D 963 9006 308	Electrolytic 10uF/50V		
C1027	00D 963 9006 463	Electrolytic 470uF/6.3V		
C1030	00D 963 9006 434	Electrolytic 47uF/16V		
C1034	00D 963 9006 515	Ceramic 1pF/50V		
C1035	00D 963 9006 560	Electrolytic 47uF/35V		
C1039	00D 963 9006 528	Ceramic chip 20pF/50V		
C1040	00D 963 9006 379	Electrolytic 1uF/50V		
C1041	00D 963 0157 706	Ceramic chip 0.022uF/50V		*
C1042	00D 963 9006 434	Electrolytic 47uF/16V		
C1049	00D 963 9006 528	Ceramic chip 20pF/50V		
C1052	00D 963 9006 308	Electrolytic 10uF/50V		
C1053	00D 963 9006 308	Electrolytic 10uF/50V		
C1054	00D 963 9005 998	Ceramic chip 24pF/50V		
C1055	00D 963 9004 753	Ceramic chip 0.047uF/50V		
C1056	00D 963 9006 379	Electrolytic 1uF/50V		
C1057	00D 963 9005 998	Ceramic chip 24pF/50V		
C1058	00D 963 9006 434	Electrolytic 47uF/16V		

Ref. No.	Part No.	Part Name	Remarks	New
C1059	00D 963 9004 753	Ceramic chip 0.047uF/50V		
C1060	00D 963 9006 434	Electrolytic 47uF/16V		
C1061	00D 963 0129 909	Ceramic chip 1200pF/50V		
C1062	00D 963 9005 312	Electrolytic 100uF/10V		
C1063	00D 960 9010 094	Ceramic chip 0.01uF/50V		
C1069	00D 963 9006 382	Electrolytic 22uF/25V		
C1070	00D 963 9005 312	Electrolytic 100uF/10V		
C1071	00D 963 9006 379	Electrolytic 1uF/50V		
C1080	00D 963 0157 706	Ceramic chip 0.022uF/50V		*
C1081	00D 963 9006 434	Electrolytic 47uF/16V		
C1150	00D 963 9006 382	Electrolytic 22uF/25V		
C1151	00D 960 9010 094	Ceramic chip 0.01uF/50V		
C1152	00D 963 9006 382	Electrolytic 22uF/25V		
C1153	00D 963 9004 575	Ceramic chip 100pF/50V		
C1154	00D 963 9004 575	Ceramic chip 100pF/50V		
C1155	00D 963 9004 575	Ceramic chip 100pF/50V		
C1156	00D 963 9004 575	Ceramic chip 100pF/50V		
C1157	00D 963 9006 382	Electrolytic 22uF/25V		
C1158	00D 963 9004 753	Ceramic chip 0.047uF/50V		
C1159	00D 963 9006 382	Electrolytic 22uF/25V		
C1160	00D 963 9006 308	Electrolytic 10uF/50V		
C1161	00D 963 9006 463	Electrolytic 470uF/6.3V		
C1162	00D 963 9006 308	Electrolytic 10uF/50V		
C1163	00D 963 9006 463	Electrolytic 470uF/6.3V		
C1164	00D 963 9006 382	Electrolytic 22uF/25V		
C1165	00D 963 9006 382	Electrolytic 22uF/25V		
C1167	00D 963 9004 753	Ceramic chip 0.047uF/50V		
C1171	00D 963 9006 382	Electrolytic 22uF/25V		
C1172	00D 963 9006 382	Electrolytic 22uF/25V		
C1173	00D 963 9004 753	Ceramic chip 0.047uF/50V		
C1181	00D 963 9006 308	Electrolytic 10uF/50V		
C1183	00D 960 9010 515	Electrolytic 0.47uF/50V		
C1188	00D 963 9006 308	Electrolytic 10uF/50V		
C1189	00D 960 9010 515	Electrolytic 0.47uF/50V		
C1207	00D 963 9003 372	Carbon chip 0 ohm 1/16W		
C1208	00D 963 9003 372	Carbon chip 0 ohm 1/16W		
C1209	00D 963 9003 372	Carbon chip 0 ohm 1/16W		
C1210	00D 963 9003 372	Carbon chip 0 ohm 1/16W		
C1215	00D 963 9003 372	Carbon chip 0 ohm 1/16W		
C1219	00D 963 9006 463	Electrolytic 470uF/6.3V		
C1222	00D 960 9010 515	Electrolytic 0.47uF/50V		
C211SW	00D 963 9004 575	Ceramic chip 100pF/50V		
C212SW	00D 963 9004 643	Ceramic chip 47pF/50V		
C213FL	00D 963 9004 575	Ceramic chip 100pF/50V		
C213FR	00D 963 9004 575	Ceramic chip 100pF/50V		
C213T	00D 963 9004 753	Ceramic chip 0.047uF/50V		
C214T	00D 963 9004 753	Ceramic chip 0.047uF/50V		
C215T	00D 963 9004 753	Ceramic chip 0.047uF/50V		
C216T	00D 963 9004 753	Ceramic chip 0.047uF/50V		
C217T	00D 963 9004 753	Ceramic chip 0.047uF/50V		
C218FL	00D 963 9004 627	Ceramic chip 33pF/50V		
C218FR	00D 963 9004 627	Ceramic chip 33pF/50V		
C218T	00D 963 9006 379	Electrolytic 1uF/50V		
C219FL	00D 963 9006 308	Electrolytic 10uF/50V		
C219FR	00D 963 9006 308	Electrolytic 10uF/50V		
C219SW	00D 963 9006 308	Electrolytic 10uF/50V		
C219T	00D 963 9006 379	Electrolytic 1uF/50V		
C220T	00D 963 9006 308	Electrolytic 10uF/50V		
C223C	00D 963 9006 382	Electrolytic 22uF/25V		
C223FL	00D 963 9006 382	Electrolytic 22uF/25V		
C223FR	00D 963 9006 382	Electrolytic 22uF/25V		

Ref. No.	Part No.	Part Name	Remarks	New
C223SBL	00D 963 9006 382	Electrolytic 22uF/25V		
C223SBR	00D 963 9006 382	Electrolytic 22uF/25V		
C223SL	00D 963 9006 382	Electrolytic 22uF/25V		
C223SR	00D 963 9006 382	Electrolytic 22uF/25V		
C223SW	00D 963 9006 382	Electrolytic 22uF/25V		
C225T	00D 963 9006 379	Electrolytic 1uF/50V		
C226T	00D 963 9006 379	Electrolytic 1uF/50V		
C227T	00D 963 9006 308	Electrolytic 10uF/50V		
C228T	00D 963 9006 434	Electrolytic 47uF/16V		
C229T	00D 963 9006 434	Electrolytic 47uF/16V		
C230T	00D 963 9006 308	Electrolytic 10uF/50V		
C231C	00D 963 9006 418	Electrolytic 3.3uF/50V		
C231FL	00D 963 9006 418	Electrolytic 3.3uF/50V		
C231FR	00D 963 9006 418	Electrolytic 3.3uF/50V		
C231SBL	00D 963 9006 418	Electrolytic 3.3uF/50V		
C231SBR	00D 963 9006 418	Electrolytic 3.3uF/50V		
C231SL	00D 963 9006 418	Electrolytic 3.3uF/50V		
C231SR	00D 963 9006 418	Electrolytic 3.3uF/50V		
C231SW	00D 963 9006 418	Electrolytic 3.3uF/50V		
C231T	00D 963 9006 308	Electrolytic 10uF/50V		
C232C	00D 960 9010 104	Ceramic 5pF/50V		
C232FL	00D 960 9010 104	Ceramic 5pF/50V		
C232FR	00D 960 9010 104	Ceramic 5pF/50V		
C232SBL	00D 960 9010 104	Ceramic 5pF/50V		
C232SBR	00D 960 9010 104	Ceramic 5pF/50V		
C232SL	00D 960 9010 104	Ceramic 5pF/50V		
C232SR	00D 960 9010 104	Ceramic 5pF/50V		
C232SW	00D 960 9010 104	Ceramic 5pF/50V		
C232T	00D 963 9006 434	Electrolytic 47uF/16V		
C233T	00D 963 9006 434	Electrolytic 47uF/16V		
C234T	00D 963 9006 434	Electrolytic 47uF/16V		
C235T	00D 963 9006 434	Electrolytic 47uF/16V		
C236T	00D 963 9006 434	Electrolytic 47uF/16V		
C237T	00D 963 9006 434	Electrolytic 47uF/16V		
C238C	00D 963 9006 418	Electrolytic 3.3uF/50V		
C238FL	00D 963 9006 418	Electrolytic 3.3uF/50V		
C239T	00D 963 9004 753	Ceramic chip 0.047uF/50V		
C240T	00D 963 9006 379	Electrolytic 1uF/50V		
C241T	00D 963 9006 308	Electrolytic 10uF/50V		
C243T	00D 963 9006 379	Electrolytic 1uF/50V		
C244T	00D 963 9006 379	Electrolytic 1uF/50V		
C245T	00D 963 9006 379	Electrolytic 1uF/50V		
C246SW	00D 963 9006 476	Electrolytic 4.7uF/50V		
C246T	00D 963 9006 308	Electrolytic 10uF/50V		
C247T	00D 963 9004 575	Ceramic chip 100pF/50V		
C248T	00D 963 9006 379	Electrolytic 1uF/50V		
C251	00D 963 9004 708	Ceramic chip 0.1uF/50V		
C252	00D 963 9004 708	Ceramic chip 0.1uF/50V		
C253	00D 963 9004 708	Ceramic chip 0.1uF/50V		
C601E	00D 963 9005 312	Electrolytic 100uF/10V		
C601I	00D 963 9003 372	Carbon chip 0 ohm 1/16W		
C602E	00D 963 9005 312	Electrolytic 100uF/10V		
C602I	00D 963 9003 372	Carbon chip 0 ohm 1/16W		
C603E	00D 963 9005 312	Electrolytic 100uF/10V		
C604E	00D 963 9006 159	Electrolytic 4700uF/16V		
C605E	00D 963 9006 463	Electrolytic 470uF/6.3V		
C606E	00D 963 9006 463	Electrolytic 470uF/6.3V		
C618E	00D 963 9006 379	Electrolytic 1uF/50V		
C620E	00D 963 9006 476	Electrolytic 4.7uF/50V		
C621E	00D 963 0157 706	Ceramic chip 0.022uF/50V		*
C622E	00D 963 9005 312	Electrolytic 100uF/10V		

Ref. No.	Part No.	Part Name	Remarks	New
C623E	00D 963 9006 476	Electrolytic 4.7uF/50V		
C624E	00D 963 9006 476	Electrolytic 4.7uF/50V		
C625E	00D 963 9006 379	Electrolytic 1uF/50V		
C627E	00D 963 0157 706	Ceramic chip 0.022uF/50V		*
C628E	00D 963 9005 312	Electrolytic 100uF/10V		
C632E	00D 963 9006 476	Electrolytic 4.7uF/50V		
C633E	00D 963 9006 379	Electrolytic 1uF/50V		
C635E	00D 963 9006 476	Electrolytic 4.7uF/50V		
C636E	00D 963 0157 706	Ceramic chip 0.022uF/50V		*
C637E	00D 963 9005 312	Electrolytic 100uF/10V		
C638E	00D 963 9006 476	Electrolytic 4.7uF/50V		
C639E	00D 963 9006 476	Electrolytic 4.7uF/50V		
C640E	00D 963 9006 476	Electrolytic 4.7uF/50V		
C641E	00D 963 9006 476	Electrolytic 4.7uF/50V		
C702L	00D 963 9004 575	Ceramic chip 100pF/50V		
C702R	00D 963 9004 575	Ceramic chip 100pF/50V		
C703L	00D 963 9004 575	Ceramic chip 100pF/50V		
C703R	00D 963 9004 575	Ceramic chip 100pF/50V		
C704L	00D 963 9004 575	Ceramic chip 100pF/50V		
C704R	00D 963 9004 575	Ceramic chip 100pF/50V		
C705L	00D 963 9004 575	Ceramic chip 100pF/50V		
C705R	00D 963 9004 575	Ceramic chip 100pF/50V		
C709L	00D 963 9006 308	Electrolytic 10uF/50V		
C709R	00D 963 9006 308	Electrolytic 10uF/50V		
C711L	00D 963 9006 557	Electrolytic 220uF/6.3V		
C711R	00D 963 9006 557	Electrolytic 220uF/6.3V		
C712L	00D 963 9004 779	Mylar film 0.024uF/50V		
C712R	00D 963 9004 779	Mylar film 0.024uF/50V		
C713L	00D 960 9008 695	Mylar film 0.0068uF/100V		
C713R	00D 960 9008 695	Mylar film 0.0068uF/100V		
C714L	00D 963 9006 476	Electrolytic 4.7uF/50V		
C714R	00D 963 9006 476	Electrolytic 4.7uF/50V		
C715L	00D 963 9004 737	Ceramic chip 0.022uF/25V		
C715R	00D 963 9004 737	Ceramic chip 0.022uF/25V		
C716L	00D 963 9006 308	Electrolytic 10uF/50V		
C717L	00D 963 9004 601	Ceramic chip 220pF/50V		
C717R	00D 963 9004 601	Ceramic chip 220pF/50V		
C718L	00D 963 9006 421	Electrolytic 47uF/10V		
C718R	00D 963 9006 421	Electrolytic 47uF/10V		
C719L	00D 963 9006 379	Electrolytic 1uF/50V		
C719R	00D 963 9006 379	Electrolytic 1uF/50V		
C720L	00D 963 9003 152	Mylar film 0.068uF/100V		
C720R	00D 963 9003 152	Mylar film 0.068uF/100V		
C721L	00D 963 9003 152	Mylar film 0.068uF/100V		
C721R	00D 963 9003 152	Mylar film 0.068uF/100V		
C723M	00D 963 9006 379	Electrolytic 1uF/50V		
C724L	00D 963 9004 698	Ceramic chip 0.01uF/50V		
C724M	00D 963 9006 379	Electrolytic 1uF/50V		
C724R	00D 963 9004 698	Ceramic chip 0.01uF/50V		
C725	00D 963 9004 698	Ceramic chip 0.01uF/50V		
C725M	00D 963 9006 379	Electrolytic 1uF/50V		
C726	00D 963 9004 698	Ceramic chip 0.01uF/50V		
C726M	00D 963 0157 609	Ceramic chip 150pF/50V		*
C727M	00D 963 9004 575	Ceramic chip 100pF/50V		
C728M	00D 963 0157 609	Ceramic chip 150pF/50V		*
C729	00D 963 9004 708	Ceramic chip 0.1uF/50V		
C729M	00D 963 9006 379	Electrolytic 1uF/50V		
C730M	00D 963 9006 308	Electrolytic 10uF/50V		
C737M	00D 963 9004 575	Ceramic chip 100pF/50V		
C738M	00D 963 9004 698	Ceramic chip 0.01uF/50V		
C901SW	00D 963 9006 476	Electrolytic 4.7uF/50V		

	Ref. No.	Part No.	Part Name	Remarks	New
	C910	00D 963 9004 575	Ceramic chip 100pF/50V		
	C911	00D 960 9010 094	Ceramic chip 0.01uF/50V		
	C912	00D 963 9004 575	Ceramic chip 100pF/50V		
	C913	00D 963 9004 575	Ceramic chip 100pF/50V		
	C914	00D 963 9004 575	Ceramic chip 100pF/50V		
	C915	00D 963 9004 575	Ceramic chip 100pF/50V		
	C916	00D 963 9004 575	Ceramic chip 100pF/50V		
	C917	00D 960 9010 094	Ceramic chip 0.01uF/50V		
	C918	00D 963 9004 575	Ceramic chip 100pF/50V		
	C920	00D 963 9004 575	Ceramic chip 100pF/50V		
OTHER PARTS GROUP					
	CB1000	00D 963 0120 908	Beads inductor		
	CB1001	00D 963 0120 908	Beads inductor		
	CB1002	00D 963 0115 609	Inductor 33uH		
	CB205	00D 963 0154 602	Beads inductor		*
	CN1000	00D 963 0086 505	7P connector socket (TUC-P)		
	CN1004	00D 963 0110 701	14P connector socket (TUC-P)		
	CN1150	00D 963 0086 505	7P connector socket (TUC-P)		
	CN1151	00D 963 0097 303	15P connector socket (TUC-P)		
	CN1154	00D 963 0097 303	15P connector socket (TUC-P)		
	CN403	00D 963 0086 709	11P connector socket (TUC-P)		
	CN508	00D 963 0159 306	9P connector cord		*
	CN509	00D 963 0159 209	7P connector cord		*
	CN557T	00D 963 0050 104	4P connector base		
	CN601	00D 963 0097 303	15P connector socket (TUC-P)		
	CN701	00D 963 0086 301	18P connector socket (TUC-P)		
	CN701M	00D 963 0160 104	4P connector cord		*
	CN703	00D 963 0086 505	7P connector socket (TUC-P)		
	CN805	00D 963 0097 206	8P connector socket (TUC-P)		
	CN806	00D 963 0086 204	19P connector socket (TUC-P)		
	CP556	00D 963 0060 903	15P connector base		
	G902	-	1P contact Ass'y		
	J712B	00D 963 9003 372	Carbon chip 0 ohm 1/16W		
	J712C	00D 963 9003 372	Carbon chip 0 ohm 1/16W		
	JK704	00D 960 0188 103	2P pin jack		
	L1000	00D 963 0131 007	Y/C SEPARATE FILTER		
	XTAL1000	00D 963 0131 405	Crystal 14.318180MHZ		
	-	00D 963 0101 707	Input cushion	1	
	-	00D 963 0094 102	PLATE INPUT	1	
	-	00D 963 0146 209	4P pin jack	2	
	-	00D 960 0268 803	6P pin jack	1	
	-	00D 963 0146 102	2P pin jack	2	
	-	00D 963 0146 209	4P pin jack	1	
	-	00D 963 0146 500	3P pin jack	1	
	-	00D 963 0146 306	6P pin jack	2	
	-	00D 963 0146 209	4P pin jack	2	
	-	00D 963 0158 200	Mini jack	1	*

DSP P.W.B. UNIT

	Ref. No.	Part No.	Part Name	Remarks	New
SEMICONDUCTORS GROUP					
	IC801	00D 963 0113 106	IC GP1FA513RZ		
	IC802	00D 963 0113 106	IC GP1FA513RZ		
	IC803	00D 963 0113 106	IC GP1FA513RZ		
	IC804	00D 963 0147 402	IC ADSP-21266		
	IC805	00D 963 0146 908	IC LH28F800BJE		
	IC806	00D 963 0158 705	IC CY7C1049CV33		*
	IC807	00D 963 0096 100	IC LC89057W		
	IC808	00D 963 0158 802	IC AD1837AAS		*
	IC809	00D 960 0266 805	IC MM74LCX244		
	IC810	00D 960 0266 805	IC MM74LCX244		
	IC811	00D 960 0266 805	IC MM74LCX244		
	IC812	00D 960 0266 902	IC MM74HCT244		
	IC814	00D 963 0102 308	IC MM74HC00MTCX		
	IC815	00D 963 0102 308	IC MM74HC00MTCX		
	IC815A	00D 963 0043 807	IC BA4510F		
	IC816	00D 963 0147 208	IC 74LVX157		
	IC816A	00D 963 0043 807	IC BA4510F		
	IC817	00D 963 0158 705	IC CY7C1049CV33		*
	IC817A	00D 963 0024 004	IC NJM2068M		
	IC818	00D 963 0147 305	IC 74LCX573		
	IC818A	00D 963 0024 004	IC NJM2068M		
	IC819	00D 963 0147 305	IC 74LCX573		
	IC819A	00D 963 0024 004	IC NJM2068M		
	IC820	00D 963 0147 101	IC SN74LVC139A		
	IC820A	00D 963 0024 004	IC NJM2068M		
	IC821	00D 963 0096 003	IC 74LCX74MTC		
	IC822	00D 960 0159 501	IC KIA7805API		
	IC823	00D 963 0111 603	IC RC1117-3.3		
	IC824	00D 963 0147 509	IC RC1117-1.2		
	IC825	00D 963 0096 003	IC 74LCX74MTC		
	IC826	00D 963 0113 009	IC GP1FA513TZ		
	Q804C	00D 960 0196 603	Transistor KTC2874B		
	Q804FL	00D 960 0196 603	Transistor KTC2874B		
	Q804FR	00D 960 0196 603	Transistor KTC2874B		
	Q804SBL	00D 960 0196 603	Transistor KTC2874B		
	Q804SBR	00D 960 0196 603	Transistor KTC2874B		
	Q804SL	00D 960 0196 603	Transistor KTC2874B		
	Q804SR	00D 960 0196 603	Transistor KTC2874B		
	Q804SW	00D 960 0196 603	Transistor KTC2874B		
	Q808	00D 963 0120 801	Transistor KRC102S		
	Q809	00D 963 0120 704	Transistor KRA102S		
	D801	00D 960 0197 000	Diode KDS160		
	D803	00D 960 0197 000	Diode KDS160		
CAPACITORS GROUP					
	C801	00D 963 9004 708	Ceramic chip 0.1uF/50V		
	C802	00D 963 9004 591	Ceramic chip 22pF/50V		
	C803	00D 963 9004 591	Ceramic chip 22pF/50V		
	C804	00D 963 9004 591	Ceramic chip 22pF/50V		
	C805	00D 963 9004 591	Ceramic chip 22pF/50V		
	C806	00D 963 9004 708	Ceramic chip 0.1uF/50V		

Ref. No.	Part No.	Part Name	Remarks	New
C807	00D 963 9004 708	Ceramic chip 0.1uF/50V		
C808	00D 963 9005 862	Electrolytic 47uF/16V		
C809	00D 963 9004 708	Ceramic chip 0.1uF/50V		
C810	00D 963 9005 862	Electrolytic 47uF/16V		
C811	00D 963 9004 591	Ceramic chip 22pF/50V		
C812	00D 963 9005 927	Electrolytic 0.1uF/50V		
C813	00D 963 9004 698	Ceramic chip 0.01uF/50V		
C814	00D 963 9005 862	Electrolytic 47uF/16V		
C815	00D 963 9005 312	Electrolytic 100uF/10V		
C817	00D 963 9005 778	Electrolytic 10uF/50V		
C818	00D 963 9005 749	Electrolytic 1uF/50V		
C819	00D 963 9005 901	Electrolytic 470uF/10V		
C820	00D 963 9005 862	Electrolytic 47uF/16V		
C821	00D 963 9005 901	Electrolytic 470uF/10V		
C830	00D 963 9005 901	Electrolytic 470uF/10V		
C831	00D 963 9004 708	Ceramic chip 0.1uF/50V		
C832	00D 963 9004 708	Ceramic chip 0.1uF/50V		
C833	00D 963 9004 698	Ceramic chip 0.01uF/50V		
C835	00D 963 9004 708	Ceramic chip 0.1uF/50V		
C836	00D 963 9004 685	Ceramic chip 1000pF/50V		
C837	00D 963 9004 685	Ceramic chip 1000pF/50V		
C838	00D 963 9004 708	Ceramic chip 0.1uF/50V		
C839	00D 963 9004 708	Ceramic chip 0.1uF/50V		
C840	00D 963 9004 708	Ceramic chip 0.1uF/50V		
C841	00D 963 9004 708	Ceramic chip 0.1uF/50V		
C842	00D 963 9004 591	Ceramic chip 22pF/50V		
C843	00D 963 9004 698	Ceramic chip 0.01uF/50V		
C844	00D 963 9004 708	Ceramic chip 0.1uF/50V		
C845	00D 963 9004 708	Ceramic chip 0.1uF/50V		
C846	00D 963 9004 708	Ceramic chip 0.1uF/50V		
C847	00D 963 9004 591	Ceramic chip 22pF/50V		
C858	00D 960 9009 856	Ceramic chip 0.022uF/50V		
C861	00D 963 9005 998	Ceramic chip 24pF/50V		
C862	00D 963 9005 998	Ceramic chip 24pF/50V		
C863	00D 963 9004 698	Ceramic chip 0.01uF/50V		
C864L	00D 963 9005 862	Electrolytic 47uF/16V		
C864R	00D 963 9005 862	Electrolytic 47uF/16V		
C865L	00D 963 9005 723	Ceramic chip 120pF/50V		
C865R	00D 963 9005 723	Ceramic chip 120pF/50V		
C866	00D 963 9004 698	Ceramic chip 0.01uF/50V		
C867	00D 963 9004 698	Ceramic chip 0.01uF/50V		
C868	00D 963 9004 698	Ceramic chip 0.01uF/50V		
C869L	00D 963 9004 575	Ceramic chip 100pF/50V		
C869R	00D 963 9004 575	Ceramic chip 100pF/50V		
C871L	00D 963 9009 500	Mylar film 0.001uF/100V		
C871R	00D 963 9009 500	Mylar film 0.001uF/100V		
C873	00D 963 9006 340	Electrolytic 100uF/25V		
C873C	00D 963 9004 672	Ceramic chip 680pF/50V		
C873FL	00D 963 9004 672	Ceramic chip 680pF/50V		
C873FR	00D 963 9004 672	Ceramic chip 680pF/50V		
C873SBL	00D 963 9004 672	Ceramic chip 680pF/50V		
C873SBR	00D 963 9004 672	Ceramic chip 680pF/50V		
C873SL	00D 963 9004 672	Ceramic chip 680pF/50V		
C873SR	00D 963 9004 672	Ceramic chip 680pF/50V		
C873SW	00D 963 9004 672	Ceramic chip 680pF/50V		
C874	00D 963 9006 340	Electrolytic 100uF/25V		
C874C	00D 963 9006 146	Ceramic chip 560pF/50V		
C874FL	00D 963 9006 146	Ceramic chip 560pF/50V		
C874FR	00D 963 9006 146	Ceramic chip 560pF/50V		
C874SBL	00D 963 9006 146	Ceramic chip 560pF/50V		
C874SBR	00D 963 9006 146	Ceramic chip 560pF/50V		

Ref. No.	Part No.	Part Name	Remarks	New
C874SL	00D 963 9006 146	Ceramic chip 560pF/50V		
C874SR	00D 963 9006 146	Ceramic chip 560pF/50V		
C874SW	00D 963 9006 146	Ceramic chip 560pF/50V		
C875C	00D 963 9005 778	Electrolytic 10uF/50V		
C875FL	00D 963 9005 778	Electrolytic 10uF/50V		
C875FR	00D 963 9005 778	Electrolytic 10uF/50V		
C875SBL	00D 963 9005 778	Electrolytic 10uF/50V		
C875SBR	00D 963 9005 778	Electrolytic 10uF/50V		
C875SL	00D 963 9005 778	Electrolytic 10uF/50V		
C875SR	00D 963 9005 778	Electrolytic 10uF/50V		
C875SW	00D 963 9005 778	Electrolytic 10uF/50V		
C876C	00D 960 9008 611	Mylar film 0.0033uF/100V		
C876FL	00D 960 9008 611	Mylar film 0.0033uF/100V		
C876FR	00D 960 9008 611	Mylar film 0.0033uF/100V		
C876SBL	00D 960 9008 611	Mylar film 0.0033uF/100V		
C876SBR	00D 960 9008 611	Mylar film 0.0033uF/100V		
C876SL	00D 960 9008 611	Mylar film 0.0033uF/100V		
C876SR	00D 960 9008 611	Mylar film 0.0033uF/100V		
C876SW	00D 960 9008 611	Mylar film 0.0033uF/100V		
C880C	00D 963 9005 778	Electrolytic 10uF/50V		
C889	00D 963 9004 698	Ceramic chip 0.01uF/50V		
C890	00D 963 9004 698	Ceramic chip 0.01uF/50V		
C891	00D 963 9004 698	Ceramic chip 0.01uF/50V		
C893	00D 963 9005 749	Electrolytic 1uF/50V		
C894	00D 963 9004 698	Ceramic chip 0.01uF/50V		
C896	00D 963 9005 927	Electrolytic 0.1uF/50V		
C902	00D 963 9005 901	Electrolytic 470uF/10V		
C907	00D 963 9005 312	Electrolytic 100uF/10V		
C912	00D 963 9004 698	Ceramic chip 0.01uF/50V		
C913	00D 963 9004 698	Ceramic chip 0.01uF/50V		
C920	00D 963 9004 902	Ceramic chip 18pF/50V		
OTHER PARTS GROUP				
CB801	00D 963 0050 502	Chip emifil		
CB802	00D 963 0050 502	Chip emifil		
CB803	00D 963 0050 502	Chip emifil		
CB804	00D 963 0050 502	Chip emifil		
CB805	00D 963 0050 502	Chip emifil		
CB806	00D 963 0050 502	Chip emifil		
CB808	00D 963 0050 502	Chip emifil		
CB810	00D 963 0050 502	Chip emifil		
CN801	00D 963 0086 301	18P connector socket (TUC-P)		
CN802	00D 963 0086 204	19P connector socket (TUC-P)		
CN803	00D 960 0239 900	13P connector socket (TUC-P)		
JACK801	00D 963 0052 500	1P pin jack		
L801	00D 963 0050 803	Inductor 4.7uH		
L802	00D 963 0050 803	Inductor 4.7uH		
L803	00D 963 0050 803	Inductor 4.7uH		
L804	00D 963 0050 803	Inductor 4.7uH		
L805	00D 963 0050 900	Inductor 2.2uH		
R831	00D 963 0120 908	Beads inductor		
R832	00D 963 0120 908	Beads inductor		
R833	00D 963 0120 908	Beads inductor		

	Ref. No.	Part No.	Part Name	Remarks	New
	XTAL1	00D 963 0095 101	Crystal 12.288MHz		
	XTAL2	00D 963 0158 103	Crystal 18.75MHZ		*

PARTS LIST OF P.W.B. UNIT ASS'Y (FOR KOREA)

MAIN P.W.B. UNIT

	Ref. No.	Part No.	Part Name	Remarks	New
SEMICONDUCTORS GROUP					
	IC101	00D 963 0110 507	IC MC7815CT		
	IC102	00D 960 0179 905	IC KIA7915		
	IC103	00D 960 0159 501	IC KIA7805API		
	IC104	00D 963 0110 604	IC MC7805CT		
	IC105	00D 960 0195 808	IC protector ICP-N15		
	IC106	00D 960 0195 808	IC protector ICP-N15		
	Q104C	00D 960 0196 506	Transistor KSC1845F		
	Q104FL	00D 960 0196 506	Transistor KSC1845F		
	Q104FR	00D 960 0196 506	Transistor KSC1845F		
	Q104SL	00D 960 0196 506	Transistor KSC1845F		
	Q104SR	00D 960 0196 506	Transistor KSC1845F		
	Q111	00D 963 0121 208	Transistor KRC107M		
	Q112	00D 960 0097 508	Transistor KRC111M		
	Q113	00D 963 0121 208	Transistor KRC107M		
	Q114	00D 963 0121 208	Transistor KRC107M		
	Q115	00D 963 0121 208	Transistor KRC107M		
	Q116	00D 960 0196 409	Transistor 2SC1740SR		
	Q117	00D 963 0121 208	Transistor KRC107M		
	Q118	00D 963 0121 208	Transistor KRC107M		
	Q151	00D 960 0196 409	Transistor 2SC1740SR		
	Q171	00D 960 0005 202	Transistor KTC3198Y		
	Q171A	00D 960 0196 302	Transistor KTA1268BL		
	Q171B	00D 960 0196 302	Transistor KTA1268BL		
	Q171C	00D 960 0196 302	Transistor KTA1268BL		
	Q171D	00D 960 0196 302	Transistor KTA1268BL		
	Q172	00D 960 0005 202	Transistor KTC3198Y		
	Q173	00D 960 0005 202	Transistor KTC3198Y		
	Q174	00D 960 0005 202	Transistor KTC3198Y		
	Q175	00D 960 0005 202	Transistor KTC3198Y		
	Q176	00D 960 0005 202	Transistor KTC3198Y		
	Q177	00D 960 0005 202	Transistor KTC3198Y		
	Q178	00D 960 0005 105	Transistor KTA1266Y		
	Q179	00D 960 0189 005	Transistor KSA916Y		
	Q180	00D 960 0196 302	Transistor KTA1268BL		
	Q181	00D 960 0196 302	Transistor KTA1268BL		
	Q182	00D 960 0005 202	Transistor KTC3198Y		
	Q183	00D 960 0005 202	Transistor KTC3198Y		
	D101	00D 963 0020 309	Diode 1SS133T		
	D102	00D 963 0020 309	Diode 1SS133T		
	D103	00D 963 0020 309	Diode 1SS133T		
	D104	00D 963 0020 309	Diode 1SS133T		
	D105	00D 963 0020 309	Diode 1SS133T		
	D121	00D 963 0020 309	Diode 1SS133T		
	D122	00D 963 0020 309	Diode 1SS133T		
	D123	00D 963 0020 309	Diode 1SS133T		
	D124	00D 963 0020 309	Diode 1SS133T		
	D125	00D 963 0020 309	Diode 1SS133T		
	D126	00D 963 0020 309	Diode 1SS133T		
	D127	00D 963 0020 309	Diode 1SS133T		
	D131A	00D 960 0197 107	Diode KBPC604		
	D131B	00D 960 0197 107	Diode KBPC604		
	D132	00D 963 0020 309	Diode 1SS133T		
	D133	00D 963 0046 202	Zener diode MTZJ18B		

Ref. No.	Part No.	Part Name	Remarks	New
D134	00D 963 0046 202	Zener diode MTZJ18B		
D136	00D 963 0058 504	Zener diode MTZJ11B		
D138A	00D 963 0058 407	Diode IN4007		
D141	00D 963 0058 407	Diode IN4007		
D142	00D 963 0058 407	Diode IN4007		
D143	00D 963 0058 407	Diode IN4007		
D144	00D 963 0058 407	Diode IN4007		
D145	00D 963 0058 407	Diode IN4007		
D146	00D 963 0058 407	Diode IN4007		
D149	00D 963 0058 407	Diode IN4007		
D150	00D 963 0058 407	Diode IN4007		
D152	00D 963 0058 407	Diode IN4007		
D153	00D 963 0058 407	Diode IN4007		
D154	00D 960 0095 908	Zener diode MTZJ8.2B		
D157	00D 960 0014 905	Zener diode MTZJ20B		
ZD310	00D 960 0095 500	Zener diode MTZJ5.1B		
ZD311	00D 960 0095 500	Zener diode MTZJ5.1B		
LED901	00D 963 0148 605	LED SML1216W 5PI R/G		
RESISTORS GROUP				
R104C	00D 963 9006 285	Metal oxide 5.6 kohm 1W		
R104FL	00D 963 9006 285	Metal oxide 5.6 kohm 1W		
R104FR	00D 963 9006 285	Metal oxide 5.6 kohm 1W		
R104SL	00D 963 9006 285	Metal oxide 5.6 kohm 1W		
R104SR	00D 963 9006 285	Metal oxide 5.6 kohm 1W		
R105C	00D 963 9006 285	Metal oxide 5.6 kohm 1W		
R105FL	00D 963 9006 285	Metal oxide 5.6 kohm 1W		
R105FR	00D 963 9006 285	Metal oxide 5.6 kohm 1W		
R105SL	00D 963 9006 285	Metal oxide 5.6 kohm 1W		
R105SR	00D 963 9006 285	Metal oxide 5.6 kohm 1W		
R106C	00D 963 0047 900	Metal film 4.7 kohm 1W		
R106FL	00D 963 0047 900	Metal film 4.7 kohm 1W		
R106FR	00D 963 0047 900	Metal film 4.7 kohm 1W		
R106SL	00D 963 0047 900	Metal film 4.7 kohm 1W		
R106SR	00D 963 0047 900	Metal film 4.7 kohm 1W		
R107C	00D 963 0047 900	Metal film 4.7 kohm 1W		
R107FL	00D 963 0047 900	Metal film 4.7 kohm 1W		
R107FR	00D 963 0047 900	Metal film 4.7 kohm 1W		
R107SL	00D 963 0047 900	Metal film 4.7 kohm 1W		
R108C	00D 963 9006 269	Metal oxide 0.22 ohm 1W		
R108FL	00D 963 9006 269	Metal oxide 0.22 ohm 1W		
R108FR	00D 963 9006 269	Metal oxide 0.22 ohm 1W		
R108SL	00D 963 9006 269	Metal oxide 0.22 ohm 1W		
R108SR	00D 963 9006 269	Metal oxide 0.22 ohm 1W		
R109C	00D 963 9006 269	Metal oxide 0.22 ohm 1W		
R109FL	00D 963 9006 269	Metal oxide 0.22 ohm 1W		
R109FR	00D 963 9006 269	Metal oxide 0.22 ohm 1W		
R109SL	00D 963 9006 269	Metal oxide 0.22 ohm 1W		
R118C	00D 963 9006 256	Metal oxide 10 ohm 1W		
R118FL	00D 963 9006 256	Metal oxide 10 ohm 1W		
R118FR	00D 963 9006 256	Metal oxide 10 ohm 1W		
R118SL	00D 963 9006 256	Metal oxide 10 ohm 1W		
R118SR	00D 963 9006 256	Metal oxide 10 ohm 1W		
R119C	00D 963 9006 256	Metal oxide 10 ohm 1W		
R119FL	00D 963 9006 256	Metal oxide 10 ohm 1W		
R119FR	00D 963 9006 256	Metal oxide 10 ohm 1W		

Ref. No.	Part No.	Part Name	Remarks	New
R119SL	00D 963 9006 256	Metal oxide 10 ohm 1W		
R135	00D 963 0144 502	Cement resistor 0.1 ohm 5W		
R136	00D 963 0144 502	Cement resistor 0.1 ohm 5W		
R141	00D 960 0180 606	Metal oxide 0.22 ohm 1W		
R142	00D 960 0180 606	Metal oxide 0.22 ohm 1W		
R148	00D 960 0180 606	Metal oxide 0.22 ohm 1W		
R149	00D 960 0180 606	Metal oxide 0.22 ohm 1W		
R151	00D 963 9003 343	Metal film 68ohm 1/4W		
R179	00D 963 9003 055	Metal film 47 kohm 1/4W (NB)		
R903H	00D 960 9009 270	Metal film 470ohm 2W		
R904H	00D 960 9009 270	Metal film 470ohm 2W		
VR101	00D 960 0091 601	Semi fixed resistor 1 kohm		
VR102	00D 960 0091 601	Semi fixed resistor 1 kohm		
VR103	00D 960 0091 601	Semi fixed resistor 1 kohm		
VR104	00D 960 0091 601	Semi fixed resistor 1 kohm		
VR105	00D 960 0091 601	Semi fixed resistor 1 kohm		
CAPACITORS GROUP				
C101C	00D 963 9006 450	Electrolytic 47uF/50V		
C101FL	00D 963 9006 450	Electrolytic 47uF/50V		
C101FR	00D 963 9006 450	Electrolytic 47uF/50V		
C101SL	00D 963 9006 450	Electrolytic 47uF/50V		
C101SR	00D 963 9006 450	Electrolytic 47uF/50V		
C102C	00D 963 9006 308	Electrolytic 10uF/50V		
C102FL	00D 963 9006 308	Electrolytic 10uF/50V		
C102FR	00D 963 9006 308	Electrolytic 10uF/50V		
C102SL	00D 963 9006 308	Electrolytic 10uF/50V		
C102SR	00D 963 9006 308	Electrolytic 10uF/50V		
C103C	00D 963 9003 084	Ceramic 100pF/500V		
C103FL	00D 963 9003 084	Ceramic 100pF/500V		
C103FR	00D 963 9003 084	Ceramic 100pF/500V		
C103SL	00D 963 9003 084	Ceramic 100pF/500V		
C103SR	00D 963 9003 084	Ceramic 100pF/500V		
C104C	00D 963 9003 084	Ceramic 100pF/500V		
C104FL	00D 963 9003 084	Ceramic 100pF/500V		
C104FR	00D 963 9003 084	Ceramic 100pF/500V		
C104SL	00D 963 9003 084	Ceramic 100pF/500V		
C105C	00D 963 9008 640	Mylar film 0.022uF/100V		
C105FL	00D 963 9008 640	Mylar film 0.022uF/100V		
C105FR	00D 963 9008 640	Mylar film 0.022uF/100V		
C105SL	00D 963 9008 640	Mylar film 0.022uF/100V		
C105SR	00D 963 9008 640	Mylar film 0.022uF/100V		
C107C	00D 963 9003 097	Mylar film 0.1uF/250V		
C107FL	00D 963 9003 097	Mylar film 0.1uF/250V		
C107FR	00D 963 9003 097	Mylar film 0.1uF/250V		
C107SL	00D 963 9003 097	Mylar film 0.1uF/250V		
C107SR	00D 963 9003 097	Mylar film 0.1uF/250V		
C131	00D 963 9003 097	Mylar film 0.1uF/250V		
C132	00D 963 9003 097	Mylar film 0.1uF/250V		
C133	00D 963 9003 097	Mylar film 0.1uF/250V		
C134	00D 963 9003 097	Mylar film 0.1uF/250V		
C135	00D 963 9003 097	Mylar film 0.1uF/250V		
C136	00D 963 0157 803	Electrolytic 12000uF/63V		*
C137	00D 963 0157 803	Electrolytic 12000uF/63V		*
C138	00D 963 9006 379	Electrolytic 1uF/50V		
C138A	00D 963 9003 097	Mylar film 0.1uF/250V		
C141	00D 963 0021 900	Mylar film 0.047uF/100V		

	Ref. No.	Part No.	Part Name	Remarks	New
	C142	00D 963 0021 900	Mylar film 0.047uF/100V		
	C143	00D 963 0021 900	Mylar film 0.047uF/100V		
	C144	00D 960 9007 201	Electrolytic 3300uF/35V		
	C145	00D 963 9003 123	Electrolytic 1000uF/35V		
	C146	00D 963 9006 379	Electrolytic 1uF/50V		
	C148	00D 963 9006 379	Electrolytic 1uF/50V		
	C150	00D 963 0021 900	Mylar film 0.047uF/100V		
	C151	00D 963 0021 900	Mylar film 0.047uF/100V		
	C152	00D 963 0021 900	Mylar film 0.047uF/100V		
	C153	00D 963 0021 104	Electrolytic 6800uF/16V		
	C154	00D 963 9006 308	Electrolytic 10uF/50V		
	C155	00D 963 0020 202	Ceramic 0.1uF/50V		
	C157	00D 963 9006 379	Electrolytic 1uF/50V		
	C158	00D 963 9003 136	Electrolytic 1000uF/25V		
	C159	00D 963 9006 379	Electrolytic 1uF/50V		
	C161	00D 963 9006 308	Electrolytic 10uF/50V		
	C171	00D 963 9005 312	Electrolytic 100uF/10V		
	C171A	00D 963 0020 202	Ceramic 0.1uF/50V		
	C171B	00D 963 0020 202	Ceramic 0.1uF/50V		
	C171C	00D 963 0020 202	Ceramic 0.1uF/50V		
	C171D	00D 963 0020 202	Ceramic 0.1uF/50V		
	C172	00D 963 9005 833	Electrolytic 220uF/6.3V		
	C173	00D 963 9005 833	Electrolytic 220uF/6.3V		
	C174	00D 963 9006 308	Electrolytic 10uF/50V		
	C175	00D 963 0149 507	Electrolytic 220uF/16V		
	C176	00D 963 9006 379	Electrolytic 1uF/50V		
	C177	00D 963 9006 379	Electrolytic 1uF/50V		
	C178	00D 963 0157 900	Electrolytic 470uF/63V		*
	C179	00D 963 9005 833	Electrolytic 220uF/6.3V		
⚠	C181	00D 963 9006 191	Ceramic 4700pF/250V(AC)		
	C182	00D 963 9006 311	Electrolytic 10uF/100V		
	C331	00D 963 9004 546	Ceramic 0.01uF/16V		
	C332	00D 963 9004 546	Ceramic 0.01uF/16V		
	C901H	00D 963 9004 533	Ceramic 0.001uF/50V		
	C902H	00D 963 9004 533	Ceramic 0.001uF/50V		
	C903H	00D 963 0020 202	Ceramic 0.1uF/50V		
	C904H	00D 960 9003 108	Ceramic 0.022uF/25V		
	C905H	00D 963 0020 202	Ceramic 0.1uF/50V		
	C906H	00D 963 9004 546	Ceramic 0.01uF/16V		
	C907H	00D 960 9006 202	Ceramic 0.01uF/50V		
OTHER PARTS GROUP					
	CB903	00D 963 0154 602	Beads inductor		*
	CB904	00D 963 0154 602	Beads inductor		*
	CN901	00D 963 0160 201	3P connector cord		*
	CN931A	00D 963 0148 809	2P connector cord		*
	CN992	00D 963 0160 007	4P connector cord		*
⚠	CP101	00D 960 0118 908	AC cord connector base		
	CP102	00D 960 0123 304	2P connector base		
	CP103	00D 960 0128 901	3P connector base		
	CP104	00D 960 0128 804	6P connector base		
	CP105	00D 963 0149 109	2P connector base(BLACK)		
	CP106	00D 960 0123 207	3P connector base		
	CP1151	00D 963 0097 507	15P connector base (TUC-P)		
	CP1153	00D 963 0097 507	15P connector base (TUC-P)		
	CP138A	00D 960 0123 207	3P connector base		

	Ref. No.	Part No.	Part Name	Remarks	New
	CP3911	00D 963 0160 900	8P connector base		*
	CP392	00D 963 0048 909	3P connector base		
	CP501	00D 963 0086 806	9P connector base (TUC-P)		
	CP502	00D 963 0085 807	7P connector base (TUC-P)		
	CP503	00D 963 0085 807	7P connector base (TUC-P)		
	CP504	00D 963 0086 903	5P connector base (TUC-P)		
	CP505	00D 963 0087 708	12P connector base (TUC-P)		
	CP555	00D 963 0111 108	14P connector base (TUC-P)		
	CP556	00D 963 0087 805	11P connector base (TUC-P)		
	CP901	00D 963 0048 909	3P connector base		
	CP931	00D 963 0149 206	2P connector base(BLUE)		
⚠	F102	00D 963 0104 801	Fuse 3.15A		
	F102A	00D 960 0005 804	Fuse clip		
	F102B	00D 960 0005 804	Fuse clip		
	G901	-	1P contact Ass'y		
	GND101	00D 960 9006 600	Terminal		
	GND102	00D 960 9006 600	Terminal		
	GND103	00D 960 9006 600	Terminal		
	JK901	00D 963 0095 402	Head phone jack		
	L101C	00D 963 0049 005	Inductor 0.5uH		
	L101FL	00D 963 0049 005	Inductor 0.5uH		
	L101FR	00D 963 0049 005	Inductor 0.5uH		
	L101SL	00D 963 0049 005	Inductor 0.5uH		
	L101SR	00D 963 0049 005	Inductor 0.5uH		
	RLY101	00D 960 0181 702	Relay (G5PA-28 24V)		
	RLY102	00D 960 0181 702	Relay (G5PA-28 24V)		
	RLY103	00D 960 0181 702	Relay (G5PA-28 24V)		
	RLY104	00D 960 0181 702	Relay (G5PA-28 24V)		
	RLY105	00D 963 0071 303	Relay (RSB24S 24V)		
⚠	RLY106	00D 960 0181 605	Relay (G5PA-1-8 12V)		
	RLY107	00D 960 0181 702	Relay (G5PA-28 24V)		
	SW391	00D 963 0045 708	Tact switch		
	SW393	00D 963 0045 708	Tact switch		
	SW901	00D 963 0045 708	Tact switch		
	SW901A	00D 963 0145 802	Push switch		
	TP101	00D 960 0161 405	3P connector base		
	TP102	00D 960 0161 405	3P connector base		
	TP103	00D 960 0161 405	3P connector base		
	TP104	00D 960 0161 405	3P connector base		
	TP105	00D 960 0161 405	3P connector base		
	VEC303	00D 963 0095 208	ENCODER SW		
	-	-	Heat sink	1	
	-	-	Heat sink	1	
	-	00D 963 0068 400	Capacitor cover	1	
	-	00D 963 0120 500	Fuse label	1	
⚠	-	00D 963 0094 911	Power trans. (Mini)	1	
	-	00D 963 0018 007	Screw (2S 3X8 ZNY/BH)	3	
	-	00D 963 0158 608	2P speaker terminal	1	*
	-	00D 963 0119 906	8P speaker terminal	2	

CPU, FRONT P.W.B. UNIT

	Ref. No.	Part No.	Part Name	Remarks	New
SEMICONDUCTORS GROUP					
	IC201	00D 963 0161 705	IC CXP740010		
	IC203	00D 960 0100 301	IC KIA7812		
	IC204	00D 963 0114 600	IC MC7806CT		
	IC301	00D 960 0180 004	IC LC75721E		
	IC302	00D 963 0074 504	IC BU2090F		
	IC803	00D 963 0113 106	IC GP1FA513RZ		
	RMC301	00D 960 0181 100	IC NJL64H380A		
	Q201	00D 960 0285 006	Transistor KRC104S		
	Q202	00D 963 0121 509	Transistor KTC3875S		
	Q203	00D 963 0121 402	Transistor KRA104S		
	Q204	00D 963 0121 606	Transistor KRC107S		
	Q205	00D 960 0196 603	Transistor KTC2874B		
	Q206	00D 960 0196 603	Transistor KTC2874B		
	Q207	00D 960 0196 603	Transistor KTC2874B		
	Q208	00D 960 0196 603	Transistor KTC2874B		
	Q216	00D 960 0097 207	Transistor KRA102M		
	Q217	00D 963 0102 803	Transistor 2SA933S		
	Q218	00D 963 0102 803	Transistor 2SA933S		
	Q219	00D 963 0102 803	Transistor 2SA933S		
	Q220	00D 963 0121 208	Transistor KRC107M		
	Q221	00D 960 0097 207	Transistor KRA102M		
	Q222	00D 960 0097 207	Transistor KRA102M		
	Q300	00D 963 0121 402	Transistor KRA104S		
	Q301	00D 963 0121 402	Transistor KRA104S		
	Q302	00D 960 0285 006	Transistor KRC104S		
	Q303	00D 960 0285 006	Transistor KRC104S		
	Q304	00D 960 0285 006	Transistor KRC104S		
	Q305	00D 963 0121 402	Transistor KRA104S		
	Q306	00D 963 0120 704	Transistor KRA102S		
	Q307	00D 963 0121 606	Transistor KRC107S		
	Q308	00D 963 0120 704	Transistor KRA102S		
	D201	00D 963 0020 309	Diode 1SS133T		
	D202	00D 963 0058 407	Diode IN4007		
	D204	00D 963 0020 309	Diode 1SS133T		
	D209	00D 960 0197 000	Diode KDS160		
	D213	00D 963 0020 309	Diode 1SS133T		
	D302	00D 963 0020 309	Diode 1SS133T		
	D303	00D 963 0020 309	Diode 1SS133T		
	D304	00D 963 0020 309	Diode 1SS133T		
	D305	00D 960 0197 000	Diode KDS160		
	D306	00D 960 0197 000	Diode KDS160		
	D307	00D 960 0197 000	Diode KDS160		
	ZD201	00D 963 0047 502	Zener diode MTZJ3.3B		
	ZD301	00D 960 0095 801	Zener diode MTZJ6.8B		
	ZD302	00D 960 0095 500	Zener diode MTZJ5.1B		
	ZD303	00D 960 0095 500	Zener diode MTZJ5.1B		
	ZD304	00D 960 0095 500	Zener diode MTZJ5.1B		
	ZD305	00D 960 0095 500	Zener diode MTZJ5.1B		
	LED301	00D 960 0197 204	LED PI5-RD/HL50RDRF4T		
	LED302	00D 960 0197 204	LED PI5-RD/HL50RDRF4T		
	LED305	00D 960 0197 204	LED PI5-RD/HL50RDRF4T		

	Ref. No.	Part No.	Part Name	Remarks	New
	LED306	00D 960 0197 204	LED P15-RD/HL50RDRF4T		
	LED307	00D 960 0197 204	LED P15-RD/HL50RDRF4T		
	LED308	00D 960 0197 204	LED P15-RD/HL50RDRF4T		
	LED309	00D 960 0197 204	LED P15-RD/HL50RDRF4T		
	LED310	00D 960 0197 204	LED P15-RD/HL50RDRF4T		
CAPACITORS GROUP					
	BC201	00D 963 0061 504	Electrolytic 8200uF/5.5V		
	C201D	00D 960 9010 816	Ceramic 0.1uF/50V		
	C201E	00D 963 9004 517	Ceramic 0.022uF/50V		
	C201F	00D 963 9004 546	Ceramic 0.01uF/16V		
	C202	00D 963 9004 698	Ceramic chip 0.01uF/50V		
	C202D	00D 963 9004 546	Ceramic 0.01uF/16V		
	C202E	00D 963 9004 517	Ceramic 0.022uF/50V		
	C202F	00D 963 9004 546	Ceramic 0.01uF/16V		
	C203	00D 963 9004 698	Ceramic chip 0.01uF/50V		
	C204	00D 963 9006 476	Electrolytic 4.7uF/50V		
	C205	00D 963 9004 562	Ceramic 0.047uF/50V		
	C221	00D 963 9005 312	Electrolytic 100uF/10V		
	C228	00D 963 9004 575	Ceramic chip 100pF/50V		
	C230	00D 963 9004 575	Ceramic chip 100pF/50V		
	C231	00D 963 9004 575	Ceramic chip 100pF/50V		
	C232	00D 963 9004 575	Ceramic chip 100pF/50V		
	C233	00D 963 9004 575	Ceramic chip 100pF/50V		
	C234	00D 963 9004 575	Ceramic chip 100pF/50V		
	C238	00D 963 9006 366	Electrolytic 0.1uF/50V		
	C239	00D 963 9006 366	Electrolytic 0.1uF/50V		
	C242	00D 963 9004 685	Ceramic chip 1000pF/50V		
	C245	00D 963 9004 575	Ceramic chip 100pF/50V		
	C248	00D 963 9004 685	Ceramic chip 1000pF/50V		
	C249	00D 963 9004 737	Ceramic chip 0.022uF/25V		
	C251	00D 963 0020 202	Ceramic 0.1uF/50V		
	C252	00D 960 9010 816	Ceramic 0.1uF/50V		
	C257	00D 963 9006 308	Electrolytic 10uF/50V		
	C262	00D 963 9006 379	Electrolytic 1uF/50V		
	C263	00D 963 9006 379	Electrolytic 1uF/50V		
	C301	00D 963 9004 546	Ceramic 0.01uF/16V		
	C3010	00D 963 9006 421	Electrolytic 47uF/10V		
	C302	00D 963 9004 546	Ceramic 0.01uF/16V		
	C3020	00D 963 0020 202	Ceramic 0.1uF/50V		
	C303	00D 963 9004 546	Ceramic 0.01uF/16V		
	C3030	00D 963 9004 591	Ceramic chip 22pF/50V		
	C304	00D 963 9004 546	Ceramic 0.01uF/16V		
	C305	00D 963 9004 685	Ceramic chip 1000pF/50V		
	C306	00D 963 9004 575	Ceramic chip 100pF/50V		
	C307	00D 963 9004 575	Ceramic chip 100pF/50V		
	C308	00D 960 9010 816	Ceramic 0.1uF/50V		
	C309	00D 963 9004 737	Ceramic chip 0.022uF/25V		
	C310	00D 963 9004 753	Ceramic chip 0.047uF/50V		
	C311	00D 963 9005 406	Ceramic chip 30pF/50V		
	C312	00D 963 9004 753	Ceramic chip 0.047uF/50V		
	C314	00D 963 0021 900	Mylar film 0.047uF/100V		
	C315	00D 963 9006 379	Electrolytic 1uF/50V		
	C316	00D 963 9006 308	Electrolytic 10uF/50V		
	C317	00D963 9005 859	Electrolytic 47uF/16V		
	C318	00D 963 9005 419	Mylar film 0.047uF/63V		
	C319	00D 963 9006 434	Electrolytic 47uF/16V		

Ref. No.	Part No.	Part Name	Remarks	New
C320	00D 963 9006 379	Electrolytic 1uF/50V		
C321	00D 963 0021 900	Mylar film 0.047uF/100V		
C322	00D 963 9006 434	Electrolytic 47uF/16V		
C323	00D 963 9004 766	Mylar film 0.1uF/100V		
C324	00D 963 9006 476	Electrolytic 4.7uF/50V		
C325	00D 963 9004 575	Ceramic chip 100pF/50V		
C326	00D 963 9006 382	Electrolytic 22uF/25V		
C327	00D 963 9006 476	Electrolytic 4.7uF/50V		
C329	00D 963 9006 531	Electrolytic 22uF/16V		
C330	00D 963 9006 531	Electrolytic 22uF/16V		
C340	00D 963 9004 575	Ceramic chip 100pF/50V		
C341	00D 963 9004 575	Ceramic chip 100pF/50V		
C347	00D 963 9004 708	Ceramic chip 0.1uF/50V		
C348	00D 963 9004 708	Ceramic chip 0.1uF/50V		
C354	00D 963 9004 708	Ceramic chip 0.1uF/50V		
OTHER PARTS GROUP				
BD205	00D 963 0050 502	Chip emifil		
BD206	00D 963 0050 502	Chip emifil		
BD207	00D 963 0154 602	Beads inductor		*
BD208	00D 963 0154 602	Beads inductor		*
BD209	00D 963 0154 602	Beads inductor		*
BD250	00D 963 0154 602	Beads inductor		*
BD301	00D 963 0050 502	Chip emifil		
BD303	00D 963 0050 502	Chip emifil		
BD304	00D 963 0050 502	Chip emifil		
CB202	00D 963 0154 602	Beads inductor		*
CB203	00D 963 0154 602	Beads inductor		*
CB207	00D 963 0154 602	Beads inductor		*
CB208	00D 963 0154 602	Beads inductor		*
CN201	00D 963 015 9801	5P SHIELD WIRE		*
CN302	00D 963 0160 502	8P connector cord		*
CN303	00D 963 0160 308	3P connector cord		*
CN605	00D 963 0159 908	3P connector cord		*
CN606	00D 963 0159 607	4P connector cord		*
CP1000	00D 963 0085 807	7P connector base (TUC-P)		
CP1001	00D 963 0111 108	14P connector base (TUC-P)		
CP1154	00D 963 0085 807	7P connector base (TUC-P)		
CP1155	00D 963 0085 807	7P connector base (TUC-P)		
CP301	00D 963 0161 103	23P FFC connector base		*
CP301A	00D 963 0161 006	23P FFC connector base		*
CP302	00D 963 0066 101	5P connector base		
CP303	00D 963 0049 102	3P connector base		
CP401	00D 963 0149 303	15P FFC connector base		
CP404	00D 963 0087 805	11P connector base (TUC-P)		
CP551	00D 963 0087 601	8P connector base (TUC-P)		
CP552	00D 963 0087 504	19P connector base (TUC-P)		
CP605	00D 963 0048 909	3P connector base		
CP606	00D 963 0050 104	4P connector base		
CP701	00D 963 0087 601	18P connector base (TUC-P)		
CP703	00D 963 0087 805	11P connector base (TUC-P)		
CP705	00D 963 0087 601	8P connector base (TUC-P)		
CP706	00D 963 0087 601	8P connector base (TUC-P)		
CP801	00D 963 0087 601	18P connector base (TUC-P)		
CP802	00D 963 0087 504	19P connector base (TUC-P)		

	Ref. No.	Part No.	Part Name	Remarks	New
	CP803	00D 960 0239 609	13P connector base (TUC-P)		
	CP804	00D 963 0087 504	19P connector base (TUC-P)		
	G903	-	1P contact Ass'y		
	GND01	00D 960 9006 600	Terminal		
	GND02	00D 960 9006 600	Terminal		
	GP301	-	1P contact Ass'y		
	GP301	-	1P contact Ass'y		
	J326	00D 963 9003 372	Carbon chip 0 ohm 1/16W		
	JIG601	00D 960 0123 605	13P connector base		
	JP353	00D 963 9003 372	Carbon chip 0 ohm 1/16W		
	L301	00D 960 0010 307	Inductor 10uH		
	L3010	00D 960 0215 908	Inductor 4.7uH		
	L302	00D 960 0128 008	Inductor 100uH		
	SW301C	00D 963 0045 708	Tact switch		
	SW302A	00D 963 0095 305	Tact switch		
	SW302B	00D 963 0095 305	Tact switch		
	SW302C	00D 963 0045 708	Tact switch		
	SW303A	00D 963 0095 305	Tact switch		
	SW303B	00D 963 0095 305	Tact switch		
	SW303C	00D 963 0045 708	Tact switch		
	SW304A	00D 963 0095 305	Tact switch		
	SW304B	00D 963 0095 305	Tact switch		
	SW304C	00D 963 0045 708	Tact switch		
	SW305A	00D 963 0095 305	Tact switch		
	SW305B	00D 963 0045 708	Tact switch		
	SW305C	00D 963 0045 708	Tact switch		
	SW306A	00D 963 0095 305	Tact switch		
	SW306B	00D 963 0095 305	Tact switch		
	SW306C	00D 963 0045 708	Tact switch		
	SW307A	00D 963 0095 305	Tact switch		
	SW307C	00D 963 0045 708	Tact switch		
	SW308C	00D 963 0045 708	Tact switch		
	SW309C	00D 963 0045 708	Tact switch		
	VEC301	00D 963 0095 208	ENCODER SW		
	VEC302	00D 963 0095 208	ENCODER SW		
	X201	00D 960 0181 003	Resonator CST12.0MTW-TF01		
	-	-	Heat sink	1	
	-	00D 963 0018 007	Screw (2S 3X8 ZNY/BH)	1	
	-	00D 960 0184 408	FLT holder	1	
	-	00D 963 0109 505	FLT (16-ST-66GNK)	1	
	-	00D 963 0158 307	DIN SOCKET DIN-416G	1	*
	-	00D 963 0146 403	3P pin jack	1	

CNT,PRE-AMP P.W.B. UNIT

	Ref. No.	Part No.	Part Name	Remarks	New
SEMICONDUCTORS GROUP					
	Q101SBL	00D 963 0044 204	Transistor 2SD2390-Y		
	Q101SBR	00D 963 0044 204	Transistor 2SD2390-Y		
	Q102SBL	00D 963 0044 107	Transistor 2SB1560-Y		
	Q102SBR	00D 963 0044 107	Transistor 2SB1560-Y		
	Q103SBL	00D 963 0058 106	Transistor 2SD947F		
	Q103SBR	00D 963 0058 106	Transistor 2SD947F		
	Q104SBL	00D 960 0196 506	Transistor KSC1845F		
	Q104SBR	00D 960 0196 506	Transistor KSC1845F		
	Q501C	00D 960 0196 603	Transistor KTC2874B		
	Q501FL	00D 960 0196 603	Transistor KTC2874B		
	Q501FR	00D 960 0196 603	Transistor KTC2874B		
	Q501SBL	00D 960 0196 603	Transistor KTC2874B		
	Q501SBR	00D 960 0196 603	Transistor KTC2874B		
	Q501SL	00D 960 0196 603	Transistor KTC2874B		
	Q501SR	00D 960 0196 603	Transistor KTC2874B		
	Q502C	00D 960 0196 205	Transistor KSA992F		
	Q502FL	00D 960 0196 205	Transistor KSA992F		
	Q502FR	00D 960 0196 205	Transistor KSA992F		
	Q502SBL	00D 960 0196 205	Transistor KSA992F		
	Q502SBR	00D 960 0196 205	Transistor KSA992F		
	Q502SL	00D 960 0196 205	Transistor KSA992F		
	Q502SR	00D 960 0196 205	Transistor KSA992F		
	Q503C	00D 960 0196 205	Transistor KSA992F		
	Q504C	00D 960 0196 506	Transistor KSC1845F		
	Q504FL	00D 960 0196 506	Transistor KSC1845F		
	Q504FR	00D 960 0196 506	Transistor KSC1845F		
	Q504SBL	00D 960 0196 506	Transistor KSC1845F		
	Q504SBR	00D 960 0196 506	Transistor KSC1845F		
	Q504SL	00D 960 0196 506	Transistor KSC1845F		
	Q504SR	00D 960 0196 506	Transistor KSC1845F		
	Q506C	00D 960 0196 603	Transistor KTC2874B		
	Q551	00D 960 0196 700	Transistor KTC3200BL		
	Q552	00D 960 0196 302	Transistor KTA1268BL		
	Q553	00D 963 0120 704	Transistor KRA102S		
	Q554	00D 963 0120 704	Transistor KRA102S		
	Q555	00D 963 0120 704	Transistor KRA102S		
	Q556	00D 963 0120 704	Transistor KRA102S		
	Q557C	00D 963 0148 508	Transistor KTA1504S		
	Q558C	00D 963 0121 606	Transistor KRC107S		
	D106	00D 963 0020 309	Diode 1SS133T		
	D107	00D 963 0020 309	Diode 1SS133T		
	D551	00D 963 0020 309	Diode 1SS133T		
	D552	00D 963 0020 309	Diode 1SS133T		
	D553	00D 963 0020 309	Diode 1SS133T		
	D554	00D 963 0020 309	Diode 1SS133T		
	D555	00D 963 0020 309	Diode 1SS133T		
	D556	00D 963 0020 309	Diode 1SS133T		
	D557	00D 963 0020 309	Diode 1SS133T		
	D558	00D 963 0020 309	Diode 1SS133T		
	D559	00D 963 0020 309	Diode 1SS133T		
	D560	00D 963 0020 309	Diode 1SS133T		
	D561	00D 963 0020 309	Diode 1SS133T		
	D562	00D 963 0058 407	Diode IN4007		
	D563	00D 963 0058 407	Diode IN4007		
	D565	00D 960 0095 500	Zener diode MTZJ5.1B		

Ref. No.	Part No.	Part Name	Remarks	New
D568C	00D 960 0197 000	Diode KDS160		
D569C	00D 960 0197 000	Diode KDS160		
D570C	00D 960 0197 000	Diode KDS160		
D573	00D 963 0058 407	Diode IN4007		
D574	00D 963 0058 407	Diode IN4007		
D575	00D 963 0058 407	Diode IN4007		
RESISTORS GROUP				
R104SBL	00D 963 9006 285	Metal oxide 5.6 kohm 1W		
R104SBR	00D 963 9006 285	Metal oxide 5.6 kohm 1W		
R105SBL	00D 963 9006 285	Metal oxide 5.6 kohm 1W		
R105SBR	00D 963 9006 285	Metal oxide 5.6 kohm 1W		
R106SBL	00D 963 0047 900	Metal film 4.7 kohm 1W		
R106SBR	00D 963 0047 900	Metal film 4.7 kohm 1W		
R107SBL	00D 963 0047 900	Metal film 4.7 kohm 1W		
R107SBR	00D 963 0047 900	Metal film 4.7 kohm 1W		
R108SBL	00D 963 9006 269	Metal oxide 0.22 ohm 1W		
R108SBR	00D 963 9006 269	Metal oxide 0.22 ohm 1W		
R109SBL	00D 963 9006 269	Metal oxide 0.22 ohm 1W		
R109SBR	00D 963 9006 269	Metal oxide 0.22 ohm 1W		
R110SBL	00D 963 9006 269	Metal oxide 0.22 ohm 1W		
R110SBR	00D 963 9006 269	Metal oxide 0.22 ohm 1W		
R111SBL	00D 963 9006 269	Metal oxide 0.22 ohm 1W		
R111SBR	00D 963 9006 269	Metal oxide 0.22 ohm 1W		
R118SBL	00D 963 9006 256	Metal oxide 10 ohm 1W		
R118SBR	00D 963 9006 256	Metal oxide 10 ohm 1W		
R119SBL	00D 963 9006 256	Metal oxide 10 ohm 1W		
R119SBR	00D 963 9006 256	Metal oxide 10 ohm 1W		
R509C	00D 960 9005 902	Metal film 1.2 kohm 1/4W		
R509FL	00D 960 9005 902	Metal film 1.2 kohm 1/4W		
R509FR	00D 960 9005 902	Metal film 1.2 kohm 1/4W		
R509SBL	00D 960 9005 902	Metal film 1.2 kohm 1/4W		
R509SBR	00D 960 9005 902	Metal film 1.2 kohm 1/4W		
R509SL	00D 960 9005 902	Metal film 1.2 kohm 1/4W		
R509SR	00D 960 9005 902	Metal film 1.2 kohm 1/4W		
R511C	00D 960 9004 301	Metal film 47 ohm 1/4W		
R511FL	00D 960 9004 301	Metal film 47 ohm 1/4W		
R511FR	00D 960 9004 301	Metal film 47 ohm 1/4W		
R511SBL	00D 960 9004 301	Metal film 47 ohm 1/4W		
R511SBR	00D 960 9004 301	Metal film 47 ohm 1/4W		
R511SL	00D 960 9004 301	Metal film 47 ohm 1/4W		
R511SR	00D 960 9004 301	Metal film 47 ohm 1/4W		
R559	00D 963 9005 642	Metal film 1.2 kohm 1W		
R565	00D 963 9005 642	Metal film 1.2 kohm 1W		
R570	00D 963 9005 642	Metal film 1.2 kohm 1W		
R575	00D 963 9006 269	Metal oxide 0.22 ohm 1W		
VR106	00D 963 0105 208	Semi fixed resistor 1 kohm		
VR107	00D 963 0105 208	Semi fixed resistor 1 kohm		
CAPACITORS GROUP				
C101SBL	00D 963 9006 450	Electrolytic 47uF/50V		
C101SBR	00D 963 9006 450	Electrolytic 47uF/50V		
C102SBL	00D 963 9006 308	Electrolytic 10uF/50V		
C102SBR	00D 963 9006 308	Electrolytic 10uF/50V		

Ref. No.	Part No.	Part Name	Remarks	New
C103SBL	00D 963 9003 084	Ceramic 100pF/500V		
C103SBR	00D 963 9003 084	Ceramic 100pF/500V		
C104SBL	00D 963 9003 084	Ceramic 100pF/500V		
C104SBR	00D 963 9003 084	Ceramic 100pF/500V		
C105SBL	00D 963 9008 640	Mylar film 0.022uF/100V		
C105SBR	00D 963 9008 640	Mylar film 0.022uF/100V		
C107SBL	00D 963 9003 097	Mylar film 0.1uF/250V		
C107SBR	00D 963 9003 097	Mylar film 0.1uF/250V		
C201PC	00D 963 9004 575	Ceramic chip 100pF/50V		
C201PFL	00D 963 9004 575	Ceramic chip 100pF/50V		
C201PFR	00D 963 9004 575	Ceramic chip 100pF/50V		
C201PSL	00D 963 9004 575	Ceramic chip 100pF/50V		
C201PSR	00D 963 9004 575	Ceramic chip 100pF/50V		
C201PSW	00D 963 9004 575	Ceramic chip 100pF/50V		
C258	00D 963 0021 104	Electrolytic 6800uF/16V		
C501C	00D 963 9006 382	Electrolytic 22uF/25V		
C501FL	00D 963 9006 382	Electrolytic 22uF/25V		
C501FR	00D 963 9006 382	Electrolytic 22uF/25V		
C501SBL	00D 963 9006 382	Electrolytic 22uF/25V		
C501SBR	00D 963 9006 382	Electrolytic 22uF/25V		
C501SL	00D 963 9006 382	Electrolytic 22uF/25V		
C501SR	00D 963 9006 382	Electrolytic 22uF/25V		
C502C	00D 963 9006 308	Electrolytic 10uF/50V		
C502FL	00D 963 9006 308	Electrolytic 10uF/50V		
C502FR	00D 963 9006 308	Electrolytic 10uF/50V		
C502SBL	00D 963 9006 308	Electrolytic 10uF/50V		
C502SBR	00D 963 9006 308	Electrolytic 10uF/50V		
C502SL	00D 963 9006 308	Electrolytic 10uF/50V		
C502SR	00D 963 9006 308	Electrolytic 10uF/50V		
C503C	00D 963 9003 165	Ceramic 220pF/500V		
C503FL	00D 963 9003 165	Ceramic 220pF/500V		
C503FR	00D 963 9003 165	Ceramic 220pF/500V		
C503SBL	00D 963 9003 165	Ceramic 220pF/500V		
C503SBR	00D 963 9003 165	Ceramic 220pF/500V		
C503SL	00D 963 9003 165	Ceramic 220pF/500V		
C503SR	00D 963 9003 165	Ceramic 220pF/500V		
C504C	00D 963 0157 502	Ceramic 220pF/50V		*
C504FL	00D 963 0157 502	Ceramic 220pF/50V		*
C504FR	00D 963 0157 502	Ceramic 220pF/50V		*
C504SBL	00D 963 0157 502	Ceramic 220pF/50V		*
C504SBR	00D 963 0157 502	Ceramic 220pF/50V		*
C504SL	00D 963 0157 502	Ceramic 220pF/50V		*
C504SR	00D 963 0157 502	Ceramic 220pF/50V		*
C505C	00D 963 9003 181	Ceramic 33pF/500V		
C505FL	00D 963 9003 181	Ceramic 33pF/500V		
C505FR	00D 963 9003 181	Ceramic 33pF/500V		
C505SBL	00D 963 9003 181	Ceramic 33pF/500V		
C505SBR	00D 963 9003 181	Ceramic 33pF/500V		
C505SL	00D 963 9003 181	Ceramic 33pF/500V		
C505SR	00D 963 9003 181	Ceramic 33pF/500V		
C506C	00D 963 9005 312	Electrolytic 100uF/10V		
C506FL	00D 963 9005 312	Electrolytic 100uF/10V		
C506FR	00D 963 9005 312	Electrolytic 100uF/10V		
C506SBL	00D 963 9005 312	Electrolytic 100uF/10V		
C506SBR	00D 963 9005 312	Electrolytic 100uF/10V		
C506SL	00D 963 9005 312	Electrolytic 100uF/10V		
C506SR	00D 963 9005 312	Electrolytic 100uF/10V		
C507C	00D 963 9003 194	Mylar film 0.0022uF/100V		
C507FL	00D 963 9003 194	Mylar film 0.0022uF/100V		
C507FR	00D 963 9003 194	Mylar film 0.0022uF/100V		
C507SBL	00D 963 9003 194	Mylar film 0.0022uF/100V		

	Ref. No.	Part No.	Part Name	Remarks	New
	C507SBR	00D 963 9003 194	Mylar film 0.0022uF/100V		
	C507SL	00D 963 9003 194	Mylar film 0.0022uF/100V		
	C507SR	00D 963 9003 194	Mylar film 0.0022uF/100V		
	C508C	00D 963 9006 382	Electrolytic 22uF/25V		
	C551	00D 963 9006 405	Electrolytic 2.2uF/50V		
	C551M	00D 963 0161 200	Electrolytic 10uF/25V		*
	C551S	00D 963 9004 562	Ceramic 0.047uF/50V		
	C552	00D 963 9006 366	Electrolytic 0.1uF/50V		
	C553	00D 963 9006 366	Electrolytic 0.1uF/50V		
	C554	00D 963 9006 366	Electrolytic 0.1uF/50V		
	C555	00D 963 9004 546	Ceramic 0.01uF/16V		
	C556	00D 963 9004 546	Ceramic 0.01uF/16V		
	C557	00D 963 9006 308	Electrolytic 10uF/50V		
	C558	00D 963 9006 366	Electrolytic 0.1uF/50V		
	C559	00D 963 0145 006	Mylar film 0.047uF/50V		
	C561	00D 963 0145 006	Mylar film 0.047uF/50V		
	C562	00D 963 9004 546	Ceramic 0.01uF/16V		
	C563	00D 963 9004 546	Ceramic 0.01uF/16V		
	C564	00D 960 0133 501	Electrolytic 2200uF/16V		
OTHER PARTS GROUP					
	CN105	00D 963 0148 702	2P connector cord		
	CN1153	00D 963 0097 303	15P connector socket (TUC-P)		
	CN501	00D 963 0085 603	5P connector socket (TUC-P)		
	CN502	00D 963 0086 602	12P connector socket (TUC-P)		
	CN503	00D 963 0086 505	7P connector socket (TUC-P)		
	CN504	00D 963 0085 506	9P connector socket (TUC-P)		
	CN505	00D 963 0086 505	7P connector socket (TUC-P)		
	CN506	00D 963 0060 903	15P connector base		*
	CN506T	00D 963 0159 704	15P connector cord		*
	CN510	00D 963 0160 405	5P connector cord		
	CN551	00D 963 0097 206	8P connector socket (TUC-P)		
	CN552	00D 963 0086 204	19P connector socket (TUC-P)		
	CN553	00D 963 0097 206	8P connector socket (TUC-P)		
	CN554	00D 963 0160 609	15P connector cord		*
	CN555	00D 963 0086 709	11P connector socket (TUC-P)		
	CN556	00D 963 0159 403	15P connector cord		*
	CN557	00D 963 0086 709	11P connector socket (TUC-P)		
	CN560	00D 963 0110 701	14P connector socket (TUC-P)		
	CN992	00D 960 0217 553	4P connector base		
	CP1154	00D 963 0097 507	15P connector base (TUC-P)		
	CP508	00D 963 0068 303	9P connector base		
	CP509	00D 963 0060 505	7P connector base		
	CP510	00D 963 0066 101	5P connector base		
	CP554	00D 963 0060 903	15P connector base		
	CP568	00D 963 0049 102	3P connector base		
	CP602D	00D 963 0097 507	15P connector base (TUC-P)		
⚠	F101	00D 963 0104 704	Fuse 2.5A		
	F101A	00D 960 0005 804	Fuse clip		
	F101B	00D 960 0005 804	Fuse clip		
	J209RM	00D 963 9003 372	Carbon chip 0 ohm 1/16W		
	L101SBL	00D 963 0049 005	Inductor 0.5uH		
	L101SBR	00D 963 0049 005	Inductor 0.5uH		

	Ref. No.	Part No.	Part Name	Remarks	New
	TP106	00D 960 0161 418	3P connector base		
	TP107	00D 960 0161 418	3P connector base		
	-	00D 960 0184 000	Screw bracket	2	
	-	00D 960 0184 000	Screw bracket	2	
	-	00D 960 0236 602	Shield plate	1	
	-	00D 960 0268 803	6P pin jack	1	
	-	00D 960 0144 202	AC outlet	1	

INPUT, VIDEO P.W.B. UNIT

	Ref. No.	Part No.	Part Name	Remarks	New
SEMICONDUCTORS GROUP					
	IC1000		IC BA7626F	J171762600010	
	IC1001	00D 963 0116 103	IC MM74HC4053MX		
	IC1002		IC BA7626F	J171762600010	
	IC1003	00D 963 0074 504	IC BU2090F		
	IC1004	00D 963 0116 103	IC MM74HC4053MX		
	IC1005	00D 963 0074 504	IC BU2090F		
	IC1006	00D 963 0116 307	IC LC7478		
	IC1007	00D 963 0116 200	IC NJM2274R		
	IC1008	00D 963 0116 103	IC MM74HC4053MX		
	IC1150		IC BA7626F	J171762600010	
	IC1151		IC BA7626F	J171762600010	
	IC1152		IC BA7626F	J171762600010	
	IC1153		IC BA7626F	J171762600010	
	IC201T	00D 963 0158 909	IC TC94A27UG		*
	IC202T	00D 963 0158 909	IC TC94A27UG		*
	IC203T	00D 960 0080 201	IC KIC9164AN		
	IC205	00D 963 0024 004	IC NJM2068M		
	IC206	00D 963 0024 004	IC NJM2068M		
	IC207	00D 963 0024 004	IC NJM2068M		
	IC208	00D 963 0159 005	IC NJM5532M		*
	IC209	00D 963 0159 005	IC NJM5532M		*
	IC210	00D 963 0159 005	IC NJM5532M		*
	IC211	00D 963 0159 005	IC NJM5532M		*
	IC603E		IC BA7626F	J171762600010	
	IC604E		IC BA7626F	J171762600010	
	IC605E	00D 960 0175 200	IC BA7625		
	IC701	00D 963 0083 207	IC TC9274N-011		
	IC701M	00D 963 0024 004	IC NJM2068M		
	IC702	00D 963 0024 004	IC NJM2068M		
	IC703	00D 963 0024 004	IC NJM2068M		
	IC704	00D 960 0174 502	IC NJM2068DD		
	IC705	00D 960 0174 201	IC TC9273N-004		
	Q1000	00D 963 0102 803	Transistor 2SA933S		
	Q1001	00D 963 0102 803	Transistor 2SA933S		
	Q1002	00D 963 0121 703	Transistor KRA107S		
	Q1003	00D 963 0121 703	Transistor KRA107S		
	Q1004	00D 963 0120 704	Transistor KRA102S		
	Q1005	00D 963 0159 102	Transistor KRC111S		*
	Q1006	00D 963 0120 801	Transistor KRC102S		
	Q1007	00D 960 0068 207	Transistor KTA1504Y		
	Q1008	00D 963 0120 704	Transistor KRA102S		
	Q1009	00D 963 0159 102	Transistor KRC111S		*
	Q1010	00D 963 0120 801	Transistor KRC102S		
	Q1011	00D 960 0068 207	Transistor KTA1504Y		
	Q1012	00D 963 0044 301	Transistor KTC2875B		
	Q1013	00D 963 0120 704	Transistor KRA102S		
	Q1014	00D 960 0068 207	Transistor KTA1504Y		
	Q1015	00D 963 0120 801	Transistor KRC102S		
	Q1016	00D 960 0068 207	Transistor KTA1504Y		
	Q1017	00D 960 0068 207	Transistor KTA1504Y		
	Q1018	00D 960 0068 207	Transistor KTA1504Y		
	Q1019	00D 960 0068 207	Transistor KTA1504Y		
	Q1020	00D 963 0066 606	Transistor KTC3875Y		
	Q1021	00D 963 0066 606	Transistor KTC3875Y		
	Q1022	00D 960 0068 207	Transistor KTA1504Y		

	Ref. No.	Part No.	Part Name	Remarks	New
	Q1023	00D 963 0102 803	Transistor 2SA933S		
	Q1024	00D 960 0005 202	Transistor KTC3198Y		
	Q1025	00D 960 0005 105	Transistor KTA1266Y		
	Q1026	00D 960 0005 105	Transistor KTA1266Y		
	Q1027	00D 960 0005 105	Transistor KTA1266Y		
	Q1028	00D 960 0005 202	Transistor KTC3198Y		
	Q1029	00D 960 0005 105	Transistor KTA1266Y		
	Q1030	00D 960 0005 202	Transistor KTC3198Y		
	Q1150	00D 963 0159 102	Transistor KRC111S		*
	Q1151	00D 960 0068 207	Transistor KTA1504Y		
	Q1152	00D 963 0159 102	Transistor KRC111S		*
	Q1155	00D 963 0159 102	Transistor KRC111S		*
	Q1157	00D 963 0159 102	Transistor KRC111S		*
	Q1160	00D 963 0159 102	Transistor KRC111S		*
	Q1161	00D 963 0159 102	Transistor KRC111S		*
	Q207T	00D 960 0196 807	Transistor 2SK117Y		
	Q208T	00D 960 0196 807	Transistor 2SK117Y		
	Q209T	00D 960 0097 003	Transistor KRA104M		
	Q210T	00D 963 0121 004	Transistor KRC104M		
	Q551SW	00D 963 0044 301	Transistor KTC2875B		
	Q552SW	00D 963 0044 301	Transistor KTC2875B		
	Q601E	00D 960 0005 105	Transistor KTA1266Y		
	Q602E	00D 960 0005 105	Transistor KTA1266Y		
	Q603E	00D 960 0005 105	Transistor KTA1266Y		
	D1000	00D 960 0197 000	Diode KDS160		
	D1001	00D 960 0197 000	Diode KDS160		
	D1002	00D 960 0197 000	Diode KDS160		
	D1003	00D 960 0197 000	Diode KDS160		
	D1004	00D 960 0197 000	Diode KDS160		
	D1005	00D 960 0197 000	Diode KDS160		
	D1012	00D 963 0020 309	Diode 1SS133T		
	D1014	00D 963 0020 309	Diode 1SS133T		
	D1150	00D 960 0197 000	Diode KDS160		
	D1151	00D 960 0197 000	Diode KDS160		
	D1152	00D 960 0197 000	Diode KDS160		
	D1153	00D 960 0197 000	Diode KDS160		
	D205T	00D 960 0197 000	Diode KDS160		
	D207T	00D 960 0197 000	Diode KDS160		
	D251	00D 960 0197 000	Diode KDS160		
	D252	00D 960 0197 000	Diode KDS160		
	D253	00D 960 0197 000	Diode KDS160		
	D254	00D 960 0197 000	Diode KDS160		
	D255	00D 960 0197 000	Diode KDS160		
	D256	00D 960 0197 000	Diode KDS160		
	D901	00D 960 0197 000	Diode KDS160		
	D902	00D 960 0197 000	Diode KDS160		
	D903	00D 960 0197 000	Diode KDS160		
	D904	00D 960 0197 000	Diode KDS160		
	ZD1000	00D 960 0095 500	Zener diode MTZJ5.1B		
	ZD701M	00D 960 0095 500	Zener diode MTZJ5.1B		
RESISTORS GROUP					
	R1031	00D 963 9005 639	Metal film 100 ohm 1W		
	R1038	00D 963 9005 639	Metal film 100 ohm 1W		
	R1059	00D 963 9005 639	Metal film 100 ohm 1W		
	R1095	00D 963 0018 007	Metal film 100 ohm 1/4W		

Ref. No.	Part No.	Part Name	Remarks	New
R1163	00D 963 9005 639	Metal film 100 ohm 1W		
R1166	00D 963 9005 639	Metal film 100 ohm 1W		
R1193	00D 963 9005 639	Metal film 100 ohm 1W		
R1199	00D 963 9005 639	Metal film 100 ohm 1W		
R1232	00D 963 9005 639	Metal film 100 ohm 1W		
R1239	00D 963 9005 639	Metal film 100 ohm 1W		
R229T	00D 963 9005 639	Metal film 100 ohm 1W		
R230T	00D 963 9005 639	Metal film 100 ohm 1W		
R738M	00D 963 9005 338	Carbon chip 1.6 kohm 1/10W		
CAPACITORS GROUP				
C1000	00D 963 9006 382	Electrolytic 22uF/25V		
C1001	00D 963 9006 382	Electrolytic 22uF/25V		
C1002	00D 963 9005 312	Electrolytic 100uF/10V		
C1003	00D 963 9004 753	Ceramic chip 0.047uF/50V		
C1004	00D 963 9006 308	Electrolytic 10uF/50V		
C1005	00D 963 9006 308	Electrolytic 10uF/50V		
C1006	00D 963 9006 382	Electrolytic 22uF/25V		
C1007	00D 963 9004 753	Ceramic chip 0.047uF/50V		
C1009	00D 963 9006 308	Electrolytic 10uF/50V		
C1010	00D 963 9006 405	Electrolytic 2.2uF/50V		
C1011	00D 963 9006 405	Electrolytic 2.2uF/50V		
C1013	00D 963 9006 382	Electrolytic 22uF/25V		
C1014	00D 963 9006 308	Electrolytic 10uF/50V		
C1016	00D 963 9006 146	Ceramic chip 560pF/50V		
C1017	00D 963 9004 575	Ceramic chip 100pF/50V		
C1018	00D 963 9004 575	Ceramic chip 100pF/50V		
C1019	00D 963 9006 308	Electrolytic 10uF/50V		
C1020	00D 963 9006 463	Electrolytic 470uF/6.3V		
C1021	00D 963 9006 560	Electrolytic 47uF/35V		
C1022	00D 963 9006 308	Electrolytic 10uF/50V		
C1023	00D 963 9006 463	Electrolytic 470uF/6.3V		
C1024	00D 963 9004 753	Ceramic chip 0.047uF/50V		
C1025	00D 963 9006 515	Ceramic 1pF/50V		
C1026	00D 963 9006 308	Electrolytic 10uF/50V		
C1027	00D 963 9006 463	Electrolytic 470uF/6.3V		
C1030	00D 963 9006 434	Electrolytic 47uF/16V		
C1034	00D 963 9006 515	Ceramic 1pF/50V		
C1035	00D 963 9006 560	Electrolytic 47uF/35V		
C1039	00D 963 9006 528	Ceramic chip 20pF/50V		
C1040	00D 963 9006 379	Electrolytic 1uF/50V		
C1041	00D 963 0157 706	Ceramic chip 0.022uF/50V		*
C1042	00D 963 9006 434	Electrolytic 47uF/16V		
C1049	00D 963 9006 528	Ceramic chip 20pF/50V		
C1052	00D 963 9006 308	Electrolytic 10uF/50V		
C1053	00D 963 9006 308	Electrolytic 10uF/50V		
C1054	00D 963 9005 998	Ceramic chip 24pF/50V		
C1055	00D 963 9004 753	Ceramic chip 0.047uF/50V		
C1056	00D 963 9006 379	Electrolytic 1uF/50V		
C1057	00D 963 9005 998	Ceramic chip 24pF/50V		
C1058	00D 963 9006 434	Electrolytic 47uF/16V		
C1059	00D 963 9004 753	Ceramic chip 0.047uF/50V		
C1060	00D 963 9006 434	Electrolytic 47uF/16V		
C1061	00D 963 0129 909	Ceramic chip 1200pF/50V		
C1062	00D 963 9005 312	Electrolytic 100uF/10V		
C1063	00D 960 9010 094	Ceramic chip 0.01uF/50V		
C1069	00D 963 9006 382	Electrolytic 22uF/25V		
C1070	00D 963 9005 312	Electrolytic 100uF/10V		

Ref. No.	Part No.	Part Name	Remarks	New
C1071	00D 963 9006 379	Electrolytic 1uF/50V		
C1080	00D 963 0157 706	Ceramic chip 0.022uF/50V		*
C1081	00D 963 9006 434	Electrolytic 47uF/16V		
C1150	00D 963 9006 382	Electrolytic 22uF/25V		
C1151	00D 960 9010 094	Ceramic chip 0.01uF/50V		
C1152	00D 963 9006 382	Electrolytic 22uF/25V		
C1153	00D 963 9004 575	Ceramic chip 100pF/50V		
C1154	00D 963 9004 575	Ceramic chip 100pF/50V		
C1155	00D 963 9004 575	Ceramic chip 100pF/50V		
C1156	00D 963 9004 575	Ceramic chip 100pF/50V		
C1157	00D 963 9006 382	Electrolytic 22uF/25V		
C1158	00D 963 9004 753	Ceramic chip 0.047uF/50V		
C1159	00D 963 9006 382	Electrolytic 22uF/25V		
C1160	00D 963 9006 308	Electrolytic 10uF/50V		
C1161	00D 963 9006 463	Electrolytic 470uF/6.3V		
C1163	00D 963 9006 463	Electrolytic 470uF/6.3V		
C1164	00D 963 9006 382	Electrolytic 22uF/25V		
C1167	00D 963 9004 753	Ceramic chip 0.047uF/50V		
C1173	00D 963 9004 753	Ceramic chip 0.047uF/50V		
C1183	00D 960 9010 515	Electrolytic 0.47uF/50V		
C1189	00D 960 9010 515	Electrolytic 0.47uF/50V		
C1207	00D 963 9003 372	Carbon chip 0 ohm 1/16W		
C1208	00D 963 9003 372	Carbon chip 0 ohm 1/16W		
C1209	00D 963 9003 372	Carbon chip 0 ohm 1/16W		
C1210	00D 963 9003 372	Carbon chip 0 ohm 1/16W		
C1215	00D 963 9003 372	Carbon chip 0 ohm 1/16W		
C1219	00D 963 9006 463	Electrolytic 470uF/6.3V		
C1222	00D 960 9010 515	Electrolytic 0.47uF/50V		
C211SW	00D 963 9004 575	Ceramic chip 100pF/50V		
C212SW	00D 963 9004 643	Ceramic chip 47pF/50V		
C213FL	00D 963 9004 575	Ceramic chip 100pF/50V		
C213FR	00D 963 9004 575	Ceramic chip 100pF/50V		
C213T	00D 963 9004 753	Ceramic chip 0.047uF/50V		
C214T	00D 963 9004 753	Ceramic chip 0.047uF/50V		
C215T	00D 963 9004 753	Ceramic chip 0.047uF/50V		
C216T	00D 963 9004 753	Ceramic chip 0.047uF/50V		
C217T	00D 963 9004 753	Ceramic chip 0.047uF/50V		
C218FL	00D 963 9004 627	Ceramic chip 33pF/50V		
C218FR	00D 963 9004 627	Ceramic chip 33pF/50V		
C218T	00D 963 9006 379	Electrolytic 1uF/50V		
C219FL	00D 963 9006 308	Electrolytic 10uF/50V		
C219FR	00D 963 9006 308	Electrolytic 10uF/50V		
C219SW	00D 963 9006 308	Electrolytic 10uF/50V		
C219T	00D 963 9006 379	Electrolytic 1uF/50V		
C220T	00D 963 9006 308	Electrolytic 10uF/50V		
C223C	00D 963 9006 382	Electrolytic 22uF/25V		
C223FL	00D 963 9006 382	Electrolytic 22uF/25V		
C223FR	00D 963 9006 382	Electrolytic 22uF/25V		
C223SBL	00D 963 9006 382	Electrolytic 22uF/25V		
C223SBR	00D 963 9006 382	Electrolytic 22uF/25V		
C223SL	00D 963 9006 382	Electrolytic 22uF/25V		
C223SR	00D 963 9006 382	Electrolytic 22uF/25V		
C223SW	00D 963 9006 382	Electrolytic 22uF/25V		
C225T	00D 963 9006 379	Electrolytic 1uF/50V		
C226T	00D 963 9006 379	Electrolytic 1uF/50V		
C227T	00D 963 9006 308	Electrolytic 10uF/50V		
C228T	00D 963 9006 434	Electrolytic 47uF/16V		
C229T	00D 963 9006 434	Electrolytic 47uF/16V		
C230T	00D 963 9006 308	Electrolytic 10uF/50V		
C231C	00D 963 9006 418	Electrolytic 3.3uF/50V		
C231FL	00D 963 9006 418	Electrolytic 3.3uF/50V		

Ref. No.	Part No.	Part Name	Remarks	New
C231FR	00D 963 9006 418	Electrolytic 3.3uF/50V		
C231SBL	00D 963 9006 418	Electrolytic 3.3uF/50V		
C231SBR	00D 963 9006 418	Electrolytic 3.3uF/50V		
C231SL	00D 963 9006 418	Electrolytic 3.3uF/50V		
C231SR	00D 963 9006 418	Electrolytic 3.3uF/50V		
C231SW	00D 963 9006 418	Electrolytic 3.3uF/50V		
C231T	00D 963 9006 308	Electrolytic 10uF/50V		
C232C	00D 960 9010 104	Ceramic 5pF/50V		
C232FL	00D 960 9010 104	Ceramic 5pF/50V		
C232FR	00D 960 9010 104	Ceramic 5pF/50V		
C232SBL	00D 960 9010 104	Ceramic 5pF/50V		
C232SBR	00D 960 9010 104	Ceramic 5pF/50V		
C232SL	00D 960 9010 104	Ceramic 5pF/50V		
C232SR	00D 960 9010 104	Ceramic 5pF/50V		
C232SW	00D 960 9010 104	Ceramic 5pF/50V		
C232T	00D 963 9006 434	Electrolytic 47uF/16V		
C233T	00D 963 9006 434	Electrolytic 47uF/16V		
C234T	00D 963 9006 434	Electrolytic 47uF/16V		
C235T	00D 963 9006 434	Electrolytic 47uF/16V		
C236T	00D 963 9006 434	Electrolytic 47uF/16V		
C237T	00D 963 9006 434	Electrolytic 47uF/16V		
C239T	00D 963 9004 753	Ceramic chip 0.047uF/50V		
C240T	00D 963 9006 379	Electrolytic 1uF/50V		
C241T	00D 963 9006 308	Electrolytic 10uF/50V		
C243T	00D 963 9006 379	Electrolytic 1uF/50V		
C244T	00D 963 9006 379	Electrolytic 1uF/50V		
C245T	00D 963 9006 379	Electrolytic 1uF/50V		
C246SW	00D 963 9006 476	Electrolytic 4.7uF/50V		
C246T	00D 963 9006 308	Electrolytic 10uF/50V		
C247T	00D 963 9004 575	Ceramic chip 100pF/50V		
C248T	00D 963 9006 379	Electrolytic 1uF/50V		
C251	00D 963 9004 708	Ceramic chip 0.1uF/50V		
C252	00D 963 9004 708	Ceramic chip 0.1uF/50V		
C253	00D 963 9004 708	Ceramic chip 0.1uF/50V		
C601E	00D 963 9005 312	Electrolytic 100uF/10V		
C601I	00D 963 9003 372	Carbon chip 0 ohm 1/16W		
C602E	00D 963 9005 312	Electrolytic 100uF/10V		
C602I	00D 963 9003 372	Carbon chip 0 ohm 1/16W		
C603E	00D 963 9005 312	Electrolytic 100uF/10V		
C604E	00D 963 9006 159	Electrolytic 4700uF/16V		
C605E	00D 963 9006 463	Electrolytic 470uF/6.3V		
C606E	00D 963 9006 463	Electrolytic 470uF/6.3V		
C618E	00D 963 9006 379	Electrolytic 1uF/50V		
C620E	00D 963 9006 476	Electrolytic 4.7uF/50V		
C621E	00D9630157706	Ceramic chip 0.022uF/50V		*
C622E	00D 963 9005 312	Electrolytic 100uF/10V		
C623E	00D 963 9006 476	Electrolytic 4.7uF/50V		
C624E	00D 963 9006 476	Electrolytic 4.7uF/50V		
C625E	00D 963 9006 379	Electrolytic 1uF/50V		
C627E	00D 963 0157 706	Ceramic chip 0.022uF/50V		*
C628E	00D 963 9005 312	Electrolytic 100uF/10V		
C632E	00D 963 9006 476	Electrolytic 4.7uF/50V		
C633E	00D 963 9006 379	Electrolytic 1uF/50V		
C635E	00D 963 9006 476	Electrolytic 4.7uF/50V		
C636E	00D 963 0157 706	Ceramic chip 0.022uF/50V		*
C637E	00D 963 9005 312	Electrolytic 100uF/10V		
C638E	00D 963 9006 476	Electrolytic 4.7uF/50V		
C639E	00D 963 9006 476	Electrolytic 4.7uF/50V		
C640E	00D 963 9006 476	Electrolytic 4.7uF/50V		
C641E	00D 963 9006 476	Electrolytic 4.7uF/50V		
C702L	00D 963 9004 575	Ceramic chip 100pF/50V		

Ref. No.	Part No.	Part Name	Remarks	New
C702R	00D 963 9004 575	Ceramic chip 100pF/50V		
C703L	00D 963 9004 575	Ceramic chip 100pF/50V		
C703R	00D 963 9004 575	Ceramic chip 100pF/50V		
C704L	00D 963 9004 575	Ceramic chip 100pF/50V		
C711L	00D 963 9006 557	Electrolytic 220uF/6.3V		
C711R	00D 963 9006 557	Electrolytic 220uF/6.3V		
C712L	00D 963 9004 779	Mylar film 0.024uF/50V		
C712R	00D 963 9004 779	Mylar film 0.024uF/50V		
C713L	00D 960 9008 695	Mylar film 0.0068uF/100V		
C713R	00D 960 9008 695	Mylar film 0.0068uF/100V		
C714L	00D 963 9006 476	Electrolytic 4.7uF/50V		
C714R	00D 963 9006 476	Electrolytic 4.7uF/50V		
C715L	00D 963 9004 737	Ceramic chip 0.022uF/25V		
C715R	00D 963 9004 737	Ceramic chip 0.022uF/25V		
C717L	00D 963 9004 601	Ceramic chip 220pF/50V		
C717R	00D 963 9004 601	Ceramic chip 220pF/50V		
C718L	00D 963 9006 421	Electrolytic 47uF/10V		
C718R	00D 963 9006 421	Electrolytic 47uF/10V		
C719L	00D 963 9006 379	Electrolytic 1uF/50V		
C719R	00D 963 9006 379	Electrolytic 1uF/50V		
C720L	00D 963 9003 152	Mylar film 0.068uF/100V		
C720R	00D 963 9003 152	Mylar film 0.068uF/100V		
C721L	00D 963 9003 152	Mylar film 0.068uF/100V		
C721R	00D 963 9003 152	Mylar film 0.068uF/100V		
C723M	00D 963 9006 379	Electrolytic 1uF/50V		
C724L	00D 963 9004 698	Ceramic chip 0.01uF/50V		
C724M	00D 963 9006 379	Electrolytic 1uF/50V		
C724R	00D 963 9004 698	Ceramic chip 0.01uF/50V		
C725	00D 963 9004 698	Ceramic chip 0.01uF/50V		
C725M	00D 963 9006 379	Electrolytic 1uF/50V		
C726	00D 963 9004 698	Ceramic chip 0.01uF/50V		
C726M	00D 963 0157 609	Ceramic chip 150pF/50V		*
C727M	00D 963 9004 575	Ceramic chip 100pF/50V		
C728M	00D 963 0157 609	Ceramic chip 150pF/50V		*
C729	00D 963 9004 708	Ceramic chip 0.1uF/50V		
C729M	00D 963 9006 379	Electrolytic 1uF/50V		
C730M	00D 963 9006 308	Electrolytic 10uF/50V		
C737M	00D 963 9004 575	Ceramic chip 100pF/50V		
C738M	00D 963 9004 698	Ceramic chip 0.01uF/50V		
C901SW	00D 963 9006 476	Electrolytic 4.7uF/50V		
C910	00D 963 9004 575	Ceramic chip 100pF/50V		
C911	00D 960 9010 094	Ceramic chip 0.01uF/50V		
C912	00D 963 9004 575	Ceramic chip 100pF/50V		
C913	00D 963 9004 575	Ceramic chip 100pF/50V		
C914	00D 963 9004 575	Ceramic chip 100pF/50V		
C915	00D 963 9004 575	Ceramic chip 100pF/50V		
C916	00D 963 9004 575	Ceramic chip 100pF/50V		
C917	00D 960 9010 094	Ceramic chip 0.01uF/50V		
C918	00D 963 9004 575	Ceramic chip 100pF/50V		
C920	00D 963 9004 575	Ceramic chip 100pF/50V		
OTHER PARTS GROUP				
CB1000	00D 963 0120 908	Beads inductor		
CB1001	00D 963 0120 908	Beads inductor		
CB1002	00D 963 0115 609	Inductor 33uH		
CB205	00D 963 0154 602	Beads inductor		*
CN1000	00D 963 0086 505	7P connector socket (TUC-P)		

Ref. No.	Part No.	Part Name	Remarks	New
CN1004	00D 963 0110 701	14P connector socket (TUC-P)		
CN1150	00D 963 0086 505	7P connector socket (TUC-P)		
CN1151	00D 963 0097 303	15P connector socket (TUC-P)		
CN1154	00D 963 0097 303	15P connector socket (TUC-P)		
CN403	00D 963 0086 709	11P connector socket (TUC-P)		
CN508	00D 963 0159 306	9P connector cord		*
CN509	00D 963 0159 209	7P connector cord		*
CN557T	00D 963 0050 104	4P connector base		
CN601	00D 963 0097 303	15P connector socket (TUC-P)		
CN701	00D 963 0086 301	18P connector socket (TUC-P)		
CN701M	00D 963 0160 104	4P connector cord		*
CN703	00D 963 0086 505	7P connector socket (TUC-P)		
CN805	00D 963 0097 206	8P connector socket (TUC-P)		
CN806	00D 963 0086 204	19P connector socket (TUC-P)		
CP556	00D 963 0060 903	15P connector base		
G902	-	1P contact Ass'y		
J712B	00D 963 9003 372	Carbon chip 0 ohm 1/16W		
J712C	00D 963 9003 372	Carbon chip 0 ohm 1/16W		
JK704	00D 960 0188 103	2P pin jack		
L1000	00D 963 0116 006	Y/C SEPARATE FILTER		
XTAL1000	00D 963 0131 405	Crystal 14.318180MHZ		
-	00D 963 0101 707	Input cushion	1	
-	00D 963 0094 102	PLATE INPUT	1	
-	00D 963 0146 209	4P pin jack	2	
-	00D 960 0268 803	6P pin jack	1	
-	00D 963 0146 102	2P pin jack	2	
-	00D 963 0146 209	4P pin jack	1	
-	00D 963 0146 500	3P pin jack	1	
-	00D 963 0146 306	6P pin jack	2	
-	00D 963 0146 209	4P pin jack	2	
-	00D 963 0158 200	Mini jack	1	*

DSP P.W.B. UNIT

Ref. No.	Part No.	Part Name	Remarks	New
SEMICONDUCTORS GROUP				
	IC801	00D 963 0113 106	IC GP1FA513RZ	
	IC802	00D 963 0113 106	IC GP1FA513RZ	
	IC803	00D 963 0113 106	IC GP1FA513RZ	
	IC804	00D 963 0147 402	IC ADSP-21266	
	IC805	00D 963 0146 908	IC LH28F800BJE	
	IC806	00D 963 0158 705	IC CY7C1049CV33	*
	IC807	00D 963 0096 100	IC LC89057W	
	IC808	00D 963 0158 802	IC AD1837AAS	*
	IC809	00D 960 0266 805	IC MM74LCX244	
	IC810	00D 960 0266 805	IC MM74LCX244	
	IC811	00D 960 0266 805	IC MM74LCX244	
	IC812	00D 960 0266 902	IC MM74HCT244	
	IC814	00D 963 0102 308	IC MM74HC00MTCX	
	IC815	00D 963 0102 308	IC MM74HC00MTCX	
	IC815A	00D 963 0043 807	IC BA4510F	
	IC816	00D 963 0147 208	IC 74LVX157	
	IC816A	00D 963 0043 807	IC BA4510F	
	IC817	00D 963 0158 705	IC CY7C1049CV33	*
	IC817A	00D 963 0024 004	IC NJM2068M	
	IC818	00D 963 0147 305	IC 74LCX573	
	IC818A	00D 963 0024 004	IC NJM2068M	
	IC819	00D 963 0147 305	IC 74LCX573	
	IC819A	00D 963 0024 004	IC NJM2068M	
	IC820	00D 963 0147 101	IC SN74LVC139A	
	IC820A	00D 963 0024 004	IC NJM2068M	
	IC821	00D 963 0096 003	IC 74LCX74MTC	
	IC822	00D 960 0159 501	IC KIA7805API	
	IC823	00D 963 0111 603	IC RC1117-3.3	
	IC824	00D 963 0147 509	IC RC1117-1.2	
	IC825	00D 963 0096 003	IC 74LCX74MTC	
	IC826	00D 963 0113 009	IC GP1FA513TZ	
	Q804C	00D 960 0196 603	Transistor KTC2874B	
	Q804FL	00D 960 0196 603	Transistor KTC2874B	
	Q804FR	00D 960 0196 603	Transistor KTC2874B	
	Q804SBL	00D 960 0196 603	Transistor KTC2874B	
	Q804SBR	00D 960 0196 603	Transistor KTC2874B	
	Q804SL	00D 960 0196 603	Transistor KTC2874B	
	Q804SR	00D 960 0196 603	Transistor KTC2874B	
	Q804SW	00D 960 0196 603	Transistor KTC2874B	
	Q808	00D 963 0120 801	Transistor KRC102S	
	Q809	00D 963 0120 704	Transistor KRA102S	
	D801	00D 960 0197 000	Diode KDS160	
	D803	00D 960 0197 000	Diode KDS160	
CAPACITORS GROUP				
	C801	00D 963 9004 708	Ceramic chip 0.1uF/50V	
	C802	00D 963 9004 591	Ceramic chip 22pF/50V	
	C803	00D 963 9004 591	Ceramic chip 22pF/50V	
	C804	00D 963 9004 591	Ceramic chip 22pF/50V	
	C805	00D 963 9004 591	Ceramic chip 22pF/50V	
	C806	00D 963 9004 708	Ceramic chip 0.1uF/50V	

Ref. No.	Part No.	Part Name	Remarks	New
C807	00D 963 9004 708	Ceramic chip 0.1uF/50V		
C808	00D 963 9005 862	Electrolytic 47uF/16V		
C809	00D 963 9004 708	Ceramic chip 0.1uF/50V		
C810	00D 963 9005 862	Electrolytic 47uF/16V		
C811	00D 963 9004 591	Ceramic chip 22pF/50V		
C812	00D 963 9005 927	Electrolytic 0.1uF/50V		
C813	00D 963 9004 698	Ceramic chip 0.01uF/50V		
C814	00D 963 9005 862	Electrolytic 47uF/16V		
C815	00D 963 9005 312	Electrolytic 100uF/10V		
C817	00D 963 9005 778	Electrolytic 10uF/50V		
C818	00D 963 9005 749	Electrolytic 1uF/50V		
C819	00D 963 9005 901	Electrolytic 470uF/10V		
C820	00D 963 9005 862	Electrolytic 47uF/16V		
C821	00D 963 9005 901	Electrolytic 470uF/10V		
C830	00D 963 9005 901	Electrolytic 470uF/10V		
C831	00D 963 9004 708	Ceramic chip 0.1uF/50V		
C832	00D 963 9004 708	Ceramic chip 0.1uF/50V		
C833	00D 963 9004 698	Ceramic chip 0.01uF/50V		
C835	00D 963 9004 708	Ceramic chip 0.1uF/50V		
C836	00D 963 9004 685	Ceramic chip 1000pF/50V		
C837	00D 963 9004 685	Ceramic chip 1000pF/50V		
C838	00D 963 9004 708	Ceramic chip 0.1uF/50V		
C839	00D 963 9004 708	Ceramic chip 0.1uF/50V		
C840	00D 963 9004 708	Ceramic chip 0.1uF/50V		
C841	00D 963 9004 708	Ceramic chip 0.1uF/50V		
C842	00D 963 9004 591	Ceramic chip 22pF/50V		
C843	00D 963 9004 698	Ceramic chip 0.01uF/50V		
C844	00D 963 9004 708	Ceramic chip 0.1uF/50V		
C845	00D 963 9004 708	Ceramic chip 0.1uF/50V		
C846	00D 963 9004 708	Ceramic chip 0.1uF/50V		
C847	00D 963 9004 591	Ceramic chip 22pF/50V		
C858	00D 960 9009 856	Ceramic chip 0.022uF/50V		
C861	00D 963 9005 998	Ceramic chip 24pF/50V		
C862	00D 963 9005 998	Ceramic chip 24pF/50V		
C863	00D 963 9004 698	Ceramic chip 0.01uF/50V		
C864L	00D 963 9005 862	Electrolytic 47uF/16V		
C864R	00D 963 9005 862	Electrolytic 47uF/16V		
C865L	00D 963 9005 723	Ceramic chip 120pF/50V		
C865R	00D 963 9005 723	Ceramic chip 120pF/50V		
C866	00D 963 9004 698	Ceramic chip 0.01uF/50V		
C867	00D 963 9004 698	Ceramic chip 0.01uF/50V		
C868	00D 963 9004 698	Ceramic chip 0.01uF/50V		
C869L	00D 963 9004 575	Ceramic chip 100pF/50V		
C869R	00D 963 9004 575	Ceramic chip 100pF/50V		
C871L	00D 963 9009 500	Mylar film 0.001uF/100V		
C871R	00D 963 9009 500	Mylar film 0.001uF/100V		
C873	00D 963 9006 340	Electrolytic 100uF/25V		
C873C	00D 963 9004 672	Ceramic chip 680pF/50V		
C873FL	00D 963 9004 672	Ceramic chip 680pF/50V		
C873FR	00D 963 9004 672	Ceramic chip 680pF/50V		
C873SBL	00D 963 9004 672	Ceramic chip 680pF/50V		
C873SBR	00D 963 9004 672	Ceramic chip 680pF/50V		
C873SL	00D 963 9004 672	Ceramic chip 680pF/50V		
C873SR	00D 963 9004 672	Ceramic chip 680pF/50V		
C873SW	00D 963 9004 672	Ceramic chip 680pF/50V		
C874	00D 963 9006 340	Electrolytic 100uF/25V		
C874C	00D 963 9006 146	Ceramic chip 560pF/50V		
C874FL	00D 963 9006 146	Ceramic chip 560pF/50V		
C874FR	00D 963 9006 146	Ceramic chip 560pF/50V		
C874SBL	00D 963 9006 146	Ceramic chip 560pF/50V		
C874SBR	00D 963 9006 146	Ceramic chip 560pF/50V		

	Ref. No.	Part No.	Part Name	Remarks	New
	C874SL	00D 963 9006 146	Ceramic chip 560pF/50V		
	C874SR	00D 963 9006 146	Ceramic chip 560pF/50V		
	C874SW	00D 963 9006 146	Ceramic chip 560pF/50V		
	C875C	00D 963 9005 778	Electrolytic 10uF/50V		
	C875FL	00D 963 9005 778	Electrolytic 10uF/50V		
	C875FR	00D 963 9005 778	Electrolytic 10uF/50V		
	C875SBL	00D 963 9005 778	Electrolytic 10uF/50V		
	C875SBR	00D 963 9005 778	Electrolytic 10uF/50V		
	C875SL	00D 963 9005 778	Electrolytic 10uF/50V		
	C875SR	00D 963 9005 778	Electrolytic 10uF/50V		
	C875SW	00D 963 9005 778	Electrolytic 10uF/50V		
	C876C	00D 960 9008 611	Mylar film 0.0033uF/100V		
	C876FL	00D 960 9008 611	Mylar film 0.0033uF/100V		
	C876FR	00D 960 9008 611	Mylar film 0.0033uF/100V		
	C876SBL	00D 960 9008 611	Mylar film 0.0033uF/100V		
	C876SBR	00D 960 9008 611	Mylar film 0.0033uF/100V		
	C876SL	00D 960 9008 611	Mylar film 0.0033uF/100V		
	C876SR	00D 960 9008 611	Mylar film 0.0033uF/100V		
	C876SW	00D 960 9008 611	Mylar film 0.0033uF/100V		
	C880C	00D 963 9005 778	Electrolytic 10uF/50V		
	C889	00D 963 9004 698	Ceramic chip 0.01uF/50V		
	C890	00D 963 9004 698	Ceramic chip 0.01uF/50V		
	C891	00D 963 9004 698	Ceramic chip 0.01uF/50V		
	C893	00D 963 9005 749	Electrolytic 1uF/50V		
	C894	00D 963 9004 698	Ceramic chip 0.01uF/50V		
	C896	00D 963 9005 927	Electrolytic 0.1uF/50V		
	C902	00D 963 9005 901	Electrolytic 470uF/10V		
	C907	00D 963 9005 312	Electrolytic 100uF/10V		
	C912	00D 963 9004 698	Ceramic chip 0.01uF/50V		
	C913	00D 963 9004 698	Ceramic chip 0.01uF/50V		
	C920	00D 963 9004 902	Ceramic chip 18pF/50V		
OTHER PARTS GROUP					
	CB801	00D 963 0050 502	Chip emifil		
	CB802	00D 963 0050 502	Chip emifil		
	CB803	00D 963 0050 502	Chip emifil		
	CB804	00D 963 0050 502	Chip emifil		
	CB805	00D 963 0050 502	Chip emifil		
	CB806	00D 963 0050 502	Chip emifil		
	CB808	00D 963 0050 502	Chip emifil		
	CB810	00D 963 0050 502	Chip emifil		
	CN801	00D 963 0086 301	18P connector socket (TUC-P)		
	CN802	00D 963 0086 204	19P connector socket (TUC-P)		
	CN803	00D 960 0239 900	13P connector socket (TUC-P)		
	JACK801	00D 963 0052 500	1P pin jack		
	L801	00D 963 0050 803	Inductor 4.7uH		
	L802	00D 963 0050 803	Inductor 4.7uH		
	L803	00D 963 0050 803	Inductor 4.7uH		
	L804	00D 963 0050 803	Inductor 4.7uH		
	L805	00D 963 0050 900	Inductor 2.2uH		
	R831	00D 963 0120 908	Beads inductor		
	R832	00D 963 0120 908	Beads inductor		
	R833	00D 963 0120 908	Beads inductor		

	Ref. No.	Part No.	Part Name	Remarks	New
	XTAL1	00D 963 0095 101	Crystal 12.288MHz		
	XTAL2	00D 963 0158 103	Crystal 18.75MHZ		*

PARTS LIST OF P.W.B. UNIT ASS'Y (FOR TAIWAN R.O.C.)

MAIN P.W.B. UNIT

	Ref. No.	Part No.	Part Name	Remarks	New
SEMICONDUCTORS GROUP					
	IC101	00D 963 0110 507	IC MC7815CT		
	IC102	00D 960 0179 905	IC KIA7915		
	IC103	00D 960 0159 501	IC KIA7805API		
	IC104	00D 963 0110 604	IC MC7805CT		
	IC105	00D 960 0195 808	IC protector ICP-N15		
	IC106	00D 960 0195 808	IC protector ICP-N15		
	Q104C	00D 960 0196 506	Transistor KSC1845F		
	Q104FL	00D 960 0196 506	Transistor KSC1845F		
	Q104FR	00D 960 0196 506	Transistor KSC1845F		
	Q104SL	00D 960 0196 506	Transistor KSC1845F		
	Q104SR	00D 960 0196 506	Transistor KSC1845F		
	Q111	00D 963 0121 208	Transistor KRC107M		
	Q112	00D 960 0097 508	Transistor KRC111M		
	Q113	00D 963 0121 208	Transistor KRC107M		
	Q114	00D 963 0121 208	Transistor KRC107M		
	Q115	00D 963 0121 208	Transistor KRC107M		
	Q116	00D 960 0196 409	Transistor 2SC1740SR		
	Q117	00D 963 0121 208	Transistor KRC107M		
	Q118	00D 963 0121 208	Transistor KRC107M		
	Q151	00D 960 0196 409	Transistor 2SC1740SR		
	Q171	00D 960 0005 202	Transistor KTC3198Y		
	Q171A	00D 960 0196 302	Transistor KTA1268BL		
	Q171B	00D 960 0196 302	Transistor KTA1268BL		
	Q171C	00D 960 0196 302	Transistor KTA1268BL		
	Q171D	00D 960 0196 302	Transistor KTA1268BL		
	Q172	00D 960 0005 202	Transistor KTC3198Y		
	Q173	00D 960 0005 202	Transistor KTC3198Y		
	Q174	00D 960 0005 202	Transistor KTC3198Y		
	Q175	00D 960 0005 202	Transistor KTC3198Y		
	Q176	00D 960 0005 202	Transistor KTC3198Y		
	Q177	00D 960 0005 202	Transistor KTC3198Y		
	Q178	00D 960 0005 105	Transistor KTA1266Y		
	Q179	00D 960 0189 005	Transistor KSA916Y		
	Q180	00D 960 0196 302	Transistor KTA1268BL		
	Q181	00D 960 0196 302	Transistor KTA1268BL		
	Q182	00D 960 0005 202	Transistor KTC3198Y		
	Q183	00D 960 0005 202	Transistor KTC3198Y		
	D101	00D 963 0020 309	Diode 1SS133T		
	D102	00D 963 0020 309	Diode 1SS133T		
	D103	00D 963 0020 309	Diode 1SS133T		
	D104	00D 963 0020 309	Diode 1SS133T		
	D105	00D 963 0020 309	Diode 1SS133T		
	D121	00D 963 0020 309	Diode 1SS133T		
	D122	00D 963 0020 309	Diode 1SS133T		
	D123	00D 963 0020 309	Diode 1SS133T		
	D124	00D 963 0020 309	Diode 1SS133T		
	D125	00D 963 0020 309	Diode 1SS133T		
	D126	00D 963 0020 309	Diode 1SS133T		
	D127	00D 963 0020 309	Diode 1SS133T		
	D131A	00D 960 0197 107	Diode KBPC604		
	D131B	00D 960 0197 107	Diode KBPC604		
	D133	00D 963 0046 202	Zener diode MTZJ18B		
	D134	00D 963 0046 202	Zener diode MTZJ18B		

Ref. No.	Part No.	Part Name	Remarks	New
D136	00D 963 0058 504	Zener diode MTZJ11B		
D138A	00D 963 0058 407	Diode IN4007		
D141	00D 963 0058 407	Diode IN4007		
D142	00D 963 0058 407	Diode IN4007		
D143	00D 963 0058 407	Diode IN4007		
D144	00D 963 0058 407	Diode IN4007		
D145	00D 963 0058 407	Diode IN4007		
D146	00D 963 0058 407	Diode IN4007		
D149	00D 963 0058 407	Diode IN4007		
D150	00D 963 0058 407	Diode IN4007		
D152	00D 963 0058 407	Diode IN4007		
D153	00D 963 0058 407	Diode IN4007		
D154	00D 960 0095 908	Zener diode MTZJ8.2B		
D157	00D 960 0014 905	Zener diode MTZJ20B		
ZD310	00D 960 0095 500	Zener diode MTZJ5.1B		
ZD311	00D 960 0095 500	Zener diode MTZJ5.1B		
LED901	00D 963 0148 605	LED SML1216W 5PI R/G		
RESISTORS GROUP				
R104C	00D 963 9006 285	Metal oxide 5.6 kohm 1W		
R104FL	00D 963 9006 285	Metal oxide 5.6 kohm 1W		
R104FR	00D 963 9006 285	Metal oxide 5.6 kohm 1W		
R104SL	00D 963 9006 285	Metal oxide 5.6 kohm 1W		
R104SR	00D 963 9006 285	Metal oxide 5.6 kohm 1W		
R105C	00D 963 9006 285	Metal oxide 5.6 kohm 1W		
R105FL	00D 963 9006 285	Metal oxide 5.6 kohm 1W		
R105FR	00D 963 9006 285	Metal oxide 5.6 kohm 1W		
R106C	00D 963 0047 900	Metal film 4.7 kohm 1W		
R106FL	00D 963 0047 900	Metal film 4.7 kohm 1W		
R106FR	00D 963 0047 900	Metal film 4.7 kohm 1W		
R106SL	00D 963 0047 900	Metal film 4.7 kohm 1W		
R106SR	00D 963 0047 900	Metal film 4.7 kohm 1W		
R107C	00D 963 0047 900	Metal film 4.7 kohm 1W		
R107FL	00D 963 0047 900	Metal film 4.7 kohm 1W		
R107FR	00D 963 0047 900	Metal film 4.7 kohm 1W		
R107SL	00D 963 0047 900	Metal film 4.7 kohm 1W		
R108C	00D 963 9006 269	Metal oxide 0.22 ohm 1W		
R108FL	00D 963 9006 269	Metal oxide 0.22 ohm 1W		
R108FR	00D 963 9006 269	Metal oxide 0.22 ohm 1W		
R108SL	00D 963 9006 269	Metal oxide 0.22 ohm 1W		
R108SR	00D 963 9006 269	Metal oxide 0.22 ohm 1W		
R109C	00D 963 9006 269	Metal oxide 0.22 ohm 1W		
R109FL	00D 963 9006 269	Metal oxide 0.22 ohm 1W		
R109FR	00D 963 9006 269	Metal oxide 0.22 ohm 1W		
R118C	00D 963 9006 256	Metal oxide 10 ohm 1W		
R118FL	00D 963 9006 256	Metal oxide 10 ohm 1W		
R118FR	00D 963 9006 256	Metal oxide 10 ohm 1W		
R118SL	00D 963 9006 256	Metal oxide 10 ohm 1W		
R118SR	00D 963 9006 256	Metal oxide 10 ohm 1W		
R119C	00D 963 9006 256	Metal oxide 10 ohm 1W		
R119FL	00D 963 9006 256	Metal oxide 10 ohm 1W		
R119FR	00D 963 9006 256	Metal oxide 10 ohm 1W		
R119SL	00D 963 9006 256	Metal oxide 10 ohm 1W		
R135	00D 963 0144 502	Cement resistor 0.1 ohm 5W		
R136	00D 963 0144 502	Cement resistor 0.1 ohm 5W		
R141	00D 960 0180 606	Metal oxide 0.22 ohm 1W		

Ref. No.	Part No.	Part Name	Remarks	New
R142	00D 960 0180 606	Metal oxide 0.22 ohm 1W		
R148	00D 960 0180 606	Metal oxide 0.22 ohm 1W		
R149	00D 960 0180 606	Metal oxide 0.22 ohm 1W		
R151	00D 963 9003 343	Metal film 68ohm 1/4W		
R179	00D 963 9003 055	Metal film 47 kohm 1/4W (NB)		
R903H	00D 960 9009 270	Metal film 470ohm 2W		
R904H	00D 960 9009 270	Metal film 470ohm 2W		
VR101	00D 960 0091 601	Semi fixed resistor 1 kohm		
VR102	00D 960 0091 601	Semi fixed resistor 1 kohm		
VR103	00D 960 0091 601	Semi fixed resistor 1 kohm		
VR104	00D 960 0091 601	Semi fixed resistor 1 kohm		
VR105	00D 960 0091 601	Semi fixed resistor 1 kohm		
CAPACITORS GROUP				
C101C	00D 963 9006 450	Electrolytic 47uF/50V		
C101FL	00D 963 9006 450	Electrolytic 47uF/50V		
C101FR	00D 963 9006 450	Electrolytic 47uF/50V		
C101SL	00D 963 9006 450	Electrolytic 47uF/50V		
C101SR	00D 963 9006 450	Electrolytic 47uF/50V		
C102C	00D 963 9006 308	Electrolytic 10uF/50V		
C102FL	00D 963 9006 308	Electrolytic 10uF/50V		
C102FR	00D 963 9006 308	Electrolytic 10uF/50V		
C102SL	00D 963 9006 308	Electrolytic 10uF/50V		
C102SR	00D 963 9006 308	Electrolytic 10uF/50V		
C103C	00D 963 9003 084	Ceramic 100pF/500V		
C103FL	00D 963 9003 084	Ceramic 100pF/500V		
C103FR	00D 963 9003 084	Ceramic 100pF/500V		
C103SL	00D 963 9003 084	Ceramic 100pF/500V		
C103SR	00D 963 9003 084	Ceramic 100pF/500V		
C104C	00D 963 9003 084	Ceramic 100pF/500V		
C104FL	00D 963 9003 084	Ceramic 100pF/500V		
C104FR	00D 963 9003 084	Ceramic 100pF/500V		
C104SL	00D 963 9003 084	Ceramic 100pF/500V		
C105C	00D 963 9008 640	Mylar film 0.022uF/100V		
C105FL	00D 963 9008 640	Mylar film 0.022uF/100V		
C105FR	00D 963 9008 640	Mylar film 0.022uF/100V		
C105SL	00D 963 9008 640	Mylar film 0.022uF/100V		
C105SR	00D 963 9008 640	Mylar film 0.022uF/100V		
C107C	00D 963 9003 097	Mylar film 0.1uF/250V		
C107FL	00D 963 9003 097	Mylar film 0.1uF/250V		
C107FR	00D 963 9003 097	Mylar film 0.1uF/250V		
C107SL	00D 963 9003 097	Mylar film 0.1uF/250V		
C107SR	00D 963 9003 097	Mylar film 0.1uF/250V		
C131	00D 963 9003 097	Mylar film 0.1uF/250V		
C132	00D 963 9003 097	Mylar film 0.1uF/250V		
C133	00D 963 9003 097	Mylar film 0.1uF/250V		
C134	00D 963 9003 097	Mylar film 0.1uF/250V		
C135	00D 963 9003 097	Mylar film 0.1uF/250V		
C136	00D 963 0157 803	Electrolytic 12000uF/63V		*
C137	00D 963 0157 803	Electrolytic 12000uF/63V		*
C138	00D 963 9006 379	Electrolytic 1uF/50V		
C141	00D 963 0021 900	Mylar film 0.047uF/100V		
C142	00D 963 0021 900	Mylar film 0.047uF/100V		
C143	00D 963 0021 900	Mylar film 0.047uF/100V		
C144	00D 960 9007 201	Electrolytic 3300uF/35V		
C145	00D 963 9003 123	Electrolytic 1000uF/35V		
C146	00D 963 9006 379	Electrolytic 1uF/50V		

	Ref. No.	Part No.	Part Name	Remarks	New
	C148	00D 963 9006 379	Electrolytic 1uF/50V		
	C150	00D 963 0021 900	Mylar film 0.047uF/100V		
	C151	00D 963 0021 900	Mylar film 0.047uF/100V		
	C152	00D 963 0021 900	Mylar film 0.047uF/100V		
	C153	00D 963 0021 104	Electrolytic 6800uF/16V		
	C154	00D 963 9006 308	Electrolytic 10uF/50V		
	C155	00D 963 0020 202	Ceramic 0.1uF/50V		
	C157	00D 963 9006 379	Electrolytic 1uF/50V		
	C158	00D 963 9003 136	Electrolytic 1000uF/25V		
	C159	00D 963 9006 379	Electrolytic 1uF/50V		
	C161	00D 963 9006 308	Electrolytic 10uF/50V		
	C171	00D 963 9005 312	Electrolytic 100uF/10V		
	C171A	00D 963 0020 202	Ceramic 0.1uF/50V		
	C171B	00D 963 0020 202	Ceramic 0.1uF/50V		
	C171C	00D 963 0020 202	Ceramic 0.1uF/50V		
	C171D	00D 963 0020 202	Ceramic 0.1uF/50V		
	C172	00D 963 9005 833	Electrolytic 220uF/6.3V		
	C173	00D 963 9005 833	Electrolytic 220uF/6.3V		
	C174	00D 963 9006 308	Electrolytic 10uF/50V		
	C175	00D 963 0149 507	Electrolytic 220uF/16V		
	C176	00D 963 9006 379	Electrolytic 1uF/50V		
⚠	C177	00D 963 9006 379	Electrolytic 1uF/50V		*
	C178	00D 963 0157 900	Electrolytic 470uF/63V		
	C179	00D 963 9005 833	Electrolytic 220uF/6.3V		
	C181	00D 963 9006 191	Ceramic 4700pF/250V(AC)		
	C182	00D 963 9006 311	Electrolytic 10uF/100V		
	C331	00D 963 9004 546	Ceramic 0.01uF/16V		
	C332	00D 963 9004 546	Ceramic 0.01uF/16V		
	C901H	00D 963 9004 533	Ceramic 0.001uF/50V		
	C902H	00D 963 9004 533	Ceramic 0.001uF/50V		
	C903H	00D 963 0020 202	Ceramic 0.1uF/50V		
	C904H	00D 960 9003 108	Ceramic 0.022uF/25V		
	C905H	00D 963 0020 202	Ceramic 0.1uF/50V		
	C906H	00D 963 9004 546	Ceramic 0.01uF/16V		
	C907H	00D 960 9006 202	Ceramic 0.01uF/50V		
OTHER PARTS GROUP					
	CB903	00D 963 0154 602	Beads inductor		*
	CB904	00D 963 0154 602	Beads inductor		*
	CN901	00D 963 0160 201	3P connector cord		*
	CN931A	00D 963 0148 809	2P connector cord		*
	CN992	00D 963 0160 007	4P connector cord		*
⚠	CP101	00D 960 0118 908	AC cord connector base		
	CP102	00D 960 0123 304	2P connector base		
	CP103	00D 960 0128 901	3P connector base		
	CP104	00D 960 0128 804	6P connector base		
	CP105	00D 963 0149 109	2P connector base(BLACK)		
	CP106	00D 960 0123 207	3P connector base		
	CP1151	00D 963 0097 507	15P connector base (TUC-P)		
	CP1153	00D 963 0097 507	15P connector base (TUC-P)		
	CP138A	00D 960 0123 207	3P connector base		
	CP3911	00D 963 0160 900	8P connector base		*
	CP392	00D 963 0048 909	3P connector base		
	CP501	00D 963 0086 806	9P connector base (TUC-P)		
	CP502	00D 963 0085 807	7P connector base (TUC-P)		
	CP503	00D 963 0085 807	7P connector base (TUC-P)		

	Ref. No.	Part No.	Part Name	Remarks	New
	CP504	00D 963 0086 903	5P connector base (TUC-P)		
	CP505	00D 963 0087 708	12P connector base (TUC-P)		
	CP555	00D 963 0111 108	14P connector base (TUC-P)		
	CP556	00D 963 0087 805	11P connector base (TUC-P)		
	CP901	00D 963 0048 909	3P connector base		
	CP931	00D 963 0149 206	2P connector base(BLUE)		
⚠	F102	00D 960 0188 705	Fuse 8A		
	F102A	00D 960 0005 804	Fuse clip		
	F102B	00D 960 0005 804	Fuse clip		
	G901	-	1P contact Ass'y		
	GND101	00D 960 9006 600	Terminal		
	GND102	00D 960 9006 600	Terminal		
	GND103	00D 960 9006 600	Terminal		
	JK901	00D 963 0095 402	Head phone jack		
	L101C	00D 963 0049 005	Inductor 0.5uH		
	L101FL	00D 963 0049 005	Inductor 0.5uH		
	L101FR	00D 963 0049 005	Inductor 0.5uH		
	L101SL	00D 963 0049 005	Inductor 0.5uH		
	L101SR	00D 963 0049 005	Inductor 0.5uH		
	RLY101	00D 960 0181 702	Relay (G5PA-28 24V)		
	RLY102	00D 960 0181 702	Relay (G5PA-28 24V)		
	RLY103	00D 960 0181 702	Relay (G5PA-28 24V)		
	RLY104	00D 960 0181 702	Relay (G5PA-28 24V)		
	RLY105	00D 963 0071 303	Relay (RSB24S 24V)		
⚠	RLY106	00D 960 0181 605	Relay (G5PA-1-8 12V)		
	RLY107	00D 960 0181 702	Relay (G5PA-28 24V)		
	SW391	00D 963 0045 708	Tact switch		
	SW393	00D 963 0045 708	Tact switch		
	SW901	00D 963 0045 708	Tact switch		
	SW901A	00D 963 0145 802	Push switch		
	TP101	00D 960 0161 405	3P connector base		
	TP102	00D 960 0161 405	3P connector base		
	TP103	00D 960 0161 405	3P connector base		
	TP104	00D 960 0161 405	3P connector base		
	TP105	00D 960 0161 405	3P connector base		
	VEC303	00D 963 0095 208	ENCODER SW		
	-	-	Heat sink	1	
	-	-	Heat sink	1	
⚠	-	00D 963 0094 924	Power trans. (Mini)	1	
	-	00D 963 0018 007	Screw (2S 3X8 ZNY/BH)	3	
	-	00D 963 0158 608	2P speaker terminal	1	*
	-	00D 963 0119 906	8P speaker terminal	2	

CPU, FRONT P.W.B. UNIT

	Ref. No.	Part No.	Part Name	Remarks	New
SEMICONDUCTORS GROUP					
	IC201	00D 963 0161 705	IC CXP740010		
	IC203	00D 960 0100 301	IC KIA7812		
	IC204	00D 963 0114 600	IC MC7806CT		
	IC301	00D 960 0180 004	IC LC75721E		
	IC302	00D 963 0074 504	IC BU2090F		
	IC803	00D 963 0113 106	IC GP1FA513RZ		
	RMC301	00D 960 0181 100	IC NJL64H380A		
	Q201	00D 960 0285 006	Transistor KRC104S		
	Q202	00D 963 0121 509	Transistor KTC3875S		
	Q203	00D 963 0121 402	Transistor KRA104S		
	Q204	00D 963 0121 606	Transistor KRC107S		
	Q205	00D 960 0196 603	Transistor KTC2874B		
	Q206	00D 960 0196 603	Transistor KTC2874B		
	Q207	00D 960 0196 603	Transistor KTC2874B		
	Q208	00D 960 0196 603	Transistor KTC2874B		
	Q216	00D 960 0097 207	Transistor KRA102M		
	Q217	00D 963 0102 803	Transistor 2SA933S		
	Q218	00D 963 0102 803	Transistor 2SA933S		
	Q219	00D 963 0102 803	Transistor 2SA933S		
	Q220	00D 963 0121 208	Transistor KRC107M		
	Q221	00D 960 0097 207	Transistor KRA102M		
	Q222	00D 960 0097 207	Transistor KRA102M		
	Q300	00D 963 0121 402	Transistor KRA104S		
	Q301	00D 963 0121 402	Transistor KRA104S		
	Q302	00D 960 0285 006	Transistor KRC104S		
	Q303	00D 960 0285 006	Transistor KRC104S		
	Q304	00D 960 0285 006	Transistor KRC104S		
	Q305	00D 963 0121 402	Transistor KRA104S		
	Q306	00D 963 0120 704	Transistor KRA102S		
	Q307	00D 963 0121 606	Transistor KRC107S		
	Q308	00D 963 0120 704	Transistor KRA102S		
	D201	00D 963 0020 309	Diode 1SS133T		
	D202	00D 963 0058 407	Diode IN4007		
	D204	00D 963 0020 309	Diode 1SS133T		
	D209	00D 960 0197 000	Diode KDS160		
	D213	00D 963 0020 309	Diode 1SS133T		
	D302	00D 963 0020 309	Diode 1SS133T		
	D303	00D 963 0020 309	Diode 1SS133T		
	D304	00D 963 0020 309	Diode 1SS133T		
	D305	00D 960 0197 000	Diode KDS160		
	D306	00D 960 0197 000	Diode KDS160		
	D307	00D 960 0197 000	Diode KDS160		
	ZD201	00D 963 0047 502	Zener diode MTZJ3.3B		
	ZD301	00D 960 0095 801	Zener diode MTZJ6.8B		
	ZD302	00D 960 0095 500	Zener diode MTZJ5.1B		
	ZD303	00D 960 0095 500	Zener diode MTZJ5.1B		
	ZD304	00D 960 0095 500	Zener diode MTZJ5.1B		
	ZD305	00D 960 0095 500	Zener diode MTZJ5.1B		
	LED301	00D 960 0197 204	LED PI5-RD/HL50RDRF4T		
	LED302	00D 960 0197 204	LED PI5-RD/HL50RDRF4T		
	LED305	00D 960 0197 204	LED PI5-RD/HL50RDRF4T		

	Ref. No.	Part No.	Part Name	Remarks	New
	LED306	00D 960 0197 204	LED P15-RD/HL50RDRF4T		
	LED307	00D 960 0197 204	LED P15-RD/HL50RDRF4T		
	LED308	00D 960 0197 204	LED P15-RD/HL50RDRF4T		
	LED309	00D 960 0197 204	LED P15-RD/HL50RDRF4T		
	LED310	00D 960 0197 204	LED P15-RD/HL50RDRF4T		
CAPACITORS GROUP					
	BC201	00D 963 0061 504	Electrolytic 8200uF/5.5V		
	C201D	00D 960 9010 816	Ceramic 0.1uF/50V		
	C201E	00D 963 9004 517	Ceramic 0.022uF/50V		
	C201F	00D 963 9004 546	Ceramic 0.01uF/16V		
	C202	00D 963 9004 698	Ceramic chip 0.01uF/50V		
	C202D	00D 963 9004 546	Ceramic 0.01uF/16V		
	C202E	00D 963 9004 517	Ceramic 0.022uF/50V		
	C202F	00D 963 9004 546	Ceramic 0.01uF/16V		
	C203	00D 963 9004 698	Ceramic chip 0.01uF/50V		
	C204	00D 963 9006 476	Electrolytic 4.7uF/50V		
	C205	00D 963 9004 562	Ceramic 0.047uF/50V		
	C221	00D 963 9005 312	Electrolytic 100uF/10V		
	C228	00D 963 9004 575	Ceramic chip 100pF/50V		
	C230	00D 963 9004 575	Ceramic chip 100pF/50V		
	C231	00D 963 9004 575	Ceramic chip 100pF/50V		
	C232	00D 963 9004 575	Ceramic chip 100pF/50V		
	C233	00D 963 9004 575	Ceramic chip 100pF/50V		
	C234	00D 963 9004 575	Ceramic chip 100pF/50V		
	C238	00D 963 9006 366	Electrolytic 0.1uF/50V		
	C239	00D 963 9006 366	Electrolytic 0.1uF/50V		
	C242	00D 963 9004 685	Ceramic chip 1000pF/50V		
	C245	00D 963 9004 575	Ceramic chip 100pF/50V		
	C248	00D 963 9004 685	Ceramic chip 1000pF/50V		
	C249	00D 963 9004 737	Ceramic chip 0.022uF/25V		
	C251	00D 963 0020 202	Ceramic 0.1uF/50V		
	C252	00D 960 9010 816	Ceramic 0.1uF/50V		
	C257	00D 963 9006 308	Electrolytic 10uF/50V		
	C262	00D 963 9006 379	Electrolytic 1uF/50V		
	C263	00D 963 9006 379	Electrolytic 1uF/50V		
	C301	00D 963 9004 546	Ceramic 0.01uF/16V		
	C3010	00D 963 9006 421	Electrolytic 47uF/10V		
	C302	00D 963 9004 546	Ceramic 0.01uF/16V		
	C3020	00D 963 0020 202	Ceramic 0.1uF/50V		
	C303	00D 963 9004 546	Ceramic 0.01uF/16V		
	C3030	00D 963 9004 591	Ceramic chip 22pF/50V		
	C304	00D 963 9004 546	Ceramic 0.01uF/16V		
	C305	00D 963 9004 685	Ceramic chip 1000pF/50V		
	C306	00D 963 9004 575	Ceramic chip 100pF/50V		
	C307	00D 963 9004 575	Ceramic chip 100pF/50V		
	C308	00D 960 9010 816	Ceramic 0.1uF/50V		
	C309	00D 963 9004 737	Ceramic chip 0.022uF/25V		
	C310	00D 963 9004 753	Ceramic chip 0.047uF/50V		
	C311	00D 963 9005 406	Ceramic chip 30pF/50V		
	C312	00D 963 9004 753	Ceramic chip 0.047uF/50V		
	C314	00D 963 0021 900	Mylar film 0.047uF/100V		
	C315	00D 963 9006 379	Electrolytic 1uF/50V		
	C316	00D 963 9006 308	Electrolytic 10uF/50V		
	C317	00D963 9005 859	Electrolytic 47uF/16V		
	C318	00D 963 9005 419	Mylar film 0.047uF/63V		
	C319	00D 963 9006 434	Electrolytic 47uF/16V		

Ref. No.	Part No.	Part Name	Remarks	New
C320	00D 963 9006 379	Electrolytic 1uF/50V		
C321	00D 963 0021 900	Mylar film 0.047uF/100V		
C322	00D 963 9006 434	Electrolytic 47uF/16V		
C323	00D 963 9004 766	Mylar film 0.1uF/100V		
C324	00D 963 9006 476	Electrolytic 4.7uF/50V		
C325	00D 963 9004 575	Ceramic chip 100pF/50V		
C326	00D 963 9006 382	Electrolytic 22uF/25V		
C327	00D 963 9006 476	Electrolytic 4.7uF/50V		
C329	00D 963 9006 531	Electrolytic 22uF/16V		
C330	00D 963 9006 531	Electrolytic 22uF/16V		
C340	00D 963 9004 575	Ceramic chip 100pF/50V		
C341	00D 963 9004 575	Ceramic chip 100pF/50V		
C347	00D 963 9004 708	Ceramic chip 0.1uF/50V		
C348	00D 963 9004 708	Ceramic chip 0.1uF/50V		
C354	00D 963 9004 708	Ceramic chip 0.1uF/50V		
OTHER PARTS GROUP				
BD205	00D 963 0050 502	Chip emifil		
BD206	00D 963 0050 502	Chip emifil		
BD207	00D 963 0154 602	Beads inductor		*
BD208	00D 963 0154 602	Beads inductor		*
BD209	00D 963 0154 602	Beads inductor		*
BD250	00D 963 0154 602	Beads inductor		*
BD301	00D 963 0050 502	Chip emifil		
BD303	00D 963 0050 502	Chip emifil		
BD304	00D 963 0050 502	Chip emifil		
CB202	00D 963 0154 602	Beads inductor		*
CB203	00D 963 0154 602	Beads inductor		*
CB207	00D 963 0154 602	Beads inductor		*
CB208	00D 963 0154 602	Beads inductor		*
CN201	00D 963 0159 801	5P SHIELD WIRE		*
CN302	00D 963 0160 502	8P connector cord		*
CN303	00D 963 0160 308	3P connector cord		*
CN605	00D 963 0159 908	3P connector cord		*
CN606	00D 963 0159 607	4P connector cord		*
CP1000	00D 963 0085 807	7P connector base (TUC-P)		
CP1001	00D 963 0111 108	14P connector base (TUC-P)		
CP1154	00D 963 0085 807	7P connector base (TUC-P)		
CP1155	00D 963 0085 807	7P connector base (TUC-P)		
CP301	00D 963 0161 103	23P FFC connector base		*
CP301A	00D 963 0161 006	23P FFC connector base		*
CP302	00D 963 0066 101	5P connector base		
CP303	00D 963 0049 102	3P connector base		
CP401	00D 963 0149 303	15P FFC connector base		
CP404	00D 963 0087 805	11P connector base (TUC-P)		
CP551	00D 963 0087 601	8P connector base (TUC-P)		
CP552	00D 963 0087 504	19P connector base (TUC-P)		
CP605	00D 963 0048 909	3P connector base		
CP606	00D 963 0050 104	4P connector base		
CP701	00D 963 0087 601	18P connector base (TUC-P)		
CP703	00D 963 0087 805	11P connector base (TUC-P)		
CP705	00D 963 0087 601	8P connector base (TUC-P)		
CP706	00D 963 0087 601	8P connector base (TUC-P)		
CP801	00D 963 0087 601	18P connector base (TUC-P)		
CP802	00D 963 0087 504	19P connector base (TUC-P)		

	Ref. No.	Part No.	Part Name	Remarks	New
	CP803	00D 960 0239 609	13P connector base (TUC-P)		
	CP804	00D 963 0087 504	19P connector base (TUC-P)		
	G903	-	1P contact Ass'y		
	GND01	00D 960 9006 600	Terminal		
	GND02	00D 960 9006 600	Terminal		
	GP301	-	1P contact Ass'y		
	GP301	-	1P contact Ass'y		
	J326	00D 963 9003 372	Carbon chip 0 ohm 1/16W		
	JIG601	00D 960 0123 605	13P connector base		
	JP353	00D 963 9003 372	Carbon chip 0 ohm 1/16W		
	L301	00D 960 0010 307	Inductor 10uH		
	L3010	00D 960 0215 908	Inductor 4.7uH		
	L302	00D 960 0128 008	Inductor 100uH		
	SW301C	00D 963 0045 708	Tact switch		
	SW302A	00D 963 0095 305	Tact switch		
	SW302B	00D 963 0095 305	Tact switch		
	SW302C	00D 963 0045 708	Tact switch		
	SW303A	00D 963 0095 305	Tact switch		
	SW303B	00D 963 0095 305	Tact switch		
	SW303C	00D 963 0045 708	Tact switch		
	SW304A	00D 963 0095 305	Tact switch		
	SW304B	00D 963 0095 305	Tact switch		
	SW304C	00D 963 0045 708	Tact switch		
	SW305A	00D 963 0095 305	Tact switch		
	SW305B	00D 963 0045 708	Tact switch		
	SW305C	00D 963 0045 708	Tact switch		
	SW306C	00D 963 0045 708	Tact switch		
	VEC301	00D 963 0095 208	ENCODER SW		
	VEC302	00D 963 0095 208	ENCODER SW		
	X201	00D 960 0181 003	Resonator CST12.0MTW-TF01		
	-	-	Heat sink	1	
	-	00D 963 0018 007	Screw (2S 3X8 ZNY/BH)	1	
	-	00D 960 0184 408	FLT holder	1	
	-	00D 963 0109 505	FLT (16-ST-66GNK)	1	
	-	00D 963 0158 307	DIN SOCKET DIN-416G	1	*
	-	00D 963 0146 403	3P pin jack	1	

CNT,PRE-AMP P.W.B. UNIT

Ref. No.	Part No.	Part Name	Remarks	New
SEMICONDUCTORS GROUP				
Q101SBL	00D 963 0044 204	Transistor 2SD2390-Y		
Q101SBR	00D 963 0044 204	Transistor 2SD2390-Y		
Q102SBL	00D 963 0044 107	Transistor 2SB1560-Y		
Q102SBR	00D 963 0044 107	Transistor 2SB1560-Y		
Q103SBL	00D 963 0058 106	Transistor 2SD947F		
Q103SBR	00D 963 0058 106	Transistor 2SD947F		
Q104SBL	00D 960 0196 506	Transistor KSC1845F		
Q104SBR	00D 960 0196 506	Transistor KSC1845F		
Q501C	00D 960 0196 603	Transistor KTC2874B		
Q501FL	00D 960 0196 603	Transistor KTC2874B		
Q501FR	00D 960 0196 603	Transistor KTC2874B		
Q501SBL	00D 960 0196 603	Transistor KTC2874B		
Q501SBR	00D 960 0196 603	Transistor KTC2874B		
Q501SL	00D 960 0196 603	Transistor KTC2874B		
Q501SR	00D 960 0196 603	Transistor KTC2874B		
Q502C	00D 960 0196 205	Transistor KSA992F		
Q502FL	00D 960 0196 205	Transistor KSA992F		
Q502FR	00D 960 0196 205	Transistor KSA992F		
Q502SBL	00D 960 0196 205	Transistor KSA992F		
Q502SBR	00D 960 0196 205	Transistor KSA992F		
Q502SL	00D 960 0196 205	Transistor KSA992F		
Q502SR	00D 960 0196 205	Transistor KSA992F		
Q503C	00D 960 0196 205	Transistor KSA992F		
Q504C	00D 960 0196 506	Transistor KSC1845F		
Q504FL	00D 960 0196 506	Transistor KSC1845F		
Q504FR	00D 960 0196 506	Transistor KSC1845F		
Q504SBL	00D 960 0196 506	Transistor KSC1845F		
Q504SBR	00D 960 0196 506	Transistor KSC1845F		
Q504SL	00D 960 0196 506	Transistor KSC1845F		
Q504SR	00D 960 0196 506	Transistor KSC1845F		
Q506C	00D 960 0196 603	Transistor KTC2874B		
Q551	00D 960 0196 700	Transistor KTC3200BL		
Q552	00D 960 0196 302	Transistor KTA1268BL		
Q553	00D 963 0120 704	Transistor KRA102S		
Q554	00D 963 0120 704	Transistor KRA102S		
Q555	00D 963 0120 704	Transistor KRA102S		
Q556	00D 963 0120 704	Transistor KRA102S		
Q557C	00D 963 0148 508	Transistor KTA1504S		
Q558C	00D 963 0121 606	Transistor KRC107S		
D106	00D 963 0020 309	Diode 1SS133T		
D107	00D 963 0020 309	Diode 1SS133T		
D551	00D 963 0020 309	Diode 1SS133T		
D552	00D 963 0020 309	Diode 1SS133T		
D553	00D 963 0020 309	Diode 1SS133T		
D554	00D 963 0020 309	Diode 1SS133T		
D555	00D 963 0020 309	Diode 1SS133T		
D556	00D 963 0020 309	Diode 1SS133T		
D557	00D 963 0020 309	Diode 1SS133T		
D558	00D 963 0020 309	Diode 1SS133T		
D559	00D 963 0020 309	Diode 1SS133T		
D560	00D 963 0020 309	Diode 1SS133T		
D561	00D 963 0020 309	Diode 1SS133T		
D562	00D 963 0058 407	Diode IN4007		
D563	00D 963 0058 407	Diode IN4007		
D565	00D 960 0095 500	Zener diode MTZJ5.1B		

Ref. No.	Part No.	Part Name	Remarks	New
D568C	00D 960 0197 000	Diode KDS160		
D569C	00D 960 0197 000	Diode KDS160		
D570C	00D 960 0197 000	Diode KDS160		
D573	00D 963 0058 407	Diode IN4007		
D574	00D 963 0058 407	Diode IN4007		
D575	00D 963 0058 407	Diode IN4007		
RESISTORS GROUP				
R104SBL	00D 963 9006 285	Metal oxide 5.6 kohm 1W		
R104SBR	00D 963 9006 285	Metal oxide 5.6 kohm 1W		
R105SBL	00D 963 9006 285	Metal oxide 5.6 kohm 1W		
R105SBR	00D 963 9006 285	Metal oxide 5.6 kohm 1W		
R106SBL	00D 963 0047 900	Metal film 4.7 kohm 1W		
R106SBR	00D 963 0047 900	Metal film 4.7 kohm 1W		
R107SBL	00D 963 0047 900	Metal film 4.7 kohm 1W		
R107SBR	00D 963 0047 900	Metal film 4.7 kohm 1W		
R108SBL	00D 963 9006 269	Metal oxide 0.22 ohm 1W		
R108SBR	00D 963 9006 269	Metal oxide 0.22 ohm 1W		
R109SBL	00D 963 9006 269	Metal oxide 0.22 ohm 1W		
R109SBR	00D 963 9006 269	Metal oxide 0.22 ohm 1W		
R110SBL	00D 963 9006 269	Metal oxide 0.22 ohm 1W		
R110SBR	00D 963 9006 269	Metal oxide 0.22 ohm 1W		
R111SBL	00D 963 9006 269	Metal oxide 0.22 ohm 1W		
R118SBL	00D 963 9006 256	Metal oxide 10 ohm 1W		
R118SBR	00D 963 9006 256	Metal oxide 10 ohm 1W		
R119SBL	00D 963 9006 256	Metal oxide 10 ohm 1W		
R119SBR	00D 963 9006 256	Metal oxide 10 ohm 1W		
R509C	00D 960 9005 902	Metal film 1.2 kohm 1/4W		
R509FL	00D 960 9005 902	Metal film 1.2 kohm 1/4W		
R509FR	00D 960 9005 902	Metal film 1.2 kohm 1/4W		
R509SBL	00D 960 9005 902	Metal film 1.2 kohm 1/4W		
R509SBR	00D 960 9005 902	Metal film 1.2 kohm 1/4W		
R509SL	00D 960 9005 902	Metal film 1.2 kohm 1/4W		
R509SR	00D 960 9005 902	Metal film 1.2 kohm 1/4W		
R511C	00D 960 9004 301	Metal film 47 ohm 1/4W		
R511FL	00D 960 9004 301	Metal film 47 ohm 1/4W		
R511FR	00D 960 9004 301	Metal film 47 ohm 1/4W		
R511SBL	00D 960 9004 301	Metal film 47 ohm 1/4W		
R511SBR	00D 960 9004 301	Metal film 47 ohm 1/4W		
R511SL	00D 960 9004 301	Metal film 47 ohm 1/4W		
R511SR	00D 960 9004 301	Metal film 47 ohm 1/4W		
R559	00D 963 9005 642	Metal film 1.2 kohm 1W		
R565	00D 963 9005 642	Metal film 1.2 kohm 1W		
R570	00D 963 9005 642	Metal film 1.2 kohm 1W		
R575	00D 963 9006 269	Metal oxide 0.22 ohm 1W		
VR106	00D 963 0105 208	Semi fixed resistor 1 kohm		
VR107	00D 963 0105 208	Semi fixed resistor 1 kohm		
CAPACITORS GROUP				
C101SBL	00D 963 9006 450	Electrolytic 47uF/50V		
C101SBR	00D 963 9006 450	Electrolytic 47uF/50V		
C102SBL	00D 963 9006 308	Electrolytic 10uF/50V		
C102SBR	00D 963 9006 308	Electrolytic 10uF/50V		
C103SBL	00D 963 9003 084	Ceramic 100pF/500V		

Ref. No.	Part No.	Part Name	Remarks	New
C103SBR	00D 963 9003 084	Ceramic 100pF/500V		
C104SBL	00D 963 9003 084	Ceramic 100pF/500V		
C104SBR	00D 963 9003 084	Ceramic 100pF/500V		
C105SBL	00D 963 9008 640	Mylar film 0.022uF/100V		
C105SBR	00D 963 9008 640	Mylar film 0.022uF/100V		
C107SBL	00D 963 9003 097	Mylar film 0.1uF/250V		
C107SBR	00D 963 9003 097	Mylar film 0.1uF/250V		
C201PC	00D 963 9004 575	Ceramic chip 100pF/50V		
C201PFL	00D 963 9004 575	Ceramic chip 100pF/50V		
C201PFR	00D 963 9004 575	Ceramic chip 100pF/50V		
C201PSL	00D 963 9004 575	Ceramic chip 100pF/50V		
C201PSR	00D 963 9004 575	Ceramic chip 100pF/50V		
C201PSW	00D 963 9004 575	Ceramic chip 100pF/50V		
C258	00D 963 0021 104	Electrolytic 6800uF/16V		
C501C	00D 963 9006 382	Electrolytic 22uF/25V		
C501FL	00D 963 9006 382	Electrolytic 22uF/25V		
C501FR	00D 963 9006 382	Electrolytic 22uF/25V		
C501SBL	00D 963 9006 382	Electrolytic 22uF/25V		
C501SBR	00D 963 9006 382	Electrolytic 22uF/25V		
C501SL	00D 963 9006 382	Electrolytic 22uF/25V		
C501SR	00D 963 9006 382	Electrolytic 22uF/25V		
C502C	00D 963 9006 308	Electrolytic 10uF/50V		
C502FL	00D 963 9006 308	Electrolytic 10uF/50V		
C502FR	00D 963 9006 308	Electrolytic 10uF/50V		
C502SBL	00D 963 9006 308	Electrolytic 10uF/50V		
C502SBR	00D 963 9006 308	Electrolytic 10uF/50V		
C502SL	00D 963 9006 308	Electrolytic 10uF/50V		
C502SR	00D 963 9006 308	Electrolytic 10uF/50V		
C503C	00D 963 9003 165	Ceramic 220pF/500V		
C503FL	00D 963 9003 165	Ceramic 220pF/500V		
C503FR	00D 963 9003 165	Ceramic 220pF/500V		
C503SBL	00D 963 9003 165	Ceramic 220pF/500V		
C503SBR	00D 963 9003 165	Ceramic 220pF/500V		
C503SL	00D 963 9003 165	Ceramic 220pF/500V		
C503SR	00D 963 9003 165	Ceramic 220pF/500V		
C504C	00D 963 0157 502	Ceramic 220pF/50V		*
C504FL	00D 963 0157 502	Ceramic 220pF/50V		*
C504FR	00D 963 0157 502	Ceramic 220pF/50V		*
C504SBL	00D 963 0157 502	Ceramic 220pF/50V		*
C504SBR	00D 963 0157 502	Ceramic 220pF/50V		*
C504SL	00D 963 0157 502	Ceramic 220pF/50V		*
C504SR	00D 963 0157 502	Ceramic 220pF/50V		*
C505C	00D 963 9003 181	Ceramic 33pF/500V		
C505FL	00D 963 9003 181	Ceramic 33pF/500V		
C505FR	00D 963 9003 181	Ceramic 33pF/500V		
C505SBL	00D 963 9003 181	Ceramic 33pF/500V		
C505SBR	00D 963 9003 181	Ceramic 33pF/500V		
C505SL	00D 963 9003 181	Ceramic 33pF/500V		
C505SR	00D 963 9003 181	Ceramic 33pF/500V		
C506C	00D 963 9005 312	Electrolytic 100uF/10V		
C506FL	00D 963 9005 312	Electrolytic 100uF/10V		
C506FR	00D 963 9005 312	Electrolytic 100uF/10V		
C506SBL	00D 963 9005 312	Electrolytic 100uF/10V		
C506SBR	00D 963 9005 312	Electrolytic 100uF/10V		
C506SL	00D 963 9005 312	Electrolytic 100uF/10V		
C506SR	00D 963 9005 312	Electrolytic 100uF/10V		
C507C	00D 963 9003 194	Mylar film 0.0022uF/100V		
C507FL	00D 963 9003 194	Mylar film 0.0022uF/100V		
C507FR	00D 963 9003 194	Mylar film 0.0022uF/100V		
C507SBL	00D 963 9003 194	Mylar film 0.0022uF/100V		
C507SBR	00D 963 9003 194	Mylar film 0.0022uF/100V		

	Ref. No.	Part No.	Part Name	Remarks	New
	C507SL	00D 963 9003 194	Mylar film 0.0022uF/100V		
	C507SR	00D 963 9003 194	Mylar film 0.0022uF/100V		
	C508C	00D 963 9006 382	Electrolytic 22uF/25V		
	C551	00D 963 9006 405	Electrolytic 2.2uF/50V		
	C551M	00D 963 0161 200	Electrolytic 10uF/25V		*
	C551S	00D 963 9004 562	Ceramic 0.047uF/50V		
	C552	00D 963 9006 366	Electrolytic 0.1uF/50V		
	C553	00D 963 9006 366	Electrolytic 0.1uF/50V		
	C554	00D 963 9006 366	Electrolytic 0.1uF/50V		
	C555	00D 963 9004 546	Ceramic 0.01uF/16V		
	C556	00D 963 9004 546	Ceramic 0.01uF/16V		
	C557	00D 963 9006 308	Electrolytic 10uF/50V		
	C558	00D 963 9006 366	Electrolytic 0.1uF/50V		
	C559	00D 963 0145 006	Mylar film 0.047uF/50V		
	C561	00D 963 0145 006	Mylar film 0.047uF/50V		
	C562	00D 963 9004 546	Ceramic 0.01uF/16V		
	C563	00D 963 9004 546	Ceramic 0.01uF/16V		
	C564	00D 960 0133 501	Electrolytic 2200uF/16V		
OTHER PARTS GROUP					
	CN106	00D 963 0159 500	2P connector cord		*
	CN1153	00D 963 0097 303	15P connector socket (TUC-P)		
	CN501	00D 963 0085 603	5P connector socket (TUC-P)		
	CN502	00D 963 0086 602	12P connector socket (TUC-P)		
	CN503	00D 963 0086 505	7P connector socket (TUC-P)		
	CN504	00D 963 0085 506	9P connector socket (TUC-P)		
	CN505	00D 963 0086 505	7P connector socket (TUC-P)		
	CN506	00D 963 0060 903	15P connector base		
	CN506T	00D 963 0159 704	15P connector cord		*
	CN510	00D 963 0160 405	5P connector cord		*
	CN551	00D 963 0097 206	8P connector socket (TUC-P)		
	CN552	00D 963 0086 204	19P connector socket (TUC-P)		
	CN553	00D 963 0097 206	8P connector socket (TUC-P)		
	CN554	00D 963 0160 609	15P connector cord		*
	CN555	00D 963 0086 709	11P connector socket (TUC-P)		
	CN556	00D 963 0159 403	15P connector cord		*
	CN557	00D 963 0086 709	11P connector socket (TUC-P)		
	CN560	00D 963 0110 701	14P connector socket (TUC-P)		
	CN992	00D 960 0217 553	4P connector base		
	CP1154	00D 963 0097 507	15P connector base (TUC-P)		
	CP508	00D 963 0068 303	9P connector base		
	CP509	00D 963 0060 505	7P connector base		
	CP510	00D 963 0066 101	5P connector base		
	CP554	00D 963 0060 903	15P connector base		
	CP568	00D 963 0049 102	3P connector base		
	CP602D	00D 963 0097 507	15P connector base (TUC-P)		
⚠	F101	00D 960 0188 705	Fuse 8A		
	F101A	00D 960 0005 804	Fuse clip		
	F101B	00D 960 0005 804	Fuse clip		
	J209RM	00D 963 9003 372	Carbon chip 0 ohm 1/16W		
	L101SBL	00D 963 0049 005	Inductor 0.5uH		
	L101SBR	00D 963 0049 005	Inductor 0.5uH		
	TP106	00D 960 0161 418	3P connector base		

	Ref. No.	Part No.	Part Name	Remarks	New
	TP107	00D 960 0161 418	3P connector base		
	-	00D 960 0184 000	Screw bracket	2	
	-	00D 960 0184 000	Screw bracket	2	
	-	00D 960 0236 602	Shield plate	1	
	-	00D 960 0268 803	6P pin jack	1	
	-	00D 960 0187 803	AC outlet(2P)	1	

INPUT, VIDEO P.W.B. UNIT

	Ref. No.	Part No.	Part Name	Remarks	New
SEMICONDUCTORS GROUP					
	IC1000		IC BA7626F	J171762600010	
	IC1001	00D 963 0116 103	IC MM74HC4053MX		
	IC1002		IC BA7626F	J171762600010	
	IC1003	00D 963 0074 504	IC BU2090F		
	IC1004	00D 963 0116 103	IC MM74HC4053MX		
	IC1005	00D 963 0074 504	IC BU2090F		
	IC1006	00D 963 0116 307	IC LC7478		
	IC1007	00D 963 0116 200	IC NJM2274R		
	IC1008	00D 963 0116 103	IC MM74HC4053MX		
	IC1150		IC BA7626F	J171762600010	
	IC1151		IC BA7626F	J171762600010	
	IC1152		IC BA7626F	J171762600010	
	IC1153		IC BA7626F	J171762600010	
	IC201T	00D 963 0158 909	IC TC94A27UG		*
	IC202T	00D 963 0158 909	IC TC94A27UG		*
	IC203T	00D 960 0080 201	IC KIC9164AN		
	IC205	00D 963 0024 004	IC NJM2068M		
	IC206	00D 963 0024 004	IC NJM2068M		
	IC207	00D 963 0024 004	IC NJM2068M		
	IC208	00D 963 0159 005	IC NJM5532M		*
	IC209	00D 963 0159 005	IC NJM5532M		*
	IC210	00D 963 0159 005	IC NJM5532M		*
	IC211	00D 963 0159 005	IC NJM5532M		*
	IC603E		IC BA7626F	J171762600010	
	IC604E		IC BA7626F	J171762600010	
	IC605E	00D 960 0175 200	IC BA7625		
	IC701	00D 963 0083 207	IC TC9274N-011		
	IC701M	00D 963 0024 004	IC NJM2068M		
	IC702	00D 963 0024 004	IC NJM2068M		
	IC703	00D 963 0024 004	IC NJM2068M		
	IC704	00D 960 0174 502	IC NJM2068DD		
	IC705	00D 960 0174 201	IC TC9273N-004		
	Q1000	00D 963 0102 803	Transistor 2SA933S		
	Q1001	00D 963 0102 803	Transistor 2SA933S		
	Q1002	00D 963 0121 703	Transistor KRA107S		
	Q1003	00D 963 0121 703	Transistor KRA107S		
	Q1004	00D 963 0120 704	Transistor KRA102S		
	Q1005	00D 963 0159 102	Transistor KRC111S		*
	Q1006	00D 963 0120 801	Transistor KRC102S		
	Q1007	00D 960 0068 207	Transistor KTA1504Y		
	Q1008	00D 963 0120 704	Transistor KRA102S		
	Q1009	00D 963 0159 102	Transistor KRC111S		*
	Q1010	00D 963 0120 801	Transistor KRC102S		
	Q1011	00D 960 0068 207	Transistor KTA1504Y		
	Q1012	00D 963 0044 301	Transistor KTC2875B		
	Q1013	00D 963 0120 704	Transistor KRA102S		
	Q1014	00D 960 0068 207	Transistor KTA1504Y		
	Q1015	00D 963 0120 801	Transistor KRC102S		
	Q1016	00D 960 0068 207	Transistor KTA1504Y		
	Q1017	00D 960 0068 207	Transistor KTA1504Y		
	Q1018	00D 960 0068 207	Transistor KTA1504Y		
	Q1019	00D 960 0068 207	Transistor KTA1504Y		
	Q1020	00D 963 0066 606	Transistor KTC3875Y		
	Q1021	00D 963 0066 606	Transistor KTC3875Y		
	Q1022	00D 960 0068 207	Transistor KTA1504Y		

	Ref. No.	Part No.	Part Name	Remarks	New
	Q1023	00D 963 0102 803	Transistor 2SA933S		
	Q1024	00D 960 0005 202	Transistor KTC3198Y		
	Q1025	00D 960 0005 105	Transistor KTA1266Y		
	Q1026	00D 960 0005 105	Transistor KTA1266Y		
	Q1027	00D 960 0005 105	Transistor KTA1266Y		
	Q1028	00D 960 0005 202	Transistor KTC3198Y		
	Q1029	00D 960 0005 105	Transistor KTA1266Y		
	Q1030	00D 960 0005 202	Transistor KTC3198Y		
	Q1150	00D 963 0159 102	Transistor KRC111S		*
	Q1151	00D 960 0068 207	Transistor KTA1504Y		
	Q1152	00D 963 0159 102	Transistor KRC111S		*
	Q1155	00D 963 0159 102	Transistor KRC111S		*
	Q1157	00D 963 0159 102	Transistor KRC111S		*
	Q1160	00D 963 0159 102	Transistor KRC111S		*
	Q1161	00D 963 0159 102	Transistor KRC111S		*
	Q207T	00D 960 0196 807	Transistor 2SK117Y		
	Q208T	00D 960 0196 807	Transistor 2SK117Y		
	Q209T	00D 960 0097 003	Transistor KRA104M		
	Q210T	00D 963 0121 004	Transistor KRC104M		
	Q551SW	00D 963 0044 301	Transistor KTC2875B		
	Q552SW	00D 963 0044 301	Transistor KTC2875B		
	Q601E	00D 960 0005 105	Transistor KTA1266Y		
	Q602E	00D 960 0005 105	Transistor KTA1266Y		
	Q603E	00D 960 0005 105	Transistor KTA1266Y		
	D1000	00D 960 0197 000	Diode KDS160		
	D1001	00D 960 0197 000	Diode KDS160		
	D1002	00D 960 0197 000	Diode KDS160		
	D1003	00D 960 0197 000	Diode KDS160		
	D1004	00D 960 0197 000	Diode KDS160		
	D1005	00D 960 0197 000	Diode KDS160		
	D1012	00D 963 0020 309	Diode 1SS133T		
	D1014	00D 963 0020 309	Diode 1SS133T		
	D1150	00D 960 0197 000	Diode KDS160		
	D1151	00D 960 0197 000	Diode KDS160		
	D1152	00D 960 0197 000	Diode KDS160		
	D1153	00D 960 0197 000	Diode KDS160		
	D205T	00D 960 0197 000	Diode KDS160		
	D207T	00D 960 0197 000	Diode KDS160		
	D251	00D 960 0197 000	Diode KDS160		
	D252	00D 960 0197 000	Diode KDS160		
	D253	00D 960 0197 000	Diode KDS160		
	D254	00D 960 0197 000	Diode KDS160		
	D255	00D 960 0197 000	Diode KDS160		
	D256	00D 960 0197 000	Diode KDS160		
	D901	00D 960 0197 000	Diode KDS160		
	D902	00D 960 0197 000	Diode KDS160		
	D903	00D 960 0197 000	Diode KDS160		
	D904	00D 960 0197 000	Diode KDS160		
	ZD1000	00D 960 0095 500	Zener diode MTZJ5.1B		
	ZD701M	00D 960 0095 500	Zener diode MTZJ5.1B		
RESISTORS GROUP					
	R1031	00D 963 9005 639	Metal film 100 ohm 1W		
	R1038	00D 963 9005 639	Metal film 100 ohm 1W		
	R1059	00D 963 9005 639	Metal film 100 ohm 1W		
	R1095	00D 963 0018 007	Metal film 100 ohm 1/4W		

Ref. No.	Part No.	Part Name	Remarks	New
R1163	00D 963 9005 639	Metal film 100 ohm 1W		
R1166	00D 963 9005 639	Metal film 100 ohm 1W		
R1193	00D 963 9005 639	Metal film 100 ohm 1W		
R1199	00D 963 9005 639	Metal film 100 ohm 1W		
R1232	00D 963 9005 639	Metal film 100 ohm 1W		
R1239	00D 963 9005 639	Metal film 100 ohm 1W		
R229T	00D 963 9005 639	Metal film 100 ohm 1W		
R230T	00D 963 9005 639	Metal film 100 ohm 1W		
R738M	00D 963 9005 338	Carbon chip 1.6 kohm 1/10W		
CAPACITORS GROUP				
C1000	00D 963 9006 382	Electrolytic 22uF/25V		
C1001	00D 963 9006 382	Electrolytic 22uF/25V		
C1002	00D 963 9005 312	Electrolytic 100uF/10V		
C1003	00D 963 9004 753	Ceramic chip 0.047uF/50V		
C1004	00D 963 9006 308	Electrolytic 10uF/50V		
C1005	00D 963 9006 308	Electrolytic 10uF/50V		
C1006	00D 963 9006 382	Electrolytic 22uF/25V		
C1007	00D 963 9004 753	Ceramic chip 0.047uF/50V		
C1009	00D 963 9006 308	Electrolytic 10uF/50V		
C1010	00D 963 9006 405	Electrolytic 2.2uF/50V		
C1011	00D 963 9006 405	Electrolytic 2.2uF/50V		
C1013	00D 963 9006 382	Electrolytic 22uF/25V		
C1014	00D 963 9006 308	Electrolytic 10uF/50V		
C1016	00D 963 9006 146	Ceramic chip 560pF/50V		
C1017	00D 963 9004 575	Ceramic chip 100pF/50V		
C1018	00D 963 9004 575	Ceramic chip 100pF/50V		
C1019	00D 963 9006 308	Electrolytic 10uF/50V		
C1020	00D 963 9006 463	Electrolytic 470uF/6.3V		
C1021	00D 963 9006 560	Electrolytic 47uF/35V		
C1022	00D 963 9006 308	Electrolytic 10uF/50V		
C1023	00D 963 9006 463	Electrolytic 470uF/6.3V		
C1024	00D 963 9004 753	Ceramic chip 0.047uF/50V		
C1025	00D 963 9006 515	Ceramic 1pF/50V		
C1026	00D 963 9006 308	Electrolytic 10uF/50V		
C1027	00D 963 9006 463	Electrolytic 470uF/6.3V		
C1030	00D 963 9006 434	Electrolytic 47uF/16V		
C1034	00D 963 9006 515	Ceramic 1pF/50V		
C1035	00D 963 9006 560	Electrolytic 47uF/35V		
C1039	00D 963 9006 528	Ceramic chip 20pF/50V		
C1040	00D 963 9006 379	Electrolytic 1uF/50V		
C1041	00D 963 0157 706	Ceramic chip 0.022uF/50V		*
C1042	00D 963 9006 434	Electrolytic 47uF/16V		
C1049	00D 963 9006 528	Ceramic chip 20pF/50V		
C1052	00D 963 9006 308	Electrolytic 10uF/50V		
C1053	00D 963 9006 308	Electrolytic 10uF/50V		
C1054	00D 963 9005 998	Ceramic chip 24pF/50V		
C1055	00D 963 9004 753	Ceramic chip 0.047uF/50V		
C1056	00D 963 9006 379	Electrolytic 1uF/50V		
C1057	00D 963 9005 998	Ceramic chip 24pF/50V		
C1058	00D 963 9006 434	Electrolytic 47uF/16V		
C1059	00D 963 9004 753	Ceramic chip 0.047uF/50V		
C1060	00D 963 9006 434	Electrolytic 47uF/16V		
C1061	00D 963 0129 909	Ceramic chip 1200pF/50V		
C1062	00D 963 9005 312	Electrolytic 100uF/10V		
C1063	00D 960 9010 094	Ceramic chip 0.01uF/50V		
C1069	00D 963 9006 382	Electrolytic 22uF/25V		
C1070	00D 963 9005 312	Electrolytic 100uF/10V		

Ref. No.	Part No.	Part Name	Remarks	New
C1071	00D 963 9006 379	Electrolytic 1uF/50V		
C1080	00D 963 0157 706	Ceramic chip 0.022uF/50V		*
C1081	00D 963 9006 434	Electrolytic 47uF/16V		
C1150	00D 963 9006 382	Electrolytic 22uF/25V		
C1151	00D 960 9010 094	Ceramic chip 0.01uF/50V		
C1152	00D 963 9006 382	Electrolytic 22uF/25V		
C1153	00D 963 9004 575	Ceramic chip 100pF/50V		
C1154	00D 963 9004 575	Ceramic chip 100pF/50V		
C1155	00D 963 9004 575	Ceramic chip 100pF/50V		
C1156	00D 963 9004 575	Ceramic chip 100pF/50V		
C1157	00D 963 9006 382	Electrolytic 22uF/25V		
C1158	00D 963 9004 753	Ceramic chip 0.047uF/50V		
C1159	00D 963 9006 382	Electrolytic 22uF/25V		
C1160	00D 963 9006 308	Electrolytic 10uF/50V		
C1161	00D 963 9006 463	Electrolytic 470uF/6.3V		
C1163	00D 963 9006 463	Electrolytic 470uF/6.3V		
C1164	00D 963 9006 382	Electrolytic 22uF/25V		
C1167	00D 963 9004 753	Ceramic chip 0.047uF/50V		
C1173	00D 963 9004 753	Ceramic chip 0.047uF/50V		
C1183	00D 960 9010 515	Electrolytic 0.47uF/50V		
C1189	00D 960 9010 515	Electrolytic 0.47uF/50V		
C1207	00D 963 9003 372	Carbon chip 0 ohm 1/16W		
C1208	00D 963 9003 372	Carbon chip 0 ohm 1/16W		
C1209	00D 963 9003 372	Carbon chip 0 ohm 1/16W		
C1210	00D 963 9003 372	Carbon chip 0 ohm 1/16W		
C1215	00D 963 9003 372	Carbon chip 0 ohm 1/16W		
C1219	00D 963 9006 463	Electrolytic 470uF/6.3V		
C1222	00D 960 9010 515	Electrolytic 0.47uF/50V		
C211SW	00D 963 9004 575	Ceramic chip 100pF/50V		
C212SW	00D 963 9004 643	Ceramic chip 47pF/50V		
C213FL	00D 963 9004 575	Ceramic chip 100pF/50V		
C213FR	00D 963 9004 575	Ceramic chip 100pF/50V		
C213T	00D 963 9004 753	Ceramic chip 0.047uF/50V		
C214T	00D 963 9004 753	Ceramic chip 0.047uF/50V		
C215T	00D 963 9004 753	Ceramic chip 0.047uF/50V		
C216T	00D 963 9004 753	Ceramic chip 0.047uF/50V		
C217T	00D 963 9004 753	Ceramic chip 0.047uF/50V		
C218FL	00D 963 9004 627	Ceramic chip 33pF/50V		
C218FR	00D 963 9004 627	Ceramic chip 33pF/50V		
C218T	00D 963 9006 379	Electrolytic 1uF/50V		
C219FL	00D 963 9006 308	Electrolytic 10uF/50V		
C219FR	00D 963 9006 308	Electrolytic 10uF/50V		
C219SW	00D 963 9006 308	Electrolytic 10uF/50V		
C219T	00D 963 9006 379	Electrolytic 1uF/50V		
C220T	00D 963 9006 308	Electrolytic 10uF/50V		
C223C	00D 963 9006 382	Electrolytic 22uF/25V		
C223FL	00D 963 9006 382	Electrolytic 22uF/25V		
C223FR	00D 963 9006 382	Electrolytic 22uF/25V		
C223SBL	00D 963 9006 382	Electrolytic 22uF/25V		
C223SBR	00D 963 9006 382	Electrolytic 22uF/25V		
C223SL	00D 963 9006 382	Electrolytic 22uF/25V		
C223SR	00D 963 9006 382	Electrolytic 22uF/25V		
C223SW	00D 963 9006 382	Electrolytic 22uF/25V		
C225T	00D 963 9006 379	Electrolytic 1uF/50V		
C226T	00D 963 9006 379	Electrolytic 1uF/50V		
C227T	00D 963 9006 308	Electrolytic 10uF/50V		
C228T	00D 963 9006 434	Electrolytic 47uF/16V		
C229T	00D 963 9006 434	Electrolytic 47uF/16V		
C230T	00D 963 9006 308	Electrolytic 10uF/50V		
C231C	00D 963 9006 418	Electrolytic 3.3uF/50V		
C231FL	00D 963 9006 418	Electrolytic 3.3uF/50V		

Ref. No.	Part No.	Part Name	Remarks	New
C231FR	00D 963 9006 418	Electrolytic 3.3uF/50V		
C231SBL	00D 963 9006 418	Electrolytic 3.3uF/50V		
C231SBR	00D 963 9006 418	Electrolytic 3.3uF/50V		
C231SL	00D 963 9006 418	Electrolytic 3.3uF/50V		
C231SR	00D 963 9006 418	Electrolytic 3.3uF/50V		
C231SW	00D 963 9006 418	Electrolytic 3.3uF/50V		
C231T	00D 963 9006 308	Electrolytic 10uF/50V		
C232C	00D 960 9010 104	Ceramic 5pF/50V		
C232FL	00D 960 9010 104	Ceramic 5pF/50V		
C232FR	00D 960 9010 104	Ceramic 5pF/50V		
C232SBL	00D 960 9010 104	Ceramic 5pF/50V		
C232SBR	00D 960 9010 104	Ceramic 5pF/50V		
C232SL	00D 960 9010 104	Ceramic 5pF/50V		
C232SR	00D 960 9010 104	Ceramic 5pF/50V		
C232SW	00D 960 9010 104	Ceramic 5pF/50V		
C232T	00D 963 9006 434	Electrolytic 47uF/16V		
C233T	00D 963 9006 434	Electrolytic 47uF/16V		
C234T	00D 963 9006 434	Electrolytic 47uF/16V		
C235T	00D 963 9006 434	Electrolytic 47uF/16V		
C236T	00D 963 9006 434	Electrolytic 47uF/16V		
C237T	00D 963 9006 434	Electrolytic 47uF/16V		
C239T	00D 963 9004 753	Ceramic chip 0.047uF/50V		
C240T	00D 963 9006 379	Electrolytic 1uF/50V		
C241T	00D 963 9006 308	Electrolytic 10uF/50V		
C243T	00D 963 9006 379	Electrolytic 1uF/50V		
C244T	00D 963 9006 379	Electrolytic 1uF/50V		
C245T	00D 963 9006 379	Electrolytic 1uF/50V		
C246SW	00D 963 9006 476	Electrolytic 4.7uF/50V		
C246T	00D 963 9006 308	Electrolytic 10uF/50V		
C247T	00D 963 9004 575	Ceramic chip 100pF/50V		
C248T	00D 963 9006 379	Electrolytic 1uF/50V		
C251	00D 963 9004 708	Ceramic chip 0.1uF/50V		
C252	00D 963 9004 708	Ceramic chip 0.1uF/50V		
C253	00D 963 9004 708	Ceramic chip 0.1uF/50V		
C601E	00D 963 9005 312	Electrolytic 100uF/10V		
C601I	00D 963 9003 372	Carbon chip 0 ohm 1/16W		
C602E	00D 963 9005 312	Electrolytic 100uF/10V		
C602I	00D 963 9003 372	Carbon chip 0 ohm 1/16W		
C603E	00D 963 9005 312	Electrolytic 100uF/10V		
C604E	00D 963 9006 159	Electrolytic 4700uF/16V		
C605E	00D 963 9006 463	Electrolytic 470uF/6.3V		
C606E	00D 963 9006 463	Electrolytic 470uF/6.3V		
C618E	00D 963 9006 379	Electrolytic 1uF/50V		
C620E	00D 963 9006 476	Electrolytic 4.7uF/50V		
C621E	00D 963 0157 706	Ceramic chip 0.022uF/50V		*
C622E	00D 963 9005 312	Electrolytic 100uF/10V		
C623E	00D 963 9006 476	Electrolytic 4.7uF/50V		
C624E	00D 963 9006 476	Electrolytic 4.7uF/50V		
C625E	00D 963 9006 379	Electrolytic 1uF/50V		
C627E	00D 963 0157 706	Ceramic chip 0.022uF/50V		*
C628E	00D 963 9005 312	Electrolytic 100uF/10V		
C632E	00D 963 9006 476	Electrolytic 4.7uF/50V		
C633E	00D 963 9006 379	Electrolytic 1uF/50V		
C635E	00D 963 9006 476	Electrolytic 4.7uF/50V		
C636E	00D 963 0157 706	Ceramic chip 0.022uF/50V		*
C637E	00D 963 9005 312	Electrolytic 100uF/10V		
C638E	00D 963 9006 476	Electrolytic 4.7uF/50V		
C639E	00D 963 9006 476	Electrolytic 4.7uF/50V		
C640E	00D 963 9006 476	Electrolytic 4.7uF/50V		
C641E	00D 963 9006 476	Electrolytic 4.7uF/50V		
C702L	00D 963 9004 575	Ceramic chip 100pF/50V		

Ref. No.	Part No.	Part Name	Remarks	New
C702R	00D 963 9004 575	Ceramic chip 100pF/50V		
C703L	00D 963 9004 575	Ceramic chip 100pF/50V		
C703R	00D 963 9004 575	Ceramic chip 100pF/50V		
C704L	00D 963 9004 575	Ceramic chip 100pF/50V		
C711L	00D 963 9006 557	Electrolytic 220uF/6.3V		
C711R	00D 963 9006 557	Electrolytic 220uF/6.3V		
C712L	00D 963 9004 779	Mylar film 0.024uF/50V		
C712R	00D 963 9004 779	Mylar film 0.024uF/50V		
C713L	00D 960 9008 695	Mylar film 0.0068uF/100V		
C713R	00D 960 9008 695	Mylar film 0.0068uF/100V		
C714L	00D 963 9006 476	Electrolytic 4.7uF/50V		
C714R	00D 963 9006 476	Electrolytic 4.7uF/50V		
C715L	00D 963 9004 737	Ceramic chip 0.022uF/25V		
C715R	00D 963 9004 737	Ceramic chip 0.022uF/25V		
C717L	00D 963 9004 601	Ceramic chip 220pF/50V		
C717R	00D 963 9004 601	Ceramic chip 220pF/50V		
C718L	00D 963 9006 421	Electrolytic 47uF/10V		
C718R	00D 963 9006 421	Electrolytic 47uF/10V		
C719L	00D 963 9006 379	Electrolytic 1uF/50V		
C719R	00D 963 9006 379	Electrolytic 1uF/50V		
C720L	00D 963 9003 152	Mylar film 0.068uF/100V		
C720R	00D 963 9003 152	Mylar film 0.068uF/100V		
C721L	00D 963 9003 152	Mylar film 0.068uF/100V		
C721R	00D 963 9003 152	Mylar film 0.068uF/100V		
C723M	00D 963 9006 379	Electrolytic 1uF/50V		
C724L	00D 963 9004 698	Ceramic chip 0.01uF/50V		
C724M	00D 963 9006 379	Electrolytic 1uF/50V		
C724R	00D 963 9004 698	Ceramic chip 0.01uF/50V		
C725	00D 963 9004 698	Ceramic chip 0.01uF/50V		
C725M	00D 963 9006 379	Electrolytic 1uF/50V		
C726	00D 963 9004 698	Ceramic chip 0.01uF/50V		
C726M	00D 963 0157 609	Ceramic chip 150pF/50V		*
C727M	00D 963 9004 575	Ceramic chip 100pF/50V		
C728M	00D 963 0157 609	Ceramic chip 150pF/50V		*
C729	00D 963 9004 708	Ceramic chip 0.1uF/50V		
C729M	00D 963 9006 379	Electrolytic 1uF/50V		
C730M	00D 963 9006 308	Electrolytic 10uF/50V		
C737M	00D 963 9004 575	Ceramic chip 100pF/50V		
C738M	00D 963 9004 698	Ceramic chip 0.01uF/50V		
C901SW	00D 963 9006 476	Electrolytic 4.7uF/50V		
C910	00D 963 9004 575	Ceramic chip 100pF/50V		
C911	00D 960 9010 094	Ceramic chip 0.01uF/50V		
C912	00D 963 9004 575	Ceramic chip 100pF/50V		
C913	00D 963 9004 575	Ceramic chip 100pF/50V		
C914	00D 963 9004 575	Ceramic chip 100pF/50V		
C915	00D 963 9004 575	Ceramic chip 100pF/50V		
C916	00D 963 9004 575	Ceramic chip 100pF/50V		
C917	00D 960 9010 094	Ceramic chip 0.01uF/50V		
C918	00D 963 9004 575	Ceramic chip 100pF/50V		
C920	00D 963 9004 575	Ceramic chip 100pF/50V		
OTHER PARTS GROUP				
CB1000	00D 963 0120 908	Beads inductor		
CB1001	00D 963 0120 908	Beads inductor		
CB1002	00D 963 0115 609	Inductor 33uH		
CB205	00D 963 0154 602	Beads inductor		*
CN1000	00D 963 0086 505	7P connector socket (TUC-P)		

Ref. No.	Part No.	Part Name	Remarks	New
CN1004	00D 963 0110 701	14P connector socket (TUC-P)		
CN1150	00D 963 0086 505	7P connector socket (TUC-P)		
CN1151	00D 963 0097 303	15P connector socket (TUC-P)		
CN1154	00D 963 0097 303	15P connector socket (TUC-P)		
CN403	00D 963 0086 709	11P connector socket (TUC-P)		
CN508	00D 963 0159 306	9P connector cord		*
CN509	00D 963 0159 209	7P connector cord		*
CN557T	00D 963 0050 104	4P connector base		
CN601	00D 963 0097 303	15P connector socket (TUC-P)		
CN701	00D 963 0086 301	18P connector socket (TUC-P)		
CN701M	00D 963 0160 104	4P connector cord		*
CN703	00D 963 0086 505	7P connector socket (TUC-P)		
CN805	00D 963 0097 206	8P connector socket (TUC-P)		
CN806	00D 963 0086 204	19P connector socket (TUC-P)		
CP556	00D 963 0060 903	15P connector base		
G902	-	1P contact Ass'y		
J712B	00D 963 9003 372	Carbon chip 0 ohm 1/16W		
J712C	00D 963 9003 372	Carbon chip 0 ohm 1/16W		
JK704	00D 960 0188 103	2P pin jack		
L1000	00D 963 0116 006	Y/C SEPARATE FILTER		
XTAL1000	00D 963 0131 405	Crystal 14.318180MHZ		
-	00D 963 0101 707	Input cushion	1	
-	00D 963 0094 102	PLATE INPUT	1	
-	00D 963 0146 209	4P pin jack	2	
-	00D 960 0268 803	6P pin jack	1	
-	00D 963 0146 102	2P pin jack	2	
-	00D 963 0146 209	4P pin jack	1	
-	00D 963 0146 500	3P pin jack	1	
-	00D 963 0146 306	6P pin jack	2	
-	00D 963 0146 209	4P pin jack	2	
-	00D 963 0158 200	Mini jack	1	*

DSP P.W.B. UNIT

	Ref. No.	Part No.	Part Name	Remarks	New
SEMICONDUCTORS GROUP					
	IC801	00D 963 0113 106	IC GP1FA513RZ		
	IC802	00D 963 0113 106	IC GP1FA513RZ		
	IC803	00D 963 0113 106	IC GP1FA513RZ		
	IC804	00D 963 0147 402	IC ADSP-21266		
	IC805	00D 963 0146 908	IC LH28F800BJE		
	IC806	00D 963 0158 705	IC CY7C1049CV33		*
	IC807	00D 963 0096 100	IC LC89057W		
	IC808	00D 963 0158 802	IC AD1837AAS		*
	IC809	00D 960 0266 805	IC MM74LCX244		
	IC810	00D 960 0266 805	IC MM74LCX244		
	IC811	00D 960 0266 805	IC MM74LCX244		
	IC812	00D 960 0266 902	IC MM74HCT244		
	IC814	00D 963 0102 308	IC MM74HC00MTCX		
	IC815	00D 963 0102 308	IC MM74HC00MTCX		
	IC815A	00D 963 0043 807	IC BA4510F		
	IC816	00D 963 0147 208	IC 74LVX157		
	IC816A	00D 963 0043 807	IC BA4510F		
	IC817	00D 963 0158 705	IC CY7C1049CV33		*
	IC817A	00D 963 0024 004	IC NJM2068M		
	IC818	00D 963 0147 305	IC 74LCX573		
	IC818A	00D 963 0024 004	IC NJM2068M		
	IC819	00D 963 0147 305	IC 74LCX573		
	IC819A	00D 963 0024 004	IC NJM2068M		
	IC820	00D 963 0147 101	IC SN74LVC139A		
	IC820A	00D 963 0024 004	IC NJM2068M		
	IC821	00D 963 0096 003	IC 74LCX74MTC		
	IC822	00D 960 0159 501	IC KIA7805API		
	IC823	00D 963 0111 603	IC RC1117-3.3		
	IC824	00D 963 0147 509	IC RC1117-1.2		
	IC825	00D 963 0096 003	IC 74LCX74MTC		
	IC826	00D 963 0113 009	IC GP1FA513TZ		
	Q804C	00D 960 0196 603	Transistor KTC2874B		
	Q804FL	00D 960 0196 603	Transistor KTC2874B		
	Q804FR	00D 960 0196 603	Transistor KTC2874B		
	Q804SBL	00D 960 0196 603	Transistor KTC2874B		
	Q804SBR	00D 960 0196 603	Transistor KTC2874B		
	Q804SL	00D 960 0196 603	Transistor KTC2874B		
	Q804SR	00D 960 0196 603	Transistor KTC2874B		
	Q804SW	00D 960 0196 603	Transistor KTC2874B		
	Q808	00D 963 0120 801	Transistor KRC102S		
	Q809	00D 963 0120 704	Transistor KRA102S		
	D801	00D 960 0197 000	Diode KDS160		
	D803	00D 960 0197 000	Diode KDS160		
CAPACITORS GROUP					
	C801	00D 963 9004 708	Ceramic chip 0.1uF/50V		
	C802	00D 963 9004 591	Ceramic chip 22pF/50V		
	C803	00D 963 9004 591	Ceramic chip 22pF/50V		
	C804	00D 963 9004 591	Ceramic chip 22pF/50V		
	C805	00D 963 9004 591	Ceramic chip 22pF/50V		
	C806	00D 963 9004 708	Ceramic chip 0.1uF/50V		

Ref. No.	Part No.	Part Name	Remarks	New
C807	00D 963 9004 708	Ceramic chip 0.1uF/50V		
C808	00D 963 9005 862	Electrolytic 47uF/16V		
C809	00D 963 9004 708	Ceramic chip 0.1uF/50V		
C810	00D 963 9005 862	Electrolytic 47uF/16V		
C811	00D 963 9004 591	Ceramic chip 22pF/50V		
C812	00D 963 9005 927	Electrolytic 0.1uF/50V		
C813	00D 963 9004 698	Ceramic chip 0.01uF/50V		
C814	00D 963 9005 862	Electrolytic 47uF/16V		
C815	00D 963 9005 312	Electrolytic 100uF/10V		
C817	00D 963 9005 778	Electrolytic 10uF/50V		
C818	00D 963 9005 749	Electrolytic 1uF/50V		
C819	00D 963 9005 901	Electrolytic 470uF/10V		
C820	00D 963 9005 862	Electrolytic 47uF/16V		
C821	00D 963 9005 901	Electrolytic 470uF/10V		
C830	00D 963 9005 901	Electrolytic 470uF/10V		
C831	00D 963 9004 708	Ceramic chip 0.1uF/50V		
C832	00D 963 9004 708	Ceramic chip 0.1uF/50V		
C833	00D 963 9004 698	Ceramic chip 0.01uF/50V		
C835	00D 963 9004 708	Ceramic chip 0.1uF/50V		
C836	00D 963 9004 685	Ceramic chip 1000pF/50V		
C837	00D 963 9004 685	Ceramic chip 1000pF/50V		
C838	00D 963 9004 708	Ceramic chip 0.1uF/50V		
C839	00D 963 9004 708	Ceramic chip 0.1uF/50V		
C840	00D 963 9004 708	Ceramic chip 0.1uF/50V		
C841	00D 963 9004 708	Ceramic chip 0.1uF/50V		
C842	00D 963 9004 591	Ceramic chip 22pF/50V		
C843	00D 963 9004 698	Ceramic chip 0.01uF/50V		
C844	00D 963 9004 708	Ceramic chip 0.1uF/50V		
C845	00D 963 9004 708	Ceramic chip 0.1uF/50V		
C846	00D 963 9004 708	Ceramic chip 0.1uF/50V		
C847	00D 963 9004 591	Ceramic chip 22pF/50V		
C858	00D 960 9009 856	Ceramic chip 0.022uF/50V		
C861	00D 963 9005 998	Ceramic chip 24pF/50V		
C862	00D 963 9005 998	Ceramic chip 24pF/50V		
C863	00D 963 9004 698	Ceramic chip 0.01uF/50V		
C864L	00D 963 9005 862	Electrolytic 47uF/16V		
C864R	00D 963 9005 862	Electrolytic 47uF/16V		
C865L	00D 963 9005 723	Ceramic chip 120pF/50V		
C865R	00D 963 9005 723	Ceramic chip 120pF/50V		
C866	00D 963 9004 698	Ceramic chip 0.01uF/50V		
C867	00D 963 9004 698	Ceramic chip 0.01uF/50V		
C868	00D 963 9004 698	Ceramic chip 0.01uF/50V		
C869L	00D 963 9004 575	Ceramic chip 100pF/50V		
C869R	00D 963 9004 575	Ceramic chip 100pF/50V		
C871L	00D 963 9009 500	Mylar film 0.001uF/100V		
C871R	00D 963 9009 500	Mylar film 0.001uF/100V		
C873	00D 963 9006 340	Electrolytic 100uF/25V		
C873C	00D 963 9004 672	Ceramic chip 680pF/50V		
C873FL	00D 963 9004 672	Ceramic chip 680pF/50V		
C873FR	00D 963 9004 672	Ceramic chip 680pF/50V		
C873SBL	00D 963 9004 672	Ceramic chip 680pF/50V		
C873SBR	00D 963 9004 672	Ceramic chip 680pF/50V		
C873SL	00D 963 9004 672	Ceramic chip 680pF/50V		
C873SR	00D 963 9004 672	Ceramic chip 680pF/50V		
C873SW	00D 963 9004 672	Ceramic chip 680pF/50V		
C874	00D 963 9006 340	Electrolytic 100uF/25V		
C874C	00D 963 9006 146	Ceramic chip 560pF/50V		
C874FL	00D 963 9006 146	Ceramic chip 560pF/50V		
C874FR	00D 963 9006 146	Ceramic chip 560pF/50V		
C874SBL	00D 963 9006 146	Ceramic chip 560pF/50V		
C874SBR	00D 963 9006 146	Ceramic chip 560pF/50V		

	Ref. No.	Part No.	Part Name	Remarks	New
	C874SL	00D 963 9006 146	Ceramic chip 560pF/50V		
	C874SR	00D 963 9006 146	Ceramic chip 560pF/50V		
	C874SW	00D 963 9006 146	Ceramic chip 560pF/50V		
	C875C	00D 963 9005 778	Electrolytic 10uF/50V		
	C875FL	00D 963 9005 778	Electrolytic 10uF/50V		
	C875FR	00D 963 9005 778	Electrolytic 10uF/50V		
	C875SBL	00D 963 9005 778	Electrolytic 10uF/50V		
	C875SBR	00D 963 9005 778	Electrolytic 10uF/50V		
	C875SL	00D 963 9005 778	Electrolytic 10uF/50V		
	C875SR	00D 963 9005 778	Electrolytic 10uF/50V		
	C875SW	00D 963 9005 778	Electrolytic 10uF/50V		
	C876C	00D 960 9008 611	Mylar film 0.0033uF/100V		
	C876FL	00D 960 9008 611	Mylar film 0.0033uF/100V		
	C876FR	00D 960 9008 611	Mylar film 0.0033uF/100V		
	C876SBL	00D 960 9008 611	Mylar film 0.0033uF/100V		
	C876SBR	00D 960 9008 611	Mylar film 0.0033uF/100V		
	C876SL	00D 960 9008 611	Mylar film 0.0033uF/100V		
	C876SR	00D 960 9008 611	Mylar film 0.0033uF/100V		
	C876SW	00D 960 9008 611	Mylar film 0.0033uF/100V		
	C880C	00D 963 9005 778	Electrolytic 10uF/50V		
	C889	00D 963 9004 698	Ceramic chip 0.01uF/50V		
	C890	00D 963 9004 698	Ceramic chip 0.01uF/50V		
	C891	00D 963 9004 698	Ceramic chip 0.01uF/50V		
	C893	00D 963 9005 749	Electrolytic 1uF/50V		
	C894	00D 963 9004 698	Ceramic chip 0.01uF/50V		
	C896	00D 963 9005 927	Electrolytic 0.1uF/50V		
	C902	00D 963 9005 901	Electrolytic 470uF/10V		
	C907	00D 963 9005 312	Electrolytic 100uF/10V		
	C912	00D 963 9004 698	Ceramic chip 0.01uF/50V		
	C913	00D 963 9004 698	Ceramic chip 0.01uF/50V		
	C920	00D 963 9004 902	Ceramic chip 18pF/50V		
OTHER PARTS GROUP					
	CB801	00D 963 0050 502	Chip emifil		
	CB802	00D 963 0050 502	Chip emifil		
	CB803	00D 963 0050 502	Chip emifil		
	CB804	00D 963 0050 502	Chip emifil		
	CB805	00D 963 0050 502	Chip emifil		
	CB806	00D 963 0050 502	Chip emifil		
	CB808	00D 963 0050 502	Chip emifil		
	CB810	00D 963 0050 502	Chip emifil		
	CN801	00D 963 0086 301	18P connector socket (TUC-P)		
	CN802	00D 963 0086 204	19P connector socket (TUC-P)		
	CN803	00D 960 0239 900	13P connector socket (TUC-P)		
	JACK801	00D 963 0052 500	1P pin jack		
	L801	00D 963 0050 803	Inductor 4.7uH		
	L802	00D 963 0050 803	Inductor 4.7uH		
	L803	00D 963 0050 803	Inductor 4.7uH		
	L804	00D 963 0050 803	Inductor 4.7uH		
	L805	00D 963 0050 900	Inductor 2.2uH		
	R831	00D 963 0120 908	Beads inductor		
	R832	00D 963 0120 908	Beads inductor		
	R833	00D 963 0120 908	Beads inductor		

	Ref. No.	Part No.	Part Name	Remarks	New
	XTAL1	00D 963 0095 101	Crystal 12.288MHz		
	XTAL2	00D 963 0158 103	Crystal 18.75MHZ		*

PARTS LIST OF P.W.B. UNIT ASS'Y (FOR JAPAN)

MAIN P.W.B. UNIT

	Ref. No.	Part No.	Part Name	Remarks	New
SEMICONDUCTORS GROUP					
	IC101	00D 963 0110 507	IC MC7815CT		
	IC102	00D 960 0179 905	IC KIA7915		
	IC103	00D 960 0159 501	IC KIA7805API		
	IC104	00D 963 0110 604	IC MC7805CT		
	IC105	00D 960 0195 808	IC protector ICP-N15		
	IC106	00D 960 0195 808	IC protector ICP-N15		
	Q104C	00D 960 0196 506	Transistor KSC1845F		
	Q104FL	00D 960 0196 506	Transistor KSC1845F		
	Q104FR	00D 960 0196 506	Transistor KSC1845F		
	Q104SL	00D 960 0196 506	Transistor KSC1845F		
	Q104SR	00D 960 0196 506	Transistor KSC1845F		
	Q111	00D 963 0121 208	Transistor KRC107M		
	Q112	00D 960 0097 508	Transistor KRC111M		
	Q113	00D 963 0121 208	Transistor KRC107M		
	Q114	00D 963 0121 208	Transistor KRC107M		
	Q115	00D 963 0121 208	Transistor KRC107M		
	Q116	00D 960 0196 409	Transistor 2SC1740SR		
	Q117	00D 963 0121 208	Transistor KRC107M		
	Q118	00D 963 0121 208	Transistor KRC107M		
	Q151	00D 960 0196 409	Transistor 2SC1740SR		
	Q171	00D 960 0005 202	Transistor KTC3198Y		
	Q171A	00D 960 0196 302	Transistor KTA1268BL		
	Q171B	00D 960 0196 302	Transistor KTA1268BL		
	Q171C	00D 960 0196 302	Transistor KTA1268BL		
	Q171D	00D 960 0196 302	Transistor KTA1268BL		
	Q172	00D 960 0005 202	Transistor KTC3198Y		
	Q173	00D 960 0005 202	Transistor KTC3198Y		
	Q174	00D 960 0005 202	Transistor KTC3198Y		
	Q175	00D 960 0005 202	Transistor KTC3198Y		
	Q176	00D 960 0005 202	Transistor KTC3198Y		
	Q177	00D 960 0005 202	Transistor KTC3198Y		
	Q178	00D 960 0005 105	Transistor KTA1266Y		
	Q179	00D 960 0189 005	Transistor KSA916Y		
	Q180	00D 960 0196 302	Transistor KTA1268BL		
	Q181	00D 960 0196 302	Transistor KTA1268BL		
	Q182	00D 960 0005 202	Transistor KTC3198Y		
	Q183	00D 960 0005 202	Transistor KTC3198Y		
	D101	00D 963 0020 309	Diode 1SS133T		
	D102	00D 963 0020 309	Diode 1SS133T		
	D103	00D 963 0020 309	Diode 1SS133T		
	D104	00D 963 0020 309	Diode 1SS133T		
	D105	00D 963 0020 309	Diode 1SS133T		
	D121	00D 963 0020 309	Diode 1SS133T		
	D122	00D 963 0020 309	Diode 1SS133T		
	D123	00D 963 0020 309	Diode 1SS133T		
	D124	00D 963 0020 309	Diode 1SS133T		
	D125	00D 963 0020 309	Diode 1SS133T		
	D126	00D 963 0020 309	Diode 1SS133T		
	D127	00D 963 0020 309	Diode 1SS133T		
	D131A	00D 960 0197 107	Diode KBPC604		
	D131B	00D 960 0197 107	Diode KBPC604		
	D132	00D 963 0020 309	Diode 1SS133T		
	D133	00D 963 0046 202	Zener diode MTZJ18B		

Ref. No.	Part No.	Part Name	Remarks	New
D134	00D 963 0046 202	Zener diode MTZJ18B		
D135	00D 963 0020 309	Diode 1SS133T		
D136	00D 963 0058 504	Zener diode MTZJ11B		
D137	00D 963 0020 309	Diode 1SS133T		
D138A	00D 963 0058 407	Diode IN4007		
D141	00D 963 0058 407	Diode IN4007		
D142	00D 963 0058 407	Diode IN4007		
D143	00D 963 0058 407	Diode IN4007		
D144	00D 963 0058 407	Diode IN4007		
D145	00D 963 0058 407	Diode IN4007		
D146	00D 963 0058 407	Diode IN4007		
D149	00D 963 0058 407	Diode IN4007		
D150	00D 963 0058 407	Diode IN4007		
D152	00D 963 0058 407	Diode IN4007		
D153	00D 963 0058 407	Diode IN4007		
D154	00D 960 0095 908	Zener diode MTZJ8.2B		
D157	00D 960 0014 905	Zener diode MTZJ20B		
ZD310	00D 960 0095 500	Zener diode MTZJ5.1B		
ZD311	00D 960 0095 500	Zener diode MTZJ5.1B		
LED901	00D 963 0148 605	LED SML1216W 5PI R/G		
RESISTORS GROUP				
R104C	00D 963 9006 285	Metal oxide 5.6 kohm 1W		
R104FL	00D 963 9006 285	Metal oxide 5.6 kohm 1W		
R104FR	00D 963 9006 285	Metal oxide 5.6 kohm 1W		
R104SL	00D 963 9006 285	Metal oxide 5.6 kohm 1W		
R104SR	00D 963 9006 285	Metal oxide 5.6 kohm 1W		
R105C	00D 963 9006 285	Metal oxide 5.6 kohm 1W		
R105FL	00D 963 9006 285	Metal oxide 5.6 kohm 1W		
R105FR	00D 963 9006 285	Metal oxide 5.6 kohm 1W		
R105SL	00D 963 9006 285	Metal oxide 5.6 kohm 1W		
R105SR	00D 963 9006 285	Metal oxide 5.6 kohm 1W		
R106C	00D 963 0047 900	Metal film 4.7 kohm 1W		
R106FL	00D 963 0047 900	Metal film 4.7 kohm 1W		
R106FR	00D 963 0047 900	Metal film 4.7 kohm 1W		
R106SL	00D 963 0047 900	Metal film 4.7 kohm 1W		
R106SR	00D 963 0047 900	Metal film 4.7 kohm 1W		
R107C	00D 963 0047 900	Metal film 4.7 kohm 1W		
R107FL	00D 963 0047 900	Metal film 4.7 kohm 1W		
R107FR	00D 963 0047 900	Metal film 4.7 kohm 1W		
R107SL	00D 963 0047 900	Metal film 4.7 kohm 1W		
R107SR	00D 963 0047 900	Metal film 4.7 kohm 1W		
R108C	00D 963 9006 269	Metal oxide 0.22 ohm 1W		
R108FL	00D 963 9006 269	Metal oxide 0.22 ohm 1W		
R108FR	00D 963 9006 269	Metal oxide 0.22 ohm 1W		
R108SL	00D 963 9006 269	Metal oxide 0.22 ohm 1W		
R108SR	00D 963 9006 269	Metal oxide 0.22 ohm 1W		
R109C	00D 963 9006 269	Metal oxide 0.22 ohm 1W		
R109FL	00D 963 9006 269	Metal oxide 0.22 ohm 1W		
R109FR	00D 963 9006 269	Metal oxide 0.22 ohm 1W		
R109SL	00D 963 9006 269	Metal oxide 0.22 ohm 1W		
R109SR	00D 963 9006 269	Metal oxide 0.22 ohm 1W		
R110C	00D 963 9006 269	Metal oxide 0.22 ohm 1W		
R118C	00D 963 9006 256	Metal oxide 10 ohm 1W		
R118FL	00D 963 9006 256	Metal oxide 10 ohm 1W		
R118FR	00D 963 9006 256	Metal oxide 10 ohm 1W		

Ref. No.	Part No.	Part Name	Remarks	New
R118SL	00D 963 9006 256	Metal oxide 10 ohm 1W		
R118SR	00D 963 9006 256	Metal oxide 10 ohm 1W		
R119C	00D 963 9006 256	Metal oxide 10 ohm 1W		
R119FL	00D 963 9006 256	Metal oxide 10 ohm 1W		
R119FR	00D 963 9006 256	Metal oxide 10 ohm 1W		
R119SL	00D 963 9006 256	Metal oxide 10 ohm 1W		
R119SR	00D 963 9006 256	Metal oxide 10 ohm 1W		
R135	00D 963 0144 502	Cement resistor 0.1 ohm 5W		
R136	00D 963 0144 502	Cement resistor 0.1 ohm 5W		
R141	00D 960 0180 606	Metal oxide 0.22 ohm 1W		
R142	00D 960 0180 606	Metal oxide 0.22 ohm 1W		
R148	00D 960 0180 606	Metal oxide 0.22 ohm 1W		
R149	00D 960 0180 606	Metal oxide 0.22 ohm 1W		
R151	00D 963 9003 343	Metal film 68ohm 1/4W		
R179	00D 963 9003 055	Metal film 47 kohm 1/4W (NB)		
R181	00D 963 0047 900	Metal film 4.7 kohm 1W		
R184	00D 963 9006 256	Metal oxide 10 ohm 1W		
R903H	00D 960 9009 270	Metal film 470ohm 2W		
R904H	00D 960 9009 270	Metal film 470ohm 2W		
VR101	00D 960 0091 601	Semi fixed resistor 1 kohm		
VR102	00D 960 0091 601	Semi fixed resistor 1 kohm		
VR103	00D 960 0091 601	Semi fixed resistor 1 kohm		
VR104	00D 960 0091 601	Semi fixed resistor 1 kohm		
VR105	00D 960 0091 601	Semi fixed resistor 1 kohm		
CAPACITORS GROUP				
C101C	00D 963 9006 450	Electrolytic 47uF/50V		
C101FL	00D 963 9006 450	Electrolytic 47uF/50V		
C101FR	00D 963 9006 450	Electrolytic 47uF/50V		
C101SL	00D 963 9006 450	Electrolytic 47uF/50V		
C101SR	00D 963 9006 450	Electrolytic 47uF/50V		
C102C	00D 963 9006 450	Electrolytic 47uF/50V		
C102FL	00D 963 9006 450	Electrolytic 47uF/50V		
C102FR	00D 963 9006 450	Electrolytic 47uF/50V		
C102SL	00D 963 9006 450	Electrolytic 47uF/50V		
C102SR	00D 963 9006 450	Electrolytic 47uF/50V		
C103C	00D 963 9003 084	Ceramic 100pF/500V		
C103FL	00D 963 9003 084	Ceramic 100pF/500V		
C103FR	00D 963 9003 084	Ceramic 100pF/500V		
C103SL	00D 963 9003 084	Ceramic 100pF/500V		
C103SR	00D 963 9003 084	Ceramic 100pF/500V		
C104C	00D 963 9003 084	Ceramic 100pF/500V		
C104FL	00D 963 9003 084	Ceramic 100pF/500V		
C104FR	00D 963 9003 084	Ceramic 100pF/500V		
C104SL	00D 963 9003 084	Ceramic 100pF/500V		
C104SR	00D 963 9003 084	Ceramic 100pF/500V		
C105C	00D 963 9008 640	Mylar film 0.022uF/100V		
C105FL	00D 963 9008 640	Mylar film 0.022uF/100V		
C105FR	00D 963 9008 640	Mylar film 0.022uF/100V		
C105SL	00D 963 9008 640	Mylar film 0.022uF/100V		
C105SR	00D 963 9008 640	Mylar film 0.022uF/100V		
C107C	00D 963 9003 097	Mylar film 0.1uF/250V		
C107FL	00D 963 9003 097	Mylar film 0.1uF/250V		
C107FR	00D 963 9003 097	Mylar film 0.1uF/250V		
C107SL	00D 963 9003 097	Mylar film 0.1uF/250V		
C107SR	00D 963 9003 097	Mylar film 0.1uF/250V		
C131	00D 963 9003 097	Mylar film 0.1uF/250V		

	Ref. No.	Part No.	Part Name	Remarks	New
	C132	00D 963 9003 097	Mylar film 0.1uF/250V		
	C133	00D 963 9003 097	Mylar film 0.1uF/250V		
	C134	00D 963 9003 097	Mylar film 0.1uF/250V		
	C135	00D 963 9003 097	Mylar film 0.1uF/250V		
	C136	00D 963 0157 803	Electrolytic 12000uF/63V		*
	C137	00D 963 0157 803	Electrolytic 12000uF/63V		*
	C138	00D 963 9006 379	Electrolytic 1uF/50V		
	C138A	00D 963 9003 097	Mylar film 0.1uF/250V		
	C141	00D 963 0021 900	Mylar film 0.047uF/100V		
	C142	00D 963 0021 900	Mylar film 0.047uF/100V		
	C143	00D 963 0021 900	Mylar film 0.047uF/100V		
	C144	00D 960 9007 201	Electrolytic 3300uF/35V		
	C145	00D 963 9003 123	Electrolytic 1000uF/35V		
	C146	00D 963 9006 340	Electrolytic 100uF/25V		
	C148	00D 963 9006 340	Electrolytic 100uF/25V		
	C150	00D 963 0021 900	Mylar film 0.047uF/100V		
	C151	00D 963 0021 900	Mylar film 0.047uF/100V		
	C152	00D 963 0021 900	Mylar film 0.047uF/100V		
	C153	00D 963 0021 104	Electrolytic 6800uF/16V		
	C154	00D 963 9006 308	Electrolytic 10uF/50V		
	C155	00D 963 0020 202	Ceramic 0.1uF/50V		
	C157	00D 963 9006 379	Electrolytic 1uF/50V		
	C158	00D 963 9003 136	Electrolytic 1000uF/25V		
	C159	00D 963 9006 379	Electrolytic 1uF/50V		
	C161	00D 963 9006 308	Electrolytic 10uF/50V		
	C171	00D 963 9005 312	Electrolytic 100uF/10V		
	C171A	00D 963 0020 202	Ceramic 0.1uF/50V		
	C171B	00D 963 0020 202	Ceramic 0.1uF/50V		
	C171C	00D 963 0020 202	Ceramic 0.1uF/50V		
	C171D	00D 963 0020 202	Ceramic 0.1uF/50V		
	C172	00D 963 9005 833	Electrolytic 220uF/6.3V		
	C173	00D 963 9005 833	Electrolytic 220uF/6.3V		
	C174	00D 963 9006 308	Electrolytic 10uF/50V		
	C175	00D 963 0149 507	Electrolytic 220uF/16V		
	C176	00D 963 9006 379	Electrolytic 1uF/50V		
	C177	00D 963 9006 379	Electrolytic 1uF/50V		
	C178	00D 963 0157 900	Electrolytic 470uF/63V		*
	C179	00D 963 9005 833	Electrolytic 220uF/6.3V		
⚠	C181	00D 963 9006 191	Ceramic 4700pF/250V(AC)		
	C182	00D 963 9006 311	Electrolytic 10uF/100V		
	C331	00D 963 9004 546	Ceramic 0.01uF/16V		
	C332	00D 963 9004 546	Ceramic 0.01uF/16V		
	C901H	00D 963 9004 533	Ceramic 0.001uF/50V		
	C902H	00D 963 9004 533	Ceramic 0.001uF/50V		
	C903H	00D 963 0020 202	Ceramic 0.1uF/50V		
	C904H	00D 960 9003 108	Ceramic 0.022uF/25V		
	C905H	00D 963 0020 202	Ceramic 0.1uF/50V		
	C906H	00D 963 9004 546	Ceramic 0.01uF/16V		
	C907H	00D 960 9006 202	Ceramic 0.01uF/50V		
OTHER PARTS GROUP					
	CB903	00D 963 0154 602	Beads inductor		*
	CB904	00D 963 0154 602	Beads inductor		*
	CN901	00D 963 0160 201	3P connector cord		*
	CN931A	00D 963 0148 809	2P connector cord		
	CN992	00D 963 0160 007	4P connector cord		*

	Ref. No.	Part No.	Part Name	Remarks	New
⚠	CP101	00D 960 0118 908	AC cord connector base		
	CP102	00D 960 0123 304	2P connector base		
	CP103	00D 960 0128 901	3P connector base		
	CP104	00D 960 0128 804	6P connector base		
	CP105	00D 963 0149 109	2P connector base(BLACK)		
	CP106	00D 960 0123 207	3P connector base		
	CP1151	00D 963 0097 507	15P connector base (TUC-P)		
	CP1153	00D 963 0097 507	15P connector base (TUC-P)		
	CP138A	00D 960 0123 207	3P connector base		
	CP3911	00D 963 0160 900	8P connector base		*
	CP392	00D 963 0048 909	3P connector base		
	CP501	00D 963 0086 806	9P connector base (TUC-P)		
	CP502	00D 963 0085 807	7P connector base (TUC-P)		
	CP503	00D 963 0085 807	7P connector base (TUC-P)		
	CP504	00D 963 0086 903	5P connector base (TUC-P)		
⚠	CP505	00D 963 0087 708	12P connector base (TUC-P)		
	CP555	00D 963 0111 108	14P connector base (TUC-P)		
	CP556	00D 963 0087 805	11P connector base (TUC-P)		
	CP901	00D 963 0048 909	3P connector base		
	CP931	00D 963 0149 206	2P connector base(BLUE)		
⚠	F102	00D 960 0194 906	Fuse 8A		
	F102A	00D 960 0005 804	Fuse clip		
	F102B	00D 960 0005 804	Fuse clip		
	G901	-	1P contact Ass'y		
	GND101	00D 960 9006 600	Terminal		
	GND102	00D 960 9006 600	Terminal		
	GND103	00D 960 9006 600	Terminal		
	JK901	00D 963 0095 402	Head phone jack		
		L101C	00D 963 0049 005	Inductor 0.5uH	
L101FL		00D 963 0049 005	Inductor 0.5uH		
	L101FR	00D 963 0049 005	Inductor 0.5uH		
	L101SL	00D 963 0049 005	Inductor 0.5uH		
	L101SR	00D 963 0049 005	Inductor 0.5uH		
⚠	RLY101	00D 960 0181 702	Relay (G5PA-28 24V)		
	RLY102	00D 960 0181 702	Relay (G5PA-28 24V)		
	RLY103	00D 960 0181 702	Relay (G5PA-28 24V)		
	RLY104	00D 960 0181 702	Relay (G5PA-28 24V)		
	RLY105	00D 963 0071 303	Relay (RSB24S 24V)		
	RLY106	00D 960 0181 605	Relay (G5PA-1-8 12V)		
	RLY107	00D 960 0181 702	Relay (G5PA-28 24V)		
	SW391	00D 963 0045 708	Tact switch		
	SW393	00D 963 0045 708	Tact switch		
	SW901	00D 963 0045 708	Tact switch		
	SW901A	00D 963 0145 802	Push switch		
	TP101	00D 960 0161 405	3P connector base		
	TP102	00D 960 0161 405	3P connector base		
	TP103	00D 960 0161 405	3P connector base		
	TP104	00D 960 0161 405	3P connector base		
	TP105	00D 960 0161 405	3P connector base		
	VEC303	00D 963 0095 208	ENCODER SW		
	-	-	Heat sink	1	

	Ref. No.	Part No.	Part Name	Remarks	New
	-	-	Heat sink	1	
	-	00D 963 0068 400	Capacitor cover	1	
	-	00D 963 0120 526	Fuse label	1	
⚠	-	00D 963 0094 908	Power trans. (Mini)	1	
	-	00D 963 0018 007	Screw (2S 3X8 ZNY/BH)	3	
	-	00D 963 0158 608	2P speaker terminal	1	*
	-	00D 963 0119 906	8P speaker terminal	2	

CPU, FRONT P.W.B. UNIT

	Ref. No.	Part No.	Part Name	Remarks	New
SEMICONDUCTORS GROUP					
	IC201	00D 963 0161 705	IC CXP740010		
	IC204	00D 963 0114 600	IC MC7806CT		
	IC205	00D 963 0147 703	IC KIA7906		
	IC272	00D 963 0147 606	IC KIA78R09API		
	IC301	00D 960 0180 004	IC LC75721E		
	IC302	00D 963 0074 504	IC BU2090F		
	IC803	00D 963 0113 106	IC GP1FA513RZ		
	RMC301	00D 960 0181 100	IC NJL64H380A		
	Q201	00D 960 0285 006	Transistor KRC104S		
	Q202	00D 963 0121 509	Transistor KTC3875S		
	Q203	00D 963 0121 402	Transistor KRA104S		
	Q204	00D 963 0121 606	Transistor KRC107S		
	Q216	00D 960 0097 207	Transistor KRA102M		
	Q217	00D 963 0102 803	Transistor 2SA933S		
	Q218	00D 963 0102 803	Transistor 2SA933S		
	Q219	00D 963 0102 803	Transistor 2SA933S		
	Q220	00D 963 0121 208	Transistor KRC107M		
	Q221	00D 960 0097 207	Transistor KRA102M		
	Q300	00D 963 0121 402	Transistor KRA104S		
	Q301	00D 963 0121 402	Transistor KRA104S		
	Q302	00D 960 0285 006	Transistor KRC104S		
	Q303	00D 960 0285 006	Transistor KRC104S		
	Q304	00D 960 0285 006	Transistor KRC104S		
	Q305	00D 963 0121 402	Transistor KRA104S		
	Q306	00D 963 0120 704	Transistor KRA102S		
	Q307	00D 963 0121 606	Transistor KRC107S		
	Q308	00D 963 0120 704	Transistor KRA102S		
	D201	00D 963 0020 309	Diode 1SS133T		
	D202	00D 963 0058 407	Diode IN4007		
	D204	00D 963 0020 309	Diode 1SS133T		
	D209	00D 960 0197 000	Diode KDS160		
	D213	00D 963 0020 309	Diode 1SS133T		
	D215	00D 963 0020 309	Diode 1SS133T		
	D218	00D 963 0020 309	Diode 1SS133T		
	D302	00D 963 0020 309	Diode 1SS133T		
	D303	00D 963 0020 309	Diode 1SS133T		
	D304	00D 963 0020 309	Diode 1SS133T		
	D305	00D 960 0197 000	Diode KDS160		
	D306	00D 960 0197 000	Diode KDS160		
	D307	00D 960 0197 000	Diode KDS160		
	ZD201	00D 963 0047 502	Zener diode MTZJ3.3B		
	ZD301	00D 960 0095 801	Zener diode MTZJ6.8B		
	ZD302	00D 960 0095 500	Zener diode MTZJ5.1B		
	ZD303	00D 960 0095 500	Zener diode MTZJ5.1B		
	ZD304	00D 960 0095 500	Zener diode MTZJ5.1B		
	ZD305	00D 960 0095 500	Zener diode MTZJ5.1B		
	LED301	00D 960 0197 204	LED PI5-RD/HL50RDRF4T		
	LED302	00D 960 0197 204	LED PI5-RD/HL50RDRF4T		
	LED303	00D 960 0197 204	LED PI5-RD/HL50RDRF4T		
	LED305	00D 960 0197 204	LED PI5-RD/HL50RDRF4T		
	LED306	00D 960 0197 204	LED PI5-RD/HL50RDRF4T		

Ref. No.	Part No.	Part Name	Remarks	New
LED307	00D 960 0197 204	LED P15-RD/HL50RDRF4T		
LED308	00D 960 0197 204	LED P15-RD/HL50RDRF4T		
LED309	00D 960 0197 204	LED P15-RD/HL50RDRF4T		
LED310	00D 960 0197 204	LED P15-RD/HL50RDRF4T		
CAPACITORS GROUP				
BC201	00D 963 0061 504	Electrolytic 8200uF/5.5V		
C201D	00D 960 9010 816	Ceramic 0.1uF/50V		
C201E	00D 963 9004 517	Ceramic 0.022uF/50V		
C202	00D 963 9004 698	Ceramic chip 0.01uF/50V		
C202D	00D 963 9004 546	Ceramic 0.01uF/16V		
C202E	00D 963 9004 517	Ceramic 0.022uF/50V		
C203	00D 963 9004 698	Ceramic chip 0.01uF/50V		
C204	00D 963 9006 476	Electrolytic 4.7uF/50V		
C205	00D 963 9004 562	Ceramic 0.047uF/50V		
C221	00D 963 9005 312	Electrolytic 100uF/10V		
C228	00D 963 9004 575	Ceramic chip 100pF/50V		
C230	00D 963 9004 575	Ceramic chip 100pF/50V		
C231	00D 963 9004 575	Ceramic chip 100pF/50V		
C232	00D 963 9004 575	Ceramic chip 100pF/50V		
C233	00D 963 9004 575	Ceramic chip 100pF/50V		
C234	00D 963 9004 575	Ceramic chip 100pF/50V		
C238	00D 963 9006 366	Electrolytic 0.1uF/50V		
C242	00D 963 9004 685	Ceramic chip 1000pF/50V		
C245	00D 963 9004 575	Ceramic chip 100pF/50V		
C248	00D 963 9004 685	Ceramic chip 1000pF/50V		
C249	00D 963 9004 737	Ceramic chip 0.022uF/25V		
C251	00D 963 0020 202	Ceramic 0.1uF/50V		
C252	00D 960 9010 816	Ceramic 0.1uF/50V		
C256	00D 963 9006 308	Electrolytic 10uF/50V		
C257	00D 963 9006 308	Electrolytic 10uF/50V		
C260	00D 963 9006 379	Electrolytic 1uF/50V		
C261	00D 963 9006 379	Electrolytic 1uF/50V		
C301	00D 963 9004 546	Ceramic 0.01uF/16V		
C3010	00D 963 9006 421	Electrolytic 47uF/10V		
C302	00D 963 9004 546	Ceramic 0.01uF/16V		
C3020	00D 963 0020 202	Ceramic 0.1uF/50V		
C303	00D 963 9004 546	Ceramic 0.01uF/16V		
C3030	00D 963 9004 591	Ceramic chip 22pF/50V		
C304	00D 963 9004 546	Ceramic 0.01uF/16V		
C305	00D 963 9004 685	Ceramic chip 1000pF/50V		
C306	00D 963 9004 575	Ceramic chip 100pF/50V		
C307	00D 963 9004 575	Ceramic chip 100pF/50V		
C308	00D 960 9010 816	Ceramic 0.1uF/50V		
C309	00D 963 9004 737	Ceramic chip 0.022uF/25V		
C310	00D 963 9004 753	Ceramic chip 0.047uF/50V		
C311	00D 963 9005 406	Ceramic chip 30pF/50V		
C312	00D 963 9004 753	Ceramic chip 0.047uF/50V		
C314	00D 963 0021 900	Mylar film 0.047uF/100V		
C315	00D 963 9006 308	Electrolytic 10uF/50V		
C316	00D 960 9009 937	Electrolytic 100uF/50V		
C317	00D963 9005 859	Electrolytic 47uF/16V		
C318	00D 963 9005 419	Mylar film 0.047uF/63V		
C319	00D 963 9006 434	Electrolytic 47uF/16V		
C320	00D 963 9006 308	Electrolytic 10uF/50V		
C321	00D 963 0021 900	Mylar film 0.047uF/100V		
C322	00D 963 9006 434	Electrolytic 47uF/16V		

Ref. No.	Part No.	Part Name	Remarks	New
C323	00D 963 9004 766	Mylar film 0.1uF/100V		
C324	00D 963 9006 476	Electrolytic 4.7uF/50V		
C325	00D 963 9004 575	Ceramic chip 100pF/50V		
C326	00D 963 9006 382	Electrolytic 22uF/25V		
C327	00D 963 9006 476	Electrolytic 4.7uF/50V		
C329	00D 963 9006 531	Electrolytic 22uF/16V		
C330	00D 963 9006 531	Electrolytic 22uF/16V		
C340	00D 963 9004 575	Ceramic chip 100pF/50V		
C341	00D 963 9004 575	Ceramic chip 100pF/50V		
C347	00D 963 9004 708	Ceramic chip 0.1uF/50V		
C348	00D 963 9004 708	Ceramic chip 0.1uF/50V		
C354	00D 963 9004 708	Ceramic chip 0.1uF/50V		
OTHER PARTS GROUP				
BD205	00D 963 0050 502	Chip emifil		
BD206	00D 963 0050 502	Chip emifil		
BD207	00D 963 0154 602	Beads inductor		*
BD208	00D 963 0154 602	Beads inductor		*
BD209	00D 963 0154 602	Beads inductor		*
BD301	00D 963 0050 502	Chip emifil		
BD303	00D 963 0050 502	Chip emifil		
BD304	00D 963 0050 502	Chip emifil		
CB202	00D 963 0154 602	Beads inductor		*
CB203	00D 963 0154 602	Beads inductor		*
CN201	00D 963 0159 801	5P SHIELD WIRE		*
CN302	00D 963 0160 502	8P connector cord		*
CN303	00D 963 0160 308	3P connector cord		*
CN605	00D 963 0159 908	3P connector cord		*
CN606	00D 96 30159 607	4P connector cord		*
CP1000	00D 963 0085 807	7P connector base (TUC-P)		
CP1001	00D 963 0111 108	14P connector base (TUC-P)		
CP1154	00D 963 0085 807	7P connector base (TUC-P)		
CP1155	00D 963 0085 807	7P connector base (TUC-P)		
CP301	00D 963 0161 103	23P FFC connector base		*
CP301A	00D 963 0161 006	23P FFC connector base		*
CP302	00D 963 0066 101	5P connector base		
CP303	00D 963 0049 102	3P connector base		
CP404	00D 963 0087 805	11P connector base (TUC-P)		
CP551	00D 963 0087 601	8P connector base (TUC-P)		
CP552	00D 963 0087 504	19P connector base (TUC-P)		
CP605	00D 963 0048 909	3P connector base		
CP606	00D 963 0050 104	4P connector base		
CP701	00D 963 0087 601	18P connector base (TUC-P)		
CP703	00D 963 0087 805	11P connector base (TUC-P)		
CP705	00D 963 0087 601	8P connector base (TUC-P)		
CP706	00D 963 0087 601	8P connector base (TUC-P)		
CP801	00D 963 0087 601	18P connector base (TUC-P)		
CP802	00D 963 0087 504	19P connector base (TUC-P)		
CP803	00D 960 0239 609	13P connector base (TUC-P)		
CP804	00D 963 0087 504	19P connector base (TUC-P)		
G903	-	1P contact Ass'y		
GND01	00D 960 9006 600	Terminal		
GND02	00D 960 9006 600	Terminal		

Ref. No.	Part No.	Part Name	Remarks	New
GP301	-	1P contact Ass'y		
GP301	-	1P contact Ass'y		
J326	00D 963 9003 372	Carbon chip 0 ohm 1/16W		
JIG601	00D 960 0123 605	13P connector base		
JP353	00D 963 9003 372	Carbon chip 0 ohm 1/16W		
L301	00D 960 0010 307	Inductor 10uH		
L3010	00D 960 0215 908	Inductor 4.7uH		
L302	00D 960 0128 008	Inductor 100uH		
SW301C	00D 963 0045 708	Tact switch		
SW302A	00D 963 0095 305	Tact switch		
SW302B	00D 963 0095 305	Tact switch		
SW302C	00D 963 0045 708	Tact switch		
SW303A	00D 963 0095 305	Tact switch		
SW303B	00D 963 0095 305	Tact switch		
SW303C	00D 963 0045 708	Tact switch		
SW304B	00D 963 0095 305	Tact switch		
SW304C	00D 963 0045 708	Tact switch		
SW305B	00D 963 0045 708	Tact switch		
SW305C	00D 963 0045 708	Tact switch		
SW306B	00D 963 0095 305	Tact switch		
SW306C	00D 963 0045 708	Tact switch		
SW307C	00D 963 0045 708	Tact switch		
SW308C	00D 963 0045 708	Tact switch		
SW309C	00D 963 0045 708	Tact switch		
VEC301	00D 963 0095 208	ENCODER SW		
VEC302	00D 963 0095 208	ENCODER SW		
X201	00D 960 0181 003	Resonator CST12.0MTW-TF01		
-	-	Heat sink	1	
-	00D 963 0018 007	Screw (2S 3X8 ZNY/BH)	2	
-	00D 960 0184 408	FLT holder	1	
-	00D 963 0109 505	FLT (16-ST-66GNK)	1	
-	00D 963 0158 307	DIN SOCKET DIN-416G	1	*
-	00D 963 0146 403	3P pin jack	1	

CNT,PRE-AMP P.W.B. UNIT

	Ref. No.	Part No.	Part Name	Remarks	New
SEMICONDUCTORS GROUP					
	Q101SBL	00D 963 0044 204	Transistor 2SD2390-Y		
	Q101SBR	00D 963 0044 204	Transistor 2SD2390-Y		
	Q102SBL	00D 963 0044 107	Transistor 2SB1560-Y		
	Q102SBR	00D 963 0044 107	Transistor 2SB1560-Y		
	Q103SBL	00D 963 0058 106	Transistor 2SD947F		
	Q103SBR	00D 963 0058 106	Transistor 2SD947F		
	Q104SBL	00D 960 0196 506	Transistor KSC1845F		
	Q104SBR	00D 960 0196 506	Transistor KSC1845F		
	Q501C	00D 960 0196 603	Transistor KTC2874B		
	Q501FL	00D 960 0196 603	Transistor KTC2874B		
	Q501FR	00D 960 0196 603	Transistor KTC2874B		
	Q501SBL	00D 960 0196 603	Transistor KTC2874B		
	Q501SBR	00D 960 0196 603	Transistor KTC2874B		
	Q501SL	00D 960 0196 603	Transistor KTC2874B		
	Q501SR	00D 960 0196 603	Transistor KTC2874B		
	Q502C	00D 960 0196 205	Transistor KSA992F		
	Q502FL	00D 960 0196 205	Transistor KSA992F		
	Q502FR	00D 960 0196 205	Transistor KSA992F		
	Q502SBL	00D 960 0196 205	Transistor KSA992F		
	Q502SBR	00D 960 0196 205	Transistor KSA992F		
	Q502SL	00D 960 0196 205	Transistor KSA992F		
	Q502SR	00D 960 0196 205	Transistor KSA992F		
	Q503C	00D 960 0196 205	Transistor KSA992F		
	Q503FL	00D 960 0196 205	Transistor KSA992F		
	Q504C	00D 960 0196 506	Transistor KSC1845F		
	Q504FL	00D 960 0196 506	Transistor KSC1845F		
	Q504FR	00D 960 0196 506	Transistor KSC1845F		
	Q504SBL	00D 960 0196 506	Transistor KSC1845F		
	Q504SBR	00D 960 0196 506	Transistor KSC1845F		
	Q504SL	00D 960 0196 506	Transistor KSC1845F		
	Q504SR	00D 960 0196 506	Transistor KSC1845F		
	Q506C	00D 960 0196 603	Transistor KTC2874B		
	Q506FL	00D 960 0196 603	Transistor KTC2874B		
	Q551	00D 960 0196 700	Transistor KTC3200BL		
	Q552	00D 960 0196 302	Transistor KTA1268BL		
	Q553	00D 963 0120 704	Transistor KRA102S		
	Q554	00D 963 0120 704	Transistor KRA102S		
	Q555	00D 963 0120 704	Transistor KRA102S		
	Q556	00D 963 0120 704	Transistor KRA102S		
	Q557C	00D 963 0148 508	Transistor KTA1504S		
	Q558C	00D 963 0121 606	Transistor KRC107S		
	D106	00D 963 0020 309	Diode 1SS133T		
	D107	00D 963 0020 309	Diode 1SS133T		
	D551	00D 963 0020 309	Diode 1SS133T		
	D552	00D 963 0020 309	Diode 1SS133T		
	D553	00D 963 0020 309	Diode 1SS133T		
	D554	00D 963 0020 309	Diode 1SS133T		
	D555	00D 963 0020 309	Diode 1SS133T		
	D556	00D 963 0020 309	Diode 1SS133T		
	D557	00D 963 0020 309	Diode 1SS133T		
	D558	00D 963 0020 309	Diode 1SS133T		
	D559	00D 963 0020 309	Diode 1SS133T		
	D560	00D 963 0020 309	Diode 1SS133T		
	D561	00D 963 0020 309	Diode 1SS133T		
	D562	00D 963 0058 407	Diode IN4007		

Ref. No.	Part No.	Part Name	Remarks	New
D563	00D 963 0058 407	Diode IN4007		
D564	00D 963 0020 309	Diode 1SS133T		
D565	00D 960 0095 500	Zener diode MTZJ5.1B		
D566	00D 963 0020 309	Diode 1SS133T		
D567	00D 963 0020 309	Diode 1SS133T		
D568	00D 963 0020 309	Diode 1SS133T		
D568C	00D 960 0197 000	Diode KDS160		
D569	00D 963 0020 309	Diode 1SS133T		
D569C	00D 960 0197 000	Diode KDS160		
D570	00D 963 0058 407	Diode IN4007		
D570C	00D 960 0197 000	Diode KDS160		
D571	00D 963 0058 407	Diode IN4007		
D573	00D 963 0058 407	Diode IN4007		
D574	00D 963 0058 407	Diode IN4007		
D575	00D 963 0058 407	Diode IN4007		
RESISTORS GROUP				
R104SBL	00D 963 9006 285	Metal oxide 5.6 kohm 1W		
R104SBR	00D 963 9006 285	Metal oxide 5.6 kohm 1W		
R105SBL	00D 963 9006 285	Metal oxide 5.6 kohm 1W		
R105SBR	00D 963 9006 285	Metal oxide 5.6 kohm 1W		
R106SBL	00D 963 0047 900	Metal film 4.7 kohm 1W		
R106SBR	00D 963 0047 900	Metal film 4.7 kohm 1W		
R107SBL	00D 963 0047 900	Metal film 4.7 kohm 1W		
R107SBR	00D 963 0047 900	Metal film 4.7 kohm 1W		
R108SBL	00D 963 9006 269	Metal oxide 0.22 ohm 1W		
R108SBR	00D 963 9006 269	Metal oxide 0.22 ohm 1W		
R109SBL	00D 963 9006 269	Metal oxide 0.22 ohm 1W		
R109SBR	00D 963 9006 269	Metal oxide 0.22 ohm 1W		
R110SBL	00D 963 9006 269	Metal oxide 0.22 ohm 1W		
R110SBR	00D 963 9006 269	Metal oxide 0.22 ohm 1W		
R111SBL	00D 963 9006 269	Metal oxide 0.22 ohm 1W		
R111SBR	00D 963 9006 269	Metal oxide 0.22 ohm 1W		
R118SBL	00D 963 9006 256	Metal oxide 10 ohm 1W		
R118SBR	00D 963 9006 256	Metal oxide 10 ohm 1W		
R119SBL	00D 963 9006 256	Metal oxide 10 ohm 1W		
R119SBR	00D 963 9006 256	Metal oxide 10 ohm 1W		
R509C	00D 960 9005 902	Metal film 1.2 kohm 1/4W		
R509FL	00D 960 9005 902	Metal film 1.2 kohm 1/4W		
R509FR	00D 960 9005 902	Metal film 1.2 kohm 1/4W		
R509SBL	00D 960 9005 902	Metal film 1.2 kohm 1/4W		
R509SBR	00D 960 9005 902	Metal film 1.2 kohm 1/4W		
R509SL	00D 960 9005 902	Metal film 1.2 kohm 1/4W		
R509SR	00D 960 9005 902	Metal film 1.2 kohm 1/4W		
R511C	00D 960 9004 301	Metal film 47 ohm 1/4W		
R511FL	00D 960 9004 301	Metal film 47 ohm 1/4W		
R511FR	00D 960 9004 301	Metal film 47 ohm 1/4W		
R511SBL	00D 960 9004 301	Metal film 47 ohm 1/4W		
R511SBR	00D 960 9004 301	Metal film 47 ohm 1/4W		
R511SL	00D 960 9004 301	Metal film 47 ohm 1/4W		
R511SR	00D 960 9004 301	Metal film 47 ohm 1/4W		
R559	00D 963 9005 642	Metal film 1.2 kohm 1W		
R565	00D 963 9005 642	Metal film 1.2 kohm 1W		
R570	00D 963 9005 642	Metal film 1.2 kohm 1W		
R575	00D 963 9006 269	Metal oxide 0.22 ohm 1W		
R576	00D 963 9006 269	Metal oxide 0.22 ohm 1W		
VR106	00D 963 0105 208	Semi fixed resistor 1 kohm		

Ref. No.	Part No.	Part Name	Remarks	New
VR107	00D 963 0105 208	Semi fixed resistor 1 kohm		
CAPACITORS GROUP				
C101SBL	00D 963 9006 450	Electrolytic 47uF/50V		
C101SBR	00D 963 9006 450	Electrolytic 47uF/50V		
C102SBL	00D 963 9006 450	Electrolytic 47uF/50V		
C102SBR	00D 963 9006 450	Electrolytic 47uF/50V		
C103SBL	00D 963 9003 084	Ceramic 100pF/500V		
C103SBR	00D 963 9003 084	Ceramic 100pF/500V		
C104SBL	00D 963 9003 084	Ceramic 100pF/500V		
C104SBR	00D 963 9003 084	Ceramic 100pF/500V		
C105SBL	00D 963 9008 640	Mylar film 0.022uF/100V		
C105SBR	00D 963 9008 640	Mylar film 0.022uF/100V		
C107SBL	00D 963 9003 097	Mylar film 0.1uF/250V		
C107SBR	00D 963 9003 097	Mylar film 0.1uF/250V		
C258	00D 963 0021 104	Electrolytic 6800uF/16V		
C259	00D 960 9009 568	Electrolytic 3300uF/25V		
C501C	00D 963 9006 382	Electrolytic 22uF/25V		
C501FL	00D 963 9006 382	Electrolytic 22uF/25V		
C501FR	00D 963 9006 382	Electrolytic 22uF/25V		
C501SBL	00D 963 9006 382	Electrolytic 22uF/25V		
C501SBR	00D 963 9006 382	Electrolytic 22uF/25V		
C501SL	00D 963 9006 382	Electrolytic 22uF/25V		
C501SR	00D 963 9006 382	Electrolytic 22uF/25V		
C502C	00D 963 9006 308	Electrolytic 10uF/50V		
C502FL	00D 963 9006 308	Electrolytic 10uF/50V		
C502FR	00D 963 9006 308	Electrolytic 10uF/50V		
C502SBL	00D 963 9006 308	Electrolytic 10uF/50V		
C502SBR	00D 963 9006 308	Electrolytic 10uF/50V		
C502SL	00D 963 9006 308	Electrolytic 10uF/50V		
C502SR	00D 963 9006 308	Electrolytic 10uF/50V		
C503C	00D 963 9003 165	Ceramic 220pF/500V		
C503FL	00D 963 9003 165	Ceramic 220pF/500V		
C503FR	00D 963 9003 165	Ceramic 220pF/500V		
C503SBL	00D 963 9003 165	Ceramic 220pF/500V		
C503SBR	00D 963 9003 165	Ceramic 220pF/500V		
C503SL	00D 963 9003 165	Ceramic 220pF/500V		
C503SR	00D 963 9003 165	Ceramic 220pF/500V		
C504C	00D9630157502	Ceramic 220pF/50V		*
C504FL	00D 963 0157 502	Ceramic 220pF/50V		*
C504FR	00D 963 0157 502	Ceramic 220pF/50V		*
C504SBL	00D 963 0157 502	Ceramic 220pF/50V		*
C504SBR	00D 963 0157 502	Ceramic 220pF/50V		*
C504SL	00D 963 0157 502	Ceramic 220pF/50V		*
C504SR	00D 963 0157 502	Ceramic 220pF/50V		*
C505C	00D 963 9003 181	Ceramic 33pF/500V		
C505FL	00D 963 9003 181	Ceramic 33pF/500V		
C505FR	00D 963 9003 181	Ceramic 33pF/500V		
C505SBL	00D 963 9003 181	Ceramic 33pF/500V		
C505SBR	00D 963 9003 181	Ceramic 33pF/500V		
C505SL	00D 963 9003 181	Ceramic 33pF/500V		
C505SR	00D 963 9003 181	Ceramic 33pF/500V		
C506C	00D 963 9005 312	Electrolytic 100uF/10V		
C506FL	00D 963 9005 312	Electrolytic 100uF/10V		
C506FR	00D 963 9005 312	Electrolytic 100uF/10V		
C506SBL	00D 963 9005 312	Electrolytic 100uF/10V		
C506SBR	00D 963 9005 312	Electrolytic 100uF/10V		
C506SL	00D 963 9005 312	Electrolytic 100uF/10V		

	Ref. No.	Part No.	Part Name	Remarks	New
	C506SR	00D 963 9005 312	Electrolytic 100uF/10V		
	C507C	00D 963 9003 194	Mylar film 0.0022uF/100V		
	C507FL	00D 963 9003 194	Mylar film 0.0022uF/100V		
	C507FR	00D 963 9003 194	Mylar film 0.0022uF/100V		
	C507SBL	00D 963 9003 194	Mylar film 0.0022uF/100V		
	C507SBR	00D 963 9003 194	Mylar film 0.0022uF/100V		
	C507SL	00D 963 9003 194	Mylar film 0.0022uF/100V		
	C507SR	00D 963 9003 194	Mylar film 0.0022uF/100V		
	C508C	00D 963 9006 382	Electrolytic 22uF/25V		
	C508FL	00D 963 9006 382	Electrolytic 22uF/25V		
	C551	00D 963 9006 405	Electrolytic 2.2uF/50V		
	C551M	00D 963 0161 200	Electrolytic 10uF/25V		*
	C551S	00D 963 9004 562	Ceramic 0.047uF/50V		
	C552	00D 963 9006 366	Electrolytic 0.1uF/50V		
	C553	00D 963 9006 366	Electrolytic 0.1uF/50V		
	C554	00D 963 9006 366	Electrolytic 0.1uF/50V		
	C555	00D 963 9004 546	Ceramic 0.01uF/16V		
	C556	00D 963 9004 546	Ceramic 0.01uF/16V		
	C557	00D 963 9006 308	Electrolytic 10uF/50V		
	C558	00D 963 9006 366	Electrolytic 0.1uF/50V		
	C559	00D 963 0145 006	Mylar film 0.047uF/50V		
	C560	00D 963 0145 006	Mylar film 0.047uF/50V		
	C561	00D 963 0145 006	Mylar film 0.047uF/50V		
	C562	00D 963 9004 546	Ceramic 0.01uF/16V		
	C563	00D 963 9004 546	Ceramic 0.01uF/16V		
	C564	00D 960 0133 501	Electrolytic 2200uF/16V		
	C565	00D 960 0133 501	Electrolytic 2200uF/16V		
OTHER PARTS GROUP					
	CN106	00D 963 0148 702	2P connector cord		
	CN1153	00D 963 0097 303	15P connector socket (TUC-P)		
	CN501	00D 963 0085 603	5P connector socket (TUC-P)		
	CN502	00D 963 0086 602	12P connector socket (TUC-P)		
	CN503	00D 963 0086 505	7P connector socket (TUC-P)		
	CN504	00D 963 0085 506	9P connector socket (TUC-P)		
	CN505	00D 963 0086 505	7P connector socket (TUC-P)		
	CN506	00D 963 0060 903	15P connector base		
	CN506T	00D 963 0159 704	15P connector cord		*
	CN510	00D 963 0160 405	5P connector cord		*
	CN551	00D 963 0097 206	8P connector socket (TUC-P)		
	CN552	00D 963 0086 204	19P connector socket (TUC-P)		
	CN554	00D 963 0160 609	15P connector cord		*
	CN555	00D 963 0086 709	11P connector socket (TUC-P)		
	CN556	00D 963 0159 403	15P connector cord		*
	CN560	00D 963 0110 701	14P connector socket (TUC-P)		
	CN992	00D 960 0217 553	4P connector base		
	CP1154	00D 963 0097 507	15P connector base (TUC-P)		
	CP508	00D 963 0068 303	9P connector base		
	CP509	00D 963 0060 505	7P connector base		
	CP510	00D 963 0066 101	5P connector base		
	CP554	00D 963 0060 903	15P connector base		
	CP568	00D 963 0049 102	3P connector base		
	CP602D	00D 963 0097 507	15P connector base (TUC-P)		
⚠	F101	00D 960 0194 906	Fuse 8A		
	F101A	00D 960 0005 804	Fuse clip		
	F101B	00D 960 0005 804	Fuse clip		

	Ref. No.	Part No.	Part Name	Remarks	New
	L101SBL L101SBR	00D 963 0049 005 00D 963 0049 005	Inductor 0.5uH Inductor 0.5uH		
	TP106 TP107	00D 960 0161 418 00D 960 0161 418	3P connector base 3P connector base		
	-	00D 960 0184 000	Screw bracket	2	
	-	00D 960 0184 000	Screw bracket	2	
	-	00D 963 0120 513	Fuse label	1	
	-	00D 960 0187 803	AC outlet(2P)	1	

INPUT, VIDEO P.W.B. UNIT

	Ref. No.	Part No.	Part Name	Remarks	New
SEMICONDUCTORS GROUP					
	IC1000		IC BA7626F	J171762600010	
	IC1001	00D 963 0116 103	IC MM74HC4053MX		
	IC1002		IC BA7626F	J171762600010	
	IC1003	00D 963 0074 504	IC BU2090F		
	IC1004	00D 963 0116 103	IC MM74HC4053MX		
	IC1005	00D 963 0074 504	IC BU2090F		
	IC1006	00D 963 0116 307	IC LC7478		
	IC1007	00D 963 0116 200	IC NJM2274R		
	IC1008	00D 963 0116 103	IC MM74HC4053MX		
	IC1009	00D 963 0148 100	IC TC90A69F		
	IC1010	00D 963 0147 907	IC TK15420MTL		
	IC1011	00D 963 0147 907	IC TK15420MTL		
	IC1012	00D 963 0147 907	IC TK15420MTL		
	IC1013	00D 963 0147 907	IC TK15420MTL		
	IC1150		IC BA7626F	J171762600010	
	IC1151		IC BA7626F	J171762600010	
	IC1152		IC BA7626F	J171762600010	
	IC1153		IC BA7626F	J171762600010	
	IC1155	00D 963 0148 207	IC LA7108M		
	IC1157	00D 963 0147 907	IC TK15420MTL		
	IC201T	00D 963 0158 909	IC TC94A27UG		*
	IC202T	00D 963 0158 909	IC TC94A27UG		*
	IC203T	00D 960 0080 201	IC KIC9164AN		
	IC205	00D 963 0024 004	IC NJM2068M		
	IC206	00D 963 0024 004	IC NJM2068M		
	IC207	00D 963 0024 004	IC NJM2068M		
	IC208	00D 963 0159 005	IC NJM5532M		*
	IC209	00D 963 0159 005	IC NJM5532M		*
	IC210	00D 963 0159 005	IC NJM5532M		*
	IC211	00D 963 0159 005	IC NJM5532M		*
	IC701	00D 963 0083 207	IC TC9274N-011		
	IC701M	00D 963 0024 004	IC NJM2068M		
	IC702	00D 963 0024 004	IC NJM2068M		
	IC703	00D 963 0024 004	IC NJM2068M		
	IC704	00D 960 0174 502	IC NJM2068DD		
	IC705	00D 960 0174 201	IC TC9273N-004		
	Q1000	00D 963 0102 803	Transistor 2SA933S		
	Q1001	00D 963 0102 803	Transistor 2SA933S		
	Q1002	00D 963 0121 703	Transistor KRA107S		
	Q1003	00D 963 0121 703	Transistor KRA107S		
	Q1004	00D 963 0120 704	Transistor KRA102S		
	Q1005	00D 963 0159 102	Transistor KRC111S		*
	Q1006	00D 963 0120 801	Transistor KRC102S		
	Q1007	00D 960 0068 207	Transistor KTA1504Y		
	Q1008	00D 963 0120 704	Transistor KRA102S		
	Q1009	00D 963 0159 102	Transistor KRC111S		*
	Q1010	00D 963 0120 801	Transistor KRC102S		
	Q1011	00D 960 0068 207	Transistor KTA1504Y		
	Q1012	00D 963 0044 301	Transistor KTC2875B		
	Q1013	00D 963 0120 704	Transistor KRA102S		
	Q1014	00D 960 0068 207	Transistor KTA1504Y		
	Q1015	00D 963 0120 801	Transistor KRC102S		
	Q1016	00D 960 0068 207	Transistor KTA1504Y		
	Q1017	00D 960 0068 207	Transistor KTA1504Y		
	Q1018	00D 960 0068 207	Transistor KTA1504Y		

Ref. No.	Part No.	Part Name	Remarks	New
Q1019	00D 960 0068 207	Transistor KTA1504Y		
Q1020	00D 963 0066 606	Transistor KTC3875Y		
Q1021	00D 963 0066 606	Transistor KTC3875Y		
Q1022	00D 960 0068 207	Transistor KTA1504Y		
Q1023	00D 963 0102 803	Transistor 2SA933S		
Q1150	00D 963 0159 102	Transistor KRC111S		*
Q1151	00D 960 0068 207	Transistor KTA1504Y		
Q1152	00D 963 0159 102	Transistor KRC111S		*
Q1153	00D 960 0068 207	Transistor KTA1504Y		
Q1155	00D 963 0159 102	Transistor KRC111S		*
Q1156	00D 960 0068 207	Transistor KTA1504Y		
Q1157	00D 963 0159 102	Transistor KRC111S		*
Q1158	00D 960 0068 207	Transistor KTA1504Y		
Q207T	00D 960 0196 807	Transistor 2SK117Y		
Q208T	00D 960 0196 807	Transistor 2SK117Y		
Q209T	00D 960 0097 003	Transistor KRA104M		
Q210T	00D 963 0121 004	Transistor KRC104M		
Q551SW	00D 963 0044 301	Transistor KTC2875B		
Q552SW	00D 963 0044 301	Transistor KTC2875B		
D1000	00D 960 0197 000	Diode KDS160		
D1001	00D 960 0197 000	Diode KDS160		
D1002	00D 960 0197 000	Diode KDS160		
D1003	00D 960 0197 000	Diode KDS160		
D1004	00D 960 0197 000	Diode KDS160		
D1005	00D 960 0197 000	Diode KDS160		
D1012	00D 963 0020 309	Diode 1SS133T		
D1014	00D 963 0020 309	Diode 1SS133T		
D1150	00D 960 0197 000	Diode KDS160		
D1151	00D 960 0197 000	Diode KDS160		
D1152	00D 960 0197 000	Diode KDS160		
D1153	00D 960 0197 000	Diode KDS160		
D1154	00D 960 0197 000	Diode KDS160		
D1155	00D 960 0197 000	Diode KDS160		
D1157	00D 960 0197 000	Diode KDS160		
D205T	00D 960 0197 000	Diode KDS160		
D207T	00D 960 0197 000	Diode KDS160		
D254	00D 960 0197 000	Diode KDS160		
D255	00D 960 0197 000	Diode KDS160		
D256	00D 960 0197 000	Diode KDS160		
D901	00D 960 0197 000	Diode KDS160		
D902	00D 960 0197 000	Diode KDS160		
D903	00D 960 0197 000	Diode KDS160		
D904	00D 960 0197 000	Diode KDS160		
ZD1000	00D 960 0095 500	Zener diode MTZJ5.1B		
ZD1013	00D 960 0095 500	Zener diode MTZJ5.1B		
ZD701M	00D 960 0095 500	Zener diode MTZJ5.1B		
RESISTORS GROUP				
R1031	00D 963 9005 639	Metal film 100 ohm 1W		
R1038	00D 963 9005 639	Metal film 100 ohm 1W		
R1059	00D 963 9005 639	Metal film 100 ohm 1W		
R1095	00D 963 0018 007	Metal film 100 ohm 1/4W		
R1140	00D 963 9003 068	Metal film 4.7 ohm 1/4W (NB)		
R1163	00D 963 9005 639	Metal film 100 ohm 1W		
R1166	00D 963 9005 639	Metal film 100 ohm 1W		
R1193	00D 963 9005 639	Metal film 100 ohm 1W		

Ref. No.	Part No.	Part Name	Remarks	New
R1199	00D 963 9005 639	Metal film 100 ohm 1W		
R229T	00D 963 9005 639	Metal film 100 ohm 1W		
R230T	00D 963 9005 639	Metal film 100 ohm 1W		
R738M	00D 963 9005 338	Carbon chip 1.6 kohm 1/10W		
CAPACITORS GROUP				
C1000	00D 963 9006 382	Electrolytic 22uF/25V		
C1001	00D 963 9006 382	Electrolytic 22uF/25V		
C1002	00D 963 9005 312	Electrolytic 100uF/10V		
C1003	00D 963 9004 753	Ceramic chip 0.047uF/50V		
C1004	00D 963 9006 308	Electrolytic 10uF/50V		
C1005	00D 963 9006 308	Electrolytic 10uF/50V		
C1006	00D 963 9006 382	Electrolytic 22uF/25V		
C1007	00D 963 9004 753	Ceramic chip 0.047uF/50V		
C1008	00D 963 9006 382	Electrolytic 22uF/25V		
C1009	00D 963 9006 308	Electrolytic 10uF/50V		
C1010	00D 963 9006 405	Electrolytic 2.2uF/50V		
C1011	00D 963 9006 405	Electrolytic 2.2uF/50V		
C1013	00D 963 9006 382	Electrolytic 22uF/25V		
C1014	00D 963 9006 308	Electrolytic 10uF/50V		
C1015	00D 963 9005 312	Electrolytic 100uF/10V		
C1016	00D 963 9006 146	Ceramic chip 560pF/50V		
C1017	00D 963 9004 575	Ceramic chip 100pF/50V		
C1018	00D 963 9004 575	Ceramic chip 100pF/50V		
C1019	00D 963 9006 308	Electrolytic 10uF/50V		
C1020	00D 963 9006 463	Electrolytic 470uF/6.3V		
C1022	00D 963 9006 308	Electrolytic 10uF/50V		
C1023	00D 963 9006 463	Electrolytic 470uF/6.3V		
C1024	00D 963 9004 753	Ceramic chip 0.047uF/50V		
C1026	00D 963 9006 308	Electrolytic 10uF/50V		
C1027	00D 963 9006 463	Electrolytic 470uF/6.3V		
C1028	00D 963 9005 312	Electrolytic 100uF/10V		
C1029	00D 963 9006 382	Electrolytic 22uF/25V		
C1030	00D 963 9006 434	Electrolytic 47uF/16V		
C1031	00D 963 9005 312	Electrolytic 100uF/10V		
C1032	00D 963 9006 382	Electrolytic 22uF/25V		
C1033	00D 963 0144 609	Ceramic chip 12pF/50V		
C1034	00D 963 9004 591	Ceramic chip 22pF/50V		
C1035	00D 963 9006 382	Electrolytic 22uF/25V		
C1036	00D 960 9010 094	Ceramic chip 0.01uF/50V		
C1037	00D 963 9006 382	Electrolytic 22uF/25V		
C1038	00D 963 9006 382	Electrolytic 22uF/25V		
C1039	00D 963 9006 528	Ceramic chip 20pF/50V		
C1040	00D 963 9006 379	Electrolytic 1uF/50V		
C1041	00D 963 0157 706	Ceramic chip 0.022uF/50V		*
C1042	00D 963 9006 434	Electrolytic 47uF/16V		
C1043	00D 963 9004 711	Ceramic chip 0.1uF/50V		
C1044	00D 960 9010 094	Ceramic chip 0.01uF/50V		
C1045	00D 960 9010 094	Ceramic chip 0.01uF/50V		
C1046	00D 963 9004 672	Ceramic chip 680pF/50V		
C1047	00D 960 9003 409	Mylar film 0.01uF/50V		
C1048	00D 963 9005 312	Electrolytic 100uF/10V		
C1049	00D 963 9006 528	Ceramic chip 20pF/50V		
C1050	00D 963 0144 609	Ceramic chip 12pF/50V		
C1051	00D 963 9004 591	Ceramic chip 22pF/50V		
C1052	00D 963 9006 308	Electrolytic 10uF/50V		
C1053	00D 963 9006 308	Electrolytic 10uF/50V		
C1054	00D 963 9005 998	Ceramic chip 24pF/50V		

	Ref. No.	Part No.	Part Name	Remarks	New
	C1055	00D 963 9006 382	Electrolytic 22uF/25V		
	C1056	00D 963 9006 379	Electrolytic 1uF/50V		
	C1057	00D 963 9005 998	Ceramic chip 24pF/50V		
	C1058	00D 963 9006 434	Electrolytic 47uF/16V		
	C1059	00D 963 9004 753	Ceramic chip 0.047uF/50V		
	C1060	00D 963 9006 382	Electrolytic 22uF/25V		
	C1061	00D 963 0129 909	Ceramic chip 1200pF/50V		
	C1062	00D 963 9005 312	Electrolytic 100uF/10V		
	C1063	00D 960 9010 094	Ceramic chip 0.01uF/50V		
	C1064	00D 963 9006 382	Electrolytic 22uF/25V		
	C1065	00D 960 9010 094	Ceramic chip 0.01uF/50V		
	C1066	00D 960 9010 094	Ceramic chip 0.01uF/50V		
	C1067	00D 960 9010 094	Ceramic chip 0.01uF/50V		
	C1068	00D 960 9010 094	Ceramic chip 0.01uF/50V		
	C1070	00D 963 9005 312	Electrolytic 100uF/10V		
	C1071	00D 963 9006 379	Electrolytic 1uF/50V		
	C1072	00D 960 9010 094	Ceramic chip 0.01uF/50V		
	C1073	00D 960 9010 094	Ceramic chip 0.01uF/50V		
	C1074	00D 963 9005 312	Electrolytic 100uF/10V		
	C1075	00D 960 9010 094	Ceramic chip 0.01uF/50V		
	C1078	00D 960 9010 515	Electrolytic 0.47uF/50V		
	C1079	00D 963 0144 609	Ceramic chip 12pF/50V		*
	C1080	00D 963 0157 706	Ceramic chip 0.022uF/50V		
	C1081	00D 963 9006 434	Electrolytic 47uF/16V		
	C1082	00D 963 9004 591	Ceramic chip 22pF/50V		
	C1151	00D 960 9010 094	Ceramic chip 0.01uF/50V		
	C1153	00D 963 9004 575	Ceramic chip 100pF/50V		
	C1154	00D 963 9004 575	Ceramic chip 100pF/50V		
	C1155	00D 963 9004 575	Ceramic chip 100pF/50V		
	C1156	00D 963 9004 575	Ceramic chip 100pF/50V		
	C1158	00D 963 9004 753	Ceramic chip 0.047uF/50V		
	C1160	00D 963 9006 308	Electrolytic 10uF/50V		
	C1161	00D 963 9006 463	Electrolytic 470uF/6.3V		
	C1162	00D 963 9006 308	Electrolytic 10uF/50V		
	C1163	00D 963 9006 463	Electrolytic 470uF/6.3V		
	C1167	00D 963 9004 753	Ceramic chip 0.047uF/50V		
	C1169	00D 963 9006 463	Electrolytic 470uF/6.3V		
	C1170	00D 963 9006 463	Electrolytic 470uF/6.3V		
	C1173	00D 963 9004 753	Ceramic chip 0.047uF/50V		
	C1181	00D 963 9006 308	Electrolytic 10uF/50V		
	C1183	00D 960 9010 515	Electrolytic 0.47uF/50V		
	C1188	00D 963 9006 308	Electrolytic 10uF/50V		
	C1189	00D 960 9010 515	Electrolytic 0.47uF/50V		
	C1197	00D 963 9006 434	Electrolytic 47uF/16V		
	C1198	00D 960 9003 409	Mylar film 0.01uF/50V		
	C1199	00D 963 9006 434	Electrolytic 47uF/16V		
	C1203	00D 963 9006 434	Electrolytic 47uF/16V		
	C1204	00D 963 9004 711	Ceramic chip 0.1uF/50V		
	C1205	00D 963 9006 434	Electrolytic 47uF/16V		
	C1206	00D 963 9004 711	Ceramic chip 0.1uF/50V		
	C1219	00D 963 9006 434	Electrolytic 47uF/16V		
	C1220	00D 963 9006 434	Electrolytic 47uF/16V		
	C1221	00D 963 9005 312	Electrolytic 100uF/10V		
	C1222	00D 963 9005 312	Electrolytic 100uF/10V		
	C211SW	00D 963 9004 575	Ceramic chip 100pF/50V		
	C212SW	00D 963 9004 643	Ceramic chip 47pF/50V		
	C213FL	00D 963 9004 575	Ceramic chip 100pF/50V		
	C213FR	00D 963 9004 575	Ceramic chip 100pF/50V		
	C218FL	00D 963 9004 627	Ceramic chip 33pF/50V		
	C218FR	00D 963 9004 627	Ceramic chip 33pF/50V		
	C218T	00D 963 9006 379	Electrolytic 1uF/50V		

	Ref. No.	Part No.	Part Name	Remarks	New
	C219FL	00D 963 9006 308	Electrolytic 10uF/50V		
	C219FR	00D 963 9006 308	Electrolytic 10uF/50V		
	C219SW	00D 963 9006 308	Electrolytic 10uF/50V		
	C219T	00D 963 9006 379	Electrolytic 1uF/50V		
	C220T	00D 963 9006 308	Electrolytic 10uF/50V		
	C223C	00D 963 9006 382	Electrolytic 22uF/25V		
	C223FL	00D 963 9006 382	Electrolytic 22uF/25V		
	C223FR	00D 963 9006 382	Electrolytic 22uF/25V		
	C223SBL	00D 963 9006 382	Electrolytic 22uF/25V		
	C223SBR	00D 963 9006 382	Electrolytic 22uF/25V		
	C223SL	00D 963 9006 382	Electrolytic 22uF/25V		
	C223SR	00D 963 9006 382	Electrolytic 22uF/25V		
	C223SW	00D 963 9006 382	Electrolytic 22uF/25V		
	C225T	00D 963 9006 379	Electrolytic 1uF/50V		
	C226T	00D 963 9006 379	Electrolytic 1uF/50V		
	C227T	00D 963 9006 308	Electrolytic 10uF/50V		
	C228T	00D 963 9006 434	Electrolytic 47uF/16V		
	C229T	00D 963 9006 434	Electrolytic 47uF/16V		
	C230T	00D 963 9006 308	Electrolytic 10uF/50V		
	C231C	00D 963 9006 418	Electrolytic 3.3uF/50V		
	C231FL	00D 963 9006 418	Electrolytic 3.3uF/50V		
	C231FR	00D 963 9006 418	Electrolytic 3.3uF/50V		
	C231SBL	00D 963 9006 418	Electrolytic 3.3uF/50V		
	C231SBR	00D 963 9006 418	Electrolytic 3.3uF/50V		
	C231SL	00D 963 9006 418	Electrolytic 3.3uF/50V		
	C231SR	00D 963 9006 418	Electrolytic 3.3uF/50V		
	C231SW	00D 963 9006 418	Electrolytic 3.3uF/50V		
	C231T	00D 963 9006 308	Electrolytic 10uF/50V		
	C232C	00D 960 9010 104	Ceramic 5pF/50V		
	C232FL	00D 960 9010 104	Ceramic 5pF/50V		
	C232FR	00D 960 9010 104	Ceramic 5pF/50V		
	C232SBL	00D 960 9010 104	Ceramic 5pF/50V		
	C232SBR	00D 960 9010 104	Ceramic 5pF/50V		
	C232SL	00D 960 9010 104	Ceramic 5pF/50V		
	C232SR	00D 960 9010 104	Ceramic 5pF/50V		
	C232SW	00D 960 9010 104	Ceramic 5pF/50V		
	C232T	00D 963 9006 434	Electrolytic 47uF/16V		
	C233T	00D 963 9006 434	Electrolytic 47uF/16V		
	C234T	00D 963 9006 434	Electrolytic 47uF/16V		
	C235T	00D 963 9006 434	Electrolytic 47uF/16V		
	C236T	00D 963 9006 434	Electrolytic 47uF/16V		
	C237T	00D 963 9006 434	Electrolytic 47uF/16V		
	C238C	00D 963 9006 418	Electrolytic 3.3uF/50V		
	C238FL	00D 963 9006 418	Electrolytic 3.3uF/50V		
	C240T	00D 963 9006 379	Electrolytic 1uF/50V		
	C241T	00D 963 9006 308	Electrolytic 10uF/50V		
	C243T	00D 963 9006 379	Electrolytic 1uF/50V		
	C244T	00D 963 9006 379	Electrolytic 1uF/50V		
	C245T	00D 963 9006 379	Electrolytic 1uF/50V		
	C246SW	00D 963 9006 476	Electrolytic 4.7uF/50V		
	C246T	00D 963 9006 308	Electrolytic 10uF/50V		
	C247T	00D 963 9004 575	Ceramic chip 100pF/50V		
	C248T	00D 963 9006 379	Electrolytic 1uF/50V		
	C251	00D 963 9003 372	Carbon chip 0 ohm 1/16W		
	C252	00D 963 9003 372	Carbon chip 0 ohm 1/16W		
	C253	00D 963 9003 372	Carbon chip 0 ohm 1/16W		
	C702L	00D 963 9004 575	Ceramic chip 100pF/50V		
	C702R	00D 963 9004 575	Ceramic chip 100pF/50V		
	C703L	00D 963 9004 575	Ceramic chip 100pF/50V		
	C703R	00D 963 9004 575	Ceramic chip 100pF/50V		
	C704L	00D 963 9004 575	Ceramic chip 100pF/50V		

Ref. No.	Part No.	Part Name	Remarks	New
C704R	00D 963 9004 575	Ceramic chip 100pF/50V		
C705L	00D 963 9004 575	Ceramic chip 100pF/50V		
C705R	00D 963 9004 575	Ceramic chip 100pF/50V		
C709L	00D 963 9006 308	Electrolytic 10uF/50V		
C709R	00D 963 9006 308	Electrolytic 10uF/50V		
C711L	00D 963 9006 557	Electrolytic 220uF/6.3V		
C711R	00D 963 9006 557	Electrolytic 220uF/6.3V		
C712L	00D 963 9004 779	Mylar film 0.024uF/50V		
C712R	00D 963 9004 779	Mylar film 0.024uF/50V		
C713L	00D 960 9008 695	Mylar film 0.0068uF/100V		
C713R	00D 960 9008 695	Mylar film 0.0068uF/100V		
C714L	00D 963 9006 476	Electrolytic 4.7uF/50V		
C714R	00D 963 9006 476	Electrolytic 4.7uF/50V		
C716L	00D 963 9006 308	Electrolytic 10uF/50V		
C717L	00D 963 9004 601	Ceramic chip 220pF/50V		
C717R	00D 963 9004 601	Ceramic chip 220pF/50V		
C718L	00D 963 9006 421	Electrolytic 47uF/10V		
C718R	00D 963 9006 421	Electrolytic 47uF/10V		
C719L	00D 963 9006 379	Electrolytic 1uF/50V		
C719R	00D 963 9006 379	Electrolytic 1uF/50V		
C720L	00D 963 9003 152	Mylar film 0.068uF/100V		
C720R	00D 963 9003 152	Mylar film 0.068uF/100V		
C721L	00D 963 9003 152	Mylar film 0.068uF/100V		
C721R	00D 963 9003 152	Mylar film 0.068uF/100V		
C723M	00D 963 9006 379	Electrolytic 1uF/50V		
C724M	00D 963 9006 379	Electrolytic 1uF/50V		
C725M	00D 963 9006 379	Electrolytic 1uF/50V		
C726M	00D 963 0157 609	Ceramic chip 150pF/50V		*
C727M	00D 963 9004 575	Ceramic chip 100pF/50V		
C728M	00D 963 0157 609	Ceramic chip 150pF/50V		*
C729	00D 963 9004 708	Ceramic chip 0.1uF/50V		
C729M	00D 963 9006 379	Electrolytic 1uF/50V		
C730M	00D 963 9006 308	Electrolytic 10uF/50V		
C737M	00D 963 9004 575	Ceramic chip 100pF/50V		
C738M	00D 963 9004 698	Ceramic chip 0.01uF/50V		
C901SW	00D 963 9006 476	Electrolytic 4.7uF/50V		
C910	00D 963 9004 575	Ceramic chip 100pF/50V		
C911	00D 960 9010 094	Ceramic chip 0.01uF/50V		
C912	00D 963 9004 575	Ceramic chip 100pF/50V		
C913	00D 963 9004 575	Ceramic chip 100pF/50V		
C914	00D 963 9004 575	Ceramic chip 100pF/50V		
C915	00D 963 9004 575	Ceramic chip 100pF/50V		
C916	00D 963 9004 575	Ceramic chip 100pF/50V		
C917	00D 960 9010 094	Ceramic chip 0.01uF/50V		
C918	00D 963 9004 575	Ceramic chip 100pF/50V		
C920	00D 963 9004 575	Ceramic chip 100pF/50V		
OTHER PARTS GROUP				
CB1000	00D 963 0120 908	Beads inductor		
CB1001	00D 963 0120 908	Beads inductor		
CB1002	00D 963 0115 609	Inductor 33uH		
CB205	00D 963 0154 602	Beads inductor		*
CN1000	00D 963 0086 505	7P connector socket (TUC-P)		
CN1004	00D 963 0110 701	14P connector socket (TUC-P)		
CN1150	00D 963 0086 505	7P connector socket (TUC-P)		
CN1151	00D 963 0097 303	15P connector socket (TUC-P)		
CN1154	00D 963 0097 303	15P connector socket (TUC-P)		

Ref. No.	Part No.	Part Name	Remarks	New
CN403	00D 963 0086 709	11P connector socket (TUC-P)		
CN508	00D 963 0159 306	9P connector cord		*
CN509	00D 963 0159 209	7P connector cord		*
CN557T	00D 963 0050 104	4P connector base		
CN701	00D 963 0086 301	18P connector socket (TUC-P)		
CN701M	00D 963 0160 104	4P connector cord		*
CN703	00D 963 0086 505	7P connector socket (TUC-P)		
CN805	00D 963 0097 206	8P connector socket (TUC-P)		
CN806	00D 963 0086 204	19P connector socket (TUC-P)		
CP556	00D 963 0060 903	15P connector base		
G902	-	1P contact Ass'y		
J1207	00D 963 9003 372	Carbon chip 0 ohm 1/16W		
J1208	00D 963 9003 372	Carbon chip 0 ohm 1/16W		
J1209	00D 963 9003 372	Carbon chip 0 ohm 1/16W		
J1210	00D 963 9003 372	Carbon chip 0 ohm 1/16W		
J1215	00D 963 9003 372	Carbon chip 0 ohm 1/16W		
J712B	00D 963 9003 372	Carbon chip 0 ohm 1/16W		
J712C	00D 963 9003 372	Carbon chip 0 ohm 1/16W		
JK704	00D 960 0188 103	2P pin jack		
L1000	00D 963 0145 200	Inductor 27uH		
L1001	00D 960 0128 008	Inductor 100uH		
L1002	00D 963 0145 200	Inductor 27uH		
L1003	00D 963 0120 908	Beads inductor		
L1004	00D 963 0145 200	Inductor 27uH		
L1005	00D 963 0145 103	Inductor 22uH		
L1006	00D 960 0128 008	Inductor 100uH		
L1007	00D 960 0128 008	Inductor 100uH		
L1008	00D 963 0120 908	Beads inductor		
XTAL1000	00D 963 0131 405	Crystal 14.318180MHZ		
-	00D 963 0101 707	Input cushion	1	
-	00D 963 0094 102	PLATE INPUT	1	
-	00D 963 0146 209	4P pin jack	2	
-	00D 960 0268 803	6P pin jack	1	
-	00D 963 0146 102	2P pin jack	2	
-	00D 963 0146 209	4P pin jack	1	
-	00D 963 0146 500	3P pin jack	1	
-	00D 963 0146 209	4P pin jack	2	
-	00D 963 0158 200	Mini jack	1	*

DSP P.W.B. UNIT

	Ref. No.	Part No.	Part Name	Remarks	New
SEMICONDUCTORS GROUP					
	IC801	00D 963 0113 106	IC GP1FA513RZ		
	IC802	00D 963 0113 106	IC GP1FA513RZ		
	IC803	00D 963 0113 106	IC GP1FA513RZ		
	IC804	00D 963 0147 402	IC ADSP-21266		
	IC805	00D 963 0146 908	IC LH28F800BJE		
	IC806	00D 963 0158 705	IC CY7C1049CV33		*
	IC807	00D 963 0096 100	IC LC89057W		
	IC808	00D 963 0158 802	IC AD1837AAS		*
	IC809	00D 960 0266 805	IC MM74LCX244		
	IC810	00D 960 0266 805	IC MM74LCX244		
	IC811	00D 960 0266 805	IC MM74LCX244		
	IC812	00D 960 0266 902	IC MM74HCT244		
	IC814	00D 963 0102 308	IC MM74HC00MTCX		
	IC815	00D 963 0102 308	IC MM74HC00MTCX		
	IC815A	00D 963 0043 807	IC BA4510F		
	IC816	00D 963 0147 208	IC 74LVX157		
	IC816A	00D 963 0043 807	IC BA4510F		
	IC817	00D 963 0158 705	IC CY7C1049CV33		*
	IC817A	00D 963 0024 004	IC NJM2068M		
	IC818	00D 963 0147 305	IC 74LCX573		
	IC818A	00D 963 0024 004	IC NJM2068M		
	IC819	00D 963 0147 305	IC 74LCX573		
	IC819A	00D 963 0024 004	IC NJM2068M		
	IC820	00D 963 0147 101	IC SN74LVC139A		
	IC820A	00D 963 0024 004	IC NJM2068M		
	IC821	00D 963 0096 003	IC 74LCX74MTC		
	IC822	00D 960 0159 501	IC KIA7805API		
	IC823	00D 963 0111 603	IC RC1117-3.3		
	IC824	00D 963 0147 509	IC RC1117-1.2		
	IC825	00D 963 0096 003	IC 74LCX74MTC		
	IC826	00D 963 0113 009	IC GP1FA513TZ		
	Q804C	00D 960 0196 603	Transistor KTC2874B		
	Q804FL	00D 960 0196 603	Transistor KTC2874B		
	Q804FR	00D 960 0196 603	Transistor KTC2874B		
	Q804SBL	00D 960 0196 603	Transistor KTC2874B		
	Q804SBR	00D 960 0196 603	Transistor KTC2874B		
	Q804SL	00D 960 0196 603	Transistor KTC2874B		
	Q804SR	00D 960 0196 603	Transistor KTC2874B		
	Q804SW	00D 960 0196 603	Transistor KTC2874B		
	Q808	00D 963 0120 801	Transistor KRC102S		
	Q809	00D 963 0120 704	Transistor KRA102S		
	D801	00D 960 0197 000	Diode KDS160		
	D803	00D 960 0197 000	Diode KDS160		
CAPACITORS GROUP					
	C801	00D 963 9004 708	Ceramic chip 0.1uF/50V		
	C802	00D 963 9004 591	Ceramic chip 22pF/50V		
	C803	00D 963 9004 591	Ceramic chip 22pF/50V		
	C804	00D 963 9004 591	Ceramic chip 22pF/50V		
	C805	00D 963 9004 591	Ceramic chip 22pF/50V		
	C806	00D 963 9004 708	Ceramic chip 0.1uF/50V		

	Ref. No.	Part No.	Part Name	Remarks	New
	C807	00D 963 9004 708	Ceramic chip 0.1uF/50V		
	C808	00D 963 9005 862	Electrolytic 47uF/16V		
	C809	00D 963 9004 708	Ceramic chip 0.1uF/50V		
	C810	00D 963 9005 862	Electrolytic 47uF/16V		
	C811	00D 963 9004 591	Ceramic chip 22pF/50V		
	C812	00D 963 9005 927	Electrolytic 0.1uF/50V		
	C813	00D 963 9004 698	Ceramic chip 0.01uF/50V		
	C814	00D 963 9005 862	Electrolytic 47uF/16V		
	C815	00D 963 9005 312	Electrolytic 100uF/10V		
	C817	00D 963 9005 778	Electrolytic 10uF/50V		
	C818	00D 963 9005 749	Electrolytic 1uF/50V		
	C819	00D 963 9005 901	Electrolytic 470uF/10V		
	C820	00D 963 9005 862	Electrolytic 47uF/16V		
	C821	00D 963 9005 901	Electrolytic 470uF/10V		
	C830	00D 963 9005 901	Electrolytic 470uF/10V		
	C831	00D 963 9004 708	Ceramic chip 0.1uF/50V		
	C832	00D 963 9004 708	Ceramic chip 0.1uF/50V		
	C833	00D 963 9004 698	Ceramic chip 0.01uF/50V		
	C835	00D 963 9004 708	Ceramic chip 0.1uF/50V		
	C836	00D 963 9004 685	Ceramic chip 1000pF/50V		
	C837	00D 963 9004 685	Ceramic chip 1000pF/50V		
	C838	00D 963 9004 708	Ceramic chip 0.1uF/50V		
	C839	00D 963 9004 708	Ceramic chip 0.1uF/50V		
	C840	00D 963 9004 708	Ceramic chip 0.1uF/50V		
	C841	00D 963 9004 708	Ceramic chip 0.1uF/50V		
	C842	00D 963 9004 591	Ceramic chip 22pF/50V		
	C843	00D 963 9004 698	Ceramic chip 0.01uF/50V		
	C844	00D 963 9004 708	Ceramic chip 0.1uF/50V		
	C845	00D 963 9004 708	Ceramic chip 0.1uF/50V		
	C846	00D 963 9004 708	Ceramic chip 0.1uF/50V		
	C847	00D 963 9004 591	Ceramic chip 22pF/50V		
	C858	00D 960 9009 856	Ceramic chip 0.022uF/50V		
	C861	00D 963 9005 998	Ceramic chip 24pF/50V		
	C862	00D 963 9005 998	Ceramic chip 24pF/50V		
	C863	00D 963 9004 698	Ceramic chip 0.01uF/50V		
	C864L	00D 963 9005 862	Electrolytic 47uF/16V		
	C864R	00D 963 9005 862	Electrolytic 47uF/16V		
	C865L	00D 963 9005 723	Ceramic chip 120pF/50V		
	C865R	00D 963 9005 723	Ceramic chip 120pF/50V		
	C866	00D 963 9004 698	Ceramic chip 0.01uF/50V		
	C867	00D 963 9004 698	Ceramic chip 0.01uF/50V		
	C868	00D 963 9004 698	Ceramic chip 0.01uF/50V		
	C869L	00D 963 9004 575	Ceramic chip 100pF/50V		
	C869R	00D 963 9004 575	Ceramic chip 100pF/50V		
	C871L	00D 963 9009 500	Mylar film 0.001uF/100V		
	C871R	00D 963 9009 500	Mylar film 0.001uF/100V		
	C873	00D 963 9006 340	Electrolytic 100uF/25V		
	C873C	00D 963 9004 672	Ceramic chip 680pF/50V		
	C873FL	00D 963 9004 672	Ceramic chip 680pF/50V		
	C873FR	00D 963 9004 672	Ceramic chip 680pF/50V		
	C873SBL	00D 963 9004 672	Ceramic chip 680pF/50V		
	C873SBR	00D 963 9004 672	Ceramic chip 680pF/50V		
	C873SL	00D 963 9004 672	Ceramic chip 680pF/50V		
	C873SR	00D 963 9004 672	Ceramic chip 680pF/50V		
	C873SW	00D 963 9004 672	Ceramic chip 680pF/50V		
	C874	00D 963 9006 340	Electrolytic 100uF/25V		
	C874C	00D 963 9006 146	Ceramic chip 560pF/50V		
	C874FL	00D 963 9006 146	Ceramic chip 560pF/50V		
	C874FR	00D 963 9006 146	Ceramic chip 560pF/50V		
	C874SBL	00D 963 9006 146	Ceramic chip 560pF/50V		
	C874SBR	00D 963 9006 146	Ceramic chip 560pF/50V		

	Ref. No.	Part No.	Part Name	Remarks	New
	C874SL	00D 963 9006 146	Ceramic chip 560pF/50V		
	C874SR	00D 963 9006 146	Ceramic chip 560pF/50V		
	C874SW	00D 963 9006 146	Ceramic chip 560pF/50V		
	C875C	00D 963 9005 778	Electrolytic 10uF/50V		
	C875FL	00D 963 9005 778	Electrolytic 10uF/50V		
	C875FR	00D 963 9005 778	Electrolytic 10uF/50V		
	C875SBL	00D 963 9005 778	Electrolytic 10uF/50V		
	C875SBR	00D 963 9005 778	Electrolytic 10uF/50V		
	C875SL	00D 963 9005 778	Electrolytic 10uF/50V		
	C875SR	00D 963 9005 778	Electrolytic 10uF/50V		
	C875SW	00D 963 9005 778	Electrolytic 10uF/50V		
	C876C	00D 960 9008 611	Mylar film 0.0033uF/100V		
	C876FL	00D 960 9008 611	Mylar film 0.0033uF/100V		
	C876FR	00D 960 9008 611	Mylar film 0.0033uF/100V		
	C876SBL	00D 960 9008 611	Mylar film 0.0033uF/100V		
	C876SBR	00D 960 9008 611	Mylar film 0.0033uF/100V		
	C876SL	00D 960 9008 611	Mylar film 0.0033uF/100V		
	C876SR	00D 960 9008 611	Mylar film 0.0033uF/100V		
	C876SW	00D 960 9008 611	Mylar film 0.0033uF/100V		
	C880C	00D 963 9005 778	Electrolytic 10uF/50V		
	C889	00D 963 9004 698	Ceramic chip 0.01uF/50V		
	C890	00D 963 9004 698	Ceramic chip 0.01uF/50V		
	C891	00D 963 9004 698	Ceramic chip 0.01uF/50V		
	C893	00D 963 9005 749	Electrolytic 1uF/50V		
	C894	00D 963 9004 698	Ceramic chip 0.01uF/50V		
	C896	00D 963 9005 927	Electrolytic 0.1uF/50V		
	C902	00D 963 9005 901	Electrolytic 470uF/10V		
	C907	00D 963 9005 312	Electrolytic 100uF/10V		
	C912	00D 963 9004 698	Ceramic chip 0.01uF/50V		
	C913	00D 963 9004 698	Ceramic chip 0.01uF/50V		
	C920	00D 963 9004 902	Ceramic chip 18pF/50V		
OTHER PARTS GROUP					
	CB801	00D 963 0050 502	Chip emifil		
	CB802	00D 963 0050 502	Chip emifil		
	CB803	00D 963 0050 502	Chip emifil		
	CB804	00D 963 0050 502	Chip emifil		
	CB805	00D 963 0050 502	Chip emifil		
	CB806	00D 963 0050 502	Chip emifil		
	CB808	00D 963 0050 502	Chip emifil		
	CB810	00D 963 0050 502	Chip emifil		
	CN801	00D 963 0086 301	18P connector socket (TUC-P)		
	CN802	00D 963 0086 204	19P connector socket (TUC-P)		
	CN803	00D 960 0239 900	13P connector socket (TUC-P)		
	JACK801	00D 963 0052 500	1P pin jack		
	L801	00D 963 0050 803	Inductor 4.7uH		
	L802	00D 963 0050 803	Inductor 4.7uH		
	L803	00D 963 0050 803	Inductor 4.7uH		
	L804	00D 963 0050 803	Inductor 4.7uH		
	L805	00D 963 0050 900	Inductor 2.2uH		
	R831	00D 963 0120 908	Beads inductor		
	R832	00D 963 0120 908	Beads inductor		
	R833	00D 963 0120 908	Beads inductor		

	Ref. No.	Part No.	Part Name	Remarks	New
	XTAL1	00D 963 0095 101	Crystal 12.288MHz		
	XTAL2	00D 963 0158 103	Crystal 18.75MHZ		*

D-VIDEO P.W.B. UNIT

	Ref. No.	Part No.	Part Name	Remarks	New
SEMICONDUCTORS GROUP					
	IC1015	00D 963 0147 907	IC TK15420MTL		
	IC1016	00D 963 0147 907	IC TK15420MTL		
	IC1154	00D 963 0148 003	IC TA1270BF		
	IC601D	00D 963 0068 002	IC BU4052BCF		
	IC602D	00D 963 0068 002	IC BU4052BCF		
	Q604D	00D 963 0121 208	Transistor KRC107M		
	Q605D	00D 963 0121 208	Transistor KRC107M		
	Q606D	00D 963 0121 208	Transistor KRC107M		
	Q607D	00D 963 0121 208	Transistor KRC107M		
	Q608D	00D 963 0121 208	Transistor KRC107M		
	Q609D	00D 963 0121 208	Transistor KRC107M		
	Q610D	00D 963 0121 208	Transistor KRC107M		
	Q611D	00D 963 0121 208	Transistor KRC107M		
	Q612D	00D 963 0120 801	Transistor KRC102S		
	Q613D	00D 960 0111 808	Transistor KRC107S		
	Q614D	00D 963 0102 803	Transistor 2SA933S		
	D1156	00D 960 0095 500	Zener diode MTZJ5.1B		
	D607D	00D 960 0197 000	Diode KDS160		
	D608D	00D 960 0197 000	Diode KDS160		
	D609D	00D 960 0197 000	Diode KDS160		
	D666D	00D 960 0197 000	Diode KDS160		
	D667D	00D 960 0197 000	Diode KDS160		
	D668D	00D 960 0197 000	Diode KDS160		
	D669D	00D 960 0197 000	Diode KDS160		
	D670D	00D 960 0197 000	Diode KDS160		
	D671D	00D 960 0197 000	Diode KDS160		
	D674D	00D 960 0197 000	Diode KDS160		
	D675D	00D 960 0197 000	Diode KDS160		
RESISTORS GROUP					
	R1198	00D 963 9003 068	Metal film 4.7 ohm 1/4W (NB)		
	VR608	00D 960 0091 601	Semi fixed resistor 1 kohm		
	VR609	00D 960 0091 601	Semi fixed resistor 1 kohm		
	VR610	00D 960 0091 601	Semi fixed resistor 1 kohm		
CAPACITORS GROUP					
	C1174	00D 963 9004 711	Ceramic chip 0.1uF/50V		
	C1175	00D 963 9004 711	Ceramic chip 0.1uF/50V		
	C1176	00D 963 9004 711	Ceramic chip 0.1uF/50V		
	C1177	00D 963 9004 711	Ceramic chip 0.1uF/50V		
	C1178	00D 963 9004 711	Ceramic chip 0.1uF/50V		
	C1179	00D 963 9004 711	Ceramic chip 0.1uF/50V		
	C1182	00D 963 9005 202	Mylar film 0.1uF/50V		
	C1184	00D 960 9010 094	Ceramic chip 0.01uF/50V		
	C1185	00D 963 9005 312	Electrolytic 100uF/10V		
	C1186	00D 960 9010 094	Ceramic chip 0.01uF/50V		
	C1187	00D 963 9005 862	Electrolytic 47uF/16V		

	Ref. No.	Part No.	Part Name	Remarks	New
	C1190	00D 963 9006 405	Electrolytic 2.2uF/50V		
	C1191	00D 963 9005 257	Mylar film 0.022uF/50V		
	C1192	00D 960 9010 094	Ceramic chip 0.01uF/50V		
	C1193	00D 963 9006 405	Electrolytic 2.2uF/50V		
	C1194	00D 963 0144 609	Ceramic chip 12pF/50V		
	C1195	00D 963 0144 900	Mylar film 0.0022uF/50V		
	C1196	00D 963 9005 972	Electrolytic 0.22uF/50V		
	C1200	00D 963 9005 202	Mylar film 0.1uF/50V		
	C1211	00D 963 9005 312	Electrolytic 100uF/10V		
	C1212	00D 963 9005 312	Electrolytic 100uF/10V		
	C1213	00D 963 9006 382	Electrolytic 22uF/25V		
	C1214	00D 963 9006 382	Electrolytic 22uF/25V		
	C1216	00D 963 9005 312	Electrolytic 100uF/10V		
	C1217	00D 963 9006 382	Electrolytic 22uF/25V		
	C1218	00D 963 9006 382	Electrolytic 22uF/25V		
	C603D	00D 963 9005 312	Electrolytic 100uF/10V		
	C606D	00D 963 9004 753	Ceramic chip 0.047uF/50V		
	C607D	00D 963 9004 575	Ceramic chip 100pF/50V		
	C608D	00D 963 9004 575	Ceramic chip 100pF/50V		
	C609D	00D 963 9004 575	Ceramic chip 100pF/50V		
	C611D	00D 963 0157 706	Ceramic chip 0.022uF/50V		*
	C615D	00D 963 9004 575	Ceramic chip 100pF/50V		
	C616D	00D 963 9004 575	Ceramic chip 100pF/50V		
	C617D	00D 963 9004 575	Ceramic chip 100pF/50V		
	C618D	00D 963 0130 105	Mylar film 1uF/63V		
	C619D	00D 963 9004 753	Ceramic chip 0.047uF/50V		
	C620D	00D 960 9010 094	Ceramic chip 0.01uF/50V		
	C629D	00D 963 9004 575	Ceramic chip 100pF/50V		
	C630D	00D 963 9004 575	Ceramic chip 100pF/50V		
	C631D	00D 963 9004 575	Ceramic chip 100pF/50V		
	C642D	00D 963 9004 575	Ceramic chip 100pF/50V		
	C643D	00D 963 9004 575	Ceramic chip 100pF/50V		
	C644D	00D 963 9004 575	Ceramic chip 100pF/50V		
	C645D	00D 963 9006 379	Electrolytic 1uF/50V		
	C646D	00D 963 9003 372	Carbon chip 0 ohm 1/16W		
	C647D	00D 963 9003 372	Carbon chip 0 ohm 1/16W		
	C648D	00D 963 9003 372	Carbon chip 0 ohm 1/16W		
	C649D	00D 963 9003 372	Carbon chip 0 ohm 1/16W		
	C650D	00D 963 9003 372	Carbon chip 0 ohm 1/16W		
	C901	00D 963 9004 575	Ceramic chip 100pF/50V		
	C902	00D 963 9004 575	Ceramic chip 100pF/50V		
	C903	00D 963 9004 575	Ceramic chip 100pF/50V		
	C904	00D 963 9004 575	Ceramic chip 100pF/50V		
	C905	00D 963 9004 575	Ceramic chip 100pF/50V		
	C906	00D 963 9004 575	Ceramic chip 100pF/50V		
	C951	00D 963 9004 575	Ceramic chip 100pF/50V		
	C952	00D 963 9004 575	Ceramic chip 100pF/50V		
	C953	00D 963 9003 372	Carbon chip 0 ohm 1/16W		
OTHER PARTS GROUP					
	CN553D	00D 963 0097 206	8P connector socket (TUC-P)		
	CN557D	00D 963 0086 709	11P connector socket (TUC-P)		
	CN602D	00D 963 0097 303	15P connector socket (TUC-P)		
	J209RM	00D 963 9003 372	Carbon chip 0 ohm 1/16W		
	JK103D	00D 963 0085 108	D connector		
	JK104D	00D 963 0085 108	D connector		

	Ref. No.	Part No.	Part Name	Remarks	New
	JK105D	00D 963 0085 108	D connector		
	JK106D	00D 963 0085 108	D connector		
	RLY601D	00D 963 0146 704	Relay (RSB6S DC6V)		
	RLY602D	00D 963 0146 704	Relay (RSB6S DC6V)		
	RLY603D	00D 963 0146 704	Relay (RSB6S DC6V)		
	RLY604D	00D 963 0146 704	Relay (RSB6S DC6V)		
	RLY605D	00D 963 0146 704	Relay (RSB6S DC6V)		
	RLY606D	00D 963 0146 704	Relay (RSB6S DC6V)		
	RLY607D	00D 963 0146 704	Relay (RSB6S DC6V)		
	RLY608D	00D 963 0146 704	Relay (RSB6S DC6V)		
	XTAL1150	00D 963 0145 404	Crystal 3.579545MHZ		
	XTAL1151	00D 963 0145 501	Resonator CSB503F2		
	-	00D 963 0158 501	2P pin jack	1	*
	-	00D 960 0268 803	6P pin jack	1	

EXPLODED VIEW (FOR U.S.A., CANADA MODEL)

Parts List

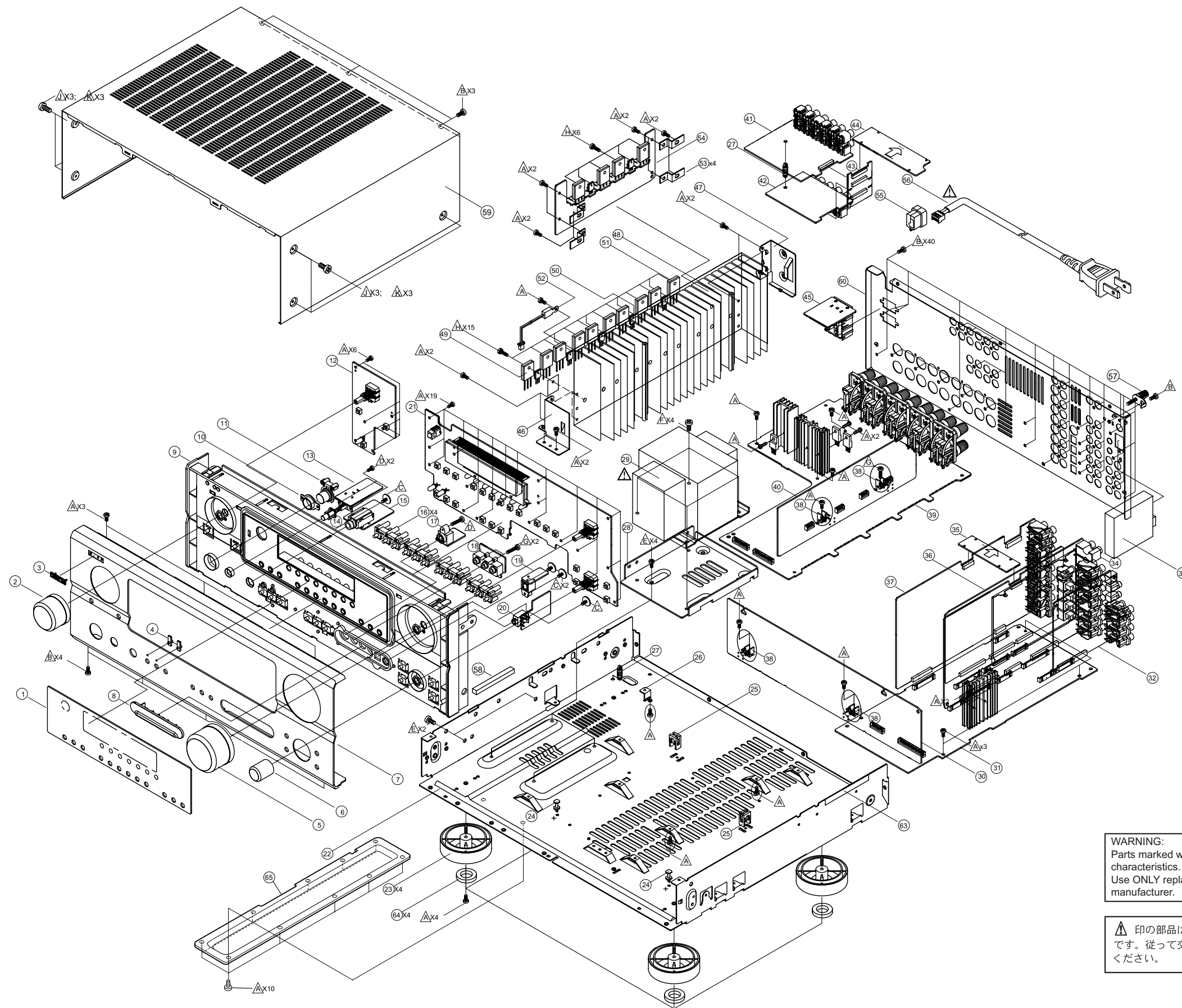



WARNING:
Parts marked with this symbol ⚠ have critical characteristics.
Use ONLY replacement parts recommended by the manufacturer.

⚠ 印の部品は安全を維持するために重要な部品です。従って交換時は必ず指定の部品を使用してください。

EXPLODED VIEW (FOR EUROPE, ASIA, KOREA MODEL)

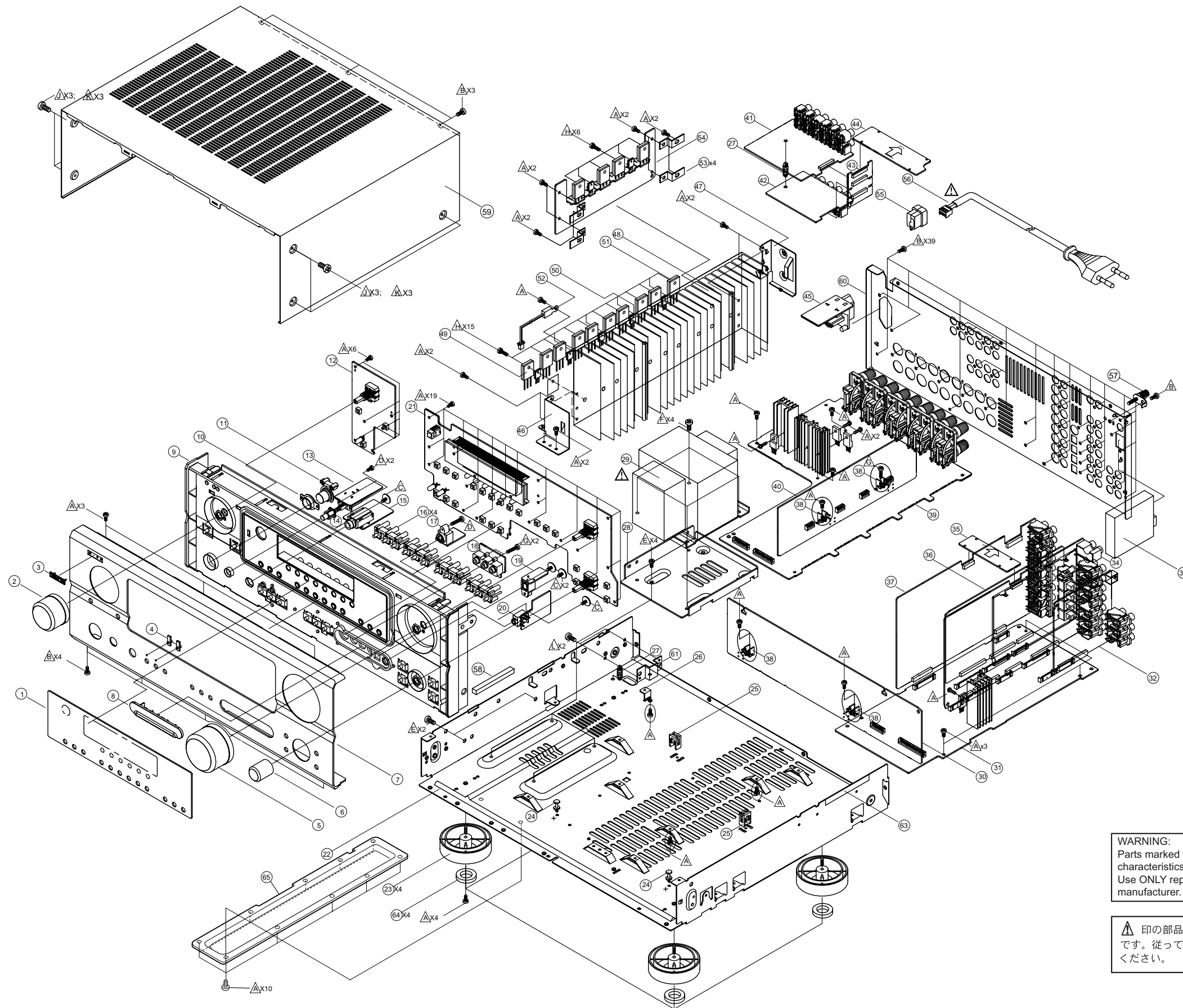
Parts List



WARNING:
Parts marked with this symbol  have critical characteristics.
Use ONLY replacement parts recommended by the manufacturer.

 印の部品は安全を維持するために重要な部品です。従って交換時は必ず指定の部品を使用してください。

EXPLODED VIEW (FOR U.K., CHINA MODEL)

Parts List

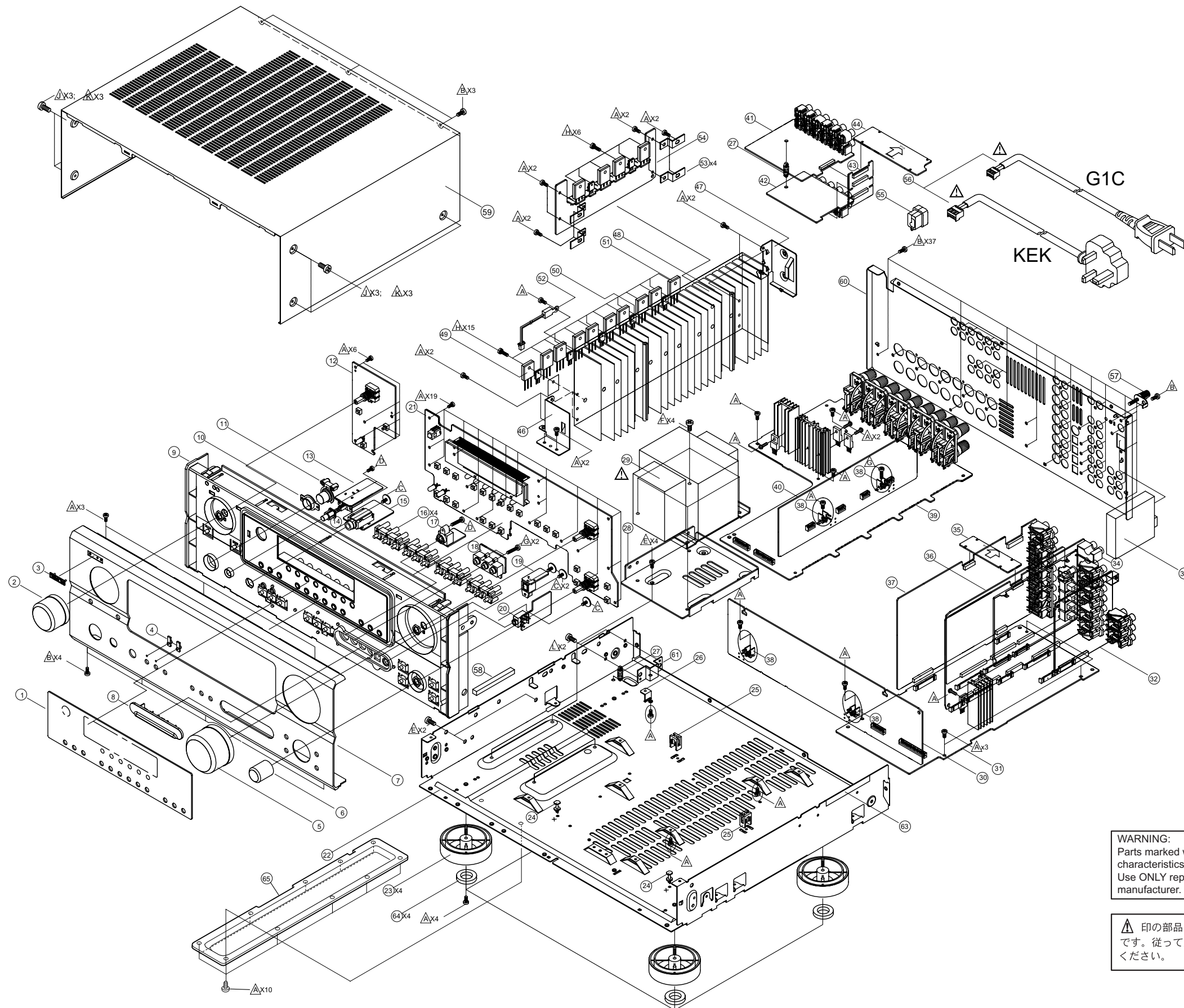



WARNING:
 Parts marked with this symbol have critical characteristics.
 Use ONLY replacement parts recommended by the manufacturer.

印の部品は安全を維持するために重要な部品です。従って交換時は必ず指定の部品を使用してください。

EXPLODED VIEW (FOR TAIWAN R.O.C. MODEL)

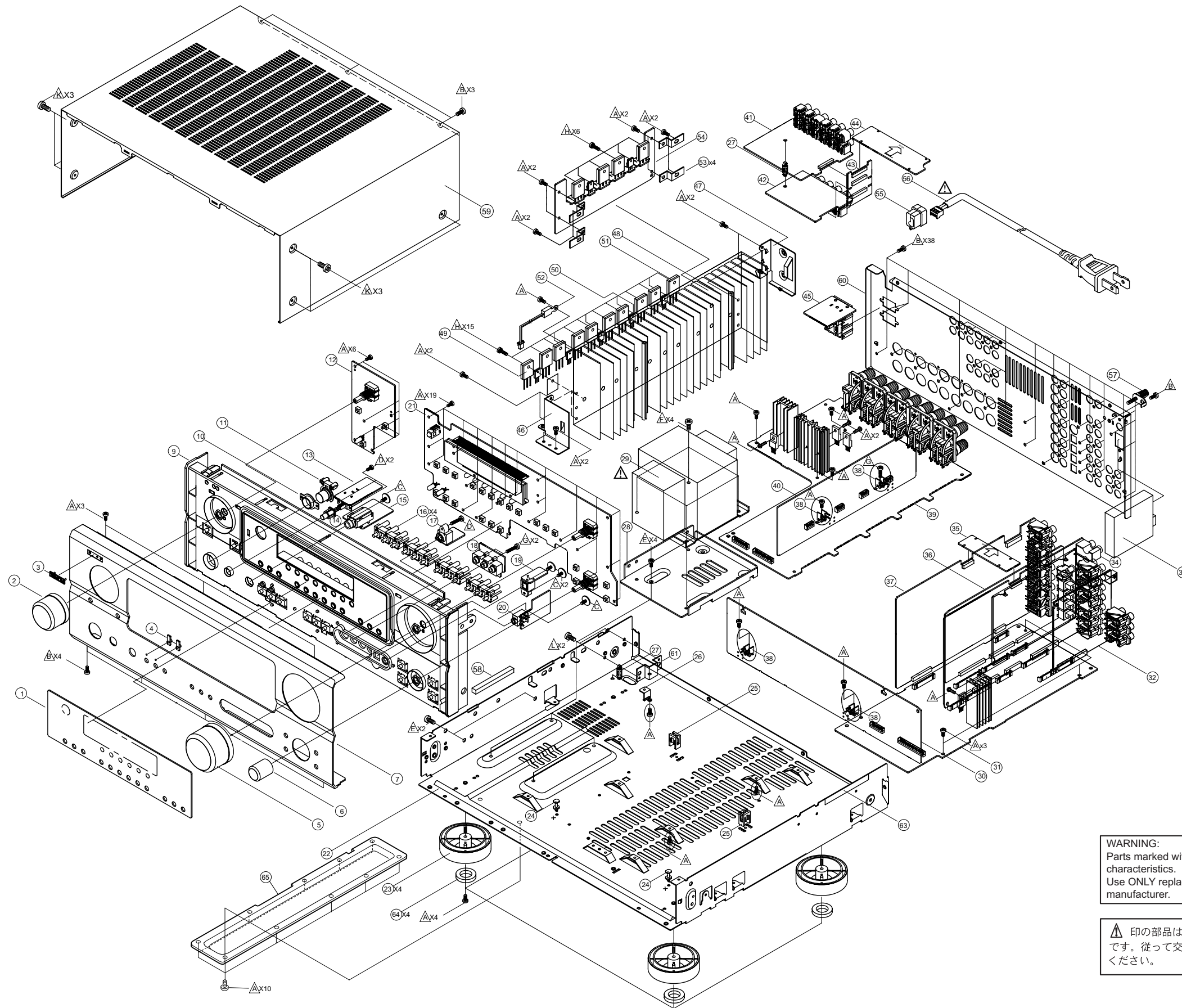
Parts List





WARNING:
Parts marked with this symbol  have critical characteristics.
Use ONLY replacement parts recommended by the manufacturer.

 印の部品は安全を維持するために重要な部品です。従って交換時は必ず指定の部品を使用してください。

EXPLODED VIEW (FOR JAPAN MODEL)

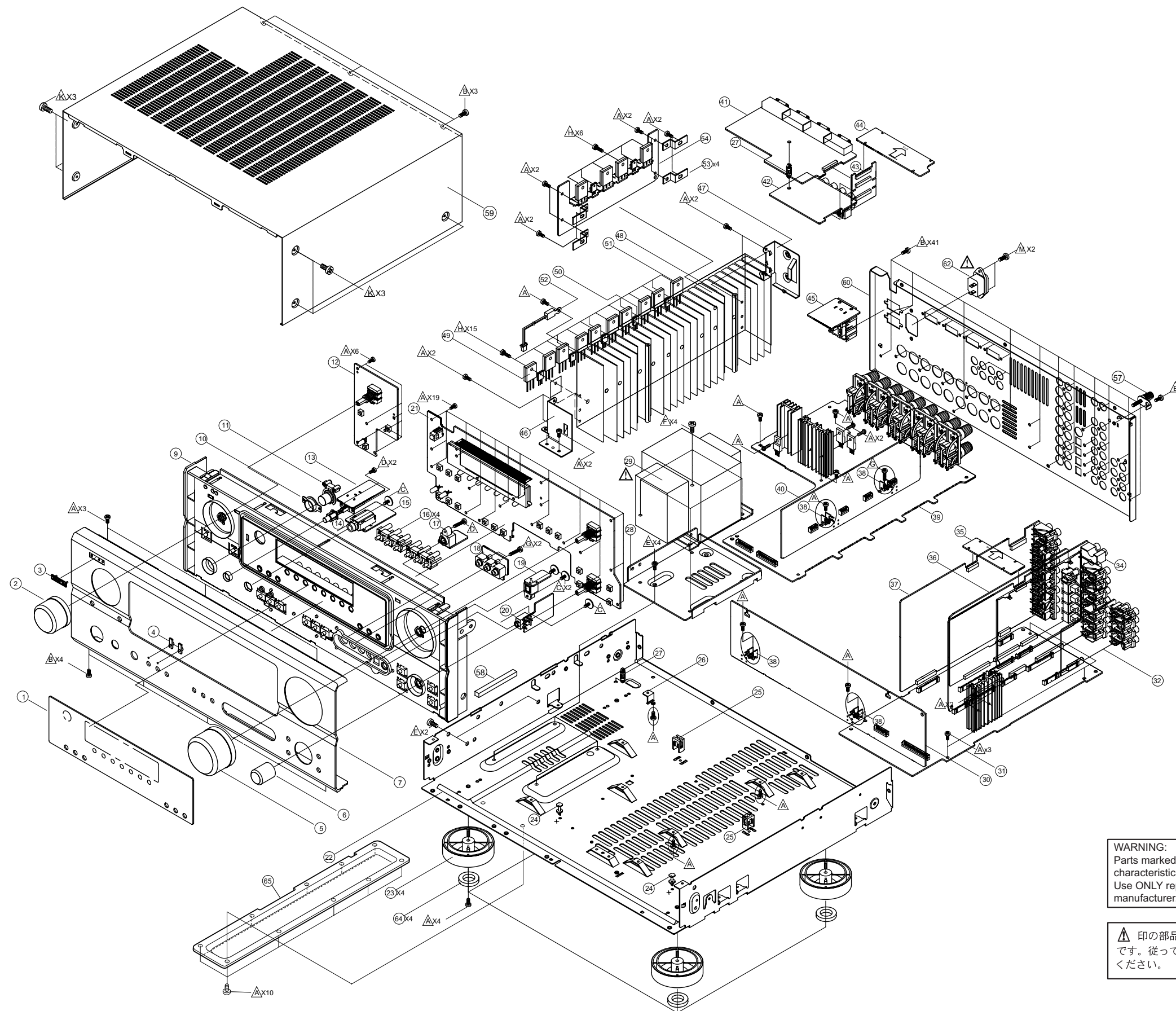
Parts List



WARNING:
Parts marked with this symbol  have critical characteristics.
Use ONLY replacement parts recommended by the manufacturer.

 印の部品は安全を維持するために重要な部品です。従って交換時は必ず指定の部品を使用してください。

PARTS LIST OF EXPLODED VIEW (FOR U.S.A. & CANADA)

Ref. No.	Part No.	Part Name	Remarks	Q'ty	New
12 13 15	00D 963 0155 009	MAIN P.W.B ASSY SWITCH P.W.B ASSY POWER SWITCH P.W.B ASSY HEAD PHONE P.W.B ASSY		1	*
44 39 17 18	00D 963 0155 106	VIDEO CNT P.W.B ASSY MAIN P.W.B ASSY CPU,FRONT P.W.B ASSY FRONT S-VIDEO P.W.B ASSY V.AUX P.W.B ASSY		1	*
19 35 21 31	00D 963 0155 203	FRONT OPTICAL P.W.B ASSY CDR-CNT P.W.B ASSY FRONT P.W.B ASSY CPU P.W.B ASSY CNT,PRE-AMP P.W.B ASSY		1	*
32 43 45 54 30 40		EXT-INPUT P.W.B ASSY VIDEO-PREOUT-CNT P.W.B ASSY OUTLET P.W.B ASSY 2CH-AMP P.W.B ASSY CNT P.W.B ASSY PRE-AMP P.W.B ASSY			
20 37 41	00D 963 0155 300	INPUT,VIDEO P.W.B ASSY MIC P.W.B ASSY VIDEO P.W.B ASSY COMPONENT P.W.B ASSY		1	*
42 34 36 1	00D 963 0155 407 00D 963 0152 109	PRE-OUT P.W.B ASSY INPUT P.W.B ASSY DSP P.W.B ASSY DSP P.W.B ASSY WINDOW		1 1	*
2	00D 963 0152 303	INPUT KNOB	AVR-2105	1	
2	00D 963 0152 400	INPUT KNOB	AVA-885	1	
3	00D 963 0051 501	DENON BADGE	AVR-2105	1	
3	00D 963 0051 527	DENON BADGE	AVA-885	1	
4	00D 963 0051 310	LED LENS		2	
5	00D 963 0152 604	VOLUME KNOB	AVR-2105	1	
5	00D 963 0152 701	VOLUME KNOB	AVA-885	1	
6	00D 963 0152 905	SELECT KNOB	AVR-2105	1	
6	00D 963 0153 001	SELECT KNOB	AVA-885	1	
7	00D 963 0149 808	FRONT PANEL	AVR-2105	1	
7	00D 963 0149 905	FRONT PANEL	AVA-885	1	
8	00D 963 0151 809	RCA COVER	AVR-2105	1	
8	00D 963 0151 906	RCA COVER	AVA-885	1	
9	00D 963 0151 207	FRONT FRAME	AVR-2105	1	
9	00D 963 0151 702	FRONT FRAME	AVA-885	1	
10	00D 963 0137 807	STANDBY LENS		1	
11	00D 963 0140 001	STANDBY BUTTON	AVR-2105	1	
11	00D 963 0140 108	STANDBY BUTTON	AVA-885	1	
14	00D 963 0139 708	POWER BUTTON	AVR-2105	1	
14	00D 963 0139 805	POWER BUTTON	AVA-885	1	
16	00D 963 0094 801	3KEY(A) BUTTON		4	
22	00D 963 0137 205	CHASSIS		1	
23	00D 963 0137 904	FOOT		4	
24	00D 963 0051 103	CARD SPACER		2	
25	00D 960 0003 301	PWB SUPPORTER		2	
26	00D 960 0184 107	SUPPORTER BRACKET		1	
27	00D 963 0044 602	P.C.SUPPORTER		2	
28	00D 963 0092 609	TRANS BRACKET		1	

	Ref. No.	Part No.	Part Name	Remarks	Q'ty	New
⚠	29	00D 963 0154 806	POWER TRANS		1	
	33	00D 963 0145 608	TUNER,FM/AM		1	
	38	00D 960 0184 000	BRACKET		4	
	46	00D 960 0184 204	HEAT SINK-B BRACKET		1	
	47	00D 960 0184 301	HEAT SINK-F BRACKET		1	
	48	-	HEAT SINK		1	
	49	00D 963 0044 107	Transistor 2SB1560-Y	Q102C, FL, FR, SL, SR	5	
	50	00D 963 0044 204	Transistor 2SD2390-Y	Q101C, FL, FR, SL, SR	5	
	51	00D 963 0058 106	Transistor 2SD947F	Q103C, 3FL, FR, SL, SR	5	
	52	00D 960 0187 900	POSISTOR		1	
	53	00D 963 0101 600	PWB BRACKET		4	
	55	00D 960 0192 403	STOPPER		1	
⚠	56	00D 963 0098 603	CORD ASSY		1	
	57	00D 960 0183 807	TERMINAL		1	
	58	00D 963 0101 804	TRANS CUSHION		1	
	59	00D 960 0183 205	TOP CABINET	AVR-2105	1	
	59	00D 963 0117 102	TOP CABINET	AVA-885	1	
	60	00D 963 0150 402	BACK PANEL	AVR-2105	1	
	60	00D 963 0150 509	BACK PANEL	AVA-885	1	
	63	-	TAPE		1	
	64	00D 960 0235 205	FOOT CUSHION		4	
	65	00D 963 0161 608	BOTTOM BRACKET		1	
★		00D 960 0155 301	CLAMP		5	
★		00D 963 0120 403	FUSE CAUTION LABEL		1	
★		00D 963 0161 404	CABLE,FLAT CARD 1.25MM		1	
★		00D 963 0161 501	CABLE,FLAT CARD 1.25MM		1	
★		00D 963 0140 409	LICENCE LABEL		1	
SCREWS						
	A	00D 963 0018 007	Screw (2S 3*8 ZNY/BH)		64	
	B	00D 960 0108 701	Screw (2S 3*10 DOT BK)		48	
	C	00D 960 9008 420	Screw (2S 3*8 WASHER)		4	
	D	00D 963 9004 054	Screw (2S 3*15 ZNY/BH)		3	
	E	00D 963 9004 025	Screw (3S 4*6 ZNY/BH)		6	
	F	00D 960 9008 417	Screw (3S 4*8 ZNY/BH)		4	
	G	00D 963 0018 104	Screw (2S 3*17 ZNY/BH)		1	
	H	00D 963 9006 175	Screw (2S 3*14 ZNY/HH)		21	
	J	00D 963 0048 307	Screw (2S 4*8 DOT BK)	AVR-2105	6	
	K	00D 963 9004 012	Screw (2S 4*8 DOT NI)	AVA-885	6	

PARTS LIST OF EXPLODED VIEW (FOR EUROPE, ASIA & KOREA)

	Ref. No.	Part No.	Part Name	Remarks	Q'ty	New
		00D 963 0155 504	MAIN P.W.B ASSY	Europe, Asia	1	*
		00D9630156406	MAIN P.W.B ASSY	Korea	1	*
	12		SWITCH P.W.B ASSY			
	13		POWER SWITCH P.W.B ASSY			
	15		HEAD PHONE P.W.B ASSY			
	44		VIDEO CNT P.W.B ASSY			
	39		MAIN P.W.B ASSY			
		00D 963 0155 805	CPU,FRONT P.W.B ASSY	Europe, Asia	1	*
		00D 963 0156 804	CPU,FRONT P.W.B ASSY	Korea	1	*
	17		FRONT S-VIDEO P.W.B ASSY			
	18		V.AUX P.W.B ASSY			
	19		FRONT OPTICAL P.W.B ASSY			
	35		CDR-CNT P.W.B ASSY			
	21		FRONT P.W.B ASSY			
	31		CPU P.W.B ASSY			
		00D 963 0155 601	CNT,PRE-AMP P.W.B ASSY	Europe, Asia	1	*
		00D 963 0156 503	CNT,PRE-AMP P.W.B ASSY	Korea	1	*
	32		EXT-INPUT P.W.B ASSY			
	43		VIDEO-PREOUT-CNT P.W.B ASSY			
	45		OUTLET P.W.B ASSY			
	54		2CH-AMP P.W.B ASSY			
	30		CNT P.W.B ASSY			
	40		PRE-AMP P.W.B ASSY			
		00D 963 0156 008	INPUT,VIDEO P.W.B ASSY	Europe, Asia	1	*
		00D 96 30156 600	INPUT,VIDEO P.W.B ASSY	Korea	1	*
	20		MIC P.W.B ASSY			
	37		VIDEO P.W.B ASSY			
	41		COMPONENT P.W.B ASSY			
	42		PRE-OUT P.W.B ASSY			
	34		INPUT P.W.B ASSY			
		00D 963 0155 407	DSP P.W.B ASSY		1	*
	36		DSP P.W.B ASSY			
	1	00D 963 0149 604	WINDOW	Europe, Asia	1	
	1	00D 963 0138 204	WINDOW	Korea	1	
	2	00D 963 0152 303	INPUT KNOB	Black model	1	
	2	00D 963 0152 400	INPUT KNOB	Silver model	1	
	2	00D 963 0152 507	INPUT KNOB	Gold model	1	
	3	00D 963 0051 501	DENON BADGE	Black model	1	
	3	00D 963 0051 527	DENON BADGE	Silver model	1	
	3	00D 963 0051 514	DENON BADGE	Gold model	1	
	4	00D 963 0051 310	LED LENS		2	
	5	00D 963 0152 604	VOLUME KNOB	Black model	1	
	5	00D 963 0152 701	VOLUME KNOB	Silver model	1	
	5	00D 963 0152 808	VOLUME KNOB	Gold model	1	
	6	00D 963 0152 905	SELECT KNOB	Black model	1	
	6	00D 963 0153 001	SELECT KNOB	Silver model	1	
	6	00D 963 0153 108	SELECT KNOB	Gold model	1	
	7	00D 963 0150 004	FRONT PANEL	Black model	1	
	7	00D 963 0150 101	FRONT PANEL	Silver model	1	
	7	00D 963 0150 208	FRONT PANEL	Gold model	1	
	8	00D 963 0151 809	RCA COVER	Europe (Black model)	1	
	8	00D 963 0151 906	RCA COVER	Europe (Silver model)	1	
	8	00D 963 0152 002	RCA COVER	Asia	1	
	9	00D 963 0151 304	FRONT FRAME	Black model	1	
	9	00D 963 0151 605	FRONT FRAME	Silver model	1	
	9	00D 963 0151 401	FRONT FRAME	Gold model	1	
	10	00D 963 0137 807	STANDBY LENS		1	

	Ref. No.	Part No.	Part Name	Remarks	Q'ty	New
	11	00D 963 0140 001	STANDBY BUTTON	Black model	1	
	11	00D 963 0140 108	STANDBY BUTTON	Silver model	1	
	11	00D 963 0140 205	STANDBY BUTTON	Gold model	1	
	14	00D 963 0139 708	POWER BUTTON	Black model	1	
	14	00D 963 0139 805	POWER BUTTON	Silver model	1	
	14	00D 963 0139 902	POWER BUTTON	Gold model	1	
	16	00D 963 0094 801	3KEY(A) BUTTON		4	
	22	00D 963 0137 205	CHASSIS		1	
	23	00D 963 0137 904	FOOT		4	
	24	00D 963 0051 103	CARD SPACER		2	
	25	00D 960 0003 301	PWB SUPPORTER		2	
	26	00D 960 0184 107	SUPPORTER BRACKET		1	
	27	00D 963 0044 602	P.C. SUPPORTER		2	
	28	00D 963 0092 609	TRANS BRACKET		1	
⚠	29	00D 963 0154 709	POWER TRANS	Europe, Asia	1	
⚠	29	00D 96 30154 903	POWER TRANS	Korea	1	
	33	00D 963 0145 608	TUNER,FM/AM	Korea	1	
	33	00D 963 0145 705	TUNER,FM/AM	Europe, Asia	1	
	38	00D 960 0184 000	BRACKET		4	
	46	00D 960 0184 204	HEAT SINK-B BRACKET		1	
	47	00D 960 0184 301	HEAT SINK-F BRACKET		1	
	48	-	HEAT SINK		1	
	49	00D 963 0044 107	Transistor 2SB1560-Y	Q102C, FL, FR, SL, SR	5	
	50	00D 963 0044 204	Transistor 2SD2390-Y	Q101C, FL, FR, SL, SR	5	
	51	00D 963 0058 106	Transistor 2SD947F	Q103C, 3FL, FR, SL, SR	5	
	52	00D 960 0187 900	POSISTOR		1	
	53	00D 963 0101 600	PWB BRACKET		4	
	55	00D 960 0192 403	STOPPER		1	
⚠	56	00D 963 0109 806	CORD ASSY	Europe, Asia	1	
⚠	56	00D 963 0098 700	CORD ASSY	Korea	1	
	57	00D 960 0183 807	TERMINAL		1	
	58	00D 963 0101 804	TRANS CUSHION		1	
	59	00D 960 0183 205	TOP CABINET	Black model	1	
	59	00D 963 0117 102	TOP CABINET	Silver model	1	
	59	00D 963 0055 510	TOP CABINET	Gold model	1	
	60	00D 963 0150 703	BACK PANEL	Europe, Asia	1	
	60	00D 963 0150 800	BACK PANEL	Korea	1	
	61	00D 963 0120 306	SIDE BRACKET		1	
	63	-	TAPE		1	
	64	00D 960 0235 205	FOOT CUSHION		4	
	65	00D 963 0161 608	BOTTOM BRACKET		1	
★		00D 960 0155 301	CLAMP		5	
★		00D 963 0161 404	CABLE,FLAT CARD 1.25MM		1	
★		00D 963 0161 501	CABLE,FLAT CARD 1.25MM		1	
★		-	BUSHING		18	
★		00D 963 0140 409	LICENCE LABEL		1	
SCREWS						
	A	00D 963 0018 007	Screw (2S 3*8 ZNY/BH)		63	
	B	00D 960 0108 701	Screw (2S 3*10 DOT BK)		47	
	C	00D 960 9008 420	Screw (2S 3*8 WASHER)		4	
	D	00D 963 9004 054	Screw (2S 3*15 ZNY/BH)		3	
	E	00D 963 9004 025	Screw (3S 4*6 ZNY/BH)		6	
	F	00D 960 9008 417	Screw (3S 4*8 ZNY/BH)		4	
	G	00D 963 0018 104	Screw (2S 3*17 ZNY/BH)		1	
	H	00D 963 9006 175	Screw (2S 3*14 ZNY/HH)		21	
	J	00D 963 0048 307	Screw (2S 4*8 DOT BK)	Black model	6	
	K	00D 963 9004 012	Screw (2S 4*8 DOT NI)	Silver, Gold model	6	
	L	00D 963 9004 041	Screw (2S 3*5 ZNY/BH)		2	

PARTS LIST OF EXPLODED VIEW (FOR U.K. & CHINA)

	Ref. No.	Part No.	Part Name	Remarks	Q'ty	New
		00D 963 0155 708	MAIN P.W.B ASSY	U.K.	1	*
		00D 963 0156 707	MAIN P.W.B ASSY	China	1	*
	12		SWITCH P.W.B ASSY			
	13		POWER SWITCH P.W.B ASSY			
	15		HEAD PHONE P.W.B ASSY			
	44		VIDEO CNT P.W.B ASSY			
	39		MAIN P.W.B ASSY			
		00D 963 0155 805	CPU,FRONT P.W.B ASSY	U.K.	1	*
		00D 963 0156 804	CPU,FRONT P.W.B ASSY	China	1	*
	17		FRONT S-VIDEO P.W.B ASSY			
	18		V.AUX P.W.B ASSY			
	19		FRONT OPTICAL P.W.B ASSY			
	35		CDR-CNT P.W.B ASSY			
	21		FRONT P.W.B ASSY			
	31		CPU P.W.B ASSY			
		00D 963 0155 902	CNT,PRE-AMP P.W.B ASSY		1	*
	32		EXT-INPUT P.W.B ASSY			
	43		VIDEO-PREOUT-CNT P.W.B ASSY			
	54		2CH-AMP P.W.B ASSY			
	30		CNT P.W.B ASSY			
	40		PRE-AMP P.W.B ASSY			
		00D 963 0156 008	INPUT,VIDEO P.W.B ASSY	U.K.	1	*
		00D 963 0156 901	INPUT,VIDEO P.W.B ASSY	China	1	*
	20		MIC P.W.B ASSY			
	37		VIDEO P.W.B ASSY			
	41		COMPONENT P.W.B ASSY			
	42		PRE-OUT P.W.B ASSY			
	34		INPUT P.W.B ASSY			
		00D 963 0155 407	DSP P.W.B ASSY		1	*
	36		DSP P.W.B ASSY			
	1	00D 963 0149 604	WINDOW	U.K.	1	
	1	00D 963 0138 204	WINDOW	China	1	
	2	00D 963 0152 303	INPUT KNOB	Black model	1	
	2	00D 963 0152 400	INPUT KNOB	Silver model	1	
	2	00D 963 0152 507	INPUT KNOB	Gold model	1	
	3	00D 963 0051 501	DENON BADGE	Black model	1	
	3	00D 963 0051 527	DENON BADGE	Silver model	1	
	3	00D 963 0051 514	DENON BADGE	Gold model	1	
	4	00D 963 0051 310	LED LENS		2	
	5	00D 963 0152 604	VOLUME KNOB	Black model	1	
	5	00D 963 0152 701	VOLUME KNOB	Silver model	1	
	5	00D 963 0152 808	VOLUME KNOB	Gold model	1	
	6	00D 963 0152 905	SELECT KNOB	Black model	1	
	6	00D 963 0153 001	SELECT KNOB	Silver model	1	
	6	00D 963 0153 108	SELECT KNOB	Gold model	1	
	7	00D 963 0150 004	FRONT PANEL	Black model	1	
	7	00D 963 0150 101	FRONT PANEL	Silver model	1	
	7	00D 963 0150 208	FRONT PANEL	Gold model	1	
	8	00D 963 0151 809	RCA COVER	U.K. (Black model)	1	
	8	00D 963 0151 906	RCA COVER	U.K. (Silver model)	1	
	9	00D 963 0151 304	FRONT FRAME	Black model	1	
	9	00D 963 0151 605	FRONT FRAME	Silver model	1	
	9	00D 963 0151 401	FRONT FRAME	Gold model	1	
	10	00D 963 0137 807	STANDBY LENS		1	
	11	00D 963 0140 001	STANDBY BUTTON	Black model	1	
	11	00D 963 0140 108	STANDBY BUTTON	Silver model	1	
	11	00D 963 0140 205	STANDBY BUTTON	Gold model	1	

	Ref. No.	Part No.	Part Name	Remarks	Q'ty	New
	14	00D 963 0139 708	POWER BUTTON	Black model	1	
	14	00D 963 0139 805	POWER BUTTON	Silver model	1	
	14	00D 963 0139 902	POWER BUTTON	Gold model	1	
	16	00D 963 0094 801	3KEY(A) BUTTON		4	
	22	00D 963 0137 205	CHASSIS		1	
	23	00D 963 0137 904	FOOT		4	
	24	00D 963 0051 103	CARD SPACER		2	
	25	00D 960 0003 301	PWB SUPPORTER		2	
	26	00D 960 0184 107	SUPPORTER BRACKET		1	
	27	00D 963 0044 602	P.C. SUPPORTER		2	
	28	00D 963 0092 609	TRANS BRACKET		1	
⚠	29	00D 963 0154 709	POWER TRANS	U.K.	1	
⚠	29	00D 963 0154 903	POWER TRANS	China	1	
	33	00D 963 0145 705	TUNER,FM/AM	U.K.	1	
	33	00D 963 0145 608	TUNER,FM/AM	China	1	
	38	00D 960 0184 000	BRACKET		4	
	46	00D 960 0184 204	HEAT SINK-B BRACKET		1	
	47	00D 960 0184 301	HEAT SINK-F BRACKET		1	
	48	-	HEAT SINK		1	
	49	00D 963 0044 107	Transistor 2SB1560-Y	Q102C, FL, FR, SL, SR	5	
	50	00D 963 0044 204	Transistor 2SD2390-Y	Q101C, FL, FR, SL, SR	5	
	51	00D 963 0058 106	Transistor 2SD947F	Q103C, 3FL, FR, SL, SR	5	
	52	00D 960 0187 900	POSISTOR		1	
	53	00D 963 0101 600	PWB BRACKET		4	
	55	00D 960 0192 403	STOPPER		1	
⚠	56	00D 963 0118 509	CORD ASSY	U.K.	1	
⚠	56	00D 963 0109 819	CORD ASSY	China	1	
	57	00D 960 0183 807	TERMINAL		1	
	58	00D 963 0101 804	TRANS CUSHION		1	
	59	00D 960 0183 205	TOP CABINET	Black model	1	
	59	00D 963 0117 102	TOP CABINET	Silver model	1	
	59	00D 963 0055 510	TOP CABINET	Gold model	1	
	60	00D 963 0150 907	BACK PANEL	U.K.	1	
	60	00D 963 0151 003	BACK PANEL	China	1	
	61	00D 963 0120 306	SIDE BRACKET		1	
	63	-	TAPE		1	
	64	00D 960 0235 205	FOOT CUSHION		4	
★	65	00D 963 0161 608	BOTTOM BRACKET		1	
★		00D 960 0155 301	CLAMP		5	
★		00D 963 0161 404	CABLE,FLAT CARD 1.25MM		1	
★		00D 963 0161 501	CABLE,FLAT CARD 1.25MM		1	
★		-	BUSHING		18	
★		00D 963 0140 409	LICENCE LABEL		1	
SCREWS						
	A	00D 963 0018 007	Screw (2S 3*8 ZNY/BH)		63	
	B	00D 960 0108 701	Screw (2S 3*10 DOT BK)		45	
	C	00D 960 9008 420	Screw (2S 3*8 WASHER)		4	
	D	00D 963 9004 054	Screw (2S 3*15 ZNY/BH)		3	
	E	00D 963 9004 025	Screw (3S 4*6 ZNY/BH)		6	
	F	00D 960 9008 417	Screw (3S 4*8 ZNY/BH)		4	
	G	00D 963 0018 104	Screw (2S 3*17 ZNY/BH)		1	
	H	00D 963 9006 175	Screw (2S 3*14 ZNY/HH)		21	
	J	00D 963 0048 307	Screw (2S 4*8 DOT BK)	Black model	6	
	K	00D 963 9004 012	Screw (2S 4*8 DOT NI)	Silver, Gold model	6	
	L	00D 963 9004 041	Screw (2S 3*5 ZNY/BH)		2	

PARTS LIST OF EXPLODED VIEW (FOR TAIWAN R.O.C.)

	Ref. No.	Part No.	Part Name	Remarks	Q'ty	New
	12 13 15	00D 963 0156 105	MAIN P.W.B ASSY SWITCH P.W.B ASSY POWER SWITCH P.W.B ASSY HEAD PHONE P.W.B ASSY		1	*
	44 39 17 18	00D 963 0156 202	VIDEO CNT P.W.B ASSY MAIN P.W.B ASSY CPU,FRONT P.W.B ASSY FRONT S-VIDEO P.W.B ASSY V.AUX P.W.B ASSY		1	*
	19 35 21 31	00D 963 0156 309	FRONT OPTICAL P.W.B ASSY CDR-CNT P.W.B ASSY FRONT P.W.B ASSY CPU P.W.B ASSY CNT,PRE-AMP P.W.B ASSY		1	*
	32 43 45 54 30 40		EXT-INPUT P.W.B ASSY VIDEO-PREOUT-CNT P.W.B ASSY OUTLET P.W.B ASSY 2CH-AMP P.W.B ASSY CNT P.W.B ASSY PRE-AMP P.W.B ASSY			
	20 37 41	00D 963 0156 600	INPUT,VIDEO P.W.B ASSY MIC P.W.B ASSY VIDEO P.W.B ASSY COMPONENT P.W.B ASSY		1	*
	42 34 36	00D 963 0155 407	PRE-OUT P.W.B ASSY INPUT P.W.B ASSY DSP P.W.B ASSY DSP P.W.B ASSY		1	*
	1	00D 963 0138 204	WINDOW		1	
	2	00D 963 0152 507	INPUT KNOB		1	
	3	00D 963 0051 514	DENON BADGE		1	
	4	00D 963 0051 310	LED LENS		2	
	5	00D 963 0152 808	VOLUME KNOB		1	
	6	00D 963 0153 108	SELECT KNOB		1	
	7	00D 963 0150 208	FRONT PANEL		1	
	9	00D 963 0151 401	FRONT FRAME		1	
	10	00D 963 0137 807	STANDBY LENS		1	
	11	00D 963 0140 205	STANDBY BUTTON		1	
	14	00D 963 0139 902	POWER BUTTON		1	
	16	00D 963 0094 801	3KEY(A) BUTTON		4	
	22	00D 963 0137 205	CHASSIS		1	
	23	00D 963 0137 904	FOOT		4	
	24	00D 963 0051 103	CARD SPACER		2	
	25	00D 960 0003 301	PWB SUPPORTER		2	
	26	00D 960 0184 107	SUPPORTER BRACKET		1	
	27	00D 963 0044 602	P.C. SUPPORTER		2	
	28	00D 963 0092 609	TRANS BRACKET		1	
	29	00D 963 0094 924	POWER TRANS		1	
	33	00D 963 0145 608	TUNER,FM/AM		1	
	38	00D 960 0184 000	SCREW BRACKET		4	
	46	00D 960 0184 204	HEAT SINK-B BRACKET		1	
	47	00D 960 0184 301	HEAT SINK-F BRACKET		1	
	48	-	HEAT SINK		1	
	49	00D 963 0044 107	Transistor 2SB1560-Y	Q102C, FL, FR, SL, SR	5	
	50	00D 963 0044 204	Transistor 2SD2390-Y	Q101C, FL, FR, SL, SR	5	
	51	00D 963 0058 106	Transistor 2SD947F	Q103C, 3FL, FR, SL, SR	5	
	52	00D 960 0187 900	POSISTOR		1	

	Ref. No.	Part No.	Part Name	Remarks	Q'ty	New
	53	00D 963 0101 600	PWB BRACKET		4	
	55	00D 960 0192 403	STOPPER		1	
⚠	56	00D 963 0160 803	CORD ASSY		1	
	57	00D 960 0183 807	TERMINAL		1	
	58	00D 963 0101 804	TRANS CUSHION		1	
	59	00D 963 0055 510	TOP CABINET		1	
	60	00D 963 0151 100	BACK PANEL		1	
	61	00D 963 0120 306	SIDE BRACKET		1	
	63	-	TAPE		1	
	64	00D 960 0235 205	FOOT CUSHION		4	
	65	00D 963 0161 608	BOTTOM BRACKET		1	
★		00D 960 0155 301	CLAMP		5	
★		00D 963 0161 404	CABLE,FLAT CARD 1.25MM		1	
★		00D 963 0161 501	CABLE,FLAT CARD 1.25MM		1	
★		-	BUSHING		18	
★		00D 963 0140 409	LICENCE LABEL		1	
SCREWS						
	A	00D 963 0018 007	Screw (2S 3*8 ZNY/BH)		59	
	B	00D 960 0108 701	Screw (2S 3*10 DOT BK)		47	
	C	00D 960 9008 420	Screw (2S 3*8 WASHER)		4	
	D	00D 963 9004 054	Screw (2S 3*15 ZNY/BH)		3	
	E	00D 963 9004 025	Screw (3S 4*6 ZNY/BH)		6	
	F	00D 960 9008 417	Screw (3S 4*8 ZNY/BH)		4	
	G	00D 963 0018 104	Screw (2S 3*17 ZNY/BH)		1	
	H	00D 963 9006 175	Screw (2S 3*14 ZNY/HH)		21	
	K	00D 963 9004 012	Screw (2S 4*8 DOT NI)		6	
	L	00D 963 9004 041	Screw (2S 3*5 ZNY/BH)		2	

PARTS LIST OF EXPLODED VIEW (FOR JAPAN)

	Ref. No.	Part No.	Part Name	Remarks	Q'ty	New
	12 13 15	00D 963 0157 007	MAIN P.W.B ASSY SWITCH P.W.B ASSY POWER SWITCH P.W.B ASSY HEAD PHONE P.W.B ASSY		1	*
	44 39 17 18	00D 963 0157 104	VIDEO CNT P.W.B ASSY MAIN P.W.B ASSY CPU,FRONT P.W.B ASSY FRONT S-VIDEO P.W.B ASSY V.AUX P.W.B ASSY		1	*
	19 35 21 31	00D 963 0157 201	FRONT OPTICAL P.W.B ASSY CDR-CNT P.W.B ASSY FRONT P.W.B ASSY CPU P.W.B ASSY CNT,PRE-AMP P.W.B ASSY		1	*
	43 45 54 30 40		VIDEO-PREOUT-CNT P.W.B ASSY OUTLET P.W.B ASSY 2CH-AMP P.W.B ASSY CNT P.W.B ASSY PRE-AMP P.W.B ASSY			
	20 37 42 34	00D 963 0157 308	INPUT,VIDEO P.W.B ASSY MIC P.W.B ASSY VIDEO P.W.B ASSY PRE-OUT P.W.B ASSY INPUT P.W.B ASSY		1	*
	36	00D 963 0155 407	DSP P.W.B ASSY DSP P.W.B ASSY		1	*
	32 41	00D 963 0157 405	D-VIDEO P.W.B ASSY EXT-INPUT P.W.B ASSY D-VIDEO P.W.B ASSY		1	*
	1	00D 963 0152 206	WINDOW		1	
	2	00D 963 0152 507	INPUT KNOB		1	
	3	00D 963 0051 514	DENON BADGE		1	
	4	00D 963 0051 310	LED LENS		2	
	5	00D 963 015 2808	VOLUME KNOB		1	
	6	00D 963 0153 108	SELECT KNOB		1	
	7	00D 963 0150 305	FRONT PANEL		1	
	9	00D 963 0151 508	FRONT FRAME		1	
	10	00D 963 0137 807	STANDBY LENS		1	
	11	00D 963 0140 205	STANDBY BUTTON		1	
	14	00D 963 0139 902	POWER BUTTON		1	
	16	00D 963 0094 801	3KEY(A) BUTTON		2	
	22	00D 963 0137 205	CHASSIS		1	
	23	00D 963 0137 904	FOOT		4	
	24	00D 963 0051 103	CARD SPACER		2	
	25	00D 960 0003 301	PWB SUPPORTER		2	
	26	00D 960 0184 107	SUPPORTER BRACKET		1	
	27	00D 963 0044 602	P.C. SUPPORTER		2	
	28	00D 963 0092 609	TRANS BRACKET		1	
⚠	29	00D 963 0094 908	POWER TRANS		1	
	38	00D 960 0184 000	SCREW BRACKET		4	
	46	00D 960 0184 204	HEAT SINK-B BRACKET		1	
	47	00D 960 0184 301	HEAT SINK-F BRACKET		1	
	48	-	HEAT SINK		1	
	49	00D 963 0044 107	Transistor 2SB1560-Y	Q102C, FL, FR, SL, SR	5	
	50	00D 963 0044 204	Transistor 2SD2390-Y	Q101C, FL, FR, SL, SR	5	
	51	00D 963 0058 106	Transistor 2SD947F	Q103C, 3FL, FR, SL, SR	5	
	52	00D 960 0187 900	POSISTOR		1	

	Ref. No.	Part No.	Part Name	Remarks	Q'ty	New
	53	00D 963 0101 600	PWB BRACKET		4	
	57	00D 960 0183 807	TERMINAL		1	
	58	00D 963 0101 804	TRANS CUSHION		1	
	59	00D 963 0055 510	TOP CABINET		1	
	60	00D 963 0150 606	BACK PANEL		1	
	64	00D 960 0235 205	FOOT CUSHION		4	
	65	00D 963 0161 608	BOTTOM BRACKET		1	
★		00D 960 0155 301	CLAMP		5	
⚠★		00D 963 0158 404	AC INLET		1	
★		00D 963 0122 207	CN,WIRE		1	
★		00D 963 0161 501	CABLE,FLAT CARD 1.25MM		1	
★		00D 963 0140 409	LICENCE LABEL		1	
SCREWS						
	A	00D 963 0018 007	Screw (2S 3*8 ZNY/BH)		59	
	B	00D 960 0108 701	Screw (2S 3*10 DOT BK)		49	
	C	00D 960 9008 420	Screw (2S 3*8 WASHER)		4	
	D	00D 963 9004 054	Screw (2S 3*15 ZNY/BH)		3	
	E	00D 963 9004 025	Screw (3S 4*6 ZNY/BH)		6	
	F	00D 960 9008 417	Screw (3S 4*8 ZNY/BH)		4	
	G	00D 963 0018 104	Screw (2S 3*17 ZNY/BH)		1	
	H	00D 963 9006 175	Screw (2S 3*14 ZNY/HH)		21	
	K	00D 963 9004 012	Screw (2S 4*8 DOT NI)		6	
	M	00D 963 9006 735	Screw (2S 3*10 BK/FH)		2	

PACKING VIEW

Parts List

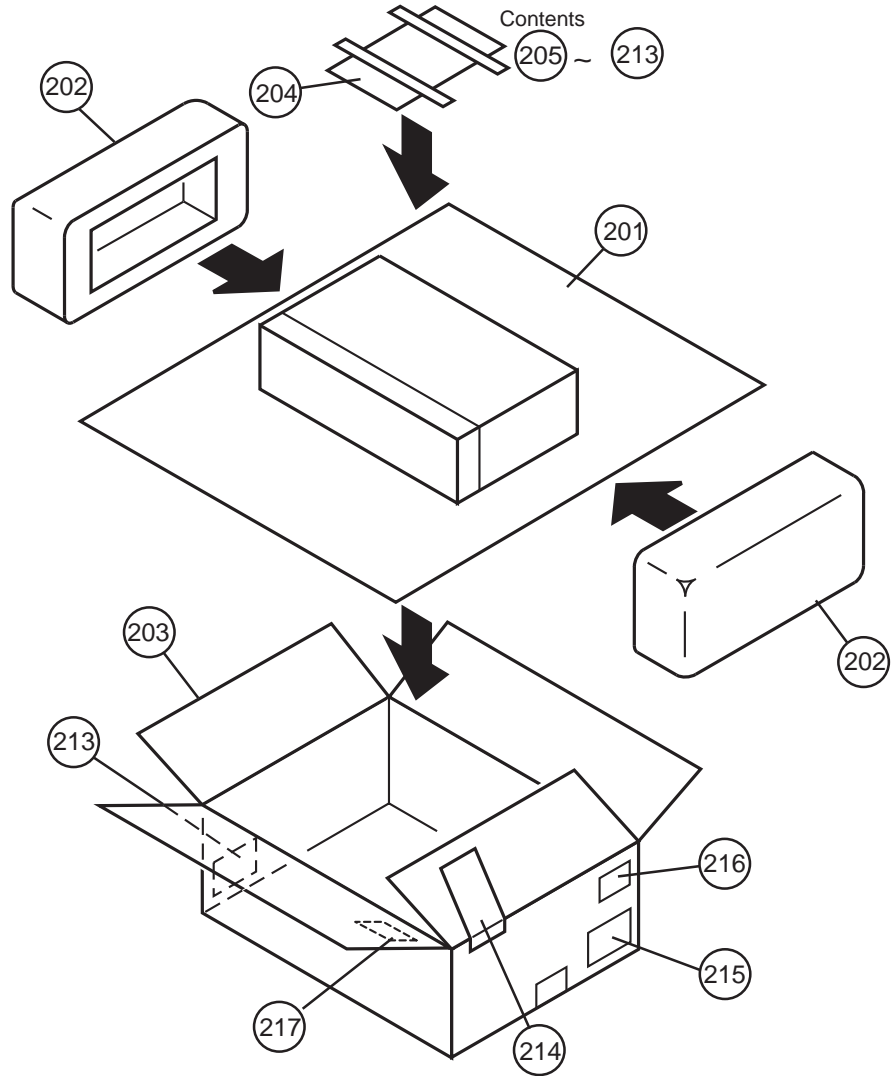

PARTS LIST OF PACKING & ACCESSORIES

Note : The symbols in the column "Remarks" indicate the following destinations.

E3 : U.S.A. & Canada model E1C : China model
 EU : U.S.A. model (AVR-885) EUT : Taiwan R.O.C. model
 E2 : Europe model E1K : Korea model
 EK : U.K. model N : Japan model
 E2A : Asia model

	Ref. No.	Part No.	Part Name	Remarks	Q'ty	New
	201	00D 960 0185 601	SET POLY BAG	E3,EU,E2,EK,E2A,E1C,EUT,N	1	
	201	00D 963 0154 505	SET POLY BAG	E1K	1	*
	202	00D 963 0112 709	CUSHION		1	
	203	00D 963 0153 807	CARTON CASE	E3	1	*
	203	00D 963 0153 904	CARTON CASE	EU	1	*
	203	00D 963 0154 000	CARTON CASE	E2,E2A	1	*
	203	00D 963 0154 204	CARTON CASE	E1C,E1K	1	*
	203	00D 963 0154 408	CARTON CASE	EK	1	*
	203	00D 963 0154 107	CARTON CASE	EUT	1	*
	203	00D 963 0154 301	CARTON CASE	N	1	*
	204	00D 963 0045 106	POLY BAG		1	
	205	00D 963 0153 302	INSTRUCTION MANUAL	E3,EU	1	*
	205	00D 963 0153 409	INSTRUCTION MANUAL	E2,EK	1	*
	205	00D 963 0153 506	INSTRUCTION MANUAL	E2A,E1C,EUT	1	*
	205	00D 963 0153 603	INSTRUCTION MANUAL	E1K	1	*
	205	00D 963 0153 700	INSTRUCTION MANUAL	N	1	*
	206	-	SERVICE STATION CARD	E3,EU,E2,EK,E2A,E1C,EUT,E1K	1	
	206	00D 515 0918 209	SERVICE STATION CARD	N	1	
	207	00D 963 0145 307	AM LOOP ANTENNA	E3,EU,E2,EK,E2A,E1C,EUT,E1K	1	*
	208	00D 963 0158 006	FM ANTENNA	E3,EU,E2,EK,E2A,E1C,EUT,E1K	1	*
	209	00D 399 0954 001	REMOCON RC-980	E3,EU	1	*
	209	00D 399 0954 014	REMOCON RC-981	E2,EK,E2A,E1C,EUT,E1K,N	1	*
	210	-	BATTERY (R6PAA)		1	
⚠	211	00D 963 0160 706	CORD ASSY	N	1	*
	212	00D 513 3214 108	NOTICE SHEET	N	1	
	213	00D 321 0037 006	OMNIDIRECTIONAL MICROPHONE		1	
	214	-	WARRANTY CARD	E3,EU	1	
	214	-	WARRANTY CARD	E1C	1	
	214	00D 515 0919 004	GUARANTEE CARD	N	1	
	215	00D 960 0092 901	CONTROL LABEL	E3,EU,E2,EK,E2A,E1C,EUT,E1K	2	
	216	-	UPC LABEL	E3	1	
	216	-	UPC LABEL	EU	1	
	216	-	POS LABEL	E2(Black model)	1	
	216	-	POS LABEL	E2(Silver model)	1	
	216	-	POS LABEL	EK(Black model)	1	
	216	-	POS LABEL	EK(Silver model)	1	
	216	00D 963 0153 205	POS LABEL	N	1	*
	217	-	CARTON LABEL	EUT	1	
	217	-	CARTON LABEL	E1C	1	
★		-	TAPE	E2A	0.007	
★		-	SERIAL NO. LABEL		2	
★		00D 963 0110 303	COLOR LABEL	Silver model	2	
★		00D 963 0110 316	COLOR LABEL	Gold model	2	
★		-	ORIGIN LABEL A	EUT	1	
★		-	ORIGIN LABEL B	EUT	1	
★		00D 963 0055 905	PAD	EK	2	

WIRING DIAGRAM

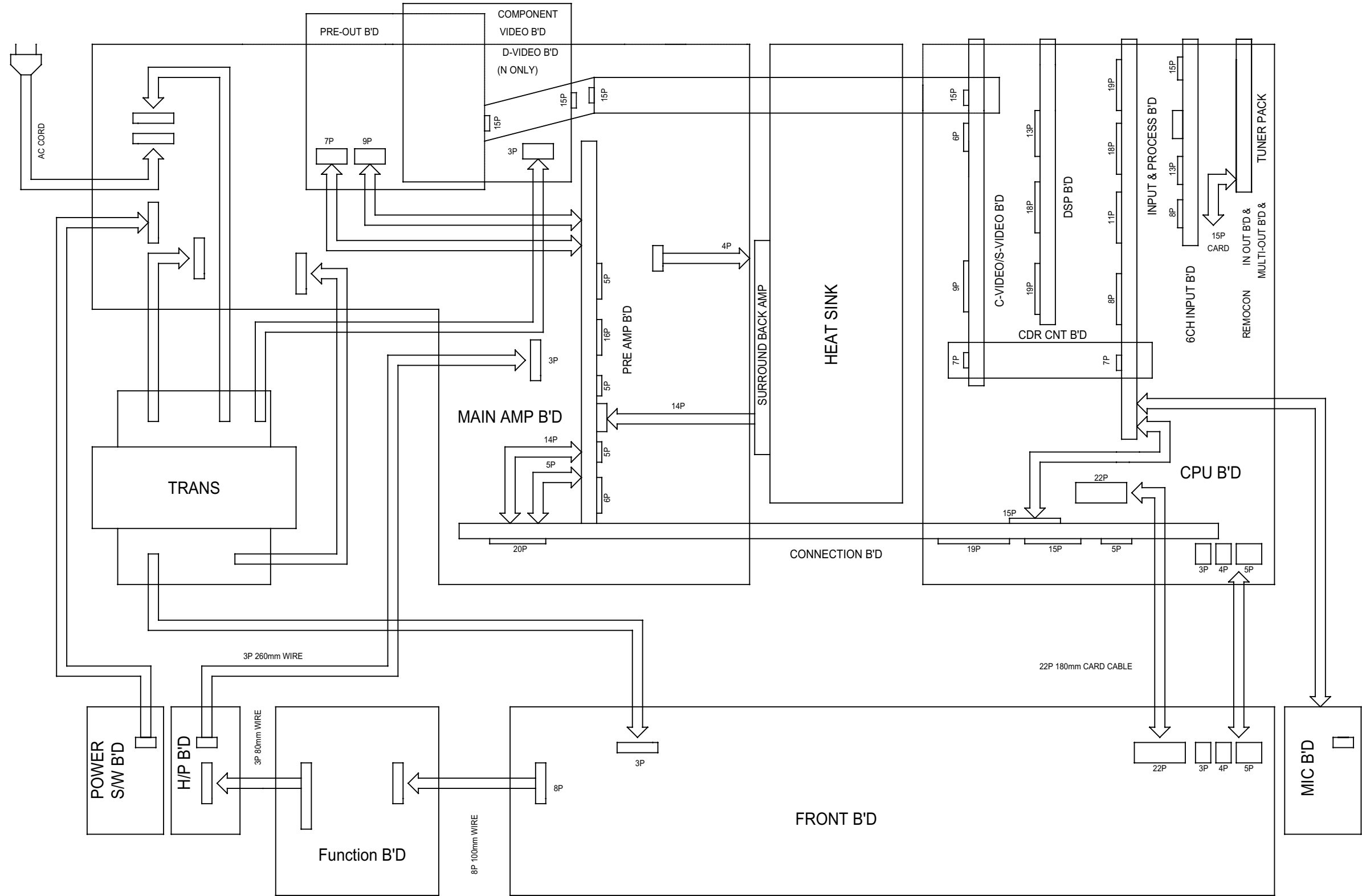

NOTE FOR SCHEMATIC DIAGRAM

WARNING:

Parts marked with this symbol  have critical characteristics.

Use ONLY replacement parts recommended by the manufacturer.

CAUTION:

Before returning the unit to the customer, make sure you make either (1) a leakage current check or (2) a line to chassis resistance check. If the leakage current exceeds 0.5 milliamps, or if the resistance from chassis to either side of the power cord is less than 460 kohms, the unit is defective.

WARNING:

DO NOT return the unit to the customer until the problem is located and corrected.

NOTICE:

ALL RESISTANCE VALUES IN OHM. k=1,000 OHM

M=1,000,000 OHM

ALL CAPACITANCE VALUES IN MICRO FARAD.

P=MICRO-MICRO FARAD

EACH VOLTAGE AND CURRENT ARE MEASURED AT NO SIGNAL INPUT CONDITION.

CIRCUIT AND PARTS ARE SUBJECT TO CHANGE WITHOUT PRIOR NOTICE.

配線図について

 印の部品は安全を維持するために重要な部品です。従って交換時は必ず指定の部品を使用してください。

注)

- (1) 指定なき抵抗値は Ω 、k は $k\Omega$ 、M は $M\Omega$ を示す。
- (2) 指定なきコンデンサーの値は μF 、p は pF を示す。
- (3) 各部の電圧は無信号の値を示す。
- (4) この配線図は基本配線図です。改良等のため変更することがありますのでご了承ください。

SCHEMATIC DIAGRAMS (1/16)

INPUT B'D PART 1

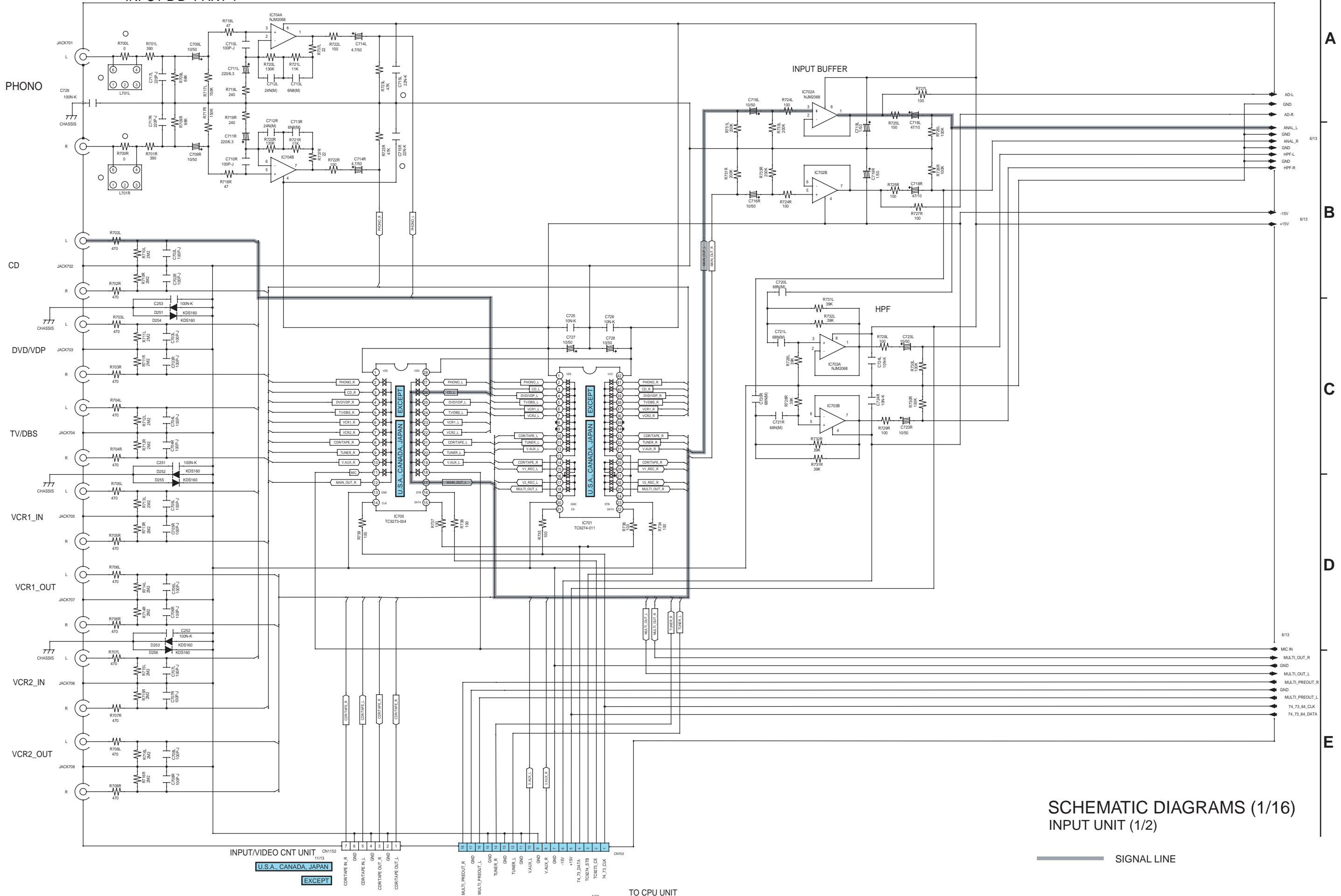

SCHEMATIC DIAGRAMS (1/16)

INPUT UNIT (1/2)

INPUT/VIDEO CNT UNIT CN1152 11/13
 U.S.A., CANADA, JAPAN EXCEPT

MULTI_PREOUT_R GND
 MULTI_PREOUT_L GND
 TUNER_R GND
 TUNER_L GND
 VAUX_L GND
 VAUX_R GND
 74_73_DATA -10V
 74_73_DATA +10V
 TC9274_STB
 TC9274_CE
 74_73_CLK

TO CPU UNIT

SCHEMATIC DIAGRAMS (3/16)

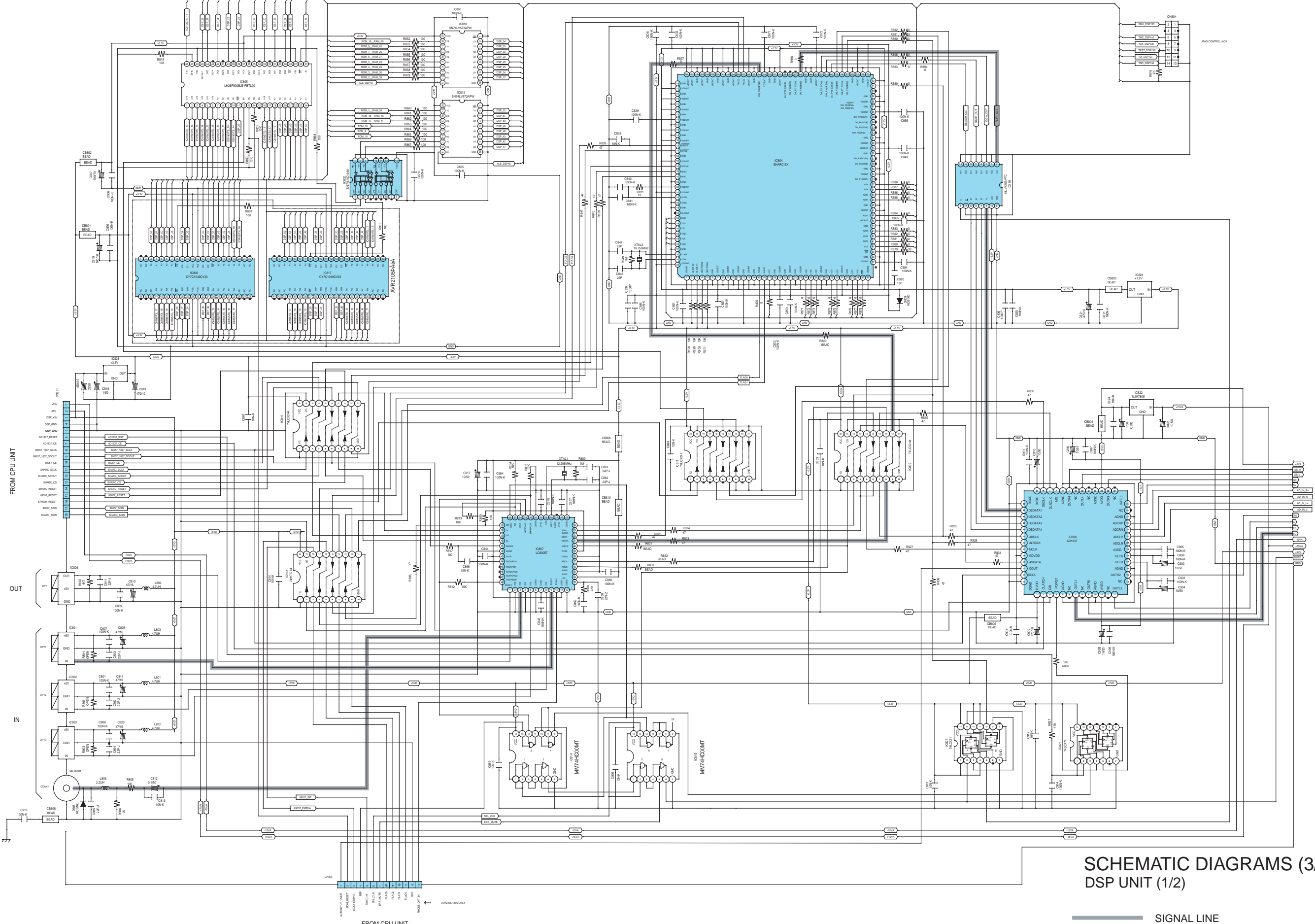

SCHEMATIC DIAGRAMS (3/16)
DSP UNIT (1/2)

— SIGNAL LINE

A
B
C
D
E

FROM CPU UNIT

← AVX485 USE ONLY

SCHEMATIC DIAGRAMS (4/16)

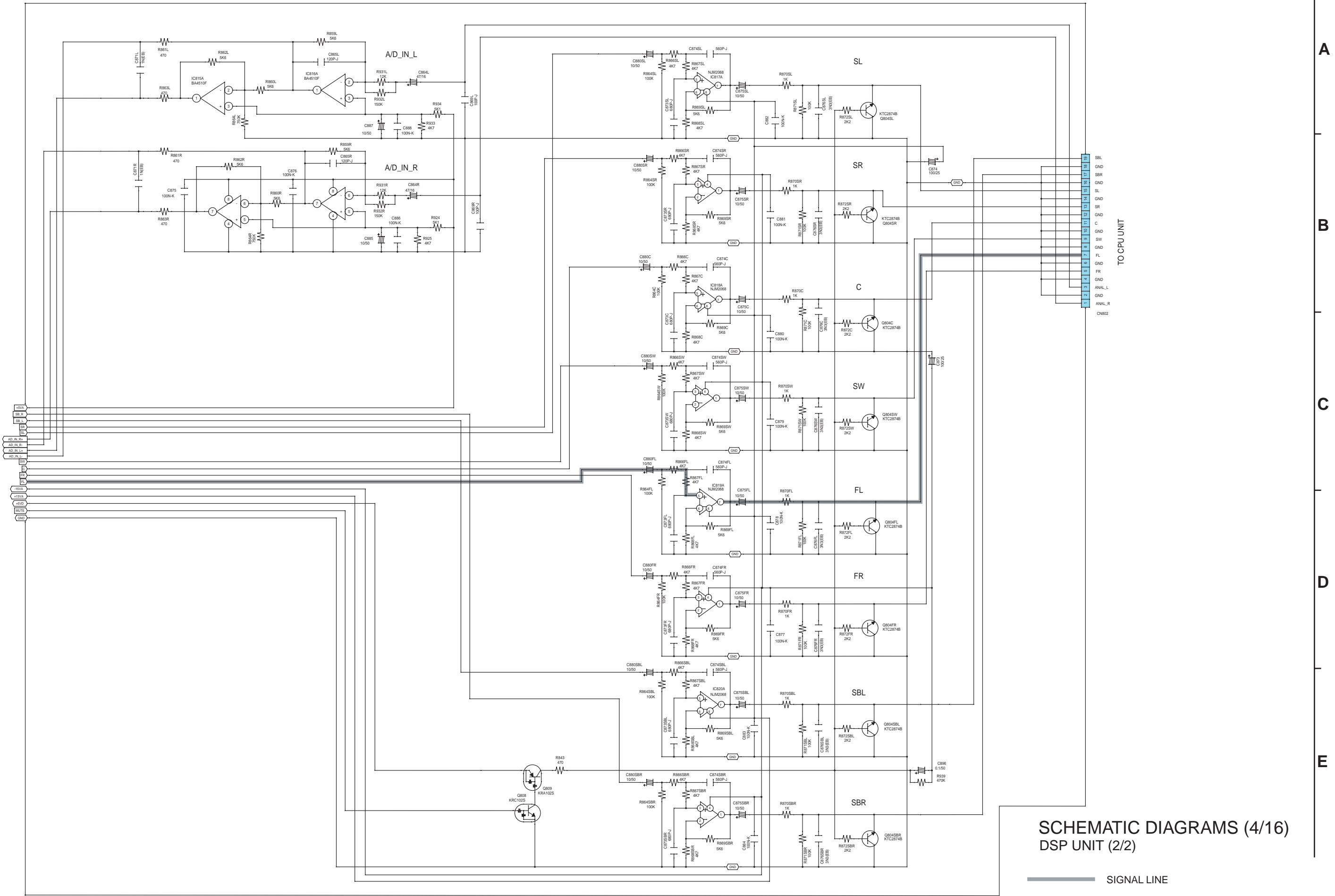

SCHEMATIC DIAGRAMS (4/16)
DSP UNIT (2/2)

— SIGNAL LINE

SCHEMATIC DIAGRAMS (6/16)

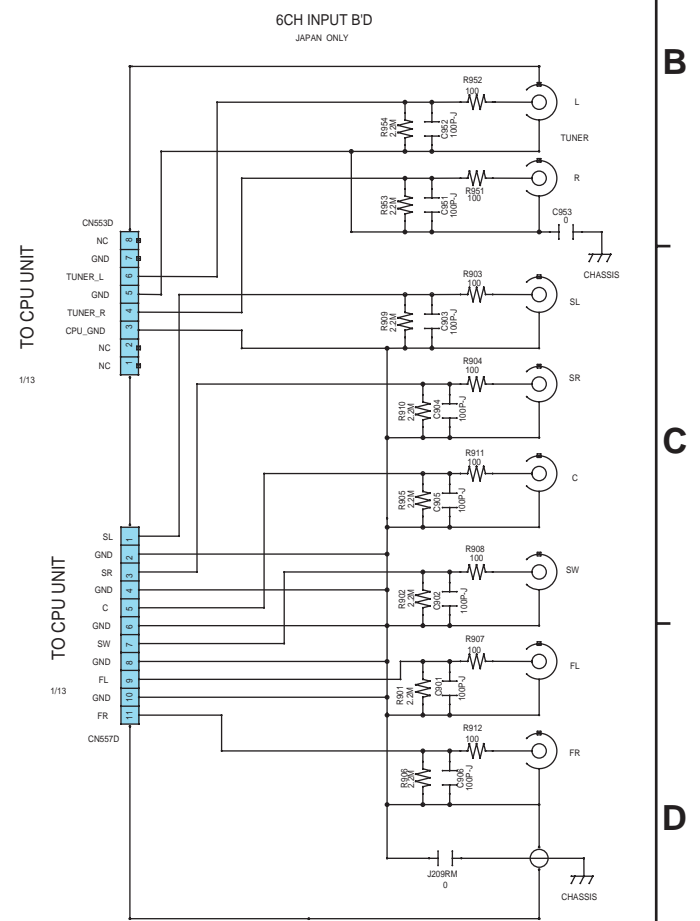
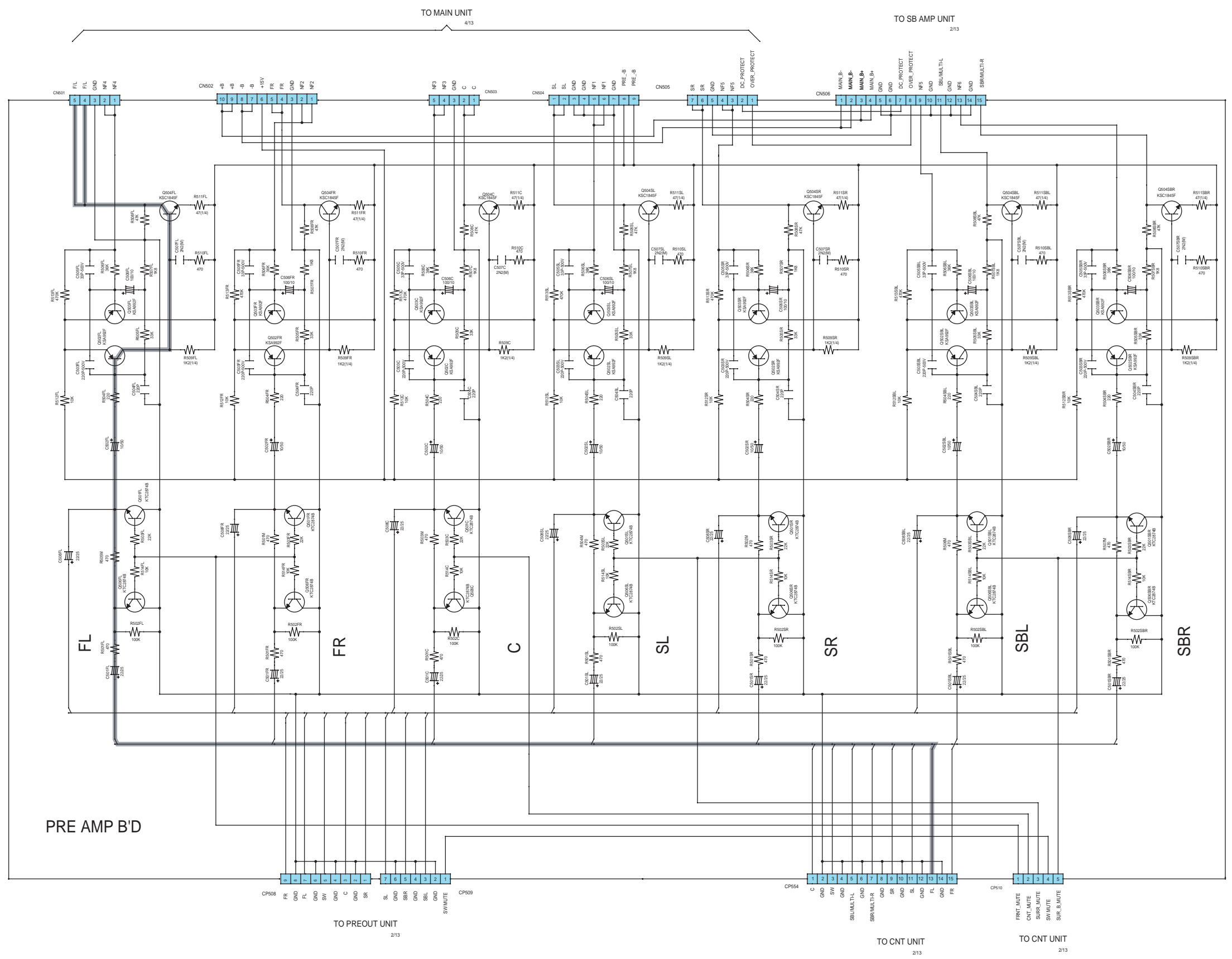

PRE AMP B'D

6CH INPUT BD
JAPAN ONLY

TO CPU UNIT
1/13

TO CPU UNIT
1/13

SCHEMATIC DIAGRAMS (6/16)
PRE AMP UNIT
6 CH INPUT UNIT

SIGNAL LINE

A
B
C
D
E

SCHEMATIC DIAGRAMS (7/16)

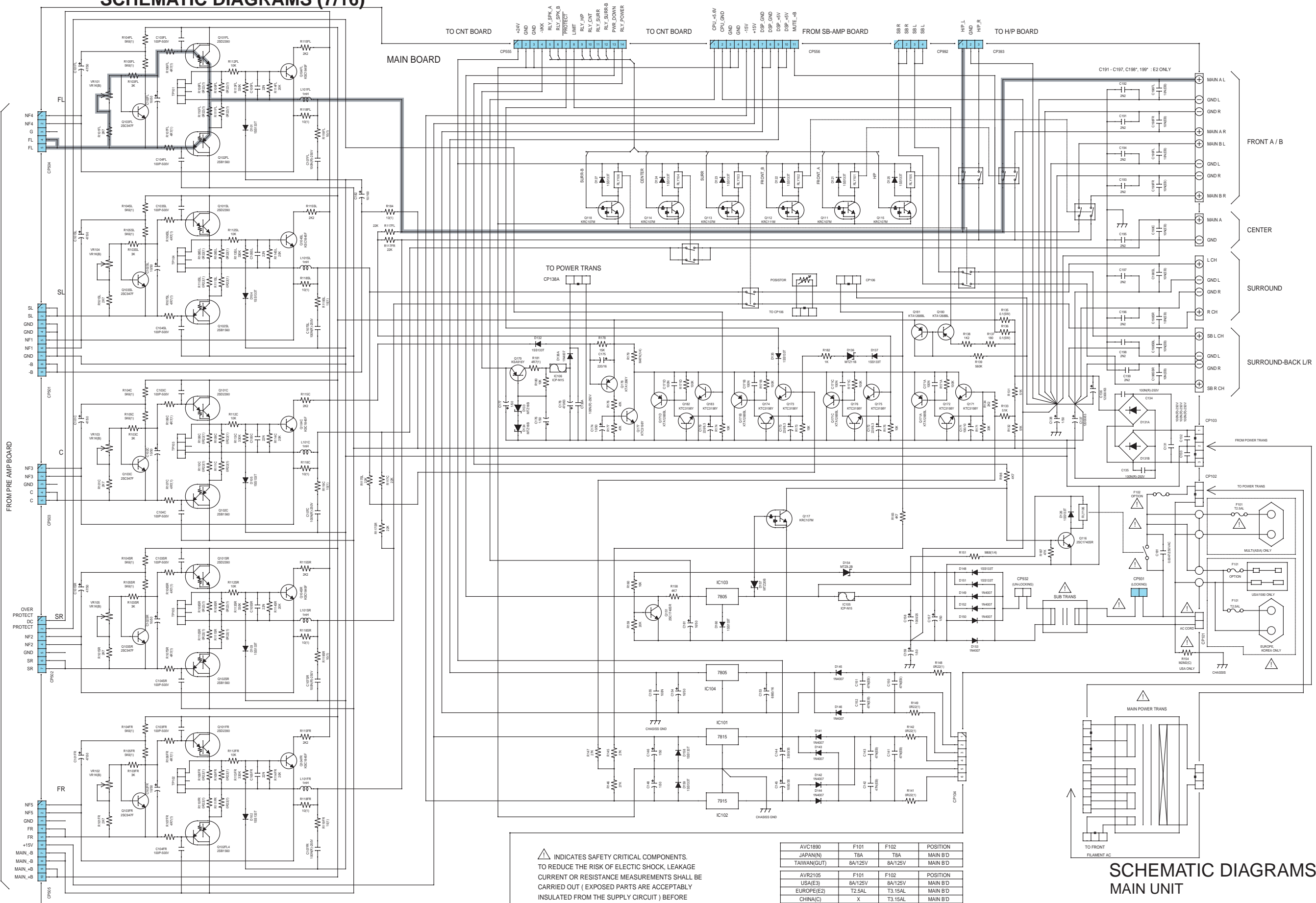

⚠ INDICATES SAFETY CRITICAL COMPONENTS.
 TO REDUCE THE RISK OF ELECTRIC SHOCK, LEAKAGE
 CURRENT OR RESISTANCE MEASUREMENTS SHALL BE
 CARRIED OUT (EXPOSED PARTS ARE ACCEPTABLY
 INSULATED FROM THE SUPPLY CIRCUIT) BEFORE
 THE APPLIANCE RETURNED TO THE CUSTOMER.

AVR1890	F101	F102	POSITION
JAPAN(J)	T8A	T8A	MAIN BD
TAIWAN(GUT)	8A/125V	8A/125V	MAIN BD

AVR2105	F101	F102	POSITION
USA(E3)	8A/125V	8A/125V	MAIN BD
EUROPE(E2)	T2.5AL	T3.15AL	MAIN BD
CHINA(C)	X	T3.15AL	MAIN BD
ASIA(G2A)	T2.5AL	T6.3AL	MAIN BD
KOREA(K)	T2.5AL	T3.15AL	MAIN BD

SCHEMATIC DIAGRAMS (7/16)
MAIN UNIT

— SIGNAL LINE

SCHMATIC DIAGRAMS (8/16)

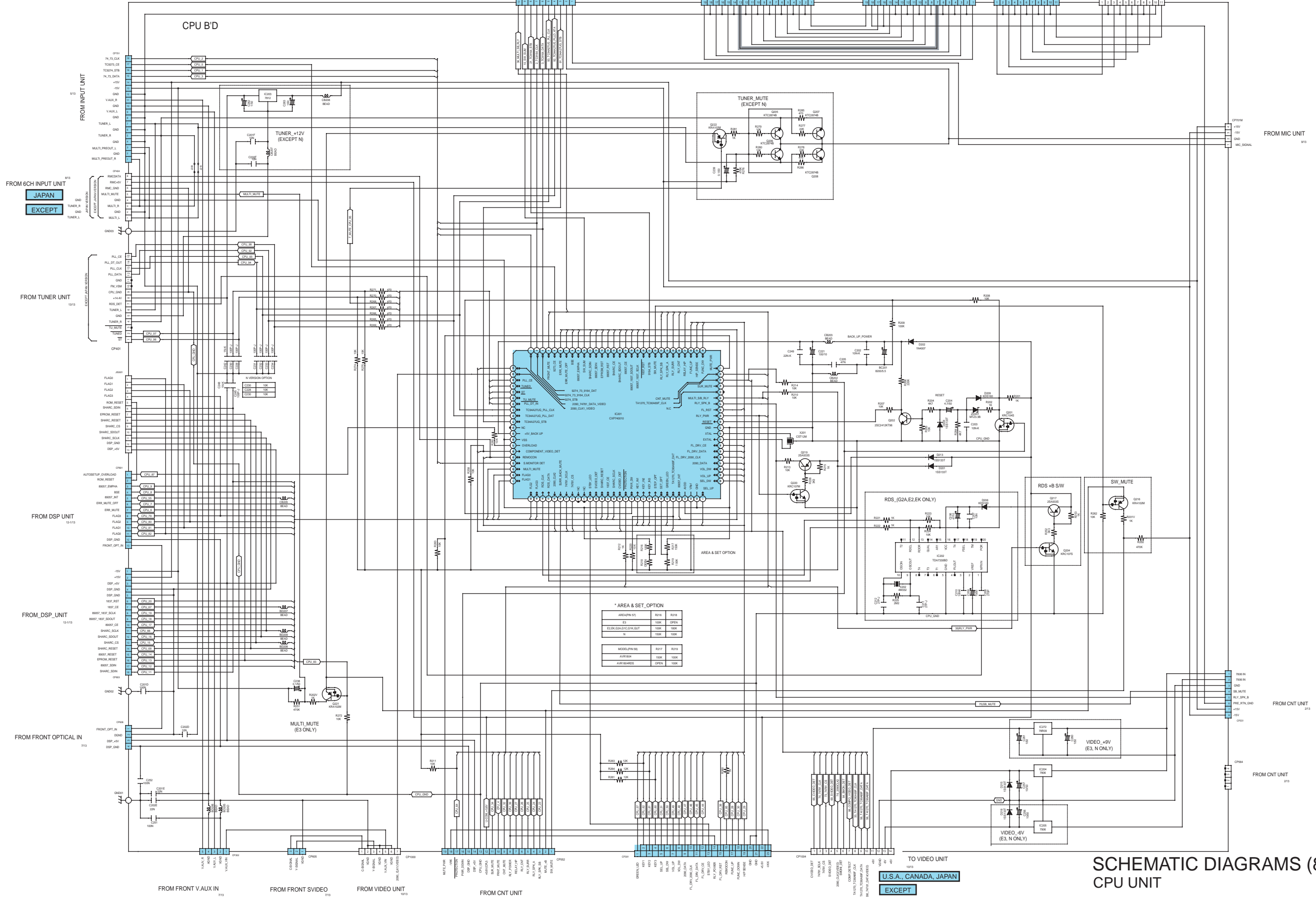

SCHMATIC DIAGRAMS (8/16) CPU UNIT

SIGNAL LINE

A
B
C
D
E

SCHEMATIC DIAGRAMS (9/16) (FOR U.S.A., CANADA & JAPAN)

VIDEO_BD PART 1: CVIDEO

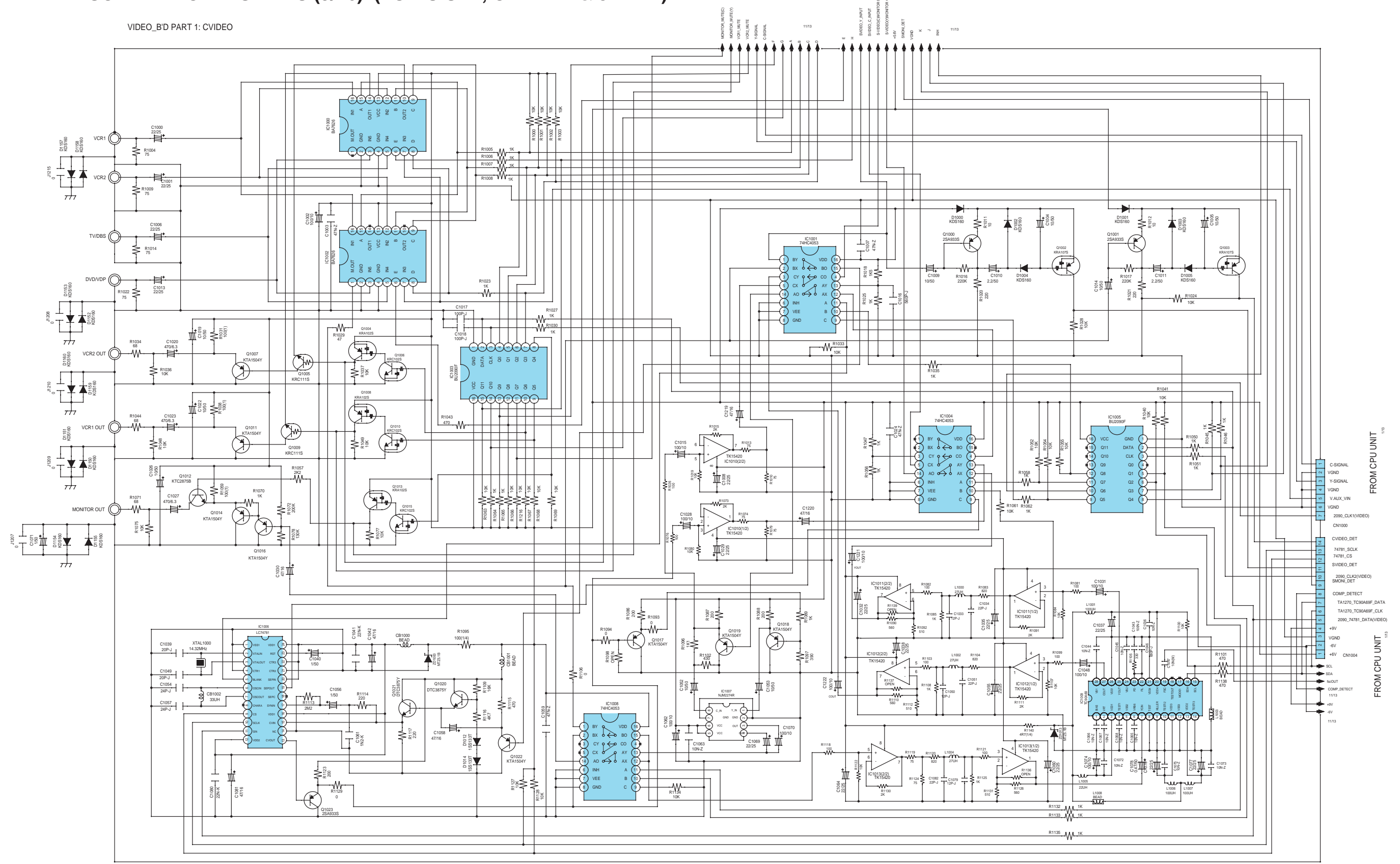

A
B
C
D
E

A	B	E	MONITOR OUT	C	D	E	V OUT1	V OUT2
L	L	-	IN1(VCR-1)	L	L	-	L	L
H	L	-	IN2(VCR-2)	L	L	-	H	L
L	H	-	IN3(V.AUX)	L	H	-	L	H
H	H	L	IN4(TV)	H	H	L	H	L
H	H	H	IN5(DV)	H	H	H	H	H

SCHEMATIC DIAGRAMS (9/16)
C-VIDEO UNIT

FROM CPU UNIT
FROM CPU UNIT

SCHEMATIC DIAGRAMS (10/16) (FOR U.S.A., CANADA & JAPAN)

VIDEO B'D PART 2 : SVIDEO

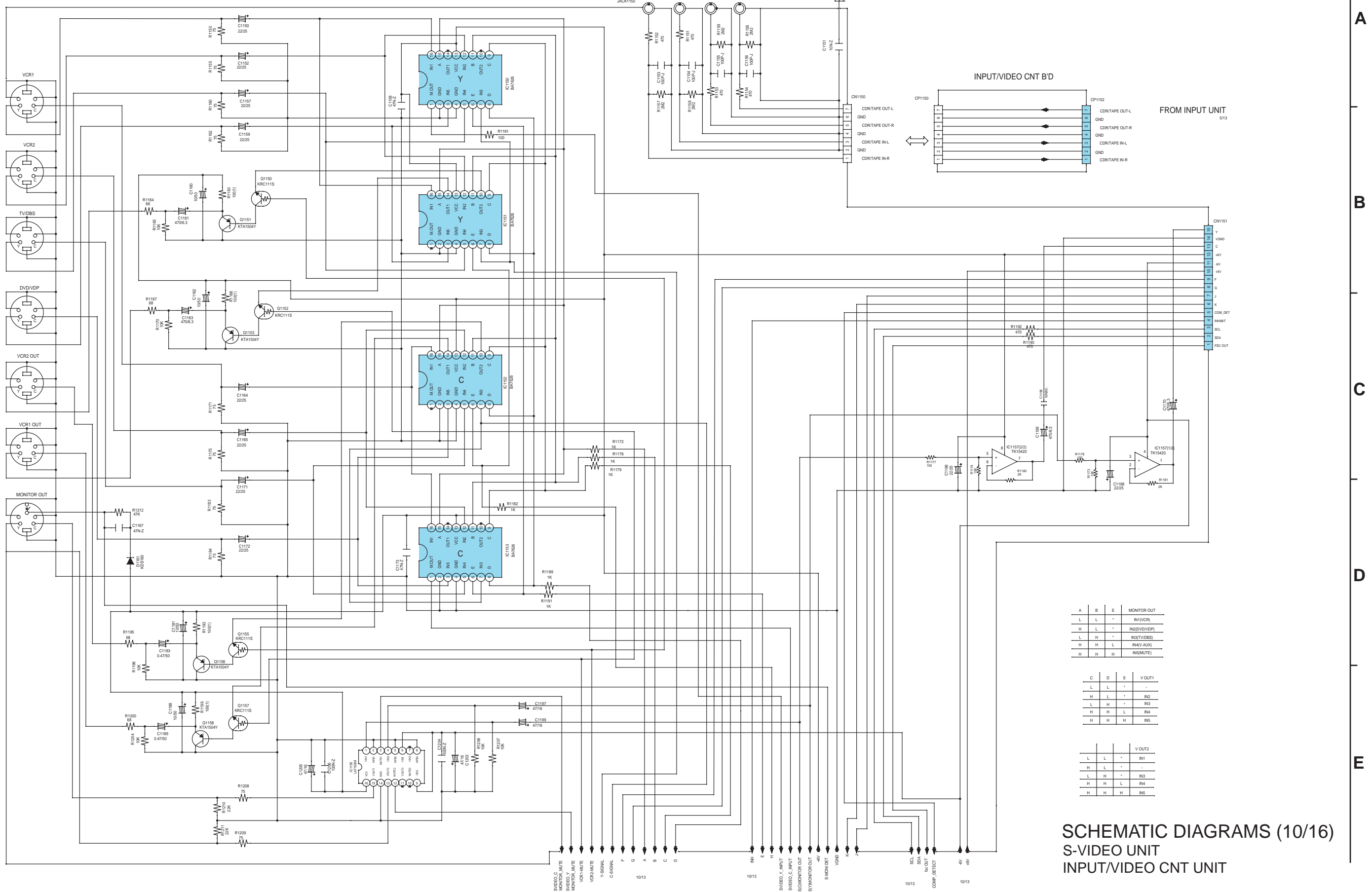

A	B	E	MONITOR OUT
L	L	*	IN1(VCR)
H	L	*	IN2(DVD/DP)
L	H	*	IN3(TV/DBS)
H	H	L	IN4(Y.AUX)
H	H	H	IN5(MUTE)

C	D	E	V OUT1
L	L	*	-
H	L	*	IN2
L	H	*	IN3
H	H	L	IN4
H	H	H	IN5

V OUT2		
L	L	*
H	L	*
L	H	*
H	H	L
H	H	H

SCHEMATIC DIAGRAMS (10/16)
S-VIDEO UNIT
INPUT/VIDEO CNT UNIT

SCHEMATIC DIAGRAMS (11/16) (FOR U.S.A. & CANADA)

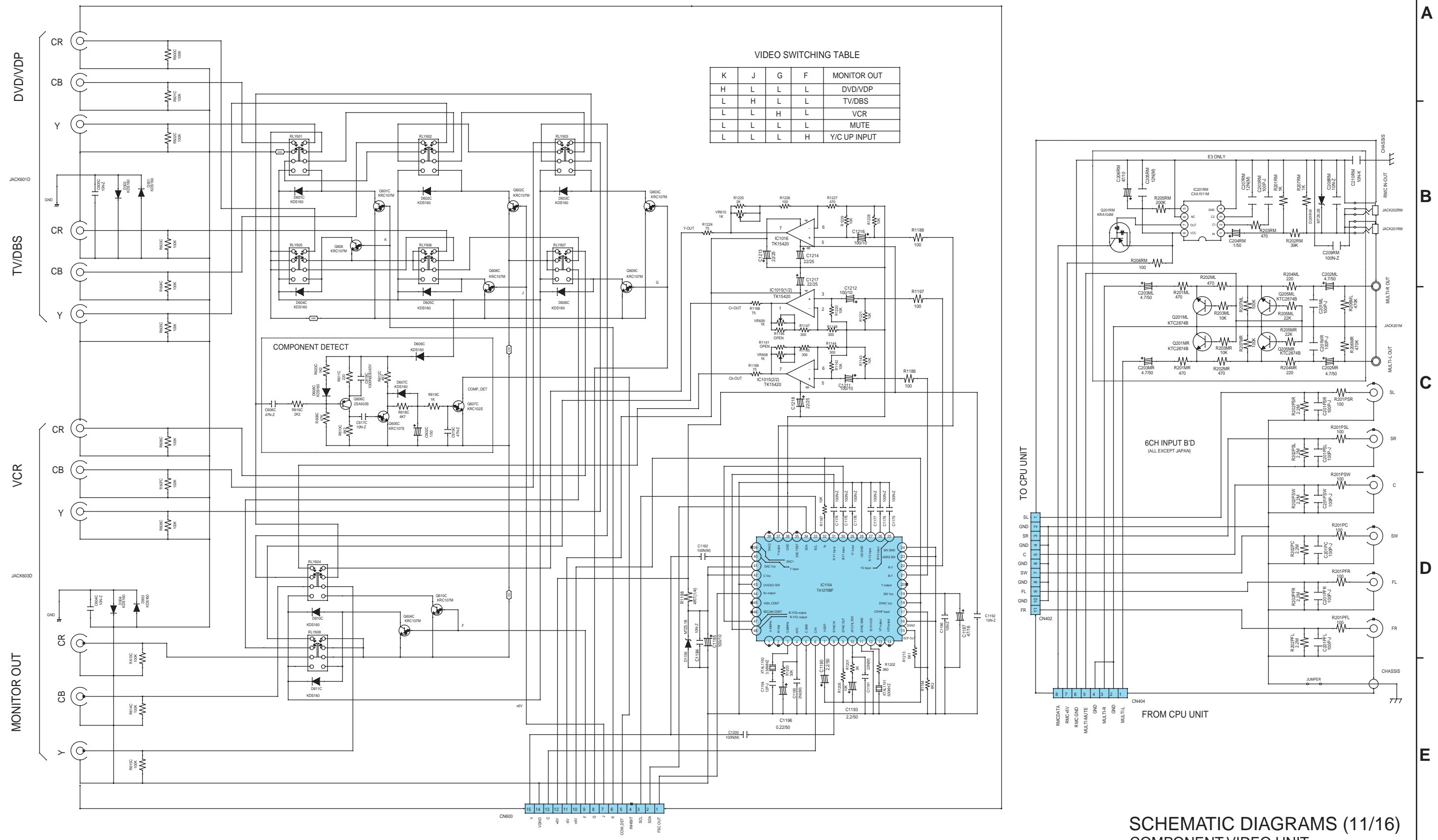

VIDEO SWITCHING TABLE

K	J	G	F	MONITOR OUT
H	L	L	L	DVD/VDP
L	H	L	L	TV/DBS
L	L	H	L	VCR
L	L	L	L	MUTE
L	L	L	H	Y/C UP INPUT

**SCHEMATIC DIAGRAMS (11/16)
COMPONENT-VIDEO UNIT**

A
B
C
D
E

SCHEMATIC DIAGRAMS (12/16) (FOR JAPAN)

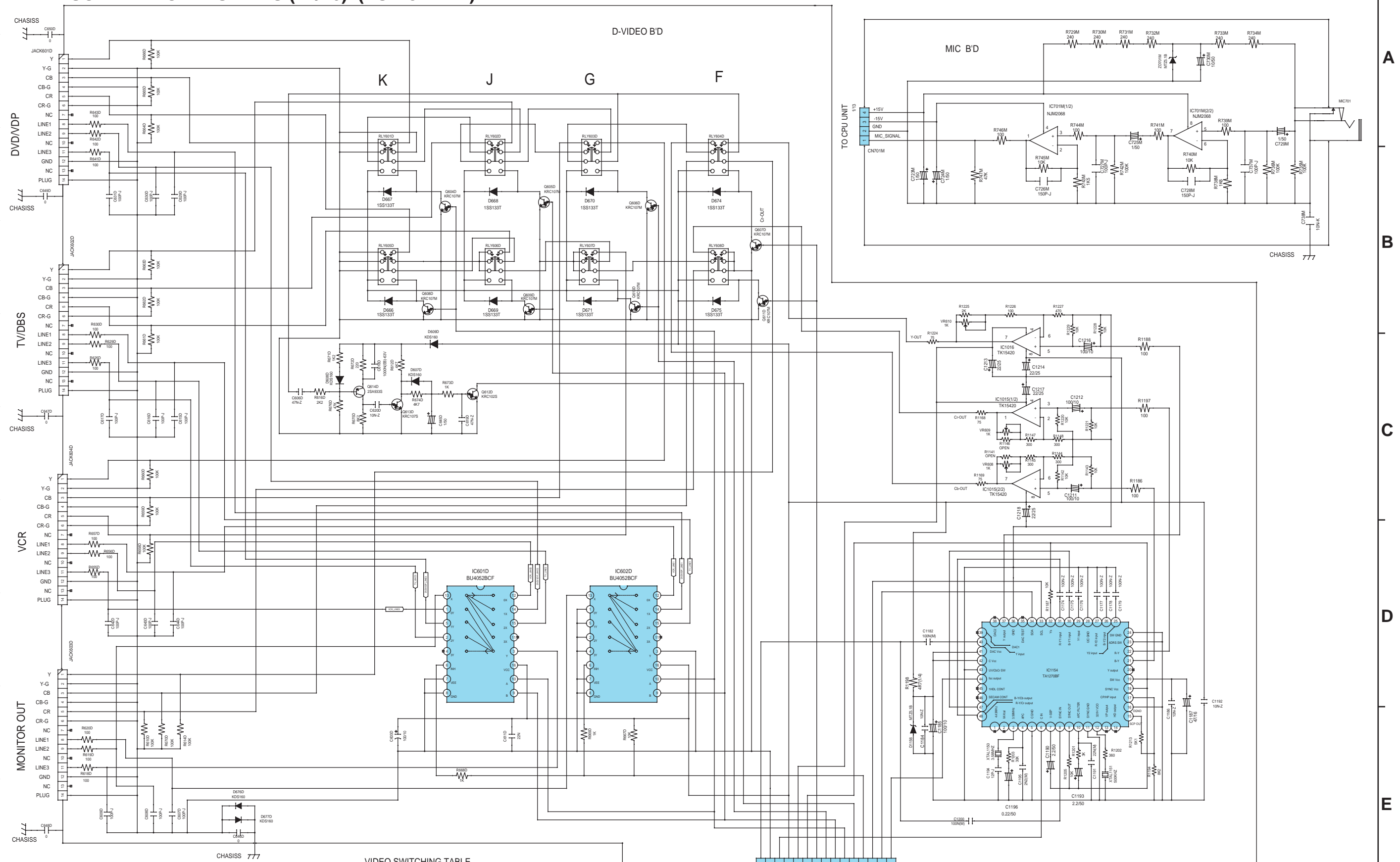

VIDEO SWITCHING TABLE

K(A)	J(B)	G	F	MONITOR OUT	LINE OUT	INH
H	L	L	L	DVD	DVD LINE1,2,3	L
L	H	L	L	TV	TV LINE1,2,3	L
L	L	H	L	VCR	VCR-1 LINE1,2,3	L
L	L	L	L	MUTE		H
L	L	L	H	Y/C UP INPUT		L

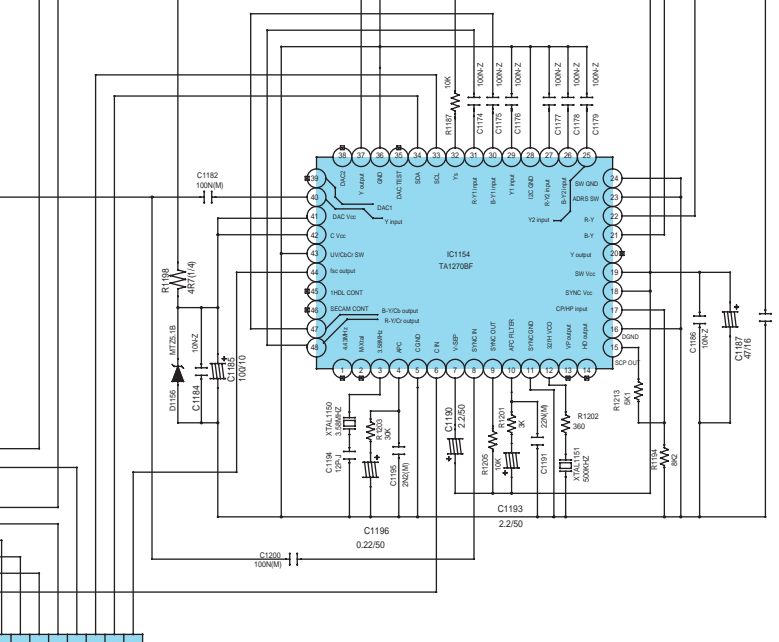
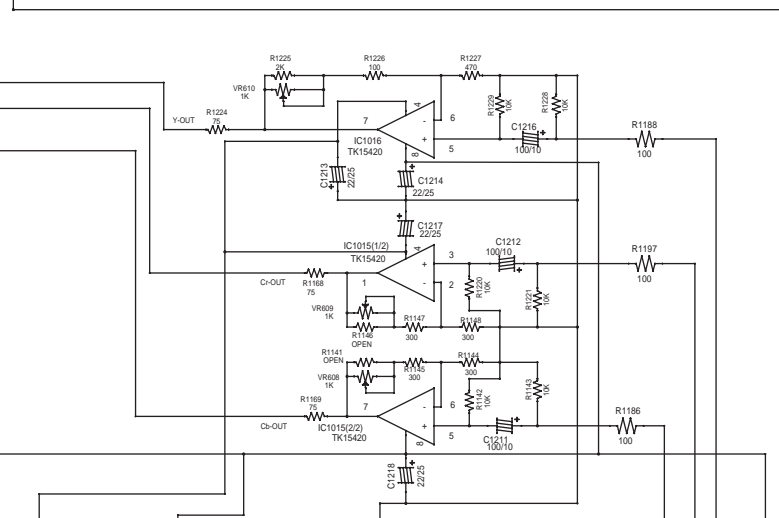
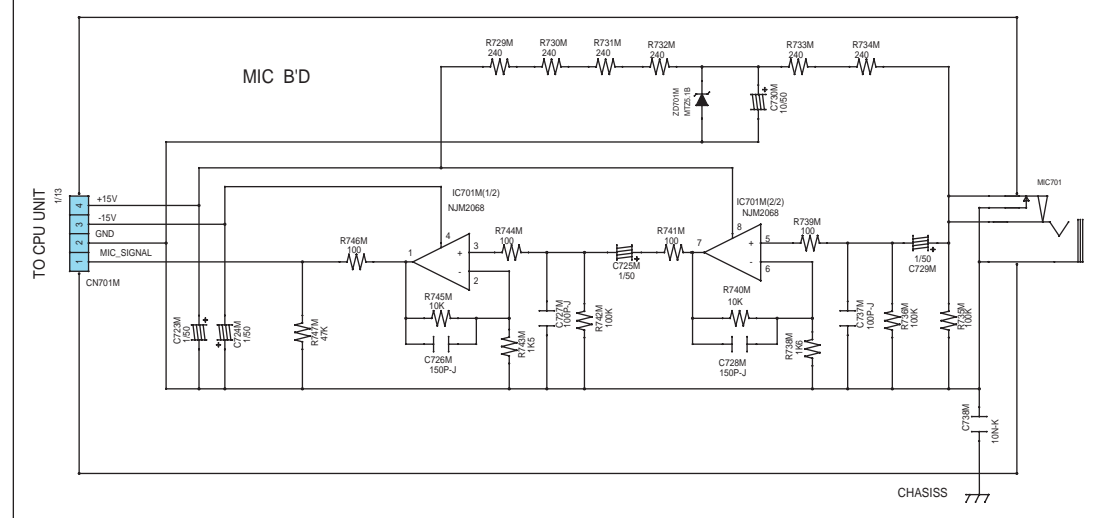

**SCHEMATIC DIAGRAMS (12/16)
D-VIDEO UNIT
MIC UNIT**

TO COMPO-PREOUT CNT UNIT
11/13

SCHEMATIC DIAGRAMS (13/16) (EXCEPT U.S.A., CANADA & JAPAN)

VIDEO_BD PART 1: CVIDEO

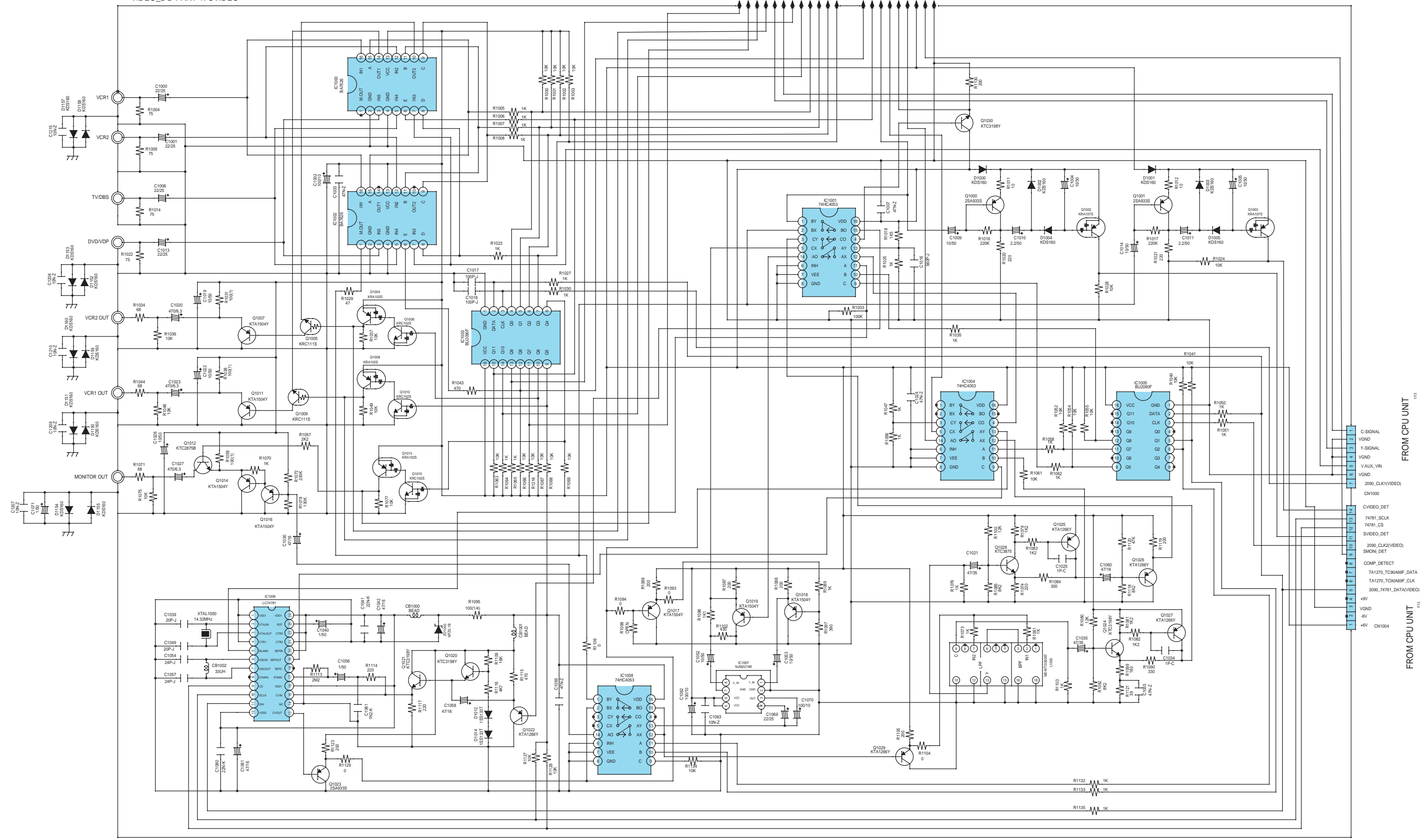

A	B	E	MONITOR OUT	C	D	E	V OUT1	V OUT2			
L	L	-	IN1(VCR)	L	L	-	-	L	L	-	IN1
H	L	-	IN2(DVD/VDP)	H	L	-	-	H	L	-	-
L	H	-	IN3(TVDBS)	L	H	-	-	L	H	-	IN3
H	H	L	IN4(V.AUX)	H	H	L	-	H	H	L	IN4
H	H	H	IN5(MUTE)	H	H	H	-	H	H	H	IN5

SCHEMATIC DIAGRAMS (13/16)
C-VIDEO UNIT

A
B
C
D
E

FROM CPU UNIT

FROM CPU UNIT

SCHEMATIC DIAGRAMS (14/16) (EXCEPT U.S.A., CANADA & JAPAN)

VIDEO B'D PART 2 : SVIDEO

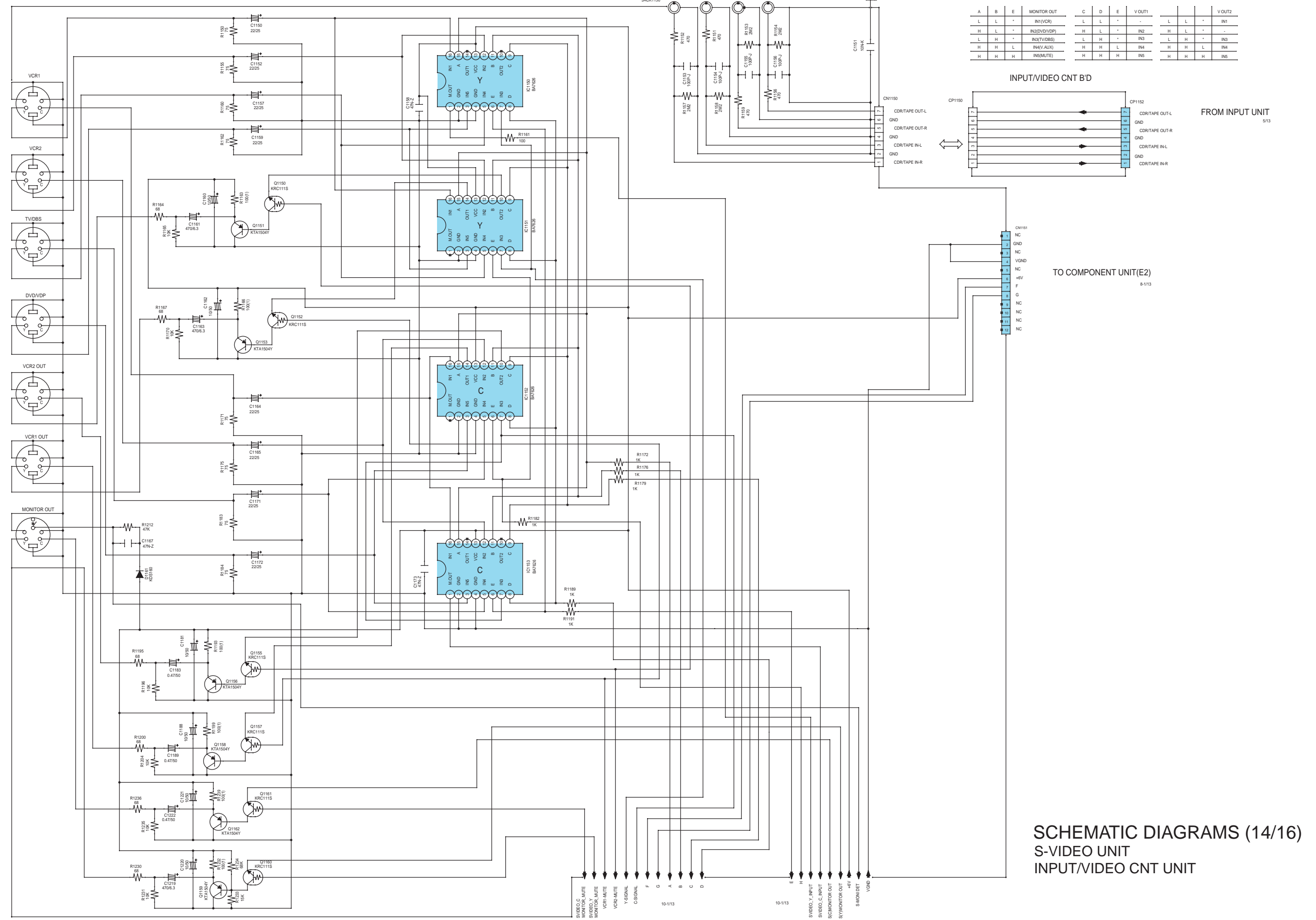

SCHEMATIC DIAGRAMS (14/16)
S-VIDEO UNIT
INPUT/VIDEO CNT UNIT

A
B
C
D
E

SCHEMATIC DIAGRAMS (15/16) (EXCEPT U.S.A., CANADA & JAPAN)

COMPONENT-VIDEO UNIT (EXCEPT E3 AND JAPAN)

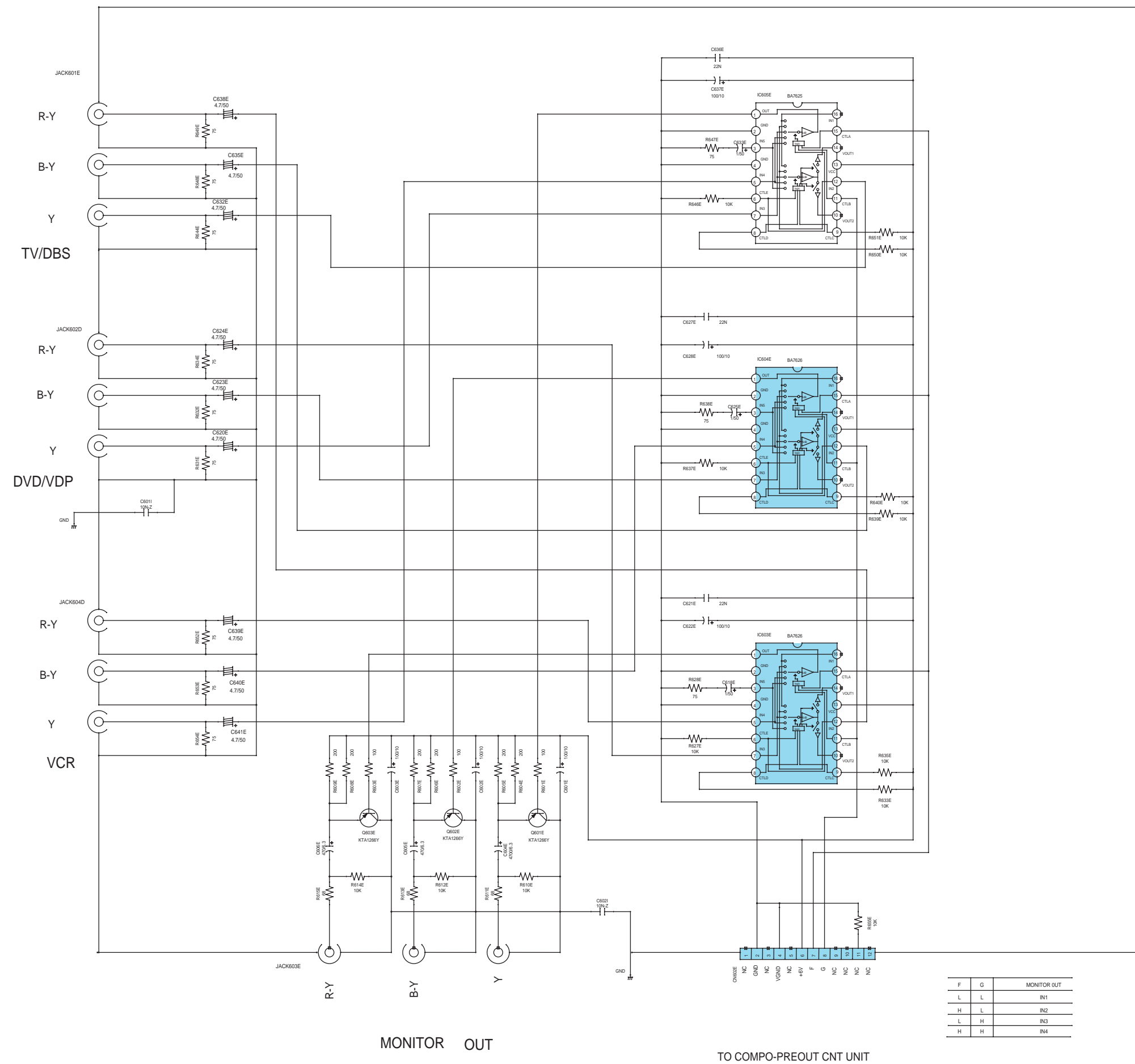

SCHEMATIC DIAGRAMS (15/16)
COMPONENT-VIDEO UNIT

F	G	MONITOR OUT
L	L	IN1
H	L	IN2
L	H	IN3
H	H	IN4

TO COMPO-PREOUT CNT UNIT

SCHEMATIC DIAGRAMS (16/16)

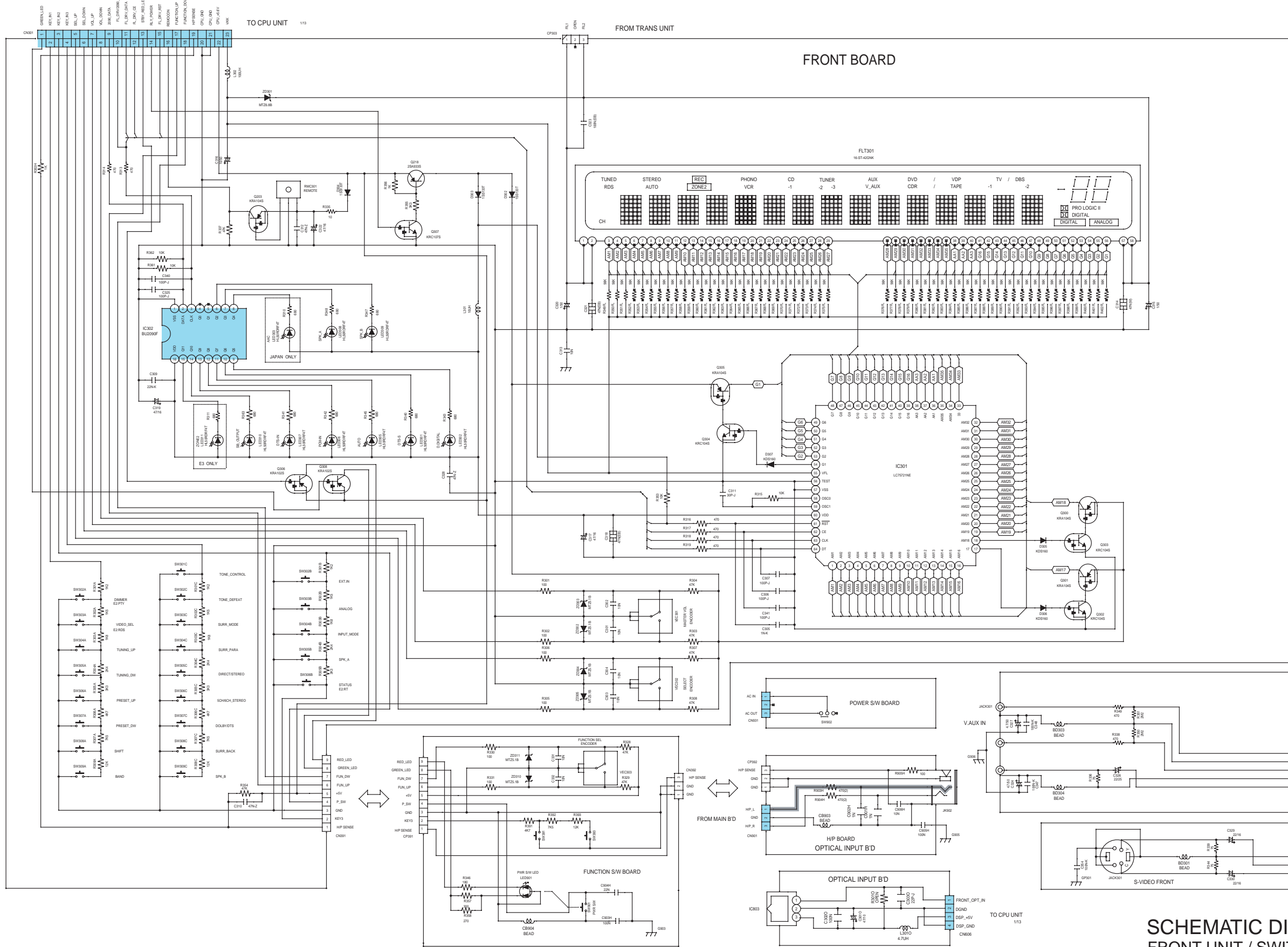

A
B
C
D
E

SCHEMATIC DIAGRAMS (16/16)
FRONT UNIT / SWITCH UNIT / HEAD
PHONE UNIT / FRONT-S-VIDEO UNIT/
OPTICAL INPUT UNIT

SIGNAL LINE