

DENON

Hi-Fi AV Surround Amplifier

SERVICE MANUAL MODEL AVC-2800 AV SURROUND AMPLIFIER

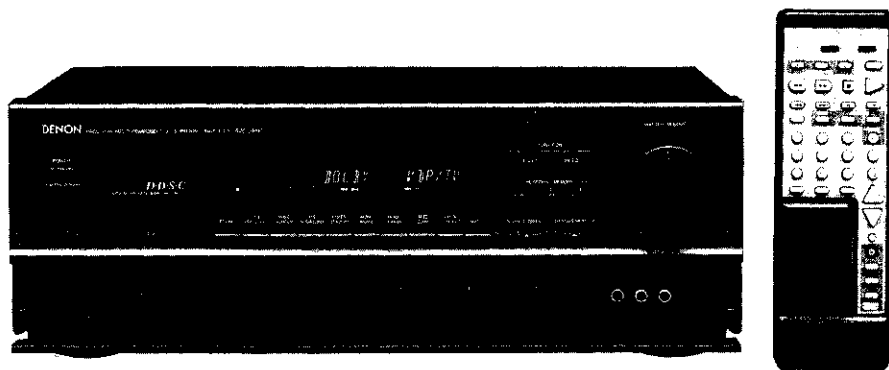

Multi-voltage model is with side wood boards.

CONTENTS

SPECIFICATIONS	2
WIRE ARRANGEMENT	3
DISASSEMBLY	4, 5
ADJUSTMENT	6
FUNCTION OF VIDEO CIRCUIT	7
SEMICONDUCTORS	8~15
PRINTED WIRING BOARD	16~19
PRINTED WIRING BOARD PARTS LIST	20~27
BLOCK DIAGRAM	28
WIRING DIAGRAM	29
SCHEMATIC DIAGRAM - (1/4), (1/2), (3/4), (4/4)	30~33
EXPLODED VIEW OF CHASSIS AND CABINET	34
PARTS LIST OF EXPLODED VIEW	35
ADDENDUM PARTS LIST	36
REMOTE CONTROL UNIT (RC-180)	37, 38
SCHEMATIC DIAGRAM	37
PARTS LIST	38

NIPPON COLUMBIA CO., LTD.

SPECIFICATIONS

- Audio Section**
(Power amplifier)
Rated output:
 (All properties shown are only for the power amplifier stage.)

	for North America model, U.K. and Europe models	for multi-Voltage model
MAIN (main 2ch driven)	85 W + 85 W (8 Ω /ohms, 20 Hz – 20 kHz with 0.05% THD)	110 W + 110 W (6 Ω /ohms, EIAJ)
CENTER (center 1ch driven)	85 W (8 Ω /ohms, 20 Hz – 20 kHz with 0.05% THD)	110 W (6 Ω /ohms, EIAJ)
REAR (rear 2ch driven)	25 W + 25 W (8 Ω /ohms, 1 kHz with 0.1% THD)	30 W + 30 W (6 Ω /ohms, EIAJ) at DOLBY PRO LOGIC WIDE MODE
- Output terminals:**

Main:	A or B 6 to 16 Ω /ohms
	A + B 12 to 16 Ω /ohms
Center:	6 to 16 Ω /ohms
Rear:	6 to 16 Ω /ohms
- (Pre-amplifier)**
Line input (Each line input – FRONT PRE OUT)
Input sensitivity / impedance: 150 mV / 47 k Ω /ohms PHONO (MM): 2.5 mV / 47 k Ω /ohms
Frequency response: 10 Hz to 50 kHz: ±3 dB
Tone control range:
 BASS: ±10 dB at 100 Hz
 TREBLE: ±10 dB at 10 kHz
Signal-to-noise ratio (FRONT PRE OUT): 92 dB
Distortion factor: 0.01% 1 kHz 1 V (STEREO mode)
Maximum headphone output: 284 mW (8 Ω /ohms)
Phono equalizer (PHONO input – REC OUT)
RIAA deviation: ±1 dB (20 Hz to 20 kHz)
Signal-to-noise ratio: 74 dB (A weighting, with 5 mV input)
Rated output / Maximum output: 150 mV / 8 V
Distortion factor: 0.03% (1 kHz, 3 V)
- Video Section**
Standard video jacks
Input and output level / impedance: 1 Vp-p / 75 Ω /ohms
Frequency response: 5 Hz to 8 MHz +0, -3 dB
S-video output jacks
Input and output level / impedance: Y (brightness) signal: 1 Vp-p / 75 Ω /ohms
 C (color) signal: 0.286 Vp-p / 75 Ω /ohms
Frequency response: 5 Hz to 10 MHz +0, -3 dB
- General**
Power supply: AC 120 V, 60 Hz (for North America model)
 AC 115/230 V, 50/60 Hz (for multi-voltage model)
 AC 230 V, 50 Hz (for U.K. and Europe models)
Power consumption: 5.0 A (for North America model)
 270 W (for multi-voltage and U.K. models)
Maximum external dimensions: 434 (W) × 161 (H) × 433 (D) mm (17-3/32" × 6-11/32" × 17-3/64") (without side wood boards model)
 470 (W) × 162 (H) × 433 (D) mm (18-1/2" × 6-3/8" × 17-3/64") (with side wood boards model)
Weight: 11.4 kg (25 lbs 3 oz) (without side wood boards model)
 12.7 kg (28 lbs 1 oz) (with side wood boards model)
 (Model with side wood boards is only multi-voltage.)
- Remote control unit (RC-180)**
Batteries: R6P/AA Type (two batteries)
External dimensions: 70 (W) × 215 (H) × 19 (D) mm (2-3/4" × 8-15/32" × 3/4")
Weight: 180 g (Approx. 6 oz) (including batteries)

WIRE ARRANGEMENT

In case of wires require unclasping or loosening to move the location to perform adjustment or part replacement, be sure to rearrange them neatly to restore properly in the same location as they were originally placed, or causing to produce a noise may occasionally occur.

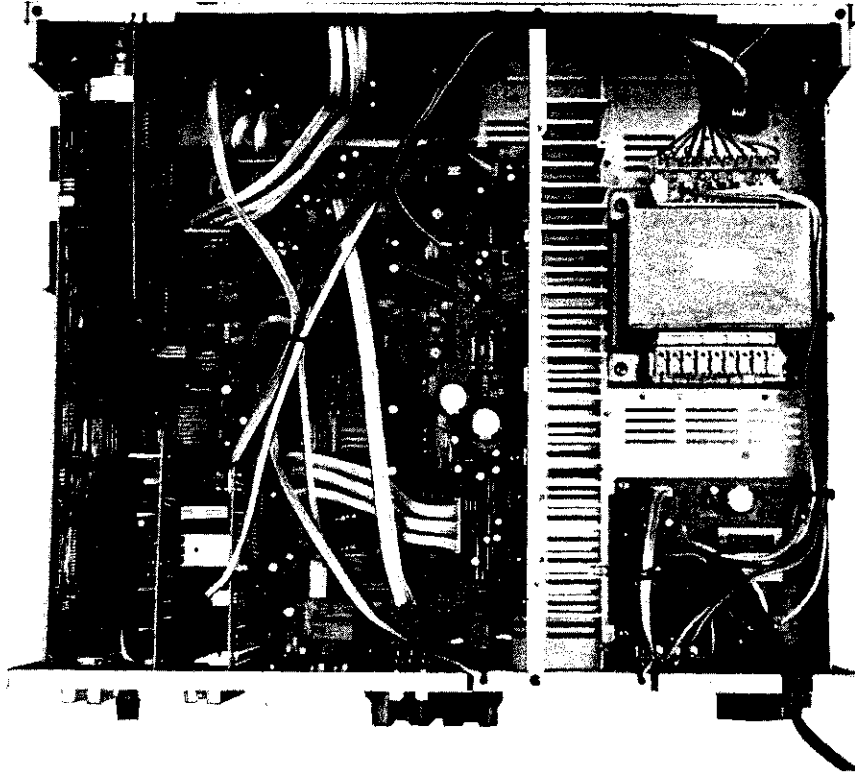

DISASSEMBLY

(To reassemble reverse disassembly)

1. Side plates

Remove 3 screws ① each on left and right sides cabinet which fix the both sides.

2. Top Cover

Remove 2 rear screws ②.

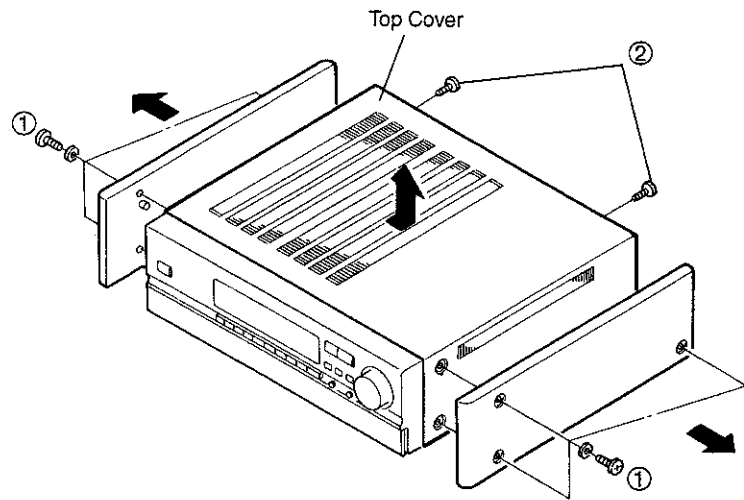

3. Front Aluminium Panel

Remove 3 upper screws ③, unfasten upper hooks at three places, and detach Panel from upper portion in arrow direction.

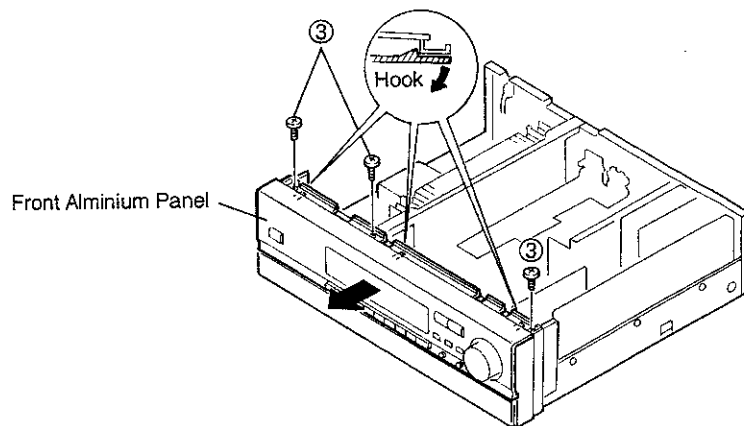

4. Front Mold Panel

- (1) Pull out Master VR Knob ④ and remove nut ⑤ .
- (2) Remove all connector of wire, connected to FLD P.W.B., tone control P.W.B., V.AUX P.W.B. and headphone P.W.B..
- (3) Remove 2 screws ⑥, 2 screws ⑦ and 2 screws ⑧ .

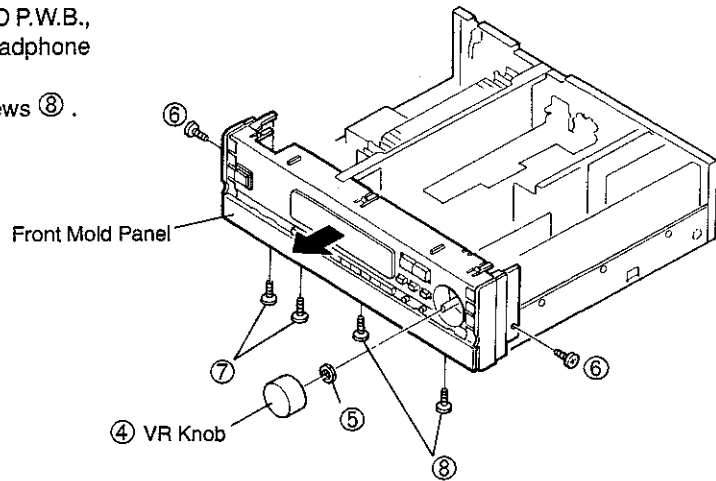

5. Rear Panel

- (1) Remove short circuit pin ⑨, and remove cord bush ⑩ .
- (2) Remove 20 terminal connecting screws ⑪ .
- (3) Remove 5 panel fixing screws (front 4, upper 1 screws ⑫).

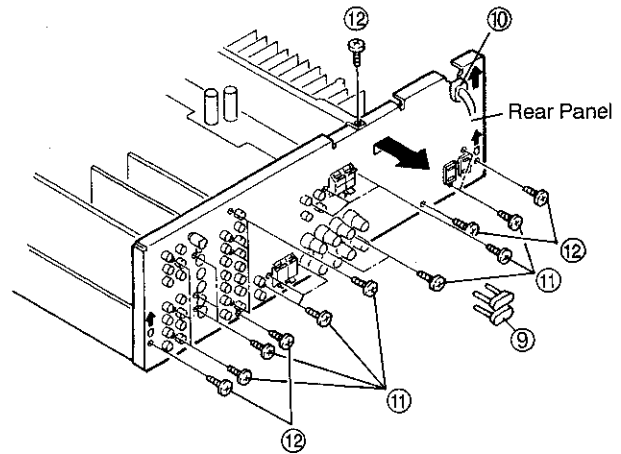

6. Main Chassis

- (1) Remove 3 screws ⑬ securing P.W.B. with Main Chassis.
- (2) Remove 6 screws ⑭ securing Front Mold Panel with Main Chassis.
- (3) Remove 2 screws ⑮ securing Side Bracket (L), (R) with Main Chassis.
- (4) Remove 2 screws ⑯ securing Power Radiator with Main Chassis.
- (5) Remove 5 screws ⑰ securing Rear Panel with Main Chassis.

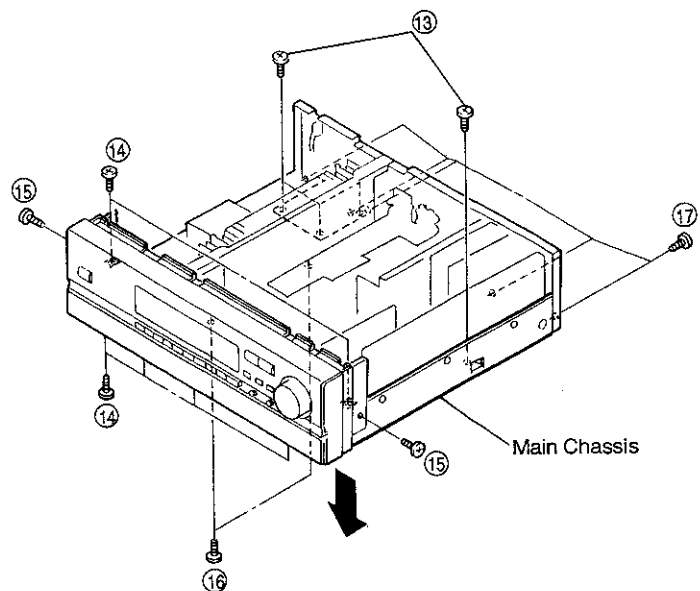

NOTE Then by pulling up, Front Panel, Power Radiator, P.W.B., Rear Panel will be detached Power Trans still remains connected; therefore make repairing on detached Chassis side-up.

ADJUSTMENT

● AUDIO SECTION

Idling Current (1U-2743-1)

Required measurement equipment: DC Voltmeter

Arrangement

(1) Avoid direct blow from an air conditioner or an electric fan, and adjust the unit at normal room temperature 15°C ~ 30°C. (59°F ~ 86°F).

(2) Presetting

- POWER (Power source switch) → OFF
- MODE (Mode button) → STEREO
- FUNCTION (Function button) → CD
- VOLUME (Volume control) → 0: fully counterclockwise (⚙ min.)
- BALANCE (Volume control) → 0: (Controls to center)
- BASS, TREBLE (Tone control) → 0: (Controls to center)
- SPEAKER-A (Speaker terminal) → No load (Do not connect speaker, dummy resistor, etc.)

Adjustment

- (1) Remove top cover and set VR401, VR402 and VR501 of 1U-2743-1 (Main Unit) at counterclockwise fully.
- (2) Connect DC Voltmeter to test points (Lch CN3L, Rch CN3M, CENTER ch CN3N).
- (3) Connect power cord to AC Line, and turn power switch "ON".
- (4) Allow 15 minutes, and turn VR401, VR402 and VR501 clockwise (⚙) and adjust the TEST POINTS voltage to 1.5 mV ± 0.5 mV DC.
- (5) After 2 minutes from preset, turn VR401, VR402 and VR501 to set the voltage to 3 mV ± 0.5mV DC.

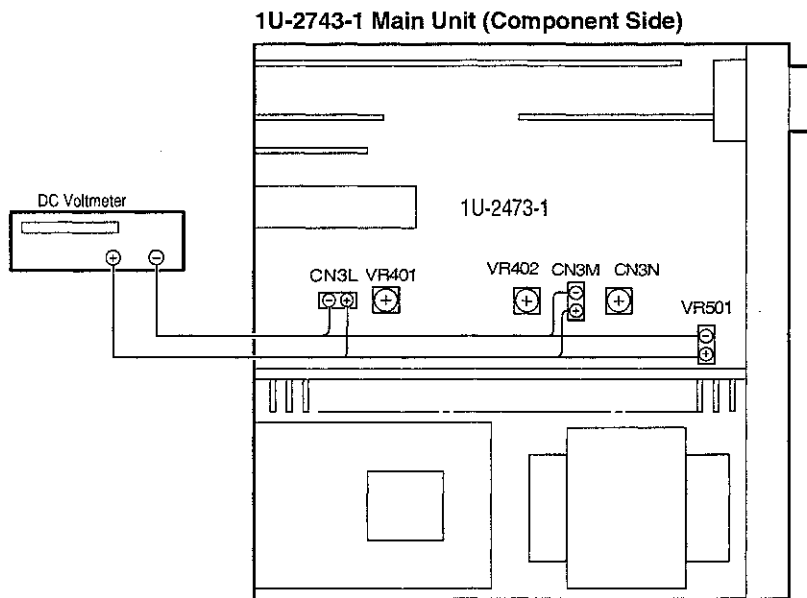

● Initiating (Memory clearing) Method

To clear memory contents of microcomputer and restore to the initial state, take the following steps;

1. Press power switch, turn off the unit, and set to standby mode.
2. Pull out power cord from wall outlet temporarily.
3. Insert power cord into outlet while simultaneously pressing two keys of AUDIO and VIDEO.
4. Press power switch to confirm that memory contents are cleared.

By completion of the above, the initial state is restored. In case the memory can not be cleared due to some reasons, repeat steps 1 though 3.

FUNCTION OF VIDEO CIRCUIT

1. Detecting S-signal Input

Each input consists the S-terminal and composite video input signal in video signal input. Y-signal (brightness) of S-terminal input is selected by selector IC (IC902) and applied to the base of TR909. TR909 separates the sync signal from Y-signal and outputs through collector. TR910 discriminates the existence of this sync signal and applied to Pin 58 of microcomputer (IC701) via reversal circuit of TR913.

The output of TR913 is: "High" in existing of S-signal, "Low" in no existing. In response to this signal, the microcomputer outputs: "Low" at existing S-signal, "High" at no existing to Pin 62, thus shifts the analog switch (IC903) and selects inputting signal to OSD (IC904).

2. Superimpose

The selected signal by analog switch (IC903) is applied to OSD (IC904) and sync discriminator circuit (IC905). IC905 performs discrimination of sync signal and existence of the signal that are required for superimposing by OSD. Pin 13 of IC905 is in "High" at signal existing and it applies to Pin 60 of microcomputer (IC701).

The microcomputer delivers the data to shift the mode of OSD for internal sync or external sync according to the input of Pin 60.

When OSD is in internal sync mode, makes the sync signal from clock signal of XL901 and outputs the video signal which carries character information from Pin 8.

In external sync mode, to superimpose the character information on the external video signal which is synced and input to Pin 10 with the horizontal and vertical signals from IC905, and emits from Pin 8.

From Pin 13 of OSD, outputs a pulse to become "High" is complying with the character output. In case to superimpose on the video signal from S-terminal input, shifts the analog switch (IC903) by the output of Pin 13 to perform chroma(C) signal ON/OFF.

SEMICONDUCTORS

● IC's

Note: Indications before IC numbers denote P.W.B. name.

- MA : Main P.W.B. Unit
- SV : S- Video P.W.B. Unit
- SU : Surround P.W.B. Unit
- FL : FLD P.W.B. Unit

TMP87CP71F-6223 (MA: IC701)

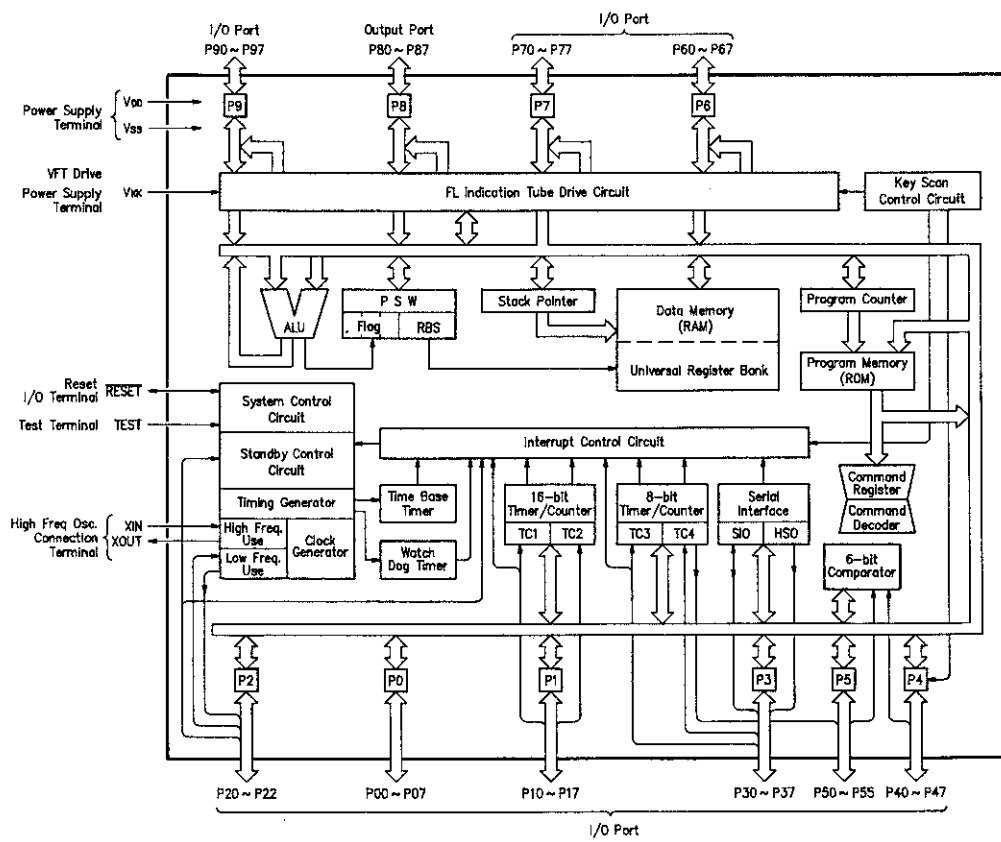
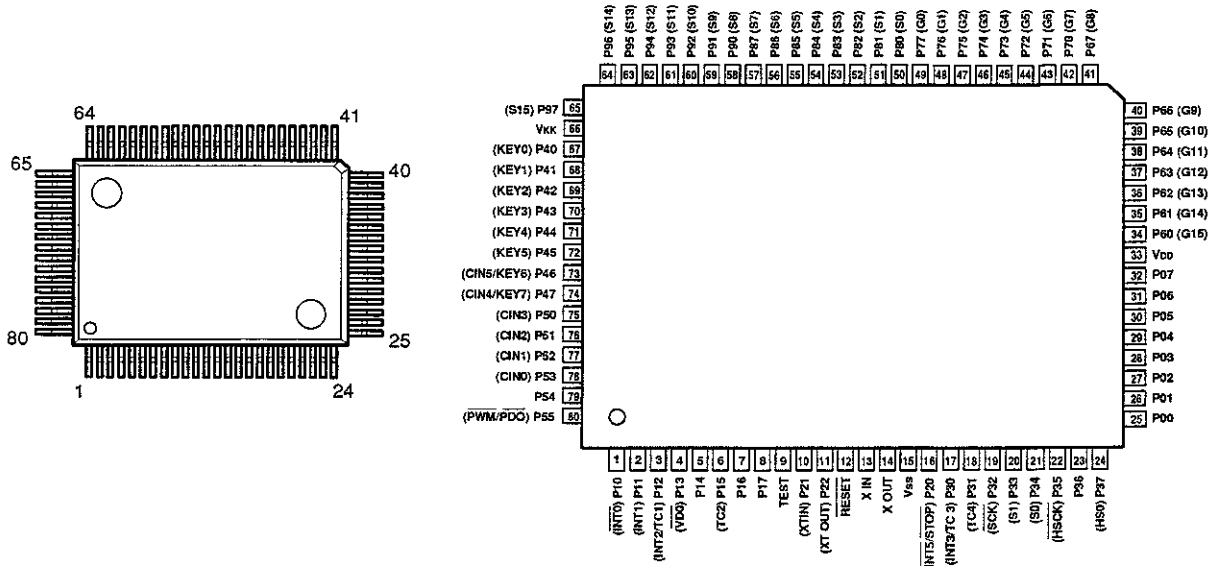

TMP87CP71F-6223 Terminal Function

Pin No.	Port Name	Symbol	I/O	Type	Op	Det	Res	Ini	Function
1	P10/INT 0	POWER DOWN	I	—	Eu	Lv	Z	—	Power down detection ("L" at power down).
2	P11/INT 1	PROTECTION	I	—	Eu	E&L	Z	—	Protection input ("H" at protection).
3	P12/INT 2		O	C	—	—	Z	L	Not used.
4	P13/DVO		O	C	—	—	Z	L	Not used.
5	P14		O	C	—	—	Z	L	Not used.
6	P15/TC2		O	C	—	—	Z	L	Not used.
7	P16		O	C	—	—	Z	L	Not used.
8	P17		O	C	—	—	Z	—	Not used.
9	TEST	TEST	I	—	GND	—	—	—	Connect to GND.
10	P21/XTIN		O	N	—	—	Z	L	Not used.
11	P22/XTO		O	N	—	—	Z	L	Not used.
12	RESET	RESET	I	—	—	—	Z	—	Reset input.
13	XIN		I	—	—	—	—	—	Oscillation circuit (4MHz).
14	XOUT		O	—	—	—	—	—	Oscillation circuit (4MHz).
15	VSS	GND	I	—	GND	—	—	—	
16	P20/INT 5	START	O	N	—	—	Z	L	Not used.
17	P30/INT 3	REMOCON	I	—	Eu	E&L	Z	—	Remote control signal input.
18	P31/TC4		O	N	—	—	Z	L	Not used.
19	P32/SCK		O	N	—	—	Z	L	Not used.
20	P33/SI		O	N	—	—	Z	L	Not used.
21	P34/S0		O	N	Eu	—	Z	L	Not used.
22	P35/HSCK	OSD CLK	O	N	Eu	S	Z	H	OSD control output (M35012).
23	P36	OSD CS	O	N	Eu	—	Z	H	OSD control output (M35012).
24	P37/HSO	OSD DATA	O	N	Eu	S	Z	L	OSD control output (M35012).
25	P00	POWER	O	C	—	—	Z	H	Power supply relay control output ("H" at ON).
26	P01	PRO. CNT-E	O	C	—	—	Z	H	Test tone control.
27	P02	PRO. CNT-A	O	C	—	—	Z	L	Test tone control.
28	P03	PRO. CNT-B	O	C	—	—	Z	L	Test tone control.
29	P04	PRO. NORMAL	O	C	—	—	Z	L	Center mode control.
30	P05	PRO. WIDE	O	C	—	—	Z	H	Center mode control.
31	P06	SURR. MODE	O	C	—	—	Z	L	Prologic shifting control output ("L" at STEREO mode).
32	P07	SIM. 1	O	C	—	—	Z	L	DSP input signal control output.
33	VDD	VDD	I	—	—	—	—	—	Connect to +5V.
34	P60	STEREO	O	P	Id	—	L	L	DSP input signal control output.
35	P61	DSP POWER	O	P	Id	—	L	L	DSP power supply control output ("H" at ON).
36	P62	DSP CLK	O	P	Id	S	L	L	DSP control output (DDSC-D).
37	P63	DSP DATA	O	P	Id	S	L	L	DSP control output (DDSC-D).
38	P64	DSP CD	O	P	Id	S	L	L	DSP control output (DDSC-D).
39	P65	DSP CS	O	P	Id	S	L	L	DSP control output (DDSC-D).
40	P66	DSP RES	O	P	Id	—	L	L	DSP control output (DDSC-D).
41	P67	CINEMA	O	P	Id	—	L	L	CINEMA control output ("H" at ON).
42	P70	AVSE	O	P	Id	—	L	H	AVSE control output ("L" at ON).
43	P71	E. VOL CLK	O	P	Id	—	L	L	Electronic volume control output. (TC9299).
44	P72	E. VOL DATA	O	P	Id	—	L	L	Electronic volume control output. (TC9299).
45	P73	E. VOL ST	O	P	Id	—	L	L	Electronic volume control output. (TC9299).
46	P74	VOL. UP	O	P	Id	—	L	L	Electronic volume control output. (BA6208F).
47	P75	VOL. DOWN	O	P	Id	—	L	L	Electronic volume control output. (BA6208F).
48	P76	FL DATA	O	P	Id	—	L	H	FL tube indication control output (MSC1937).
49	P77	FL RES	O	P	Id	—	L	L	FL tube indication control output (MSC1937).
50	P80	FL CLK	O	P	Id	—	L	H	FL tube indication control output (MSC1937).
51	P81	STANDBY LED	O	P	Id	—	L	H	Standby indication LED drive output ("H" at lighted).

Pin No.	Port Name	Symbol	I/O	Type	Op	Det	Res	Ini	Function
52	P82	TONE DEFEAT /DIRECT	O	P	Id	—	L	H	Tone defeat/direct control output ("L" at ON).
53	P83	H/P PRE MUTE	O	P	Id	—	L	H	Headphone and pre-out relay control output ("L" at MUTE).
54	P84	SP-CENTER	O	P	Id	—	L	L	Center speaker relay control output ("L" at MUTE).
55	P85	SP-REAR	O	P	Id	—	L	L	Rear speaker relay control output ("L" at MUTE).
56	P86	SP-B	O	P	Id	—	L	L	Front B speaker relay control output ("L" at MUTE).
57	P87	SP-A	O	P	Id	—	L	H	Front A speaker relay control output ("L" at MUTE).
58	P90	S-MONITOR DET.	I	—	Eu	Lv	L	—	S-monitor connection existence judgement ("L" at connecting).
59	P91	S-SIGNAL DET.	I	—	Eu	Lv	L	—	S-signal input control ("H" at S-signal input).
60	P92	OSD SYNC DET.	I	—	Eu	Lv	L	—	OSD sync shifting ("H" at external sync).
61	P93	S2	O	P	Id	—	L	—	Video signal shifting control output.
62	P94	S1	O	P	Id	—	L	—	Video signal shifting control output.
63	P95	FUNC CLK	O	P	Id	S	L	L	Function control output (TC9273).
64	P96	FUNC DATA	O	P	Id	S	L	L	Function control output (TC9273).
65	P97	FUNC ST	O	P	Id	—	L	L	Function control output (TC9273).
66	VKK	VKK	I	—	—	—	—	—	Connect to GND.
67	P40/KEY0	OSD RES	O	N	Eu	—	Z	H	OSD control output (M35012).
68	P41/KEY1	A	O	N	Eu	—	Z	H	Video input control ("L" at selection) BA7625, BA7626.
69	P42/KEY2	B	O	N	Eu	—	Z	H	Video input control ("L" at selection) BA7625, BA7626.
70	P43/KEY3	C	O	N	Eu	—	Z	H	Video output control ("L" at selection) BA7625, BA7626.
71	P44/KEY4	D	O	N	Eu	—	Z	H	Video output control ("L" at selection) BA7625, BA7626.
72	P45/KEY5	E	O	N	Eu	—	Z	H	Video input/output control ("L" at selection) BA7625, BA7626.
73	P46/CIN5	MODE	I	—	Eu	Lv	Z	—	Forward country shifting input.
74	P47/CIN4	KEY5	I	—	Eu	Lv	Z	—	Button input 5.
75	P50/CIN3	KEY4	I	—	Eu	Lv	Z	—	Button input 4.
76	P51/CIN2	KEY3	I	—	Eu	Lv	Z	—	Button input 3.
77	P52/CIN1	KEY2	I	—	Eu	Lv	Z	—	Button input 2.
78	P53/CIN0	KEY1	I	—	Eu	Lv	Z	—	Button input 1.
79	P54	TAPE INH	O	N	Eu	—	Z	H	TAPE INH. control output ("L" at INH).
80	P55/PMW	MULTI MUTE	O	N	Eu	—	Z	L	Multi control output ("H" at MULTI output in MUTE).

NOTE:

- Pin No. : Terminal number of microcomputer.
Port Name : The name entered in the data sheet of microcomputer.
Symbol : Symbolized interface function.
I/O : Input or output of part.
 "I" = Input port
 "O" = Output port
Type : Composition of port in case of output port.
 "C" = CMOS output
 "N" = NMOS open drain output
 "P" = PMOS open drain output.
Op : Pull up/Pull down selection information.
 "lu" = Inner microcomputer pull up
 "ld" = Inner microcomputer pull down
 "Eu" = External microcomputer pull up
 "Ed" = External microcomputer pull down
Det : Indicates judging state of input port. Level detection is "Lv"; Edge detection is "Ed"; Detection by both shifting is "E&L";
Serial data detection is "S" (Serial data output is also "S").
Res : State at reset.
 "H" = Outputs High Level at reset
 "L" = Outputs Low Level at reset
 "Z" = Becomes High Impedance mode at reset.
Ini : Initial output state.
Function : Function and logical level explanation of signals to be interface.

LC78835M (SU: IC210, 211)
LC7886MN (SU: IC207)

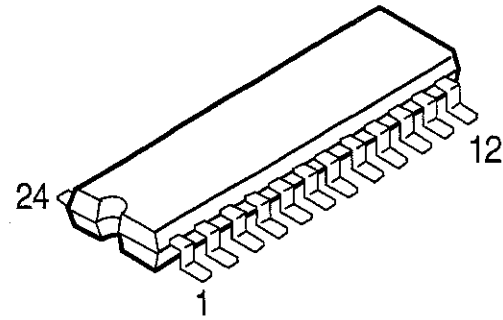

LC78835M

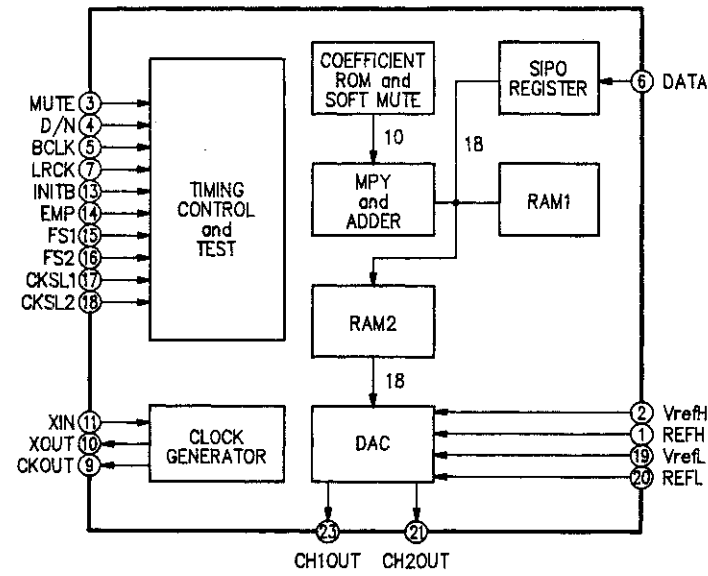
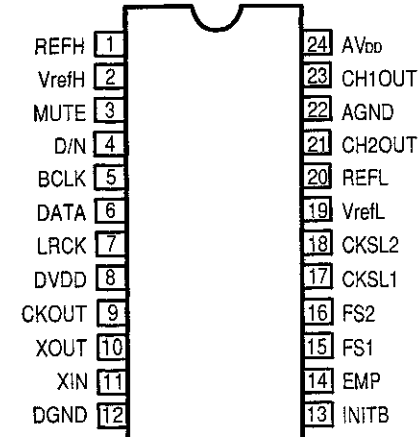

LC7886MN

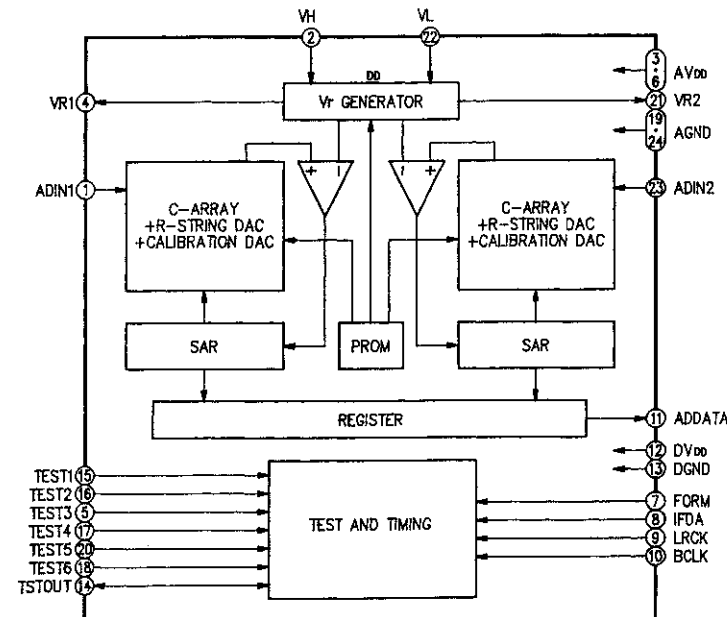
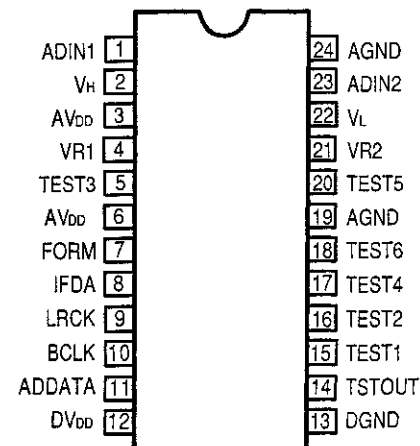

LC78835M Terminal Function

Pin No.	Symbol	Function						
1	REFH	Reference voltage "H" pin. Normally connected to AGND via a capacitor.						
2	VrefH	Reference voltage "H" input pin.						
3	MUTE	Muting signal input pin. Soft muting on at "H".						
4	D/N	Standard/high speed operation mode switching pin. High speed operation at "H", standard operation at "L".						
5	BCLK	Bit clock input pin.						
6	DATA	Digital audio data input pin. Input with 2's compliment, MSB first.						
7	LRCK	LR clock input pin. CH1 at "H" and CH2 at "L".						
8	DV _{DD}	Digital system power supply pin.						
9	CKOUT	Clock output pin. Clock of XIN frequency.						
10	XOUT	Crystal oscillator output pin (system clock output pin).						
11	XIN	Crystal oscillator output pin (system clock output pin).						
12	DGND	Digital system ground pin						
13	INITB	Initialization signal input pin. Initialization performed at "L".						
14	EMB	De-emphasis filter on/off switching pin. on at "H" and off at "L".						
15	FS1	Selection pins for the 32kHz/44.1kHz/48kHz modes of the de-emphasis filter. Connect to DGND.						
16	FS2							
17	CKSL1	System Clock selection pins.						
18	CKSL2	<table border="1"> <tr> <td>CKSL1</td> <td>CKSL2</td> <td>System Clock</td> </tr> <tr> <td>H</td> <td>H</td> <td>512fs</td> </tr> </table>	CKSL1	CKSL2	System Clock	H	H	512fs
CKSL1	CKSL2	System Clock						
H	H	512fs						
19	VrefL	Reference voltage "L" input pin.						
20	REFL	Reference voltage "L" pin. Normally connected to AGND via a capacitor.						
21	CH2OUT	CH2 analog output pin.						
22	AGND	Analog system ground pin.						
23	CH1OUT	CH1 analog output pin.						
24	AV _{DD}	Analog system power supply pin.						

LC7886MN Terminal Function

Pin No.	Symbol	Function
1	ADIN1	CH1 analog input terminal.
2	V _H	Reference voltage "H" input terminal.
3	AV _{DD}	Analog power supply voltage terminal.
4	VR1	CH1 (V _H +V _L)/2 reference voltage output terminal.
5	TEST3	Test terminal. Normally, connect to analog GND.
6	AV _{DD}	Analog power supply voltage terminal.
7	FORM	Input terminal responds to: FORM = "L" level, LRCK = CH1 at "H" level, LRCK = CH2 at "L" level.
8	IFDA	Input terminal responds to: IFDA = Digital data is 16-bit at "L" level.
9	LRCK	Input terminal: Designates CH1, CH2 of output digital data (ADDATA) (Refer to Pin 7 FORM).
10	BCLK	Input terminal: Bit clock terminal. Clock to output digital data to bit serial.
11	ADDATA	Data output terminal: Bit serial output from MSB side. Data is output by 2's complement system.
12	DV _{DD}	Digital power supply voltage terminal.
13	DGND	Digital GND terminal.
14	TSTOUT	Test terminal. normally, connect to digital GND.
15	TEST1	
16	TEST2	
17	TEST4	
18	TEST6	
19	AGND	
20	TEST5	Test terminal. Normally, connect to analog GND.
21	VR2	CH2 (V _H +V _L)/2 reference voltage output terminal.
22	V _L	Reference voltage "L" input terminal.
23	ADIN2	CH2 analog input terminal.
24	AGND	Analog GND terminal.

M35012-089SP (SV: IC904)

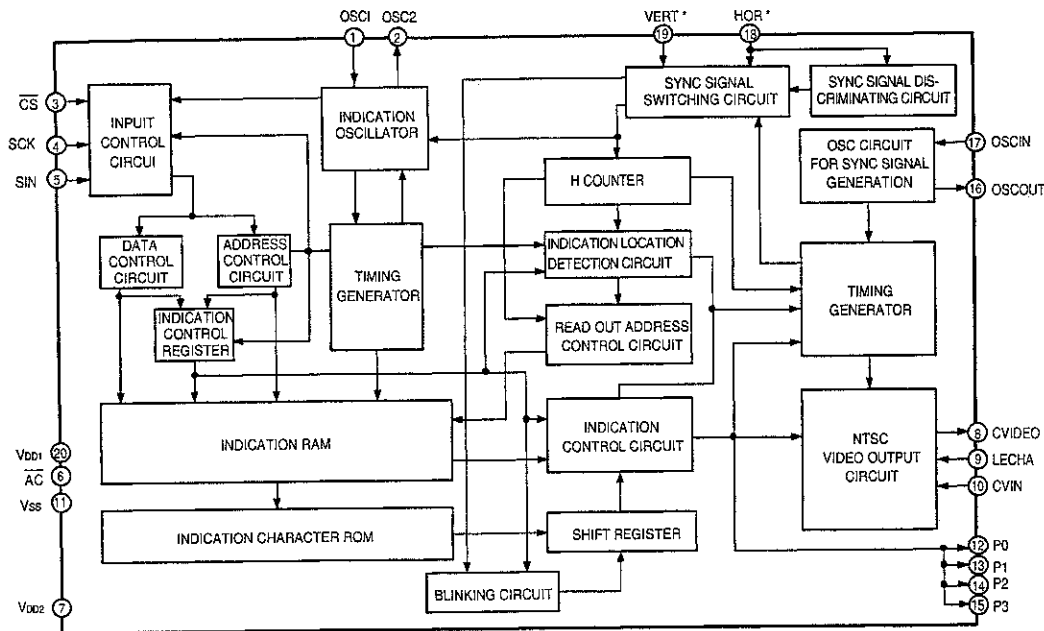
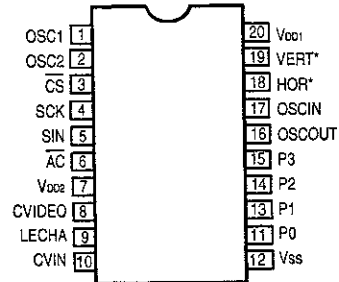
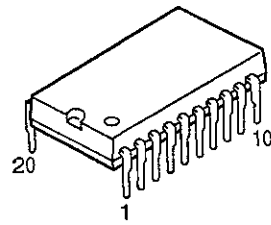

M35012-089SP Terminal Function

Pin No.	Symbol	Name	I/O	Function
1	OSC1	Osc. circuit ext. terminal.	I	External terminal for indication oscillator circuit. Standard OSC. freq. is approx. 7MHz. With this OSC. freq., decides horizontal indication locatin and character width.
2	OSC2		O	
3	CS	Chip select input	I	Chip select terminal and turns to "L" when transfer serial data. Hysteresis input. Pull up resistor is built-in.
4	SCK	Serial clock input	I	Takes in serial data of SIN at SCK rise when CS terminal is in "L". Hysteresis input. Pull up resists is built-in.
5	SIN	Serial data Input	I	Serial input of register for indication control and data, and address for indication data memoly. hysteresis input. Pull up resistor is built-in.
6	AC	Auto-clear input	I	Resets internal circuit of IC at "L" mode. Hysteresis input, Pull up resistor is built-in.
7	VDD2	Power supply	—	Power supply terminal of analog system. Connect to +5V.
8	CVIDEO	Combined video output	O	Output terminal of combined video signal. Outputs 2Vp-p combined video signal. Character output, etc. Overlap CVIN signal and outputs at superimpose.
9	LECHA	Character level input	I	Input terminal deciding character output level in combined video signal. color of character is white.
10	CVIN	Combined video input	I	Input terminal of external combined video signal. Character output etc. overlap this external combined video signal.
11	VSS	Ground	—	Ground terminal. Connect to GND.
12	P0	Output port P0	O	General output or character background signal BL NK1* output is switchable. Polarity can be selected at ROM mask.
13	P1	Output port P1	O	General output or character background signal CO1* output is switchable. Polarity can be selected at ROM mask.
14	P2	Output port P2	O	General output or character background signal BLNK2* output is switchable. Polarity can be selected at ROM mask.

Pin No.	Symbol	Name	I/O	Function
15	P3	Output port P3	O	General output or character background signal CO2* output is switchable. Polarity can be selected at ROM mask.
16	OSCOOUT	Ext. terminal for sync sig. OSC. Circuit	O	Terminal for external use of sync signal OSC. circuit. Use the freq.: 14.32MHz at NTSC system, 17.73MHz at PAL. system, 14.30MHz at MPAL system.
17	OSCIN		I	
18	HOR*	Horizontal sync signal	I	Inputs horizontal sync signal. Hysteresis input.
19	VERT*	Vertical Sync signal	I	Inputs vertical sync signal. Hysteresis input. Polarity can be selected at ROM mask.
20	VDD1	Power supply	—	Power supply terminal of digital system. Connect to +5V.

TC9273N-007 (SU: IC103)
TC9273N-004 (SU: IC104)

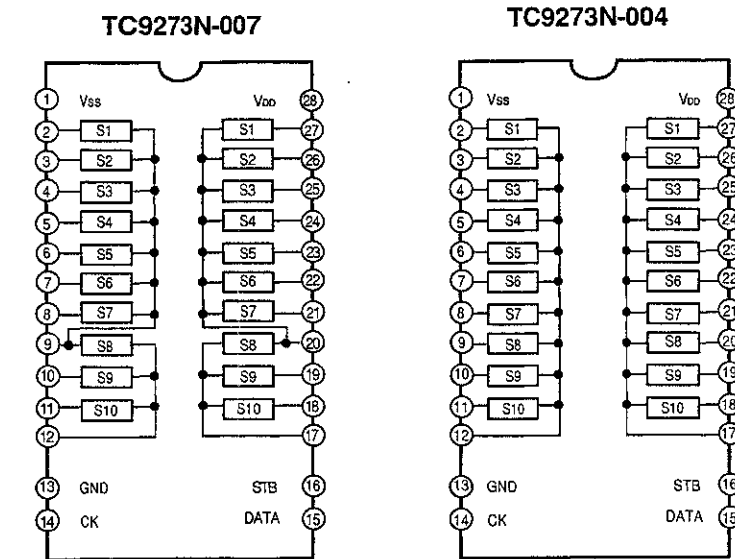
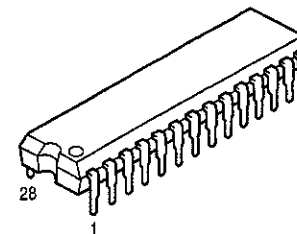

TC9273N Terminal Function

Pin No.	Symbol	Name	Function	Note
1	VSS	-Power Terminal	Dual Power Use: VDD = 8.0~17V GND = 0V VSS = -8.0~-17V	Single Power Use: VDD = 8.0~18V VSS = GND = 0V
13	GND	Digital Ground		
28	VDD	+Power Terminal		
2-12 17-27	S1-11	I/O Terminal	Input terminal of analog switch.	—
14	CK	Clock Input	Clock input for data transfer.	Low level Border Input Terminal
15	DATA	Data Input	Serial input for switch setting.	
16	STB	Strobe Input	Strobe input for data writing.	

DDSC-A
(SU: IC201)

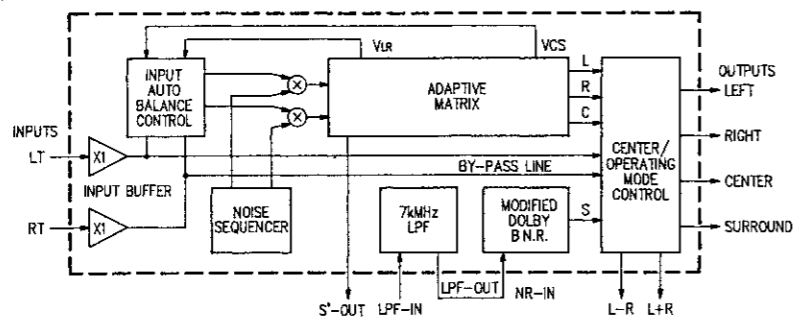
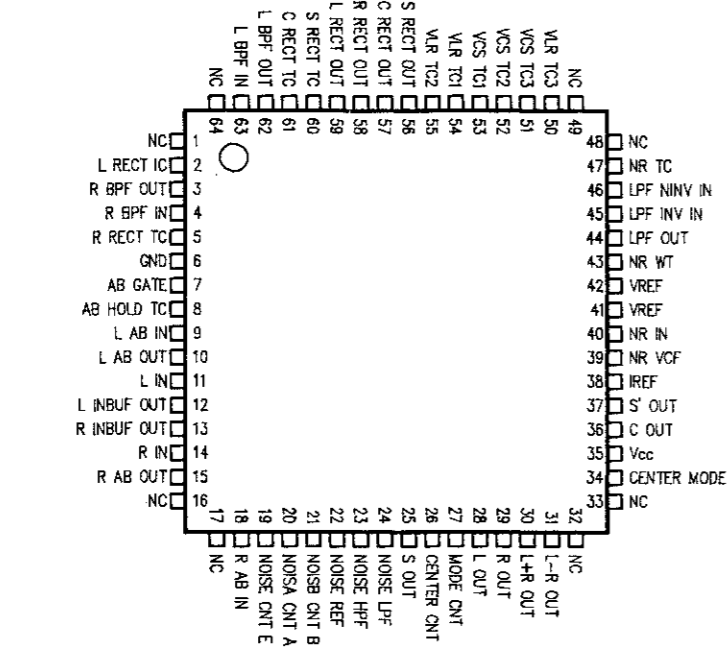

DDSC-D
(SU: IC208)

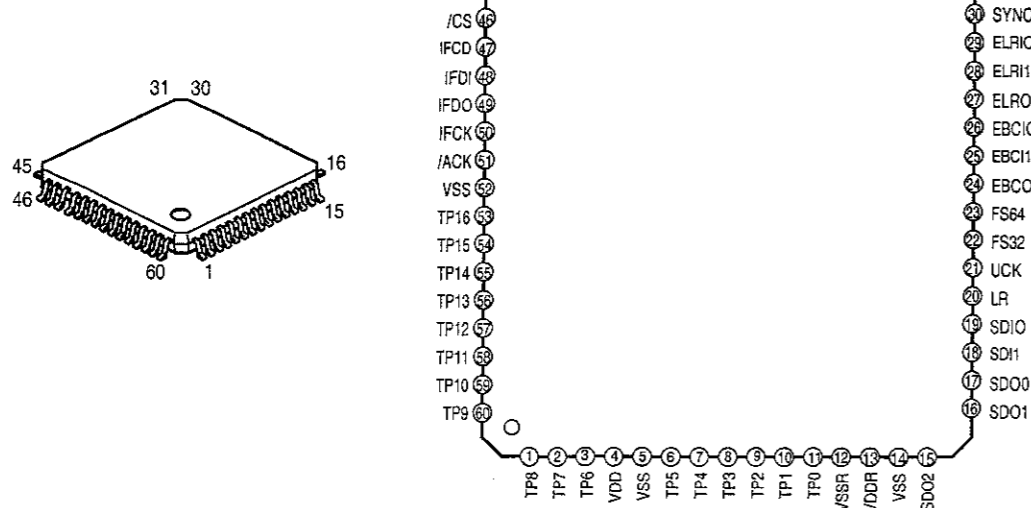

TC4053BP (SU: IC804)

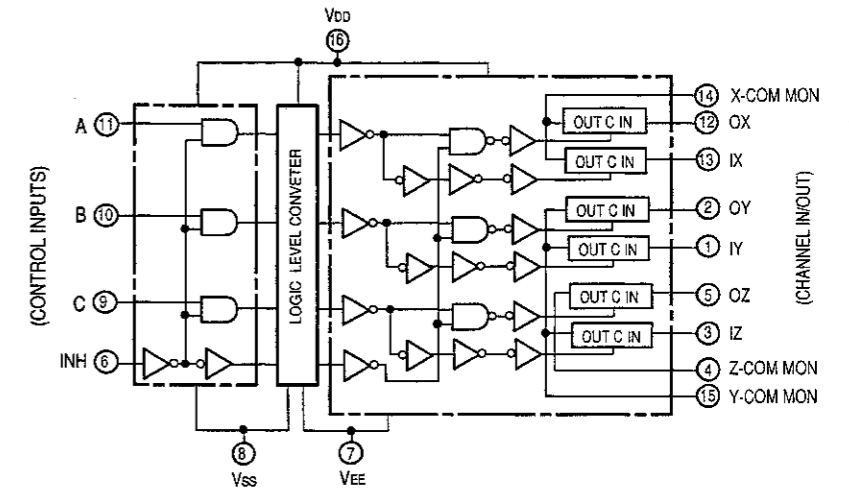
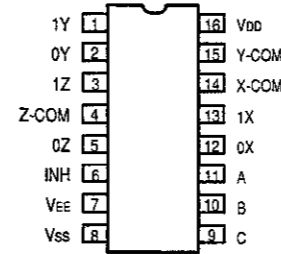
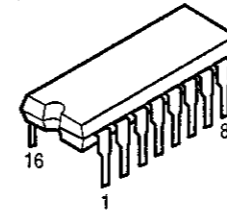

NJM2229S (SV: IC905)

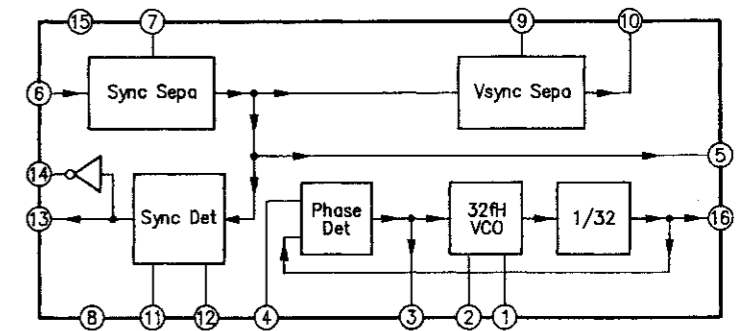
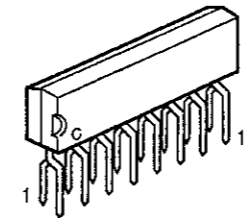

BA7625 (SU: 801) (SV: IC902)
BA7626 (SV: 901)

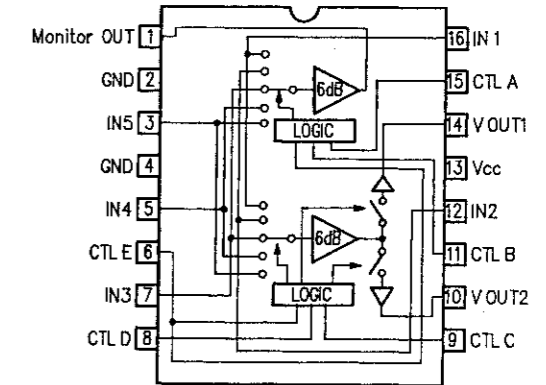
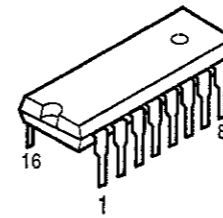

A	B	E	MONITOR OUT
L	L	*	IN 1
H	L	*	IN 2
L	H	*	IN 3
H	H	L	IN 4
H	H	H	IN 5

C	D	E	V OUT 1
L	L	*	—
H	L	*	IN 2
L	H	*	IN 3
H	H	L	IN 4
H	H	H	IN 5

C	D	E	V OUT 2
L	L	*	IN 1
H	L	*	—
L	H	*	IN 3
H	H	L	IN 4
H	H	H	IN 5

Note 1: * mark means that feasible for either H or L.
 Note 2: Each input terminal is provided with sink chip clamp (BA7625).
 Each input terminal takes 20kohm at the end (BA7626).

BA15218
 (FL: IC565)
 (SU: IC102,381)

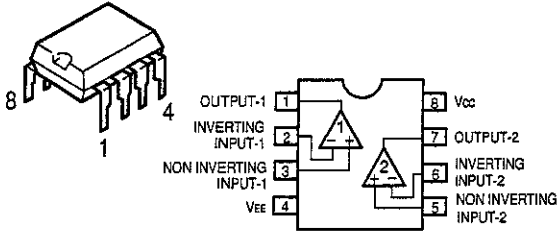

BA4558F (SU: IC106,205,302,304,307,308)
BA15218F (SU: IC305)
BA4558F or NJM2068MD (SU: IC101)

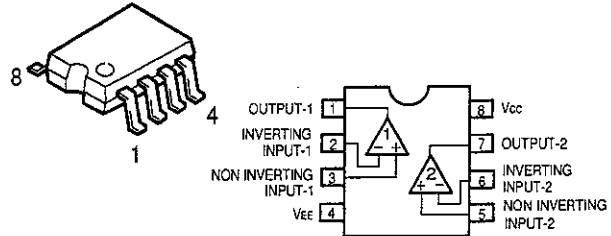

BA6208F (SU: IC306)

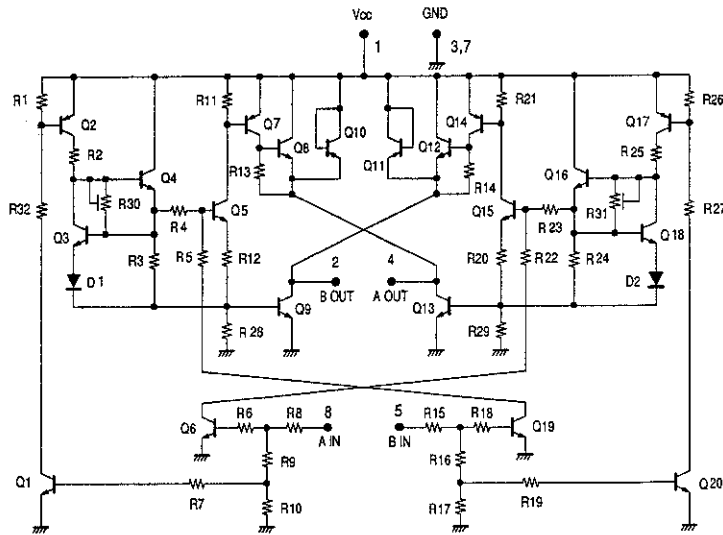
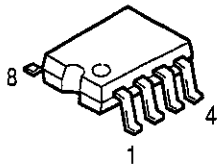

BU4066BCF (SU: IC202)

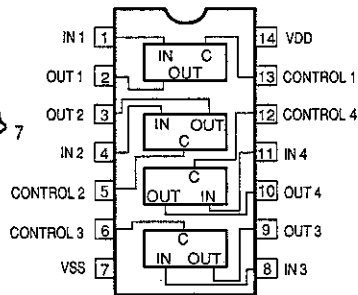
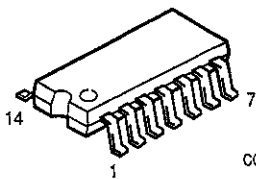

LC4966 (SU: IC213)

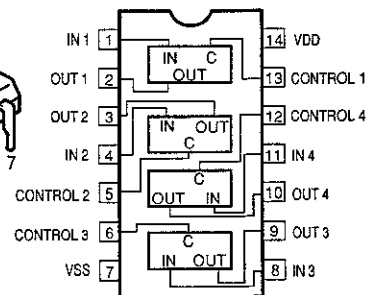
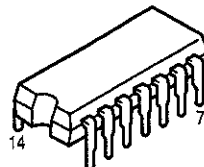

TC9299P (SU: IC301, 303)

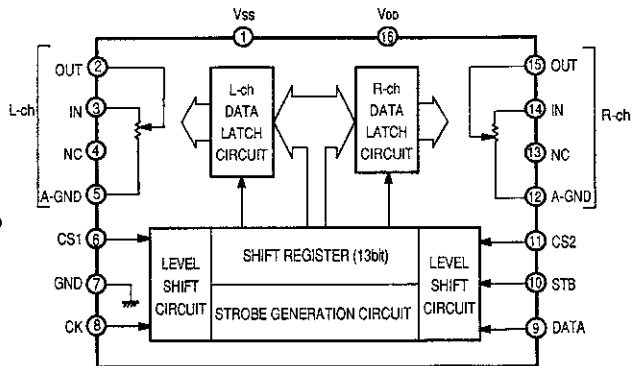
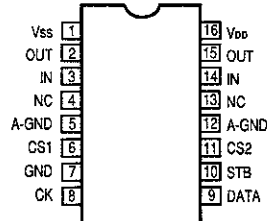
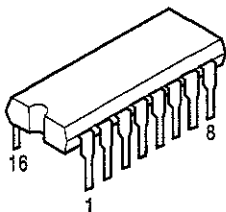

MC74HC4053N (SV: IC903)

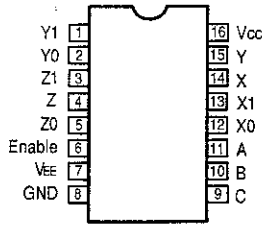
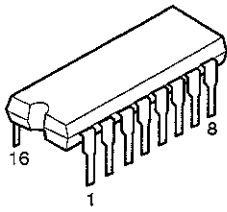

Control Inputs		Select			ON Switches		
		Enable	C	B	A	Z0	Y0
L	L	L	L	L	Z0	Y0	X0
L	L	L	L	H	Z0	Y0	X1
L	L	L	H	L	Z0	Y1	X0
L	L	L	H	H	Z0	Y1	X1
L	H	L	L	L	Z1	Y0	X0
L	H	L	L	H	Z1	Y0	X1
L	H	H	L	L	Z1	Y1	X0
L	H	H	L	H	Z1	Y1	X1
H	X	X	X	X	None		

X = Don't Care

MSC1937-03RS (FL: IC751)

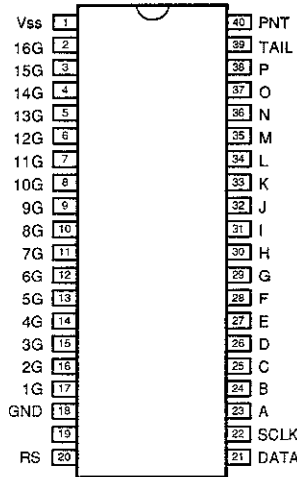
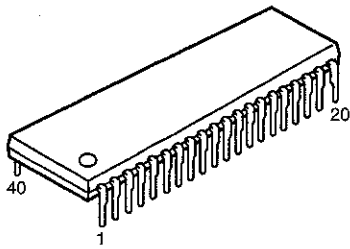

Pin No.	Terminal Function
1	Power Supply (+5V)
3	Digit 1 Output
?	?
17	Digit 17 Output
18	GND
19	---
20	POWER-ON-RESET
21	Data Input
22	Shift Clock Input
23	Segment A Output
?	?
38	Segment P Output
39	---
40	POINT Output

SI-18752 (FL: IC655,656)

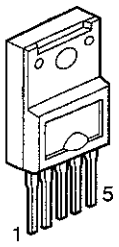

1. +IN
2. IN
3. VEE
4. Output
5. +Vcc

NJM7915FA (FL: IC654)

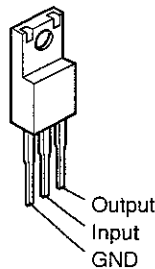

NJM7805FA(S) or MCT7805CT (SU: IC203,204)

MC7806CT or MCT7806CT or NJM7806FA(S) (FL: IC601)(SU: IC803)

- NJM7806FA(S) (SV: IC806)
- NJM7815FA(S) (FL: IC803)
- NJM7820FA(S) (FL: IC653)

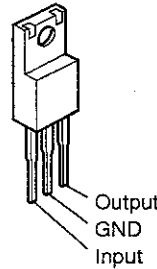

● IC PROTECTOR

- ICP-N15 (FL: IC602)
- ICP-N20 (FL: IC651, 652)

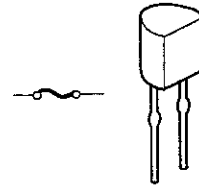

● OTHERS

SBX1610-52 (Remote Control Sensor) (FL: IC752)

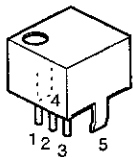

1. Vcc
2. Output
3. GND
4. Case Fin
5. Case Fin

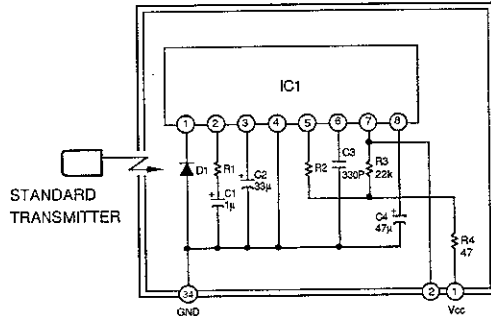

- IC1 : CX20106A Chip
- D1 : PIN Photodiode Chip
- C1,C2,C4 : Aluminum Electrolytic Capacitor
- C3 : SL Characteristic ±5%
- R1 : Gain control resistor
- R2 : fo control resistor (Using ±1%)
- R (Other than above items) : ±5%

● TRANSISTORS

2SA970 (BL)
2SA988 (E/F)
2SA1015 (GR)
2SC1815(Y),(BL)
2SC1841 (E/F)
2SC2878 (A/B)

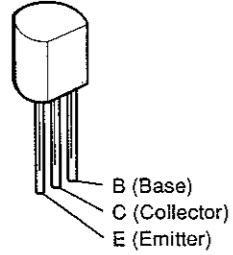

2SB1041 (R)
2SD1292 (R)

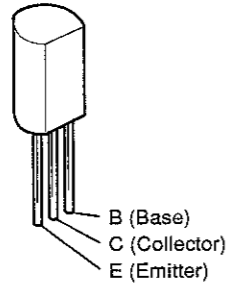

2SA1491 (O/P/Y)(Z)
2SC3855 (O/P/Y)(Z)

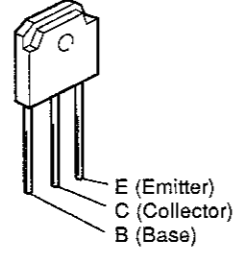

2SB1328 (P)
2SD2004 (P)

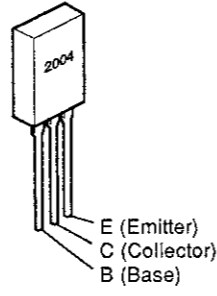

DTA114ES
DTC114ES
DTC144ES

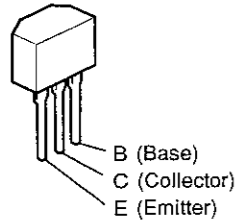

DTA114ES

PNP Type

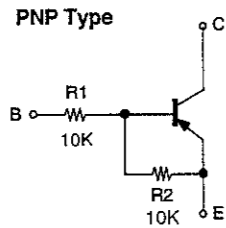

DTC114ES
DTC144ES

NPN Type

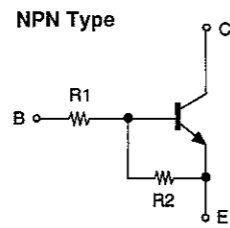

	R1	R2
DTC114ES	10kohm	10kohm
DTC144ES	47kohm	47kohm

2SA933S (S)
2SC1740S (E)

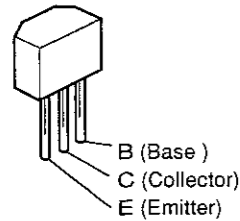

2SK184 (GR)/(BL)

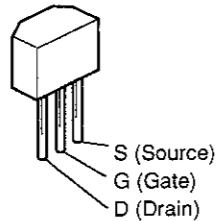

2SC2412K (S)
2SC3326 (A/B)

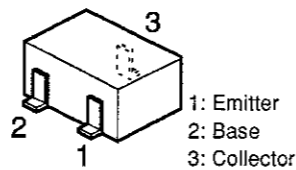

DTA144EK
DTC114YK
DTC143TK
DTC144EK

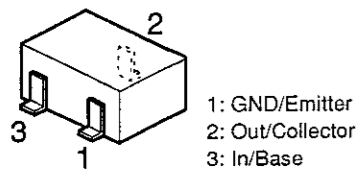

DTC114YK
DTC143TK
DTC144EK

NPN Type

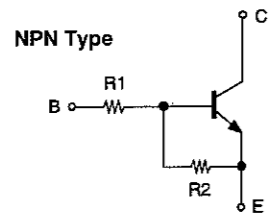

	R1	R2
DTC114YK	10kohm	47kohm
DTC143TK	4.7kohm	—
DTC144ES	47kohm	47kohm

DTA144EK

PNP Type

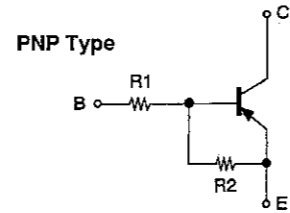

	R1	R2
DTA144EK	47kohm	47kohm

● DIODES (included LED)

1SS270A
1S2076A

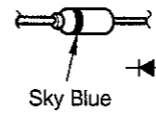

MTZJ3.3A MTZJ8.2A
MTZJ5.1A MTZJ13A
MTZJ7.5A MTZJ18A

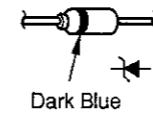

1SR35-200A

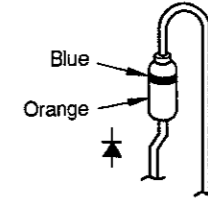

DSM1D2 (Type 3)

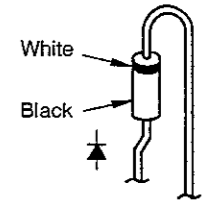

SF0R1A42
(Thyristor)
(MA: SC601)

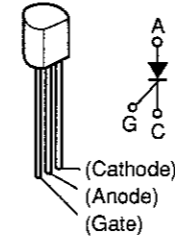

S4VB20F (FL: D652)
(MA: D615, 616)

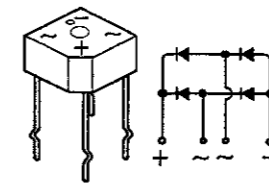

SEL1210S (Red)
(FL: LD751)

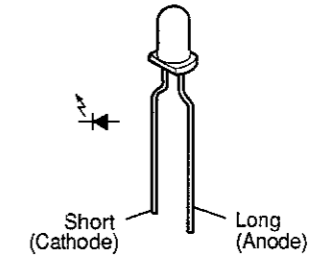

● POSISTOR
PTH9M04BB222TS2F333
(FL: P651)



● FL DISPLAY FIP16FM7R (Part No.: 3934156001)(FL751)

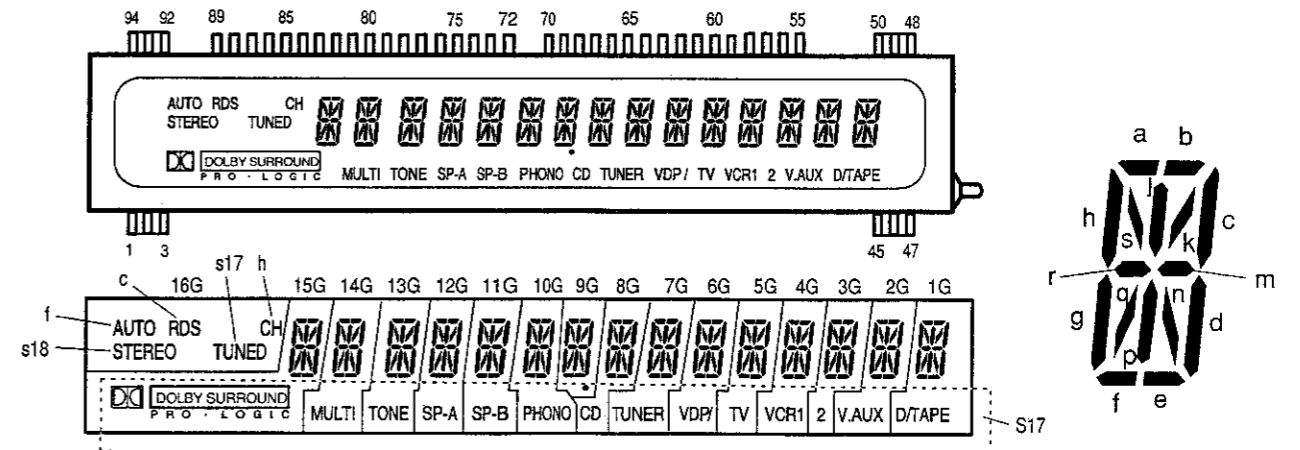

(UPPER)

TERMINAL No.	94	93	92	91	90	89	88	87	86	85	84	83	82	81								
ELECTRODE	F1	F1	F1	NP	NP	a	b	c	j	k	s	h	r	m								
TERMINAL No.	80	79	78	77	76	75	74	73	72	71	70	69	68	67	66	65	64	63	62	61		
ELECTRODE	P	P	P	P	P	P	P	P	P	NP	16G	15G	14G	13G	12G	11G	10G	9G	8G	7G		
TERMINAL No.										60	59	58	57	56	55	54	53	52	51	50	49	48
ELECTRODE										6G	5G	4G	3G	2G	1G	NP	NP	NP	NP	F2	F2	F2

(LOWER)

TERMINAL No.										35	36	37	38	39	40	41	42	43	44	45	46	47
ELECTRODE										NP	NP	NP	NP	NP	NP	NP	NP	NP	NP	F2	F2	F2
TERMINAL No.	15	16	17	18	19	20	21	22	23	24	25	26	27	28	29	30	31	32	33	34		
ELECTRODE	NP	NP	NP	NP	NP	NP	NP	NP	NP	NP	NP	NP	NP	NP	NP	NP	NP	NP	NP	NP	NP	NP
TERMINAL No.	1	2	3	4	5	6	7	8	9	10	11	12	13	14								
ELECTRODE	F1	F1	F1	NP	NP	NP	NP	NP	NP	NP	NP	NP	NP	NP								

Notes: F: Filament G: Grid A: Anode NP: No Pin

PRINTED WIRING BOARD (Pattern Side)

1

2

3

4

5

6

7

8

1U-2743 MAIN AMP UNIT ASS'Y

A

B

C

D

E

1U-2743 Main AMP Unit Ass'y	
1	Main Amp Unit
2	Head Phone Unit

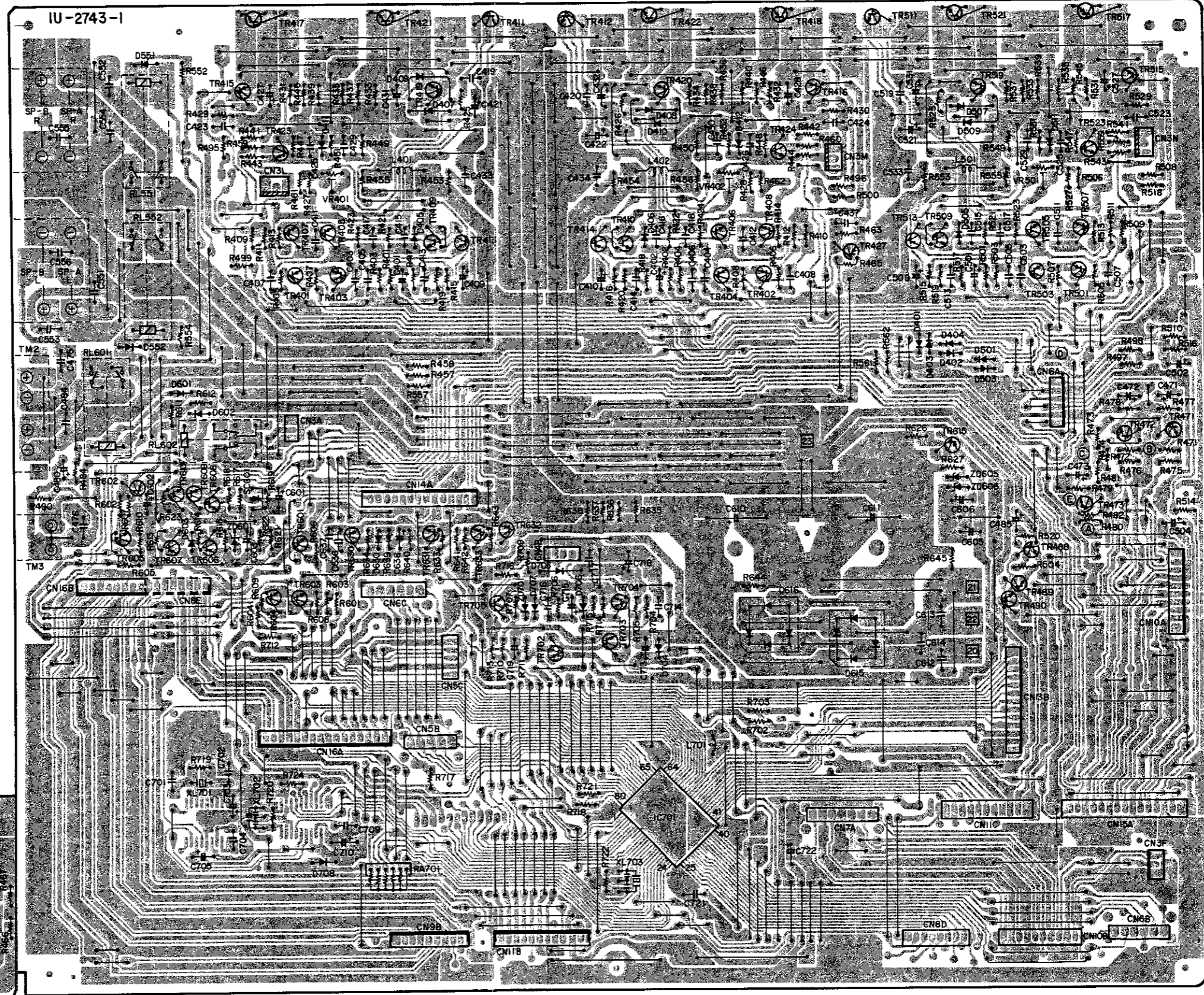

1 2 3 4 5 6 7 8

1U-2744 SURROUND UNIT ASS'Y

1U-2744 Surround Unit Ass'y	
1	Surround Unit
2	Volume Unit
3	Video Unit
4	Voltage Sel Unit

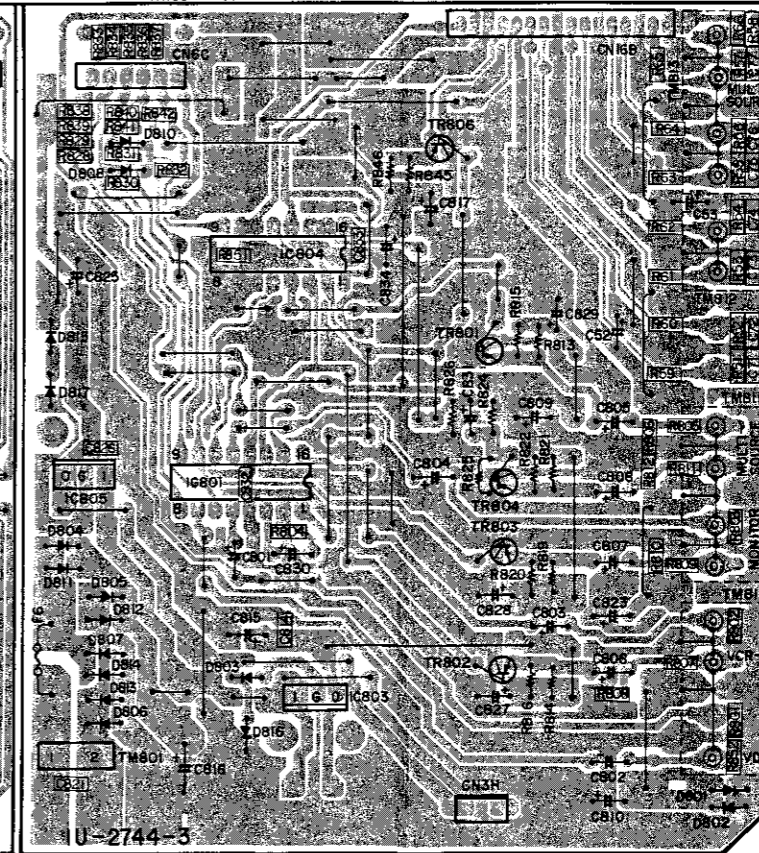
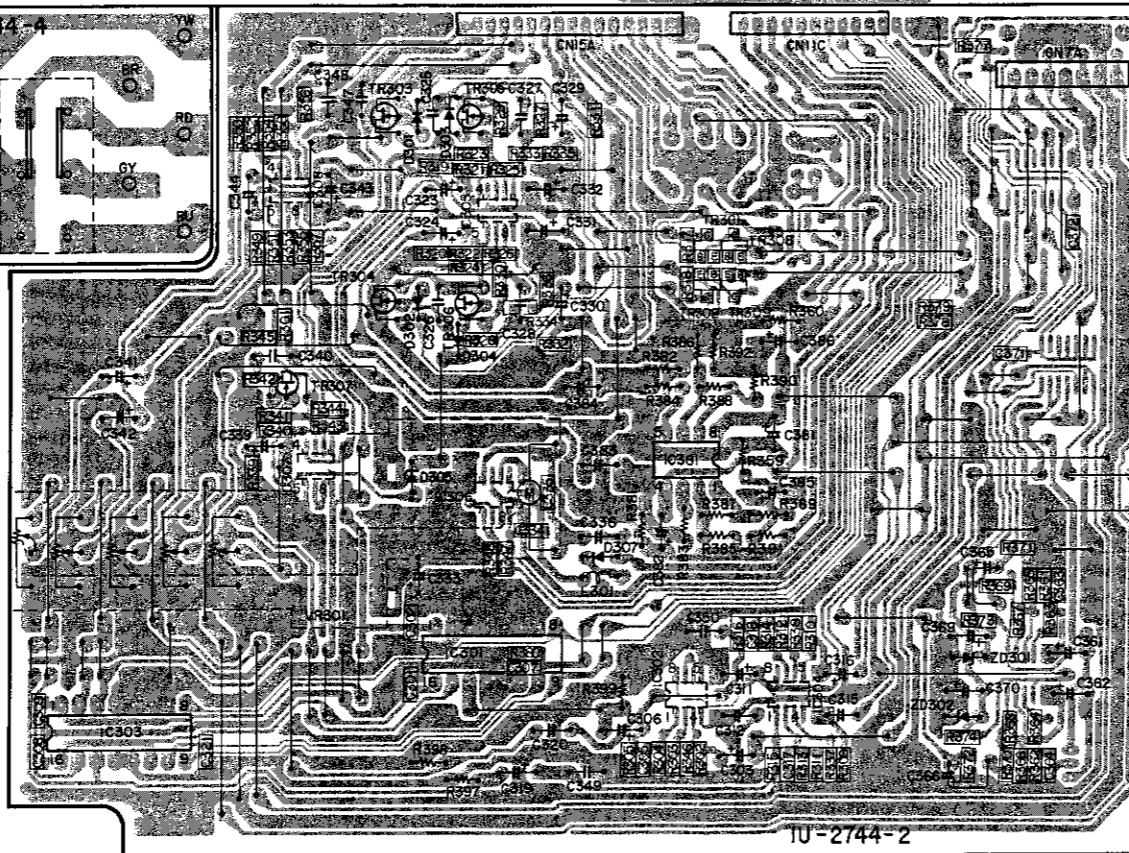
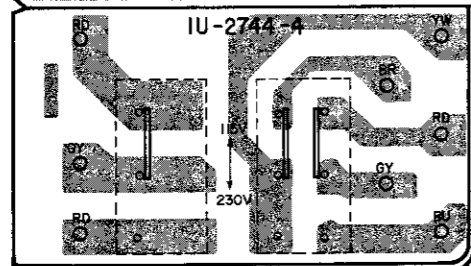
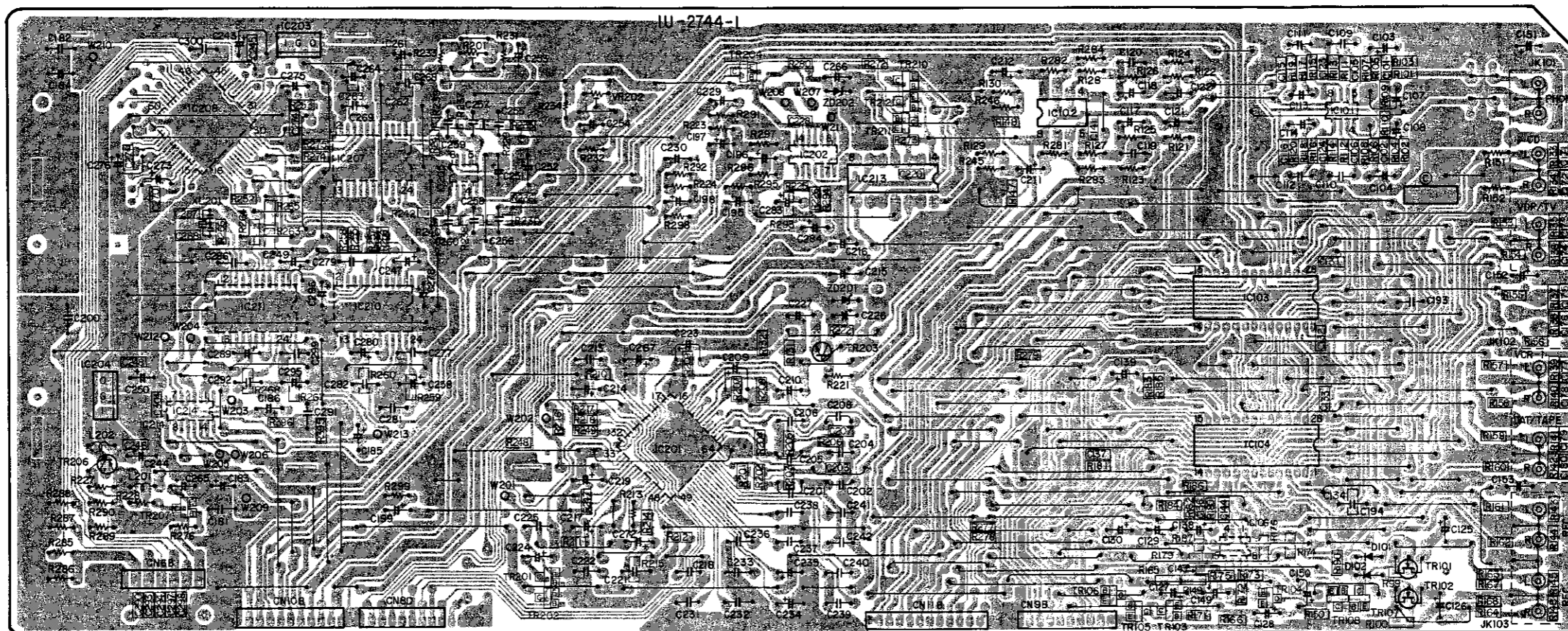

A
B
C
D
E

1 2 3 4 5 6 7 8

1U-2745 FLD UNIT ASS'Y

A

1U-2745 FLD Unit Ass'y	
1	FLD Unit
2	Power Supply Unit
3	—
4	Tact Switch Unit
5	Tone Unit
6	Rear Amp. Unit

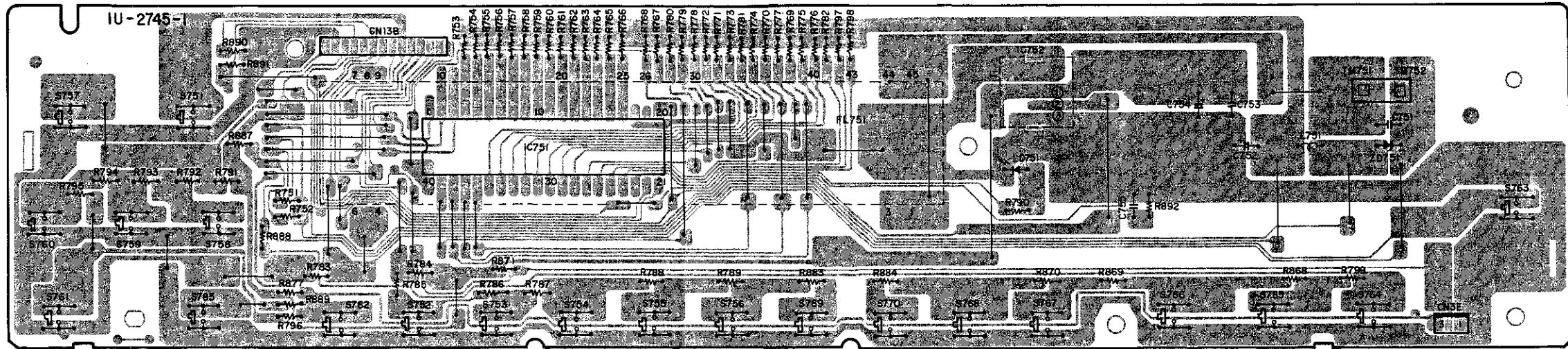

B

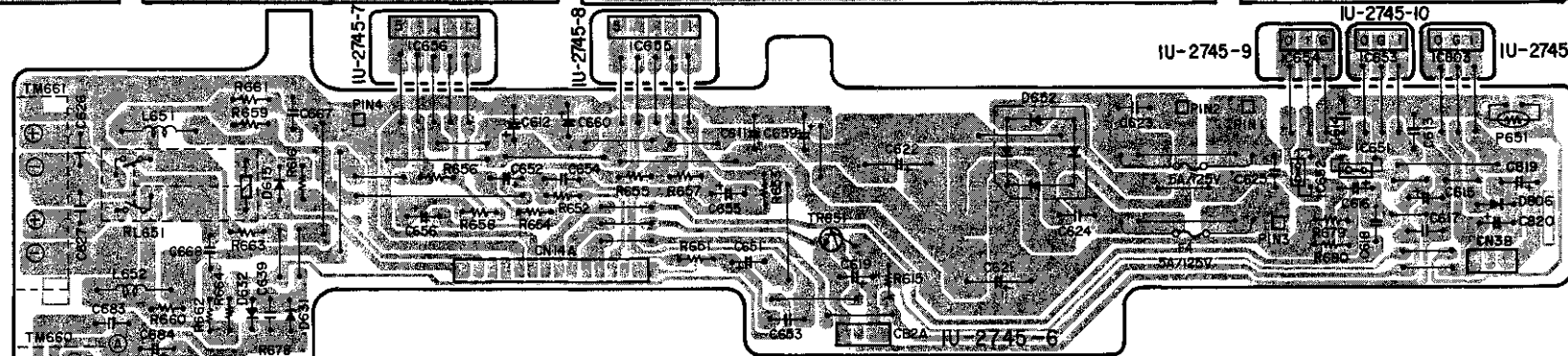

C

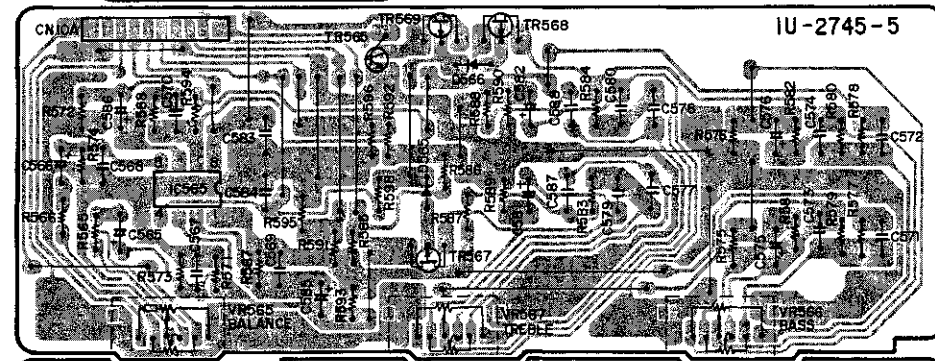

D

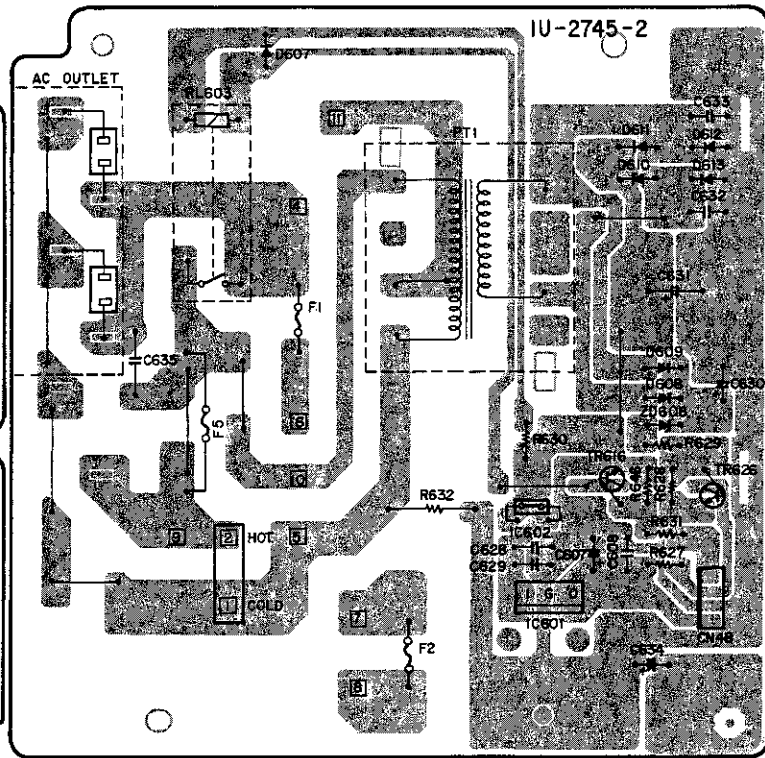

E

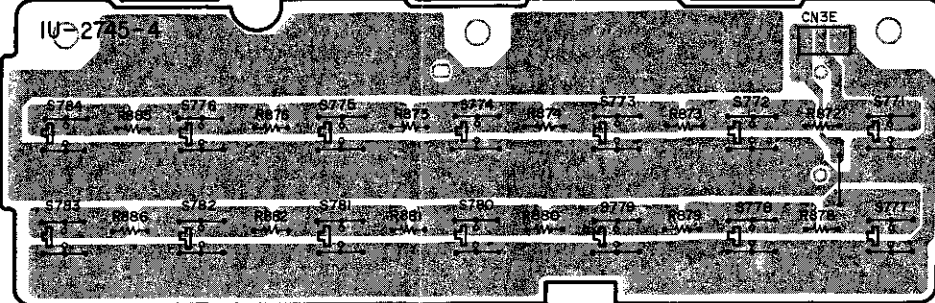

1 2 3 4 5 6 7 8

1U-2746 S-VIDEO UNIT ASS'Y

1U-2746 S-Video Unit Ass'y	
1	S-Video Unit
2	V-Aux. Unit
3	Regulator Unit

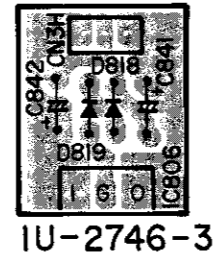
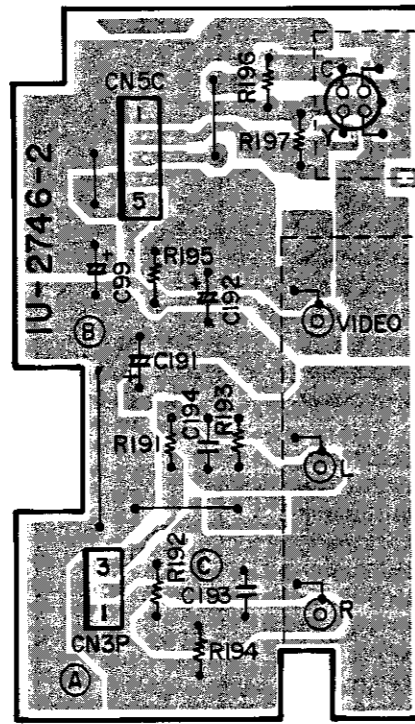
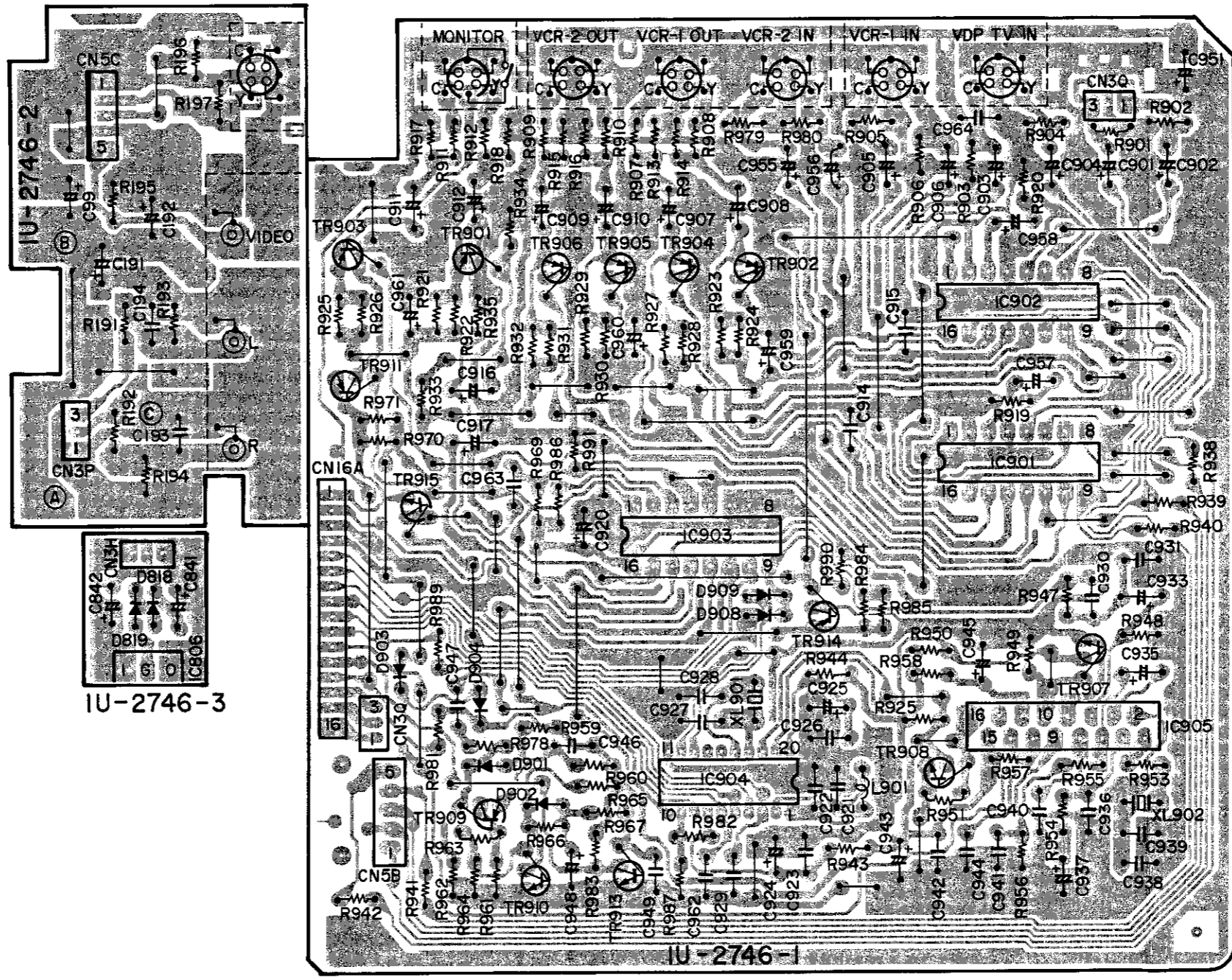

A
B
C
D
E

NOTE FOR PARTS LIST

- Part indicated with the mark "◎" are not always in stock and possibly to take a long period of time for supplying, or in some case supplying of part may be refused.
- When ordering of part, clearly indicate "1" and "I" (i) to avoid mis-supplying.
- Ordering part without stating its part number can not be supplied.
- Part indicated with the mark "★" is not illustrated in the exploded view.
- Not including Carbon Film ±5%, 1/4W Type in the P.W.Board parts list. (Refer to the Schematic Diagram for those parts.)

WARNING:

Parts marked with this symbol  have critical characteristics. Use ONLY replacement parts recommended by the manufacturer.

Resistors

Ex: RN	14K	2E	182	G	FR
Type	Shape and performance	Power	Resistance	Allowable error	Others
RD : Carbon	2B : 1/8W	F : ±1%	P : Pulse-resistant type		
RC : Composition	2E : 1/4W	G : ±2%	NL : Low noise type		
RS : Metal oxide film	2H : 1/2W	J : ±5%	NB : Non-burning type		
RW : Winding	3A : 1W	K : ±10%	FR : Fuse-resistor		
RN : Metal film	3D : 2W	M : ±20%	F : Lead wire forming		
RK : Metal mixture	3F : 3W				
	3H : 5W				

Resistance

1 8 2 ⇒ 1800 ohm = 1.8 kohm
Indicates number of zeros after effective number.
2-digit effective number.

• Units: ohm

1 R 2 ⇒ 1.2 ohm
1-digit effective number.
2-digit effective number, decimal point indicated by R.

• Units: ohm

Capacitors

Ex: CE	04W	1H	2R2	M	BP
Type	Shape and performance	Dielectric strength	Capacity	Allowable error	Others
CE : Aluminum foil electrolytic	0J : 6.3V	F : ±1%	HS : High stability type		
CA : Aluminum solid electrolytic	1A : 10V	G : ±2%	BP : Non-polar type		
CS : Tantalum electrolytic	1C : 16V	J : ±5%	HR : Ripple-resistant type		
CO : Film	1E : 25V	K : ±10%	DL : For charge and discharge		
CK : Ceramic	1V : 35V	M : ±20%	HF : For assuring high frequency		
CC : Ceramic	1H : 50V	Z : ±80%	U : UL part		
CP : Oil	2A : 100V	-20%	C : CSA part		
CM : Mica	2B : 125V	P : ±100%	W : UL-CSA type		
CF : Metallized	2C : 160V	-0%	F : Lead wire forming		
CH : Metallized	2D : 200V	C : ±0.25pF			
	2E : 250V	D : ±0.5pF			
	2H : 500V	-			
	2J : 630V	-			

Capacity (electrolyte only)

2 2 2 ⇒ 2200µF
Indicates number of zeros after effective number.
2-digit effective number.

• Units: µF.

2 R 2 ⇒ 2.2µF
1-digit effective number.
2-digit effective number, decimal point indicated by R.

• Units: µF.

Capacity (except electrolyte)

2 2 2 ⇒ 2200pF = 0.0022µF
(More than 2) — Indicates number of zeros after effective number.
2-digit effective number.

• Units: pF.

2 2 1 ⇒ 220pF
(0 or 1) — Indicates number of zeros after effective number.
2-digit effective number.

• Units: pF.

• When the dielectric strength is indicated in AC, "AC" is included after the dielectric strength value.

P.W.B. ASS'Y PARTS LIST
1U-2743 A,C,D MAIN UNIT ASS'Y

- A: Multi-Voltage model
- C: U.S.A. & CANADA models
- D: U.K. & EUROPE models

Ref. No.	Parts No.	Parts Name	Remarks	Ref. No.	Parts No.	Parts Name	Remarks
SEMICONDUCTORS GROUP							
IC701	262 2030 016	IC TMP87CP71F-6223	µ-com	D601-603	276 0432 903	Diode 1SS270A	
TR401-404	271 0094 919	Transistor 2SA970(BL)		△ D615,616	276 0398 007	Diode S4VB20F	Bridge
TR405-410	273 0235 923	Transistor 2SC1841(E/F)		D630	276 0432 903	Diode 1SS270A	
TR411,412	273 0198 002	Transistor 2SC1815(Y)		D704	276 0432 903	Diode 1SS270A	
TR413,414	271 0131 924	Transistor 2SA988(E/F)		D705	276 0049 914	Diode 1S2076A	
TR415,416	272 0107 906	Transistor 2SB1328(P)		D706-708	276 0432 903	Diode 1SS270A	
TR419,420	274 0151 000	Transistor 2SD2004(P)		ZD601	276 0644 911	Zener Diode MTZJ7.5A	7.5 V
TR423,424	273 0235 923	Transistor 2SC1841(E/F)		ZD605,606	276 0645 907	Zener Diode MTZJ18A	18 V
TR427	271 0131 924	Transistor 2SA988(E/F)		ZD701	276 0634 905	Zener Diode MTZJ3.3A	3.3 V
TR471-473	273 0253 918	Transistor 2SC2878(A/B)		SC601	279 0016 904	Thyristor SF0R1A42	
TR488	269 0020 906	Transistor DTC114ES	Built in Resistor	RESISTORS GROUP (Not included Carbon Film ±5%,1/4W Type. Refer to the Schematic Diagram for those parts.)			
TR489	269 0046 906	Transistor DTA114ES	Built in Resistor	△ R409-412	241 2380 963	Carbon Film 2.2kohm 1/4W(NB)	RD14B2E222JNBS
TR490	269 0020 906	Transistor DTC114ES	Built in Resistor	△ R413,414	241 2315 967	Fusible 68ohm 1/4W(FR)	RD14B2E680GFRS
TR501	271 0094 919	Transistor 2SA970(BL)		△ R421-424	241 2377 976	Carbon Film 130ohm 1/4W(NB)	RD14B2E131JNBS
TR503	271 0094 919	Transistor 2SA970(BL)		△ R431,432	241 2378 920	Carbon Film 220ohm 1/4W(NB)	RD14B2E221JNBS
TR505	273 0235 923	Transistor 2SC1841(E/F)		△ R439-440	244 2043 982	Metal Oxide 0.22ohm 1W	RS14B3AR22JNBS(S)
TR507	273 0235 923	Transistor 2SC1841(E/F)		△ R445-448	241 2380 950	Carbon Film 2kohm 1/4W(NB)	RD14B2E202JNBS
TR509	273 0235 923	Transistor 2SC1841(E/F)		△ R449,450	244 2051 987	Metal Oxide 4.7ohm 1W	RS14B3A4R7JNBS(S)
TR511	273 0198 002	Transistor 2SC1815(Y)		△ R453,454	244 2051 987	Metal Oxide 4.7ohm 1W	RS14B3A4R7JNBS(S)
TR513	271 0131 924	Transistor 2SA988(E/F)		△ R466-469	244 2051 958	Metal Oxide 220ohm 1W	RS14B3A221JNBS(S)
TR515	272 0107 906	Transistor 2SB1328(P)		△ R509	241 2380 963	Carbon Film 2.2kohm 1/4W(NB)	RD14B2E222JNBS
TR519	274 0151 000	Transistor 2SD2004(P)		△ R511	241 2380 963	Carbon Film 2.2kohm 1/4W(NB)	RD14B2E222JNBS
TR523	273 0235 923	Transistor 2SC1841(E/F)		△ R513	241 2315 967	Fusible 68ohm 1/4W(FR)	RD14B2E680GFRS
TR601-606	273 0388 906	Transistor 2SC1740S(E)		△ R521	241 2377 976	Carbon Film 130ohm 1/4W(NB)	RD14B2E131JNBS
TR607	271 0192 905	Transistor 2SA933S(S)		△ R523	241 2377 976	Carbon Film 130ohm 1/4W(NB)	RD14B2E131JNBS
TR608	273 0388 906	Transistor 2SC1740S(E)		△ R531	241 2378 920	Carbon Film 220ohm 1/4W(NB)	RD14B2E221JNBS
TR609	271 0192 905	Transistor 2SA933S(S)		△ R533	244 2043 982	Metal Oxide 0.22ohm 1W	RS14B3AR22JNBS(S)
TR610	273 0388 906	Transistor 2SC1740S(E)		△ R535	244 2043 982	Metal Oxide 0.22ohm 1W	RS14B3AR22JNBS(S)
TR615	272 0131 901	Transistor 2SB1041(R)		△ R537	244 2043 982	Metal Oxide 0.22ohm 1W	RS14B3AR22JNBS(S)
TR630	271 0192 905	Transistor 2SA933S(S)		△ R539	244 2043 982	Metal Oxide 0.22ohm 1W	RS14B3AR22JNBS(S)
TR631	273 0388 906	Transistor 2SC1740S(E)		△ R545	241 2380 950	Carbon Film 2kohm 1/4W(NB)	RD14B2E202JNBS
TR632,633	271 0131 924	Transistor 2SA988(E/F)		△ R547	241 2380 950	Carbon Film 2kohm 1/4W(NB)	RD14B2E202JNBS
TR702	269 0046 906	Transistor DTA114ES	Built in Resistor	△ R549	244 2051 987	Metal Oxide 4.7ohm 1W	RS14B3A4R7JNBS(S)
TR703	269 0040 902	Transistor DTC144ES	Built in Resistor	△ R552	241 2378 920	Carbon Film 220ohm 1/4W(NB)	RD14B2E221JNBS
TR704	273 0388 906	Transistor 2SC1740S(E)		△ R553	244 2051 987	Metal Oxide 4.7ohm 1W	RS14B3A4R7JNBS(S)
TR705	269 0020 906	Transistor DTC114ES	Built in Resistor	△ R554	241 2378 920	Carbon Film 220ohm 1/4W(NB)	RD14B2E221JNBS
D401-406	276 0432 903	Diode 1SS270A		△ R611	241 2378 920	Carbon Film 220ohm 1/4W(NB)	RD14B2E221JNBS
D407-410	276 0049 914	Diode 1S2076A		△ R612	244 2055 936	Metal Oxide 1.2kohm 1W	RS14B3A122JNBS(S)
D411,412	276 0432 903	Diode 1SS270A		△ R621	244 2043 940	Metal Oxide 2.2kohm 1W	RS14B3A222JNBS(S)
D501	276 0432 903	Diode 1SS270A		△ R626	241 2376 964	Carbon Film 47ohm 1/4W(NB)	RD14B2E470JNBS
D503	276 0432 903	Diode 1SS270A		△ R635-638	244 2043 982	Metal Oxide 0.22ohm 1W	RS14B3AR22JNBS(S)
D505	276 0432 903	Diode 1SS270A		△ R709	241 2387 940	Carbon Film 4.7ohm 1/4W(NB)	RD14B2E4R7JNBS
D507	276 0049 914	Diode 1S2076A		VR401,402	211 6093 912	Semi Fixed Resistor 4.7kohm	
D509	276 0049 914	Diode 1S2076A					
D511	276 0432 903	Diode 1SS270A					
D551,552	276 0432 903	Diode 1SS270A					

Ref. No.	Parts No.	Parts Name	Remarks
VR501	211 6093 912	Semi Fixed Resistor 4.7kohm	
RA701	246 2053 033	Resistor Array 4.7kohmx5	RK99=472JP5

CAPACITORS GROUP

C401,402	254 4260 980	Electrolytic 10 μ F/50 V	CE04W1H100M
C403,404	253 1179 945	Ceramic Cap. 220 pF /50 V	CK45B1H221K
C405,406	253 1179 987	Ceramic Cap. 470 pF /50 V	CK45B1H471K
C407,408	255 1264 966	Mylar Film 0.0033 μ F/50 V	CQ93M1H332J(B)
C409,410	254 4256 949	Electrolytic 100 μ F/25 V	CE04W1E101M
C411,412	253 4474 906	Ceramic Cap. 15 pF /500 V	CC45SL2H150J
C413,414	253 4536 941	Ceramic Cap. 15 pF /50 V	CC45SL1H150J
C415,416	255 1265 936	Mylar Film 0.01 μ F/50 V	CQ93M1H103J(B)
C417,418	255 1264 940	Mylar Film 0.0022 μ F/50 V	CQ93M1H222J(B)
C419,420	253 1181 904	Ceramic Cap. 0.01 μ F/50 V	CK45F1H103Z
C421,422	254 4260 948	Electrolytic 1 μ F/50 V	CE04W1H010M
C423,424	253 1128 909	Ceramic Cap. 220 pF /500 V	CK45B2H221K
C425,426	255 1265 936	Mylar Film 0.01 μ F/50 V	CQ93M1H103J(B)
C427,428	254 4262 917	Electrolytic 10 μ F/63 V	CE04W1J100M
C429,430	256 1042 903	Metalized 0.1 μ F/250 V	CF93A2E104K
C431,432	254 4262 917	Electrolytic 10 μ F/63 V	CE04W1J100M
C433,434	256 1042 903	Metalized 0.1 μ F/250 V	CF93A2E104K
C437	255 1265 936	Mylar Film 0.01 μ F/50 V	CQ93M1H103J(B)
C471-473	254 4260 980	Electrolytic 10 μ F/50 V	CE04W1H100M
C475,476	253 1181 904	Ceramic Cap. 0.01 μ F/50 V	CK45F1H103Z
C480	254 4254 938	Electrolytic 47 μ F/16 V	CE04W1C470M
C496	253 9039 906	BC Ceramic Cap. 0.1 μ F/25 V	CK45=1E104Z
C501	254 4260 980	Electrolytic 10 μ F/50 V	CE04W1H100M
C502	254 4254 909	Electrolytic 10 μ F/16 V	CE04W1C100M
C503	253 1179 945	Ceramic Cap. 220 pF /50 V	CK45B1H221K
C504	254 4254 909	Electrolytic 10 μ F/16 V	CE04W1C100M
C505	253 1179 987	Ceramic Cap. 470 pF /50 V	CK45B1H471K
C507	255 1264 966	Mylar Film 0.0033 μ F/50 V	CQ93M1H332J(B)
C509	254 4256 949	Electrolytic 100 μ F/25 V	CE04W1E101M
C511	253 4474 906	Ceramic Cap. 15 pF /500 V	CC45SL2H150J
C513	253 4536 941	Ceramic Cap. 15 pF /50 V	CC45SL1H150J
C515	255 1265 936	Mylar Film 0.01 μ F/50 V	CQ93M1H103J(B)
C517	255 1264 940	Mylar Film 0.0022 μ F/50 V	CQ93M1H222J(B)
C519	253 1181 904	Ceramic Cap. 0.01 μ F/50 V	CK45F1H103Z
C521	254 4260 948	Electrolytic 1 μ F/50 V	CE04W1H010M
C523	253 1128 909	Ceramic Cap. 220 pF /500 V	CK45B2H221K
C525	255 1265 936	Mylar Film 0.01 μ F/50 V	CQ93M1H103J(B)
C527	254 4262 917	Electrolytic 10 μ F/63 V	CE04W1J100M
C529	256 1042 903	Metalized 0.1 μ F/250 V	CF93A2E104K
C531	254 4262 917	Electrolytic 10 μ F/63 V	CE04W1J100M
C533	256 1042 903	Metalized 0.1 μ F/250 V	CF93A2E104K
C555,556	253 1181 904	Ceramic Cap. 0.01 μ F/50 V	CK45F1H103Z
C601	254 4260 993	Electrolytic 22 μ F/50 V	CE04W1H220M
C602	254 4250 945	Electrolytic 330 μ F/6.3 V	CE04W0J331M
C603	254 4261 905	Electrolytic 33 μ F/50 V	CE04W1H330M
C605	254 4260 980	Electrolytic 10 μ F/50 V	CE04W1H100M
C606	254 4260 948	Electrolytic 1 μ F/50 V	CE04W1H010M

Ref. No.	Parts No.	Parts Name	Remarks
C610,611	254 4362 707	Electrolytic 10000 μ F/63 V	CE04W1J103MC(DL)
C612,613	253 1151 905	Ceramic Cap. 4700 pF /500 V	CK45B2H472P
C614	256 1042 903	Metalized 0.1 μ F/250 V	CF93A2E104K
C636,637	253 1181 904	Ceramic Cap. 0.01 μ F/50 V	CK45F1H103Z
C638	254 4254 909	Electrolytic 10 μ F/16 V	CE04W1C100M
C710	254 4254 909	Electrolytic 10 μ F/16 V	CE04W1C100M
C713	254 4250 932	Electrolytic 220 μ F/6.3 V	CE04W0J221M
C714	256 1034 982	Metalized 0.12 μ F/50 V	CF93A1H124J
C715	254 4258 905	Electrolytic 4.7 μ F/35 V	CE04W1V4R7M
C716,717	253 1181 904	Ceramic Cap. 0.01 μ F/50 V	CK45F1H103Z
C718	254 4250 783	Electrolytic 3300 μ F/6.3 V	CE68W0J332MC
C719	254 4260 906	Electrolytic 0.1 μ F/50 V	CE04W1H0R1M
C721	253 1146 907	Ceramic Cap. 0.01 μ F/50 V	CK45F1H103Z
C722	254 4260 948	Electrolytic 1 μ F/50 V	CE04W1H010M

OTHER GROUP

			Q'ty
	—	(P.W.Board)	(1)
L401,402	235 0068 004	Inductor 1mH	2
L501	235 0068 004	Inductor 1mH	1
L701	235 0060 989	Inductor 120 μ H	1
RL551,552	214 9003 005	Relay	2
RL601	214 0167 005	Relay(G5Z-2A)	1
RL602	214 0127 003	Relay(RY-12W)	1
XL701	399 0178 007	Crystal 4.332 MHz	1
XL703	399 0191 903	Ceramic Resonator	1
	205 0472 013	8 P SP Terminal	1
	204 8341 004	Headphone Jack	1
	204 8354 004	Headphone Jack	1
	205 0592 003	4 P Push Terminal	1
	205 8225 007	2 P Connector Base	1
	205 0315 002	2 P Connector Base	1
CN3L,M,N	205 0190 036	3 P NH Conn. Base	3
CN5B	205 0696 051	JL Connector (BT-E)	1
CN6B,C	205 0696 064	JL Connector (BT-E)	2
CN7A	205 0696 077	JL Connector (BT-E)	1
CN8D	205 0535 002	8 P Conn. Base	1
CN9B	205 0535 015	9 P Conn. Base	1
CN10B	205 0535 057	10 P Conn. Base	1
CN11B,C	205 0535 099	11 P Conn. Base	2
CN15A	205 0707 018	15 P Conn. Base	1
CN16A,B	205 0772 001	16 P Conn. Base (9110B)	2
CN3A,F	205 0343 032	3 P Conn. Base (KR-PH)	2
CN6A	205 0343 061	6 P Conn. Base (KR-PH)	1
CN10A	205 0375 000	10 P Conn. Base (KR-PH)	1
CN13B	205 0375 039	13 P Conn. Base (KR-PH)	1
		Multi model	1
		U.S.A. & U.K. models	1
		Multi model	1
		U.S.A. & U.K. models	1
		Multi model	1
		U.S.A. & U.K. models	1

1U-2744 A,C,D SURROUND UNIT ASS'Y

A: Multi-Voltage model

C: U.S.A. & CANADA models

D: U.K. & EUROPE models

Ref. No.	Parts No.	Parts Name	Remarks	Q'ty	Ref. No.	Parts No.	Parts Name	Remarks
CN14A	205 0375 042	14 P Conn. Base (KR-PH)		1	SEMICONDUCTORS GROUP			
CN3A	203 5012 045	3 P SAN-PH Conn. Cord	L=560	1	IC101	263 0672 903	IC BA4558F	
CN4B	203 6458 006	4 P PH-SAN Conn. Cord	L=470	1	IC102	263 0565 007	IC BA15218	
CN5C	203 8368 013	5 P PH-SAN Conn. Cord	L=300	1	IC103	262 2034 009	IC TC9273N-007	
	203 0526 073	1 P Contact Ass'y	Black L=80	1	IC104	262 2033 000	IC TC9273N-004	
	415 0309 071	PVC Tube (L=10)		6	IC106	263 0672 903	IC BA4558F	
					IC201	263 0938 003	IC DDSC-A	
					IC202	262 1875 900	IC BU4066BCF	Regulator +5 V
					IC203,204	263 0809 006	IC NJM7805FA(S)	
					IC205	263 0672 903	IC BA4558F	
					IC207	262 2032 904	IC LC7886MN-TRM	
					IC208	262 2025 102	IC DDSC-D	
					IC210,211	262 1824 906	IC LC78835M	
					IC213	263 0359 006	IC LC4966	
					IC301	262 2031 002	IC TC9299P	
					IC302	263 0672 903	IC BA4558F	
					IC303	262 2031 002	IC TC9299P	
					IC304	263 0672 903	IC BA4558F	
					IC305	263 0615 902	IC BA15218F	
					IC306	263 0905 900	IC BA6208F	
					IC307,308	263 0672 903	IC BA4558F	
					IC381	263 0565 007	IC BA15218	
					IC801	263 0856 004	IC BA7625	Regulator +6 V
					IC803	263 0648 005	IC MC7806C	
					IC804	262 0522 005	IC TC4053BP	
					TR101,102	275 0061 902	FET 2SK184(GR)/(BL)	
					TR103,104	273 0348 904	Transistor 2SC3326 A/B	
					TR105	269 0055 900	Transistor DTA144EK	Built in Resistor
					TR106	269 0091 901	Transistor DTC143TK	Built in Resistor
					TR107	269 0055 900	Transistor DTA144EK	Built in Resistor
					TR108	269 0091 901	Transistor DTC143TK	Built in Resistor
					TR201,202	269 0054 901	Transistor DTC144EK	Built in Resistor
					TR203	274 0169 908	Transistor 2SD1292(R)	
					TR204	269 0055 900	Transistor DTA144EK	Built in Resistor
					TR206	272 0131 901	Transistor 2SB1041(R)	
					TR207	273 0384 900	Transistor 2SC2412K(S)	
					TR210,211	269 0054 901	Transistor DTC144EK	Built in Resistor
					TR212	269 0055 900	Transistor DTA144EK	Built in Resistor
					TR301,302	269 0055 900	Transistor DTA144EK	Built in Resistor
					TR303-307	275 0061 902	FET 2SK184(GR)/(BL)	
					TR308,309	269 0054 901	Transistor DTC144EK	Built in Resistor
					TR381	269 0054 901	Transistor DTC144EK	Built in Resistor
					TR382	269 0055 900	Transistor DTA144EK	Built in Resistor
					TR383	269 0144 905	Transistor DTC144YK	Built in Resistor
					TR801-804	271 0102 924	Transistor 2SA1015(GR)	
					TR806	271 0102 924	Transistor 2SA1015(GR)	
					D101,102	276 0432 903	Diode 1SS270A	

Ref. No.	Parts No.	Parts Name	Remarks
D301-305	276 0432 903	Diode 1SS270A	
D307	276 0432 903	Diode 1SS270A	
D381	276 0432 903	Diode 1SS270A	
D801-803	276 0432 903	Diode 1SS270A	
D804-807	276 0548 910	Diode DSM1D2	
ZD201	276 0644 979	Zener Diode MTZJ13A	13 V
ZD202	276 0644 911	Zener Diode MTZJ7.5A	7.5 V

RESISTORS GROUP (Not included Carbon Film $\pm 5\%$, 1/4W Type. Refer to the Schematic Diagram for those parts.)

R051-058	247 0015 966	Chip Carbon 2.7Mohm 1/10W	RM73B--275J
R059-066	247 0006 962	Chip Carbon 470ohm 1/10W	RM73B--471J
R099	247 0013 900	Chip Carbon 220kohm 1/10W	RM73B--224J
R100	247 0013 900	Chip Carbon 220kohm 1/10W	RM73B--224J
R101,102	247 0006 946	Chip Carbon 390ohm 1/10W	RM73B--391J
R103,104	247 0012 969	Chip Carbon 150kohm 1/10W	RM73B--154J
R105,106	247 0011 986	Chip Carbon 68kohm 1/10W	RM73B--683J
R107,108	247 0004 922	Chip Carbon 47ohm 1/10W	RM73B--470J
R109,110	247 0005 992	Chip Carbon 240ohm 1/10W	RM73B--241J
R111,112	247 0012 956	Chip Carbon 130kohm 1/10W	RM73B--134J
R113,114	247 0011 944	Chip Carbon 47kohm 1/10W	RM73B--473J
R115,116	247 0003 949	Chip Carbon 22ohm 1/10W	RM73B--220J
R117,118	247 0005 905	Chip Carbon 100ohm 1/10W	RM73B--101J
R119,120	247 0013 984	Chip Carbon 470kohm 1/10W	RM73B--474J
R133-136	247 0015 966	Chip Carbon 2.7Mohm 1/10W	RM73B--275J
R139-146	247 0015 966	Chip Carbon 2.7Mohm 1/10W	RM73B--275J
R147,148	247 0005 905	Chip Carbon 100ohm 1/10W	RM73B--101J
R149,150	247 0012 927	Chip Carbon 100kohm 1/10W	RM73B--104J
R153,154	247 0006 962	Chip Carbon 470ohm 1/10W	RM73B--471J
R157-164	247 0006 962	Chip Carbon 470ohm 1/10W	RM73B--471J
R165-168	247 0012 927	Chip Carbon 100kohm 1/10W	RM73B--104J
R171,172	247 0009 901	Chip Carbon 4.7kohm 1/10W	RM73B--472J
R173,174	247 0005 905	Chip Carbon 100ohm 1/10W	RM73B--101J
R175,176	247 0007 945	Chip Carbon 1kohm 1/10W	RM73B--102J
R179,180	247 0005 905	Chip Carbon 100ohm 1/10W	RM73B--101J
R181-184	247 0012 998	Chip Carbon 200kohm 1/10W	RM73B--204J
R185,186	247 0005 905	Chip Carbon 100ohm 1/10W	RM73B--101J
R187	247 0011 944	Chip Carbon 47kohm 1/10W	RM73B--473J
R190	247 0011 944	Chip Carbon 47kohm 1/10W	RM73B--473J
R201	247 0009 956	Chip Carbon 7.5kohm 1/10W	RM73B--751J
R202	247 0011 944	Chip Carbon 47kohm 1/10W	RM73B--473J
R203	247 0010 929	Chip Carbon 15kohm 1/10W	RM73B--153J
R204	247 0009 956	Chip Carbon 7.5kohm 1/10W	RM73B--751J
R205	247 0011 944	Chip Carbon 47kohm 1/10W	RM73B--473J
R206	247 0010 929	Chip Carbon 15kohm 1/10W	RM73B--153J
R207	247 0016 923	Chip Carbon 4.7Mohm 1/10W	RM73B--475J
R208,209	247 0011 960	Chip Carbon 56kohm 1/10W	RM73B--563J
R210	247 0012 927	Chip Carbon 100kohm 1/10W	RM73B--104J
R211	247 0019 988	Chip Carbon 100kohm 1/10W	RM73B--104F($\pm 1\%$)
R217,218	247 0008 999	Chip Carbon 4.3kohm 1/10W	RM73B--432J

Ref. No.	Parts No.	Parts Name	Remarks
R222	247 0006 962	Chip Carbon 470ohm 1/10W	RM73B--471J
R225,226	247 0009 930	Chip Carbon 6.2kohm 1/10W	RM73B--622J
R229,230	247 0011 944	Chip Carbon 47kohm 1/10W	RM73B--473J
R235,236	247 0013 984	Chip Carbon 470kohm 1/10W	RM73B--474J
R237-240	247 0008 928	Chip Carbon 2.2kohm 1/10W	RM73B--222J
R241,242	247 0004 922	Chip Carbon 47ohm 1/10W	RM73B--470J
R247-249	247 0005 905	Chip Carbon 100ohm 1/10W	RM73B--101J
R252	247 0007 916	Chip Carbon 750ohm 1/10W	RM73B--751J
R253	247 0005 905	Chip Carbon 100ohm 1/10W	RM73B--101J
R255-257	247 0007 916	Chip Carbon 750ohm 1/10W	RM73B--751J
R258	247 0005 905	Chip Carbon 100ohm 1/10W	RM73B--101J
R259,260	247 0006 962	Chip Carbon 470ohm 1/10W	RM73B--471J
R263-265	247 0007 916	Chip Carbon 750ohm 1/10W	RM73B--751J
R266	247 0014 967	Chip Carbon 1 Mohm 1/10W	RM73B--105J
R267,268	247 0006 962	Chip Carbon 470ohm 1/10W	RM73B--471J
R272	247 0007 987	Chip Carbon 1.5kohm 1/10W	RM73B--152J
R273	247 0011 944	Chip Carbon 47kohm 1/10W	RM73B--473J
R274,275	247 0007 916	Chip Carbon 750ohm 1/10W	RM73B--751J
R277-279	247 0009 985	Chip Carbon 10kohm 1/10W	RM73B--103J
R280	247 0011 944	Chip Carbon 47kohm 1/10W	RM73B--473J
R293,294	247 0011 944	Chip Carbon 47kohm 1/10W	RM73B--473J
R301	247 0007 945	Chip Carbon 1kohm 1/10W	RM73B--102J
R303	247 0007 945	Chip Carbon 1kohm 1/10W	RM73B--102J
R304	247 0008 928	Chip Carbon 2.2kohm 1/10W	RM73B--222J
R305	247 0005 905	Chip Carbon 100ohm 1/10W	RM73B--101J
R311,312	247 0007 945	Chip Carbon 1kohm 1/10W	RM73B--102J
R313,314	247 0009 972	Chip Carbon 9.1kohm 1/10W	RM73B--912J
R315,316	247 0006 962	Chip Carbon 470ohm 1/10W	RM73B--471J
R317,318	247 0009 985	Chip Carbon 10kohm 1/10W	RM73B--103J
R319,320	247 0012 927	Chip Carbon 100kohm 1/10W	RM73B--104J
R321,322	247 0005 905	Chip Carbon 100ohm 1/10W	RM73B--101J
R323,324	247 0008 928	Chip Carbon 2.2kohm 1/10W	RM73B--222J
R325,326	247 0010 929	Chip Carbon 15kohm 1/10W	RM73B--153J
R327,328	247 0008 944	Chip Carbon 2.7kohm 1/10W	RM73B--272J
R329,330	247 0005 905	Chip Carbon 100ohm 1/10W	RM73B--101J
R331,332	247 0012 927	Chip Carbon 100kohm 1/10W	RM73B--104J
R333-336	247 0007 945	Chip Carbon 1kohm 1/10W	RM73B--102J
R337,338	247 0005 905	Chip Carbon 100ohm 1/10W	RM73B--101J
R339	247 0012 927	Chip Carbon 100kohm 1/10W	RM73B--104J
R340	247 0005 905	Chip Carbon 100ohm 1/10W	RM73B--101J
R341	247 0008 928	Chip Carbon 2.2kohm 1/10W	RM73B--222J
R342,343	247 0010 916	Chip Carbon 13kohm 1/10W	RM73B--133J
R344	247 0005 905	Chip Carbon 100ohm 1/10W	RM73B--101J
R345	247 0012 927	Chip Carbon 100kohm 1/10W	RM73B--104J
R346	247 0005 905	Chip Carbon 100ohm 1/10W	RM73B--101J
R347,348	247 0009 985	Chip Carbon 10kohm 1/10W	RM73B--103J
R349,350	247 0013 984	Chip Carbon 470kohm 1/10W	RM73B--474J
R351,352	247 0005 905	Chip Carbon 100ohm 1/10W	RM73B--101J
R353,354	247 0008 928	Chip Carbon 2.2kohm 1/10W	RM73B--222J
R355	247 0010 929	Chip Carbon 15kohm 1/10W	RM73B--153J
R356,357	247 0006 962	Chip Carbon 470ohm 1/10W	RM73B--471J
R358	247 0010 929	Chip Carbon 15kohm 1/10W	RM73B--153J
R378-380	247 0009 985	Chip Carbon 10kohm 1/10W	RM73B--103J
R395,396	247 0011 944	Chip Carbon 47kohm 1/10W	RM73B--473J
R802-804	247 0004 977	Chip Carbon 75ohm 1/10W	RM73B--750J

Ref. No.	Parts No.	Parts Name	Remarks
R805	247 0004 964	Chip Carbon 68ohm 1/10W	RM73B--680J
R806	247 0009 985	Chip Carbon 10kohm 1/10W	RM73B--103J
R807	247 0004 964	Chip Carbon 68ohm 1/10W	RM73B--680J
R808	247 0009 985	Chip Carbon 10kohm 1/10W	RM73B--103J
R809	247 0004 964	Chip Carbon 68ohm 1/10W	RM73B--680J
R810	247 0009 985	Chip Carbon 10kohm 1/10W	RM73B--103J
R811	247 0004 964	Chip Carbon 68ohm 1/10W	RM73B--680J
R812	247 0009 985	Chip Carbon 10kohm 1/10W	RM73B--103J
R828-832	247 0009 985	Chip Carbon 10kohm 1/10W	RM73B--103J
R833-837	247 0012 927	Chip Carbon 100kohm 1/10W	RM73B--104J
R852	247 0004 977	Chip Carbon 75ohm 1/10W	RM73B--750J
△ R221	241 2375 907	Carbon Film 10ohm 1/4W(NB)	RD14B2E100JNBS
△ R393	241 2375 929	Carbon Film 220ohm 1/4W(NB)	RD14B2E221JNBS
VR301	211 0637 002	Variable Resister 100kohm	

CAPACITORS GROUP

C052,053	254 4260 948	Electrolytic 1 μF/50 V	CE04W1H010M
C101,102	257 0005 944	Chip Ceramic 220 pF /50 V	CC73SL1H221J
C103,104	254 4254 909	Electrolytic 10 μF/16 V	CE04W1C100M
C105,106	257 0004 961	Chip Ceramic 100 pF /50 V	CC73SL1H101J
C107,108	254 4250 932	Electrolytic 220 μF/6.3 V	CE04W0J221M
C109,110	255 4199 999	Plastic Film 0.024 μF/50 V	CQ93M1H243J(MRZ)
C111,112	255 1265 907	Plastic Film 0.0068 μF/50 V	CQ93M1H682J(B)
C113,114	254 4260 951	Electrolytic 2.2 μF/50 V	CE04W1H2R2M
C115,116	257 0012 982	Chip Ceramic 0.022μF /50 V	CK73F1H223Z
C117,118	254 4260 951	Electrolytic 2.2 μF/50 V	CE04W1H2R2M
C119,120	253 1179 945	Ceramic Cap. 220 pF /50 V	CK45B1H221K
C121,122	254 4260 948	Electrolytic 1 μF/50 V	CE04W1H010M
C125-128	254 4254 909	Electrolytic 10 μF/16 V	CE04W1C100M
C129,130	254 4260 948	Electrolytic 1 μF/50 V	CE04W1H010M
C131-134	257 0012 982	Chip Ceramic 0.022μF /50 V	CK73F1H223Z
C136,137	257 0005 944	Chip Ceramic 220 pF /50 V	CC73SL1H221J
C138,139	254 4260 951	Electrolytic 2.2 μF/50 V	CE04W1H2R2M
C149,150	254 4254 909	Electrolytic 10 μF/16 V	CE04W1C100M
C151-153	254 4260 948	Electrolytic 1 μF/50 V	CE04W1H010M
C185,186	254 4260 919	Electrolytic 0.22 μF/50 V	CE04W1HR22M
C195,196	254 4254 909	Electrolytic 10 μF/16 V	CE04W1C100M
C197,198	254 4260 948	Electrolytic 1 μF/50 V	CE04W1H010M
C199	254 4254 909	Electrolytic 10 μF/16 V	CE04W1C100M
C201,202	256 1034 979	Metalized 0.1 μF/50 V	CF93A1H104J
C203	257 0006 969	Chip Ceramic 680 pF /50 V	CC73SL1H681J
C204	256 1034 937	Metalized 0.047 μF/50 V	CF93A1H473J
C205,206	256 1034 979	Metalized 0.1 μF/50 V	CF93A1H104J
C207	257 0006 969	Chip Ceramic 680 pF /50 V	CC73SL1H681J
C208	256 1034 937	Metalized 0.047 μF/50 V	CF93A1H473J
C209	254 4254 912	Electrolytic 22 μF/16 V	CE04W1C220M
C210	254 4254 909	Electrolytic 10 μF/16 V	CE04W1C100M
C211,212	254 4260 951	Electrolytic 2.2 μF/50 V	CE04W1H2R2M
C213	255 1264 982	Plastic Film 0.0047 μF/50 V	CQ93M1H472J(B)
C214	254 4254 912	Electrolytic 22 μF/16 V	CE04W1C220M
C217	254 4250 958	Electrolytic 470 μF/6.3 V	CE04W0J471M

Ref. No.	Parts No.	Parts Name	Remarks
C219	254 4254 941	Electrolytic 100 μF/16 V	CE04W1C101M
C220	257 0012 966	Chip Ceramic 0.01μF /50 V	CK73F1H103Z
C223,224	254 4254 909	Electrolytic 10 μF/16 V	CE04W1C100M
C225	256 1035 910	Metalized 0.22 μF/50 V	CF93A1H224J
C226	254 4256 907	Electrolytic 10 μF/25 V	CE04W1E100M
C227	254 4254 938	Electrolytic 47 μF/16 V	CE04W1C470M
C228	257 0012 966	Chip Ceramic 0.01μF /50 V	CK73F1H103Z
C229,230	254 4260 906	Electrolytic 0.1 μF/50 V	CE04W1H0R1M
C231-233	256 1035 910	Metalized 0.22 μF/50 V	CF93A1H224J
C234,235	254 4260 977	Electrolytic 4.7 μF/50 V	CE04W1H4R7M
C236	256 1035 910	Metalized 0.22 μF/50 V	CF93A1H224J
C237-240	256 1034 979	Metalized 0.1 μF/50 V	CF93A1H104J
C241,242	255 1265 978	Plastic Film 0.022 μF/50 V	CQ93M1H223J(B)
C243,244	254 4260 948	Electrolytic 1 μF/50 V	CE04W1H010M
C245,246	257 0012 966	Chip Ceramic 0.01μF /50 V	CK73F1H103Z
C247	254 4260 948	Electrolytic 1 μF/50 V	CE04W1H010M
C248	257 0012 966	Chip Ceramic 0.01μF /50 V	CK73F1H103Z
C249-252	254 4260 948	Electrolytic 1 μF/50 V	CE04W1H010M
C253,254	254 4254 909	Electrolytic 10 μF/16 V	CE04W1C100M
C255,256	255 1265 936	Plastic Film 0.01 μF/50 V	CQ93M1H103J(B)
C257,258	255 1264 924	Plastic Film 0.0015 μF/50 V	CQ93M1H152J(B)
C259,260	255 1265 981	Plastic Film 0.027 μF/50 V	CQ93M1H273J(B)
C261	254 4254 938	Electrolytic 47 μF/16 V	CE04W1C470M
C262,263	257 0004 961	Chip Ceramic 100 pF /50 V	CC73SL1H101J
C264	254 4250 958	Electrolytic 470 μF/6.3 V	CE04W0J471M
C265,266	254 4260 948	Electrolytic 1 μF/50 V	CE04W1H010M
C267	254 4252 930	Electrolytic 100 μF/10 V	CE04W1A101M
C268,269	253 1179 903	Ceramic Cap. 100 pF/50 V	CK45B1H101K
C270,271	257 0014 935	Chip Ceramic 0.1μF /25 V	CK73F1E104Z
C273	254 4254 938	Electrolytic 47 μF/16 V	CE04W1C470M
C274	257 0014 935	Chip Ceramic 0.1μF /25 V	CK73F1E104Z
C275,276	254 4254 938	Electrolytic 47 μF/16 V	CE04W1C470M
C277	253 1179 903	Ceramic Cap. 100 pF/50 V	CK45B1H101K
C278	254 4254 909	Electrolytic 10 μF/16 V	CE04W1C100M
C279	253 9039 906	BC Ceramic 0.1 μF/25 V	CK45-1E104Z
C280	254 4254 909	Electrolytic 10 μF/16 V	CE04W1C100M
C281,282	255 1265 994	Plastic Film 0.033 μF/50 V	CQ93M1H333J(B)
C283,284	254 4260 919	Electrolytic 0.22 μF/50 V	CE04W1HR22M
C285	254 4252 930	Electrolytic 100 μF/10 V	CE04W1A101M
C286	253 9039 906	BC Ceramic 0.1 μF/25 V	CK45-1E104Z
C289	254 4254 909	Electrolytic 10 μF/16 V	CE04W1C100M
C291,292	255 1265 952	Plastic Film 0.015 μF/50 V	CQ93M1H153J(B)
C295	254 4252 930	Electrolytic 100 μF/10 V	CE04W1A101M
C296	254 4254 909	Electrolytic 10 μF/16 V	CE04W1C100M
C299	253 1179 903	Ceramic Cap. 100 pF/50 V	CK45B1H101K
C300	253 1120 907	Ceramic Cap. 4700 pF /50 V	CK45B1H472K
C301,302	257 0012 982	Chip Ceramic 0.022μF /50 V	CK73F1H223Z
C305	257 0004 961	Chip Ceramic 100 pF /50 V	CC73SL1H101J
C306	254 4254 909	Electrolytic 10 μF/16 V	CE04W1C100M
C307	257 0005 944	Chip Ceramic 220 pF /50 V	CC73SL1H221J
C308,309	257 0012 982	Chip Ceramic 0.022μF /50 V	CK73F1H223Z
C311,312	254 4260 948	Electrolytic 1 μF/50 V	CE04W1H010M
C317,318	257 0006 972	Chip Ceramic 750 pF /50 V	CC73SL1H751J
C319,320	254 4254 909	Electrolytic 10 μF/16 V	CE04W1C100M
C321	257 0005 944	Chip Ceramic 220 pF /50 V	CC73SL1H221J
C323,324	254 4254 909	Electrolytic 10 μF/16 V	CE04W1C100M
C325,326	256 1034 982	Metalized 0.12 μF/50 V	CF93A1H124J

Ref. No.	Parts No.	Parts Name	Remarks	Ref. No.	Parts No.	Parts Name	Remarks	Q'ty
C327,328	255 1265 965	Plastic Film 0.018 μF/50 V	CQ93M1H183J(B)		204 8266 008	4 P Pin Jack(S-GND)	U.S.A. & U.K. models	2
C329-333	254 4260 948	Electrolytic 1 μF/50 V	CE04W1H010M		204 8376 008	6 P Pin Jack(S-GND) AU Flash	Multi-Voltage model	1
C334,335	257 0012 966	Chip Ceramic 0.01μF /50 V	CK73F1H103Z		204 8278 009	6 P Pin Jack(S-GND)	U.S.A. & U.K. models	1
C336	254 3056 917	Electrolytic 1 μF/50 V	CE04D1H010MBP (Bipole)		204 8312 004	4 P Pin Jack AU Flash	Multi-Voltage model	2
C339	254 4254 909	Electrolytic 10 μF/16 V	CE04W1C100M		204 8313 003	4 P Pin Jack(S-GND)	U.S.A. & U.K. models	2
C340	255 1264 940	Plastic Film 0.0022 μF/50 V	CQ93M1H222J(B)		204 8377 007	6 P Pin Jack(S-GND) AU Flash	Multi-Voltage model	1
C341,342	254 4254 909	Electrolytic 10 μF/16 V	CE04W1C100M		204 8365 006	6 P Pin Jack(S-GND)	U.S.A. & U.K. models	1
C343,344	254 4260 948	Electrolytic 1 μF/50 V	CE04W1H010M		204 8481 003	1 P Pin Jack(S-GND) AU Flash	Multi-Voltage model	1
C347-350	255 1265 952	Plastic Film 0.015 μF/50 V	CQ93M1H153J(B)		204 8474 007	1 P Pin Jack(S-GND)	U.S.A. & U.K. models	1
C381,382	254 4260 948	Electrolytic 1 μF/50 V	CE04W1H010M		205 0075 025	2 P Terminal		2
C383-386	254 4254 909	Electrolytic 10 μF/16 V	CE04W1C100M		CN8D	205 0536 001	8 P Conn. Socket	1
C801-804	254 4260 977	Electrolytic 4.7 μF/50 V	CE04W1H4R7M		CN9B	205 0536 014	9 P Conn. Socket	1
C805-808	254 4250 958	Electrolytic 470 μF/6.3 V	CE04W0J471M		CN10B	205 0536 056	10 P Conn. Socket	1
C809	254 4252 930	Electrolytic 100 μF/10 V	CE04W1A101M		CN11B,11C	205 0536 098	11 P Conn. Socket	2
C810	254 4260 948	Electrolytic 1 μF/50 V	CE04W1H010M		CN15A	205 0708 017	15 P Conn. Socket	1
C814	257 0012 966	Chip Ceramic 0.01μF /50 V	CK73F1H103Z		CN16B	205 0773 000	16 P Conn. Base-L(9110)	1
C815	254 4260 980	Electrolytic 10 μF/50 V	CE04W1H100M		CN6B,6C	205 0748 064	JL Connector (R)	2
C816	254 4255 704	Electrolytic 3300 μF/16 V	CE04W1C332MC		CN7A	205 0748 077	3 P Conn. Base(KR-PH)	1
C816	254 4472 707	Electrolytic 4700 μF/16 V	CE04W1C472MC(SMG)		CN3H	205 0343 032	3 P Conn. Base(KR-PH)	1
C817	254 4254 909	Electrolytic 10 μF/16 V	CE04W1C100M		417 0476 007	Radiator		1
C821	257 0012 966	Chip Ceramic 0.01μF /50 V	CK73F1H103Z		473 7002 018	Tapping Screw (S)3x8		1
C823	254 4260 948	Electrolytic 1 μF/50 V	CE04W1H010M		414 0695 009	Shield Plate		1
C826	257 0012 966	Chip Ceramic 0.01μF /50 V	CK73F1H103Z		513 2356 009	Fuse Label for F006	Multi-Voltage & U.K. models	1
C827-829	254 4254 909	Electrolytic 10 μF/16 V	CE04W1C100M		203 0608 001	1 P SIN Cord Ass'y	Gray L=240	1
C830	254 4260 948	Electrolytic 1 μF/50 V	CE04W1H010M		203 0608 014	1 P SIN Cord Ass'y	Red L=300	1
C831	254 4252 930	Electrolytic 100 μF/10 V	CE04W1A101M		203 0608 027	1 P SIN Cord Ass'y	Blue L=250	1
C832	257 0012 982	Chip Ceramic 0.022μF /50 V	CK73F1H223Z		203 0608 030	1 P SIN Cord Ass'y	Brown L=270	1
C833	257 0012 966	Chip Ceramic 0.01μF /50 V	CK73F1H103Z		203 0608 043	1 P SIN Cord Ass'y	Yellow L=230	1
C834	254 4254 909	Electrolytic 10 μF/16 V	CE04W1C100M		203 0608 043	1 P SIN Cord Ass'y	Orange L=230	1
					203 0608 056	1 P SIN Cord Ass'y	Gray L=450	1
					203 0608 059	1 P SIN Cord Ass'y	Gray L=410	1
					203 0608 072	1 P SIN Cord Ass'y	Red L=200	1
OTHER GROUP				Q'ty				
	—	(P.W.Board)		(1)				
L201	235 0060 989	Inductor 120μH		1				
L301	235 0060 989	Inductor 120μH		1				
XL201	399 0246 900	Ceramic Resonator	CST16.38MXW0C 4-TF01	1				
⚠	212 2611 003	Slide Switch	Multi-Voltage model	2				
⚠	F006	Fuse 2.0 A	Multi-Voltage model	1				
⚠	F006	Fuse 2.0 A	U.S.A. model	1				
	202 0040 909	Fuse Clip		2				
RL381	214 0127 003	Relay (RY-12W)		1				
	204 8393 007	4 P Pin Jack(S-GND) AU Flash	Multi-Voltage model	2				

1U-2745 A,C,D FLD UNIT ASS'Y

A: Multi-Voltage model
 C: U.S.A. & CANADA models
 D: U.K. & EUROPE models

Ref. No.	Parts No.	Parts Name	Remarks
SEMICONDUCTORS GROUP			
IC565	263 0565 007	IC BA15218	
IC601	263 0648 005	IC :MC7806CT	Regulator +6 V
IC602	268 0073 905	IC ICP-N15	IC Protector 15 V
IC651,652	268 0074 904	IC ICP-N20	IC Protector 20 V
IC653	263 0986 000	IC NJM7820FA(S)	Regulator +20 V
IC654	263 0561 001	IC NJM7915FA	Regulator -15 V
IC655,656	263 0855 005	IC :SI-18752	
IC655,656	263 0993 006	IC LM3875	U.K. & Europe models only
IC751	262 2035 008	IC MSC1937-03RS	μ-com
IC752	499 0150 008	IC SBX1610-52	Remocon Sensor
IC803	263 0812 006	IC NJM7815FA(S)	Regulator +15 V
TR616	273 0388 906	Transistor 2SC1740S(E)	
TR626	273 0388 906	Transistor 2SC1740S(E)	
TR651	273 0388 906	Transistor 2SC1740S(E)	
D607	276 0432 903	Diode 1SS270A	
D608-613	276 0553 905	Diode 1SR35-200A	
D615	276 0432 903	Diode 1SS270A	
△ D652	276 0338 007	Diode S4VB20F	Bridge
ZD608	276 0644 911	Zener Diode MTZJ7.5A	7.5 V
ZD751	276 0644 924	Zener Diode MTZJ8.2A	8.2 V
P651	279 0034 067	Posistor PTH9M04BB222TS2F333	
LD751	393 9434 906	LED SEL1210S	Red
RESISTORS GROUP (Not included Carbon Film ±5%,1/4W Type. Refer to the Schematic Diagram for those parts.)			
△ R616	241 2378 920	Carbon Film 220ohm 1/4W(NB)	RD14B2E221JNBS
△ R630	241 2375 978	Carbon Film 20ohm 1/4W(NB)	RD14B2E200JNBS
△ R661,682	244 2051 987	Metal Oxide 4.7ohm 1W (NB)	RS14B3A4R7JNBS(S)
VR565	211 0798 103	Variable Resister 100kohm	
VR566	211 0797 117	Variable Resister 30kohm	
VR567	211 0797 133	Variable Resister 10kohm	
CAPACITORS GROUP			
C565,566	254 4260 980	Electrolytic 10 μF/50 V	CE04W1H100M
C567-570	253 4538 949	Ceramic Cap. 100 pF /50 V	CC45SL1H101J
C571,572	255 1264 940	Mylar Film 0.0022μF/50 V	CQ93M1H222J(B)
C573,574	256 1035 907	Metalized 0.18μF/50 V	CF93A1H184J
C575,576	254 4260 948	Electrolytic 1 μF/50 V	CE04W1H010M
C579,580	255 1265 949	Mylar Film 0.012μF/50 V	CQ93M1H123J(B)
C581,582	254 4260 922	Electrolytic 0.33 μF/50 V	CE04W1HR33M

Ref. No.	Parts No.	Parts Name	Remarks
C583,584	253 1181 917	Ceramic Cap. 0.022μF/50 V	CK45F1H223Z
C585,586	254 4254 938	Electrolytic 47 μF/16 V	CE04W1C470M
C587,588	256 1034 940	Metalized 0.056μF/50 V	CF93A1H563J
C607	254 4260 980	Electrolytic 10 μF/50 V	CE04W1H100M
C608	253 1181 904	Ceramic Cap. 0.01μF/50 V	CK45F1H103Z
C611,612	254 4260 948	Electrolytic 1 μF/50 V	CE04W1H010M
C613,614	253 1181 904	Ceramic Cap. 0.01μF/50 V	CK45F1H103Z
C615,616	254 4260 980	Electrolytic 10 μF/50 V	CE04W1H100M
C617,618	253 1181 904	Ceramic Cap. 0.01μF/50 V	CK45F1H103Z
C619	254 4254 938	Electrolytic 47 μF/16 V	CE04W1C470M
C621,622	254 4259 726	Electrolytic 4700 μF/35 V	CE04W1V472MC
C623,624	253 1151 905	Ceramic Cap. 4700 pF /500 V	CK45E2H472P
C625	256 1042 903	Metalized 0.1μF/250 V	CF93A2E104K
C626,627	255 1265 936	Mylar Film 0.01μF/50 V	CQ93M1H103J(B)
C628	253 1181 904	Ceramic Cap. 0.01μF/50 V	CK45F1H103Z
C630	254 4260 948	Electrolytic 1 μF/50 V	CE04W1H010M
C631	254 4256 790	Electrolytic 2200 μF/25 V	CE04W1E222MC
C632,633	253 1181 904	Ceramic Cap. 0.01μF/50 V	CK45F1H103Z
C634	254 4260 948	Electrolytic 1 μF/50 V	CE04W1H010M
△ C635	253 8014 702	Ceramic Cap. 0.01μF/400 V	CK45F2GAC103MC (AC)
C639	253 1181 904	Ceramic Cap. 0.01μF/50 V	CK45F1H103Z
C651,652	254 4260 951	Electrolytic 2.2 μF/50 V	CE04W1H2R2M
C653,654	253 4538 949	Ceramic Cap. 100 pF /50 V	CC45SL1H101J
C655,656	254 4254 938	Electrolytic 47 μF/16 V	CE04W1C470M
C659,660	254 4260 948	Electrolytic 1 μF/50 V	CE04W1H010M
C667,668	256 1034 979	Metalized 0.1μF/50 V	CF93A1H104J
C681,682	253 4538 949	Ceramic Cap. 100 pF /50 V	CC45SL1H101J
C683,684	253 1181 904	Ceramic Cap. 0.01μF/50 V	CK45F1H103Z
C685,686	253 4538 949	Ceramic Cap. 100 pF /50 V	CC45SL1H101J
C751	256 1034 979	Metalized 0.1μF/50 V	CF93A1H104J
C752	254 4261 921	Electrolytic 100 μF/50 V	CE04W1H101M
C753	253 1181 904	Ceramic Cap. 0.01μF/50 V	CK45F1H103Z
C754	254 4250 945	Electrolytic 330 μF/6.3 V	CE04W0J331M
C755	253 1179 903	Ceramic Cap. 100 pF /50 V	CK45B1H101K
C819	254 4260 948	Electrolytic 1 μF/50 V	CE04W1H010M
C820	254 4254 909	Electrolytic 10 μF/16 V	CE04W1C100M
OTHER GROUP			
		(P.W.Board)	(1)
L651,652	235 0068 004	Inductor 1 mH	2
L751	235 0060 989	Inductor 120μH	1
S751-785	212 5604 910	Tact Switch	35
FL751	393 4156 001	FLD (FIP16FM7R)	1
△ F001	206 1036 011	Fuse 6.3 A	Multi-Voltage model 1
△ F001	206 1046 014	Fuse 8 A	U.S.A. model 1
△ F001	206 1015 074	Fuse 3.15 A	U.K. model 1

1U-2746 A,C,D S-VIDEO UNIT ASS'Y

A: Multi-Voltage model
 C: U.S.A. & CANADA models
 D: U.K. & EUROPE models

Ref. No.	Parts No.	Parts Name	Remarks	Q'ty
△ F002	206 1015 074	Fuse 3.15 A	Multi-Voltage model	1
△ F003,004	206 1046 027	Fuse 5 A	U.S.A. model	2
△ F005	206 1046 043	Fuse 10 A	U.S.A. model	1
△ F006	206 1015 022	Fuse 2.5 A	Multi-Voltage model	1
	202 0040 909	Fuse Clip	Multi-Voltage model	4
	202 0040 909	Fuse Clip	U.S.A. model	8
	202 0040 909	Fuse Clip	U.K. model	2
	513 2329 049	Fuse Label for F001	Multi-Voltage model	1
	513 2329 052	Fuse Label for F002	Multi-Voltage model	1
	513 2329 065	Fuse Label for F001	U.K. model	1
△ RL603	214 0170 098	Relay (TV-9)		1
RL651	214 0167 005	Relay (G5Z-2A)		1
	204 8393 007	4 P Pin Jack(S-GND)	Multi-Voltage model	1
	204 8266 008	4 P Pin Jack(S-GND)	U.S.A. & U.K. models	1
	205 0592 003	4 P Push Terminal		1
△	233 6146 005	Power Trans (Mini)	Multi-Voltage model	1
△	233 6018 007	Power Trans (Mini)	U.S.A. model	1
△	233 6058 012	Power Trans (Mini)	U.K. model	1
	205 0075 025	2 P Terminal		1
CN3E	205 0343 032	3 P Conn. Base (KR-PH)		1
CN4B	205 0343 045	4 P Conn. Base (KR-PH)		1
CN3E	203 5038 003	3 P KR-DS Conn. Cord	L=100	1
CN6A	204 0461 005	6 P PH-SAN Conn. Cord	L=280	1
CN10A	204 2593 010	10 P PH-SAN Conn. Cord	L=80	1
CN13B	204 6503 006	13 P PH-SAN Conn. Cord	L=230	1
CN14A	204 6504 005	14 P PH-SAN Conn. Cord	L=150	1
	205 0185 025	2 P Wire Holder		1
	415 0309 039	P.V.C. Tube (L=25)		2

Ref. No.	Parts No.	Parts Name	Remarks
SEMICONDUCTORS GROUP			
IC806	263 0793 002	IC NJM7806FA(S)	Regulator +6 V
IC901	263 0857 003	IC BA7626	μ-com
IC902	263 0856 004	IC BA7625	
IC903	262 2067 005	IC MC74HC4053N	
IC904	262 2036 010	IC M35012-089 SP	
IC905	263 0682 003	IC NJM2229S	
TR901-906	271 0102 924	Transistor 2SA1015(GR)	Built in Resistor
TR909	271 0102 924	Transistor 2SA1015(GR)	
TR910	273 0198 918	Transistor 2SC1815(BL)	
TR911	271 0102 924	Transistor 2SA1015(GR)	
TR913	269 0020 906	Transistor DTC114ES	
TR914	271 0102 924	Transistor 2SA1015(GR)	
D818	276 0432 903	Diode 1SS270A	
D901-904	276 0432 903	Diode 1SS270A	
D908,909	276 0432 903	Diode 1SS270A	
RESISTORS GROUP (Not included Carbon Film ±5%, 1/4W Type. Refer to the Schematic Diagram for those parts.)			
△ R943,944	241 2387 908	Carbon Film 1ohm 1/4W(NB)	RD14B2E010JNBS
CAPACITORS GROUP			
C099	254 4260 948	Electrolytic 1 μF/50 V	CE04W1H010M
C191,192	254 4260 948	Electrolytic 1 μF/50 V	CE04W1H010M
C841,842	254 4254 909	Electrolytic 10 μF/16 V	CE04W1C100M
C901-906	254 4260 977	Electrolytic 4.7 μF/50 V	CE04W1H4R7M
C907	254 4250 932	Electrolytic 220 μF/6.3 V	CE04W0J221M
C908	254 4250 958	Electrolytic 470 μF/6.3 V	CE04W0J471M
C909	254 4250 932	Electrolytic 220 μF/6.3 V	CE04W0J221M
C910	254 4250 958	Electrolytic 470 μF/6.3 V	CE04W0J471M
C911	254 4250 932	Electrolytic 220 μF/6.3 V	CE04W0J221M
C912	254 4250 958	Electrolytic 470 μF/6.3 V	CE04W0J471M
C914,915	253 1181 917	Ceramic Cap. 0.022μF/50 V	CK45F1H223Z
C916,917	254 4252 930	Electrolytic 100 μF/10 V	CE04W1A101M
C920	254 4254 909	Electrolytic 10 μF/16 V	CE04W1C100M
C921,922	253 4537 924	Ceramic Cap. 33 pF /50 V	CC45SL1H330J
C923	253 1181 904	Ceramic Cap. 0.01μF/50 V	CK45F1H103Z
C924,925	254 4254 938	Electrolytic 47 μF/16 V	CE04W1C470M
C926	253 1181 904	Ceramic Cap. 0.01μF/50 V	CK45F1H103Z
C927,928	253 4536 983	Ceramic Cap. 22 pF /50 V	CC45SL1H220J
C929	253 4537 924	Ceramic Cap. 33 pF /50 V	CC45SL1H330J
C930	255 1265 978	Mylar Film 0.022μF/50 V	CQ93M1H223J(B)
C931	253 4538 949	Ceramic Cap. 100 pF /50 V	CC45SL1H101J
C933	254 4260 977	Electrolytic 4.7 μF/50 V	CE04W1H4R7M
C935	254 4260 948	Electrolytic 1 μF/50 V	CE04W1H010M
C936	256 1034 953	Metalized 0.067μF/50 V	CF93A1H683J

Ref. No.	Parts No.	Parts Name	Remarks
C937	254 4260 948	Electrolytic 1 μF/50 V	CE04W1H010M
C938	255 1264 966	Mylar Film 0.0033μF/50 V	CQ93M1H332J(B)
C939	253 1179 987	Ceramic Cap. 470 pF /50 V	CK45B1H471K
C940	253 1179 929	Ceramic Cap. 150 pF /50 V	CK45B1H151K
C941	255 1264 911	Mylar Film 0.0012μF/50 V	CQ93M1H122J(B)
C942	253 1181 904	Ceramic Cap. 0.01μF/50 V	CK45F1H103Z
C943	254 4252 930	Electrolytic 100 μF/10 V	CE04W1A101M
C944	255 1264 908	Mylar Film 0.001μF/50 V	CQ93M1H102J(B)
C945	254 4254 909	Electrolytic 10 μF/16 V	CE04W1C100M
C946,947	256 1034 937	Metalized 0.047μF/50 V	CF93A1H473J
C948	254 4260 948	Electrolytic 1 μF/50 V	CE04W1H010M
C949	256 1034 937	Metalized 0.047μF/50 V	CF93A1H473J
C951	254 4260 948	Electrolytic 1 μF/50 V	CE04W1H010M
C955,956	254 4260 977	Electrolytic 4.7 μF/50 V	CE04W1H4R7M
C957,958	254 4260 948	Electrolytic 1 μF/50 V	CE04W1H010M
C959-961	254 4254 909	Electrolytic 10 μF/16 V	CE04W1C100M
C962	253 1118 906	Ceramic Cap. 3300 pF /50 V	CK45B1H332K
C964	253 1181 904	Ceramic Cap. 0.01μF/50 V	CK45F1H103Z
OTHER GROUP			
		(P.W.Board)	(1)
L901	235 0060 963	Inductor 15μH	1
XL901	399 0153 006	Crystal 14.32 MHz-12PF	1
XL901	399 0114 003	Crystal 17.73 MHz	U.K. model only 1
XL902	399 0105 009	Ceramic Resonator	CSB503F2 1
	204 8414 009	2 P S-Terminal AU Flash	Multi-Voltage model 1
	204 8414 012	2 P S-Terminal	U.S.A. & U.K. model 1
	204 8415 008	3 P S-Terminal AU Flash	Multi-Voltage model 1
	204 8415 011	3 P S-Terminal	U.S.A. & U.K. model 1
	205 0906 000	1 P S-Terminal (SW) AU Flash	Multi-Voltage model 1
	205 0902 004	1 P S-Terminal (SW)	U.S.A. & U.K. model 1
	204 8427 009	S-Terminal (3.5) AU Flash	Multi-Voltage model 1
	205 0903 003	S-Terminal (3.5)	U.S.A. & U.K. model 1
	204 8342 003	3 P Pin Jack(C-GND)	Multi-Voltage model 1
	204 8404 006	3 P Pin Jack(C-GND)	U.S.A. & U.K. model 1
CN3F	205 0343 032	3 P Conn. Base (KR-PH)	1
CN5C	205 0343 058	5 P Conn. Base (KR-PH)	1
CN5B	205 0748 051	5 P J.L Connector (R)	1
CN16A	205 0773 000	16 P Conn. Base-L(9110)	1
CN3H	203 5012 029	3 P SAN-PH Conn. Cord	L=330 1
CN3Q	203 4701 001	3 P SAN-SAN Conn. Cord	L=150 1
	203 0426 021	1 P Contact Ass'y	Black L=140 1
	203 0606 003	1 P SIN Conn. Cord	1

BLOCK DIAGRAM

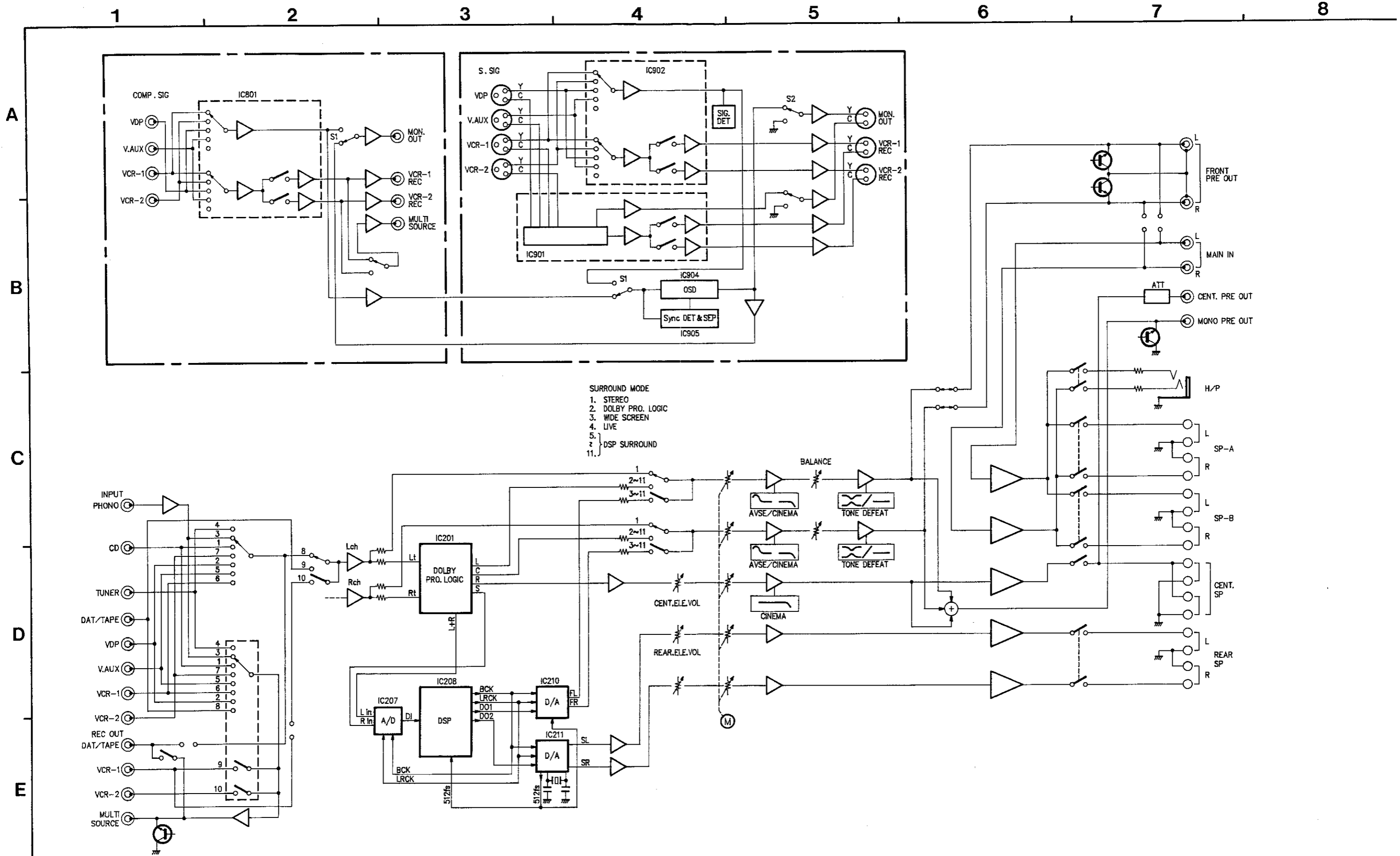

WIRING DIAGRAM

1 2 3 4 5 6

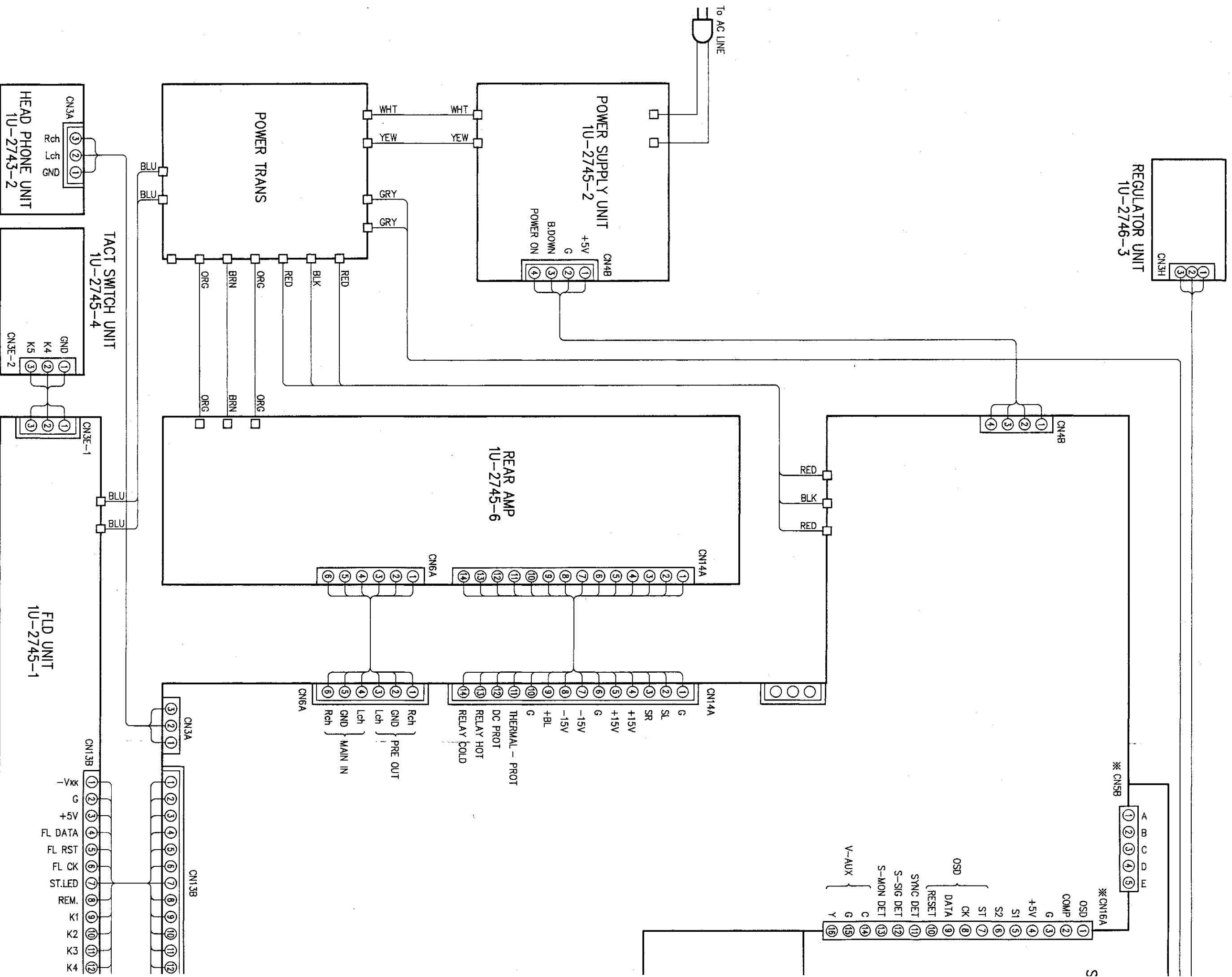

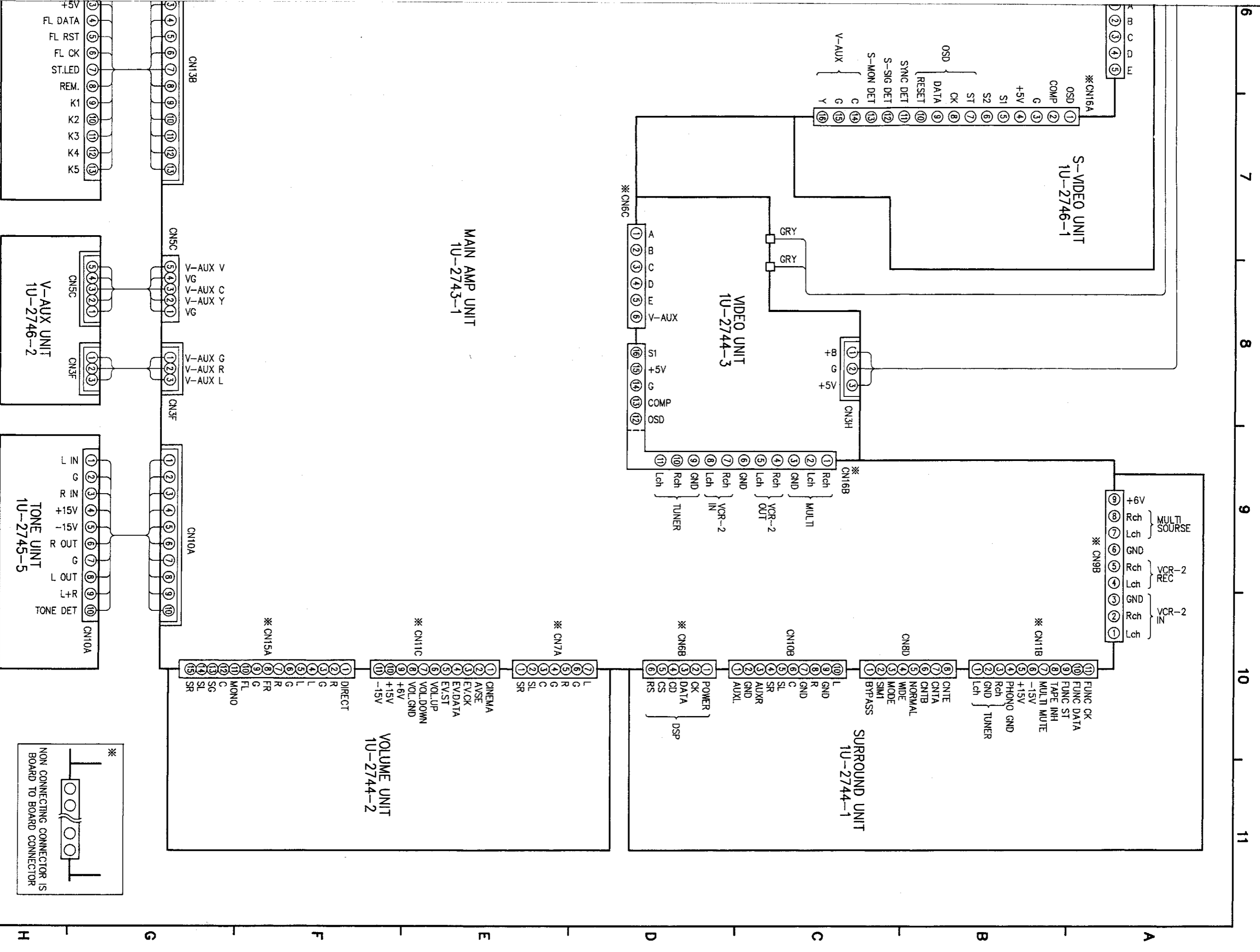

SCHEMATIC DIAGRAM - (1/4)

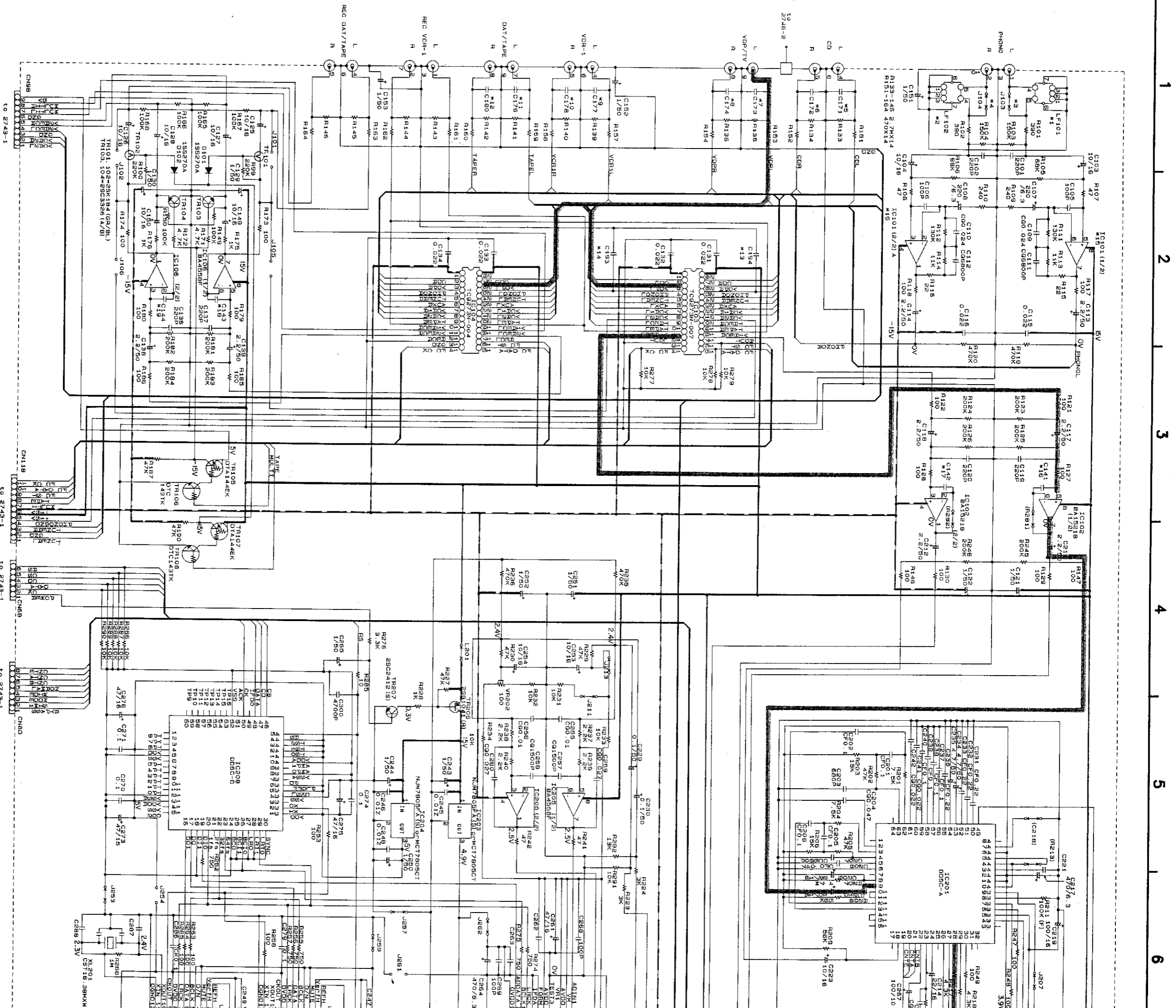

NOTES
 ALL RESISTANCE VALUES IN OHM, K=1,000 OHM, M=1,000,000 OHM
 ALL CAPACITANCE VALUES IN MICRO FARAD, P=PICTO MICRO FARAD
 EACH VOLTAGE AND CURRENT ARE MEASURED AT NO SIGNAL INPUT
 CONDITION.
 CIRCUIT AND PARTS ARE SUBJECT TO CHANGE WITHOUT PRIOR
 NOTICE.

WARNING:
 Parts marked with this symbol  have critical characteristics.
 Use ONLY replacement parts recommended by the manufacturer.
CAUTION:
 Before returning the unit to the customer, make sure you make either (1) a
 leakage current check or (2) a line to chassis resistance check. If the leakage
 current exceeds 0.5 milliamperes, or if the resistance from chassis to either side
 of the power cord is less than 240 kohms, the unit is defective.
WARNING:
 DO NOT return the unit to the customer until the problem is located and
 corrected.

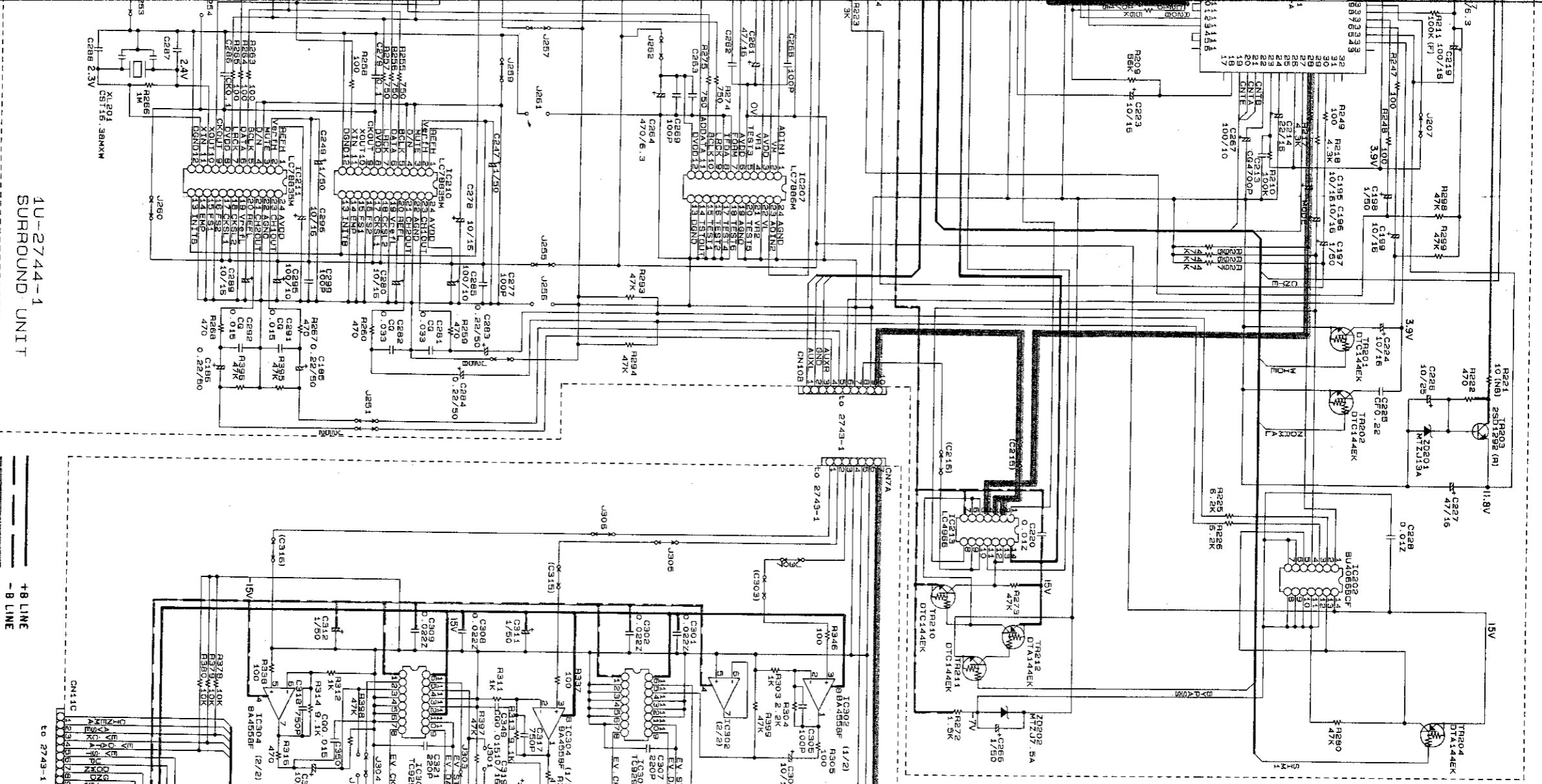

1U-2744-1
SURROUND UNIT

--- +8 LINE
--- -8 LINE
--- SIGNAL LINE

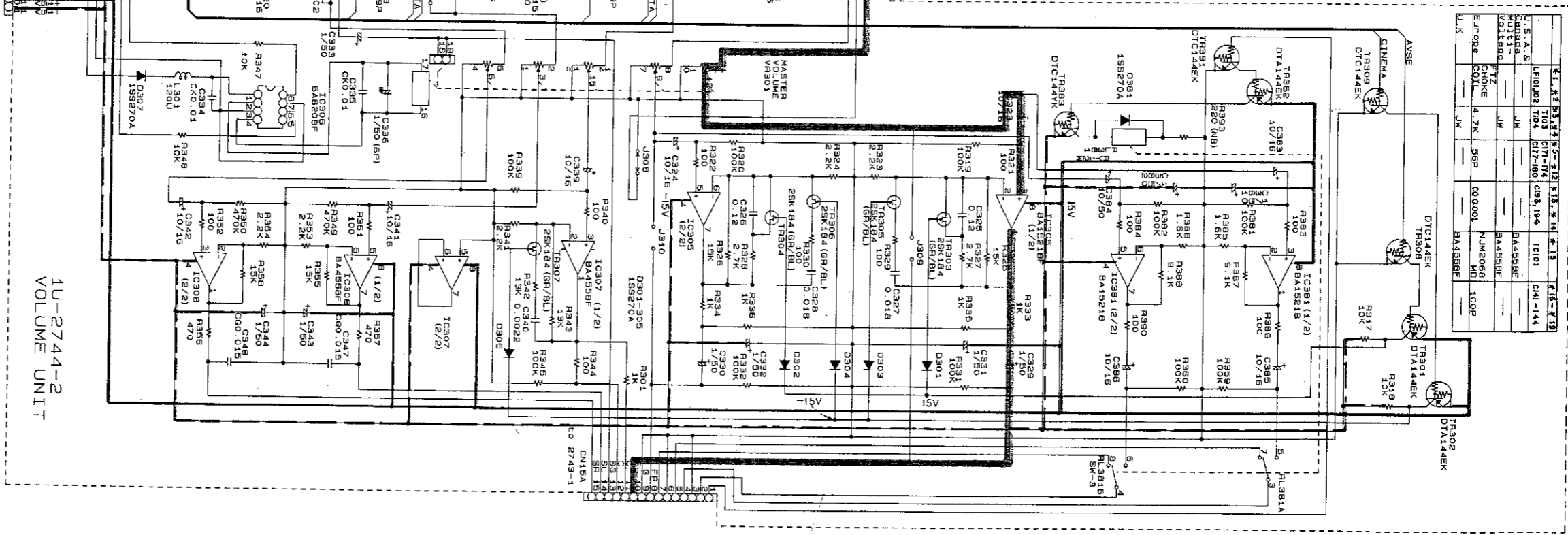

1U-2744-2
VOLUME UNIT

U.S.A.S.	U.S.A.S.	U.S.A.S.	U.S.A.S.	U.S.A.S.	U.S.A.S.
LF10J02 T04	C17-180	C93,194	IC101	CM1-144	
NUMERICAL	TYPE	VALUE	MANUFACTURE	NO.	100P
EUCODR. CODE	4.7K	50P	BA455BF		

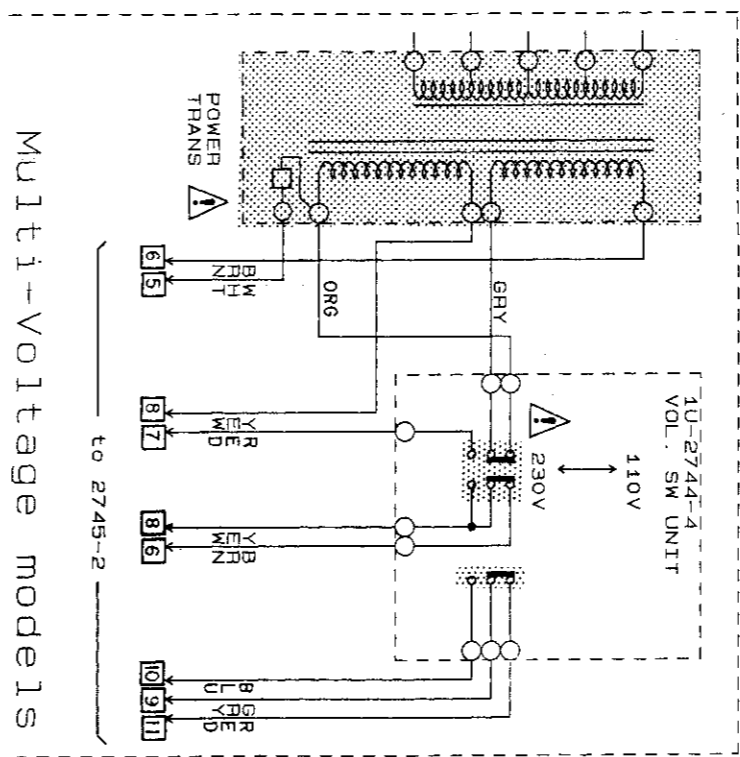
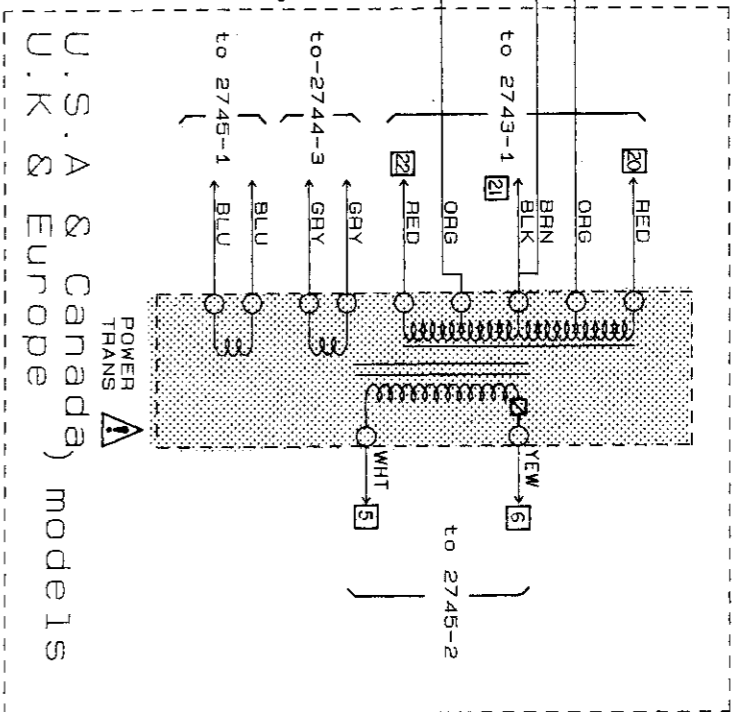
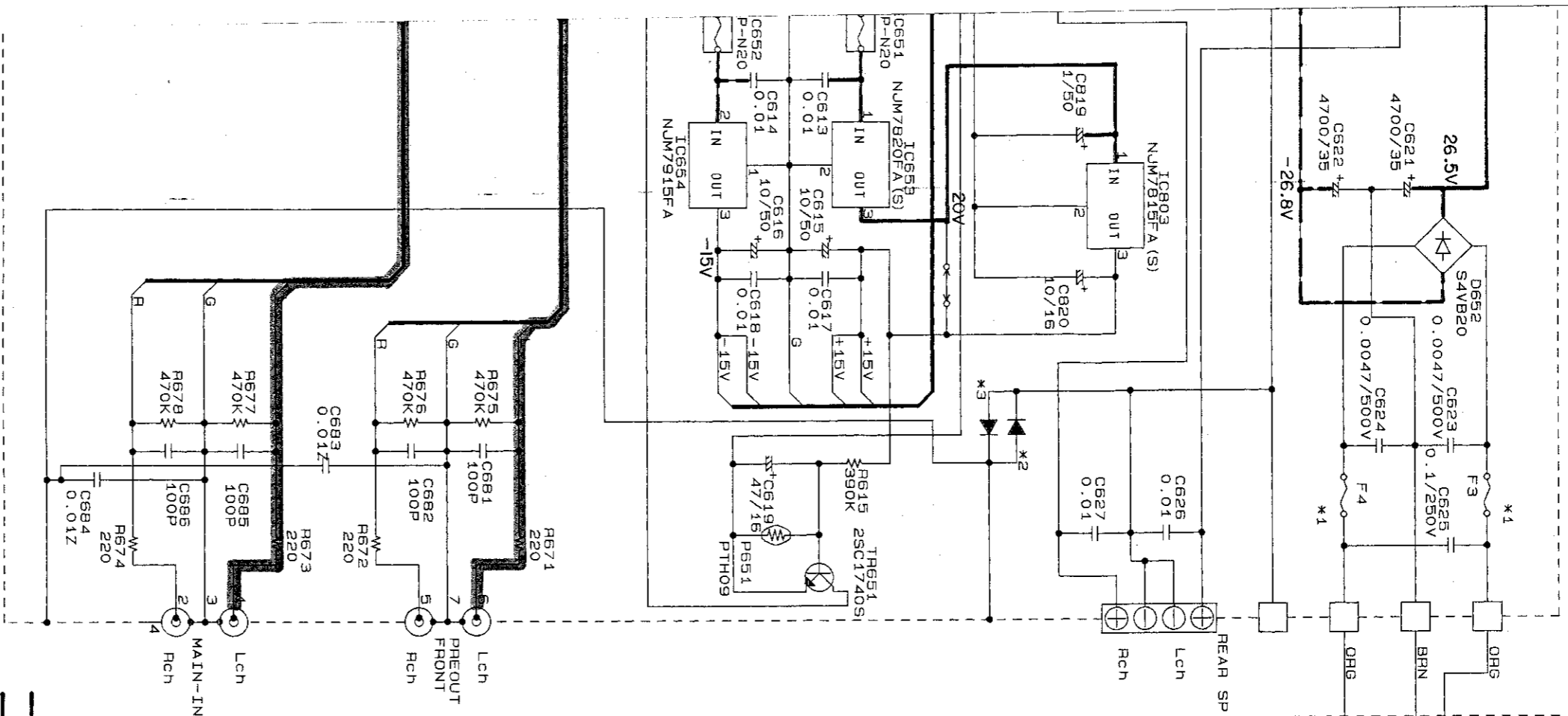

	*1	*2	*3	*4
U.S.A. & Canada	F3, F4	C639	C679, C680	IC655, IC656
Multi-Voltage	JW	CKO.01Z	---	SI-18752
U.K.	JW	CKO.01Z	---	SI-18752
Europe	JW	CK0.01Z	CKISOP	SI-18752

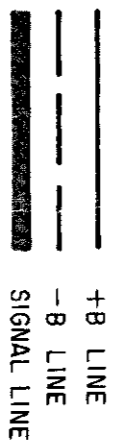

have critical characteristics. Recommended by the manufacturer. Please, make sure you make either (1) a chassis resistance check, if the leakage resistance from chassis to either side terminals, the unit is defective.

until the problem is located and

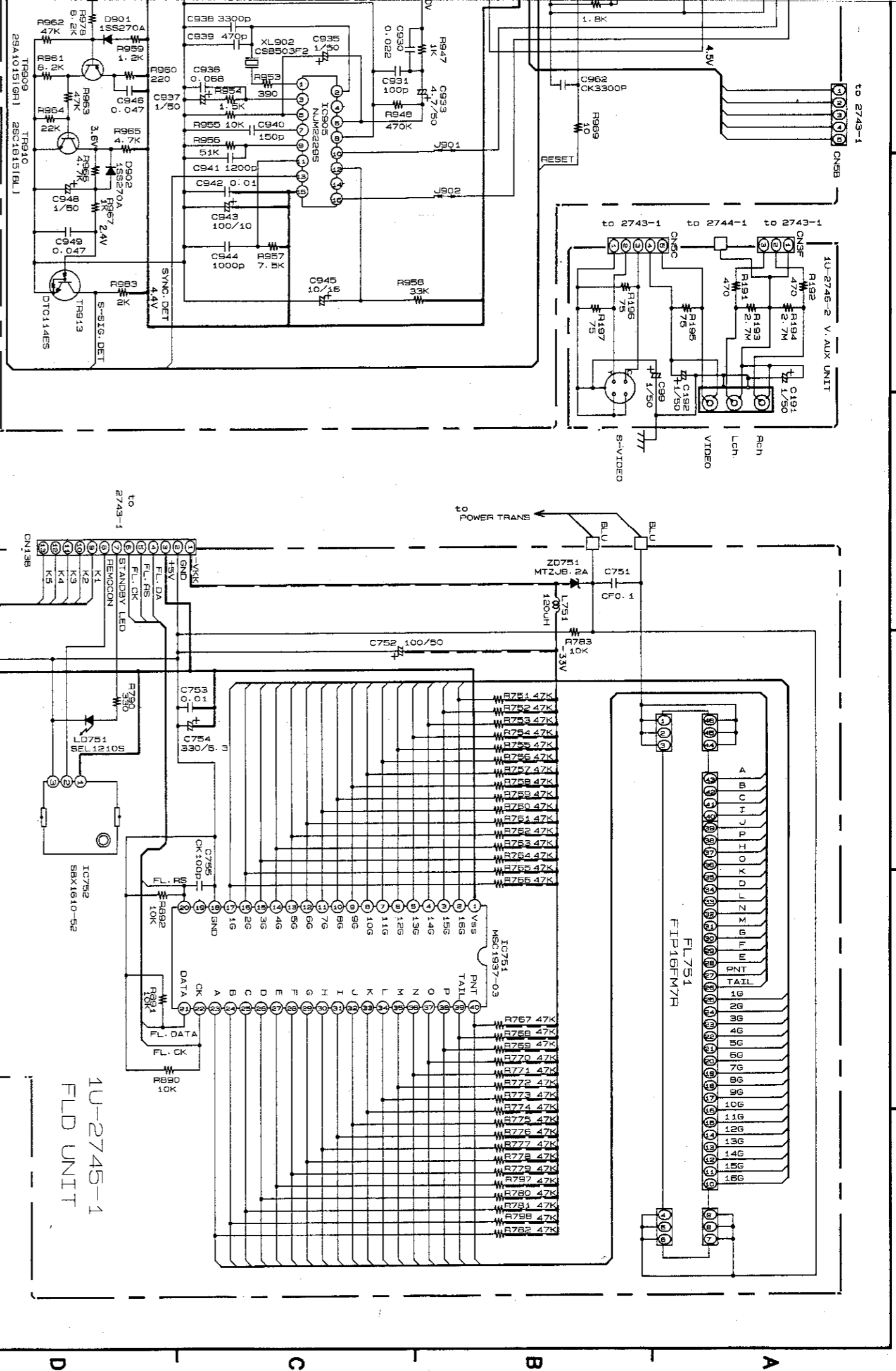

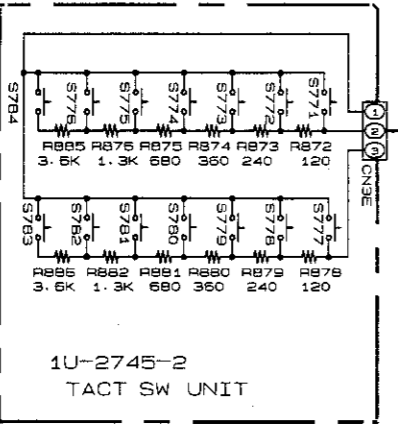

U.S.A. & Canada	*1 XL301	*2 C927 (928)	*3 F006	*4 E4/125V	*5 C816	*6	*7	*8 C171-174	*9 C924
MULTI-Voltage	14.32MHz	12P	10P	2.5A/250V	3300/15	---	---	---	47/15
Europe	17.73MHz	10P	12P	2.5A/250V	3300/15	---	---	---	47/15
U.K.	17.73MHz	10P	12P	2.5A/250V	3300/15	---	---	---	47/15

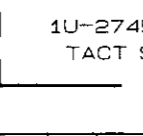
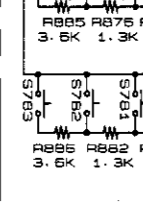
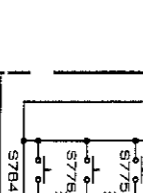
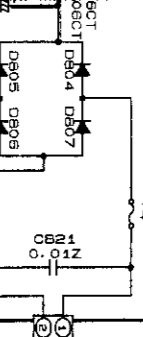
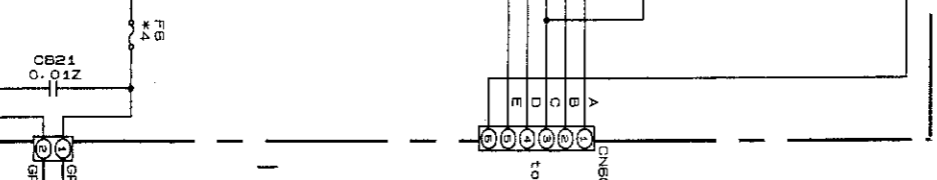

PARAMETER	K4	K5
EFFECT	CLEAR	CLEAR
VIDEO SELECT	+	+
SP-A CENTER	SP-A	SP-A
SP-B REAR	SP-B	SP-B
CENTER MODE	AVSE	CENTER MODE
MULTI CINEMA	MULTI	MULTI

K1	K2	K3
AUDIO	VIDEO	POWER
CLASSIC CONCERT	PERSONAL 1	---
JAZZ CLUB	PERSONAL 2	---
ROCK ARENA	PERSONAL 3	---
MOND MOVIE	TABE MONITOR	STEREO
SUPER STUDIO	MATRIX	DOLBY PRO LOGIC
LIVE SURROUND	DIRECT	WIDE SCREEN



WARNING:
Parts marked with this symbol  have critical characteristics.
Use ONLY replacement parts recommended by the manufacturer.

CAUTION:
Before returning the unit to the customer, make sure you make either (1) a leakage current check or (2) a line to chassis resistance check. If the leakage current exceeds 0.5 milliamperes, or if the resistance from chassis to either side of the power cord is less than 240 kohms, the unit is defective.

WARNING:
DO NOT return the unit to the customer until the problem is located and corrected.

NOTES:
ALL RESISTANCE VALUES IN OHM, K=1,000 OHM, M=1,000,000 OHM
ALL CAPACITANCE VALUES IN MICRO FARAD.
P=MICRO-MICRO FARAD
EACH VOLTAGE AND CURRENT ARE MEASURED AT NO SIGNAL INPUT CONDITION.
CIRCUIT AND PARTS ARE SUBJECT TO CHANGE WITHOUT PRIOR NOTICE.

LEGEND:
+B LINE
-B LINE
SIGNAL LINE

EXPLODED VIEW OF CHASSIS AND CABINET

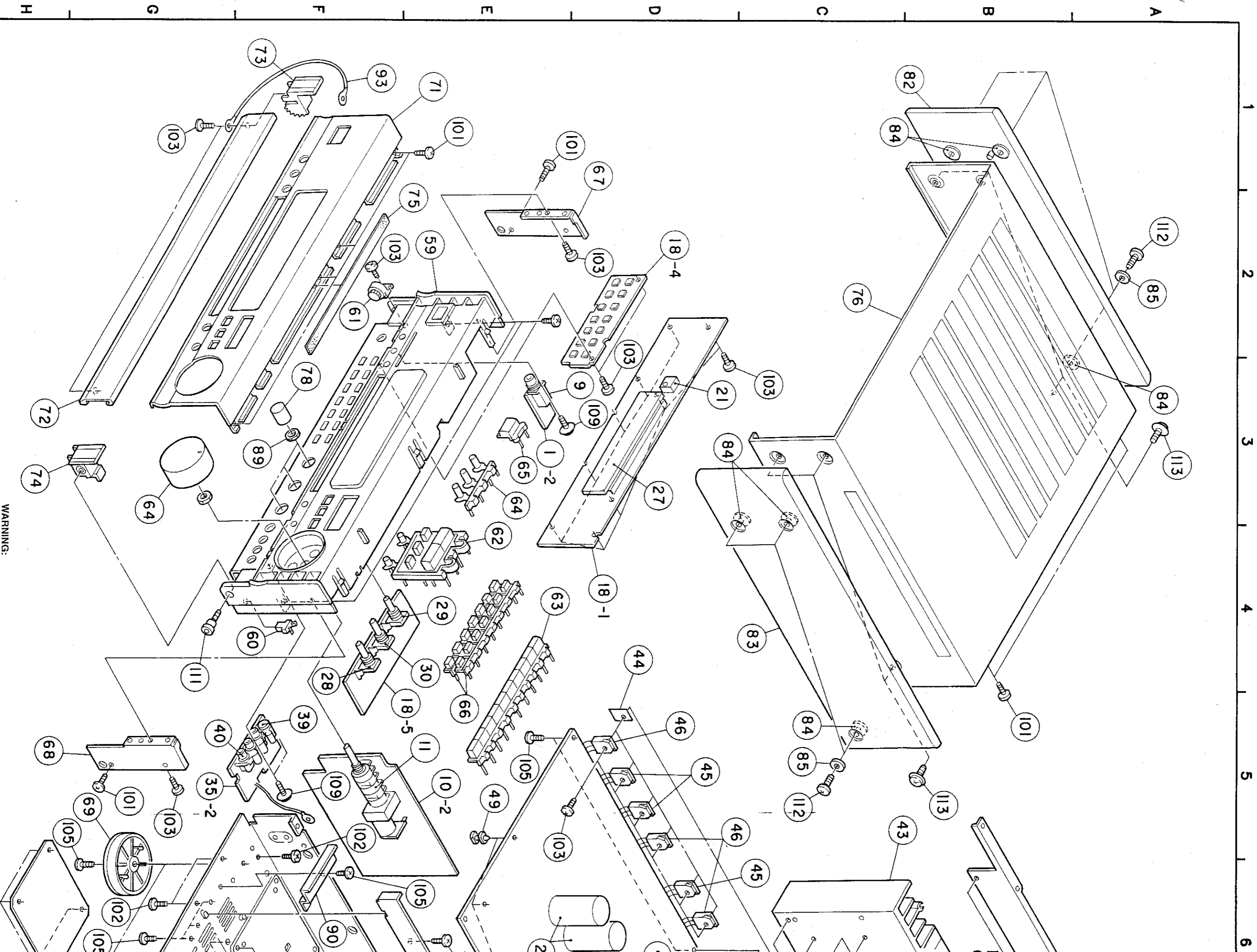

WARNING:
Parts marked with this symbol  have critical characteristics.
Use ONLY replacement parts recommended by the manufacturer.

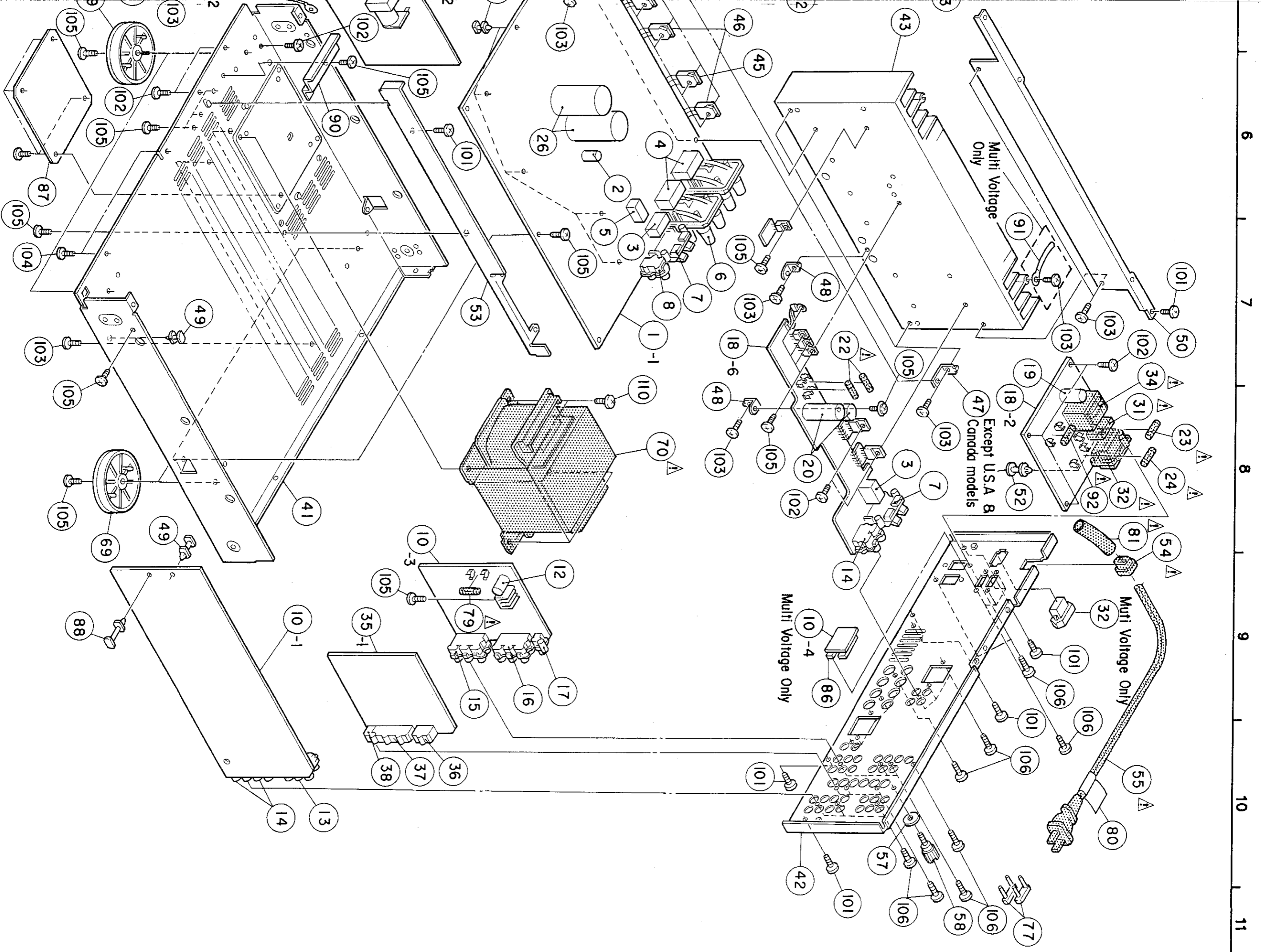

PARTS LIST OF EXPLODED VIEW

Ref. No.	Parts No.	Parts Name	Remarks	Q'ty	Ref. No.	Parts No.	Parts Name	Remarks	Q'ty
1	Note	Main Amp. Unit Ass'y		1s	45	273 0389 002	Transistor 2SC3855(O/P/Y)(Z)	TR421,422,521	3
1-1	—	Main Amp. Unit		(1)	46	271 0240 006	Transistor 2SA1491(O/P/Y)(Z)	TR417,418,517	3
1-2	—	Headphone Unit		(1)	47	412 3225 108	*P.W.B. Bracket(A)		2
2	254 4250 783	Chemicon 3300µF/6.3 V	C718	1	48	412 3724 007	L Bracket		2
3	214 0167 005	Relay (G5Z-2A)	RL601,651	2	49	412 2814 002	Card Spacer (L=8)		7
4	214 9003 005	Relay	RL551,552	2	50	412 3876 007	*Radiator Bracket		1
5	214 0127 003	Relay (RY-12W)	RL381,602	2	51	—			
6	205 0472 013	8 P SP Terminal		1	52	Note	Card Spacer (L=12)		1
7	205 0592 003	4 P Push Terminal	for Speaker	2	53	411 1305 108	*Center Chassis		1
8	Note	2 P Connector Base		1	54	445 0056 008	Cord Bush		1
9	Note	Head Phone Jack	AU Flash	1	55	Note	AC Cord With Plug		1
10	Note	Surround Unit Ass'y		1s	56	445 8004 007	Wire Clamper		9
10-1	—	Surround Unit		(1)	57	477 0018 001	Washer (P-87)		1
10-2	—	Volume Unit		(1)	58	205 0071 016	Terminal Ass'y	GND	1
10-3	—	Video Unit		(1)	59	Note	Inner Panel Ass'y		1
10-4	—	Voltage Sel. Unit		(1)	60	435 0125 000	Latch (4T02)		1
11	211 0637 002	Variable Resistor 100kohm	VR301	1	61	421 9007 007	Mini Damper		1
12	Note	Chemicon n µF/16 V	C816	1	62	Note	*Tact Button (A)		1
13	Note	6 P Pin Jack(S-GND)	AU Flash	1	63	Note	*Function Button		1
14	Note	4 P Pin Jack(S-GND)	AU Flash	3	64	Note	VR Knob Ass'y		1
15	Note	4 P Pin Jack	AU Flash	2	65	Note	Push Button (P)		1
16	Note	6 P Pin Jack(S-GND)	AU Flash	1	66	Note	*Tact Button (B)		2
17	Note	1 P Pin Jack(S-GND)	AU Flash	1	67	412 3878 102	*Side Bracket (L)		1
18	Note	FLD Unit Ass'y		1s	68	412 3879 101	*Side Bracket (R)		1
18-1	—	FLD Unit		(1)	69	104 0194 108	Foot Ass'y		4
18-2	—	Power Supply Unit		(1)	70	Note	*Power Trans		1
18-3	—	—		(1)	71	Note	Front Panel		1
18-4	—	Tact Switch Unit		(1)	72	Note	Trap Door		1
18-5	—	Tone Unit		(1)	73	401 0165 203	Hinge (L)		1
18-6	—	Rear Amp. Unit		(1)	74	401 0166 309	Hinge (R)		1
19	254 4256 790	Chemicon 2200µF/25 V	C631	1	75	122 0183 049	Spacer		1
20	254 4259 726	Chemicon 4700µF/35 V	C621,622	2	76	Note	Top Cover		1
21	499 0150 008	Remocon Sensor SBX1610-52		1	77	205 0752 005	Short Pin		2
22	Note	Fuse n A	F003,004	2	78	Note	Vol. Knob (B)		3
23	Note	Fuse n A	F001	1	79	Note	Fuse n A	F006	1
24	Note	Fuse n A	F005	1	80	Note	Preset Label		1
25	—	—			81	Note	U.L. Tube (B,C)		1
26	254 4362 707	Chemicon 10000µF/63 V	C610,611	2	82	Note	Wood Board (L)		1
27	393 4156 001	FLD (FIP16FM7R)	FL751	1	83	Note	Wood Board (R)		1
28	211 0798 103	Variable Resistor 100kohm	VR565	1	84	Note	Felt Sheet		6
29	211 0797 117	Variable Resistor 30kohm	VR566	1	85	Note	Washer φ5		6
30	211 0797 133	Variable Resistor 10kohm	VR567	1	86	Note	Slide Switch	Voltage Sel. Sw.	2
31	214 0170 005	Relay (TV-B)	RL603	1	87	412 3933 005	Safety Cover		1
32	Note	AC Outlet		1	88	412 2814 015	Card Spacer (L=14)		2
33	—	—			89	475 6138 002	M 9 Volume Nut		2
34	Note	Power Trans. (Mini)		1	90	412 3938 000	Support Bracket		1
35	Note	S-Video Unit Ass'y		1s	91	Note	Cord Holder (L=50)		1
35-1	—	S-Video Unit		(1)	92	Note	Fuse n A	F002	1
35-2	—	V-Aux. Unit		(1)	93	203 0532 012	1 P Contact Ass'y		1
36	Note	2 P S-Terminal	AU Flash	1	94	—			
37	Note	3 P S-Terminal	AU Flash	1	95	—			
38	Note	1 P S-Terminal (SW)	AU Flash	1					
39	Note	S-Terminal (3.5)	AU Flash	1					
40	Note	3 P Pin Jack(C-GND)		1					
41	411 1304 109	*Main Chassis		1					
42	Note	*Rear Panel		1					
43	417 0506 003	*Power Radiator		1					
44	415 0234 007	Insulating Sheet		6					

SCREWS

101	473 7015 018	Tapping Screw(S)3x8	Black	12
102	473 8007 009	Cup Screw 3x12		10
103	Note	Tapping Screw(P)3x8		28

Ref. No.	Parts No.	Parts Name	Remarks	Q'ty
104	—	—		
105	Note	Tapping Screw(S)3x8		n
106	Note	Fixing Screw		n
107	—	—		
108	—	—		
109	477 0262 006	Special Screw		3
110	473 7004 016	Tapping Screw(S)4x6		4
111	471 9020 018	Special Screw		1
112	Note	Tapping Screw(S)4x20	Black	6
113	—	—		
114	—	—		
PACKING & ACCESSORIES (Not included EXPLODED VIEW.)				
150	504 9102 029	Styrene Paper		1
151	Note	Poly Cover		n
152	503 1147 102	Cushion Ass'y		1
153	399 0245 008	Remote Control	RC-180	1
154	Note	Carton Case		1
155	Note	Envelope Sub Ass'y		1s
155-1	505 8006 019	Envelope		(1)
155-2	Note	*Inst. Manual(E)		(1)
155-2	Note	*Inst. Manual(C)		(1)
155-2	Note	*Inst. Manual(F)		(1)
155-3	515 0671 106	Service Station List		(1)
155-4	—	Batteries		(2)
156	Note	Envelope		1
157	Note	AC Adapter (4.B)		1
158	—	—		

NOTE FOR PARTS LIST

- Part indicated with the mark "◎" are not always in stock and possibly to take a long period of time for supplying, or in some case supplying of part may be refused.
- When ordering of part, clearly indicate "1" and "1" (i) to avoid mis-supplying.
- Ordering part without stating its part number can not be supplied.
- Part indicated with the mark "★" is not illustrated in the exploded view.
- Not including Carbon Film ±5%, 1/6W, 1/4W Type in the P.W.Board parts list. (Refer to the Schematic Diagram for those parts.)

WARNING:

Parts marked with this symbol  have critical characteristics. Use ONLY replacement parts recommended by the manufacturer.

ADDENDUM PARTS LIST

Ref. No.	Parts Name		Parts No.					
			M.-Voltage Black	M.-Voltage Gold	U.S.A. Black	Canada Black	U.K. Black	Europe Black
1	Main Amp. Unit Ass'y	(1s)	1U-2743 A	1U-2743 A	1U-2743 C	1U-2743 C	1U-2743 D	1U-2743 D
8	2 P Connector Base	(1)	205 8225 007	205 8225 007	205 0315 002	205 0315 002	205 0315 002	205 0315 002
9	Headphone Jack	(1)	204 8341 004	204 8341 004	204 8354 004	204 8354 004	204 8354 004	204 8354 004
10	Surround Unit Ass'y	(1s)	1U-2744 A	1U-2744 A	1U-2744 C	1U-2744 C	1U-2744 D	1U-2744 D
12	Chemicon n μF/n V C816	(1)	254 4254 704 3300μF/16 V	254 4254 704 3300μF/16 V	254 4472 707 4700μF/16 V	254 4472 707 4700μF/16 V	254 4472 707 4700μF/16 V	254 4472 707 4700μF/16 V
13	6 P Pin Jack(S-GND)	(1)	204 8376 008	204 8376 008	204 8278 009	204 8278 009	204 8278 009	204 8278 009
14	4 P Pin Jack(S-GND)	(3)	204 8393 007	204 8393 007	204 8266 008	204 8266 008	204 8266 008	204 8266 008
15	4 P Pin Jack	(2)	204 8312 004	204 8312 004	204 8313 003	204 8313 003	204 8313 003	204 8313 003
16	6 P Pin Jack(S-GND)	(1)	204 8377 007	204 8377 007	204 8365 006	204 8365 006	204 8365 006	204 8365 006
17	1 P Pin Jack(S-GND)	(1)	204 8481 003	204 8481 003	204 8474 007	204 8474 007	204 8474 007	204 8474 007
18	FLD Unit Ass'y	(1s)	1U-2745 A	1U-2745 A	1U-2745 C	1U-2745 C	1U-2745 D	1U-2745 D
22	Fuse n A (F003.004)	(2)	—	—	206 1046 027 5 A	206 1046 027 5 A	—	—
23	Fuse n A (F001)	(1)	206 1036 011 6.3 A	206 1036 011 6.3 A	206 1046 014 8 A	206 1046 014 8 A	206 1015 074 3.15 A	206 1015 074 3.15 A
24	Fuse n A (F005)	(1)	—	—	206 1046 043 10 A	206 1046 043 10 A	—	—
32	AC Outlet	(1)	203 3942 007	203 3942 007	—	—	—	—
34	Power Trans(Mini)	(1)	233 6146 005	233 6146 005	233 6018 007	233 6018 007	233 6058 012	233 6058 012
35	S-Video Unit Ass'y	(1s)	1U-2746 A	1U-2746 A	1U-2746 C	1U-2746 C	1U-2746 D	1U-2746 D
36	2 P S-Terminal	(1)	204 8414 009	204 8414 009	204 8414 012	204 8414 012	204 8414 012	204 8414 012
37	3 P S-Terminal	(1)	204 8415 008	204 8415 008	204 8415 011	204 8415 011	204 8415 011	204 8415 011
38	1 P S-Terminal(SW)	(1)	205 0906 000	205 0906 000	205 0902 004	205 0902 004	205 0902 004	205 0902 004
39	S-Terminal(3.5)	(1)	204 8427 009	204 8427 009	205 0903 003	205 0903 003	205 0903 003	205 0903 003
40	3 P Pin Jack(C-GND)	(1)	204 8342 003	204 8342 003	204 8404 006	204 8404 006	204 8404 006	204 8404 006
42	Rear Panel	(1)	105 1137 125	105 1137 125	105 1137 138	105 1137 138	105 1137 196	105 1137 196
52	Card Spacer (L=12)	(1)	412 2814 057	412 2814 057	—	—	412 2814 057	412 2814 057
55	AC Cord With Plug	(1)	206 2070 005	206 2070 005	206 2060 002	206 2060 002	206 2131 009	206 2063 009
59	Inner Panel Ass'y	(1)	146 1521 114	146 1521 127	146 1521 130	146 1521 130	146 1521 114	146 1521 114
62	Tact Button (A)	(1)	113 1691 002	113 1691 015	113 1691 002	113 1691 002	113 1691 002	113 1691 002
63	Function Button	(1)	113 1692 001	113 1692 014	113 1692 001	113 1692 001	113 1692 001	113 1692 001
64	VR Knob Ass'y	(1)	112 0726 108	112 0726 111	112 0726 108	112 0726 108	112 0726 108	112 0726 108
65	Push Button (P)	(1)	113 1292 281	113 1292 294	113 1292 281	113 1292 281	113 1292 281	113 1292 281
66	Tact Button (B)	(2)	113 1693 000	113 1693 013	113 1693 000	113 1693 000	113 1693 000	113 1693 000
70	Power Trans	(1)	233 6135 003	233 6135 003	233 6125 000	233 6125 000	233 6155 012	233 6155 012
71	Front Panel	(1)	144 2398 117	144 2398 120	144 2398 117	144 2398 117	144 2398 117	144 2398 117
72	Trap Door	(1)	144 1941 167	144 1941 170	144 1941 167	144 1941 167	144 1941 167	144 1941 167
76	Top Cover	(1)	102 0406 560	102 0406 544	102 0406 557	102 0406 557	102 0406 557	102 0406 557
78	Vol. Knob(B)	(3)	112 0555 007	112 0555 023	112 0555 007	112 0555 007	112 0555 007	112 0555 007
79	Fuse n A (F006)	(1)	206 1015 022 2.5 A	206 1015 022 2.5 A	206 1039 063 2.0 A	206 1039 063 2.0 A	206 1015 032 2.5 A	206 1015 032 2.5 A
80	Preset Label	(1)	515 8030 008	515 8030 008	—	—	—	—
81	U.L Tube	(1)	415 0546 070	415 0546 070	—	—	415 0546 070	415 0546 070
82	Wood Board (L)	(1)	101 2491 033	101 2491 033	—	—	—	—
83	Wood Board (R)	(1)	101 2492 032	101 2492 032	—	—	—	—
84	Felt Sheet	(6)	124 0032 015	124 0032 015	—	—	—	—
85	Washer φ5	(6)	475 1006 016	475 1006 016	—	—	—	—
86	Slide Switch	(2)	212 2611 003	212 2611 003	—	—	—	—
91	Cord Holder	(1)	445 0048 016	445 0048 016	—	—	—	—
92	Fuse n A (F002)	(1)	206 1015 074 3.15 A	206 1015 074 3.15 A	—	—	—	—

Ref. No.	Parts Name		Parts No.					
			M.-Voltage Black	M.-Voltage Gold	U.S.A. Black	Canada Black	U.K. Black	Europe Black
SCREWS								
103	Tapping Screw (P)3x8	(n)	473 7500 015 (28)	473 7500 015 (28)	473 7500 015 (26)	473 7500 015 (26)	473 7500 015 (27)	473 7500 015 (27)
105	Tapping Screw (S)3x8	(n)	473 7002 018 (30)	473 7002 018 (30)	473 7002 018 (29)	473 7002 018 (29)	473 7002 018 (29)	473 7002 018 (29)
106	Fixing Screw	(n)	477 0064 107 (20)	477 0064 107 (20)	477 0064 107 (18)	477 0064 107 (18)	477 0064 107 (16)	477 0064 107 (16)
112	Tapping Screw (S)4x20	(6)	473 7007 039	473 7007 039	—	—	—	—
113	3 P Swelling Screw	(6)	—	—	477 0263 005	477 0263 005	477 0263 005	477 0263 005
PACKING & ACCESSORIES (Not included EXPLODED VIEW.)								
151	Poly Cover	(n)	505 9102 019 (2)	505 9102 019 (2)	505 9102 019 (1)	505 9102 019 (1)	505 9102 019 (1)	505 9102 019 (1)
154	Carton Case	(1)	501 1821 011	501 1821 011	501 1821 024	501 1821 024	501 1821 024	501 1821 024
155	Envelope Sub. Ass'y	(1s)	GEN 2883 -1	GEN 2883 -1	GEN 2883 -2	GEN 2883 -2	GEN 2883 -2	GEN 2883 -2
155-2	Inst. Manual (E)	(1)	511 2706 006	511 2706 006	511 2706 006	511 2706 006	511 2758 009	511 2758 009
155-2	Inst. Manual (C)	(1)	511 2707 005	511 2707 005	—	—	—	—
155-2	Inst. Manual (F)	(1)	—	—	—	511 2724 004	—	—
156	Envelope	(1)	505 8006 006	505 8006 006	—	—	—	—
157	AC Adapter(4.8)	(1)	202 0043 003	202 0043 003	—	—	—	—
160	Side Pad	(2)	504 0159 013	504 0159 013	—	—	—	—
161	Color Label(Gold)	(2)	—	513 9111 001	—	—	—	—
162	UPC Label	(1)	—	—	517 0104 022	517 0104 035	—	—
163	DEL Warranty Home	(1)	—	—	515 0690 006	—	—	—
164	DCI Warranty Home	(1)	—	—	—	515 0627 105	—	—
165	Caution Label (A)	(1)	—	—	513 2341 001	513 2341 001	—	—
166	Fuse Caution Label (B)	(1)	—	—	513 2357 008	513 2357 008	—	—

NOTE FOR PARTS LIST

- Part indicated with the mark "◎" are not always in stock and possibly to take a long period of time for supplying, or in some case supplying of part may be refused.
- When ordering of part, clearly indicate "1" and "I" (i) to avoid mis-supplying.
- Ordering part without stating its part number can not be supplied.
- Part indicated with the mark "★" is not illustrated in the exploded view.
- Not including Carbon Film ±5%, 1/6W, 1/4W Type in the P.W.Board parts list. (Refer to the Schematic Diagram for those parts.)

WARNING:

Parts marked with this symbol  have critical characteristics. Use ONLY replacement parts recommended by the manufacturer.

REMOTE CONTROL UNIT (RC-180)

1 2 3 4 5 6 7 8

SCHEMATIC DIAGRAM

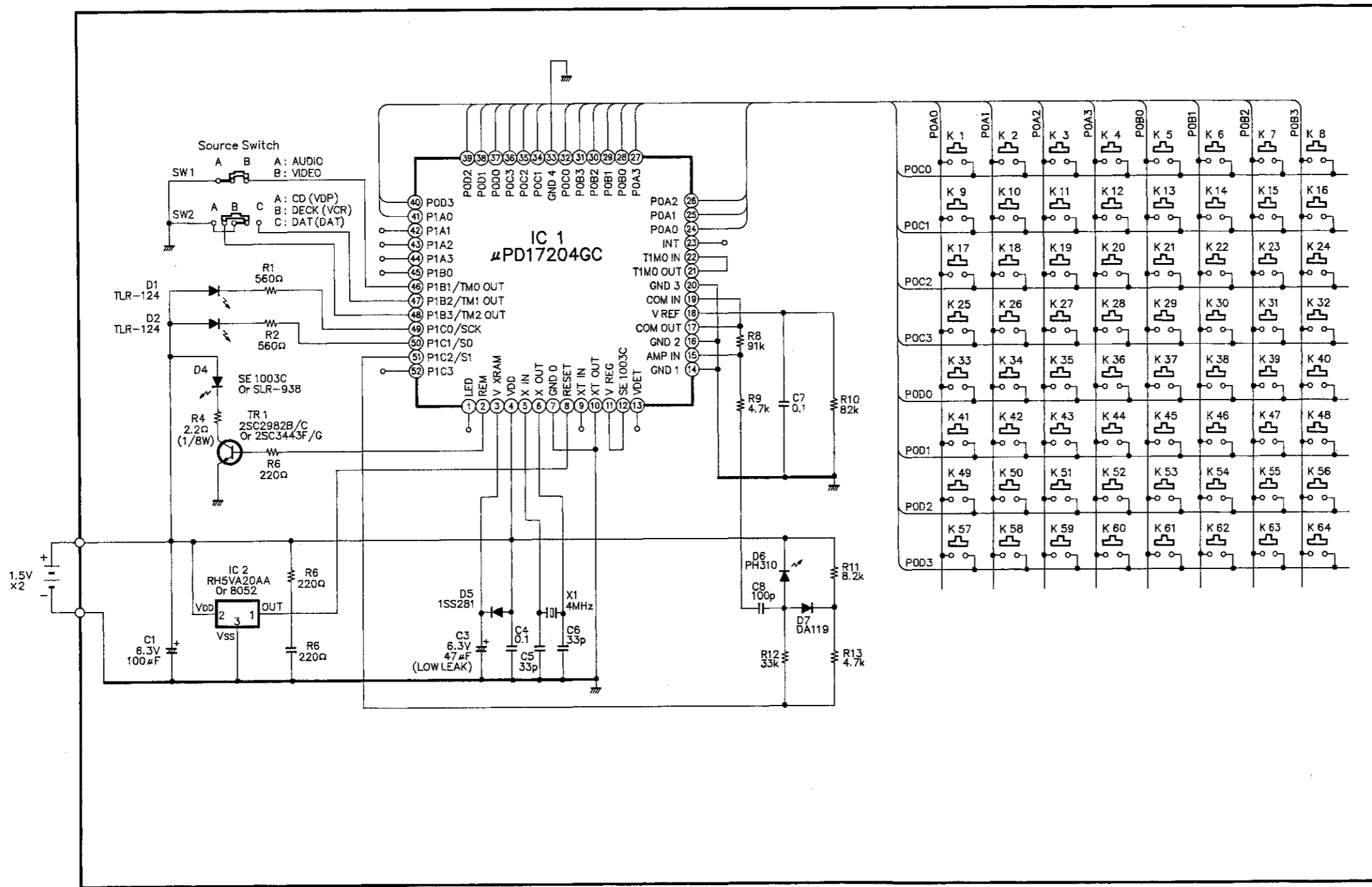

KEY LAYOUT

K1			
K9	K10	K11	K12
K17	K18	K19	K20
K25	K26	K27	K28
K33	K34	K35	K36
K41	K42	K43	K44
K49	K50	K51	K52
K57	K58	K59	K60
K61	K62	K63	K64
K53	K54	K55	K56
K45	K46	K47	
K37	K38	K39	K40
K29	K30	K31	K32
K21	K22	K23	K24
K13	K14	K15	K16
K5	K6	K7	K8

Slide SW Source Name

P1B1	Mode
H	AUDIO
L	VIDEO

P1B2	P1B3	Source
H	H	CD (VDP)
H	L	DECK (VCR)
L	H	DAT (TV)
L	L	DECK (VCR)

A
B
C
D
E

REMOTE CONTROL UNIT ASS'Y PARTS LIST PARTS LIST OF EXPLODED VIEW

Ref. No.	Part No.	Part Name	Remarks	Ref. No.	Part No.	Part Name	Remarks	Q'ty
SEMICONDUCTORS GROUP								
IC1	9H3 1000	IC μ PD17204GC-538	μ -Com	1	9H3 1000	Case Top Ass'y		1
IC2	9H3 1000 158	IC RH5VA20AA	VOL. Detector	2	—	—		
TR1	9H3 1000 070	Transistor 2SC3443BF/BG	Chip	3	9H3 1000	Switch Rubber		1
or	9H3 1000 070	Transistor 2SC2982B/C	Chip	4	9H3 1000 146	Case Bottom Ass'y		1
D1,2	9H3 1000 028	LED TLR124	Visible-Red	5	9H3 1000 147	Cover Battery		1
D4	9H3 1000 131	LED SE1003-C	Infrared	6	9H3 1000 148	IR Filter		1
D5	9H3 1000 087	Diode 1SS281 (1)		7	9H3 1000 150	Switch Button		2
D6	9H3 1000 029	Diode PH310	Photo-PIN	8	—	—		
D7	9H3 1000 071	Diode DA119/DA118	Chip	9	9H3 1000 153	Spring Coil		1
or		Diode 1SS196		10	9H3 1000 151	Spring Coil		1
RESISTORS GROUP				11	9H3 1000 152	Spring Coil		1
R1,2	247 0006 988	Chip Resistor 560ohm, 1/10W	RM73B--561J	12	9H3 1000 154	Tapping Screw 2x6		1
R4	247 0001 909	Chip Resistor 2.2ohm, 1/10W	RM73B--2R2J	13	9H3 1000 155	Tapping Screw 2x5		1
R6	247 0005 989	Chip Resistor 220ohm, 1/10W	RM73B--221J	14	9H3 1000 156	P.W.Unit Ass'y		1 ^S
R7	247 0012 927	Chip Resistor 100kohm, 1/10W	RM73B--104J	15	—	Label		1
R8	247 0012 914	Chip Resistor 91kohm, 1/10W	RM73B--913J	16	—	Sheet		1
R9	247 0009 901	Chip Resistor 4.7kohm, 1/10W	RM73B--472J					
R10	247 0012 901	Chip Resistor 82kohm, 1/10W	RM73B--823J					
R11	247 0009 969	Chip Resistor 8.2kohm, 1/10W	RM73B--822J					
R12	247 0011 902	Chip Resistor 33kohm, 1/10W	RM73B--333J					
R13	247 0009 901	Chip Resistor 4.7kohm, 1/10W	RM73B--472J					
J7,8	247 0018 905	Chip Resistor 0ohm, 1/10W	RM73B--0R0K					
CAPACITORS GROUP								
C1	254 4213 034	Electrolytic 100 μ F/6.3V	CE04W0J101M					
C2	—	Chip Ceramic 0.33 μ F/25V	CK73F1E334Z					
C3	254 4213 021	Electrolytic 47 μ F/6.3V	CE04W0J470M					
C4	257 0014 935	Chip Ceramic 0.1 μ F/25V	CK73F1E104Z					
C5,6	257 0003 946	Chip Ceramic 33PF/50V	CK73SL1H330J					
C7	257 0014 935	Chip Ceramic 0.1 μ F/25V	CK73F1E104Z					
C8	257 0004 961	Chip Ceramic 100PF/50V	CC73SL1H101J					
OTHER GROUP								
	—	(P.W. Board)						(1)
X1	9H3 1000 088	Ceramic Resonator	KBR4.0M503					1
SW1	9H3 1000 089	Slide Switch 1-2						1
SW2	9H3 1000	Slide Switch 1-3						1
	—	Port Wrapping						2