

# DENON

Hi-Fi AV Surround Amplifier

## SERVICE MANUAL MODEL AVC-A1 AV SURROUND AMPLIFIER

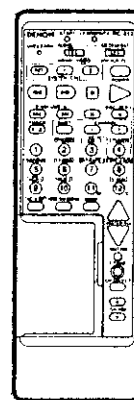

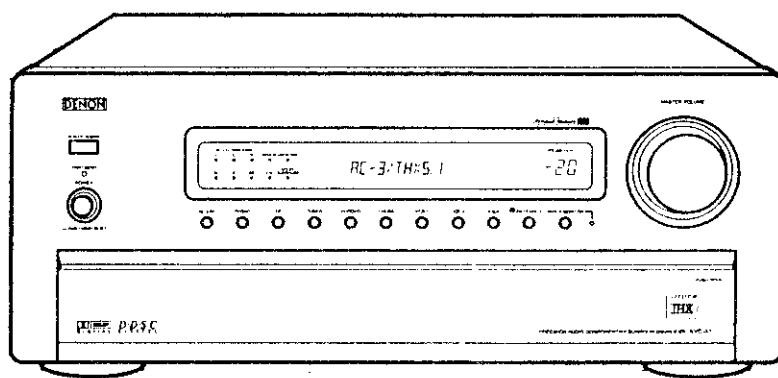







### — TABLE OF CONTENTS —

OPERATING INSTRUCTIONS .....	2-16
SPECIFICATIONS .....	17
WIRE ARRANGEMENT .....	18
DISASSEMBLY .....	19-23
ADJUSTMENT .....	24, 25
FUNCTION OF NEW CIRCUIT .....	26, 27
SEMICONDUCTORS .....	28-51
PRINTED WIRING BOARD .....	52-57
NOTE FOR PARTS LIST .....	58
PRINTED WIRING BOARD PARTS LIST .....	58-73
EXPLODED VIEW OF CHASSIS AND CABINET .....	74
PARTS LIST OF EXPLODED VIEW .....	75
BLOCK DIAGRAM .....	76
BLOCK LEVEL DIAGRAM .....	77
WIRING DIAGRAM .....	79
SCHEMATIC DIAGRAM .....	80-93
REMOTE CONTROL UNIT (RC-813) .....	95, 96
SCHEMATIC DIAGRAM .....	95
PARTS LIST .....	96





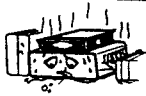



• Some illustration using in this service manual are slightly different from the actual set.

## NIPPON COLUMBIA CO., LTD.

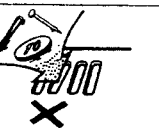
**NOTE ON USE**

 <ul style="list-style-type: none"> <li>Avoid high temperatures. Allow for sufficient heat dispersion when installed on a rack.</li> </ul>	 <ul style="list-style-type: none"> <li>Keep the set free from moisture, water, and dust.</li> </ul>	 <ul style="list-style-type: none"> <li>Do not let foreign objects in the set.</li> </ul>
 <ul style="list-style-type: none"> <li>Handle the power cord carefully. Hold the plug when unplugging the cord.</li> </ul>	 <ul style="list-style-type: none"> <li>Unplug the power cord when not using the set for long periods of time.</li> </ul>	 <ul style="list-style-type: none"> <li>Do not let insecticides, benzene, and thinner come in contact with the set.</li> </ul>
<ul style="list-style-type: none"> <li>Do not obstruct the ventilation holes.</li> </ul>	 <ul style="list-style-type: none"> <li>*(For sets with ventilation holes)</li> <li>Do not obstruct the ventilation holes.</li> </ul>	 <ul style="list-style-type: none"> <li>Never disassemble or modify the set in any way.</li> </ul>

**使用注意事項**

 <p><b>防止高熱</b></p> <ul style="list-style-type: none"> <li>勿將本機放置於烈日曝曬或靠近發熱器材的位置。</li> </ul>	 <p><b>注意濕氣、水和塵</b></p> <ul style="list-style-type: none"> <li>勿將本機放置於潮濕或靠近水管的位置，花瓶或裝有水的物件均不宜置在本機上方。</li> </ul>	 <p><b>勿讓雜物掉入機內</b></p> <ul style="list-style-type: none"> <li>特別留意勿讓針、髮夾、硬幣等落入本機。</li> </ul>
<p><b>機架/機櫃安裝注意</b></p> <ul style="list-style-type: none"> <li>避免將本機裝於密封的機架內。</li> <li>裝於機架或機櫃時，要配備足夠大的通風孔，以加強散熱。</li> </ul>	 <p><b>當你外出時</b></p> <ul style="list-style-type: none"> <li>長時間不用本機時，與如外出旅行時，請將機架拉離電源插座。</li> </ul>	 <p><b>保護機殼</b></p> <ul style="list-style-type: none"> <li>避免在本機附近噴灑殺蟲劑，也勿用汽油、天拿水或其他溶劑清潔機殼，因這些化學品易引起漆面顏色改變。清潔要用軟布，在用化學品處理過的布條抹時小心地守說明書規定。</li> </ul>
 <p><b>留意電源線</b></p> <ul style="list-style-type: none"> <li>從插座拔出插頭時切勿拉電線，要抓緊住插頭將其拔出。</li> </ul>	 <p><b>應有通風孔的機殼</b></p> <p><b>勿堵塞機殼的通風孔</b></p> <ul style="list-style-type: none"> <li>堵塞通風孔會損壞本機。</li> <li>各通風孔對本機內部散熱異常重要，必須特別留意，若通風孔有物件阻擋，或有使機內溫度升得很高。</li> </ul>	 <p><b>勿打開機殼</b></p> <ul style="list-style-type: none"> <li>打開機殼頂蓋或蓋板，及伸手入機殼內部是危險的。切勿打開機殼，如本機表現有不妥當時，宜立刻拉下電源插頭，再將機殼入櫃內或靠近電源插頭。</li> </ul>

■ We greatly appreciate your purchase of the AVC-A1.  
 ■ To be sure you take maximum advantage of all the features the AVC-A1 has to offer, read these instructions carefully and use the set properly. Be sure to keep this manual for future reference should any questions or problems arise.

**TABLE OF CONTENTS**

1	Before Using	3	7	Operations	20-24
2	Cautions on Installation	3	8	Using the Surround Function	24-30
3	Cautions on Handling	3	9	Last Function Memory	30
4	Connections	4-9	10	Initialization of the Microprocessor	30
5	System Setup	9-15	11	Troubleshooting	31
6	Remote Control Unit	16-20	12	Specifications	32

**ACCESSORIES**

Check that the following parts are included in addition to the main unit:

①	Operating instructions	1	④	R6P/AA batteries	2
②	Service station list	1	⑤	AC power cord (for Asia model)	2
③	Remote control unit (RC-813)	1		(for Taiwan R.O.C. model)	1

**1 BEFORE USING**

Pay attention to the following before using this unit:

- **Moving the set**  
To prevent short circuits or damaged wires in the connection cords, always unplug the power cord and disconnect the connection cords between all other audio components when moving the set.
- **Before turning the power switch on**  
Check once again that all connections are proper and that there are not problems with the connection cords. Always set the power switch to the standby position before connecting and disconnecting connection cords.

- Store this instructions in a safe place. After reading, store this instructions a safe place
- Note that the illustrations in this instructions may differ from the actual set for explanation purposes.

**2 CAUTIONS ON INSTALLATION**

Noise or disturbance of the picture may be generated if this unit or any other electronic equipment using microprocessors is used near a tuner or TV.

- If this happens, take the following steps:  
 1. Install this unit as far as possible from the tuner or TV.  
 2. Set the antenna wires from the tuner or TV away from this unit's power cord and input/output connection cords.  
 3. Noise or disturbance tends to occur particularly when using indoor antennas or 300 Ω/ohms feeder wires. We recommend using outdoor antennas and 75 Ω/ohms coaxial cables.

For heat dispersal, leave at least 10 cm of space between the top, back and sides of this unit and the wall or other components.

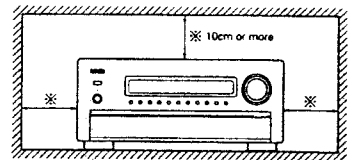

**3 CAUTIONS ON HANDLING**

- **Switching the input function when input jacks are not connected**  
A clicking noise may be produced if the input function is switched when nothing is connected to the input jacks. If this happens, either turn down the MASTER VOLUME control or connect components to the input jacks.
- **Muting of PRE OUT jacks and SPEAKER terminals**  
The PRE OUT jacks and SPEAKER terminals include a muting circuit. Because of this, the output signals are greatly reduced for several seconds after the power switch is turned on or input function, surround mode or any other set-up is changed. If the volume is turned up during this time, the output will be very high after the muting circuit stops functioning. Always wait until the muting circuit turns off before adjusting the volume.

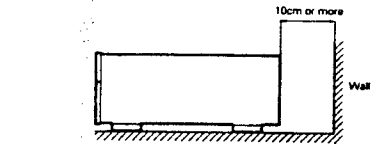

- Whenever the power switch is in the OFF state, the apparatus is still connected on AC line voltage. Please be sure to unplug the cord when you leave home for, say, a vacation.
- **Opening and closing the door**  
This unit has a door on the front panel. Press the "PUSH OPEN" mark on the upper right side of the door to unlatch and open it. To close it, press it until a click is heard.

**NOTE:** The door opens out automatically once it is unlatched, but it may stop halfway. This is not a malfunction. In this case, pull down the door lightly to open it.

## 4 CONNECTIONS

- Do not plug in the power cord until all connections have been completed.
- Be sure to connect the left and right channels properly. (left with left, right with right)
- Insert the plugs securely. Incomplete connections will result in the generation of noise.

- Note that binding pin plug cords together with power cords or placing them near a power transformer will result in generating hum or other noise.
- Noise or humming may be generated if a connected audio equipment is used independently without turning the power of this unit on. If this happens, turn on the power of this unit.

### 4-1 Connecting the audio components

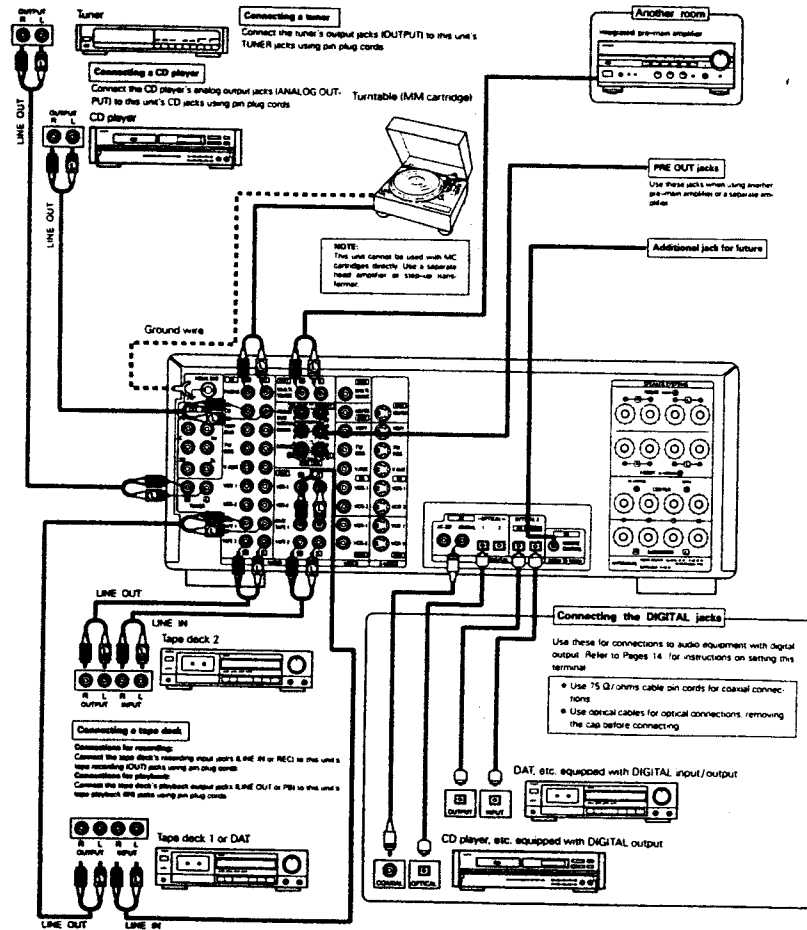

### 4-2 Connecting the video equipments

To connect the video signal, connect using a 75 Ω/ohms video signal cable cord. Using an improper cable can result in a drop in video quality.

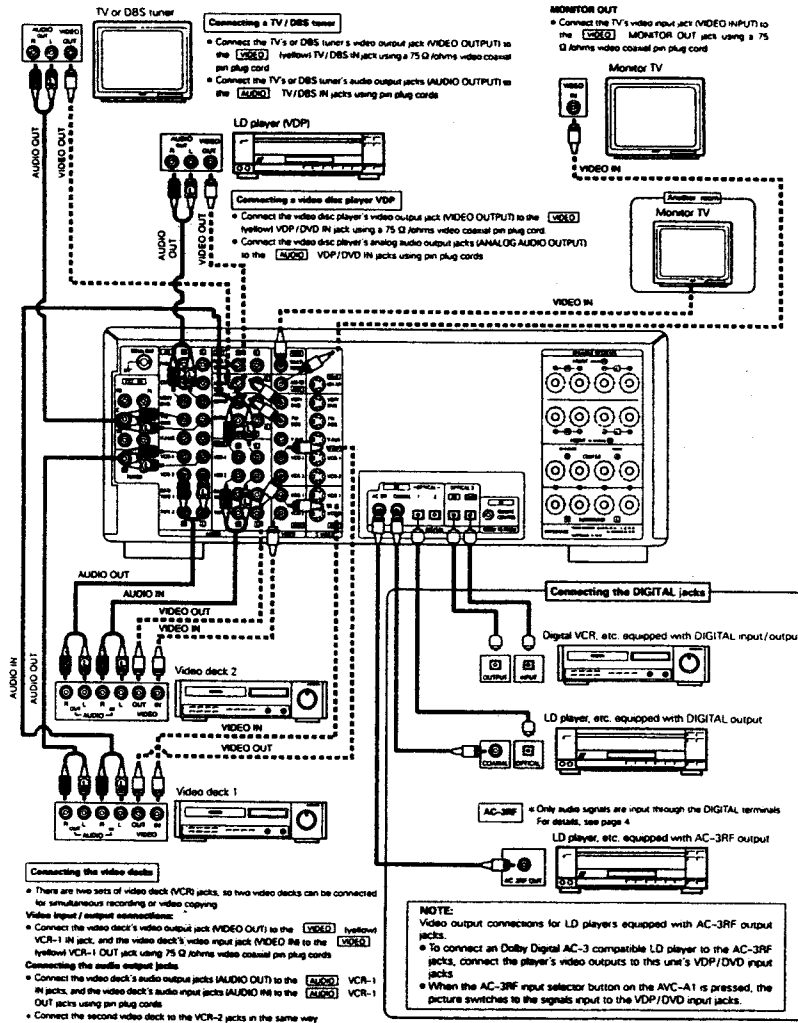

4-3 Connecting the S-video jacks

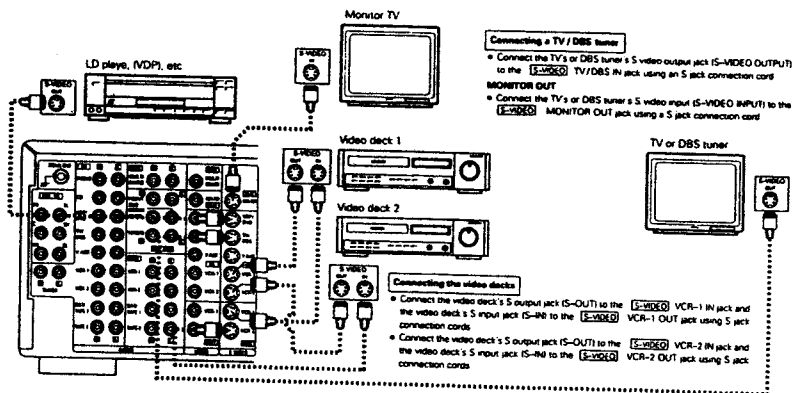

- A note on the S input jacks**  
The input selectors for the S inputs and pin jack inputs work in conjunction with each other.
- Precaution when using S-jacks**  
This unit's S-jacks (input and output) and video pin jacks (input and output) have independent circuit structures, so that video signals input from the S-jacks are only output from the S-jack outputs and video signals input from the pin jacks are only output from the pin jack outputs. When connecting this unit with equipment that is equipped with S-jacks, keep the above point in mind and make connections according to the equipment's instruction manuals.

4-4 Connecting the EXT. IN jack

The EXT. IN (EXTERNAL INPUTS) jack is used for the input of multi-channel audio, such as MPEG multi-channel.

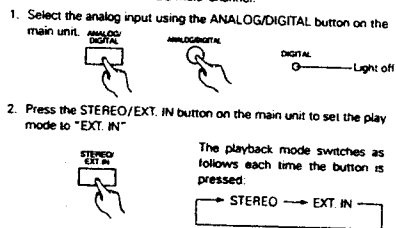

After setting, the input signals connected to the FL (Front Left), FR (Front Right), C (Center), SW (SubWoofer), SL (Surround Left) and SR (Surround Right) input jacks are output directly to the front (left and right), center, subwoofer and surround (left and right) speaker systems without passing through the surround circuit.

**Surround input terminals**

- If your component has only one surround output terminal, connect it to either the SL (surround left) or SR (surround right) terminal on the AVC-A1. The signals will automatically be divided between the left and right surround channels before being output.

**NOTES:**

- This jack cannot be operated in play modes other than the "EXT. IN" mode. Also, no signals are output from channels not connected to input jacks.
- The "EXT. IN" mode can be set for any function. To enjoy together with pictures, set this mode after selecting a function to which video signals are input.

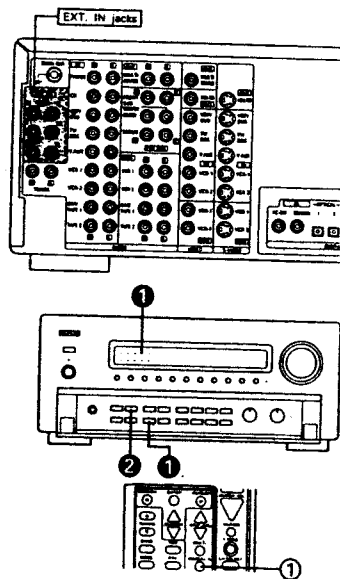

4-5 Connecting the AC power cord and AC OUTLET(S)

■ ASIA MODEL ONLY

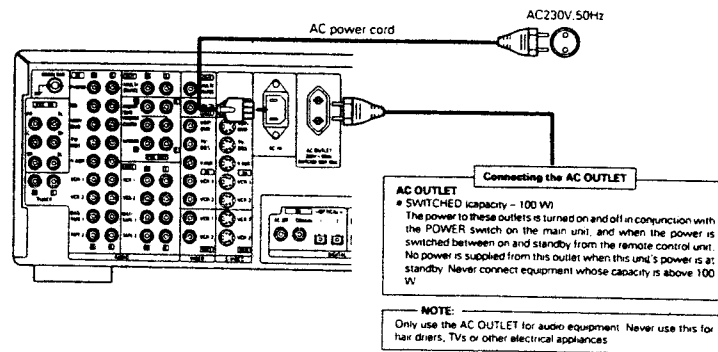

■ TAIWAN R.O.C. MODEL ONLY

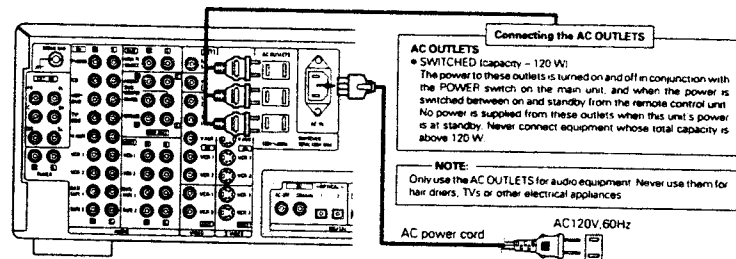

#### 4-6 Speaker system connections

- Connect the speaker terminals with the speakers making sure that the polarities are matched (+ with +, - with -). Mismatching of polarities will result in weak central sound, unclear orientation of the various instruments, and the sense of direction of the stereo being impaired.
- When making connections, take care that none of the individual conductors of the speaker cord come in contact with adjacent terminals, with other speaker cord conductors, or with the rear panel.

##### Speaker Impedance

- When speaker systems A and B are used separately, speakers with an impedance of from 8 to 16  $\Omega$ /ohms can be connected for use as front and center speakers.
- Be careful when using two pairs of front or center speakers (A + B) at the same time, since use of speakers with an impedance of less than 16  $\Omega$ /ohms will lead to damage.
- Speakers with an impedance of 8 to 16  $\Omega$ /ohms can be connected for use as surround speakers.
- The protection circuit may operate or damage may occur when speakers with an impedance outside of the above range are used.

##### Precautions when connecting speakers

- If a speaker is placed near a TV or video monitor, the colors on the screen may be disturbed by the speaker's magnetism. If this should happen, move the speaker away to a position where it does not have this effect.

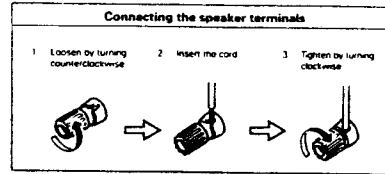

**NOTE:**  
NEVER touch the speaker terminals when the power is on. Doing so could result in electric shocks.

Connection jack for subwoofer with built-in amplifier (bass woofer), etc.

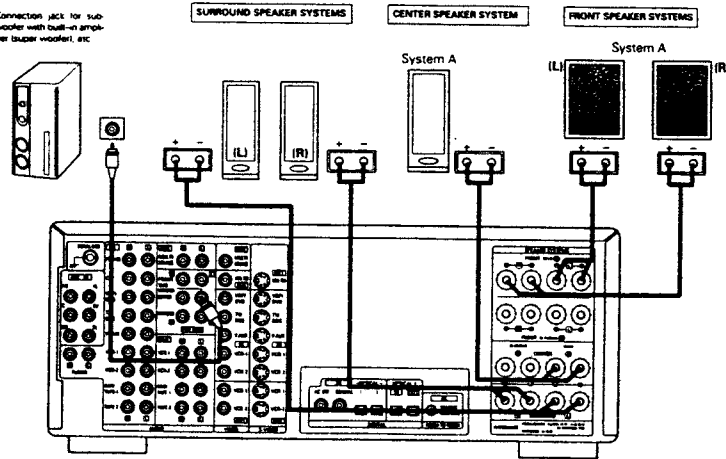

#### CAUTION

##### Protective Circuit

This set is equipped with a high speed protective circuit. This circuit protects the internal circuitry from damage due to large currents flowing when the speaker jacks are not completely connected or when an output is generated by a short circuit. This protective circuit's operation cuts off the output to the speakers and "PROTECT" display appears. In such a case, be sure to turn the power to the set off and check the connections to the speakers. Then turn the power on again. After muting for several seconds, the set will operate normally.

#### Bi-wiring procedure

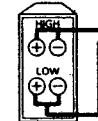
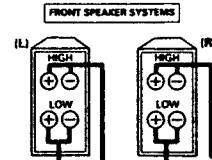

**SPEAKER SYSTEM (BI-WIRING)**  
When bi-wiring with bi-wirable speakers, connect the mid and high range terminals to SYSTEM (A) for SYSTEM (B), the low range terminals to SYSTEM (B) for SYSTEM (A).

- About bi-wiring: If your speakers have bi-wiring terminals, you can achieve higher quality sound by adding cords and using bi-wiring, as shown on the diagram below.
- By connecting speaker systems to both the speaker A and B terminals, you can play the same music source simultaneously in different rooms. (Use speakers with impedances of 16  $\Omega$ /ohms.)
- By adding an integrated amplifier, you can use the multi-source terminals to play the other music source simultaneously in different rooms. (See page 23)

#### 5 SYSTEM SETUP

After connections with other components have been made, make the various settings on the monitor using this unit's on screen display. These settings must be made in order to complete the AV system in your listening room. (Please do not connect headphones in these settings.)

Make the seven settings described below.

- 1 Speaker Configuration
- 2 Delay Time
- 3 Channel Level
- 4 Subwoofer Peak Limit Level
- 5 Digital Inputs (only when an AV component is connected to the digital input jacks)
- 6 AC-3
- 7 On Screen Display

##### NOTES:

- The output from the S MONITOR OUT terminal has priority for the on screen display. If you want to always output the on screen display signals to the video output, do not connect a cable to the S MONITOR OUT terminal.
- The on screen display is not displayed for the MULTI SOURCE OUT terminal.
- This model's on screen function is designed for high resolution monitor displays. Small characters may be difficult to read on small displays or low resolution TVs.

Use the following buttons on the remote control unit to make the settings:

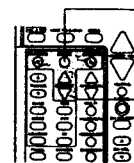

##### "ENTER" button

Press this to switch the display on the screen. Also use this button to complete the setting on the screen.

##### "CURSOR" buttons

◀ and ▶ : Use these to move the cursors (◀ and ▶) to the left and right on the screen.  
▲ and ▼ : Use these to move the cursors (▲ and ▼) up and down on the screen.

**5-1 Before setting up the system**

- 1 Turn on the power and press the ENTER button  
The "Menu" screen (screen 1) appears on the monitor.



- 2 Use the CURSOR buttons to specify "System Setup"



- 3 Press the ENTER button to switch the screen



The "System Setup Menu" screen (screen 2) appears on the monitor

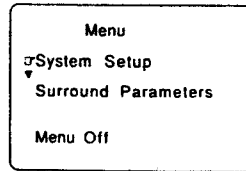

( screen 1 )

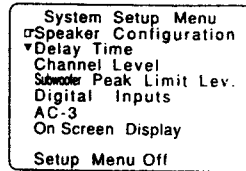

( screen 2 )

**5-2 Setting the speaker configuration**

- 1 Use the CURSOR buttons to specify "Speaker Configuration" from the "System Setup Menu" screen (screen 2).



- 2 Press the ENTER button.



The "Speaker Configuration" screen (screen 3) appears on the monitor.

- 3 Use the CURSOR buttons and select the different types of speakers connected and their size parameters.

To select the speakers:



To select the parameters:



The selected parameters are highlighted

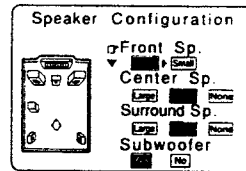

( screen 3 )

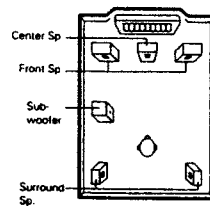

**Parameters**

- Large** Select this when using speakers that can fully reproduce low sounds of below 80 Hz
- Small** Select this when using speakers that cannot reproduce low sounds of below 80 Hz with sufficient volume. When this setting is selected, low frequencies of below 80 Hz are assigned to the subwoofer
- None** Select this when no speakers are installed.
- Yes/No** Select "Yes" when a subwoofer is installed, "No" when a subwoofer is not installed

- \* To take full advantage of the performance of the Home-THX certified speaker systems, set the front, center and surround speaker size parameters to "Small" and the subwoofer to "Yes".

- 4 After the above selections are completed, press the ENTER button again  
The "System Setup Menu" screen reappears

**5-3 Setting the delay time**

Input the listening position and the distance of the different speakers

- 1 Use the CURSOR buttons to specify "Delay Time" from the "System Setup Menu" screen (screen 4)



- 2 Press the ENTER button



The "Delay Time" screen (screen 5) appears on the monitor

- 3 Use the CURSOR buttons to specify the unit of distance.



**NOTE:** The settings are reset to their initial values when switching between meters and feet

- 4 Use the CURSOR buttons to input the listening position and the distance of the different speakers (screen 6-A)

To select the speakers:



To select the distance:



- \* Select "Default" to return to the initial settings (refer to page 15)

- 5 After the above selections are completed, press the ENTER button again  
The "System Setup Menu" screen reappears.  
This procedure automatically sets the optimum surround delay time for the listening room.

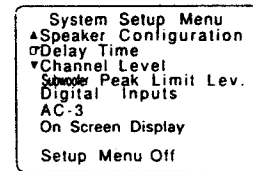

( screen 4 )

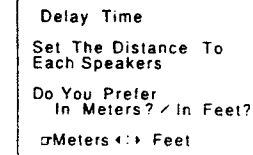

( screen 5 )

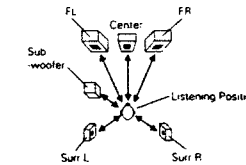

- \* Please note that the difference of distance for every speaker should be 15 ft (4.5 m) or less. If you set an invalid distance, a CAUTION notice, such as screen 6-B will appear. In this case, please relocate the blinking speaker(s) so that its distance is no larger than the value shown in highlighted line. Then press the ENTER button again.

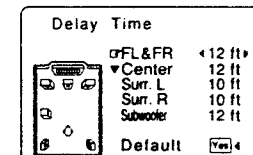

( screen 6-A )

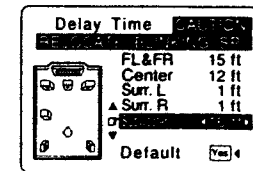

( screen 6-B )

#### 5-4 Setting the channel level

Use test tones to adjust the volume of the different speakers

- Use the CURSOR buttons to specify "Channel Level" from the "System Setup Menu" screen. (screen 7)



- Press the ENTER button



The "Channel Level" screen (screen 8) appears on the monitor

- Use the CURSOR buttons to select "Test Tone Mode", then select "Auto" or "Manual".



- Use the CURSOR buttons to select "Test Tone Start", then select "Yes".



- If the "Auto" mode is selected: Test tones are automatically emitted from the different speakers.

The test tones are emitted from the different speakers in the following order, at 4-second intervals the first time and second time around, 2-second intervals the third time around and on:

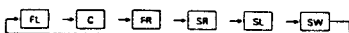

Use the CURSOR buttons to adjust all the speakers to the same volume. (screen 9)



- If the "Manual" mode is selected: Use the cursor buttons to select the speakers from which to emit the test tones and adjust the volume. (screen 10)

To adjust the volume:



To select the speaker:



The level of each channel should be adjusted to 75 dB (C-weighted, slow meter mode) on a sound level meter at the listening position. If a sound level meter is not available adjust the channels by ear so the sound levels are the same. Because adjusting the subwoofer level test tone by ear is difficult, use a well known music selection and adjust for natural balance.  
NOTE: When adjusting the level of an active subwoofer system, you may also need to adjust the subwoofer's own volume control

- After the above settings are completed, press the ENTER button again. The "System Setup Menu" screen (screen 2) reappears. To cancel the settings, select "Level Clear" and "Yes" on the "Channel Level" screen, then make the settings again.  
NOTES:
  - The output channel levels for all the surround modes are set to the same conditions when the channel level setting on the system setup menu is conducted.
  - When the level clear operation is performed, all channel levels for all modes are set to 0 dB.

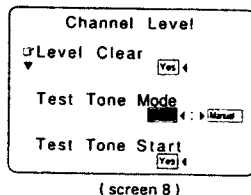
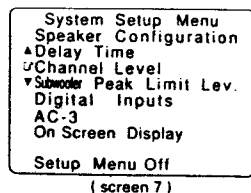

(screen 8)

The test tone is emitted from the speaker whose indicator is highlighted

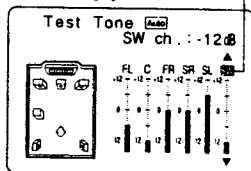

(screen 9)

The test tone is emitted from the speaker whose indicator is highlighted.

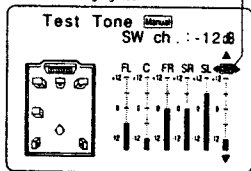

(screen 10)

#### 5-5 Subwoofer Peak Limit Level Setting

This unit features a subwoofer peak limit control which prevents distortion and damage in the loudspeaker system by controlling the maximum bass volume level. With this feature you may set the maximum bass level for the system. This feature operates with or without a subwoofer in the system.

- Use the CURSOR buttons to specify "Subwoofer Peak Limit Lev." from the "System Setup Menu" screen. (screen 11)



- Press the ENTER button



The "Subwoofer Peak Limit Level Setting" screen (screen 12) appears

- Use the left CURSOR button to select "ON"



The screen changes (screen 13)

- Use the CURSOR buttons to select "Setting Start" and "Yes"



The screen changes (screen 14) and a test noise is output from the subwoofer. (Clear the subwoofer's peak limit level setting by specifying "Peak Limiter" and "OFF")

- Use the right CURSOR button to increase the test noise output level until the loudspeaker system's bass sound is distorted. Bass distortion can be heard as an obvious overload. When you hear that the bass sound is distorted, press the down CURSOR button



This unit automatically sets the subwoofer peak limit level so the bass level will never be louder than the test noise signal.

**CAUTION!**

- The master volume is set to "0" when test tones are output.
- The test tones are for confirming the low frequency playback limits and are played at an extremely high level. When using a low output subwoofer, be very careful about irregular operations exceeding clipping by for example turning down the subwoofer's attenuator before starting then slowly turning the attenuator up to the listening level. Also, when the subwoofer is set to "No" in the speaker configuration, the test tones are output from the front speakers. When using front speakers with low input power handling, check that the sound is not clipped at sections where the signal is strong on the CD music source before starting the peak limit setting. The peak limit setting should not be performed if the music source cannot be played with the master volume set at "-15". Set the front speakers to "Small" and the subwoofer to "Yes" in the speaker configuration. When this is done, the low frequencies are cut, so the effect is insufficient. We strongly recommend adding a subwoofer.
- If the test tone is clipped when it is set to "-18 dB", set the peak limit to "-18 dB". In this case, the input power handling of the subwoofer or front speakers is insufficient so clipping may occur when playing music. We recommend switching to a subwoofer with a higher input power handling.

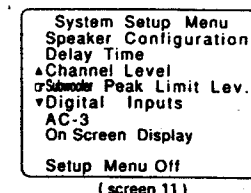

(screen 11)

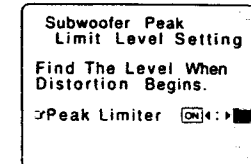

(screen 12)

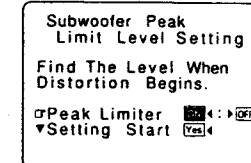

(screen 13)

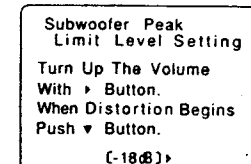

(screen 14)

**5-6 Digital inputs setup**

Input the types of components connected to the digital input terminals.

- 1 Use the CURSOR buttons to specify "Digital Inputs" from the "System Setup Menu" screen (screen 15)



- 2 Press the ENTER button



The "Digital Inputs Setup" screen appears (screen 16)

- 3 Use the cursor buttons to input the types of components connected to the digital input terminals

To select the input terminal:      To select the type of component:



\* Select "OFF" if nothing is connected

Select "Default" to return to the initial settings (refer to page 15)

- 4 After the above settings are completed, press the ENTER button again. The "System Setup Menu" screen reappears.

**NOTES:**

- OPTICAL-3 INPUT is equipped with optical output for digital recording to DAT, MD or Digital VCR. Connect the optical recording devices to the input/output of OPTICAL-3 for digital recording. For "OPTICAL-3", CD, VDP/DVD, TV/DBS and V.AUX cannot be set.
- When you connect such a recording device to OPTICAL-3 OUTPUT, the output of the device is allowed to be connected only to OPTICAL-3 INPUT. Invalid connection may cause a trouble, such as noise arising or serious damage to loudspeakers or amplifiers, etc.
- PHONO, TUNER and TAPE-2 cannot be selected at "digital input terminal setting".

**5-7 Dolby Digital AC-3**

When playing Dolby Digital AC-3 sources, the input level is corrected automatically. Set the dialog normalization function.

- 1 Use the CURSOR buttons to specify "AC-3" from the "System Setup Menu" screen (screen 17)



- 2 Press the ENTER button.



The "AC-3" screen appears. (Screen 18)

- 3 Use the CURSOR buttons to select "ON" or "OFF"



- 4 After the above settings are completed, press the ENTER button again. The "System Setup Menu" screen reappears

**When playing Dolby Digital AC-3 sources**

**NOTE:** If dialog normalization is set to "OFF", it may not be possible to set the master volume to greater than -5 dB, depending on the number of speakers and the output channel level setting. In the HOME THX CINEMA mode as well, even if dialog normalization is set to "ON", it may not be possible to set the master volume to greater than -5 dB depending on the above conditions

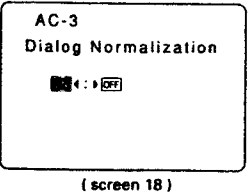
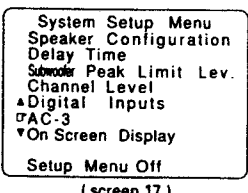
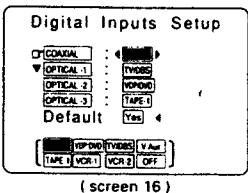
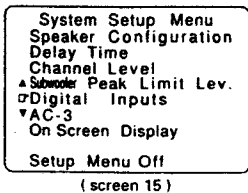

**5-8 On Screen Display**

"ON" or "OFF" can be selected for functions other than the ones on the menu screen

- 1 Use the CURSOR buttons to specify "On Screen Display" from the "System Setup Menu" screen (screen 19)



- 2 Press the ENTER button



The "On Screen Display" screen (screen 20) appears on the monitor

- 3 Use the CURSOR buttons to select "ON" or "OFF"



- 4 After the above settings are completed, press the ENTER button again. The "System Setup Menu" screen reappears

\* This completes the system setup operations. Once the system is set up, there is no need to make the settings again unless other components or speakers are connected or the speaker layout is changed.

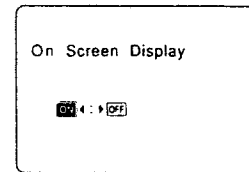
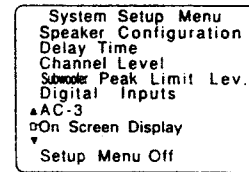

**5-9 Operation after completing system setup**

- 1 Use the CURSOR buttons to specify "Setup Menu Off" from the "System Setup Menu" screen. (screen 21)



- 2 Press the ENTER button twice to turn off the on screen display

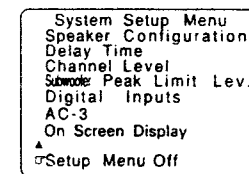

**SYSTEM SETUP DEFAULT VALUE**

① Speaker Configuration	Front Sp Small	Center Sp Small	Surround Sp Small		Subwoofer Yes
② Delay Time	FL & FR 12 ft (3.6 m)	Center 12 ft (3.6 m)	Surr. L 10 ft (3.0 m)	Surr. R 10 ft (3.0 m)	Subwoofer 12 ft (3.6 m)
③ Channel Level	FL 0 dB	FR 0 dB	Center 0 dB	Surr. L 0 dB	Surr. R 0 dB
④ Subwoofer Peak Limit Lev	Peak Limiter: OFF				
⑤ Digital Inputs	COAXIAL CD	OPTICAL-1 TV/DBS	OPTICAL-2 VDP/DVD	OPTICAL-3 TAPE-1	
⑥ AC-3	Dialog Normalization: ON				
⑦ On Screen Display	ON				

Playback with the above setting is possible upon shipment from the factory and after initializing (refer to page 30)





TV

A \ B	ON SELECT	A	ON VCR
①	DENON	—	—
② (PHONO)	HITACHI A	HITACHI B	—
③ (CD)	DAIICHI A	DAIICHI B	—
④ (TUNER)	PANASONIC	—	—
⑤ (VDP/DVD)	JVC VICTORI	—	—
⑥ (TV/DBS)	SONY A	—	—
⑦ (TAPE-1)	PIONEER	—	—
⑧ (TAPE-2/MON)	TOSHIBA	—	—
⑨ (VCR-1)	SANYO A	SANYO B	—
⑩ (VCR-2)	SHARP	—	—
⑪ / D	NEC A	NEC B	NEC C
⑫ / E (V AUX)	PHILIPS A	PHILIPS B	PHILIPS C
⑬	RCA A	RCA B	—
⑭	GENERAL ELECTRIC A	GENERAL ELECTRIC B	—
⑮	MAGNAVOX A	MAGNAVOX B	MAGNAVOX C

**NOTES:**

- The signals for the pressed buttons are emitted while setting the preset memory. To avoid accidental operation, cover the remote control unit's transmitting window while setting the preset memory.
- Some models and years of manufacture of components of the manufacturers listed on Table 6-2 cannot be used

**6-3 Operation after components are registered**

- Set the slide switch to "VIDEO".
- Set the slide switch to the component to be registered (VDP, VCR or TV).

- Use the buttons shown below to operate the video component. (Some models cannot be used.) For details, refer to the respective component's manual.

**a. VDP**

POWER : Power on/off  
 ◀▶ : Manual search (reverse and forward)  
 ■ : Stop  
 ▶ : Play  
 ⏪ : Auto search  
 ■ : Pause

**b. VCR**

POWER : Power on/off  
 ◀▶ : Manual search (reverse and forward)  
 ■ : Stop  
 ▶ : Play  
 ■ : Pause  
 CHANNEL : Channel selection  
 +, -

**c. TV**

POWER : Power on/off  
 VOLUME : Volume up/down  
 ▲▼ : TV/VCR  
 CHANNEL : Channel selection  
 +, -

**6-4 Remote control unit learning function**

If your AV components are not DENON products or if operation is not possible with the preset memory settings, the components' remote control signals can be "learned" to enable remote control operation.

The buttons that can be "learned" are the CD, DAT and DECK system buttons (see page 16) and the VDP, VCR and TV system buttons (see page 18). (For the TV only, the A block buttons can also be "learned".)

- Press the USE/LEARN selector button with the tip of a pen etc., to set the learn mode. Both the START and LEARNED/TX indicators flash.
- Set the program switch to the side to be "learned". Set to the AUDIO side for the CD, tape deck or DAT position, to the VIDEO side for the VDP, VCR or TV position.
- Set the program switch to the position to be "learned".
- Set the remote control units so they are facing each other, then press the button to be "learned" on this unit's remote control unit.

**NOTE:** Use button ① / 0 as the 0 number button, but ton ⑫ / E as the enter button.

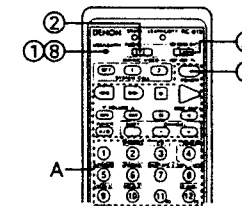

- Check that the START LED is lit, then press the button to be "learned" on the other remote control unit.
- Once the START LED turns off and the LEARNED/TX LED lights, release the button on the other remote control unit.
- To "learn" other buttons, repeat steps 2 to 6.
- Once the learning operation is completed, press the USE/LEARN selector button again. The two LEDs stop flashing and the learning mode is cancelled.

Check that the stored codes work properly.

- NOTES:**
- Up to 26 codes can be "learned", but this number may be lower if the codes are long.
  - If a non-learnable button is pressed or two or more buttons are pressed at once, the two LEDs will once again light when the button(s) is released.
  - If the codes could not be stored, the LEARNED/TX LED does not light after the START LED turns off. For limited number of models, codes cannot be stored in RC-813.
  - If the two LEDs start flashing rapidly after the START LED lights, this means that the memory is already full, and the code you have just attempted to store was not stored. To "learn" that code, first perform the resetting operation.

### 6-5 Clearing "learned" remote control signals and the preset memory settings

- 1 Press the USE/LEARN selector button with the tip of a pen, etc., to set the learn mode.
- 2 To clear "learned" remote control signals, set the slide switch to the position at which the signals were "learned". To clear the preset memory settings, set the slide switch to "VIDEO".
- 3 Set the slide switch to the position at which the signals were "learned" or at which the preset memory settings were set.

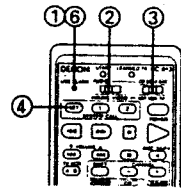
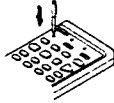

- 4 Press the SYSTEM CALL SET button, and hold it in for at least four seconds.
- 5 When both the START and LEARNED / TX LEDs light simultaneously, all the stored codes are cleared.
- 6 Press the USE/LEARN selector button.



## 7 OPERATIONS

### 7-1 Preparations for playback

- 1 Check that all connections are proper.
  - 2 Set to the center position.
  - 3 Set the remote control unit's slide switch to the AUDIO position. (only when operating with the remote control unit)
  - 4 Turn on the power. Press the POWER switch (button).
- ON/STANDBY**  
The power turns on and "ON/STANDBY" indicator is lit. Several seconds are required from the time the power switch is set to the "ON" position until sound is output. This is due to the built-in muting circuit that prevents noise when the power switch is turned on and off.  
Set the POWER switch to this position to turn the power on and off from the included remote control unit (RC-813).

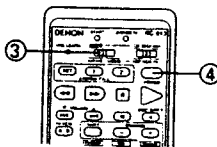
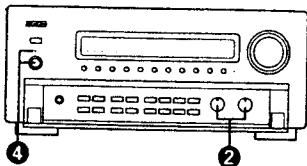
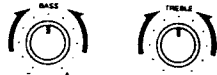

### 7-2 Playing the analog program source

- 1 Press the button for the program source to be played. EX: CD
  - 2 Select the ANALOG input.
  - 3 Select the STEREO or EXT IN mode.
- The play mode switches in the following order each time the STEREO/EXT IN button on the main unit is pressed:  
STEREO → EXT IN
- \* EXT IN mode  
This mode is for playing the multi-channel audio signals of an MPEG multi-channel decoder, etc., connected to the main unit's EXT IN jacks (refer to page 6)
- 4 Start playback on the selected component. For operating instructions, refer to the various components' manuals.

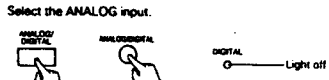
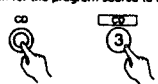

The play mode switches in the following order each time the STEREO/EXT IN button on the main unit is pressed:



\* EXT IN mode  
This mode is for playing the multi-channel audio signals of an MPEG multi-channel decoder, etc., connected to the main unit's EXT IN jacks (refer to page 6)

### 7-3 Playing the digital program source

- 1 Press the button for the program source to be played that is connected to the digital input jacks. EX: CD
  - 2 Select the DIGITAL input.
  - 3 Check that the "DIGITAL" indicator is lit red.
- When digital signals are input properly, the DIGITAL indicator switches from red to green.
- \* If the indicator is not lit green, check that the system setup's input setting (refer to page 14) and the connections are proper, that the component's power is turned on, etc.
- 4 Start playback on the selected component. For operating instructions, refer to the various components' manuals.

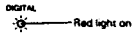
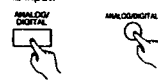

When digital signals are input properly, the DIGITAL indicator switches from red to green.

\* If the indicator is not lit green, check that the system setup's input setting (refer to page 14) and the connections are proper, that the component's power is turned on, etc.

4 Start playback on the selected component. For operating instructions, refer to the various components' manuals.

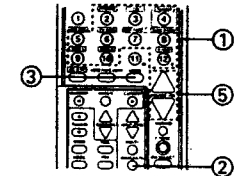
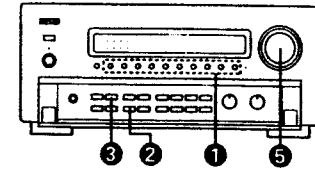

5 Adjust the MASTER VOLUME control.

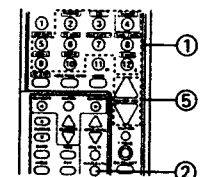
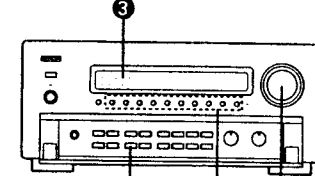

5 Adjust the MASTER VOLUME control.

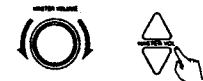

NOTE: If a CD-ROM is played, the "DIGITAL" indicator is lit green but no sound is heard

**7-4 Adjusting the TONE control**

1. Adjust the BASS and TREBLE.

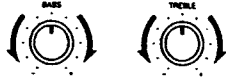

Turn the control clockwise to increase the bass or treble, counter-clockwise to decrease it

2. Select the DIRECT mode if there is no need to adjust the sound

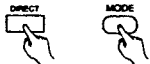

**7-5 Simulcast playback**

Use this switch to monitor a video source other than the audio source

1. Press the VIDEO SELECT button repeatedly until the desired source appears on the display.

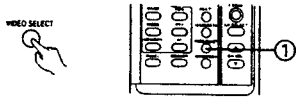

\* Cancelling simulcast playback.

- Select "SOURCE" using the video select button
- Switch the program source to the component connected to the video or AC-3RF input.

**7-7 Listen with headphones**

Connect the headphones to the PHONES jack. The pre-out output (including the speaker output) is automatically turned off when headphones are connected

**NOTE:**

To prevent hearing loss, do not raise the volume level excessively when using headphones.

**7-8 On screen display**

Each time an operation is performed, a description of that operation appears on the display connected to the unit's VIDEO MONITOR OUT terminal. Also, the unit's operating status can be checked during playback by pressing the remote control unit's ON SCREEN button



Such information as the position of the input selector and the surround parameter settings is output in sequence.

**7-9 Front panel display**

Descriptions of the unit's operations are also displayed on the front panel display. In addition, the display can be switched to check the unit's operating status while playing a source by pressing the PANEL button

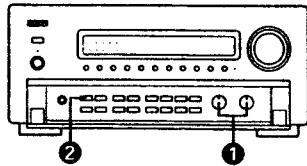

**7-6 Using the muting function**

Use this to turn off the audio output temporarily

1. Press the MUTING button.
- \* Cancelling MUTING mode  
Press the MUTING button again.

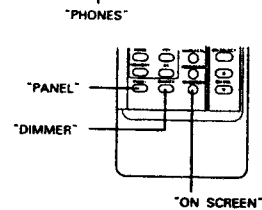
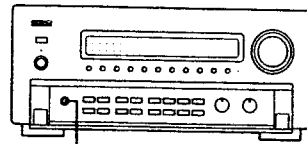
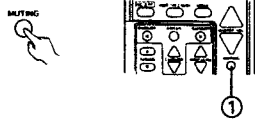

**7-10 Using the dimmer function.**

Use this to change the brightness of the display. The display brightness changes in four steps (bright, medium, dim and off) by pressing the remote control unit's DIMMER button repeatedly.



**7-11 Multi-source REC OUT recording / playback**

While listening to or watching the currently playing program source, you can record another program source (REC OUT mode), or by connecting the input jacks of an amplifier, etc., located away from the AVC-A1 (for example in another room) to the MULTI SOURCE output jacks, you can output the program source to the other location (room) (MULTI mode)

**■ Recording a source other than the one currently playing (REC OUT mode)**

1. Press the REC/MULTI MODE button until "REC OUT SOURCE" appears on the display



2. Select the source to be output to the recording output terminal. Press the REC/MULTI SOURCE button repeatedly until the desired source appears on the display



The indicator of the selected program source lights on the display at this time.

3. Set to the audio or video recording mode

For operating instructions, refer to the manuals of the components to be used for audio or video recording.

- \* The signals of the source except the digital input selected with the REC OUT mode are also output from the MULTI SOURCE AUDIO/VIDEO OUT terminals.
- \* Digital signals are only output from the recording output terminals and MULTI SOURCE OUT terminals after conversion into analog signals when playing the digital input in the stereo mode
- \* To cancel the REC OUT mode. Press the REC/MULTI MODE button or the REC/MULTI SOURCE button repeatedly until "SOURCE" appears on the display.

**■ Playing a source other than the one currently playing in a different room (MULTI mode)**

1. Press the REC/MULTI MODE button repeatedly until "M-SOURCE SOURCE" appears on the display.



2. Select the source to be output to the MULTI SOURCE output terminal. Press the REC/MULTI SOURCE button repeatedly until the desired source appears on the display. The indicator of the selected program source lights on the display at this time. The "MULTI" indicator lights on the display at this time.



- \* When the MULTI button on the remote control unit is pressed, the source to be output from the MULTI SOURCE terminals can be selected. (This cannot be selected when the main unit is in the REC OUT mode.)
- \* The digital signals are not output from the MULTI SOURCE AUDIO/VIDEO OUT terminals.
- \* To cancel the MULTI mode. Press the REC/MULTI MODE button or the MULTI button on the remote control unit repeatedly until "SOURCE" appears on the display.

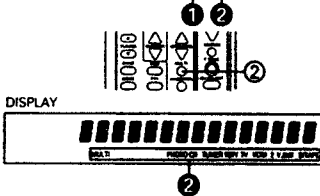
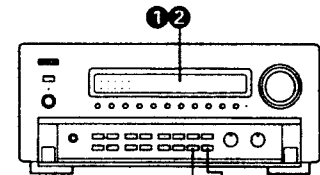
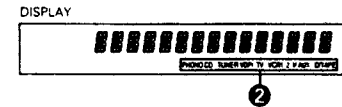
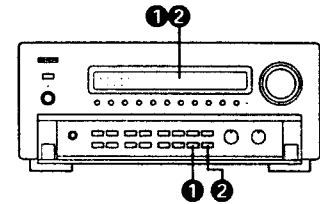

**NOTE:**  
The signals of the source selected in the MULTI mode are also output from the DAT/TAPE-1 and VCR recording output terminals.

**Multi-source and multi-zone playback**

By connecting another pre-main amplifier, etc., to the MULTI SOURCE [OUT] jacks, you can listen to a source other than the one in the main room in other room. To connect the video signal, use a 75 Ω/ohms cable designed specifically for video signals. Using an improper cable can result in a drop in sound quality

## 7-12 System call (remote control unit)

This function allows you to preset frequently used operation patterns in the remote control unit then automatically send a series of up to ten remote control codes with a single button.

### Presetting

1. Press the SET button



2. Press the buttons for the codes to be sent, changing the position of the slide switch as necessary (Up to ten buttons can be set) Buttons which have been "learned" and buttons which have been preset can also be selected

3. Press the SYSTEM CALL button ("1" or "2") at which you want to store the codes The setting is now stored

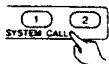

### Recalling

4. Press the SYSTEM CALL button ("1" or "2") at which the desired codes have been stored The series of codes is now sent.

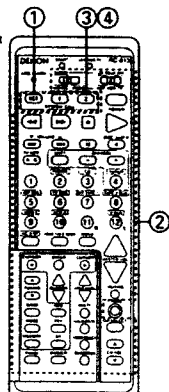

## 8 USING THE SURROUND FUNCTION

### 8-1 Dolby Surround & Home THX Cinema Surround

This unit is equipped with digital signal processing sections for decoding and reproducing movie soundtracks the same way as in movie theaters

#### 8-1-1 Dolby Surround

##### 1. DOLBY SURROUND PRO LOGIC

When using conventional video tapes, laser discs, TV programs or CDs with the mark, Dolby Pro Logic provides extremely natural sound movement and positioning, immersing you in the on screen action. Pro Logic uses a directional emphasis circuit to decode four output channels (front left and right, center and surround left and right) from the two audio channels provided on the software.

##### 2. DOLBY DIGITAL

When you connect an LD player with an AC-3 RF output and play laser discs with the mark, you can experience improved sound spatiality, positioning, and impact compared with Pro Logic. This is because Dolby Digital delivers up to 5 totally discrete, full frequency audio channels (front left and right, center, and surround left and right), plus a bass-only effects channel. Since the signal is digital from the input of the program source until to the output of this unit, a high quality and clarity of surround sound results.

Dolby Digital is a system developed by Dolby Laboratories that transmits 5.1 channels of digital signals. The surround system developed for movie theaters using this system is called "Dolby SR-D (Surround Digital)". Whereas the conventional Dolby Pro Logic Surround is an analog matrix system, Dolby SR-D is a digital discrete system in which the different channels are completely independent. This makes it possible to achieve a realistic sound field with a "three-dimensional" feel, giving the sound a sense of distance, movement and relative position, and creating a surprisingly real and powerful sense of presence when playing movie software in AV rooms.

There are "5.1 ch" playback channels: three front channels (front left, center and front right), two surround channels (surround left and surround right), plus "0.1 channel" called LFE (Low Frequency Effect) for low bass effect sounds of 120 Hz or less. The signals are recorded on the software in fully discrete fashion, eliminating crosstalk between channels and making it possible to control the sound field in the listening/viewing space with greater precision.

In addition, the frequency range of the five channels extends up to 20 kHz, (the same as CDs), resulting in clear sound with greater richness of expression. Also, Dolby Digital will be used on DVDs, the next generation AV medium.

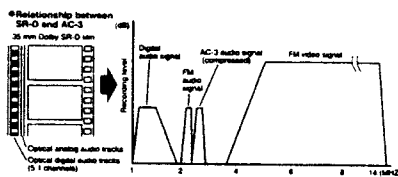

##### Dolby Digital and Pro Logic

Home surround method	Dolby Digital	Dolby Pro Logic
No. recording channels (maximum)	5.1 ch	2 ch
No. playback channels	5.1 ch	4 ch
Playback channels	L, R, C, SL, SR and SW	L, R, C, S (SW recommended)
Audio processing	Digital discrete processing, AC-3 encoding / decoding	Analog matrix processing, Dolby Surround
Upper reproduction limit of surround channel	20 kHz	7 kHz

Manufactured under license from Dolby Laboratories Licensing Corporation "Dolby," "AC-3," "Pro Logic" and the double-D symbol are trademarks of Dolby Laboratories Licensing Corporation. Copyright 1992 Dolby Laboratories, Inc. All rights reserved.

### 8-1-2 Home THX Cinema surround

Use the HOME THX CINEMA mode along with the Dolby Surround processing described above to experience movie sound in your own listening room that matches what you would hear in the best movie theater or movie production studio. Use the HOME THX CINEMA mode for all movies on disc, tape, or television broadcast. For optimal multichannel sound performance, we recommend the use of THX loudspeaker systems. This model's HOME THX CINEMA mode is based on the THX 5.1 format.

THX 5.1 is a format proposed by the Lucasfilm Company for achieving in the home the same sound effects reproduced in movie theaters. It produces the same acoustic characteristics as on the dubbing stage through further digital processing of the Dolby Digital's 5.1 channel digital signals in order to correct for the differences between the acoustic characteristics of movie theaters created on the dubbing stage when producing the sound track and the acoustic characteristics of home audio equipment. Thanks to this, the sound image when watching movie software in your AV room at home is nearer the image the movie's producer was aiming for in movie theaters and the sound field is better matched to the picture. The HOME THX CINEMA mode creates a more real world of sound and picture for your home theater.

Manufactured under license from Lucasfilm Ltd. U.S. patent numbers 5,043,970; 5,189,703; and 5,222,059. Foreign patents pending. Lucasfilm and THX are registered trademarks of Lucasfilm Ltd.

### 8-2 Before playing with the surround function

Before playing with the surround function, be sure to use the test tones to adjust the playback level from the different speakers. This adjustment can be performed with the system setup (see page 12) or from the remote control unit, as described below. Adjusting with the remote control unit using the test tones is only possible in the "Auto" mode and only effective in the DOLBY SURROUND PRO LOGIC and HOME THX CINEMA modes. The adjusted levels for the different modes are automatically stored in the memory.

1. Press the T TONE button



2. Test tones are output from the different speakers. Use the channel volume adjust buttons to adjust so that the volume of the test tones is the same for all the speakers.



3. After completing the adjustment, press the T TONE button again.

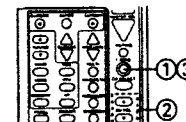

After adjusting using the test tones, adjust the channel levels either according to the playback sources or to suit your tastes, as described below.

1. Press the (CH) SELECT button to select the speaker to be adjusted.



2. Adjust the level of the selected speaker.

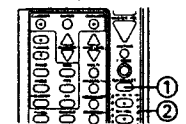
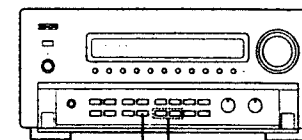

**8-3 Using the Dolby Surround Pro Logic mode**

1. Set the DOLBY SURROUND PRO LOGIC mode.



\* Conventional program sources will automatically be decoded with Dolby Surround Pro Logic, while Dolby Digital AC-3 program sources will be decoded with Dolby Digital AC-3

2. If necessary, adjust the input level when analog sources are used to obtain maximum dynamic range without overload



Set so that the "OVER LOAD" indicator does not light at places where the volume is high

\* For digital input sources, there is no need to adjust the input level (These buttons will not operate and the indicator will not light.)  
 \* The current input source, input level, etc., can be checked on the on screen display. (screen 22)

3. Play a program source with the **DOLBY SURROUND PRO LOGIC** or **DOLBY DIGITAL AC-3** mark. For operating instructions, refer to the various components' manuals.

**8-4 Using the Dolby Digital AC-3 mode**

1. Switch the audio input to AC-3RF input (a) or digital input (b). The VDP picture is linked to the AC-3RF signals

- a. **AC-3RF (VDP AUTO or VDP AC-3RF) input**  
 Select the AC-3 RF input.



When the button is pressed, the video input automatically switches to VDP/DVD. The input mode switches as follows each time the button is pressed:

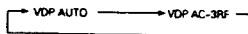

This input mode makes it possible to play the Dolby Digital AC-3 audio, digital audio or analog audio signals recorded on the source by switching between the priority and fixed modes for the AC-3RF, digital (optical/coaxial) or analog input jacks with the VDP/DVD function.

- VDP AUTO ..... When AC-3RF signals and digital and analog signals are input from the LD, the signals are automatically selected with the following priority: AC-3RF → digital or analog.
- VDP AC-3 RF ..... AC-3RF fixed input

**NOTES:**

- In the "VDP AUTO" mode, when an LD with the Dolby Digital AC-3 audio is detected, the decoder switches automatically and the Dolby Digital AC-3 audio is played. Also, in any mode other than normal LD player playback, no Dolby Digital AC-3 signals are detected, so the mode automatically switches to PCM or analog audio.
- In the "VDP AUTO" mode, when the mode changes from pause, chapter search, etc., to playback during playback of the Dolby Digital AC-3 audio on an LD, the PCM or analog sound may be output momentarily before the mode is switched to the Dolby Digital AC-3 audio mode. If this happens, the sound will not be interrupted if you switch to the "VDP AC-3RF" (AC-3RF fixed input) mode.
- The AC-3RF input mode setting is reset to "VDP AUTO" when the power is turned off using the power switch on the remote control unit or on the main unit.

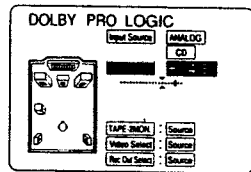
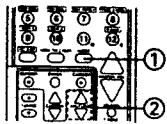
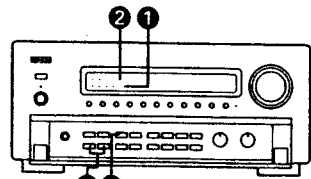

( screen 22 )

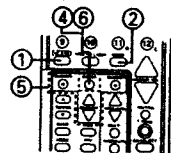
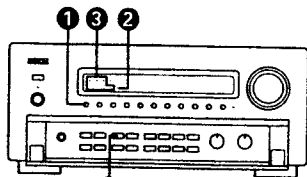

**b. Digital input**

Select the digital input. Refer to page 21, 7-3, 1, 2 and 3

2. Set the DOLBY SURROUND PRO LOGIC mode

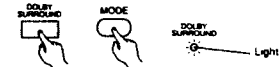

3. Play a program source with the **DOLBY SURROUND PRO LOGIC** mark or a program source with Dolby Digital AC-3 formats.

The indicators below showing the signals included in the software light (The number of channels differs according to the software)

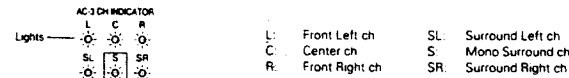

(This only lights when the surround signals are monaural.)

Also, the following indicator lights if the software contains Low Frequency Effect sounds:

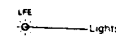

- 4-1. Adjust the sound for the program source using the on screen display

- 4-2. Press the ENTER button.



- 4-3. Use the CURSOR buttons to specify "Surround Parameters" (screen 23)



- 4-4. Press the ENTER button to switch the screen



5. Use the CURSOR buttons to move the cursor on the screen and set the parameters. (screen 24)

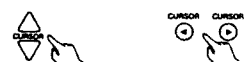

6. After the above settings are completed, press the ENTER button.

**NOTES:**

- With this model, Dolby Digital encoded signals can only be played in the DOLBY SURROUND PRO LOGIC, DOLBY DIGITAL AC-3, DIRECT and STEREO modes. Other surround mode buttons will not function during the Dolby Digital signal playback.
- When the mode is switched to Dolby Digital encoded signals while playing PCM digital signals or analog signals in the MONO, SCH STEREO, SUPER STADIUM, ROCK ARENA, JAZZ CLUB, CLASSIC CONCERT or MATRIX surround mode, the mode is forcibly switched to the DOLBY SURROUND PRO LOGIC mode.

**■ Surround parameters**

- CINEMA EQ ..... Use "CINEMA equalizer" if dialogue audio track sound scratchy when playing movie software. (The higher frequency component is lowered.) (Only effective in the DOLBY SURROUND PRO LOGIC, DOLBY DIGITAL modes.)
- D. COMP ..... "Dynamic Range Compression" compresses the dynamic range. This is only effective for Dolby Digital program sources. — There are four parameters: "OFF" → "LOW" → "MID" (MIDDLE) → "HI" (HIGH)

NOTE: When "Default" is selected and the cursor button is pressed, "CINEMA EQ" and "D.COMP" are automatically set to "OFF".

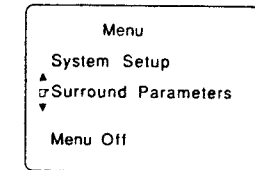

( screen 23 )

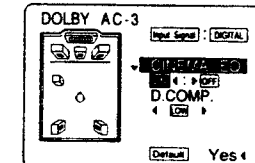

( screen 24 )

### 8-5 Using the Home THX Cinema mode with Dolby Surround Pro Logic

- 1 Set the HOME THX CINEMA mode



Select the HOME THX CINEMA mode for all movies on disc, tape, or television broadcasts! This mode is activated simultaneously with either DOLBY SURROUND PRO LOGIC or DOLBY DIGITAL. The THX processing will allow you to hear the sound as if you were in the best movie theater or movie production studio.

- 2 If necessary, adjust the input level when analog sources are used to obtain maximum dynamic range without overload (screen 25)



Set so that the indicator does not light at places where the volume is high.

- \* For digital input sources, there is no need to adjust the input level (These buttons will not operate and the indicator will not light.)
  - \* The current input source, input level, etc., can be checked on the on screen display.
- 3 Play a program source with the **DOLBY SURROUND PRO LOGIC** or **DOLBY DIGITAL** mark

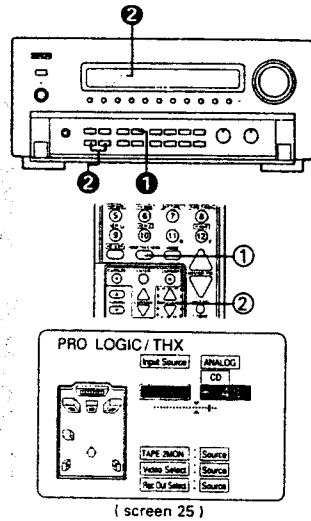

### 8-6 Using the Home THX Cinema mode with Dolby Digital AC-3

- 1 Select AC-3 RF input (refer to page 26) or digital input (refer to page 21)

- 2 Set the HOME THX CINEMA mode



- 3 Play a program source with the **DOLBY DIGITAL** mark or a program source with Dolby Digital formats. The indicators below showing the signals included in the software light. (The number of channels differs according to the software.)

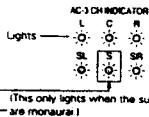

L: Front Left ch  
C: Center ch  
R: Front Right ch  
SL: Surround Left ch  
S: Mono Surround ch  
SR: Surround Right ch

Also, the following indicator lights if the software contains Low Frequency Effect sounds:

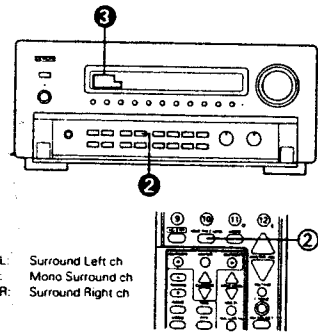
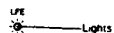

### 8-7 DSP surround simulation

This unit is equipped with a high precision D S P (Digital Signal Processor) for processing signals digitally to simulate sound fields. Select the surround mode according to the playback source and adjust the parameters according to the conditions in the listening room to achieve realistic venue ambience.

These surround modes can be used with program sources not recorded in Dolby Surround Pro Logic or Dolby Digital except WIDE SCREEN mode. Types of surround modes and their characteristics

1	WIDE SCREEN	Use this to enjoy program sources, with the atmosphere of a movie theater. This mode is suited for program sources recorded in Dolby Surround Pro Logic or Dolby Digital.
2	MONO	Use this when playing monaural signals, for example AM broadcasts or news programs.
3	SCH STEREO	The signals of the left and right channels are distributed to the different speakers to achieve a stereo sound from all directions at the listening position.
4	SUPER STADIUM	Use this to enjoy program sources such as football or baseball games with the atmosphere of a stadium.
5	ROCK ARENA	The powerful reverberations of this mode produce a sound field which recreates the excitement of live concerts. This mode is effective for rock, popular music, etc.
6	JAZZ CLUB	This mode creates the sound field of a live house with a low ceiling and hard wall reverberations. The result is that the artist seems to be performing right before your eyes.
7	CLASSIC CONCERT	This mode creates a sound field simulating a large concert hall, rich in reverberation. This mode is characterized by composed acoustics, and is perfect for playing classical music, etc.
8	MATRIX	Use this to enjoy stereo music sources with rich reverberations.

\* Depending on the program source being played, the effect may not be very noticeable. In this case, try other surround modes, without worrying about their names, to create a sound field suited to your tastes.

#### Personal Memory Plus function ... for EASY USE

This unit automatically stores the surround mode adding selected effects for all input sources. The corresponding surround mode is recalled automatically each time an input source is selected.

### 8-8 Using the DSP surround simulation

- 1 Select the surround mode according to the input source

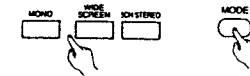

The surround mode switches in the following order each time the DSP SIMULATION button is pressed:  
SUPER STADIUM → ROCK ARENA → JAZZ CLUB → CLASSIC CONCERT → MATRIX

- 2 Press the unit ENTER button and call out the "Menu" screen from the on screen display.



- 3 Use the CURSOR buttons to specify "Surround Parameters" (screen 26)



- 4 Press the ENTER button. The screen switches.

- 5 Move the cursor on the screen and make the various settings (screen 27)

- 6 After the above settings are completed, press the ENTER button.

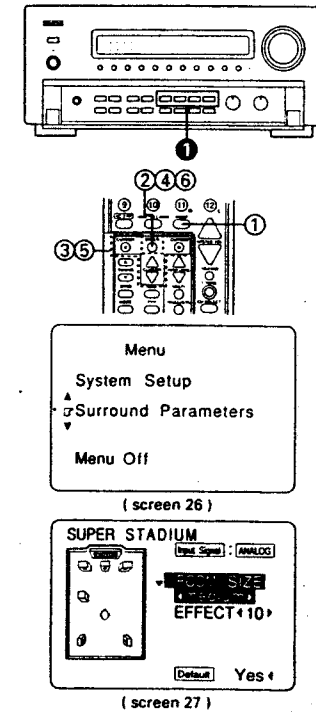

**Surround modes and parameters**

- CINEMA EQ** Use "CINEMA equalizer" if dialogues sound scratchy when playing movie software. (The higher frequency component is lowered.) (Only effective in the DOLBY SURROUND PRO LOGIC, DOLBY DIGITAL AC-3 and WIDE SCREEN modes.)
- ROOM SIZE** "ROOM SIZE" refers to the size of the sound field. — There are five parameters: "small" → "med.s." → "medium" → "med.l." → "large"
- EFFECT LEVEL** "EFFECT LEVEL" refers to the strength of the effect sounds. If the sound becomes distorted, lower the level. Parameter "1" → "15"
- DELAY TIME** This can be set to between 0 and 360 msec for the MATRIX mode.
- D. COMP.** "Dynamic Range Compression" compresses the dynamic range. This is only effective for Dolby Digital program sources. — There are four parameters: "OFF" → "LOW" → "MID" (MIDDLE) → "HI" (HIGH)

**NOTE:** When "Default" is selected and the cursor button is pressed, "CINEMA EQ." and "D.COMP." are automatically set to "OFF". "ROOM SIZE" is set to "medium", "EFFECT LEVEL" is set to "10" and "DELAY TIME" is set to "30 msec".

**Surround modes and parameters**

MODE	OUTPUT CHANNEL				PARAMETER SOURCE (Default)				
	FRONT L/R	CENTER	SURROUND	SUBWOOFER	CINEMA EQ	ROOM SIZE	EFFECT LEVEL	DELAY TIME	D. COMP.
DIRECT	○	+	+	⊕	+	+	+	+	○
STEREO	○	+	+	⊕	+	+	+	+	○
WIDE SCREEN	○	+	+	⊕	+	+	+	+	○
MONO	△	△	△	○	CHOFF	OMedium	OH8	+	○
DOLBY SURROUND PRO LOGIC (THE CINEMA ON)	○	+	+	⊕	+	+	+	+	○
(THE CINEMA OFF)	○	○	○	○	CHOFF	+	+	+	○
DOLBY DIGITAL AC-3 (THE CINEMA ON)	○	+	+	⊕	+	+	+	+	○
(THE CINEMA OFF)	○	○	○	○	CHOFF	+	+	+	○
SCH STEREO	○	+	+	⊕	+	+	+	+	○
SUPER STADIUM	○	+	+	⊕	+	OMedium	OH10	+	○
ROCK ARENA	○	+	+	⊕	+	OMedium	OH10	+	○
JAZZ CLUB	○	+	+	⊕	+	OMedium	OH10	+	○
CLASSIC CINEMA	○	+	+	⊕	+	OMedium	OH10	+	○
MATRIX	○	○	○	○	+	+	OD0 msec	+	○

- Signal present or controllable
  - △ Select one according to the speaker configuration setting
  - ⊕ Can be turned on and off according to the speaker configuration setting
  - × No signal or not controllable
- \* When the front speakers are large, no signals are output to the subwoofer, regardless of the speaker settings.

**9 LAST FUNCTION MEMORY**

- This unit is equipped with a last function memory which stores the input and output setting conditions as they were immediately before the power is switched off. This function eliminates the need to perform complicated resettings when the power is switched on.
- The unit is also equipped with a back-up memory. This function provides approximately one week of memory storage when the main unit's power switch is off and with the power cord disconnected.

**10 INITIALIZATION OF THE MICROPROCESSOR**

When the indication of the display is not normal or when the operation of the unit does not show the reasonable result, the initialization of the microprocessor is required by the following procedure.

- Switch off the unit using the main unit's power switch.
- Hold the following AC-3 RF button and PHONO button, and turn the main unit's power switch on.
- Check that the entire display is flashing with an interval of about 1 second, and release your fingers from the 2 buttons and the microprocessor will be initialized.

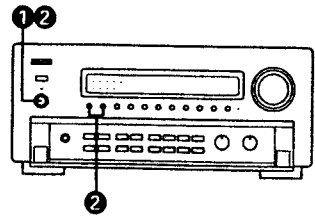

**11 TROUBLESHOOTING**

- If a problem should arise, first check the following:
- Are the connections correct?
  - Have you operated the amplifier according to the Operating Instructions?
  - Are the speakers, turntable, and other components operating properly?

If this unit is not operating properly, check the items listed in the table below. Should the problem persist, there may be a malfunction. Disconnect the power immediately and contact your store of purchase.

	Symptom	Cause	Measures	Page	
Common problems arising when listening to the CD, records, tapes, and Hi-Fi broadcasts, etc.	DISPLAY not lit and sound not produced when power switch set to on	• Power cord not plugged in securely	• Check the insertion of the power cord plug • Turn the power on with the remote control unit after turning the POWER switch on	7 20	
	DISPLAY lit but sound not produced	• Speaker cords not securely connected • Improper position of the audio function button • Volume control set to minimum • MUTING is on • Digital signals not input. Digital input selected. • The play mode is set to "EXT IN"	• Connect securely • Set to a suitable position • Turn volume up to suitable level • Switch off MUTING • Input digital signals or select input jacks to which digital signals are being input • Set the play mode to "STEREO"	8, 9 21 21 22 21 6, 21	
	-PROTECT- display appears	• Speaker terminals are short-circuited • Block the ventilation holes of the set • The unit is operating at continuous high power conditions and/or inadequate ventilation	• Switch power off, connect speakers properly, then switch power back on • Turn off the set's power, then ventilate it well to cool it down. Once the set is cooled down, turn the power back on. • Turn off the set's power, then ventilate it well to cool it down. Once the set is cooled down, turn the power back on.	8, 9 2 2	
	Sound produced only from one channel	• Incomplete connection of speaker cords • Incomplete connection of input/output cords	• Connect securely • Connect securely	8, 9 4 ~ 9	
	Positions of instruments reversed during stereo playback	• Reverse connections of left and right speakers or left and right input/output cords	• Check left and right connections	4 ~ 9	
	The on screen display is not displayed	• "On screen display" is set to off on the system setup menu screen	• Set "on screen display" on the system setup menu screen to on	15	
	When playing records	Humming noise produced when record is playing	• Ground wire of turntable not connected properly • Incomplete PHONO jack connection • TV or radio transmission antenna nearby	• Connect securely • Connect securely • Contact your store of purchase	4 4 —
		Howling noise produced when volume is high	• Turntable and speaker systems too close together • Floor is unstable and vibrates easily	• Separate as much as possible • Use cushions to absorb speaker vibrations transmitted by floor. If turntable is not equipped with insulators, use audio insulators (commonly available)	— —
		Sound is distorted	• Stylus pressure too weak • Dust or dirt on stylus • Cartridge defective	• Apply proper stylus pressure • Check stylus • Replace cartridge	— — —
		Volume is weak	• MC cartridge being used	• Replace with MM cartridge or use a head amplifier or step-up transformer	4
Remote control unit	This unit does not operate properly when remote control unit is used	• Batteries dead • Remote control unit too far from this unit. • Obstacle between this unit and remote control unit • Different button is being pressed • ⊕ and ⊖ ends of battery inserted in reverse	• Replace with new batteries • Move closer. • Remove obstacle • Press the proper button • Insert batteries properly	16 16 16 — 16	



## SPECIFICATIONS

• <b>Audio section</b>	
<b>(Power amplifier)</b>	
<b>Rated output:</b> (All properties shown are only for the power amplifier stage.)	Stereo (2ch driven) 140 W × 2 ch (8 Ω / ohms, 20 Hz ~ 20 kHz with 0.05% T.H.D.) 170 W × 2 ch (8 Ω / ohms, 1 kHz with 0.7% T.H.D.)
<b>Dynamic power:</b>	Surround 140 W × 5 ch (8 Ω / ohms, 1 kHz with 0.7% T.H.D.) 170 W × 2 ch (8 Ω / ohms) 280 W × 2 ch (4 Ω / ohms) 350 W × 2 ch (2 Ω / ohms)
<b>Output terminals:</b>	Front / Center: A or B or Bi-wiring 8 to 16 Ω / ohms A + B 16 Ω / ohms Surround: 8 to 16 Ω / ohms
<b>(Analog)</b>	
<b>Input sensitivity / input impedance:</b>	200 mV / 47 kΩ / kohms
<b>Frequency response:</b>	10 Hz ~ 100 kHz: +0, -3 dB (DIRECT mode)
<b>S / N:</b>	105 dB (DIRECT mode)
<b>Distortion:</b>	0.005% (20 Hz ~ 20 kHz) (DIRECT mode)
<b>Rated output / maximum output:</b>	1.2 V / 8 V
<b>Maximum headphones output:</b>	284 mW (8 Ω / ohms)
<b>Phono equalizer (PHONO input — REC OUT)</b>	
<b>Input Sensitivity:</b>	2.5 mV
<b>RIAA deviation:</b>	± 1 dB (20 Hz to 20 kHz)
<b>Signal-to-noise ratio:</b>	74 dB (A weighting, with 5 mV input)
<b>Rated output / Maximum output:</b>	150 mV / 8 V
<b>Distortion factor:</b>	0.03% (1 kHz, 3 V)
<b>(Digital)</b>	
<b>D / A output:</b>	Rated output: 2 V (at 0 dB playback) Total harmonic distortion: 0.005% (1 kHz, at 0 dB) S/N ratio: 102 dB Dynamic range: 96 dB Format - Digital audio interface
<b>Digital input:</b>	
• <b>Video section</b>	
<b>(Standard video jacks)</b>	
<b>Input / output level and impedance:</b>	1 Vp-p, 75 Ω / ohms
<b>Frequency response:</b>	5 Hz ~ 10 MHz +0, -3 dB
<b>(S-video jacks)</b>	
<b>Input / output level and impedance:</b>	Y (brightness) signal: 1 Vp-p, 75 Ω / ohms C (color) signal: 0.286 Vp-p, 75 Ω / ohms
<b>Frequency response:</b>	5 Hz ~ 10 MHz +0, -3 dB
• <b>General</b>	
<b>Power supply:</b>	AC 230 V, 50 Hz (for Asia model) AC 120 V, 60 Hz (for Taiwan R.O.C. model)
<b>Power consumption:</b>	500 W
<b>Maximum external dimensions:</b>	434 (W) × 181 (H) × 486 (D) mm (17-3/32" × 7-1/8" × 19-1/8")
<b>Weight:</b>	24.5 kg (54 lbs)
• <b>Remote control unit (RC-813)</b>	
<b>Batteries:</b>	R6P/AA Type (two batteries)
<b>External dimensions:</b>	70 (W) × 215 (H) × 19 (D) mm (2-3/4" × 8-15/32" × 3/4")
<b>Weight:</b>	180 g (Approx. 6 oz) (including batteries)

\* For purposes of improvement, specifications and design are subject to change without notice.

## WIRE ARRANGEMENT

In case of wires require unclasp or loosening to move the location to perform adjustment or part replacement, be sure to rearrange them neatly to restore property in the same location as they were originally placed, or causing to produce a noise may occasionally occur.

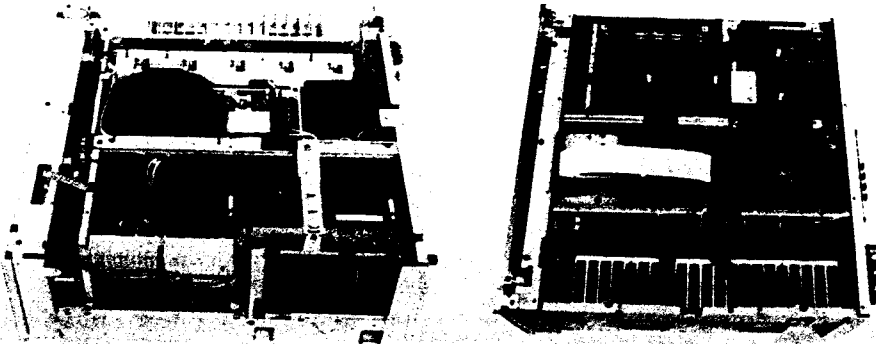
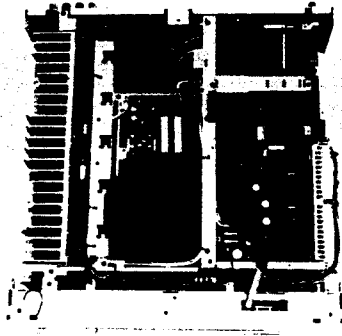

## DISASSEMBLY

(To reassemble reverse disassembly)

Note: When detached the Bottom Cover, do not remove the Back Panel except the unit is in the normal putting state.

### 1. Top Cover

Remove 10 screws (A) fixing the Top Cover and 4 screws (B) mounting the Rear Panel, then detach the Top Cover as shown in the arrow direction.

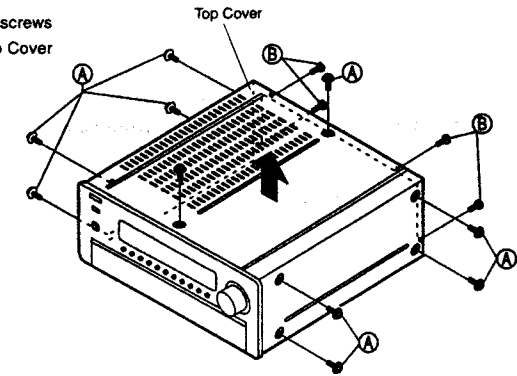

### 2. Front Panel

Remove 3 upper screws (C) and 5 below screws (D), pull out 2 Tone Knobs. After removing the Front Panel as shown in the arrow direction, and disconnect FFC cable which connected to the FLD P.W.Board, 5P connector and power switch connector, then detach the Front panel.

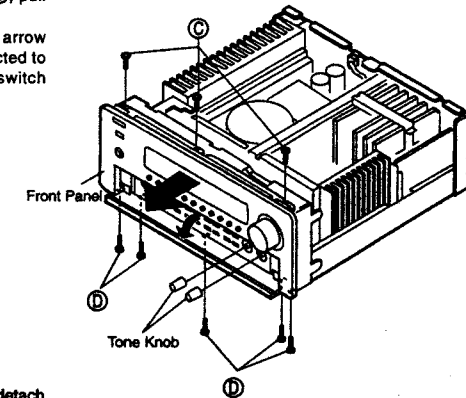

### 3. Each Front Panel P.W.Board

Pull out the Master VR Knob and remove the Nut. Remove 6 screws (E) mounting the Front Panel and detach the Remocon Unit (1U-2949-3) and the Power SW Unit (1U-2949-11). Remove 7 screws (F) mounting the Front Panel and detach the switch Unit (1U-2951-5). Remove a screw (G) and 9 screw (H) mounting the Front Panel, and detach the Master VR Unit (1U-2951-4) and the Display Unit (1U-1951-3) together.

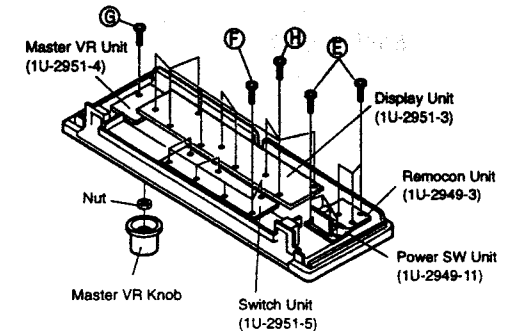

#### 4. MCON Unit (1U-2953-2)

Remove 22 screws ① fixing the Bottom Cover, and detach the Bottom Cover.

Remove 10 screws ② mounting the Back Panel, and detach the Back Plate.

##### Notes:

- When servicing the unit, do not detach the Back Panel except the unit is in the normal putting state.
- Be careful that when removing 10 screws ② mounting the Back plate and digital input (Coaxial & AC3-RF), the digital coaxial & AC3-RF will not actuate normally.

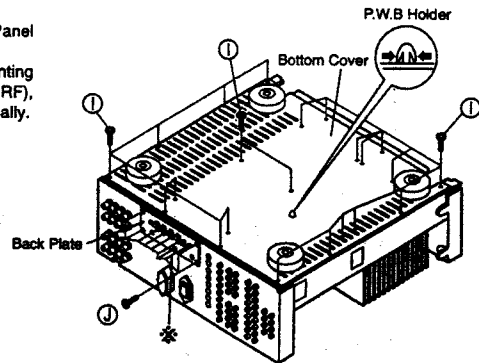

Remove 6 screws ③ fixing the MCON Unit, detach the MCON Unit (1U-2953-2) as shown in the arrow direction, then disconnect a connector and 2 FFC cables.

##### Caution:

When detached the Bottom Cover, if you want to place the unit in the normal putting state, be sure to unfasten the Holder \* before.

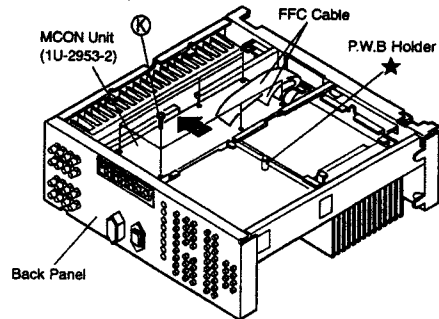

#### 5. Each P.W.Board

##### 5-1 Power Radiator

Remove 2 screws ④ fixing the Power Radiator.

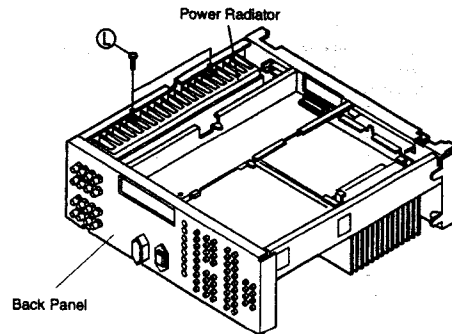

Remove 10 screws ⑤ fixing the Support Bracket, Support Bracket and shield chassis, and detach them.  
Remove 3 screws ⑥, then detach the Power Radiator.

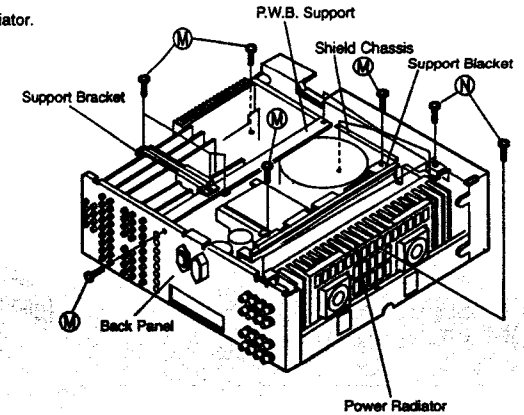

##### 5-2 Each P.W.Board mounting the Back Panel

Remove 4 screws ⑦ fixing the Back Panel and 18 Screws ⑧ Fixing the Tuner Unit (1U-2948-2), Audio in Unit (1U-2948-1), Pre Amp Unit (1U-2949-1), C. Video Unit (1U-2951-2), S. Video Unit (1U-2951-1) and Power Unit (1U-2952-4), then detach the each P.W.Board as shown in the arrow direction.

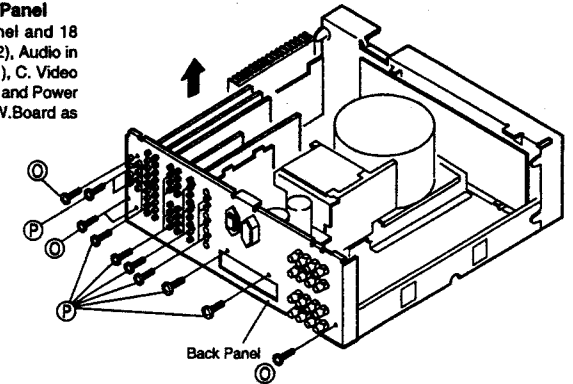

##### 5-3 EXT. IN Unit (1U-2948-3) and Wiring Unit (1U-2950-2)

Remove 1 screw ⑨ fixing the shield Bracket and remove 2 screws ⑩ fixing the EXT. IN Unit (1U-2948-3), then detach the Tunner Unit.

Remove 4 screws ⑪ fixing the wiring Unit (1U-2950-2), then detach the Wiring Unit.

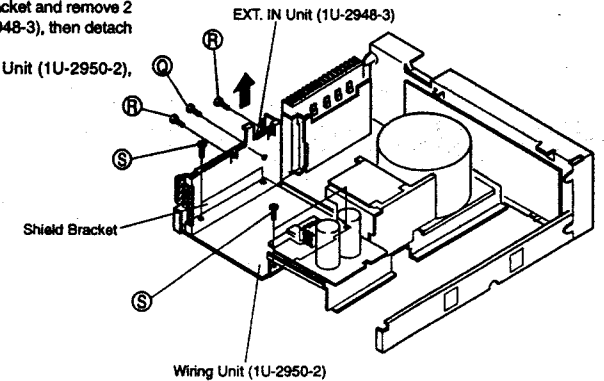

**5-4 Radiator SUB Ass'y (P. Supply-2 Unit 1U-2949D-2, P. Supply-3 Unit 1U-2950-1)**

Remove 2 screws ① fixing the Radiator and remove 2 screws ② fixing the P. Supply-3 Unit (1U-2950-1), then disconnect each connector and detach the Radiator SUB Ass'y as shown in the arrow direction.

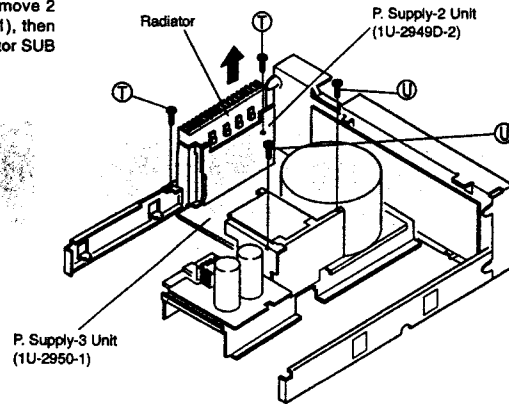

**5-5 P. Supply-4 Unit (1U-2949-6) and P. Supply-1 Unit (1U-2952-2)**

Remove 4 screws ③ and detach the P. Supply-1 Unit (1U-2952-2).

Remove 4 screws ④, then detach the P. Supply-4 Unit (1U-2949-6)

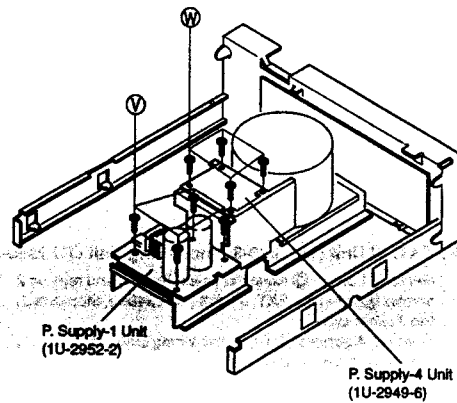

**5-6 H/P Unit (1U-2949-4), Tone-2 Unit (1U-2950-3) and DSP Unit (1U-2953-1)**

Remove 2 screws ⑤, then detach the DSP Unit (1U-2953-1).

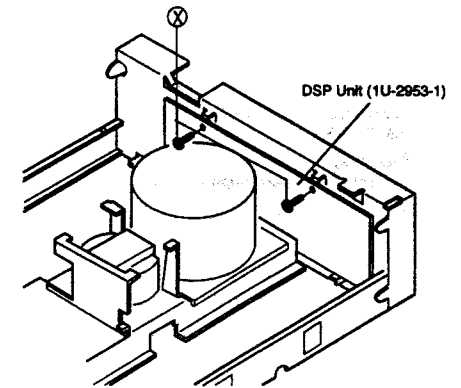

Remove a screw ⑥ and undo a Snap Plate as shown in figure, then detach the H/P Unit (1U-2949-4).

Remove 2 Nuts and detach the Tone-2 Unit (1U-2950-3).

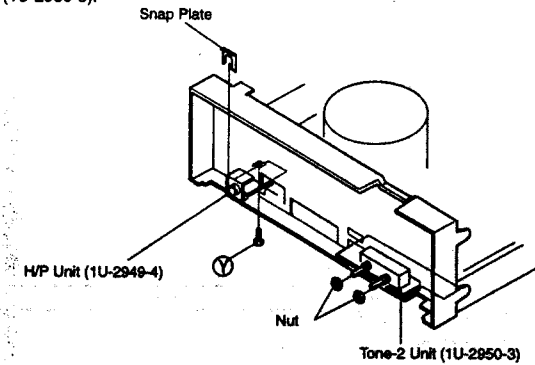



**Confirming for Digital Block (1U-2953-1, 2)**

When the unit is in normal operation, the digital signals provide as shown in figure and confirm the test points with corresponding waveforms.

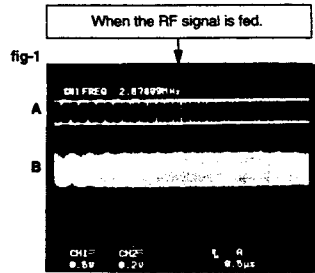

A: IC306 82 pin  
B: IC301 1 pin

Vertical: IC306 82 pin 5V/div  
IC301 1 pin 2V/div  
Horizontal: 0.5 µS/div

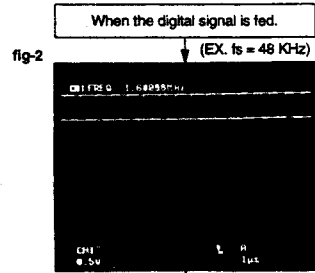

IC316 14 pin (OPT)  
IC316 3 pin (COAX)  
IC18 10 pin

Vertical: 5V/div  
Horizontal: 1.0 µS/div

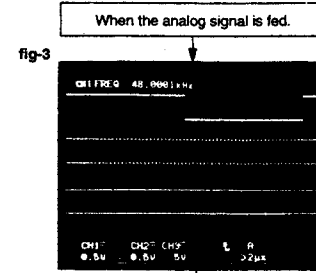

A: IC102 17 pin  
B: IC102 16 pin  
C: IC102 15 pin

Vertical: 5V/div  
Horizontal: 0.5 µS/div

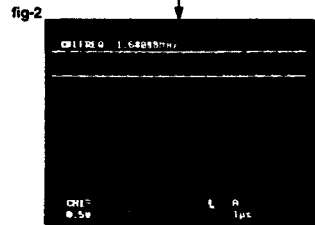

IC304 8 pin  
IC18 10 pin

DIG-DATA (Bi-Phase DATA)

Vertical: 5V/div  
Horizontal: 1.0 µS/div

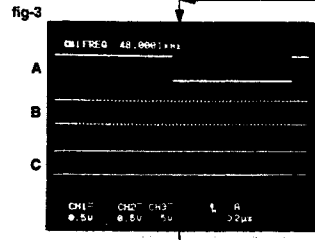

A: IC18 11 pin  
B: IC18 12 pin  
C: IC18 19 pin

Vertical: 5V/div  
Horizontal: 2 µS/div

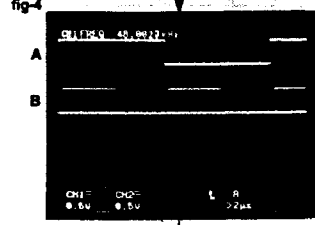

A: IC1 95 pin  
B: IC1 101 pin

Vertical: 5V/div  
Horizontal: 2 µS/div

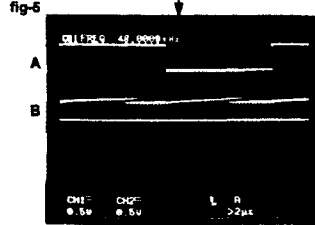

A: IC501 - 503 20 pin  
B: IC501 - 503 22 pin

Vertical: 5V/div  
Horizontal: 2 µS/div

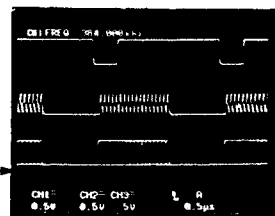

A: IC504 - 506 13 pin  
B: IC504 - 506 11 pin  
C: IC504 - 506 14 pin

Vertical: 5V/div  
Horizontal: 0.5 µS/div

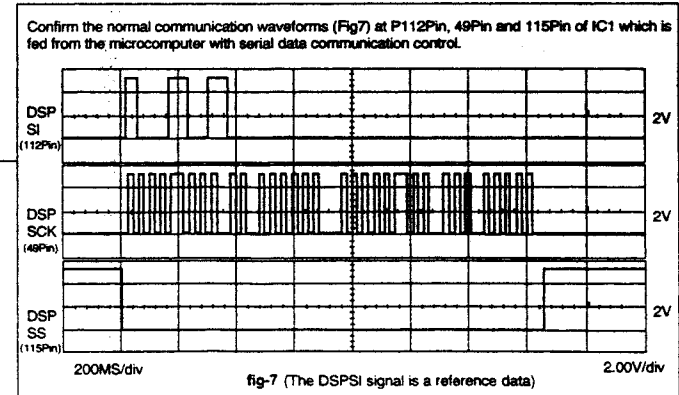

## FUNCTION OF NEW CIRCUIT

### Circuit Description

#### DOLBY AC-3

DOLBY AC-3 is a format of new surround signal reproduces maximum 5 channels, i. e. FRONT-LEFT, -RIGHT, CENTER and SURROUND-LEFT, -RIGHT ;plus exclusive subwoofer signal (0.1 ch), totally 5.1 channels from the exclusive digital signal.

Following is the featuring points of AC-3.

- (1) Makes surround channel into stereo.
- (2) Provides optimum separation due to independent processing of each channel signal.  
(AC-3: More than 80 dB, PRO LOGIC: Approx. 25-40 dB)
- (3) Resultant surpassed orientation feeling and movement feeling obtained from uniform frequency characteristic.  
(AC-3: 20Hz-20kHz all channels, PRO LOGIC: 20 Hz-20 kHz FRONT, CENTER channels 20 Hz-7 kHz SURROUND channels)
- (4) With the high-efficient signal coding technique, one digital cable permits transmission maintaining the above features.

Comparative Diagram of PRO LOGIC and AC-3

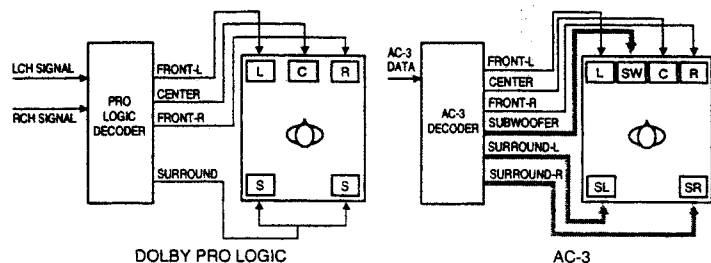

Two kinds of input signals: one corresponds "AC-3RF" signal emitting from LD player; the other is universal optical or coaxial digital format "IEC958" overlapped with "AC-3 exclusive" digital signal. AC-3RF signal is connected via the terminals "AC-3RF OUT" equipped with AC-3 corresponding LD player and "AC-3RF" input of AVC-A1 with a general coaxial digital cable. An applied signal to AVC-A1 goes through demodulator IC(IC305), delivered to DSP (IC1) through input selector (IC315), DIR (IC18) and executed decode processing of AC-3.

The other one is connected in the same way as universal optical or coaxial digital signal. AVC-A1 corresponds with automatic shifting of AC-3 and other signal (PCM) according to input signal.

The signal of each input terminal is delivered to selector (IC315) and applied the same process as to AC-3RF afterward. AC-3 data and PCM data are transmitted with a common line.

DSP (IC1) performs AC-3 decoding process, DOLBY PRO LOGIC process and PCM digital process and PCM digital process by shifting. Decoded signal to each channel after passed through DSP2 (IC2) is D/A converted and delivered to volume control.

Block Diagram of AC-3, PCM Input Section (1U-2953)

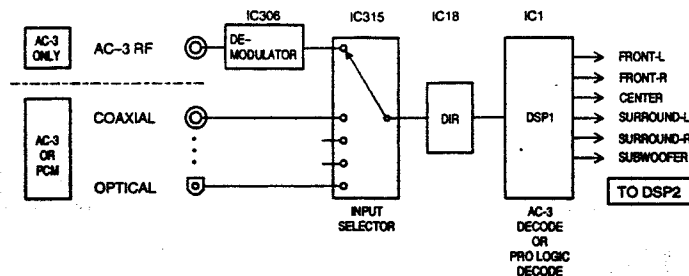

#### THX

THX is a tone quality improving technique of surround reproduction, to perform signal processing by positively combining either one of AC-3 or DOLBY PRO LOGIC.

THX makes the following additional process to AC-3 and DOLBY PRO LOGIC.

- (1) Filtering process based on human auditory sense and sound characteristic of movie theater.
- (2) Makes non-inter relation for surround channels
- (3) Non-clipping process for subwoofer channel.

AVP-A1 executes THX process with DSP2(IC2) to AC-3 or PRO LOGIC signal processed by DSP1 (IC1). Every operation mode shifting of surround mode is performed by micro computer. (Refer to Block Diagram)

#### CONTROL ADVISABILITY OF EACH MODE

	FRONT L.LEV.	FRONT R.LEV.	CENTER LEVEL	SURROUND L.LEV.	SURROUND R.LEV.	S. WOOFER LEVEL	INPUT LEVEL	ROOM SIZE	EFFECT LEVEL	DELAY TIME	CINEMA EQ	D. COMP	TEST TONE
DIRECT	○	○	X	X	X	○*4	X	X	X	X	X	○*7	○*8
STEREO	○	○	X	X	X	○*3	○*6	X	X	X	X	○*7	
MONO	○*5	○*5	○*5	X	X	○*3	○*6	X	X	X	X	X	
5CH STEREO	○	○	○*1	○*2	○*2	○*3	○*6	X	X	X	X	X	
DOLBY AC-3 or DOLBY PROLOGIC	○	○	○*1	○*2	○*2	○*3	○*6	X	X	X	○	○*7	
THX CINEMA	○	○	○*1	○*2	○*2	○*3	○*6	X	X	X	X	X	
WIDE SCREEN	○	○	○*1	○*2	○*2	○*3	○*6	○	○	X	○	○*7	
SUPER STADIUM	○	○	○*1	○*2	○*2	○*3	○*6	○	○	X	X	○*7	
ROCK ARENA	○	○	○*1	○*2	○*2	○*3	○*6	○	○	X	X	○*7	
JAZZ CLUB	○	○	○*1	○*2	○*2	○*3	○*6	○	○	X	X	○*7	
CLASSIC CONCERT	○	○	○*1	○*2	○*2	○*3	○*6	○	○	X	X	○*7	
MATRIX	○	○	○*1	○*2	○*2	○*3	○*6	X	X	○	X	○*7	

○ : Feasible to control

X : Infeasible to control

- \*1 : According to the contents of set up menu, when no center speaker is provided, with no controlling and sets - ∞ data to center electronic volume.
- \*2 : According to the contents of set up menu, when no rear speaker is provided, with no controlling and sets - ∞ data to rear electronic volume.
- \*3 : According to the contents of set up menu, when no woofer is provided, with no controlling and sets - ∞ data to woofer electronic volume.
- \*4 : No controlling when front speaker is set to LARGE.
- \*5 : According to the contents of set up menu, when no center speaker is provided, controls front L/R and not to control center. And when center speaker is set to SMALL or LARGE, controls center and not to control front L/R.
- \*6 : Feasible to control only at analog input. Note that, this function corresponds to each input channel.
- \*7 : Feasible to control only at AC-3 input.
- \*8 : Feasible to control TEST TONE in all modes of set up menu.

Additional note : Each mode's FRONT/CENTER/SURROUND/S. WOOFER DELAY should be set according to the setting contents of delay time for set up menu.

**DIGITAL/ANALOG, SURROUND MODE IN EACH INPUT FUNCTION AND INITIAL SETTING OF DIGITAL FUNCTION**

INPUT FUNCTION	DIGITAL/ANALOG	SURROUND MODE	DIGITAL FUNCTION
PHONO	FORCED ANALOG	STEREO	INFEASIBLE TO SET
CD	ANALOG	STEREO	COAXIAL
TUNER	FORCED ANALOG	STEREO	INFEASIBLE TO SET
VDP/DVD	ANALOG	DOLBY PRO LOGIC	OPTICAL-2
AC-3 RF	AUTO (FORCED DIGITAL)	DOLBY AC-3	AC-3 RF
TV/DBS	ANALOG	STEREO	OPTICAL-1
V. AUX	ANALOG	STEREO	OFF
VCR-1	ANALOG	WIDE SCREEN	OFF
VCR-2	ANALOG	STEREO	OFF
DAT/TAPE-1	ANALOG	STEREO	OPTICAL-3
TAPE-2	FORCED ANALOG	STEREO	INFEASIBLE TO SET

**INITIAL SETTING OF EACH MODE**

	FRONT L LEVEL	FRONT R LEVEL	CENTER LEVEL	SURROUND L LEVEL	SURROUND R LEVEL	S. WOOFER LEVEL	INPUT LEVEL	ROOM SIZE	EFFECT LEVEL	DELAY TIME	CINEMA EQ	DIALOG #1	DYNAMIC #1
DIRECT	0 dB	0 dB	—	—	—	0 dB	—	—	—	—	—	ON	OFF
STEREO	0 dB	0 dB	—	—	—	0 dB	0 dB	—	—	—	—	ON	OFF
MONO	—	—	0 dB	—	—	0 dB	0 dB	—	—	—	—	—	—
5CH STEREO	0 dB	0 dB	0 dB	0 dB	0 dB	0 dB	0 dB	—	—	—	—	—	—
DOLBY AC-3 or DOLBY PROLOGIC	0 dB	0 dB	0 dB	0 dB	0 dB	0 dB	0 dB	—	—	—	OFF	ON	OFF
SUPER STADIUM	0 dB	0 dB	0 dB	0 dB	0 dB	0 dB	0 dB	MED	10	—	—	—	—
ROCK ARENA	0 dB	0 dB	0 dB	0 dB	0 dB	0 dB	0 dB	MED	10	—	—	—	—
JAZZ CLUB	0 dB	0 dB	0 dB	0 dB	0 dB	0 dB	0 dB	MED	10	—	—	—	—
CLASSIC CONCERT	0 dB	0 dB	0 dB	0 dB	0 dB	0 dB	0 dB	MED	10	—	—	—	—
MATRIX	0 dB	0 dB	0 dB	0 dB	0 dB	0 dB	0 dB	—	—	30m sec	—	—	—

\*1 : Conditions in case for setting AC-3 data to ZR38500.

Others :

- Set MULTI/REC SELECT to SOURCE.
- Set TAPE MONITOR to OFF.
- Set VIDEO SELECT to OFF.
- Set MASTER VOL to - ∞.
- Each input should be set to analog input.
- Set TEST TONE to OFF.

- In case DEFAULT is selected for SURR. PARAMETERS setting menu, sets the appropriate parameter of ROOM SIVE, EFFECT LEVEL, DELAY, CINEMA, D. COMP to the initial value of above table.

**SEMICONDUCTORS**

● IC's

Note: Indications before IC numbers denote P.W.B. name.

- AU : Audio IN. Unit
- VI : Video P.W.B. Unit
- DS : DSP P.W.B. Unit
- PS : Power Supply P.W.B. Unit
- Pr : Pre Amp P.W.B. Unit

TMP87CS71F\*\*\*\* (DS: IC401)  
 TMP87CP71F\*\*\*\* (DS: IC402)

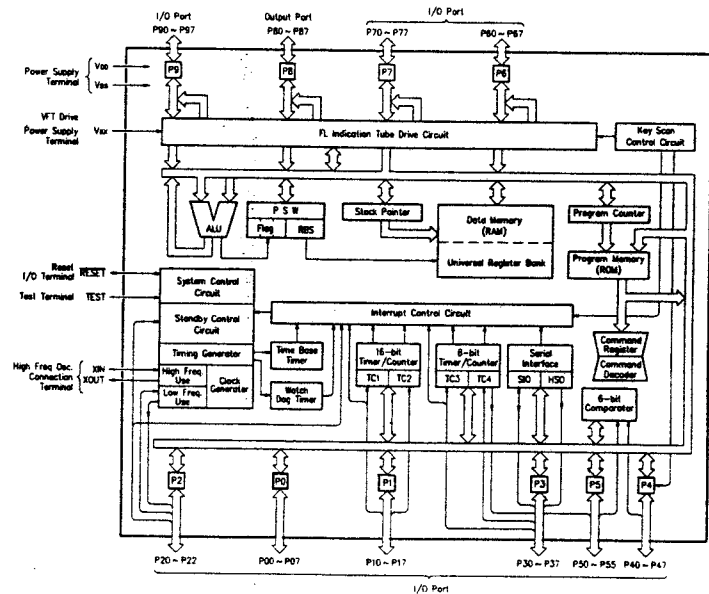
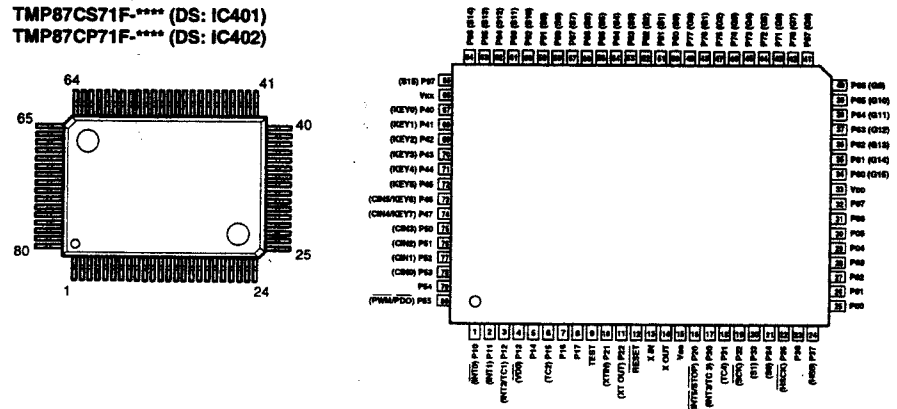



TMP87CS71F-\*\*\*\* (IC401) Terminal Function

Pin No.	Port Name	Symbol	I/O	Type	Op	Det	Res	Ini	Function
1	P10/INT 0	PROTECTION IN	I	—	Eu	E&L	Z	L	Protection detecting input. (H: Detection)
2	P11/INT 1	DSP CLK IN	I	—	Eu	Ed	Z	H	DSP control terminal.
3	P12/INT 2	NC	O	C	—	—	Z	H	No connection
4	P13/DVO	NC	O	C	—	—	Z	L	No connection
5	P14	NC	O	C	—	—	Z	L	No connection
6	P15/TC2	NC	O	C	—	—	Z	L	No connection
7	P16	NC	O	C	—	—	Z	L	No connection
8	P17	NC	I	—	Eu	Lv	Z	—	No connection
9	TEST	TEST	I	—	GND	S	—	—	Connect to ground.
10	P21/XTIN	NC	O	N	—	—	Z	L	No connection
11	P22/XTO	SCL	O	N	Eu	—	Z	H	MAIN-SUB microcomputer communication control terminal.
12	RESET	RESET	I	—	Eu	Lv	L	—	Reset input.
13	XIN	XIN	I	—	—	—	—	—	Oscillator circuit terminal. (4MHz)
14	XOUT	XOUT	O	—	—	—	—	—	Oscillator circuit terminal. (4MHz)
15	VSS	VSS	I	—	GND	—	—	—	Ground.
16	P20/INT 5	POWER OFF	I	—	Eu	Lv	Z	—	Power OFF detection terminal. (L: Power OFF)
17	P30/INT 3	REMOCON	I	—	Eu	E&L	Z	—	Remote signal input.
18	P31/TC4	SDA	O	N	Eu	S	Z	H	MAIN-SUB microcomputer communication control terminal.
19	P32/SCK	NC	O	N	—	—	Z	L	No connection
20	P33/SI	NC	O	N	—	—	Z	L	No connection
21	P34/SO	NC	O	N	—	—	Z	L	No connection
22	P35/HSCK	OSD CLK	O	N	Eu	S	Z	H	OSD control output. (M35015)
23	P36	OSD CS	O	N	Eu	—	Z	H	OSD control output. (M35015)
24	P37/HSO	OSD DATA	O	N	Eu	S	Z	L	OSD control output. (M35015)
25	P00	OSD RES	O	C	—	—	Z	H	OSD control output. (M35015)
26	P01	FRONT SP	O	C	—	—	Z	H	Front SP out relay control output. (L: Mute)
27	P02	CENTER SP	O	C	—	—	Z	H	Center SP out relay control output. (L: Mute)
28	P03	REAR SP	O	C	—	—	Z	H	Rear SP out relay control output. (L: Mute)
29	P04	LED CK	O	C	—	S	Z	H	LED control terminal. (M66313)
30	P05	LED DATA	O	C	—	S	Z	H	LED control terminal. (M66313)
31	P06	LED LE	O	C	—	—	Z	H	LED control terminal. (M66313)
32	P07	LED OE	O	C	—	—	Z	H	LED control terminal. (M66313)
33	VDD	VDD	I	—	—	—	—	—	Connect to +5V power supply.
34	P60	VOL MUTE	O	P	Id	—	L	L	Control signal at minus infinite of master volume. (H: infinite)
35	P61	AC-3 RF DET.	I	—	—	—	L	L	AC-3 RF signal judgment input. (L: AC-3 data input)
36	P62	E. VOL CE2	O	P	Id	—	L	L	Master volume control output. (LC7536) (Center/Sub woofer, Rear L/R)
37	P63	E. VOL CE1	O	P	Id	—	L	L	Master volume control output. (LC7536) (Front L/R)
38	P64	E. VOL DATA	O	P	Id	—	L	H	Electronic volume control output. (LC7536)
39	P65	E. VOL CK	O	P	Id	—	L	H	Electronic volume control output. (LC7536)
40	P66	IN VOL ST	O	P	Id	—	L	L	Input volume control output. (TC9299)
41	P67	A/D RES	O	P	Id	—	L	L	A/D control terminal. (L: Reset and analog input)
42	P70	SEL	O	P	Id	—	L	H	DIR control terminal. (CS8412)
43	P71	SELCK	O	P	Id	—	L	H	DIR control terminal. (CS8412) (H: Digital, L: Analog)
44	P72	AC-3 MUTE	O	P	Id	—	L	H	Digital mute control terminal. (L: AC-3)
45	P73	FL RES	O	P	Id	—	L	L	Fluorescent display control output. (MSC1937)
46	P74	FL DATA	O	P	Id	S	L	H	Fluorescent display control output. (MSC1937)
47	P75	FL CLK	O	P	Id	S	L	H	Fluorescent display control output. (MSC1937)
48	P76	DSF1	O	P	Id	—	L	H	Digital filter emphasis forced OFF signal.
49	P77	NC	I	—	Id	—	L	L	No connection
50	P80	STANDBY LED	O	P	Id	—	L	H	Standby indication LED drive output. (H: Lighting)
51	P81	FRONT	O	P	Id	—	L	H	Front PRE out relay control output. (L: Mute)
52	P82	CENTER	O	P	Id	—	L	L	Center PRE out relay control output. (L: Mute)
53	P83	REAR	O	P	Id	—	L	L	Rear PRE out relay control output. (L: Mute)
54	P84	MULTI	O	P	Id	—	L	L	MULTI PRE out relay control output. (L: Mute)
55	P85	SUBWOOFER	O	P	Id	—	L	L	MONO PRE out relay control output. (L: Mute)

Pin No.	Port Name	Symbol	I/O	Type	Op	Det	Res	Ini	Function
56	P86	H/P	O	P	Id	—	L	H	H/P PRE out relay control output. (L: Mute)
57	P87	POWER	O	P	Id	—	L	H	Power supply relay control output. (H: ON)
58	P90	OVL	I	—	—	—	L	—	Over load detecting input. (H: Over load)
59	P91	AC-3 DET.	I	—	—	—	L	—	AC-3 decode data input terminal. (L: AC-3 decode)
60	P92	F0	I	—	—	—	L	—	DIR control input terminal. (CS8412)
61	P93	F1	I	—	—	—	L	—	DIR control input terminal. (CS8412)
62	P94	F2	I	—	—	—	L	—	DIR control input terminal. (CS8412)
63	P95	CSI	I	—	—	—	L	—	DIR control input terminal. (CS8412) (H: PCM)
64	P96	ERR	I	—	—	—	L	—	DIR control input terminal. (CS8412) (H: ERR)
65	P97	DSF2	I	—	Id	—	L	L	Digital filter emphasis forced OFF signal.
66	VKK	VKK	I	—	—	—	—	—	Connect to ground.
67	P40/KEY0	S-MONITOR DET.	I	—	Eu	Lv	Z	—	Judgment whether S monitor is contacted or not. (L: Connecting)
68	P41/KEY1	S-SIGNAL DET.	I	—	Eu	Lv	Z	—	S signal input control. (H: S signal input)
69	P42/KEY2	OSD SYNC DET.	I	—	Eu	Lv	Z	—	OSD sync switching signal. (H: External sync)
70	P43/KEY3	MVOL SELA	I	—	Eu	Lv	Z	H	Master volume setting signal. (Rotary encode)
71	P44/KEY4	MVOL SELB	I	—	Eu	Lv	Z	H	Master volume setting signal. (Rotary encode)
72	P45/KEY5	H/P DET.	I	—	Eu	Lv	Z	L	H/P input detection signal. (H: Detecting)
73	P46/CIN5	MODE	I	—	Eu	Lv	Z	—	Export country mode switching input.
74	P47/CIN4	KEY5	I	—	Eu	Lv	Z	H	Key input 5.
75	P50/CIN3	KEY4	I	—	Eu	Lv	Z	H	Key input 4.
76	P51/CIN2	KEY3	I	—	Eu	Lv	Z	H	Key input 3.
77	P52/CIN1	KEY2	I	—	Eu	Lv	Z	H	Key input 2.
78	P53/CIN0	KEY1	I	—	Eu	Lv	Z	H	Key input 1.
79	P54	SUB SYNC 1	I	—	Eu	Lv	Z	H	SUB microcomputer sync input.
80	P55/PMW	SO/ZORAN	I	—	Eu	Lv	Z	H	DSP data input terminal. (ZR38500)

## NOTE:

Pin No. : Terminal number of microcomputer.

Port Name : The name entered in the data sheet of microcomputer.

Symbol : Symbolized interface function.

I/O : Input or out of part.

"I" = Input port

"O" = Output port

Type : Composition of port in case of output port.

"C" = CMOS output

"N" = NMOS open drain output

"P" = PMOS open drain output

Op : Pull up/Pull down selection information.

"Iu" = Inner microcomputer pull up

"Id" = Inner microcomputer pull down

"Eu" = External microcomputer pull up

"Ed" = External microcomputer pull down

Det : Indicates judging state of input port. Level detection is "LV"; Edge detection is "Ed"; Detection by both shifting is "E&amp;L";

Serial data detection is "S" (Serial data output is also "S").

Res : State at reset.

"H" = Outputs High Level at reset

"L" = Outputs Low Level at reset

"Z" = Becomes High impedance mode at reset

Ini : Initial output state.

Function : Function and logical level explanation of signals to be interface.

TMP87CP71AF-\*\*\*\* (IC402) Terminal Function

Pin No.	Port Name	Symbol	I/O	Type	Op	Det	Res	Ini	Function
1	P10/INT 0	DEM0D RES	O	C	—	—	Z	H	Demodulator reset control terminal. (L: Reset)
2	P11/INT 1	DEM0D POWER	O	C	—	—	Z	L	Demodulator power ON/OFF control terminal. (H: ON)
3	P12/INT 2	A/D POWER	O	C	—	—	Z	H	A/D converter power ON/OFF control terminal. (H: ON)
4	P13/DVO	FGAIN	O	C	—	—	Z	L	DIRECT GAIN control. (H: ON)
5	P14	DISCHARGE	O	C	—	—	Z	H	Pop noise prevention control terminal. (H: Power ON)
6	P15/TC2	NC	O	C	—	—	Z	L	No connection
7	P16	NC	O	C	—	—	Z	H	No connection
8	P17	NC	O	C	—	—	Z	L	No connection
9	TEST	TEST	I	—	GND	—	—	—	Connect to ground.
10	P21/X TIN	SUB SYNC1	O	N	Eu	—	Z	H	SUB microcomputer sync output.
11	P22/X TO	TONE	O	N	Eu	—	Z	L	Tone control terminal. (L: Direct, THX CINEMA test tone PEAK LIMITER ON)
12	RESET	RESET	I	—	Eu	Lv	L	—	Reset input.
13	XIN	XIN	I	—	—	—	—	—	Oscillator circuit terminal. (4 MHz)
14	XOUT	XOUT	O	—	—	—	—	—	Oscillator circuit terminal. (4 MHz)
15	VSS	VSS	I	—	GND	—	—	—	Ground.
16	P20/INT 5	POWER OFF	I	—	Eu	Lv	Z	—	Power OFF detection terminal. (L: Power OFF)
17	P30/INT 3	NC	O	—	—	S	Z	L	No connection
18	P31/TC4	SQ/MOT	O	—	—	S	Z	L	No connection
19	P32/SCK	SCL	I	—	Eu	S	Z	—	MAIN-SUB microcomputer communication control terminal.
20	P33/SI	SDA	I	—	Eu	S	Z	—	MAIN-SUB microcomputer communication control terminal.
21	P34/SO	DSP RES (MOT)	O	N	—	—	Z	H	DSP control terminal. (DSP56004) (L: Reset)
22	P35/HSCK	DSP CLK	O	N	Eu	S	Z	H	DSP control terminal. (ZR38500, DSP56004)
23	P36	ZORAN SS	O	N	Eu	—	Z	H	DSP control terminal. (ZR38500)
24	P37/HSO	DSP DATA	O	N	Eu	S	Z	H	DSP control terminal. (ZR38500, DSP56004)
25	P00	MOT SS	O	C	—	—	Z	H	DSP control terminal. (DSP56004)
26	P01	DSP RES(ZORAN)	O	C	—	—	Z	H	DSP control terminal. (ZORAN) (L: Reset)
27	P02	FUNC ST4	O	C	—	—	Z	L	Function control output (NJU7313AL) Hi-vision.
28	P03	FUNC ST3	O	C	—	—	Z	L	Function control output (TC9273) REC INH.
29	P04	FUNC ST2N	O	C	—	—	Z	L	Function control output (TC9273) REC OUT.
30	P05	FUNC ST1	O	C	—	—	Z	L	Function control output (TC9274N) INPUT.
31	P06	FUNC DATA	O	C	—	S	Z	L	Function control output (TC9274N, NJU7313AL).
32	P07	FUNC CK	O	C	—	S	Z	L	Function control output (TC9274N, NJU7313AL).
33	VDD	VDD	I	—	—	—	Z	—	Connect to +5V power supply.
34	P60	VIN A	O	P	Id	—	L	L	Video input control. (TC4051)
35	P61	VIN B	O	P	Id	—	L	L	Video input control. (TC4051)
36	P62	VIN C	O	P	Id	—	L	L	Video input control. (TC4051)
37	P63	VREC A	O	P	Id	—	L	L	Video output control. (TC4051)
38	P64	VREC B	O	P	Id	—	L	L	Video output control. (TC4051)
39	P65	VREC C	O	P	Id	—	L	L	Video output control. (TC4051)
40	P66	VINH 1	O	P	Id	—	L	L	Video output inhibit control. (HD14066)
41	P67	VINH 2	O	P	Id	—	L	L	Video output inhibit control. (HD14066)
42	P70	NC	I	—	—	—	Z	—	No connection.
43	P71	S1	O	P	Id	—	L	—	Video signal switching control output.
44	P72	S1	O	P	Id	—	L	—	Video signal switching control output.
45	P73	S2	O	P	Id	—	L	—	Video signal switching control output.
46	P74	NC	I	—	—	—	Z	—	No connection
47	P75	G 2	O	P	Id	—	L	—	LED display digit control signal.
48	P76	G 1	O	P	Id	—	L	—	LED display digit control signal.
49	P77	G 0	O	P	Id	—	L	—	LED display digit control signal.
50	P80	S (a)	O	P	Id	—	L	—	LED display segment control signal.
51	P81	S (b)	O	P	Id	—	L	—	LED display segment control signal.
52	P82	S (c)	O	P	Id	—	L	—	LED display segment control signal.
53	P83	S (d)	O	P	Id	—	L	—	LED display segment control signal.
54	P84	S (e)	O	P	Id	—	L	—	LED display segment control signal.
55	P85	S (f)	O	P	Id	—	L	—	LED display segment control signal.

Pin No.	Port Name	Symbol	I/O	Type	Op	Det	Res	Ini	Function
56	P86	S (g)	O	P	Id	—	L	—	LED display segment control signal.
57	P87	S (h)	O	P	Id	—	L	—	LED display segment control signal.
58	P90	NC	I	—	—	—	Z	—	No connection
59	P91	DSP POWER	O	P	Id	—	L	L	DSP power supply control output. (H: ON)
60	P92	DIN A	O	P	Id	—	L	L	Digital input control terminal. (TC74HC151)
61	P93	DIN B	O	P	Id	—	L	L	Digital input control terminal. (TC74HC151)
62	P94	DIN C	O	P	Id	—	L	L	Digital input control terminal. (TC74HC151)
63	P95	DREC A	O	P	Id	—	L	L	Digital input control terminal. (TC74HC151)
64	P96	DREC B	O	P	Id	—	L	L	Digital input control terminal. (TC74HC151)
65	P97	DREC C	O	P	Id	—	L	L	Digital input control terminal. (TC74HC151)
66	VKK	GND	I	—	—	—	—	—	Connect to ground.
67	P40/KEY0	NC	I	—	GND	—	Z	L	No connection
68	P41/KEY1	NC	I	—	GND	—	Z	L	No connection
69	P42/KEY2	NC	I	—	GND	—	Z	L	No connection
70	P43/KEY3	NC	I	—	GND	—	Z	L	No connection
71	P44/KEY4	NC	I	—	GND	—	Z	L	No connection
72	P45/KEY5	NC	I	—	GND	—	Z	L	No connection
73	P46/CIN5	NC	I	—	GND	—	Z	L	No connection
74	P47/CIN4	NC	I	—	GND	—	Z	L	No connection
75	P50/CIN3	NC	I	—	GND	—	Z	L	No connection
76	P51/CIN2	H/P DET	I	—	Eu	Lv	Z	L	H/P input detection terminal. (H: detecting)
77	P52/CIN1	THERMAL	I	—	Eu	Lv	Z	L	Temperature detection, set with A/D input.
78	P53/CIN0	AUDIO LEVEL	I	—	Eu	Lv	Z	L	Signal level detection, set with A/D input.
79	P54	FAN	O	N	Eu	—	Z	H	FAN control terminal. (L: actuation)
80	P55/PMW	FAN OFF	O	N	Eu	—	Z	H	FAN control terminal. (L: actuation)

## NOTE:

- Pin No. : Terminal number of microcomputer.
- Port Name : The name entered in the data sheet of microcomputer.
- Symbol : Symbolized interface function.
- I/O : Input or out of part.  
 "I" = Input port  
 "O" = Output port
- Type : Composition of port in case of output port.  
 "C" = CMOS output  
 "N" = NMOS open drain output  
 "P" = PMOS open drain output
- Op : Pull up/Pull down selection information.  
 "Iu" = Inner microcomputer pull up  
 "Id" = Inner microcomputer pull down  
 "Eu" = External microcomputer pull up  
 "Ed" = External microcomputer pull down
- Det : Indicates judging state of input port. Level detection is "LV"; Edge detection is "Ed"; Detection by both shifting is "E&L"; Serial data detection is "S" (Serial data output is also "S").
- Res : State at reset.  
 "H" = Outputs High Level at reset  
 "L" = Outputs Low Level at reset  
 "Z" = Becomes High impedance mode at reset
- Ini : Initial output state.
- Function : Function and logical level explanation of signals to be interface.

MCM6205DJ15  
(DS: IC051, 052, 053, 308)

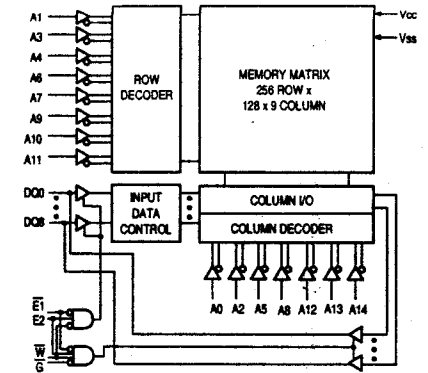
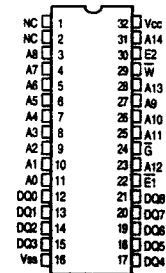
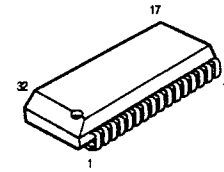

MCM6205D-15 Terminal Function

Pin No.	Symbol	I/O	Function
1	N.C.	-	No connection.
2	N.C.	-	No connection.
3	A8	I	Address 8 input.
4	A7	I	Address 7 input.
5	A6	I	Address 6 input.
6	A5	I	Address 5 input.
7	A4	I	Address 4 input.
8	A3	I	Address 3 input.
9	A2	I	Address 2 input.
10	A1	I	Address 1 input.
11	A0	I	Address 0 input.
12	DQ0	I/O	Data input/output.
13	DQ1	I/O	Data input/output.
14	DQ2	I/O	Data input/output.
15	DQ3	I/O	Data input/output.
16	GND	-	Ground.
17	DQ4	I/O	Data input/output.
18	DQ5	I/O	Data input/output.
19	DQ6	I/O	Data input/output.
20	DQ7	I/O	Data input/output.
21	DQ8	I/O	Data input/output.
22	E	I	Chip enable input.
23	A12	I	Address 12 input.
24	G	I	Output buffer control input signal.
25	A11	I	Address 11 input.
26	A10	I	Address 10 input.
27	A9	I	Address 9 input.
28	A13	I	Address 13 input.
29	W	I	Write enable input.
30	E2	I	Chip enable input.
31	A14	I	Address 14 input.
32	Vcc	-	+5V power supply.

**CS8412CS**  
(DS: IC18)

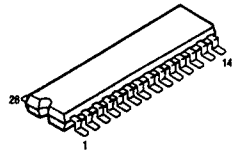

Top View

1	C	28	VERF
2	Cd F1	27	Ce F2
3	Cc F0	26	SDATA
4	Cd E2	25	ERF
5	Ca E1	24	M1
6	CQ/E0	23	M0
7	VD+	22	VA+
8	DGND	21	AGND
9	RXP	20	FILT
10	R0XN	19	MCK
11	FSYNC	18	M2
12	SCK	17	M3
13	CS12/FCK	16	SEL
14	U	15	CBL

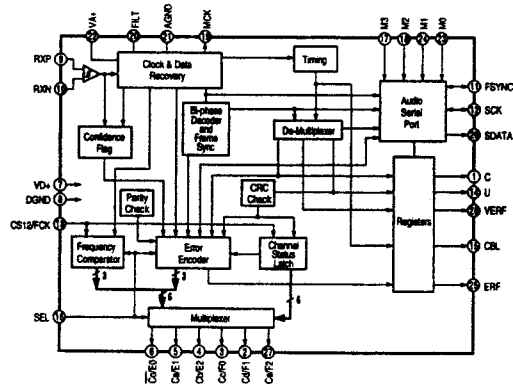

**CS8412CS Terminal Function**

Pin No.	Symbol	I/O	Function
1	C	I	C.S. bit input.
2	Cd F1	O	C.S. bit output/Frequency indication (H: C.S. bit output, L: Frequency indication).
3	Cc F0	O	CO="0" in C.S. bit is for professional use, and CO="1" is for general use.
4	Cd E2	O	C.S. bit output/Error indication (H: C.S. bit output, L: Error indication).
5	Ca E1	O	CO="0" in C.S. bit is for professional use, and CO="1" is for general use.
6	CQ/E0	O	
7	VD+	-	Digital +5V power supply.
8	DGND	-	Connect to digital ground.
9	RXP	I	Differential line receiver signal. Compatible with RS422.
10	R0XN	I	
11	FSYNC	I/O	Frame sync signal.
12	SCK	I/O	Serial clock signal, 32 clock is included with each audio sample in output status.
13	CS12/FCK	I	Channel selection/Reference frequency (H: Channel selection, L: Reference frequency). CS12 selects the channel output to C.S. terminal. "0" is for sub frame 1, and "1" is for sub frame2. Input frequency can be detected by 6.144 MHz clock input to FCK.
14	U	I	User (U) bit terminal.
15	CBL	O	C.S. block output terminal.
16	SEL	I	C.S. F2-F0, E2-E0 selection signal (H: C.S. bit output, L: Frequency/Error indication).
17	M3	I	Serial port mode select signal.
18	M2	I	
19	MCK	I	Master clock signal (Low jitter clock output with 256 times of receiving frequency).
20	FILT	I	Filter terminal, connect resistor 1kohm and capacitor 0.047 μF between this terminal and AGND.
21	AGND	-	Connect to analog ground.
22	VA+	-	Analog +5V power supply (Noise for this power supply should be minimized as lower as possible since it affects jitter's performance of playback clock directly).
23	M0	I	Serial port mode select signal.
24	M1	I	
25	ERF	O	Error flag signal.
26	SDATA	O	Serial data signal.
27	Ce F2	O	C.S. bit output/Frequency indication (H: C.S. bit output, L: Frequency indication). CO="0" in C.S. bit is for professional use, and CO="1" is for general use.
28	VERF	O	Parity and Error flag signal.

**MSC1937-03RS**  
(VI: IC102)

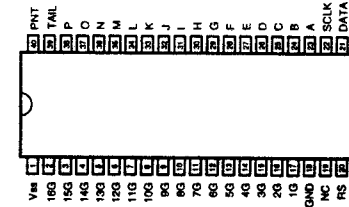
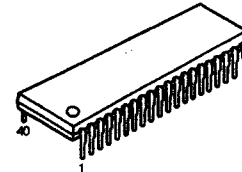

**MSC1937-03RS Terminal Function**

Pin No.	Symbol	I/O	Function
1	Vss	-	Power supply (+5V).
2	16G	O	Digit 16 output.
3	15G	O	Digit 15 output.
4	14G	O	Digit 14 output.
5	13G	O	Digit 13 output.
6	12G	O	Digit 12 output.
7	11G	O	Digit 11 output.
8	10G	O	Digit 10 output.
9	9G	O	Digit 9 output.
10	8G	O	Digit 8 output.
11	7G	O	Digit 7 output.
12	6G	O	Digit 6 output.
13	5G	O	Digit 5 output.
14	4G	O	Digit 4 output.
15	3G	O	Digit 3 output.
16	2G	O	Digit 2 output.
17	1G	O	Digit 1 output.
18	GND	-	Ground.
19	NC	-	No connection.
20	RS	I	POWER-ON-RESET. (H: RESET)
21	DATA	I	Data input.
22	SCLK	I	Shift clock input.
23	A	O	Segment A output.
24	B	O	Segment B output.
25	C	O	Segment C output.
26	D	O	Segment D output.
27	E	O	Segment E output.
28	F	O	Segment F output.
29	G	O	Segment G output.
30	H	O	Segment H output.
31	I	O	Segment I output.
32	J	O	Segment J output.
33	K	O	Segment K output.
34	L	O	Segment L output.
35	M	O	Segment M output.
36	N	O	Segment N output.
37	O	O	Segment O output.
38	P	O	Segment P output.
39	TAIL	-	No connection.
40	PNT	O	Point output.

**LC7536**  
(AU: IC503, 504)  
(Pr: IC601, 604)

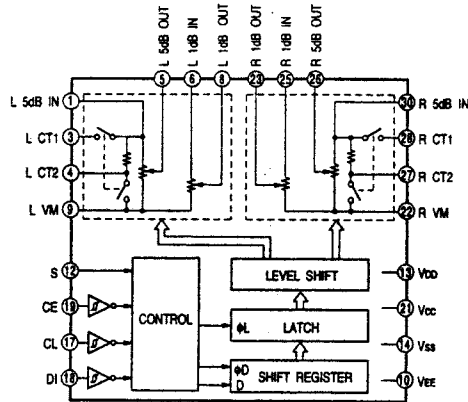
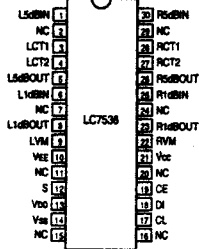
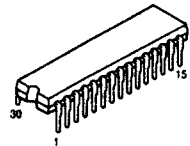

**LC7536 Terminal Function**

Pin No.	Symbol	I/O	Function
1	L 5dB IN	I	Input terminal for 5dB step attenuator, it should be driven with low impedance path.
2	NC	-	No connection.
3	L CT1	I	For loudness control, connect a capacitor between CT1 and 5dB IN with high frequency compensation, and also connect a capacitor between CT2 and Vm with low frequency compensation.
4	L CT2	I	
5	L 5dBOUT	O	Output terminal for 5dB step attenuator with approx. 1Mohm load impedance.
6	L 1dBIN	I	Input terminal for 1dB step attenuator, it should be driven with low impedance.
7	NC	-	No connection.
8	L 1dBOUT	O	Output terminal for 1dB step attenuator with approx. 47kohm - 1Mohm load impedance.
9	L Vm	I	Common terminal for volume control.
10	VEE	I	Connect to power supply.
11	NC	-	No connection.
12	S	I	Selection terminal for address code during data format.
13	VDD	I	Connect to power supply (Pay attention to the rising time so that Vcc does rise up faster than VDD when the power turns).
14	VSS	I	Connect to power supply.
15	NC	-	No connection.
16	NC	-	No connection.
17	CL	I	Input terminal for controlling LC7536 serial data with 0 - 5V amplitude.
18	DI	I	
19	CE	I	
20	NC	-	No connection.
21	VCC	I	Connect power supply (Pay attention to the rising time so that VCC does not rise up faster than VDD when the power turns).
22	R Vm	I	Common terminal for volume control.
23	R 1dBOUT	O	Output terminal for 1dB step attenuator with approx. 47kohm - 1Mohm load impedance.
24	NC	-	No connection.
25	R 1dBIN	I	Input terminal for 1dB step attenuator, it should be driven with low impedance.
26	R 5dBOUT	O	Output terminal for 5dB step attenuator with approx. 1Mohm load impedance.
27	R CT2	I	For loudness control, connect a capacitor between CT1 and 5dBIN with high frequency compensation, and also connect a capacitor between CT2 and Vm with low frequency compensation.
28	R CT1	I	
29	NC	-	No connection.
30	R 5dBIN	I	Input terminal for 5dB step attenuator, it should be driven with low impedance path.

**DF1760U**  
(DS: IC102)

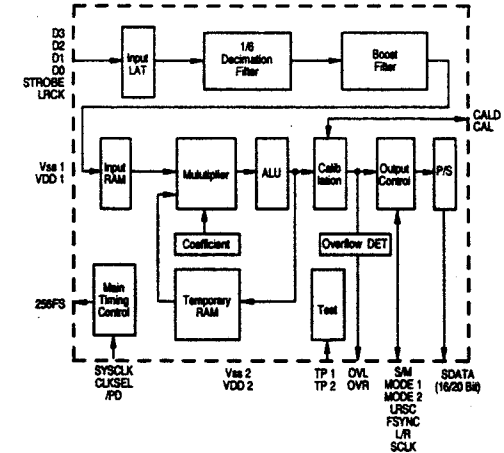
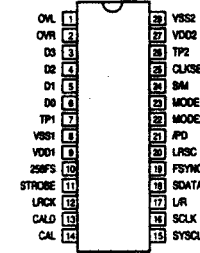
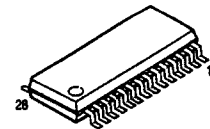

**DF1760U Terminal Function**

Pin No.	Symbol	I/O	Function
1	OVL	O	Lch overflow detection (H: Detection).
2	OVR	O	Rch overflow detection (H: Detection).
3	D3	I	Data input (MSB side).
4	D2	I	Data input.
5	D1	I	Data input.
6	D0	I	Data input (LSB side).
7	TP1	-	Test terminal (No connection).
8	VSS1	-	Ground for modulator.
9	VDD1	-	+5V power supply for modulator.
10	256fs	O	System clock output (256fs).
11	STROBE	I	Data strobe input (128fs).
12	LRCK	I	L/R clock input.
13	CALD	I	Calibration selecting (L: Effective).
14	CAL	O	Calibration input (H: During Execution).
15	SYSCLK	I	System clock input (256fs/384fs).
16	SCLK	I/O	Data clock (32fs-64fs).
17	L/R	I/O	L/R channel dividing clock signal.
18	SDATA	O	Serial data input.
19	FSYNC	I/O	Frame sync clock signal (2fs).
20	LRSC	I	L/R logical switching.
21	/PD	I	Power down mode (L: Power down).
22	MODE2	I	Output data model selection.
23	MODE1	I	Output data model selection.
24	SM	I	Slave/Master mode selection (H: Slave).
25	CLKSEL	I	System clock selection (H: 256fs).
26	TP2	-	Test terminal (No connection).
27	VDD2	-	Digital power supply (+5V).
28	VSS2	-	Digital ground.

**M35015-204SP**  
(VI: IC414)

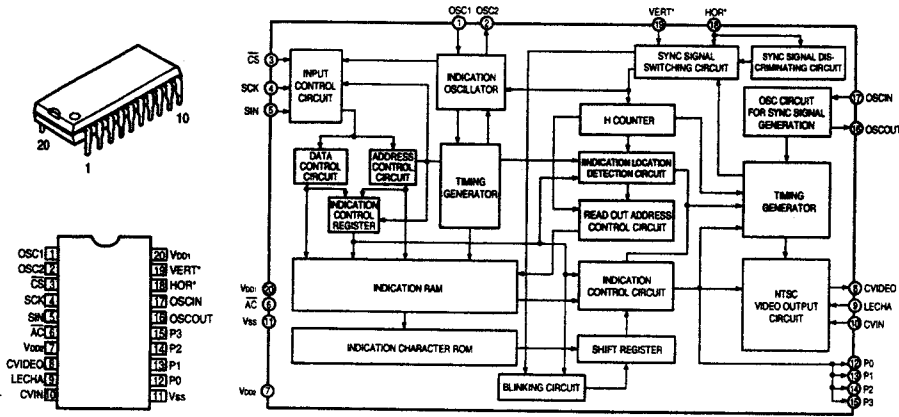

**M35015-204SP Terminal Function**

Pin No.	Symbol	Name	I/O	Function
1	OSC1	Osc. circuit ext.	I	External terminal for indication oscillator circuit. Standard OSC. freq. is approx. 7MHz.
2	OSC2	terminal.	O	With this OSC. freq., decides horizontal indicatin and character width.
3	CS	Chip select input	I	Chip select terminal and turns to "L" when transfer serial data. Hysteresis input. Pull up resistor is built-in.
4	SCK	Serial clock input	I	Takes in serial data of SIN at SCK rise when CS terminal is in "L". Hysteresis input. Pull up resist is built-in.
5	SIN	Serial data input	I	Serial input of register for indication control and data, and address for indication data memory. Hysteresis input. Pull up resistor is built-in.
6	AC	Auto-clear input	I	Resets internal circuit of IC at "L" mode. Hysteresis input. Pull up resistor is built-in.
7	VDD2	Power supply	—	Power supply terminal of analog system. Connect to +5V.
8	CVIDEO	Combined video output	O	Output terminal of combined video signal. Outputs 2Vp-p combined signal. Character output, etc. Overlap CVIN signal and outputs at superimpose.
9	LECHA	Character level input	I	Input terminal deciding character output level in combined video signal. color of character is white.
10	CVIN	Combined video input	I	Input terminal of external combined video signal. Character output etc. overlap this external combined video signal.
11	VSS	Ground	—	Ground terminal. Connect to GND.
12	P0	Output port p0	O	General output or character background signal BL NK1* output is switchable. Polarity can be selected at ROM mask.
13	P1	Output port P1	O	General output or character background signal CO1* output is switchable. Polarity can be selected at ROM mask.
14	P2	Output port P2	O	General output or character background signal BLNK2* output is switchable. Polarity can be selected at ROM mask.
15	P3	Output port P3	O	General output or character background signal CO2* output is switchable. Polarity can be selected at ROM mask.
16	OSCOUT	Ext. terminal for sync sig.	O	Terminal for external use of sync signal OSC. circuit. Use the freq.: 14.32MHz at NTSC system, 17.73MHz at PAL. system, 14.30MHz at MPAL system.
17	OSCIN	OSC. Circuit	I	
18	HOR*	Horizontal sync signal	I	Inputs horizontal sync signal. Hysteresis input.
19	VERT*	Vertical sync signal	—	Input vertical sync signal. Hysteresis input. Polarity can be selected at ROM mask.
20	VDD1	Power supply	I	Power supply terminal of digital system. Connect to +5V.

**PCM1760U (DS: IC101)**

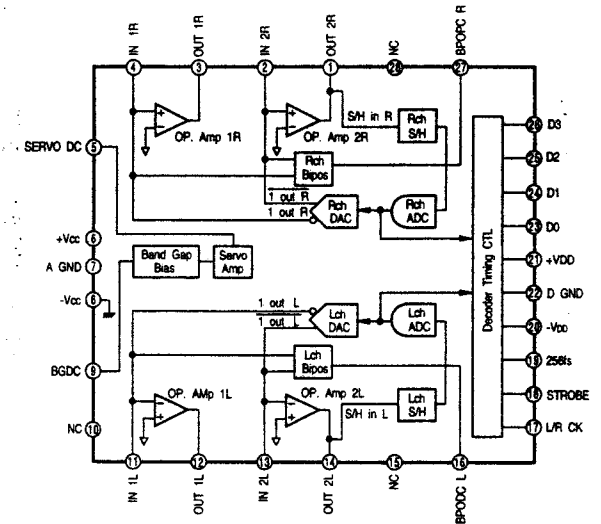
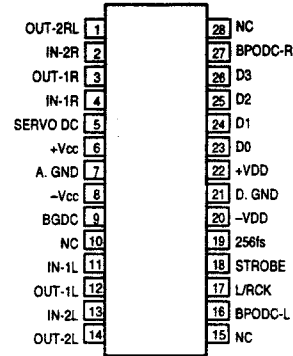
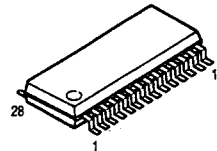

**PCM1760U Terminal Function**

Pin No.	I/O	Symbol	Function
1	O	OUT-2R	Rch Amp. -2R output.
2	I	IN-2R	Rch Amp. -2R input.
3	O	OUT-1R	Rch Amp. -1R output.
4	I	IN-1R	Rch Amp. -2R input.
5	—	SERVO DC	Servo decoupling terminal.
6	—	+Vcc	Analog +5V power supply.
7	—	A. GND	Analog ground.
8	—	-Vcc	Analog -5V power supply.
9	—	BGDC	Band gap decoupling terminal.
10	—	NC	No connection.
11	I	IN-1L	Lch Amp-1L input.
12	O	OUT-1L	Lch Amp-1L output.
13	I	IN-2L	Lch Amp-2L input.
14	O	OUT-2L	Lch Amp-2L output.
15	—	NC	No connection.
16	—	BPODC-L	Lch bipolar offset decoupling terminal.
17	O	L/R CK	L/R clock output (64fs).
18	O	STROBE	Data strobe output (128fs).
19	I	256fs	System clock input (256fs).
20	—	-VDD	Digital -5V power supply.
21	—	D. GND	Digital ground.
22	—	+VDD	Digital +5V power supply.
23	O	D0	Data output (LSB side).
24	O	D1	Data output.
25	O	D2	Data output.
26	O	D3	Data output (MSB side).
27	—	BPODC-R	Rch bipolar offset decoupling terminal.
28	—	NC	No. connection.

TC514256BZL-60 (DS: IC005, 006)

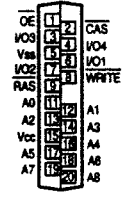
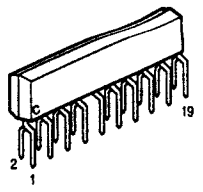

TC514256BZL-60 Terminal Function

Pin No.	Symbol	Function
1	OE	Output enable signal.
2	CAS	Column address strobe signal.
3	I/O3	Data input/output.
4	I/O4	Data input/output.
5	Vss	Ground.
6	I/O1	Data input/output.
7	I/O2	Data input/output.
8	WRITE	Read/write input.
9	RAS	Low address strobe signal.
10	N.C.	No connection.
11	A0	Address input.
12	A1	Address input.
13	A2	Address input.
14	A3	Address input.
15	Vcc	+5V power supply
16	A4	Address input.
17	A5	Address input.
18	A6	Address input.
19	A7	Address input.
20	A8	Address input.

ZR38500 (A3) (DS: IC001)

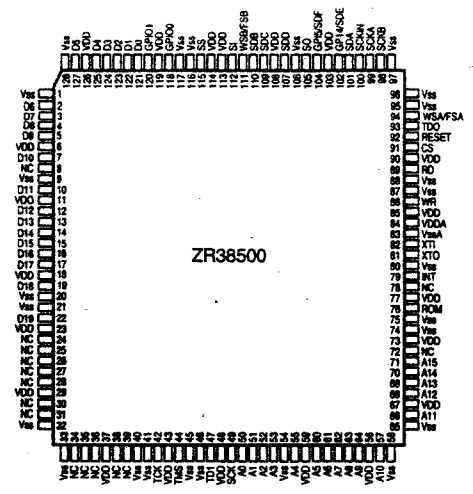
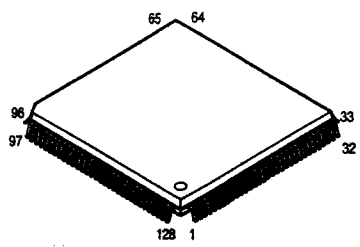

TC9273N-004 (AU: IC111) (Pr: IC751)

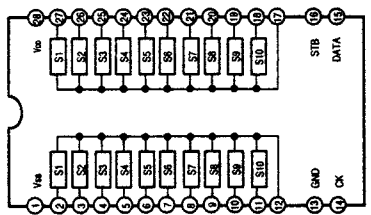
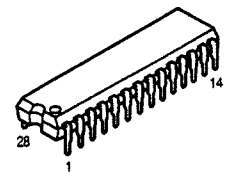

TC9273N-004 Terminal Function

Pin No.	Symbol	I/O	Function
1	Vss	-	Use for double power supply: V <sub>DD</sub> = 8.0 - 17V GND = 0V V <sub>SS</sub> = -8.0 - -17V Use for signal power terminal: V <sub>DD</sub> = 8.0 - 18V V <sub>SS</sub> = GND = 0V
2-12	S1-10	I	Analog switch input terminal.
13	GND	-	Use for double power supply: V <sub>DD</sub> = 8.0 - 17V GND = 0V V <sub>SS</sub> = -8.0 - -17V Use for signal power terminal: V <sub>DD</sub> = 8.0 - 18V V <sub>SS</sub> = GND = 0V
14	CK	I	Clock input for data transfer.
15	DATA	I	Serial input for switch setting.
16	STB	I	Strobe input for data reading.
17-27	S1-10	I	Analog switch input terminal.
28	Vcc	-	Use for double power supply: V <sub>DD</sub> = 8.0 - 17V GND = 0V V <sub>SS</sub> = -8.0 - -17V Use for signal power terminal: V <sub>DD</sub> = 8.0 - 18V V <sub>SS</sub> = GND = 0V

DSP56004 (DS: IC002)

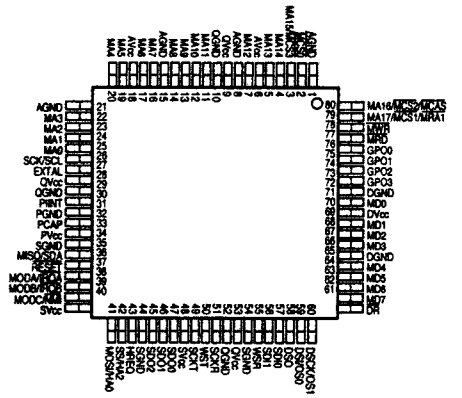
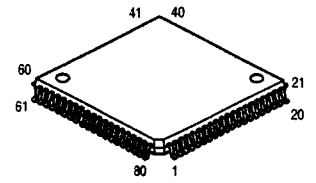

**NJU7313AL**  
(AU: IC605)

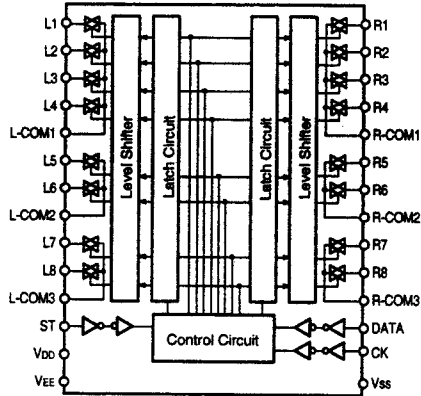
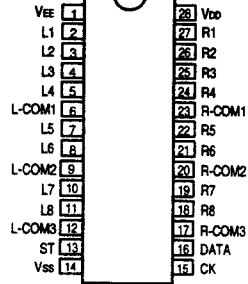
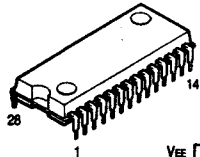

**PCM69AP**  
(DG: IC504, 505, 506)

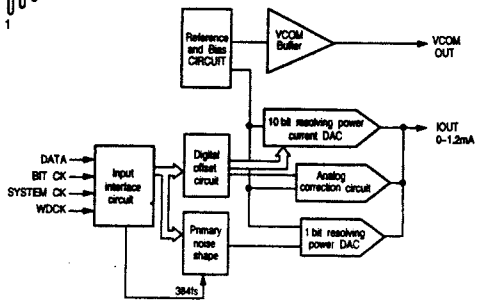
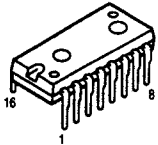

Pin No.	Function
1	+Vcc (Analog power supply)
2	Vcom. Lch
3	Lout. Lch
4	Servo. DC
5	REF. DC
6	Lout. Rich
7	Vcom. Rich
8	A-GND (Analog common)
9	D-GND (Digital common)
10	DATA Rich
11	BCK
12	SYS CLK
13	WDCK
14	DATA Lch
15	TP1
16	+Vcc (Digital power supply)

**M66310FP**  
(VI: IC101)

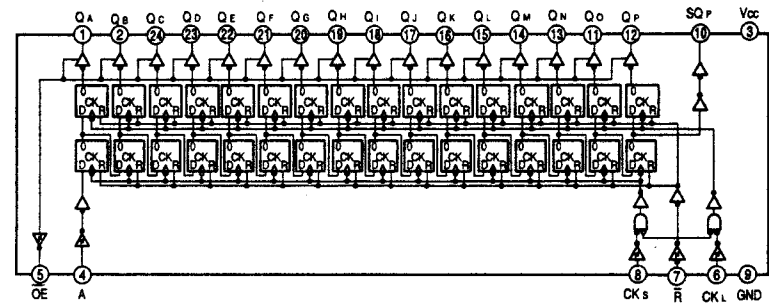
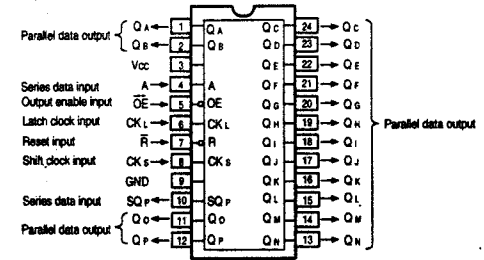
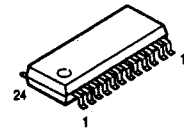

**SG-531PH (33MHz)**  
(DS: IC003)  
**SG-531PH (46.08MHz)**  
(DS: IC307)  
**SG-531PH (12.288MHz)**  
(DS: IC103)

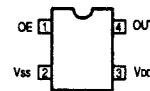
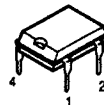

**NJM360M**  
(DS: IC303)

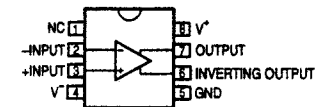
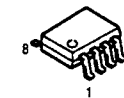



HD74HC04FP (DS: IC014)  
 HD74HC14FP (DS: IC008)  
 HD74HC74FP (DS: IC016, 013)  
 TC74HC00AF (DS: IC019, 007)  
 TC74HC164AF (DS: IC011, 012)  
 TC74HC266AF (DS: IC015)  
 TC74HCU04AF (DS: IC304, 309, 314)

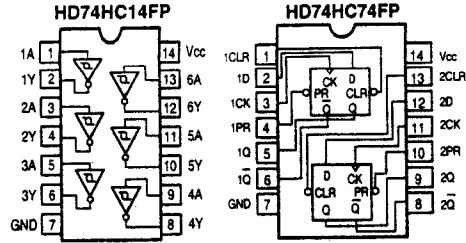
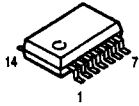

PD4606A  
 (DS: IC306)

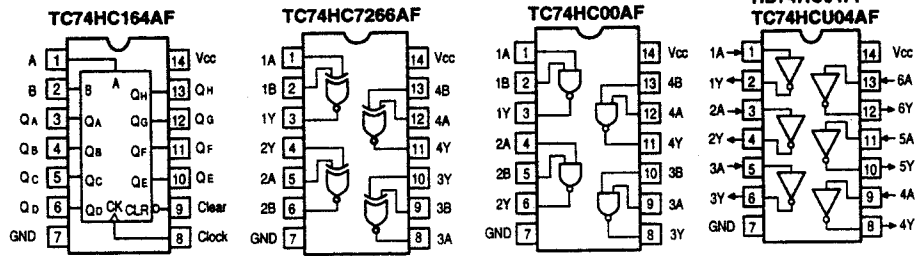
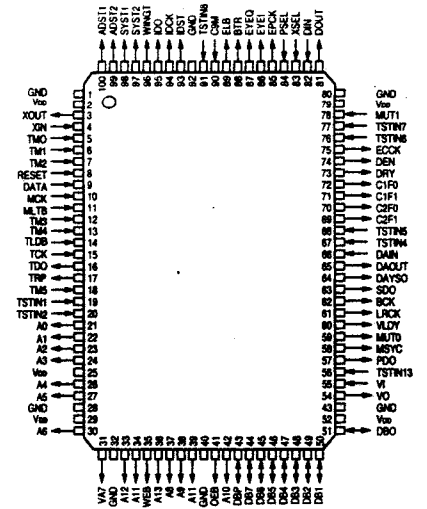
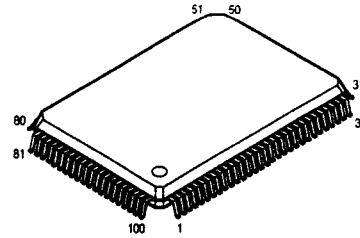

BA15218F (DS: IC302, 305) (Pr: IC471)  
 (AU: IC301, 104-109)  
 NJM5532M (AU: IC114) (PS: IC801,802)  
 (Pr: IC603, 606)  
 NJM2068MD (Pr: IC602, 605)  
 (DS: IC154-156, 507-509)  
 (AU: IC101-103, 113, 501, 502, 505-508)

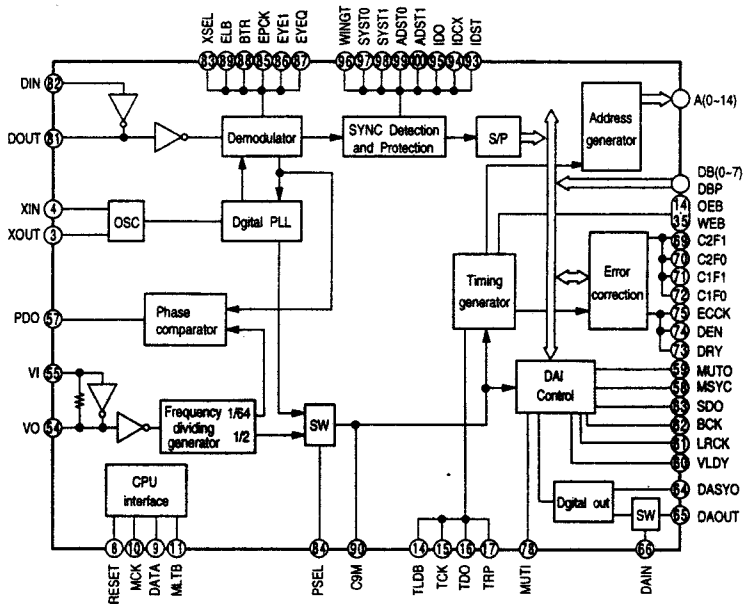
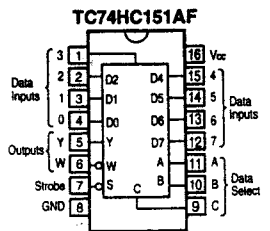
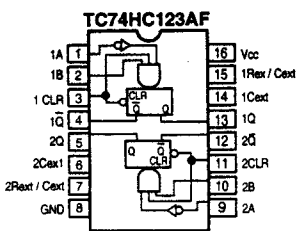
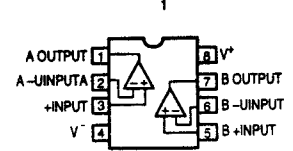
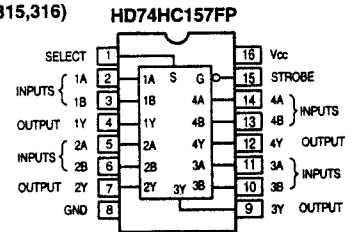
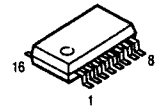

NJM7805FA (S) (Pr: IC403)  
 (PS: IC901, 905)  
 NJM7806FA (S) (PS: IC402, 903)  
 NJM7812FA (S) (AU: IC306)  
 NJM7815FA (Pr: IC405)

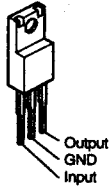

NJM7905FA (Pr: IC404) (PS: IC902)  
 NJM7906FA (PS: IC904)  
 NJM7915FA (Pr: IC406)

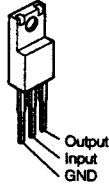

SM5841HS (DS: IC501-503)

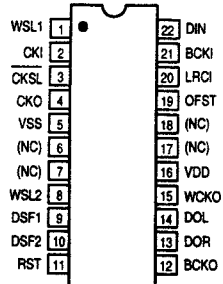
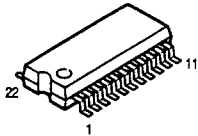

MC14577CP  
 (VI: 301-303, 308, 401, 402, 406, 409, 412, 416)  
 (DS: IC301)  
 OP275GP  
 (Pr: IC510)  
 NJM2068DDC  
 (Pr: IC509)  
 NJM4566AD  
 (Pr: IC651)

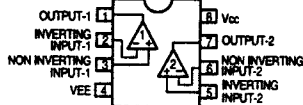
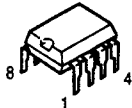

LA1265 (S) (AU: IC303)

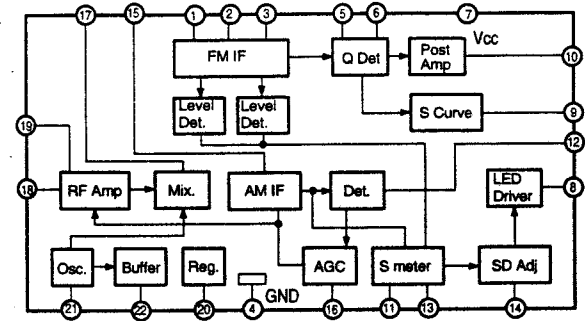
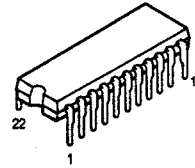

LA3401 (AU: IC302)

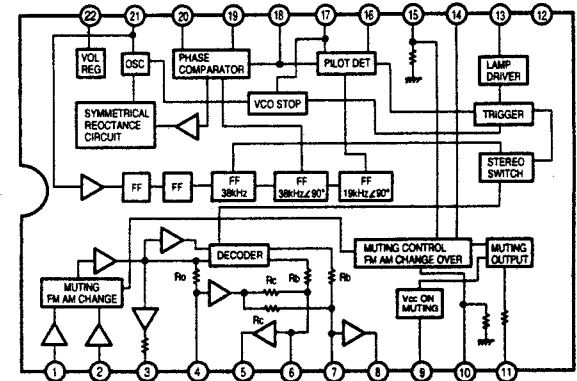
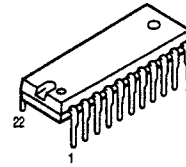

LM7001 (AU: IC305)

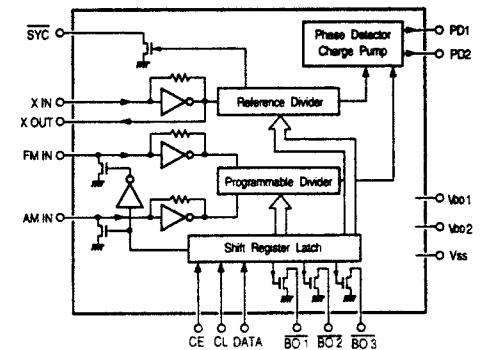
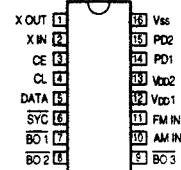
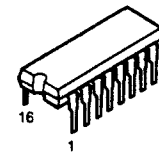

TC9274N-002(AU: IC110)

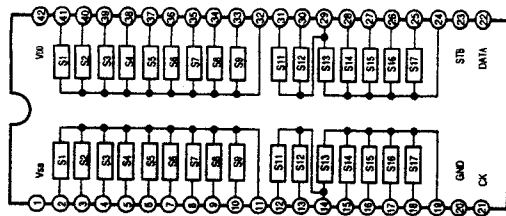
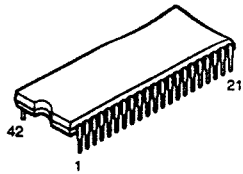

MC74HC4053N (VI: IC413)

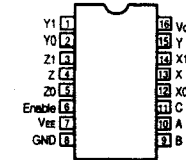
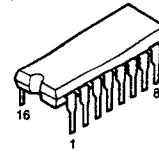

Control Inputs		Select			ON Switches		
		Enable	C	B			
L	L	L	L	L	Z0	Y0	X0
L	L	L	L	H	Z0	Y0	X1
L	L	L	H	L	Z0	Y1	X0
L	L	L	H	H	Z0	Y1	X1
L	H	L	L	L	Z1	Y0	X0
L	H	L	L	H	Z1	Y0	X1
L	H	L	H	L	Z1	Y1	X0
L	H	L	H	H	Z1	Y1	X1
H	X	X	X	X	None		

X = Don't Care

TC9299P (AU: IC112)

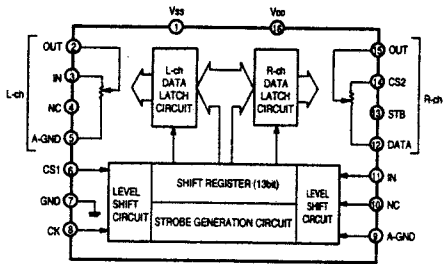
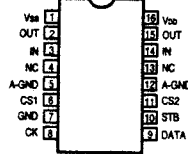
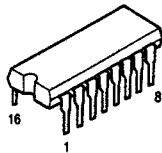

NJM2229S (VI: IC415)

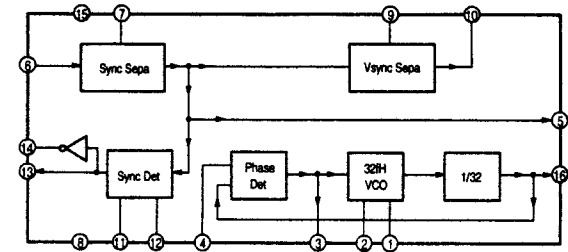
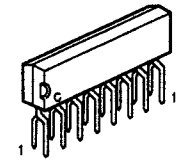

TC4051BP (VI: 304, 305, 403, 404, 407, 408)

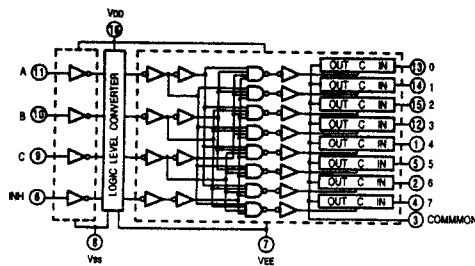
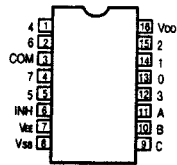
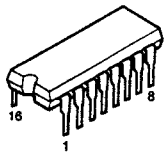

HD14066BP (VI: IC306, 307, 405, 411)

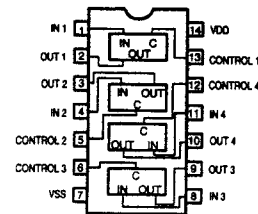
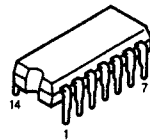

CX20106A (DS: IC317)

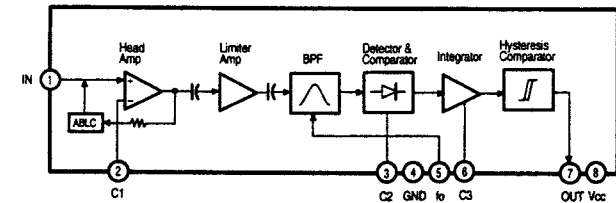
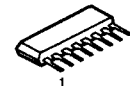

● IC PROTECTOR

ICP-N15 (AU: IC307) (PS: IC401)

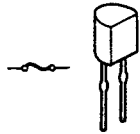

● OPTICAL

INPUT  
GP1F32R  
(DS: IC310, 311, 312)

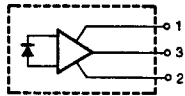
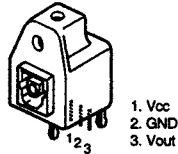

OUTPUT  
GP1F32T  
(DS: IC313)

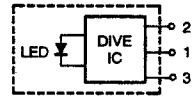
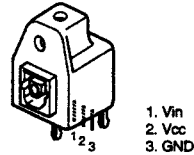

LED :Ga Al As  
DRIVE IC :Silicon

● OTHER

GP1U271X (Remote Control Sensor)  
(Pr: IC461)

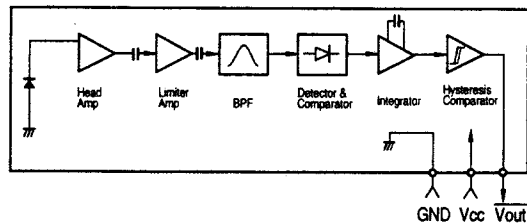
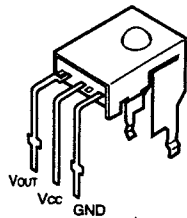

● TRANSISTORS

2SA970 (BL)  
2SA988 (E/F)  
2SC1815 (Y), (BL)  
2SC2878 (A/B)  
2SC1841 (E/F)

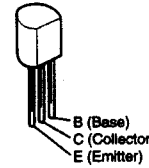

DTA114ES  
DTC143ES  
DTC144ES  
RN1241

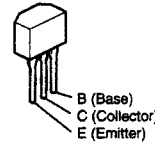

DTA114TK  
DTA114EK  
DTA124EK  
DTA143EK  
DTC114EK  
DTC144EK  
DTC323TK  
RN2402

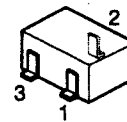

1: GND/Emitter  
2: Out/Collector  
3: In/Base

2SB1041 (R)  
2SD1292 (R)

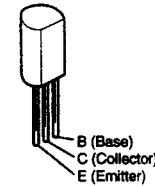

DTA114ES

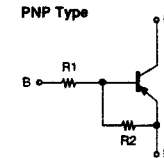

	R1	R2
DTA114ES	10kohm	10kohm

DTA114TK  
DTA114EK  
DTA124EK  
DTA143EK  
DTA144EK

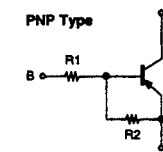

	R1	R2
DTA114TK	10kohm	—
DTA114EK	10kohm	10kohm
DTA124EK	22kohm	22kohm
DTA143EK	4.7kohm	4.7kohm
RN2402	10kohm	10kohm

2SB1317 (s)  
2SD1975 (s)

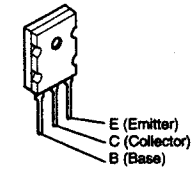

DTC143ES  
DTC144ES  
RN1241

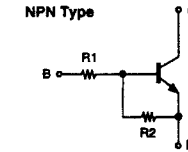

	R1	R2
DTC143ES	4.7kohm	4.7kohm
DTC144ES	47kohm	47kohm
RN1241	5.6kohm	—

DTC114EK  
DTC144EK  
DTC323TK

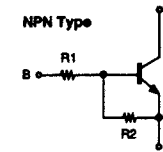

	R1	R2
DTC114EK	10kohm	10kohm
DTC144EK	47kohm	47kohm

2SA933S (S)  
2SC1740S (E)  
2SC2458 (BL)

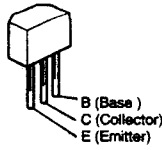

2SK184 (GR)/(BL)

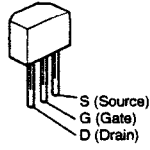

2SK209 (Y/GR)

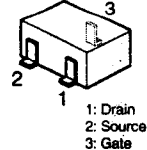

2SA1037K (S/R) 2SC2712 (Y/GR)  
2SC2412K (S) 2SC2996 (Y)  
2SC3326 (A/B)

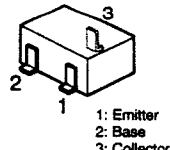

2SD1762 (E/F)

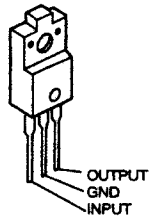

2SK365 (BL/GR)

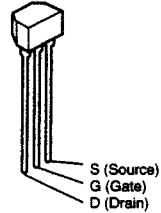

2SB1328 (P/Q)  
2SD2004 (P/Q)

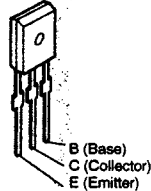

2SA1633F31

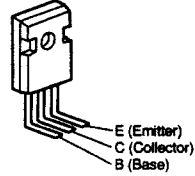

● DIODES (included LED)

1SS270A  
1S2076A

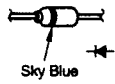

MTZJ3.3A MTZJ36A  
MTZJ6.2A HZSSA-1  
MTZJ7.5A HZS7C-1  
MTZJ9.1A HZS12A-1



1SR35-200A

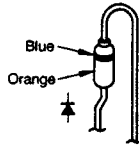

DSM1D2 (Type 3)

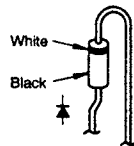

KV1851-TL  
(DS: CD301)

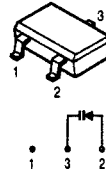

4D4B42(LC1)  
(PS: D901)

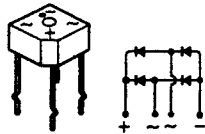

MA151A

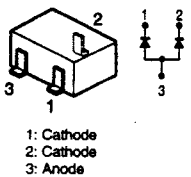

SEL1210S (Red)  
(VI: LD101-108,111)  
SEL4214S  
(Pr: LD461)

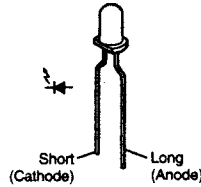

SML1216W  
(VI: LD109, 110)

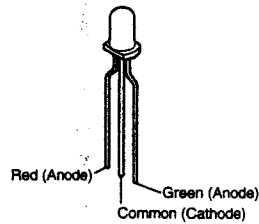

S10VB20F9 (D-450)

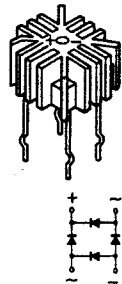

● DISPLAY

FD DISPLAY FIP16FM7R (Part No.: 3934156001) (VI: FL101)

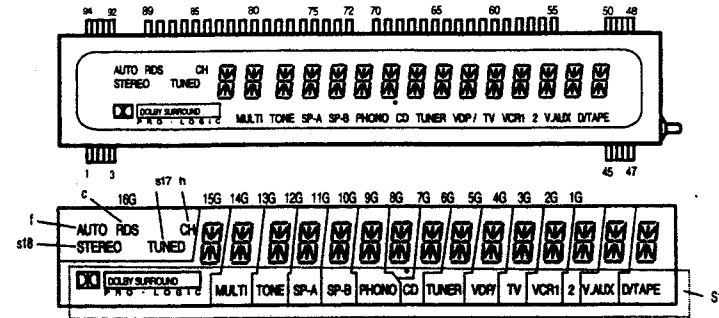

(UPPER)

TERMINAL No.	94	93	92	91	90	89	88	87	86	85	84	83	82	81								
ELECTRODE	F1	F1	F1	NP	NP	P	P	P	P	P	P	P	P	P								
TERMINAL No.	80	79	78	77	76	75	74	73	72	71	70	69	68	67	66	65	64	63	62	61		
ELECTRODE	P	P	P	P	P	P	P	P	P	NP	16G	15G	14G	13G	12G	11G	10G	9G	8G	7G		
TERMINAL No.										60	59	58	57	56	55	54	53	52	51	50	49	48
ELECTRODE										6G	5G	4G	3G	2G	1G	NP	NP	NP	NP	F2	F2	F2

(UPPER)

TERMINAL No.										35	36	37	38	39	40	41	42	43	44	45	46	47	
ELECTRODE										NP	NP	NP	NP	NP	NP	NP	NP	NP	NP	NP	F2	F2	F2
TERMINAL No.	15	16	17	18	19	20	21	22	23	24	25	26	27	28	29	30	31	32	33	34			
ELECTRODE	NP	NP	NP	NP	NP	NP	NP	NP	NP	NP	NP	NP	NP	NP	NP	NP	NP	NP	NP	NP	NP	NP	NP
TERMINAL No.	1	2	3	4	5	6	7	8	9	10	11	12	13	14									
ELECTRODE	F1	F1	F1	NP	NP	NP	NP	NP	NP	NP	NP	NP	NP	NP									

LB-303VA  
(VI: LD114)

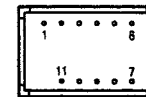
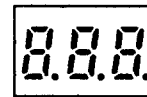

(BOTTOM VIEW)



Pin connection

Pin No.	Function
1	c Segment cathode
2	Digit 1 common anode
3	d Segment cathode
4	Digit 2 common anode
5	Digit 3 common anode
6	D.P cathode
7	b Segment cathode
8	f Segment cathode
9	a Segment cathode
10	e Segment cathode
11	g Segment cathode

PRINTED WIRING BOARD

1

2

3

4

5

6

7

8

1U-2948A AUDIO IN UNIT ASS'Y

A

B

C

D

E

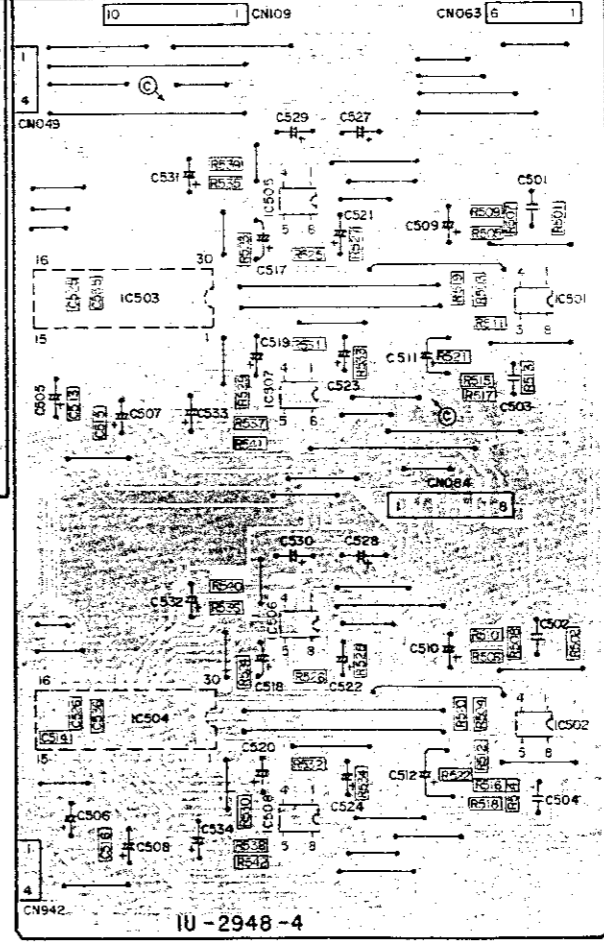
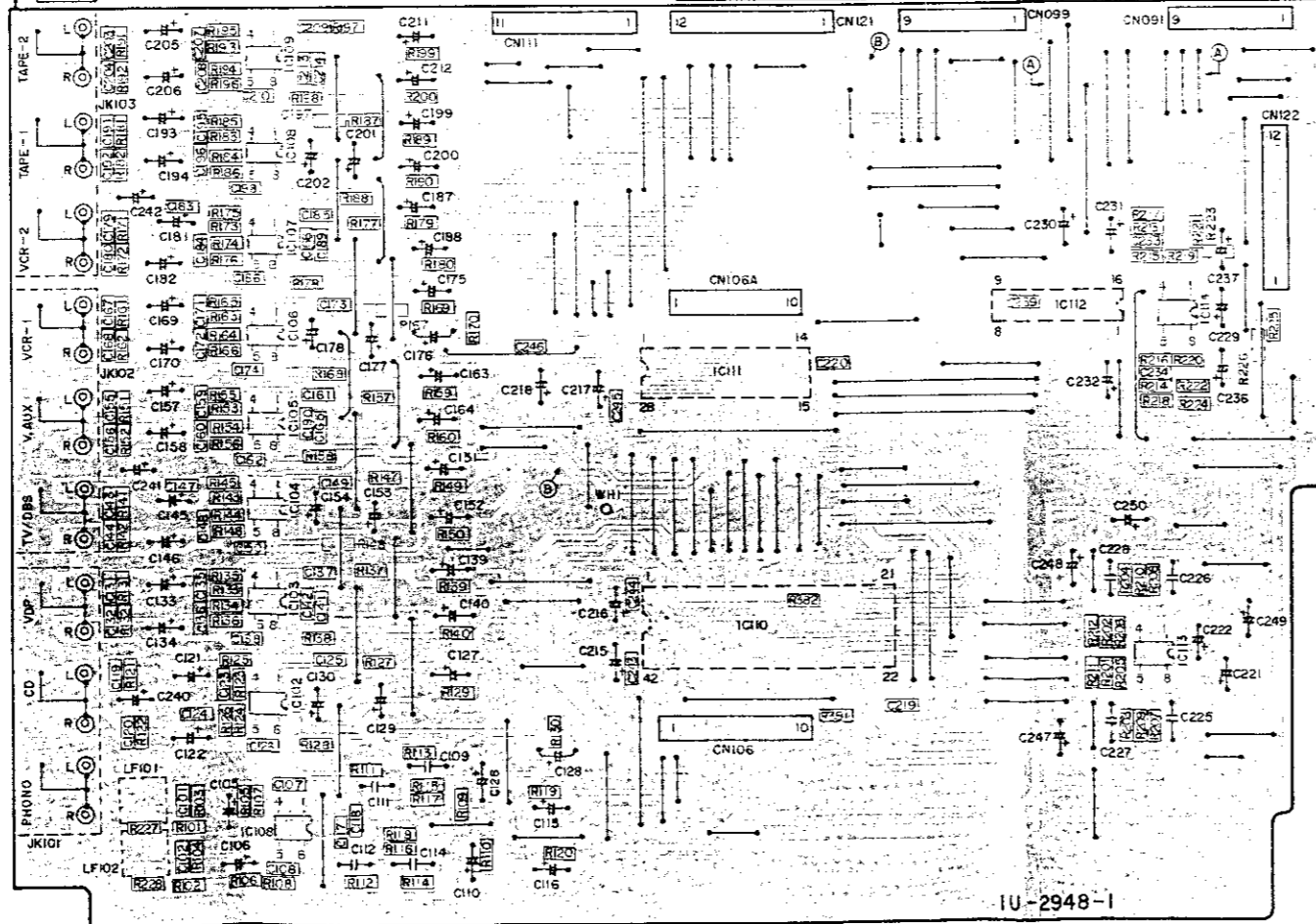
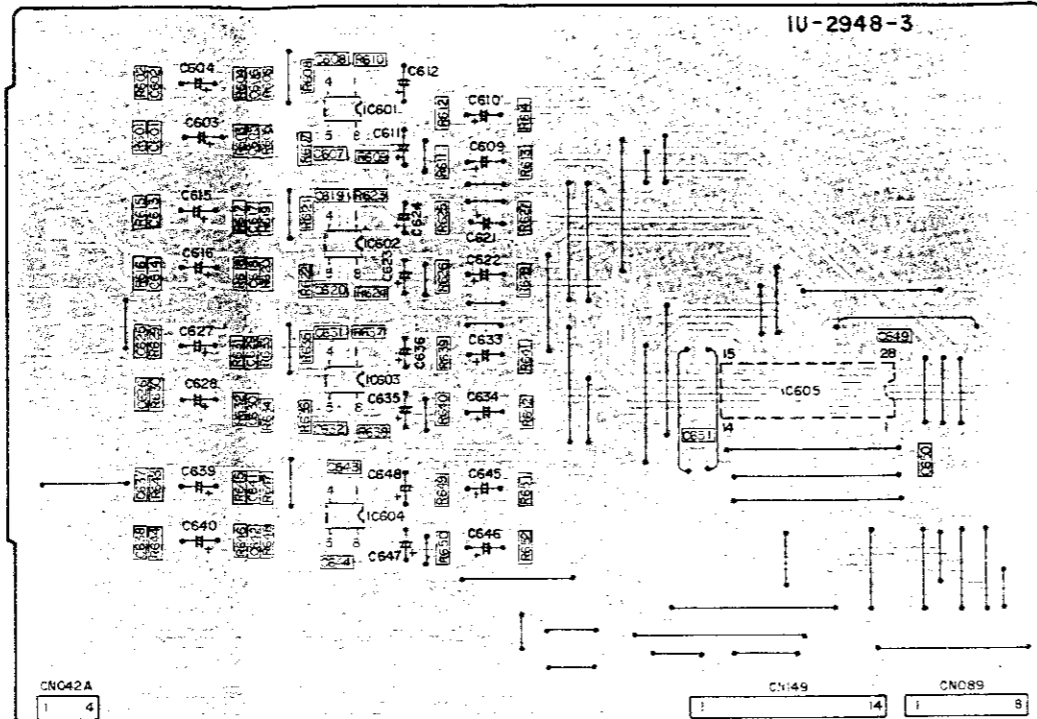

1 2 3 4 5 6 7 8

IU-2949E PRE AMP. UNIT ASS'Y

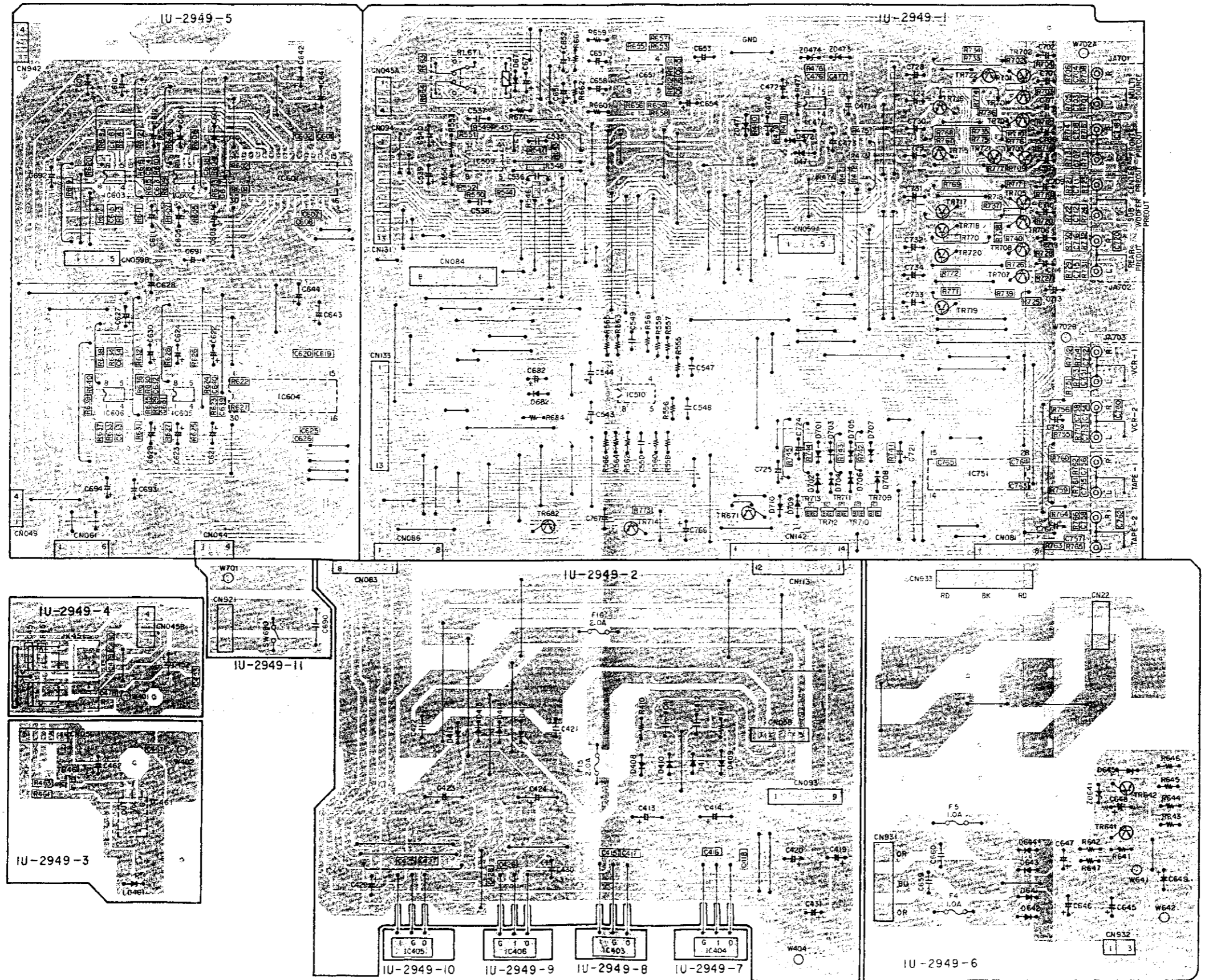

A  
B  
C  
D  
E

1

2

3

4

5

6

7

8

1U-2950A P.SUPPLY-3 UNIT ASS'Y

A

B

C

D

E

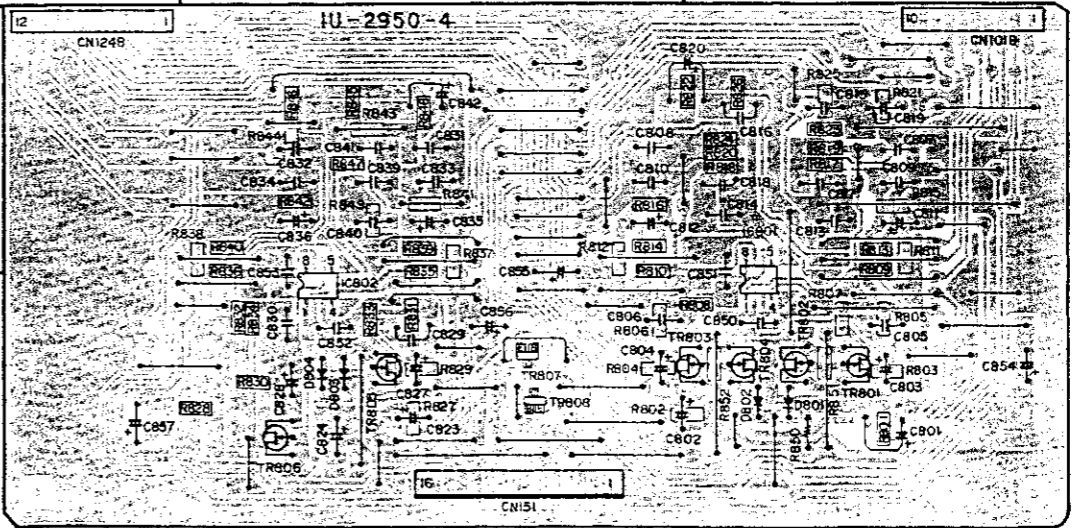
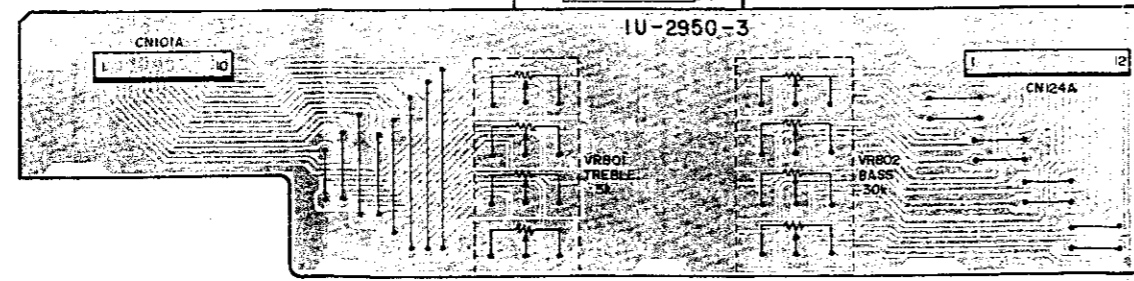
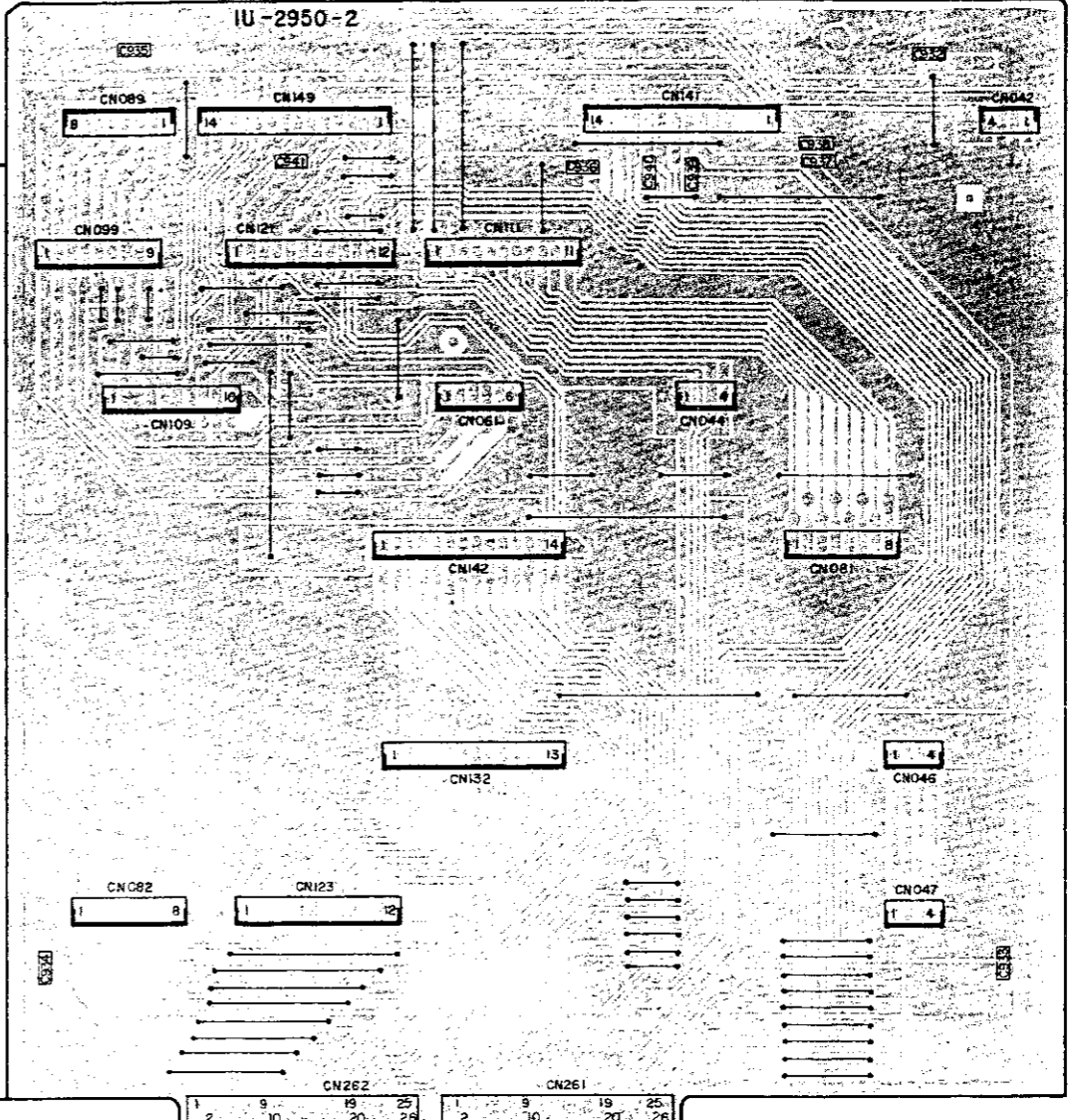
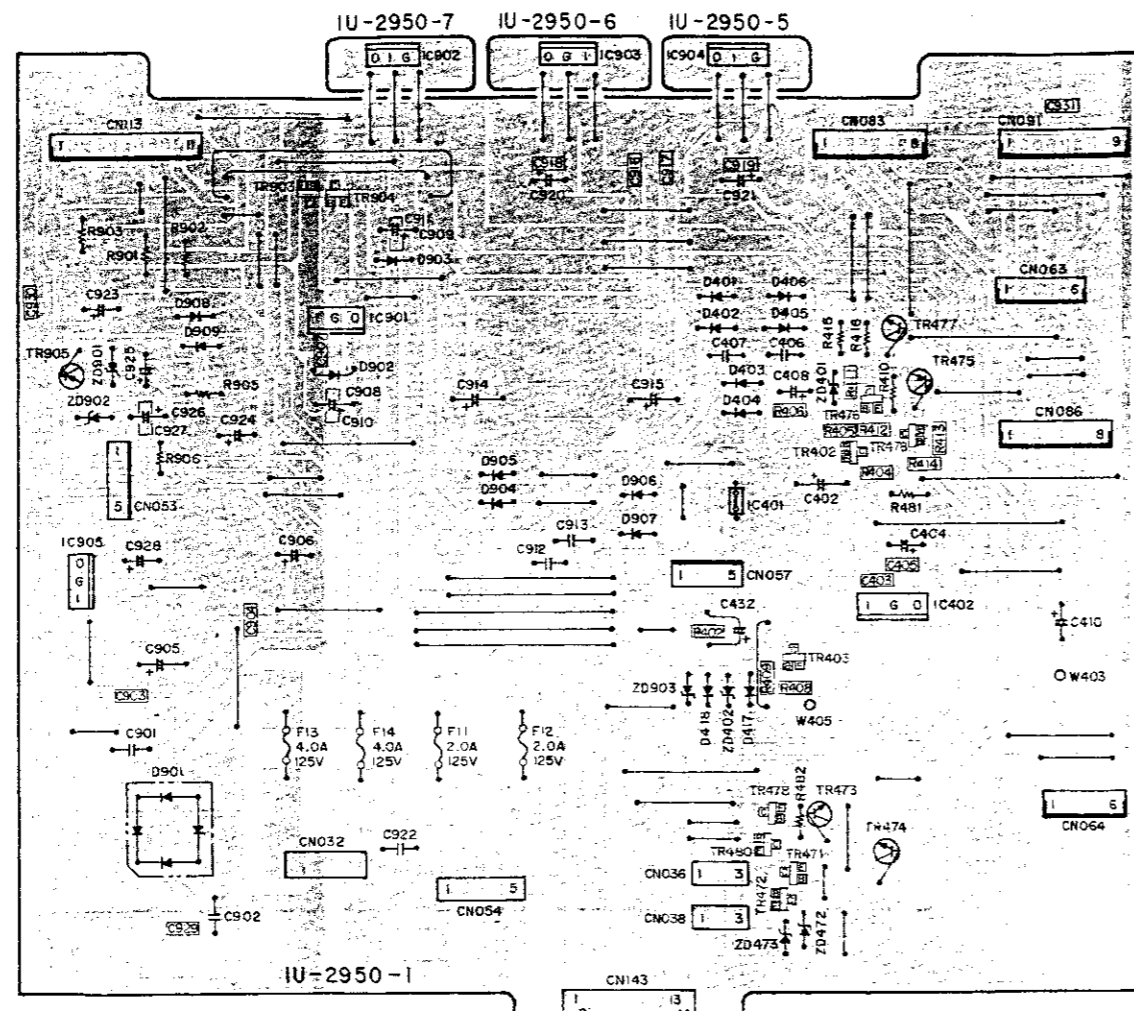

1U-2944A POWER AMP.-2 UNIT ASS'Y

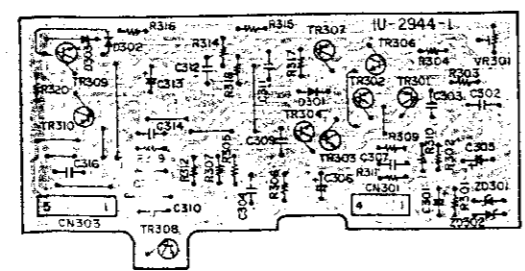



1U-2951A S-VIDEO UNIT ASS'Y

1 2 3 4 5 6 7 8

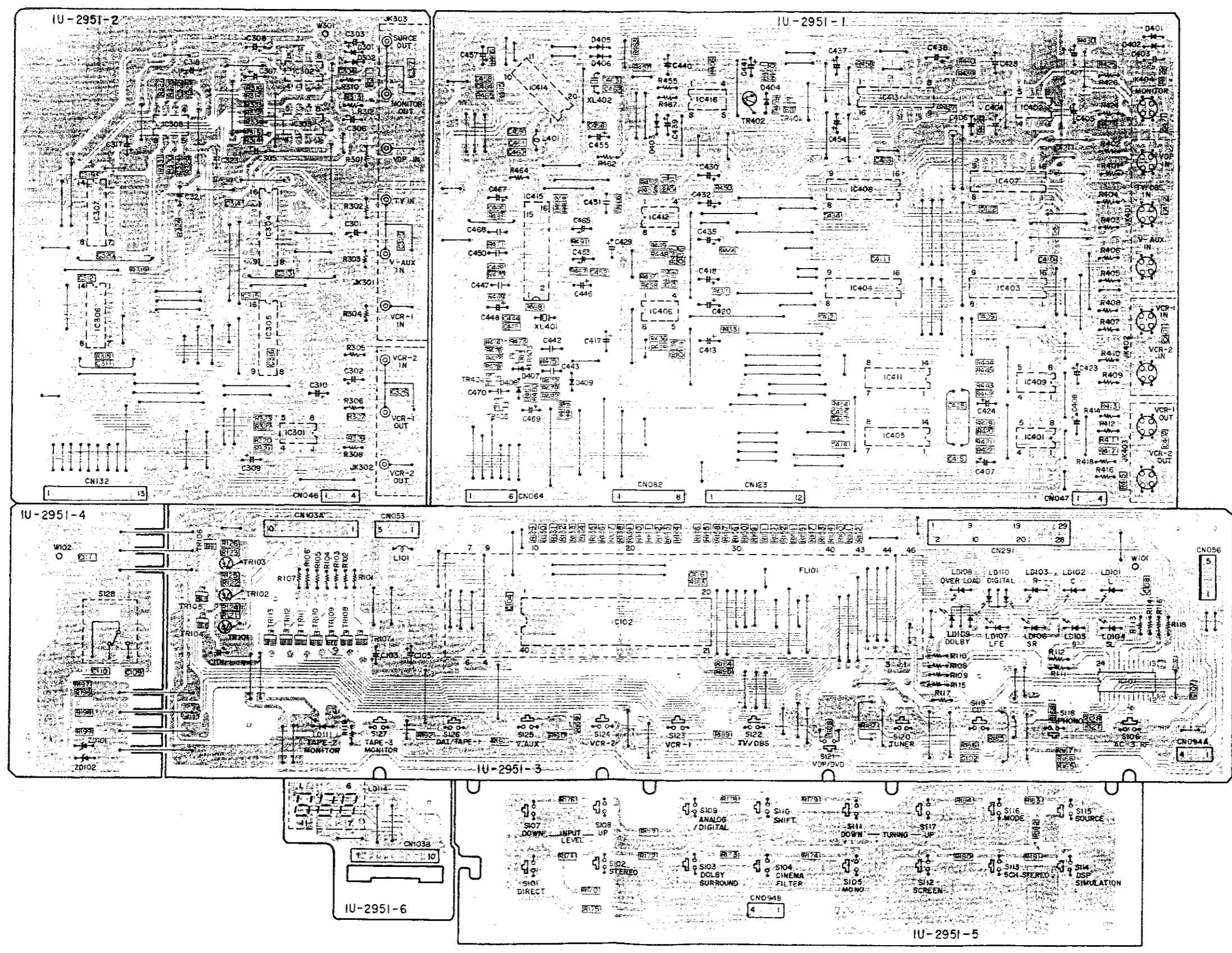

A  
B  
C  
D  
E

1U-2952E POWER AMP.-1 UNIT ASS'Y

1 2 3 4 5 6 7 8

A  
B  
C  
D  
E

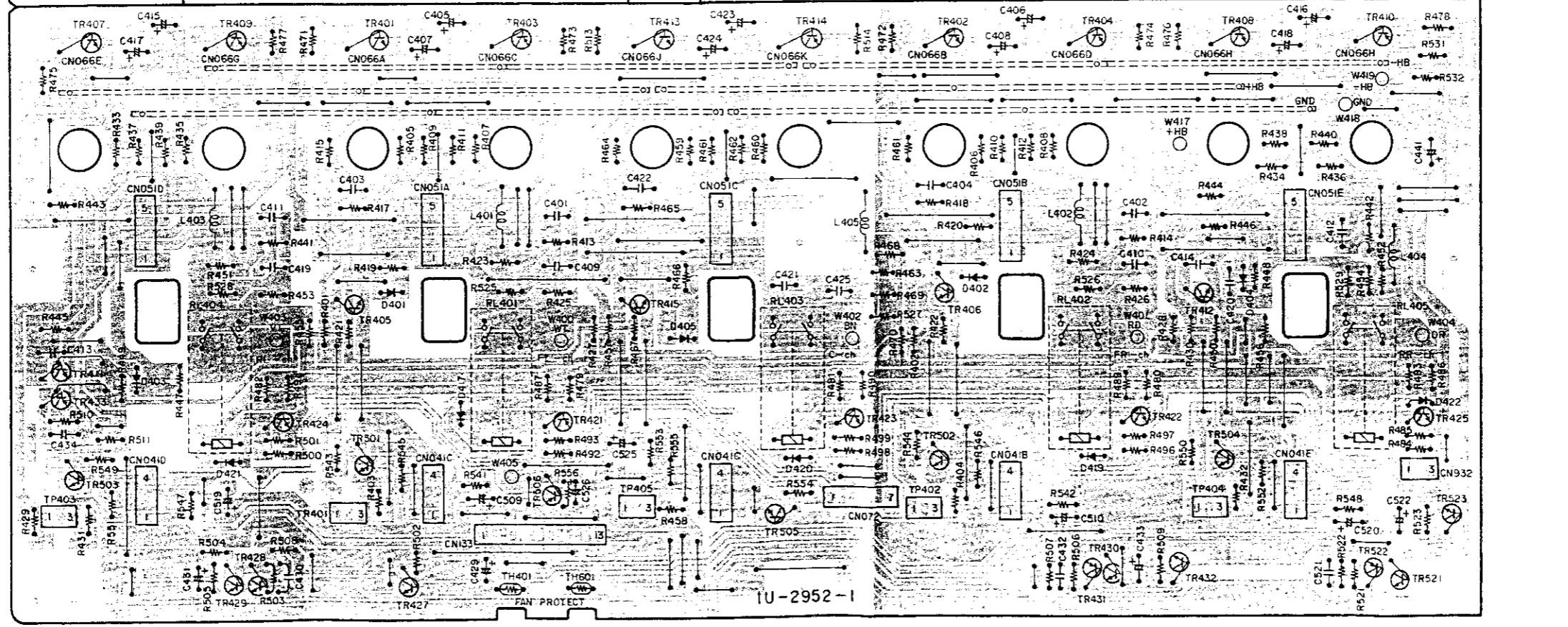
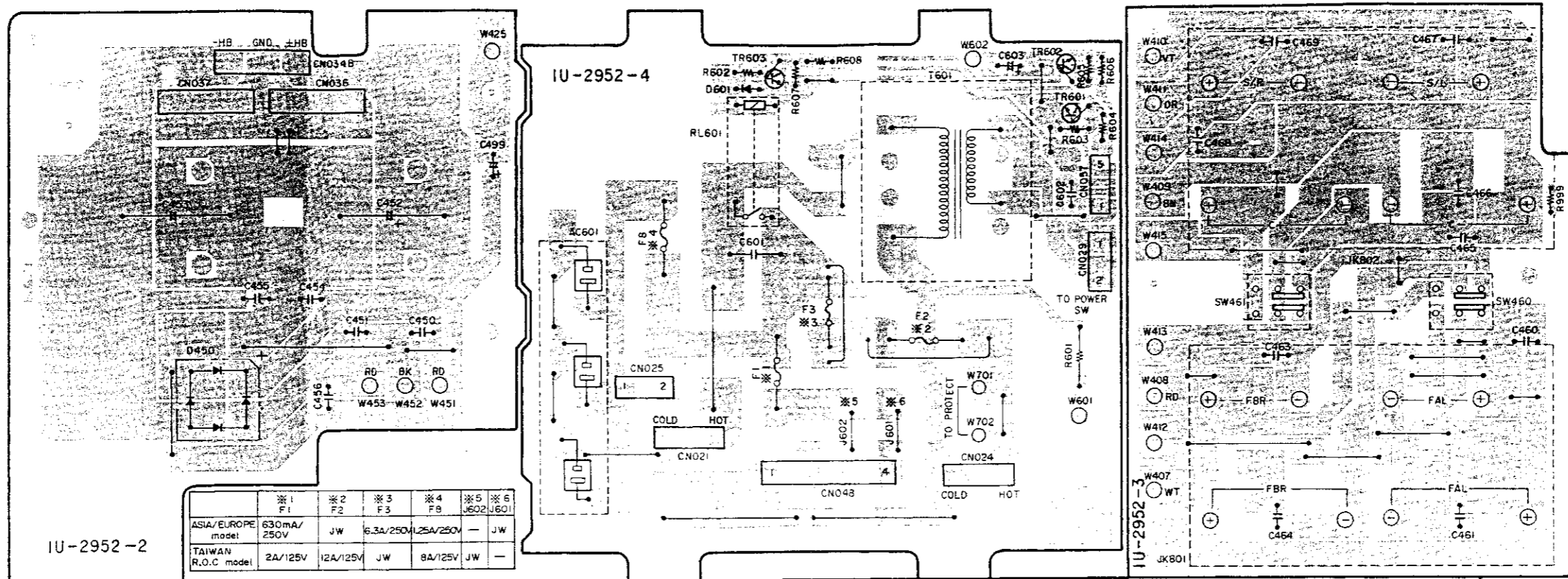

1 2 3 4 5 6 7 8

1U-2953A DSP UNIT ASS'Y

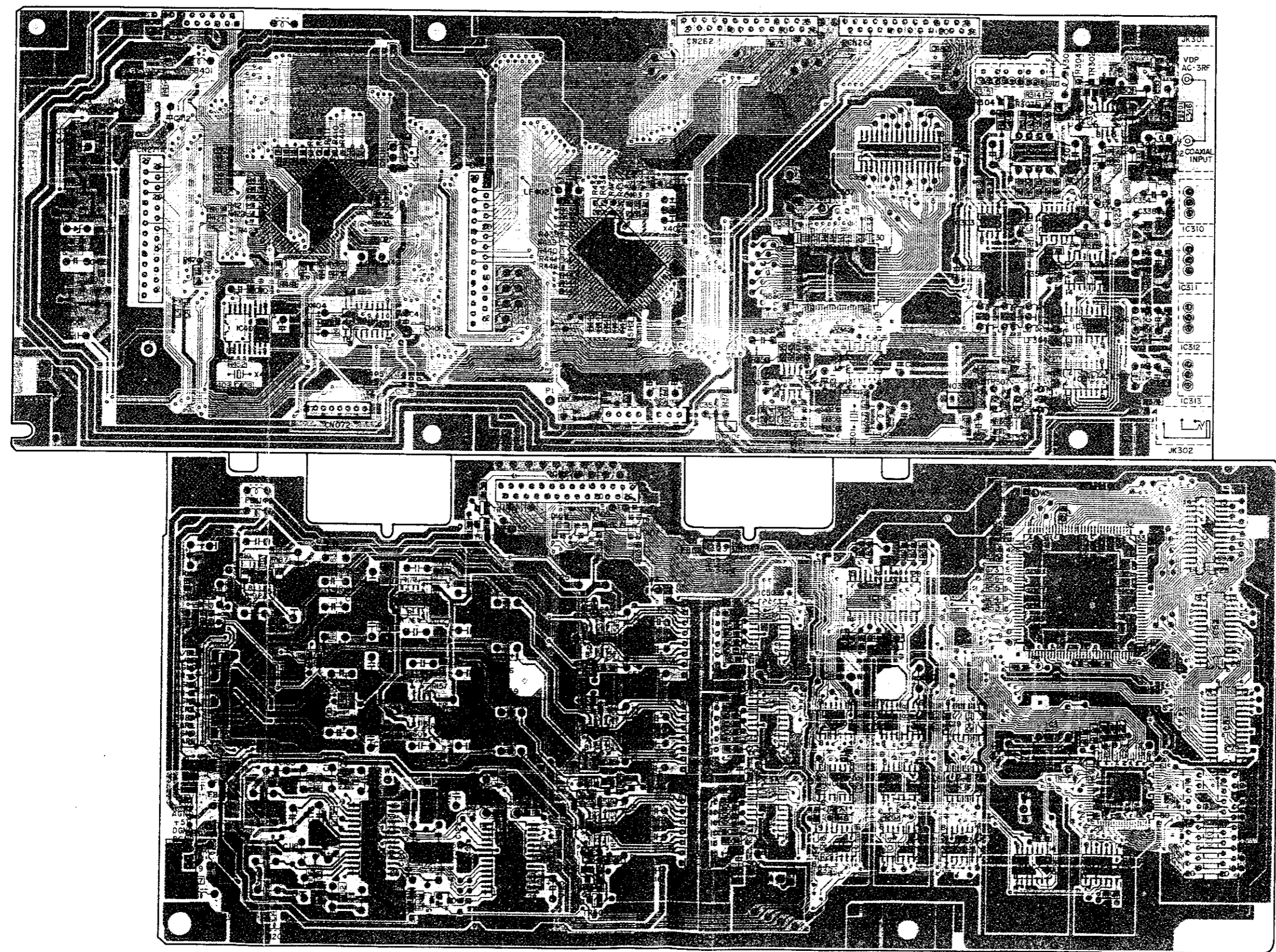

A  
B  
C  
D  
E

## NOTE FOR PARTS LIST

- Part indicated with the mark "⊙" are not always in stock and possibly to take a long period of time for supplying, or in some case supplying of part may be refused.
- When ordering of part, clearly indicate "1" and "I" (i) to avoid mis-supplying.
- Ordering part without stating its part number can not be supplied.
- Part indicated with the mark "★" is not illustrated in the exploded view.
- Not including Carbon Film ±5%, 1/4W Type in the P.W.Board parts list. (Refer to the Schematic Diagram for those parts.)

**WARNING:**

Parts marked with this symbol  have critical characteristics.  
Use ONLY replacement parts recommended by the manufacturer.

### ● Resistors

Ex.: **RN** **14K** **2E** **182** **G** **FR**  
 Type Shape Power Resist- Allowable Others  
 and per- ance error Others  
 formance

RD : Carbon	2B : 1/8W	F : ±1%	P : Pulse-resistant type
RC : Composition	2E : 1/4W	G : ±2%	NL : Low noise type
RS : Metal oxide film	2H : 1/2W	J : ±5%	NB : Non-burning type
RW : Winding	3A : 1W	K : ±10%	FR : Fuse-resistor
RN : Metal film	3D : 2W	M : ±20%	F : Lead wire forming
RK : Metal mixture	3F : 3W		
	3H : 5W		

**\* Resistance**

$1 \overset{8}{R} 2 \Rightarrow 1800 \text{ ohm} = 1.8 \text{ kohm}$   
 Indicates number of zeros after effective number.  
 2-digit effective number.

• Units: ohm

$1 \overset{R}{R} 2 \Rightarrow 1.2 \text{ ohm}$   
 1-digit effective number.  
 2-digit effective number, decimal point indicated by R.

• Units: ohm

### ● Capacitors

Ex.: **CE** **04W** **1H** **2R2** **M** **BP**  
 Type Shape Dielectric Capacity Allowable Others  
 and per- strength error Others  
 formance

CE : Aluminum foil electrolytic	0J : 6.3V	F : ±1%	HS : High stability type
CA : Aluminum solid electrolytic	1A : 10V	G : ±2%	BP : Non-polar type
CS : Tantalum electrolytic	1C : 18V	J : ±5%	HR : Ripple-resistant type
CQ : Film	1E : 25V	K : ±10%	DL : For change and discharge
CK : Ceramic	1V : 35V	M : ±20%	HF : For assuring high frequency
CC : Ceramic	1H : 50V	Z : +80%	U : UL part
CP : Oil	2A : 100V	-20%	C : CSA part
CM : Mica	2B : 125V	P : +100%	W : UL-CSA type
CF : Metallized	2C : 160V	-0%	F : Lead wire forming
CH : Metallized	2D : 200V	C : ±0.25pF	
	2E : 250V	D : ±0.5pF	
	2H : 500V	= : Others	
	2J : 630V		

**\* Capacity (electrolyte only)**

$2 \overset{2}{R} 2 \Rightarrow 2200\mu\text{F}$   
 Indicates number of zeros after effective number.  
 2-digit effective number.

• Units: μF.

$2 \overset{R}{R} 2 \Rightarrow 2.2\mu\text{F}$   
 1-digit effective number.  
 2-digit effective number, decimal point indicated by R.

• Units: μF.

**\* Capacity (except electrolyte)**

$2 \overset{2}{R} 2 \Rightarrow 2200\text{pF} = 0.0022\mu\text{F}$   
 (More than 2) — Indicates number of zeros after effective number.  
 2-digit effective number.

• Units: μF.

$2 \overset{2}{R} 1 \Rightarrow 220\text{pF}$   
 (0 or 1) — Indicates number of zeros after effective number.  
 2-digit effective number.

• Units: pF.

• When the dielectric strength is indicated in AC, "AC" is included after the dielectric strength value.

**PARTS LIST OF P.W.B. UNIT ASS'Y**  
**1U-2944A POWER AMP.-2 UNIT ASS'Y**

**1U-2948A AUDIO IN UNIT ASS'Y**

Ref. No.	Part No.	Part Name	Remarks
<b>SEMICONDUCTORS GROUP</b>			
TR301,302	271 0094 919	Transistor 2SA970(BL)	
TR303,304	273 0333 003	Transistor 2SC3423(O/Y)	
TR306	273 0333 003	Transistor 2SC3423(O/Y)	
TR307	271 0202 002	Transistor 2SA1360 (O/Y)	
TR308	273 0198 002	Transistor 2SC1815(Y)	
TR309	274 0151 916	Transistor 2SD2004(P/Q)	
TR310	272 0107 919	Transistor 2SB1328(P/Q)	
D301	276 0432 903	Diode 1SS270A	
D302,303	276 0048 914	Diode 1S2076A	
ZD301,302	278 0473 904	Zener diode HZS12A-1	12V
<b>RESISTORS GROUP</b>			
R304	244 2052 999	Metal oxide 10kohm 1W	RS14B3A103JNBS(S)
R306,307	241 2380 983	Carbon film 2.2kohm 1/4W(NB)	RD14B2E22JNBS
R312	241 2315 967	Carbon film 68ohm 1/4W(FR)	RD14B2E680GFRS
R317,318	241 2435 928	Carbon film 130ohm 1/4W(FR)	RD14B2E131GFRS
R320	241 2378 920	Carbon film 220ohm 1/4W(NB)	RD14B2E221JNBS
VR301	211 6095 965	Semi fixed resistor 4.7kohm	V06QB472
<b>CAPACITORS GROUP</b>			
C301	254 4261 918	Electrolytic 47µF/50V	CE04W1H470M
C302	253 1179 987	Ceramic 470pF/50V	CK45B1H471K
C303	253 1179 945	Ceramic 220pF/50V	CK45B1H221K
C304	255 1264 982	Mylar film 4700pF/50V	CQ93M1H472J(B)
C305	254 4258 769	Electrolytic 220µF/35V	CE04W1V221MC
C306	254 4256 774	Electrolytic 470µF/25V	CE04W1E471MC
C307	253 4488 905	Ceramic 56pF/500V	CC45SL2H560J
C309	253 4470 900	Ceramic 10pF/500V	CC45SL2H100D
C310	255 1265 936	Mylar film 0.01µF/50V	CQ93M1H103J(B)
C313	254 4261 730	Electrolytic 220µF/50V	CE04W1H221M
C314	253 1128 909	Ceramic 220pF/500V	CK45B2H221K
C315,316	255 4235 934	Mylar film 0.01µF/100V	CQ93P2A103J(NH)
<b>OTHER PARTS GROUP</b>			
CN301	205 0731 042	4Pconnector base-L	1
CN303	205 0731 055	5Pconnector base-L	1
	415 0309 055	P.V.C. tube (L=07)	10

Ref. No.	Part No.	Part Name	Remarks
<b>SEMICONDUCTORS GROUP</b>			
IC101	263 0896 909	IC NJM2068MD	
IC102,103	263 0898 907	IC NJM5532MD	
IC104-109	263 0615 902	IC BA15218F	
IC110	262 2219 002	IC TC9274N-002	
IC111	262 2033 000	IC TC9273N-004	
IC112	262 2031 002	IC TC9299P	
IC113	263 0896 909	IC NJM2068MD	
IC114	263 0898 907	IC NJM5532MD	
IC305	262 2348 009	IC LM7001UJ	
IC501,502	263 0896 909	IC NJM2068MD	
IC503,504	262 2214 007	IC LC7536	
IC505-508	263 0896 909	IC NJM2068MD	
IC601-604	263 0898 907	IC NJM5532MD	
IC605	262 1853 100	IC NJL313AL	
<b>RESISTORS GROUP</b>			
R101,102	247 0006 946	Carbon chip 390ohm 1/10W	RM73B-391J
R103,104	247 0011 986	Carbon chip 68kohm 1/10W	RM73B-683J
R105,106	247 0012 969	Carbon chip 150kohm 1/10W	RM73B-154J
R107,108	247 0004 922	Carbon chip 47ohm 1/10W	RM73B-470J
R109,110	247 0005 992	Carbon chip 240ohm 1/10W	RM73B-241J
R111,112	247 0012 956	Carbon chip 130kohm 1/10W	RM73B-134J
R113,114	247 0009 998	Carbon chip 11kohm 1/10W	RM73B-113J
R115,116	247 0003 949	Carbon chip 22ohm 1/10W	RM73B-220J
R117,118	247 0005 905	Carbon chip 100ohm 1/10W	RM73B-101J
R119,120	247 0011 944	Carbon chip 47kohm 1/10W	RM73B-473J
R121,122	247 0011 973	Carbon chip 62kohm 1/10W	RM73B-623J
R123,124	247 0013 984	Carbon chip 470kohm 1/10W	RM73B-474J
R125,126	247 0008 962	Carbon chip 470ohm 1/10W	RM73B-471J
R127,128	247 0005 905	Carbon chip 100ohm 1/10W	RM73B-101J
R129,130	247 0011 944	Carbon chip 47kohm 1/10W	RM73B-473J
R131,132	247 0011 973	Carbon chip 62kohm 1/10W	RM73B-623J
R133,134	247 0013 984	Carbon chip 470kohm 1/10W	RM73B-474J
R135,136	247 0006 962	Carbon chip 470ohm 1/10W	RM73B-471J
R137,138	247 0005 905	Carbon chip 100ohm 1/10W	RM73B-101J
R139,140	247 0011 944	Carbon chip 47kohm 1/10W	RM73B-473J
R141,142	247 0011 973	Carbon chip 62kohm 1/10W	RM73B-623J
R143,144	247 0013 984	Carbon chip 470kohm 1/10W	RM73B-474J
R145,146	247 0006 962	Carbon chip 470ohm 1/10W	RM73B-471J
R147,148	247 0005 905	Carbon chip 100ohm 1/10W	RM73B-101J
R149,150	247 0011 944	Carbon chip 47kohm 1/10W	RM73B-473J
R151,152	247 0011 973	Carbon chip 62kohm 1/10W	RM73B-623J
R153,154	247 0013 984	Carbon chip 470kohm 1/10W	RM73B-474J
R155,156	247 0006 962	Carbon chip 470ohm 1/10W	RM73B-471J
R157,158	247 0005 905	Carbon chip 100ohm 1/10W	RM73B-101J
R159,160	247 0011 944	Carbon chip 47kohm 1/10W	RM73B-473J
R161,162	247 0011 973	Carbon chip 62kohm 1/10W	RM73B-623J
R163,164	247 0013 984	Carbon chip 470kohm 1/10W	RM73B-474J
R165,166	247 0006 962	Carbon chip 470ohm 1/10W	RM73B-471J

Ref. No.	Part No.	Part Name	Remarks
R167,168	247 0005 905	Carbon chip 100ohm 1/10W	RM73B-101J
R169,170	247 0011 944	Carbon chip 47kohm 1/10W	RM73B-473J
R171,172	247 0011 973	Carbon chip 62kohm 1/10W	RM73B-623J
R173,174	247 0013 984	Carbon chip 470kohm 1/10W	RM73B-474J
R175,176	247 0006 962	Carbon chip 470ohm 1/10W	RM73B-471J
R177,178	247 0005 905	Carbon chip 100ohm 1/10W	RM73B-101J
R179,180	247 0011 944	Carbon chip 47kohm 1/10W	RM73B-473J
R181,182	247 0011 973	Carbon chip 62kohm 1/10W	RM73B-623J
R183,184	247 0013 984	Carbon chip 470kohm 1/10W	RM73B-474J
R185,186	247 0006 962	Carbon chip 470ohm 1/10W	RM73B-471J
R187,188	247 0005 905	Carbon chip 100ohm 1/10W	RM73B-101J
R189,190	247 0011 944	Carbon chip 47kohm 1/10W	RM73B-473J
R191,192	247 0011 973	Carbon chip 62kohm 1/10W	RM73B-623J
R193,194	247 0013 984	Carbon chip 470kohm 1/10W	RM73B-474J
R195,196	247 0006 962	Carbon chip 470ohm 1/10W	RM73B-471J
R197,198	247 0005 905	Carbon chip 100ohm 1/10W	RM73B-101J
R199,200	247 0011 944	Carbon chip 47kohm 1/10W	RM73B-473J
R201,202	247 0012 927	Carbon chip 100kohm 1/10W	RM73B-104J
R203,204	247 0005 905	Carbon chip 100ohm 1/10W	RM73B-101J
R205-210	247 0010 916	Carbon chip 13kohm 1/10W	RM73B-133J
R211,212	247 0012 927	Carbon chip 100kohm 1/10W	RM73B-104J
R213,214	247 0012 901	Carbon chip 82kohm 1/10W	RM73B-823J
R215,216	247 0005 905	Carbon chip 100ohm 1/10W	RM73B-101J
R217,218	247 0008 957	Carbon chip 3kohm 1/10W	RM73B-302J
R219,220	247 0008 931	Carbon chip 2.4kohm 1/10W	RM73B-242J
R221-224	247 0005 905	Carbon chip 100ohm 1/10W	RM73B-101J
R225,226	247 0012 927	Carbon chip 100kohm 1/10W	RM73B-104J
R227,228	247 0009 901	Carbon chip 4.7kohm 1/10W	RM73B-472J
R501,502	247 0012 927	Carbon chip 100kohm 1/10W	RM73B-104J
R503-506	247 0008 902	Carbon chip 1.8kohm 1/10W	RM73B-182J
R507,508	247 0008 973	Carbon chip 3.6kohm 1/10W	RM73B-362J
R509,510	247 0004 922	Carbon chip 47ohm 1/10W	RM73B-470J
R511-516	247 0008 902	Carbon chip 1.8kohm 1/10W	RM73B-182J
R517,518	247 0004 922	Carbon chip 47ohm 1/10W	RM73B-470J
R519-522	247 0011 944	Carbon chip 47kohm 1/10W	RM73B-473J
R523,524	247 0013 984	Carbon chip 470kohm 1/10W	RM73B-474J
R525,526	247 0005 905	Carbon chip 100ohm 1/10W	RM73B-101J
R527,528	247 0011 944	Carbon chip 47kohm 1/10W	RM73B-473J
R529,530	247 0013 984	Carbon chip 470kohm 1/10W	RM73B-474J
R531,532	247 0005 905	Carbon chip 100ohm 1/10W	RM73B-101J
R533,534	247 0011 944	Carbon chip 47kohm 1/10W	RM73B-473J
R535-538	247 0012 927	Carbon chip 100kohm 1/10W	RM73B-104J
R539-542	247 0005 905	Carbon chip 100ohm 1/10W	RM73B-101J
R601,602	247 0011 973	Carbon chip 62kohm 1/10W	RM73B-623J
R603,604	247 0013 984	Carbon chip 470kohm 1/10W	RM73B-474J
R605,606	247 0006 962	Carbon chip 470ohm 1/10W	RM73B-471J
R609,610	247 0018 905	Carbon chip 0ohm 1/10W	RM73B-0R0K
R611,612	247 0005 905	Carbon chip 100ohm 1/10W	RM73B-101J
R613,614	247 0011 944	Carbon chip 47kohm 1/10W	RM73B-473J
R615,616	247 0011 973	Carbon chip 62kohm 1/10W	RM73B-623J
R617,618	247 0013 984	Carbon chip 470kohm 1/10W	RM73B-474J

Ref. No.	Part No.	Part Name	Remarks
R619,620	247 0006 962	Carbon chip 470ohm 1/10W	RM73B-471J
R623,624	247 0018 905	Carbon chip 0ohm 1/10W	RM73B-0R0K
R625,626	247 0005 905	Carbon chip 100ohm 1/10W	RM73B-101J
R627,628	247 0011 944	Carbon chip 47kohm 1/10W	RM73B-473J
R629,630	247 0011 973	Carbon chip 62kohm 1/10W	RM73B-623J
R631,632	247 0013 984	Carbon chip 470kohm 1/10W	RM73B-474J
R633,634	247 0006 962	Carbon chip 470ohm 1/10W	RM73B-471J
R637,638	247 0018 905	Carbon chip 0ohm 1/10W	RM73B-0R0K
R639,640	247 0005 905	Carbon chip 100ohm 1/10W	RM73B-101J
R641,642	247 0011 944	Carbon chip 47kohm 1/10W	RM73B-473J
R643,644	247 0011 973	Carbon chip 62kohm 1/10W	RM73B-623J
R645,646	247 0013 984	Carbon chip 470kohm 1/10W	RM73B-474J
R647,648	247 0006 962	Carbon chip 470ohm 1/10W	RM73B-471J
R649,650	247 0005 905	Carbon chip 100ohm 1/10W	RM73B-101J
R651,652	247 0011 944	Carbon chip 47kohm 1/10W	RM73B-473J
<b>CAPACITORS GROUP</b>			
C101,102	257 0005 944	Ceramic chip 220pF/50V	CE04W1H221J
C105,106	254 4254 909	Electrolytic 10µF/16V	CE04W1C100M
C107,108	257 0004 961	Ceramic chip 100pF/50V	CC73SL1H101J
C109,110	254 4250 932	Electrolytic 220µF/6.3V	CE04W0J221M
C111,112	255 4199 999	Mylar film 0.024µF/50V	CQ92M1H243J(MRZ)
C113,114	255 1265 907	Mylar film 6800pF/50V	CQ93M1H682J(B)
C115,116	254 4254 938	Electrolytic 47µF/16V	CE04W1C470M
C117,118	257 0012 982	Ceramic chip 0.022µF/50V	CK73F1H223J
C119,120	257 0005 986	Ceramic chip 330pF/50V	CC73SL1H331J
C121,122	254 4260 980	Electrolytic 10µF/50V	CE04W1H100M
C123-126	257 0004 961	Ceramic chip 100pF/50V	CC73SL1H101J
C127,128	254 4261 918	Electrolytic 47µF/50V	CE04W1H470M
C129,130	254 4260 948	Electrolytic 1µF/50V	CE04W1H010M
C131,132	257 0005 986	Ceramic chip 330pF/50V	CC73SL1H331J
C133,134	254 4254 909	Electrolytic 10µF/16V	CE04W1C100M
C135-138	257 0004 961	Ceramic chip 100pF/50V	CC73SL1H101J
C139,140	254 4254 938	Electrolytic 47µF/16V	CE04W1C470M
C141,142	257 0012 982	Ceramic chip 0.022µF/50V	CK73F1H223J
C143,144	257 0005 986	Ceramic chip 330pF/50V	CC73SL1H331J
C145,146	254 4254 909	Electrolytic 10µF/16V	CE04W1C100M
C147-150	257 0004 961	Ceramic chip 100pF/50V	CC73SL1H101J
C151,152	254 4254 938	Electrolytic 47µF/16V	CE04W1C470M
C153,154	254 4260 948	Electrolytic 1µF/50V	CE04W1H010M
C155,15			

Ref. No.	Part No.	Part Name	Remarks
C187,188	254 4254 938	Electrolytic 47µF/16V	CE04W1C470M
C189,190	257 0012 982	Ceramic chip 0.022µF/50V	CK73F1H223Z
C191,192	257 0005 986	Ceramic chip 330pF/50V	CC73SL1H331J
C193,194	254 4254 909	Electrolytic 10µF/16V	CE04W1C100M
C195-198	257 0004 961	Ceramic chip 100pF/50V	CC73SL1H101J
C199,200	254 4254 938	Electrolytic 47µF/16V	CE04W1C470M
C201,202	254 4260 948	Electrolytic 1µF/50V	CE04W1H010M
C203,204	257 0005 986	Ceramic chip 330pF/50V	CC73SL1H331J
C205,206	254 4254 909	Electrolytic 10µF/16V	CE04W1C100M
C207-210	257 0004 961	Ceramic chip 100pF/50V	CC73SL1H101J
C211,212	254 4254 938	Electrolytic 47µF/16V	CE04W1C470M
C213,214	257 0012 982	Ceramic chip 0.022µF/50V	CK73F1H223Z
C215,216	254 4260 980	Electrolytic 10µF/50V	CE04W1H100M
C217,218	254 4256 949	Electrolytic 100µF/25V	CE04W1E101M
C221,222	254 4260 948	Electrolytic 1µF/50V	CE04W1H010M
C225-228	256 1035 910	Metalized 0.22µF/16V	CF93A1H224J
C229,230	254 4256 949	Electrolytic 100µF/25V	CE04W1E101M
C231,232	254 4254 909	Electrolytic 10µF/16V	CE04W1C100M
C233,234	257 0004 961	Ceramic chip 100pF/50V	CC73SL1H101J
C236,237	254 4254 941	Electrolytic 100µF/16V	CE04W1C101M
C240-242	254 4260 948	Electrolytic 1µF/50V	CE04W1H010M
C247,248	254 4254 909	Electrolytic 10µF/16V	CE04W1C100M
C249,250	254 4254 938	Electrolytic 47µF/16V	CE04W1C470M
C501,502	253 4536 941	Ceramic 15pF/50V	CC45SL1H150J
C503,504	253 4537 924	Ceramic 33pF/50V	CC45SL1H330J
C505-508	254 4260 948	Electrolytic 1µF/50V	CE04W1H010M
C509-512	254 4261 918	Electrolytic 47µF/50V	CE04W1H470M
C513-516	257 0012 982	Ceramic chip 0.022µF/50V	CK73F1H223Z
C517-524	254 4260 980	Electrolytic 10µF/50V	CE04W1H100M
C527-530	254 4260 948	Electrolytic 1µF/50V	CE04W1H010M
C531-534	254 4260 993	Electrolytic 22µF/50V	CE04W1H220M
C535,536	257 0012 966	Ceramic chip 0.01µF/50V	CK73F1H103Z
C601,602	257 0005 986	Ceramic chip 330pF/50V	CC73SL1H331J
C603,604	254 4254 909	Electrolytic 10µF/16V	CE04W1C100M
C605-608	257 0004 961	Ceramic chip 100pF/50V	CC73SL1H101J
C609,610	254 4254 938	Electrolytic 47µF/16V	CE04W1C470M
C611,612	254 4260 948	Electrolytic 1µF/50V	CE04W1H010M
C613,614	257 0005 986	Ceramic chip 330pF/50V	CC73SL1H331J
C615,616	254 4254 909	Electrolytic 10µF/16V	CE04W1C100M
C617-620	257 0004 961	Ceramic chip 100pF/50V	CC73SL1H101J
C621,622	254 4254 938	Electrolytic 47µF/16V	CE04W1C470M
C623,624	254 4260 948	Electrolytic 1µF/50V	CE04W1H010M
C625,626	257 0005 986	Ceramic chip 330pF/50V	CC73SL1H331J
C627,628	254 4254 909	Electrolytic 10µF/16V	CE04W1C100M
C629-632	257 0004 961	Ceramic chip 100pF/50V	CC73SL1H101J
C633,634	254 4254 938	Electrolytic 47µF/16V	CE04W1C470M
C635,636	254 4260 948	Electrolytic 1µF/50V	CE04W1H010M
C637,638	257 0005 986	Ceramic chip 330pF/50V	CC73SL1H331J
C639,640	254 4254 909	Electrolytic 10µF/16V	CE04W1C100M
C641-644	257 0004 961	Ceramic chip 100pF/50V	CC73SL1H101J
C645,646	254 4254 938	Electrolytic 47µF/16V	CE04W1C470M

Ref. No.	Part No.	Part Name	Remarks
C647,648	254 4260 948	Electrolytic 1 F/50V	CE04W1H010M
C649,650	257 0012 982	Ceramic chip 0.022 F/50V	CK73F1H223Z
<b>OTHER PARTS GROUP</b>			
CN42	205 0885 082	4P connector socket (TUC-P)	1
CN49	205 0805 046	4 P connector socket(917B)	1
CN63	205 0942 019	6P connector socket(TUC-P)	1
CN84	205 0986 046	8P connector plug (TKC-A)	1
CN89	205 0885 095	8P connector socket (TUC-P)	1
CN91	205 0885 037	9P connector socket (TUC-P)	1
CN99	205 0885 037	9P connector socket (TUC-P)	1
CN106	205 0409 002	10P dip socket	2
CN109	205 0885 053	10P connector socket (TUC-P)	1
CN111	205 0885 066	11P connector socket (TUC-P)	1
CN121	205 0885 079	12P connector socket (TUC-P)	1
CN122	205 0480 021	12P KR connector base(L)	1
CN149	205 0885 011	14P connector socket (TUC-P)	1
CN942	205 0805 046	4 P connector socket(917B)	1
JK101-103	204 8543 019	6P pin jack	3
JK601	204 8514 006	4P pin jack (S-GND)	1
JK602	204 8529 004	4P pin jack (SW)	1
LF101,102	235 9003 002	FTZ choke coil	2
W106	002 9022 069	10C R.wire Assy	1
	414 0799 109	Shield plate	1
	001 0155 013	Wire cord	1

## 1U-2949E PRE AMP UNIT ASSY

Ref. No.	Part No.	Part Name	Remarks
<b>SEMICONDUCTORS GROUP</b>			
IC403	263 0809 006	IC NJM7805FA(S)	
IC404	263 0554 005	IC NJM7905FA	
IC405	263 0812 006	IC NJM7815FA(S)	
IC406	263 0561 001	IC NJM7812FA	
IC461	499 0290 007	Remote sensor GP1U271X	
IC471	263 0615 902	IC BA15218F	
IC509	263 0609 002	IC NJM2068DDC	
IC510	263 0890 009	IC OP275GP	
IC601	262 2214 007	IC LC7536	
IC602	263 0896 909	IC NJM2068MD	
IC603	263 0898 907	IC NJM5532MD	
IC604	262 2214 007	IC LC7536	
IC605	263 0896 909	IC NJM2068MD	
IC606	263 0898 907	IC NJM5532MD	
IC651	263 0995 004	IC NJM4556AD	
IC751	262 2033 000	IC TC9273N-004	
TR461	269 0083 901	Transistor DTA114EK	
TR641	269 0107 900	Transistor RN1241(A/B)	
TR642	273 0317 906	Transistor 2SC2458(BL)	
TR671	269 0018 905	Transistor DTC143ES(4.7K-4.7K)	
TR682	269 0018 905	Transistor DTC143ES(4.7K-4.7K)	
TR701-708	273 0253 918	Transistor 2SC2878(A/B)	
TR709-713	269 0083 901	Transistor DTA114EK	
TR714	269 0046 906	Transistor DTA114ES(10K-10K)	
TR715-722	273 0253 918	Transistor 2SC2878(A/B)	
D408-415	276 0548 910	Diode DSM1D2	
D471,472	276 0432 903	Diode 1SS270A	
D641-644	276 0553 905	Diode 1SR35-200A	
D645	276 0432 903	Diode 1SS270A	
D671	276 0432 903	Diode 1SS270A	
D682	276 0432 903	Diode 1SS270A	
D701-708	276 0432 903	Diode 1SS270A	
D709	276 0553 905	Diode 1SR35-200A	
ZD471	276 0458 903	Zener diode HZSSA-1	5V
ZD473,474	276 0458 903	Zener diode HZSSA-1	5V
ZD641	276 0466 908	Zener diode HZS7C-1	7V
LD461	393 9408 903	LED SEL-4214S	Red
<b>RESISTORS GROUP</b>			
R410,411	241 2387 908	Carbon film 10hm 1/4W(NB)	RD14B2E01JNBS
R451	247 0005 905	Carbon chip 100ohm 1/10W	RM73B-101J
R461	247 0006 933	Carbon chip 360ohm 1/10W	RM73B-361J
R463	247 0005 905	Carbon chip 100ohm 1/10W	RM73B-101J
R473-475	247 0012 927	Carbon chip 100kohm 1/10W	RM73B-104J
R476	247 0013 926	Carbon chip 270kohm 1/10W	RM73B-274J
R478	247 0012 927	Carbon chip 100kohm 1/10W	RM73B-104J
R479	247 0007 945	Carbon chip 1kohm 1/10W	RM73B-102J
R480	247 0011 928	Carbon chip 30kohm 1/10W	RM73B-393J
R543-546	247 0008 960	Carbon chip 3.3kohm 1/10W	RM73B-332J
R547-550	247 0007 958	Carbon chip 1.1kohm 1/10W	RM73B-112J
R551,552	247 0005 905	Carbon chip 100ohm 1/10W	RM73B-101J
R601,602	247 0010 961	Carbon chip 22kohm 1/10W	RM73B-223J
R603,604	247 0013 900	Carbon chip 220kohm 1/10W	RM73B-224J
R605,606	247 0005 905	Carbon chip 100ohm 1/10W	RM73B-101J
R607,608	247 0011 944	Carbon chip 47kohm 1/10W	RM73B-473J
R609,610	247 0012 927	Carbon chip 100kohm 1/10W	RM73B-104J
R611,612	247 0005 905	Carbon chip 100ohm 1/10W	RM73B-101J
R613	247 0008 966	Carbon chip 3.9kohm 1/10W	RM73B-392J
R614	247 0007 974	Carbon chip 1.3kohm 1/10W	RM73B-132J
R615,616	247 0008 973	Carbon chip 3.6kohm 1/10W	RM73B-362J
R617,618	247 0006 962	Carbon chip 470ohm 1/10W	RM73B-471J
R619,620	247 0012 927	Carbon chip 100kohm 1/10W	RM73B-104J
R621,622	247 0010 961	Carbon chip 22kohm 1/10W	RM73B-223J
R623,624	247 0013 900	Carbon chip 220kohm 1/10W	RM73B-224J
R625,626	247 0005 905	Carbon chip 100ohm 1/10W	RM73B-101J
R627,628	247 0011 944	Carbon chip 47kohm 1/10W	RM73B-473J
R629,630	247 0012 927	Carbon chip 100kohm 1/10W	RM73B-104J
R631,632	247 0005 905	Carbon chip 100ohm 1/10W	RM73B-101J
R633,634	247 0009 930	Carbon chip 6.2kohm 1/10W	RM73B-622J
R635,636	247 0007 916	Carbon chip 750ohm 1/10W	RM73B-751J
R637,638	247 0006 962	Carbon chip 470ohm 1/10W	RM73B-471J
R639,640	247 0012 927	Carbon chip 100kohm 1/10W	RM73B-104J
R643-646	244 2043 924	Metal oxide 68ohm 1W	RS14B3A680JNBS(S)
R648,649	243 2079 021	Winding 33ohm 10W	RW78A4A330K-(UL)
R651,652	247 0013 984	Carbon chip 470kohm 1/10W	RM73B-474J
R653,654	247 0005 905	Carbon chip 100ohm 1/10W	RM73B-101J
R655,656	247 0009 927	Carbon chip 5.6kohm 1/10W	RM73B-562J
R657,658	247 0007 945	Carbon chip 1kohm 1/10W	RM73B-102J
R659,660	244 2051 961	Metal oxide 4.7ohm 1W	RS14B3A4R7JNBS(S)
R671	241 2379 974	Carbon film 910ohm 1/4W(NB)	RD14B2E911JNBS
R684	241 2379 974	Carbon film 910ohm 1/4W(NB)	RD14B2E911JNBS
R701,702	247 0007 945	Carbon chip 1kohm 1/10W	RM73B-102J
R703-706	247 0012 927	Carbon chip 100kohm 1/10W	RM73B-104J
R707,708	247 0005 989	Carbon chip 220ohm 1/10W	RM73B-221J
R709,710	247 0006 962	Carbon chip 470ohm 1/10W	RM73B-471J
R711-714	247 0012 927	Carbon chip 100kohm 1/10W	RM73B-104J
R715,716	247 0005 989	Carbon chip 220ohm 1/10W	RM73B-221J

1U-2950A P.SUPPLY-3 UNIT ASS'Y

Ref. No.	Part No.	Part Name	Remarks
R717,718	247 0007 945	Carbon chip 1kohm 1/10W	RM73B-102J
R719-722	247 0012 927	Carbon chip 100kohm 1/10W	RM73B-104J
R723,724	247 0005 989	Carbon chip 220ohm 1/10W	RM73B-221J
R725,726	247 0007 945	Carbon chip 1kohm 1/10W	RM73B-102J
R727-730	247 0012 927	Carbon chip 100kohm 1/10W	RM73B-104J
R731,732	247 0005 989	Carbon chip 220ohm 1/10W	RM73B-221J
R733,734	247 0011 944	Carbon chip 47kohm 1/10W	RM73B-473J
R735-740	247 0010 961	Carbon chip 22kohm 1/10W	RM73B-223J
R741-745	247 0013 984	Carbon chip 470kohm 1/10W	RM73B-474J
R751,752	247 0006 962	Carbon chip 470ohm 1/10W	RM73B-471J
R753,754	247 0015 966	Carbon chip 2.7Mohm 1/10W	RM73B-275J
R755,756	247 0006 962	Carbon chip 470ohm 1/10W	RM73B-471J
R757,758	247 0015 966	Carbon chip 2.7Mohm 1/10W	RM73B-275J
R759,760	247 0006 962	Carbon chip 470ohm 1/10W	RM73B-471J
R761,762	247 0015 966	Carbon chip 2.7Mohm 1/10W	RM73B-275J
R763,764	247 0006 962	Carbon chip 470ohm 1/10W	RM73B-471J
R765,766	247 0015 966	Carbon chip 2.7Mohm 1/10W	RM73B-275J
R767-772	247 0009 985	Carbon chip 10kohm 1/10W	RM73B-103J
R773	247 0005 989	Carbon chip 220ohm 1/10W	RM73B-221J
R774,775	247 0010 961	Carbon chip 22kohm 1/10W	RM73B-223J
R776,777	247 0006 962	Carbon chip 470ohm 1/10W	RM73B-471J
<b>CAPACITORS GROUP</b>			
C411,412	256 1034 979	Metalized 0.1µF/50V	CF93A1H104J
C413,414	254 4259 700	Electrolytic 2200µF/35V	CE04W1V222MC
C415-418	257 0012 966	Ceramic chip 0.01µF/50V	CK73F1H103Z
C419,420	254 4258 947	Electrolytic 47µF/35V	CE04W1V470M
C421,422	256 1034 979	Metalized 0.1µF/50V	CF93A1H104J
C423,424	254 4259 700	Electrolytic 2200µF/35V	CE04W1V222MC
C425-428	257 0012 966	Ceramic chip 0.01µF/50V	CK73F1H103Z
C429,430	254 4258 947	Electrolytic 47µF/35V	CE04W1V470M
C431	254 4260 948	Electrolytic 1µF/50V	CE04W1H010M
C451	257 0012 966	Ceramic chip 0.01µF/50V	CK73F1H103Z
C452	254 4260 948	Electrolytic 1µF/50V	CE04W1H010M
C453	257 0012 966	Ceramic chip 0.01µF/50V	CK73F1H103Z
C461	257 0014 935	Ceramic chip 0.1µF/25V	CK73F1E104Z
C462	254 4305 968	Electrolytic 1µF/50V	CE04W1H010M(SRE)
C471	254 4260 977	Electrolytic 4.7µF/50V	CE04W1H4R7M
C472,473	254 4260 948	Electrolytic 1µF/50V	CE04W1H010M
C474	254 4260 935	Electrolytic 0.47µF/50V	CE04W1HR47M
C478	257 0012 966	Ceramic chip 0.01µF/50V	CK73F1H103Z
C479,480	257 0007 900	Ceramic chip 1000pF/50V	CC73SL1H102J
C535-538	255 4201 968	Mylar film 470pF/50V	CQ93P1H471J
C539,540	254 4260 948	Electrolytic 1µF/50V	CE04W1H010M
C543,544	254 4260 980	Electrolytic 10µF/50V	CE04W1H100M
C547,548	255 4200 901	Mylar film 100pF/50V	CQ93P1H101J
C549,550	255 4200 985	Mylar film 220pF/50V	CQ93P1H221J
C601,602	257 0012 982	Ceramic chip 0.022µF/50V	CK73F1H223Z
C603-606	254 4254 909	Electrolytic 10µF/16V	CE04W1C100M
C608	257 0012 966	Ceramic chip 0.01µF/50V	CK73F1H103Z

Ref. No.	Part No.	Part Name	Remarks
C609,610	254 4260 948	Electrolytic 1µF/50V	CE04W1H010M
C611,612	254 4254 909	Electrolytic 10µF/16V	CE04W1C100M
C613-616	257 0004 961	Ceramic chip 100pF/50V	CC73SL1H101J
C619,620	257 0012 982	Ceramic chip 0.022µF/50V	CK73F1H223Z
C621-624	254 4254 909	Electrolytic 10µF/16V	CE04W1C100M
C626	257 0012 966	Ceramic chip 0.01µF/50V	CK73F1H103Z
C627,628	254 4260 948	Electrolytic 1µF/50V	CE04W1H010M
C629,630	254 4254 909	Electrolytic 10µF/16V	CE04W1C100M
C631-634	257 0004 961	Ceramic chip 100pF/50V	CC73SL1H101J
C637-640	257 0004 961	Ceramic chip 100pF/50V	CC73SL1H101J
C641-644	254 4260 948	Electrolytic 1µF/50V	CE04W1H010M
C645,646	254 4258 785	Electrolytic 470µF/35V	CE04W1V471MC
C647	254 4260 951	Electrolytic 2.2µF/50V	CE04W1H2R2M
C648	254 4252 927	Electrolytic 47µF/10V	CE04W1A470M
C649-652	254 4260 948	Electrolytic 1µF/50V	CE04W1H010M
C653,654	254 4254 909	Electrolytic 10µF/16V	CE04W1C100M
C655,656	257 0004 961	Ceramic chip 100pF/50V	CC73SL1H101J
C657,658	254 4254 909	Electrolytic 10µF/16V	CE04W1C100M
C659,660	253 1148 905	Ceramic 0.022µF/50V	CK45F1H223Z
C671	254 4260 948	Electrolytic 1µF/50V	CE04W1H010M
C682	254 4260 948	Electrolytic 1µF/50V	CE04W1H010M
C690	253 8014 702	Ceramic 0.01µF/400V(AC)	CK45F2GAC103MC
C691-694	254 4254 909	Electrolytic 10µF/16V	CE04W1C100M
C701,702	254 4254 909	Electrolytic 10µF/16V	CE04W1C100M
C703,704	257 0004 961	Ceramic chip 100pF/50V	CC73SL1H101J
C705,706	254 4254 909	Electrolytic 10µF/16V	CE04W1C100M
C707,708	257 0004 961	Ceramic chip 100pF/50V	CC73SL1H101J
C709,710	254 4254 909	Electrolytic 10µF/16V	CE04W1C100M
C711,712	257 0004 961	Ceramic chip 100pF/50V	CC73SL1H101J
C713,714	254 4254 909	Electrolytic 10µF/16V	CE04W1C100M
C715,716	257 0004 961	Ceramic chip 100pF/50V	CC73SL1H101J
C717	254 4260 948	Electrolytic 1µF/50V	CE04W1H010M
C718	257 0012 966	Ceramic chip 0.01µF/50V	CK73F1H103Z
C719	254 4260 948	Electrolytic 1µF/50V	CE04W1H010M
C720	257 0012 966	Ceramic chip 0.01µF/50V	CK73F1H103Z
C721	254 4260 948	Electrolytic 1µF/50V	CE04W1H010M
C724,725	254 4260 948	Electrolytic 1µF/50V	CE04W1H010M
C727-734	254 4254 909	Electrolytic 10µF/16V	CE04W1C100M
C751-758	257 0004 961	Ceramic chip 100pF/50V	CC73SL1H101J
C759	254 4260 948	Electrolytic 1µF/50V	CE04W1H010M
C760	257 0012 966	Ceramic chip 0.01µF/50V	CK73F1H103Z
C761	254 4260 948	Electrolytic 1µF/50V	CE04W1H010M
C762	257 0012 966	Ceramic chip 0.01µF/50V	CK73F1H103Z
C763,764	257 0012 982	Ceramic chip 0.022µF/50V	CK73F1H223Z
C766	254 4252 778	Electrolytic 1000µF/10V	CE04W1A102MC
C767	254 3055 905	Electrolytic 4.7µF/35V	CE04D1V4R7MBP

Ref. No.	Part No.	Part Name	Remarks	Q'ty
<b>OTHER PARTS GROUP</b>				
CN022	205 0606 025	2P wrapping terminal		1
CN044	205 0885 082	4P connector socket (TUC-P)		1
CN045	205 0355 046	4 P KR connector base (L)		2
CN049	205 1028 000	4P connector base (9176)		1
CN056	203 8207 077	5P KR-DA connector cord		1
CN058	205 0233 058	5P EH connector base		1
CN059	205 0985 034	5P connector socket (TKC-A)		1
CN059	205 0986 032	5P connector plug (TKC-A)		1
CN061	205 0942 019	6P connector socket(TUC-P)		1
CN081	205 0885 095	8P connector socket (TUC-P)		1
CN083	205 0885 095	8P connector socket (TUC-P)		1
CN084	205 0885 005	8P connector socket (TKC-A)		1
CN086	205 0885 095	8P connector socket (TUC-P)		1
CN093	205 0343 090	9 P connector base (KR-PH)		1
CN113	205 0885 068	11P connector socket (TUC-P)		1
CN131	205 0480 034	13P KR connector base (L)		1
CN133	205 0480 034	13P KR connector base (L)		1
CN142	205 0885 011	14P connector socket (TUC-P)		1
CN921	205 0581 001	2P VH connector base		1
CN931	205 0087 039	3 P wrapping terminal		1
CN932	203 5012 061	3P SAN-PH connector cord		1
CN933	205 0348 037	3P wrapping terminal		1
CN942	205 1028 000	4P connector base (9176)		1
F004,005	202 0040 909	Fuse clip		2
F004,005	206 1015 029	Fuse 1A T	Asia/Europe model	2
F004,005	206 1039 034	Fuse 1A	Taiwan model	2
F015,016	202 0040 909	Fuse clip		2
F015,016	206 1015 061	Fuse 2A	Asia/Europe model	2
F015,016	206 1039 063	Fuse 2.0A T	Taiwan model	2
JA701-704	204 8540 012	4P pin jack		4
JK501	204 8217 031	Headphone jack (BK(AU))		1
RL641	214 0188 000	Relay VS-12MBNR-SM2(TV-8)		1
RL671	214 0127 003	Relay (RY-12W)		1
RL682	214 0127 003	Relay (RY-12W)		1
SW690	212 1031 008	Power switch (TV-5)		1
	202 0040 909	Fuse clip		4
	513 2585 003	Fuse label	Asia/Europe model	2
	513 2585 032	Fuse label	Asia/Europe model	2

Ref. No.	Part No.	Part Name	Remarks
<b>SEMICONDUCTORS GROUP</b>			
IC401	268 0073 905	IC ICP-N15	IC protector
IC402	263 0793 002	IC NJM7806FA(S)	
IC801,802	263 0898 907	IC NJM5532MD	
IC901	263 0809 006	IC NJM7805FA(S)	
IC902	263 0554 005	IC NJM7905FA	
IC903	263 0793 002	IC NJM7806FA(S)	
IC904	263 0683 002	IC NJM7906FA	
IC905	263 0809 006	IC NJM7805FA(S)	
TR402	273 0384 900	Transistor 2SC2412K(S)	
TR471	269 0083 901	Transistor DTA114EK	
TR472	269 0082 902	Transistor DTC114EK	
TR473	273 0435 901	Transistor 2SC1740SLN(E)	
TR474	274 0120 002	Transistor 2SD1762(E/F)	
TR475	272 0131 901	Transistor 2SB1041(F)	
TR476	271 0238 908	Transistor 2SA1037K(S/R)	
TR477	274 0169 908	Transistor 2SD1292(R)	
TR478	273 0384 900	Transistor 2SC2412K(S)	
TR801-806	275 0061 902	Transistor 2SK184(GR/V)(BL)	
TR807	269 0083 901	Transistor DTA114EK	
TR808	269 0082 902	Transistor DTC114EK	
F004,005	202 0040 909	Fuse clip	
F004,005	206 1015 029	Fuse 1A T	Asia/Europe model
F004,005	206 1039 034	Fuse 1A	Taiwan model
F015,016	202 0040 909	Fuse clip	
F015,016	206 1015 061	Fuse 2A	Asia/Europe model
F015,016	206 1039 063	Fuse 2.0A T	Taiwan model
D401-406	276 0553 905	Diode 1SR35-200A	
D801-804	276 0432 903	Diode 1SS270A	
D901	276 0424 005	Diode 4D4842 (LC1)	
D902,903	276 0432 903	Diode 1SS270A	
D904-907	276 0548 910	Diode DSM1D2	
D908,909	276 0553 905	Diode 1SR35-200A	
ZD401	276 0644 911	Zener diode MTJZ7.5A	7.5V
ZD901	276 0645 978	Zener diode MTJZ3.6A	3.6V
ZD902,903	276 0644 937	Zener diode MTJZ9.1A	9.1V
<b>RESISTORS GROUP</b>			
R402	247 0009 901	Carbon chip 4.7kohm 1/10W	RM73B-472J
R404	247 0009 901	Carbon chip 4.7kohm 1/10W	RM73B-472J
R405	247 0009 985	Carbon chip 10kohm 1/10W	RM73B-103J
R406	247 0010 958	Carbon chip 20kohm 1/10W	RM73B-203J
R411	247 0012 927	Carbon chip 100kohm 1/10W	RM73B-104J
R412-414	247 0009 985	Carbon chip 10kohm 1/10W	RM73B-103J
R482	244 2043 940	Metal oxide 2.2kohm 1W	RS1483A22JN6S(S)

Ref. No.	Part No.	Part Name	Remarks	Ref. No.	Part No.	Part Name	Remarks
R801,802	247 0011 973	Carbon chip 62kohm 1/10W	RM73B-623J	C819,820	254 4260 935	Electrolytic 0.47μF/50V	CE04W1HR47M
R803,804	247 0007 987	Carbon chip 1.5kohm 1/10W	RM73B-152J	C823	254 4260 948	Electrolytic 1μF/50V	CE04W1H010M
R805,806	247 0011 973	Carbon chip 62kohm 1/10W	RM73B-623J	C824	254 4305 968	Electrolytic 1μF/16V	CE04W1H010M(SRE)
R807,808	247 0009 985	Carbon chip 10kohm 1/10W	RM73B-103J	C827	254 4254 938	Electrolytic 47μF/16V	CE04W1C470M
R809,810	247 0007 961	Carbon chip 1.2kohm 1/10W	RM73B-122J	C828	254 4299 964	Electrolytic 47μF/16V	CE04W1C470M(SRE)
R811,812	247 0005 989	Carbon chip 220ohm 1/10W	RM73B-221J	C829,830	255 4200 901	Mylar film 1000pF/50V	CQ93P1H101J
R-13,814	247 0009 972	Carbon chip 9.1kohm 1/10W	RM73B-912J	C831,832	255 1264 908	Mylar film 1000pF/50V	CQ93M1H102J(B)
R815,816	247 0008 902	Carbon chip 1.8kohm 1/10W	RM73B-182J	C833,834	256 1035 907	Metalized 0.18μF/50V	CF93A1H184J
R817,818	247 0002 924	Carbon chip 6.8ohm 1/10W	RM73B-6R8K	C835,836	254 4260 948	Electrolytic 1μF/50V	CE04W1H010M
R819,820	247 0005 976	Carbon chip 200ohm 1/10W	RM73B-201J	C839	255 1264 937	Mylar film 1800pF/50V	CQ93M1H182J(B)
R821,822	247 0004 906	Carbon chip 39ohm 1/10W	RM73B-390J	C840	255 1265 949	Mylar film 0.012μF/50V	CQ93M1H123J(B)
R823,824	247 0005 905	Carbon chip 100ohm 1/10W	RM73B-101J	C841	256 1034 966	Metalized 0.082μF/50V	CF93A1H823J
R825,826	247 0012 927	Carbon chip 100kohm 1/10W	RM73B-104J	C842	254 4260 935	Electrolytic 0.47μF/50V	CE04W1HR47M
R827,828	247 0011 973	Carbon chip 62kohm 1/10W	RM73B-623J	C854-856	254 4260 980	Electrolytic 10μF/50V	CE04W1H100M
R829,830	247 0007 987	Carbon chip 1.5kohm 1/10W	RM73B-152J	C857	254 4306 925	Electrolytic 10μF/50V	CE04W1H100M(SRE)
R831,832	247 0011 973	Carbon chip 62kohm 1/10W	RM73B-623J	C901,902	253 1146 907	Ceramic 0.01μF/50V	CK45F1H103Z
R833,834	247 0009 985	Carbon chip 10kohm 1/10W	RM73B-103J	C903,904	257 0012 966	Ceramic chip 0.01μF/50V	CK73F1H103Z
R835,836	247 0007 961	Carbon chip 1.2kohm 1/10W	RM73B-122J	C905	254 4363 706	Electrolytic 8200pF/25V	CE04W1E822MC
R837,838	247 0005 989	Carbon chip 220ohm 1/10W	RM73B-221J	C906	254 4256 787	Electrolytic 1000pF/25V	CE04W1E102MC
R839,840	247 0009 972	Carbon chip 9.1kohm 1/10W	RM73B-912J	C907	257 0012 966	Ceramic chip 0.01μF/50V	CK73F1H103Z
R841,842	247 0008 902	Carbon chip 1.8kohm 1/10W	RM73B-182J	C908,909	254 4258 947	Electrolytic 47μF/35V	CE04W1V470M
R843,844	247 0006 962	Carbon chip 470ohm 1/10W	RM73B-471J	C910,911	257 0012 966	Ceramic chip 0.01μF/50V	CK73F1H103Z
R845,846	247 0012 927	Carbon chip 100kohm 1/10W	RM73B-104J	C912,913	253 1146 907	Ceramic 0.01μF/50V	CK45F1H103Z
R847	247 0005 976	Carbon chip 200ohm 1/10W	RM73B-201J	C914,915	254 4257 702	Electrolytic 3300pF/25V	CE04W1E332MC
R848	247 0004 906	Carbon chip 39ohm 1/10W	RM73B-390J	C916-919	257 0012 966	Ceramic chip 0.01μF/50V	CK73F1H103Z
R849	247 0002 924	Carbon chip 6.8ohm 1/10W	RM73B-6R8K	C920,921	254 4258 947	Electrolytic 47μF/35V	CE04W1V470M
R851,852	247 0013 900	Carbon chip 220kohm 1/10W	RM73B-224J	C922	256 1034 979	Metalized 0.1μF/50V	CF93A1H104J
R901	241 2376 919	Carbon film 30ohm 1/4W(NB)	RD1482E300JNBS	C923,924	254 4261 743	Electrolytic 330μF/50V	CE04W1H331M
R903	241 2375 907	Carbon film 10ohm 1/4W(NB)	RD1482E100JNBS	C925,926	254 4260 948	Electrolytic 1μF/50V	CE04W1H010M
R905	241 2387 940	Carbon film 4.7ohm 1/4W(NB)	RD1482E4R7JNBS	C927	257 0012 966	Ceramic chip 0.01μF/50V	CK73F1H103Z
VR801	211 0860 015	Variable resistor 5kohm		C928	254 4254 909	Electrolytic 10μF/16V	CE04W1C100M
VR802	211 0860 002	Variable resistor 30kohm		C929-935	257 0014 935	Ceramic chip 0.1μF/25V	CK73F1E104Z
				C936,937	257 0008 983	Ceramic chip 1000pF/50V	CK73B1H102K
				C939	257 0008 983	Ceramic chip 1000pF/50V	CK73B1H102K

## CAPACITORS GROUP

Ref. No.	Part No.	Part Name	Remarks
C402	254 4256 790	Electrolytic 2200μF/25V	CE04W1E222MC
C403	257 0012 966	Ceramic chip 0.01μF/50V	CK73F1H103Z
C404	254 4254 909	Electrolytic 10μF/16V	CE04W1C100M
C405	257 0012 966	Ceramic chip 0.01μF/50V	CK73F1H103Z
C406,407	253 1146 907	Ceramic 0.01μF/50V	CK45F1H103Z
C408	254 4260 948	Electrolytic 1μF/50V	CE04W1H010M
C410	254 4260 948	Electrolytic 1μF/50V	CE04W1H010M
C801-804	254 4260 948	Electrolytic 1μF/50V	CE04W1H010M
C805,806	255 4200 901	Mylar film 100pF/50V	CQ93P1H101J
C807,808	255 1264 906	Mylar film 1000pF/50V	CQ93M1H102J(B)
C809,810	256 1035 907	Metalized 0.18μF/50V	CF93A1H184J
C811,812	254 4260 948	Electrolytic 1μF/50V	CE04W1H010M
C813,814	255 1264 937	Mylar film 1800pF/50V	CQ93M1H182J(B)
C815,816	255 1265 949	Mylar film 0.012μF/50V	CQ93M1H123J(B)
C817,818	256 1034 966	Metalized 0.082μF/50V	CF93A1H823J

## OTHER PARTS GROUP

Ref. No.	Part No.	Part Name	Remarks	Q'ty
CN032	205 0653 036	3P VH connector base		1
CN036	205 0233 032	3 P EH connector base		1
CN038	205 0233 032	3 P EH connector base		1
CN042	205 0884 083	4P connector base (TUC-P)		1
CN044	205 0884 083	4P connector base (TUC-P)		1
CN046	205 0884 083	4P connector base (TUC-P)		1
CN047	205 0884 083	4P connector base (TUC-P)		1
CN053	205 0343 058	5P EH connector base		1
CN054	205 0233 058	5P EH connector base		1
CN057	205 0343 058	5P EH connector base		1
CN061	205 0943 018	6P connector base (TUC-P)		1
CN063	205 0943 018	6P connector base (TUC-P)		1
CN064	205 0943 018	6P connector base (TUC-P)		1
CN081	205 0884 096	8P connector base (TUC-P)		1
CN082	205 0884 096	8P connector base (TUC-P)		1
CN083	205 0884 096	8P connector base (TUC-P)		1

## 1U-2951A S-VIDEO UNIT ASS'Y

Ref. No.	Part No.	Part Name	Remarks	Q'ty	Ref. No.	Part No.	Part Name	Remarks
CN086	205 0884 096	8P connector base (TUC-P)		1	SEMICONDUCTORS GROUP			
CN089	205 0884 096	8P connector base (TUC-P)		1	IC101	262 2302 906	IC M66310FP-200C	
CN091	205 0884 038	8P connector base (TUC-P)		1	IC102	262 2035 008	IC MSC1937-03RS	
CN099	205 0884 038	8P connector base (TUC-P)		1	IC301-303	263 1018 003	IC MC14577CP	
CN101	205 0884 054	10P connector base (TUC-P)		1	IC304,305	262 1108 004	IC TC4051BP	
CN101	205 0885 053	10P connector socket (TUC-P)		1	IC306,307	262 0276 005	IC HD14066BP	
CN108	205 0884 054	10P connector base (TUC-P)		1	IC308	263 1018 003	IC MC14577CP	
CN111	205 0884 067	11P connector base (TUC-P)		1	IC401,402	263 1018 003	IC MC14577CP	
CN113	205 0884 067	11P connector base (TUC-P)		1	IC403,404	262 1108 004	IC TC4051BP	
CN121	205 0884 070	12P connector base (TUC-P)		1	IC405	262 0276 005	IC HD14066BP	
CN123,124	205 0884 070	12P connector base (TUC-P)		1	IC406	263 1018 003	IC MC14577CP	
CN124	205 0885 079	12P connector socket (TUC-P)		1	IC407,408	262 1108 004	IC TC4051BP	
CN132	205 0943 005	13P connector base (TUC-P)		1	IC409	263 1018 003	IC MC14577CP	
CN142	205 0884 012	14P connector base (TUC-P)		1	IC411	262 0276 005	IC HD14066BP	
CN143	205 1030 014	14P connector socket (TRC-X)		1	IC412	263 1018 003	IC MC14577CP	
CN149	205 0884 012	14P connector base (TUC-P)		1	IC413	262 0267 005	IC MC74HC4053N	
CN151	205 0375 055	15P connector base (KR-PH)		1	IC414	262 2311 007	IC M35015-***SP	
CN261,262	205 1030 001	26P connector socket (TRC-X)		2	IC415	263 0682 003	IC NJM2229S	
F011-014	202 0040 909	Fuse clip		8	IC416	263 1018 003	IC MC14577CP	
F011,012	206 1015 061	Fuse 2A	Asia/Europe model	2	TR101-103	272 0131 901	Transistor 2SB1041(R)	
F011,012	206 1039 063	Fuse 2.0A T	Taiwan model	2	TR104-113	269 0082 902	Transistor DTC114EK	
F013,014	206 1015 087	Fuse 4A	Asia/Europe model	2	TR401	273 0384 900	Transistor 2SC2412K(S)	
F013,014	206 1039 092	Fuse 4.0A T	Taiwan model	2	TR402	273 0198 918	Transistor 2SC1815(BL)	
AS001	417 0253 026	Radiator		1	TR403	271 0238 908	Transistor 2SA1037K(S/R)	
AS002	471 3304 015	Screw 3X8 CBS-Z		1	TR404	273 0384 900	Transistor 2SC2412K(S)	
AS003	417 0253 026	Radiator		1	TR405	269 0082 902	Transistor DTC114EK	
AS004	471 3304 015	Screw 3X8 CBS-Z		1	D403-406	276 0432 903	Diode 1SS270A	
	513 2585 032	Fuse label	Asia/Europe model	2	D407-409	276 0432 903	Diode 1SS270A	
	513 2585 058	Fuse label	Asia/Europe model	2	ZD101,102	276 0637 902	Zener diode MTZJ6.2A	6.2V
					LD101-104	393 9434 906	LED SEL1210S	Red
					LD105-108	393 9434 906	LED SEL1210S	Red
					LD109,110	393 9491 004	LED SML1216W	Red/Green
					LD111	393 9434 906	LED SEL1210S	Red
					LD114	393 9549 008	LED LB-303VA	Red
					RESISTORS GROUP			
					R121-123	247 0009 985	Carbon chip 10kohm 1/10W	RM73B-103J
					R124-126	247 0007 945	Carbon chip 1kohm 1/10W	RM73B-102J
					R127,128	247 0009 985	Carbon chip 10kohm 1/10W	RM73B-103J
					R129-162	247 0011 944	Carbon chip 47kohm 1/10W	RM73B-473J
					R163,164	247 0009 901	Carbon chip 4.7kohm 1/10W	RM73B-472J
					R165-169	247 0007 945	Carbon chip 1kohm 1/10W	RM73B-102J
					R170	247 0005 976	Carbon chip 200ohm 1/10W	RM73B-201J
					R171	247 0006 917	Carbon chip 300ohm 1/10W	RM73B-301J
					R172	247 0006 933	Carbon chip 360ohm 1/10W	RM73B-361J



Ref. No.	Part No.	Part Name	Remarks
R173	247 0007 945	Carbon chip 1kohm 1/10W	RM73B-102J
R174	247 0008 957	Carbon chip 3kohm 1/10W	RM73B-302J
R175	247 0005 976	Carbon chip 200ohm 1/10W	RM73B-201J
R176	247 0006 917	Carbon chip 300ohm 1/10W	RM73B-301J
R177	247 0006 933	Carbon chip 360ohm 1/10W	RM73B-361J
R178	247 0007 945	Carbon chip 1kohm 1/10W	RM73B-102J
R179	247 0008 957	Carbon chip 3kohm 1/10W	RM73B-302J
R180	247 0005 976	Carbon chip 200ohm 1/10W	RM73B-201J
R181	247 0006 917	Carbon chip 300ohm 1/10W	RM73B-301J
R182	247 0006 933	Carbon chip 360ohm 1/10W	RM73B-361J
R183	247 0007 945	Carbon chip 1kohm 1/10W	RM73B-102J
R184	247 0008 957	Carbon chip 3kohm 1/10W	RM73B-302J
R185	247 0005 976	Carbon chip 200ohm 1/10W	RM73B-201J
R186	247 0006 917	Carbon chip 300ohm 1/10W	RM73B-301J
R187	247 0006 933	Carbon chip 360ohm 1/10W	RM73B-361J
R188	247 0007 945	Carbon chip 1kohm 1/10W	RM73B-102J
R189	247 0008 957	Carbon chip 3kohm 1/10W	RM73B-302J
R190	247 0005 976	Carbon chip 200ohm 1/10W	RM73B-201J
R191	247 0006 917	Carbon chip 300ohm 1/10W	RM73B-301J
R192	247 0006 933	Carbon chip 360ohm 1/10W	RM73B-361J
R195	247 0009 901	Carbon chip 4.7kohm 1/10W	RM73B-472J
R196,197	247 0011 944	Carbon chip 47kohm 1/10W	RM73B-473J
R198,199	247 0005 905	Carbon chip 100ohm 1/10W	RM73B-101J
R307	247 0010 961	Carbon chip 22kohm 1/10W	RM73B-223J
R309	247 0010 961	Carbon chip 22kohm 1/10W	RM73B-223J
R311	247 0010 961	Carbon chip 22kohm 1/10W	RM73B-223J
R313	247 0010 961	Carbon chip 22kohm 1/10W	RM73B-223J
R314	247 0009 985	Carbon chip 10kohm 1/10W	RM73B-103J
R315	247 0005 905	Carbon chip 100ohm 1/10W	RM73B-101J
R316	247 0009 985	Carbon chip 10kohm 1/10W	RM73B-103J
R317	247 0005 905	Carbon chip 100ohm 1/10W	RM73B-101J
R318	247 0009 985	Carbon chip 10kohm 1/10W	RM73B-103J
R319	247 0010 958	Carbon chip 20kohm 1/10W	RM73B-203J
R320	247 0009 985	Carbon chip 10kohm 1/10W	RM73B-103J
R321	247 0005 905	Carbon chip 100ohm 1/10W	RM73B-101J
R322	247 0009 985	Carbon chip 10kohm 1/10W	RM73B-103J
R323	247 0005 905	Carbon chip 100ohm 1/10W	RM73B-101J
R324	247 0005 905	Carbon chip 100ohm 1/10W	RM73B-101J
R325	247 0009 985	Carbon chip 10kohm 1/10W	RM73B-103J
R326	247 0008 975	Carbon chip 510ohm 1/10W	RM73B-511J
R327	247 0006 988	Carbon chip 560ohm 1/10W	RM73B-561J
R328	247 0005 905	Carbon chip 100ohm 1/10W	RM73B-101J
R329	247 0009 985	Carbon chip 10kohm 1/10W	RM73B-103J
R330	247 0008 975	Carbon chip 510ohm 1/10W	RM73B-511J
R331	247 0006 991	Carbon chip 620ohm 1/10W	RM73B-621J
R332	247 0005 905	Carbon chip 100ohm 1/10W	RM73B-101J
R333	247 0009 985	Carbon chip 10kohm 1/10W	RM73B-103J
R334	247 0005 905	Carbon chip 100ohm 1/10W	RM73B-101J
R411	247 0010 961	Carbon chip 22kohm 1/10W	RM73B-223J
R413	247 0010 961	Carbon chip 22kohm 1/10W	RM73B-223J

Ref. No.	Part No.	Part Name	Remarks
R415	247 0010 961	Carbon chip 22kohm 1/10W	RM73B-223J
R417	247 0010 961	Carbon chip 22kohm 1/10W	RM73B-223J
R419	247 0005 905	Carbon chip 100ohm 1/10W	RM73B-101J
R420	247 0009 985	Carbon chip 10kohm 1/10W	RM73B-103J
R421	247 0005 905	Carbon chip 100ohm 1/10W	RM73B-101J
R422	247 0009 985	Carbon chip 10kohm 1/10W	RM73B-103J
R423	247 0010 961	Carbon chip 22kohm 1/10W	RM73B-223J
R425	247 0010 961	Carbon chip 22kohm 1/10W	RM73B-223J
R427	247 0005 905	Carbon chip 100ohm 1/10W	RM73B-101J
R428	247 0009 985	Carbon chip 10kohm 1/10W	RM73B-103J
R429	247 0002 966	Carbon chip 10ohm 1/10W	RM73B-100J
R431	247 0005 905	Carbon chip 100ohm 1/10W	RM73B-101J
R432	247 0009 985	Carbon chip 10kohm 1/10W	RM73B-103J
R433	247 0005 905	Carbon chip 100ohm 1/10W	RM73B-101J
R434	247 0009 985	Carbon chip 10kohm 1/10W	RM73B-103J
R435	247 0008 975	Carbon chip 510ohm 1/10W	RM73B-511J
R436	247 0006 988	Carbon chip 560ohm 1/10W	RM73B-561J
R437	247 0006 975	Carbon chip 510ohm 1/10W	RM73B-511J
R438	247 0006 988	Carbon chip 560ohm 1/10W	RM73B-561J
R439	247 0009 985	Carbon chip 10kohm 1/10W	RM73B-103J
R440	247 0005 905	Carbon chip 100ohm 1/10W	RM73B-101J
R441,442	247 0009 985	Carbon chip 10kohm 1/10W	RM73B-103J
R443	247 0005 905	Carbon chip 100ohm 1/10W	RM73B-101J
R444	247 0009 985	Carbon chip 10kohm 1/10W	RM73B-103J
R445,446	247 0005 905	Carbon chip 100ohm 1/10W	RM73B-101J
R447	247 0009 985	Carbon chip 10kohm 1/10W	RM73B-103J
R448	247 0006 975	Carbon chip 510ohm 1/10W	RM73B-511J
R449	247 0006 988	Carbon chip 560ohm 1/10W	RM73B-561J
R450	247 0005 905	Carbon chip 100ohm 1/10W	RM73B-101J
R451	247 0009 985	Carbon chip 10kohm 1/10W	RM73B-103J
R452	247 0008 975	Carbon chip 510ohm 1/10W	RM73B-511J
R453	247 0006 988	Carbon chip 560ohm 1/10W	RM73B-561J
R454	247 0010 958	Carbon chip 20kohm 1/10W	RM73B-203J
R456	247 0009 985	Carbon chip 10kohm 1/10W	RM73B-103J
R457	247 0005 905	Carbon chip 100ohm 1/10W	RM73B-101J
R458,459	247 0009 985	Carbon chip 10kohm 1/10W	RM73B-103J
R460	247 0009 930	Carbon chip 6.2kohm 1/10W	RM73B-622J
R461	247 0005 976	Carbon chip 200ohm 1/10W	RM73B-201J
R462	241 2387 908	Carbon film 1ohm 1/4W(NB)	RD1482E010UNBS
R463	247 0007 945	Carbon chip 1kohm 1/10W	RM73B-102J
R464	241 2387 908	Carbon film 1ohm 1/4W(NB)	RD1482E010UNBS
R465	247 0002 966	Carbon chip 10ohm 1/10W	RM73B-100J
R466	247 0007 945	Carbon chip 1kohm 1/10W	RM73B-102J
R467	247 0013 984	Carbon chip 470kohm 1/10W	RM73B-474J
R468	247 0006 946	Carbon chip 390ohm 1/10W	RM73B-391J
R469	247 0007 987	Carbon chip 1.5kohm 1/10W	RM73B-152J
R470	247 0009 985	Carbon chip 10kohm 1/10W	RM73B-103J
R471	247 0011 957	Carbon chip 51kohm 1/10W	RM73B-513J
R472	247 0007 961	Carbon chip 1.2kohm 1/10W	RM73B-122J
R473	247 0009 969	Carbon chip 8.2kohm 1/10W	RM73B-822J
R474	247 0011 944	Carbon chip 47kohm 1/10W	RM73B-473J
R475	247 0005 989	Carbon chip 220ohm 1/10W	RM73B-221J

Ref. No.	Part No.	Part Name	Remarks
R476	247 0009 969	Carbon chip 8.2kohm 1/10W	RM73B-822J
R477	247 0011 944	Carbon chip 47kohm 1/10W	RM73B-473J
R478	247 0010 961	Carbon chip 22kohm 1/10W	RM73B-223J
R479,480	247 0009 901	Carbon chip 4.7kohm 1/10W	RM73B-472J
R481	247 0007 945	Carbon chip 1kohm 1/10W	RM73B-102J
R482	247 0008 915	Carbon chip 2kohm 1/10W	RM73B-202J
R483	247 0009 958	Carbon chip 7.5kohm 1/10W	RM73B-752J
R484	247 0011 902	Carbon chip 33kohm 1/10W	RM73B-333J
R485	247 0007 945	Carbon chip 1kohm 1/10W	RM73B-102J
R486	247 0008 902	Carbon chip 1.3kohm 1/10W	RM73B-182J
R488	247 0011 944	Carbon chip 47kohm 1/10W	RM73B-473J
R489	247 0008 915	Carbon chip 2kohm 1/10W	RM73B-202J
R491,492	247 0018 905	Carbon chip 0ohm 1/10W	RM73B-0R0K
<b>CAPACITORS GROUP</b>			
C101	254 4252 969	Electrolytic 470µF/10V	CE04W1A471M
C102	257 0014 935	Ceramic chip 0.1µF/25V	CK73F1E104Z
C103	254 4261 921	Electrolytic 100µF/50V	CE04W1H101M
C104	257 0010 900	Ceramic chip 0.01µF/50V	CK73F1H103K
C105	254 4250 945	Electrolytic 330µF6.3V	CE04W0J331M
C106	257 0004 961	Ceramic chip 100pF/50V	CC73SL1H101J
C107	257 0008 983	Ceramic chip 1000pF/50V	CK73B1H102K
C109,110	257 0010 900	Ceramic chip 0.01µF/50V	CK73B1H103K
C301-303	254 4260 948	Electrolytic 1µF/50V	CE04W1H010M
C304	257 0014 935	Ceramic chip 0.1µF/25V	CK73F1E104Z
C305-310	254 4254 938	Electrolytic 47µF/16V	CE04W1C470M
C311-316	257 0012 966	Ceramic chip 0.01µF/50V	CK73F1H103Z
C317,318	254 4254 938	Electrolytic 47µF/16V	CE04W1C470M
C319,320	257 0012 966	Ceramic chip 0.01µF/50V	CK73F1H103Z
C321	254 4252 930	Electrolytic 100µF/10V	CE04W1A101M
C323	254 4252 930	Electrolytic 100µF/10V	CE04W1A101M
C325-327	257 0014 935	Ceramic chip 0.1µF/25V	CK73F1E104Z
C401,402	257 0014 935	Ceramic chip 0.1µF/25V	CK73F1E104Z
C403	254 4260 948	Electrolytic 1µF/50V	CE04W1H010M
C404,405	254 4254 938	Electrolytic 47µF/16V	CE04W1C470M
C406	254 4252 930	Electrolytic 100µF/10V	CE04W1A101M
C407,408	254 4254 938	Electrolytic 47µF/16V	CE04W1C470M
C409-412	257 0012 966	Ceramic chip 0.01µF/50V	CK73F1H103Z
C413	254 4252 930	Electrolytic 100µF/10V	CE04W1A101M
C415,416	257 0012 966	Ceramic chip 0.01µF/50V	CK73F1H103Z
C417	254 4254 938	Electrolytic 47µF/16V	CE04W1C470M
C418	254 4252 930	Electrolytic 100µF/10V	CE04W1A101M
C420	254 4254 938	Electrolytic 47µF/16V	CE04W1C470M
C421,422	257 0012 966	Ceramic chip 0.01µF/50V	CK73F1H103Z
C423,434	254 4254 938	Electrolytic 47µF/16V	CE04W1C470M
C425,426	257 0012 966	Ceramic chip 0.01µF/50V	CK73F1H103Z
C429	254 4254 938	Electrolytic 47µF/16V	CE04W1C470M
C430	254 4252 930	Electrolytic 100µF/10V	CE04W1A101M
C432	254 4254 938	Electrolytic 47µF/16V	CE04W1C470M
C433,434	257 0012 966	Ceramic chip 0.01µF/50V	CK73F1H103Z

Ref. No.	Part No.	Part Name	Remarks
C435	254 4252 930	Electrolytic 100µF/10V	CE04W1A101M
C437,438	254 4254 909	Electrolytic 10µF/16V	CE04W1C100M
C439	254 4254 938	Electrolytic 47µF/16V	CE04W1C470M
C440	254 4252 930	Electrolytic 100µF/10V	CE04W1A101M
C441	254 4254 938	Electrolytic 47µF/16V	CE04W1C470M
C442,443	256 1034 937	Metallized 0.047µF/50V	CF93A1H473J
C444	257 0009 940	Ceramic chip 3300pF/50V	CK73B1H332K
C445	257 0008 941	Ceramic chip 470pF/50V	CK73B1H471K
C446	254 4260 948	Electrolytic 1µF/50V	CE04W1H010M
C447	256 1034 953	Metallized 0.068µF/50V	CF93A1H683J
C448	254 4260 948	Electrolytic 1µF/50V	CE04W1H010M
C449	257 0005 902	Ceramic chip 150pF/50V	CC73SL1H151J
C450	255 1264 911	Mylar film 1200pF/50V	CQ83M1H122J(B)
C451	255 1265 978	Mylar film 0.022µF/50V	CQ93M1H223J(B)
C452	257 0004 961	Ceramic chip 100pF/50V	CC73SL1H101J
C453	254 4260 977	Electrolytic 4.7µF/50V	CE04W1H477M
C454	254 4254 909	Electrolytic 10µF/16V	CE04W1C100M
C455	254 4254 938	Electrolytic 47µF/16V	CE04W1C470M
C456	257 0012 966	Ceramic chip 0.01µF/50V	CK73F1H103Z
C457	254 4254 938	Electrolytic 47µF/16V	CE04W1C470M
C458	257 0012 966	Ceramic chip 0.01µF/50V	CK73F1H103Z
C459-461	257 0003 946	Ceramic chip 33pF/50V	CC73SL1H330J
C462	257 0002 947	Ceramic chip 12pF/50V	CC73SL1H120J
C463	257 0002 921	Ceramic chip 10pF/50V	CC73SL1H100J
C464	257 0009 940	Ceramic chip 3300pF/50V	CK73B1H332K
C465	254 4254 909	Electrolytic 10µF/16V	CE04W1C100M
C466	257 0012 966	Ceramic chip 0.01µF/50V	CK73F1H103Z
C467	254 4252 930	Electrolytic 100µF/10V	CE04W1A101M
C468	255 1264 908	Mylar film 1000pF/50V	CQ83M1H102J(B)
C469	254 4260 948	Electrolytic 1µF/50V	CE04W1H010M
C470	256 1034 937	Metallized 0.047µF/50V	CF93A1H473J
C471,472	257 0014 935	Ceramic chip 0.1µF/25V	CK73F1E104Z
<b>OTHER PARTS GROUP</b>			
FL101	393 4158 001	FLD FIP16FM7R	1
CN046,047	205 0885 082	4P connector socket (TUC-P)	2
CN053	205 0355 059	5P KR connector base (L)	1
CN056	205 0343 058	5P connector base(KR-PH)	1
CN064	205 0942 019	6P connector socket (TUC-P)	1
CN082	205 0885 095	8P connector socket (TUC-P)	1
CN094	203 6218 055		

## 1U-2952E POWER AMP.-1 UNIT ASS'Y

Ref. No.	Part No.	Part Name	Remarks	Q'ty
L101	235 0060 989	Inductor 120μH		1
L401	235 0060 963	Inductor 15μH		1
S101-127	212 5604 910	Tact switch		27
S128	212 0373 000	Rotary encoder EC16B		1
XL401	399 0105 009	Resonator CSB503F2		1
XL402	399 0153 006	Crystal 14.32MHz-12PF		1
SEMICONDUCTORS GROUP				
TR405,406	273 0235 923	Transistor 2SC1841(E/F)		
TR411,412	273 0235 923	Transistor 2SC1841(E/F)		
TR415	273 0235 923	Transistor 2SC1841(E/F)		
TR421-425	273 0388 906	Transistor 2SC1740S(E)		
TR427	273 0388 906	Transistor 2SC1740S(E)		
TR428	269 0040 902	Transistor DTC144ES(47K-47K)		
TR429	273 0388 906	Transistor 2SC1740S(E)		
TR430	273 0303 910	Transistor 2SC1740S(S)		
TR431	271 0192 905	Transistor 2SA933S(S)		
TR432	273 0303 910	Transistor 2SC1740S(S)		
TR433	271 0131 924	Transistor 2SA988(E/F)		
TR435	272 0107 919	Transistor 2SB1328(P/Q)		
TR521	273 0303 910	Transistor 2SC1740S(S)		
TR522	271 0192 905	Transistor 2SA933S(S)		
TR523	273 0303 910	Transistor 2SC1740S(S)		
TR601,602	273 0388 906	Transistor 2SC1740S(E)		
TR603	271 0192 905	Transistor 2SA933S(S)		
D401-405	276 0432 903	Diode 1SS270A		
D417	276 0432 903	Diode 1SS270A		
D419-422	276 0432 903	Diode 1SS270A		
D450	276 0371 006	Diode S10VB20F9		
D601	276 0432 903	Diode 1SS270A		
RESISTORS GROUP				
R405-412	244 2043 982	Metal oxide 0.22ohm 1W	RS14B3AR22JNBS(S)	
R413,414	244 2051 987	Metal oxide 4.7ohm 1W	RS14B3AMR7JNBS(S)	
R415-418	241 2380 950	Carbon film 2kohm 1/4W(NB)	RD14B2E202JNBS	
R425,426	244 2043 985	Metal oxide 20ohm 1W	RS14B3A200JNBS(S)	
R433-440	244 2043 982	Metal oxide 0.22ohm 1W	RS14B3AR22JNBS(S)	
R441,442	244 2051 987	Metal oxide 4.7ohm 1W	RS14B3AMR7JNBS(S)	
R443-446	241 2380 950	Carbon film 2kohm 1/4W(NB)	RD14B2E202JNBS	
R453,454	244 2043 985	Metal oxide 20ohm 1W	RS14B3A200JNBS(S)	
R458-462	244 2043 982	Metal oxide 0.22ohm 1W	RS14B3AR22JNBS(S)	
R463	244 2051 987	Metal oxide 4.7ohm 1W	RS14B3AMR7JNBS(S)	
R464,465	241 2380 950	Carbon film 2kohm 1/4W(NB)	RD14B2E202JNBS	
R469	244 2043 985	Metal oxide 20ohm 1W	RS14B3A200JNBS(S)	
R471-478	241 2387 908	Carbon film 1ohm 1/4W(NB)	RD14B2E010JNBS	
R479-483	244 2050 933	Metal oxide 180ohm 1W	RS14B3A181JNBS(S)	
R513,514	241 2387 908	Carbon film 1ohm 1/4W(NB)	RD14B2E010JNBS	
R525-529	244 2043 985	Metal oxide 20ohm 1W	RS14B3A200JNBS(S)	
R531	241 2387 940	Carbon film 4.7ohm 1/4W(NB)	RD14B2E47JNBS	
R532	241 2376 964	Carbon film 47ohm 1/4W(NB)	RD14B2E470JNBS	
R602	241 2375 978	Carbon film 20ohm 1/4W(NB)	RD14B2E200JNBS	

Ref. No.	Part No.	Part Name	Remarks	Q'ty
CAPACITORS GROUP				
C401,402	256 1042 974	Metalized 0.022μF/250V	CF93A2E223K	
C403,404	253 1146 907	Ceramic 0.01μF/50V	CK45F1H103Z	
C405-408	254 4263 987	Electrolytic 10μF/100V	CE04W2A100M	
C409,410	256 1042 903	Metalized 0.1μF/250V	CF93A2E104K	
C411,412	256 1042 974	Metalized 0.022μF/250V	CF93A2E223K	
C413,414	253 1146 907	Ceramic 0.01μF/50V	CK45F1H103Z	
C415-418	254 4263 987	Electrolytic 10μF/100V	CE04W2A100M	
C419,420	256 1042 903	Metalized 0.1μF/250V	CF93A2E104K	
C421	256 1042 974	Metalized 0.022μF/250V	CF93A2E223K	
C422	253 1146 907	Ceramic 0.01μF/50V	CK45F1H103Z	
C423,424	254 4263 987	Electrolytic 10μF/100V	CE04W2A100M	
C425	256 1042 903	Metalized 0.1μF/250V	CF93A2E104K	
C429	254 4254 938	Electrolytic 47μF/16V	CE04W1C470M	
C430	253 9039 906	BC Ceramic cap. 0.1μF/25V	CK45=1E104Z	
C431	254 4254 938	Electrolytic 47μF/16V	CE04W1C470M	
C432	253 9039 906	BC Ceramic cap. 0.1μF/25V	CK45=1E104Z	
C433	254 4250 945	Electrolytic 330μF/6.3V	CE04W0J331M	
C434	253 1181 904	Ceramic 0.01μF/50V	CK45F1H103Z	
C441	254 4264 025	Electrolytic 100μF/100V	CE04W2A101M	
C450,451	256 1042 903	Metalized 0.1μF/250V	CF93A2E104K	
C452,453	254 6208 005	Electrolytic 15000μF/71V	CE68W=153M(DL)	
C454-456	256 1042 903	Metalized 0.1μF/250V	CF93A2E104K	
C460,461	255 1265 936	Mylar film 0.01μF/50V	C093M1H103J(B)	
C463-469	255 1265 936	Mylar film 0.01μF/50V	C093M1H103J(B)	
C499	254 4260 948	Electrolytic 1μF/50V	CE04W1H010M	
C509,510	254 4260 980	Electrolytic 10μF/50V	CE04W1H100M	
C519,520	254 4260 980	Electrolytic 10μF/50V	CE04W1H100M	
C521	253 9039 906	BC Ceramic cap. 0.1μF/25V	CK45=1E104Z	
C525	254 4250 945	Electrolytic 330μF/6.3V	CE04W0J331M	
C525	254 4260 980	Electrolytic 10μF/50V	CE04W1H100M	
C601	253 8014 702	Ceramic 0.01μF/400V(AC)	CK45F2GAC103MC	
C602	256 1034 979	Metalized 0.1μF/50V	CF93A1H104J	
C603	254 4260 948	Electrolytic 1μF/50V	CE04W1H010M	
OTHER PARTS GROUP				
CN021	205 0442 001	2P wrapping terminal		1
CN024	205 0606 025	2P wrapping terminal		1
CN025	205 0581 001	2P VH connector base		1
CN029	205 0581 001	2P VH connector base		1
CN034	205 0087 039	3 P wrapping terminal		1
CN036,037	205 0087 039	3 P wrapping terminal		2
CN041	205 0666 049	4P connector base(9130)		5
CN048	205 0581 030	4P VH connector base		1
CN051	205 0666 052	5P connector base(9130)		5
CN057	205 0343 058	5P connector base(KR-PH)		1
CN066	205 0915 062	6P BB connector		10
CN072	205 0343 074	7P connector base(KR-PH)		1
CN133	205 0375 039	13P connector base(KR-PH)		1
CN932	205 0343 032	3P connector base(KR-PH)		1
F001	206 1036 008	Fuse 6.3A	Asia/Europe model	1
F001	206 1039 063	Fuse 2.0A T	Taiwan model	1
F002	206 1051 012	Fuse 15A	Taiwan model	1
F003	206 1036 011	Fuse 6.3A	Asia/Europe model	1
F006	206 1015 032	Fuse 2.5A	Asia/Europe model	1
F008	206 1046 014	Fuse 8A	Taiwan model	1
JK801,802	205 1027 001	8P SP terminal (V-1)		2
L401-405	235 0068 004	Inductor 1mH		5
RL401-405	214 0154 005	Relay(VB24SMBU)		5
RL601	214 0188 000	Relay VS-12MBNR-SM2(TV-9)		1
T601	233 6074 009	Power trans. (Mini) -ES	Asia/Europe model	1
T601	233 5818 004	Power trans. (Mini) -EU	Taiwan model	1
TH601	279 0034 025	Posistor PTH9M048F222TS2F333		1
TP401-405	205 0154 030	3P NH connector base		5
W412-415	203 0641 071	1P contact Ass'y		4
W417	203 0641 055	1P contact Ass'y		1
W418	203 0641 042	1P contact Ass'y		1
W419	203 0641 068	1P contact Ass'y		1
W451	203 0641 084	1P contact Ass'y		1
W452	203 0641 071	1P contact Ass'y		1
W453	203 0641 084	1P contact Ass'y		1
W701	203 0608 085	1P SIN cord Ass'y		1
W702	203 0608 098	1P SIN		1
	202 0040 909	Fuse clip		6
	279 0034 054	Posistor PTH9M048C222TS2F333	TH401	1
	415 0309 026	P.V.C. tube (L=20)		4
	412 4185 102	Bus bar		6
	205 1034 007	M3 Screw terminal		1
	203 0411 010	Connecting cord Ass'y		1
	203 0411 023	Connecting cord Ass'y		1
	203 0411 036	Connecting cord Ass'y		1
	203 0411 049	Connecting cord Ass'y		1
	203 0411 052	Connecting cord Ass'y		1
	513 2585 090	Fuse label	Asia/Europe model	1
	513 2585 074	Fuse label	Asia/Europe model	1
	513 2654 002	Fuse label	Asia/Europe model	1
	513 2654 015	Fuse label	Taiwan model	1
	EP- 5870	Fuse holder	Taiwan model	1

## 1U-2953A DSP UNIT ASS'Y

Ref. No.	Part No.	Part Name	Remarks	Ref. No.	Part No.	Part Name	Remarks	Ref. No.	Part No.	Part Name	Remarks	Ref. No.	Part No.	Part Name	Remarks
<b>SEMICONDUCTORS GROUP</b>				<b>RESISTORS GROUP</b>											
IC001	282 2312 006	IC ZR38500(A3)		TR304	271 0238 908	Transistor 2SA1633F31(E/F)		R133	247 0018 905	Carbon chip 0ohm 1/10W	RM73B-OROK	R358,359	247 0011 944	Carbon chip 47kohm 1/10W	RM73B-473J
IC002	282 2205 003	IC DSP5600A		TR305	272 0131 901	Transistor 2SB1041(F)		R137	247 0018 905	Carbon chip 0ohm 1/10W	RM73B-OROK	R360	247 0009 985	Carbon chip 10kohm 1/10W	RM73B-103J
IC003	399 0299 009	IC SG-531PH(33MHz)		TR306	271 0238 908	Transistor 2SA1633F31(E/F)		R151,152	247 0012 927	Carbon chip 100kohm 1/10W	RM73B-104J	R361	247 0009 901	Carbon chip 4.7kohm 1/10W	RM73B-472J
IC005,006	282 2206 002	IC TC5142568ZL-60		TR307	274 0169 908	Transistor 2SD1292(F)		R153-160	247 0009 901	Carbon chip 4.7kohm 1/10W	RM73B-472J	R362	247 0009 985	Carbon chip 10kohm 1/10W	RM73B-103J
IC007	282 1718 902	IC TC74HC00AF		TR308	273 0384 900	Transistor 2SC2412K(S)		R161,162	247 0005 989	Carbon chip 220ohm 1/10W	RM73B-221J	R363	247 0012 927	Carbon chip 100kohm 1/10W	RM73B-104J
IC008	282 1840 902	IC HD74HC14FP		TR309	269 0083 901	Transistor DTA114EK		R163,164	247 0008 960	Carbon chip 3.3kohm 1/10W	RM73B-332J	R364-366	247 0009 985	Carbon chip 10kohm 1/10W	RM73B-103J
IC011,012	282 1638 901	IC TC74HC164AF		TR401	269 0083 901	Transistor DTA114EK		R165-168	247 0012 927	Carbon chip 100kohm 1/10W	RM73B-104J	R367-369	247 0009 901	Carbon chip 4.7kohm 1/10W	RM73B-472J
IC013	282 1665 903	IC HD74HC74FP		TR402	269 0054 901	Transistor DTC144EK		R169-176	247 0009 901	Carbon chip 4.7kohm 1/10W	RM73B-472J	R370	247 0004 977	Carbon chip 75ohm 1/10W	RM73B-750J
IC014	282 1673 908	IC HD74HC04FP		TR403	273 0384 900	Transistor 2SC2412K(S)		R177,178	247 0005 989	Carbon chip 220ohm 1/10W	RM73B-221J	R371	247 0005 905	Carbon chip 100kohm 1/10W	RM73B-101J
IC015	282 2217 907	IC TC74HC7286AF		TR404,405	269 0054 901	Transistor DTC144EK		R178,180	247 0008 960	Carbon chip 3.3kohm 1/10W	RM73B-332J	R372	247 0008 928	Carbon chip 2.2kohm 1/10W	RM73B-222J
IC016	282 1665 903	IC HD74HC74FP		D101-106	276 0438 910	Diode MA151A		R181-184	247 0012 927	Carbon chip 100kohm 1/10W	RM73B-104J	R373	247 0011 944	Carbon chip 47kohm 1/10W	RM73B-473J
IC017	282 1641 901	IC HD74HC157FP		D108-110	276 0438 910	Diode MA151A		R185-182	247 0009 901	Carbon chip 4.7kohm 1/10W	RM73B-472J	R374	247 0005 905	Carbon chip 100kohm 1/10W	RM73B-101J
IC018	282 2212 902	IC CS8412CS		D301-303	276 0438 910	Diode MA151A		R183,184	247 0005 989	Carbon chip 220ohm 1/10W	RM73B-221J	R375	247 0011 928	Carbon chip 39kohm 1/10W	RM73B-393J
IC019	282 1718 902	IC TC74HC00AF		D401-403	276 0438 910	Diode MA151A		R195,196	247 0008 960	Carbon chip 3.3kohm 1/10W	RM73B-332J	R376	247 0007 945	Carbon chip 1kohm 1/10W	RM73B-102J
IC020	282 1348 903	IC TC74HC123AF		D404	276 0553 905	Diode 1SR35-200A		R197,198	247 0012 927	Carbon chip 100kohm 1/10W	RM73B-104J	R377	247 0004 922	Carbon chip 47ohm 1/10W	RM73B-470J
IC051-053	282 2347 903	IC N341255SJ-12		CD301	276 0663 905	Diode KV1851-TL		R378	247 0012 972	Carbon chip 160kohm 1/10W	RM73B-164J	R379	247 0005 905	Carbon chip 100kohm 1/10W	RM73B-101J
IC101	282 2300 908	IC PCM1760U		ZD401	278 0634 905	Zener diode MTZJ3.3A	3.3V	R301-304	247 0009 985	Carbon chip 10kohm 1/10W	RM73B-103J	R401	247 0009 985	Carbon chip 10kohm 1/10W	RM73B-103J
IC102	282 2301 907	IC DF1780U						R305	247 0006 975	Carbon chip 510ohm 1/10W	RM73B-511J	R402	247 0012 927	Carbon chip 100kohm 1/10W	RM73B-104J
IC103	399 0300 008	IC SG-531PH(12.288MHz)						R306	247 0004 980	Carbon chip 82ohm 1/10W	RM73B-820J	R403	247 0009 985	Carbon chip 10kohm 1/10W	RM73B-103J
IC154-156	263 0896 909	IC NJM2068MD						R307-309	247 0007 945	Carbon chip 1kohm 1/10W	RM73B-102J	R404	247 0009 901	Carbon chip 4.7kohm 1/10W	RM73B-472J
IC301	263 1018 003	IC MC14577CP						R310	247 0009 901	Carbon chip 4.7kohm 1/10W	RM73B-472J	R404-411	247 0009 901	Carbon chip 4.7kohm 1/10W	RM73B-472J
IC302	263 0615 902	IC BA1521BF						R311	247 0005 947	Carbon chip 150ohm 1/10W	RM73B-151J	R412-415	247 0009 985	Carbon chip 10kohm 1/10W	RM73B-103J
IC303	263 1039 901	IC NJM360M						R312	247 0008 928	Carbon chip 2.2kohm 1/10W	RM73B-222J	R424	247 0009 985	Carbon chip 10kohm 1/10W	RM73B-103J
IC304	262 1205 907	IC TC74HCU04AF						R313	247 0006 920	Carbon chip 330ohm 1/10W	RM73B-331J	R426	247 0006 975	Carbon chip 510ohm 1/10W	RM73B-511J
IC305	263 0615 902	IC BA1521BF						R314-316	247 0007 945	Carbon chip 1kohm 1/10W	RM73B-102J	R426	247 0018 905	Carbon chip 0ohm 1/10W	RM73B-OROK
IC306	282 2211 000	IC PD4806A						R318,319	247 0007 945	Carbon chip 1kohm 1/10W	RM73B-102J	R427	247 0007 945	Carbon chip 1kohm 1/10W	RM73B-102J
IC307	399 0298 000	IC SG-531PH(46.08MHz)						R320	247 0009 985	Carbon chip 10kohm 1/10W	RM73B-103J	R428	247 0005 905	Carbon chip 100kohm 1/10W	RM73B-101J
IC308	282 2324 900	IC MCM8205DU15						R321,322	247 0007 945	Carbon chip 1kohm 1/10W	RM73B-102J	R432-434	247 0009 901	Carbon chip 4.7kohm 1/10W	RM73B-472J
IC309	282 1205 907	IC TC74HCU04AF						R323,324	247 0008 944	Carbon chip 2.7kohm 1/10W	RM73B-272J	R435-451	247 0009 985	Carbon chip 10kohm 1/10W	RM73B-103J
IC310-312	269 0007 007	IC GP1F32R						R325,326	247 0018 905	Carbon chip 0ohm 1/10W	RM73B-OROK	R454	247 0009 985	Carbon chip 10kohm 1/10W	RM73B-103J
IC313	269 0098 006	IC GP1F32T (OPT. OUT)						R327	247 0005 905	Carbon chip 100ohm 1/10W	RM73B-101J	R455	247 0013 900	Carbon chip 220kohm 1/10W	RM73B-224J
IC315,316	262 2213 901	IC TC74HC151AF						R328	247 0011 986	Carbon chip 68kohm 1/10W	RM73B-683J	R456	247 0009 985	Carbon chip 10kohm 1/10W	RM73B-103J
IC317	263 0755 008	IC CX20106A						R329	247 0004 964	Carbon chip 88ohm 1/10W	RM73B-880J	R457	247 0009 901	Carbon chip 4.7kohm 1/10W	RM73B-472J
IC401	282 2354 006	IC TMP87CS17F****						R331,332	247 0009 985	Carbon chip 10kohm 1/10W	RM73B-103J	R458	247 0009 985	Carbon chip 10kohm 1/10W	RM73B-103J
IC402	282 2355 005	IC TMP87CP71F****						R333,334	247 0013 900	Carbon chip 220kohm 1/10W	RM73B-224J	R459	247 0007 945	Carbon chip 1kohm 1/10W	RM73B-102J
IC501-503	282 2210 904	IC SM5841HS						R335	247 0009 958	Carbon chip 7.5kohm 1/10W	RM73B-752J	R460	247 0009 901	Carbon chip 4.7kohm 1/10W	RM73B-472J
IC504	282 2351 009	IC PCM89AP-K						R336	247 0005 905	Carbon chip 100ohm 1/10W	RM73B-101J	R461,462	247 0007 945	Carbon chip 1kohm 1/10W	RM73B-102J
IC505,506	282 2145 008	IC PCM89AP						R337-341	247 0009 985	Carbon chip 10kohm 1/10W	RM73B-103J	R463	241 2387 940	Carbon film 4.7ohm 1/4W(NB)	RD1482E4R7J.NBS
IC507-509	263 0896 909	IC NJM2068MD						R342	247 0007 945	Carbon chip 1kohm 1/10W	RM73B-102J	R464	247 0018 905	Carbon chip 0ohm 1/10W	RM73B-OROK
TR109	269 0083 901	Transistor DTA114EK						R343	247 0012 927	Carbon chip 100kohm 1/10W	RM73B-104J	R466-469	247 0009 985	Carbon chip 10kohm 1/10W	RM73B-103J
TR151-156	273 0414 906	Transistor 2SC3326(A/B)						R344	247 0013 900	Carbon chip 220kohm 1/10W	RM73B-224J	R470-472	247 0009 901	Carbon chip 4.7kohm 1/10W	RM73B-472J
TR301	273 0384 900	Transistor 2SC2412K(S)						R345	247 0010 961	Carbon chip 22kohm 1/10W	RM73B-223J	R473	247 0008 928	Carbon chip 2.2kohm 1/10W	RM73B-222J
TR302	269 0119 901	Transistor DTA124EK						R346	247 0012 927	Carbon chip 100kohm 1/10W	RM73B-104J	R481-486	247 0009 901	Carbon chip 4.7kohm 1/10W	RM73B-472J
TR303	273 0384 900	Transistor 2SC2412K(S)						R347,348	247 0009 985	Carbon chip 10kohm 1/10W	RM73B-103J	R487	247 0009 985	Carbon chip 10kohm 1/10W	RM73B-103J
								R349	247 0011 944	Carbon chip 47kohm 1/10W	RM73B-473J	R501-515	247 0006 920	Carbon chip 330ohm 1/10W	RM73B-331J
								R350	247 0005 921	Carbon chip 120ohm 1/10W	RM73B-121J	R517,518	247 0007 961	Carbon chip 1.2kohm 1/10W	RM73B-122J
								R351-9353	247 0009 985	Carbon chip 10kohm 1/10W	RM73B-103J	R519,520	247 0006 988	Carbon chip 560ohm 1/10W	RM73B-561J
								R354	247 0007 945	Carbon chip 1kohm 1/10W	RM73B-102J	R521-524	247 0009 943	Carbon chip 6.8kohm 1/10W	RM73B-682J
								R355	247 0014 967	Carbon chip 1Mohm 1/10W	RM73B-105J	R525,526	247 0007 961	Carbon chip 1.2kohm 1/10W	RM73B-122J
								R356	247 0006 962	Carbon chip 470ohm 1/10W	RM73B-471J	R527,528	247 0006 988	Carbon chip 560ohm 1/10W	RM73B-561J
								R357	247 0012 969	Carbon chip 150kohm 1/10W	RM73B-154J				

Ref. No.	Part No.	Part Name	Remarks
R529	247 0009 943	Carbon chip 8.2kohm 1/10W	RM73B-882J
R530	247 0009 989	Carbon chip 8.2kohm 1/10W	RM73B-822J
R531	247 0009 943	Carbon chip 8.8kohm 1/10W	RM73B-882J
R532	247 0009 989	Carbon chip 8.2kohm 1/10W	RM73B-822J
R533,534	247 0007 961	Carbon chip 1.2kohm 1/10W	RM73B-122J
R535,536	247 0006 988	Carbon chip 580ohm 1/10W	RM73B-561J
R537-540	247 0009 943	Carbon chip 8.8kohm 1/10W	RM73B-882J
<b>CAPACITORS GROUP</b>			
C015	257 0006 983	Ceramic chip 1000pF/50V	CK73B1H102K
C016	257 0012 966	Ceramic 0.1µF/25V	CK73B1E104K
C017	257 0008 983	Ceramic chip 1000pF/50V	CK73B1H102K
C018	257 0014 935	Ceramic chip 0.1µF/25V	CK73F1E104Z
C019	257 0012 966	Ceramic 0.1µF/25V	CK73B1E104K
C020	257 0006 985	Ceramic chip 820pF/50V	CC73SL1H821J
C021	257 0014 935	Ceramic chip 0.1µF/25V	CK73F1E104Z
C022	257 0012 966	Ceramic 0.1µF/25V	CK73B1E104K
C023	257 0014 935	Ceramic chip 0.1µF/25V	CK73F1E104Z
C024	257 0008 983	Ceramic chip 1000pF/50V	CK73B1H102K
C025-043	257 0012 966	Ceramic 0.1µF/25V	CK73B1E104K
C044	256 1034 937	Mylar film 1200pF/50V	CQ93P1H122J
C045,046	257 0012 966	Ceramic 0.1µF/25V	CK73B1E104K
C047	254 4260 951	Electrolytic 2.2µF/50V	CE04W1H2R2M
C048-053	257 0012 966	Ceramic 0.1µF/25V	CK73B1E104K
C054	257 0008 983	Ceramic chip 1000pF/50V	CK73B1H102K
C055	257 0014 935	Ceramic chip 0.1µF/25V	CK73F1E104Z
C056	257 0012 966	Ceramic 0.1µF/25V	CK73B1E104K
C057	257 0008 983	Ceramic chip 1000pF/50V	CK73B1H102K
C058	257 0014 935	Ceramic chip 0.1µF/25V	CK73F1E104Z
C059	257 0012 966	Ceramic 0.1µF/25V	CK73B1E104K
C060	257 0008 983	Ceramic chip 1000pF/50V	CK73B1H102K
C061	257 0012 966	Ceramic 0.1µF/25V	CK73B1E104K
C062	254 4260 948	Electrolytic 1µF/50V	CE04W1H010M
C063	257 0014 935	Ceramic chip 0.1µF/25V	CK73F1E104Z
C064	257 0008 983	Ceramic chip 1000pF/50V	CK73B1H102K
C065	257 0014 935	Ceramic chip 0.1µF/25V	CK73F1E104Z
C066	257 0012 966	Ceramic 0.1µF/25V	CK73B1E104K
C067	257 0014 935	Ceramic chip 0.1µF/25V	CK73F1E104Z
C068-070	257 0012 966	Ceramic 0.1µF/25V	CK73B1E104K
C071	257 0014 935	Ceramic chip 0.1µF/25V	CK73F1E104Z
C072	257 0012 966	Ceramic 0.1µF/25V	CK73B1E104K
C073,074	257 0008 983	Ceramic chip 1000pF/50V	CK73B1H102K
C075	257 0014 935	Ceramic chip 0.1µF/25V	CK73F1E104Z
C076	256 1034 979	Metalized 0.1µF/50V	CF93A1H104J
C077	257 0012 966	Ceramic 0.1µF/25V	CK73B1E104K
C078	257 0008 983	Ceramic chip 1000pF/50V	CK73B1H102K
C079-082	257 0012 966	Ceramic 0.1µF/25V	CK73B1E104K
C101-104	255 4202 967	Mylar film 1200pF/50V	CQ93P1H122J
C105,106	255 4200 965	Mylar film 220pF/50V	CQ93P1H221J
C107-110	255 4202 967	Mylar film 1200pF/50V	CQ93P1H122J
C111-114	254 4254 909	Electrolytic 10µF/16V	CE04W1C100M

Ref. No.	Part No.	Part Name	Remarks
C115,116	257 0014 935	Ceramic chip 0.1µF/25V	CK73F1E104Z
C117-120	254 4254 909	Electrolytic 10µF/16V	CE04W1C100M
C121,122	257 0014 935	Ceramic chip 0.1µF/25V	CK73F1E104Z
C123	254 4254 909	Electrolytic 10µF/16V	CE04W1C100M
C124	257 0014 935	Ceramic chip 0.1µF/25V	CK73F1E104Z
C125	254 4254 909	Electrolytic 10µF/16V	CE04W1C100M
C126	257 0014 935	Ceramic chip 0.1µF/25V	CK73F1E104Z
C127	257 0004 961	Ceramic chip 100pF/50V	CC73SL1H101J
C128	256 1034 979	Metalized 0.1µF/50V	CF93A1H104J
C129	257 0012 966	Ceramic 0.1µF/25V	CK73B1E104K
C130	257 0008 983	Ceramic chip 1000pF/50V	CK73B1H102K
C131	257 0014 935	Ceramic chip 0.1µF/25V	CK73F1E104Z
C137,138	257 0012 966	Ceramic 0.1µF/25V	CK73B1E104K
C140-142	257 0012 966	Ceramic 0.1µF/25V	CK73B1E104K
C145,146	257 0008 983	Ceramic chip 1000pF/50V	CK73B1H102K
C148	257 0008 983	Ceramic chip 1000pF/50V	CK73B1H102K
C151,152	257 0012 966	Ceramic 0.1µF/25V	CK73B1E104K
C153-158	255 1265 907	Mylar film 6800pF/50V	CQ93M1H682(B)
C159,160	254 4196 944	Electrolytic 1µF/50V	CE04W1H010M(SRA)
C161,162	255 4201 968	Mylar film 470pF/50V	CQ93P1H471J
C163,164	255 4201 984	Mylar film 560pF/50V	CQ93P1H561J
C165,166	254 4252 930	Electrolytic 100µF/10V	CE04W1A101M
C167,168	257 0008 983	Ceramic chip 1000pF/50V	CK73B1H102K
C175,176	254 4196 944	Electrolytic 1µF/50V	CE04W1H010M(SRA)
C177	255 4201 968	Mylar film 470pF/50V	CQ93P1H471J
C178	256 1034 953	Metalized 0.068µF/50V	CF93A1H683J
C179	255 4201 984	Mylar film 560pF/50V	CQ93P1H561J
C180	256 1034 979	Metalized 0.1µF/50V	CF93A1H104J
C181,182	254 4193 905	Electrolytic 10µF/16V	CE04W1C100M(SRA)
C181,192	254 4196 944	Electrolytic 1µF/50V	CE04W1H010M(SRA)
C183,194	255 4201 968	Mylar film 470pF/50V	CQ93P1H471J
C185,186	255 4201 984	Mylar film 560pF/50V	CQ93P1H561J
C187,198	254 4193 905	Electrolytic 10µF/16V	CE04W1C100M(SRA)
C245-250	257 0014 935	Ceramic chip 0.1µF/25V	CK73F1E104Z
C251,252	254 4196 944	Electrolytic 1µF/50V	CE04W1H010M(SRA)
C253,254	254 4260 948	Electrolytic 1µF/50V	CE04W1H010M
C303	257 0011 941	Ceramic 0.022µF/25V	CK73B1E223K
C304-307	254 4260 948	Electrolytic 1µF/50V	CE04W1H010M
C308	257 0004 932	Ceramic chip 75pF/50V	CC73SL1H750J
C309,310	257 0010 900	Ceramic chip 0.01µF/50V	CK73B1H103K
C311	254 4254 909	Electrolytic 10µF/16V	CE04W1C100M
C312	257 0012 966	Ceramic 0.1µF/25V	CK73B1E104K
C313	256 1035 952	Metalized 0.47µF/50V	CF93A1H474J
C314	257 0008 983	Ceramic chip 1000pF/50V	CK73B1H102K
C315	256 1035 952	Metalized 0.47µF/50V	CF93A1H474J
C316	257 0014 935	Ceramic chip 0.1µF/25V	CK73F1E104Z
C318-321	257 0012 966	Ceramic 0.1µF/25V	CK73B1E104K
C322,323	254 4254 909	Electrolytic 10µF/16V	CE04W1C100M
C324-326	257 0012 966	Ceramic 0.1µF/25V	CK73B1E104K
C327	254 3053 936	Electrolytic 47µF/16V	CE04D1C470MBP

Ref. No.	Part No.	Part Name	Remarks
C328	257 0011 996	Ceramic 0.1µF/25V	CK73B1E104K
C329	257 0010 900	Ceramic chip 0.01µF/50V	CK73B1H103K
C330,331	254 4260 948	Electrolytic 1µF/50V	CE04W1H010M
C332	254 4254 909	Electrolytic 10µF/16V	CE04W1C100M
C333	257 0012 966	Ceramic 0.1µF/25V	CK73F1E104Z
C334	257 0010 900	Ceramic chip 0.01µF/50V	CK73B1H103K
C335	254 4252 930	Electrolytic 100µF/10V	CE04W1A101M
C336	257 0002 963	Ceramic chip 15pF/50V	CC73SL1H150J
C338	254 4254 938	Electrolytic 47µF/16V	CE04W1C470M
C339	257 0014 935	Ceramic chip 0.1µF/25V	CK73F1E104Z
C340	254 4254 938	Electrolytic 47µF/16V	CE04W1C470M
C341	257 0011 996	Ceramic 0.1µF/25V	CK73B1E104K
C342	254 4254 938	Electrolytic 47µF/16V	CE04W1C470M
C343	257 0011 996	Ceramic 0.1µF/25V	CK73B1E104K
C344	254 4254 938	Electrolytic 47µF/16V	CE04W1C470M
C345	257 0011 996	Ceramic 0.1µF/25V	CK73B1E104K
C346,347	257 0012 966	Ceramic 0.1µF/25V	CK73B1E104K
C349	257 0003 904	Ceramic chip 22pF/50V	CC73SL1H220J
C350	254 4254 909	Electrolytic 10µF/16V	CE04W1C100M
C351-353	257 0012 966	Ceramic 0.1µF/25V	CK73B1E104K
C354	254 4256 923	Electrolytic 33µF/25V	CE04W1E330M
C355,356	254 4260 948	Electrolytic 1µF/50V	CE04W1H010M
C357	254 4260 964	Electrolytic 3.3µF/50V	CE04W1H3R3M
C358	257 0005 986	Ceramic chip 330pF/50V	CC73SL1H331J
C359	257 0014 935	Ceramic chip 0.1µF/25V	CK73F1E104Z
C360	257 0012 966	Ceramic 0.1µF/25V	CK73B1E104K
C401,402	257 0014 935	Ceramic chip 0.1µF/25V	CK73F1E104Z
C412	254 4254 909	Electrolytic 10 F/16V	CE04W1C100M
C413	254 4250 932	Electrolytic 220µF/6.3V	CE04W0J221M
C414	256 1034 982	Metalized 0.12µF/50V	CF93A1H124J
C415	254 4254 909	Electrolytic 10µF/16V	CE04W1C100M
C416	257 0012 966	Ceramic 0.1µF/25V	CK73B1E104K
C417	259 0007 702	Back up cap. 8200µF/5.5V	SB CAP-822-C
C418	257 0012 966	Ceramic 0.1µF/25V	CK73B1E104K
C472	257 0012 966	Ceramic 0.1µF/25V	CK73B1E104K
C473,474	257 0008 983	Ceramic chip 1000pF/50V	CK73B1H102K
C476-482	257 0008 983	Ceramic chip 1000pF/50V	CK73B1H102K
C501-503	254 4193 905	Electrolytic 10µF/16V	CE04W1C100M(SRA)
C504-506	257 0012 966	Ceramic 0.1µF/25V	CK73B1E104K
C507-509	254 4193 905	Electrolytic 10µF/16V	CE04W1C100M(SRA)
C510-515	257 0012 966	Ceramic 0.1µF/25V	CK73B1E104K
C516-518	254 4193 905	Electrolytic 10µF/16V	CE04W1C100M(SRA)
C519-530	254 4252 930	Electrolytic 100µF/10V	CE04W1A101M
C531-542	257 0004 961	Ceramic chip 100pF/50V	CC73SL1H101J
C543-545	257 0012 966	Ceramic 0.1µF/25V	CK73B1E104K
C546-551	257 0008 983	Ceramic chip 1000pF/50V	CK73B1H102K

Ref. No.	Part No.	Part Name	Remarks	Qty
<b>OTHER PARTS GROUP</b>				
CN033	205 0343 032	3P connector base(KR-PH)		2
CN072	205 0343 074	7P connector base(KR-PH)		1
CN093	205 0355 091	9 P KR connector base (L)		1
CN122	205 0480 021	12P KR connector base(L)		1
CN143	205 1032 012	14P connector plug (TRC-X)		1
CN261,262	205 1032 009	26P connector plug (TRC-X)		2
CN271	205 0702 084	27P FFC connector base(L)		1
CN271	205 0815 023	27P FFC base (BTM)		1
CN291	205 0815 036	29P FFC base (BTM)		1
FB010	235 0106 908	Chip emilli (21A05)		1
FB101,102	235 0106 908	Chip emilli (21A05)		2
FB103	235 0049 900	Beads inductor		1
FB104	235 0106 908	Chip emilli (21A05)		1
FB105	235 0049 900	Beads inductor		1
FB106	235 0106 908	Chip emilli (21A05)		1
FB107	235 0049 900	Beads inductor		1
FB106-110	235 0106 908	Chip emilli (21A05)		3
FB111	235 0049 900	Beads inductor		1
FB112	235 0106 908	Chip emilli (21A05)		1
FB113-115	235 0049 900	Beads inductor		3
FB117-120	235 0049 900	Beads inductor		4
FB121-123	235 0106 908	Chip emilli (21A05)		3
FB301	235 0106 908	Chip emilli (21A05)		1
FB401,402	235 0049 900	Beads inductor		2
FB501-506	235 0106 908	Chip emilli (21A05)		6
JK301	204 8357 030	2P pin jack	2P PIN JACK	1
JK302	204 8260 004	Mini jack	MINI JACK	1
L301	235 0060 905			

# EXPLODED VIEW OF CHASSIS AND CABINET

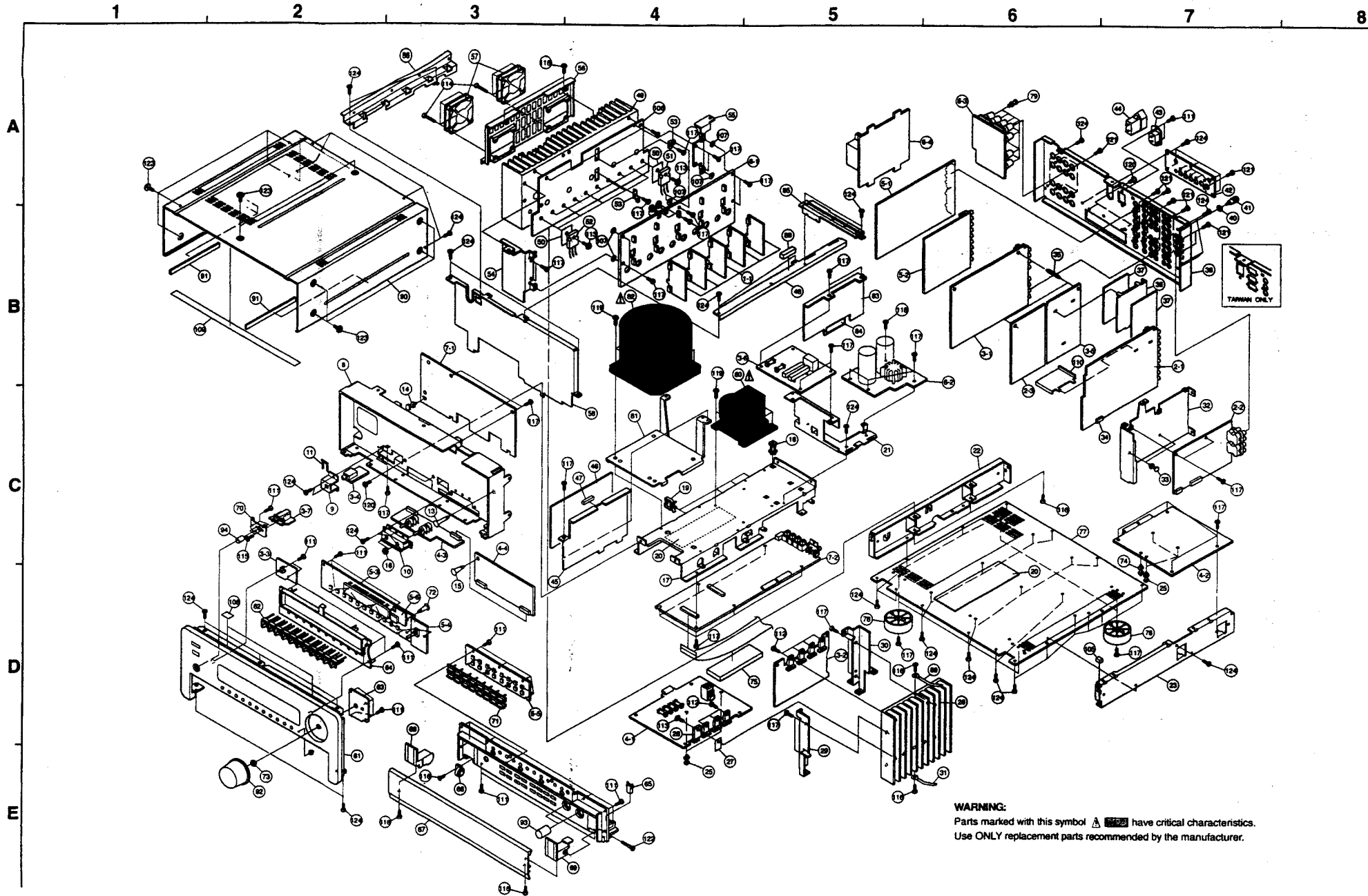

**WARNING:**  
Parts marked with this symbol  have critical characteristics.  
Use **ONLY** replacement parts recommended by the manufacturer.

## PARTS LIST OF EXPLODED VIEW

Ref. No.	Part No.	Part Name	Remarks	Qty	Ref. No.	Part No.	Part Name	Remarks	Qty
1	1U-2944A	Power amp.-2 P.W.B. unit assy		1s	26	417 0538 000	Radiator		1
1-1	1U-2944A-1	Power amp.-2 P.W.B. unit		(5)	27	415 0234 007	Insulating sheet		1
2	1U-2948D	Audio in P.W.B. unit assy		1s	28	271 0276 009	Transistor 2SA1633F31(E/F)		1
2-1	1U-2948D-1	Audio in P.W.B. unit		(1)	29	412 4146 008	Radiator support (F)		1
2-2	1U-2948D-3	Ext. in P.W.B. unit		(1)	30	412 4147 007	Radiator support (R)		1
2-3	1U-2948D-4	E.Vol.-1 P.W.B. unit		(1)	31	445 0048 016	Cord holder (L50)		1
3	1U-2949D	Pre amp. P.W.B. unit assy		1s	32	414 0782 103	Shield bracket (TU)		1
3-1	1U-2949D-1	Pre amp. P.W.B. unit		(1)	33	412 2814 044	Card spacer (L=6)		2
3-2	1U-2949D-2	Power supply-2 P.W.B. unit		(1)	34	461 0390 038	Rubber sheet		2
3-3	1U-2949D-3	Remote control P.W.B. unit		(1)	35	449 0133 004	P.W.B. Holder		1
3-4	1U-2949D-4	H/P P.W.B. unit		(1)	36	414 0800 108	Shield plate		1
3-5	1U-2949D-5	E.Vol.-2 P.W.B. unit		(1)	37	415 0680 046	Spacer		2
3-6	1U-2949D-6	Power supply-4 P.W.B. unit		(1)	38	105 1209 477	Back panel	Asia model	1
4	1U-2950	Power supply-3 P.W.B. unit assy		1s	105 1224 009	Back panel	Europe model	1	
4-1	1U-2950-1	Power supply-3 P.W.B. unit		(1)	105 1224 012	Back panel	Taiwan model	1	
4-2	1U-2950-2	Wiring P.W.B. unit		(1)	39	477 0096 007	Push rivet		16
4-3	1U-2950-3	Tone-1 P.W.B. unit		(1)	40	477 0018 001	Washer (P-87)		1
4-4	1U-2950-4	Tone-2 P.W.B. unit		(1)	41	205 0071 016	Terminal assy		1
5	1U-2951A	S-Video P.W.B. unit assy		1s	42	105 1211 025	Back plate		1
5-1	1U-2951A-1	S-Video P.W.B. unit		(1)					
5-2	1U-2951A-2	C-Video P.W.B. unit		(1)					
5-3	1U-2951A-3	Display P.W.B. unit		(1)					
5-4	1U-2951A-4	Volume LED P.W.B. unit		(1)	45	414 0797 004	Shield plate (A)		1
5-5	1U-2951A-5	Master volume P.W.B. unit		(1)	46	415 0680 020	Spacer		1
5-6	1U-2951A-6	Switch P.W.B. unit		(1)	47	461 0390 083	Rubber sheet		1
6	1U-2952D	Power amp.-1 P.W.B. unit assy		1s	48	412 4150 104	P.W.B. Support		1
6-1	1U-2952D-1	Power amp.-1 P.W.B. unit		(1)	49	417 0537 205	Power radiator		1
6-2	1U-2952D-2	Power supply-1 P.W.B. unit		(1)	50	415 0787 004	MICA Sheet (NO.19C)		10
6-3	1U-2952D-3	SP Terminal P.W.B. unit		(1)	51	272 0147 005	Transistor 2SB1317(S)		5
6-4	1U-2952D-4	Power supply-5 P.W.B. unit		(1)	52	274 0184 006	Transistor 2SD1975(S)		5
7	1U-2953	DSP P.W.B. unit assy		1s	53	412 4127 001	P.W.B. Bracket (B)		2
7-1	1U-2953-1	DSP P.W.B. unit		(1)	54	412 4144 107	Radiator bracket (F)		1
7-2	1U-2953-2	Moon. P.W.B. unit		(1)	55	412 4145 106	Radiator bracket (R)		1
8	411 1350 409	Front chassis		1	56	412 4168 002	Fan bracket		1
9	412 4155 109	Phone bracket		1	57	421 1897 005	Motor fan		2
10	412 4154 003	VR Bracket		1	58	414 0784 208	Shield chassis (D)		1
11	441 1793 008	Snap plate		1	59	—			1
12	412 2741 007	P.W.B. Holder (H=8)		1	60	—			1
13	449 0033 052	Locking card spacer		1	61	144 2515 217	F. Panel assy		1
14	412 2814 002	Card spacer (L=8)		4	62	113 1791 012	Selector knob		11
15	412 2814 057	Card spacer (L=12)		1	63	412 4177 006	VR Bracket		1
16	—	9 Nut		2	64	146 1647 111	FLD Frame assy		1
17	411 1349 203	Trans. chassis		1	65	435 0128 007	Latch (29K0)		1
18	415 9032 006	P.C.B. Holder (T)		1	66	421 0726 002	Mini. damper		1
19	445 0114 005	Wire clip		4	67	144 2516 119	Door		1
20	415 0680 033	Spacer		2	68	401 0165 216	Hinge (L)		1
21	412 4148 006	P.W.B. Bracket		1	69	401 0166 312	Hinge (R)		1
22	411 1351 107	Side chassis(L)		1	70	412 4163 007	Switch bracket		1
23	411 1352 106	Side chassis(R)		1	71	113 1464 006	Push knob		2
24	—	—		1	72	412 2741 036	P.W.B. holder (H=10)		1
25	412 2814 028	Card spacer (L=10)		5	73	—	7 nut		1
					74	449 0133 017	P.W.B. holder		1

Ref. No.	Part No.	Part Name	Remarks	Qty	Ref. No.	Part No.	Part Name	Remarks	Qty
75	461 0830 019	Rubber sheet		1	<b>PACKING &amp; ACCESSORIES (Not included EXPLODED VIEW)</b>				
76	415 0445 032	Insulating sheet		1	141	504 0092 060	Stylen paper		1
77	105 1207 204	Bottom cover		1	142	504 9102 029	Stylen paper		1
78	104 0173 213	Foot assy		4	143	505 9102 019	Poly. cover		1
79	—	—		1	144	503 1221 002	Cushion ass'y		1
					145	505 8006 019	Envelope		1
81	412 4157 000	Trans. bracket		1	146	511 3059 008	Inst. manual	Asia model	1
						511 3060 000	Inst. manual	Europe model	1
					147	502 0896 006	Inst. manual		1
83	414 0796 100	Shield plate (B)		1	148	515 0671 407	S.S. List (EX)		1
84	461 0315 039	Cushion sheet		1	149	399 0325 009	Remote control unit	RC-813	1
85	412 4151 006	Support bracket (A)		1	150	—	Battery		2
86	412 4152 102	Support bracket (B)		1					
87	445 8004 007	Wire clamp		7	152	206 2148 005	AC cord (BS3P)	Asia model	1
88	461 0538 051	Rubber sheet		1	153	501 1950 128	Spacer	Taiwan model	1
89	445 0048 003	Cord holder (L76)		1	501 1950 115	Spacer	Asia & Europe model	1	
90	102 0576 238	Top cover		1	154	501 1951 017	Carton case	Europe model	1
91	461 0501 005	Rubber sheet		4	501 1951 020	Carton case	Asia model	1	
92	112 0774 011	Knob assy (M)		1	501 1951 033	Carton case	Taiwan model	1	
93	112 0685 113	Knob (MARU)		2	513 9111 001	Color label (GOLD)	Asia & Taiwan model	1	
94	113 1792 011	Power knob assy		1	155	513 2641 028	KOLIN label (T)	Taiwan model	1
95	203 6387 025	4P KR-KR Ribbon 650	CN045	1	156	513 1389 006	Control card base		1
96	204 6354 064	12P KR-KR Ribbon 425	CN122	1	158	513 1349 004	Thermal carbon film		1
97	204 2549 051	9P KR-KR Ribbon 150	CN093	1					
98	203 4525 012	3P PH-PH Shield wire	CN033	1					
99	204 2543 086	7P KR-KR Ribbon 225	CN072	1					
100	203 8341 085	5P KR-KR Ribbon 225	CN053,057	2					
101	203 4930 018	3P VH-VH Connector cord	CN029	1					
102	204 6591 005	13P-15P PH con. cord	CN133	1					
103	009 0133 013	27P FFC cable	CN271	1					
104	009 0134 012	29P FFC cable	CN291	1					
105	461 0390 054	Rubber sheet		1					
106	417 4001 009	CU plate		1					
107	427 0231 008	4W (S)		6					
108	461 0867 008	AFM cushion		2					
109	—	380 10		1					
110	414 0799 109	Shield plate		1					
<b>SCREWS</b>									
111	473 7505 007	2.6X8 CBTS (P)-Z		32					
112	473 7005 002	3X10 CBTS (S)-Z		7					
113	473 8007 009	3X12 cup screw		11					
114	473 7005 044	3X20 CBTS (S)-Z		8					
115	471 3303 016	3X6 CBS-Z		2					
116	473 7500 015	3X8 CBTS (P)-Z		10					
117	473 7002 018	3X8 CBTS (S)-Z		54					
118	473 7003 017	3X8 CFTS (S)-B		1					
119	473 7007 013	4X10 CBTS (S)-B		8					
120	473 7007 000	4X8 CBTS (S)-B		4					
121	477 0064 107	Fixing screw		27					
122	473 7514 001	Special screw		1					
123	471 9043 008	Special screw		10					
124	473 7015 018	3X8 CBTS (S)-B		62					

BLOCK DIAGRAM

1 2 3 4 5 6 7 8

A

B

C

D

E

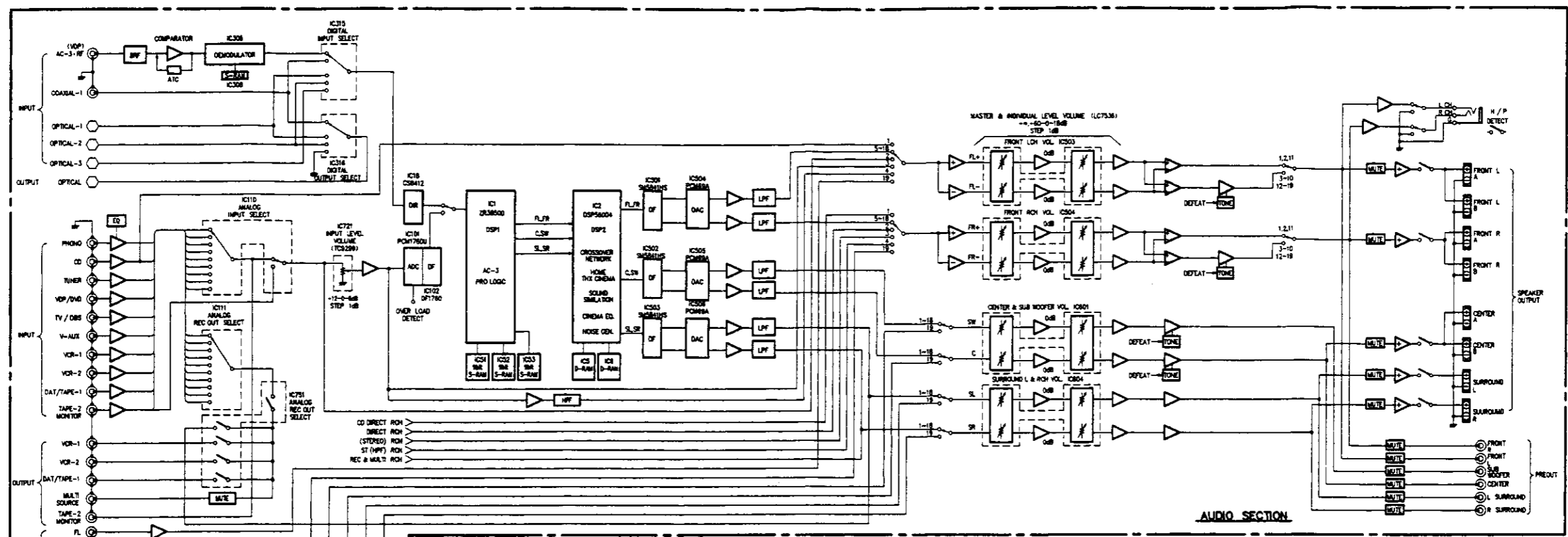

SURROUND MODEL	
INPUT SIGNAL: ANALOG	INPUT SIGNAL: DIGITAL
1. DIRECT (CD)	7. WIDE SCREEN
2. DIRECT (TOUCH)	8. MONO
3. STEREO SURROUND: NO	9. 5CH STEREO
4. STEREO SURROUND: YES	10. DSP SIMULATION
5. DOLBY SURROUND	11. DIRECT
6. DOLBY SURROUND with THX	12. STEREO
	13. DOLBY SURROUND
	14. DOLBY SURROUND with THX
	15. WIDE SCREEN
	16. MONO
	17. 5CH STEREO
	18. DSP SIMULATION

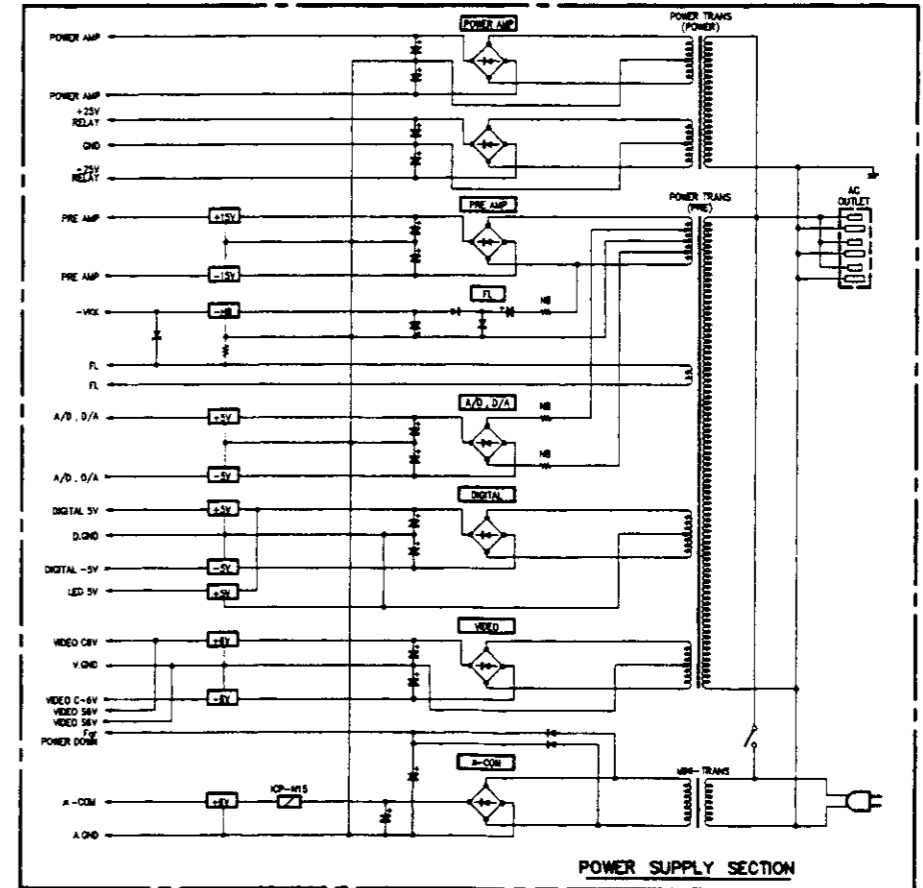
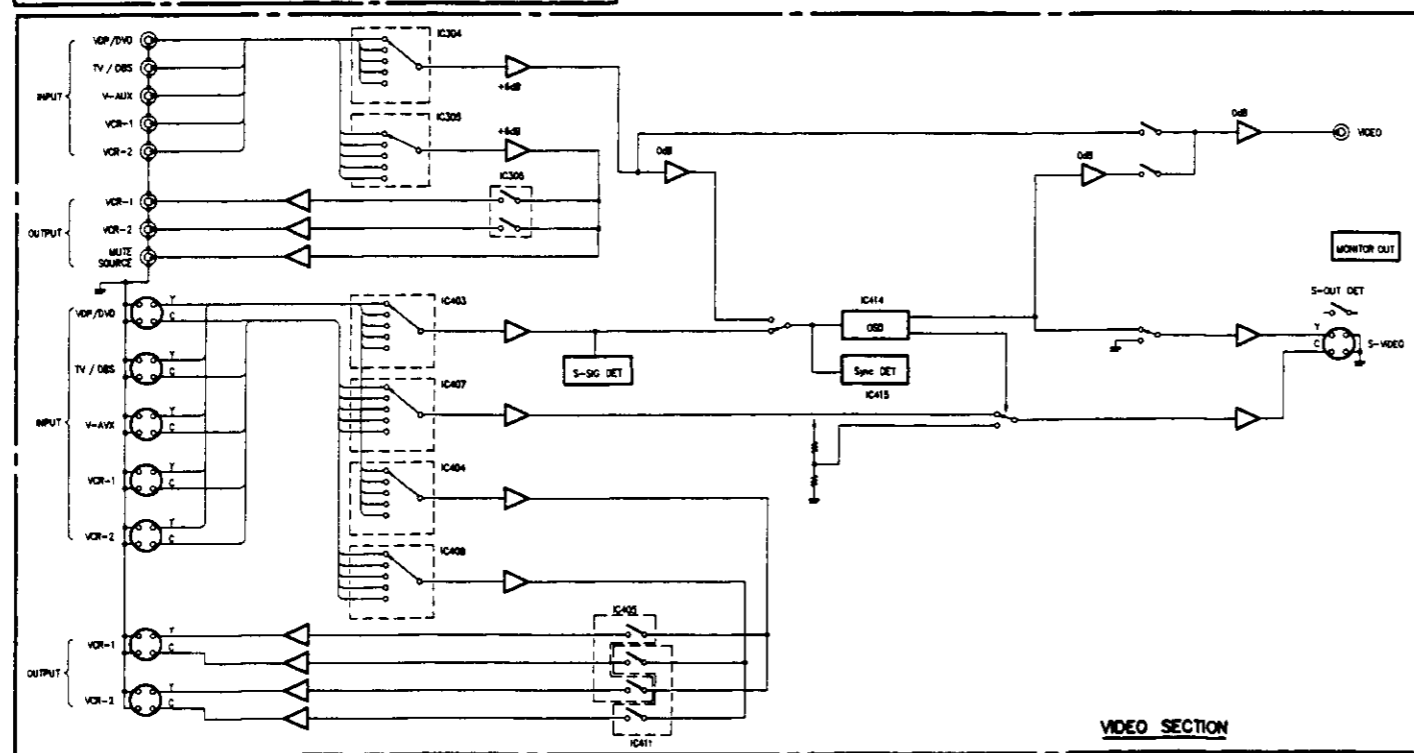

# BLOCK LEVEL DIAGRAM

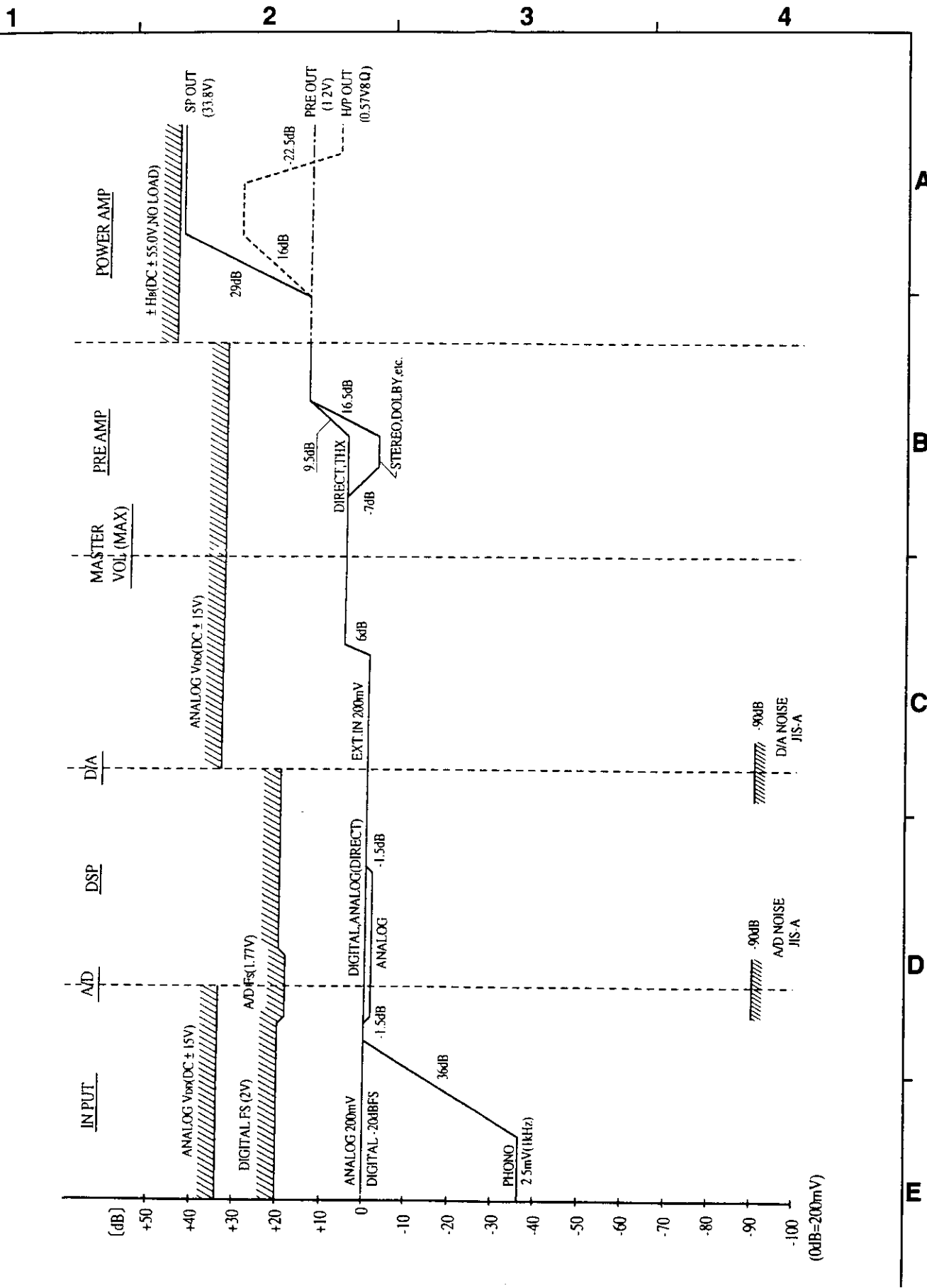







SCHEMATIC DIAGRAM (1/16)

1 2 3 4 5 6

A  
B  
C  
D  
E  
F  
G  
H

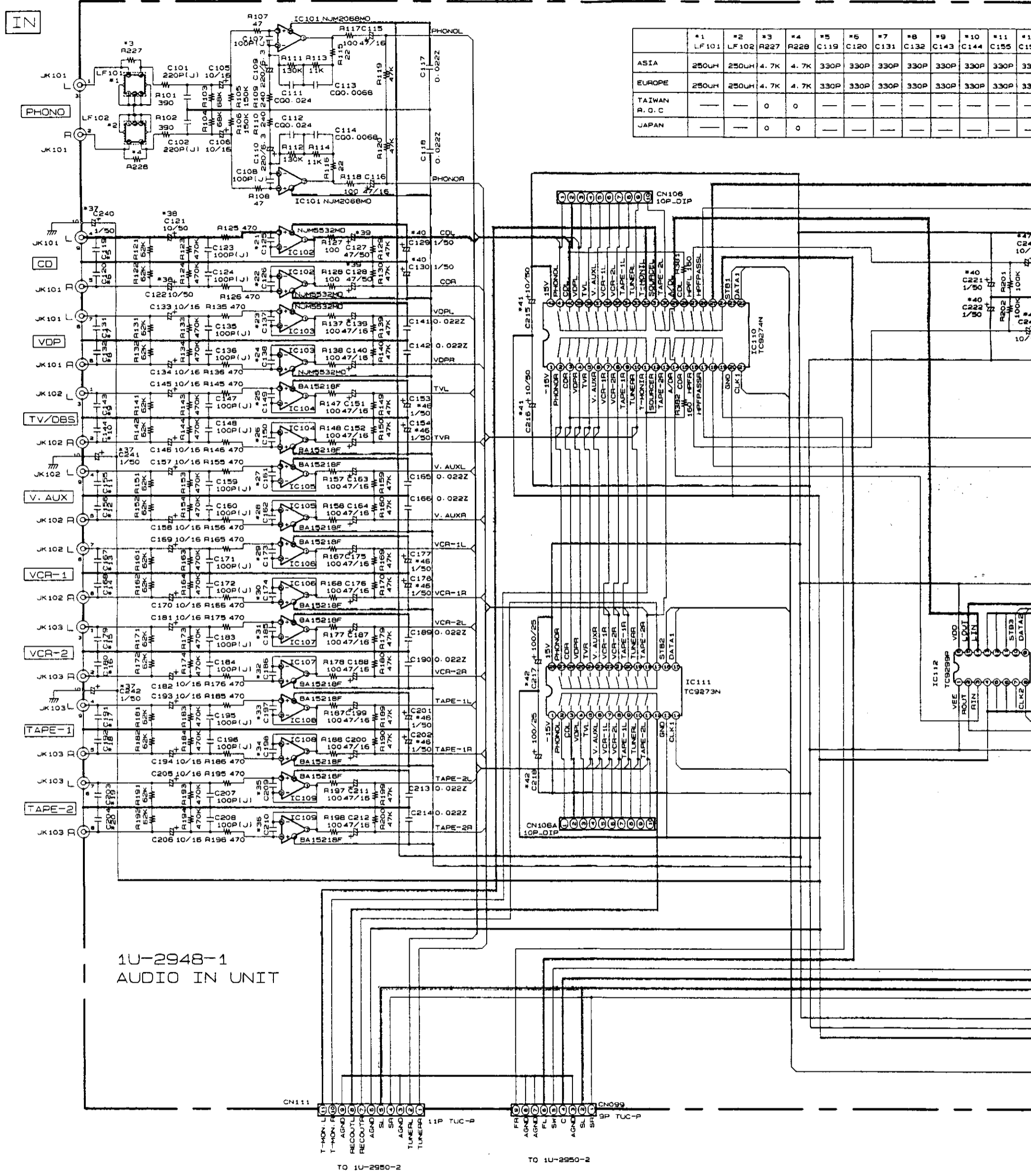

	*1	*2	*3	*4	*5	*6	*7	*8	*9	*10	*11	*12
ASIA	250uH	250uH	4.7K	4.7K	330P	330P	330P	330P	330P	330P	330P	330P
EUROPE	250uH	250uH	4.7K	4.7K	330P	330P	330P	330P	330P	330P	330P	330P
TAI.WAN R.O.C			0	0								
JAPAN			0	0								

1U-2948-1  
AUDIO IN UNIT

	*37	*38	*39	*40	*41	*42	*43	*44	*45	*46	*47	*48
	C240-C242	C121 C122	C127 C128	C129, C130 C221, C222	C215 C216	C217 C218	C229 C230	C231 C232	C236 C237	C153, C154, C202 C177, C178, C201, C248	C247 C249	C250
ASIA/EUROPE	1/50	10/50	47/50	1/50	10/50	100/25	100/25	10/16	100/16	1/50	10/16	47/16
TAIWAN R.O.C	1/50	10/50	47/50	1/50	10/50	100/25	100/25	10/16	100/16	1/50	10/16	47/16
JAPAN	1/50 (ASF)	4.7/50 (ARS)	47/50 (ASF)	COO.01 (NH)	4.7/50 (ARS)	100/25 (ASF)	100/25 (ASF)	10/16 (ASF)	100/16 (ASF)	1/50 (ASF)	10/16 (ASF)	47/16 (ASF)

NOTES  
ALL RESISTANCE VALUES IN OHM. 1=1,000 OHM.  
ALL CAPACITANCE VALUES IN MICRO FARAD.  
EACH VOLTAGE AND CURRENT ARE MEASURED UNDER  
CONDITION.  
CIRCUIT AND PARTS ARE SUBJECT TO CHANGE  
NOTICE.

*5	*6	*7	*8	*9	*10	*11	*12	*13	*14	*15	*16	*17	*18	*19	*20	*21	*22	*23	*24	*25	*26	*27	*28	*29	*30	*31	*32	*33	*34	*35	*36
C119	C120	C131	C132	C143	C144	C155	C156	C167	C168	C179	C180	C191	C192	C203	C204	C125	C126	C137	C138	C149	C150	C161	C162	C173	C174	C185	C186	C197	C198	C209	C210
330P	330P	330P	330P	330P	330P	330P	330P	330P	330P	330P	330P	330P	330P	330P	330P	100P	100P	100P	100P	100P	100P	100P	100P	100P	100P	100P	100P	100P	100P	100P	
330P	330P	330P	330P	330P	330P	330P	330P	330P	330P	330P	330P	330P	330P	330P	330P	100P	100P	100P	100P	100P	100P	100P	100P	100P	100P	100P	100P	100P	100P	100P	
—	—	—	—	—	—	—	—	—	—	—	—	—	—	—	—	—	—	—	—	—	—	—	—	—	—	—	—	—	—	—	—
—	—	—	—	—	—	—	—	—	—	—	—	—	—	—	—	—	—	—	—	—	—	—	—	—	—	—	—	—	—	—	—

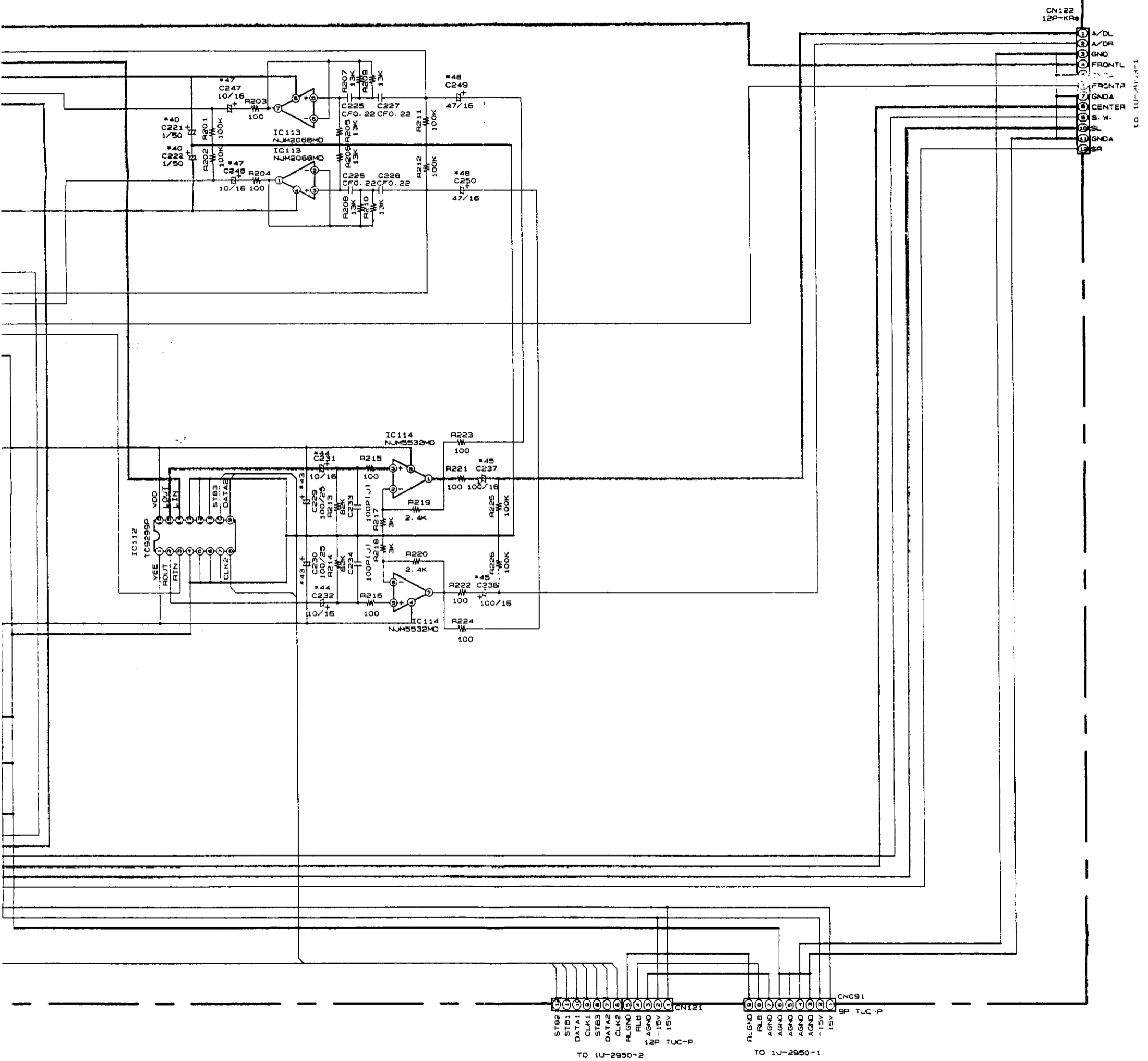

**NOTES**  
 ALL RESISTANCE VALUES IN OHM. k=1,000 OHM, M=1,000,000 OHM  
 ALL CAPACITANCE VALUES IN MICRO FARAD. P=MICRO-MICRO FARAD  
 EACH CAPACITANCE AND CURRENT ARE MEASURED AT NO SIGNAL INPUT CONDITION.  
 CIRCUIT AND PARTS ARE SUBJECT TO CHANGE WITHOUT PRIOR NOTICE.

**WARNING:**  
 Parts marked with this symbol have critical characteristics. Use ONLY replacement parts recommended by the manufacturer.

**CAUTION:**  
 Before returning the unit to the customer, make sure you make either (1) a leakage current check or (2) a line to chassis resistance check. If the leakage current exceeds 0.5 milamps, or if the resistance from chassis to either side of the power card is less than 240 kohms, the unit is defective.

**WARNING:**  
 DO NOT return the unit to the customer until the problem is located and corrected.

+B LINE  
 -B LINE  
 SIGNAL LINE

6

7

8

9

10

11

A

B

C

D

E

F

G

H

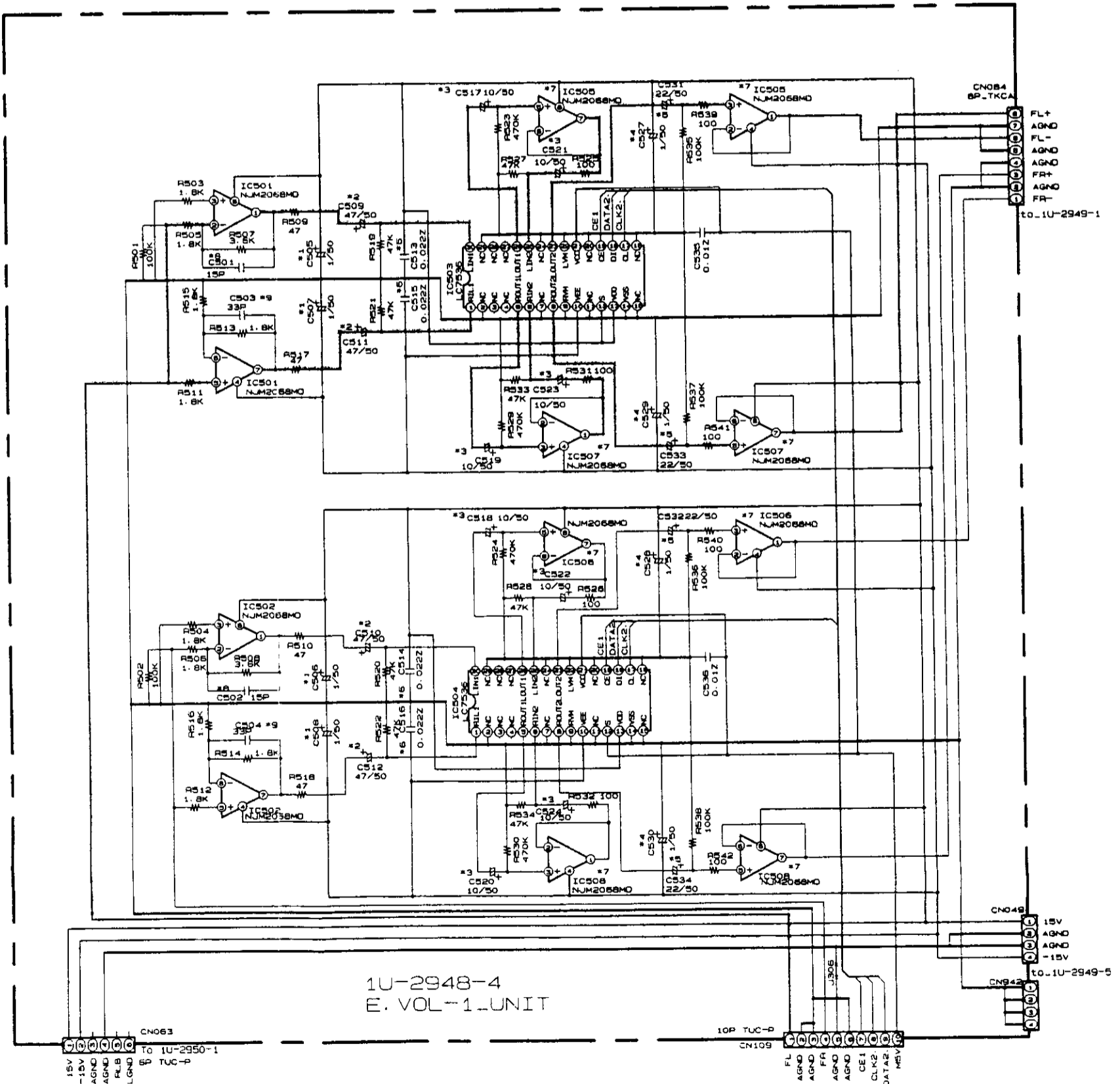

1U-2948-4  
E. VOL-1 UNIT

	#1 C505-C508	#2 C509-C512	#3 C517-C524	#4 C527-C530	#5 C531-C534	#6 C513-C516	#7 IC505-508	#8 C501, 502	#9 C503, 504
ASIA/EUROPE	1/50	47/50	10/50	1/50	22/50	0.022Z	NJM2068M	15P	30P
TAIWAN R.O.C	1/50	47/50	10/50	10/50	22/50	—	NJM5532M	C015P(NH)	C030P(NH)
JAPAN	1/50 (ARSA)	47/50 (ARSA)	10/50 (ARSA)	10/50 (ARSA)	22/50 (ARSA)	—	NJM5532M	C015P(NH)	C030P(NH)

--- +B LINE  
--- -B LINE  
--- SIGNAL LINE

--- +B LINE  
--- -B LINE  
--- SIGNAL LINE

SCHEMATIC DIAGRAM (4/16)

1 2 3 4 5

A

B

C

D

E

F

G

H

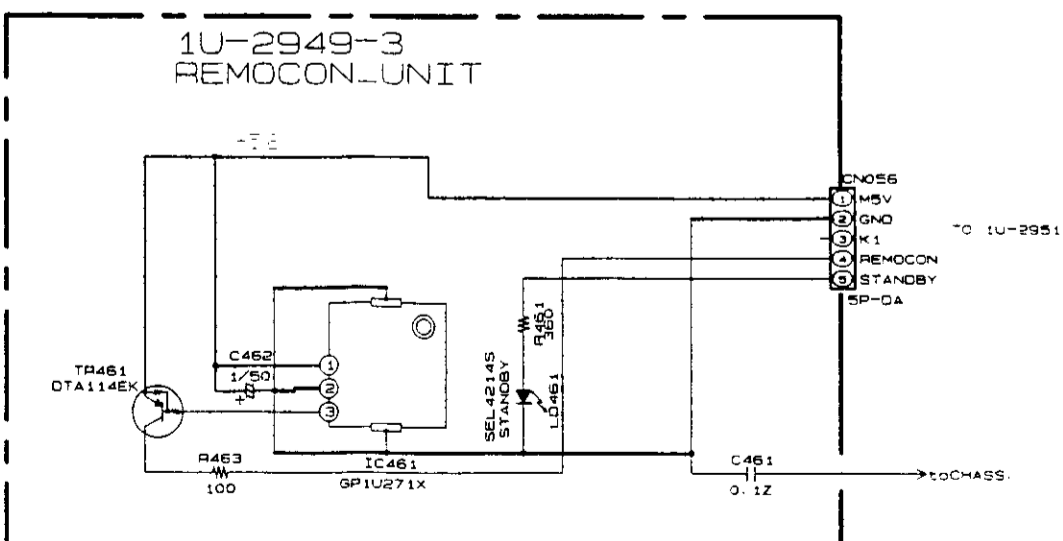
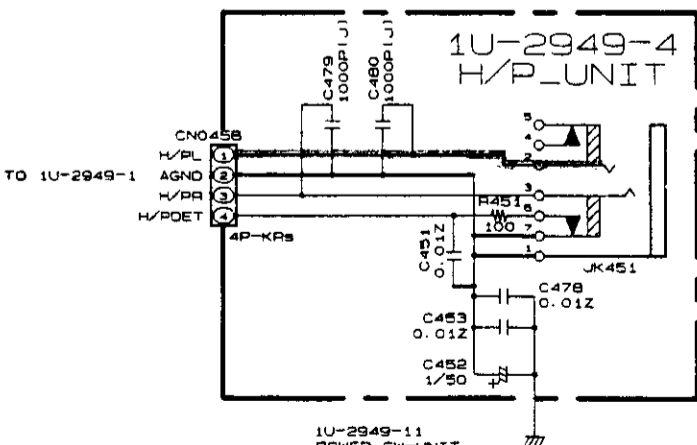
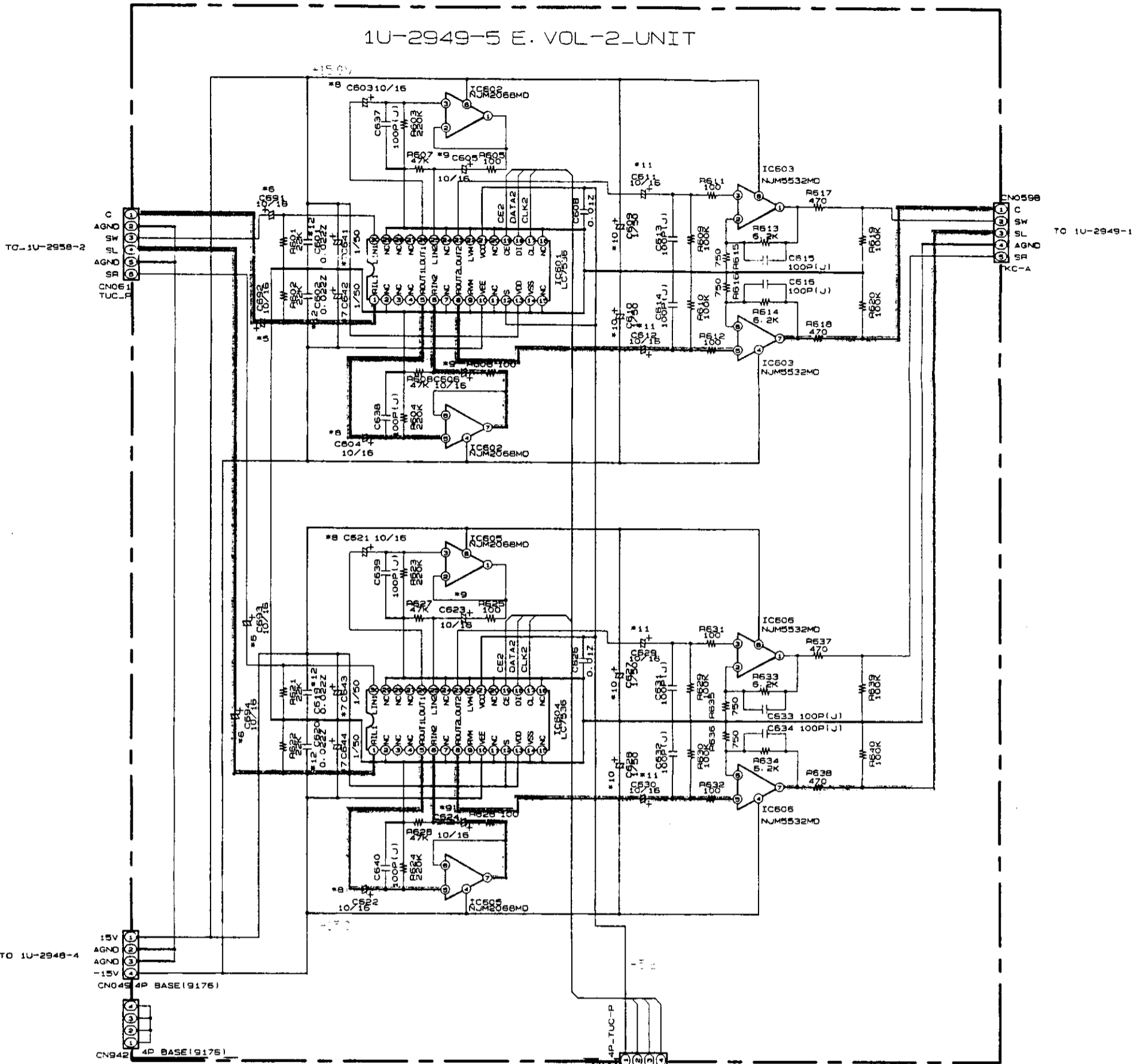

# SCHEMATIC DIAGRAM (2/16) (3/16)

1 2 3 4 5

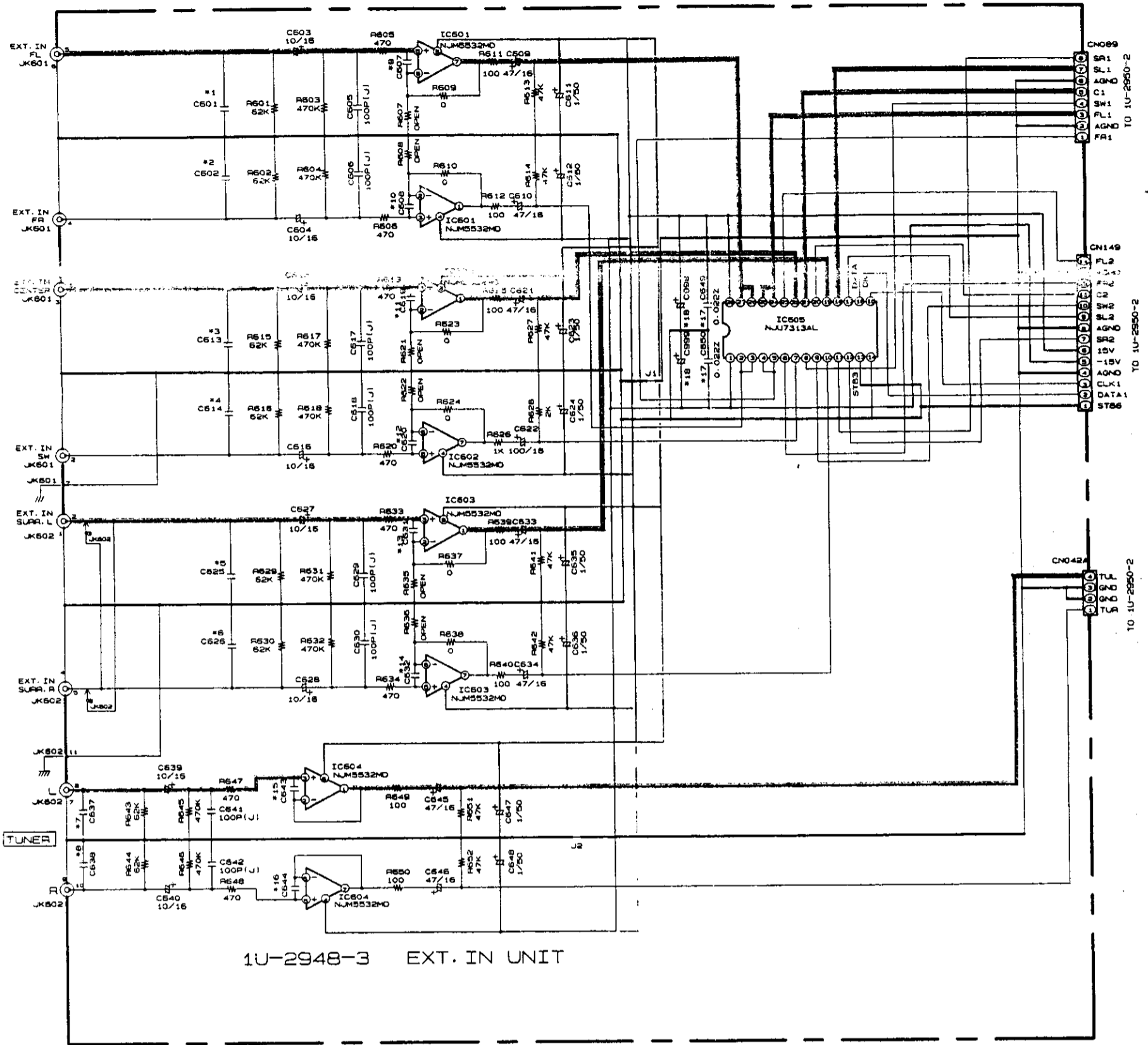

1U-2948-3 EXT. IN UNIT

	*1 C601	*2 C602	*3 C613	*4 C614	*5 C625	*6 C626	*7 C637	*8 C638	*9 C607	*10 C608	*11 C619	*12 C620	*13 C631	*14 C632	*15 C643	*16 C644	*17 C649. 650	*18 C998. 999
ASIA	330P	330P	330P	330P	330P	330P	330P	330P	100P	100P	100P	100P	100P	100P	100P	100P	0.022Z	—
EUROPE	330P	330P	330P	330P	330P	330P	330P	330P	100P	100P	100P	100P	100P	100P	100P	100P	0.022Z	—
TAIWAN R. O. C.	—	—	—	—	—	—	—	—	—	—	—	—	—	—	—	—	0.022Z	—
JAPAN	—	—	—	—	—	—	—	—	—	—	—	—	—	—	—	—	C00.01 (NH)	100/50 (ARS)

**NOTES**  
 ALL RESISTANCE VALUES IN OHM. K=1,000 OHM, M=1,000,000 OHM  
 ALL CAPACITANCE VALUES IN MICRO FARAD. P=MICRO-MICRO FARAD  
 EACH VOLTAGE AND CURRENT ARE MEASURED AT NO SIGNAL INPUT  
 CONDITION.  
 CIRCUIT AND PARTS ARE SUBJECT TO CHANGE WITHOUT PRIOR  
 NOTICE.

**WARNING:**  
 Parts marked with this symbol have critical characteristics.  
 Use ONLY replacement parts recommended by the manufacturer.

**CAUTION:**  
 Before returning the unit to the customer, make sure you make either (1) a leakage current check or (2) a line to chassis resistance check. If the leakage current exceeds 0.5 milliamps, or if the resistance from chassis to either side of the power cord is less than 240 kohms, the unit is defective.

**WARNING:**  
 DO NOT return the unit to the customer until the problem is located and corrected.

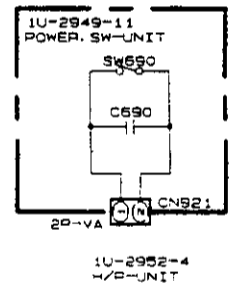
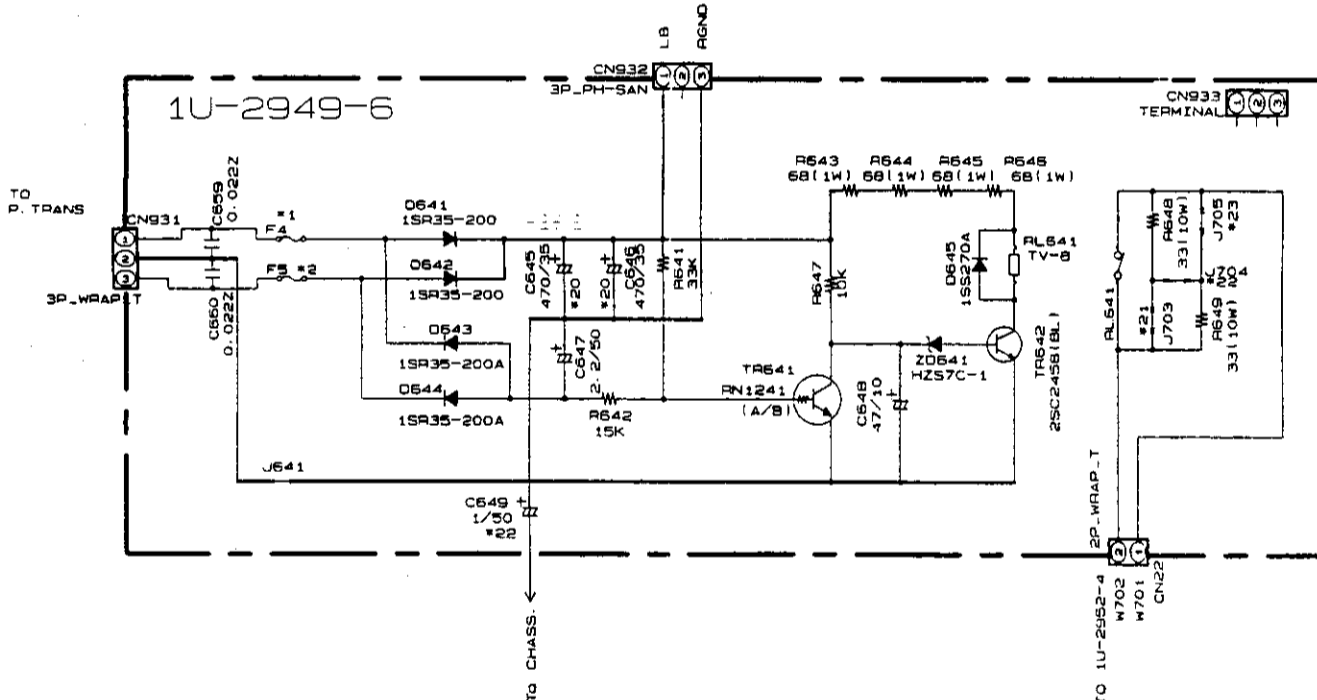
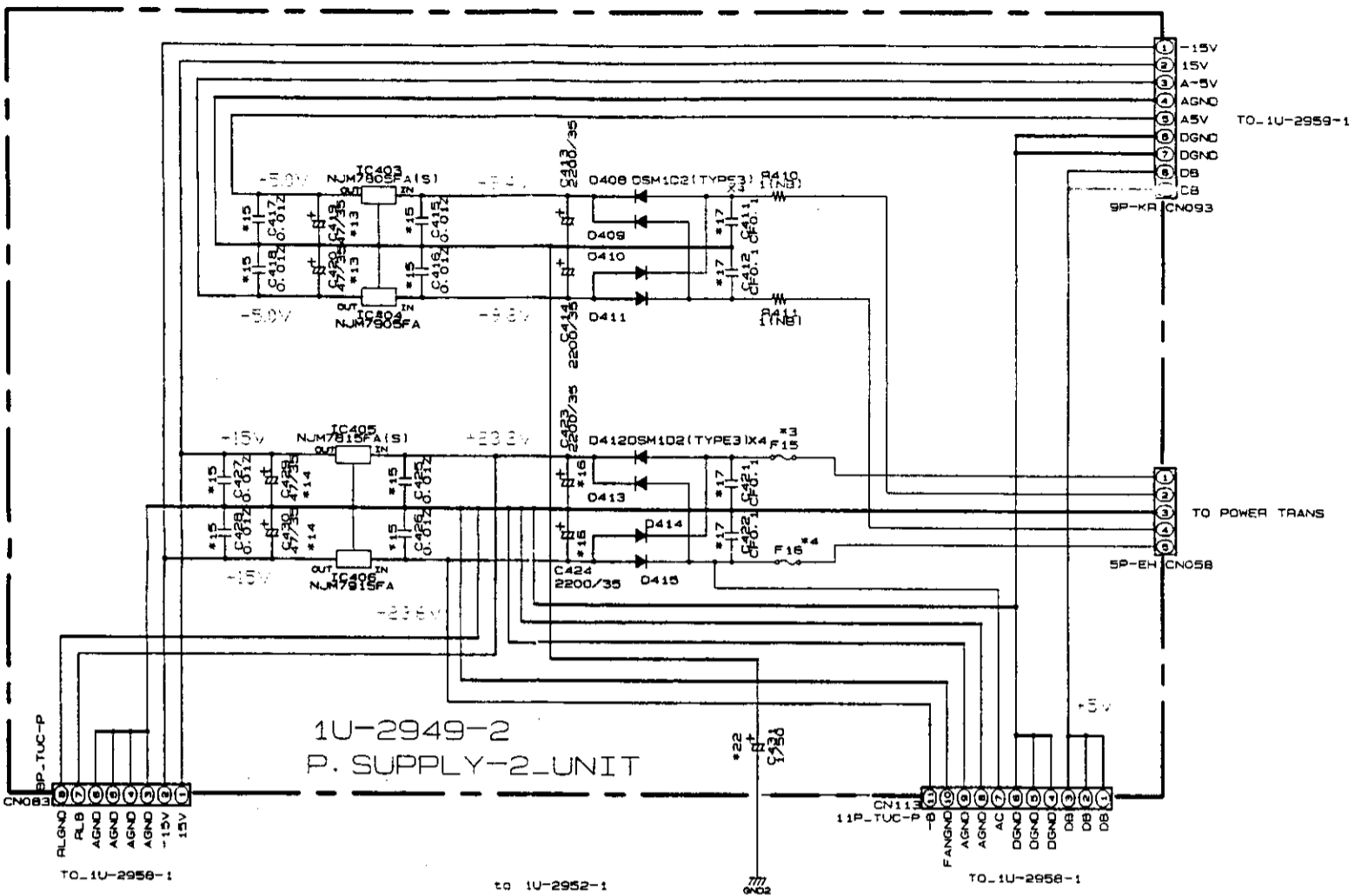

	*5 C692	*6 C691 C693, C694	*7 C641-C644	*8 C603, C604 C621, C622	*9 C605, C606 C623, C624	*10 C609, C610 C627, C628	*11 C611, C612 C629, C630	*12 C601, C602 C619, C620	*13 C419, C420	*14 C429, C430	*15 C415, C418 C425, C428	*16 C423, C424	*17 C411, C412 C421, C422	*18 C659, C660
ASIA/EUROPE	10/16	10/16	1/50	10/16	10/16	1/50	10/16	0.022Z	47/35	47/35	0.012	2200/35	CF0.1	0.022Z
TAIWAN R.O.C	10/50 (ARS)	10/50 (ASF)	C00.01 (NH)	10/50 (ARS)	10/50 (ASF)	1/50 (ASF)	10/50 (ARS)	---	47/50 (ASF)	47/50 (ARS)	---	2200/50 (ASF)	C00.01 (NH)	C00.01 (NH)

	*19 C431, C649	*20 C645
ASIA/EUROPE	1/50	470/35
TAIWAN R.O.C	1/50 (ASF)	470/35 (ASF)
JAPAN	1/50 (ASF)	470/35 (ASF)

	*21 J703	*22 J704	*23 J705
ASIA/EUROPE	—	○	—
TAIWAN R.O.C	○	—	○
JAPAN	○	—	○

	*1 F4	*2 F5	*3 F15	*4 F16
ASIA	1A/250V 2061015029	1A/250V 2061015029	2A/250V 2061015061	2A/250V 2061015061
EUROPE	1A/250V 2061015029	1A/250V 2061015029	2A/250V 2061015061	2A/250V 2061015061
TAIWAN R.O.C	1A/125V 2061039034	1A/125V 2061039034	2A/125V 2061039063	2A/125V 2061039063
JAPAN	1A/125V 2061053007	1A/125V 2061053007	2A/125V 2061035041	2A/125V 2061035041

----- +B LINE  
 - - - - - -B LINE  
 \_\_\_\_\_ SIGNAL LINE

**NOTES**  
 ALL RESISTANCE VALUES IN OHM, k=1,000 OHM, M=1,000,000 OHM  
 ALL CAPACITANCE VALUES IN MICRO FARAD, P=MICRO-MICRO FARAD  
 EACH VOLTAGE AND CURRENT ARE MEASURED AT NO SIGNAL INPUT CONDITION.  
 CIRCUIT AND PARTS ARE SUBJECT TO CHANGE WITHOUT PRIOR NOTICE.

**WARNING:**  
 Parts marked with this symbol have critical characteristics. Use ONLY replacement parts recommended by the manufacturer.

**CAUTION:**  
 Before returning the unit to the customer, make sure you make either (1) a leakage current check or (2) a line to chassis resistance check. If the leakage current exceeds 0.5 millamps, or if the resistance from chassis to either side of the power cord is less than 240 kohms, the unit is defective.

**WARNING:**  
 DO NOT return the unit to the customer until the problem is located and corrected.





A  
B  
C  
D  
E  
F  
G  
H

1U-2950-4 TONE-2 UNIT

1U-2950-3 TONE-1 UNIT

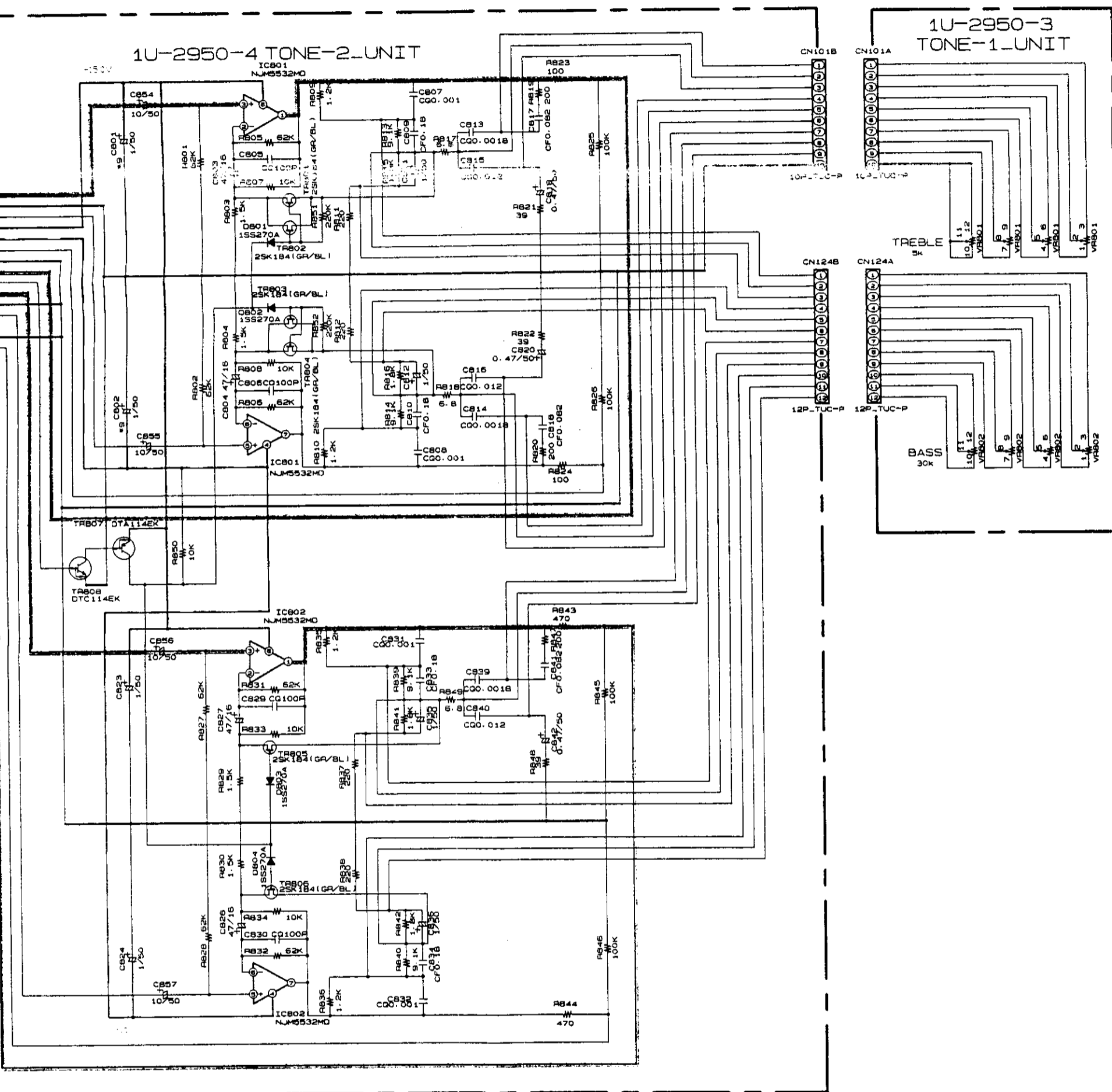

	#1	#2	#3	#4	#5	#6	#7	#8	#9	#10
	C999	C928	C908, 909 C920, 921	C403, 405, 903, 904, 907 C910, 911, 916-918, 921	C914, 915	C406, 407, 901 C902, 912, 913	C404	C410	C801, 802	C854-856
ASIA/EUROPE	—	10/16	47/35	0.01Z	3300/25	0.01Z	10/16	1/50	1/50	10/50
TAIWAN R.O.C	—	10/16	47/35	—	3300/25	0.01Z	10/16	1/50	1/50	10/50
JAPAN	C99.01 (NH)	10/50 (ASF)	47/35 (ASF)	—	3300/25 (ASF)	0.01 (NH)	10/50 (ASF)	1/50 (ASF)	1/50 (ASF)	10/50 (ASF)

----- +B LINE  
 - - - - - -B LINE  
 \_\_\_\_\_ SIGNAL LINE

**NOTES**  
 ALL RESISTANCE VALUES IN OHM. k=1,000 OHM, M=1,000,000 OHM  
 ALL CAPACITANCE VALUES IN MICRO FARAD. P=MICRO-MICRO FARAD  
 EACH VOLTAGE AND CURRENT ARE MEASURED AT NO SIGNAL INPUT  
 CONDITION.  
 CIRCUIT AND PARTS ARE SUBJECT TO CHANGE WITHOUT PRIOR  
 NOTICE.

**WARNING:**  
 Parts marked with this symbol have critical characteristics.  
 Use ONLY replacement parts recommended by the manufacturer.

**CAUTION:**  
 Before returning the unit to the customer, make sure you make either (1) a  
 leakage current check or (2) a line to chassis resistance check. If the leakage  
 current exceeds 0.5 milliamps, or if the resistance from chassis to either side  
 of the power cord is less than 240 kohms, the unit is defective.

**WARNING:**  
 DO NOT return the unit to the customer until the problem is located and  
 corrected.

SCHEMATIC DIAGRAM (6/16)

1 2 3 4 5 6

TO 1U-2950-3 (CN151)

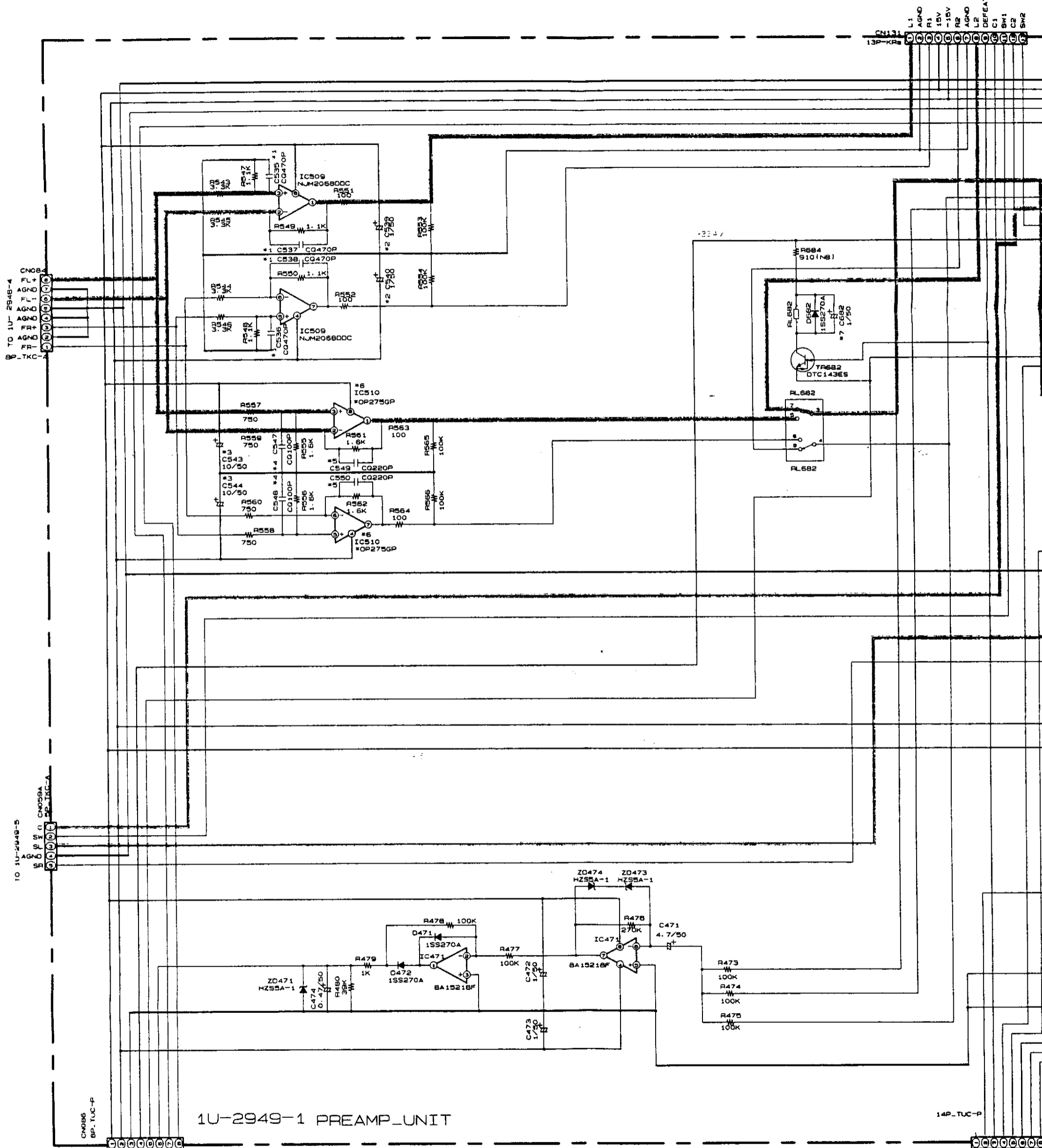

1U-2949-1 PREAMP\_UNIT

	*1	*2	*3	*4	*5	*6	*7
	C535-538	C539, 540	C543, C544	C547, 548	C549, 550	IC510	C571, 582
ASIA/EUROPE	CQ470P	1/50	10/50	CQ1000P	CQ220P	OP275GP	1/50
TAIWAN R.O.C							
JAPAN	CQ470P (NH)	10/50 (ARS)	1/50 (ARSA)	CQ1000P (NH)	CQ220P (NH)	OP271	1/50 (ASF)

NOTES  
ALL RESISTANCE VALUES IN C  
ALL CAPACITANCE VALUES IN  
EACH VOLTAGE AND CURREN  
CONDITION.  
CIRCUIT AND PARTS ARE SUB  
NOTICE.

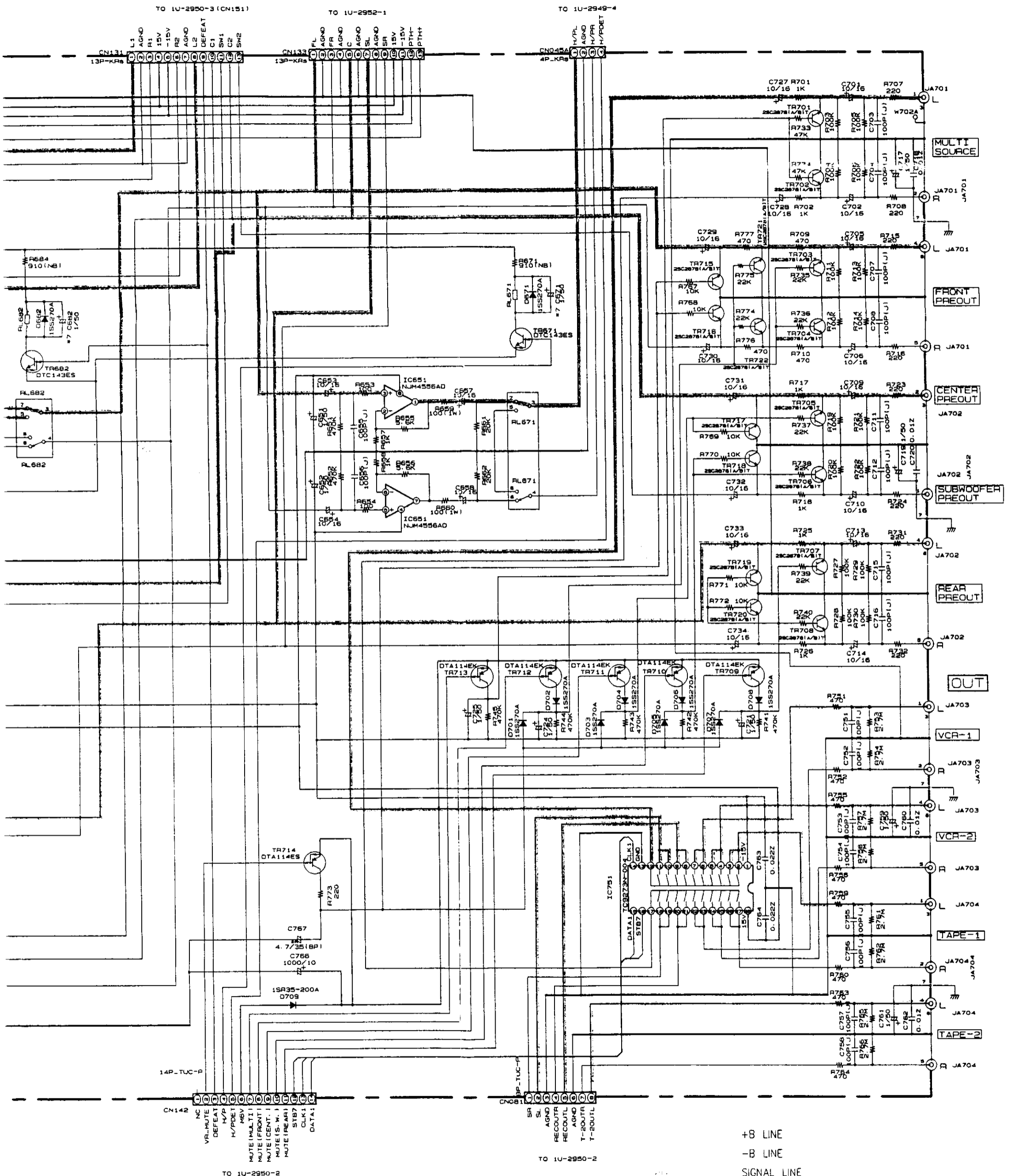

TO 1U-2950-3 (CN151)

TO 1U-2952-1

TO 1U-2949-4

14P\_TUC-P

BP\_TUC-F

TO 1U-2950-2

TO 1U-2950-2

+B LINE  
-B LINE  
SIGNAL LINE

**NOTES**  
ALL RESISTANCE VALUES IN OHM, K=1,000 OHM, M=1,000,000 OHM  
ALL CAPACITANCE VALUES IN MICRO FARAD, P=MICRO-MICRO FARAD  
EACH VOLTAGE AND CURRENT ARE MEASURED AT NO SIGNAL INPUT CONDITION.  
CIRCUIT AND PARTS ARE SUBJECT TO CHANGE WITHOUT PRIOR NOTICE.

**WARNING:**  
Parts marked with this symbol have critical characteristics. Use ONLY replacement parts recommended by the manufacturer.

**CAUTION:**  
Before returning the unit to the customer, make sure you make either (1) a leakage current check or (2) a line to chassis resistance check. If the leakage current exceeds 0.5 milamps, or if the resistance from chassis to either side of the power cord is less than 240 kohms, the unit is defective.

**WARNING:**  
DO NOT return the unit to the customer until the problem is located and corrected.

**SCHEMATIC DIAGRAM (7/16) (8/16)**

1                      2                      3                      4                      5                      6

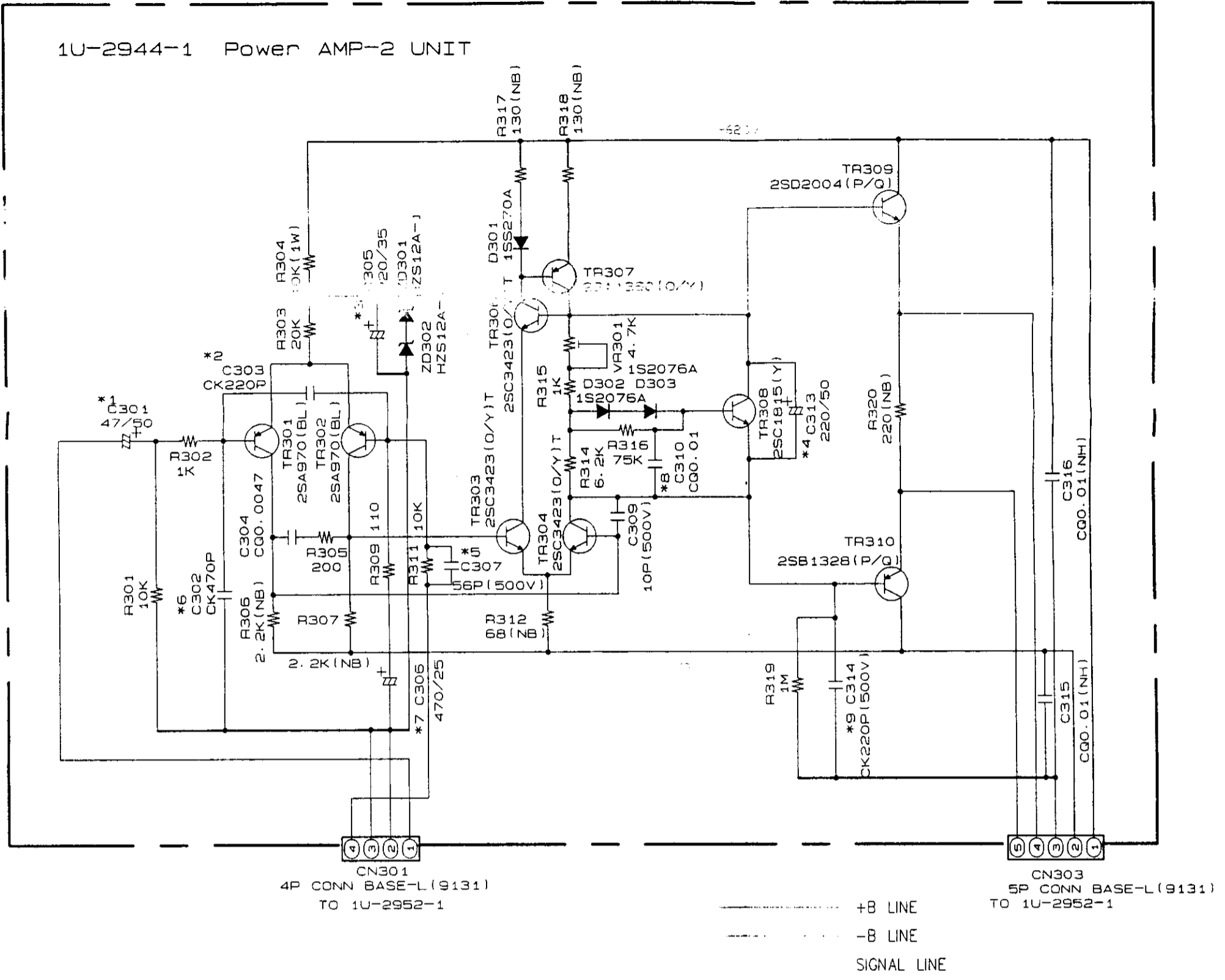

	*1	*2	*3	*4	*5	*6	*7	*8	*9
	C301	C303	C305	C313	C307	C302	C306	C310	C314
ASIA/EUROPE TAIWAN R. O. C	47/50	CK220P	220/35	220/50	56P [500V]	CK470P	470/25	C00.01	220P [500V]
JAPAN	47/50 (ASF)	CQ220P (NH)	220/50 (ASF)	220/50 (ASF)	CQ56P (NH)	CQ470P (NH)	470/25 (ASF)	CQ0.01 (NH)	CQ220P (NH)

**NOTES**  
 ALL RESISTANCE VALUES IN OHM. k=1,000 OHM, M=1,000,000 OHM  
 ALL CAPACITANCE VALUES IN MICRO FARAD. P=MICRO-MICRO FARAD  
 EACH VOLTAGE AND CURRENT ARE MEASURED AT NO SIGNAL INPUT  
 CONDITION.  
 CIRCUIT AND PARTS ARE SUBJECT TO CHANGE WITHOUT PRIOR  
 NOTICE.

**WARNING:**  
 Parts marked with this symbol have critical characteristics.  
 Use ONLY replacement parts recommended by the manufacturer.

**CAUTION:**  
 Before returning the unit to the customer, make sure you make either (1) a  
 leakage current check or (2) a line to chassis resistance check. If the leakage  
 current exceeds 0.5 milliamps, or if the resistance from chassis to either side  
 of the power cord is less than 240 kohms, the unit is defective.

**WARNING:**  
 DO NOT return the unit to the customer until the problem is located and  
 corrected.

TO  
 1U-2950-1  
 P. SUPPLY-4  
 UNIT  
 CN057  
 CN057  
 5P-

	*1 F1	*2 F2	*3 F3
ASIA	630mA/250V 2061036008	JW	6.3A/2 206101
EUROPE	630mA/250V 2061036008	JW	6.3A/2 206101
TAIWAN R. O. C	2A/125V 2061039063	15A/125V 2061051012	JW
JAPAN	2A/125V 2061035041	15A/125V 2061017030	JW

6 7 8 9 10 11

A  
B  
C  
D  
E  
F  
G  
H

C316  
C00.01(NH)  
C315  
C00.01(NH)  
303  
DNN BASE-L(9131)  
2952-1

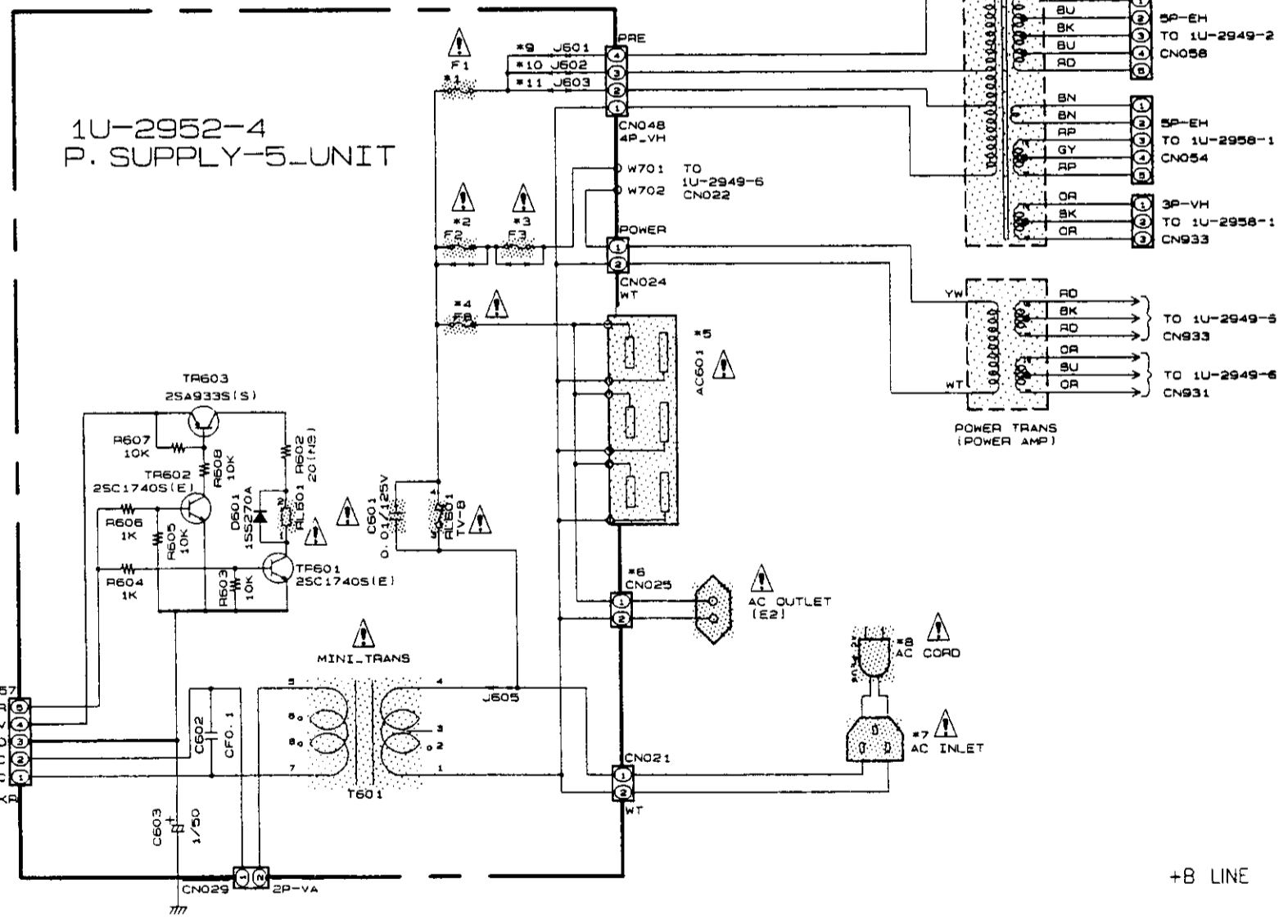

*9	C314
	220P(500V)
	CQ220P(NH)

*1	*2	*3	*4	*5	*6	*7	*8	*9	*10	*11
F1	F2	F3	F8	AC601	CN025	AC INLET	AC CORD	J601	J602	J603
0mA/250V 51036008	JW	6.3A/250V 2061015061	2.5A/250V 2061015032	---	2P VH	2P 2033970008	2062154002 2062148005	JW	---	---
0mA/250V 51036008	JW	6.3A/250V 2061015061	2.5A/250V 2061015032	---	2P VH	2P 2033970008	2062154002	JW	---	---
1/125V 51039063	15A/125V 2061051012	JW	8A/125V 2061046014	3P AC OUTLET	---	3P 2033962003	2062150103	---	JW	---
1/125V 51035041	15A/125V 2061017030	JW	8A/125V 2061052008	3P AC OUTLET	---	3P 2033962003	2062150103	---	---	JW

+B LINE

# SCHEMATIC DIAGRAM (9/16)

1 2 3 4 5 6

A

B

C

D

E

F

G

H

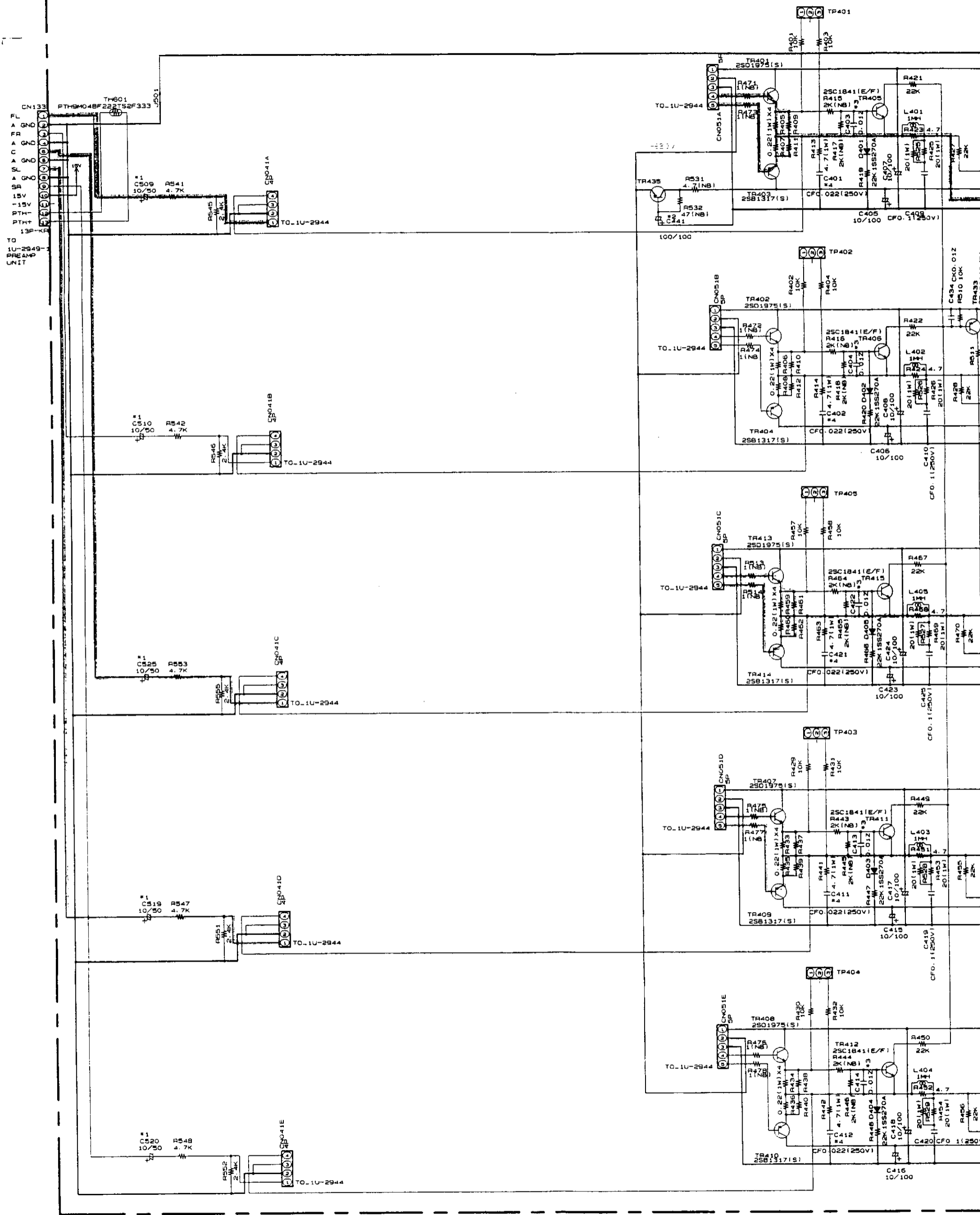

1U-2952-1 POWERAMP UNIT

1U-2952-2 POWER SUPPLY-1

SP TERMINAL UNIT  
1U-2952-3

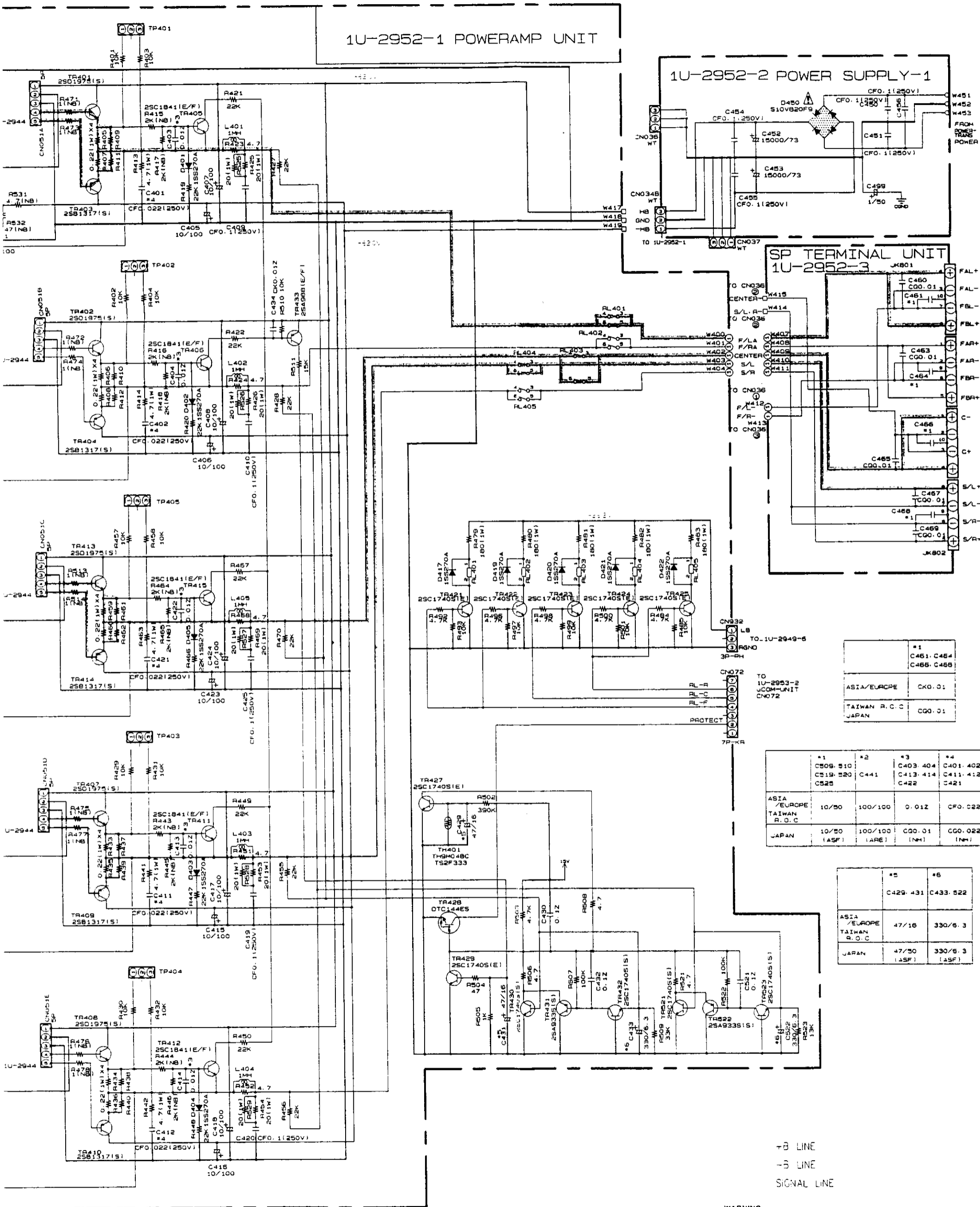

#1	C461, C464 C465, C468
ASIA/EUROPE	CGO. 01
TAIWAN R. O. C	CGO. 01
JAPAN	CGO. 01

#1	C509, 510 C519, 520 C525	#2	C441	#3	C403, 404 C413, 414 C422	#4	C401, 402 C411, 412 C421
ASIA / EUROPE	10/50	100/100	0.01Z	CGO. 022			
TAIWAN R. O. C	10/50	100/100	CGO. 01	CGO. 022			
JAPAN	(ASF)	(ARE)	(NH)	(NH)			

#5	C429, 431	#6	C433, 522
ASIA / EUROPE	47/16	330/6.3	
TAIWAN R. O. C	47/50	330/6.3	
JAPAN	(ASF)	(ASF)	

+B LINE  
-B LINE  
SIGNAL LINE

**NOTES**  
ALL RESISTANCE VALUES IN OHM, K=1,000 OHM, M=1,000,000 OHM  
ALL CAPACITANCE VALUES IN MICRO FARAD, P=MICRO-MICRO FARAD  
EACH VOLTAGE AND CURRENT ARE MEASURED AT NO SIGNAL INPUT CONDITION  
CIRCUIT AND PARTS ARE SUBJECT TO CHANGE WITHOUT PRIOR NOTICE

**WARNING:**  
Parts marked with this symbol have critical characteristics. Use ONLY replacement parts recommended by the manufacturer.

**CAUTION:**  
Before returning the unit to the customer, make sure you make either (1) a leakage current check or (2) a line to chassis resistance check. If the leakage current exceeds 0.5 millamps, or if the resistance from chassis to either side of the power cord is less than 240 koms, the unit is defective.

**WARNING:**  
DO NOT return the unit to the customer until the problem is located and corrected.



SCHMATIC DIAGRAM (10/16)

1 2 3 4 5 6

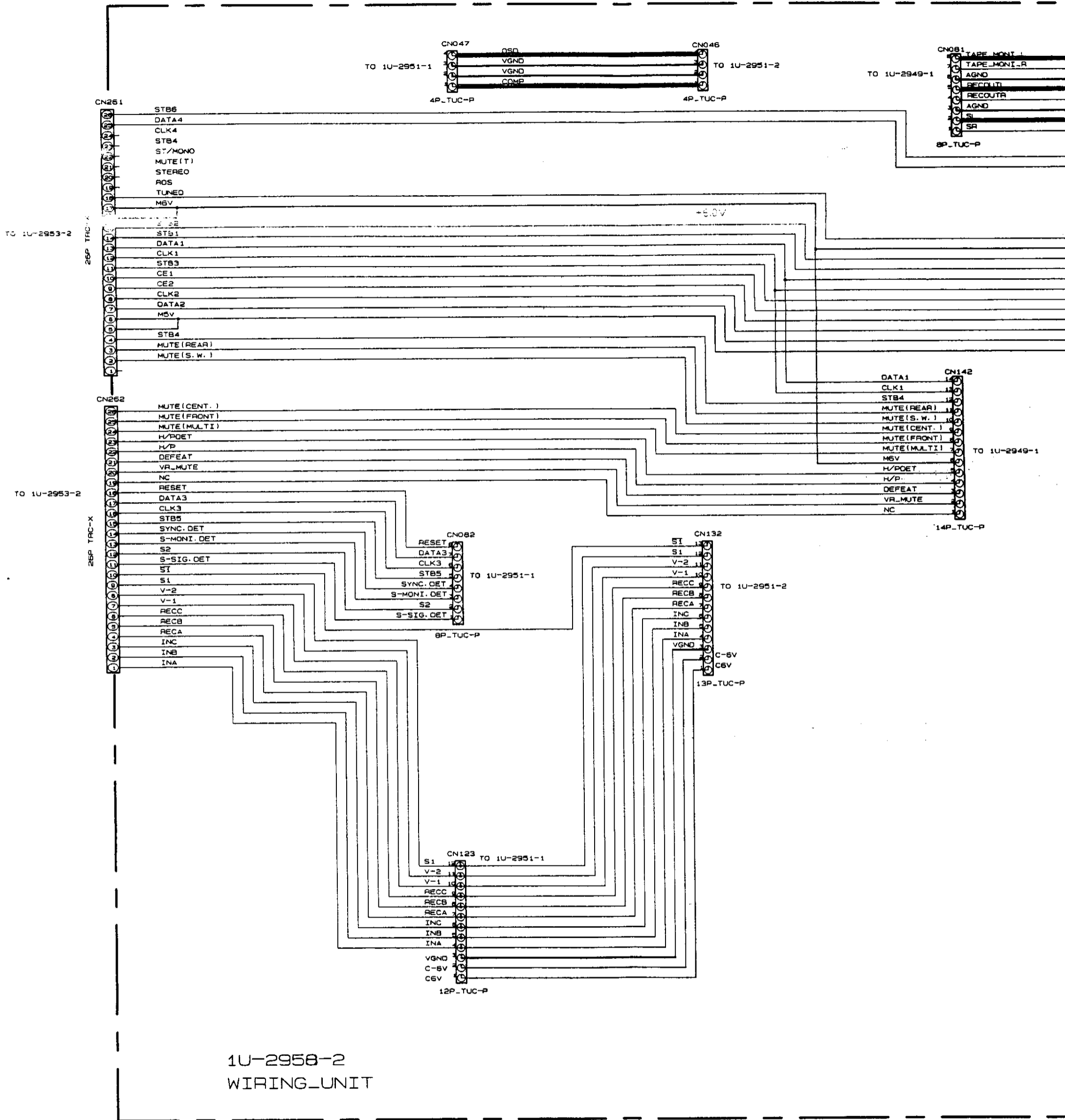

1U-2958-2  
WIRING\_UNIT

**NOTES**  
ALL RESISTANCE VALUES IN OHM. k=1,000 OHM, M=1,000,000 OHM  
ALL CAPACITANCE VALUES IN MICRO FARAD. P=MICRO-MICRO FARAD  
EACH VOLTAGE AND CURRENT ARE MEASURED AT NO SIGNAL INPUT CONDITION.  
CIRCUIT AND PARTS ARE SUBJECT TO CHANGE WITHOUT PRIOR NOTICE.

**WARNING:**  
Parts marked with this symbol have critical characteristics. Use ONLY replacement parts recommended by the manufacturer.

**CAUTION:**  
Before returning the unit to the customer, make sure you make leakage current check or (2) a line to chassis resistance check. current exceeds 0.5 milliamps, or if the resistance from chassis of the power cord is less than 240 kohms, the unit is defective.

**WARNING:**  
DO NOT return the unit to the customer until the problem is located and corrected.

6 7 8 9 10 11

A  
B  
C  
D  
E  
F  
G  
H

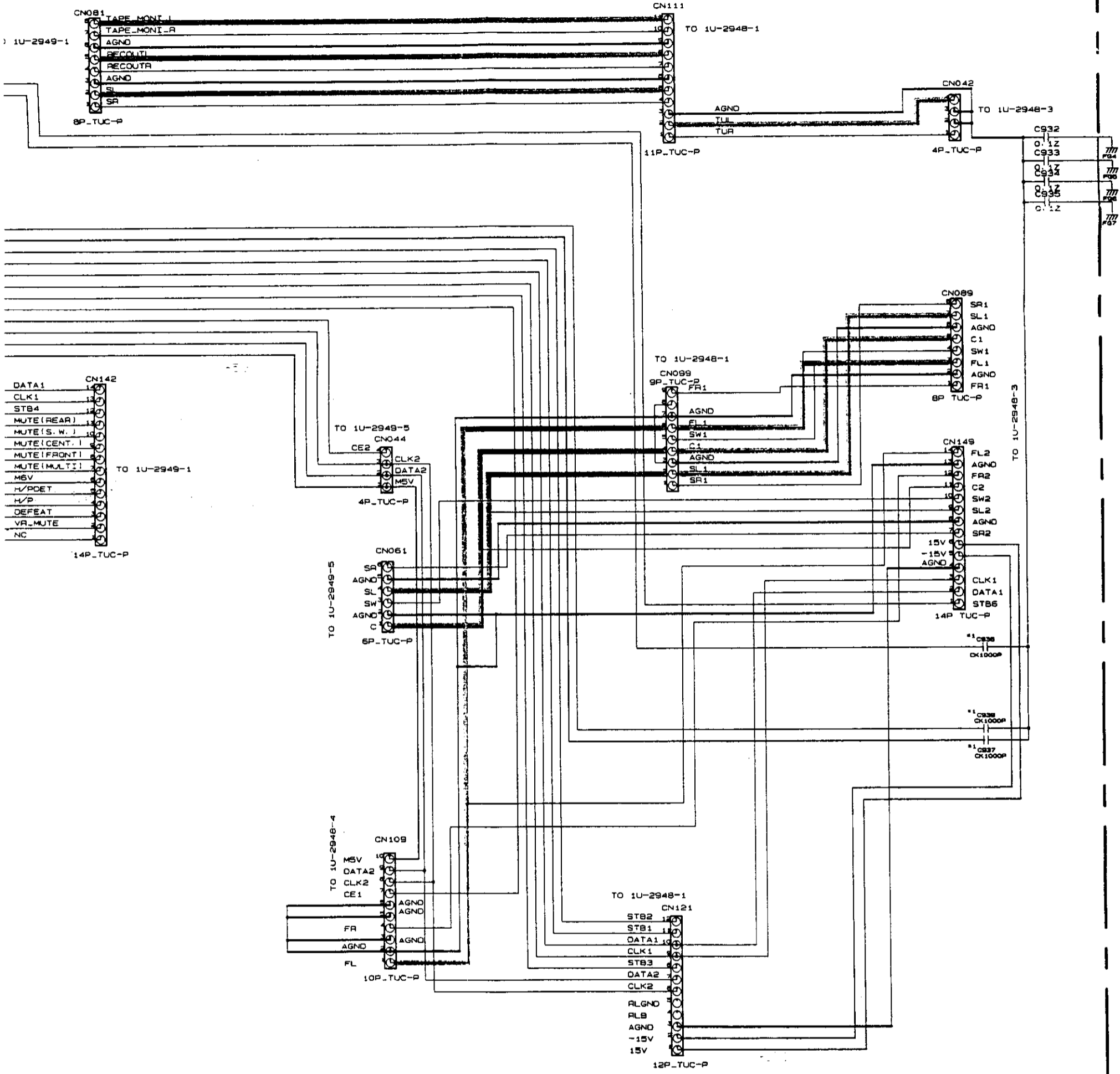

with this symbol have critical characteristics. Replacement parts recommended by the manufacturer.

When returning the unit to the customer, make sure you make either (1) a continuity check or (2) a line to chassis resistance check. If the leakage current is 0.5 milliamps, or if the resistance from chassis to either side of the cord is less than 240 kohms, the unit is defective.

When returning the unit to the customer until the problem is located and

	*1 C936, 937, 939
ASIA/EUROPE	1000P
TAIWAN R.O.C	
JAPAN	

----- +B LINE  
 - - - - - -B LINE  
 \_\_\_\_\_ SIGNAL LINE

# SCHEMATIC DIAGRAM (11/16)

1 2 3 4 5 6

A  
B  
C  
D  
E  
F  
G  
H

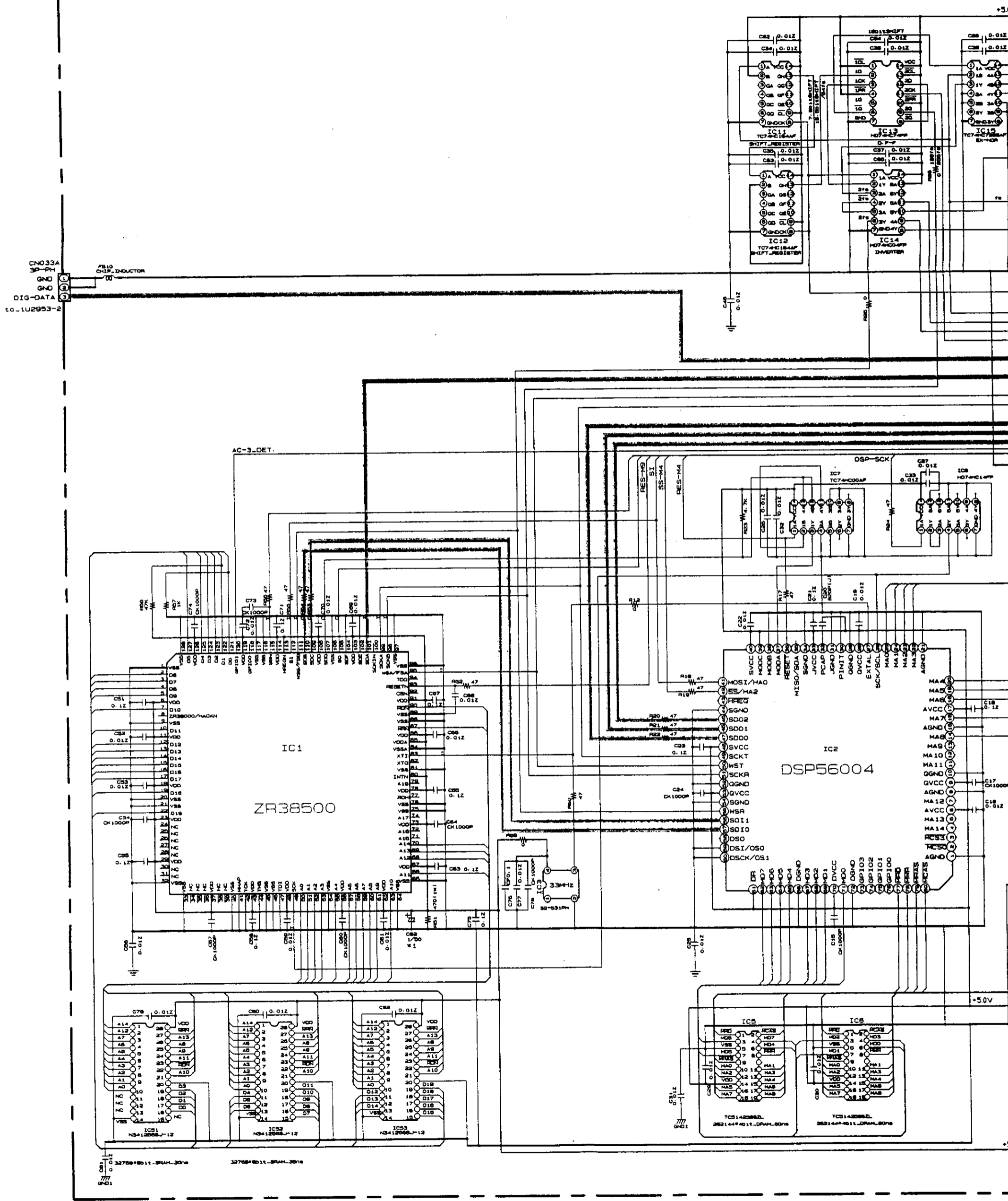

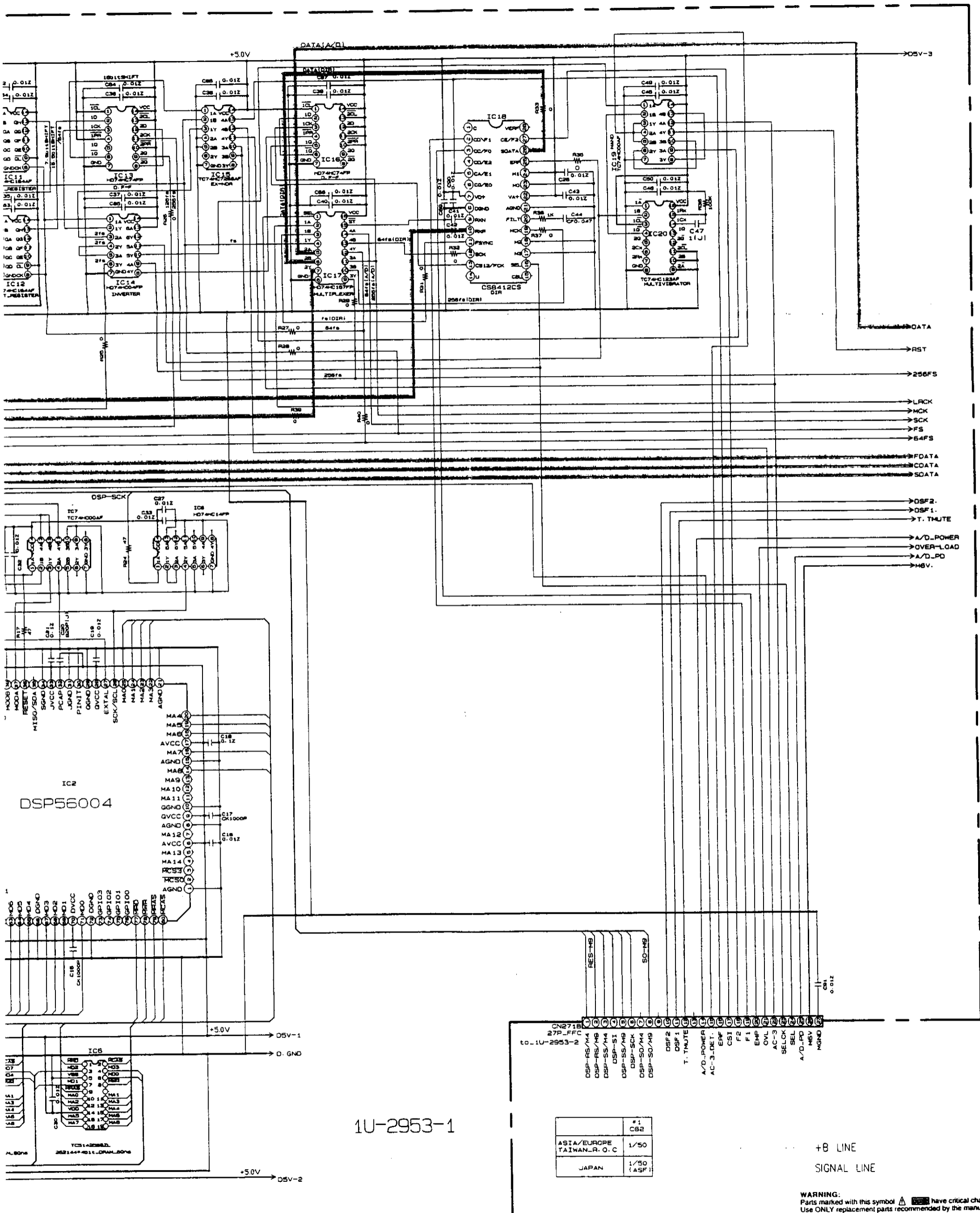

1U-2953-1

	#1
ASIA/EUROPE	1/50
TAIWAN_R. O. C	
JAPAN	1/50 (ASF)

+B LINE SIGNAL LINE

**NOTES**  
 ALL RESISTANCE VALUES IN OHM. k=1,000 OHM, M=1,000,000 OHM  
 ALL CAPACITANCE VALUES IN MICRO FARAD. P=MICRO-MICRO FARAD  
 EACH VOLTAGE AND CURRENT ARE MEASURED AT NO SIGNAL INPUT CONDITION.  
 CIRCUIT AND PARTS ARE SUBJECT TO CHANGE WITHOUT PRIOR NOTICE.

**WARNING:**  
 Parts marked with this symbol have critical characteristics. Use ONLY replacement parts recommended by the manufacturer.

**CAUTION:**  
 Before returning the unit to the customer, make sure you make either (1) a leakage current check or (2) a line to chassis resistance check. If the leakage current exceeds 0.5 milliamperes, or if the resistance from chassis to either side of the power cord is less than 240 kohms, the unit is defective.

**WARNING:**  
 DO NOT return the unit to the customer until the problem is located and corrected.

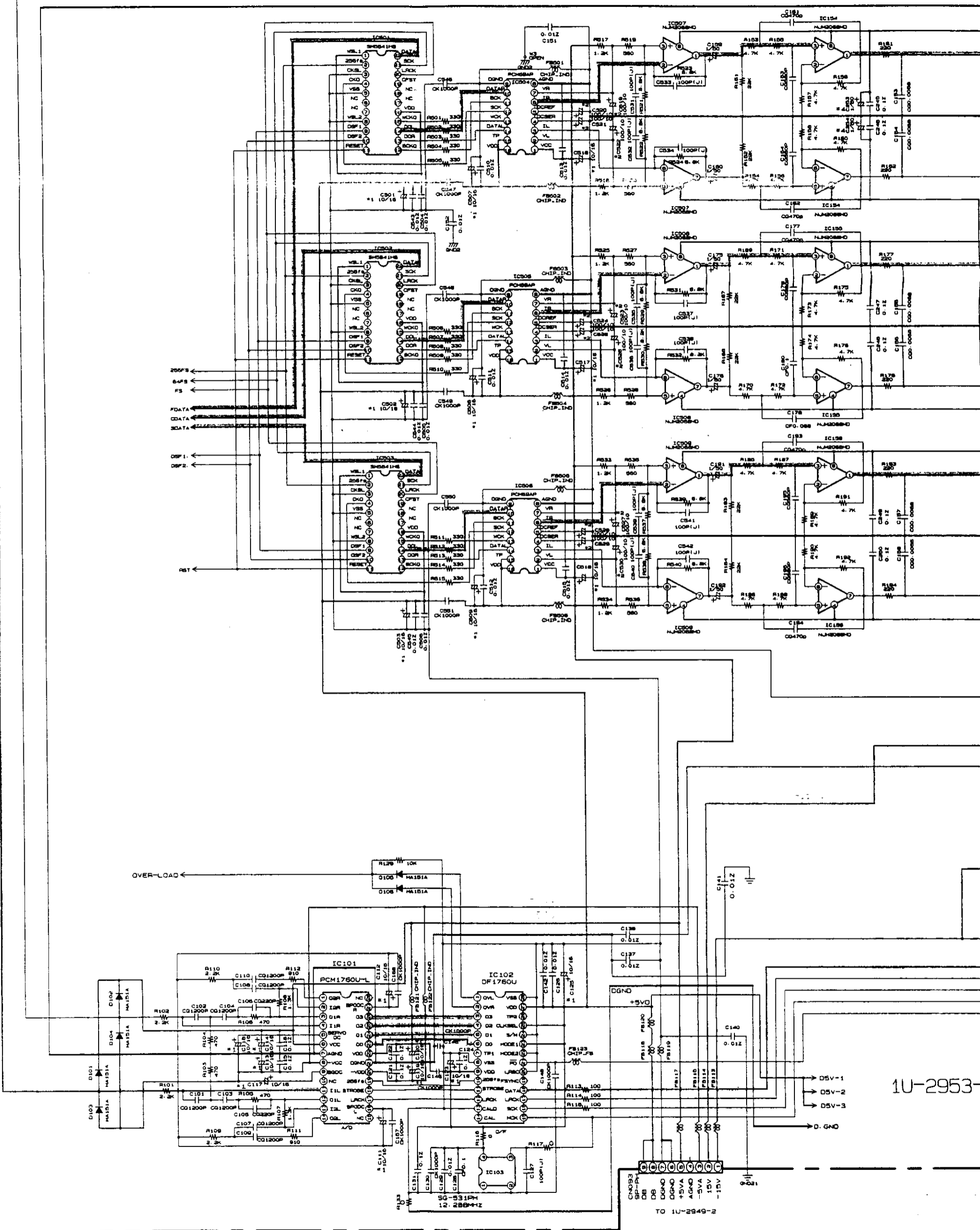

1U-2953

6 7 8 9 10 11

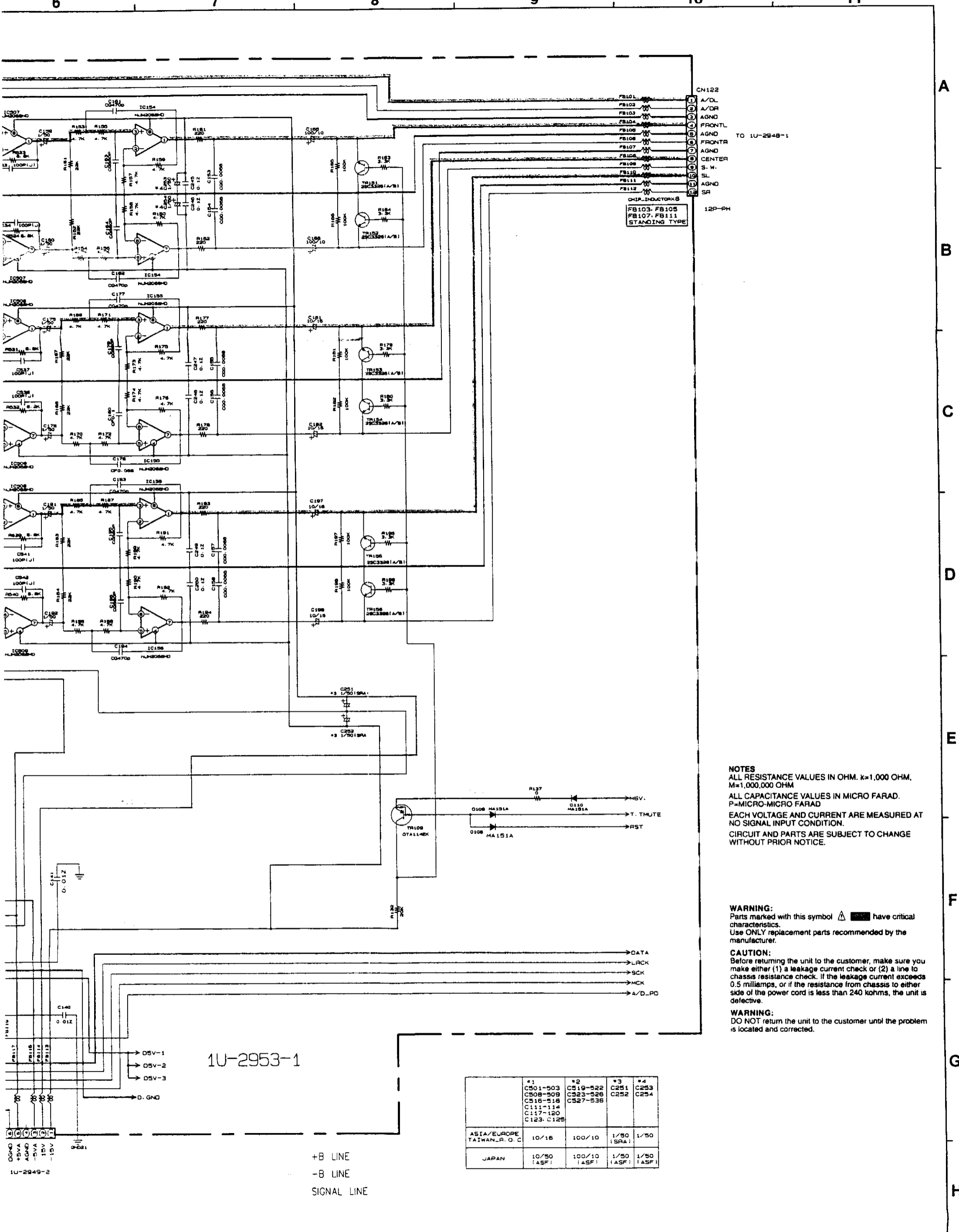

**NOTES**  
 ALL RESISTANCE VALUES IN OHM. K=1,000 OHM, M=1,000,000 OHM  
 ALL CAPACITANCE VALUES IN MICRO FARAD. P=MICRO-MICRO FARAD  
 EACH VOLTAGE AND CURRENT ARE MEASURED AT NO SIGNAL INPUT CONDITION.  
 CIRCUIT AND PARTS ARE SUBJECT TO CHANGE WITHOUT PRIOR NOTICE.

**WARNING:**  
 Parts marked with this symbol have critical characteristics. Use ONLY replacement parts recommended by the manufacturer.

**CAUTION:**  
 Before returning the unit to the customer, make sure you make either (1) a leakage current check or (2) a line to chassis resistance check. If the leakage current exceeds 0.5 milliamps, or if the resistance from chassis to either side of the power cord is less than 240 kohms, the unit is defective.

**WARNING:**  
 DO NOT return the unit to the customer until the problem is located and corrected.

1U-2953-1

	#1	#2	#3	#4
	C501-503	C519-522	C251	C253
	C508-509	C523-526	C252	C254
	C516-518	C527-536		
	C111-114			
	C117-120			
	C123, C125			
ASIA/EUROPE TAIWAN, P. O. C.	10/15	100/10	1/50 (SRA)	1/50
JAPAN	10/50 (ASF)	100/10 (ASF)	1/50 (ASF)	1/50 (ASF)

+B LINE  
 -B LINE  
 SIGNAL LINE

1U-2949-2

A  
 B  
 C  
 D  
 E  
 F  
 G  
 H

# SCHEMATIC DIAGRAM (13/16)

1 2 3 4 5 6

1U-2953-2

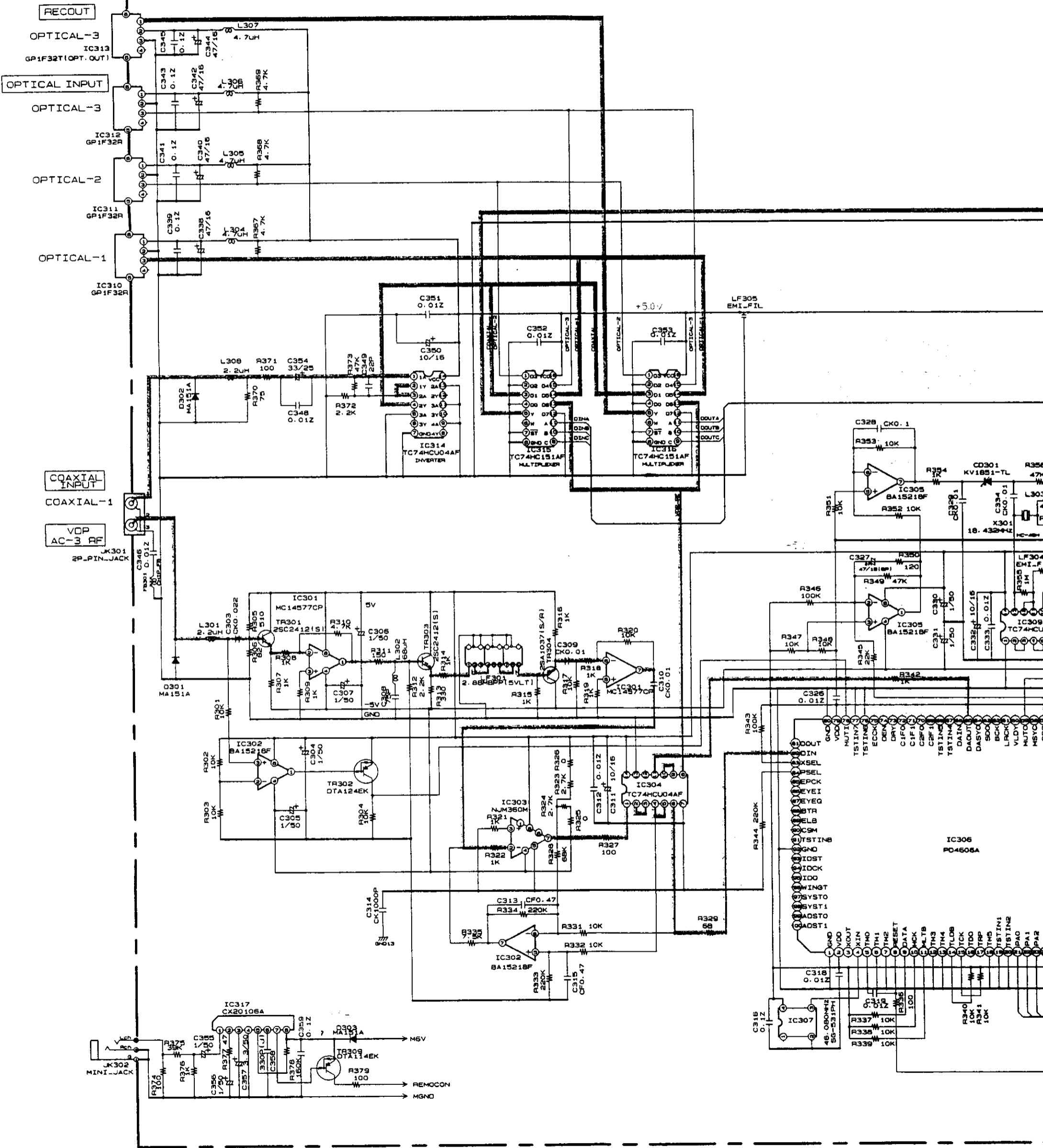

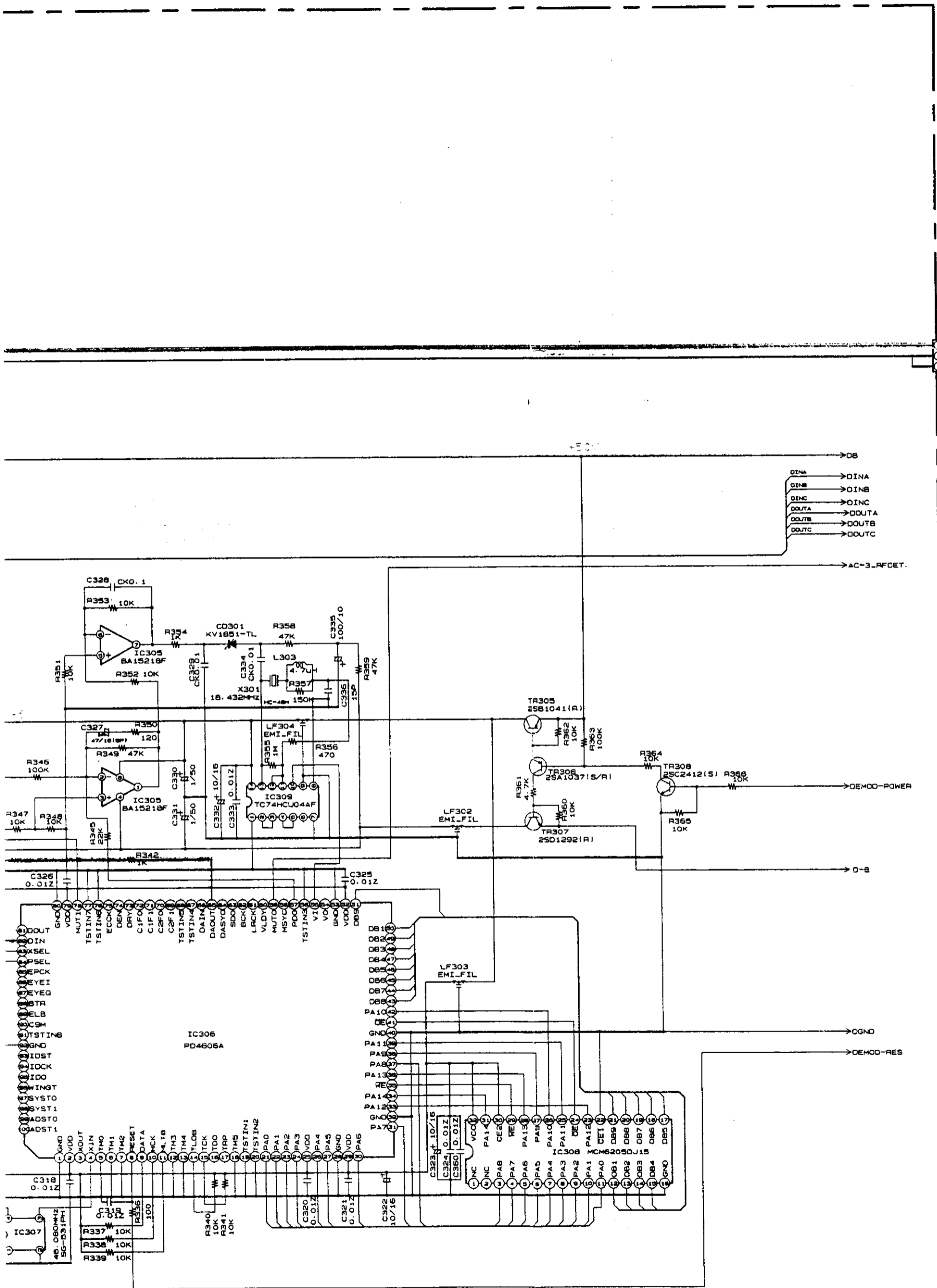

CN033B  
 3P-PH  
 1 DIG-DATA  
 2 GND  
 3 GND  
 to 1U-2953-1

DB  
 DINA → DINA  
 DINB → DINB  
 DINC → DINC  
 DOUTA → DOUTA  
 DOUTB → DOUTB  
 DOUTC → DOUTC

AC-3-RFDET.

CEMOD-POWER

D-B

OGND

DEMCO-RES

**NOTES**  
 ALL RESISTANCE VALUES IN OHM. k=1,000 OHM.  
 M=1,000,000 OHM  
 ALL CAPACITANCE VALUES IN MICRO FARAD.  
 P=MICRO-MICRO FARAD  
 EACH VOLTAGE AND CURRENT ARE MEASURED AT  
 NO SIGNAL INPUT CONDITION.  
 CIRCUIT AND PARTS ARE SUBJECT TO CHANGE  
 WITHOUT PRIOR NOTICE.

**WARNING:**  
 Parts marked with the symbol have critical characteristics.  
 Use ONLY replacement parts recommended by the manufacturer.

**CAUTION:**  
 Before returning the unit to the customer, make sure you make either (1) a leakage current check or (2) a line to chassis resistance check. If the leakage current exceeds 0.5 milliamps, or if the resistance from chassis to either side of the power cord is less than 240 kohms, the unit is defective.

**WARNING:**  
 DO NOT return the unit to the customer until the problem is located and corrected.

+B LINE  
 -B LINE  
 SIGNAL LINE



# SCHEMATIC DIAGRAM (14/16)

1 2 3 4 5 6

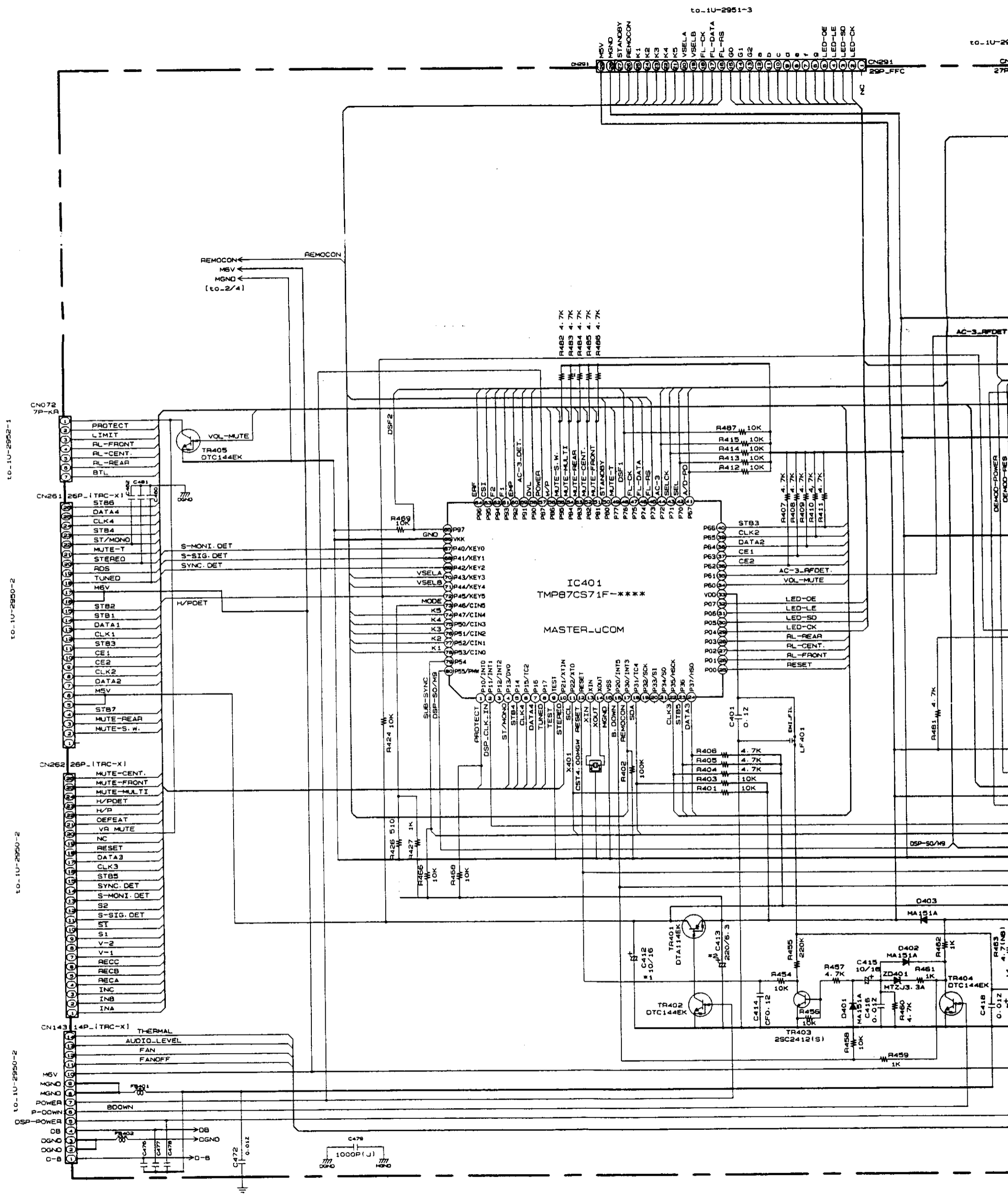

6

7

8

9

10

11

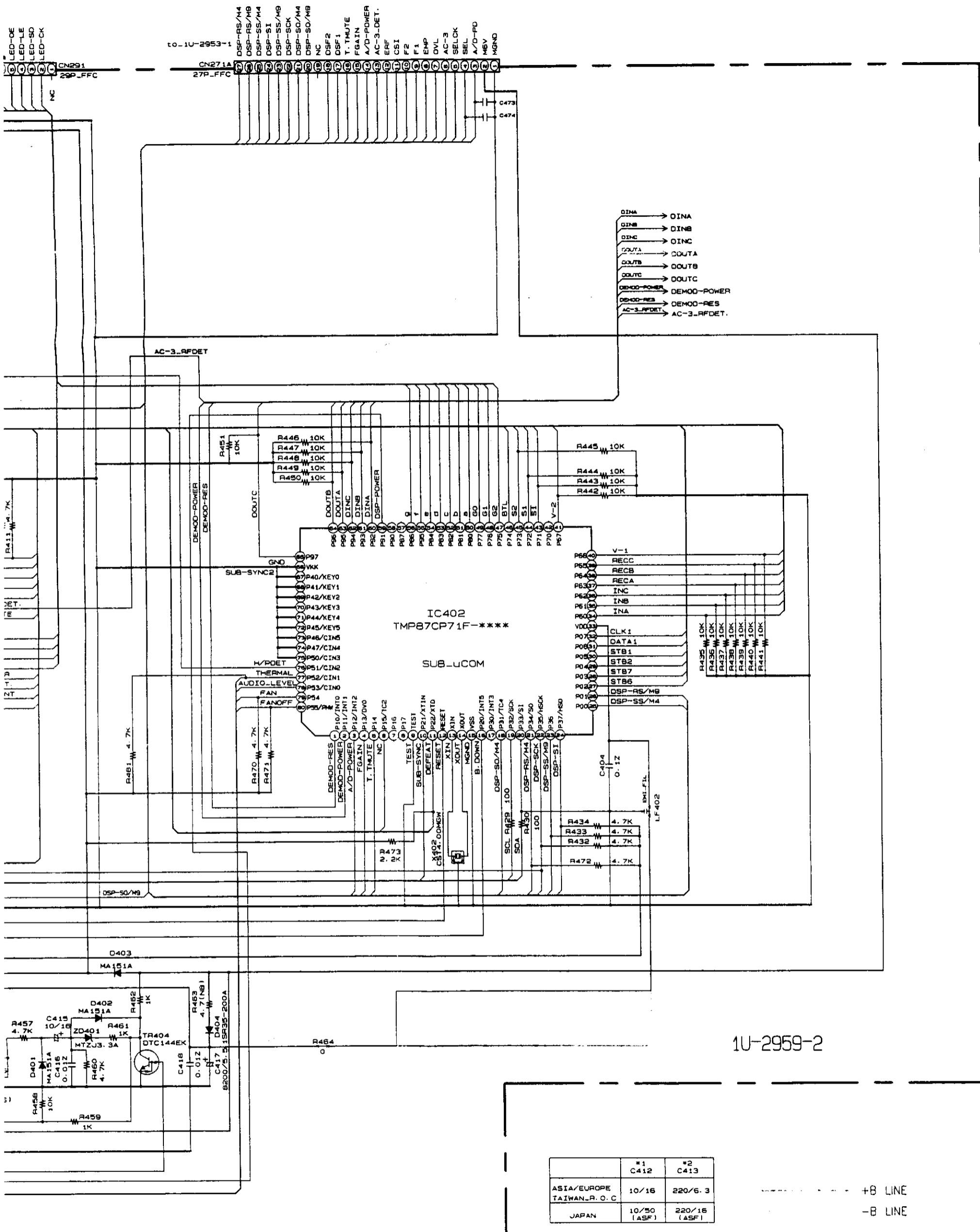

A  
B  
C  
D  
E  
F  
G  
H

1U-2959-2

	#1 C412	#2 C413
ASIA/EUROPE	10/16	220/6.3
TAIWAN_P. O. C		
JAPAN	10/50 (ASF)	220/16 (ASF)

+B LINE  
-B LINE

NOTES  
ALL RESISTANCE VALUES IN OHM. k=1,000 OHM. M=1,000,000 OHM  
ALL CAPACITANCE VALUES IN MICRO FARAD. P=MICRO-MICRO FARAD  
EACH VOLTAGE AND CURRENT ARE MEASURED AT NO SIGNAL INPUT  
CONDITION.  
CIRCUIT AND PARTS ARE SUBJECT TO CHANGE WITHOUT PRIOR  
NOTICE.

WARNING:  
Parts marked with this symbol have critical characteristics.  
Use ONLY replacement parts recommended by the manufacturer.

CAUTION:  
Before returning the unit to the customer, make sure you make either (1) a  
leakage current check or (2) a line to chassis resistance check. If the leakage  
current exceeds 0.5 milliamps, or if the resistance from chassis to either side  
of the power cord is less than 240 kohms, the unit is defective.

WARNING:  
DO NOT return the unit to the customer until the problem is located and  
corrected.

# SCHEMATIC DIAGRAM (15/16)

1 2 3 4 5 6

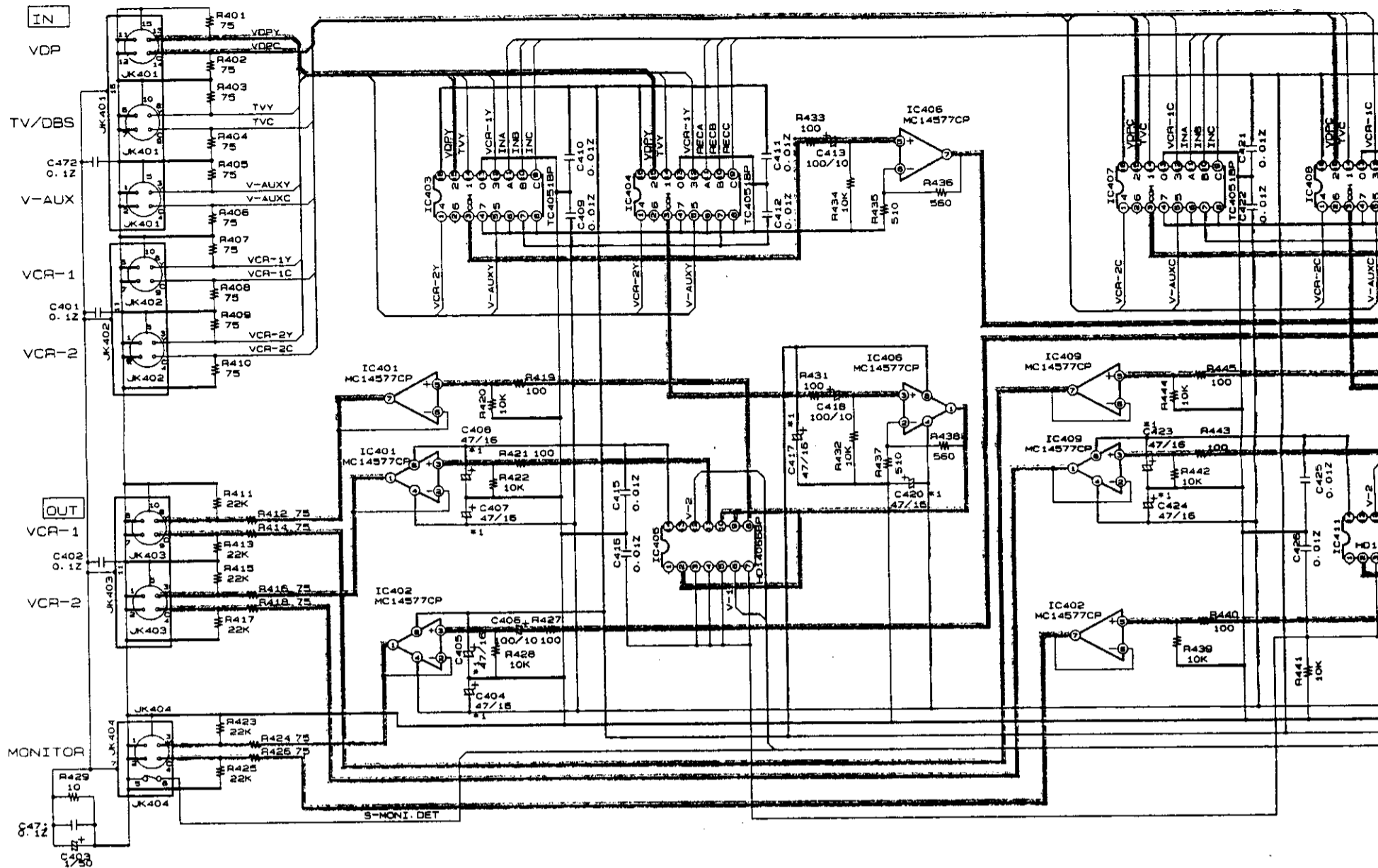

1U-2951-1  
S-VIDEO UNIT

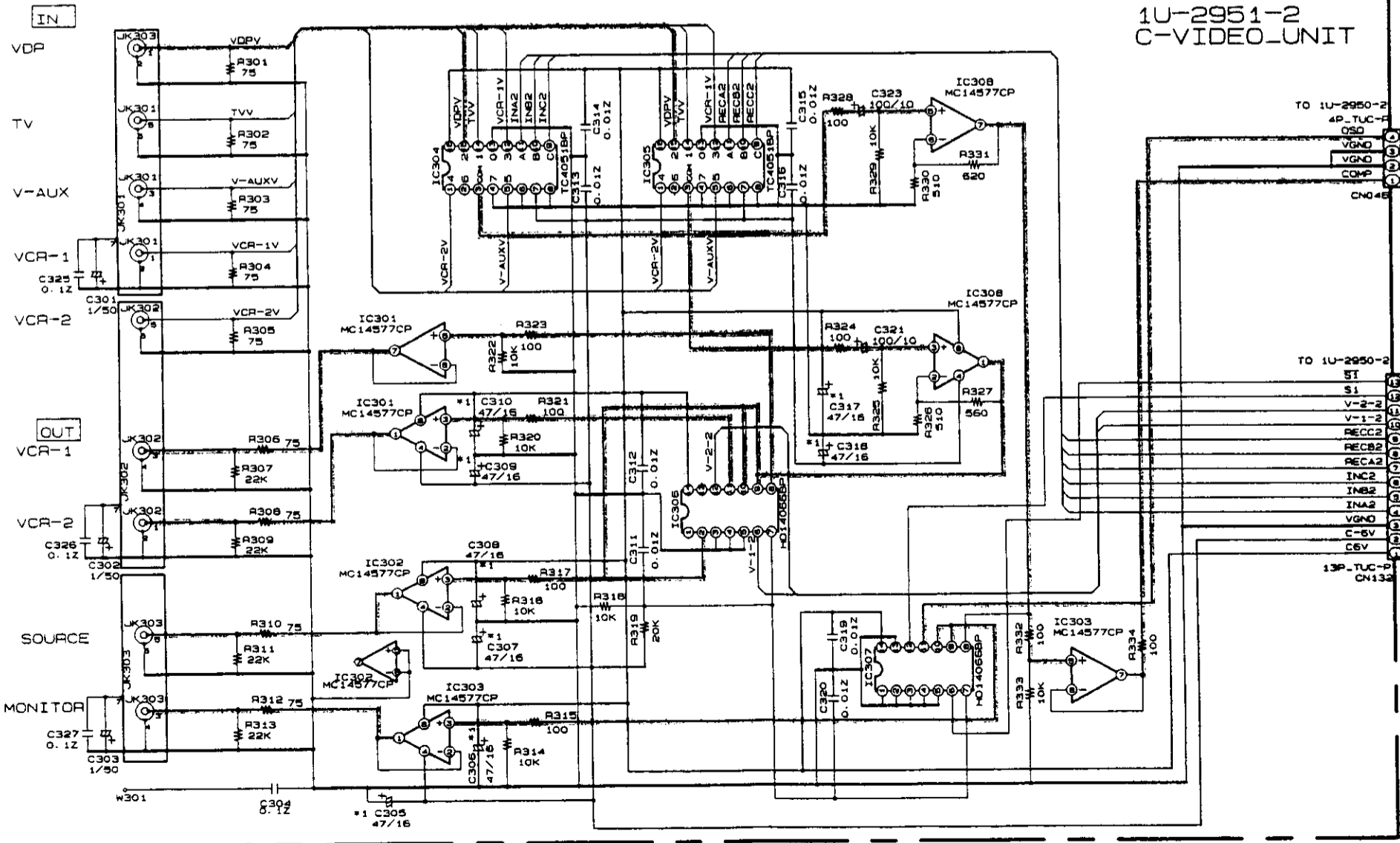

1U-2951-2  
C-VIDEO UNIT

TO 1U-2950-2  
TO 1U-2950-2  
TO 1U-2950-2  
TO 1U-2950-1

TO 1U-2950-2  
TO 1U-2950-2  
TO 1U-2950-2  
TO 1U-2950-1



SCHEMATIC DIAGRAM (16/16)

1 2 3 4 5 6 7

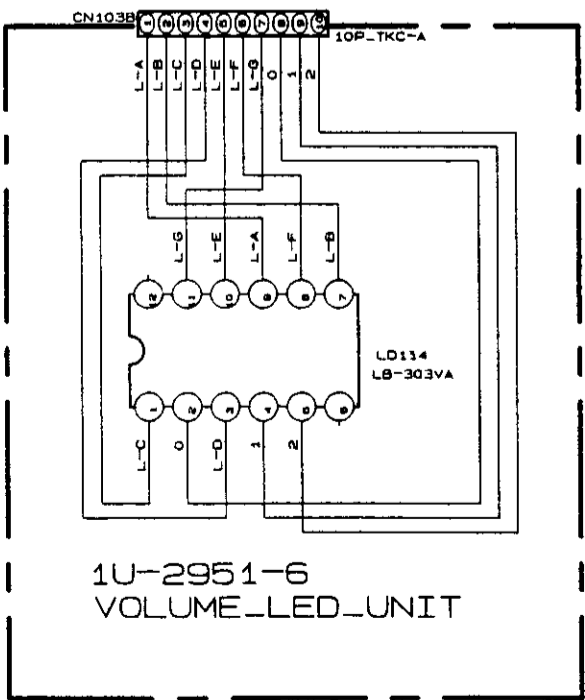
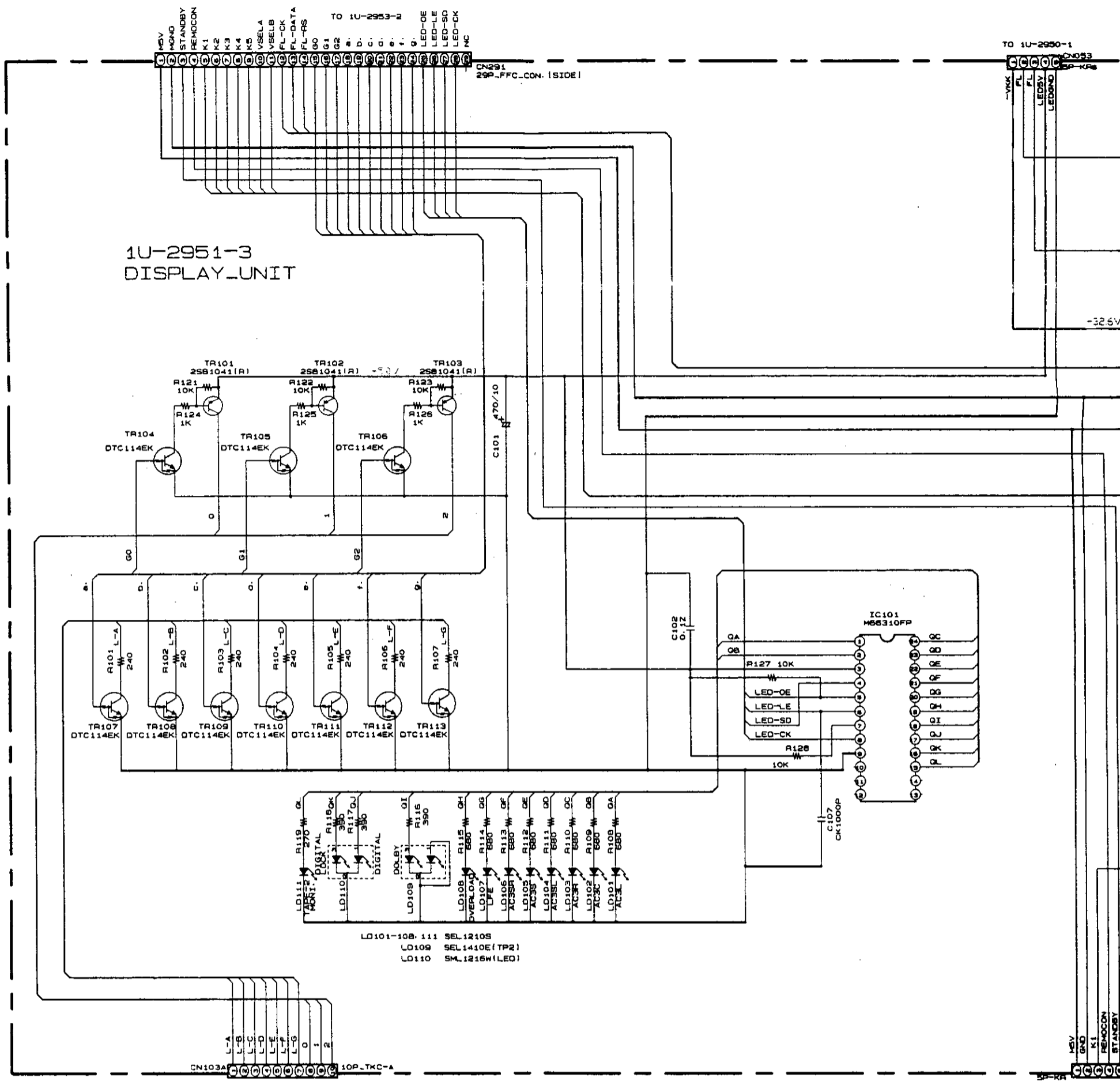

	#1	#2
	C103	C105
ASIA/EUROPE	100/50	330/6.3
TAIWAN R.O.C.	100/50	330/6.3
JAPAN	100/50 (ASF)	330/6.3 (ASF)

TO 1U-2949-

6 7 8 9 10 11

A  
B  
C  
D  
E  
F  
G  
H

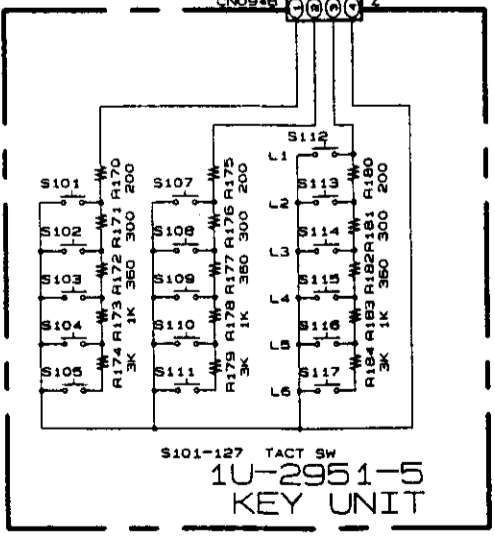
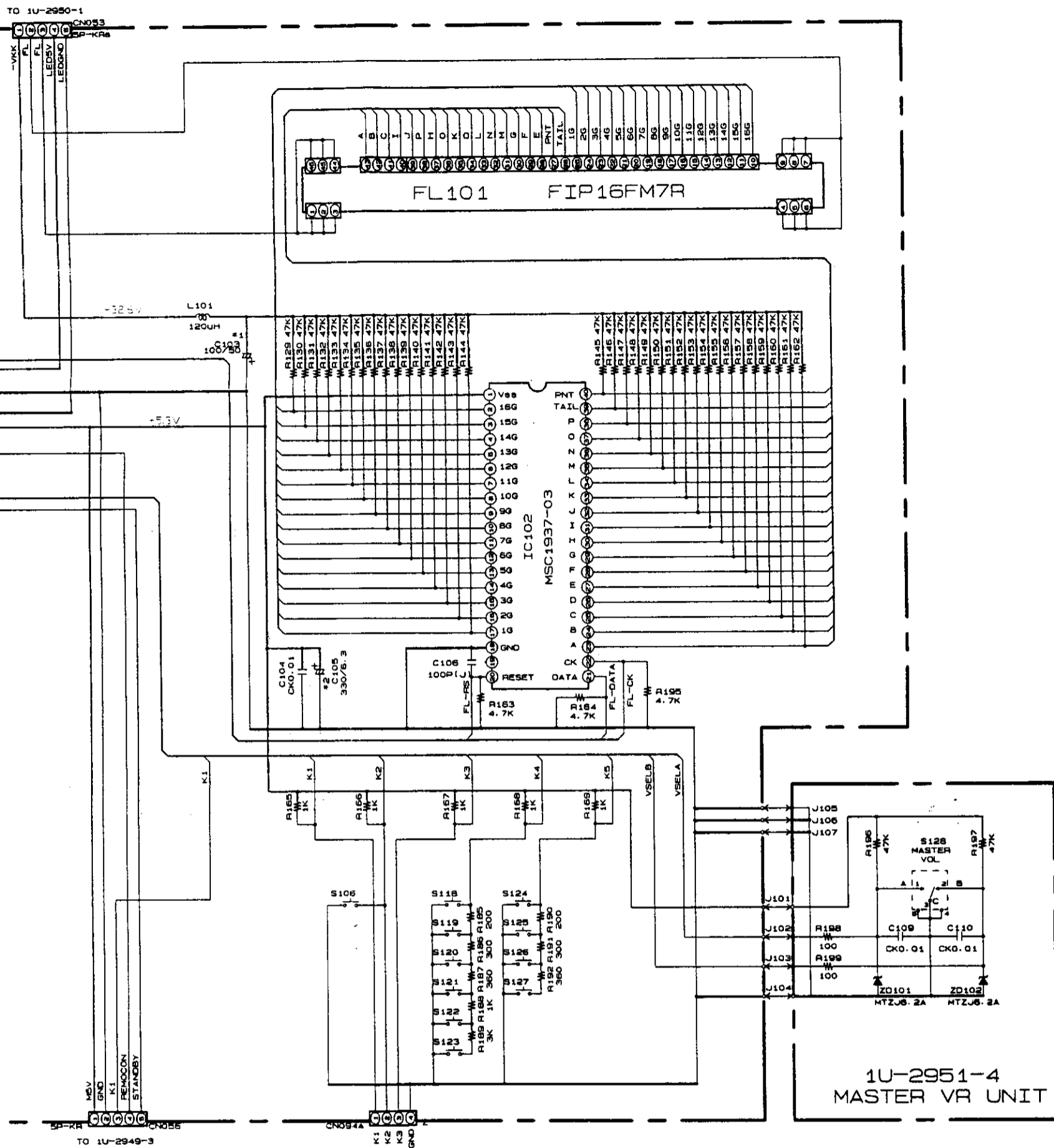

	K1	K2	K3	K4	K5
L1		AC3RF	WIDE SCREEN	PHONO	VCR-2
L2	DIRECT	INPUT LEVEL DOWN	5CH STEREO	CD	V. AUX
L3	STEREO	INPUT LEVEL UP	DSP SIMULATION	TUNER	DAT /TAPE-1
L4	DOLBY SURROUND	ANALOG/DIGITAL	REC/MULTI SOURCE	VDP/DVD	TAPE-2 MONI.
L5	HOME THX CINEMA	CH VR SHIFT	REC/MULTI MODE	TV/DBS	
L6	MONO	CH VR DOWN	CH VR UP	VCR-1	

----- +B LINE  
 - - - - - -B LINE

**NOTES**  
 ALL RESISTANCE VALUES IN OHM. K=1,000 OHM, M=1,000,000 OHM  
 ALL CAPACITANCE VALUES IN MICRO FARAD. P=MICRO-MICRO FARAD  
 EACH VOLTAGE AND CURRENT ARE MEASURED AT NO SIGNAL INPUT CONDITION.  
 CIRCUIT AND PARTS ARE SUBJECT TO CHANGE WITHOUT PRIOR NOTICE.

**WARNING:**  
 Parts marked with this symbol have critical characteristics. Use ONLY replacement parts recommended by the manufacturer.

**CAUTION:**  
 Before returning the unit to the customer, make sure you make either (1) a leakage current check or (2) a line to chassis resistance check. If the leakage current exceeds 0.5 milliamps, or if the resistance from chassis to either side of the power cord is less than 240 kohms, the unit is defective.

**WARNING:**  
 DO NOT return the unit to the customer until the problem is located and corrected.

2  
 :105  
 130/6.3  
 130/6.3  
 (ASF)

# REMOTE CONTROL UNIT (RC-813)

1 2 3 4 5 6 7 8

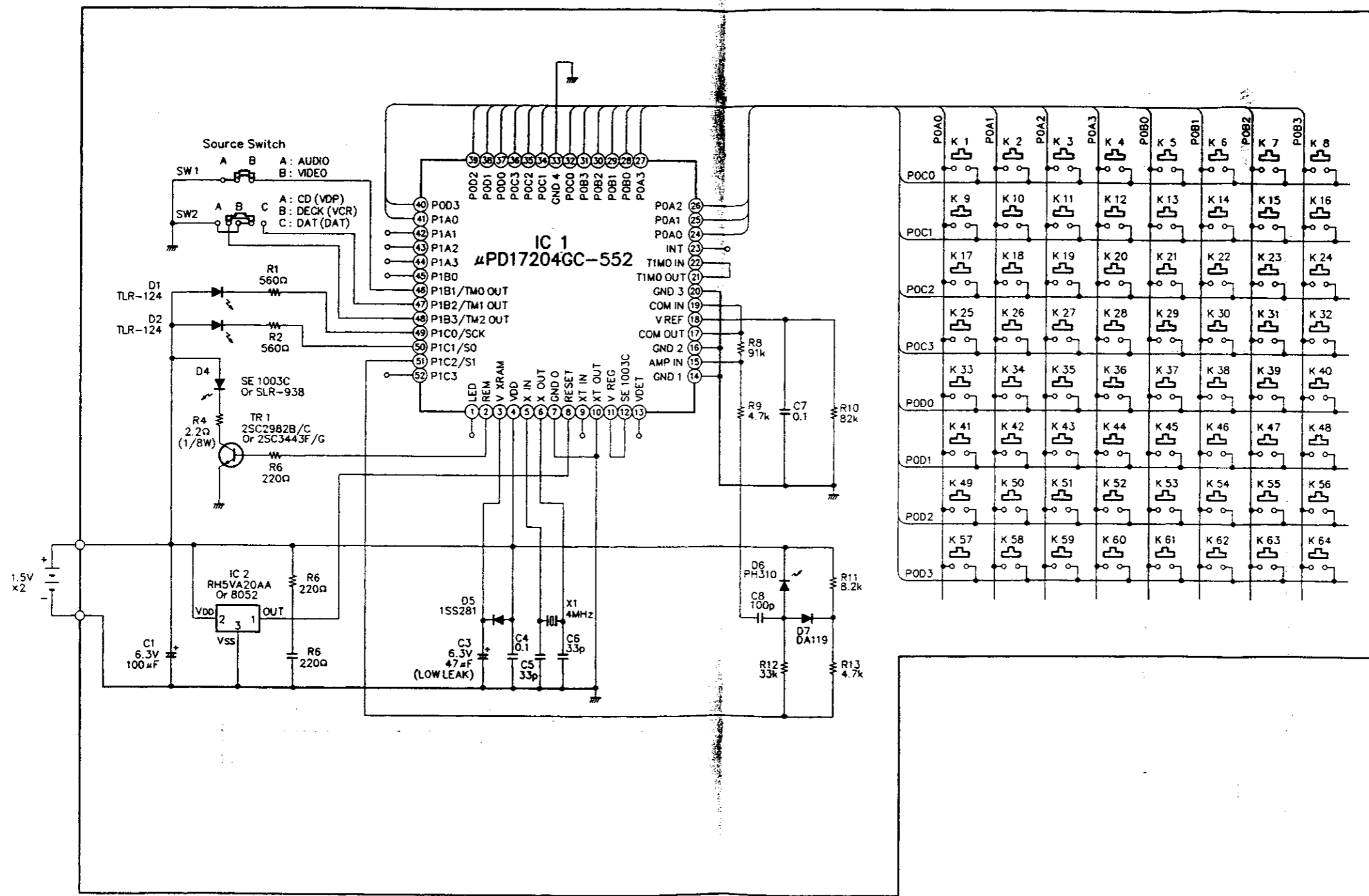

A  
B  
C  
D  
E

EXPLODED VIEW OF REMOTE CONTROL UNIT

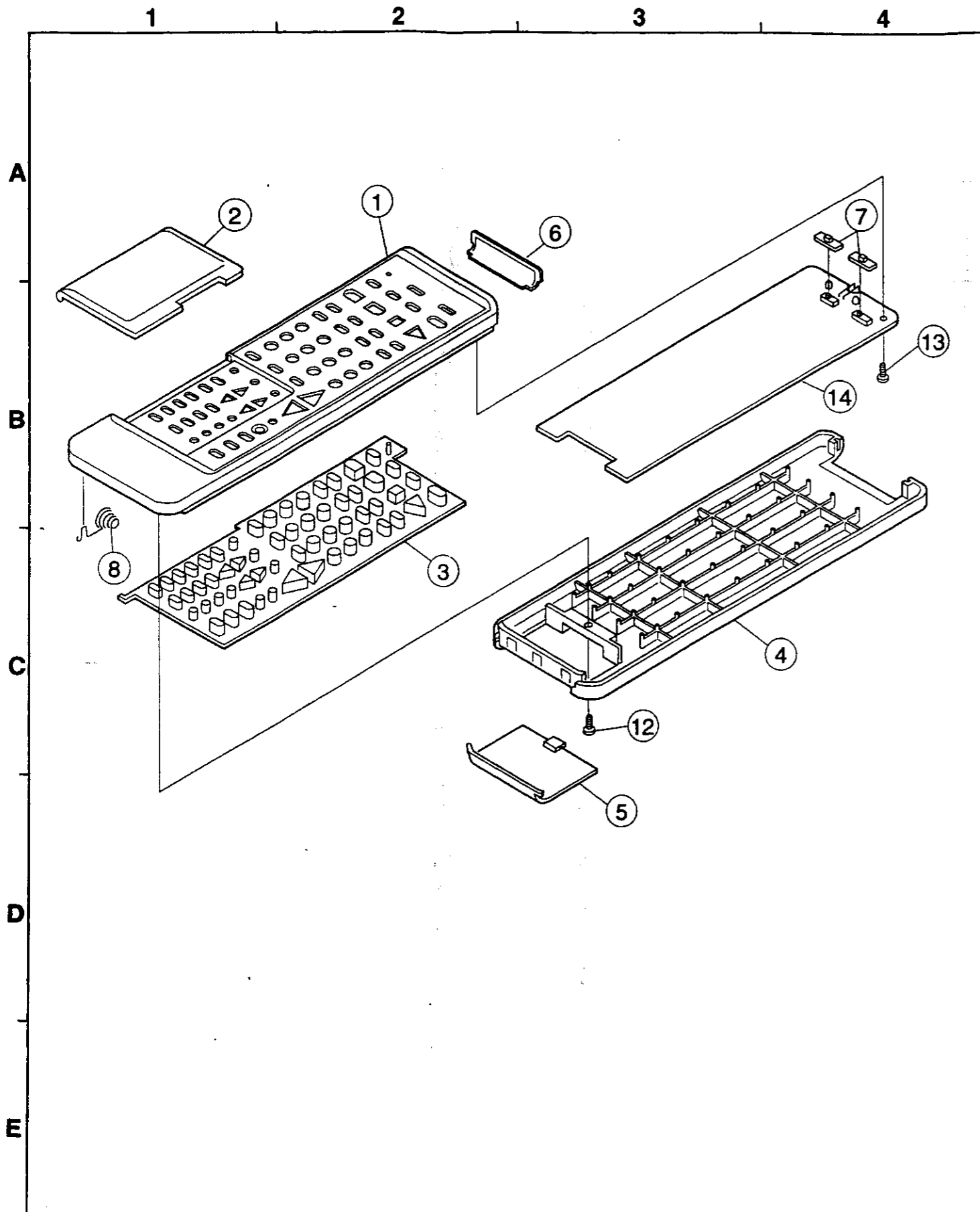

REMOTE CONTROL UNIT (RC-813)  
PRINTED WIRING BOARD PARTS LIST

Ref. No.	Part No.	Part Name	Remarks	Qty
<b>SEMICONDUCTORS GROUP</b>				
IC1	9H3 1000 169	IC $\mu$ PD17204GC-538	$\mu$ -Com	
IC2	9H3 1000 158	IC RH5VA20AA	vol. Detector	
TR1	9H3 1000 070	Transistor 2SC3443BF/BG	Chip	
or	9H3 1000 070	Transistor 2SC2982B/C	Chip	
D1,2	9H3 1000 028	LED TLR124	Visible-Red	
D4	9H3 1000 131	LED SE1003-C	Infrared	
D5	9H3 1000 087	Diode 1SS281 (1)		
D6	9H3 1000 029	Diode PH310	Photo-PIN	
D7	9H3 1000 071	Diode DA119/DA118	Chip	
or	276 0574 900	Diode 1SS196		
<b>RESISTORS GROUP</b>				
R1,2	247 0006 988	Carbon Chip 560 ohm, 1/10W	RM73B-561J	
R4	247 0001 909	Carbon Chip 2.2 ohm, 1/10W	RM73B-2R2J	
R6	247 0005 989	Carbon Chip 220 ohm, 1/10W	RM73B-221J	
R7	247 0012 927	Carbon Chip 100 kohm, 1/10W	RM73B-104J	
R8	247 0012 914	Carbon Chip 91 kohm, 1/10W	RM73B-913J	
R9	247 0009 901	Carbon Chip 4.7 kohm, 1/10W	RM73B-472J	
R10	247 0012 901	Carbon Chip 82 kohm, 1/10W	RM73B-823J	
R11	247 0009 969	Carbon Chip 8.2 kohm, 1/10W	RM73B-822J	
R12	247 0011 902	Carbon Chip 33 kohm, 1/10W	RM73B-333J	
R13	247 0009 901	Carbon Chip 4.7 kohm, 1/10W	RM73B-472J	
J7,8	247 0018 905	Carbon Chip 0 ohm, 1/10W	RM73B-0R0K	
<b>CAPACITORS GROUP</b>				
C1	254 4213 034	Electrolytic 100 $\mu$ F/6.3V	CE04W0J101M	
C2	257 0015 905	Ceramic Chip 0.33 $\mu$ F/25V	CK73F1E334Z	
C3	254 4213 021	Electrolytic 47 $\mu$ F/6.3V	CE04W0J470M	
C4	257 0014 935	Ceramic Chip 0.1 $\mu$ F/25V	CK73F1E104Z	
C5,6	257 0003 946	Ceramic Chip 33PF/50V	CK73SL1H330J	
C7	257 0014 935	Ceramic Chip 0.1 $\mu$ F/25V	CK73F1E104Z	
C8	257 0004 961	Ceramic Chip 100PF/50V	CC73SL1H101J	
<b>OTHER GROUP</b>				
		(P.W. Board)		(1)
X1	9H3 1000 088	Ceramic Resonator	KBR4.0M503	1
SW1	9H3 1000 089	Slide Switch 1-2		1
SW2	—	Slide Switch 1-3		1
	—	Port Wrapping		2

REMOTE CONTROL UNIT ASS'Y PARTS LIST

Ref. No.	Part No.	Part Name	Remarks	Qty
1	9H3 1000 163	Top Case (RC-813) Ass'y		1s
2	9H3 1000 168	Cover		1
3	9H3 1000 169	Switch Rubber		1
4	9H3 1000 166	Bottom Case		1
5	9H3 1000 167	Battery Cover		1
6	9H3 1000 148	Filter		1
7	9H3 1000 150	Slide knob		2
8	9H3 1000 152	Coil Spring		1
9	—	—		
10	—	—		
11	—	—		
12	9H3 1000 154	Tapping Screw 2x6		1
13	9H3 1000 107	Tapping Screw 2x5		1
14	9H3 1000 161	Main P.W.B. Ass'y		1s