

DENON

For U.S.A., Canada, Europe,
Asia, China, Hong Kong &
Taiwan R.O.C. model

Hi-Fi Component

SERVICE MANUAL

MODEL AVR-1802/882

AV SURROUND RECEIVER

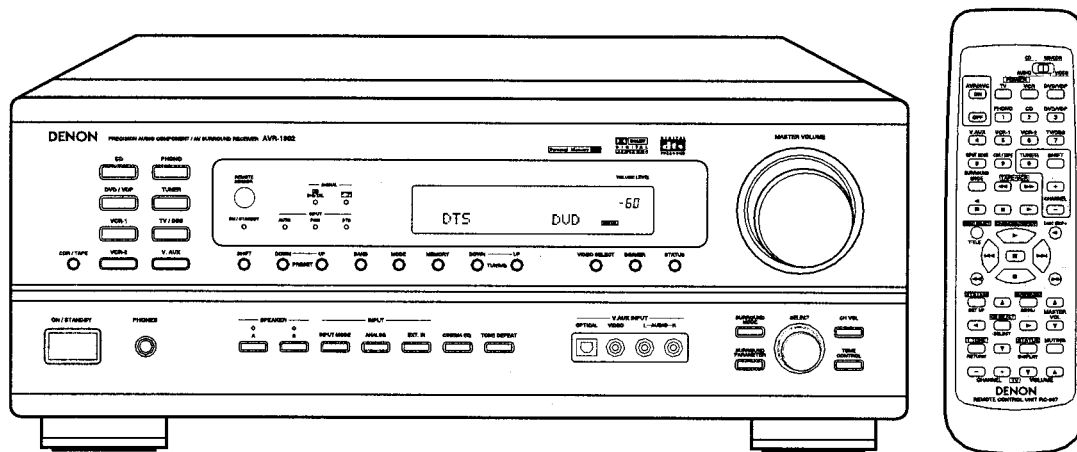

● Some illustrations using in this service manual are slightly different from the actual set.

NIPPON COLUMBIA CO., LTD.

14-14, AKASAKA 4-CHOME, MINATO-KU, TOKYO 107-8011 JAPAN
Telephone: 03 (3584) 8111

SAFETY PRECAUTIONS

The following check should be performed for the continued protection of the customer and service technician.

LEAKAGE CURRENT CHECK

Before returning the unit to the customer, make sure you make either (1) a leakage current check or (2) a line to chassis resistance check. If the leakage current exceeds 0.5 milliamps, or if the resistance from chassis to either side of the power cord is less than 460 kohms, the unit is defective.

SPECIFICATIONS

■ Audio section

Power amplifier

Rated output:

Front:	80W + 80W 115W + 115W 130W + 130W	(8Ω/ohms, 20Hz ~20kHz with 0.08% T.H.D) (6Ω/ohms, 1kHz with 0.7% T.H.D) (U.S.A., Canada & Europe Models) (6Ω/ohms, EIAJ) (Asia Model)
Center:	80W 115W 130W	(8Ω/ohms, 20Hz ~20kHz with 0.08% T.H.D) (6Ω/ohms, 1kHz with 0.7% T.H.D) (U.S.A., Canada & Europe Models) (6Ω/ohms, EIAJ) (Asia Model)
Surround:	80W + 80W 115W + 115W 130W + 130W	(8Ω/ohms, 20Hz ~20kHz with 0.08% T.H.D) (6Ω/ohms, 1kHz with 0.7% T.H.D) (U.S.A., Canada & Europe Models) (6Ω/ohms, EIAJ) (Asia Model)

Output terminals:

Front:	A or B 6 to 16Ω/ohms A + B 12 to 16Ω/ohms
Center/Surround:	6 to 16Ω/ohms

Analog

LINE input - PRE OUT

Input Sensitivity/input impedance:

200mV/47kΩ/kohms

Frequency response:

10Hz~100kHz: +1, -3dB (TONE DEFEAT ON)

S/N ratio:

100dB (IHF-A weighted) (TONE DEFEAT ON)

■ Video section

Standard video jacks

Input/output level and impedance:

1Vp-p, 75Ω/ohms

Frequency response:

5Hz~10MHz — +1, -3dB

S-video jacks

Input/output level and impedance:

Y (brightness) signal — 1Vp-p, 75Ω/ohms

C (color) signal — 0.286Vp-p, 75Ω/ohms

Frequency response:

5Hz~10MHz — +1, -3dB

■ Tuner section

Receiving range:

U.S.A. & Canada Models

Europe &

Asia (for China) Models

Asia (for Multiple voltage) Models

[FM] (note: μV at 75Ω/ohms, 0dBf = 1x10⁻¹⁵W)

87.50MHz~107.90MHz

87.50MHz~108.00MHz

87.50MHz~107.90MHz (0.2MHz steps)

87.50MHz~108.00MHz (0.05MHz steps)

Usable sensitivity:

50dB quieting sensitivity:

1.0 μV (11.2dBf)

MONO

1.6 μV (15.3dBf)

STEREO

23 μV (38.5dBf)

S/N ratio:

MONO

80dB (IHF-A weighted)

STEREO

75dB (IHF-A weighted)

Total harmonic distortion:

MONO

0.15% (1kHz)

STEREO

0.3% (1kHz)

[AM]

520kHz~1710kHz

522kHz~1611kHz

520kHz~1710kHz (10kHz steps)

522kHz~1611kHz (9kHz steps)

18 μV

■ General

Power supply:

U.S.A., Canada Models

Europe Model

Asia (for Multiple voltage) Model

Asia (for China) Model

AC120V, 60Hz

AC230V, 50Hz

AC115/230V, 50/60Hz

AC220V, 50Hz

Power consumption:

Maximum external dimensions:

Mass:

4.5A (U.S.A. & Canada model), 230W (Europe & Asia model)

434 (W) × 171 (H) × 417 (D)mm (17-3/32" × 6-47/64" × 16-7/16")

10.9kg (24lbs 0.5 oz)

■ Remote control unit (RC-897)

Batteries:

External dimensions:

Mass:

R6P/AA Type(two batteries)

54 (W) × 172.5 (H) × 29 (D)mm (2-1/8" × 6-51/64" × 1-9/64")

120g (Approx. 4.2 oz) (including batteries)

* For purposes of improvement, specifications and design are subject to change without notice.

DISASSEMBLY

(To reassemble reverse disassembly)

Top Cover

Remove 6 screws ① and 3 screws ②, detach the Top Cover in the arrow direction.

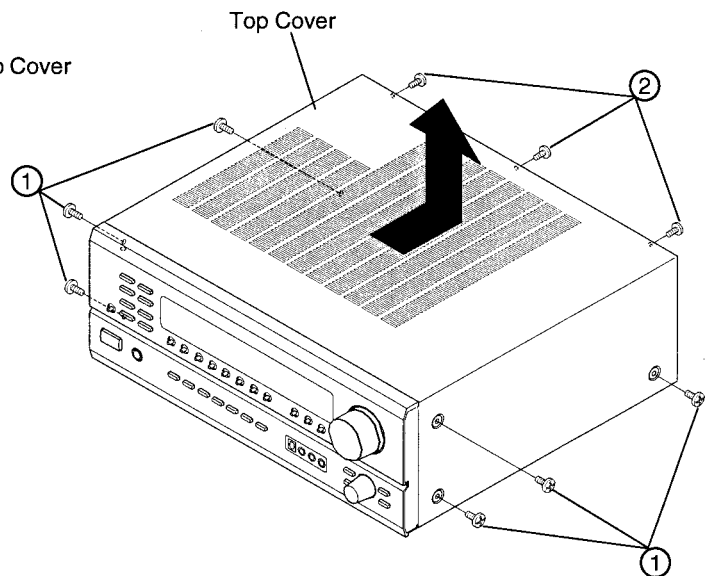

Front Panel

1. Remove 2 screws ③.
2. Remove 4 screws ④.
3. Detach the Front Panel in the arrow direction.

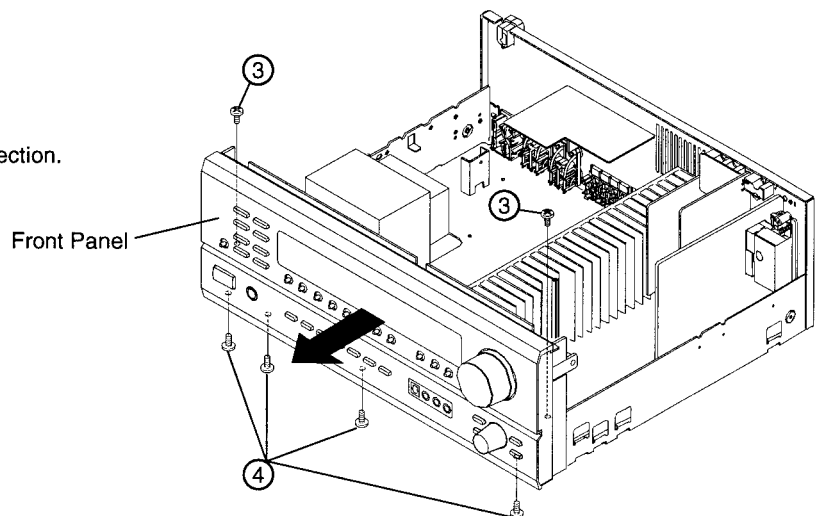

Rear Panel

1. Remove cord bushing ⑤ from the Rear Panel.
2. Remove 36 screw ⑥.
3. Detach the Rear Panel in the arrow direction.

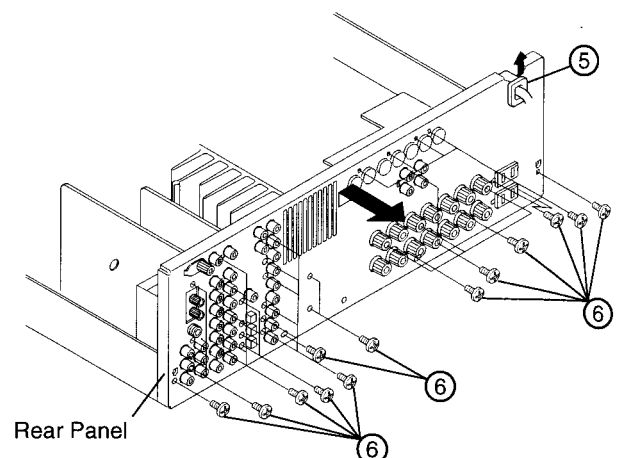

ADJUSTMENT

Tuner Section

CONNECTION DIAGRAM OF MEASURING INSTRUMENTS

● FM

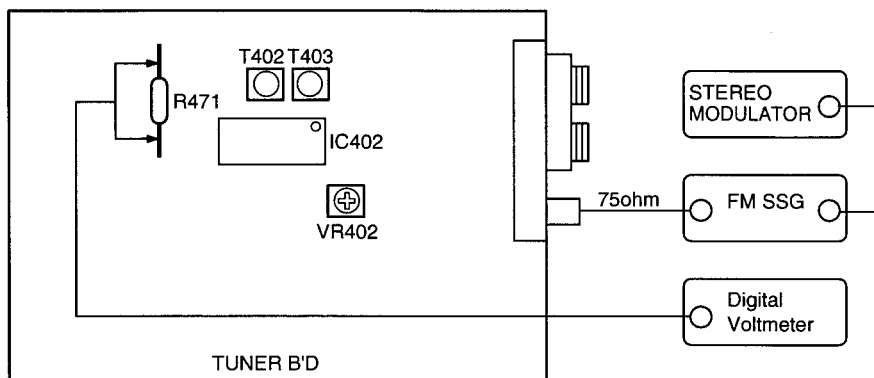

FM ALIGNMENT

Step	Alignment Item	Tuning Frequency Setting	Input					Output		Adjustment	
			Type	Frequency	Input Level	Modulation	Coupling	Type	Connect to	Points	Adjust to
1	Center Adjustment	98.1MHz (98.0MHz)	FM SSG	98.1MHz	60dBμ	—	Antenna Terminal	Digital Voltmeter	R471	T402	± 50mV
2	Distortion	98.1MHz (98.0MHz)	FM SSG	98.1MHz	60dBμ	Mono 1kHz 100%	Antenna Terminal	Distortion Meter	Output Terminal (L)	T403	Minimum Distortion
3	Repeat Steps 1 and 2										
4	Signal Level	98.1MHz (98.0MHz)	FM SSG	98.1MHz	20dBμ	OFF	Antenna Terminal	Light "TUNED" on FL Display	VR402		20 ⁺¹⁴ ₋₁₀ dB

● AM

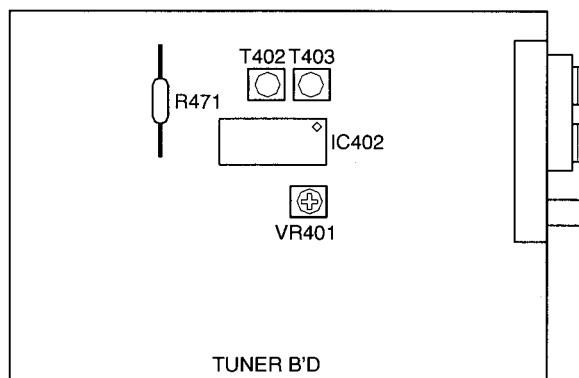

AM ALIGNMENT

Step	Alignment Item	Frequency	Input	Output		Adjustment		Remarks
				Type	Connect to	Points	Adjust to	
1	Signal Level	999 (1000) kHz	AM SSG	—	—	VR401	Light "TUNED" on FL Display	SSG OUTPUT 74dBμ (EMF)

Audio Section

Idling Current

Required measurement equipment : DC Voltmeter

Preparation

- (1) Avoid direct blow from an air conditioner or an electric fan, and adjust the unit at normal room temperature 15 °C ~ 30 °C (59 °F ~ 86 °F).
- (2) Presetting
 - POWER (Power source switch) → OFF
 - SPEAKER (Speaker terminal) → No load (Do not connect speaker, dummy resistor, etc.)

Adjustment

- (1) Remove top cover and set VR101, VR102, VR103, VR104, VR105 on Amp. Unit at full counterclockwise (\odot) position.
- (2) Connect DC Voltmeter to test points (FRONT-Lch: TP104, FRONT-Rch: TP105, CENTER ch: TP103, SURROUND-Lch: TP101, SURROUND-Rch: TP102).
- (3) Connect power cord to AC Line, and turn power switch "ON".
- (4) Presetting.

MASTER VOLUME	: "----" counterclockwise (\odot min.)
MODE	: 5CH STEREO
FUNCTION	: CD
- (5) Within 2 minutes after the power on, turn VR101 clockwise (\odot) to adjust the TEST POINT voltage to 1.5 mV \pm 0.5 mV DC.
- (6) After 10 minutes from the preset above, turn VR101 to set the voltage to 2.5 mV \pm 0.5 mV DC.
- (7) Adjust the Variable Resistors of other channels in the same way.

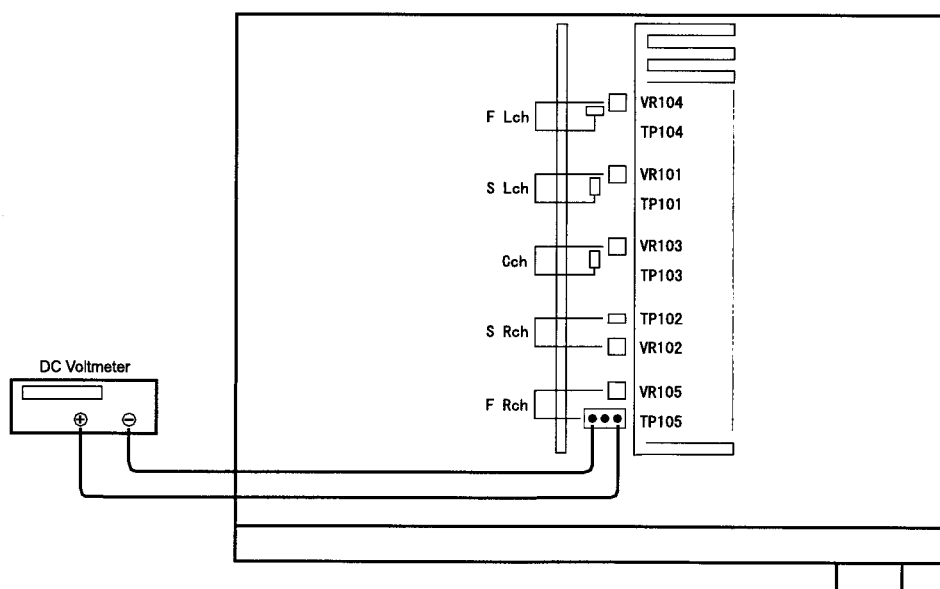

LEVEL DIAGRAM

LEVEL DIAGRAM

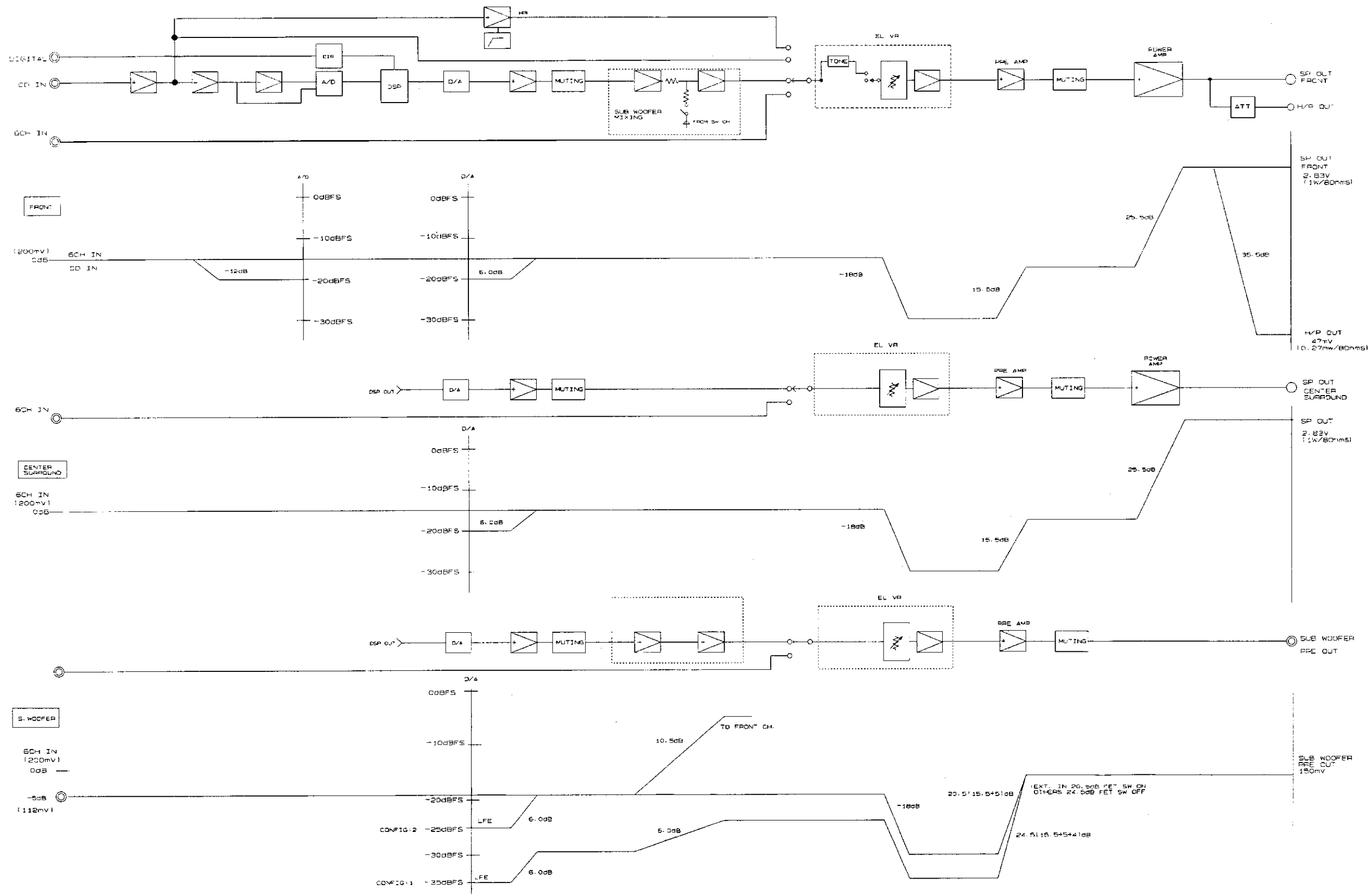

A
B
C
D
E
6

SEMICONDUCTORS

- ICs
 - CS493263-CL
 - (AU: IC812)

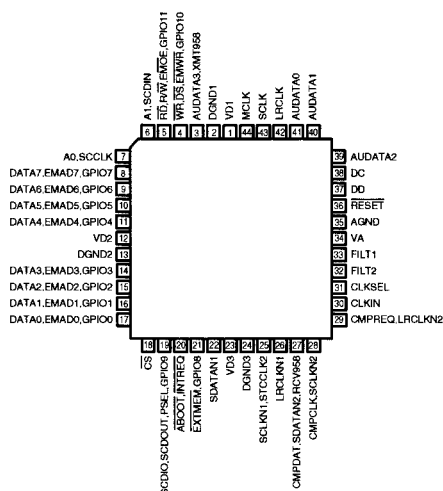

CS493263-CL Terminal Function

Pin No.	Pin Name	Function
1	VD1	Digital positive supply
2	DGND1	Digital supply ground
3	AUDATA3, XMT958	SPDIF transmitter output, Digital audio output 3
4	WR, DS, EMWR, GPIO10	Host write strobe or host data strobe or external memory write enable or general purpose input & output number 10
5	RD, RW, EMOE, GPIO11	Host parallel output enable or host parallel R/W or external memory output enable or general purpose input & output number11
6	A1, SC DIN	Host address bit one or SPI serial control data input
7	A0, SCCLK	Host parallel address bit zero or serial control port clock
8	DATA7, EMAD7, GPIO7	
9	DATA6, EMAD6, GPIO6	
10	DATA5, EMAD5, GPIO5	
11	DATA4, EMAD4, GPIO4	
12	VD2	Digital positive supply
13	DGND2	Digital supply ground
14	DATA3, EMAD3, GPIO3	
15	DATA2, EMAD2, GPIO2	
16	DATA1, EMAD1, GPIO1	
17	DATA0, EMAD0, GPIO0	
18	CS	Host parallel chip select, host serial SPI chip select
19	SCDIO, SC DOUT, PSEL, GPIO9	Serial control port data input and output, parallel port type select
20	INTREQ, ABOOT	Control port interrupt request, automatic boot enable
21	EXTMEM, GPIO8	External memory chip select or general purpose input & output number 8
22	SDATAN1	PCM audio data input number one
23	VD3	Digital positive supply
24	DGND3	Digital supply ground
25	SCLKN1, STCCLK2	PCM audio input bit clock
26	LRCLKN1	PCM audio input sample rate clock
27	CMPDAT, SDATAN2, RCV958	PCM audio data input number two
28	CMPCLK, SCLKN2	PCM audio input bit clock
29	CMPREQ, LRCLKN2	PCM audio input sample rate clock
30	CLKIN	Master clock input
31	CLKSEL	DSP clock select
32	FILT2	Phase locked loop filter
33	FILT1	Phase locked loop filter
34	VA	Analog positive supply
35	AGND	Analog supply ground
36	RESET	Master reset input
37	DD	Reserved
38	DC	Reserved
39	AUDATA2	Digital audio output 2
40	AUDATA1	Digital audio output 1
41	AUDATA0	Digital audio output 0
42	LRCLK	Audio output sample rate clock
43	SCLK	Audio output bit clock
44	MCLK	Audio master clock

LC89055W (IC810)

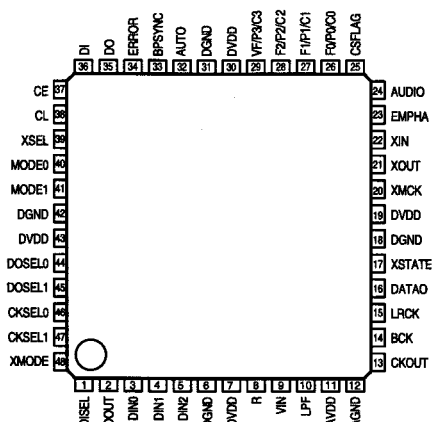

LC89055W Terminal Function

Pin No.	Pin Name	I/O	Function
1	DISEL	I	Data input terminal (select input pin of DIN0, DIN1)
2	DOOUT	O	Input bi-phase data through output terminal
3	DIN0	I	Amp built-in coaxial/optical input correspond data input terminal
4	DIN1	I	Amp built-in coaxial/optical input correspond data input terminal
5	DIN2	I	Optical input correspond data input terminal
6	DGND		Digital GND
7	DVDD		Digital power supply
8	R	I	VCO gain control input terminal
9	VIN	I	VCO free-run frequency setting input terminal
10	LPF	O	PLL loop filter setting terminal
11	AVDD		Analog power supply
12	AGND		Analog GND
13	CKOUT	O	Clock output terminal (256fs, 384fs, 512fs, X'tal osc., VCO free-run osc.)
14	BCK	O	64fs clock output terminal
15	LRCK	O	fs clock output terminal (L: Rch, H: Lch, I ² S: Reverse)
16	DATAO	O	Data output terminal
17	XSTATE	O	Input data detecting result output terminal
18	DGND		Digital GND
19	DVDD		Digital power supply
20	XMCK	O	X'tal osc. clock output terminal (24.576MHz or 12.288MHz)
21	XOUT	O	X'tal osc. connection output terminal
22	XIN	I	X'tal osc. connection input terminal, external signal input possible (24.576MHz or 12.288MHz)
23	EMPHA	O	Emphasis information output terminal of channel status
24	AUDIO	O	Bit1 output terminal of channel status
25	CSFLAG	O	Top 40bit revise flag output terminal of channel status
26	F0/P0/C0	O	Input fs cal. sig. out/data type out/input word inf. output terminal
27	F1/P1/C1	O	Input fs cal. sig. out/data type out/input word inf. output terminal
28	F2/P2/C2	O	Input fs cal. sig. out/data type out/input word inf. output terminal
29	VF/P3/C3	O	Validity flag out/data type out/input word inf. output terminal
30	DVDD		Digital power supply
31	DGND		Digital GND
32	AUTO	O	Non PCM burst data transfer detect sig. output terminal
33	BPSYNC	O	Non PCM burst data preamble Pa, Pb, Pc, Pd sync sig. output terminal
34	ERROR	O	PLL lock error, data error flag output terminal
35	DO	O	CPU I/F read data output terminal
36	DI	I	CPU I/F write data input terminal
37	CE	I	CPU I/F chip enable input terminal
38	CL	I	CPU I/F chip enable input terminal
39	XSEL	I	Frequency select input pin of XIN X'tal osc. (24.576MHz or 12.288MHz)
40	MODE0	I	Mode setting input terminal
41	MODE1	I	Mode setting input terminal
42	DGND		Digital GND
43	DVDD		Digital power supply
44	DOSEL0	I	Data output format select input terminal
45	DOSEL1	I	Data output format select input terminal
46	CKSEL0	I	Output clock select input terminal
47	CKSEL1	I	Output clock select input terminal
48	XMODE	I	Reset input terminal

• For latch-up countermeasure, set digital (DVDD) and analog (AVDD) power on/off in the same timing.

AK4527BVQ (IC813)

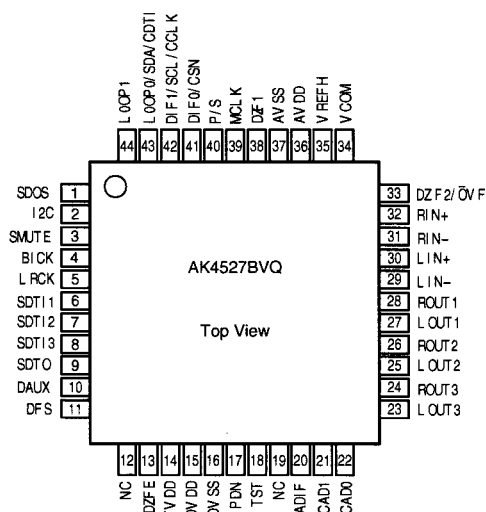

AK4527BVQ Terminal Function

Pin No.	Pin Name	I/O	Function
1	SDOS	I	SDTO source select pin, L: Internal ADC output, H: DAUX input
2	I2C	I	Serial control mode select pin, L: 3-core serial, H: I ² C bus
3	SMUTE	I	Soft mute pin, H: Soft mute start, L: Release
4	BICK	I	Audio serial data clock pin
5	LRCK	I	Input channel clock pin
6	SDTI1	I	DAC1 audio serial data input pin
7	SDTI2	I	DAC2 audio serial data input pin
8	SDTI3	I	DAC3 audio serial data input pin
9	SDTO	O	Audio serial data output pin
10	DAUX	I	Auxiliary audio serial data input pin
11	DFS	I	Double speed sampling mode pin, L: Normal, H: Double
12	NC	—	No Connect, No internal bonding
13	DZFE	I	Zero input detect enable pin
14	TVDD	—	Power pin for output buffer, 2.7V~5.5V
15	DVDD	—	Digital power pin, 4.5V~5.5V
16	DVSS	—	Digital GND pin, 0V
17	PDN	I	Power down & reset pin, L: Powered-down and register initialized, Reset with PDN when switching CAD0-1
18	TST	I	Test pin, connected to DVSS
19	NC	—	No Connect, No internal bonding
20	ADIF	I	Analog Input Format Select pin
21	CAD1	I	Chip address-1 pin
22	CAD0	I	Chip address-0 pin
23	LOUT3	O	DAC3L channel analog out pin
24	ROUT3	O	DAC3R channel analog out pin
25	LOUT2	O	DAC2L channel analog out pin
26	ROUT2	O	DAC2R channel analog out pin
27	LOUT1	O	DAC1L channel analog out pin
28	ROUT1	O	DAC1R channel analog out pin
29	LIN-	I	L-ch analog inverted input pin
30	LIN+	I	L-ch analog non-inverted input pin
31	RIN-	I	R-ch analog inverted input pin
32	RIN+	I	R-ch analog non-inverted input pin
33	DZF2/OVF	O	0 input detect 2 pin/Analog input overflow detect pin
34	VCOM	O	Common V-out pin, AVDD/2, connect large capacitor to avoid noise
35	VREFH	I	Ref. V input pin, AVDD
36	AVDD	—	Analog GND pin, 4.5V~5.5V
37	AVSS	—	Analog GND pin, 0V
38	DZF1	O	0 input detect pin, H: Input data of G1 is 8192 times "0" in a raw or RSTN bit "0", L: When P/S="0"
39	MCLK	I	Master clock input pin
40	P/S	I	Parallel/Serial select pin, L: Serial control
41	DIF0	I	Audio data I/F format 0 pin (parallel control)
	CSN	I	Chip select pin (3-wire serial control), connect to DVDD when I ² C bus control
42	DIF1	I	Audio data I/F format 1 pin (parallel control)
	SCL/CCLK	I	Control data clock pin (serial control), I ² C="L": CCLK (3-wire serial), I ² C="H": SCL (I ² C bus)
43	LOOP0	I	Loop back mode 0 pin (parallel control), effects digital loop back ADC to all DAC
	SDA/CDTI	I/O	Control data input pin (serial control), I ² C="L": CCTI (3-wire serial), I2C="H" SDA (I ² C bus)
44	LOOP1	I	Loop back mode 1 pin, from SDTI1 to all DAC

LC72131 (IC401)

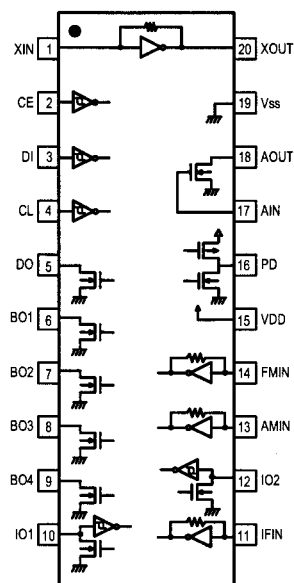

LA1266 (IC402)

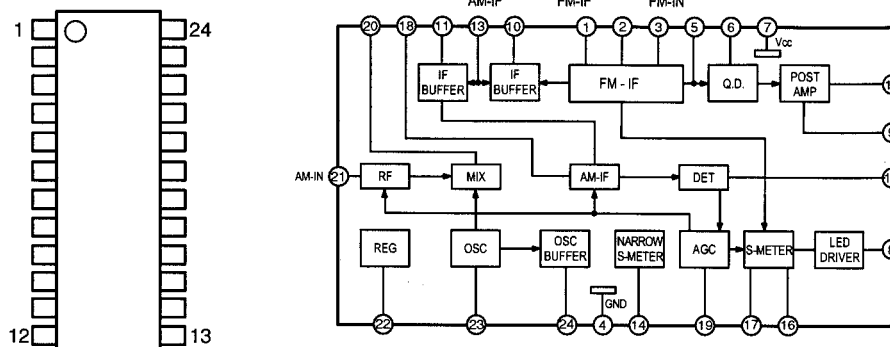

LA3401 (IC403)

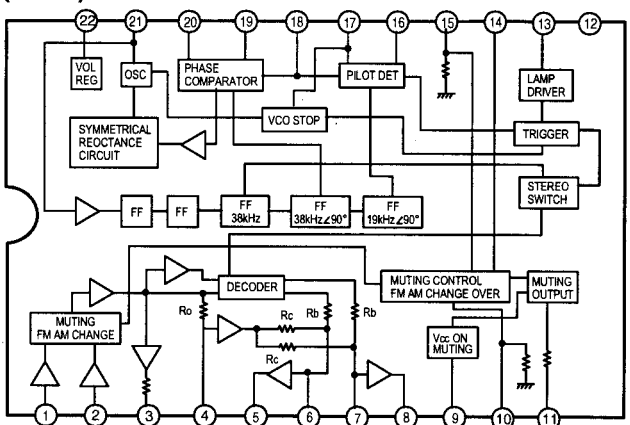

BU2090F (IC302, 602)

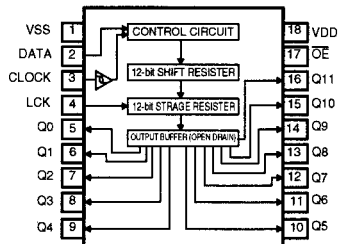

TDA7330BD (IC202)

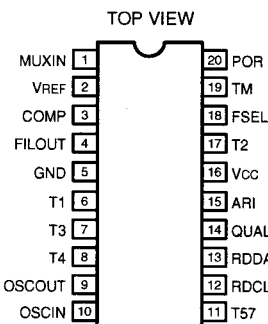

MM74LCX244 (IC818,819)

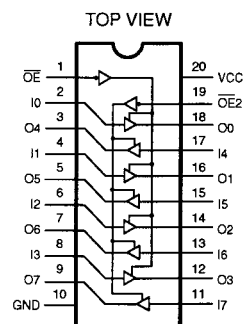

MM74HC151 (IC832)

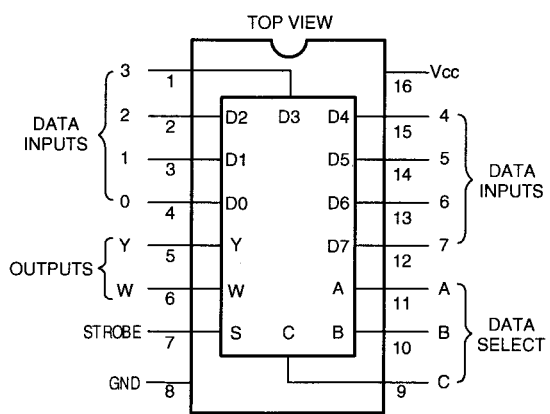

RC1117S25T (IC820)
RC1117S33T (IC811)

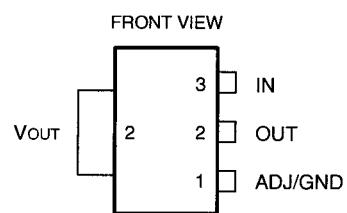

LC75721E (IC301)

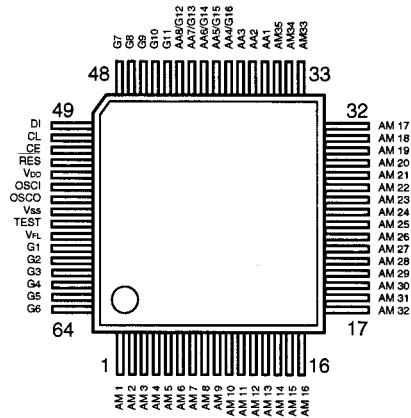

LC75721E Terminal Function

Symbol	Function
V _{DD}	Power terminal +5V
V _{SS}	Power terminal GND
V _{FL}	Power terminal FL drive
DI	Serial data transfer terminal
CL	DI: Data
CE	CL: Clock
CE	CE: Chip enable
OSCI	External CR connecting terminal
OSCO	
RES	System reset terminal
AM1-AM35	Anode output terminal
AA1-AA3	Anode/Grid output terminal
AA4/G16	
AA5/G15	
AA6/G14	
AA7/G13	
AA8/G12	
G1-G11	Grid output terminal
TEST	LSI test terminal

KIC9164AN (IC203)

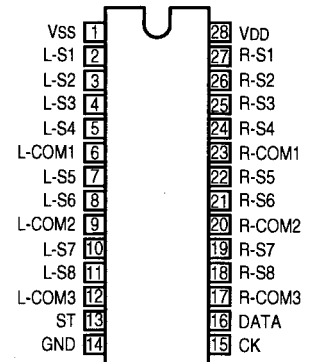

BA7626 (IC601, 651, 652)

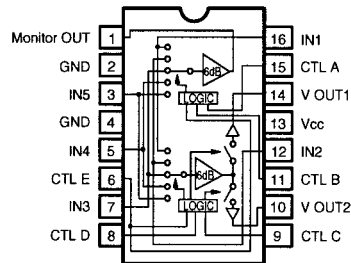

A	B	E	MONITOR OUT
L	L	*	IN 1
H	L	*	IN 2
L	H	*	IN 3
H	H	L	IN 4
H	H	H	IN 5

C	D	E	V OUT 1
L	L	*	—
H	L	*	IN 2
L	H	*	IN 3
H	H	L	IN 4
H	H	H	IN 5

C	D	E	V OUT 2
L	L	*	IN 1
H	L	*	—
L	H	*	IN 3
H	H	L	IN 4
H	H	H	IN 5

Note 1: * mark means that feasible for either H or L.
 Note 2: Each input terminal is provided with sink chip clamp (BA7625).
 Each input terminal takes 20kohm at the end (BA7626).

M27W201 (IC807)

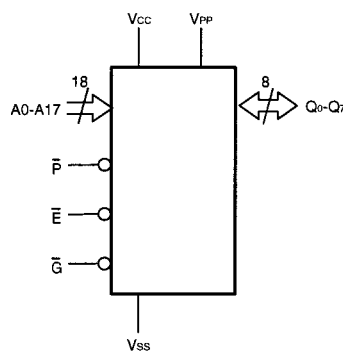
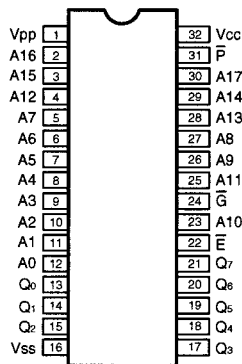

NJM2068DD (IC205-210, 551, 702-704, 814-816)
BA4510F (IC805-806)
NJM2068MD (IC814-816)

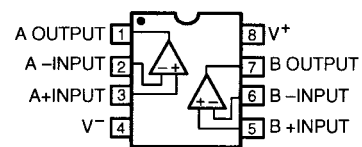

SN74LV00APW (IC822)

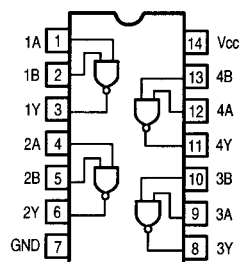

74HCU04 (IC803)

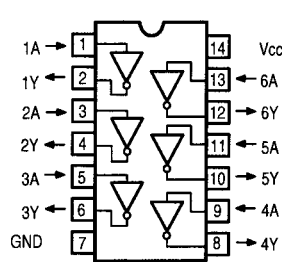

KIA78R05PI (IC653)

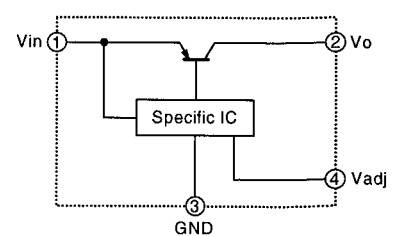

SN74LV4040 (IC831)

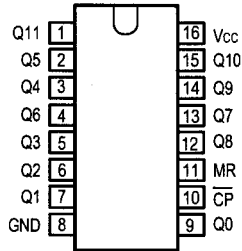

Terminal Function

INPUTS		OUTPUTS
CP	MR	Qn
↑	L	no change
↓	L	count
X	H	L

H=HIGH voltage level
 L=LOW voltage level
 X=don't care
 ↑=LOW-to-HIGH clock transition
 ↓=HIGH-to-LOW clock transition

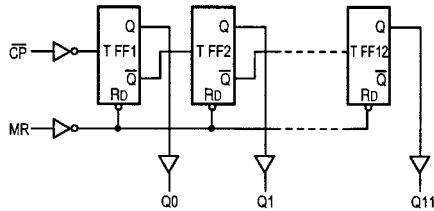

**KIA7805AP (IC104)
 KIA7815AP (IC101)
 NJM7805FA(S) (IC103, 829)**



NJM7915FA (IC102)



MM74LCX574 (IC808, 809)

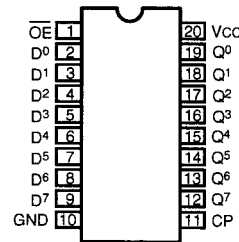

MM74HCT244 (IC828, 830)

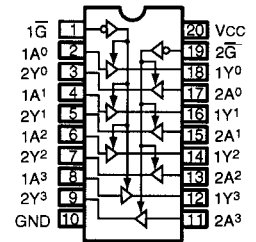

TC9184AP (IC552)

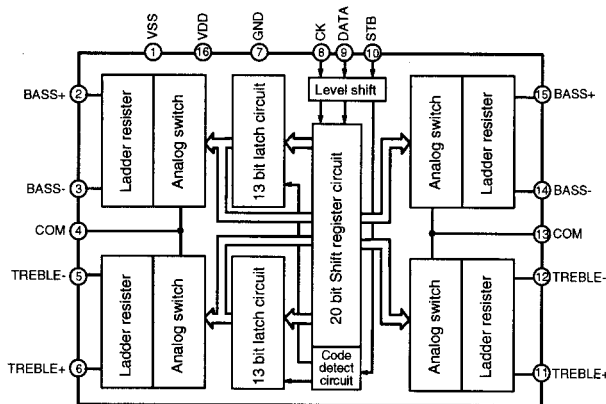
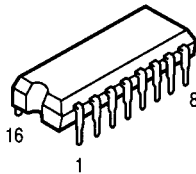

● **IC PROTECTOR**

ICP-N15 (IC105)

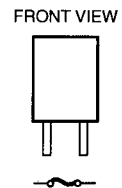

● **POSISTOR**

P43T7D330BW16

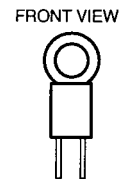

● **OPTICAL**

INPUT GP1FA502RZ (IC817)

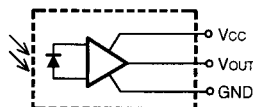
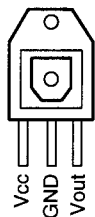

OUTPUT GP1FA502TZ (IC801, 802, 803)

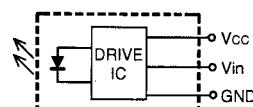
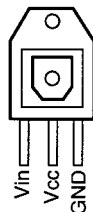

● **IR SENSOR**

NJL64H380A(RMC301)

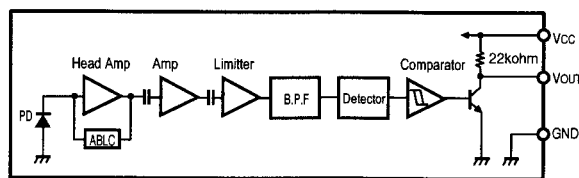
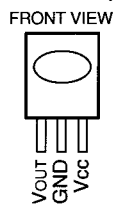

● FL DISPLAY

16-st-42GNK (FL301)

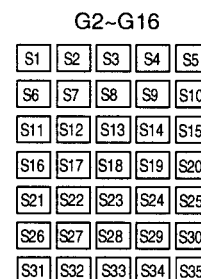
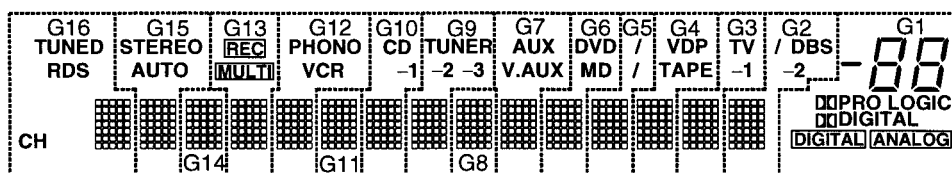
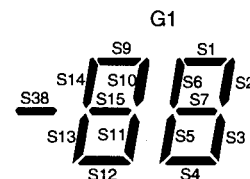
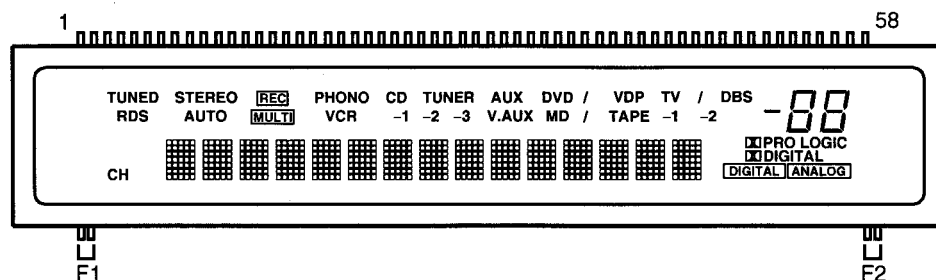

Pin Assignment

PIN NO.	1	2	3	4	5	6	7	8	9	10	11	12	13	14	15	16	17	18	19	20
CONNECTION	F1	F1	S1	S2	S3	S4	S5	S6	S7	S8	S9	S10	S11	S12	S13	S14	S15	S16	S17	S18
PIN NO.	21	22	23	24	25	26	27	28	29	30	31	32	33	34	35	36	37	38	39	40
CONNECTION	S19	S20	S21	S22	S23	S24	S25	S26	S27	S28	S29	S30	S31	S32	S33	S34	S35	S36	S37	S38
PIN NO.	41	42	43	44	45	46	47	48	49	50	51	52	53	54	55	56	57	58		
CONNECTION	G16	G15	G14	G13	G12	G11	G10	G9	G8	G7	G6	G5	G4	G3	G2	G1	F2	F2		

F1, F2 : Filament
 G1~G16: Grid
 S1~S38 : Anode

Anode & Grid Assignment

	G1	G2-G16		G1	G2-G16		G1	G2-G16		G1	G2-G16
S1	S1	S1	S10	S10	S10	S19	---	S19	S28	---	S28
S2	S2	S2	S11	S11	S11	S20	---	S20	S29	---	S29
S3	S3	S3	S12	S12	S12	S21	---	S21	S30	---	S30
S4	S4	S4	S13	S13	S13	S22	---	S22	S31	---	S31
S5	S5	S5	S14	S14	S14	S23	---	S23	S32	---	S32
S6	S6	S6	S15	S15	S15	S24	---	S24	S33	---	S33
S7	S7	S7	S16	---	S16	S25	---	S25	S34	---	S34
S8	---	S8	S17	DIGITAL	S17	S26	---	S26	S35	---	S35
S9	S9	S9	S18	PRO LOGIC	S18	S27	---	S27			

	G1	G2	G3	G4	G5	G6	G7	G8	G9	G10	G11	G12	G13	G14	G15	G16
S36	DIGITAL	/	TV	VDP	/(DVD)	DVD	AUX	---	TUNER	CD	---	PHONO	REC	---	STEREO	TUNED
S37	ANALOG	-2	-1	TAPE	/(MD)	MD	V.AUX	---	-2	-1	---	VCR	MULTI	---	AUTO	RDS
S38	S38	DBS	---	---	---	---	---	---	-3	---	---	---	---	---	---	CH

● TRANSISTORS

2SC2412K
KTC3880S

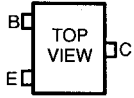

DTA114EK
DTA114YK
DTA144EK
DTC114EK
DTC114YK
DTC144EK

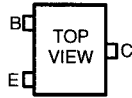

DTA Series

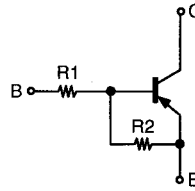

	R1	R2
DTA114EK	10kohm / Ω	10kohm / Ω
DTA114ES	10kohm / Ω	10kohm / Ω
DTA114YK	10kohm / Ω	47kohm / Ω
DTA144EK	47kohm / Ω	47kohm / Ω

DTC Series

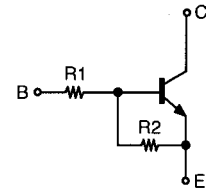

	R1	R2
DTC114EK	10kohm / Ω	10kohm / Ω
DTC114TS	10kohm / Ω	—
DTC114YK	10kohm / Ω	47kohm / Ω
DTC114YS	10kohm / Ω	47kohm / Ω
DTC144EK	47kohm / Ω	47kohm / Ω
DTC144ES	47kohm / Ω	47kohm / Ω

2SC1740S
2SC3199Y
KSA916Y
KSA992F
KSC1845F
KTA1266Y
KTA1268BL
KTC2874B
KTC3198Y
KTC3200BL



DTA114ES
DTC114TS
DTC114YS
DTC144ES



2SK117



● DIODES (LED included)

MTZJ3.3B
MTZJ5.1B
MTZJ5.6B
MTZJ6.8B
MTZJ7.5A
MTZJ7.5B
MTZJ11B
MTZJ18B
MTZJ20B

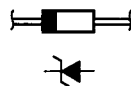

1N4007
1SS133

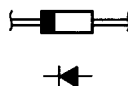

KDS160



HL-50RDRF4T

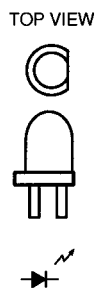

KBPC604

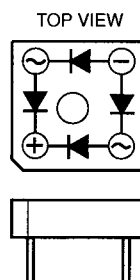

PRINTED WIRING BOARDS

1 2 3 4 5 6 7 8

MAIN P.W.B. Ass'y (for U.S.A., Canada, Europe & China Models)

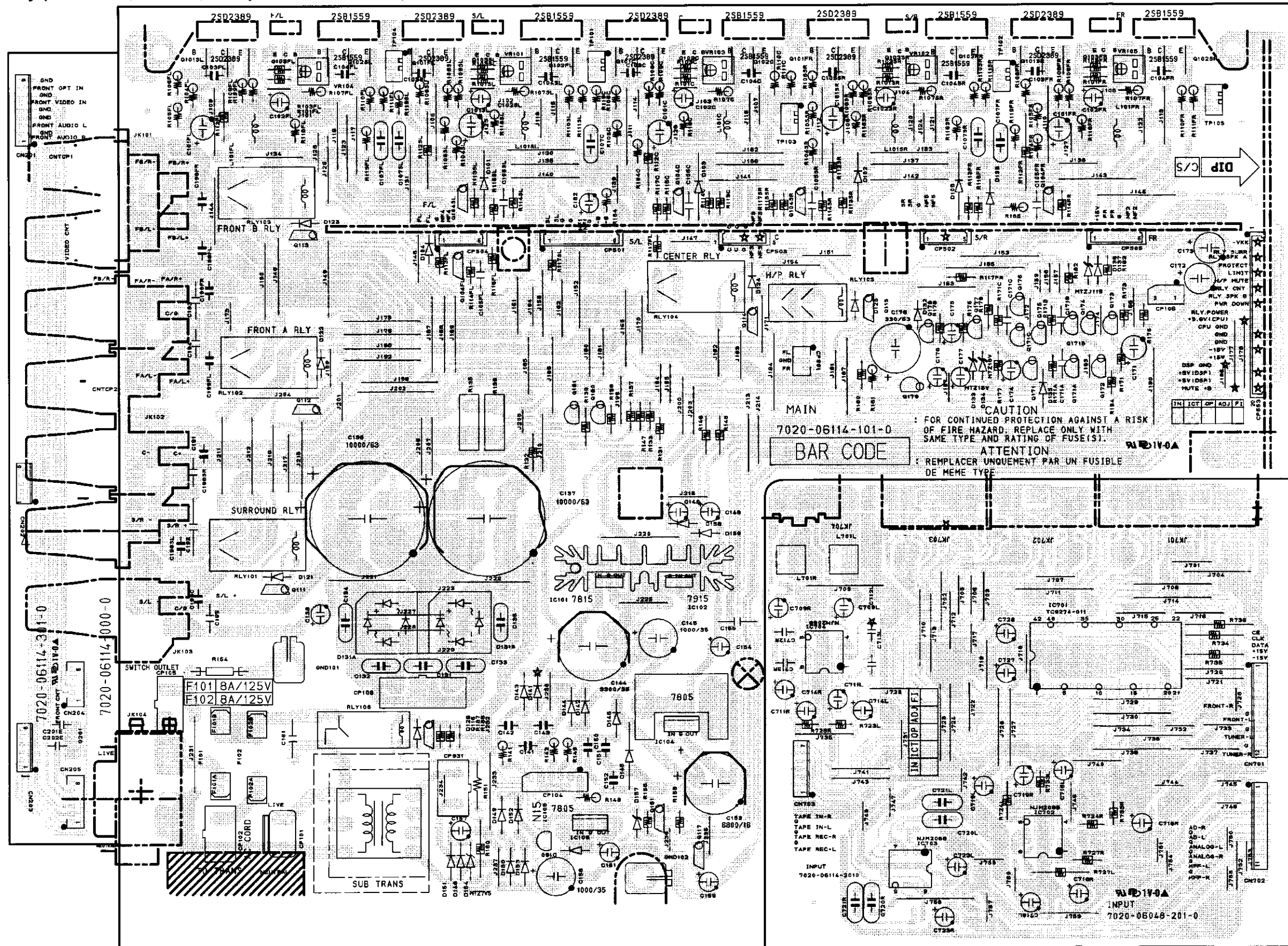

COMPONENT SIDE

1 2 3 4 5 6 7 8

MAIN P.W.B. Ass'y (for U.S.A. , Canada, Europe & China Models)

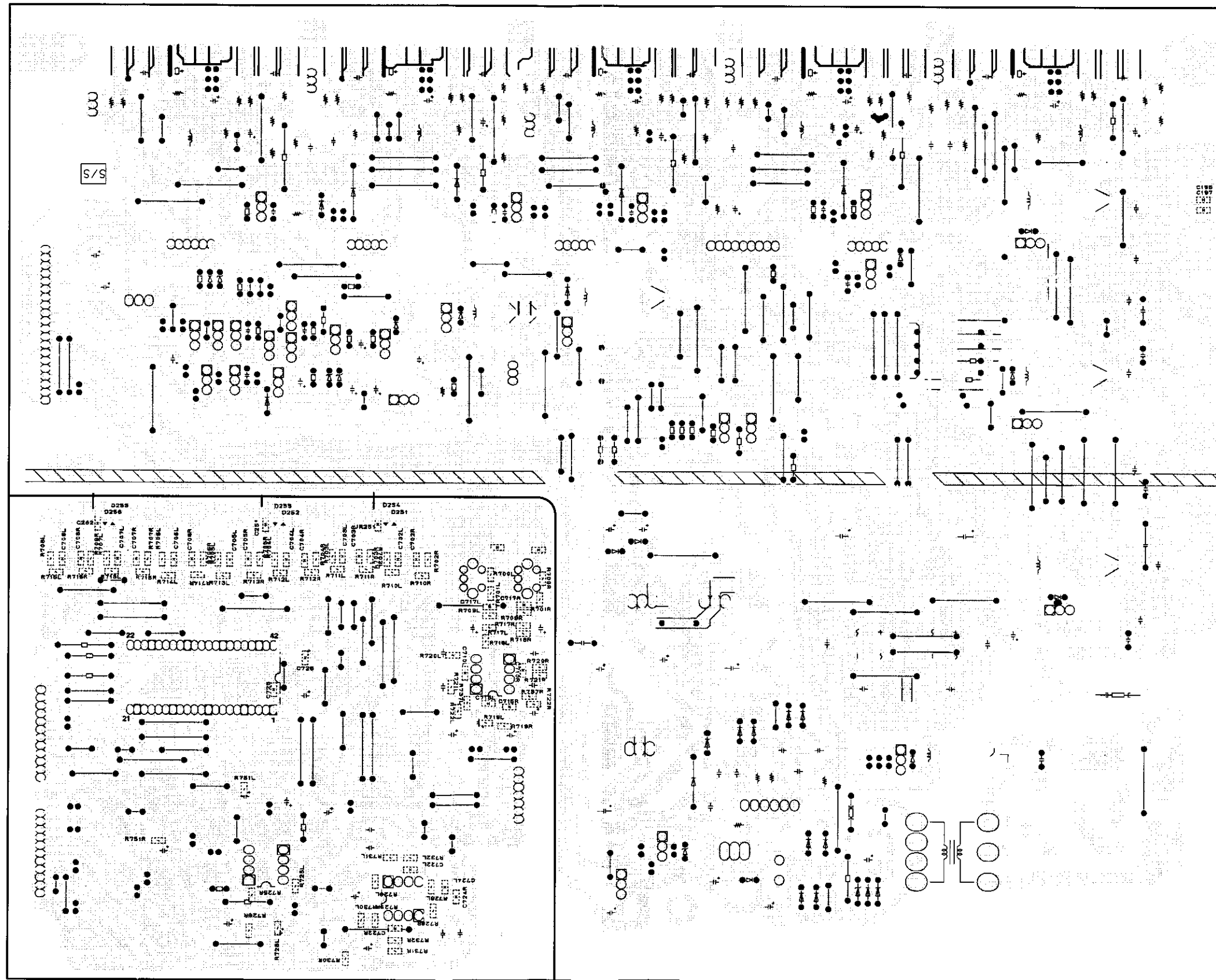

C198
C197
C191
C191

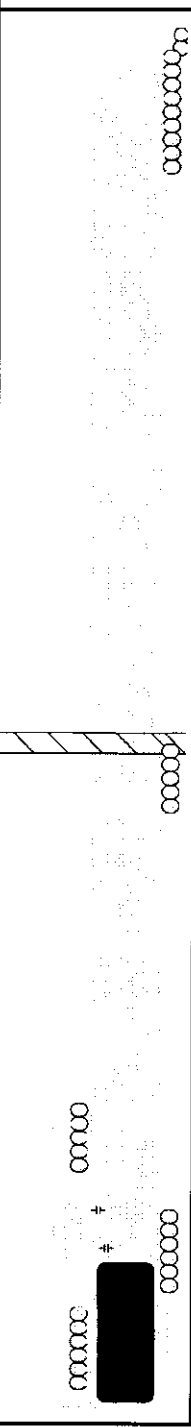

FOIL SIDE

A
B
C
D
E

1 2 3 4 5 6 7 8

MAIN P.W.B. Ass'y (for Asia, Hong Kong & Taiwan R.O.C. Models)

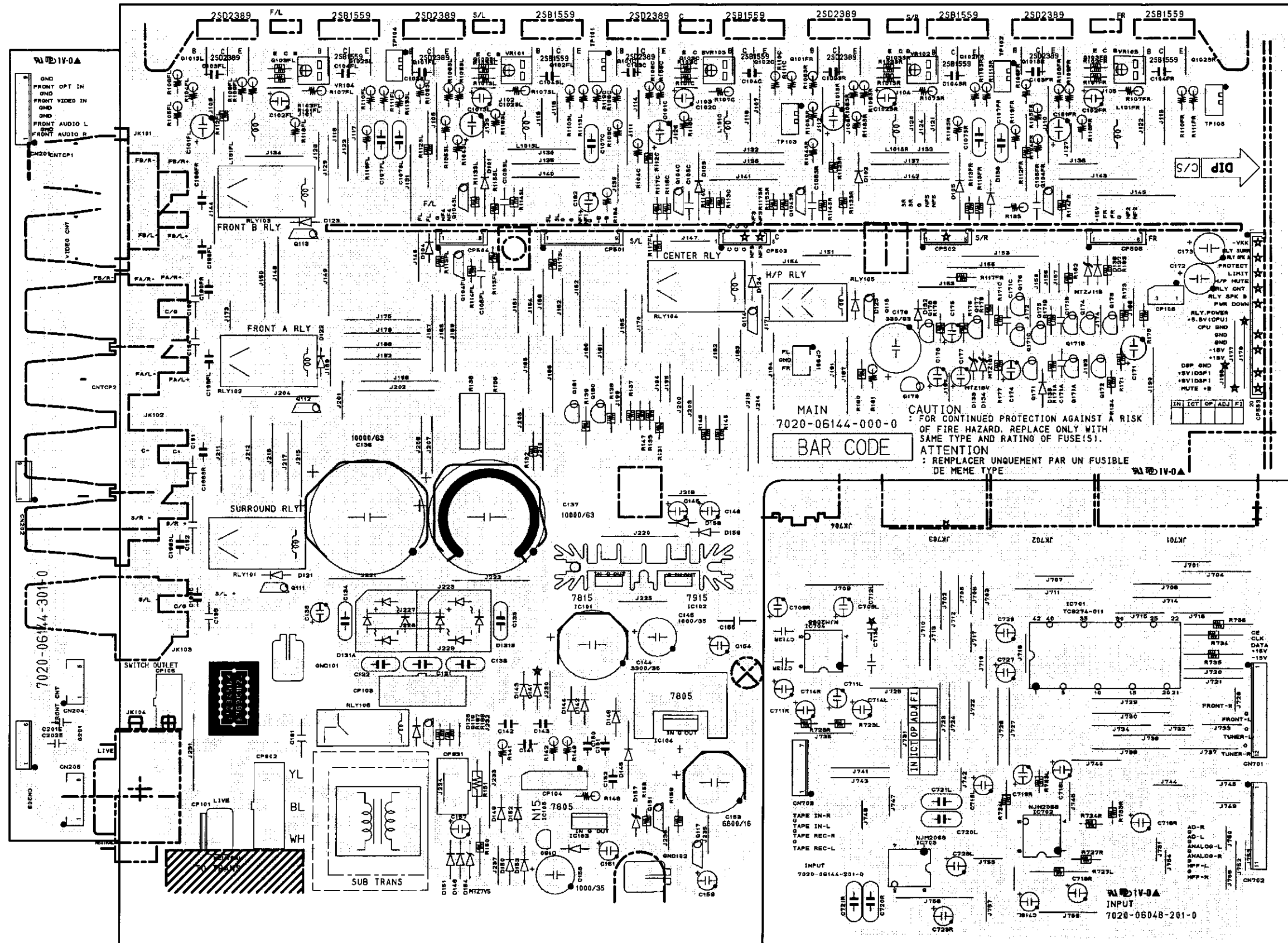

COMPONENT SIDE

A
B
C
D
E

1 2 3 4 5 6 7 8

MAIN P.W.B. Ass'y (for Asia, Hong Kong & Taiwan R.O.C. Models)

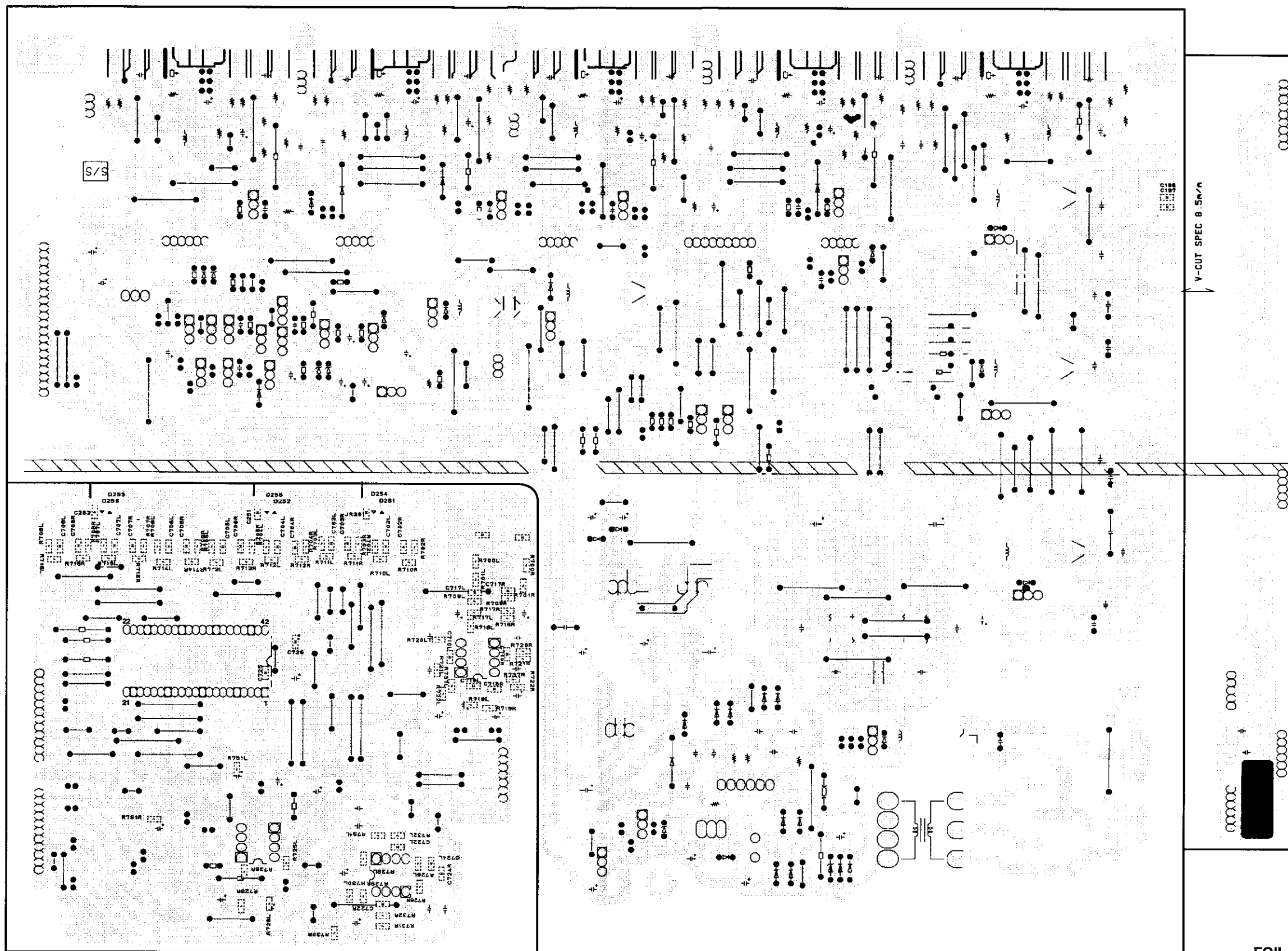

FOIL SIDE

A
B
C
D
E

PROCESSOR P.W.B. Ass'y

1 2 3 4 5 6 7 8

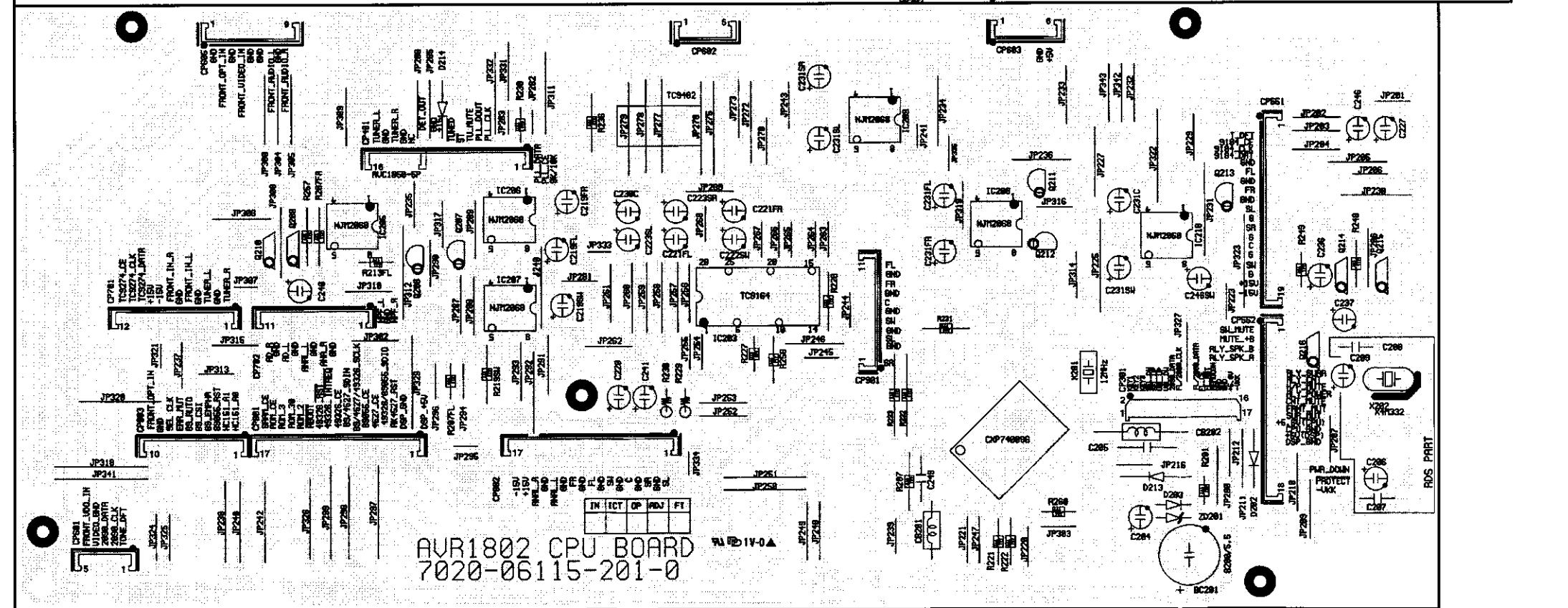
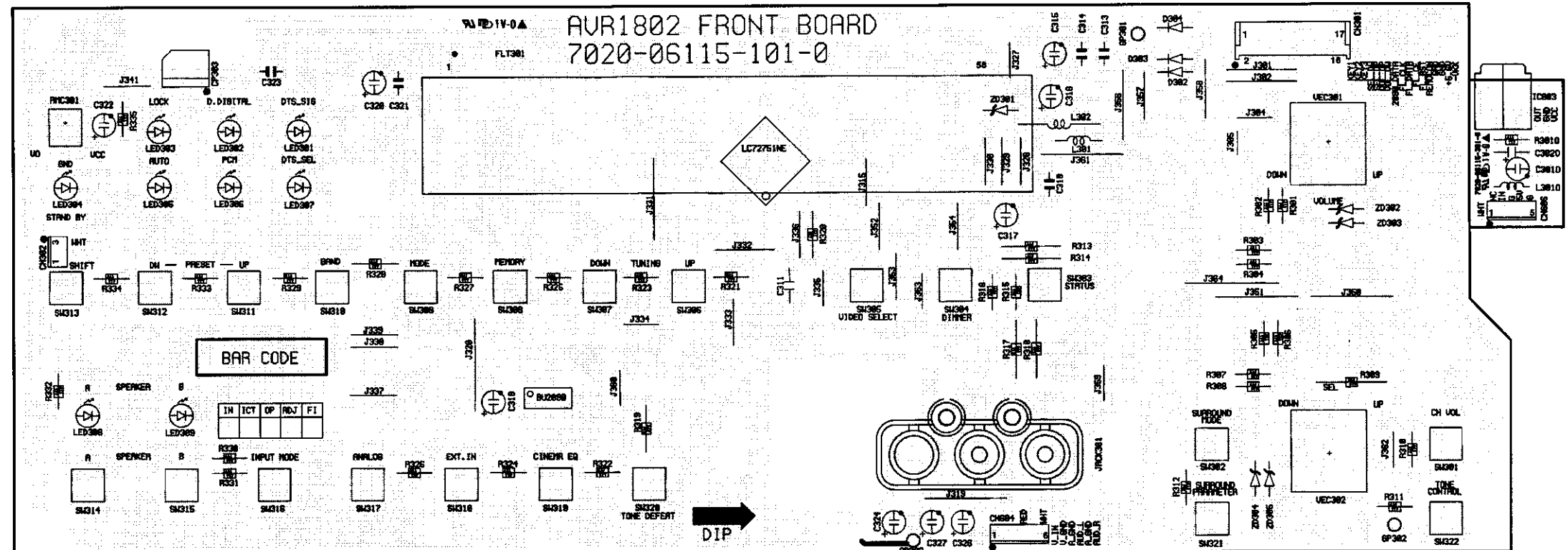

A
B
C
D
E

COMPONENT SIDE

PROCESSOR P.W.B. Ass'y

1 2 3 4 5 6 7 8

A
B
C
D
E

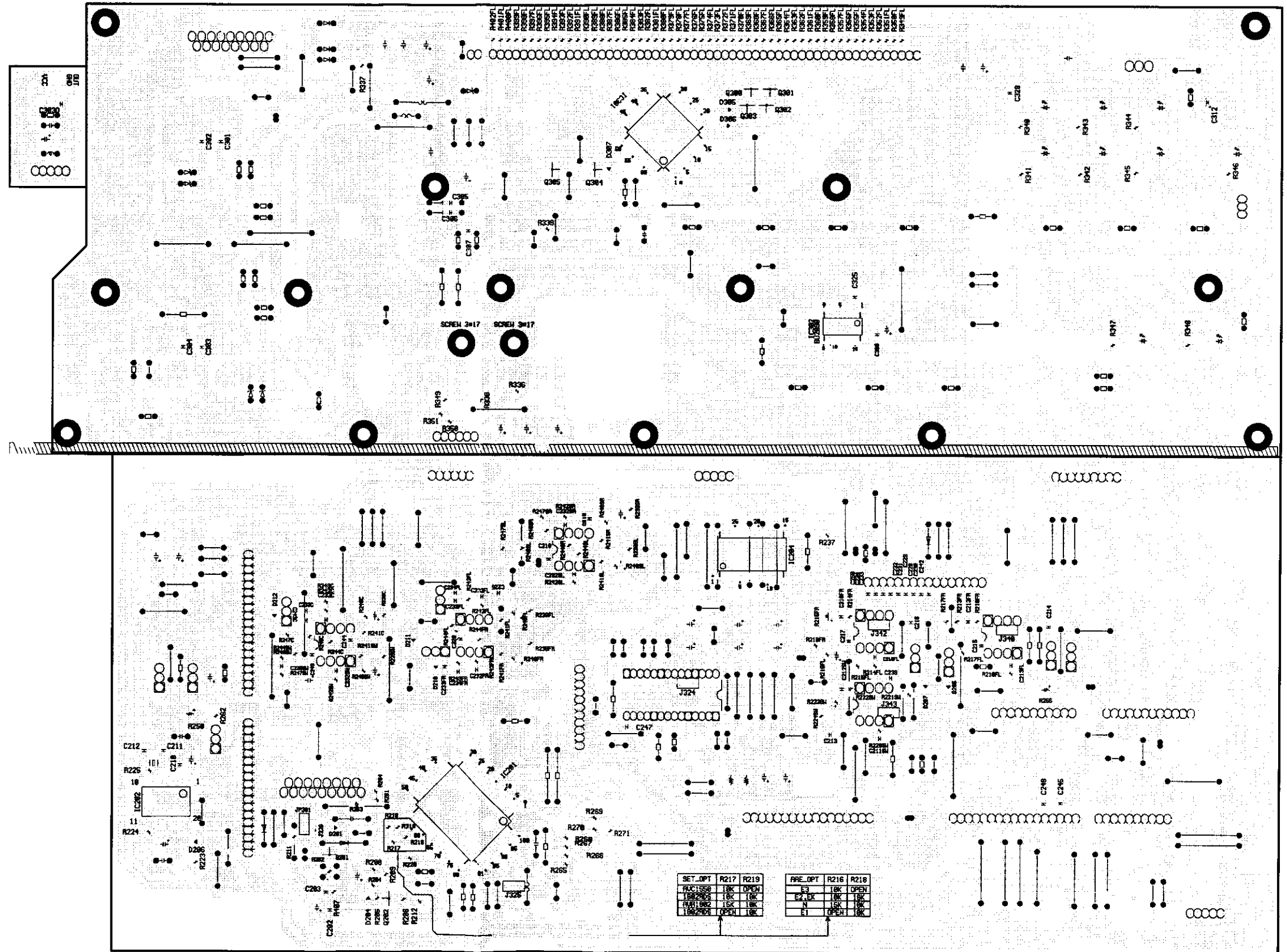

FOIL SIDE

1 2 3 4 5 6 7 8

CNT P.W.B. Ass'y

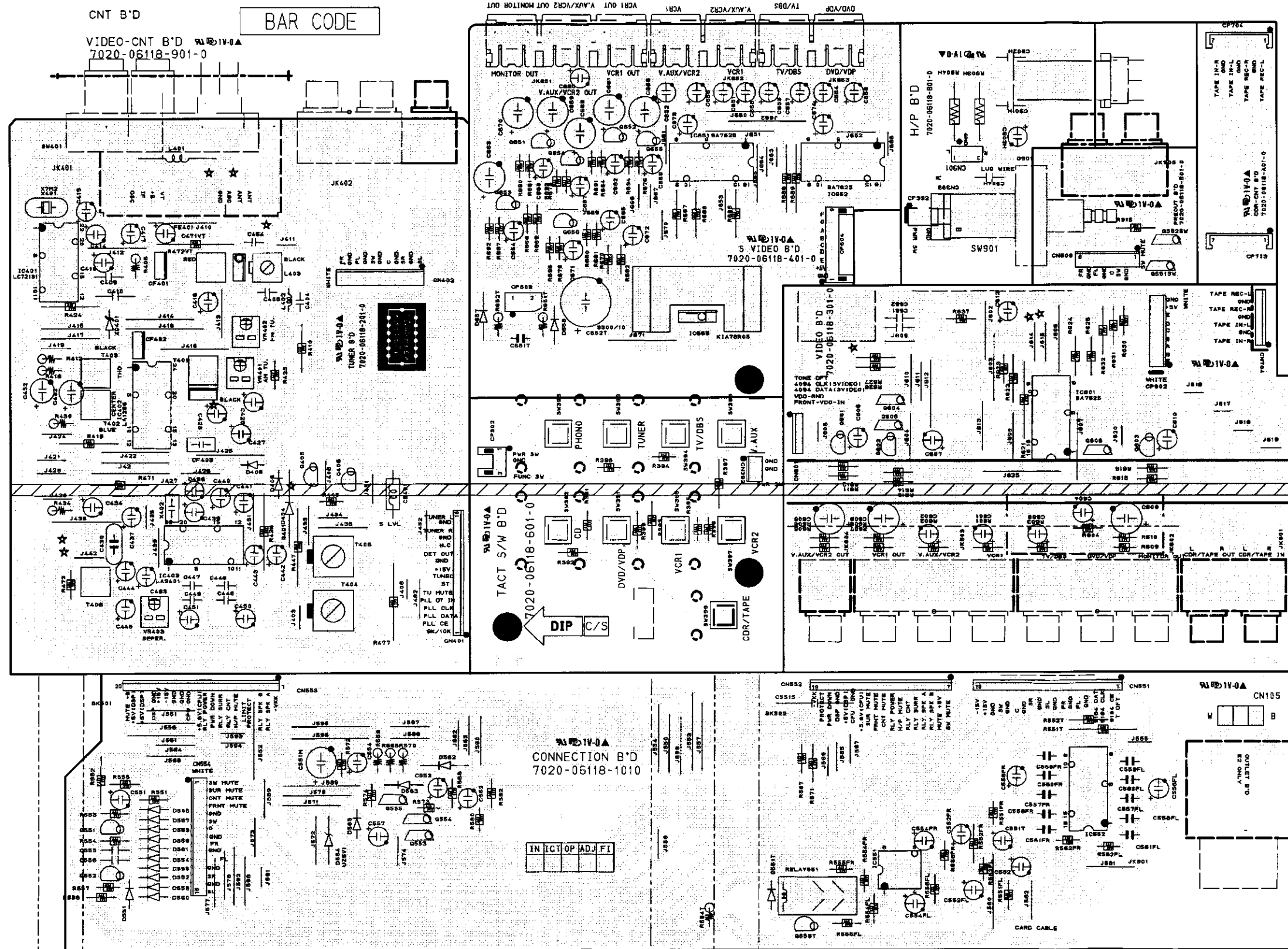

COMPONENT SIDE

1

2

3

4

5

6

7

8

CNT P.W.B. Ass'y

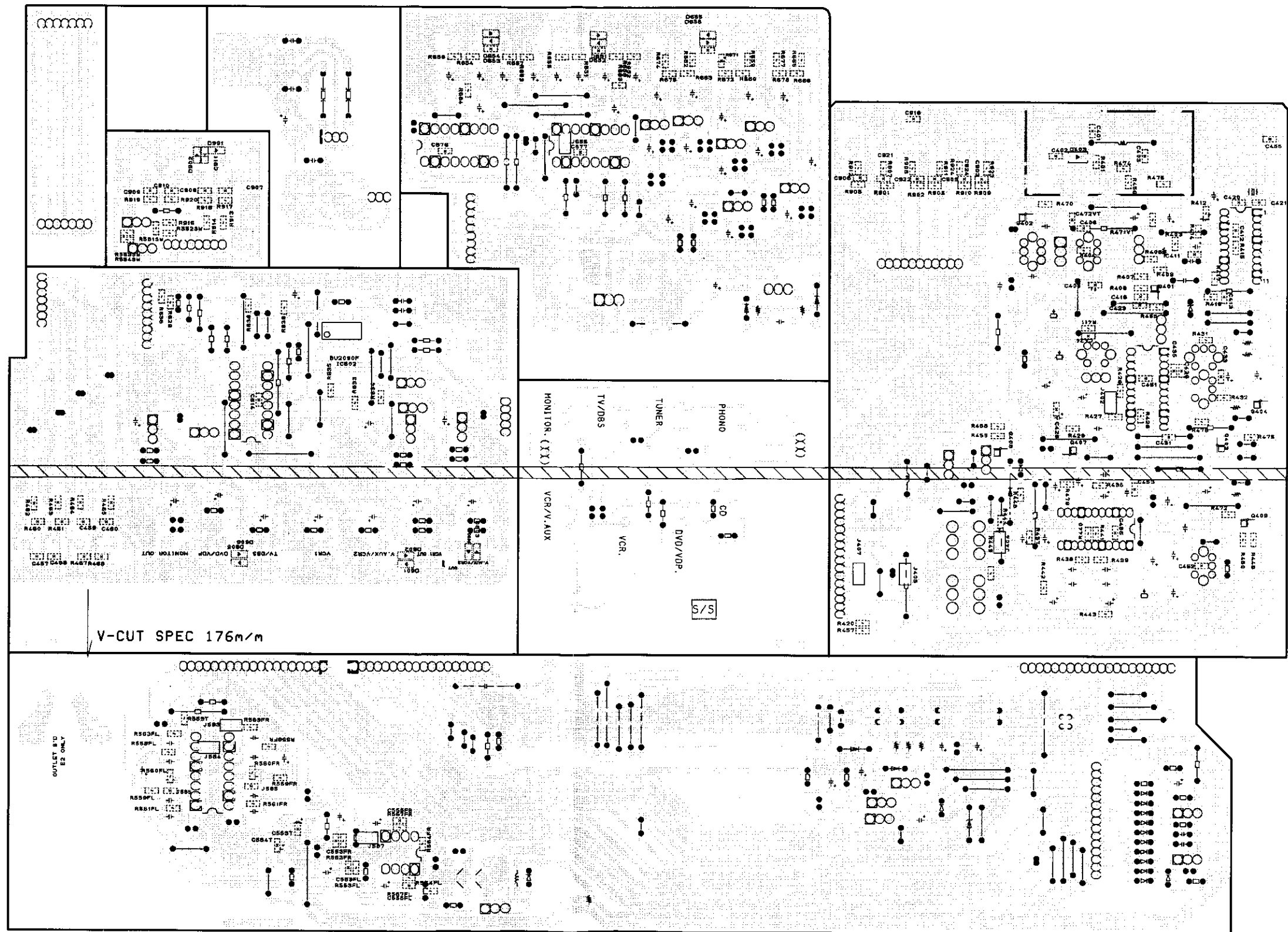

A

B

C

D

E

FOIL SIDE

1

2

3

4

5

6

7

8

PRE-AMP P.W.B. Ass'y

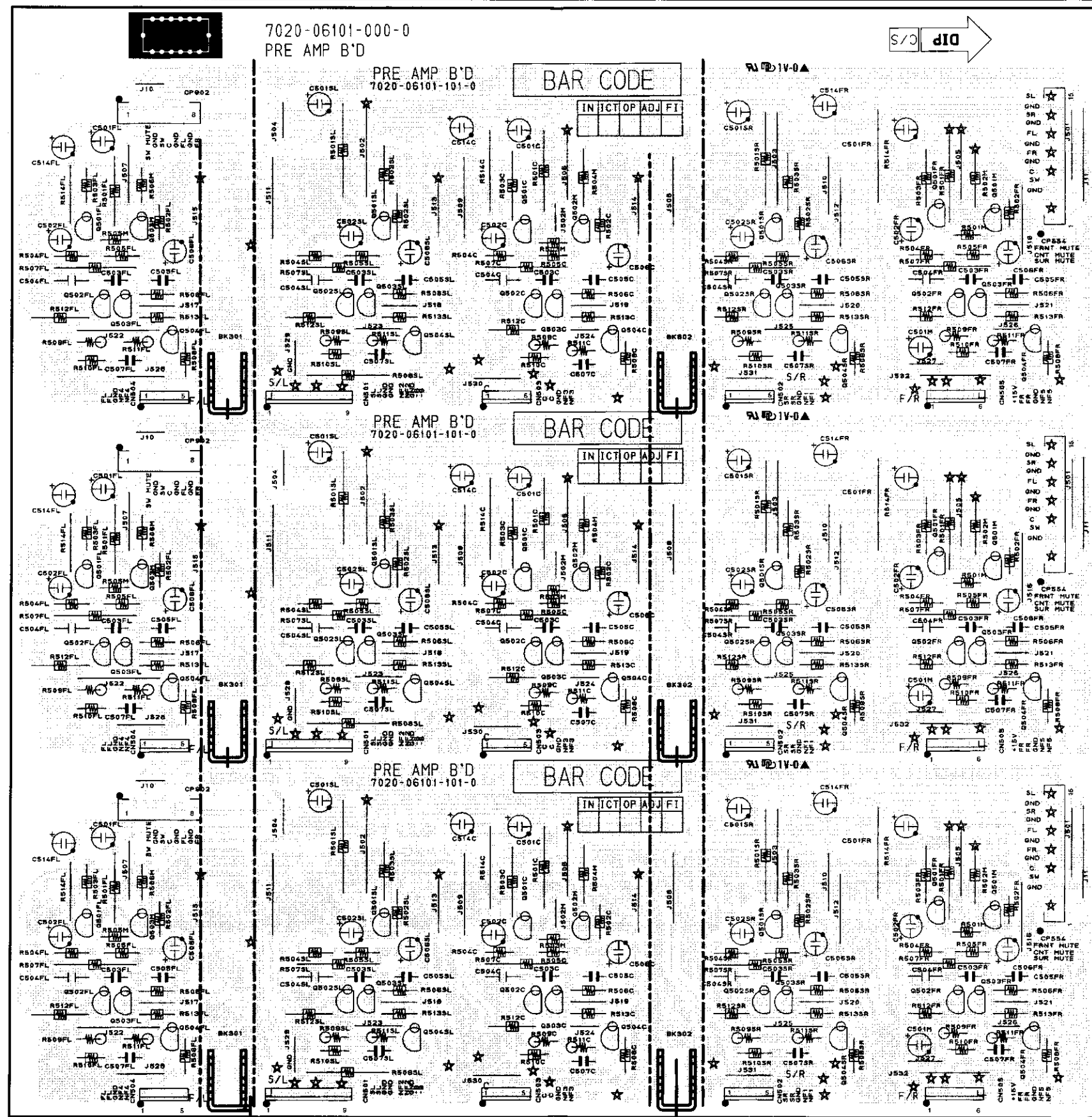

A

B

C

D

E

COMPONENT SIDE

PRE-AMP P.W.B. Ass'y

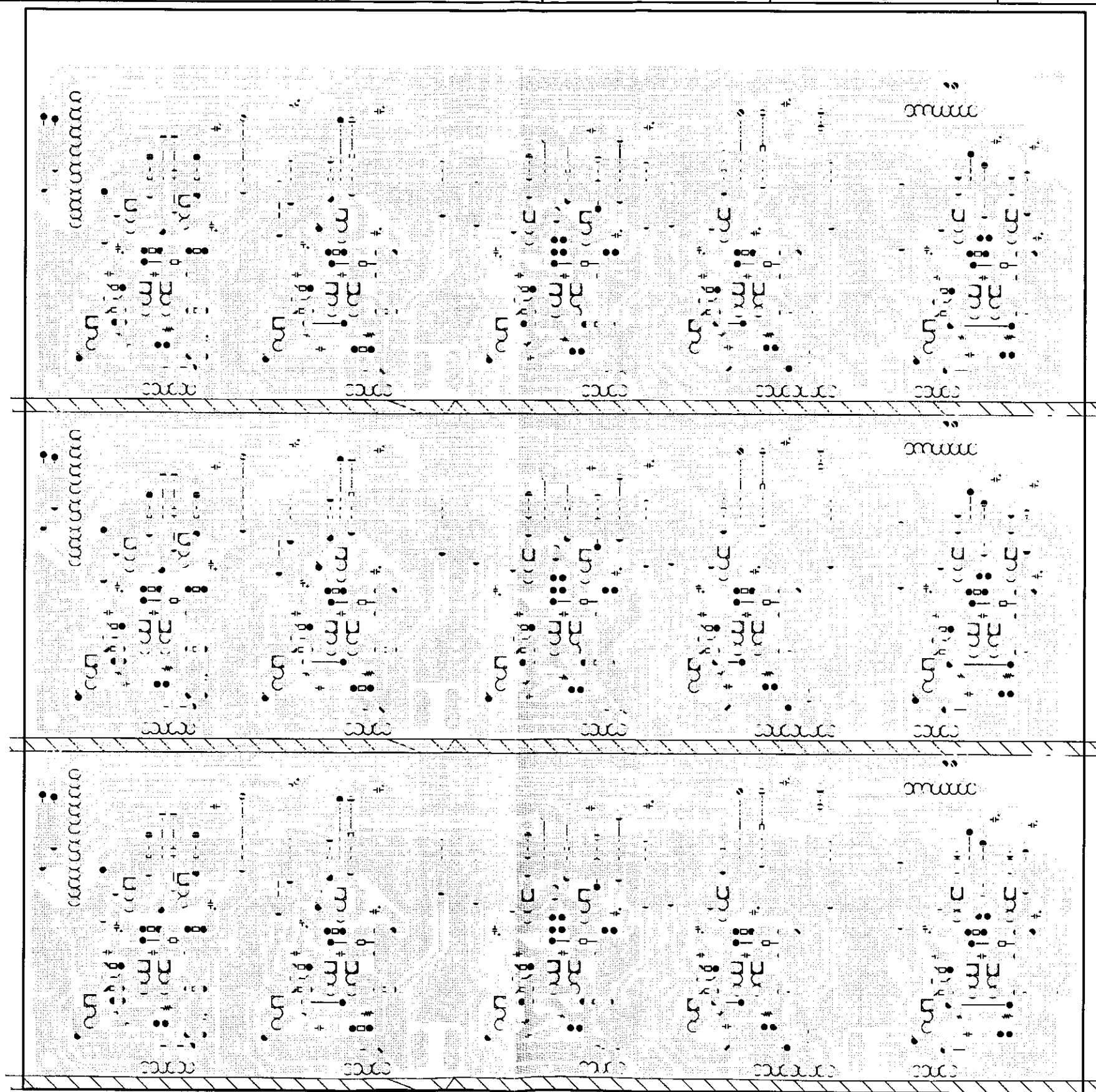

FOIL SIDE

DSP P.W.B. Ass'y

1 2 3 4 5 6 7 8

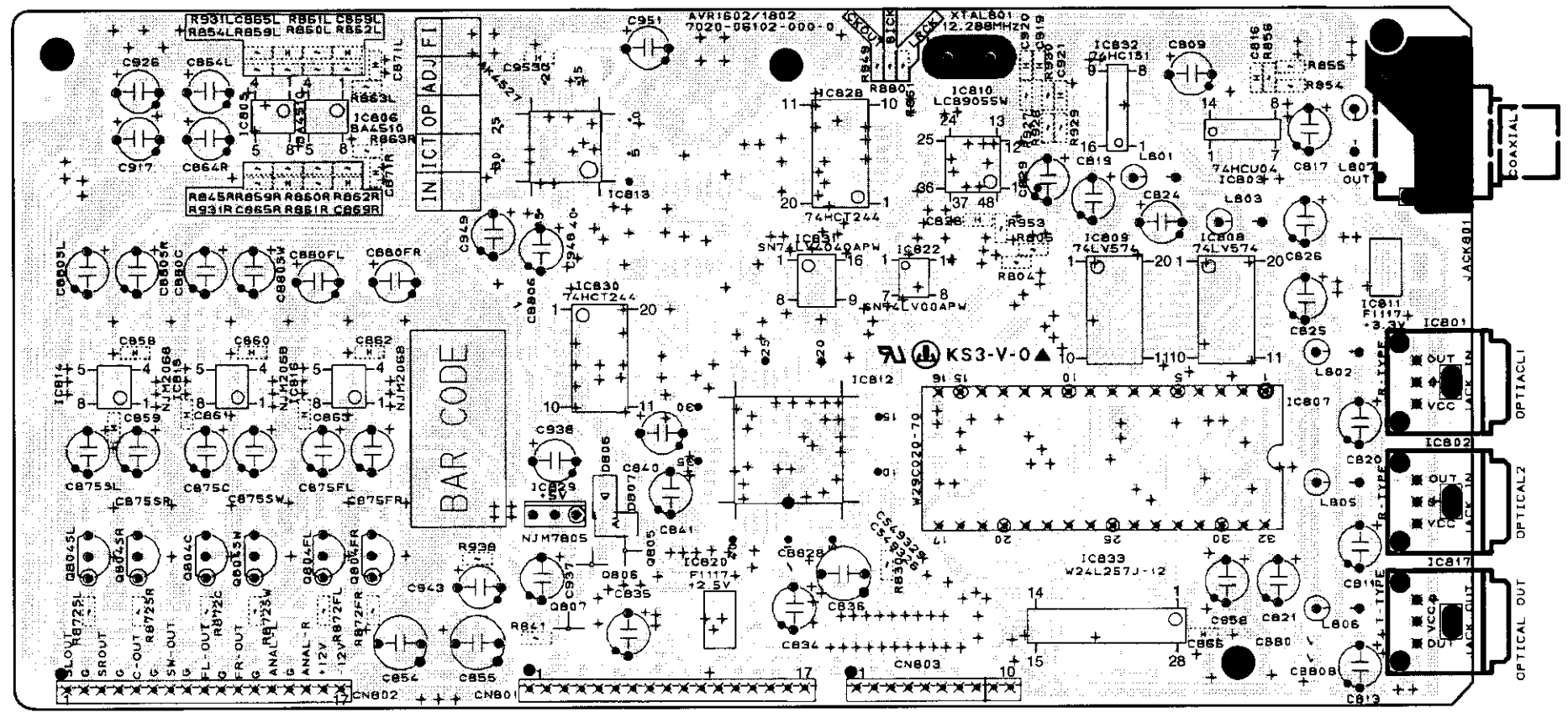

COMPONENT SIDE

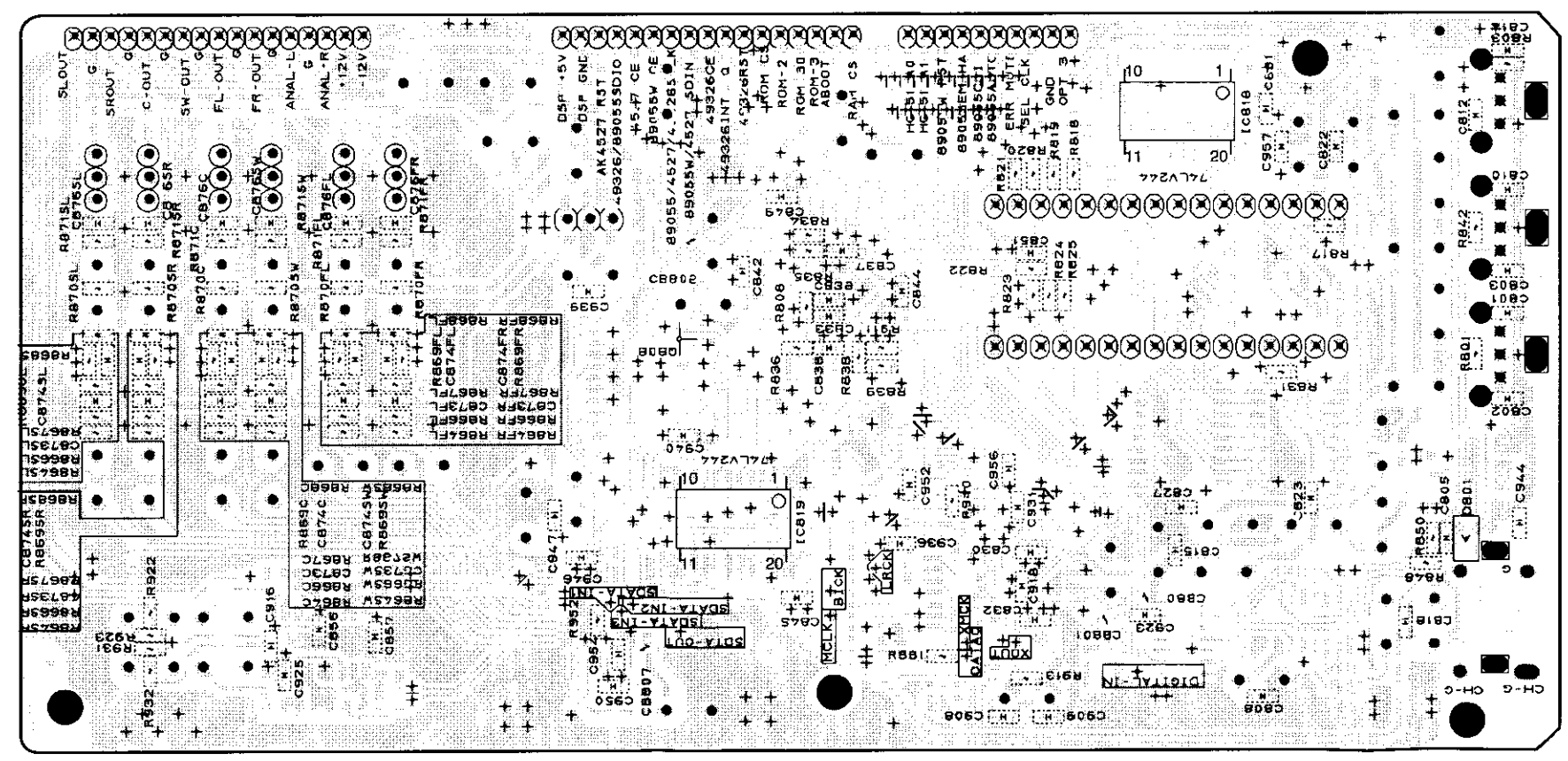

FOIL SIDE

A
B
C
D
E

1

2

3

4

VOLTAGE P.W.B. Ass'y

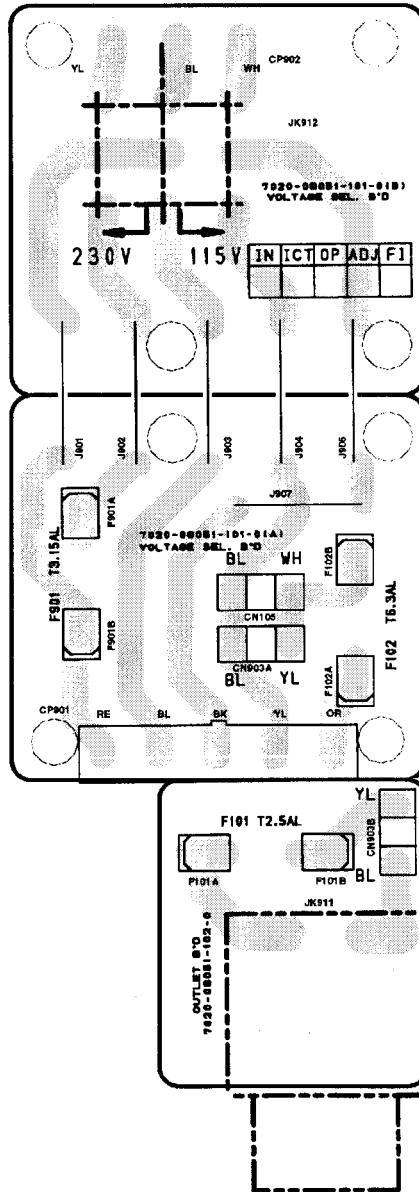

A

B

C

D

E

COMPONENT SIDE

NOTE FOR PARTS LIST

- Part indicated with the mark "⊗" are not always in stock and possibly to take a long period of time for supplying, or in some case supplying of part may be refused.
- When ordering of part, clearly indicate "1" and "I" (i) to avoid mis-supplying.
- Ordering part without stating its part number can not be supplied.
- Part indicated with the mark "★" is not illustrated in the exploded view.
- Not including Carbon Film ±5%, 1/4W Type in the P.W.Board parts list. (Refer to the Schematic Diagram for those parts.)

WARNING:

Parts marked with this symbol  have critical characteristics.
Use ONLY replacement parts recommended by the manufacturer.

● Resistors

Ex.: **RN 14K 2E 182 G FR**
 Type Shape and performance Power Resistance Allowable error Others

RD : Carbon	2B : 1/8W	F : ±1%	P : Pulse-resistant type
RC : Composition	2E : 1/4W	G : ±2%	NL : Low noise type
RS : Metal oxide film	2H : 1/2W	J : ±5%	NB : Non-burning type
RW : Winding	3A : 1W	K : ±10%	FR : Fuse-resistor
RN : Metal film	3D : 2W	M : ±20%	F : Lead wire forming
RK : Metal mixture	3F : 3W		
	3H : 5W		

*** Resistance**

$\overset{1}{\text{R}} \overset{2}{\text{R}} \Rightarrow 1800 \text{ ohm} = 1.8 \text{ kohm}$
 Indicates number of zeros after effective number.
 2-digit effective number.

• Units: ohm

$\overset{1}{\text{R}} \overset{2}{\text{R}} \Rightarrow 1.2 \text{ ohm}$
 1-digit effective number.
 2-digit effective number, decimal point indicated by R.

• Units: ohm

● Capacitors

Ex.: **CE 04W 1H 2R2 M BP**
 Type Shape and performance Dielectric strength Capacity Allowable error Others

CE : Aluminum foil electrolytic	0J : 6.3V	F : ±1%	HS : High stability type
CA : Aluminum solid electrolytic	1A : 10V	G : ±2%	BP : Non-polar type
CS : Tantalum electrolytic	1C : 16V	J : ±5%	HR : Ripple-resistant type
CQ : Film	1E : 25V	K : ±10%	DL : For charge and discharge
CK : Ceramic	1V : 35V	M : ±20%	HF : For assuring high frequency
CC : Ceramic	1H : 50V	Z : +80%	U : UL part
CP : Oil	2A : 100V	-20%	C : CSA part
CM : Mica	2B : 125V	P : +100%	W : UL-CSA type
CF : Metallized	2C : 160V	-0%	F : Lead wire forming
CH : Metallized	2D : 200V	C : ±0.25pF	
	2E : 250V	D : ±0.5pF	
	2H : 500V	= : Others	
	2J : 630V		

*** Capacity (electrolyte only)**

$\overset{2}{\text{R}} \overset{2}{\text{R}} \Rightarrow 2200\mu\text{F}$
 Indicates number of zeros after effective number.
 2-digit effective number.

• Units: μF.

$\overset{2}{\text{R}} \overset{2}{\text{R}} \Rightarrow 2.2\mu\text{F}$
 1-digit effective number.
 2-digit effective number, decimal point indicated by R.

• Units: μF.

*** Capacity (except electrolyte)**

$\overset{2}{\text{R}} \overset{2}{\text{R}} \Rightarrow 2200\text{pF} = 0.0022\mu\text{F}$
 (More than 2) — Indicates number of zeros after effective number.
 2-digit effective number.

• Units: pF.

$\overset{2}{\text{R}} \overset{2}{\text{R}} \overset{1}{\text{R}} \Rightarrow 220\text{pF}$
 (0 or 1) — Indicates number of zeros after effective number.
 2-digit effective number.

• Units: pF.

• When the dielectric strength is indicated in AC, "AC" is included after the dielectric strength value.

PARTS LIST OF P.W.B. UNIT

MAIN P.W.B. ASS'Y

Note: The symbols in the column "Remarks" indicate the following destinations.
 E3: U.S.A. model, Canada model E1C: China model
 EU: U.S.A. model (AVR-882) E1H: Hong Kong model
 E2: Europe model E1T: Taiwan R.O.C. model
 E1: Asia model

Ref. No.	Part No.	Part Name	Remarks	Ref. No.	Part No.	Part Name	Remarks
SEMICONDUCTORS GROUP							
IC101	963 0057 903	IC KIA7815AP		R106FL,FR	963 9003 068	Metal film 4.7 ohm 1/4W (NB)	
IC102	963 0044 806	IC NJM7915FA		R106SL,SR	963 9003 068	Metal film 4.7 ohm 1/4W (NB)	
IC103	960 0196 001	IC NJM7805FA (S)		R107C	963 9003 068	Metal film 4.7 ohm 1/4W (NB)	
IC104	963 0057 709	IC KIA7805AP		R107FL,FR	963 9003 068	Metal film 4.7 ohm 1/4W (NB)	
IC105	960 0195 808	IC protector ICP-N15		R107SL,SR	963 9003 068	Metal film 4.7 ohm 1/4W (NB)	
IC701	963 0083 207	IC TC9274N-011		R108C	244 2043 982	Metal oxide 0.22ohm 1W	
IC702-704	960 0174 502	IC NJM2068DD		R108FL,FR	244 2043 982	Metal oxide 0.22ohm 1W	
Q104C	960 0196 506	Transistor KSC1845F		R108SL,SR	244 2043 982	Metal oxide 0.22ohm 1W	
Q104FL,FR	960 0196 506	Transistor KSC1845F		R109C	244 2043 982	Metal oxide 0.22ohm 1W	
Q104SL,SR	960 0196 506	Transistor KSC1845F		R109FL,FR	244 2043 982	Metal oxide 0.22ohm 1W	
Q111-115	960 0196 904	Transistor DTC114YS (NPN)		R109SL,SR	244 2043 982	Metal oxide 0.22ohm 1W	
Q116	960 0196 409	Transistor 2SC1740SR		R110C	244 2043 982	Metal oxide 0.22ohm 1W	
Q117	960 0196 904	Transistor DTC114YS (NPN)		R110FL,FR	244 2043 982	Metal oxide 0.22ohm 1W	
Q151	960 0196 409	Transistor 2SC1740SR		R110SL,SR	244 2043 982	Metal oxide 0.22ohm 1W	
Q171-177	960 0005 202	Transistor KTC3198 (Y)		R111C	244 2043 982	Metal oxide 0.22ohm 1W	
Q171A-C	960 0196 302	Transistor KTA1268BL		R111FL,FR	244 2043 982	Metal oxide 0.22ohm 1W	
Q178	960 0005 105	Transistor KTA1266Y		R111SL,SR	244 2043 982	Metal oxide 0.22ohm 1W	
Q179	960 0189 005	Transistor KSA916Y		R118C	244 2043 937	Metal oxide 10 ohm 1W	
Q180,181	960 0196 302	Transistor KTA1268BL		R118FL,FR	244 2043 937	Metal oxide 10 ohm 1W	
D101-105	963 0020 309	Diode 1SS133T		R118SL,SR	244 2043 937	Metal oxide 10 ohm 1W	
D121-126	963 0020 309	Diode 1SS133T		R119C	244 2043 937	Metal oxide 10 ohm 1W	
D131A,B	960 0197 107	Diode KBPC604		R119FL,FR	244 2043 937	Metal oxide 10 ohm 1W	
D132	963 0020 309	Diode 1SS133T		R119SL,SR	244 2043 937	Metal oxide 10 ohm 1W	
D133,134	963 0046 202	Zener diode MTZJ18B		R135,136	963 0045 203	Winding 0.1 ohm 5W	
D135	963 0020 309	Diode 1SS133T		R141,142	244 2043 982	Metal oxide 0.22 ohm 1W	
D136	963 0058 504	Zener diode MTZJ11B		R148,149	244 2043 982	Metal oxide 0.22 ohm 1W	
D137	963 0020 309	Diode 1SS133T		R151	963 9003 343	Metal film 68ohm 1/4W	
D138	963 0058 407	Diode IN4007		R154	963 0043 108	Metal film 2.2 Mohm 1/2W	
D141-146	963 0058 407	Diode IN4007		R179	963 9003 055	Metal film 47 kohm 1/4W (NB)	
D148	963 0020 309	Diode 1SS133T		R181	963 9003 068	Metal film 4.7 ohm 1/4W (NB)	
D149,150	963 0058 407	Diode IN4007		R184	244 2043 937	Metal oxide 10 ohm 1W	
D151	963 0020 309	Diode 1SS133T		R185	963 9003 039	Metal film 1 ohm 1/4W	
D152,153	963 0058 407	Diode IN4007		R700L,R	963 9003 372	Carbon chip 0 ohm 1/16W	
D154	963 0047 405	Zener diode MTZJ7.5B		R701L,R	963 9004 290	Carbon chip 390 ohm 1/16W	
D157	960 0014 905	Zener diode MTZJ20B		R702L,R	963 9004 339	Carbon chip 470 ohm 1/16W	
D158-160	963 0020 309	Diode 1SS133T		R703L,R	963 9004 339	Carbon chip 470 ohm 1/16W	
D251-256	960 0197 000	Diode KDS160		R704L,R	963 9004 339	Carbon chip 470 ohm 1/16W	
RESISTORS GROUP							
R104C	244 2052 957	Metal oxide 5.6kohm 1W		R705L,R	963 9004 339	Carbon chip 470 ohm 1/16W	
R104FL,FR	244 2052 957	Metal oxide 5.6kohm 1W		R706L,R	963 9004 339	Carbon chip 470 ohm 1/16W	
R104SL,SR	244 2052 957	Metal oxide 5.6kohm 1W		R707L,R	963 9004 339	Carbon chip 470 ohm 1/16W	
R105C	244 2052 957	Metal oxide 5.6kohm 1W		R708L,R	963 9004 339	Carbon chip 470 ohm 1/16W	
R105FL,FR	244 2052 957	Metal oxide 5.6kohm 1W		R709L,R	963 9004 452	Carbon chip 68 kohm 1/16W	
R105SL,SR	244 2052 957	Metal oxide 5.6kohm 1W		R710L,R	963 9004 245	Carbon chip 2.2 Mohm 1/16W	
R106C	963 9003 068	Metal film 4.7 ohm 1/4W (NB)		R711L,R	963 9004 245	Carbon chip 2.2 Mohm 1/16W	
				R712L,R	963 9004 245	Carbon chip 2.2 Mohm 1/16W	
				R713L,R	963 9004 245	Carbon chip 2.2 Mohm 1/16W	
				R714L,R	963 9004 245	Carbon chip 2.2 Mohm 1/16W	
				R715L,R	963 9004 245	Carbon chip 2.2 Mohm 1/16W	
				R716L,R	963 9004 245	Carbon chip 2.2 Mohm 1/16W	
				R717L,R	963 9004 164	Carbon chip 150 kohm 1/16W	
				R718L,R	963 9004 326	Carbon chip 47 ohm 1/10W	

Ref. No.	Part No.	Part Name	Remarks	Ref. No.	Part No.	Part Name	Remarks
R719L,R	963 9004 258	Carbon chip 240 ohm 1/10W		C171A-C	963 9004 818	Ceramic 0.1 μ F/50V	
R720L,R	963 9004 148	Carbon chip 130 kohm 1/16W		C172,173		Electrolytic 220 μ F/6.3V	
R721L,R	963 9004 106	Carbon chip 11 kohm 1/10W		C174		Electrolytic 10 μ F/35V	
R722L,R	963 9003 385	Carbon chip 100 ohm 1/16W		C175		Electrolytic 4.7 μ F/50V	
R725L,R	963 9003 385	Carbon chip 100 ohm 1/16W		C176,177		Electrolytic 1 μ F/50V	
R726L,R	963 9004 083	Carbon chip 100 kohm 1/16W		C178	963 9003 149	Electrolytic 330 μ F/63V	
R728L,R	963 9004 300	Carbon chip 39 kohm 1/16W		△ C181	960 0177 208	Ceramic 0.047 μ F/250V(AC)	
R729L,R	963 9003 385	Carbon chip 100 ohm 1/16W		C182		Electrolytic 10 μ F/100V	
R730L,R	963 9004 083	Carbon chip 100 kohm 1/16W		C251,252	963 9004 698	Ceramic chip 0.01 μ F/50V	
R731L,R	963 9004 300	Carbon chip 39 kohm 1/16W		C709L,R		Electrolytic 10 μ F/35V	
R732L,R	963 9004 300	Carbon chip 39 kohm 1/16W		C710L,R	963 9004 685	Ceramic chip 1000pF/50V	
R737L,R	963 9004 193	Carbon chip 22 ohm 1/16W		C711L,R		Electrolytic 220 μ F/6.3V	
R751L,R	963 9004 083	Carbon chip 100 kohm 1/16W		C712L,R	963 9004 779	Mylar film 0.024 μ F/50V	
VR101~105	960 0091 601	Semi fixed resistor 1 kohm		C713L,R	960 9008 695	Mylar film 0.0068 μ F/100V	
CAPACITORS GROUP				C714L,R		Electrolytic 4.7 μ F/50V	
C101C		Electrolytic 47 μ F/50V		C715L,R	963 9004 737	Ceramic chip 0.022 μ F/25V	
C101FL,FR		Electrolytic 47 μ F/50V		C716L,R		Electrolytic 10 μ F/35V	
C101SL,SR		Electrolytic 47 μ F/50V		C717L,R	963 9004 601	Ceramic chip 220pF/50V	
C102C		Electrolytic 10 μ F/50V		C718L,R		Electrolytic 47 μ F/10V	
C102FL,FR		Electrolytic 10 μ F/50V		C719L,R		Electrolytic 1 μ F/50V	
C102SL,SR		Electrolytic 10 μ F/50V		C720L,R	963 9003 152	Mylar film 0.068 μ F/100V	
C103C	963 9003 084	Ceramic 100pF/500V		C721L,R	963 9003 152	Mylar film 0.068 μ F/100V	
C103FL,FR	963 9003 084	Ceramic 100pF/500V		C723L,R		Electrolytic 10 μ F/35V	
C103SL,SR	963 9003 084	Ceramic 100pF/500V		C724L,R	963 9004 698	Ceramic chip 0.01 μ F/50V	
C104C	963 9003 084	Ceramic 100pF/500V		C725,726	963 9004 698	Ceramic chip 0.01 μ F/50V	
C104FL,FR	963 9003 084	Ceramic 100pF/500V		C727,728		Electrolytic 10 μ F/35V	
C104SL,SR	963 9003 084	Ceramic 100pF/500V		OTHER PARTS GROUP			
C105C	960 9003 108	Ceramic 0.022 μ F/25V		CN201	963 0085 506	9P connector socket (TUC-P)	1
C105FL,FR	960 9003 108	Ceramic 0.022 μ F/25V		CN202	963 0085 603	5P connector socket (TUC-P)	1
C105SL,SR	960 9003 108	Ceramic 0.022 μ F/25V		CN203	963 0085 700	6P connector socket (TUC-P)	1
C107C	963 9003 097	Mylar film 0.1 μ F/250V		CN701	963 0086 602	12P connector socket (TUC-P)	1
C107FL,FR	963 9003 097	Mylar film 0.1 μ F/250V		CN702	963 0086 709	11P connector socket (TUC-P)	1
C107SL,SR	963 9003 097	Mylar film 0.1 μ F/250V		CN704	963 0086 505	7P connector socket (TUC-P)	1
C131~135	963 9003 097	Mylar film 0.1 μ F/250V		CP101	960 0197 505	2P connector base	1
C136,137	963 0087 203	Electrolytic 10000 μ F/63V		CP102	960 0123 304	2P connector base	1
C138		Electrolytic 1 μ F/50V		CP103	960 0128 901	3P connector base	1
C141~143	963 0021 900	Mylar film 0.047 μ F/100V		CP104	960 0128 804	6P connector base	1
C144	960 9007 201	Electrolytic 3300 μ F/10V		CP106	960 0123 207	3P connector base	1
C145	963 9003 123	Electrolytic 1000 μ F/35V		CP501	963 0086 806	9P connector base (TUC-P)	1
C146		Electrolytic 1 μ F/50V		CP502~504	963 0086 903	5P connector base (TUC-P)	4
C148		Electrolytic 1 μ F/50V		CP505	963 0087 009	6P connector base (TUC-P)	1
C150~C152	963 0021 900	Mylar film 0.047 μ F/100V		CP553	963 0087 106	20P connector base (TUC-P)	1
C153	963 0021 104	Electrolytic 6800 μ F/16V		CP901	963 0048 909	3P connector base	1
C154		Electrolytic 47 μ F/10V		△ F101,102	960 0188 705	Fuse 8A	E3
C155	963 9004 559	Ceramic 0.1 μ F/50V					2
C157		Electrolytic 1 μ F/50V					
C158	963 9003 136	Electrolytic 1000 μ F/25V					
C159		Electrolytic 1 μ F/50V					
C161		Electrolytic 10 μ F/35V					
C171		Electrolytic 100 μ F/10V					

PROCESSOR P.W.B. ASS'Y

Ref. No.	Part No.	Part Name	Remarks	Q'ty	Ref. No.	Part No.	Part Name	Remarks
△ F101	960 0142 602	Fuse 2.5A	E2	1	SEMICONDUCTORS GROUP			
△ F102	960 0044 709	Fuse 3.15A	E2,E1C	1	IC201	963 0084 303	IC CXP740096-135Q	E2
△ F101A,B	960 0005 804	Fuse clip	E3,E2	2	IC202	963 0057 602	IC TDA7330BD	
△ F102A,B	960 0005 804	Fuse clip	E3,E2,E1C	2	IC203	960 0080 201	IC KIC9164AN	
GND101,102	960 9006 600	Terminal		2	IC204	963 0043 603	IC KIC9482F	
JK103	960 0194 809	2P speaker terminal		1	IC205-210	960 0174 502	IC NJM2068DD	
△ JK104	960 0187 803	AC outlet(2P)	E3	1	IC301	960 0180 004	IC LC75721E	E2
L101C	963 0049 005	Inductor 0.5μH		1	IC302	963 0074 504	IC BU2090F	
L101FL,FR	963 0049 005	Inductor 0.5μH		2	IC803	269 0186 002	IC GP1FA502RZ	
L101SL,SR	963 0049 005	Inductor 0.5μH		2	RMC301	960 0181 100	IC NJL64H380A	
L701L,R	235 9003 002	FTZ CHOKE COIL	E2	2	Q201	269 0054 901	Transistor DTC144EK	
RLY101-104	960 0181 702	Relay (G5PA-28 24V)		4	Q202	963 0045 902	Transistor 2SC2412KT	
RLY105	963 0071 303	Relay (RSB24S 24V)		1	Q207,208	960 0196 807	Transistor 2SK117Y	
RLY106	960 0181 605	Relay (G5PA-1-8 12V)		1	Q209	269 0093 904	Transistor DTA144ES	
TP101-105	960 0161 405	3P connector base		5	Q210	269 0040 902	Transistor DTC144ES	
—	—	Heat sink		1	Q211-213	960 0196 807	Transistor 2SK117Y	
—	—	Heat sink		1	Q214	269 0046 906	Transistor DTA114ES	
△ —	960 0185 708	Power trans. (Mini)	E3	1	Q215	269 0020 906	Transistor DTC114ES	
△ —	960 0185 711	Power trans. (Mini)	E2	1	Q216	269 0046 906	Transistor DTA114ES	
△ —	960 0185 737	Power trans. (Mini)	E1,E1H,E1T	1	Q300,301	269 0055 900	Transistor DTA144EK	
△ —	960 0185 724	Power trans. (Mini)	E1C	1	Q302-304	269 0054 901	Transistor DTC144EK	
—	963 0018 007	Screw (2S 3x8 ZNY/BH)		3	Q305	269 0055 900	Transistor DTA144EK	
—	960 0188 608	4P speaker terminal		1	D201	960 0197 000	Diode KDS160	
—	963 0074 009	8P speaker terminal		1	D202	963 0058 407	Diode IN4007	
—	960 0188 103	2P pin jack		1	D203	963 0020 309	Diode 1SS133T	
—	960 0188 200	4P pin jack		2	D204,205	960 0197 000	Diode KDS160	
—	960 0188 307	6P pin jack		1	D206	960 0197 000	Diode KDS160	
—	963 0066 114	5P connector base		1	D207	960 0197 000	Diode KDS160	
—	963 0075 600	6P connector base		1	D210-212	960 0197 000	Diode KDS160	
—	963 0068 400	Capacitor cover	E2	1	D213	963 0020 309	Diode 1SS133T	
					D214	963 0058 407	Diode IN4007	
					D302-304	963 0020 309	Diode 1SS133T	
					D305-307	960 0197 000	Diode KDS160	
					ZD201	963 0047 502	Zener diode MTZJ3.3B	
					ZD301	960 0095 801	Zener diode MTZJ6.8B	
					ZD302-305	960 0095 607	Zener diode MTZJ5.6B	
					LED301,302	960 0197 204	LED PI5-RD/HL50RDRF4T	
					LED304-309	960 0197 204	LED PI5-RD/HL50RDRF4T	
					RESISTORS GROUP			
					R202	963 9003 398	Carbon chip 1 kohm 1/16W	
					R204	963 9004 342	Carbon chip 4.7 kohm 1/16W	
					R205	963 9004 070	Carbon chip 10 kohm 1/16W	

Ref. No.	Part No.	Part Name	Remarks	Ref. No.	Part No.	Part Name	Remarks
R206	963 9004 232	Carbon chip 220 kohm 1/16W		R247SW	963 9004 339	Carbon chip 470 ohm 1/16W	
R208	963 9003 398	Carbon chip 1 kohm 1/16W		R250	963 9004 368	Carbon chip 470 kohm 1/16W	
R209	963 9004 070	Carbon chip 10 kohm 1/16W		R255	963 9004 368	Carbon chip 470 kohm 1/16W	
R210FL,FR	963 9004 313	Carbon chip 4.3 kohm 1/16W		R261	963 9004 122	Carbon chip 12 kohm 1/16W	
R211	963 9004 070	Carbon chip 10 kohm 1/16W		R262	963 9004 070	Carbon chip 10 kohm 1/16W	
R212	963 9003 398	Carbon chip 1 kohm 1/16W		R263,264	963 9004 122	Carbon chip 12 kohm 1/16W	
R213FR	963 9004 151	Carbon chip 15 kohm 1/16W		R265-271	963 9004 339	Carbon chip 470 ohm 1/16W	
R214FL,FR	963 9004 151	Carbon chip 15 kohm 1/16W		R336	963 9004 465	Carbon chip 75 ohm 1/16W	
R215FL,FR	963 9003 385	Carbon chip 100 ohm 1/16W		R337	963 9004 342	Carbon chip 4.7 kohm 1/16W	
R216	963 9004 070	Carbon chip 10 kohm 1/16W	E3,E2	R338	963 9004 339	Carbon chip 470 ohm 1/16W	
R216FL,FR	963 9004 083	Carbon chip 100 kohm 1/16W		R339	963 9004 119	Carbon chip 1.2 kohm 1/16W	
R217	963 9004 151	Carbon chip 15 kohm 1/16W		R340-348	963 9004 436	Carbon chip 680 ohm 1/16W	
R217FL,FR	963 9004 410	Carbon chip 6.2 kohm 1/16W		R349	963 9004 339	Carbon chip 470 ohm 1/16W	
R218	963 9004 070	Carbon chip 10 kohm 1/16W	E2,E1,E1C,E1H,E1T	R349FL-402FL	963 9004 397	Carbon chip 56 kohm 1/16W	
R219,220	963 9004 070	Carbon chip 10 kohm 1/16W		R350,351	963 9004 245	Carbon chip 2.2 Mohm 1/16W	
R223,224	963 9004 070	Carbon chip 10 kohm 1/16W	E2	R407	963 9004 342	Carbon chip 4.7 kohm 1/16W	
R220SW	963 9004 481	Carbon chip 8.2 kohm 1/16W		CAPACITORS GROUP			
R221SW	963 9004 287	Carbon chip 3.6 kohm 1/10W		BC201	963 0061 504	Electrolytic 8200µF/5.5V	
R222SW	963 9004 481	Carbon chip 8.2 kohm 1/16W		C202,203	963 9004 698	Ceramic chip 0.01µF/50V	
R223,224	963 9003 372	Carbon chip 0 ohm 1/16W		C204		Electrolytic 4.7µF/50V	
R223SW	963 9003 385	Carbon chip 100 ohm 1/16W		C206		Electrolytic 47µF/16V	E2
R224SW	963 9004 083	Carbon chip 100 kohm 1/16W	E2	C207	963 9004 546	Ceramic 0.01µF/16V	E2
R225	963 9004 245	Carbon chip 2.2Mohm 1/16W		C208	963 9004 805	Ceramic 270pF/50V	E2
R229,230	960 9003 807	Metal film 100 ohm 1/4W		C209		Electrolytic 10µF/35V	E2
R237	963 9003 398	Carbon chip 1 kohm 1/16W		C210	963 9004 698	Ceramic chip 0.01µF/50V	E2
R239C	963 9004 083	Carbon chip 100 kohm 1/16W		C211	963 9004 614	Ceramic chip 27pF/50V	E2
R239FL,FR	963 9004 083	Carbon chip 100 kohm 1/16W		C211SW	963 9004 575	Ceramic chip 100pF/50V	
R239SL,SR	963 9004 083	Carbon chip 100 kohm 1/16W		C212	963 9004 614	Ceramic chip 27pF/50V	E2
R239SW	963 9004 083	Carbon chip 100 kohm 1/16W		C212SW	963 9004 643	Ceramic chip 47pF/50V	
R240C	963 9003 385	Carbon chip 100 ohm 1/16W		C213-219	963 9004 753	Ceramic chip 0.047µF/50V	
R240FL,FR	963 9003 385	Carbon chip 100 ohm 1/16W		C213FL,FR	963 9004 575	Ceramic chip 100pF/50V	
R240SL,SR	963 9003 385	Carbon chip 100 ohm 1/16W		C218FL,FR	963 9004 627	Ceramic chip 33pF/50V	
R240SW	963 9003 385	Carbon chip 100 ohm 1/16W		C219FL,FR		Electrolytic 10µF/35V	
R241C	963 9004 083	Carbon chip 100 kohm 1/16W		C219SW,220		Electrolytic 10µF/35V	
R241FL,FR	963 9004 083	Carbon chip 100 kohm 1/16W		C221FL,FR		Electrolytic 4.7µF/50V	
R241SL,SR	963 9004 083	Carbon chip 100 kohm 1/16W		C222SW		Electrolytic 4.7µF/50V	
R241SW	963 9004 083	Carbon chip 100 kohm 1/16W		C223SL,SR		Electrolytic 4.7µF/50V	
R242C	963 9004 478	Carbon chip 7.5 kohm 1/10W		C225,226	963 9004 753	Ceramic chip 0.047µF/50V	
R242FL,FR	963 9004 478	Carbon chip 7.5 kohm 1/10W		C227		Electrolytic 10µF/35V	
R242SL,SR	963 9004 478	Carbon chip 7.5 kohm 1/10W		C228-C234	963 9004 575	Ceramic chip 100pF/50V	
R242SW	963 9004 449	Carbon chip 6.8 kohm 1/16W		C230C,231C		Electrolytic 4.7µF/50V	
R243C	963 9004 070	Carbon chip 10 kohm 1/16W		C231FL,FR		Electrolytic 10µF/35V	
R243FL,FR	963 9004 070	Carbon chip 10 kohm 1/16W		C231SL,SR		Electrolytic 4.7µF/50V	
R244C	963 9004 135	Carbon chip 1.3 kohm 1/10W		C231SW		Electrolytic 4.7µF/50V	
R244FL,FR	963 9004 135	Carbon chip 1.3 kohm 1/10W		C232C	963 9004 669	Ceramic chip 56pF/50V	
R244SL,SR	963 9004 135	Carbon chip 1.3 kohm 1/10W		C232FL,FR	963 9004 669	Ceramic chip 56pF/50V	
R244SW	963 9004 407	Carbon chip 620 ohm 1/16W		C232SL,SR	963 9004 630	Ceramic chip 39pF/50V	
R246C	963 9004 083	Carbon chip 100 kohm 1/16W		C232SW	963 9004 669	Ceramic chip 56pF/50V	
R246SL,SR	963 9004 083	Carbon chip 100 kohm 1/16W					
R246SW	963 9004 083	Carbon chip 100 kohm 1/16W					
R247C	963 9004 339	Carbon chip 470 ohm 1/16W					
R247SL,SR	963 9004 339	Carbon chip 470 ohm 1/16W					

Ref. No.	Part No.	Part Name	Remarks	Ref. No.	Part No.	Part Name	Remarks	Q'ty
C233C	963 9004 724	Ceramic chip 2200pF/50V		OTHER PARTS GROUP				
C233FL,FR	963 9004 724	Ceramic chip 2200pF/50V		CB201,202	963 0053 800	BEADS INDUCTOR		2
C234FL,FR	963 9004 672	Ceramic chip 680pF/50V		CN301	960 0197 602	17P FFC connector base		1
C235SW	963 9004 575	Ceramic chip 100pF/50V		CN302	963 0087 300	3P connector cord		1
C236		Electrolytic 4.7μF/50V		CP301	960 0197 709	17P FFC connector base		1
C237		Electrolytic 0.1μF/50V		CP301	963 0049 102	3P connector base		1
C239	963 9004 753	Ceramic chip 0.047μF/50V		CP401	963 0087 407	16P connector base (TUC-P)		1
C240		Electrolytic 1μF/50V		CP551	963 0087 504	19P connector base (TUC-P)		1
C241		Electrolytic 10μF/35V		CP552	963 0087 601	18P connector base (TUC-P)		1
C242	963 9004 588	Ceramic chip 100pF/50V		CP601,602	963 0086 903	5P connector base (TUC-P)		2
C243,244	963 9004 753	Ceramic chip 0.047μF/50V		CP603	963 0087 009	6P connector base (TUC-P)		1
C243C	963 9004 672	Ceramic chip 680pF/50V		CP605	963 0086 806	9P connector base (TUC-P)		1
C245	963 9004 575	Ceramic chip 100pF/50V		CP701	963 0087 708	12P connector base (TUC-P)		1
C246		Electrolytic 10μF/35V		CP702	963 0087 805	11P connector base (TUC-P)		1
C246SW		Electrolytic 4.7μF/50V		CP801,802	963 0087 902	17P connector base (TUC-P)		2
C247	963 9004 575	Ceramic chip 100pF/50V		CP803	963 0088 008	10P connector base (TUC-P)		1
C248	963 9004 588	Ceramic chip 1000pF/50V		CP901	963 0060 806	11P connector base		1
C249	960 9003 108	Ceramic 0.022μF/25V		GP301	963 0088 202	1P contact Ass'y		1
C250	963 9004 575	Ceramic chip 100pF/50V		GP303	963 0088 202	1P contact Ass'y		1
C301-304	963 9004 698	Ceramic chip 0.01μF/50V		J324,325	963 9003 369	Carbon chip 0 ohm 1/8W		2
C305-307	963 9004 575	Ceramic chip 100pF/50V		J326	963 9003 372	Carbon chip 0 ohm 1/16W		1
C309	963 9004 737	Ceramic chip 0.022μF/25V		J340	963 9003 369	Carbon chip 0 ohm 1/8W		1
C311	963 9004 494	Ceramic 30pF/50V		J342,343	963 9003 369	Carbon chip 0 ohm 1/8W		2
C312	963 9004 753	Ceramic chip 0.047μF/50V		JK301	963 0067 508	3P pin jack		1
C313	963 9004 504	Ceramic 0.01μF/50V		JP301	963 9003 369	Carbon chip 0 ohm 1/8W		1
C314	963 0021 900	Mylar film 0.047μF/100V		L301	960 0010 307	Inductor 10μH		1
C315		Electrolytic 1μF/50V		L302	960 0128 008	Inductor 100μH		1
C316		Electrolytic 10μF/50V		L3010	963 0050 803	Inductor 4.7μH		1
C317		Electrolytic 47μF/10V		SW301-322	963 0045 708	Tact switch		22
C318	963 0021 900	Mylar film 0.047μF/100V		VEC301,302	960 0181 207	Rotary encoder		2
C319		Electrolytic 10μF/35V		X201	960 0181 003	Resonator CST12.0MTW-TF01		1
C320		Electrolytic 1μF/50V		X202	960 0091 805	Crystal 4.332MHz	E2	1
C321	963 0021 900	Mylar film 0.047μF/100V		—	960 0184 408	FLT holder		1
C322		Electrolytic 47μF/10V		—	960 0180 509	FLT (16-ST-42GNK)		1
C323	963 9004 766	Mylar film 0.1μF/100V						
C324		Electrolytic 1μF/50V						
C325	963 9004 575	Ceramic chip 100pF/50V						
C326		Electrolytic 4.7μF/50V						
C327		Electrolytic 1μF/50V						
C328	963 9004 753	Ceramic chip 0.047μF/50V						
C3010		Electrolytic 47μF/10V						
C3020	963 9004 818	Ceramic 0.1μF/50V						
C3030	963 9004 591	Ceramic chip 22pF/50V						

CNT P.W.B. ASS'Y

Ref. No.	Part No.	Part Name	Remarks	Ref. No.	Part No.	Part Name	Remarks
SEMICONDUCTORS GROUP				R405	960 9003 807	Metal film 100 ohm 1/4W	
IC401	963 0043 700	IC LC72131		R406	963 9004 342	Carbon chip 4.7 kohm 1/16W	
IC402	963 0043 904	IC LA1266		R407	963 9004 407	Carbon chip 620 ohm 1/16W	E3,E1,E1C,E1H,E1T
IC403	963 0044 000	IC LA3401		R407	963 9004 436	Carbon chip 680 ohm 1/16W	E2
IC551	960 0174 502	IC NJM2068DD		R408	963 9004 119	Carbon chip 1.2 kohm 1/16W	E3,E1,E1C,E1H,E1T
IC552	963 0043 506	IC TC9184AP		R408	963 9004 436	Carbon chip 680 ohm 1/16W	E2
IC601	963 0083 304	IC BA7626		R409	963 9004 339	Carbon chip 470 ohm 1/16W	
IC602	963 0074 504	IC BU2090F		R411	963 9004 452	Carbon chip 68 kohm 1/16W	
IC651,652	963 0083 304	IC BA7626		R412	963 9004 834	Carbon chip 5.6 kohm 1/16W	
IC663	963 0057 806	IC KIA78R05PI		R413	960 9006 503	Metal film 220ohm 1/4W	
Q401	960 0189 102	Transistor KTC3880S-O		R414	963 9004 216	Carbon chip 2.2 kohm 1/16W	
Q402-404	269 0083 901	Transistor DTA114EK		R415	963 9003 398	Carbon chip 1 kohm 1/16W	
Q405,406	960 0196 603	Transistor KTC2874B		R416	241 2379 945	Metal film 680 ohm 1/4W	
Q407	963 0024 208	Transistor DTC114YK		R417	963 9003 398	Carbon chip 1 kohm 1/16W	
Q408	269 0083 901	Transistor DTA114EK		R418	963 9004 274	Carbon chip 33 kohm 1/16W	
Q409	960 0189 102	Transistor KTC3880S-O	E2	R420	963 9003 372	Carbon chip 0 ohm 1/16W	
Q551	960 0196 700	Transistor KTC3200BL		R426,427	963 9004 070	Carbon chip 10 kohm 1/16W	
Q551SW,552SW	960 0196 603	Transistor KTC2874B		R428	963 9004 847	Carbon chip 3.3 kohm 1/16W	E3
Q552	960 0196 302	Transistor KTA1268BL		R428	963 9004 070	Carbon chip 10 kohm 1/16W	E2
Q553-555	269 0046 906	Transistor DTA114ES		R428	963 9004 449	Carbon chip 6.8 kohm 1/16W	E1,E1C,E1H,E1T
Q553T	960 0196 904	Transistor DTC114YS (NPN)		R429	963 9004 850	Carbon chip 82 ohm 1/16W	
Q601-603	960 0005 105	Transistor KTA1266Y		R430	960 9003 807	Metal film 100 ohm 1/4W	
Q604-606	963 0075 406	Transistor DTC114TS		R431	963 9004 371	Carbon chip 5.1 kohm 1/16W	
Q651-656	960 0005 105	Transistor KTA1266Y		R432	963 9004 070	Carbon chip 10 kohm 1/16W	
D403	960 0197 000	Diode KDS160		R434	960 9003 807	Metal film 100 ohm 1/4W	
D404-406	963 0020 309	Diode 1SS133T		R435	963 9004 847	Carbon chip 3.3 kohm 1/16W	
D551,551T	963 0020 309	Diode 1SS133T		R437	963 9004 083	Carbon chip 100 kohm 1/16W	
D552-561	963 0020 309	Diode 1SS133T		R438,439	963 9004 083	Carbon chip 100 kohm 1/16W	E3,E2,E1,E1C,E1H,E1T
D562,563	963 0058 407	Diode IN4007		R438,439	963 9004 164	Carbon chip 150 kohm 1/16W	E2
D564	960 0095 500	Zener diode MTZJ5.1B		R440,441	963 9004 863	Carbon chip 120 kohm 1/16W	E3,E2,E1,E1C,E1H,E1T
D565	963 0020 309	Diode 1SS133T		R440,441	963 9004 232	Carbon chip 220 kohm 1/16W	E2
D601-606	960 0197 000	Diode KDS160		R442,443	963 9004 847	Carbon chip 3.3 kohm 1/16W	E3,E2,E1,E1C,E1H,E1T
D651-D656	960 0197 000	Diode KDS160		R442,443	963 9004 216	Carbon chip 2.2 kohm 1/16W	E2
D652T	963 0061 601	Electrolytic 3300µF/10V		R444,445	963 9004 481	Carbon chip 8.2 kohm 1/16W	E3,E2,E1,E1C,E1H,E1T
D657,658	963 0058 407	Diode IN4007		R444,445	963 9004 847	Carbon chip 3.3 kohm 1/16W	E2
D901,902	960 0197 000	Diode KDS160		R448	963 9004 216	Carbon chip 2.2 kohm 1/16W	
ZD401	960 0095 500	Zener diode MTZJ5.1B		R449	963 9004 216	Carbon chip 2.2 kohm 1/16W	E2
RESISTORS GROUP				R450	963 9003 398	Carbon chip 1 kohm 1/16W	E2
R401	963 9004 821	Carbon chip 10 ohm 1/16W		R455	963 9004 876	Carbon chip 330 ohm 1/16W	
R403	963 9004 339	Carbon chip 470 ohm 1/16W		R456	963 9003 385	Carbon chip 100 ohm 1/16W	
R404	963 9004 083	Carbon chip 100 kohm 1/16W		R458,459	963 9004 342	Carbon chip 4.7 kohm 1/16W	
				R460,461	963 9004 245	Carbon chip 2.2 Mohm 1/16W	
				R462-465	963 9004 339	Carbon chip 470 ohm 1/16W	
				R467,468	963 9004 245	Carbon chip 2.2 Mohm 1/16W	
				R470	963 9003 398	Carbon chip 1 kohm 1/16W	
				R471VT	963 9004 203	Carbon chip 220 ohm 1/16W	
				R474	963 9004 889	Carbon chip 180 ohm 1/16W	E3,E2
				R475	963 9004 122	Carbon chip 12 kohm 1/16W	
				R476	963 9004 397	Carbon chip 56 kohm 1/16W	
				R478	963 9004 070	Carbon chip 10 kohm 1/16W	
				R479	963 9004 083	Carbon chip 100 kohm 1/16W	

Ref. No.	Part No.	Part Name	Remarks
R551SW,552SW	963 9004 339	Carbon chip 470 ohm 1/16W	
R553FL,FR	963 9004 083	Carbon chip 100 kohm 1/16W	
R553SW	963 9004 229	Carbon chip 22 kohm 1/16W	
R553T	963 9003 398	Carbon chip 1 kohm 1/16W	
R554SW	963 9004 070	Carbon chip 10 kohm 1/16W	
R554T	244 2052 928	Metal film 47 ohm 1W	
R558FL,FR	963 9004 342	Carbon chip 4.7 kohm 1/16W	
R559	244 2055 996	Metal film 1.2 kohm 1W	
R559FL,FR	963 9004 229	Carbon chip 22 kohm 1/16W	
R560FL,FR	963 9004 384	Carbon chip 510 kohm 1/16W	
R561FL,FR	963 9004 274	Carbon chip 33 kohm 1/16W	
R563FL,FR	963 9004 290	Carbon chip 390 ohm 1/16W	
R564FL,FR	963 9004 339	Carbon chip 470 ohm 1/16W	
R565	244 2055 996	Metal film 1.2 kohm 1W	
R567FL,FR	963 9004 368	Carbon chip 470 kohm 1/16W	
R570	244 2055 996	Metal film 1.2 kohm 1W	
R629	963 9004 070	Carbon chip 10 kohm 1/16W	
R633-636	963 9004 070	Carbon chip 10 kohm 1/16W	
R638,639	963 9004 070	Carbon chip 10 kohm 1/16W	
R651-658	963 9004 465	Carbon chip 75 ohm 1/16W	
R651T,652T	244 2043 982	Metal oxide 0.22 ohm 1W	
R659	963 9004 423	Carbon chip 68 ohm 1/10W	
R660	963 9004 070	Carbon chip 10 kohm 1/16W	
R662	963 9004 423	Carbon chip 68 ohm 1/10W	
R663	963 9004 070	Carbon chip 10 kohm 1/16W	
R665	963 9004 423	Carbon chip 68 ohm 1/10W	
R666	963 9004 070	Carbon chip 10 kohm 1/16W	
R671	963 9004 423	Carbon chip 68 ohm 1/10W	
R672	963 9004 070	Carbon chip 10 kohm 1/16W	
R674	963 9004 423	Carbon chip 68 ohm 1/10W	
R675	963 9004 070	Carbon chip 10 kohm 1/16W	
R677	963 9004 423	Carbon chip 68 ohm 1/10W	
R678	963 9004 070	Carbon chip 10 kohm 1/16W	
R683,684	963 9004 465	Carbon chip 75 ohm 1/16W	
R901,902	963 9004 245	Carbon chip 2.2 Mohm 1/16W	
R903H,904H	960 9009 270	Metal film 470ohm 2W	
R905,906	963 9004 245	Carbon chip 2.2 Mohm 1/16W	
R907,908	963 9003 385	Carbon chip 100 ohm 1/16W	
R909,910	963 9004 245	Carbon chip 2.2 Mohm 1/16W	
R911,912	963 9003 385	Carbon chip 100 ohm 1/16W	
R913,914	963 9004 203	Carbon chip 220 ohm 1/16W	
R916	963 9004 203	Carbon chip 220 ohm 1/16W	
R917-920	963 9004 083	Carbon chip 100 kohm 1/16W	
R923,924	963 9003 385	Carbon chip 100 ohm 1/16W	
VR401	960 0096 606	Semi fixed resistor 20kohm	
VR402	960 0096 402	Semi fixed resistor 100kohm	
VR403	963 0052 005	Semi fixed resistor 200kohm	

Ref. No.	Part No.	Part Name	Remarks
CAPACITORS GROUP			
C401,402	963 9004 685	Ceramic chip 1000pF/50V	
C403	963 9004 737	Ceramic chip 0.022µF/25V	
C404	963 9004 892	Ceramic 2pF/50V	
C405	963 9004 737	Ceramic chip 0.022µF/25V	
C406	963 9004 902	Ceramic chip 18pF/50V	
C408	960 9004 709	Ceramic 6pF/50V	
C409	963 9004 520	Ceramic 100pF/50V	
C410	963 9004 915	Ceramic 470pF/50V	
C411	963 9004 685	Ceramic chip 1000pF/50V	
C412	963 9004 737	Ceramic chip 0.022µF/25V	
C413	963 9004 575	Ceramic chip 100pF/50V	
C414		Electrolytic 2.2µF/50V	
C415		Electrolytic 47µF/16V	
C416		Electrolytic 10µF/35V	
C417		Electrolytic 100µF/16V	
C418	963 9004 698	Ceramic chip 0.01µF/50V	
C419		Electrolytic 10µF/35V	
C420	963 9004 591	Ceramic chip 22pF/50V	
C421	963 9004 928	Ceramic chip 24pF/50V	
C423,424	963 9004 737	Ceramic chip 0.022µF/25V	
C425		Electrolytic 4.7µF/50V	
C426		Electrolytic 3.3µF/50V	
C427		Electrolytic 4.7µF/50V	
C428	963 9004 737	Ceramic chip 0.022µF/25V	
C430	963 0021 900	Mylar film 0.047µF/100V	
C431	963 9004 627	Ceramic chip 33pF/50V	
C432		Electrolytic 47µF/16V	
C433	963 9004 737	Ceramic chip 0.022µF/25V	
C434		Electrolytic 1µF/50V	E3
C434		Electrolytic 0.33µF/50V	E2,E1,E1C,E1H,E1T
C435,436	963 9004 737	Ceramic chip 0.022µF/25V	
C437		Electrolytic 47µF/16V	
C438		Electrolytic 1µF/50V	
C439		Electrolytic 0.22µF/50V	
C440,441		Electrolytic 1µF/50V	
C442		Electrolytic 2.2µF/50V	
C443		Electrolytic 10µF/35V	
C444		Electrolytic 4.7µF/50V	
C445		Electrolytic 10µF/35V	
C446,447	963 9004 940	Ceramic 270pF/50V	E3
C446,447	963 9004 957	Ceramic 330pF/50V	E2
C446,447	963 9004 931	Ceramic 180pF/50V	E1,E1C,E1H,E1T
C448,449	963 9004 960	Ceramic 470pF/50V	
C448,449	963 9004 957	Ceramic 330pF/50V	E1,E1C,E1H,E1T
C450,451		Electrolytic 10µF/35V	
C452		Electrolytic 100µF/16V	
C453	963 9004 614	Ceramic chip 27pF/50V	
C456	963 9004 672	Ceramic chip 680pF/50V	
C457-460	963 9004 575	Ceramic chip 100pF/50V	
C461	963 9004 591	Ceramic chip 22pF/50V	
C462	963 9004 656	Ceramic chip 470pF/50V	E2

Ref. No.	Part No.	Part Name	Remarks	Ref. No.	Part No.	Part Name	Remarks	
C463	963 9004 782	Mylar film 0.056 μ F/100V		C901H,902H	963 9004 533	Ceramic 0.001 μ F/50V		
C464	963 9004 973	Ceramic 3pF/50V		C903	963 9004 575	Ceramic chip 1000pF/50V		
C471VT		Electrolytic 1 μ F/50V		C903H		Electrolytic 1 μ F/50V		
C472VT	963 9004 753	Ceramic chip 0.047 μ F/50V		C904H	960 9003 108	Ceramic 0.022 μ F/25V		
C551		Electrolytic 2.2 μ F/50V		C905,906	963 9004 575	Ceramic chip 100pF/50V		
C551M		Electrolytic 100 μ F/35V		C907-910	963 9004 575	Ceramic chip 100pF/50V		
C551S	963 9004 562	Ceramic 0.047 μ F/50V		C911	963 9004 698	Ceramic chip 0.01 μ F/50V		
C551T,552T		Electrolytic 100 μ F/16V		C918	963 9004 698	Ceramic chip 0.01 μ F/50V		
C552-554		Electrolytic 0.1 μ F/50V		C921,922	963 9004 575	Ceramic chip 100pF/50V		
C552FL,FR		Electrolytic 10 μ F/35V		C924	963 9004 575	Ceramic chip 100pF/50V		
C553FL,FR	963 9004 575	Ceramic chip 100pF/50V		OTHER PARTS GROUP				
C553T,554T	963 9004 708	Ceramic chip 0.1 μ F/50V					Q'ty	
C554FL,FR		Electrolytic 10 μ F/35V		CF401,402	960 0187 104	Ceramic filter SFE10.7MA8	E3	2
C555,556	963 9004 546	Ceramic 0.01 μ F/16V		CF401,402	960 0177 509	Ceramic filter SFE10.7MS3GH	E2	2
C555FL,FR	963 9004 643	Ceramic chip 47pF/50V		CF401	960 0187 104	Ceramic filter SFE10.7MA8	E1,E1C,E1H,E1T	1
C556FL,FR		Electrolytic 10 μ F/35V		CF402	960 0177 509	Ceramic filter SFE10.7MS3GH	E1,E1C,E1H,E1T	1
C557		Electrolytic 10 μ F/35V		CF403	960 0187 609	Ceramic resonator		1
C557FL,FR	963 0024 703	Mylar film 0.01 μ F/100V		CN392	963 0086 000	2P connector cord		1
C558FL,FR	963 9004 782	Mylar film 0.056 μ F/100V		CN401	963 0086 107	16P connector socket (TUC-P)		1
C559FL,FR	963 9008 640	Mylar film 0.022 μ F/100V		CN506	963 0059 008	8P connector cord		1
C560FL,FR	960 9008 611	Mylar film 0.0033 μ F/100V		CN551	963 0086 204	19P connector socket (TUC-P)		1
C561FL,FR	960 9008 695	Mylar film 0.0068 μ F/100V		CN552	963 0086 301	18P connector socket (TUC-P)		1
C601-604		Electrolytic 4.7 μ F/50V		CN553	963 0086 408	20P connector socket (TUC-P)		1
C605		Electrolytic 470 μ F/6.3V		CN601	963 0085 603	5P connector socket (TUC-P)		1
C606,607		Electrolytic 10 μ F/35V		CN704	963 0086 505	7P connector socket (TUC-P)		1
C608,609		Electrolytic 470 μ F/6.3V		CP302	963 0049 908	3P connector base		1
C610		Electrolytic 10 μ F/35V		CP392	963 0048 909	3P connector base		1
C612		Electrolytic 100 μ F/16V		CP602	963 0085 904	9P connector cord		1
C614	963 9004 753	Ceramic chip 0.047 μ F/50V		CP603	960 0123 207	3P connector base		1
C651-658		Electrolytic 4.7 μ F/50V		CP703,704	963 0085 807	7P connector base (TUC-P)		2
C651T	963 0021 900	Mylar film 0.047 μ F/100V		FE401	960 0187 706	Front end		1
C659		Electrolytic 470 μ F/6.3V		G401	963 0088 202	1P contact Ass'y		1
C660		Electrolytic 10 μ F/50V		G901	963 0088 202	1P contact Ass'y		1
C661		Electrolytic 470 μ F/6.3V		J402	963 9003 369	Carbon chip 0 ohm 1/8W		1
C662		Electrolytic 10 μ F/50V		J404	963 9003 369	Carbon chip 0 ohm 1/8W		1
C663		Electrolytic 470 μ F/6.3V		J407	963 9003 369	Carbon chip 0 ohm 1/8W		1
C664		Electrolytic 10 μ F/50V		J583,584	963 9003 369	Carbon chip 0 ohm 1/8W		2
C665		Electrolytic 100 μ F/10V		J585,586	963 9003 372	Carbon chip 0 ohm 1/16W		2
C666		Electrolytic 470 μ F/6.3V		J587	963 9003 369	Carbon chip 0 ohm 1/8W		1
C667		Electrolytic 10 μ F/50V		J655	963 9003 369	Carbon chip 0 ohm 1/8W		1
C668		Electrolytic 470 μ F/6.3V		L401	963 0052 102	Inductor 1 μ H		1
C669		Electrolytic 10 μ F/50V		L402	960 0010 307	Inductor 10 μ H		1
C670		Electrolytic 470 μ F/6.3V						
C671		Electrolytic 10 μ F/50V						
C672		Electrolytic 100 μ F/10V						
C673,674		Electrolytic 1 μ F/50V						
C676,677	963 9004 753	Ceramic chip 0.047 μ F/50V						
C680		Electrolytic 1 μ F/50V						
C681,682	963 9004 520	Ceramic 100pF/50V						

PRE-AMP P.W.B. ASS'Y

Ref. No.	Part No.	Part Name	Remarks	Q'ty	Ref. No.	Part No.	Part Name	Remarks
L403	963 0056 409	MW IF COIL RBW07VB-K5025 BLK		1	SEMICONDUCTORS GROUP			
RELAY551	963 0083 100	Relay (RSB12S DC12V)		1	Q501C	960 0196 603	Transistor KTC2874B	
SW391-399	963 0045 708	Tact switch		9	Q501FL,FR	960 0196 603	Transistor KTC2874B	
SW401	963 0056 700	SW,SLIDE		1	Q501M	960 0196 603	Transistor KTC2874B	
SW901	960 0176 209	Push switch	E3	1	Q501SL,SR	960 0196 603	Transistor KTC2874B	
SW901	963 0056 603	Push switch	E2,E1,E1C,E1H,E1T	1	Q502C	960 0196 205	Transistor KSA992F	
T401	960 0186 600	MW IF COIL PCFMAF-270		1	Q502FL,FR	960 0196 205	Transistor KSA992F	
T402	960 0007 349	FM DET TRANS		1	Q502M,503M	960 0196 603	Transistor KTC2874B	
T403	960 0007 352	FM DET TRANS		1	Q502SL,SR	960 0196 205	Transistor KSA992F	
T404,405	960 0071 207	MPX filter	E2	2	Q503C	960 0196 205	Transistor KSA992F	
T406	960 0037 607	Antibirdie filter	E2	1	Q503FL,FR	960 0196 205	Transistor KSA992F	
X401	960 0187 405	Crystal 7.2 MHz		1	Q503SL,SR	960 0196 205	Transistor KSA992F	
X402	963 0043 302	Resonator CSB456F11		1	Q504C	960 0196 506	Transistor KSC1845F	
—	960 0184 000	Screw bracket		2	Q504FL,FR	960 0196 506	Transistor KSC1845F	
—	963 0054 003	Shield tuner pack		1	Q504SL,SR	960 0196 506	Transistor KSC1845F	
—	—	Plate		1	RESISTORS GROUP			
—	963 0052 403	3P antenna terminal		1	R509C	960 9005 902	Metal film 1.2 kohm 1/4W	
—	960 0188 307	6P pin jack		1	R509FL,FR	960 9005 902	Metal film 1.2 kohm 1/4W	
—	963 0061 708	Plate		1	R509SL,SR	960 9005 902	Metal film 1.2 kohm 1/4W	
—	963 0057 000	1P pin jack		1	R511C	960 9004 301	Metal film 47 ohm 1/4W	
—	960 0188 200	4P pin jack		1	R511FL,FR	960 9004 301	Metal film 47 ohm 1/4W	
—	960 0188 404	3P pin jack		2	R511SL,SR	960 9004 301	Metal film 47 ohm 1/4W	
—	—	Heat sink		1	CAPACITORS GROUP			
—	963 0018 007	Screw (2S 3x8 ZNY/BH)		1	C501C		Electrolytic 22μF/16V	
—	960 0181 304	3P S terminal		1	C501FL,FR		Electrolytic 22μF/16V	
—	960 0181 401	4P S terminal		2	C501M		Electrolytic 10μF/35V	
—	960 0188 200	4P pin jack		1	C501SL,SR		Electrolytic 22μF/16V	
—	960 0187 502	Head phone jack (D6.5)		1	C502C		Electrolytic 10μF/35V	
—	—	Wire clamp		2	C502FL,FR		Electrolytic 10μF/35V	
					C502SL,SR		Electrolytic 10μF/35V	
					C503C	963 9003 165	Ceramic 220pF/500V	
					C503FL,FR	963 9003 165	Ceramic 220pF/500V	
					C503SL,SR	963 9003 165	Ceramic 220pF/500V	
					C504C	963 9003 178	Ceramic 220pF/50V	
					C504FL,FR	963 9003 178	Ceramic 220pF/50V	
					C504SL,SR	963 9003 178	Ceramic 220pF/50V	
					C505C	963 9003 181	Ceramic 33pF/500V	
					C505FL,FR	963 9003 181	Ceramic 33pF/500V	
					C505SL,SR	963 9003 181	Ceramic 33pF/500V	
					C506C		Electrolytic 100μF/10V	
					C506FL,FR		Electrolytic 100μF/10V	
					C506SL,SR		Electrolytic 100μF/10V	
					C507C	963 9003 194	Mylar film 0.0022μF/100V	
					C507FL,FR	963 9003 194	Mylar film 0.0022μF/100V	
					C507SL,SR	963 9003 194	Mylar film 0.0022μF/100V	
					C514C		Electrolytic 22μF/16V	
					C514FL,FR		Electrolytic 22μF/16V	

DSP P.W.B. ASS'Y

Ref. No.	Part No.	Part Name	Remarks	Q'ty	Ref. No.	Part No.	Part Name	Remarks	
OTHER PARTS GROUP					SEMICONDUCTORS GROUP				
CN501	963 0085 506	9P connector socket (TUC-P)		1	IC801,802	269 0186 002	IC GP1FA502RZ		
CN502-504	963 0085 603	5P connector socket (TUC-P)		3	IC803	963 0073 903	IC 74VHCU04		
CN505	963 0085 700	6P connector socket (TUC-P)		1	IC805,806	963 0043 807	IC BA4510F		
CP506	963 0060 709	8P connector base		1	IC807	963 0073 709	IC M27W201-80B6		
CP554	963 0060 903	15P connector base		1	IC807S	963 0025 508	32P IC socket		
—	960 0184 000	Screw bracket		2	IC808,809	963 0074 407	IC MM74LCX574WMX		
					IC810	960 0195 507	IC LC89055W		
					IC811	963 0074 805	IC RC1117S33ST		
					IC812	963 0079 208	IC CS49326-CL		
					IC813	963 0074 601	IC AK4527B-VQ		
					IC814-816	963 0024 004	IC NJM2068MD		
					IC817	269 0189 009	IC GP1FA502TZ		
					IC818,819	963 0074 203	IC MM74LCX244WMX		
					IC820	963 0074 708	IC RC1117S25T		
					IC822	960 0195 109	IC SN74LV00APW		
					IC828	963 0074 300	IC MM74HCT244WMX		
					IC829	960 0196 001	IC NJM7805FA (S)		
					IC830	963 0074 300	IC MM74HCT244WMX		
					IC831	960 0195 303	IC SN74LV4040APWR		
					IC832	963 0074 106	IC MM74HC151MX		
					Q804C	960 0196 603	Transistor KTC2874B		
					Q804FL,FR	960 0196 603	Transistor KTC2874B		
					Q804SL,SR	960 0196 603	Transistor KTC2874B		
					Q804SW	960 0196 603	Transistor KTC2874B		
					Q805	269 0083 901	Transistor DTA114EK		
					Q806	269 0082 902	Transistor DTC114EK		
					Q807	269 0083 901	Transistor DTA114EK		
					Q808	269 0082 902	Transistor DTC114EK		
					D801	960 0197 000	Diode KDS160		
					D806,807	960 0197 000	Diode KDS160		
					RESISTORS GROUP				
					R801	963 9004 342	Carbon chip 4.7 kohm 1/16W		
					R803	963 9004 342	Carbon chip 4.7 kohm 1/16W		
					R804,805	963 9003 385	Carbon chip 100 ohm 1/16W		
					R808	963 9004 274	Carbon chip 33 kohm 1/16W		
					R817-825	963 9004 070	Carbon chip 10 kohm 1/16W		
					R830	963 9004 342	Carbon chip 4.7 kohm 1/16W		
					R831	963 9004 070	Carbon chip 10 kohm 1/16W		
					R834,835	963 9004 342	Carbon chip 4.7 kohm 1/16W		
					R836	963 9004 070	Carbon chip 10 kohm 1/16W		
					R838	963 9004 070	Carbon chip 10 kohm 1/16W		
					R839	963 9004 342	Carbon chip 4.7 kohm 1/16W		
					R841	963 9004 339	Carbon chip 470 ohm 1/16W		
					R842	963 9004 342	Carbon chip 4.7 kohm 1/16W		
					R845R	963 9004 355	Carbon chip 47 kohm 1/16W		
					R848	963 9003 385	Carbon chip 100 ohm 1/16W		
					R850	963 9004 465	Carbon chip 75 ohm 1/16W		
					R854	963 9004 216	Carbon chip 2.2 kohm 1/16W		

Ref. No.	Part No.	Part Name	Remarks	Ref. No.	Part No.	Part Name	Remarks
R854L	963 9004 355	Carbon chip 47 kohm 1/16W		R931L,R	963 9004 177	Carbon chip 18 kohm 1/16W	
R855	963 9004 083	Carbon chip 100 kohm 1/16W		R932	963 9004 342	Carbon chip 4.7 kohm 1/16W	
R856	963 9004 070	Carbon chip 10 kohm 1/16W		R938	963 9004 368	Carbon chip 470 kohm 1/16W	
R859L,R	963 9004 342	Carbon chip 4.7 kohm 1/16W		R940	963 9004 070	Carbon chip 10 kohm 1/16W	
R860L,R	963 9004 342	Carbon chip 4.7 kohm 1/16W		R949	963 9004 326	Carbon chip 47 ohm 1/16W	
R861	963 9004 326	Carbon chip 47 ohm 1/16W		R952,953	963 9003 385	Carbon chip 100 ohm 1/16W	
R861L,R	963 9004 339	Carbon chip 470 ohm 1/16W		CAPACITORS GROUP			
R862L,R	963 9004 342	Carbon chip 4.7 kohm 1/16W		C801	963 9004 711	Ceramic chip 0.1µF/50V	
R863L,R	963 9004 339	Carbon chip 470 ohm 1/16W		C802,803	963 9004 591	Ceramic chip 22pF/50V	
R864C	963 9004 083	Carbon chip 100 kohm 1/16W		C805	963 9004 591	Ceramic chip 22pF/50V	
R864FL,FR	963 9004 083	Carbon chip 100 kohm 1/16W		C808	963 9004 711	Ceramic chip 0.1µF/50V	
R864SL,SR	963 9004 083	Carbon chip 100 kohm 1/16W		C809		Electrolytic 47µF/10V	
R864SW	963 9004 083	Carbon chip 100 kohm 1/16W		C810	963 9004 711	Ceramic chip 0.1µF/50V	
R866C	963 9004 342	Carbon chip 4.7 kohm 1/16W		C811		Electrolytic 47µF/10V	
R866FL,FR	963 9004 342	Carbon chip 4.7 kohm 1/16W		C812	963 9004 711	Ceramic chip 0.1µF/50V	
R866SL,SR	963 9004 342	Carbon chip 4.7 kohm 1/16W		C813		Electrolytic 47µF/10V	
R866SW	963 9004 342	Carbon chip 4.7 kohm 1/16W		C814	963 9004 591	Ceramic chip 22pF/50V	
R867C	963 9004 342	Carbon chip 4.7 kohm 1/16W		C815	963 9004 711	Ceramic chip 0.1µF/50V	
R867FL,FR	963 9004 342	Carbon chip 4.7 kohm 1/16W		C816	963 9004 591	Ceramic chip 22pF/50V	
R867SL,SR	963 9004 342	Carbon chip 4.7 kohm 1/16W		C817		Electrolytic 0.1µF/50V	
R867SW	963 9004 342	Carbon chip 4.7 kohm 1/16W		C818	963 9004 711	Ceramic chip 0.1µF/50V	
R868C	963 9004 342	Carbon chip 4.7 kohm 1/16W		C819,820		Electrolytic 47µF/10V	
R868FL,FR	963 9004 342	Carbon chip 4.7 kohm 1/16W		C821		Electrolytic 100µF/10V	
R868SL,SR	963 9004 342	Carbon chip 4.7 kohm 1/16W		C822,823	963 9004 711	Ceramic chip 0.1µF/50V	
R868SW	963 9004 342	Carbon chip 4.7 kohm 1/16W		C824		Electrolytic 47µF/10V	
R869C	963 9004 342	Carbon chip 4.7 kohm 1/16W		C825		Electrolytic 1µF/50V	
R869FL,FR	963 9004 342	Carbon chip 4.7 kohm 1/16W		C826		Electrolytic 10µF/35V	
R869SL,SR	963 9004 342	Carbon chip 4.7 kohm 1/16W		C827	963 9004 711	Ceramic chip 0.1µF/50V	
R869SW	963 9004 342	Carbon chip 4.7 kohm 1/16W		C828	963 9004 698	Ceramic chip 0.01µF/50V	
R870C	963 9003 398	Carbon chip 1 kohm 1/16W		C829		Electrolytic 10µF/35V	
R870FL,FR	963 9003 398	Carbon chip 1 kohm 1/16W		C830-832	963 9004 711	Ceramic chip 0.1µF/50V	
R870SL,SR	963 9003 398	Carbon chip 1 kohm 1/16W		C833	963 9004 656	Ceramic chip 470pF/50V	
R870SW	963 9003 398	Carbon chip 1 kohm 1/16W		C834		Electrolytic 10µF/35V	
R871C	963 9004 083	Carbon chip 100 kohm 1/16W		C835		Electrolytic 1µF/50V	
R871FL,FR	963 9004 083	Carbon chip 100 kohm 1/16W		C836		Electrolytic 220µF/6.3V	
R871SL,SR	963 9004 083	Carbon chip 100 kohm 1/16W		C837,838	963 9004 711	Ceramic chip 0.1µF/50V	
R871SW	963 9004 083	Carbon chip 100 kohm 1/16W		C839	963 9004 698	Ceramic chip 0.01µF/50V	
R872C	963 9004 216	Carbon chip 2.2 kohm 1/16W		C840		Electrolytic 2.2µF/50V	
R872FL,FR	963 9004 216	Carbon chip 2.2 kohm 1/16W		C841		Electrolytic 47µF/10V	
R872SL,SR	963 9004 216	Carbon chip 2.2 kohm 1/16W		C842	963 9004 711	Ceramic chip 0.1µF/50V	
R872SW	963 9004 216	Carbon chip 2.2 kohm 1/16W		C844	963 9004 711	Ceramic chip 0.1µF/50V	
R880,881	963 9004 326	Carbon chip 47 ohm 1/16W		C845	963 9004 698	Ceramic chip 0.01µF/50V	
R911	963 9004 070	Carbon chip 10 kohm 1/16W		C849	963 9004 698	Ceramic chip 0.01µF/50V	
R913	963 9004 096	Carbon chip 1 Mohm 1/16W		C851	963 9004 698	Ceramic chip 0.01µF/50V	
R922	963 9004 342	Carbon chip 4.7 kohm 1/16W		C854,855		Electrolytic 100µF/25V	
R923	963 9004 410	Carbon chip 6.2 kohm 1/16W		C856-863	963 9004 711	Ceramic chip 0.1µF/50V	
R927	963 9004 465	Carbon chip 75 ohm 1/16W		C864L,864R		Electrolytic 10µF/35V	
R928	963 9004 371	Carbon chip 5.1 kohm 1/16W		C865L,R	963 9004 575	Ceramic chip 100pF/50V	
R929	963 9004 481	Carbon chip 8.2 kohm 1/16W		C866	963 9004 698	Ceramic chip 0.01µF/50V	
R930	963 9004 261	Carbon chip 3 kohm 1/16W		C869L,R	963 9004 575	Ceramic chip 100pF/50V	
R931	963 9004 410	Carbon chip 6.2 kohm 1/16W		C871L,R	963 9004 685	Ceramic chip 1000pF/50V	

Ref. No.	Part No.	Part Name	Remarks	Ref. No.	Part No.	Part Name	Remarks	Q'ty
C873C	963 9004 672	Ceramic chip 680pF/50V		OTHER PARTS GROUP				
C873FL,FR	963 9004 672	Ceramic chip 680pF/50V		CB801	963 0050 502	Chip emifil		1
C873SL,SR	963 9004 672	Ceramic chip 680pF/50V		CB803-808	963 0050 502	Chip emifil		6
C873SW	963 9004 672	Ceramic chip 680pF/50V		CB828	963 0050 502	Chip emifil		1
C874C	963 9004 672	Ceramic chip 680pF/50V						
C874FL,FR	963 9004 672	Ceramic chip 680pF/50V		CN801,802	963 0085 302	17P connector socket (TUC-P)		2
C874SL,SR	963 9004 672	Ceramic chip 680pF/50V		CN803	963 0085 409	10P connector socket (TUC-P)		1
C874SW	963 9004 672	Ceramic chip 680pF/50V						
C875C		Electrolytic 10 μ F/35V		JACK801	963 0052 500	1P pin jack		1
C875FL,FR		Electrolytic 10 μ F/35V						
C875SL,SR		Electrolytic 10 μ F/35V		L801,802	963 0050 803	Inductor 4.7 μ H		2
C875SW		Electrolytic 10 μ F/35V		L803	963 0050 900	Inductor 2.2 μ H		1
C876C	963 9004 740	Ceramic chip 3300pF/50V		L805,806	963 0050 803	Inductor 4.7 μ H		2
C876FL,FR	963 9004 740	Ceramic chip 3300pF/50V		L807	963 0050 900	Inductor 2.2 μ H		1
C876SL,SR	963 9004 740	Ceramic chip 3300pF/50V						
C876SW	963 9004 740	Ceramic chip 3300pF/50V		XTAL801	960 0180 907	Crystal 12.288MHz		1
C880C		Electrolytic 10 μ F/35V						
C880FL,FR		Electrolytic 10 μ F/35V						
C880SL,SR		Electrolytic 10 μ F/35V						
C880SW		Electrolytic 10 μ F/35V						
C908,909	963 9004 614	Ceramic chip 27pF/50V						
C916	963 9004 711	Ceramic chip 0.1 μ F/50V						
C917		Electrolytic 10 μ F/35V						
C918	963 9004 711	Ceramic chip 0.1 μ F/50V						
C919	963 9004 698	Ceramic chip 0.01 μ F/50V						
C920	963 9004 711	Ceramic chip 0.1 μ F/50V						
C921	963 9004 698	Ceramic chip 0.01 μ F/50V						
C923	963 9004 711	Ceramic chip 0.1 μ F/50V						
C925	963 9004 711	Ceramic chip 0.1 μ F/50V						
C926		Electrolytic 10 μ F/35V						
C931	963 9004 698	Ceramic chip 0.01 μ F/50V						
C936	963 9004 711	Ceramic chip 0.1 μ F/50V						
C937		Electrolytic 10 μ F/35V						
C938		Electrolytic 1 μ F/50V						
C939,940	963 9004 698	Ceramic chip 0.01 μ F/50V						
C943		Electrolytic 0.1 μ F/50V						
C944	963 9004 698	Ceramic chip 0.01 μ F/50V						
C946,947	963 9004 711	Ceramic chip 0.1 μ F/50V						
C948		Electrolytic 10 μ F/35V						
C949		Electrolytic 2.2 μ F/50V						
C950	963 9004 711	Ceramic chip 0.1 μ F/50V						
C951		Electrolytic 100 μ F/10V						
C952,953	963 9004 711	Ceramic chip 0.1 μ F/50V						
C954	963 9004 698	Ceramic chip 0.01 μ F/50V						
C956	963 9004 685	Ceramic chip 1000pF/50V						
C957	963 9004 711	Ceramic chip 0.1 μ F/50V						
C958		Electrolytic 100 μ F/10V						

VOLTAGE P.W.B. ASS'Y

Ref. No.	Part No.	Part Name	Remarks	Q'ty
OTHER PARTS GROUP				
CN105	963 0059 202	2P connector cord	E1,E1H,E1T	1
CN903	963 0058 805	2P connector cord	E1,E1H,E1T	1
CP901	963 0061 203	5P connector base	E1,E1H,E1T	1
CP902	963 0059 309	3P connector cord	E1,E1H,E1T	1
△ F101	960 0142 602	Fuse 2.5A	E1,E1H,E1T	1
△ F101A,B	960 0005 804	Fuse clip	E1,E1H,E1T	2
△ F102	963 0044 709	Fuse 3.15A	E1,E1H,E1T	1
△ F102A,B	960 0005 804	Fuse clip	E1,E1H,E1T	2
△ F901	963 0057 107	Fuse 6.3A	E1,E1H,E1T	1
△ F901A,B	960 0005 804	Fuse clip	E1,E1H,E1T	2
△ JK911	960 0143 203	AC outlet	E1,E1H,E1T	1
△ JK912	963 0056 904	SLIDE SW	E1,E1H,E1T	1

EXPLODED VIEW

WARNING:
 Parts marked with this symbol  have critical characteristics.
 Use **ONLY** replacement parts recommended by the manufacturer.

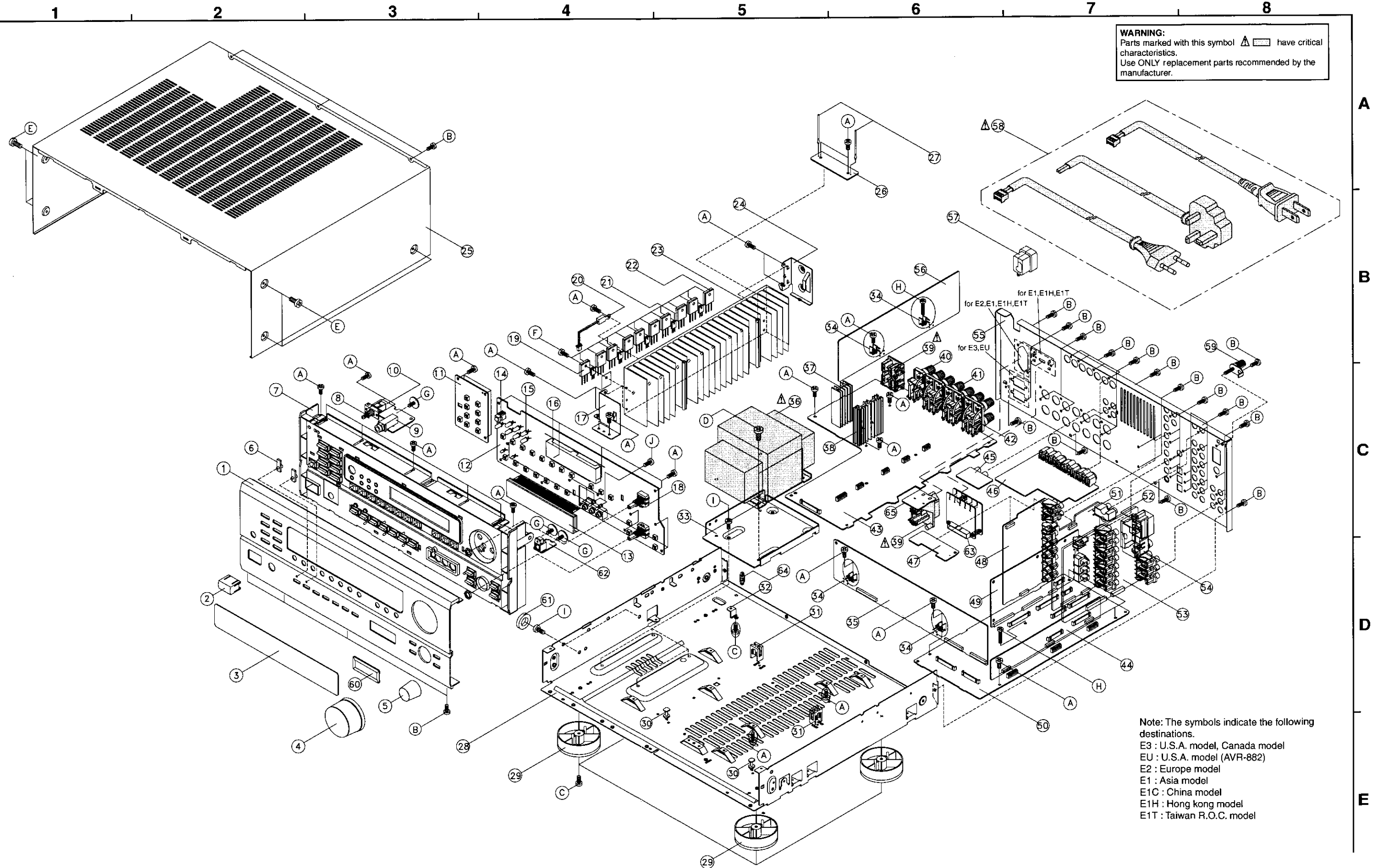

Note: The symbols indicate the following destinations.
 E3 : U.S.A. model, Canada model
 EU : U.S.A. model (AVR-882)
 E2 : Europe model
 E1 : Asia model
 E1C : China model
 E1H : Hong kong model
 E1T : Taiwan R.O.C. model

Note: The symbols in the column "Remarks" indicate the following destinations.
 E3: U.S.A. model, Canada model E1C: China model
 EU: U.S.A. model (AVR-882) E1H: Hong Kong model
 E2: Europe model E1T: Taiwan R.O.C. model
 E1: Asia model

PARTS LIST OF EXPLODED VIEW

Ref. No.	Part No.	Part Name	Remarks	Q'ty	Ref. No.	Part No.	Part Name	Remarks	Q'ty	
	963 0082 606	Main P.W.B assy	for E3, EU	1	3	963 0082 305	Window		1	
	963 0082 622		for E2	1	4	963 0054 906	Main volume knob	for Black model	1	
	963 0082 635		for E1C	1		963 0055 002	Main volume knob (GO):MOLD	for E2 (Gold model)	1	
	963 0082 648		for E1, E1H, E1T	1		112 0839 008	Main volume knob (GO) : AL	for E1, E1C, E1H, E1T	1	
43		Main P.W.B assy		1	5	963 0054 809	Select knob(BK)	for E3, EU, E2/Black model	1	
	44	Front-CNT P.W.B assy		1		963 0055 109	Select knob (GO) : MOLD	for E2 (Gold model)	1	
	51	Input P.W.B assy		1		112 0835 015	Select knob (GO) : AL	for E1, E1C, E1H, E1T	1	
	963 0082 703	Processor P.W.B assy	for E3, EU	1	6	963 0051 307	Lens		2	
	963 0082 729		for E2	1	7	963 0082 208	Front frame	for Black model	1	
	963 0082 732		for E1C	1		963 0082 211		for Gold model	1	
	963 0082 745		for E1, E1H, E1T	1	8	960 0176 209	Push switch	for E3, EU	1	
12		Front P.W.B assy		1		963 0056 603	Push switch	for E1, E1C, E1H, E1T, E2	1	
	50	CPU P.W.B assy		1	9	960 0187 502	Head phone jack (D6.5)	for E3, EU, E2	1	
	62	Front-Optical P.W.B assy		1		960 0176 306	Head phone jack (D6.5)	for E1, E1C, E1H, E1T	1	
	963 0082 907	CNT P.W.B assy	for E3, EU	1	13	960 0180 509	FLT (16-ST-42GNK)		1	
	963 0082 923		for E2	1	14	960 0181 100	IC NJL64H380A	RMC301	1	
	963 0082 936		for E1C	1	15	960 0197 204	LED PI5-RD/HL50RDRF4T	LED301-309	8	
	963 0082 949		for E1, E1H, E1T	1	16	960 0184 408	FLT holder		1	
10		Head phone P.W.B assy		1	17	960 0184 301	Heat sink bracket F		1	
	11	Switch P.W.B assy		1	18	960 0181 207	Rotary encoder (L=25)	VEC301	1	
	26	Video-CNT P.W.B assy		1		960 0181 207	Rotary encoder (L=25)	VEC302	1	
	35	CNT P.W.B assy		1		963 0084 109	Rotary encoder (L=20)	VEC302 (for E1, E1C, E1H, E1T)	1	
	45	Preout P.W.B assy		1	19	963 0044 107	Transistor 2SB1560Y	Q102C,FL,FR,SL,SR	5	
	46	S-Video P.W.B assy		1	20	960 0187 900	Posistor P43T7D330BW16		1	
	47	CDR-CNT P.W.B assy		1	21	963 0058 106	Transistor 2SD947F	Q103C,FL,FR,SL,SR	5	
	48	Video P.W.B assy		1	22	963 0044 204	Transistor 2SD2390Y	Q101C,FL,FR,SL,SR	5	
	53	Tuner P.W.B assy		1	23	—	Heat sink		1	
	65	Outlet P.W.B assy		1	24	960 0184 204	Heat sink bracket B		1	
	963 0082 800	Pre-Amp P.W.B assy	for E3, EU	1	25	960 0183 205	Top cabinet	for Black model	1	
	963 0082 826		for E2	1		963 0055 507	Top cabinet	for Gold model	1	
	963 0082 839		for E1C	1	27	—	Wire clamp		2	
	963 0082 842		for E1, E1H, E1T	1	28	960 0198 216	Chassis		1	
56		Pre-Amp P.W.B assy		1	29	960 0183 904	Foot assy		4	
				1	30	963 0051 103	Card spacer		2	
				1	31	960 0003 301	PCB supporter		2	
	963 0083 003	DSP P.W.B assy	for E3, EU	1	32	960 0184 107	Supporter bracket		1	
	963 0083 029		for E2	1	33	960 0192 306	Trans bracket		1	
	963 0083 032		for E1C	1	34	960 0184 000	Screw bracket		4	
	963 0083 045		for E1, E1H, E1T	1	36	963 0088 503	Power trans	for E3, EU	1	
49		DSP P.W.B assy		1		963 0088 516		for E2	1	
				1		963 0088 529		for E1, E1H, E1T	1	
				1		963 0088 532		for E1C	1	
63	963 0088 600	Voltage P.W.B assy	for E1,E1H,E1T	1	37	—	Heat sink		1	
		Voltage P.W.B assy	for E1,E1H,E1T	1	38	—	Heat sink		1	
1	963 0082 004	Front panel	for E3	1	39	960 0187 803	AC outlet(2P)	JK104 For E3,EU	1	
	963 0082 062		for EU	1	39	960 0143 203	AC outlet	for E2,E1,E1H,E1T	1	
	963 0082 017		for E2 (Black model)	1	40	960 0194 809	2P speaker terminal	JK103	1	
	963 0082 020		for E2 (Gold model)	1	41	963 0074 009	8P speaker terminal		1	
	963 0082 046		for E1 (Gold model)	1	42	960 0188 608	4P speaker terminal		1	
	963 0082 059		for E1 (Black model)	1	52	963 0088 406	Plate		1	
	2	960 0185 009	Power button	for Black model	1	54	963 0054 003	Shield tuner pack		1
		963 0055 206	Power button (GO)	for Gold model	1					

Ref. No.	Part No.	Part Name	Remarks	Q'ty
55	963 0082 101	Back panel	for E3	1
	963 0082 156		for 882EU	1
	963 0082 114		for E2	1
	963 0082 130		for E1, E1H, E1T	1
	963 0082 143		for E1C	1
57	960 0192 403	Cord bush		1
△	960 0166 400	AC cord assy	for E3, EU	1
	960 0165 304		for E2	1
	963 0060 408		for E1, E1T	1
	960 0143 009		for E1H	1
	963 0060 301		for E1C	1
59	960 0183 807	Terminal		1
60	963 0088 309	Cover	for E3, EU, E2/Black	1
	963 0088 312		for E2/Gold	1
61	963 0051 200	Cushion		2
64	963 0044 602	supporter	for E2, E1, E1C, E1H, E1T	1
★	960 0093 104	Push livet	for E2, E1, E1C, E1H, E1T	14
★	963 0061 407	FFC cable		1
A	963 0018 007	Screw (2S 3×8 ZNY/BH)		50
B	960 0108 701	Screw (2S 3×10 DOT BK)		43
C	963 0048 200	Screw (2S 3×10 ZNY/BH)		10
D	960 9008 417	Screw (3S 4×8 ZNY/BH)		4
E	963 0048 307	Screw (2S 4×8 DOT BK)		6
F	963 9004 009	Screw (2S 3×14 WASHER ZNY/HH)		15
G	960 9008 420	Screw (2S 3×8 WASHER)		3
H	963 0018 104	Screw (2S 3×17 ZNY/BH)		2
I	963 9004 025	Screw (3S 4×6 ZNY/BH)		6
J	963 9004 054	Screw (2S 3×15 ZNY/BH)		2

PACKING VIEW

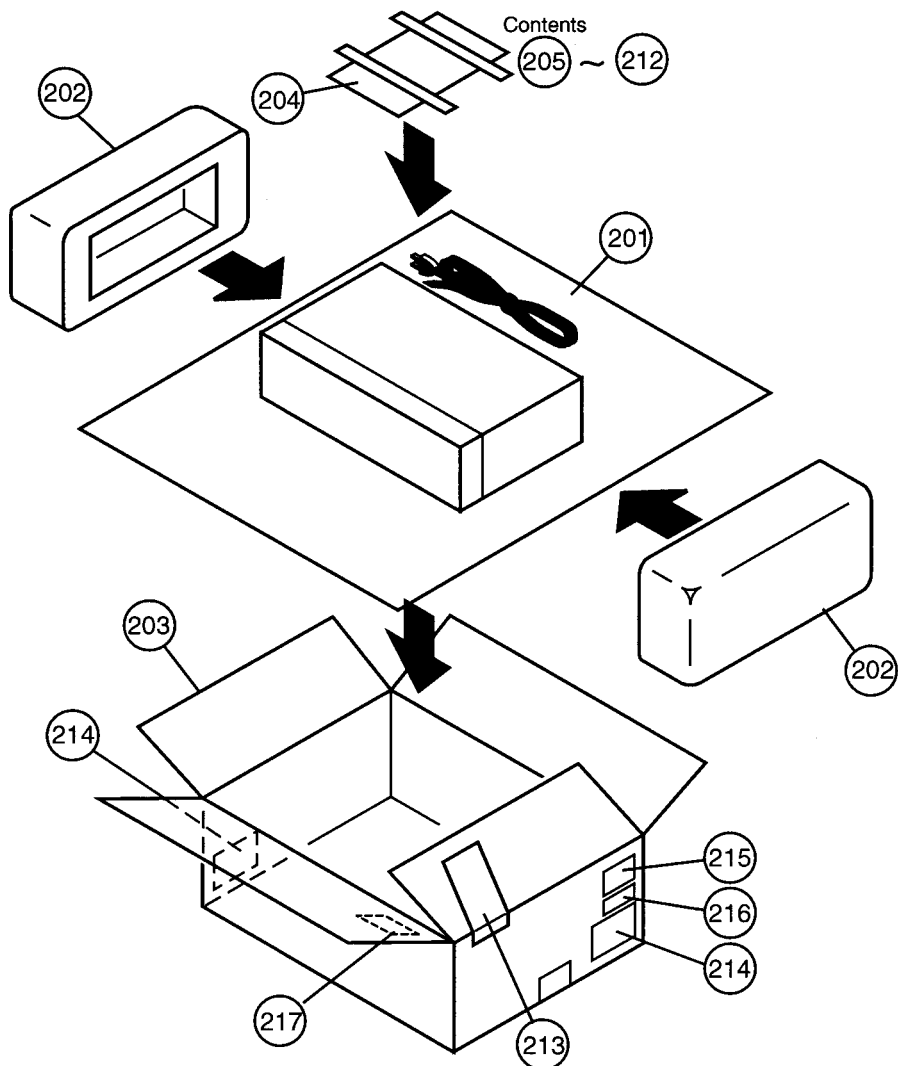

Note: The symbols in the column "Remarks" indicate the following destinations.
 E3: U.S.A. model, Canada model E1C: China model
 EU: U.S.A. model (AVR-882) E1H: Hong Kong model
 E2: Europe model E1T: Taiwan R.O.C. model
 E1: Asia model

PARTS LIST OF PACKING & ACCESSORIES

Ref. No.	Part No.	Part Name	Remarks	Q'ty	Ref. No.	Part No.	Part Name	Remarks	Q'ty
201	960 0185 601	Set poly bag		1	210	—	Battery (R6P/AA)		2
202	960 0185 504	Cushion		2	211	963 0052 704	FM antenna adapter		1
203	963 0082 509	Carton case	for E3,E2	1	212	963 0061 300	AC plug adapter	for E1T	1
203	963 0085 205	Carton case	for EU	1	213	515 0817 009	DEL Warranty home	for E3,EU	1
203	963 0082 512	Carton case	for E1,E1C,E1T	1	214	—	Control label		2
203	963 0082 525	Carton case	for E1H	1	215	—	UPC label	for E3	1
204	963 0045 106	Poly bag		1	215	—	UPC label	for EU	1
205	963 0082 402	Instruction manual	for E3,EU	1	215	—	EAN label	for E2(Black model)	1
205	963 0082 415	Instruction manual	for E2	1	215	—	EAN label	for E2(Gold model)	1
205	963 0082 428	Instruction manual	for E1,E1H,E1T	1	216	—	Carton label	for E1C	1
205	963 0082 428	Instruction manual	for E1C	1	217	—	Kolin label	for E1T	1
206	515 0867 101	S.S. list		1	★	513 3322 003	Label (RDS,RADIO TEXT)	for E2	2
207	963 0052 306	AM loop antenna		1	★	—	Label (CCIB)	for E1C	2
208	963 0052 209	FM antenna		1	★	513 9111 001	Color label (Gold)	for Gold model	2
209	963 0084 002	Remocon RC-897		1	★	963 0055 905	Pad	for E1H	2

BLOCK DIAGRAM

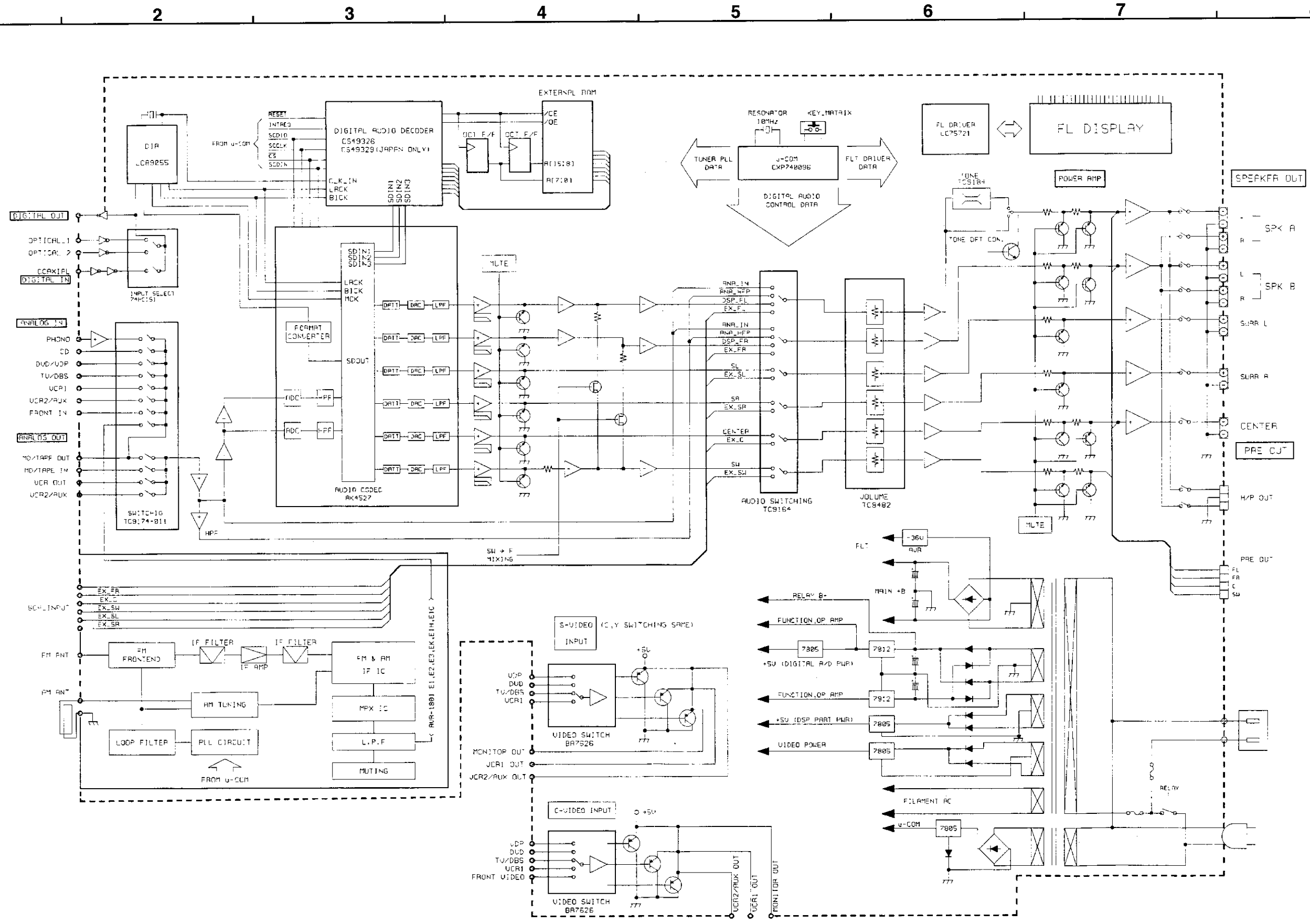

WIRING DIAGRAM

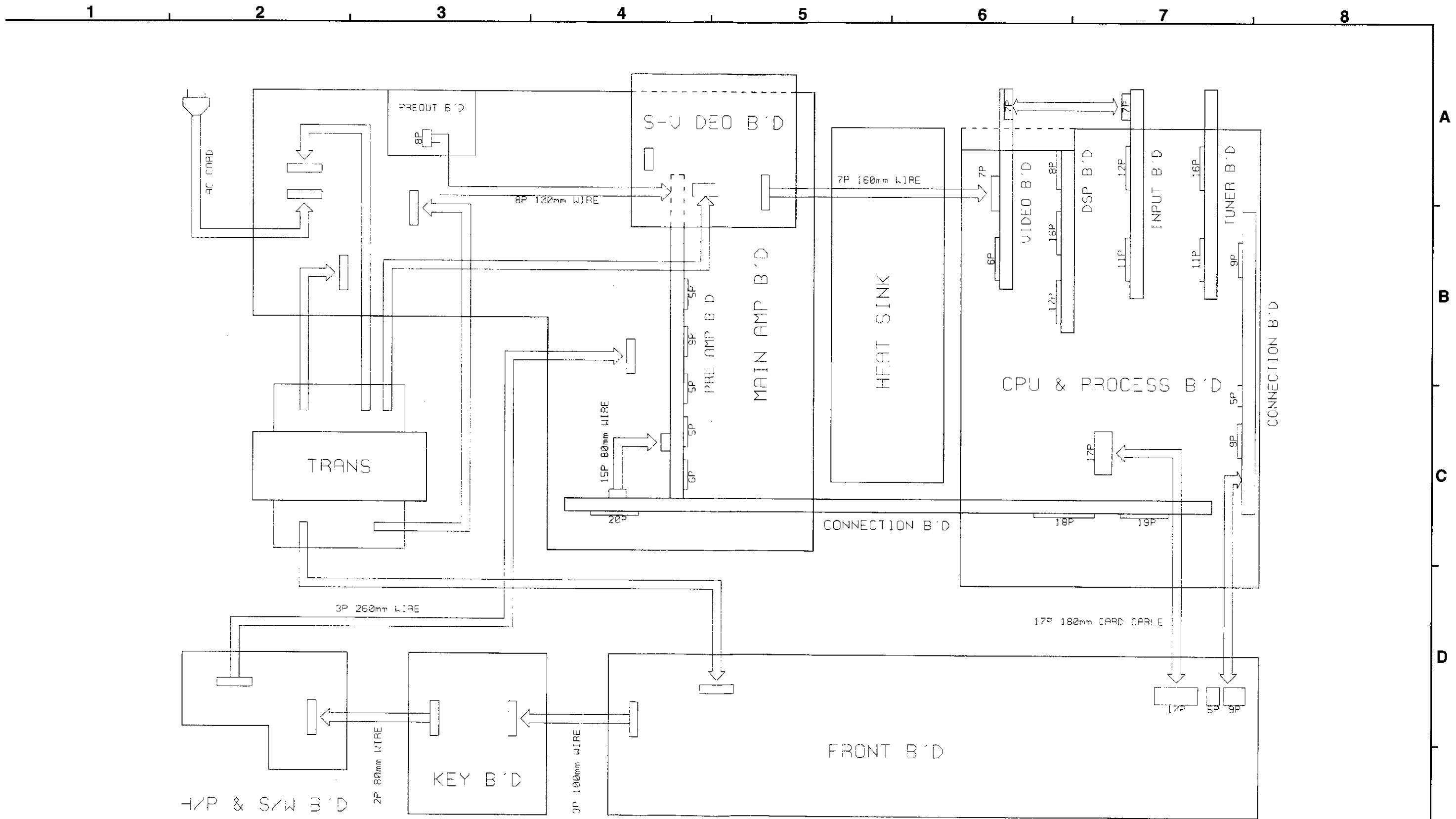

AVR1802 WIRING DIAGRAM

SCHEMATIC DIAGRAMS (1/8)

1 2 3 4 5 6 7 8 9 10 11

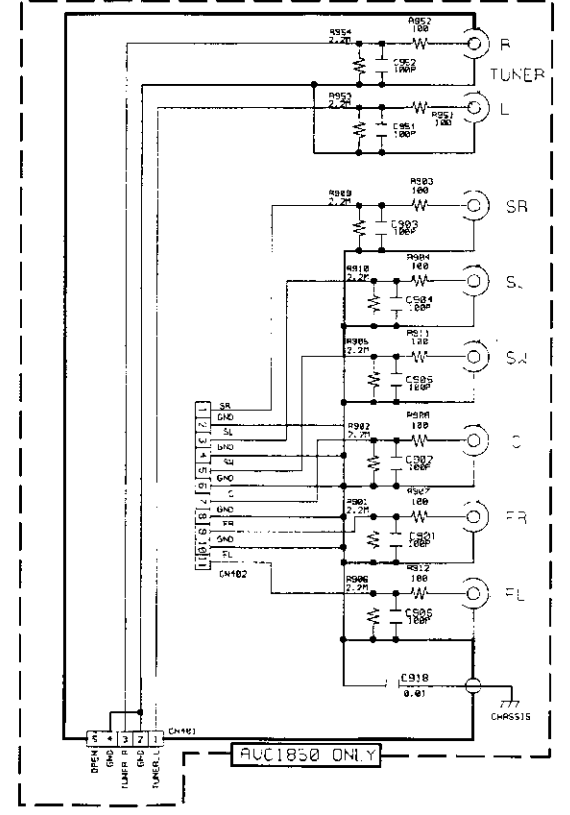
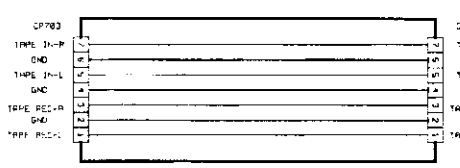
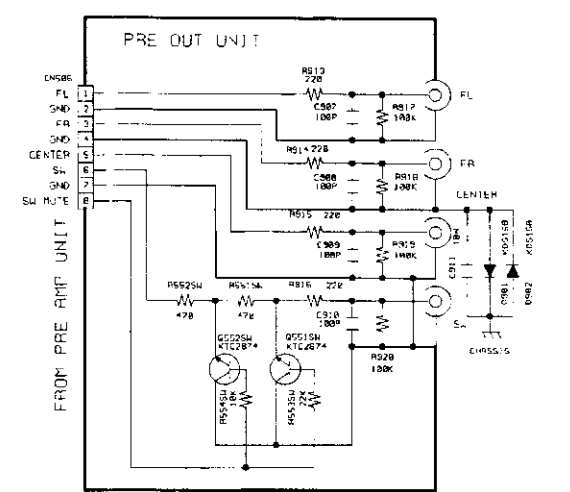
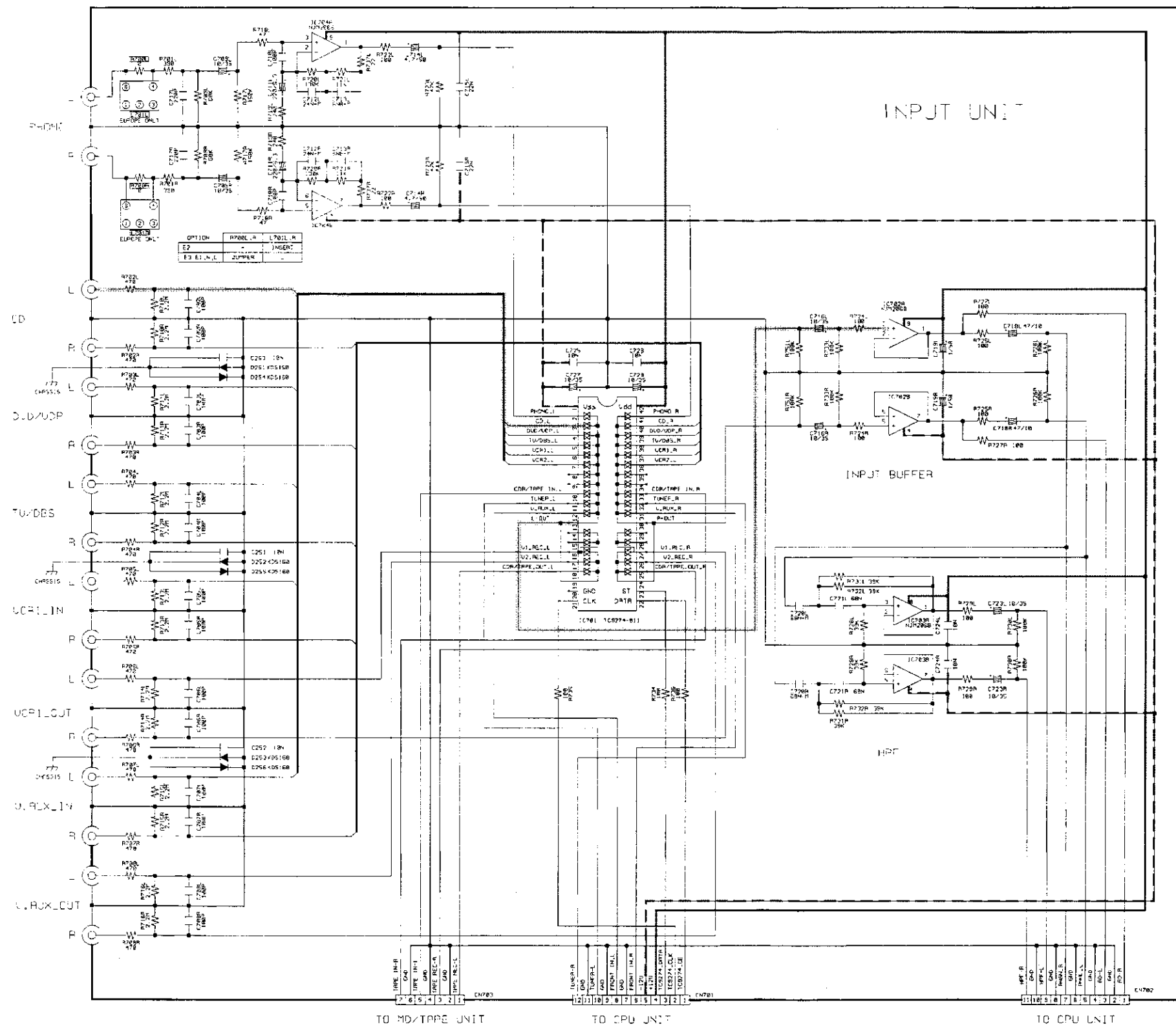

— + B LINE
 - - - - B LINE
 ——— SIGNAL LINE

WARNING:
 Parts marked with this symbol have critical characteristics. Use ONLY replacement parts recommended by the manufacturer.

CAUTION:
 Before returning the unit to the customer, make sure you make either (1) a leakage current check or (2) a line to chassis resistance check. If the leakage current exceeds 0.5 milliamps, or if the resistance from chassis to either side of the power cord is less than 460kohms, the unit is defective.

WARNING:
 DO NOT return the unit to the customer until the problem is located and corrected.

NOTICE
 ALL RESISTANCE VALUES IN OHM. k=1,000 OHM M=1,000,000 OHM
 ALL CAPACITANCE VALUES IN MICRO FARAD. P=MICRO-MICRO FARAD
 EACH VOLTAGE AND CURRENT ARE MEASURED AT NO SIGNAL INPUT CONDITION.
 CIRCUIT AND PARTS ARE SUBJECT TO CHANGE WITHOUT PRIOR NOTICE.

SCHEMATIC DIAGRAMS (1/8)
INPUT UNIT
CDR-CNT UNIT
PRE OUT UNIT

SCHEMATIC DIAGRAMS (1/8)

1

2

3

4

5

6

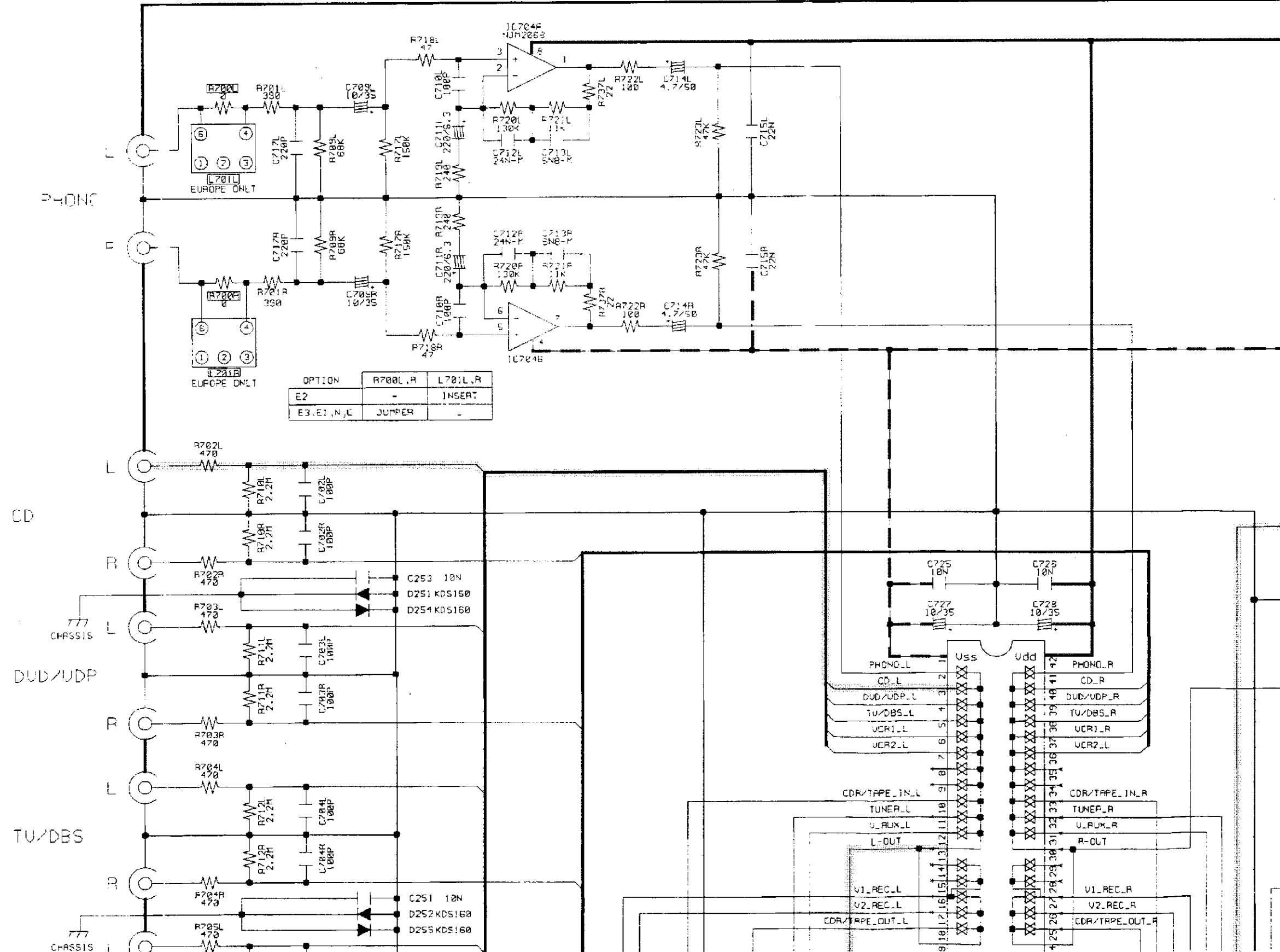

6

7

8

9

10

11

INPUT UNIT

INPUT BUFFER

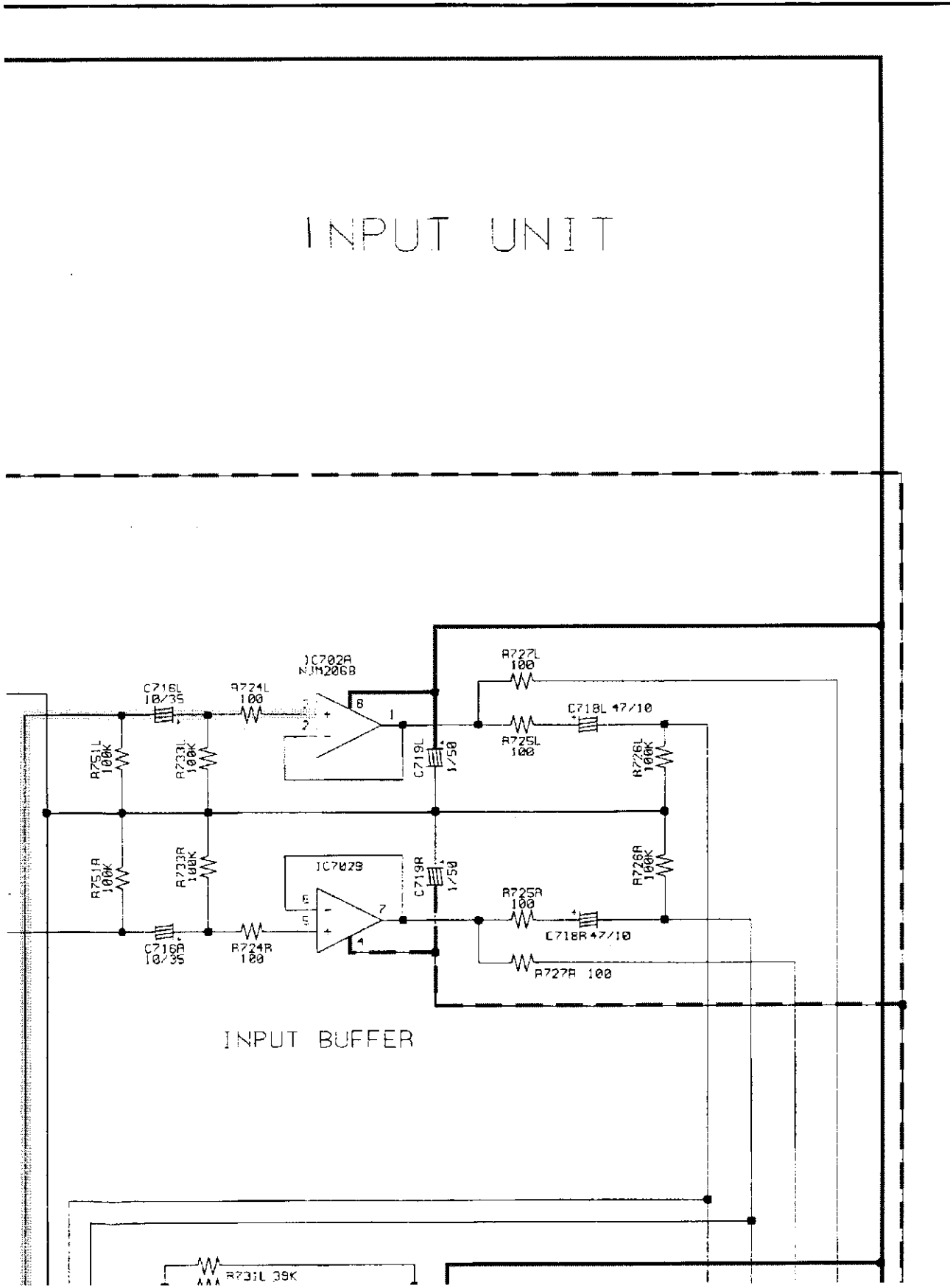

PRE OUT UNIT

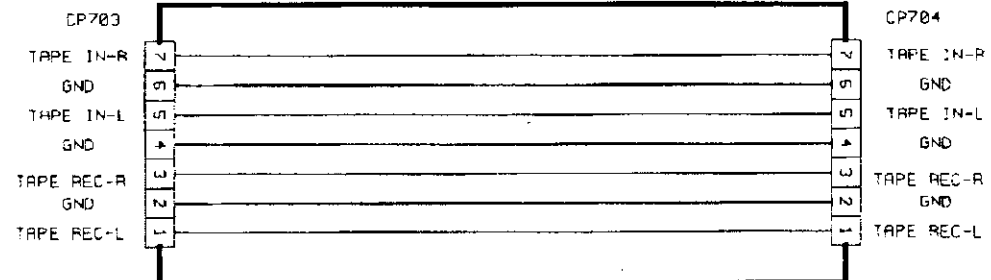
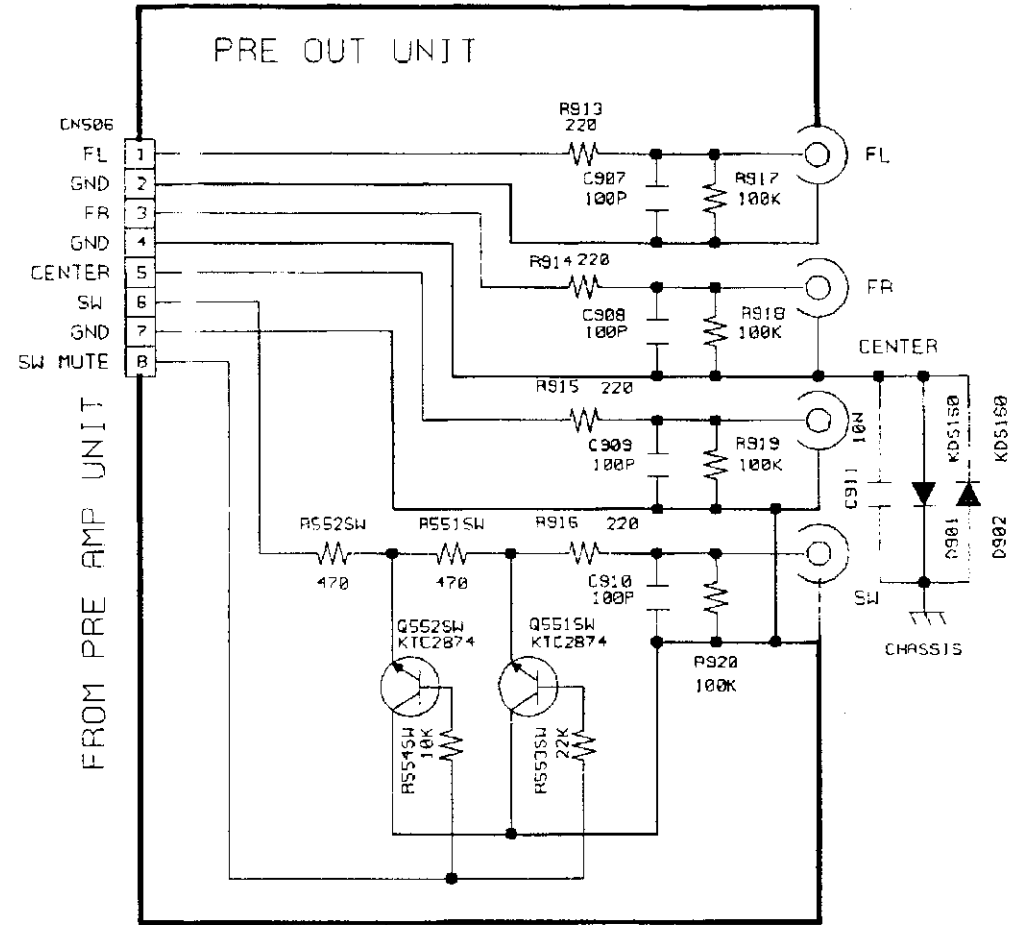

TUNER

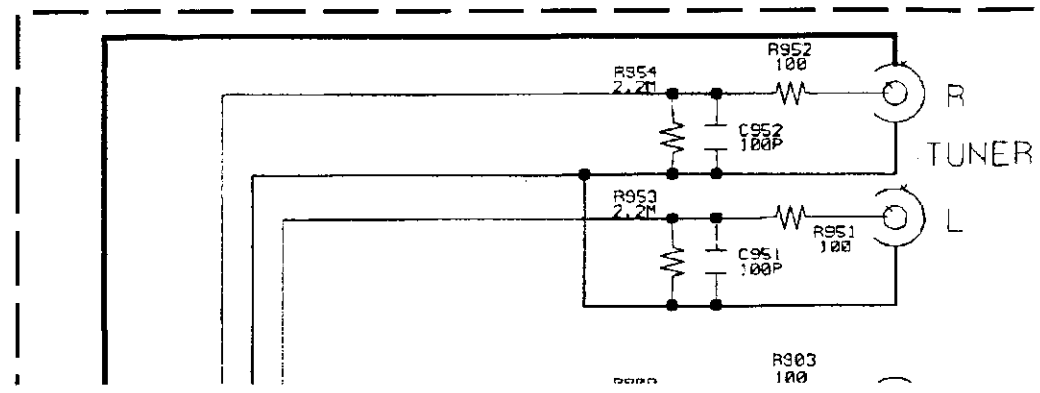

A

B

C

D

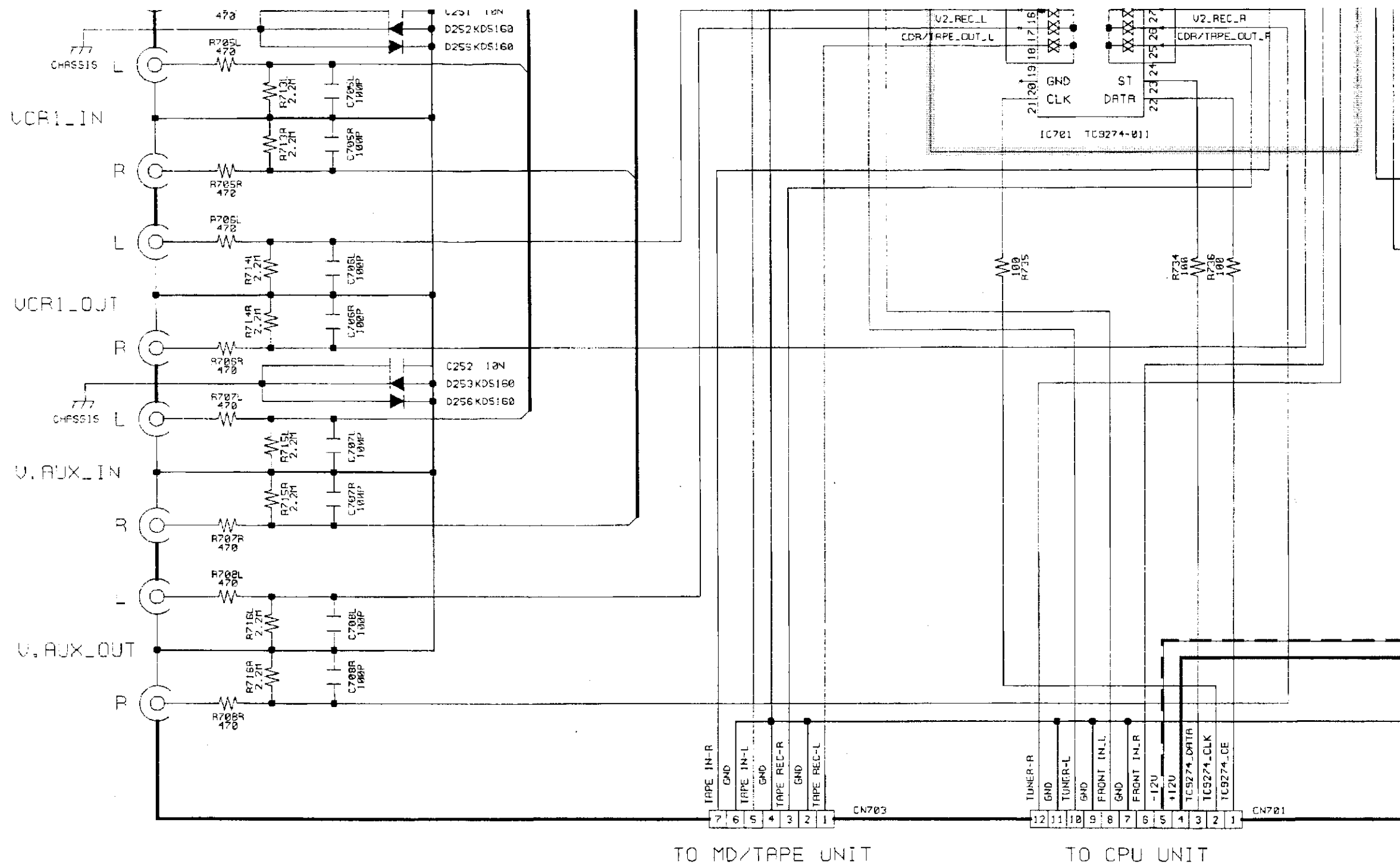

NOTICE
 ALL RESISTANCE VAL
 ALL CAPACITANCE VA
 EACH VOLTAGE AND C
 CONDITION.
 CIRCUIT AND PARTS A
 NOTICE.

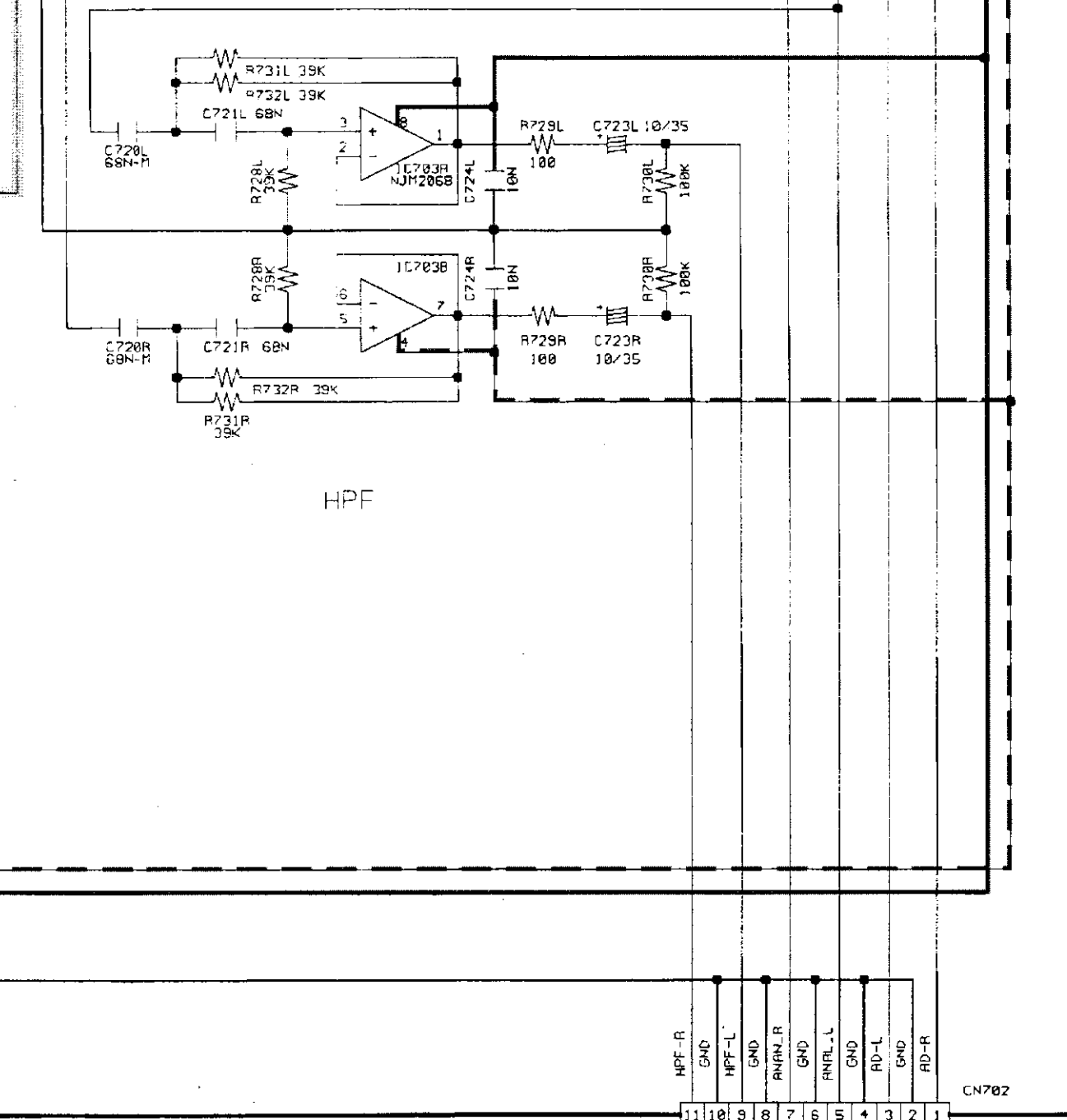

TO CPU UNIT

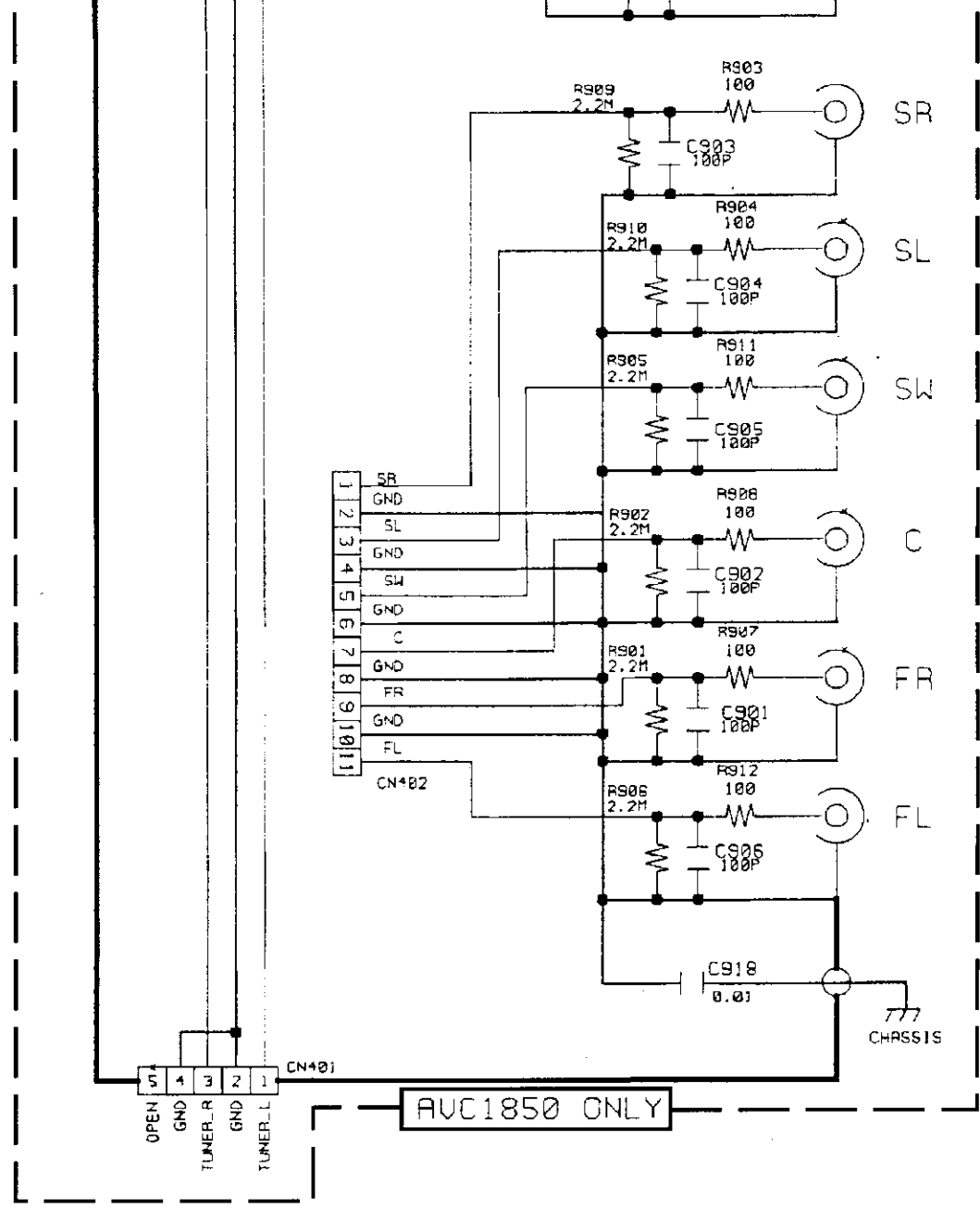

————— + B LINE
 - - - - - - - - - - B LINE
 SIGNAL LINE

SCHEMATIC DIAGRAMS (1/8)
 INPUT UNIT
 CDR-CNT UNIT
 PRE OUT UNIT

WARNING:
 Parts marked with this symbol  have critical characteristics.
 Use ONLY replacement parts recommended by the manufacture.

CAUTION:
 Before returning the unit to the customer, make sure you make either (1) a leakage current check or (2) a line to chassis resistance check. If the leakage current exceeds 0.5 milliamps, or if the resistance from chassis to either side of the power card is less than 460kohms, the unit is defective.

WARNING:
 DO NOT return the unit to the customer until the problem is located and corrected.

CE VALUES IN OHM. k=1,000 OHM M=1,000,000 OHM
 NCE VALUES IN MICRO FARAD. P=MICRO-MICRO FARAD
 E AND CURRENT ARE MEASUERD AT MO SIGNAL INPUT

PARTS ARE SUBJECT TO CHANGE WITHOUT PRIOR

E
F
G
H

SCHEMATIC DIAGRAMS (2/8)

1 2 3 4 5 6 7 8 9 10 11

| | | |
|---------------------------|---------|--------------|
| | IC812 | IC833 |
| -N | CS49329 | W24L257AJ-12 |
| E3, E2, E1, E1H, E1T, E1C | CS49326 | |

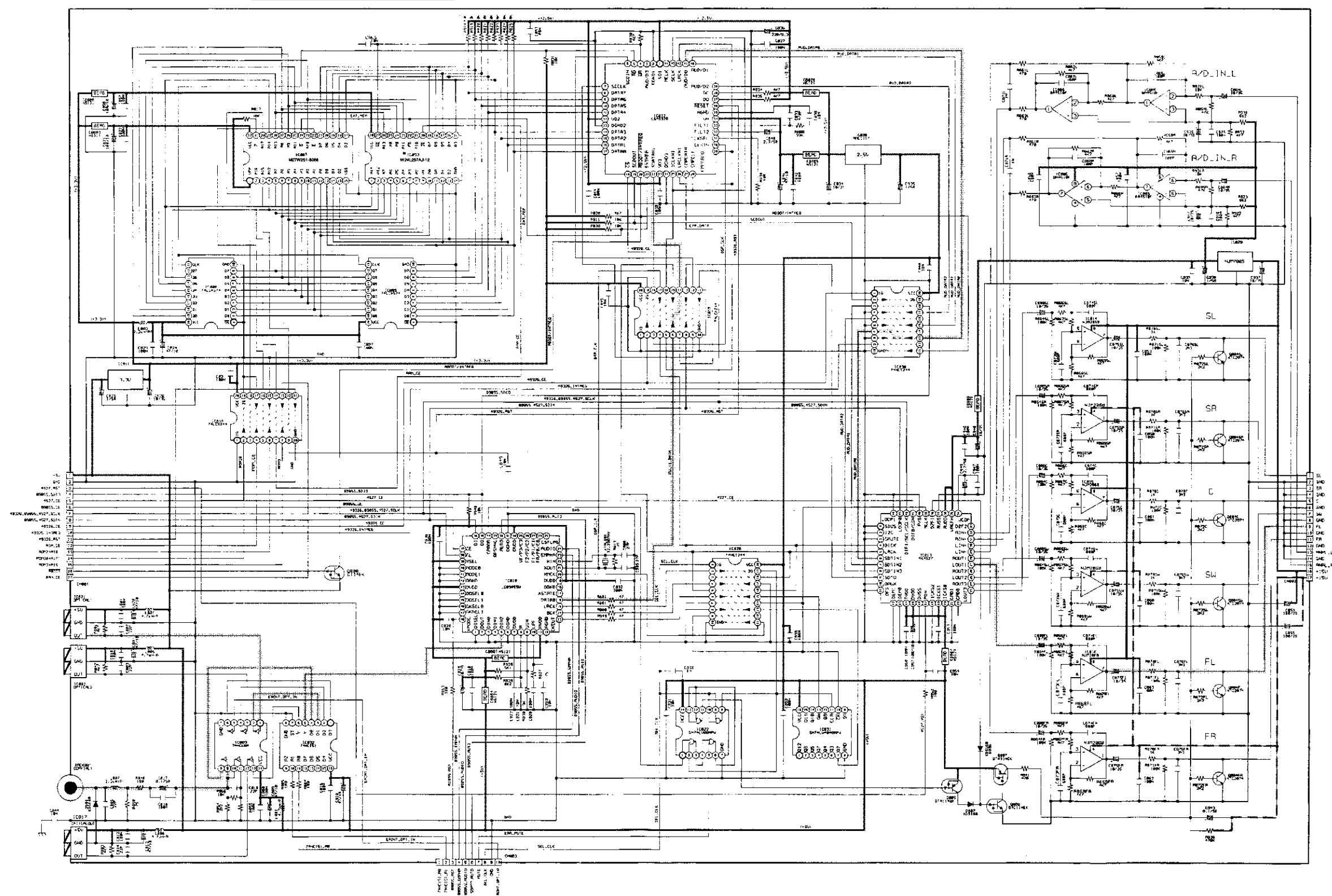

150
151
152
153
154
155
156
157
158
159
160
161
162
163
164
165
166
167
168
169
170
171
172
173
174
175
176
177
178
179
180
181
182
183
184
185
186
187
188
189
190
191
192
193
194
195
196
197
198
199
200

A
B
C
D
E
F
G
H

— + B LINE
 - - - - - B LINE
 ·········· SIGNAL LINE

WARNING:
 Parts marked with this symbol Δ have critical characteristics.
 Use ONLY replacement parts recommended by the manufacture.

CAUTION:
 Before returning the unit to the customer, make sure you make either (1) a leakage current check or (2) a line to chassis resistance check. If the leakage current exceeds 0.5 millamps, or if the resistance from chassis to either side of the power card is less than 460kohms, the unit is defective.

WARNING:
 DO NOT return the unit to the customer until the problem is located and corrected.

NOTICE
 ALL RESISTANCE VALUES IN OHM. k=1,000 OHM M=1,000,000 OHM
 ALL CAPACITANCE VALUES IN MICRO FARAD. P=MICRO-MICRO FARAD
 EACH VOLTAGE AND CURRENT ARE MEASURED AT NO SIGNAL INPUT CONDITION.
 CIRCUIT AND PARTS ARE SUBJECT TO CHANGE WITHOUT PRIOR NOTICE.

SCHEMATIC DIAGRAMS (2/8)
 DSP UNIT

SCHEMATIC DIAGRAMS (2/8)

1

2

3

4

5

6

| | | |
|---------------------------|---------|--------------|
| | IC812 | IC833 |
| - N | CS49329 | W24L257AJ-12 |
| E3, E2, E1, E1H, E1T, E1C | CS49326 | |

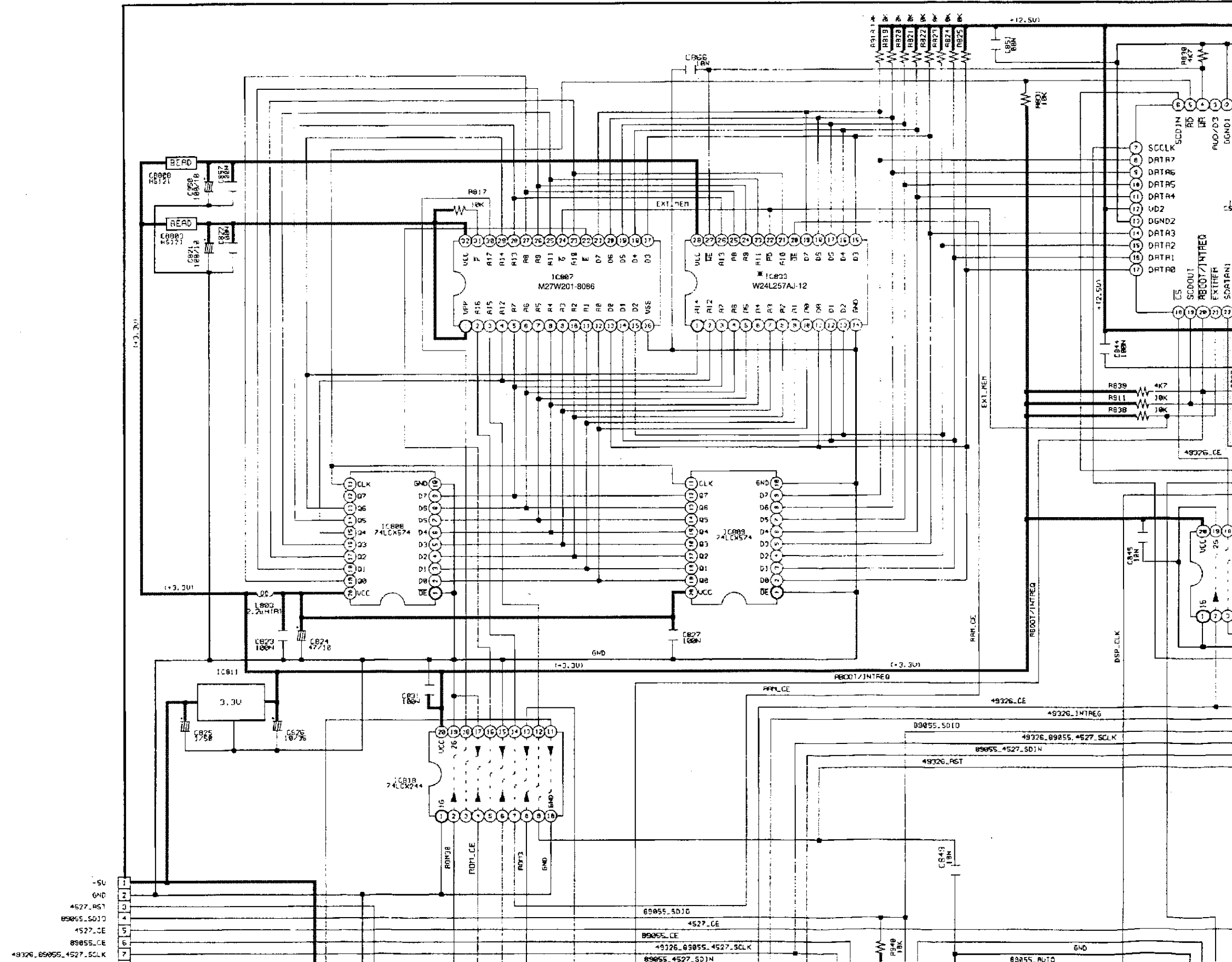

6

7

8

9

10

11

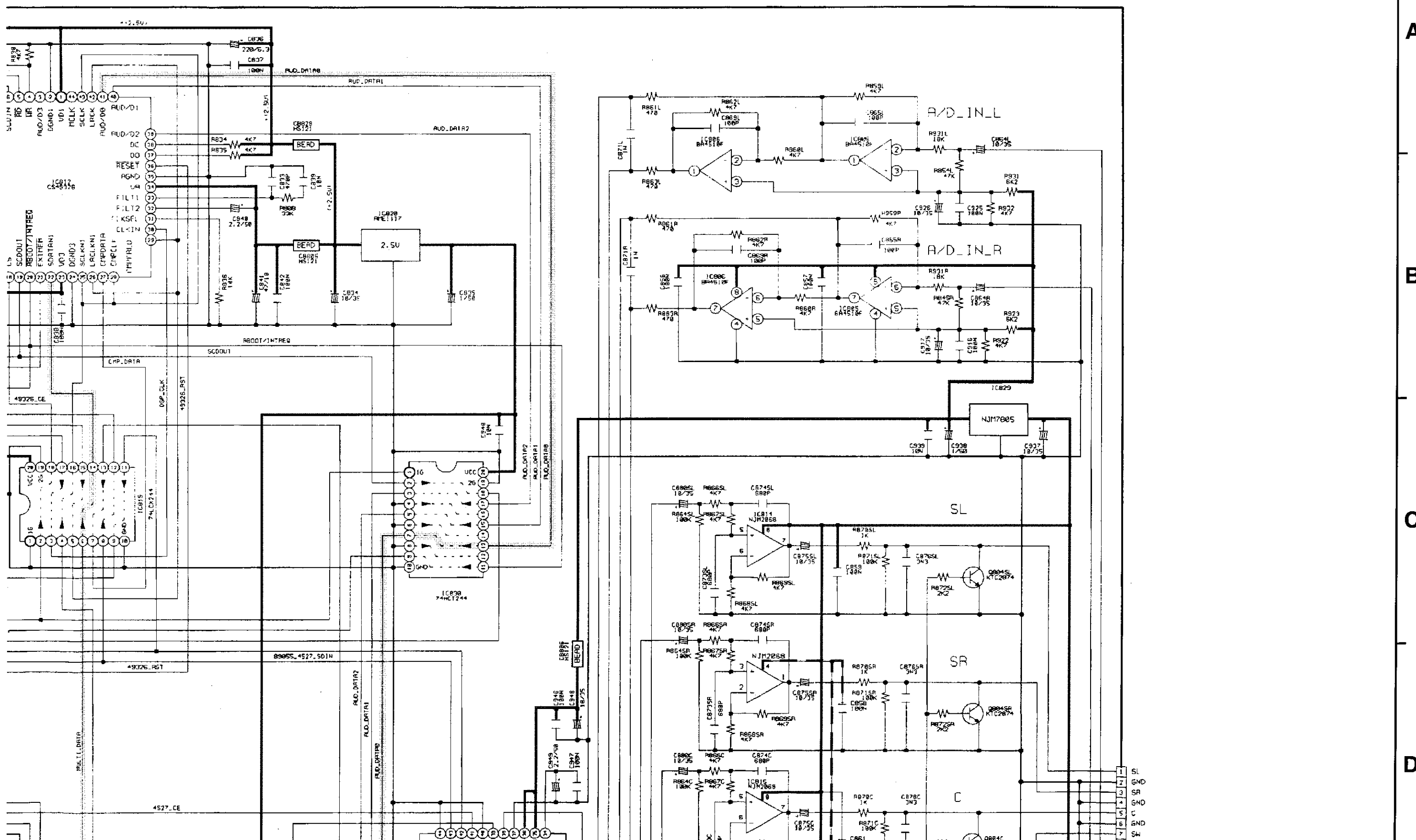

A

B

C

D

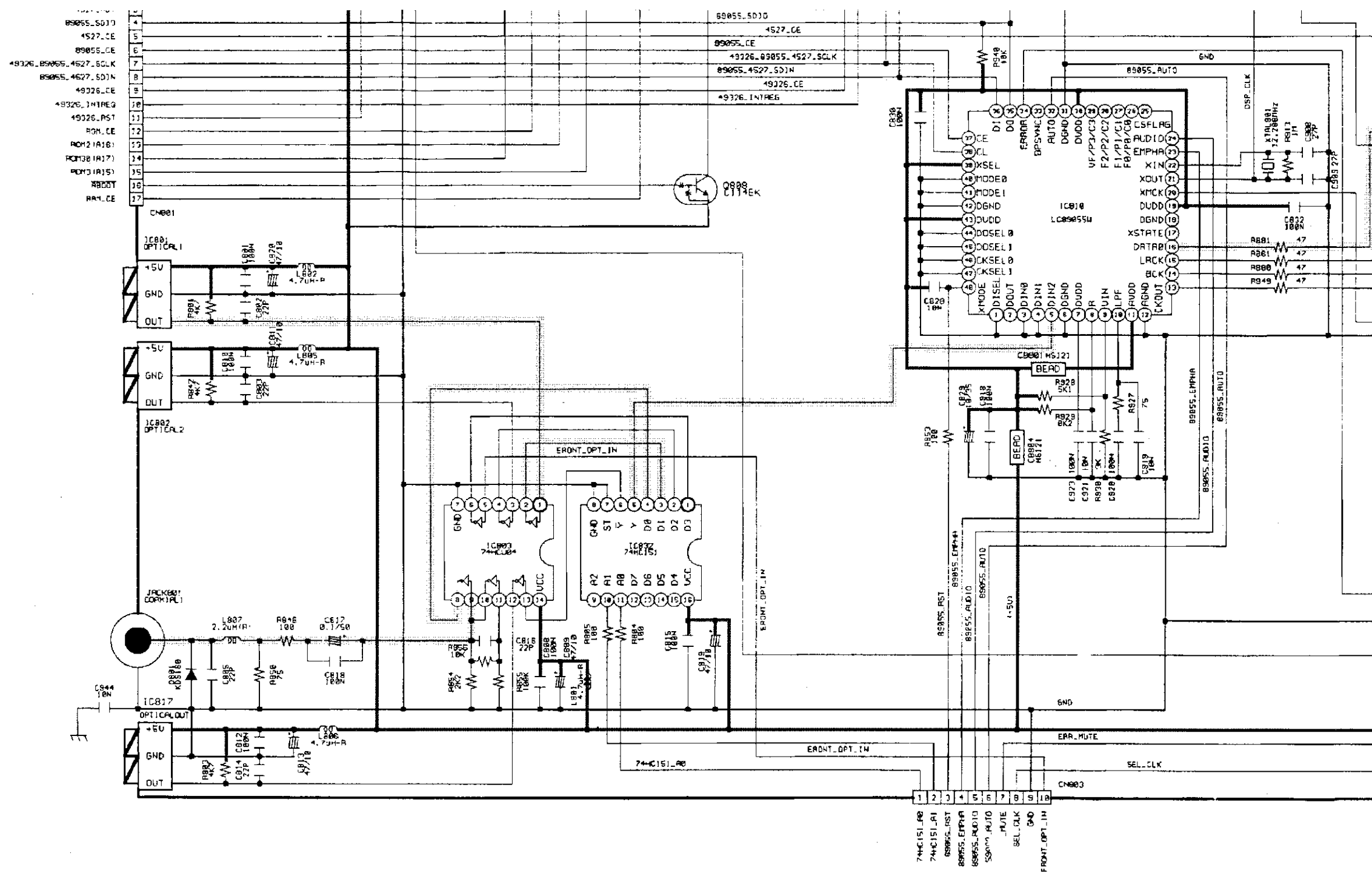

NOTICE
 ALL RESISTANCE VALUES
 ALL CAPACITANCE VALUES
 EACH VOLTAGE AND CURRENT
 CONDITION.
 CIRCUIT AND PARTS ARE
 NOTICE.

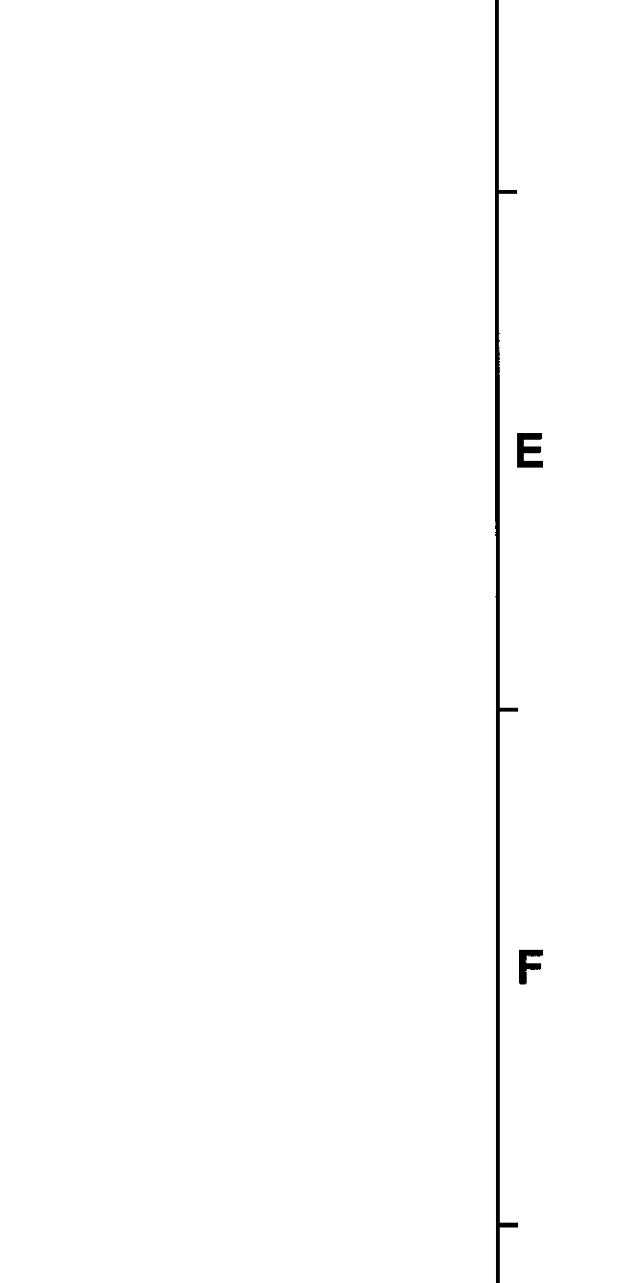
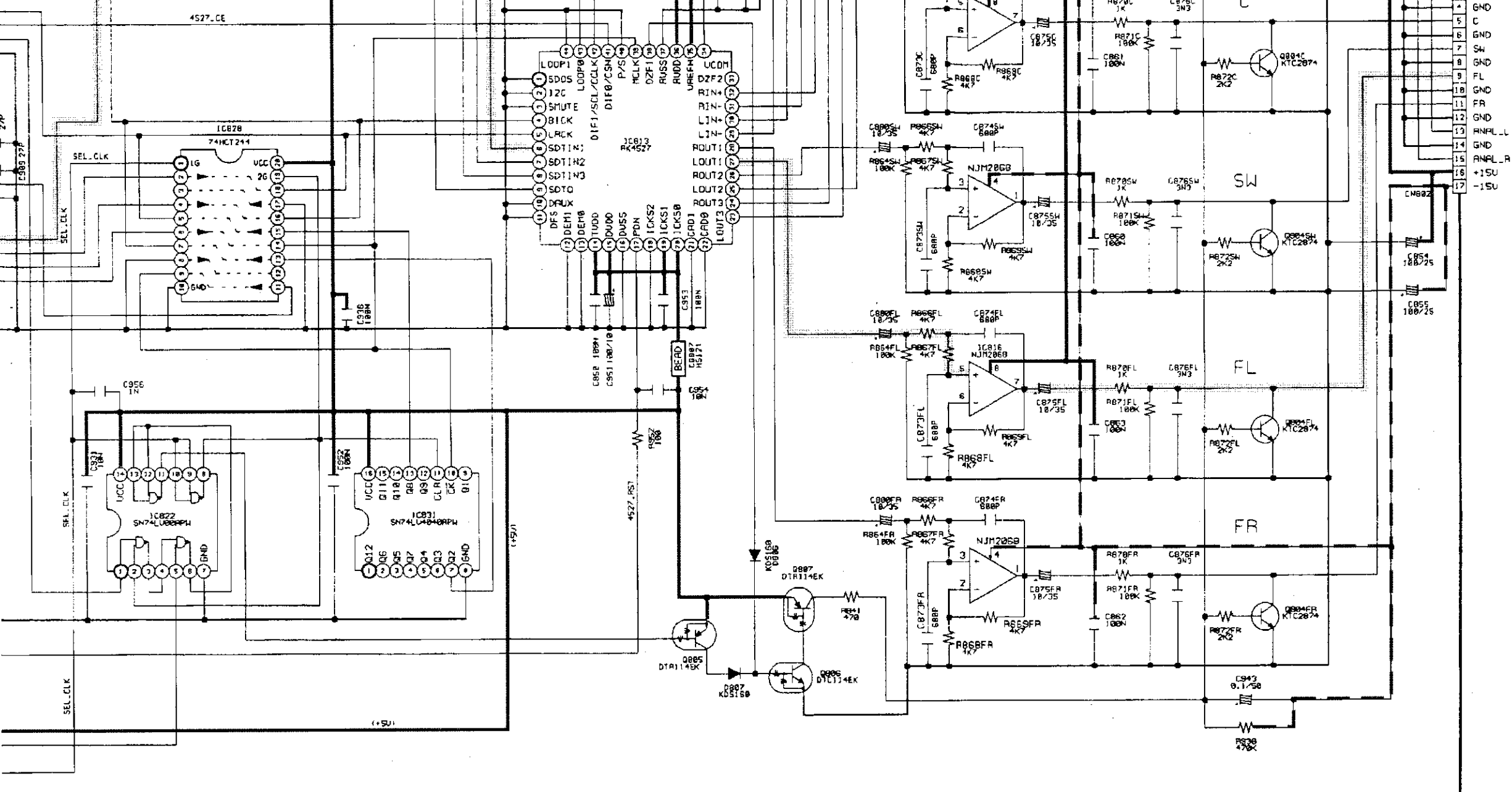

WARNING:

Parts marked with this symbol have critical characteristics. Use ONLY replacement parts recommended by the manufacture.

CAUTION:

Before returning the unit to the customer, make sure you make either (1) a leakage current check or (2) a line to chassis resistance check. If the leakage current exceeds 0.5 milliamps, or if the resistance from chassis to either side of the power card is less than 460kohms, the unit is defective.

WARNING:

DO NOT return the unit to the customer until the problem is located and corrected.

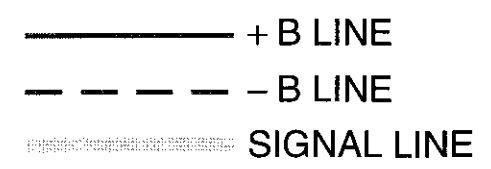

**SCHEMATIC DIAGRAMS (2/8)
DSP UNIT**

CE VALUES IN OHM. k=1,000 OHM M=1,000,000 OHM
NCE VALUES IN MICRO FARAD. P=MICRO-MICRO FARAD
E AND CURRENT ARE MEASURED AT MO SIGNAL INPUT

PARTS ARE SUBJECT TO CHANGE WITHOUT PRIOR

E
F
G
H

SCHEMATIC DIAGRAMS (3/8)

1 2 3 4 5 6 7 8 9 10 11

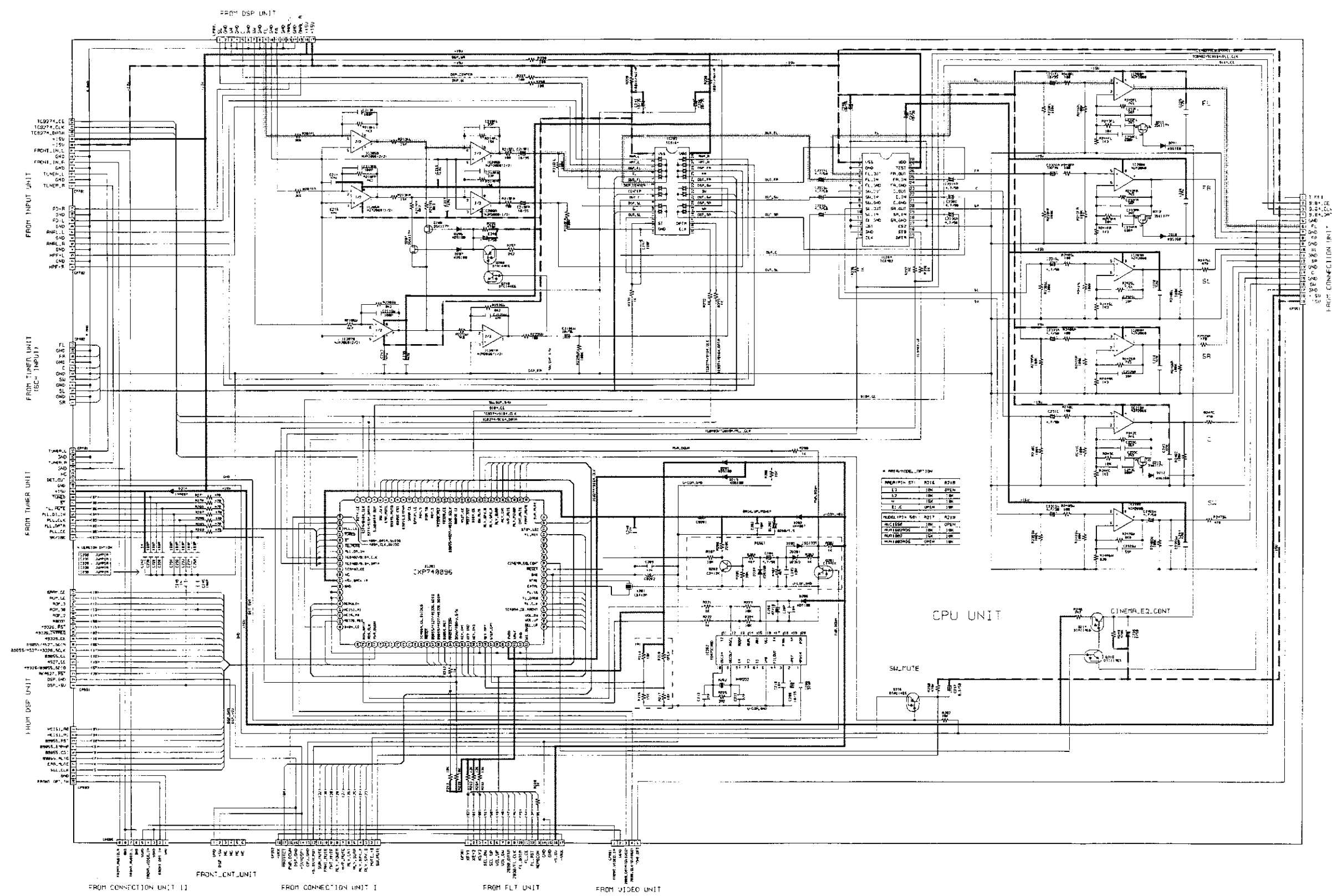

RESISTOR VALUE LIST

| RESISTOR NO. | VALUE | RESISTOR NO. | VALUE |
|--------------|-------|--------------|-------|
| R1 | 10K | R10 | 10K |
| R2 | 10K | R11 | 10K |
| R3 | 10K | R12 | 10K |
| R4 | 10K | R13 | 10K |
| R5 | 10K | R14 | 10K |
| R6 | 10K | R15 | 10K |
| R7 | 10K | R16 | 10K |
| R8 | 10K | R17 | 10K |
| R9 | 10K | R18 | 10K |

NOTICE
 ALL RESISTANCE VALUES IN OHM, k=1,000 OHM M=1,000,000 OHM
 ALL CAPACITANCE VALUES IN MICRO FARAD, P=MICRO-MICRO FARAD
 EACH VOLTAGE AND CURRENT ARE MEASURED AT MO SIGNAL INPUT CONDITION.
 CIRCUIT AND PARTS ARE SUBJECT TO CHANGE WITHOUT PRIOR NOTICE.

WARNING:
 Parts marked with this symbol Δ have critical characteristics.
 Use ONLY replacement parts recommended by the manufacture.

CAUTION:
 Before returning the unit to the customer, make sure you make either (1) a leakage current check or (2) a line to chassis resistance check. If the leakage current exceeds 0.5 millamps, or if the resistance from chassis to either side of the power card is less than 460kohms, the unit is defective.

WARNING:
 DO NOT return the unit to the customer until the problem is located and corrected.

SCHEMATIC DIAGRAMS (3/8)
CPU UNIT

SCHEMATIC DIAGRAMS (3/8)

1

2

3

4

5

6

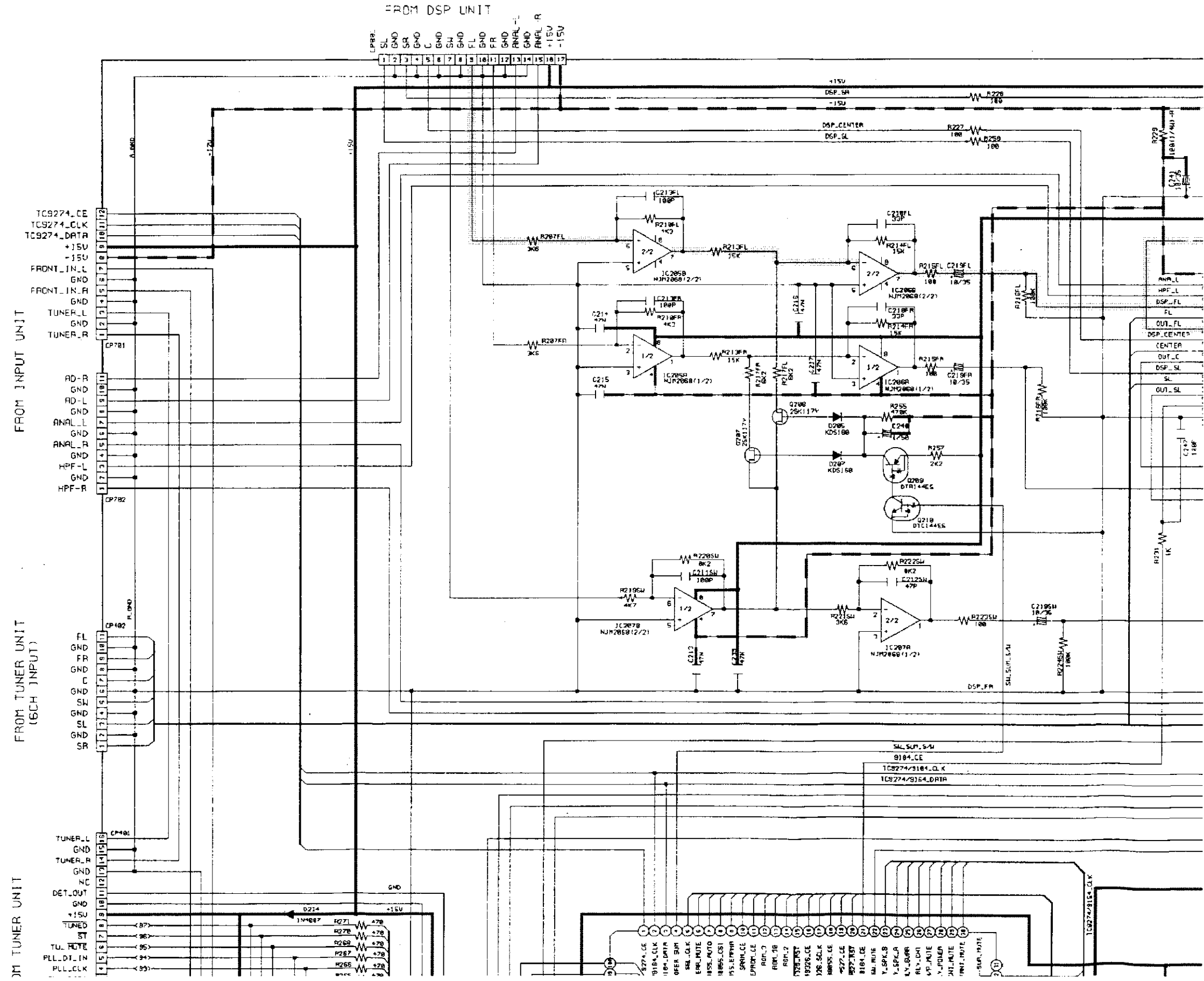

6 7 8 9 10 11

A
B
C
D

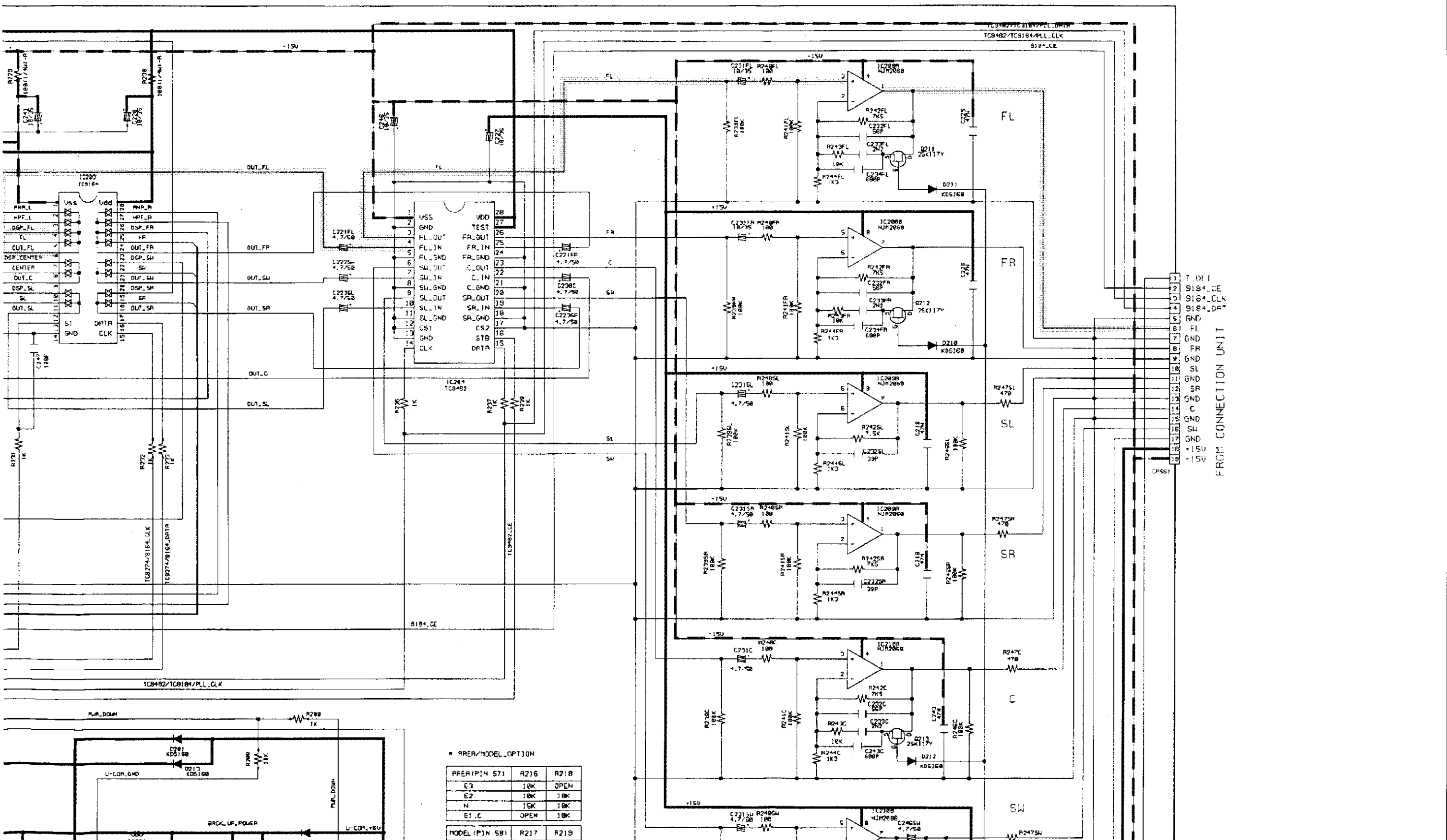

■ ARER/MODEL_OPTION

| | | |
|---------------|------|------|
| ARER (PIN 57) | R216 | R218 |
| E3 | 10K | OPEN |
| E2 | 10K | 10K |
| N | 10K | 10K |
| E3.C | OPEN | 10K |

| | | |
|----------------|------|------|
| MODEL (PIN 58) | R217 | R219 |
|----------------|------|------|

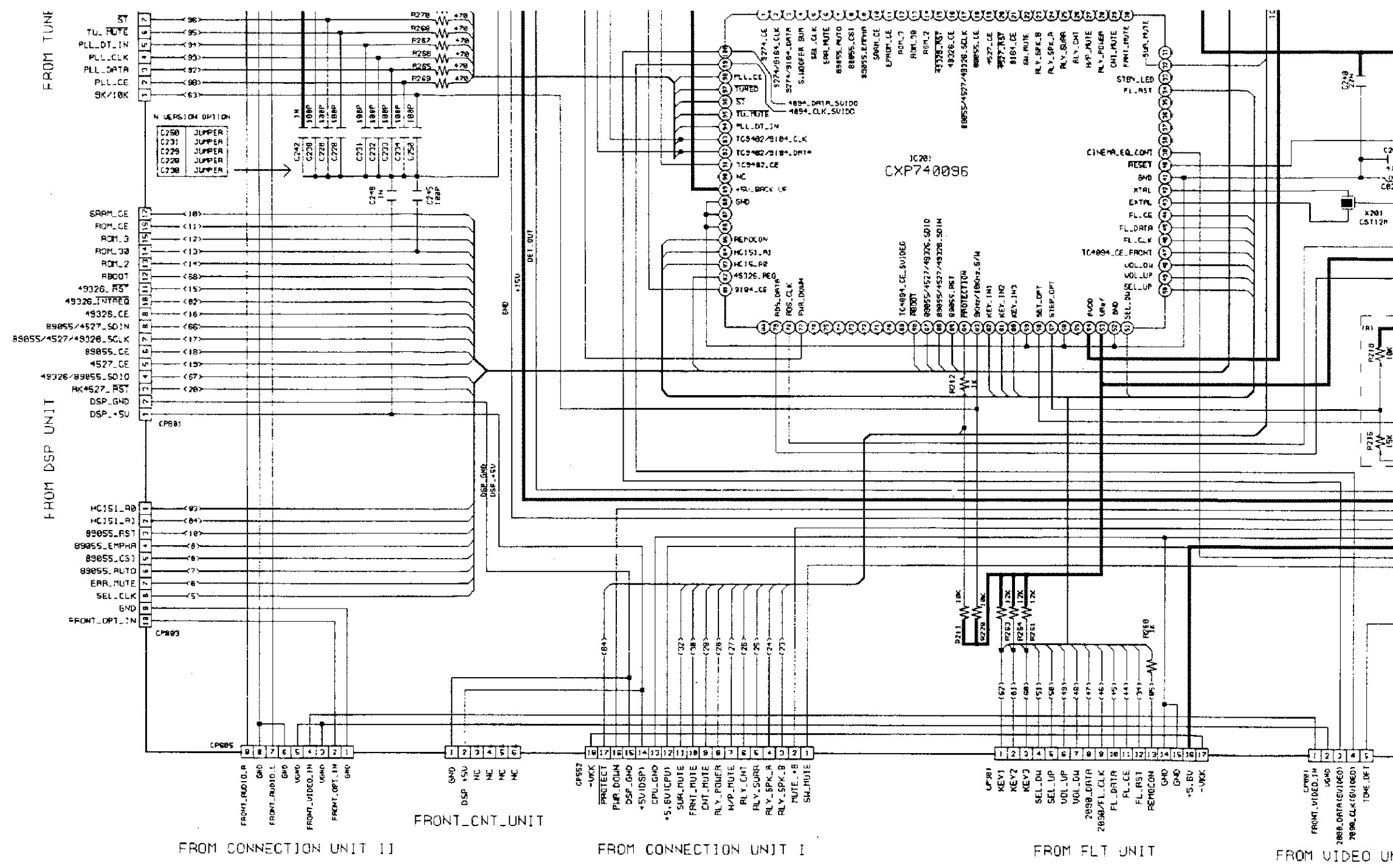

NOTICE
 ALL RESISTANCE VAL
 ALL CAPACITANCE VA
 EACH VOLTAGE AND
 CONDITION.
 CIRCUIT AND PARTS
 NOTICE.

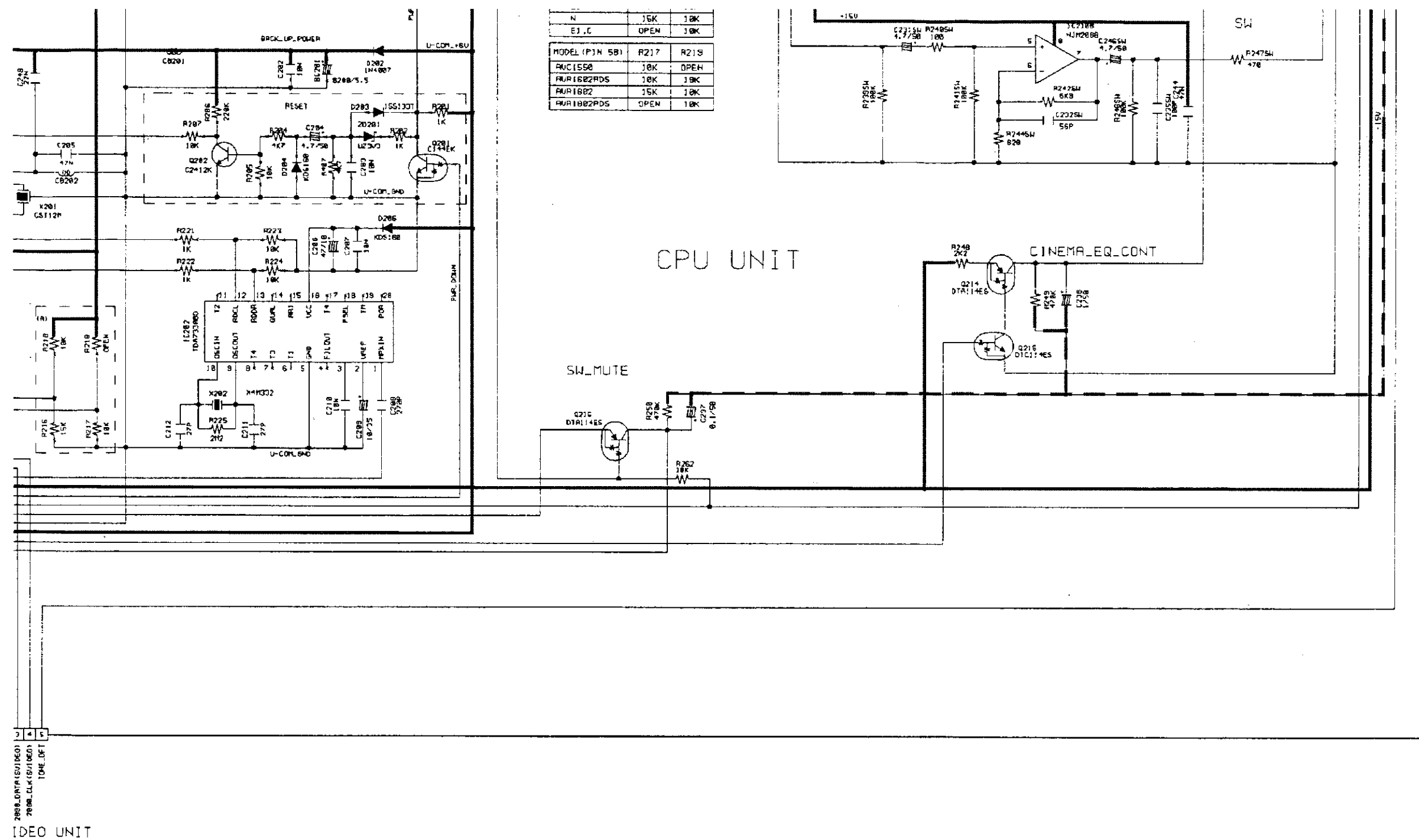

WARNING:

Parts marked with this symbol  have critical characteristics. Use ONLY replacement parts recommended by the manufacture.

CAUTION:

Before returning the unit to the customer, make sure you make either (1) a leakage current check or (2) a line to chassis resistance check. If the leakage current exceeds 0.5 milliamps, or if the resistance from chassis to either side of the power card is less than 460kohms, the unit is defective.

WARNING:

DO NOT return the unit to the customer until the problem is located and corrected.

**SCHEMATIC DIAGRAMS (3/8)
CPU UNIT**

SCHEMATIC DIAGRAMS (4/8)

1 2 3 4 5 6 7 8 9 10 11

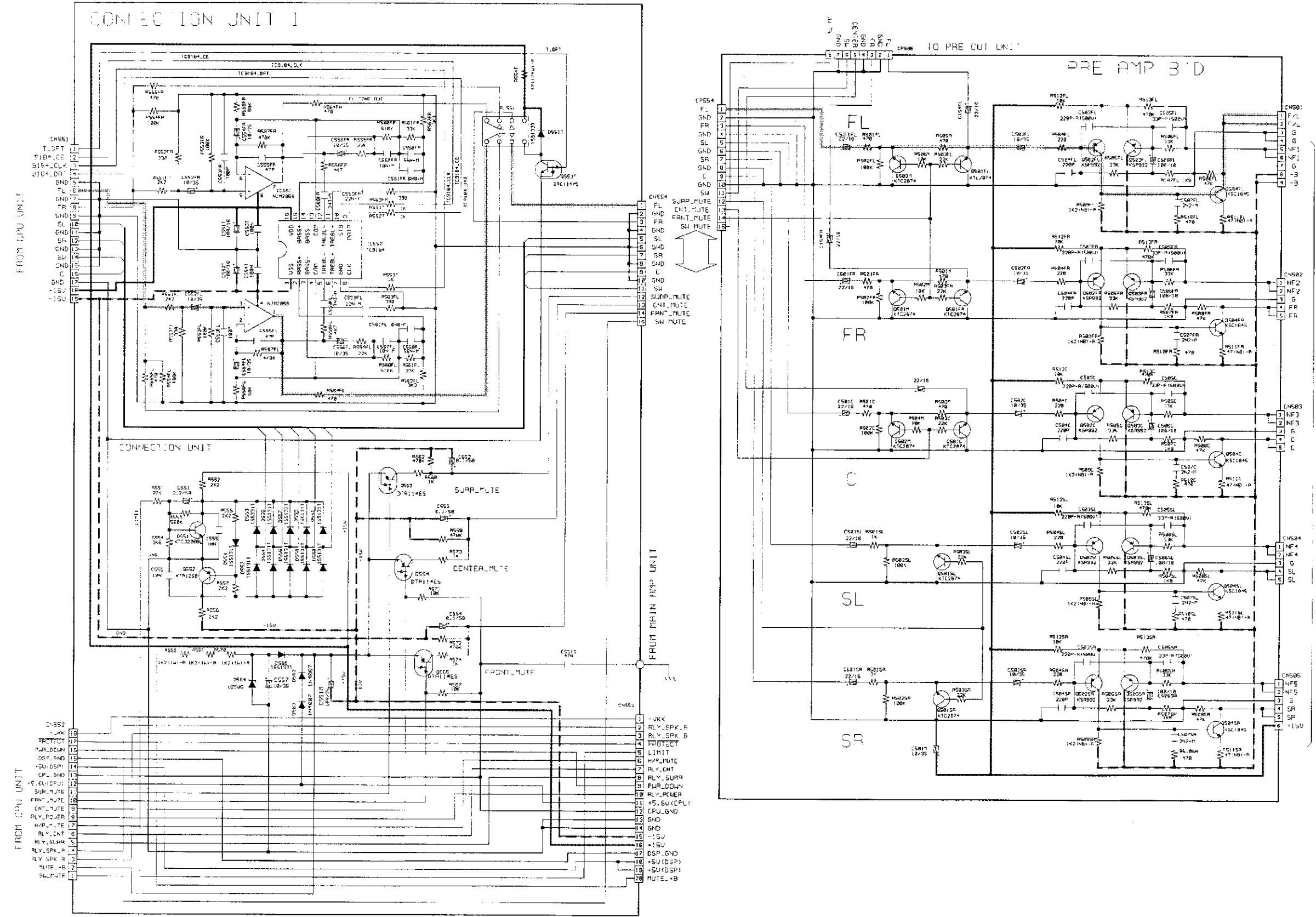

FROM CPU UNIT

FROM CPU UNIT

FROM MAIN AMP UNIT

TO MAIN AMP UNIT

CH551
 T_CPT
 S1B4_CLK
 S1B4_DR
 GND
 FL
 FR
 SL
 SR
 C
 GND
 +5V
 +15V

CH552
 +VCC
 PROTECT
 SUPR_MUTE
 DSP_GND
 CPU_GND
 +5V(DSP)
 SUPR_MUTE
 FRNT_MUTE
 CNT_MUTE
 RLY_POWER
 RLY_ENT
 RLY_SLGM
 RLY_SPK_A
 RLY_SPK_B
 MUTE_B
 SUPR_MUTE

CH553
 +VCC
 PROTECT
 SUPR_MUTE
 DSP_GND
 CPU_GND
 +5V(DSP)
 SUPR_MUTE
 FRNT_MUTE
 CNT_MUTE
 RLY_POWER
 RLY_ENT
 RLY_SLGM
 RLY_SPK_A
 RLY_SPK_B
 MUTE_B
 SUPR_MUTE

CH554
 FL
 FR
 GND
 SL
 SR
 C
 GND
 +5V
 +15V

CH555
 +VCC
 RLY_SPK_A
 RLY_SPK_B
 PROTECT
 LIMIT
 MUTE_B
 RLY_ENT
 RLY_SLGM
 RLY_SPK_A
 RLY_SPK_B
 +5V(DSP)
 +5V(DSP)
 MUTE_B

NOTICE
 ALL RESISTANCE VALUES IN OHM. k=1,000 OHM M=1,000,000 OHM
 ALL CAPACITANCE VALUES IN MICRO FARAD. P=MICRO-MICRO FARAD
 EACH VOLTAGE AND CURRENT ARE MEASURED AT MO SIGNAL INPUT
 CONDITION.
 CIRCUIT AND PARTS ARE SUBJECT TO CHANGE WITHOUT PRIOR
 NOTICE.

WARNING:
 Parts marked with this symbol Δ have critical characteristics.
 Use ONLY replacement parts recommended by the manufacturer.

CAUTION:
 Before returning the unit to the customer, make sure you make either (1) a
 leakage current check or (2) a line to chassis resistance check. If the leakage
 current exceeds 0.5 milliamperes, or if the resistance from chassis to either side
 of the power card is less than 460kohms, the unit is defective.

WARNING:
 DO NOT return the unit to the customer until the problem is located and
 corrected.

——— +B LINE
 - - - -B LINE
 ——— SIGNAL LINE

SCHEMATIC DIAGRAMS (4/8)
 CNT UNIT
 PRE-AMP UNIT

SCHEMATIC DIAGRAMS (4/8)

1

2

3

4

5

6

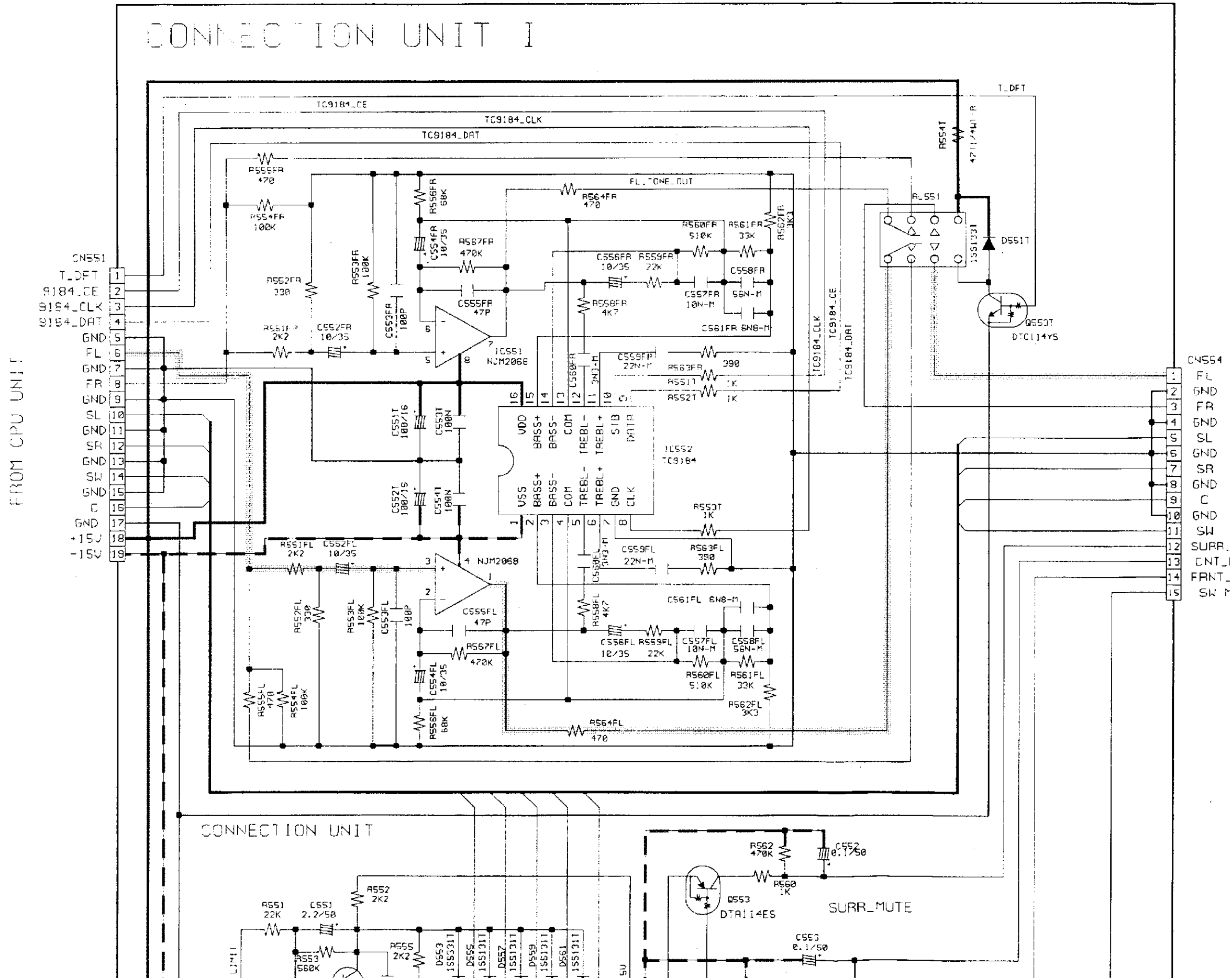

6

7

8

9

10

11

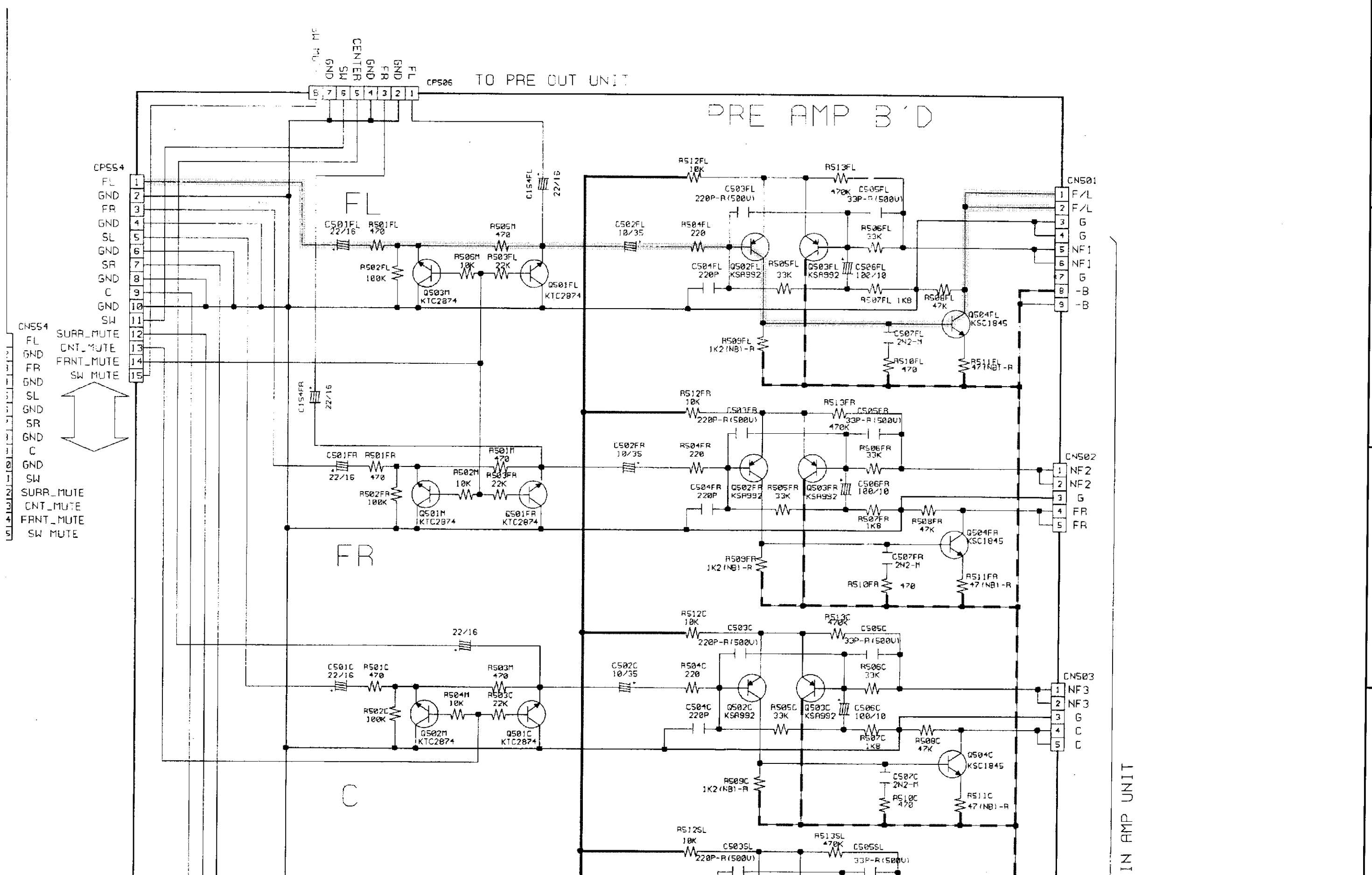

A

B

C

D

AIN AMP UNIT

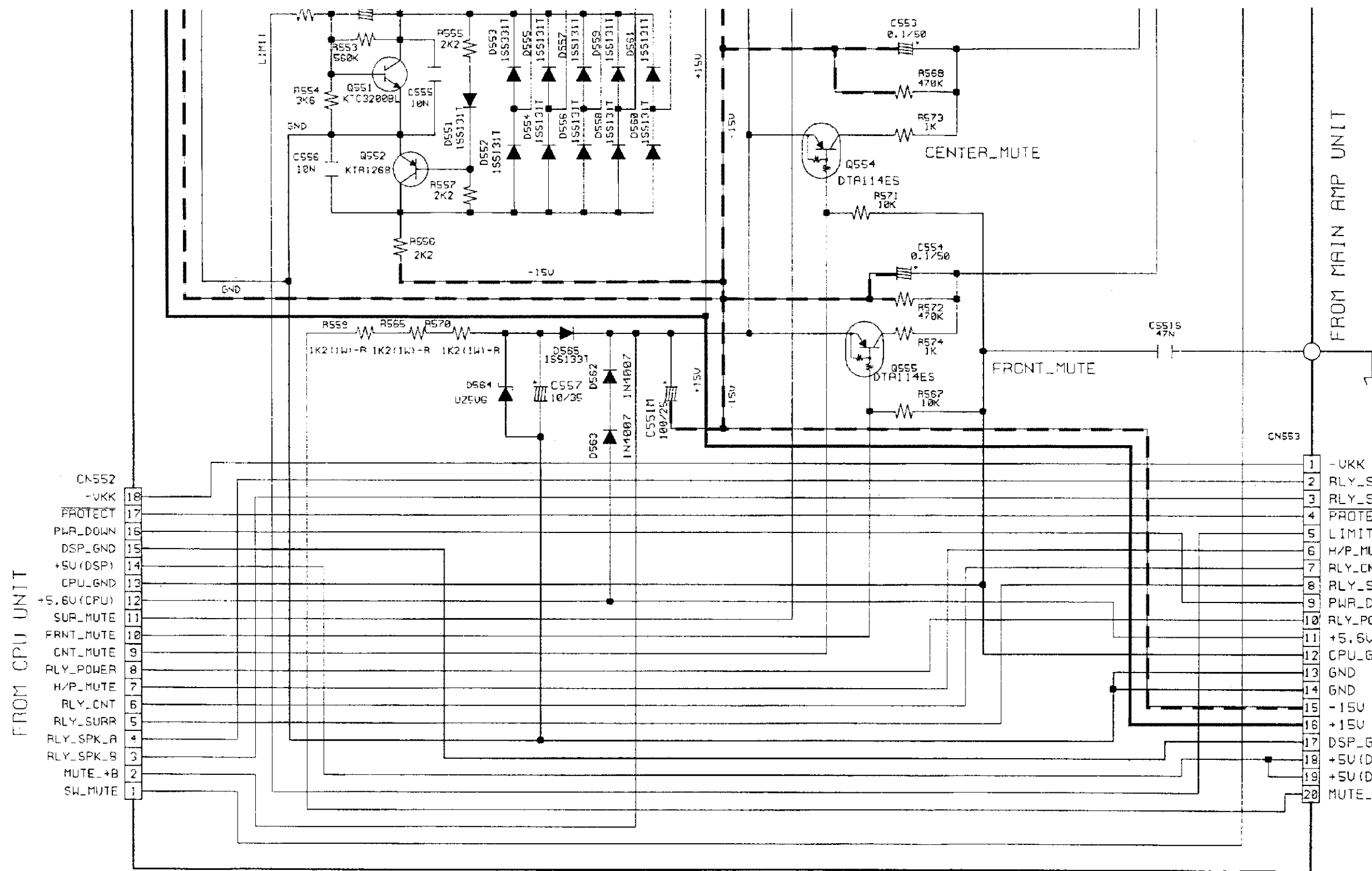

NOTICE
 ALL RESISTANCE VAL
 ALL CAPACITANCE VA
 EACH VOLTAGE AND
 CONDITION.
 CIRCUIT AND PARTS
 NOTICE.

FROM MAIN AMP UNIT

- VKK
- RLY_SPK_A
- RLY_SPK_B
- PROTECT
- LIMIT
- H/P_MUTE
- RLY_CNT
- RLY_SURR
- PWR_DOWN
- RLY_POWER
- +5.6V (CPU)
- CPU_GND
- GND
- GND
- 15V
- +15V
- DSP_GND
- +5V (DSP)
- +5V (DSP)
- MUTE_+B

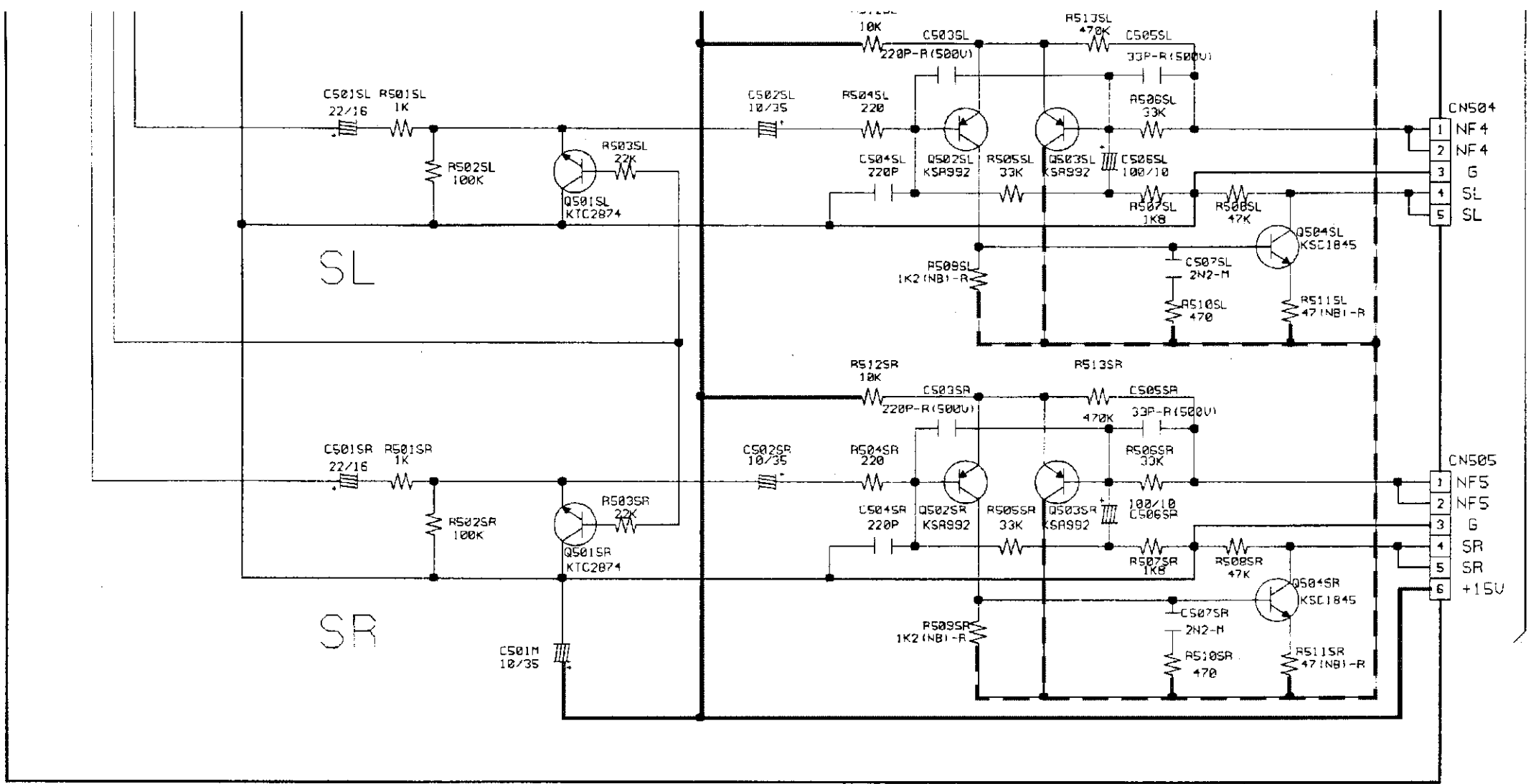

TO MAIN A

E

F

G

H

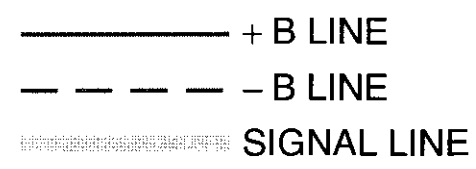

WARNING:
Parts marked with this symbol have critical characteristics. Use ONLY replacement parts recommended by the manufacture.

CAUTION:
Before returning the unit to the customer, make sure you make either (1) a leakage current check or (2) a line to chassis resistance check. If the leakage current exceeds 0.5 milliamps, or if the resistance from chassis to either side of the power card is less than 460kohms, the unit is defective.

WARNING:
DO NOT return the unit to the customer until the problem is located and corrected.

SCHEMATIC DIAGRAMS (4/8)
CNT UNIT
PRE-AMP UNIT

CE VALUES IN OHM. k=1,000 OHM M=1,000,000 OHM
NCE VALUES IN MICRO FARAD. P=MICRO-MICRO FARAD
E AND CURRENT ARE MEASUERD AT MO SIGNAL INPUT

PARTS ARE SUBJECT TO CHANGE WITHOUT PRIOR

SCHEMATIC DIAGRAMS (5/8)

1 2 3 4 5 6 7 8 9 10 11

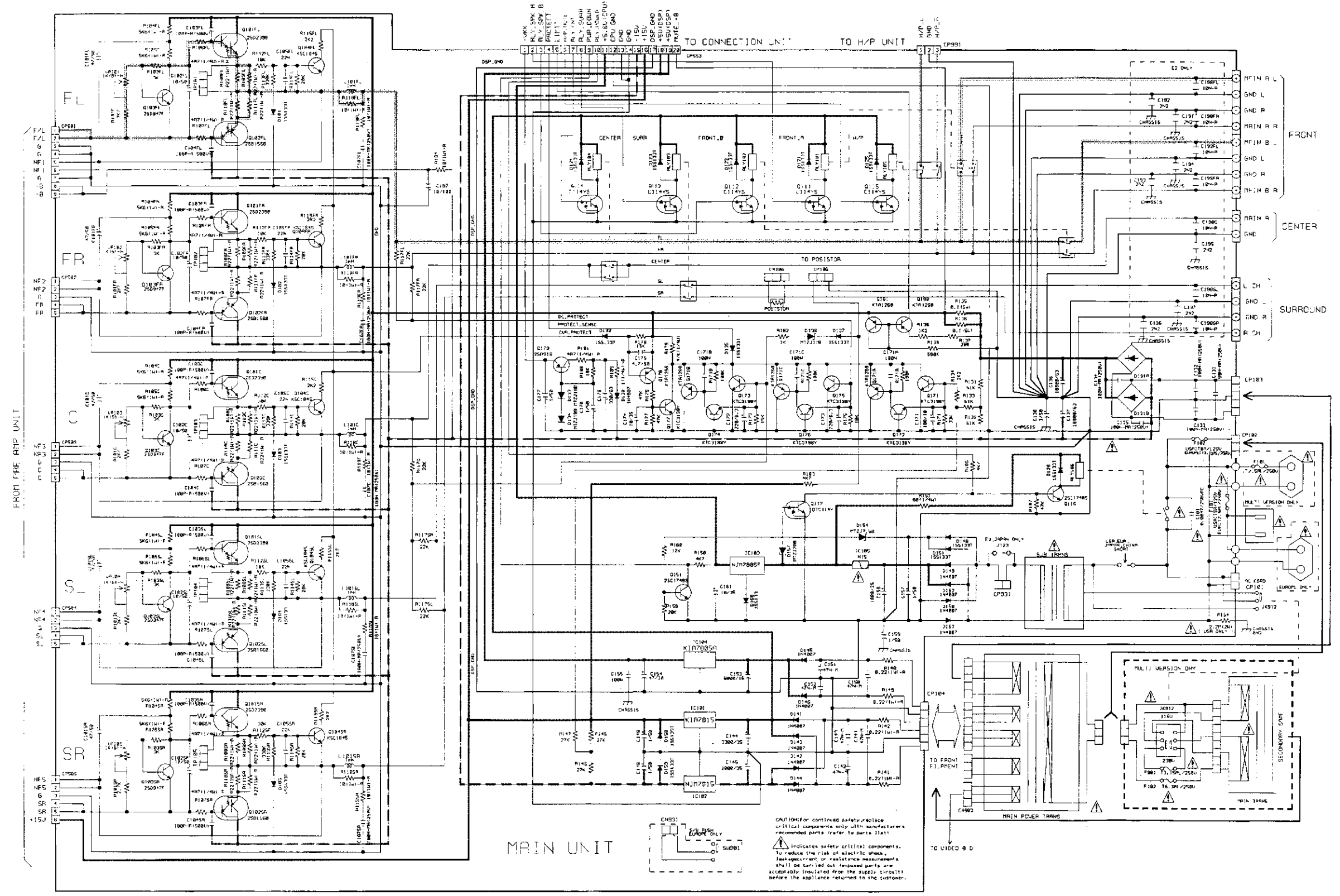

MAIN UNIT

— + B LINE
 - - - - B LINE
 SIGNAL LINE

WARNING:
 Parts marked with this symbol have critical characteristics. Use ONLY replacement parts recommended by the manufacture.

CAUTION:
 Before returning the unit to the customer, make sure you make either (1) a leakage current check or (2) a line to chassis resistance check. If the leakage current exceeds 0.5 milliamps, or if the resistance from chassis to either side of the power card is less than 460kohms, the unit is defective.

WARNING:
 DO NOT return the unit to the customer until the problem is located and corrected.

NOTICE
 ALL RESISTANCE VALUES IN OHM. k=1,000 OHM M=1,000,000 OHM
 ALL CAPACITANCE VALUES IN MICRO FARAD. P=MICRO-MICRO FARAD
 EACH VOLTAGE AND CURRENT ARE MEASURED AT MO SIGNAL INPUT CONDITION.
 CIRCUIT AND PARTS ARE SUBJECT TO CHANGE WITHOUT PRIOR NOTICE.

SCHEMATIC DIAGRAMS (5/8)
 MAIN UNIT
 VOLTAGE UNIT
 OUTLET UNIT

SCHEMATIC DIAGRAMS (5/8)

1

2

3

4

5

6

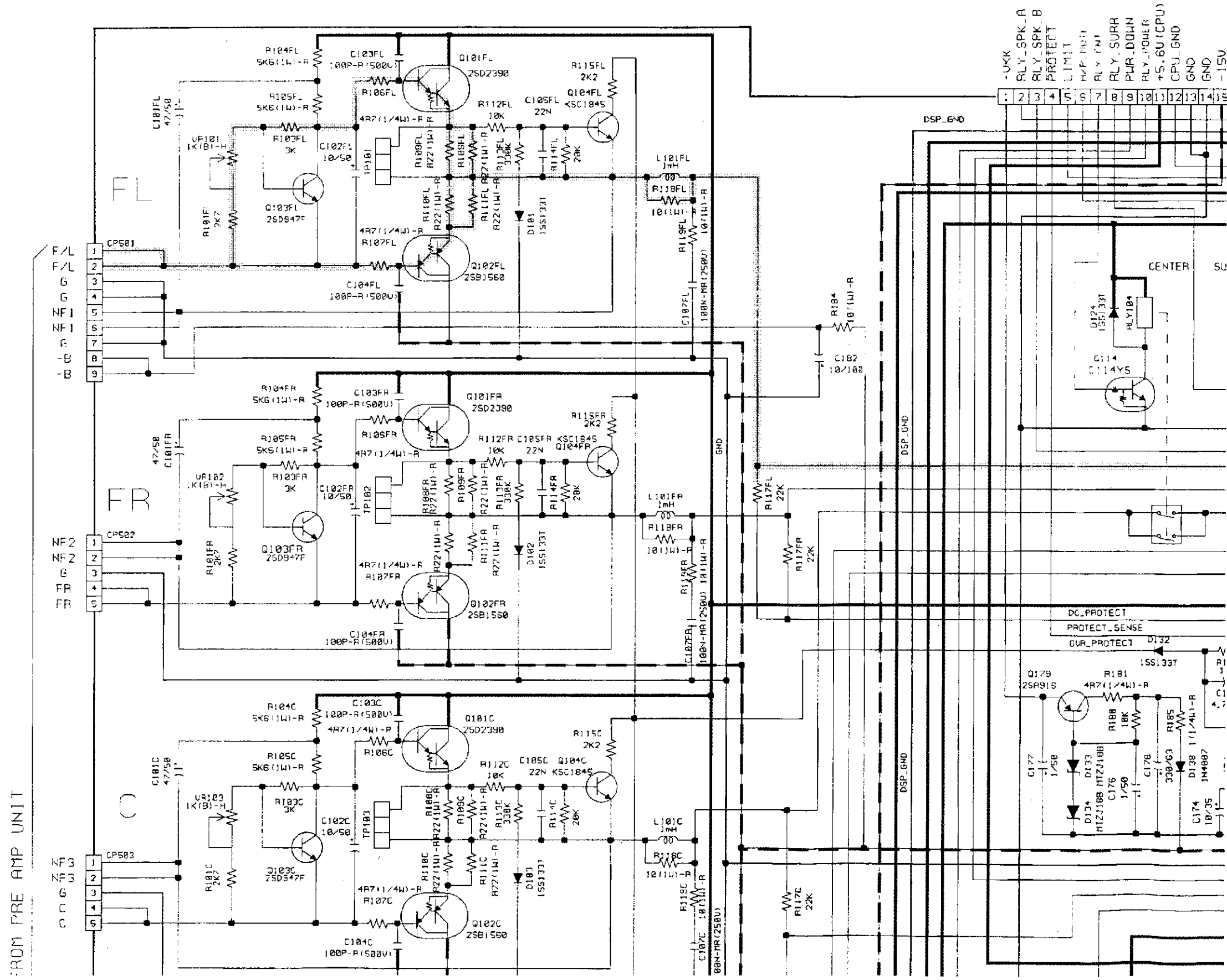

ROM PRE AMP UNIT

6

7

8

9

10

11

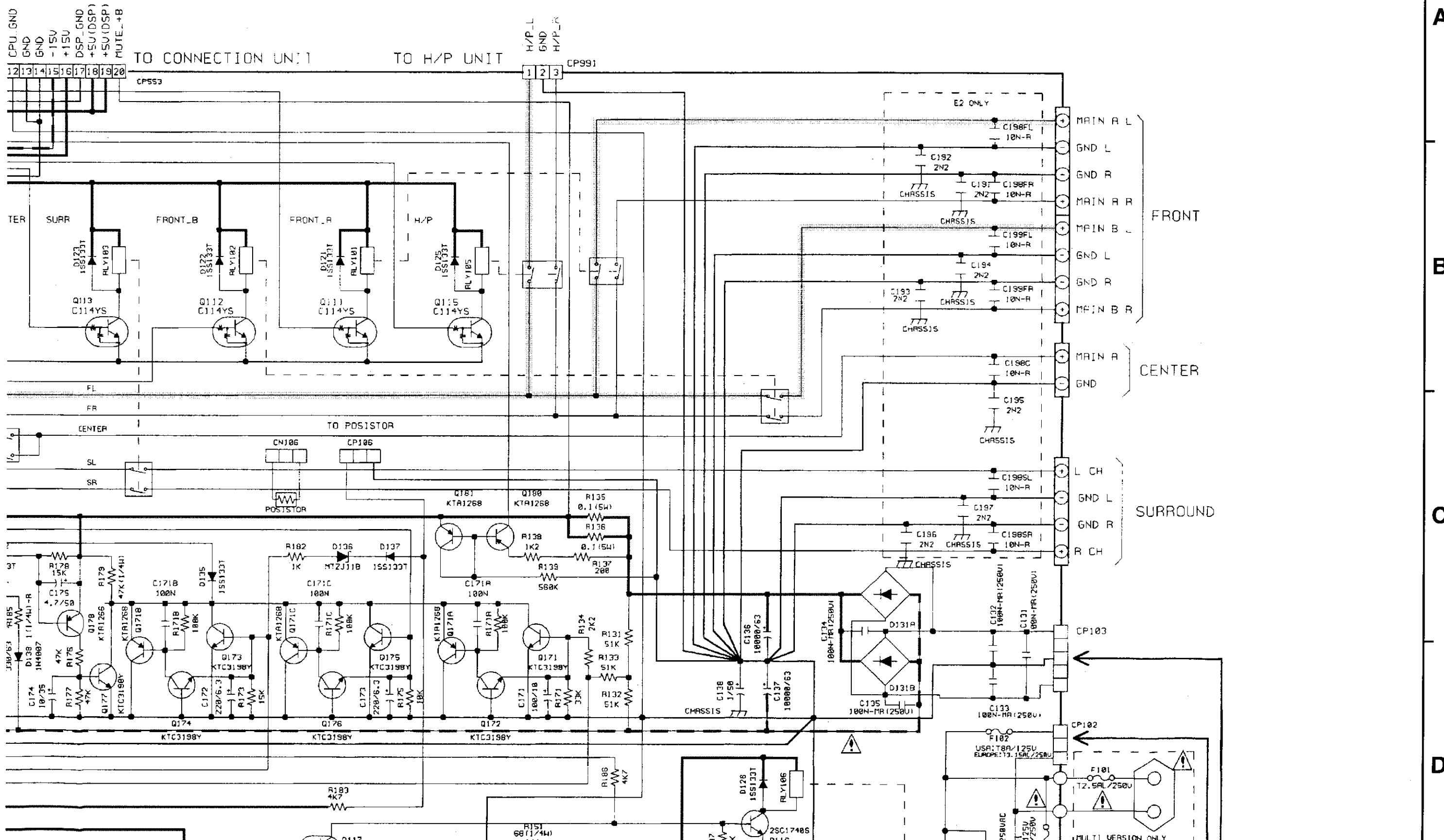

A

B

C

D

CPU_GND
GND
GND
-15V
+15V
DSP_GND
+5U(DSP)
+5U(DSP)
MUTE_+B

TO CONNECTION UNIT

TO H/P UNIT

H/P_L
GND
H/P_R

CP991

E2 ONLY

FRONT

CENTER

SURROUND

CP103

CP102

F102
USA: T8A/125U
EUROPE: 113.15A/250U

F101
T2.5A/250U

250VAC

250VAC

MULTI VERSION ONLY

FROM F

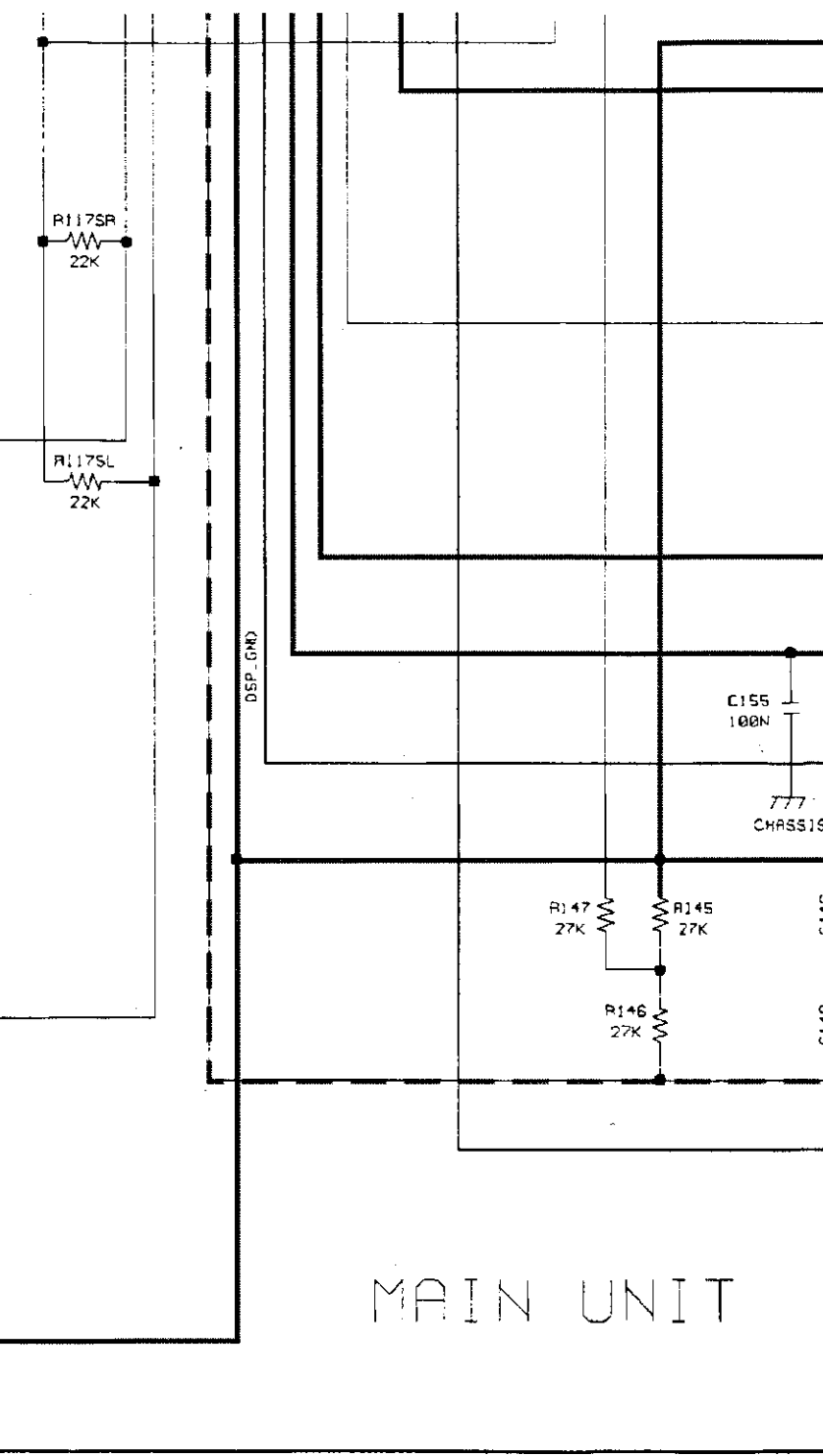
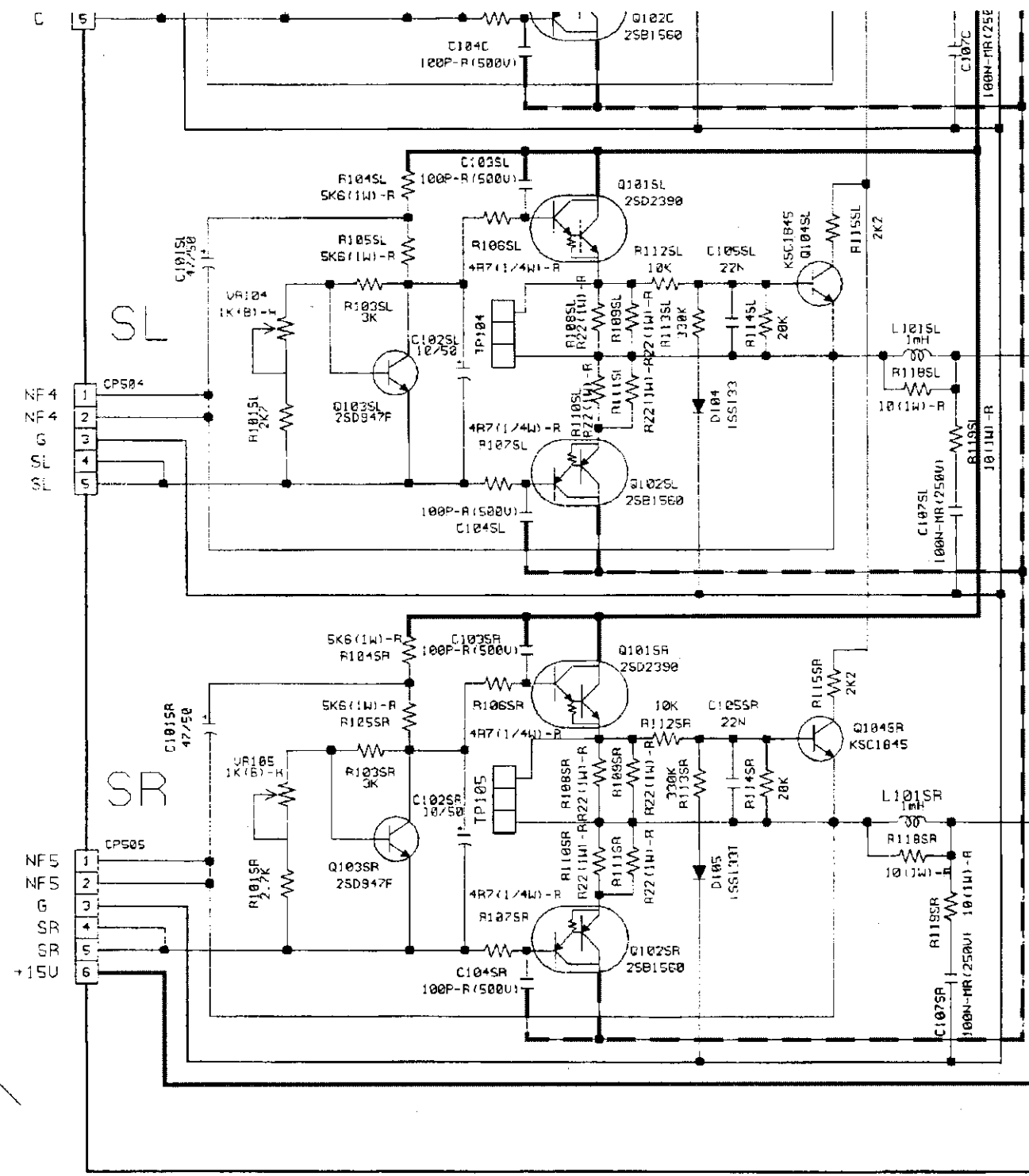

MAIN UNIT

NOTICE
 ALL RESISTANCE VALU
 ALL CAPACITANCE VAL
 EACH VOLTAGE AND C
 CONDITION.
 CIRCUIT AND PARTS A
 NOTICE.

E

F

G

H

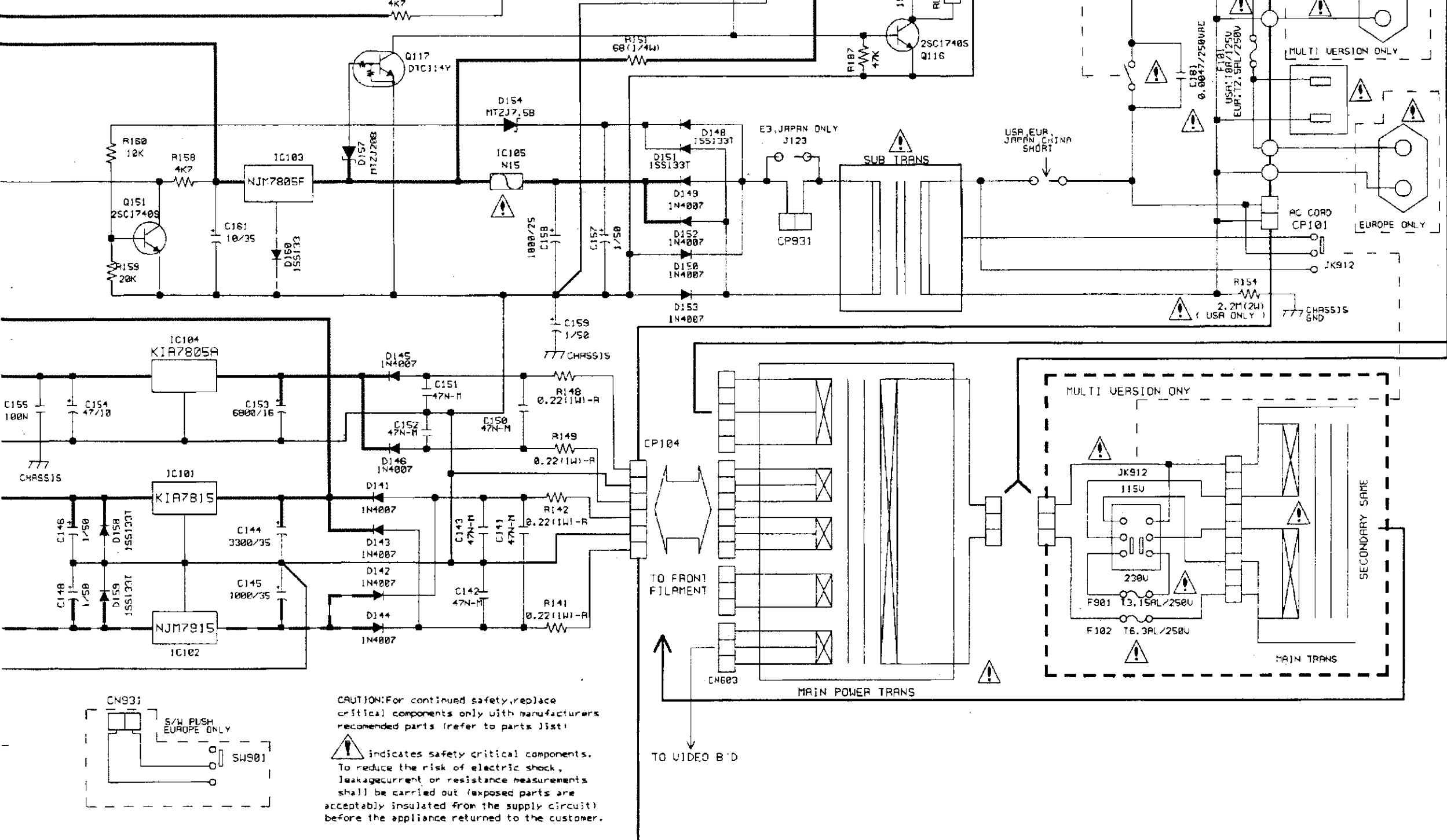

CAUTION: For continued safety, replace critical components only with manufacturers recommended parts (refer to parts list)

⚠ indicates safety critical components. To reduce the risk of electric shock, leakage current or resistance measurements shall be carried out (exposed parts are acceptably insulated from the supply circuit) before the appliance returned to the customer.

RESISTOR VALUES IN OHM. k=1,000 OHM M=1,000,000 OHM
 CAPACITOR VALUES IN MICRO FARAD. P=MICRO-MICRO FARAD
 CURRENT VALUES ARE MEASURED AT MO SIGNAL INPUT

PARTS ARE SUBJECT TO CHANGE WITHOUT PRIOR NOTICE

WARNING:
 Parts marked with this symbol have critical characteristics. Use ONLY replacement parts recommended by the manufacture.

CAUTION:
 Before returning the unit to the customer, make sure you make either (1) a leakage current check or (2) a line to chassis resistance check. If the leakage current exceeds 0.5 milliamps, or if the resistance from chassis to either side of the power card is less than 460kohms, the unit is defective.

WARNING:
 DO NOT return the unit to the customer until the problem is located and corrected.

— + B LINE
 - - - - B LINE
 [dotted line] SIGNAL LINE

SCHEMATIC DIAGRAMS (5/8)
 MAIN UNIT
 VOLTAGE UNIT
 OUTLET UNIT

SCHMATIC DIAGRAMS (6/8)

1 2 3 4 5 6 7 8 9 10 11

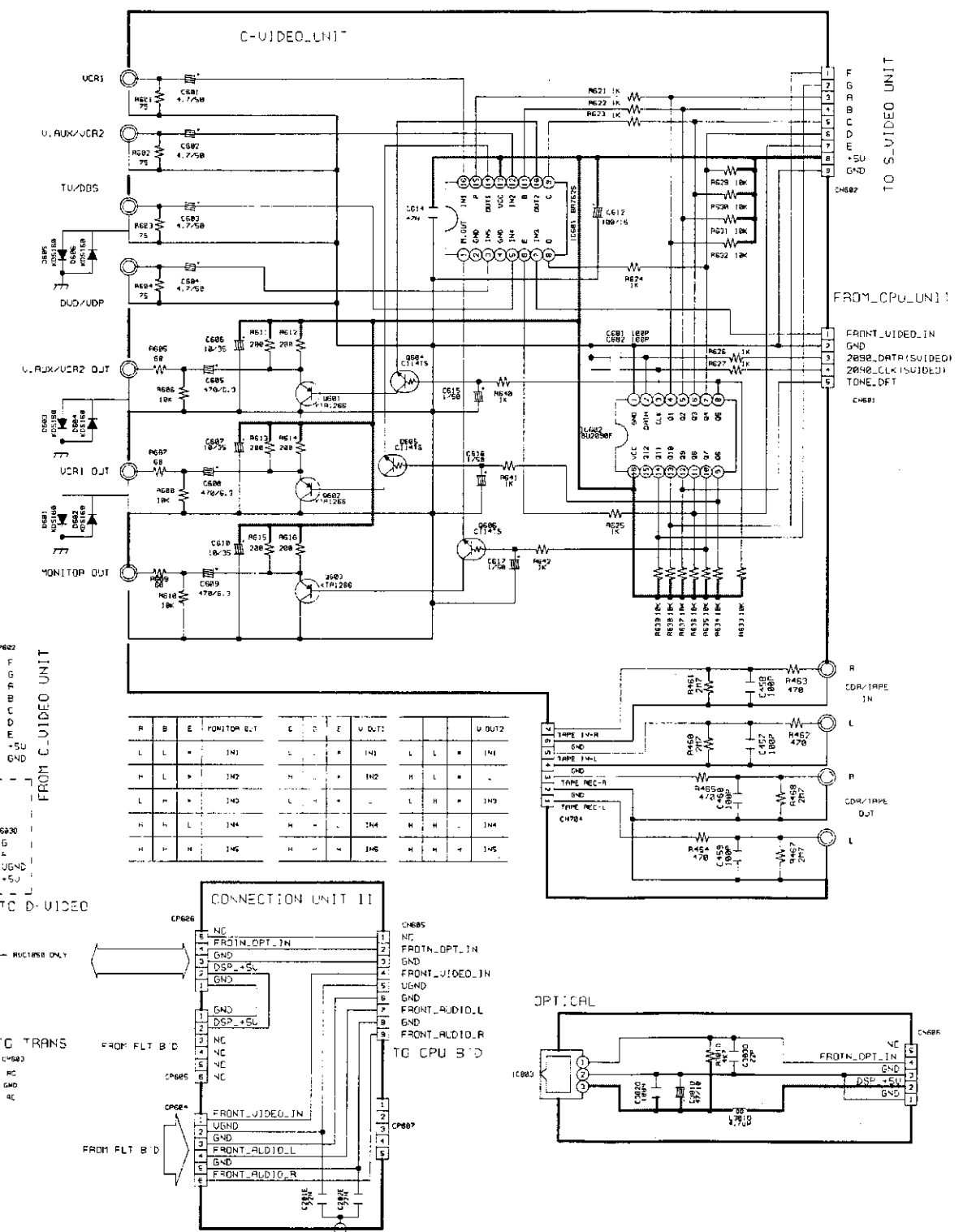
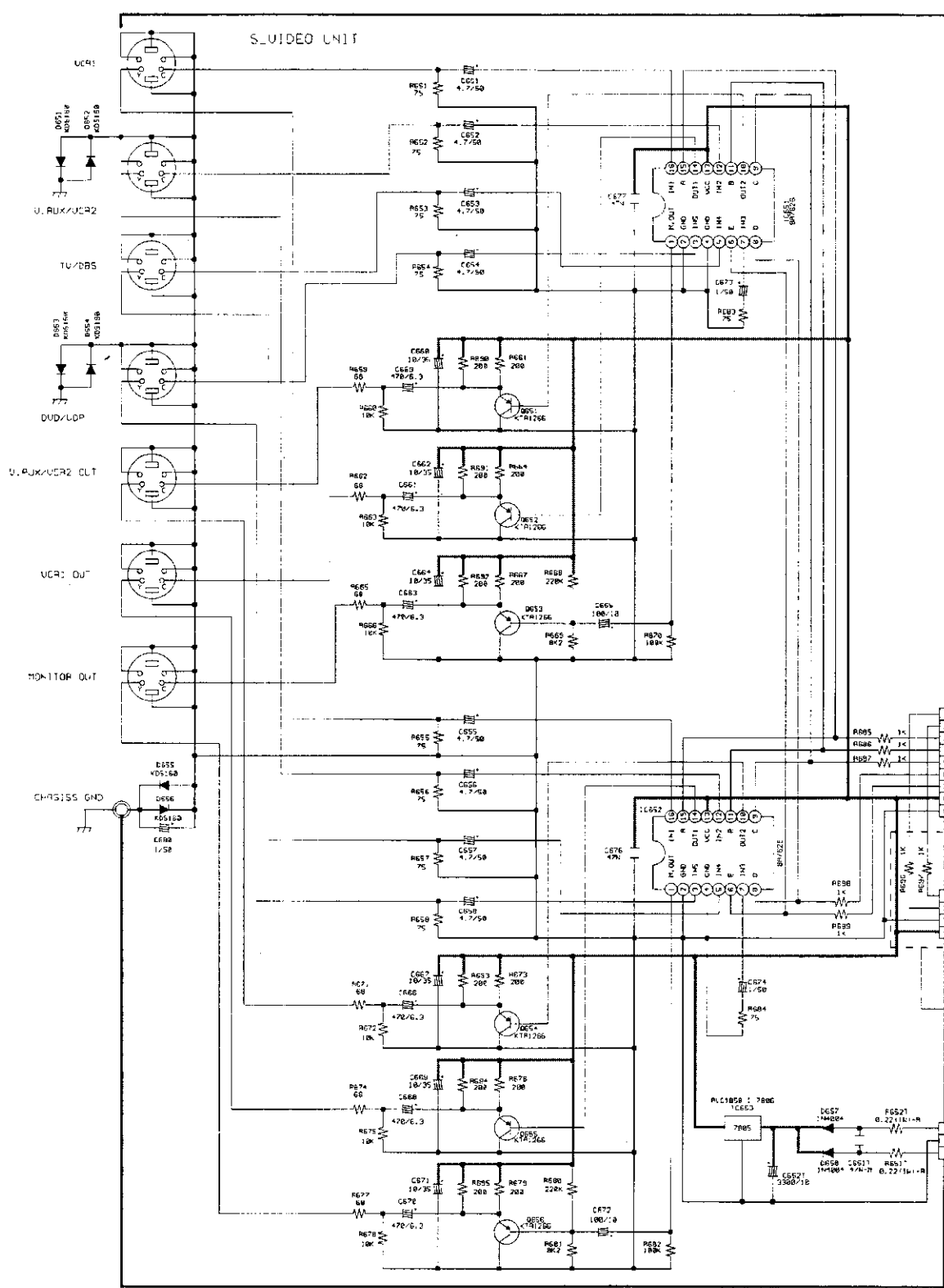

| R | B | E | MONITOR OUT | C | D | E | V | OUT | | | |
|---|---|---|-------------|---|---|---|-----|-----|---|---|-----|
| L | L | * | 1N1 | L | * | * | 1N1 | L | L | * | 1N1 |
| H | L | * | 1N2 | H | * | * | 1N2 | H | L | * | |
| L | H | * | 1N3 | L | * | * | 1N3 | L | H | * | 1N3 |
| H | H | L | 1N4 | H | * | * | 1N4 | H | H | * | 1N4 |
| H | H | H | 1N5 | H | * | * | 1N5 | H | H | * | 1N5 |

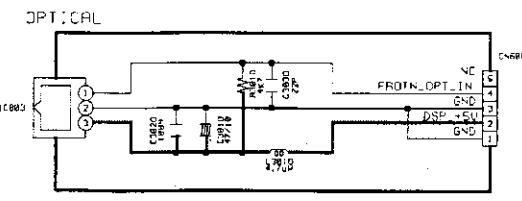
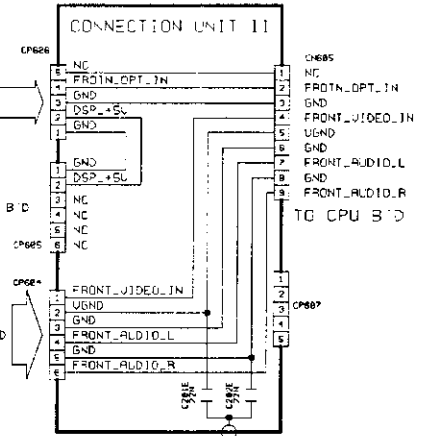

NOTICE
 ALL RESISTANCE VALUES IN OHM. k=1,000 OHM M=1,000,000 OHM
 ALL CAPACITANCE VALUES IN MICRO FARAD. P=MICRO-MICRO FARAD
 EACH VOLTAGE AND CURRENT ARE MEASURED AT NO SIGNAL INPUT
 CONDITION.
 CIRCUIT AND PARTS ARE SUBJECT TO CHANGE WITHOUT PRIOR
 NOTICE.

WARNING:
 Parts marked with this symbol Δ have critical characteristics.
 Use ONLY replacement parts recommended by the manufacture.
CAUTION:
 Before returning the unit to the customer, make sure you make either (1) a
 leakage current check or (2) a line to chassis resistance check. If the leakage
 current exceeds 0.5 milliamps, or if the resistance from chassis to either side
 of the power cord is less than 460kohms, the unit is defective.
WARNING:
 DO NOT return the unit to the customer until the problem is located and
 corrected.

SCHMATIC DIAGRAMS (6/8)
 VIDEO UNIT
 S-VIDEO UNIT
 FRONT CNT UNIT
 OPTICAL UNIT

SCHEMATIC DIAGRAMS (6/8)

1

2

3

4

5

6

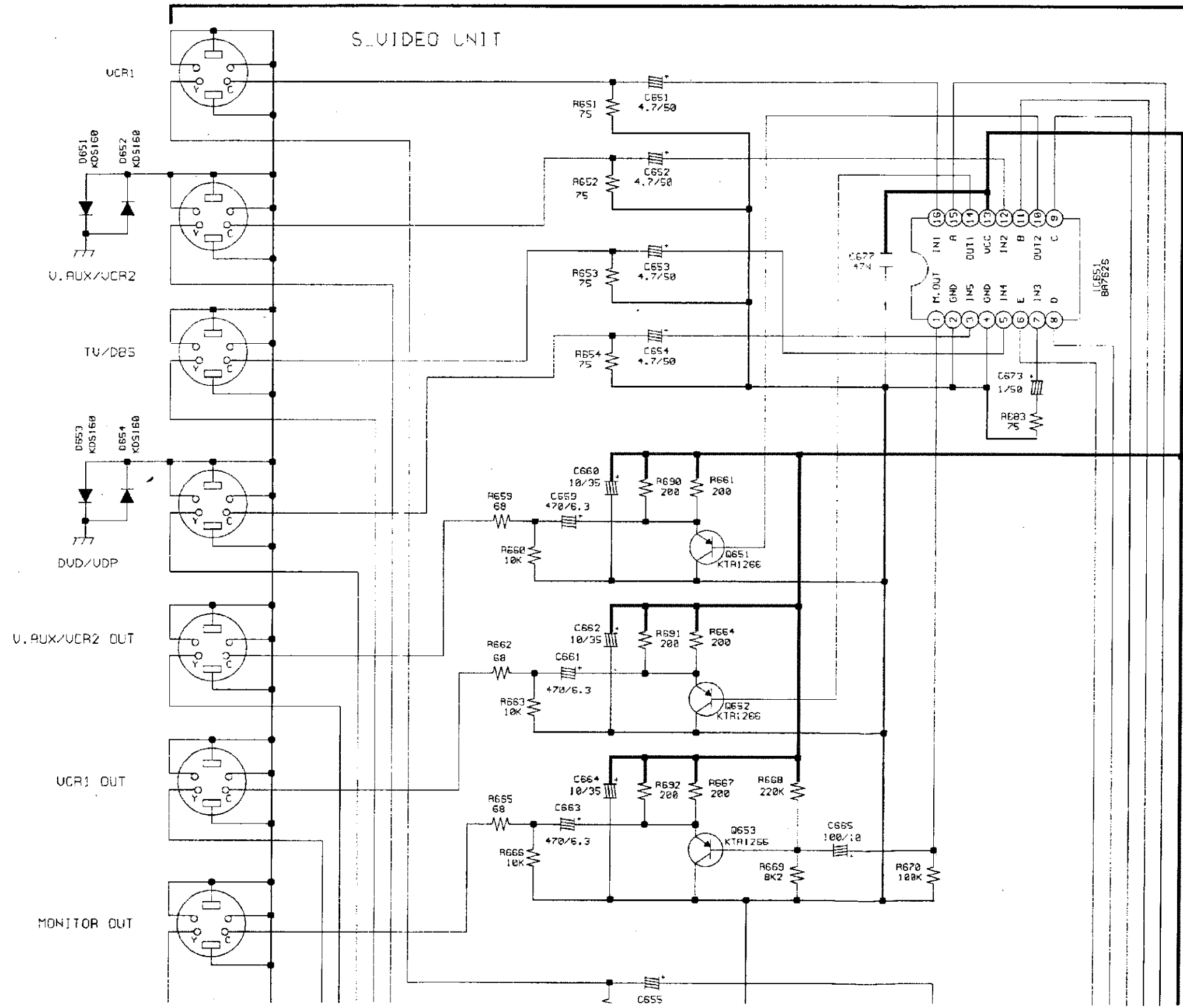

6

7

8

9

10

11

A

B

C

D

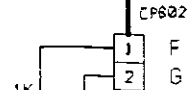
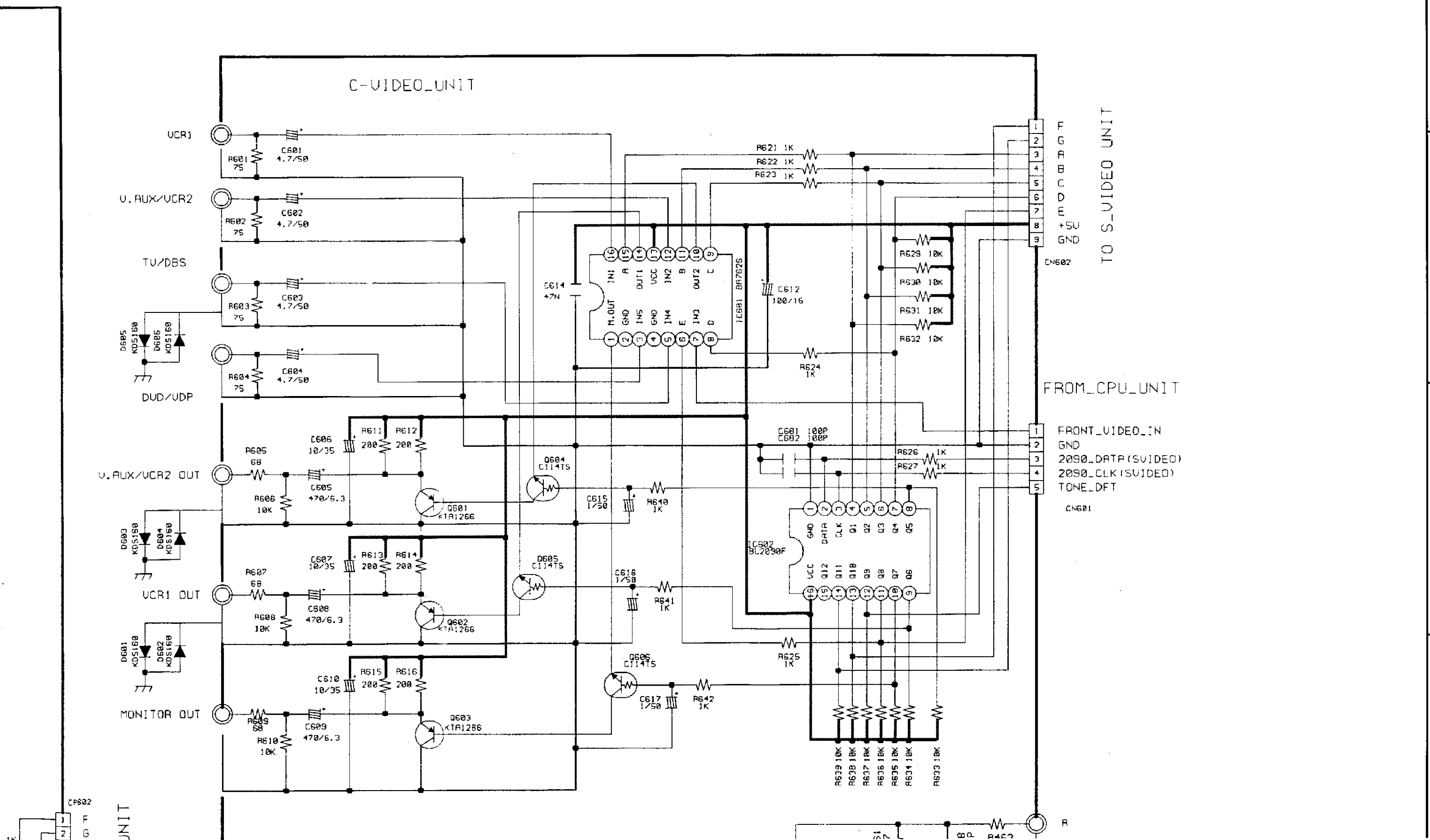

UNIT

TO S-VIDEO UNIT

1 F
2 G
3 A
4 B
5 C
6 D
7 E
8 +5V
9 GND

CN602

FROM CPU UNIT

1 FRONT_VIDEO_IN
2 GND
3 2090_DATA (SVIDEO)
4 2090_CLK (SVIDEO)
5 TONE_DFT

CN601

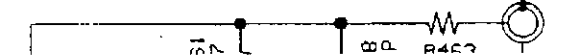

R

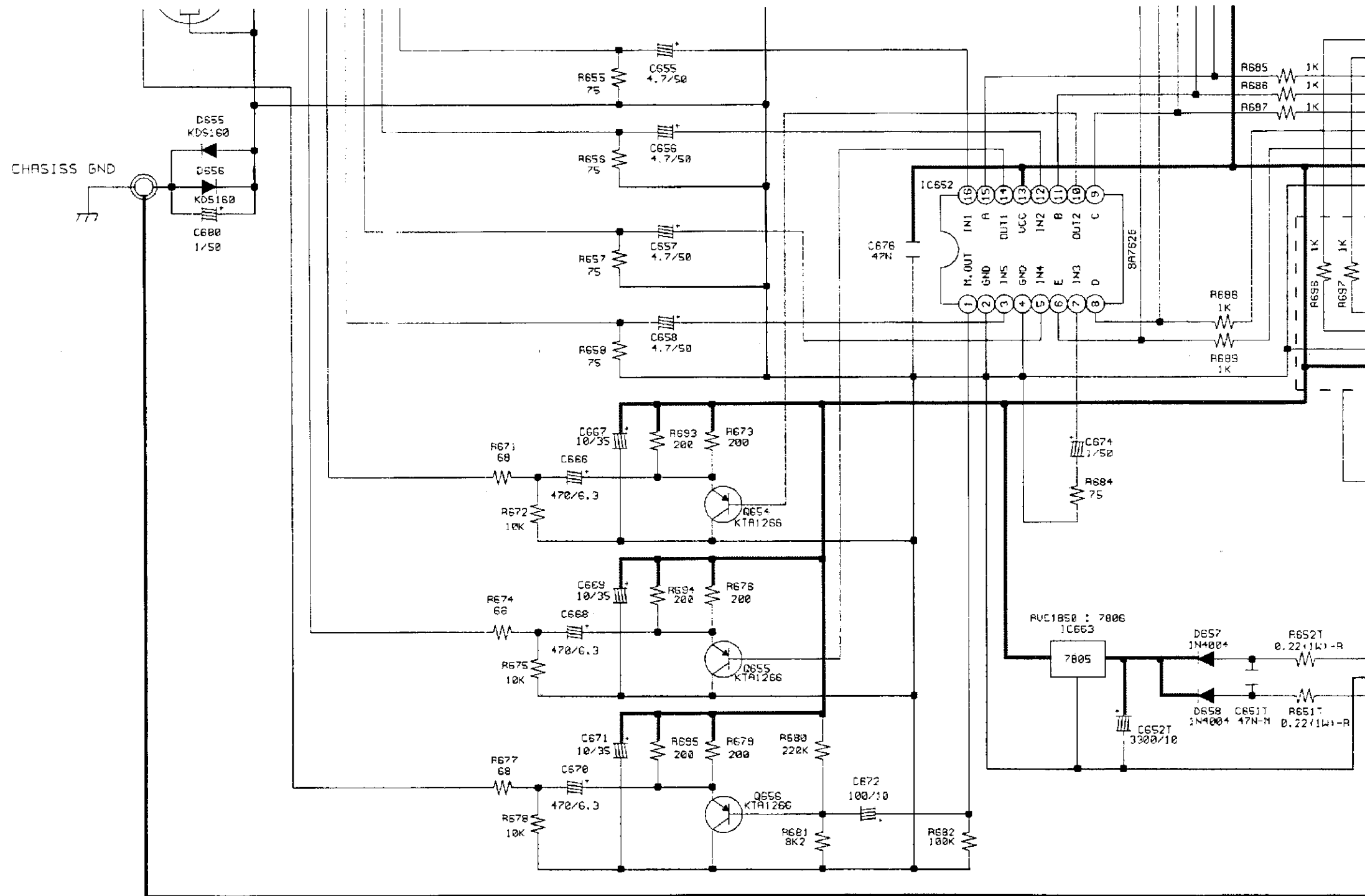

NOTICE
 ALL RESISTANCE VAL
 ALL CAPACITANCE VA
 EACH VOLTAGE AND C
 CONDITION.
 CIRCUIT AND PARTS A
 NOTICE.

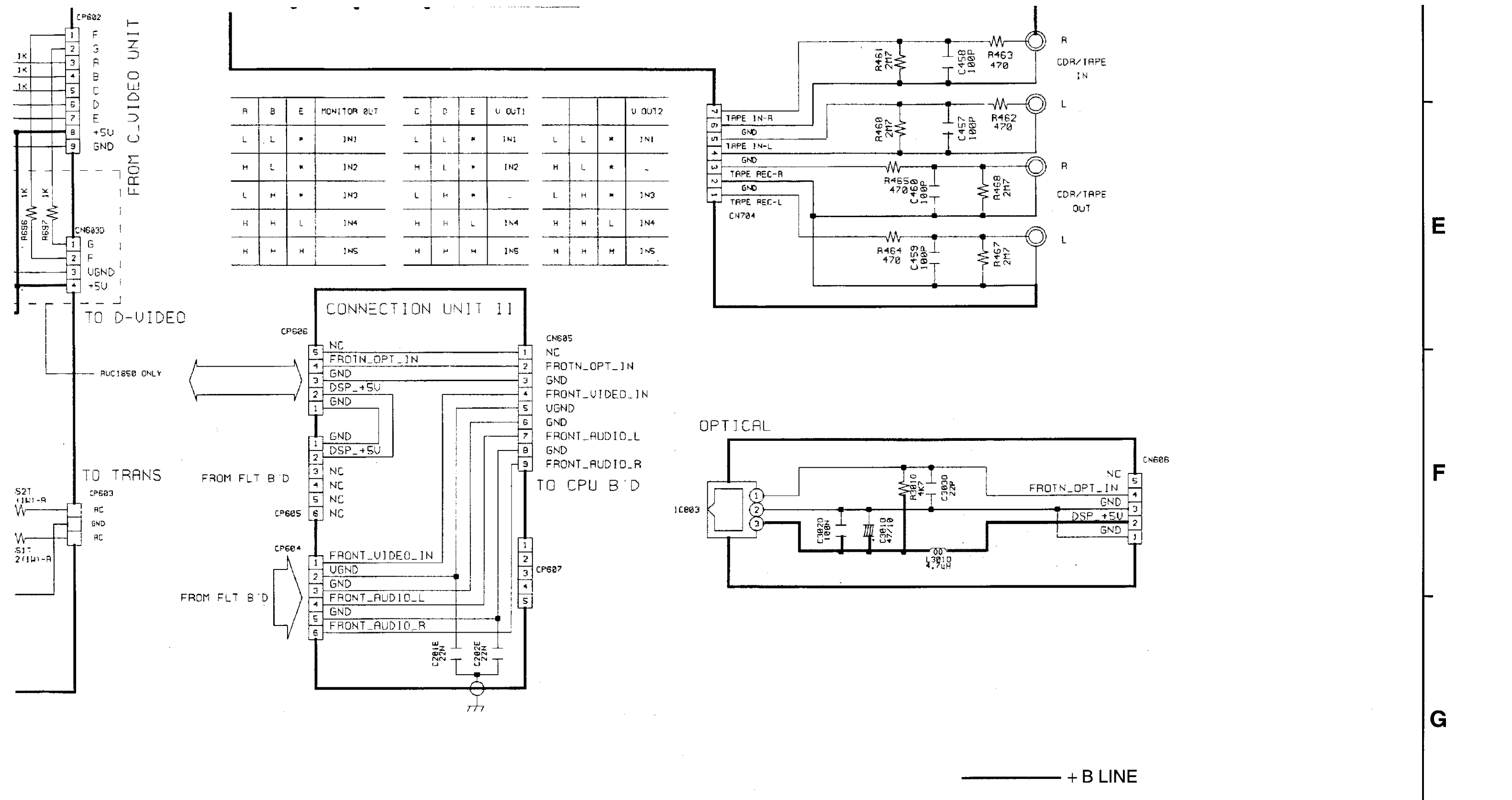

E

F

G

H

SCHEMATIC DIAGRAMS (7/8)

1 2 3 4 5 6 7 8 9 10 11

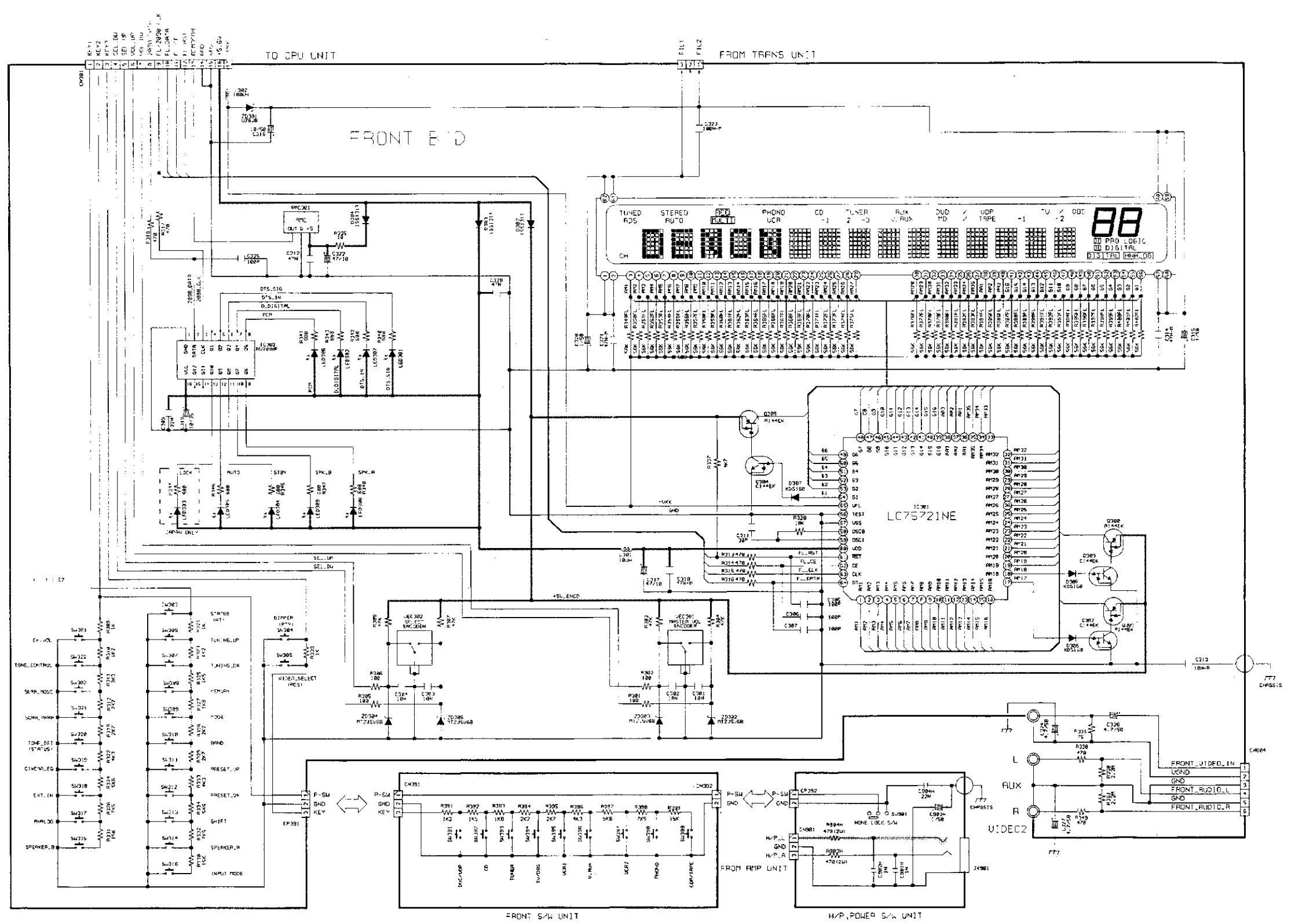

— + B LINE
 - - - - - SIGNAL LINE

WARNING:
 Parts marked with this symbol  have critical characteristics. Use ONLY replacement parts recommended by the manufacturer.

CAUTION:
 Before returning the unit to the customer, make sure you make either (1) a leakage current check or (2) a line to chassis resistance check. If the leakage current exceeds 0.5 millamps, or if the resistance from chassis to either side of the power cord is less than 480kohms, the unit is defective.

WARNING:
 DO NOT return the unit to the customer until the problem is located and corrected.

NOTICE
 ALL RESISTANCE VALUES IN OHM. k=1,000 OHM M=1,000,000 OHM
 ALL CAPACITANCE VALUES IN MICRO FARAD. P=MICRO-MICRO FARAD
 EACH VOLTAGE AND CURRENT ARE MEASURED AT NO SIGNAL INPUT CONDITION.
 CIRCUIT AND PARTS ARE SUBJECT TO CHANGE WITHOUT PRIOR NOTICE.

SCHEMATIC DIAGRAMS (7/8)
 FRONT UNIT
 TACT SW UNIT
 HEAD PHONE UNIT

SCHEMATIC DIAGRAMS (7/8)

1

2

3

4

5

6

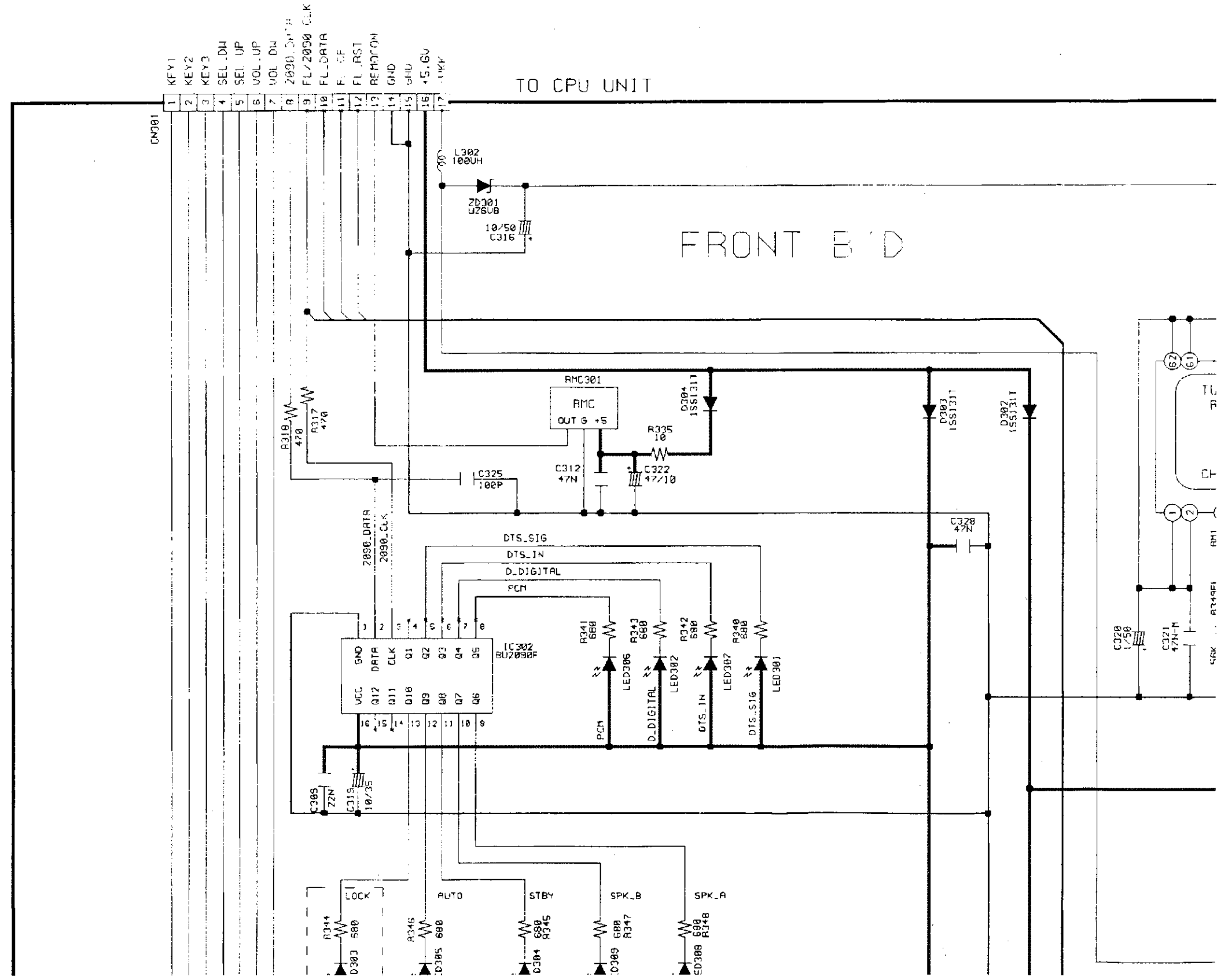

6

7

8

9

10

11

A

B

C

D

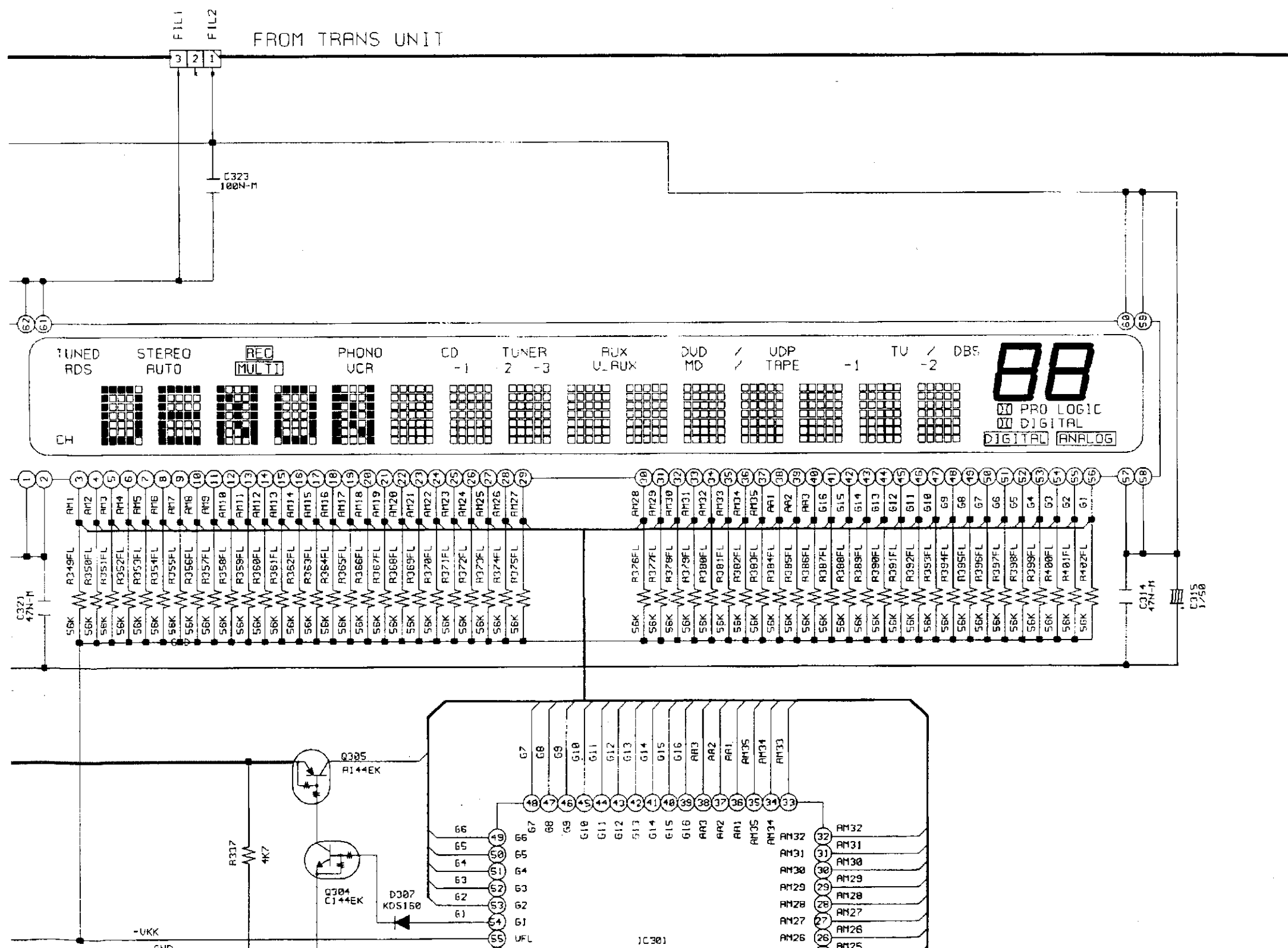

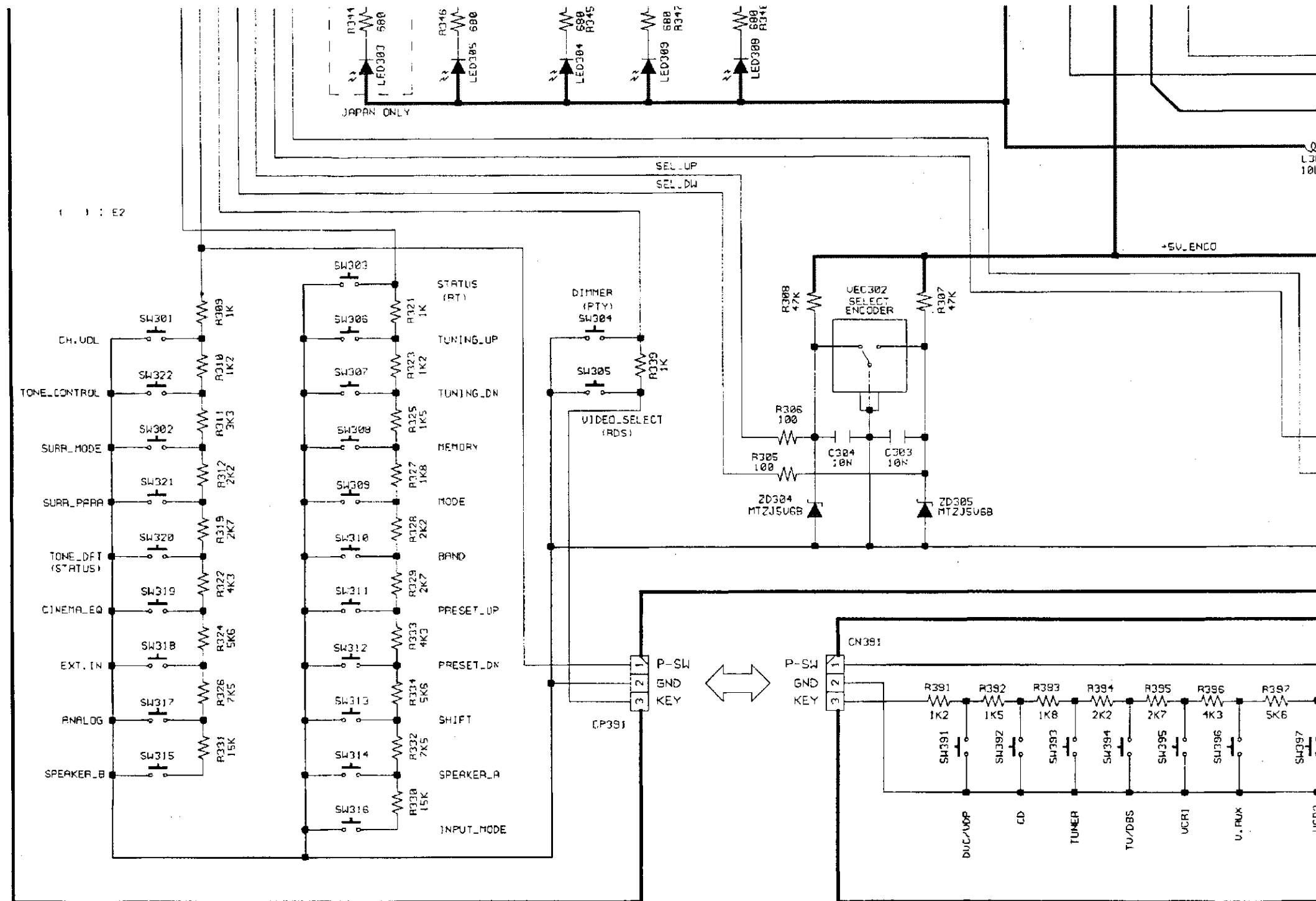

FRONT SW UNIT

NOTICE
 ALL RESISTANCE VAL
 ALL CAPACITANCE VA
 EACH VOLTAGE AND C
 CONDITION.
 CIRCUIT AND PARTS A
 NOTICE.

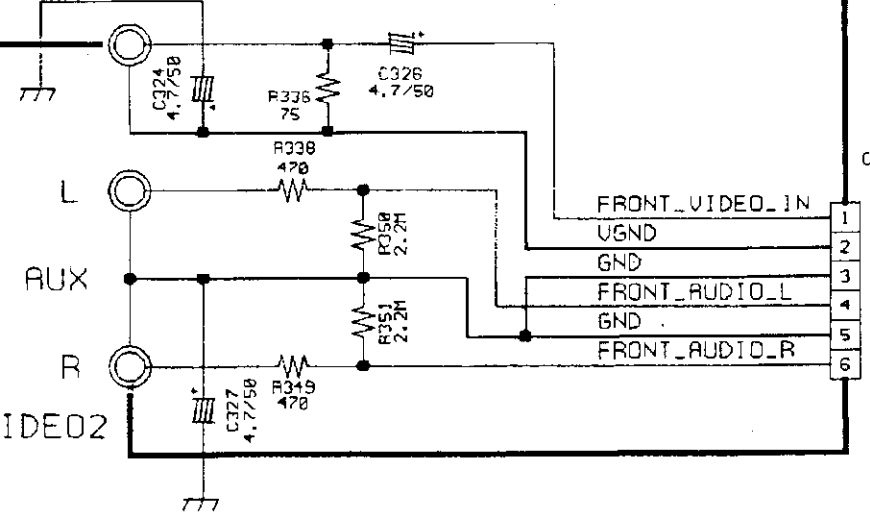
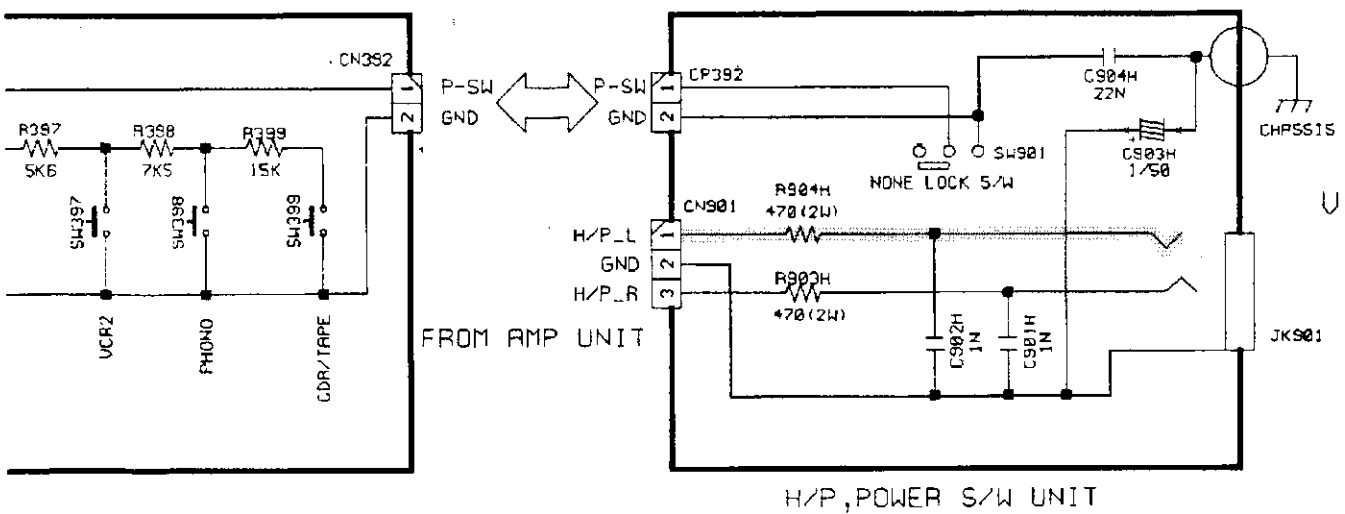
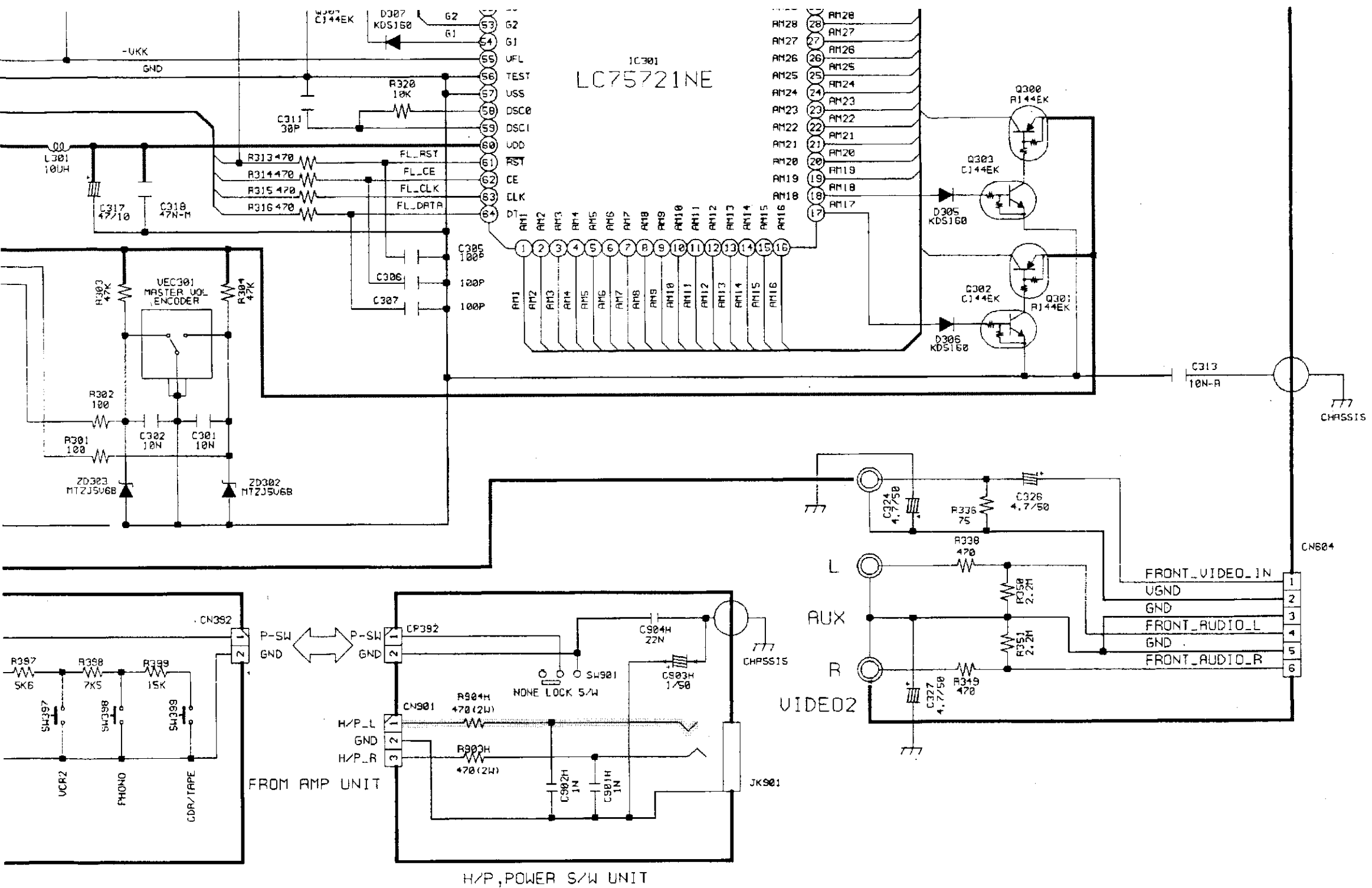

+ B LINE
 SIGNAL LINE

WARNING:
 Parts marked with this symbol have critical characteristics. Use ONLY replacement parts recommended by the manufacture.

CAUTION:
 Before returning the unit to the customer, make sure you make either (1) a leakage current check or (2) a line to chassis resistance check. If the leakage current exceeds 0.5 milliamps, or if the resistance from chassis to either side of the power card is less than 460kohms, the unit is defective.

WARNING:
 DO NOT return the unit to the customer until the problem is located and corrected.

SCHEMATIC DIAGRAMS (7/8)
 FRONT UNIT
 TACT S/W UNIT
 HEAD PHONE UNIT

CE VALUES IN OHM. k=1,000 OHM M=1,000,000 OHM
 NCE VALUES IN MICRO FARAD. P=MICRO-MICRO FARAD
 E AND CURRENT ARE MEASUERD AT MO SIGNAL INPUT

PARTS ARE SUBJECT TO CHANGE WITHOUT PRIOR

E
F
G
H

SCHMATIC DIAGRAMS (8/8)

1 2 3 4 5 6 7 8 9 10 11

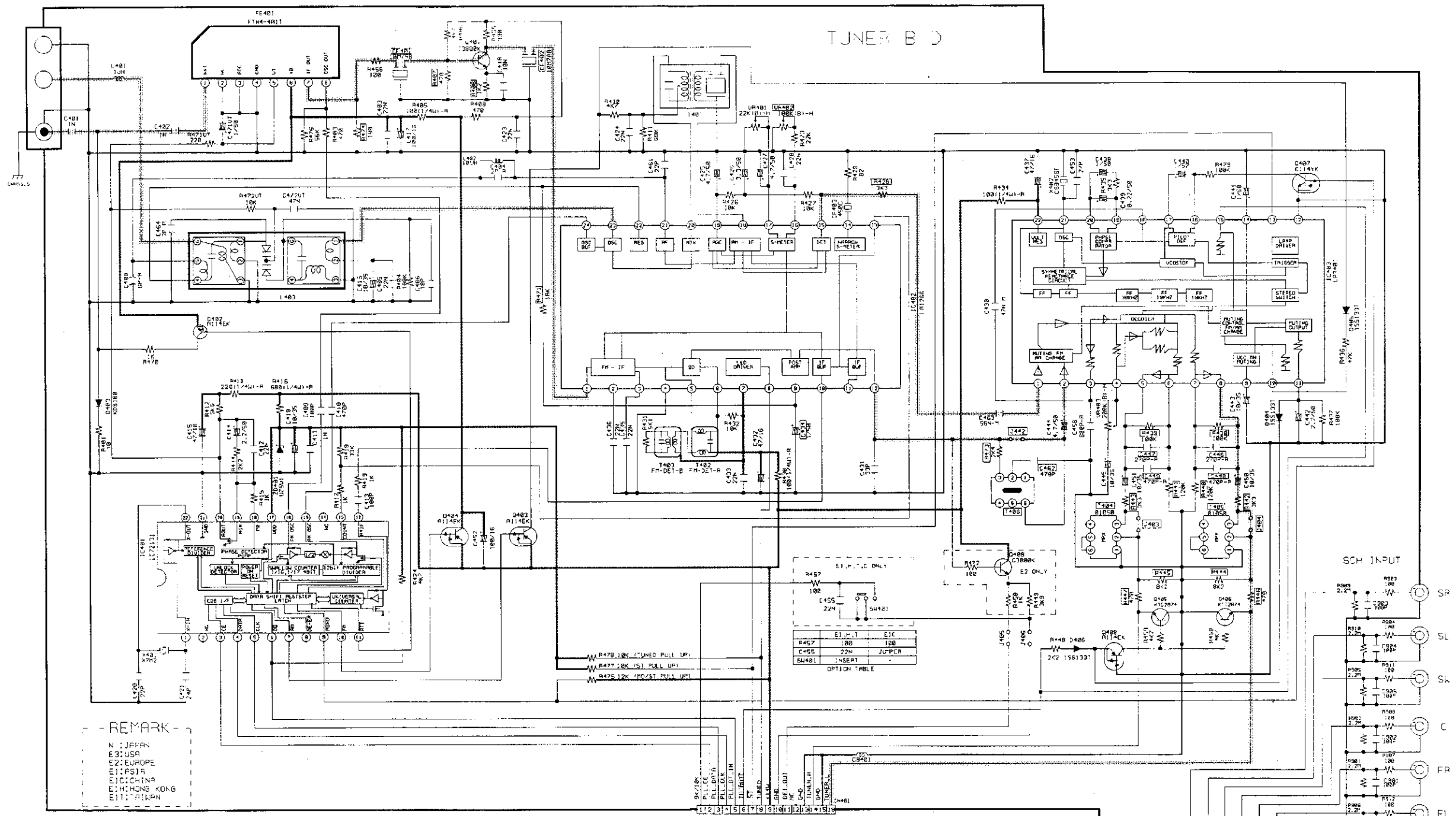

REMARK
 N: JAPAN
 E3: USA
 E2: EUROPE
 E1: PSJR
 EIC: CHINA
 EIC: HONG KONG
 E11: TAIWAN

| | R-NO. | E3 | E2 | E1, C, H, T |
|--------------|------------|------------|------------|-------------|
| IF AMP | CF401 | SFE10.7MHZ | SFE10.7MS3 | SFE10.7MHZ |
| | CF402 | SFE10.7MHZ | SFE10.7MS3 | SFE10.7MS3 |
| | R474 | 100 | 100 | - |
| OUTPUT LEVEL | R407 | 620 | 600 | 620 |
| | R408 | 1.2K | 600 | 1.2K |
| | R428 | 3.3K | 10K | 5.0K |
| | R473 | JUMPER | 2.4K | JUMPER |
| | R444, R445 | 8.2K | 3.3K | 8.2K |
| R442, R443 | 3.3K | 2.2K | 3.3K | |

| | R-NO. | E3 | E2 | E1, C, H, T |
|-----------------|------------|--------|--------|-------------|
| ANT BOARD | T425 | - | INSERT | - |
| | J442 | JUMPER | - | JUMPER |
| VIDEO PROCESSOR | C462 | - | 470P | - |
| | T404, T405 | - | INSERT | - |
| | J403, J404 | JUMPER | - | JUMPER |
| | R440, R441 | 120K | 220K | 120K |
| RDS | R438, R439 | 100K | 150K | 100K |
| | C44E, C44F | 270P | 330P | 100P |
| RDS | J405, J406 | - | INSERT | - |

| | R-NO. | E3 | E2 | E1, C, H, T |
|------|------------|--------|---------|-------------|
| ETC | C44B, C449 | 470P | - | 330P |
| | R446, R447 | JUMPER | 470 | JUMPER |
| RDS | R471 | 10K | 39K | 39K |
| | U1402 | 100KB | 100KB | 100KB |
| | C434 | 1/50 | 0.33/50 | 0.33/50 |
| | R449 | - | 3.9K | - |
| R450 | - | 1K | - | |
| R472 | - | 100 | - | |
| Q409 | - | C3680K | - | |

NOTICE
 ALL RESISTANCE VALUES IN OHM, K=1,000 OHM M=1,000,000 OHM
 ALL CAPACITANCE VALUES IN MICRO FARAD, P=MICRO-MICRO FARAD
 EACH VOLTAGE AND CURRENT ARE MEASURED AT NO SIGNAL INPUT CONDITION.
 CIRCUIT AND PARTS ARE SUBJECT TO CHANGE WITHOUT PRIOR NOTICE.

WARNING:
 Parts marked with this symbol have critical characteristics. Use ONLY replacement parts recommended by the manufacturer.
 CAUTION:
 Before returning the unit to the customer, make sure you make either (1) a leakage current check or (2) a line to chassis resistance check. If the leakage current exceeds 0.5 milliamps, or if the resistance from chassis to either side of the power card is less than 450kohms, the unit is defective.
 WARNING:
 DO NOT return the unit to the customer until the problem is located and corrected.

+ B LINE
 SIGNAL LINE
 SCHEMATIC DIAGRAMS (8/8)
 TUNER UNIT

SCHEMATIC DIAGRAMS (8/8)

1

2

3

4

5

6

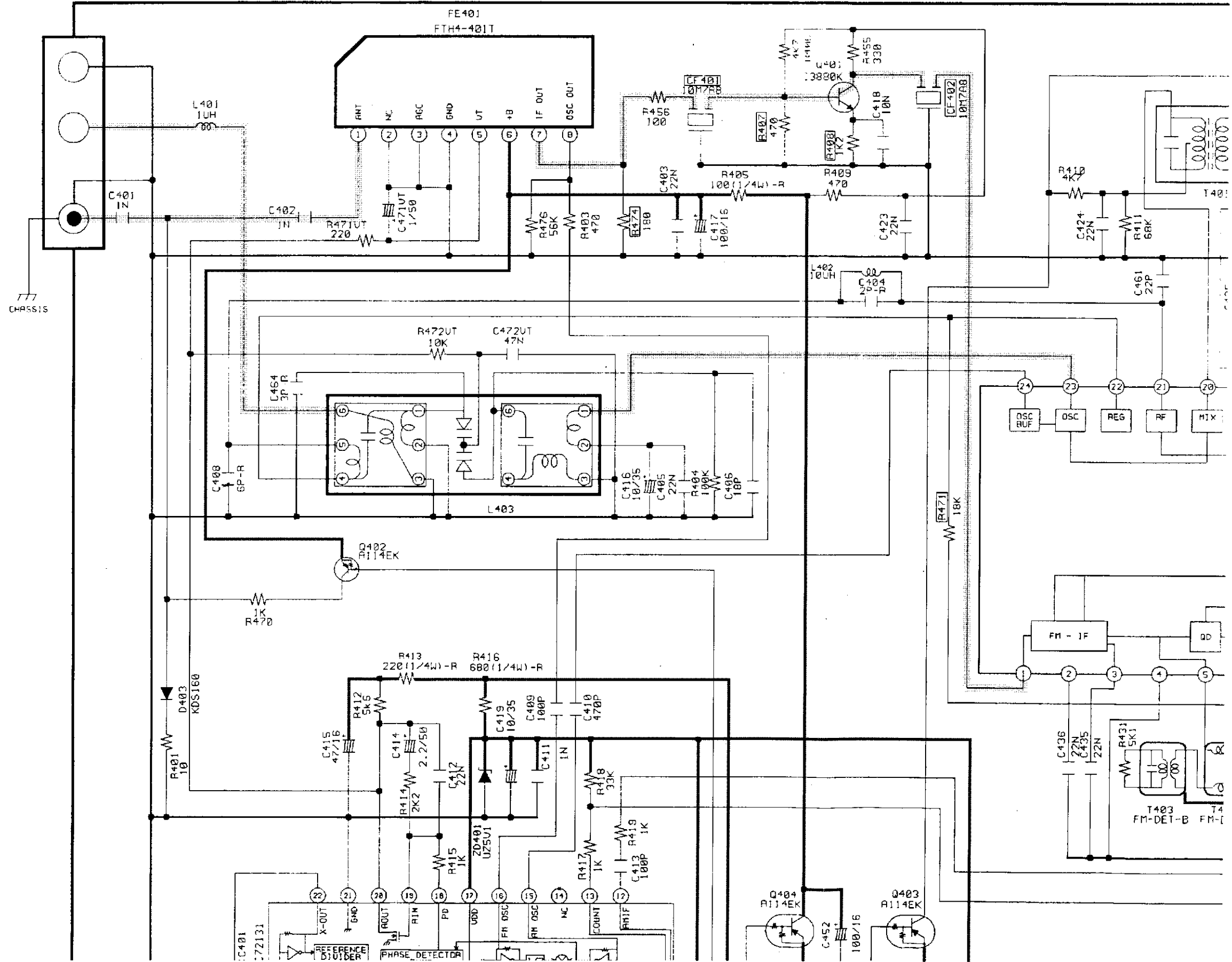

6

7

8

9

10

11

TUNER B D

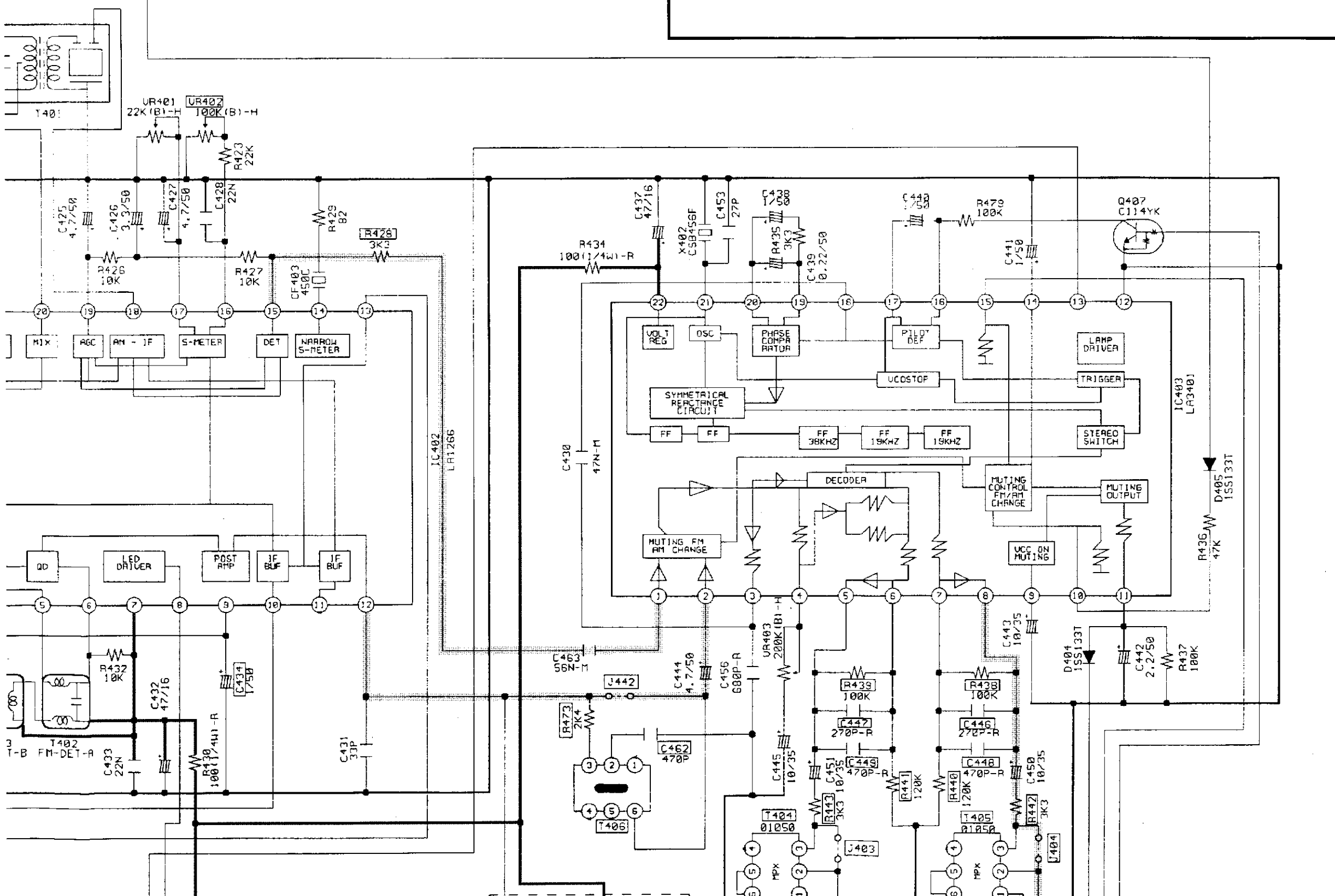

A

B

C

D

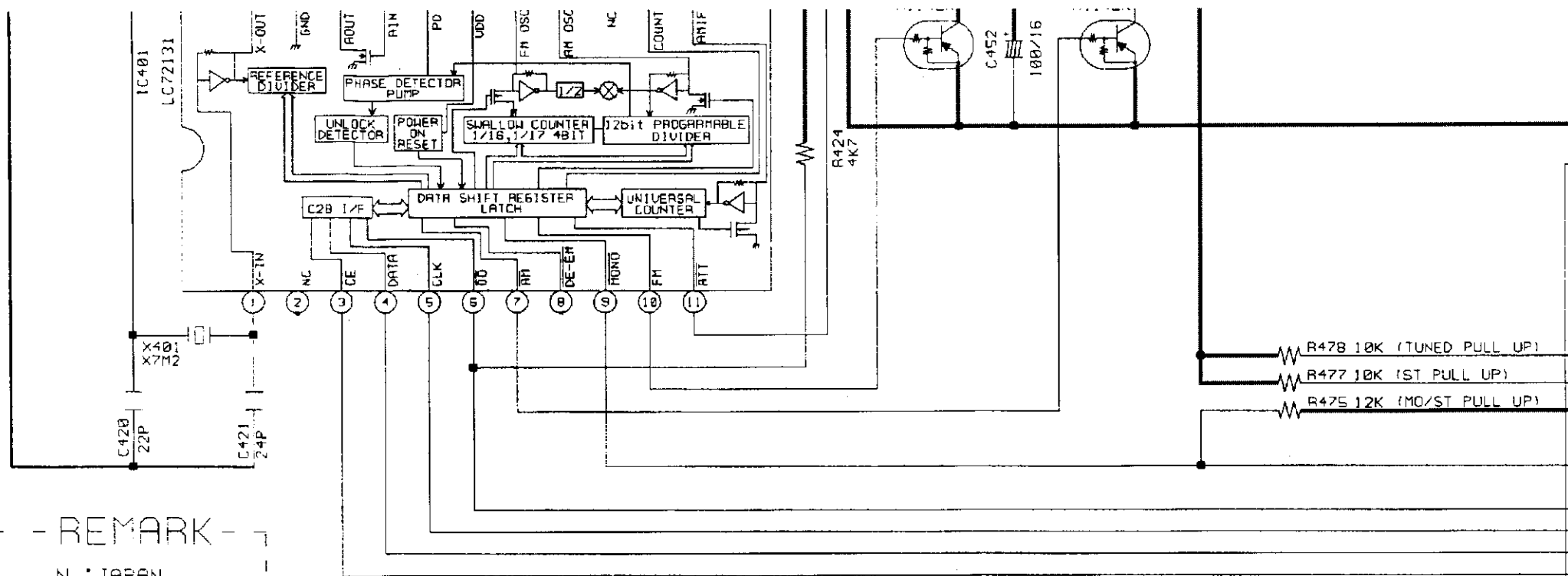

REMARK
 N : JAPAN
 E3: USA
 E2: EUROPE
 E1: ASIA
 E1C: CHINA
 E1H: HONG KONG
 E1T: TAIWAN

| | R-NO. | E3 | E2 | E1, C, H, T |
|--------------|------------|------------|------------|-------------|
| IF AMP | CF401 | SFE10.7MA8 | SFE10.7MS3 | SFE10.7MA8 |
| | CF402 | SFE10.7MA8 | SFE10.7MS3 | SFE10.7MS3 |
| | R474 | 180 | 180 | - |
| | R407 | 620 | 680 | 620 |
| | R408 | 1.2K | 680 | 1.2K |
| OUTPUT LEVEL | R428 | 3.3K | 10K | 6.8K |
| | R473 | JUMPER | 2.4K | JUMPER |
| | R444, R445 | 8.2K | 3.3K | 8.2K |
| | R442, R443 | 3.3K | 2.2K | 3.3K |

| | R-NO. | E3 | E2 | E1, C, H, T |
|-------------|------------|--------|--------|-------------|
| ANT BIRDIE | T405 | - | INSERT | - |
| | J442 | JUMPER | - | JUMPER |
| | C462 | - | 470P | - |
| DE EMPHASIS | T404, T405 | - | INSERT | - |
| | J403, J404 | JUMPER | - | JUMPER |
| | R440, R441 | 120K | 220K | 120K |
| | R438, R439 | 100K | 150K | 100K |
| | C446, C447 | 270P | 330P | 180P |
| RDS | J405, 406 | - | INSERT | - |

NOTICE
 ALL RESISTANCE VALUE
 ALL CAPACITANCE VALUE
 EACH VOLTAGE AND CURRENT
 CONDITION.
 CIRCUIT AND PARTS LIST
 NOTICE.

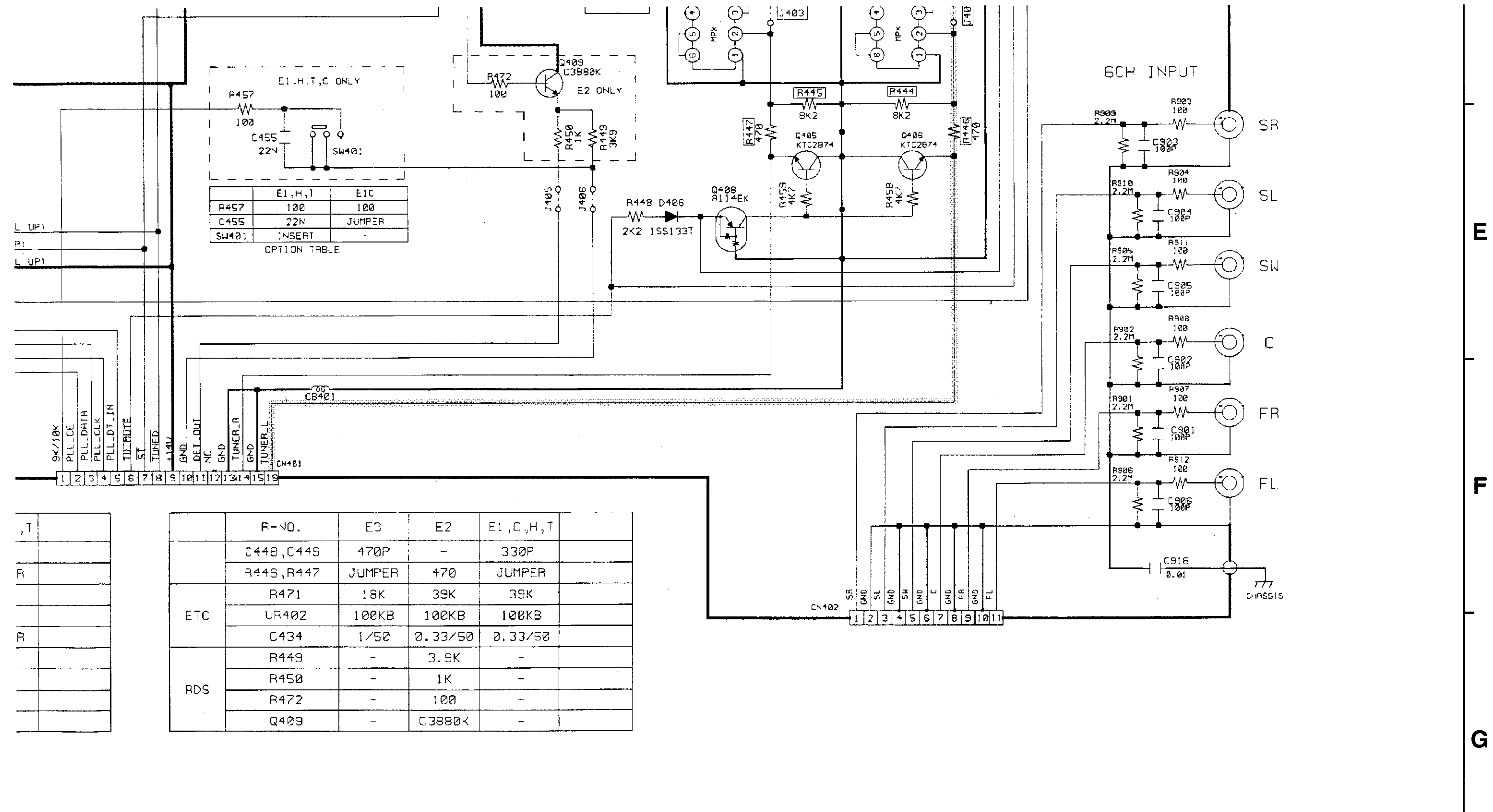

OPTION TABLE

| | E1,H,T | E1C |
|-------|--------|--------|
| R457 | 100 | 100 |
| C455 | 22N | JUMPER |
| SW401 | INSERT | - |

| R-NO. | E3 | E2 | E1,C,H,T |
|-----------|--------|---------|----------|
| C448,C449 | 470P | - | 330P |
| R446,R447 | JUMPER | 470 | JUMPER |
| R471 | 18K | 39K | 39K |
| UR402 | 100KB | 100KB | 100KB |
| C434 | 1/50 | 0.33/50 | 0.33/50 |
| R449 | - | 3.9K | - |
| R450 | - | 1K | - |
| R472 | - | 100 | - |
| Q409 | - | C3880K | - |

WARNING:

Parts marked with this symbol have critical characteristics. Use ONLY replacement parts recommended by the manufacture.

CAUTION:

Before returning the unit to the customer, make sure you make either (1) a leakage current check or (2) a line to chassis resistance check. If the leakage current exceeds 0.5 milliamps, or if the resistance from chassis to either side of the power card is less than 460kohms, the unit is defective.

WARNING:

DO NOT return the unit to the customer until the problem is located and corrected.

————— + B LINE
 - - - - - SIGNAL LINE

SCHEMATIC DIAGRAMS (8/8)
TUNER UNIT

RESISTOR VALUES IN OHM. k=1,000 OHM M=1,000,000 OHM
 CAPACITOR VALUES IN MICRO FARAD. P=MICRO-MICRO FARAD
 VOLTAGE AND CURRENT ARE MEASURED AT MO SIGNAL INPUT

PARTS ARE SUBJECT TO CHANGE WITHOUT PRIOR NOTICE

E

F

G

H