

DENON

For U.S.A., Canada, Europe,
Asia, China, Taiwan R.O.C.
& Korea model

SERVICE MANUAL

Ver. 2

MODEL AVR-1404/484

AV SURROUND RECEIVER

注意

サービスをおこなう前に、このサービスマニュアルを必ずお読みください。本機は、火災、感電、けがなどに対する安全性を確保するために、さまざまな配慮をおこなっており、また法的には「電気用品安全法」にもとづき、所定の許可を得て製造されております。従ってサービスをおこなう際は、これらの安全性が維持されるよう、このサービスマニュアルに記載されている注意事項を必ずお守りください。

● For purposes of improvement, specifications and design are subject to change without notice.

● 本機の仕様は性能改良のため、予告なく変更することがあります。
● 補修用性能部品の保有期間は、製造打切後8年です。

● Please use this service manual with referring to the operating instructions without fail.

● 修理の際は、必ず取扱説明書を参照の上、作業を行ってください。

● Some illustrations using in this service manual are slightly different from the actual set.

● 本文中に使用しているイラストは、説明の都合上現物と多少異なる場合があります。

DENON, Ltd.

16-11, YUSHIMA 3-CHOME, BUNKYO-KU, TOKYO 113-0034 JAPAN

SAFETY PRECAUTIONS

The following check should be performed for the continued protection of the customer and service technician.

LEAKAGE CURRENT CHECK

Before returning the unit to the customer, make sure you make either (1) a leakage current check or (2) a line to chassis resistance check. If the leakage current exceeds 0.5 milliamps, or if the resistance from chassis to either side of the power cord is less than 460 kohms, the unit is defective.

注意 サービス、点検時には次のことにご注意願います。

◎注意事項をお守りください!

サービスのとき特に注意を必要とする箇所については、キャビネット、部品、シャーシなどにラベルや捺印で、注意事項を表示しています。これらの注意書きおよび取扱説明書などの注意事項を必ずお守りください。

◎感電に注意!

- (1) このセットは、交流電圧が印加されていますので、通電時に内部金属部に触れると感電することがあります。従って通電サービス時には、絶縁トランスの使用や手袋の着用、部品交換には、電源プラグを抜くなどして、感電にご注意ください。
- (2) 内部には、高電圧の部分がありますので、通電時の取扱には、十分ご注意ください。

(絶縁チェックの方法)

電源コンセントから電源プラグを抜き、アンテナや、プラグなどを外し、電源スイッチを入れます。500V絶縁抵抗計を用いて、電源プラグのそれぞれの端子と、外部露出金属部〔アンテナ端子、ヘッドホン端子、マイク端子、入力端子など〕との間で、絶縁抵抗値が1MΩ以上であること、この値以下のときは、セットの点検修理が必要です。

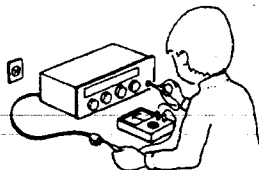
**◎指定部品の使用!**

セットの部品は難燃性や耐電圧など安全上の特性を持ったものとなっています。従って交換部品は、使用されていたものと同じ特性の部品を使用してください。特に配線図、部品表に△印で指定されている安全上重要な部品は必ず指定のものをご使用ください。

注意 安全上重要な部品について

◎部品の取付けや配線の引きまわしは、元どおり! 安全上、テープやチューブなどの絶縁材料を使用したり、プリント基板から浮かして取付けた部品があります。また内部配線は引きまわしやクランプによって発熱部品や高圧部品に接近しないように配慮されていますので、これらは必ず元どおりにしてください。

本機に使用している多くの電気部品、および機構部品は安全上、特別な特性を持っています。この特性はほとんどの場合、外観では判別つきにくく、また、もとの部品より高い定格(定格電力、耐圧)を持ったものを使用しても安全性が維持されることは、限りません。安全上の特性を持った部品は、このサービスマニュアルの配線図、部品表につきのように表示していますので、必ず指定されている部品番号のものを使用願います。

◎サービス後は安全点検を!

サービスのために取り外したねじ、部品、配線などが元どおりになっているか、またサービスした個所の周辺を劣化させてしまったところがないかなどを点検し、外部金属端子部と、電源プラグの刃の間の絶縁チェックをおこなうなど、安全性が確保されていることを確認してください。

(1)配線図… △マークで表示しています。

(2)部品表… △マークで表示しています。

指定された部品と異なるものを使用した場合には、感電、火災などの危険を生じる恐れがあります。

DISASSEMBLY

(Follow the procedure below in reverse order when reassembling.)

1. Top Cover

- (1) Remove 6 screws ① and 3 screws ②, detach the Top cover in the arrow direction.

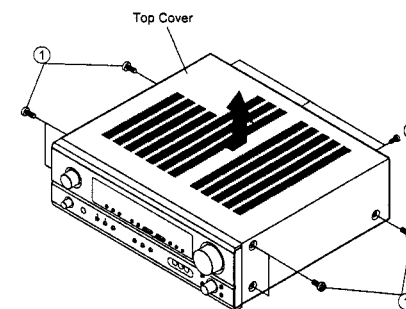

2. Front Panel

- (1) Remove 4 screws ③ and 2 screws ④.
(2) Detach the Front Panel in the arrow direction.

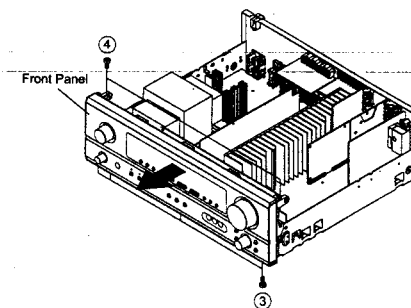

3. Rear Panel

- (1) Remove cord bushing ⑤ from the Rear Panel.
(2) Remove 30 screws ⑥.
(3) Detach the Rear Panel in the arrow direction.

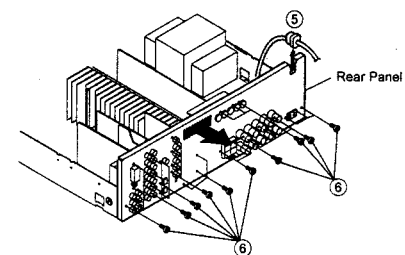

LEVEL DIAGRAMS (1/2)

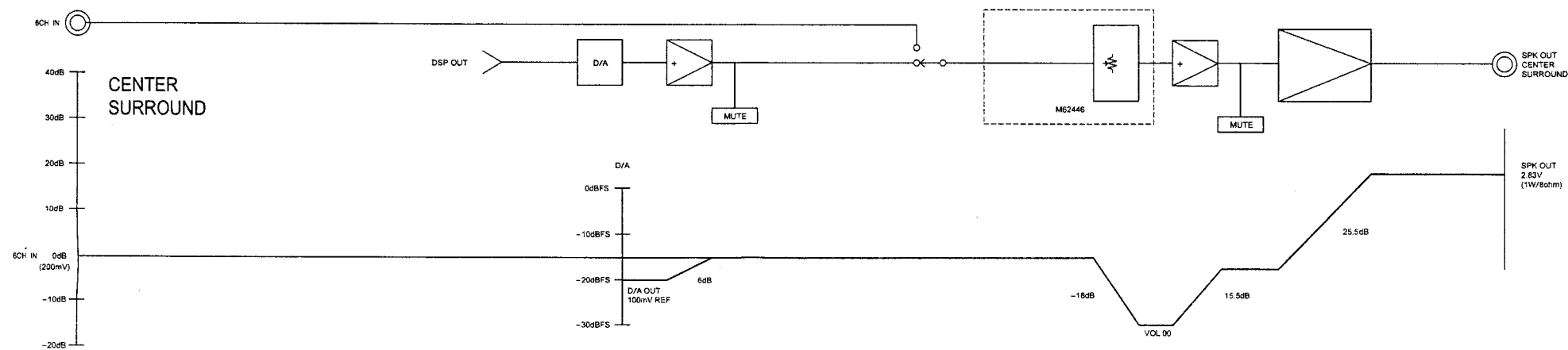
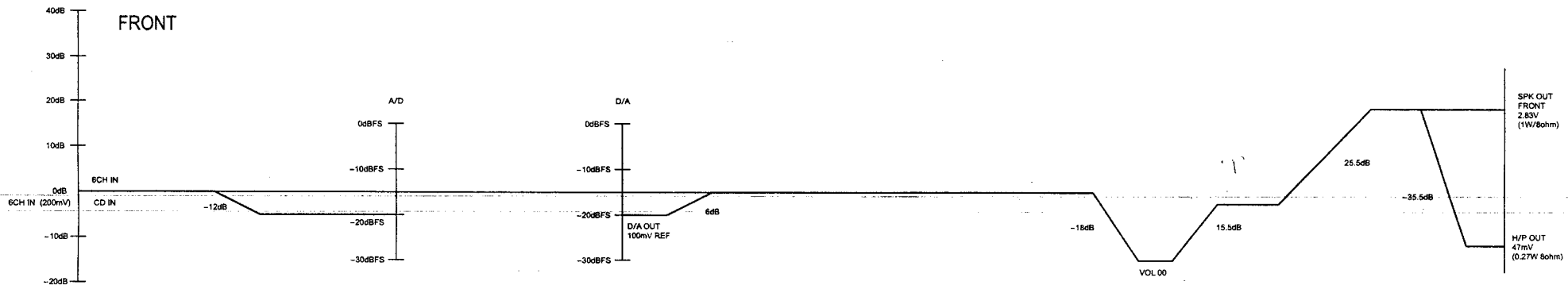
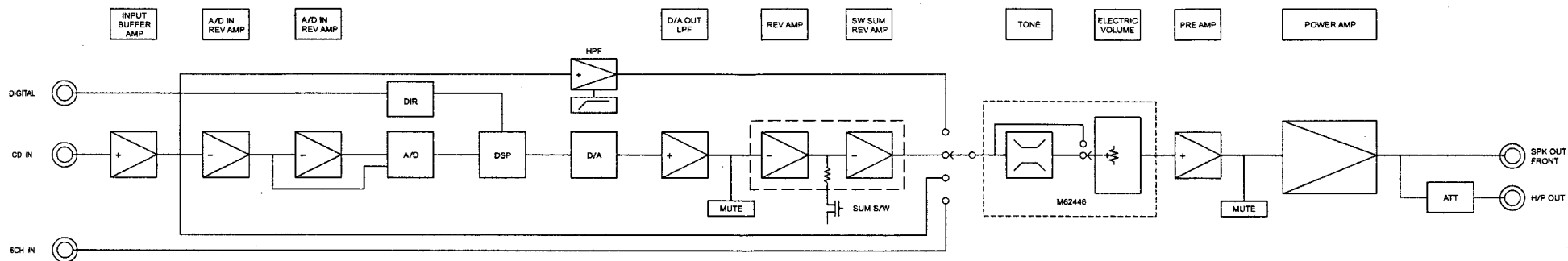

LEVEL DIAGRAMS (2/2)

SUB_WOOFER

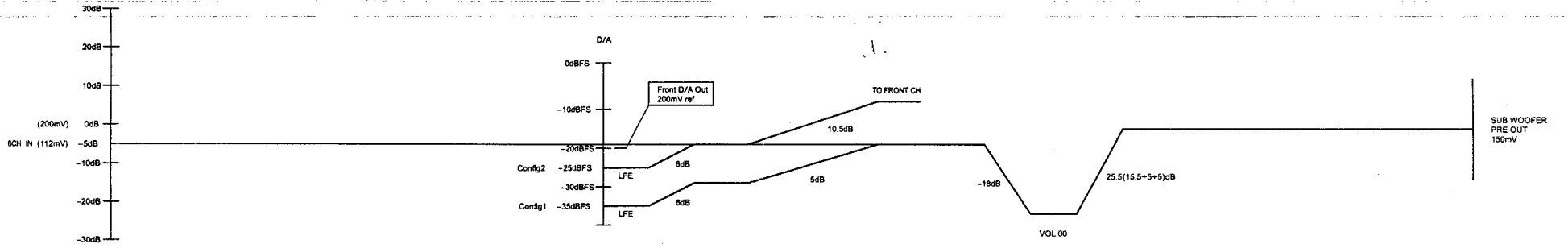
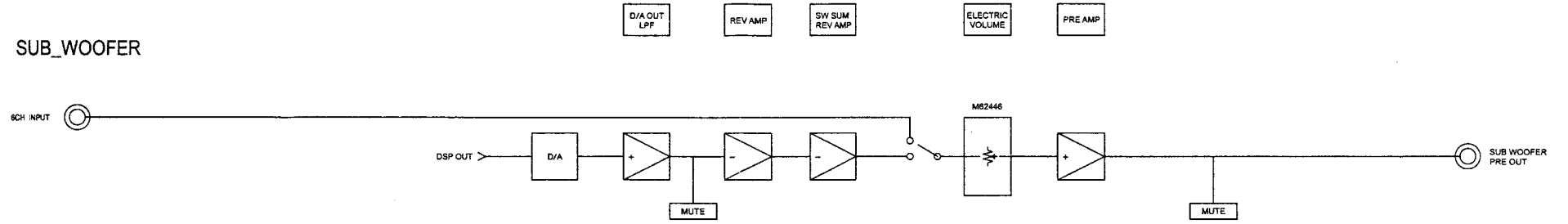

BLOCK DIAGRAM

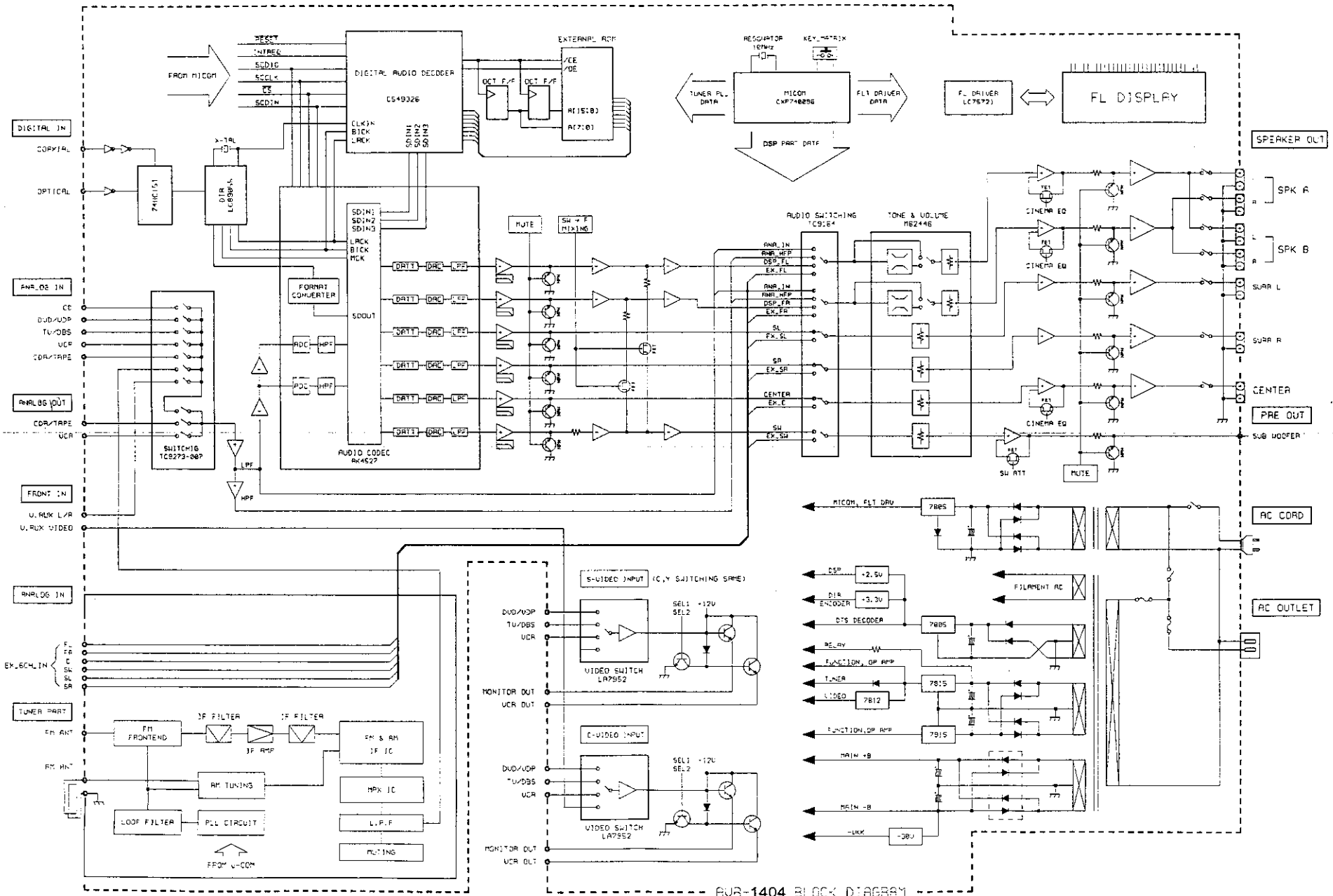

AVR-1404 BLOCK DIAGRAM

ADJUSTMENT

Tuner Section

CONNECTION DIAGRAM OF MEASURING INSTRUMENTS

● FM

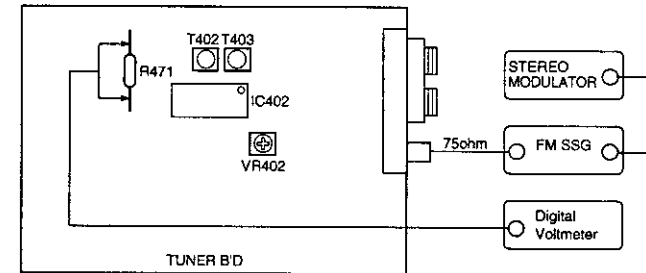

FM ALIGNMENT

Step	Alignment Item	Tuning Frequency Setting	Input					Output		Adjustment	
			Type	Frequency	Input Level	Modulation	Coupling	Type	Connect to	Points	Adjust to
1	Center Adjustment	98.1MHz (98.0MHz)	FM SSG	98.1MHz	60dB μ	Mono 1kHz 100%	Antenna Terminal	Digital Voltmeter	R471	T402	$\pm 50mV$
2	Distortion	98.1MHz (98.0MHz)	FM SSG	98.1MHz	60dB μ	Mono 1kHz 100%	Antenna Terminal	Distortion Meter	Output Terminal (L)	T403	Minimum Distortion
3	Repeat Steps 1 and 2										
4	Signal Level	98.1MHz (98.0MHz)	FM SSG	98.1MHz	20dB μ	OFF	Antenna Terminal	Light "TUNED" on FL Display	VR402		20 \pm 1 dB

● AM

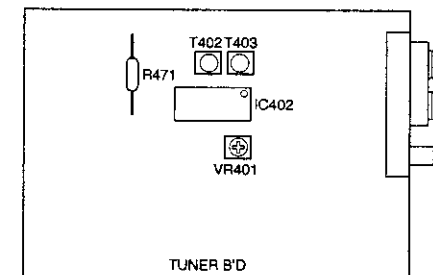

AM ALIGNMENT

Step	Alignment Item	Frequency	Input	Output		Adjustment		Remarks
				Type	Connect to	Points	Adjust to	
1	Signal Level	999 (1000) kHz	AM SSG	—	—	VR401	Light "TUNED" on FL Display	SSG OUTPUT 74dB μ (EMF)

Audio Section

Idling Current

Required measurement equipment : DC Voltmeter

Preparation

- (1) Avoid direct blow from an air conditioner or an electric fan, and adjust the unit at normal room temperature 15 °C ~ 30 °C (59 °F ~ 86 °F).
- (2) Presetting
 - POWER (Power source switch) → OFF
 - SPEAKER (Speaker terminal) → No load (Do not connect speaker, dummy resistor, etc.)

Adjustment

- (1) Remove top cover and set VR101, VR102, VR103, VR104, VR105 on Amp. Unit at full counterclockwise (◯) position.
- (2) Connect DC Voltmeter to test points (FRONT-Lch: TP104, FRONT-Rch: TP105, CENTER ch: TP103, SURROUND-Lch: TP101, SURROUND-Rch: TP102).
- (3) Connect power cord to AC Line, and turn power switch "ON".
- (4) Presetting.
 - MASTER VOLUME : "----" counterclockwise (◯) min.
 - MODE : 5CH STEREO
 - FUNCTION : CD
- (5) Within 2 minutes after the power on, turn VR101 clockwise (◯) to adjust the TEST POINT voltage to 1.5 mV ±0.5 mV DC.
- (6) After 10 minutes from the preset above, turn VR101 to set the voltage to 2.5 mV ±0.5 mV DC.
- (7) Adjust the Variable Resistors of other channels in the same way.

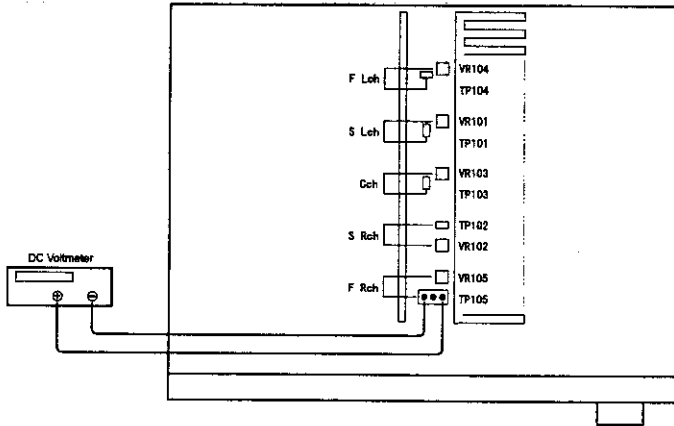

SEMICONDUCTORS

- IC's
- CXP740096
- (IC201)

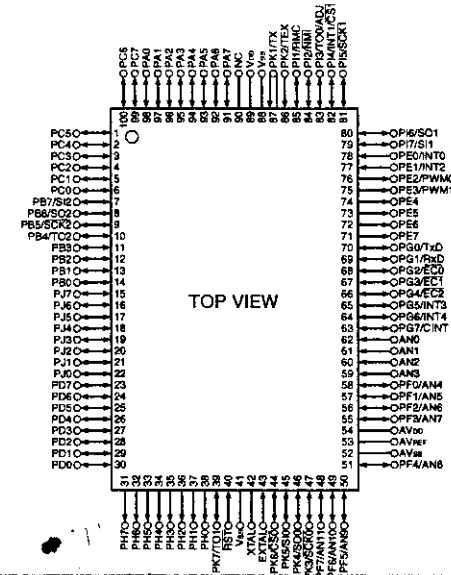

CXP740096 Terminal Function

Pin No.	Pin Name	I/O	Function
1	9273 STB	O	TC9273 CONTROL
2	9273 9164 CLK	O	TC9273/TC9164 CONTROL
3	9273 9164 DAT	O	TC9273/TC9164 CONTROL
4	SW SUM	O	SW SUMMING CONTROL
5	SEL_CLK	O	SEL_CLK
6	ERR MUTE	O	ERR MUTE
7	89055 AUTO	O	LC89055 CONTROL
8	89055 AUDIO	I	LC89055 CONTROL
9	89055 EMPHA	I	LC89055 CONTROL
10	SRAM CE	O	SRAM (IC833) CONTROL
11	49326 ABOOT	O	CS49326 CONTROL
12	ROM 3	O	ROM (IC807) CONTROL
13	ROM 30	O	ROM (IC807) CONTROL
14	ROM 2	O	ROM (IC807) CONTROL
15	49326 RST	O	CS94326 RESET
16	49326 CE	O	CS94326 CE
17	SCLK	O	LC89055/AK4527/CS49326 CLOCK
18	89055 CE	O	LC89055 CE
19	4527 CE	O	AK4527 CE
20	4527 RST	O	AK4527 RESET
21	9164 ST	O	TC9164 CONTROL
22	SW MUTE	O	SW MUTE
23	RELAY FRONT B	O	FRONT B RELAY

Pin No.	Pin Name	I/O	Function
24	RELAY FRONT A	O	FRONT A RELAY
25	RELAY SURR	O	SURROUND RELAY
28	RELAY CNT	O	CENTER RELAY
27	RELAY H/P	O	H/P RELAY
28	RELAY POWER	O	POWER RELAY
29	CNT MUTE	O	CENTER MUTE
30	FRONT MUTE	O	FRONT MUTE
31	VIDEO MUTE	O	VIDEO MUTE
32	SURR MUTE	O	SURROUND MUTE
33	NC	-	
34	FL DRV RST	O	LC75721NE RESET
35	NC	-	
36	NC	-	
37	NC	-	
38	SW ATT CTRL	O	SW. ATT. CONTROL
39	CINE EQ CTRL	O	CINEMA EQ. CONTROL
40	RESET	I	RESET
41	GND	I	
42	XTAL	-	
43	EXTAL	-	
44	FL DRV CE	O	LC75721NE CE
45	FL DRV DATA	O	LC75721NE DATA
46	FL DRV/2090 CLK	O	CONTROL CLOCK
47	2090 DATA	O	BU2090F DATA
48	VOL DOWN	I	ENCODER INPUT (VOLUME)
49	VOL UP	I	ENCODER INPUT (VOLUME)
50	SEL DOWN	I	ENCODER INPUT (SELECT)
51	SEL UP	I	ENCODER INPUT (SELECT)
52	AVss	-	
53	VREF	-	
54	AVdd	-	
55	NC	-	
56	GND	-	
57	STEP OPT	I	AREA SELECT
58	SET OPT	I	MODEL SELECT
59	GND	-	
60	KEY IN3	I	KEY INPUT
61	KEY IN2	I	KEY INPUT
62	KEY IN1	I	KEY INPUT
63	9K/10K STEP	I	TUNER STEP SELECT
64	PROTECT	I	PROTECTION
65	89055 RST	O	LC89055 RESET
66	SDIN	I	LC89055/AK4527/CS49326 DATA INPUT
67	SDIO	O	LC89055/AK4527/CS49326 SDIO
68	ROM CE	O	ROM (IC807) CONTROL
69	FUNC DOWN	I	ENCODER INPUT (FUNCTION)
70	FUNC UP	I	ENCODER INPUT (FUNCTION)
71	NC	-	
72	NC	-	
73	NC	-	
74	NC	-	
75	NC	-	
76	NC	-	
77	PWR DOWN	I	POWER DOWN DETECT
78	RDS CLK	I	TDA7330 CONTROL CLOCK
79	RDS DATA	I	TDA7330 CONTROL DATA

Pin No.	Pin Name	I/O	Function
80	NC	-	
81	NC	-	
82	49326 INTREQ	I	CS49326 INTREQ
83	74HC151 A0	O	IC832 CONTROL
84	74HC151 A1	O	IC832 CONTROL
85	REMOCON	I	REMOTE CONTROL SIGNAL INPUT
86	GND	-	
87	GND	-	
88	Vss	-	
89	Vdd	-	VDD BACK UP
90	NC	-	
91	M62446 CE	O	M62446 CONTROL
92	PLL DATA	O	M62446/PLL CONTROL
93	PLL CLK	O	M62446/PLL CONTROL
94	PLL DT IN	I	PLL CONTROL
95	TU MUTE	O	TUNER MUTE
96	STEREO	I	STEREO DETECT
97	TUNED	I	TUNED DETECT
98	PLL CE	O	PLL CONTROL
99	SEL 2	O	LA7952 CONTROL (VIDEO)
100	SEL 1	O	LA7952 CONTROL (VIDEO)

**CS49326-CL
(IC812)**

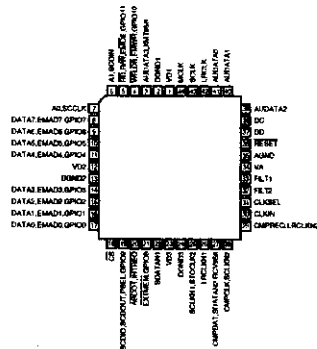

CS49326-CL Terminal Function

Pin No.	Pin Name	Function
1	VD1	Digital positive supply
2	DGND1	Digital supply ground
3	AUDATA3_XMT958	SPDIF transmitter output, Digital audio output 3
4	W/R_CS, EMWR, GPIO10	Host write strobe or host data strobe or external memory write enable or general purpose input & output number 10
5	R/D_R/W, EMOE, GPIO11	Host parallel output enable or host parallel R/W or external memory output enable or general purpose input & output number 11
6	A1, SCDIN	Host address bit one or SPI serial control data input
7	A0, SCCLK	Host parallel address bit zero or serial control port clock
8	DATA7, EMAD7, GPIO7	
9	DATA6, EMAD6, GPIO6	
10	DATA5, EMAD5, GPIO5	
11	DATA4, EMAD4, GPIO4	
12	VD2	Digital positive supply
13	DGND2	Digital supply ground
14	DATA3, EMAD3, GPIO3	
15	DATA2, EMAD2, GPIO2	
16	DATA1, EMAD1, GPIO1	
17	DATA0, EMAD0, GPIO0	
18	CS	Host parallel chip select, host serial SPI chip select
19	SCDIO, SCDOOUT, PSEL, GPIO9	Serial control port data input and output, parallel port type select
20	INTREQ, ABOOT	Control port interrupt request, automatic boot enable
21	EXTMEM, GPIO8	External memory chip select or general purpose input & output number 8
22	SDATAN1	PCM audio data input number one
23	VD3	Digital positive supply
24	DGND3	Digital supply ground
25	SCLKN1, STCLK2	PCM audio input bit clock
26	LRCLKIN1	PCM audio input sample rate clock
27	CMPDAT, SDATAN2, RCV958	PCM audio data input number two
28	CMPCLK, SCLKN2	PCM audio input bit clock
29	CMPFREQ, LRCLKN2	PCM audio input sample rate clock
30	CLKIN	Master clock input
31	CLKSEL	DSP clock select
32	FILT2	Phase locked loop filter
33	FILT1	Phase locked loop filter
34	VA	Analog positive supply
35	AGND	Analog supply ground
36	RESET	Master reset input
37	DD	Reserved
38	DC	Reserved
39	AUDATA2	Digital audio output 2
40	AUDATA1	Digital audio output 1
41	AUDATA0	Digital audio output 0
42	LRCLK	Audio output sample rate clock
43	SCLK	Audio output bit clock
44	MCLK	Audio master clock

LC89055W (IC810)

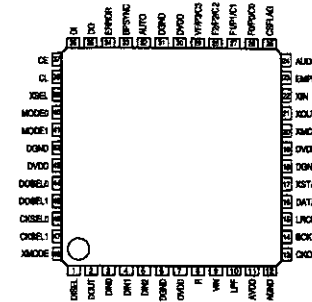

LC89055W Terminal Function

Pin No.	Pin Name	I/O	Function
1	DISEL	I	Data input terminal (select input pin of DINO, DIN1)
2	DOUT	O	Input bi-phase data through output terminal
3	DINO	I	Amp built-in coaxial/optical input correspond data input terminal
4	DIN1	I	Amp built-in coaxial/optical input correspond data input terminal
5	DIN2	I	Optical input correspond data input terminal
6	DGND		Digital GND
7	DVDD		Digital power supply
8	R	I	VCO gain control input terminal
9	VIN	I	VCO free-run frequency setting input terminal
10	LPF	O	PLL loop filter setting terminal
11	AVDD		Analog power supply
12	AGND		Analog GND
13	CKOUT	O	Clock output terminal (256fs, 384fs, 512fs, X'tal osc., VCO free-run osc.)
14	BCK	O	64fs clock output terminal
15	LRCK	O	fs clock output terminal (L: Rch, H: Lch, IFS: Reverse)
16	DATA0	O	Data output terminal
17	XSTATE	O	Input data detecting result output terminal
18	DGND		Digital GND
19	DVDD		Digital power supply
20	XMODE	O	X'tal osc. clock output terminal (24.576MHz or 12.288MHz)
21	XOUT	O	X'tal osc. connection output terminal
22	XIN	I	X'tal osc. connection input terminal, external signal input possible (24.576MHz or 12.288MHz)
23	EMPHA	O	Emphasis information output terminal of channel status
24	AUDIO	O	Bit1 output terminal of channel status
25	CSFLAG	O	Top 40bit revise flag output terminal of channel status
26	F0/P0/C0	O	Input fs cal. sig. out/data type out/input word inf. output terminal
27	F1/P1/C1	O	Input fs cal. sig. out/data type out/input word inf. output terminal
28	F2/P2/C2	O	Input fs cal. sig. out/data type out/input word inf. output terminal
29	VF/P3/C3	O	Validity flag out/data type out/input word inf. output terminal
30	DVDD		Digital power supply
31	DGND		Digital GND
32	AUTO	O	Non PCM burst data transfer detect sig. output terminal
33	BPSYNC	O	Non PCM burst data preamble Pa, Pb, Pc, Pd sync sig. output terminal
34	ERROR	O	PLL lock error, data error flag output terminal
35	DO	O	CPU/I/FD read data output terminal
36	DI	I	CPU I/F write data input terminal
37	CE	I	CPU I/F chip enable input terminal
38	CL	I	CPU I/F chip enable input terminal
39	XSEL	I	Frequency select input pin of XIN X'tal osc. (24.576MHz or 12.288MHz)
40	MODE0	I	Mode setting input terminal
41	MODE1	I	Mode setting input terminal
42	DGND		Digital GND
43	DVDD		Digital power supply
44	DOSEL0	I	Data output format select input terminal
45	DOSEL1	I	Data output format select input terminal
46	CKSEL0	I	Output clock select input terminal
47	CKSEL1	I	Output clock select input terminal
48	XMODE	I	Reset input terminal

* For latch-up countermeasure, set digital (DVDD) and analog (AVDD) power on/off in the same timing.

AK4527BVQ (IC813)

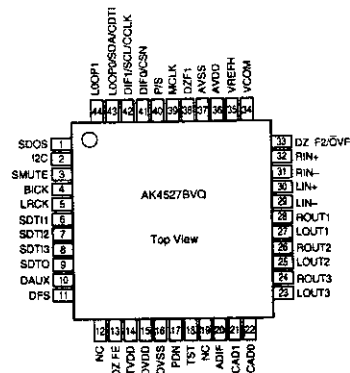

AK4527BVQ Terminal Function

Pin No.	Pin Name	I/O	Function
1	SDOS	I	SDTO source select pin, L: Internal ADC output, H: DAUX input
2	I2C	I	Serial control mode select pin, L: 3-core serial, H: I ² C bus
3	SMUTE	I	Soft mute pin, H: Soft mute start, L: Release
4	BICK	I	Audio serial data clock pin
5	LRCK	I	Input channel clock pin
6	SDTI1	I	DAC1 audio serial data input pin
7	SDTI2	I	DAC2 audio serial data input pin
8	SDTI3	I	DAC3 audio serial data input pin
9	SDTO	O	Audio serial data output pin
10	DAUX	I	Auxiliary audio serial data input pin
11	DFS	I	Double speed sampling mode pin, L: Normal, H: Double
12	NC	---	No Connect, No internal bonding
13	DZFE	I	Zero input detect enable pin
14	TVDD	---	Power pin for output buffer, 2.7V-5.5V
15	DVDD	---	Digital power pin, 4.5V-5.5V
16	DVSS	---	Digital GND pin, 0V
17	PDN	I	Power down & reset pin, L: Powered-down and register initialized, Reset with PDN when switching P/S or CAD0-1
18	TST	I	Test pin, connected to DVSS
19	NC	---	No Connect, No internal bonding
20	ADIF	I	Analog Input Format Select pin
21	CAD1	I	Chip address-1 pin
22	CAD0	I	Chip address-0 pin
23	LOUT3	O	DAC3L channel analog out pin
24	ROUT3	O	DAC3R channel analog out pin
25	LOUT2	O	DAC2L channel analog out pin
26	ROUT2	O	DAC2R channel analog out pin
27	LOUT1	O	DAC1L channel analog out pin
28	ROUT1	O	DAC1R channel analog out pin
29	LIN-	I	L-ch analog inverted input pin
30	LIN+	I	L-ch analog non-inverted input pin
31	RIN-	I	R-ch analog inverted input pin
32	RIN+	I	R-ch analog non-inverted input pin
33	DZF2/OVF	O	0 input detect 2 pin/Analog input overflow detect pin
34	VCOM	O	Common V-out pin, AVDD/2, connect large capacitor to avoid noise
35	VREFH	I	Ref. V input pin, AVDD
36	AVDD	---	Analog GND pin, 4.5V-5.5V
37	AVSS	---	Analog GND pin, 0V
38	DZF1	O	0 input detect pin, H: Input data of G1 is 8192 times "0" in a raw or RSTN bit "0"
39	MCLK	I	Master clock input pin
40	P/S	I	Parallel/Serail select pin, L: Serial control
41	DIF0	I	Audio data I/F format 0 pin (parallel control)
42	CSN	I	Chip select pin (3-wire serial control), connect to DVDD when I ² C bus control
43	DIF1	I	Audio data I/F format 1 pin (parallel control)
44	SCL/CCLK	I	Control data clock pin (serial control), I ² C="L": CCLK (3-wire serial), I ² C="H": SCL (I ² C bus)
45	LOOP0	I	Loop back mode 0 pin (parallel control), effects digital loop back ADC to all DAC
46	SDA/CDTI	I/O	Control data input pin (serial control), I ² C="L": CDTI (3-wire serial), I ² C="H" SDA (I ² C bus)
47	LOOP1	I	Loop back mode 1 pin, from SDTI1 to all DAC

LC72131 (IC401)

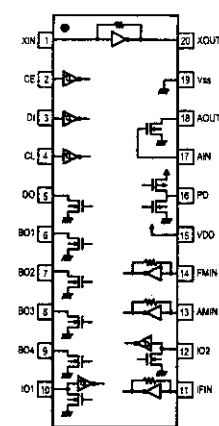

LA1266 (IC402)

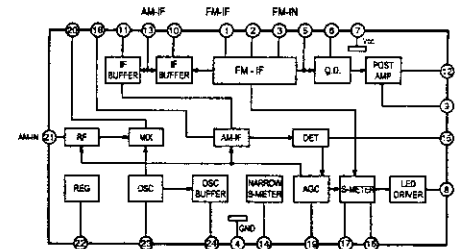
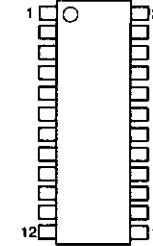

LA3401 (IC403)

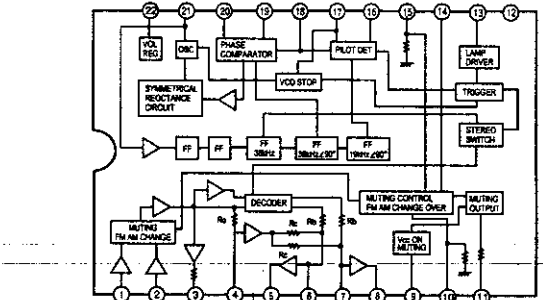

BU2090F (IC302)

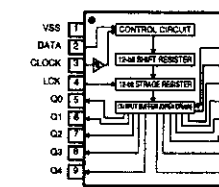

TDA7330BD (IC202)

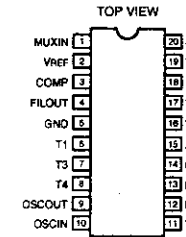

MM74LCX244 (IC818,819)

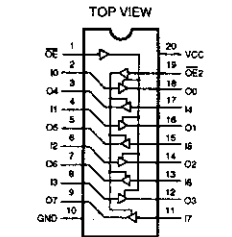

MM74HC151 (IC832)

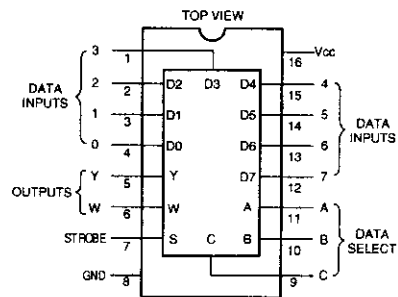

RC1117S25T (IC820)
RC1117S33ST (IC811)

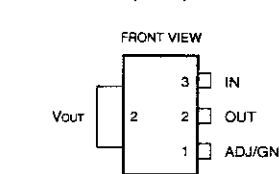

LC75721E (IC301)

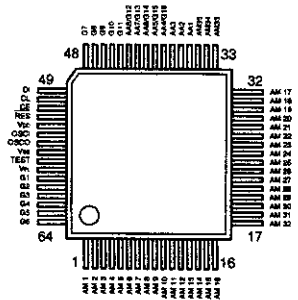

LC75721E Terminal Function

Symbol	Function
Vcc	Power terminal +5V
Vss	Power terminal GND
DI	Serial data transfer terminal
CL	CL: Data
CE	CE: Clock
CE	CE: Chip enable
OSCI	External CR connecting terminal
OSCO	External CR connecting terminal
RES	System reset terminal
AM1-AM35	Anode output terminal
AA1-AA3	Anode/Grid output terminal
AA4/G18	Anode/Grid output terminal
AA5/G15	Anode/Grid output terminal
AA6/G14	Anode/Grid output terminal
AA7/G13	Anode/Grid output terminal
AA8/G12	Anode/Grid output terminal
G1-G11	Grid output terminal
TEST	LSI test terminal

KIC9164AN (IC221)

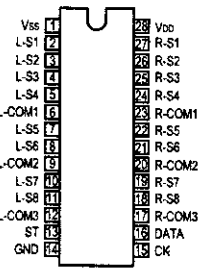

TC9273N-007 (IC701)

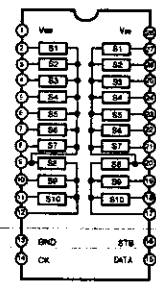

TC9273N Terminal Function

Pin No.	Symbol	Name	Function
1	Vcc	+ Power Terminal	Dual Power Use: Vcc=8.0-17V Single Power Use: Vcc=8.0-18V
13	GND	Digital Ground	GND=0V
28	Vcc	+ Power Terminal	Vss=-8.0-17V
2-12	S1-S10	I/O Terminal	Input terminal of analog switch.
14	CK	Clock Input	Clock input for data transfer.
15	DATA	Data Input	Serial input for switch setting.
16	STB	Strobe Input	Strobe Input Strobe input for data writing.

W27W201 (IC807)

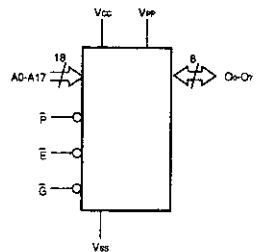
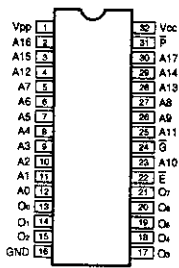

NJM2068DD (IC241,251,261,271,281,291,702,703)
BA4510F (IC805,806)
NJM2068MD (IC814-816)

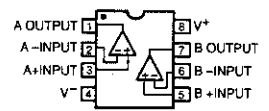

SN74LV00APW (IC822)

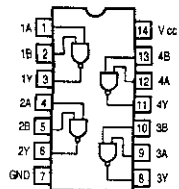

74HCU04 (IC803)

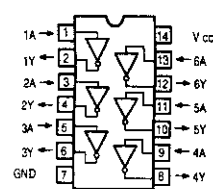

LA7952 (IC601,651,652)

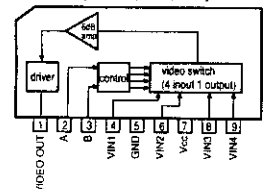

SN74LV4040 (IC831)

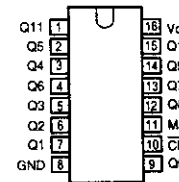

Terminal Function

INPUTS		OUTPUTS
CP	MR	Qn
↑	L	no change
↓	L	count
X	H	L

H=HIGH voltage level
L=LOW voltage level
X=don't care
↑=LOW-to-HIGH clock transition
↓=HIGH-to-LOW clock transition

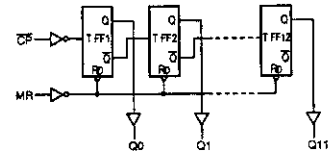

M62446FP (IC231)

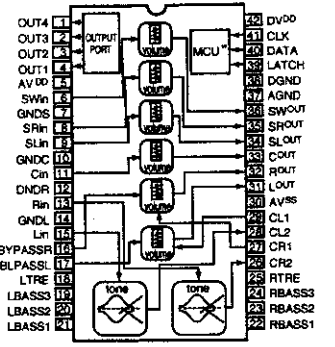

KIA7805AP (IC104)

KIA7815AP (IC101)
NJM7805FA (IC103,829)
NJM7812FA (IC602)

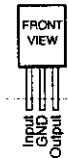

NJM7915FA (IC102)

MM74LCX574 (IC808,809)

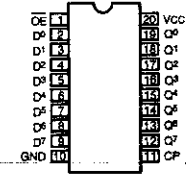

MM74HCT244 (IC828,830)

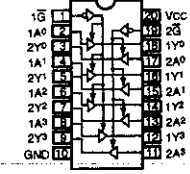

OPTICAL

INPUT
GP1FA502RZ (IC802)

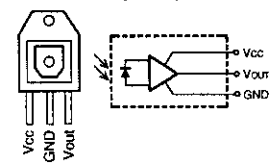

IC PROTECTOR

ICP-N15 (IC105)

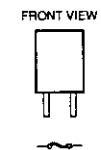

IR SENSOR

NJL64H380A(RMC301)

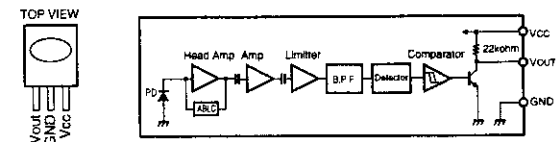

POSISTOR

P437D330BW16



● TRANSISTORS

DTA114ES
DTC114TS
DTC114YS
DTC144ES

DTA114EK
DTA114YK
DTA144EK
DTC114EK
DTC114YK
DTC144EK

DTA Series

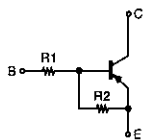

	R1	R2
DTA114EK	10kohm / Ω	10kohm / Ω
DTA114ES	10kohm / Ω	10kohm / Ω
DTA114YK	10kohm / Ω	47kohm / Ω
DTA144EK	47kohm / Ω	47kohm / Ω

DTC Series

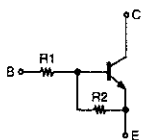

	R1	R2
DTC114EK	10kohm / Ω	10kohm / Ω
DTC114TS	10kohm / Ω	—
DTC114YK	10kohm / Ω	47kohm / Ω
DTC114YS	10kohm / Ω	47kohm / Ω
DTC144EK	47kohm / Ω	47kohm / Ω
DTC144ES	47kohm / Ω	47kohm / Ω

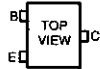
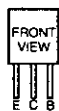

2SC1740S
2SC3199Y
KSA916Y
KSA992F
KSC1845F
KTA1266Y
KTA1268BL
KTC2874B
KTC3198Y
KTC3200BL

2SC2412K
KTC3880S

2SK117

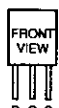
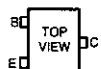

● DIODES (LED included)

MTZJ3.3B
MTZJ5.1B
MTZJ5.6B
MTZJ6.8B
MTZJ7.5A
MTZJ7.5B
MTZJ11B
MTZJ18B
MTZJ20B



1N4007
1N4148



1N4148WS



HL-50RDRF4T

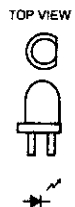

KBPC604

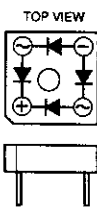

FL DISPLAY

16-ST-66GNK (FL301)

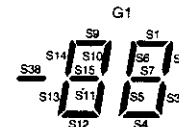
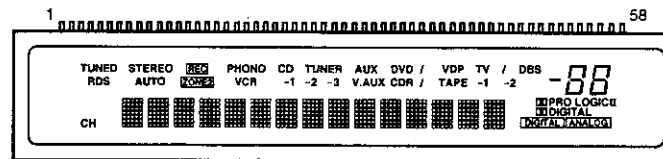

G2-G16

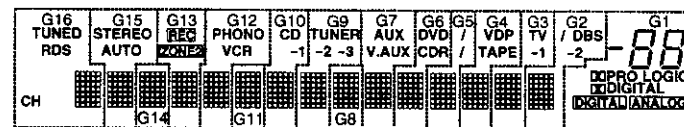

Pin Assignment

PIN NO.	1	2	3	4	5	6	7	8	9	10	11	12	13	14	15	16	17	18	19	20
CONNECTION	F1	F1	S1	S2	S3	S4	S5	S6	S7	S8	S9	S10	S11	S12	S13	S14	S15	S16	S17	S18
PIN NO.	21	22	23	24	25	26	27	28	29	30	31	32	33	34	35	36	37	38	39	40
CONNECTION	S19	S20	S21	S22	S23	S24	S25	S26	S27	S28	S29	S30	S31	S32	S33	S34	S35	S36	S37	S38
PIN NO.	41	42	43	44	45	46	47	48	49	50	51	52	53	54	55	56	57	58		
CONNECTION	G16	G15	G14	G13	G12	G11	G10	G9	G8	G7	G6	G5	G4	G3	G2	G1	F2	F2		

F1, F2 : Filament
G1-G16: Grid
S1-S38 : Anode

Anode & Grid Assignment

	G1	G2-G16		G1	G2-G16		G1	G2-G16		G1	G2-G16
S1	S1	S1	S10	S10	S10	S19	—	S19	S28	—	S28
S2	S2	S2	S11	S11	S11	S20	—	S20	S29	—	S29
S3	S3	S3	S12	S12	S12	S21	—	S21	S30	—	S30
S4	S4	S4	S13	S13	S13	S22	—	S22	S31	—	S31
S5	S5	S5	S14	S14	S14	S23	—	S23	S32	—	S32
S6	S6	S6	S15	S15	S15	S24	—	S24	S33	—	S33
S7	S7	S7	S16	—	S16	S25	—	S25	S34	—	S34
S8	—	S8	S17	PRO LOGIC II	S17	S26	—	S26	S35	—	S35
S9	S9	S9	S18	PRO LOGIC I	S18	S27	—	S27			

	G1	G2	G3	G4	G5	G6	G7	G8	G9	G10	G11	G12	G13	G14	G15	G16
S36	DIGITAL	/	TV	VDP	(DVD)	DVD	AUX	—	TUNER	CD	—	PHONO	REC	—	STEREO	TUNED
S37	ANALOG	-2	-1	TAPE	(MD)	CDR	V.AUX	—	-2	-1	—	VCR	ZONE2	—	AUTO	RDS
S38	S38	DBS	—	—	—	—	—	-3	—	—	—	—	—	—	—	CH

PRINTED WIRING BOARDS

MAIN P.W.B. UNIT

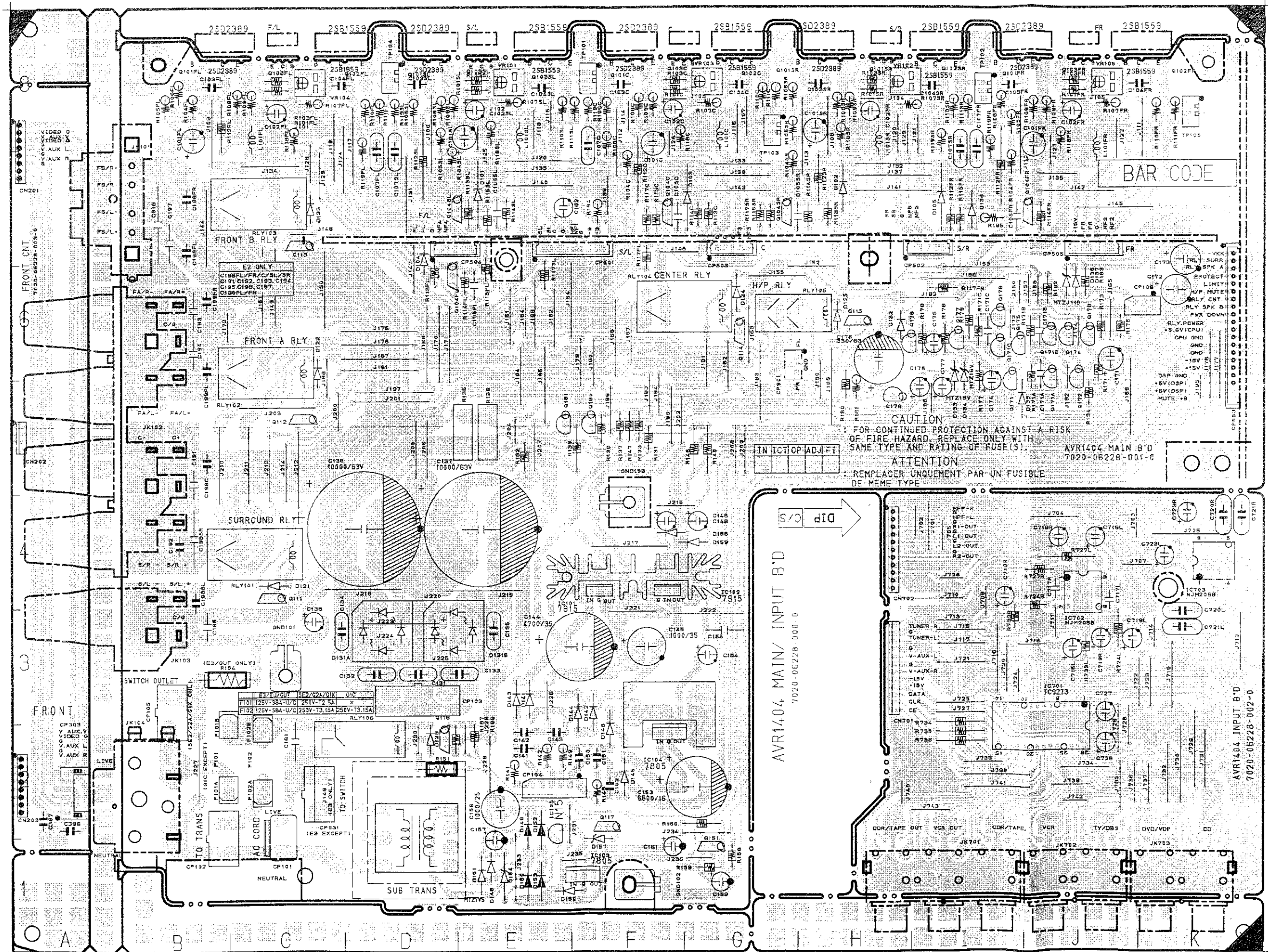

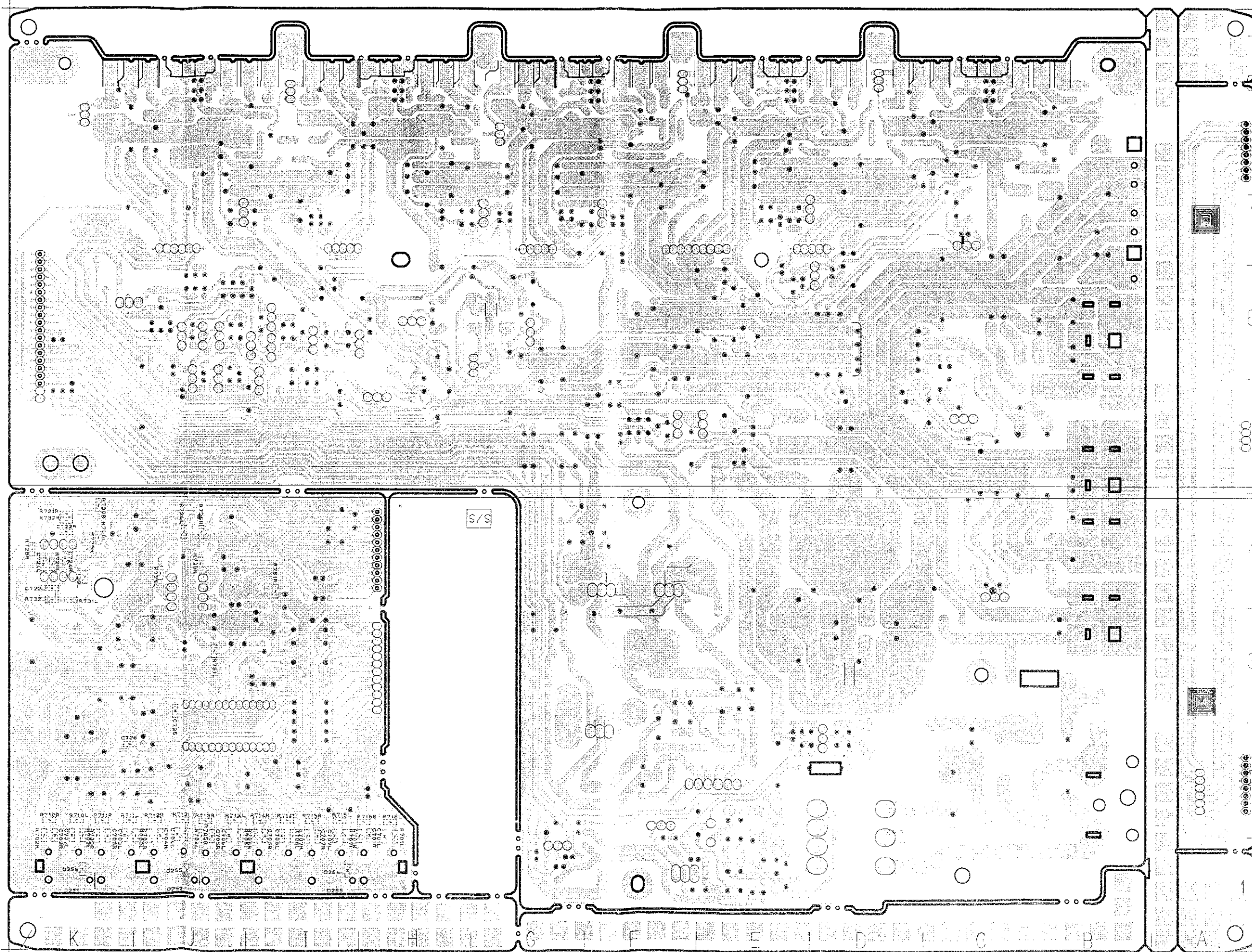

FOIL SIDE

CPU P.W.B. UNIT

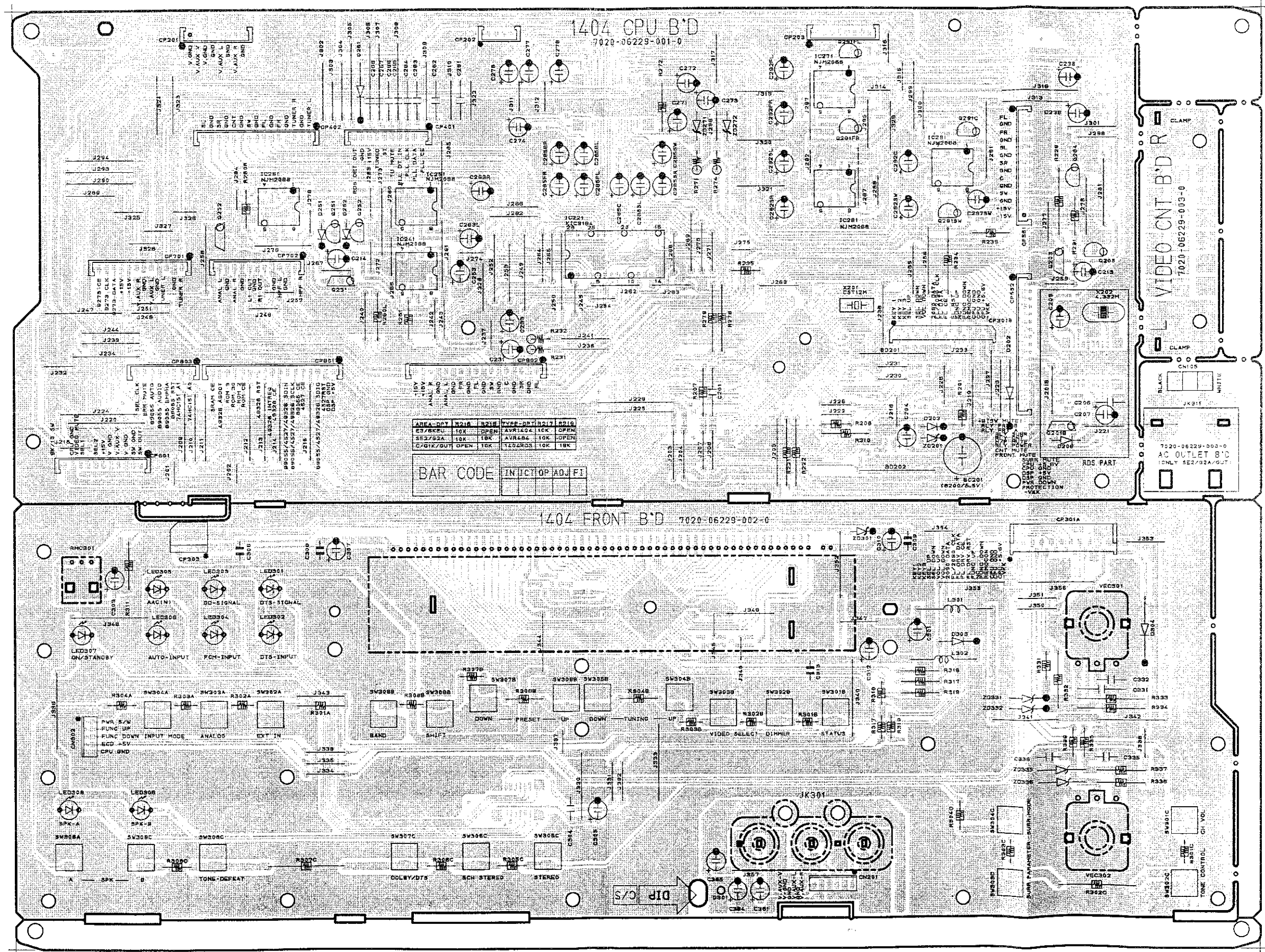

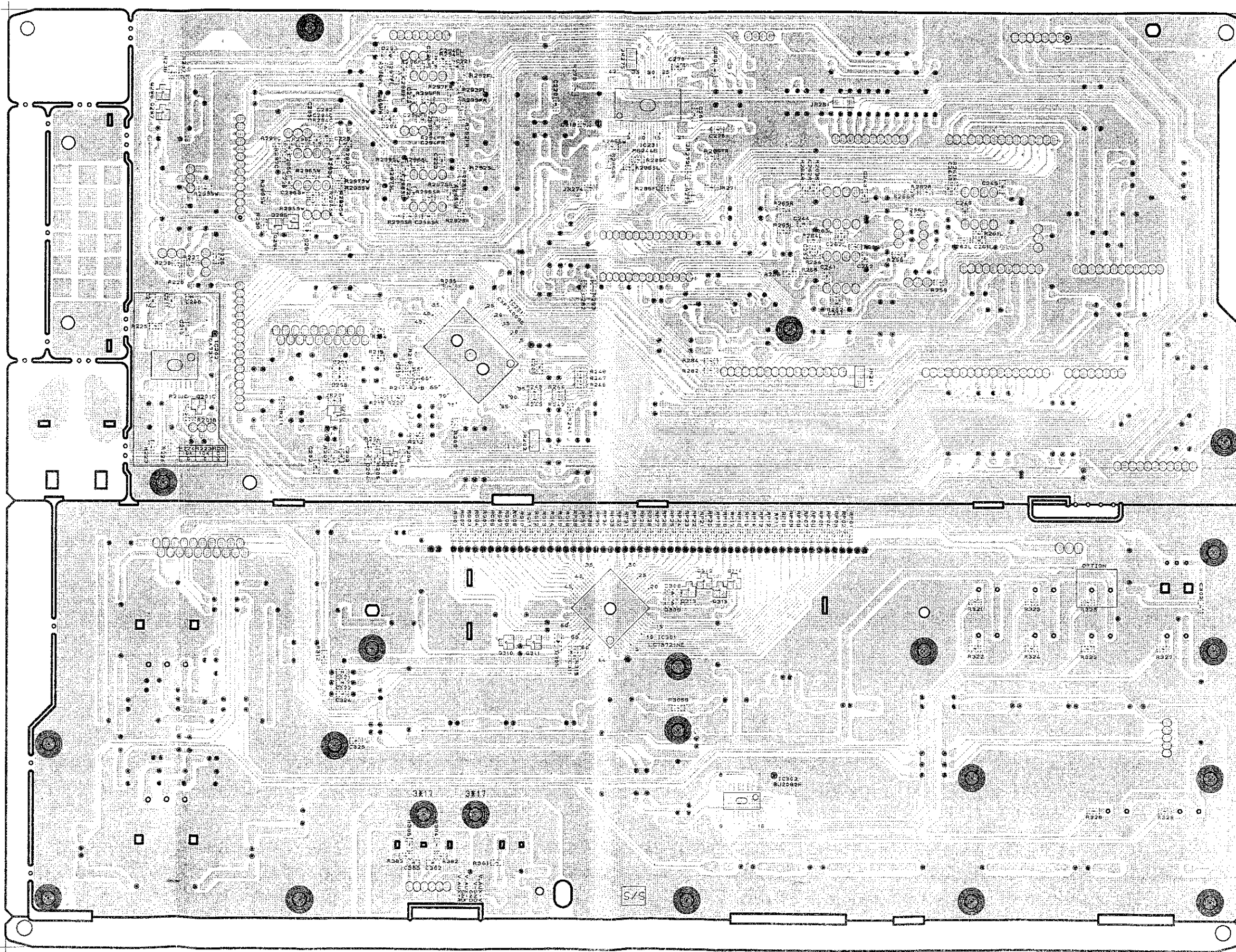

FOIL SIDE

CONNECTION P.W.B. UNIT

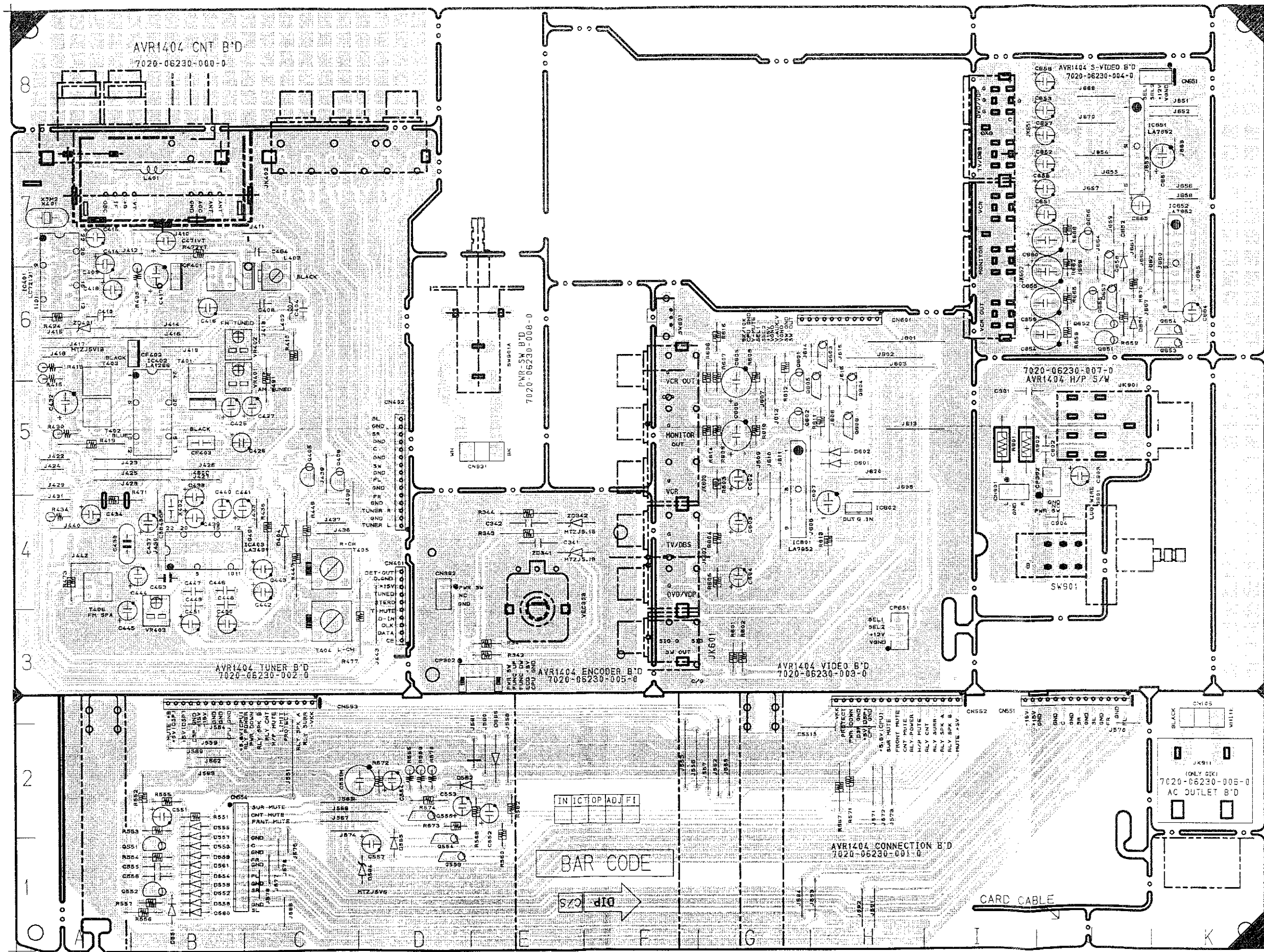

COMPONENT SIDE

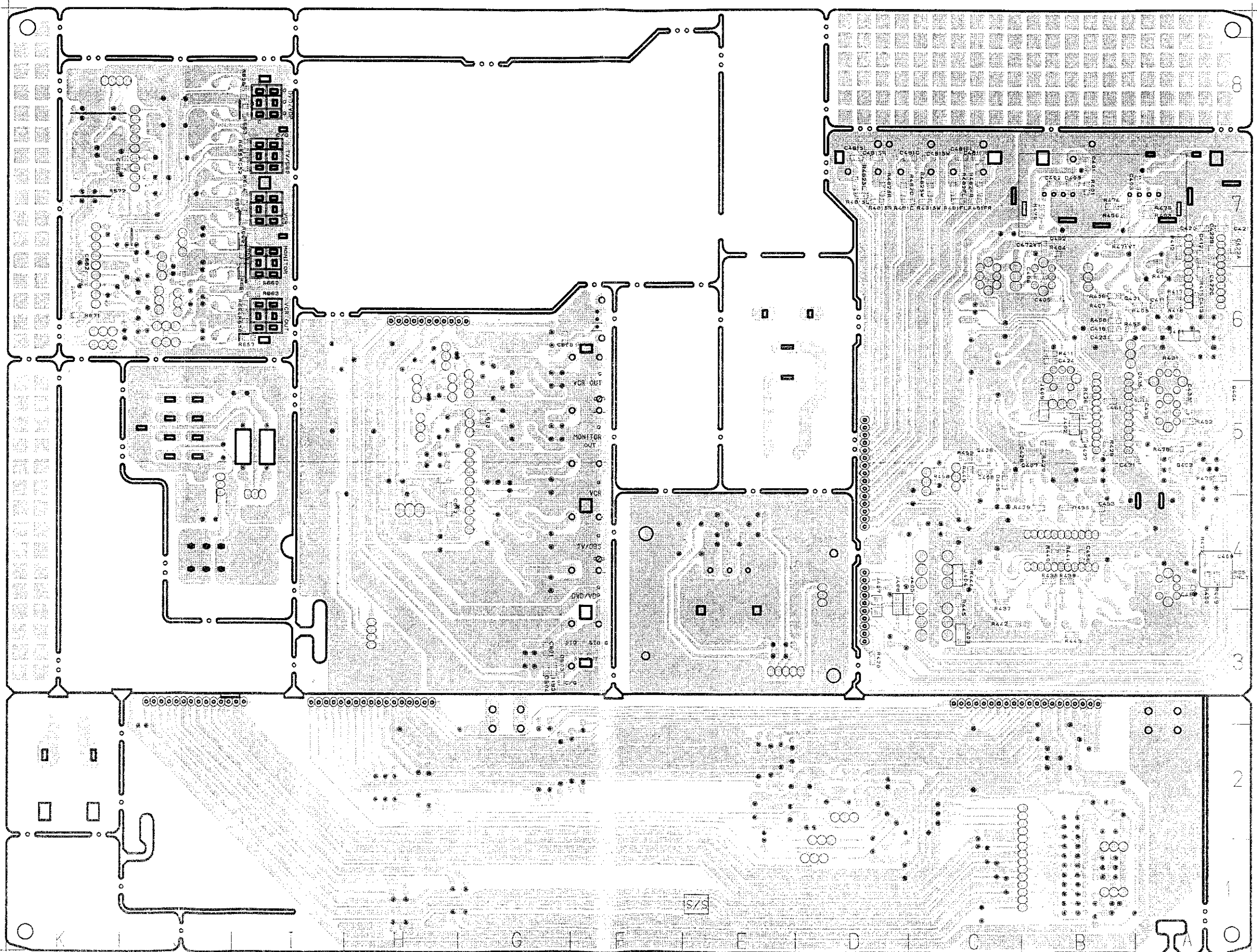

FOIL SIDE

PRE AMP P.W.B. UNIT

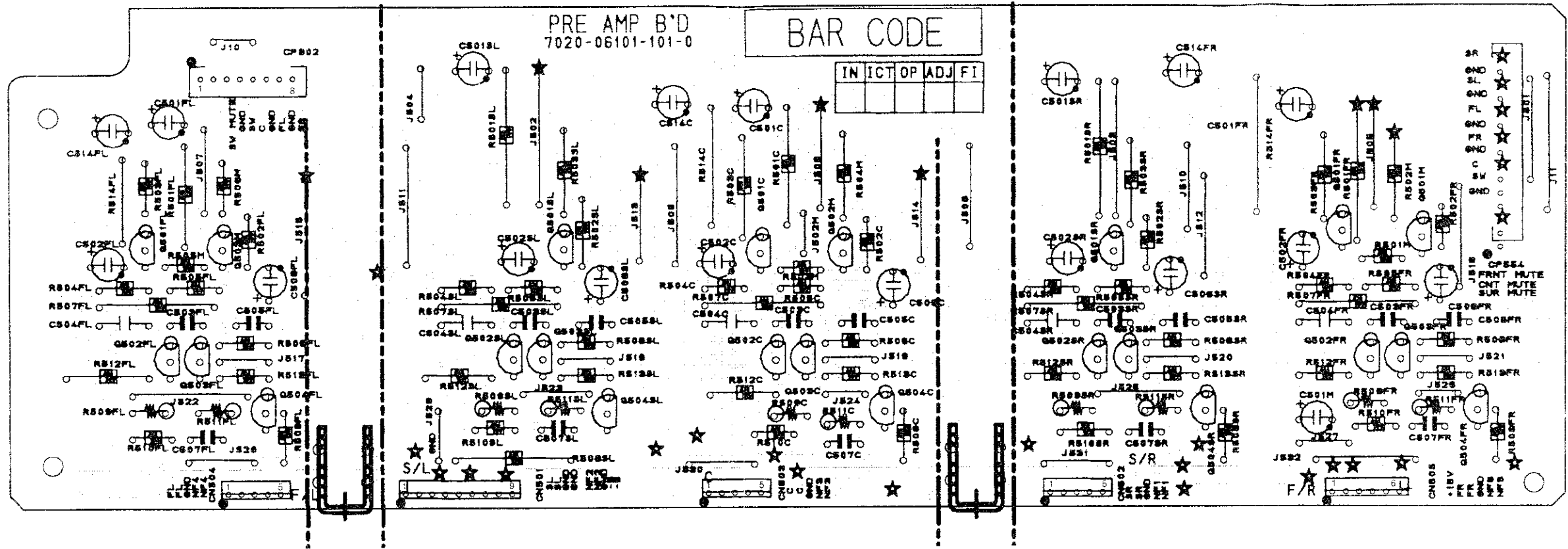

COMPONENT SIDE

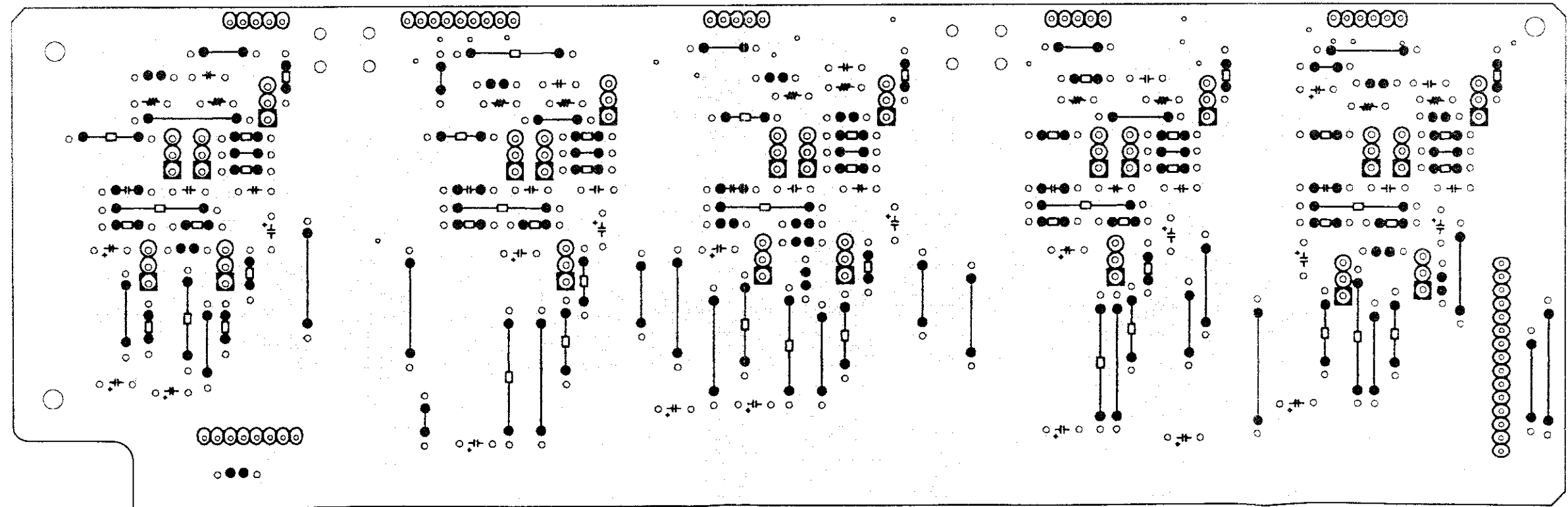

FOIL SIDE

DSP P.W.B. UNIT

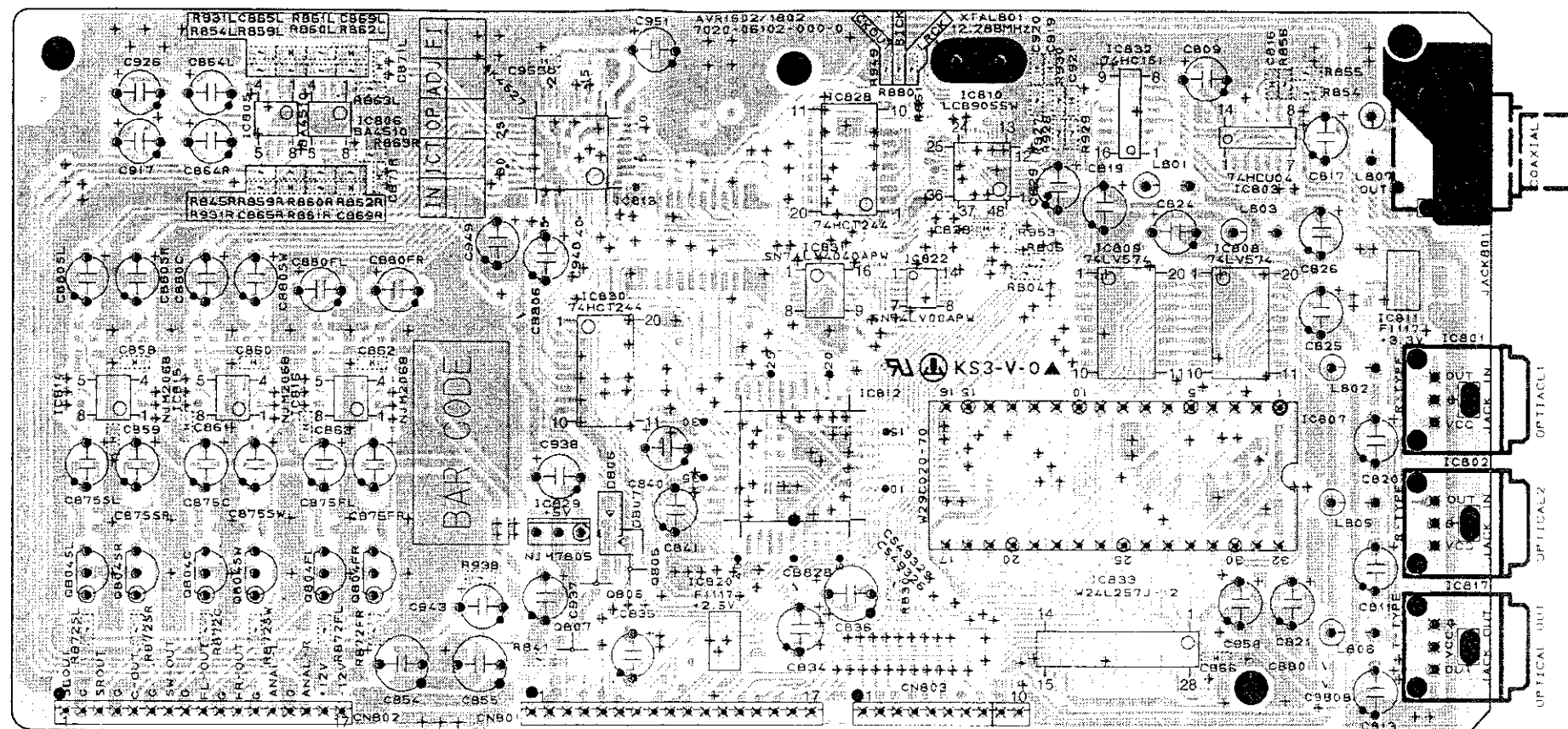

COMPONENT SIDE

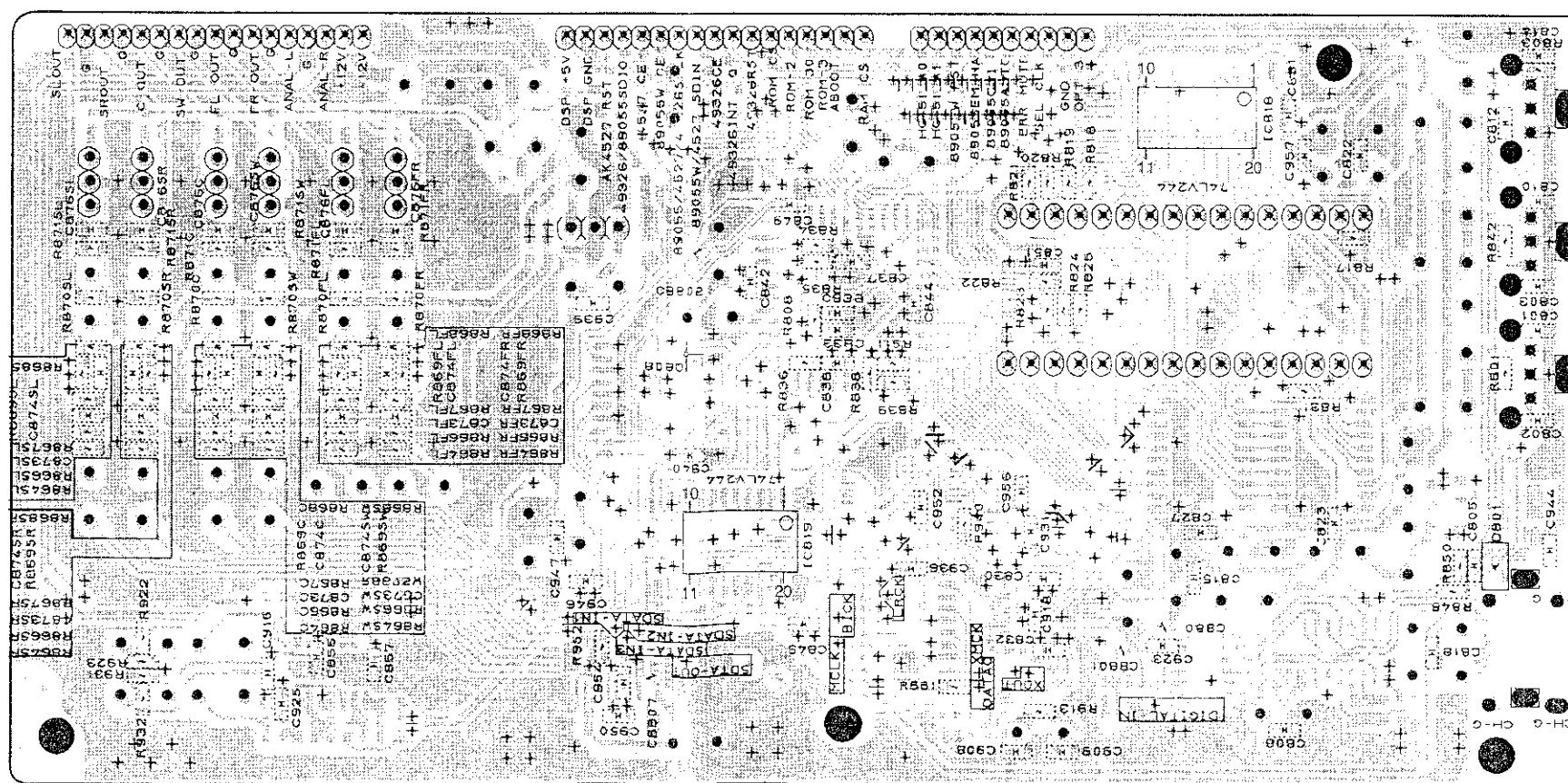

FOIL SIDE

NOTE FOR PARTS LIST

- Part indicated with the mark "⊙" are not always in stock and possibly to take a long period of time for supplying, or in some case supplying of part may be refused.
- When ordering of part, clearly indicate "I" and "I" (i) to avoid mis-supplying.
- Ordering part without stating its part number can not be supplied.
- Part indicated with the mark "★" is not illustrated in the exploded view.
- Not including Carbon Film Resistor ±5%, 1/4W Type in the P.W.Board parts list. (Refer to the Schematic Diagram for those parts.)
- Not including Carbon Chip Resistor 1/16W Type in the P.W.Board parts list. (Refer to the Schematic Diagram for those parts.)

WARNING:

Parts marked with this symbol \triangle have critical characteristics. Use ONLY replacement parts recommended by the manufacturer.

● Resistors

Ex.: RN 14K 2E 182 G FR
 Type Shape Power Resist- Allowable Others
 performance ance error

RD : Carbon	2B : 1/8W	F : ±1%	P : Pulse-resistant type
RC : Composition	2E : 1/4W	G : ±2%	NL : Low noise type
RS : Metal oxide film	2H : 1/2W	J : ±5%	NB : Non-burning type
RW : Winding	3A : 1W	K : ±10%	FR : Fuse-resistor
RN : Metal film	3D : 2W	M : ±20%	F : Lead wire forming
RK : Metal mixture	3F : 3W		
	3H : 5W		

*** Resistance**

$\overset{1}{\uparrow} \overset{2}{\uparrow} \overset{3}{\uparrow} \Rightarrow 1800 \text{ ohm} = 1.8 \text{ kohm}$
 Indicates number of zeros after effective number.
 2-digit effective number.

• Units: ohm

$\overset{1}{\uparrow} \overset{R}{\uparrow} \overset{2}{\uparrow} \Rightarrow 1.2 \text{ ohm}$
 1-digit effective number.
 2-digit effective number, decimal point indicated by R.

• Units: ohm

● Capacitors

Ex.: CE 04W 1H 2R2 M BP
 Type Shape Dielectric Capacity Allowable Others
 performance strength error

CE : Aluminum foil electrolytic	0J : 6.3V	F : ±1%	HS : High stability type
CA : Aluminum solid electrolytic	1A : 10V	G : ±2%	BP : Non-polar type
CS : Tantalum electrolytic	1C : 16V	J : ±5%	HR : Ripple-resistant type
CO : Film	1E : 25V	K : ±10%	DL : For charge and discharge
CK : Ceramic	1V : 35V	M : ±20%	HF : For assuring high frequency
CC : Ceramic	1H : 50V	Z : +80%	U : UL part
CP : Oil	2A : 100V	-20%	C : CSA part
CM : Mica	2B : 125V	P : +100%	W : UL-CSA type
CF : Metallized	2C : 160V	-0%	F : Lead wire forming
CH : Metallized	2D : 200V	C : ±0.25pF	
	2E : 250V	D : ±0.5pF	
	2H : 500V	= : Others	
	2J : 630V		

*** Capacity (electrolyte only)**

$\overset{2}{\uparrow} \overset{2}{\uparrow} \overset{2}{\uparrow} \Rightarrow 2200\mu\text{F}$
 Indicates number of zeros after effective number.
 2-digit effective number.

• Units: μF .

$\overset{2}{\uparrow} \overset{R}{\uparrow} \overset{2}{\uparrow} \Rightarrow 2.2\mu\text{F}$
 1-digit effective number.
 2-digit effective number, decimal point indicated by R.

• Units: μF .

*** Capacity (except electrolyte)**

$\overset{2}{\uparrow} \overset{2}{\uparrow} \overset{2}{\uparrow} \Rightarrow 2200\text{pF} = 0.0022\mu\text{F}$
 (More than 2) Indicates number of zeros after effective number.
 2-digit effective number.

• Units: pF.

$\overset{2}{\uparrow} \overset{2}{\uparrow} \overset{1}{\uparrow} \Rightarrow 220\text{pF}$
 (0 or 1) Indicates number of zeros after effective number.
 2-digit effective number.

• Units: pF.

• When the dielectric strength is indicated in AC, "AC" is included after the dielectric strength value.

部品表について

- 印の部品は常時在庫していませんので供給に長時間を要することがあります。場合によっては、供給をお断りすることがあります。
- 部品を発注する際は特に数字の "1" と英字の "I" との区別をはっきり記入してください。
- 部品番号を表示していない部品は供給できません。
- \triangle 印の部品は安全上重要な部品です。交換するときは、安全および性能維持のため必ず指定の部品をご使用ください。
- ★印のついている部品は分解図中には記載していません。
- カーボン抵抗器 ±5%、1/4W 型は記載していません。定数は回路図を参照願います。
- カーボンチップ抵抗器 1/16W 型は記載していません。定数は回路図を参照願います。
- 部品表の抵抗器、コンデンサの品名記号の読み方は表を参照してください。

●抵抗器

例) RN 14K 2E 182 G FR
 種類 形状特性 電力 抵抗値 許容差 その他

RD : カーボン	2B : 1/8 W	F : ±1%	P : 耐パルス形
RC : 固定体	2E : 1/4 W	G : ±2%	NL : 低雑音形
RS : 金属系皮膜	2H : 1/2 W	J : ±5%	NB : 不燃形
RW : 巻線	3A : 1 W	K : ±10%	FR : ヒューズ抵抗
RN : 金属皮膜	3D : 2 W	M : ±20%	F : リード線成形
RK : 金属混合体	3F : 3 W		
	3H : 5 W		

*** 抵抗値**

$\overset{18}{\uparrow} \overset{2}{\uparrow} \Rightarrow 1800\Omega = 1.8\text{k}\Omega$
 有効数字につづく0の数を表わす。
 2桁の有効数字を表わす。

$\overset{1R}{\uparrow} \overset{2}{\uparrow} \Rightarrow 1.2\Omega$
 1桁の有効数字を表わす。
 2桁の有効数字で小数点はRで表わす。
 : 単位は Ω

●コンデンサ

例) CE 04W 1H 2R2 M BP
 種類 形状特性 耐圧 容量 許容差 その他

CE : アルミ箔電解	0J : 6.3 V	F : ±1%	HS : 高安定形
CA : アルミ固体電解	1A : 10 V	G : ±2%	BP : 無極性形
CS : タンタル電解	1C : 16 V	J : ±5%	HR : 耐リップル形
CQ : フィルム	1E : 25 V	K : ±10%	DL : 充放電対策用
CK : セラミック	1V : 35 V	M : ±20%	HF : 高周波保護用
CC : セラミック	1H : 50 V	Z : +80%	U : UL 部品
CP : オイル	2A : 100 V	-20%	C : CSA 部品
CM : マイカ	2B : 125 V	P : +100%	W : UL-CSA 部品
CF : メタライズド	2C : 160 V	-0%	F : リード線成形
CH : メタライズド	2D : 200 V	C : ±0.25pF	
	2E : 250 V	D : ±0.5pF	
	2H : 500 V	= : その他	
	2J : 630 V		

*** 容量値**

●電解コンデンサの場合

$\overset{22}{\uparrow} \overset{2}{\uparrow} \Rightarrow 2200\mu\text{F}$
 有効数字につづく0の数を表わす。
 2桁の有効数字を表わす。
 : 単位は μF

$\overset{2R}{\uparrow} \overset{2}{\uparrow} \Rightarrow 2.2\mu\text{F}$
 1桁の有効数字を表わす。
 2桁の有効数字で小数点はRで表わす。
 : 単位は μF

●電解コンデンサ以外の場合

$\overset{22}{\uparrow} \overset{2}{\uparrow} \Rightarrow 2200\text{pF} = 0.0022\mu\text{F}$
 有効数字につづく0の数を表わす。
 (0の数が2以上の場合)
 2桁の有効数字を表わす。
 : 単位はpF

$\overset{22}{\uparrow} \overset{1}{\uparrow} \Rightarrow 220\text{pF}$
 有効数字につづく0の数を表わす。
 (0の数が0または1の場合)
 2桁の有効数字を表わす。
 : 単位はpF

●耐圧を交流で表示する場合は、耐圧表示の次に「AC」を表示します。

PARTS LIST OF P.W.B. UNIT

Note: The symbols in the column "Remarks" indicate the following destinations.
 E3: U.S.A. & Canada model EU: U.S.A. model (AVR-484)
 E2A: Asia model E1C: China model
 E1K: Korea model

E2: Europe model
 EUT: Taiwan R.O.C. model

MAIN P.W.B. UNIT ASS'Y

Ref. No.	Part No.	Part Name	Remarks	Q'ty	New
SEMICONDUCTORS GROUP					
IC101	963 0110 507	IC MC7815CT			*
IC102	963 0021 502	IC KIA7915PI			
IC103	960 0159 501	IC KIA7805API			
IC104	963 0110 604	IC MC7805CT			*
IC105	960 0195 808	IC ICP-N15			
IC701	960 0174 308	IC TC9273N-007			
IC702,703	960 0179 701	IC NJM2068DD			
Q104C	960 0196 506	Transistor KSC1845F			
Q104FL,104FR	960 0196 506	Transistor KSC1845F			
Q104SL,104SR	960 0196 506	Transistor KSC1845F			
Q111-115	960 0196 904	Transistor DTC114YS			
Q116	960 0196 409	Transistor 2SC1740SR			
Q117	960 0196 904	Transistor DTC114YS			
Q151	960 0196 409	Transistor 2SC1740SR			
Q171	960 0005 202	Transistor KTC3198Y			
Q171A-171C	960 0196 302	Transistor KTA1268BL			
Q172-177	960 0005 202	Transistor KTC3198Y			
Q178	960 0005 105	Transistor KTA1266Y			
Q179	960 0189 005	Transistor KSA916Y			
Q180,181	960 0196 302	Transistor KTA1268BL			
D101-105	963 0096 508	Diode 1N4148			
D121-126	963 0096 508	Diode 1N4148			
D131A,131B	960 0197 107	Diode KBPC804			
D132	963 0096 508	Diode 1N4148			
D133,134	963 0046 202	Zener diode MTZJ18B			
D135	963 0096 508	Diode 1N4148			
D136	963 0058 504	Zener diode MTZJ11B			
D137	963 0096 508	Diode 1N4148			
D138	963 0058 407	Diode 1N4007			
D141-146	963 0058 407	Diode 1N4007			
D148	963 0096 508	Diode 1N4148			
D149,150	963 0058 407	Diode 1N4007			
D151	963 0096 508	Diode 1N4148			
D152,153	963 0058 407	Diode 1N4007			
D154	963 0047 405	Zener diode MTZJ7.5B			
D157	963 0058 708	Zener diode MTZJ20B			
D158-160	963 0096 508	Diode 1N4148			
RESISTORS GROUP					
R104C	963 9005 451	Metal oxide 5.6 kohm 1W (NB)			
R104FL,104FR	963 9005 451	Metal oxide 5.6 kohm 1W (NB)			
R104SL,104SR	963 9005 451	Metal oxide 5.6 kohm 1W (NB)			
R105C	963 9005 451	Metal oxide 5.6 kohm 1W (NB)			
R105FL,105FR	963 9005 451	Metal oxide 5.6 kohm 1W (NB)			
R105SL,105SR	963 9005 451	Metal oxide 5.6 kohm 1W (NB)			

Ref. No.	Part No.	Part Name	Remarks	Q'ty	New
R106C	963 9005 464	Metal film 4.7 ohm 1W			
R106FL,106FR	963 9005 464	Metal film 4.7 ohm 1W			
R106SL,106SR	963 9005 464	Metal film 4.7 ohm 1W			
R107C	963 9005 464	Metal film 4.7 ohm 1W			
R107FL,107FR	963 9005 464	Metal film 4.7 ohm 1W			
R107SL,107SR	963 9005 464	Metal film 4.7 ohm 1W			
R108C	963 9005 477	Metal oxide 0.22 ohm 1W (NB)			
R108FL,108FR	963 9005 477	Metal oxide 0.22 ohm 1W (NB)			
R108SL,108SR	963 9005 477	Metal oxide 0.22 ohm 1W (NB)			
R109C	963 9005 477	Metal oxide 0.22 ohm 1W (NB)			
R109FL,109FR	963 9005 477	Metal oxide 0.22 ohm 1W (NB)			
R109SL,109SR	963 9005 477	Metal oxide 0.22 ohm 1W (NB)			
R110C	963 9005 477	Metal oxide 0.22 ohm 1W (NB)			
R110FL,110FR	963 9005 477	Metal oxide 0.22 ohm 1W (NB)			
R110SL,110SR	963 9005 477	Metal oxide 0.22 ohm 1W (NB)			
R111C	963 9005 477	Metal oxide 0.22 ohm 1W (NB)			
R111FL,111FR	963 9005 477	Metal oxide 0.22 ohm 1W (NB)			
R111SL,111SR	963 9005 477	Metal oxide 0.22 ohm 1W (NB)			
R118C	963 9005 480	Metal oxide 10 ohm 1W (NB)			
R118FL,118FR	963 9005 480	Metal oxide 10 ohm 1W (NB)			
R118SL,118SR	963 9005 480	Metal oxide 10 ohm 1W (NB)			
R119C	963 9005 480	Metal oxide 10 ohm 1W (NB)			
R119FL,119FR	963 9005 480	Metal oxide 10 ohm 1W (NB)			
R119SL,119SR	963 9005 480	Metal oxide 10 ohm 1W (NB)			
R135,136	963 0045 203	Winding 0.1 ohm 5W			
R141,142	963 9006 201	Metal film 0.22 ohm 1W			*
R148,149	963 9006 201	Metal film 0.22 ohm 1W			*
R151	963 9005 493	Metal film 68 ohm 1/4W			
R154	963 0043 108	Metal film 2.2 Mohm 1/2W	for E3,EU,EUT		
R179	963 9003 055	Metal film 47 kohm 1/4W			
R181	963 9005 464	Metal film 4.7 ohm 1W			
R184	963 9005 480	Metal oxide 10 ohm 1W (NB)			
R185	963 9005 655	Metal film 22 ohm 1/4W			
VR101-105	960 0091 601	Semi fixed resistor 1 kohm			
CAPACITORS GROUP					
C101C	963 9005 888	Electrolytic 47uF/50V			
C101FL,101FR	963 9005 888	Electrolytic 47uF/50V			
C101SL,101SR	963 9005 888	Electrolytic 47uF/50V			
C102C	963 9005 778	Electrolytic 10uF/50V			
C102FL,102FR	963 9005 778	Electrolytic 10uF/50V			
C102SL,102SR	963 9005 778	Electrolytic 10uF/50V			
C103C	963 9003 084	Ceramic 100pF/500V			
C103FL,103FR	963 9003 084	Ceramic 100pF/500V			
C103SL,103SR	963 9003 084	Ceramic 100pF/500V			
C104C	963 9003 084	Ceramic 100pF/500V			
C104FL,104FR	963 9003 084	Ceramic 100pF/500V			
C104SL,104SR	963 9003 084	Ceramic 100pF/500V			
C105C	960 9003 108	Ceramic 0.022uF/25V			
C105FL,105FR	960 9003 108	Ceramic 0.022uF/25V			
C105SL,105SR	960 9003 108	Ceramic 0.022uF/25V			
C107C	963 9003 097	Mylar film 0.1uF/250V			
C107FL,107FR	963 9003 097	Mylar film 0.1uF/250V			

Ref. No.	Part No.	Part Name	Remarks	Q'ty	New
C107SL,107SR	963 9003 097	Mylar film 0.1uF/250V			
C131-135	963 9003 097	Mylar film 0.1uF/250V			
C136,137	963 9006 188	Electrolytic 10000uF/63V			
C138	960 9009 898	Electrolytic 1uF/50V			
C141-143	963 0021 900	Mylar film 0.047uF/100V			
C144	963 9003 110	Electrolytic 4700uF/35V			
C145	963 9003 123	Electrolytic 1000uF/35V			
C146	960 9009 898	Electrolytic 1uF/50V			
C148	960 9009 898	Electrolytic 1uF/50V			
C150-152	963 0021 900	Mylar film 0.047uF/100V			
C153	963 0021 104	Electrolytic 6800uF/16V			
C154	963 9005 778	Electrolytic 10uF/50V			
C155	963 0020 202	Ceramic 0.1uF/50V			
C157	960 9009 898	Electrolytic 1uF/50V			
C158	963 9003 136	Electrolytic 1000uF/25V			
C159	960 9009 898	Electrolytic 1uF/50V			
C161	963 9005 778	Electrolytic 10uF/50V			
C171	963 9005 312	Electrolytic 100uF/10V			
C171A-171C	963 0020 202	Ceramic 0.1uF/50V			
C172,173	960 9009 953	Electrolytic 220uF/10V			
C174	963 9005 778	Electrolytic 10uF/50V			
C175	963 9005 914	Electrolytic 4.7uF/50V			
C176,177	960 9009 898	Electrolytic 1uF/50V			
C178	963 9003 149	Electrolytic 330uF/63V			
△ C181	963 9006 191	Ceramic 4700pF/250V (AC)			
C182	963 9005 781	Electrolytic 10uF/100V			
C191-197	963 9006 007	Ceramic 2200pF/16V	for E2		
C198C	963 0024 703	Mylar film 0.01uF/100V	for E2		
C198FL,198FR	933 0024 703	Mylar film 0.01uF/100V	for E2		
C198SL,198SR	963 0024 703	Mylar film 0.01uF/100V	for E2		
C199FL,199FR	963 0024 703	Mylar film 0.01uF/100V	for E2		
C386,387	963 9004 517	Ceramic 0.022uF/50V	for E2,E2A,E1C,E1K		
C701L,701R	963 9004 575	Ceramic chip 100pF/50V	for E2		
C702L,702R	963 9004 575	Ceramic chip 100pF/50V	for E2		
C703L,703R	963 9004 575	Ceramic chip 100pF/50V	for E2		
C704L,704R	963 9004 575	Ceramic chip 100pF/50V	for E2		
C705L,705R	963 9004 575	Ceramic chip 100pF/50V	for E2		
C706L,706R	963 9004 575	Ceramic chip 100pF/50V	for E2		
C707L,707R	963 9004 575	Ceramic chip 100pF/50V	for E2		
C716L,716R	963 9005 778	Electrolytic 10uF/50V			
C718L,718R	963 9005 778	Electrolytic 10uF/50V			
C719L,719R	963 9005 778	Electrolytic 10uF/50V			
C720L,720R	963 9003 152	Mylar film 0.068uF/100V			
C721L,721R	963 9003 152	Mylar film 0.068uF/100V			
C723L,723R	963 9005 778	Electrolytic 10uF/50V			
C724L,724R	963 9004 698	Ceramic chip 0.01uF/50V			
C725,726	963 9004 698	Ceramic chip 0.01uF/50V			
C727 C728	963 9005 778	Electrolytic 10uF/50V			
OTHER PARTS GROUP					
CN201	963 0097 206	8P connector base			
CN202	960 0252 000	4P connector base			
CN203	963 0097 206	8P connector base			
CN701	963 0086 602	12P connector base			

Ref. No.	Part No.	Part Name	Remarks	Q'ty	New
CN702	963 0086 709	11P connector base			
CP101	960 0118 908	2P connector base			
CP102	960 0123 304	2P connector base			
CP103	963 0066 208	3P connector base			
CP104	960 0128 804	6P connector base			
CP105	960 0123 304	2P connector base	for E2,E2A		
CP106	960 0123 207	3P connector base			
CP303	963 0075 600	6P connector base			
CP501	963 0086 806	9P connector base			
CP502-504	963 0086 903	5P connector base			
CP505	963 0087 009	6P connector base			
CP553	963 0087 106	20P connector base			
CP901	963 0048 909	3P connector base			
CP931	960 0123 304	2P connector base	for E2,E2A,E1C,EUT,E1K		
△ F101	960 0188 705	Fuse 125V-8A	for E3,EU,EUT		
△ F101	963 0104 704	Fuse 250V-T2.5A	for E2,E2A,E1K		
△ F102	960 0188 705	Fuse 125V-8A	for E3,EU,EUT		
△ F102	963 0104 801	Fuse 250V-T3.15A	for E2,E2A,E1C,E1K		
F101A,101B	960 0005 804	Fuse clip	for E3,EU,E2,E2A,EUT,E1K		
F102A,102B	960 0005 804	Fuse clip			
G201	-	1P lug wire L=60 BK	for E2,E2A,E1C,E1K		
GND101-103	960 9006 600	GND terminal			
L101C	963 0049 005	Inductor 0.5uH			
L101FL,101FR	963 0049 005	Inductor 0.5uH			
L101SL,101SR	963 0049 005	Inductor 0.5uH			
RLY101-104	960 0181 702	Relay G5PA-28 24V 5A			
RLY105	963 0071 303	Relay RSB24S 24V 2A30VDC			
RLY106	960 0181 605	Relay G5PA-1 12V 5A			
TP101-105	960 0161 405	3P connector base			
△	963 0094 924	Sub trans.	for E3,EU,EUT		
△	963 0094 937	Sub trans.	for E2,E2A		
△	963 0094 911	Sub trans.	for E1C,E1K		
△	963 0093 909	AC outlet	for E3,EU,EUT		
	-	Heat sink			
	-	Heat sink			
	963 0068 400	Condenser cover	for E2,E2A,E1C,E1K		
	963 0018 007	Screw 3x8 CBTS(B)			
	960 0158 308	4P Terminal			
	960 0194 809	2P Terminal			
	963 0074 009	8P Terminal			
	960 0194 702	4P pin jack			
	960 0188 307	6P pin jack			

PRE AMP P.W.B. UNIT ASS'Y

Ref. No.	Part No.	Part Name	Remarks	Q'ty	New
SEMICONDUCTORS GROUP					
Q501C	960 0196 603	Transistor KTC2874B			
Q501FL,501FR	960 0196 603	Transistor KTC2874B			
Q501SL,501SR	960 0196 603	Transistor KTC2874B			
Q502C	960 0196 205	Transistor KSA992F			
Q502FL,502FR	960 0196 205	Transistor KSA992F			
Q502SL,502SR	960 0196 205	Transistor KSA992F			
Q503C	960 0196 205	Transistor KSA992F			
Q503FL,503FR	960 0196 205	Transistor KSA992F			
Q503SL,503SR	960 0196 205	Transistor KSA992F			
Q504C	960 0196 506	Transistor KSC1845F			
Q504FL,504FR	960 0196 506	Transistor KSC1845F			
Q504SL,504SR	960 0196 506	Transistor KSC1845F			
RESISTORS GROUP					
R509C	963 9005 587	Metal film 1.2 kohm 1/4W			
R509FL,509FR	963 9005 587	Metal film 1.2 kohm 1/4W			
R509SL,509SR	963 9005 587	Metal film 1.2 kohm 1/4W			
R511C	963 9005 590	Metal film 47 ohm 1/4W			
R511FL,511FR	963 9005 590	Metal film 47 ohm 1/4W			
R511SL,511SR	963 9005 590	Metal film 47 ohm 1/4W			
CAPACITORS GROUP					
C501C	963 9005 820	Electrolytic 22uF/16V			
C501FL,501FR	963 9005 820	Electrolytic 22uF/16V			
C501M	963 9005 765	Electrolytic 10uF/35V			
C501SL,501SR	963 9005 820	Electrolytic 22uF/16V			
C502C	963 9005 765	Electrolytic 10uF/35V			
C502FL,502FR	963 9005 765	Electrolytic 10uF/35V			
C502SL,502SR	963 9005 765	Electrolytic 10uF/35V			
C503C	963 9003 165	Ceramic 220pF/500V			
C503FL,503FR	963 9003 165	Ceramic 220pF/500V			
C503SL,503SR	963 9003 165	Ceramic 220pF/500V			
C504C	963 9003 178	Ceramic 220pF/50V			
C504FL,504FR	963 9003 178	Ceramic 220pF/50V			
C504SL,504SR	963 9003 178	Ceramic 220pF/50V			
C505C	963 9003 181	Ceramic 33pF/500V			
C505FL,505FR	963 9003 181	Ceramic 33pF/500V			
C505SL,505SR	963 9003 181	Ceramic 33pF/500V			
C506C	963 9005 312	Electrolytic 100uF/10V			
C506FL,506FR	963 9005 312	Electrolytic 100uF/10V			
C506SL,506SR	963 9005 312	Electrolytic 100uF/10V			
C507C	963 9003 194	Mylar film 0.0022uF/100V			
C507FL,507FR	963 9003 194	Mylar film 0.0022uF/100V			
C507SL,507SR	963 9003 194	Mylar film 0.0022uF/100V			

Ref. No.	Part No.	Part Name	Remarks	Q'ty	New
OTHER PARTS GROUP					
CN501	963 0085 506	9P connector base			
CN502-504	963 0085 603	5P connector base			
CN505	963 0085 700	6P connector base			
CP554	963 0050 405	14P connector base			
	960 0184 000	Screw bracket			

CNT P.W.B. UNIT ASS'Y

Ref. No.	Part No.	Part Name	Remarks	Q'ty	New
SEMICONDUCTORS GROUP					
IC401	963 0043 700	IC LC72131			
IC402	963 0043 904	IC LA1286			
IC403	963 0044 000	IC LA3401			
IC601	960 0180 101	IC LA7952			
IC602	963 0074 902	IC NJM7812FA			
IC651.652	960 0180 101	IC LA7952			
Q401	963 0099 301	Transistor KTC3880S			
Q402	963 0079 305	Transistor DTA114YK			
Q403,404	963 0058 203	Transistor DTA114EK			
Q405,406	960 0196 603	Transistor KTC2874B			
Q407	963 0079 305	Transistor DTC114YK			
Q408	963 0058 203	Transistor DTA114EK			
Q409	963 0099 301	Transistor KTC3880S	for E2,E2A		
Q551	960 0196 700	Transistor KTC3200BL			
Q552	960 0196 302	Transistor KTA1268BL			
Q553-555	963 0075 309	Transistor DTA114ES			
Q601,602	960 0096 800	Transistor 2SC3199Y			
Q603,604	960 0196 904	Transistor DTC114YS			
Q605,606	963 0075 406	Transistor DTC114TS			
Q651,652	960 0096 800	Transistor 2SC3199Y			
Q653,654	960 0196 904	Transistor DTC114YS			
Q655,656	960 0096 800	Transistor 2SC3199Y			
Q657,658	960 0196 904	Transistor DTC114YS			
D403	963 0096 605	Diode 1N4148WS (chip)			
D404	963 0096 508	Diode 1N4148			
D405,406	963 0096 605	Diode 1N4148WS (chip)			
D551-561	963 0096 508	Diode 1N4148			
D562,563	963 0058 407	Diode 1N4007			
D564	960 0095 500	Zener diode MTZJ5.1B			
D565	963 0096 508	Diode 1N4148			
D601,602	963 0096 508	Diode 1N4148			
D651,652	963 0096 508	Diode 1N4148			
ZD341,342	960 0095 500	Zener diode MTZJ5.1B			
ZD401	960 0095 500	Zener diode MTZJ5.1B			
RESISTORS GROUP					
R405	963 9005 545	Metal film 100 ohm 1/4W			
R413	963 9005 558	Metal film 220 ohm 1/4W			
R416	963 9005 561	Metal film 680 ohm 1/4W			
R430	963 9005 545	Metal film 100 ohm 1/4W			
R434	963 9005 545	Metal film 100 ohm 1/4W			
R559	963 9005 642	Metal film 1.2 kohm 1W			
R565	963 9005 642	Metal film 1.2 kohm 1W			
R570	963 9005 642	Metal film 1.2 kohm 1W			
R901,902	963 9005 574	Metal film 470 ohm 2W			
VR401	960 0096 606	Semi fixed resistor 20 kohm			
VR402	963 0056 205	Semi fixed resistor 50 kohm	for E3,EU,E1C,EUT,E1K		
VR402	960 0096 402	Semi fixed resistor 100 kohm	for E2,E2A		

Ref. No.	Part No.	Part Name	Remarks	Q'ty	New
VR403	963 0052 005	Semi fixed resistor 200 kohm			
CAPACITORS GROUP					
C341,342	963 9004 546	Ceramic 0.01uF/16V			
C401,402	963 9004 685	Ceramic chip 1000pF/50V			
C403	963 9004 737	Ceramic chip 0.022uF/25V			
C404	963 9004 892	Ceramic 2pF/50V			
C405	963 9004 737	Ceramic chip 0.022uF/25V			
C406	963 9005 435	Ceramic chip 18pF/50V			
C408	960 9004 709	Ceramic 6pF/50V			
C409	963 9004 520	Ceramic 100pF/50V			
C410	963 9004 915	Ceramic 470pF/50V			
C411	963 9004 685	Ceramic chip 1000pF/50V			
C412	963 9004 737	Ceramic chip 0.022uF/25V			
C413	963 9004 575	Ceramic chip 100pF/50V			
C414	963 9005 846	Electrolytic 2.2uF/50V			
C415	963 9005 862	Electrolytic 47uF/16V			
C416	963 9005 778	Electrolytic 10uF/50V			
C417	963 9005 794	Electrolytic 100uF/16V			
C418	963 9004 698	Ceramic chip 0.01uF/50V			
C419	963 9005 778	Electrolytic 10uF/50V			
C420	963 9004 591	Ceramic chip 22pF/50V			
C421	963 9005 998	Ceramic chip 24pF/50V			
C422C	963 9004 575	Ceramic chip 100pF/50V			
C423,424	963 9004 737	Ceramic chip 0.022uF/25V			
C425	963 9005 914	Electrolytic 4.7uF/50V			
C426	963 9006 214	Electrolytic 3.3uF/50V			
C427	963 9005 914	Electrolytic 4.7uF/50V			
C428	963 9004 737	Ceramic chip 0.022uF/25V			
C430	963 0021 900	Mylar film 0.047uF/100V			
C431	963 9004 627	Ceramic chip 33pF/50V			
C432	963 9005 862	Electrolytic 47uF/16V			
C433	963 9004 737	Ceramic chip 0.022uF/25V			
C434	960 9009 898	Electrolytic 1uF/50V	for E3,EU		
C434	963 9005 985	Electrolytic 0.33uF/50V	for E2,E2A,E1C,EUT,E1K		
C435,436	963 9004 737	Ceramic chip 0.022uF/25V			
C437	963 9005 862	Electrolytic 47uF/16V			
C438	960 9009 898	Electrolytic 1uF/50V			
C439	963 9005 972	Electrolytic 0.22uF/50V			
C440,441	960 9009 898	Electrolytic 1uF/50V			
C442	963 9005 846	Electrolytic 2.2uF/50V			
C443	963 9005 778	Electrolytic 10uF/50V			
C444	963 9005 914	Electrolytic 4.7uF/50V			
C445	963 9005 778	Electrolytic 10uF/50V			
C446,447	963 9005 053	Ceramic 270pF/50V	for E3,EU		
C446,447	963 9005 448	Ceramic 330pF/50V	for E2,E2A		
C446,447	963 9004 931	Ceramic 180pF/50V	for E1C,EUT,E1K		
C448,449	963 9004 960	Ceramic 470pF/50V	for E3,EU		
C448,449	963 9005 448	Ceramic 330pF/50V	for E1C,EUT,E1K		
C450,451	963 9005 778	Electrolytic 10uF/50V			
C453	963 9004 614	Ceramic chip 27pF/50V			
C456	963 9004 672	Ceramic chip 680pF/50V			
C461	963 9004 591	Ceramic chip 22pF/50V			
C462	963 9004 656	Ceramic chip 470pF/50V	for E2,E2A		

Ref. No.	Part No.	Part Name	Remarks	Q'ty	New
C463	963 9004 782	Mylar film 0.056uF/100V			
C464	963 9004 973	Ceramic 3pF/50V			
C471VT	960 9009 898	Electrolytic 1uF/50V			
C472VT	963 9004 753	Ceramic chip 0.047uF/50V			
C481C	963 9004 575	Ceramic chip 100pF/50V			
C481FL,481FR	963 9004 575	Ceramic chip 100pF/50V			
C481SL,481SR	963 9004 575	Ceramic chip 100pF/50V			
C481SW	963 9004 575	Ceramic chip 100pF/50V			
C551	963 9005 846	Electrolytic 2.2uF/50V			
C551M	963 9005 817	Electrolytic 100uF/35V			
C551S	963 9004 562	Ceramic 0.047uF/50V			
C552-554	963 9005 927	Electrolytic 0.1uF/50V			
C555,556	963 9004 546	Ceramic 0.01uF/16V			
C557	963 9005 778	Electrolytic 10uF/50V			
C601	963 9004 575	Ceramic chip 100pF/50V			
C602-604	963 9005 862	Electrolytic 47uF/16V			
C605,606	963 9005 891	Electrolytic 470uF/6.3V			
C607	963 9005 794	Electrolytic 100uF/16V			
C611	963 9004 698	Ceramic chip 0.01uF/50V			
C612,613	963 9004 753	Ceramic chip 0.047uF/50V			
C651-653	963 9005 309	Electrolytic 47uF/10V			
C654,655	963 9005 901	Electrolytic 470uF/10V			
C656-658	963 9005 309	Electrolytic 47uF/10V			
C659,660	963 9005 901	Electrolytic 470uF/10V			
C661	963 9005 794	Electrolytic 100uF/16V			
C662,663	963 9004 753	Ceramic chip 0.047uF/50V			
C664,665	960 9009 898	Electrolytic 1uF/50V			
C901,902	963 9004 533	Ceramic 0.001uF/50V			
C903	960 9009 898	Electrolytic 1uF/50V			
C904	960 9003 108	Ceramic 0.022uF/25V	for E3,EU		
OTHER PARTS GROUP					
CF401	960 0187 104	FM ceramic filter SFE10.7MA8	for E3,EU,E1C,EUT,E1K		
CF401	960 0177 509	FM ceramic filter SFE10.7MS3	for E2,E2A		
CF402	960 0187 104	FM ceramic filter SFE10.7MA8	for E3,EU		
CF402	960 0177 509	FM ceramic filter SFE10.7MS3	for E2,E2A,E1C,EUT,E1K		
CF403	960 0187 609	Ceramic resonator BFU450C			
CN105	963 0089 405	2P connector cord	for E1K		
CN392	963 0087 300	3P connector cord			
CN401	963 0085 409	10P connector base			
CN402	963 0097 303	15P connector base			
CN551	963 0110 701	14P connector base			
CN552	963 0085 302	17P connector base			
CN553	963 0086 408	20P connector base			
CN554	963 0090 708	14P connector cord			
CN601	963 0086 709	11P connector base			
CN651	963 0090 805	4P connector cord			
CN901	963 0090 902	3P connector cord			
CN931	963 0089 502	2P connector cord	for E2,E2A,E1C,EUT,E1K		
CP302	960 0254 901	5P connector base			
CP392	963 0048 909	3P connector base	for E3,EU		
CP651	963 0050 104	4P connector base			

Ref. No.	Part No.	Part Name	Remarks	Q'ty	New
FE401	960 0187 706	FM tuner FTE4-401TB			
G401	-	1P lug wire L=60 BK	for E3,EU		
G901	-	1P lug wire L=100 BK	for E2,E2A,E1C,EUT,E1K		
G901	-	1P lug wire L=100 BK			
L401	963 0052 102	Inductor 1uH			
L402	960 0010 307	Inductor 10uH			
L403	963 0056 409	MW IF coil RBW07VB			
SW901	960 0176 209	Push switch	for E3,EU		
SW931	963 0098 807	Push switch	for E2,E2A,E1C,EUT,E1K		
T401	960 0186 600	MW IF coil PCFMAF-270			
T402	960 0007 349	FM IF coil M292MEA-K5611FKG			
T403	960 0007 352	FM IF coil 292MEA-K5612X			
T404,405	960 0071 207	MPX filter 253AGG-K5001-KR	for E2,E2A		
T406	960 0037 607	Antibirdie filter T126SE-K5256	for E2,E2A		
VEC303	963 0095 208	Encoder EC16B24SA			
X401	960 0187 405	Crystal 7.2MHz			
X402	963 0043 302	Ceramic resonator CSB456F11			
	960 0184 000	Screw bracket			
	963 0054 003	Shield cover			
	963 0099 000	Earth plate			
	963 0110 002	AM plate			
	963 0052 403	3P Terminal			
	960 0194 508	1P pin jack			
	960 0194 605	2P pin jack			
	960 0188 404	3P pin jack			
	960 0188 307	6P pin jack			
	963 0110 808	3P DIN jack			
	963 0110 905	2P DIN jack			
	960 0144 202	AC outlet	for E1K		
	963 0095 402	Headphone jack			

CPU P.W.B. UNIT ASS'Y

Ref. No.	Part No.	Part Name	Remarks	Q'ty	New
SEMICONDUCTORS GROUP					
IC201	963 0111 001	IC CXP740096-175Q			
IC202	963 0057 602	IC TDA7330BD	for E2,E2A		
IC221	960 0080 201	IC KIC9164AN			
IC231	963 0093 608	IC M62446AFP			
IC241	960 0179 701	IC NJM2068DD			
IC251	960 0179 701	IC NJM2068DD			
IC261	960 0179 701	IC NJM2068DD			
IC271	960 0179 701	IC NJM2068DD			
IC281	960 0179 701	IC NJM2068DD			
IC291	960 0179 701	IC NJM2068DD			
IC301	960 0180 004	IC LC75721E			
IC302	963 0074 504	IC BU2090F			
RMC301	960 0181 100	Remote sensor NJL64H380A			
Q201	963 0075 008	Transistor DTC144EK			
Q201B	963 0102 803	Transistor 2SA933S	for E2,E2A		
Q201C	963 0079 305	Transistor DTC114YK	for E2,E2A		
Q202	963 0045 902	Transistor 2SC2412K			
Q203	963 0075 309	Transistor DTA114ES			
Q204,205	960 0196 603	Transistor KTC2874B			
Q231	963 0075 309	Transistor DTA114ES			
Q232	963 0075 503	Transistor DTC144ES			
Q251,252	960 0196 807	FET 2SK117Y			
Q291C	960 0196 807	FET 2SK117Y			
Q291FL,291FR	960 0196 807	FET 2SK117Y			
Q291SW	960 0196 807	FET 2SK117Y			
Q294	963 0058 203	Transistor DTA114EK			
Q295	963 0075 008	Transistor DTC144EK			
Q296	963 0058 203	Transistor DTA114EK			
Q297	963 0075 008	Transistor DTC144EK			
Q310	963 0058 203	Transistor DTA114EK			
Q311	963 0075 105	Transistor DTC144EK			
Q312	963 0058 203	Transistor DTA114EK			
Q313	963 0075 105	Transistor DTC144EK			
Q314	963 0058 203	Transistor DTA114EK			
Q315	963 0075 105	Transistor DTC144EK			
D201	963 0096 605	Diode 1N4148WS (chip)			
D202	963 0058 407	Diode 1N4007			
D203	963 0096 508	Diode 1N4148			
D204,205	963 0096 605	Diode 1N4148WS (chip)			
D206	963 0096 508	Diode 1N4148	for E2,E2A		
D251,252	963 0096 508	Diode 1N4148			
D261	963 0058 407	Diode 1N4007			
D291-294	963 0096 605	Diode 1N4148WS (chip)			
D303,304	963 0096 508	Diode 1N4148			
D305	963 0096 605	Diode 1N4148WS (chip)			
D308,309	963 0096 605	Diode 1N4148WS (chip)			
ZD201	963 0047 502	Zener diode MTZJ3.3B			
ZD271,272	960 0222 603	Zener diode MTZJ7.5A			
ZD301	960 0095 801	Zener diode MTZJ6.8B			
ZD331,332	960 0095 500	Zener diode MTZJ5.1B			

Ref. No.	Part No.	Part Name	Remarks	Q'ty	New
ZD335,336	960 0095 500	Zener diode MTZJ5.1B			
LED301-304	960 0197 204	LED PI5-RD/HL50RDRF4T			
LED306-309	960 0197 204	LED PI5-RD/HL50RDRF4T			
RESISTORS GROUP					
R231,232	963 9005 600	Metal film 100 ohm 1W			
R271	963 9005 613	Metal film 220 ohm 1W			
R274	963 9005 613	Metal film 220 ohm 1W			
CAPACITORS GROUP					
BC201	963 0061 504	Electric double layer 8200uF/5.5V			
C201	963 9004 546	Ceramic 0.01uF/16V			
C202	963 9004 711	Ceramic chip 0.1uF/50V			
C203	963 9004 698	Ceramic chip 0.01uF/50V			
C204	963 9005 914	Electrolytic 4.7uF/50V			
C205	963 9004 711	Ceramic chip 0.1uF/50V			
C206	963 9005 859	Electrolytic 47uF/16V	for E2,E2A		
C207	963 9004 546	Ceramic 0.01uF/16V	for E2,E2A		
C208	963 9004 614	Ceramic chip 270pF/50V	for E2,E2A		
C209	963 9005 778	Electrolytic 10uF/50V	for E2,E2A		
C210	963 9004 698	Ceramic chip 0.01uF/50V	for E2,E2A		
C211,212	963 9004 614	Ceramic chip 27pF/50V	for E2,E2A		
C213	963 9005 927	Electrolytic 0.1uF/50V			
C214	960 9009 898	Electrolytic 1uF/50V			
C219-226	963 9004 753	Ceramic chip 0.047uF/50V			
C231	963 9005 875	Electrolytic 47uF/25V			
C233	963 9005 875	Electrolytic 47uF/25V			
C236	963 9005 875	Electrolytic 47uF/25V			
C238	963 9005 875	Electrolytic 47uF/25V			
C241-246	963 9004 753	Ceramic chip 0.047uF/50V			
C251	963 9004 575	Ceramic chip 100pF/50V			
C252	963 9004 643	Ceramic chip 47pF/50V			
C253	963 9005 778	Electrolytic 10uF/50V			
C261-263	963 9004 520	Ceramic 100pF/50V			
C261L C261R	963 9004 575	Ceramic chip 100pF/50V			
C262L,262R	963 9004 627	Ceramic chip 33pF/50V			
C263L,263R	963 9005 778	Electrolytic 10uF/50V			
C264-266	963 9004 520	Ceramic 100pF/50V	for E1C,EUT,E1K		
C267,268	963 9004 520	Ceramic 100pF/50V			
C271	963 9005 859	Electrolytic 47uF/16V			
C272	960 9009 898	Electrolytic 1uF/50V			
C273	963 9005 859	Electrolytic 47uF/16V			
C274	963 9006 227	Electrolytic 0.33uF/50V			
C275	963 9005 367	Ceramic chip 0.015uF/50V			
C276,277	963 9006 214	Electrolytic 3.3uF/50V			
C278	963 9006 227	Electrolytic 0.33uF/50V			
C279	963 9005 367	Ceramic chip 0.015uF/50V			
C280,281	963 9005 370	Ceramic chip 8200pF/50V			
C282	963 9004 575	Ceramic chip 100pF/50V			
C285BL 285BR	963 9005 914	Electrolytic 4.7uF/50V			

Ref. No.	Part No.	Part Name	Remarks	Q'ty	New
C285C	963 9005 914	Electrolytic 4.7uF/50V			
C285FL,285FR	963 9005 914	Electrolytic 4.7uF/50V			
C285SL,285SR	963 9005 914	Electrolytic 4.7uF/50V			
C285SW	963 9005 914	Electrolytic 4.7uF/50V			
C292C	963 9005 914	Electrolytic 4.7uF/50V			
C292FL,292FR	963 9005 778	Electrolytic 10uF/50V			
C292SL,292SR	963 9005 778	Electrolytic 10uF/50V			
C292SW	963 9005 914	Electrolytic 4.7uF/50V			
C294C	963 9005 383	Ceramic chip 2700pF/50V			
C294FL,294FR	963 9005 396	Ceramic chip 4700pF/50V			
C295C	963 9004 575	Ceramic chip 100pF/50V			
C295FL,295FR	963 9004 672	Ceramic chip 680pF/50V			
C296C	963 9004 630	Ceramic chip 39pF/50V			
C296FL,296FR	963 9005 422	Ceramic chip 82pF/50V			
C296SL,296SR	963 9004 630	Ceramic chip 39pF/50V			
C296SW	963 9004 575	Ceramic chip 100pF/50V			
C297SW	963 9005 914	Electrolytic 4.7uF/50V			
C301	963 9005 778	Electrolytic 10uF/50V			
C302	963 9004 753	Ceramic chip 0.047uF/50V			
C303	963 9005 859	Electrolytic 47uF/16V			
C304	960 9003 108	Ceramic 0.022uF/25V			
C305	963 9005 859	Electrolytic 47uF/16V			
C306	963 9004 766	Mylar film 0.1uF/100V			
C307	960 9009 898	Electrolytic 1uF/50V			
C308,309	963 0021 900	Mylar film 0.047uF/100V			
C310	960 9009 898	Electrolytic 1uF/50V			
C311	963 9005 406	Ceramic chip 30pF/50V			
C312	963 9005 859	Electrolytic 47uF/16V			
C313	963 9005 419	Mylar film 0.047uF/63V			
C321	963 9004 685	Ceramic chip 1000pF/50V			
C322	963 9004 575	Ceramic chip 100pF/50V			
C324,325	963 9004 575	Ceramic chip 100pF/50V			
C331,332	963 9004 546	Ceramic 0.01uF/16V			
C335,336	963 9004 546	Ceramic 0.01uF/16V			
C381	963 9005 859	Electrolytic 47uF/16V			
C382,383	963 9004 575	Ceramic chip 100pF/50V			
C384,385	960 9009 898	Electrolytic 1uF/50V			
OTHER PARTS GROUP					
BD201	963 0053 800	Beads inductor			
CN105	963 0089 405	2P connector cord	for E2,E2A		
CN201	963 0096 906	6P connector cord			
CP201	963 0097 400	8P connector base			
CP202	960 0252 107	4P connector base			
CP203	963 0097 400	8P connector base			
CP301A	963 0111 205	20P FPC connector base			*
CP301B	963 0111 302	20P FPC connector base			*
CP303	963 0049 102	3P connector base			
CP401	963 0088 008	10P connector base			
CP402	963 0097 507	15P connector base			
CP551	963 0111 108	14P connector base			*
CP552	963 0087 902	17P connector base			

Ref. No.	Part No.	Part Name	Remarks	Q'ty	New
CP601	963 0087 805	11P connector base			
CP701	963 0087 708	12P connector base			
CP702	963 0087 805	11P connector base			
CP801,802	963 0087 902	17P connector base			
CP803	963 0097 400	8P connector base			
FL301	963 0109 505	FLT 16-ST-66GNK			*
G301	963 0088 202	1P lug wire L=80 BK			
JK301	963 0084 206	3P pin jack			
L302	960 0010 307	Inductor 10uH			
SW301B	963 0095 305	Tact switch			
SW301C	963 0045 708	Tact switch			
SW302A,302B	963 0095 305	Tact switch			
SW302C	963 0045 708	Tact switch			
SW303A,303B	963 0095 305	Tact switch			
SW303C	963 0045 708	Tact switch			
SW304A,304B	963 0095 305	Tact switch			
SW304C	963 0045 708	Tact switch			
SW305A	963 0045 708	Tact switch			
SW305B	963 0095 305	Tact switch			
SW305C	963 0045 708	Tact switch			
SW306B	963 0095 305	Tact switch			
SW306C	963 0045 708	Tact switch			
SW307B	963 0095 305	Tact switch			
SW307C	963 0045 708	Tact switch			
SW308B	963 0095 305	Tact switch			
SW308C	963 0045 708	Tact switch			
SW309B	963 0095 305	Tact switch			
SW309C	963 0045 708	Tact switch			
VEC301,302	963 0095 208	Encoder EC16B24SA			
X201	960 0181 003	Ceramic resonator CST12.0MTW			
X202	963 0099 505	Crystal 4.332MHz	for E2,E2A		
⚠	960 0143 203	AC outlet	for E2,E2A		
	960 0184 408	FLT holder			
	960 0260 005	Wire clamp			

DSP P.W.B. UNIT ASS'Y

Ref. No.	Part No.	Part Name	Remarks	Q'ty	New
SEMICONDUCTORS GROUP					
IC802	269 0186 002	Optical connector GP1FA502RZ			
IC803	963 0073 903	IC 74VHC04			
IC805,806	963 0043 807	IC BA4510F			
IC807	963 0073 709	IC M27W201			
IC807S	963 0025 508	32P IC socket			
IC808,809	963 0074 407	IC MM74LCX574WMX			
IC810	960 0195 507	IC LC89055W(ES4)			
IC811	963 0111 603	IC RC1117S33ST			
IC812	963 0111 409	IC CS49326-CL			
IC813	963 0074 601	IC AK4527B-VQ			
IC814-816	963 0024 004	IC NJM2068M			
IC818,819	963 0074 203	IC MM74LCX244WMX			
IC820	963 0111 506	IC RC1117S25T			
IC822	960 0195 109	IC SN74LV00APW			
IC828	963 0074 300	IC MM74HCT244WMX			
IC829	960 0196 001	IC NJM7805FA			
IC830	963 0074 300	IC MM74HCT244WMX			
IC831	960 0195 303	IC SN74LV4040APWR			
IC832	963 0074 106	IC MM74HC151MX			
Q804C	960 0196 603	Transistor KTC2874B			
Q804FL,804FR	960 0196 603	Transistor KTC2874B			
Q804SL,804SR	960 0196 603	Transistor KTC2874B			
Q804SW	960 0196 603	Transistor KTC2874B			
Q805	963 0058 203	Transistor DTA114EK			
Q806	963 0058 203	Transistor DTC114EK			
Q807	963 0058 203	Transistor DTA114EK			
Q808	963 0058 203	Transistor DTC114EK			
D801	963 0096 605	Diode 1N4148WS (chip)			
D806,807	963 0096 605	Diode 1N4148WS (chip)			
CAPACITORS GROUP					
C803	963 9004 591	Ceramic chip 22pF/50V			
C805	963 9004 591	Ceramic chip 22pF/50V			
C808	963 9004 711	Ceramic chip 0.1uF/50V			
C809	963 9005 862	Electrolytic 47uF/16V			
C810	963 9004 711	Ceramic chip 0.1uF/50V			
C811	963 9005 862	Electrolytic 47uF/16V			
C815	963 9004 711	Ceramic chip 0.1uF/50V			
C816	963 9004 591	Ceramic chip 22pF/50V			
C817	963 9005 927	Electrolytic 0.1uF/50V			
C818	963 9004 711	Ceramic chip 0.1uF/50V			
C819	963 9005 862	Electrolytic 47uF/16V			
C821	963 9005 312	Electrolytic 100uF/10V			
C822,823	963 9004 711	Ceramic chip 0.1uF/50V			
C824	963 9005 862	Electrolytic 47uF/16V			
C825	960 9009 898	Electrolytic 1uF/50V			
C826	963 9005 778	Electrolytic 10uF/50V			
C827	963 9004 711	Ceramic chip 0.1uF/50V			
C828	963 9004 698	Ceramic chip 0.01uF/50V			
C829	963 9005 778	Electrolytic 10uF/50V			

Ref. No.	Part No.	Part Name	Remarks	Q'ty	New
C830-832	963 9004 711	Ceramic chip 0.1uF/50V			
C833	963 9004 656	Ceramic chip 470pF/50V			
C834	963 9005 778	Electrolytic 10uF/50V			
C835	960 9009 898	Electrolytic 1uF/50V			
C836	960 9009 953	Electrolytic 220uF/10V			
C837,838	963 9004 711	Ceramic chip 0.1uF/50V			
C839	963 9004 698	Ceramic chip 0.01uF/50V			
C840	963 9005 846	Electrolytic 2.2uF/50V			
C841	963 9005 862	Electrolytic 47uF/16V			
C842	963 9004 711	Ceramic chip 0.1uF/50V			
C844	963 9004 711	Ceramic chip 0.1uF/50V			
C845	963 9004 698	Ceramic chip 0.01uF/50V			
C849	963 9004 698	Ceramic chip 0.01uF/50V			
C851	963 9004 698	Ceramic chip 0.01uF/50V			
C854,855	963 9005 804	Electrolytic 100uF/25V			
C856-863	963 9004 711	Ceramic chip 0.1uF/50V			
C864L,864R	963 9005 778	Electrolytic 10uF/50V			
C865L,865R	963 9004 575	Ceramic chip 100pF/50V			
C866	963 9004 698	Ceramic chip 0.01uF/50V			
C869L,869R	963 9004 575	Ceramic chip 100pF/50V			
C871L,871R	963 9004 685	Ceramic chip 1000pF/50V			
C873C	963 9004 672	Ceramic chip 680pF/50V			
C873FL,873FR	963 9004 672	Ceramic chip 680pF/50V			
C873SL,873SR	963 9004 672	Ceramic chip 680pF/50V			
C873SW	963 9004 672	Ceramic chip 680pF/50V			
C874C	963 9004 672	Ceramic chip 680pF/50V			
C874FL,874FR	963 9004 672	Ceramic chip 680pF/50V			
C874SL,874SR	963 9004 672	Ceramic chip 680pF/50V			
C874SW	963 9004 672	Ceramic chip 680pF/50V			
C875C	963 9005 778	Electrolytic 10uF/50V			
C875FL,875FR	963 9005 778	Electrolytic 10uF/50V			
C875SL,875SR	963 9005 778	Electrolytic 10uF/50V			
C875SW	963 9005 778	Electrolytic 10uF/50V			
C876C	963 9004 740	Ceramic chip 3300pF/50V			
C876FL,876FR	963 9004 740	Ceramic chip 3300pF/50V			
C876SL,876SR	963 9004 740	Ceramic chip 3300pF/50V			
C876SW	963 9004 740	Ceramic chip 3300pF/50V			
C880C	963 9005 778	Electrolytic 10uF/50V			
C880FL,880FR	963 9005 778	Electrolytic 10uF/50V			
C880SL,880SR	963 9005 778	Electrolytic 10uF/50V			
C880SW	963 9005 778	Electrolytic 10uF/50V			
C908,909	963 9004 614	Ceramic chip 27pF/50V			
C916	963 9004 711	Ceramic chip 0.1uF/50V			
C917	963 9005 778	Electrolytic 10uF/50V			
C918	963 9004 711	Ceramic chip 0.1uF/50V			
C919	963 9004 698	Ceramic chip 0.01uF/50V			
C920	963 9004 711	Ceramic chip 0.1uF/50V			
C921	963 9004 698	Ceramic chip 0.01uF/50V			
C923	963 9004 711	Ceramic chip 0.1uF/50V			
C925	963 9004 711	Ceramic chip 0.1uF/50V			
C926	963 9005 778	Electrolytic 10uF/50V			
C931	963 9004 698	Ceramic chip 0.01uF/50V			
C936	963 9004 711	Ceramic chip 0.1uF/50V			
C937	963 9005 778	Electrolytic 10uF/50V			
C938	960 9009 898	Electrolytic 1uF/50V			
C939,940	963 9004 698	Ceramic chip 0.01uF/50V			

Ref. No.	Part No.	Part Name	Remarks	Q'ty	New
C943	963 9005 927	Electrolytic 0.1uF/50V			
C944	963 9004 698	Ceramic chip 0.01uF/50V			
C946,947	963 9004 711	Ceramic chip 0.1uF/50V			
C948	963 9005 778	Electrolytic 10uF/50V			
C949	963 9005 846	Electrolytic 2.2uF/50V			
C950	963 9004 711	Ceramic chip 0.1uF/50V			
C951	963 9005 312	Electrolytic 100uF/10V			
C952,953	963 9004 711	Ceramic chip 0.1uF/50V			
C954	963 9004 698	Ceramic chip 0.01uF/50V			
C956	963 9004 685	Ceramic chip 1000pF/50V			
C957	963 9004 711	Ceramic chip 0.1uF/50V			
C958	963 9005 312	Electrolytic 100uF/10V			
OTHER PARTS GROUP					
CB801	963 0050 502	Chip beads HB-IT2012			
CB803-808	963 0050 502	Chip beads HB-IT2012			
CB828	963 0050 502	Chip beads HB-IT2012			
CN801,802	963 0085 302	17P connector base			
CN803	963 0097 206	8P connector base			
JACK801	963 0052 500	1P pin jack			
L801	963 0050 803	Inductor 4.7uH			
L803	963 0050 900	Inductor 2.2uH			
L805	963 0050 803	Inductor 4.7uH			
L807	963 0050 900	Inductor 2.2uH			
XTAL801	963 0095 101	Crystal 12.288MHz			

EXPLODED VIEW

Parts List

WARNING:
 Parts marked with this symbol  have critical characteristics.
 Use ONLY replacement parts recommended by the manufacturer.

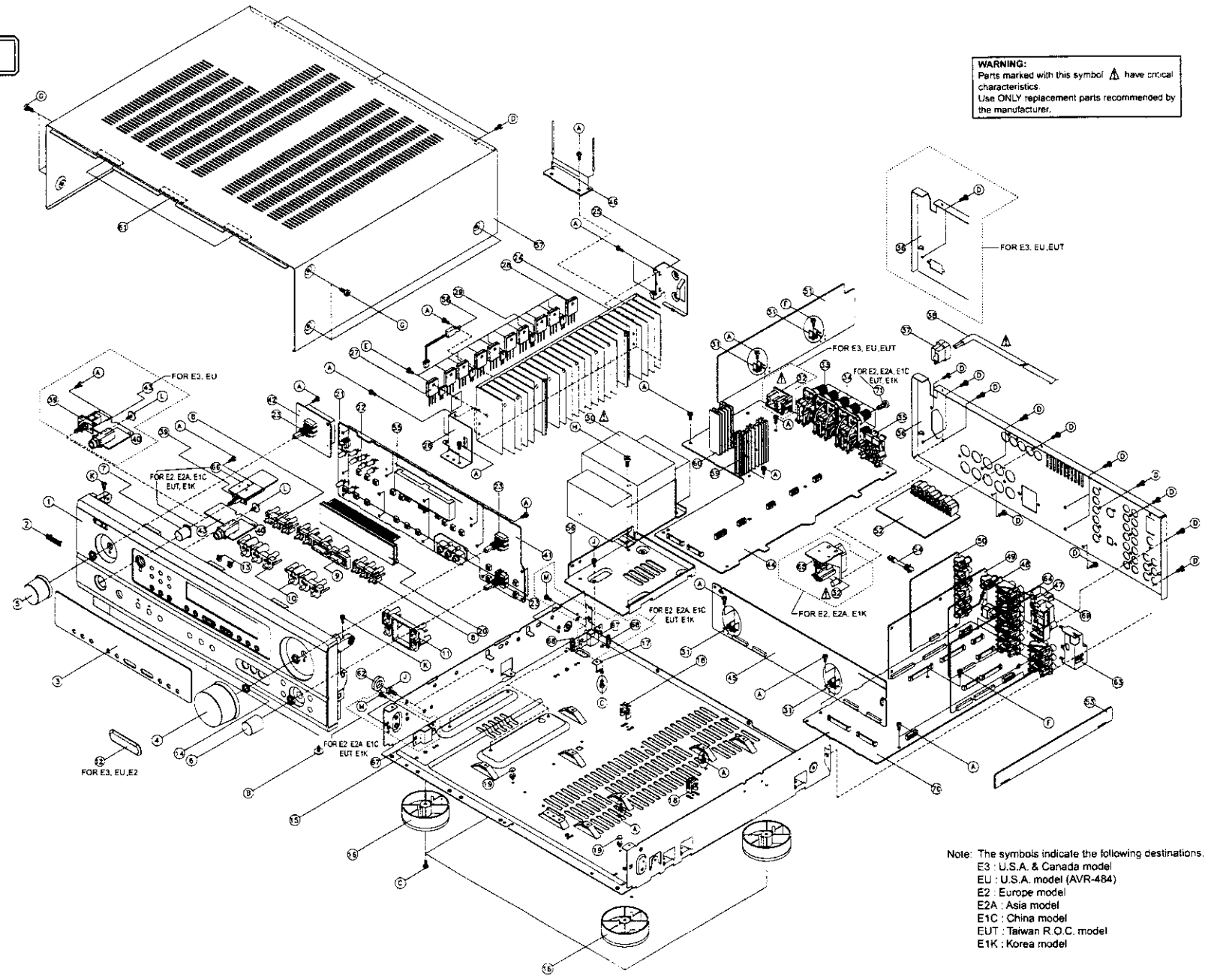

Note: The symbols indicate the following destinations.
 E3 : U.S.A. & Canada model
 EU : U.S.A. model (AVR-484)
 E2 : Europe model
 E2A : Asia model
 E1C : China model
 EUT : Taiwan R.O.C. model
 E1K : Korea model

PARTS LIST OF EXPLODED VIEW

Note: The symbols in the column "Remarks" indicate the following destinations.
 E3: U.S.A. & Canada model EU: U.S.A. model (AVR-484) E2: Europe model
 E2A: Asia model E1C: China model EUT: Taiwan R.O.C. model
 E1K: Korea model

Ref. No.	Part No.	Part Name	Remarks	Q'ty	New
44A	963 0108 001	Main P.W.B. Ass'y	for E3,EU	1	*
44A	963 0108 014	Main P.W.B. Ass'y	for E2	1	*
44A	963 0108 027	Main P.W.B. Ass'y	for E2A	1	*
44A	963 0108 030	Main P.W.B. Ass'y	for E1C	1	*
44A	963 0108 043	Main P.W.B. Ass'y	for EUT	1	*
44A	963 0108 056	Main P.W.B. Ass'y	for E1K	1	*
44	-	Main P.W.B.			
48	-	Input P.W.B.			
53	-	Front CNT P.W.B.			
51A	963 0108 108	Pre-amp P.W.B. Ass'y		1	*
51	-	Pre-amp P.W.B.			
42A	963 0108 205	CNT P.W.B. Ass'y	for E3,EU	1	*
42A	963 0108 218	CNT P.W.B. Ass'y	for E2,E2A	1	*
42A	963 0108 221	CNT P.W.B. Ass'y	for E1C,EUT	1	*
42A	963 0108 234	CNT P.W.B. Ass'y	for E1K	1	*
42	-	Encoder P.W.B.			
43	-	Headphone P.W.B.			
45	-	CNT P.W.B.			
47	-	Tuner P.W.B.			
50	-	C-Video P.W.B.			
52	-	S-Video P.W.B.			
65	-	Outlet P.W.B.	for E1K		
66	-	Power SW P.W.B.	for E2,E2A,E1C,EUT,E1K		
41A	963 0108 302	CPU P.W.B. Ass'y	for E3,EU	1	*
41A	963 0108 315	CPU P.W.B. Ass'y	for E2,E2A	1	*
41A	963 0108 328	CPU P.W.B. Ass'y	for E1C,EUT,E1K	1	*
41	-	Front P.W.B.			
46	-	Video CNT P.W.B.			
65	-	Outlet P.W.B.	for E2,E2A		
70	-	CPU P.W.B.			
49A	963 0108 409	DSP P.W.B. Ass'y		1	*
49	-	DSP P.W.B.			
1	963 0108 506	Front panel	for E3	1	*
1	963 0108 519	Front panel	for EU	1	*
1	963 0108 522	Front panel	for E2	1	*
1	963 0108 535	Front panel	for E2A	1	*
1	963 0108 548	Front panel	for E1C,EUT,E1K	1	*
2	963 0051 501	DENON badge	for black model	1	*
2	963 0051 527	DENON badge	for silver model	1	*
2	963 0051 514	DENON badge	for gold model	1	*
3	963 0093 116	Display window	for E3,EU,E1C,EUT,E1K	1	*
3	963 0093 129	Display window	for E2,E2A	1	*
4	963 0108 603	Volume knob	for black model	1	*
4	963 0108 629	Volume knob	for silver model	1	*
4	963 0108 616	Volume knob	for gold model	1	*
5	963 0108 700	Function knob	for black model	1	*
5	963 0108 726	Function knob	for silver model	1	*
5	963 0108 713	Function knob	for gold model	1	*
6	963 0108 807	Select knob	for black model	1	*
6	963 0108 810	Select knob	for silver model	1	*
6	963 0093 420	Select knob	for gold model	1	*

Ref. No.	Part No.	Part Name	Remarks	Q'ty	New
7	963 0093 514	Power button	for black model	1	
7	963 0108 904	Power button	for silver model	1	*
7	963 0093 527	Power button	for gold model	1	
8	963 0094 801	3 key button (A)		2	
9	963 0098 205	6 key button		1	
10	963 0094 623	3 key button (B)	for black model	2	
10	963 0109 000	3 key button (B)	for silver model	2	*
10	963 0109 013	3 key button (B)	for gold model	2	*
11	963 0109 107	4 key button	for black model	1	*
11	963 0109 110	4 key button	for silver model	1	*
11	963 0094 720	4 key button	for gold model	1	
12	963 0109 204	RCA cover	for E3,EU, black model	1	*
12	963 0109 217	RCA cover	for E2, silver model	1	*
13	960 0191 417	LED lens		2	
14	963 0092 900	Knob spring		1	
15	963 0109 301	Main chassis		1	
16	960 0183 904	Foot	for black & gold model	4	
16	963 0109 408	Foot	for silver model	4	*
17	960 0184 107	Supporter bracket		1	
18	960 0003 301	PWB supporter		2	
19	963 0051 103	Card spacer		2	
20	963 0109 505	FLT 16-ST-66GNK		1	*
21	960 0181 100	Remote sensor NJL64H380A		1	
22	960 0197 204	LED P15-RD/HL50RDRF4T		8	
23	963 0095 208	Encoder EC16B24SA		3	
24	-	Heat sink		1	
25	960 0184 204	Heat sink bracket B		1	
26	960 0184 301	Heat sink bracket F		1	
27	960 0090 107	Transistor 2SB1599Y	Q102C,102FL,102FR,102SL,102SR	5	
28	960 0090 000	Transistor 2SD2389Y	Q101C,101FL,101FR,101SL,101SR	5	
29	963 0058 106	Transistor 2SD947F	Q103C,103FL,103FR,103SL,103SR	5	
30	963 0109 802	Power trans	for E3,EU,EUT	1	*
30	963 0109 615	Power trans	for E2,E2A	1	*
30	963 0109 628	Power trans	for E1C,E1K	1	*
31	960 0184 000	Screw bracket		4	
32	963 0093 909	AC outlet	for E3,EU,EUT	1	
32	960 0143 203	AC outlet	for E2,E2A	1	
32	960 0144 202	AC outlet	for E1K	1	
33	960 0194 809	2P Terminal		1	
34	963 0074 009	8P Terminal		1	
35	960 0158 308	4P Terminal		1	
36	963 0109 709	Back chassis	for E3	1	*
36	963 0109 712	Back chassis	for EU	1	*
36	963 0109 725	Back chassis	for E2,E2A	1	*
36	963 0109 738	Back chassis	for E1C	1	*
36	963 0109 741	Back chassis	for EUT	1	*
36	963 0109 754	Back chassis	for E1K	1	*
37	960 0192 403	AC cord stopper		1	
38	963 0098 603	AC cord	for E3,EU,EUT	1	
38	963 0109 806	AC cord	for E2,E2A	1	*
38	963 0109 819	AC cord	for E1C	1	*
38	963 0098 700	AC cord	for E1K	1	
39	960 0176 208	Push switch	for E3,EU	1	
39	963 0098 807	Push switch	for E2,E2A,E1C,EUT,E1K	1	
40	963 0095 402	Headphone jack		1	
54	963 0061 902	Fastener		1	

Ref. No.	Part No.	Part Name	Remarks	Q'ty	New
55	960 0184 408	FLT holder		1	
56	963 0092 609	Trans bracket		1	
57	963 0053 017	Top cover	for black model	1	
57	963 0109 903	Top cover	for silver model	1	*
57	963 0092 502	Top cover	for gold model	1	
58	960 0187 900	Posistor P43T7D330BW16		1	
59	-	Heat sink		1	
60	-	Heat sink		1	
61	963 0089 104	Rubber sheet		3	
62	963 0072 302	Rubber cushion		2	
63	963 0054 003	Shield cover		1	
64	963 0098 000	Earth plate		1	
67	963 0081 607	Side bracket	for E2,E2A,E1C,EUT,E1K	2	
68	963 0044 602	P.C. supporter	for E3,EU,EUT	1	
68	963 0044 602	P.C. supporter	for E2,E2A,E1C,E1K	2	
69	963 0110 002	AM plate		1	*
71	963 0093 104	Terminal bushing	for E2,E2A,E1C,EUT,E1K	10	
★ 72	960 0244 403	Wire clamper (L=50)	for E1K	1	
★ 73	960 0155 301	Wire clamp band		6	
★ 74	963 0054 207	Fuse caution label	for E3,EU	1	
★ 75	963 0098 001	20P FCC cable		1	
SCREWS					
A	963 0018 007	Screw 3x8 CBTS(B)-Z		37	
B	960 9008 527	Screw 3x8 CBTS(B) W-B	for black model	4	
B	960 9008 420	Screw 3x8 CBTS(B) W-Z	for gold & silver model	4	
C	963 0048 200	Screw 3x10 CBTS(B)-Z		5	
D	960 0108 714	Screw 3x10 CBTS(B) DOT-B	for E3,EU,E2,E2A,EUT,E1K	33	
D	960 0108 714	Screw 3x10 CBTS(B) DOT-B	for E1C	15	*
E	963 9006 175	Screw 3x14 CHTS(B) SW W-Z		15	
F	963 0018 104	Screw 3x17 CBTS(B)-Z		4	
G	963 0048 307	Screw 4x8 CBTS(B) DOT-B	for black model	6	
G	963 9004 012	Screw 4x8 CBTS(B) DOT-Ni	for gold & silver model	6	
H	960 9008 417	Screw 4x8 CBTS SW W-Z		4	
J	963 9004 025	Screw 4x6 CBTS(S)-Z		6	
K	963 9004 038	Screw 3x8 CBTS(B) W-Z		2	
L	960 9006 420	Screw 3x8 CBTS(B) W-Z		1	
M	963 9004 041	Screw 3x5 CBTS(B)-Z	for E2,E2A,E1C,EUT,E1K	4	

PACKING VIEW

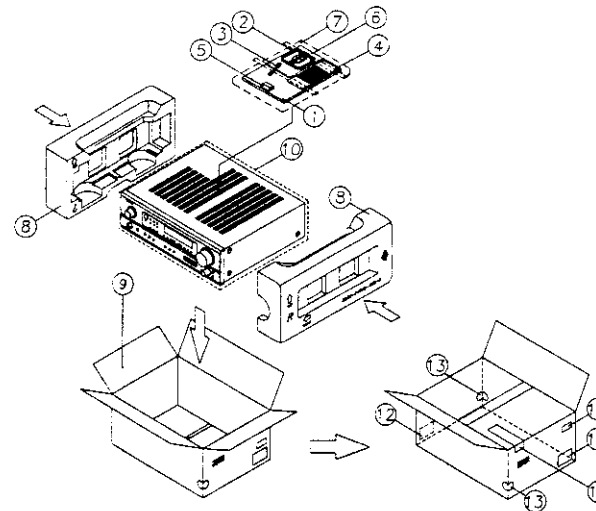

PARTS LIST OF PACKING & ACCESSORIES

Note: The symbols in the column "Remarks" indicate the following destinations.
 E3: U.S.A. & Canada model EU: U.S.A. model (AVR-484) E2: Europe model
 E2A: Asia model E1C: China model EUT: Taiwan R.O.C. model
 E1K: Korea model

Ref. No.	Part No.	Part Name	Remarks	Q'ty	New
1	963 0110 109	Instruction manual	for E3,EU	1	*
1	963 0110 112	Instruction manual	for E2	1	*
1	963 0110 125	Instruction manual	for E2A,E1C,EUT	1	*
1	963 0110 138	Instruction manual	for E1K	1	*
2	963 0052 306	AM loop antenna		1	
3	963 0052 209	FM antenna		1	
4	399 0878 006	Remote controller RC-942		1	*
5	-	Battery		2	
6	-	Service station list (EX)		1	
7	963 0045 106	Poly. bag		1	
8	960 0193 101	Cushion		1	
9	963 0110 206	Carton case	for E3	1	*
9	963 0110 219	Carton case	for EU	1	*
9	963 0110 222	Carton case	for E2, E2A	1	*
9	963 0110 235	Carton case	for E1C, E1K	1	*
9	963 0110 248	Carton case	for EUT	1	*
10	960 0185 601	Poly. Bag (set)		1	
11	-	UPC label	for E3	1	
11	-	UPC label	for EU	1	
11	-	UPC label	for E2	1	
12	-	Control card		2	
13	963 0110 303	Color label (silver)	for E2, silver model	1	
13	963 0110 316	Color label (gold)	for E2A, E1C, EUT, E1K, gold model	2	
14	-	Warranty card	for E3, EU	1	
★	15	963 0110 400	Box label	1	
★	16	963 0110 413	Kolin label (box)	1	

WIRING DIAGRAM

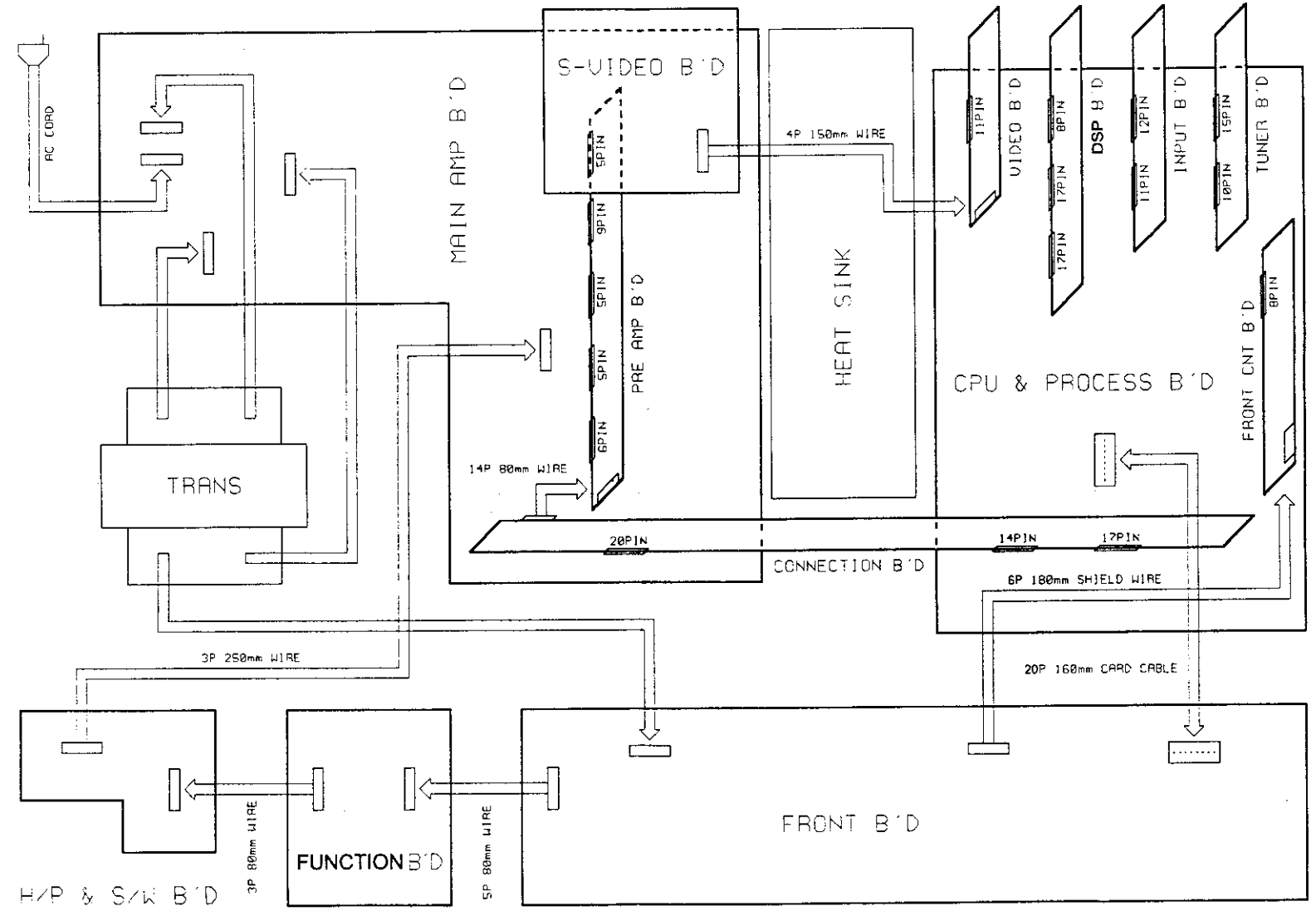

AVR-1404 WIRING DIAGRAM

NOTE FOR SCHEMATIC DIAGRAM

配線図について

WARNING:

Parts marked with this symbol \triangle have critical characteristics. Use ONLY replacement parts recommended by the manufacturer.

CAUTION:

Before returning the unit to the customer, make sure you make either (1) a leakage current check or (2) a line to chassis resistance check. If the leakage current exceeds 0.5 milliamps, or if the resistance from chassis to either side of the power cord is less than 460 kohms, the unit is defective.

WARNING:

DO NOT return the unit to the customer until the problem is located and corrected.

NOTICE:

ALL RESISTANCE VALUES IN OHM. k=1,000 OHM

M=1,000,000 OHM

ALL CAPACITANCE VALUES IN MICRO FARAD.

P=MICRO-MICRO FARAD

EACH VOLTAGE AND CURRENT ARE MEASURED AT

NO SIGNAL INPUT CONDITION.

CIRCUIT AND PARTS ARE SUBJECT TO CHANGE

WITHOUT PRIOR NOTICE.

\triangle 印の部品は安全を維持するために重要な部品です。従って交換時は必ず指定の部品を使用してください。

注)

- (1) 指定なき抵抗値は Ω 、k は k Ω 、M は M Ω を示す。
- (2) 指定なきコンデンサーの値は μF 、p は pF を示す。
- (3) 各部の電圧は無信号の値を示す。
- (4) この配線図は基本配線図です。改良等のため変更することがありますのでご了承ください。

SCHEMATIC DIAGRAMS (1/7)

1

2

3

4

5

6

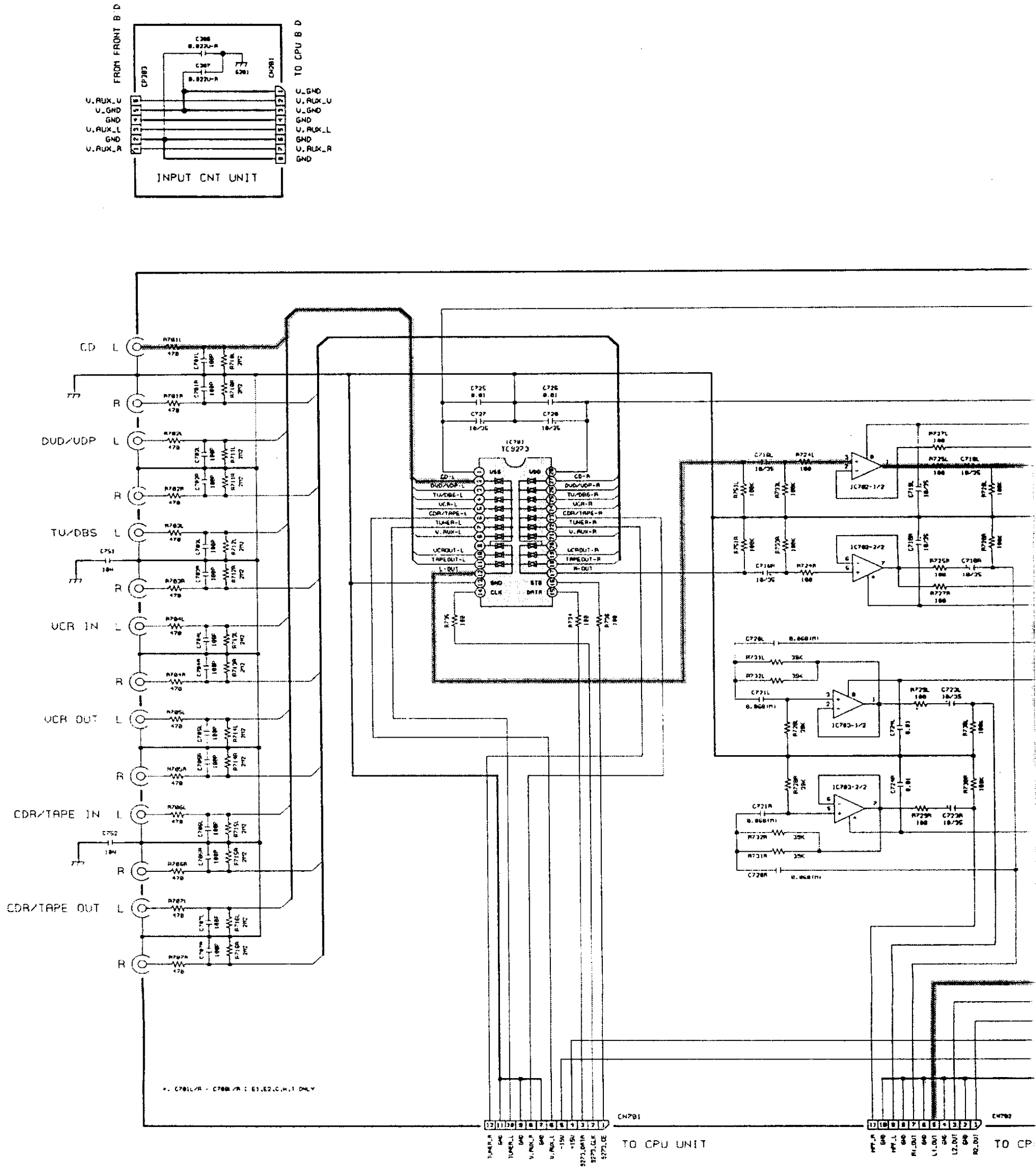

6 7 8 9 10 11

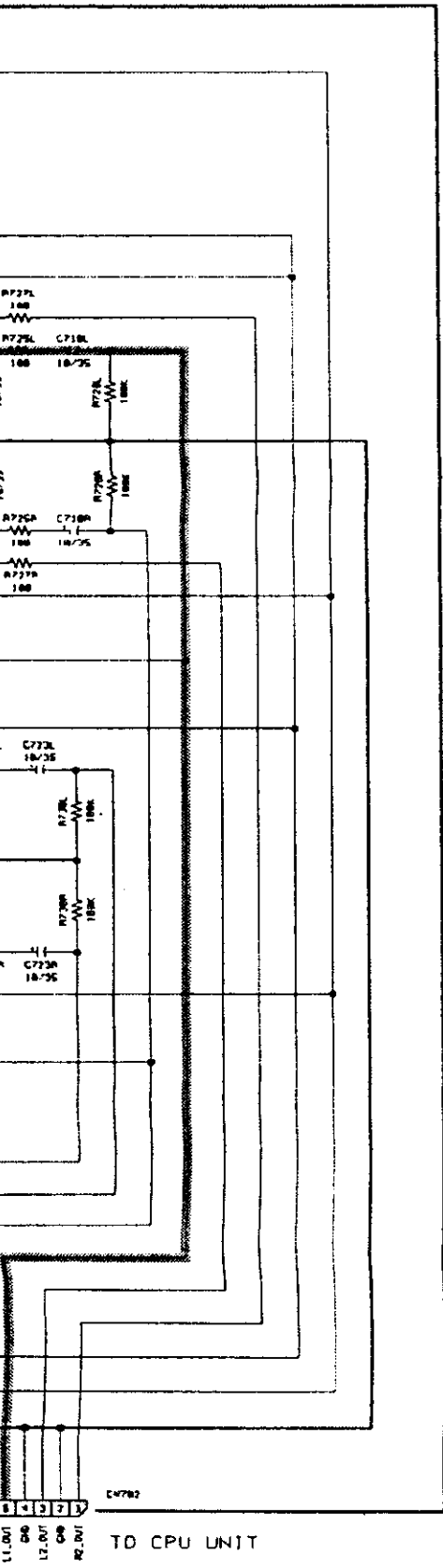
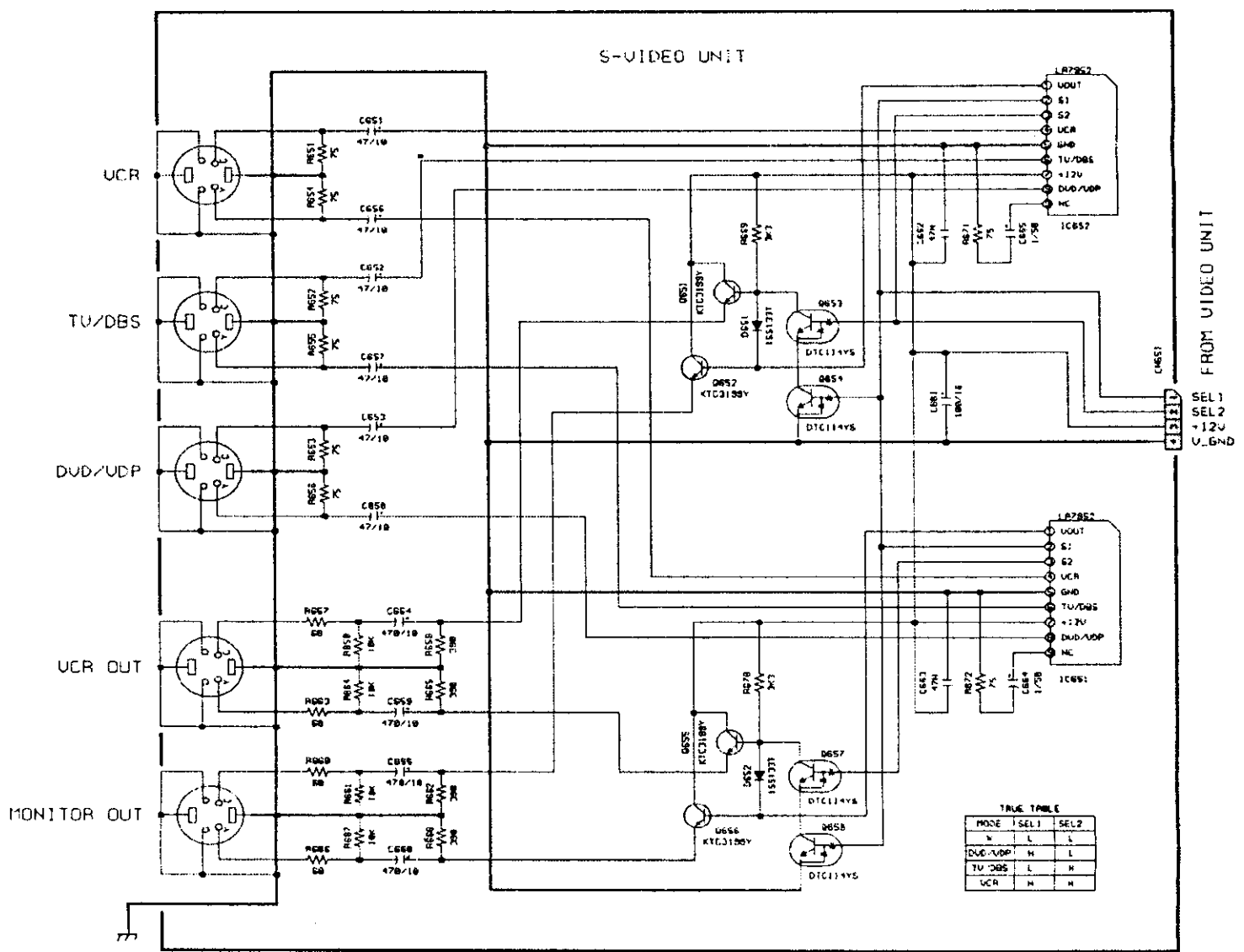
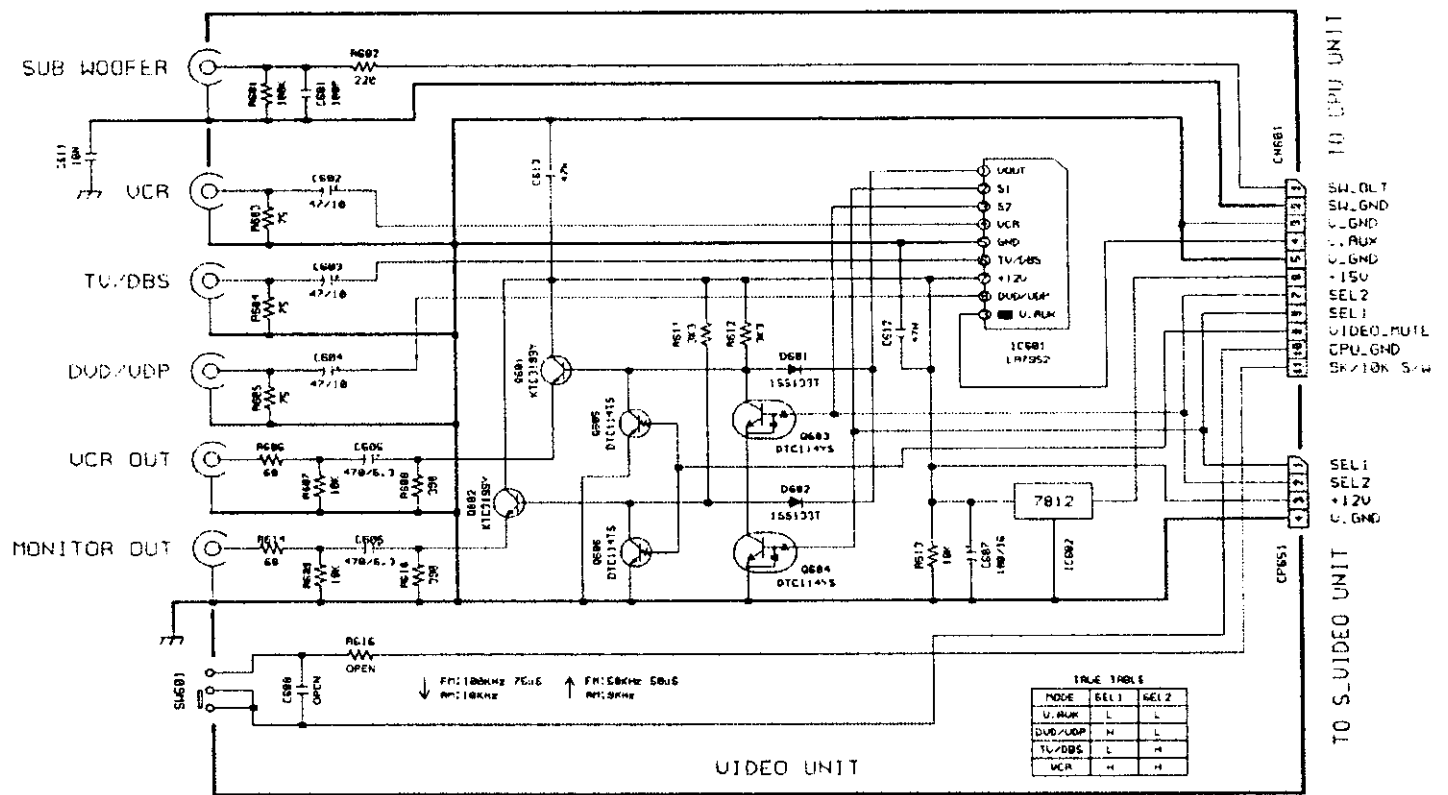

TO CPU UNIT

SCHEMATIC DIAGRAMS (1/7)
INPUT UNIT
C-VIDEO UNIT
S-VIDEO UNIT
INPUT CNT UNIT

SIGNAL LINE

A
B
C
D
E
F
G
H

6 7 8 9 10 11

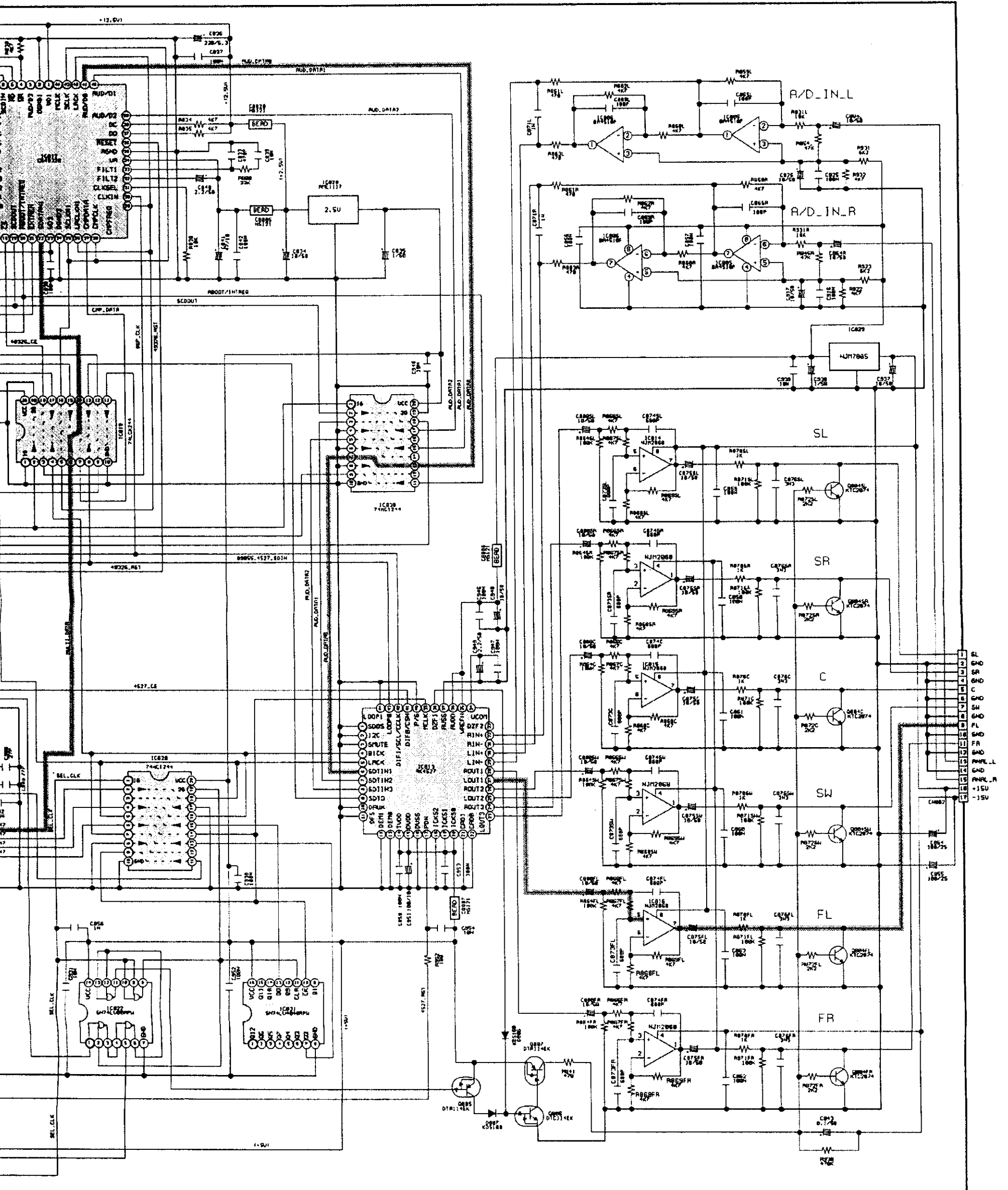

A
B
C
D
E
F
G
H

--- SIGNAL LINE

SCHEMATIC DIAGRAMS (2/7)
DSP UNIT

SCHEMATIC DIAGRAMS (3/7)

1

2

3

4

5

6

CPU BOARD

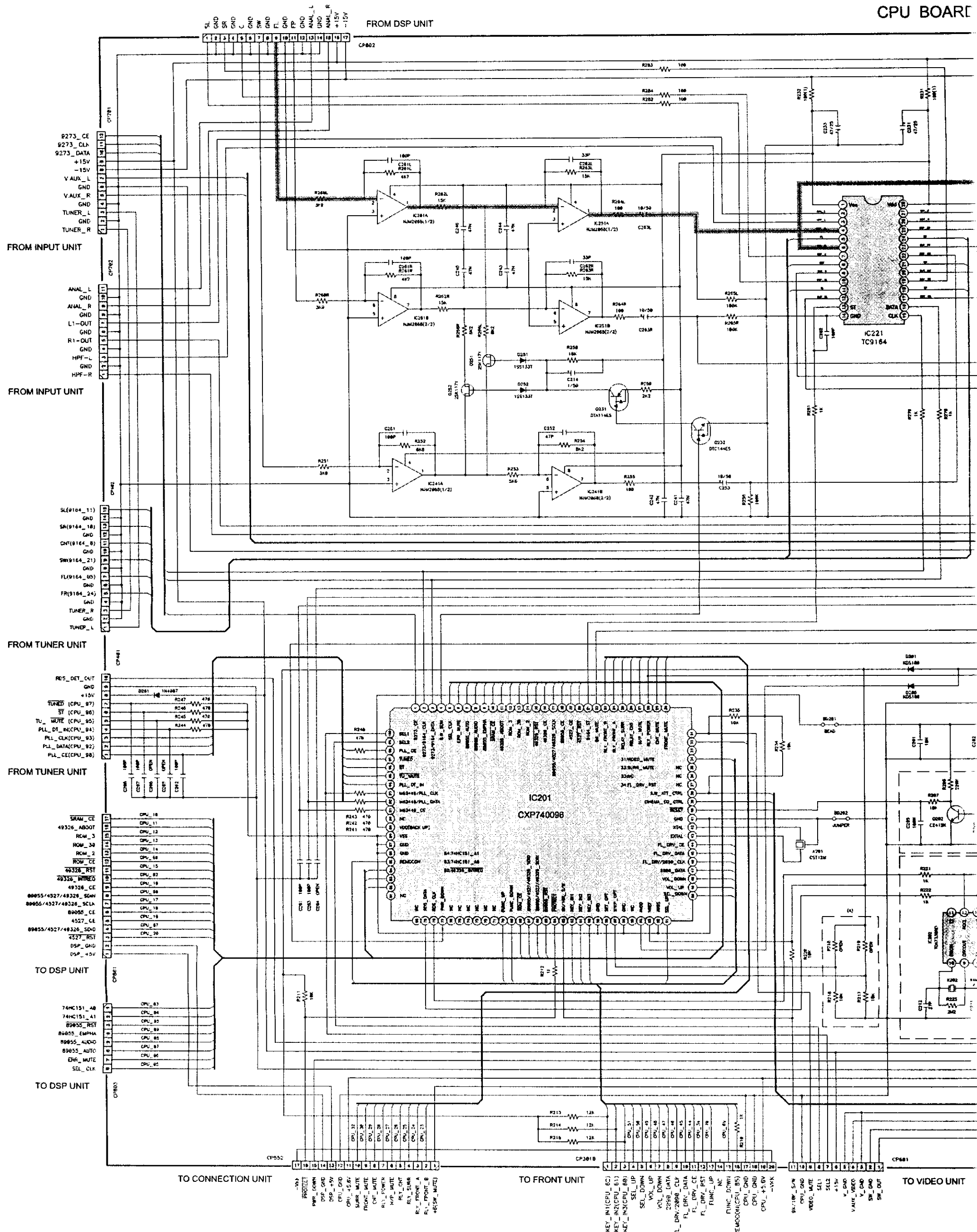

6 7 8 9 10 11

CPU BOARD

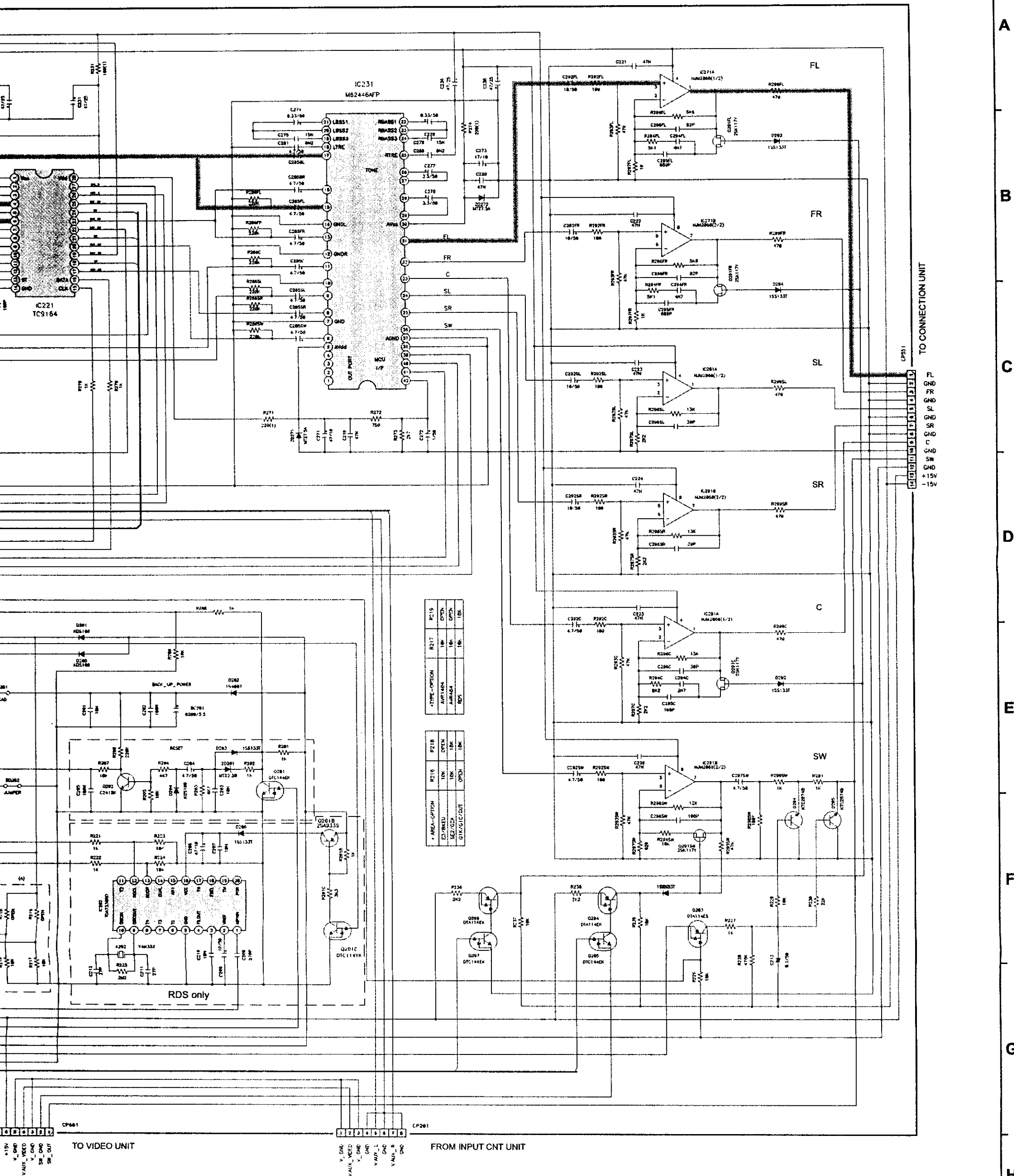

*TYPE-OPTION	R215	OPEN	10K
	R217	OPEN	10K
	R218	OPEN	10K
	R219	OPEN	10K

*AREA-OPTION	R216	OPEN	10K
	R217	OPEN	10K
	R218	OPEN	10K
	R219	OPEN	10K

SIGNAL LINE
SCHEMATIC DIAGRAMS (3/7)
CPU UNIT

A
B
C
D
E
F
G
H

6

7

8

9

10

11

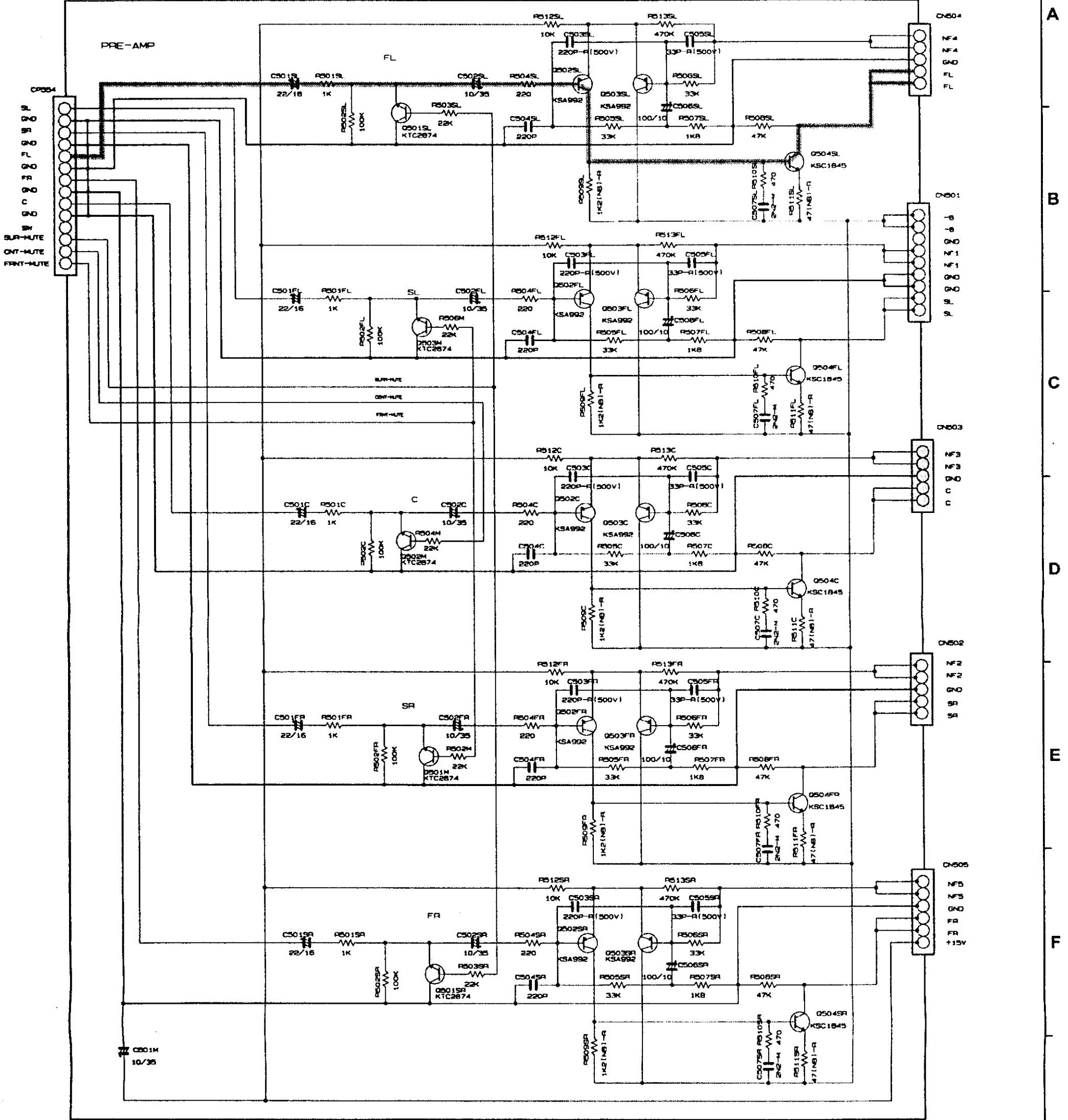

A
B
C
D
E
F
G
H

SIGNAL LINE
CNT UNIT
PRE-AMP UNIT

SCHEMATIC DIAGRAMS (4/7)

1 2 3 4 5

SCHEMATIC

DIAGRAM

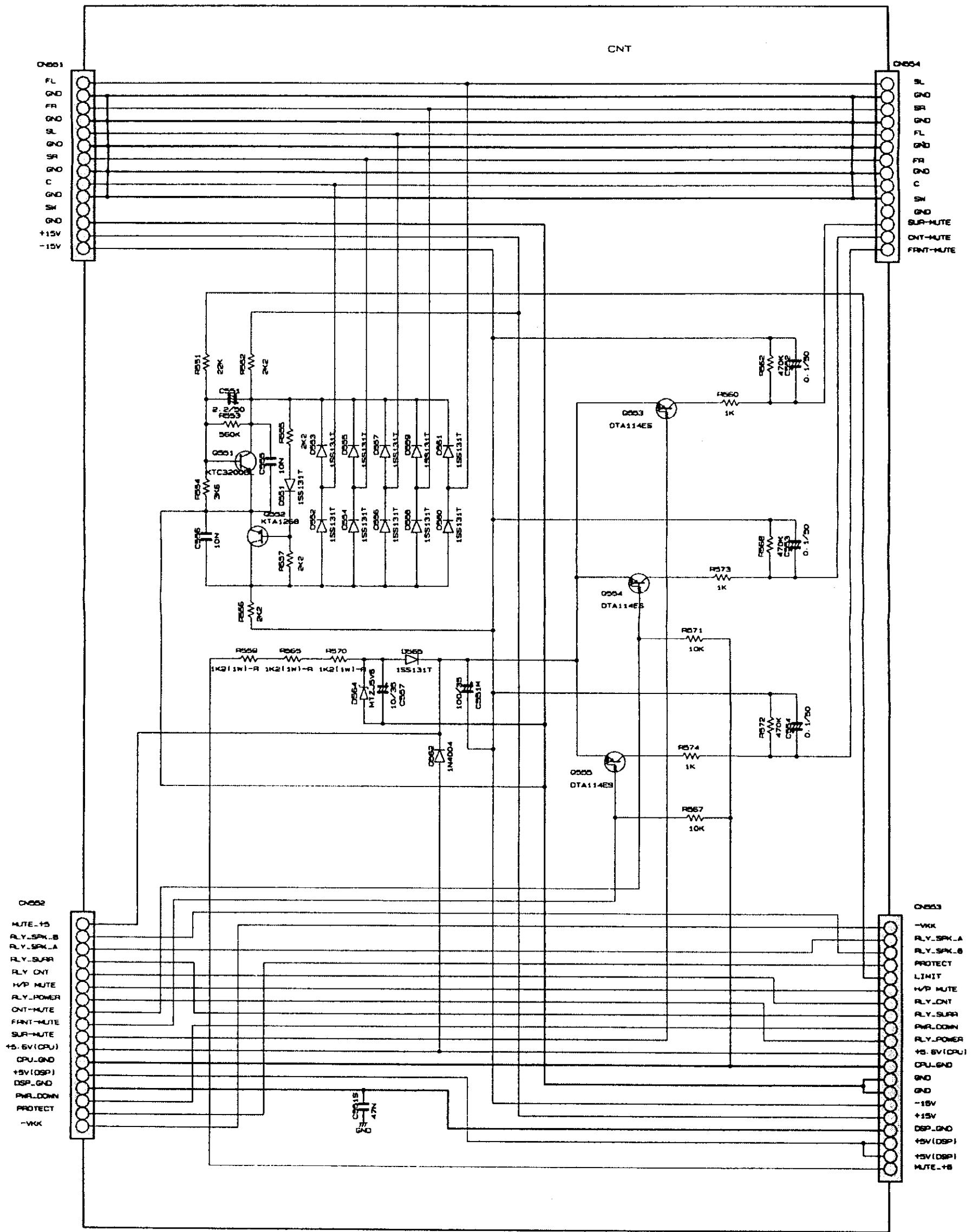

SCHEMATIC DIAGRAMS (5/7)

1 2 3 4 5 6

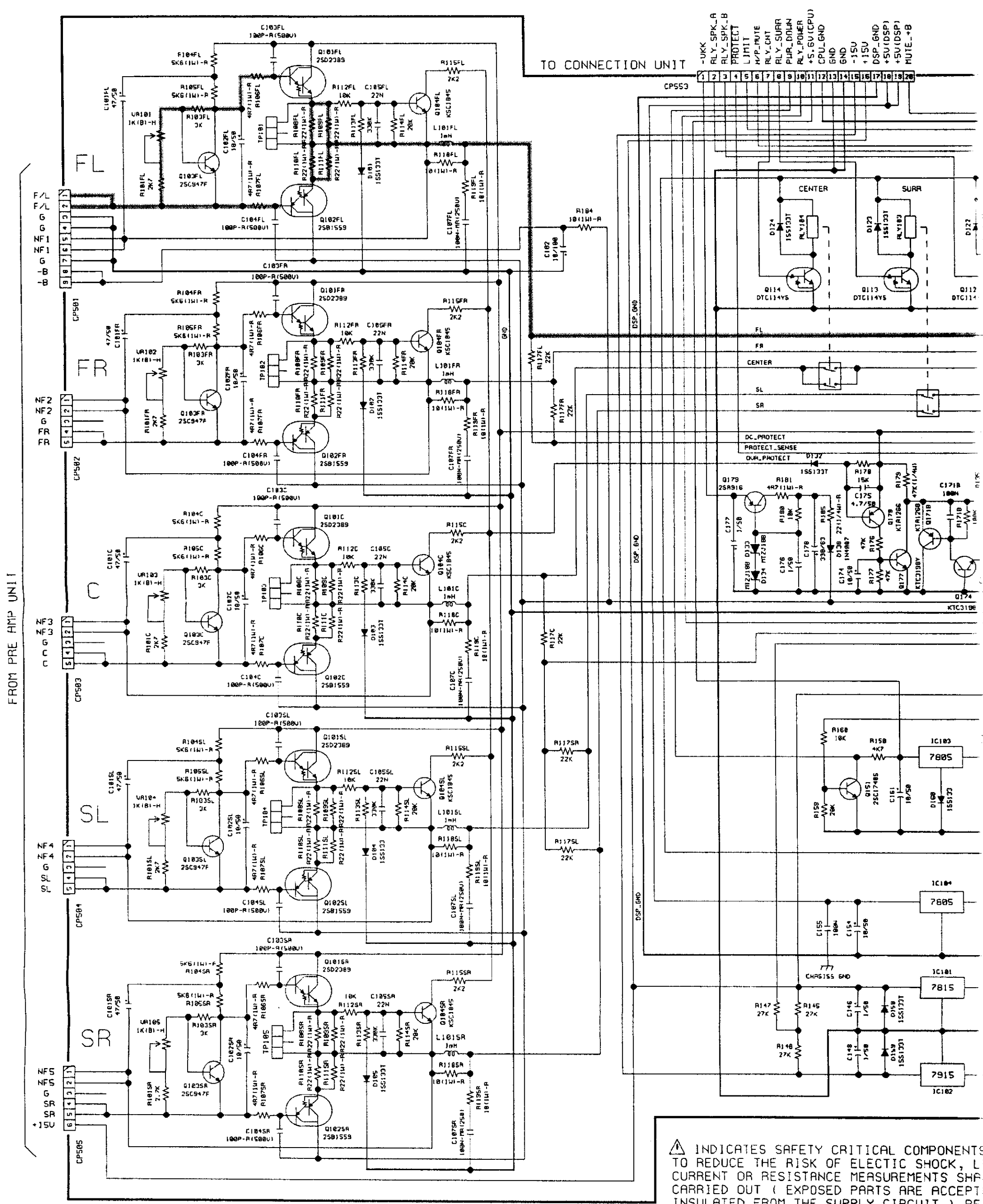

⚠ INDICATES SAFETY CRITICAL COMPONENTS TO REDUCE THE RISK OF ELECTRIC SHOCK, CURRENT OR RESISTANCE MEASUREMENTS SHAP CARRIED OUT (EXPOSED PARTS ARE ACCEPT INSULATED FROM THE SUPPLY CIRCUIT) BE THE APPLIANCE RETURNED TO THE CUSTOMER

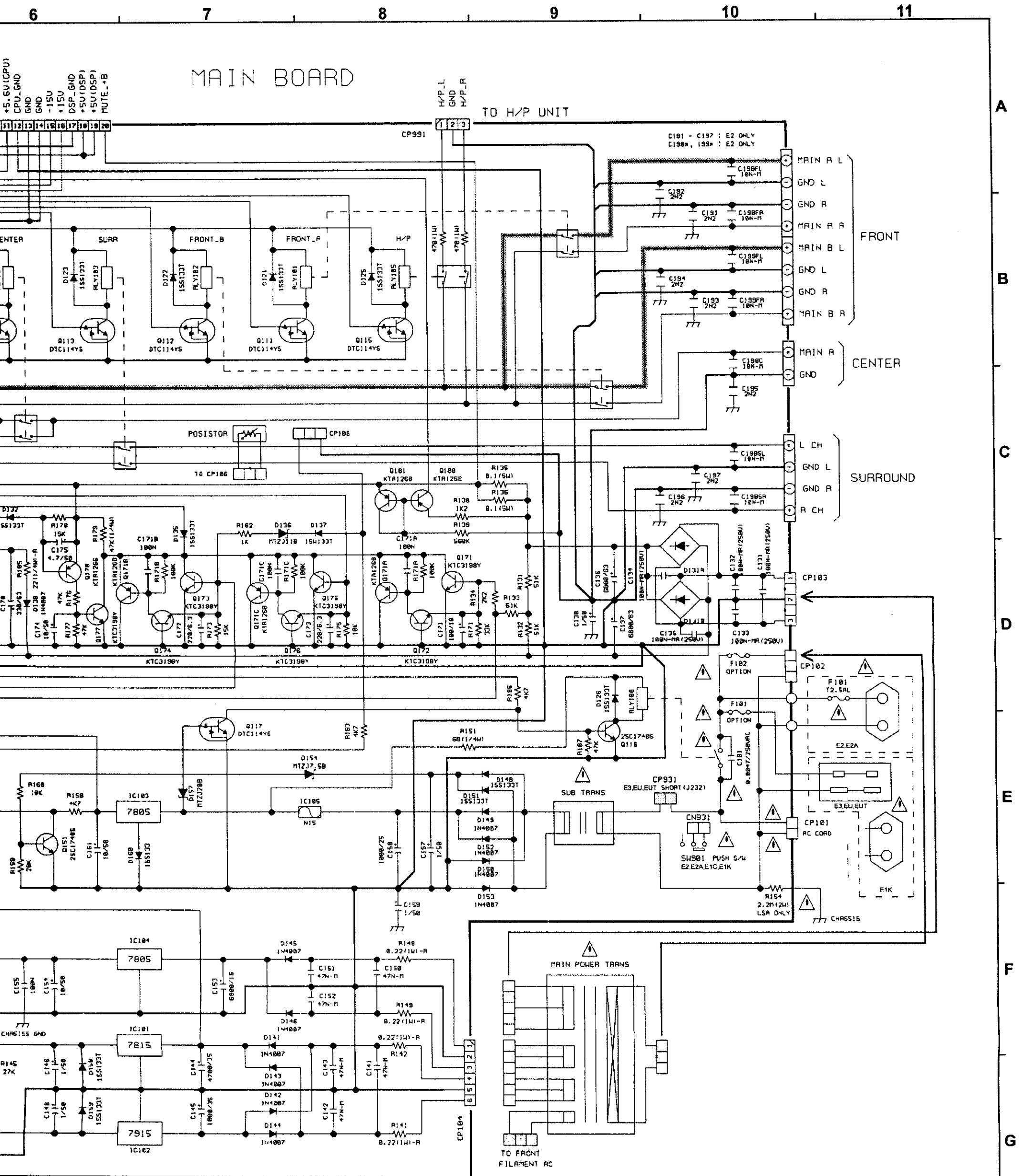

SAFETY CRITICAL COMPONENTS.
 RISK OF ELECTRIC SHOCK, LEAKAGE
 DISTANCE MEASUREMENTS SHALL BE
 PROPOSED PARTS ARE ACCEPTABLY
 (THE SUPPLY CIRCUIT) BEFORE
 TURNED TO THE CUSTOMER.

AVR-1404	F101	F102
E3,EU,EUT	8A/125V	8A/125V
E2	T2.5AL	T3.15AL
E1C	X	T3.15AL
E2A,E1K	T2.5AL	T3.15AL

SIGNAL LINE
 SCHEMATIC DIAGRAMS (5/7)
 MAIN UNIT

SCHEMATIC DIAGRAMS (6/7)

1 2 3 4 5 6

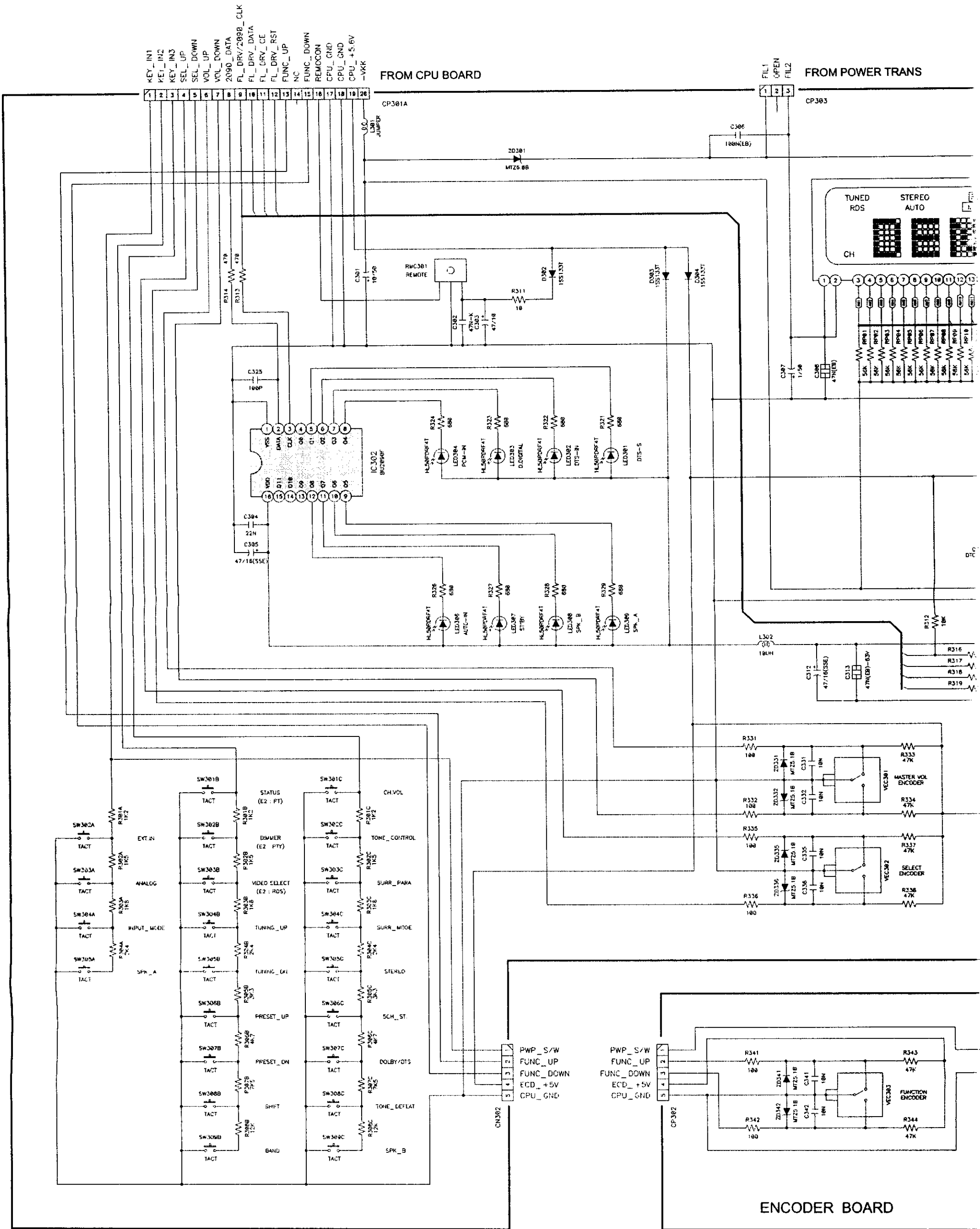

6 7 8 9 10 11

A
B
C
D
E
F
G
H

POWER TRANS

FRONT BOARD

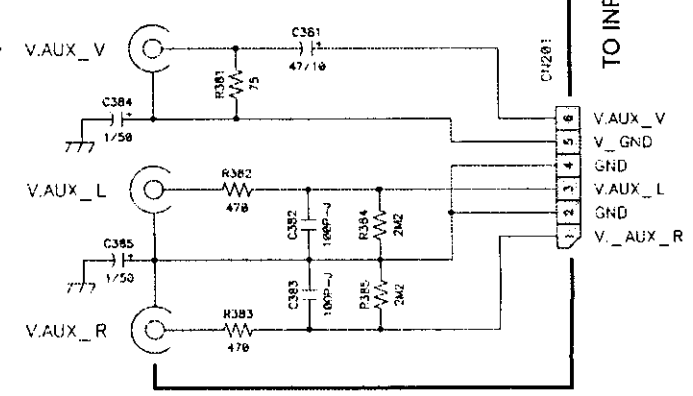
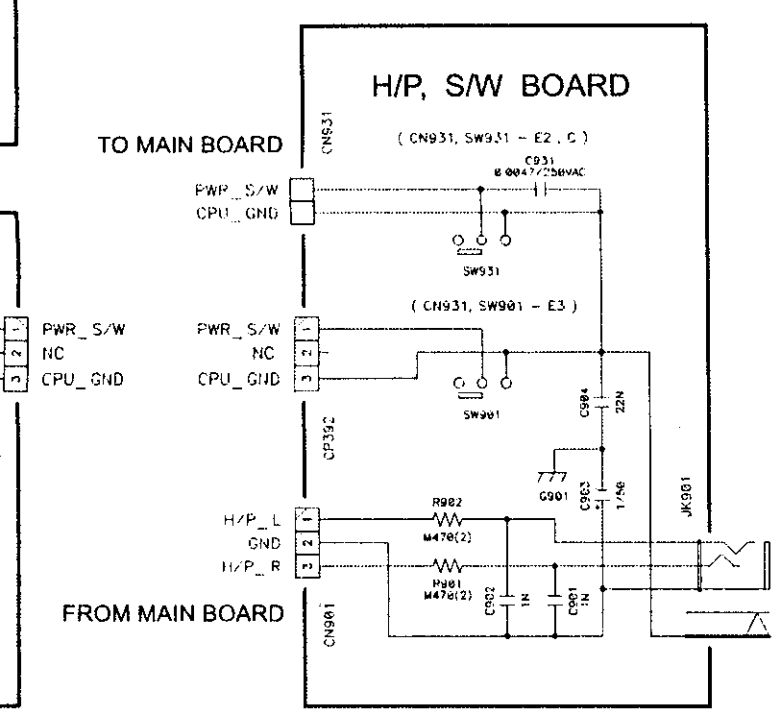
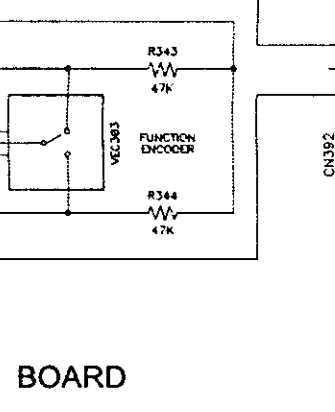
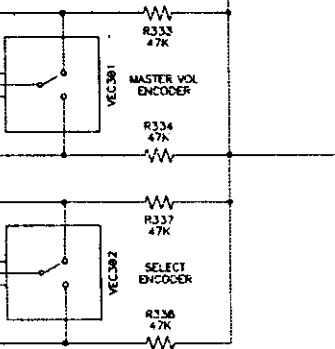
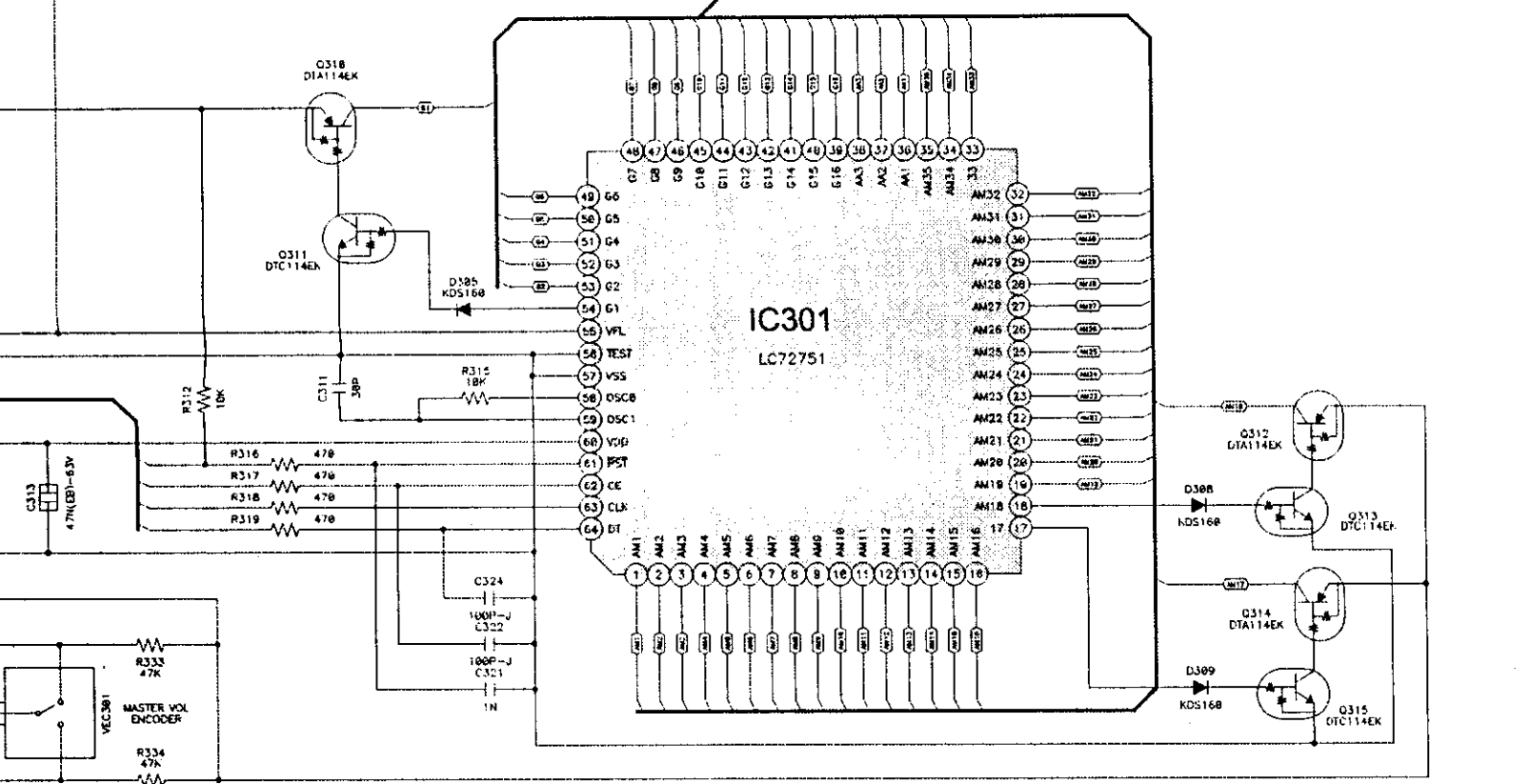
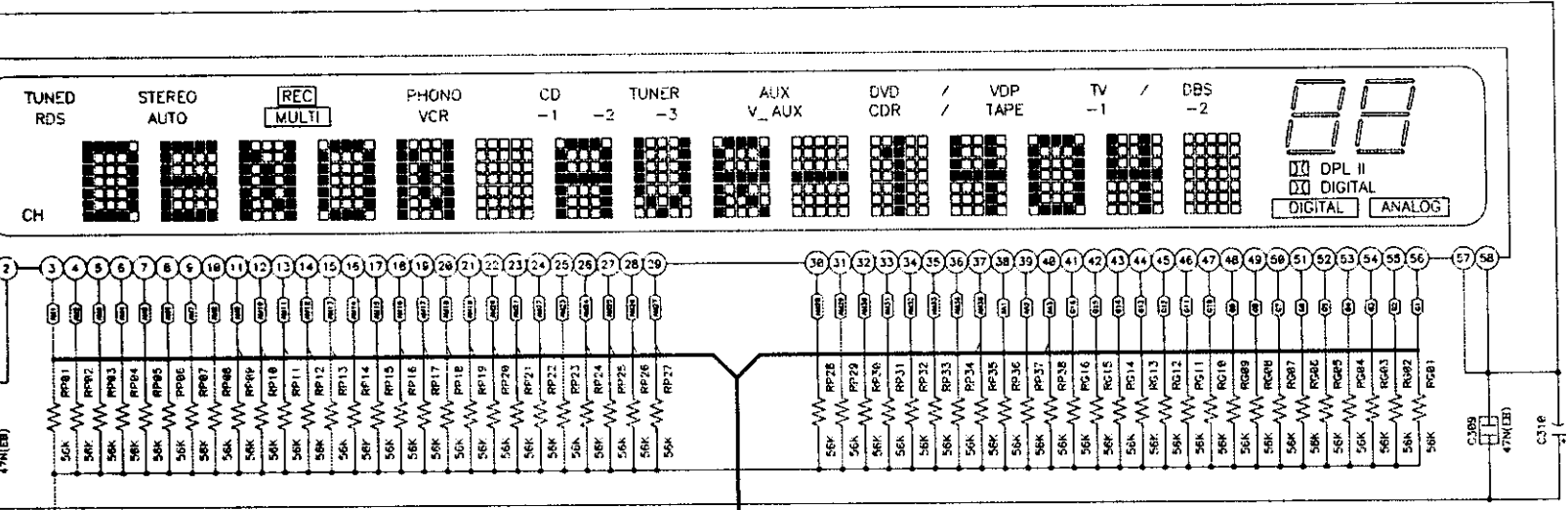

SCHEMATIC DIAGRAMS (6/7)
FRONT UNIT
ENCODER UNIT
H/P & S/W UNIT

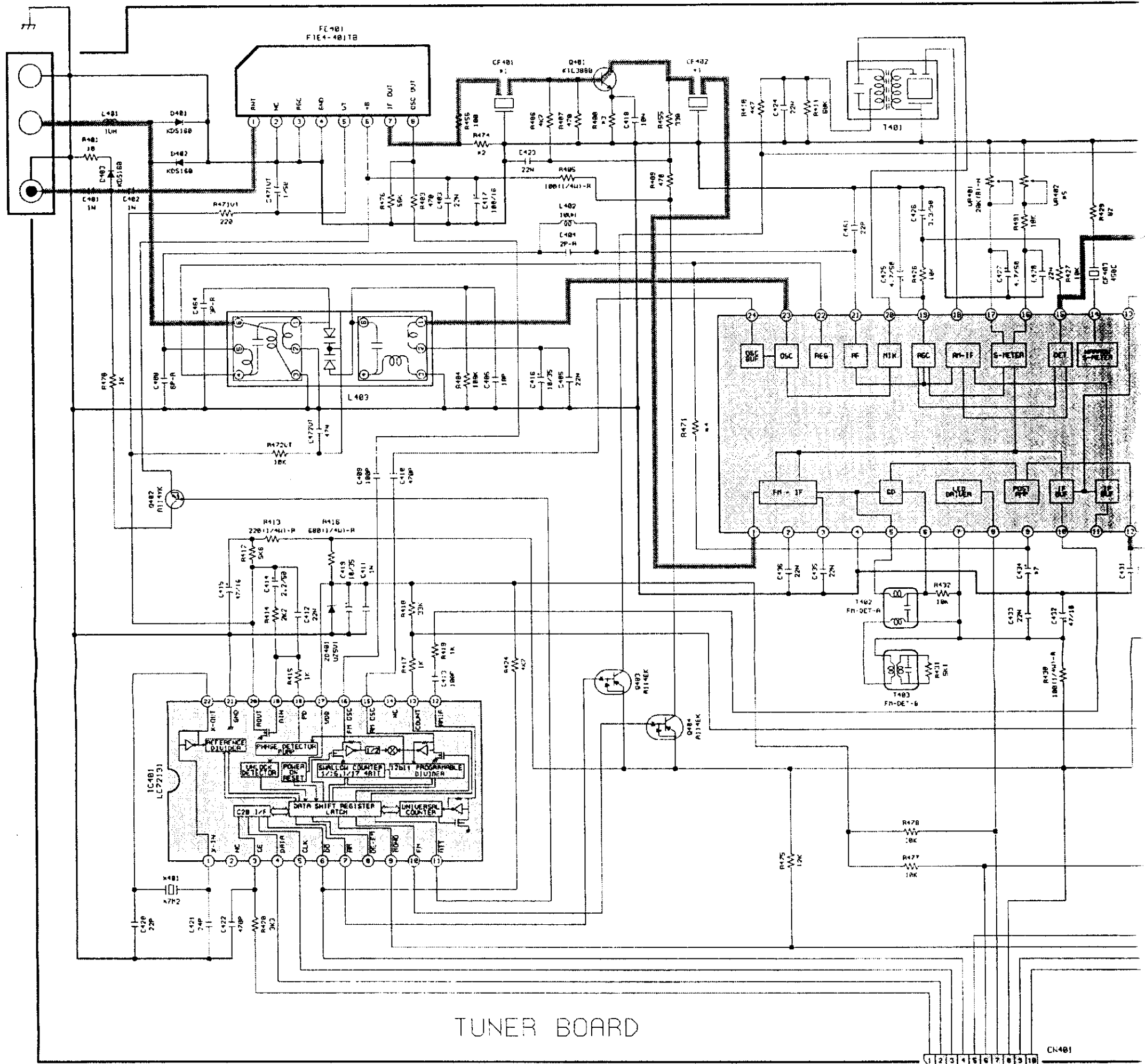

TUNER BOARD

	R-NG.	USA (E3)	E2, E2A	E1C, EUT, E1K
*1	CF401/CF402	SFE10.7MPB	SFE10.7MS3	10.7MAB/MS3
*2	R474	-	180	-
*3	R407/R408	470/1.2K	620/680	620/1.2K
*4	R471	18K	39K	39K
*5	UR402	50KB	100<B	50KB
*6	R428	3.3K	10K	6.8K
*7	C434	1/50	0.33/50	0.33/50
*8	R473	-	2.4K	-

	R-NG.	USA (E3)	E2, E2A	E1C, EUT, E1K
*9	J442	JUMPER	-	JUMPER
*10	T406	-	ANTI-BIRDIE	-
*11	C452	-	470P	-
*12	R472	-	100	-
*13	Q409	-	KTC3980	-
*14	R449	-	3.9K	-
*15	R450	-	1K	-
*16	R438, R439	100K	150K	100K

	R-NG.	USA (E3)	E2, E2A	E1C, EUT, E1K
*17	C4			
*18	C4			
*19	R4			
*20	R4			
*21	J4			
*22	T4			
*23	R-			
*24	R-			

1 PULL-UP
 2 PLL-DATA
 3 PLL-CLK
 4 PLL-DI-IN
 5 TUNING
 6 ST
 7 TUNED
 8 +15V
 9 GND
 10 RDS-DET-DUI

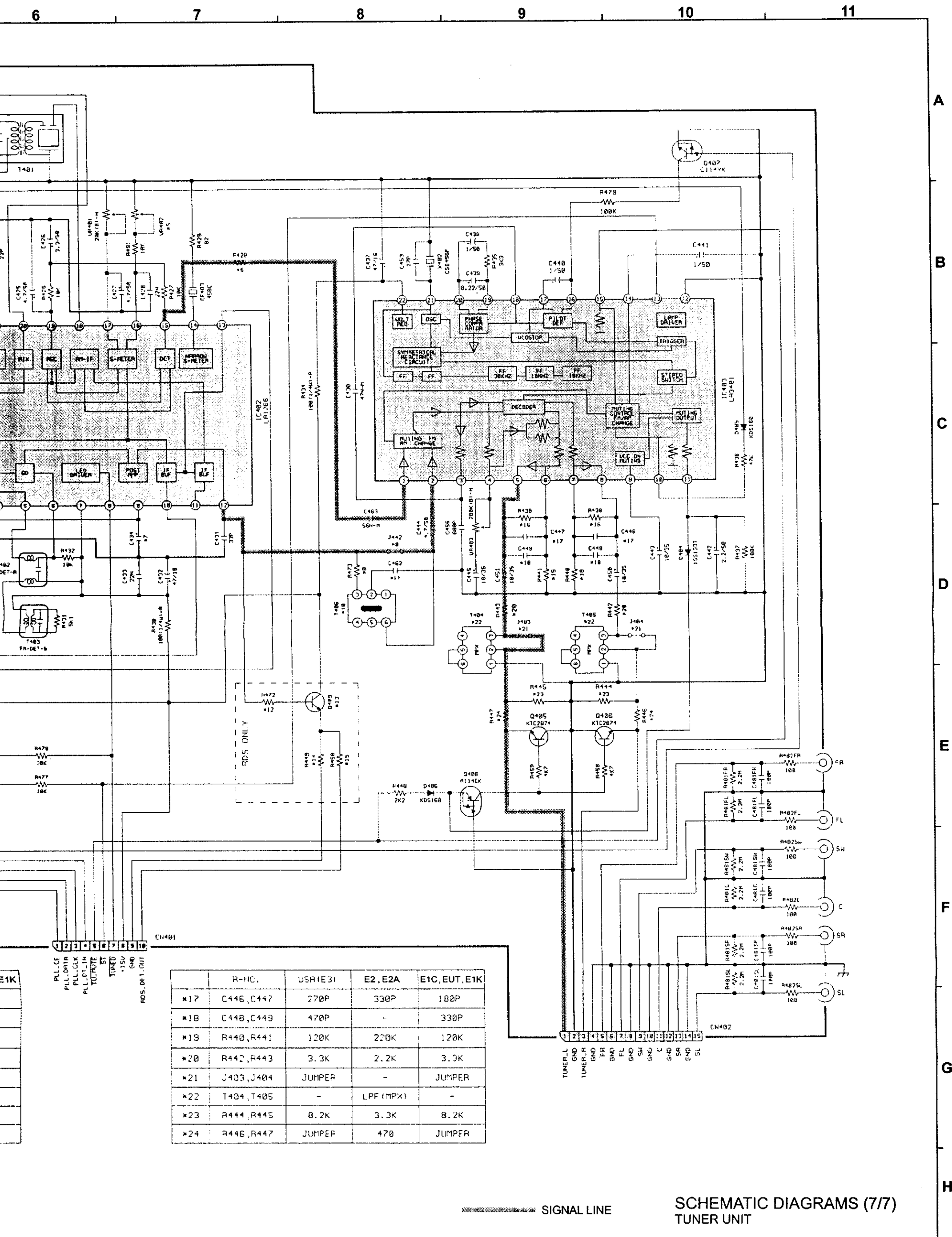

	R-NC.	USHIE31	E2, E2A	E1C, EUT, E1K
*17	C446, C447	270P	330P	100P
*18	C448, C449	470P	-	330P
*19	R440, R441	120K	220K	120K
*20	R442, R443	3.3K	2.2K	3.3K
*21	J403, J404	JUMPER	-	JUMPER
*22	T404, T405	-	LPF (MPX)	-
*23	R444, R445	8.2K	3.3K	8.2K
*24	R446, R447	JUMPER	470	JUMPER

SCHEMATIC DIAGRAMS (7/7)
TUNER UNIT

SIGNAL LINE