

# DENON

For U.S.A., Canada, Europe, U.K.,  
Australia, Asia, China, Hong Kong,  
Taiwan R.O.C. & Korea model

Hi-Fi Component

## SERVICE MANUAL

# MODEL AVR-1603/683

### AV SURROUND RECEIVER

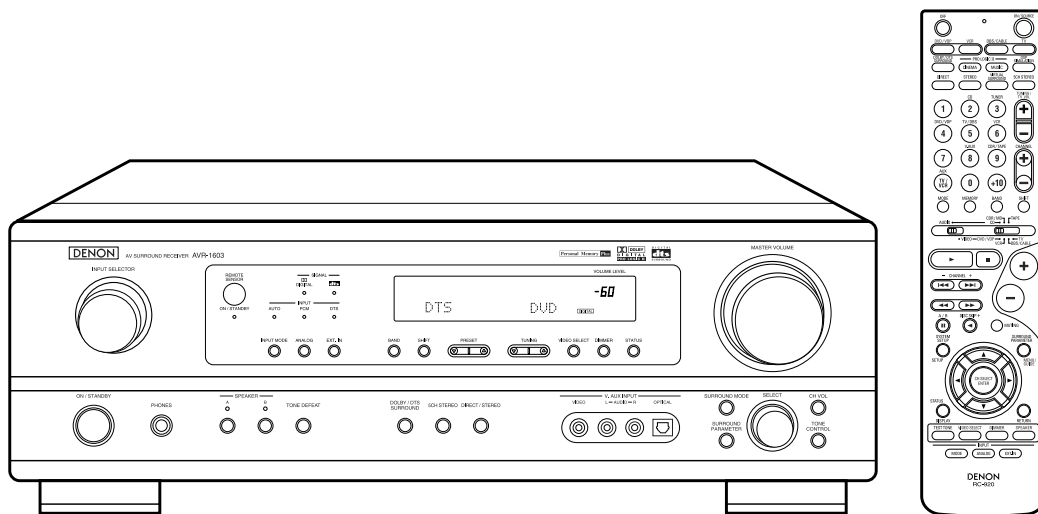

• Some illustrations using in this service manual are slightly different from the actual set.

## DENON, Ltd.

16-11, YUSHIMA 3-CHOME, BUNKYOU-KU, TOKYO 113-0034 JAPAN  
Telephone: 03 (3837) 5321

## SAFETY PRECAUTIONS

The following check should be performed for the continued protection of the customer and service technician.

### LEAKAGE CURRENT CHECK

Before returning the unit to the customer, make sure you make either (1) a leakage current check or (2) a line to chassis resistance check. If the leakage current exceeds 0.5 milliamps, or if the resistance from chassis to either side of the power cord is less than 460 kohms, the unit is defective.

## SPECIFICATIONS

### Audio Section

#### Power Amplifier

<b>Rated output:</b>	Front:	80W+80W	(8Ω/ohms, 20Hz~20kHz with 0.08% T.H.D ) (U.S.A., & Canada Models)
		70W+70W	(8Ω/ohms, 20Hz~20kHz with 0.08% T.H.D ) (Europe, U.K., Australia & Asia)
		110W+110W	(6Ω/ohms, 1kHz with 0.7% T.H.D ) (U.S.A., & Canada Models)
		100W+100W	(6Ω/ohms, 1kHz with 0.7% T.H.D ) (Europe, U.K. & Australia Models)
		110W+110W	(6Ω/ohms, EIAJ ) (Asia Model)
	Center:	80W	(8Ω/ohms, 20Hz~20kHz with 0.08% T.H.D ) (U.S.A., & Canada Models)
		70W	(8Ω/ohms, 20Hz~20kHz with 0.08% T.H.D ) (Europe, U.K. & Australia & Asia)
		110W	(6Ω/ohms, 1kHz with 0.7% T.H.D ) (U.S.A., & Canada Models)
		100W	(6Ω/ohms, 1kHz with 0.7% T.H.D ) (Europe, U.K. & Australia Models)
		110W	(6Ω/ohms, EIAJ ) (Asia Model)
	Surround:	80W+80W	(8Ω/ohms, 20Hz~20kHz with 0.08% T.H.D ) (U.S.A., & Canada Models)
		70W+70W	(8Ω/ohms, 20Hz~20kHz with 0.08% T.H.D ) (Europe, U.K. & Australia & Asia)
		110W+110W	(6Ω/ohms, 1kHz with 0.7% T.H.D ) (U.S.A., & Canada Models)
		100W+100W	(6Ω/ohms, 1kHz with 0.7% T.H.D ) (Europe, U.K. & Australia Models)
		110W+110W	(6Ω/ohms, EIAJ ) (Asia Model)
<b>Output terminals:</b>	Front:	A or B	6 to 16Ω/ohms
		A+B	12 to 16Ω/ohms
	Center/Surround:		6 to 16Ω/ohms
<b>LINE input - SPEAKER OUT</b>			
<b>Input sensitivity/input impedance:</b> 200mV/47kΩ/kohms			
<b>Frequency response:</b> 10Hz~100kHz: +1, -3dB (TONE DEFEAT ON)			
<b>S/N ratio:</b> 98dB (IHF-A weighted) (TONE DEFEAT ON)			

### Video Section

#### Standard video jacks

**Input/output level and impedance:** 1Vp-p, 75Ω/ohms  
**Frequency response:** 5Hz~10MHz — +1, -3dB

#### S-video jacks

**Input/output level and impedance:** Y(brightness)signal — 1Vp-p, 75Ω/ohms  
 C(color)signal — 0.286Vp-p, 75Ω/ohms  
**Frequency response:** 5Hz~10MHz: — +1, -3dB

#### Color component video jacks (U.S.A. & Canada Models)

**Input/output level and impedance:** Y(brightness)signal — 1Vp-p, 75Ω/ohms  
 Pb/Cb(blue)signal — 0.7Vp-p, 75Ω/ohms  
 Pr/Cr(red)signal — 0.7Vp-p, 75Ω/ohms  
**Frequency response:** 5Hz~27MHz: — +0, -3dB

### Tuner section

<b>Receiving range:</b>	U.S.A., & Canada Models:	<b>[FM]</b> (note: μV at 75Ω/ohms, 0dBf = 1×10 <sup>-15</sup> W)	<b>[AM]</b>
	Europe U.K. & Australia Models:	87.50MHz~107.90MHz	520kHz~1710kHz
	Asia Model:	87.50MHz~108.00MHz	522kHz~1611kHz
<b>Usable sensitivity:</b>		87.50MHz~107.90MHz (0.2MHz steps)	520kHz~1710kHz (10kHz steps)
		87.50MHz~108.00MHz (0.05MHz steps)	522kHz~1611kHz (9kHz steps)
		1.0μV (11.2dBf)	18μV
<b>50 dB quieting sensitivity:</b>	MONO	1.6μV (15.3dBf)	
	STEREO	23μV (38.5dBf)	
<b>S/N ratio:</b>	MONO	80dB (IHF-A weighted)	
	STEREO	75dB (IHF-A weighted)	
<b>Total harmonic distortion:</b>	MONO	0.15% (1kHz)	
	STEREO	0.3% (1kHz)	

## ■ General

<b>Power supply:</b>	AC120V, 60Hz (U.S.A. & Canada Models) AC230V, 50Hz (Europe, U.K. & Australia Models) AC115/230V, 50/60Hz (Asia Model)
<b>Power consumption:</b>	4.0A (USA & Canada model) 210W (Europe, U.K., Australia & Asia models)
<b>Maximum external dimensions:</b>	434 (W) × 147 (H) × 417 (D) mm (17-3/32" × 5-25/32" × 1-23/64")
<b>Mass:</b>	10.4kg (22 lbs 14.9 oz)

## ■ Remote control unit (RC-920)

<b>Batteries:</b>	R6P/AA Type (two batteries)
<b>External dimensions:</b>	55 (W) × 225 (H) × 34.5 (D) mm (2-11/64" × 8-55/64" × 1-9/64")
<b>Mass:</b>	165g (Approx. 5.8 oz) (including batteries)

\* For purposes of improvement, specifications and design are subject to change without notice.

## DISASSEMBLY

(Follow the procedure below in the reverse order when reassembling)

### 1. Top Cover

Remove 6 screws ① and 3 screws ②, then detach the Top Cover to the arrow direction.

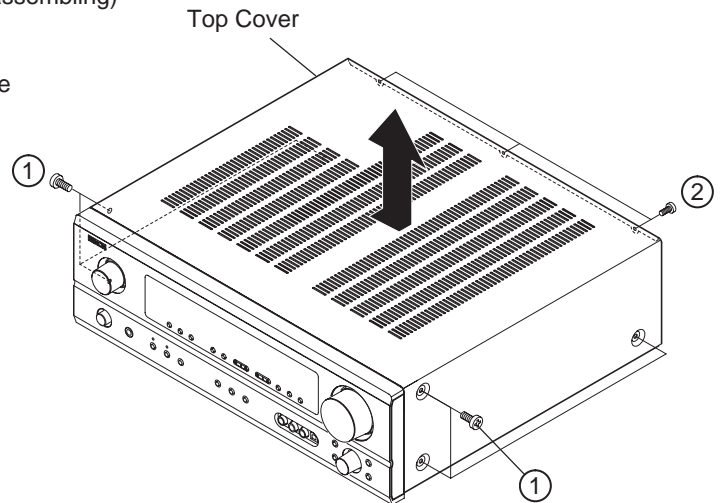

### 2. Front Panel

- (1) Remove 4 screws ③ and 3 screws ④.
- (2) Disconnect 3 connectors and FFC coming from the Front Panel side.
- (3) Disconnect the connector coming from the Trans., and detach the Front Panel to the arrow direction.

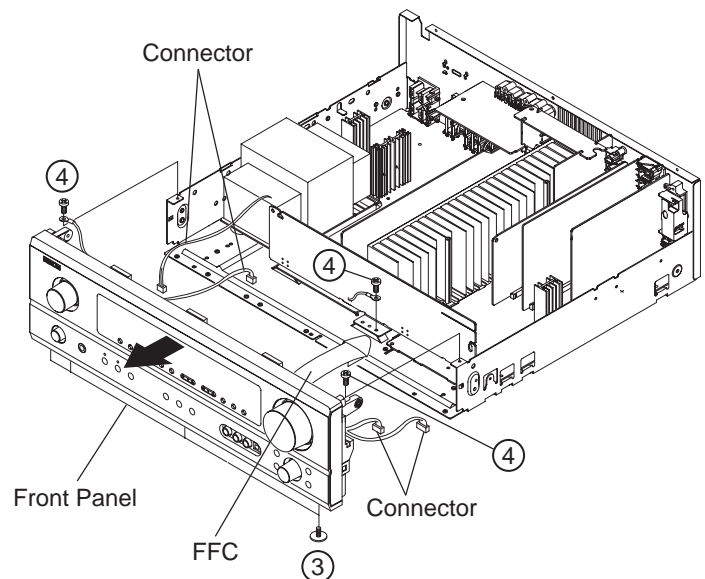

### 3. Rear Panel

- (1) Take off the AC cord ⑤.
- (2) Remove 32 screws ⑥ (36 pieces for U.S.A. & Canada models).
- (3) Detach the Rear Panel to the arrow direction.

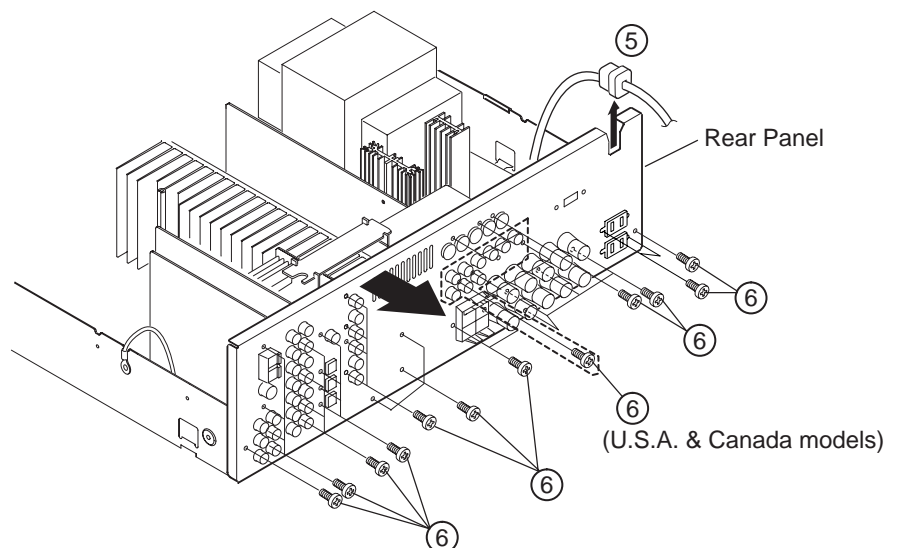

LEVEL DIAGRAMS

1 2 3 4 5 6 7 8

FRONT/CENTER/SURROUND

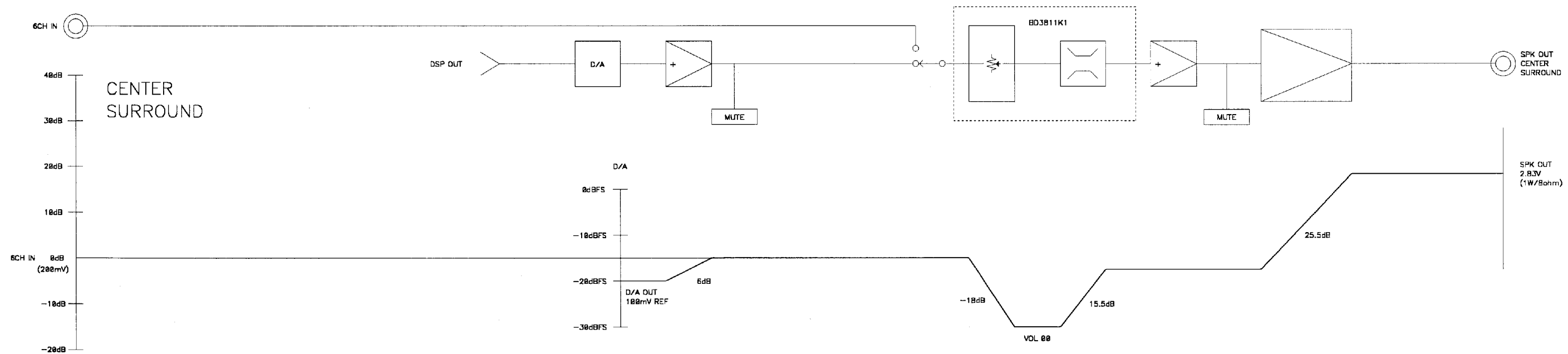
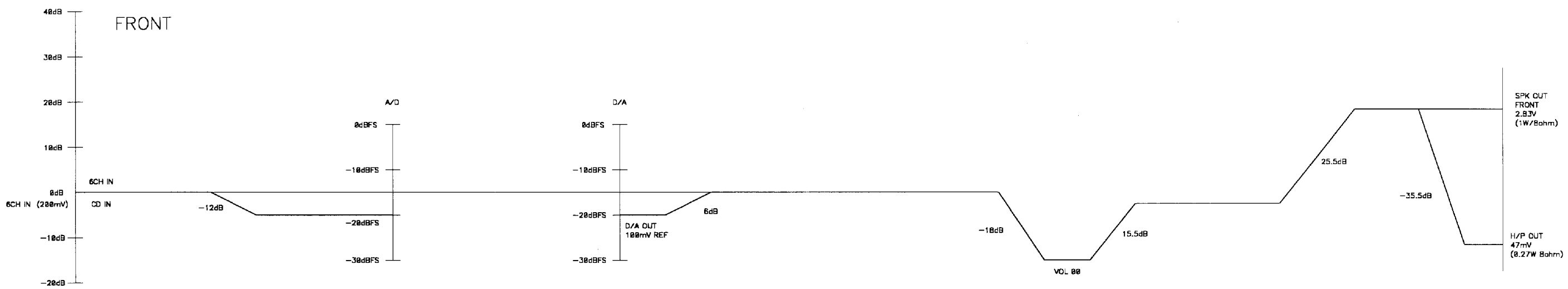
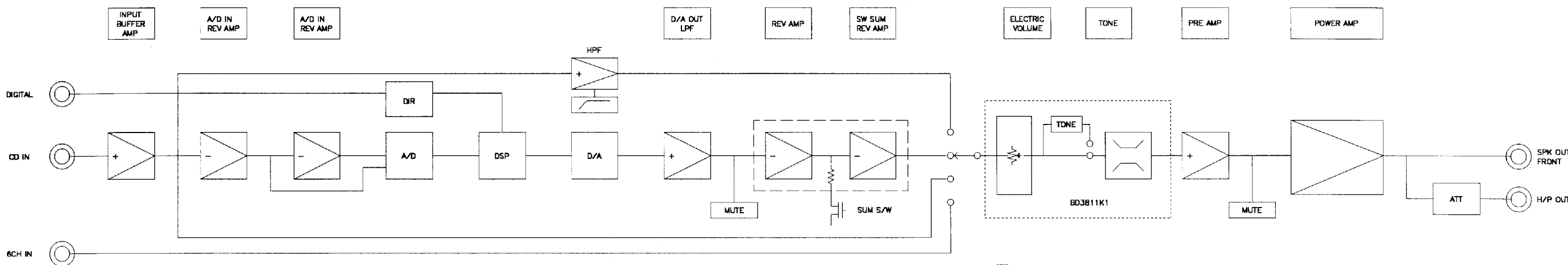

A  
B  
C  
D  
E

1 2 3 4 5 6 7 8

SUB WOOFER

SUB\_WOOFER

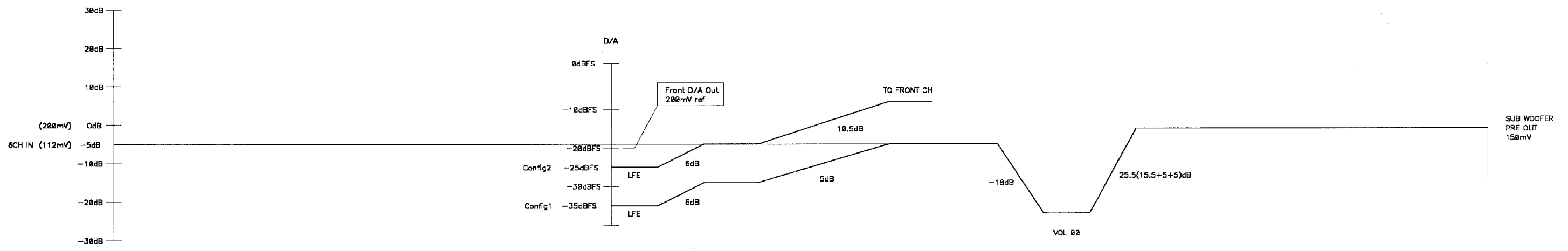
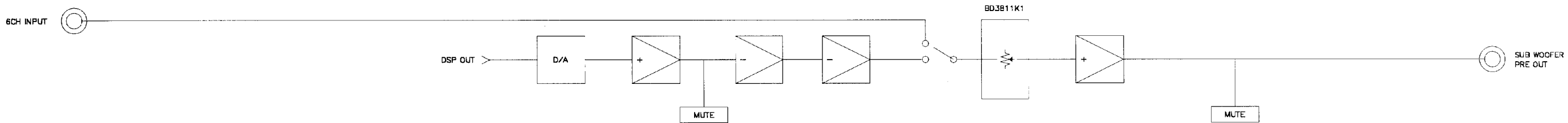

A  
B  
C  
D  
E

BLOCK DIAGRAM

AVC-1570 / AVR-1603 BLOCK DIAGRAM

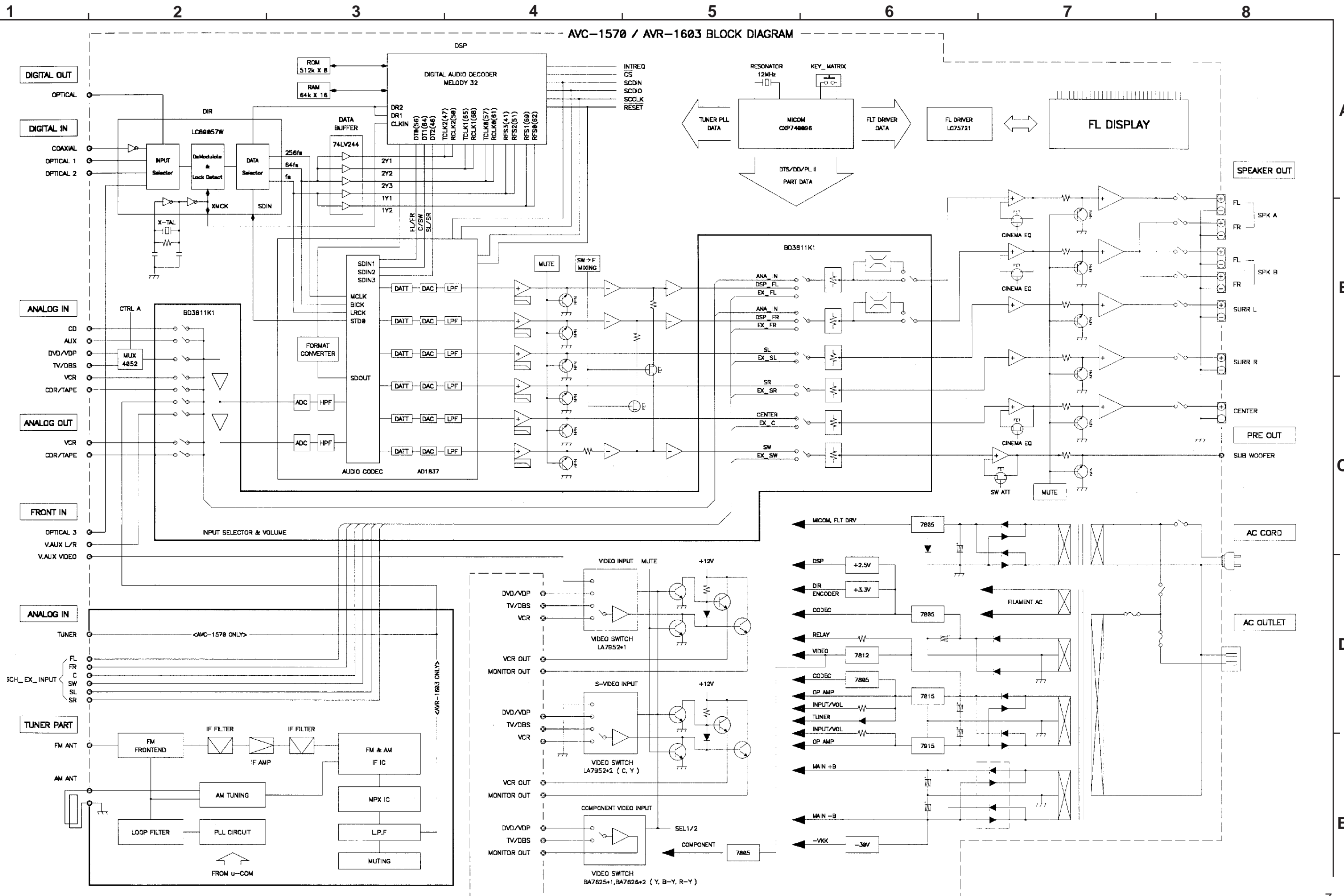

# ADJUSTMENT

## Tuner Section

### CONNECTION DIAGRAM OF MEASURING INSTRUMENTS

● FM

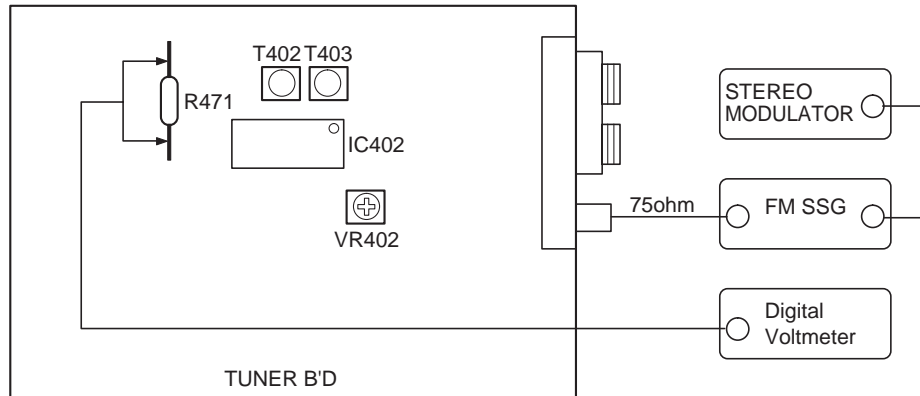

### FM ALIGNMENT

Step	Alignment Item	Tuning Frequency Setting	Input					Output		Adjustment	
			Type	Frequency	Input Level	Modulation	Coupling	Type	Connect to	Points	Adjust to
1	Center Adjustment	98.1MHz (98.0MHz)	FM SSG	98.1MHz	60dBμ	Mono 1kHz 100%	Antenna Terminal	Digital Voltmeter	R471	T402	± 50mV
2	Distortion	98.1MHz (98.0MHz)	FM SSG	98.1MHz	60dBμ	Mono 1kHz 100%	Antenna Terminal	Distortion Meter	Output Terminal (L)	T403	Minimum Distortion
3	Repeat Steps 1 and 2										
4	Signal Level	98.1MHz (98.0MHz)	FM SSG	98.1MHz	20dBμ	OFF	Antenna Terminal	Light "TUNED" on FL Display	VR402		20 <sup>+14</sup> / <sub>-10</sub> dB

● AM

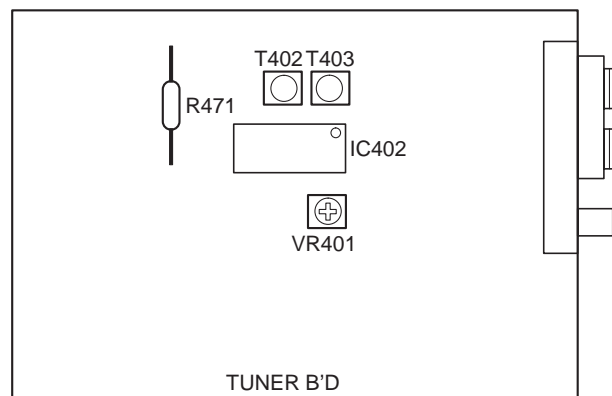

### AM ALIGNMENT

Step	Alignment Item	Frequency	Input	Output		Adjustment		Remarks
				Type	Connect to	Points	Adjust to	
1	Signal Level	999 (1000) kHz	AM SSG	—	—	VR401	Light "TUNED" on FL Display	SSG OUTPUT 74dBμ (EMF)



## Audio Section

### Idling Current

Required measurement equipment : DC Voltmeter

### Preparation

- (1) Avoid direct blow from an air conditioner or an electric fan, and adjust the unit at normal room temperature 15 °C ~ 30 °C (59 °F ~ 86 °F).
- (2) Presetting
  - POWER (Power source switch) → OFF
  - SPEAKER (Speaker terminal) → No load (Do not connect speaker, dummy resistor, etc.)

### Adjustment

- (1) Remove top cover and set VR101, VR102, VR103, VR104, VR105 on Amp. Unit at full counterclockwise ( ⚙ ) position.
- (2) Connect DC Voltmeter to test points (FRONT-Lch: TP104, FRONT-Rch: TP105, CENTER ch: TP103, SURROUND-Lch: TP101, SURROUND-Rch: TP102).
- (3) Connect power cord to AC Line, and turn power switch "ON".
- (4) Presetting.
 

MASTER VOLUME	: "---	counterclockwise ( ⚙ min.)
MODE	: 5CH STEREO	
FUNCTION	: CD	
- (5) Within 2 minutes after the power on, turn VR101 clockwise ( ⚙ ) to adjust the TEST POINT voltage to 1.5 mV  $\pm$ 0.5 mV DC.
- (6) After 10 minutes from the preset above, turn VR101 to set the voltage to 2.5 mV  $\pm$ 0.5 mV DC.
- (7) Adjust the Variable Resistors of other channels in the same way.

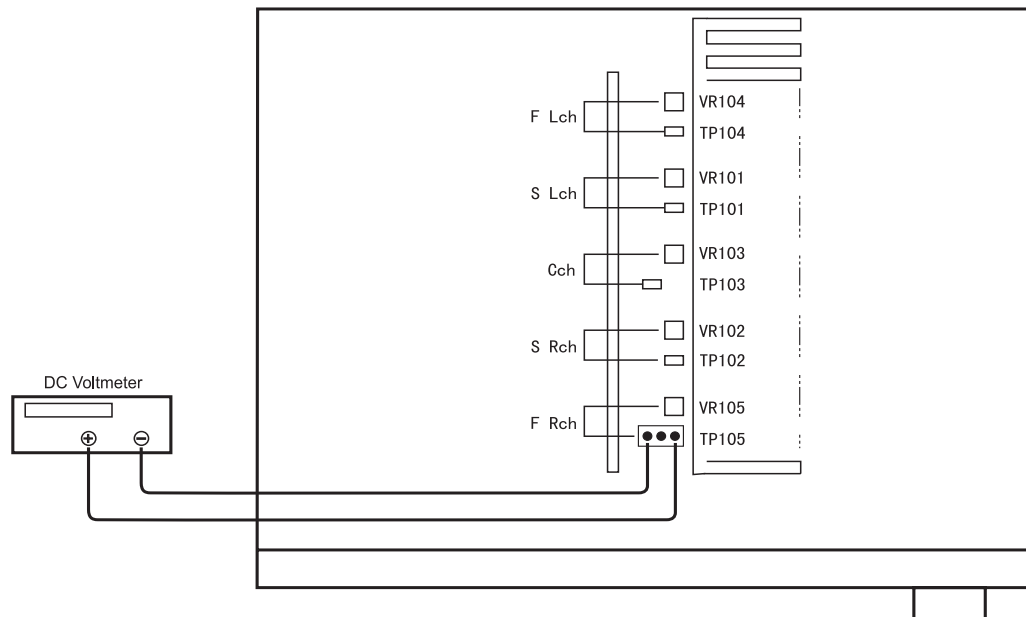

# SEMICONDUCTORS

● IC's  
**CXP740096**  
 (IC201)

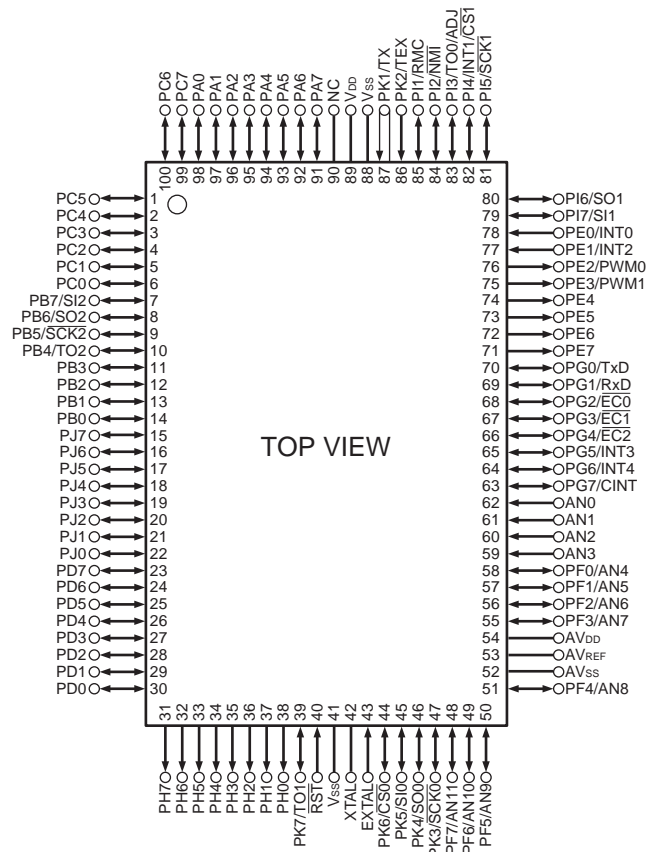

**CXP740096 Terminal Function**

Pin No.	Pin Name	I/O	Function
1	3811K1MUTE	O	BD3811K1 CONTROL
2	3811K1CLK	O	BD3811K1 CONTROL
3	3811K1DATA	O	BD3811K1 CONTROL
4	CDR/TAPE	O	CDR/TAPE INHIBIT
5	VCR	O	VCR INHIBIT
6	ERR MUTE	O	ERR MUTE
7	ERR MUTE OFF	O	ERR MUTE OFF
8	89057 AUDIO	I	LC89057 CONTROL
9	89057 EMPHA	I	LC89057 CONTROL
10	SW SUM	O	SW SUMMING CONTROL
11	M32 SDIN	I	DATA INPUT FROM MELODY32
12	89057 SDIN	I	DATA INPUT FROM LC89057
13	EPROM RESET	O	EPROM RESET
14	89057 RESET	O	LC89057 RESET
15	M32 CS	O	MELODY32 CS
16	M32 SDOUT	O	MELODY32 CONTROL DATA
17	89057 CE	O	LC89057 CE
18	89057 SDOUT	O	CONTROL DATA
19	89057 SCLK	O	CONTROL CLOCK
20	1837 RESET	O	CODEC RESET
21	NC	—	
22	SW MUTE	O	SW MUTE
23	RELAY F-B	O	FRONT B RELAY

Pin No.	Pin Name	I/O	Function
24	RELAY F-A	O	FRONT A RELAY
25	RELAY SURR	O	SURROUND RELAY
26	RELAY CNT	O	CENTER RELAY
27	RELAY H/P	O	H/P RELAY
28	FUNC UP	I	ENCODER INPUT(FUNCTION)
29	H/P DETECT	I	H/P DETECT
30	FUNC DOWN	I	ENCODER INPUT(FUNCTION)
31	NC	—	
32	CNT MUTE	O	CENTER MUTE
33	FRONT MUTE	O	FRONT MUTE
34	SURR MUTE	O	SURROUND MUTE
35	NC	—	
36	NC	—	
37	NC	—	
38	FL DRV RESET	O	LC75721NE RESET
39	RELAY POWER	O	POWER RELAY
40	RESET	I	RESET
41	GND	I	
42	XTAL	—	
43	EXTAL	—	
44	FL DRV CE	O	LC75721NE CE
45	FL DRV DATA	O	LC75721NE DATA
46	FL DRV/2090 CLK	O	CONTROL CLOCK
47	2090 DATA	O	BU2090F DATA
48	VOL DOWN	I	ENCODER INPUT(VOLUME)
49	VOL UP	I	ENCODER INPUT(VOLUME)
50	SEL DOWN	I	ENCODER INPUT(SELECT)
51	SEL UP	I	ENCODER INPUT(SELECT)
52	AVSS	—	
53	VREF	—	
54	AVDD	—	
55	NC	—	
56	GND	—	
57	STEP OPT	I	AREA SELECT
58	SET OPT	I	MODEL SELECT
59	GND	—	
60	KEY IN3	I	KEY INPUT
61	KEY IN2	I	KEY INPUT
62	KEY IN1	I	KEY INPUT
63	9K/10K STEP	I	TUNER STEP SELECT
64	PROTECT	I	PROTECTION
65	89057 INT	I	LC89057 INTERRUPT
66	M32 SCLK	O	MELODY32 CLOCK
67	1837 CE	O	CODEC CE
68	M32 RESET	O	MELODY32 RESET
69	NC	—	
70	NC	—	
71	NC	—	
72	NC	—	
73	NC	—	
74	NC	—	
75	NC	—	
76	NC	—	

Pin No.	Pin Name	I/O	Function
77	PWR DOWN	I	POWER DOWN DETECT
78	RDS CLK	O	TDA7330 CONTROL CLOCK
79	RDS DATA	O	TDA7330 CONTROL DATA
80	NC	—	
81	VIDEO MUTE	O	VIDEO MUTE
82	M32 INTREQ	I/O	MELODY32 CONTROL
83	VIDEO SEL1	O	VIDEO SELECT1
84	VIDEO SEL2	O	VIDEO SELECT2
85	REMOCON	I	REMOTE CONTROL SIGNAL INPUT
86	GND	—	
87	GND	—	
88	VSS	—	
89	VDD	—	
90	NC	—	
91	NC	—	
92	PLL DATA	O	PLL CONTROL
93	PLL CLK	O	PLL CONTROL
94	PLL DT IN	O	PLL CONTROL
95	TU MUTE	O	TUNER MUTE
96	STEREO	I	STEREO DETECT
97	TUNED	I	TUNED DETECT
98	PLL CE	O	PLL CONTROL
99	NC	—	
100	NC	—	

## MELODY32 (IC802)

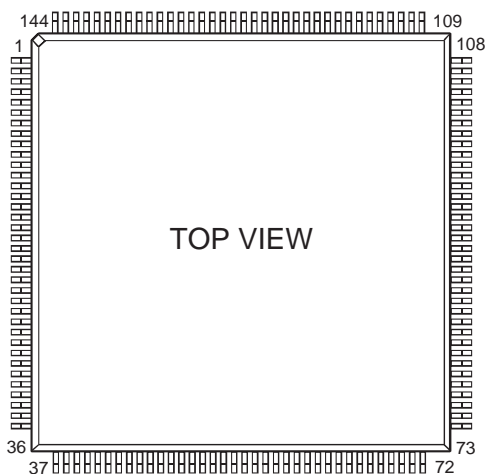

## MELODY32 Terminal Function

Pin No.	Pin Name	Pin No.	Pin Name	Pin No.	Pin Name	Pin No.	Pin Name	Pin No.	Pin Name	Pin No.	Pin Name
1	D14	25	V <sub>DD</sub> EXT	49	DR2	73	RESET	97	A11	121	WR
2	D15	26	HACK	50	RCLK2	74	TDO	98	A12	122	RD
3	HAD0	27	HCMS	51	RFS2	75	TDI	99	A13	123	D0
4	HAD1	28	HCIOMS	52	RXD	76	TMS	100	V <sub>DD</sub> EXT	124	D1
5	GND	29	GND	53	TXD	77	GND	101	A14	125	D2
6	HAD2	30	HALE	54	GND	78	TCK	102	A15	126	D3
7	HAD3	31	HRD	55	GND	79	TRST	103	A16	127	V <sub>DD</sub> DINT
8	HAD4	32	HWR	56	DT0	80	GND	104	A17	128	D4
9	HAD5	33	GND	57	TCLK0	81	EMU	105	GND	129	GND
10	HAD6	34	PF0	58	V <sub>DD</sub> DINT	82	V <sub>DD</sub> DINT	106	A18	130	CLKOUT
11	HAD7	35	PF1	59	TF50	83	OPMODE	107	A19	131	V <sub>DD</sub> EXT
12	HAD8	36	PF2	60	DR0	84	A0	108	A20	132	CLKIN
13	V <sub>DD</sub> EXT	37	PF3	61	RCLK0	85	A1	109	A21	133	XTAL
14	HAD9	38	PF4	62	RFS0	86	A2	110	BGH	134	GND
15	HAD10	39	PF5	63	V <sub>DD</sub> EXT	87	A3	111	BG	135	D5
16	GND	40	V <sub>DD</sub> EXT	64	DT1	88	A4	112	BR	136	D6
17	HAD11	41	PF6	65	TCLK1	89	A5	113	BMS	137	D7
18	HAD12	42	PF7	66	TFS1	90	V <sub>DD</sub> EXT	114	IOMS	138	D8
19	V <sub>DD</sub> DINT	43	TMR0	67	DR1	91	A6	115	MS0	139	D9
20	HAD13	44	TMR1	68	RCLK1	92	A7	116	MS1	140	D10
21	HAD14	45	TMR2	69	RFS1	93	A8	117	MS2	141	D11
22	HAD15	46	DT2	70	BMODE0	94	GND	118	V <sub>DD</sub> EXT	142	D12
23	HA16	47	TCLK2	71	BMODE1	95	A9	119	MS3	143	V <sub>DD</sub> EXT
24	HACK_P	48	TFS2	72	BYPASS	96	A10	120	ACK	144	D13

AD1837 (IC808)

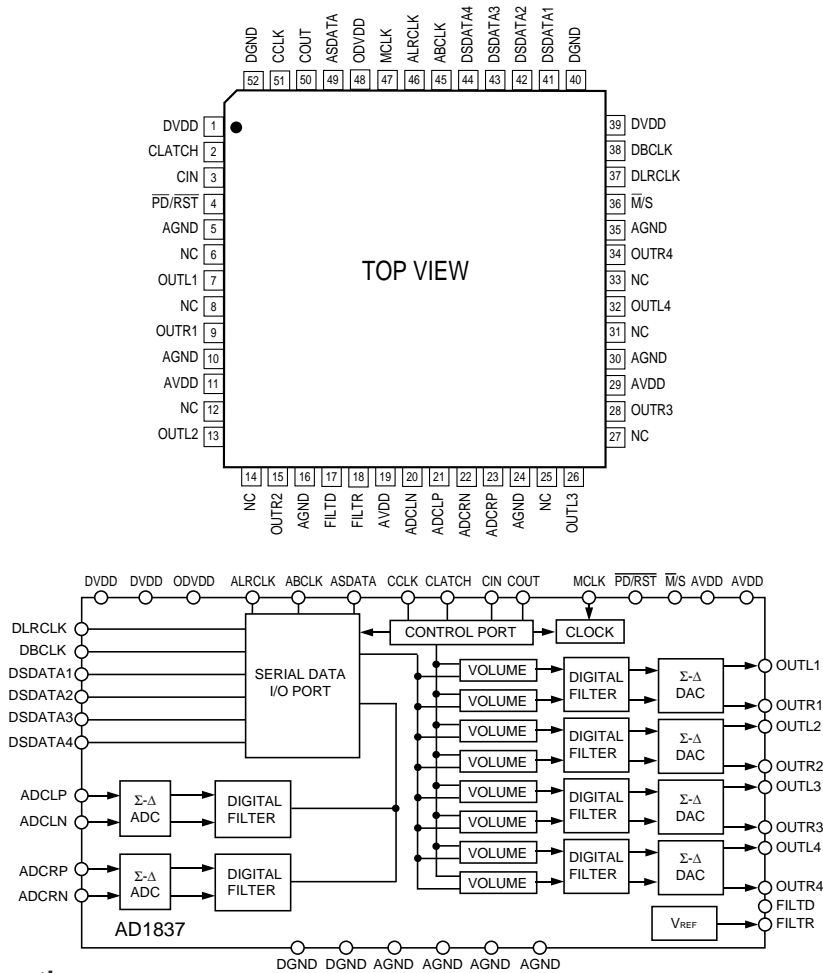

AD1837 Terminal Function

Pin No.	Pin Name	Input/Output	Description
1,39	DVDD		Digital Power Supply. Connect to digital 5V supply.
2	CLATCH	I	Latch Input for Control Data
33	CIN	I	Serial Control Input
4	PD/RST	I	Power-Down/Reset
5,10,16,24,30,35	AGND		Analog Ground
6,12,25,31	NC		Not connected
7,13,26,32	OUTLx	O	DACx Left Channel Output
8,14,27,33	NC		Not connected
9,15,28,34	OUTRx	O	DACx Right Channel Output
11,19,29	AVDD		Analog Power Supply. Connect to analog 5V supply.
17	FILTD		Filter Capacitor Connection. Recommend 10μF/100nF.
18	FILTR		Reference Filter Capacitor Connection. Recommended 10μF/100nF.
20	ADCLN	I	ADC Left Channel Negative Input
21	ADCLP	I	ADC Left Channel Positive Input
22	ADCRN	I	ADC Right Channel Negative Input
23	ADCRP	I	ADC Right Channel Positive Input
36	M/S	I	ADC Master/Slave Select
37	DLRCLK	I/O	DAC LR Clock
38	DBCLK	I/O	DAC Bit Clock
40,52	DGND		Digital Ground
41-44	DSDATAx	I	DACx Input Data (Left and Right Supply)
45	ABCLK	I/O	ADC Bit Clock
46	ALRCLK	I/O	ADC LR Clock
47	MCLK	I	Master Clock Input
48	ADVDD		Digital Output Driver Power Supply
49	ASDATA	O	ADC Serial Data Output
50	COUT	O	Output for Control Data
51	CCLK	I	Control Clock Input for Control Data

LC89057W (IC807)

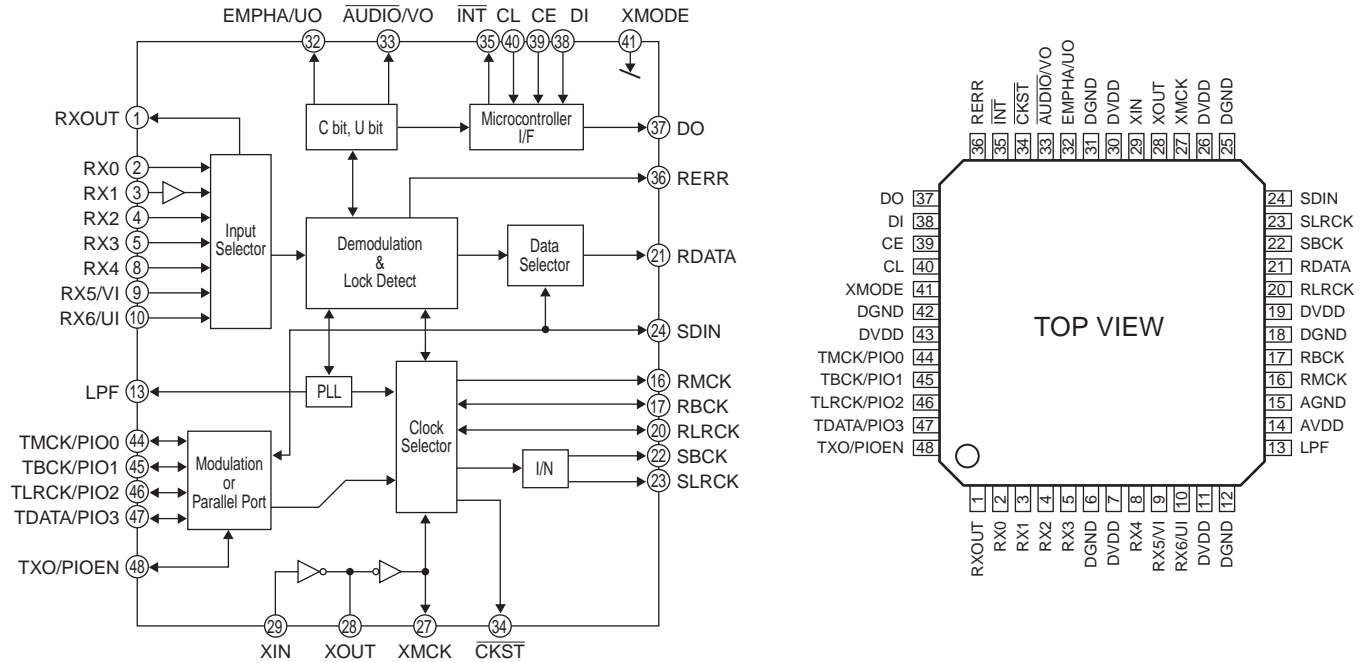

LC89057W Terminal Function

Pin No.	Pin Name	I/O	Function
1	RXOUT	O	Input bi-phase select data output terminal
2	RX0	I <sub>s</sub>	TTL compatible digital data input terminal
3	RX1	I	Coaxial compatible amp built-in digital data input terminal
4	RX2	I <sub>s</sub>	TTL compatible digital data input terminal
5	RX3	I <sub>s</sub>	TTL compatible digital data input terminal
6	DGND	—	Digital GND
7	DVDD	—	Digital power
8	RX4	I <sub>s</sub>	TTL compatible digital data input terminal
9	RX5/VI	I <sub>s</sub>	TTL compatible digital data/Validity flag input terminal for modulation
10	RX6/UI	I <sub>s</sub>	TTL compatible digital data/User data input terminal for modulation
11	DVDD	—	Digital power for PLL
12	DGND	—	Digital GND for PLL
13	LPF	O	PLL loop filter connecting terminal
14	AVDD	—	Analog power for PLL
15	AGND	—	Analog GND for PLL
16	RMCK	O	RMCK clock output terminal (256fs, 512fs, XIN, VCO)
17	RBCK	O/I	RBCK clock in/output terminal (64fs)
18	DGND	—	Digital GND
19	DVDD	—	Digital power
20	RLRCK	O/I	RLRCK clock in/output terminal (fs)
21	RDATA	O	Serial audio data output terminal
22	SBCK	O	SBCK clock output terminal (32fs, 64fs, 128fs)
23	SLRCK	O	SLRCK clock output terminal (fs/2, fs, 2fs)
24	SDIN	I <sub>s</sub>	Serial audio data input terminal
25	DGND	—	Digital GND
26	DVDD	—	Digital power
27	XMCK	O	Osc. amp output terminal

Pin No.	Pin Name	I/O	Function
28	XOUT	O	X'tal osc. connecting output terminal
29	XIN	I	X'tal osc. connection, external clock input terminal (24.576MHz or 12.288MHz)
30	DVDD	—	Digital power
31	DGND	—	Digital GND
32	EMPHA/UO	I/O	Emphasis information/U-data output/Chip address setting terminal
33	AUDIO/VO	I/O	Non-PCM detect/V-flag output/ Chip address setting terminal
34	CKST	I/O	Clock switch transition period output/Demodulation master or slave function switching terminal
35	INT	I/O	Interrupt output for $\mu$ com (Interrupt factor selectable)/Modulation or general I/O switching terminal
36	RERR	O	PLL lock error, data error flag output
37	DO	O	$\mu$ com I/F, read out data output terminal (3-state)
38	DI	I <sub>s</sub>	$\mu$ com I/F, write data input terminal
39	CE	I <sub>s</sub>	$\mu$ com I/F, chip enable input terminal
40	CL	I <sub>s</sub>	$\mu$ com I/F, clock input terminal
41	XMODE	I <sub>s</sub>	System reset input terminal
42	DGND	—	Digital GND
43	DVDD	—	Digital power
44	TMCK/PIO0	I/O	256fs system clock input for modulation/General I/O in/output terminal
45	TBCK/PIO1	I/O	64fs bit clock input for modulation/General I/O in/output terminal
46	TLRCK/PIO2	I/O	fs clock input for modulation/General I/O in/output terminal
47	TDATA/PIO3	I/O	Serial audio data input for modulation/General I/O in/output terminal
48	TXO/PIOEN	O/I	Modulation data output/ General I/O enable input terminal

\* For latch-up countermeasure, perform each power supply ON/OFF in the same timing.

**LC72131 (IC401)**

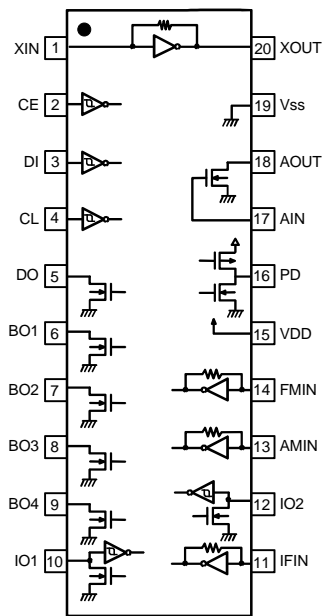

**LA1266 (IC402)**

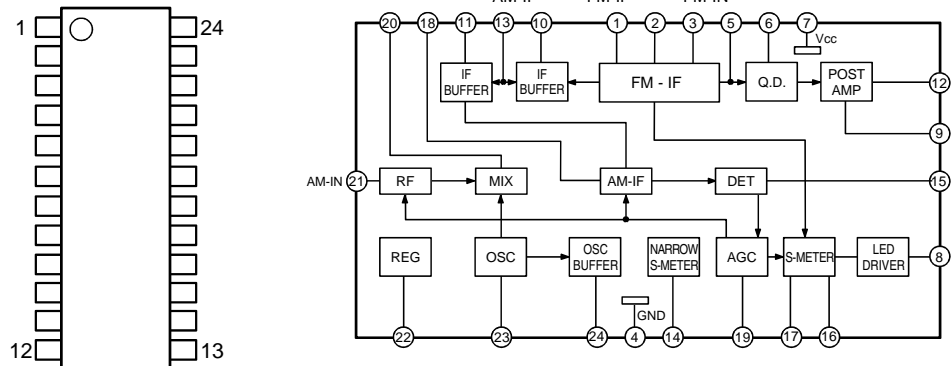

**LA3401 (IC403)**

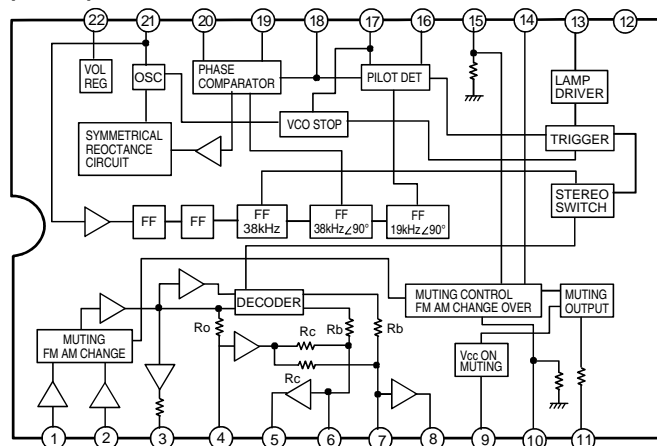



**M29W800AT (IC805)**

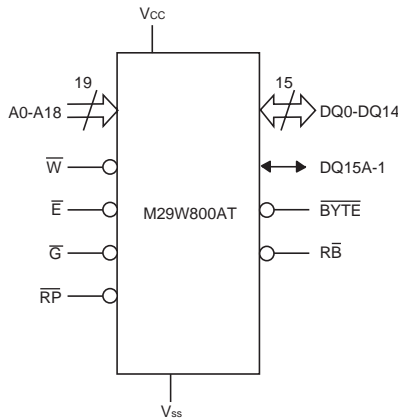
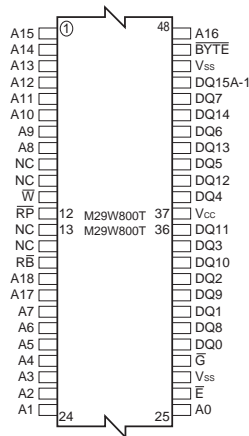

**PIN DESCRIPTION**

Symbol	Pin Name
A0-A18	Address Inputs
DQ0-DQ7	Data Input/Outputs, Command Inputs
DQ8-DQ14	Data Input/Outputs
DQ15A-1	Data Input/Output or Address Input
$\bar{E}$	Chip Enable
$\bar{G}$	Output Enable
$\bar{W}$	Write Enable
$\bar{R}\bar{P}$	Reset/Block Temporary Unprotect
$\bar{R}\bar{B}$	Ready/Busy Output
BYTE	Byte/Word Organization
Vcc	Supply Voltage
Vss	Ground
NC	No Connected Internally
DU	Don't Use as Internally Connected

**IS61LV6416 (IC806)**

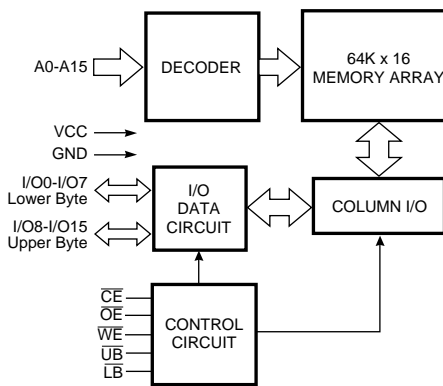
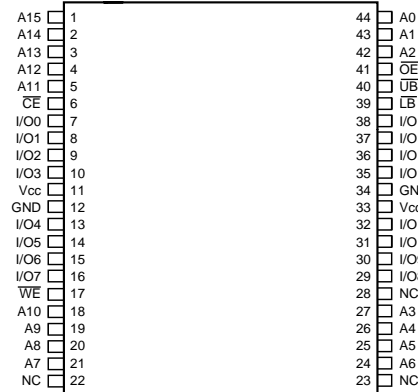

**PIN DESCRIPTION**

Symbol	Pin Name
A0-A15	Address inputs
I/O0-I/O15	Data Inputs/Outputs
$\bar{C}\bar{E}$	Chip Enable Input
$\bar{O}\bar{E}$	Output Enable Input
$\bar{W}\bar{E}$	Write Enable Input
$\bar{L}\bar{B}$	Lower-byte Control (I/O0-I/O7)
$\bar{U}\bar{B}$	Upper-byte Control (I/O8-I/O15)
NC	No Connection
Vcc	Power
GND	Ground

**BD3811K1 (IC701)**

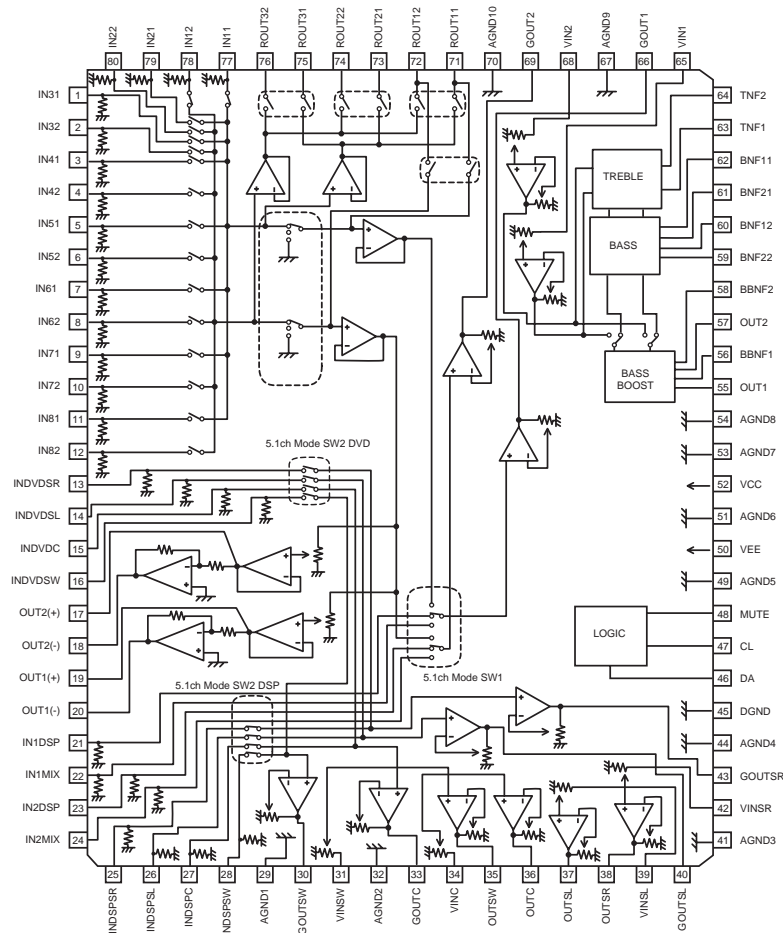

**LC75721E (IC301)**

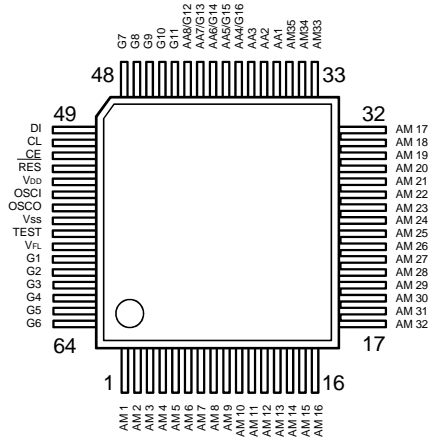

**LC75721E Terminal Function**

Symbol	Function
V <sub>DD</sub>	Power terminal +5V
V <sub>SS</sub>	Power terminal GND
V <sub>FL</sub>	Power terminal FL drive
DI	Serial data transfer terminal
CL	DI: Data
CE	CL: Clock
	CE: Chip enable
OSCI	External CR connecting terminal
OSCO	
RES	System reset terminal
AM1~AM35	Anode output terminal
AA1~AA3	
AA4/G16	
AA5/G15	Anode/Grid output terminal
AA6/G14	
AA7/G13	
AA8/G12	
G1~G11	Grid output terminal
TEST	LSI test terminal

**MM74LCX244 (IC809~811)**

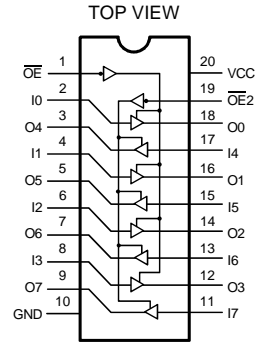

**74LCX74 (IC821)**

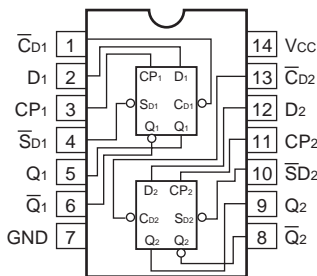

**Pin Descriptions**

Pin Names	Description
D <sub>1</sub> , D <sub>2</sub>	Data Inputs
CP <sub>1</sub> , CP <sub>2</sub>	Clock Pulse Inputs
$\overline{CD}_1$ , $\overline{CD}_2$	Direct Clear Inputs
$\overline{SD}_1$ , $\overline{SD}_2$	Direct Set Inputs
Q <sub>1</sub> , $\overline{Q}_1$ , Q <sub>2</sub> , $\overline{Q}_2$	Outputs

**BU2090F (IC302)**

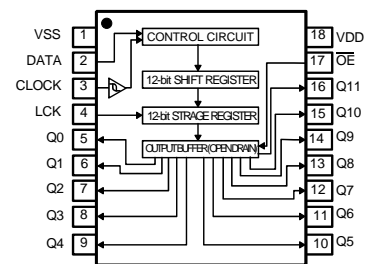

**TDA7330BD (IC202)**

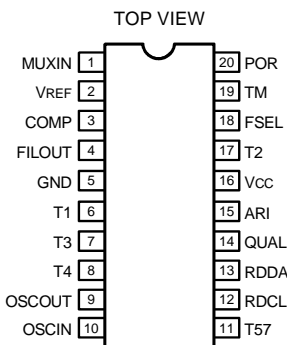

**MM74LCX02 (IC813)**

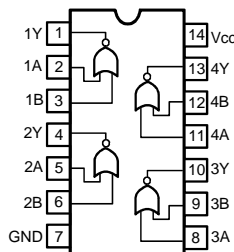

**NJM2068MD (IC815~820, 721, 761, 762, 763, 781, 782, 783, 817, 818, 819) BA4510F (IC815, 816)**

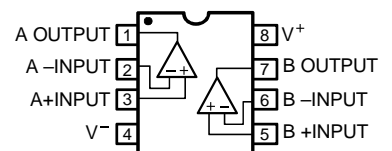

**SN74LV00APW (IC814)**

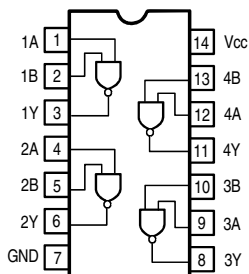

**74HCU04 (IC803)**

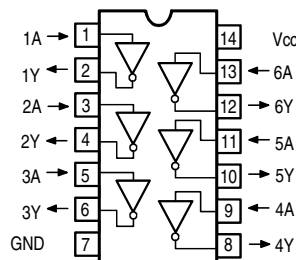

**LA7952 (IC601, 621, 622)**

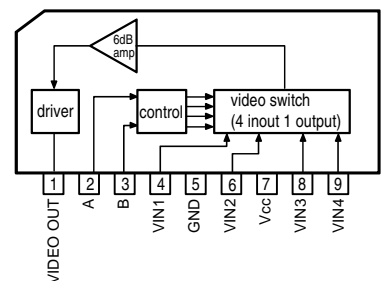

**BA7625 (IC651)**  
**BA7626 (IC652,653)**

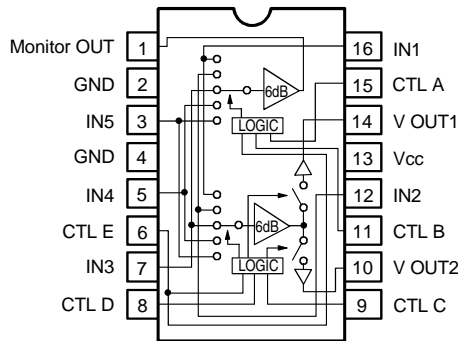

A	B	E	MONITOR OUT
L	L	*	IN 1
H	L	*	IN 2
L	H	*	IN 3
H	H	L	IN 4
H	H	H	IN 5

C	D	E	V OUT 1
L	L	*	—
H	L	*	IN 2
L	H	*	IN 3
H	H	L	IN 4
H	H	H	IN 5

C	D	E	V OUT 2
L	L	*	IN 1
H	L	*	—
L	H	*	IN 3
H	H	L	IN 4
H	H	H	IN 5

Note 1: \* mark means that feasible for either H or L.  
 Note 2: Each input terminal is provided with sink chip clamp (BA7625).  
 Each input terminal takes 20kohm at the end (BA7626).

**KIA7806AP (IC602)**  
**KIA7805AP (IC104,103,822)**  
**KIA7815AP (IC101)**  
**KIA7812AP (IC271)**

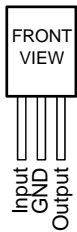

**KIA7915PI (IC102)**

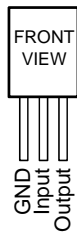

**RC1117S25T (IC824)**  
**RC1117S33ST (IC823)**

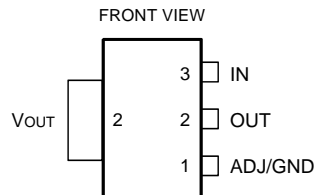

**MM74HCT244 (IC812)**

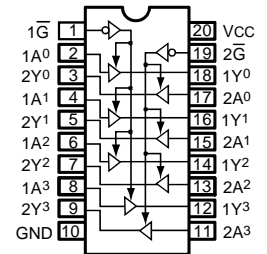

● **OPTICAL**

**INPUT**  
**GP1FA502RZ (IC801~803)**

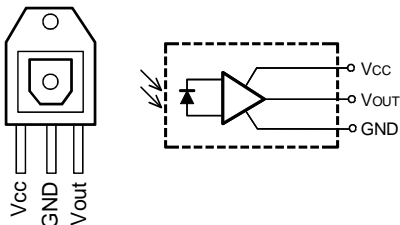

**OUTPUT**  
**GP1FA502TZ (IC817)**

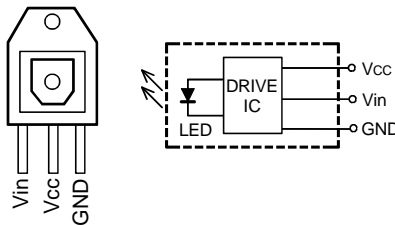

● **IC PROTECTOR**

**ICP-N15 (IC105)**

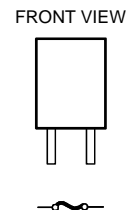

● **IR SENSOR**

**NJL64H380A (RMC301)**

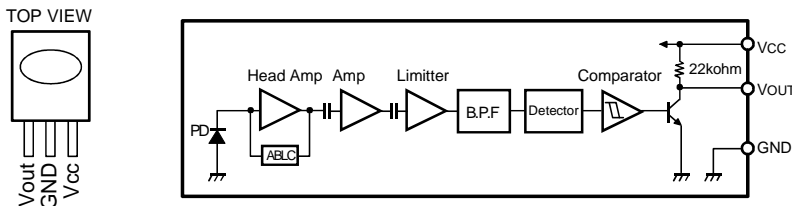

● **POSISTOR**

**P43T7D330BW16**

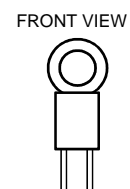

● TRANSISTORS

DTA114ES  
DTC114TS  
DTC114YS  
DTC144ES

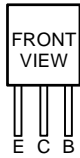

DTA114EK  
DTA114YK  
DTA144EK  
DTC114EK  
DTC114YK  
DTC144EK

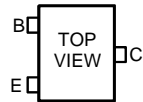

DTA Series

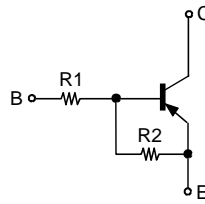

	R1	R2
DTA114EK	10kohm /Ω	10kohm /Ω
DTA114ES	10kohm /Ω	10kohm /Ω
DTA114YK	10kohm /Ω	47kohm /Ω
DTA144EK	47kohm /Ω	47kohm /Ω

DTC Series

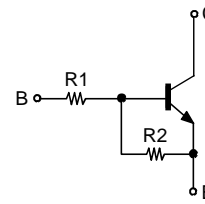

	R1	R2
DTC114EK	10kohm /Ω	10kohm /Ω
DTC114TS	10kohm /Ω	—
DTC114YK	10kohm /Ω	47kohm /Ω
DTC114YS	10kohm /Ω	47kohm /Ω
DTC144EK	47kohm /Ω	47kohm /Ω
DTC144ES	47kohm /Ω	47kohm /Ω

2SC1740S  
2SC3199Y  
KSA916Y  
KSA992F  
KSC1845F  
KTA1266Y  
KTA1268BL  
KTC2874B  
KTC3198Y  
KTC3200BL

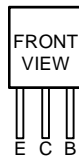

2SC2412K  
KTC3880S

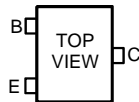

2SK117



2SD947F

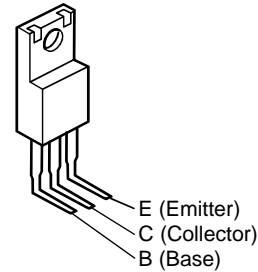

2SD3290Y  
2SB1560Y

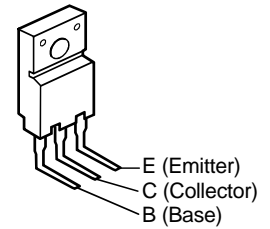

● DIODES (LED included)

MTZJ3.3B  
MTZJ5.1B  
MTZJ6.8B  
MTZJ7.5A  
MTZJ8.2B  
MTZJ11B  
MTZJ18B  
MTZJ20B

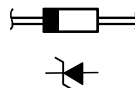

1N4007  
1SS133

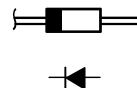

KDS160



HL-50RDRF4T

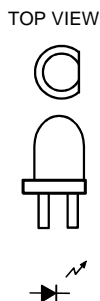

KBPC604

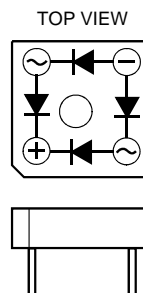

● FL DISPLAY

16-st-42GNK (FL301)

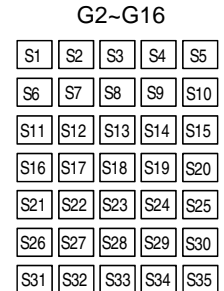
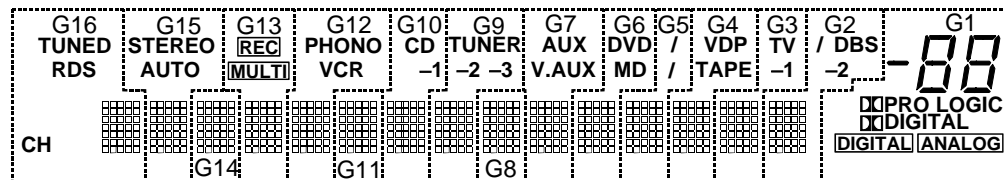
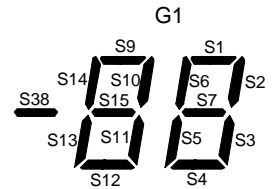
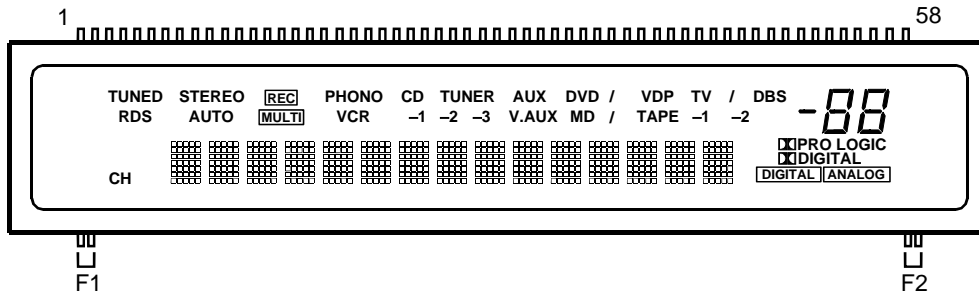

Pin Assignment

PIN NO.	1	2	3	4	5	6	7	8	9	10	11	12	13	14	15	16	17	18	19	20
CONNECTION	F1	F1	S1	S2	S3	S4	S5	S6	S7	S8	S9	S10	S11	S12	S13	S14	S15	S16	S17	S18
PIN NO.	21	22	23	24	25	26	27	28	29	30	31	32	33	34	35	36	37	38	39	40
CONNECTION	S19	S20	S21	S22	S23	S24	S25	S26	S27	S28	S29	S30	S31	S32	S33	S34	S35	S36	S37	S38
PIN NO.	41	42	43	44	45	46	47	48	49	50	51	52	53	54	55	56	57	58		
CONNECTION	G16	G15	G14	G13	G12	G11	G10	G9	G8	G7	G6	G5	G4	G3	G2	G1	F2	F2		

F1, F2 : Filament  
 G1-G16: Grid  
 S1-S38 : Anode

Anode & Grid Assignment

	G1	G2-G16		G1	G2-G16		G1	G2-G16		G1	G2-G16
S1	S1	S1	S10	S10	S10	S19	—	S19	S28	—	S28
S2	S2	S2	S11	S11	S11	S20	—	S20	S29	—	S29
S3	S3	S3	S12	S12	S12	S21	—	S21	S30	—	S30
S4	S4	S4	S13	S13	S13	S22	—	S22	S31	—	S31
S5	S5	S5	S14	S14	S14	S23	—	S23	S32	—	S32
S6	S6	S6	S15	S15	S15	S24	—	S24	S33	—	S33
S7	S7	S7	S16	—	S16	S25	—	S25	S34	—	S34
S8	—	S8	S17	DIGITAL	S17	S26	—	S26	S35	—	S35
S9	S9	S9	S18	PRO LOGIC	S18	S27	—	S27			

	G1	G2	G3	G4	G5	G6	G7	G8	G9	G10	G11	G12	G13	G14	G15	G16
S36	DIGITAL	/	TV	VDP	/(DVD)	DVD	AUX	—	TUNER	CD	—	PHONO	REC	—	STEREO	TUNED
S37	ANALOG	-2	-1	TAPE	/(MD)	MD	V.AUX	—	-2	-1	—	VCR	MULTI	—	AUTO	RDS
S38	S38	DBS	—	—	—	—	—	—	-3	—	—	—	—	—	—	CH

PRINTED WIRING BOARDS

1 2 3 4 5 6 7 8  
MAIN P.W.B. UNIT(for U.S.A., Canada, U.K., Europe, China, Korea & Australia models)

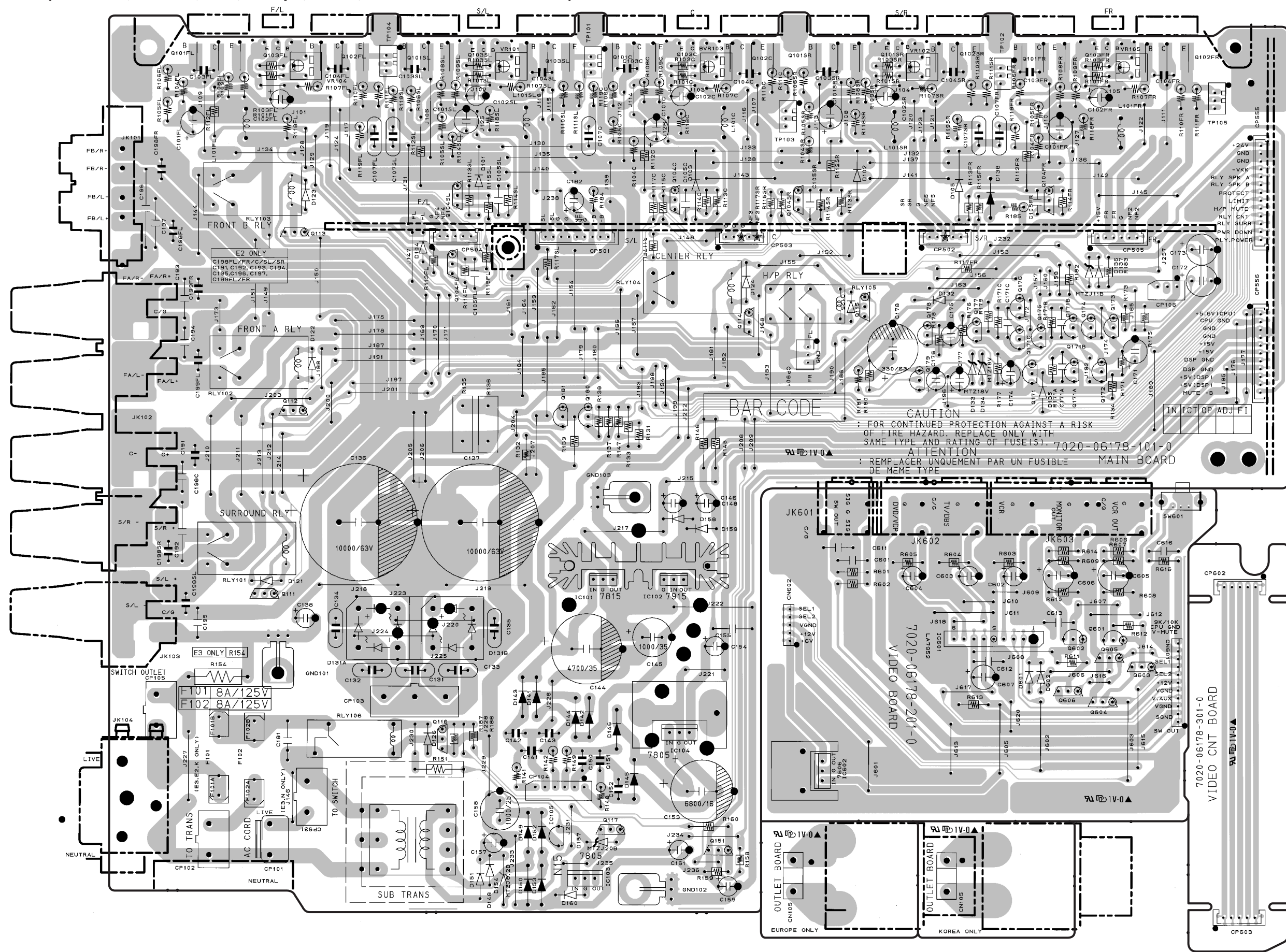

A  
B  
C  
D  
E

COMPONENT SIDE

1 2 3 4 5 6 7 8  
MAIN P.W.B. UNIT(for Asia, HongKong, & Taiwan R.O.C. models)

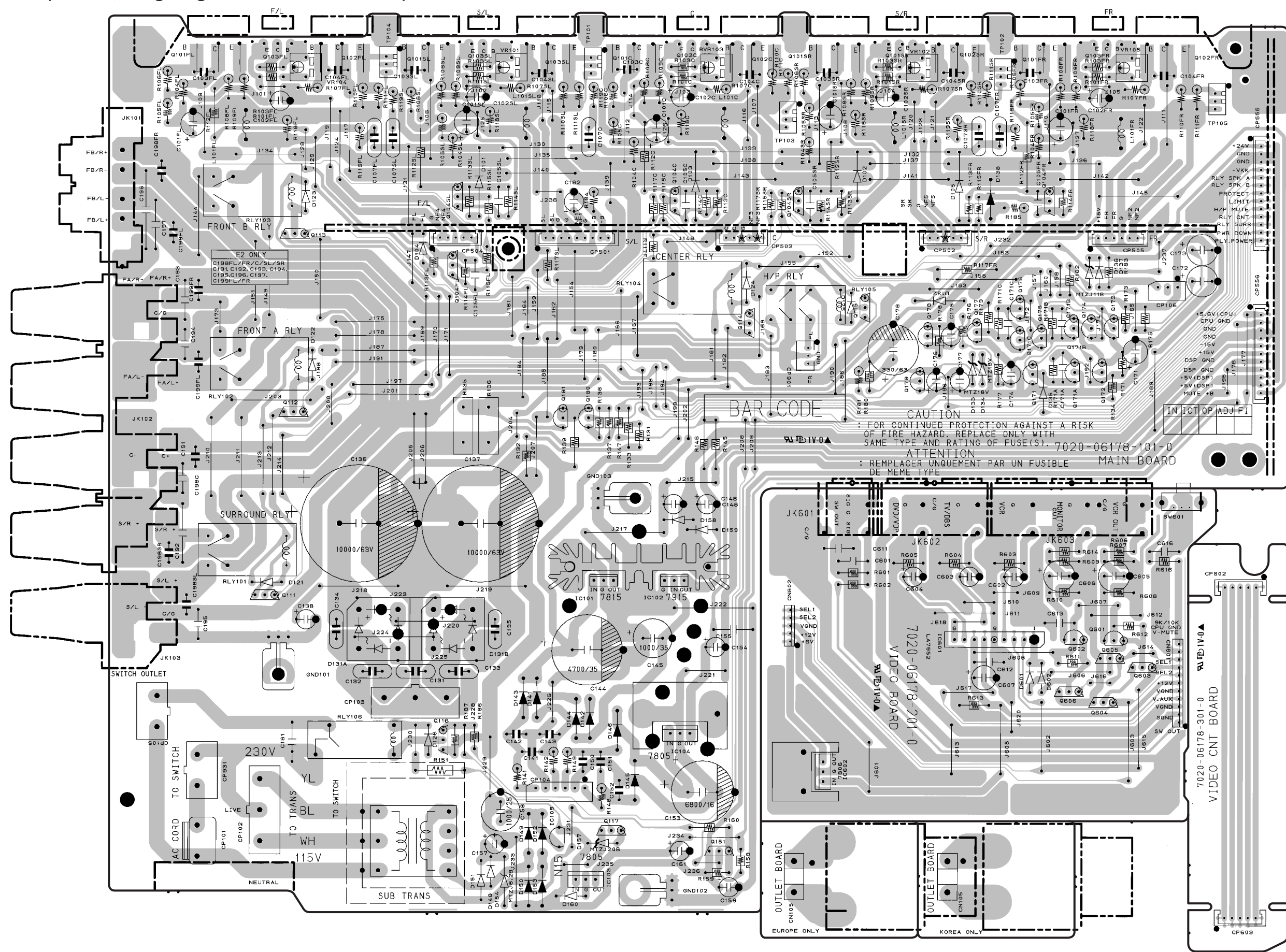

COMPONENT SIDE

A  
B  
C  
D  
E

1 2 3 4 5 6 7 8  
CPU P.W.B. UNIT

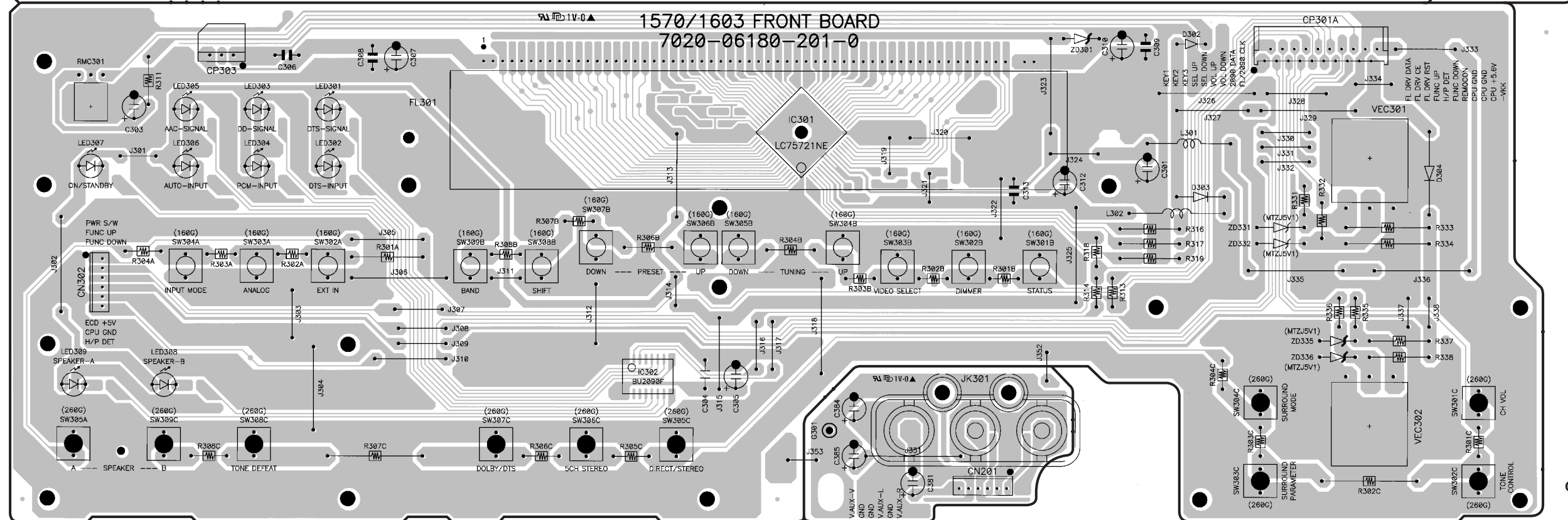
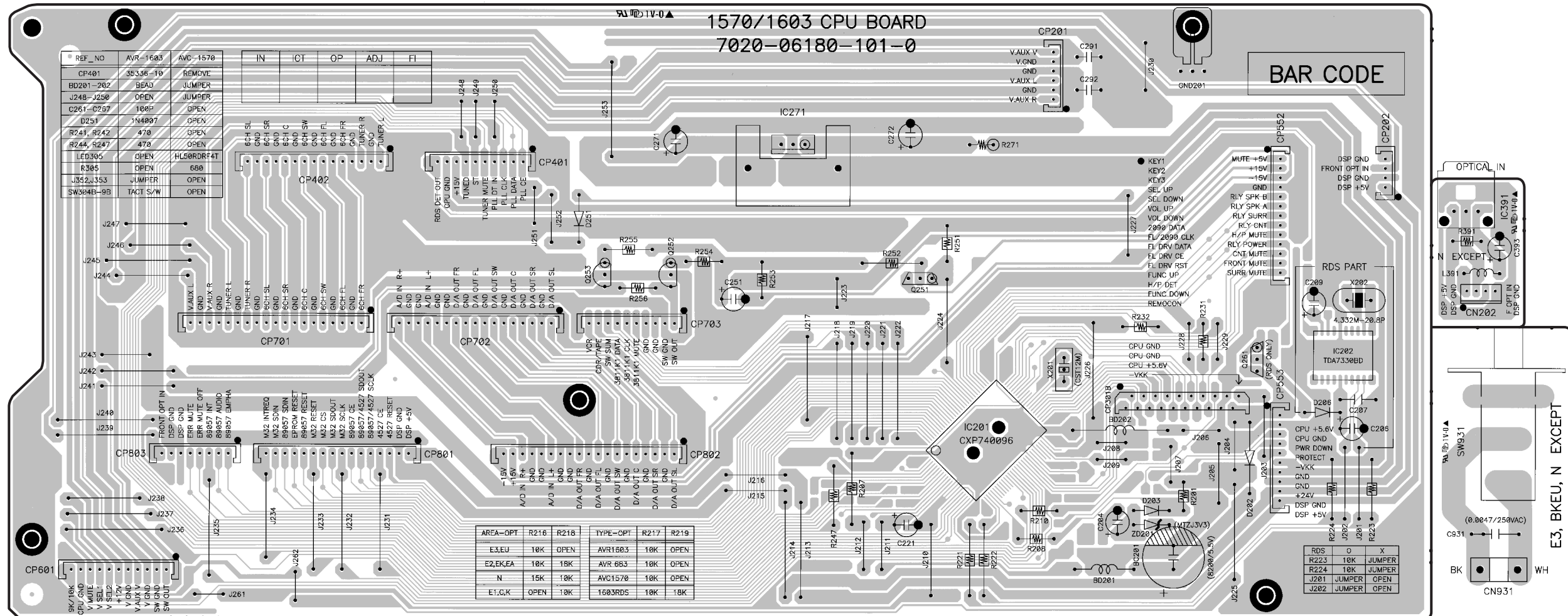

COMPONENT SIDE

A

B

C

D

E



1 2 3 4 5 6 7 8

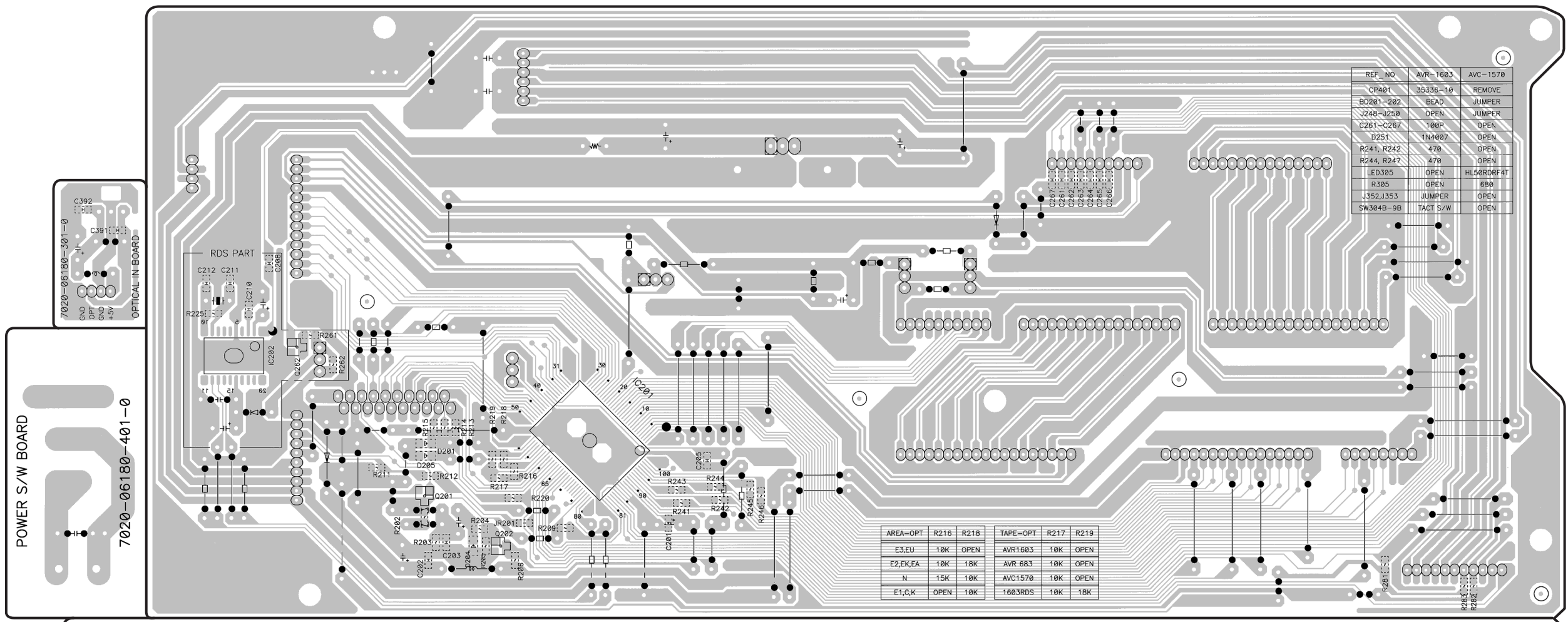

A

B

C

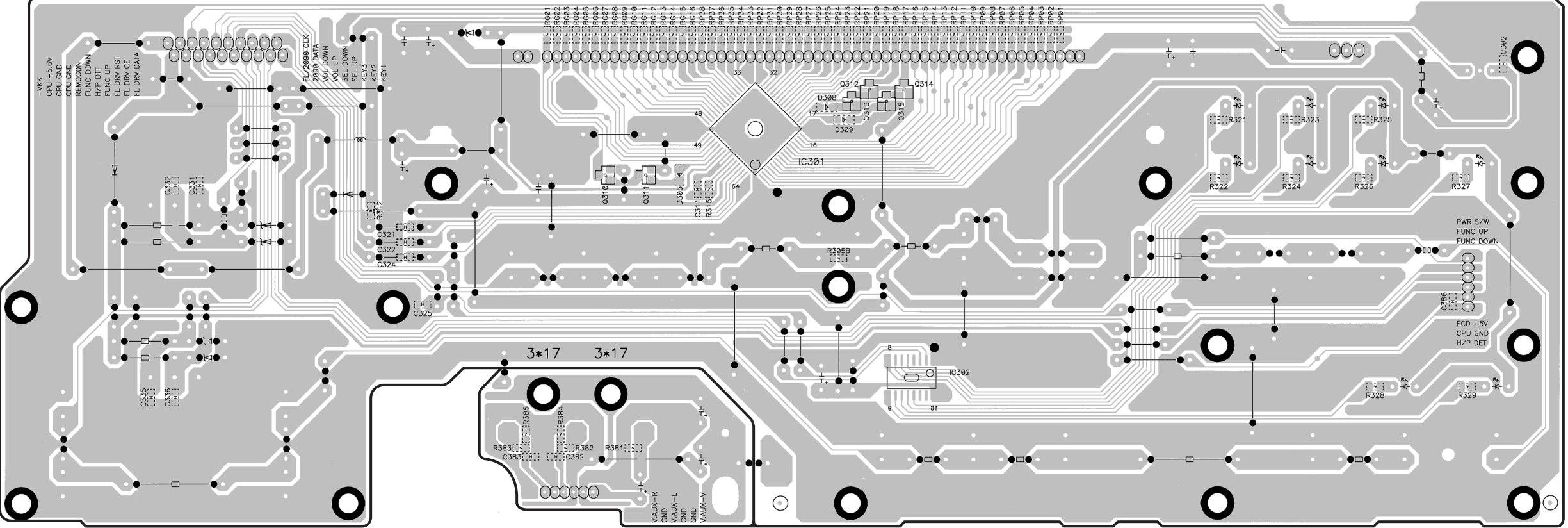

D

E

FOIL SIDE

CNT P.W.B. UNIT

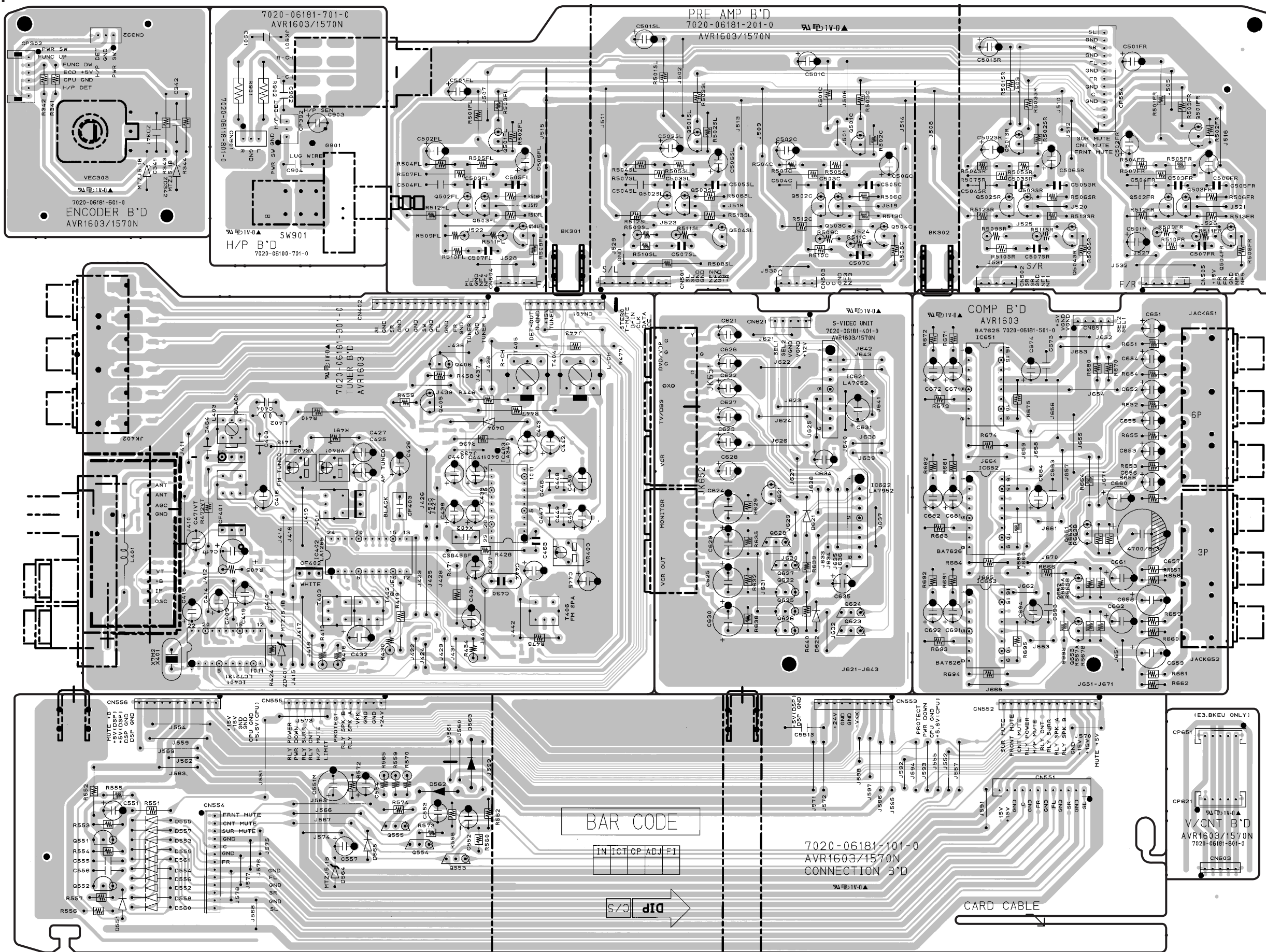

COMPONENT SIDE

1 2 3 4 5 6 7 8

A

B

C

D

E

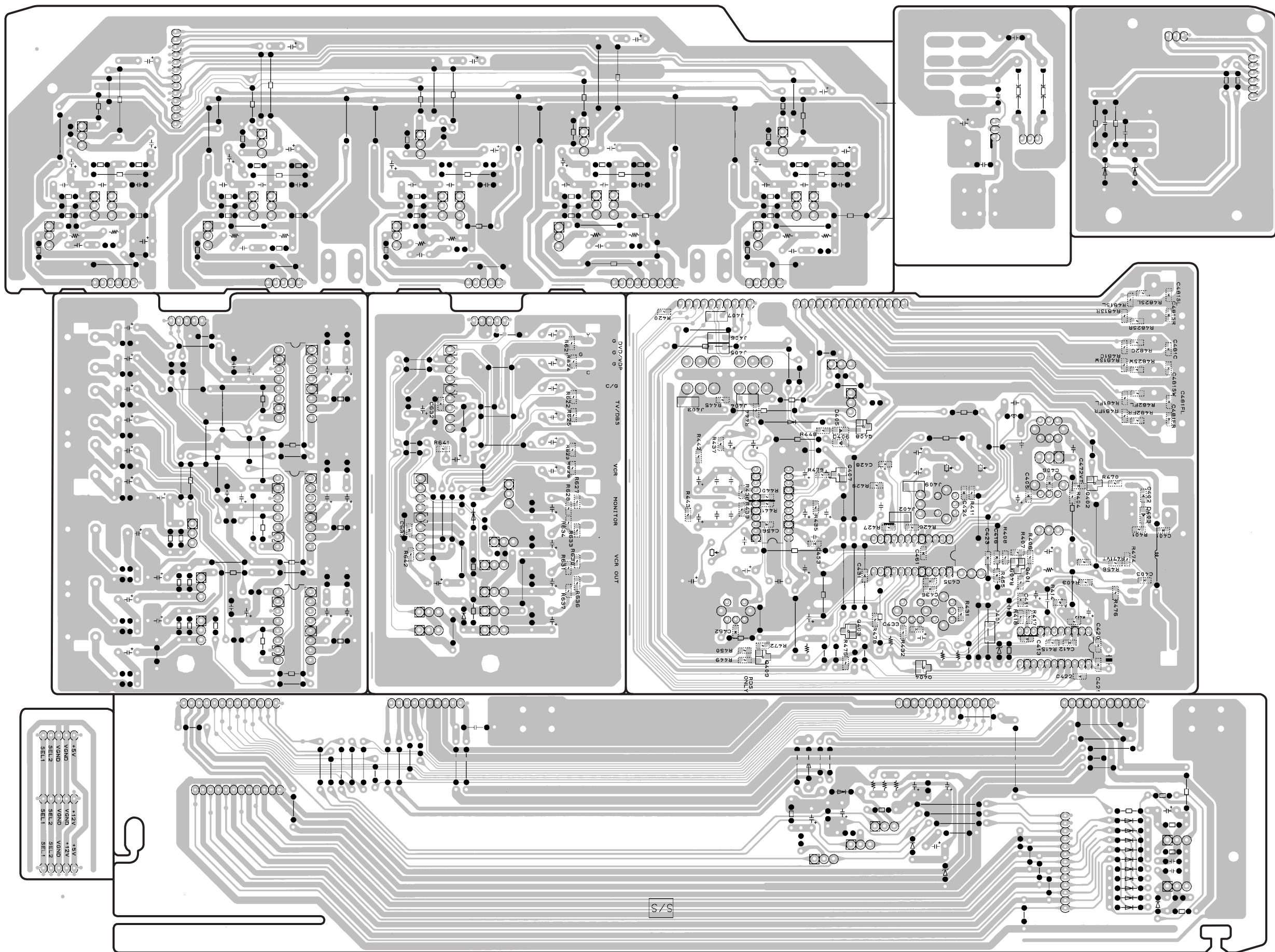

FOIL SIDE

1 2 3 4 5 6 7 8  
INPUT-VOL P.W.B. UNIT

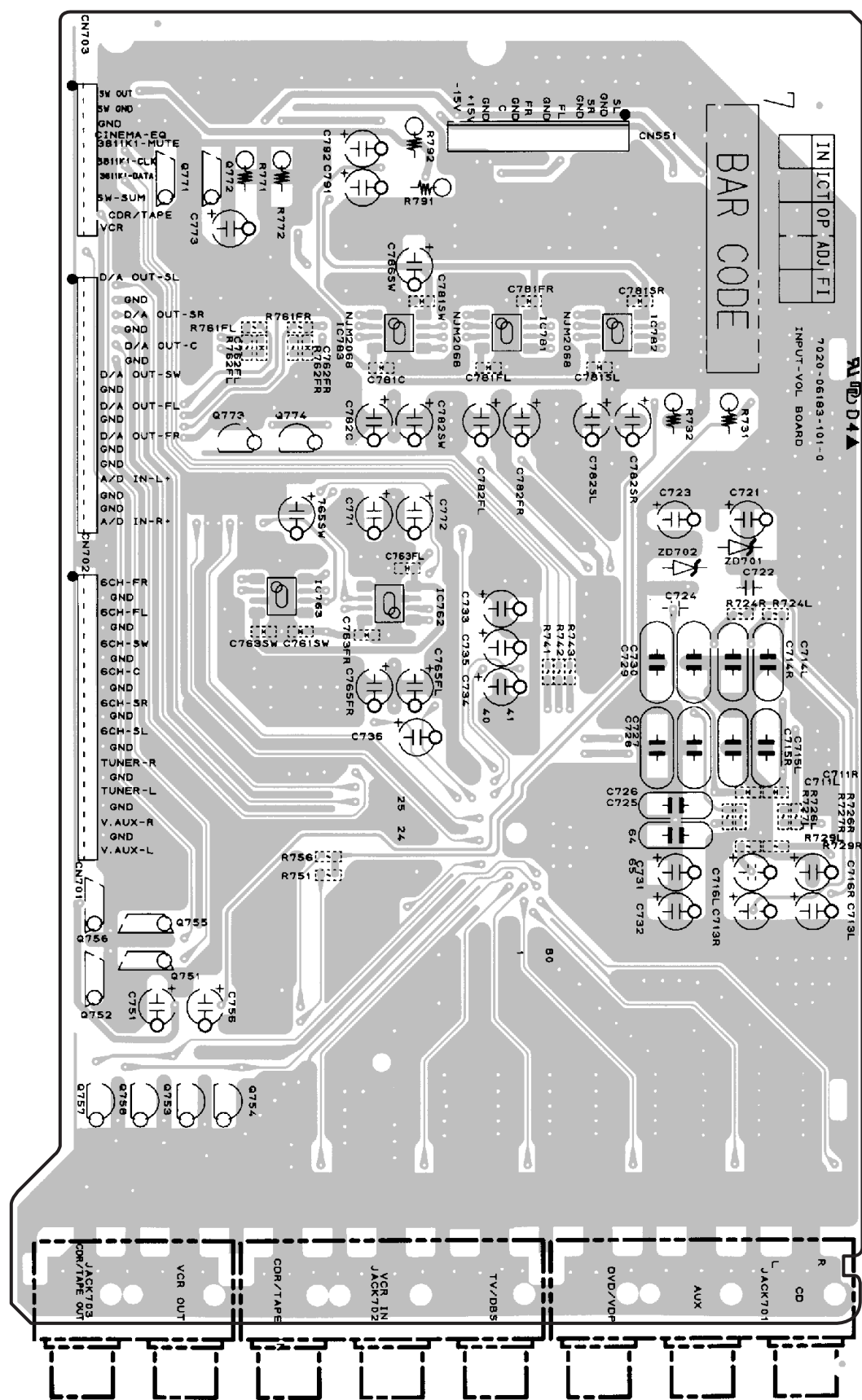

COMPONENT SIDE

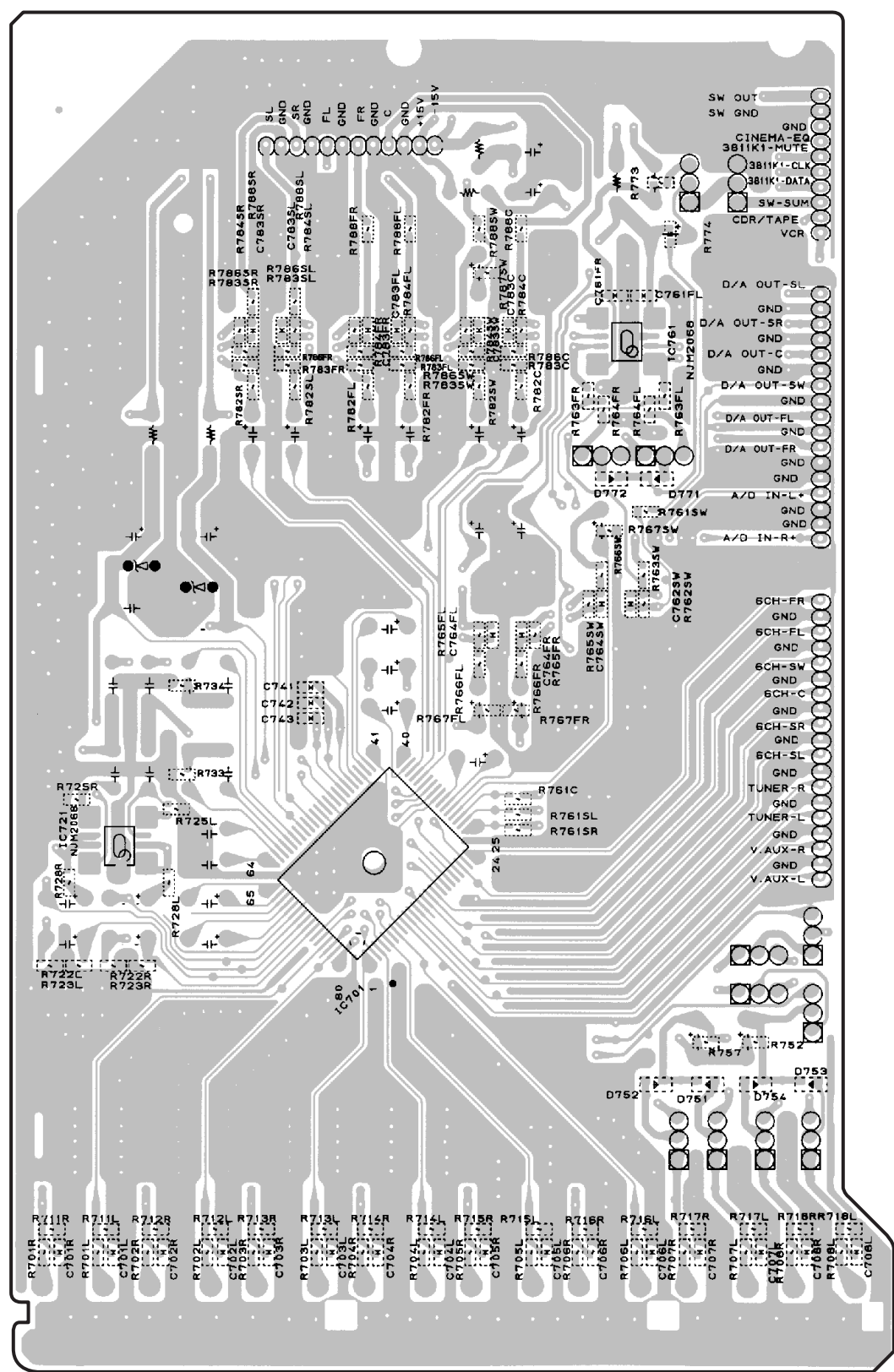

FOIL SIDE

A  
B  
C  
D  
E

DSP P.W.B. UNIT

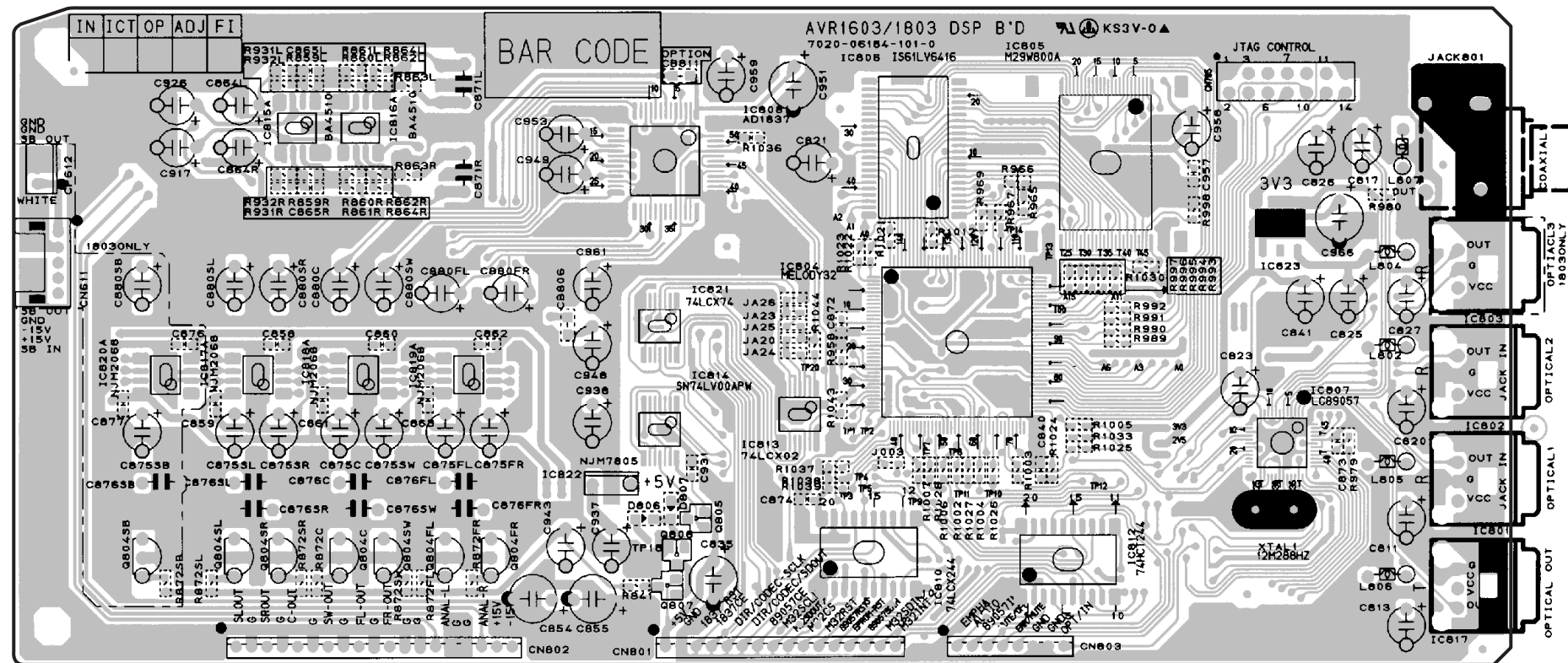

COMPONENT SIDE

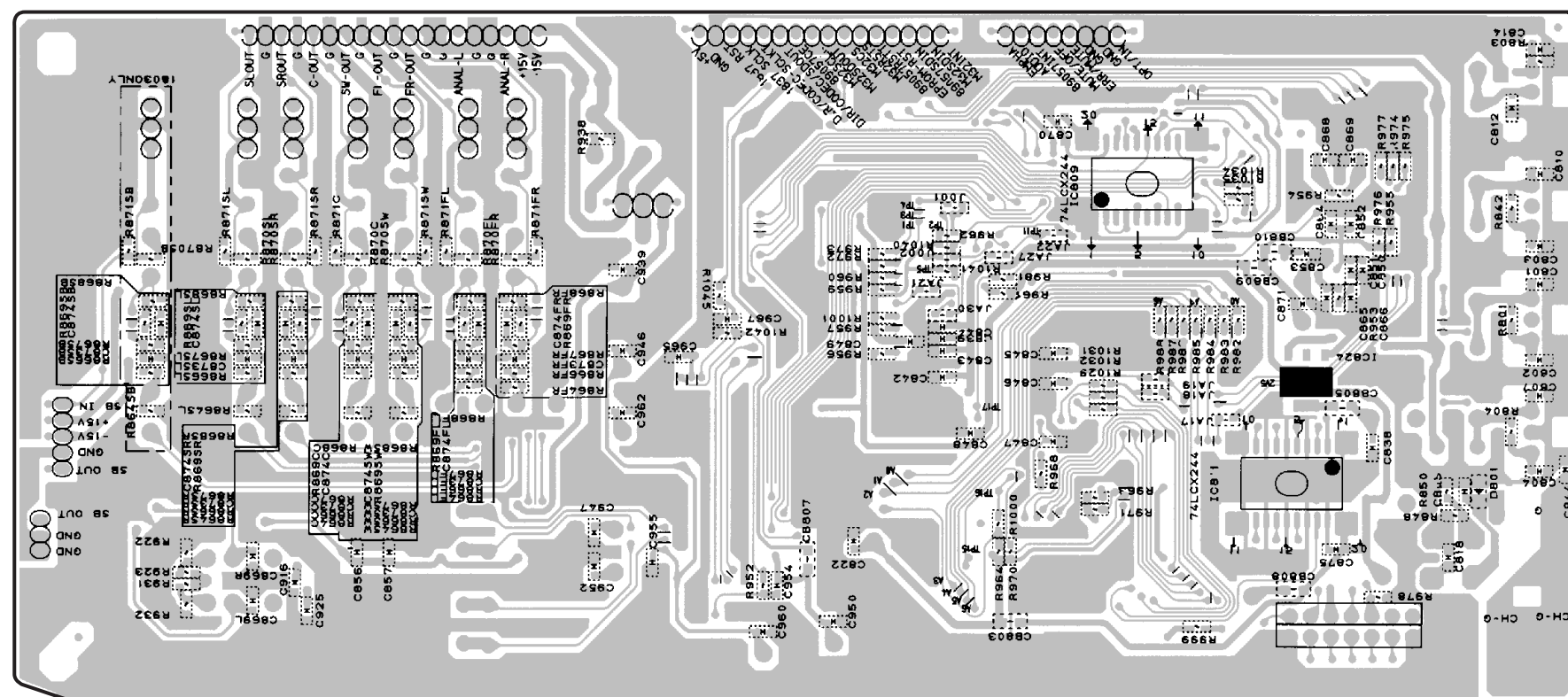

FOIL SIDE

A  
B  
C  
D  
E

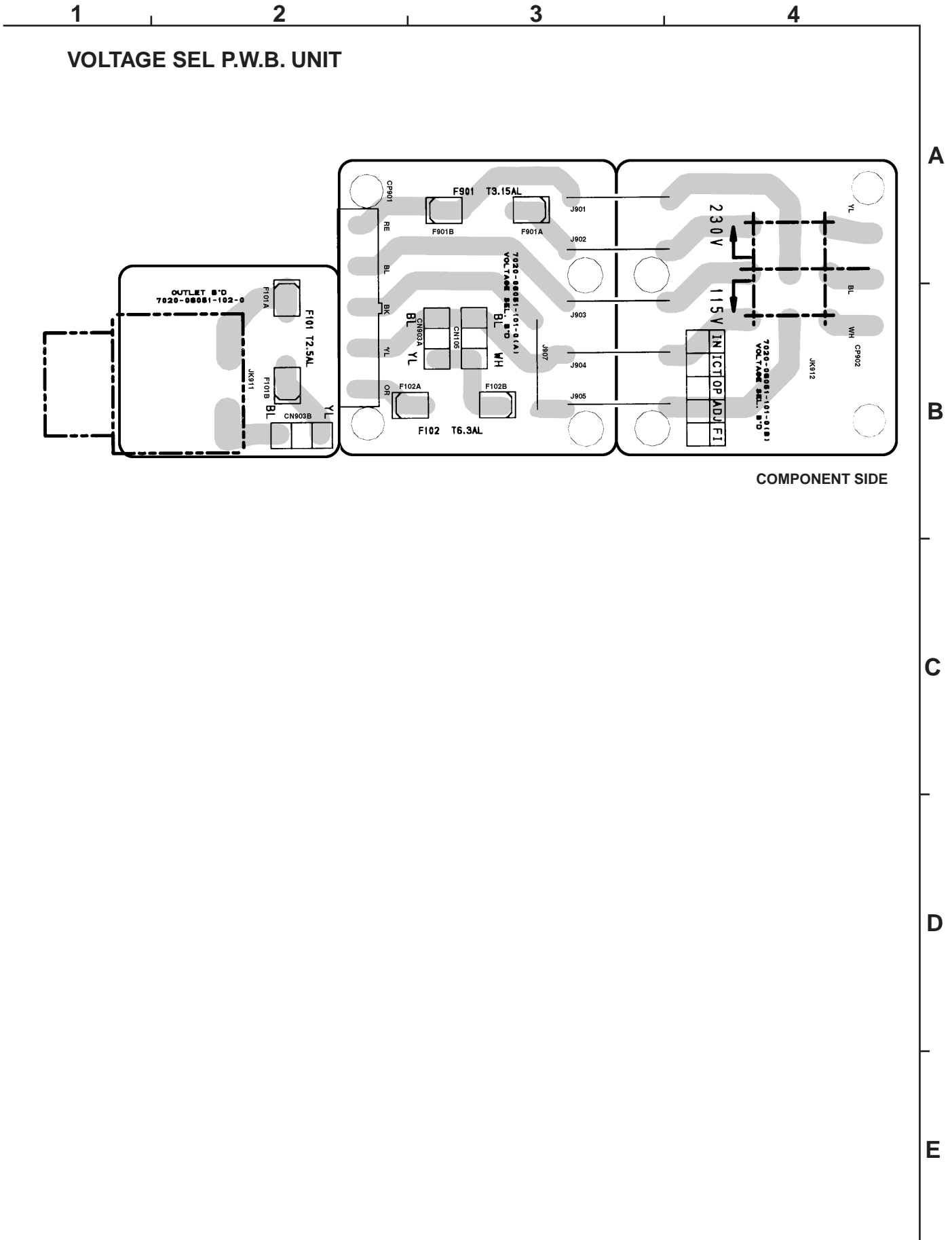

# NOTE FOR PARTS LIST

- Part indicated with the mark "⊙" are not always in stock and possibly to take a long period of time for supplying, or in some case supplying of part may be refused.
- When ordering of part, clearly indicate "1" and "I" (i) to avoid mis-supplying.
- Ordering part without stating its part number can not be supplied.
- Part indicated with the mark "★" is not illustrated in the exploded view.
- Not including Carbon Film ±5%, 1/4W Type in the P.W.Board parts list. (Refer to the Schematic Diagram for those parts.)

**WARNING:**

Parts marked with this symbol  have critical characteristics.  
Use ONLY replacement parts recommended by the manufacturer.

● **Resistors**

Ex.: RN 14K 2E 182 G FR  
 Type Shape Power Resist- Allowable Others  
 and per- ance error

RD : Carbon	2B : 1/8W	F : ±1%	P : Pulse-resistant type
RC : Composition	2E : 1/4W	G : ±2%	NL : Low noise type
RS : Metal oxide film	2H : 1/2W	J : ±5%	NB : Non-burning type
RW : Winding	3A : 1W	K : ±10%	FR : Fuse-resistor
RN : Metal film	3D : 2W	M : ±20%	F : Lead wire forming
RK : Metal mixture	3F : 3W		
	3H : 5W		

\* **Resistance**

1 8 2 ⇒ 1800 ohm = 1.8 kohm  
 ↑     ↑     ↑  
 1-digit effective number.     2-digit effective number.

• Units: ohm

1 R 2 ⇒ 1.2 ohm  
 ↑     ↑     ↑  
 1-digit effective number.     2-digit effective number, decimal point indicated by R.

• Units: ohm

● **Capacitors**

Ex.: CE 04W 1H 2R2 M BP  
 Type Shape Dielectric Capacity Allowable Others  
 and per- strength error

CE : Aluminum foil electrolytic	0J : 6.3V	F : ±1%	HS : High stability type
CA : Aluminum solid electrolytic	1A : 10V	G : ±2%	BP : Non-polar type
CS : Tantalum electrolytic	1C : 16V	J : ±5%	HR : Ripple-resistant type
CQ : Film	1E : 25V	K : ±10%	DL : For charge and discharge
CK : Ceramic	1V : 35V	M : ±20%	HF : For assuring high frequency
CC : Ceramic	1H : 50V	Z : +80%	U : UL part
CP : Oil	2A : 100V	-20%	C : CSA part
CM : Mica	2B : 125V	P : +100%	W : UL-CSA type
CF : Metallized	2C : 160V	-0%	F : Lead wire forming
CH : Metallized	2D : 200V	C : ±0.25pF	
	2E : 250V	D : ±0.5pF	
	2H : 500V	= : Others	
	2J : 630V		

\* **Capacity (electrolyte only)**

2 2 2 ⇒ 2200µF  
 ↑     ↑     ↑  
 1-digit effective number.     2-digit effective number.

• Units: µF.

2 R 2 ⇒ 2.2µF  
 ↑     ↑     ↑  
 1-digit effective number.     2-digit effective number, decimal point indicated by R.

• Units: µF.

\* **Capacity (except electrolyte)**

2 2 2 ⇒ 2200pF=0.0022µF  
 ↑     ↑     ↑  
 (More than 2) — Indicates number of zeros after effective number.     2-digit effective number.

• Units: pF.

2 2 1 ⇒ 220pF  
 ↑     ↑     ↑  
 (0 or 1) — Indicates number of zeros after effective number.     2-digit effective number.

• Units: pF.

• When the dielectric strength is indicated in AC, "AC" is included after the dielectric strength value.

# PARTS LIST OF P.W.B. UNIT ASS'Y

## MAIN P.W.B. ASS'Y

Note : The symbols in the column "Remarks" indicate the following destinations.

- E3 : U.S.A. & Canada model
- EU : U.S.A. model (AVR-683)
- E2 : Europe model
- EK : U.K. model
- EA : Australia model
- E1 : Asia model
- E1C : China model
- E1H : Hong Kong model
- E1T : Taiwan R.O.C. model
- E1K : Korea model

Ref. No.	Part No.	Part Name	Remarks	Ref. No.	Part No.	Part Name	Remarks
<b>SEMICONDUCTORS GROUP</b>				<b>RESISTORS GROUP</b>			
IC101	963 0057 903	IC KIA7815AP		D123	963 0096 508	Diode 1N4148-52RE	
IC102	963 0021 502	IC KIA7915PI		D124	963 0096 508	Diode 1N4148-52RE	
IC103	960 0159 501	IC KIA7805API		D125	963 0096 508	Diode 1N4148-52RE	
IC104	963 0057 709	IC KIA7805AP		D126	963 0096 508	Diode 1N4148-52RE	
IC105	960 0195 808	IC ICP-N15		D131A	960 0197 107	Diode KBPC604 6A	
IC601	960 0180 101	IC LA7952		D131B	960 0197 107	Diode KBPC604 6A	
IC602	960 0044 108	IC KIA7806AP	for E3	D132	963 0096 508	Diode 1N4148-52RE	
Q104C	960 0196 506	Transistor KSC1845F		D133	963 0046 202	Zener diode MTZJ18B	
Q104FL	960 0196 506	Transistor KSC1845F		D134	963 0046 202	Zener diode MTZJ18B	
Q104FR	960 0196 506	Transistor KSC1845F		D135	963 0096 508	Diode 1N4148-52RE	
Q104SL	960 0196 506	Transistor KSC1845F		D136	963 0058 504	Zener diode MTZJ11B-0.5W	
Q104SR	960 0196 506	Transistor KSC1845F		D137	963 0096 508	Diode 1N4148-52RE	
Q111	960 0196 904	Transistor DTC114YS		D138	963 0058 407	Diode 1N4007	
Q112	960 0196 904	Transistor DTC114YS		D141	963 0058 407	Diode 1N4007	
Q113	960 0196 904	Transistor DTC114YS		D142	963 0058 407	Diode 1N4007	
Q114	960 0196 904	Transistor DTC114YS		D143	963 0058 407	Diode 1N4007	
Q115	960 0196 904	Transistor DTC114YS		D144	963 0058 407	Diode 1N4007	
Q116	960 0196 409	Transistor 2SC1740SR		D145	963 0058 407	Diode 1N4007	
Q117	960 0196 904	Transistor DTC114YS		D146	963 0058 407	Diode 1N4007	
Q151	960 0196 409	Transistor 2SC1740SR		D148	963 0096 508	Diode 1N4148-52RE	
Q171	960 0005 202	Transistor KTC3198Y		D149	963 0058 407	Diode 1N4007	
Q171A	960 0196 302	Transistor KTA1268BL		D150	963 0058 407	Diode 1N4007	
Q171B	960 0196 302	Transistor KTA1268BL		D151	963 0096 508	Diode 1N4148-52RE	
Q171C	960 0196 302	Transistor KTA1268BL		D152	963 0058 407	Diode 1N4007	
Q172	960 0005 202	Transistor KTC3198Y		D153	963 0058 407	Diode 1N4007	
Q173	960 0005 202	Transistor KTC3198Y		D154	960 0095 908	Zener diode MTZJ8.2B	
Q174	960 0005 202	Transistor KTC3198Y		D157	963 0058 708	Zener diode MTZJ20B	
Q175	960 0005 202	Transistor KTC3198Y		D158	963 0096 508	Diode 1N4148-52RE	
Q176	960 0005 202	Transistor KTC3198Y		D159	963 0096 508	Diode 1N4148-52RE	
Q177	960 0005 202	Transistor KTC3198Y		D160	963 0096 508	Diode 1N4148-52RE	
Q178	960 0005 105	Transistor KTA1266Y		D601	963 0096 508	Diode 1N4148-52RE	
Q179	960 0189 005	Transistor KSA916Y		D602	963 0096 508	Diode 1N4148-52RE	
Q180	960 0196 302	Transistor KTA1268BL					
Q181	960 0196 302	Transistor KTA1268BL					
Q601	960 0005 202	Transistor KTC3198Y					
Q602	960 0005 202	Transistor KTC3198Y					
Q603	960 0196 904	Transistor DTC114YS					
Q604	960 0196 904	Transistor DTC114YS					
Q605	960 0196 904	Transistor DTC114YS					
Q606	960 0196 904	Transistor DTC114YS					
D101	963 0096 508	Diode 1N4148-52RE					
D102	963 0096 508	Diode 1N4148-52RE					
D103	963 0096 508	Diode 1N4148-52RE					
D104	963 0096 508	Diode 1N4148-52RE					
D105	963 0096 508	Diode 1N4148-52RE					
D121	963 0096 508	Diode 1N4148-52RE					
D122	963 0096 508	Diode 1N4148-52RE					
				R104C	963 9005 451	Metal oxide 5.6 kohm 1W	
				R104FL	963 9005 451	Metal oxide 5.6 kohm 1W	
				R104FR	963 9005 451	Metal oxide 5.6 kohm 1W	
				R104SL	963 9005 451	Metal oxide 5.6 kohm 1W	
				R104SR	963 9005 451	Metal oxide 5.6 kohm 1W	
				R105C	963 9005 451	Metal oxide 5.6 kohm 1W	
				R105FL	963 9005 451	Metal oxide 5.6 kohm 1W	
				R105FR	963 9005 451	Metal oxide 5.6 kohm 1W	
				R105SL	963 9005 451	Metal oxide 5.6 kohm 1W	
				R105SR	963 9005 451	Metal oxide 5.6 kohm 1W	
				R106C	963 0047 900	Metal film 4.7 kohm 1W	
				R106FL	963 0047 900	Metal film 4.7 kohm 1W	
				R106FR	963 0047 900	Metal film 4.7 kohm 1W	
				R106SL	963 0047 900	Metal film 4.7 kohm 1W	
				R106SR	963 0047 900	Metal film 4.7 kohm 1W	
				R107C	963 0047 900	Metal film 4.7 kohm 1W	
				R107FL	963 0047 900	Metal film 4.7 kohm 1W	



Ref. No.	Part No.	Part Name	Remarks	Ref. No.	Part No.	Part Name	Remarks
R107FR	963 0047 900	Metal film 4.7 kohm 1W		<b>CAPACITORS GROUP</b>			
R107SL	963 0047 900	Metal film 4.7 kohm 1W		C101C	093 9005 888	Electrolytic 47uF/50V	
R107SR	963 0047 900	Metal film 4.7 kohm 1W		C101FL	093 9005 888	Electrolytic 47uF/50V	
R108C	963 9005 477	Metal oxide 0.22 ohm 1W		C101FR	093 9005 888	Electrolytic 47uF/50V	
R108FL	963 9005 477	Metal oxide 0.22 ohm 1W		C101SL	093 9005 888	Electrolytic 47uF/50V	
R108FR	963 9005 477	Metal oxide 0.22 ohm 1W		C101SR	093 9005 888	Electrolytic 47uF/50V	
R108SL	963 9005 477	Metal oxide 0.22 ohm 1W		C102C	963 9005 752	Electrolytic 10uF/35V	
R108SR	963 9005 477	Metal oxide 0.22 ohm 1W		C102FL	963 9005 752	Electrolytic 10uF/35V	
R109C	963 9005 477	Metal oxide 0.22 ohm 1W		C102FR	963 9005 752	Electrolytic 10uF/35V	
R109FR	963 9005 477	Metal oxide 0.22 ohm 1W		C102SL	963 9005 752	Electrolytic 10uF/35V	
R109FL	963 9005 477	Metal oxide 0.22 ohm 1W		C102SR	963 9005 752	Electrolytic 10uF/35V	
R109SL	963 9005 477	Metal oxide 0.22 ohm 1W		C103C	963 9003 084	Ceramic 100pF/500V	
R109SR	963 9005 477	Metal oxide 0.22 ohm 1W		C103FL	963 9003 084	Ceramic 100pF/500V	
R110C	963 9005 477	Metal oxide 0.22 ohm 1W		C103FR	963 9003 084	Ceramic 100pF/500V	
R110FR	963 9005 477	Metal oxide 0.22 ohm 1W		C103SL	963 9003 084	Ceramic 100pF/500V	
R110FL	963 9005 477	Metal oxide 0.22 ohm 1W		C103SR	963 9003 084	Ceramic 100pF/500V	
R110SL	963 9005 477	Metal oxide 0.22 ohm 1W		C104C	963 9003 084	Ceramic 100pF/500V	
R110SR	963 9005 477	Metal oxide 0.22 ohm 1W		C104FL	963 9003 084	Ceramic 100pF/500V	
R111C	963 9005 477	Metal oxide 0.22 ohm 1W		C104FR	963 9003 084	Ceramic 100pF/500V	
R111FL	963 9005 477	Metal oxide 0.22 ohm 1W		C104SL	963 9003 084	Ceramic 100pF/500V	
R111FR	963 9005 477	Metal oxide 0.22 ohm 1W		C104SR	963 9003 084	Ceramic 100pF/500V	
R111SL	963 9005 477	Metal oxide 0.22 ohm 1W		C105C	960 9003 108	Ceramic 0.022uF/25V	
R111SR	963 9005 477	Metal oxide 0.22 ohm 1W		C105FL	960 9003 108	Ceramic 0.022uF/25V	
R118C	963 9005 480	Metal oxide 10 ohm 1W		C105FR	960 9003 108	Ceramic 0.022uF/25V	
R118FL	963 9005 480	Metal oxide 10 ohm 1W		C105SL	960 9003 108	Ceramic 0.022uF/25V	
R118FR	963 9005 480	Metal oxide 10 ohm 1W		C105SR	960 9003 108	Ceramic 0.022uF/25V	
R118SL	963 9005 480	Metal oxide 10 ohm 1W		C107C	963 9003 097	Mylar film 0.1uF/250V	
R118SR	963 9005 480	Metal oxide 10 ohm 1W		C107FL	963 9003 097	Mylar film 0.1uF/250V	
R119C	963 9005 480	Metal oxide 10 ohm 1W		C107FR	963 9003 097	Mylar film 0.1uF/250V	
R119FL	963 9005 480	Metal oxide 10 ohm 1W		C107SL	963 9003 097	Mylar film 0.1uF/250V	
R119FR	963 9005 480	Metal oxide 10 ohm 1W		C107SR	963 9003 097	Mylar film 0.1uF/250V	
R119SL	963 9005 480	Metal oxide 10 ohm 1W		C131	963 9003 097	Mylar film 0.1uF/250V	
R119SR	963 9005 480	Metal oxide 10 ohm 1W		C132	963 9003 097	Mylar film 0.1uF/250V	
R135	963 0045 203	Winding 0.1 ohm 5W		C133	963 9003 097	Mylar film 0.1uF/250V	
R136	963 0045 203	Winding 0.1 ohm 5W		C134	963 9003 097	Mylar film 0.1uF/250V	
R141	960 0180 606	Metal film 0.22 ohm 1W		C135	963 9003 097	Mylar film 0.1uF/250V	
R142	960 0180 606	Metal film 0.22 ohm 1W		C136	963 0087 203	Electrolytic 10000uF/63V	
R148	960 0180 606	Metal film 0.22 ohm 1W		C137	963 0087 203	Electrolytic 10000uF/63V	
R149	960 0180 606	Metal film 0.22 ohm 1W		C138	963 9005 749	Electrolytic 1uF/50V	
R151	963 9003 343	Metal film 68 ohm 1/4W		C141	963 0021 900	Mylar film 0.047uF/100V	
R154	963 0043 108	Metal film 2.2 Mohm 2W	for E3,EU	C142	963 0021 900	Mylar film 0.047uF/100V	
R179	963 9003 055	Metal film 47 kohm 1/4W		C143	963 0021 900	Mylar film 0.047uF/100V	
R181	963 0047 900	Metal film 4.7 kohm 1W		C144	963 9003 110	Electrolytic 4700uF/35V	
R185	963 9005 655	Metal film 22 ohm 1/4W		C145	963 9003 123	Electrolytic 1000uF/35V	
VR101	960 0091 601	Semi fixed resistor 1kohm		C146	963 9005 749	Electrolytic 1uF/50V	
VR102	960 0091 601	Semi fixed resistor 1kohm		C148	963 9005 749	Electrolytic 1uF/50V	
VR103	960 0091 601	Semi fixed resistor 1kohm		C150	963 0021 900	Mylar film 0.047uF/100V	
VR104	960 0091 601	Semi fixed resistor 1kohm		C151	963 0021 900	Mylar film 0.047uF/100V	
VR105	960 0091 601	Semi fixed resistor 1kohm		C152	963 0021 900	Mylar film 0.047uF/100V	
				C153	963 0021 104	Electrolytic 6800uF/16V	
				C154	963 9005 752	Electrolytic 10uF/35V	
				C155	963 0020 202	Ceramic 0.1uF/50V	

Ref. No.	Part No.	Part Name	Remarks	New	Ref. No.	Part No.	Part Name	Remarks	Q'ty	New
C157	963 9005 749	Electrolytic 1uF/50V			<b>OTHER PARTS GROUP</b>					
C158	963 9003 136	Electrolytic 1000uF/25V			CN601	963 0086 709	11P connector socket		1	
C159	963 9005 749	Electrolytic 1uF/50V			CN602	963 0085 603	5P connector socket		1	
C161	963 9005 752	Electrolytic 10uF/35V			CP101	960 0118 908	AC cord connector base		1	
C171	963 9005 312	Electrolytic 100uF/10V			CP102	960 0128 901	3P connector base	for E3,EU,E2, E1C,E1K,EK,EA	1	
C171A	963 0020 202	Ceramic 0.1uF/50V				960 0128 901	3P connector base	for E1,E1H,E1T	1	
C171B	963 0020 202	Ceramic 0.1uF/50V			CP103	960 0128 901	3P connector base		1	
C171C	963 0020 202	Ceramic 0.1uF/50V			CP104	960 0128 804	6P connector base		1	
C172	963 9005 833	Electrolytic 220uF/6.3V			CP105	960 0123 304	3P connector base	for E2,E1, E1H,E1K,E1T	1	
C173	963 9005 833	Electrolytic 220uF/6.3V			CP106	960 0123 207	3P connector base		1	
C174	963 9005 752	Electrolytic 10uF/35V			CP501	963 0086 806	9P connector base		1	
C175	963 9005 914	Electrolytic 4.7uF/50V			CP502-504	963 0086 903	5P connector base		3	
C176	963 9005 749	Electrolytic 1uF/50V			CP505	963 0087 009	6P connector base		1	
C177	963 9005 749	Electrolytic 1uF/50V			CP555	960 0239 609	13P connector base		1	
C178	963 9003 149	Electrolytic 330uF/63V			CP556	963 0087 805	11P connector base		1	
C181	963 0076 104	Ceramic 0.047uF/250V(AC)	for E2,EK,EA		CP602,603	963 0086 903	5P connector base		2	
C182	963 9004 795	Electrolytic 10uF/100V			CP901	963 0048 909	3P connector base		1	
C191	963 9006 007	Ceramic 2200pF/16V	for E2,EK,EA	*	CP931	960 0123 304	3P connector base	for E2,E1,E1C, E1K,E1H,E1T	1	
C192	963 9006 007	Ceramic 2200pF/16V	for E2,EK,EA	*	△ F101,102	960 0188 705	Fuse 125V-S8A	for E3,EU	2	
C193	963 9006 007	Ceramic 2200pF/16V	for E2,EK,EA	*	△ F101	960 0142 602	Fuse 250V-S2.5A	for E2,E1K,EK,EA	1	
C194	963 9006 007	Ceramic 2200pF/16V	for E2,EK,EA	*	△ F102	963 0044 709	Fuse 250V-S3.15A	for E2,E1C, E1K,EK,EA	1	
C195	963 9006 007	Ceramic 2200pF/16V	for E2,EK,EA	*	F101A,102A	960 0005 804	Fuse clip holder		2	
C196	963 9006 007	Ceramic 2200pF/16V	for E2,EK,EA	*	F101B,102B	960 0005 804	Fuse clip holder		2	
C197	963 9006 007	Ceramic 2200pF/16V	for E2,EK,EA	*	F102A,F102B	960 0005 804	Fuse clip holder	for E1C	2	
C198C	960 9006 202	Ceramic 0.01uF/50V	for E2,EK,EA		GND101-103	960 9006 600	Terminal		3	
C198FL	960 9006 202	Ceramic 0.01uF/50V	for E2,EK,EA		JK103	960 0194 809	2P speaker terminal		1	
C198FR	960 9006 202	Ceramic 0.01uF/50V	for E2,EK,EA		△ JK104	960 0187 803	AC outlet(2P)	for E3,EU	1	
C198SL	960 9006 202	Ceramic 0.01uF/50V	for E2,EK,EA			960 0143 203	AC outlet	for E2,EK,EA	1	
C198SR	960 9006 202	Ceramic 0.01uF/50V	for E2,EK,EA		L101C,FL, FR,SL,SR	963 0049 005	Inductor 0.5uh		5	
C199FL	960 9006 202	Ceramic 0.01uF/50V	for E2,EK,EA		RLY101-104	960 0181 702	Relay G5PA-2		4	
C199FR	960 9006 202	Ceramic 0.01uF/50V	for E2,EK,EA		RLY105	963 0071 303	Relay RSB24S		1	
C601	963 9004 520	Ceramic 100pF/50V			RLY106	960 0181 605	Relay G5PA-1-8		1	
C602	963 9005 309	Electrolytic 47uF/10V			TP101-105	960 0161 405	3P connector base		1	
C603	963 9005 309	Electrolytic 47uF/10V				963 0076 104	Ceramic 0.047uf/250V(AC)		1	
C604	963 9005 309	Electrolytic 47uF/10V				960 0158 308	SW Push block		1	
C605	963 9005 891	Electrolytic 470uF/6.3V				963 0074 009	8P Speaker terminal		1	
C606	963 9005 891	Electrolytic 470uF/6.3V				960 0194 508	1P Pin jack		1	
C607	963 9005 794	Electrolytic 100uF/16V				960 0194 605	2P Pin jack		1	
C611	963 9004 546	Ceramic 0.01uF/16V				960 0188 404	3P Pin jack		1	
C612	963 9004 562	Ceramic 0.047uF/50V				—	Heat sink reg TR		1	*
C613	963 9004 562	Ceramic 0.047uF/50V								

## CPU P.W.B. ASS'Y

Ref. No.	Part No.	Part Name	Remarks	Q'ty	New	Ref. No.	Part No.	Part Name	Remarks
	—	Heat sink reg TR		1	*	<b>SEMICONDUCTORS GROUP</b>			
	—	Heat sink		1	*	IC201	963 0095 800	IC CXP740096-156Q	
△	963 0094 924	Mini trans	for E3	1	*	IC202	963 0057 602	IC TDA7330BD	
△	963 0094 937	Mini trans	for E2,EK,EA	1	*	IC271	960 0222 506	IC KIA7812AP	
△	963 0094 911	Mini trans	for E1C	1	*	IC301	960 0180 004	IC LC75721E	
△	963 0094 940	Mini trans	for E1H	1	*	IC302	963 0074 504	IC BU2090F	
△	963 0094 911	Mini trans	for E1K	1	*	IC391	963 0084 905	IC GP1FA502RZ	
△	963 0094 940	Mini trans	for E1T	1	*	Q201	963 0075 202	Transistor DTC144EK	
△	963 0094 940	Mini trans	for E1	1	*	Q202	963 0045 902	Transistor 2SC2412KT96(BR)	
△	963 0094 924	Mini trans	for EU	1	*	Q251	963 0075 309	Transistor DTA114ES	
	963 0018 007	Screw 3x8 B-type ZNY/BH		1		Q252	960 0196 603	Transistor KTC2874B	
	963 0018 007	Screw 3x8 B-type ZNY/BH		1		Q253	960 0196 603	Transistor KTC2874B	
						Q310	963 0058 203	Transistor DTA114EK	
						Q311	963 0058 203	Transistor DTC114EK	
						Q312	963 0058 203	Transistor DTA114EK	
						Q313	963 0058 203	Transistor DTC114EK	
						Q314	963 0058 203	Transistor DTA114EK	
						Q315	963 0058 203	Transistor DTC114EK	
						D201	963 0096 605	Diode 1N4148WS	
						D202	963 0058 407	Diode 1N4007	
						D203	963 0096 508	Diode 1N4148-52RE	
						D204	963 0096 605	Diode 1N4148WS	
						D205	963 0096 605	Diode 1N4148WS	
						D206	963 0096 508	Diode 1N4148-52RE	for E2,EK,EA
						D251	963 0058 407	Diode 1N4007	
						D302	963 0096 508	Diode 1N4148-52RE	
						D303	963 0096 508	Diode 1N4148-52RE	
						D304	963 0096 508	Diode 1N4148-52RE	
						D305	963 0096 605	Diode 1N4148WS	
						D308	963 0096 605	Diode 1N4148WS	
						D309	963 0096 605	Diode 1N4148WS	
						ZD201	963 0047 502	Zener diode MTZJ3.3B	
						ZD301	960 0095 802	Zener diode MTZJ6.8B	
						ZD331	960 0095 500	Zener diode MTZJ5.1B	
						ZD332	960 0095 500	Zener diode MTZJ5.1B	
						ZD335	960 0095 500	Zener diode MTZJ5.1B	
						ZD336	960 0095 500	Zener diode MTZJ5.1B	
						LED301-304	960 0197 204	LED HL50RDRF4T	
						LED306-309	960 0197 204	LED HL50RDRF4T	

Ref. No.	Part No.	Part Name	Remarks	Ref. No.	Part No.	Part Name	Remarks
<b>RESISTORS GROUP</b>				<b>CAPACITORS GROUP</b>			
R202	963 9003 398	Carbon chip 1 kohm 1/16W		RP06	963 9004 397	Carbon chip 56 kohm 1/16W	
R203	963 9004 342	Carbon chip 4.7 kohm 1/16W		RP07	963 9004 397	Carbon chip 56 kohm 1/16W	
R204	963 9004 342	Carbon chip 4.7 kohm 1/16W		RP08	963 9004 397	Carbon chip 56 kohm 1/16W	
R205	963 9004 070	Carbon chip 10 kohm 1/16W		RP09	963 9004 397	Carbon chip 56 kohm 1/16W	
R206	963 9004 232	Carbon chip 220 kohm 1/16W		RP10	963 9004 397	Carbon chip 56 kohm 1/16W	
R209	963 9004 083	Carbon chip 100 kohm 1/16W		RP11	963 9004 397	Carbon chip 56 kohm 1/16W	
R211	963 9004 070	Carbon chip 10 kohm 1/16W		RP12	963 9004 397	Carbon chip 56 kohm 1/16W	
R212	963 9003 398	Carbon chip 1 kohm 1/16W		RP13	963 9004 397	Carbon chip 56 kohm 1/16W	
R213	963 9004 122	Carbon chip 12 kohm 1/16W		RP14	963 9004 397	Carbon chip 56 kohm 1/16W	
R214	963 9004 122	Carbon chip 12 kohm 1/16W		RP15	963 9004 397	Carbon chip 56 kohm 1/16W	
R215	963 9004 122	Carbon chip 12 kohm 1/16W		RP16	963 9004 397	Carbon chip 56 kohm 1/16W	
R216	963 9004 070	Carbon chip 10 kohm 1/16W	for E3,E2,EK,EA,EU	RP17	963 9004 397	Carbon chip 56 kohm 1/16W	
R217	963 9004 070	Carbon chip 10 kohm 1/16W		RP18	963 9004 397	Carbon chip 56 kohm 1/16W	
R218	963 9004 177	Carbon chip 18 kohm 1/16W	for E2,EK,EA	RP19	963 9004 397	Carbon chip 56 kohm 1/16W	
	963 9004 070	Carbon chip 10 kohm 1/16W	for E1,E1C,E1H,E1K,E1T	RP20	963 9004 397	Carbon chip 56 kohm 1/16W	
R219	963 9004 177	Carbon chip 18 kohm 1/16W	for E2,EK,EA	RP21	963 9004 397	Carbon chip 56 kohm 1/16W	
R220	963 9004 070	Carbon chip 10 kohm 1/16W		RP22	963 9004 397	Carbon chip 56 kohm 1/16W	
R225	963 9004 245	Carbon chip 2.2 Mohm 1/16W	for E2,EK,EA	RP23	963 9004 397	Carbon chip 56 kohm 1/16W	
R241	963 9004 339	Carbon chip 470 ohm 1/16W		RP24	963 9004 397	Carbon chip 56 kohm 1/16W	
R242	963 9004 339	Carbon chip 470 ohm 1/16W		RP25	963 9004 397	Carbon chip 56 kohm 1/16W	
R243	963 9004 339	Carbon chip 470 ohm 1/16W		RP26	963 9004 397	Carbon chip 56 kohm 1/16W	
R244	963 9004 339	Carbon chip 470 ohm 1/16W		RP27	963 9004 397	Carbon chip 56 kohm 1/16W	
R245	963 9004 339	Carbon chip 470 ohm 1/16W		RP28	963 9004 397	Carbon chip 56 kohm 1/16W	
R246	963 9004 339	Carbon chip 470 ohm 1/16W		RP29	963 9004 397	Carbon chip 56 kohm 1/16W	
R271	963 9005 626	Metal oxide 4.7 ohm 1W		RP30	963 9004 397	Carbon chip 56 kohm 1/16W	
R281	963 9004 070	Carbon chip 10 kohm 1/16W		RP31	963 9004 397	Carbon chip 56 kohm 1/16W	
R282	963 9004 070	Carbon chip 10 kohm 1/16W		RP32	963 9004 397	Carbon chip 56 kohm 1/16W	
R283	963 9004 070	Carbon chip 10 kohm 1/16W		RP33	963 9004 397	Carbon chip 56 kohm 1/16W	
R305B	963 9004 847	Carbon chip 3.3 kohm 1/16W		RP34	963 9004 397	Carbon chip 56 kohm 1/16W	
R312	963 9004 070	Carbon chip 10 kohm 1/16W		RP35	963 9004 397	Carbon chip 56 kohm 1/16W	
R315	963 0075 105	Carbon chip 10 kohm 1/16W		RP36	963 9004 397	Carbon chip 56 kohm 1/16W	
R321	963 9004 436	Carbon chip 680 ohm 1/16W		RP37	963 9004 397	Carbon chip 56 kohm 1/16W	
R322	963 9004 436	Carbon chip 680 ohm 1/16W		RP38	963 9004 397	Carbon chip 56 kohm 1/16W	
R323	963 9004 436	Carbon chip 680 ohm 1/16W					
R324	963 9004 436	Carbon chip 680 ohm 1/16W					
R326	963 9004 436	Carbon chip 680 ohm 1/16W					
R327	963 9004 436	Carbon chip 680 ohm 1/16W					
R328	963 9004 436	Carbon chip 680 ohm 1/16W					
R329	963 9004 436	Carbon chip 680 ohm 1/16W					
R381	963 9004 465	Carbon chip 75 ohm 1/16W					
R382	963 9004 339	Carbon chip 470 ohm 1/16W					
R383	963 9004 339	Carbon chip 470 ohm 1/16W					
R384	963 9004 245	Carbon chip 2.2 Mohm 1/16W					
R385	963 9004 245	Carbon chip 2.2 Mohm 1/16W					
RG01	963 9004 397	Carbon chip 56 kohm 1/16W					
RP02	963 9004 397	Carbon chip 56 kohm 1/16W					
RP03	963 9004 397	Carbon chip 56 kohm 1/16W					
RP04	963 9004 397	Carbon chip 56 kohm 1/16W					
RP05	963 9004 397	Carbon chip 56 kohm 1/16W					
				BC201	963 0061 504	Electrolytic 8200uF/5.5V	
				C201	963 9004 698	Ceramic chip 0.01uF/50V	
				C202	963 9004 711	Ceramic chip 0.1uF/50V	
				C203	963 9004 698	Ceramic chip 0.01uF/50V	
				C204	963 9005 914	Electrolytic 4.7uF/50V	
				C205	963 9004 711	Ceramic chip 0.1uF/50V	
				C206	096 3905 309	Electrolytic 47uF/10V	for E2,EK,EA
				C207	963 9004 546	Ceramic 0.01uF/16V	for E2,EK,EA
				C208	963 9005 354	Ceramic chip 270pF/50V	for E2,EK,EA
				C209	963 9005 752	Electrolytic 10uF/35V	for E2,EK,EA
				C210	963 9004 698	Ceramic chip 0.01uF/50V	for E2,EK,EA
				C211	963 9004 614	Ceramic chip 27pF/50V	for E2,EK,EA
				C212	963 9004 614	Ceramic chip 27pF/50V	for E2,EK,EA
				C221	963 9005 312	Electrolytic 100uF/10V	
				C251	963 9005 927	Electrolytic 0.1uF/50V	
				C261	963 9004 575	Ceramic chip 100pF/50V	

Ref. No.	Part No.	Part Name	Remarks	Ref. No.	Part No.	Part Name	Remarks	Q'ty
C262	963 9004 575	Ceramic chip 100pF/50V		<b>OTHER PARTS GROUP</b>				
C263	963 9004 575	Ceramic chip 100pF/50V		BD201,202	963 0053 800	Beads inductor		2
C264	963 9004 575	Ceramic chip 100pF/50V		CN201	963 0096 906	6P wire		1
C265	963 9004 575	Ceramic chip 100pF/50V		CN202	963 0099 408	4P wire		1
C266	963 9004 575	Ceramic chip 100pF/50V		CN302	963 0096 702	6P wire		1
C267	963 9004 575	Ceramic chip 100pF/50V		CN931	963 0089 502	2P wire	for E2,E1,G1C,G1H, G1K,G1T,EK,EA	1
C271	963 9005 794	Electrolytic 100uF/16V		CP201	963 0097 604	6P connector base		1
C272	963 9005 752	Electrolytic 10uF/35V		CP202	963 0050 104	4P connector base		1
C301	963 9005 778	Electrolytic 10uF/50V		CP301A	963 0097 905	20P connector base		1
C302	963 9004 753	Ceramic chip 0.047uF/50V		CP301B	960 0129 007	20P FFC connector base		1
C303	963 9005 309	Electrolytic 47uF/10V		CP303	963 0049 102	3P connector base		1
C304	960 9003 108	Ceramic 0.022uF/25V		CP401	963 0088 008	10P connector base		1
C305	963 9005 859	Electrolytic 47uF/16V		CP402	963 0097 507	15P connector base		1
C306	963 9004 766	Mylar film 0.1uF/100V		CP552	960 0239 609	13P connector base		1
C307	963 9005 749	Electrolytic 1uF/50V		CP553	963 0088 008	10P connector base		1
C308	963 0021 900	Mylar film 0.047uF/100V		CP601	963 0087 805	11P connector base		1
C309	963 0021 900	Mylar film 0.047uF/100V		CP701	963 0087 504	19P connector base		1
C310	963 9005 749	Electrolytic 1uF/50V		CP702	963 0087 902	17P connector base		1
C311	963 9005 406	Ceramic chip 30pF/50V		CP703	963 0088 008	10P connector base		1
C312	963 9005 859	Electrolytic 47uF/16V		CP801	963 0087 407	16P connector base		1
C313	963 9005 419	Mylar film 0.047uF/63V		CP802	963 0087 504	19P connector base		1
C321	963 9004 685	Ceramic chip 1000pF/50V		CP803	963 0097 400	8P connector base		1
C322	963 9004 575	Ceramic chip 100pF/50V		FL301	960 0180 509	FI 16-ST-42GNK		1
C324	963 9004 575	Ceramic chip 100pF/50V		G301	963 0088 202	1P contact ass'y		1
C325	963 9004 575	Ceramic chip 100pF/50V		JK301	963 0084 206	3P jack		1
C331	963 9004 698	Ceramic chip 0.01uF/50V		L301	960 0128 008	Inductor 100uh		1
C332	963 9004 698	Ceramic chip 0.01uF/50V		L302	960 0010 307	Inductor 10uh		1
C335	963 9004 698	Ceramic chip 0.01uF/50V		L391	960 0215 908	Inductor 4.7uh		1
C336	963 9004 698	Ceramic chip 0.01uF/50V		RMC301	960 0181 100	Remocon module		1
C381	963 9005 309	Electrolytic 47uF/10V		SW301B-309B	963 0095 305	Tact SW		9
C382	963 9004 575	Ceramic chip 100pF/50V		SW301C-309C	963 0045 708	Tact SW		9
C383	963 9004 575	Ceramic chip 100pF/50V		SW302A-304A	963 0095 305	Tact SW		3
C384	963 9005 749	Electrolytic 1uF/50V		SW305A	963 0045 708	Tact SW		1
C385	963 9005 749	Electrolytic 1uF/50V		SW931	963 0098 807	SW push	for E2,E1,G1C,G1H, G1K,G1T,EK,EA	1
C386	963 9004 753	Ceramic chip 0.047uF/50V		VEC301,302	963 0095 208	Encoder SW		2
C391	963 9004 591	Ceramic chip 22pF/50V		X201	960 0181 003	Ceramic resonator CST12.0MTW		1
C392	963 9004 711	Ceramic chip 0.1uF/50V		X202	963 0099 505	Crystal 4.332MHz	for E2,EK,EA	1
C393	963 9005 859	Electrolytic 47uF/16V		—	—	Heat sink		1
C931	963 0076 104	Ceramic 0.047uF/250V(AC)		963 0018 007	963 0018 007	Screw 3x8 B-type ZNY/BH		1
				960 0184 408	960 0184 408	FLT holder		1

## CNT P.W.B. ASS'Y

Ref. No.	Part No.	Part Name	Remarks	Ref. No.	Part No.	Part Name	Remarks
<b>SEMICONDUCTORS GROUP</b>				<b>SEMICONDUCTORS GROUP</b>			
IC401	963 0043 700	IC LC72131-PLL		Q626	960 0005 202	Transistor KTC3198Y	
IC402	963 0043 904	IC LA1266		Q627	960 0196 904	Transistor DTC114YS	
IC403	963 0044 000	IC LA3401		Q628	960 0196 904	Transistor DTC114YS	
IC621	960 0180 101	IC LA7952		Q651	960 0005 105	Transistor KTA1266Y	for E3,EU
IC622	960 0180 101	IC LA7952		Q652	960 0005 105	Transistor KTA1266Y	for E3,EU
IC651	960 0175 200	IC BA7625	for E3,EU	Q653	960 0005 105	Transistor KTA1266Y	for E3,EU
IC652	963 0083 304	IC BA7626	for E3,EU	D403	963 0096 605	Diode 1N4148WS	
IC653	963 0083 304	IC BA7626	for E3,EU	D404	963 0096 508	Diode 1N4148-52RE	
Q401	963 0099 301	Transistor KTC3880S-O		D405	963 0096 605	Diode 1N4148WS	
Q402	963 0079 305	Transistor DTA114YK		D406	963 0096 605	Diode 1N4148WS	
Q403	963 0058 203	Transistor DTA114EK		D551	963 0096 508	Diode 1N4148-52RE	
Q404	963 0058 203	Transistor DTA114EK		D552	963 0096 508	Diode 1N4148-52RE	
Q405	960 0196 603	Transistor KTC2874B		D553	963 0096 508	Diode 1N4148-52RE	
Q406	960 0196 603	Transistor KTC2874B		D554	963 0096 508	Diode 1N4148-52RE	
Q407	963 0079 305	Transistor DTC114YK		D555	963 0096 508	Diode 1N4148-52RE	
Q408	963 0058 203	Transistor DTA114EK		D556	963 0096 508	Diode 1N4148-52RE	
Q409	963 0099 301	Transistor KTC3880S-O	for E2,EK,EA	D557	963 0096 508	Diode 1N4148-52RE	
Q501C	960 0196 603	Transistor KTC2874B		D558	963 0096 508	Diode 1N4148-52RE	
Q501FL	960 0196 603	Transistor KTC2874B		D559	963 0096 508	Diode 1N4148-52RE	
Q501FR	960 0196 603	Transistor KTC2874B		D560	963 0096 508	Diode 1N4148-52RE	
Q501SL	960 0196 603	Transistor KTC2874B		D561	963 0096 508	Diode 1N4148-52RE	
Q501SR	960 0196 603	Transistor KTC2874B		D562	963 0058 407	Diode 1N4007	
Q502C	960 0196 205	Transistor KSA992F		D563	963 0058 407	Diode 1N4007	
Q502FL	960 0196 205	Transistor KSA992F		D564	960 0095 500	Zener diode MTZJ5.1B	
Q502FR	960 0196 205	Transistor KSA992F		D565	963 0096 508	Diode 1N4148-52RE	
Q502SL	960 0196 205	Transistor KSA992F		D621	963 0096 508	Diode 1N4148-52RE	
Q502SR	960 0196 205	Transistor KSA992F		D622	963 0096 508	Diode 1N4148-52RE	
Q503C	960 0196 205	Transistor KSA992F		ZD341	960 0095 500	Zener diode MTZJ5.1B	
Q503FL	960 0196 205	Transistor KSA992F		ZD342	960 0095 500	Zener diode MTZJ5.1B	
Q503FR	960 0196 205	Transistor KSA992F		ZD401	960 0095 500	Zener diode MTZJ5.1B	
Q503SL	960 0196 205	Transistor KSA992F		<b>RESISTORS GROUP</b>			
Q503SR	960 0196 205	Transistor KSA992F		R401	963 9004 821	Carbon chip 10 ohm 1/16W	
Q504C	960 0196 506	Transistor KSC1845F		R403	963 9004 339	Carbon chip 470 ohm 1/16W	
Q504FL	960 0196 506	Transistor KSC1845F		R404	963 9004 083	Carbon chip 100 kohm 1/16W	
Q504FR	960 0196 506	Transistor KSC1845F		R405	960 9003 807	Metal film 100 ohm 1/4W	
Q504SL	960 0196 506	Transistor KSC1845F		R406	963 9004 342	Carbon chip 4.7 kohm 1/16W	
Q504SR	960 0196 506	Transistor KSC1845F		R407	963 9004 339	Carbon chip 470 ohm 1/16W	for E3,EU
Q551	960 0196 700	Transistor KTC3200BL			963 9005 008	Carbon chip 620 ohm 1/16W	for E2,E1,E1C,E1H, E1K,E1T,EK,EA
Q552	960 0196 302	Transistor KTA1268BL		R408	963 9004 119	Carbon chip 1.2 kohm 1/16W	for E3,EU,E1,E1C, E1H,E1K,E1T
Q553	963 0075 309	Transistor DTA114ES			963 9004 436	Carbon chip 680 ohm 1/16W	for E2,EK,EA
Q554	963 0075 309	Transistor DTA114ES		R409	963 9004 339	Carbon chip 470 ohm 1/16W	
Q555	963 0075 309	Transistor DTA114ES		R411	963 9005 011	Carbon chip 68 kohm 1/16W	
Q621	960 0005 202	Transistor KTC3198Y		R412	963 9004 834	Carbon chip 5.6 kohm 1/16W	
Q622	960 0005 202	Transistor KTC3198Y		R413	960 9006 503	Metal film 220 ohm 1/4W	
Q623	960 0196 904	Transistor DTC114YS					
Q624	960 0196 904	Transistor DTC114YS					
Q625	960 0005 202	Transistor KTC3198Y					

Ref. No.	Part No.	Part Name	Remarks	Ref. No.	Part No.	Part Name	Remarks
R414	963 9004 216	Carbon chip 2.2 kohm 1/16W		R481FR	963 9004 245	Carbon chip 2.2 Mohm 1/16W	
R415	963 9003 398	Carbon chip 1 kohm 1/16W		R481SL	963 9004 245	Carbon chip 2.2 Mohm 1/16W	
R416	963 9005 561	Metal oxide 680 ohm 1W		R481SR	963 9004 245	Carbon chip 2.2 Mohm 1/16W	
R417	963 9003 398	Carbon chip 1 kohm 1/16W		R481SW	963 9004 245	Carbon chip 2.2 Mohm 1/16W	
R418	963 9004 274	Carbon chip 33 kohm 1/16W		R482C	963 9003 385	Carbon chip 100 ohm 1/16W	
R420	963 9004 847	Carbon chip 3.3 kohm 1/16W		R482FL	963 9003 385	Carbon chip 100 ohm 1/16W	
R426	963 9004 070	Carbon chip 10 kohm 1/16W		R482FR	963 9003 385	Carbon chip 100 ohm 1/16W	
R427	963 9004 070	Carbon chip 10 kohm 1/16W		R482SL	963 9003 385	Carbon chip 100 ohm 1/16W	
R429	963 9004 850	Carbon chip 82 ohm 1/16W		R482SR	963 9003 385	Carbon chip 100 ohm 1/16W	
R430	960 9003 807	Metal film 100 ohm 1/4W		R482SW	963 9003 385	Carbon chip 100 ohm 1/16W	
R431	963 9004 371	Carbon chip 5.1 kohm 1/16W		R509C	960 9005 902	Metal film 1.2 kohm 1/4W	
R432	963 9004 070	Carbon chip 10 kohm 1/16W		R509FL	960 9005 902	Metal film 1.2 kohm 1/4W	
R434	960 9003 807	Metal film 100 ohm 1/4W		R509FR	960 9005 902	Metal film 1.2 kohm 1/4W	
R435	963 9004 847	Carbon chip 3.3 kohm 1/16W		R509SL	960 9005 902	Metal film 1.2 kohm 1/4W	
R437	963 9004 083	Carbon chip 100 kohm 1/16W		R509SR	960 9005 902	Metal film 1.2 kohm 1/4W	
R438	963 9004 083	Carbon chip 100 kohm 1/16W	for E3,EU,E1,E1C, E1H,E1K,E1T	R511C	960 9004 301	Metal film 47 ohm 1/4W	
	963 9004 164	Carbon chip 150 kohm 1/16W	for E2,EK,EA	R511FL	960 9004 301	Metal film 47 ohm 1/4W	
R439	963 9004 083	Carbon chip 100 kohm 1/16W	for E3,EU,E1,E1C, E1H,E1K,E1T	R511FR	960 9004 301	Metal film 47 ohm 1/4W	
	963 9004 164	Carbon chip 150 kohm 1/16W	for E2,EK,EA	R511SL	960 9004 301	Metal film 47 ohm 1/4W	
R440	963 9004 863	Carbon chip 120 kohm 1/16W	for E3,EU,E1,E1C, E1H,E1K,E1T	R511SR	960 9004 301	Metal film 47 ohm 1/4W	
	963 9004 232	Carbon chip 220 kohm 1/16W	for E2,EK,EA	R559	963 9005 642	Metal film 1.2 kohm 1W	
R441	963 9004 863	Carbon chip 120 kohm 1/16W	for E3,EU,E1,E1C, E1H,E1K,E1T	R565	963 9005 642	Metal film 1.2 kohm 1W	
	963 9004 232	Carbon chip 220 kohm 1/16W	for E2,EK,EA	R570	963 9005 642	Metal film 1.2 kohm 1W	
R442	963 9004 847	Carbon chip 3.3 kohm 1/16W	for E3,EU,E1,E1C, E1H,E1K,E1T	R621	963 9004 465	Carbon chip 75 ohm 1/16W	
	963 9004 216	Carbon chip 2.2 kohm 1/16W	for E2,EK,EA	R622	963 9004 465	Carbon chip 75 ohm 1/16W	
R443	963 9004 847	Carbon chip 3.3 kohm 1/16W	for E3,E1,E1C,E1H, E1K,E1T,EU	R623	963 9004 465	Carbon chip 75 ohm 1/16W	
	963 9004 216	Carbon chip 2.2 kohm 1/16W	for E2,EK,EA	R624	963 9004 465	Carbon chip 75 ohm 1/16W	
R444	963 9004 481	Carbon chip 8.2 kohm 1/16W	for E3,EU,E1,E1C, E1H,E1K,E1T	R625	963 9004 465	Carbon chip 75 ohm 1/16W	
	963 9004 847	Carbon chip 3.3 kohm 1/16W	for E2,EK,EA	R626	963 9004 465	Carbon chip 75 ohm 1/16W	
R445	963 9004 481	Carbon chip 8.2 kohm 1/16W	for E3,EU,E1,E1C, E1H,E1K,E1T	R627	963 9005 943	Carbon chip 68 ohm 1/16W	
	963 9004 847	Carbon chip 3.3 kohm 1/16W	for E2,EK,EA	R628	963 9004 070	Carbon chip 10 kohm 1/16W	
R448	963 9004 216	Carbon chip 2.2 kohm 1/16W		R630	963 9005 943	Carbon chip 68 ohm 1/16W	
R449	963 9005 037	Carbon chip 3.9 kohm 1/16W	for E2,EK,EA	R631	963 9004 070	Carbon chip 10 kohm 1/16W	
R450	963 9003 398	Carbon chip 1 kohm 1/16W	for E2,EK,EA	R634	963 9004 070	Carbon chip 10 kohm 1/16W	
R455	963 9004 876	Carbon chip 330 ohm 1/16W		R635	963 9003 275	Carbon film 390 ohm 1/5W	
R456	963 9003 385	Carbon chip 100 ohm 1/16W		R637	963 9004 070	Carbon chip 10 kohm 1/16W	
R470	963 9003 398	Carbon chip 1 kohm 1/16W		R641	963 9004 465	Carbon chip 75 ohm 1/16W	
R471VT	963 9004 203	Carbon chip 220 ohm 1/16W		R901	960 9009 270	Metal film 470 ohm 2W	
R472	963 9003 385	Carbon chip 100 ohm 1/16W	for E2,EK,EA	R902	960 9009 270	Metal film 470 ohm 2W	
R474	963 9004 889	Carbon chip 180 ohm 1/16W	for E2,EK,EA	VR401	960 0096 606	Semi fixed resistor 20kohm	
R475	963 9004 122	Carbon chip 12 kohm 1/16W		VR402	963 0056 205	Semi fixed resistor 50kohm	for E3,E1,E1C,E1H, E1K,E1T,EU
R476	963 9004 397	Carbon chip 56 kohm 1/16W			960 0096 402	Semi fixed resistor 100kohm	for E2,EK,EA
R478	963 9004 070	Carbon chip 10 kohm 1/16W		VR403	963 0052 005	Semi fixed resistor 200kohm	
R479	963 9004 083	Carbon chip 100 kohm 1/16W					
R481C	963 9004 245	Carbon chip 2.2 Mohm 1/16W					
R481FL	963 9004 245	Carbon chip 2.2 Mohm 1/16W					

Ref. No.	Part No.	Part Name	Remarks	Ref. No.	Part No.	Part Name	Remarks
<b>CAPACITORS GROUP</b>							
C341	963 9004 546	Ceramic 0.01uF/16V			963 9005 448	Ceramic 330pF/50V	for E2,EK,EA
C342	963 9004 546	Ceramic 0.01uF/16V			963 9004 931	Ceramic 180pF/50V	for E1,E1C,E1H,E1K,E1T
C401	963 9004 685	Ceramic chip 1000pF/50V		C448	963 9004 960	Ceramic 470pF/50V	for E3,EU
C402	963 9004 685	Ceramic chip 1000pF/50V			963 9005 448	Ceramic 330pF/50V	for E1,E1C,E1H,E1K,E1T
C403	963 9004 737	Ceramic chip 0.022uF/25V		C449	963 9004 960	Ceramic 470pF/50V	for E3,EU
C404	963 9004 892	Ceramic 2pF/50V			963 9005 448	Ceramic 330pF/50V	for E1,E1C,E1H,E1K,E1T
C405	963 9004 737	Ceramic chip 0.022uF/25V		C450	963 9005 765	Electrolytic 10uF/35V	
C406	963 9004 902	Ceramic chip 18pF/50V		C451	963 9005 765	Electrolytic 10uF/35V	
C408	960 9004 709	Ceramic 6pF/50V		C453	963 9004 614	Ceramic chip 27pF/50V	
C409	963 9004 520	Ceramic 100pF/50V		C456	963 9004 672	Ceramic chip 680pF/50V	
C410	963 9004 915	Ceramic 470pF/50V		C461	963 9004 591	Ceramic chip 22pF/50V	
C411	963 9004 685	Ceramic chip 1000pF/50V		C462	963 9004 654	Ceramic chip 470pF/50V	for E2,EK,EA
C412	963 9004 737	Ceramic chip 0.022uF/25V		C463	963 9004 782	Mylar film 0.056uF/100V	
C413	963 9004 575	Ceramic chip 100pF/50V		C464	963 9004 973	Ceramic 3pF/50V	
C414	963 9005 846	Electrolytic 2.2uF/50V		C471VT	963 9005 749	Electrolytic 1uF/50V	
C415	963 9005 862	Electrolytic 47uF/16V		C472VT	963 9004 753	Ceramic chip 0.047uF/50V	
C416	963 9005 765	Electrolytic 10uF/35V		C481C	963 9004 575	Ceramic chip 100pF/50V	
C417	963 9005 794	Electrolytic 100uF/16V		C481FL	963 9004 575	Ceramic chip 100pF/50V	
C418	963 9004 698	Ceramic chip 0.01uF/50V		C481FR	963 9004 575	Ceramic chip 100pF/50V	
C419	963 9005 765	Electrolytic 10uF/35V		C481SL	963 9004 575	Ceramic chip 100pF/50V	
C420	963 9004 591	Ceramic chip 22pF/50V		C481SR	963 9004 575	Ceramic chip 100pF/50V	
C421	963 9005 998	Ceramic chip 24pF/50V		C481SW	963 9004 575	Ceramic chip 100pF/50V	
C423	963 9004 737	Ceramic chip 0.022uF/25V		C501C	963 9005 820	Electrolytic 22uF/16V	
C424	963 9004 737	Ceramic chip 0.022uF/25V		C501FL	963 9005 820	Electrolytic 22uF/16V	
C425	963 9005 914	Electrolytic 4.7uF/50V		C501FR	963 9005 820	Electrolytic 22uF/16V	
C426	963 9005 956	Electrolytic 3.3uF/50V		C501M	963 9005 765	Electrolytic 10uF/35V	
C427	963 9005 914	Electrolytic 4.7uF/50V		C501SL	963 9005 820	Electrolytic 22uF/16V	
C428	963 9004 737	Ceramic chip 0.022uF/25V		C501SR	963 9005 820	Electrolytic 22uF/16V	
C430	963 0021 900	Mylar film 0.047uF/100V		C502C	963 9005 765	Electrolytic 10uF/35V	
C431	963 9004 627	Ceramic chip 33pF/50V		C502FL	963 9005 765	Electrolytic 10uF/35V	
C432	963 9005 862	Electrolytic 47uF/16V		C502FR	963 9005 765	Electrolytic 10uF/35V	
C433	963 9004 737	Ceramic chip 0.022uF/25V		C502SL	963 9005 765	Electrolytic 10uF/35V	
C434	963 9005 749	Electrolytic 1uF/50V	for E3,EU	C502SR	963 9005 765	Electrolytic 10uF/35V	
	963 9005 985	Electrolytic 0.33uF/50V	for E2,E1,E1C,E1H, E1K,E1T,EK,EA	C503C	963 9003 165	Ceramic 220pF/500V	
C435	963 9004 737	Ceramic chip 0.022uF/25V		C503FL	963 9003 165	Ceramic 220pF/500V	
C436	963 9004 737	Ceramic chip 0.022uF/25V		C503FR	963 9003 165	Ceramic 220pF/500V	
C437	963 9005 862	Electrolytic 47uF/16V		C503SL	963 9003 165	Ceramic 220pF/500V	
C438	963 9005 749	Electrolytic 1uF/50V		C503SR	963 9003 165	Ceramic 220pF/500V	
C439	963 9005 972	Electrolytic 0.22uF/50V		C504C	963 9003 178	Ceramic 220pF/50V	
C440	963 9005 749	Electrolytic 1uF/50V		C504FL	963 9003 178	Ceramic 220pF/50V	
C441	963 9005 749	Electrolytic 1uF/50V		C504FR	963 9003 178	Ceramic 220pF/50V	
C442	963 9005 846	Electrolytic 2.2uF/50V		C504SL	963 9003 178	Ceramic 220pF/50V	
C443	963 9005 765	Electrolytic 10uF/35V		C504SR	963 9003 178	Ceramic 220pF/50V	
C444	963 9005 914	Electrolytic 4.7uF/50V		C505C	963 9003 181	Ceramic 33pF/500V	
C445	963 9005 765	Electrolytic 10uF/35V		C505FL	963 9003 181	Ceramic 33pF/500V	
C446	963 9005 053	Ceramic 270pF/50V	for E3,EU	C505FR	963 9003 181	Ceramic 33pF/500V	
	963 9005 448	Ceramic 330pF/50V	for E2,EK,EA	C505SL	963 9003 181	Ceramic 33pF/500V	
	963 9004 931	Ceramic 180pF/50V	for E1,E1C,E1H,E1K,E1T	C505SR	963 9003 181	Ceramic 33pF/500V	
C447	963 9005 053	Ceramic 270pF/50V	for E3,EU	C506C	963 9005 312	Electrolytic 100uF/10V	
				C506FL	963 9005 312	Electrolytic 100uF/10V	
				C506FR	963 9005 312	Electrolytic 100uF/10V	



Ref. No.	Part No.	Part Name	Remarks	Ref. No.	Part No.	Part Name	Remarks	Q'ty
C506SL	963 9005 312	Electrolytic 100uF/10V		C691	963 9005 749	Electrolytic 1uF/50V		
C506SR	963 9005 312	Electrolytic 100uF/10V		C692	963 9005 749	Electrolytic 1uF/50V		
C507C	963 9003 194	Mylar film 0.0022uF/100V		C693	963 9003 108	Ceramic 0.022uF/25V		
C507FL	963 9003 194	Mylar film 0.0022uF/100V		C694	963 9005 312	Electrolytic 100uF/10V		
C507FR	963 9003 194	Mylar film 0.0022uF/100V		C901	963 9004 533	Ceramic 0.001uF/50V		
C507SL	963 9003 194	Mylar film 0.0022uF/100V		C902	963 9004 533	Ceramic 0.001uF/50V		
C507SR	963 9003 194	Mylar film 0.0022uF/100V		C903	963 9005 749	Electrolytic 1uF/50V		
C551	963 9005 846	Electrolytic 2.2uF/50V		C904	963 9003 108	Ceramic 0.022uF/25V		
C551M	963 9005 817	Electrolytic 100uF/35V		<b>OTHER PARTS GROUP</b>				
C551S	963 9004 562	Ceramic 0.047uF/50V		CF401,402	960 0187 104	Ceramic filter	for E3,EU	2
C552	963 9005 927	Electrolytic 0.1uF/50V		CF401,402	960 0177 509	Ceramic filter	for E2,EK,EA	2
C553	963 9005 927	Electrolytic 0.1uF/50V		CF401	960 0187 104	Ceramic filter	for E1,E1,b, E1K,E1H,E1T	1
C554	963 9005 927	Electrolytic 0.1uF/50V		CF402	960 0177 509	Ceramic filter	for E1,E1,b, E1K,E1H,E1T	1
C555	963 9004 546	Ceramic 0.01uF/16V		CF403	960 0187 609	Ceramic resonator		1
C556	963 9004 546	Ceramic 0.01uF/16V		CN392	963 0087 300	3P wire		1
C557	963 9005 752	Electrolytic 10uF/35V		CN401	963 0085 409	10P connector socket		1
C621	963 9005 309	Electrolytic 47uF/10V		CN402	963 0097 303	15P connector socket		1
C622	963 9005 309	Electrolytic 47uF/10V		CN501	963 0085 506	9P connector socket		1
C623	963 9005 309	Electrolytic 47uF/10V		CN502-504	963 0085 603	5P connector socket		3
C624	963 9005 891	Electrolytic 470uF/6.3V		CN505	963 0085 700	6P connector socket		1
C625	963 9005 891	Electrolytic 470uF/6.3V		CN552	960 0239 900	13P connector socket		1
C626	963 9005 309	Electrolytic 47uF/10V		CN553	963 0085 409	10P connector socket		1
C627	963 9005 309	Electrolytic 47uF/10V		CN555	960 0239 900	13P connector socket		1
C628	963 9005 309	Electrolytic 47uF/10V		CN554	963 0097 002	13P wire		1
C629	963 9005 891	Electrolytic 470uF/6.3V		CN556	963 0086 709	11P connector socket		1
C630	963 9005 891	Electrolytic 470uF/6.3V		CN603	963 0085 603	5P connector socket		1
C631	963 9005 794	Electrolytic 100uF/16V		CN621	963 0085 603	5P connector socket		1
C632	963 9004 753	Ceramic chip 0.047uF/50V		CN651	963 0085 603	5P connector socket	for E3,EU	1
C633	963 9004 753	Ceramic chip 0.047uF/50V		CN901	963 0090 902	3P wire		1
C634	963 9005 749	Electrolytic 1uF/50V		CP302	963 0075 600	6P connector base		1
C635	963 9005 749	Electrolytic 1uF/50V		CP392	963 0048 909	3P connector base		1
C651	963 9005 914	Electrolytic 4.7uF/50V		CP551	963 0097 701	12P connector base		1
C652	963 9005 914	Electrolytic 4.7uF/50V		CP554	963 0097 808	13P connector base		1
C653	963 9005 914	Electrolytic 4.7uF/50V		CP621	963 0086 903	5P connector base		1
C654	963 9005 914	Electrolytic 4.7uF/50V		CP651	963 0086 903	5P connector base	for E3,EU	1
C655	963 9005 914	Electrolytic 4.7uF/50V		FE401	960 0187 706	Front end FTE4-401TB		1
C656	963 9005 914	Electrolytic 4.7uF/50V		G401	—	1P contact ass'y		1
C657	963 9005 969	Electrolytic 4700uF/6.3V		G901	—	1P contact ass'y		1
C658	963 9005 891	Electrolytic 470uF/6.3V		JK901	963 0095 402	Head phone jack		1
C659	963 9005 891	Electrolytic 470uF/6.3V		L401	963 0052 102	Inductor 1uh		1
C660	963 9005 312	Electrolytic 100uF/10V		L402	960 0010 307	Inductor 10uh		1
C661	963 9005 312	Electrolytic 100uF/10V		L403	963 0056 409	If MW coil		1
C662	963 9005 312	Electrolytic 100uF/10V						
C671	963 9005 749	Electrolytic 1uF/50V						
C672	963 9005 749	Electrolytic 1uF/50V						
C673	963 9003 108	Ceramic 0.022uF/25V						
C674	963 9005 312	Electrolytic 100uF/10V						
C681	963 9005 749	Electrolytic 1uF/50V						
C682	963 9005 749	Electrolytic 1uF/50V						
C683	963 9003 108	Ceramic 0.022uF/25V						
C684	963 9005 312	Electrolytic 100uF/10V						

## INPUT VOLUME P.W.B. ASS'Y

Ref. No.	Part No.	Part Name	Remarks	Q'ty	Ref. No.	Part No.	Part Name	Remarks
SW901	960 0176 209	Push SW	for E3,EU	1	<b>SEMICONDUCTORS GROUP</b>			
T401	960 0186 600	If MW coil PCFMAF-270		1	IC701	963 0096 401	IC BD3811K1	
T402	960 0007 349	If FM coil M292MEA-K5611FKG		1	IC721	963 0024 004	IC NJM2068M	
T403	960 0007 352	If FM coil 292MEA-K5612X		1	IC761	963 0024 004	IC NJM2068M	
T404	960 0071 207	MPX filter	for E2,EK,EA	1	IC762	963 0024 004	IC NJM2068M	
T405	960 0071 207	MPX filter	for E2,EK,EA	1	IC763	963 0024 004	IC NJM2068M	
T406	960 0037 607	Antibirdie filter	for E2,EK,EA	1	IC781	963 0024 004	IC NJM2068M	
					IC782	963 0024 004	IC NJM2068M	
					IC783	963 0024 004	IC NJM2068M	
VEC303	963 0095 208	Encoder SW		1	Q751	963 0075 503	Transistor DTC144ES	
X401	963 0099 107	Crystal 7.2MHz		1	Q752	963 0075 503	Transistor DTA114ES	
X402	963 0043 302	Ceramic resonator CSB456F11		1	Q753	960 0196 807	Transistor 2SK117Y	
	963 0052 403	3P antenna terminal		1	Q754	960 0196 807	Transistor 2SK117Y	
	963 0099 204	3P pin jack	for E3,EU	1	Q755	963 0075 503	Transistor DTC144ES	
	960 0181 304	3P S terminal		1	Q756	963 0075 309	Transistor DTA114ES	
	960 0181 401	4P S terminal		1	Q757	960 0196 807	Transistor 2SK117Y	
	960 0188 307	6P pin jack		1	Q758	960 0196 807	Transistor 2SK117Y	
	960 0188 404	6P pin jack		1	Q771	963 0075 503	Transistor DTC144ES	
	960 0184 000	Bracket		4	Q772	963 0075 309	Transistor DTA114ES	
	963 0054 003	Tuner pack shield		1	Q773	960 0196 807	Transistor 2SK117Y	
	963 0099 000	Earth "D"plate		1	Q774	960 0196 807	Transistor 2SK117Y	
					D751	963 0096 605	Diode 1N4148WS	
					D752	963 0096 605	Diode 1N4148WS	
					D753	963 0096 605	Diode 1N4148WS	
					D754	963 0096 605	Diode 1N4148WS	
					D771	963 0096 605	Diode 1N4148WS	
					D772	963 0096 605	Diode 1N4148WS	
					ZD701	960 0222 603	Zener diode MTZJ7.5A	
					ZD702	960 0222 603	Zener diode MTZJ7.5A	
					<b>RESISTORS GROUP</b>			
					R701L	963 9004 339	Carbon chip 470 ohm 1/16W	
					R701R	963 9004 339	Carbon chip 470 ohm 1/16W	
					R702L	963 9004 339	Carbon chip 470 ohm 1/16W	
					R702R	963 9004 339	Carbon chip 470 ohm 1/16W	
					R703L	963 9004 339	Carbon chip 470 ohm 1/16W	
					R703R	963 9004 339	Carbon chip 470 ohm 1/16W	
					R704L	963 9004 339	Carbon chip 470 ohm 1/16W	
					R704R	963 9004 339	Carbon chip 470 ohm 1/16W	
					R705L	963 9004 339	Carbon chip 470 ohm 1/16W	
					R705R	963 9004 339	Carbon chip 470 ohm 1/16W	
					R706L	963 9004 339	Carbon chip 470 ohm 1/16W	
					R706R	963 9004 339	Carbon chip 470 ohm 1/16W	
					R707L	963 9004 339	Carbon chip 470 ohm 1/16W	
					R707R	963 9004 339	Carbon chip 470 ohm 1/16W	
					R708L	963 9004 339	Carbon chip 470 ohm 1/16W	
					R708R	963 9004 339	Carbon chip 470 ohm 1/16W	
					R711L	963 9004 245	Carbon chip 2.2 Mohm 1/16W	
					R711R	963 9004 245	Carbon chip 2.2 Mohm 1/16W	

Ref. No.	Part No.	Part Name	Remarks	Ref. No.	Part No.	Part Name	Remarks
R712L	963 9004 245	Carbon chip 2.2 Mohm 1/16W		R763SW	963 9004 834	Carbon chip 5.6 kohm 1/16W	
R712R	963 9004 245	Carbon chip 2.2 Mohm 1/16W		R764FL	963 9004 410	Carbon chip 6.2 kohm 1/16W	
R713L	963 9004 245	Carbon chip 2.2 Mohm 1/16W		R764FR	963 9004 410	Carbon chip 6.2 kohm 1/16W	
R713R	963 9004 245	Carbon chip 2.2 Mohm 1/16W		R765FL	963 9004 151	Carbon chip 15 kohm 1/16W	
R714L	963 9004 245	Carbon chip 2.2 Mohm 1/16W		R765FR	963 9004 151	Carbon chip 15 kohm 1/16W	
R714R	963 9004 245	Carbon chip 2.2 Mohm 1/16W		R765SW	963 9004 478	Carbon chip 7.5 kohm 1/16W	
R715L	963 9004 245	Carbon chip 2.2 Mohm 1/16W		R766FL	963 9003 385	Carbon chip 100 ohm 1/16W	
R715R	963 9004 245	Carbon chip 2.2 Mohm 1/16W		R766FR	963 9003 385	Carbon chip 100 ohm 1/16W	
R716L	963 9004 245	Carbon chip 2.2 Mohm 1/16W		R766SW	963 9003 385	Carbon chip 100 ohm 1/16W	
R716R	963 9004 245	Carbon chip 2.2 Mohm 1/16W		R767FL	963 9004 083	Carbon chip 100 kohm 1/16W	
R717L	963 9004 245	Carbon chip 2.2 Mohm 1/16W		R767FR	963 9004 083	Carbon chip 100 kohm 1/16W	
R717R	963 9004 245	Carbon chip 2.2 Mohm 1/16W		R767SW	963 9004 083	Carbon chip 100 kohm 1/16W	
R718L	963 9004 245	Carbon chip 2.2 Mohm 1/16W		R771	963 9005 639	Metal film 100 ohm 1W	
R718R	963 9004 245	Carbon chip 2.2 Mohm 1/16W		R772	963 9005 639	Metal film 100 ohm 1W	
R722L	963 9004 083	Carbon chip 100 kohm 1/16W		R773	963 9004 216	Carbon chip 2.2 kohm 1/16W	
R722R	963 9004 083	Carbon chip 100 kohm 1/16W		R774	963 9004 070	Carbon chip 10 kohm 1/16W	
R723L	963 9004 083	Carbon chip 100 kohm 1/16W		R782C	963 9003 385	Carbon chip 100 ohm 1/16W	
R723R	963 9004 083	Carbon chip 100 kohm 1/16W		R782FL	963 9003 385	Carbon chip 100 ohm 1/16W	
R724L	963 9003 385	Carbon chip 100 ohm 1/16W		R782FR	963 9003 385	Carbon chip 100 ohm 1/16W	
R724R	963 9003 385	Carbon chip 100 ohm 1/16W		R782SL	963 9003 385	Carbon chip 100 ohm 1/16W	
R725L	963 9004 300	Carbon chip 39 kohm 1/16W		R782SR	963 9003 385	Carbon chip 100 ohm 1/16W	
R725R	963 9004 300	Carbon chip 39 kohm 1/16W		R782SW	963 9003 385	Carbon chip 100 ohm 1/16W	
R726L	963 9004 300	Carbon chip 39 kohm 1/16W		R783C	963 9004 355	Carbon chip 4.7 kohm 1/16W	
R726R	963 9004 300	Carbon chip 39 kohm 1/16W		R783FL	963 9004 355	Carbon chip 4.7 kohm 1/16W	
R727L	963 9004 300	Carbon chip 39 kohm 1/16W		R783FR	963 9004 355	Carbon chip 4.7 kohm 1/16W	
R727R	963 9004 300	Carbon chip 39 kohm 1/16W		R783SL	963 9004 355	Carbon chip 4.7 kohm 1/16W	
R728L	963 9003 385	Carbon chip 100 ohm 1/16W		R783SR	963 9004 355	Carbon chip 4.7 kohm 1/16W	
R728R	963 9003 385	Carbon chip 100 ohm 1/16W		R783SW	963 9004 355	Carbon chip 4.7 kohm 1/16W	
R729L	963 9004 083	Carbon chip 100 kohm 1/16W		R784C	963 9005 684	Carbon chip 13 kohm 1/16W	
R729R	963 9004 083	Carbon chip 100 kohm 1/16W		R784FL	963 9004 478	Carbon chip 7.5 kohm 1/16W	
R731	963 9005 668	Metal film 220 ohm 1W		R784FR	963 9004 478	Carbon chip 7.5 kohm 1/16W	
R732	963 9005 668	Metal film 220 ohm 1W		R784SL	963 9005 684	Carbon chip 13 kohm 1/16W	
R733	963 9004 342	Carbon chip 4.7 kohm 1/16W		R784SR	963 9005 684	Carbon chip 13 kohm 1/16W	
R734	963 9004 342	Carbon chip 4.7 kohm 1/16W		R784SW	963 9004 122	Carbon chip 12 kohm 1/16W	
R741	963 9004 339	Carbon chip 470 ohm 1/16W		R786C	963 9004 216	Carbon chip 2.2 kohm 1/16W	
R742	963 9004 339	Carbon chip 470 ohm 1/16W		R786FL	963 9005 671	Carbon chip 1.3 kohm 1/16W	
R743	963 9004 339	Carbon chip 470 ohm 1/16W		R786FR	963 9005 671	Carbon chip 1.3 kohm 1/16W	
R751	963 9004 216	Carbon chip 2.2 kohm 1/16W		R786SL	963 9004 216	Carbon chip 2.2 kohm 1/16W	
R752	963 9004 070	Carbon chip 10 kohm 1/16W		R786SR	963 9004 216	Carbon chip 2.2 kohm 1/16W	
R756	963 9004 216	Carbon chip 2.2 kohm 1/16W		R786SW	963 9005 008	Carbon chip 620 ohm 1/16W	
R757	963 9004 070	Carbon chip 10 kohm 1/16W		R787SW	963 9004 083	Carbon chip 100 kohm 1/16W	
R761C	963 9003 385	Carbon chip 100 ohm 1/16W		R788C	963 9004 339	Carbon chip 470 ohm 1/16W	
R761FL	963 9005 707	Carbon chip 3.6 kohm 1/16W		R788FL	963 9004 339	Carbon chip 470 ohm 1/16W	
R761FR	963 9005 707	Carbon chip 3.6 kohm 1/16W		R788FR	963 9004 339	Carbon chip 470 ohm 1/16W	
R761SL	963 9003 385	Carbon chip 100 ohm 1/16W		R788SL	963 9004 339	Carbon chip 470 ohm 1/16W	
R761SR	963 9003 385	Carbon chip 100 ohm 1/16W		R788SR	963 9004 339	Carbon chip 470 ohm 1/16W	
R761SW	963 9005 037	Carbon chip 3.9 kohm 1/16W		R788SW	963 9003 398	Carbon chip 1 kohm 1/16W	
R762FL	963 9004 342	Carbon chip 4.7 kohm 1/16W		R791	963 9005 639	Metal film 100 ohm 1W	
R762FR	963 9004 342	Carbon chip 4.7 kohm 1/16W		R792	963 9005 639	Metal film 100 ohm 1W	
R762SW	963 9004 449	Carbon chip 6.8 kohm 1/16W					
R763FL	963 9004 151	Carbon chip 15 kohm 1/16W					
R763FR	963 9004 151	Carbon chip 15 kohm 1/16W					

Ref. No.	Part No.	Part Name	Remarks	Ref. No.	Part No.	Part Name	Remarks
<b>CAPACITORS GROUP</b>				C762FR	963 9004 575	Ceramic chip 100pF/50V	
C701L	963 9004 575	Ceramic chip 100pF/50V	for E2,EK,EA	C762SW	963 9004 575	Ceramic chip 100pF/50V	
C701R	963 9004 575	Ceramic chip 100pF/50V	for E2,EK,EA	C763FL	963 9004 753	Ceramic chip 0.047uF/50V	
C702L	963 9004 575	Ceramic chip 100pF/50V	for E2,EK,EA	C763FR	963 9004 753	Ceramic chip 0.047uF/50V	
C702R	963 9004 575	Ceramic chip 100pF/50V	for E2,EK,EA	C763SW	963 9004 753	Ceramic chip 0.047uF/50V	
C703L	963 9004 575	Ceramic chip 100pF/50V	for E2,EK,EA	C764FL	963 9004 627	Ceramic chip 33pF/50V	
C703R	963 9004 575	Ceramic chip 100pF/50V	for E2,EK,EA	C764FR	963 9004 627	Ceramic chip 33PF/50V	
C704L	963 9004 575	Ceramic chip 100pF/50V	for E2,EK,EA	C764SW	963 9004 643	Ceramic chip 47pF/50V	
C704R	963 9004 575	Ceramic chip 100pF/50V	for E2,EK,EA	C765FL	963 9005 765	Electrolytic 10uF/35V	
C705L	963 9004 575	Ceramic chip 100pF/50V	for E2,EK,EA	C765FR	963 9005 765	Electrolytic 10uF/35V	
C705R	963 9004 575	Ceramic chip 100pF/50V	for E2,EK,EA	C765SW	963 9005 765	Electrolytic 10uF/35V	
C706L	963 9004 575	Ceramic chip 100pF/50V	for E2,EK,EA	C771	963 9005 875	Electrolytic 47uF/25V	
C706R	963 9004 575	Ceramic chip 100pF/50V	for E2,EK,EA	C772	963 9005 875	Electrolytic 47uF/25V	
C707L	963 9004 575	Ceramic chip 100pF/50V	for E2,EK,EA	C773	963 9005 749	Electrolytic 1uF/50V	
C707R	963 9004 575	Ceramic chip 100pF/50V	for E2,EK,EA	C781C	963 9004 753	Ceramic chip 0.047uF/50V	
C708L	963 9004 575	Ceramic chip 100pF/50V	for E2,EK,EA	C781FL	963 9004 753	Ceramic chip 0.047uF/50V	
C708R	963 9004 575	Ceramic chip 100pF/50V	for E2,EK,EA	C781FR	963 9004 753	Ceramic chip 0.047uF/50V	
C711L	963 9004 698	Ceramic chip 0.01uF/50V		C781SL	963 9004 753	Ceramic chip 0.047uF/50V	
C711R	963 9004 698	Ceramic chip 0.01uF/50V		C781SR	963 9004 753	Ceramic chip 0.047uF/50V	
C713L	963 9005 765	Electrolytic 10uF/35V		C781SW	963 9004 753	Ceramic chip 0.047uF/50V	
C713R	963 9005 765	Electrolytic 10uF/35V		C782C	963 9005 914	Electrolytic 4.7uF/50V	
C714L	963 9003 152	Mylar film 0.068uF/100V		C782FL	963 9005 765	Electrolytic 10uF/35V	
C714R	963 9003 152	Mylar film 0.068uF/100V		C782FR	963 9005 765	Electrolytic 10uF/35V	
C715L	963 9003 152	Mylar film 0.068uF/100V		C782SL	963 9005 765	Electrolytic 10uF/35V	
C715R	963 9003 152	Mylar film 0.068uF/100V		C782SR	963 9005 765	Electrolytic 10uF/35V	
C716L	963 9005 765	Electrolytic 10uF/35V		C782SW	963 9005 914	Electrolytic 4.7uF/50V	
C716R	963 9005 765	Electrolytic 10uF/35V		C783C	963 9004 630	Ceramic chip 39pF/50V	
C721	963 9005 875	Electrolytic 47uF/25V		C783FL	963 9004 669	Ceramic chip 56pF/50V	
C722	960 9004 602	Ceramic 0.047uF/50V		C783FR	963 9004 669	Ceramic chip 56pF/50V	
C723	963 9005 875	Electrolytic 47uF/25V		C783SL	963 9004 630	Ceramic chip 39pF/50V	
C724	960 9004 602	Ceramic 0.047uF/50V		C783SR	963 9004 630	Ceramic chip 39pF/50V	
C725	963 9005 736	Mylar film 0.0047uF/100V		C783SW	963 9004 575	Ceramic chip 100pF/50V	
C726	963 9005 736	Mylar film 0.0047uF/100V		C786SW	963 9005 914	Electrolytic 4.7uF/50V	
C727	963 9004 766	Mylar film 0.1uF/100V		C791	963 9005 875	Electrolytic 47uF/25V	
C728	963 9004 766	Mylar film 0.1uF/100V		C792	963 9005 875	Electrolytic 47uF/25V	
C729	963 9004 766	Mylar film 0.1uF/100V		<b>OTHER PARTS GROUP</b>			
C730	963 9004 766	Mylar film 0.1uF/100V		CN551	963 0096 809	12P shield wire	1
C731	963 9005 765	Electrolytic 10uF/35V		CN701	963 0086 204	19P connector socket	1
C732	963 9005 765	Electrolytic 10uF/35V		CN702	963 0085 302	17P connector socket	1
C733	963 9005 765	Electrolytic 10uF/35V		CN703	963 0085 409	10P connector socket	1
C734	963 9005 765	Electrolytic 10uF/35V			960 0188 200	4P pin jack	1
C735	963 9005 765	Electrolytic 10uF/35V			960 0188 307	6P pin jack	1
C736	963 9005 765	Electrolytic 10uF/35V			963 0094 102	Plate input	1
C741	963 9004 575	Ceramic chip 100pF/50V			963 0094 005	Input cushion	1
C742	963 9004 575	Ceramic chip 100pF/50V					
C743	963 9004 575	Ceramic chip 100pF/50V					
C751	963 9005 749	Electrolytic 1uF/50V					
C756	963 9005 749	Electrolytic 1uF/50V					
C761FL	963 9004 753	Ceramic chip 0.047uF/50V					
C761FR	963 9004 753	Ceramic chip 0.047uF/50V					
C761SW	963 9004 753	Ceramic chip 0.047uF/50V					
C762FL	963 9004 575	Ceramic chip 100pF/50V					

## DSP P.W.B. ASS'Y

Ref. No.	Part No.	Part Name	Remarks	Ref. No.	Part No.	Part Name	Remarks
<b>SEMICONDUCTORS GROUP</b>							
IC802	963 0084 905	IC GP1FA502RZ		R863L	963 9004 339	Carbon chip 470 ohm 1/16W	
IC803	963 0084 905	IC GP1FA502RZ		R863R	963 9004 339	Carbon chip 470 ohm 1/16W	
IC804	963 0096 304	IC DSP MELODY 32 LQFP		R864C	963 9004 083	Carbon chip 100 kohm 1/16W	
IC805	963 0095 703	IC M29W800AT		R864FL	963 9004 083	Carbon chip 100 kohm 1/16W	
IC806	963 0095 606	IC IS61LV6416-12T		R864FR	963 9004 083	Carbon chip 100 kohm 1/16W	
IC807	963 0096 100	IC LC89057W		R864L	963 9005 930	Carbon chip 750 kohm 1/10W	
IC808	963 0096 207	IC AD1837		R864R	963 9005 930	Carbon chip 750 kohm 1/10W	
IC809	963 0074 203	IC MM74LCX244WMX		R864SL	963 9004 083	Carbon chip 100 kohm 1/16W	
IC810	963 0074 203	IC MM74LCX244WMX		R864SR	963 9004 083	Carbon chip 100 kohm 1/16W	
IC811	963 0074 203	IC MM74LCX244WMX		R864SW	963 9004 083	Carbon chip 100 kohm 1/16W	
IC812	963 0074 300	IC MM74HCT244WMX		R866C	963 9004 342	Carbon chip 4.7 kohm 1/16W	
IC813	963 0095 907	IC 74LCX02MTC		R866FL	963 9004 342	Carbon chip 4.7 kohm 1/16W	
IC814	960 0195 109	IC SN74LV00APW		R866FR	963 9004 342	Carbon chip 4.7 kohm 1/16W	
IC815A	963 0043 807	IC BA4510F-T1		R866SL	963 9004 342	Carbon chip 4.7 kohm 1/16W	
IC816A	963 0043 807	IC BA4510F-T1		R866SR	963 9004 342	Carbon chip 4.7 kohm 1/16W	
IC817A	963 0024 004	IC NJM2068M		R866SW	963 9004 342	Carbon chip 4.7 kohm 1/16W	
IC818A	963 0024 004	IC NJM2068M		R867C	963 9004 342	Carbon chip 4.7 kohm 1/16W	
IC819A	963 0024 004	IC NJM2068M		R867FL	963 9004 342	Carbon chip 4.7 kohm 1/16W	
IC817	963 0085 001	IC GP1FA502TZ		R867FR	963 9004 342	Carbon chip 4.7 kohm 1/16W	
IC821	963 0096 003	IC 74LCX74MTC		R867SL	963 9004 342	Carbon chip 4.7 kohm 1/16W	
IC822	960 0159 501	IC KIA7805API		R867SR	963 9004 342	Carbon chip 4.7 kohm 1/16W	
IC823	963 0074 805	IC RC1117S33ST		R867SW	963 9004 342	Carbon chip 4.7 kohm 1/16W	
IC824	963 0074 708	IC RC1117S25T		R868C	963 9004 342	Carbon chip 4.7 kohm 1/16W	
Q804C	960 0196 603	Transistor KTC2874B		R868FL	963 9004 342	Carbon chip 4.7 kohm 1/16W	
Q804FL	960 0196 603	Transistor KTC2874B		R868FR	963 9004 342	Carbon chip 4.7 kohm 1/16W	
Q804FR	960 0196 603	Transistor KTC2874B		R868SL	963 9004 342	Carbon chip 4.7 kohm 1/16W	
Q804SL	960 0196 603	Transistor KTC2874B		R868SR	963 9004 342	Carbon chip 4.7 kohm 1/16W	
Q804SR	960 0196 603	Transistor KTC2874B		R868SW	963 9004 342	Carbon chip 4.7 kohm 1/16W	
Q804SW	960 0196 603	Transistor KTC2874B		R869C	963 9004 342	Carbon chip 4.7 kohm 1/16W	
Q805	963 0058 203	Transistor DTA114EK		R869FL	963 9004 342	Carbon chip 4.7 kohm 1/16W	
Q806	963 0058 203	Transistor DTC114EK		R869FR	963 9004 342	Carbon chip 4.7 kohm 1/16W	
Q807	963 0058 203	Transistor DTA114EK		R869SL	963 9004 342	Carbon chip 4.7 kohm 1/16W	
D801	963 0096 605	Diode 1N4148WS		R869SR	963 9004 342	Carbon chip 4.7 kohm 1/16W	
D806	963 0096 605	Diode 1N4148WS		R869SW	963 9004 342	Carbon chip 4.7 kohm 1/16W	
D807	963 0096 605	Diode 1N4148WS		R870C	963 9003 398	Carbon chip 1 kohm 1/16W	
<b>RESISTORS GROUP</b>							
R803	963 9004 342	Carbon chip 4.7 kohm 1/16W		R870FL	963 9003 398	Carbon chip 1 kohm 1/16W	
R841	963 9004 339	Carbon chip 470 ohm 1/16W		R870FR	963 9003 398	Carbon chip 1 kohm 1/16W	
R848	963 9003 385	Carbon chip 100 ohm 1/16W		R870SL	963 9003 398	Carbon chip 1 kohm 1/16W	
R850	963 9004 465	Carbon chip 75 ohm 1/16W		R870SR	963 9003 398	Carbon chip 1 kohm 1/16W	
R859L	963 9004 834	Carbon chip 5.6 kohm 1/16W		R870SW	963 9003 398	Carbon chip 1 kohm 1/16W	
R859R	963 9004 834	Carbon chip 5.6 kohm 1/16W		R871C	963 9004 083	Carbon chip 100 kohm 1/16W	
R860L	963 9004 834	Carbon chip 5.6 kohm 1/16W		R871FL	963 9004 083	Carbon chip 100 kohm 1/16W	
R860R	963 9004 834	Carbon chip 5.6 kohm 1/16W		R871FR	963 9004 083	Carbon chip 100 kohm 1/16W	
R861L	963 9004 339	Carbon chip 470 ohm 1/16W		R871SL	963 9004 083	Carbon chip 100 kohm 1/16W	
R861R	963 9004 339	Carbon chip 470 ohm 1/16W		R871SR	963 9004 083	Carbon chip 100 kohm 1/16W	
R862L	963 9004 834	Carbon chip 5.6 kohm 1/16W		R871SW	963 9004 083	Carbon chip 100 kohm 1/16W	
R862R	963 9004 834	Carbon chip 5.6 kohm 1/16W		R872C	963 9004 216	Carbon chip 2.2 kohm 1/16W	
				R872FL	963 9004 216	Carbon chip 2.2 kohm 1/16W	
				R872FR	963 9004 216	Carbon chip 2.2 kohm 1/16W	
				R872SL	963 9004 216	Carbon chip 2.2 kohm 1/16W	
				R872SR	963 9004 216	Carbon chip 2.2 kohm 1/16W	
				R872SW	963 9004 216	Carbon chip 2.2 kohm 1/16W	

Ref. No.	Part No.	Part Name	Remarks	Ref. No.	Part No.	Part Name	Remarks	
R922	963 9004 342	Carbon chip 4.7 kohm 1/16W		R996	963 9004 326	Carbon chip 47 ohm 1/16W		
R923	963 9004 410	Carbon chip 6.2 kohm 1/16W		R997	963 9004 326	Carbon chip 47 ohm 1/16W		
R931	963 9004 410	Carbon chip 6.2 kohm 1/16W		R998	963 9004 070	Carbon chip 10 kohm 1/16W		
R931L	963 9004 122	Carbon chip 12 kohm 1/16W		R999	963 9004 070	Carbon chip 10 kohm 1/16W		
R931R	963 9004 122	Carbon chip 12 kohm 1/16W						
R932	963 9004 342	Carbon chip 4.7 kohm 1/16W		R1000	963 9004 326	Carbon chip 47 ohm 1/16W		
R932L	963 9004 164	Carbon chip 150 kohm 1/16W		R1001	963 9004 070	Carbon chip 10 kohm 1/16W		
R932R	963 9004 164	Carbon chip 150 kohm 1/16W		R1002	963 9004 326	Carbon chip 47 ohm 1/16W		
R938	963 9004 368	Carbon chip 470 kohm 1/16W		R1003	963 9004 326	Carbon chip 47 ohm 1/16W		
R952	963 9003 385	Carbon chip 100 ohm 1/16W		R1004	963 9004 326	Carbon chip 47 ohm 1/16W		
R953	963 9004 203	Carbon chip 220 ohm 1/16W		R1005	963 9003 372	Carbon chip 0 ohm 1/16W		
R954	963 9004 096	Carbon chip 1 Mohm 1/16W		R1006	963 9004 326	Carbon chip 47 ohm 1/16W		
R955	963 9004 070	Carbon chip 10 kohm 1/16W		R1007	963 9004 326	Carbon chip 47 ohm 1/16W		
R956	963 9004 070	Carbon chip 10 kohm 1/16W		R1012	963 9004 326	Carbon chip 47 ohm 1/16W		
R957	963 9004 070	Carbon chip 10 kohm 1/16W		R1021	963 9004 326	Carbon chip 47 ohm 1/16W		
R958	963 9004 070	Carbon chip 10 kohm 1/16W		R1022	963 9004 326	Carbon chip 47 ohm 1/16W		
R959	963 9004 070	Carbon chip 10 kohm 1/16W		R1023	963 9004 326	Carbon chip 47 ohm 1/16W		
R960	963 9004 070	Carbon chip 10 kohm 1/16W		R1024	963 9004 326	Carbon chip 47 ohm 1/16W		
R961	963 9004 070	Carbon chip 10 kohm 1/16W		R1025	963 9004 326	Carbon chip 47 ohm 1/16W		
R962	963 9004 070	Carbon chip 10 kohm 1/16W		R1027	963 9004 326	Carbon chip 47 ohm 1/16W		
R963	963 9004 070	Carbon chip 10 kohm 1/16W		R1029	963 9004 326	Carbon chip 47 ohm 1/16W		
R964	963 9004 070	Carbon chip 10 kohm 1/16W		R1030	963 9004 326	Carbon chip 47 ohm 1/16W		
R965	963 9004 070	Carbon chip 10 kohm 1/16W		R1031	963 9004 326	Carbon chip 47 ohm 1/16W		
R966	963 9004 070	Carbon chip 10 kohm 1/16W		R1032	963 9004 326	Carbon chip 47 ohm 1/16W		
R967	963 9004 070	Carbon chip 10 kohm 1/16W		R1033	963 9003 372	Carbon chip 0 ohm 1/16W		
R968	963 9004 070	Carbon chip 10 kohm 1/16W		R1034	963 9003 372	Carbon chip 0 ohm 1/16W		
R969	963 9004 070	Carbon chip 10 kohm 1/16W		R1035	963 9003 372	Carbon chip 0 ohm 1/16W		
R970	963 9004 070	Carbon chip 10 kohm 1/16W		R1036	963 9003 372	Carbon chip 0 ohm 1/16W		
R971	963 9004 070	Carbon chip 10 kohm 1/16W		R1037	963 9004 070	Carbon chip 10 kohm 1/16W		
R972	963 9004 070	Carbon chip 10 kohm 1/16W		R1038	963 9004 070	Carbon chip 10 kohm 1/16W		
R973	963 9004 070	Carbon chip 10 kohm 1/16W		R1039	963 9004 070	Carbon chip 10 kohm 1/16W		
R974	963 9004 070	Carbon chip 10 kohm 1/16W		R1040	963 9004 070	Carbon chip 10 kohm 1/16W		
R975	963 9004 070	Carbon chip 10 kohm 1/16W		R1041	963 9004 070	Carbon chip 10 kohm 1/16W		
R976	963 9004 070	Carbon chip 10 kohm 1/16W		R1043	963 9004 326	Carbon chip 47 ohm 1/16W		
R977	963 9004 070	Carbon chip 10 kohm 1/16W		R1044	963 9004 326	Carbon chip 47 ohm 1/16W		
R978	963 9005 697	Carbon chip 2 kohm 1/16W		R1045	963 9004 339	Carbon chip 470 ohm 1/16W		
R979	963 9003 385	Carbon chip 100 ohm 1/16W						
R981	963 9004 326	Carbon chip 47 ohm 1/16W		<b>CAPACITORS GROUP</b>				
R982	963 9004 326	Carbon chip 47 ohm 1/16W		C801	963 9004 708	Ceramic chip 0.1uF/50V		
R983	963 9004 326	Carbon chip 47 ohm 1/16W		C802	963 9004 591	Ceramic chip 22pF/50V		
R984	963 9004 326	Carbon chip 47 ohm 1/16W		C803	963 9004 591	Ceramic chip 22pF/50V		
R985	963 9004 326	Carbon chip 47 ohm 1/16W		C805	963 9004 591	Ceramic chip 22pF/50V		
R986	963 9004 326	Carbon chip 47 ohm 1/16W		C810	963 9004 708	Ceramic chip 0.1uF/50V		
R987	963 9004 326	Carbon chip 47 ohm 1/16W		C811	963 9005 309	Electrolytic 47uF/10V		
R988	963 9004 326	Carbon chip 47 ohm 1/16W		C812	963 9004 708	Ceramic chip 0.1uF/50V		
R989	963 9004 326	Carbon chip 47 ohm 1/16W		C813	963 9005 309	Electrolytic 47uF/10V		
R990	963 9004 326	Carbon chip 47 ohm 1/16W		C814	963 9004 591	Ceramic chip 22pF/50V		
R991	963 9004 326	Carbon chip 47 ohm 1/16W		C817	963 9005 927	Electrolytic 0.1uF/50V		
R992	963 9004 326	Carbon chip 47 ohm 1/16W		C818	963 9004 698	Ceramic chip 0.01uF/50V		
R993	963 9004 326	Carbon chip 47 ohm 1/16W		C820	963 9005 309	Electrolytic 47uF/10V		
R994	963 9004 326	Carbon chip 47 ohm 1/16W		C821	963 9005 312	Electrolytic 100uF/10V		
R995	963 9004 326	Carbon chip 47 ohm 1/16W		C822	963 9004 708	Ceramic chip 0.1uF/50V		

Ref. No.	Part No.	Part Name	Remarks	Ref. No.	Part No.	Part Name	Remarks
C823	963 9005 752	Electrolytic 10uF/35V		C873SW	963 9004 672	Ceramic chip 680pF/50V	
C825	963 9005 749	Electrolytic 1uF/50V		C874	963 9004 698	Ceramic chip 0.01uF/50V	
C826	963 9005 752	Electrolytic 10uF/35V		C874C	963 9004 672	Ceramic chip 680pF/50V	
C835	963 9005 901	Electrolytic 470uF/10V		C874FL	963 9004 672	Ceramic chip 680pF/50V	
C838	963 9004 708	Ceramic chip 0.1uF/50V		C874FR	963 9004 672	Ceramic chip 680pF/50V	
C839	963 9004 708	Ceramic chip 0.1uF/50V		C874SL	963 9004 672	Ceramic chip 680pF/50V	
C840	963 9004 698	Ceramic chip 0.01uF/50V		C874SR	963 9004 672	Ceramic chip 680pF/50V	
C841	963 9005 846	Electrolytic 2.2uF/50V		C874SW	963 9004 672	Ceramic chip 680pF/50V	
C842	963 9004 708	Ceramic chip 0.1uF/50V		C875	963 9004 698	Ceramic chip 0.01uF/50V	
C843	963 9004 708	Ceramic chip 0.1uF/50V		C875C	963 9005 752	Electrolytic 10uF/35V	
C844	963 9004 708	Ceramic chip 0.1uF/50V		C875FL	963 9005 752	Electrolytic 10uF/35V	
C845	963 9004 708	Ceramic chip 0.1uF/50V		C875FR	963 9005 752	Electrolytic 10uF/35V	
C846	963 9004 708	Ceramic chip 0.1uF/50V		C875SL	963 9005 752	Electrolytic 10uF/35V	
C847	963 9004 708	Ceramic chip 0.1uF/50V		C875SR	963 9005 752	Electrolytic 10uF/35V	
C848	963 9004 708	Ceramic chip 0.1uF/50V		C875SW	963 9005 752	Electrolytic 10uF/35V	
C849	963 9004 708	Ceramic chip 0.1uF/50V		C876C	963 9008 611	Mylar film 0.0033uF/100V	
C850	963 9004 708	Ceramic chip 0.1uF/50V		C876FL	963 9008 611	Mylar film 0.0033uF/100V	
C851	963 9004 708	Ceramic chip 0.1uF/50V		C876FR	963 9008 611	Mylar film 0.0033uF/100V	
C852	963 9004 708	Ceramic chip 0.1uF/50V		C876SL	963 9008 611	Mylar film 0.0033uF/100V	
C853	963 9004 708	Ceramic chip 0.1uF/50V		C876SR	963 9008 611	Mylar film 0.0033uF/100V	
C854	963 9005 804	Electrolytic 100uF/25V		C876SW	963 9008 611	Mylar film 0.0033uF/100V	
C855	963 9005 804	Electrolytic 100uF/25V		C880C	963 9005 752	Electrolytic 10uF/35V	
C856	963 9004 708	Ceramic chip 0.1uF/50V		C880FL	963 9005 752	Electrolytic 10uF/35V	
C857	963 9004 708	Ceramic chip 0.1uF/50V		C880FR	963 9005 752	Electrolytic 10uF/35V	
C858	963 9004 708	Ceramic chip 0.1uF/50V		C880SL	963 9005 752	Electrolytic 10uF/35V	
C859	963 9004 708	Ceramic chip 0.1uF/50V		C880SR	963 9005 752	Electrolytic 10uF/35V	
C860	963 9004 708	Ceramic chip 0.1uF/50V		C880SW	963 9005 752	Electrolytic 10uF/35V	
C861	963 9004 708	Ceramic chip 0.1uF/50V					
C862	963 9004 708	Ceramic chip 0.1uF/50V		C916	963 9004 708	Ceramic chip 0.1uF/50V	
C863	963 9004 708	Ceramic chip 0.1uF/50V		C917	963 9005 752	Electrolytic 10uF/35V	
C864	963 9004 708	Ceramic chip 0.1uF/50V		C925	963 9004 708	Ceramic chip 0.1uF/50V	
C864L	963 9005 862	Electrolytic 47uF/16V		C926	963 9005 752	Electrolytic 10uF/35V	
C864R	963 9005 862	Electrolytic 47uF/16V		C931	963 9004 698	Ceramic chip 0.01uF/50V	
C865	963 9004 737	Ceramic chip 0.022uF/25V		C937	963 9005 752	Electrolytic 10uF/35V	
C865L	963 9005 723	Ceramic chip 120pF/50V		C938	963 9005 749	Electrolytic 1uF/50V	
C865R	963 9005 723	Ceramic chip 120pF/50V		C939	963 9004 698	Ceramic chip 0.01uF/50V	
C866	963 9004 708	Ceramic chip 0.1uF/50V		C943	963 9005 927	Electrolytic 0.1uF/50V	
C868	963 9005 998	Ceramic chip 24pF/50V		C944	963 9004 698	Ceramic chip 0.01uF/50V	
C869	963 9005 998	Ceramic chip 24pF/50V		C946	963 9004 708	Ceramic chip 0.1uF/50V	
C869L	963 9004 575	Ceramic chip 100pF/50V		C947	963 9004 708	Ceramic chip 0.1uF/50V	
C869R	963 9004 575	Ceramic chip 100pF/50V		C948	963 9005 752	Electrolytic 10uF/35V	
C870	963 9004 698	Ceramic chip 0.01uF/50V		C949	963 9005 752	Electrolytic 10uF/35V	
C871	963 9004 708	Ceramic chip 0.1uF/50V		C950	963 9004 708	Ceramic chip 0.1uF/50V	
C871L	963 9009 500	Mylar film 0.001uF/100V		C951	963 9005 901	Electrolytic 470uF/10V	
C871R	963 9009 500	Mylar film 0.001uF/100V		C952	963 9004 708	Ceramic chip 0.1uF/50V	
C872	963 9004 708	Ceramic chip 0.1uF/50V		C953	963 9005 752	Electrolytic 10uF/35V	
C873	963 9004 698	Ceramic chip 0.01uF/50V		C955	963 9004 708	Ceramic chip 0.1uF/50V	
C873C	963 9004 672	Ceramic chip 680pF/50V		C957	963 9004 708	Ceramic chip 0.1uF/50V	
C873FL	963 9004 672	Ceramic chip 680pF/50V		C958	963 9005 312	Electrolytic 100uF/10V	
C873FR	963 9004 672	Ceramic chip 680pF/50V		C959	963 9005 752	Electrolytic 10uF/35V	
C873SL	963 9004 672	Ceramic chip 680pF/50V		C960	963 9004 708	Ceramic chip 0.1uF/50V	
C873SR	963 9004 672	Ceramic chip 680pF/50V		C961	963 9005 752	Electrolytic 10uF/35V	

**VOLTAGE SEL. P.W.B. ASS'Y**  
**(for Asia, Hong Kong & Taiwan R.O.C. model only)**

Ref. No.	Part No.	Part Name	Remarks	Q'ty
C962	963 9004 708	Ceramic chip 0.1uF/50V		
C965	963 9004 708	Ceramic chip 0.1uF/50V		
C966	963 9005 901	Electrolytic 470uF/10V		
C967	963 9004 708	Ceramic chip 0.1uF/50V		
<b>OTHER PARTS GROUP</b>				<b>Q'ty</b>
CB803	963 0050 502	Chip emifil		1
CB805-810	963 0050 502	Chip emifil		6
CN801	963 0086 107	16P connector socket		1
CN802	963 0086 204	19P connector socket		1
CN803	963 0097 206	8P connector socket		1
JACK801	963 0052 500	Coaxial		1
L802	963 0050 803	Inductor 4.7uh		1
L805,806	963 0050 803	Inductor 4.7uh		2
L807	963 0050 900	Inductor 2.2uh		1
XTAL1	963 0095 101	Crystal 12.288MHz		1
<b>OTHER PARTS GROUP (E1,G1H,G1T model only)</b>				
CP901	963 0061 203	5P connector base	for E1,E1H,E1T	1
CP902	963 0059 309	3P wire	for E1,E1H,E1T	1
CN105	963 0059 105	2P wire	for E1,E1H,E1T	1
CN903	963 0058 805	2P wire	for E1,E1H,E1T	1
△ F101	960 0142 602	Fuse 250V-T2.5A	for E1,E1H,E1T	1
F101A	960 0005 804	Fuse clip	for E1,E1H,E1T	1
F101B	960 0005 804	Fuse clip	for E1,E1H,E1T	1
△ F102	963 0057 107	Fuse 250V-T6.3A	for E1,E1H,E1T	1
F102A	960 0005 804	Fuse clip	for E1,E1H,E1T	1
F102B	960 0005 804	Fuse clip	for E1,E1H,E1T	1
△ F901	963 0044 709	Fuse 250V-T3.15A	for E1,E1H,E1T	1
F901A	960 0005 804	Fuse clip	for E1,E1H,E1T	1
F901B	960 0005 804	Fuse clip	for E1,E1H,E1T	1
△ JK911	960 0143 203	AC outlet	for E1,E1H,E1T	1
JK912	963 0056 904	Slide SW	for E1,E1H,E1T	1
	963 0051 103	Card spacer	for E1,E1H,E1T	1
	963 0044 602	P.C. supporter	for E1,E1H,E1T	2



# EXPLODED VIEW

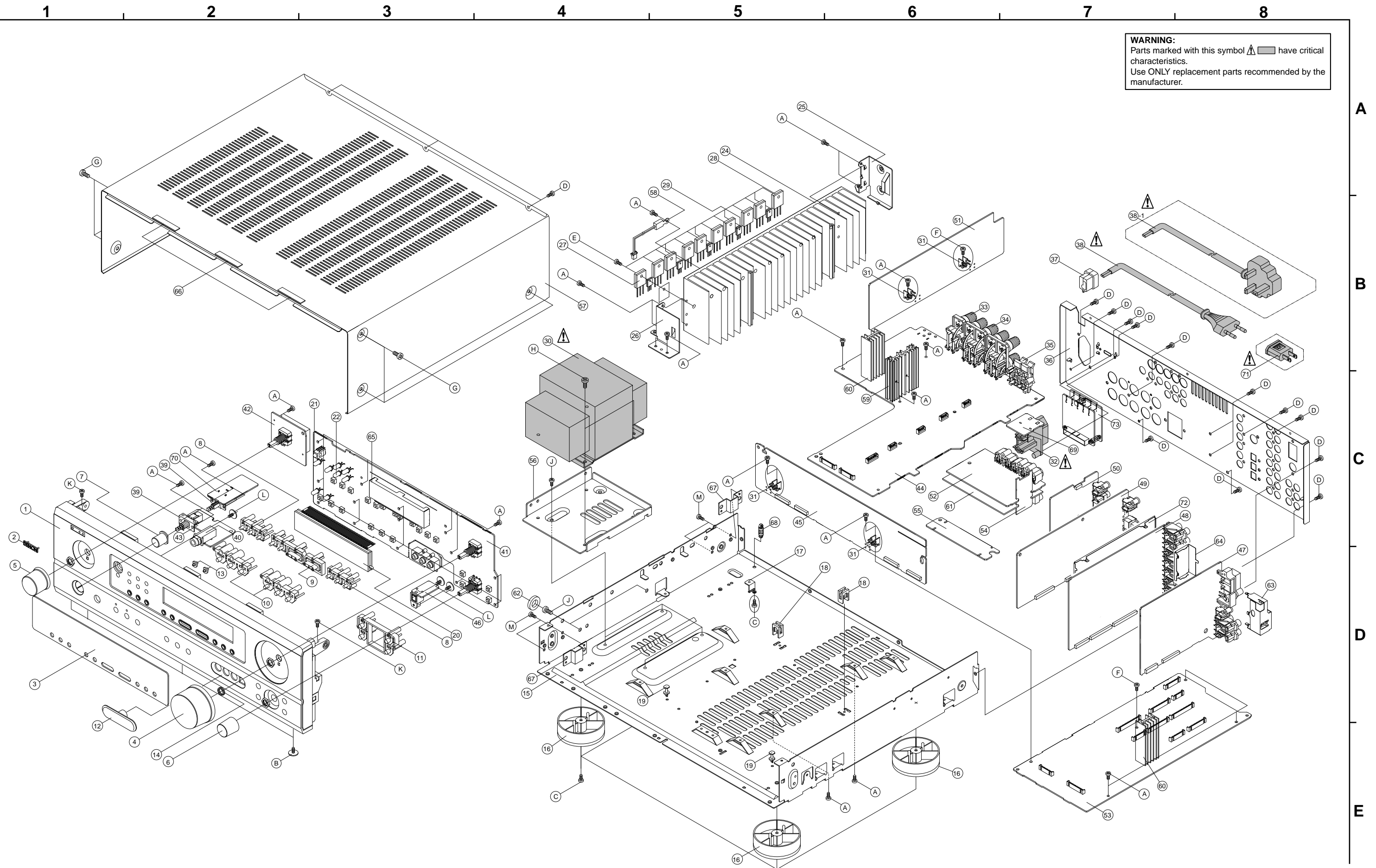

A  
B  
C  
D  
E

Note : The symbols in the column "Remarks" indicate the following destinations.

E3 : U.S.A. & Canada model      E1 : Asia model  
 EU : U.S.A. model (AVR-683)    E1C : China model  
 E2 : Europe model                E1H : Hong Kong model  
 EK : U.K. model                    E1T : Taiwan R.O.C. model  
 EA : Australia model              E1K : Korea model

### PARTS LIST OF EXPLODED VIEW

Ref. No.	Part No.	Part Name	Remarks	Q'ty	Ref. No.	Part No.	Part Name	Remarks	Q'ty		
	963 0092 010	Main P.W.B. Total Ass'y	for E3,EU	1		963 0093 022	Front Panel	for EU	1		
	963 0092 023		for E2,EK,EA			963 0093 035	Front Panel	for E2,EK,EA	1		
	963 0092 036		for E1,E1T,E1H			963 0093 048	Front Panel	for E1,E1C,E1T, E1H,E1K	1		
	963 0092 049		for E1C			2	963 0051 501	DENON Badge	for black model	1	
	963 0092 052		for E1K				963 0051 514	DENON Badge	for gold model	1	
44		Main P.W.B. Sub Ass'y		3	963 0093 116	Window	for E3,EU,E1,E1C,E1T,E1H,E1K	1			
50		Video P.W.B. Sub Ass'y			963 0093 129	Window	for E2,EK,EA	1			
55		Video CNT P.W.B. Sub Ass'y		4	963 0093 213	Volume Knob	for black model	1			
69		Outlet P.W.B. Sub Ass'y	for E2,E1,E1T,E1H,E1K		963 0093 200	Volume Knob	for gold model	1			
	963 0092 117	CPU P.W.B. Total Ass'y	for E3,EU	1	5	963 0093 310	Function Knob	for black model	1		
	963 0092 120		for E2,EK,EA			963 0093 307	Function Knob	for gold model	1		
	963 0092 133		for E1,E1T,E1H			6	963 0093 417	Select Knob	for black model	1	
	963 0092 146		for E1C			963 0093 420	Select Knob	for gold model	1		
	963 0092 159		for E1K			7	963 0093 514	Power Push Button	for black model	1	
41		Front P.W.B. Sub Ass'y			963 0093 501	Power Push Button	for gold model	1			
46		Optical-In P.W.B. Sub Ass'y		8	963 0094 801	3key(A) Button		2			
53		CPU P.W.B. Sub Ass'y		9	963 0098 205	6key Button		1			
70		Power-Sw P.W.B. Sub Ass'y	for E2,EK,EA,E1 E1C,E1T,E1H,E1K		10	963 0094 610	3key(B) Button	for black model	2		
	963 0094 403	Voltage Sel P.W.B. Total Ass'y	for E1,E1T,E1H	1		963 0094 607	3key(B) Button	for gold model	2		
	73	Voltage Sel P.W.B. Sub Ass'y				11	963 0094 717	4key Button	for black model	1	
	963 0092 214	CNT P.W.B. Total Ass'y	for E3,EU	1		963 0094 704	4key Button	for gold model	1		
	963 0092 227		for E2,EK,EA			12	963 0098 302	RCA Cover	for E2,EK,EA,E3,EU	1	
	963 0092 230		for E1,E1T,E1H			13	960 0191 417	Lens LED		2	
	963 0092 243		for E1C			14	963 0092 900	Knob Spring		1	
	963 0092 256		for E1K			15	963 0098 108	Main Chassis		1	
42		Encoder P.W.B. Sub Ass'y			16	960 0183 904	Foot Ass'y		4		
43		Head Phone P.W.B. Sub Ass'y			17	960 0184 107	Bracket Supporter		1		
45		CNT P.W.B. Sub Ass'y			18	960 0003 301	Supporter P.W.B.		2		
47		Tuner P.W.B. Sub Ass'y			19	963 0051 103	Card Spacer		2		
51		Pre-Amp P.W.B. Sub Ass'y			20	960 0180 509	Display FLT 16-ST-42GNK		1		
52		S-Video P.W.B. Sub Ass'y			21	960 0181 100	Remocon Module		1		
54		S-Video CNT P.W.B. Sub Ass'y			22	960 0197 204	LED HL50RDRF4T		8		
61		C-Video P.W.B. Sub Ass'y	for E3,EU		24	—	Main Heat Sink	for E3,EU	1		
	963 0092 311	Input-Vol P.W.B. Total Ass'y	for E3,EU	1		—	Main Heat Sink	for E2,EK,EA,E1, E1C,E1T,E1H,E1K	1		
	963 0092 324		for E2,EK,EA			25	960 0184 204	Heat Sink-B Bracket		1	
	963 0092 337		for E1,E1T,E1H			26	960 0184 301	Heat Sink-F Bracket		1	
	963 0092 340		for E1C			27	963 0044 107	Transistor 2SB1560-Y	for E3,EU	5	
	963 0092 353		for E1K				960 0090 107	Transistor 2SB1559Y	for E2,EK,EA,E1, E1C,E1T,E1H,E1K	5	
48		Input-Vol P.W.B. Sub Ass'y			28	963 0044 204	Transistor 2SD2390-Y	for E3,EU	5		
	963 0092 418	DSP P.W.B. Total Ass'y	for E3,EU	1		960 0090 000	Transistor 2SD2389Y	for E2,EK,EA,E1, E1C,E1T,E1H,E1K	5		
	963 0092 421		for E2,EK,EA			29	963 0058 106	Transistor 2SD947F		5	
	963 0092 434		for E1,E1T,E1H			△	30	963 0098 506	Power Trans	for E3,EU	1
	963 0092 447		for E1C				963 0098 409	Power Trans	for E2,EK,EA	1	
	963 0092 450		for E1K				963 0098 412	Power Trans	for E1,E1T,E1H	1	
49		DSP P.W.B. Sub Ass'y			963 0098 425	Power Trans	for E1K,E1C	1			
	963 0093 019	Front Panel	for E3	1	31	960 0184 000	Bracket Screw		2		
					△	32	960 0181 508	AC Outlet(2P)	for E3,EU	1	
							960 0143 203	AC Outlet	for E2,EK,EA,E1,E1T,E1H	1	
					960 0144 202	AC Outlet	for E1K	1			
					33	960 0194 809	2P Pin Jack		1		

Ref. No.	Part No.	Part Name	Remarks	Q'ty	Ref. No.	Part No.	Part Name	Remarks	Q'ty	
34	963 0074 009	8P Pin Jack		1	<b>SCREWS</b>					
35	960 0158 308	Push SW Block		1	A	963 0018 007	Screw, Tap Tite 3x8 B-Type Zny/Bh	for E3,EU,E2,EK,EA	44	
36	963 0092 719	Back Chassis	for E3	1		963 0018 007	Screw, Tap Tite 3x8 B-Type Zny/Bh	for E1,E1C,E1T,E1H,E1K	41	
	963 0092 722	Back Chassis	for EU	1	B	960 9008 527	Screw 3x8 Bk Washer Pi12	for E3,EU,E2,EK,EA	4	
	963 0092 735	Back Chassis	for E2,EK,EA	1		960 9008 420	Screw 3x8 Zny Washer Pi12	for E1,E1C,E1T,E1H,E1K	7	
	963 0092 748	Back Chassis	for E1,E1T,E1H	1	C	963 0048 200	Screw, Tap Tite 3x10 B-Type Zny/Bh		5	
	963 0092 751	Back Chassis	for E1K	1	D	960 0108 714	Screw, Tap Tite 3x10 B-Type(Dot) Bk/Bh	for E3,EU,E2,EK,EA	40	
	963 0092 764	Back Chassis	for E1C	1		960 0108 714	Screw, Tap Tite 3x10 B-Type(Dot) Bk/Bh	for E1,E1C,E1T,E1H,E1K	42	
37	960 0192 403	AC Cord Stopper		1	E	963 9004 009	Screw, Tapping Ass'y		15	
△	38	963 0098 603	Cord Ass'y	for E3,EU	1	F	963 0018 104	Screw, Tap Tite 3x17 B-Type Zny/Bh		4
		960 0202 500	Cord Ass'y	for E2	1	G	963 0048 307	Screw 4x8 B-Type(Dot) Bk/Bh	for black model	6
		963 0099 602	Cord Ass'y	for EA			963 9004 012	Screw 4x8 B-Type(Dot) Ni/Bh	for gold model	6
		963 0060 408	Cord Ass'y	for E1,E1T	1	H	960 9008 417	Screw, Tap Tite 4x8 P+S-Washer Zny/Bh		4
		960 0143 009	Cord Ass'y	for EK,E1H	1	J	963 9004 025	Screw, Tap Tite 4x6 S-Type Zny/Bh		6
		963 0098 700	Cord Ass'y	for E1K	1	K	963 9004 038	Screw 3x8 B-Type Zny		2
		963 0060 301	Cord Ass'y	for E1C	1	L	960 9008 420	Screw 3x8 Zny Washer Pi12	for E3,EU,E2,EK,EA	3
39	960 0176 209	Push SW	for E3,EU	1		960 9008 420	Screw 3x8 Zny Washer Pi12	for E1,E1C,E1T,E1H,E1K	7	
		963 0098 807	Push SW	for E2,EK,EA,E1, E1C,E1T,E1H,E1K	1	M	963 9004 041	Screw 3x5 Zny/Bh	for E2,EK,EA,E1, E1T,E1K,E1H,E1C	4
40	963 0095 402	Head Phone Jack		1						
56	963 0098 904	Trans Bracket		1						
57	963 0053 017	Top Cabinet	for black model	1						
		963 0092 502	Top Cabinet	for gold model	1					
58	960 0187 900	Posistor		1						
59	—	Heat Sink Reg TR		1						
60	—	Heat Sink Reg TR		1						
62	963 0072 302	Rubber Cushion		2						
63	963 0054 003	Shield Tuner Pack		1						
64	963 0099 000	Earth "D"Plate		1						
65	960 0184 408	Flt Holder		1						
66	963 0089 104	Rubber Sheet (Cabinet)		3						
67	963 0081 607	Side Bracket	for E2,EK,EA,E1, E1C,E1T,E1H,E1K	2						
68	963 0044 602	Supporter P.C.		1						
71	963 0041 300	AC Adapter	for E1T	1						
72	963 0094 102	Plate Input		1						
★	960 0155 301	Clamp		4						
★	960 0093 104	Bushing Terminal		10						
★	963 0098 001	Cable Flat Card	for E3,EU,E2,EK,E1,E1C,E1K	1						
★	963 0054 207	Fuse Caution Label	for E3,EU	1						
★	963 0060 000	Fuse Caution Label	for E2,EK,EA,E1K	1						
★	963 0090 504	Fuse Caution Label	for E1C	1						

# PACKING VIEW

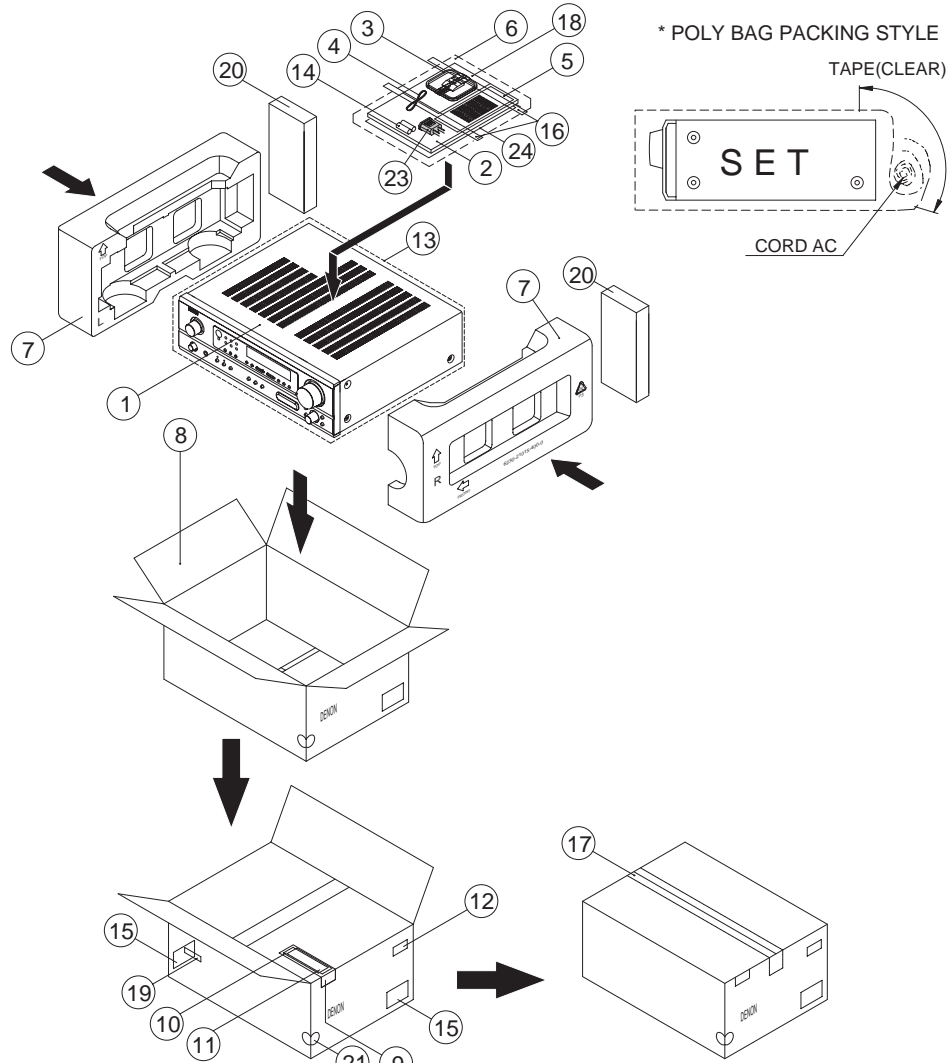

**Note :** The symbols in the column "Remarks" indicate the following destinations.  
 E3 : U.S.A. & Canada model      E1 : Asia model  
 EU : U.S.A. model (AVR-683)      E1C : China model  
 E2 : Europe model                  E1H : Hong Kong model  
 EK : U.K. model                      E1T : Taiwan R.O.C. model  
 EA : Australia model                E1K : Korea model

## PARTS LIST OF PACKING & ACCESSORIES

Ref. No.	Part No.	Part Name	Remarks	Q'ty	Ref. No.	Part No.	Part Name	Remarks	Q'ty
2	963 0091 011	Instruction manual	for E3,EU	1		—	UPC label	for EU	1
	963 0091 024	Instruction manual	for E2,EK,EA	1		—	Label E2 pos	for E2	1
	963 0091 037	Instruction manual	for E1,E1H,E1T	1		—	Label Ek pos	for EK	2
	963 0091 040	Instruction manual	for E1C	1	13	960 0185 601	Set poly bag		1
	963 0091 053	Instruction manual	for E1K	1	14	—	Battery		2
3	963 0052 306	AM antenna wire		1	15	930 0092 901	Control label		2
4	963 0052 209	FM antenna wire		1	16	—	Tape		1
5	963 0091 105	Remocon RC920		1	17	—	Tape packing		1
6	963 0045 106	Poly bag		1	18	—	Card S. S. List		1
7	960 0193 101	Cushion snow L/R		1	19	—	Label (RDS/Radio text)	for E2,EK,EA	1
8	963 0091 215	Carton case	for E3,E2	1	20	963 0055 918	Pad snow	for EK,EA,E1H	2
	963 0091 228	Carton case	for EU	1	21	—	Label color	for gold model	2
	963 0091 231	Carton case	for EK,EA	1	▲ 23	963 0061 300	AC adapter	for E1T	1
	963 0091 244	Carton case	for E1,E1C,E1T,E1K	1	★	—	Label kolin (rating)	for E1T	1
	963 0091 257	Carton case	for E1H	1	★	—	Label kolin (box)	for E1T	1
9	—	Card envelope(warranty)	for E3,EU	1	★	—	Box label	for E1C	1
10	—	Warranty card	for E3,EU	1	★	—	Card warranty	for E1K	1
11	960 0185 300	Registration card	for E3,EU	1	★	963 0025 809	Preset label	for E1,E1T,E1H	1
12	—	UPC label	for E3	1	★	—	Serial No. Label		1

# WIRING DIAGRAM

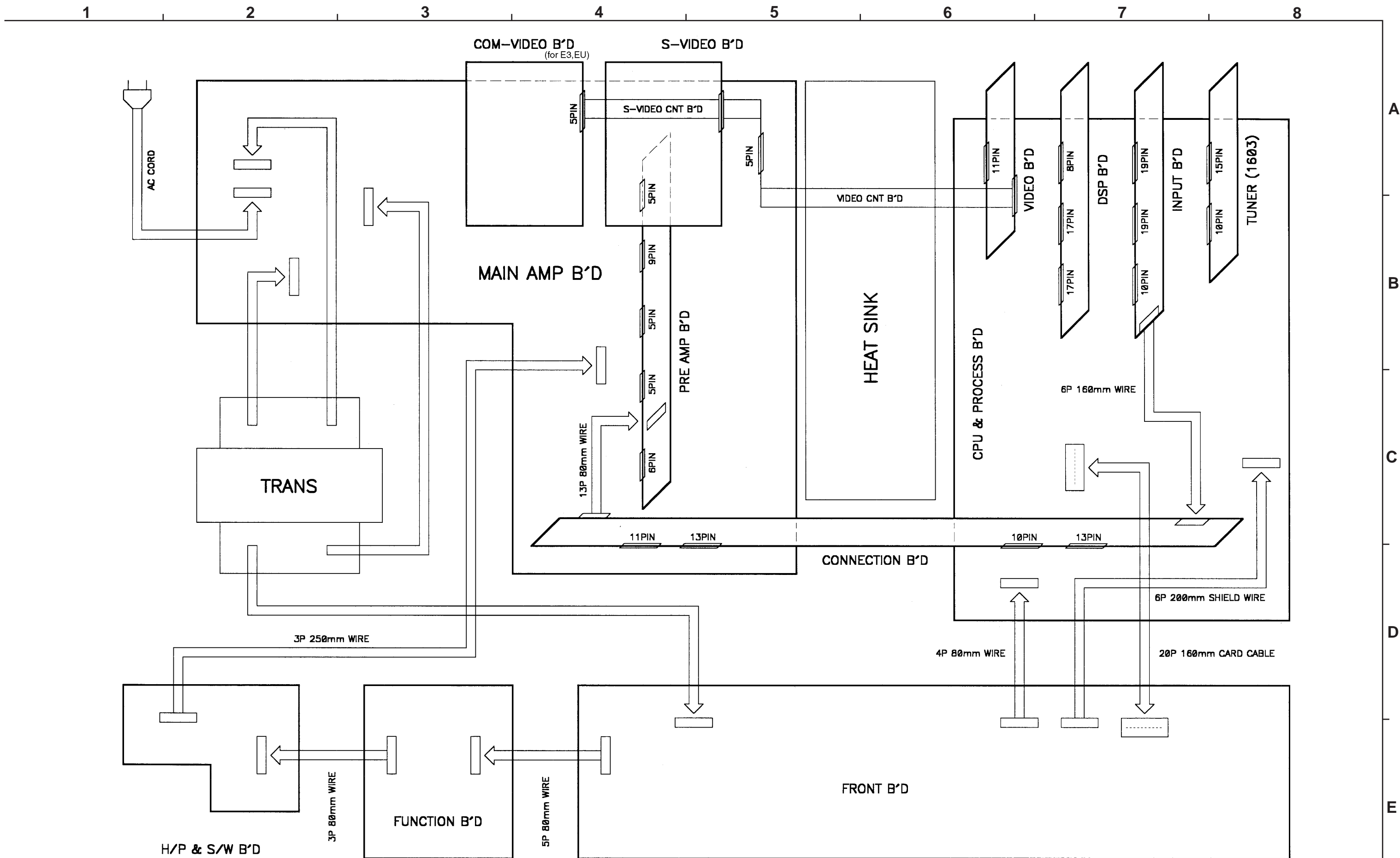

**SCHEMATIC DIAGRAMS (1/8)**

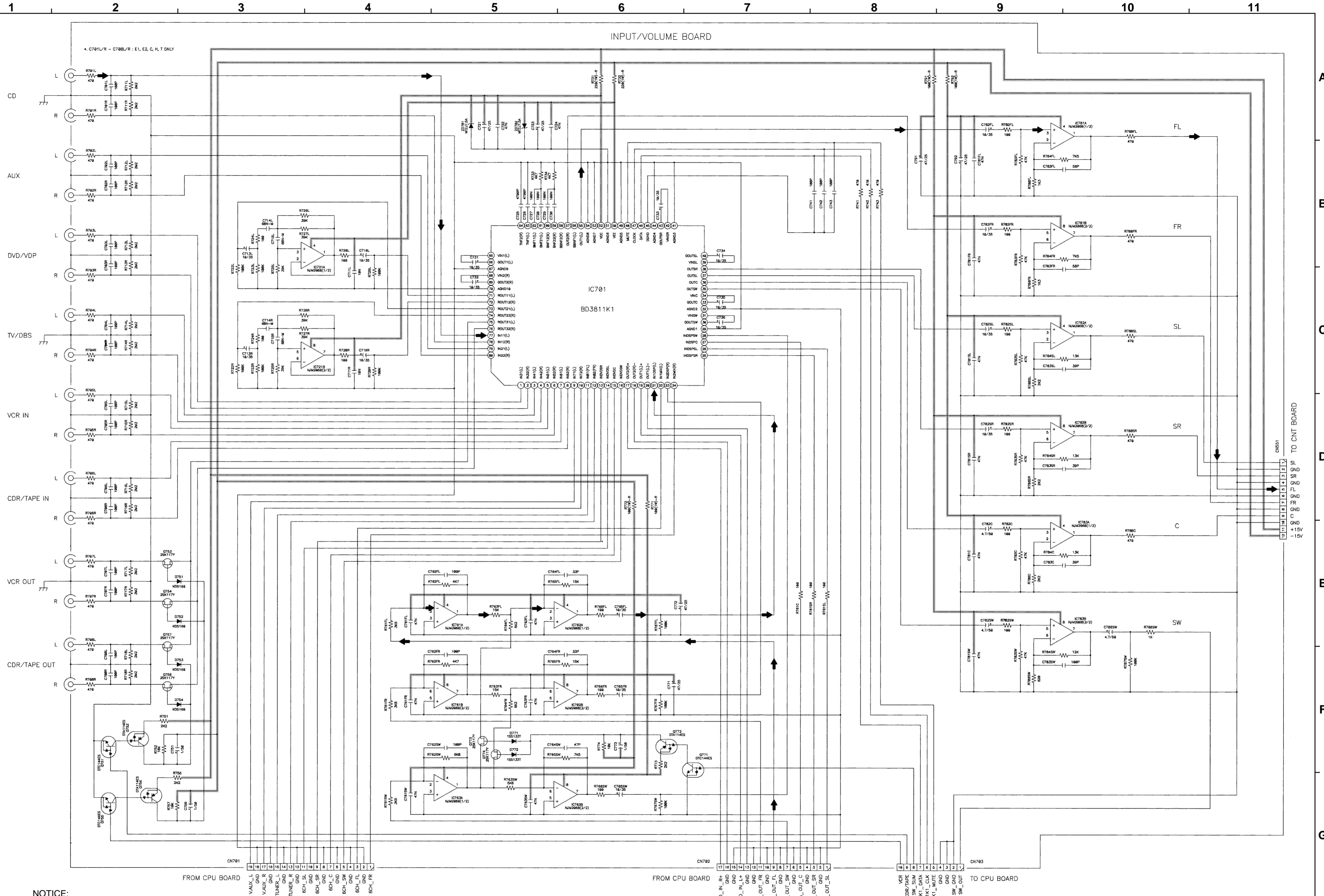

**NOTICE:**  
 ALL RESISTANCE VALUES IN OHM. K=1,000 OHM M=1,000,000 OHM  
 ALL CAPACITANCE VALUES IN MICRO FARAD. P=MICRO-MICRO FARAD  
 EACH VOLTAGE AND CURRENT ARE MEASURED AT NO SIGNAL INPUT  
 CONDITION.  
 CIRCUIT AND PARTS ARE SUBJECT TO CHANGE WITHOUT PRIOR  
 NOTICE.  
**WARNING:**  
 Parts marked with this symbol  $\Delta$  have critical characteristics.  
 Use ONLY replacement parts recommended by the manufacturer.

**CAUTION:**  
 Before returning the unit to the customer, make sure you make either (1) a  
 leakage current check or (2) a line to chassis resistance check. If the leakage  
 current exceeds 0.5 millamps, or if the resistance from chassis to either side  
 of the power card is less than 460kohms, the unit is defective.

**WARNING:**  
 DO NOT return the unit to the customer until the problem is located and  
 corrected.

± B LINE  
 SIGNAL LINE

**SCHEMATIC DIAGRAMS (1/8)**  
INPUT-VOL UNIT

**SCHEMATIC DIAGRAMS (1/8)**

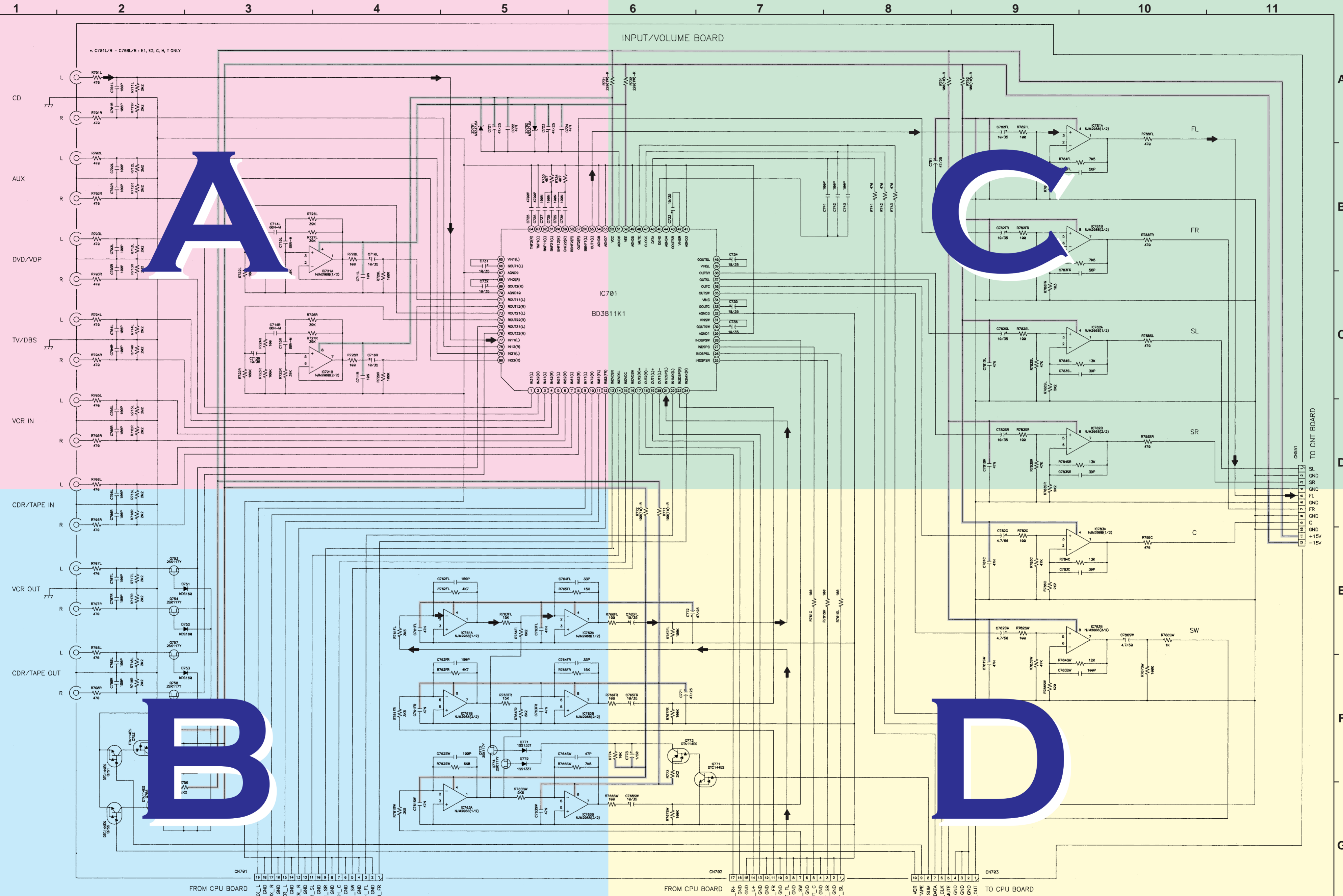

**NOTICE:**  
 ALL RESISTANCE VALUES IN OHM. K=1,000 OHM M=1,000,000 OHM  
 ALL CAPACITANCE VALUES IN MICRO FARAD. P=MICRO-MICRO FARAD  
 EACH VOLTAGE AND CURRENT ARE MEASURED AT NO SIGNAL INPUT CONDITION.  
 CIRCUIT AND PARTS ARE SUBJECT TO CHANGE WITHOUT PRIOR NOTICE.  
**WARNING:**  
 Parts marked with this symbol have critical characteristics. Use ONLY replacement parts recommended by the manufacturer.

**CAUTION:**  
 Before returning the unit to the customer, make sure you make either (1) a leakage current check or (2) a line to chassis resistance check. If the leakage current exceeds 0.5 millamps, or if the resistance from chassis to either side of the power card is less than 460kohms, the unit is defective.

**WARNING:**  
 DO NOT return the unit to the customer until the problem is located and corrected.

— ± B LINE  
 → SIGNAL LINE

**SCHEMATIC DIAGRAMS (1/8)**  
INPUT-VOL UNIT

# SCHEMATIC DIAGRAMS (1/8)

1

2

3

4

5

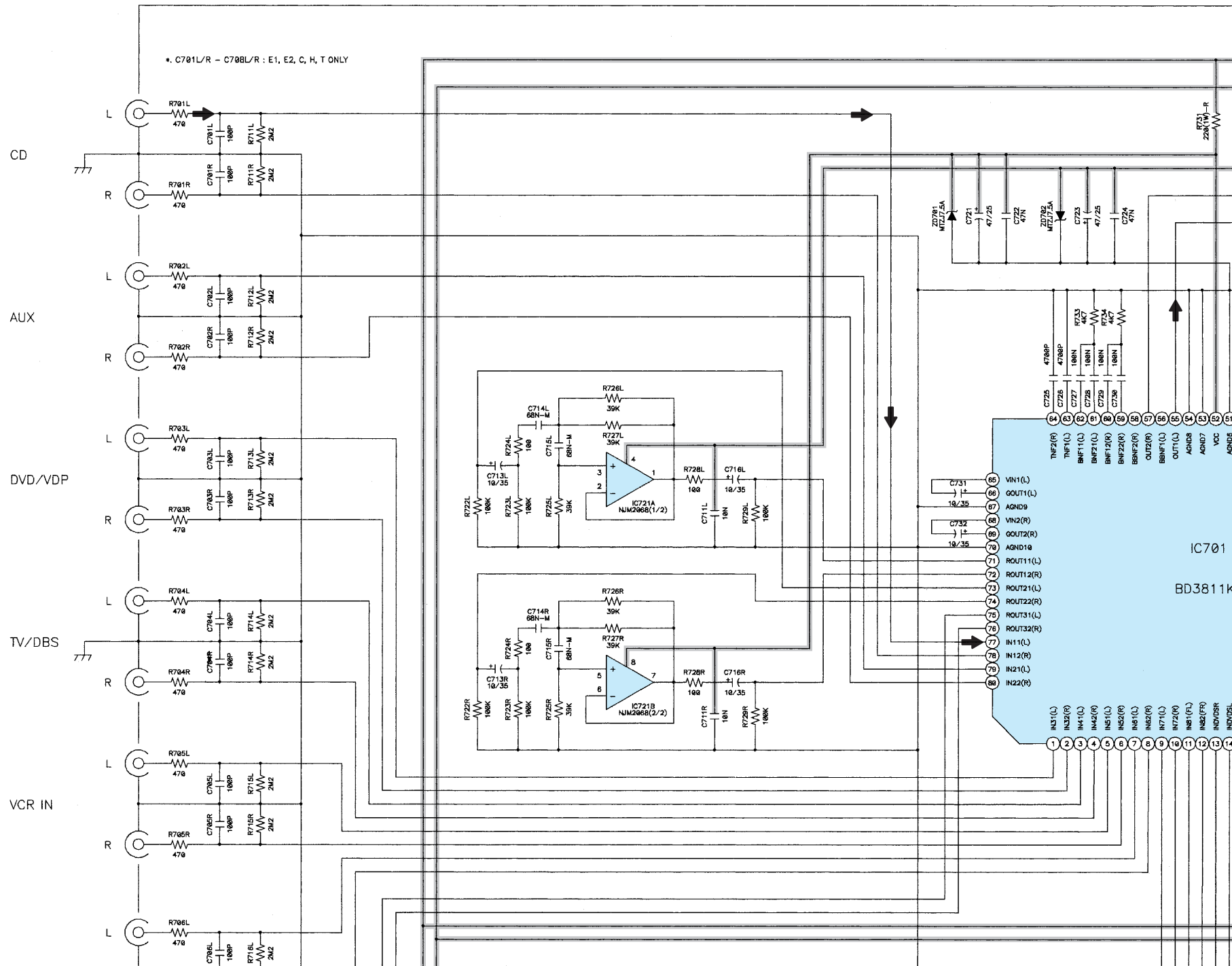



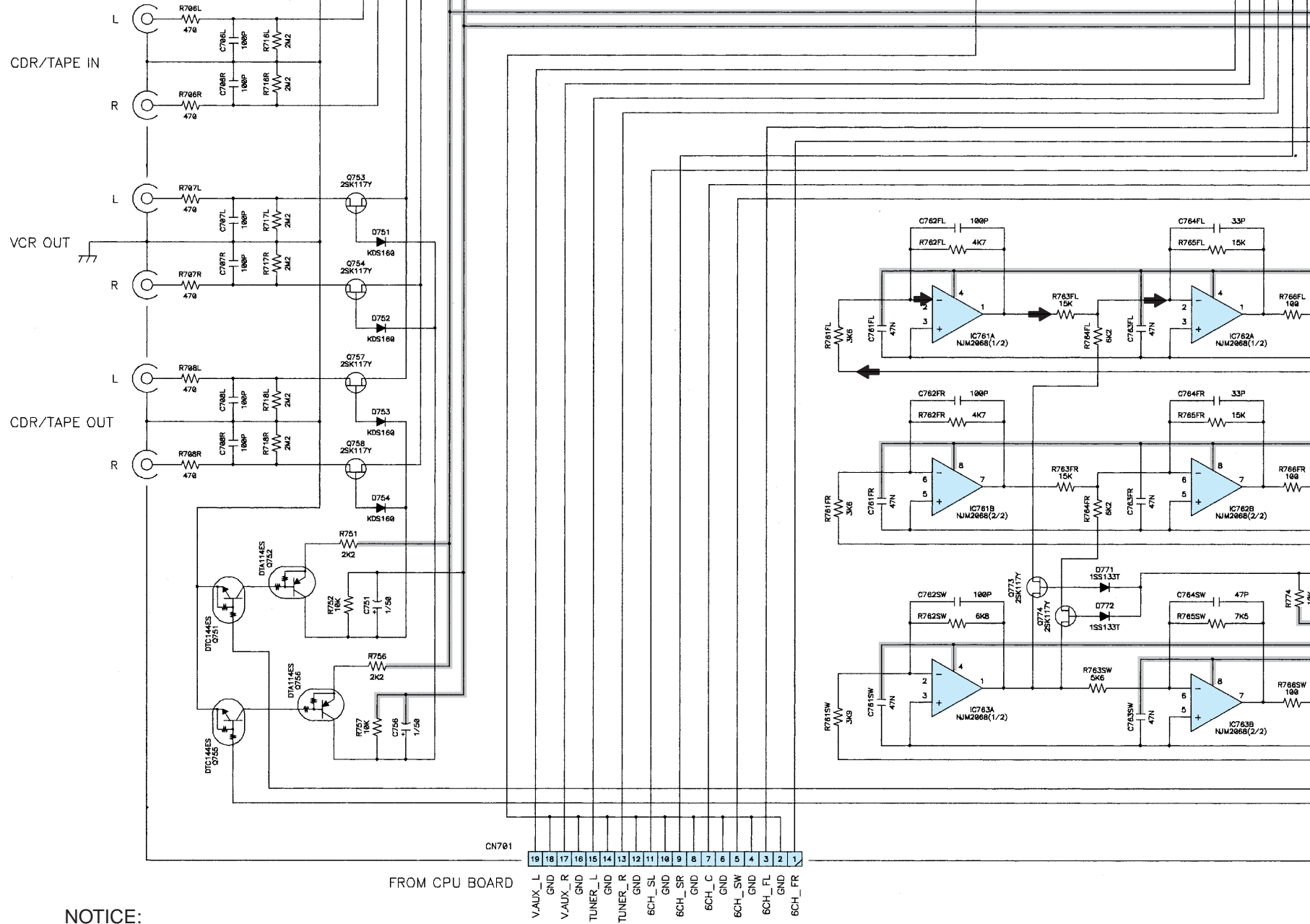

**NOTICE:**  
 ALL RESISTANCE VALUES IN OHM. k=1,000 OHM M=1,000,000 OHM  
 ALL CAPACITANCE VALUES IN MICRO FARAD. P=MICRO-MICRO FARAD  
 EACH VOLTAGE AND CURRENT ARE MEASURED AT NO SIGNAL INPUT  
 CONDITION.  
 CIRCUIT AND PARTS ARE SUBJECT TO CHANGE WITHOUT PRIOR  
 NOTICE.

**WARNING:**  
 Parts marked with this symbol   have critical characteristics.  
 Use ONLY replacement parts recommended by the manufacture.

**CAUTION:**  
 Before returning the unit to the customer, make sure you make either (1) a leakage current check or (2) a line to chassis resistance check. If the leakage current exceeds 0.5 milliamps, or if the resistance from chassis to either side of the power card is less than 460kohms, the unit is defective.

**WARNING:**  
 DO NOT return the unit to the customer until the problem is located and corrected.

6

7

8

9

10

11

INPUT/VOLUME BOARD

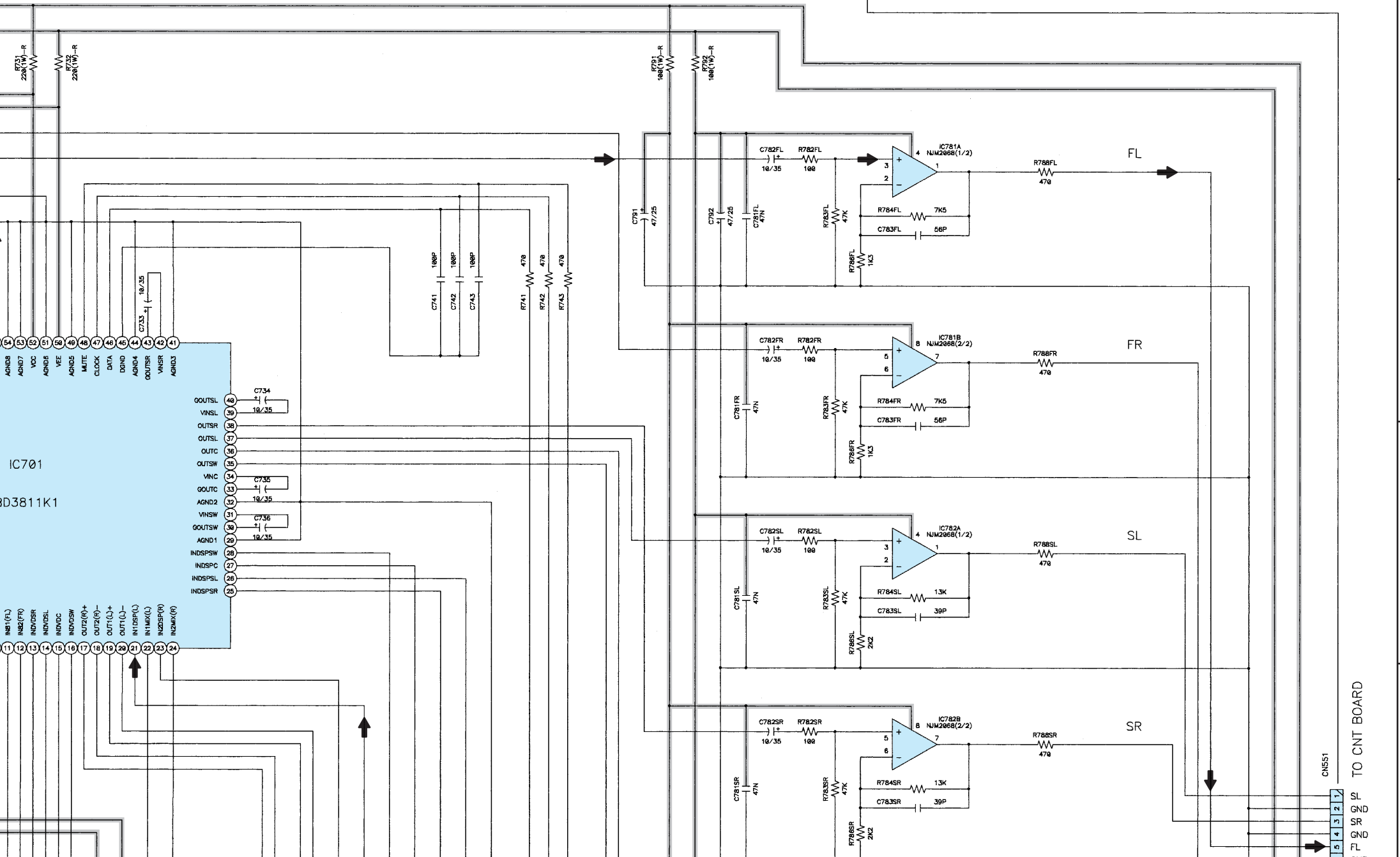

A

B

C

D

TO CNT BOARD

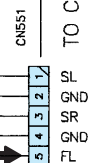

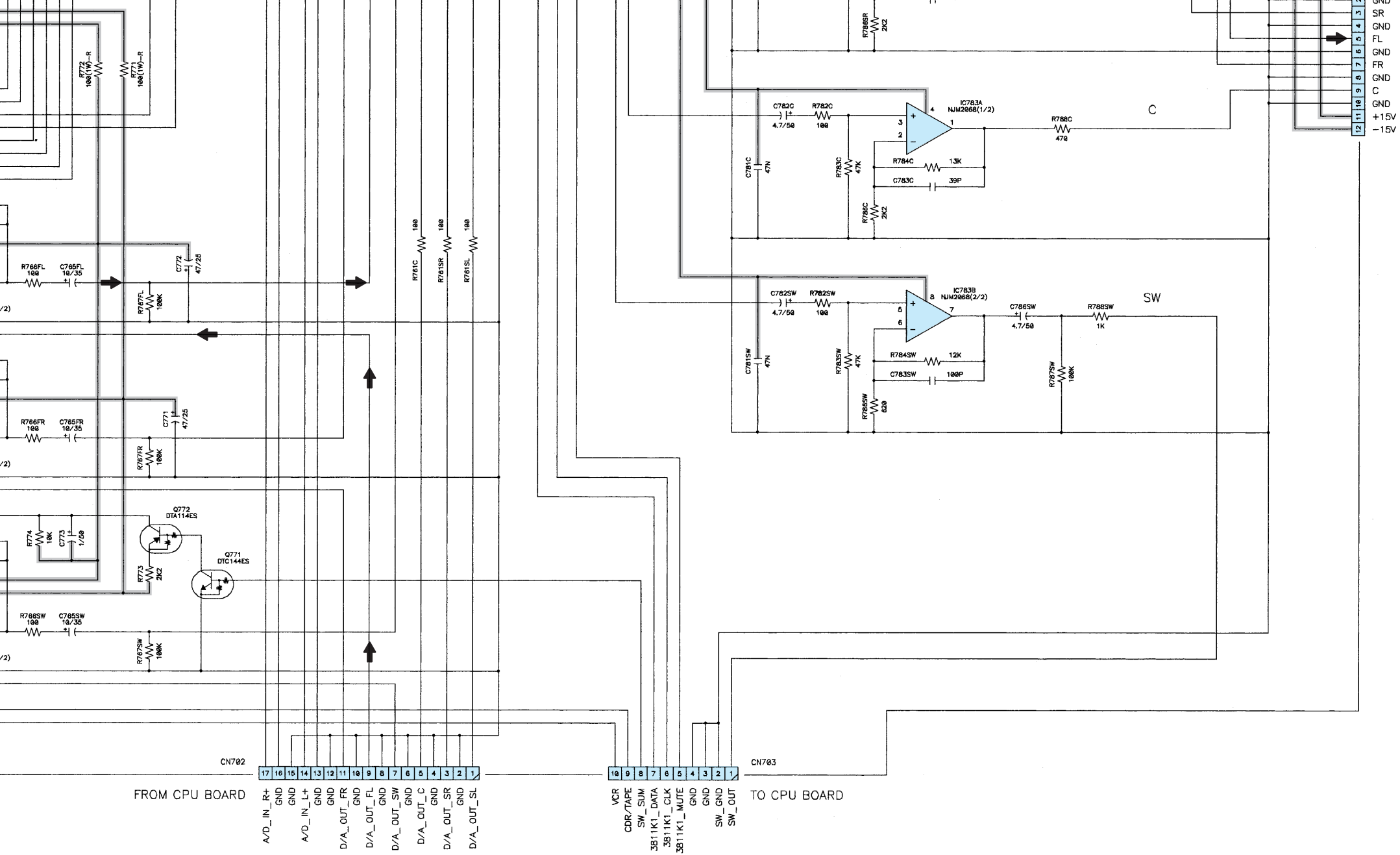

**SCHEMATIC DIAGRAMS (1/8)**  
**INPUT-VOL UNIT**

**SCHEMATIC DIAGRAMS (2/8)**

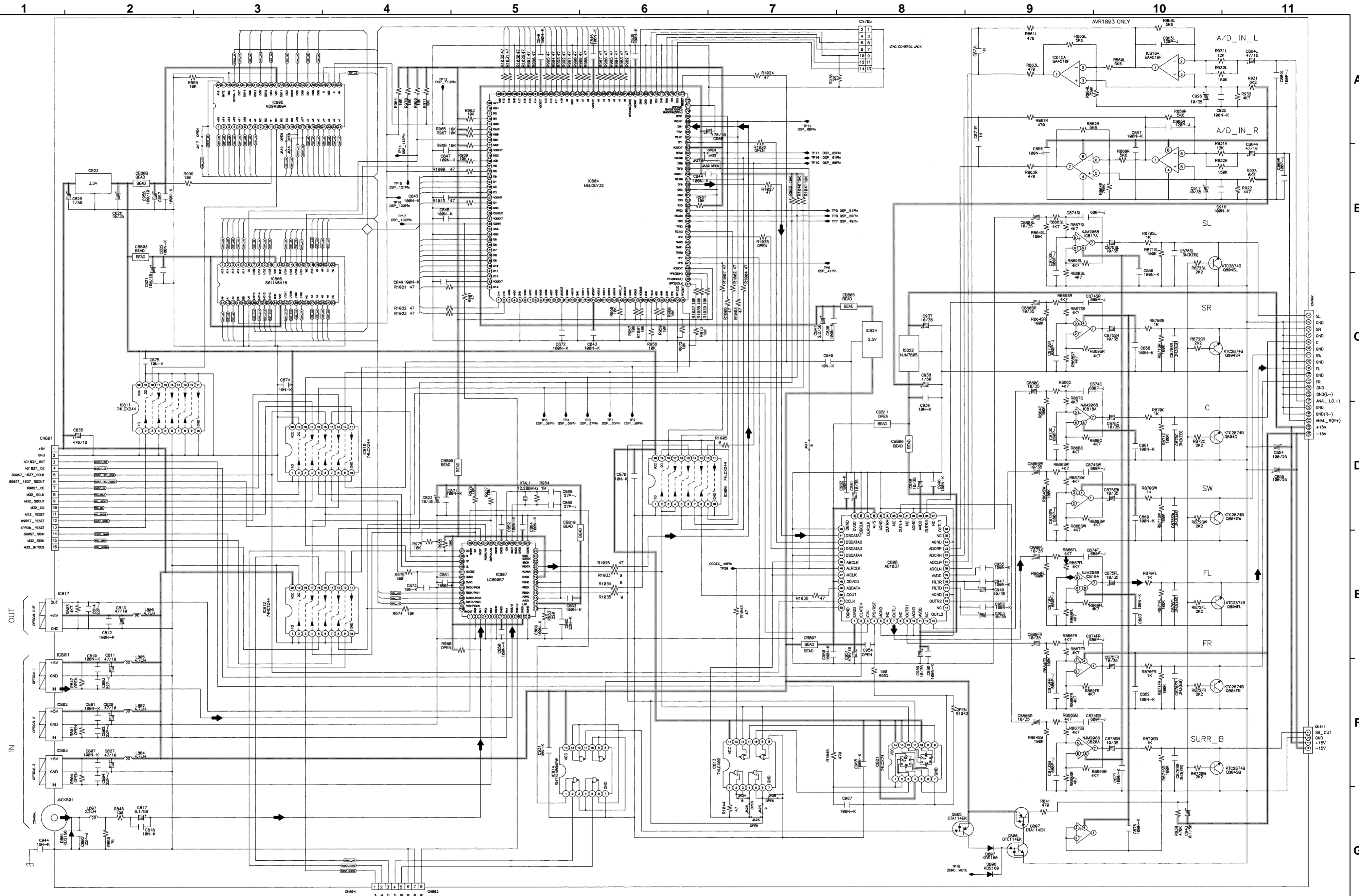

**NOTICE:**  
 ALL RESISTANCE VALUES IN OHM. k=1,000 OHM M=1,000,000 OHM  
 ALL CAPACITANCE VALUES IN MICRO FARAD. P=MICRO-MICRO FARAD  
 EACH VOLTAGE AND CURRENT ARE MEASURED AT NO SIGNAL INPUT CONDITION.  
 CIRCUIT AND PARTS ARE SUBJECT TO CHANGE WITHOUT PRIOR NOTICE.  
**WARNING:**  
 DO NOT return the unit to the customer until the problem is located and corrected.

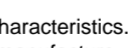
**WARNING:**  
 Parts marked with this symbol  have critical characteristics.  
 Use ONLY replacement parts recommended by the manufacturer.  
**CAUTION:**  
 Before returning the unit to the customer, make sure you make either (1) a leakage current check or (2) a line to chassis resistance check. If the leakage current exceeds 0.5 millamps, or if the resistance from chassis to either side of the power card is less than 460kohms, the unit is defective.

— ± B LINE  
 SIGNAL LINE

**SCHEMATIC DIAGRAMS (2/8)**  
 DSP UNIT

SCHMATIC DIAGRAMS (2/8)

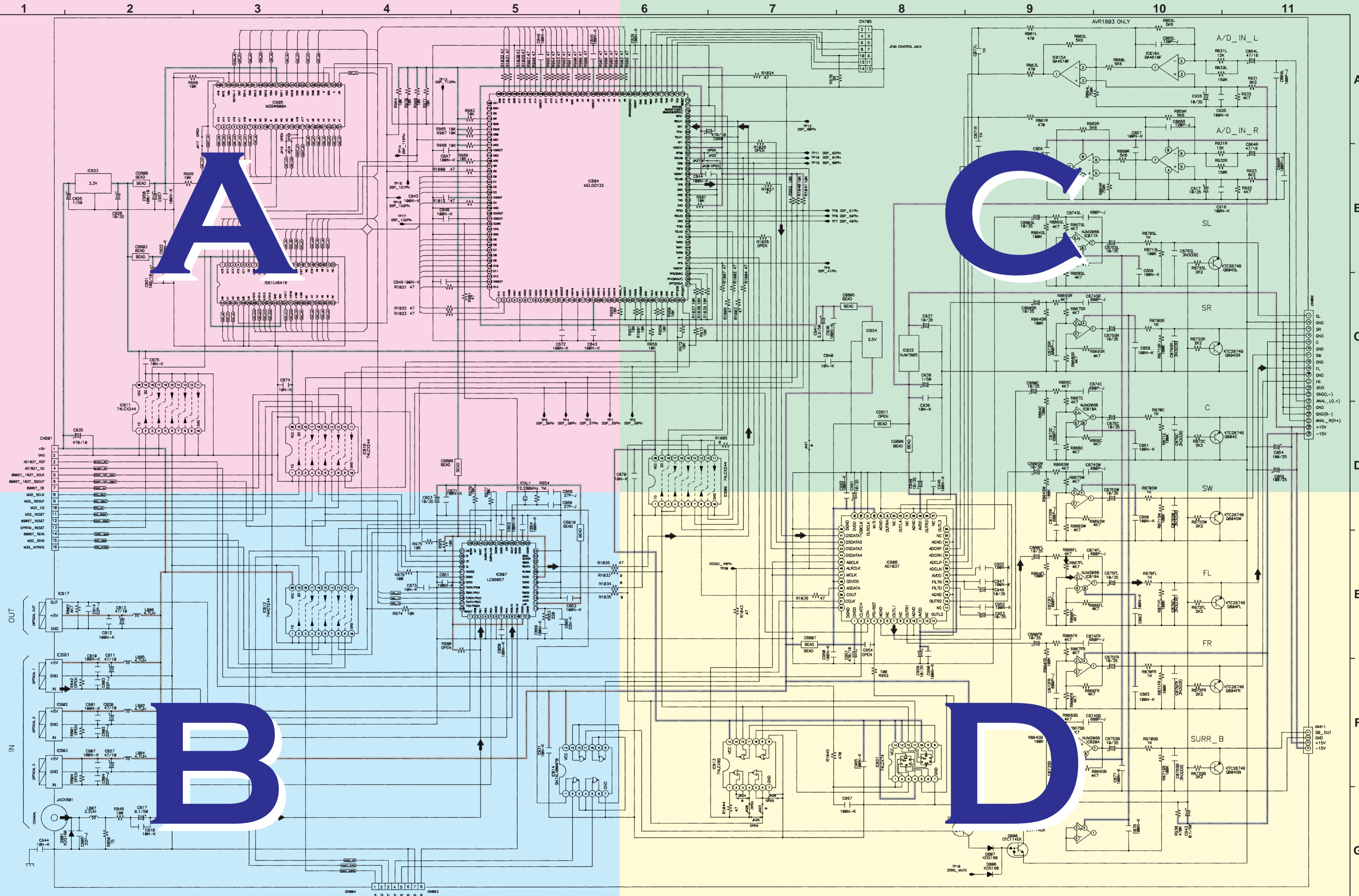

**NOTICE:**  
 ALL RESISTANCE VALUES IN OHM, k=1,000 OHM M=1,000,000 OHM  
 ALL CAPACITANCE VALUES IN MICRO FARAD, P=MICRO-MICRO FARAD  
 EACH VOLTAGE AND CURRENT ARE MEASURED AT NO SIGNAL INPUT  
 CONDITION.  
 CIRCUIT AND PARTS ARE SUBJECT TO CHANGE WITHOUT PRIOR  
 NOTICE.  
**WARNING:**  
 DO NOT return the unit to the customer until the problem is located and  
 corrected.

**WARNING:**  
 Parts marked with this symbol  $\Delta$  have critical characteristics.  
 Use ONLY replacement parts recommended by the manufacture.  
**CAUTION:**  
 Before returning the unit to the customer, make sure you make either (1) a  
 leakage current check or (2) a line to chassis resistance check. If the leakage  
 current exceeds 0.5 milliamps, or if the resistance from chassis to either side  
 of the power card is less than 460kohms, the unit is defective.

— ± B LINE  
 — SIGNAL LINE

SCHMATIC DIAGRAMS (2/8)  
 DSP UNIT

# SCHEMATIC DIAGRAMS (2/8)

1

2

3

4

5

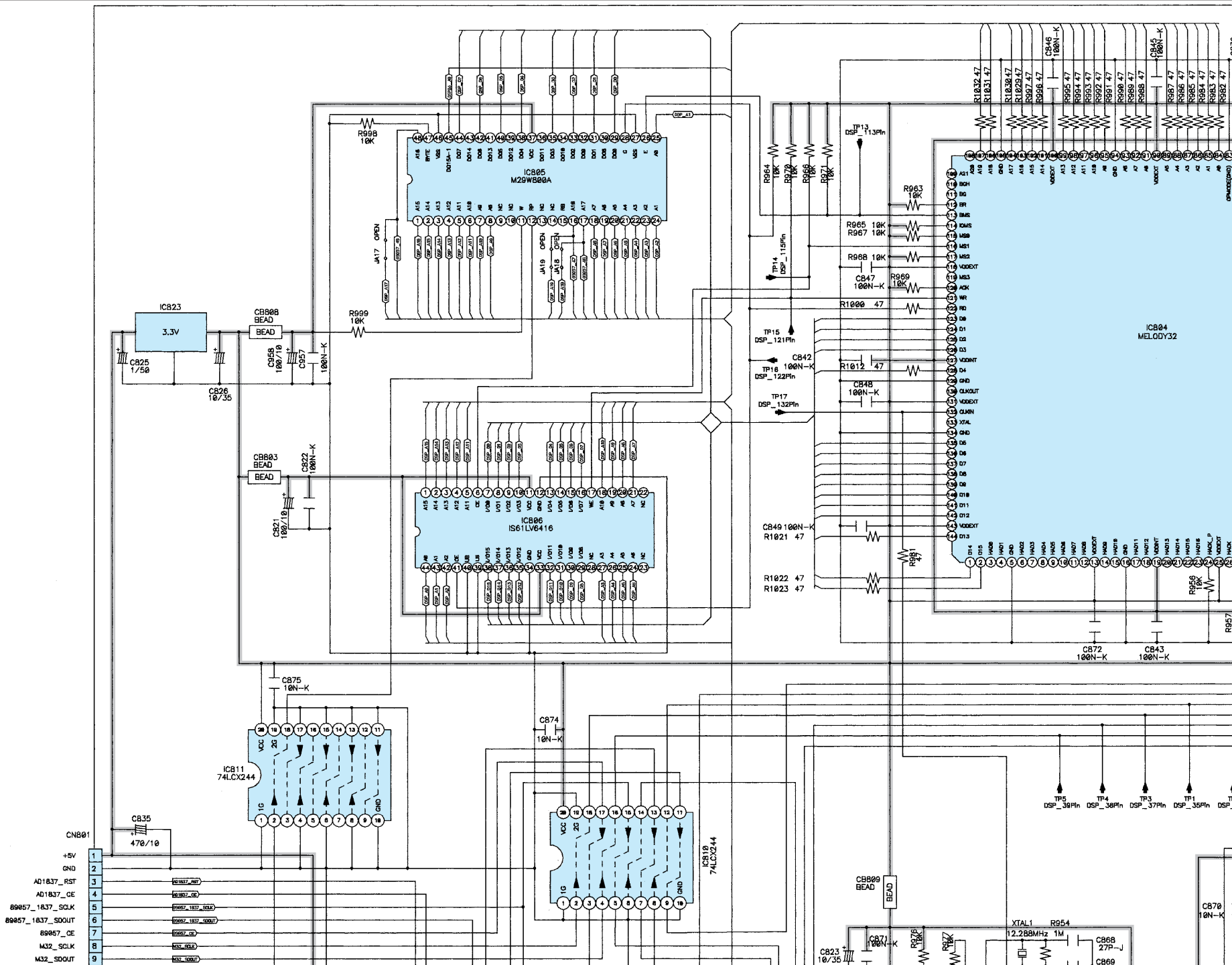

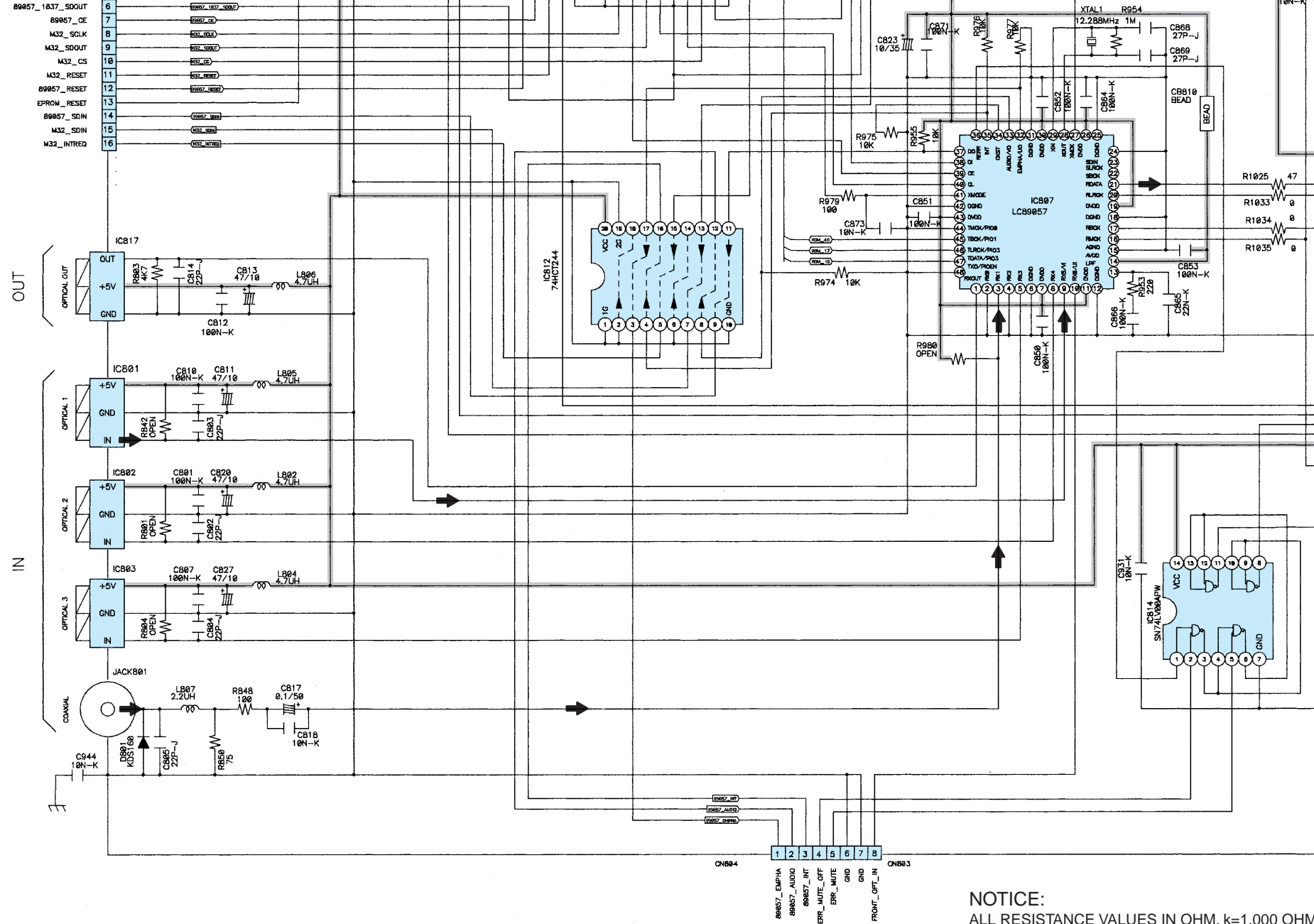

**NOTICE:**  
 ALL RESISTANCE VALUES IN OHM. k=1,000 OHM  
 ALL CAPACITANCE VALUES IN MICRO FARAD. P=  
 EACH VOLTAGE AND CURRENT ARE MEASUREMENT  
 CONDITION.  
 CIRCUIT AND PARTS ARE SUBJECT TO CHANGE  
 NOTICE.

**WARNING:**  
 DO NOT return the unit to the customer until the pro  
 corrected.

6

7

8

9

10

11

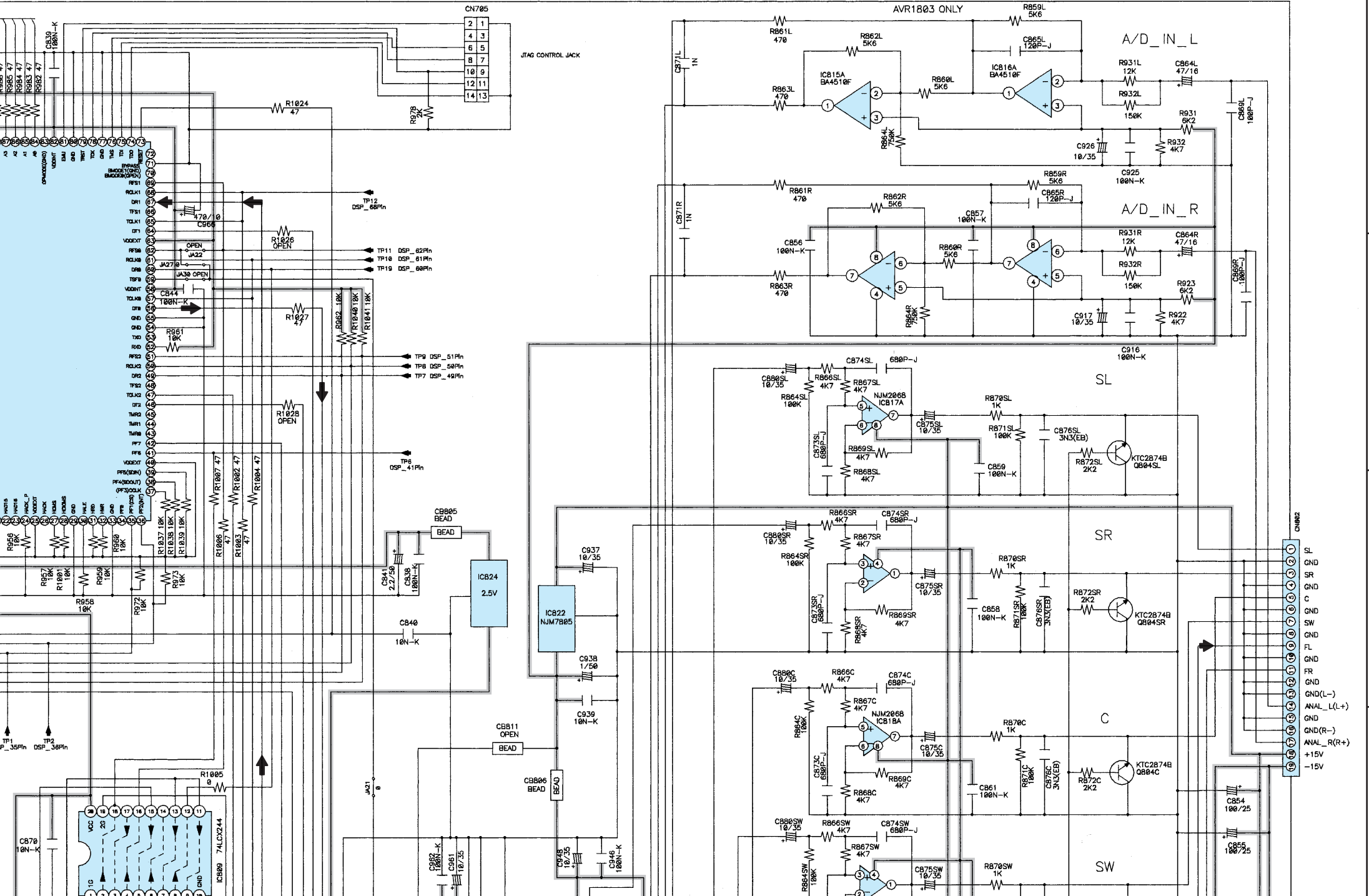

A

B

C

D



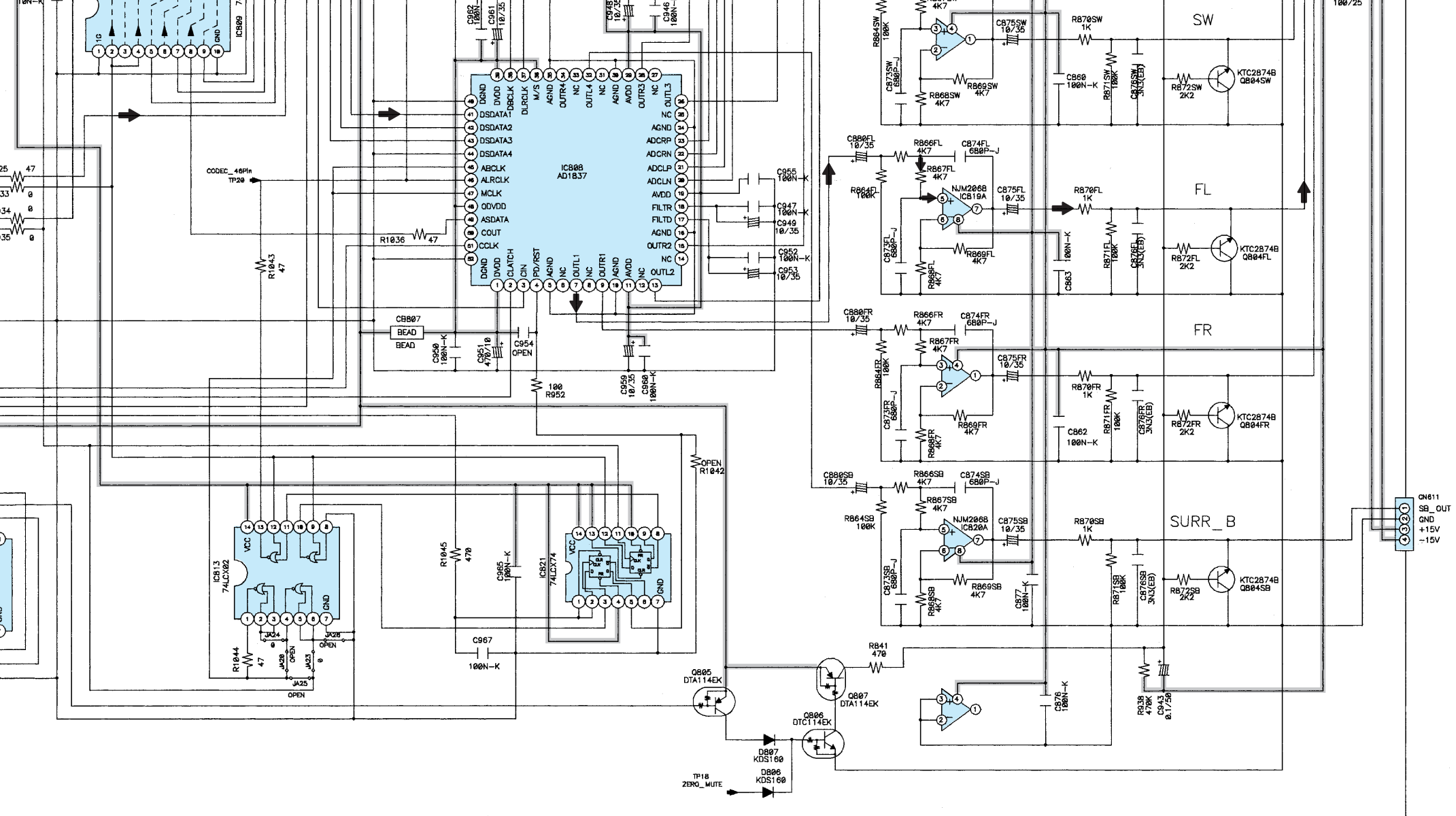



00 OHM M=1,000,000 OHM  
 RAD. P=MICRO-MICRO FARAD  
 ASUERD AT NO SIGNAL INPUT

CHANGE WITHOUT PRIOR

il the problem is located and

**WARNING:**  
 Parts marked with this symbol   have critical characteristics.  
 Use ONLY replacement parts recommended by the manufacture.

**CAUTION:**  
 Before returning the unit to the customer, make sure you make either (1) a leakage current check or (2) a line to chassis resistance check. If the leakage current exceeds 0.5 milliamps, or if the resistance from chassis to either side of the power card is less than 460kohms, the unit is defective.

 ± B LINE  
 SIGNAL LINE

**SCHEMATIC DIAGRAMS (2/8)**  
**DSP UNIT**

**SCHEMATIC DIAGRAMS (3/8)**

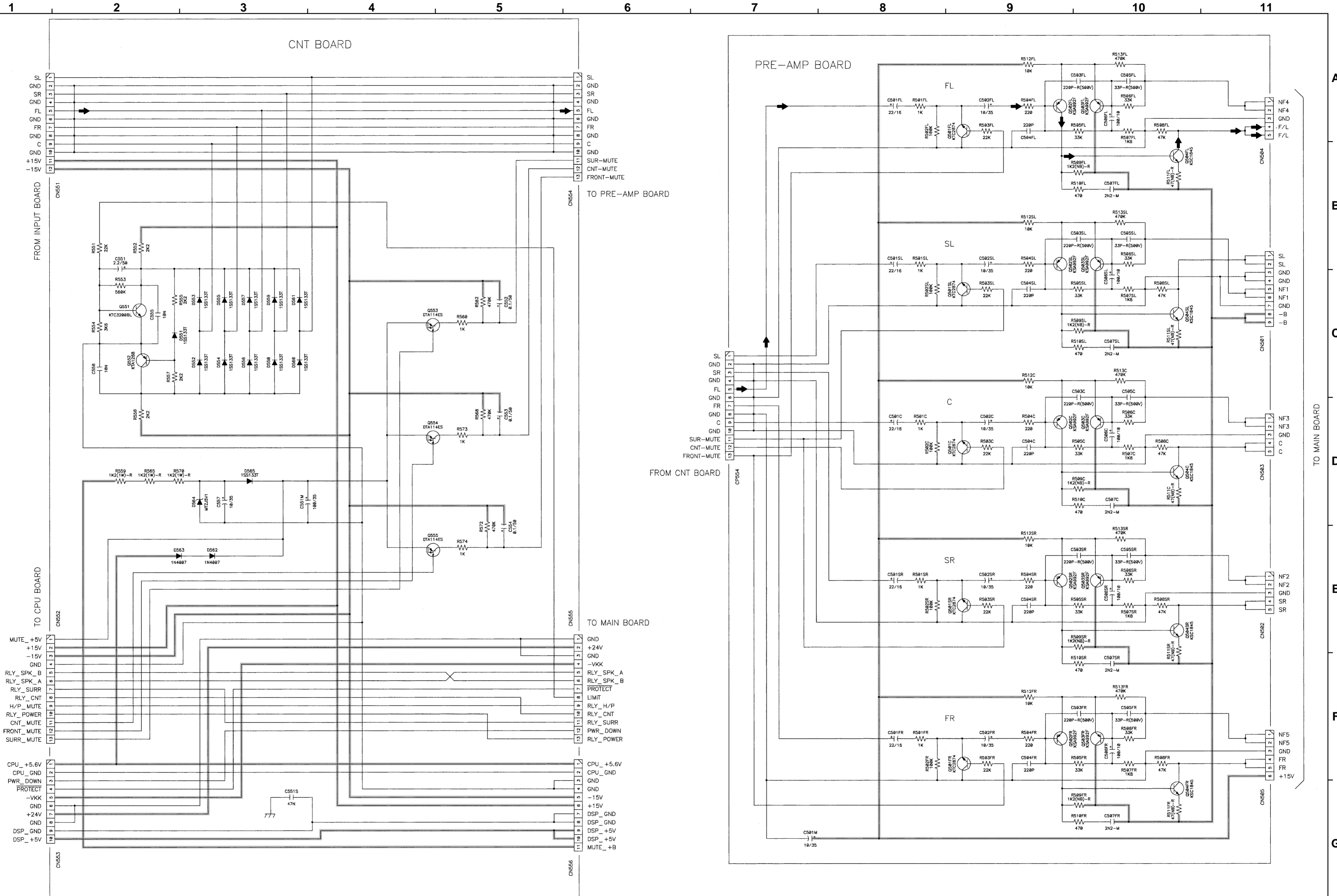

**NOTICE:**  
 ALL RESISTANCE VALUES IN OHM. k=1,000 OHM M=1,000,000 OHM  
 ALL CAPACITANCE VALUES IN MICRO FARAD. P=MICRO-MICRO FARAD  
 EACH VOLTAGE AND CURRENT ARE MEASURED AT NO SIGNAL INPUT  
 CONDITION.  
 CIRCUIT AND PARTS ARE SUBJECT TO CHANGE WITHOUT PRIOR  
 NOTICE.  
**WARNING:**  
 Parts marked with this symbol have critical characteristics.  
 Use ONLY replacement parts recommended by the manufacture.

**CAUTION:**  
 Before returning the unit to the customer, make sure you make either (1) a leakage current check or (2) a line to chassis resistance check. If the leakage current exceeds 0.5 milliamps, or if the resistance from chassis to either side of the power card is less than 460kohms, the unit is defective.  
**WARNING:**  
 DO NOT return the unit to the customer until the problem is located and corrected.

**SCHEMATIC DIAGRAMS (3/8)**  
 CNT UNIT  
 PRE-AMP UNIT

SCHMATIC DIAGRAMS (3/8)

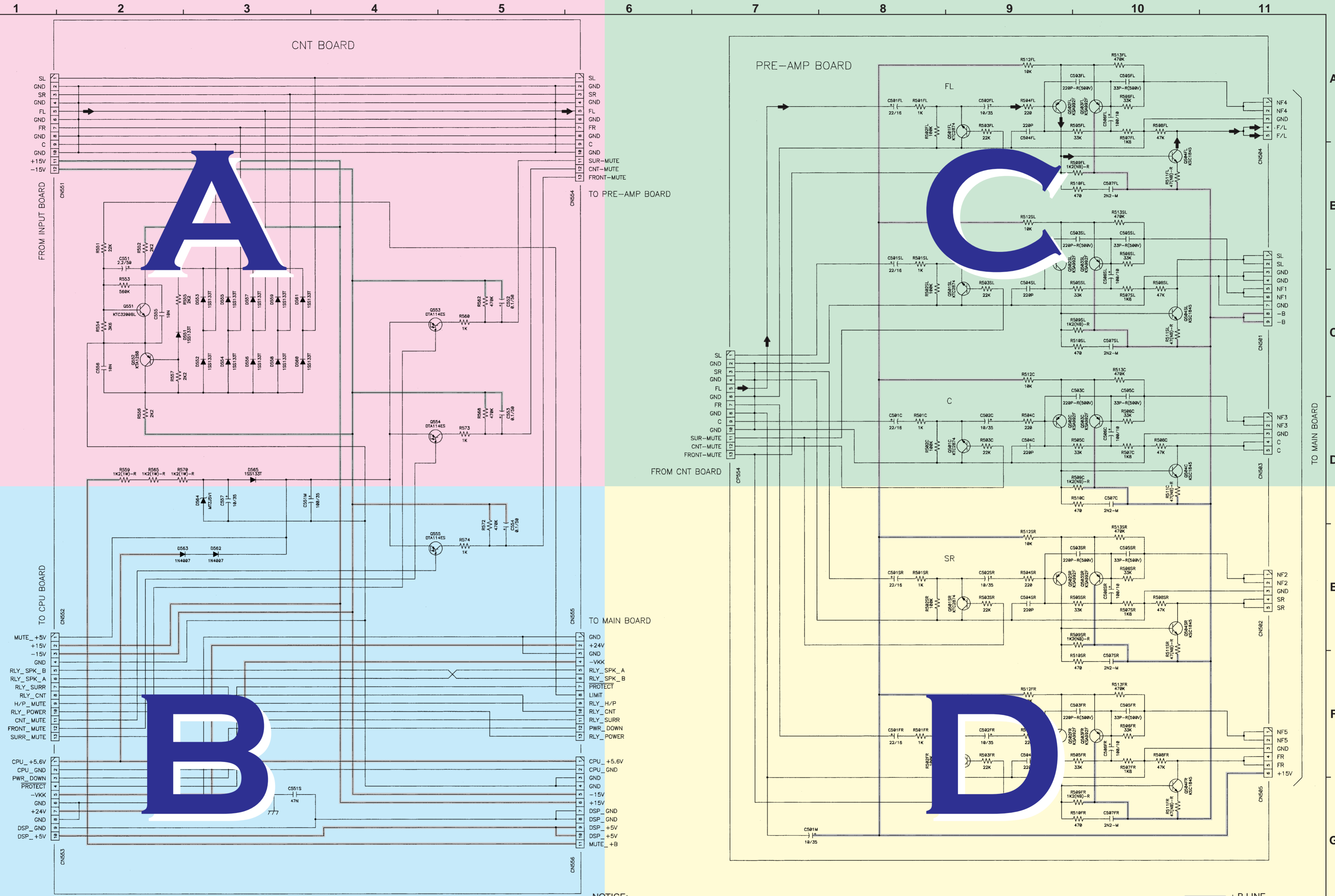

**NOTICE:**  
 ALL RESISTANCE VALUES IN OHM. k=1,000 OHM M=1,000,000 OHM  
 ALL CAPACITANCE VALUES IN MICRO FARAD. P=MICRO-MICRO FARAD  
 EACH VOLTAGE AND CURRENT ARE MEASURED AT NO SIGNAL INPUT  
 CONDITION.  
 CIRCUIT AND PARTS ARE SUBJECT TO CHANGE WITHOUT PRIOR  
 NOTICE.  
**WARNING:**  
 Parts marked with this symbol have critical characteristics.  
 Use ONLY replacement parts recommended by the manufacture.

**CAUTION:**  
 Before returning the unit to the customer, make sure you make either (1) a  
 leakage current check or (2) a line to chassis resistance check. If the leakage  
 current exceeds 0.5 milliamps, or if the resistance from chassis to either side  
 of the power card is less than 460kohms, the unit is defective.  
**WARNING:**  
 DO NOT return the unit to the customer until the problem is located and  
 corrected.

SCHMATIC DIAGRAMS (3/8)  
 CNT UNIT  
 PRE-AMP UNIT

# SCHEMATIC DIAGRAMS (3/8)

1

2

3

4

5

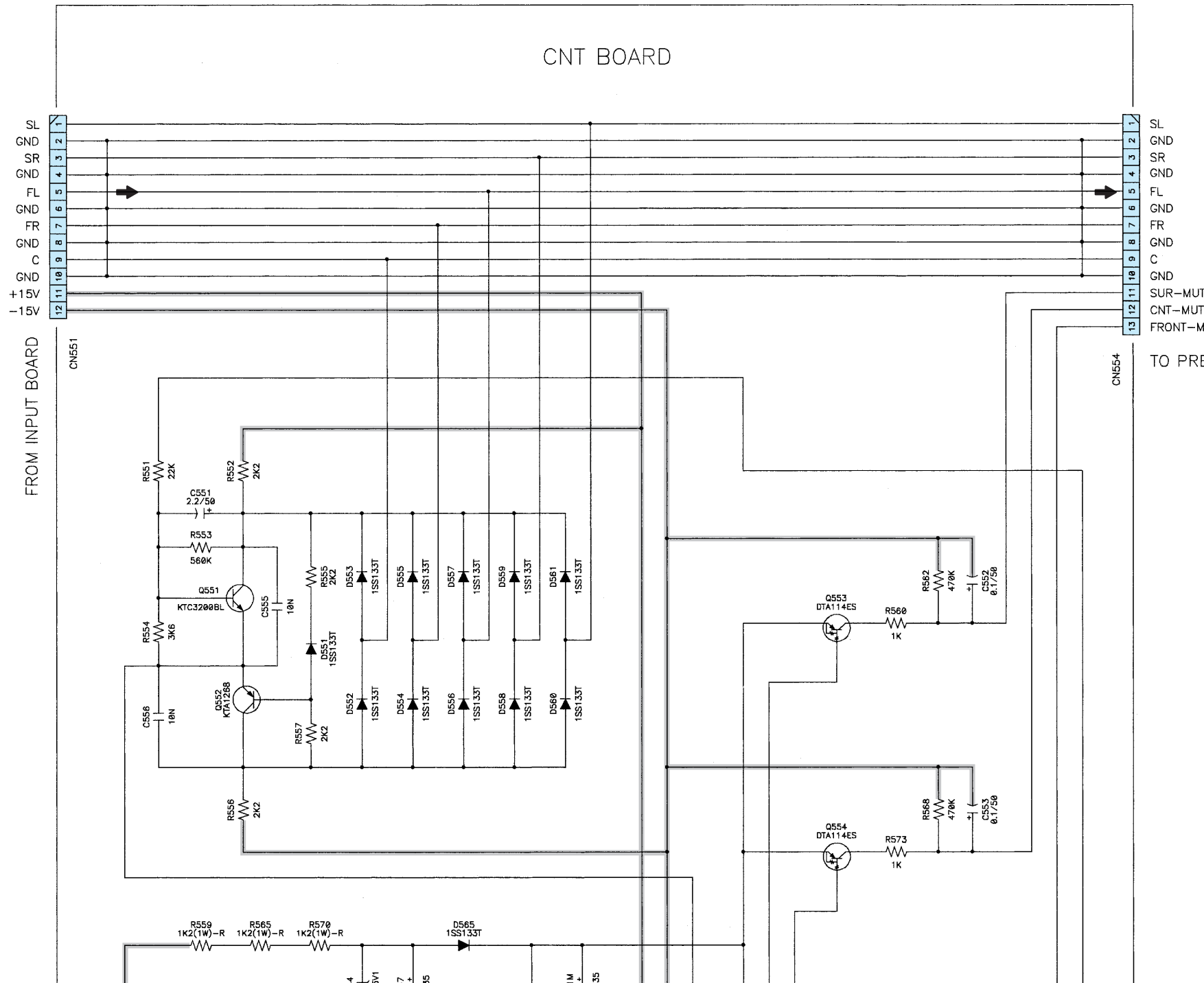

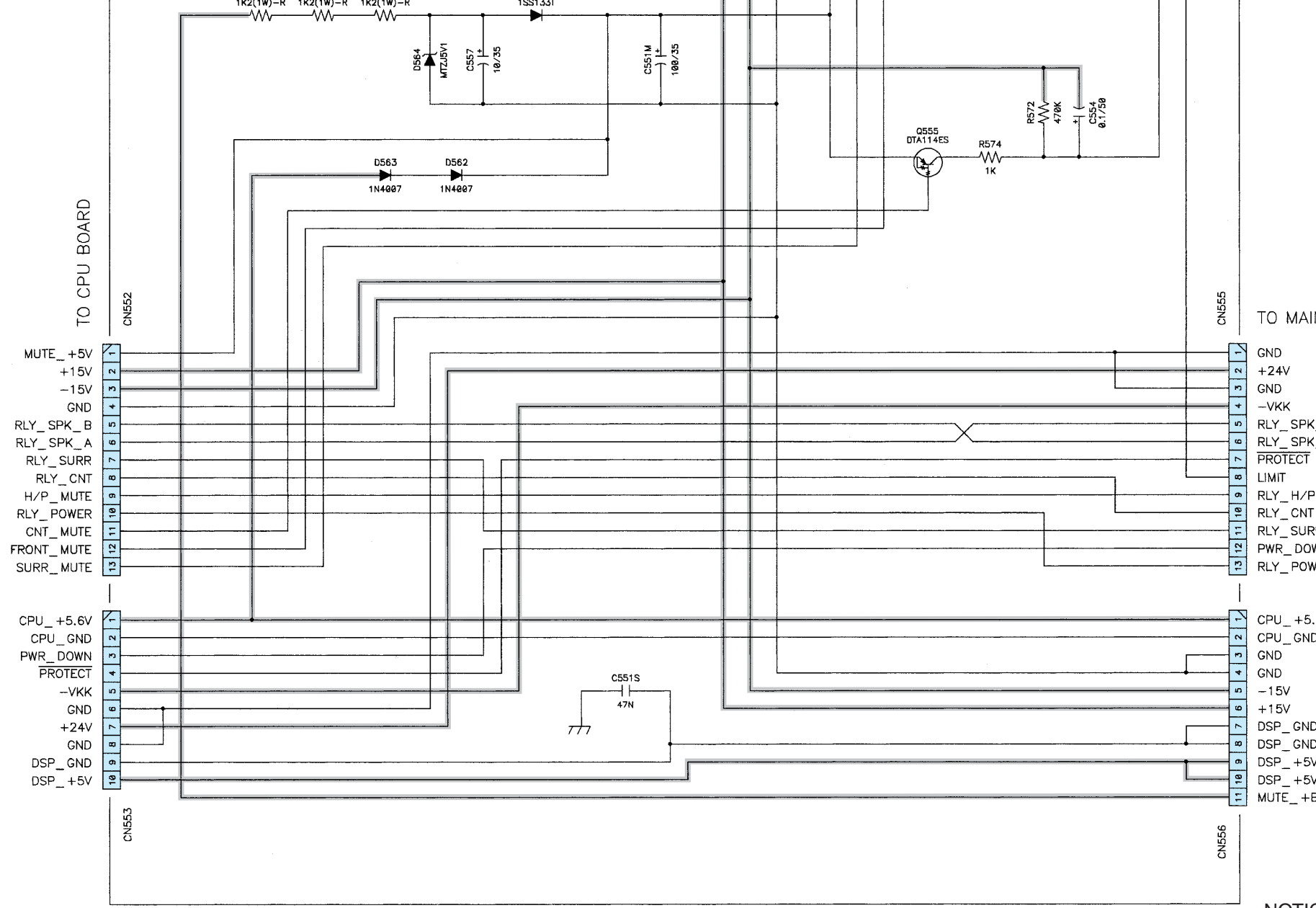

TO MAIN

- 1 GND
- 2 +24V
- 3 GND
- 4 -VKK
- 5 RLY\_SPK\_B
- 6 RLY\_SPK\_A
- 7 PROTECT
- 8 LIMIT
- 9 RLY\_H/P
- 10 RLY\_CNT
- 11 RLY\_SURR
- 12 PWR\_DOW
- 13 RLY\_POWER
- 1 CPU\_+5.
- 2 CPU\_GND
- 3 GND
- 4 GND
- 5 -15V
- 6 +15V
- 7 DSP\_GND
- 8 DSP\_GND
- 9 DSP\_+5V
- 10 DSP\_+5V
- 11 MUTE\_+5V
- 12 MUTE\_+5V

NOTICE  
 ALL RE  
 ALL CA  
 EACH V  
 CONDI  
 CIRCU  
 NOTICE  
 WARN  
 Parts m  
 Use ON

6

7

8

9

10

11

PRE-AMP BOARD

FL

SL

C

- SL
- GND
- SR
- GND
- FL
- GND
- FR
- GND
- C
- GND
- SUR-MUTE
- CNT-MUTE
- FRONT-MUTE

FROM CNT BOARD

CP554

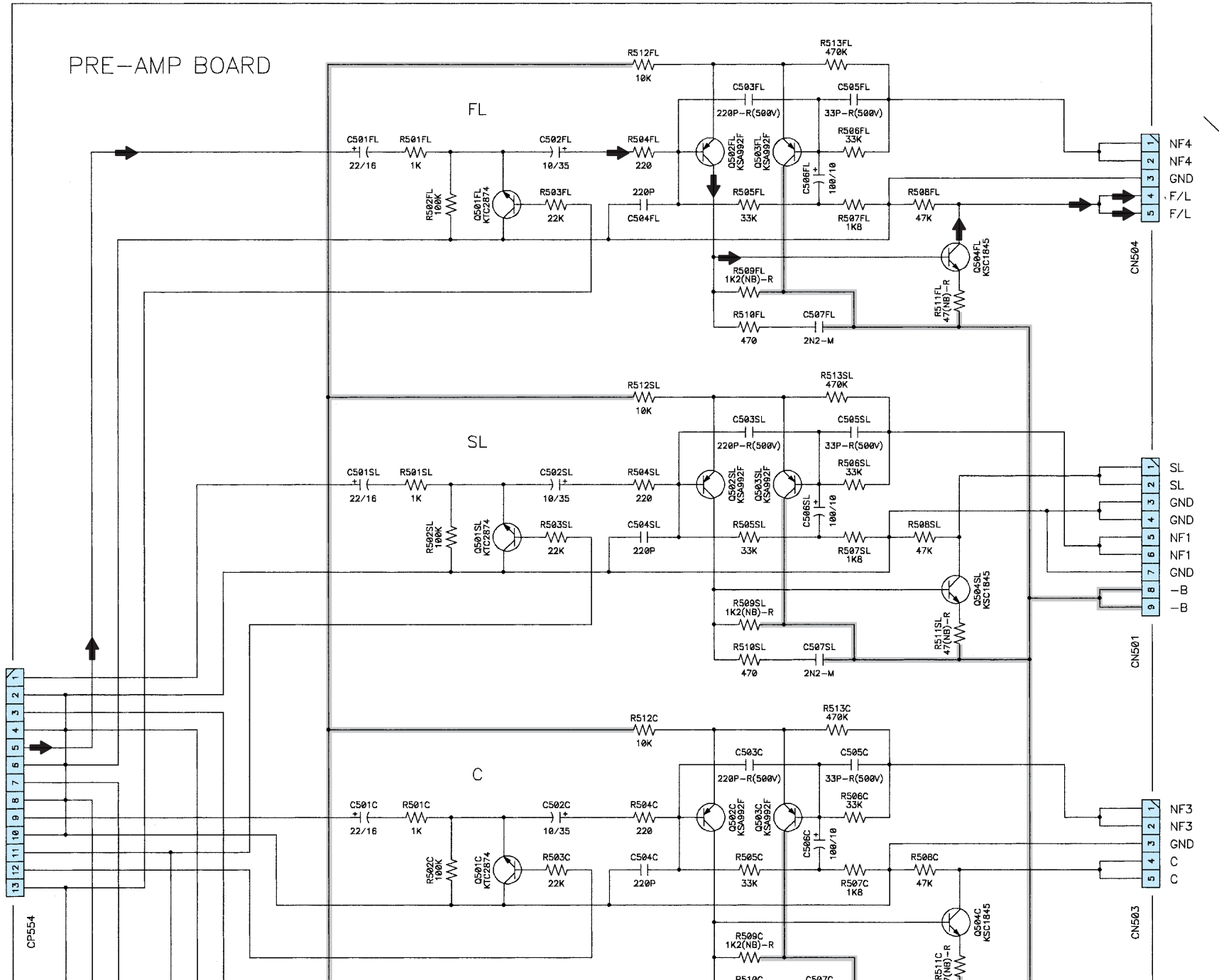

A

B

C

D

TO MAIN BOARD

- NF4
- NF4
- GND
- F/L
- F/L

- SL
- SL
- GND
- GND
- NF1
- NF1
- GND
- L-B
- L-B

- NF3
- NF3
- GND
- C
- C

TO MAIN BOARD

- GND
- 24V
- GND
- VKK
- RLY\_SPK\_A
- RLY\_SPK\_B
- PROTECT
- LIMIT
- RLY\_H/P
- RLY\_CNT
- RLY\_SURR
- PWR\_DOWN
- RLY\_POWER
- CPU\_+5.6V
- CPU\_GND
- GND
- GND
- 15V
- +15V
- DSP\_GND
- DSP\_GND
- DSP\_+5V
- DSP\_+5V
- MUTE\_+B

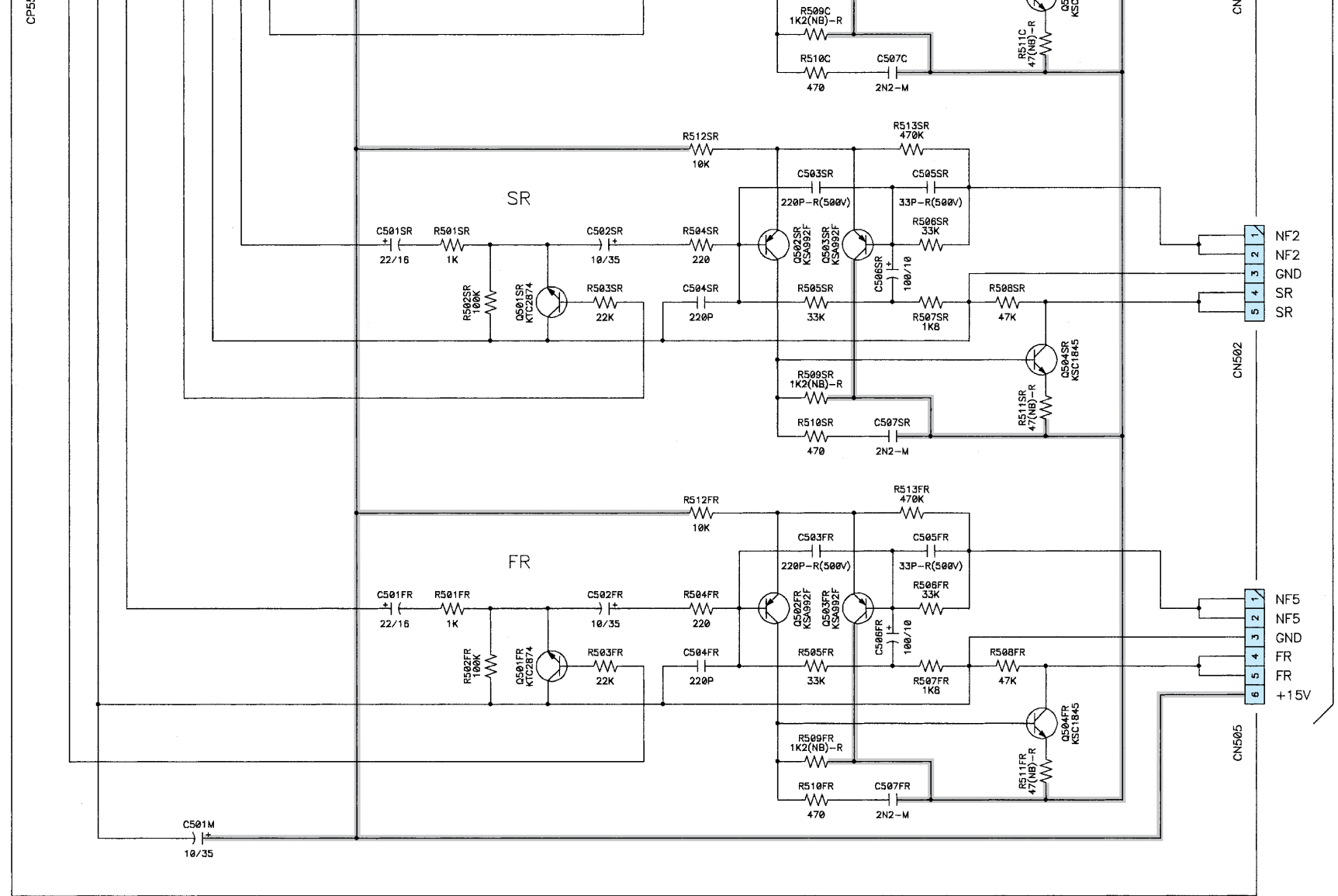

**NOTICE:**  
 ALL RESISTANCE VALUES IN OHM. k=1,000 OHM M=1,000,000 OHM  
 ALL CAPACITANCE VALUES IN MICRO FARAD. P=MICRO-MICRO FARAD  
 EACH VOLTAGE AND CURRENT ARE MEASURED AT NO SIGNAL INPUT  
 CONDITION.  
 CIRCUIT AND PARTS ARE SUBJECT TO CHANGE WITHOUT PRIOR  
 NOTICE.  
**WARNING:**  
 Parts marked with this symbol have critical characteristics.  
 Use ONLY replacement parts recommended by the manufacture.

**CAUTION:**  
 Before returning the unit to the customer, make sure you make either (1) a  
 leakage current check or (2) a line to chassis resistance check. If the leakage  
 current exceeds 0.5 milliamps, or if the resistance from chassis to either side  
 of the power card is less than 460kohms, the unit is defective.  
**WARNING:**  
 DO NOT return the unit to the customer until the problem is located and  
 corrected.

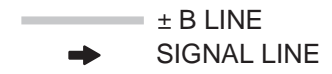

**SCHEMATIC DIAGRAMS (3/8)**  
 CNT UNIT  
 PRE-AMP UNIT

SCHEMATIC DIAGRAMS (4/8)

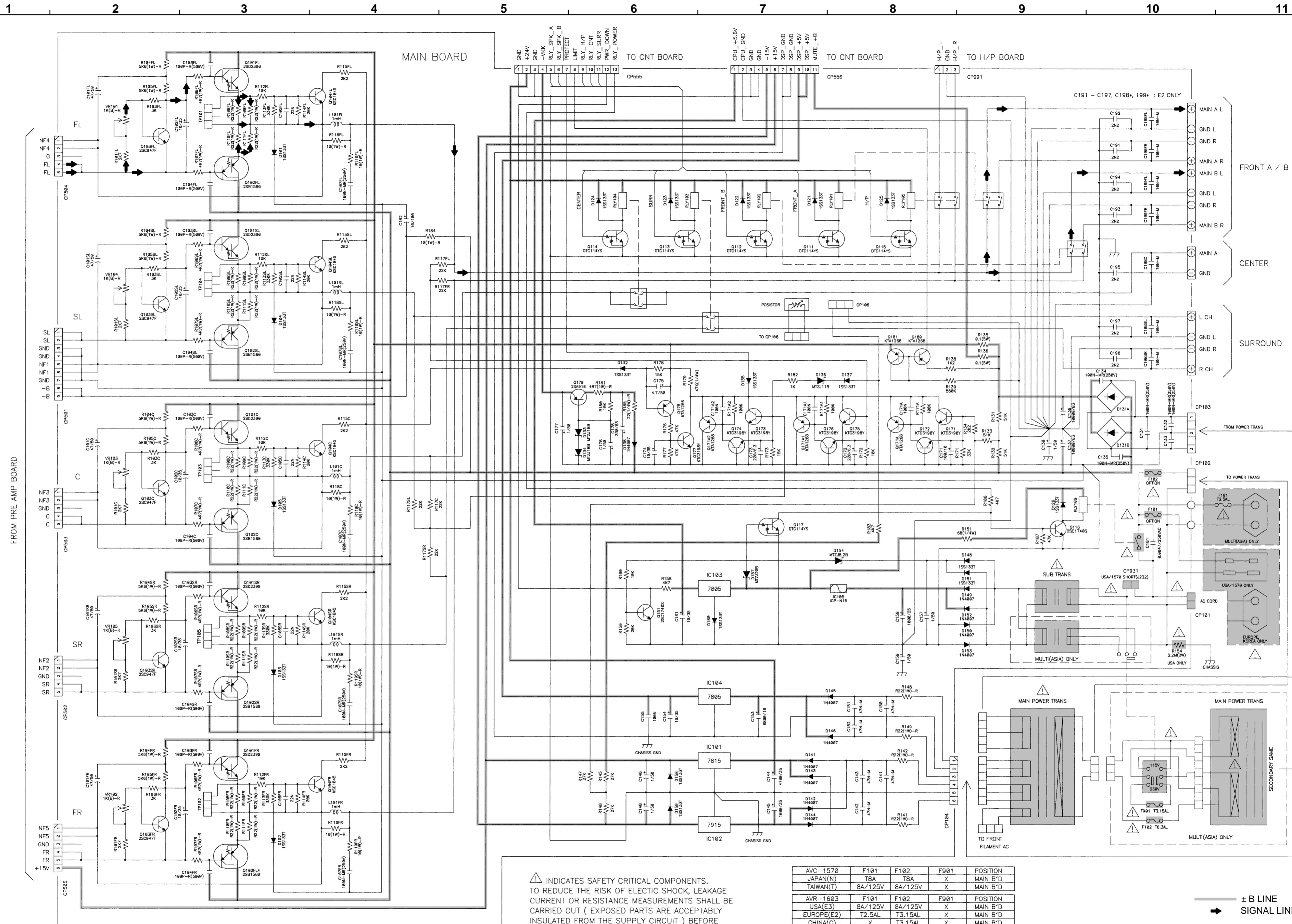

**NOTICE:**  
 ALL RESISTANCE VALUES IN OHM. k=1,000 OHM M=1,000,000 OHM  
 ALL CAPACITANCE VALUES IN MICRO FARAD. P=MICRO-MICRO FARAD  
 EACH VOLTAGE AND CURRENT ARE MEASURED AT NO SIGNAL INPUT  
 CONDITION.  
 CIRCUIT AND PARTS ARE SUBJECT TO CHANGE WITHOUT PRIOR  
 NOTICE.

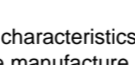
**WARNING:**  
 Parts marked with this symbol  have critical characteristics.  
 Use ONLY replacement parts recommended by the manufacture.  
**CAUTION:**  
 Before returning the unit to the customer, make sure you make either (1) a leakage current check or (2) a line to chassis resistance check. If the leakage current exceeds 0.5 milliamperes, or if the resistance from chassis to either side of the power card is less than 460kohms, the unit is defective.

**WARNING:**  
 DO NOT return the unit to the customer until the problem is located and corrected.

AVR-1570	F101	F102	F901	POSITION
JAPAN(N)	T8A	T8A	X	MAIN B'D
TAIWAN(T)	8A/125V	8A/125V	X	MAIN B'D
AVR-1603	F101	F102	F901	POSITION
USA(E3)	8A/125V	8A/125V	X	MAIN B'D
EUROPE(E2)	T2.5AL	T3.15AL	X	MAIN B'D
CHINA(C)	T2.5AL	T3.15AL	X	MAIN B'D
ASIA(H,T,E1)	T2.5AL	T6.3AL	T3.15AL	V.SEL B'D
KOREA(K)	T2.5AL	T3.15AL	X	MAIN B'D

SCHEMATIC DIAGRAMS (4/8)  
 MAIN UNIT  
 OUTLINE  
 VOLTAGE SEL UNIT



**SCHEMATIC DIAGRAMS (4/8)**

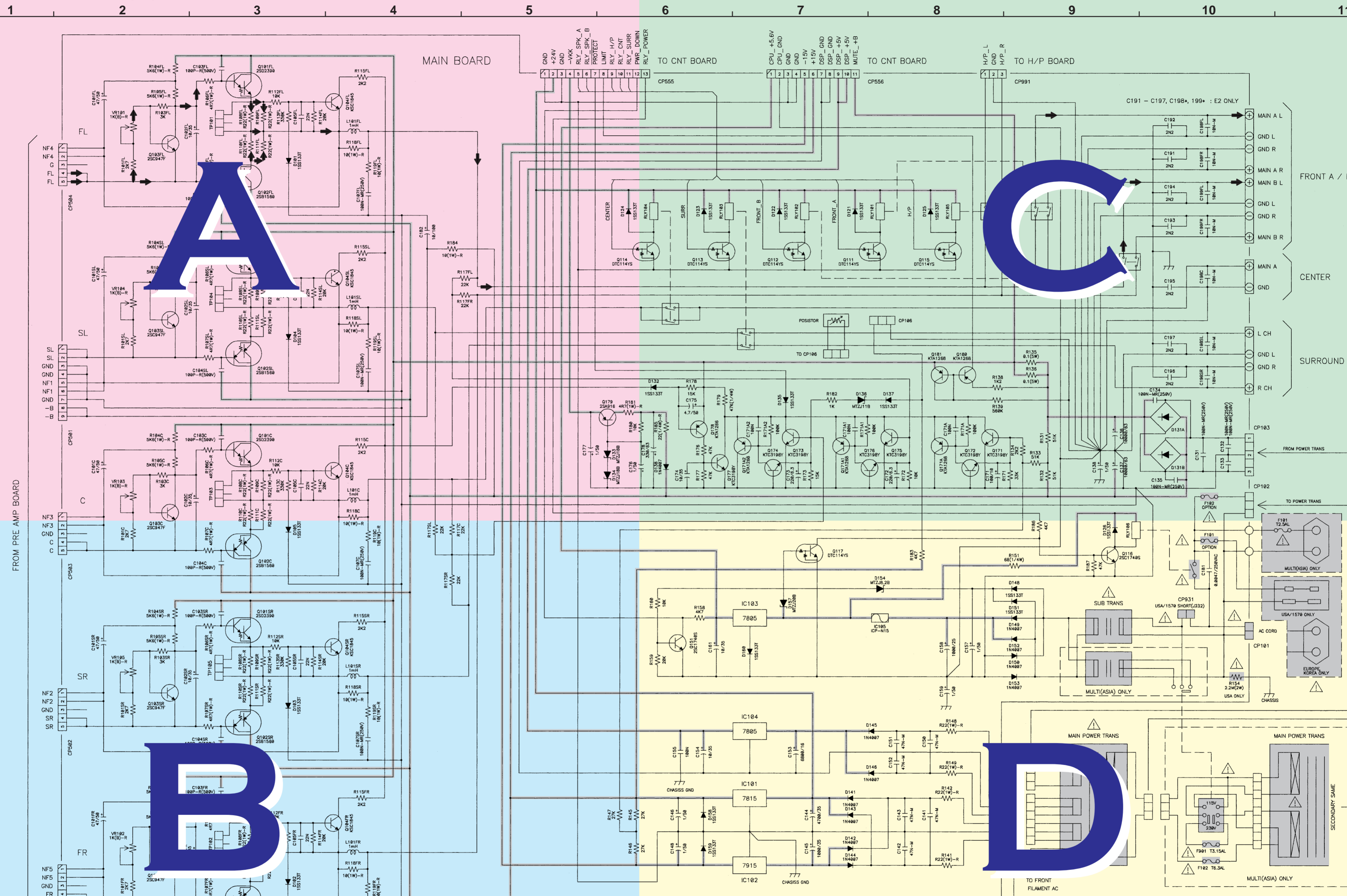

**NOTICE:**  
 ALL RESISTANCE VALUES IN OHM. k=1,000 OHM M=1,000,000 OHM  
 ALL CAPACITANCE VALUES IN MICRO FARAD. P=MICRO-MICRO FARAD  
 EACH VOLTAGE AND CURRENT ARE MEASURED AT NO SIGNAL INPUT  
 CONDITION.  
 CIRCUIT AND PARTS ARE SUBJECT TO CHANGE WITHOUT PRIOR  
 NOTICE.

**WARNING:**  
 Parts marked with this symbol have critical characteristics.  
 USE ONLY replacement parts recommended by the manufacture.  
**CAUTION:**  
 Before returning the unit to the customer, make sure you make either (1) a leakage current check or (2) a line to chassis resistance check. If the leakage current exceeds 0.5 milliamps, or if the resistance from chassis to either side of the power card is less than 460kohms, the unit is defective.

**WARNING:**  
 DO NOT return the unit to the customer until the problem is located and corrected.

INDICATES SAFETY CRITICAL COMPONENTS.  
 TO REDUCE THE RISK OF ELECTRIC SHOCK, LEAKAGE CURRENT OR RESISTANCE MEASUREMENTS SHALL BE CARRIED OUT ( EXPOSED PARTS ARE ACCEPTABLY INSULATED FROM THE SUPPLY CIRCUIT ) BEFORE THE APPLIANCE RETURNED TO THE CUSTOMER.

AVC-1570	F101	F102	F901	POSITION
JAPAN(N)	T8A	T8A	X	MAIN B'D
TAIWAN(T)	8A/125V	8A/125V	X	MAIN B'D
AVR-1603	F101	F102	F901	POSITION
USA(E3)	8A/125V	8A/125V	X	MAIN B'D
EUROPE(E2)	T2.5AL	T3.15AL	X	MAIN B'D
CHINA(C)	X	X	X	MAIN B'D
ASIA(H,T,E1)	T2.5AL	T6.3AL	T3.15AL	V.SEL B'D
KOREA(K)	T2.5AL	T3.15AL	X	MAIN B'D

± B LINE  
 SIGNAL LINE

**SCHEMATIC DIAGRAMS (4/8)**  
 MAIN UNIT  
 OUTLET UNIT  
 VOLTAGE SEL UNIT

# SCHEMATIC DIAGRAMS (4/8)

1

2

3

4

5

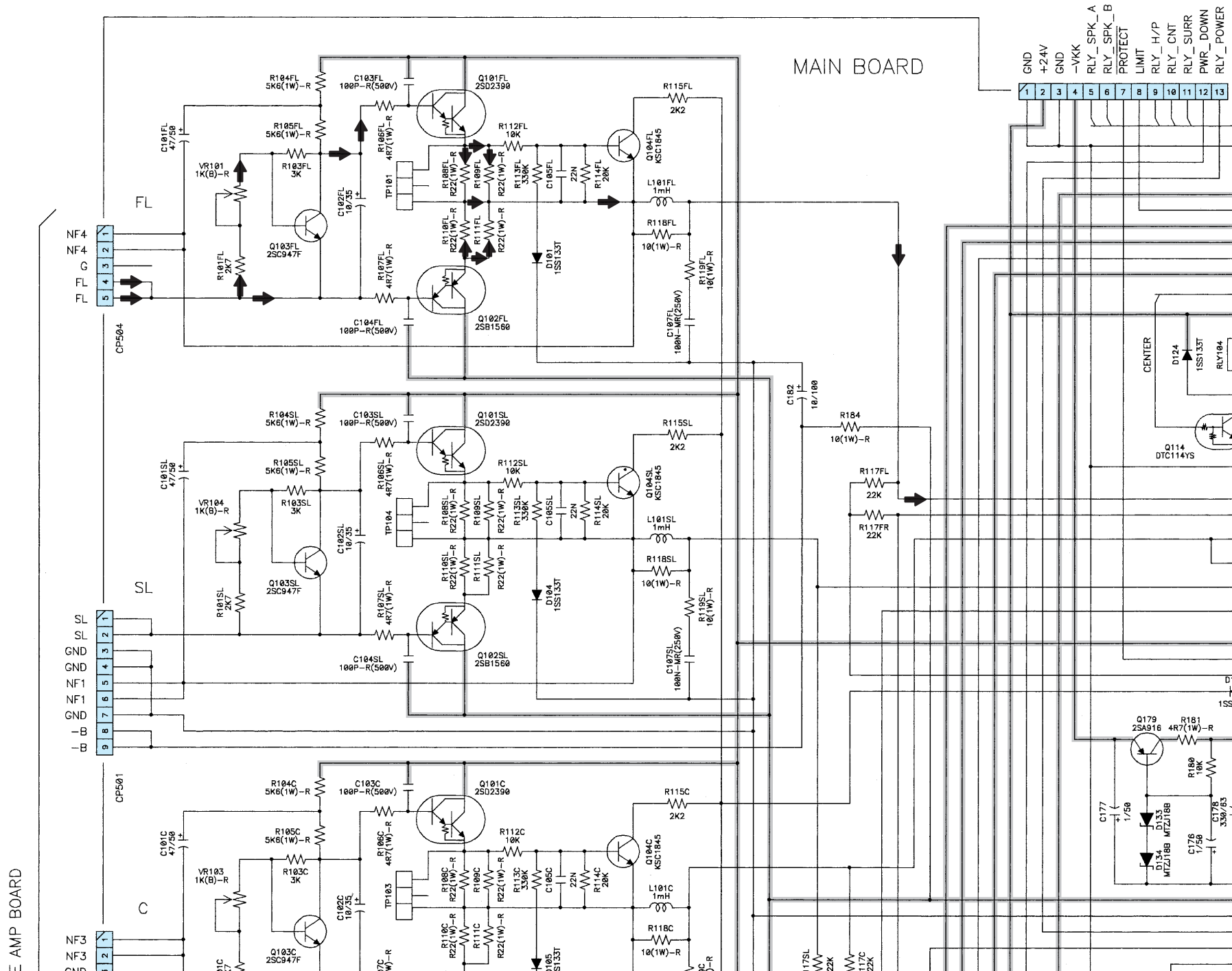

FROM PRE AMP

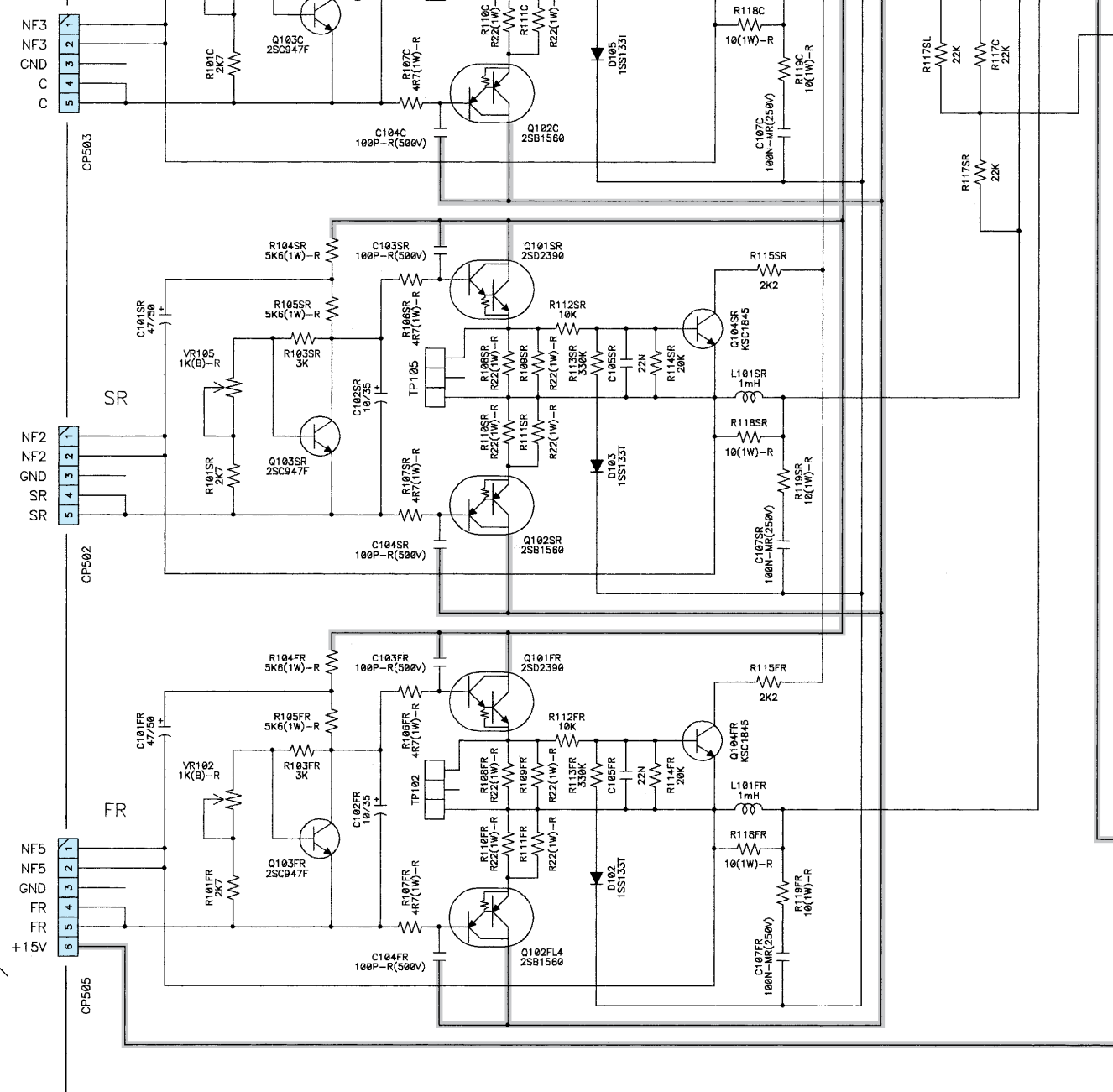

**NOTICE:**  
 ALL RESISTANCE VALUES IN OHM. k=1,000 OHM M=1,000,000 OHM  
 ALL CAPACITANCE VALUES IN MICRO FARAD. P=MICRO-MICRO FARAD  
 EACH VOLTAGE AND CURRENT ARE MEASURED AT NO SIGNAL INPUT  
 CONDITION.  
 CIRCUIT AND PARTS ARE SUBJECT TO CHANGE WITHOUT PRIOR  
 NOTICE.

**WARNING:**  
 Parts marked with this symbol  have critical characteristics.  
 Use ONLY replacement parts recommended by the manufacture.

**CAUTION:**  
 Before returning the unit to the customer, make sure you make either (1) a  
 leakage current check or (2) a line to chassis resistance check. If the leakage  
 current exceeds 0.5 milliamps, or if the resistance from chassis to either side  
 of the power card is less than 460kohms, the unit is defective.

 INDICATES SAFETY OF THE UNIT.  
 TO REDUCE THE RISK OF ELECTRICAL SHOCK,  
 CURRENT OR RESISTANCE CHECKS MUST BE  
 CARRIED OUT ( EXPOSED PARTS MUST BE  
 INSULATED FROM THE CHASSIS).  
 THE APPLIANCE RETURNED TO THE MANUFACTURER.

**WARNING:**  
 DO NOT return the unit to the manufacturer  
 until corrected.

6

7

8

9

10

11

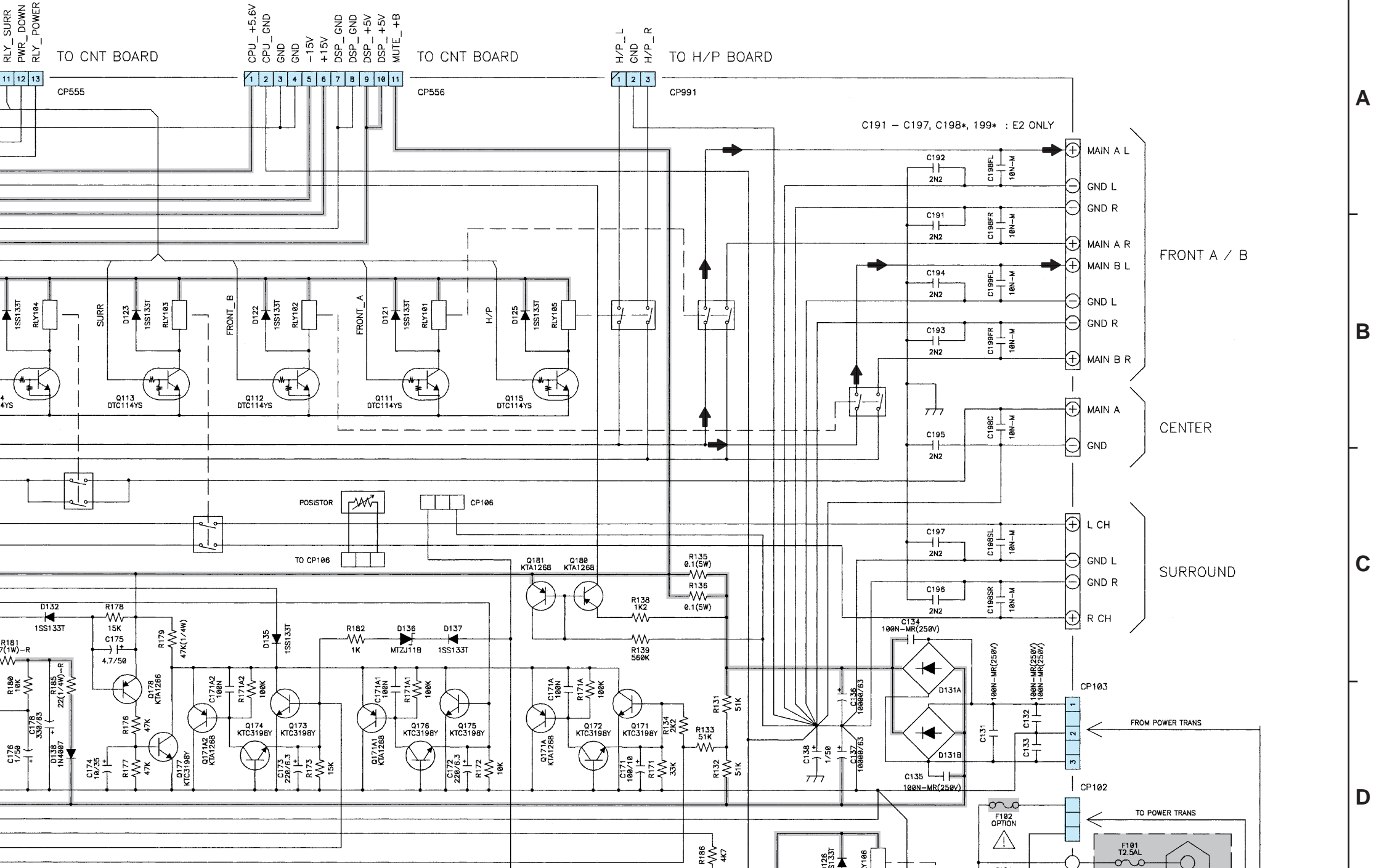

A

B

C

D

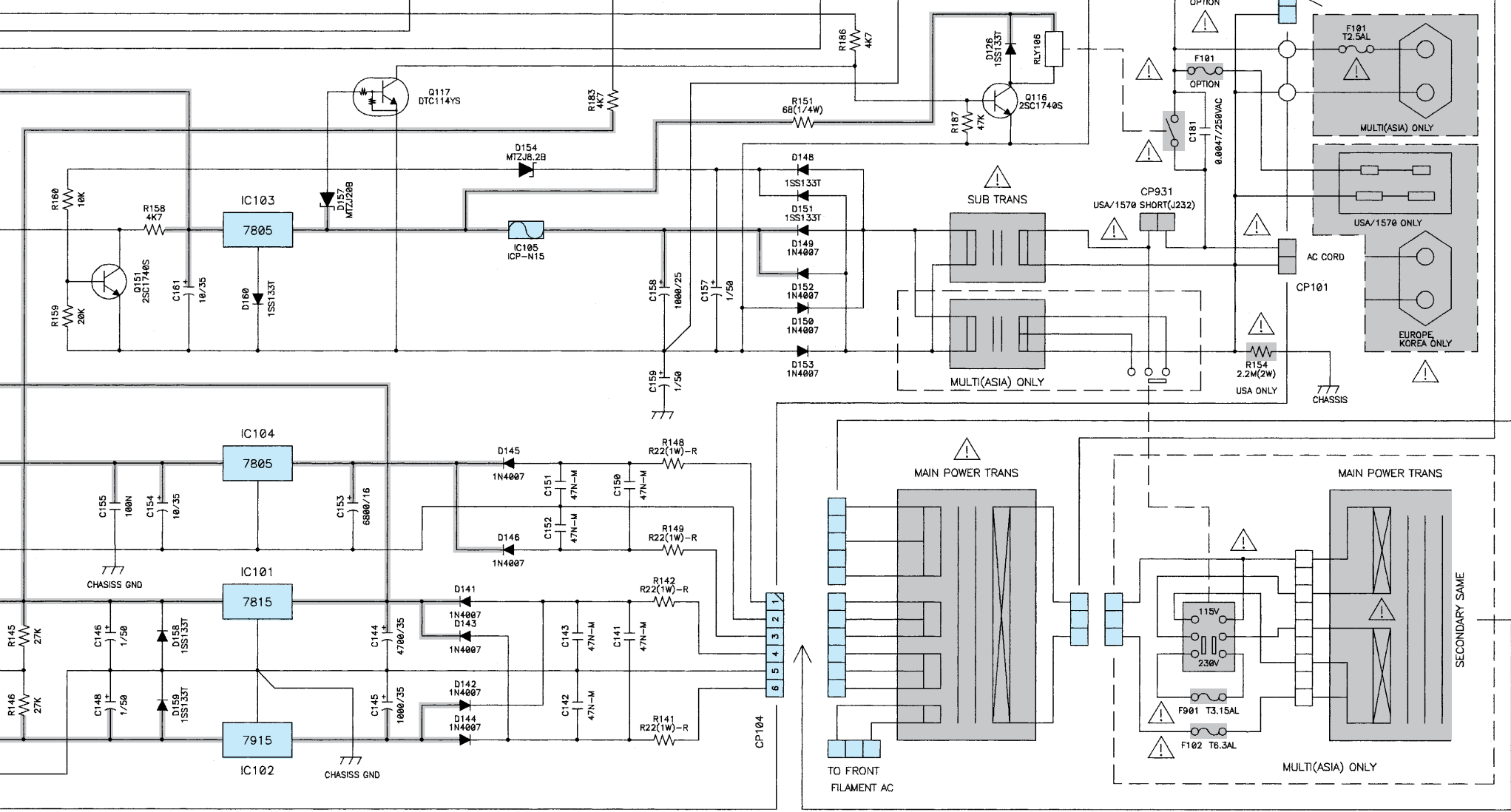

SAFETY CRITICAL COMPONENTS.  
 RISK OF ELECTRIC SHOCK, LEAKAGE  
 RESISTANCE MEASUREMENTS SHALL BE  
 EXPOSED PARTS ARE ACCEPTABLY  
 ( THE SUPPLY CIRCUIT ) BEFORE  
 RETURNED TO THE CUSTOMER.

WARNING:  
 Do not return the unit to the customer until the problem is located and  
 fixed.

AVC-1570	F101	F102	F901	POSITION
JAPAN(N)	T8A	T8A	X	MAIN B'D
TAIWAN(T)	8A/125V	8A/125V	X	MAIN B'D

AVR-1603	F101	F102	F901	POSITION
USA(E3)	8A/125V	8A/125V	X	MAIN B'D
EUROPE(E2)	T2.5AL	T3.15AL	X	MAIN B'D
CHINA(C)	X	T3.15AL	X	MAIN B'D
ASIA(H,T,E1)	T2.5AL	T6.3AL	T3.15AL	V.SEL B'D
KOREA(K)	T2.5AL	T3.15AL	X	MAIN B'D

SCHEMATIC DIAGRAMS (4/8)  
 MAIN UNIT  
 OUTLET UNIT  
 VOLTAGE SEL UNIT

**SCHEMATIC DIAGRAMS (5/8)**

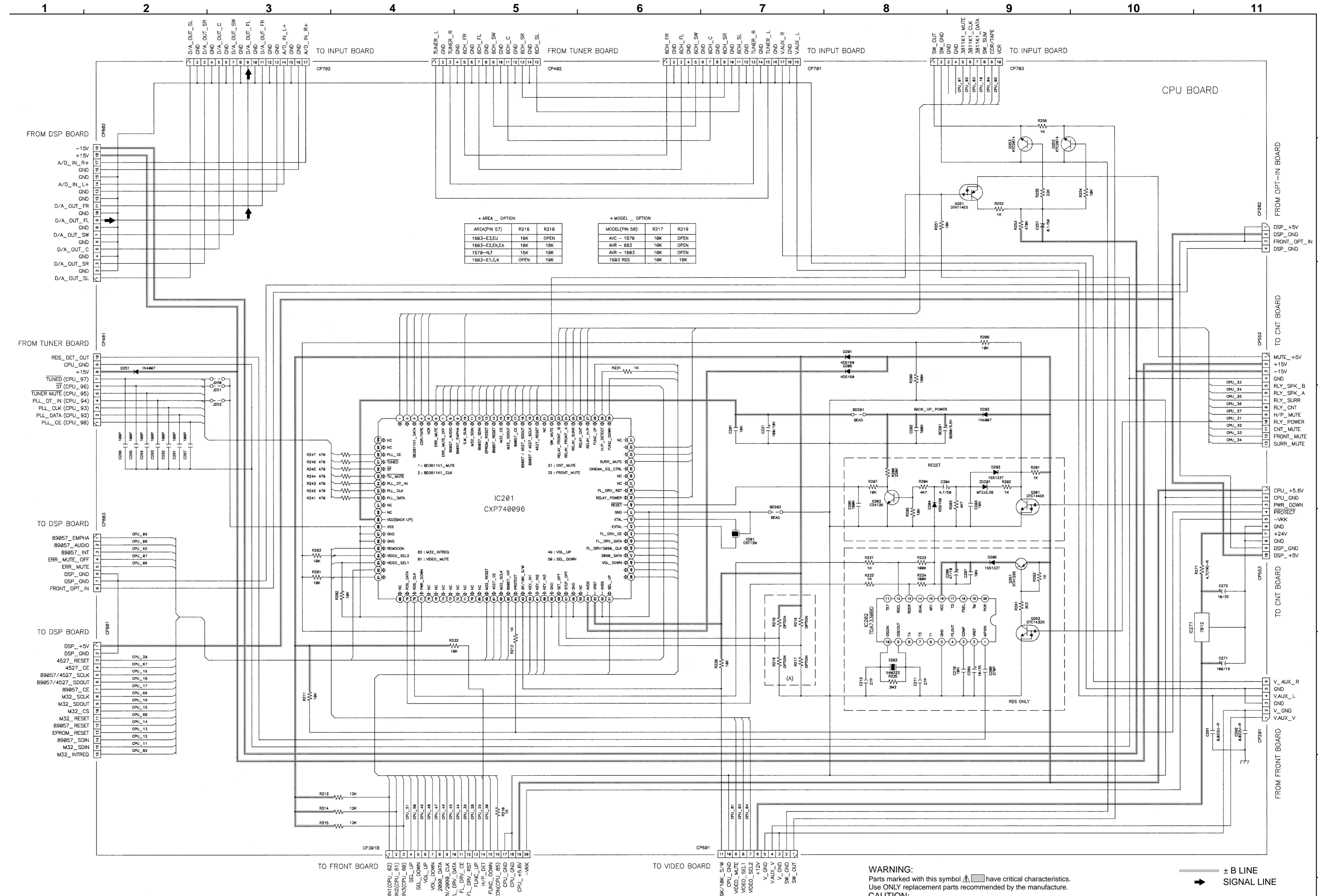

**NOTICE:**  
 ALL RESISTANCE VALUES IN OHM. k=1,000 OHM M=1,000,000 OHM  
 ALL CAPACITANCE VALUES IN MICRO FARAD. P=MICRO-MICRO FARAD  
 EACH VOLTAGE AND CURRENT ARE MEASURED AT NO SIGNAL INPUT  
 CONDITION.  
 CIRCUIT AND PARTS ARE SUBJECT TO CHANGE WITHOUT PRIOR  
 NOTICE.

**WARNING:**  
 Parts marked with this symbol  $\Delta$  have critical characteristics.  
 Use ONLY replacement parts recommended by the manufacturer.  
**CAUTION:**  
 Before returning the unit to the customer, make sure you make either (1) a  
 leakage current check or (2) a line to chassis resistance check. If the leakage  
 current exceeds 0.5 millamps, or if the resistance from chassis to either side  
 of the power card is less than 460kohms, the unit is defective.  
**WARNING:**  
 DO NOT return the unit to the customer until the problem is located and  
 corrected.

**SCHEMATIC DIAGRAMS (5/8)**  
CPU UNIT

SCHEMATIC DIAGRAMS (5/8)

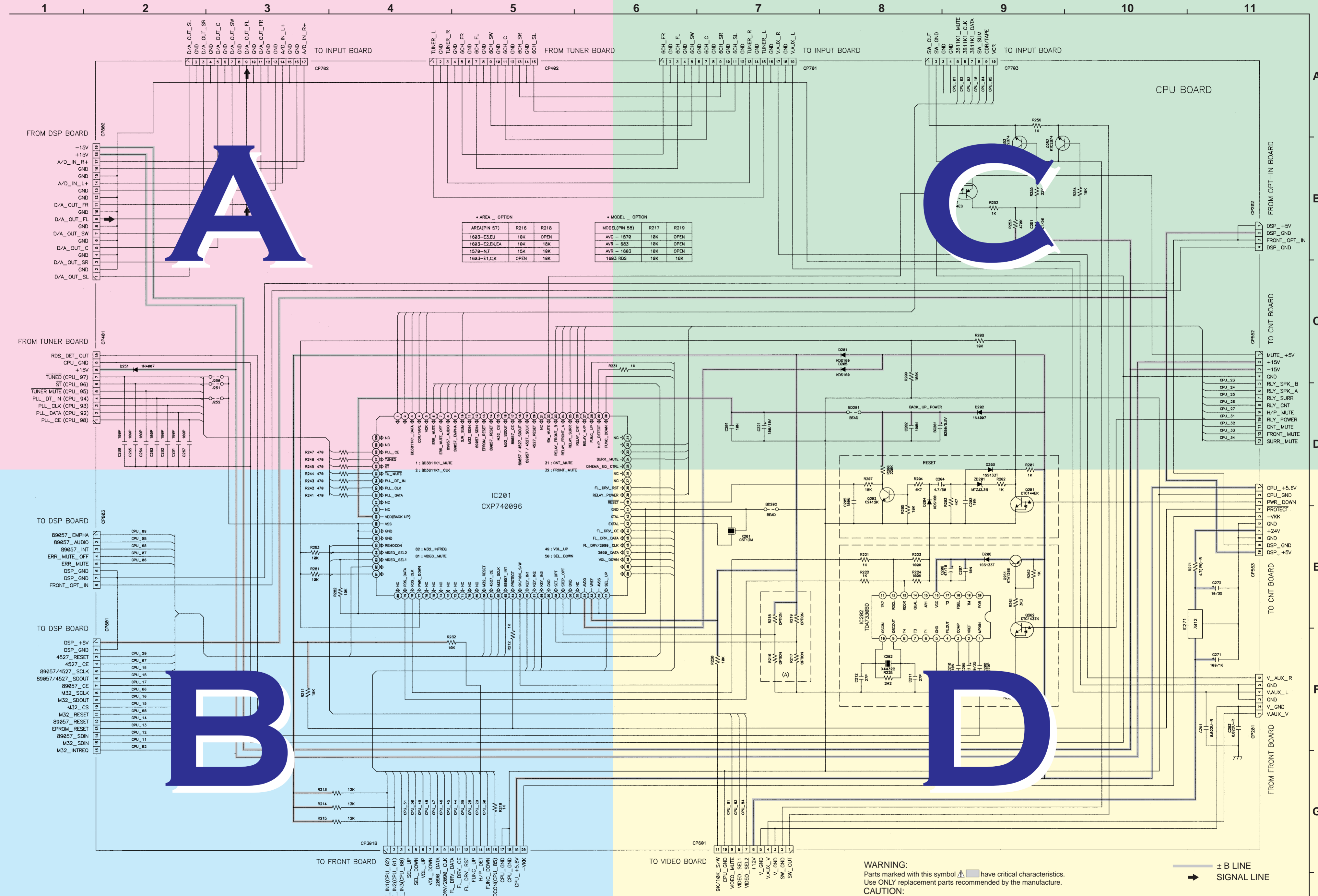

**WARNING:**  
Parts marked with this symbol  $\Delta$  have critical characteristics. Use ONLY replacement parts recommended by the manufacturer.

**CAUTION:**  
Before returning the unit to the customer, make sure you make either (1) a leakage current check or (2) a line to chassis resistance check. If the leakage current exceeds 0.5 millamps, or if the resistance from chassis to either side of the power card is less than 460kohms, the unit is defective.

**WARNING:**  
DO NOT return the unit to the customer until the problem is located and corrected.

**NOTICE:**  
ALL RESISTANCE VALUES IN OHM. k=1,000 OHM M=1,000,000 OHM  
ALL CAPACITANCE VALUES IN MICRO FARAD. P=MICRO-MICRO FARAD  
EACH VOLTAGE AND CURRENT ARE MEASURED AT NO SIGNAL INPUT CONDITION.  
CIRCUIT AND PARTS ARE SUBJECT TO CHANGE WITHOUT PRIOR NOTICE.

SCHEMATIC DIAGRAMS (5/8) CPU UNIT

# SCHEMATIC DIAGRAMS (5/8)

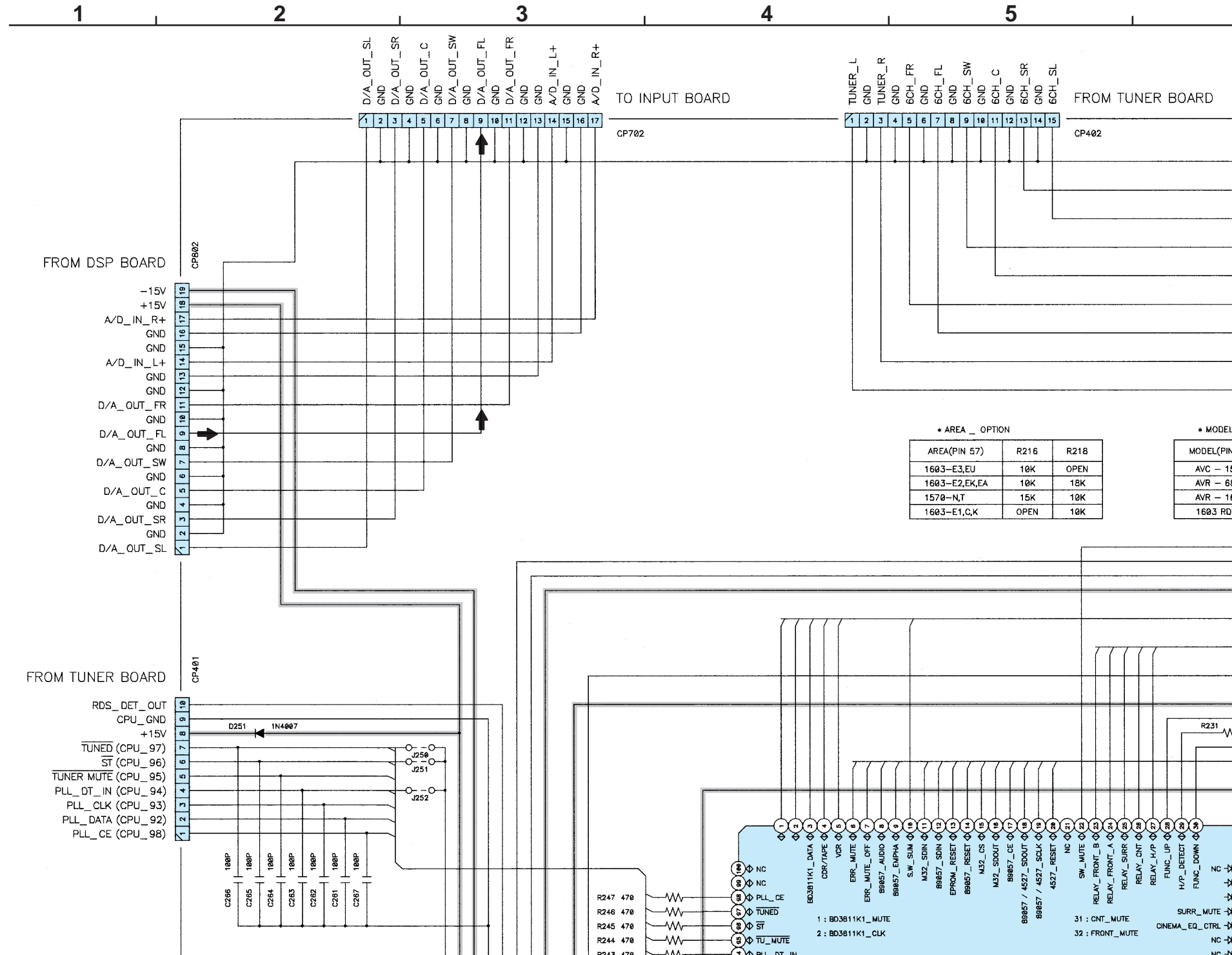

\* AREA \_ OPTION

AREA(PIN 57)	R216	R218
1603-E3,EU	10K	OPEN
1603-E2,EK,EA	10K	18K
1570-N,T	15K	10K
1603-E1,C,K	OPEN	10K

\* MODEL

MODEL(PIN
AVC - 15
AVR - 68
AVR - 14
1603 RD

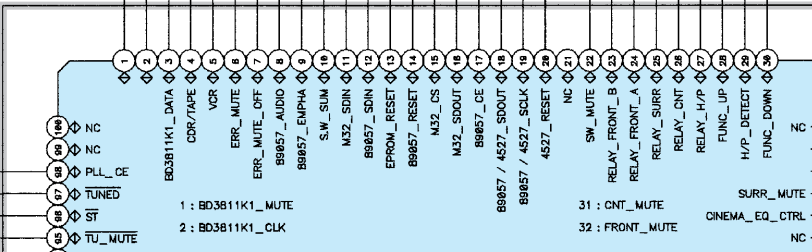



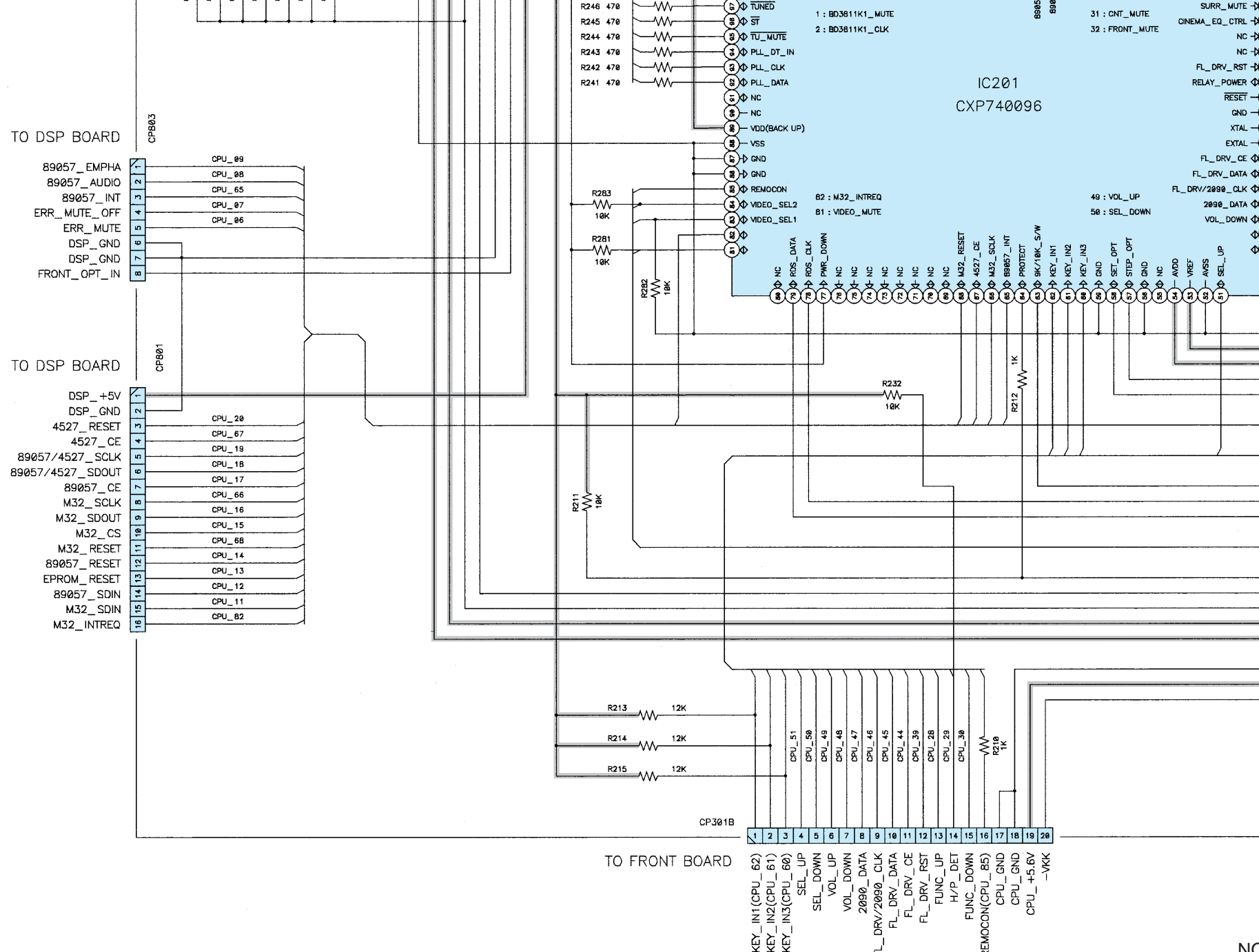

NO  
 ALI  
 ALI  
 EAO  
 CO  
 CIR  
 NO

6 7 8 9 10 11

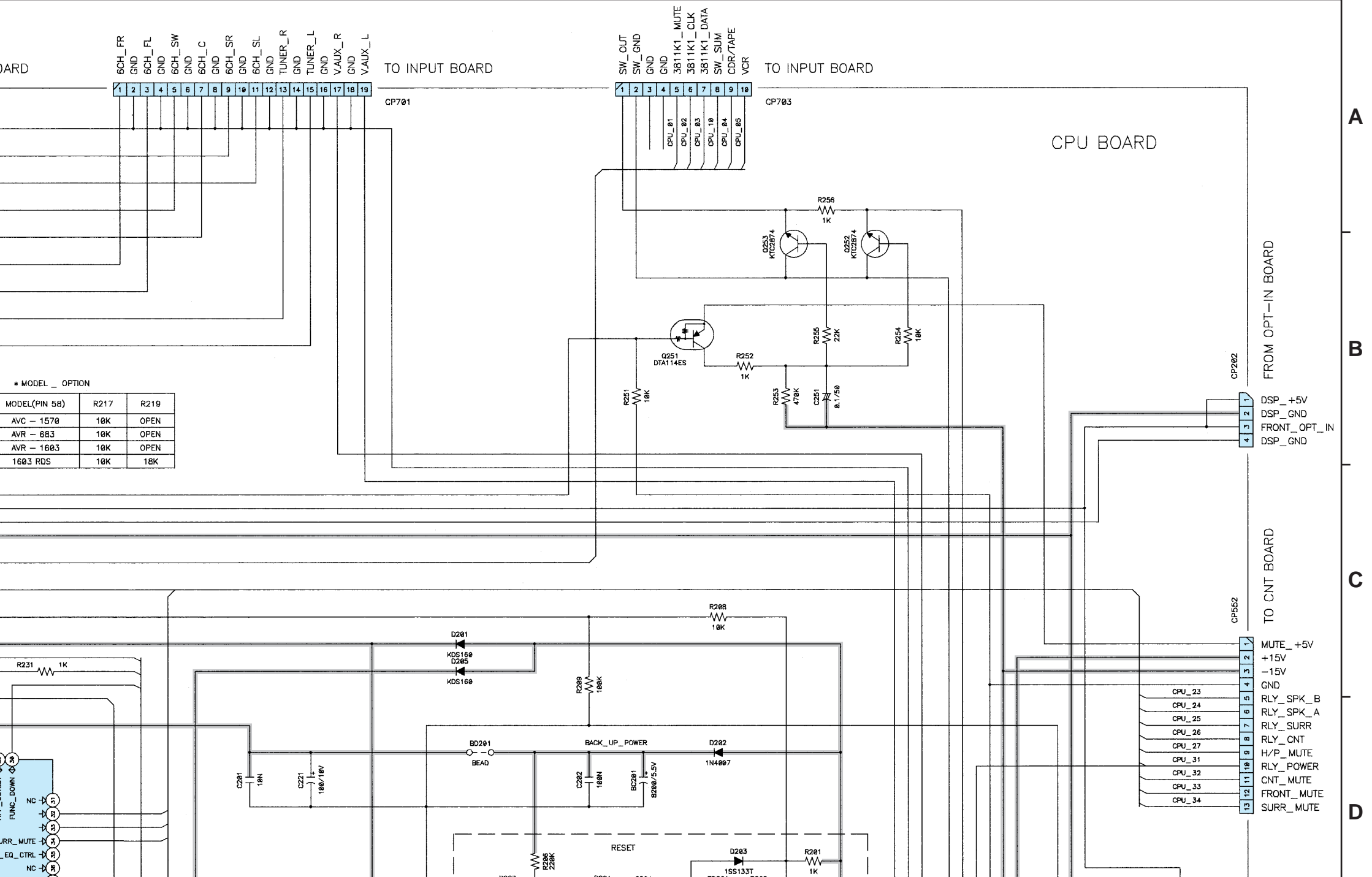

A  
B  
C  
D

\* MODEL \_ OPTION

MODEL(PIN 5B)	R217	R219
AVC - 1570	10K	OPEN
AVR - 683	10K	OPEN
AVR - 1603	10K	OPEN
1603 RDS	10K	18K

- FROM OPT-IN BOARD
- 1 DSP\_+5V
  - 2 DSP\_GND
  - 3 FRONT\_OPT\_IN
  - 4 DSP\_GND
- TO CNT BOARD
- 1 MUTE\_+5V
  - 2 +15V
  - 3 -15V
  - 4 GND
  - 5 RLY\_SPK\_B
  - 6 RLY\_SPK\_A
  - 7 RLY\_SURR
  - 8 RLY\_CNT
  - 9 H/P\_MUTE
  - 10 RLY\_POWER
  - 11 CNT\_MUTE
  - 12 FRONT\_MUTE
  - 13 SURR\_MUTE

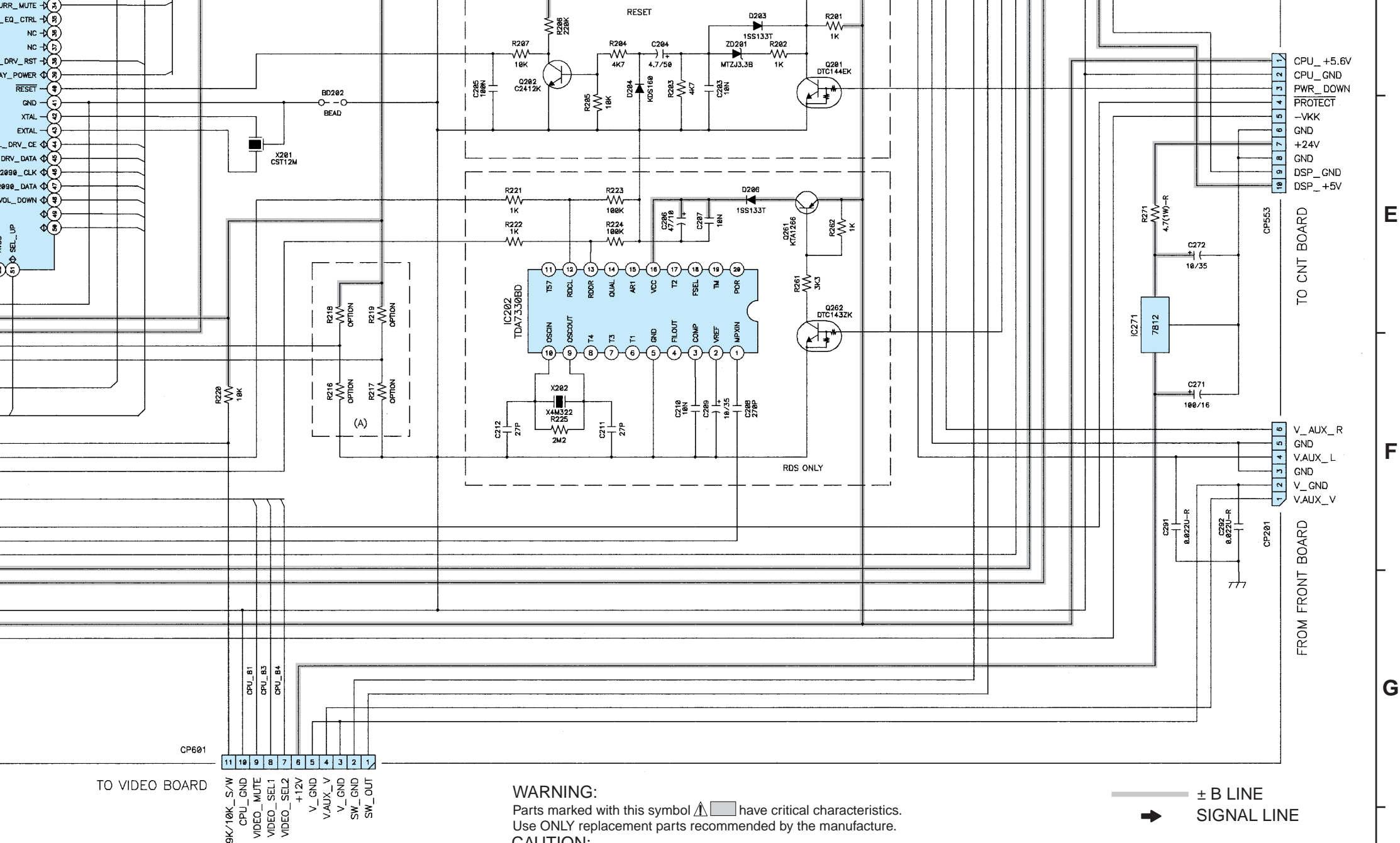

**NOTICE:**  
 ALL RESISTANCE VALUES IN OHM. k=1,000 OHM M=1,000,000 OHM  
 ALL CAPACITANCE VALUES IN MICRO FARAD. P=MICRO-MICRO FARAD  
 EACH VOLTAGE AND CURRENT ARE MEASURED AT NO SIGNAL INPUT  
 CONDITION.  
 CIRCUIT AND PARTS ARE SUBJECT TO CHANGE WITHOUT PRIOR  
 NOTICE.

**WARNING:**  
 Parts marked with this symbol have critical characteristics.  
 Use ONLY replacement parts recommended by the manufacturer.

**CAUTION:**  
 Before returning the unit to the customer, make sure you make either (1) a leakage current check or (2) a line to chassis resistance check. If the leakage current exceeds 0.5 milliamps, or if the resistance from chassis to either side of the power card is less than 460kohms, the unit is defective.

**WARNING:**  
 DO NOT return the unit to the customer until the problem is located and corrected.

## SCHEMATIC DIAGRAMS (5/8) CPU UNIT

± B LINE  
 SIGNAL LINE

**SCHEMATIC DIAGRAMS (6/8)**

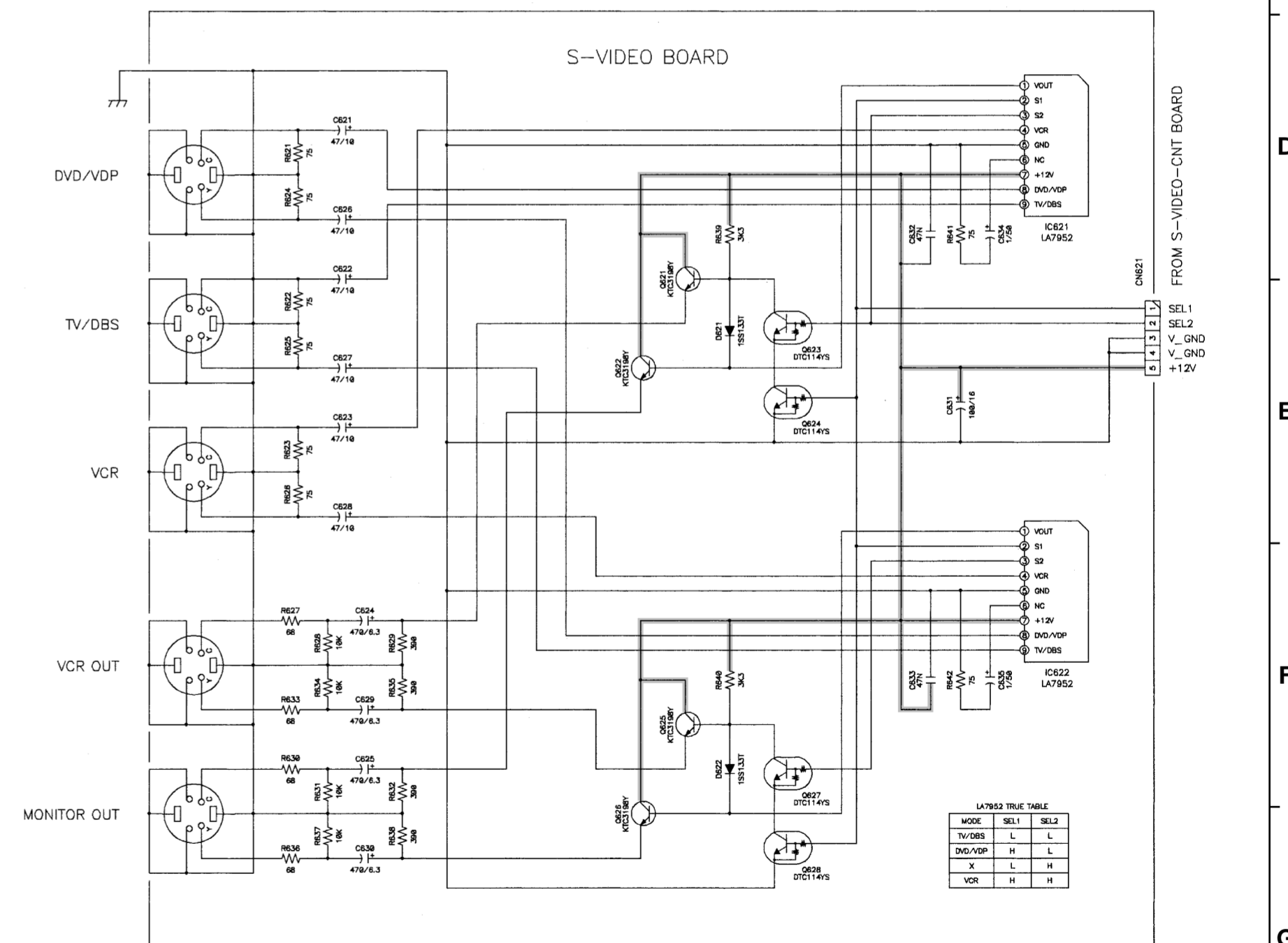
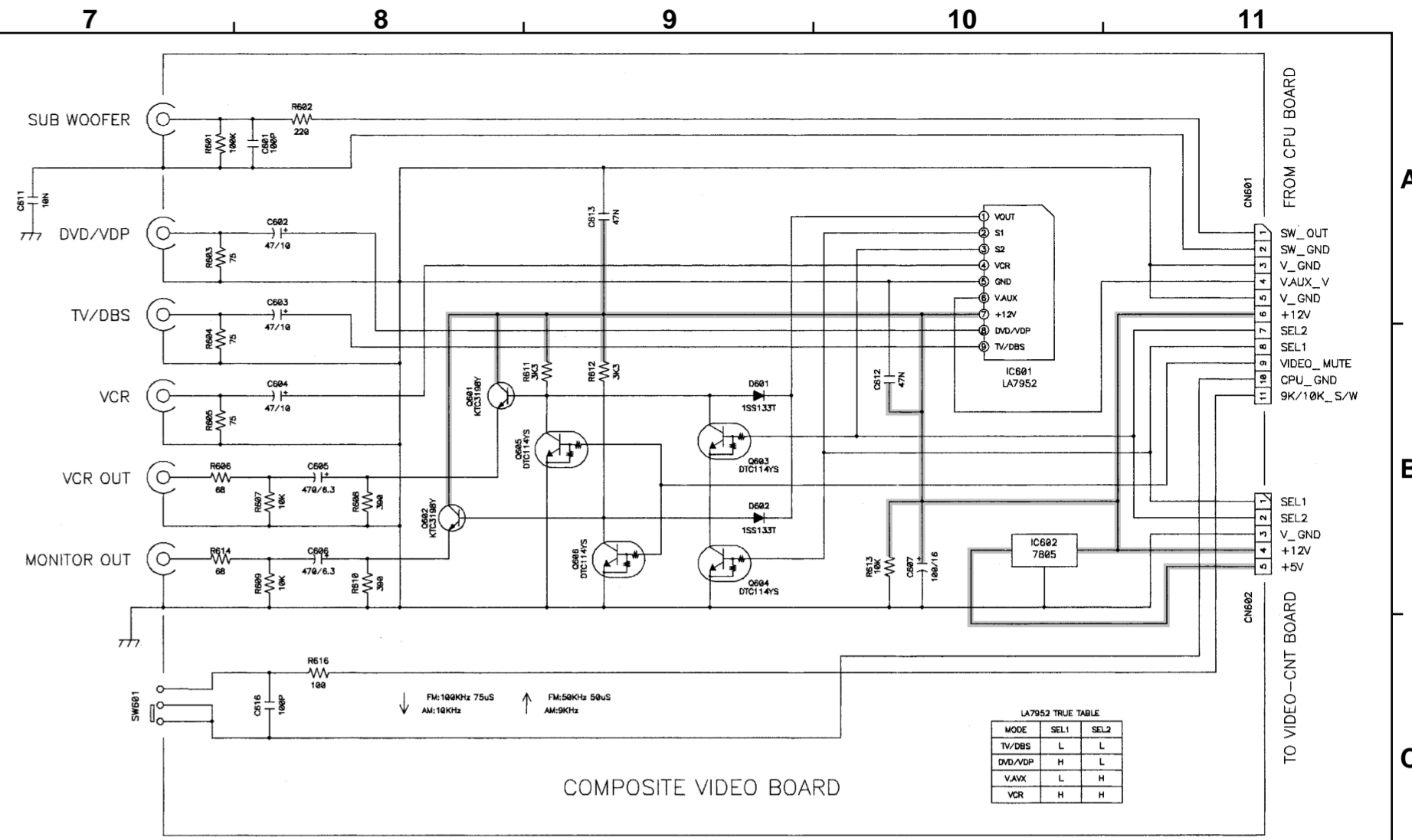
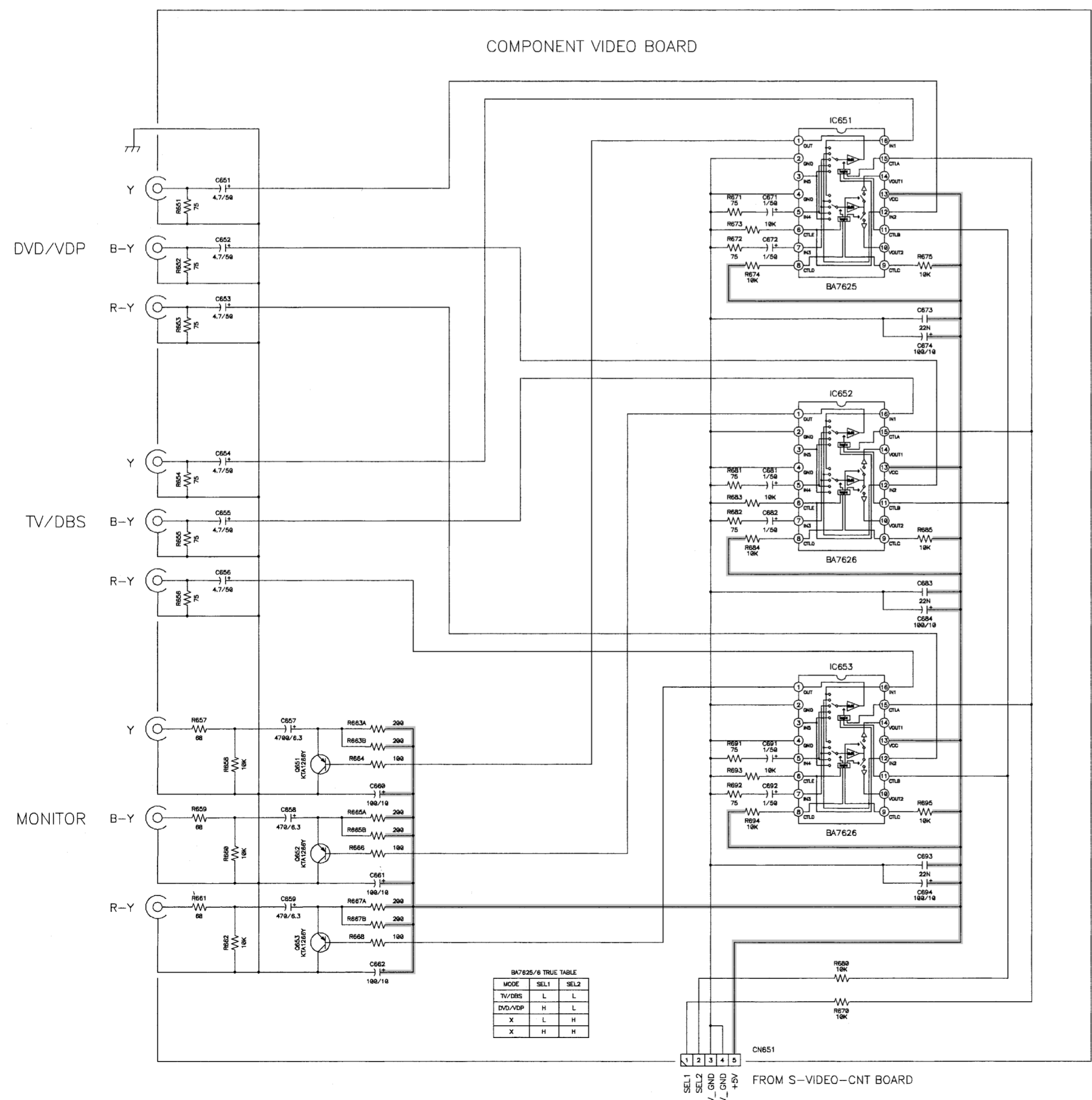
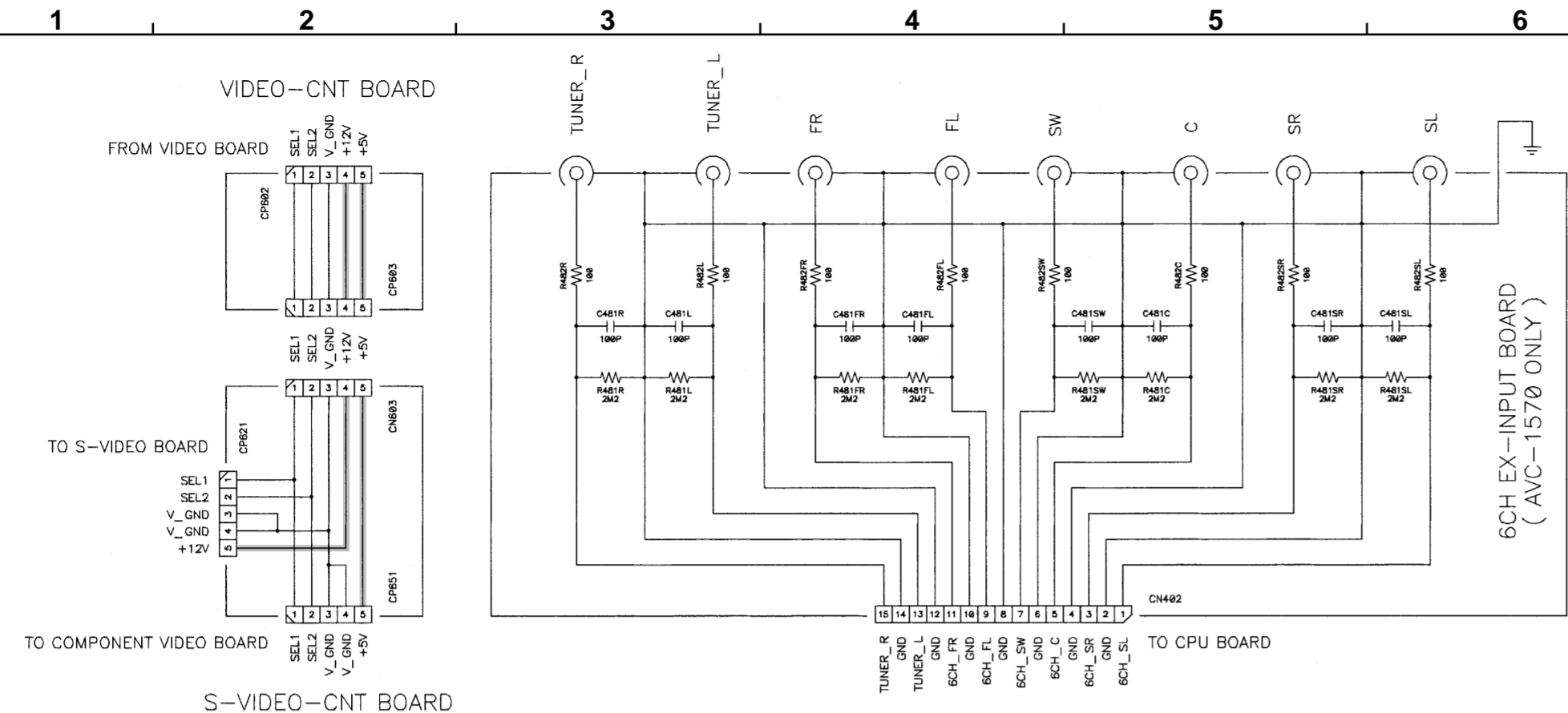

**NOTICE:**  
 ALL RESISTANCE VALUES IN OHM. k=1,000 OHM M=1,000,000 OHM  
 ALL CAPACITANCE VALUES IN MICRO FARAD. P=MICRO-MICRO FARAD  
 EACH VOLTAGE AND CURRENT ARE MEASURED AT NO SIGNAL INPUT CONDITION.  
 CIRCUIT AND PARTS ARE SUBJECT TO CHANGE WITHOUT PRIOR NOTICE.

**WARNING:**  
 Parts marked with this symbol have critical characteristics.  
 Use ONLY replacement parts recommended by the manufacture.

**CAUTION:**  
 Before returning the unit to the customer, make sure you make either (1) a leakage current check or (2) a line to chassis resistance check. If the leakage current exceeds 0.5 millamps, or if the resistance from chassis to either side of the power card is less than 460kohms, the unit is defective.

**WARNING:**  
 DO NOT return the unit to the customer until the problem is located and corrected.

**SCHEMATIC DIAGRAMS (6/8)**

VIDEO UNIT  
 VIDEO CNT UNIT  
 S-VIDEO UNIT  
 S-VIDEO CNT UNIT  
 C-VIDEO UNIT



**SCHEMATIC DIAGRAMS (6/8)**

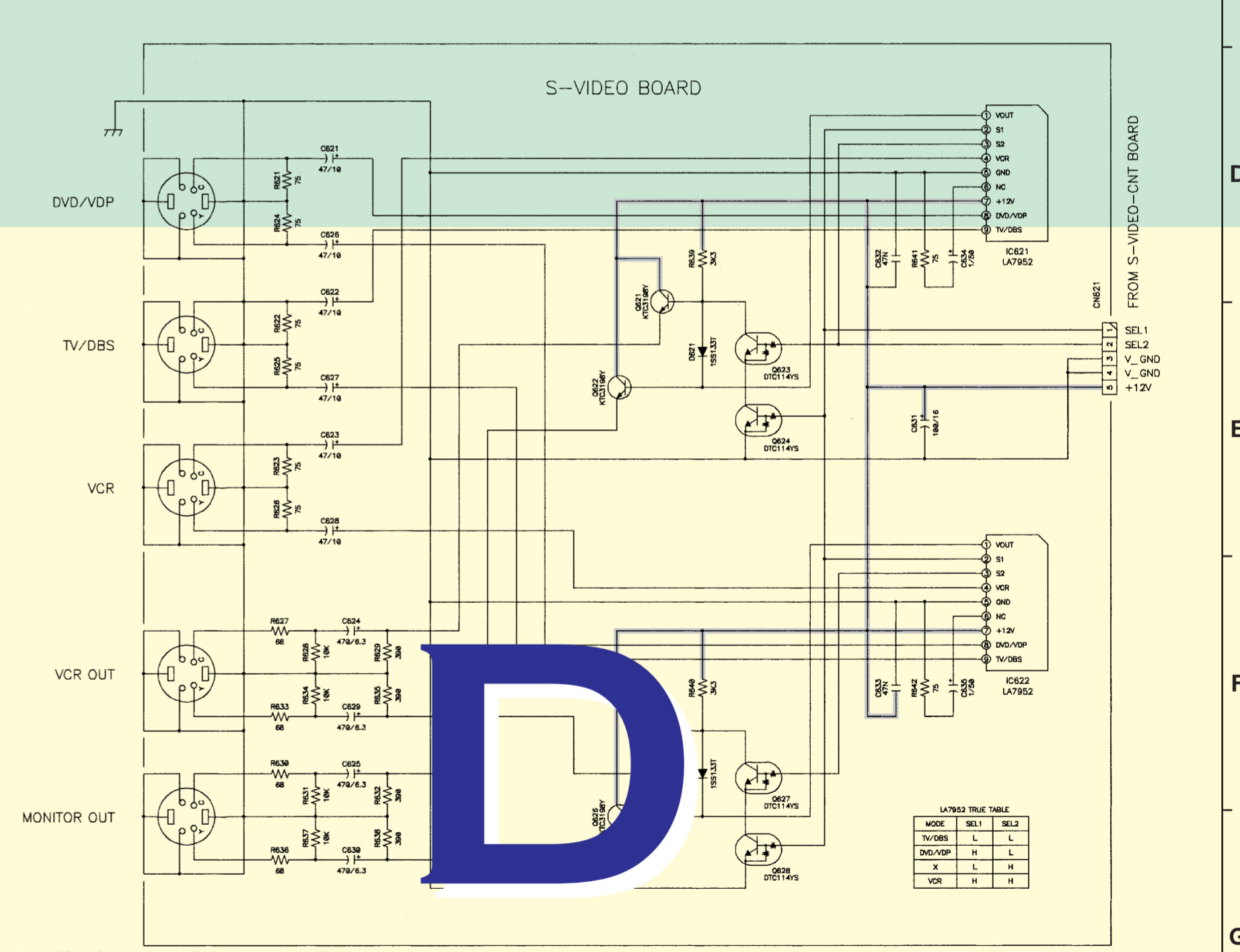
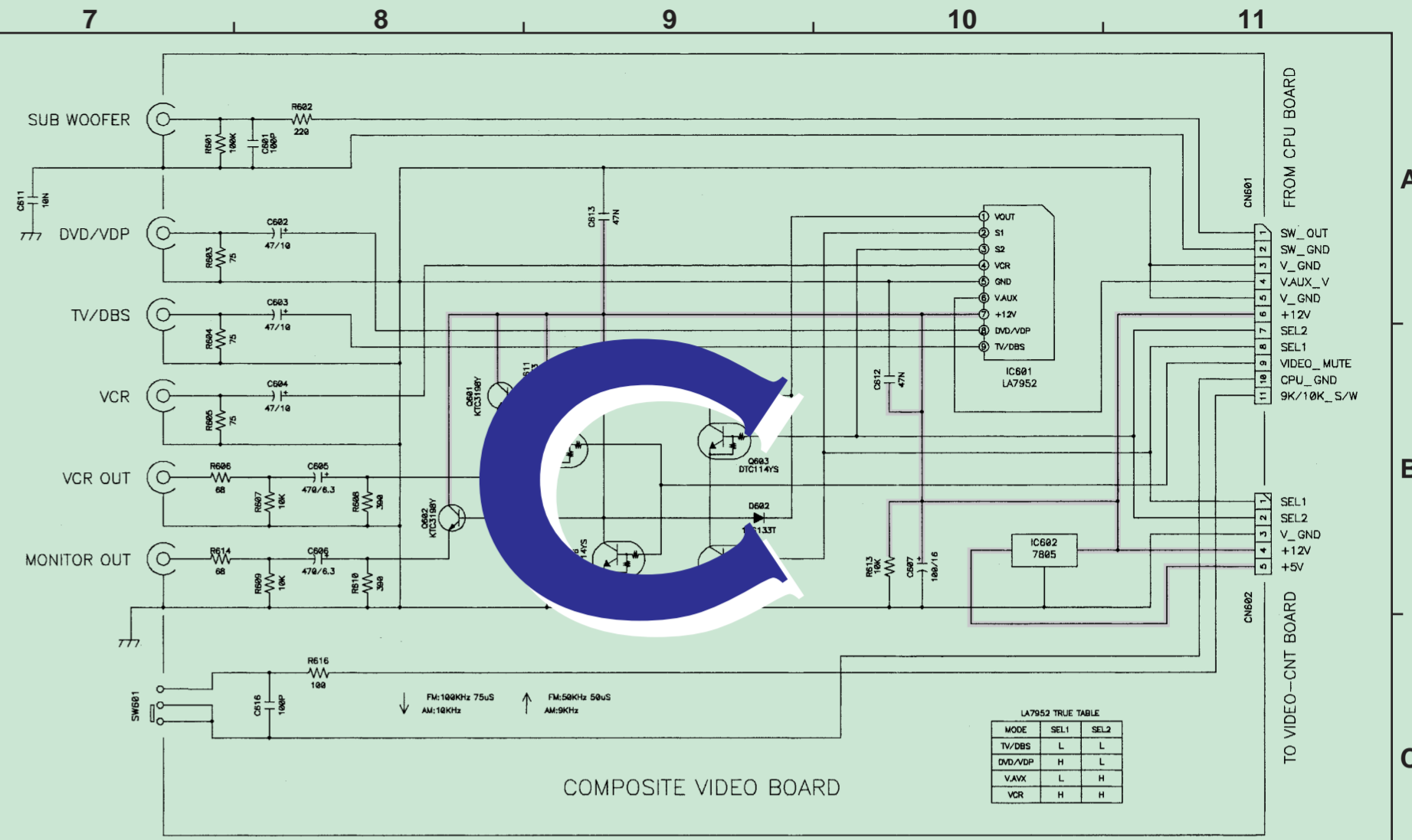
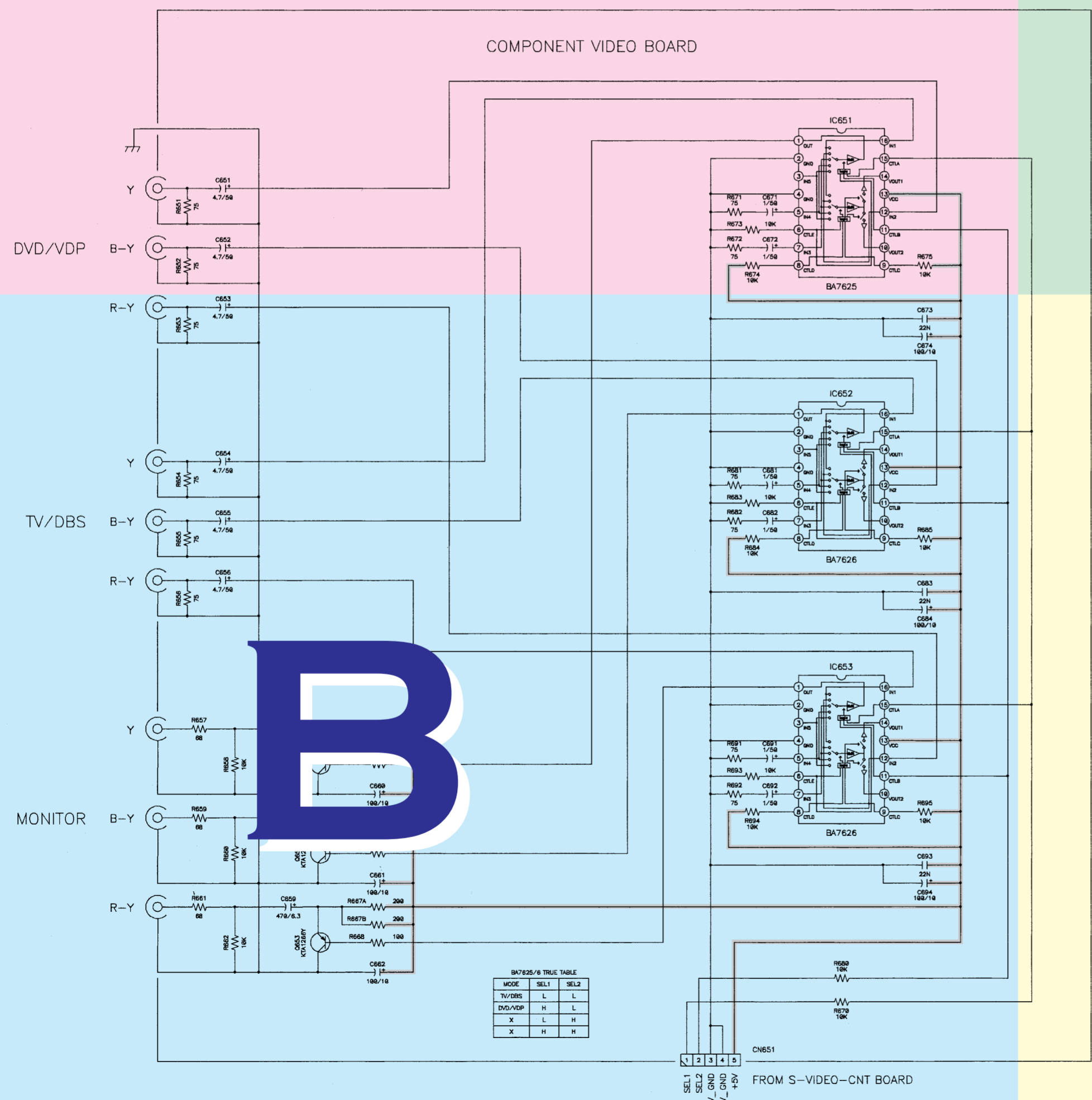
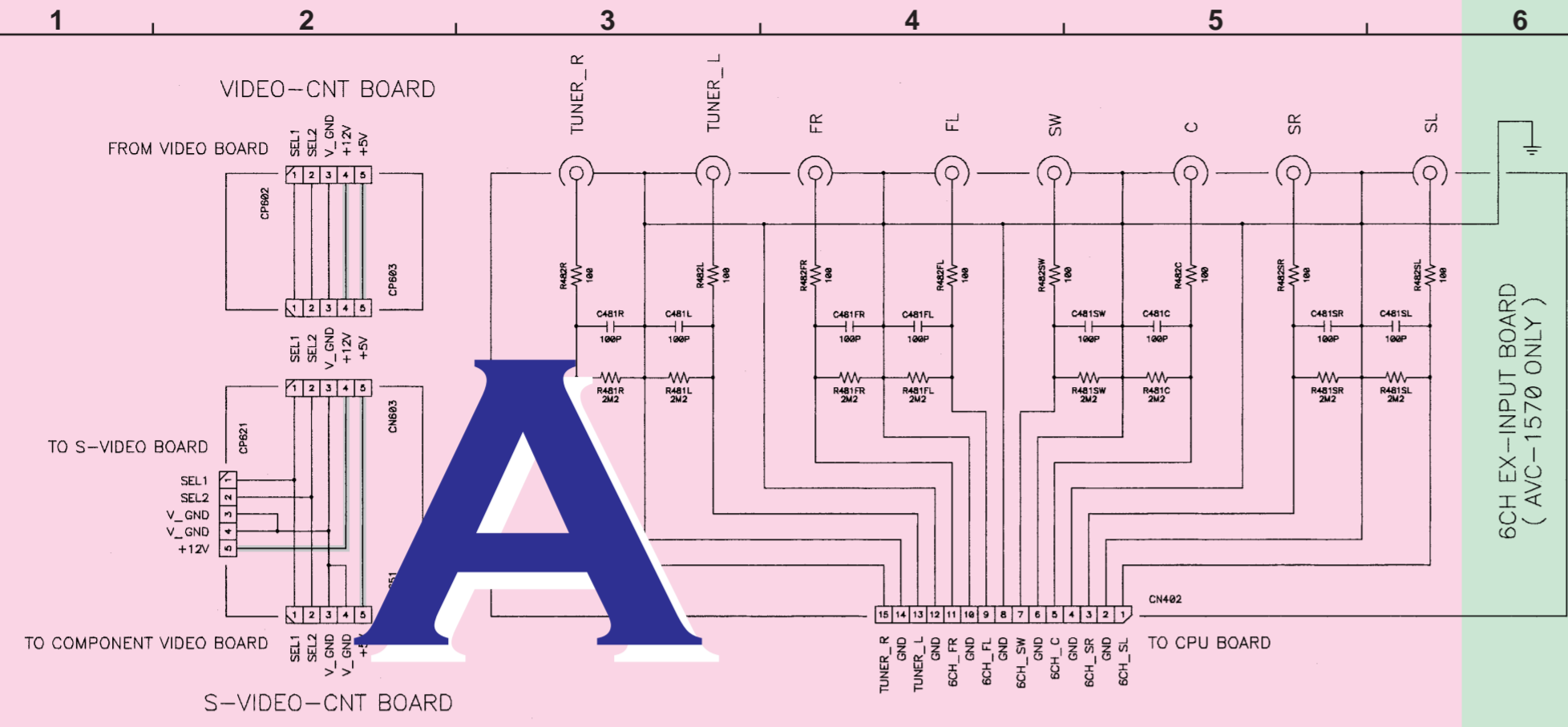

**NOTICE:**  
 ALL RESISTANCE VALUES IN OHM. k=1,000 OHM M=1,000,000 OHM  
 ALL CAPACITANCE VALUES IN MICRO FARAD. P=MICRO-MICRO FARAD  
 EACH VOLTAGE AND CURRENT ARE MEASURED AT NO SIGNAL INPUT CONDITION.  
 CIRCUIT AND PARTS ARE SUBJECT TO CHANGE WITHOUT PRIOR NOTICE.

**WARNING:**  
 Parts marked with this symbol have critical characteristics.  
 Use ONLY replacement parts recommended by the manufacture.

**CAUTION:**  
 Before returning the unit to the customer, make sure you make either (1) a leakage current check or (2) a chassis resistance check. If the leakage current exceeds 0.5 millamps, or if the resistance from chassis to either side of the power card is less than 460kohms, the unit is defective.

**WARNING:**  
 DO NOT return the unit to the customer until the problem is located and corrected.

**SCHEMATIC DIAGRAMS (6/8)**  
 VIDEO UNIT  
 VIDEO CNT UNIT  
 S-VIDEO UNIT  
 S-VIDEO CNT UNIT  
 C-VIDEO UNIT

± B LINE  
 SIGNAL LINE

# SCHEMATIC DIAGRAMS (6/8)

1

2

3

4

5

## VIDEO-CNT BOARD

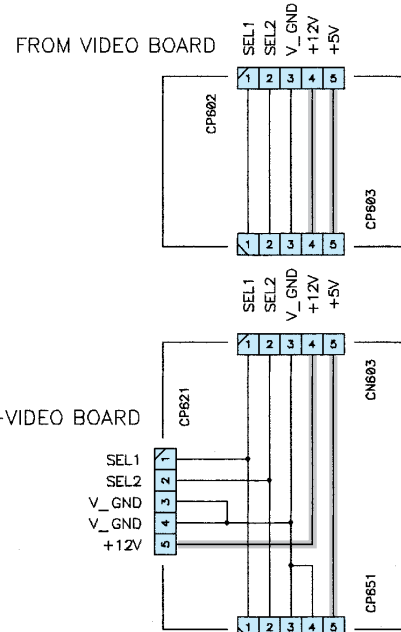

TO S-VIDEO BOARD

## S-VIDEO-CNT BOARD

TO COMPONENT VIDEO BOARD

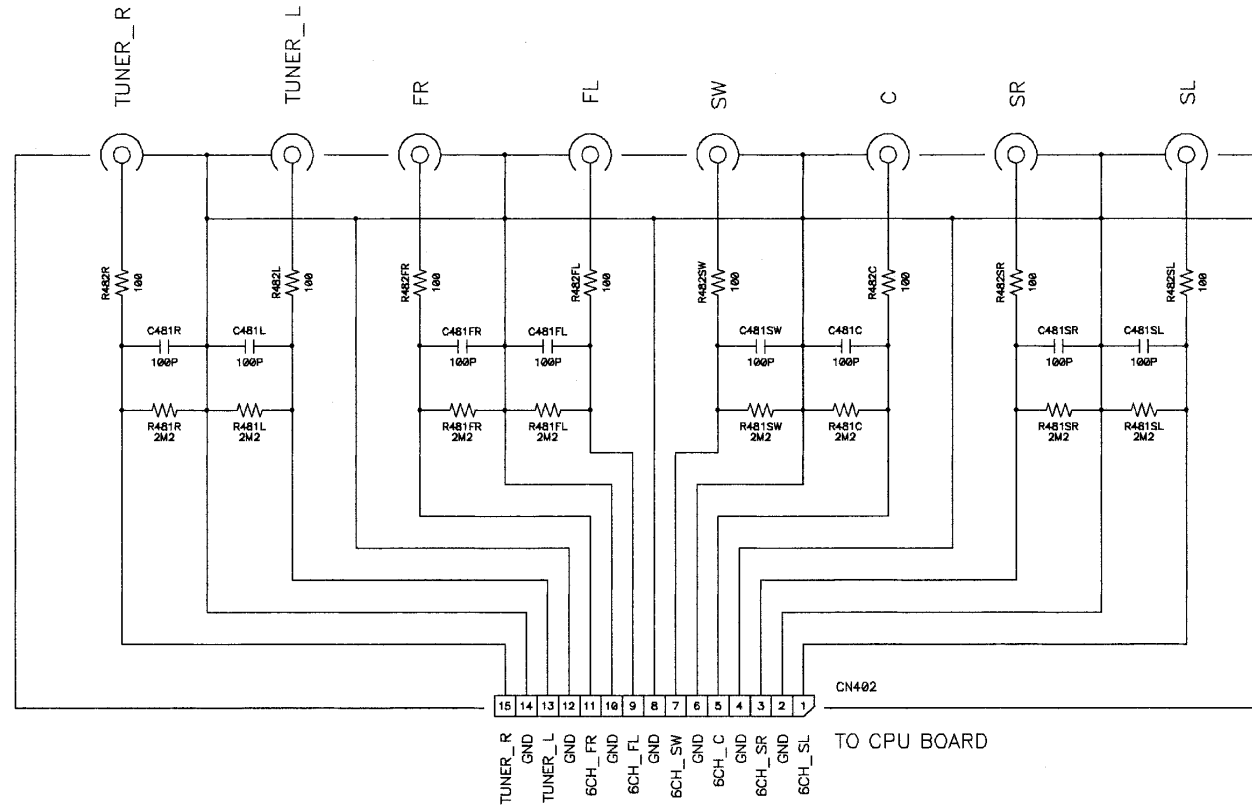

TO CPU BOARD

## COMPONENT VIDEO BOARD

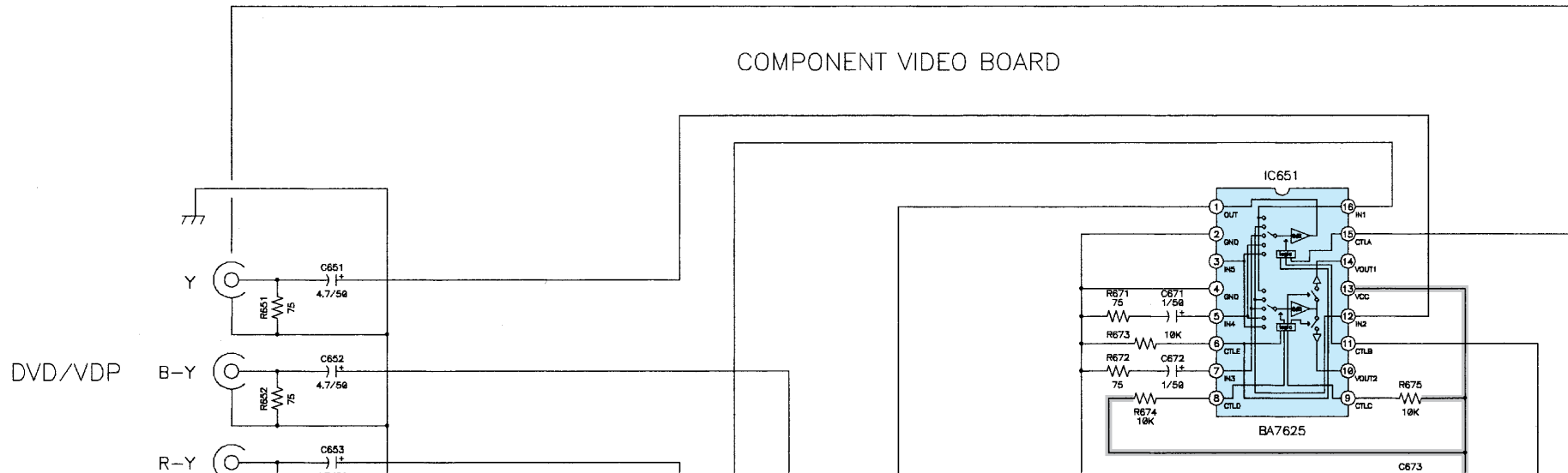

TV/DBS

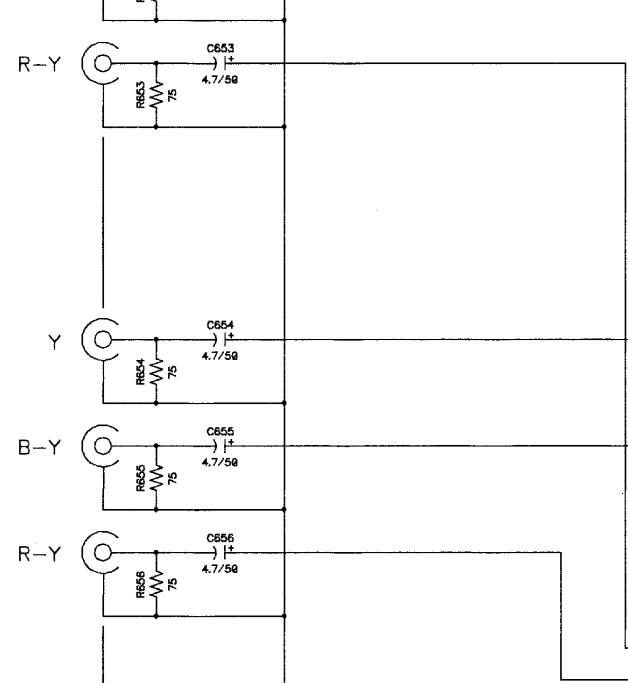

MONITOR

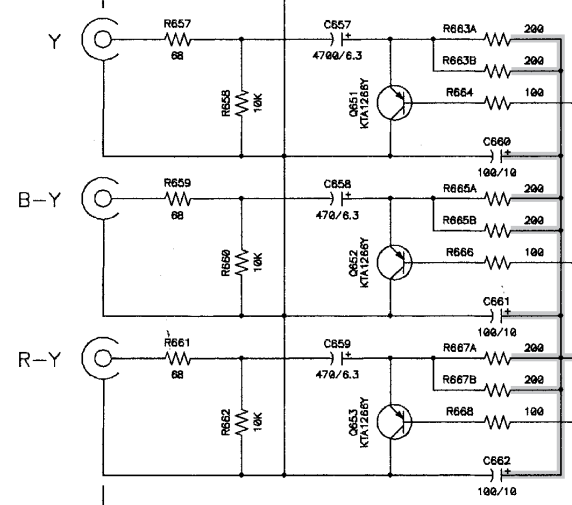

BA7625/6 TRUE TABLE

MODE	SEL1	SEL2
TV/DBS	L	L
DVD/VDP	H	L
X	L	H
X	H	H

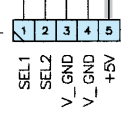

FROM S-VIDEO-CNT BOARD

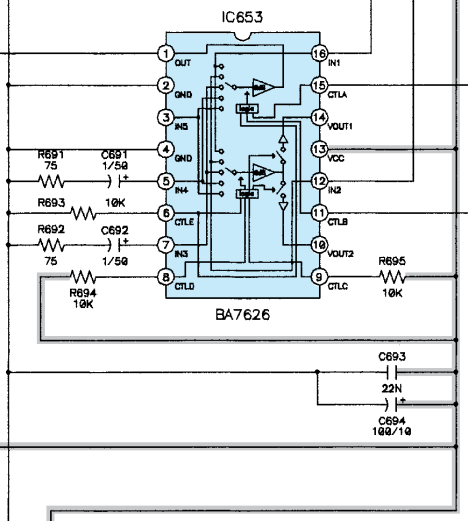
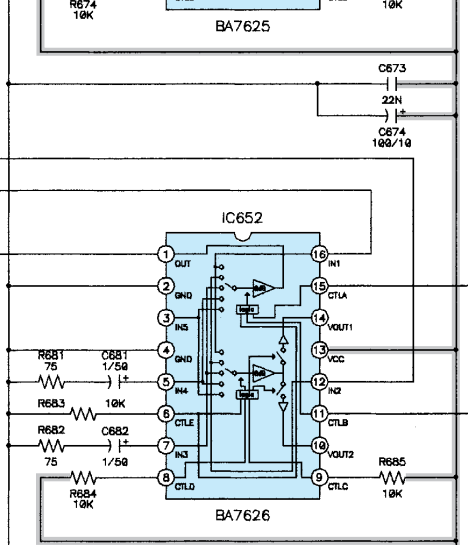

6

7

8

9

10

11

6CH EX-INPUT BOARD  
(AVC-1570 ONLY)

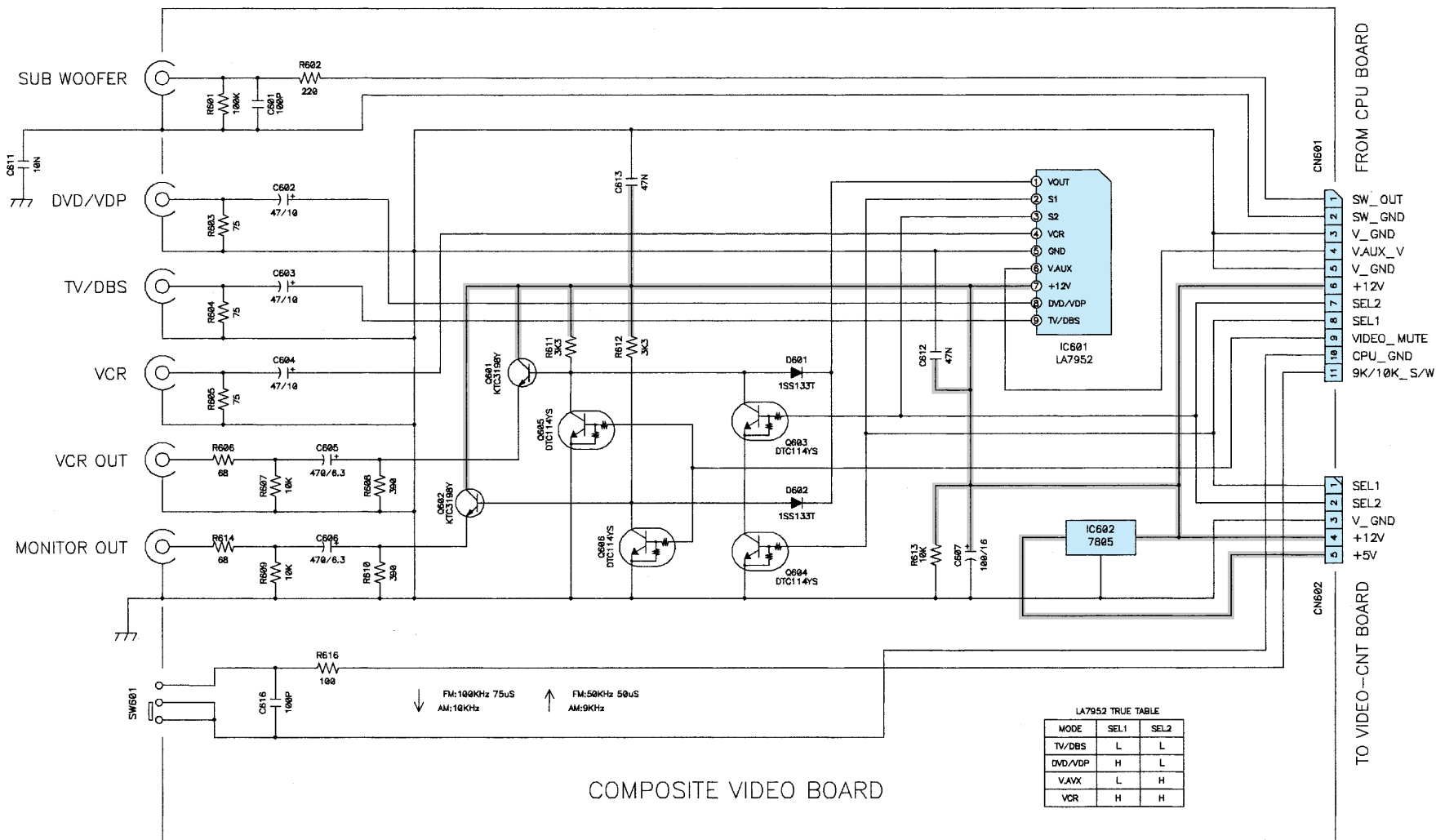

COMPOSITE VIDEO BOARD

S-VIDEO BOARD

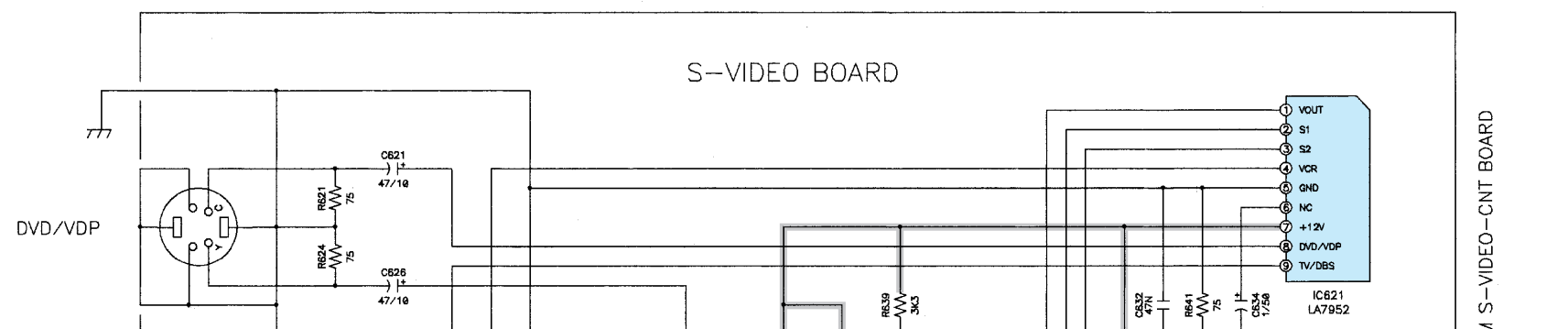

S-VIDEO BOARD

A

B

C

D

FROM CPU BOARD

TO VIDEO-CNT BOARD

TO S-VIDEO BOARD

- 1 SW\_OUT
- 2 SW\_GND
- 3 V\_GND
- 4 V.AUX\_V
- 5 V\_GND
- 6 +12V
- 7 SEL2
- 8 SEL1
- 9 VIDEO\_MUTE
- 10 CPU\_GND
- 11 9K/10K\_S/W

- 1 SEL1
- 2 SEL2
- 3 V\_GND
- 4 +12V
- 5 +5V



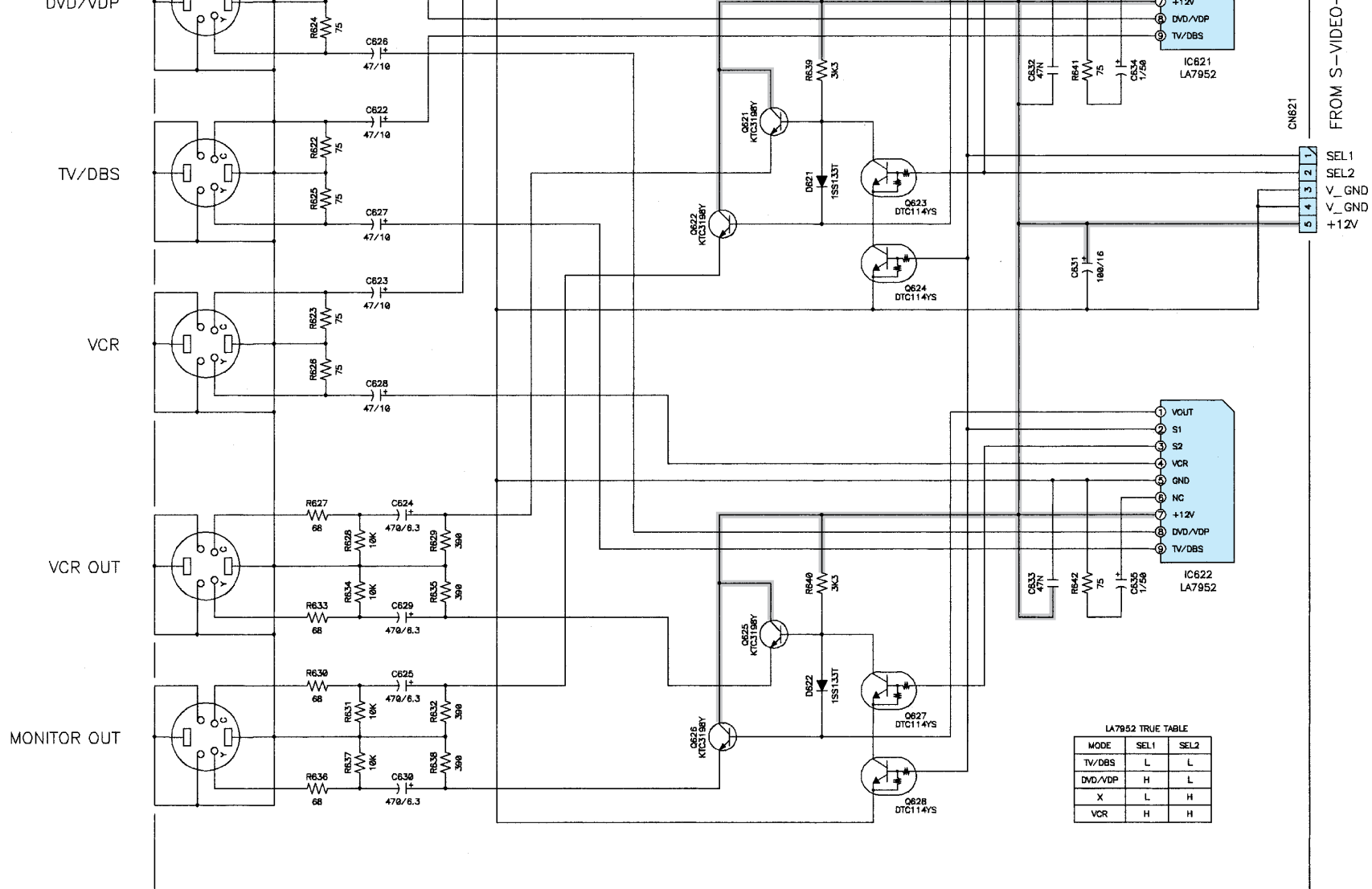

**NOTICE:**

ALL RESISTANCE VALUES IN OHM. k=1,000 OHM M=1,000,000 OHM  
 ALL CAPACITANCE VALUES IN MICRO FARAD. P=MICRO-MICRO FARAD  
 EACH VOLTAGE AND CURRENT ARE MEASURED AT NO SIGNAL INPUT  
 CONDITION.

CIRCUIT AND PARTS ARE SUBJECT TO CHANGE WITHOUT PRIOR  
 NOTICE.

**WARNING:**

Parts marked with this symbol have critical characteristics.  
 Use ONLY replacement parts recommended by the manufacturer.

**CAUTION:**

Before returning the unit to the customer, make sure you make either (1) a  
 leakage current check or (2) a line to chassis resistance check. If the leakage  
 current exceeds 0.5 milliamps, or if the resistance from chassis to either side  
 of the power card is less than 460kohms, the unit is defective.

**WARNING:**

DO NOT return the unit to the customer until the problem is located and  
 corrected.

**SCHEMATIC DIAGRAMS (6/8)**

- VIDEO UNIT
- VIDEO CNT UNIT
- S-VIDEO UNIT
- S-VIDEO CNT UNIT
- C-VIDEO UNIT

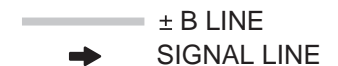

E  
F  
G  
H

SCHMATIC DIAGRAMS (7/8)

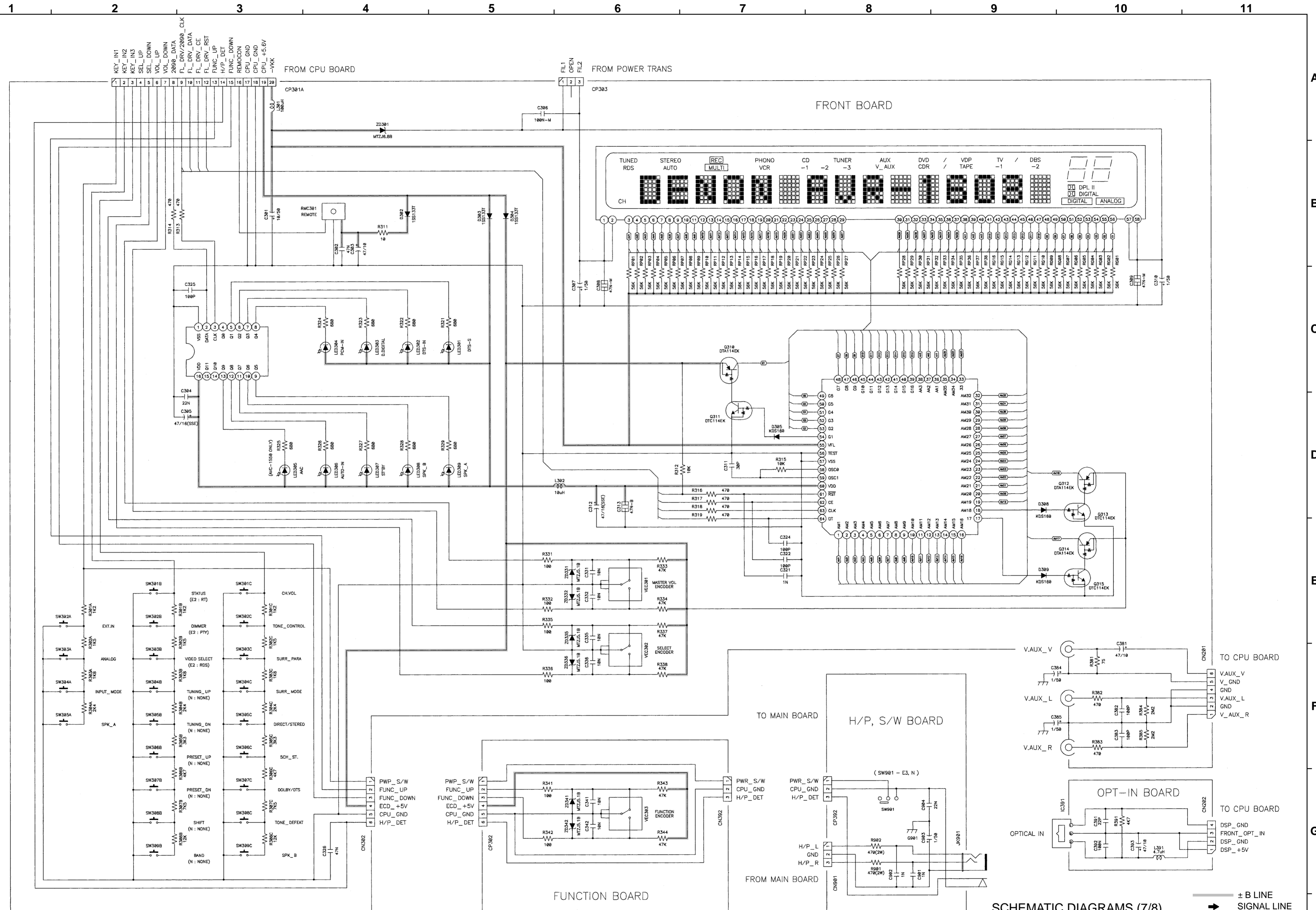

**NOTICE:**  
 ALL RESISTANCE VALUES IN OHM. k=1,000 OHM M=1,000,000 OHM  
 ALL CAPACITANCE VALUES IN MICRO FARAD. P=MICRO-MICRO FARAD  
 EACH VOLTAGE AND CURRENT ARE MEASURED AT NO SIGNAL INPUT  
 CONDITION.  
 CIRCUIT AND PARTS ARE SUBJECT TO CHANGE WITHOUT PRIOR  
 NOTICE.

**WARNING:**  
 Parts marked with this symbol have critical characteristics.  
 Use ONLY replacement parts recommended by the manufacturer.

**CAUTION:**  
 Before returning the unit to the customer, make sure you make either (1) a  
 leakage current check or (2) a line to chassis resistance check. If the leakage  
 current exceeds 0.5 milliamperes, or if the resistance from chassis to either side  
 of the power card is less than 460kohms, the unit is defective.

**WARNING:**  
 DO NOT return the unit to the customer until the problem is located and  
 corrected.

**SCHMATIC DIAGRAMS (7/8)**  
 FRONT UNIT  
 OPTICAL-IN UNIT  
 POWER-SW UNIT  
 ENCODER UNIT  
 HEADPHONE UNIT

→ ± B LINE SIGNAL LINE

SCHMATIC DIAGRAMS (7/8)

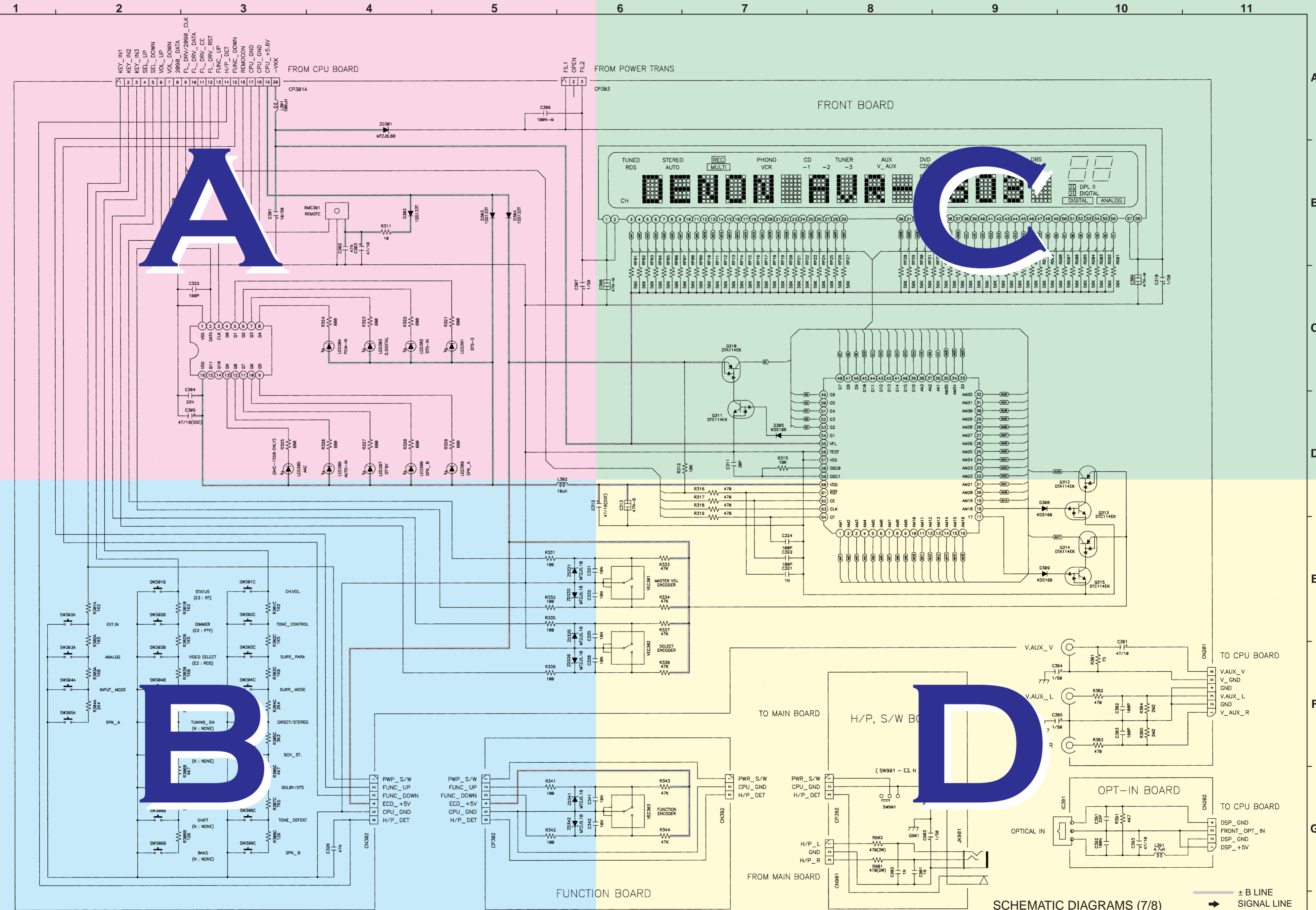

**NOTICE:**  
 ALL RESISTANCE VALUES IN OHM, k=1,000 OHM M=1,000,000 OHM  
 ALL CAPACITANCE VALUES IN MICRO FARAD, P=MICRO-MICRO FARAD  
 EACH VOLTAGE AND CURRENT ARE MEASURED AT NO SIGNAL INPUT  
 CONDITION.  
 CIRCUIT AND PARTS ARE SUBJECT TO CHANGE WITHOUT PRIOR  
 NOTICE.

**WARNING:**  
 Parts marked with this symbol  $\Delta$  have critical characteristics.  
 Use ONLY replacement parts recommended by the manufacturer.  
**CAUTION:**  
 Before returning the unit to the customer, make sure you make either (1) a  
 leakage current check or (2) a line to chassis resistance check. If the leakage  
 current exceeds 0.5 milliamperes, or if the resistance from chassis to either side  
 of the power card is less than 460kohms, the unit is defective.

**WARNING:**  
 DO NOT return the unit to the customer until the problem is located and  
 corrected.

**SCHMATIC DIAGRAMS (7/8)**  
 FRONT UNIT  
 OPTICAL-IN UNIT  
 POWER-SW UNIT  
 ENCODER UNIT  
 HEADPHONE UNIT

± B LINE  
 SIGNAL LINE

# SCHEMATIC DIAGRAMS (7/8)

1

2

3

4

5

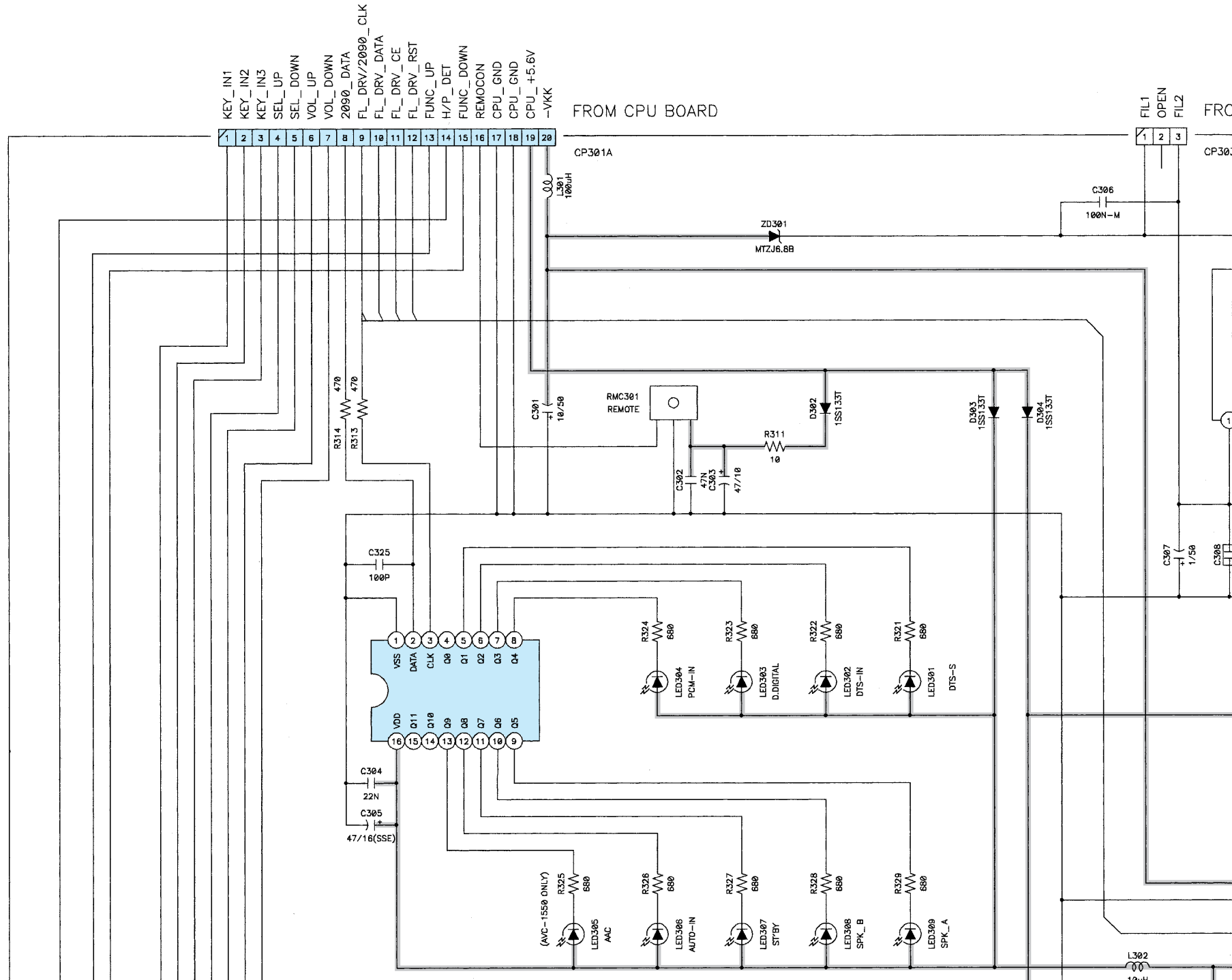

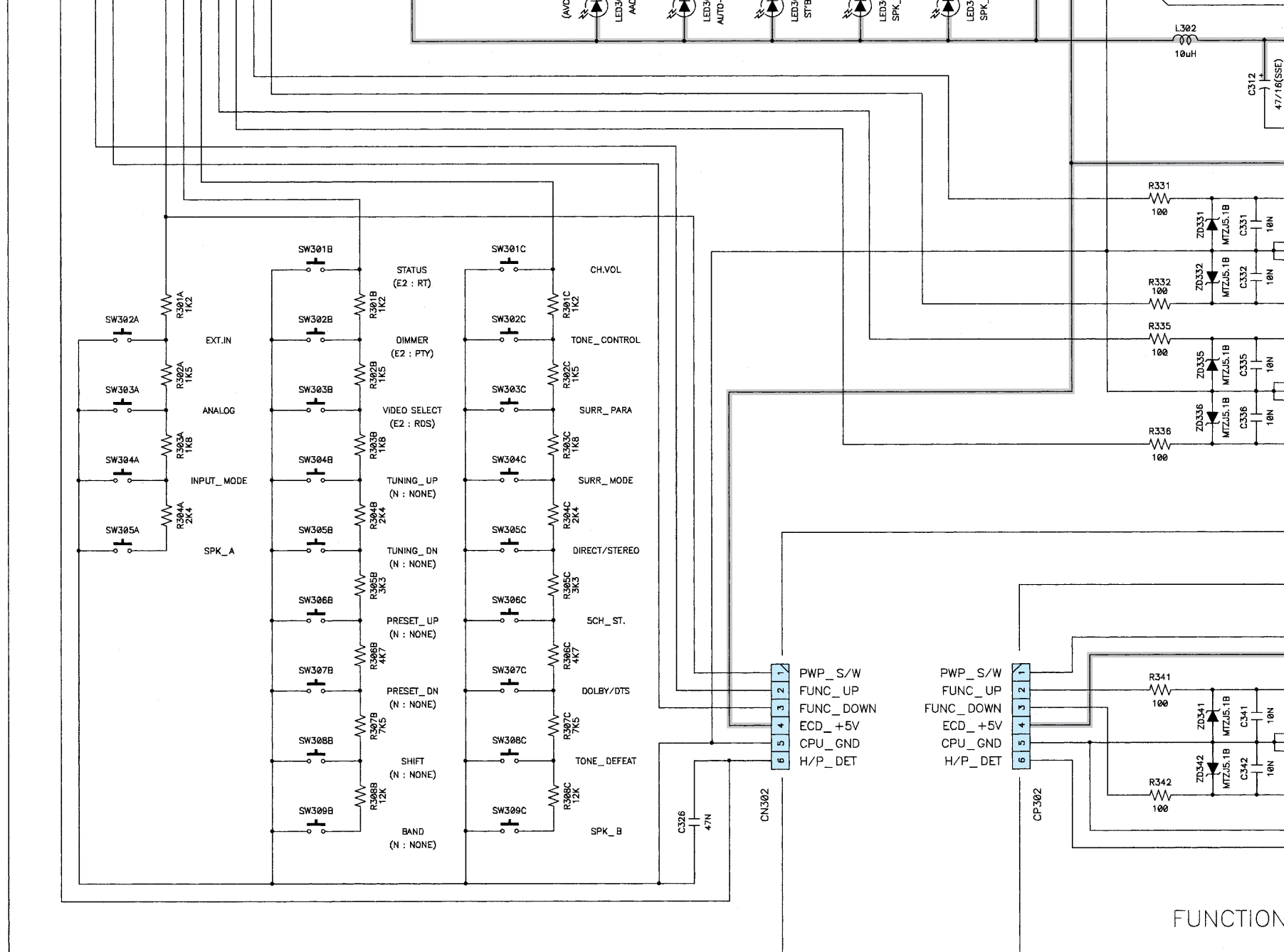

**NOTICE:**  
 ALL RESISTANCE VALUES IN OHM. k=1,000 OHM M=1,000,000 OHM  
 ALL CAPACITANCE VALUES IN MICRO FARAD. P=MICRO-MICRO FARAD  
 EACH VOLTAGE AND CURRENT ARE MEASURED AT NO SIGNAL INPUT  
 CONDITION.  
 CIRCUIT AND PARTS ARE SUBJECT TO CHANGE WITHOUT PRIOR  
 NOTICE.

**WARNING:**  
 Parts marked with this symbol have critical characteristics.  
 Use ONLY replacement parts recommended by the manufacture.

**CAUTION:**  
 Before returning the unit to the customer, make sure you make either (1) a  
 leakage current check or (2) a line to chassis resistance check. If the leakage  
 current exceeds 0.5 milliamps, or if the resistance from chassis to either side  
 of the power card is less than 460kohms, the unit is defective.

**WARNING:**  
 DO NOT return the unit to the customer until it is  
 corrected.

6

7

8

9

10

11

A

B

C

D

FROM POWER TRANS

CP303

### FRONT BOARD

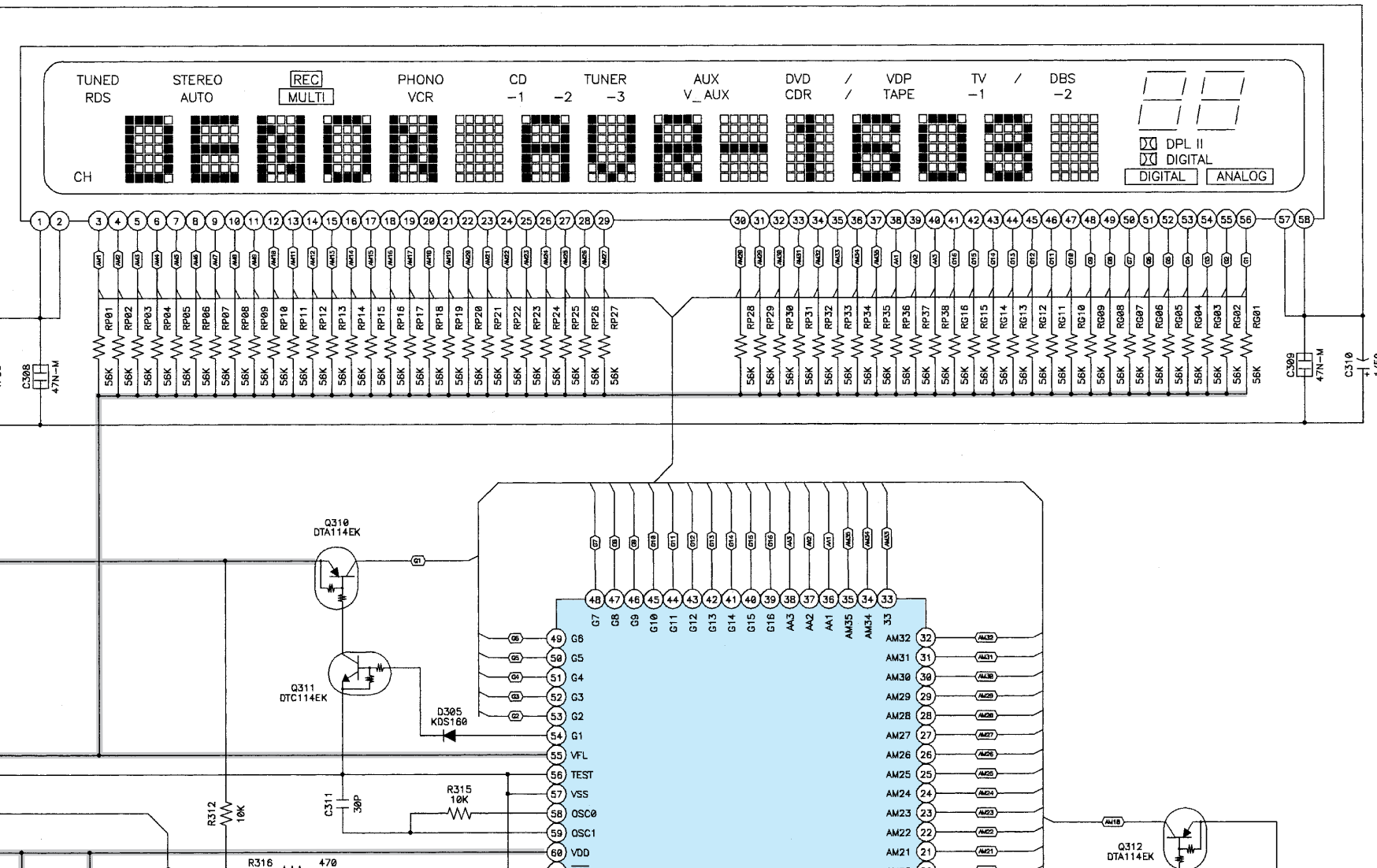

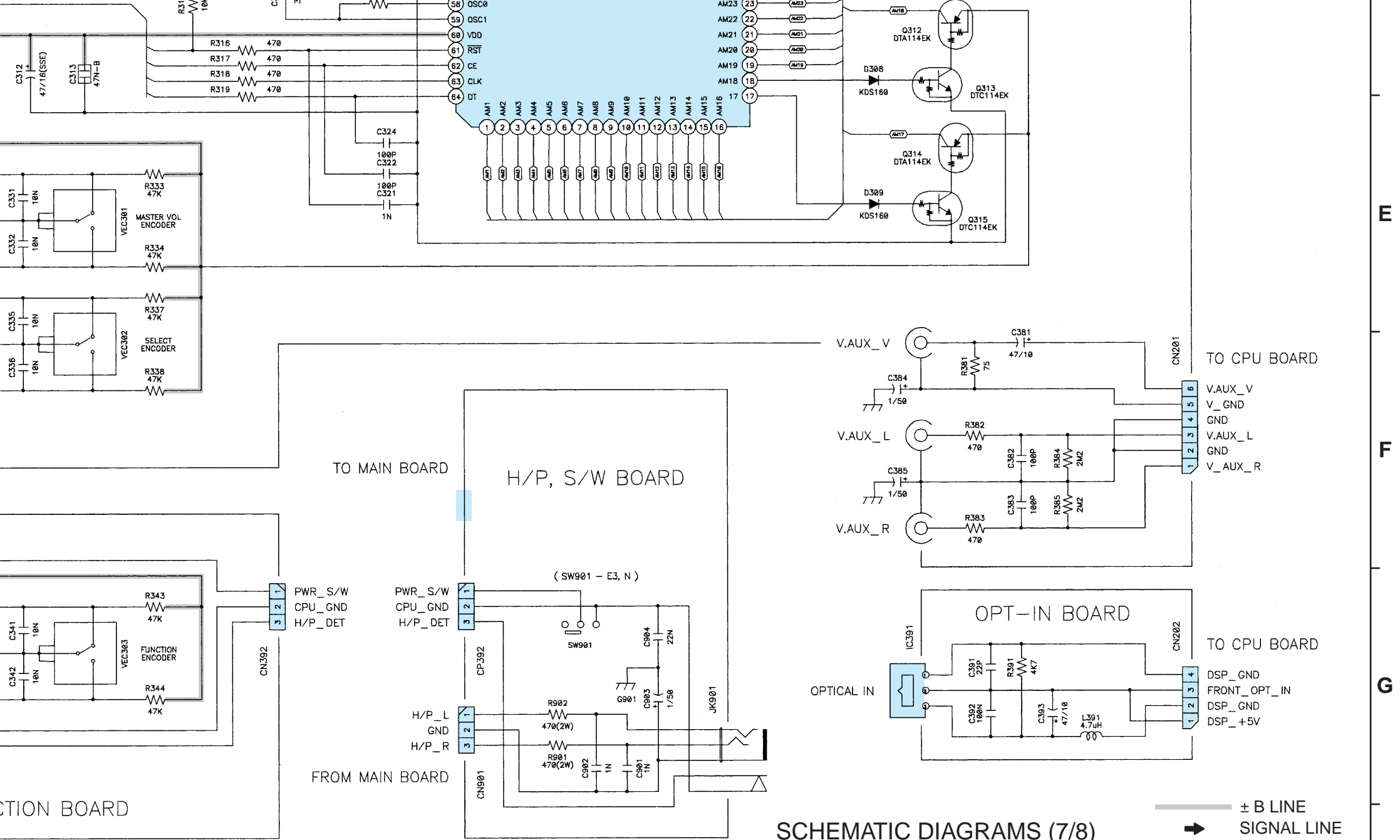

**SCHEMATIC DIAGRAMS (7/8)**

- FRONT UNIT
- OPTICAL-IN UNIT
- POWER-SW UNIT
- ENCODER UNIT
- HEADPHONE UNIT

— ± B LINE SIGNAL LINE  
 - - - - - SIGNAL LINE

to the customer until the problem is located and

**SCHEMATIC DIAGRAMS (8/8)**

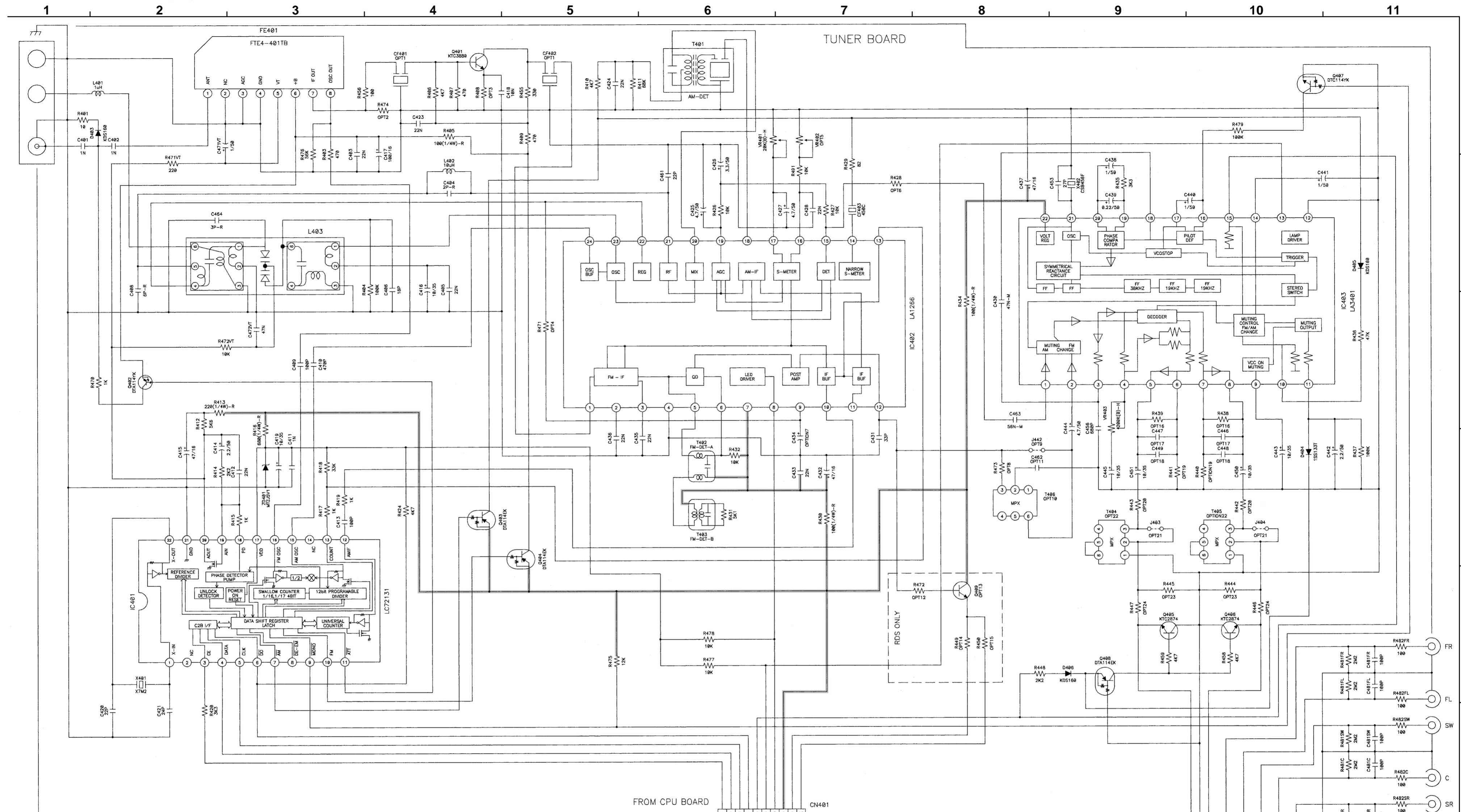

R-NO.	USA(E3)	EUROPE(E2)	MULTI, C, K
OPT1	CF401/CF402	SFE10.7MA8	SFE10.7MS3
OPT2	R474	-	180
OPT3	R407/R408	470/1.2K	620/680
OPT4	R471	18K	39K
OPT5	VR402	50KB	100KB
OPT6	R428	3.3K	10K
OPT7	C434	1/50	0.33/50
OPT8	R473	-	2.4K

R-NO.	USA(E3)	EUROPE(E2)	MULTI, C, K
OPT9	J442	JUMPER	-
OPT10	T406	-	ANTI-BIRDIE
OPT11	C462	-	470P
OPT12	R472	-	100
OPT13	Q409	-	KTC3880
OPT14	R449	-	3.9K
OPT15	R450	-	1K
OPT16	R438,R439	100K	150K

R-NO.	USA(E3)	EUROPE(E2)	MULTI, C, K
OPT17	C446,C447	270P	330P
OPT18	C448,C449	470P	-
OPT19	R440,R441	120K	220K
OPT20	R442,R443	3.3K	2.2K
OPT21	J403,J404	JUMPER	-
OPT22	T404,T405	-	LPF(MPX)
OPT23	R444,R445	8.2K	3.3K
OPT24	R446,R447	JUMPER	470

**NOTICE:**  
 ALL RESISTANCE VALUES IN OHM. k=1,000 OHM M=1,000,000 OHM  
 ALL CAPACITANCE VALUES IN MICRO FARAD. P=MICRO-MICRO FARAD  
 EACH VOLTAGE AND CURRENT ARE MEASURED AT NO SIGNAL INPUT  
 CONDITION.  
 CIRCUIT AND PARTS ARE SUBJECT TO CHANGE WITHOUT PRIOR  
 NOTICE.

**WARNING:**  
 Parts marked with this symbol have critical characteristics.  
 Use ONLY replacement parts recommended by the manufacturer.  
**CAUTION:**  
 Before returning the unit to the customer, make sure you make either (1) a  
 leakage current check or (2) a line to chassis resistance check. If the leakage  
 current exceeds 0.5 millamps, or if the resistance from chassis to either side  
 of the power card is less than 460kohms, the unit is defective.

**WARNING:**  
 DO NOT return the unit to the customer until the problem is located and  
 corrected.

± B LINE  
 SIGNAL LINE

**SCHEMATIC DIAGRAMS (8/8)  
 TUNER UNIT**



**SCHEMATIC DIAGRAMS (8/8)**

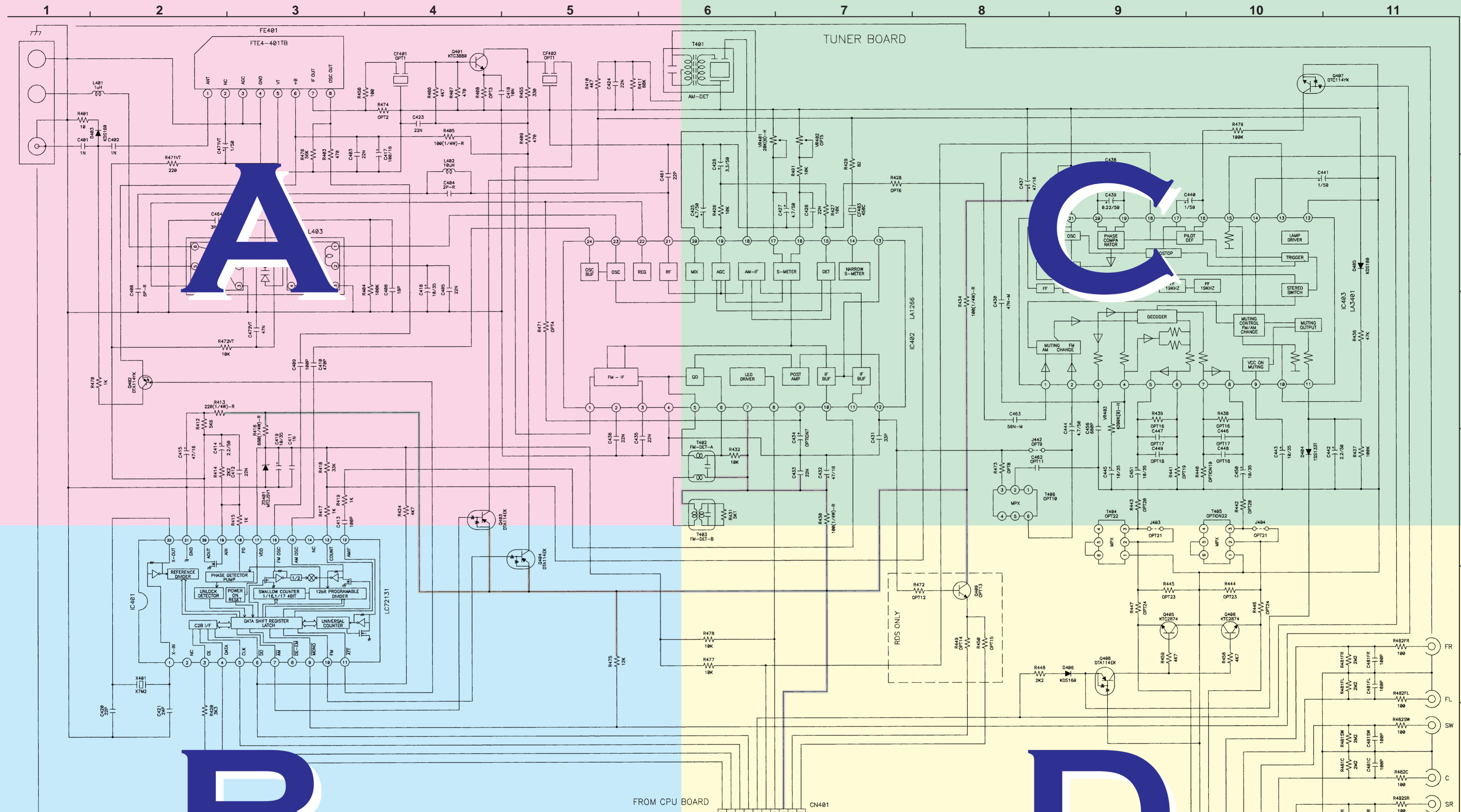

R-NO.	USA	EUROPE(E2)	TI, C, K
OPT1	CF401/CF402	SFE10	SFE10.7MS3 AB/MS3
OPT2	R474		
OPT3	R407/R408	470/1.2K	0.20/0.50 620/1.2K
OPT4	R471	18K	39K 39K
OPT5	VR402	50KB	100KB 50KB
OPT6	R428	3.3K	10K 6.8K
OPT7	C434	1/50	0.33/50 0.33/50
OPT8	R473		2.4K

R-NO.	USA(E3)	EUROPE(E2)	MULTI, C, K
OPT9	J442		JUMPER
OPT10	T406		ANTI-BIRDIE
OPT11	C462		470P
OPT12	R472		100
OPT13	Q409		KTC3880
OPT14	R449		3.9K
OPT15	R450		1K
OPT16	R438,R439	100K	150K 100K

R-NO.	USA(E3)	EUROPE(E2)	MULTI, C, K
OPT17	C446,C447	270P	330P 180P
OPT18	C448,C449	470P	
OPT19	R440,R441	120K	220K
OPT20	R442,R443	3.3K	2.2K 3.3K
OPT21	J403,J404	JUMPER	JUMPER
OPT22	T404,T405		LPF(MPX)
OPT23	R444,R445	8.2K	3.3K 8.2K
OPT24	R446,R447	JUMPER	470 JUMPER

**NOTICE:**  
 ALL RESISTANCE VALUES IN OHM. k=1,000 OHM M=1,000,000 OHM  
 ALL CAPACITANCE VALUES IN MICRO FARAD. P=MICRO-MICRO FARAD  
 EACH VOLTAGE AND CURRENT ARE MEASURED AT NO SIGNAL INPUT  
 CONDITION.  
 CIRCUIT AND PARTS ARE SUBJECT TO CHANGE WITHOUT PRIOR  
 NOTICE.

**WARNING:**  
 Parts marked with this symbol  $\triangle$  have critical characteristics.  
 Use ONLY replacement parts recommended by the manufacturer.  
**CAUTION:**  
 Before returning the unit to the customer, make sure you make either (1) a  
 leakage current check or (2) a line to chassis resistance check. If the leakage  
 current exceeds 0.5 milliamperes, or if the resistance from chassis to either side  
 of the power card is less than 460kohms, the unit is defective.

**WARNING:**  
 DO NOT return the unit to the customer until the problem is located and  
 corrected.

**SCHEMATIC DIAGRAMS (8/8)**  
**TUNER UNIT**

± B LINE  
 SIGNAL LINE

# SCHEMATIC DIAGRAMS (8/8)

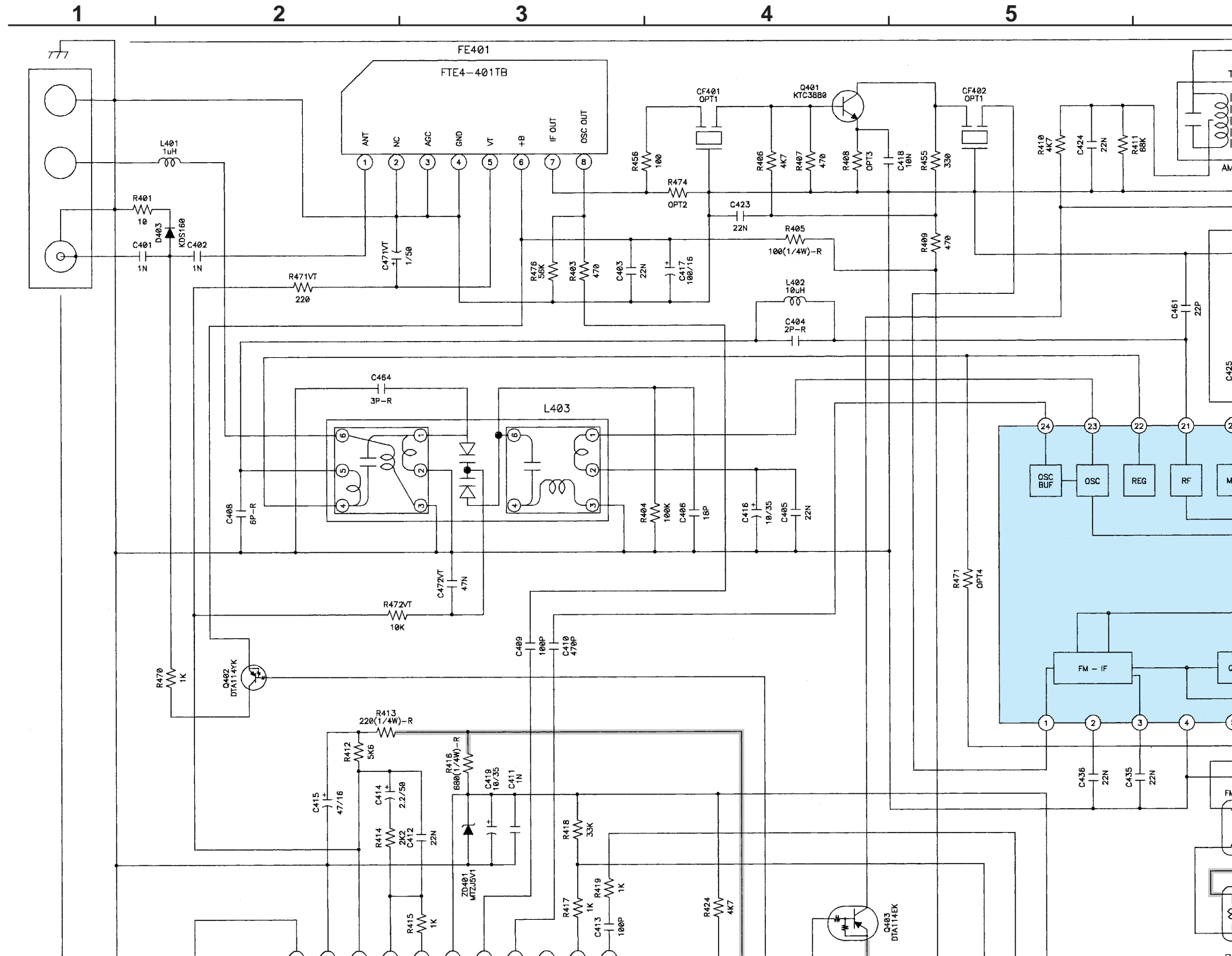

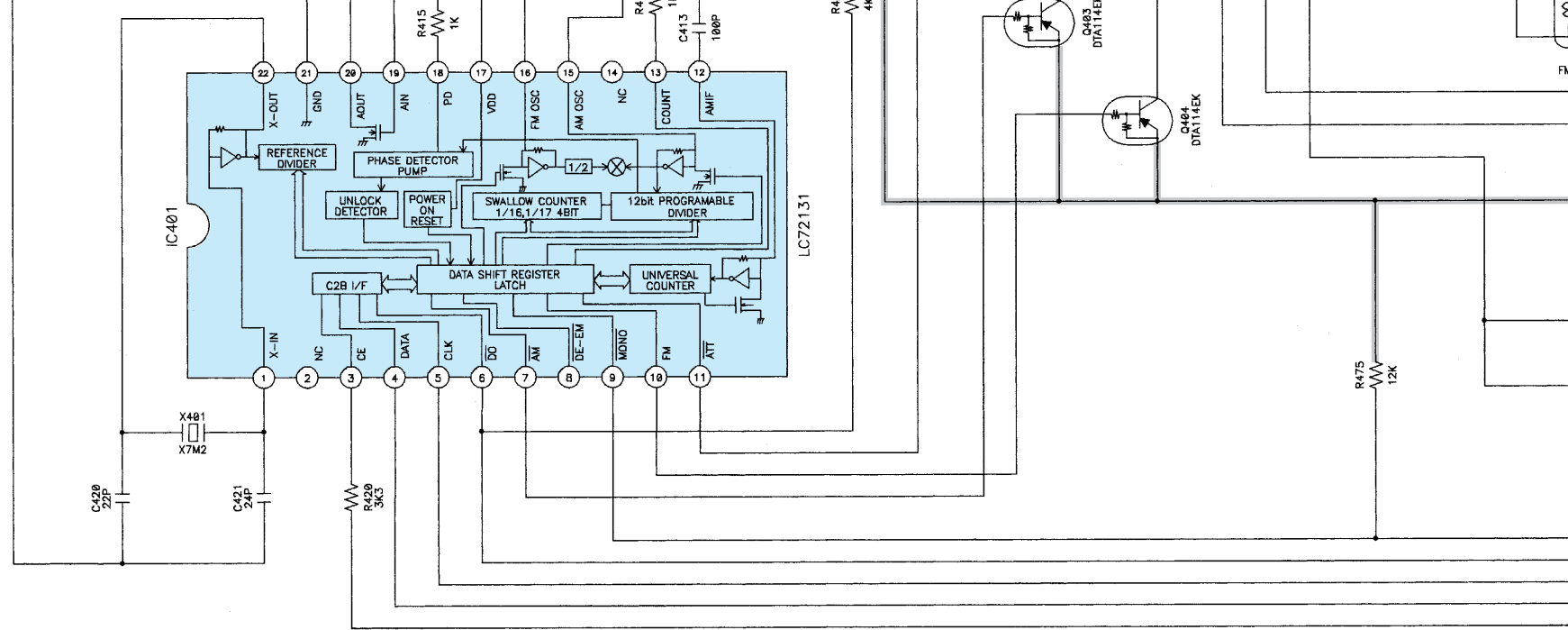

FROM CPU BO

	R-NO.	USA(E3)	EUROPE(E2)	MULTI, C, K
OPT1	CF401/CF402	SFE10.7MA8	SFE10.7MS3	10.7MA8/MS3
OPT2	R474	-	180	-
OPT3	R407/R408	470/1.2K	620/680	620/1.2K
OPT4	R471	18K	39K	39K
OPT5	VR402	50KB	100KB	50KB
OPT6	R428	3.3K	10K	6.8K
OPT7	C434	1/50	0.33/50	0.33/50
OPT8	R473	-	2.4K	-

	R-NO.	USA(E3)	EUROPE(E2)	MULTI, C, K
OPT9	J442	JUMPER	-	JUMPER
OPT10	T406	-	ANTI-BIRDIE	-
OPT11	C462	-	470P	-
OPT12	R472	-	100	-
OPT13	Q409	-	KTC3880	-
OPT14	R449	-	3.9K	-
OPT15	R450	-	1K	-
OPT16	R438,R439	100K	150K	100K

**NOTICE:**

ALL RESISTANCE VALUES IN OHM. k=1,000 OHM M=1,000,000 OHM  
 ALL CAPACITANCE VALUES IN MICRO FARAD. P=MICRO-MICRO FARAD  
 EACH VOLTAGE AND CURRENT ARE MEASURED AT NO SIGNAL INPUT  
 CONDITION.  
 CIRCUIT AND PARTS ARE SUBJECT TO CHANGE WITHOUT PRIOR  
 NOTICE.

**WARNING:**

Parts marked with this symbol  have critical characteristics.  
 Use ONLY replacement parts recommended by the manufacture.

**CAUTION:**

Before returning the unit to the customer, make sure you make either (1) a  
 leakage current check or (2) a line to chassis resistance check. If the leakage  
 current exceeds 0.5 milliamps, or if the resistance from chassis to either side  
 of the power card is less than 460kohms, the unit is defective.

**WARNING:**

DO NOT return the unit to the  
 corrected.

6

7

8

9

10

11

TUNER BOARD

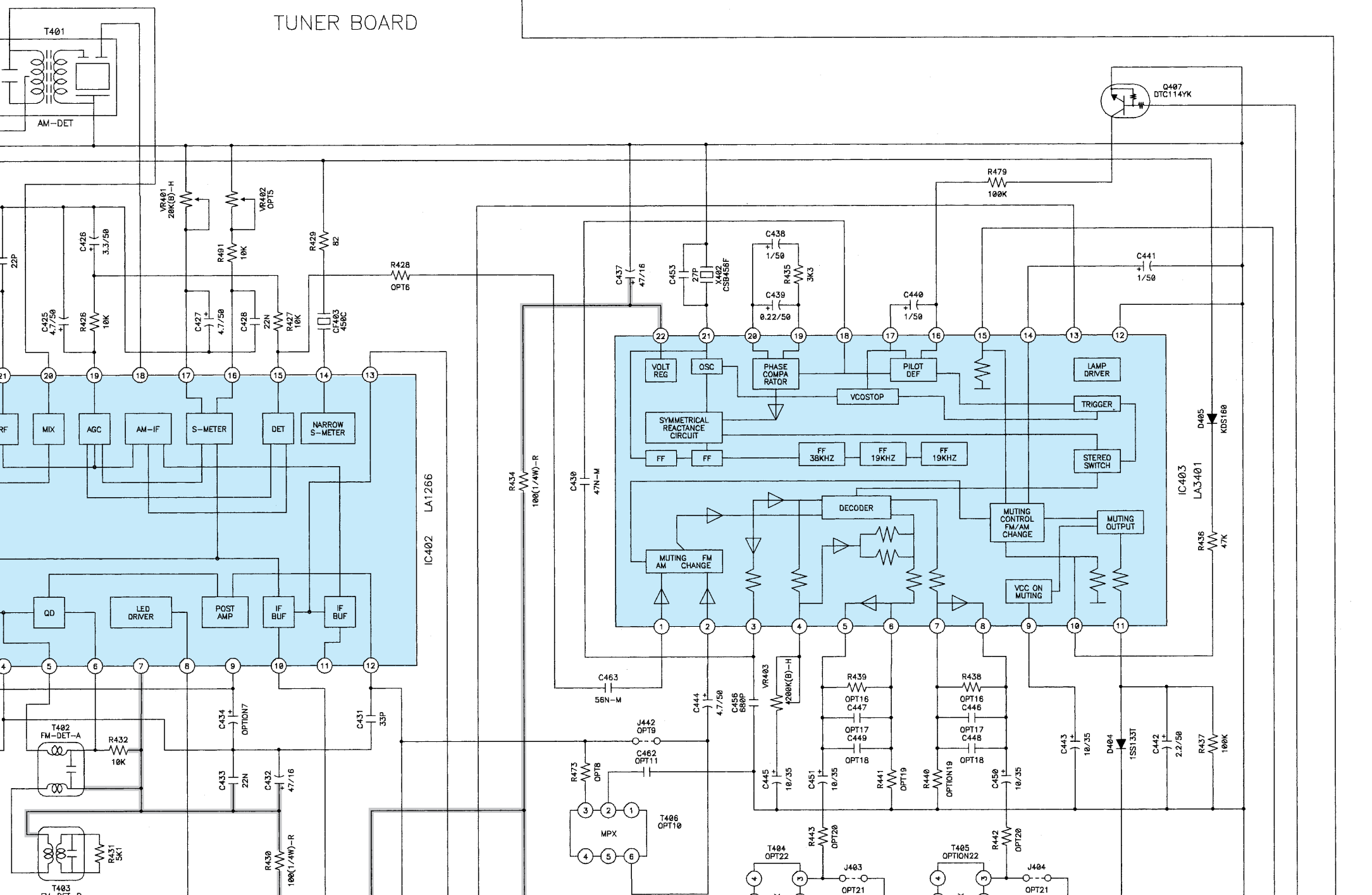

A

B

C

D

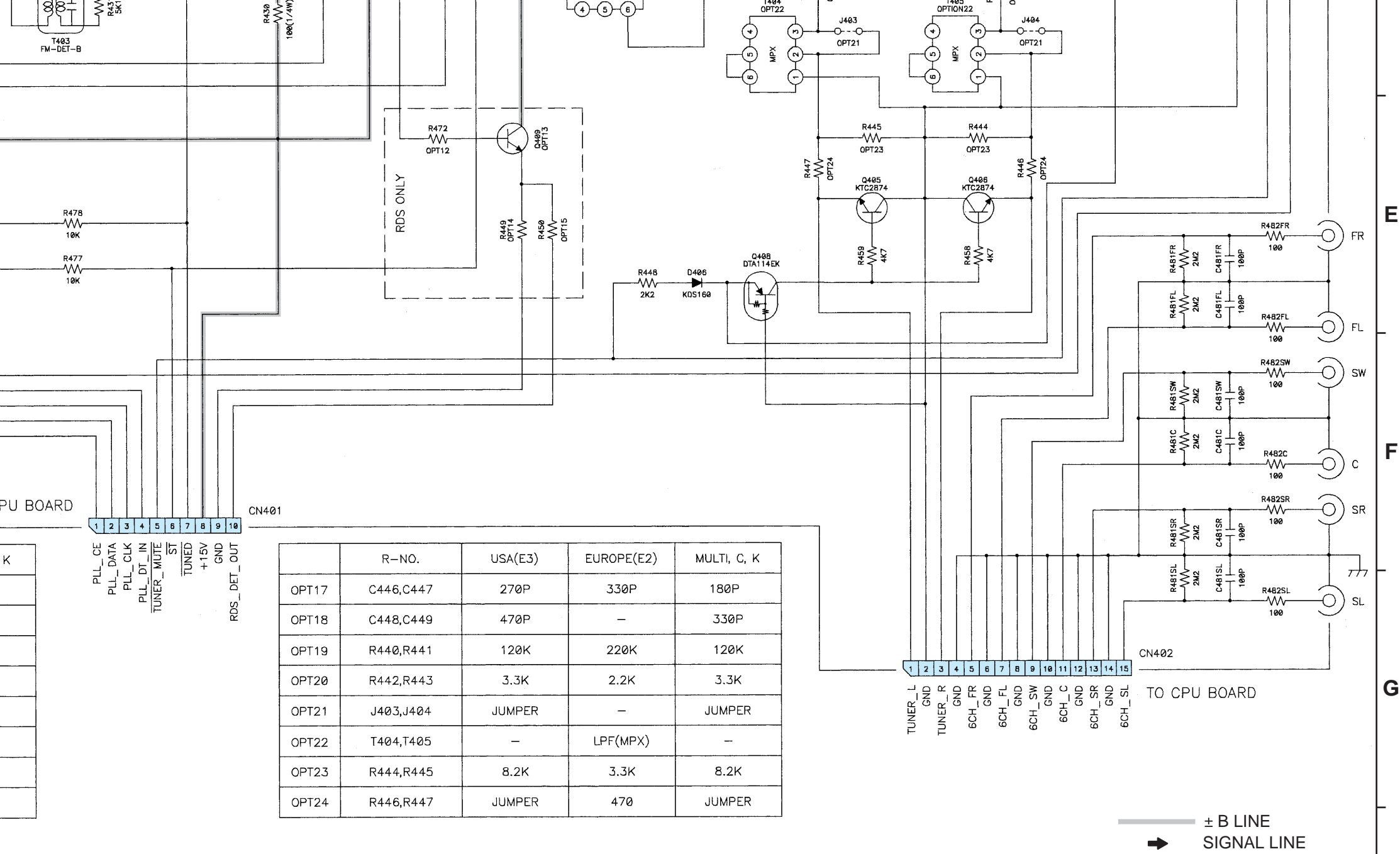

unit to the customer until the problem is located and

**SCHEMATIC DIAGRAMS (8/8)  
TUNER UNIT**