

# DENON

Hi-Fi Component

## SERVICE MANUAL

# MODEL AVR-1800/87

### AV SURROUND RECEIVER

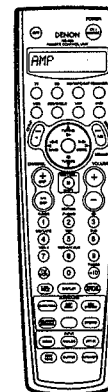
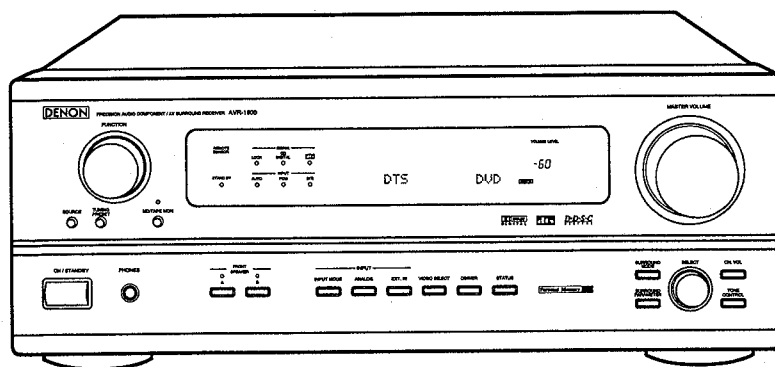

#### — TABLE OF CONTENTS —

SAFETY PRECAUTIONS .....	2	SCHMATIC DIAGRAM .....	61-72
SPECIFICATIONS .....	2	(1/12) 1U-3197 AUDIO/DSP UNIT (1/3) .....	61
WIRE ARRANGEMENT .....	3	(2/12) 1U-3197 AUDIO/DSP UNIT (2/3) .....	62
DISASSEMBLY .....	4-6	(3/12) 1U-3197 AUDIO/DSP UNIT (3/3) .....	63
LEVEL DIAGRAM .....	7,8	(4/12) 1U-3233-1 EXT IN VR UNIT .....	64
CLOCK FLOW & WAVE FORM IN DIGITAL BLOCK .....	9,10	(5/12) 1U-3234-2 CONNECT UNIT .....	65
ADJUSTMENT .....	11,12	(6/12) 1U-3235-1 REGULATOR UNIT .....	66
SEMICONDUCTORS .....	12-27	1U-3235-2 AMP UNIT .....	66
PRINTED WIRING BOARDS .....	28-36	1U-3235-3 H/P & P.SW UNIT .....	66
NOTE FOR PARTS LIST .....	37	1U-3235-4 FRONT UNIT .....	66
PARTS LIST OF P.W.B UNIT .....	38-53	(7/12) 1U-3232-1 POWER UNIT .....	67
PARTS LIST OF EXPLODED VIEW .....	54	1U-3233-4 P.SW UNIT .....	67
EXPLODED VIEW .....	55	1U-3236-1 VOLTAGE SELECT UNIT	
ADDENDUM PARTS LIST OF EXPLODED VIEW .....	56	(Asia, Hong Kong Model Only) .....	67
ADDENDUM PARTS LIST OF PACKING & ACCESSORIES ..	56	1U-3236-2 VOLTAGE SELECT UNIT	
PACKING VIEW .....	57	(Asia, Hong Kong Model Only) .....	67
PARTS LIST OF PACKING & ACCESSORIES .....	57	(8/12) 1U-3234-3 PRE OUT UNIT .....	68
BLOCK DIAGRAM .....	59	1U-3234-4 DIGITAL INPUT UNIT .....	68
WIRING DIAGRAMS .....	60	1U-3234-5 DIGITAL IN-2 UNIT .....	68
		(9/12) 1U-3235-5 TUNER UNIT .....	69
		(10/12) 1U-3234-1 CONTROL UNIT .....	70
		(11/12) 1U-3233-2 DISPLAY UNIT .....	71
		1U-3233-3 VOL UNIT .....	71
		(12/12) 1U-3232-2 C. VIDEO UNIT .....	72

● Some illustrations using in this service manual are slightly different from the actual set.

## NIPPON COLUMBIA CO., LTD.

## SAFETY PRECAUTIONS

The following check should be performed for the continued protection of the customer and service technician.

### LEAKAGE CURRENT CHECK

Before returning the unit to the customer, make sure you make either (1) a leakage current check or (2) a line to chassis resistance check. If the leakage current exceeds 0.5 milliamps, or if the resistance from chassis to either side of the power cord is less than 460 kohms, the unit is defective.

## SPECIFICATIONS

### AUDIO SECTION

#### (Power Amplifier)

Rated output: (All properties shown are only for the power amplifier stage.)	Stereo (2ch driven): 75 W + 75 W (8 Ω/ohms, 20 Hz ~ 20 kHz with 0.05 % T.H.D.) 110 W + 110 W (6 Ω/ohms, 1 kHz with 0.7 % T.H.D.)
Dynamic power:	100 W × 2 ch (8 Ω/ohms) 145 W × 2 ch (4 Ω/ohms) 170 W × 2 ch (2 Ω/ohms)
Output terminals:	Surround/Center: 6 ~ 16 Ω/ohms Front: A or B 6 ~ 16 Ω/ohms A + B 8 ~ 16 Ω/ohms

#### (Analog)

Input sensitivity/input impedance:	200 mV/47 kΩ/kohms
Frequency response:	10 Hz ~ 50 kHz: +0, -3 dB
S/N:	102 dB
Distortion:	0.01 % (20 Hz ~ 20 kHz)
Rated output/maximum output:	1.2 V/7 V

#### (Digital)

D/A output:	Rated output - 2 V (at 0 dB playback) Total harmonic distortion - 0.008% (1 kHz, at 0 dB) S/N ratio - 102 dB Dynamic range - 96 dB Format - Digital audio interface
Digital input:	

#### (Phono equalizer (PHONO input-REC OUT))

Input sensitivity:	2.5 mV
RIAA deviation:	±1 dB (20 Hz to 20 kHz)
Signal-to-noise ratio:	74 dB (A weighting, with 5 mV input)
Rated output/Maximum output:	150 mV/7 V
Distortion factor:	0.03% (1 kHz, 3 V)

### VIDEO SECTION

#### (Standard Video Jacks)

Input/output level and impedance:	1 Vp-p, 75 Ω/ohms
Frequency response:	5 Hz ~ 10 MHz - +0, -3 dB

### TUNER SECTION

Receiving range:	<b>[FM]</b> (Note: μV at 75 Ω/ohms, 0 dBf = $1 \times 10^{-15}$ W) 87.50 MHz ~ 107.90 MHz (for North America model) 87.50 MHz ~ 108.00 MHz (for Europe, China, Hong Kong, Taiwan R.O.C. and Multiple voltage models)	<b>[AM]</b> 520 kHz ~ 1710 kHz (for North America model) 522 kHz ~ 1611 kHz (for Europe, China, Hong Kong, Taiwan R.O.C. and Multiple voltage models)
Usable sensitivity:	1.0 μV (11.2 dBf)	18 μV
50 dB quieting sensitivity:	MONO 1.6 μV (15.3 dBf) STEREO 23 μV (38.5 dBf)	
S/N ratio:	MONO 80 dB STEREO 75 dB	
Total harmonic distortion (at 1 kHz):	MONO 0.15 % STEREO 0.3 %	

### GENERAL

Power supply:	AC120 V, 60 Hz (for North America and Taiwan R.O.C. models) AC230 V, 50 Hz (for Europe model) AC220 V, 50 Hz (for China model) AC115/230 V, 50/60 Hz (for Hong Kong and Multiple voltage models)
Power consumption:	4.5 A (for North America model) 270 W (for Europe, China, Hong Kong, Taiwan R.O.C. and Multiple voltage models)
Maximum external dimensions:	434 (W) × 171 (H) × 416 (D) mm (17-3/32" × 6-47/64" × 16-3/8")
Weight:	11.4 kg (25 lbs. 2 oz.)

### REMOTE CONTROL UNIT (RC-863: for North America, China, Hong Kong, Taiwan R.O.C. and Multiple voltage models) (RC-868: for Europe model)

Batteries:	R6P/AA Type (three batteries)
External dimensions:	61 (W) × 230 (H) × 34 (D) mm (2-13/32" × 9-1/16" × 1-11/32")
Weight:	200 g (Approx. 7 oz.) (including batteries)

## WIRE ARRANGEMENT

If wire bundles are untied or moved to perform adjustment or parts replacement etc., be sure to rearrange them neatly as they were originally bundled or placed afterward. Otherwise, incorrect arrangement can be a cause of noise generation.

### Wire arrangement viewed from the top

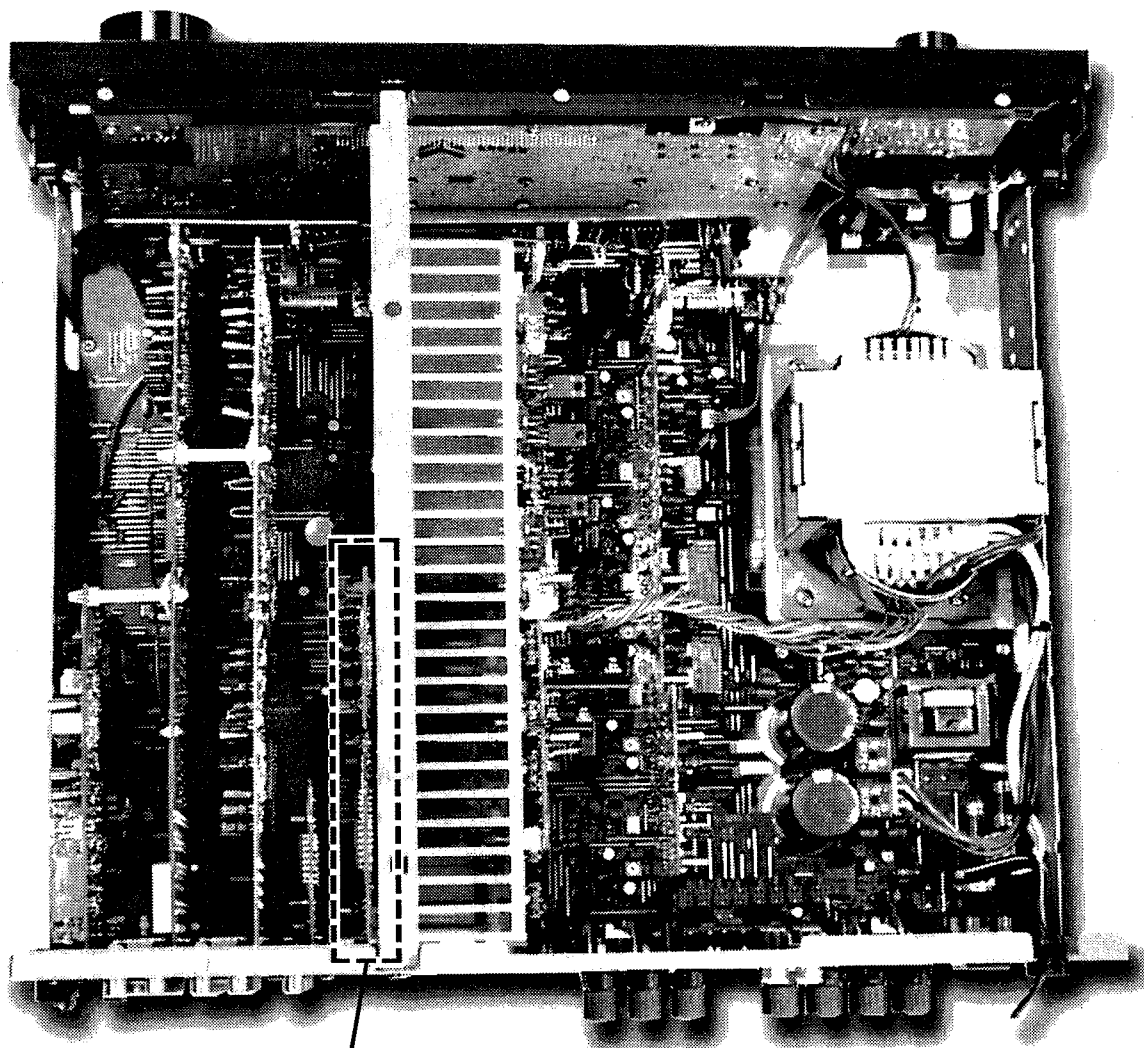

Not used in AVR-1800/87

## DISASSEMBLY

(Follow the procedure below in reverse order when reassembling)

### 1. Top Cover

Remove 3 screws ① on the rear and 6 screws ② on both sides to detach the Top Cover as shown in the arrow direction.

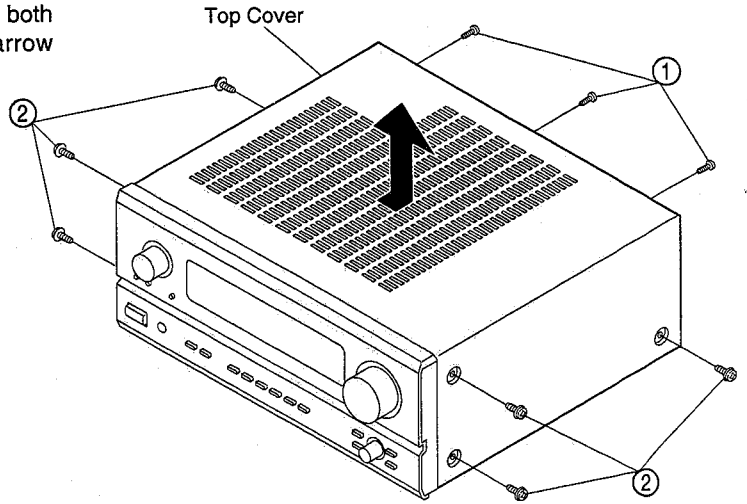

### 2. Front Panel

- (1) Remove 7 screws ③ from the top and bottom edges of the Front Panel.
- (2) Release 4 top and bottom hooks, then detach the Front Panel as shown in the arrow direction.

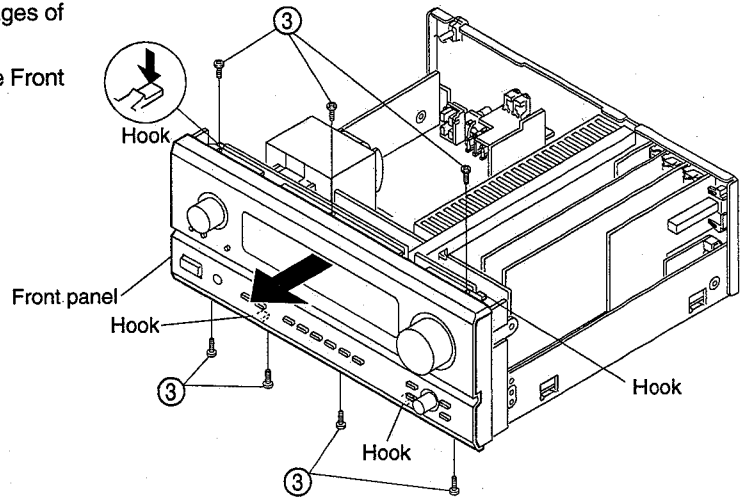

### 3. Inner Panel

Pull out the Inner Panel in the arrow direction after removing 3 screws ④.

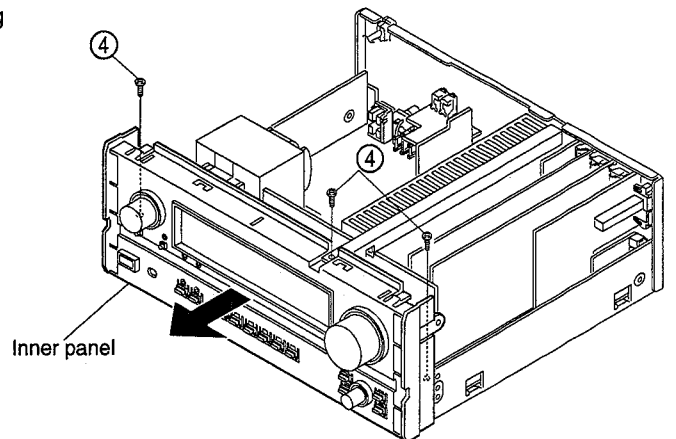

#### 4. Inner Panel Ass'y

- (1) Remove 3 round and 1 square knobs, and unscrew 4 nuts.
- (2) Remove 19 screws (5) fixing each P.W.B.

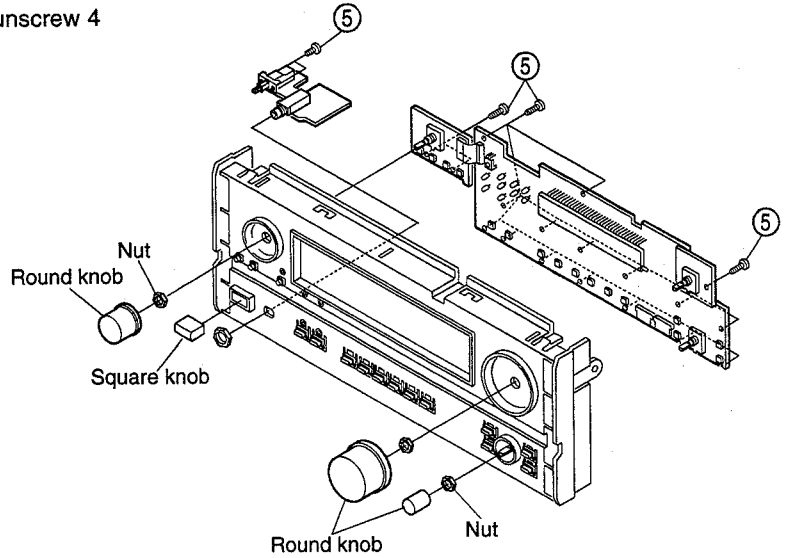

#### 5. Amp Unit

- (1) Remove 1 screw (6) to detach Pre-out Unit (7).
- (2) Take off the Amp Unit (8) as shown in the arrow direction after removing 1 screw (9).

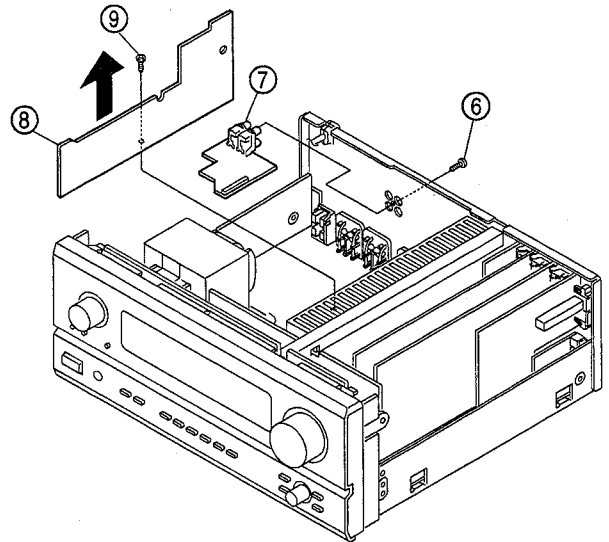

#### 6. Regulator Unit

- Take off the Regulator Unit (10) as shown in the arrow direction after removing 8 screws (11).

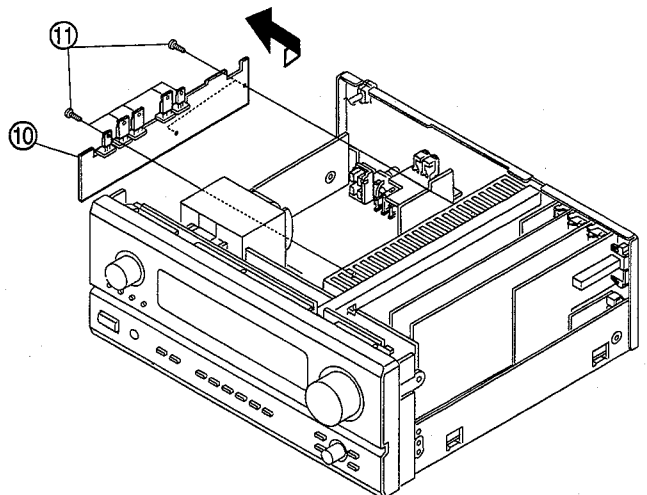

### 7. S-Video / C-video / Audio-in & DSP / Ext-in & VR / Digital-in / Tuner Unit

- (1) Remove 32 screws ⑫ to detach the Rear Panel.
- (2) Take off the objective P.W.B. upward.

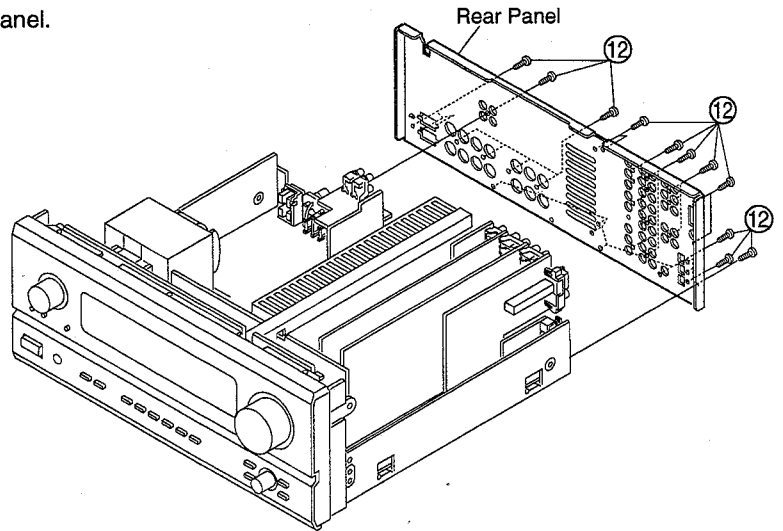

### 8. How to Check Power Amp / $\mu$ -com Unit with Power-on

- (1) Remove 12 screws ⑬, 1 screw ⑭, and 4 screws ⑮ fixing to the Chassis.
- (2) Pull up the Unit to separate from the Chassis.

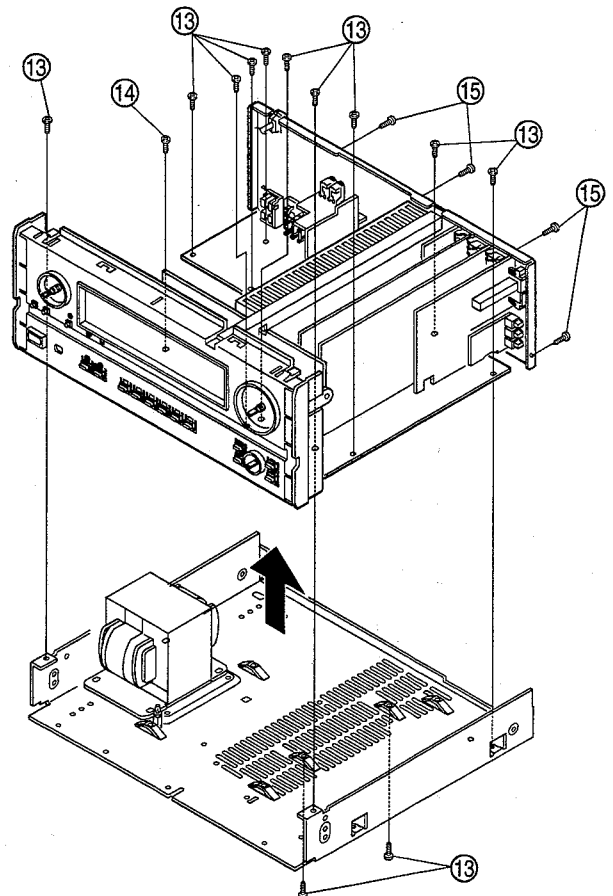

LEVEL DIAGRAM

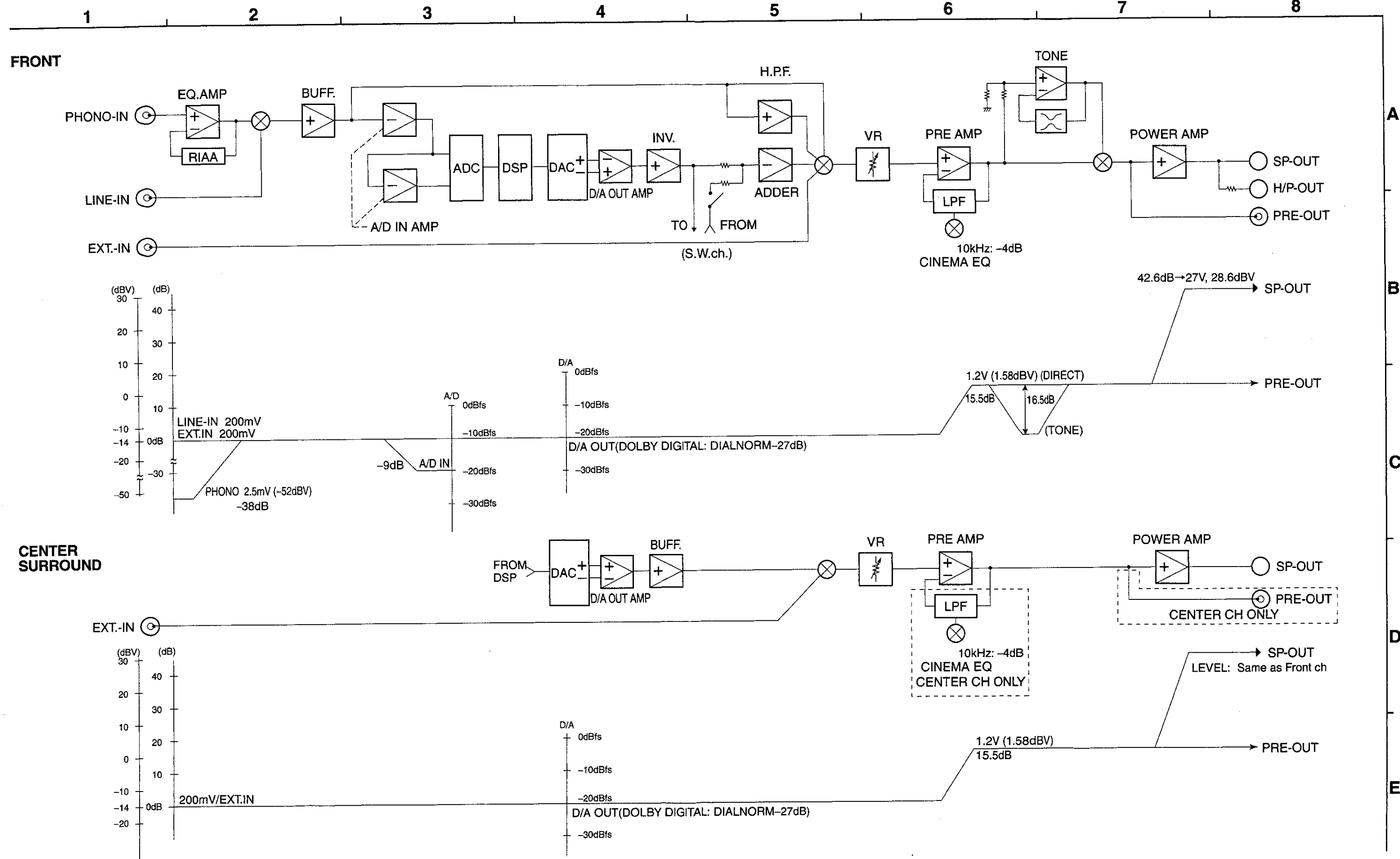

SUBWOOFER

A

B

C

D

E

1 2 3 4 5 6 7 8

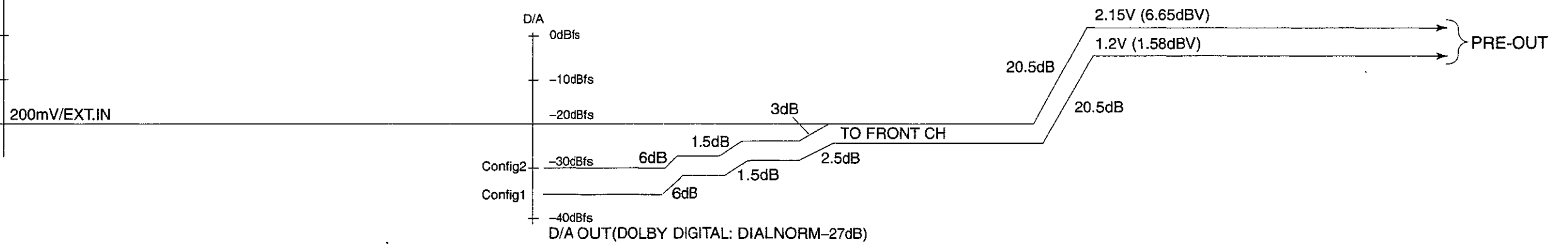
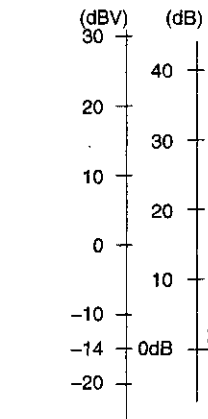
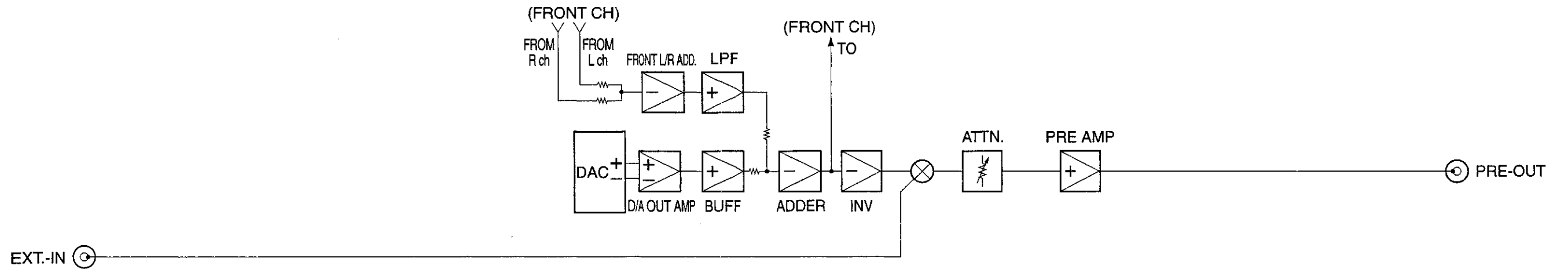



# CLOCK FLOW & WAVE FORM IN DIGITAL BLOCK

## Wave Form

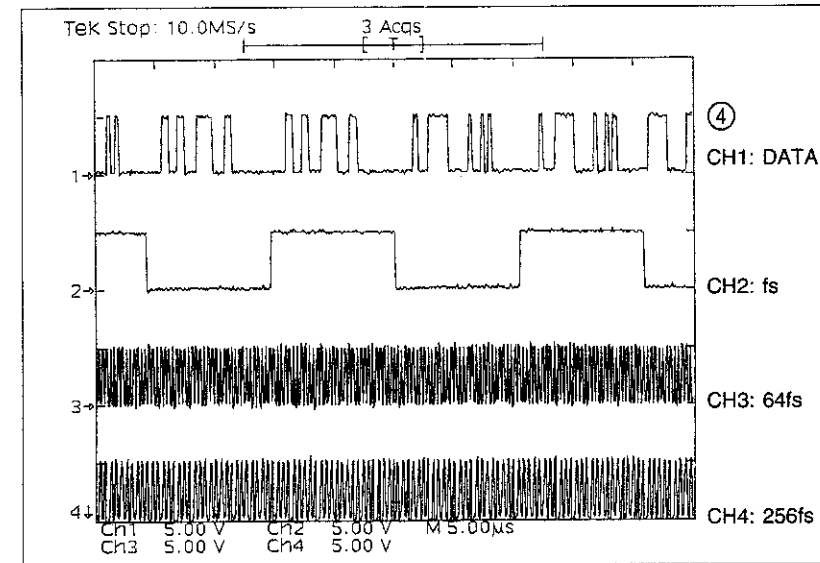
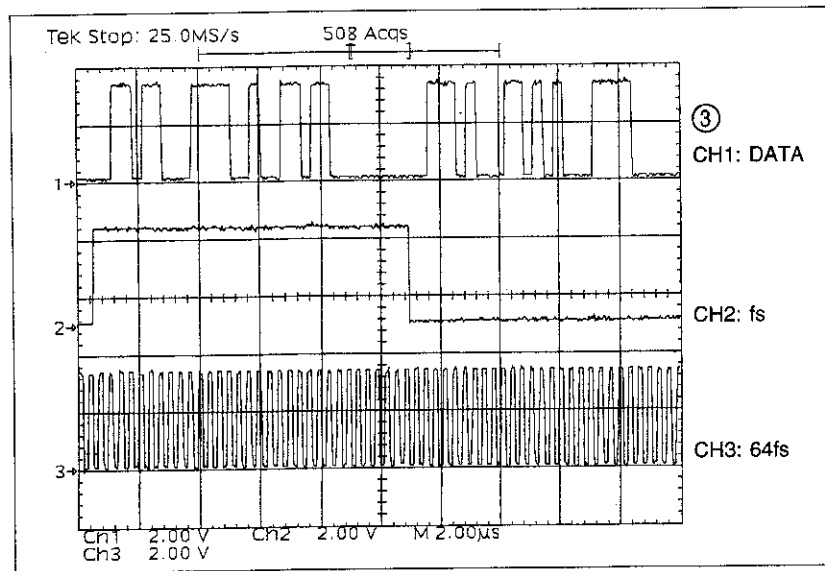
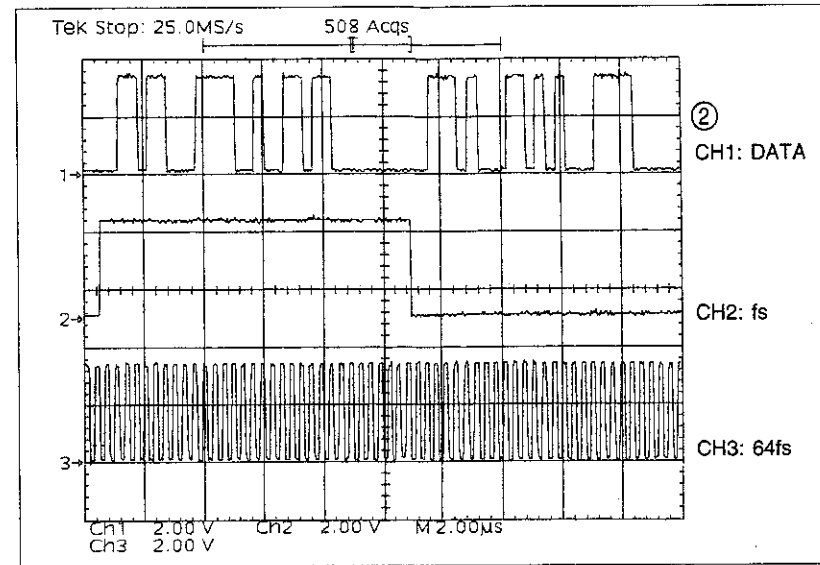
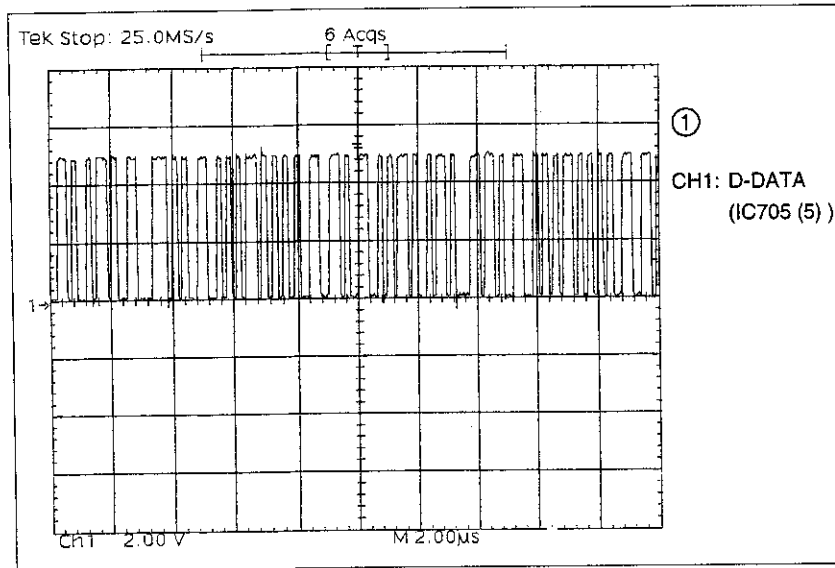

Clock Flow

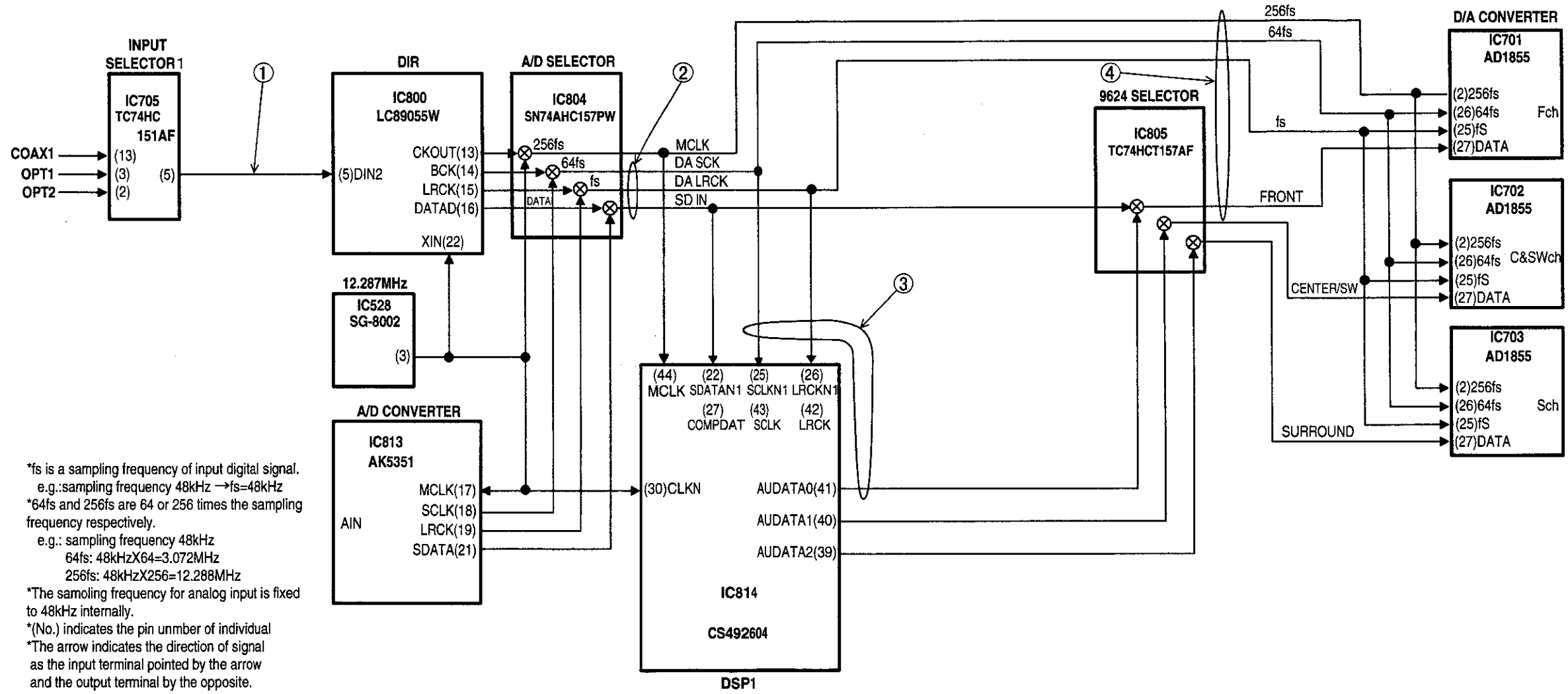

\*fs is a sampling frequency of input digital signal.  
 e.g.: sampling frequency 48kHz → fs=48kHz  
 \*64fs and 256fs are 64 or 256 times the sampling frequency respectively.  
 e.g.: sampling frequency 48kHz  
 64fs: 48kHzX64=3.072MHz  
 256fs: 48kHzX256=12.288MHz  
 \*The sampling frequency for analog input is fixed to 48kHz internally.  
 \*(No.) indicates the pin number of individual  
 \*The arrow indicates the direction of signal as the input terminal pointed by the arrow and the output terminal by the opposite.

- DOLBY DIGITAL Decode
- DTS Decode
- Down-Mix Processing

A  
B  
C  
D  
E

1 2 3 4 5 6 7 8

# ADJUSTMENT

## Tuner Section

### CONNECTION DIAGRAM OF MEASURING INSTRUMENTS

● FM

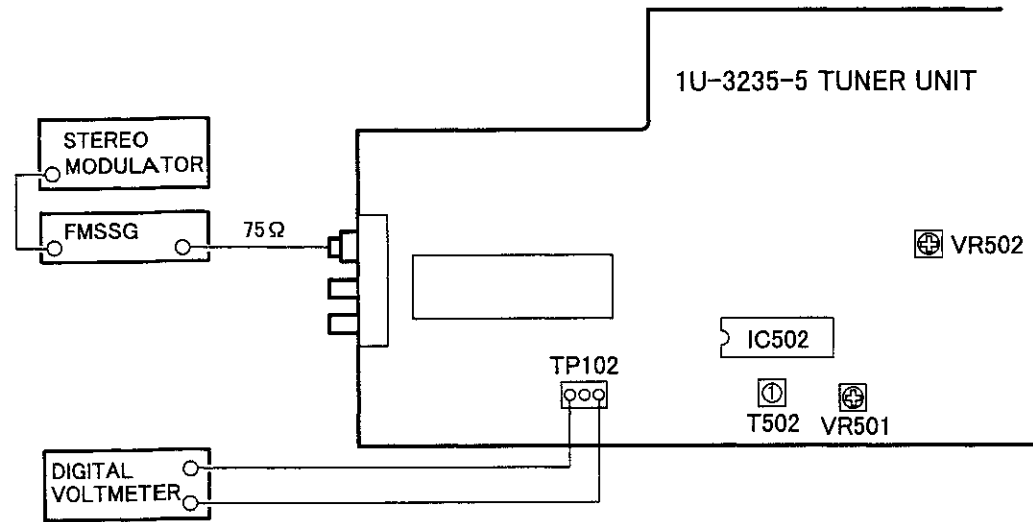

● AM

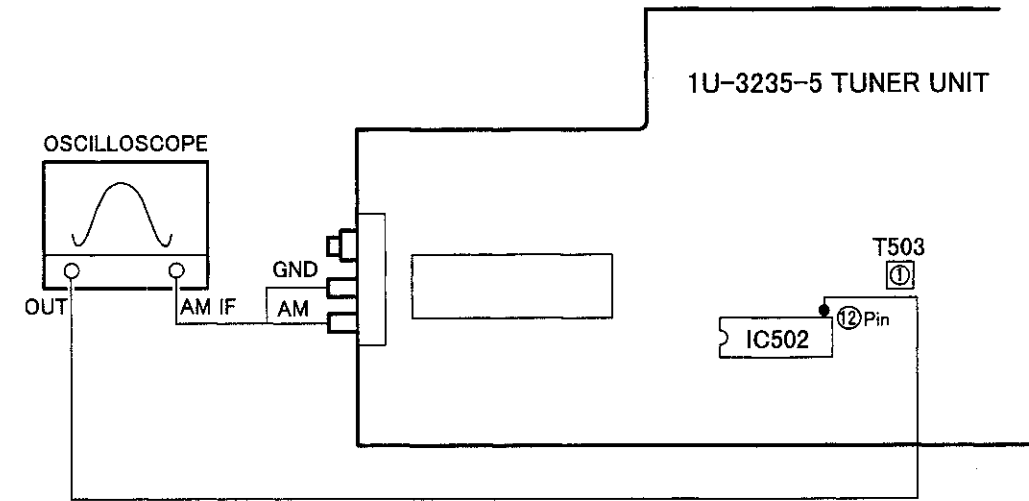

### FM/MPX ALIGNMENT

Step	Alignment Item	Tuning Frequency Setting	Input					Output		Adjust		Remarks
			Type	Frequency	Input Level	Modulation	Coupling	Type	Connect to	Points	Adjust to	
1	Tuning Center	98.1 MHz	FM SSG	98.1 MHz	60 dB $\mu$	None	Antenna Terminal	Digital Voltmeter	TP102	T502	$\pm 50$ mV	Function : FM Mode : Auto
2	Separation	98.1 MHz	FM SSG	98.1 MHz	60 dB $\mu$	Stereo (L) 1kHz 100%	Antenna Terminal	AC Voltmeter	AUDIO OUT Terminal (R)	VR502	Maximum Separation	—
3	Signal Level	98.1 MHz	FM SSG	98.1 MHz	20 dB $\mu$	Off	Antenna Terminal	—	—	VR501	Light "TUNED" FLD Character	—

### AM ALIGNMENT

Step	Alignment Item	Frequency	Input	Output		Adjustment		Remarks
				Type	Connect to	Points	Adjust to	
1	IF	—	IF SWEEP (Input level is not over to work A.G.C.)	Oscilloscope	IC502 12Pin	T503	Maximum height and best symmetry curve	

### Audio Section

#### Idling Current (1U-3232-1)

Required measurement equipment : DC Voltmeter

#### Preparation

- (1) Avoid direct blow from an air conditioner or an electric fan, and adjust the unit at normal room temperature 15 °C ~ 30 °C (59 °F ~ 86 °F).
- (2) Presetting
  - POWER (Power source switch) → OFF
  - SPEAKER (Speaker terminal) → No load (Do not connect speaker, dummy resistor, etc.)

#### Adjustment

- (1) Remove top cover and set VR501, VR502, VR503, VR504, VR505, on 1U-3232-1 (Power Unit) at counterclockwise ( ◯ ) fully.
- (2) Connect DC Voltmeter to test points (FRONT-Lch: TP501, FRONT-Rch: TP502, CENTER ch: TP505, SURROUND-Lch: TP503, SURROUND-Rch: TP504).
- (3) Connect power cord to AC Line, and turn power switch "ON".
- (4) Presetting.
  - MASTER VOLUME : "-" counterclockwise ( ◯ min.)
  - MODE : 5CH STEREO
  - FUNCTION : CD
- (5) Allow 2 minutes, and turn VR501 clockwise ( ◯ ) and adjust the TEST POINT voltage to 1.5 mV ±0.5 mV DC.
- (6) After 10 minutes from preset, turn VR501 to set the voltage to 3 mV ±0.5 mV DC.
- (7) Adjust the Variable Resistors of other channels in the same way.
- (8) After 5 minutes from (6), turn VR501 to set the voltage to 3 mV ±0.5 mV DC.
- (9) Adjust the Variable Resistors of other channels in the same way.

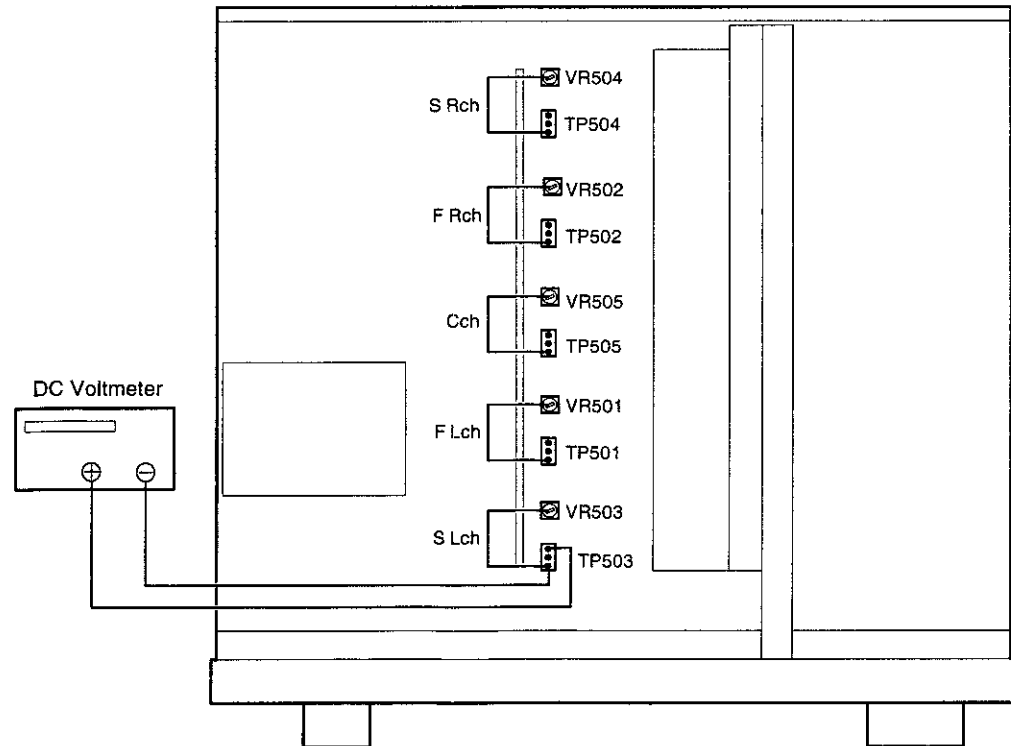

### SEMICONDUCTORS

#### ● IC's

**Note:** Abbreviation ahead of IC No. indicates the name of P.W.B.  
 PO: Power P.W.B.  
 EX: Exit in P.W.B.  
 CO: Control P.W.B.  
 RE: Regulator P.W.B.  
 AU: Audio/DSP P.W.B.

#### LC89055W (AU: IC800)

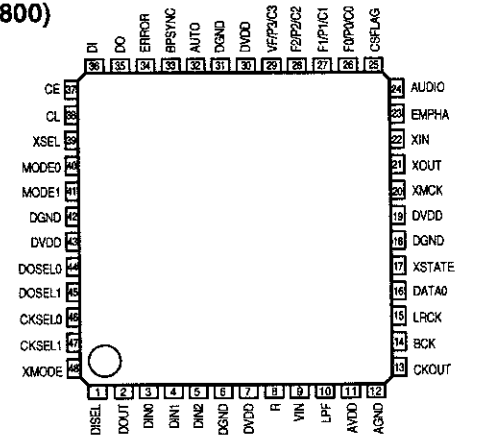

#### LC89055W Terminal Function

Pin No.	Pin Name	I/O	Function
1	DISEL	I	Data input terminal (select input pin of DIN0, DIN1)
2	DOUT	O	Input bi-phase data through output terminal
3	DIN0	I	Amp built-in coaxial/optical input correspond data input terminal
4	DIN1	I	Amp built-in coaxial/optical input correspond data input terminal
5	DIN2	I	Optical input correspond data input terminal
6	DGND		Digital GND
7	DVDD		Digital power supply
8	R	I	VCO gain control input terminal
9	VIN	I	VCO free-run frequency setting input terminal
10	LPF	O	PLL loop filter setting terminal
11	AVDD		Analog power supply
12	AGND		Analog GND
13	CKOUT	O	Clock output terminal (256fs, 384fs, 512fs, X'tal osc., VCO free-run osc.)
14	BCK	O	64fs clock output terminal
15	LRCK	O	fs clock output terminal (L: Rch, H: Lch, I2S: Reverse)
16	DATA0	O	Data output terminal
17	XSTATE	O	Input data detecting result output terminal
18	DGND		Digital GND
19	DVDD		Digital power supply
20	XMCK	O	X'tal osc. clock output terminal (24.576MHz or 12.288MHz)
21	XOUT	O	X'tal osc. connection output terminal
22	XIN	I	X'tal osc. connection output terminal
23	EMPHA	O	Emphasis information output terminal of channel status
24	AUDIO	O	Bit1 output terminal of channel status
25	CSFLAG	O	Top 40bit revise flag output terminal of channel status
26	F0/P0/C0	O	Input fs cal. sig. out / data type out / input word inf. output terminal
27	F1/P1/C1	O	Input fs cal. sig. out / data type out / input word inf. output terminal
28	F2/P2/C2	O	Input fs cal. sig. out / data type out / input word inf. output terminal
29	VF/P3/C3	O	Validity flag out / data type out / input word inf. output terminal
30	DVDD		Digital power supply
31	DGND		Digital GND
32	AUTO	O	Non PCM burst data transfer detect sig. output terminal
33	BPSYNC	O	Non PCM burst data preamble Pa, Pb, Pc, Pd sync sig. output terminal
34	ERROR	O	PLL lock error, data error flag output terminal
35	DO	O	CPU I/F read data output terminal
36	DI	I	CPU I/F write data input terminal
37	CE	I	CPU I/F chip enable input terminal
38	CL	I	CPU I/F clock input terminal
39	XSEL	I	Frequency select input pin of XIN X'tal osc. (24.576MHz or 12.288MHz)
40	MODE0	I	Mode setting input terminal
41	MODE1	I	Mode setting input terminal
42	DGND		Digital GND
43	DVDD		Digital power supply
44	DOSEL0	I	Data output format select input terminal
45	DOSEL1	I	Data output format select input terminal
46	CKSEL0	I	Output clock select input terminal
47	CKSEL1	I	Output clock select input terminal
48	XMODE	I	Reset input terminal

\* For latch-up countermeasure, set digital (DVDD) and analog (AVDD) power on/off in the same timing.

**TMP88CU74F**  
(CO: IC303)

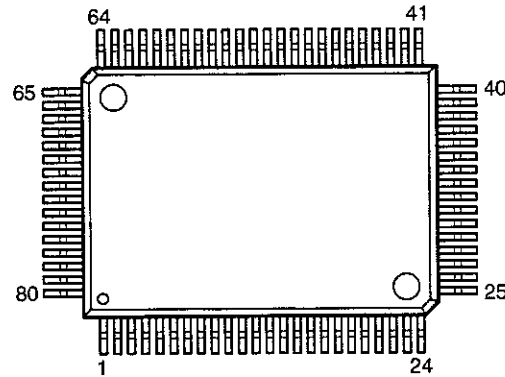

**TMP88CU74F Terminal Function**

Pin No.	Name	Symbol	I/O	Type	Op	Det	Res	Init	Function
1	P02/S01	RDS RESET	O	C	---	---	Z	L	RDS reset output (LC7074)
2	P03		O	C	---	---	Z	L	Fixed to L
3	P04	ST/MONO	O	C	---	---	Z	L	STEREO/MONO control signal, L: STEREO
4	P05	PLFL DATA	O	C	---	---	Z	L	PLL, FL control terminal (LC72131 & LC75721NE)
5	P06	PLL STB	O	C	---	---	Z	L	PLL control terminal (LC72131)
6	P07	PLFL CLK	O	C	---	---	Z	L	PLL, FL control terminal (LC72131 & LC75721NE)
7	Vss	Vss	I	---	GND	---	---	L	GND
8	Xout	Xout	O	---	---	---	---	---	XTAL
9	Xin	Xin	I	---	---	---	---	---	XTAL
10	RESET_	RESET_	I	---	Eu	Lv	L	---	Reset input
11	P22/XTOUT	TUNED_	I	---	Eu	Lv	Z	---	Tuning detect, L: Tuned
12	P21/XTIN	STEREO_	I	---	Eu	Lv	Z	---	L: At stereo receive
13	TEST	TEST	I	---	GND	S	---	---	Connect to GND
14	P20/INT5_	B.DOWN_	I	---	Eu	Lv	Z	---	Power down detect, L: Power down
15	P10/INT0_	PROTECT_	I	---	Ed	E&L	Z	---	PROTECTION detect input, H: Detect
16	P11/INT1	RDS START	I	---	---	---	Z	L	RDS data input (LC7074)
17	P12		O	C	---	---	Z	L	Fixed to L
18	P13		O	C	---	---	Z	L	Fixed to L
19	P14		O	C	---	---	Z	L	Fixed to L
20	P15/INT3	REMOCON	I	---	Ed	E&L	Z	---	Remote control signal input
21	P16/INT2	ACK	O	C	---	---	Z	L	MAIN-SUB CPU comm. control terminal
22	P17/INT4	REQ	I	---	Eu	---	Z	L	MAIN-SUB CPU comm. control terminal
23	P30/SCL	SI	I	C					MAIN-SUB CPU comm. control terminal
24	P31/SDA	SO	O	C					MAIN-SUB CPU comm. control terminal
25	P32/SCK0_	CLK	O	C					MAIN-SUB CPU comm. control terminal
26	P40/AIN0	MODE	I	---	Eu	Lv	Z	---	Destination switching input
27	P41/AIN1	KEY1	I	---	Eu	Lv	Z	---	Button input 1
28	P42/AIN2	KEY2	I	---	Eu	Lv	Z	---	Button input 2
29	P43/AIN3	KEY3	I	---	Eu	Lv	Z	---	Button input 3
30	P44/AIN4	FUNC STB1	O	C	---	---	Z	---	Function control output (TC9274N), INPUT
31	P45/AIN5	FUNC/T. CON CLK	O	C	---	---	Z	L	Function control output (TC9274N, TC9273), TONE control output (TC9184P)
32	P46/AIN6	FUNC/T. CON DATA	O	C	---	---	Z	L	Function control output (TC9274N, TC9273), TONE control output (TC9184P)
33	P47/AIN7	FUNC STB2	O	C	---	---	Z	L	Function control output (NJU7313), 6CH EXT. IN
34	P50/AIN8	E.VOL STB	O	C	---	---	L	L	Elect. volume control output (TC9459)
35	P51/AIN9	TONE STB	O	C	---	---	L	L	TONE control output (TC9184P)
36	P52/AIN10	E.VOL DATA	O	C	---	---	L	H	Elect. volume control output (TC9459)
37	P53/AIN11	E.VOL CLK	O	C	---	---	L	H	Elect. volume control output (TC9459)
38	VASS	VASS	I						Ref. volt (GND)
39	VAREF	VAREF	I						Ref. volt (VDD)
40	VDD	VDD	I						Power supply

Pin No.	Name	Symbol	I/O	Type	Op	Det	Res	Init	Function
41	P60	FL CE	O	P	Ed	S	L	H	FL display control output (LC75712NE)
42	P61	FL RES	O	P	Ed	S	L	H	FL display control output (LC75712NE)
43	P62		O	P	Ed	---	Z	L	Fixed to L
44	P63	FA-RELAY	O	P	Id	---	L	L	Front SP relay A control terminal, L: Mute
45	P64	FB-RELAY	O	P	Id	---	L	L	Front SP relay B control terminal, L: Mute
46	P65	C-RELAY	O	P	Id	---	L	L	Center SP relay control terminal, L: Mute
47	P66	S-RELAY	O	P	Id	---	L	H	Surround SP relay control terminal, L: Mute
48	P67	PRE F MUTE	O	P	Ed	---	L	H	Front PRE OUT mute control terminal, L: Mute
49	P70	PRE C MUTE	O	P	Ed	---	L	L	Center PRE OUT mute control terminal, L: Mute
50	P71	PRE S MUTE	O	P	Ed	---	L	L	Surround PRE OUT mute control terminal, L: Mute
51	P72	SUB WOOFER MUTE	O	P	Ed	---	L	H	Sub-woofer PRE OUT mute control terminal, L: Mute
52	P73	H/P RELAY	O	P	Id	---	L	H	H/P OUT relay control terminal, L: Mute
53	P74	EXP OE	O	P	Ed	---	L	H	Port expander control terminal (TC4094B)
54	P75	EXP CLK	O	P	Ed	---	L	L	Port expander control terminal (TC4094B)
55	P76	EXP DATA	O	P	Ed	---	L	L	Port expander control terminal (TC4094B)
56	P77	EXP STB	O	P	Ed	---	L	L	Port expander control terminal (TC4094B)
57	P80	POWER	O	P	Id	---	L	H	Power relay control output, H: ON
58	P81	RESET2	O	P	Id	---	L	L	Reset signal output to sub-CPU, H: Reset
59	P82	SUB-CPU-B-DOWN	O	P	Id	---	L	L	B-DOWN signal output to sub-CPU
60	P83	TAPE MON. LED	O	P	Id	---	L	L	TAPE MONITOR LED indicator control, H: MONITOR
61	P84	STANDBY	O	P	Id	---	L	H	Standby LED drive output H: Light
62	P85	(DIRECT)	O	P	Id	---	L	L	DIRECT relay control, H: DIRECT
63	P86	(S1)	O	P	Id	---	L	---	Video signal switching control output
64	P87	(S2)	O	P	Id	---	L	---	Fixed to L
65	P90	TUNER MUTE	O	P	Ed	---	L	H	TUNER mute control terminal, H: Mute
66	P91		O	P	Id	---	L	H	Not Used
67	P92		O	P	Id	Lv	Z	---	Fixed to L
68	P93		O	P	Id	Lv	Z	---	Fixed to L
69	P94		O	P	Id	Lv	Z	---	Fixed to L
70	P95	SEL A (M)	I	---	Eu	Lv	Z	---	Master volume rotation detect input (rotary encoder)
71	P96	SEL B (M)	I	---	Eu	Lv	Z	---	Master volume rotation detect input (rotary encoder)
72	P97	CINEMA EQ	O	P	Eu	Lv	Z	L	CINEMA EQ control output, H: ON
73	PD0	VOL MUTE	O	P	Ed	---	L	L	Master volume minimum control, L: Min.
74	PD1	SEL C (S)	I	---	Eu	Lv	Z	---	Surround mode rotation detect input (rotary encoder)
75	PD2	SEL D (S)	I	---	Eu	Lv	Z	---	Surround mode rotation detect input (rotary encoder)
76	PD3	SEL E (F)	I	---	Eu	Lv	Z	---	Input selector switch rotation detect input (rotary encoder)
77	PD4	SEL F (F)	I	---	Eu	Lv	Z	---	Input selector switch rotation detect input (rotary encoder)
78	Vkk	Vkk	---	---	---	---	---	---	GND fixed
79	P00/SCK1_	RDS CLK	I	---	---	S	Z	---	RDS clock input (LC7074)
80	P01/SI1	RDS DATA	I	---	---	S	Z	---	RDS data input (LC7074)

**NOTE:**

- Pin No. : Terminal number of microcomputer.
- Port Name : The name entered in the data sheet of microcomputer.
- Symbol : Symbolized interface function.
- I/O : Input or out of part.
  - "I" = input port
  - "O" = output port
- Type : Composition of port in case of output port.
  - "C" = CMOS output
  - "N" = NMOS open drain output
  - "P" = PMOS open drain output
- Op : Pull up/Pull down selection information.
  - "lu" = Inner microcomputer pull up
  - "ld" = Inner microcomputer pull down
  - "Eu" = External microcomputer pull up
  - "Ed" = External microcomputer pull down
- Det : Indicates judging state of input port. Level detection is "Lv"; Edge detection is "Ed"; Detection by both shifting is "E&L"; Serial data detection is "S" (Serial data output is also "S").
- Res : State at reset.
  - "H" = Outputs High Level at reset
  - "L" = Outputs Low Level at reset
  - "Z" = Becomes High impedance mode at reset
- Ini : Initial output state.
- Function : Function and logical level explanation of signals to be interface.

TMP93CS41F (AU: IC301)

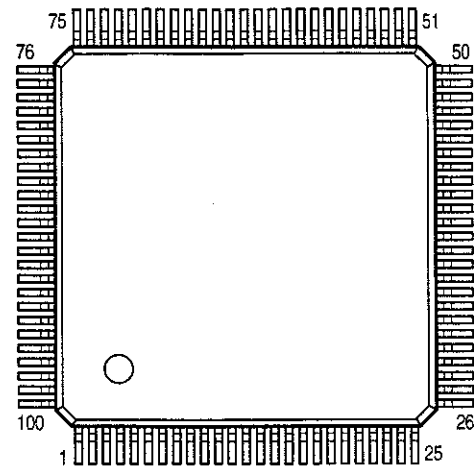

TMP93CS41F Terminal Function

Pin No.	Name	Symbol	I/O	Type	Op	Det	Res	Init	Function
1	V REFL		—	—	—	—	—	—	A/D ref. GND
2	A Vss	←	—	—	—	—	—	—	A/D GND
3	A Vcc	←	—	—	—	—	—	—	AD +5V
4	_NMI		I	—	—	—	—	—	Not used (fixed to H)
5	P70/TI0	C15	O	C	—	—	L	L	Fixed to L (DSP ROM address cont. out bit 15, not used)
6	P71/TO1	C16	O	C	—	—	L	L	DSP program ROM address cont. output bit 16
7	P72/TO2	C17	O	C	—	—	L	L	DSP program ROM address cont. output bit 17
8	P73/TO3		O	C	—	—	L	L	
9	P80/INT4/TI4	_INTREQ	I/O	C	Eu	E↓&L	Z	—	DSP request input and cont. output (L: Rq & cont.)
10	P81/INT5/TI5	B. DOWN_	I	—	Eu	E↑&L	Z	—	Power down detect (H: Detected)
11	P82/TO4	DSP SS	O	C	—	—	H	H	DSP chip select cont. output (L: Data out)
12	P83/TO5	_REQ	O	C	Eu	—	H	L	MAIN-SUB CPU comm. control output (L: Comm. request from sub)
13	P84/INT6/TI6	_ACK	I	—	Eu	E↓&L	—	—	MAIN-SUB CPU comm. control input (L: Ack. return from main)
14	P85/INT7/TI7	ERR	I	—	—	E↑&L	—	—	DIR control input terminal (LC89055Q)(H: ERR)
15	P86/TO6	_DSP RESET	O	C	—	—	L	L	DSP reset output terminal (L: Reset)
16	P87/INT0	_CS	I	—	—	E↑&L	—	—	DIR control input terminal (LC89055Q), when CH status change L→H
17	P90/TXD0	SI	O	C					MAIN-SUB CPU comm. control terminal (data output)
18	P91/RXD0	SO	I	—					MAIN-SUB CPU comm. control terminal (data input)
19	P92/_CTS0/SCLK0	CLK	I	C					MAIN-SUB CPU comm. control terminal (I2C clock in/output)
20	P93/TXD1	DSP DATA	O	C	—	—	L	L	DSP data output terminal
21	P94/RXD1	DSP SO	I	—	—	Lv	—	—	DSP status data input terminal
22	P95/SCLK1	DSP CLK	O	C	—	—	Z	L	DSP data clock output terminal
23	AM8/_16	←	—	—	—	—	—	—	Fixed to +5V
24	CLK		O	C	Eu	—	—	—	
25	Vcc	←	—	—	—	—	—	—	+5V
26	Vss	I/O1	—	—	—	—	—	—	GND
27	X1	Xin	I	—	—	—	—	—	X'tal connection
28	X2	Xout	O	—	—	—	—	—	X'tal connection
29	_EA	←	—	—	—	—	—	—	Fixed to GND
30	_RESET	RESET2_	I	—	Eu	Lv	L	—	Reset input (controlled by main CPU)
31	P96/XT1	A/D RESET	O	N	Eu	—	H	H	A/D control terminal (L: Reset)
32	P97/XT2		O	C	Ed	—	L	L	
33	TEST1	←	I	—	—	—	—	—	Connected to TEST2
34	TEST2	←	I	—	—	—	—	—	Connected to TEST1
35	PA0	DINA	O	C	Ed	—	L	L	Digital input switching control output
36	PA1	DINB	O	C	Ed	—	L	L	Digital input switching control output
37	PA2	DINC	O	C	Ed	—	L	L	Digital input switching control output
38	PA3		O	C	Ed	—	L	L	
39	PA4	DIRECT	O	C	Ed	—	L	L	Digital direct data switch cont. terminal (H: Direct)
40	PA5		O	C	Ed	—	L	L	

Pin No.	Name	Symbol	I/O	Type	Op	Det	Res	Init	Function
41	PA6	DEEMP	O	C	Ed	—	L	L	DAC de-emphasis filter cont. out terminal (H: ON)
42	PA7/SCOUT	96k-DAC	O	C	—	—	Z	L	DAC control terminal (H: Sample frequency 96kHz)
43	ALE	←	O	C	—	—	L	L	Address latch enable
44	Vcc		—	—	—	—	—	—	+5V
45	P00/AD0	AD0	I/O	C	—	—	Z	L	EPROM data in D0 / address out A0
46	P01/AD1	AD1	I/O	C	—	—	Z	L	EPROM data in D1 / address out A1
47	P02/AD2	AD2	I/O	C	—	—	Z	L	EPROM data in D2 / address out A2
48	P03/AD3	AD3	I/O	C	—	—	Z	L	EPROM data in D3 / address out A3
49	P04/AD4	AD4	I/O	C	—	—	Z	L	EPROM data in D4 / address out A4
50	P05/AD5	AD5	I/O	C	—	—	Z	L	EPROM data in D5 / address out A5
51	P06/AD6	AD6	I/O	C	—	—	Z	L	EPROM data in D6 / address out A6
52	P07/AD7	AD7	I/O	C	—	—	Z	L	EPROM data in D7 / address out A7
53	P10/AD8/A8	A8	O	C	—	—	Z	L	EPROM address out A8
54	P11/AD9/A9	A9	O	C	—	—	Z	L	EPROM address out A9
55	P12/AD10/A10	A10	O	C	—	—	Z	L	EPROM address out A10
56	P13/AD11/A11	A11	O	C	—	—	Z	L	EPROM address out A11
57	P14/AD12/A12	A12	O	C	—	—	Z	L	EPROM address out A12
58	P15/AD13/A13	A13	O	C	—	—	Z	L	EPROM address out A13
59	P16/AD14/A14	A14	O	C	—	—	Z	L	EPROM address out A14
60	P17/AD15/A15	A15	O	C	—	—	Z	L	EPROM address out A15
61	_WDTOUT	←	O	C	—	—	Z	H	Watch dog output
62	Vss	←	—	—	—	—	—	—	GND
63	Vcc	←	—	—	—	—	—	—	+5V
64	P20/A0/A16	A16	O	C	—	—	Z	L	EPROM address out A16
65	P21/A1/A17	DIR CLK	O	C	—	—	Z	L	DIR control terminal (LC89055Q) control clock output
66	P22/A2/A18	DIR CE	O	C	—	—	Z	L	DIR control terminal (LC89055Q) control chip enable output
67	P23/A3/A19	DIR MOSI	O	C	—	—	Z	L	DIR control terminal (LC89055Q) control data output
68	P24/A4/A20	DIR MISO	I	—	—	Lv	—	—	DIR control terminal (LC89055Q) control data input
69	P25/A5/A21	SW-SUM	O	C	—	—	L	L	Subwoofer output summation cont. output
70	P26/A6/A22	DAC-RESET	O	C	—	—	L	H	DAC control terminal (L: Power down mode, ↑ (rising edge) Reset)
71	P27/A7/A23	SEL CK	O	C	—	—	Z	L	ADC/DIR data clock switching control terminal (L: ADC)
72	P30/_RD	_RD	O	C	—	—	Z	L	Flash memory control terminal
73	P31/_WR	_WR	O	C	—	—	Z	L	Flash memory control terminal
74	P32/_HWR	CSI	I	—	—	Lv	—	—	DIR control input terminal (L: PCM)
75	P33/_WAIT	ERR MUTE_	O	C	—	—	L	L	Pop noise preventive mute control output (L: Mute)
76	P34/_BUSRQ		O	C	—	—	Z	L	
77	P35/_BUSRQ	DIG. (AC3) MUTE	O	C	—	—	Z	L	Digital mute control output (L: AC-3 or DTS decode enable)
78	P36/_R/W		O	C	—	—	Z	L	
79	P37/_RAS	DIR RESET	O	C	—	—	Z	L	DIR control output (LC89055Q) (L: Reset)
80	P40/_CS0/_CAS0		O	C	—	—	Z	L	
81	P41/_CS1/_CAS1		O	C	—	—	Z	L	
82	P42/_CS2/_CAS2	_CS0	O	C	—	—	Z	L	Flash memory control terminal
83	P60/PG00	DSP C. RESET	O	C	—	—	Z	L	DSP reset output terminal (L: Reset)
84	P61/PG01	SCDOUT	I	—	—	Lv	—	—	DSP status data input terminal
85	P62/PG02	DSP C. CS	O	C	—	—	Z	L	DSP chip select cont. output (L: Data out)
86	P63/PG03	DSP C. CLK	O	C	—	—	Z	L	DSP data clock output terminal
87	P64/PG10	SCDIN	O	C	—	—	Z	L	DSP data output terminal
88	P65/PG11		O	C	—	—	Z	L	
89	P66/PG12		O	C	—	—	Z	L	
90	P67/PG13		O	C	—	—	Z	L	
91	Vss	←	—	—	—	—	—	—	GND
92	P50/AN0		I	—	Eu	Lv	Z	—	
93	P51/AN1		I	—	Eu	Lv	Z	—	
94	P52/AN2	EMP	I	—	—	Lv	—	—	H: EMP on
95	P53/AN3	96K DET	I	—	—	Lv	—	—	96k signal detect input, H: 96k
96	P54/AN4		I	—	Eu	Lv	Z	—	
97	P55/AN5		I	—	Eu	Lv	Z	—	
98	P56/AN6		I	—	Eu	Lv	Z	—	
99	P57/AN7		I	—	Eu	Lv	Z	—	
100	V REFH	←	—	—	—	—	—	—	AD ref. +5V

**CS492604-CLR**  
(AU: IC814)

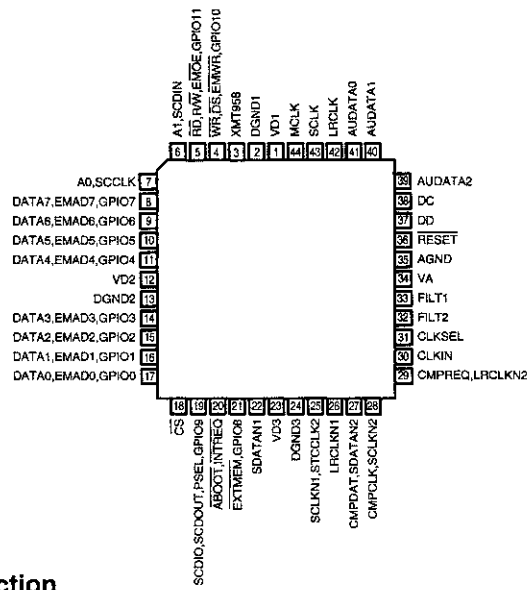

**CS492604-CLR Terminal Function**

Pin No.	Pin Name	Function
1	VD1	Digital positive supply
2	DGND1	Digital supply ground
3	XMT958	SPDIF transmitter output
4	WR, DS, EMWR, GPIO10	Host write strobe or host data strobe or external memory write enable or general purpose input & output number10
5	RD, R/W, EMOE, GPIO11	Host parallel output enable or host parallel R/W or external memory outout enable or general purpose input & output number11
6	A1, SCDIN	Host address bit one or SPI serial control data input
7	A0, SCCLK	Host parallel address bit zero or serial control port clock
8	DATA7, EMAD7, GPIO7	
9	DATA6, EMAD6, GPIO6	
10	DATA5, EMAD5, GPIO5	
11	DATA4, EMAD4, GPIO4	
12	VD2	Digital positive supply
13	DGND2	Digital supply ground
14	DATA3, EMAD3, GPIO3	
15	DATA2, EMAD2, GPIO2	
16	DATA1, EMAD1, GPIO1	
17	DATA0, EMAD0, GPIO0	
18	CS	Host parallel chip select, host serial SPI chip select
19	SCDIO, SCDOUT, PSEL, GPIO9	Serial control port data input and output, parallel port type select
20	INTREQ, ABOOT	Control port interrupt request, automatic boot enable
21	EXTMEM, GPIO8	External memory chip select or general purpose input & output number 8
22	SDATAN1	PCM audio data input number one
23	VD3	Digital positive supply
24	DGND3	Digital supply ground
25	SCLKN1, STCCLK2	PCM audio input bit clock
26	LRCLKN1	PCM audio input sample rate clock
27	CMPDAT, SDATAN2	PCM audio data input number two
28	CMPCLK, SCLKN2	PCM audio input bit clock
29	CMPREQ, LRCLKN2	PCM audio input sample rate clock
30	CLKIN	Master clock input
31	CLKSEL	DSP clock select
32	FILT2	Phase locked loop filter
33	FILT1	Phase-locked loop filter
34	VA	Analog positive supply
35	AGND	Analog supply ground
36	RESET	Master reset input
37	DD	Reserved
38	DC	Reserved
39	AUDATA2	Digital audio output 2
40	AUDATA1	Digital audio output 1
41	AUDATA0	Digital audio output 0
42	LRCLK	Audio output sample rate clock
43	SCLK	Audio output bit clock
44	MCLK	Audio master clock

LC75721E (EX: IC101)

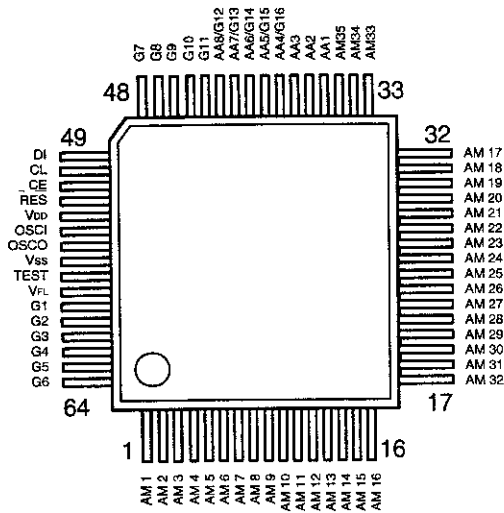

Symbol	Function
V <sub>DD</sub>	Power terminal +5V
V <sub>SS</sub>	Power terminal GND
V <sub>FL</sub>	Power terminal FL drive
DI CL CE	Serial data transfer terminal DI: Data CL: Clock CE: Chip enable
OSC1 OSCO	External CR connecting terminal
RES	System reset terminal
AM1~AM35 AA1~AA3	Anode output terminal
AA4/G16 AA5/G15 AA6/G14 AA7/G13 AA8/G12	Anode/Grid output terminal
G1~G11	Grid output terminal
TEST	LSI test terminal

AD1855 (AU: IC701, 702, 703)

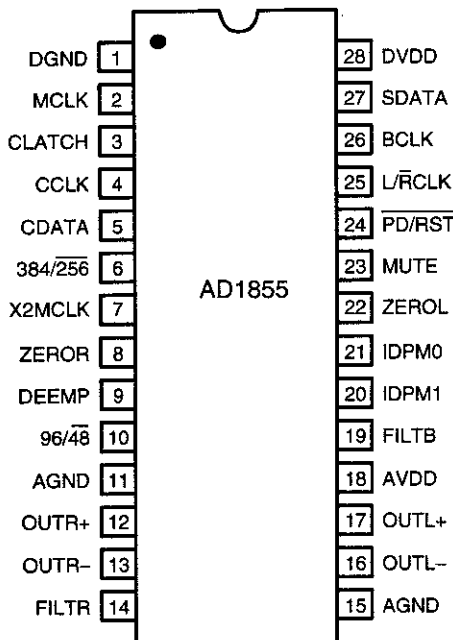

Pin No.	Name	I/O	Description
1	DGND	I	Digital Ground.
2	MCLK	I	Master Clock Input.
3	CLATCH	I	Latch input for control data.
4	CCLK	I	Control clock input for control data.
5	CDATA	I	Serial control input.
6	384/256	I	Selects the master clock mode.
7	X2MCLK	I	Selects internal clock doubler (LO) or internal clock=MCLK (HI)
8	ZEROR	O	Right Channel Zero Flag Output.
9	DEEMP	I	De-Emphasis.
10	96/48	I	Selects 48 kHz (LO) or 96 kHz Sample Frequency Control.
11,15	AGND	I	Analog Ground.
12	OUTR+	O	Right Channel Positive line level analog output.
13	OUTR-	O	Right Channel Negative line level analog output.
14	FILTR	O	Voltage Reference Filter Capacitor Connection.
16	OUTL-	O	Left Channel Negative line level analog output.
17	OUTL+	O	Left Channel Positive line level analog output.
18	AVDD	I	Analog Power supply.
19	FILTB	O	Filter Capacitor connection.
20	IDPM1	I	Input serial data port mode control one.
21	IDPM0	I	Input serial data port mode control zero.
22	ZEROL	O	Left Channel Zero Flag output.
23	MUTE	I	Mute. Assert HI to mute both stereo analog outputs.
24	PD/RST	I	Power-Down/Reset.
25	L/RCLK	I	Left/Right clock input for input data.
26	BCLK	I	Bit clock input for input data.
27	SDATA	I	Serial input.
28	DVDD	I	Digital Power Supply.



**AK5351 (AU: IC813)**

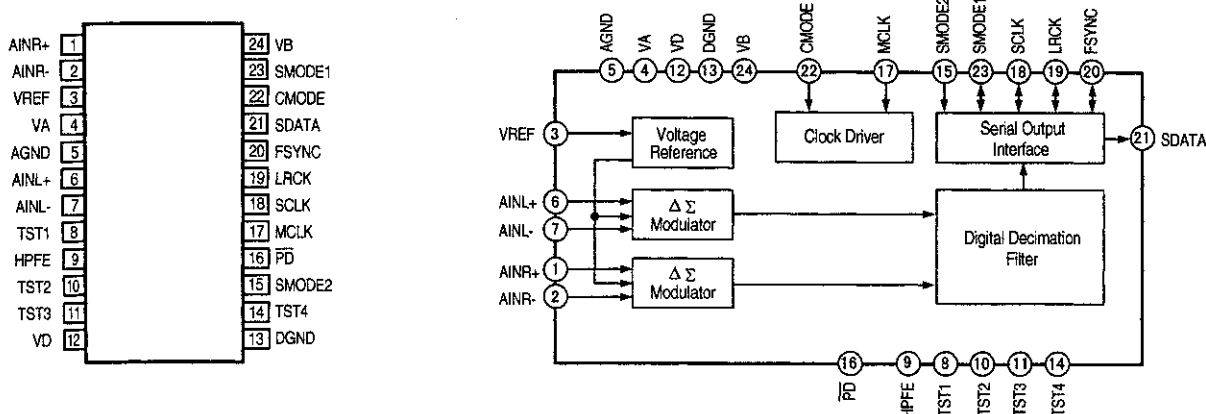

**AK5351 Terminal Function**

Pin No.	Symbol	I/O	Function
1	AINR+	I	Rch analog non-inverted input pin.
2	AINR-	I	Rch analog inverted input pin
3	VREF	O	Vref. output pin (VA-2.6V)
4	VA	---	Analog part power supply pin (+5V)
5	AGND	---	Analog ground pin
6	AINL+	I	Lch analog non-inverted input pin
7	AINL-	I	Lch analog inverted input pin
8	TST1		Test pin
9	HPFE	I	Hi-pass filter enable pin, "H": ON, "L": OFF
10	TST2		Test pin
11	TST3		Test pin
12	VD	---	Digital part power supply pin (+5V)
13	DGND	---	Digital ground pin
14	TST4		Test pin
15	SMODE2	I	Interface clock select pin
16	PD	I	Power down pin, "L": power down mode
17	MCLK	I	Master clock input pin, CMODE="H": 384fs, "L": 256fs
18	SCLK	I/O	Serial data clock pin
19	LRCK	I/O	Input channel select pin
20	FSYNC	I/O	Frame sync clock pin
21	SDATA	O	Serial data output pin
22	CMODE	I	Master clock select pin, "H": MCLK=384fs, "L": 256fs
23	SMODE1	I	Interface clock select pin
24	VB	---	Bulk power supply pin (+5V)

**TC9274N-011 (AU: IC107)**

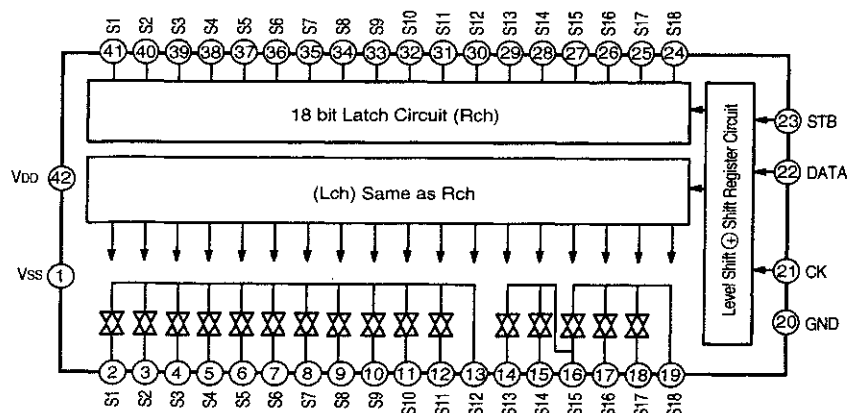
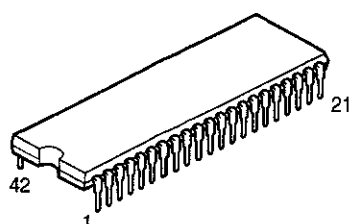

Europe model only  
SAA6579T (CO: IC301)

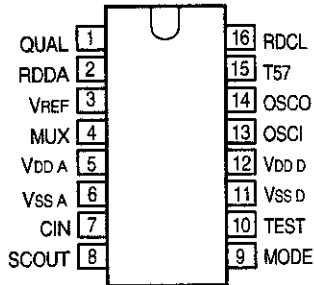
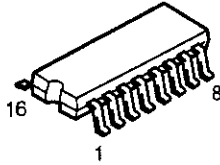

SAA6579T Terminal Function

Pin No.	Symbol	Function
1	QUAL	Quality indication output.
2	RDDA	RDS data output.
3	VREF	Reference voltage output (0.5 V <sub>DD A</sub> ).
4	MUX	Multiplex signal input.
5	V <sub>DD A</sub>	+5V power supply for analog part.
6	V <sub>SS A</sub>	Ground for analog part (0V).
7	CIN	Subcarrier input to comparator.
8	SCOUT	Subcarrier output of reconstruction filter.
9	MODE	Oscillation mode/test control input.
10	TEST	Test enable input.
11	V <sub>SS D</sub>	Ground for digital part (0V).
12	V <sub>DD D</sub>	+5V power supply for digital part.
13	OSCI	Oscillator input.
14	OSCO	Oscillator output.
15	T57	57kHz clock signal output.
16	RDCL	RDS clock output.

TC4094BF (CO: IC304, EX: IC103)

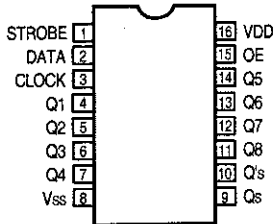
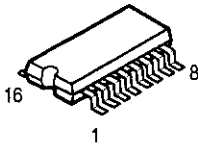

CO: IC304

Port	Symbol	Function
Q1	A	Video input switching
Q2	B	Video input switching
Q3	C	Video input switching
Q4	D	Video output switching
Q5	E	Video output switching
Q6	F	Video output switching (DVD/TV)
Q7	G	Video output switching (DVD/TV)
Q8	Not Used	

EX: IC103

Port	Symbol	Function
Q1	LOCK LED	"LOCK" LED drive output (H: Lock)
Q2	DOLBY DIGITAL LED	"DOLBY DIGITAL" LED drive output (H: D.Digital)
Q3	dts LED	"dts" LED drive output (H: dts)
Q4	AUTO LED	"AUTO" LED drive output (H: input mode "AUTO")
Q5	DTS LED	"DTS" LED drive output (H: input mode "DTS")
Q6	PCM LED	"PCM" LED drive output (H: input mode "PCM")
Q7	FRONT SP-A LED	"FRONT SPEAKER A" LED drive output
Q8	FRONT SP-B LED	"FRONT SPEAKER B" LED drive output

TC9184AP (CO: IC102)

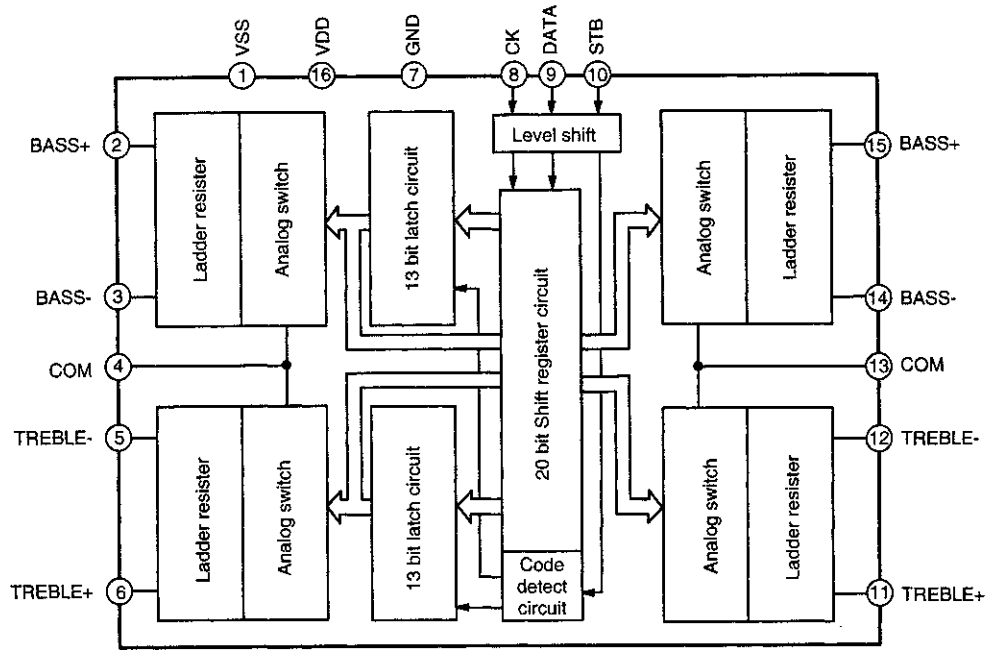
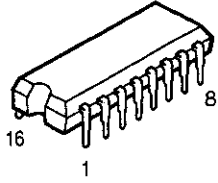

LA1265 (S)  
(RE: IC502)

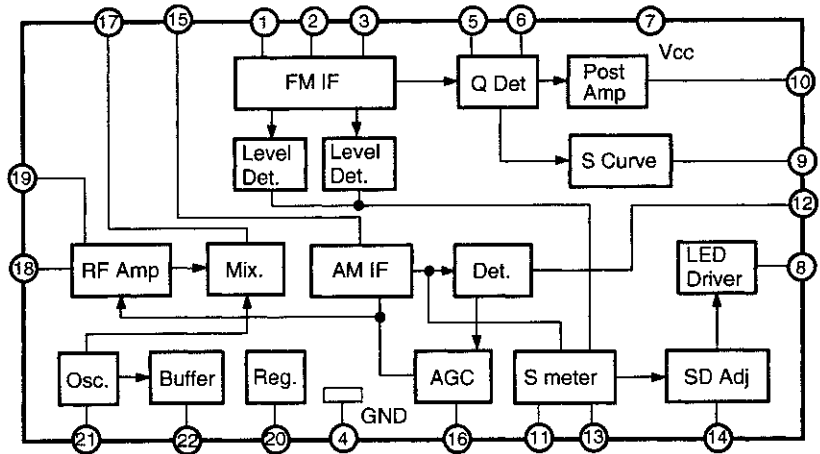
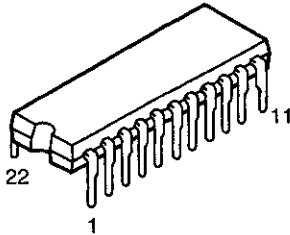

SN74LV573ANS (AU: IC302)

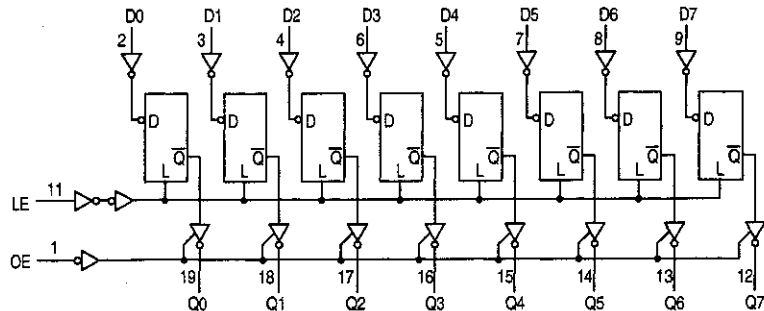
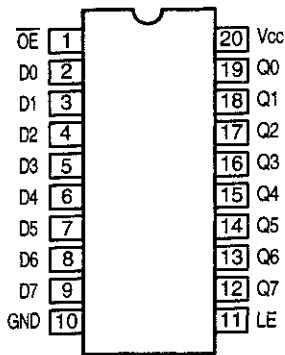

SN74AHC157PW  
 (AU: IC804)  
 TC74VHC123AFT  
 (AU: IC801, 806)  
 TC74HC151AF  
 (CO: IC705)  
 TC74HCT157AF  
 (AU: IC805)

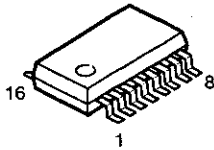

SN74AHC157PW

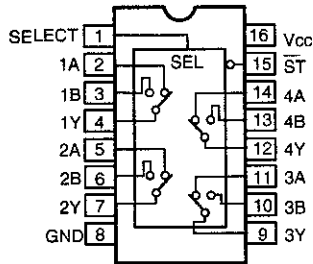

TC74VHC123AFT

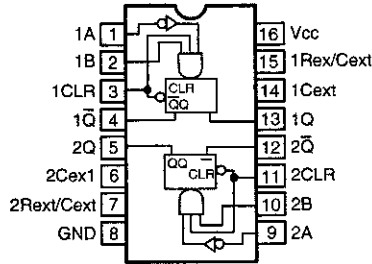

TC74HC151AF

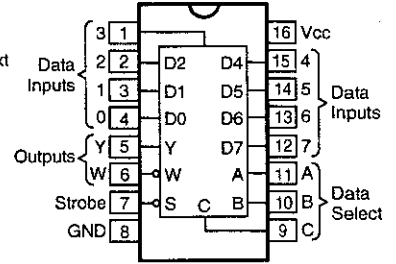

TC74HCT157AF

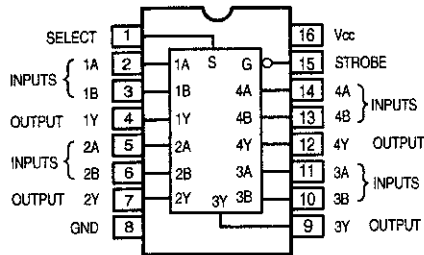

W29EE011P-90 (AU: IC303)  
 W29C020P-90 (AU: IC817)

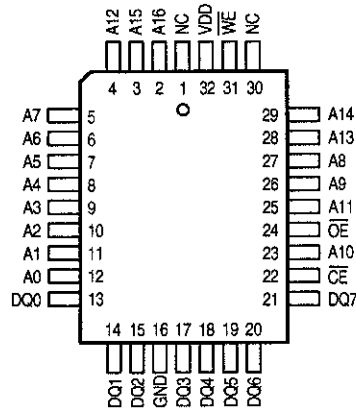

Terminal Function

Name	Function
A0 - A16	Address input
DQ0 - DQ7	Data in/output
CE	Chip enable
OE	Output enable
WE	Write enable
V <sub>DD</sub>	Power terminal
GND	GND
NC	No connection

LA3401  
 (RE: IC503)

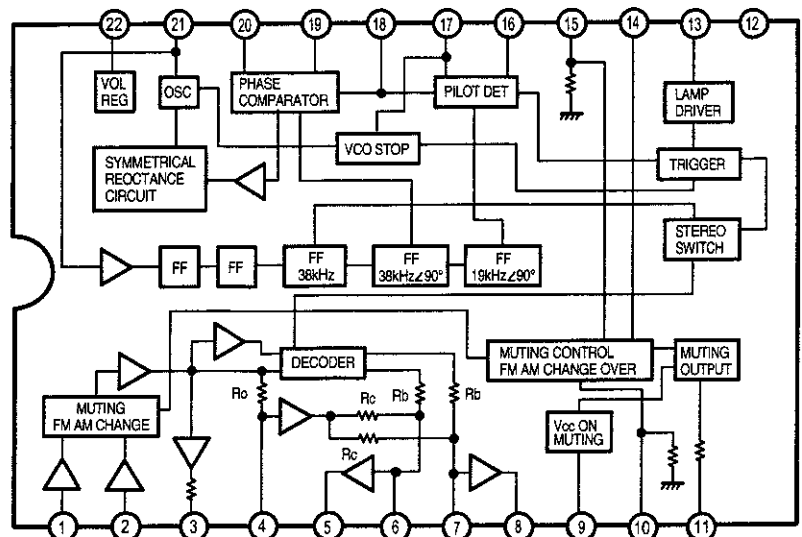
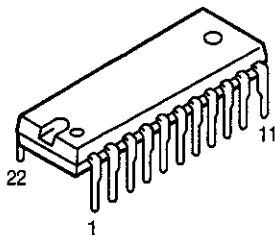

**LC7074M (CO: IC302)**  
(Europe model only)

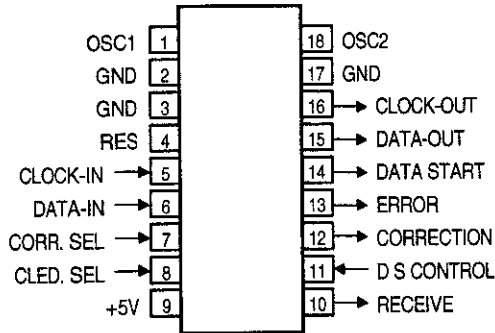
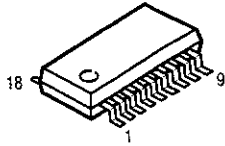

**TC74HCT7007AF**  
(AU: IC821)

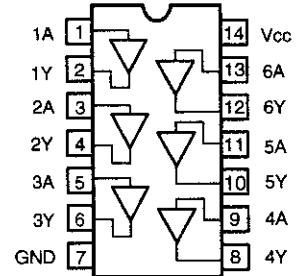
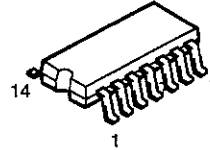

**SN74LV14APW (AU: IC809)**  
**SN74LV00APW (AU: IC807, 808)**  
**TC74HCU04AF (CO: IC704)**

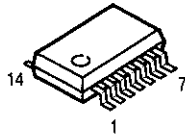

**SN74LV14APW**

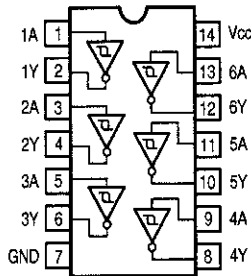

**SN74LV00APW**

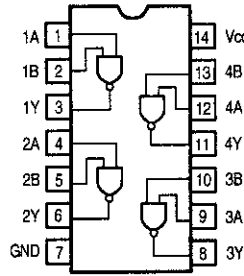

**TC74HCU04AF**

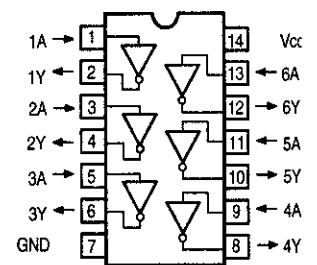

**SN74AHC574APW**  
(AU: IC815, 816)

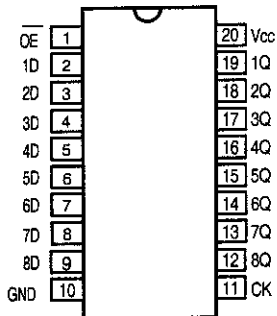

**Logic symbol**

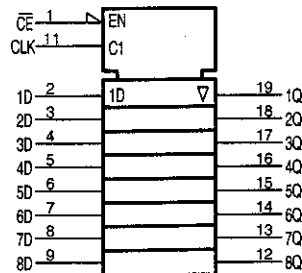

**Function Table**  
(each flip-flop)

INPUTS			OUTPUT
OE	CLK	D	Q
L	↑	H	H
L	↑	L	L
L	H or L	X	Q0
H	X	X	Z

**BA7625**  
(PO: IC402, 450)

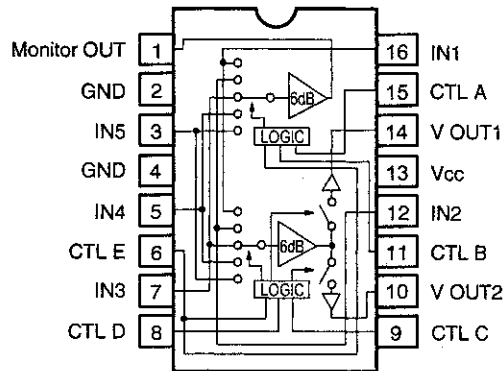
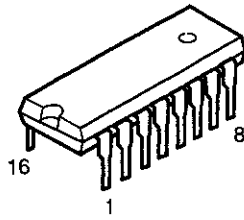

A	B	E	MONITOR OUT
L	L	*	IN 1
H	L	*	IN 2
L	H	*	IN 3
H	H	L	IN 4
H	H	H	IN 5

C	D	E	V OUT 1
L	L	*	—
H	L	*	IN 2
L	H	*	IN 3
H	H	L	IN 4
H	H	H	IN 5

C	D	E	V OUT 2
L	L	*	IN 1
H	L	*	—
L	H	*	IN 3
H	H	L	IN 4
H	H	H	IN 5

Note 1: \* mark means that feasible for either H or L.  
 Note 2: Each input terminal is provided with sink chip clamp (BA7625).  
 Each input terminal takes 20kohm at the end (BA7626).

**BA4510F** (AU: IC811, 812)  
**NJM2068MD**(EX: IC301~304,308~310,701,801~803)  
 (CO: IC103,104)  
 (AU: IC106,109,731~733,)

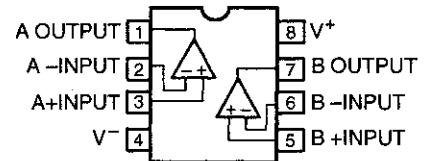
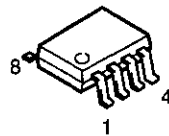

**LC72131M** (RE: IC507)

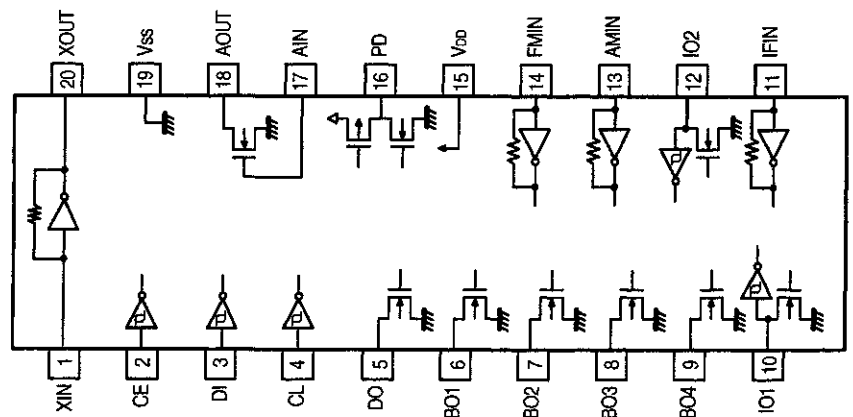
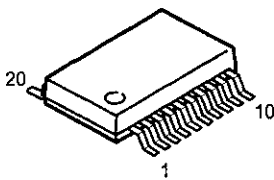

**NJU7313AL (EX: IC311)**

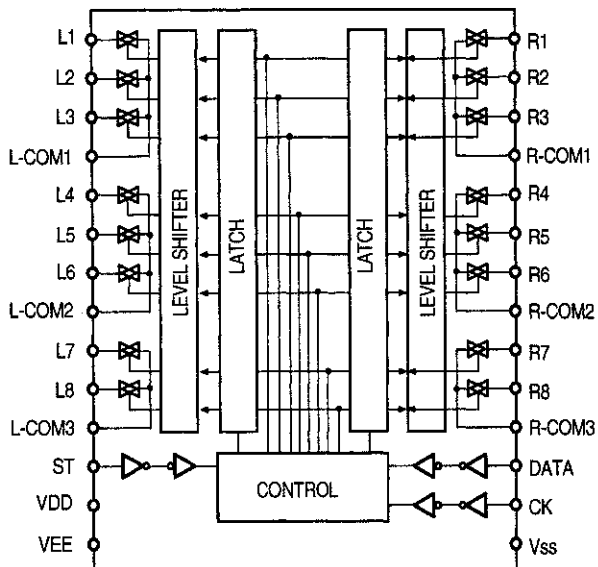
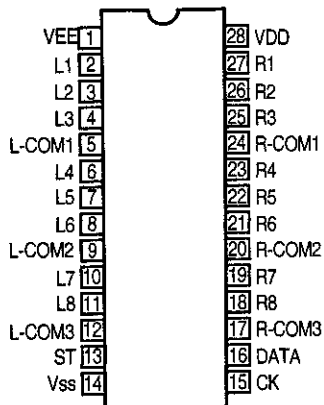
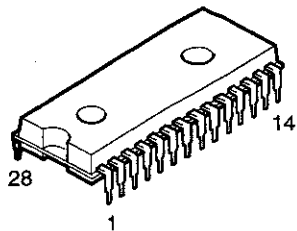

**TC9459N (EX: IC805-807)**

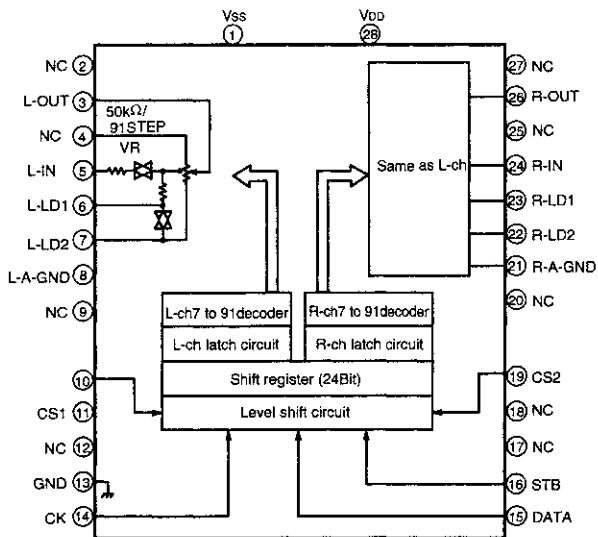
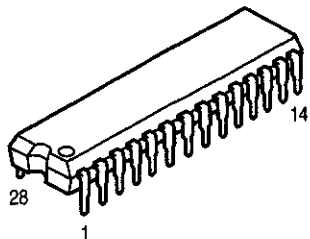

**BU4052BC (PO: IC401)**

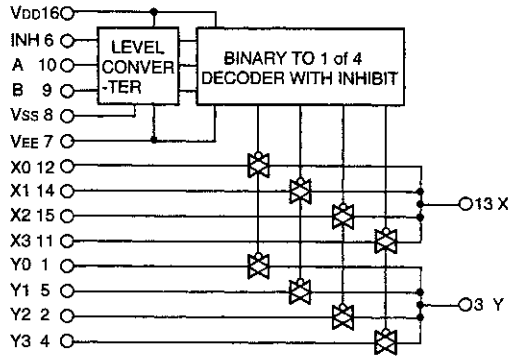
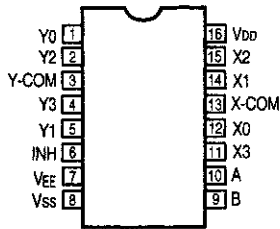
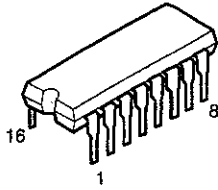

**TRUTH TABLE**

INHIBIT	A	B	ON SWITCH
L	L	L	X0 Y0
L	H	L	X1 Y1
L	L	H	X2 Y2
L	H	H	X3 Y3
H	X	X	NONE

X: don't Care

- NJM7805FA (S) (RE: IC902, 903)
- NJM7806FA (S)
- (PO: IC502)
- (RE: IC904)
- NJM7812FA (S) (RE: IC906)
- BA033T (AU: 819)

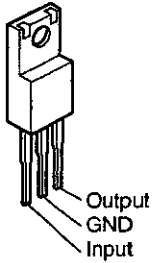

**NJM7912FA (RE: IC907)**

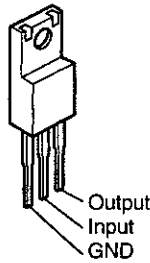

**SG-8002DCPT (12.287MHz)**  
(AU: XL802)

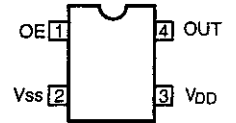
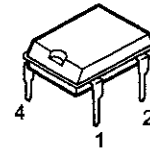



● TRANSISTORS

2SA970 (BL)  
2PA1015GR  
2SA988 (E/F)  
2SC1841 (E/F)  
2SC2878 (A/B)  
2PC1815 (BL)

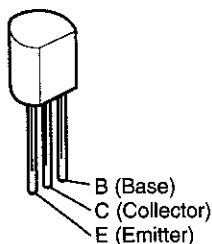

2SC2705 (O) / (Y)

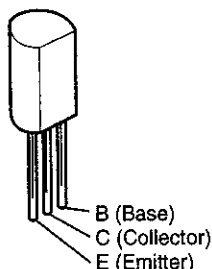

2SA1491  
2SC3855

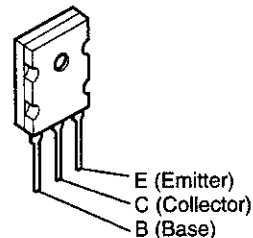

2SB1186A  
2SD1763A

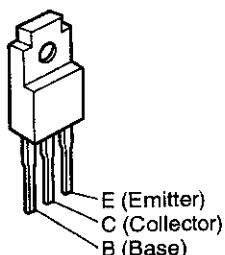

2SA1670 (O/P/Y)

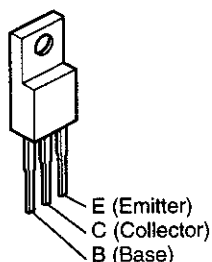

2SC4495

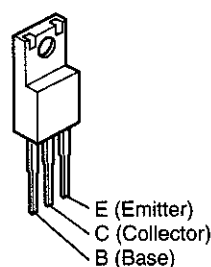

DTA114TK  
DTA114EK  
DTA144EK  
DTC114EK  
DTC144EK  
DTC323TK  
RN2402

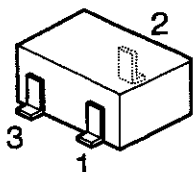

1: GND/Emitter  
2: Out/Collector  
3: In/Base

DTA114TK  
DTA114EK  
DTA144EK  
RN2402

PNP Type

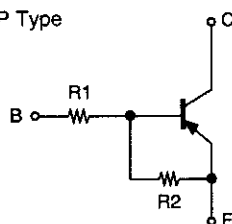

	R1	R2
DTA114TK	10kohm	-
DTA114EK	10kohm	10kohm
DTA144EK	47kohm	47kohm
RN2402	10kohm	10kohm

DTC114EK  
DTC144EK  
DTC323TK

NPN Type

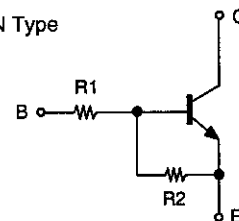

	R1	R2
DTC114EK	10kohm	10kohm
DTC144EK	47kohm	47kohm
DTC323TK	2.2kohm	-

2SA933S (S)  
2SC3311A  
2SC1645S (B)

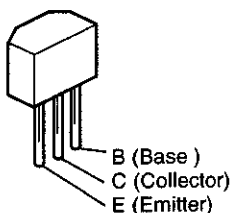

2SK209 (GR)

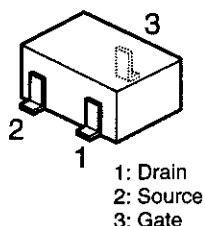

1: Drain  
2: Source  
3: Gate

2SA1182 Y/O  
2SC2996 (Y)  
2SC3326 (A/B)  
2SD601A

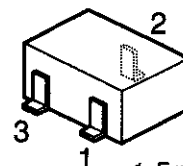

1: Emitter  
2: Collector  
3: Base

● DIODES (included LED)

1SS270A

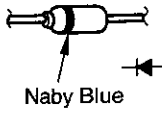

MTZJ3.3A MTZJ7.5A  
MTZJ5.6A MTZJ9.1A  
MTZJ6.2A MTZJ36A

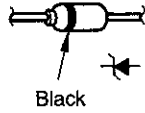

1SR35-400A

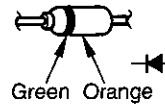

DSM1D2(Type 3)

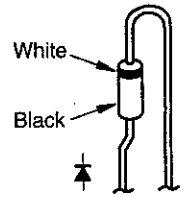

S4VB20

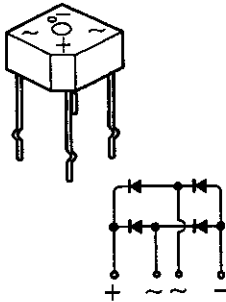

SEL1210S (Red)  
SEL4214S

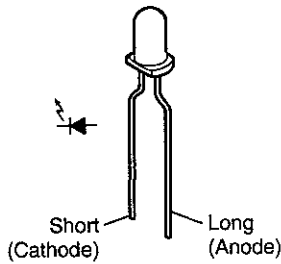

DAN202K

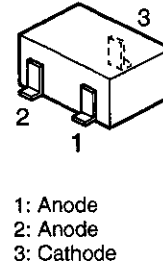

DAP202K

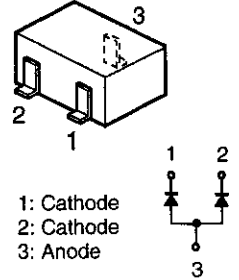

● IC PROTECTOR

ICP-N15 (PO: IC501)

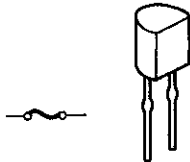

● OPTICAL

INPUT  
GP1F37R1 (CO: IC702, 703)

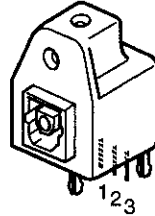

1. Vcc  
2. GND  
3. Vout

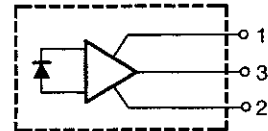

● OTHERS

GP1U271X (Remote Control Sensor)  
(EX: IC102)

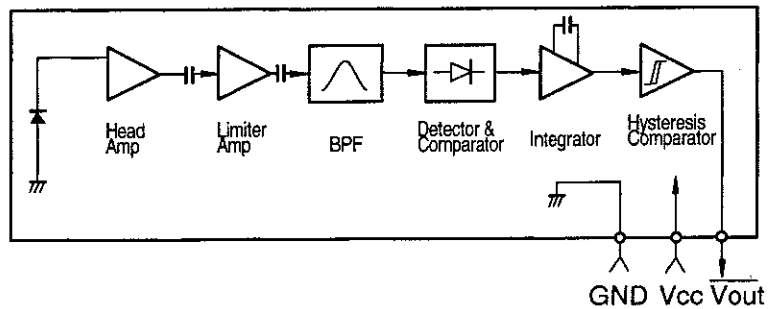
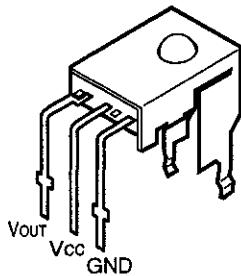

● FL DISPLAY CM1690C (VI : FL101)

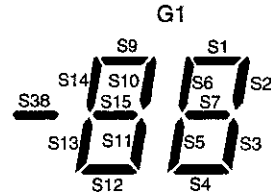
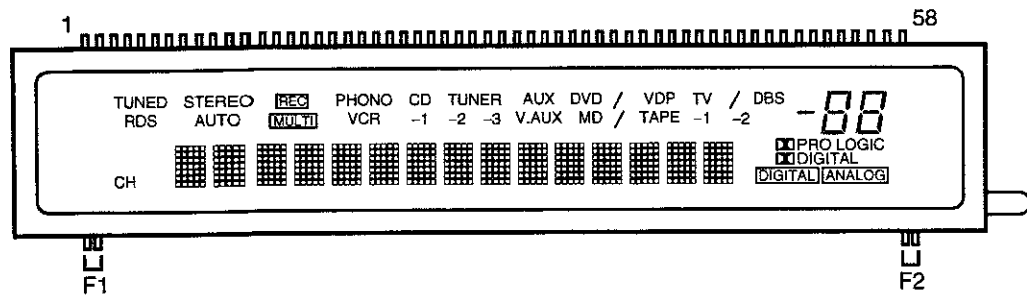

G2-G16

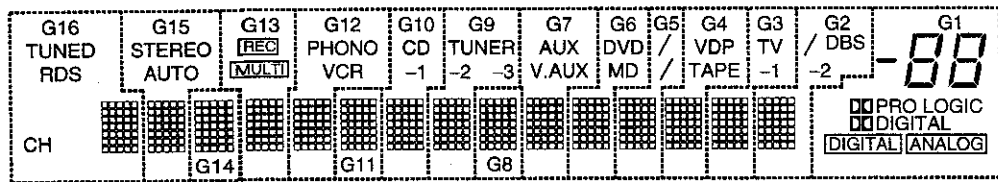
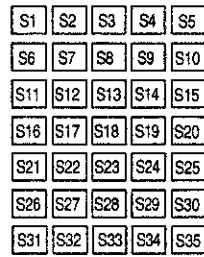

Pin Assignment

PIN NO.	1	2	3	4	5	6	7	8	9	10	11	12	13	14	15	16	17	18	19	20
CONNECTION	F1	F1	S1	S2	S3	S4	S5	S6	S7	S8	S9	S10	S11	S12	S13	S14	S15	S16	S17	S18
PIN NO.	21	22	23	24	25	26	27	28	29	30	31	32	33	34	35	36	37	38	39	40
CONNECTION	S19	S20	S21	S22	S23	S24	S25	S26	S27	S28	S29	S30	S31	S32	S33	S34	S35	S36	S37	S38
PIN NO.	41	42	43	44	45	46	47	48	49	50	51	52	53	54	55	56	57	58		
CONNECTION	G16	G15	G14	G13	G12	G11	G10	G9	G8	G7	G6	G5	G4	G3	G2	G1	F2	F2		

F1,F2 : Filament  
G1-G16 : Grid  
S1-S38 : Anode

Anode & Grid Assignment

	G1	G2-G16		G1	G2-G16		G1	G2-G16		G1	G2-G16
S1	S1	S1	S10	S10	S10	S19	---	S19	S28	---	S28
S2	S2	S2	S11	S11	S11	S20	---	S20	S29	---	S29
S3	S3	S3	S12	S12	S12	S21	---	S21	S30	---	S30
S4	S4	S4	S13	S13	S13	S22	---	S22	S31	---	S31
S5	S5	S5	S14	S14	S14	S23	---	S23	S32	---	S32
S6	S6	S6	S15	S15	S15	S24	---	S24	S33	---	S33
S7	S7	S7	S16	---	S16	S25	---	S25	S34	---	S34
S8	S8	S8	S17	---	S17	S26	---	S26	S35	---	S35
S9	S9	S9	S18	PRO LOGIC	S18	S27	---	S27			

	G1	G2	G3	G4	G5	G6	G7	G8	G9	G10	G11	G12	G13	G14	G15	G16
S36	DIGITAL	/	TV	VDP	(DVD)	DVD	AUX	---	TUNER	CD	---	PHONO	REC	---	STEREO	TUNED
S37	ANALOG	-2	-1	TAPE	(/MD)	MD	V.AUX	---	-2	-1	---	VCR	MULTI	---	AUTO	RDS
S38	S38	DBS	---	---	---	---	---	---	-3	---	---	---	---	---	---	CH

PRINTED WIRING BOARDS

1 2 3 4 5 6 7 8

1U-3197 AUDIO / DSP P.W.B. UNIT Ass'y  
COMPONENT SIDE

A

B

C

D

E

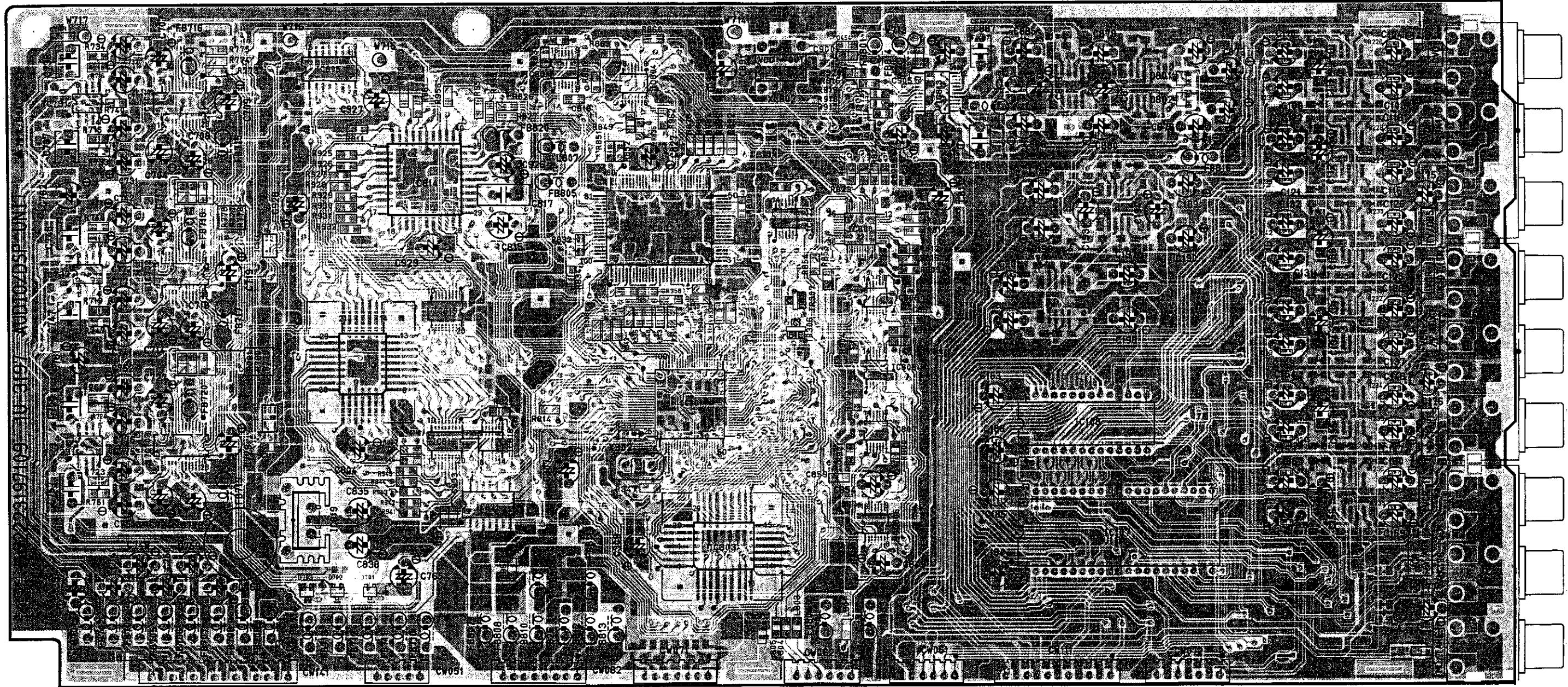



1 2 3 4 5 6 7 8

FOIL SIDE

A

B

C

D

E

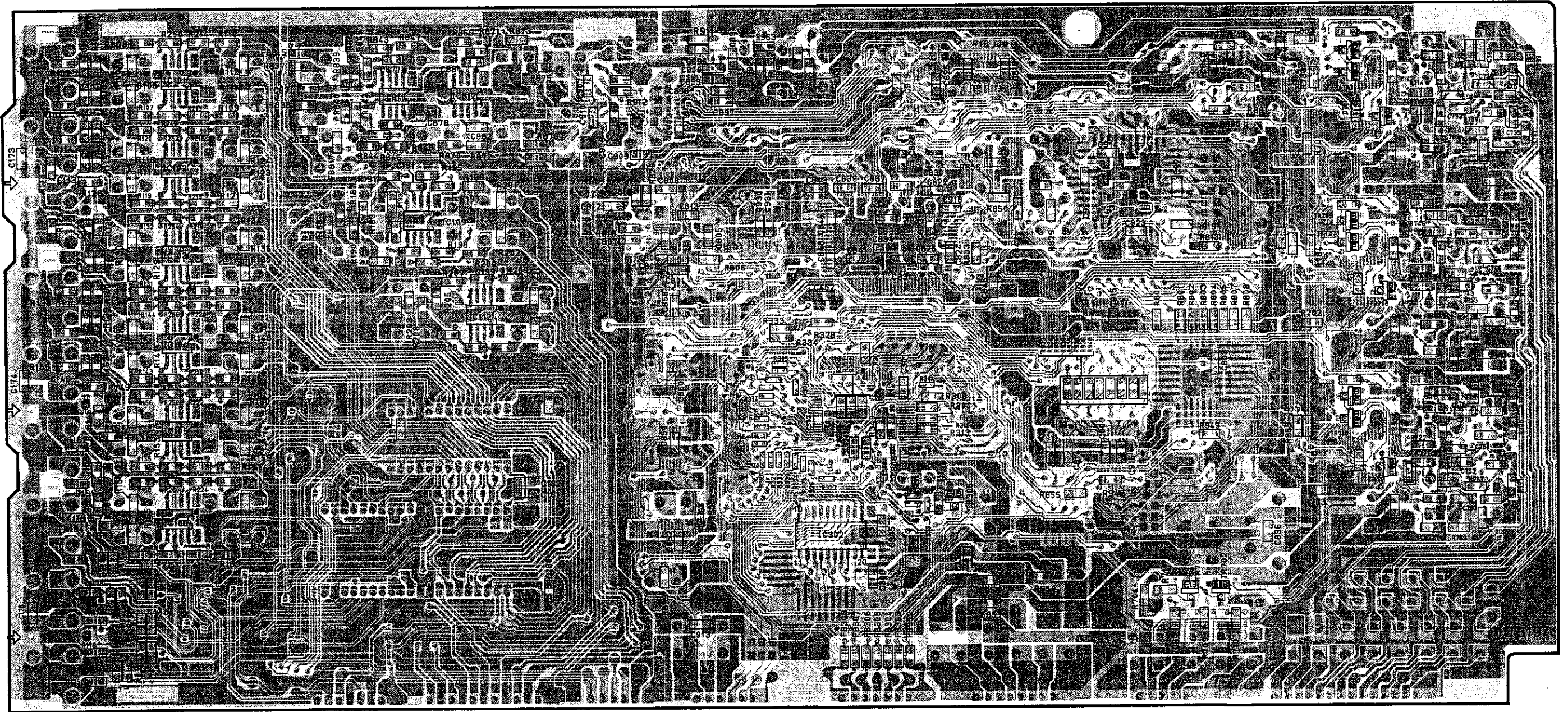







1 2 3 4 5 6 7 8

FOIL SIDE

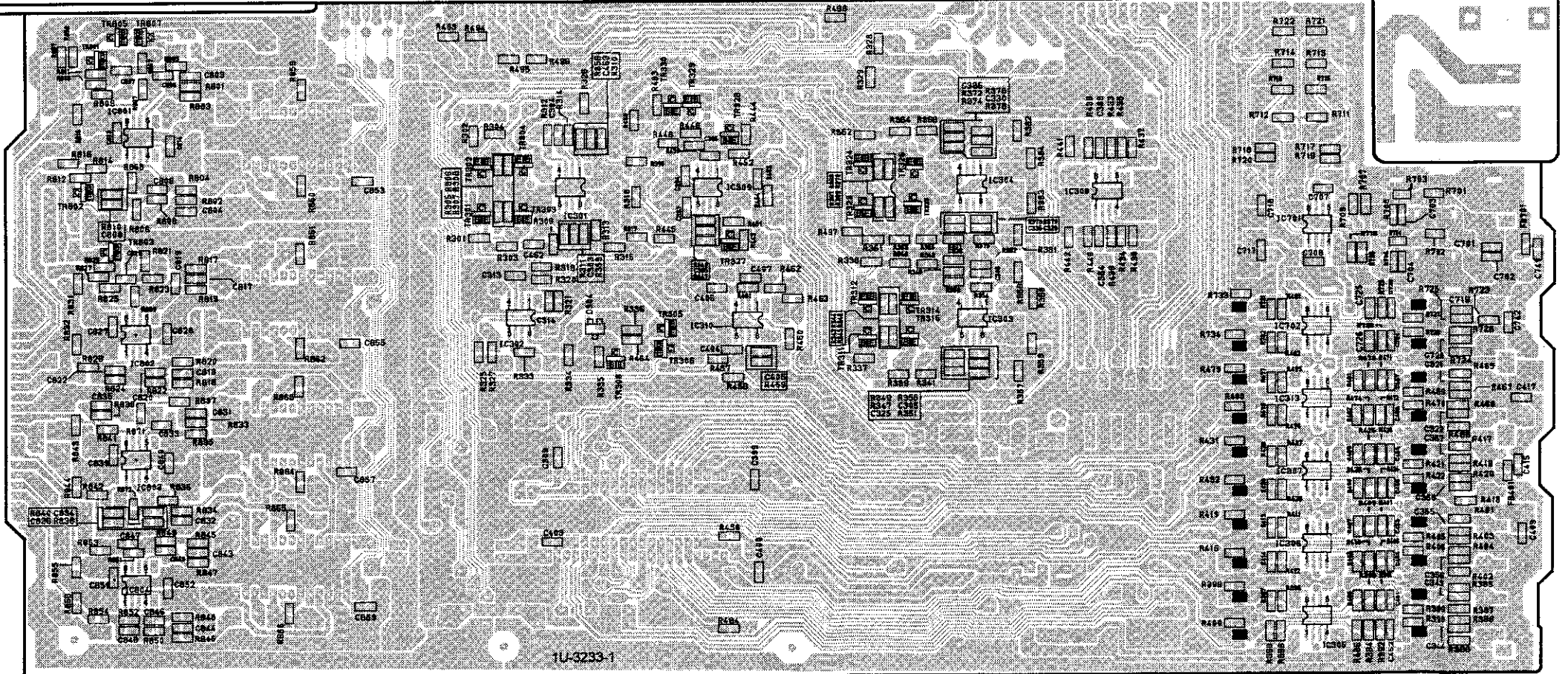
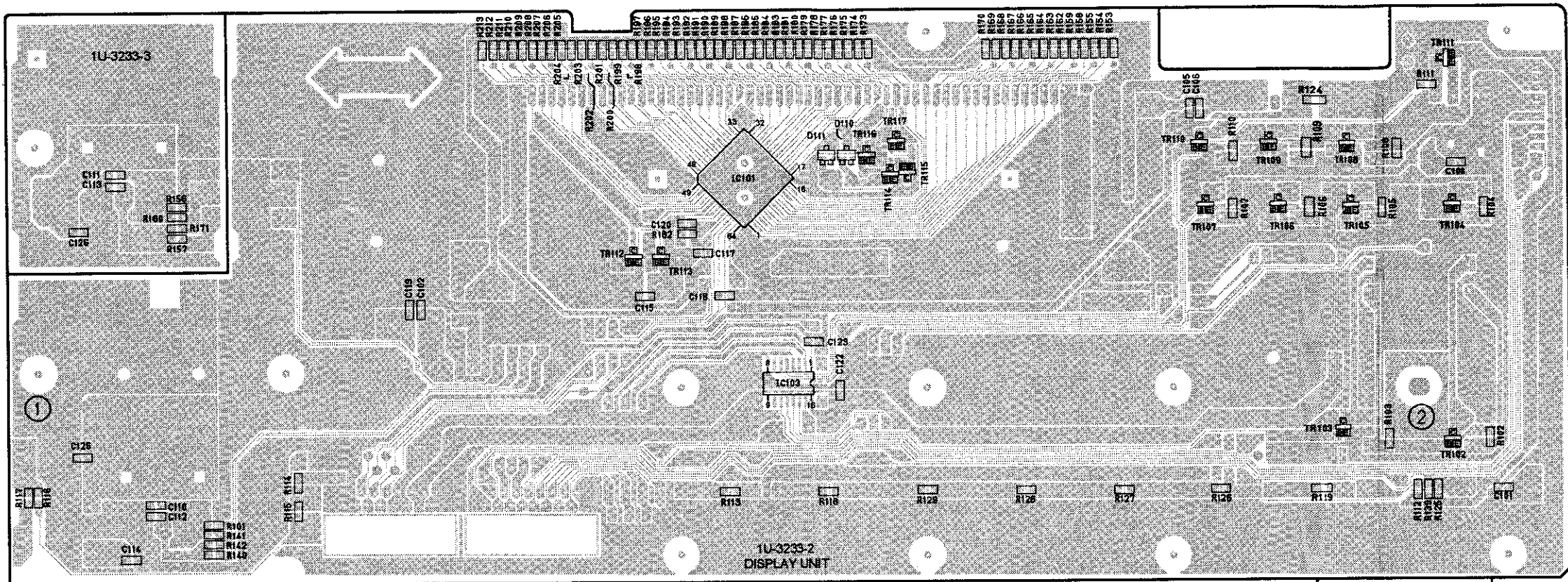

A

B

C

D

E







1 2 3 4 5 6 7 8

FOIL SIDE

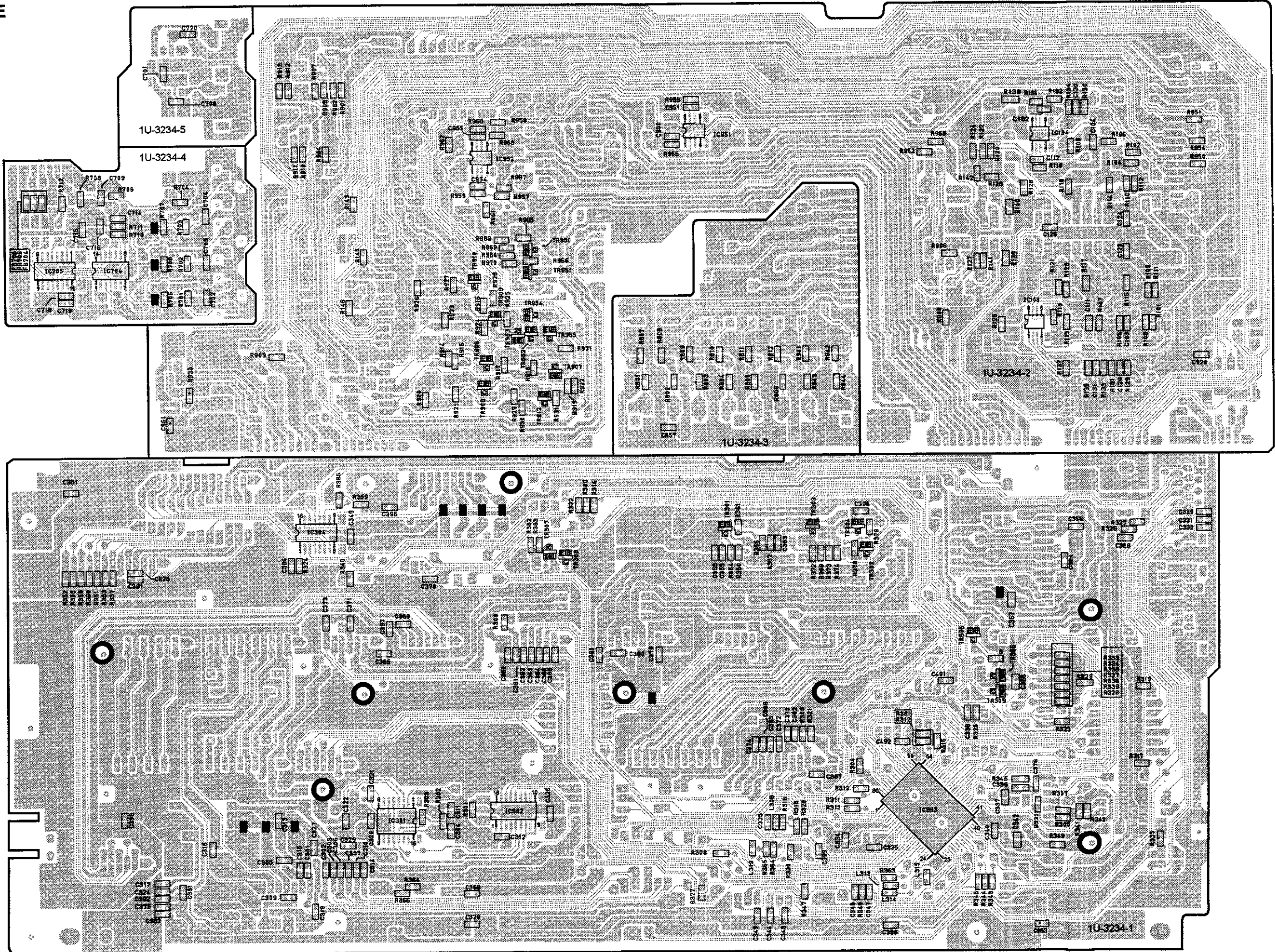

A

B

C

D

E





1

2

3

4

5

6

7

8

FOIL SIDE

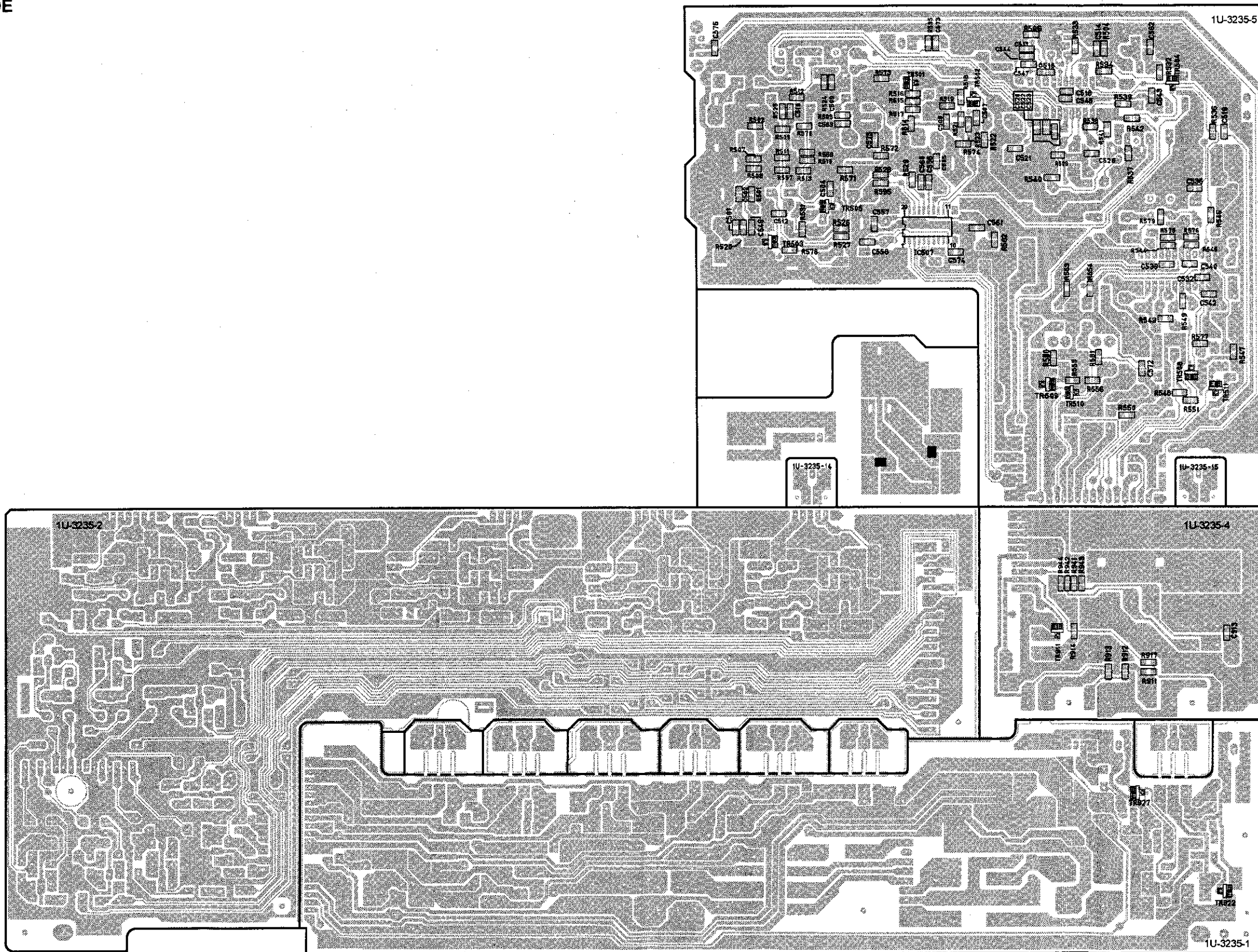

A

B

C

D

E





## NOTE FOR PARTS LIST

- Part indicated with the mark "⊗" are not always in stock and possibly to take a long period of time for supplying, or in some case supplying of part may be refused.
- When ordering of part, clearly indicate "1" and "I" (i) to avoid mis-supplying.
- Ordering part without stating its part number can not be supplied.
- Part indicated with the mark "★" is not illustrated in the exploded view.
- Not including Carbon Film ±5%, 1/4W Type in the P.W.Board parts list. (Refer to the Schematic Diagram for those parts.)

### WARNING:

Parts marked with this symbol  have critical characteristics. Use ONLY replacement parts recommended by the manufacturer.

### ● Resistors

Ex.: RN 14K 2E 182 G FR  
 Type Shape and performance Power Resistance Allowable error Others

RD : Carbon	2B : 1/8W	F : ±1%	P : Pulse-resistant type
RC : Composition	2E : 1/4W	G : ±2%	NL : Low noise type
RS : Metal oxide film	2H : 1/2W	J : ±5%	NB : Non-burning type
RW : Winding	3A : 1W	K : ±10%	FR : Fuse-resistor
RN : Metal film	3D : 2W	M : ±20%	F : Lead wire forming
RK : Metal mixture	3F : 3W		
	3H : 5W		

#### \* Resistance

$\overset{1}{\text{B}} \overset{2}{\text{}} \Rightarrow 1800 \text{ ohm} = 1.8 \text{ kohm}$   
 Indicates number of zeros after effective number.  
 2-digit effective number.

• Units: ohm

$\overset{1}{\text{R}} \overset{2}{\text{}} \Rightarrow 1.2 \text{ ohm}$   
 1-digit effective number.  
 2-digit effective number, decimal point indicated by R.

• Units: ohm

### ● Capacitors

Ex.: CE 04W 1H 2R2 M BP  
 Type Shape and performance Dielectric Capacity Allowable error Others

CE : Aluminum foil electrolytic	0J : 6.3V	F : ±1%	HS : High stability type
CA : Aluminum solid electrolytic	1A : 10V	G : ±2%	BP : Non-polar type
CS : Tantalum electrolytic	1C : 16V	J : ±5%	HR : Ripple-resistant type
CQ : Film	1E : 25V	K : ±10%	DL : For charge and discharge
CK : Ceramic	1V : 35V	M : ±20%	HF : For assuring high frequency
CC : Ceramic	1H : 50V	Z : +80%	U : UL part
CP : Oil	2A : 100V	-20%	C : CSA part
CM : Mica	2B : 125V	P : +100%	W : UL-CSA type
CF : Metallized	2C : 160V	-0%	F : Lead wire forming
CH : Metallized	2D : 200V	C : ±0.25pF	
	2E : 250V	D : ±0.5pF	
	2H : 500V	= : Others	
	2J : 630V		

#### \* Capacity (electrolyte only)

$\overset{2}{\text{}} \overset{2}{\text{}} \overset{2}{\text{}} \Rightarrow 2200\mu\text{F}$   
 Indicates number of zeros after effective number.  
 2-digit effective number.

• Units: μF.

$\overset{2}{\text{R}} \overset{2}{\text{}} \Rightarrow 2.2\mu\text{F}$   
 1-digit effective number.  
 2-digit effective number, decimal point indicated by R.

• Units: μF.

#### \* Capacity (except electrolyte)

$\overset{2}{\text{}} \overset{2}{\text{}} \overset{2}{\text{}} \Rightarrow 2200\text{pF} = 0.0022\mu\text{F}$   
 (More than 2) — Indicates number of zeros after effective number.  
 2-digit effective number.

• Units: μF.

$\overset{2}{\text{}} \overset{2}{\text{}} \overset{1}{\text{}} \Rightarrow 220\text{pF}$   
 (0 or 1) — Indicates number of zeros after effective number.  
 2-digit effective number.

• Units: pF.

• When the dielectric strength is indicated in AC, "AC" is included after the dielectric strength value.

# PARTS LIST OF P.W.B. UNIT 1U-3197 AUDIO/DSP UNIT ASS'Y

Note: The symbols in the column "Remarks" indicate the following destinations.  
 E3: U.S.A. & Canada model      E1C: China model  
 EU: U.S.A. model (AVR-87)      E1H: Hong Kong model  
 E2: Europe model      E3T: Taiwan R.O.C. model  
 E1: Asia model

Ref. No.	Part No.	Part Name	Remarks
<b>SEMICONDUCTORS GROUP</b>			
IC106	263 0896 909	IC NJM2068MD	
IC107	262 2545 006	IC TC9274N-011	
IC109	263 0896 909	IC NJM2068MD	
IC301	262 2615 004	IC TMP93CS41F	
IC302	262 2682 901	IC SN74LV573ANS	
IC303	262 2723 006	IC W29EE011P-90 (18)	
IC701-703	262 2674 906	IC AD1855JRSRL	
IC731-733	263 0896 909	IC NJM2068MD	
IC800	262 2675 015	IC LC89055W	
IC801	262 2608 901	IC TC74VHC123AFT	
IC804	262 2609 900	IC SN74AHC157PW	
IC805	262 2284 901	IC TC74HCT157AF	
IC806	262 2608 901	IC TC74VHC123AFT	
IC807,808	262 2519 906	IC SN74LV00APW	
IC809	262 2557 900	IC SN74LV14APW	
IC811,812	263 0934 900	IC BA4510F	
IC813	262 2426 905	IC AK5351-VF	
IC814	262 2657 907	IC CS492604	
IC815,816	262 2660 907	IC SN74AHC574PW	
IC817	262 2724 005	IC W29C020P-90 (18)	
IC819	263 1048 002	IC BA033T	
IC821	262 2376 903	IC TC74HCT7007AF	
IC822	262 2557 900	IC SN74LV14APW	
TR305	269 0082 902	Transistor DTC114EK	
TR702	269 0082 902	Transistor DTC114EK	
TR703-712	269 0083 901	Transistor DTA114EK	
D701-703	276 0560 901	Diode DAN202K	
<b>RESISTORS GROUP</b>			
R101,102	247 0005 905	Carbon chip 100ohm 1/10W	RM73B--101J for E3,EU,E1,E1C, E1H,E3T
R101,102	247 0006 962	Carbon chip 470ohm 1/10W	RM73B--471J for E2
R103,104	247 0015 966	Carbon chip 2.7Mohm 1/10W	RM73B--275J
R107-110	247 0018 905	Carbon chip 0ohm 1/10W	RM73B--0R0K
R113,114	247 0005 905	Carbon chip 100ohm 1/10W	RM73B--101J for E3,EU,E1,E1C, E1H,E3T
R113,114	247 0006 962	Carbon chip 470ohm 1/10W	RM73B--471J for E2
R115,116	247 0015 966	Carbon chip 2.7Mohm 1/10W	RM73B--275J
R119-122	247 0018 905	Carbon chip 0ohm 1/10W	RM73B--0R0K

Ref. No.	Part No.	Part Name	Remarks
R125,126	247 0005 905	Carbon chip 100ohm 1/10W	RM73B--101J for E3,EU,E1,E1C, E1H,E3T
R125,126	247 0006 962	Carbon chip 470ohm 1/10W	RM73B--471J for E2
R127,128	247 0015 966	Carbon chip 2.7Mohm 1/10W	RM73B--275J
R131-134	247 0018 905	Carbon chip 0ohm 1/10W	RM73B--0R0K
R137,138	247 0005 905	Carbon chip 100ohm 1/10W	RM73B--101J for E3,EU,E1,E1C, E1H,E3T
R137,138	247 0006 962	Carbon chip 470ohm 1/10W	RM73B--471J for E2
R139,140	247 0015 966	Carbon chip 2.7Mohm 1/10W	RM73B--275J
R143-146	247 0018 905	Carbon chip 0ohm 1/10W	RM73B--0R0K
R149,150	247 0005 905	Carbon chip 100ohm 1/10W	RM73B--101J for E3,EU,E1,E1C, E1H,E3T
R149,150	247 0006 962	Carbon chip 470ohm 1/10W	RM73B--471J for E2
R151,152	247 0015 966	Carbon chip 2.7Mohm 1/10W	RM73B--275J
R155-158	247 0018 905	Carbon chip 0ohm 1/10W	RM73B--0R0K
R161,162	247 0005 905	Carbon chip 100ohm 1/10W	RM73B--101J for E3,EU,E1,E1C, E1H,E3T
R161,162	247 0006 962	Carbon chip 470ohm 1/10W	RM73B--471J for E2
R163-166	247 0012 927	Carbon chip 100kohm 1/10W	RM73B--104J
R167,168	247 0006 962	Carbon chip 470ohm 1/10W	RM73B--471J
R169,170	247 0004 922	Carbon chip 47ohm 1/10W	RM73B--470J
R171,172	247 0012 927	Carbon chip 100kohm 1/10W	RM73B--104J
R173,174	247 0015 966	Carbon chip 2.7Mohm 1/10W	RM73B--275J
R175,176	247 0006 962	Carbon chip 470ohm 1/10W	RM73B--471J
R177,178	247 0015 966	Carbon chip 2.7Mohm 1/10W	RM73B--275J
R179,180	247 0006 962	Carbon chip 470ohm 1/10W	RM73B--471J
R181,182	247 0015 966	Carbon chip 2.7Mohm 1/10W	RM73B--275J
R183,184	247 0006 962	Carbon chip 470ohm 1/10W	RM73B--471J
R187-190	247 0012 927	Carbon chip 100kohm 1/10W	RM73B--104J
R191,192	247 0005 905	Carbon chip 100ohm 1/10W	RM73B--101J
R195-200	247 0018 905	Carbon chip 0ohm 1/10W	RM73B--0R0K
R201,202	247 0012 927	Carbon chip 100kohm 1/10W	RM73B--104J
R213-224	247 0018 905	Carbon chip 0ohm 1/10W	RM73B--0R0K
R225-234	247 2018 903	Carbon chip 0ohm 1/16W	RM73B--0R0K
R237-246	247 2018 903	Carbon chip 0ohm 1/16W	RM73B--0R0K
R249-258	247 0018 905	Carbon chip 0ohm 1/10W	RM73B--0R0K
R301,302	247 0009 985	Carbon chip 10kohm 1/10W	RM73B--103J
R303	247 2003 989	Carbon chip 33ohm 1/16W	RM73B--330J
R304	247 0009 901	Carbon chip 4.7kohm 1/10W	RM73B--472J
R305,306	247 2003 989	Carbon chip 33ohm 1/16W	RM73B--330J
R307	247 0009 985	Carbon chip 10kohm 1/10W	RM73B--103J

Ref. No.	Part No.	Part Name	Remarks	Ref. No.	Part No.	Part Name	Remarks
R308	247 2003 989	Carbon chip 33ohm 1/16W	RM73B--330J	R816	247 0018 905	Carbon chip 0ohm 1/10W	RM73B--0R0K
R309	247 0009 985	Carbon chip 10kohm 1/10W	RM73B--103J	R817	247 0009 969	Carbon chip 8.2kohm 1/10W	RM73B--822J
R311,312	247 2003 989	Carbon chip 33ohm 1/16W	RM73B--330J	R818	247 0008 957	Carbon chip 3kohm 1/10W	RM73B--302J
R313	247 0009 985	Carbon chip 10kohm 1/10W	RM73B--103J	R819	247 0009 914	Carbon chip 5.1kohm 1/10W	RM73B--512J
R314--327	247 2003 989	Carbon chip 33ohm 1/16W	RM73B--330J	R820	247 0004 977	Carbon chip 75ohm 1/10W	RM73B--750J
R328	247 0009 985	Carbon chip 10kohm 1/10W	RM73B--103J	R822-825	247 0004 922	Carbon chip 47ohm 1/10W	RM73B--470J
R332	247 2018 903	Carbon chip 0ohm 1/16W	RM73B--0R0K	R826,827	247 0009 901	Carbon chip 4.7kohm 1/10W	RM73B--472J
R334	247 0018 905	Carbon chip 0ohm 1/10W	RM73B--0R0K	R828	247 0009 985	Carbon chip 10kohm 1/10W	RM73B--103J
R337	247 2011 942	Carbon chip 47kohm 1/16W	RM73B--473J	R829	247 0018 905	Carbon chip 0ohm 1/10W	RM73B--0R0K
R338	247 0009 985	Carbon chip 10kohm 1/10W	RM73B--103J	R830	247 0014 967	Carbon chip 1Mohm 1/10W	RM73B--105J
R340	247 0009 985	Carbon chip 10kohm 1/10W	RM73B--103J	R831	247 0011 902	Carbon chip 33kohm 1/10W	RM73B--333J
R345,346	247 0018 905	Carbon chip 0ohm 1/10W	RM73B--0R0K	R835	247 0005 989	Carbon chip 220ohm 1/10W	RM73B--221J
R351	247 0009 985	Carbon chip 10kohm 1/10W	RM73B--103J	R837-840	247 0009 901	Carbon chip 4.7kohm 1/10W	RM73B--472J
R352,353	247 0018 905	Carbon chip 0ohm 1/10W	RM73B--0R0K	R841,842	247 0011 944	Carbon chip 47kohm 1/10W	RM73B--473J
R701-703	257 0008 983	Ceramic chip 1000pF/50V	CK73B1H102K	R843,844	247 0009 998	Carbon chip 11kohm 1/10W	RM73B--113J
R705-707	247 0009 985	Carbon chip 10kohm 1/10W	RM73B--103J	R847,848	247 0008 986	Carbon chip 3.9kohm 1/10W	RM73B--392J
R708-710	247 0007 945	Carbon chip 1kohm 1/10W	RM73B--102J	R849	247 0018 905	Carbon chip 0ohm 1/10W	RM73B--0R0K
R711	247 0018 905	Carbon chip 0ohm 1/10W	RM73B--0R0K	R854,855	247 0018 905	Carbon chip 0ohm 1/10W	RM73B--0R0K
R713,714	247 0008 986	Carbon chip 3.9kohm 1/10W	RM73B--392J	R860	247 0004 922	Carbon chip 47ohm 1/10W	RM73B--470J
R715,716	247 0008 902	Carbon chip 1.8kohm 1/10W	RM73B--182J	R863	247 0005 905	Carbon chip 100ohm 1/10W	RM73B--101J
R717,718	247 0008 986	Carbon chip 3.9kohm 1/10W	RM73B--392J	R869-872	247 0009 901	Carbon chip 4.7kohm 1/10W	RM73B--472J
R719,720	247 0008 902	Carbon chip 1.8kohm 1/10W	RM73B--182J	R873-876	247 0006 920	Carbon chip 330ohm 1/10W	RM73B--331J
R721,722	247 0008 986	Carbon chip 3.9kohm 1/10W	RM73B--392J	R881	247 0004 922	Carbon chip 47ohm 1/10W	RM73B--470J
R723,724	247 0008 902	Carbon chip 1.8kohm 1/10W	RM73B--182J	R885	247 0004 922	Carbon chip 47ohm 1/10W	RM73B--470J
R725-728	247 0009 969	Carbon chip 8.2kohm 1/10W	RM73B--822J	R894	247 0004 922	Carbon chip 47ohm 1/10W	RM73B--470J
R731,732	247 0008 986	Carbon chip 3.9kohm 1/10W	RM73B--392J	R895,896	247 0005 905	Carbon chip 100ohm 1/10W	RM73B--101J
R733,734	247 0008 902	Carbon chip 1.8kohm 1/10W	RM73B--182J	R899	247 0012 927	Carbon chip 100kohm 1/10W	RM73B--104J
R735,736	247 0009 914	Carbon chip 5.1kohm 1/10W	RM73B--512J	R901,902	247 0018 905	Carbon chip 0ohm 1/10W	RM73B--0R0K
R739,740	247 0009 914	Carbon chip 5.1kohm 1/10W	RM73B--512J	R903	247 0012 927	Carbon chip 100kohm 1/10W	RM73B--104J
R741,742	247 0006 988	Carbon chip 560ohm 1/10W	RM73B--561J	R904	247 0018 905	Carbon chip 0ohm 1/10W	RM73B--0R0K
R743,744	247 0007 990	Carbon chip 1.6kohm 1/10W	RM73B--162J	R909	247 0018 905	Carbon chip 0ohm 1/10W	RM73B--0R0K
R745,746	247 0008 986	Carbon chip 3.9kohm 1/10W	RM73B--392J	R912	247 0018 905	Carbon chip 0ohm 1/10W	RM73B--0R0K
R747,748	247 0008 902	Carbon chip 1.8kohm 1/10W	RM73B--182J	R916-920	247 0005 905	Carbon chip 100ohm 1/10W	RM73B--101J
R749,750	247 0009 914	Carbon chip 5.1kohm 1/10W	RM73B--512J	R925-948	247 0005 905	Carbon chip 100ohm 1/10W	RM73B--101J
R753,754	247 0009 914	Carbon chip 5.1kohm 1/10W	RM73B--512J	R951	247 0018 905	Carbon chip 0ohm 1/10W	RM73B--0R0K
R755,756	247 0006 988	Carbon chip 560ohm 1/10W	RM73B--561J	R955-957	247 0004 922	Carbon chip 47ohm 1/10W	RM73B--470J
R757,758	247 0007 990	Carbon chip 1.6kohm 1/10W	RM73B--162J	R962,963	247 0004 922	Carbon chip 47ohm 1/10W	RM73B--470J
R759,760	247 0008 986	Carbon chip 3.9kohm 1/10W	RM73B--392J	<b>CAPACITORS GROUP</b>			
R761,762	247 0008 902	Carbon chip 1.8kohm 1/10W	RM73B--182J	C101,102	257 0005 986	Ceramic chip 330pF/50V	CC73SL1H331J for E2
R763,764	247 0009 914	Carbon chip 5.1kohm 1/10W	RM73B--512J	C113,114	257 0005 986	Ceramic chip 330pF/50V	CC73SL1H331J for E2
R767,768	247 0009 914	Carbon chip 5.1kohm 1/10W	RM73B--512J	C123,124	257 0005 986	Ceramic chip 330pF/50V	CC73SL1H331J for E2
R769,770	247 0006 988	Carbon chip 560ohm 1/10W	RM73B--561J	C135,136	257 0005 986	Ceramic chip 330pF/50V	CC73SL1H331J for E2
R771,772	247 0007 990	Carbon chip 1.6kohm 1/10W	RM73B--162J	C145,146	257 0005 986	Ceramic chip 330pF/50V	CC73SL1H331J for E2
R773-781	247 0009 985	Carbon chip 10kohm 1/10W	RM73B--103J	C155,156	254 4524 943	Electrolytic 1μF/50V	CE04W1H010M(SMG/RE3)
R783-785	247 0018 905	Carbon chip 0ohm 1/10W	RM73B--0R0K				
R800-808	247 0009 985	Carbon chip 10kohm 1/10W	RM73B--103J				
R810,811	247 0009 985	Carbon chip 10kohm 1/10W	RM73B--103J				
R813	247 0009 985	Carbon chip 10kohm 1/10W	RM73B--103J				
R814	247 0009 901	Carbon chip 4.7kohm 1/10W	RM73B--472J				
R815	247 0009 985	Carbon chip 10kohm 1/10W	RM73B--103J				

Ref. No.	Part No.	Part Name	Remarks	Ref. No.	Part No.	Part Name	Remarks
C157,158	257 0005 986	Ceramic chip 330pF/50V	CC73SL1H331J for E2	C753~756	257 0005 928	Ceramic chip 180pF/50V	CC73SL1H181J
C159,160	254 4524 985	Electrolytic 10µF/50V	CE04W1H100M(SMG/RE3)	C757,758	255 1264 940	Mylar film 2200pF/50V	CQ93M1H222J(B)
C165,166	254 4524 985	Electrolytic 10µF/50V	CE04W1H100M(SMG/RE3)	C759~762	254 4538 900	Electrolytic 10µF/16V	CE04W1C100M(SMG/RE3)
C167~172	257 0004 961	Ceramic chip 100pF/50V	CC73SL1H101J	C763,764	257 0014 935	Ceramic chip 0.1µF/25V	CK73F1E104Z
C173,174	257 0012 966	Ceramic chip 0.01µF/50V	CK73F1H103Z	C767,768	254 4538 926	Electrolytic 33µF/16V	CE04W1C330M(SMG/RE3)
C178	257 0012 966	Ceramic chip 0.01µF/50V	CK73F1H103Z	C769,770	257 0006 943	Ceramic chip 560pF/50V	CC73SL1H561J
C180,181	257 0012 966	Ceramic chip 0.01µF/50V	CK73F1H103Z	C771,772	254 4538 926	Electrolytic 33µF/16V	CE04W1C330M(SMG/RE3)
C184,185	254 4524 943	Electrolytic 1µF/50V	CE04W1H010M(SMG/RE3)	C773,774	257 0006 943	Ceramic chip 560pF/50V	CC73SL1H561J
C188	257 0008 983	Ceramic chip 1000pF/50V	CK73B1H102K	C775,776	254 4538 926	Electrolytic 33µF/16V	CE04W1C330M(SMG/RE3)
C189,190	254 4538 900	Electrolytic 10µF/16V	CE04W1C100M(SMG/RE3)	C777~784	257 0006 943	Ceramic chip 560pF/50V	CC73SL1H561J
C193,194	254 4524 943	Electrolytic 1µF/50V	CE04W1H010M(SMG/RE3)	C800~803	257 0014 935	Ceramic chip 0.1µF/25V	CK73F1E104Z
C195,196	254 4538 942	Electrolytic 100µF/16V	CE04W1C101M(SMG/RE3) for E2	C804	254 4524 943	Electrolytic 1µF/50V	CE04W1H010M(SMG/RE3)
C195,196	254 4538 900	Electrolytic 10µF/16V	CE04W1C100M(SMG/RE3) for E3,EU,E1,E1C,E1H,E3T	C805,806	257 0014 935	Ceramic chip 0.1µF/25V	CK73F1E104Z
C301,302	257 0011 983	Ceramic chip 0.047µF/25V	CK73B1E473K	C807	257 0012 966	Ceramic chip 0.01µF/50V	CK73F1H103Z
C305	257 0012 966	Ceramic chip 0.01µF/50V	CK73F1H103Z	C808	257 0011 996	Ceramic chip 0.1µF/25V	CK73B1E104K
C306	257 0011 983	Ceramic chip 0.047µF/25V	CK73B1E473K	C809	257 0014 935	Ceramic chip 0.1µF/25V	CK73F1E104Z
C307	254 4524 943	Electrolytic 1µF/50V	CE04W1H010M(SMG/RE3)	C810	257 0011 909	Ceramic chip 0.01µF/25V	CK73B1E103K
C308	257 0014 935	Ceramic chip 0.1µF/25V	CK73F1E104Z	C811	254 4524 943	Electrolytic 1µF/50V	CE04W1H010M(SMG/RE3)
C309	254 4524 943	Electrolytic 1µF/50V	CE04W1H010M(SMG/RE3)	C812,813	257 0014 935	Ceramic chip 0.1µF/25V	CK73F1E104Z
C311~313	257 0012 966	Ceramic chip 0.01µF/50V	CK73F1H103Z	C815	254 4524 956	Electrolytic 2.2µF/50V	CE04W1H2R2M(SMG/RE3)
C452,453	257 0010 984	Ceramic chip 0.047µF/50V	CK73B1H473K	C817	256 1059 912	Metallized 0.22µF/50V	CF93A1H224J(JL)
C701	257 0014 935	Ceramic chip 0.1µF/25V	CK73F1E104Z	C818	257 0008 983	Ceramic chip 1000pF/50V	CK73B1H102K
C704	254 4536 928	Electrolytic 100µF/10V	CE04W1A101M(SMG/RE3)	C819	257 0012 966	Ceramic chip 0.01µF/50V	CK73F1H103Z
C705,706	257 0014 935	Ceramic chip 0.1µF/25V	CK73F1E104Z	C820	257 0014 935	Ceramic chip 0.1µF/25V	CK73F1E104Z
C707,708	254 4538 900	Electrolytic 10µF/16V	CE04W1C100M(SMG/RE3)	C821	257 0005 986	Ceramic chip 330pF/50V	CC73SL1H331J
C709	254 4536 931	Electrolytic 220µF/10V	CE04W1A221M(SMG/RE3)	C825	257 0012 966	Ceramic chip 0.01µF/50V	CK73F1H103Z
C711	257 0014 935	Ceramic chip 0.1µF/25V	CK73F1E104Z	C835	254 4538 900	Electrolytic 10µF/16V	CE04W1C100M(SMG/RE3)
C714	254 4536 928	Electrolytic 100µF/10V	CE04W1A101M(SMG/RE3)	C838	254 4524 943	Electrolytic 1µF/50V	CE04W1H010M(SMG/RE3)
C715,716	257 0014 935	Ceramic chip 0.1µF/25V	CK73F1E104Z	C840	257 0012 966	Ceramic chip 0.01µF/50V	CK73F1H103Z
C717	254 4538 900	Electrolytic 10µF/16V	CE04W1C100M(SMG/RE3)	C849	254 4524 930	Electrolytic 0.47µF/50V	CE04W1HR47M(SMG/RE3)
C718	254 4538 900	Electrolytic 10µF/16V	CE04W1C100M(SMG/RE3)	C850~852	257 0012 966	Ceramic chip 0.01µF/50V	CK73F1H103Z
C719	254 4536 931	Electrolytic 220µF/10V	CE04W1A221M(SMG/RE3)	C854	254 4524 930	Electrolytic 0.47µF/50V	CE04W1HR47M(SMG/RE3)
C721	257 0014 935	Ceramic chip 0.1µF/25V	CK73F1E104Z	C856~860	257 0012 966	Ceramic chip 0.01µF/50V	CK73F1H103Z
C724	254 4536 928	Electrolytic 100µF/10V	CE04W1A101M(SMG/RE3)	C869,870	254 4524 943	Electrolytic 1µF/50V	CE04W1H010M(SMG/RE3)
C725,726	257 0014 935	Ceramic chip 0.1µF/25V	CK73F1E104Z	C871,872	257 0014 935	Ceramic chip 0.1µF/25V	CK73F1E104Z
C727,728	254 4538 900	Electrolytic 10µF/16V	CE04W1C100M(SMG/RE3)	C873~876	254 4538 900	Electrolytic 10µF/16V	CE04W1C100M(SMG/RE3)
C729	254 4536 931	Electrolytic 220µF/10V	CE04W1A221M(SMG/RE3)	C877,878	257 0004 961	Ceramic chip 100pF/50V	CC73SL1H101J
C731,732	254 4538 926	Electrolytic 33µF/16V	CE04W1C330M(SMG/RE3)	C879,880	254 4538 900	Electrolytic 10µF/16V	CE04W1C100M(SMG/RE3)
C733~736	257 0005 928	Ceramic chip 180pF/50V	CC73SL1H181J	C881,882	257 0004 961	Ceramic chip 100pF/50V	CC73SL1H101J
C737,738	255 1264 940	Mylar film 2200pF/50V	CQ93M1H222J(B)	C885,886	254 4538 900	Electrolytic 10µF/16V	CE04W1C100M(SMG/RE3)
C739,740	254 4538 900	Electrolytic 10µF/16V	CE04W1C100M(SMG/RE3)	C887,888	255 1264 924	Mylar film 1500pF/50V	CQ93M1H152J(B)
C741,742	254 4538 926	Electrolytic 33µF/16V	CE04W1C330M(SMG/RE3)	C891	254 4538 942	Electrolytic 100µF/16V	CE04W1C101M(SMG/RE3)
C743~746	257 0005 928	Ceramic chip 180pF/50V	CC73SL1H181J	C892	257 0012 966	Ceramic chip 0.01µF/50V	CK73F1H103Z
C747,748	255 1264 940	Mylar film 2200pF/50V	CQ93M1H222J(B)	C893	257 0008 983	Ceramic chip 1000pF/50V	CK73B1H102K
C749,750	254 4538 900	Electrolytic 10µF/16V	CE04W1C100M(SMG/RE3)	C895	257 0014 935	Ceramic chip 0.1µF/25V	CK73F1E104Z
C751,752	254 4538 926	Electrolytic 33µF/16V	CE04W1C330M(SMG/RE3)	C897	257 0008 983	Ceramic chip 1000pF/50V	CK73B1H102K
				C899	257 0008 983	Ceramic chip 1000pF/50V	CK73B1H102K
				C900	257 0011 909	Ceramic chip 0.01µF/25V	CK73B1E103K
				C901,902	257 0008 983	Ceramic chip 1000pF/50V	CK73B1H102K
				C903	254 4536 928	Electrolytic 100µF/10V	CE04W1A101M(SMG/RE3)



1U-3232 POWER UNIT ASS'Y

Ref. No.	Part No.	Part Name	Remarks
C904	257 0014 935	Ceramic chip 0.1μF/25V	CK73F1E104Z
C906	254 4538 900	Electrolytic 10μF/16V	CE04W1C100M(SMG/RE3)
C907,908	257 0014 935	Ceramic chip 0.1μF/25V	CK73F1E104Z
C910	257 0014 935	Ceramic chip 0.1μF/25V	CK73F1E104Z
C911	254 4538 900	Electrolytic 10μF/16V	CE04W1C100M(SMG/RE3)
C913	257 0012 966	Ceramic chip 0.01μF/50V	CK73F1H103Z
C915,916	257 0012 966	Ceramic chip 0.01μF/50V	CK73F1H103Z
C919,920	257 0014 935	Ceramic chip 0.1μF/25V	CK73F1E104Z
C922-925	257 0014 935	Ceramic chip 0.1μF/25V	CK73F1E104Z
C926-929	254 4536 928	Electrolytic 100μF/10V	CE04W1A101M(SMG/RE3)
C930	257 0014 935	Ceramic chip 0.1μF/25V	CK73F1E104Z
C931	257 0012 966	Ceramic chip 0.01μF/50V	CK73F1H103Z
C932	257 0014 935	Ceramic chip 0.1μF/25V	CK73F1E104Z
C933	257 0012 966	Ceramic chip 0.01μF/50V	CK73F1H103Z
OTHER PARTS GROUP			
			Q'ty
CW051	205 0885 008	5P connector socket (TUC-P)	1
CW061,062	205 0942 019	6P connector socket (TUC-P)	2
CW071,072	205 0942 022	7P connector socket (TUC-P)	2
CW082	205 0885 095	8P connector socket (TUC-P)	1
CW111	205 0885 066	11P connector socket (TUC-P)	1
CW141	205 0885 011	14P connector socket (TUC-P)	1
FB302-308	235 0106 908	EMI filter	7
FB701,702	235 0049 900	Beads inductor	2
FB704-714	235 0049 900	Beads inductor	11
FB715	244 2043 937	Metal oxide 10ohm 1W	RS14B3A100JNBS(S)
FB717	244 2043 937	Metal oxide 10ohm 1W	RS14B3A100JNBS(S)
FB719	244 2043 937	Metal oxide 10ohm 1W	RS14B3A100JNBS(S)
FB800-804	235 0049 900	Beads inductor	5
FB807-814	235 0049 900	Beads inductor	8
FB815	235 0106 908	EMI filter	1
FB816	235 0049 900	Beads inductor	1
FB817	235 0106 908	EMI filter	1
JK106-108	204 8513 010	6P pin jack (S-GND)	3
L801	235 0106 908	EMI filter	1
L803-805	235 0106 908	EMI filter	3
X302	399 0532 902	Ceramic resonator	GST12.5MTW-TF01
XL802	399 0575 008	Crystal 12.287MHz	SG-8002DCPT
	207 0021 004	IC socket	for IC303,817
	001 0063 095	Vinyl wire	
	412 4571 000	Earth plate(C)	

Ref. No.	Part No.	Part Name	Remarks
SEMICONDUCTORS GROUP			
IC401	262 2692 001	IC BU4052BC	
IC402	263 0856 004	IC BA7625	
IC450	263 0856 004	IC BA7625	
IC501	268 0073 905	IC ICP-N15	
IC502	263 0793 002	IC NJM7806FA(S)	
TR401-403	271 0290 904	Transistor 2PA1015GR	
TR507,508	273 0454 908	Transistor 2SC1645S(B)	
TR511,512	274 0158 016	Transistor 2SD1763A(E)	
TR513,514	272 0115 011	Transistor 2SB1186A(E)	
TR519,520	273 0235 923	Transistor 2SC1841(E/F)	
TR527,528	273 0454 908	Transistor 2SC1645S(B)	
TR531,532	274 0158 016	Transistor 2SD1763A(E)	
TR533,534	272 0115 011	Transistor 2SB1186A(E)	
TR539,540	273 0235 923	Transistor 2SC1841(E/F)	
TR544	273 0454 908	Transistor 2SC1645S(B)	
TR546	274 0158 016	Transistor 2SD1763A(E)	
TR547	272 0115 011	Transistor 2SB1186A(E)	
TR550	273 0235 923	Transistor 2SC1841(E/F)	
TR551	271 0131 924	Transistor 2SA988(E/F)	
TR554	273 0429 904	Transistor 2SC3311A	
TR555	271 0192 905	Transistor 2SA933S(S)	
TR556,557	273 0429 904	Transistor 2SC3311A	
TR558	271 0192 905	Transistor 2SA933S(S)	
TR559-566	273 0429 904	Transistor 2SC3311A	
D401-404	276 0432 903	Diode 1SS270A	
D501-505	276 0432 903	Diode 1SS270A	
D507-512	276 0704 903	Diode 1SR35-400A	
D513-517	276 0432 903	Diode 1SS270A	
D518,519	276 0305 001	Diode S4VB20	
D520	276 0432 903	Diode 1SS270A	
D526-535	276 0432 903	Diode 1SS270A	
ZD501	276 0644 911	Zener diode MTZJ7.5A	
ZD502-511	276 0634 905	Zener diode MTZJ3.3A	
RESISTORS GROUP			
R525-528	244 2052 957	Metal oxide 5.6kohm 1W	RS14B3A562JNBS(S)
R537,538	241 2378 962	Carbon film 330ohm 1/4W(NB)	RD14B2E331JNBS
R539-542	241 2387 908	Carbon film 1ohm 1/4W(NB)	RD14B2E010JNBS
R543-550	244 2043 982	Metal oxide 0.22ohm 1W	RS14B3AR22JNBS(S)
R551,552	241 2379 987	Carbon film 1kohm 1/4W(NB)	RD14B2E102JNBS
R557,558	244 2043 937	Metal oxide 10ohm 1W	RS14B3A100JNBS(S)
R567,568	244 2043 937	Metal oxide 10ohm 1W	RS14B3A100JNBS(S)
R571	244 2043 937	Metal oxide 10ohm 1W	RS14B3A100JNBS(S)
R605-608	244 2052 957	Metal oxide 5.6kohm 1W	RS14B3A562JNBS(S)
R619,620	241 2378 962	Carbon film 330ohm 1/4W(NB)	RD14B2E331JNBS

Ref. No.	Part No.	Part Name	Remarks
R621~624	241 2387 908	Carbon film 1ohm 1/4W(NB)	RD14B2E010JNBS
R625~632	244 2043 982	Metal oxide 0.22ohm 1W	RS14B3AR22JNBS(S)
R633,634	241 2379 987	Carbon film 1kohm 1/4W(NB)	RD14B2E102JNBS
R639~642	244 2043 937	Metal oxide 10ohm 1W	RS14B3A100JNBS(S)
R647,648	244 2043 937	Metal oxide 10ohm 1W	RS14B3A100JNBS(S)
R672,673	244 2052 957	Metal oxide 5.6kohm 1W	RS14B3A562JNBS(S)
R679	241 2378 962	Carbon film 330ohm 1/4W(NB)	RD14B2E331JNBS
R680,681	241 2387 908	Carbon film 1ohm 1/4W(NB)	RD14B2E010JNBS
R682~685	244 2043 982	Metal oxide 0.22ohm 1W	RS14B3AR22JNBS(S)
R686	241 2379 987	Carbon film 1kohm 1/4W(NB)	RD14B2E102JNBS
R690	244 2043 937	Metal oxide 10ohm 1W	RS14B3A100JNBS(S)
R694	244 2043 937	Metal oxide 10ohm 1W	RS14B3A100JNBS(S)
R714,715	243 2039 032	Winding 0.1ohm 5W	RW99=3H0R1K
R734	242 2009 001	Composition 2.2Mohm 1/2W	RC05GF2H225K(UL) for E3,EU,E3T
R757,758	244 2052 960	Metal oxide 220ohm 1W	RS14B3A221JNBS(S)
VR501~505	211 6132 909	Semi fixed resistor 4.7kohm	V06PB472
<b>CAPACITORS GROUP</b>			
C401~405	254 4306 909	Electrolytic 4.7µF/50V	CE04W1H4R7M(SRE)
C406~408	254 6190 906	Electrolytic 330µF/6.3V	CE04W0J331M(SRA)
C410	254 4302 974	Electrolytic 100µF/10V	CE04W1A101M(SRE)
C411,412	254 4299 906	Electrolytic 10µF/16V	CE04W1C100M(SRE)
C413	254 4305 968	Electrolytic 1µF/50V	CE04W1H010M(SRE)
C414	253 1181 917	Ceramic 0.022µF/50V	CK45F1H223Z
C415	254 4299 906	Electrolytic 10µF/16V	CE04W1C100M(SRE)
C416	254 4302 974	Electrolytic 100µF/10V	CE04W1A101M(SRE)
C420	253 1181 904	Ceramic 0.01µF/50V	CK45F1H103Z
C422	253 1181 917	Ceramic 0.022µF/50V	CK45F1H223Z
C423	254 4299 906	Electrolytic 10µF/16V	CE04W1C100M(SRE)
C441	254 4306 909	Electrolytic 4.7µF/50V	CE04W1H4R7M(SRE)
C442	254 4305 968	Electrolytic 1µF/50V	CE04W1H010M(SRE)
C443	253 1181 917	Ceramic 0.022µF/50V	CK45F1H223Z
C444	254 4299 906	Electrolytic 10µF/16V	CE04W1C100M(SRE)
C445~447	254 4306 909	Electrolytic 4.7µF/50V	CE04W1H4R7M(SRE)
C450	254 4306 909	Electrolytic 4.7µF/50V	CE04W1H4R7M(SRE)
C501,502	253 4543 905	Ceramic 220pF/500V	CC45SL2H221J
C505,506	253 4543 905	Ceramic 220pF/500V	CC45SL2H221J
C509	253 4543 905	Ceramic 220pF/500V	CC45SL2H221J
C513,514	254 4525 913	Electrolytic 47µF/50V	CE04W1H470M(SMG/RE3)
C515,516	254 4527 982	Electrolytic 10µF/100V	CE04W2A100M(SMG/RE3)
C521	256 1058 971	Metallized 0.1µF/50V	CF93A1H104J(JL)
C522	256 1058 971	Metallized 0.1µF/50V	CF93A1H104J(JL)
C525,526	256 1058 939	Metallized 0.047µF/50V	CF93A1H473J(JL) for E2
C525,526	255 1265 978	Mylar film 0.022µF/50V	CQ93M1H223J(B) for E3,EU,E1,E1C,E1H,E3T
C541,542	254 4525 913	Electrolytic 47µF/50V	CE04W1H470M(SMG/RE3)
C545,546	254 4527 982	Electrolytic 10µF/100V	CE04W2A100M(SMG/RE3)
C549,550	256 1058 971	Metallized 0.1µF/50V	CF93A1H104J(JL)

Ref. No.	Part No.	Part Name	Remarks
C553,554	256 1058 939	Metallized 0.047µF/50V	CF93A1H473J(JL) for E2
C553,554	255 1265 978	Mylar film 0.022µF/50V	CQ93M1H223J(B) for E3,EU,E1,E1C,E1H,E3T
C566	254 4525 913	Electrolytic 47µF/50V	CE04W1H470M(SMG/RE3)
C567	254 4527 982	Electrolytic 10µF/100V	CE04W2A100M(SMG/RE3)
C570	256 1058 971	Metallized 0.1µF/50V	CF93A1H104J(JL)
C572	256 1058 939	Metallized 0.047µF/50V	CF93A1H473J(JL) for E2
C572	255 1265 978	Mylar film 0.022µF/50V	CQ93M1H223J(B) for E3,EU,E1,E1C,E1H,E3T
C573	253 1181 904	Ceramic 0.01µF/50V	CK45F1H103Z
C583	254 4538 900	Electrolytic 10µF/16V	CE04W1C100M(SMG/RE3)
C584	253 9039 906	Ceramic 0.1µF/25V	CK45=1E104Z
C585	254 6190 906	Electrolytic 330µF/6.3V	CE04W0J331M(SRA)
C586	253 9039 906	Ceramic 0.1µF/25V	CK45=1E104Z
C587	254 4533 947	Electrolytic 330µF/6.3V	CE04W0J331M(SMG/RE3)
C588	253 1181 904	Ceramic 0.01µF/50V	CK45F1H103Z
C589	254 4538 900	Electrolytic 10µF/16V	CE04W1C100M(SMG/RE3)
C590	254 4524 943	Electrolytic 1µF/50V	CE04W1H010M(SMG/RE3)
C591~593	253 1181 904	Ceramic 0.01µF/50V	CK45F1H103Z
C594	254 4403 721	Electrolytic 2200µF/25V	CE04W1E222M(SMG)
C595	254 4524 943	Electrolytic 1µF/50V	CE04W1H010M(SMG/RE3)
C599	256 1058 971	Metallized 0.1µF/50V	CF93A1H104J(JL)
C601	254 4524 943	Electrolytic 1µF/50V	CE04W1H010M(SMG/RE3)
C602	254 6213 702	Electrolytic 10000µF/71V	CE68W==103M(DL)
C603,604	256 1042 903	Metallized 0.1µF/250V	CF93A2E104K
C605	254 6213 702	Electrolytic 10000µF/71V	CE68W==103M(DL)
C606~608	256 1042 903	Metallized 0.1µF/250V	CF93A2E104K
C609~612	255 1265 936	Mylar film 0.01µF/50V	CQ93M1H103J(B)
C613~616	255 1265 936	Mylar film 0.01µF/50V	CQ93M1H103J(B) for E2
C617,618	256 1058 939	Metallized 0.047µF/50V	CF93A1H473J(JL) for E2
C617,618	255 1265 978	Mylar film 0.022µF/50V	CQ93M1H223J(B) for E3,EU,E1,E1C,E1H,E3T
C631,632	255 1265 936	Mylar film 0.01µF/50V	CQ93M1H103J(B) for E2
C646	254 4262 784	Electrolytic 470µF/63V	CE04W1J471M
C648	253 8014 702	Ceramic 0.01µF/400V(AC)	CK45F2GAC103MC
C649	255 1265 936	Mylar film 0.01µF/50V	CQ93M1H103J(B) for E2
<b>OTHER PARTS GROUP</b>			
AC501	203 3978 002	AC outlet (2P)	for E3,EU,E3T
CW121	205 0885 079	12P connector socket (TUC-P)	1
CX021	205 0581 001	2P VH connector base	for E2,E1,E1C, E1H,E3T
CX022	205 0768 002	2P VH connector base(BLK)	1

1U-3233 EXT. IN UNIT ASS'Y

Ref. No.	Part No.	Part Name	Remarks	Q'ty	Ref. No.	Part No.	Part Name	Remarks
CX023	205 1093 006	2P VH connector base	for E2,E1,E1H	1	<b>SEMICONDUCTORS GROUP</b>			
CX024	205 0581 001	2P VH connector base		1	IC101	262 2549 002	IC LC75721E	
CX031	205 0343 032	3P connector base(KR-PH)		1	IC102	499 0290 007	Remocon sensor GP1U271X	
CX032	205 0841 000	3P AC conector base (BK)	for E1,E1H	1	IC103	262 2375 904	IC TC4094BF	
CX033	205 0825 000	3P AC connector base		1	IC301~304	263 0896 909	IC NJM2068MD	
CX054-057	205 0884 009	5P connector base(TUC-P)		4	IC308,309	263 0896 909	IC NJM2068MD	
CX074	205 0943 021	7P connector base(TUC-P)		1	IC310	263 0896 909	IC NJM2068MD	
CX085	205 0884 096	8P connector base(TUC-P)		1	IC311	262 1853 100	IC NJU7313AL	
CX092	205 0884 038	9P connector base(TUC-P)		1	IC701	263 0896 909	IC NJM2068MD	
CX960-969	205 1064 064	6P pin header(TXX)V		10	IC801-803	263 0896 909	IC NJM2068MD	
△ F1	206 1046 001	Fuse 6.3A	for E3,EU,E3T	1	IC805-807	262 2662 002	IC TC9459N	
△ F1	206 1015 032	Fuse 2.5A	for E2,E1C	1	TR102~110	269 0082 902	Transistor DTC114EK	
△ F1	206 1015 090	Fuse 5A	for E1,E1H	1	TR111	269 0083 901	Transistor DTA114EK	
△ F8	206 1046 014	Fuse 8A	for E3,EU,E3T	1	TR112	269 0055 900	Transistor DTA144EK	
△ F8	206 1015 032	Fuse 2.5A	for E2,E1,E1H	1	TR113~115	269 0054 901	Transistor DTC144EK	
FF501,502	202 0040 909	Fuse clip		2	TR116,117	269 0055 900	Transistor DTA144EK	
FH501,502	202 0040 909	Fuse clip		2	TR301~304	273 0414 906	Transistor 2SC3326(A/B)	
JK401	204 8516 017	3P pin jack		1	TR305	269 0055 900	Transistor DTA144EK	
JK402	204 8583 008	2P pin jack (VIDEO)		1	TR306	269 0054 901	Transistor DTC144EK	
JK403	204 8516 017	3P pin jack		1	TR308	275 0094 908	FET 2SK209-GR	
JK601	205 0472 026	8P SP terminal (EAEK)		1	TR311,312	273 0414 906	Transistor 2SC3326(A/B)	
JK603	205 1108 001	6P SP terminal (E3)		1	TR314,315	273 0414 906	Transistor 2SC3326(A/B)	
RL501	214 0200 001	Relay(EC2-12N35)		1	TR323~326	273 0414 906	Transistor 2SC3326(A/B)	
RL502-505	214 0195 006	Relay(FTR-F1)		4	TR327,328	275 0094 908	FET 2SK209-GR	
RL506	214 0188 000	Relay VS-12MBNR-SM2(TV-8)		1	TR329	269 0054 901	Transistor DTC144EK	
SC501	279 0016 904	Thyristor SF0R1A42		1	TR330	269 0055 900	Transistor DTA144EK	
△ T501	233 6073 107	Power trans. (Mini) -E3	for E3,EU,E3T	1	TR801-803	275 0094 908	FET 2SK209-GR	
△ T501	233 6058 025	Power trans. (Mini) -E2	for E2,E1C	1	TR805	269 0083 901	Transistor DTA114EK	
△ T501	233 6278 009	Power trans. (Mini) -E1	for E1,E1H	1	TR807	269 0054 901	Transistor DTC144EK	
TP501-505	205 0133 035	3 P NH connector base		5	D101,102	276 0637 902	Zener diode MTZJ6.2A	
TP510	205 0133 035	3 P NH connector base		1	D104	276 0644 937	Zener diode MTZJ9.1A	
	513 2585 074	Fuse label	for F1		D105	276 0637 902	Zener diode MTZJ6.2A	
	513 2654 060	Fuse label	for E2,E1C		D107	276 0637 902	Zener diode MTZJ6.2A	
	513 2585 074	Fuse label	for E1,E1H		D109	276 0432 903	Diode 1SS270A	
	415 0299 000	Condenser cover	for C648		D110,111	276 0559 909	Diode DAP202K	
			for E2,E1,E1H		D304	276 0559 909	Diode DAP202K	
					D323,324	276 0432 903	Diode 1SS270A	
					D801-803	276 0432 903	Diode 1SS270A	
					LD102-110	393 9434 906	LED SEL1210S	Red
					FL101	393 8033 007	FLD (CM1690C)	

Ref. No.	Part No.	Part Name	Remarks
<b>RESISTORS GROUP</b>			
R101	247 0005 905	Carbon chip 100ohm 1/10W	RM73B--101J
R102~110	247 0007 903	Carbon chip 680ohm 1/10W	RM73B--681J
R111	247 0005 905	Carbon chip 100ohm 1/10W	RM73B--101J
R112	247 0007 945	Carbon chip 1kohm 1/10W	RM73B--102J
R113	247 0005 976	Carbon chip 200ohm 1/10W	RM73B--201J
R114	247 0006 917	Carbon chip 300ohm 1/10W	RM73B--301J
R115	247 0006 975	Carbon chip 510ohm 1/10W	RM73B--511J
R116	247 0007 945	Carbon chip 1kohm 1/10W	RM73B--102J
R117,118	247 0008 957	Carbon chip 3kohm 1/10W	RM73B--302J
R124	247 0009 985	Carbon chip 10kohm 1/10W	RM73B--103J
R125	247 0007 945	Carbon chip 1kohm 1/10W	RM73B--102J
R126	247 0005 976	Carbon chip 200ohm 1/10W	RM73B--201J
R127	247 0006 917	Carbon chip 300ohm 1/10W	RM73B--301J
R128	247 0006 975	Carbon chip 510ohm 1/10W	RM73B--511J
R129	247 0007 945	Carbon chip 1kohm 1/10W	RM73B--102J
R139	247 0007 945	Carbon chip 1kohm 1/10W	RM73B--102J
R140	247 0005 905	Carbon chip 100ohm 1/10W	RM73B--101J
R141,142	247 0009 901	Carbon chip 4.7kohm 1/10W	RM73B--472J
R153~155	247 0011 986	Carbon chip 68kohm 1/10W	RM73B--683J
R156,157	247 0005 905	Carbon chip 100ohm 1/10W	RM73B--101J
R158,159	247 0011 986	Carbon chip 68kohm 1/10W	RM73B--683J
R160	247 0009 901	Carbon chip 4.7kohm 1/10W	RM73B--472J
R162~170	247 0011 986	Carbon chip 68kohm 1/10W	RM73B--683J
R171	247 0009 901	Carbon chip 4.7kohm 1/10W	RM73B--472J
R173,174	247 0011 986	Carbon chip 68kohm 1/10W	RM73B--683J
R175,176	247 0011 944	Carbon chip 47kohm 1/10W	RM73B--473J
R177~181	247 0011 986	Carbon chip 68kohm 1/10W	RM73B--683J
R182	247 0009 985	Carbon chip 10kohm 1/10W	RM73B--103J
R183~212	247 0011 986	Carbon chip 68kohm 1/10W	RM73B--683J
R213	247 0011 944	Carbon chip 47kohm 1/10W	RM73B--473J
R301~304	247 0005 976	Carbon chip 200ohm 1/10W	RM73B--201J
R305~308	247 0011 902	Carbon chip 33kohm 1/10W	RM73B--333J
R309,310	247 0012 927	Carbon chip 100kohm 1/10W	RM73B--104J
R311,312	247 0005 905	Carbon chip 100ohm 1/10W	RM73B--101J
R313,314	247 0018 905	Carbon chip 0ohm 1/10W	RM73B--0R0K
R315,316	247 0005 905	Carbon chip 100ohm 1/10W	RM73B--101J
R317,318	247 0012 927	Carbon chip 100kohm 1/10W	RM73B--104J
R319~321	247 0011 944	Carbon chip 47kohm 1/10W	RM73B--473J
R325	247 0010 974	Carbon chip 24kohm 1/10W	RM73B--243J
R326	247 0011 944	Carbon chip 47kohm 1/10W	RM73B--473J
R327	247 0010 974	Carbon chip 24kohm 1/10W	RM73B--243J
R328,329	247 0011 944	Carbon chip 47kohm 1/10W	RM73B--473J
R333	247 0005 905	Carbon chip 100ohm 1/10W	RM73B--101J
R334	247 0012 927	Carbon chip 100kohm 1/10W	RM73B--104J
R336	247 0011 944	Carbon chip 47kohm 1/10W	RM73B--473J
R337~340	247 0005 976	Carbon chip 200ohm 1/10W	RM73B--201J
R341,342	247 0007 990	Carbon chip 1.6kohm 1/10W	RM73B--162J
R343~346	247 0011 902	Carbon chip 33kohm 1/10W	RM73B--333J
R347,348	247 0012 927	Carbon chip 100kohm 1/10W	RM73B--104J

Ref. No.	Part No.	Part Name	Remarks
R349,350	247 0005 905	Carbon chip 100ohm 1/10W	RM73B--101J
R352	247 0009 901	Carbon chip 4.7kohm 1/10W	RM73B--472J
R354	247 0009 914	Carbon chip 5.1kohm 1/10W	RM73B--512J
R355	247 0018 905	Carbon chip 0ohm 1/10W	RM73B--0R0K
R357~360	247 0005 905	Carbon chip 100ohm 1/10W	RM73B--101J
R361~364	247 0005 976	Carbon chip 200ohm 1/10W	RM73B--201J
R365,366	247 0007 990	Carbon chip 1.6kohm 1/10W	RM73B--162J
R367~370	247 0011 902	Carbon chip 33kohm 1/10W	RM73B--333J
R371,372	247 0012 927	Carbon chip 100kohm 1/10W	RM73B--104J
R373,374	247 0005 905	Carbon chip 100ohm 1/10W	RM73B--101J
R378,379	247 0018 905	Carbon chip 0ohm 1/10W	RM73B--0R0K
R381,382	247 0005 905	Carbon chip 100ohm 1/10W	RM73B--101J
R383,384	247 0012 927	Carbon chip 100kohm 1/10W	RM73B--104J
R385,386	247 0005 905	Carbon chip 100ohm 1/10W	RM73B--101J for E3,EU,E1,E1C, E1H,E3T
R385,386	247 0006 962	Carbon chip 470ohm 1/10W	RM73B--471J for E2
R387,388	247 0015 966	Carbon chip 2.7Mohm 1/10W	RM73B--275J
R391,392	247 0018 905	Carbon chip 0ohm 1/10W	RM73B--0R0K
R395~398	247 0018 905	Carbon chip 0ohm 1/10W	RM73B--0R0K
R401,402	247 0005 905	Carbon chip 100ohm 1/10W	RM73B--101J for E3,EU,E1,E1C, E1H,E3T
R401,402	247 0006 962	Carbon chip 470ohm 1/10W	RM73B--471J for E2
R403,404	247 0015 966	Carbon chip 2.7Mohm 1/10W	RM73B--275J
R407,408	247 0018 905	Carbon chip 0ohm 1/10W	RM73B--0R0K
R411~414	247 0018 905	Carbon chip 0ohm 1/10W	RM73B--0R0K
R417,418	247 0005 905	Carbon chip 100ohm 1/10W	RM73B--101J for E3,EU,E1,E1C, E1H,E3T
R417,418	247 0006 962	Carbon chip 470ohm 1/10W	RM73B--471J for E2
R419,420	247 0015 966	Carbon chip 2.7Mohm 1/10W	RM73B--275J
R423,424	247 0018 905	Carbon chip 0ohm 1/10W	RM73B--0R0K
R427,430	247 0018 905	Carbon chip 0ohm 1/10W	RM73B--0R0K
R433~438	247 0011 928	Carbon chip 39kohm 1/10W	RM73B--393J
R439,440	247 0004 922	Carbon chip 47ohm 1/10W	RM73B--470J
R441,442	247 0012 927	Carbon chip 100kohm 1/10W	RM73B--104J
R445	247 0009 901	Carbon chip 4.7kohm 1/10W	RM73B--472J
R446,447	247 0008 960	Carbon chip 3.3kohm 1/10W	RM73B--332J
R448~450	247 0009 901	Carbon chip 4.7kohm 1/10W	RM73B--472J
R451,452	247 0005 905	Carbon chip 100ohm 1/10W	RM73B--101J
R453,454	247 0012 927	Carbon chip 100kohm 1/10W	RM73B--104J
R455	247 0011 944	Carbon chip 47kohm 1/10W	RM73B--473J
R456	247 0018 905	Carbon chip 0ohm 1/10W	RM73B--0R0K
R457	247 0010 916	Carbon chip 13kohm 1/10W	RM73B--133J
R458	247 0009 901	Carbon chip 4.7kohm 1/10W	RM73B--472J
R459	247 0009 927	Carbon chip 5.6kohm 1/10W	RM73B--562J
R460	247 0009 901	Carbon chip 4.7kohm 1/10W	RM73B--472J

Ref. No.	Part No.	Part Name	Remarks
R461	247 0009 930	Carbon chip 6.2kohm 1/10W	RM73B--622J
R462	247 0005 905	Carbon chip 100ohm 1/10W	RM73B--101J
R463	247 0012 927	Carbon chip 100kohm 1/10W	RM73B--104J
R464	247 0007 945	Carbon chip 1kohm 1/10W	RM73B--102J
R481,482	247 0018 905	Carbon chip 0ohm 1/10W	RM73B--0R0K
R483	247 0007 945	Carbon chip 1kohm 1/10W	RM73B--102J
R485-490	247 0018 905	Carbon chip 0ohm 1/10W	RM73B--0R0K
R493-498	247 0012 927	Carbon chip 100kohm 1/10W	RM73B--104J
R701,702	247 0007 974	Carbon chip 1.3kohm 1/10W	RM73B--132J for E2
R701,702	247 0018 905	Carbon chip 0ohm 1/10W	RM73B--0R0K for E3,EU,E1,E1C,E1H,E3T
R703,704	247 0006 946	Carbon chip 390ohm 1/10W	RM73B--391J
R705,706	247 0011 986	Carbon chip 68kohm 1/10W	RM73B--683J
R707,708	247 0012 969	Carbon chip 150kohm 1/10W	RM73B--154J
R709,710	247 0004 922	Carbon chip 47ohm 1/10W	RM73B--470J
R711,712	247 0005 992	Carbon chip 240ohm 1/10W	RM73B--241J
R713,714	247 0012 956	Carbon chip 130kohm 1/10W	RM73B--134J
R715,716	247 0009 998	Carbon chip 11kohm 1/10W	RM73B--113J
R717,718	247 0003 949	Carbon chip 22ohm 1/10W	RM73B--220J
R719,720	247 0004 922	Carbon chip 47ohm 1/10W	RM73B--470J
R721,722	247 0011 944	Carbon chip 47kohm 1/10W	RM73B--473J
R723,724	247 0005 905	Carbon chip 100ohm 1/10W	RM73B--101J for E3,EU,E1,E1C, E1H,E3T
R723,724	247 0006 962	Carbon chip 470ohm 1/10W	RM73B--471J for E2
R725,726	247 0015 966	Carbon chip 2.7Mohm 1/10W	RM73B--275J
R729-732	247 0018 905	Carbon chip 0ohm 1/10W	RM73B--0R0K
R801,802	247 0012 927	Carbon chip 100kohm 1/10W	RM73B--104J
R803,804	247 0005 905	Carbon chip 100ohm 1/10W	RM73B--101J
R805,806	247 0007 916	Carbon chip 750ohm 1/10W	RM73B--751J
R807,808	247 0009 943	Carbon chip 6.8kohm 1/10W	RM73B--682J
R809,810	247 0009 901	Carbon chip 4.7kohm 1/10W	RM73B--472J
R811,812	247 0011 944	Carbon chip 47kohm 1/10W	RM73B--473J
R813,814	247 0005 905	Carbon chip 100ohm 1/10W	RM73B--101J
R815-818	247 0012 927	Carbon chip 100kohm 1/10W	RM73B--104J
R819,820	247 0005 905	Carbon chip 100ohm 1/10W	RM73B--101J
R821,822	247 0007 916	Carbon chip 750ohm 1/10W	RM73B--751J
R823	247 0009 943	Carbon chip 6.8kohm 1/10W	RM73B--682J
R824	247 0009 969	Carbon chip 8.2kohm 1/10W	RM73B--822J
R825	247 0009 901	Carbon chip 4.7kohm 1/10W	RM73B--472J
R827,828	247 0005 905	Carbon chip 100ohm 1/10W	RM73B--101J
R829	247 0011 944	Carbon chip 47kohm 1/10W	RM73B--473J
R831,834	247 0012 927	Carbon chip 100kohm 1/10W	RM73B--104J
R835,836	247 0005 905	Carbon chip 100ohm 1/10W	RM73B--101J
R837,838	247 0007 916	Carbon chip 750ohm 1/10W	RM73B--751J
R839,840	247 0009 901	Carbon chip 4.7kohm 1/10W	RM73B--472J
R841,842	247 0005 905	Carbon chip 100ohm 1/10W	RM73B--101J
R843,844	247 0012 927	Carbon chip 100kohm 1/10W	RM73B--104J

Ref. No.	Part No.	Part Name	Remarks
R857	247 0009 985	Carbon chip 10kohm 1/10W	RM73B--103J
R858	247 0007 945	Carbon chip 1kohm 1/10W	RM73B--102J
R859-864	247 0011 944	Carbon chip 47kohm 1/10W	RM73B--473J
R867-869	247 0012 927	Carbon chip 100kohm 1/10W	RM73B--104J
R871,872	247 0012 927	Carbon chip 100kohm 1/10W	RM73B--104J
CAPACITORS GROUP			
C102	257 0014 935	Ceramic chip 0.1µF/25V	CK73F1E104Z
C103	254 4193 905	Electrolytic 10µF/16V	CE04W1C100M(SRA)
C104	254 4196 944	Electrolytic 1µF/50V	CE04W1H010M(SRA)
C107	256 1058 971	Metallized 0.1µF/50V	CF93A1H104J(JL)
C109	254 4196 999	Electrolytic 22µF/50V	CE04W1H220M(SRA)
C110-113	257 0012 966	Ceramic chip 0.01µF/50V	CK73F1H103Z
C115	257 0012 966	Ceramic chip 0.01µF/50V	CK73F1H103Z
C117	257 0008 983	Ceramic chip 1000pF/50V	CK73B1H102K
C120	257 0003 933	Ceramic chip 30pF/50V	CC73SL1H300J
C121	254 4193 905	Electrolytic 10µF/16V	CE04W1C100M(SRA)
C122	257 0012 982	Ceramic chip 0.022µF/50V	CK73F1H223Z
C125	257 0012 966	Ceramic chip 0.01µF/50V	CK73F1H103Z
C301,302	254 4538 900	Electrolytic 10µF/16V	CE04W1C100M(SMG/RE3)
C307,308	254 4538 900	Electrolytic 10µF/16V	CE04W1C100M(SMG/RE3)
C311,312	254 4538 900	Electrolytic 10µF/16V	CE04W1C100M(SMG/RE3)
C318	256 1058 984	Metallized 0.12µF/50V	CF93A1H124J(JL)
C319	256 1058 942	Metallized 0.056µF/50V	CF93A1H563J(JL)
C320	254 4538 900	Electrolytic 10µF/16V	CE04W1C100M(SMG/RE3)
C323,324	254 4538 900	Electrolytic 10µF/16V	CE04W1C100M(SMG/RE3)
C325,326	257 0004 961	Ceramic chip 100pF/50V	CC73SL1H101J
C327,328	254 4538 900	Electrolytic 10µF/16V	CE04W1C100M(SMG/RE3)
C331-334	254 4538 900	Electrolytic 10µF/16V	CE04W1C100M(SMG/RE3)
C335,336	257 0004 961	Ceramic chip 100pF/50V	CC73SL1H101J
C337,338	254 4538 900	Electrolytic 10µF/16V	CE04W1C100M(SMG/RE3)
C341	254 4538 900	Electrolytic 10µF/16V	CE04W1C100M(SMG/RE3)
C343,344	257 0005 986	Ceramic chip 330pF/50V	CC73SL1H331J for E2
C355,356	257 0005 986	Ceramic chip 330pF/50V	CC73SL1H331J for E2
C367,368	257 0005 986	Ceramic chip 330pF/50V	CC73SL1H331J for E2
C379-382	256 1058 955	Metallized 0.068µF/50V	CF93A1H683J(JL)
C385,386	254 4524 943	Electrolytic 1µF/50V	CE04W1H010M(SMG/RE3)
C387,388	254 4538 900	Electrolytic 10µF/16V	CE04W1C100M(SMG/RE3)
C389,390	254 4524 943	Electrolytic 1µF/50V	CE04W1H010M(SMG/RE3)
C395,396	257 0004 961	Ceramic chip 100pF/50V	CC73SL1H101J
C397,398	254 4538 900	Electrolytic 10µF/16V	CE04W1C100M(SMG/RE3)
C399,400	257 0012 966	Ceramic chip 0.01µF/50V	CK73F1H103Z
C401,402	254 4524 943	Electrolytic 1µF/50V	CE04W1H010M(SMG/RE3)
C403	257 0008 983	Ceramic chip 1000pF/50V	CK73B1H102K
C405	257 0004 961	Ceramic chip 100pF/50V	CC73SL1H101J
C407	257 0004 961	Ceramic chip 100pF/50V	CC73SL1H101J
C408	254 4538 900	Electrolytic 10µF/16V	CE04W1C100M(SMG/RE3)
C409	257 0014 935	Ceramic chip 0.1µF/25V	CK73F1E104Z

Ref. No.	Part No.	Part Name	Remarks	Ref. No.	Part No.	Part Name	Remarks	Q'ty
C412	254 4524 943	Electrolytic 1μF/50V	CE04W1H010M(SMG/RE3)	<b>OTHER PARTS GROUP</b>				
C414	254 4524 943	Electrolytic 1μF/50V	CE04W1H010M(SMG/RE3)	CW052	205 0885 008	5P connector socket (TUC-P)		1
C416	254 4524 943	Electrolytic 1μF/50V	CE04W1H010M(SMG/RE3)	CW063	205 0942 019	6P connector socket (TUC-P)		1
C459-461	254 4524 901	Electrolytic 0.1μF/50V	CE04W1H0R1M(SMG/RE3)	CW079	205 0942 022	7P connector socket (TUC-P)		1
C462,463	257 0004 961	Ceramic chip 100pF/50V	CC73SL1H101J	CW083	205 0885 095	8P connector socket (TUC-P)		1
C703,704	257 0005 944	Ceramic chip 220pF/50V	CC73SL1H221J	CW091	205 0885 037	9P connector socket (TUC-P)		1
C705,706	254 4538 900	Electrolytic 10μF/16V	CE04W1C100M(SMG/RE3)	CW101	205 1000 002	10P FJ connector plug		1
C707,708	257 0004 961	Ceramic chip 100pF/50V	CC73SL1H101J	CW112	205 0885 066	11P connector socket (TUC-P)		1
C709,710	254 4533 934	Electrolytic 220μF/6.3V	CE04W0J221M(SMG/RE3)	CW123	205 0885 079	12P connector socket (TUC-P)		1
C711,712	255 4199 999	Mylar film 0.024μF/50V	CQ92M1H243J(MRZ)	CW161,162	205 1055 028	16P connector base (TKC-V)		2
C713,714	255 1265 907	Mylar film 6800pF/50V	CQ93M1H682J(B)	CX932	205 1121 033	3P CON.BASE-L(5268)		1
C715,716	254 4538 900	Electrolytic 10μF/16V	CE04W1C100M(SMG/RE3)	CY021	205 0581 001	2P VH connector base	for E2,E1,E1C, E1H,E3T	1
C717,718	257 0012 982	Ceramic chip 0.022μF/50V	CK73F1H223Z	FB101	235 0049 900	Beads inductor		1
C719,720	257 0005 986	Ceramic chip 330pF/50V	CC73SL1H331J for E2	FB701	247 0018 905	Carbon chip 0ohm 1/10W	RM73B-OR0K	1
C725,726	247 0018 905	Carbon chip 4.7Mohm 1/10W	RM73B--475K	JK301	204 8513 010	6P pin jack (S-GND)		1
C729,730	254 4524 943	Electrolytic 1μF/50V	CE04W1H010M(SMG/RE3)	JK701	204 8545 004	4P pin jack (GND)		1
C741,742	257 0014 935	Ceramic chip 0.1μF/25V	CK73F1E104Z	L301-304	235 0049 900	Beads inductor		4
C801,802	254 4538 900	Electrolytic 10μF/16V	CE04W1C100M(SMG/RE3)	L701,702	235 9003 002	FTZ choke coil	for E2	2
C803,804	257 0003 988	Ceramic chip 47pF/50V	CC73SL1H470J	S101-112	212 5611 903	Tact switch		12
C807,808	257 0004 961	Ceramic chip 100pF/50V	CC73SL1H101J	S113	212 0373 000	Rotary encoder EC16B		1
C809,810	255 1265 923	Mylar film 8200pF/50V	CQ93M1H822J(B)	S114	212 0422 003	Rotary encoder		1
C811,812	254 4524 943	Electrolytic 1μF/50V	CE04W1H010M(SMG/RE3)	S901	212 1030 009	Power switch (TV-5)	for E2,E1,E1C, E1H,E3T	1
C813,814	257 0012 982	Ceramic chip 0.022μF/50V	CK73F1H223Z	ST002	205 0452 004	Style pin		1
C815,816	254 4538 900	Electrolytic 10μF/16V	CE04W1C100M(SMG/RE3)		203 0526 002	1P connector cord Ass'y	W724	1
C817,818	257 0003 988	Ceramic chip 47pF/50V	CC73SL1H470J		203 0525 029	1P SIN cord Ass'y	W726 to W727	1
C821,822	257 0004 961	Ceramic chip 100pF/50V	CC73SL1H101J		414 0799 109	Shield plate		1
C823	255 1265 923	Mylar film 8200pF/50V	CQ93M1H822J(B)					
C825,826	254 4524 943	Electrolytic 1μF/50V	CE04W1H010M(SMG/RE3)					
C827,828	257 0012 982	Ceramic chip 0.022μF/50V	CK73F1H223Z					
C829,830	254 4538 900	Electrolytic 10μF/16V	CE04W1C100M(SMG/RE3)					
C831,832	257 0003 988	Ceramic chip 47pF/50V	CC73SL1H470J					
C835,836	257 0004 961	Ceramic chip 100pF/50V	CC73SL1H101J					
C837,838	254 4524 943	Electrolytic 1μF/50V	CE04W1H010M(SMG/RE3)					
C839,840	257 0012 982	Ceramic chip 0.022μF/50V	CK73F1H223Z					
C853	257 0008 983	Ceramic chip 1000pF/50V	CK73B1H102K					
C855	257 0008 983	Ceramic chip 1000pF/50V	CK73B1H102K					
C857	257 0008 983	Ceramic chip 1000pF/50V	CK73B1H102K					
C860	254 4524 943	Electrolytic 1μF/50V	CE04W1H010M(SMG/RE3)					
C861,862	254 4538 939	Electrolytic 47μF/16V	CE04W1C470M(SMG/RE3) for E2					
C861,862	254 4538 900	Electrolytic 10μF/16V	CE04W1C100M(SMG/RE3) for E3,EU,E1,E1C,E1H,E3T					
C863,864	254 4538 900	Electrolytic 10μF/16V	CE04W1C100M(SMG/RE3)					
C869,870	254 4538 939	Electrolytic 47μF/16V	CE04W1C470M(SMG/RE3) for E2					
C869,870	254 4524 969	Electrolytic 3.3μF/50V	CE04W1H3R3M(SMG/RE3) for E3,EU,E1,E1C,E1H,E3T					
C871	254 4524 969	Electrolytic 3.3μF/50V	CE04W1H3R3M(SMG/RE3)					
C873,874	254 4524 969	Electrolytic 3.3μF/50V	CE04W1H3R3M(SMG/RE3)					

## 1U-3234 CONTROL UNIT ASS'Y

Ref. No.	Part No.	Part Name	Remarks	Ref. No.	Part No.	Part Name	Remarks
<b>SEMICONDUCTORS GROUP</b>				R114,115	247 0011 928	Carbon chip 39kohm 1/10W	RM73B--393J
IC102	262 2616 003	IC TC9184AP		R116	247 0013 984	Carbon chip 470kohm 1/10W	RM73B--474J
IC103,104	263 0896 909	IC NJM2068MD		R117,118	247 0014 909	Carbon chip 560kohm 1/10W	RM73B--564J
IC301	262 1701 906	IC SAA6579T	for E2	R119,120	247 0004 922	Carbon chip 47ohm 1/10W	RM73B--470J
IC302	262 1929 908	IC LC7074M	for E2	R121,122	247 0009 927	Carbon chip 5.6kohm 1/10W	RM73B--562J
IC303	262 2722 007	IC TMP88CU74F		R123,124	247 0010 987	Carbon chip 27kohm 1/10W	RM73B--273J
IC304	262 2375 904	IC TC4094BF		R125,126	247 0007 945	Carbon chip 1kohm 1/10W	RM73B--102J
IC702,703	269 0178 007	IC GP1F37R (OPT. IN)		R127,128	247 0012 927	Carbon chip 100kohm 1/10W	RM73B--104J
IC704	262 1205 907	IC TC74HCU04AF		R129-132	247 0018 905	Carbon chip 0ohm 1/10W	RM73B--0R0K
IC705	262 2213 901	IC TC74HC151AF		R135,136	247 0018 905	Carbon chip 0ohm 1/10W	RM73B--0R0K
TR301	274 0163 904	Transistor 2SD601A		R141-143	247 0005 905	Carbon chip 100ohm 1/10W	RM73B--101J
TR302	271 0291 903	Transistor 2SA1182Y/O		R145,146	247 0005 905	Carbon chip 100ohm 1/10W	RM73B--101J
TR303	269 0054 901	Transistor DTC144EK		R304-307	247 0009 985	Carbon chip 10kohm 1/10W	RM73B--103J
TR304	269 0082 902	Transistor DTC114EK		R308	247 0005 905	Carbon chip 100ohm 1/10W	RM73B--101J
TR305	269 0055 900	Transistor DTA144EK		R309	247 0009 985	Carbon chip 10kohm 1/10W	RM73B--103J
TR306	269 0054 901	Transistor DTC144EK		R310,311	247 0007 945	Carbon chip 1kohm 1/10W	RM73B--102J
TR307	269 0083 901	Transistor DTA114EK		R312	247 0009 985	Carbon chip 10kohm 1/10W	RM73B--103J
TR308,309	269 0054 901	Transistor DTC144EK		R313	247 0007 945	Carbon chip 1kohm 1/10W	RM73B--102J
TR901	271 0131 924	Transistor 2SA988(E/F)		R314	247 0009 985	Carbon chip 10kohm 1/10W	RM73B--103J
TR902	273 0445 001	Transistor 2SC4495		R315	247 0018 905	Carbon chip 0ohm 1/10W	RM73B--0R0K
TR904,905	271 0131 924	Transistor 2SA988(E/F)		R316	247 0005 905	Carbon chip 100ohm 1/10W	RM73B--101J
TR906-908	269 0083 901	Transistor DTA114EK		R318	247 0005 905	Carbon chip 100ohm 1/10W	RM73B--101J
TR910	269 0083 901	Transistor DTA114EK		R320	247 0005 905	Carbon chip 100ohm 1/10W	RM73B--101J
TR911	271 0131 924	Transistor 2SA988(E/F)		R324-326	247 0009 901	Carbon chip 4.7kohm 1/10W	RM73B--472J
D301	276 0432 903	Diode 1SS270A	for E2	R327	247 0009 985	Carbon chip 10kohm 1/10W	RM73B--103J
D302	276 0432 903	Diode 1SS270A		R329	247 0009 985	Carbon chip 10kohm 1/10W	RM73B--103J
D303	276 0634 905	Zener diode MTZJ3.3A		R330	247 0005 905	Carbon chip 100ohm 1/10W	RM73B--101J
D304	276 0432 903	Diode 1SS270A		R331	247 0009 985	Carbon chip 10kohm 1/10W	RM73B--103J
D305,306	276 0704 903	Diode 1SR35-400A		R333,334	247 0009 985	Carbon chip 10kohm 1/10W	RM73B--103J
D701	276 0432 903	Diode 1SS270A		R335	247 0011 944	Carbon chip 47kohm 1/10W	RM73B--473J
D901-911	276 0432 903	Diode 1SS270A		R340-342	247 0009 985	Carbon chip 10kohm 1/10W	RM73B--103J
D913	276 0704 903	Diode 1SR35-400A		R343,344	247 0005 905	Carbon chip 100ohm 1/10W	RM73B--101J
D914	276 0645 978	Zener diode MTZJ36A		R345	247 0018 905	Carbon chip 0ohm 1/10W	RM73B--0R0K
D915	276 0704 903	Diode 1SR35-400A		R346	247 0005 905	Carbon chip 100ohm 1/10W	RM73B--101J
D916	276 0643 996	Zener diode MTZJ5.6A		R347	247 0018 905	Carbon chip 0ohm 1/10W	RM73B--0R0K
D917	276 0704 903	Diode 1SR35-400A		R347	247 0007 945	Carbon chip 1kohm 1/10W	RM73B--102J for E2
<b>RESISTORS GROUP</b>				R347	247 0009 901	Carbon chip 4.7kohm 1/10W	RM73B--472J for E1,E1H
R101,102	247 0008 928	Carbon chip 2.2kohm 1/10W	RM73B--222J	R348	247 0018 905	Carbon chip 0ohm 1/10W	RM73B--0R0K for E3,EU
R103,104	247 0006 946	Carbon chip 390ohm 1/10W	RM73B--391J	R348	247 0009 901	Carbon chip 4.7kohm 1/10W	RM73B--472J for E1C,E3T
R105,106	247 0013 984	Carbon chip 470kohm 1/10W	RM73B--474J	R348	247 0009 914	Carbon chip 5.1kohm 1/10W	RM73B--512J for E1,E1H
R107,108	247 0005 905	Carbon chip 100ohm 1/10W	RM73B--101J	R349	247 0018 905	Carbon chip 0ohm 1/10W	RM73B--0R0K
R109,110	247 0012 901	Carbon chip 82kohm 1/10W	RM73B--823J	R350	247 0009 985	Carbon chip 10kohm 1/10W	RM73B--103J
R111,112	247 0009 901	Carbon chip 4.7kohm 1/10W	RM73B--472J	R351-353	247 0012 927	Carbon chip 100kohm 1/10W	RM73B--104J
R113	247 0013 984	Carbon chip 470kohm 1/10W	RM73B--474J	R354	247 0013 900	Carbon chip 220kohm 1/10W	RM73B--224J
				R355	247 0012 927	Carbon chip 100kohm 1/10W	RM73B--104J

Ref. No.	Part No.	Part Name	Remarks
R356	247 0009 985	Carbon chip 10kohm 1/10W	RM73B--103J
R357~360	247 0012 927	Carbon chip 100kohm 1/10W	RM73B--104J
R361,362	247 0009 901	Carbon chip 4.7kohm 1/10W	RM73B--472J
R363~365	247 0005 905	Carbon chip 100ohm 1/10W	RM73B--101J
R366	247 0018 905	Carbon chip 0ohm 1/10W	RM73B--0R0K for E1,E1H
R368	247 0007 945	Carbon chip 1kohm 1/10W	RM73B--102J
R372,373	247 0007 945	Carbon chip 1kohm 1/10W	RM73B--102J
R374	247 0009 985	Carbon chip 10kohm 1/10W	RM73B--103J
R375	241 2387 940	Carbon film 4.7ohm 1/4W(NB)	RD14B2E4R7JNBS
R376	247 0009 985	Carbon chip 10kohm 1/10W	RM73B--103J
R377	247 0009 985	Carbon chip 10kohm 1/10W	RM73B--103J for E2
R378~383	247 0009 985	Carbon chip 10kohm 1/10W	RM73B--103J
R384	247 0007 974	Carbon chip 1.3kohm 1/10W	RM73B--132J for E1,E1H
R385	247 0018 905	Carbon chip 0ohm 1/10W	RM73B--0R0K
R702,703	247 0018 905	Carbon chip 0ohm 1/10W	RM73B--0R0K
R706,707	247 0009 901	Carbon chip 4.7kohm 1/10W	RM73B--472J
R708	247 0004 977	Carbon chip 75ohm 1/10W	RM73B--750J
R709	247 0005 905	Carbon chip 100ohm 1/10W	RM73B--101J
R710	247 0008 928	Carbon chip 2.2kohm 1/10W	RM73B--222J
R711	247 0011 944	Carbon chip 47kohm 1/10W	RM73B--473J
R712	247 0018 905	Carbon chip 0ohm 1/10W	RM73B--0R0K
R801~804	247 0005 989	Carbon chip 220ohm 1/10W	RM73B--221J
R807~810	247 0012 927	Carbon chip 100kohm 1/10W	RM73B--104J
R901~904	247 0008 928	Carbon chip 2.2kohm 1/10W	RM73B--222J
R907	247 0014 909	Carbon chip 560kohm 1/10W	RM73B--564J
R909	247 0004 977	Carbon chip 75ohm 1/10W	RM73B--750J
R910	247 0008 902	Carbon chip 1.8kohm 1/10W	RM73B--182J
R911	247 0010 961	Carbon chip 22kohm 1/10W	RM73B--223J
R912	247 0008 973	Carbon chip 3.6kohm 1/10W	RM73B--362J
R913	247 0014 909	Carbon chip 560kohm 1/10W	RM73B--564J
R914	247 0013 984	Carbon chip 470kohm 1/10W	RM73B--474J
R915	247 0007 945	Carbon chip 1kohm 1/10W	RM73B--102J
R916	247 0009 985	Carbon chip 10kohm 1/10W	RM73B--103J
R917	247 0013 984	Carbon chip 470kohm 1/10W	RM73B--474J
R918	247 0007 945	Carbon chip 1kohm 1/10W	RM73B--102J
R919	247 0009 985	Carbon chip 10kohm 1/10W	RM73B--103J
R920	247 0013 984	Carbon chip 470kohm 1/10W	RM73B--474J
R921	247 0007 945	Carbon chip 1kohm 1/10W	RM73B--102J
R922	247 0009 985	Carbon chip 10kohm 1/10W	RM73B--103J
R926	247 0013 984	Carbon chip 470kohm 1/10W	RM73B--474J
R927	247 0007 945	Carbon chip 1kohm 1/10W	RM73B--102J
R928	247 0009 985	Carbon chip 10kohm 1/10W	RM73B--103J
R932	241 2387 940	Carbon film 4.7ohm 1/4W (NB)	RD14B2E4R7JNBS
R933	247 0009 985	Carbon chip 10kohm 1/10W	RM73B--103J
R934	244 2055 996	Metal oxide 1.2kohm 1W	RS14B3A122JNBS(S)
R939,940	244 2055 996	Metal oxide 1.2kohm 1W	RS14B3A122JNBS(S)

Ref. No.	Part No.	Part Name	Remarks
<b>CAPACITORS GROUP</b>			
C101,102	254 4524 956	Electrolytic 2.2μF/50V	CE04W1H2R2M(SMG/RE3)
C103,104	257 0004 961	Ceramic chip 100pF/50V	CC73SL1H101J
C105,106	254 4524 969	Electrolytic 3.3μF/50V	CE04W1H3R3M(SMG/RE3)
C107,108	256 1058 942	Metallized 0.056μF/50V	CF93A1H563J(JL)
C109,110	255 1265 907	Mylar film 6800pF/50V	CQ93M1H682J(B)
C111,112	257 0004 961	Ceramic chip 100pF/50V	CC73SL1H101J
C113,114	255 1265 949	Mylar film 0.012μF/50V	CQ93M1H123J(B)
C115,116	255 1264 953	Mylar film 2700pF/50V	CQ93M1H272J(B)
C117,118	254 4538 939	Electrolytic 47μF/16V	CE04W1C470M(SMG/RE3) for E2
C117,118	254 4524 972	Electrolytic 4.7μF/50V	CE04W1H4R7M(SMG/RE3) for E3,EU,E1,E1C,E1H,E3T
C119,120	255 1265 978	Mylar film 0.022μF/50V	CQ93M1H223J(B)
C121,122	254 4524 972	Electrolytic 4.7μF/50V	CE04W1H4R7M(SMG/RE3)
C123,124	257 0014 935	Ceramic chip 0.1μF/25V	CK73F1E104Z
C303	257 0008 983	Ceramic chip 1000pF/50V	CK73B1H102K for E3,EU,E1,E1H
C304	257 0003 920	Ceramic chip 27pF/50V	CC73SL1H270J for E2
C305	257 0010 984	Ceramic chip 0.047μF/50V	CK73B1H473K
C308	254 4524 956	Electrolytic 2.2μF/50V	CE04W1H2R2M(SMG/RE3) for E2
C311	257 0003 920	Ceramic chip 27pF/50V	CC73SL1H270J for E2
C312	257 0012 966	Ceramic chip 0.01μF/50V	CK73F1H103Z for E2
C314	257 0008 983	Ceramic chip 1000pF/50V	CK73B1H102K
C316	254 4538 900	Electrolytic 10μF/16V	CE04W1C100M(SMG/RE3) for E2
C317	257 0010 984	Ceramic chip 0.047μF/50V	CK73B1H473K
C321	257 0006 943	Ceramic chip 560pF/50V	CC73SL1H561J for E2
C323	254 4538 900	Electrolytic 10μF/16V	CE04W1C100M(SMG/RE3) for E2
C325	257 0008 983	Ceramic chip 1000pF/50V	CK73B1H102K
C339	254 4536 957	Electrolytic 470μF/10V	CE04W1A471M(SMG/RE3)
C340	257 0014 935	Ceramic chip 0.1μF/25V	CK73F1E104Z
C341	254 4538 939	Electrolytic 47μF/16V	CE04W1C470M(SMG/RE3)
C342	257 0010 984	Ceramic chip 0.047μF/50V	CK73B1H473K
C348	254 4538 939	Electrolytic 47μF/16V	CE04W1C470M(SMG/RE3)
C349	257 0012 966	Ceramic chip 0.01μF/50V	CK73F1H103Z
C350	256 1058 984	Metallized 0.12μF/50V	CF93A1H124J(JL)
C352	254 4304 927	Electrolytic 4.7μF/35V	CE04W1V4R7M(SRE)
C353	257 0012 966	Ceramic chip 0.01μF/50V	CK73F1H103Z
C354	254 4300 963	Electrolytic 100μF/6.3V	CE04W0J101M(SRE)
C355	257 0012 966	Ceramic chip 0.01μF/50V	CK73F1H103Z
C356	257 0008 983	Ceramic chip 1000pF/50V	CK73B1H102K
C357	259 0007 702	Back up cap. 8200μF/5.5V	SB CAP==822=C
C358	257 0008 983	Ceramic chip 1000pF/50V	CK73B1H102K
C359	254 4533 934	Electrolytic 220μF/6.3V	CE04W0J221M(SMG/RE3)



Ref. No.	Part No.	Part Name	Remarks
C367	257 0012 966	Ceramic chip 0.01μF/50V	CK73F1H103Z
C373	257 0008 983	Ceramic chip 1000pF/50V	CK73B1H102K for E2,E1,E1C,E1H,E3T
C375	257 0010 984	Ceramic chip 0.047μF/50V	CK73B1H473K
C377	254 4538 900	Electrolytic 10μF/16V	CE04W1C100M(SMG/RE3)
C385	257 0008 983	Ceramic chip 1000pF/50V	CK73B1H102K for E2,E1C,E3T
C390	256 1058 971	Metallized 0.1μF/50V	CF93A1H104J(JL)
C393	257 0008 983	Ceramic chip 1000pF/50V	CK73B1H102K
C395	257 0008 983	Ceramic chip 1000pF/50V	CK73B1H102K for E1, E1H
C397	257 0008 983	Ceramic chip 1000pF/50V	CK73B1H102K
C398	257 0004 961	Ceramic chip 100pF/50V	CC73SL1H101J
C399	257 0008 983	Ceramic chip 1000pF/50V	CK73B1H102K
C491	257 0008 983	Ceramic chip 1000pF/50V	CK73B1H102K for E3,EU,E1,E1H
C701	257 0014 935	Ceramic chip 0.1μF/25V	CK73F1E104Z
C703,704	257 0014 935	Ceramic chip 0.1μF/25V	CK73F1E104Z
C706,707	254 4538 939	Electrolytic 47μF/16V	CE04W1C470M(SMG/RE3)
C709	257 0014 935	Ceramic chip 0.1μF/25V	CK73F1E104Z
C710	254 4524 969	Electrolytic 3.3μF/50V	CE04W1H3R3M(SMG/RE3)
C714	257 0003 904	Ceramic chip 22pF/50V	CC73SL1H220J
C715,716	257 0012 966	Ceramic chip 0.01μF/50V	CK73F1H103Z
C717	254 4538 900	Electrolytic 10μF/16V	CE04W1C100M(SMG/RE3)
C718,719	257 0012 966	Ceramic chip 0.01μF/50V	CK73F1H103Z
C857	257 0012 966	Ceramic chip 0.01μF/50V	CK73F1H103Z
C858	254 4524 943	Electrolytic 1μF/50V	CE04W1H010M(SMG/RE3)
C901	253 1181 904	Ceramic 0.01μF/50V	CK45F1H103Z
C902	254 4524 956	Electrolytic 2.2μF/50V	CE04W1H2R2M(SMG/RE3)
C903	253 1181 904	Ceramic 0.01μF/50V	CK45F1H103Z
C909	254 4524 943	Electrolytic 1μF/50V	CE04W1H010M(SMG/RE3)
C911	254 4527 908	Electrolytic 0.1μF/100V	CE04W2A0R1M(SMG/RE3)
C912	254 4524 985	Electrolytic 10μF/50V	CE04W1H100M(SMG/RE3)
C914	254 4524 901	Electrolytic 0.1μF/50V	CE04W1H0R1M(SMG/RE3)
C916~918	254 4524 901	Electrolytic 0.1μF/50V	CE04W1H0R1M(SMG/RE3)
C919	254 4522 958	Electrolytic 100μF/35V	CE04W1V101M(SMG/RE3)
C920	257 0012 966	Ceramic chip 0.01μF/50V	CK73F1H103Z
C961	257 0012 966	Ceramic chip 0.01μF/50V	CK73F1H103Z
C962	254 4524 943	Electrolytic 1μF/50V	CE04W1H010M(SMG/RE3)
C981	257 0010 984	Ceramic chip 0.047μF/50V	CK73B1H473K
C983	257 0008 983	Ceramic chip 1000pF/50V	CK73B1H102K for E2,E1C,E3T
C984	253 1180 921	Ceramic 1000pF/50V	CK45B1H102K for E2,E1C,E3T

Ref. No.	Part No.	Part Name	Remarks	Q'ty
<b>OTHER PARTS GROUP</b>				
CW064	205 0942 019	6P connector socket (TUC-P)		1
CW066	205 0942 019	6P connector socket (TUC-P)		1
CW085	205 0885 095	8P connector socket (TUC-P)		1
CW092	205 0885 037	9P connector socket (TUC-P)		1
CW116	205 0885 066	11P connector socket (TUC-P)		1
CW124	205 0885 079	12P connector socket (TUC-P)		1
CW156	205 0885 040	15P connector socket (TUC-P)		1
CX051,052	205 0884 009	5P connector base (TUC-P)		2
CX061-066	205 0943 018	6P connector base (TUC-P)		6
CX071,072	205 0943 021	7P connector base (TUC-P)		2
CX073	205 1000 015	7P FJ connector plug		1
CX075,076	205 1000 015	7P FJ connector plug		2
CX079	205 0943 021	7P connector base (TUC-P)		1
CX082,083	205 0884 096	8P connector base (TUC-P)		2
CX091	205 0884 038	9P connector base (TUC-P)		1
CX111,112	205 0884 067	11P connector base (TUC-P)		2
CX116,117	205 0884 067	11P connector base (TUC-P)		2
CX121	205 0884 070	12P connector base (TUC-P)		1
CX123,124	205 0884 070	12P connector base (TUC-P)		2
CX141	205 0884 012	14P connector base (TUC-P)		1
CX151	205 0884 041	15P connector base (TUC-P)		1
CX161,162	205 1056 027	16P connector socket TKC-V		2
FB302	235 0049 900	Beads inductor		1
FB304,305	235 0049 900	Beads inductor		2
FB704~706	247 0018 905	Carbon chip 0ohm 1/10W	RM73B-0R0K	3
JK701	204 8593 001	1P pin jack (OR,NI)		1
JK801	204 8540 009	4P pin jack		1
L308	235 0131 902	EMI filter	BLM21B272S	1
L313~315	235 0131 902	EMI filter	BLM21B272S	3
L319	235 0131 902	EMI filter	BLM21B272S	1
L703	235 0060 905	Inductor 2.2μH		1
L704,705	235 0060 918	Inductor 4.7μH		2
ST004,005	205 0452 004	Style pin		2
W708,709	205 1034 010	M3 Screw terminal		2
X301	399 0178 007	Crystal	4.332MHz for E2	1
XL301	399 0191 903	Ceramic resonator	CST4.00MGW-TF01 for E2	1
XL302	399 0532 902	Ceramic resonator	CST12.5MTW-TF01	1
	203 0438 093	1P SIN connector Ass'y		1
	203 0438 080	1P SIN connector Ass'y		1

1U-3235 REGULATOR UNIT ASS'Y

Ref. No.	Part No.	Part Name	Remarks
<b>SEMICONDUCTORS GROUP</b>			
IC501	216 9013 004	FM front end(U) S	for E2
IC501	216 0102 008	Front end	for E3,EU,E1,E1C,E1H,E3T
IC502	263 0891 001	IC LA1265(S)	
IC503	263 0439 007	IC LA3401	
IC507	262 2450 900	IC LC72131M	
IC902,903	263 0809 006	IC NJM7805FA(S)	
IC904	263 0793 002	IC NJM7806FA(S)	
IC906	263 0801 004	IC NJM7812FA(S)	
IC907	263 0641 002	IC NJM7912FA	
TR501	275 0074 902	FET 2SK211-Y/GR	for E2
TR502	273 0411 909	Transistor 2SC2996-Y	
TR503,504	269 0083 901	Transistor DTA114EK	
TR505	269 0114 906	Transistor RN2402	
TR508	269 0054 901	Transistor DTC144EK	
TR509,510	269 0066 902	Transistor DTC323TK	
TR511	269 0086 908	Transistor DTA114TK	
TR801-804	273 0253 918	Transistor 2SC2878(A/B)	
TR809-814	273 0253 918	Transistor 2SC2878(A/B)	
TR815-818	271 0094 919	Transistor 2SA970(BL)	
TR819,820	273 0281 906	Transistor 2SC2705(O)/(Y)	
TR821,822	273 0253 918	Transistor 2SC2878(A/B)	
TR823-826	271 0094 919	Transistor 2SA970(BL)	
TR827,828	273 0281 906	Transistor 2SC2705(O)/(Y)	
TR829	273 0253 918	Transistor 2SC2878(A/B)	
TR830,831	271 0094 919	Transistor 2SA970(BL)	
TR832	273 0281 906	Transistor 2SC2705(O)/(Y)	
TR911	269 0082 902	Transistor DTC114EK	
TR917	273 0429 904	Transistor 2SC3311A	
TR918-920	271 0262 000	Transistor 2SA1670(O/P/Y)	
D501	276 0432 903	Diode 1SS270A	
D503-505	276 0432 903	Diode 1SS270A	
D911-913	276 0432 903	Diode 1SS270A	
D914,915	276 0704 903	Diode 1SR35-400A	
D917-921	276 0704 903	Diode 1SR35-400A	
D922	276 0305 001	Diode S4VB20	
D924	276 0704 903	Diode 1SR35-400A	
ZD917,918	276 0637 902	Zener diode MTZJ6.2A	
ZD502	276 0644 937	Zener diode MTZJ9.1A	
LD901	393 9408 903	LED SEL-4214S	
PT901	279 0034 054	Posistor PTH9M04BC222TS2F333	

Ref. No.	Part No.	Part Name	Remarks
<b>RESISTORS GROUP</b>			
R501	247 0002 966	Carbon chip 10ohm 1/10W	RM73B-100J
R502	247 0018 905	Carbon chip 0ohm 1/10W	RM73B-0R0K
R503	247 0007 945	Carbon chip 1kohm 1/10W	for E2 RM73B-102J
R504-512	247 0018 905	Carbon chip 0ohm 1/10W	RM73B-0R0K
R514	247 0005 905	Carbon chip 100ohm 1/10W	RM73B-101J
R515	247 0005 905	Carbon chip 100ohm 1/10W	RM73B-101J for E3,EU,E1,E1C,E1H,E3T
R516	247 0006 920	Carbon chip 330ohm 1/10W	RM73B-331J for E2
R516	247 0007 945	Carbon chip 1kohm 1/10W	RM73B-102J for E3,EU,E1,E1C,E1H,E3T
R517	247 0006 920	Carbon chip 330ohm 1/10W	RM73B-331J for E2
R518	247 0005 989	Carbon chip 220ohm 1/10W	RM73B-221J
R519	247 0006 962	Carbon chip 470ohm 1/10W	RM73B-471J
R520	247 0007 945	Carbon chip 1kohm 1/10W	RM73B-102J
R521	247 0009 901	Carbon chip 4.7kohm 1/10W	RM73B-472J
R522	247 0006 920	Carbon chip 330ohm 1/10W	RM73B-331J
R523	247 0007 961	Carbon chip 1.2kohm 1/10W	RM73B-122J
R524	247 0012 927	Carbon chip 100kohm 1/10W	RM73B-104J
R525	247 0007 945	Carbon chip 1kohm 1/10W	RM73B-102J
R526	247 0009 927	Carbon chip 5.6kohm 1/10W	RM73B-562J
R527-529	247 0007 945	Carbon chip 1kohm 1/10W	RM73B-102J
R531,532	247 0018 905	Carbon chip 0ohm 1/10W	RM73B-0R0K
R533	247 0010 929	Carbon chip 15kohm 1/10W	RM73B-153J for E3,EU,E1,E1C,E1H,E3T
R534	247 0005 921	Carbon chip 120ohm 1/10W	RM73B-121J
R535	247 0010 945	Carbon chip 18kohm 1/10W	RM73B-183J for E3,EU
R535	247 0011 928	Carbon chip 39kohm 1/10W	RM73B-393J for E2,E1,E1C,E1H,E3T
R536	247 0008 944	Carbon chip 2.7kohm 1/10W	RM73B-272J for E2
R536	247 0018 905	Carbon chip 0ohm 1/10W	RM73B-0R0K for E3,EU,E1,E1C,E1H,E3T
R537	247 0011 986	Carbon chip 68kohm 1/10W	RM73B-683J
R538	247 0009 943	Carbon chip 6.8kohm 1/10W	RM73B-682J
R539	247 0009 927	Carbon chip 5.6kohm 1/10W	RM73B-562J
R540,541	247 0009 985	Carbon chip 10kohm 1/10W	RM73B-103J
R542,543	247 0008 960	Carbon chip 3.3kohm 1/10W	RM73B-332J
R544,545	247 0012 969	Carbon chip 150kohm 1/10W	RM73B-154J for E2
R544,545	247 0012 927	Carbon chip 100kohm 1/10W	RM73B-104J for E3,EU,E1,E1C,E1H,E3T
R546	247 0011 928	Carbon chip 39kohm 1/10W	RM73B-393J
R547	247 0012 927	Carbon chip 100kohm 1/10W	RM73B-104J
R548	247 0009 985	Carbon chip 10kohm 1/10W	RM73B-103J
R549	247 0012 927	Carbon chip 100kohm 1/10W	RM73B-104J
R550	247 0009 927	Carbon chip 5.6kohm 1/10W	RM73B-562J
R551	247 0009 985	Carbon chip 10kohm 1/10W	RM73B-103J

Ref. No.	Part No.	Part Name	Remarks	Ref. No.	Part No.	Part Name	Remarks
R553,554	247 0008 960	Carbon chip 3.3kohm 1/10W	RM73B--332J	C518	257 0010 984	Ceramic chip 0.047 $\mu$ F/50V	CK73B1H473K
R555,556	247 0008 960	Carbon chip 3.3kohm 1/10W	RM73B--332J	C519	257 0004 961	Ceramic chip 100pF/50V	CC73SL1H101J
R555,556	247 0009 927	Carbon chip 5.6kohm 1/10W	RM73B--562J	C520	257 0004 961	Ceramic chip 100pF/50V	CC73SL1H101J
R569	247 0009 927	Carbon chip 5.6kohm 1/10W	RM73B--562J	C521~523	257 0010 900	Ceramic chip 0.01 $\mu$ F/50V	CK73B1H103K
R570	247 0009 985	Carbon chip 10kohm 1/10W	RM73B--103J	C524	254 4524 930	Electrolytic 0.47 $\mu$ F/50V	CE04W1HR47M(SMG/RE3)
R571~574	247 0018 905	Carbon chip 0ohm 1/10W	RM73B--0R0K	C525	254 4524 985	Electrolytic 10 $\mu$ F/50V	CE04W1H100M(SMG/RE3)
R575,576	247 0012 998	Carbon chip 200kohm 1/10W	RM73B--204J	C526	257 0010 942	Ceramic chip 0.022 $\mu$ F/50V	CK73B1H223K
R575,576	247 0012 943	Carbon chip 120kohm 1/10W	RM73B--124J	C527	254 4524 943	Electrolytic 1 $\mu$ F/50V	CE04W1H010M(SMG/RE3)
R577	247 0010 961	Carbon chip 22kohm 1/10W	RM73B--223J	C527	254 4524 927	Electrolytic 0.33 $\mu$ F/50V	CE04W1HR33M(SMG/RE3)
R578	247 0018 905	Carbon chip 0ohm 1/10W	RM73B--0R0K	C528	254 4538 939	Electrolytic 47 $\mu$ F/16V	CE04W1C470M(SMG/RE3)
R579~581	247 0018 905	Carbon chip 0ohm 1/10W	RM73B--0R0K	C529	254 4524 943	Electrolytic 1 $\mu$ F/50V	CE04W1H010M(SMG/RE3)
R582	247 0018 905	Carbon chip 0ohm 1/10W	RM73B--0R0K	C530	254 4524 914	Electrolytic 0.22 $\mu$ F/50V	CE04W1HR22M(SMG/RE3)
R595	247 0018 905	Carbon chip 0ohm 1/10W	RM73B--0R0K	C531	254 4524 943	Electrolytic 1 $\mu$ F/50V	CE04W1H010M(SMG/RE3)
R713,714	244 2052 960	Metal oxide 220ohm 1W	RS14B3A221JNBS(S)	C532	257 0010 900	Ceramic chip 0.01 $\mu$ F/50V	CK73B1H103K
R861,862	241 2376 964	Carbon film 47ohm 1/4W(NB)	RD14B2E470JNBS	C533	256 1058 939	Metallized 0.047 $\mu$ F/50V	CF93A1H473J(JL)
R887,888	241 2376 964	Carbon film 47ohm 1/4W(NB)	RD14B2E470JNBS	C534	256 1058 942	Metallized 0.056 $\mu$ F/50V	CF93A1H563J(JL)
R901	241 2376 964	Carbon film 47ohm 1/4W(NB)	RD14B2E470JNBS	C535	254 3053 910	Electrolytic 22 $\mu$ F/16V	CE04D1C220MBP
R911	247 0006 917	Carbon chip 300ohm 1/10W	RM73B--301J	C536	257 0004 961	Ceramic chip 100pF/50V	CC73SL1H101J
R912	247 0006 975	Carbon chip 510ohm 1/10W	RM73B--511J	C537	254 4538 913	Electrolytic 22 $\mu$ F/16V	CE04W1C220M(SMG/RE3)
R913	247 0007 945	Carbon chip 1kohm 1/10W	RM73B--102J	C538	254 4538 913	Electrolytic 22 $\mu$ F/16V	CE04W1C220M(SMG/RE3)
R914	247 0007 903	Carbon chip 680ohm 1/10W	RM73B--681J	C539,540	257 0006 972	Ceramic chip 750pF/50V	CC73SL1H751J
R917	247 0005 976	Carbon chip 200ohm 1/10W	RM73B--201J	C539,540	257 0005 986	Ceramic chip 330pF/50V	CC73SL1H331J
R941,942	247 0005 905	Carbon chip 100ohm 1/10W	RM73B--101J	C539,540	257 0006 930	Ceramic chip 510pF/50V	CC73SL1H511J
R943,944	247 0009 901	Carbon chip 4.7kohm 1/10W	RM73B--472J	C541	254 4524 956	Electrolytic 2.2 $\mu$ F/50V	CE04W1HR22M(SMG/RE3)
R949~951	241 2376 919	Carbon film 30ohm 1/4W(NB)	RD14B2E300JNBS	C544	257 0010 900	Ceramic chip 0.01 $\mu$ F/50V	CK73B1H103K
R963	241 2375 907	Carbon film 10ohm 1/4W(NB)	RD14B2E100JNBS	C545,546	254 4538 900	Electrolytic 10 $\mu$ F/16V	CE04W1C100M(SMG/RE3)
VR501	211 6132 925	Semi fixed resistor 10ohm	V06PB103	C557,558	257 0002 963	Ceramic chip 15pF/50V	CC73SL1H150J
VR502	211 6132 983	Semi fixed resistor 100ohm	V06PB104	C559	254 4524 943	Electrolytic 1 $\mu$ F/50V	CE04W1H010M(SMG/RE3)
<b>CAPACITORS GROUP</b>				C561	257 0012 966	Ceramic chip 0.01 $\mu$ F/50V	CK73F1H103Z
C501,502	257 0008 983	Ceramic chip 1000pF/50V	CK73B1H102K	C562	257 0014 935	Ceramic chip 0.1 $\mu$ F/25V	CK73F1E104Z
C503~305	257 0010 900	Ceramic chip 0.01 $\mu$ F/50V	CK73B1H103K	C570	254 4538 900	Electrolytic 10 $\mu$ F/16V	CE04W1C100M(SMG/RE3)
C507,308	257 0010 900	Ceramic chip 0.01 $\mu$ F/50V	CK73B1H103K	C571	254 4524 943	Electrolytic 1 $\mu$ F/50V	CE04W1H010M(SMG/RE3)
C509	257 0002 947	Ceramic chip 12pF/50V	CC73SL1H120J	C574	257 0004 961	Ceramic chip 100pF/50V	CC73SL1H101J
C510	257 0010 900	Ceramic chip 0.01 $\mu$ F/50V	CK73B1H103K	C575	257 0012 966	Ceramic chip 0.01 $\mu$ F/50V	CK73F1H103Z
C511	254 4538 939	Electrolytic 47 $\mu$ F/16V	CE04W1C470M(SMG/RE3)	C576	257 0008 983	Ceramic chip 1000pF/50V	CK73B1H102K
C512	257 0010 900	Ceramic chip 0.01 $\mu$ F/50V	CK73B1H103K				for E1,E1H
C513	254 4524 943	Electrolytic 1 $\mu$ F/50V	CE04W1H010M(SMG/RE3)	C721,722	255 1264 908	Mylar film 1000pF/50V	CQ93M1H102J(B)
C514	257 0012 966	Ceramic chip 0.01 $\mu$ F/50V	CK73F1H103Z	C723	253 9039 906	Ceramic 0.1 $\mu$ F/25V	CK45~1E104Z
C515	254 4538 939	Electrolytic 47 $\mu$ F/16V	CE04W1C470M(SMG/RE3)	C813,814	254 4538 913	Electrolytic 22 $\mu$ F/16V	CE04W1C220M(SMG/RE3)
C516,517	257 0010 900	Ceramic chip 0.01 $\mu$ F/50V	CK73B1H103K	C817~820	254 4538 913	Electrolytic 22 $\mu$ F/16V	CE04W1C220M(SMG/RE3)
				C823,824	254 4538 913	Electrolytic 22 $\mu$ F/16V	CE04W1C220M(SMG/RE3)

Ref. No.	Part No.	Part Name	Remarks	Ref. No.	Part No.	Part Name	Remarks	Q'ty
C825,826	254 4538 942	Electrolytic 100μF/16V	CE04W1C101M(SMG/RE3) for E2	<b>OTHER PARTS GROUP</b>				
C825,826	254 4538 913	Electrolytic 22μF/16V	CE04W1C220M(SMG/RE3) for E3,EU,E1,E1C,E1H,E3T	CF501	261 0146 006	Ceramic filter FMCFSK107M2-A	for E2	1
C829,830	254 4524 985	Electrolytic 10μF/50V	CE04W1H100M(SMG/RE3)	CF501	261 0135 907	Ceramic filter MA8	for E3,EU,E1, E1C,E1H,E3T	1
C831~834	253 1179 945	Ceramic 220pF/50V	CK45B1H221K	CF502	261 0146 006	Ceramic filter FMCFSK107M2-A	for E2	1
C835,836	254 4538 955	Electrolytic 220μF/16V	CE04W1C221M(SMG/RE3) for E2	CF502	261 0136 906	Ceramic filter MS2G	for E3,EU,E1, E1C,E1H,E3T	1
C835,836	254 4538 939	Electrolytic 47μF/16V	CE04W1C470M(SMG/RE3) for E3,EU,E1,E1C,E1H,E3T	CF503	261 0079 005	Ceramic resonator	CSB456F11	1
C837,838	255 1264 966	Mylar film 3300pF/50V	CQ93M1H332J(B)	CF504	261 0031 001	Ceramic filter BFU450C4		1
C839,840	253 4482 901	Ceramic 33pF/500V	CC45SL2H330J	CF505	261 0116 007	Ceramic filter SFU450B3		1
C841,842	254 4538 913	Electrolytic 22μF/16V	CE04W1C220M(SMG/RE3)	CW054~057	205 0885 008	5P connector socket (TUC-P)		4
C845,846	254 4524 985	Electrolytic 10μF/50V	CE04W1H100M(SMG/RE3)	CW065	205 0942 019	6P connector socket (TUC-P)		1
C847~850	253 1179 945	Ceramic 220pF/50V	CK45B1H221K	CW073	205 1081 018	7P FJ connector base		1
C851,852	254 4538 939	Electrolytic 47μF/16V	CE04W1C470M(SMG/RE3)	CW074	205 0942 022	7P connector socket (TUC-P)		1
C853,854	255 1264 966	Mylar film 3300pF/50V	CQ93M1H332J(B)	CW075,076	205 1081 018	7P FJ connector base		1
C855,856	253 4482 901	Ceramic 33pF/500V	CC45SL2H330J	CW117	205 0885 066	11P connector socket (TUC-P)		1
C859	254 4524 985	Electrolytic 10μF/50V	CE04W1H100M(SMG/RE3)	CW151	205 0885 040	15P connector socket (TUC-P)		1
C860	254 4538 913	Electrolytic 22μF/16V	CE04W1C220M(SMG/RE3)	CX037	205 0343 032	3P connector base(KR-PH)	for E3,EU	1
C862	254 4524 985	Electrolytic 10μF/50V	CE04W1H100M(SMG/RE3)	CX087	205 1120 089	8P connector base(5267)		1
C863,864	253 1179 945	Ceramic 220pF/50V	CK45B1H221K	CX101	205 1081 005	10P FJ connector base		1
C865	254 4538 939	Electrolytic 47μF/16V	CE04W1C470M(SMG/RE3)	CX156	205 0884 041	15P connector base (TUC-P)		1
C866	255 1264 966	Mylar film 3300pF/50V	CQ93M1H332J(B)	CY031	205 0343 032	3P connector base(KR-PH)		1
C867	253 4482 901	Ceramic 33pF/500V	CC45SL2H330J	CY037	205 0343 032	3P connector base(KR-PH)	for E3,EU	1
C914,915	253 1181 904	Ceramic 0.01μF/50V	CK45F1H103Z	Δ F11~14	206 1039 076	Fuse 2.5A	for E3,EU,E3T	4
C937	254 4538 939	Electrolytic 47μF/16V	CE04W1C470M(SMG/RE3)	Δ F11~14	206 1015 032	Fuse 2.5A	for E2,E1,E1C,E1H	4
C938	253 9039 906	Ceramic 0.1μF/25V	CK45=1E104Z	FB501	235 0049 900	Beads inductor		1
C939~941	253 1181 904	Ceramic 0.01μF/50V	CK45F1H103Z	FF901~904	202 0040 909	Fuse clip		4
C943~944	253 1181 904	Ceramic 0.01μF/50V	CK45F1H103Z	FH901-904	202 0040 909	Fuse clip		4
C946	254 4541 939	Electrolytic 47μF/25V	CE04W1E470M(SMG/RE3)	JK501	205 0847 004	3P antenna terminal (PAL/F)		1
C947~950	254 4541 939	Electrolytic 47μF/25V	CE04W1E470M(SMG/RE3)	JK702	204 8264 071	Headphone jack (GOLD)	for E1,E1H	1
C951~952	254 4524 943	Electrolytic 1μF/50V	CE04W1H010M(SMG/RE3)	JK702	204 8264 013	Headphone jack (NI)	for E3,EU,E2, E1C,E3T	1
C954,955	254 4524 943	Electrolytic 1μF/50V	CE04W1H010M(SMG/RE3)	L504	235 0060 905	Inductor 2.2μH		1
C957,958	254 4406 702	Electrolytic 3300μF/16V	CE04W1C332M(SMG)	LF501	232 9010 009	Antibirdie filter	for E2	1
C959	254 4524 943	Electrolytic 1μF/50V	CE04W1H010M(SMG/RE3)	LF503,504	232 0085 004	LPF	for E2	2
C960,961	253 1181 904	Ceramic 0.01μF/50V	CK45F1H103Z	S901	212 0373 000	Rotary encorder EC16B		1
C962	254 4403 705	Electrolytic 6800μF/25V	CE04W1E682M(SMG)	S902,903	212 5611 903	Tact switch		2
C963	254 4403 718	Electrolytic 1000μF/25V	CE04W1E102M(SMG)	S905	212 5611 903	Tact switch		1
C965~968	256 1058 971	Metallized 0.1μF/50V	CF93A1H104J(JL)	SW901	212 0420 005	1P push switch	for E3,EU	1
C969,970	254 4524 943	Electrolytic 1μF/50V	CE04W1H010M(SMG/RE3)					
C975,976	254 4524 943	Electrolytic 1μF/50V	CE04W1H010M(SMG/RE3)					

1U-3236 VOLTAGE SEL. UNIT ASS'Y

Ref. No.	Part No.	Part Name	Remarks	Q'ty	Ref. No.	Part No.	Part Name	Remarks	Q'ty
T501	231 2096 001	MW ant.-osc. coil		1	<b>OTHER PARTS GROUP</b>				
T502	231 2085 009	FM DET trans.		1	CX042	205 0581 030	4P VH connector base	for E1,E1H	1
T503	231 1138 009	AM IFT		1	<del>FF901</del>	<del>202 0040 909</del>	<del>Fuse 2.5A</del>	for E1,E1H	1
TP102	205 0133 035	3 P NH connector base		1	FF901	202 0040 909	Fuse clip	for E1,E1H	1
W712	203 0526 002	1P contact Ass'y		1	FH901	202 0040 909	Fuse clip	for E1,E1H	1
W726	205 1034 010	M3 Screw terminal		1	<del>SS801</del>	<del>212 4810 006</del>	<del>Slide switch</del>	for E1,E1H	1
XL503	399 0075 003	Crystal 7.2MHz		1		513 2585 074	Fuse label	for E1,E1H	1
S501	212 0408 001	Slide switch	for E1,E1H	1					
	203 0356 010	Earth wire		1					
	415 0309 026	P.V.C. tube (L=20)		2					
	513 2585 074	Fuse label	for E2,E1,E1C,E1H	4					

Note: The symbols in the column "Remarks" indicate the following destinations.  
 E3: U.S.A. & Canada model      E1C: China model  
 EU: U.S.A. model (AVR-87)      E1H: Hong Kong model  
 E2: Europe model      E3T: Taiwan R.O.C. model  
 E1: Asia model

**PARTS LIST OF EXPLODED VIEW**

Ref. No.	Part No.	Part Name	Remarks	Q'ty	Ref. No.	Part No.	Part Name	Remarks	Q'ty
1	Note	Power unit Ass'y		1	46	102 0603 033	Top cover	Gold model	1
1-1		Power unit			47	—	Insulating sheet		10
1-2		C.video unit			48	513 3337 001	Caution label	for E3,EU	1
2	Note	EXT.in unit Ass'y		1	49	412 2955 107	Side bracket	for E2,E1,E1C,E1H	1
2-1		EXT.in volume unit			A 50	203 9942 007	AC outlet	for E2,E1,E1H	1
2-2		Display unit			51	412 4556 009	Earth plate(B)		1
2-3		Volume unit			52	412 4557 008	Earth plate(A)		1
2-4		Power switch unit			★ 53	Note	Rating label/sheet		1
3	Note	Control unit Ass'y		1	54	146 2151 004	Blind sheet	Gold model	1
3-1		Control unit			★ 55	203 4871 067	3P KR-KR ribbon wire 175	CN031 for CX,CY031 H/P	1
3-2		Connect unit			★ 56	203 4871 038	3P KR-KR ribbon wire 100	CN037 for CX,CY037 P/5W for E3,EU	1
3-3		Preout unit			★ 57	445 8004 007	Wire clasper.		3
3-4		Digital in-1 unit			★ 58	477 0096 007	Push rivet	for SP terminal	14
3-5		Digital in-2 unit			★ 59	515 8030 040	Preset label	for AC cord for E1,E1H	1
4	Note	Regulator unit Ass'y		1	★ 60	Note	Caution label		1
4-1		Regulator unit			★ 61	513 2481 000	Serial no.sheet	for E3T	1
4-2		Amp. unit			<b>SCREWS &amp; NUTS</b>				
4-3		H/P & P.SW unit			101	473 7500 015	Screw 3x8 CBTS(P)-Z		19
4-4		Front unit			102	473 7501 001	Screw 3x10 CBTS(P)-Z		10
4-5		Tuner unit			103	473 7501 030	Screw 3x20 CBTS(P)-Z		1
5	Note	Audio/DSP unit Ass'y		1	104	473 7015 018	Screw 3x8 CBTS(S)-B		Note
7	1U-3236A	Voltage SEL. unit Ass'y	for E1,E1H	1	105	473 7005 002	Screw 3x10 CBTS(S)-Z		28
11	411 1372 526	Main chassis		1	106	473 8007 009	Cup screw 3x12		10
13	412 4210 002	Bracket		2	107	473 7004 016	Screw 4x6 CBTS(S)-Z		4
14	104 0194 205	Foot Ass'y		4	108	473 8064 000	Screw 4x8 CBTS(B)-B-3P	Black model	6
15	449 0133 017	P.W.B. holder		Note	108	473 8064 013	Screw 4x8 CBTS(B)-N-3P	Gold model	6
16	412 3548 005	P.W.B. catcher		1	109	477 0064 107	Fixing screw		Note
A 17	Note	AC cord		1	111	473 7006 056	Screw 3x20 CBTS(S)-B		1
18	412 2814 028	Card spacer (L=10)		Note					
20	409 0052 019	Holder (A)		2					
21	Note	Back panel		1					
22	445 0056 008	Cord bush		1					
23	205 1116 006	Terminal Ass'y		1					
24	146 2139 220	Inner panel	Black model	1					
24	146 2139 233	Inner panel	Gold model	1					
26	475 6124 003	12 Nut		1					
27	—	9 Nut		3					
28	Note	Front panel Ass'y		1					
32	417 0588 005	Radiator		1					
33	273 0389 031	Transistor 2SC3855 LB(O/P/Y)(Z)	TR515,516,535,536,548	5					
34	271 0240 035	Transistor 2SA1491 LB(O/P/Y)(Z)	TR517,518,537,538,549	5					
35	412 4127 001	P.W.B.bracket(B)		2					
39	412 2741 007	P.W.B.holder (H=8)		1					
40	412 4296 107	Radiator bracket		1					
A 41	Note	Power trans. (Main)		1					
42	112 0844 006	Knob (M) Ass'y	Black model	1					
42	112 0844 019	Knob (M) Ass'y	Gold model	1					
43	112 0846 004	Knob (F) Ass'y	Black model	1					
43	112 0846 017	Knob (F) Ass'y	Gold model	1					
44	112 0848 002	Knob (S) Ass'y	Black model	1					
44	112 0848 015	Knob (S) Ass'y	Gold model	1					
45	113 1873 105	Push knob	Black model	1					
45	113 1873 118	Push knob	Gold model	1					
46	102 0603 020	Top cover	Black model	1					

# EXPLODED VIEW

**WARNING:**  
 Parts marked with this symbol  have critical characteristics.  
 Use ONLY replacement parts recommended by the manufacturer.

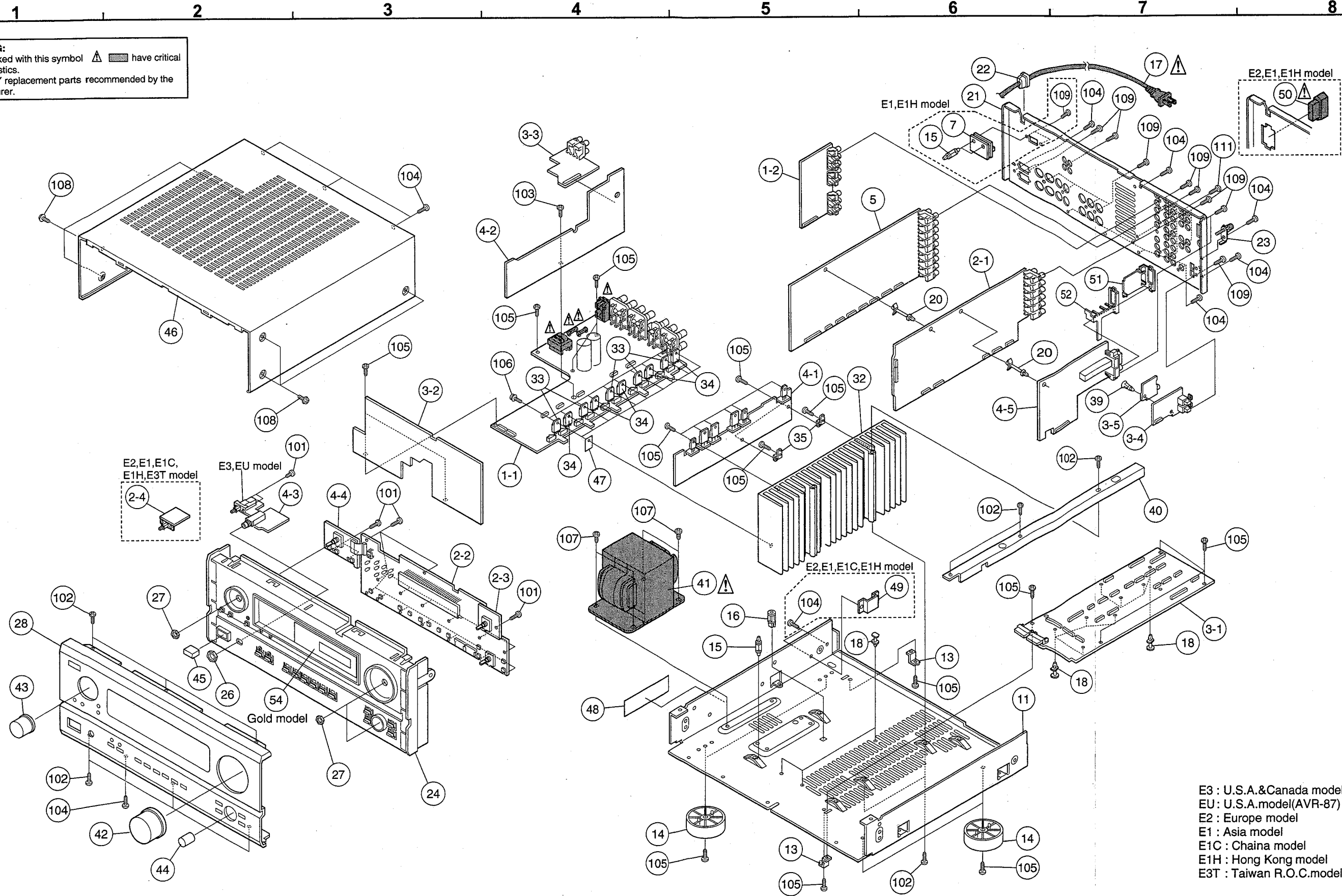

- E3 : U.S.A.&Canada model
- EU : U.S.A.model(AVR-87)
- E2 : Europe model
- E1 : Asia model
- E1C : China model
- E1H : Hong Kong model
- E3T : Taiwan R.O.C.model

**ADDENDUM PARTS LIST OF EXPLODED VIEW**

Ref. No.	Part Name	U.S.A. & Canada Model		U.S.A. Model (AVR-87)		Europe Model		Asia Model		China Model		Hong Kong Model		Taiwan R.O.C. Model		Remarks
		Part No.	Q'ty	Part No.	Q'ty	Part No.	Q'ty	Part No.	Q'ty	Part No.	Q'ty	Part No.	Q'ty	Part No.	Q'ty	
1	Power unit Ass'y	1U-3232H		1U-3232H		1U-3232K		1U-3232L		1U-3232M		1U-3232P		1U-3232J		
1-1	Power unit															
1-2	C.video unit															
2	EXT.in unit Ass'y	1U-3233H		1U-3233H		1U-3233K		1U-3233L		1U-3233M		1U-3233L		1U-3233J		
2-1	EXT.in volume unit															
2-2	Display unit															
2-3	Volume unit															
2-4	Power switch unit	—		—												
3	Control unit Ass'y	1U-3234H		1U-3234H		1U-3234K		1U-3234L		1U-3234M		1U-3234L		1U-3234J		
3-1	Control unit															
3-2	Connect unit															
3-3	Preout unit															
3-4	Digital in-1 unit															
3-5	Digital in-2 unit															
4	Regulator unit Ass'y	1U-3235H		1U-3235H		1U-3235K		1U-3235L		1U-3235M		1U-3235L		1U-3235J		
4-1	Regulator unit															
4-2	Amp. unit															
4-3	H/P & P.SW unit															
4-4	Front unit															
4-5	Tuner unit															
5	Audio/DSP unit Ass'y	1U-3197H		1U-3197H		1U-3197K		1U-3197L		1U-3197M		1U-3197L		1U-3197J		
15	P.W.B. holder	449 0133 017	1	449 0133 017	1	449 0133 017	1	449 0133 017	3	449 0133 017	3	449 0133 017	3	449 0133 017	1	
17	AC cord	206 2160 009		206 2160 009		206 2089 106		206 2175 007		206 2174 008		206 2177 005		206 2160 009		
18	Card spacer (L=10)	412 2814 028	11	412 2814 028	11	412 2814 028	12	412 2814 028	11	412 2814 028	11	412 2814 028	11	412 2814 028	11	
21	Back panel	105 1316 289		105 1323 120		105 1323 104		105 1323 117		105 1323 188		105 1323 117		105 1323 162		
28	Front panel Ass'y(Black model)	144 2677 003		144 2677 016		144 2677 045		144 2677 029		144 2677 029		144 2677 029		144 2677 029		
28	Front panel Ass'y(Gold model)	—		—		144 2677 058		144 2677 032		144 2677 032		144 2677 032		144 2677 032		
41	Power trans. (Main)	233 6304 009		233 6304 009		233 6305 008		233 6306 007		233 6305 008		233 6306 007		233 6304 009		
53	Rating label(China)	—		—		—		—		513 3345 019		—		—		
53	Rating sheet(T)	—		—		—		—		—		—		513 2769 052		
60	Caution label	—		—		—		—		513 3343 008		—		513 2482 009		
<b>SCREWS &amp; NUTS</b>																
104	Screw 3X8 CBTS(S)-B	473 7015 018	10	473 7015 018	10	473 7015 018	12	473 7015 018	12	473 7015 018	12	473 7015 018	12	473 7015 018	10	
109	Fixing screw	477 0064 107	29	477 0064 107	29	477 0064 107	25	477 0064 107	29	477 0064 107	27	477 0064 107	29	477 0064 107	29	

**ADDENDUM PARTS LIST OF PACKING & ACCESSORIES**

Ref. No.	Part Name	U.S.A. & Canada Model		U.S.A. Model (AVR-87)		Europe Model		Asia Model		China Model		Hong Kong Model		Taiwan R.O.C. Model		Remarks
		Part No.	Q'ty	Part No.	Q'ty	Part No.	Q'ty	Part No.	Q'ty	Part No.	Q'ty	Part No.	Q'ty	Part No.	Q'ty	
205	Instruction manual	511 3497 000		511 3506 001		511 3524 009		511 3513 007		511 3514 006		511 3513 007		511 3513 007		
209	Remote control unit(RC-863)	399 0554 003		399 0554 003		—		399 0554 003		399 0554 003		399 0554 003		399 0554 003		
209	Remote control unit(RC-868)	—		—		399 0578 005		—		—		—		—		
211	Carton case	501 2052 009		501 2052 012		501 2052 009		501 2052 009		501 2052 009		501 2052 025		501 2052 009		



**PACKING VIEW**

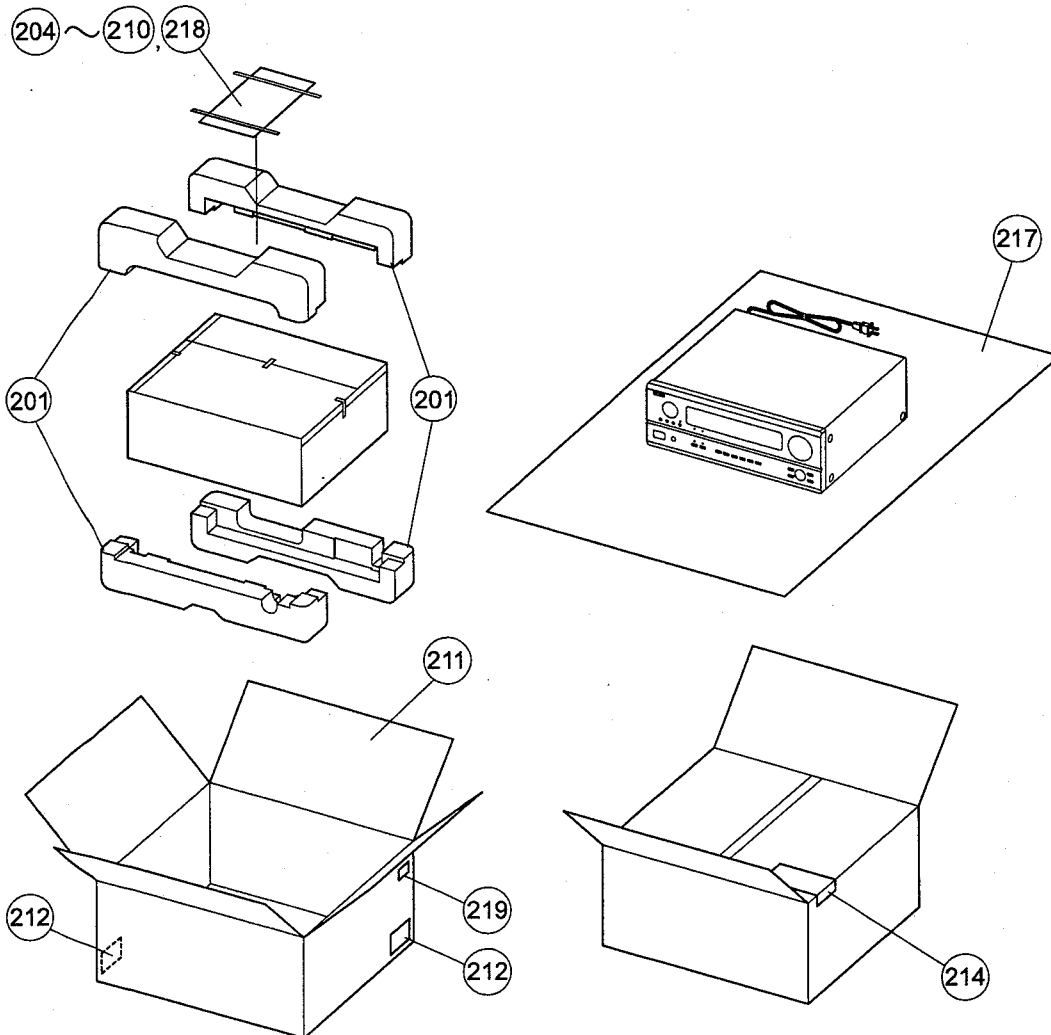

**Note:** The symbols in the column "Remarks" indicate the following destinations.  
 E3: U.S.A. & Canada model      E1C: China model  
 EU: U.S.A. model (AVR-87)      E1H: Hong Kong model  
 E2: Europe model      E3T: Taiwan R.O.C. model  
 E1: Asia model

**PARTS LIST OF PACKING & ACCESSORIES**

Ref. No.	Part No.	Part Name	Remarks	Q'ty	Ref. No.	Part No.	Part Name	Remarks	Q'ty
201	503 1330 003	Cushion Ass'y		1	211	Note	Carton case		1
★ 202	503 1333 000	Cushion	for E1H	1	212	513 1389 006	Control card		1
204	505 8006 019	Envelope		1	214	515 0690 307	DEL warranty home	for E3,EU	1
205	Note	Instruction manual		1	★ 215	513 9111 001	Color label (gold)	Gold model	2
206	231 0922 009	Loop antenna		1	217	504 0192 009	Cabinet sheet		1
207	395 0023 008	FM antenna Ass'y		1	218	—	Battery(R6P/AA×3)		1
208	529 0079 008	FM ant.adapter		1	219	513 3327 008	Bar code label	for E3,EU,E2	1
209	Note	Remote control unit		1	★ 220	513 3322 003	Label(RDS)	for E2	2
210	515 0671 708	S.S. list (EX)		1	★ 221	513 3195 036	KOLIN label(T)	for E3T	1

**MEMO:**

BLOCK DIAGRAM

1 2 3 4 5 6

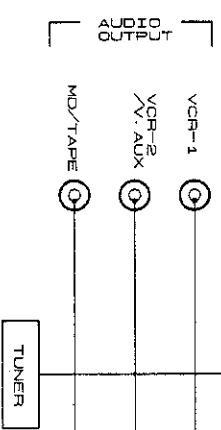
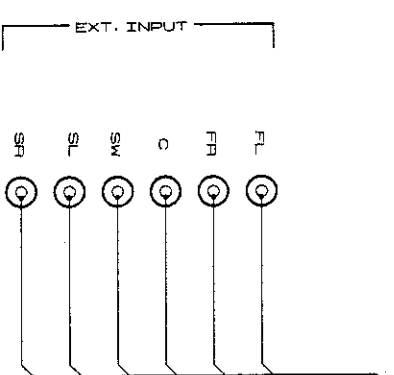
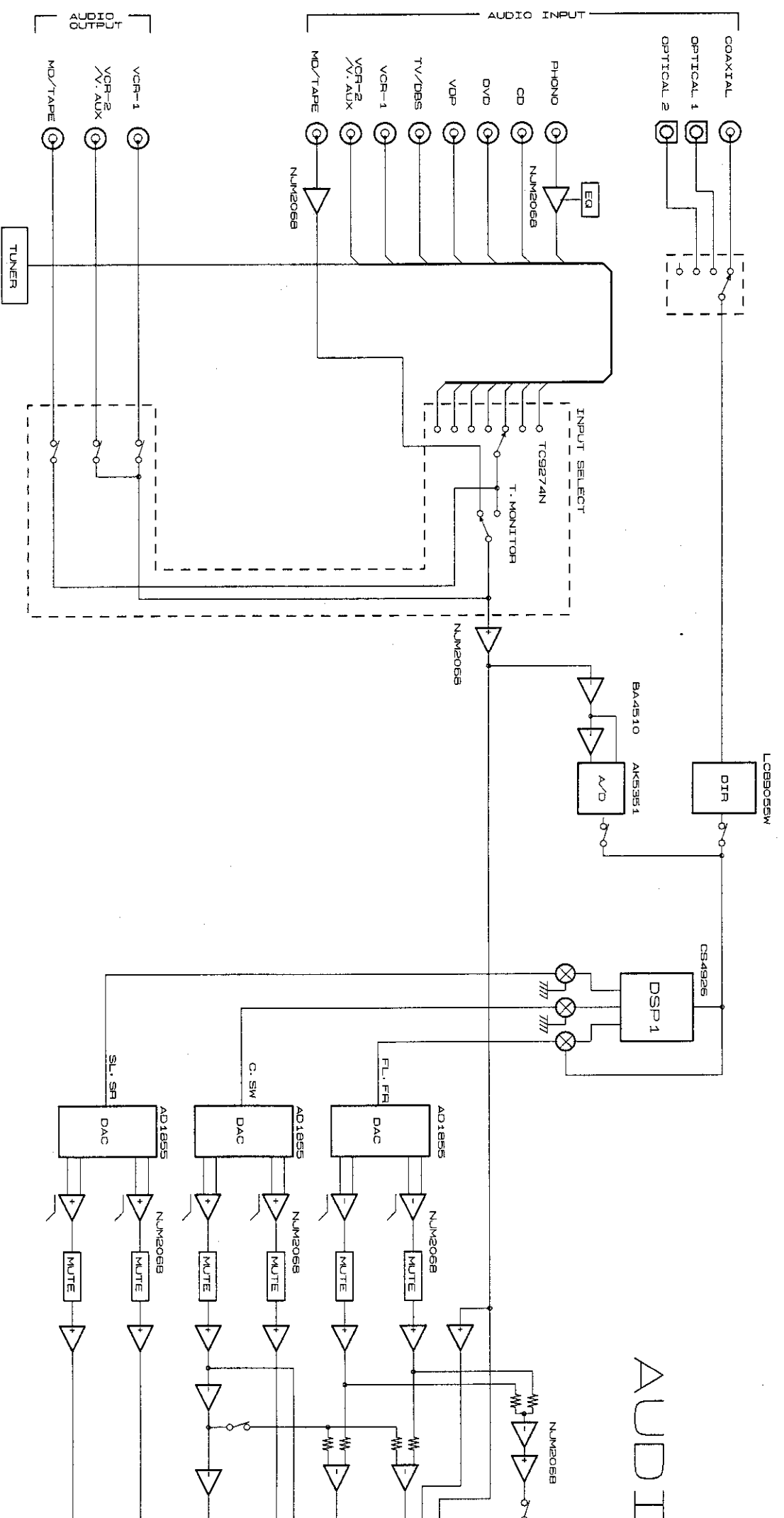
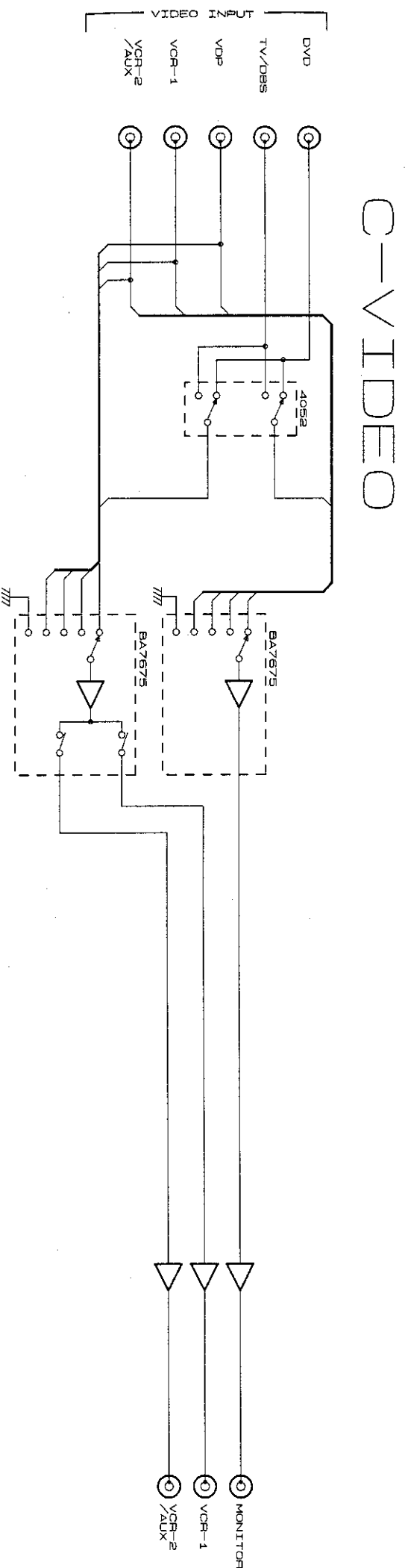

7 8 9 10 11

MONITOR  
YCR-1  
YCR-2  
YDUX  
VIDEO OUT

# AUDIO SIGNAL

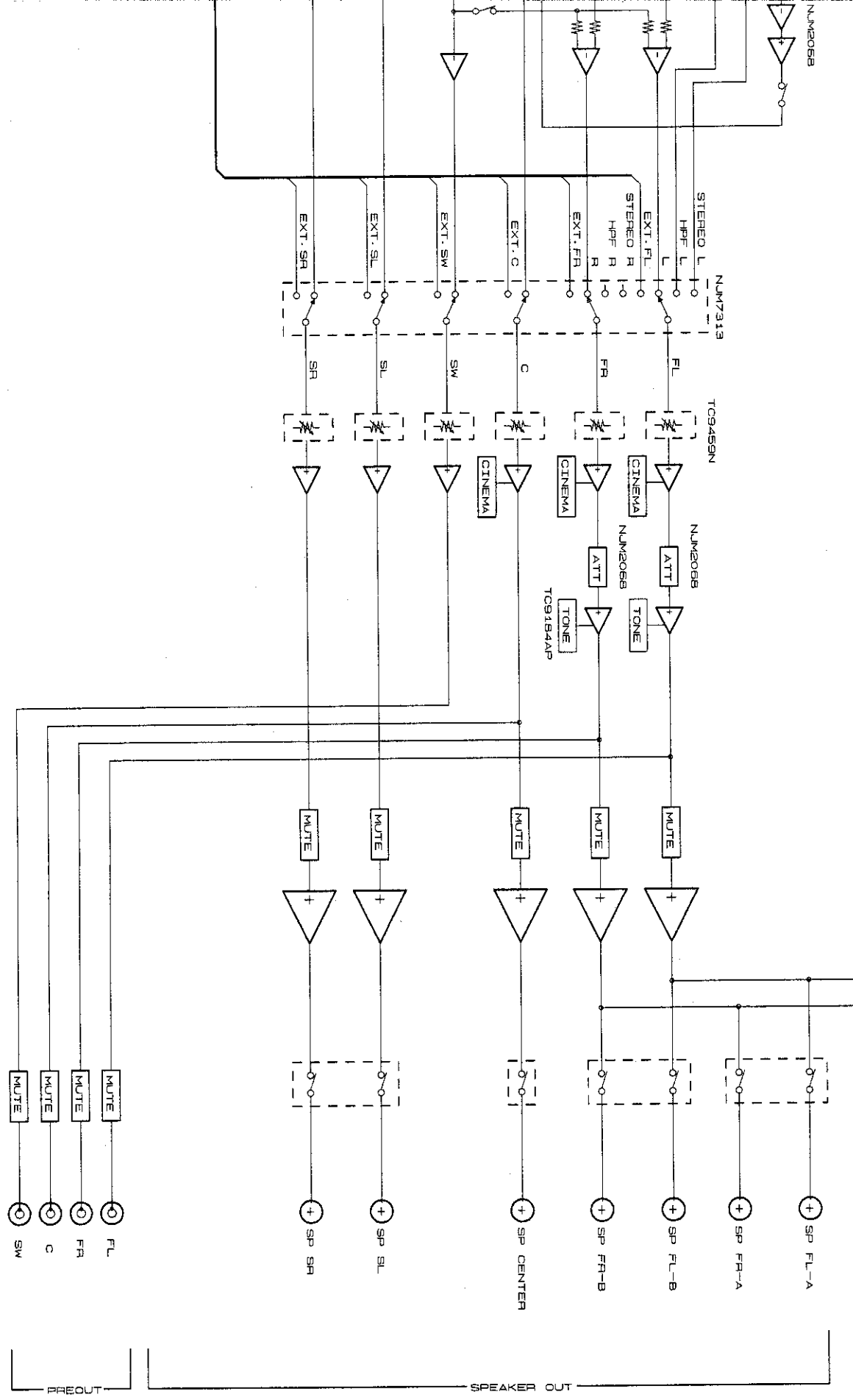

A B C D E F G H

WIRING DIAGRAM

1 2 3 4 5 6

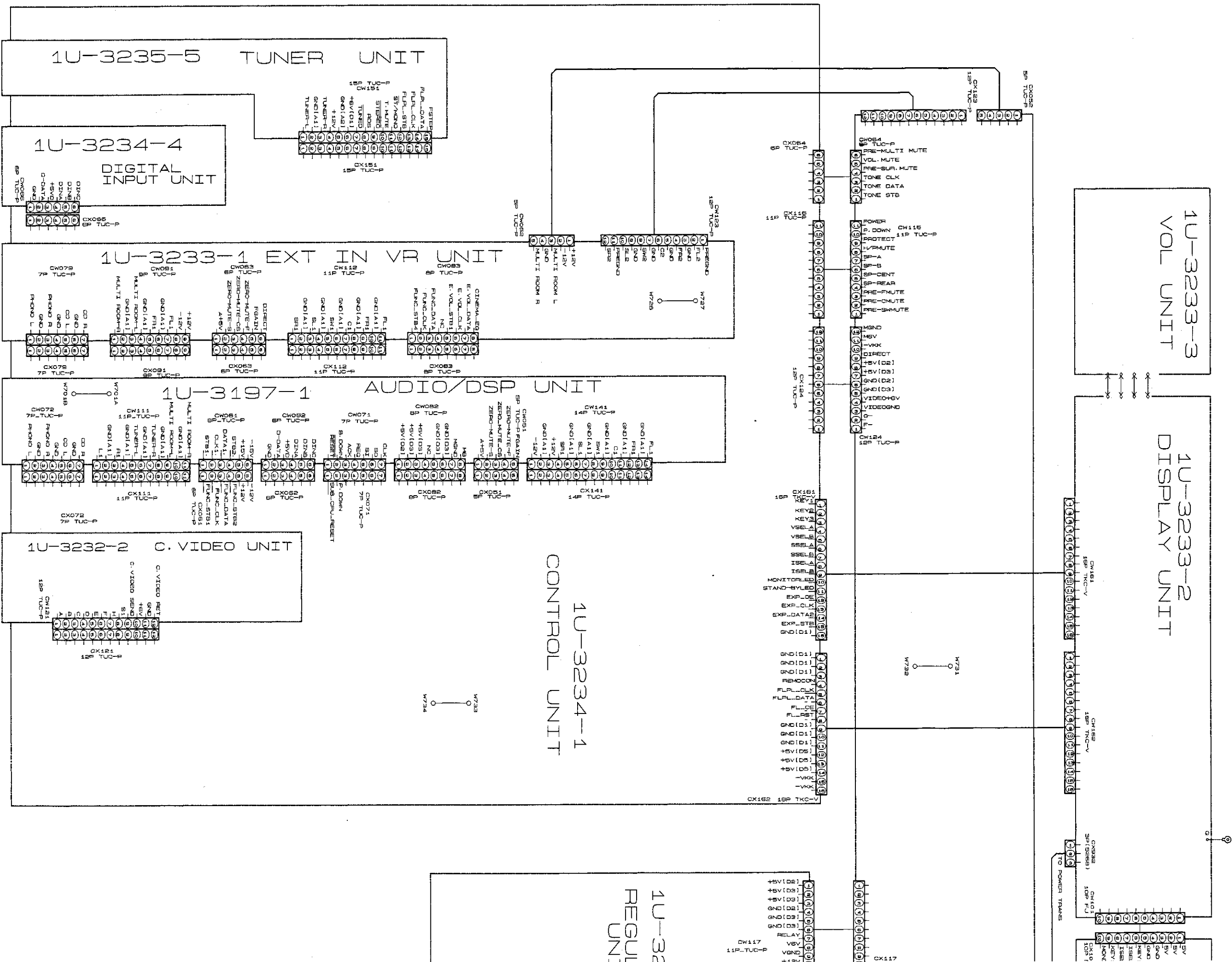

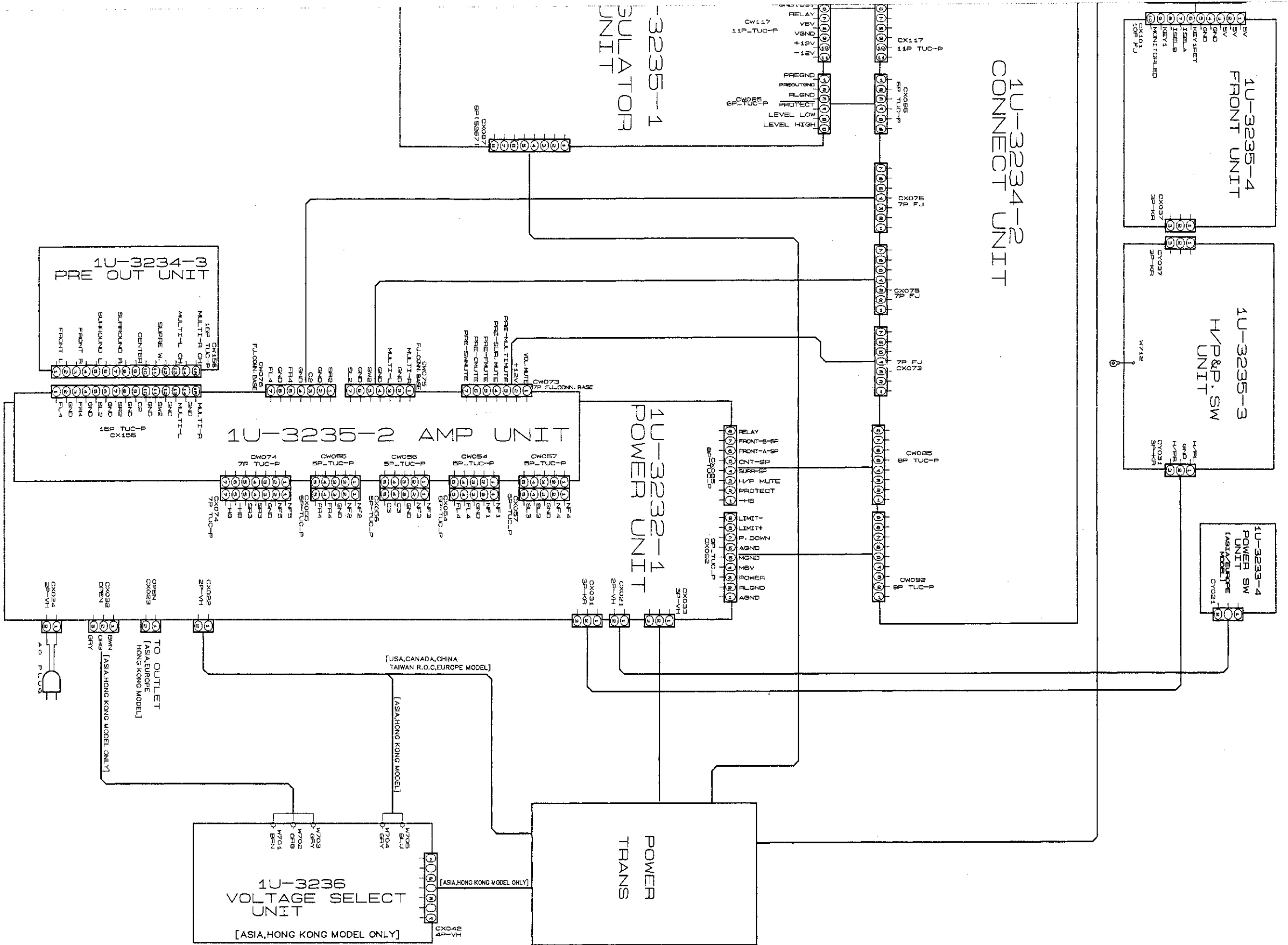

1U-3234-2  
CONNECT UNIT

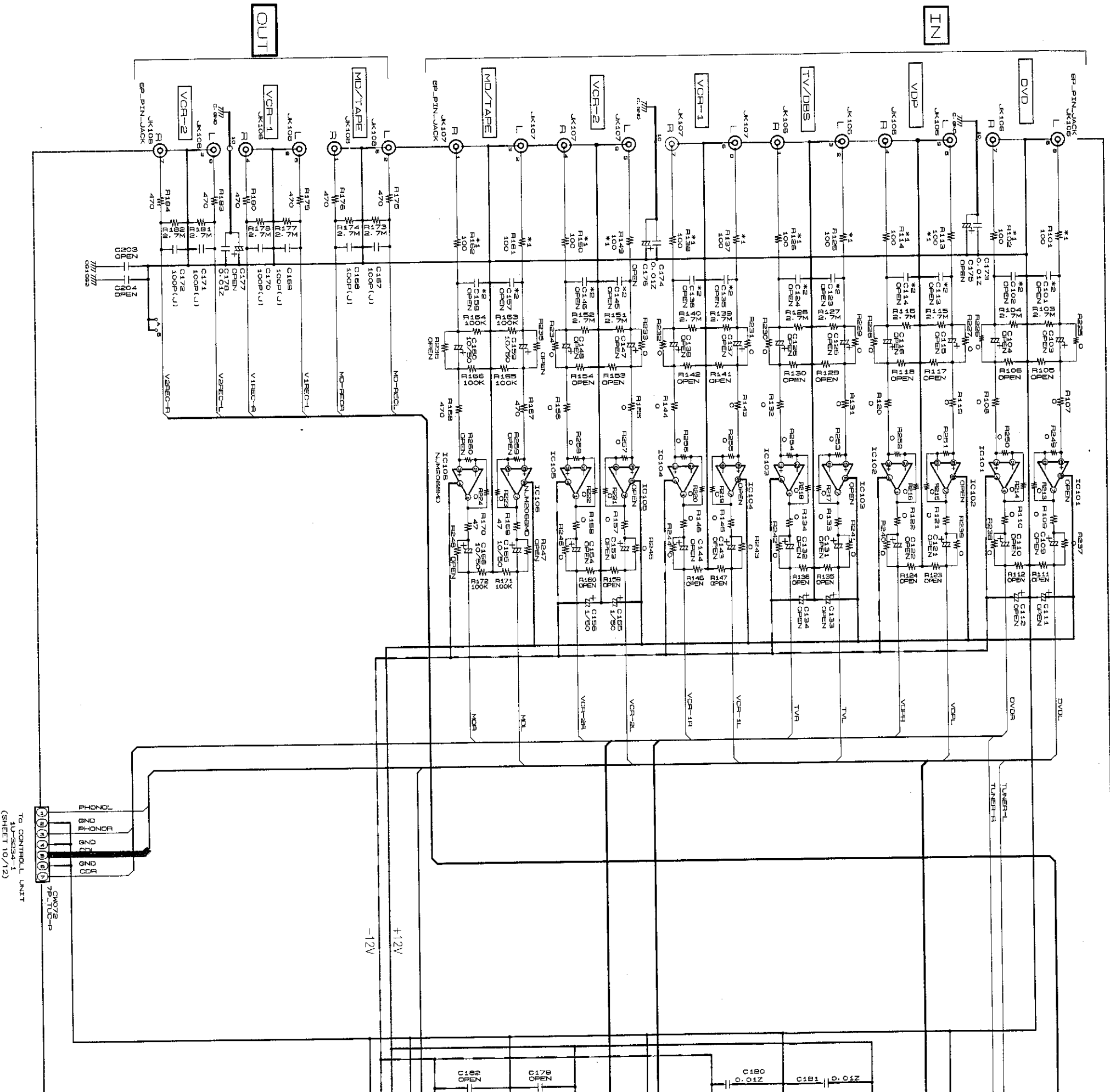

	*1	*2	*3
* USA	R101, 100	C101, 100P(U)	C199, 100
* CANADA	R101, 100	C101, 100P(U)	C199, 100
* ASIA	R101, 100	C101, 100P(U)	C199, 100
* EUROPE	R101, 100	C101, 100P(U)	C199, 100

**NOTICE**  
 ALL RESISTANCE VALUES IN OHM. K=1,000 OHM M=1,000,000 OHM  
 ALL CAPACITANCE VALUES IN MICRO FARAD. P=MICRO-MICRO FARAD  
 EACH VOLTAGE AND CURRENT ARE MEASURED AT NO SIGNAL INPUT  
 CONDITION.  
 CIRCUIT AND PARTS ARE SUBJECT TO CHANGE WITHOUT PRIOR  
 NOTICE.



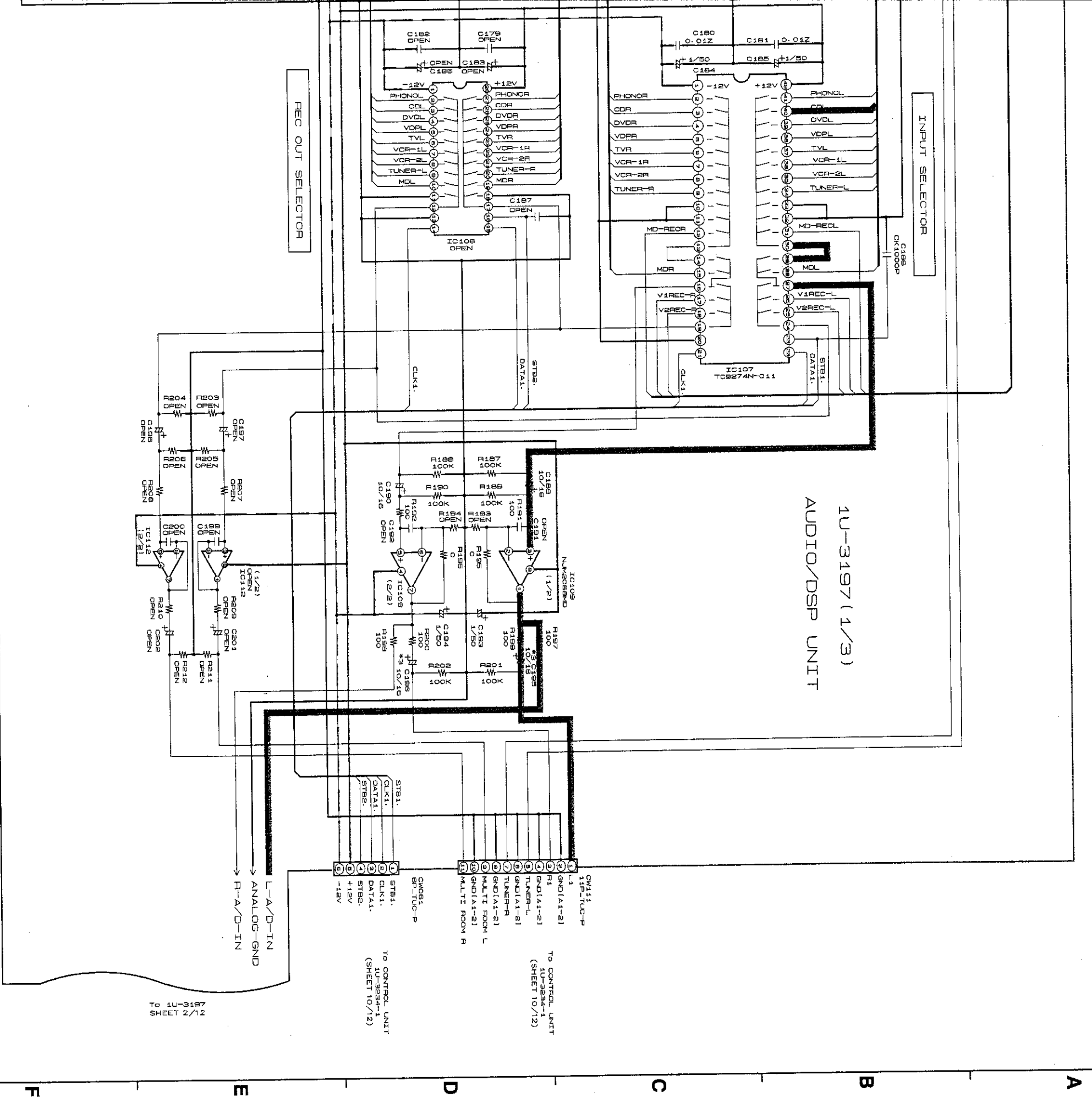

\_\_\_\_\_ +B LINE  
 - - - - - -B LINE  
 \_\_\_\_\_ SIGNAL LINE

**WARNING:** Parts marked with this symbol  have critical characteristics. Use ONLY replacement parts recommended by the manufacturer.

**CAUTION:** Before returning the unit to the customer, make sure you make either (1) a leakage current check or (2) a line to chassis resistance check. If the leakage current exceeds 0.5 milliamperes, or if the resistance from chassis to either side of the power cord is less than 460 Kohms, the unit is defective.

**WARNING:** DO NOT return the unit to the customer until the problem is located and corrected.

SCHEMATIC DIAGRAMS (1/12)  
1U-3197 AUDIO / DSP UNIT (1/3)

SCHEMATIC DIAGRAMS

1 2 3 4 5 6

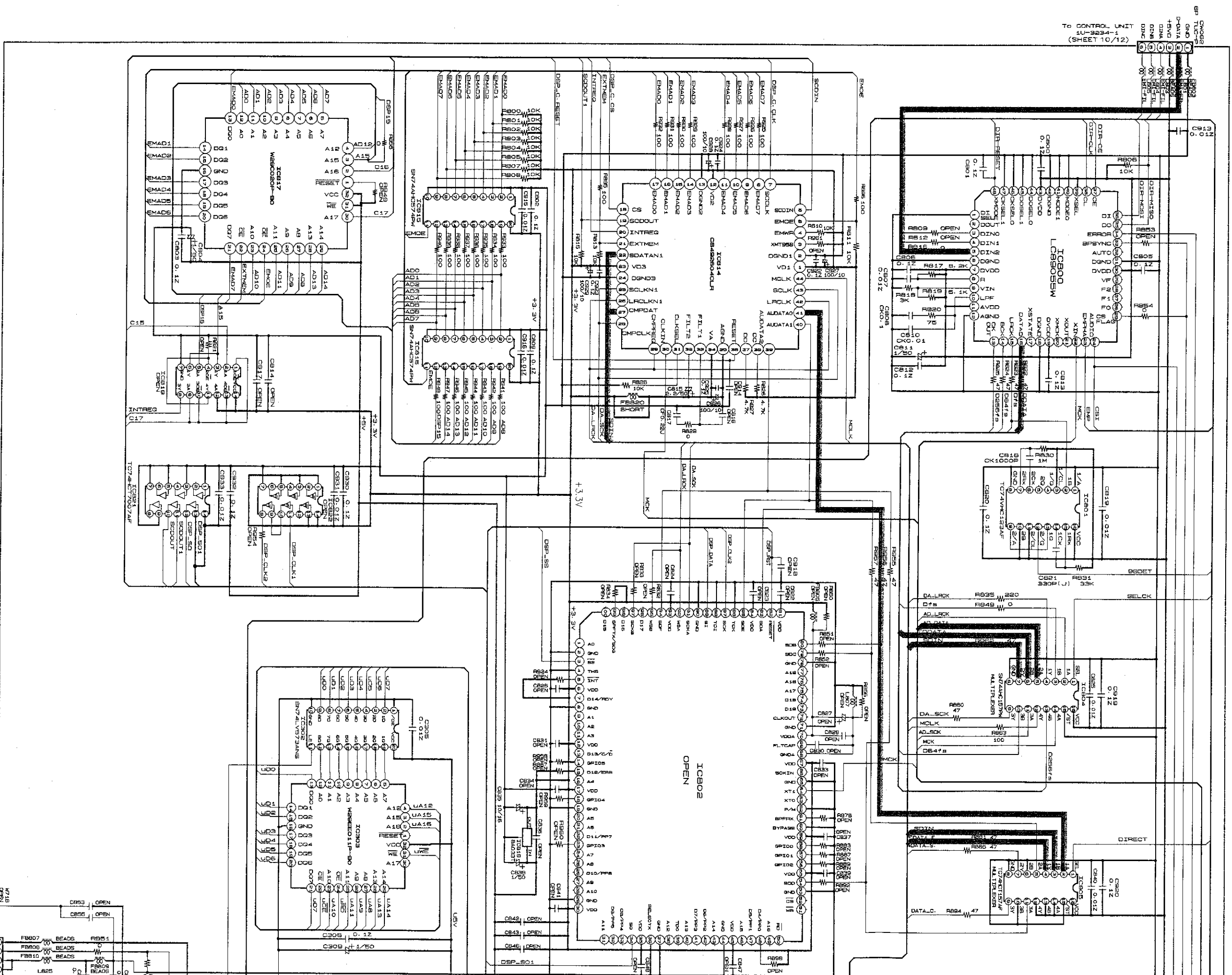

**NOTICE**  
 ALL RESISTANCE VALUES IN OHM, K=1,000 OHM, M=1,000,000 OHM  
 ALL CAPACITANCE VALUES IN MICRO FARAD. P=MICRO-MICRO FARAD  
 EACH VOLTAGE AND CURRENT ARE MEASURED AT NO SIGNAL INPUT  
 CONDITION.  
 CIRCUIT AND PARTS ARE SUBJECT TO CHANGE WITHOUT PRIOR  
 NOTICE.

**WARNING:**  
 Parts marked with this symbol  have critical characteristics.  
 Use ONLY replacement parts recommended by the manufacturer.  
**CAUTION:**  
 Before returning the unit to the customer, make sure you make either (1) a  
 leakage current check or (2) a line to chassis resistance check. If the leakage  
 current exceeds 0.5 milliamperes, or if the resistance from chassis to either side  
 of the power cord is less than 460 kohms, the unit is defective.  
**WARNING:**  
 DO NOT return the unit to the customer until the problem is located and  
 corrected.

TO CONTROL UNIT  
 1U-2234-1  
 (SHEET 10/12)

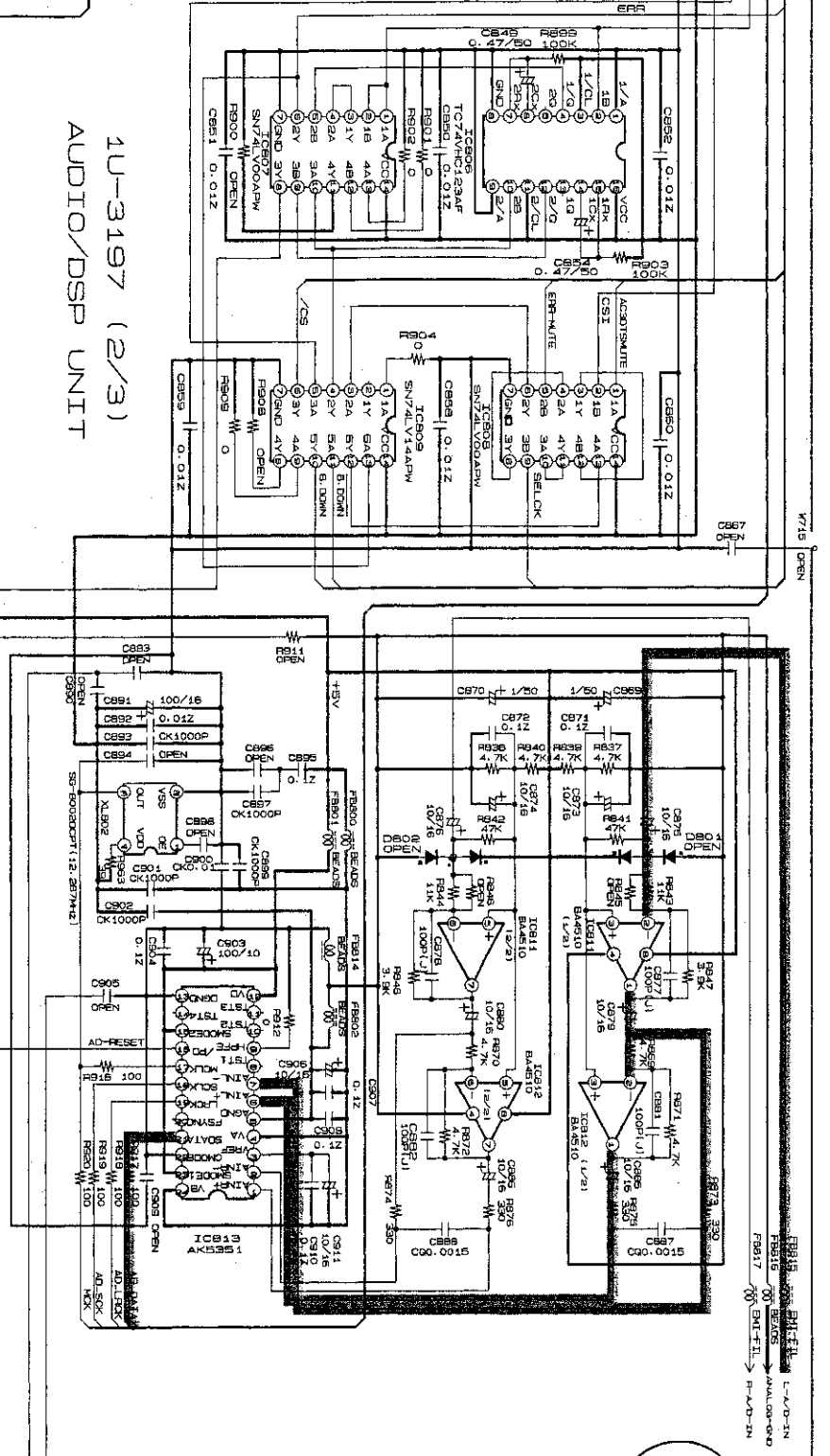

1U-3197 (2/3)  
AUDIO/DSP UNIT

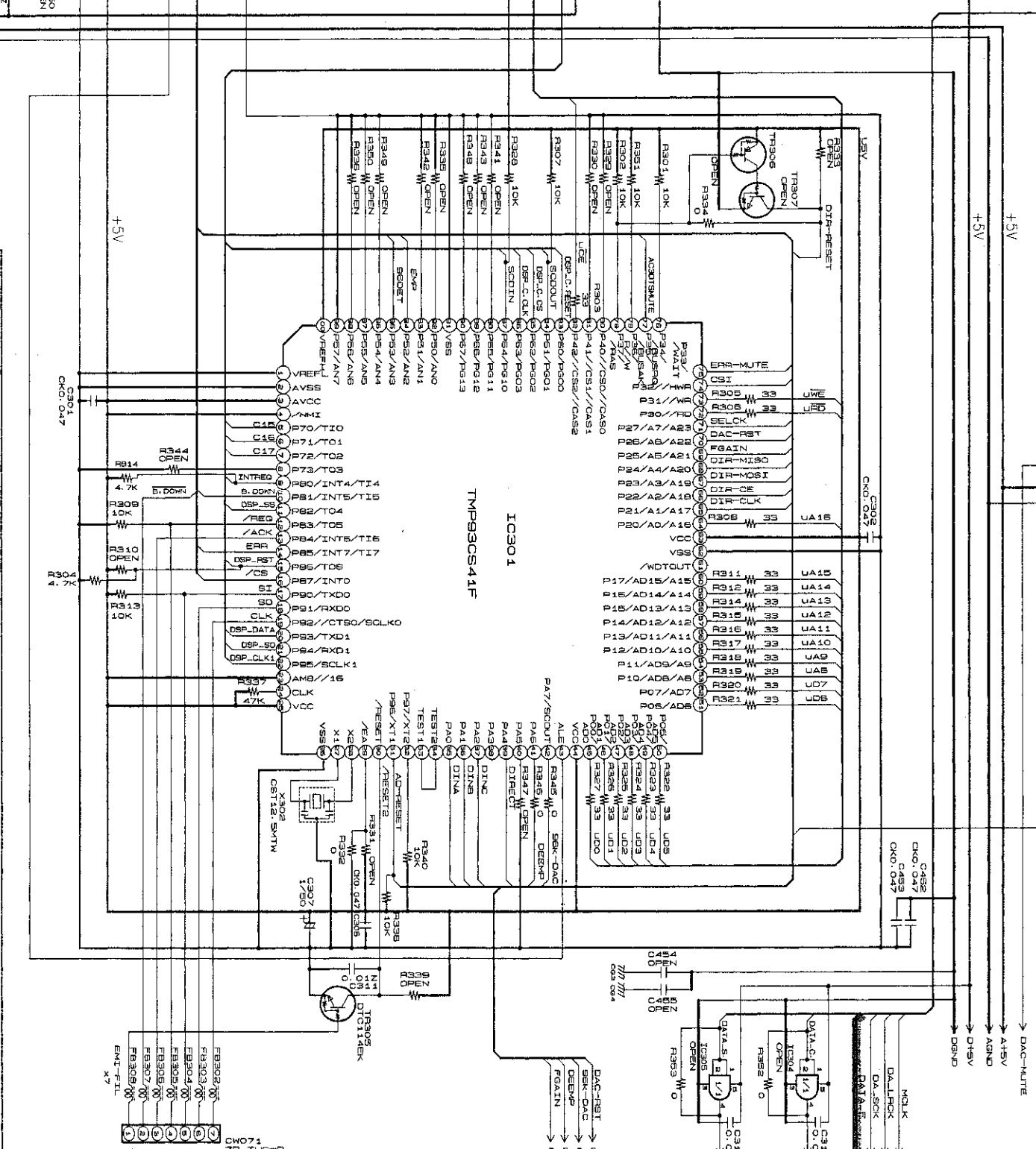

TO CONTROL UNIT  
1U-3197-1  
(SHEET 10/12)

TO AUDIO/DSP UNIT  
1U-3197  
(sheet 3/12)

TO AUDIO/DSP UNIT  
1U-3197  
(sheet 3/12)

+B LINE  
SIGNAL LINE

SCHEMATIC DIAGRAMS (2/12)  
1U-3197 AUDIO / DSP UNIT (2/3)

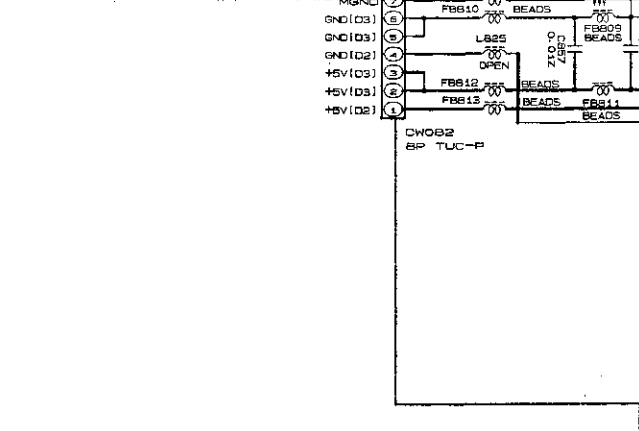

TO 1U-3197  
SHEET 1/12

1U-3197 (3/3)  
AUDIO/DSP UNIT

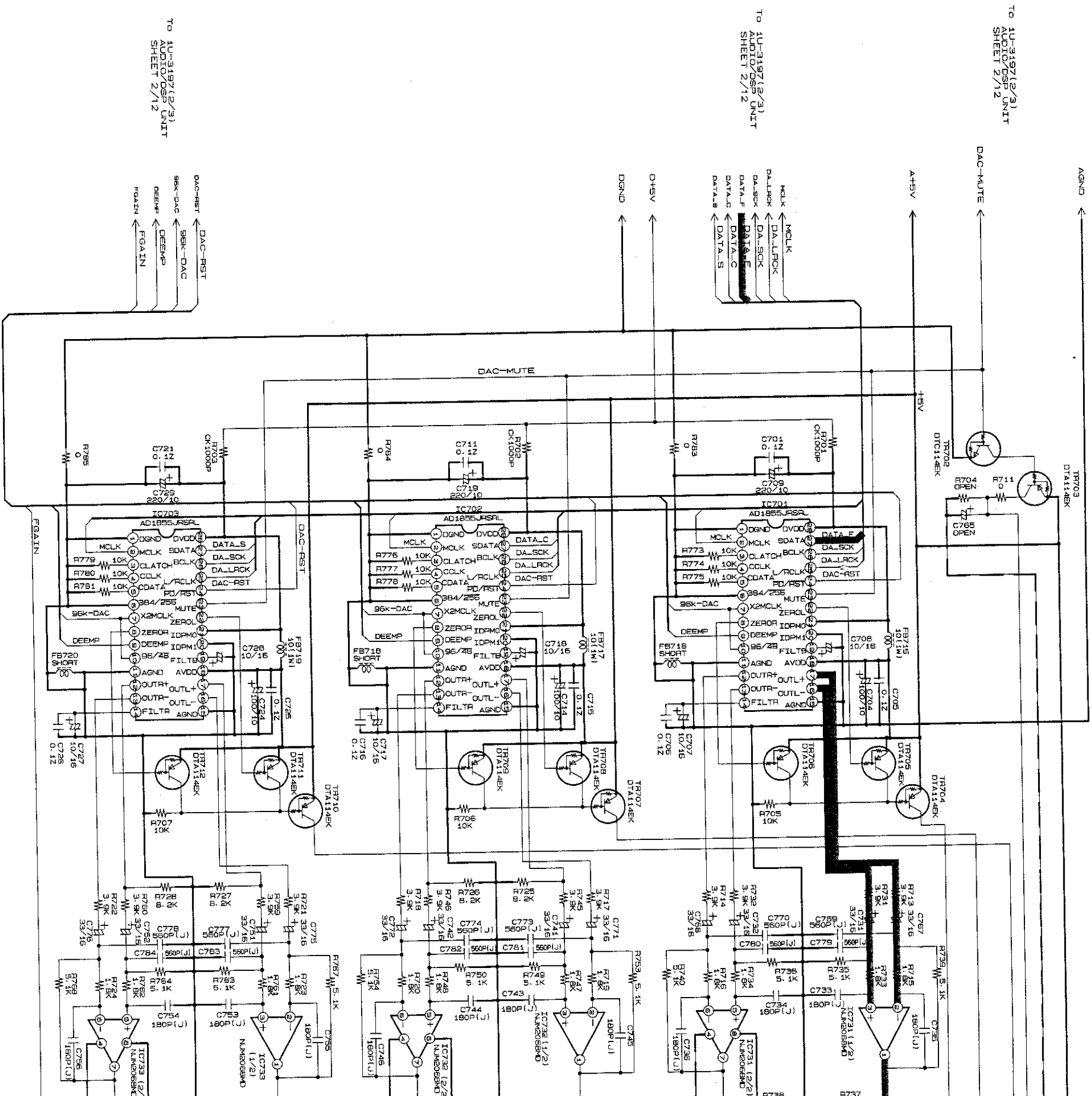

TO 1U-3197(2/3)  
AUDIO/DSP UNIT  
SHEET 2/12

TO 1U-3197(2/3)  
AUDIO/DSP UNIT  
SHEET 2/12

TO 1U-3197(2/3)  
AUDIO/DSP UNIT  
SHEET 2/12

7

8

9

10

11

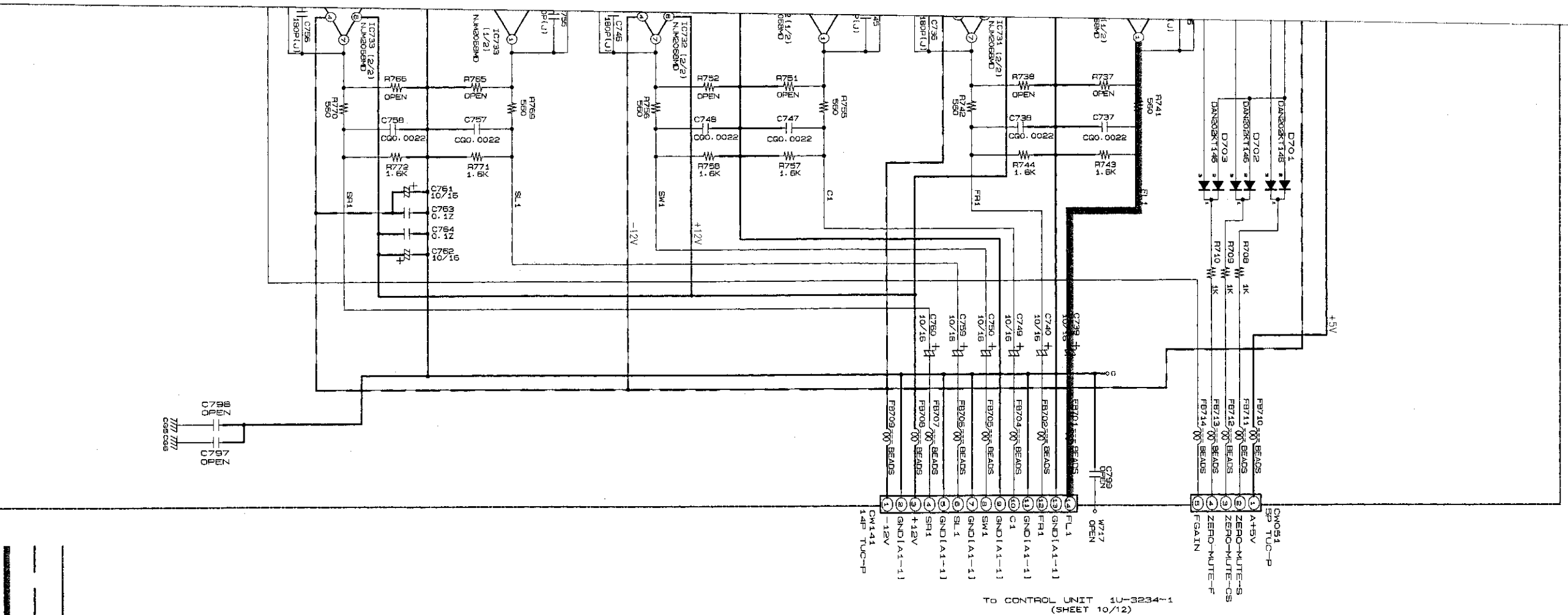

TO CONTROL UNIT 1U-3234-1 (SHEET 10/12)

**NOTICE**  
 ALL RESISTANCE VALUES IN OHM, K=1,000 OHM, M=1,000,000 OHM.  
 ALL CAPACITANCE VALUES IN MICRO FARAD. P=MICRO-MICRO FARAD.  
 EACH VOLTAGE AND CURRENT ARE MEASURED AT NO SIGNAL INPUT  
 CONDITION.  
 CIRCUIT AND PARTS ARE SUBJECT TO CHANGE WITHOUT PRIOR  
 NOTICE.

**WARNING:**  
 Parts marked with this symbol  $\Delta$  have critical characteristics.  
 Use ONLY replacement parts recommended by the manufacturer.

**CAUTION:**  
 Before returning the unit to the customer, make sure you make either (1) a  
 leakage current check or (2) a line to chassis resistance check. If the leakage  
 current exceeds 0.5 milliamperes, or if the resistance from chassis to either side  
 of the power cord is less than 460 kohms, the unit is defective.

**WARNING:**  
 DO NOT return the unit to the customer until the problem is located and  
 corrected.

— +B LINE  
 - - - -B LINE  
 ——— SIGNAL LINE

**SCHEMATIC DIAGRAMS (3/12)**  
 1U-3197 AUDIO / DSP UNIT (3/3)



SCHEMATIC DIAGRAMS (4/12)

1 2 3 4 5 6

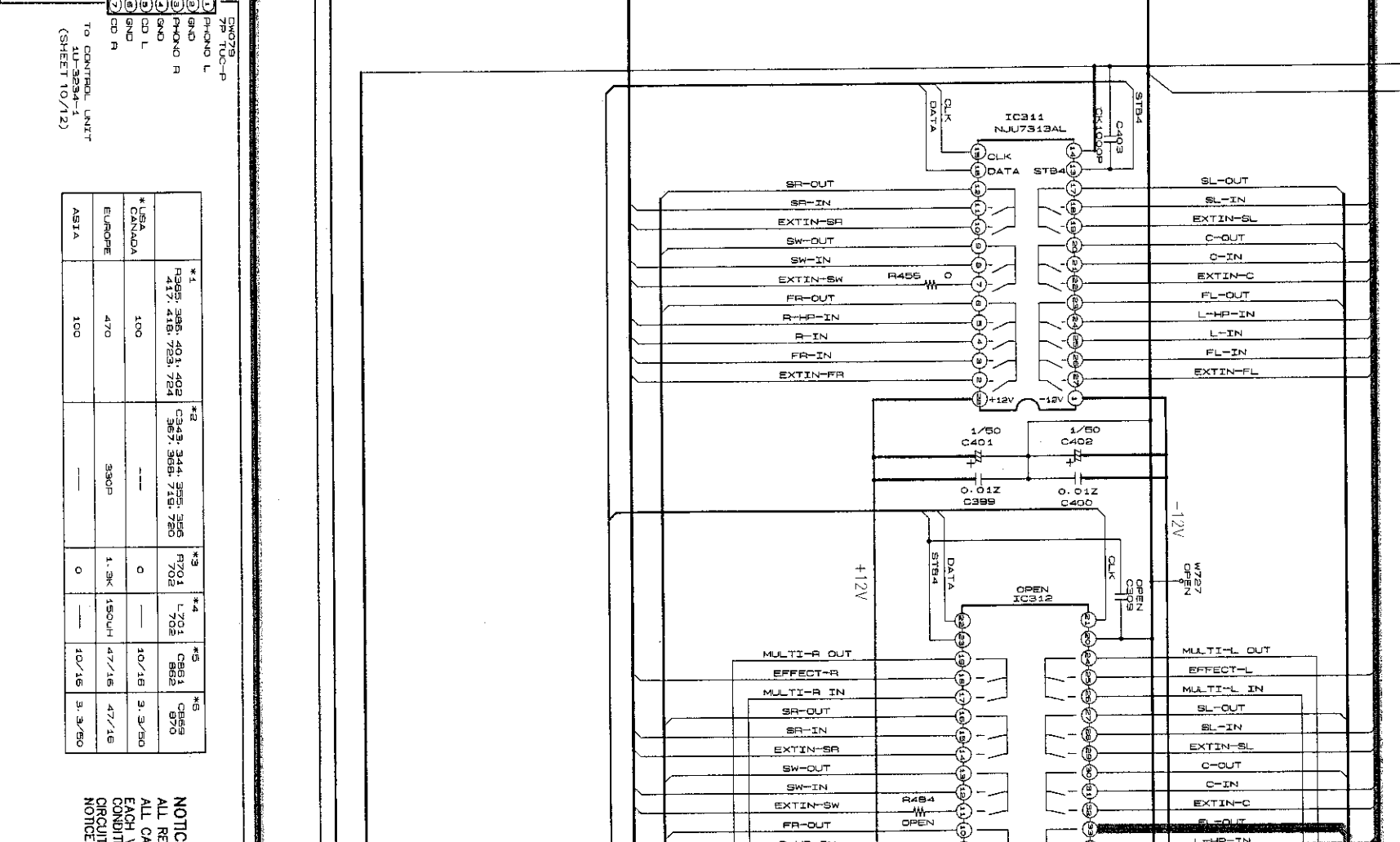
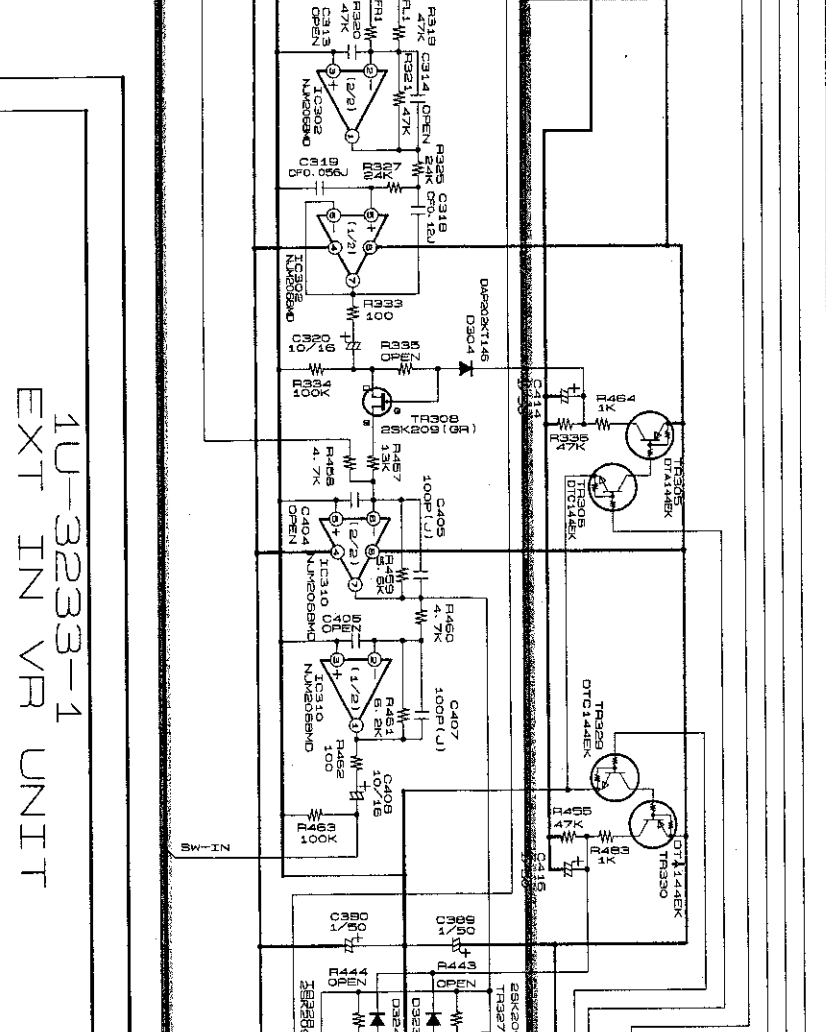
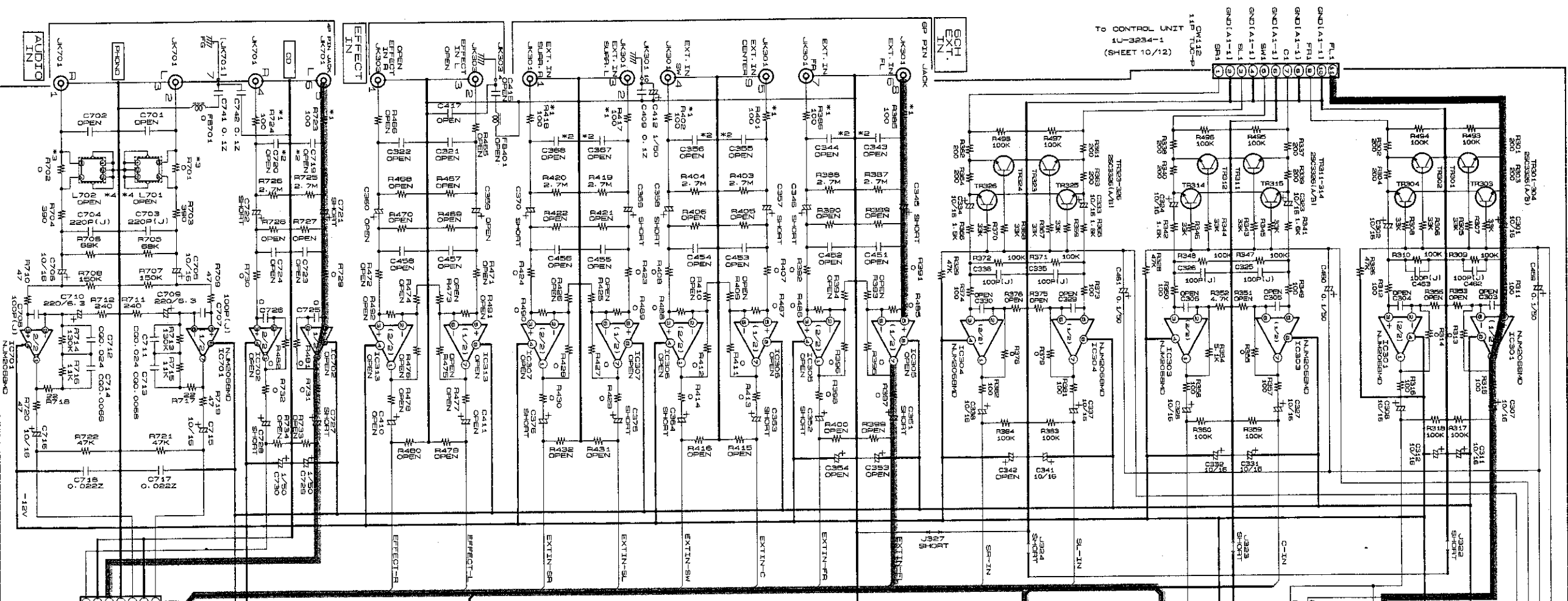

*1	*2	*3	*4	*5	*6
R365 385-401 402 417, 418-753, 724	C345-344, 355 356	R701 702	L701 702	CB51 552	CB59 570
USA	---	0	---	10/18	3, 3/50
CANADA	---	0	---	10/18	3, 3/50
EUROPE	470	330P	1.5K 150UH	47/16	47/16
ASIA	100	0	---	10/16	3, 3/50

NOTICE  
ALL CAP  
EACH VC  
CONDUCT  
CIRCUIT  
NOTICE

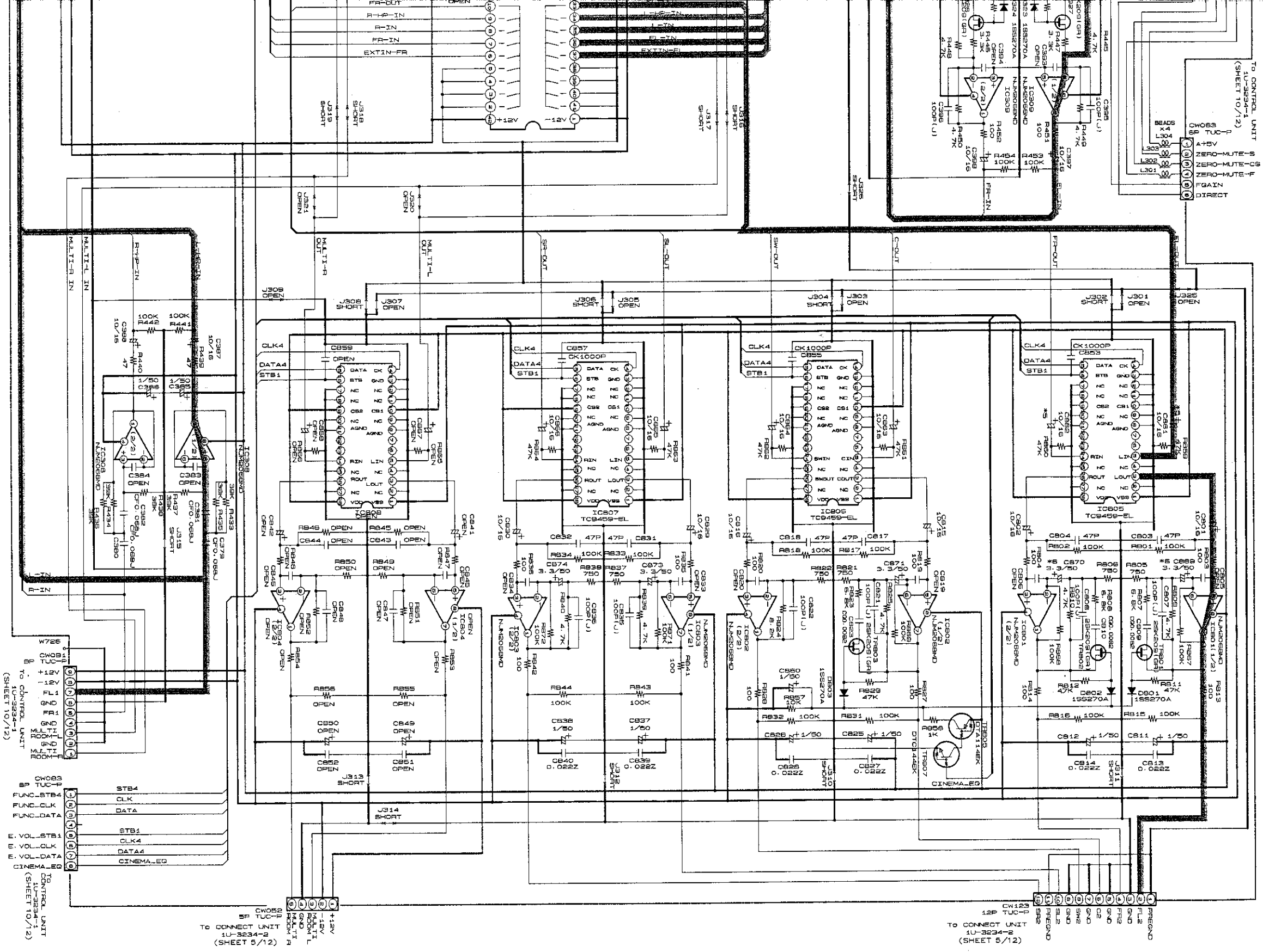

**NOTE**  
 RESISTANCE VALUES IN OHM, k=1,000 OHM M=1,000,000 OHM  
 CAPACITANCE VALUES IN MICRO FARAD, P=MICRO-MICRO FARAD  
 VOLTAGE AND CURRENT ARE MEASURED AT NO SIGNAL INPUT  
 AND PARTS ARE SUBJECT TO CHANGE WITHOUT PRIOR

**WARNING:**  
 Parts marked with this symbol  have critical characteristics.  
 Use ONLY replacement parts recommended by the manufacturer.  
**CAUTION:**  
 Before returning the unit to the customer, make sure you make either (1) a leakage current check or (2) a line to chassis resistance check. If the leakage current exceeds 0.5 millamps, or if the resistance from chassis to either side of the power cord is less than 460 kohms, the unit is defective.  
**WARNING:**  
 DO NOT return the unit to the customer until the problem is located and corrected.

**SCHEMATIC DIAGRAMS (4/12)**  
 1U-3233-1 EXT IN VR UNIT

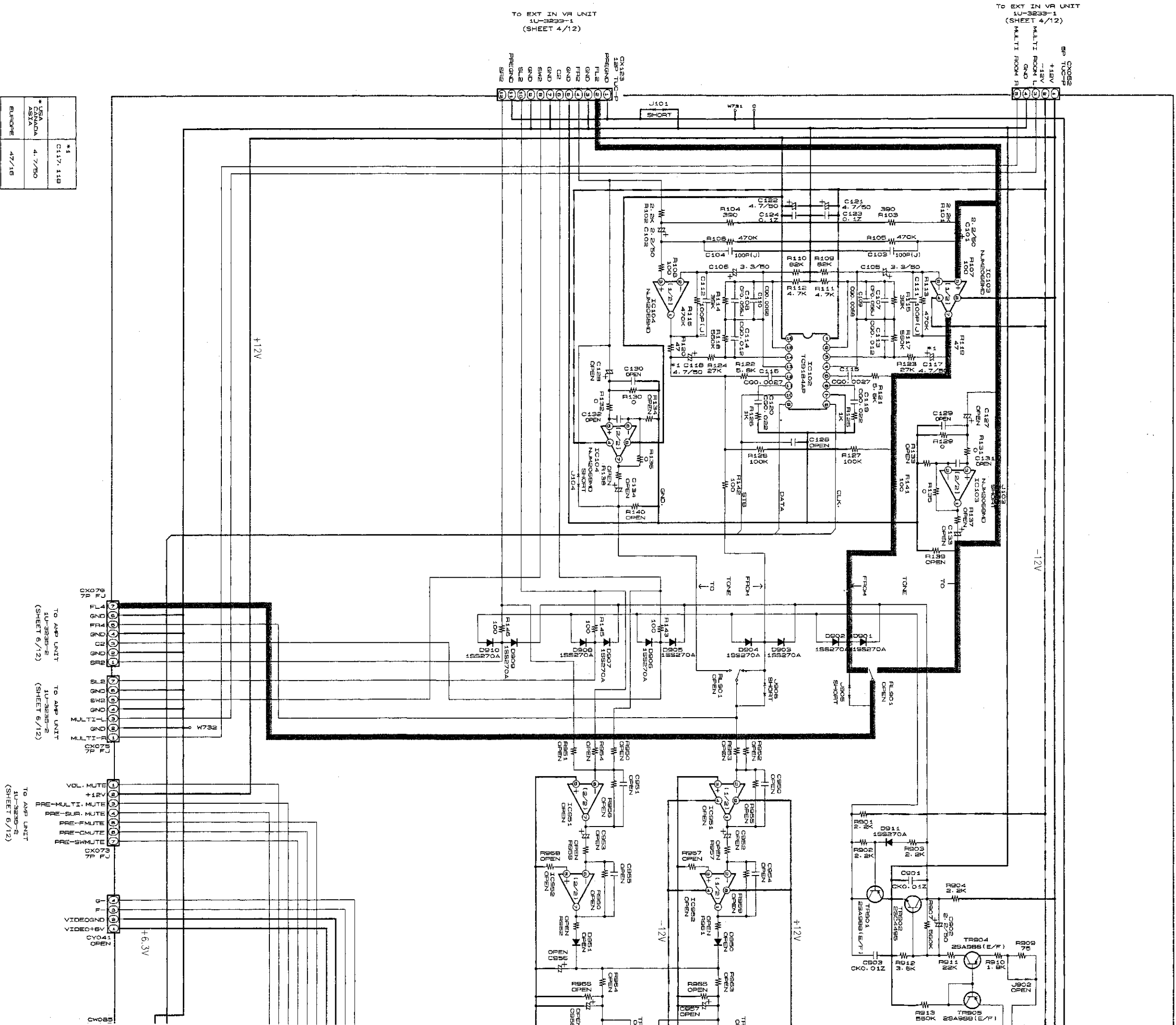

*1	C117, 118
*USA	4.7/50
*CANADA	4.7/50
ASIA	
EUROPE	47/16

**NOTICE**  
 ALL RESISTANCE VALUES IN OHM, K=1,000 OHM, M=1,000,000 OHM  
 ALL CAPACITANCE VALUES IN MICRO FARAD, P=MICRO-MICRO FARAD  
 EACH VOLTAGE AND CURRENT ARE MEASURED AT NO SIGNAL INPUT  
 CONDITION.  
 CIRCUIT AND PARTS ARE SUBJECT TO CHANGE WITHOUT PRIOR  
 NOTICE.

**WARNING:**  
 Parts marked with  
 Use ONLY replacer  
**CAUTION:**  
 Before returning the  
 leakage current ch  
 current exceeds 0.1  
 of the power cord  
**WARNING:**  
 DO NOT return the  
 corrected.

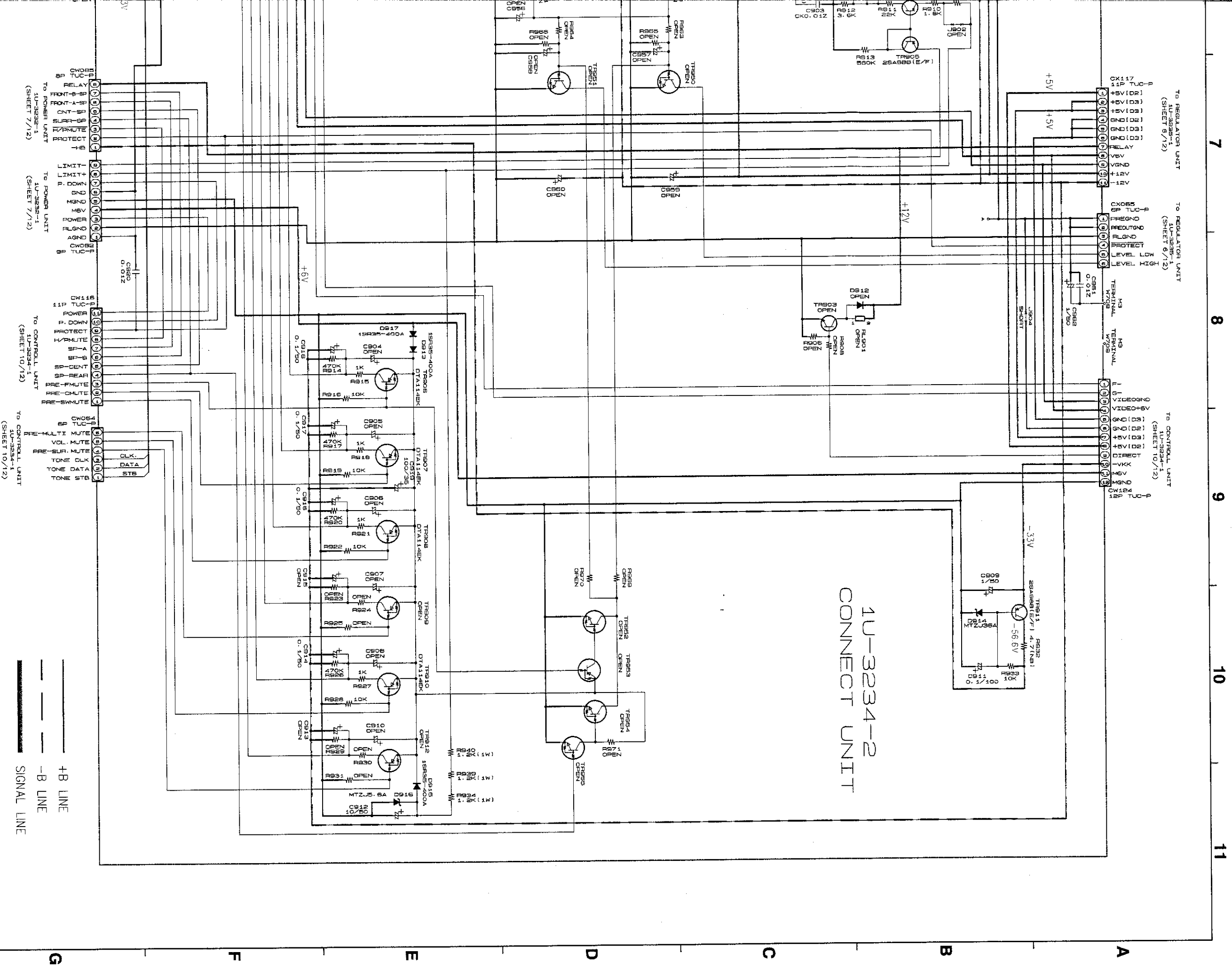

1U-3234-2  
CONNECT UNIT

————— +B LINE  
 - - - - - -B LINE  
 \_\_\_\_\_ SIGNAL LINE

**WARNING:**  
Parts marked with this symbol have critical characteristics. Only replacement parts recommended by the manufacturer.

**AUTON:**  
Before returning the unit to the customer, make sure you make either (1) a leakage current check or (2) a line to chassis resistance check. If the leakage current exceeds 0.5 millamps, or if the resistance from chassis to either side of the power cord is less than 450 kohms, the unit is defective.

**WARNING:**  
Do NOT return the unit to the customer until the problem is located and corrected.

SCHEMATIC DIAGRAMS (5/12)  
1U-3234-2 CONNECT UNIT

SCHEMATIC DIAGRAMS (6/12)

1 2 3 4 5 6

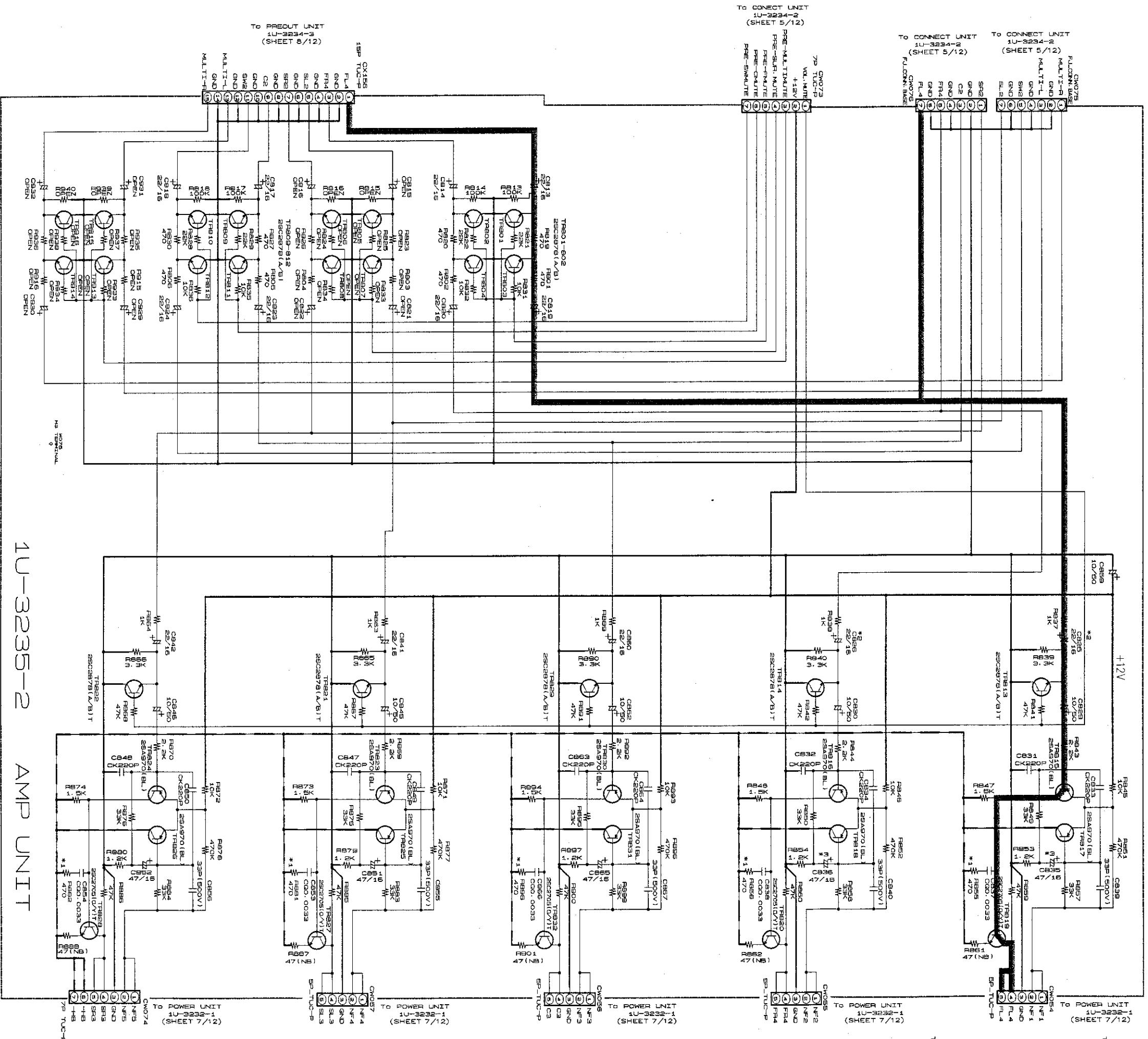

1U-3235-2 AMP UNIT

	*1	*2	*3	*4	*5	*6	*7
* USA	R855, 856, 881 R82, 858	C825 855	C835 885	CX037 CY037	SW001	F11, 14 13, 14	Q917, 920 921, 924
* CANADA	470	22/16	47/18	3P KR	2, 5A/120V	15R35-400A	
ASIA	470	22/16	47/18		2, 5A/230V	15R35-400A	
TAIWAN	470	22/16	47/18		2, 5A/120V	15R35-400A	
EUROPE	330	100/18	220/16		2, 5A/230V	15R35-400A	
JAPAN	470	22/16	47/18	3P KR	2, 5A/120V	DSM10E1 (TPP83)	

**NOTICE**  
 ALL RESISTANCE VALUES IN OHM, K=1,000 OHM, M=1,000,000 OHM.  
 ALL CAPACITANCE VALUES IN MICRO FARAD, P=MICRO-MICRO FARAD  
 CONDITION.  
 EACH VOLTAGE AND CURRENT ARE MEASURED AT NO SIGNAL INPUT  
 CIRCUIT AND PARTS ARE SUBJECT TO CHANGE WITHOUT PRIOR  
 NOTICE.

**WARNING:**  
 Parts marked with this symbol must be replaced with the original or an equivalent part.  
 Use ONLY replacement parts recommended by the manufacturer.  
**CAUTION:**  
 Before returning the unit to the rack, check for correct polarity of the lead current check or (2) a if the current exceeds 0.5 milliamperes, or if the power cord is less than 4 feet long, check the power cord.  
**WARNING:**  
 DO NOT return the unit to the rack until the power cord is corrected.



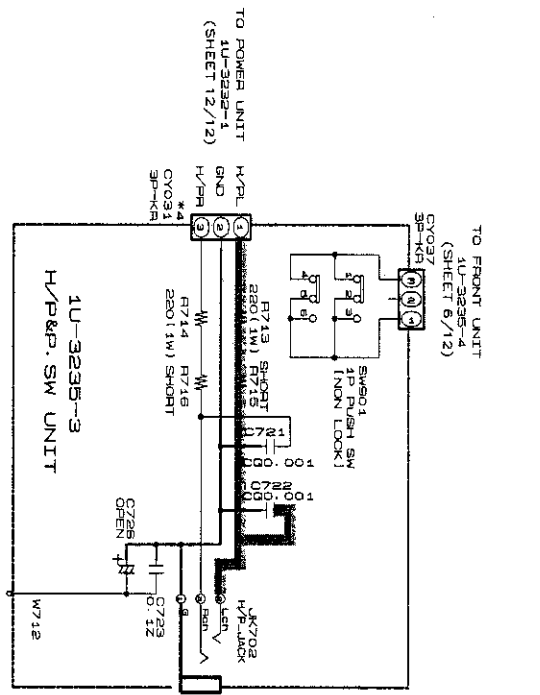
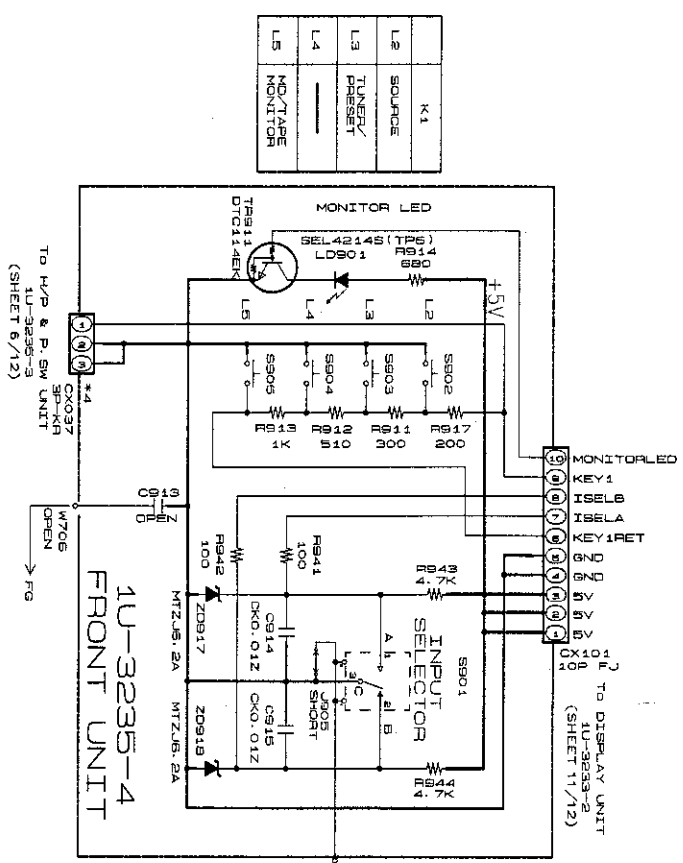
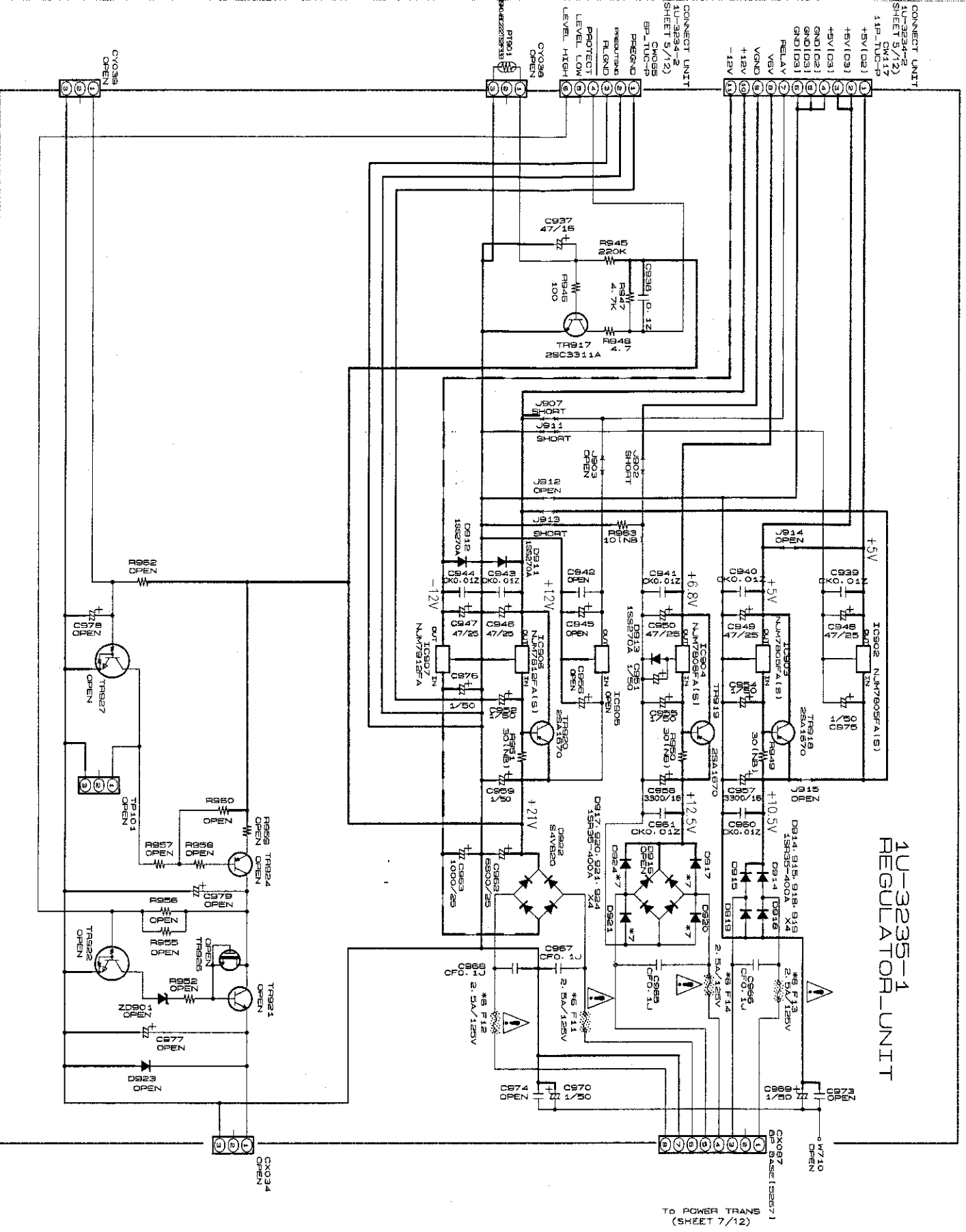

— +B LINE  
 - - - -B LINE  
 ——— SIGNAL LINE

Label A have critical characteristics. as recommended by the manufacturer.

the customer, make sure you make either (1) a (2) a line to chassis resistance check. If the leakage is on the right side of the chassis to either side from 450 Kohms, the unit is defective. the customer until the problem is located and

**SCHEMATIC DIAGRAMS (6/12)**  
 1U-3235-1 REGULATOR UNIT  
 1U-3235-2 AMP UNIT  
 1U-3235-3 H/P & P.S.W UNIT  
 1U-3235-4 FRONT UNIT

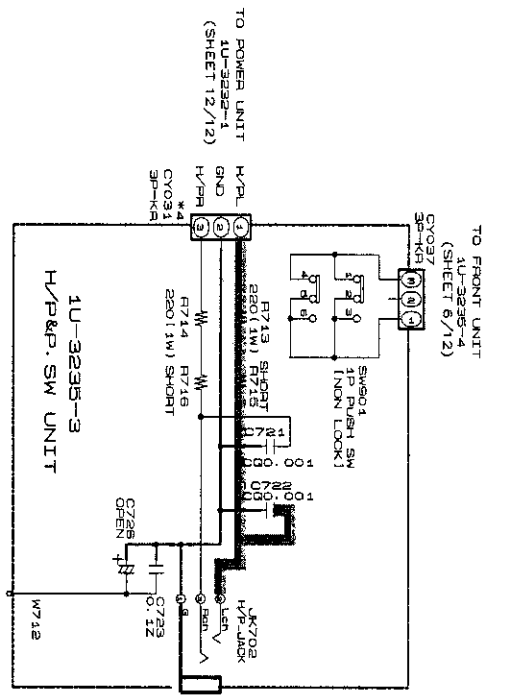
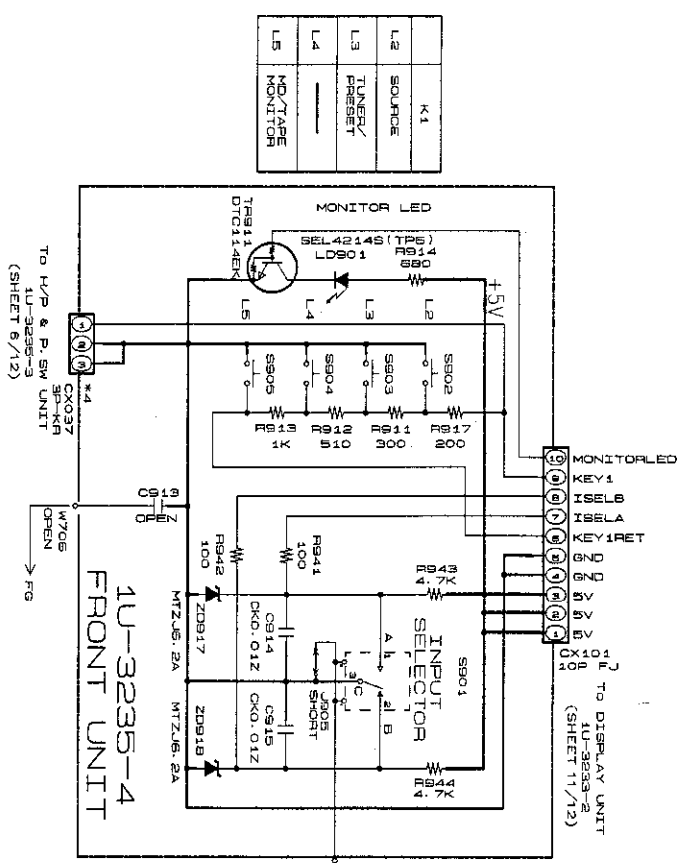
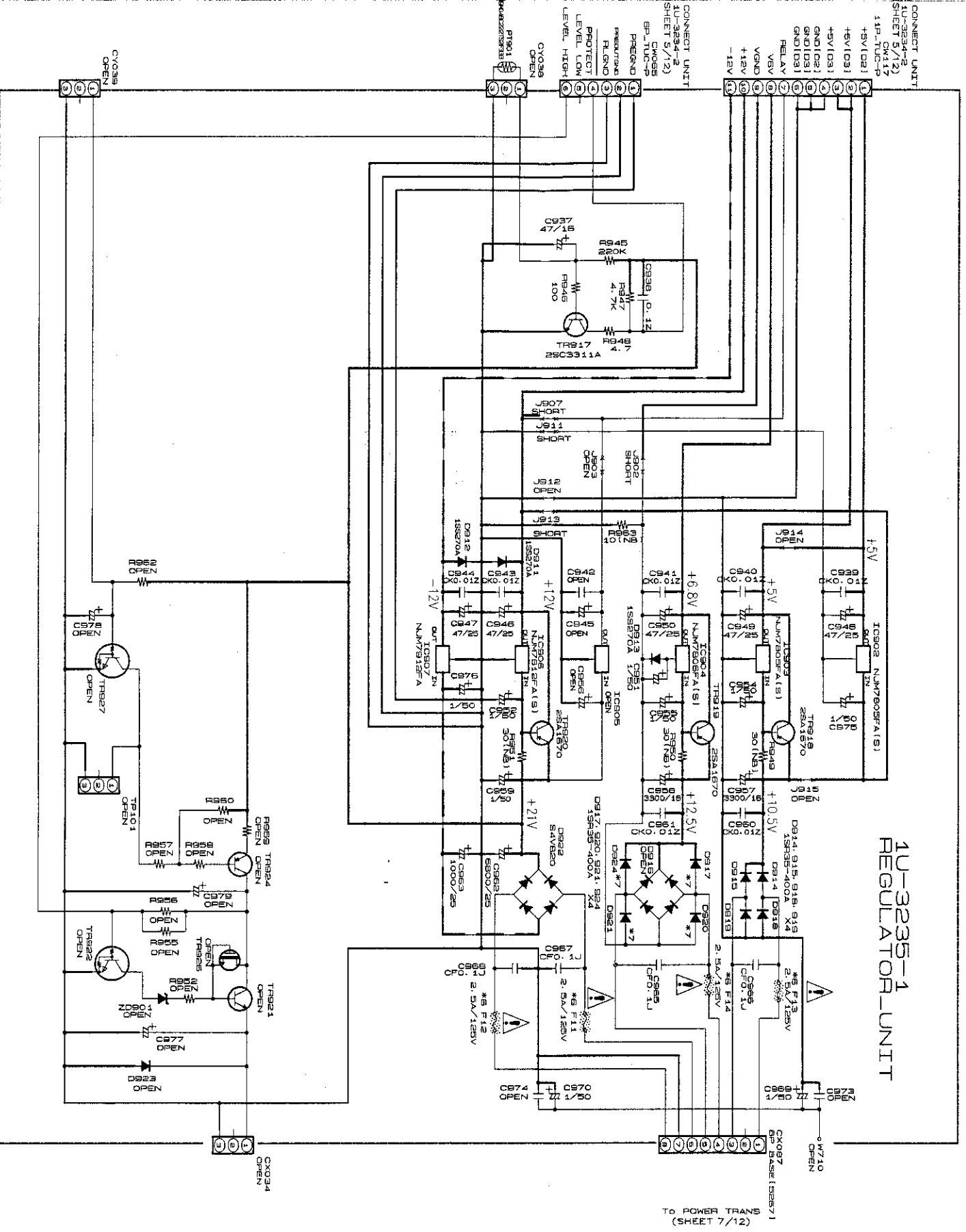

Label A have critical characteristics. Recommended by the manufacturer.

the customer, make sure you make either (1) a line to chassis resistance check. If the leakage is on either side of the chassis, the unit is defective. If the leakage is on 450 Kohms, the unit is defective.

the customer until the problem is located and

**SCHEMATIC DIAGRAMS (6/12)**

- 1U-3235-1 REGULATOR UNIT
- 1U-3235-2 AMP UNIT
- 1U-3235-3 H/P & P.S.W UNIT
- 1U-3235-4 FRONT UNIT

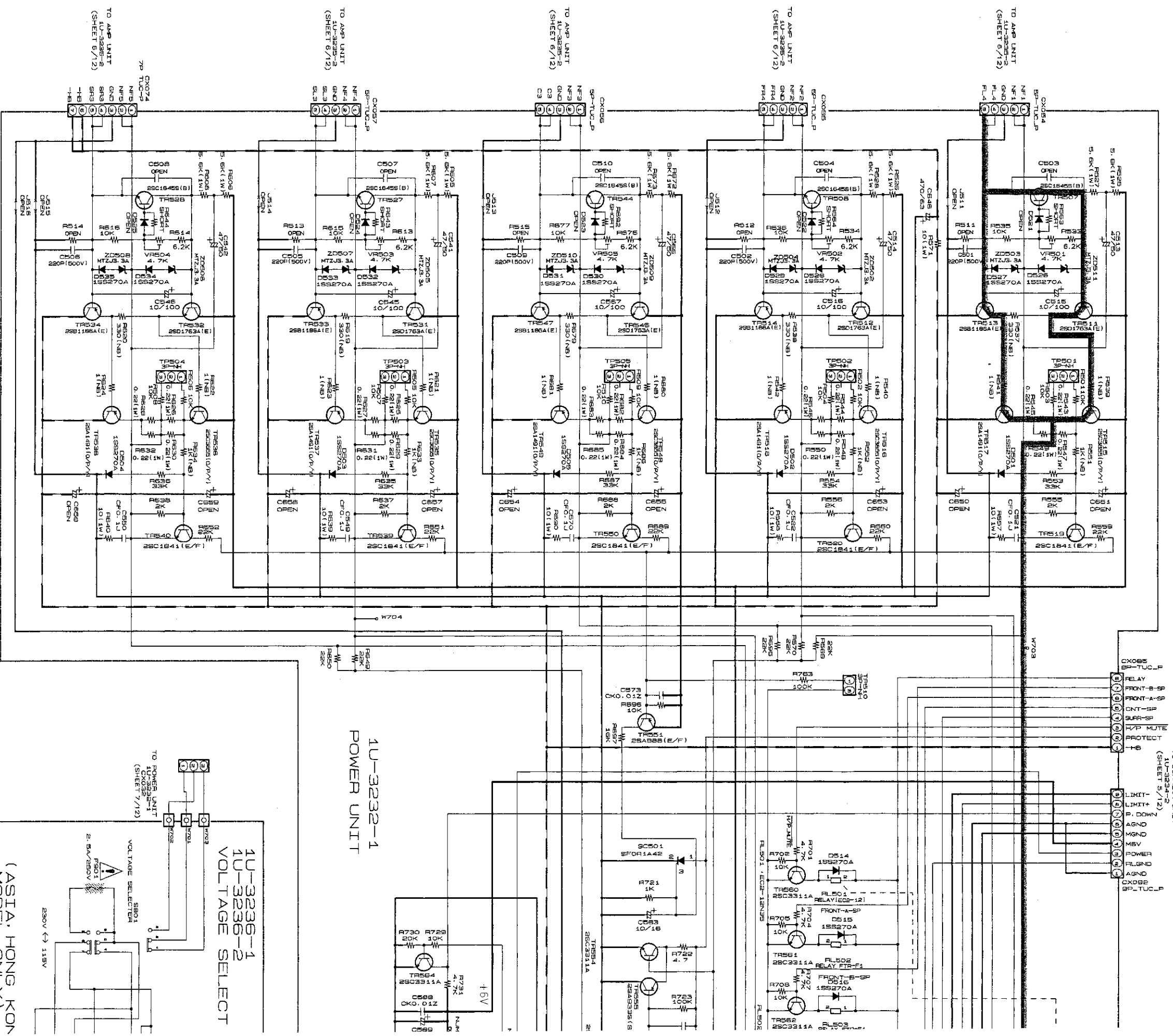

NO.	*1	*2	*3	*4	*5	*6	*7	*8	*9	*10	*11	*12	*13
USA CANADA	F1	FB	TR01	CK02A	ACR01	R734	COO.525 525 553 518.514.515 519.517.517 517 518 519	COO.012	COO.01	SHORT	CK02B	SA01	POWER TRANS
EUROPE	2.5A/250V	2.5A/250V	2336073107	---	---	---	COO.047U	COO.022	COO.01	OPEN	---	---	233604009
ASIA HONG KONG	5A/250V	2.5A/250V	233627800B	BP VH	---	---	COO.022	COO.022	COO.01	OPEN	BP B.ASE	P. SW	233606007
CHINA	2.5A/250V	---	233609802B	---	---	---	COO.022	COO.022	COO.022	OPEN	---	P. SW	233630002B
TAIWAN N.O.C	5.3A/125V	5A/125V	2336073107	---	BP AC OUTLET	2.2M	COO.022	COO.022	---	OPEN	---	P. SW	2336304009
JAPAN	5A/125V	5A/125V	2336026019	---	BP AC OUTLET	---	COO.022	---	---	SHORT	---	---	2336088003

1U-3236-1  
1U-3236-2  
VOLTAGE SELECT

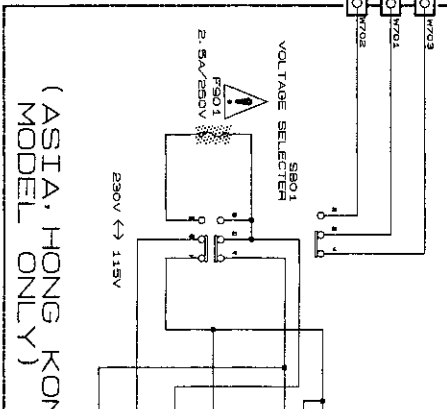

(ASIA, HONG KONG MODEL ONLY)

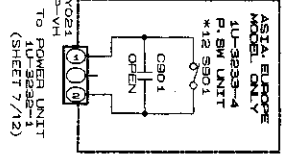

WAI Part Use  
WAI CAI  
WAI  
DO  
COR

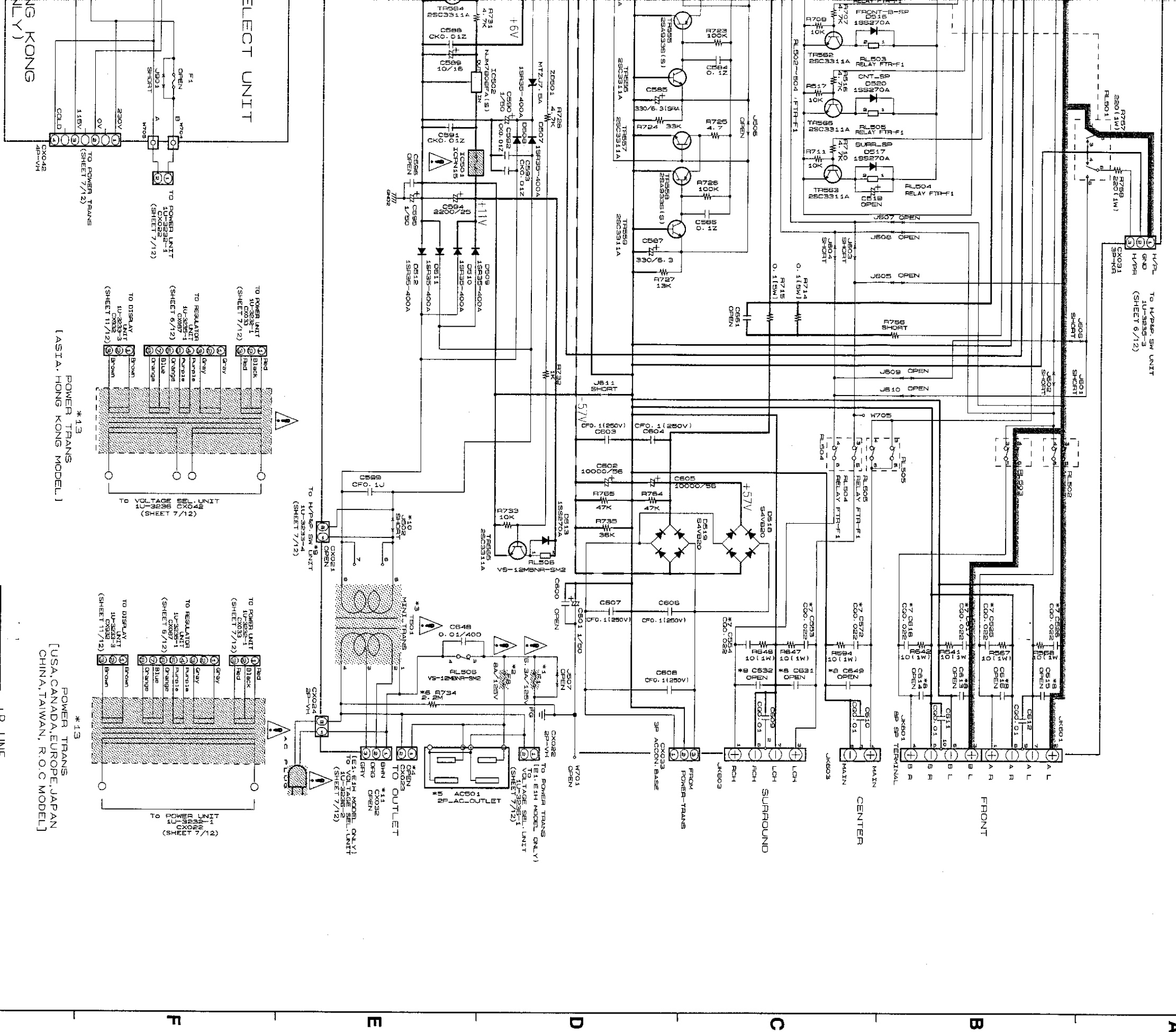

**NOTICE**  
 ALL RESISTANCE VALUES IN OHM, K=1,000 OHM, M=1,000,000 OHM  
 ALL CAPACITANCE VALUES IN MICRO FARAD. P=PICTO-MICRO FARAD  
 EACH VOLTAGE AND CURRENT ARE MEASURED AT NO SIGNAL INPUT  
 CONDITION.  
 CIRCUIT AND PARTS ARE SUBJECT TO CHANGE WITHOUT PRIOR  
 NOTICE.

**WARNING:**  
 Parts marked with this symbol  have critical characteristics.  
 Use ONLY replacement parts recommended by the manufacturer.

**CAUTION:**  
 Before returning the unit to the customer, make sure you make either (1) a  
 leakage current check or (2) a line to chassis resistance check. If the leakage  
 current exceeds 0.5 millamps, or if the resistance from chassis to either side  
 of the power cord is less than 460 Kohms, the unit is defective.

**WARNING:**  
 DO NOT return the unit to the customer until the problem is located and  
 corrected.

+B LINE  
 -B LINE  
 SIGNAL LINE

**SCHEMATIC DIAGRAMS (7/12)**  
 1U-3232-1 POWER UNIT  
 1U-3233-4 P SW UNIT  
 1U-3236-1 VOLTAGE SELECT UNIT (ASIA,HONG KONG MODEL ONLY)  
 1U-3236-2 VOLTAGE SELECT UNIT (ASIA,HONG KONG MODEL ONLY)

SCHEMATIC DIAGRAMS (8/12)

1 2 3 4 5 6

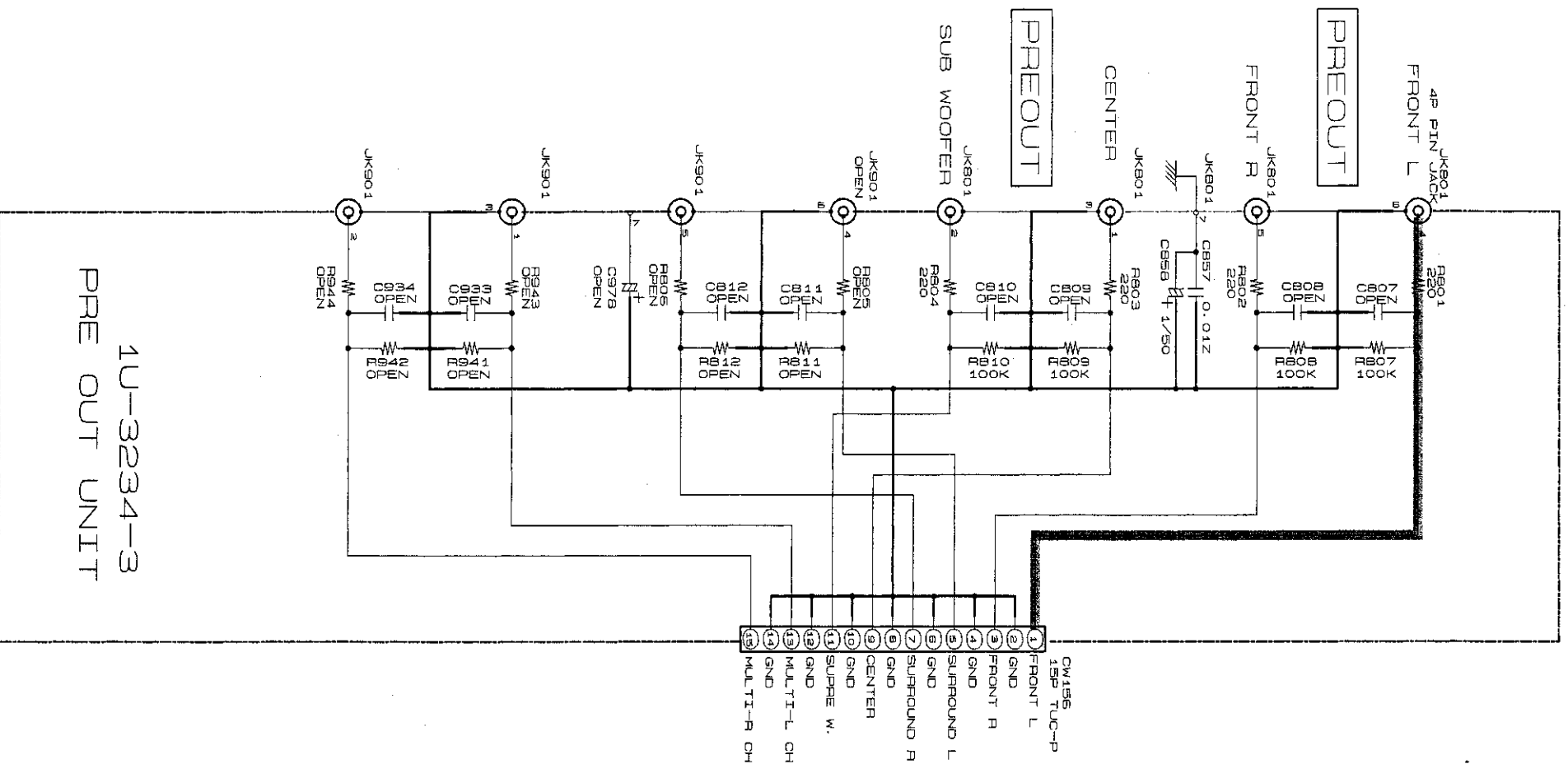

TO AMP UNIT  
1U-3235-2  
(SHEET 6/12)

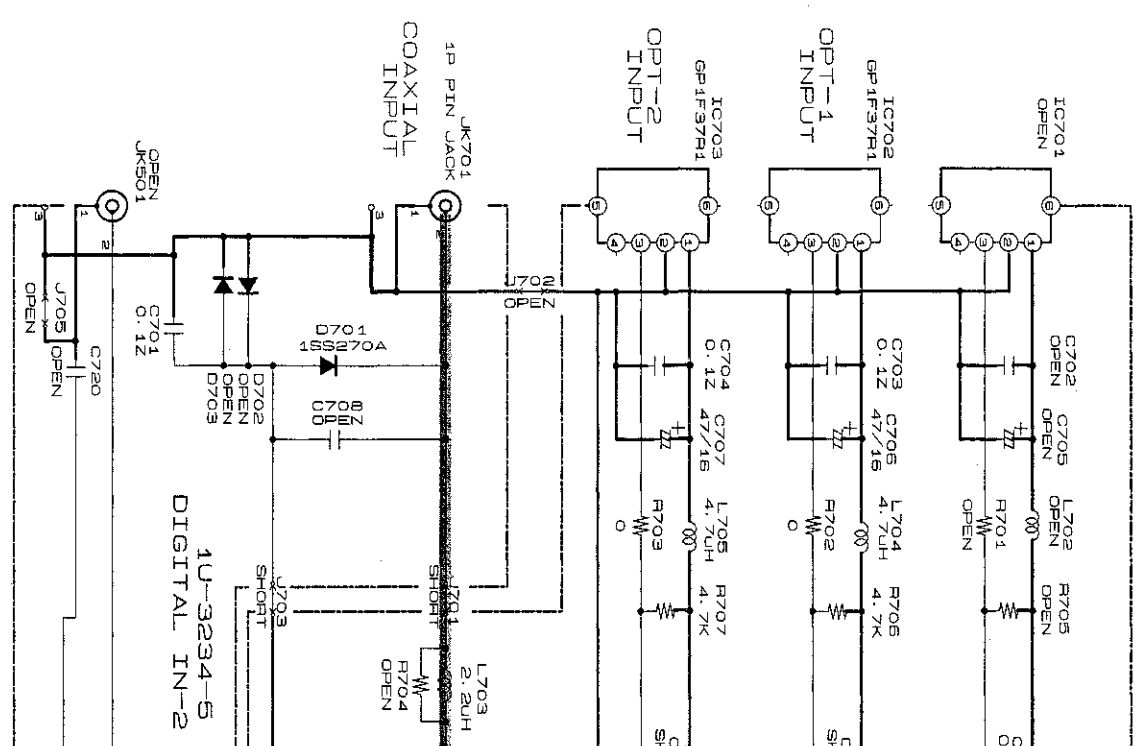

**NOTICE**  
ALL RESISTANCE VALUES IN OHM, K=1,000 OHM, M=1,000,000 OHM.  
ALL CAPACITANCE VALUES IN MICRO FARAD, P=MICRO-MICRO FARAD  
EACH VOLTAGE AND CURRENT ARE MEASURED AT NO SIGNAL INPUT  
CONDITION.  
CIRCUIT AND PARTS ARE SUBJECT TO CHANGE WITHOUT PRIOR  
NOTICE.

**WARNING:**  
Ports marked with this symbol  have critical characteristics.  
Use ONLY replacement parts recommended by the manufacturer.

**CAUTION:**  
Before returning the unit to the customer, make sure you make either (1) a leakage current check or (2) a line to chassis resistance check. If the leakage current exceeds 0.5 milliamps, or if the resistance from chassis to either side of the power cord is less than 460 kohms, the unit is defective.

**WARNING:**  
DO NOT return the unit to the customer until the problem is located and corrected.

# 1U-3234-4 DIGITAL INPUT UNIT

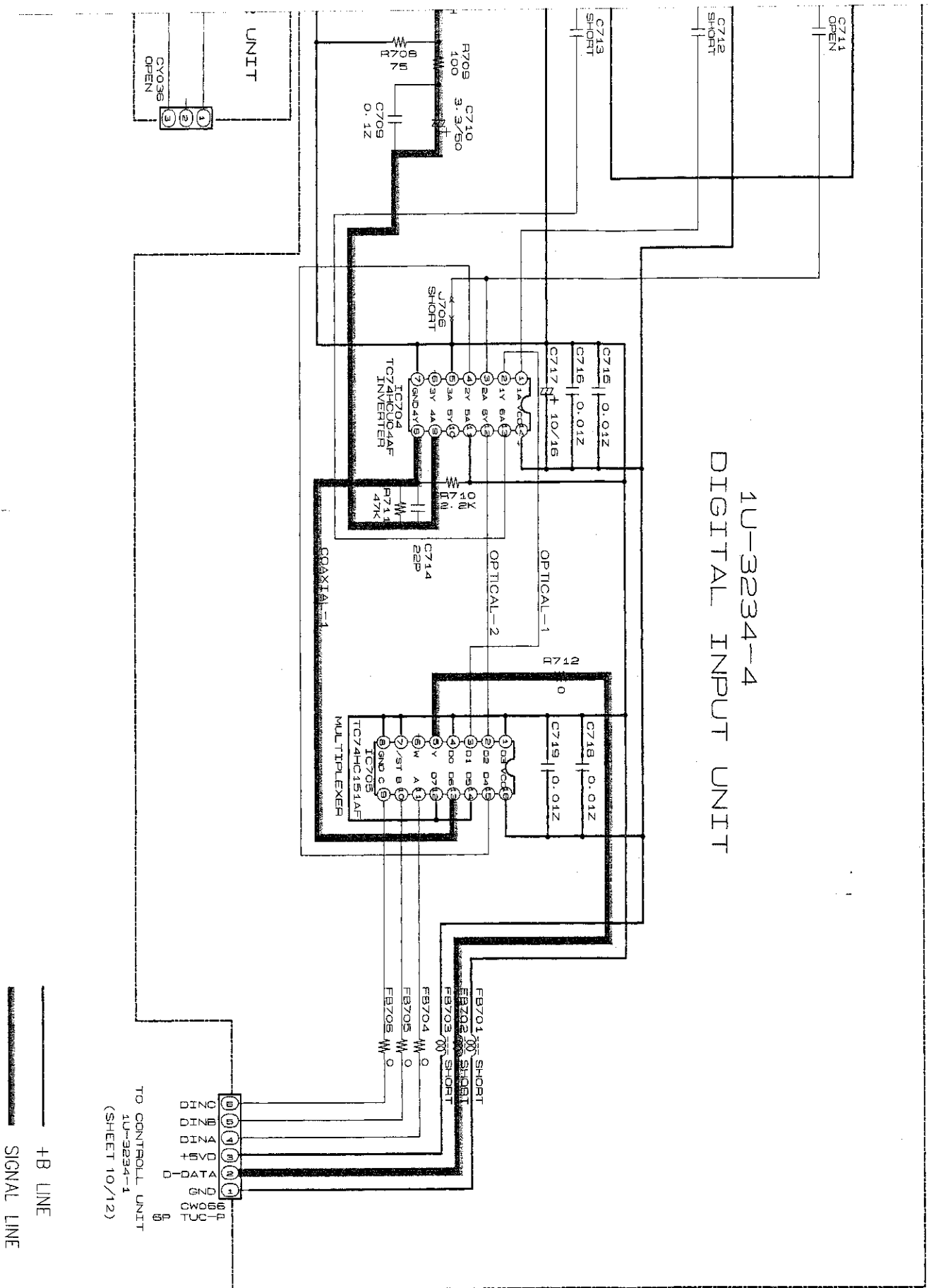

——— +B LINE  
 - - - - - SIGNAL LINE

TO CONTROL UNIT  
 1U-3234-1  
 (SHEET 10/12)

SCHEMATIC DIAGRAMS (8/12)  
 1U-3234-3 PRE OUT UNIT  
 1U-3234-4 DIGITAL INPUT UNIT  
 1U-3234-5 DIGITAL IN-2 UNIT



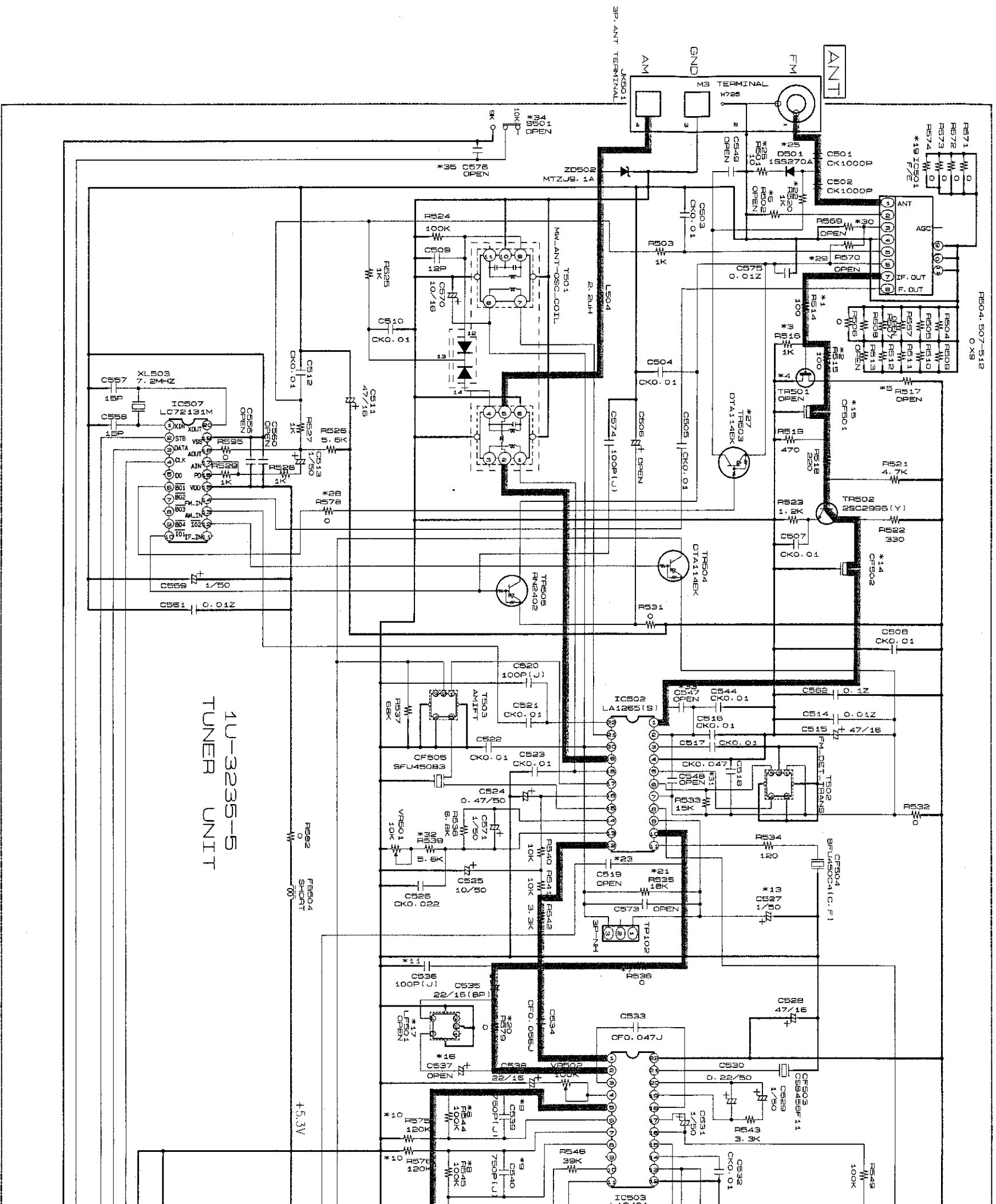

1U-3235-B  
TUNER UNIT

**NOTICE**  
ALL RESISTANCE VALUES IN OHM, K=1,000 OHM M=1,000,000 OHM  
ALL CAPACITANCE VALUES IN MICRO FARAD, P=MICRO-MICRO FARAD  
EACH VOLTAGE AND CURRENT ARE MEASURED AT NO SIGNAL INPUT  
CONDITION.  
CIRCUIT AND PARTS ARE SUBJECT TO CHANGE WITHOUT PRIOR  
NOTICE

**WARNING:**  
Parts marked with this symbol  have critical characteristics.  
Use ONLY replacement parts recommended by the manufacturer.

**CAUTION:**  
Before returning the unit to the customer, make sure you make either (1) a  
leakage current check or (2) a line to chassis resistance check. If the leakage  
current exceeds 0.5 millamps, or if the resistance from chassis to either side  
of the power cord is less than 460 kohms, the unit is defective.

**WARNING:**  
DO NOT return the unit to the customer until the problem is located and  
corrected.

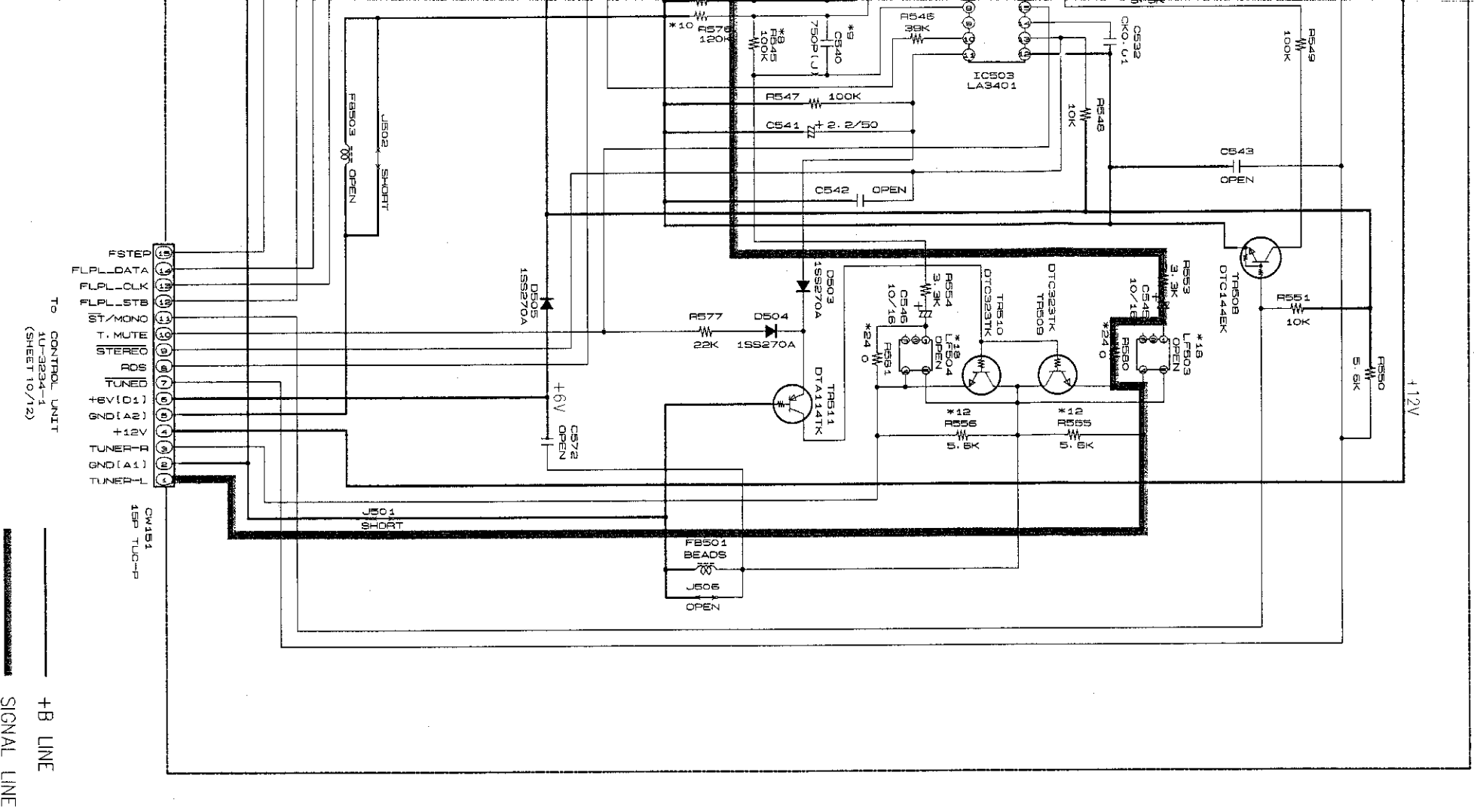

TO CONTROL UNIT  
(SHEET 10/12)

TO CONTROL UNIT  
(SHEET 10/12)

* NO	USA CANADA	E1/E1H	E1C/ E3T	EUROPE	JAPAN
1 R514	100	100		100	100
2 R515		100			0
3 R516		1K		330	330
4 TR501			2SK211(GR1)		
5 R517			330		
6 R502			0		
7 R535		0	2.7K	5.6K	
8 R544, 545		100K	150K	130K	
9 C539, 540	750P	510P	330P	390P	
10 R575, 576		120K	200K	150K	
11 C535		100P		100P	
12 R555, 556		5.6K	3.3K	3.3K	
13 C527	1/50	0.33/50	0.33/50	0.33/50	
14 C502		SFE 10.7MS2G	FMCFSK107 M2-A	SFE 10.7MS2G	
15 C501		SFE 7MA8	FMCFSK107 M2-A	SFE 7MA8	
16 C537			22/16		
17 LFS01			ANTI PIRHOIS FILTER		
18 LFS03, 504			LPF 2330085004	LPF 2330085004	
19 IC501		F/E 2160102008	F/E 216013004	F/E 216012005	
20 R579		0		0	
21 R535	15K	39K	39K	15K	
22 R520		1K	1K		
23 C518			CK100P		
24 R580, 581		0			
25 DS01		1SS270A	1SS270A		
26 R501		10	10		
27 TR503		DTA114BK	DTA114BK		
28 R578		0	0		
29 R570			10K		
30 R559			5.6K		
31 C548				CK200P	
32 R539		5.6K	5.6K		
33 C547				100P	
34 SS01		SW			
35 C576		CK1000P			

SCHEMATIC DIAGRAMS (9/12)  
1U-3235-5 TUNER UNIT

# SCHEMATIC DIAGRAMS (10/12)

1 2 3 4 5 6

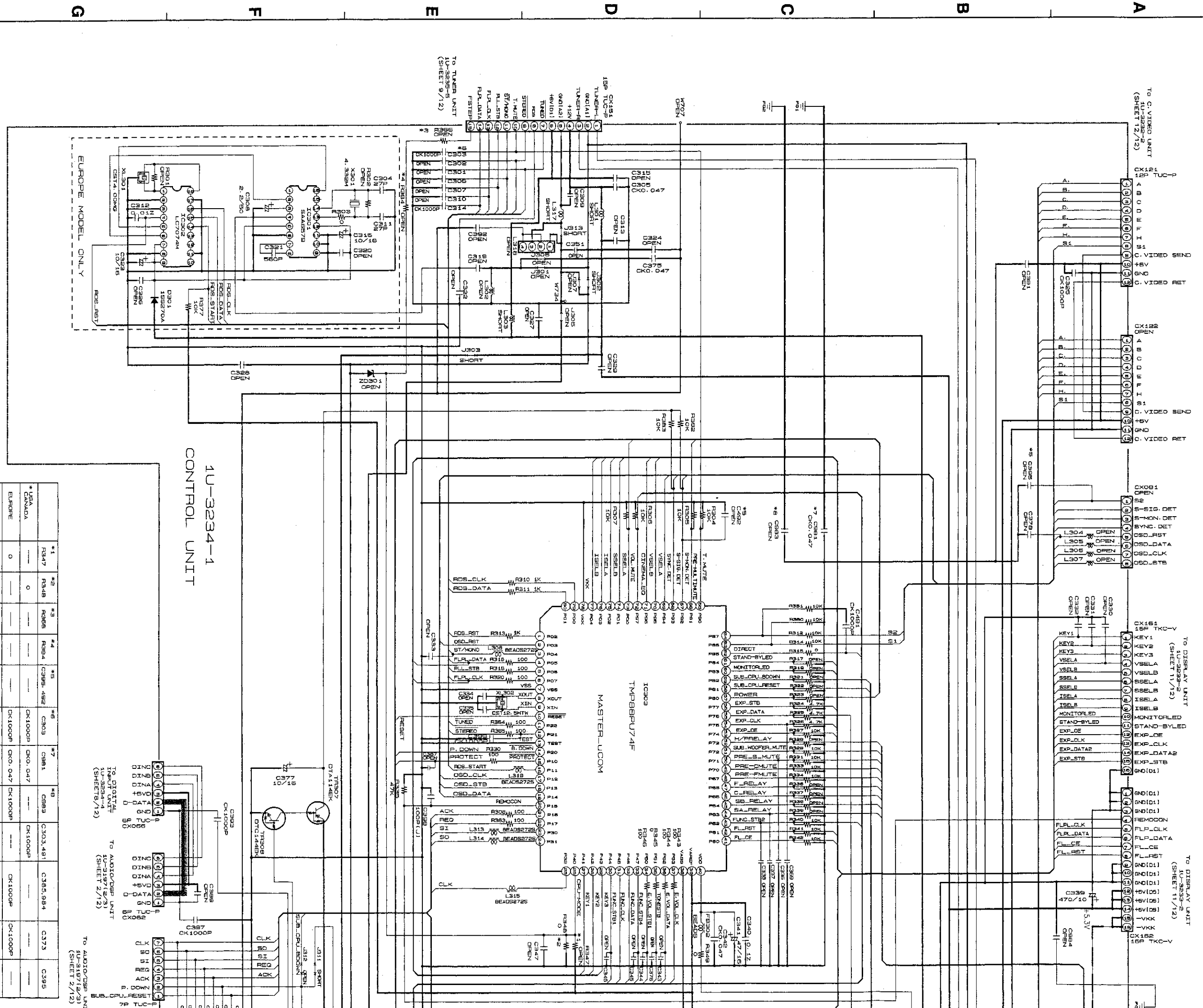

	*1	*2	*3	*4	*5	*6	*7	*8	*9	*10	*11	*12	*13	*14	*15	*16	*17	*18	*19	*20	*21	*22
USA	R347	R348	R366	R364	C395, 482	C303	C381	C383	C303, 481	C385, 984	C373	C395										
CANADA		0				CK1000P	CK0, 047		CK1000P													
EUROPE	0					CK1000P	CK0, 047	CK1000P														
ASIA	1K	5, 1K	0		1, 3K																	
KOREA																						
JAPAN																						
F.O.C.	4.7K	4.7K				CK1000P	CK0, 047	CK1000P	CK1000P	CK1000P	CK1000P	CK1000P										

NI AL EA CR NI  
NI AL EA CR NI  
NI AL EA CR NI

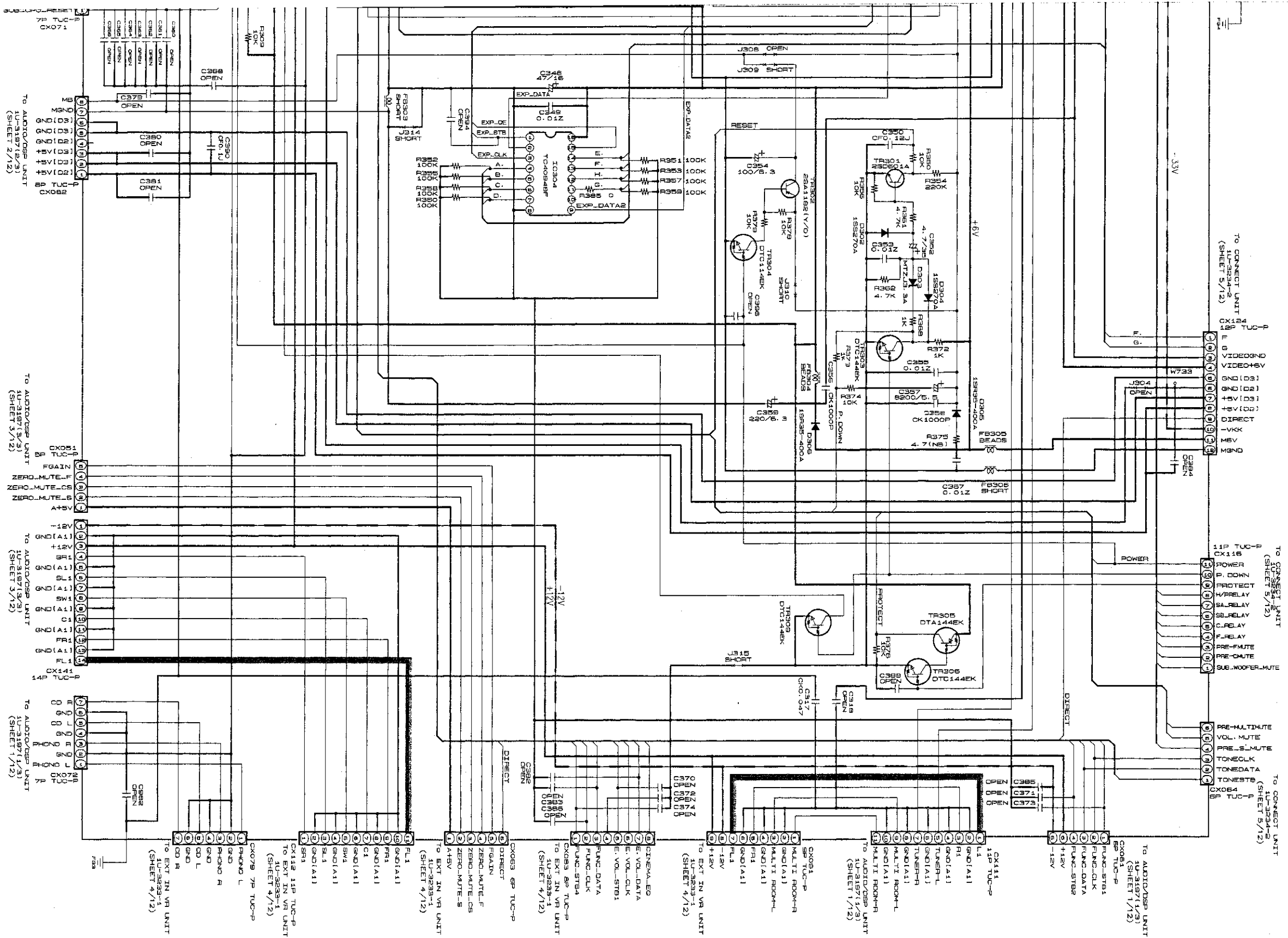

**NOTICE**  
 ALL RESISTANCE VALUES IN OHM, K=1,000 OHM, M=1,000,000 OHM  
 EACH CAPACITANCE VALUES IN MICRO FARAD, P=MICRO-MICRO FARAD  
 EACH VOLTAGE AND CURRENT ARE MEASURED AT NO SIGNAL INPUT  
 CONDITION.  
 CIRCUIT AND PARTS ARE SUBJECT TO CHANGE WITHOUT PRIOR  
 NOTICE.

**WARNING:**  
 Parts marked with this symbol  have critical characteristics.  
 Use ONLY replacement parts recommended by the manufacturer.  
**CAUTION:**  
 Before returning the unit to the customer, make sure you make either (1) a  
 leakage current check or (2) a line to chassis resistance check. If the leakage  
 current exceeds 0.5 milliamperes, or if the resistance from chassis to either side  
 of the power cord is less than 450 Kohms, the unit is defective.  
**WARNING:**  
 DO NOT return the unit to the customer until the problem is located and  
 corrected.

— +B LINE  
 - - - - -B LINE  
 ——— SIGNAL LINE

**SCHEMATIC DIAGRAMS (10/12)**  
 1U-3294-1 CONTROL UNIT

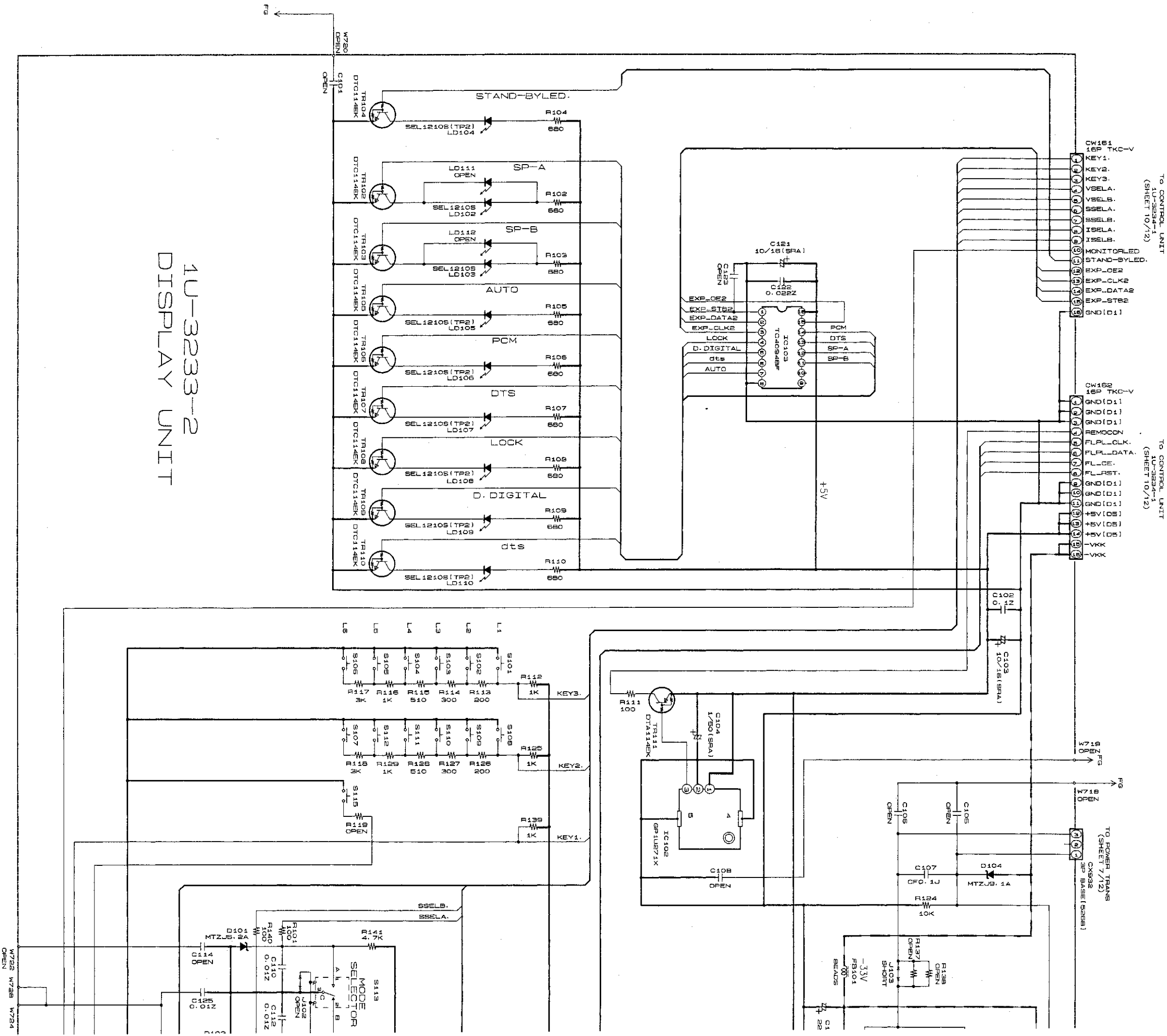

**NOTICE**  
 ALL RESISTANCE VALUES IN OHM, K=1,000 OHM M=1,000,000 OHM  
 ALL CAPACITANCE VALUES IN MICRO FARAD, P=MICRO-MICRO FARAD  
 EACH VOLTAGE AND CURRENT ARE MEASURED AT NO SIGNAL INPUT  
 CONDITION.  
 CIRCUIT AND PARTS ARE SUBJECT TO CHANGE WITHOUT PRIOR  
 NOTICE.

**WARNING:**  
 Parts marked with this symbol  have critical characteristics.  
 Use ONLY replacement parts recommended by the manufacturer.

**CAUTION:**  
 Before returning the unit to the customer, make sure you make either (1) a  
 leakage current check or (2) a line to chassis resistance check. If the leakage  
 current exceeds 0.5 milliamperes, or if the resistance from chassis to either side  
 of the power cord is less than 460 Kohms, the unit is defective.

**WARNING:**  
 DO NOT return the unit to the customer until the problem is located and  
 corrected.

7

8

9

10

11

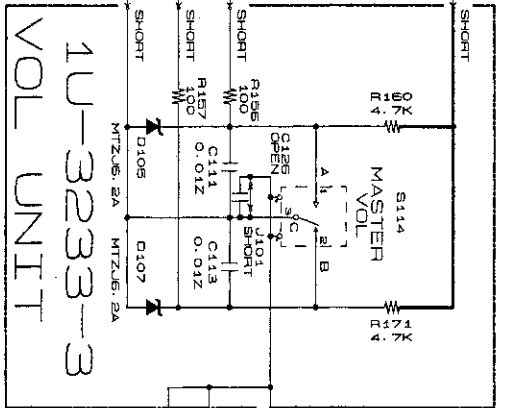
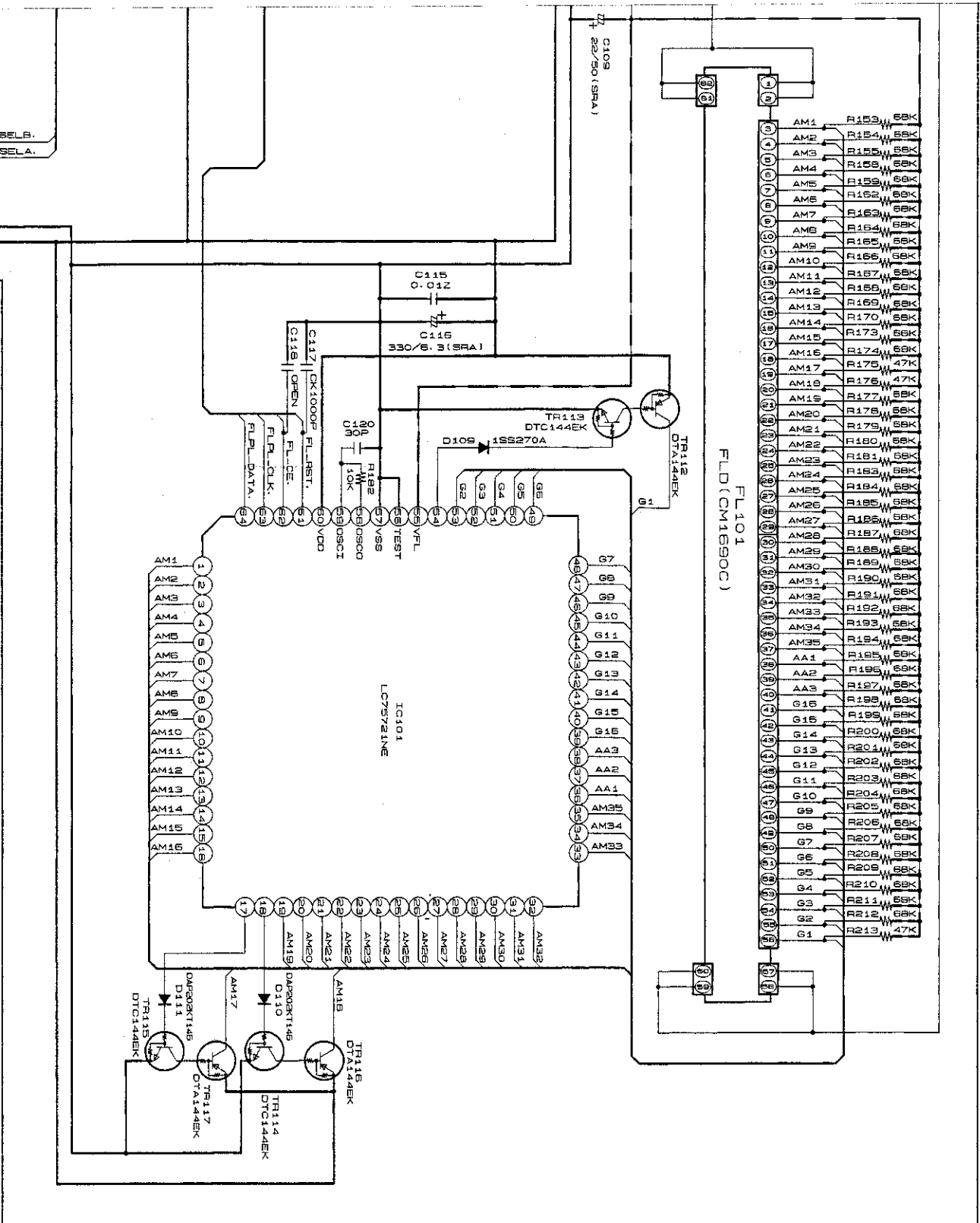

1	K1	K2	K3
2	POWER	SP A	SP B
3	SOURCE	INPUT MODE	STATUS
4	TUNER PRESET	ANALOG	SURROUND MODE
5	—	EXT. IN	SURROUND PARAMETER
6	—	VIDEO SELECT	CH. VOL
7	—	MONITOR	TONE CONTROL

+B LINE  
 -B LINE

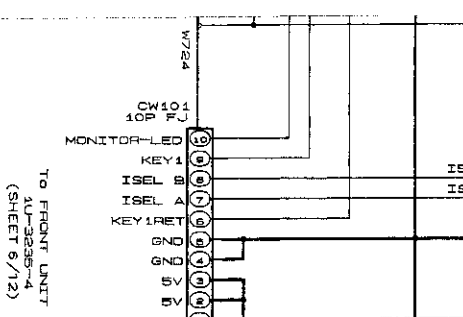

TO FRONT UNIT  
 1U-3233-4  
 (SHEET 8/12)

SCHEMATIC DIAGRAMS (11/12)  
 1U-3233-2 DISPLAY UNIT  
 1U-3233-3 VOL UNIT



SCHEMATIC DIAGRAMS (12/12)

1 2 3 4 5 6

1U-3232-2  
C. VIDEO UNIT

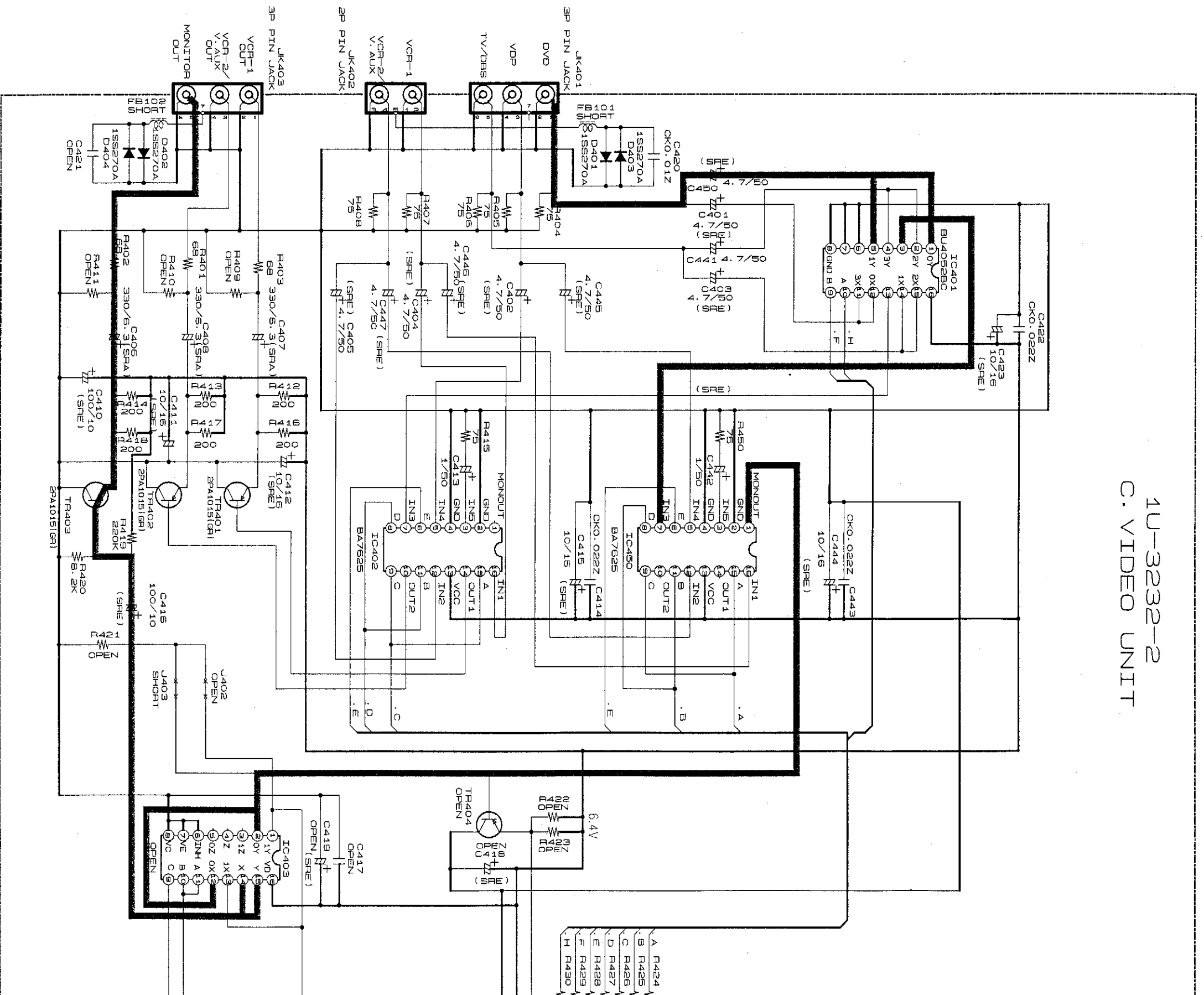

**NOTICE**  
ALL RESISTANCE VALUES IN OHM, K=1,000 OHM M=1,000,000 OHM  
ALL CAPACITANCE VALUES IN MICRO FARAD. P=MICRO-MICRO FARAD  
EACH VOLTAGE AND CURRENT ARE MEASURED AT NO SIGNAL INPUT  
CONDITION.  
CIRCUIT AND PARTS ARE SUBJECT TO CHANGE WITHOUT PRIOR  
NOTICE.

**WARNING:**  
Parts marked with this symbol  have critical characteristics.  
Use ONLY replacement parts recommended by the manufacturer.

**CAUTION:**  
Before returning the unit to the customer, make sure you make a leakage current check or (2) a line to chassis resistance check. If current exceeds 0.5 milliamperes, or if the resistance from chassis to the power cord is less than 450 kohms, the unit is defective.

**WARNING:**  
DO NOT return the unit to the customer until the problem is located and corrected.

7

8

9

10

11

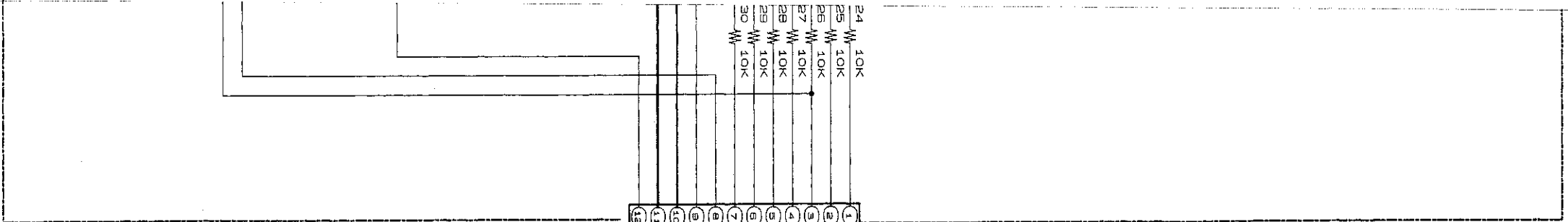

TO CONTROL UNIT  
4U-3234-1  
(SHEET 10/12)

CW121  
12P TUC-P  
A  
B  
C  
D  
E  
F  
G  
H  
S1  
C. VIDEO SEND  
H.V.  
GND  
C. VIDEO RET

— +B LINE  
— SIGNAL LINE

istics.

urer.

hecke either (1) a  
eck. If the leakage  
assis to either side  
ctive.

is located and