

DENON

Hi-Fi AV Surround Receiver

SERVICE MANUAL MODEL AVR-2700 AV SURROUND RECEIVER

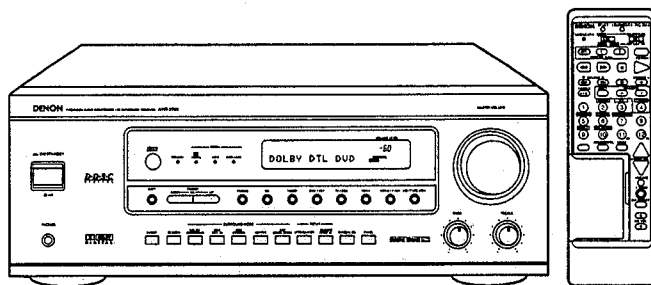

— TABLE OF CONTENTS —

WIRE ARRANGEMENT	2
DISASSEMBLY	3, 4
BLOCK DIAGRAM	5
LEVEL DIAGRAM	6
ADJUSTMENT	6-8
FUNCTION OF NEW CIRCUIT	9-11
SEMICONDUCTORS	12-28
PRINTED WIRING BOARD	29-33
NOTE FOR PARTS LIST	34
PARTS LIST OF P.W.B. UNIT ASS'Y	34-45
EXPLODED VIEW OF CHASSIS AND CABINET	46
PARTS LIST OF EXPLODED VIEW	47
WIRING DIAGRAM	48
SCHEMATIC DIAGRAM	49-57
REMOTE CONTROL UNIT (RC-844)	59-60
SCHEMATIC DIAGRAM	59
EXPLODED VIEW	60
PARTS LIST	60

• Some illustrations using in this service manual are slightly different from the actual set.

NIPPON COLUMBIA CO., LTD.

SAFETY PRECAUTIONS

The following check should be performed for the continued protection of the customer and service technician.

LEAKAGE CURRENT CHECK

Before returning the unit to the customer, make sure you make either (1) a leakage current check or (2) a line to chassis resistance check. If the leakage current exceeds 0.5 milliamps, or if the resistance from chassis to either side of the power cord is less than 460 kohms, the unit is defective.

WIRE ARRANGEMENT

In case of wires require unclasping or loosening to move the location the perform adjustment or part replacement, be sure to rearrange them neatly to restore properly in the same location as they were originally placed, or causing to produce a noise may occasionally occur.

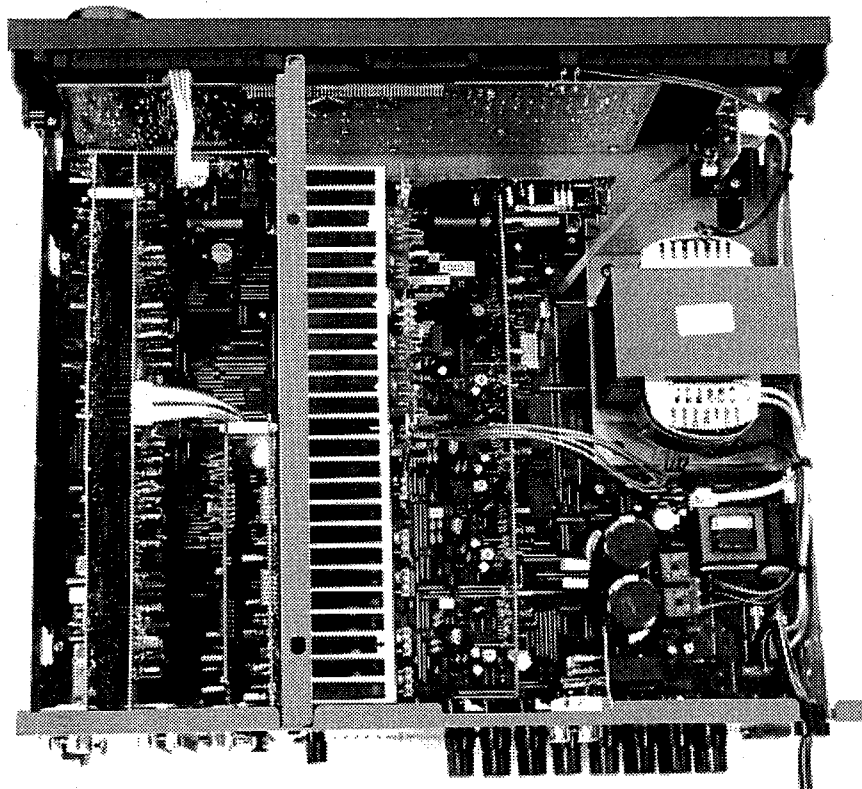

DISASSEMBLY

(Follow the procedure below in reverse order when reassembling)

Front Aluminium Panel

1. Pull out 3 Knobs.
2. Remove 4 screws ① and ②.
3. Unfasten 3 upper hooks and 2 lower hooks.

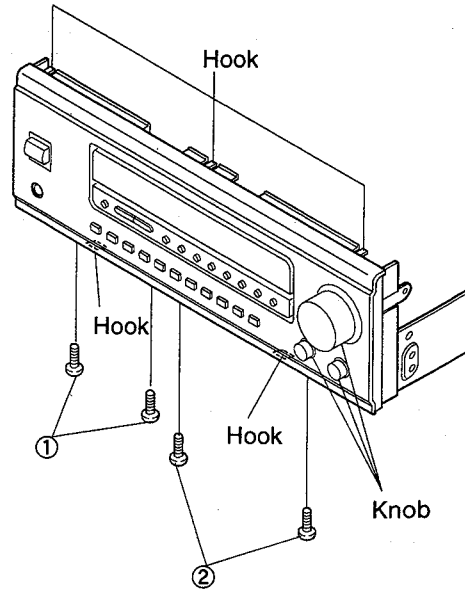

Front Mold Panel

1. Remove 4 screws ③, ④.
2. Detach the Front Mold Panel straightforward in the arrow direction as it connects with connectors.

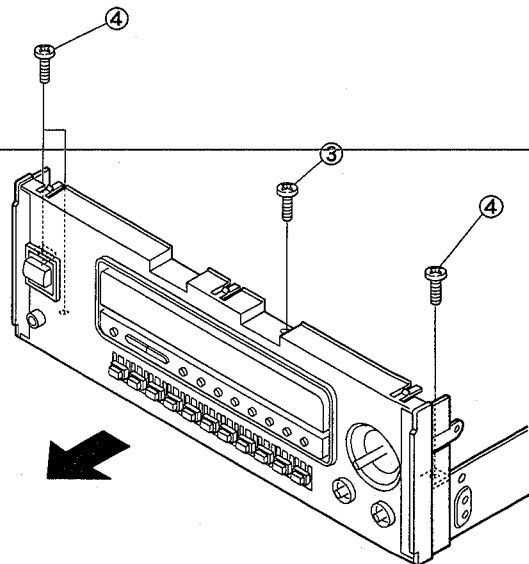

● Disassembling P.W.Board

3. Remove 3 nuts ⑤ and 10 screws ⑥, ⑦, ⑧.

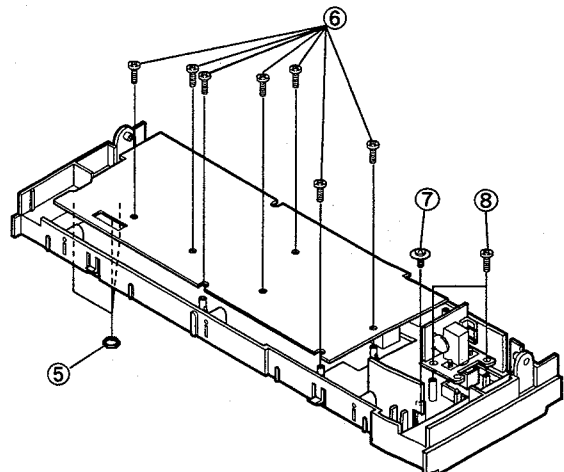

Tuner/Vr, Audio In/DSP, Video and S-Video

1. Remove 28 screws ⑦, ⑧.
2. Disconnect the connector, pulling the objective Unit in the arrow direction.

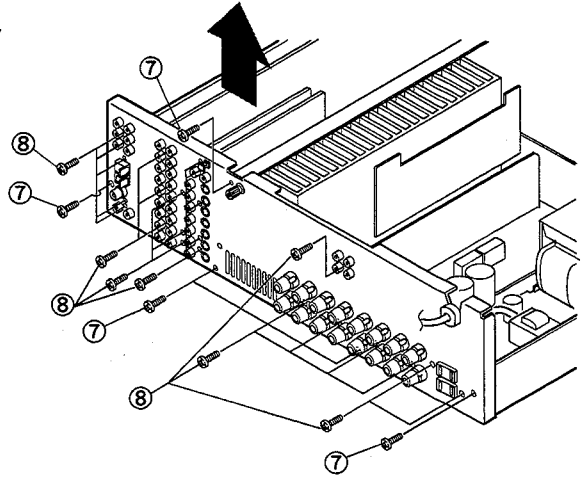

Amp Unit

1. Remove 1 screws ⑨.
2. Disconnect from the connector, pulling the Amp Unit in the arrow direction ①.

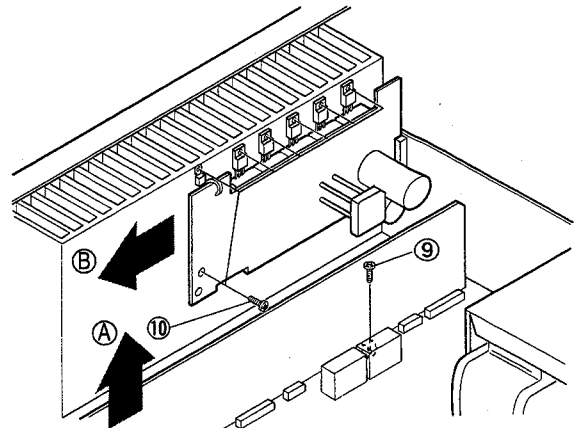

Regulator Unit

1. Remove 7 screw ⑩.
2. Disconnect from the connector, pulling the Regulator Unit direction ②.

When Maintenance for Control Unit (1U-3107-1) and Power Unit (1U-3108-1)

1. Unfasten the Front Aluminium Panel.
2. Remove 17 screws ⑪, ⑫, ⑬.
3. Unfasten the hooks of Holder ④.
4. Then separate Chassis only, and by standing it in the arrow direction, it is possible to check with power on.

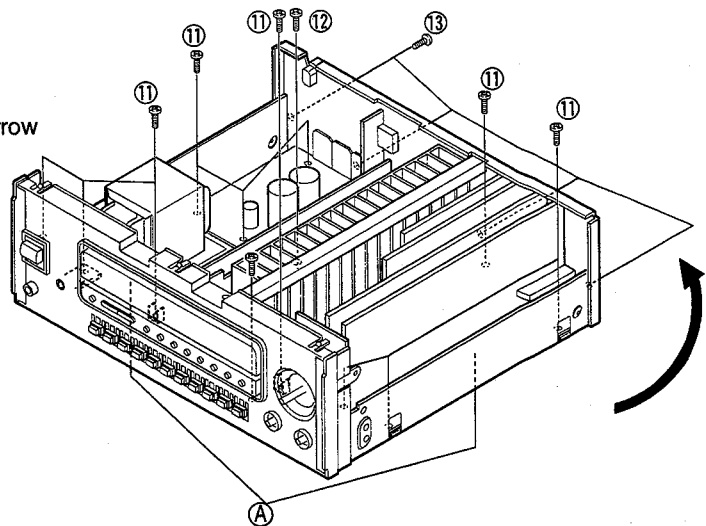

BLOCK DIAGRAM

1 2 3 4 5 6 7 8

VIDEO SECTION

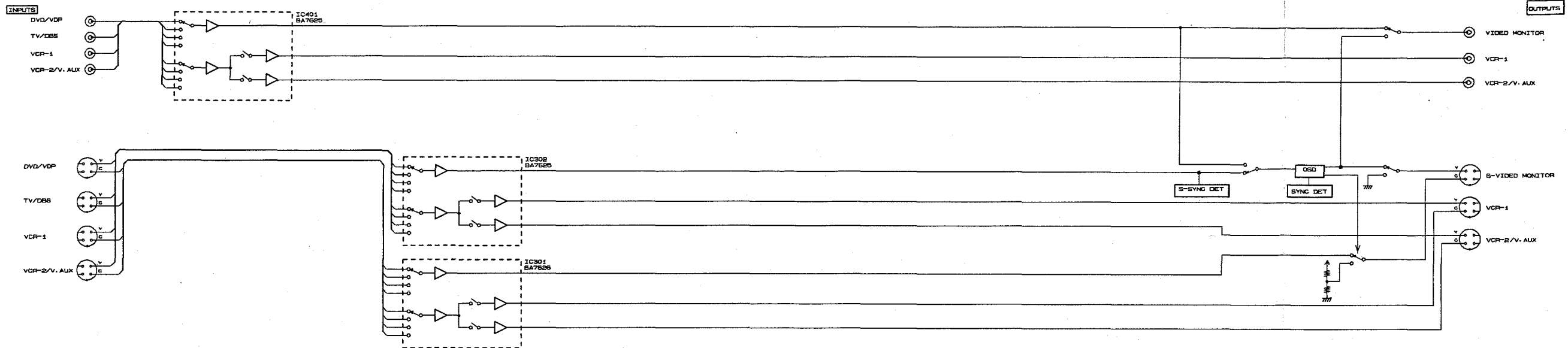

AUDIO SECTION

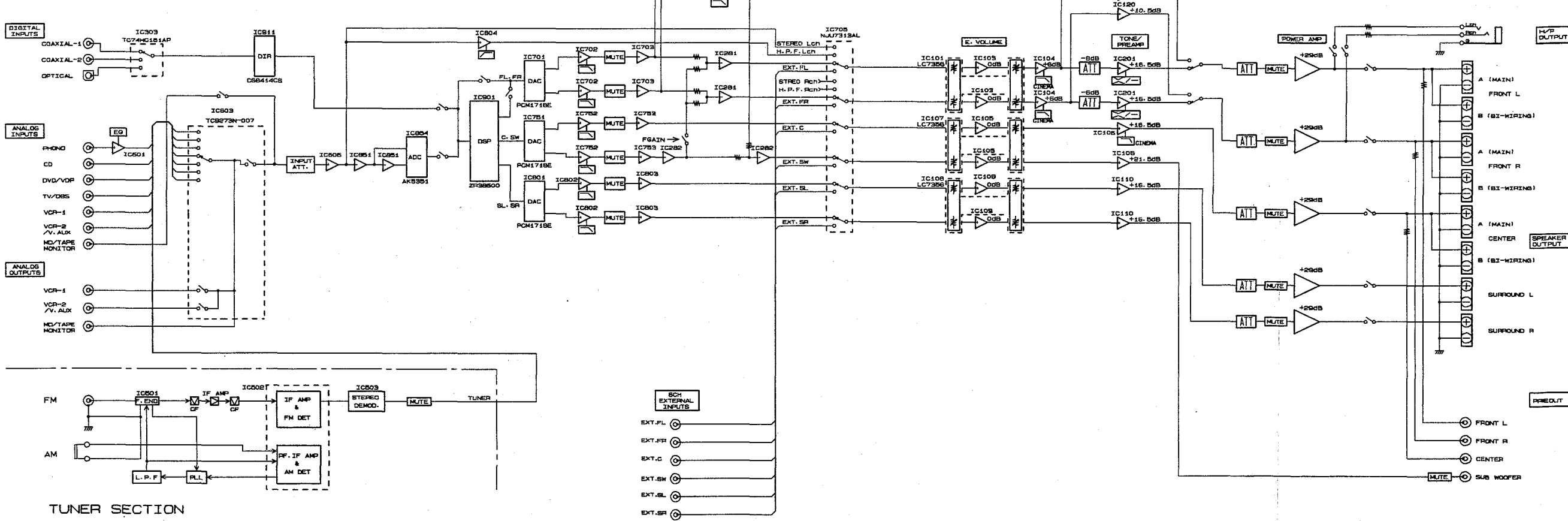

TUNER SECTION

A B C D E

LEVEL DIAGRAM

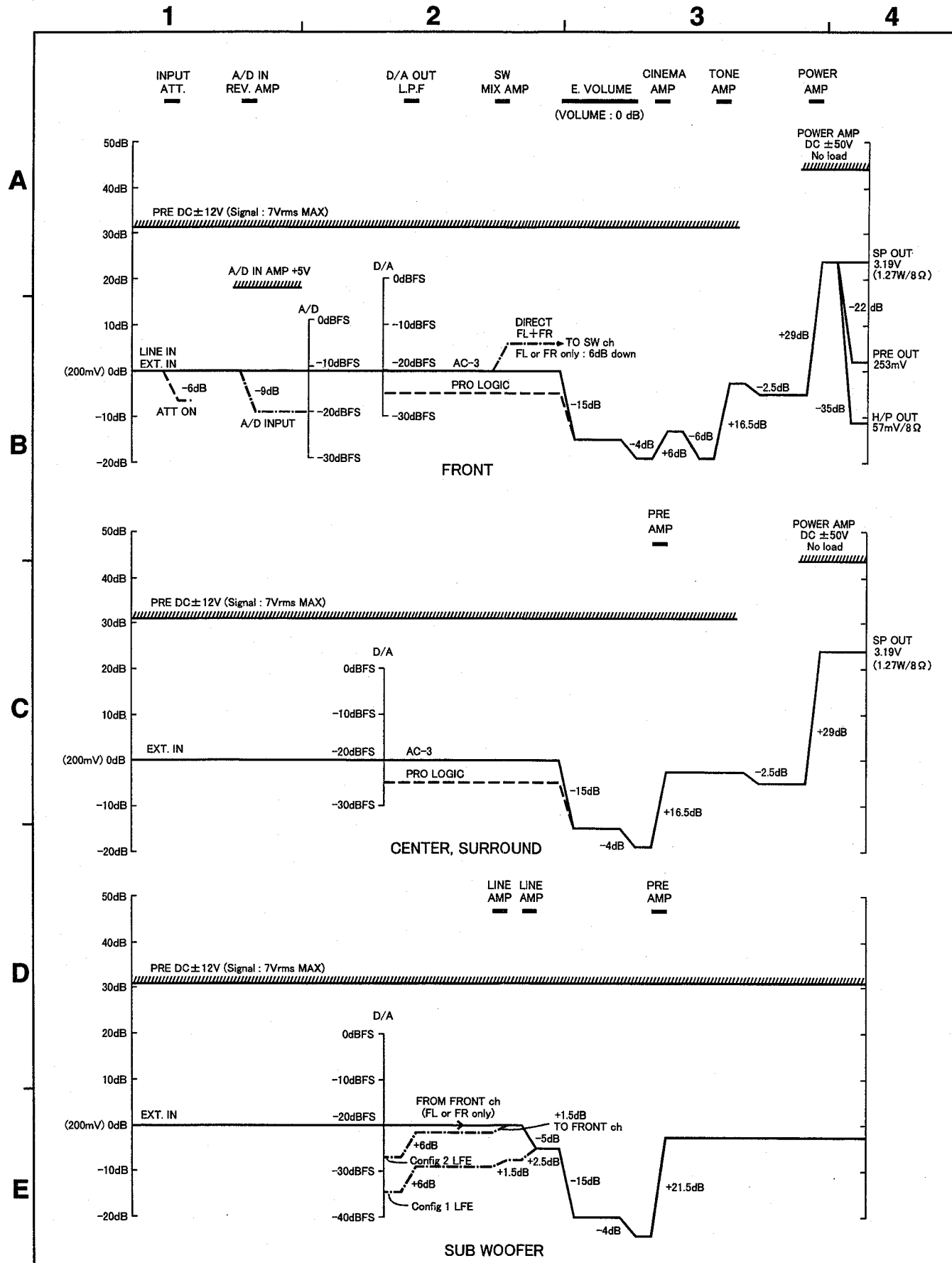

ADJUSTMENT

Tuner Section

CONNECTION DIAGRAM OF MEASURING INSTRUMENTS

● FM

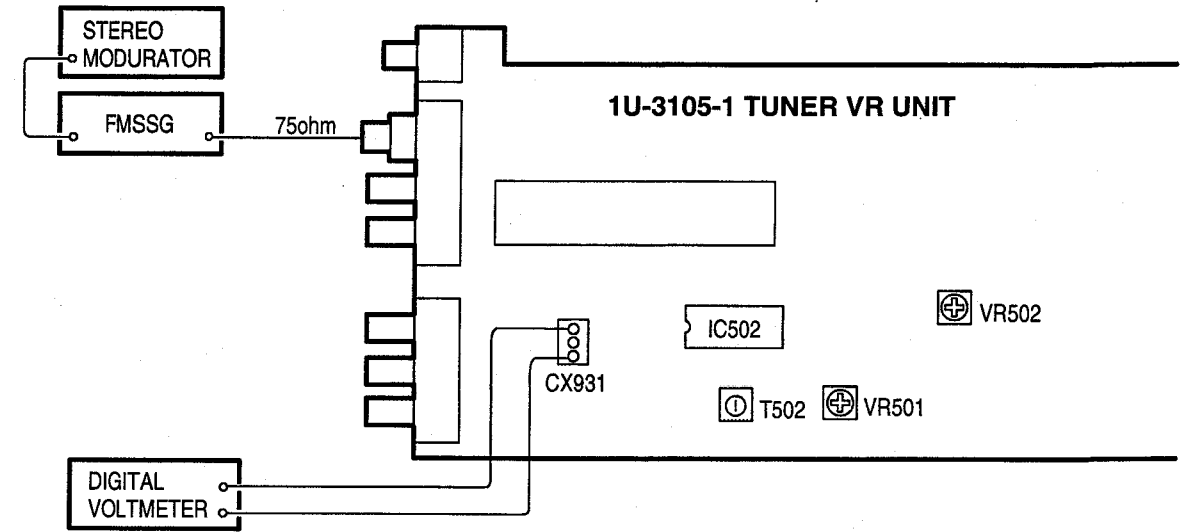

● AM

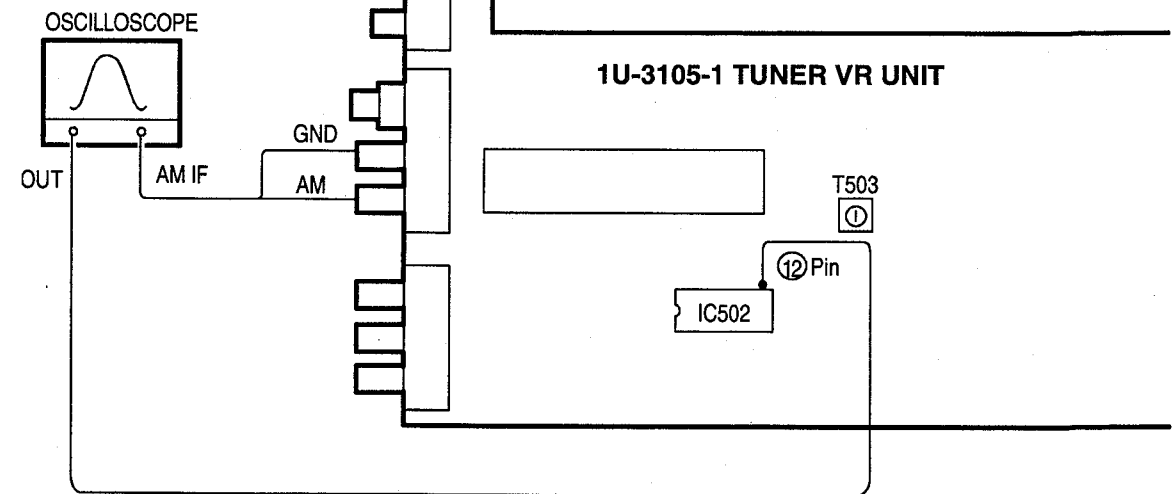

FM/MPX ALIGNMENT

Step	Alignment Item	Tuning Frequency Setting	Input			Output			Adjust		Remarks	
			Type	Frequency	Input Level	Modulation	Coupling	Type	Connect to	Points		Adjust to
1	Tuning Center	98.1 MHz	FM SSG	98.1 MHz	60 dB?	None	Antenna Terminal	Digital Voltmeter	CX931	T502	± 50mV	Function : FM Mode : Auto
2	Separation	98.1 MHz	FM SSG	98.1 MHz	60 dB?	Stereo (L) 1KHz 100%	Antenna Terminal	AC Voltmeter	AUDIO OUT Terminal (R)	VR502	Maximum Separation	—
3	Signal Level	98.1 MHz	FM SSG	98.1 MHz	20 dB?	Off	Antenna Terminal	—	—	VR501	Light "TUNED" FLD Character	—

AM ALIGNMENT

Step	Alignment Item	Frequency	Input	Output			Remarks
				Type	Connect to	Points	
1	IF	—	IF SWEEP (Input level is not over to work A.G.C.)	Oscilloscope	IC502 12Pin	T503	Maximum height and best symmetry curve

Audio Section

Idling Current (1U-3108-1)

Required measurement equipment : DC Voltmeter

Arrangement

- (1) Avoid direct blow from an air conditioner or an electric fan, and adjust the unit at normal room temperature 15 °C ~ 30 °C (59 °F ~ 86 °F).
- (2) Presetting
 - POWER (Power source switch) → OFF
 - BASS, TREBLE (Tone control) → FLAT: (Controls to center)
 - SPEAKER (Speaker terminal) → No load (Do not connect speaker, dummy resistor, etc.)

Adjustment

- (1) Remove top cover and set VR501, VR502, VR503, VR504, VR505, on 1U-3108-1 (Power Unit) at counterclockwise (\odot) fully.
- (2) Connect DC Voltmeter to test points (FRONT-Lch: TP501, FRONT-Rch: TP502, CENTER ch: TP505, SURROUND-Lch: TP503, SURROUND-Rch: TP504).
- (3) Connect power cord to AC Line, and turn power switch "ON".
- (4) Presetting.

MASTER VOLUME	: "--" counterclockwise (\odot min.)
MODE	: 5CH STEREO
FUNCTION	: CD
- (5) Allow 2 minutes, and turn VR501 clockwise (\odot) and adjust the TEST POINTS voltage to 1.5 mV \pm 0.5 mV DC.
- (6) After 10 minutes from preset, turn VR501 to set the voltage to 3 mV \pm 0.5 mV DC.
- (7) Adjust the Variable Resistors of other channels in the same way.

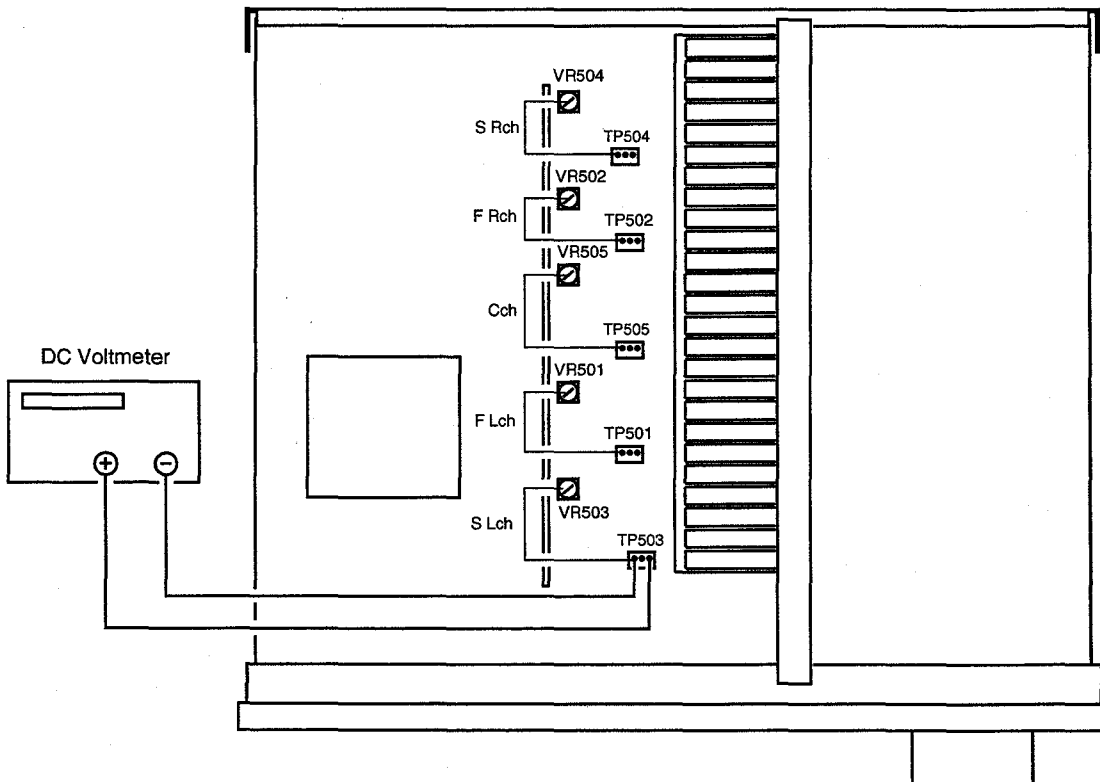

FUNCTION OF NEW CIRCUIT

Circuit Description

DOLBY DIGITAL (AC-3)

DOLBY DIGITAL (AC-3) is a format of new surround signal reproduces maximum 5 channels, i. e. FRONT-LEFT, -RIGHT, CENTER and SURROUND-LEFT, -RIGHT ;plus exclusive subwoofer signal (0.1 ch), totally 5.1 channels from the exclusive digital signal.

Following are the featuring points of DOLBY DIGITAL (AC-3).

- (1) Makes surround channel into stereo.
- (2) Provides optimum separation due to independent processing of each channel signal.
(DOLBY DIGITAL: More than 80 dB, PRO LOGIC: Approx. 25~40 dB)
- (3) Resultant surpassed orientation feeling and movement feeling obtained from flat frequency characteristic.
(DOLBY DIGITAL: 20Hz~20kHz all channels, PRO LOGIC: 20 Hz~20 kHz FRONT, CENTER channels 20 Hz~7 kHz SURROUND channels)
- (4) With the high-efficient signal coding technique, one digital cable permits transmission maintaining the above features.

Comparative Diagram of PRO LOGIC and DOLBY DIGITAL

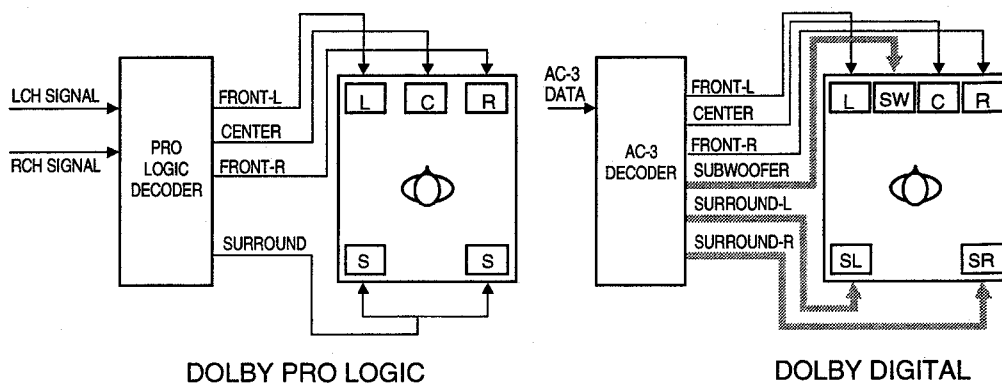

The DOLBY DIGITAL (AC-3) input signal is a composite signal composed of universal optical or coaxial digital format (IEC958) and "AC-3 exclusive" digital signal. It is connected in the same way as ordinary optical or coaxial digital signal connection. AVR-2700 adapts itself to the DOLBY DIGITAL (AC-3) or other signal (PCM) automatically corresponding to the signal inputted. The applied signal to each input terminal is delivered to DSP (IC901) through input selector (IC303) and executed Dolby digital decode processing. The DOLBY DIGITAL (AC-3) data and PCM data are transferred on a common signal line.

DSP (IC901) performs AC-3 decoding process, DOLBY PRO LOGIC process and PCM digital process and PCM digital process by shifting. Decoded signal to each channel after passed through DSP1 (IC901) is D/A converted and delivered to volume control.

Block Diagram of AC-3, PCM Input Section

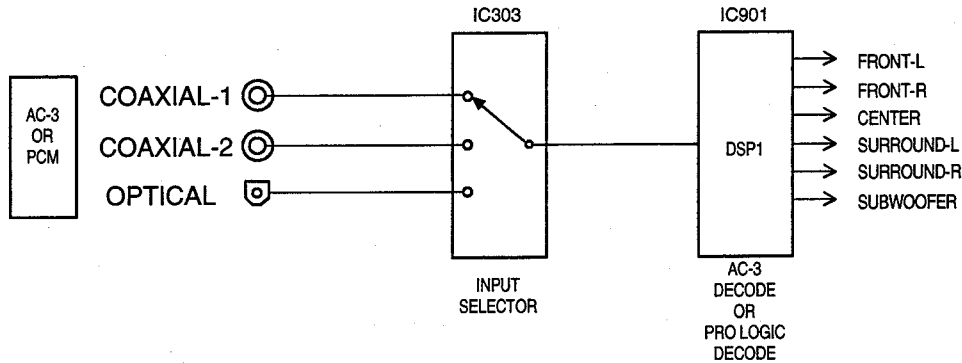

CONTROL ADVISABILITY OF EACH MODE

	FRONT L LEV.	FRONT R LEV.	CENTER LEVEL	SURROUND L LEVEL	SURROUND R LEVEL	S. WOOFER LEVEL	INPUT ATTENUATOR	ROOM SIZE	EFFECT LEVEL	DELAY TIME	CINEMA EQ.	D. COMP.	TEST TONE
DIRECT	○	○	X	X	X	○*3	○*4	X	X	X	X	○*5	○*6
STEREO	○	○	X	X	X	○*3	○*4	X	X	X	X	○*5	
6CH EXT. IN	○	○	○*1	○*2	○*2	○*3	X	X	X	X	X	X	
5CH STEREO	○	○	○*1	○*2	○*2	○*3	○*4	X	X	X	X	X	
DOLBY AC-3 or DOLBY PROLOGIC	○	○	○*1	○*2	○*2	○*3	○*4	X	X	X	○	○*5	
MONO MOVIE	○	○	○*1	○*2	○*2	○*3	○*4	○	○	X	X	X	
ROCK ARENA	○	○	○*1	○*2	○*2	○*3	○*4	○	○	X	X	X	
JAZZ CLUB	○	○	○*1	○*2	○*2	○*3	○*4	○	○	X	X	X	
VIDEO GAME	○	○	○*1	○*2	○*2	○*3	○*4	○	○	X	X	X	
MATRIX	○	○	○*1	○*2	○*2	○*3	○*4	X	X	○	X	X	

○ : Feasible to control X : Infeasible to control

- *1 : According to the contents of set up menu, when no center speaker is provided, with no controlling and sets - ○○ data to center electronic volume.
- *2 : According to the contents of set up menu, when no surround speaker is provided, with no controlling and sets - ○○ data to surround electronic volume.
- *3 : According to the contents of set up menu, when no woofer is provided, with no controlling and sets - ○○ data to woofer electronic volume.
- *4 : Feasible to control only at analog input. Note that, this function corresponds to each input channel.
- *5 : Feasible to control only at AC-3 input.
- *6 : Feasible to control TEST TONE in all modes of set up menu.

Additional note : Each mode's FRONT/CENTER/SURROUND/S. WOOFER DELAY should be set according to the setting contents of delay time for set up menu.

DIGITAL/ANALOG, SURROUND MODE IN EACH INPUT FUNCTION AND INITIAL SETTING OF DIGITAL FUNCTION

INPUT FUNCTION	DIGITAL/ANALOG	SURROUND MODE	DIGITAL FUNCTION
PHONO	FORCED ANALOG	STEREO	INFEASIBLE TO SET
CD	ANALOG	STEREO	COAXIAL-1
TUNER	FORCED ANALOG	STEREO	INFEASIBLE TO SET
DVD/VDP	ANALOG	DOLBY PRO LOGIC or DOLBY DIGITAL	OPTICAL-1
TV/DBS	ANALOG	STEREO	COAXIAL-2
VCR-1	ANALOG	DOLBY PRO LOGIC	OFF
VCR-2/V.AUX	ANALOG	STEREO	OFF
MD/TAPE	FORCED ANALOG	STEREO	INFEASIBLE TO SET

INITIAL SETTING OF EACH MODE

	FRONT L LEV.	FRONT R LEV	CENTER LEVEL	SURROUND L LEVEL	SURROUND R LEVEL	S. WOOFER LEVEL	INPUT ATTENUATOR	ROOM SIZE	EFFECT LEVEL	DELAY TIME	CINEMA EQ	D. COMP. *1
DIRECT	0 dB	0 dB	—	—	—	0 dB	—	—	—	—	—	OFF
STEREO	0 dB	0 dB	—	—	—	0 dB	0 dB	—	—	—	—	OFF
6CH EXT. IN	0 dB	0 dB	0 dB	0 dB	0 dB	0 dB	—	—	—	—	—	—
5CH STEREO	0 dB	0 dB	0 dB	0 dB	0 dB	0 dB	0 dB	—	—	—	—	—
DOLBY AC-3 or DOLBY PROLOGIC	0 dB	0 dB	0 dB	0 dB	0 dB	0 dB	0 dB	—	—	—	OFF	OFF
MONO MOVIE	0 dB	0 dB	0 dB	0 dB	0 dB	0 dB	0 dB	MED	10	—	—	—
ROCK ARENA	0 dB	0 dB	0 dB	0 dB	0 dB	0 dB	0 dB	MED	10	—	—	—
JAZZ CLUB	0 dB	0 dB	0 dB	0 dB	0 dB	0 dB	0 dB	MED	10	—	—	—
VIDEO GAME	0 dB	0 dB	0 dB	0 dB	0 dB	0 dB	0 dB	MED	10	—	—	—
MATRIX	0 dB	0 dB	0 dB	0 dB	0 dB	0 dB	0 dB	—	—	30m sec	—	—

*1 : Conditions in case for setting AC-3 data to ZR38600.

Others: ● Set TAPE MONITOR to OFF.

● Set VIDEO SELECT to OFF.

● Set MASTER VOL to -∞.

● Each input should be set to analog input.

● Set TEST TONE to OFF.

● In case DEFAULT is selected for SURR. PARAMETERS setting menu, sets the appropriate parameter of ROOM SIZE, EFFECT LEVEL, DELAY, CINEMA, D. COMP FRONT LEVEL, CENTER LEVEL, SURR LEVEL, SW LEVEL to the initial value of above table.

SEMICONDUCTORS

● IC's

Note: Indications before IC numbers denote P.W.B. name.

TU : Tuner, Volume, Amp Unit

VI : Video, Display Unit

CO : Control, Power Unit

PA : Power Amp Unit

AU : Audio in, DSP Unit

TMP87CS71F-**** (CO: IC113)

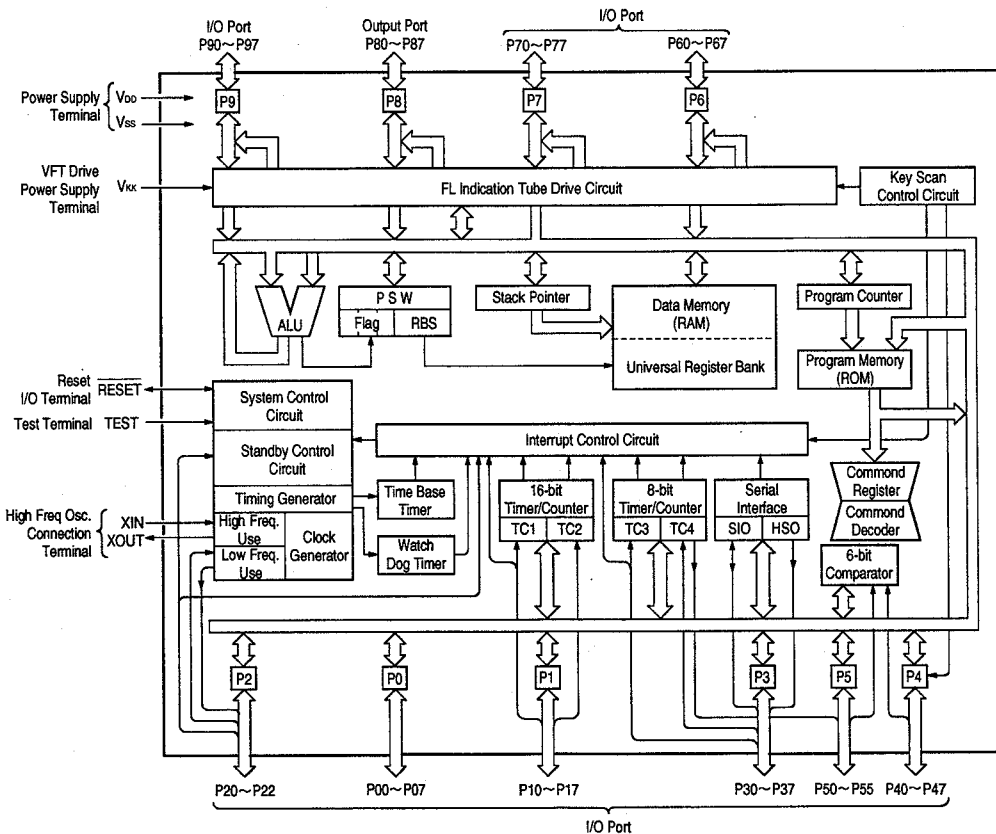
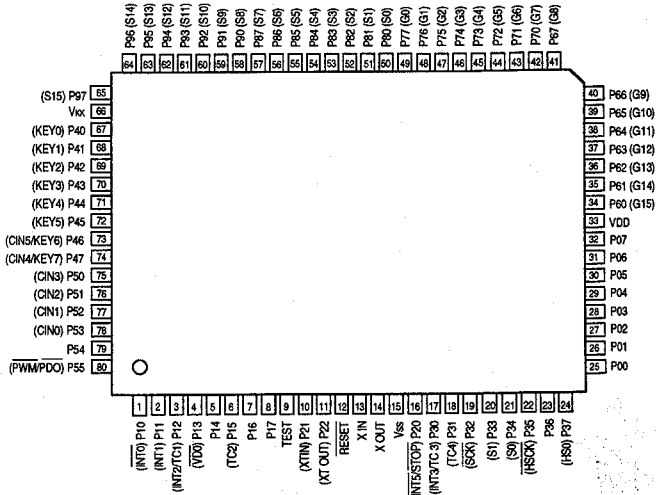
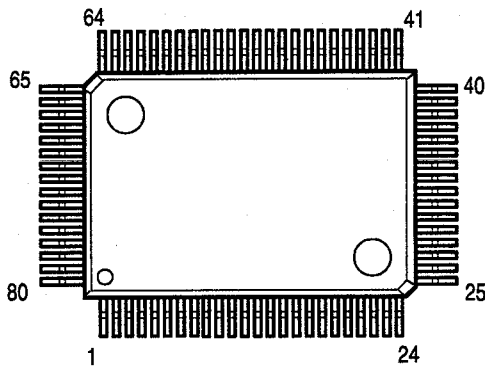

TMP87CS71F-**** (IC113) Terminal Function

Pin No.	Port Name	Symbol	I/O	Type	Op	Det	Res	Ini	Function
1	P10/INT 0	PROTECTION IN	I	—	Eu	E&L	Z	—	Protection detecting input. (L: Detection)
2	P11/INT 1	DSP CLK IN	I	—	Eu	Ed	Z	—	DSP control terminal.
3	P12/INT 2	RDS START	I	—	Eu	Ed	Z	H	RDS data input (LC7074). *E2 model only.
4	P13/DVO	STEREO/MONO	O	C	—	—	Z	L	STEREO/MONO control signal. (L: STEREO receiving)
5	P14	PLL-ST	O	C	—	—	Z	L	LM72131 control output.
6	P15/TC2	TAPE MONITOR	O	C	—	—	Z	H	Tape monitor control output. (H: Tape monitor ON).
7	P16	INPUT ATT	O	C	—	—	Z	H	Input attenuate control terminal. (L: 6dB attenuate).
8	P17	TUNED SIGNAL	I	—	Eu	Lv	Z	—	Tuning detection. (L: Tuning)
9	TEST	TEST	I	—	GND	S	—	—	Connect to ground.
10	P21/XTIN	STEREO SIGNAL	I	—	Eu	Lv	Z	—	STEREO control signal. (L: STEREO receiving)
11	P22/XTO	SCL	O	N	Eu	—	Z	H	MAIN-SUB microcomputer communication control terminal.
12	RESET	RESET	I	—	Eu	Lv	L	—	Reset input.
13	XIN	XIN	I	—	—	—	—	—	Oscillator circuit terminal. (4MHz)
14	XOUT	XOUT	O	—	—	—	—	—	Oscillator circuit terminal. (4MHz)
15	VSS	VSS	I	—	GND	—	—	—	Ground.
16	P20/INT 5	POWER OFF	I	—	Eu	Lv	Z	—	Power OFF detection terminal. (L: Power OFF)
17	P30/INT 3	REMOCON	I	—	Ed	E&L	Z	—	Remote signal input.
18	P31/TC4	SDA	O	N	Eu	S	Z	H	MAIN-SUB microcomputer communication control terminal.
19	P32/SCK	RDS CLK	I	—	—	S	Z	—	RDS clock input (LC7074). *E2 model only.
20	P33/SI	RDS DATA	I	—	—	S	Z	—	RDS data input (LC7074). *E2 model only.
21	P34/SO	RDS RES	O	N	Eu	—	Z	H	RDS reset output (LC7074). *E2 model only.
22	P35/HSCK	OSD CLK	O	N	Eu	S	Z	H	OSD control output. (M35015)
23	P36	OSD CS	O	N	Eu	—	Z	H	OSD control output. (M35015)
24	P37/HSO	OSD DATA	O	N	Eu	S	Z	L	OSD control output. (M35015)
25	P00	OSD RES	O	C	—	—	Z	H	OSD control output. (M35015)
26	P01	FL RES	O	C	—	—	Z	L	Fluorescent display control output. (LC75711NE)
27	P02	FLPL DATA	O	C	—	S	Z	H	Fluorescent display & PLL control output. (LC75711NE & LC72131)
28	P03	FLPL CLK	O	C	—	S	Z	H	Fluorescent display & PLL control output. (LC75711NE & LC72131)
29	P04	FUNC ST2	O	C	—	—	Z	L	Function control output. (NJU7313AL) 5.1CH decoder.
30	P05	FUNC CK	O	C	—	S	Z	L	Function control output. (TC9273N, NJU7313AL)
31	P06	FUNC DATA	O	C	—	S	Z	L	Function control output. (TC9273N, NJU7313AL)
32	P07	FUNC ST1	O	C	—	—	Z	L	Function control output. (TC9273N).
33	VDD	VDD	I	—	—	—	—	—	Connect to +5V power supply.
34	P60	E. VOL CE2	O	P	Id	—	L	L	Electronic volume control output. (LC7536) (Center/Sub woofer, Surround L/R)
35	P61	E. VOL CE1	O	P	Id	—	L	L	Electronic volume control output. (LC7536) (Front L/R)
36	P62	E. VOL CK	O	P	Id	—	L	H	Electronic volume control output. (LC7536)
37	P63	E. VOL DATA	O	P	Id	—	L	H	Electronic volume control output. (LC7536)
38	P64	CINEMA EQ	O	P	Id	—	L	H	Cinema Eq control output. (H: ON)
39	P65	ERR MUTE	O	P	Id	—	L	H	Pop noise prevention control terminal. (H: Power ON)
40	P66	96DET	I	—	Id	—	L	L	Sampling frequency detection terminal. (H: 96kHz)
41	P67	SELCK	O	P	Id	—	L	H	DIR control terminal. (CS8414) (H: Digital, L: Analog)
42	P70	TUNER MUTE	O	P	Id	—	H	H	Tuner mute output. (H: Mute)
43	P71	SEL	O	P	Id	—	L	H	DIR control terminal. (CS8414)
44	P72	FL CE	O	P	Id	—	L	H	Fluorescent display control output. (LC75711NE)
45	P73	STANDBY LED	O	P	Id	—	L	H	Standby indication LED drive output. (H: Lighting)
46	P74	DOLBY DIGITAL LED	O	P	Id	—	L	L	Dolby Digital indication LED drive output. (H: Lighting)
47	P75	LOCK LED	O	P	Id	—	L	L	Lock indication LED drive output. (H: Lighting)
48	P76	OVER LOAD LED	O	P	Id	—	L	L	Over load indication LED drive output. (H: Lighting)
49	P77	VOL MUTE	O	P	Id	—	L	L	Control signal at minus infinite of master volume. (L: infinite)
50	P80	SW-MUTE	O	P	Id	—	L	H	Subwoofer mute output. (L: Mute)
51	P81	SP-A	O	P	Id	—	L	H	Front speaker relay control output. (L: Mute)
52	P82	RL-C	O	P	Id	—	L	H	Center speaker relay control output. (L: Mute)
53	P83	RL-S	O	P	Id	—	L	L	Surround speaker relay control output. (L: Mute)
54	P84	H/P MUTE	O	P	Id	—	L	H	Headphone relay control output. (L: Mute)
55	P85	DIRECT	O	P	Id	—	L	H	Direct relay control output. (H: Direct)

Pin No.	Port Name	Symbol	I/O	Type	Op	Det	Res	Ini	Function
56	P86	POWER	O	P	Id	—	L	H	Power supply relay control output. (H: ON)
57	P87	AC-3 MUTE	O	P	Id	—	L	H	Digital mute control terminal (L: AC-3).
58	P90	OVL	I	—	Id	—	L	—	Over load detecting input. (H: Over load)
59	P91	AC-3 DET.	I	—	Id	—	L	—	AC-3 decode data input terminal. (L: AC-3 decode)
60	P92	F0	I	—	—	—	L	—	DIR control input terminal. (CS8414)
61	P93	F1	I	—	—	—	L	—	DIR control input terminal. (CS8414)
62	P94	F2	I	—	—	—	L	—	DIR control input terminal. (CS8414)
63	P95	CSI	I	—	Id	—	L	—	DIR control input terminal. (ZR38600) (L: PCM)
64	P96	ERR	I	—	Id	—	L	—	DIR control input terminal. (ZR38600) (H: ERR)
65	P97	S1	O	P	Id	—	L	H	Video signal switching control output.
66	VKK	VKK	I	—	—	—	—	—	Connect to ground.
67	P40/KEY0	S-MONITOR DET.	I	—	Eu	Lv	Z	—	Judgment whether S monitor is connected or not. (L: Connecting)
68	P41/KEY1	S-SIGNAL DET.	I	—	Eu	Lv	Z	—	S signal input control. (H: S signal input)
69	P42/KEY2	OSD SYNC DET.	I	—	Eu	Lv	Z	—	OSD sync switching signal. (H: External sync)
70	P43/KEY3	MVOL SELB	I	—	Eu	Lv	Z	H	Master volume setting signal. (Rotary encode)
71	P44/KEY4	MVOL SELA	I	—	Eu	Lv	Z	H	Master volume setting signal. (Rotary encode)
72	P45/KEY5	S2	O	N	Eu	—	L	—	Video signal switching control output.
73	P46/CIN5	MODE	I	—	Eu	Lv	Z	—	Export country mode switching input.
74	P47/CIN4	DAC PD	O	N	Eu	—	L	—	DAC power down control terminal. (L: Power down).
75	P50/CIN3	KEY4	I	—	Eu	Lv	Z	H	Key input 4.
76	P51/CIN2	KEY3	I	—	Eu	Lv	Z	H	Key input 3.
77	P52/CIN1	KEY2	I	—	Eu	Lv	Z	H	Key input 2.
78	P53/CIN0	KEY1	I	—	Eu	Lv	Z	H	Key input 1.
79	P54	SUB SYNC 1	I	—	Eu	Lv	Z	H	SUB microcomputer sync input.
80	P55/PMW	SO/ZORAN	I	—	Eu	Lv	Z	H	DSP data input terminal. (ZR38600)

NOTE:

Pin No. : Terminal number of microcomputer.

Port Name : The name entered in the data sheet of microcomputer.

Symbol : Symbolized interface function.

I/O : Input or out of part.

Type : Composition of port in case of output port.
"I" = Input port
"O" = Output portOp : Pull up/Pull down selection information.
"C" = CMOS output
"N" = NMOS open drain output
"P" = PMOS open drain outputDet : Indicates judging state of input port. Level detection is "LV"; Edge detection is "Ed"; Detection by both shifting is "E&L"; Serial data detection is "S" (Serial data output is also "S").
Res : State at reset.
"H" = Outputs High Level at reset
"L" = Outputs Low Level at reset
"Z" = Becomes High impedance mode at reset

Ini : Initial output state.

Function : Function and logical level explanation of signals to be interface.

TMP87CM43N-**** (AU: IC903)

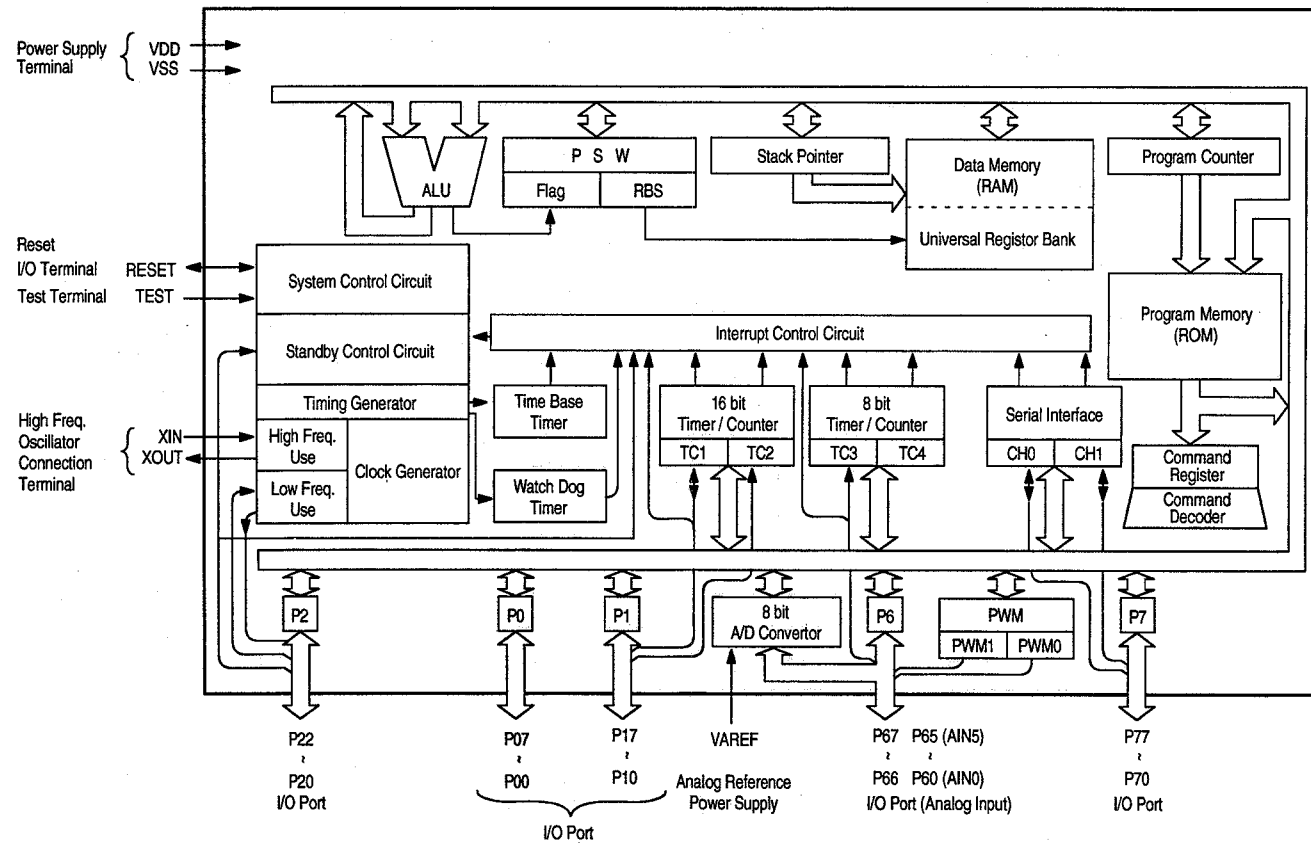
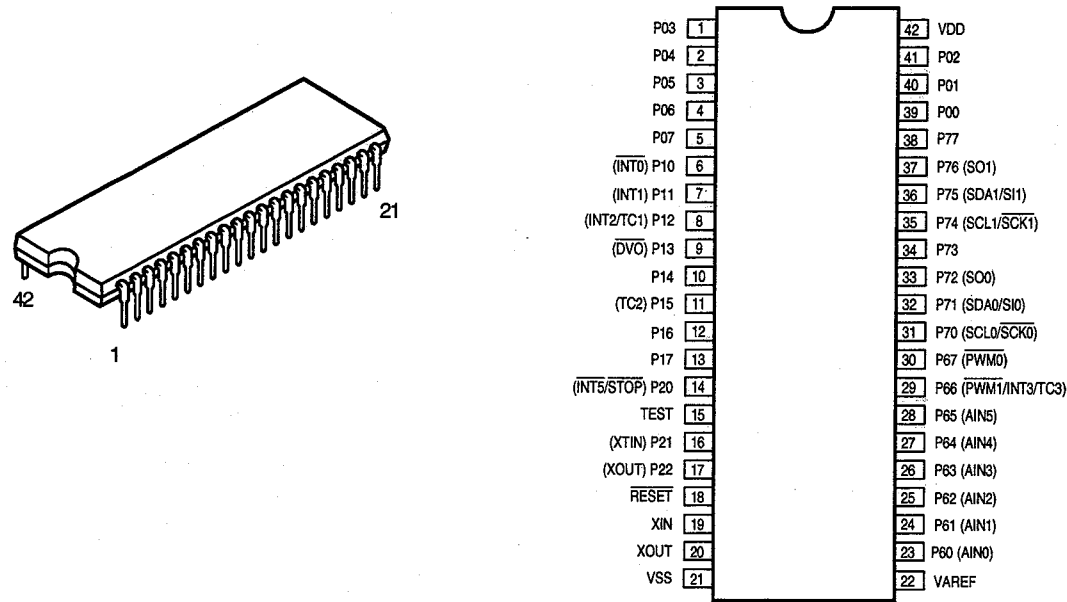

TMP87CM43N-*** Terminal Function

Pin No.	Port Name	Symbol	I/O	Type	Op	Det	Res	Ini	Function
1	P03	DSP POWER	O	C	—	—	L	L	DSP power supply control output (H: ON).
2	P04	DSP RES	O	C	—	—	Z	H	DSP control terminal (ZR38600) (L: reset).
3	P05	DSP DATA	O	C	—	S	Z	H	DSP control terminal (ZR38600).
4	P06	DSP SS	O	C	—	—	Z	L	DSP control terminal (ZR38600).
5	P07	DSP CLK	O	C	—	S	Z	H	DSP control terminal (ZR38600).
6	P10/INT 0	DIN B	O	C	—	—	Z	L	Digital input control terminal (TC74HC151).
7	P11/INT 1	DIN C	O	C	—	—	Z	L	Digital input control terminal (TC74HC151).
8	P12/INT 2	DFS 2	O	C	—	—	Z	L	DAC emphasis control terminal.
9	P13/DV0	DFS 1	O	C	—	—	Z	H	DAC emphasis control terminal.
10	P14	FGAIN	O	C	—	—	Z	H	Gain selection control terminal.
11	P15/TC2		O	C	—	—	Z	L	
12	P16		O	C	—	—	Z	L	
13	P17		O	C	—	—	Z	L	
14	P20/INT 5		O	N	—	—	Z	L	
15	TEST	TEST	I	—	GND	—	—	L	Connect with GND.
16	P21/XTIN		I	—	—	—	Z	L	Connect with GND.
17	P22/XTO		I	—	—	—	Z	L	Connect with GND.
18	RESET	RESET	I	—	Eu	Lv	L	—	Reset input.
19	XIN	XIN	I	—	—	—	—	—	Oscillator circuit (4 MHz).
20	XOUT	XOUT	O	—	—	—	—	—	Oscillator circuit (4 MHz).
21	VSS	VSS	I	—	GND	—	—	—	Connect with GND.
22	VAREF	VAREF	I	—	GND	—	—	—	Connect with GND.
23	P60	A	O	N	Eu	—	Z	L	Video input control terminal (BA7625, BA7626) (L: Select).
24	P61	B	O	N	Eu	—	Z	L	Video input control terminal (BA7625, BA7626) (L: Select).
25	P62	C	O	N	Eu	—	Z	L	Video input control terminal (BA7625, BA7626) (L: Select).
26	P63	D	O	N	Eu	—	Z	L	Video input control terminal (BA7625, BA7626) (L: Select).
27	P64	E	O	N	Eu	—	Z	L	Video input control terminal (BA7625, BA7626) (L: Select).
28	P65		I	—	—	—	Z	L	Connect with GND.
29	P66		I	—	—	—	Z	L	Connect with GND.
30	P67		I	—	—	—	Z	L	Connect with GND.
31	P70/SCL	SCL	I	—	Eu	S	Z	—	MAIN-SUB microcomputer communication control terminal.
32	P71/SDA	SDA	I	—	Eu	S	Z	—	MAIN-SUB microcomputer communication control terminal.
33	P72	SUB SYNC1	O	N	Eu	—	Z	H	SUB microcomputer sync output.
34	P73	B. DOWN	I	—	Eu	Lv	Z	—	Detect for stopping power supply (L: stopping power supply).
35	P74		I	—	—	—	Z	L	Connect with GND.
36	P75		I	—	—	—	Z	L	Connect with GND.
37	P76		I	—	—	—	Z	L	Connect with GND.
38	P77		I	—	—	—	Z	L	Connect with GND.
39	P00	A/D RES	O	C	—	—	Z	L	A/D control terminal (L: reset, H: analog input).
40	P01		O	N	—	—	Z	L	
41	P02	DIRECT	O	C	—	—	Z	L	Direct mode control terminal (H: Direct).
42	VDD	VDD	I	—	—	—	Z	—	Connect with +5V.

LC7536
(TU: IC101, 107, 108)

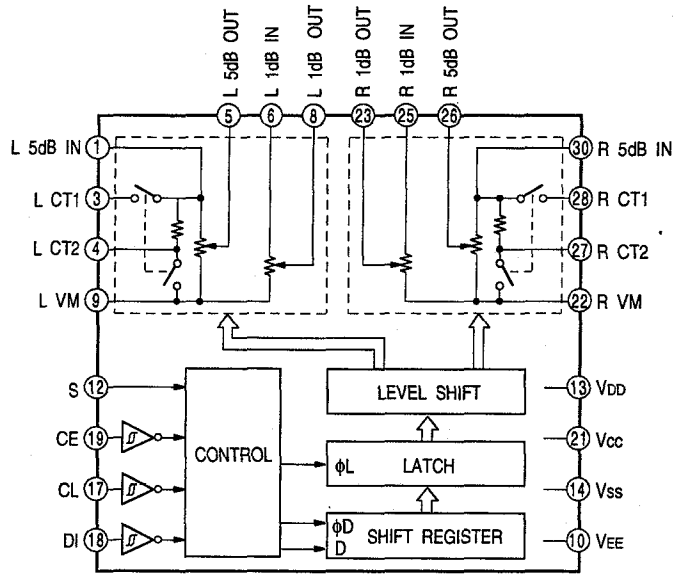
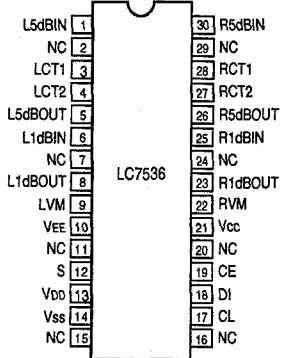
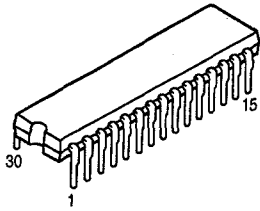

LC7536 Terminal Function

Pin No.	Symbol	I/O	Function
1	L 5dB IN	I	Input terminal for 5dB step attenuator, it should be driven with low impedance path.
2	NC	-	No connection.
3	L CT1	I	For loudness control, connect a capacitor between CT1 and 5dB IN with high frequency compensation, and also connect a capacitor between CT2 and Vm with low frequency compensation.
4	L CT2		
5	L 5dBOUT	O	Output terminal for 5dB step attenuator with approx. 1Mohm load impedance.
6	L 1dBIN	I	Input terminal for 1dB step attenuator, it should be driven with low impedance.
7	NC	-	No connection.
8	L 1dBOUT	O	Output terminal for 1dB step attenuator with approx. 47kohm ~ 1Mohm load impedance.
9	L Vm		Common terminal for volume control.
10	VEE	I	Connect to power supply.
11	NC	-	No connection.
12	S		Selection terminal for address code during data format.
13	VDD	I	Connect to power supply (Pay attention to the rising time so that Vcc does rise up faster than VDD when the power turns).
14	VSS	I	Connect to power supply.
15	NC	-	No connection.
16	NC	-	No connection.
17	CL	I	Input terminal for controlling LC7536 serial data with 0 ~ 5V amplitude.
18	DI		
19	CE		
20	NC		
21	Vcc	I	Connect power supply (Pay attention to the rising time so that Vcc does not rise up faster than VDD when the power turns).
22	R Vm		Common terminal for volume control.
23	R 1dBOUT	O	Output terminal for 1dB step attenuator with approx. 47kohm ~ 1Mohm load impedance.
24	NC	-	No connection.
25	R 1dBIN	I	Input terminal for 1dB step attenuator, it should be driven with low impedance.
26	R 5dBOUT	O	Output terminal for 5dB step attenuator with approx. 1Mohm load impedance.
27	R CT2	I	For loudness control, connect a capacitor between CT1 and 5dBIN with high frequency compensation, and also connect a capacitor between CT2 and Vm with low frequency compensation.
28	R CT1		
29	NC	-	No connection.
30	R SdBIN	I	Input terminal for 5dB step attenuator, it should be driven with low impedance path.

M35015-204SP
(VI: IC308)

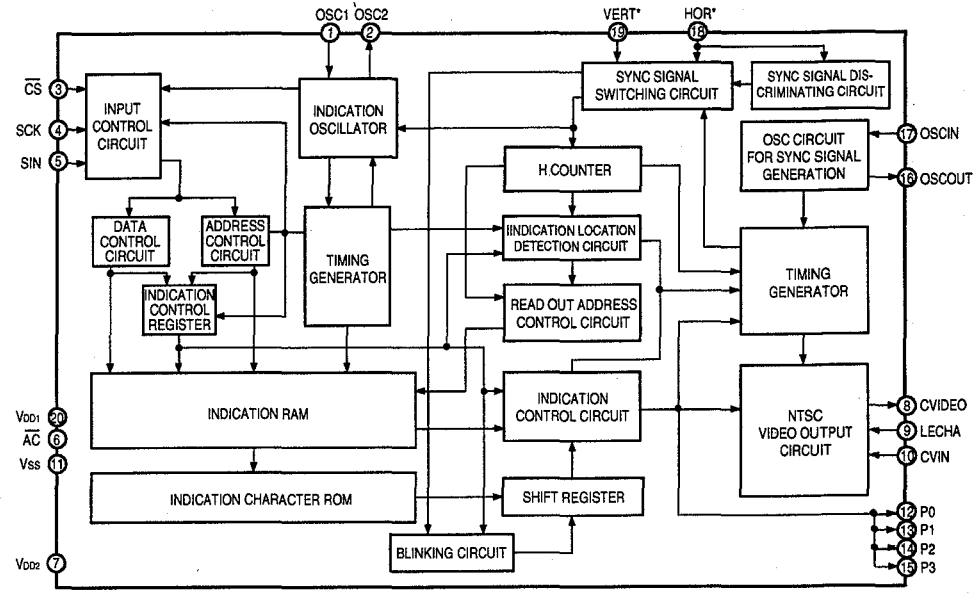
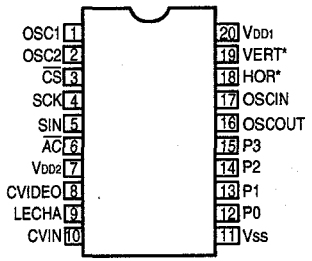
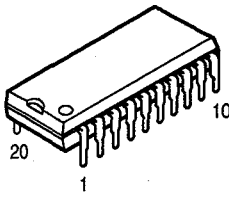

M35015-204SP Terminal Function

Pin No.	Symbol	Name	I/O	Function
1	OSC1	Osc. circuit ext.	I	External terminal for indication oscillator circuit. Standard OSC. freq. is approx. 7MHz. With this OSC. freq., decides horizontal indicatin and character width.
2	OSC2	terminal.	O	
3	\overline{CS}	Chip select input	I	Chip select terminal and turns to "L" when transfer serial data. Hysteresis input. Pull up resistor is built-in.
4	SCK	Serial clock input	I	Takes in serial data of SIN at SCK rise when CS terminal is in "L". Hysteresis input. Pull up rersist is built-in.
5	SIN	Serial data input	I	Serial input of register for indication control and data, and address for indication data memory. Hysteresis input. Pull up rersistor is built-in.
6	\overline{AC}	Auto-clear input	I	Resets internal circuit of IC at "L" mode. Hysteresi input. Pull up resistor is built-in.
7	VDD2	Power supply	—	Power supply terminal of analog system. Connect to +5V.
8	CVIDEO	Combined video output	O	Output terminal of combined video signal. Outputs 2Vp-p combined signal. Character output, etc. Overlap CVIN signal and outputs at superimpose.
9	LECHA	Character level input	I	Input terminal deciding character output level in combined video signal. color of character is white.
10	CVIN	Combined video input	I	Input terminal of external combined video signal. Character output etc. overlap this external combined video signal.
11	VSS	Ground	—	Ground terminal. Connect to GND.
12	P0	Output port p0	O	General output or character background signal BL NK1* output is switchable. Polarity can be selected at ROM mask.
13	P1	Output port P1	O	General output or character background signal CO1* output is switchable. Polarity can be selected at ROM mask.
14	P2	Output port P2	O	General output or character background signal BLNK2* output is switchable. Polarity can be selected at ROM mask.
15	P3	Output port P3	O	General output or character background signal CO2* output is switchable. Polarity can be selected at ROM mask.
16	OSCOUT	Ext. terminal for sync sig. OSC. Circuit	O	Terminal for external use of sync signal OSC. circuit. Use the freq.: 14.32MHz at NTSC system, 17.73MHz at PAL. system, 14.30MHz at MPAL system.
17	OSCIN		I	
18	HOR*	Horizontal sync signal	I	Inputs horizontal sync signal. Hysteresis input.
19	VERT*	Vertical sync signal	—	Input vertical sync signal. Hysteresis input. Polarity can be selected at ROM mask.
20	VDD1	Power supply	I	Power supply terminal of digital system. Connect to +5V.

ZR38600 (AU: IC901)

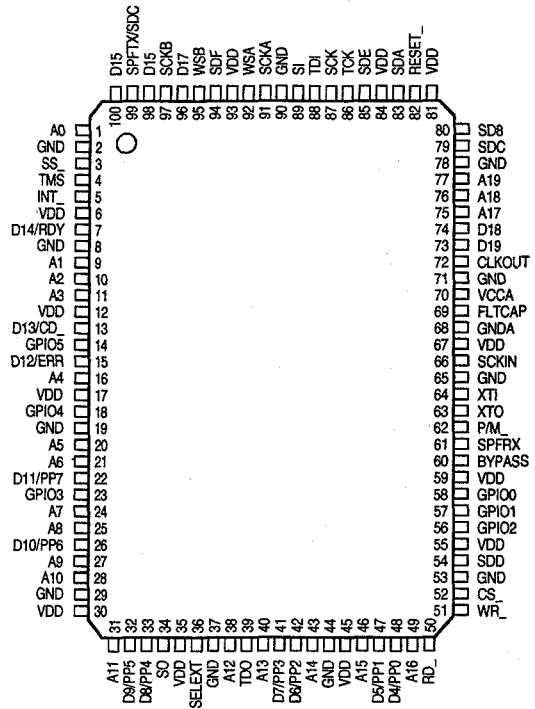
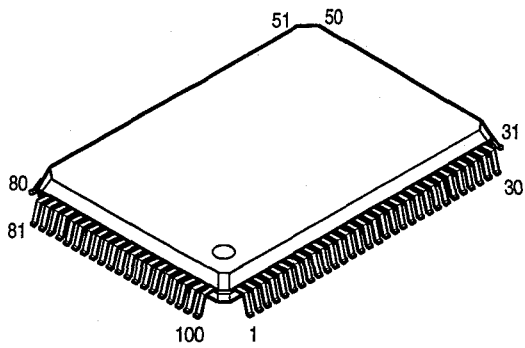

NJU7313AL (TU: IC705)

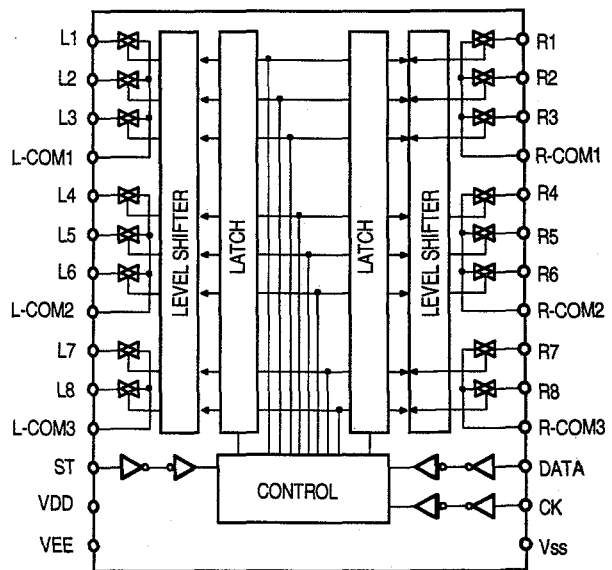
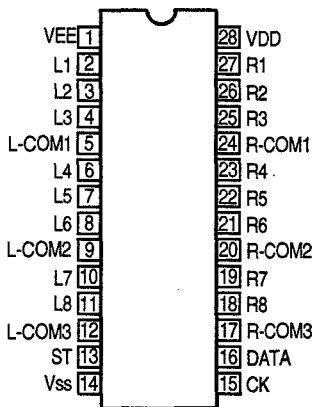
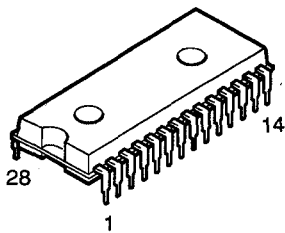

AK5351 (AU: IC854)

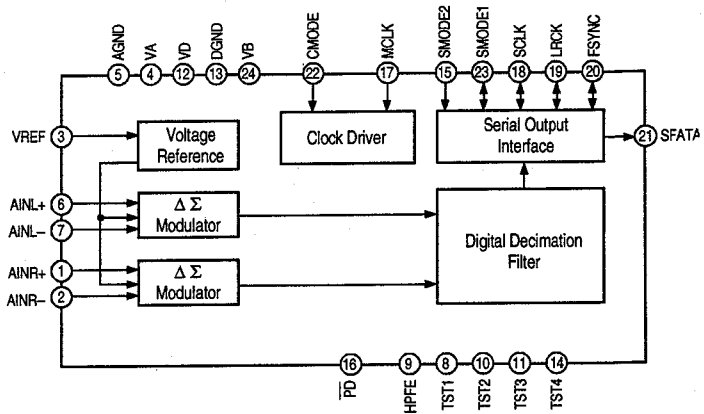
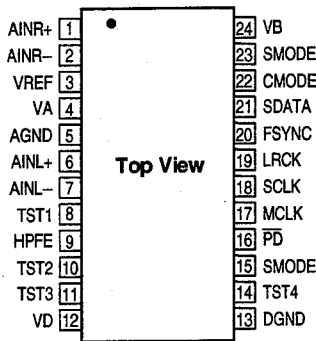

AK5351 Terminal Function

Pin No.	Symbol	I/O	Function
1	AINR+	I	Rch analog non-inverted input pin.
2	AINR-	I	Rch analog inverted input pin
3	VREF	O	Vref. output pin (VA-2.6V)
4	VA	—	Analog part power supply pin (+5V)
5	AGND	—	Analog ground pin
6	AINL+	I	Lch analog non-inverted input pin
7	AINL-	I	Lch analog inverted input pin
8	TST1		Test pin
9	HPFE	I	Hi-pass filter enable pin, "H": ON, "L": OFF
10	TST2		Test pin
11	TST3		Test pin
12	VD	—	Digital part power supply pin (+5V)
13	DGND	—	Digital ground pin
14	TST4		Test pin
15	SMODE2	I	Interface clock select pin
16	PD	I	Power down pin, "L": power down mode
17	MCLK	I	Master clock input pin, CMODE="H": 384fs, "L": 256fs
18	SCLK	I/O	Serial data clock pin
19	LRCK	I/O	Input channel select pin
20	FSYNC	I/O	Frame sync clock pin
21	SDATA	O	Serial data output pin
22	CMODE	I	Master clock select pin, "H": MCLK=384fs, "L": 256fs
23	SMODE2	I	Interface clock select pin
24	VB	—	Bulk power supply pin (+5V)

TC74HCU04AP
(VI: IC307)

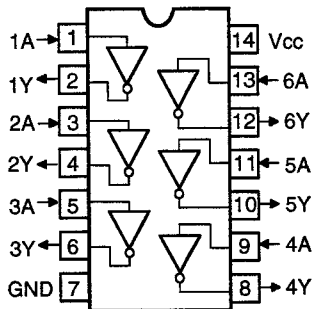
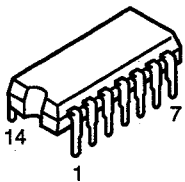

TC74HC151AP
(VI: IC303)

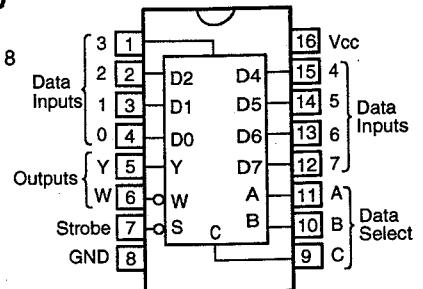
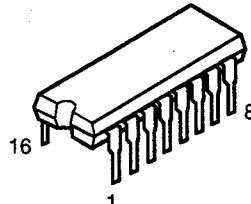

CS8414CS (AU: IC911)

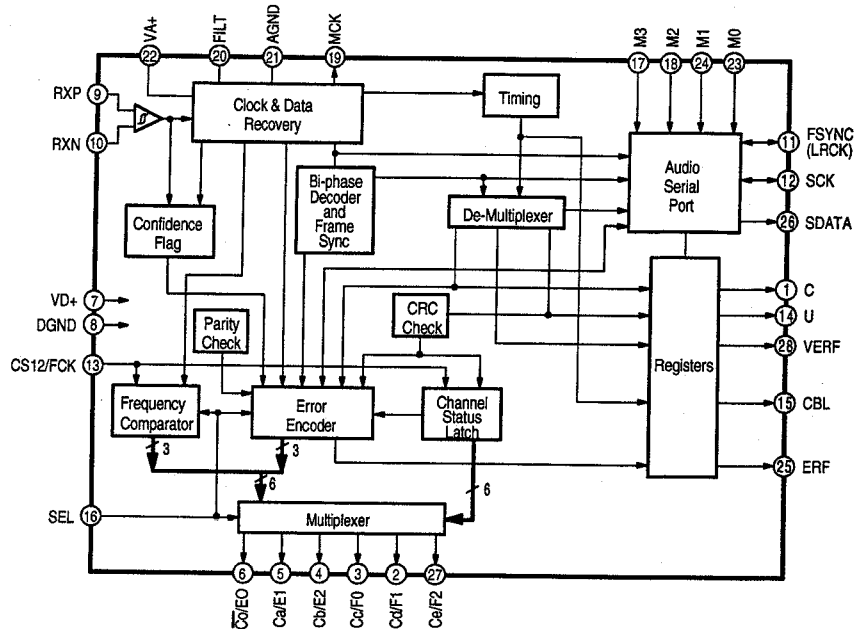
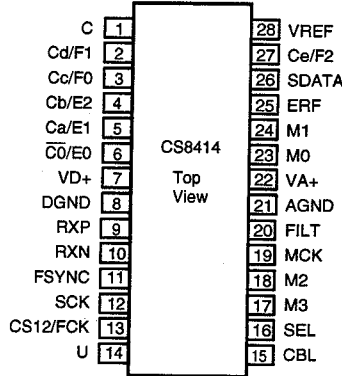
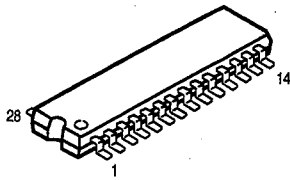

CS8414CS Terminal Function

Pin No.	Symbol	I/O	Function
1	C	I	C.S. bit input.
2	Cd F1	O	C.S. bit output/Frequency indication (H: C.S. bit output, L: Frequency indication).
3	Cc F0		CO="0" in C.S. bit is for professional use, and CO="1" is for general use.
4	Cd E2	O	C.S. bit output/Error indication (H: C.S. bit output, L: Error indication).
5	Ca E1		CO="0" in C.S. bit is for professional use, and CO="1" is for general use.
6	C0/E0		
7	VD+	—	Digital +5V power supply.
8	DGND	—	Connect to digital ground.
9	RXP	I	Differential line receiver signal. Compatible with RS422.
10	RXN		
11	FSYNC	I/O	Frame sync signal.
12	SCK	I/O	Serial clock signal, 32 clock is included with each audio sample in output status.
13	CS12/FCK	I	Channel selection/Reference frequency (H: Channel selection, L: Reference frequency). CS12 selects the channel output to C.S. terminal. "0" is for sub frame 1, and "1" is for sub frame2. Input frequency can be detected by 6.144 MHz clock input to FCK.
14	U	I	User (U) bit terminal.
15	CBL	O	C.S. block output terminal.
16	SEL	I	C.S. F2-F0, E2-E0 selection signal (H: C.S. bit output, L: Frequency/Error indication).
17	M3	I	Serial port mode select signal
18	M2		
19	MCK	I	Master clock signal (Low jitter clock output with 256 times of receiving frequency).
20	FILT	I	Filter terminal, connect resistor 1kohm and capacitor 0.047 μF between this terminal and AGND.
21	AGND	—	Connect to analog ground.
22	VA+	—	Analog +5V power supply (Noise for this power supply should be minimized as lower as possible since it affects jitter's performance of playback clock directly).
23	M0	I	Serial port mode select signal.
24	M1		
25	ERF	O	Error flag aignal.
26	SDATA	O	Serial data signal.
27	Ce F2	O	C.S. bit output/Frequency indication (H: C.S. bit output, L: Frequency indication). CO="0" in C.S. bit is for professional use, and CO="1" is for general use.
28	VERF	O	Parity and Error flag signal.

TC4053BP (VI: IC402)

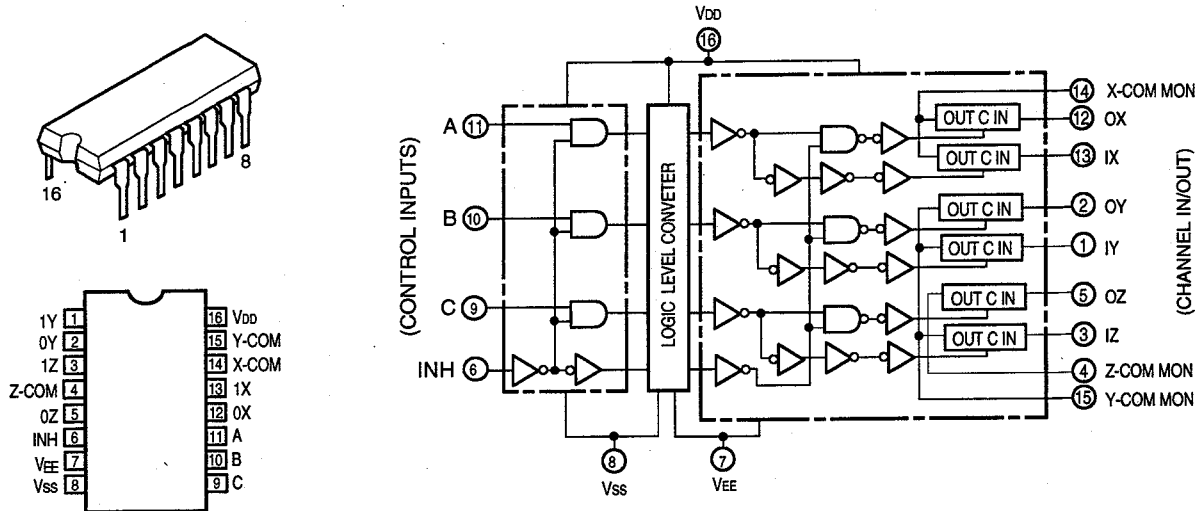

**SN74HC14NS (AU: IC906)
TC74HC00AF (AU: IC904)
HD74HC74FP (AU: IC909)**

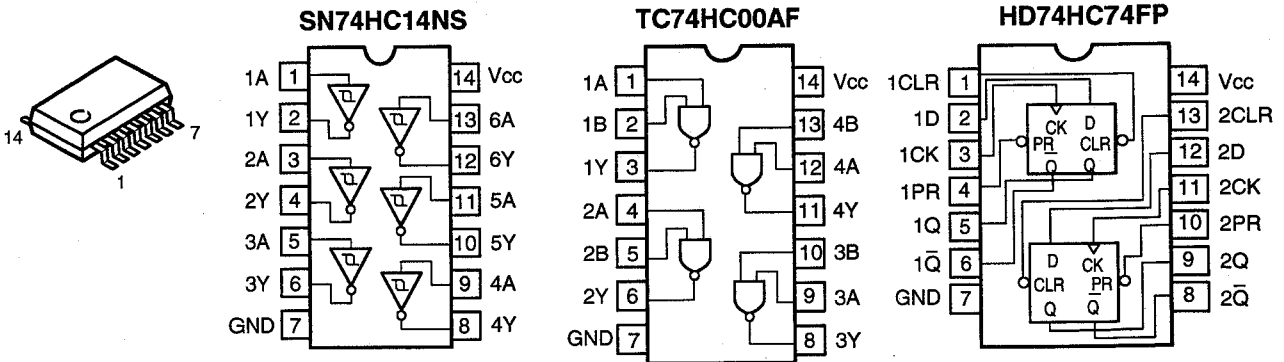

**TC74HC123AF (AU: IC905, 907)
TC74HCT157AF (AU: IC908)
HD74HC157FP (AU: IC910)**

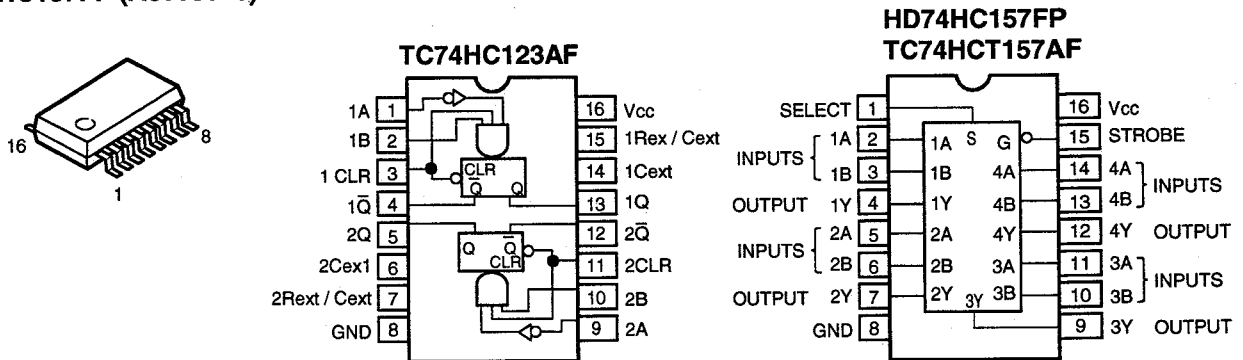

NJM2068DDC
(VI: IC201) (CO: IC120)

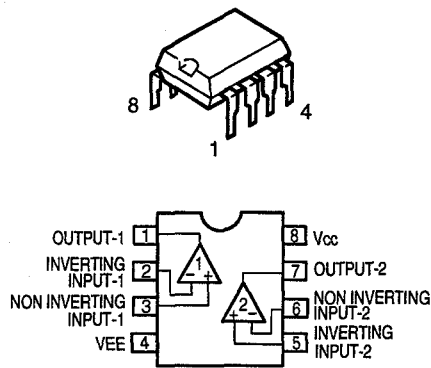

TC74HCT7007AF
(AU: IC902)

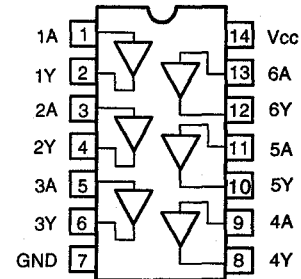
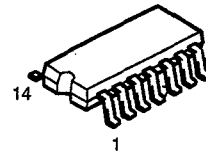

MC74HC4053N
(VI: IC304)

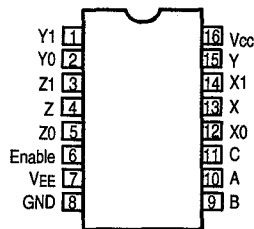
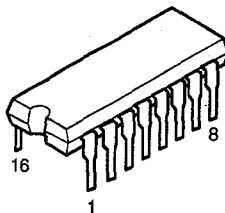

Enable	Control Inputs			ON Switches		
	C	B	A	Z0	Y0	X0
L	L	L	L	Z0	Y0	X0
L	L	L	H	Z0	Y0	X1
L	L	H	L	Z0	Y1	X0
L	L	H	H	Z0	Y1	X1
L	H	L	L	Z1	Y0	X0
L	H	L	H	Z1	Y0	X1
L	H	H	L	Z1	Y1	X0
L	H	H	H	Z1	Y1	X1
H	X	X	X	None		

X = Don't Care

NJM2229S (VI: IC305)

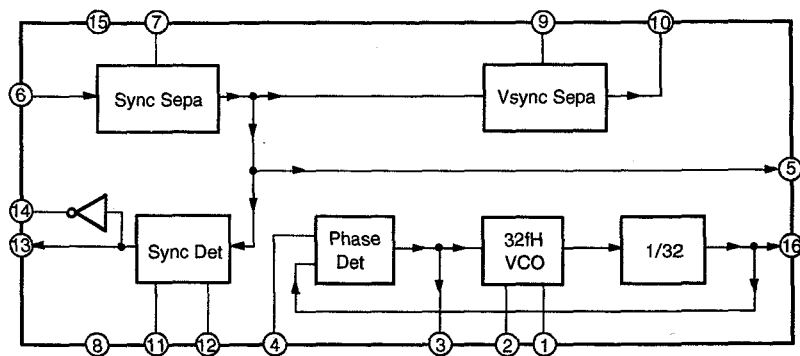
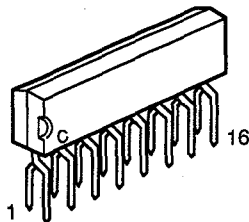

BA7625 (VI: IC302, 401)
BA7626 (VI: IC301)

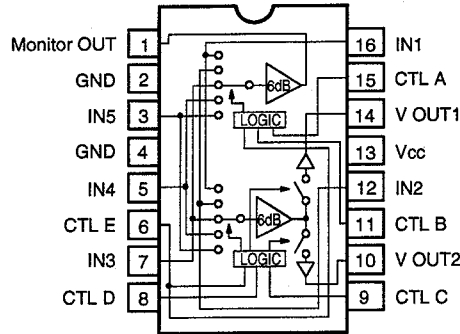
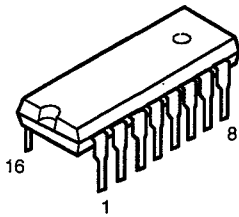

A	B	E	MONITOR OUT
L	L	*	IN 1
H	L	*	IN 2
L	H	*	IN 3
H	H	L	IN 4
H	H	H	IN 5

C	D	E	V OUT 1
L	L	*	—
H	L	*	IN 2
L	H	*	IN 3
H	H	L	IN 4
H	H	H	IN 5

C	D	E	V OUT 2
L	L	*	IN 1
H	L	*	—
L	H	*	IN 3
H	H	L	IN 4
H	H	H	IN 5

Note 1: * mark means that feasible for either H or L.
 Note 2: Each input terminal is provided with sink chip clamp (BA7625).
 Each input terminal takes 20kohm at the end (BA7626).

LA1265 (S)
(TU: IC502)

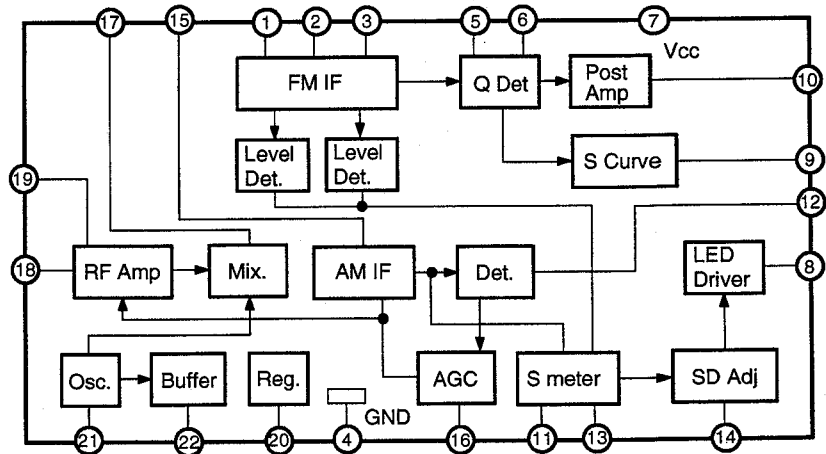
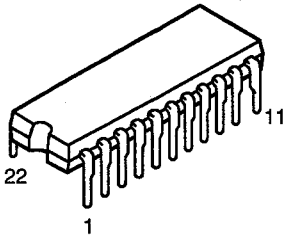

LA3401
(TU: IC503)

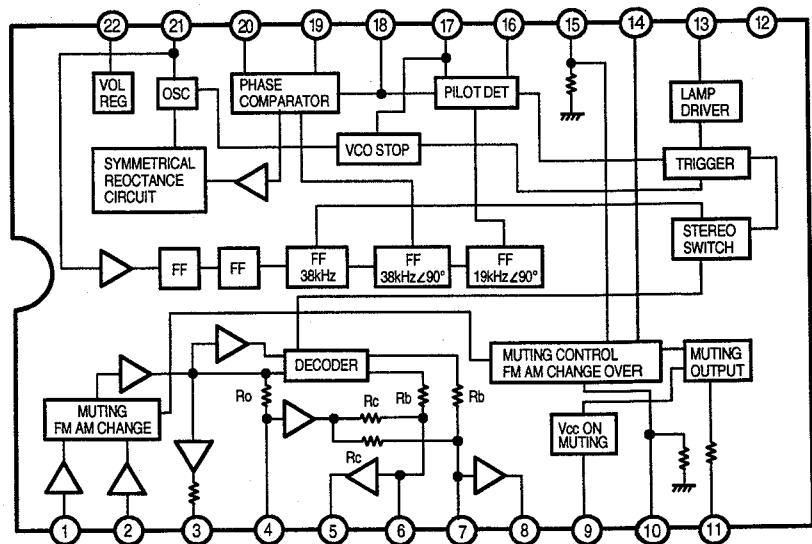
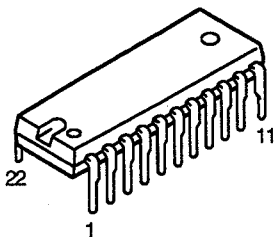

- BA15218F (AU: IC731)
(CO: IC282)
- BA4510 (AU: IC851, 852)
- NJM2068MD (AU: IC601, 702, 703, 752, 753, 802, 803, 804)
(CO: IC281)
(TU: IC103, 104, 105, 106, 109, 110)
- NJM5532MD (AU: IC606)

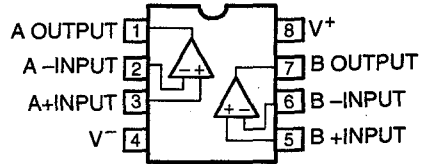
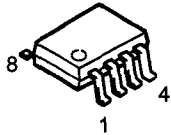

LC7213M (TU: IC507)

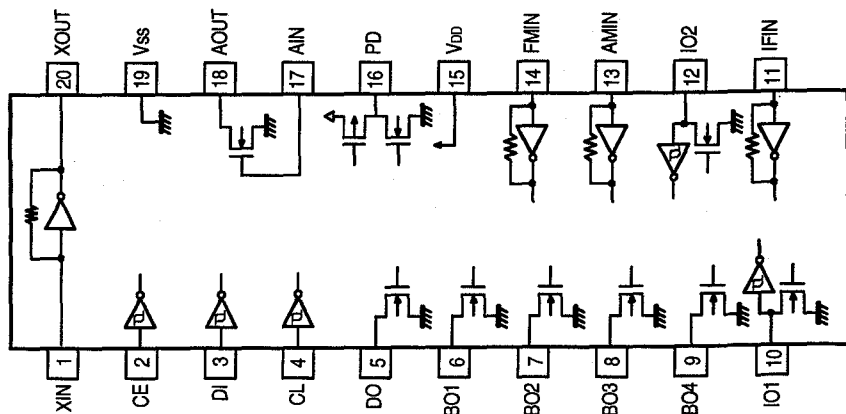
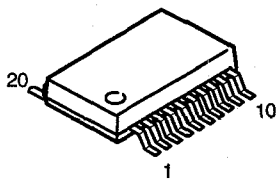

TC9273N-007 (AU: IC603)

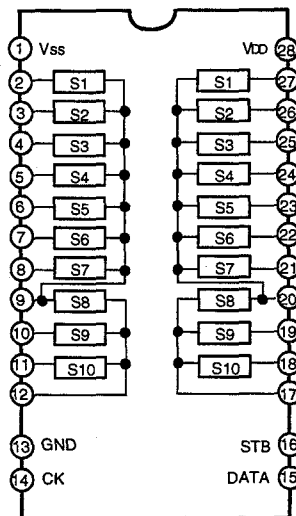
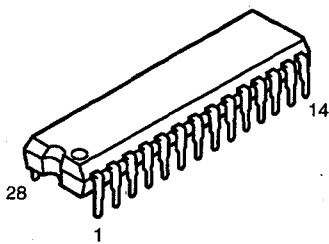

TC9273N Terminal Function

Pin No.	Symbol	Name	Function	Note
1	Vss	-Power Terminal	Dual Power Use: VDD = 8.0~17 V GND = 0V Vss = -8.0~17V	Signal Power Use: VDD = 8.0~18V Vss = GND = 0V
13	GND	Digital Ground		
28	VDD	+Power Terminal		
2~12 17~27	S1~11	I/O Terminal	Input terminal of analog switch.	---
14	CK	Clock Input	Clock input for data transfer.	Low level Border Input Terminal
15	DATA	Data Input	Serial input for switch setting.	
16	STB	Strobe Input	Strobe input for data writing..	

LC75711NE (VI: IC102)

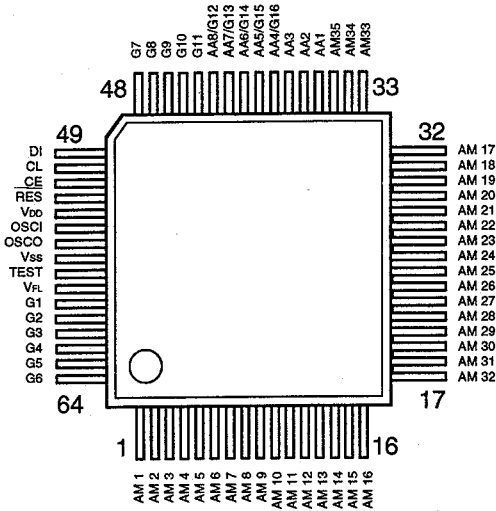

Symbol	Function
V _{DD}	Power terminal +5V
V _{SS}	Power terminal GND
V _{FL}	Power terminal FL drive
DI CL CE	Serial data transfer terminal DI: Data CL: Clock CE: Chip enable
OSC1 OSCO	External CR connecting terminal
RES	System reset terminal
AM1~AM35 AA1~AA3	Anode output terminal
AA4/G16 AA5/G15 AA6/G14 AA7/G13 AA8/G12	Anode/Grid output terminal
G1~G11	Grid output terminal
TEST	LSI test terminal

PCM1716E (AU: IC701, 751, 801)

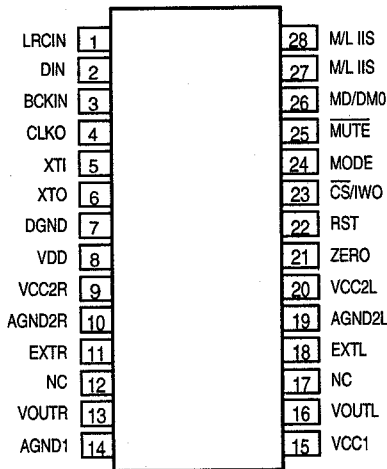

Pin No.	Name	I/O	Description
1	LRCIN	I	Left & Right clock input. This clock is equal to the sampling rate-fs. *1
2	DIN	I	Serial audio data input.
3	BCKIN	O	Bit clock input for serial audio data.
4	CLKO	—	Buffered output of oscillator. Equivalent to system clock.
5	XTI	—	Oscillator input (External clock input).
6	XTO	I	Oscillator output.
7	DGND	I	Digital ground.
8	VDD		Digital power. +5V
9	VCC2R	I	Digital power. +5V
10	AGND2R		Analog power. +5
11	EXTR		R-ch, common pin of analog amp.
12	NC	—	No connection.
13	VOUTR	—	R-ch, analog voltage output of audio signal.
14	AGND1		Analog ground
15	VCC1	I	Analog power. +5V
16	VOUTL	I	L-ch, analog voltage output of audio signal.
17	NC	I	Non connection.
18	EXTL	I/O	L-ch, common pin of analog output amp.
19	AGND2L	I/O	Analog ground.
20	VCC2L	I/O	Analog power. +5V
21	ZERO	O	Zero data flag.
22	RST	I	Reset. When this pin is low, the DF & modulations are held in reset. *2
23	CS/IWO	I	Chip select / Input format selection When this pin is low, the MODE Control is effective. *3
24	MODE	—	Mode control Select. (H: Software, L: Hardware) *2
25	MUTE		Mute control. *2
26	MD / DM0		Mode control, data / De-emphasis selection 1. *2
27	MC / DM1		Mode control, BCK / De-emphasis selection 2. *2
28	ML / IIS		Mode control, WDCK / input format selection. *2

NOTE1: Pins 1, 2, 3; Schmitt Trigger input.

NOTE2: Pins 22, 24, 25, 26, 27, 28; Schmitt Trigger input with pull-up resistor.

NOTE3: Pin 23; Schmitt trigger input with pull-down resistor.

NJM7805FA (S) (PA: IC506, 507)
 NJM7806FA (S) (PA: IC502, 505)
 NJM7812FA (S) (PA: IC503)
 BA033T (AU: IC900)

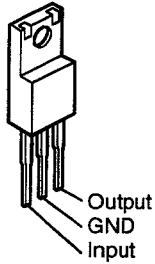

NJM7912FA (PA: IC504)

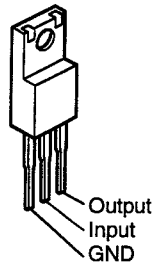

SG-531PH (12.288MHz)
 (AU: IC855)

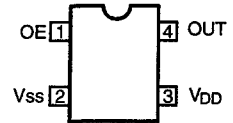
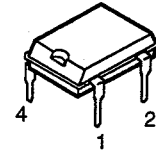

● IC PROTECTOR
 ICP-N15 (PA: IC501)

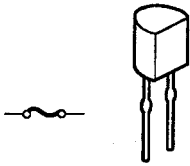

● OPTICAL
 INPUT
 GP1F37R
 (VI: IC306)

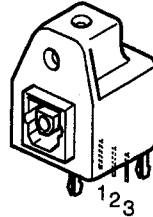

1. Vcc
 2. GND
 3. Vout

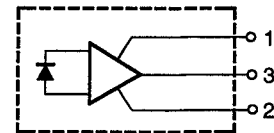

● OTHER
 GP1U271X (Remote Control Sensor)
 (VI: IC101)

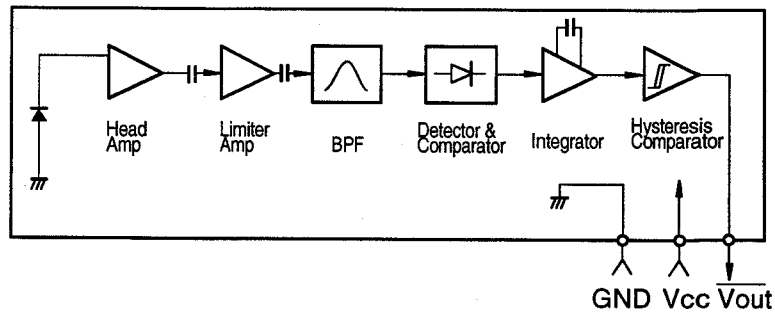
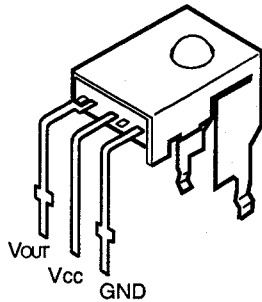

● TRANSISTORS

2PA1015GR
 2SA970 (BL)
 2SA988 (E/F)
 2PA1815 (BL)
 2SC1841 (E/F)
 2SC2878 (A/B)

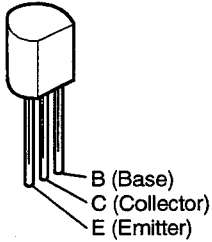

2SC2705 (O)/(Y)

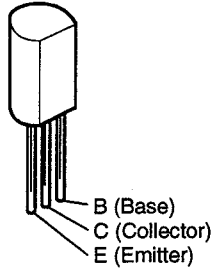

2SA1489 (O/P/Y)
 2SA1491 (O/P/Y)
 2SC3855 (O/P/Y)

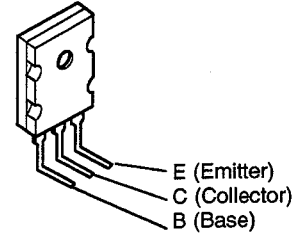

DTA114ES
 DTC114ES

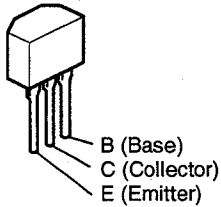

DTA114ES

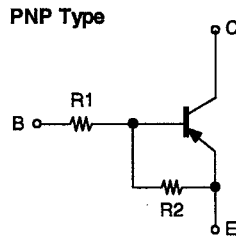

	R1	R2
DTA114ES	10kohm	10kohm

DTC114ES

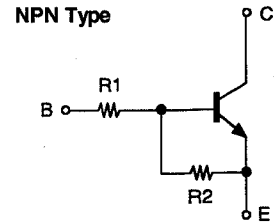

	R1	R2
DTC114ES	10kohm	10kohm

DTA114TK
 DTA114EK
 DTA144EK
 DTC114EK
 DTC144EK
 DTC323TK
 RN2402

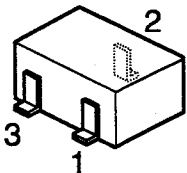

1: GND/Emitter
 2: Out/Collector
 3: In/Base

DTA114TK
 DTA114EK
 DTA144EK
 RN2402

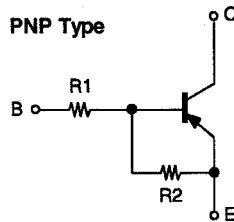

	R1	R2
DTA114TK	10kohm	-
DTA114EK	10kohm	10kohm
DTA144EK	47kohm	47kohm
RN2402	10kohm	10kohm

DTC114EK
 DTC144EK
 DTC323TK

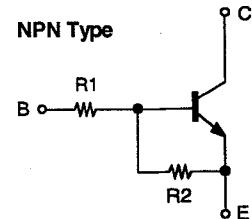

	R1	R2
DTC114EK	10kohm	10kohm
DTC144EK	47kohm	47kohm
DTC323TK	2.2kohm	-

2SA933S (S)
2SC3311A
2SC1740S (S)

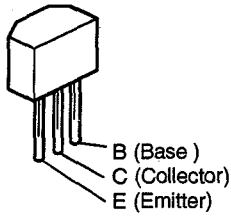

2SK209 (GR)

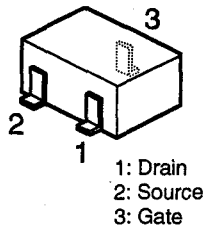

2SC2996 (Y)
2SC3326 (A/B)
2SD601A

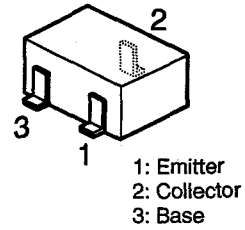

2SA1725 (O/P/Y)
2SC4495

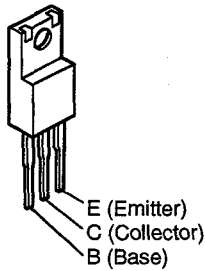

2SB1328 (Q)
2SD2004 (Q)

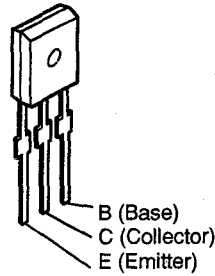

● DIODES (included LED)

1SS270A

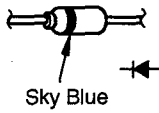

MTZJ3.3A MTZJ7.5A
MTZJ5.6A MTZJ9.1A
MTZJ6.2A MTZJ36A

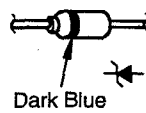

1SR35-200A

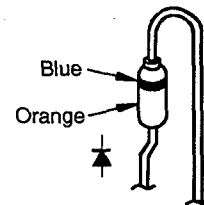

S4VB20
(PA: D518, 519, 520)

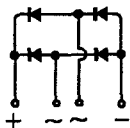
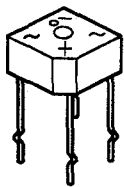

SEL1210S (Red)
(VI: LD101, 102, 104)
SEL1410E (Green)
(VI: LD103)

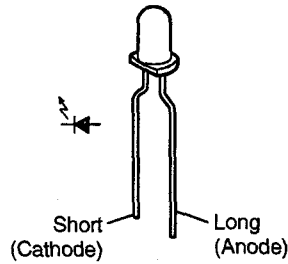

MA151WK

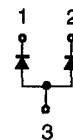
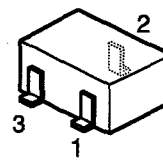

MA151A

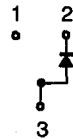
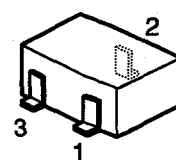

FL DISPLAY CM1690C (VI : FL101)

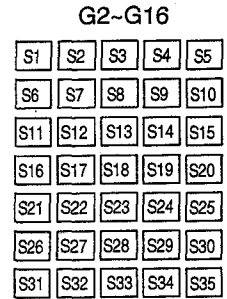
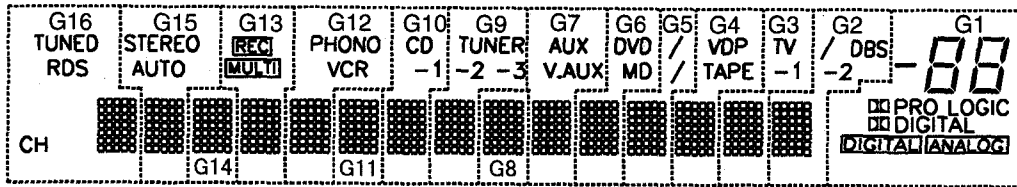
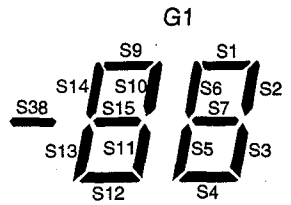
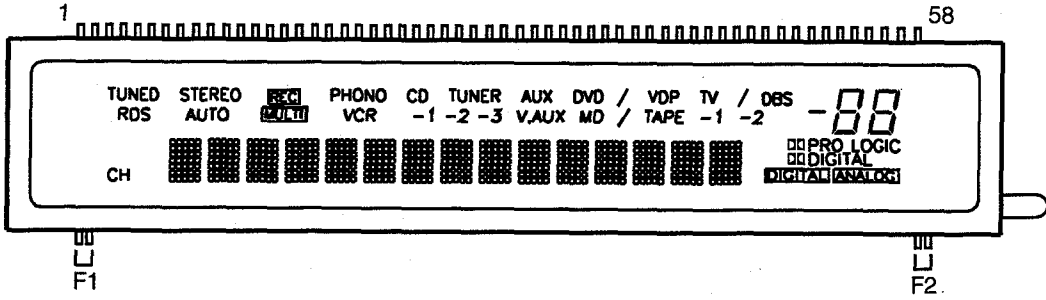

Pin Assignment

PIN NO.	1	2	3	4	5	6	7	8	9	10	11	12	13	14	15	16	17	18	19	20
CONNECTION	F1	F1	S1	S2	S3	S4	S5	S6	S7	S8	S9	S10	S11	S12	S13	S14	S15	S16	S17	S18
PIN NO.	21	22	23	24	25	26	27	28	29	30	31	32	33	34	35	36	37	38	39	40
CONNECTION	S19	S20	S21	S22	S23	S24	S25	S26	S27	S28	S29	S30	S31	S32	S33	S34	S35	S36	S37	S38
PIN NO.	41	42	43	44	45	46	47	48	49	50	51	52	53	54	55	56	57	58		
CONNECTION	G16	G15	G14	G13	G12	G11	G10	G9	G8	G7	G6	G5	G4	G3	G2	G1	F2	F2		

F1,F2 : Filament
 G1~G16 : Grid
 S1~S38 : Anode

Anode & Grid Assignment

	G1	G2-G16		G1	G2-G16		G1	G2-G16		G1	G2-G16
S1	S1	S1	S10	S10	S10	S19	---	S19	S28	---	S28
S2	S2	S2	S11	S11	S11	S20	---	S20	S29	---	S29
S3	S3	S3	S12	S12	S12	S21	---	S21	S30	---	S30
S4	S4	S4	S13	S13	S13	S22	---	S22	S31	---	S31
S5	S5	S5	S14	S14	S14	S23	---	S23	S32	---	S32
S6	S6	S6	S15	S15	S15	S24	---	S24	S33	---	S33
S7	S7	S7	S16	---	S16	S25	---	S25	S34	---	S34
S8	S8	S8	S17	DIGITAL	S17	S26	---	S26	S35	---	S35
S9	S9	S9	S18	PRO LOGIC	S18	S27	---	S27			

	G1	G2	G3	G4	G5	G6	G7	G8	G9	G10	G11	G12	G13	G14	G15	G16
S36	DIGITAL	/	TV	VDP	/(DVD)	DVD	AUX	---	TUNER	CD	---	PHONO	REC	---	STEREO	TUNED
S37	ANALOG		-1	TAPE	/(MD)	MD	V.MAX	---	-2	-1	---	VCR	MULTI	---	AUTO	RDS
S38	S38	DBS	---	---	---	---	---	---	-3	---	---	---	---	---	---	CH

PRINTED WIRING BOARD PATTERNS

1 2 3 4 5 6 7 8

1U-3105 TUNER AMP. UNIT

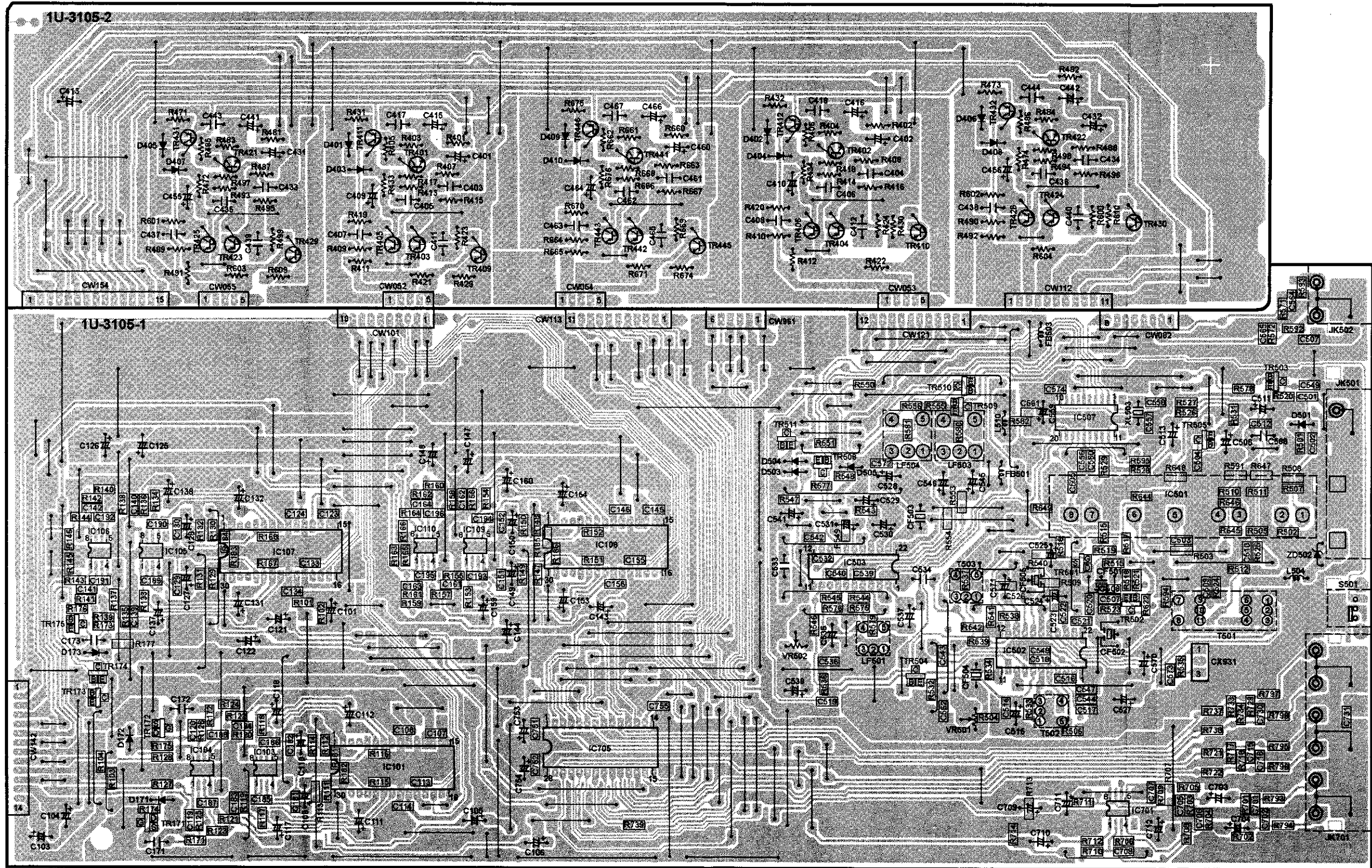

A
B
C
D
E

1 2 3 4 5 6 7 8

1U-3106 DISPLAY VIDEO UNIT

A

B

C

D

E

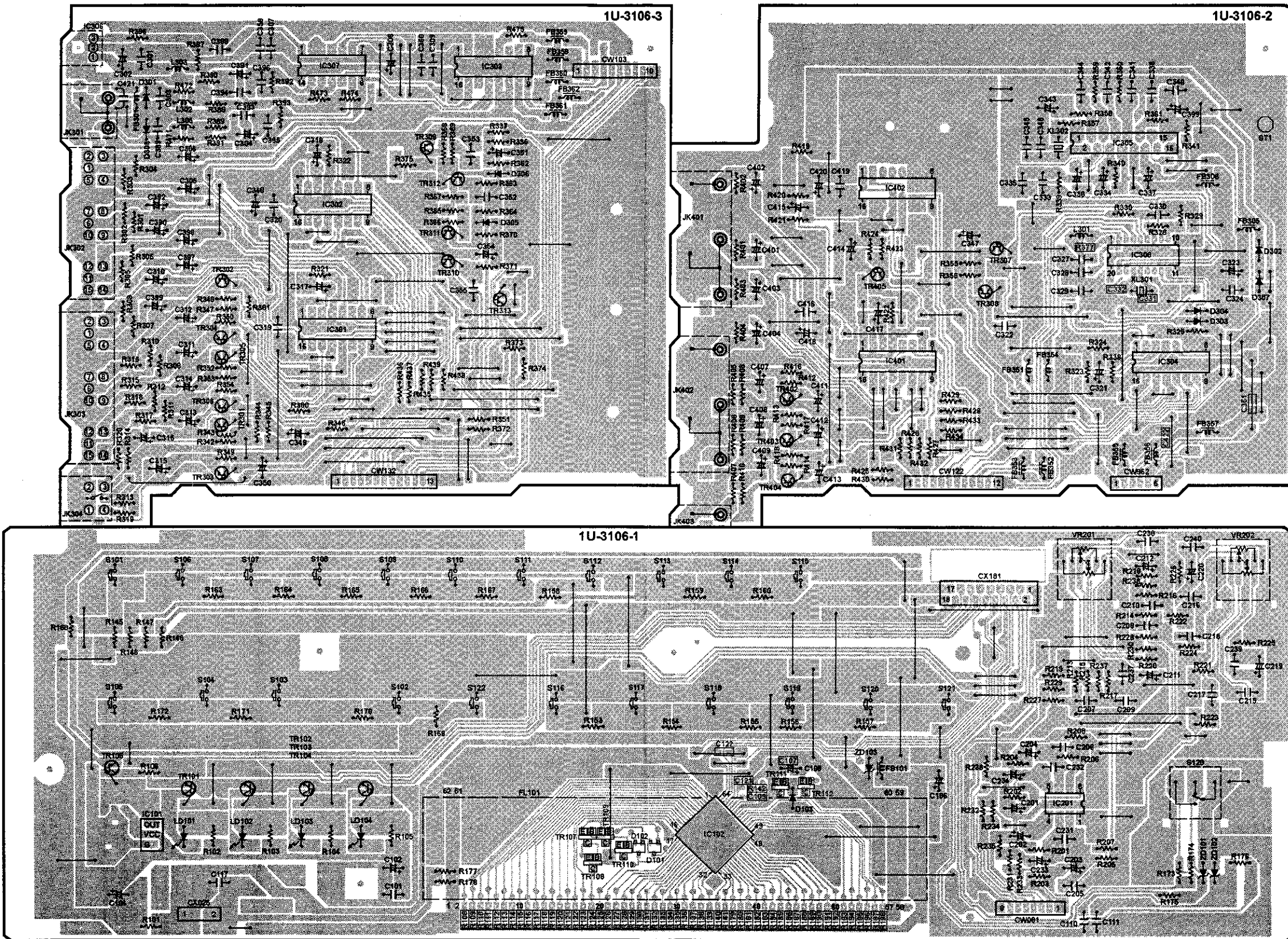

1 2 3 4 5 6 7 8

1U-3108 POWER AMP. UNIT

A

B

C

D

E

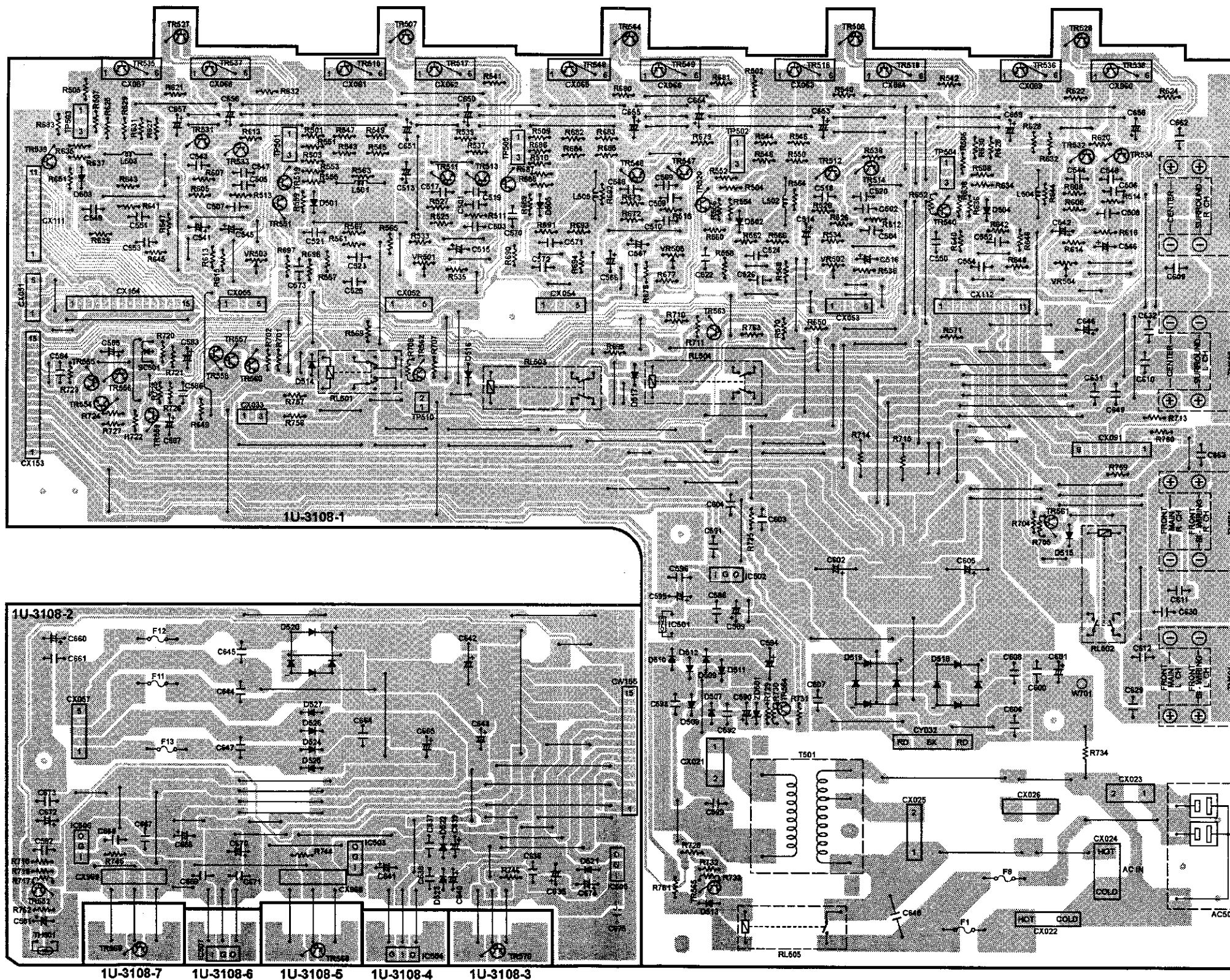

1U-3108-7 1U-3108-6 1U-3108-5 1U-3108-4 1U-3108-3

1 2 3 4 5 6 7 8

1U-3109 AUDIO IN DSP UNIT

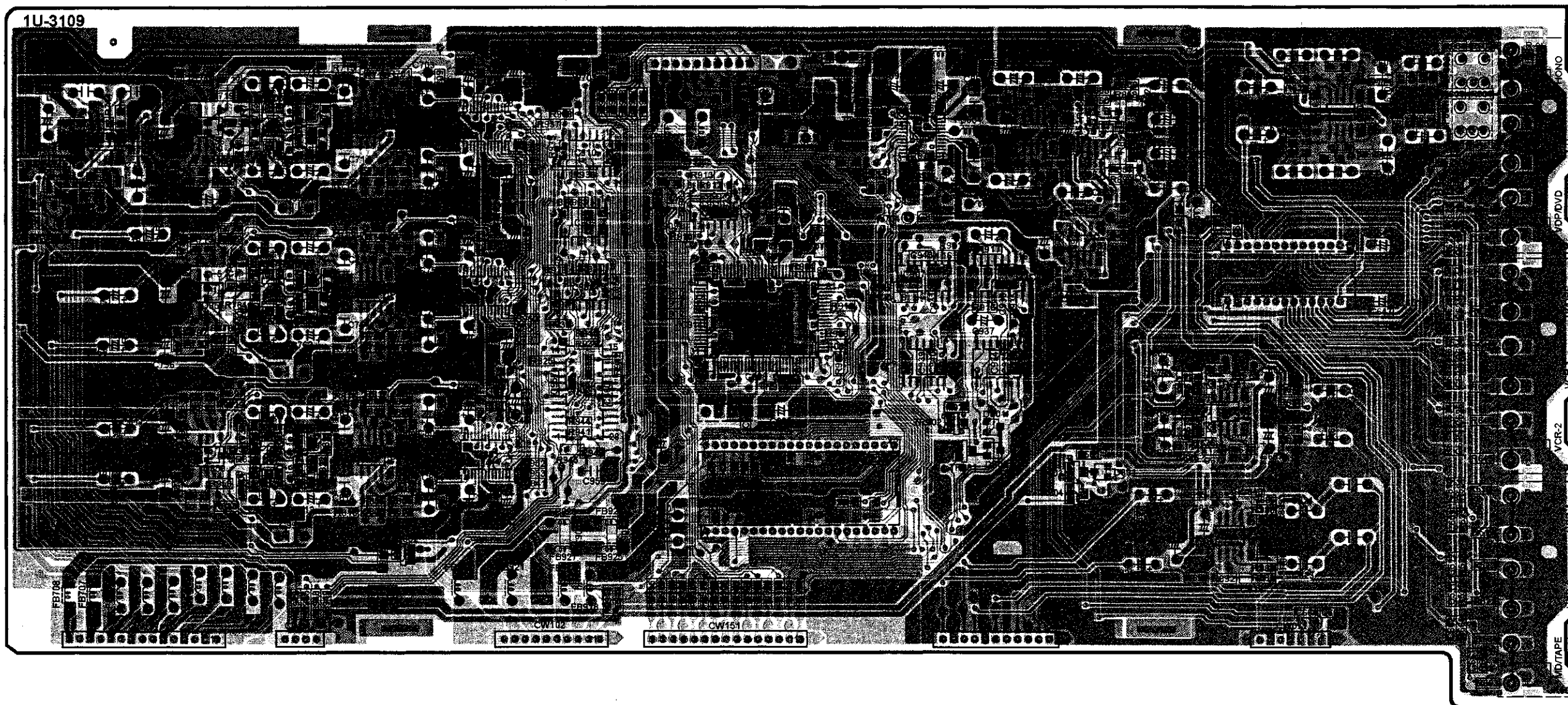

A

B

C

D

E

NOTE FOR PARTS LIST

- Part indicated with the mark "⊙" are not always in stock and possibly to take a long period of time for supplying, or in some case supplying of part may be refused.
 - When ordering of part, clearly indicate "1" and "I" (i) to avoid mis-supplying.
 - Ordering part without stating its part number can not be supplied.
 - Part indicated with the mark "★" is not illustrated in the exploded view.
 - Not including Carbon Film ±5%, 1/4W Type in the P.W.Board parts list. (Refer to the Schematic Diagram for those parts.)
- WARNING:**
Parts marked with this symbol  have critical characteristics.
Use ONLY replacement parts recommended by the manufacturer.

● Resistors

Ex.: **RN** 14**K** 2**E** 1**B2** **G** **ER**
 Type Shape Power Resist- Allowable Others
 and performance ance error

RD : Carbon	2B : 1/8W	F : ±1%	P : Pulse-resistant type
RC : Composition	2E : 1/4W	G : ±2%	NL : Low noise type
RS : Metal oxide film	2H : 1/2W	J : ±5%	NB : Non-burning type
RW : Winding	3A : 1W	K : ±10%	FR : Fuse-resistor
RN : Metal film	3D : 2W	M : ±20%	F : Lead wire forming
RK : Metal mixture	3F : 3W		
	3H : 5W		

*** Resistance**

$\overset{1}{\text{R}} \overset{2}{\text{R}} \Rightarrow 1800 \text{ ohm} = 1.8 \text{ kohm}$
 Indicates number of zeros after effective number.
 2-digit effective number.
 • Units: ohm

$\overset{1}{\text{R}} \overset{2}{\text{R}} \Rightarrow 1.2 \text{ ohm}$
 1-digit effective number.
 2-digit effective number, decimal point indicated by R.
 • Units: ohm

● Capacitors

Ex.: **CE** 0**4W** 1**H** 2**R2** **M** **BP**
 Type Shape Dielectric Capacity Allowable Others
 and performance strength error

CE : Aluminum foil electrolytic	OJ : 6.3V	F : ±1%	HS : High stability type
CA : Aluminum solid electrolytic	1A : 10V	G : ±2%	BP : Non-polar type
CS : Tantalum electrolytic	1C : 16V	J : ±5%	HR : Ripple-resistant type
CO : Film	1E : 25V	K : ±10%	DL : For charge and discharge
CK : Ceramic	1V : 35V	M : ±20%	HF : For assuring high frequency
CC : Ceramic	1H : 50V	Z : +80%	U : UL part
CP : Oil	2A : 100V	-20%	C : CSA part
CM : Mica	2B : 125V	P : +100%	W : UL-CSA type
CF : Metallized	2C : 160V	-0%	F : Lead wire forming
CH : Metallized	2D : 200V	C : ±0.25pF	
	2E : 250V	D : ±0.5pF	
	2H : 500V	= : Others	
	2J : 630V		

*** Capacity (electrolyte only)**

$\overset{2}{\text{R}} \overset{2}{\text{R}} \Rightarrow 2200\mu\text{F}$
 Indicates number of zeros after effective number.
 2-digit effective number.
 • Units: μF .

$\overset{2}{\text{R}} \overset{2}{\text{R}} \Rightarrow 2.2\mu\text{F}$
 1-digit effective number.
 2-digit effective number, decimal point indicated by R.
 • Units: μF .

*** Capacity (except electrolyte)**

$\overset{2}{\text{R}} \overset{2}{\text{R}} \Rightarrow 2200\text{pF} = 0.0022\mu\text{F}$
 (More than 2) — Indicates number of zeros after effective number.
 2-digit effective number.
 • Units: pF.

$\overset{2}{\text{R}} \overset{2}{\text{R}} \overset{1}{\text{R}} \Rightarrow 220\text{pF}$
 (0 or 1) — Indicates number of zeros after effective number.
 2-digit effective number.
 • Units: pF.

• When the dielectric strength is indicated in AC, "AC" is included after the dielectric strength value.

PARTS LIST OF P.W.B. UNIT 1U-3105 TUNER AMP UNIT

Ref. No.	Part No.	Part Name	Remarks	Ref. No.	Part No.	Part Name	Remarks
SEMICONDUCTORS GROUP				R127,128	247 0005 905	Carbon chip 100 ohm 1/10W	RM73B--101J
IC101	262 2214 007	IC LC7536		R129,130	247 0011 944	Carbon chip 47 kohm 1/10W	RM73B--473J
IC103-106	263 0896 909	IC NJM2068MD		R131,132	247 0013 900	Carbon chip 220 kohm 1/10W	RM73B--224J
IC107,108	262 2214 007	IC LC7536		R133,134	247 0005 905	Carbon chip 100 ohm 1/10W	RM73B--101J
IC109,110	263 0896 909	IC NJM2068MD		R135,136	247 0012 927	Carbon chip 100 kohm 1/10W	RM73B--104J
IC501	216 0102 008	Front end		R137,138	247 0005 905	Carbon chip 100 ohm 1/10W	RM73B--101J
IC502	263 0891 001	IC LA1265(S)		R139,140	247 0007 916	Carbon chip 750 ohm 1/10W	RM73B--751J
IC503	263 0439 007	IC LA3401		R141	247 0009 901	Carbon chip 4.7 kohm 1/10W	RM73B--472J
IC507	262 2450 900	IC LC72131M-TLM		R142	247 0009 985	Carbon chip 10 kohm 1/10W	RM73B--103J
IC705	262 1853 100	IC NJU7313AL		R143,144	247 0005 905	Carbon chip 100 ohm 1/10W	RM73B--101J
TR171,172	275 0094 908	FET 2SK209-GR		R145,146	247 0012 927	Carbon chip 100 kohm 1/10W	RM73B--104J
TR173	269 0083 901	Transistor DTA114EK		R147,148	247 0011 944	Carbon chip 47 kohm 1/10W	RM73B--473J
TR174	269 0054 901	Transistor DTC144EK		R149,150	247 0013 900	Carbon chip 220 kohm 1/10W	RM73B--224J
TR175	275 0094 908	FET 2SK209-GR		R151,152	247 0011 944	Carbon chip 47 kohm 1/10W	RM73B--473J
TR401,402	273 0253 918	Transistor 2SC2878(A/B)		R153,154	247 0005 905	Carbon chip 100 ohm 1/10W	RM73B--101J
TR403-406	271 0094 919	Transistor 2SA970(BL)		R155,156	247 0012 927	Carbon chip 100 kohm 1/10W	RM73B--104J
TR409,410	273 0281 906	Transistor 2SC2705(O)(Y)		R157,158	247 0005 905	Carbon chip 100 ohm 1/10W	RM73B--101J
TR421,422	273 0253 918	Transistor 2SC2878(A/B)		R159,160	247 0007 916	Carbon chip 750 ohm 1/10W	RM73B--751J
TR423-426	271 0094 919	Transistor 2SA970(BL)		R161,162	247 0009 901	Carbon chip 4.7 kohm 1/10W	RM73B--472J
TR429,430	273 0281 906	Transistor 2SC2705(O)(Y)		R163	247 0005 905	Carbon chip 100 ohm 1/10W	RM73B--101J
TR441	273 0253 918	Transistor 2SC2878(A/B)		R164	247 0005 905	Carbon chip 100 ohm 1/10W	RM73B--101J
TR442,443	271 0094 919	Transistor 2SA970(BL)		R165,166	247 0012 927	Carbon chip 100 kohm 1/10W	RM73B--104J
TR445	273 0281 906	Transistor 2SC2705(O)(Y)		R167,168	247 0011 944	Carbon chip 47 kohm 1/10W	RM73B--473J
TR502	273 0411 909	Transistor 2SC2996-Y		R171,172	247 0006 920	Carbon chip 330 ohm 1/10W	RM73B--331J
TR503,504	269 0083 901	Transistor DTA114EK		R173	247 0009 943	Carbon chip 6.8 kohm 1/10W	RM73B--682J
TR505	269 0114 906	Transistor RN2402		R174-177	247 0011 944	Carbon chip 47 kohm 1/10W	RM73B--473J
TR508	269 0054 901	Transistor DTC144EK		R181-186	247 0018 905	Carbon chip 0 ohm 1/10W	RM73B--OROK
TR509,510	269 0066 902	Transistor DTC323TK		R429,430	241 2376 964	Carbon film 47 ohm 1/4W(NB)	RD14B2E470JNBS
TR511	269 0086 908	Transistor DTA114TK		R501	247 0002 966	Carbon chip 10 ohm 1/10W	RM73B--100J
D171-173	276 0432 903	Diode 1SS270A		R503	247 0007 945	Carbon chip 1 kohm 1/10W	RM73B--102J
D501	276 0432 903	Diode 1SS270A		R504,505	247 0018 905	Carbon chip 0 ohm 1/10W	RM73B--OROK
D503-505	276 0432 903	Diode 1SS270A		R507-512	247 0018 905	Carbon chip 0 ohm 1/10W	RM73B--OROK
ZD502	276 0644 937	Zener diode MTZJ9.1A	9.1V	R514	247 0005 905	Carbon chip 100 ohm 1/10W	RM73B--101J
RESISTORS GROUP				R515	247 0005 905	Carbon chip 100 ohm 1/10W	RM73B--101J
R101	247 0009 901	Carbon chip 4.7 kohm 1/10W	RM73B--472J	R516	247 0007 945	Carbon chip 1 kohm 1/10W	RM73B--102J
R102	247 0008 960	Carbon chip 3.3 kohm 1/10W	RM73B--332J	R518	247 0005 989	Carbon chip 220 ohm 1/10W	RM73B--221J
R111,112	247 0011 944	Carbon chip 47 kohm 1/10W	RM73B--473J	R519	247 0006 962	Carbon chip 470 ohm 1/10W	RM73B--471J
R113,114	247 0013 900	Carbon chip 220 kohm 1/10W	RM73B--224J	R520	247 0007 945	Carbon chip 1 kohm 1/10W	RM73B--102J
R115,116	247 0011 944	Carbon chip 47 kohm 1/10W	RM73B--473J	R521	247 0009 901	Carbon chip 4.7 kohm 1/10W	RM73B--472J
R117,118	247 0005 905	Carbon chip 100 ohm 1/10W	RM73B--101J	R522	247 0006 920	Carbon chip 330 ohm 1/10W	RM73B--331J
R119,120	247 0012 927	Carbon chip 100 kohm 1/10W	RM73B--104J	R523	247 0007 961	Carbon chip 1.2 kohm 1/10W	RM73B--122J
R121,122	247 0005 905	Carbon chip 100 ohm 1/10W	RM73B--101J	R524	247 0012 927	Carbon chip 100 kohm 1/10W	RM73B--104J
R123-126	247 0007 945	Carbon chip 1 kohm 1/10W	RM73B--102J	R525	247 0007 945	Carbon chip 1 kohm 1/10W	RM73B--102J
				R526	247 0009 927	Carbon chip 5.6 kohm 1/10W	RM73B--562J
				R527	247 0009 985	Carbon chip 10 kohm 1/10W	RM73B--103J
				R528	247 0008 944	Carbon chip 2.7 kohm 1/10W	RM73B--272J
				R529	247 0007 945	Carbon chip 1 kohm 1/10W	RM73B--102J
				R531	247 0018 905	Carbon chip 0 ohm 1/10W	RM73B--OROK
				R532	247 0018 905	Carbon chip 0 ohm 1/10W	RM73B--OROK
				R533	247 0010 929	Carbon chip 15 kohm 1/10W	RM73B--153J
				R534	247 0005 921	Carbon chip 120 ohm 1/10W	RM73B--121J
				R535	247 0010 945	Carbon chip 18 kohm 1/10W	RM73B--183J

Ref. No.	Part No.	Part Name	Remarks	Ref. No.	Part No.	Part Name	Remarks
R536	247 0018 905	Carbon chip 0 ohm 1/10W	RM73B--0R0K	C123,124	257 0012 982	Ceramic chip 0.022μF/50V	CK73F1H223Z
R537	247 0011 986	Carbon chip 68 kohm 1/10W	RM73B--683J	C125,126	254 4260 948	Electrolytic 1μF/50V	CE04W1H010M
R538	247 0009 943	Carbon chip 6.8 kohm 1/10W	RM73B--682J	C127,128	254 4254 909	Electrolytic 10μF/16V	CE04W1C100M
R539	247 0009 927	Carbon chip 5.6 kohm 1/10W	RM73B--562J	C131,132	254 4254 909	Electrolytic 10μF/16V	CE04W1C100M
R540,541	247 0009 985	Carbon chip 10 kohm 1/10W	RM73B--103J	C134	257 0012 966	Ceramic chip 0.01μF/50V	CK73F1H103Z
R542,543	247 0008 960	Carbon chip 3.3 kohm 1/10W	RM73B--332J	C137,138	254 4254 909	Electrolytic 10μF/16V	CE04W1C100M
R544,545	247 0012 927	Carbon chip 100 kohm 1/10W	RM73B--104J	C141,142	257 0004 961	Ceramic chip 100 pF/50V	CC73SL1H101J
R546	247 0011 973	Carbon chip 62 kohm 1/10W	RM73B--623J	C143,144	254 4254 909	Electrolytic 10μF/16V	CE04W1C100M
R547	247 0012 927	Carbon chip 100 kohm 1/10W	RM73B--104J	C145,146	257 0012 982	Ceramic chip 0.022μF/50V	CK73F1H223Z
R548	247 0009 985	Carbon chip 10 kohm 1/10W	RM73B--103J	C147,148	254 4260 948	Electrolytic 1μF/50V	CE04W1H010M
R549	247 0012 927	Carbon chip 100 kohm 1/10W	RM73B--104J	C149,150	254 4254 909	Electrolytic 10μF/16V	CE04W1C100M
R550	247 0009 927	Carbon chip 5.6 kohm 1/10W	RM73B--562J	C153,154	254 4254 909	Electrolytic 10μF/16V	CE04W1C100M
R551	247 0009 985	Carbon chip 10 kohm 1/10W	RM73B--103J	C156	257 0012 966	Ceramic chip 0.01μF/50V	CK73F1H103Z
R553,554	247 0008 960	Carbon chip 3.3 kohm 1/10W	RM73B--332J	C159,160	254 4254 909	Electrolytic 10μF/16V	CE04W1C100M
R555	247 0009 927	Carbon chip 5.6 kohm 1/10W	RM73B--562J	C163,164	257 0004 961	Ceramic chip 100pF/50V	CC73SL1H101J
R571,572	247 0015 966	Carbon chip 2.7 Mohm 1/10W	RM73B--275J	C171,172	256 1058 955	Metalized 0.068μF/50V	CF93A1H683J (JL)
R575,576	247 0012 943	Carbon chip 120 kohm 1/10W	RM73B--124J	C173	255 1265 923	Mylar film 8200 pF/50V	CQ93M1H822J(B)
R577	247 0010 961	Carbon chip 22 kohm 1/10W	RM73B--223J	C401,402	254 4260 980	Electrolytic 10μF/50V	CE04W1H100M
R578	247 0018 905	Carbon chip 0 ohm 1/10W	RM73B--0R0K	C403,404	253 4538 949	Ceramic 100 pF/50V	CC45SL1H101J(DD-3)
R579	247 0018 905	Carbon chip 0 ohm 1/10W	RM73B--0R0K	C405,406	253 4537 924	Ceramic 33 pF/50V	CC45SL1H330J(DD-3)
R580	247 0018 905	Carbon chip 0 ohm 1/10W	RM73B--0R0K	C407,408	253 4482 901	Ceramic 33 pF/500V	CC45SL2H330J
R581	247 0018 905	Carbon chip 0 ohm 1/10W	RM73B--0R0K	C409,410	254 4254 938	Electrolytic 47μF/16V	CE04W1C470M
R582	247 0018 905	Carbon chip 0 ohm 1/10W	RM73B--0R0K	C411,412	255 4202 941	Polypropylene film 1000 pF/50V	CQ93P1H102J
R592,593	247 0006 962	Carbon chip 470 ohm 1/10W	RM73B--471J	C413	254 4260 980	Electrolytic 10μF/50V	CE04W1H100M
R595	247 0018 905	Carbon chip 0 ohm 1/10W	RM73B--0R0K	C415,416	254 4254 912	Electrolytic 22μF/16V	CE04W1C220M
R609,610	241 2376 964	Carbon film 47 ohm 1/4W(NB)	RD14B2E470JNBS	C431,432	254 4260 980	Electrolytic 10μF/50V	CE04W1H100M
R644	247 0018 905	Carbon chip 0 ohm 1/10W	RM73B--0R0K	C433,434	253 4538 949	Ceramic 100 pF/50V	CC45SL1H101J(DD-3)
R647-649	247 0018 905	Carbon chip 0 ohm 1/10W	RM73B--0R0K	C435,436	253 4537 924	Ceramic 33 pF/50V	CC45SL1H330J(DD-3)
R674	241 2376 964	Carbon film 47 ohm 1/4W(NB)	RD14B2E470JNBS	C437,438	253 4482 901	Ceramic 33 pF/500V	CC45SL2H330J
R701,702	247 0015 966	Carbon chip 2.7 Mohm 1/10W	RM73B--275J	C439,440	255 4202 941	Polypropylene film 1000 pF/50V	CQ93P1H102J
R705,706	247 0006 962	Carbon chip 470 ohm 1/10W	RM73B--471J	C441,442	254 4254 912	Electrolytic 22μF/16V	CE04W1C220M
R717,718	247 0015 966	Carbon chip 2.7 Mohm 1/10W	RM73B--275J	C455,456	254 4254 938	Electrolytic 47μF/16V	CE04W1C470M
R721,722	247 0006 962	Carbon chip 470 ohm 1/10W	RM73B--471J	C460	254 4260 980	Electrolytic 10μF/50V	CE04W1H100M
R733,734	247 0015 966	Carbon chip 2.7 Mohm 1/10W	RM73B--275J	C461	253 4538 949	Ceramic 100 pF/50V	CC45SL1H101J(DD-3)
R737,738	247 0006 962	Carbon chip 470 ohm 1/10W	RM73B--471J	C462	253 4537 924	Ceramic 33 pF/50V	CC45SL1H330J(DD-3)
R739	247 0018 905	Carbon chip 0 ohm 1/10W	RM73B--0R0K	C463	253 4482 901	Ceramic 33 pF/500V	CC45SL2H330J
R793-798	247 0018 905	Carbon chip 0 ohm 1/10W	RM73B--0R0K	C464	254 4254 938	Electrolytic 47μF/16V	CE04W1C470M
VR501	211 6132 925	Semi fixed resistor 10 kohm	V06PB103	C465	255 4202 941	Polypropylene film 1000 pF/50V	CQ93P1H102J
VR502	211 6132 983	Semi fixed resistor 100 kohm	V06PB104	C466	254 4254 912	Electrolytic 22μF/16V	CE04W1C220M
CAPACITORS GROUP				C501,502	257 0008 983	Ceramic chip 1000 pF/50V	CK73B1H102K
C103,104	254 4260 977	Electrolytic 4.7μF/50V	CE04W1H4R7M	C503-505	257 0010 900	Ceramic chip 0.01μF/50V	CK73B1H103K
C105,106	254 4260 980	Electrolytic 10μF/50V	CE04W1H100M	C507,508	257 0010 900	Ceramic chip 0.01μF/50V	CK73B1H103K
C107,108	257 0012 982	Ceramic chip 0.022μF/50V	CK73F1H223Z	C509	257 0002 947	Ceramic chip 12 pF/50V	CC73SL1H120J
C109-112	254 4260 980	Electrolytic 10μF/50V	CE04W1H100M	C510	257 0010 900	Ceramic chip 0.01μF/50V	CK73B1H103K
C114	257 0012 966	Ceramic chip 0.01μF/50V	CK73F1H103Z	C511	254 4254 938	Electrolytic 47μF/16V	CE04W1C470M
C117,118	254 4260 980	Electrolytic 10μF/50V	CE04W1H100M	C512	257 0010 900	Ceramic chip 0.01μF/50V	CK73B1H103K
C119,120	257 0004 961	Ceramic chip 100 pF/50V	CC73SL1H101J	C513	254 4260 948	Electrolytic 1μF/50V	CE04W1H010M
C121,122	254 4254 909	Electrolytic 10μF/16V	CE04W1C100M	C514	257 0012 966	Ceramic chip 0.01 μF/50V	CK73F1H103Z
				C515	254 4254 938	Electrolytic 47μF/16V	CE04W1C470M
				C516,517	257 0010 900	Ceramic chip 0.01μF/50V	CK73B1H103K
				C520	257 0004 961	Ceramic chip 100pF/50V	CC73SL1H101J

Ref. No.	Part No.	Part Name	Remarks	Ref. No.	Part No.	Part Name	Remarks	Q'ty
C521-523	257 0010 900	Ceramic chip 0.01μF/50V	CK73B1H103K	FB501	235 0049 900	Beads inductor		1
C524	254 4260 935	Electrolytic 0.47μF/50V	CE04W1HR47M	JK501	205 0847 004	3P antenna terminal (PAL/F)		1
C525	254 4260 980	Electrolytic 10μF/50V	CE04W1H100M	JK502	204 8562 003	2P pin jack (S-GND)		1
C526	257 0010 942	Ceramic chip 0.022μF/50V	CK73B1H223K	JK701	204 8513 010	6P pin jack		
C527	254 4260 948	Electrolytic 1μF/50V	CE04W1H010M	L504	235 0060 905	Inductor 2.2 μH		1
C528	254 4254 938	Electrolytic 47μF/16V	CE04W1C470M	L510	235 0060 950	Inductor 10 μH		1
C529	254 4260 948	Electrolytic 1μF/50V	CE04W1H010M	T501	231 2096 001	MW ant.-osc. coil		1
C530	254 4260 919	Electrolytic 0.22μF/50V	CE04W1HR22M	T502	231 2085 009	FM DET trans.		1
C531	254 4260 948	Electrolytic 1μF/50V	CE04W1H010M	T503	231 1138 009	AM IFT		1
C532	257 0010 900	Ceramic chip 0.01μF/50V	CK73B1H103K	XL503	399 0075 003	Crystal 7.2 MHz		1
C533	256 1058 939	Metalized 0.047μF/50V	CF93A1H473J (JL)		205 1034 010	M3 Screw terminal		1
C534	256 1058 942	Metalized 0.056μF/50V	CF93A1H563J (JL)					
C535	254 3053 910	Electrolytic 22μF/16V	CE04D1C220MBP					
C536	257 0004 961	Ceramic chip 100 pF/50V	CC73SL1H101J					
C538	254 4254 912	Electrolytic 22μF/16V	CE04W1C220M					
C539,540	257 0006 972	Ceramic chip 750 pF/50V	CC73SL1H751J					
C541	254 4260 951	Electrolytic 2.2μF/50V	CE04W1H2R2M					
C544	257 0010 900	Ceramic chip 0.01μF/50V	CK73B1H103K					
C545,546	254 4254 909	Electrolytic 10μF/16V	CE04W1C100M					
C557,558	257 0002 963	Ceramic chip 15 pF/50V	CC73SL1H150J					
C559	254 4260 948	Electrolytic 1μF/50V	CE04W1H010M					
C561	257 0012 966	Ceramic chip 0.01 μF/50V	CK73F1H103Z					
C562	257 0014 935	Ceramic chip 0.1 μF/25V	CK73F1E104Z					
C570	254 4254 909	Electrolytic 10μF/16V	CE04W1C100M					
C571	254 4260 948	Electrolytic 1μF/50V	CE04W1H010M					
C574	257 0004 961	Ceramic chip 100 pF/50V	CC73SL1H101J					
C587	257 0014 935	Ceramic chip 0.1μF/25V	CK73F1E104Z					
C588	256 1058 900	Metalized 0.027μF/50V	CF93A1H273J (JL)					
C731	257 0014 935	Ceramic chip 0.1μF/25V	CK73F1E104Z					
C751,752	257 0012 966	Ceramic chip 0.01μF/50V	CK73F1H103Z					
C753,754	254 4260 977	Electrolytic 4.7μF/50V	CE04W1H4R7M					
OTHER PARTS				Q'ty				
CF501	261 0135 907	Ceramic filter MA8						1
CF502	261 0136 906	Ceramic filter MS2G						1
CF503	261 0079 005	Ceramic resonator CSB456F11						1
CF504	261 0031 001	Ceramic filter BFU450C4						1
CF505	261 0116 007	Ceramic filter SFU450B3						1
CW052-055	205 0885 008	5P connector socket (TUC-P)						4
CW082	205 0885 095	8P connector socket (TUC-P)						1
CW101	205 0885 053	10P connector socket (TUC-P)						1
CW112,113	205 0885 066	11P connector socket (TUC-P)						2
CW121	205 0885 079	12P connector socket (TUC-P)						1
CW142	205 0885 011	14P connector socket (TUC-P)						1
CW154	205 0885 040	15P connector socket (TUC-P)						1
CW961	205 0942 019	6P connector socket (TUC-P)						1
CX931	205 0190 036	3P NH connector base						1

1U-3106 DISPLAY VIDEO UNIT

Ref. No.	Part No.	Part Name	Remarks	Ref. No.	Part No.	Part Name	Remarks
SEMICONDUCTORS GROUP				RESISTORS GROUP			
IC101	499 0290 007	Remocon sensor GP1U271X		R108-123	247 0011 986	Carbon chip 68 kohm 1/10W	RM73B-683J
IC102	262 2451 006	IC LC75711NE		R124,125	247 0011 944	Carbon chip 47 kohm 1/10W	RM73B-473J
IC201	263 0609 002	IC NJM2068DDC		R126-141	247 0011 986	Carbon chip 68 kohm 1/10W	RM73B-683J
IC301	263 0857 003	IC BA7626		R142	247 0009 985	Carbon chip 10 kohm 1/10W	RM73B-103J
IC302	263 0856 004	IC BA7625		R179-197	247 0011 986	Carbon chip 68 kohm 1/10W	RM73B-683J
IC303	262 2492 007	IC TC74HC151AP		R198	247 0011 944	Carbon chip 47 kohm 1/10W	RM73B-473J
IC304	262 2067 005	IC MC74HC4053N		R377	247 0018 905	Carbon chip 0 ohm 1/10W	RM73B-0R0K
IC305	263 0682 003	IC NJM2229S		VR201	211 0883 018	Variable resistor 30 kohm	V14P25FC303K
IC306	269 0172 003	Optical connector GP1F37R		VR202	211 0883 005	Variable resistor 10 kohm	V14P25FC103K
IC307	262 1265 002	IC TC74HCU04AP		CAPACITORS GROUP			
IC308	262 2311 007	IC M35015-204SP		C101	253 9039 906	Ceramic 0.1μF/25V	CK45=1E104Z(DD-3)
IC401	263 0856 004	IC BA7625		C102	254 4254 909	Electrolytic 10μF/16V	CE04W1C100M
IC402	262 0522 005	IC TC4053BP		C104	254 4196 944	Electrolytic 1μF/50V	CE04W1H010M (SRA)
TR101-104	269 0020 906	Transistor DTC114ES(10K-10K)		C106	254 4261 921	Electrolytic 100μF/50V	CE04W1H101M
TR106	269 0046 906	Transistor DTA114ES(10K-10K)		C107	257 0012 966	Ceramic chip 0.01μF/50V	CK73F1H103Z
TR107	269 0054 901	Transistor DTC144EK		C108	254 4250 945	Electrolytic 330μF/6.3V	CE04W0J331M
TR108	269 0055 900	Transistor DTA144EK		C109	257 0003 933	Ceramic chip 30 pF/50V	CC73SL1H300J
TR109	269 0054 901	Transistor DTC144EK		C110,111	253 1181 904	Ceramic 0.01μF/50V	CK45F1H103Z(DD-3)
TR110	269 0055 900	Transistor DTA144EK		C117	256 1058 971	Metalized 0.1μF/50V	CF93A1H104J (JL)
TR111	269 0054 901	Transistor DTC144EK		C121	257 0008 983	Ceramic chip 1000 pF/50V	CK73B1H102K
TR112	269 0055 900	Transistor DTA144EK		C201,202	254 4260 948	Electrolytic 1μF/50V	CE04W1H010M
TR301-307	271 0290 904	Transistor 2PA1015GR		C203,204	254 4254 938	Electrolytic 47μF/16V	CE04W1C470M
TR309	271 0290 904	Transistor 2PA1015GR		C205,206	253 4537 924	Ceramic 33 pF/50V	CC45SL1H330J(DD-3)
TR310	269 0020 906	Transistor DTC114ES(10K-10K)		C207,208	255 1264 940	Mylar film 2200 pF/50V	CQ93M1H222J(B)
TR311	273 0446 903	Transistor 2PC1815BL		C209,210	256 1059 909	Metalized 0.18μF/50V	CF93A1H184J (JL)
TR312,313	271 0290 904	Transistor 2PA1015GR		C211,212	254 4260 948	Electrolytic 1μF/50V	CE04W1H010M
TR402-405	271 0290 904	Transistor 2PA1015GR		C215,216	255 1265 949	Mylar film 0.012μF/50V	CQ93M1H123J(B)
D101,102	276 0438 910	Diode MA151A	6.2V	C217,218	256 1058 942	Metalized 0.056μF/50V	CF93A1H563J (JL)
D103	276 0432 903	Diode 1SS270A	9.1V	C219,220	254 4260 922	Electrolytic 0.33μF/50V	CE04W1HR33M
D301-308	276 0432 903	Diode 1SS270A		C231,232	253 4538 949	Ceramic 100 pF/50V	CC45SL1H101J(DD-3)
ZD101,102	276 0637 902	Zener diode MTZJ6.2A	6.2V	C233,234	254 4260 980	Electrolytic 10μF/50V	CE04W1H100M
ZD103	276 0644 937	Zener diode MTZJ9.1A	9.1V	C301	253 9039 906	Ceramic 0.1μF/25V	CK45=1E104Z(DD-3)
LD101,102	393 9434 906	LED SEL1210S	Red	C302	254 4254 938	Electrolytic 47μF/16V	CE04W1C470M
LD103	393 9452 904	LED SEL1410E	Green	C304	254 4254 925	Electrolytic 33μF/16V	CE04W1C330M
LD104	393 9434 906	LED SEL1210S	Red	C305,306	254 4260 977	Electrolytic 4.7μF/50V	CE04W1H4R7M
FL101	393 8033 007	FLD (CM1690C)		C307	253 1181 904	Ceramic 0.01μF/50V	CK45F1H103Z(DD-3)
				C308	254 4254 909	Electrolytic 10μF/16V	CE04W1C100M
				C309	253 1181 904	Ceramic 0.01μF/50V	CK45F1H103Z(DD-3)
				C310	254 4260 977	Electrolytic 4.7μF/50V	CE04W1H4R7M
				C311	254 4250 932	Electrolytic 220μF/6.3V	CE04W0J221M
				C312	254 4250 958	Electrolytic 470μF/6.3V	CE04W0J471M
				C313	254 4250 932	Electrolytic 220μF/6.3V	CE04W0J221M
				C314	254 4250 958	Electrolytic 470μF/6.3V	CE04W0J471M
				C315	254 4250 932	Electrolytic 220μF/6.3V	CE04W0J221M
				C316	254 4250 958	Electrolytic 470μF/6.3V	CE04W0J471M
				C317,318	254 4260 948	Electrolytic 1μF/50V	CE04W1H010M

Ref. No.	Part No.	Part Name	Remarks
C319,320	253 1181 917	Ceramic 0.022μF/50V	CK45F1H223Z(DD-3)
C321	254 4254 909	Electrolytic 10μF/16V	CE04W1C100M
C323	254 4252 930	Electrolytic 100μF/10V	CE04W1A101M
C324	253 1181 904	Ceramic 0.01μF/50V	CK45F1H103Z(DD-3)
C327~329	253 4537 924	Ceramic 33 pF/50V	CC45SL1H330J(DD-3)
C330	253 9030 963	Ceramic 0.01μF/25V	CK45=1E103K
C331	257 0002 921	Ceramic chip 10 pF/50V	CC73SL1H100D
C332	257 0002 947	Ceramic chip 12 pF/50V	CC73SL1H120J
C333	255 1265 978	Mylar film 0.022μF/50V	CQ93M1H223J(B)
C334	254 4260 977	Electrolytic 4.7μF/50V	CE04W1H4R7M
C335	253 4538 949	Ceramic 100 pF/50V	CC45SL1H101J(DD-3)
C336	254 4260 948	Electrolytic 1μF/50V	CE04W1H010M
C337	254 4254 909	Electrolytic 10μF/16V	CE04W1C100M
C338	255 1264 908	Mylar film 1000 pF/50V	CQ93M1H102J(B)
C339	254 4252 930	Electrolytic 100μF/10V	CE04W1A101M
C340	253 1181 904	Ceramic 0.01μF/50V	CK45F1H103Z(DD-3)
C341	255 1264 911	Mylar film 1200 pF/50V	CQ93M1H122J(B)
C342	253 1179 929	Ceramic 150 pF/50V	CK45B1H151K(DD-3)
C343	254 4260 948	Electrolytic 1μF/50V	CE04W1H010M
C344	256 1058 955	Metalized 0.068μF/50V	CF93A1H683J (JL)
C345	253 1179 987	Ceramic 470 pF/50V	CK45B1H471K(DD-3)
C346	253 9030 934	Ceramic 3300 pF/25V	CK45=1E332K
C347,348	254 4254 909	Electrolytic 10μF/16V	CE04W1C100M
C349,350	254 4252 930	Electrolytic 100μF/10V	CE04W1A101M
C352,353	256 1058 939	Metalized 0.047μF/50V	CF93A1H473J (JL)
C354	254 4260 948	Electrolytic 1μF/50V	CE04W1H010M
C355	256 1058 939	Metalized 0.047μF/50V	CF93A1H473J (JL)
C358	253 1181 904	Ceramic 0.01μF/50V	CK45F1H103Z(DD-3)
C360	253 1181 904	Ceramic 0.01μF/50V	CK45F1H103Z(DD-3)
C390	254 4260 977	Electrolytic 4.7μF/50V	CE04W1H4R7M
C391	254 4254 925	Electrolytic 33μF/16V	CE04W1C330M
C392	254 4260 977	Electrolytic 4.7μF/50V	CE04W1H4R7M
C393,394	253 1181 904	Ceramic 0.01μF/50V	CK45F1H103Z(DD-3)
C395,396	253 4536 983	Ceramic 22 pF/50V	CC45SL1H220J(DD-3)
C397~399	254 4260 977	Electrolytic 4.7μF/50V	CE04W1H4R7M
C401~404	254 4260 977	Electrolytic 4.7μF/50V	CE04W1H4R7M
C407~409	254 4250 958	Electrolytic 470μF/6.3V	CE04W0J471M
C411	254 4254 909	Electrolytic 10μF/16V	CE04W1C100M
C413	254 4254 909	Electrolytic 10μF/16V	CE04W1C100M
C415	254 4252 930	Electrolytic 100μF/10V	CE04W1A101M
C416	253 1181 917	Ceramic 0.022μF/50V	CK45F1H223Z(DD-3)
C417	254 4260 948	Electrolytic 1μF/50V	CE04W1H010M
C418	254 4254 909	Electrolytic 10μF/16V	CE04W1C100M
C419	253 1181 904	Ceramic 0.01μF/50V	CK45F1H103Z(DD-3)
C420	254 4254 909	Electrolytic 10μF/16V	CE04W1C100M

Ref. No.	Part No.	Part Name	Remarks	Q'ty
OTHER PARTS				
CW081	204 2446 015	8P PH-SAN cord		1
CW103	204 2593 010	10P PH-SAN connector cord		1
CW122	205 0885 079	12P connector socket (TUC-P)		1
CW132	205 0942 006	13P connector socket (TUC-P)		1
CW962	205 0942 019	6P connector socket (TUC-P)		1
CX025	205 0644 003	2P wrapping terminal		1
CX181	205 1055 031	18P connector base (TKC-V)		1
FB101	235 0049 900	Beads inductor		1
FB305,306	235 0049 900	Beads inductor		2
JK301	204 8552 000	2P pin jack (FG-DIG)		1
JK302,303	204 8415 011	3P S-terminal		2
JK304	205 0902 004	1P S-terminal (SW)		1
JK401,402	204 8516 017	3P pin jack		2
JK403	204 8512 008	1P pin jack		1
L301	235 0060 963	Inductor 15μH		1
L302	235 0060 905	Inductor 2.2μH		1
L303	235 0060 918	Inductor 4.7μH		1
L305	235 0060 905	Inductor 2.2μH		1
S101~122	212 5609 902	Tact switch		22
S128	212 0373 000	Rotary encorder EC16B		1
XL301	399 0153 006	Crystal 14.32MHZ-12PF		1
XL302	399 0105 009	Ceramic resonator CSB503F2		1

1U-3107 CONTROL UNIT

Ref. No.	Part No.	Part Name	Remarks	Ref. No.	Part No.	Part Name	Remarks
SEMICONDUCTORS GROUP				SEMICONDUCTORS GROUP			
IC113	262 2485 001	IC TMP87CS71F-****	MAIN-UCOM	R171-173	247 0007 945	Carbon chip 1 kohm 1/10W	RM73B--102J
IC120	263 0609 002	IC NJM2068DDC		R174	247 0009 985	Carbon chip 10 kohm 1/10W	RM73B--103J
IC281	263 0896 909	IC NJM2068MD		R186-189	247 0009 985	Carbon chip 10 kohm 1/10W	RM73B--103J
IC282	263 0615 902	IC BA15218F		R190	247 0012 927	Carbon chip 100 kohm 1/10W	RM73B--104J
TR102	269 0083 901	Transistor DTA114EK		R191-193	247 0009 901	Carbon chip 4.7 kohm 1/10W	RM73B--472J
TR103	269 0054 901	Transistor DTC144EK		R194	247 0009 985	Carbon chip 10 kohm 1/10W	RM73B--103J
TR104	274 0163 904	Transistor 2SD601A		R198	247 0009 985	Carbon chip 10 kohm 1/10W	RM73B--103J
TR105	269 0054 901	Transistor DTC144EK		R201	247 0009 985	Carbon chip 10 kohm 1/10W	RM73B--103J
TR106	271 0131 924	Transistor 2SA988(E/F)		R202	247 0013 900	Carbon chip 220 kohm 1/10W	RM73B--224J
TR112,113	269 0046 906	Transistor DTA114ES(10K-10K)		R203	247 0009 985	Carbon chip 10 kohm 1/10W	RM73B--103J
TR114	269 0054 901	Transistor DTC144EK		R204	247 0009 901	Carbon chip 4.7 kohm 1/10W	RM73B--472J
TR115	269 0055 900	Transistor DTA144EK		R205	247 0009 985	Carbon chip 10 kohm 1/10W	RM73B--103J
TR116,117	275 0094 908	FET 2SK209-GR		R206	247 0009 901	Carbon chip 4.7 kohm 1/10W	RM73B--472J
TR118	269 0055 900	Transistor DTA144EK		R207-209	247 0007 945	Carbon chip 1 kohm 1/10W	RM73B--102J
TR120	269 0020 906	Transistor DTC114ES(10K-10K)		R210	241 2387 940	Carbon film 4.7 ohm 1/4W(NB)	RD14B2E4R7JNBS
TR121	273 0429 904	Transistor 2SC3311A		R212	241 2387 940	Carbon film 4.7 ohm 1/4W(NB)	RD14B2E4R7JNBS
TR281	269 0054 901	Transistor DTC144EK		R224,225	244 2055 996	Metal oxide 1.2 kohm 1W	RS14B3A122JNBS(S)
TR282	269 0055 900	Transistor DTA144EK		R226	244 2055 996	Metal oxide 1.2 kohm 1W	RS14B3A122JNBS(S)
TR283	275 0094 908	FET 2SK209-GR		R231	247 0011 944	Carbon chip 47 kohm 1/10W	RM73B--473J
TR567,568	273 0253 918	Transistor 2SC2878(A/B)		R281-286	247 0009 901	Carbon chip 4.7 kohm 1/10W	RM73B--472J
TR603,604	271 0131 924	Transistor 2SA988(E/F)		R287,288	247 0005 905	Carbon chip 100 ohm 1/10W	RM73B--101J
TR605	273 0445 001	Transistor 2SC4495		R289,290	247 0012 927	Carbon chip 100 kohm 1/10W	RM73B--104J
TR606	271 0131 924	Transistor 2SA988(E/F)		R291	247 0009 901	Carbon chip 4.7 kohm 1/10W	RM73B--472J
D102	276 0553 905	Diode 1SR35-200A		R292	247 0009 927	Carbon chip 5.6 kohm 1/10W	RM73B--562J
D103	276 0432 903	Diode 1SS270A		R293	247 0009 901	Carbon chip 4.7 kohm 1/10W	RM73B--472J
D105	276 0432 903	Diode 1SS270A		R294	247 0009 930	Carbon chip 6.2 kohm 1/10W	RM73B--622J
D106,107	276 0553 905	Diode 1SR35-200A		R295	247 0005 905	Carbon chip 100 ohm 1/10W	RM73B--101J
D120	276 0432 903	Diode 1SS270A		R296	247 0012 927	Carbon chip 100 kohm 1/10W	RM73B--104J
D125,126	276 0553 905	Diode 1SR35-200A		R297	247 0011 944	Carbon chip 47 kohm 1/10W	RM73B--473J
D128-131	276 0432 903	Diode 1SS270A		R299	247 0009 998	Carbon chip 11 kohm 1/10W	RM73B--113J
D280	276 0432 903	Diode 1SS270A		R751,752	244 2052 960	Metal oxide 220 ohm 1W	RS14B3A221JNBS(S)
D601-611	276 0432 903	Diode 1SS270A		CAPACITORS GROUP			
ZD100	276 0645 978	Zener diode MTZJ36A	36V	C101	257 0012 966	Ceramic chip 0.01µF/50V	CK73F1H103Z
ZD102	276 0643 996	Zener diode MTZJ5.6A	5.6V	C121,122	254 4260 948	Electrolytic 1µF/50V	CE04W1H010M
ZD103	276 0634 905	Zener diode MTZJ3.3A	3.3V	C123,124	254 4260 980	Electrolytic 10µF/50V	CE04W1H100M
RESISTORS GROUP				C127,128	253 1179 903	Ceramic 100 pF/50V	CK45B1H101K(DD-3)
R152,153	247 0009 985	Carbon chip 10 kohm 1/10W	RM73B--103J	C129,130	254 4260 980	Electrolytic 10µF/50V	CE04W1H100M
R155,156	247 0009 985	Carbon chip 10 kohm 1/10W	RM73B--103J	C141	257 0008 983	Ceramic chip 1000 pF/50V	CK73B1H102K
R158	247 0018 905	Carbon chip 0 ohm 1/10W	RM73B--0R0K	C147	257 0008 983	Ceramic chip 1000 pF/50V	CK73B1H102K
R160-167	247 0009 985	Carbon chip 10 kohm 1/10W	RM73B--103J	C148	257 0008 983	Ceramic chip 1000 pF/50V	CK73B1H102K
				C149	257 0008 983	Ceramic chip 1000 pF/50V	CK73B1H102K
				C158,159	257 0004 903	Ceramic chip 56 pF/50V	CC73SL1H560J
				C172	257 0014 935	Ceramic chip 0.1µF/25V	CK73F1E104Z
				C173	254 4254 909	Electrolytic 10µF/16V	CE04W1C100M
				C174	254 4250 932	Electrolytic 220µF/6.3V	CE04W0J221M
				C175	256 1058 984	Metalized 0.12µF/50V	CF93A1H124J (JL)
				C176	254 4260 977	Electrolytic 4.7µF/50V	CE04W1H4R7M
				C177	257 0012 966	Ceramic chip 0.01µF/50V	CK73F1H103Z
				C178	259 0007 702	Back up cap. 8200µF/5.5V	SB CAP==822=C

Ref. No.	Part No.	Part Name	Remarks	Ref. No.	Part No.	Part Name	Remarks	Q'ty
C179	257 0012 966	Ceramic chip 0.01μF/50V	CK73F1H103Z	CX142	205 0884 012	14P connector base (TUC-P)		1
C181	254 4252 969	Electrolytic 470μF/10V	CE04W1A471M	CX151	205 0884 041	15P connector base (TUC-P)		1
C186	257 0008 983	Ceramic chip 1000 pF/50V	CK73B1H102K	CX155-157	205 0884 041	15P connector base (TUC-P)		3
C191,192	254 4260 948	Electrolytic 1μF/50V	CE04W1H010M					
				CX961-963	205 0943 018	6P connector base (TUC-P)		3
C218,219	254 4260 977	Electrolytic 4.7μF/50V	CE04W1H4R7M	CY021	205 0581 001	2P VH connector base		1
C220	254 4260 980	Electrolytic 10μF/50V	CE04W1H100M	CY033	205 0343 032	3P connector base (KR-PH)		1
C232	257 0008 983	Ceramic chip 1000 pF/50V	CK73B1H102K					
C237,238	257 0004 961	Ceramic chip 100 pF/50V	CC73SL1H101J	FB101,102	235 0049 900	Beads inductor		3
C241	257 0008 983	Ceramic chip 1000 pF/50V	CK73B1H102K	FB120,121	235 0049 900	Beads inductor		2
C247	257 0008 983	Ceramic chip 1000 pF/50V	CK73B1H102K	FB122,123	235 0106 908	Chip emifil (21A05)		2
C251	257 0008 983	Ceramic chip 1000 pF/50V	CK73B1H102K	FB126	235 0106 908	Chip emifil (21A05)		1
C253,254	257 0008 983	Ceramic chip 1000 pF/50V	CK73B1H102K	FB127	235 0049 900	Beads inductor		1
C260,261	257 0008 983	Ceramic chip 1000 pF/50V	CK73B1H102K	FB128	235 0106 908	Chip emifil (21A05)		1
C270-276	257 0008 983	Ceramic chip 1000 pF/50V	CK73B1H102K					
C283,284	254 4254 909	Electrolytic 10μF/16V	CE04W1C100M	FB502	235 0049 900	Beads inductor		1
C285	254 4260 948	Electrolytic 1μF/50V	CE04W1H010M					
C286	257 0014 935	Ceramic chip 0.1μF/25V	CK73F1E104Z	JK501	204 8545 004	4P pin jack (GND)		1
C287	254 4260 948	Electrolytic 1μF/50V	CE04W1H010M	JK502	204 8264 013	Head phone jack (NI)		1
C288	257 0014 935	Ceramic chip 0.1μF/25V	CK73F1E104Z					
C291	254 4254 909	Electrolytic 10μF/16V	CE04W1C100M	RL120	214 0127 003	Relay (RY-12W)		1
C293-296	257 0004 961	Ceramic chip 100 pF/50V	CC73SL1H101J					
				Δ S501	212 1031 006	Power switch (TV-5)		1
C615	253 1181 904	Ceramic 0.01μF/50V	CK45F1H103Z(DD-3)					
C617	254 4254 912	Electrolytic 22μF/16V	CE04W1C220M	T101,102	205 1034 010	M3 Screw terminal		2
C619	254 4260 948	Electrolytic 1μF/50V	CE04W1H010M					
C620	253 1181 904	Ceramic 0.01μF/50V	CK45F1H103Z(DD-3)	X103	399 0191 903	Ceramic 4.00 MHz	CST4.00MGW-TF01	1
C621-624	254 4254 938	Electrolytic 47μF/16V	CE04W1C470M					
C633,634	253 1180 921	Ceramic 1000 pF/50V	CK45B1H102K(DD-3)					
C637	254 4260 980	Electrolytic 10μF/50V	CE04W1H100M					
C638,639	253 1181 904	Ceramic 0.01μF/50V	CK45F1H103Z(DD-3)					
OTHER PARTS								
								Q'ty
CW051	205 0885 008	5P connector socket (TUC-P)						1
CW091	205 0885 037	9P connector socket (TUC-P)						1
CW111	205 0885 066	11P connector socket (TUC-P)						1
CW153	205 0885 040	15P connector socket (TUC-P)						1
CW156	205 0885 040	15P connector socket (TUC-P)						1
CW181	205 1056 030	18P connector socket TKC-V						1
CW963	205 0942 019	6P connector socket (TUC-P)						1
CX041	205 0884 083	4P connector base (TUC-P)						1
CX071	205 0943 021	7P connector base (TUC-P)						1
CX081	205 0343 087	8P connector base (KR-PH)						1
CX082	205 0884 096	8P connector base (TUC-P)						1
CX101,102	205 0884 054	10P connector base (TUC-P)						2
CX113,114	205 0884 067	11P connector base (TUC-P)						2
CX121,122	205 0884 070	12P connector base (TUC-P)						2
CX132	205 0943 005	13P connector base (TUC-P)						1

1U-3108 POWER AMP. UNIT

Ref. No.	Part No.	Part Name	Remarks	Ref. No.	Part No.	Part Name	Remarks
SEMICONDUCTORS GROUP				CAPACITORS GROUP			
△ IC501	268 0073 905	IC ICP-N15		R571	244 2043 937	Metal oxide 10 ohm 1W	RS14B3A100JNBS(S)
IC502	263 0793 002	IC NJM7806FA(S)		R605-608	244 2052 957	Metal oxide 5.6 kohm 1W	RS14B3A562JNBS(S)
IC503	263 0801 004	IC NJM7812FA(S)		R619,620	241 2378 962	Carbon film 330 ohm 1/4W(NB)	RD14B2E331JNBS
IC504	263 0641 002	IC NJM7912FA		R621-624	241 2387 908	Carbon film 1 ohm 1/4W(NB)	RD14B2E010JNBS
IC505	263 0793 002	IC NJM7806FA(S)		R625-632	244 2043 982	Metal oxide 0.22 ohm 1W	RS14B3AR22JNBS(S)
IC506,507	263 0809 006	IC NJM7805FA(S)		R639,640	244 2043 937	Metal oxide 10 ohm 1W	RS14B3A100JNBS(S)
TR507,508	273 0303 910	Transistor 2SC1740S(S)		R672,673	244 2052 957	Metal oxide 5.6 kohm 1W	S14B3A562JNBS(S)
TR511,512	274 0151 929	Transistor 2SD2004(Q)		R679	241 2378 962	Carbon film 330 ohm 1/4W(NB)	RD14B2E331JNBS
TR513,514	272 0107 922	Transistor 2SB1328(Q)		R680,681	241 2387 908	Carbon film 1 ohm 1/4W(NB)	RD14B2E010JNBS
TR519,520	273 0235 923	Transistor 2SC1841(E/F)		R682-685	244 2043 982	Metal oxide 0.22 ohm 1W	S14B3AR22JNBS(S)
TR527,528	273 0303 910	Transistor 2SC1740S(S)		R690	244 2043 937	Metal oxide 10 ohm 1W	S14B3A100JNBS(S)
TR531,532	274 0151 929	Transistor 2SD2004(Q)		R714,715	243 2039 032	Winding 0.1 ohm 5W	RW99-3H0R1K
TR533,534	272 0107 922	Transistor 2SB1328(Q)		R734	242 2009 001	Composition 2.2 Mohm 1/2W	RC05GF2H225K(UL)
TR539,540	273 0235 923	Transistor 2SC1841(E/F)		R744-746	241 2376 919	Carbon film 30 ohm 1/4W(NB)	RD14B2E300JNBS
TR544	273 0303 910	Transistor 2SC1740S(S)		R757,758	244 2052 960	Metal oxide 220 ohm 1W	S14B3A221JNBS(S)
TR546	274 0151 929	Transistor 2SD2004(Q)		VR501-505	211 6132 909	Semi fixed resistor 4.7 kohm	V06PB472
TR547	272 0107 922	Transistor 2SB1328(Q)		RESISTORS GROUP			
TR550	273 0235 923	Transistor 2SC1841(E/F)		R525-528	244 2052 957	Metal oxide 5.6 kohm 1W	RS14B3A562JNBS(S)
TR551	271 0131 924	Transistor 2SA988(E/F)		R537,538	241 2378 962	Carbon film 330 ohm 1/4W(NB)	RD14B2E331JNBS
TR552	273 0429 904	Transistor 2SC3311A		R539-542	241 2387 908	Carbon film 1 ohm 1/4W(NB)	RD14B2E010JNBS
TR554	273 0429 904	Transistor 2SC3311A		R543-550	244 2043 982	Metal oxide 0.22 ohm 1W	RS14B3AR22JNBS(S)
TR555	271 0192 905	Transistor 2SA933S(S)		R557,558	244 2043 937	Metal oxide 10 ohm 1W	S14B3A100JNBS(S)
TR556,557	273 0429 904	Transistor 2SC3311A					
TR558	271 0192 905	Transistor 2SA933S(S)					
TR559-565	273 0429 904	Transistor 2SC3311A					
TR569,570	271 0254 018	Transistor 2SA1725(O/P/Y)					
D501-505	276 0432 903	Diode 1SS270A					
D507-512	276 0553 905	Diode 1SR35-200A					
D513-517	276 0432 903	Diode 1SS270A					
D518-520	276 0305 001	Diode S4VB20					
D521-523	276 0432 903	Diode 1SS270A					
D524-527	276 0553 905	Diode 1SR35-200A					
ZD501	276 0644 911	Zener diode MTZJ7.5A	7.5V				
SC501	279 0016 904	Thyristor SF0R1A42					
TH501	279 0034 067	Posistor PTH9M04BB222TS2F333					
C513,514	254 4261 918	Electrolytic 47μF/50V		C513,514	254 4261 918	Electrolytic 47μF/50V	CE04W1H470M
C515,516	254 4263 987	Electrolytic 10μF/100V		C515,516	254 4263 987	Electrolytic 10μF/100V	CE04W2A100M
C517-520	253 4494 902	Ceramic 100 pF/500V		C517-520	253 4494 902	Ceramic 100 pF/500V	CC45SL2H101J
C521,522	256 1058 971	Metalized 0.1μF/50V		C521,522	256 1058 971	Metalized 0.1μF/50V	CF93A1H104J (JL)
C541,542	254 4261 918	Electrolytic 47μF/50V		C541,542	254 4261 918	Electrolytic 47μF/50V	CE04W1H470M
C543,544	253 4494 902	Ceramic 100 pF/500V		C543,544	253 4494 902	Ceramic 100 pF/500V	CC45SL2H101J
C545,546	254 4263 987	Electrolytic 10μF/100V		C545,546	254 4263 987	Electrolytic 10μF/100V	CE04W2A100M
C547,548	253 4494 902	Ceramic 100 pF/500V		C547,548	253 4494 902	Ceramic 100 pF/500V	CC45SL2H101J
C549,550	256 1058 971	Metalized 0.1μF/50V		C549,550	256 1058 971	Metalized 0.1μF/50V	CF93A1H104J (JL)
C566	254 4261 918	Electrolytic 47μF/50V		C566	254 4261 918	Electrolytic 47μF/50V	CE04W1H470M
C567	254 4263 987	Electrolytic 10μF/100V		C567	254 4263 987	Electrolytic 10μF/100V	CE04W2A100M
C568,569	253 4494 902	Ceramic 100 pF/500V		C568,569	253 4494 902	Ceramic 100 pF/500V	CC45SL2H101J
C570	256 1058 971	Metalized 0.1μF/50V		C570	256 1058 971	Metalized 0.1μF/50V	CF93A1H104J (JL)
C573	253 1181 904	Ceramic 0.01μF/50V		C573	253 1181 904	Ceramic 0.01μF/50V	CK45F1H103Z(DD-3)
C581	254 4254 938	Electrolytic 47μF/16V		C581	254 4254 938	Electrolytic 47μF/16V	CE04W1C470M
C582	253 9039 906	Ceramic 0.1μF/25V		C582	253 9039 906	Ceramic 0.1μF/25V	CK45=1E104Z(DD-3)
C583	254 4254 909	Electrolytic 10μF/16V		C583	254 4254 909	Electrolytic 10μF/16V	CE04W1C100M
C584	253 9039 906	Ceramic 0.1μF/25V		C584	253 9039 906	Ceramic 0.1μF/25V	CK45=1E104Z(DD-3)
C585	254 4250 945	Electrolytic 330μF/6.3V		C585	254 4250 945	Electrolytic 330μF/6.3V	CE04W0J331M
C586	253 9039 906	Ceramic 0.1μF/25V		C586	253 9039 906	Ceramic 0.1μF/25V	CK45=1E104Z(DD-3)
C587	254 4250 945	Electrolytic 330μF/6.3V		C587	254 4250 945	Electrolytic 330μF/6.3V	CE04W0J331M
C588	253 1181 904	Ceramic 0.01μF/50V		C588	253 1181 904	Ceramic 0.01μF/50V	CK45F1H103Z(DD-3)
C589	254 4254 909	Electrolytic 10μF/16V		C589	254 4254 909	Electrolytic 10μF/16V	CE04W1C100M
C590	254 4260 948	Electrolytic 1μF/50V		C590	254 4260 948	Electrolytic 1μF/50V	CE04W1H010M
C591-593	253 1181 904	Ceramic 0.01μF/50V		C591-593	253 1181 904	Ceramic 0.01μF/50V	CK45F1H103Z(DD-3)
C594	254 4256 790	Electrolytic 2200μF/25V		C594	254 4256 790	Electrolytic 2200μF/25V	CE04W1E222MC
C595	254 4260 948	Electrolytic 1μF/50V		C595	254 4260 948	Electrolytic 1μF/50V	CE04W1H010M
C599	256 1058 971	Metalized 0.1μF/50V		C599	256 1058 971	Metalized 0.1μF/50V	CF93A1H104J (JL)
C601	254 4260 948	Electrolytic 1μF/50V		C601	254 4260 948	Electrolytic 1μF/50V	CE04W1H010M

Ref. No.	Part No.	Part Name	Remarks	Ref. No.	Part No.	Part Name	Remarks	Q'ty
C602	254 6200 003	Electrolytic 10000µF/56V	CE68W==103MC(DL)	FH501-505	202 0040 909	Fuse clip		10
C603,604	256 1042 903	Metalized 0.1µF/250V	CF93A2E104K	L501-505	235 0068 004	Inductor 1µH		5
C605	254 6200 003	Electrolytic 10000µF/56V	CE68W==103MC(DL)	RL501	214 0127 003	Relay (RY-12W)		1
C606-608	256 1042 903	Metalized 0.1µF/250V	CF93A2E104K	RL502-504	214 0195 006	Relay FTR-F1		3
C609-612	255 1265 936	Mylar film 0.01µF/50V	CQ93M1H103J(B)	△ RL505	214 0188 000	Relay VS-12MBNR-SM2(TV-8)		1
C635	254 4254 938	Electrolytic 47µF/16V	CE04W1C470M	△ T501	233 6073 000	Power trans. (Mini)-EU		1
C636-638	253 1181 904	Ceramic 0.01µF/50V	CK45F1H103Z(DD-3)	TM501,502	205 0472 013	8P SP terminal (EAEK)		2
C639,640	254 4256 936	Electrolytic 47µF/25V	CE04W1E470M	TP501-505	205 0190 036	3P NH connector base		5
C641	254 4260 948	Electrolytic 1µF/50V	CE04W1H010M		415 0309 026	P.V.C. tube (L=20)	for TH501	2
C642	254 4403 747	Electrolytic 10000µF/25V	CE04W1E103MC (SMG)	△ AC501	203 3976 002	AC outlet (2P)		1
C643	254 4256 787	Electrolytic 1000µF/25V	CE04W1E102MC					
C644,645	256 1058 971	Metalized 0.1µF/50V	CF93A1H104J (JL)					
C646	254 4262 784	Electrolytic 470µF/63V	CE04W1J471MC					
C647	256 1058 971	Metalized 0.1µF/50V	CF93A1H104J (JL)					
△ C648	253 8014 702	Ceramic 0.01µF/400V(AC)	CK45F2GAC103MC					
C660	254 4260 948	Electrolytic 1µF/50V	CE04W1H010M					
C664	253 1181 904	Ceramic 0.01µF/50V	CK45F1H103Z(DD-3)					
C665	254 4406 702	Electrolytic 3300µF/16V	CE04W1C332MC(SMG)					
C666	254 4254 938	Electrolytic 47µF/16V	CE04W1C470M					
C667-669	253 1181 904	Ceramic 0.01µF/50V	CK45F1H103Z(DD-3)					
C670	254 4256 936	Electrolytic 47µF/25V	CE04W1E470M					
C671	253 1181 904	Ceramic 0.01µF/50V	CK45F1H103Z(DD-3)					
C672	254 4260 948	Electrolytic 1µF/50V	CE04W1H010M					
C675	253 1181 904	Ceramic 0.01µF/50V	CK45F1H103Z(DD-3)					
OTHER PARTS								
								Q'ty
CW155	205 0885 040	15P connector socket (TUC-P)						1
CX021	205 0581 001	2P VH connector base						1
CX022	205 0606 025	2P wrapping terminal						1
CX024	205 0606 025	2P wrapping terminal						1
CX033	205 0343 032	3P connector base (KR-PH)						1
CX051-055	205 0884 009	5P connector base (TUC-P)						5
CX057	205 0233 058	5P EH connector base						1
CX061-069	205 1064 064	6P pin header (TXX)V						9
CX091	205 0884 038	9P connector base (TUC-P)						1
CX111,112	205 0884 067	11P connector base (TUC-P)						2
CX153,154	205 0884 041	15P connector base (TUC-P)						2
CX960	205 1064 064	6P pin header (TXX)V						1
CX968	205 1037 062	6P pin header (TXX)						1
CY032	205 0087 039	3P wrapping terminal						1
△ F1	206 1046 001	Fuse 6.3A UL 20mm						1
△ F8	206 1046 014	Fuse 8A						1
△ F11,12	206 1039 076	Fuse 2.5A						2
△ F13	206 1039 076	Fuse 2.5A						1

1U-3109 AUDIO IN DSP UNIT

Ref. No.	Part No.	Part Name	Remarks	Ref. No.	Part No.	Part Name	Remarks
SEMICONDUCTORS GROUP				RESISTORS GROUP			
IC601	263 0896 909	IC NJM2068MD		D731	276 0438 910	Diode MA151A	
IC603	262 2034 009	IC TC9273N-007		D856,857	276 0438 949	Diode MA151WK	
IC606	263 0898 907	IC NJM5532MD		D859	276 0438 949	Diode MA151WK	
IC701	262 2490 902	IC PCM1716E		D901,902	276 0438 910	Diode MA151A	
IC702,703	263 0896 909	IC NJM2068MD					
IC731	263 0615 902	IC BA15218F					
IC751	262 2490 902	IC PCM1716E					
IC752,753	263 0896 909	IC NJM2068MD					
IC801	262 2490 902	IC PCM1716E		R519-522	247 0006 962	Carbon chip 470 ohm 1/10W	RM73B-471J
IC802-804	263 0896 909	IC NJM2068MD		R523-526	247 0015 966	Carbon chip 2.7 Mohm 1/10W	RM73B-275J
IC851,852	263 0934 900	IC BA4510F		R601,602	247 0018 905	Carbon chip 0 ohm 1/10W	RM73B-0R0K
IC853	263 0673 902	IC BA10393F		R603,604	247 0006 946	Carbon chip 390 ohm 1/10W	RM73B-391J
IC854	262 2426 905	IC AK5351-VF		R605,606	247 0011 986	Carbon chip 68 kohm 1/10W	RM73B-683J
IC855	399 0300 008	Crystal SG-531PH(12.288MHZ)		R607,608	247 0012 969	Carbon chip 150 kohm 1/10W	RM73B-154J
				R609,610	247 0004 922	Carbon chip 47 ohm 1/10W	RM73B-470J
IC900	263 1048 002	IC BA033T		R611,612	247 0005 992	Carbon chip 240 ohm 1/10W	RM73B-241J
IC901	262 2370 103	IC ZR38600(B6)		R613,614	247 0012 956	Carbon chip 130 kohm 1/10W	RM73B-134J
IC902	262 2376 903	IC TC74HCT7007AF		R615,616	247 0009 998	Carbon chip 11 kohm 1/10W	RM73B-113J
IC903	262 2489 007	IC TMP87CM43N-****		R617,618	247 0003 949	Carbon chip 22 ohm 1/10W	RM73B-220J
IC904	262 1718 902	IC TC74HC00AF		R619,620	247 0005 905	Carbon chip 100 ohm 1/10W	RM73B-101J
IC905	262 1348 903	IC TC74HC123AF		R621,622	247 0011 944	Carbon chip 47 kohm 1/10W	RM73B-473J
IC906	262 2385 907	IC SN74HC14NS		R625-634	247 0015 966	Carbon chip 2.7 Mohm 1/10W	RM73B-275J
IC907	262 1348 903	IC TC74HC123AF		R635-644	247 0006 962	Carbon chip 470 ohm 1/10W	RM73B-471J
IC908	262 2284 901	IC TC74HCT157AF		R663,664	247 0006 962	Carbon chip 470 ohm 1/10W	RM73B-471J
IC909	262 1665 903	IC HD74HC74FP		R665,666	247 0015 966	Carbon chip 2.7 Mohm 1/10W	RM73B-275J
IC910	262 1641 901	IC HD74HC157FP		R667,668	247 0012 927	Carbon chip 100 kohm 1/10W	RM73B-104J
IC911	262 2491 901	IC CS8414-CS		R671,672	247 0011 944	Carbon chip 47 kohm 1/10W	RM73B-473J
TR601,602	275 0094 908	FET 2SK209-GR		R673,674	247 0018 905	Carbon chip 0 ohm 1/10W	RM73B-0R0K
TR603	269 0055 900	Transistor DTA144EK		R677,678	247 0005 905	Carbon chip 100 ohm 1/10W	RM73B-101J
TR604	269 0054 901	Transistor DTC144EK		R679,680	247 0012 927	Carbon chip 100 kohm 1/10W	RM73B-104J
TR701-704	273 0414 906	Transistor 2SC3326(A/B)		R681	247 0011 944	Carbon chip 47 kohm 1/10W	RM73B-473J
TR707	269 0083 901	Transistor DTA114EK		R683,684	247 0012 927	Carbon chip 100 kohm 1/10W	RM73B-104J
TR731	275 0094 908	FET 2SK209-GR		R685,686	247 0005 905	Carbon chip 100 ohm 1/10W	RM73B-101J
TR732	269 0055 900	Transistor DTA144EK		R691,692	247 0005 905	Carbon chip 100 ohm 1/10W	RM73B-101J
TR733	269 0054 901	Transistor DTC144EK		R701-708	247 0009 901	Carbon chip 4.7 kohm 1/10W	RM73B-472J
TR751-754	273 0414 906	Transistor 2SC3326(A/B)		R709,710	247 0012 927	Carbon chip 100 kohm 1/10W	RM73B-104J
TR757	269 0083 901	Transistor DTA114EK		R711	247 0007 945	Carbon chip 1 kohm 1/10W	RM73B-102J
TR801-804	273 0414 906	Transistor 2SC3326(A/B)		R712	247 0004 922	Carbon chip 47 ohm 1/10W	RM73B-470J
TR807	269 0083 901	Transistor DTA114EK		R713,714	247 0012 927	Carbon chip 100 kohm 1/10W	RM73B-104J
TR852	269 0083 901	Transistor DTA114EK		R715,716	247 0005 989	Carbon chip 220 ohm 1/10W	RM73B-221J
TR901,902	269 0082 902	Transistor DTC114EK		R717-720	247 0007 961	Carbon chip 1.2 kohm 1/10W	RM73B-122J
TR903	269 0054 901	Transistor DTC144EK		R721-724	247 0008 960	Carbon chip 3.3 kohm 1/10W	RM73B-332J
D601	276 0438 949	Diode MA151WK		R725,726	247 0012 927	Carbon chip 100 kohm 1/10W	RM73B-104J
				R727,728	247 0009 943	Carbon chip 6.8 kohm 1/10W	RM73B-682J
				R729,730	247 0009 943	Carbon chip 6.8 kohm 1/10W	RM73B-682J
				R735,736	247 0005 905	Carbon chip 100 ohm 1/10W	RM73B-101J
				R737,738	247 0012 927	Carbon chip 100 kohm 1/10W	RM73B-104J
				R741-743	247 0011 944	Carbon chip 47 kohm 1/10W	RM73B-473J
				R744,745	247 0010 974	Carbon chip 24 kohm 1/10W	RM73B-243J

Ref. No.	Part No.	Part Name	Remarks
R746	247 0005 905	Carbon chip 100 ohm 1/10W	RM73B--101J
R747	247 0012 927	Carbon chip 100 kohm 1/10W	RM73B--104J
R748	247 0011 944	Carbon chip 47 kohm 1/10W	RM73B--473J
R751	247 0009 901	Carbon chip 4.7 kohm 1/10W	RM73B--472J
R752	247 0009 985	Carbon chip 10 kohm 1/10W	RM73B--103J
R753	247 0009 901	Carbon chip 4.7 kohm 1/10W	RM73B--472J
R754	247 0009 985	Carbon chip 10 kohm 1/10W	RM73B--103J
R755-758	247 0009 901	Carbon chip 4.7 kohm 1/10W	RM73B--472J
R759,760	247 0012 927	Carbon chip 100 kohm 1/10W	RM73B--104J
R761	247 0007 945	Carbon chip 1 kohm 1/10W	RM73B--102J
R762	247 0004 922	Carbon chip 47 ohm 1/10W	RM73B--470J
R763,764	247 0012 927	Carbon chip 100 kohm 1/10W	RM73B--104J
R765,766	247 0005 989	Carbon chip 220 ohm 1/10W	RM73B--221J
R767-770	247 0005 976	Carbon chip 200 ohm 1/10W	RM73B--201J
R771-774	247 0008 960	Carbon chip 3.3 kohm 1/10W	RM73B--332J
R775,776	247 0010 932	Carbon chip 16 kohm 1/10W	RM73B--163J
R777,778	247 0005 905	Carbon chip 100 ohm 1/10W	RM73B--101J
R781	247 0018 905	Carbon chip 0 ohm 1/10W	RM73B--0R0K
R782	247 0009 914	Carbon chip 5.1 kohm 1/10W	RM73B--512J
R784	247 0009 901	Carbon chip 4.7 kohm 1/10W	RM73B--472J
R785,786	247 0005 905	Carbon chip 100 ohm 1/10W	RM73B--101J
R787,788	247 0012 927	Carbon chip 100 kohm 1/10W	RM73B--104J
R789,790	247 0007 990	Carbon chip 1.6 kohm 1/10W	RM73B--162J
R801-808	247 0009 901	Carbon chip 4.7 kohm 1/10W	RM73B--472J
R809,810	247 0012 927	Carbon chip 100 kohm 1/10W	RM73B--104J
R811	247 0007 945	Carbon chip 1 kohm 1/10W	RM73B--102J
R812	247 0004 922	Carbon chip 47 ohm 1/10W	RM73B--470J
R813,814	247 0012 927	Carbon chip 100 kohm 1/10W	RM73B--104J
R815,816	247 0005 989	Carbon chip 220 ohm 1/10W	RM73B--221J
R817-820	247 0007 945	Carbon chip 1 kohm 1/10W	RM73B--102J
R821-824	247 0008 960	Carbon chip 3.3 kohm 1/10W	RM73B--332J
R825,826	247 0010 932	Carbon chip 16 kohm 1/10W	RM73B--163J
R827,828	247 0005 905	Carbon chip 100 ohm 1/10W	RM73B--101J
R831,832	247 0018 905	Carbon chip 0 ohm 1/10W	RM73B--0R0K
R835,836	247 0005 905	Carbon chip 100 ohm 1/10W	RM73B--101J
R837,838	247 0012 927	Carbon chip 100 kohm 1/10W	RM73B--104J
R839,840	247 0007 990	Carbon chip 1.6 kohm 1/10W	RM73B--162J
R851-854	247 0009 901	Carbon chip 4.7 kohm 1/10W	RM73B--472J
R855,856	247 0011 944	Carbon chip 47 kohm 1/10W	RM73B--473J
R857,858	247 0009 998	Carbon chip 11 kohm 1/10W	RM73B--113J
R859,860	247 0008 986	Carbon chip 3.9 kohm 1/10W	RM73B--392J
R861-864	247 0009 901	Carbon chip 4.7 kohm 1/10W	RM73B--472J
R865-868	247 0006 920	Carbon chip 330 ohm 1/10W	RM73B--331J
R869	247 0019 991	Carbon chip 4.7 kohm 1/10W	RM73B--472F
R870	247 0020 906	Carbon chip 12 kohm 1/10W	RM73B--123F
R871-873	247 0009 901	Carbon chip 4.7 kohm 1/10W	RM73B--472J
R874,875	247 0018 905	Carbon chip 0 ohm 1/10W	RM73B--0R0K
R878-880	247 0005 905	Carbon chip 100 ohm 1/10W	RM73B--101J
R882	247 0011 944	Carbon chip 47 kohm 1/10W	RM73B--473J
R883,884	247 0005 905	Carbon chip 100 ohm 1/10W	RM73B--101J
R885-887	247 0010 916	Carbon chip 13 kohm 1/10W	RM73B--133J
R889	247 0010 916	Carbon chip 13 kohm 1/10W	RM73B--133J

Ref. No.	Part No.	Part Name	Remarks
R892,893	247 0018 905	Carbon chip 0 ohm 1/10W	RM73B--0R0K
R894,895	247 0005 905	Carbon chip 100 ohm 1/10W	RM73B--101J
R896,897	247 0012 927	Carbon chip 100 kohm 1/10W	RM73B--104J
R899,900	247 0012 969	Carbon chip 150 kohm 1/10W	RM73B--154J
R901	247 0009 985	Carbon chip 10 kohm 1/10W	RM73B--103J
R902	247 0004 922	Carbon chip 47 ohm 1/10W	RM73B--470J
R904,905	247 0004 922	Carbon chip 47 ohm 1/10W	RM73B--470J
R906,907	247 0018 905	Carbon chip 0 ohm 1/10W	RM73B--0R0K
R908	247 0009 901	Carbon chip 4.7 kohm 1/10W	RM73B--472J
R909,910	247 0018 905	Carbon chip 0 ohm 1/10W	RM73B--0R0K
R913-915	247 0018 905	Carbon chip 0 ohm 1/10W	RM73B--0R0K
R916,917	247 0012 927	Carbon chip 100 kohm 1/10W	RM73B--104J
R918	247 0018 905	Carbon chip 0 ohm 1/10W	RM73B--0R0K
R920	247 0014 967	Carbon chip 1 Mohm 1/10W	RM73B--105J
R921	247 0011 902	Carbon chip 33 kohm 1/10W	RM73B--333J
R922	247 0011 944	Carbon chip 47 kohm 1/10W	RM73B--473J
R929	247 0018 905	Carbon chip 0 ohm 1/10W	RM73B--0R0K
R931-933	247 0004 922	Carbon chip 47 ohm 1/10W	RM73B--470J
R934	247 0011 944	Carbon chip 47 kohm 1/10W	RM73B--473J
R935	247 0004 922	Carbon chip 47 ohm 1/10W	RM73B--470J
R936	247 0018 905	Carbon chip 0 ohm 1/10W	RM73B--0R0K
R937,938	247 0004 922	Carbon chip 47 ohm 1/10W	RM73B--470J
R939-942	247 0018 905	Carbon chip 0 ohm 1/10W	RM73B--0R0K
R943	247 0007 945	Carbon chip 1 kohm 1/10W	RM73B--102J
R944	247 0018 905	Carbon chip 0 ohm 1/10W	RM73B--0R0K
R951	247 0009 901	Carbon chip 4.7 kohm 1/10W	RM73B--472J
R952	247 0009 985	Carbon chip 10 kohm 1/10W	RM73B--103J
R953-955	247 0004 922	Carbon chip 47 ohm 1/10W	RM73B--470J
R956-958	247 0011 944	Carbon chip 47 kohm 1/10W	RM73B--473J
R985,986	247 0010 916	Carbon chip 13 kohm 1/10W	RM73B--133J

CAPACITORS GROUP

C601,602	257 0005 944	Ceramic chip 220 pF/50V	CC73SL1H221J
C603,604	254 4254 909	Electrolytic 10µF/16V	CE04W1C100M
C605,606	257 0004 961	Ceramic chip 100 pF/50V	CC73SL1H101J
C607,608	254 4250 932	Electrolytic 220µF/6.3V	CE04W0J221M
C609,610	255 4199 999	Mylar film 0.024µF/50V	CQ92M1H243J(MRZ)
C611,612	255 1265 907	Mylar film 6800 pF/50V	CQ93M1H682J(B)
C613,614	254 4260 977	Electrolytic 4.7µF/50V	CE04W1H487M
C615,616	257 0012 982	Ceramic chip 0.022µF/50V	CK73F1H223Z
C645	257 0012 966	Ceramic chip 0.01µF/50V	CK73F1H103Z
C647	257 0012 966	Ceramic chip 0.01µF/50V	CK73F1H103Z
C649	254 4260 977	Electrolytic 4.7µF/50V	CE04W1H4R7M
C651	254 4260 977	Electrolytic 4.7µF/50V	CE04W1H4R7M
C655,656	254 4254 909	Electrolytic 10µF/16V	CE04W1C100M
C657,658	254 4260 948	Electrolytic 1µF/50V	CE04W1H010M
C671,672	254 4254 938	Electrolytic 47µF/16V	CE04W1C470M
C701-704	254 4254 909	Electrolytic 10µF/16V	CE04W1C100M
C705-708	257 0006 969	Ceramic chip 680 pF/50V	CC73SL1H681J
C711,712	254 4254 909	Electrolytic 10µF/16V	CE04W1C100M
C713,714	255 1265 952	Mylar film 0.015µF/50V	CQ93M1H153J(B)

Ref. No.	Part No.	Part Name	Remarks	Ref. No.	Part No.	Part Name	Remarks
C715,716	254 4254 938	Electrolytic 47μF/16V	CE04W1C470M	C895,896	257 0014 935	Ceramic chip 0.1μF/25V	CK73F1E104Z
C717,718	254 4254 909	Electrolytic 10μF/16V	CE04W1C100M	C897,898	254 4254 909	Electrolytic 10μF/16V	CE04W1C100M
C733	256 1058 942	Metalized 0.056μF/50V	CF93A1H563J (JL)	C899	257 0014 935	Ceramic chip 0.1μF/25V	CK73F1E104Z
C721,722	257 0003 988	Ceramic chip 47 pF/50V	CC73SL1H470J	C901,902	257 0012 966	Ceramic chip 0.01μF/50V	CK73F1H103Z
C734	256 1058 984	Metalized 0.12μF/50V	CF93A1H124J (JL)	C903	254 4260 948	Electrolytic 1μF/50V	CE04W1H010M
C735,736	257 0014 935	Ceramic chip 0.1μF/25V	CK73F1E104Z	C905	254 4254 909	Electrolytic 10μF/16V	CE04W1C100M
C737	254 4254 909	Electrolytic 10μF/16V	CE04W1C100M	C906	257 0012 966	Ceramic chip 0.01μF/50V	CK73F1H103Z
C742	254 4254 909	Electrolytic 10μF/16V	CE04W1C100M	C907	257 0014 935	Ceramic chip 0.1μF/25V	CK73F1E104Z
C743,744	257 0014 935	Ceramic chip 0.1μF/25V	CK73F1E104Z	C908	257 0012 966	Ceramic chip 0.01μF/50V	CK73F1H103Z
C745-747	254 4254 909	Electrolytic 10μF/16V	CE04W1C100M	C909	257 0007 900	Ceramic chip 1000 pF/50V	CC73SL1H102J
C748,749	257 0014 935	Ceramic chip 0.1μF/25V	CK73F1E104Z	C913	257 0012 966	Ceramic chip 0.01μF/50V	CK73F1H103Z
C751-754	254 4254 909	Electrolytic 10μF/16V	CE04W1C100M	C914	257 0007 900	Ceramic chip 1000 pF/50V	CC73SL1H102J
C755	257 0006 969	Ceramic chip 680 pF/50V	CC73SL1H681J	C915	257 0012 966	Ceramic chip 0.01μF/50V	CK73F1H103Z
C756	257 0011 983	Ceramic chip 0.047μF/25V	CK73B1E473K	C916	257 0014 935	Ceramic chip 0.1μF/25V	CK73F1E104Z
C757	257 0006 969	Ceramic chip 680 pF/50V	CC73SL1H681J	C917	257 0012 966	Ceramic chip 0.01μF/50V	CK73F1H103Z
C758	257 0011 967	Ceramic chip 0.033μF/25V	CK73B1E333K	C918	257 0011 983	Ceramic chip 0.047μF/25V	CK73B1E473K
C761,762	254 4254 909	Electrolytic 10μF/16V	CE04W1C100M	C919	257 0012 966	Ceramic chip 0.01μF/50V	CK73F1H103Z
C763,764	255 1265 952	Mylar film 0.015μF/50V	CQ93M1H153J(B)	C920	257 0014 935	Ceramic chip 0.1μF/25V	CK73F1E104Z
C765-768	254 4254 909	Electrolytic 10μF/16V	CE04W1C100M	C921	257 0012 966	Ceramic chip 0.01μF/50V	CK73F1H103Z
C775	257 0004 961	Ceramic chip 100 pF/50V	CC73SL1H101J	C922	257 0007 900	Ceramic chip 1000 pF/50V	CC73SL1H102J
C776	257 0010 900	Ceramic chip 0.01μF/50V	CK73B1H103K	C923	257 0012 966	Ceramic chip 0.01μF/50V	CK73F1H103Z
C792	254 4254 909	Electrolytic 10μF/16V	CE04W1C100M	C927	257 0008 983	Ceramic chip 1000 pF/50V	CK73B1H102K
C793,794	257 0014 935	Ceramic chip 0.1μF/25V	CK73F1E104Z	C928,929	257 0004 903	Ceramic chip 56 pF/50V	CC73SL1H560J
C795-797	254 4254 909	Electrolytic 10μF/16V	CE04W1C100M	C930	257 0005 944	Ceramic chip 220 pF/50V	CC73SL1H221J
C798,799	257 0014 935	Ceramic chip 0.1μF/25V	CK73F1E104Z	C931	257 0008 983	Ceramic chip 1000 pF/50V	CK73B1H102K
C801-804	254 4254 909	Electrolytic 10μF/16V	CE04W1C100M	C932	257 0014 935	Ceramic chip 0.1μF/25V	CK73F1E104Z
C805-808	257 0006 969	Ceramic chip 680 pF/50V	CC73SL1H681J	C934	257 0012 966	Ceramic chip 0.01μF/50V	CK73F1H103Z
C811,812	254 4254 909	Electrolytic 10μF/16V	CE04W1C100M	C936	257 0012 966	Ceramic chip 0.01μF/50V	CK73F1H103Z
C813,814	255 1265 952	Mylar film 0.015μF/50V	CQ93M1H153J(B)	C937,938	254 4260 935	Electrolytic 0.47μF/50V	CE04W1HR47M
C815-818	254 4254 909	Electrolytic 10μF/16V	CE04W1C100M	C940,941	257 0012 966	Ceramic chip 0.01μF/50V	CK73F1H103Z
C821-824	256 1059 912	Metalized 0.22μF/50V	CF93A1H224J (JL)	C942	257 0008 983	Ceramic chip 1000 pF/50V	CK73B1H102K
C825,826	254 4254 909	Electrolytic 10μF/16V	CE04W1C100M	C943	257 0005 986	Ceramic chip 330 pF/50V	CC73SL1H331J
C827,828	257 0004 961	Ceramic chip 100 pF/50V	CC73SL1H101J	C947	254 4252 930	Electrolytic 100μF/10V	CE04W1A101M
C835,836	254 4260 948	Electrolytic 1μF/50V	CE04W1H010M	C948	257 0012 966	Ceramic chip 0.01μF/50V	CK73F1H103Z
C842	254 4254 909	Electrolytic 10μF/16V	CE04W1C100M	C949	257 0008 983	Ceramic chip 1000 pF/50V	CK73B1H102K
C843,844	257 0014 935	Ceramic chip 0.1μF/25V	CK73F1E104Z	C950	257 0012 966	Ceramic chip 0.01μF/50V	CK73F1H103Z
C845-847	254 4254 909	Electrolytic 10μF/16V	CE04W1C100M	C951	257 0008 983	Ceramic chip 1000 pF/50V	CK73B1H102K
C848,849	257 0014 935	Ceramic chip 0.1μF/25V	CK73F1E104Z	C952	257 0012 966	Ceramic chip 0.01μF/50V	CK73F1H103Z
C851,852	257 0014 935	Ceramic chip 0.1μF/25V	CK73F1E104Z	C953	257 0008 983	Ceramic chip 1000 pF/50V	CK73B1H102K
C853,854	254 4254 909	Electrolytic 10μF/16V	CE04W1C100M	C954-958	257 0012 966	Ceramic chip 0.01μF/50V	CK73F1H103Z
C855,856	254 4260 948	Electrolytic 1μF/50V	CE04W1H010M	C959	256 1058 939	Metalized 0.047μF/50V	CF93A1H473J (JL)
C857,858	254 4254 909	Electrolytic 10μF/16V	CE04W1C100M	C960	257 0014 935	Ceramic chip 0.1μF/25V	CK73F1E104Z
C859,860	255 1264 924	Mylar film 1500 pF/50V	CQ93M1H152J(B)	C961-964	254 4254 909	Electrolytic 10μF/16V	CE04W1C100M
C861	254 4260 948	Electrolytic 1μF/50V	CE04W1H010M	C965-968	257 0004 961	Ceramic chip 100 pF/50V	CC73SL1H101J
C862	257 0014 935	Ceramic chip 0.1μF/25V	CK73F1E104Z	C995	257 0008 983	Ceramic chip 1000 pF/50V	CK73B1H102K
C865	257 0008 983	Ceramic chip 1000 pF/50V	CK73B1H102K	C997-999	256 1058 971	Metalized 0.1μF/50V	CF93A1H104J (JL)
C866	257 0012 966	Ceramic chip 0.01μF/50V	CK73F1H103Z				
C867	254 4254 941	Electrolytic 100μF/16V	CE04W1C101M				
C888,889	257 0008 983	Ceramic chip 1000 pF/50V	CK73B1H102K				
C890	257 0008 983	Ceramic chip 1000 pF/50V	CK73B1H102K				
C892,893	257 0014 935	Ceramic chip 0.1μF/25V	CK73F1E104Z				
C894	254 4254 909	Electrolytic 10μF/16V	CE04W1C100M				

Ref. No.	Part No.	Part Name	Remarks	Q'ty
OTHER PARTS				
CW041	205 0885 082	4P connector socket (TUC-P)		1
CW071	205 0942 022	7P connector socket (TUC-P)		1
CW102	205 0885 053	10P connector socket (TUC-P)		1
CW114	205 0885 066	11P connector socket (TUC-P)		1
CW151	205 0885 040	15P connector socket (TUC-P)		1
CW157	205 0885 040	15P connector socket (TUC-P)		1
CX103	205 0375 000	10P connector base (KR-PH)		1
FB701-709	235 0049 900	Beads inductor		9
FB851-854	235 0049 900	Beads inductor		4
FB901-917	235 0106 908	Chip emifil (21A05)		17
FB918,919	235 0049 900	Beads inductor		2
FB923-928	235 0049 900	Beads inductor		6
FB929	235 0106 908	Chip emifil (21A05)		1
FB930	235 0049 900	Beads inductor		1
FB931-933	235 0106 908	Chip emifil (21A05)		3
FB934	235 0049 900	Beads inductor		4
FB935-940	235 0106 908	Chip emifil (21A05)		6
FB941	235 0049 900	Beads inductor		1
FB942,943	235 0106 908	Chip emifil (21A05)		2
FB945,946	235 0106 908	Chip emifil (21A05)		2
JK501	204 8543 006	6 P pin jack		1
JK601,602	204 8543 006	6 P pin jack		2
X901	399 0191 903	Ceramic 4.00 MHz	CST4.00MGW -TF01	1

EXPLODED VIEW OF CHASSIS AND CABINET

1 2 3 4 5 6 7 8

A

B

C

D

E

WARNING:
Parts marked with this symbol  have critical characteristics.
Use **ONLY** replacement parts recommended by the manufacturer.

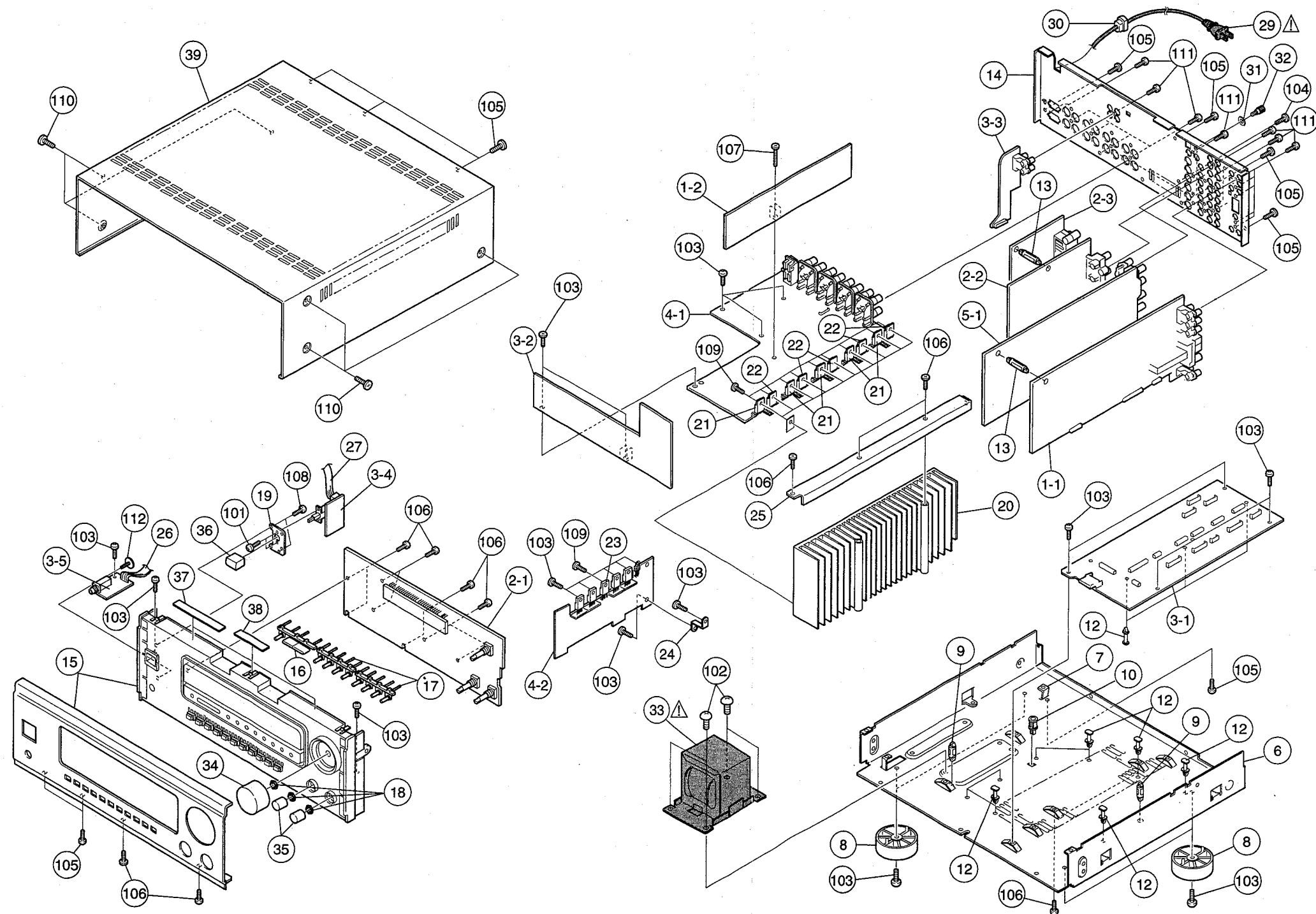

PARTS LIST OF EXPLODED VIEW

Ref. No.	Part No.	Part Name	Remarks	Q'ty	Ref. No.	Part No.	Part Name	Remarks	Q'ty
1	1U-3105	Tuner amp. unit ass'y		1	SCREWS				
1-1	1U-3105-1	Tuner VR unit			101	471 3303 016	Screw 3 x 6 CBS-Z		2
1-2	1U-3105-2	Amp. unit			102	473 7004 016	Screw 4 x 6 CBTS (S)-Z		4
2	1U-3106	Display video unit ass'y		1	103	473 7005 002	Screw 3 x 10 CBTS(S)-Z		24
2-1	1U-3106-1	Display unit			104	473 7006 043	Screw 3 x 14 CBTS (S)-B		1
2-2	1U-3106-2	C - video unit			105	473 7015 018	Screw 3 x 8 CBTS(S)-B		11
2-3	1U-3106-3	S - video unit			106	473 7501 001	Screw 3 x 10 CBTS (P)-Z		15
3	1U-3107	Control unit ass'y		1	107	473 7501 030	Screw 3 x 20 CBTS (P)-Z		1
3-1	1U-3107-1	Control unit			108	473 7505 007	Screw 2.6 x 8 CBTS(P)-Z		2
3-2	1U-3107-2	Connect unit			109	473 8007 009	Cup screw 3 x 12		11
3-3	1U-3107-3	Pre out unit			110	473 8064 000	Screw 4 x 8 CBTS(B)-B-3P		6
3-4	1U-3107-4	Power switch unit			111	477 0064 107	Fixing screw		24
3-5	1U-3107-5	Headphones unit			112	477 0262 006	Special screw		1
4	1U-3108	Power amp. unit ass'y		1	PACKING & ACCESSORIES				
4-1	1U-3108-1	Power amp. unit			201	504 9102 029	Stylen paper		1
4-2	1U-3108-2	Regulator unit			202	505 9102 019	Poly. cover		1
5	1U-3109	Audio in DSP unit ass'y		1	203	503 1236 204	Cushion ass'y		1
5-1	1U-3109-1	Audio in DSP unit			204	505 8006 019	Envelope		1
6	411 1372 416	Main chassis		1	205	511 3263 001	Instruction manual		1
7	412 4210 002	Bracket		1	206	231 0922 009	Loop antenna		1
8	104 0194 205	Foot ass'y		4	207	395 0023 008	FM antenna ass'y		1
9	449 0133 017	PWB holder		2	208	399 0498 004	RC-844 remocon unit		1
10	412 3548 005	P.W.B. catcher		1	209	515 0671 601	Service station list (EX)		1
12	412 2814 028	Card spacer (L=10)		11	210	529 0079 008	FM ant. adapter		1
13	449 0133 004	PWB holder		2	211	501 1988 048	Carton case		1
14	105 1281 000	Back panel		1	212	513 1389 006	Control card base		1
15	146 2065 019	Inner panel ass'y		1	213	513 1349 004	Thermal carbon film		1
16	113 1804 006	Tuning knob		1	214	517 1318 066	UPC label		1
17	113 1805 005	Function knob		2					
18	-	9 nut		3					
19	412 4163 007	Switch bracket		1					
20	417 0569 008	Power radiator		1					
21	273 0389 031	Transistor 2SC3855 LB(O/P/Y)(Z)		5					
22	271 0240 035	Transistor 2SA1491 LB(O/P/Y)(Z)		5					
23	271 0239 020	Transistor 2SA1489 LB1 (O/P/Y)		1					
24	412 4127 001	P.W.B. bracket (B)		1					
25	412 4296 000	Radiator bracket		1					
26	203 4871 067	3P KR-KR ribbon 175	CN033	1					
27	203 2374 029	2P VA-VA cord	CN021	1					
28	445 8004 007	Wire clasper		3					
△ 29	206 2060 002	AC cord (polarized)		1					
30	445 0056 008	Cord bush		1					
31	477 0018 014	Washer (P-87) D10		1					
32	205 0071 016	Terminal ass'y		1					
△ 33	233 6253 008	Power trans. (EU/EC)		1					
34	112 0744 067	VR. knob ass'y		1					
35	112 0685 100	Knob (MARU)		2					
36	113 9213 000	P. knob (P) ass'y		1					
37	461 0976 009	Rubber sheet		2					
38	461 0976 012	Rubber sheet		1					
39	102 0590 036	Top cover		1					

1

2

3

4

5

6

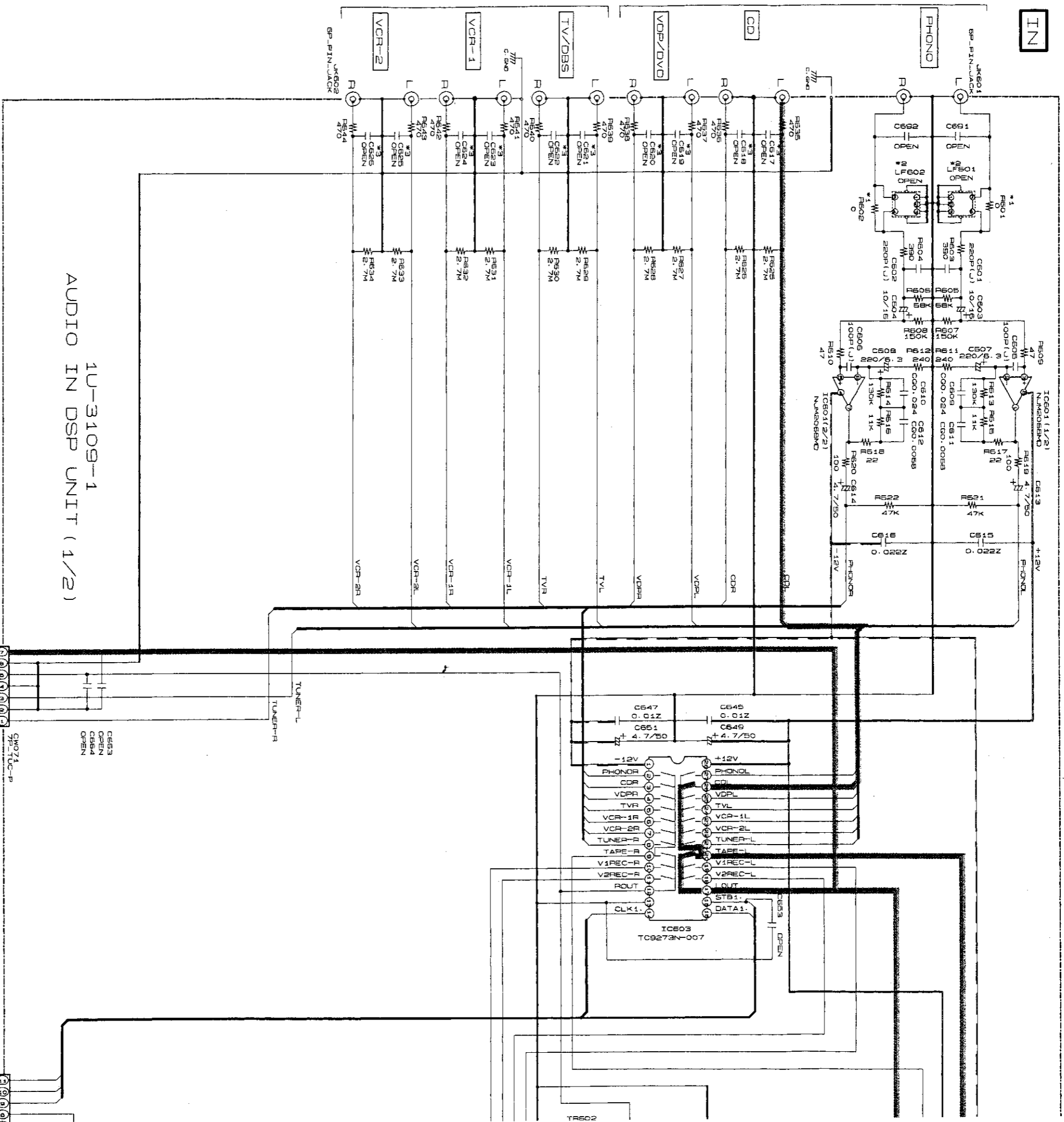

1U-3109-1
AUDIO IN DSP UNIT (1/2)

USA	*1	RS01: 502	*2	LF601: 502	*3	CE17~26	*4	CE00~512 CE51, CE2
TAIWAN		0						
ASIA		4.7K		L.P.F		330P		100P
EUROPE								

TO CONTROL UNIT
1U-3107-1
(SHEET 20/10)

NOTICE
ALL RESISTANCE VALUES IN OHM. K=1,000 OHM. M=1,000,000
ALL CAPACITANCE VALUES IN MICRO FARAD. P=MICRO-MICRO
EACH VOLTAGE AND CURRENT ARE MEASURED AT NO SIGNAL
CONDITION.
CIRCUIT AND PARTS ARE SUBJECT TO CHANGE WITHOUT PRIOR
NOTICE.

TO CON
1U-
(SHE
N
LATT
CLK1
DATA1

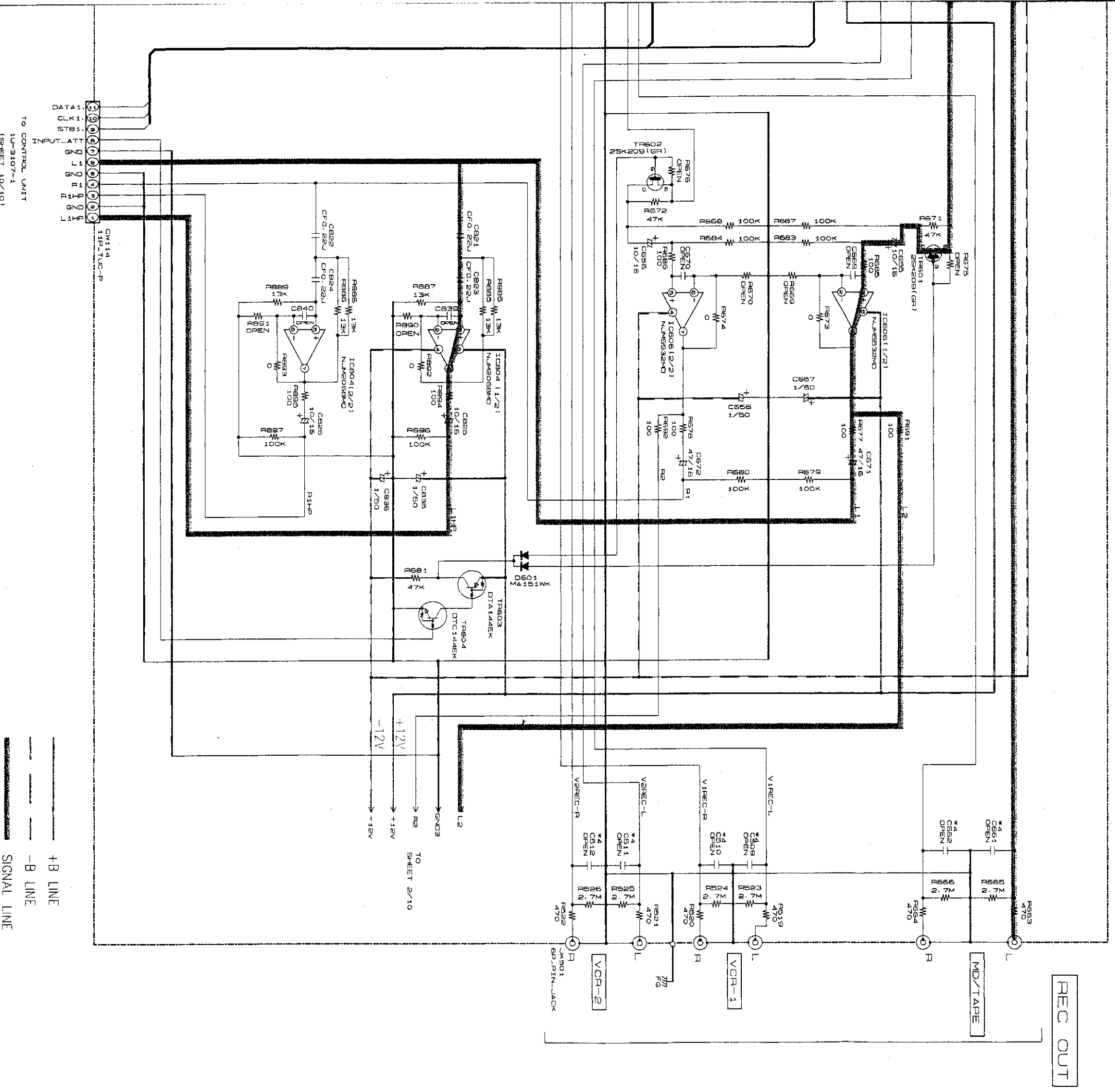

TO CONTROL UNIT
 1U-3107-1
 (SHEET 10/10)

--- +B LINE
 --- -B LINE
 --- SIGNAL LINE

WARNING: Parts marked with this symbol have critical characteristics. Use ONLY replacement parts recommended by the manufacturer.

CAUTION: Before returning the unit to the customer, make sure you make either (1) 0 leakage current check or (2) a line to chassis resistance check. If the leakage current exceeds 0.5 milliamperes, or if the resistance from chassis to either side of the power cord is less than 460 kohms, the unit is defective.

WARNING: DO NOT return the unit to the customer until the problem is located and corrected.

M, k=1,000 OHM M=1,000,000 OHM
 MICRO FARAD, P=MICRO-MICRO FARAD
 ARE MEASURED AT NO SIGNAL INPUT
 CT TO CHANGE WITHOUT PRIOR

SCHEMATIC DIAGRAM (1/10)

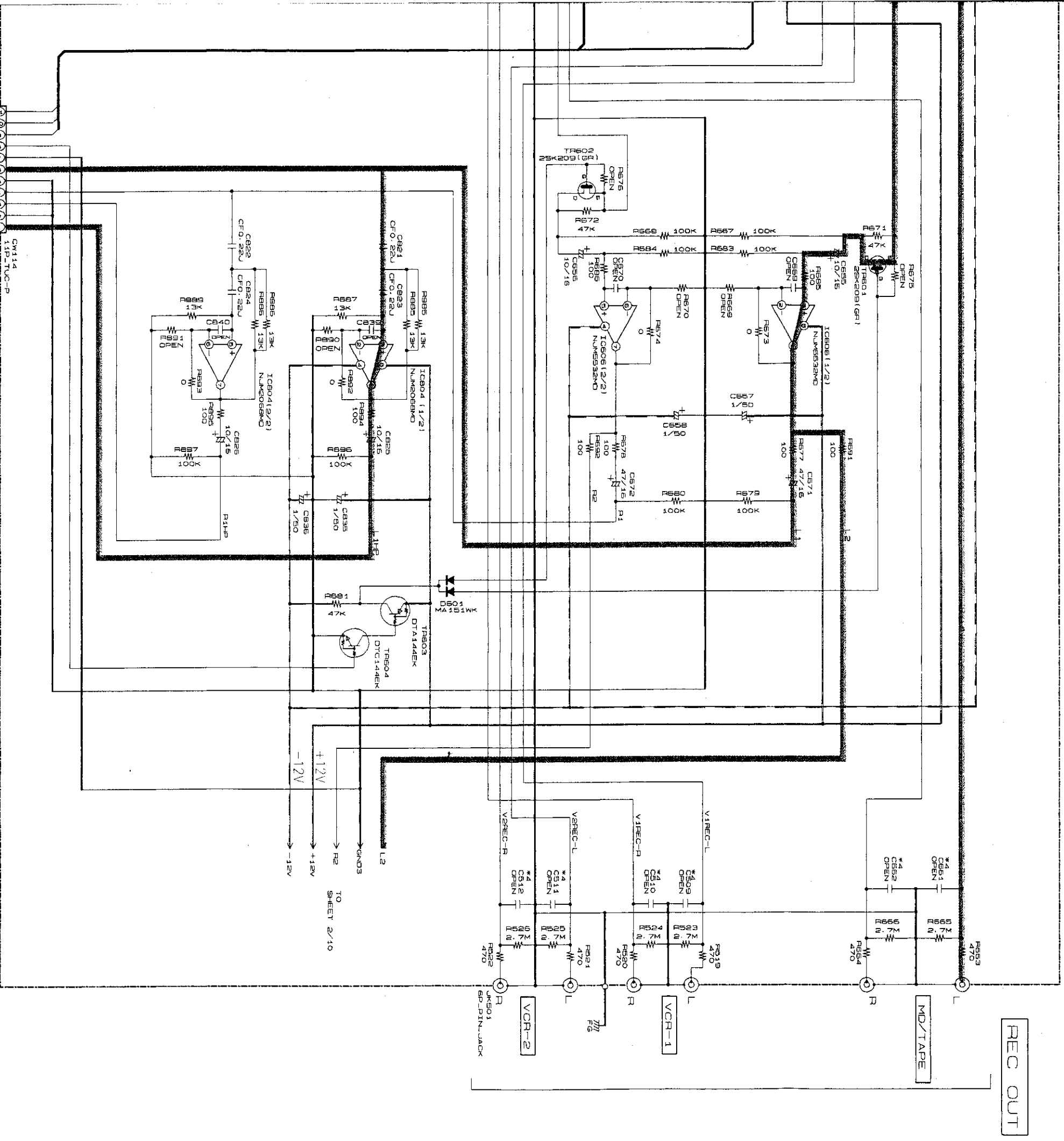

TO CONTROL UNIT
 1U-3107-1
 (SHEET 10/10)

----- +B LINE
 - - - - - -B LINE
 _____ SIGNAL LINE

WARNING:

Parts marked with this symbol have critical characteristics. Use ONLY replacement parts recommended by the manufacturer.

CAUTION:

Before returning the unit to the customer, make sure you make either (1) a leakage current check or (2) a line to chassis resistance check. If the leakage current exceeds 0.5 milliamps, or if the resistance from chassis to either side of the power cord is less than 460 kohms, the unit is defective.

WARNING:

DO NOT return the unit to the customer until the problem is located and corrected.

SCHEMATIC DIAGRAM (1/10)

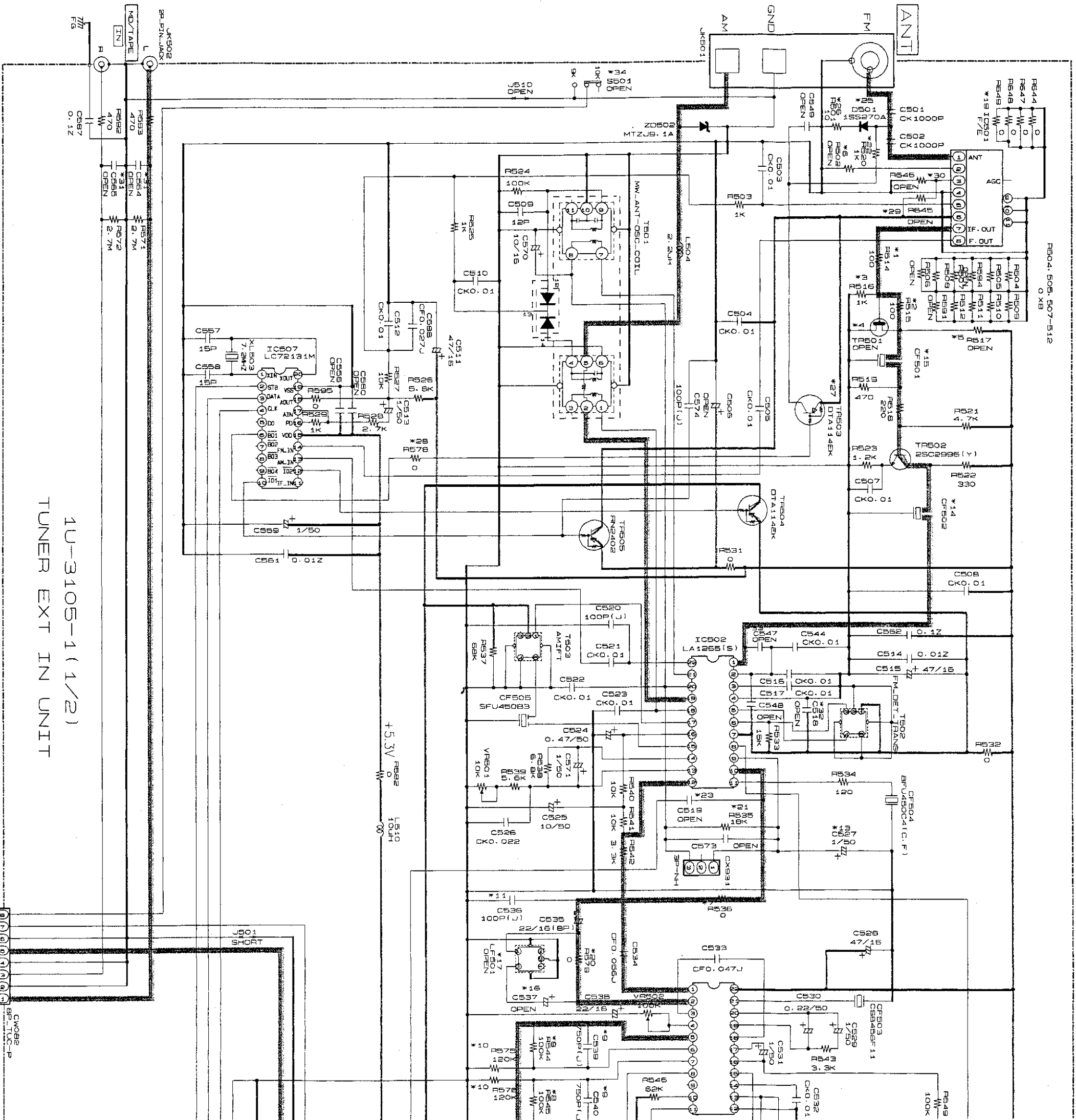

1U-3105-1 (1/2)
TUNER EXT IN UNIT

NOTICE
ALL RESISTANCE VALUES IN OHM, k=1,000 OHM, M=1,000,000 OHM.
ALL CAPACITANCE VALUES IN MICRO FARAD. P=MICRO-MICRO FARAD.
EACH VOLTAGE AND CURRENT ARE MEASURED AT NO SIGNAL INPUT
CONDITION.
CIRCUIT AND PARTS ARE SUBJECT TO CHANGE WITHOUT PRIOR
NOTICE.

WARNING:
Parts marked with this symbol  have critical characteristics.
Use ONLY replacement parts recommended by the manufacturer.

CAUTION:
Before returning the unit to the customer, make sure you make either (1) a leakage current check or (2) a line to chassis resistance check. If the leakage current exceeds 0.5 milliamperes, or if the resistance from chassis to either side of the power cord is less than 460 kohms, the unit is defective.

WARNING:
DO NOT return the unit to the customer until the problem is located and corrected.

To CONTROL UNIT
1U-3107-1
SHEET 10/10

SCHEMATIC DIAGRAM (4/10)

1 2 3 4 5 6

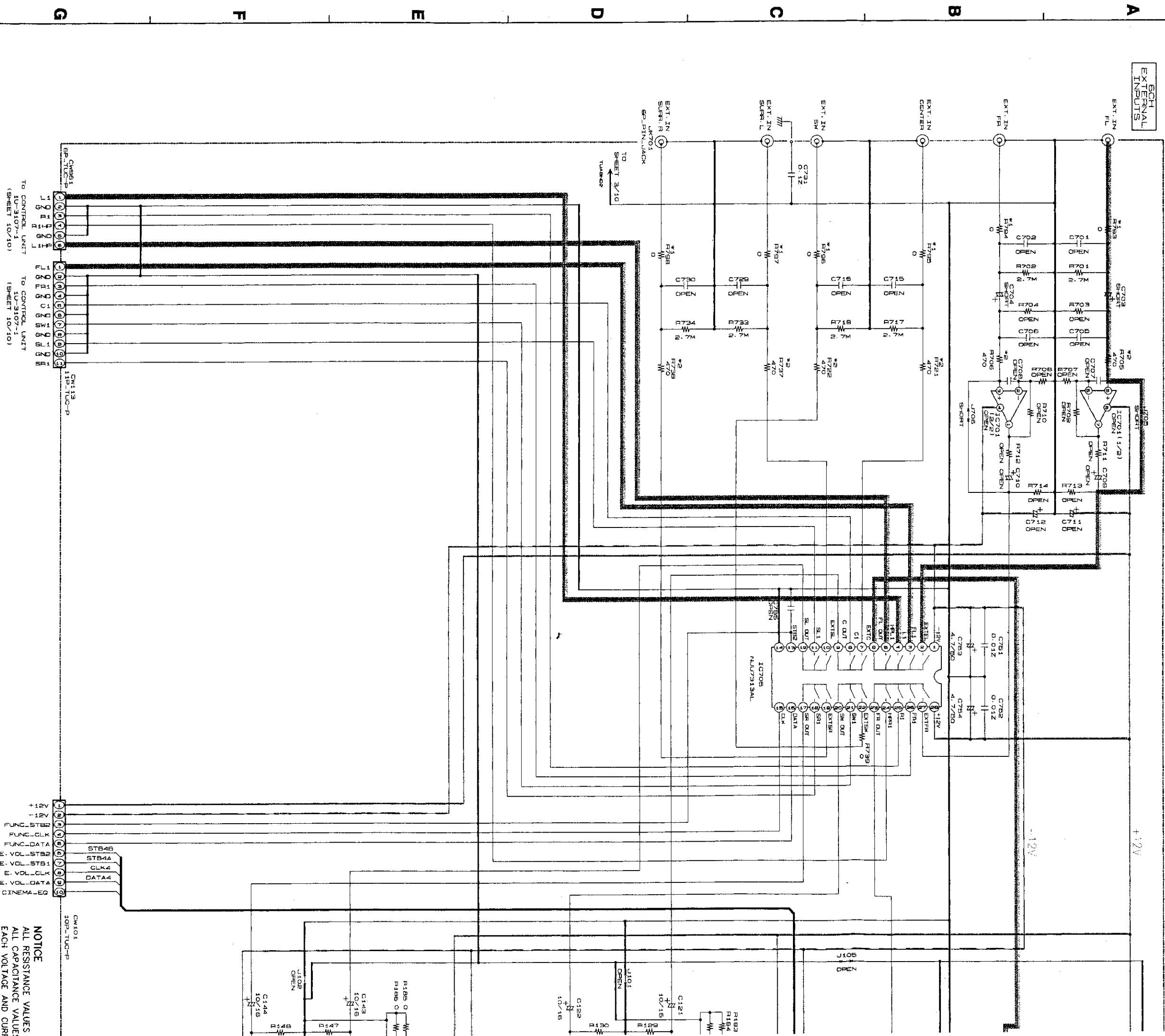

USA	*1	R793~798	*2	R705, 706, 721, 722, 727, 728	*3	C701, 702, 715, 716, 726, 730	*4	C707, 708
JAPAN		0		470				
EUROPE		470		100		330P		

NOTICE
 ALL RESISTANCE VALUES 1
 ALL CAPACITANCE VALUES
 EACH VOLTAGE AND CURR
 CONDITION.
 CIRCUIT AND PARTS ARE :

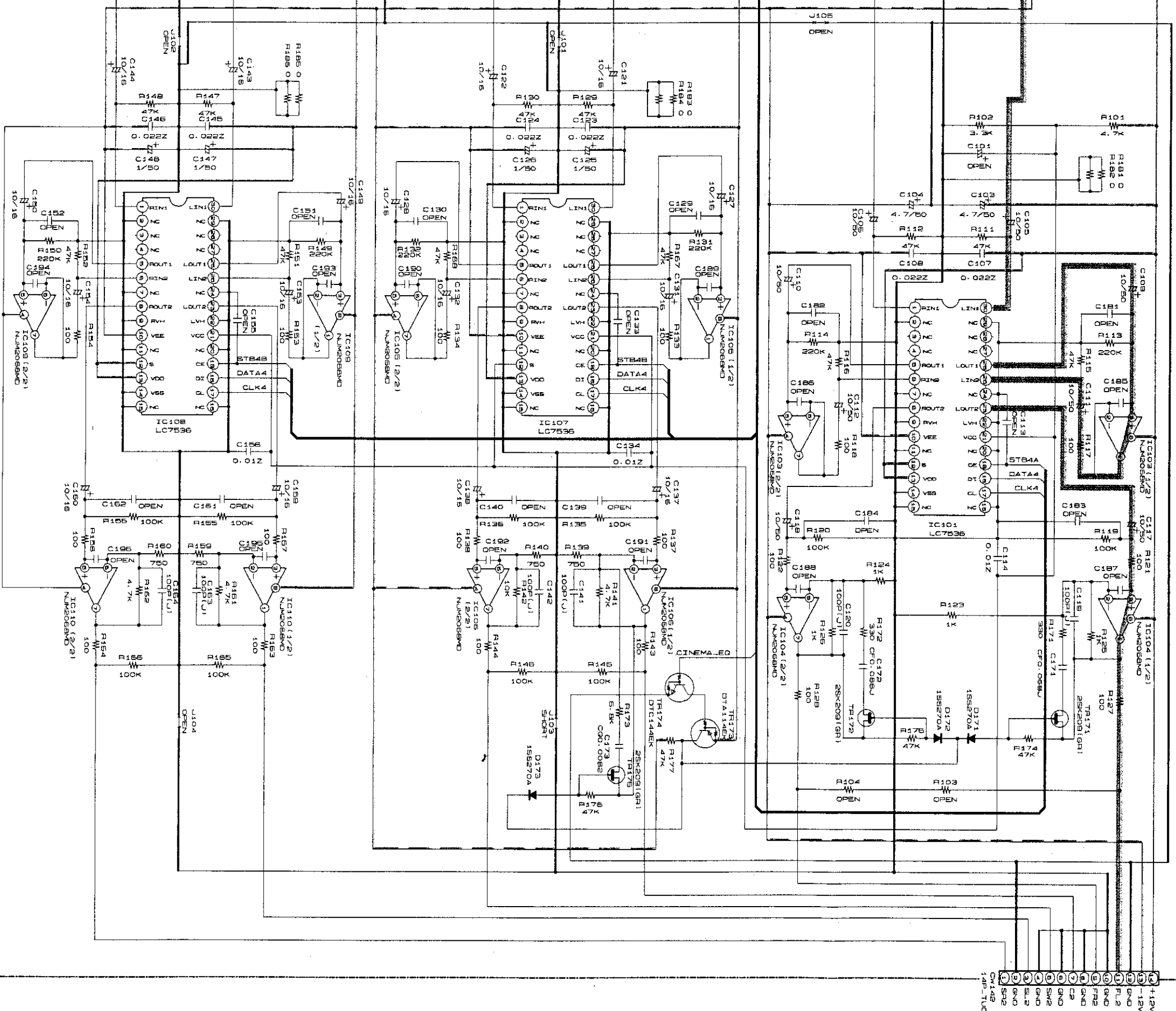

1U-3105(2/2)
TUNER EXT IN UNIT

NOTICE
ALL RESISTANCE VALUES IN OHM, K=1,000 OHM, M=1,000,000 OHM.
ALL CAPACITANCE VALUES IN MICRO-FARAD, P=MICRO-MICRO-FARAD.
EACH VOLTAGE AND CURRENT ARE MEASURED AT NO SIGNAL INPUT
CONDITION.
CIRCUIT AND PARTS ARE SUBJECT TO CHANGE WITHOUT PRIOR
NOTICE.

WARNING:
Parts marked with this symbol  have critical characteristics.
Use ONLY replacement parts recommended by the manufacturer.

CAUTION:
Before returning the unit to the customer, make sure you make either (1) a leakage current check or (2) a line to chassis resistance check. If the leakage current exceeds 0.5 milliamps, or if the resistance from chassis to either side of the power cord is less than 460 kohms, the unit is defective.

WARNING:
DO NOT return the unit to the customer until the problem is located and corrected.

+B LINE
-B LINE
SIGNAL LINE

To CONNECT UNIT
1U-3107-2
(SHEET 7/10)

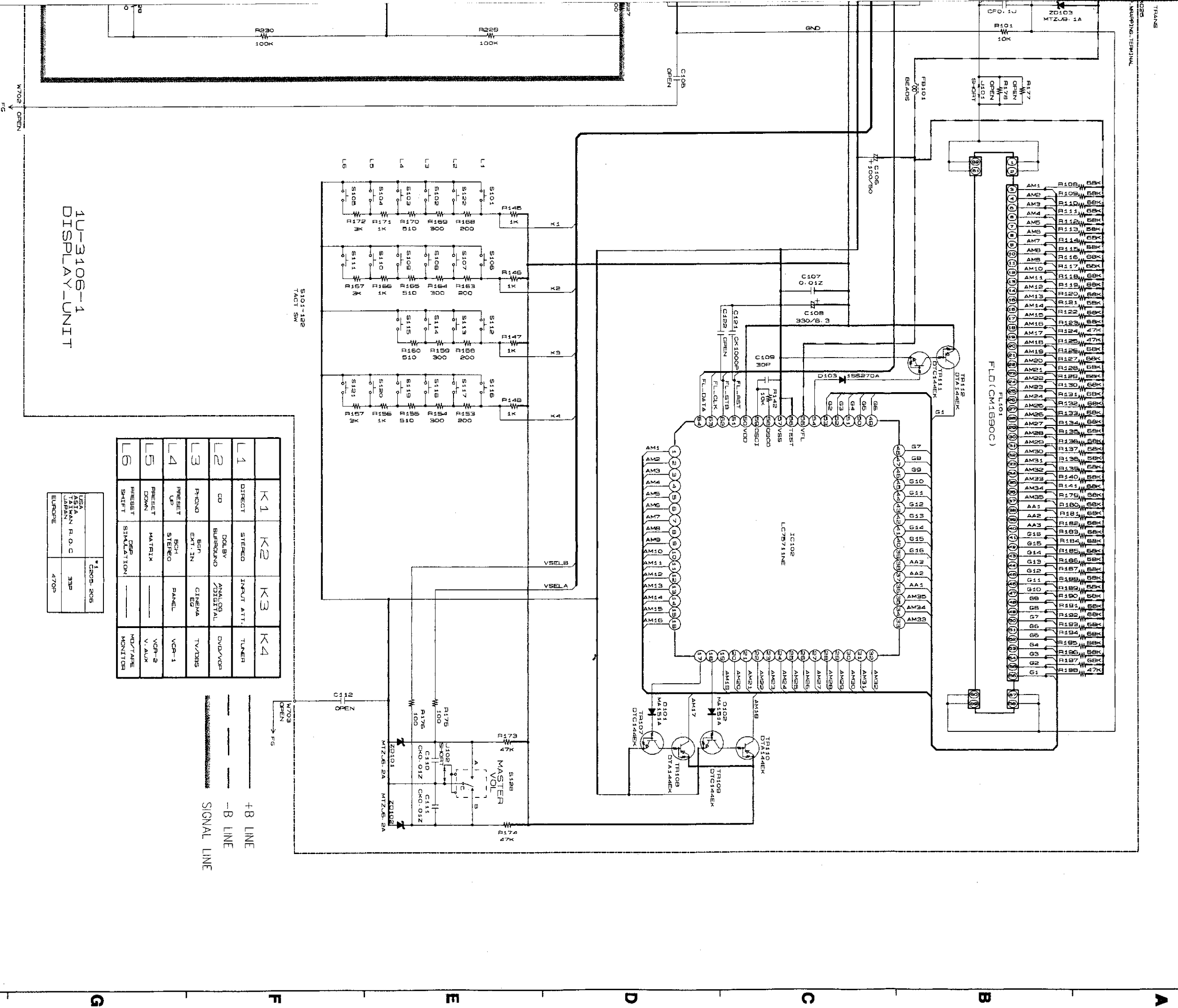

1U-3106-1
DISPLAY UNIT

K1	K2	K3	K4
DIRECT	STEREO	INPUT ATT.	TUNER
CD	DOLBY SURROUND	ANALOG/DIGITAL	DVD/VR
PHONO	SCN EXT. IN	CINEMA ED	TV/DBS
PRESET UP	RCH STEREO	PANEL	VR-1
PRESET DOWN	MATRIX		VR-2
PRESET SHIFT	DSP SIMULATION		V.AUX
			HD/TAPE MONITOR

USA	*C203, 2018
ASIAN	33P
JAPAN	
EUROPE	470P

+B LINE
-B LINE
SIGNAL LINE

SCHEMATIC DIAGRAM (5/10)

SCHEMATIC DIAGRAM (6/10)(7/10)

1

2

3

4

5

6

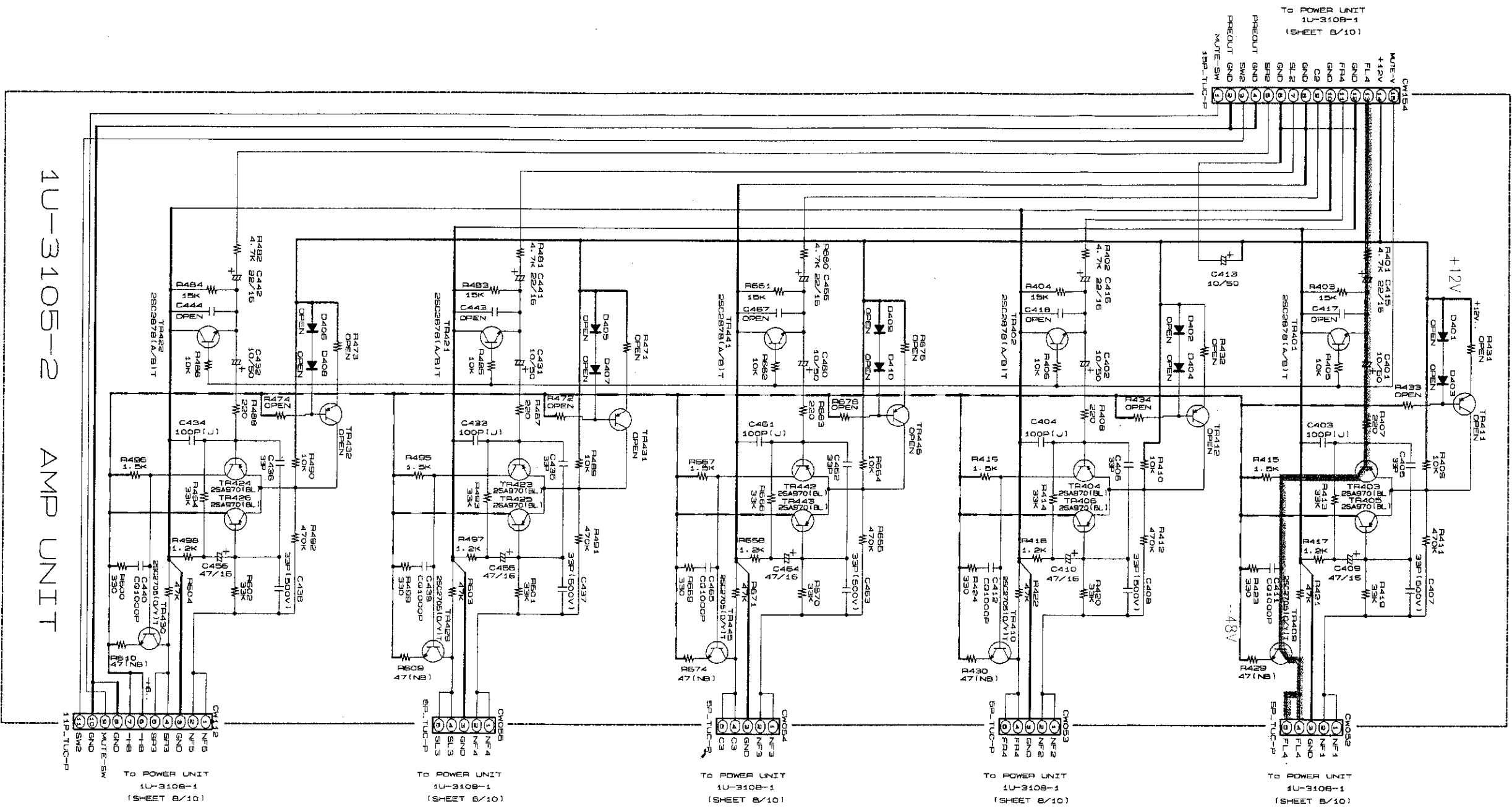

USA	*1	C405, 405	*2	C415, 415	*3	C435, 435, 462
ASIA		39P		47/16		33P
JAPAN				22/15		
EUROPE		220P		100/16		220P

1U-3105-2 AMP UNIT

(6/10) (6/10) (6/10) (6/10) (6/10) (6/10)

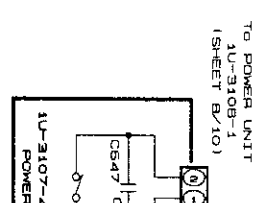
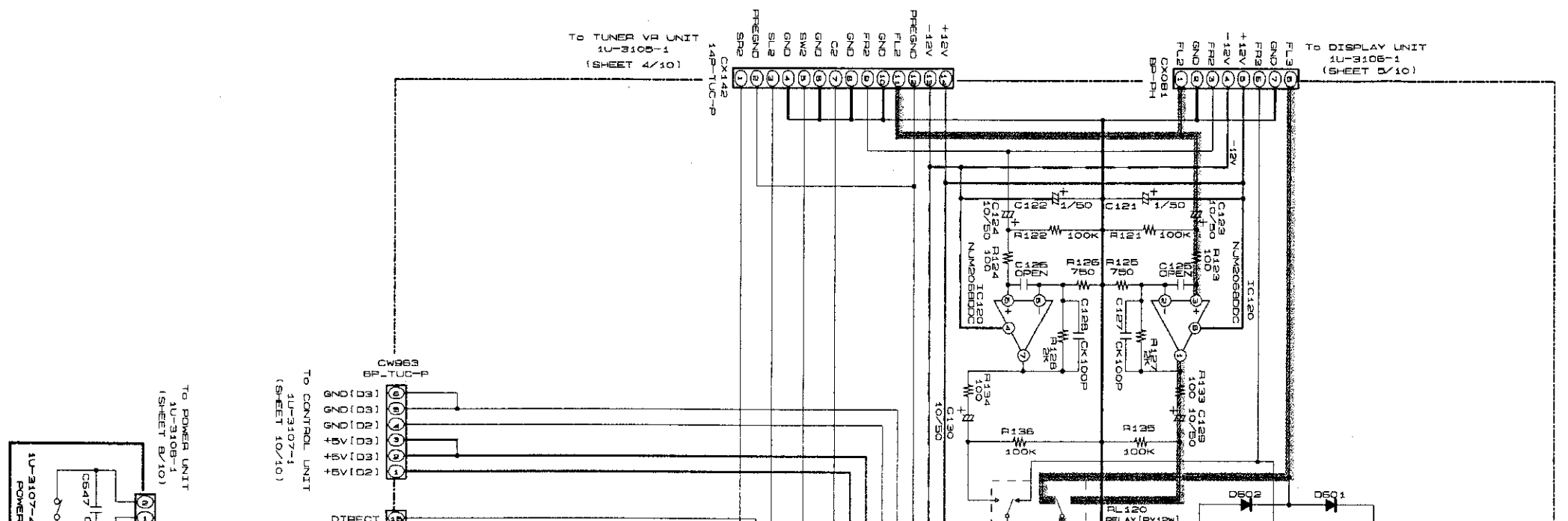

TO POWER UNIT 1U-3108-1 (SHEET 6/10)

TO CONTROL UNIT 1U-3107-1 (SHEET 10/10)

(7/10)

(6/10)

(7/10)

SCHEMATIC DIAGRAM (6/10)(7/10)

1

2

3

4

5

6

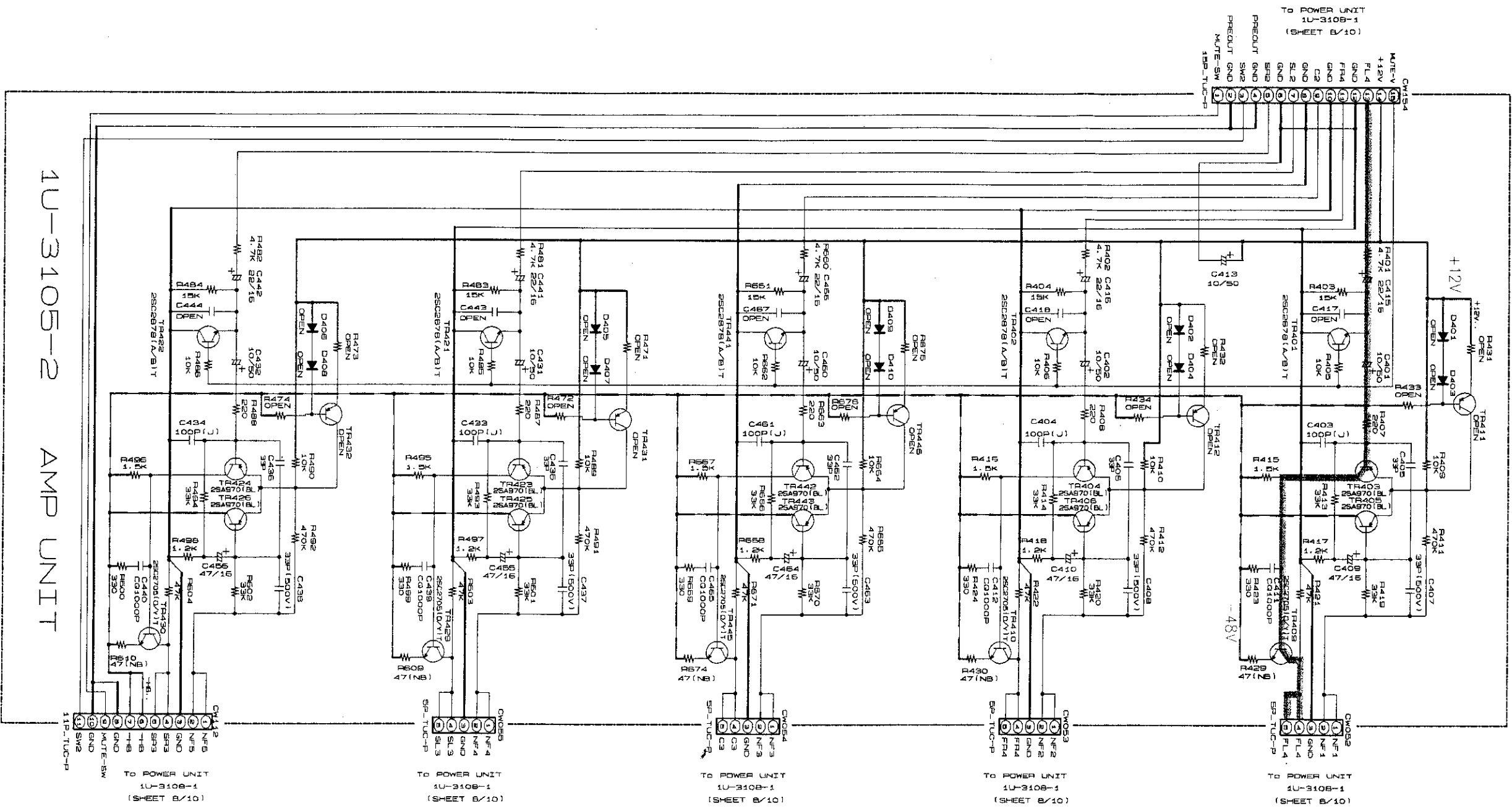

1U-3105-2 AMP UNIT

USA	*1	C400, 405	*2	C409, 410	*3	C415, 416	*4	C435, 436, 462
ASIA		33P		47/15		22/15		33P
JAPAN								
EUROPE		220P		100/15		47/15		220P

(6/10)

(6/10)

(7/10)

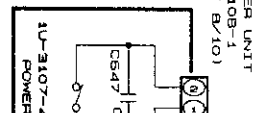
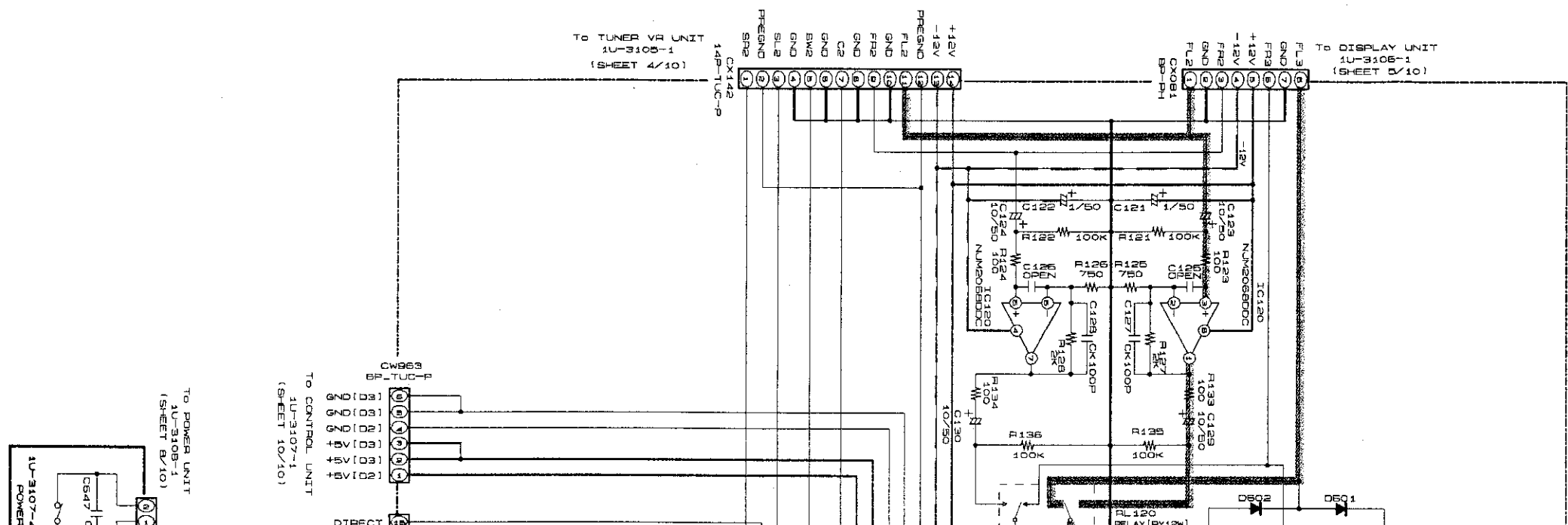

(7/10)

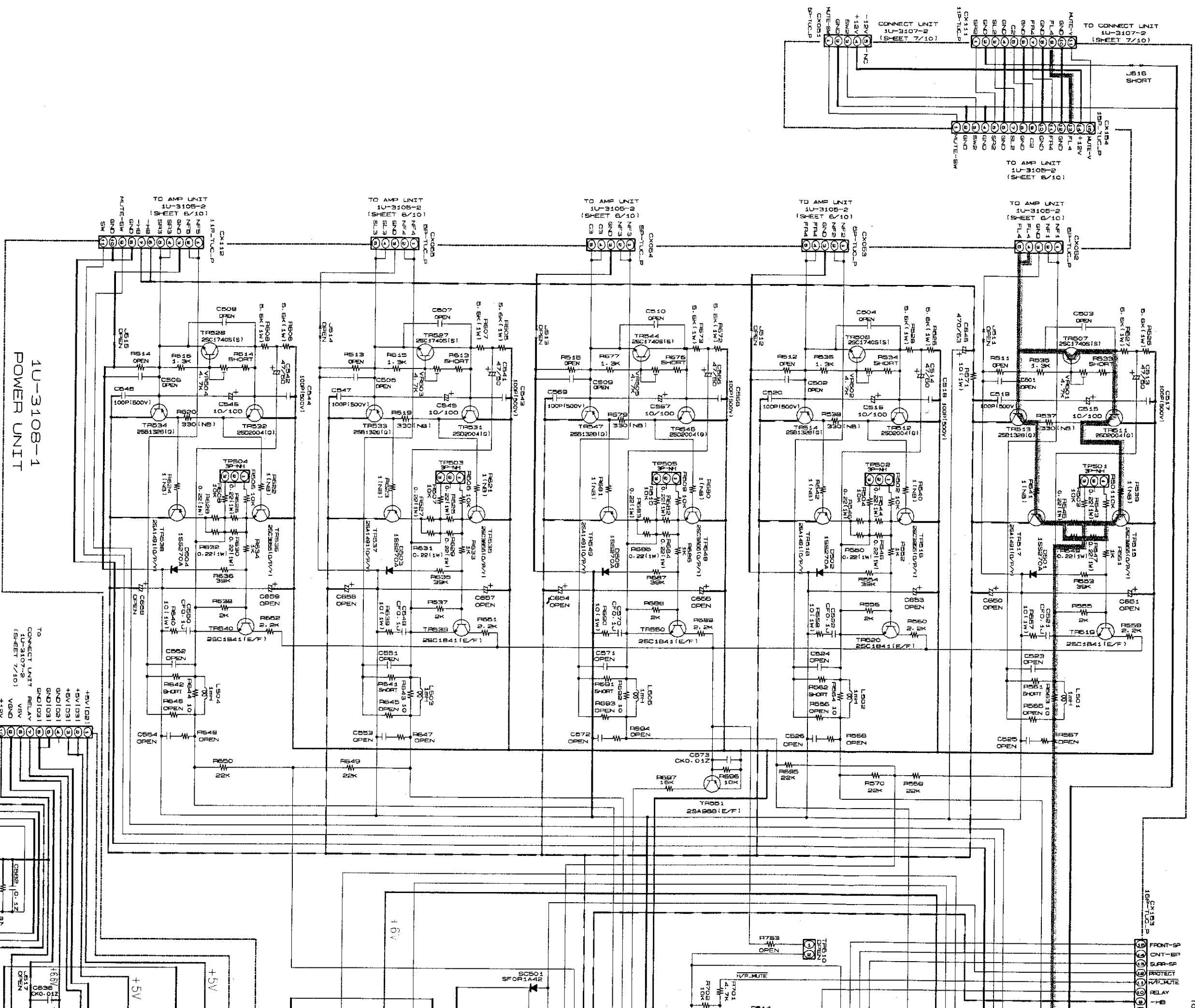

1U-3108-1
POWER UNIT

NOTICE
ALL RESISTANCE VALUES IN OHM, K=1,000 OHM, M=1,000,000 OHM.
ALL CAPACITANCE VALUES IN MICRO FARAD, P=MINI-MICRO FARAD
EACH VOLTAGE AND CURRENT ARE MEASURED AT NO SIGNAL INPUT
CONDITION.
CIRCUIT AND PARTS ARE SUBJECT TO CHANGE WITHOUT PRIOR
NOTICE.

WARNING:
Parts marked with this symbol have critical characteristics.
Use ONLY replacement parts recommended by the manufacturer.

CAUTION:
Before returning the unit to the customer, make sure you make either (1) a
leakage current check or (2) a line to chassis resistance check. If the leakage
current exceeds 0.5 millamps, or if the resistance from chassis to either side
of the power cord is less than 460 kohms, the unit is defective.

WARNING:
DO NOT return the unit to the customer until the problem is located and
corrected.

	*1 F.1	*2 F.8	*3 F.
1	7814	7814	7814
2	7815	7815	7815
3	7816	7816	7816
4	7817	7817	7817
5	7818	7818	7818
6	7819	7819	7819
7	7820	7820	7820
8	7821	7821	7821
9	7822	7822	7822
10	7823	7823	7823
11	7824	7824	7824
12	7825	7825	7825
13	7826	7826	7826
14	7827	7827	7827
15	7828	7828	7828
16	7829	7829	7829
17	7830	7830	7830
18	7831	7831	7831
19	7832	7832	7832
20	7833	7833	7833
21	7834	7834	7834
22	7835	7835	7835
23	7836	7836	7836
24	7837	7837	7837
25	7838	7838	7838
26	7839	7839	7839
27	7840	7840	7840
28	7841	7841	7841
29	7842	7842	7842
30	7843	7843	7843
31	7844	7844	7844
32	7845	7845	7845
33	7846	7846	7846
34	7847	7847	7847
35	7848	7848	7848
36	7849	7849	7849
37	7850	7850	7850
38	7851	7851	7851
39	7852	7852	7852
40	7853	7853	7853
41	7854	7854	7854
42	7855	7855	7855
43	7856	7856	7856
44	7857	7857	7857
45	7858	7858	7858
46	7859	7859	7859
47	7860	7860	7860
48	7861	7861	7861
49	7862	7862	7862
50	7863	7863	7863
51	7864	7864	7864
52	7865	7865	7865
53	7866	7866	7866
54	7867	7867	7867
55	7868	7868	7868
56	7869	7869	7869
57	7870	7870	7870
58	7871	7871	7871
59	7872	7872	7872
60	7873	7873	7873
61	7874	7874	7874
62	7875	7875	7875
63	7876	7876	7876
64	7877	7877	7877
65	7878	7878	7878
66	7879	7879	7879
67	7880	7880	7880
68	7881	7881	7881
69	7882	7882	7882
70	7883	7883	7883
71	7884	7884	7884
72	7885	7885	7885
73	7886	7886	7886
74	7887	7887	7887
75	7888	7888	7888
76	7889	7889	7889
77	7890	7890	7890
78	7891	7891	7891
79	7892	7892	7892
80	7893	7893	7893
81	7894	7894	7894
82	7895	7895	7895
83	7896	7896	7896
84	7897	7897	7897
85	7898	7898	7898
86	7899	7899	7899
87	7900	7900	7900
88	7901	7901	7901
89	7902	7902	7902
90	7903	7903	7903
91	7904	7904	7904
92	7905	7905	7905
93	7906	7906	7906
94	7907	7907	7907
95	7908	7908	7908
96	7909	7909	7909
97	7910	7910	7910
98	7911	7911	7911
99	7912	7912	7912
100	7913	7913	7913

SCHEMATIC DIAGRAM (9/10)

1 2 3 4 5 6

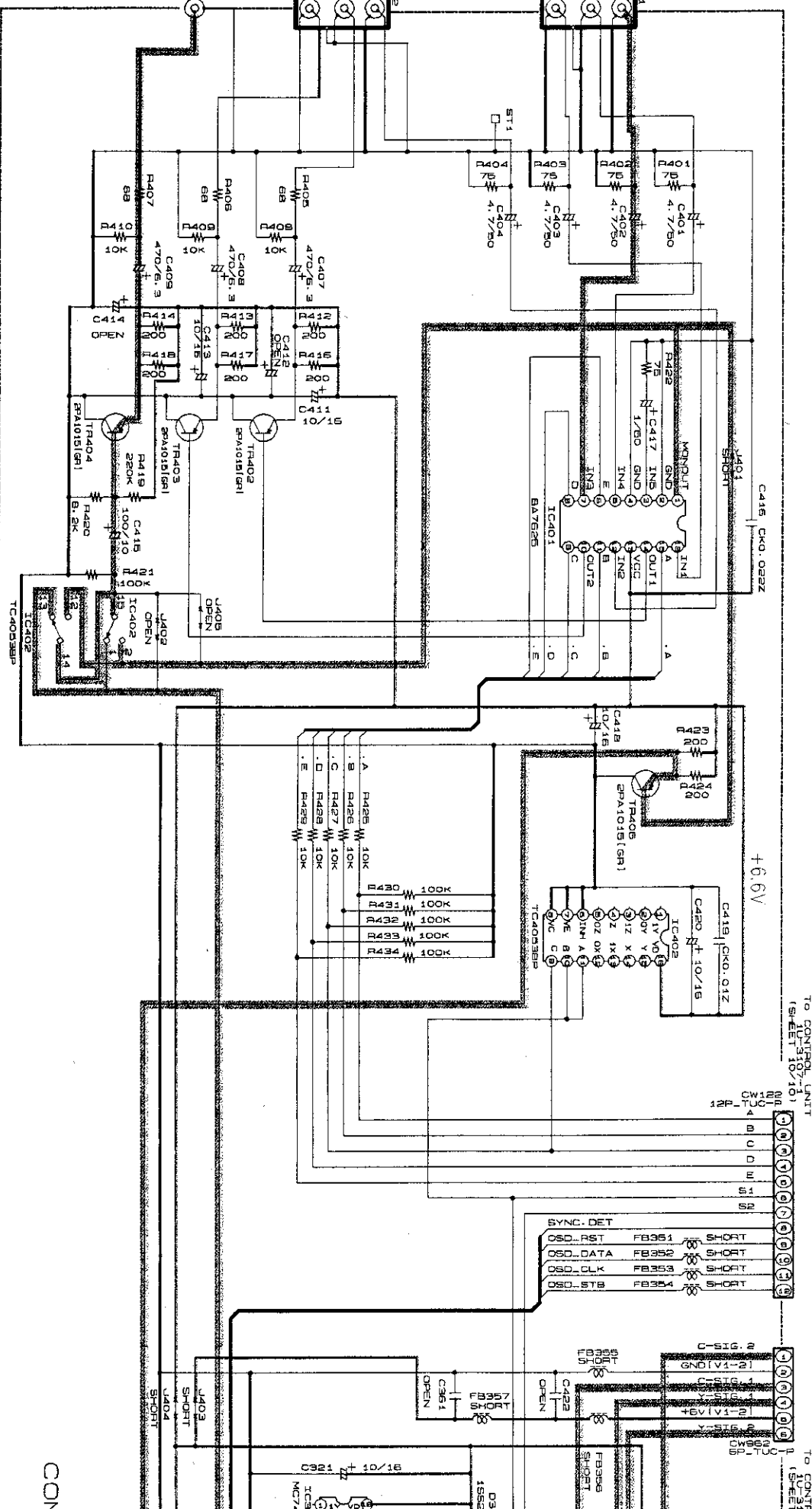
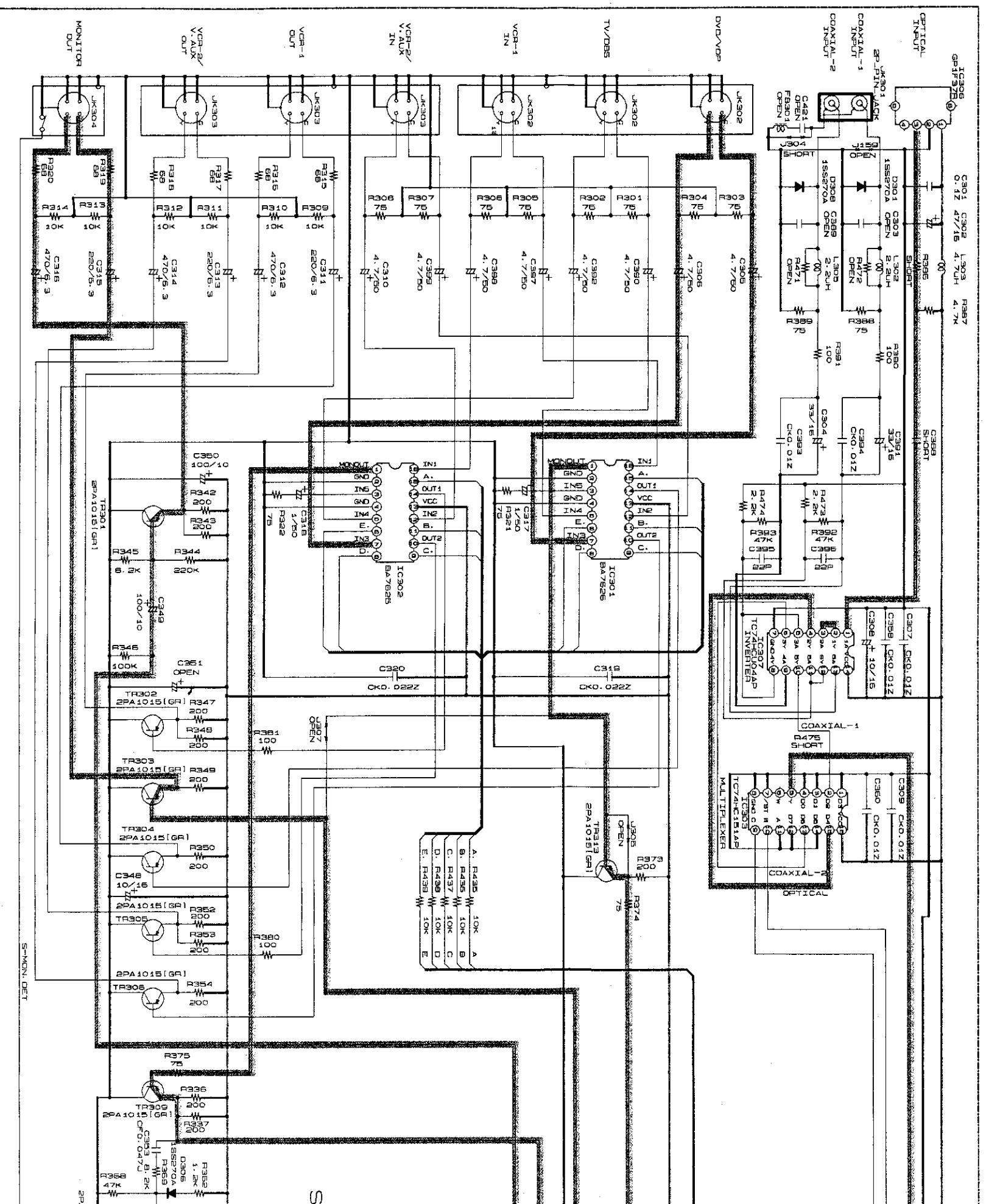

CON

REMOTE CONTROL UNIT (RC-844)

1 2 3 4 5 6 7 8

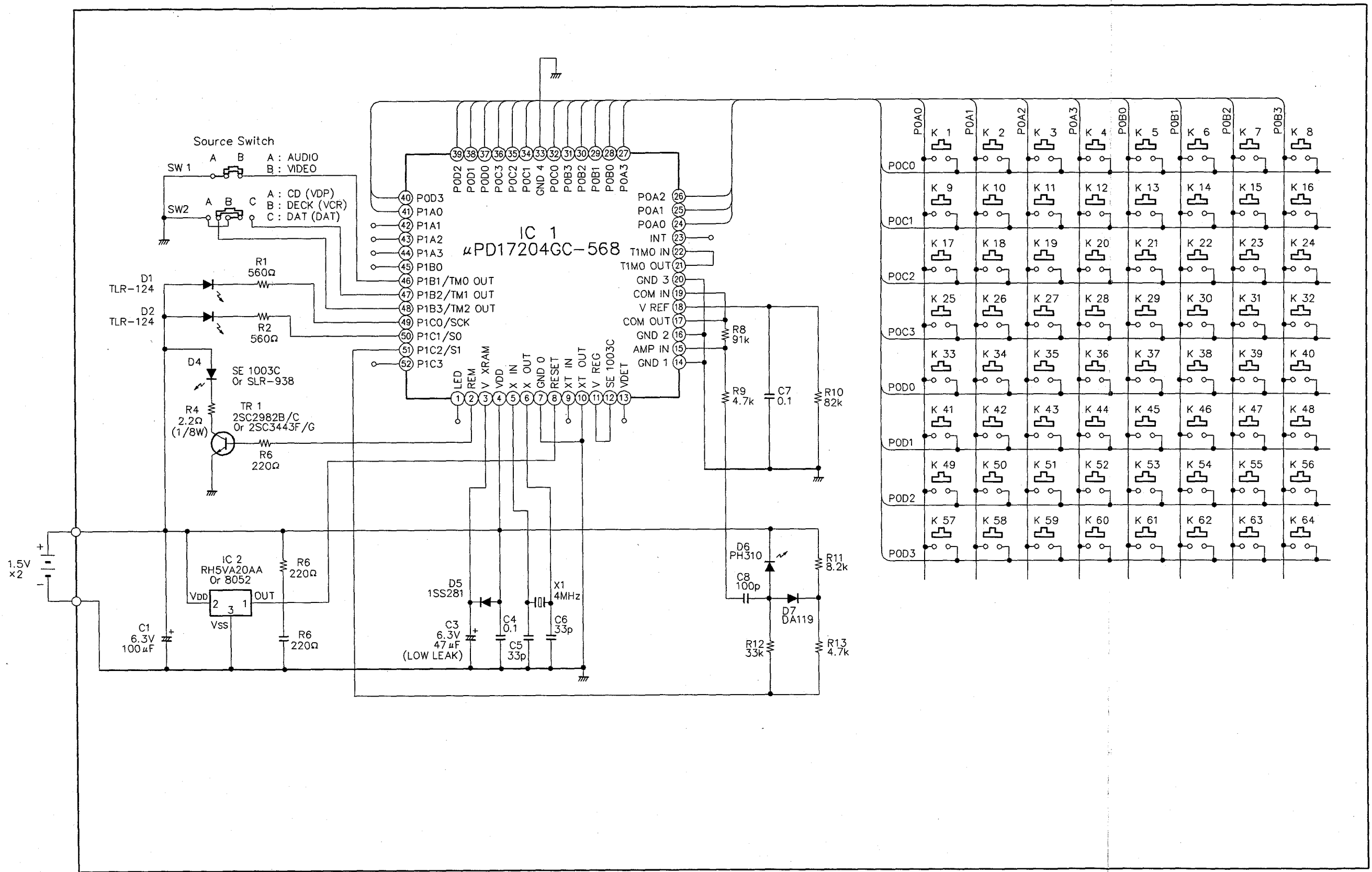

A
B
C
D
E

EXPLODED VIEW OF REMOTE CONTROL UNIT (RC-844)

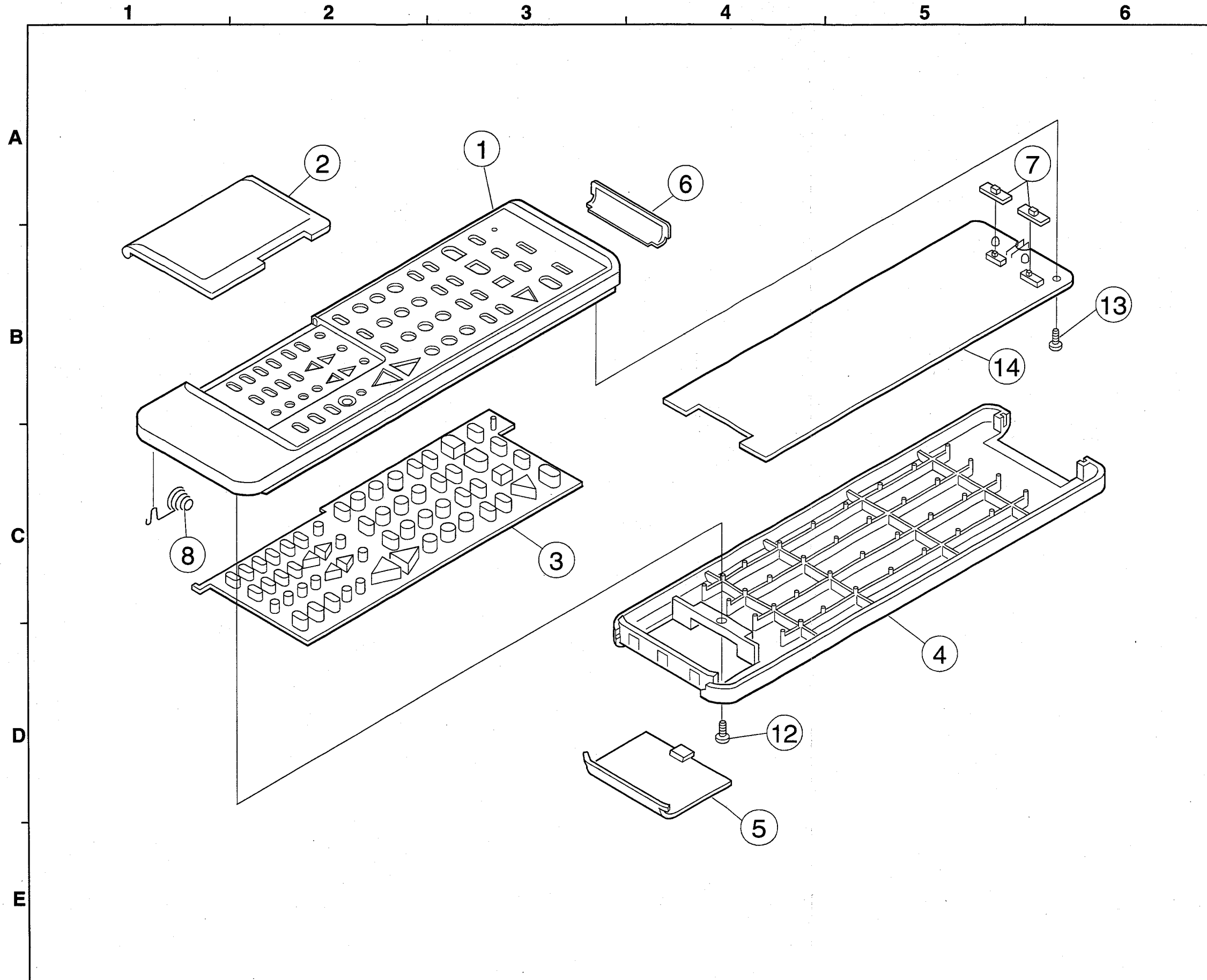

PARTS LIST OF REMOTE CONTROL UNIT (RC-844)

Ref. No.	Part No.	Part Name	Remarks	Q'ty
● 1	9H3 1000 188	Top Case (RC844) Ass'y		1s
● 2	9H3 1000 168	Cover		1
● 3	9H3 1000 182	Switch Rubber		1
● 4	9H3 1000 166	Bottom Case		1
● 5	9H3 1000 167	Battery Cover		1
● 6	9H3 1000 148	Filter		1
● 7	9H3 1000 150	Slide Knob		2
● 8	9H3 1000 152	Coil Spring		1
12	9H3 1000 185	Tapping Screw 2x5		1
13	9H3 1000 107	Tapping Screw 2x5		1
14	9H3 1000 195	Main P.W.B. Ass'y		
IC1	9H3 1000 194	IC μ PD17204GC-568	μ -Com	1
IC2	9H3 1000 158	IC RH5VA10AA	vol.Detector	1
Q1	9H3 1000 070	Transistor 2SC2982	Chip	1
D1,2	9H3 1000 028	LED TLR124	Visible-Red	2
D4	9H3 1000 131	LED SE1003-C	Infrared	1
D5	9H3 1000 087	Diode 1SS281		1
D6	9H3 1000 029	Diode PH310	Photo-PIN	1
D7	9H3 1000 071	Diode DA119	Chip	1
X1	9H3 1000 088	Ceramic Resonator	KBR4.0M503	1
SW1	9H3 1000 089	Slide Switch		1
SW2	9H3 1000 074	Slide Switch		1
C1	254 4213 034	Electrolytic 100 μ F/6.3V	CE04W0J101M	1
C3	254 4213 021	Electrolytic 47 μ F/6.3V	CE04W0J470M	1

DENON

Hi-Fi AV Surround Receiver

For Europe Model

SERVICE MANUAL MODEL AVR-2700 AV SURROUND RECEIVER

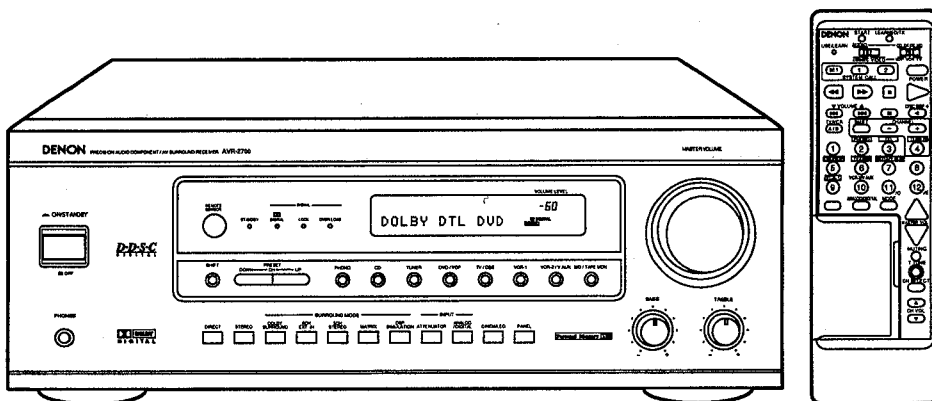

This service manual is supplement for Europe model. For servicing, refer to the service manual of AVR-2700 (For U.S.A. model) already issued at the same time.

— TABLE OF CONTENTS —

- ADDITIONAL SEMICONDUCTORS 2
- NOTE FOR PARTS LIST 3
- ADDENDUM PARTS LIST OF PRINTED WIRING BOARD 4-5
- SCHEMATIC DIAGRAM 5
- EXPLODED VIEW OF CHASSIS AND CABINET 6
- ADDENDUM PARTS LIST OF EXPLODED VIEW 7

• Some illustrations using in this service manual are slightly different from the actual set.

NIPPON COLUMBIA CO., LTD.

SAFETY PRECAUTIONS

The following check should be performed for the continued protection of the customer and service technician.

LEAKAGE CURRENT CHECK

Before returning the unit to the customer, make sure you make either (1) a leakage current check or (2) a line to chassis resistance check. If the leakage current exceeds 0.5 milliamps, or if the resistance from chassis to either side of the power cord is less than 460 kohms, the unit is defective.

ADDITIONAL SEMICONDUCTORS

SAA6579T (CO: IC111)

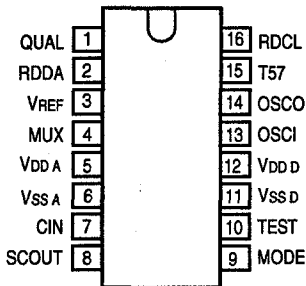
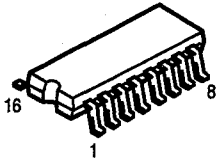

SAA6579T Terminal Function

Pin No.	Symbol	Function
1	QUAL	Quality indication output.
2	RDDA	RDS data output.
3	VREF	Reference voltage output (0.5 VDD A).
4	MUX	Multiplex signal input.
5	VDD A	+5V power supply for analog part.
6	VSS A	Ground for analog part (0V).
7	CIN	Subcarrier input to comparator.
8	SCOUT	Subcarrier output of reconstruction filter.
9	MODE	Oscillation mode/test control input.
10	TEST	Test enable input.
11	VSS D	Ground for digital part (0V).
12	VDD D	+5V power supply for digital part.
13	OSC I	Oscillator input.
14	OSC O	Oscillator output.
15	T57	57kHz clock signal output.
16	RDCL	RDS clock output.

LC7074M (CO: IC112)

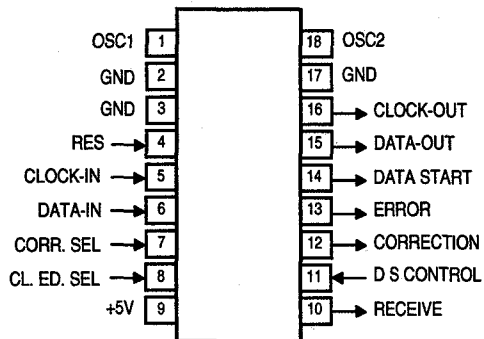
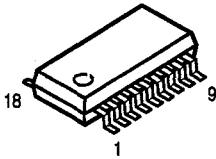

NOTE FOR PARTS LIST

- Part indicated with the mark "⊙" are not always in stock and possibly to take a long period of time for supplying, or in some case supplying of part may be refused.
- When ordering of part, clearly indicate "1" and "I" (i) to avoid mis-supplying.
- Ordering part without stating its part number can not be supplied.
- Part indicated with the mark "★" is not illustrated in the exploded view.
- Not including Carbon Film ±5%, 1/4W Type in the P.W.Board parts list. (Refer to the Schematic Diagram for those parts.)

WARNING:

Parts marked with this symbol Δ have critical characteristics. Use ONLY replacement parts recommended by the manufacturer.

● **Resistors**

Ex.: RN 14K 2E 182 G FR
 Type Shape Power Resist- Allowable Others
 and per- ance error
 performance

RD : Carbon	2B : 1/8W	F : ±1%	P : Pulse-resistant type
RC : Composition	2E : 1/4W	G : ±2%	NL : Low noise type
RS : Metal oxide film	2H : 1/2W	J : ±5%	NB : Non-burning type
RW : Winding	3A : 1W	K : ±10%	FR : Fuse-resistor
RN : Metal film	3D : 2W	M : ±20%	F : Lead wire forming
RK : Metal mixture	3F : 3W		
	3H : 5W		

* Resistance

$\overset{1}{\uparrow} \text{8} \overset{2}{\downarrow} \Rightarrow 1800 \text{ ohm} = 1.8 \text{ kohm}$
 Indicates number of zeros after effective number.
 2-digit effective number.

• Units: ohm

$\overset{1}{\uparrow} \text{R} \overset{2}{\downarrow} \Rightarrow 1.2 \text{ ohm}$
 1-digit effective number.
 2-digit effective number, decimal point indicated by R.

• Units: ohm

● **Capacitors**

Ex.: CE 04W 1H 2R2 M BP
 Type Shape Dielectric Capacity Allowable Others
 and per- strength error
 performance

CE : Aluminum foil electrolytic	0J : 6.3V	F : ±1%	HS : High stability type
CA : Aluminum solid electrolytic	1A : 10V	G : ±2%	BP : Non-polar type
CS : Tantalum electrolytic	1C : 16V	J : ±5%	HR : Ripple-resistant type
CO : Film	1E : 25V	K : ±10%	DL : For charge and discharge
CK : Ceramic	1V : 35V	M : ±20%	HF : For assuring high frequency
CC : Ceramic	1H : 50V	Z : +80%	U : UL part
CP : Oil	2A : 100V	-20%	C : CSA part
CM : Mica	2B : 125V	P : +100%	W : UL-CSA type
CF : Metallized	2C : 160V	-0%	F : Lead wire forming
CH : Metallized	2D : 200V	C : ±0.25pF	
	2E : 250V	D : ±0.5pF	
	2H : 500V	= : Others	
	2J : 630V		

* Capacity (electrolyte only)

$\overset{2}{\uparrow} \overset{2}{\downarrow} \overset{2}{\downarrow} \Rightarrow 2200\mu\text{F}$
 Indicates number of zeros after effective number.
 2-digit effective number.

• Units: μF.

$\overset{2}{\uparrow} \text{R} \overset{2}{\downarrow} \Rightarrow 2.2\mu\text{F}$
 1-digit effective number.
 2-digit effective number, decimal point indicated by R.

• Units: μF.

* Capacity (except electrolyte)

$\overset{2}{\uparrow} \overset{2}{\downarrow} \overset{2}{\downarrow} \Rightarrow 2200\text{pF} = 0.0022\mu\text{F}$
 (More than 2) — Indicates number of zeros after effective number.
 2-digit effective number.

• Units: μF.

$\overset{2}{\uparrow} \overset{2}{\downarrow} \overset{1}{\downarrow} \Rightarrow 220\text{pF}$
 (0 or 1) — Indicates number of zeros after effective number.
 2-digit effective number.

• Units: pF.

• When the dielectric strength is indicated in AC, "AC" is included after the dielectric strength value.

ADDENDUM PARTS LIST OF P.W.B. UNIT ASS'Y 1U-3105 TUNER AMP. UNIT A'SSY

Ref. No.	U.S.A. Model		Europe Model	
	Part No.	Part Name	Part No.	Part Name
	1U-3105	Tuner amp. unit ass'y	1U-3105B	Tuner amp. unit ass'y
IC501	216 0102 008	Front end	216 9013 004	FM front end (U) S
TR501	—	—	275 0074 902	FET 2SK211-Y/GR
R502	—	—	247 0018 905	Carbon chip 0 ohm 1/10W±10%
R515	247 0005 905	Carbon chip 100 ohm 1/10W ±5%	247 0011 928	Carbon chip 39 kohm 1/10W±5%
R516	247 0007 945	Carbon chip 1 kohm 1/10W ±5%	247 0006 920	Carbon chip 330 ohm 1/10W ±5%
R517	—	—	247 0006 920	Carbon chip 330 ohm 1/10W ±5%
R535	247 0010 945	Carbon chip 18 kohm 1/10W ±5%	—	—
R536	247 0018 905	Carbon chip 0 ohm 1/10W ±10%	247 0008 944	Carbon chip 2.7 kohm 1/10W ±5%
R544,545	247 0012 927	Carbon chip 100 kohm 1/10W ±5%	247 0012 969	Carbon chip 150 kohm 1/10W±5%
R555,556	247 0009 927	Carbon chip 5.6 kohm 1/10W ±5%	247 0008 960	Carbon chip 3.3 kohm 1/10W ±5%
R575,576	247 0012 943	Carbon chip 120 kohm 1/10W ±5%	247 0012 998	Carbon chip 200 kohm 1/10W ±5%
R579-581	247 0018 905	Carbon chip 0 ohm 1/10W ±10%	—	—
R645	—	—	247 0009 985	Carbon chip 10 kohm 1/10W ±5%
R646	—	—	247 0009 927	Carbon chip 5.6 kohm 1/10W ±5%
R705,706	247 0006 962	Carbon chip 470 ohm 1/10W ±5%	247 0005 905	Carbon chip 100 ohm 1/10W ±5%
R721,722	247 0006 962	Carbon chip 470 ohm 1/10W ±5%	247 0005 905	Carbon chip 100 ohm 1/10W ±5%
R737,738	247 0006 962	Carbon chip 470 ohm 1/10W ±5%	247 0005 905	Carbon chip 100 ohm 1/10W ±5%
R793-798	247 0018 905	Carbon chip 0 ohm 1/10W ±10%	247 0006 962	Carbon chip 470 ohm 1/10W ±5%
C405,406	253 4537 924	Ceramic 33 pF/50V ±5%	253 1179 945	Ceramic 220 pF/50V ±10%
C409,410	254 4254 938	Electrolytic 47 μF/16V ±20%	254 4254 941	Electrolytic 100 μF/16V ±20%
C415,416	254 4254 912	Electrolytic 22 μF/16V ±20%	254 4254 938	Electrolytic 47 μF/16V ±20%
C435,436	253 4537 924	Ceramic 33 pF/50V ±5%	253 1179 945	Ceramic 220 pF/50V ±10%
C462	253 4537 924	Ceramic 33 pF/50V ±5%	253 1179 945	Ceramic 220 pF/50V ±10%
C518	—	—	257 0005 960	Ceramic chip 270 pF/50V ±5%
C519	—	—	257 0004 961	Ceramic chip 100 pF/50V ±5%
C527	254 4260 948	Electrolytic 1 μF/50V ±20%	254 4260 922	Electrolytic 0.33 μF/50V ±20%
C536	257 0004 961	Ceramic chip 100 pF/50V ±5%	—	—
C537	—	—	254 4254 912	Electrolytic 22 μF/16V ±20%
C539,540	257 0006 972	Ceramic chip 750 pF/50V ±5%	257 0005 986	Ceramic chip 330 pF/50V ±5%
C564,565	—	—	257 0005 986	Ceramic chip 330 pF/50V ±5%
C701,702	—	—	257 0005 986	Ceramic chip 330 pF/50V ±5%
C715,716	—	—	257 0005 986	Ceramic chip 330 pF/50V ±5%
C729,730	—	—	257 0005 986	Ceramic chip 330 pF/50V ±5%
CF501	261 0135 907	Ceramic filter MA8	261 0146 006	Ceramic filter FMCFK107M2-A
CF502	261 0136 906	Ceramic filter MS2G	261 0146 006	Ceramic filter FMCFK107M2-A
LF501	—	—	232 9010 009	Antibirdie filter
LF503,504	—	—	232 0085 004	LPF

1U-3106 DISPLAY VIDEO UNIT ASS'Y

Ref. No.	U.S.A. Model		Europe Model	
	Part No.	Part Name	Part No.	Part Name
C205,206	1U-3106	Display video unit ass'y	1U-3106B	Display video unit ass'y
	253 4537 924	Ceramic 33 pF/50V ±5%	253 1179 987	Ceramic 470 pF/50V ±10%

1U-3107 CONTROL UNIT ASS'Y

Ref. No.	U.S.A. Model		Europe Model	
	Part No.	Part Name	Part No.	Part Name
	1U-3107	Control unit ass'y	1U-3107B	Control unit ass'y
IC111	—	—	262 1701 906	IC SAA6579T
IC112	—	—	262 1929 908	IC LC7074M-TE-R
D101	—	—	276 0432 903	Diode 1SS270A
R168	—	—	247 0018 905	Carbon chip 0 ohm 1/10W ±10%
R196	—	Short	—	Open
R197	—	Open	—	Short
R200	—	—	247 0009 985	Carbon chip 10 kohm 1/10W ±5%
C165,166	—	—	257 0003 920	Ceramic chip 27 pF/50V ±5%
C167	—	—	254 4260 951	Electrolytic 2.2 μF/50V ±20%
C168	—	—	254 4254 909	Electrolytic 10 μF/16V ±20%
C169	—	—	257 0006 943	Ceramic chip 560 pF/50V ±5%
C170	—	—	257 0012 966	Ceramic chip 0.01 μF/50V 80%, ±20%
C171	—	—	254 4254 909	Electrolytic 10 μF/16V ±20%
C186	257 0008 983	Ceramic chip 1000 pF/50V±5%	—	—
X101	—	—	399 0178 007	Crystal 4.332 MHz
X102	—	—	399 0191 903	Ceramic 4.00 MHz

1U-3109 AUDIO IN DSP UNIT ASS'Y

Ref. No.	U.S.A. Model		Europe Model	
	Part No.	Part Name	Part No.	Part Name
	1U-3109	Audio in DSP unit ass'y	1U-3109A	Audio in DSP unit ass'y
R601,602	247 0018 905	Carbon chip 0 ohm 1/10W ±10%	247 0007 974	Carbon chip 1.3 kohm 1/10W ±5%
C509-512	—	—	257 0004 961	Ceramic chip 100 pF/50V ±5%
C617-626	—	—	257 0005 986	Ceramic chip 330 pF/50V ±5%
C661,662	—	—	257 0004 961	Ceramic chip 100 pF/50V ±5%
C887	—	—	257 0008 983	Ceramic chip 1000 pF/50V ±5%
C888,889	257 0008 983	Ceramic chip 1000 pF/50V ±5%	—	—
C945	—	—	257 0004 987	Ceramic chip 120 pF/50V ±5%
C996	—	—	247 0018 905	Carbon chip 0 ohm 1/10W ±10%
LF601,602	—	—	235 9003 002	FTZ choke coil
W702,703	—	—	001 0025 017	Vinyl wire
—	—	—	414 0851 005	Shield bracket
—	—	—	203 0312 038	Wire ass.

1U-3108 POWER AMP. UNIT ASS'Y

Ref. No.	U.S.A. Model		Europe Model		Remarks
	Part No.	Part Name	Part No.	Part Name	
	1U-3108	Power amp. unit ass'y	1U-3108B	Power amp. unit ass'y	
R734	242 2009 001	Composition 2.2 Mohm 1/2W ±10%	—	—	
ΔAC501	203 3976 002	AC outlet (2P)	—	—	
CX23	—	—	205 0581 001	2P VH connector base	
CX26	—	—	205 0348 024	2P wrapping terminal	
ΔF1	206 1046 001	Fuse 6.3A UL 20mm	206 1015 074	Fuse 3.15A	
ΔF8	206 1046 014	Fuse 8A	206 1015 032	Fuse 2.5A	
ΔF11,12	206 1039 076	Fuse 2.5A	206 1015 032	Fuse 2.5A	
ΔF13	206 1039 076	Fuse 2.5A	206 1015 032	Fuse 2.5A	
ΔT501	233 6073 000	Power trans. (Mini)—EU	233 6058 012	Power trans. (Mini)—E2	
—	—	—	415 0299 000	Condenser cover	for C684
—	—	—	513 2585 045	Fuse label	for F1
—	—	—	513 2585 074	Fuse label	for F8,11,12,13

SCHEMATIC DIAGRAM (POWER TRANS)

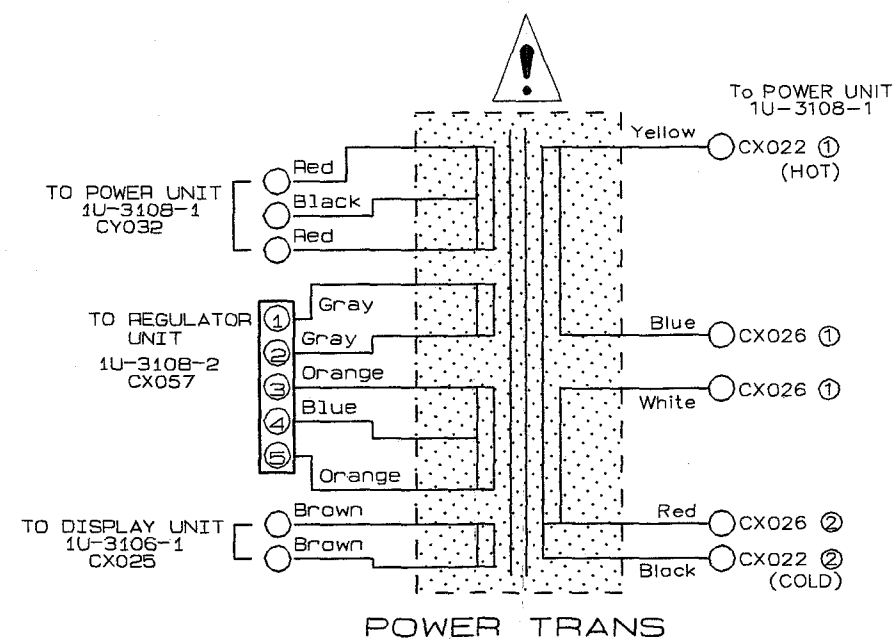

EXPLODED VIEW OF CHASSIS AND CABINET

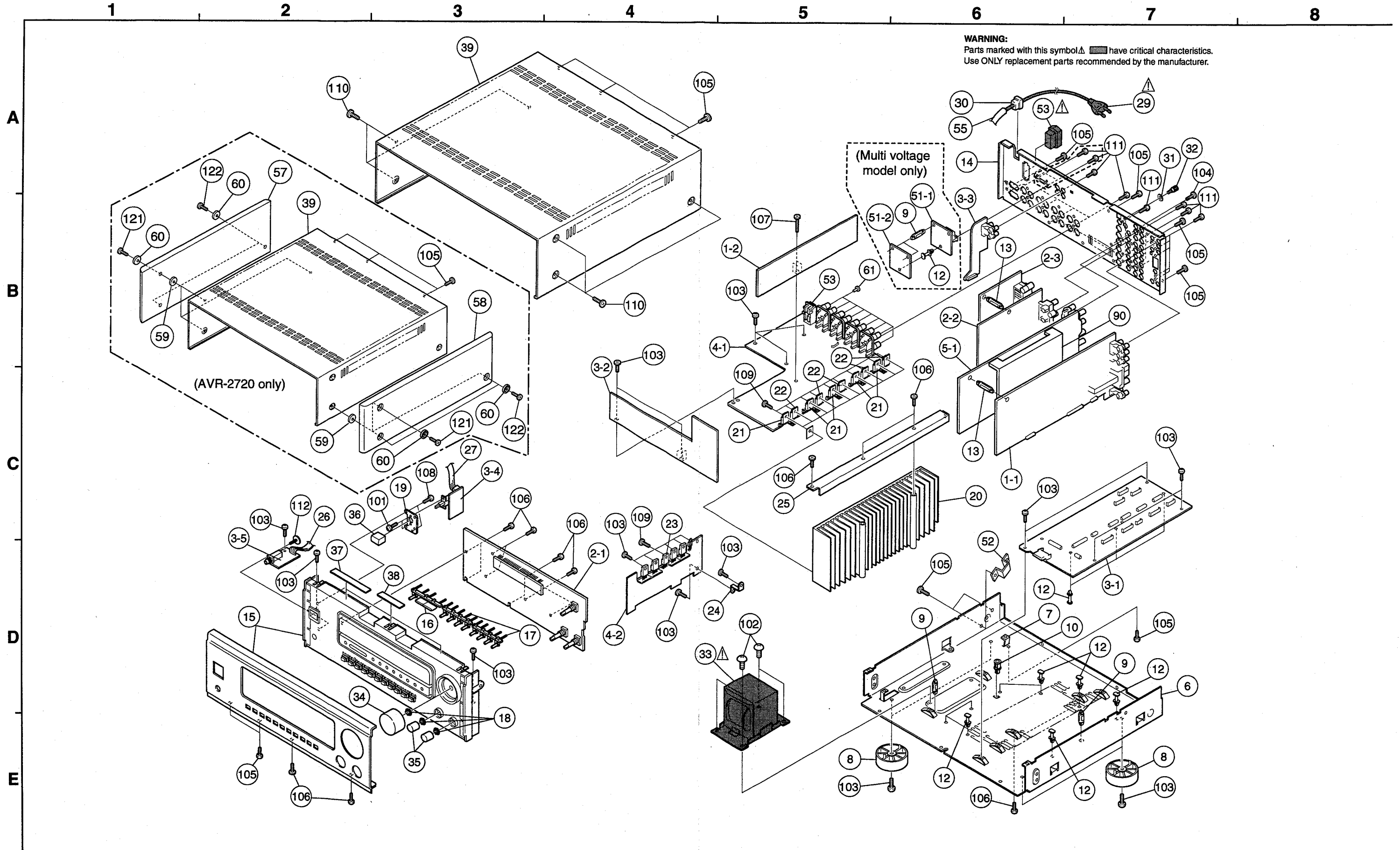

ADDENDUM PARTS LIST OF EXPLODED VIEW

Ref. No.	Part Name	U.S.A. Model		Europe Model	
		Part No.	Q'ty	Part No.	Q'ty
14	Back panel	105 1281 000		105 1281 039	
15	Inner panel ass'y	146 2065 019		146 2065 048	
△ 29	AC cord	206 2060 002		206 2063 009	
△ 33	Power trans.	233 6253 008		233 6254 007	
52	Side bracket	—		412 2955 107	
△ 53	AC outlet	203 3976 002		203 3942 007	
54	3P VH connector cord	—		203 5177 016	
55	UL tube (8.3)	—		415 0546 070	
56	Caution label	513 3156 004		—	
61	Push rivet	—	—	477 0096 007	16
90	Earth plate	—		414 0852 004	
105	Screw 3x8 CBTS(S)-B	473 7015 018	11	473 7015 018	13
111	Fixing screw	477 0064 107	23	477 0064 107	21
205	Instruction manual	511 3263 001		511 3286 004	
208	RC-844 remocon unit	399 0498 004		—	
208	RC-845 remocon unit	—		399 0498 017	
214	UPC label	517 1318 066		—	
214	E2 POS label	—		517 1356 031	
224	DEL warranty home	515 0690 307		—	