

# DENON

Hi-Fi AV Surround Receiver

## SERVICE MANUAL MODEL AVR-3200 AV SURROUND RECEIVER

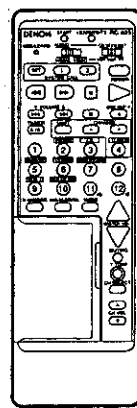
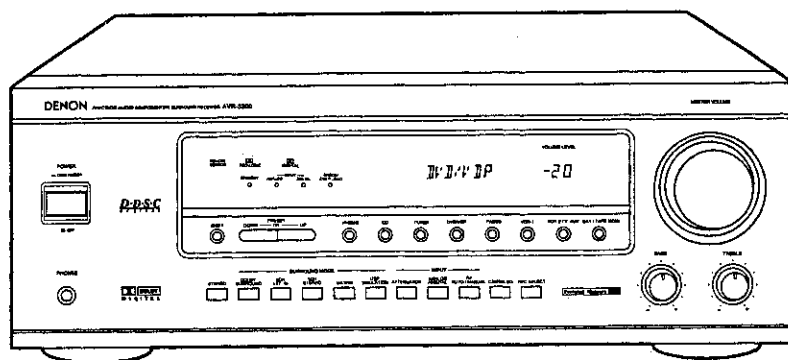

### — TABLE OF CONTENTS —

OPERATING INSTRUCTIONS .....	2-20
SPECIFICATIONS .....	20
WIRE ARRANGEMENT .....	21
DISASSEMBLY .....	22-23
ADJUSTMENT .....	24-27
FUNCTION OF NEW CIRCUIT .....	28, 29
SEMICONDUCTORS .....	30-48
PRINTED WIRING BOARD .....	49-54
NOTE FOR PARTS LIST .....	54
PRINTED WIRING BOARD PARTS LIST .....	55-69
PARTS LIST OF EXPLODED VIEW .....	70
EXPLODED VIEW OF CHASSIS AND CABINET .....	71
BLOCK DIAGRAM .....	72
BLOCK LEVEL DIAGRAM .....	73
WIRING DIAGRAM .....	75
SCHEMATIC DIAGRAM .....	76-86
REMOTE CONTROL UNIT (RC-825) .....	87, 88
SCHEMATIC DIAGRAM .....	87
PARTS LIST .....	88

• Some illustration using in this service manual are slightly different from the actual set.

## NIPPON COLUMBIA CO., LTD.

# OPERATING INSTRUCTIONS

## SAFETY INSTRUCTIONS

1. Read Instructions - All the safety and operating instructions should be read before the appliance is operated.
2. Retain Instructions - The safety and operating instructions should be retained for future reference.
3. Read Warnings - All warnings on the appliance and in the operating instructions should be adhered to.
4. Follow Instructions - All operating and use instructions should be followed.
5. Water and Moisture - The appliance should not be used near water, for example, near a bathtub, washbowl, kitchen sink, laundry tub, a wet basement, or near a swimming pool, and the like.
6. Carts and Stands - The appliance should be used only with a cart or stand that is recommended by the manufacturer.
- 6A. An appliance and cart combination should be connected with care. Quick stops, kicks, slips, trips, and uneven surfaces may cause the appliance and cart combination to overturn.
7. Wall or Ceiling Mounting - The appliance should be mounted to a wall or ceiling only as recommended by the manufacturer.
8. Ventilation - The appliance should be situated so that its location or position does not interfere with its proper ventilation. For example, the appliance should not be situated on a bed, sofa, rug, or similar surface that may block the ventilation openings; or, placed in a built-in installation, such as a bookcase or cabinet, that may impede the flow of air through the ventilation openings.
9. Heat - The appliance should be situated away from heat sources such as radiators, heat registers, stoves, or other appliances (including amplifiers) that produce heat.
10. Power Sources - The appliance should be connected to a power supply only of the type described in the operating instructions or as marked on the appliance.
11. Grounding or Polarization - Precautions should be taken so that the grounding or polarization means of an appliance is not defeated.
12. Power-Cord Protection - Power-supply cords should be routed so that they are not likely to be walked on or pinched by items placed upon or against them, paying particular attention to cords at plugs, convenience receptacles, and the point where they exit from the appliance.
14. Cleaning - The appliance should be cleaned only as recommended by the manufacturer.
15. Power Lines - An outdoor antenna should be located away from power lines.
16. Outdoor Antenna Grounding - If an outside antenna is connected to the receiver, be sure the antenna system is grounded so as to provide some protection against voltage surges and built-up static charges. Article 810 of the National Electrical Code, ANSI/NFPA 70, provides information with regard to proper grounding of the mast and supporting structure, grounding of the lead-in wire to an antenna-discharge unit, size of grounding conductors, location of antenna-discharge unit, connection to grounding electrodes, and requirements for the grounding electrode. See Figure A.
17. Nonuse Periods - The power cord of the appliance should be unplugged from the outlet when left unused for a long period of time.
18. Object and Liquid Entry - Care should be taken so that objects do not fall and liquids are not spilled into the enclosure through openings.
19. Damage Requiring Service - The appliance should be serviced by qualified service personnel when:
  - A. The power-supply cord or the plug has been damaged, or
  - B. Objects have fallen, or liquid has been spilled into the appliance, or
  - C. The appliance has been exposed to rain, or
  - D. The appliance does not appear to operate normally or exhibits a marked change in performance, or
  - E. The appliance has been dropped, or the enclosure damaged.
20. Servicing - The user should not attempt to service the appliance beyond that described in the operating instructions. All other servicing should be referred to qualified service personnel.

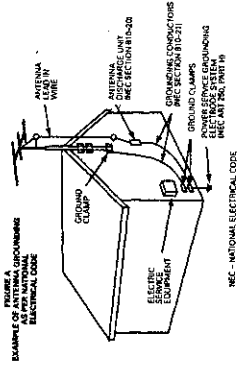

### SAFETY PRECAUTIONS

**CAUTION**

**RISK OF ELECTRIC SHOCK**

**DO NOT OPEN**

**CAUTION: TO REDUCE THE RISK OF ELECTRIC SHOCK, DO NOT REMOVE COVER (OR BACK). NO USER SERVICEABLE PARTS INSIDE. REFER SERVICING TO QUALIFIED SERVICE PERSONNEL.**

The lightning flash with arrowhead symbol, within an equilateral triangle, is intended to alert the user to the presence of uninsulated "dangerous voltage" within the product's enclosure that may be of sufficient magnitude to constitute a risk of electric shock to persons.

The exclamation point within an equilateral triangle is intended to alert the user to the presence of important operating and maintenance (servicing) instructions in the literature accompanying the appliance.

**WARNING: TO REDUCE THE RISK OF FIRE OR ELECTRIC SHOCK, DO NOT EXPOSE THIS APPLIANCE TO RAIN OR MOISTURE.**

**CAUTION**

TO PREVENT ELECTRIC SHOCK DO NOT USE THIS (POLARIZED) PLUG WITH AN EXTENSION CORD, RECEPTACLE OR OTHER OUTLET UNLESS THE BLADES CAN BE FULLY INSERTED TO PREVENT BLADE EXPOSURE.

**ATTENTION**

POUR PREVENIR LES CHOCX ELECTRIQUES NE PAS UTILISER CETTE FICHE POLARISEE AVEC UN PROLONGATEUR, UNE PRISE DE COURANT OU UNE AUTRE SORTIE DE COURANT, SAUF SI LES LAMES PEUVENT ETRE INSEREES A FOND SANS EN LAISSER AUCUNE PARTIE A DECOUVERT.

TABLE OF CONTENTS

1	Note on Use	4	6	Operations	24-29
2	Before Using	5	9	Using the Surround Function	29-34
3	Cautions on Installation	5	10	Listening to the Radio	35-37
4	Cautions on Handling	5	11	Last Function Memory	37
5	Connections	6-10	12	Initialization of the Microprocessor	37
6	System Setup	11-18	13	Troubleshooting	38
7	Remote Control Unit	19-23	14	Specifications	39

ACCESSORIES

Check that the following parts are included in addition to the main unit:

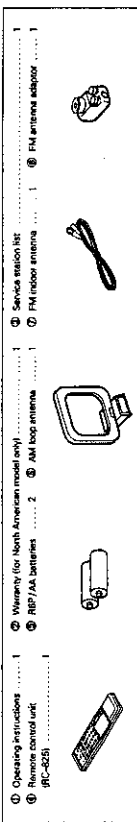

NOTE ON USE

	<ul style="list-style-type: none"> <li>Avoid high temperatures. Allow for sufficient heat dissipation when installed on a rack.</li> </ul>		<ul style="list-style-type: none"> <li>Do not let foreign objects in the set.</li> </ul>
	<ul style="list-style-type: none"> <li>Handle the power cord carefully. Hold the plug when unplugging the cord.</li> </ul>		<ul style="list-style-type: none"> <li>Do not let insecticides, benzene, and thinner come in contact with the set.</li> </ul>
	<ul style="list-style-type: none"> <li>Do not obstruct the ventilation holes.</li> </ul>		<ul style="list-style-type: none"> <li>Never disassemble or modify the set in any way.</li> </ul>

BEFORE USING

Pay attention to the following before using this unit:

- Moving the set**  
To prevent short circuits or damaged wires in the connection cords, always unplug the power cord and disconnect the connection cords between all other audio components when moving the set.
- Before turning the power switch on**  
Check once again that all connections are proper and that there are not problems with the connection cords. Always set the power switch to the standby position before connecting and disconnecting connection cords.

- Store this instructions in a safe place. After reading, store this instructions along with the warranty in a safe place. Also fill in the items on the back page for your convenience.
- Note that the illustrations in this instructions may differ from the actual set for explanation purposes.

CAUTIONS ON INSTALLATION

- Noise or disturbance of the picture may be generated if this unit or any other electronic equipment using microprocessors is used near a tuner or TV.
- If this happens, take the following steps:
- Install this unit as far as possible from the tuner or TV.
  - Set the antenna wires from the tuner or TV away from this unit's power cord and input/output connection cords.
  - Noise or disturbance tends to occur particularly when using indoor antennas or 300 Ω/ohms feeder wires. We recommend using outdoor antennas and 75 Ω/ohms coaxial cables.

For heat dispersal, leave at least 10 cm of space between the top, back and sides of this unit and the wall or other components.

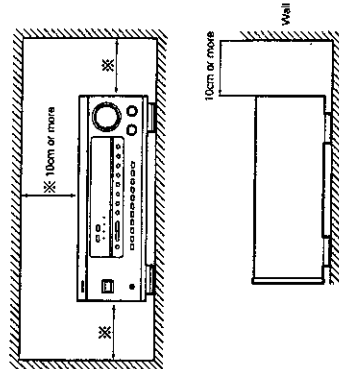

CAUTIONS ON HANDLING

- Switching the input function when input jacks are not connected  
A clicking noise may be produced if the input function is switched when nothing is connected to the input jacks. If this happens, either turn down the MASTER VOLUME control or connect components to the input jacks.
- Muting of PRE OUT jacks  
The PRE-OUT jacks include a muting circuit. Because of this, the output signals are greatly reduced for several seconds after the power switch is turned on or input function, surround mode or any other set-up is changed. If the volume is turned up during this time, the output will be very high after the muting circuit stops functioning. Always wait until the muting circuit turns off before adjusting the volume.

- Whenever the power switch is in the OFF state, the apparatus is still connected on some AC line voltages. Please be sure to unplug the cord when you leave home for, say, a vacation.

5 CONNECTIONS

- Do not plug in the power cord until all connections have been completed.
- Be sure to connect the left and right channels properly (left with left, right with right).
- Noise or humming may be generated if a connected audio equipment is used independently without turning the power of this unit on. If this happens, turn on the power of the this unit.
- Use the AC OUTLETS for audio equipment only. Do not use them for hair driers, etc.

Connecting the audio components

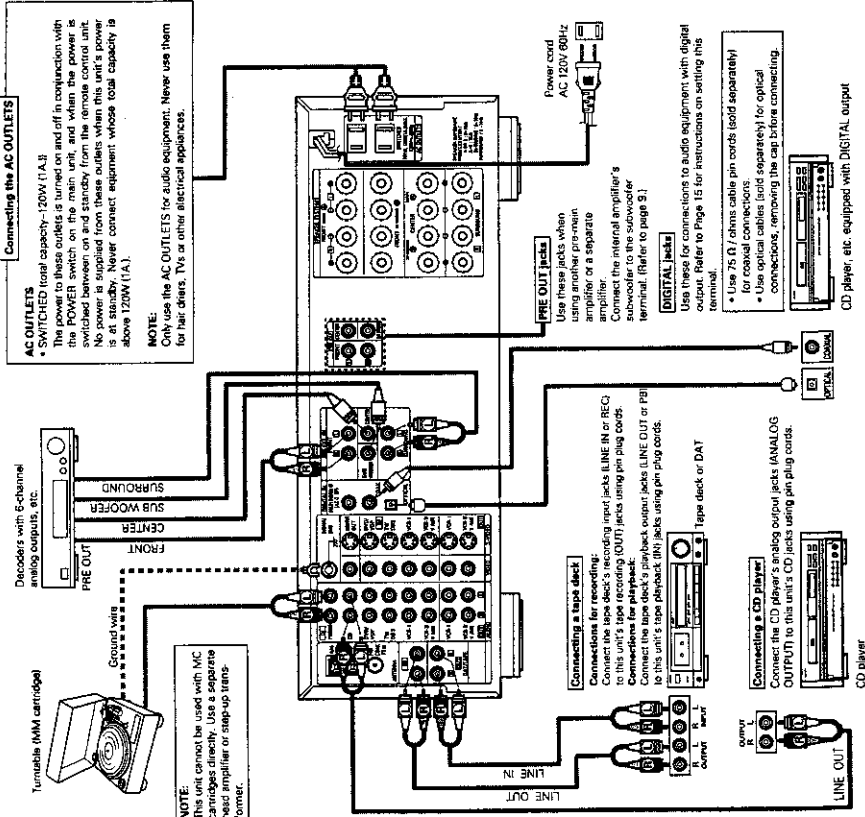

Connecting the video equipments

- To connect the video signal, connect using a 75 Ω/ohms video signal cable cord. Using an improper cable can result in a drop in sound quality.
- TV or DRS tuner
- Connecting a TV/DRS tuner
- TV/DRS
- Connect the TV's or DRS tuner's video output jack (VIDEO OUTPUT) to the VIDEO IN jack using a 75 Ω/ohms video coaxial pin plug cord.
- Connect the TV's or DRS tuner's audio output jack (AUDIO OUTPUT) to the AUDIO IN jack using pin plug cords.
- LD player (MDP) or DVD player
- Connecting a video disc player (VDP) or a DVD player
- Connect the video disc player's (DVD player's) video output jack (VIDEO OUTPUT) to the VIDEO IN jack using a 75 Ω / 3mm video coaxial pin plug cord.
- Connect the video disc player's (DVD player's) audio output jack (AUDIO OUTPUT) to the AUDIO IN jack using pin plug cords.
- \* For better sound quality, we recommend using the DVD player with digital rather than analog connections.
- VDP and DVD players can also be connected to the VCR-1 or VCR-2 (V.AUM) terminals.

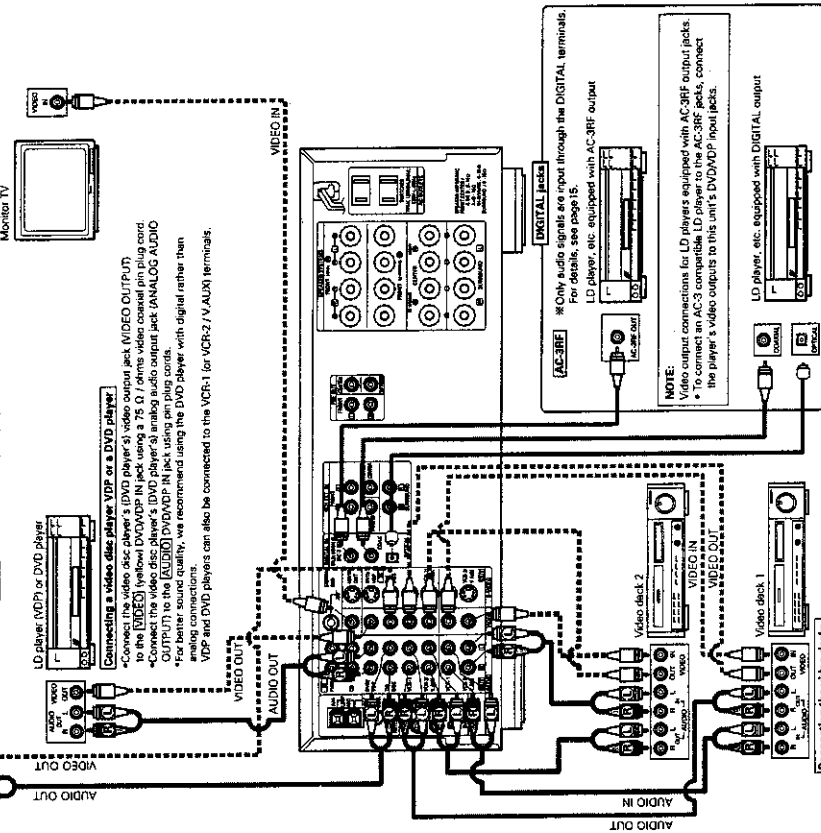

**Speaker system connections**

- Connect the speaker terminals with the speakers making sure that like polarities are matched (⊕ with ⊕, ⊖ with ⊖). Mismatching of polarities will result in weak central sound, unclear orientation of the various instruments, and the sense of direction of the stereo being impaired.
- When making connections, take care that none of the individual conductors of the speaker cord come in contact with adjacent terminals, with other speaker cord conductors, or with the rear panel. Use banana plugs the speaker cords touch or if their core wire is thick and it is difficult to connect the cord to the speaker terminal.

**Speaker impedance**

- When speaker systems A and B are used separately, speakers with an impedance of from 8 to 16 Ω/ohms can be connected for use as front and center speakers.
- Be careful when using two pairs of front or center speakers (A + B) at the same time, since use of speakers with an impedance of less than 16 Ω/ohms will lead to damage.
- Speakers with an impedance of B to 16 Ω/ohms can be connected for use as surround speakers.
- The protection circuit may operate or damage may occur when speakers with an impedance outside of the above range are used.

**Connecting the speaker terminals**

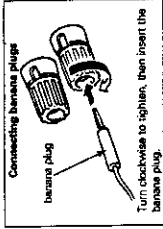
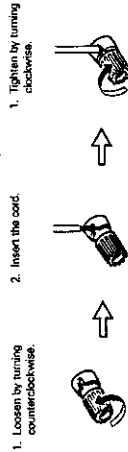

**CENTER SPEAKER SYSTEM**

**FRONT SPEAKER SYSTEMS**

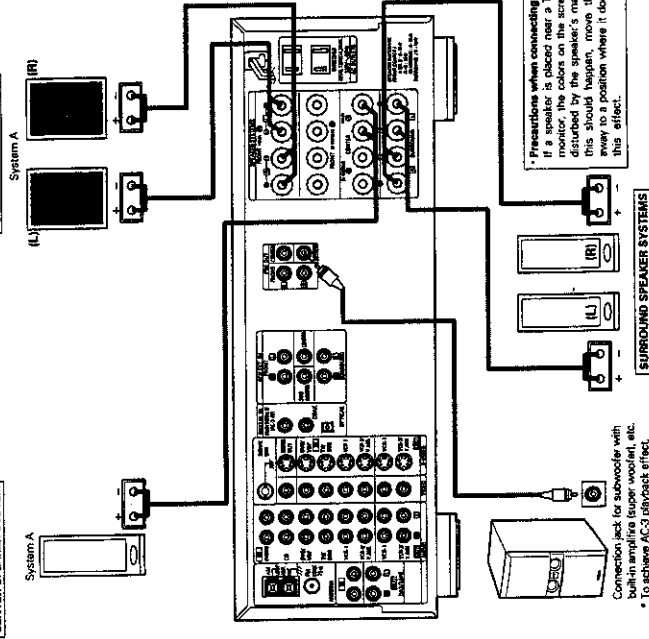

**\* Precautions when connecting speakers**  
If a speaker is placed near a TV, there is a danger of the speaker's magnetism being disturbed by the speaker's magnetism. If this should happen, move the speaker away to a position where it does not have this effect.

Connection jack for subwoofer with built-in amplifier (super woofer), etc.  
• To achieve AC/3 playback effect, use a unit that can sufficiently reproduce frequencies of order 80 Hz.

**Connecting the S-video terminals**

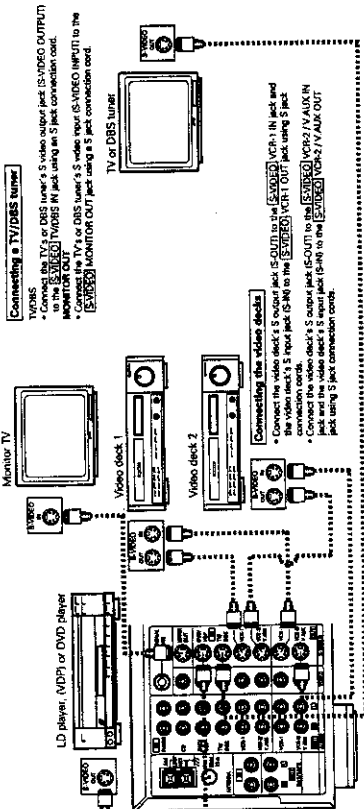

- **A note on the S input jacks**  
The input selectors for the S inputs and pin jack inputs work in conjunction with each other.
- **Precautions when using S-jacks**  
This unit's S-jacks (input and output) and video pin jacks (input and output) have independent circuit structures, so that video signals input from the S-jacks are only output from the S-jack outputs and video signals input from the pin jacks are only output from the pin jack outputs. When connecting this unit with equipment that is equipped with S-jacks, keep the above point in mind and make connections according to the equipment's instruction manuals.

**Connecting the antenna terminals**

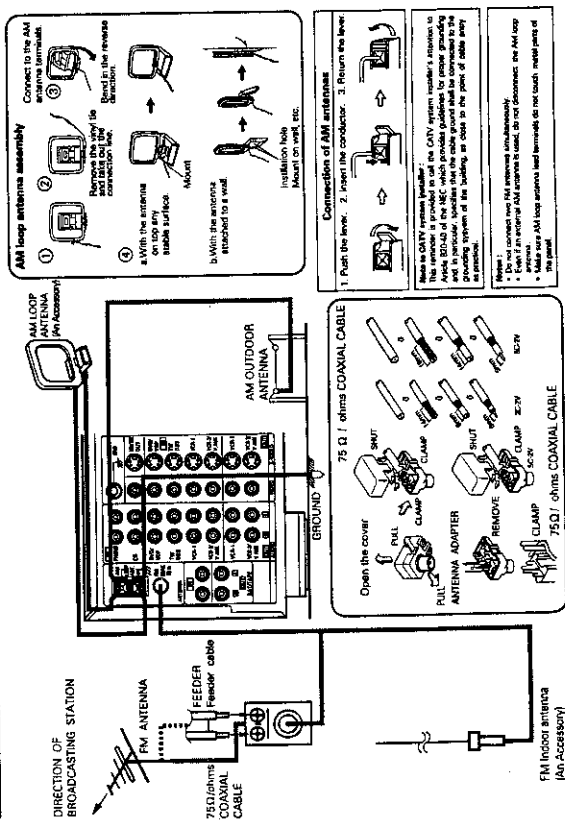

FM Indoor antenna (An-Accessory)

**6 SYSTEM SETUP**

After connections with other components have been made, make the various settings on the monitor connected to the MONITOR OUT terminal using this unit's on screen display function. These settings must be made in order to complete the AV system in your listening room.

Make the seven settings described below.

Caution:

Do not play any apparatus connected to this set while in setting item ① or ②, below, or some malfunction may occur.

- ① Speaker Configuration
- ② Delay Time
- ③ Auto Tuner Preset
- ④ Channel Level
- ⑤ Digital Input (only when an AV component is connected to the digital input jacks)
- ⑥ DOLBY DIGITAL
- ⑦ On Screen Display

**NOTES:**

- The output from the S MONITOR OUT terminal has priority for the on screen display. For example, the S-video signals have priority if signals are input from a component on which both the S-video and regular video input terminals are connected and the output monitor is connected to both the S-video and regular video output terminals. If you want to always output the on screen display signals to the video output, do not connect a cable to the S MONITOR OUT terminal.
- This model's on screen display function is designed for high resolution monitor displays. Small characters may be difficult to read on small displays or low resolution TVs.

Use the following buttons on the remote control unit to make the settings:

\* Set to the AVR/AVC side.

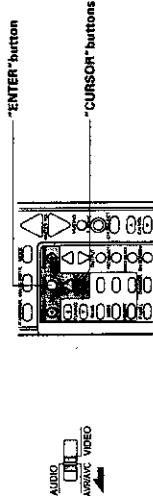

**Before setting up the system**

- 1** Press the POWER switch on the main unit or the POWER button on the remote control unit to turn on the power.
  - Press the ENTER button.
- 2** Press the ENTER button.
  - The "Tuner-PreSet Stations" menu is only displayed when the input function is set to "TUNER".
  - The "Surround Parameters" are not displayed when the parameters that should be set in the selected surround mode are not there. Examples include "5CH STEREO", "6CH EXT. IN", and "STEREO" (with PCM analog input modes).
- 3** Use the CURSOR  $\Delta$  and  $\nabla$  buttons to set the  $\square$  mark to "System Setup".
  - Press the ENTER button.
- 4** Press the ENTER button to switch the screen.
  - Press the ENTER button.

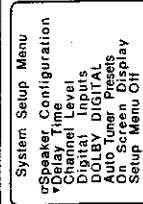
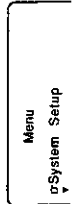
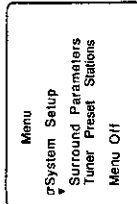

• About bi-wiring: If your speakers have bi-wiring terminals, you can achieve higher quality sound by adding cords and using bi-wiring, as shown on the diagram below.

• By connecting speaker systems to both the speaker A and B terminals, you can play the same music source simultaneously in different rooms. (Use speakers with impedances of 16  $\Omega$  (ohms).)

**Bi-wiring procedure**

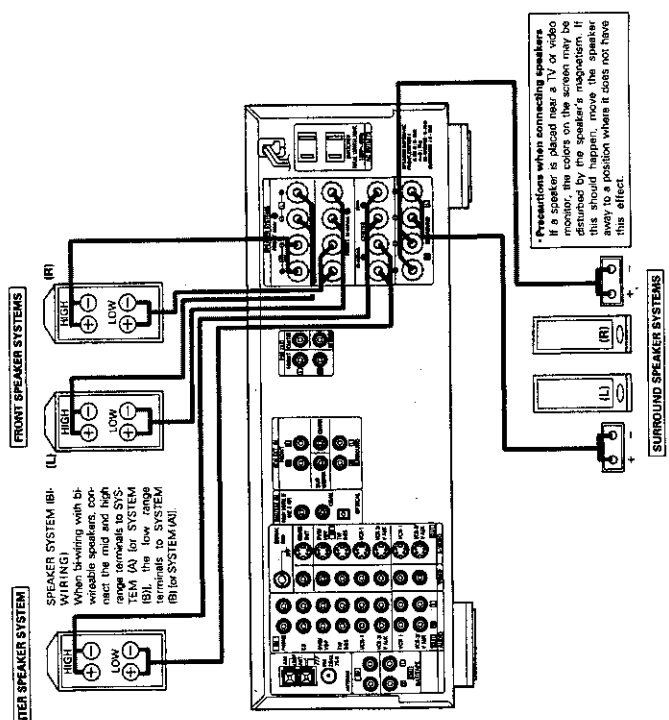

**Precautions when connecting speakers:** If a speaker is placed near a TV or video monitor, the sound may be distorted or damaged by the speaker's magnetism. If this should happen, move the speaker away to a position where it does not have this effect.

**Protector circuit**

This set has a built-in high speed protector circuit which protects the internal circuitry from strong currents that may be generated if the speakers are used with their cords insecurely connected to the speaker terminals or if the cords are short-circuited. If this protector circuit is activated, the speaker output is automatically cut off, the display turns off and the STANDBY LED flashes rapidly. If this should happen, be sure to turn off the set's power, then check the speaker cord connections once again before turning the power back on. The sound will be muted for several seconds, after which the set will operate normally.

**Setting the speaker configuration**

**1** Use the CURSOR  $\Delta$  and  $\nabla$  buttons to set the  $\square$  mark to "Speaker Configuration".

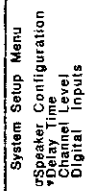

**2** Press the ENTER button to switch the screen.

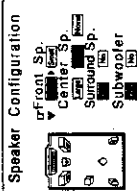

**3** Use the CURSOR  $\Delta$  and  $\nabla$  buttons to set the  $\square$  mark to the speaker to be set.

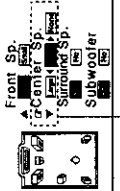

Example: Center speaker selected and parameter set to "Small".

**4** Use the CURSOR  $\leftarrow$  and  $\rightarrow$  buttons to highlight the parameter to be set.

**Parameters**  
 Large ..... Select this when using speakers that can fully reproduce low sounds of below 80 Hz.  
 Small ..... Select this when using speakers that cannot reproduce low sounds of below 80 Hz with sufficient volume.  
 None ..... When this setting is selected, low frequencies of below 80 Hz are assigned to the subwoofer.  
 Yes/No ..... Select "Yes" when surround speakers and a subwoofer are installed. "No", when they are not installed.  
**NOTE:** \* Select "Large" or "Small" not according to the physical size of the speaker, but according to the bass reproduction capacity at 80 Hz. If you cannot determine the best setting, try comparing the sound when set to "Small" and when set to "Large", at a level that will not damage the speakers.  
 \* When "None" has been selected for the center speaker, "No" cannot be selected for the surround speakers. Also note that when "No" has been selected for the surround speakers, "None" cannot be selected for the center speaker.

**5** Press the ENTER button to enter the setting. The "System Setup Menu" screen reappears.

**Caution:**  
 In case the subwoofer is not used, be sure to set "Subwoofer = No", or the bass sound of front channel is divided to subwoofer channel and not reproduced in some mode.

**Setting the delay time**

Input the distances from the listening position to the speakers and set the surround delay time.

**Preparations:**  
 Measure the distances from the listening position to the speakers (L1 to L3 on the diagram at the right).

- L1: Distance from center speaker to listening position
- L2: Distance from front speakers to listening position
- L3: Distance from rear speakers to listening position

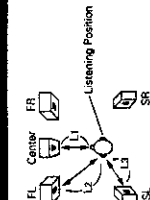

**1** Use the CURSOR  $\Delta$  and  $\nabla$  buttons to set the  $\square$  mark to "Delay Time".

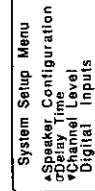

Press the ENTER button to switch the screen.

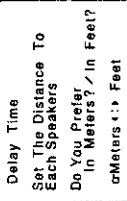

**3** Use the CURSOR  $\leftarrow$  and  $\rightarrow$  buttons to select the unit of distance. Highlight the desired unit, "Meters" or "Feet".

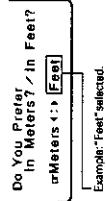

**4** Selecting "Meters" or "Feet" in Step 3 will automatically change the screen to the one on the right.

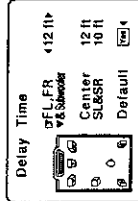

**5** Use the CURSOR  $\Delta$  and  $\nabla$  buttons to set the  $\square$  mark to speaker to be set.

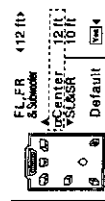

**6** Use the CURSOR  $\leftarrow$  and  $\rightarrow$  buttons to set the distance from the speaker to the listening position.

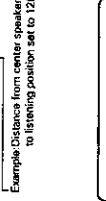

- \* The number changes in units of 1 foot (or 0.1 meters) each time one of the buttons is pressed. Select the value closest to the measured distance.
- \* The settings are reset to the factory settings when the  $\square$  mark is set to "Default" and "Yes". (Refer to page 16).
- \* If you set an invalid distance, a CAUTION notice, such as screen appear as shown right. In this case, please relocate the blinking speaker(s) so that its distance is no larger than the value shown in highlighted line. Then press the ENTER button again.
- \* Set in such a way that the distance to the center speaker is the same as or up to 5 feet (1.5 meters) shorter than the distance to the front left and front right speakers and the subwoofer.
- \* Set in such a way that the distance to the surround left and right speakers is the same as or up to 15 feet (4.5 meters) shorter than the distance to the front left and front right speakers and the subwoofer.

**7** Press the ENTER button to enter the setting. The "System Setup Menu" screen reappears. This procedure automatically sets the optimum surround delay time for the listening room.

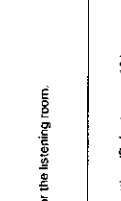

**NOTE:**  
 If the unit of distance is changed after the delay time is set, the setting is cleared and reset to the factory setting. (Refer to page 16.)

**Setting the channel level**

Use the following procedure to adjust the balance of the playing level between the different channels. This sets the balance of the playing levels between the different channels to the same balance for all the surround modes. Make the adjustment from the listening position while listening to the test tone output from each speaker.

**1**  Use the CURSOR  $\Delta$  and  $\nabla$  buttons to set the  $\square$  mark to "Channel Level".

System Setup Menu

- $\blacktriangle$ Speaker Configuration
- $\blacktriangle$ Delay Time
- $\blacktriangle$ Channel Level
- $\blacktriangledown$ Digital Inputs
- $\blacktriangledown$ DOLBY DIGITAL
- $\blacktriangledown$ Auto Tuner Presets
- $\blacktriangledown$ On Screen Display Setup
- $\blacktriangledown$ Menu Off

**2**  Press the ENTER button to switch the screen.

Channel Level

- $\blacktriangle$ Level Clear
- Test Tone Mode  $\blacktriangle$  :  $\square$  Manual
- Test Tone Start

**3**  Use the CURSOR  $\Delta$  and  $\nabla$  buttons to set the  $\square$  mark to "Test Tone Mode".

Channel Level

- $\blacktriangle$ Level Clear
- Test Tone Mode  $\blacktriangle$  :  $\square$  Manual
- Test Tone Start

Example: "Auto" mode selected.

**4**  Use the CURSOR  $\blacktriangleleft$  and  $\blacktriangleright$  buttons to select the mode. Highlight "Auto" or "Manual" to select that mode.

Auto: Adjust the level while listening to the test tones output automatically from the different speakers.  
Manual: Select the speaker from which to output the test tone to adjust the level.

**5**  Use the CURSOR  $\Delta$  and  $\nabla$  buttons to set the  $\square$  mark to "Test Tone Start".

**6**  Press the CURSOR  $\blacktriangleleft$  button and is set to "Yes".

**7 A. If the "Auto" mode is selected:**  
Test tones are automatically emitted from the different speakers. The test tones are emitted from the different speakers in the following order, at 4-second intervals the first time and second time around, 2-second intervals the third time around and on:

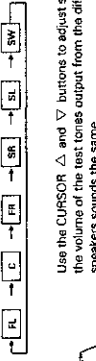

Use the CURSOR  $\Delta$  and  $\nabla$  buttons to adjust so that the volume of the test tones output from the different speakers sounds the same. The volume can be adjusted in units of 1 dB from -12 to +12 dB.

Sound level meter

Highlighted

Test Tone SW ch : -12dB

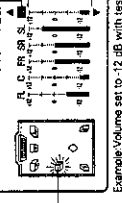

Example: Volume set to -12 dB with test tone being output from subwoofer.

**B. If the "Manual" mode is selected:**  
Use the CURSOR  $\blacktriangleleft$  and  $\blacktriangleright$  buttons to highlight and select the speaker from which you want to output test tones. Then use the CURSOR  $\Delta$  and  $\nabla$  buttons to adjust so that the volume of the test tones output from the different speakers sounds the same.

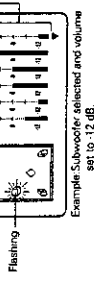

The level of each channel should be adjusted to 75 dB (C-weighted, slow meter, mode) on a sound level meter at the listening position. If a sound level meter is not available adjust the channels by ear so the sound levels are the same. Because adjusting the subwoofer level test tones by ear is difficult, use a well known music selection and adjust for natural balance.

**NOTE:** When adjusting the level of an active subwoofer system, you may also need to adjust the subwoofer's own volume control.

**8**  Press the ENTER button to enter the setting. The "Channel Level" screen reappears. To cancel the settings, select "Level Clear" and "Yes" on the "Channel Level" screen, then make the settings again.

**NOTE:** When the level clear operation is performed, all channel levels for all modes are set to 0 dB.

**Digital input setup**

input the types of components connected to the digital input terminals.

**1**  Use the CURSOR  $\Delta$  and  $\nabla$  buttons to set the  $\square$  mark to "Digital Inputs".

System Setup Menu

- Speaker Configuration
- Delay Time
- $\blacktriangle$ Channel Level
- $\blacktriangledown$ Digital Inputs
- $\blacktriangledown$ DOLBY DIGITAL
- $\blacktriangledown$ Auto Tuner Presets
- $\blacktriangledown$ On Screen Display Setup
- $\blacktriangledown$ Menu Off

**2**  Press the ENTER button to switch the screen.

Digital Inputs Setup

- $\blacktriangle$ COAXIAL
- $\blacktriangle$ OPTICAL
- Default  $\square$  :  $\square$  YES

**3**  Use the CURSOR  $\Delta$  and  $\nabla$  buttons to set the  $\square$  mark to the connector whose input you want to set (COAXIAL or OPTICAL).

Digital Inputs Setup

- $\blacktriangle$ COAXIAL
- $\blacktriangle$ OPTICAL
- Default  $\square$  :  $\square$  YES

Example: COAXIAL connector selected and input device set to CD.

**4**  Use the CURSOR  $\blacktriangleleft$  and  $\blacktriangleright$  buttons to highlight and select the type of device connected to the various terminals.

**5**  Press the ENTER button to enter the setting. The "System Setup Menu" screen reappears.

\* The settings are reset to the factory settings when the  $\square$  mark is set to "Default" and "Yes". (Refer to page 18.)

**NOTE:** PHONO, TUNER and DAT/TAPE cannot be selected.



**DOLBY DIGITAL**

Use the following procedure to set the level of the LFE (Low-Frequency Effect) included in the source when playing program sources recorded in Dolby Digital.

- If the subwoofer clips due to the LFE signal during Dolby Digital playback, adjust the level as needed.

- 

Use the CURSOR  $\Delta$  and  $\nabla$  buttons to set the [F] mark to "DOLBY DIGITAL".

System Setup Menu  
Speaker Configuration  
Delay Time  
Channel Level  
Digital Inputs  
DOLBY DIGITAL  
Auto Tuner Presets  
On Screen Display  
Setup Menu Off
- 

Press the ENTER button to switch the screen.

DOLBY DIGITAL  
LFE Trim 0 dB  
Default [F]  $\leftarrow$
- 

Use the CURSOR  $\Delta$  and  $\nabla$  buttons to set the [F] mark to "LFE Trim".

DOLBY DIGITAL  
LFE Trim -10 dB  
Default [F]  $\leftarrow$
- 

Use the CURSOR  $\leftarrow$  and  $\rightarrow$  buttons to set the LFE level. The level can be adjusted in units of 1 dB from -10 to 0 dB. Set to the desired level according to the speaker systems being used and the source to be played.

Example: LFE level set to -10 dB
- 

Press the ENTER button to enter the setting. The "System Setup Menu" screen reappears.

\* The settings are reset to the factory settings when the [F] mark is set to "Default" and "Yes". (Refer to page 18).

**Auto Tuner Presets**

Use this to automatically search for FM broadcasts and store up to 40 stations at preset channels A1 to B, B1 to B, C1 to B, D1 to B and E1 to B.

**NOTE:**  
If an FM station cannot be preset automatically due to poor reception, use the "Manual tuning" operation to tune in the station, then preset it using the manual "Preset memory" operation. (Refer to page 36).

- 

Use the CURSOR  $\Delta$  and  $\nabla$  buttons to set the [F] mark to "Auto Tuner Presets".

System Setup Menu  
Speaker Configuration  
Delay Time  
Channel Level  
Digital Inputs  
DOLBY DIGITAL  
Auto Tuner Presets  
On Screen Display  
Setup Menu Off
- 

Press the ENTER button to switch the screen.

Auto Tuning & Preset Station Memory  
Storing Preset Memory  
Start [F] 4
- 

Press the CURSOR  $\leftarrow$  button.

Auto Tuning & Preset Station Memory  
Storing Preset Memory  
Start [F] 4
- 

The set automatically starts searching for FM stations.

  - "Search" flashes on the screen.
  - "Completed" appears once searching is completed.

Searching: When searching is completed, the display switches to "Completed".
- 

When searching is completed, the screen automatically returns to the "System Setup Menu".

\* For instructions on checking the frequencies of the preset stations, refer to page 27.

**On Screen Display**

This set is equipped with an on-screen display function that displays information on the various operations on the monitor TV connected to the VIDEO MONITOR OUT connector on the rear panel. These messages are superimposed on the picture when a video source is being played and displayed on a blue background when no video source is being played. Use the following procedure to turn this function on and off.

- 

Use the CURSOR  $\Delta$  and  $\nabla$  buttons to set the [F] mark to "On Screen Display".

System Setup Menu  
Speaker Configuration  
Delay Time  
Channel Level  
Digital Inputs  
DOLBY DIGITAL  
Auto Tuner Presets  
On Screen Display  
Setup Menu Off
- 

Press the ENTER button to switch the screen.

On Screen Display  
[F]  $\leftarrow$  [F]

**7 REMOTE CONTROL UNIT**

Following the procedure outlined below, insert the batteries before using the remote control unit.

**Range of operation of the remote control unit**

Point the remote control unit at the remote control sensor as shown on the diagram at the left.

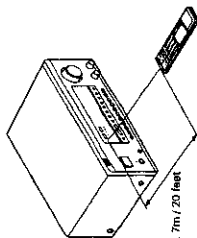

**NOTES:**

- The remote control unit can be used from a straight distance of approximately 7 meters/20 feet, but this distance will shorten or operation will become difficult if there are obstacles between the remote control unit and the remote control sensor, if the remote control sensor is exposed to direct sunlight or other strong light, or if operated from an angle.
- Neon signs or other devices emitting pulsed-type noise nearby may result in malfunction, so keep the set as far away from such devices as possible.

**Inserting the batteries**

- Press as shown by the arrow and slide
- Insert the SUM3 batteries properly, as shown on the diagram.
- Close the lid.

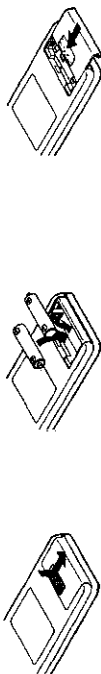

**NOTES:**

- Use only AA, R6P, UM-3 batteries for replacement.
- Be sure the polarities are correct. (See the illustration inside the battery compartment.)
- Remove the batteries if the remote control transmitter will not be used for an extended period of time.
- If batteries leak, dispose of them immediately. Avoid touching the leaked material or letting it come in contact with clothing, etc. Clean the battery compartment thoroughly before installing new batteries.
- Have replacement batteries on hand so that the old batteries can be replaced as quickly as possible when the time comes.
- The codes that have been learned may be lost if removed batteries are not replaced within about 5 minutes.

**System code buttons**

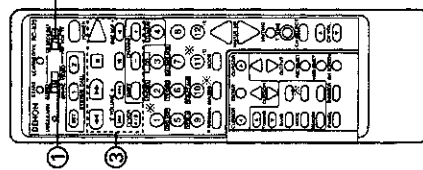

DENON remote-controllable audio components can be controlled using this unit's remote control unit. Note that some components, however, cannot be operated with this remote control unit.

- Set to slide switch to "AUDIO" ("AVR/AVC").
- Set the slide switch to the position for the component to be operated (CD, DECK or DAT).



Use the buttons shown below to operate the audio component. For details, refer to the respective component's manual.

**a. For CD players and DAT:**



- Manual search (reverse and forward)
- Stop
- Play
- Auto search
- Pause
- Disc selection
- SKIP + (CD changer only)
- SKIP -

**b. For tape decks (DECK):**



- Reverse
- Forward
- Stop
- Forward play
- Pause
- A/B deck selection
- Reverse play

\* These buttons does not function, depending on the part set memory or the learning function.

**3**

Use the CURSOR and buttons to select "ON" or "OFF". Highlight the desired setting.



On Screen Display

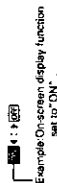

**4**

Press the ENTER button to enter the setting.



This completes the system setup operations. Once the system is set up, there is no need to make the settings again unless other components or speakers are connected or the speaker layout is changed.

**Operation after completing system setup**

**1**

Use the CURSOR and buttons to set the "Setup Menu Off".



- System Setup Menu
- Speaker Configuration
- Delay Time
- Channel Levels
- Channel Assignments
- DOLBY DIGITAL
- Auto Tuner
- Presets
- On Screen Display
- Setup Menu Off

**2**

Press the enter button twice to turn off the on screen display.



**SYSTEM SETUP DEFAULT VALUE**

① SPEAKER CONFIGURATION	Front Sp. Small	Center Sp. Small	Surround Sp. Yes	Subwoofer Yes
② DELAY TIME	FL, FR & Subwoofer 12 ft. (3.6 m)	Center 12 ft. (3.6 m)	SL & SR 10 ft. (3.0 m)	
③ CHANNEL LEVEL	FL 0 dB	FR 0 dB	SL 0 dB	SR 0 dB
④ DIGITAL INPUTS	COAXIAL: CD OPTICAL: DVD/VDP			
⑤ DOLBY DIGITAL	LFE Trim 0 dB			
⑥ AUTO TUNER PRESETS	A1 ~ A8	87.5/89.1/90.1/90.1/90.1/90.1/90.1/90.1 MHz		
	B1 ~ B8	520/600/1000/1400/1500/1710 kHz/90.1/90.1 MHz		
	C1 ~ C8	90.1 MHz		
	D1 ~ D8	90.1 MHz		
	E1 ~ E8	90.1 MHz		
⑦ ON-SCREEN DISPLAY	ON			

Playback with the above setting is possible upon shipment from the factory and after initializing (refer to page 37).

**Preset memory**

DENON and other makes of components can be operated by setting the preset memory for your make of video component. **Operation is not possible for some models, however, in this case use the learning function (see page 22) to store the remote control signals.** For instructions on clearing the preset memory, see page 23.

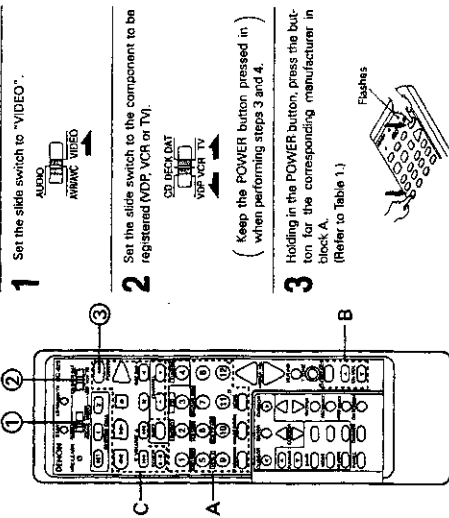

4 Next, while holding in the POWER button, press the button for the code in block B. (Refer to Table 7-2.) The operation is completed when the LEARNED/TX LED lights.



5 To continue registering other components, repeat steps 2 to 4.

Flashes

Keep the POWER button pressed in when performing steps 3 and 4.

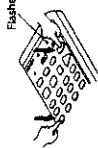

The LEARNED/TX LED flashes.

This remote control unit can be used to operate components of other manufacturers without using the learning function by registering the manufacturer of the component as shown on Table 1.

**Table 1: Combinations of Personal System Codes for Different Manufacturers**

"VDP"		"VCR"	
A	B	A	B
① (PHONO)	DENON A	① (PHONO)	HITACHI A
② (CD)	DENON B	② (CD)	MITSUBISHI B
③ (TUNER)	DENON C	③ (TUNER)	MITSUBISHI C
④ (DVD/VDP)	DENON D	④ (TUNER)	PANASONIC A
⑤ (TV/DBS)	DENON E	⑤ (DVD/VDP)	PANASONIC B
⑥ (I&M/TAPE-MON)	DENON F	⑥ (TV/DBS)	PANASONIC C
⑦ (VCR-1)	DENON G	⑦ (I&M/TAPE-MON)	SONY A
⑧ (VCR-2/AUX)	DENON H	⑧ (VCR-1)	SONY B
⑨ (VCR-3)	DENON I	⑨ (VCR-2/AUX)	SONY C
⑩ (VCR-4)	DENON J	⑩ (VCR-3)	TOSHIBA A
⑪ (VCR-5)	DENON K	⑪ (VCR-4)	TOSHIBA B
⑫ (VCR-6)	DENON L	⑫ (VCR-5)	SANTO A
⑬ (VCR-7)	DENON M	⑬ (VCR-6)	SANTO B
⑭ (VCR-8)	DENON N	⑭ (VCR-7)	SHARP A
⑮ (VCR-9)	DENON O	⑮ (VCR-8)	SHARP B
⑯ (VCR-10)	DENON P	⑯ (VCR-9)	SHARP C
⑰ (VCR-11)	DENON Q	⑰ (VCR-10)	NEC A
⑱ (VCR-12)	DENON R	⑱ (VCR-11)	NEC B
⑲ (VCR-13)	DENON S	⑲ (VCR-12)	NEC C
⑳ (VCR-14)	DENON T	⑳ (VCR-13)	PHILIPS A
㉑ (VCR-15)	DENON U	㉑ (VCR-14)	PHILIPS B
㉒ (VCR-16)	DENON V	㉒ (VCR-15)	PHILIPS C
㉓ (VCR-17)	DENON W	㉓ (VCR-16)	RCA A
㉔ (VCR-18)	DENON X	㉔ (VCR-17)	RCA B
㉕ (VCR-19)	DENON Y	㉕ (VCR-18)	GENERAL ELECTRIC A
㉖ (VCR-20)	DENON Z	㉖ (VCR-19)	GENERAL ELECTRIC B
㉗ (VCR-21)	DENON AA	㉗ (VCR-20)	GENERAL ELECTRIC C
㉘ (VCR-22)	DENON AB	㉘ (VCR-21)	MAGNAVOX A
㉙ (VCR-23)	DENON AC	㉙ (VCR-22)	MAGNAVOX B
㉚ (VCR-24)	DENON AD	㉚ (VCR-23)	MAGNAVOX C

**"TV"**

A	B	ON/STANBY	CH. SELECT	CH. INFO
① (PHONO)	DENON/HITACHI	—	—	—
② (CD)	MITSUBISHI A	—	—	—
③ (TUNER)	MITSUBISHI B	—	—	—
④ (DVD/VDP)	PANASONIC A	—	—	—
⑤ (TV/DBS)	PANASONIC B	—	—	—
⑥ (I&M/TAPE-MON)	JVC (VICTOR)	—	—	—
⑦ (VCR-1)	SONY	—	—	—
⑧ (VCR-2/AUX)	PIONEER	—	—	—
⑨ (VCR-3)	TOSHIBA	—	—	—
⑩ (VCR-4)	SANTO A	—	—	—
⑪ (VCR-5)	SHARP	—	—	—
⑫ (VCR-6)	NEC A	—	—	—
⑬ (VCR-7)	PHILIPS A	—	—	—
⑭ (VCR-8)	RCA A	—	—	—
⑮ (VCR-9)	GENERAL ELECTRIC A	—	—	—
⑯ (VCR-10)	GENERAL ELECTRIC B	—	—	—
⑰ (VCR-11)	MAGNAVOX A	—	—	—

**NOTES:**

- The signals for the pressed buttons are emitted while setting the preset memory. To avoid accidental operation, cover the remote control unit's transmitting window while setting the preset memory.
- Some models and years of manufacture of components of the manufacturers listed on Table 1 cannot be used.

**Operation after components are registered**

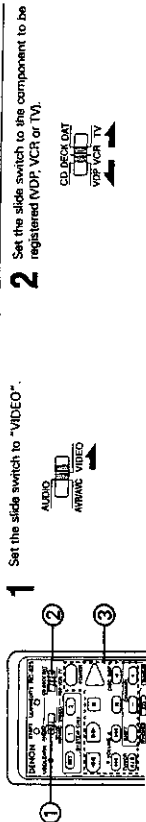

3 Use the buttons shown below to operate the video component. (Some models cannot be used.) For details, refer to the respective component's manual.

**a. VDP**

**b. VCR**

**c. TV**

POWER : Power on/off  
 Manual search (reverse and forward)  
 Stop  
 Play  
 Auto search  
 Pause

POWER : Power on/off  
 Manual search (reverse and forward)  
 Stop  
 Play  
 Pause

POWER : Power on/off  
 VOLUME : Volume up/down  
 TV/VCR : TV/video selection  
 CHANNEL : Channel selection

**Remote control unit learning function**

If your AV components are not DENON products or if operation is not possible with the preset memory settings, the components' remote control signals can be "learned" to enable remote control operation. The buttons that can be "learned" are the CD, DAT and DECK system buttons (see page 19) and the VCR, VCR and TV system buttons (see page 21). (For the TV only, the A block buttons can also be "learned".)

**1** Press the USE/LEARN selector button with the tip of a pen, etc., to set the learn mode. Both the START and LEARNED/TX LEDs indicate a flash.

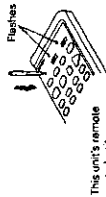

This unit's remote control unit

**2** Set the program switch to the side to be "learned". Set to the AUDIO side if the CD, tape deck or DAT position, to the VIDEO side for the VCR, VCR or TV position.



**3** Set the program switch to the position to be "learned".



**4** Set the remote control units so they are facing each other, then press the button to be "learned" on this unit's remote control unit.

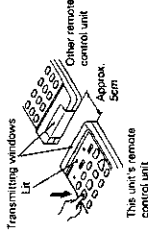

The indicator stops flashing and the START LED lights. The learnable buttons are the buttons which can be operated with the DENON system codes for the CD player, DAT and tape deck, the buttons which can be operated with the preset memory for the VCR, VCR and TV. For the TV only, however, the buttons in the section indicated "A" on the diagram above can also be "learned". Use these to "learn" TV channels.

**NOTE:** Use button 0 as the 0 number button, button 0/E as the enter button.

**5** Check that the START LED is lit, then press the button to be "learned" on the other remote control unit.

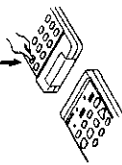

**6** Once the START LED turns off and the LEARNED/TX LED lights, release the button on the other remote control unit.

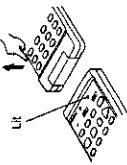

The two LEDs start flashing again.

**7** To "learn" other buttons, repeat steps 2 to 6.

**8** Once the learning operation is completed, press the USE/LEARN selector button again. The two LEDs stop flashing and the learning mode is cancelled.

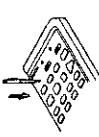

Check that the stored codes work properly.

**NOTES:**

- Up to 26 codes can be "learned", but this number may be lower if the codes are long.
- If a non-learnable button is pressed or two or more buttons are pressed at once, the two LEDs will once again light when the button(s) is released.
- If the codes could not be stored, the LEARNED/TX LED does not light after the START LED turns off. For limited number of models, codes cannot be stored in RC-825.
- If the two LEDs start flashing rapidly after the START LED lights, this means that the memory is already full, and the code you have just attempted to store was not stored.
- To "learn" that code, first perform the resetting operation.

**Clearing "learned" remote control signals and the preset memory settings**

**1** Press the USE/LEARN selector button with the tip of a pen, etc., to set the learn mode.

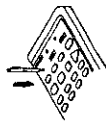

**2** To clear "learned" remote control signals, set the slide switch to the position at which the signals were "learned". To clear the preset memory settings, set the slide switch to "VIDEO".



**3** Set the slide switch to the position at which the signals were "learned" or at which the preset memory settings were set.



**4** Press the SYSTEM CALL SET button, and hold it in for at least four seconds.



**5** When both the START and LEARNED/TX LEDs light simultaneously, all the stored codes are cleared.



**6** Press the USE/LEARN selector button.

**8 OPERATIONS**

**Preparations for playback**

**Preparations:**  
Check that all connections are proper.

**1** Set to the center position.



**2** Set the remote control unit's slide switch to the AUDIO position, only when operating with the remote control unit.



**3** Turn on the power.  
Press the POWER switch (button).



• **ON/STANDBY**

The power turns on and "STANDBY" indicator is lit. Set the slide switch to the "ON/STANDBY" position until sound is output. This is due to the protection circuit that prevents noise when the power switch is turned on and off.

Set the POWER switch to this position to turn the power on and off from the included remote control unit (RC-825).

• **OFF**

The power turns off and "STANDBY" indicator is off. In this position, the power cannot be turned on and off from the remote control unit.

**Playing the analog program source**

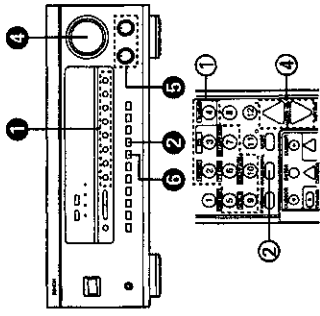

**1** Press the button for the program source to be played.  
**EX 1: CD**



**EX 2: DAT/TAPE**

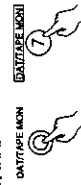

• Press the button once to switch the source to DAT/TAPE input, again to cancel DAT/TAPE input.

**2** Select the ANALOG input mode.



Check that the "ANALOG" indicator is lit.

**3** Start playback on the selected component. For operating instructions, refer to the various components' manuals.

**4** Adjust the MASTER VOLUME control.



The volume is indicated on the set's display.

• The volume can be adjusted in units of 1 dB from -60 to 0 to +18 dB.

**5** Adjust the BASS and TREBLE.



Turn the control clockwise to increase the bass or treble, counterclockwise to decrease it.

**6** If the indicator lights when the "OVER LOAD" LED is lit, press the ATTENUATOR button.



• The input level is lowered by -8 dB.  
**Notes:** • For digital input sources, there is no need to adjust the ATTENUATOR.  
(This button will not operate.)

• If the indicator does not turn off when this button is pressed, adjust the output level on the player.  
• This button cannot be used when playing in the 6-channel EXT IN mode.

**Playing the digital program source**

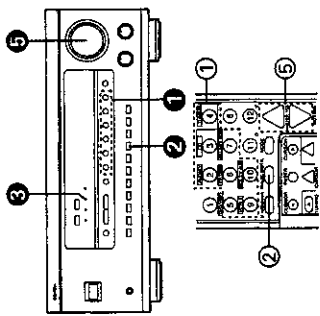

- 2 Select the DIGITAL input mode.  
ANALOG / DIGITAL
  - 3 Check that the "DIGITAL" indicator is lit.  
DIGITAL light on / ERROR OVERLOAD light off
- When digital signals are input properly, the "ERROR / OVERLOAD" indicator is not lit.  
\* If the "ERROR/OVERLOAD" indicator is lit, check that the system setup's input setting (refer to page 15) and the connections are proper, that the component's power is turned on, etc.
- 4 Start playback on the selected component.  
For operating instructions, refer to the various components' manuals.
  - 5 Adjust the MASTER VOLUME control.

1 Press the button for the program source to be played that is connected to the digital input jacks.  
EX: CD



**NOTE:**

- NEVER try to play CD-ROM discs.
- If a CD-ROM is played, the "DIGITAL" indicator is lit green but no sound is heard.

**Simulcast playback**

Use this switch to monitor a video source other than the audio source.

- 1 Press the VIDEO SELECT button repeatedly until the desired source appears on the display.

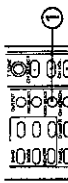

The video source switches as follows each time the button is pressed:

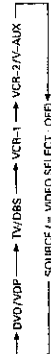

- \* Cancelling simulcast playback
- Select "SOURCE" using the video select button
- Switch the program source to the component connected to the video.

**Using the muting function**

Use this to turn off the audio output temporarily.

- 1 Press the MUTING button.  
\* Cancelling MUTING mode  
Press the MUTING button again.

\* Caution: Switching off the power of the unit and the remote control unit will cancel the settings.

**Listen with headphones**

- 1 Connect the headphones to the PHONES jack of the front panel.
- 2 Press the OUTPUT button to play the sound over the headphones only.

• The output to the speaker and pre-out jacks is turned off and no sound is produced from the speakers.

\* Caution: Switching off the power of the unit and the remote control unit will cancel the settings.

**On screen display**

The input and output sources and the surround setting, etc., are displayed on the monitor TV, so the various functions can be checked visually at a glance.

- 1 Press the ON SCREEN button.

The display switches as follows each time the button is pressed (the following screens are examples):

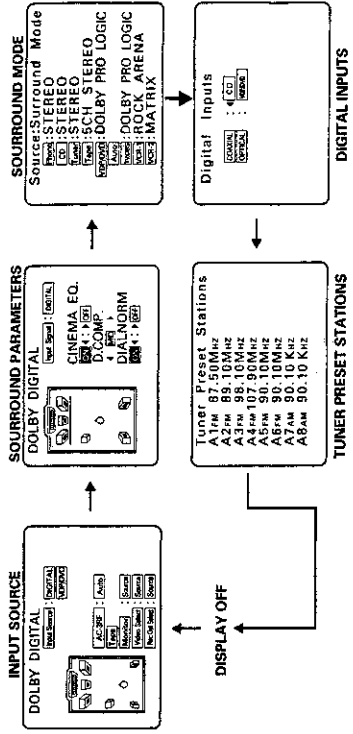

**Front panel display**

When an operation is performed on the main unit or on the remote control unit that operation appears on the display, making it possible to check the operation visually. The set's operating status can also be checked on the display using the procedure described below.

1 Press the **PANEL** button.

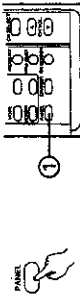

The input and output sources and the surround setting, etc., appear in order on the display each time the button is pressed.

**Recording the currently playing program source**

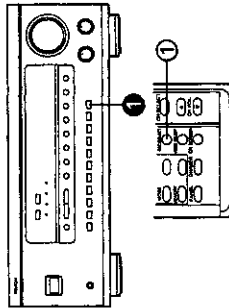

1 Press the **REC SELECT** button and set the recording output to "SOURCE".



2 Set the cassette deck, video deck or other recording device to the recording mode. For instructions, refer to the device's operating manual.

To record the sound from a tape deck, set the REC OUT mode to DAT TAPE.

**Using the dimmer function**

Use this function to adjust the brightness of the main unit's display.

1 Press the **DIMMER** button.

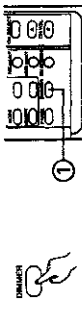

The brightness changes in the following order each time the button is pressed:

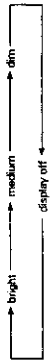

**Recording using the REC OUT selector**

Use the following procedure to record a source other than the one currently playing.

1 Press the **REC SELECT** button and set the recording output to the source to be recorded.

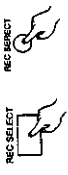

Example: Source to be recorded set to PHONO

2 Set the video deck or other recording device to the recording mode. For instructions, refer to the device's operating manual.

**Tape monitor function**

When a three-head tape deck is used, the sound actually being recorded can be monitored during recording by pressing the **DAT TAPE MONITOR** button.

Press the button again to cancel monitoring.

**NOTES:**

- Only the currently playing source can be recorded on the tape deck.
- Digital input signals cannot be recorded. To record, connect to the analog input terminals.
- It is not possible to record between the video jack and the S-video jack.
- If the input function is set to PHONO, CD or TUNER when "TV/DBS" is selected with the REC OUT selector, the picture signals selected with the "TV/DBS" setting are output from the MONITOR OUT terminal.

**System call (remote control unit)**

This function allows you to preset frequently used operation patterns in the remote control unit then automatically send a series of up to ten remote control codes with a single button.

1 **Presetting**  
Press the **SET** button.



3 Press the **SYSTEM CALL** button ("1" or "2") at which you want to store the codes. The setting is now stored.



2 Press the buttons for the codes to be sent, changing the position of the slide switch as necessary. Up to ten buttons can be set. Buttons which have been "learned" and buttons which have been preset can also be selected.

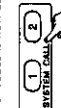

4 **Recalling**  
Press the **SYSTEM CALL** button ("1" or "2") at which the desired codes have been stored. The series of codes is now sent.

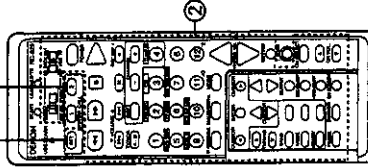

**9 USING THE SURROUND FUNCTION**

**Dolby Surround**

This unit is equipped with digital signal processing sections for decoding and reproducing movie soundtracks the same way as in movie theaters.

**1. DOLBY PRO LOGIC**

When using conventional video tapes, laser discs, TV programs or CDs with the **PRO LOGIC** mark, Dolby Pro Logic provides extremely natural sound movement and positioning, immersing you in the on-screen action. Pro Logic uses a directional emphasis circuit to decode four output channels (front left and right, center and surround) from the two audio channels provided on the software.

This set is equipped with four Pro Logic play modes: Normal, Phantom, Wide and 5-channel. The set automatically selects the optimum mode according to the system setup's speaker configuration settings.

**2. DOLBY DIGITAL**

When you connect the DVD player or an LD player with an AC-3RF output to the **AC-3RF** input terminal and play DVD laser discs with **DOLBY DIGITAL** (or **EXCEL**) mark, you can experience improved sound spatiality, positioning and impact compared with Pro Logic. This is because Dolby Digital separates the audio signals into 5.1 channels (front left, center, and surround left and right) plus a bass-only effects channel. Since the signals are digital from the input of the program source until the output of this unit, a higher quality and clarity of surround sound results.

Dolby Digital AC-3 (Audio Coding 3) is a system developed by Dolby Laboratories that transmits 5.1 channels of digital signals. The surround system developed for movie theaters using this system is called "Dolby SR-D (Surround Digital)". Whereas the conventional Dolby Pro Logic Surround is an analog matrix system, Dolby SR-D is a digital discrete system in which the different channels are completely independent. This makes it possible to achieve a realistic sound field with realistic positions and create a spacious, real and powerful sense of presence when playing movie software in AV rooms.

There are "5.1 ch." playback channels: three front channels (front left, center and front right), two surround channels (surround left and surround right), plus "0.1 channel" called LFE (Low Frequency Effect) for low bass effect sounds of 120 Hz or less. The signals are recorded on the software in fully discrete fashion, eliminating crosstalk between channels and making it possible to control the sound field in the listening/viewing space with greater precision. In addition, the frequency range of the five channels extends up to 20 kHz, (the same as CDs), resulting in clear sound with greater richness of expression.

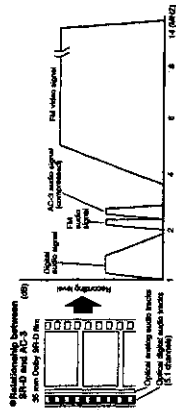

**Dolby Digital and Pro Logic**

Surround channels	Dolby Digital	Dolby Pro Logic
No. of playback channels	5.1 ch.	5.1 ch.
Playback channels	L, R, C, SL, SR and SW	L, R, C, SL, SR and SW
Audio processing	Digital discrete processing, AC-3	Analog matrix processing, Dolby
Upper reproduction limit of surround channel	20 kHz	17 kHz

Manufactured under license from Dolby Laboratories Licensing Corporation. "Dolby", "AC-3", "Pro Logic" and the double-D symbol are trademarks of Dolby Laboratories Licensing Corporation. Copyright 1992 Dolby Laboratories, Inc. All rights reserved.

**Before playing with the surround function**

Before playing with the surround function, be sure to use the test tones to adjust the playback level from the different speakers. This adjustment can be performed with the system setup (see page 14, 15) or from the remote control unit, as described below. Adjusting with the remote control unit using the test tones is only possible in the "Auto" mode and only effective in the DOLBY PRO LOGIC and DOLBY DIGITAL modes. The adjusted levels are automatically stored in the memory.

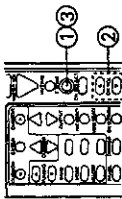

1 Press the test tone button.



After adjusting using the test tones, adjust the channel levels either according to the playback sources or to suit your tastes, as described below.

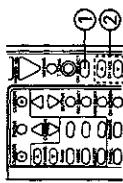

1 Press the channel select button to select the speaker to be adjusted.

2 Adjust the level of the selected speaker.

**Using the Dolby Pro Logic mode**

Play a pre-recorded source with the mark.

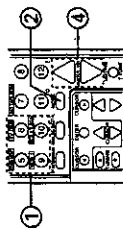
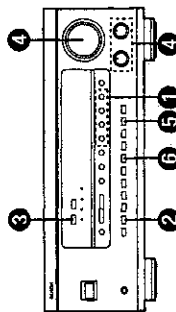

1 Press the button for the EX-VCR-1 program source to be played.

2 Set the DOLBY SURROUND mode.



3 Start playback on the selected component. For operating instructions, refer to the various components' manuals.

4 Adjust the MASTER VOLUME and TONE controls.



5 Press the CINEMA EQ button when playing back movie video software and the speech portion is felt to be harsh upon the ears. The output frequency response of the center and front speakers becomes closer to that in a theater and the sound becomes more pleasant to the ears.



**Using the Dolby Digital mode**

Play a pre-recorded source (LD or DVD) with the mark.

1 Press the DVD/VDP button.

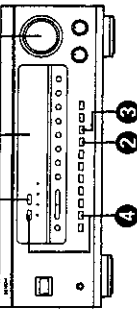

2 Select the DIGITAL input mode.

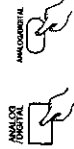

3 Select the audio input mode. The mode switches as shown on the light each time the button is pressed.

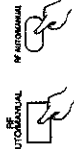

DVD AUTO ..... Some video discs with Dolby Digital AC-3 audio have only digital or analog audio. When using such discs, this mode automatically switches the audio input according to the type of audio (Dolby Digital (AC-3), digital or analog) being played. DVD AC-3RF ..... Only the Dolby Digital (AC-3) audio is played.

**NOTES:**

- In the "DVD AUTO" mode, when the mode changes from pause, chapter search, etc., to playback during playback of the Dolby Digital audio on an LD, the PCM or analog sound may be output momentarily before the mode is switched to the Dolby Digital audio mode. If this happens, the sound will not be interrupted if you switch to the "DVD AC-3RF" (AC-3RF fixed input) mode.
- The audio input mode setting is reset to "DVD AUTO" when the power is turned off using the power switch on the remote control unit or on the main unit.

4



Set the DOLBY SURROUND mode.

5

Start playback on the selected component. For operating instructions, refer to the various components' manuals. When Dolby Digital (AC-3) encoded signals are played, the PRO LOGIC indicator turns off and the Dolby Digital indicator lights.

- The PRO LOGIC indicator lights when a 2-channel Dolby Digital (AC-3) signal is input.

6

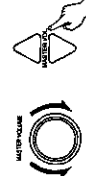

Adjust the MASTER VOLUME control.

7

Set the surround parameter on the monitor according to the source and adjust the tone. First press the ENTER button.

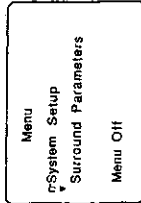



### DSP surround simulation

This unit is equipped with a high precision D.S.P. (Digital Signal Processor) for processing signals digitally to simulate sound fields. Select the surround mode according to the playback source and adjust the parameters according to the conditions in the listening room to achieve realistic venue ambience.

#### Types of surround modes and their characteristics

1	STEREO	Sound is produced from the two front channels. (Nothing is output from the Surround and center channels.)
2	6CH EXT. IN	Connect the output of the external Dolby Digital decoder to this unit's 6CH EXT IN.
3	5CH STEREO	The signals of the left and right channels are distributed to the different speakers to achieve a stereo sound from all directions at the listening position.
4	MATRIX	Use this to enjoy stereo music sources with rich reverberations.
5	MONO MOVIE	In this mode, a sense of expansion is added to monaural audio sources. This mode is best suited for playing old movies or movie tapes recorded in monaural.
6	ROCK ARENA	The powerful reverberations of this mode produce a sound field which recreates the excitement of live concerts. This mode is effective for rock, popular music, etc.
7	JAZZ CLUB	This mode creates the sound field of a live house with a low ceiling and hard wall reverberations. The result is that the artist seems to be performing right before your eyes.
8	VIDEO GAME	Use this to enjoy video game sources.

\* Depending on the program source being played, the effect may not be very noticeable. In this case, try other surround modes, without worrying about their names, to create a sound field suited to your tastes.

#### Personal Memory Plus function ... for EASY USE

This unit automatically stores the surround mode adding selected effects for all input sources. The corresponding surround mode is recalled automatically each time an input source is selected.

### Using the DSP surround simulation

Preparations: Select the input device and start playback.

#### 1 Select the surround mode according to the input source.

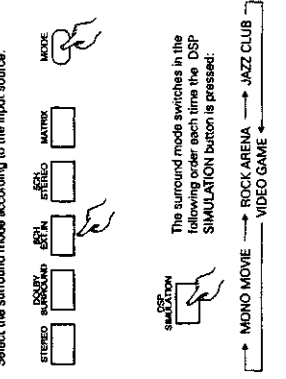

#### 2 Set the surround parameter on the monitor according to the source and adjust the tone.

First press the ENTER button.

\* Displayed only when the input source is "TUNER".

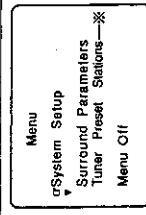

#### 8 Use the CURSOR Δ and ▽ buttons to set the [ ] mark to the "Surround Parameters".

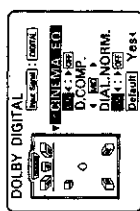

#### 9 Press the ENTER button to switch the screen.

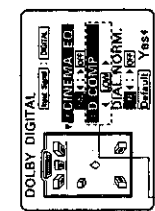

#### 10 Use the CURSOR Δ and ▽ buttons to set the [ ] mark to the parameter to be set.



#### 11 Use the CURSOR ◀ and ▶ buttons to set the parameter. Display or highlight the characters for the desired setting.



#### Surround parameters

**CINEMA EQ** ..... Use "CINEMA EQUALIZER" if dialogue audio track sound scratchy when playing movie software. (The higher frequency component is lowered.) (Only effective in the Dolby Pro Logic, Dolby Digital modes.) This parameter can also be turned on and off with the CINEMA button on the main unit.

**D. COMP** ..... "DYNAMIC RANGE COMPRESSION" compresses the dynamic range. This is only effective for Dolby Digital program sources. -- There are four parameters: "OFF" ↔ "LOW" ↔ "MID" ↔ "HIGH" (Only effective in the Dolby Digital modes.)

**DIAL. NORM** ..... "DIALOG NORMALIZATION" automatically adjusts the playback level during source playback to the optimum value. This parameter is only valid for settings that use the center surround speaker with Dolby Digital program sources and in the "Speaker Configuration" screen of the "Systems Setup" menu. (Only effective in the Dolby Digital modes.)

**NOTE:** "DIAL. NORM." automatically restores the power to "ON" when the power of the unit has been switched "OFF".

\* The settings are reset to the factory settings when the [ ] mark is set to "Default". "Yes" is highlighted. (Refer to page 34.)

#### 12 Press the ENTER button to enter the setting.



\* If for a certain source you feel that the bass is too strong, adjust the LFE level in the system setup's DOLBY DIGITAL setting. (Refer to page 16.)

**NOTE:** With this model, Dolby Digital encoded signals can only be played in the Dolby Pro Logic, Dolby Digital and STEREO modes.

Other surround mode buttons will not function during the Dolby Digital signal playback.

When playing back in the Dolby Pro Logic mode, depending on the settings of each output channel, it may not be possible to make a setting of the master volume that exceeds -3 dB.

10 LISTENING TO THE RADIO

Auto tuning

- 1 Set the input function to "TUNER".

- 2 Watching the display, press the BAND button to select the desired band (AM or FM).

- 3 Press the MODE button to set the auto tuning mode.

- 4 Press the TUNING UP or DOWN button.

NOTE:

- When in the auto tuning mode on the FM band, the "STEREO" indicator lights on the display when a stereo broadcast is tuned in. At open frequencies, the noise is muted and the "TUNED" and "STEREO" indicators turn off.
- Automatic searching begins, then stops when a station is tuned in.

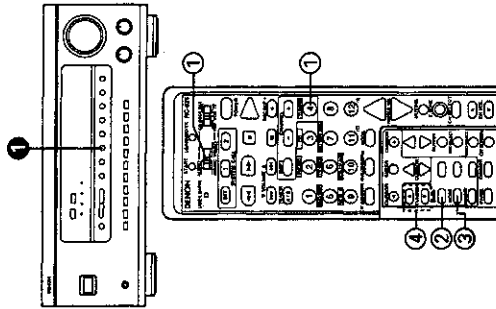

Manual tuning

- 1 Set the input function to "TUNER".
- 2 Watching the display, press the BAND button to select the desired band (AM or FM).

- 3 Press the MODE button to set the manual tuning mode. Check that the display's "AUTO" indicator turns off.
- 4 Press the TUNING UP or DOWN button to tune in the desired station. The frequency changes continuously when the button is held in.

- NOTE:
- When the manual tuning mode is set, FM stereo broadcasts are received in monaural and the "STEREO" indicator turns off.

- 3 Use the CURSOR  $\Delta$  and  $\nabla$  buttons to set the  $\square$  mark to "Surround Parameters".

- 4 Press the ENTER button to switch the screen. (The diagram at the right shows an example of the display for when the surround mode is set to MONO MOVIE.)

- 5 Use the CURSOR  $\Delta$  and  $\nabla$  buttons to set the  $\square$  mark to the parameter to be set.
  - The parameters that can be set differ according to the surround mode. For details, see the table below.

- 6 Use the CURSOR  $\leftarrow$  and  $\rightarrow$  buttons to set the parameter. Display or highlight the characters for the desired setting.

Surround parameters

ROOM SIZE ..... "room size" refers to the size of the sound field. -- There are five parameters: "Small", "med.S.", "medium", "large" and "bige".

EFFECT LEVEL ..... "Effect level" refers to the strength of the effect sounds. If the sound becomes distorted, lower the level. Parameter DELAY TIME ..... This can be set to between 0 and 140 msec for the MATRIX mode.

- \* The settings are reset to the factory settings when the  $\square$  mark is set to "Default" and "Yes" is highlighted. (See the table below.)

- 7 Press the ENTER button to enter the setting.

NOTES:

- \* For analog sound only, if the ERROR/OVERLOAD indicator lights during playback, press the ATTENUATOR button on the main unit to lower the input level by -6 dB so that the indicator does not light. Note that when playing back the 6CH EXT. IN mode, the setting of the INPUT ATTENUATOR is invalid and that it is operable.
- When the mode is switched to Dolby Digital encoded signals while playing PCM digital signals or analog signals in the surround modes except STEREO, the mode is forcibly switched to the Dolby Surround mode. 6 CH EXT. IN, 5 CH STEREO, MATRIX, MONO MOVIE, ROCK ARENA, JAZZ CLUB or VIDEO GAME.
- To listen to the signal of equipment that is connected to the "5.1 CH EXT. IN" input jack, make sure the video input of the equipment is selecting the connected function and select "5.1 CH EXT. IN" with the "5.1 CH EXT. IN" mode button or with the remote control mode button.

Surround modes and parameters

The following table shows the presence or absence of signals in the various modes, and whether or not they can be controlled. Initial settings are indicated in parentheses.

MODE	CURRENT CHANNEL (or all)			PARAMETER SOURCE											
	FRONT L/R	CENTER	REAR/SURROUND	CELESTIA EQ	ROOM SIZE	EFFECT LEVEL	DELAY TIME	D. COMP.	CH. EXT. IN	5.1 CH EXT. IN	5.1 CH EXT. IN	5.1 CH EXT. IN	5.1 CH EXT. IN	5.1 CH EXT. IN	5.1 CH EXT. IN
STEREO	○	○	○	○	○	○	○	○	○	○	○	○	○	○	○
DOLBY DIGITAL	○	○	○	○	○	○	○	○	○	○	○	○	○	○	○
6CH EXT. IN	○	○	○	○	○	○	○	○	○	○	○	○	○	○	○
5CH STEREO	○	○	○	○	○	○	○	○	○	○	○	○	○	○	○
MATRIX	○	○	○	○	○	○	○	○	○	○	○	○	○	○	○
MONO MOVIE	○	○	○	○	○	○	○	○	○	○	○	○	○	○	○
ROCK ARENA	○	○	○	○	○	○	○	○	○	○	○	○	○	○	○
JAZZ CLUB	○	○	○	○	○	○	○	○	○	○	○	○	○	○	○
VIDEO GAME	○	○	○	○	○	○	○	○	○	○	○	○	○	○	○

- : Signal present or controllable.
- △ : Select one according to the speaker configuration setting.
- : The "INPUT ATTENUATOR" can only operate with analog inputs. The initial setting value is "0 dB". Note that this button is stored with each input source.

### WIRE ARRANGEMENT

In case of wires require unclasping or loosening to move the location to perform adjustment or part replacement, be sure to rearrange them neatly to restore properly in the same location as they were originally placed, or causing to produce a noise may occasionally occur.

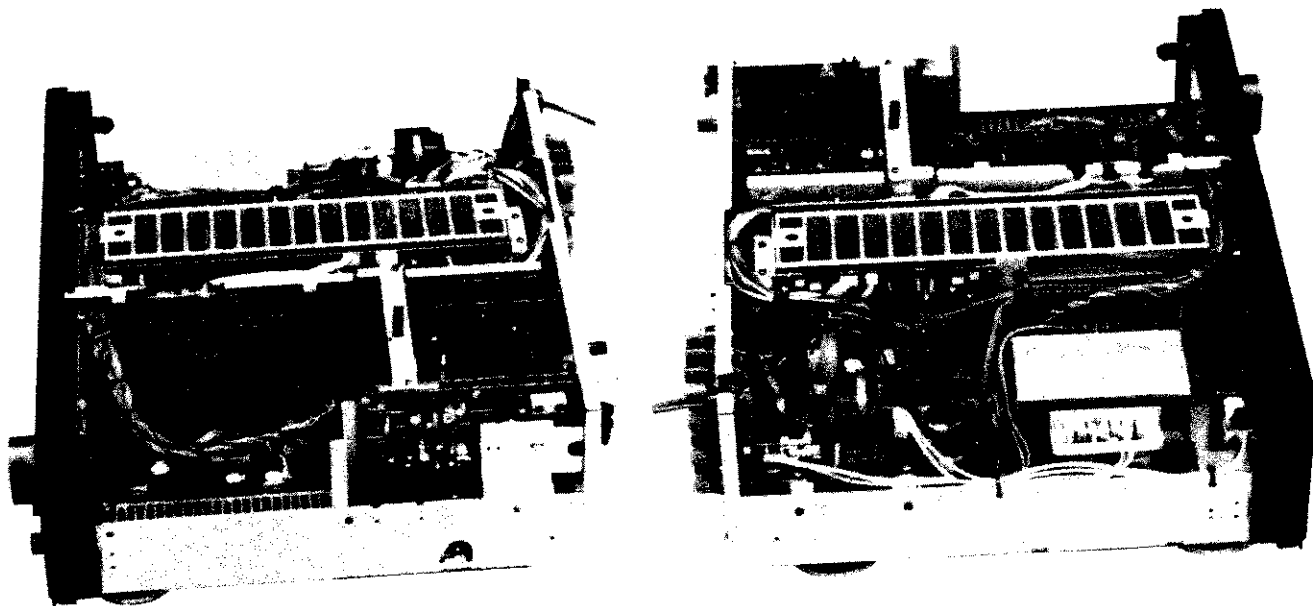
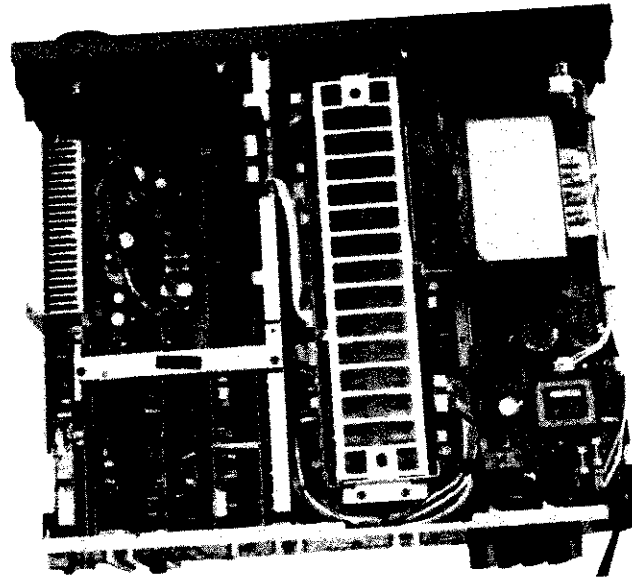

## DISASSEMBLY

(To reassemble reverse disassembly)

### 1. Front Aluminium Panel

- 1) Pull out 3 Knobs.
- 2) Remove 2 screws ① and 2 screws ②.
- 3) Unfasten 3 upper hooks and 2 below hooks.

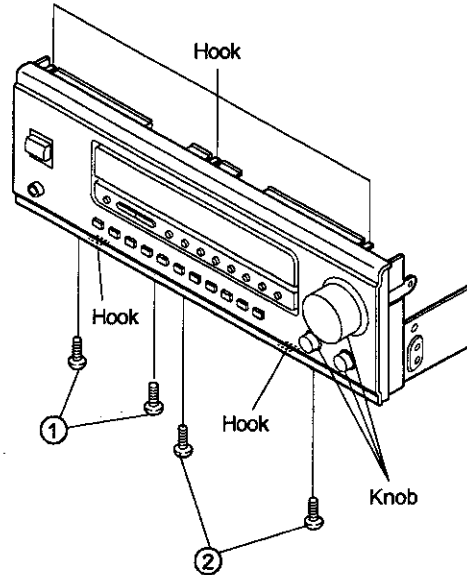

### 2. Front Mold Panel

- 1) Remove a screw ③ and 4 screws ④.
- 2) Remove 3 nuts ⑤.
- 3) Detach the Front Mold Panel in the arrow direction as it connects with connectors.

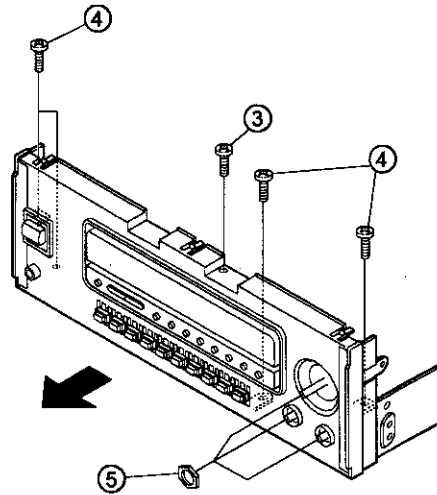

### 3. Power Amp. Unit

Remove 4 screws ⑥, then pull out the Power Amp. Unit upwards.

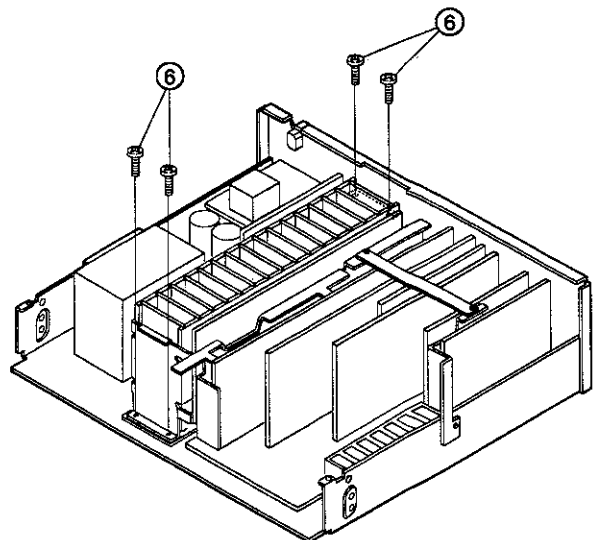

#### 4. When Maintenance for Main Unit (1U-2994-1)

##### ● In case the Power Supply is ON

- 1) Remove 2 screws ④ fixing the Front Mold Panel when detached the Front Aluminium Panel and the Power Amp. Unit.
- 2) Remove 3 screws ⑦ and ⑧ fixing the bracket.
- 3) Remove 2 screws ⑨ fixing the Power Supply Unit.
- 4) Remove 5 screws ⑩ fixing the Main Unit (1U-2994-1).
- 5) Remove 4 screws ⑪ fixing the Rear Panel.
- 6) Remove 2 screws ⑫ fixing the Tuner Unit.
- 7) Remove a screw ⑬.

Then separate the chassis only for maintenance.

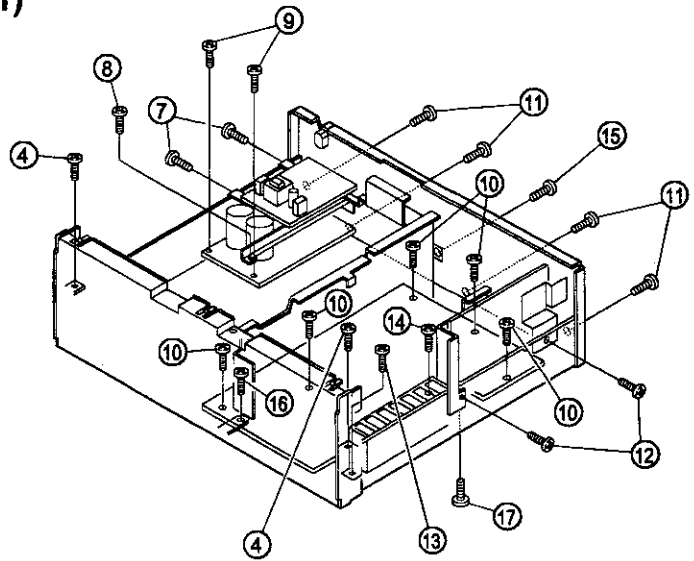

##### ● In case the Power Supply is OFF

- 1) Remove 7 screws ⑩ and ⑬, ⑭ fixing the Main Unit (1U-2994-1).
- 2) Remove 3 screws ⑪ and ⑮ fixing the Rear Panel.
- 3) Remove a screw fixing the Preout Unit (1U-2997-5) of the Rear Panel side, and two below screws.
- 4) Remove 4 screws fixing the SP terminal of the Rear Panel side and 2 screws fixing the AC Outlets.

# ADJUSTMENT

## Tuner Section

### CONNECTION DIAGRAM OF MEASURING INSTRUMENTS

● FM

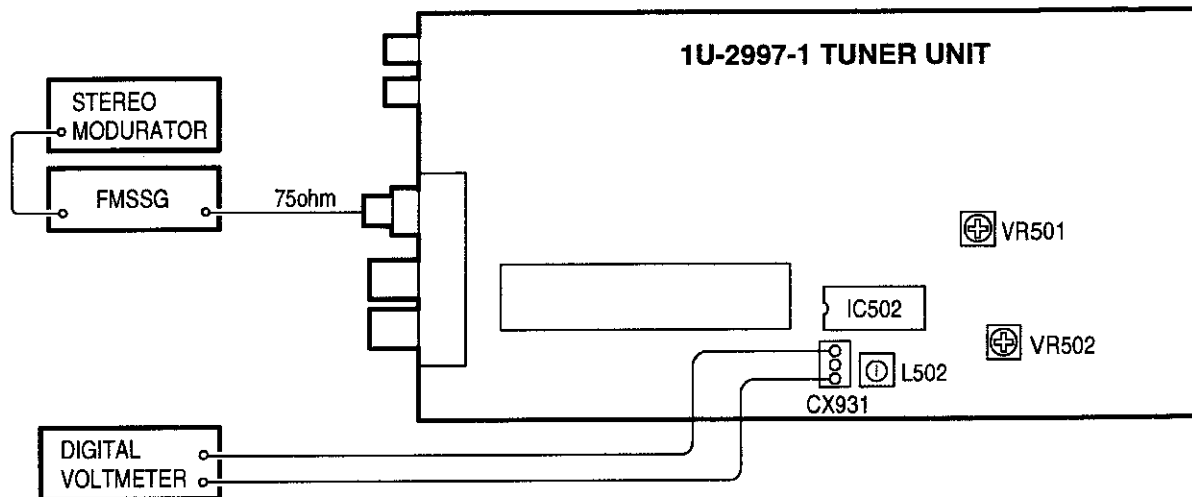

● AM

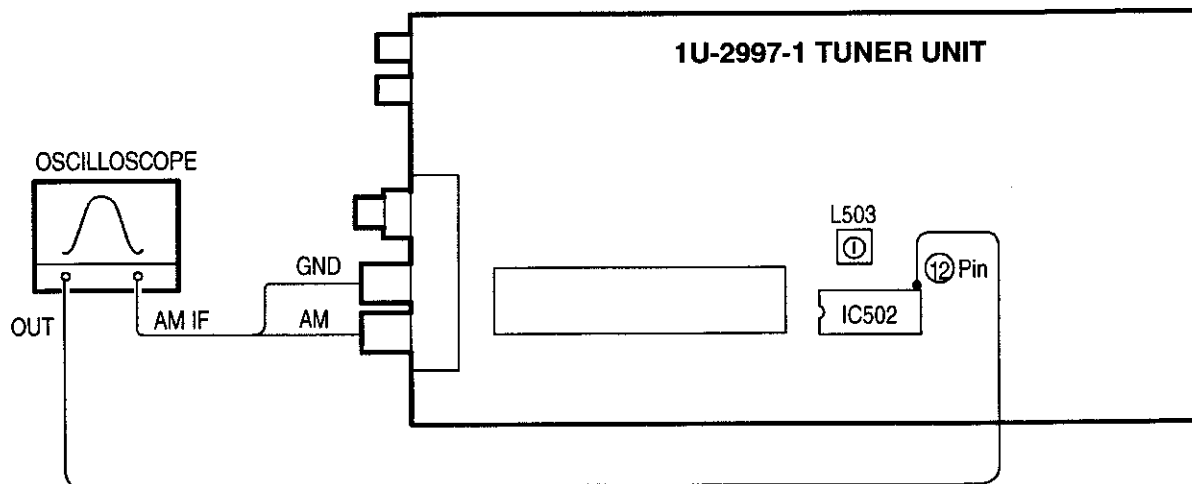

**FM/MPX ALIGNMENT**

Step	Alignment Item	Tuning Frequency Setting	Input			Output			Adjust		Remarks	
			Type	Frequency	Input Level	Modulation	Coupling	Type	Connect to	Points		Adjust to
1	Tuning Center	98.1 MHz	FM SSG	98.1 MHz	60 dB $\mu$	None	Antenna Terminal	Digital Voltmeter	CX931	L502	$\pm$ 50mV	Function : FM Mode : Auto
2	Separation	98.1 MHz	FM SSG	98.1 MHz	60 dB $\mu$	Stereo (L) 1KHz 100%	Antenna Terminal	AC Voltmeter	AUDIO OUT Terminal (R)	VR502	Maximum Separation	—
3	Signal Level	98.1 MHz	FM SSG	98.1 MHz	20 dB $\mu$	Off	Antenna Terminal	—	—	VR501	Light "TUNED" FLD Character	—

**AM ALIGNMENT**

Step	Alignment Item	Frequency	Input	Output		Remarks
				Type	Connect to	
1	IF	—	IF SWEEP (Input level is not over to work A.G.C.)	Oscilloscope	IC502 12Pin	Maximum height and best symmetry curve
					L503	
					Adjust to	

## Audio Section

### Idling Current (1U-2995-2, 1U-2995-3)

Required measurement equipment : DC Voltmeter

#### Arrangement

- (1) Avoid direct blow from an air conditioner or an electric fan, and adjust the unit at normal room temperature 15 °C ~ 30 °C (59 °F ~ 86 °F).
- (2) Presetting
  - POWER (Power source switch) → OFF
  - VOLUME (Volume control) → "---" : fully counterclockwise (⊖ min.)
  - BASS, TREBLE (Tone control) → FLAT: (Controls to center)
  - SPEAKER-A (Speaker terminal) → No load (Do not connect speaker, dummy resistor, etc.)

#### Adjustment

- (1) Remove top cover and set VR701, VR702, VR801 on 1U-2995-2 (Front Amp Unit) and VR901, VR902 on 1U-2995-3 (Surround Amp Unit) at counterclockwise (⊖) fully.
- (2) Connect DC Voltmeter to test points (FRONT-Lch: TP701, FRONT-Rch: TP702, CENTER ch: TP801, SURROUND-Lch: TP901, SURROUND-Rch: TP902).
- (3) Connect power cord to AC Line, and turn power switch "ON".
- (4) Presetting.           MODE       : 5ch STEREO  
                              FUNCTION : CD
- (5) Allow 2 minutes, and turn VR701 clockwise (⊕) and adjust the TEST POINTS voltage to 1.5 mV ±0.5 mV DC.
- (6) After 10 minutes from preset, turn VR701 to set the voltage to 3 mV ±0.5 mV DC.
- (7) Adjust the Variable Resistors of other channels in the same way.

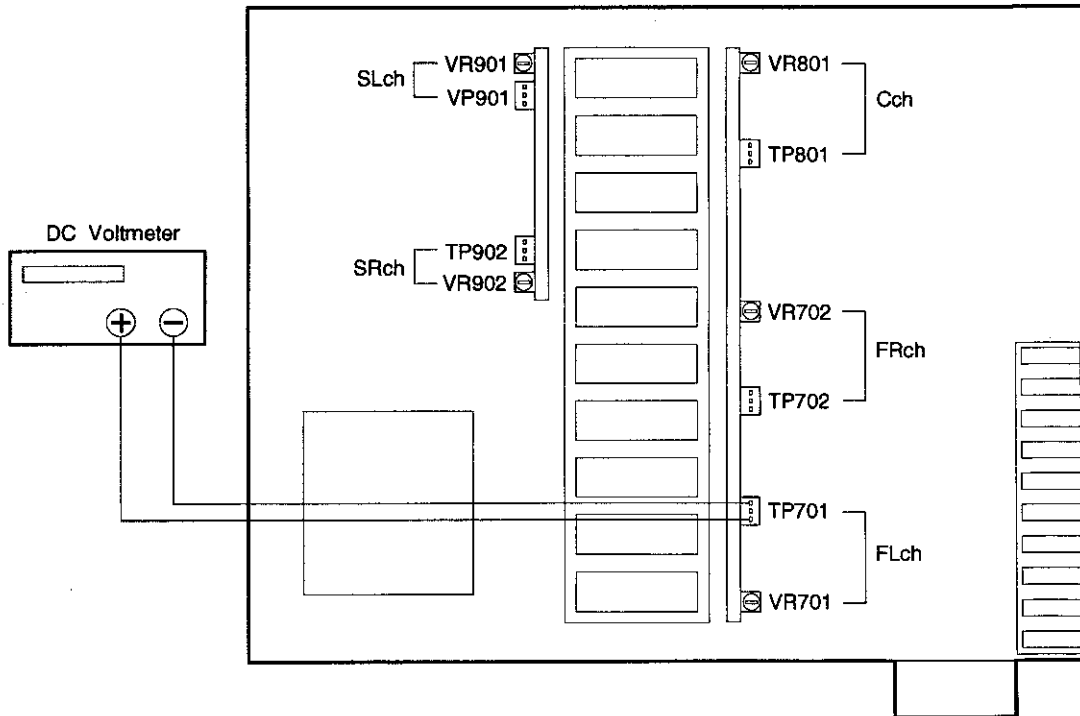



### DIGITAL/ANALOG, SURROUND MODE IN EACH INPUT FUNCTION AND INITIAL SETTING OF DIGITAL FUNCTION

INPUT FUNCTION	DIGITAL/ANALOG	SURROUND MODE	DIGITAL FUNCTION
PHONO	FORCED ANALOG	STEREO	INFEASIBLE TO SET
CD	ANALOG	STEREO	COAXIAL
TUNER	FORCED ANALOG	STEREO	INFEASIBLE TO SET
DVD/VDP	ANALOG	DOLBY PRO LOGIC	OPTICAL-1
TV/DBS	ANALOG	STEREO	OFF
VCR-1	ANALOG	DOLBY PRO LOGIC	OFF
VCR-2/V.AUX	ANALOG	STEREO	OFF
DAT/TAPE	FORCED ANALOG	STEREO	OFF

### INITIAL SETTING OF EACH MODE

	FRONT L LEV.	FRONT R LEV	CENTER LEVEL	SURROUND L LEV	SURROUND R LEV	S. WOOFER LEVEL	INPUT ATTENUATOR	ROOM SIZE	EFFECT LEVEL	DELAY TIME	CINEMA EQ	DIALOG *1	DYNAMIC *1
STEREO	0 dB	0 dB	—	—	—	0 dB	0 dB	—	—	—	—	ON	OFF
6CH EXT. IN	0 dB	0 dB	0 dB	0 dB	0 dB	0 dB	—	—	—	—	—	—	—
5CH STEREO	0 dB	0 dB	0 dB	0 dB	0 dB	0 dB	—	—	—	—	—	—	—
DOLBY AC-3 or DOLBY PROLOGIC	0 dB	0 dB	0 dB	0 dB	0 dB	0 dB	0 dB	—	—	—	OFF	ON	OFF
MONO MOVIE	0 dB	0 dB	0 dB	0 dB	0 dB	0 dB	0 dB	MED	10	—	—	—	—
ROCK ARENA	0 dB	0 dB	0 dB	0 dB	0 dB	0 dB	0 dB	MED	10	—	—	—	—
JAZZ CLUB	0 dB	0 dB	0 dB	0 dB	0 dB	0 dB	0 dB	MED	10	—	—	—	—
VIDEO GAME	0 dB	0 dB	0 dB	0 dB	0 dB	0 dB	0 dB	MED	10	—	—	—	—
MATRIX	0 dB	0 dB	0 dB	0 dB	0 dB	0 dB	0 dB	—	—	30m sec	—	—	—

\*1 : Conditions in case for setting AC-3 data to ZR38600.

Others: ● Set REC SELECT to SOURCE.

● Set TAPE MONITOR to OFF.

● Set VIDEO SELECT to OFF.

● Set MASTER VOL to -∞.

● Each input should be set to analog input.

● Set TEST TONE to OFF.

● In case DEFAULT is selected for SURR. PARAMETERS setting menu, sets the appropriate parameter of ROOM SIZE, EFFECT LEVEL, DELAY, CINEMA, D. COMP to the initial value of above table.

# SEMICONDUCTORS

## ● IC's

**Note:** Indications before IC numbers denote P.W.B. name.

- MA** : Main P.W.B. Unit
- PA** : Power Amp Unit
- VI** : Video & Display Unit
- TU** : Tuner Unit
- AU** : Audio & DSP Unit
- EV** : E. Vol Unit

### TMP87CS71F-\*\*\*\* (MA: IC113)

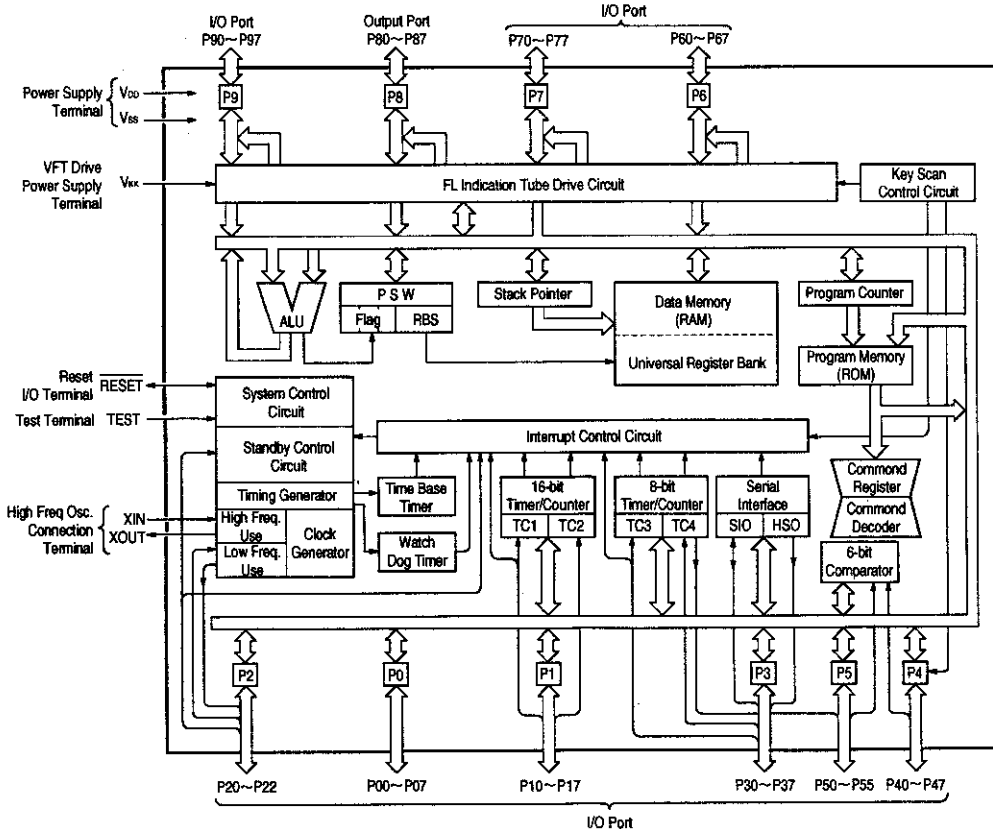
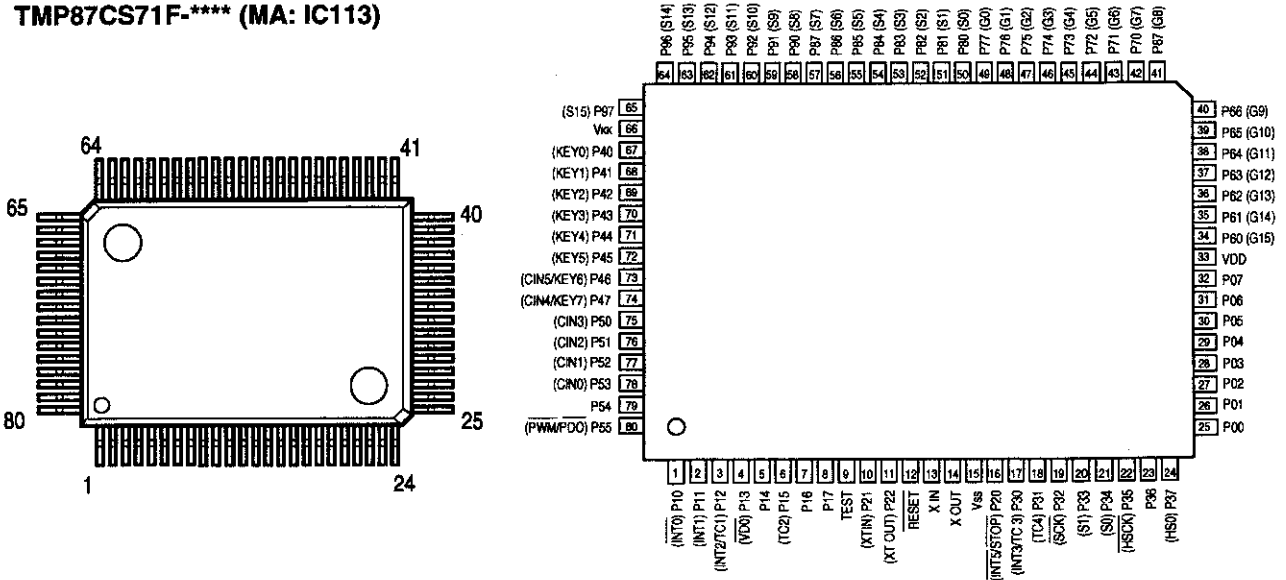

**Preset memory**

**Preparations:** Use the "Auto tuning" or "Manual tuning" operation to tune in the station to be preset in the memory.

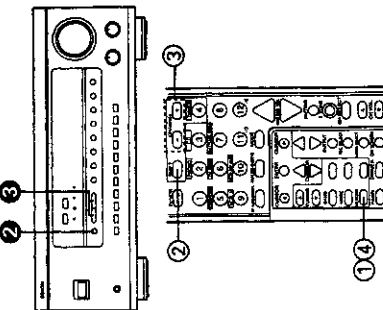

- 1 Press the MEMORY button.
- 2 Press the SHIFT button and select the desired memory block (A to E).
- 3 Press the PRESET UP or DOWN button to select the desired preset channel (1 to 8).
- 4 Press the MEMORY button again to store the station in the preset memory.

\* To preset other channels, repeat steps 1 to 4.  
A total of 40 broadcast stations can be preset— 8 stations (channels 1 to 8) in each of blocks A to E.

**Recalling preset stations**

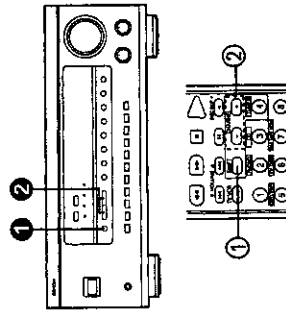

- 1 Watching the display, press the SHIFT button to select the preset memory block.
- 2 Watching the display, press the PRESET UP or DOWN button to select the desired preset channel.

**Recalling preset stations with the on screen display**

- 1 Press the ENTER button and call out the "Menu" screen from the on screen display.
  - Menu
  - System Setup
  - Surround Parameters
  - Tuner Preset Stations
  - Menu Off
- 2 Use the CURSOR Δ and ▽ buttons to set the mark to "Tuner Preset Stations".
  - Surround Parameters
  - Tuner Preset Stations
  - Menu Off
- 3 Press the ENTER button.
  - The frequencies of the preset stations are displayed.
- 4 Use the CURSOR Δ and ▽ buttons to highlight the station to be tuned in.
  - If the desired station is not displayed, press the CURSOR button and display the next page.
- 5 Press the CURSOR button. The selected station is tuned in.
  - Tuner Preset Stations
  - At 87.50MHz
  - At 88.50MHz
  - At 89.30MHz
  - At 87.50MHz
  - At 88.50MHz
  - At 106.50MHz
  - At 107.90MHz

**11 LAST FUNCTION MEMORY**

- This unit is equipped with a last function memory which stores the input and output setting conditions as they were immediately before the power is switched off.
- The unit is also equipped with a back-up memory. This function provides approximately one week of memory storage when the main unit's power switch is off and with the power cord disconnected.

**12 INITIALIZATION OF THE MICROPROCESSOR**

When the indication of the display is not normal or when the operation of the unit does not show the reasonable result, the initialization of the microprocessor is required by the following procedure.

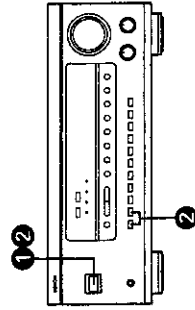

- 1 Switch off the unit using the main unit's power switch.
- 2 Hold the following STEREO button and DOLBY SURROUND button, and turn the main unit's power switch on.
- 3 Check that the entire display is flashing with an interval of about 1 second, and release your fingers from the 2 buttons and the microprocessor will be initialized.

**13 TROUBLESHOOTING**

If a problem should arise, first check the following:

1. Are the connections correct?
2. Have you operated the receiver according to the Operating Instructions?
3. Are the speakers, turntable, and other components operating properly?

If this unit is not operating properly, check the items listed in the table below. Should the problem persist, there may be a malfunction. Disconnect the power immediately and contact your store of purchase.

Symptom	Cause	Measures	Page
DISPLAY not lit and sound not produced when power switch set to on.	Power cord not plugged in securely.	<ul style="list-style-type: none"> <li>Check the insertion of the power cord plug into the power outlet.</li> <li>Turn the power on with the remote control unit after turning the POWER switch on.</li> </ul>	6, 24
DISPLAY lit but sound not produced.	<ul style="list-style-type: none"> <li>Speaker cords not securely connected.</li> <li>Improper position of the audio function button.</li> <li>Volume control set to minimum.</li> <li>Volume control set to maximum.</li> <li>Digital signals not input. Digital input selected.</li> </ul>	<ul style="list-style-type: none"> <li>Connect securely.</li> <li>Set to a suitable position.</li> <li>Turn volume up to suitable level.</li> <li>Turn volume down to minimum.</li> <li>Input digital signals or select input jacks to which digital signals are being input.</li> </ul>	9, 10, 25, 26, 25, 26, 26
DISPLAY is not displayed and the DISPLAY-LED flashes at a high rate.	<ul style="list-style-type: none"> <li>Speaker terminals are short-circuited.</li> <li>Block the ventilation holes of the set.</li> </ul>	<ul style="list-style-type: none"> <li>Switch power off, connect speakers properly, and check the speaker connections.</li> <li>Turn off the set's power, then ventilate it well to cool it down.</li> </ul>	9, 10
Sound produced only from one channel.	<ul style="list-style-type: none"> <li>The unit is operating at continuous high power or conditions and/or inadequate ventilation.</li> </ul>	<ul style="list-style-type: none"> <li>Turn off the set's power, then ventilate it well to cool it down.</li> <li>Once the set is cooled down, turn the power back on.</li> </ul>	5
Sound produced only from one channel.	<ul style="list-style-type: none"> <li>Incomplete connection of speaker cords.</li> <li>Incomplete connection of input/output cords.</li> </ul>	<ul style="list-style-type: none"> <li>Connect securely.</li> <li>Connect securely.</li> </ul>	9, 10, 6-8
Positions of luminance reversed during stereo playback.	<ul style="list-style-type: none"> <li>Reverse connections of left and right speaker and left and right input/output cords.</li> </ul>	<ul style="list-style-type: none"> <li>Check left and right connections.</li> </ul>	6-10
The on screen display is not displayed.	<ul style="list-style-type: none"> <li>"On screen display" is set to off on the system setup menu screen.</li> </ul>	<ul style="list-style-type: none"> <li>Set "on screen display" on the system setup menu screen to on.</li> </ul>	17
Humming noise produced when record is playing.	<ul style="list-style-type: none"> <li>Ground wire of turntable not connected properly.</li> <li>PHONO jack connection.</li> <li>TV or radio transmission antenna nearby.</li> </ul>	<ul style="list-style-type: none"> <li>Connect securely.</li> <li>Connect securely.</li> <li>Contact your store of purchase.</li> </ul>	6
Howling noise produced when volume is high.	<ul style="list-style-type: none"> <li>Turntable and speaker systems too close together.</li> <li>Floor is unstable and vibrates easily.</li> </ul>	<ul style="list-style-type: none"> <li>Separate as much as possible.</li> <li>Use cushions to absorb speaker vibrations transmitted by floor. If turntable is not stable, use a turntable mat. Use audio mat if one is not available.</li> </ul>	6
Sound is distorted.	<ul style="list-style-type: none"> <li>Style pressure too weak.</li> <li>Dust or dirt on stylus.</li> <li>Cartridge deflection.</li> </ul>	<ul style="list-style-type: none"> <li>Apply proper stylus pressure.</li> <li>Check stylus.</li> <li>Replace cartridge.</li> </ul>	6
Volume is weak.	<ul style="list-style-type: none"> <li>MC cartridge being used.</li> </ul>	<ul style="list-style-type: none"> <li>Replace with MM cartridge or use a head amplifier or step-up transformer.</li> </ul>	6
This unit does not operate properly when remote control unit is used.	<ul style="list-style-type: none"> <li>Batteries dead.</li> <li>Remote control unit too far from this unit.</li> <li>Obstacle between this unit and remote control unit.</li> <li>Different buttons being pressed.</li> <li>IR and IR ends of battery inserted in reverse.</li> </ul>	<ul style="list-style-type: none"> <li>Replace with new batteries.</li> <li>Move closer.</li> <li>Remove obstacle.</li> <li>Press the proper button.</li> <li>Insert batteries properly.</li> </ul>	19, 19, 19
ERROR/OPER/LOAD LED lights.	<ul style="list-style-type: none"> <li>During analog input playback.</li> <li>During digital input playback.</li> </ul>	<ul style="list-style-type: none"> <li>See page 25.</li> <li>See page 26.</li> </ul>	19

**14 SPECIFICATIONS**

- **Audio section (Power amplifier)**
  - Rated output: 85 W + 85 W (8 Ω/ohms, 20 Hz ~ 20 kHz with 0.05% T.H.D.)
  - Center: 85 W + 85 W (8 Ω/ohms, 20 Hz ~ 20 kHz with 0.05% T.H.D.)
  - Surround: 85 W + 85 W (8 Ω/ohms, 20 Hz ~ 20 kHz with 0.05% T.H.D.)
  - 105 W x 2 ch (8 Ω/ohms)
  - 170 W x 2 ch (4 Ω/ohms)
  - 215 W x 2 ch (2 Ω/ohms)
  - Front/Center: A or B or Bi-wiring
  - Surround: A + B
  - Output terminals: B to 16 Ω/ohms, 16 Ω/ohms
- **Dynamic power:** 8 to 16 Ω/ohms
- **Output terminals:** 8 to 16 Ω/ohms
- **(Analog)**
  - Input sensitivity / input impedance: 200 mV/47 kΩ / kohms
  - Frequency response: 10 Hz ~ 150 kHz +1, -3 dB
  - S/N: 96 dB
  - Distortion: 0.05% (20 Hz ~ 20 kHz)
  - Rated output: 1.2 V
  - Maximum headphones output: 27 mW (8 Ω/ohms)
  - Phono equalizer (PHONO input—REC OUT) input sensitivity: 2.5 mV ±1 dB (20 Hz to 20 kHz)
  - RIAA deviation: 74 dB (A weighting, with 5 mV input)
  - Rated output / Maximum output: 150 mV / 8 V
  - S/N: 0.03% (1 kHz, 3V)
  - Distortion factor: Rated output - 2 V (at 0 dB playback)
  - Total harmonic distortion - 0.01% (1 kHz, at 0 dB)
  - S/N ratio - 102 dB
  - Dynamic range - 93 dB
  - Format - Digital audio interface
- **D/A output:** 1 Vp-p, 75 Ω/ohms
- **Digital input:** 5 Hz ~ 10 MHz +1, -3 dB
- **Video section (Standard video jacks)**
  - Input/output level and impedance: Y (brightness) signal - 1 Vp-p, 75 Ω/ohms
  - C (color) signal - 0.298 Vp-p, 75 Ω/ohms
  - Frequency response: Y (brightness) signal - 5 Hz ~ 10 MHz +1, -3 dB
  - Input/output level and impedance: C (color) signal - 10 Hz ~ 10 MHz +1, -3 dB
- **Frequency response:** 50 dB
- **Tuner section**
  - Receiving Range: 87.5 MHz ~ 107.9 MHz
  - Usable Sensitivity: 1.0 μV (11.2 dBf)
  - 50 dB Quieting Sensitivity: MONO 1.6 μV (15.3 dBf)
  - S/N: (HF-AI): MONO 23 μV (38.5 dBf)
  - Total Harmonic Distortion (at 1 kHz): STEREO 50 dB
  - MONO 75 dB
  - STEREO 0.15%
  - MONO 0.3%
  - STEREO 0.3%
- **General**
  - Power supply: AC 120 V, 60 Hz
  - Power consumption: 5.6 A
  - Maximum external dimensions: 434 (W) x 181 (H) x 416 (D) mm (17-3/32" x 6-11/32" x 16-3/8")
  - Weight: 14.8 kg (32 lbs 10 oz)
  - Remote control unit (RC-825) Batteries: R6P/AA Type (two batteries)
  - External dimensions: 70 (W) x 215 (H) x 18 (D) mm (2-3/4" x 8-15/32" x 3/4")
  - Weight: 180 g (Approx. 6 oz) (including batteries)

\* For purposes of improvement, specifications and design are subject to change without notice.

Hz)

IC303 15 pin (OPT)  
 IC303 2 pin (COAX)  
 IC457 61 pin

Vertical: 5V/div  
 Horizontal: 1.0 mS/div

fig.2-3

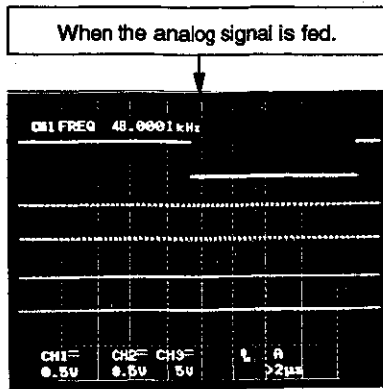

A: IC515 14 pin  
 B: IC515 15 pin  
 C: IC515 16 pin

Vertical: 5V/div  
 Horizontal: 0.5 mS/div

Confirm the normal communication waveforms (Fig.5) at 89Pin, 87Pin and 3Pin of IC457 which is fed from the microcomputer with serial data communication control.

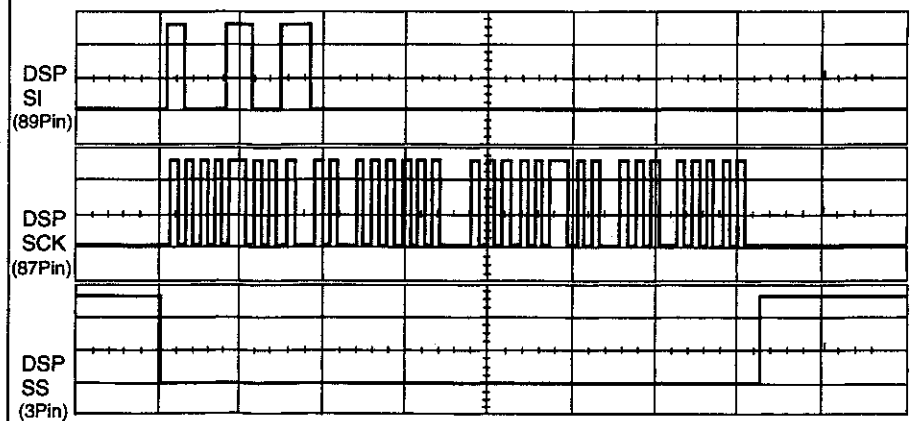

200MS/div

2.00V/div

fig.5 (The DSPSI signal is a reference data)

fig.4

A: IC504 ~ 506 13 pin  
 B: IC504 ~ 506 11 pin  
 C: IC504 ~ 506 14 pin

Vertical: 5V/div  
 Horizontal: 0.5 mS/div

DSP (IC457) performs AC-3 decoding process, DOLBY PRO LOGIC process and PCM digital process and PCM digital process by shifting. Decoded signal to each channel after passed through DSP1 (IC457) is D/A converted and delivered to volume control.

**Block Diagram of AC-3, PCM Input Section (1U-2998)**

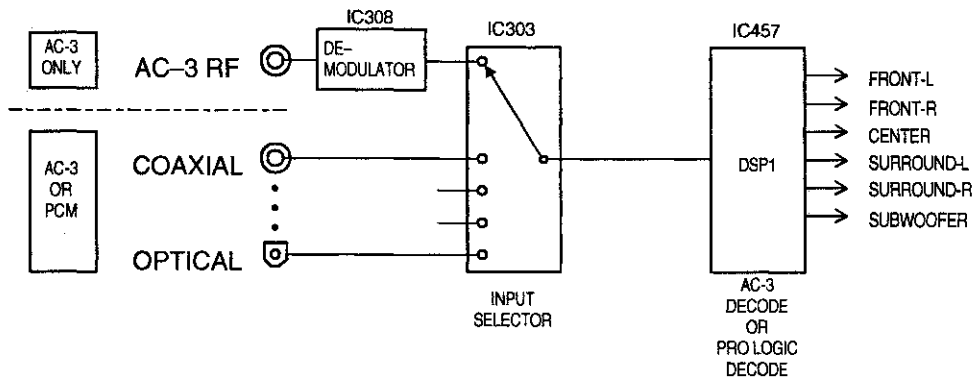

**CONTROL ADVISABILITY OF EACH MODE**

	FRONT L LEV.	FRONT R LEV	CENTER LEVEL	SURROUND L LEV	SURROUND R LEV	S. WOOFER LEVEL	INPUT ATTENUATOR	ROOM SIZE	EFFECT LEVEL	DELAY TIME	CINEMA EQ	D. COMP	DIAL. NORM.	TEST TONE
STEREO	○	○	X	X	X	○*3	○*4	X	X	X	X	○*5	○*5	○*6
6CH EXT. IN	○	○	○	○	○	—	—	—	—	—	—	—	—	
5CH STEREO	○	○	○*1	○*2	○*2	○*3	○*4	X	X	X	X	X	X	
DOLBY AC-3 or DOLBY PROLOGIC	○	○	○*1	○*2	○*2	○*3	○*4	X	X	X	○	○*5	○*5	
MONO MOVIE	○	○	○*1	○*2	○*2	○*3	○*4	○	○	X	X	○*5	○*5	
ROCK ARENA	○	○	○*1	○*2	○*2	○*3	○*4	○	○	X	X	○*5	○*5	
JAZZ CLUB	○	○	○*1	○*2	○*2	○*3	○*4	○	○	X	X	○*5	○*5	
VIDEO GAME	○	○	○*1	○*2	○*2	○*3	○*4	○	○	X	X	○*5	○*5	
MATRIX	○	○	○*1	○*2	○*2	○*3	○*4	X	X	○	X	○*5	○*5	

○ : Feasible to control      X : Infeasible to control

- \*1 : According to the contents of set up menu, when no center speaker is provided, with no controlling and sets - ○○ data to center electronic volume.
- \*2 : According to the contents of set up menu, when no rear speaker is provided, with no controlling and sets - ○○ data to rear electronic volume.
- \*3 : According to the contents of set up menu, when no woofer is provided, with no controlling and sets - ○○ data to woofer electronic volume.
- \*4 : Feasible to control only at analog input. Note that, this function corresponds to each input channel.
- \*5 : Feasible to control only at AC-3 input.
- \*6 : Feasible to control TEST TONE in all modes of set up menu.

Additional note : Each mode's FRONT/CENTER/SURROUND/S. WOOFER DELAY should be set according to the setting contents of delay time for set up menu.

Pin No.	Port Name	Symbol	I/O	Type	Op	Det	Res	Ini	Function
56	P86	POWER	O	P	Id	—	L	H	Power supply relay control output. (H: ON)
57	P87	AC-3 MUTE	O	P	Id	—	L	H	Digital mute control terminal (L: AC-3).
58	P90	OVL	I	—	—	—	L	—	Over load detecting input. (H: Over load)
59	P91	AC-3 DET.	I	—	—	—	L	—	AC-3 decode data input terminal. (L: AC-3 decode)
60	P92	NC	I	P	Id	—	L	L	No connection.
61	P93	NC	I	P	Id	—	L	L	No connection.
62	P94	NC	I	P	Id	—	L	L	No connection.
63	P95	CSI	I	—	—	—	L	—	DIR control input terminal. (CS8412) (H: PCM)
64	P96	ERR	I	—	—	—	L	—	DIR control input terminal. (CS8412) (H: ERR)
65	P97	NC	I	P	Id	—	L	L	No connection.
66	VKK	VKK	I	—	—	—	—	—	Connect to ground.
67	P40/KEY0	S-MONITOR DET.	I	—	Eu	Lv	Z	—	Judgment whether S monitor is connected or not. (L: Connecting)
68	P41/KEY1	S-SIGNAL DET.	I	—	Eu	Lv	Z	—	S signal input control. (H: S signal input)
69	P42/KEY2	OSD SYNC DET.	I	—	Eu	Lv	Z	—	OSD sync switching signal. (H: External sync)
70	P43/KEY3	MVOL SELB	I	—	Eu	Lv	Z	H	Master volume setting signal. (Rotary encode)
71	P44/KEY4	MVOL SELA	I	—	Eu	Lv	Z	H	Master volume setting signal. (Rotary encode)
72	P45/KEY5	NC	O	—	—	Lv	Z	L	
73	P46/CIN5	MODE	I	—	Eu	Lv	Z	—	Connect to GND.
74	P47/CIN4	KEY5	I	—	Eu	Lv	Z	H	Key input 5.
75	P50/CIN3	KEY4	I	—	Eu	Lv	Z	H	Key input 4.
76	P51/CIN2	KEY3	I	—	Eu	Lv	Z	H	Key input 3.
77	P52/CIN1	KEY2	I	—	Eu	Lv	Z	H	Key input 2.
78	P53/CIN0	KEY1	I	—	Eu	Lv	Z	H	Key input 1.
79	P54	SUB SYNC 1	I	—	Eu	Lv	Z	H	SUB microcomputer sync input.
80	P55/PMW	SO/ZORAN	I	—	Eu	Lv	Z	H	DSP data input terminal. (ZR38600)

**NOTE:**

Pin No. : Terminal number of microcomputer.

Port Name : The name entered in the data sheet of microcomputer.

Symbol : Symbolized interface function.

I/O : Input or out of part.

"I" = Input port

"O" = Output port

Type : Composition of port in case of output port.

"C" = CMOS output

"N" = NMOS open drain output

"P" = PMOS open drain output

Op : Pull up/Pull down selection information.

"Iu" = Inner microcomputer pull up

"Id" = Inner microcomputer pull down

"Eu" = External microcomputer pull up

"Ed" = External microcomputer pull down

Det : Indicates judging state of input port. Level detection is "LV"; Edge detection is "Ed"; Detection by both shifting is "E&L"; Serial data detection is "S" (Serial data output is also "S").

Res : State at reset.

"H" = Outputs High Level at reset

"L" = Outputs Low Level at reset

"Z" = Becomes High impedance mode at reset

Ini : Initial output state.

Function : Function and logical level explanation of signals to be interface.

**TMP87CM43N-\*\*\* Terminal Function**

Pin No.	Port Name	Symbol	I/O	Type	Op	Det	Res	Ini	Function
1	P03	DSP POWER	O	C	—	—	L	L	DSP power supply control output (H: ON).
2	P04	DSP RES(ZORAN)	O	C	—	—	Z	H	DSP control terminal (ZR38600) (L: reset).
3	P05	DSP DATA	O	C	—	S	Z	H	DSP control terminal (ZR38600).
4	P06	ZORAN SS	O	C	—	—	Z	L	DSP control terminal (ZR38600).
5	P07	DSP CLK	O	C	—	S	Z	H	DSP control terminal (ZR38600).
6	P10/INT 0	DIN A	O	C	—	—	Z	L	Digital input control terminal (TC74HC151).
7	P11/INT 1	DIN B	O	C	—	—	Z	L	Digital input control terminal (TC74HC151).
8	P12/INT 2	DFS 2	O	C	—	—	Z	L	Digital filter emphasis control terminal.
9	P13/DV0	DFS 1	O	C	—	—	Z	H	Digital filter emphasis control terminal.
10	P14	FGAIN	O	C	—	—	Z	H	Gain selection control terminal.
11	P15/TC2	F0	O	—	—	—	Z	L	
12	P16	F1	O	—	—	—	Z	L	
13	P17	F2	O	—	—	—	Z	L	
14	P20/INT 5	SEL	O	—	—	—	Z	L	
15	TEST	TEST	I	—	GND	—	—	L	Connect with GND.
16	P21/XTIN		I	—	—	—	Z	L	Open, or connect with GND.
17	P22/XT0		I	—	—	—	Z	L	Open, or connect with GND.
18	RESET	RESET	I	—	Eu	Lv	L	—	Reset input.
19	XIN	XIN	I	—	—	—	—	—	Oscillator circuit (4 MHz).
20	XOUT	XOUT	O	—	—	—	—	—	Oscillator circuit (4 MHz).
21	VSS	VSS	I	—	GND	—	—	—	Connect with GND.
22	VAREF	VAREF	I	—	GND	—	—	—	Connect with GND.
23	P60		I	—	—	—	Z	L	Open, or connect with GND.
24	P61		I	—	—	—	Z	L	Open, or connect with GND.
25	P62		I	—	—	—	Z	L	Open, or connect with GND.
26	P63		I	—	—	—	Z	L	Open, or connect with GND.
27	P64		I	—	—	—	Z	L	Open, or connect with GND.
28	P65		I	—	—	—	Z	L	Open, or connect with GND.
29	P66		I	—	—	—	Z	L	Open, or connect with GND.
30	P67		I	—	—	—	Z	L	Open, or connect with GND.
31	P70/SCL	SCL	I	—	Eu	S	Z	—	MAIN-SUB microcomputer communication control terminal.
32	P71/SDA	SDA	I	—	Eu	S	Z	—	MAIN-SUB microcomputer communication control terminal.
33	P72	SUB SYNC1	O	N	Eu	—	Z	H	SUB microcomputer sync output.
34	P73		I	—	Eu	Lv	Z	—	Detect for stoping power supply (L: stoping power supply).
35	P74		I	—	—	—	Z	L	Open, or connect with GND.
36	P75		I	—	—	—	Z	L	Open, or connect with GND.
37	P76		I	—	—	—	Z	L	Open, or connect with GND.
38	P77		I	—	—	—	Z	L	Open, or connect with GND.
39	P00	DEMOD RES	O	C	—	—	Z	H	Demodulator reset control terminal (L: reset).
40	P01	DEMOD POWER	O	C	—	—	Z	L	Demodulator POWER ON/OFF control terminal (H: ON).
41	P02	DEMOD ON	O	C	—	—	Z	L	Demodulator oscillating control terminal (H: oscillating).
42	VDD	VDD	I	—	—	—	Z	—	Connect with +5V.



**LC7536**  
(EV: IC101, 107, 108)

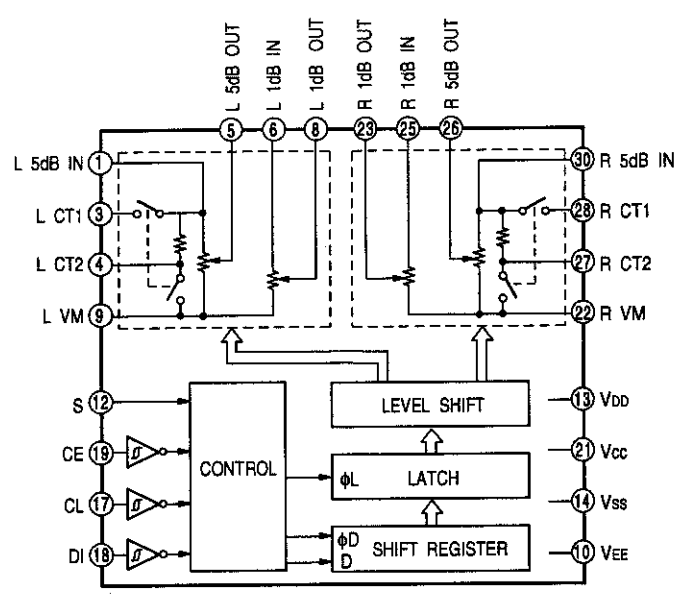
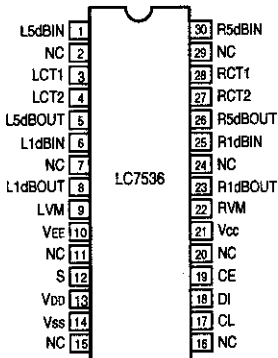
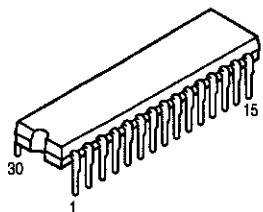

**LC7536 Terminal Function**

Pin No.	Symbol	I/O	Function
1	L 5dB IN	I	Input terminal for 5dB step attenuator, it should be driven with low impedance path.
2	NC	-	No connection.
3	L CT1		For loudness control, connect a capacitor between CT1 and 5dB IN with high frequency compensation, and also connect a capacitor between CT2 and Vm with low frequency compensation.
4	L CT2		
5	L 5dBOUT	O	Output terminal for 5dB step attenuator with approx. 1Mohm load impedance.
6	L 1dBIN	I	Input terminal for 1dB step attenuator, it should be driven with low impedance.
7	NC	-	No connection.
8	L 1dBOUT	O	Output terminal for 1dB step attenuator with approx. 47kohm ~ 1Mohm load impedance.
9	L VM		Common terminal for volume control.
10	VEE	I	Connect to power supply.
11	NC	-	No connection.
12	S		Selection terminal for address code during data format.
13	VDD	I	Connect to power supply (Pay attention to the rising time so that Vcc does rise up faster than VDD when the power turns).
14	VSS	I	Connect to power supply.
15	NC	-	No connection.
16	NC	-	No connection.
17	CL		Input terminal for controlling LC7536 serial data with 0 ~ 5V amplitude.
18	DI	I	
19	CE		
20	NC	-	No connection.
21	VCC	I	Connect power supply (Pay attention to the rising time so that Vcc does not rise up faster than VDD when the power turns).
22	R VM		Common terminal for volume control.
23	R 1dBOUT	O	Output terminal for 1dB step attenuator with approx. 47kohm ~ 1Mohm load impedance.
24	NC	-	No connection.
25	R 1dBIN	I	Input terminal for 1dB step attenuator, it should be driven with low impedance.
26	R 5dBOUT	O	Output terminal for 5dB step attenuator with approx. 1Mohm load impedance.
27	R CT2		For loudness control, connect a capacitor between CT1 and 5dBIN with high frequency compensation, and also connect a capacitor between CT2 and Vm with low frequency compensation.
28	R CT1		
29	NC	-	No connection.
30	R SdBIN	I	Input terminal for 5dB step attenuator, it should be driven with low impedance path.

**MSC1937-03RS**  
(VI: IC102)

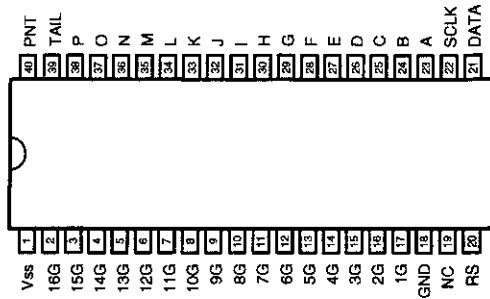
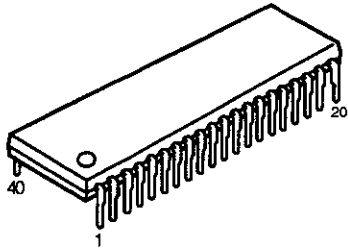

**MSC1937-03RS Terminal Function**

Pin No.	Symbol	I/O	Function
1	Vss	-	Power supply (+5V).
2	16G	O	Digit 16 output.
3	15G	O	Digit 15 output.
4	14G	O	Digit 14 output.
5	13G	O	Digit 13 output.
6	12G	O	Digit 12 output.
7	11G	O	Digit 11 output.
8	10G	O	Digit 10 output.
9	9G	O	Digit 9 output.
10	8G	O	Digit 8 output.
11	7G	O	Digit 7 output.
12	6G	O	Digit 6 output.
13	5G	O	Digit 5 output.
14	4G	O	Digit 4 output.
15	3G	O	Digit 3 output.
16	2G	O	Digit 2 output.
17	1G	O	Digit 1 output.
18	GND	-	Ground.
19	NC	-	No connection.
20	RS	I	POWER-ON-RESET. (H: RESET)
21	DATA	I	Data input.
22	SCLK	I	Shift clock input.
23	A	O	Segment A output.
24	B	O	Segment B output.
25	C	O	Segment C output.
26	D	O	Segment D output.
27	E	O	Segment E output.
28	F	O	Segment F output.
29	G	O	Segment G output.
30	H	O	Segment H output.
31	I	O	Segment I output.
32	J	O	Segment J output.
33	K	O	Segment K output.
34	L	O	Segment L output.
35	M	O	Segment M output.
36	N	O	Segment N output.
37	O	O	Segment O output.
38	P	O	Segment P output.
39	TAIL	-	No connection.
40	PNT	O	Point output.

**M35015-204SP**  
(VI: IC303)

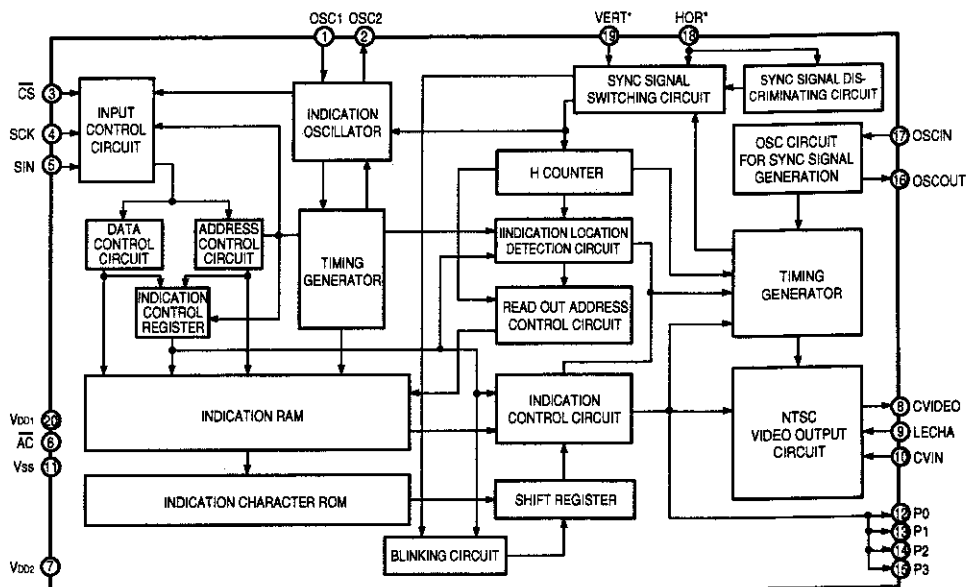
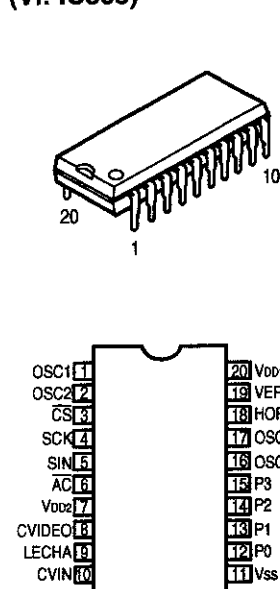

**M35015-204SP Terminal Function**

Pin No.	Symbol	Name	I/O	Function
1	OSC1	Osc. circuit ext. terminal.	I	External terminal for indication oscillator circuit. Standard OSC. freq. is approx. 7MHz. With this OSC. freq., decides horizontal indicatin and character width.
2	OSC2		O	
3	CS	Chip select input	I	Chip select terminal and turns to "L" when transfer serial data. Hysteresis input. Pull up resistor is built-in.
4	SCK	Serial clock input	I	Takes in serial data of SIN at SCK rise when CS terminal is in "L". Hysteresis input. Pull up resist is built-in.
5	SIN	Serial data input	I	Serial input of register for indication control and data, and address for indication data memory. Hysteresis input. Pull up resistor is built-in.
6	AC	Auto-clear input	I	Resets internal circuit of IC at "L" mode. Hysteresi input. Pull up resistor is built-in.
7	VDD2	Power supply	—	Power supply terminal of analog system. Connect to +5V.
8	CVIDEO	Combined video output	O	Output terminal of combined video signal. Outputs 2Vp-p combined signal. Character output, etc. Overlap CVIN signal and outputs at superimpose.
9	LECHA	Character level input	I	Input terminal deciding character output level in combined video signal. color of character is white.
10	CVIN	Combined video input	I	Input terminal of external combined video signal. Character output etc. overlap this external combined video signal.
11	VSS	Ground	—	Ground terminal. Connect to GND.
12	P0	Output port p0	O	General output or character background signal BL NK1* output is switchable. Polarity can be selected at ROM mask.
13	P1	Output port P1	O	General output or character background signal CO1* output is switchable. Polarity can be selected at ROM mask.
14	P2	Output port P2	O	General output or character background signal BLNK2* output is switchable. Polarity can be selected at ROM mask.
15	P3	Output port P3	O	General output or character background signal CO2* output is switchable. Polarity can be selected at ROM mask.
16	OSCOUT	Ext. terminal for sync sig. OSC. Circuit	O	Terminal for external use of sync signal OSC. circuit. Use the freq.: 14.32MHz at NTSC system, 17.73MHz at PAL. system, 14.30MHz at MPAL system.
17	OSCIN		I	
18	HOR*	Horizontal sync signal	I	Inputs horizontal sync signal. Hysteresis input.
19	VERT*	Vertical sync signal	—	Input vertical sync signal. Hysteresis input. Polarity can be selected at ROM mask.
20	VDD1	Power supply	I	Power supply terminal of digital system. Connect to +5V.

**BR62256F-70LL**  
(AU: IC306)

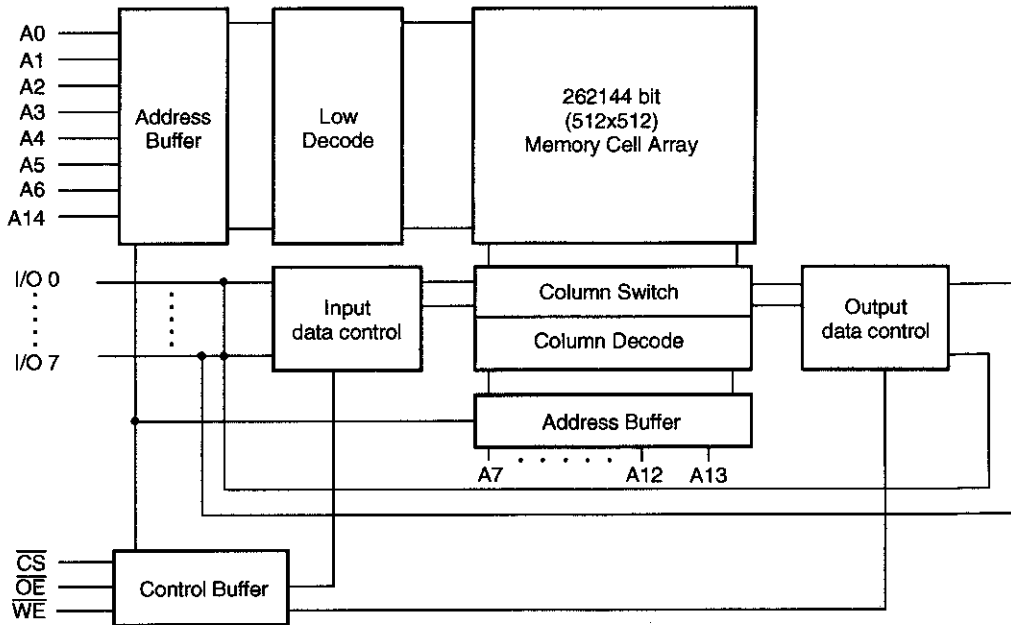
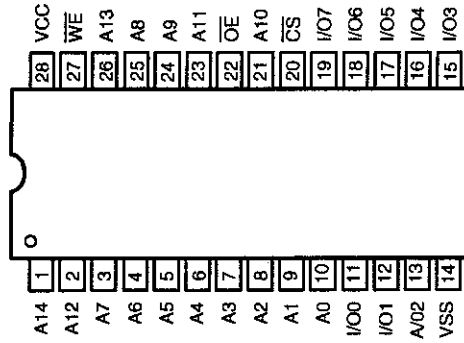
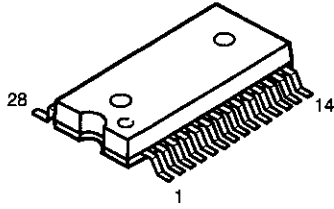

**BR62256F-70LL Terminal Function**

Pin No.	Symbol	I/O	Function
1-10	A0-A7, A12, A14	I	32K byte memory address input.
11-13	I/O0-I/O2	I/O	8 bit data input/output.
14	Vss	—	GND
15-19	I/O3-I/O7	I/O	8 bit data input/output.
20	CS	I	Chip select control input.
21	A10	I	32K byte memory address input.
22	OE	I	Output enable control input.
23-26	A8, A9, A11, A13	I	32K byte memory address input.
27	WE	I	Write enable control input.
28	Vcc	—	+5V power supply.

**PM4007A**  
(AU: IC308)

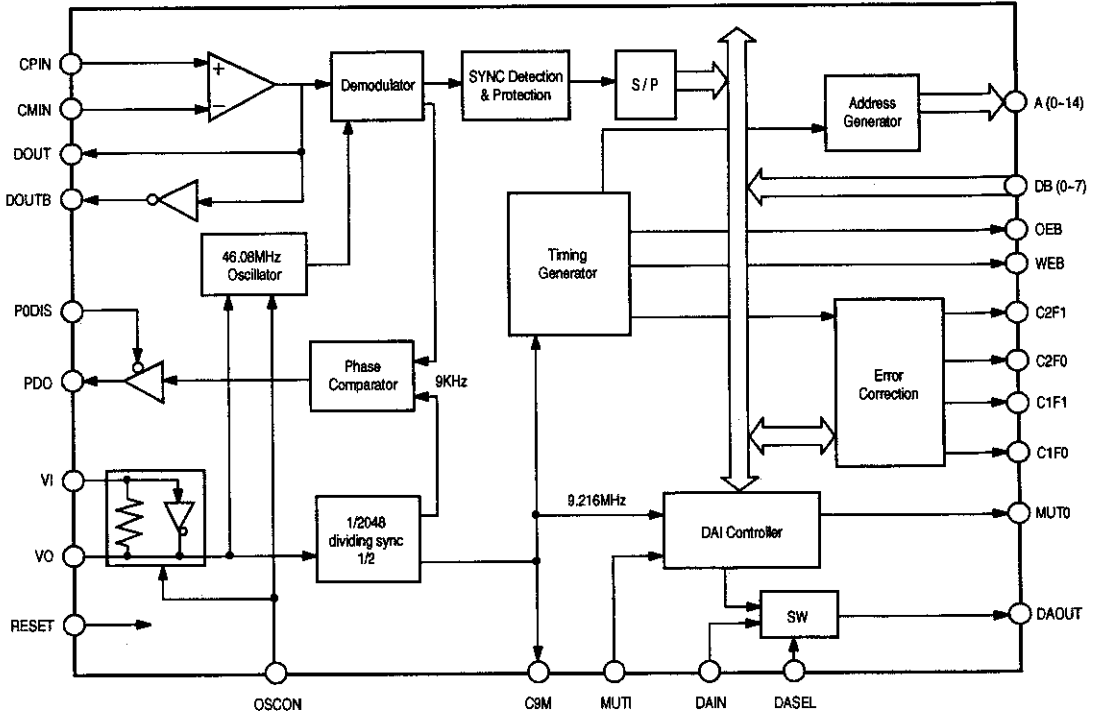
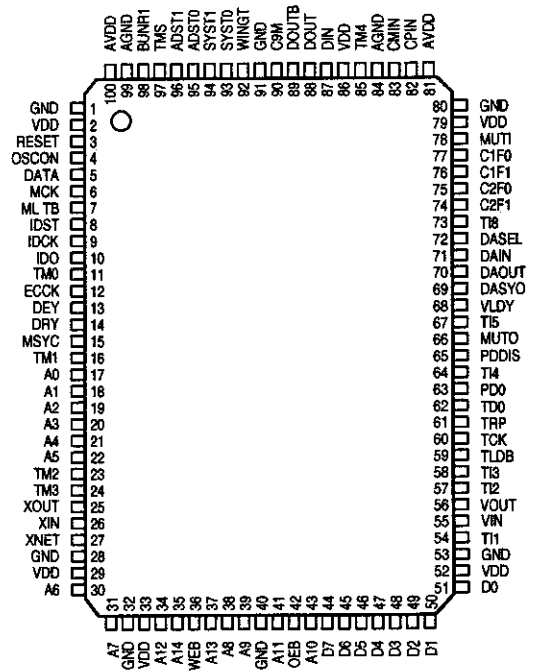
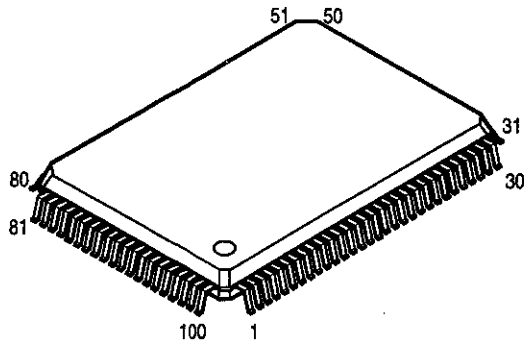

ZR38600 (AU: IC457)

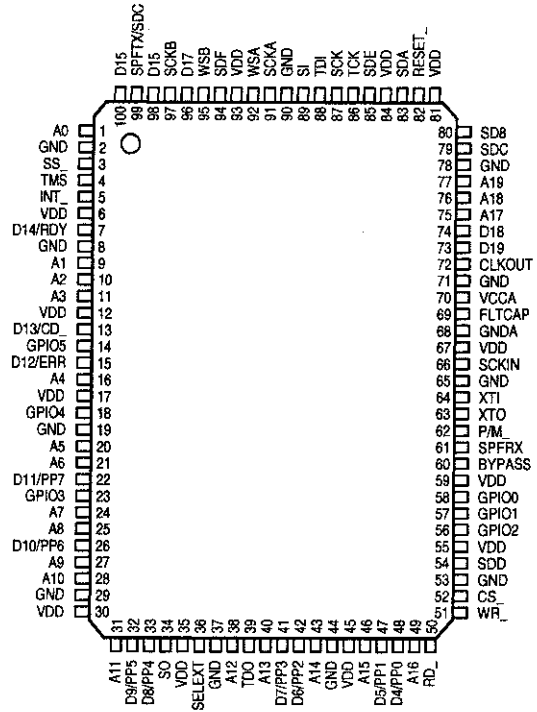
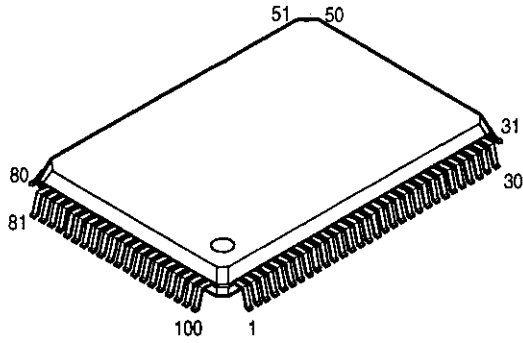

NJU7313AL (AU: IC704)

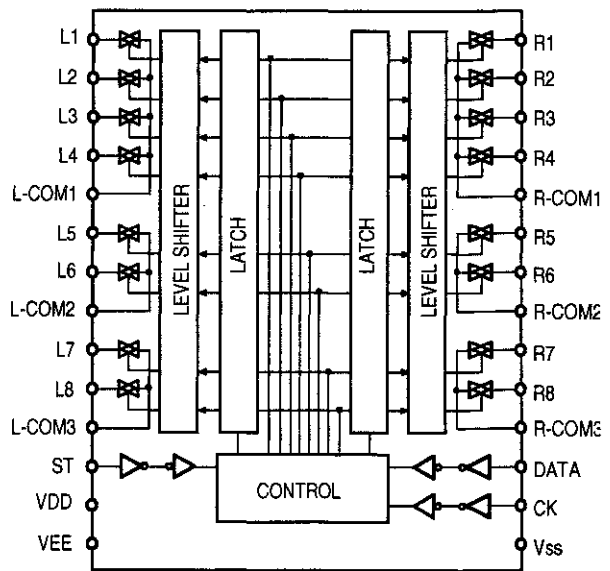
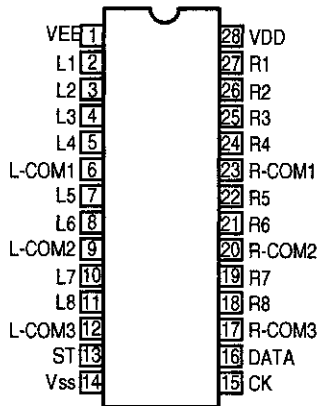
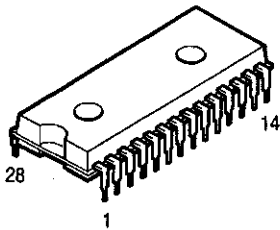

**AK5340VS**  
(AU: IC515)

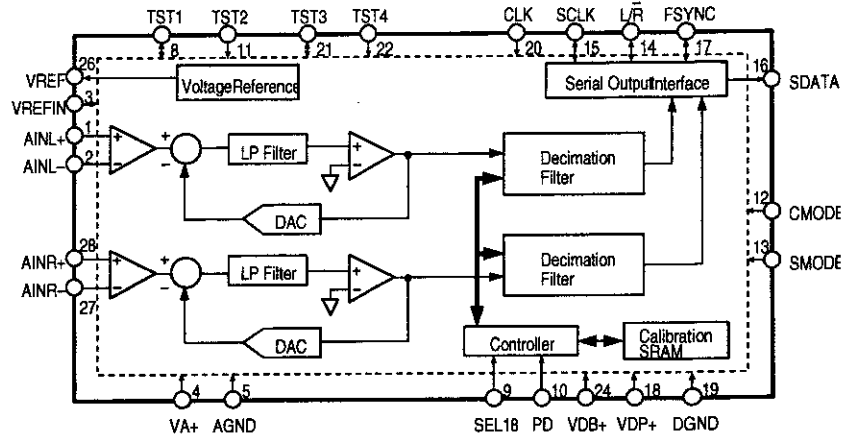
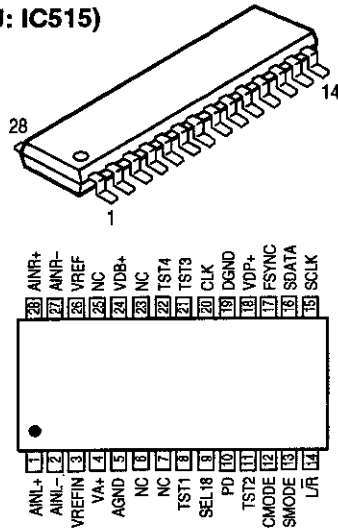

**AK5340VS Terminal Function**

Pin No.	Symbol	I/O	Function
1	AINL+	I	L ch analog non inverting input.
2	AINL-	I	L ch analog inverting input.
3	VREFIN	I	Reference voltage input.
4	VA+	—	Analog +5V power supply.
5	AGND	—	Analog ground.
6	NC		No connection.
7	NC		No connection.
8	TST1		Test terminal, open or connect to DGND.
9	SEL18	I	Output data length selecting terminal (built in pull down resistance) (L: 16 bit, H: 18 bit).
10	PD	I	Power down signal (H: Power down).
11	TST2		Test terminal, open or connect to DGND.
12	CMODE	I	Master clock selecting terminal. L: CLK = 256fs (12.288MHz @fs = 48kHz) H: CLK = 384fs (18.432MHz @fs = 48kHz)
13	SMODE	I	Interface clock selecting terminal (L: Slave mode, H: Master mode).
14	L/R	I/O	Input channel selecting terminal. Slave mode: fs clock input. Master mode: fs clock output.
15	SCLK	I/O	Serial data clock terminal. Slave mode: 32fs – 64fs clock input. Master mode: 64fs clock output.
16	SDATA	O	Serial data output terminal, data sequence output from MSB with 2's complement.
17	FSYNC	I/O	Frame sync clock terminal. Slave mode: Enable SDATA output at H. Master mode: 2fs clock output.
18	VDP+	—	Digital +5V power supply.
19	DGND	—	Digital ground.
20	CLK	I	Master clock input terminal. CMODE = "H" = 384fs CMODE = "L" = 256fs
21	TST3		Test terminal, open or connect to DGND.
22	TST4		Test terminal, open or connect to DGND.
23	NC		No connection.
24	VDB+	—	Digital +5V power supply.
25	NC		No connection.
26	VREF	O	Reference voltage output.
27	AINR-	I	R ch analog inverting input.
28	AINR+	I	R ch analog non inverting input.

Note: All other terminals except the above are no connection (NC). NC terminals are not bonded internally.

**PCM69AP**  
(AU: IC504~506)

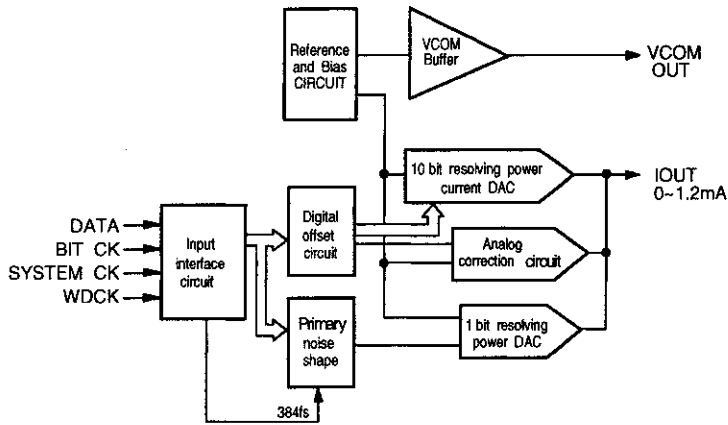
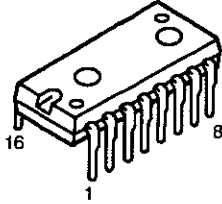

Pin No.	Function
1	+Vcc (Analog power supply)
2	Vcom. Lch
3	Lout. Lch
4	Servo. DC
5	REF. DC
6	Lout. Rch
7	Vcom. Rch
8	A-GND (Analog common)
9	D-GND (Digital common)
10	DATA Rch
11	BCK
12	SYS CLK
13	WDCK
14	DATA Lch
15	TP1
16	+VDD (Digital power supply)

**TC9273N-007 (AU: IC602)**  
**TC9273N-004 (AU: IC603)**

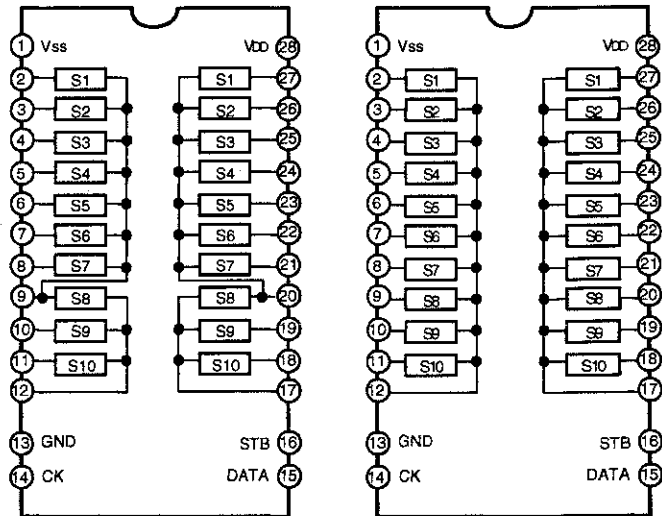
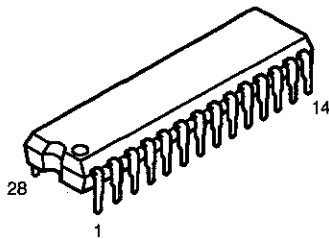

**TC9273N Terminal Function**

Pin No.	Symbol	Name	Function	Note
1	Vss	-Power Terminal	Dual Power Use: VDD = 8.0~17 V GND = 0V Vss = -8.0~17V Signal Power Use: VDD = 8.0~18V Vss = GND = 0V	—
13	GND	Digital Ground		
28	VDD	+Power Terminal		
2~12 17~27	S1~11	I/O Terminal	Input terminal of analog switch.	—
14	CK	Clock Input	Clock input for data transfer.	Low level Border Input Terminal
15	DATA	Data Input	Serial input for switch setting.	
16	STB	Strobe Input	Strobe input for data writing..	



LA1265 (S)  
(TU: IC502)

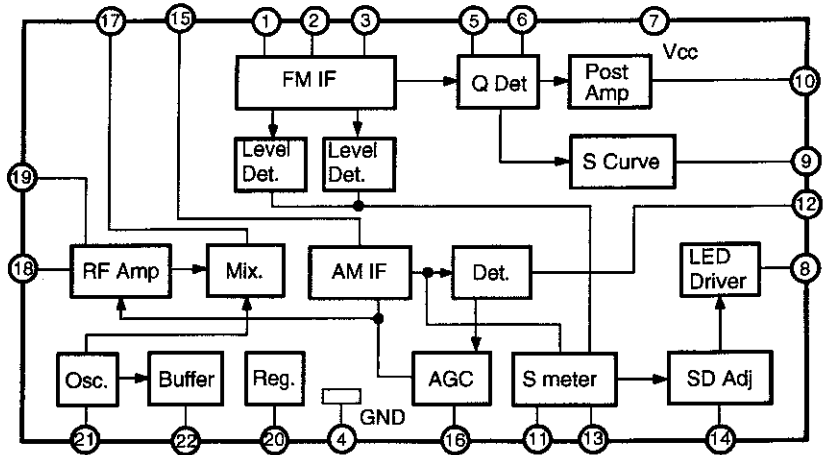
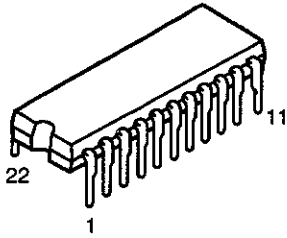

LA3401  
(TU: IC503)

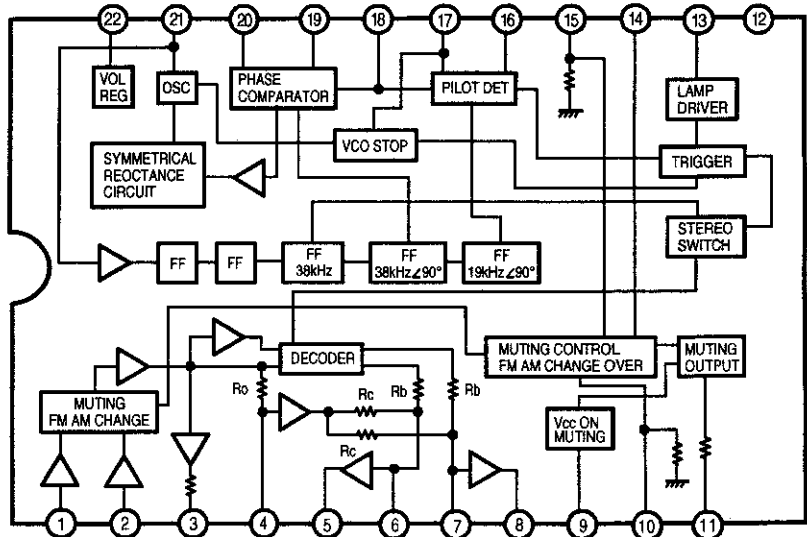
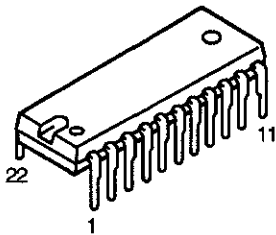

LM7001 (TU: IC505)

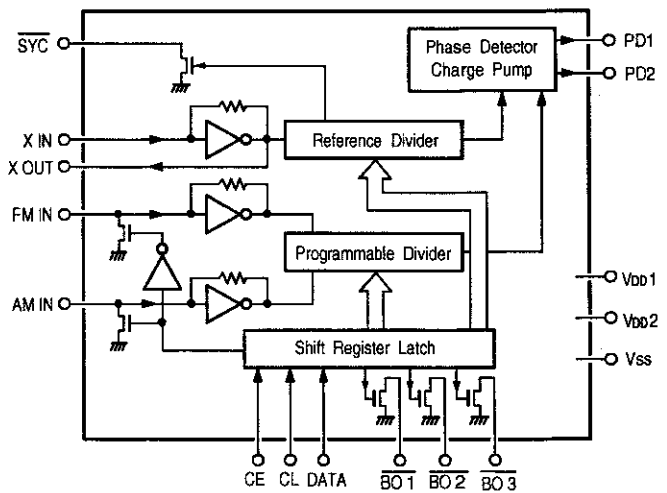
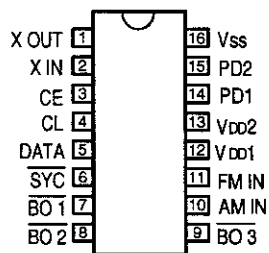
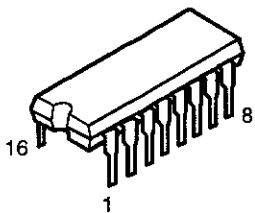

**BA7625 (VI: IC302, 401)**  
**BA7626 (VI: IC301)**

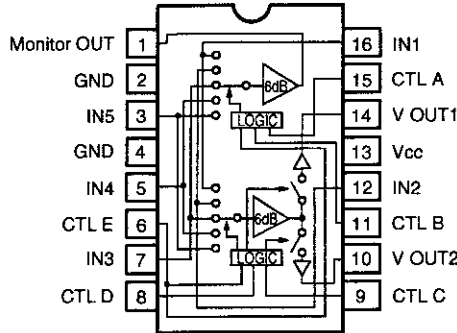
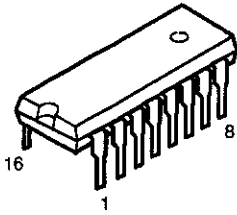

A	B	E	MONITOR OUT
L	L	*	IN 1
H	L	*	IN 2
L	H	*	IN 3
H	H	L	IN 4
H	H	H	IN 5

C	D	E	V OUT 1
L	L	*	---
H	L	*	IN 2
L	H	*	IN 3
H	H	L	IN 4
H	H	H	IN 5

C	D	E	V OUT 2
L	L	*	IN 1
H	L	*	---
L	H	*	IN 3
H	H	L	IN 4
H	H	H	IN 5

Note 1: \* mark means that feasible for either H or L.  
 Note 2: Each input terminal is provided with sink chip clamp (BA7625).  
 Each input terminal takes 20kohm at the end (BA7626).

**MC74HC4053N**  
 (VI: IC304)

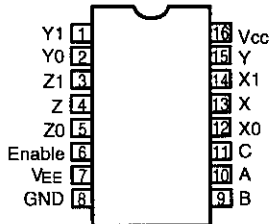
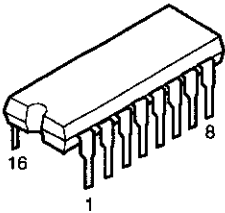

Enable	Select			ON Switches		
	C	B	A	Z0	Y0	X0
L	L	L	L	Z0	Y0	X0
L	L	L	H	Z0	Y0	X1
L	L	H	L	Z0	Y1	X0
L	L	H	H	Z0	Y1	X1
L	H	L	L	Z1	Y0	X0
L	H	L	H	Z1	Y0	X1
L	H	H	L	Z1	Y1	X0
L	H	H	H	Z1	Y1	X1
H	X	X	X	None		

X = Don't Care

**NJM2229S (VI: IC305)**

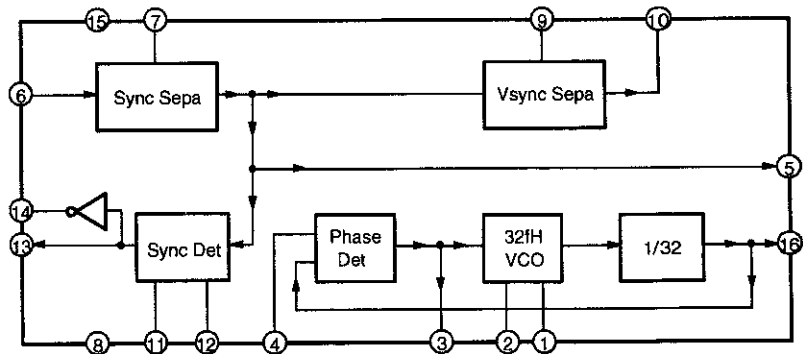
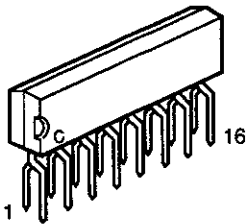

**TC4053BP (VI: IC402)**

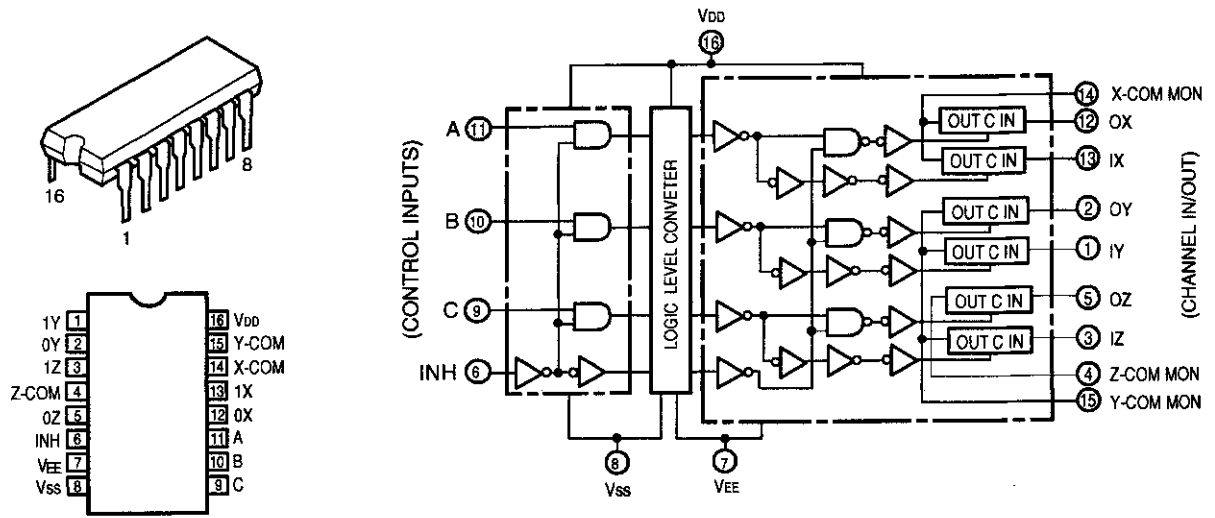

**SN74HC14NS (AU: IC456)  
SN74HCU04NS (AU: IC302)  
TC74HC00AF (AU: IC454)**

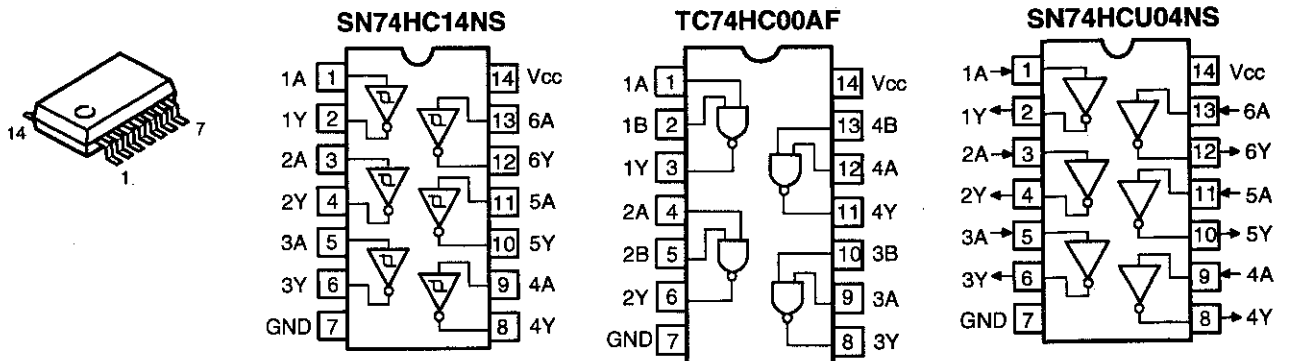

**TC74HC123AF (AU: IC455)  
SN74HC151NS (AU: IC303)**

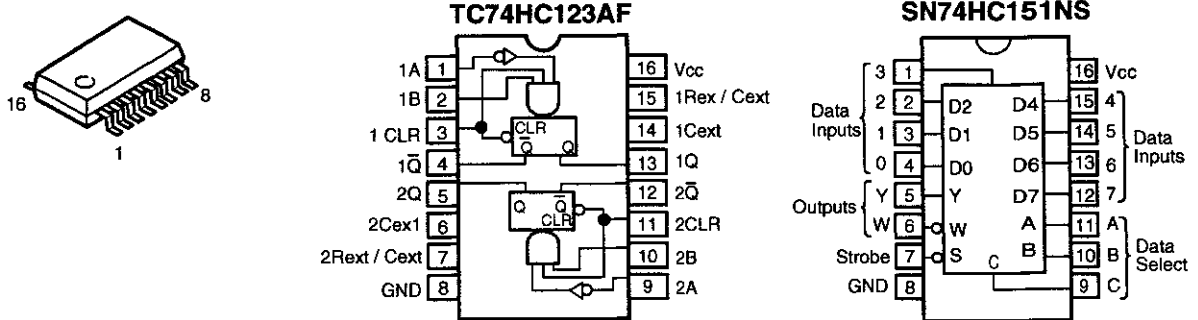

**TC74HCT7007AF**  
(AU: IC458)

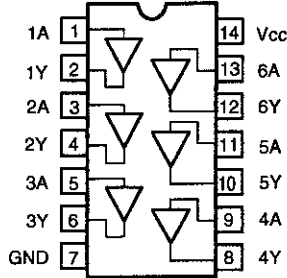
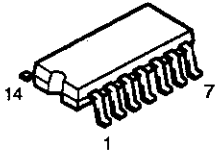

**TC4094BF**  
(MA: IC121, 122)

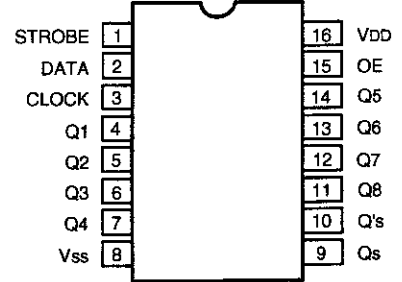
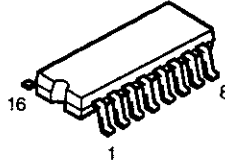

**MC14577CP**  
(AU: IC304)  
**NJM2068DDC**  
(PA: IC701, 703, 901)  
(VI: IC201)

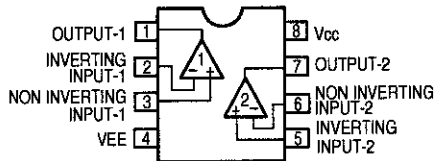
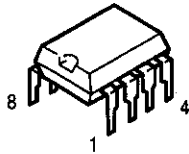

**SM5841HS** (AU: IC501~503)

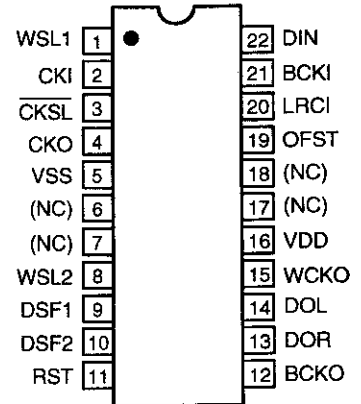
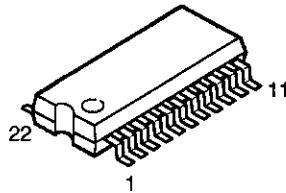

**NJM2115M** (AU: IC513, 514)  
**BA15218F** (TU: IC504)  
(AU: IC604~606, 701~703, 803~806)  
(EV: IC103, 105, 106, 109, 110)  
**NJM2068MD**(AU: IC507~512,601)  
(EV: IC104)

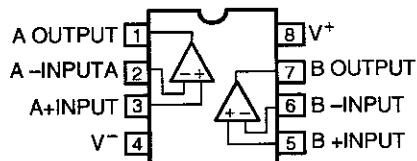
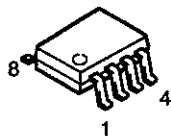

**SG-531PH (12.288MHz)**  
(DS: IC515)

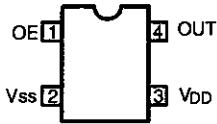
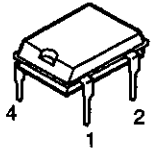

**NJM7805FA (S) (MA: IC116, 117)**  
**NJM7806FA (S) (PA: IC704)**  
(VI: IC403, 404)  
**NJM7812FA (S) (TU: IC506)**  
**NJM7815FA (MA: IC114)**  
**BA033T (AU: IC460)**

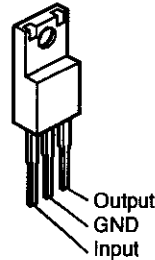

**NJM7905FA (MA: IC118)**  
**NJM7915FA (MA: IC115)**

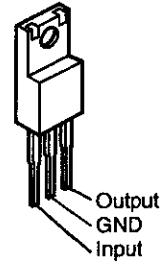

● **IC PROTECTOR**

**ICP-N15 (TU: IC507) (PA: IC705)**

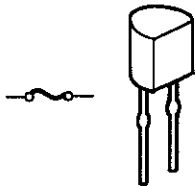

● **OPTICAL INPUT**

**GP1F32R**  
(AU: IC301)

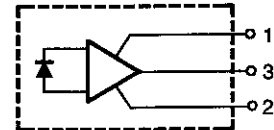
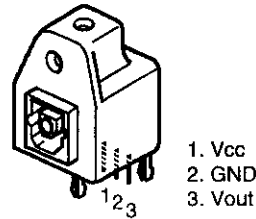

● **OTHER**

**GP1U271X (Remote Control Sensor)**  
(VI: IC101)

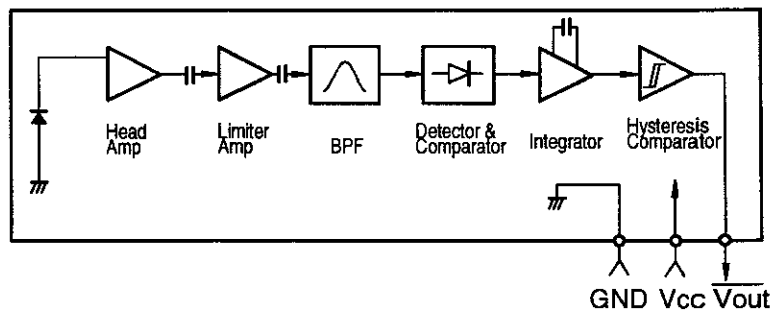
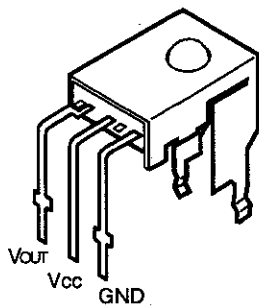

● TRANSISTORS

2PA1015GR  
 2PC1815BL  
 2SA970 (BL)  
 2SA988 (E/F)  
 2SC2878 (A/B)

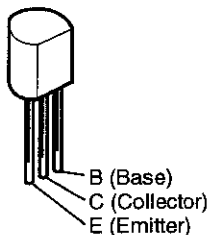

2SA1145 (O)/(Y)  
 2SB1041 (R)  
 2SC2705 (O)/(Y)  
 2SD1292 (R)

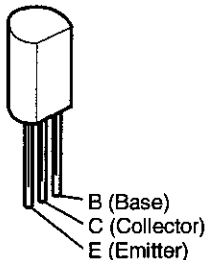

2SA1491  
 2SC3855

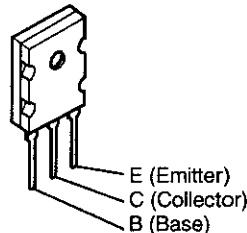

DTA114ES  
 DTC143ES  
 DTC144ES  
 RN2202

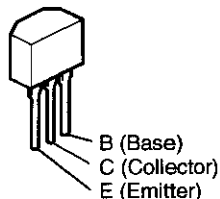

DTA114ES  
 RN2202

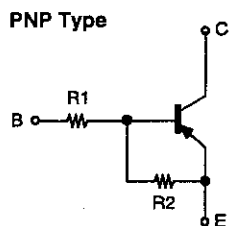

	R1	R2
DTA114ES	10kohm	10kohm
RN2202	10kohm	10kohm

DTC143ES  
 DTC144ES

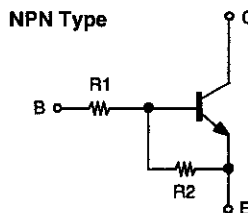

	R1	R2
DTC143ES	4.7kohm	4.7kohm
DTC144ES	47kohm	47kohm

DTA114EK  
 DTA124EK  
 DTA143EK  
 DTA144EK  
 DTC114EK  
 DTC144EK  
 DTC323TK  
 RN2402

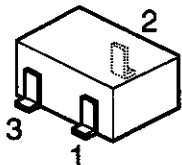

1: GND/Emitter  
 2: Out/Collector  
 3: In/Base

DTA114EK  
 DTA124U  
 DTA143EK  
 DTA144EK

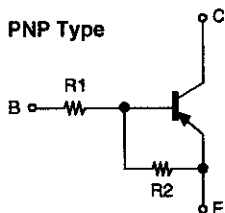

	R1	R2
DTA114EK	10kohm	10kohm
DTA124EK	22kohm	22kohm
DTA143EK	4.7kohm	4.7kohm
DTA144EK	47kohm	47kohm
RN2402	10kohm	10kohm

DTC114EK  
 DTC144EK  
 DTC323TK

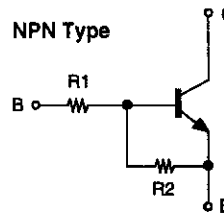

	R1	R2
DTC114EK	10kohm	10kohm
DTC144EK	47kohm	47kohm
DTC323TK	2.2kohm	-

2SA933S (S)  
2SC1740S (E)  
2SC2058S (Q)

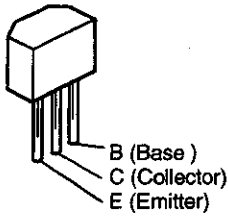

2SK184 (GR)(BL)  
2SK381 (B)(C)

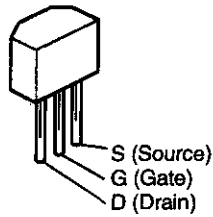

2SK209 (GR)

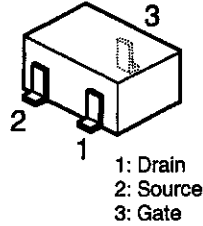

2SB709A  
2SD601A

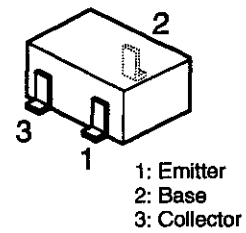

2SK365 (BL/GR)

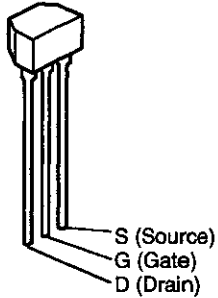

2SB1328 (P/Q)  
2SD2004 (P/Q)

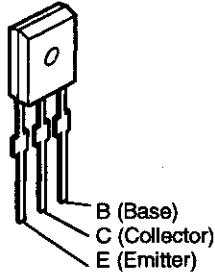

2SA1633F31

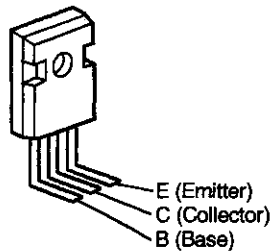

● DIODES (included LED)

1SS270A  
1S2076A

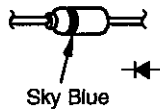

MTZJ3.3A MTZJ36A  
MTZJ5.6A HZS5A-1  
MTZJ7.5A HZS7C-1  
MTZJ9.1A HZS12A-1

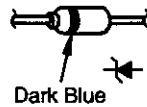

1SR35-200A

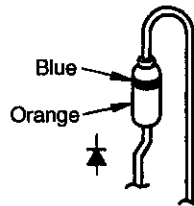

DSM1D2 (Type 3)

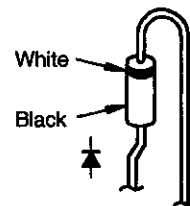

KV1851-TL  
(AU: CD303)

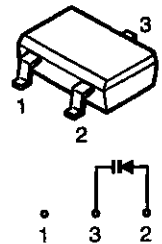

S4VB20  
(MA: D117)

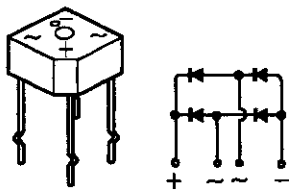

MA151A

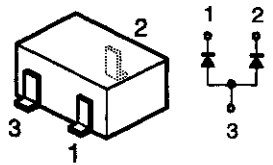

1: Cathode  
2: Cathode  
3: Anode

SEL1210S (Red)  
(VI: LD101, 106)  
SEL1410E (Green)  
(VI: LD102, 105)

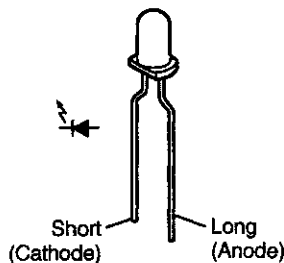

LD-603MG (Green)  
(VI: LD103)  
LD-603VR (Red)  
(VI: LD104)

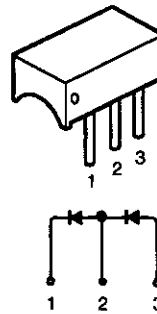

S10VB20F9  
(TU: D601)

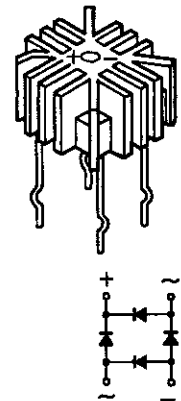

● FL DISPLAY FIP16FM7R (Part No.: 3934156001)(FL751)

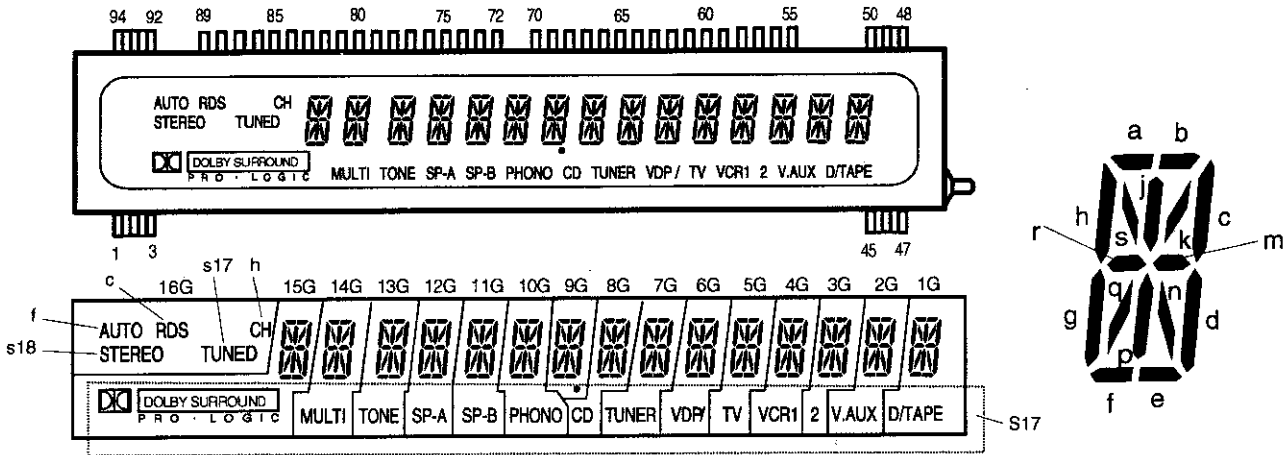

(UPPER)

TERMINAL No.	94	93	92	91	90	89	88	87	86	85	84	83	82	81							
ELECTRODE	F1	F1	F1	NP	NP	P	P	P	P	P	P	P	P	P							
TERMINAL No.	80	79	78	77	76	75	74	73	72	71	70	69	68	67	66	65	64	63	62	61	
ELECTRODE	P	P	P	P	P	P	P	P	P	NP	16G	15G	14G	13G	12G	11G	10G	9G	8G	7G	
TERMINAL No.									60	59	58	57	56	55	54	53	52	51	50	49	48
ELECTRODE									6G	5G	4G	3G	2G	1G	NP	NP	NP	NP	F2	F2	F2

(LOWER)

TERMINAL No.									35	36	37	38	39	40	41	42	43	44	45	46	47	
ELECTRODE									NP	NP	NP	NP	NP	NP	NP	NP	NP	NP	NP	F2	F2	F2
TERMINAL No.	15	16	17	18	19	20	21	22	23	24	25	26	27	28	29	30	31	32	33	34		
ELECTRODE	NP	NP	NP	NP	NP	NP	NP	NP	NP	NP	NP	NP	NP	NP	NP	NP	NP	NP	NP	NP		
TERMINAL No.	1	2	3	4	5	6	7	8	9	10	11	12	13	14								
ELECTRODE	F1	F1	F1	NP	NP	NP	NP	NP	NP	NP	NP	NP	NP	NP								

Notes: F: Filament G: Grid A: Anode NP: No Pin



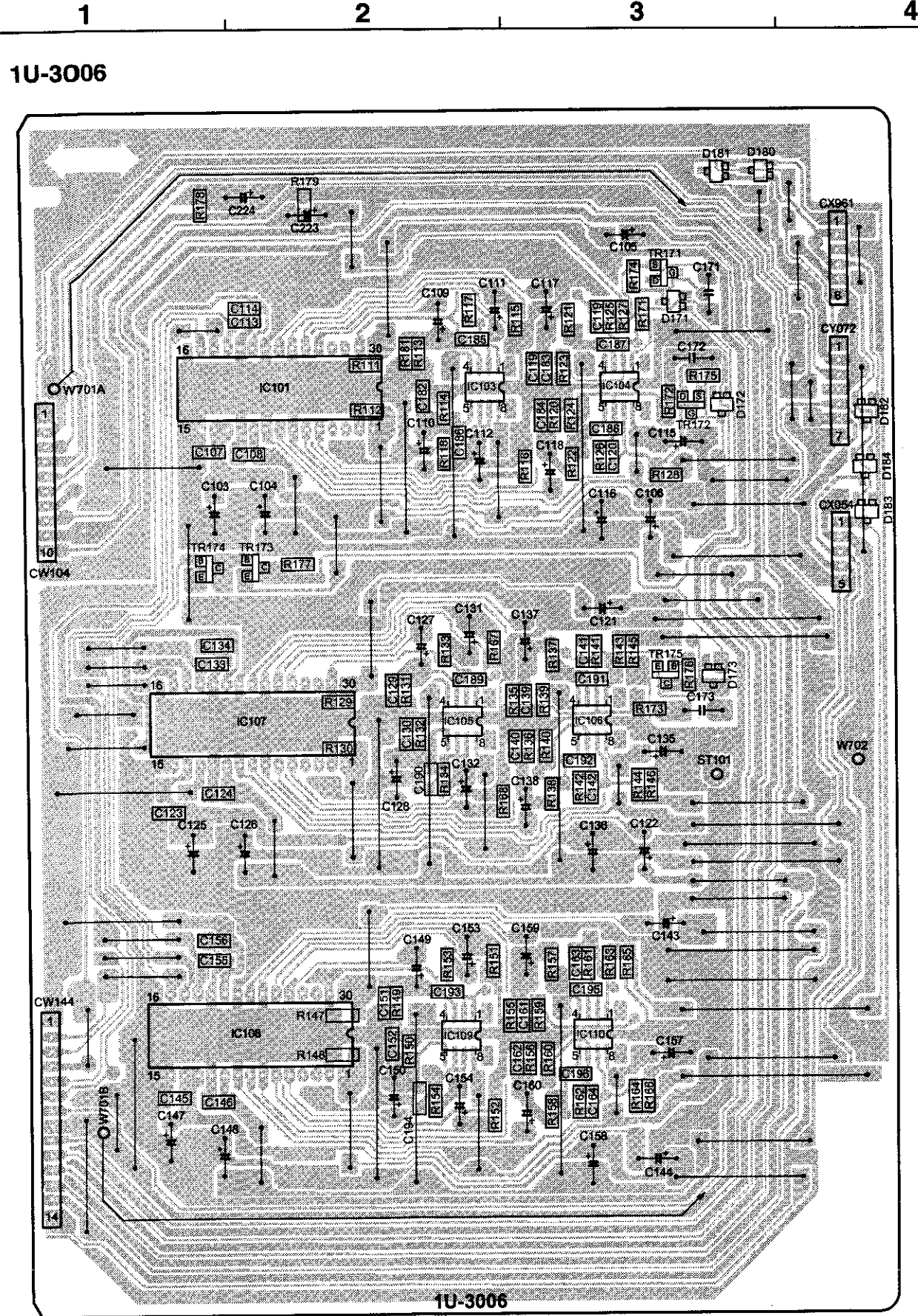

**NOTE FOR PARTS LIST**

- Part indicated with the mark "⊙" are not always in stock and possibly to take a long period of time for supplying, or in some case supplying of part may be refused.
  - When ordering of part, clearly indicate "1" and "I" (i) to avoid mis-supplying.
  - Ordering part without stating its part number can not be supplied.
  - Part indicated with the mark "\*" is not illustrated in the exploded view.
  - Not including Carbon Film ±5%, 1/4W Type in the P.W.Board parts list. (Refer to the Schematic Diagram for those parts.)
- WARNING:**  
Parts marked with this symbol  $\Delta$   $\blacksquare$  have critical characteristics. Use ONLY replacement parts recommended by the manufacturer.

**● Resistors**

Ex.: RN 14K 2E 182 G ER

RD : Carbon	2B : 1/8W	F : ±1%	P : Pulse-resistant type
RC : Composition	2E : 1/4W	G : ±2%	NL : Low noise type
RS : Metal oxide film	2H : 1/2W	J : ±5%	NB : Non-burning type
RW : Winding	3A : 1W	K : ±10%	FR : Fuse-resistor
RN : Metal film	3D : 2W	M : ±20%	F : Lead wire forming
RK : Metal mixture	3F : 3W		
	3H : 5W		

\* Resistance

1 2 3 ⇒ 1800 ohm = 1.8 kohm  
Indicates number of zeros after effective number.  
2-digit effective number.

• Units: ohm

1 2 3 ⇒ 1.2 ohm  
1-digit effective number.  
2-digit effective number, decimal point indicated by R.

• Units: ohm

**● Capacitors**

Ex.: CE 04W 1H 2R2 M BP

CE : Aluminum foil electrolytic	0J : 6.3V	F : ±1%	HS : High stability type
CA : Aluminum solid electrolytic	1A : 10V	G : ±2%	BP : Non-polar type
CS : Tantalum electrolytic	1C : 16V	J : ±5%	HR : Ripple-resistant type
CQ : Film	1E : 25V	K : ±10%	DL : For charge and discharge
CK : Ceramic	1V : 35V	M : ±20%	HF : For assuring high frequency
CC : Ceramic	1H : 50V	Z : +80%	U : UL part
CP : Oil	2A : 100V	-20%	C : CSA part
CM : Mica	2B : 125V	+100%	W : UL-CSA type
CF : Metallized	2C : 160V	-0%	F : Lead wire forming
CH : Metallized	2D : 200V	±0.25pF	
	2E : 250V	±0.5pF	
	2H : 500V	= : Others	
	2J : 630V		

\* Capacity (electrolyte only)

2 2 2 ⇒ 2200μF  
Indicates number of zeros after effective number.  
2-digit effective number.

• Units: μF.

2 R 2 ⇒ 2.2μF  
1-digit effective number.  
2-digit effective number, decimal point indicated by R.

• Units: μF.

\* Capacity (except electrolyte)

2 2 2 ⇒ 2200pF=0.0022μF  
(More than 2) — Indicates number of zeros after effective number.  
2-digit effective number.

• Units: pF.

2 2 1 ⇒ 220pF  
(0 or 1) — Indicates number of zeros after effective number.  
2-digit effective number.

• Units: pF.

• When the dielectric strength is indicated in AC, "AC" is included after the dielectric strength value.

1 2 3 4 5 6 7 8

1U-2998

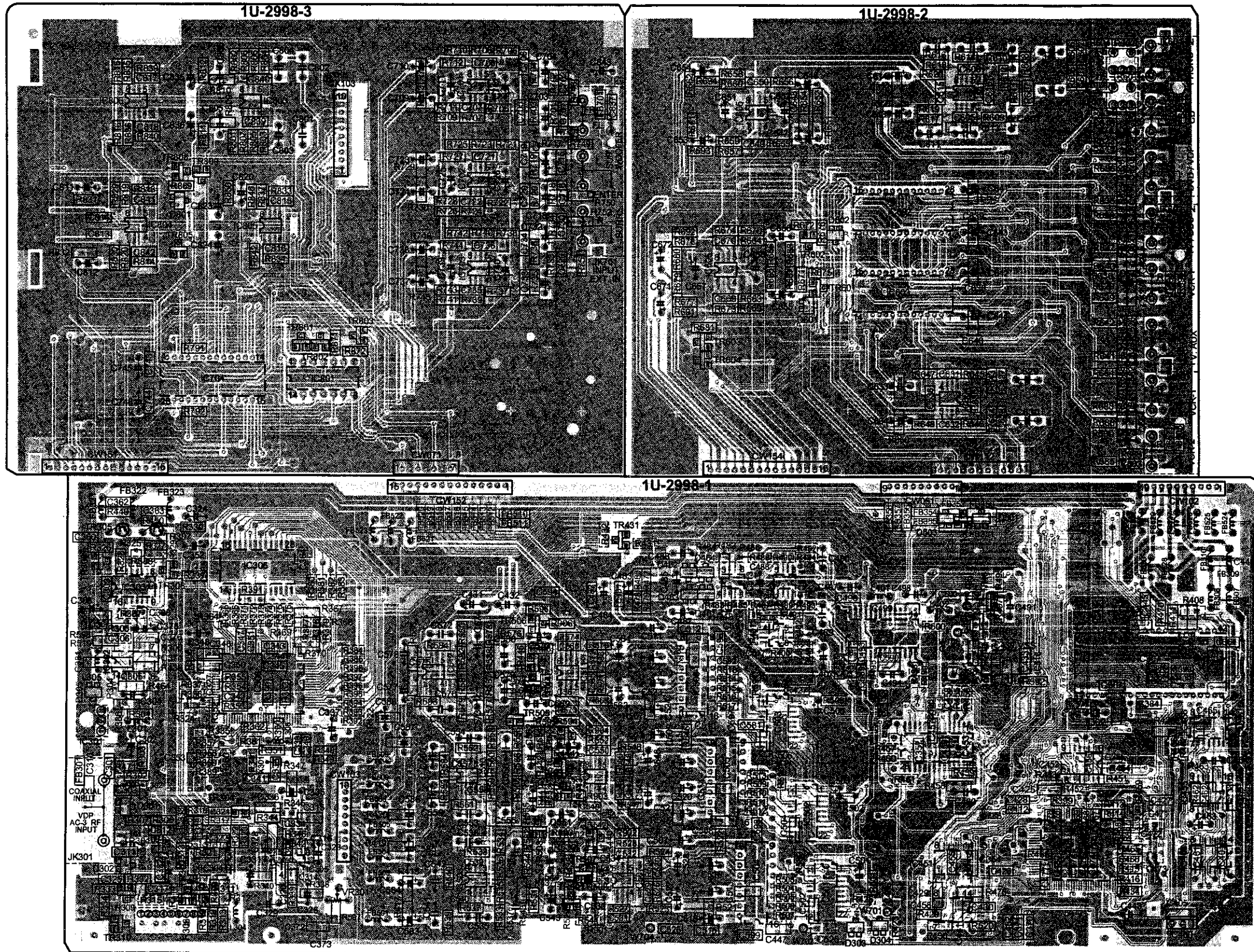

A  
B  
C  
D  
E



PRINTED WIRING BOARD

1 2 3 4 5 6 7 8

1U-2994

1U-2994-1

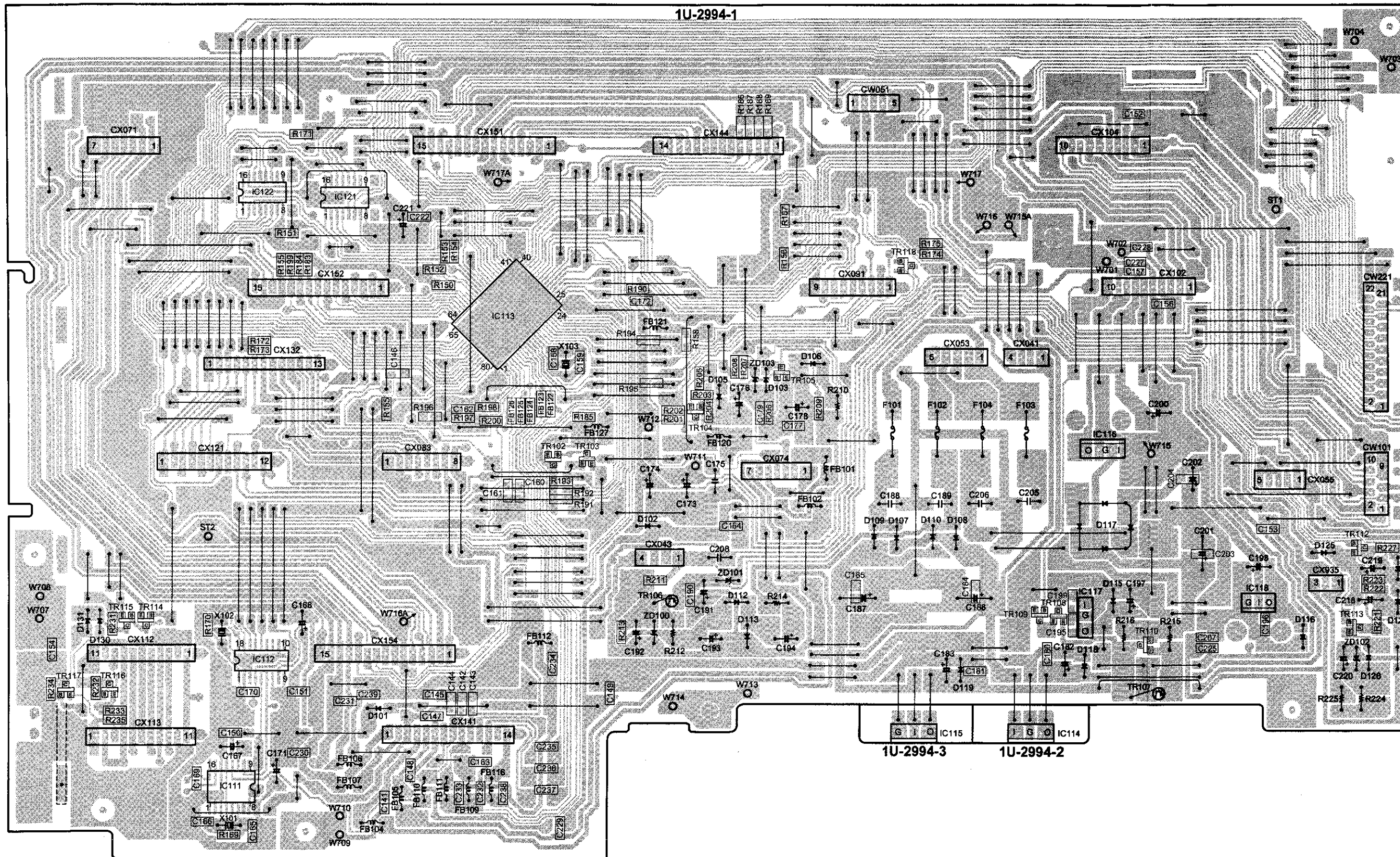

1U-2994-3 1U-2994-2

A B C D E



1

2

3

4

5

6

7

8

1U-2995

A

B

C

D

E

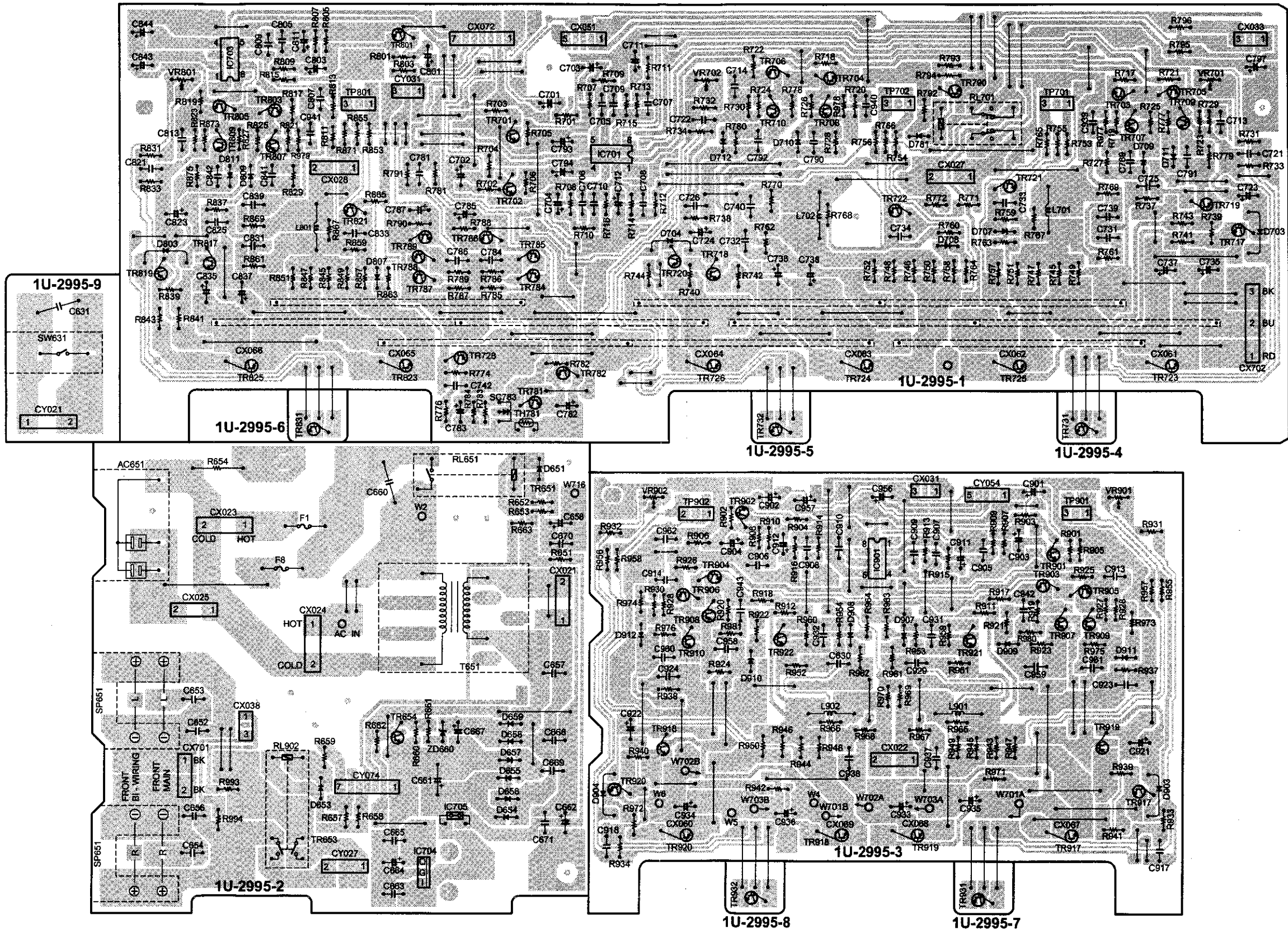



1 2 3 4 5 6 7 8

1U-2996

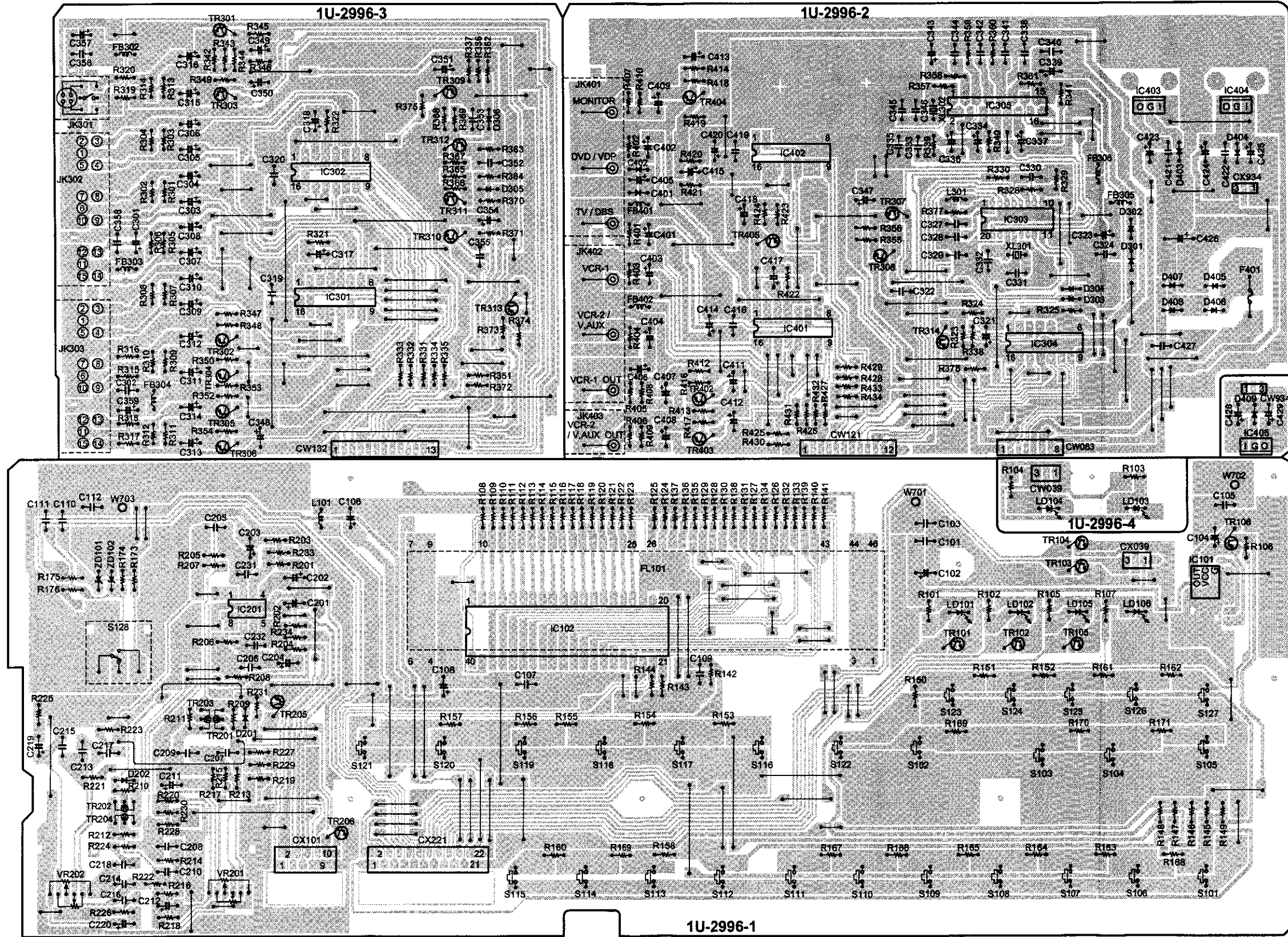

A  
B  
C  
D  
E

1

2

3

4

5

6

7

8

1U-2997

A

B

C

D

E

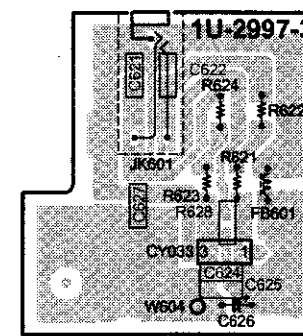
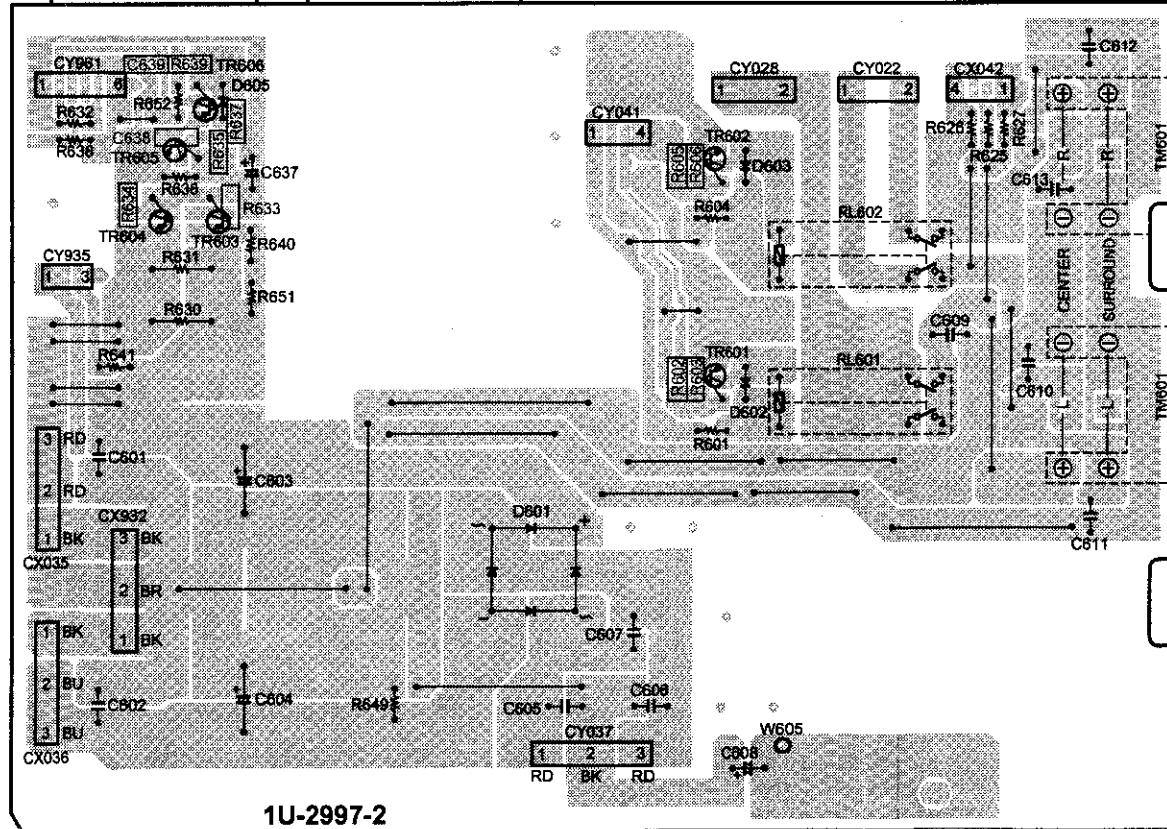
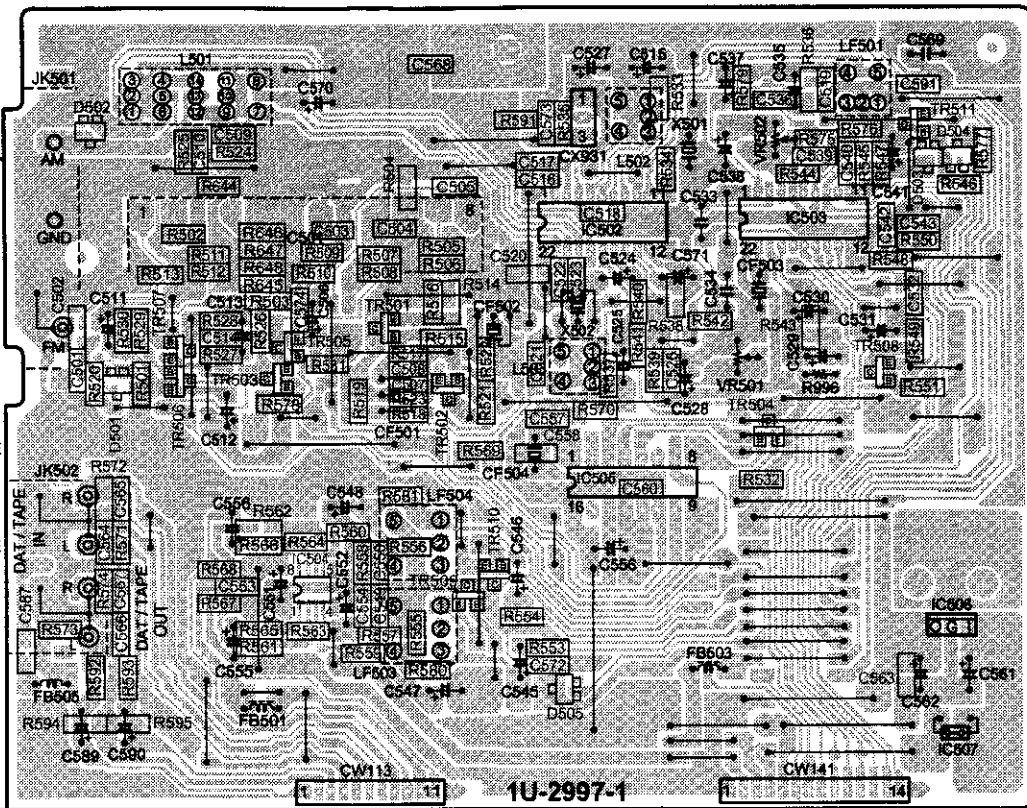
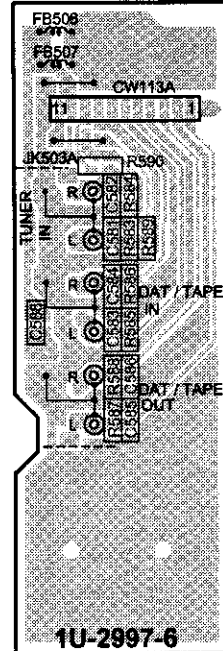
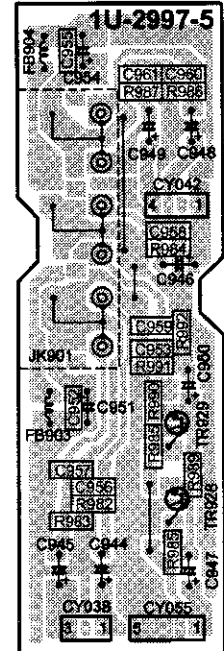



## PARTS LIST OF P.W.B. UNIT ASS'Y

### 1U-2994 MAIN UNIT ASS'Y

Ref. No.	Part No.	Part Name	Remarks	Ref. No.	Part No.	Part Name	Remarks
<b>SEMICONDUCTORS GROUP</b>							
IC113	262 2373 100	IC TMP87CS71F-****	master-ucom	R206	247 0009 901	Carbon chip 4.7kohm 1/10W	RM73B--472J
IC114	263 0812 006	IC NJM7815FA(S)		R207~209	247 0007 945	Carbon chip 1kohm 1/10W	RM73B--102J
IC115	263 0561 001	IC NJM7915FA		R210	241 2387 940	Carbon film 4.7ohm 1/4W(NB)	RD14B2E4R7JNBS
IC116,117	263 0809 006	IC NJM7805FA(S)		R211	247 0009 985	Carbon chip 10kohm 1/10W	RM73B--103J
IC118	263 0554 005	IC NJM7905FA		R212	241 2387 940	Carbon film 4.7ohm 1/4W(NB)	RD14B2E4R7JNBS
IC121,122	262 2375 904	IC TC4094BF		R213	247 0009 985	Carbon chip 10kohm 1/10W	RM73B--103J
TR102	269 0083 901	Transistor DTA114EK		R214	241 2375 907	Carbon film 10ohm 1/4W(NB)	RD14B2E100JNBS
TR103	269 0054 901	Transistor DTC144EK		R216	241 2376 919	Carbon film 30ohm 1/4W(NB)	RD14B2E300JNBS
TR104	274 0163 904	Transistor 2SD601A		R221	247 0005 989	Carbon chip 220ohm 1/10W	RM73B--221J
TR105	269 0054 901	Transistor DTC144EK		R222,223	247 0012 927	Carbon chip 100kohm 1/10W	RM73B--104J
TR106	271 0131 924	Transistor 2SA988(E/F)		R224,225	244 2055 996	Metal oxide 1.2kohm 1W	RS14B3A122JNBS(S)
TR108	269 0047 905	Transistor DTA143EK		R227	247 0005 989	Carbon chip 220ohm 1/10W	RM73B--221J
TR109	269 0054 901	Transistor DTC144EK		R231	247 0011 944	Carbon chip 47kohm 1/10W	RM73B--473J
TR112,113	269 0083 901	Transistor DTA114EK		R232	247 0013 900	Carbon chip 220kohm 1/10W	RM73B--224J
TR114	269 0054 901	Transistor DTC144EK		R233	247 0012 998	Carbon chip 200kohm 1/10W	RM73B--204J
TR115	269 0055 900	Transistor DTA144EK		R234	247 0013 900	Carbon chip 220kohm 1/10W	RM73B--224J
TR116,117	275 0094 908	FET 2SK209-GR		R235	247 0012 998	Carbon chip 200kohm 1/10W	RM73B--204J
TR118	269 0055 900	Transistor DTA144EK		<b>CAPACITORS GROUP</b>			
D117	276 0305 001	Diode S4VB20		C141,142	257 0008 983	Ceramic chip 1000pF/50V	CK73B1H102K
D102	276 0553 905	Diode 1SR35-200A		C144	257 0008 983	Ceramic chip 1000pF/50V	CK73B1H102K
D103	276 0432 903	Diode 1SS270A		C149	257 0008 983	Ceramic chip 1000pF/50V	CK73B1H102K
D105	276 0432 903	Diode 1SS270A		C153	257 0008 983	Ceramic chip 1000pF/50V	CK73B1H102K
D106	276 0553 905	Diode 1SR35-200A		C155,156	257 0008 983	Ceramic chip 1000pF/50V	CK73B1H102K
D107~110	276 0548 910	Diode DSM1D2		C158,159	257 0004 903	Ceramic chip 56pF/50V	CC73SL1H560J
D112,113	276 0553 905	Diode 1SR35-200A		C160	257 0008 983	Ceramic chip 1000pF/50V	CK73B1H102K
D115,116	276 0432 903	Diode 1SS270A		C164	257 0012 966	Ceramic chip 0.01μF/50V	CK73F1H103Z
D118,119	276 0432 903	Diode 1SS270A		C172	257 0014 935	Ceramic chip 0.1μF/25V	CK73F1E104Z
D125,126	276 0553 905	Diode 1SR35-200A		C173	254 4254 909	Electrolytic 10μF/16V	CE04W1C100M
D128~131	276 0432 903	Diode 1SS270A		C174	254 4250 932	Electrolytic 220μF/6.3V	CE04W0J221M
ZD100	276 0645 978	Zener diode MTZJ36A	36V	C175	256 1034 982	Metalized 0.12μF/50V	CF93A1H124J
ZD101	276 0644 937	Zener diode MTZJ9.1A	9.1V	C176	254 4258 905	Electrolytic 4.7μF/35V	CE04W1V4R7M
ZD102	276 0643 996	Zener diode MTZJ5.6A	5.6V	C177	257 0012 966	Ceramic chip 0.01μF/50V	CK73F1H103Z
ZD103	276 0634 905	Zener diode MTZJ3.3A	3.3V	C178	259 0007 702	Back up cap. 8200μF/5.5V	SB CAP==822=C
<b>RESISTORS GROUP</b>				C179~181	257 0012 966	Ceramic chip 0.01μF/50V	CK73F1H103Z
R150~156	247 0009 985	Carbon chip 10kohm 1/10W	RM73B--103J	C182,183	254 4258 947	Electrolytic 47μF/35V	CE04W1V470M
R158	247 0018 905	Carbon chip 0ohm 1/10W	RM73B--0R0K	C184,185	257 0012 966	Ceramic chip 0.01μF/50V	CK73F1H103Z
R171~175	247 0009 985	Carbon chip 10kohm 1/10W	RM73B--103J	C186,187	254 4259 700	Electrolytic 2200μF/35V	CE04W1V222MC
R183~189	247 0009 985	Carbon chip 10kohm 1/10W	RM73B--103J	C188,189	256 1034 979	Metalized 0.1μF/50V	CF93A1H104J
R190	247 0012 927	Carbon chip 100kohm 1/10W	RM73B--104J	C190	257 0012 966	Ceramic chip 0.01μF/50V	CK73F1H103Z
R191~193	247 0009 901	Carbon chip 4.7kohm 1/10W	RM73B--472J	C191,192	254 4260 948	Electrolytic 1μF/50V	CE04W1H010M
R194,195	247 0009 985	Carbon chip 10kohm 1/10W	RM73B--103J	C193	254 4261 743	Electrolytic 330μF/50V	CE04W1H331M
R196	247 0018 905	Carbon chip 0ohm 1/10W	RM73B--0R0K	C194	254 4262 771	Electrolytic 330μF/63V	CE04W1J331MC
R198~201	247 0009 985	Carbon chip 10kohm 1/10W	RM73B--103J	C195,196	257 0012 966	Ceramic chip 0.01μF/50V	CK73F1H103Z
R202	247 0013 900	Carbon chip 220kohm 1/10W	RM73B--224J	C197,198	254 4258 947	Electrolytic 47μF/35V	CE04W1V470M
R203	247 0009 985	Carbon chip 10kohm 1/10W	RM73B--103J	C199	257 0012 966	Ceramic chip 0.01μF/50V	CK73F1H103Z
R204	247 0009 901	Carbon chip 4.7kohm 1/10W	RM73B--472J	C200	254 4254 909	Electrolytic 10μF/16V	CE04W1C100M
R205	247 0009 985	Carbon chip 10kohm 1/10W	RM73B--103J	C201	254 4403 705	Electrolytic 6800μF/25V	CE04W1E682MC
				C202	254 4256 787	Electrolytic 1000μF/25V	CE04W1E102MC
				C203,204	257 0012 966	Ceramic chip 0.01μF/50V	CK73F1H103Z
				C205,206	253 1181 904	Ceramic 0.01μF/50V	CK45F1H103Z
				C208	256 1034 979	Metalized 0.1μF/50V	CF93A1H104J

1U-2995 POWER AMP. UNIT

Ref. No.	Part No.	Part Name	Remarks	
C218,219	254 4260 977	Electrolytic 4.7μF/50V	CE04W1H4R7M	
C220	254 4260 980	Electrolytic 10μF/50V	CE04W1H100M	
C221	254 4254 938	Electrolytic 47μF/16V	CE04W1C470M	
C222	257 0012 966	Ceramic chip 0.01μF/50V	CK73F1H103Z	
C234,235	257 0012 966	Ceramic chip 0.01μF/50V	CK73F1H103Z	
C239	257 0008 983	Ceramic chip 1000pF/50V	CK73B1H102K	
<b>OTHER PARTS GROUP</b>				<b>Q'ty</b>
CW101	205 1056 001	10P connector socket TKC-V		1
CW221	205 1056 014	22P connector socket TKC-V		1
CX041	205 0343 045	4P connector base(KR-PH)		1
CX043	205 0233 045	4P EH connector base		1
CX053	205 0233 058	5P EH connector base		1
CX055	205 0343 058	5P connector base(KR-PH)		1
CX071	205 0943 021	7P connector base (TUC-P)		1
CX074	205 0343 074	7P connector base(KR-PH)		1
CX083	205 0884 096	8P connector base (TUC-P)		1
CX091	205 0884 038	9P connector base (TUC-P)		1
CX102	205 0884 054	10P connector base (TUC-P)		1
CX104	205 0884 054	10P connector base (TUC-P)		1
CX112,113	205 0884 067	11P connector base (TUC-P)		2
CX121	205 0884 070	12P connector base (TUC-P)		1
CX132	205 0943 005	13P connector base (TUC-P)		1
CX141	205 0884 012	14P connector base (TUC-P)		1
CX144	205 0884 012	14P connector base (TUC-P)		1
CX151,152	205 0884 041	15P connector base (TUC-P)		2
CX154	205 0884 041	15P connector base (TUC-P)		1
CX935	205 0343 032	3P connector base(KR-PH)		1
F101,102	202 0040 909	Fuse clip		4
F103,104	202 0040 909	Fuse clip		4
F101-104	206 1039 076	Fuse 2.5A		4
FB101~103	235 0049 900	Beads inductor		3
FB104~107	235 0049 900	Beads inductor		4
FB109~111	235 0049 900	Beads inductor		3
FB112~115	235 0049 900	Beads inductor		4
FB116	235 0049 900	Beads inductor		1
FB120,121	235 0049 900	Beads inductor		2
FB122~125	235 0106 908	Chip emifil (21A05)		4
FB126	235 0106 908	Chip emifil (21A05)		1
FB127	235 0049 900	Beads inductor		1
X103	399 0191 903	Ceramic resonator	CST4.00MGW -TF01	1
ST001,002	205 0452 017	Style Pin		2
	417 0476 010	Radiator	IC116, IC118	2
	471 3304 015	Screw 3X8 CBS-Z		2

Ref. No.	Part No.	Part Name	Remarks
<b>SEMICONDUCTORS GROUP</b>			
IC701	263 0609 002	IC NJM2068DDC	
IC703	263 0609 002	IC NJM2068DDC	
IC704	263 0793 002	IC NJM7806FA(S)	
IC705	268 0073 905	IC ICP-N15	IC protector
IC901	263 0609 002	IC NJM2068DDC	
TR651	273 0429 904	Transistor 2SC3311A	
TR653,654	273 0429 904	Transistor 2SC3311A	
TR701,702	273 0253 918	Transistor 2SC2878(A/B)	
TR703,704	273 0235 923	Transistor 2SC1841(E/F)	
TR705~708	271 0131 924	Transistor 2SA988(E/F)	
TR709,710	273 0235 923	Transistor 2SC1841(E/F)	
TR717,718	274 0151 916	Transistor 2SD2004(P/Q)	
TR719,720	272 0107 919	Transistor 2SB1328(P/Q)	
TR721,722	273 0235 923	Transistor 2SC1841(E/F)	
TR728	271 0131 924	Transistor 2SA988(E/F)	
TR731,732	273 0323 000	Transistor 2SC3421 O/Y	
TR781	269 0040 902	Transistor DTC144ES (47K-47K)	
TR782	273 0429 904	Transistor 2SC3311A	
TR784	273 0429 904	Transistor 2SC3311A	
TR785	271 0192 905	Transistor 2SA933S(S)	
TR786,787	273 0429 904	Transistor 2SC3311A	
TR788	271 0192 905	Transistor 2SA933S(S)	
TR789,790	273 0429 904	Transistor 2SC3311A	
TR801	273 0253 918	Transistor 2SC2878(A/B)	
TR803	273 0235 923	Transistor 2SC1841(E/F)	
TR805	271 0131 924	Transistor 2SA988(E/F)	
TR807	271 0131 924	Transistor 2SA988(E/F)	
TR809	273 0235 923	Transistor 2SC1841(E/F)	
TR817	274 0151 916	Transistor 2SD2004(P/Q)	
TR819	272 0107 919	Transistor 2SB1328(P/Q)	
TR821	273 0235 923	Transistor 2SC1841(E/F)	
TR831	273 0323 000	Transistor 2SC3421 O/Y	
TR901,902	273 0253 918	Transistor 2SC2878(A/B)	
TR903,904	273 0235 923	Transistor 2SC1841(E/F)	
TR905~908	271 0131 924	Transistor 2SA988(E/F)	
TR909,910	273 0235 923	Transistor 2SC1841(E/F)	
TR917,918	274 0151 916	Transistor 2SD2004(P/Q)	
TR919,920	272 0107 919	Transistor 2SB1328(P/Q)	
TR921,922	273 0235 923	Transistor 2SC1841(E/F)	
TR931,932	273 0323 000	Transistor 2SC3421 O/Y	
D651	276 0432 903	Diode 1SS270A	
D653	276 0432 903	Diode 1SS270A	
D654~659	276 0553 905	Diode 1SR35-200A	



Ref. No.	Part No.	Part Name	Remarks
D703,704	276 0049 914	Diode 1S2076A	
D707-712	276 0432 903	Diode 1SS270A	
D781	276 0432 903	Diode 1SS270A	
D803	276 0049 914	Diode 1S2076A	
D807	276 0432 903	Diode 1SS270A	
D809	276 0432 903	Diode 1SS270A	
D811	276 0432 903	Diode 1SS270A	
D903,904	276 0049 914	Diode 1S2076A	
D907-912	276 0432 903	Diode 1SS270A	
ZD660	276 0644 911	Zener diode MTZJ7.5A	7.5V

**RESISTORS GROUP**

R651	241 2375 978	Carbon film 20ohm 1/4W(NB)	RD14B2E200JNBS
R654	242 0073 000	Composition 2.2Mohm 1/2W	RC05GF2H225K
R659	244 2050 933	Metal oxide 180ohm 1W	RS14B3A181JNBS(S)
R725,726	241 2379 932	Carbon film 620ohm 1/4W(NB)	RD14B2E621JNBS
R727,728	241 2377 989	Carbon film 150ohm 1/4W(NB)	RD14B2E151JNBS
R739,740	241 2378 920	Carbon film 220ohm 1/4W(NB)	RD14B2E221JNBS
R741-744	241 2387 908	Carbon film 1ohm 1/4W(NB)	RD14B2E010JNBS
R745-752	244 2043 982	Metal oxide 0.22ohm 1W	RS14B3AR22JNBS(S)
R757-760	241 2380 950	Carbon film 2kohm 1/4W(NB)	RD14B2E202JNBS
R761,762	244 2051 987	Metal oxide 4.7ohm 1W	RS14B3A4R7JNBS(S)
R769,770	244 2043 937	Metal oxide 10ohm 1W	RS14B3A100JNBS(S)
R777,778	241 2379 932	Carbon film 620ohm 1/4W(NB)	RD14B2E621JNBS
R779,780	241 2377 989	Carbon film 150ohm 1/4W(NB)	RD14B2E151JNBS
R792	244 2052 986	Metal oxide 750ohm 1W	RS14B3A751JNBS(S)
R795,796	244 2052 960	Metal oxide 220ohm 1W	RS14B3A221JNBS(S)
R821,922	241 2379 932	Carbon film 620ohm 1/4W(NB)	RD14B2E621JNBS
R825	241 2379 932	Carbon film 620ohm 1/4W(NB)	RD14B2E621JNBS
R827	241 2379 932	Carbon film 620ohm 1/4W(NB)	RD14B2E621JNBS
R829	241 2377 989	Carbon film 150ohm 1/4W(NB)	RD14B2E151JNBS
R839	241 2378 920	Carbon film 220ohm 1/4W(NB)	RD14B2E221JNBS
R841	241 2387 908	Carbon film 1ohm 1/4W(NB)	RD14B2E010JNBS
R841,942	241 2387 908	Carbon film 1ohm 1/4W(NB)	RD14B2E010JNBS
R843	241 2387 908	Carbon film 1ohm 1/4W(NB)	RD14B2E010JNBS
R845	244 2043 982	Metal oxide 0.22ohm 1W	RS14B3AR22JNBS(S)
R847	244 2043 982	Metal oxide 0.22ohm 1W	RS14B3AR22JNBS(S)
R849	244 2043 982	Metal oxide 0.22ohm 1W	RS14B3AR22JNBS(S)
R851	244 2043 982	Metal oxide 0.22ohm 1W	RS14B3AR22JNBS(S)
R857	241 2380 950	Carbon film 2kohm 1/4W(NB)	RD14B2E202JNBS
R859	241 2380 950	Carbon film 2kohm 1/4W(NB)	RD14B2E202JNBS
R861	244 2051 987	Metal oxide 4.7ohm 1W	RS14B3A4R7JNBS(S)
R869	244 2043 937	Metal oxide 10ohm 1W	RS14B3A100JNBS(S)
R875	241 2377 989	Carbon film 150ohm 1/4W(NB)	RD14B2E151JNBS
R923,924	241 2377 989	Carbon film 150ohm 1/4W(NB)	RD14B2E151JNBS

Ref. No.	Part No.	Part Name	Remarks
R939,940	241 2378 920	Carbon film 220ohm 1/4W(NB)	RD14B2E221JNBS
R943-950	244 2043 982	Metal oxide 0.22ohm 1W	RS14B3AR22JNBS(S)
R951,952	244 2051 987	Metal oxide 4.7ohm 1W	RS14B3A4R7JNBS(S)
R953,954	241 2380 950	Carbon film 2kohm 1/4W(NB)	RD14B2E202JNBS
R959,960	241 2380 950	Carbon film 2kohm 1/4W(NB)	RD14B2E202JNBS
R967,968	244 2043 937	Metal oxide 10ohm 1W	RS14B3A100JNBS(S)
R971,972	241 2387 908	Carbon film 1ohm 1/4W(NB)	RD14B2E010JNBS
R973,974	241 2379 932	Carbon film 620ohm 1/4W(NB)	RD14B2E621JNBS
R975,976	241 2377 989	Carbon film 150ohm 1/4W(NB)	RD14B2E151JNBS
VR701,702	211 6129 909	Semi fixed resistor 4.7kohm	K06QB472
VR801	211 6129 909	Semi fixed resistor 4.7kohm	K06QB472
VR901	211 6129 909	Semi fixed resistor 4.7kohm	K06QB472
VR902	211 6129 909	Semi fixed resistor 4.7kohm	K06QB472

**CAPACITORS GROUP**

C652-654	255 1265 936	Mylar film 0.01µF/50V	CQ93M1H103J(B)
C656	255 1265 936	Mylar film 0.01µF/50V	CQ93M1H103J(B)
C657	256 1034 979	Metalized 0.1µF/50V	CF93A1H104J
C658	254 4260 948	Electrolytic 1µF/50V	CE04W1H010M
C660	253 8014 702	Ceramic 0.01µF/400V(AC)	CK45F2GAC103MC
C661	254 4256 790	Electrolytic 2200µF/25V	CE04W1E222MC
C662	254 4260 948	Electrolytic 1µF/50V	CE04W1H010M
C663	253 1181 904	Ceramic 0.01µF/50V	CK45F1H103Z
C664	254 4254 909	Electrolytic 10µF/16V	CE04W1C100M
C665	253 1181 904	Ceramic 0.01µF/50V	CK45F1H103Z
C667	254 4260 948	Electrolytic 1µF/50V	CE04W1H010M
C668,669	253 1181 904	Ceramic 0.01µF/50V	CK45F1H103Z
C701,702	254 4260 980	Electrolytic 10µF/50V	CE04W1H100M
C703,704	254 4260 951	Electrolytic 2.2µF/50V	CE04W1H2R2M
C705,706	253 4444 907	Ceramic 220pF/50V	CC45SL1H221J
C707,708	253 4537 908	Ceramic 27pF/50V	CC45SL1H270J
C709,710	253 4538 949	Ceramic 100pF/50V	CC45SL1H101J
C711,712	254 4261 918	Electrolytic 47µF/50V	CE04W1H470M
C713,714	253 4537 966	Ceramic 47pF/50V	CC45SL1H470J
C721,722	255 1265 936	Mylar film 0.01µF/50V	CQ93M1H103J(B)
C723,724	254 4263 987	Electrolytic 10µF/100V	CE04W2A100M
C725,726	253 1128 909	Ceramic 220pF/500V	CK45B2H221K
C731,732	255 1265 978	Mylar film 0.022µF/50V	CQ93M1H223J(B)
C733,734	253 1181 904	Ceramic 0.01µF/50V	CK45F1H103Z
C735-738	254 4263 987	Electrolytic 10µF/100V	CE04W2A100M
C738,740	256 1034 979	Metalized 0.1µF/50V	CF93A1H104J
C742	253 1181 904	Ceramic 0.01µF/50V	CK45F1H103Z
C781	253 9039 906	BC ceramic cap. 0.1µF/25V	CK45-1E104Z
C782	254 4254 938	Electrolytic 47µF/16V	CE04W1C470M
C783	254 4254 912	Electrolytic 22µF/16V	CE04W1C220M
C784	253 9039 906	BC ceramic cap. 0.1µF/25V	CK45-1E104Z
C785	254 4250 945	Electrolytic 330µF/6.3V	CE04W0J331M
C786	253 9039 906	BC ceramic cap. 0.1µF/25V	CK45-1E104Z

Ref. No.	Part No.	Part Name	Remarks	Q'ty
C787	254 4250 945	Electrolytic 330µF/6.3V	CE04W0J331M	
C789-792	256 1034 979	Metalized 0.1µF/50V	CF93A1H104J	
C793,794	254 4260 948	Electrolytic 1µF/50V	CE04W1H010M	
C801	254 4260 980	Electrolytic 10µF/50V	CE04W1H100M	
C803	254 4260 951	Electrolytic 2.2µF/50V	CE04W1H2R2M	
C805	253 4444 907	Ceramic 220pF/50V	CC45SL1H221J	
C807	253 4537 908	Ceramic 27pF/50V	CC45SL1H270J	
C809	253 4538 949	Ceramic 100pF/50V	CC45SL1H101J	
C811	254 4261 918	Electrolytic 47µF/50V	CE04W1H470M	
C813	253 4537 966	Ceramic 47pF/50V	CC45SL1H470J	
C821	255 1265 936	Mylar film 0.01µF/50V	CQ93M1H103J(B)	
C823	254 4263 987	Electrolytic 10µF/100V	CE04W2A100M	
C825	253 1128 909	Ceramic 220pF/500V	CK45B2H221K	
C831	255 1265 978	Mylar film 0.022µF/50V	CQ93M1H223J(B)	
C833	253 1181 904	Ceramic 0.01µF/50V	CK45F1H103Z	
C835	254 4263 987	Electrolytic 10µF/100V	CE04W2A100M	
C837	254 4263 987	Electrolytic 10µF/100V	CE04W2A100M	
C839	256 1034 979	Metalized 0.1µF/50V	CF93A1H104J	
C841,842	256 1034 979	Metalized 0.1µF/50V	CF93A1H104J	
C843,844	254 4260 948	Electrolytic 1µF/50V	CE04W1H010M	
C901,902	254 4260 980	Electrolytic 10µF/50V	CE04W1H100M	
C903,904	254 4260 951	Electrolytic 2.2µF/50V	CE04W1H2R2M	
C905,906	253 4444 907	Ceramic 220pF/50V	CC45SL1H221J	
C907,908	253 4537 908	Ceramic 27pF/50V	CC45SL1H270J	
C909,910	253 4538 949	Ceramic 100pF/50V	CC45SL1H101J	
C911,912	254 4261 918	Electrolytic 47µF/50V	CE04W1H470M	
C913,914	253 4537 966	Ceramic 47pF/50V	CC45SL1H470J	
C917,918	255 1265 936	Mylar film 0.01µF/50V	CQ93M1H103J(B)	
C921,922	254 4263 987	Electrolytic 10µF/100V	CE04W2A100M	
C923,924	253 1128 909	Ceramic 220pF/500V	CK45B2H221K	
C929,930	255 1265 978	Mylar film 0.022µF/50V	CQ93M1H223J(B)	
C931,932	253 1181 904	Ceramic 0.01µF/50V	CK45F1H103Z	
C933-936	254 4263 987	Electrolytic 10µF/100V	CE04W2A100M	
C937,938	256 1034 979	Metalized 0.1µF/50V	CF93A1H104J	
C939-943	253 4537 966	Ceramic 47pF/50V	CC45SL1H470J	
C956,957	254 4260 948	Electrolytic 1µF/50V	CE04W1H010M	
C958-961	256 1034 979	Metalized 0.1µF/50V	CF93A1H104J	
C962	253 9039 906	Ceramic 0.1µF/25V	CK45=1E104Z	
<b>OTHER PARTS GROUP</b>				<b>Q'ty</b>
AC651	203 3876 002	AC outlet (2P)		1
CX021,022	205 0581 001	2P VH connector base		2
CX023,024	205 0606 025	2P wrapping terminal		2
CX027	205 0581 001	2P VH connector base		1
CX028	205 0581 056	2P VH connector base		1
CX031	205 0343 032	3P connector base(KR-PH)		1
CX033	205 0343 032	3P connector base(KR-PH)		1
CX038	205 0343 032	3P connector base(KR-PH)		1

Ref. No.	Part No.	Part Name	Remarks	Q'ty
CX051	205 0355 059	5P KR connector base(L)		1
CX060-069	205 1037 062	6P KR pin header (TXX)		10
CX072	205 0355 075	7P KR connector base(L)		1
CX701	205 0087 026	2P wrapping terminal		
CX702	205 0087 039	3 P wrapping terminal		1
CY027	205 0581 001	2P VH connector base		1
CY031	205 0343 032	3P connector base(KR-PH)		
CY054	205 0343 058	5P connector base(KR-PH)		1
F001,008	202 0040 909	Fuse clip		4
F001,008	206 1046 014	Fuse 8A		2
L701,702	235 0068 004	Inductor 1µH		2
L801	235 0068 004	Inductor 1µH		1
L901	235 0068 004	Inductor 1µH		1
L902	235 0068 004	Inductor 1µH		1
RL651	214 0188 000	Relay VS-12MBNR-SM2(TV-8)		1
RL701	214 0190 001	Relay (MR82-12USR)		1
RL902	214 0129 001	Relay (DH2TU)		1
SC783	279 0016 904	Thyristor SF0R1A42		1
SP651	205 0632 002	8P SP terminal (V-1)		1
AT651	233 5819 004	Power trans. (Mini)-EU		1
TH781	279 0034 054	Posistor PTH9M04BC222TS2F333		1
TP701,702	205 0154 030	3P NH connector base		2
TP801	205 0154 030	3P NH connector base		1
TP901,902	205 0154 030	3P NH connector base		2
	412 4165 102	Bus bar		4
	412 4263 004	Bus bar (30X1)		2
	415 0309 026	P.V.C. tube (L=20)	for TH781	2
	417 0476 010	Radiator	for IC704	1
	471 3304 015	Screw 3X8 CBS-Z		1

## 1U-2996 VIDEO &amp; DISPLAY UNIT

Ref. No.	Part No.	Part Name	Remarks	Ref. No.	Part No.	Part Name	Remarks
<b>SEMICONDUCTORS GROUP</b>				<b>RESISTORS GROUP</b>			
IC101	499 0290 007	Remocon sensor GP1U271X		VR201	211 0883 018	Variable resistor 30kohm	V14P25FC303K
IC102	262 2035 008	IC MSC1937-03RS		VR202	211 0883 005	Variable resistor 10kohm	V14P25FC103K
IC201	263 0609 002	IC NJM2068DDC		<b>CAPACITORS GROUP</b>			
IC301	263 0857 003	IC BA7626		C101	253 9039 906	BC ceramic cap. 0.1 $\mu$ F/25V	CK45=1E104Z
IC302	263 0856 004	IC BA7625		C102	254 4252 969	Electrolytic 470 $\mu$ F/10V	CE04W1A471M
IC303	262 2311 007	IC M35015-***SP		C104	254 4260 948	Electrolytic 1 $\mu$ F/50V	CE04W1H010M
IC304	262 2067 005	IC MC74HC4053N		C105	253 9039 906	BC ceramic cap. 0.1 $\mu$ F/25V	CK45=1E104Z
IC305	263 0682 003	IC NJM2229S		C106	254 4261 921	Electrolytic 100 $\mu$ F/50V	CE04W1H101M
IC401	263 0856 004	IC BA7625		C107	253 1181 904	Ceramic 0.01 $\mu$ F/50V	CK45F1H103Z
IC402	262 0522 005	IC TC4053BP		C108	254 4250 945	Electrolytic 330 $\mu$ F/6.3V	CE04W0J331M
IC403	263 0793 002	IC NJM7806FA(S)		C109	253 1179 903	Ceramic 100pF/50V	CK45B1H101K
IC405	263 0793 002	IC NJM7806FA(S)		C110,111	253 1181 904	Ceramic 0.01 $\mu$ F/50V	CK45F1H103Z
TR101~105	269 0020 906	Transistor DTC114ES(10K-10K)		C201,202	254 4260 948	Electrolytic 1 $\mu$ F/50V	CE04W1H010M
TR106	269 0046 906	Transistor DTA114ES(10K-10K)		C203,204	254 4254 938	Electrolytic 47 $\mu$ F/16V	CE04W1C470M
TR201~204	275 0061 902	FET 2SK184(GR)/(BL)		C205,206	253 4537 924	Ceramic 33pF/50V	CC45SL1H330J
TR205	269 0046 906	Transistor DTA114ES(10K-10K)		C207,208	255 1264 940	Mylar film 2200pF/50V	CQ93M1H222J(B)
TR206	269 0020 906	Transistor DTC114ES(10K-10K)		C209,210	256 1035 907	Metallized 0.18 $\mu$ F/50V	CF93A1H184J
TR301~307	271 0290 904	Transistor 2PA1015GR		C211,212	254 4260 948	Electrolytic 1 $\mu$ F/50V	CE04W1H010M
TR309	271 0290 904	Transistor 2PA1015GR		C215,216	255 1265 949	Mylar film 0.012 $\mu$ F/50V	CQ93M1H123J(B)
TR310	269 0020 906	Transistor DTC114ES(10K-10K)		C217,218	256 1034 940	Metallized 0.056 $\mu$ F/50V	CF93A1H563J
TR311	273 0446 903	Transistor 2PC1815BL		C219,220	254 4260 922	Electrolytic 0.33 $\mu$ F/50V	CE04W1HR33M
TR312	271 0290 904	Transistor 2PA1015GR		C231,232	253 4538 949	Ceramic 100pF/50V	CC45SL1H101J
TR314	271 0290 904	Transistor 2PA1015GR		C233,234	254 3052 937	Electrolytic 100 $\mu$ F/50V	CE04W1A101MBP
TR402~405	271 0290 904	Transistor 2PA1015GR		C301	254 4260 948	Electrolytic 1 $\mu$ F/50V	CE04W1H010M
D201,202	276 0432 903	Diode 1SS270A		C302	253 1181 904	Ceramic 0.01 $\mu$ F/50V	CK45F1H103Z
D301~306	276 0432 903	Diode 1SS270A		C303~310	254 4260 977	Electrolytic 4.7 $\mu$ F/50V	CE04W1H4R7M
D401~403	276 0432 903	Diode 1SS270A		C311	254 4250 932	Electrolytic 220 $\mu$ F/6.3V	CE04W0J221M
D405~408	276 0548 910	Diode DSM1D2		C312	254 4250 958	Electrolytic 470 $\mu$ F/6.3V	CE04W0J471M
D409	276 0432 903	Diode 1SS270A		C313	254 4250 932	Electrolytic 220 $\mu$ F/6.3V	CE04W0J221M
ZD101,102	276 0637 902	Zener diode MTZJ6.2A	6.2V	C314	254 4250 958	Electrolytic 470 $\mu$ F/6.3V	CE04W0J471M
LD101	393 9434 906	LED SEL1210S	Red	C315	254 4250 932	Electrolytic 220 $\mu$ F/6.3V	CE04W0J221M
LD102	393 9452 904	LED SEL1410E	green	C316	254 4250 958	Electrolytic 470 $\mu$ F/6.3V	CE04W0J471M
LD103	393 9567 006	LED LD-603MG	PRO-LOGK	C317,318	254 4260 948	Electrolytic 1 $\mu$ F/50V	CE04W1H010M
LD104	393 9566 007	LED LD-603VR	DIGITAL	C319,320	253 1181 917	Ceramic 0.022 $\mu$ F/50V	CK45F1H223Z
LD105	393 9452 904	LED SEL1410E	green	C321	254 4254 909	Electrolytic 10 $\mu$ F/16V	CE04W1C100M
LD106	393 9434 906	LED SEL1210S	Red	C323	254 4252 930	Electrolytic 100 $\mu$ F/10V	CE04W1A101M
FL101	393 4156 001	FLD FIP16FM7R		C324	253 1181 904	Ceramic 0.01 $\mu$ F/50V	CK45F1H103Z
				C327~329	253 4537 924	Ceramic 33pF/50V	CC45SL1H330J
				C330	253 9030 963	BC ceramic cap. 0.01 $\mu$ F/25V	CK45=1E103K
				C331	253 4536 909	Ceramic 10pF/50V	CC45SL1H100D
				C332	253 4536 925	Ceramic 12pF/50V	CC45SL1H120J
				C333	255 1265 978	Mylar film 0.022 $\mu$ F/50V	CQ93M1H223J(B)
				C334	254 4260 977	Electrolytic 4.7 $\mu$ F/50V	CE04W1H4R7M
				C335	253 4538 949	Ceramic 100pF/50V	CC45SL1H101J
				C336	254 4260 948	Electrolytic 1 $\mu$ F/50V	CE04W1H010M
				C337	254 4254 909	Electrolytic 10 $\mu$ F/16V	CE04W1C100M
				C338	255 1264 908	Mylar film 1000pF/50V	CQ93M1H102J(B)
				C339	254 4252 930	Electrolytic 100 $\mu$ F/10V	CE04W1A101M

Ref. No.	Part No.	Part Name	Remarks
C340	253 1181 904	Ceramic 0.01μF/50V	CK45F1H103Z
C341	255 1264 911	Mylar film 1200pF/50V	CQ93M1H122J(B)
C342	253 1179 929	Ceramic 150pF/50V	CK45B1H151K
C343	254 4260 948	Electrolytic 1μF/50V	CE04W1H010M
C344	256 1034 953	Metalized 0.068μF/50V	CF93A1H683J
C345	253 1179 987	Ceramic 470pF/50V	CK45B1H471K
C346	253 9030 934	BC ceramic cap. 1000pF/25V	CK45=1E332K
C347,348	254 4254 909	Electrolytic 10μF/16V	CE04W1C100M
C349,350	254 4252 930	Electrolytic 100μF/10V	CE04W1A101M
C351	254 4254 909	Electrolytic 10μF/16V	CE04W1C100M
C352,353	256 1034 937	Metalized 0.047μF/50V	CF93A1H473J
C354	254 4260 948	Electrolytic 1μF/50V	CE04W1H010M
C355	256 1034 937	Metalized 0.047μF/50V	CF93A1H473J
C356	253 1181 904	Ceramic 0.01μF/50V	CK45F1H103Z
C357	254 4260 948	Electrolytic 1μF/50V	CE04W1H010M
C358	253 1181 904	Ceramic 0.01μF/50V	CK45F1H103Z
C359	254 4260 948	Electrolytic 1μF/50V	CE04W1H010M
C401-404	254 4260 977	Electrolytic 4.7μF/50V	CE04W1H4R7M
C405,406	254 4260 948	Electrolytic 1μF/50V	CE04W1H010M
C407-409	254 4250 958	Electrolytic 470μF/6.3V	CE04W0J471M
C411-413	254 4254 909	Electrolytic 10μF/16V	CE04W1C100M
C414,415	254 4252 930	Electrolytic 100μF/10V	CE04W1A101M
C416	253 1181 917	Ceramic 0.022μF/50V	CK45F1H223Z
C417	254 4260 948	Electrolytic 1μF/50V	CE04W1H010M
C418	254 4254 909	Electrolytic 10μF/16V	CE04W1C100M
C419	253 1181 904	Ceramic 0.01μF/50V	CK45F1H103Z
C420	254 4254 909	Electrolytic 10μF/16V	CE04W1C100M
C421,422	253 1181 904	Ceramic 0.01μF/50V	CK45F1H103Z
C423	254 4254 909	Electrolytic 10μF/16V	CE04W1C100M
C425	254 4254 909	Electrolytic 10μF/16V	CE04W1C100M
C426	254 4472 707	Electrolytic 4700μF/16V	CE04W1C472MC
C427	253 1181 904	Ceramic 0.01μF/50V	CK45F1H103Z
C428,429	254 4254 909	Electrolytic 10μF/16V	CE04W1C100M

Ref. No.	Part No.	Part Name	Remarks	Q'ty
FB302-306	235 0049 900	Beads inductor		6
JK301	205 0902 004	1P S-terminal (SW)		1
JK302,303	204 8415 011	3P S-terminal		2
JK401,402	204 8516 017	3P pin jack		2
JK403	204 8512 008	1P pin jack		1
L101	235 0060 989	Inductor 120μH		1
L301	235 0060 963	Inductor 15μH		1
S101-122	212 5604 910	Tact switch		22
S128	212 0373 000	Rotary encorder EC16B		1
XL301	399 0153 006	Crystal 14.32MHZ-12PF		1
XL302	399 0105 009	Ceramic resonator CSB503F2		1
	417 0476 010	Radiator	for IC403	1
	471 3304 015	Screw 3X8 CBS-Z		1

OTHER PARTS GROUP				Q'ty
CW083	205 0885 095	8P connector socket (TUC-P)		1
CW121	205 0885 079	12P connector socket (TUC-P)		1
CW132	205 0942 006	13P connector socket(TUC-P)		1
CX039	205 0355 033	3P KR connector base (L)		1
CX101	205 1055 002	10P connector base (TKC-V)		1
CX221	205 1055 015	22P connector base (TKC-V)		1
CX934	205 0343 032	3P connector base(KR-PH)		1
F401	202 0040 909	Fuse clip		2
F401	206 1039 076	Fuse 2.5A		1

## 1U-2997 TUNER UNIT

Ref. No.	Part No.	Part Name	Remarks	Ref. No.	Part No.	Part Name	Remarks
<b>SEMICONDUCTORS GROUP</b>				R538	247 0009 943	Carbon chip 6.8kohm 1/10W	RM73B--682J
IC501	216 0102 008	Front end		R539	247 0009 927	Carbon chip 5.6kohm 1/10W	RM73B--562J
IC502	263 0891 001	IC LA1265(S)		R540,541	247 0009 985	Carbon chip 10kohm 1/10W	RM73B--103J
IC503	263 0439 007	IC LA3401		R542,543	247 0008 960	Carbon chip 3.3kohm 1/10W	RM73B--332J
IC504	263 0615 902	IC BA15218F		R544,545	247 0012 927	Carbon chip 100kohm 1/10W	RM73B--104J
IC505	262 2348 009	IC LM7001JU		R546	247 0011 973	Carbon chip 62kohm 1/10W	RM73B--623J
IC506	263 0801 004	IC NJM7812FA(S)		R547	247 0012 927	Carbon chip 100kohm 1/10W	RM73B--104J
IC507	268 0073 905	IC ICP-N15	IC protector	R548	247 0009 985	Carbon chip 10kohm 1/10W	RM73B--103J
TR502	273 0411 909	Transistor 2SC2996-Y		R549	247 0012 927	Carbon chip 100kohm 1/10W	RM73B--104J
TR503,504	269 0083 901	Transistor DTA114EK		R550	247 0009 927	Carbon chip 5.6kohm 1/10W	RM73B--562J
TR505	269 0114 906	Transistor RN2402		R551	247 0009 985	Carbon chip 10kohm 1/10W	RM73B--103J
TR506	273 0403 904	Transistor 2SC2712-Y/GR		R553-556	247 0008 960	Carbon chip 3.3kohm 1/10W	RM73B--332J
TR507	275 0075 901	FET 2SK209-Y/GR		R557,558	247 0012 927	Carbon chip 100kohm 1/10W	RM73B--104J
TR508	269 0054 901	Transistor DTC144EK		R559,560	247 0005 905	Carbon chip 100ohm 1/10W	RM73B--101J
TR509,510	269 0066 902	Transistor DTC323TK		R561,562	247 0009 985	Carbon chip 10kohm 1/10W	RM73B--103J
TR511	269 0086 908	Transistor DTA114TK		R563,564	247 0008 986	Carbon chip 3.9kohm 1/10W	RM73B--392J
TR601,602	273 0429 904	Transistor 2SC3311A		R565,566	247 0005 905	Carbon chip 100ohm 1/10W	RM73B--101J
TR928,929	273 0253 918	Transistor 2SC2878(A/B)		R567,568	247 0008 960	Carbon chip 3.3kohm 1/10W	RM73B--332J
D501-505	276 0438 910	Diode MA151A		R569	247 0009 985	Carbon chip 10kohm 1/10W	RM73B--103J
D601	276 0371 006	Diode S10VB20F9		R571,572	247 0011 973	Carbon chip 62kohm 1/10W	RM73B--623J
D602,603	276 0432 903	Diode 1SS270A		R573,574	247 0015 966	Carbon chip 2.7Mohm 1/10W	RM73B--275J
<b>RESISTORS GROUP</b>				R575,576	247 0012 943	Carbon chip 120kohm 1/10W	RM73B--124J
R501	247 0002 966	Carbon chip 10ohm 1/10W	RM73B--100J	R577	247 0010 961	Carbon chip 22kohm 1/10W	RM73B--223J
R503	247 0007 945	Carbon chip 1kohm 1/10W	RM73B--102J	R578-581	247 0018 905	Carbon chip 0ohm 1/10W	RM73B--0R0K
R504-514	247 0018 905	Carbon chip 0ohm 1/10W	RM73B--0R0K	R592,593	247 0018 905	Carbon chip 0ohm 1/10W	RM73B--0R0K
R515	247 0005 905	Carbon chip 100ohm 1/10W	RM73B--101J	R594,595	247 0012 998	Carbon chip 200kohm 1/10W	RM73B--204J
R516	247 0007 945	Carbon chip 1kohm 1/10W	RM73B--102J	R601	244 2050 933	Metal oxide 180ohm 1W	RS14B3A181JNBS(S)
R518	247 0005 989	Carbon chip 220ohm 1/10W	RM73B--221J	R602	247 0009 901	Carbon chip 4.7kohm 1/10W	RM73B--472J
R519	247 0006 962	Carbon chip 470ohm 1/10W	RM73B--471J	R603	247 0009 985	Carbon chip 10kohm 1/10W	RM73B--103J
R520	247 0007 945	Carbon chip 1kohm 1/10W	RM73B--102J	R604	244 2050 933	Metal oxide 180ohm 1W	RS14B3A181JNBS(S)
R521	247 0009 901	Carbon chip 4.7kohm 1/10W	RM73B--472J	R605	247 0009 901	Carbon chip 4.7kohm 1/10W	RM73B--472J
R522	247 0006 920	Carbon chip 330ohm 1/10W	RM73B--331J	R606	247 0009 985	Carbon chip 10kohm 1/10W	RM73B--103J
R523	247 0007 961	Carbon chip 1.2kohm 1/10W	RM73B--122J	R621	244 2052 960	Metal oxide 220ohm 1W	RS14B3A221JNBS(S)
R524,525	247 0012 927	Carbon chip 100kohm 1/10W	RM73B--104J	R623	244 2052 960	Metal oxide 220ohm 1W	RS14B3A221JNBS(S)
R526	247 0005 905	Carbon chip 100ohm 1/10W	RM73B--101J	R641	244 2055 996	Metal oxide 1.2kohm 1W	RS14B3A122JNBS(S)
R527	247 0009 969	Carbon chip 8.2kohm 1/10W	RM73B--822J	R644	247 0018 905	Carbon chip 0ohm 1/10W	RM73B--0R0K
R528	247 0008 986	Carbon chip 3.9kohm 1/10W	RM73B--392J	R647,648	247 0018 905	Carbon chip 0ohm 1/10W	RM73B--0R0K
R529	247 0006 946	Carbon chip 390ohm 1/10W	RM73B--391J	R982-984	247 0007 903	Carbon chip 680ohm 1/10W	RM73B--681J
R530	247 0005 947	Carbon chip 150ohm 1/10W	RM73B--151J	R985	247 0009 985	Carbon chip 10kohm 1/10W	RM73B--103J
R531	247 0018 905	Carbon chip 0ohm 1/10W	RM73B--0R0K	R988	247 0010 961	Carbon chip 22kohm 1/10W	RM73B--223J
R532	247 0005 921	Carbon chip 120ohm 1/10W	RM73B--121J	R989	247 0007 945	Carbon chip 1kohm 1/10W	RM73B--102J
R533	247 0010 929	Carbon chip 15kohm 1/10W	RM73B--153J	R990,991	247 0012 927	Carbon chip 100kohm 1/10W	RM73B--104J
R534	247 0005 921	Carbon chip 120ohm 1/10W	RM73B--121J	R992	247 0005 989	Carbon chip 220ohm 1/10W	RM73B--221J
R535	247 0010 945	Carbon chip 18kohm 1/10W	RM73B--183J	VR501	211 6093 941	Semi fixed resistor 10kohm	V06PB103
R536	247 0018 905	Carbon chip 0ohm 1/10W	RM73B--0R0K	VR502	211 6093 970	Semi fixed resistor 100kohm	V06PB104
R537	247 0011 986	Carbon chip 68kohm 1/10W	RM73B--683J				

Ref. No.	Part No.	Part Name	Remarks
<b>CAPACITORS GROUP</b>			
C501,502	257 0008 983	Ceramic chip 1000pF/50V	CK73B1H102K
C503-505	257 0010 900	Ceramic chip 0.01μF/50V	CK73B1H103K
C507,508	257 0010 900	Ceramic chip 0.01μF/50V	CK73B1H103K
C509	257 0002 947	Ceramic chip 12pF/50V	CC73SL1H120J
C510	257 0010 900	Ceramic chip 0.01μF/50V	CK73B1H103K
C511	254 4260 906	Electrolytic 0.1μF/50V	CE04W1H0R1M
C512	254 4254 954	Electrolytic 220μF/16V	CE04W1C221M
C513	254 3056 917	Electrolytic 1μF/50V	CE04D1H010MBP
C514	257 0010 942	Ceramic chip 0.022μF/50V	CK73B1H223K
C515	254 4254 938	Electrolytic 47μF/16V	CE04W1C470M
C516,517	257 0010 900	Ceramic chip 0.01μF/50V	CK73B1H103K
C520	257 0004 961	Ceramic chip 100pF/50V	CC73SL1H101J
C521-523	257 0010 900	Ceramic chip 0.01μF/50V	CK73B1H103K
C524	254 4260 935	Electrolytic 0.47μF/50V	CE04W1HR47M
C525	254 4260 980	Electrolytic 10μF/50V	CE04W1H100M
C526	257 0010 942	Ceramic chip 0.022μF/50V	CK73B1H223K
C527	254 4260 948	Electrolytic 1μF/50V	CE04W1H010M
C528	254 4254 938	Electrolytic 47μF/16V	CE04W1C470M
C529	254 4260 948	Electrolytic 1μF/50V	CE04W1H010M
C530	254 4260 919	Electrolytic 0.22μF/50V	CE04W1HR22M
C531	254 4260 948	Electrolytic 1μF/50V	CE04W1H010M
C532	257 0010 900	Ceramic chip 0.01μF/50V	CK73B1H103K
C533	256 1034 937	Metallized 0.047μF/50V	CF93A1H473J
C534	256 1034 940	Metallized 0.056μF/50V	CF93A1H563J
C535	254 3053 910	Electrolytic 22μF/16V	CE04D1C220MBP
C536	257 0004 961	Ceramic chip 100pF/50V	CC73SL1H101J
C538	254 4254 912	Electrolytic 22μF/16V	CE04W1C220M
C539,540	257 0006 972	Ceramic chip 750pF/50V	CC73SL1H751J
C541	254 4260 951	Electrolytic 2.2μF/50V	CE04W1H2R2M
C544	253 1181 904	Ceramic 0.01μF/50V	CK45F1H103Z
C545-548	254 4254 909	Electrolytic 10μF/16V	CE04W1C100M
C551,552	254 4260 948	Electrolytic 1μF/50V	CE04W1H010M
C553,554	257 0008 983	Ceramic chip 1000pF/50V	CK73B1H102K
C555,556	254 4254 912	Electrolytic 22μF/16V	CE04W1C220M
C557,558	257 0002 976	Ceramic chip 16pF/50V	CC73SL1H160J
C559	254 4260 948	Electrolytic 1μF/50V	CE04W1H010M
C560	257 0010 900	Ceramic chip 0.01μF/50V	CK73B1H103K
C561,562	254 4260 948	Electrolytic 1μF/50V	CE04W1H010M
C563	257 0010 900	Ceramic chip 0.01μF/50V	CK73B1H103K
C568	257 0010 900	Ceramic chip 0.01μF/50V	CK73B1H103K
C569	253 1146 907	Ceramic 0.01μF/50V	CK45F1H103Z
C570	254 4254 909	Electrolytic 10μF/16V	CE04W1C100M
C571	254 4260 948	Electrolytic 1μF/50V	CE04W1H010M
C574	257 0004 961	Ceramic chip 100pF/50V	CC73SL1H101J
C587	257 0010 900	Ceramic chip 0.01μF/50V	CK73B1H103K
C589,590	254 4254 909	Electrolytic 10μF/16V	CE04W1C100M
C591	254 0008 983	Ceramic chip 1000pF/50V	CK73B1H102K
C601,602	256 1042 903	Metallized 0.1μF/250V	CF93A2E104K
C603,604	254 6211 005	Electrolytic 12000μF/63V	CE68W1J123M(DL)
C605-607	256 1042 903	Metallized 0.1μF/250V	CF93A2E104K

Ref. No.	Part No.	Part Name	Remarks
C608	254 4260 948	Electrolytic 1μF/50V	CE04W1H010M
C609-613	255 1265 936	Mylar film 0.01μF/50V	CQ93M1H103J(B)
C621,622	257 0007 900	Ceramic chip 1000pF/50V	CC73SL1H102J
C624,625	257 0010 900	Ceramic chip 0.01μF/50V	CK73B1H103K
C631	253 8014 702	Ceramic 0.01μF/400V(AC)	CK45F2GAC103MC
C944-947	254 4254 938	Electrolytic 47μF/16V	CE04W1C470M
C950	254 4254 912	Electrolytic 22μF/16V	CE04W1C220M
C951	254 4260 948	Electrolytic 1μF/50V	CE04W1H010M
C952	257 0010 900	Ceramic chip 0.01μF/50V	CK73B1H103K
C953	257 0004 961	Ceramic chip 100pF/50V	CC73SL1H101J
<b>OTHER PARTS GROUP</b>			
CF501	261 0135 907	Ceramic filter MA8	1
CF502	261 0136 906	Ceramic filter MS2G	1
CF503	261 0079 005	Resonator CSB456F11	1
CF504	399 0075 003	Crystal 7.2 MHz	1
CW113	205 0885 066	11P connector socket (TUC-P)	1
CW141	205 0885 011	14P connector socket (TUC-P)	1
CX035,036	205 0087 039	3 P wrapping terminal	2
CX042	205 0343 045	4P connector base(KR-PH)	1
CX931	205 0190 036	3P NH connector base	1
CX932	205 0087 039	3 P wrapping terminal	1
CY021,022	205 0581 001	2P VH connector base	2
CY028	205 0581 056	2P VH connector base	1
CY033	205 0343 032	3P connector base(KR-PH)	1
CY037	205 0087 039	3 P wrapping terminal	1
CY038	205 0343 032	3P connector base(KR-PH)	1
CY041,042	205 0343 045	4P connector base(KR-PH)	2
CY055	205 0343 058	5P connector base(KR-PH)	1
CY935	205 0343 032	3P connector base(KR-PH)	1
FB501	235 0049 900	Beads inductor	1
FB503	235 0049 900	Beads inductor	1
FB505	235 0049 900	Beads inductor	1
FB903	235 0049 900	Beads inductor	1
JK501	205 0847 004	3P antenna terminal (PAL/F)	1
JK502	204 8545 004	4P pin jack (GND)	1
JK601	204 8264 013	Headphone jack (NI)	1
JK901	204 8540 009	4 P pin jack	1
L501	231 2096 001	MW ant.-osc. coil	1
L502	231 2085 009	FM det. trans.	1

1U-2998 AUDIO & DSP UNIT

Ref. No.	Part No.	Part Name	Remarks	Q'ty	Ref. No.	Part No.	Part Name	Remarks
L503	231 1138 009	AM IFT		1	<b>SEMICONDUCTORS GROUP</b>			
RL601	214 0154 005	Relay (VB24SMBU)		1	IC301	269 0097 007	IC GP1F32R	
RL602	214 0129 001	Relay (DH2TU)		1	IC302	262 2384 908	IC SN74HCU04NS	
ASW631	212 1031 008	Power switch (TV-5)		1	IC303	262 2386 906	IC SN74HC151NS	
TM601	205 0632 002	8P SP terminal (V-1)		1	IC304	263 1018 003	IC MC14577CP	
X501	261 0031 001	Ceramic filter BFU450C4		1	IC305	263 0687 901	IC BA4560FT	
X502	261 0116 007	Ceramic filter SFU450B3		1	IC306	262 2371 908	IC BR62256F-70LL	
	414 0819 005	Earth plate		1	IC307	262 2374 002	IC TMP87CM43N-****	SUB-UCOM
	417 0476 010	Radiator	for IC506	1	IC308	262 2372 004	IC PM4007A	
	471 3304 015	Screw 3X8 CBS-Z		1	IC454	262 1718 902	IC TC74HC00AF	
					IC455	262 1348 903	IC TC74HC123AF	
					IC456	262 2385 907	IC SN74HC14NS	
					IC457	262 2370 006	IC ZR38600	
					IC458	262 2376 903	IC TC74HCT7007AF	
					IC460	263 1048 002	IC BA033T	
					IC501~503	262 2210 904	IC SM5841HS	
					IC504~506	262 2145 008	IC PCM69AP	
					IC507~512	263 0896 909	IC NJM2068MD	
					IC513,514	263 1047 906	IC NJM2115M	
					IC515	262 2158 901	IC AK5340-VS-E1	
					IC516	399 0300 008	IC SG-531PH(12.288MHz)	
					IC517	263 0673 902	IC BA10393F	
					IC601	263 0896 909	IC NJM2068MD	
					IC602	262 2034 009	IC TC9273N-007	
					IC603	262 2033 000	IC TC9273N-004	
					IC604~606	263 0615 902	IC BA15218F	
					IC701~703	263 0615 902	IC BA15218F	
					IC704	262 1853 100	IC NJU7313AL	
					IC803~806	263 0615 902	IC BA15218F	
					TR301,302	274 0163 904	Transistor 2SD601A	
					TR303,304	272 0125 904	Transistor 2SB709A	
					TR309,310	274 0163 904	Transistor 2SD601A	
					TR431	269 0083 901	Transistor DTA114EK	
					TR501~512	273 0414 906	Transistor 2SC3326(A/B)	
					TR513	269 0082 902	Transistor DTC114EK	
					TR601	275 0075 901	FET 2SK209-Y/GR	
					TR603	269 0055 900	Transistor DTA144EK	
					TR604	269 0054 901	Transistor DTC144EK	
					TR805	275 0094 908	FET 2SK209-GR	
					TR808	269 0055 900	Transistor DTA144EK	
					TR809	269 0054 901	Transistor DTC144EK	

Ref. No.	Part No.	Part Name	Remarks
D301~303	276 0438 910	Diode MA151A	
D461~464	276 0438 910	Diode MA151A	
D501	276 0438 910	Diode MA151A	
D503	276 0438 910	Diode MA151A	
D601,602	276 0438 910	Diode MA151A	
D801	276 0438 910	Diode MA151A	
CD303	276 0663 905	Diode KV1851-TL	

**RESISTORS GROUP**

R300	247 0011 944	Carbon chip 47kohm 1/10W	RM73B--473J
R302	247 0004 977	Carbon chip 75ohm 1/10W	RM73B--750J
R303	247 0005 989	Carbon chip 220ohm 1/10W	RM73B--221J
R305	247 0011 944	Carbon chip 47kohm 1/10W	RM73B--473J
R306	247 0006 988	Carbon chip 560ohm 1/10W	RM73B--561J
R307	247 0004 993	Carbon chip 91ohm 1/10W	RM73B--910J
R308~310	247 0007 945	Carbon chip 1kohm 1/10W	RM73B--102J
R311	247 0009 901	Carbon chip 4.7kohm 1/10W	RM73B--472J
R312	247 0005 947	Carbon chip 150ohm 1/10W	RM73B--151J
R313	247 0008 928	Carbon chip 2.2kohm 1/10W	RM73B--222J
R314~317	247 0007 945	Carbon chip 1kohm 1/10W	RM73B--102J
R318	247 0009 985	Carbon chip 10kohm 1/10W	RM73B--103J
R319,320	247 0007 945	Carbon chip 1kohm 1/10W	RM73B--102J
R321	247 0009 901	Carbon chip 4.7kohm 1/10W	RM73B--472J
R322	247 0007 945	Carbon chip 1kohm 1/10W	RM73B--102J
R323	247 0008 960	Carbon chip 3.3kohm 1/10W	RM73B--332J
R324	247 0007 945	Carbon chip 1kohm 1/10W	RM73B--102J
R332	247 0008 902	Carbon chip 1.8kohm 1/10W	RM73B--182J
R333,334	247 0009 985	Carbon chip 10kohm 1/10W	RM73B--103J
R335,336	247 0009 901	Carbon chip 4.7kohm 1/10W	RM73B--472J
R337	247 0008 986	Carbon chip 3.9kohm 1/10W	RM73B--392J
R339	247 0012 927	Carbon chip 100kohm 1/10W	RM73B--104J
R340	247 0009 969	Carbon chip 8.2kohm 1/10W	RM73B--822J
R341	247 0010 987	Carbon chip 27kohm 1/10W	RM73B--273J
R342	247 0011 986	Carbon chip 68kohm 1/10W	RM73B--683J
R343,344	247 0009 985	Carbon chip 10kohm 1/10W	RM73B--103J
R345	247 0005 921	Carbon chip 120ohm 1/10W	RM73B--121J
R346~349	247 0011 944	Carbon chip 47kohm 1/10W	RM73B--473J
R350	247 0004 922	Carbon chip 47ohm 1/10W	RM73B--470J
R351	247 0018 905	Carbon chip 0ohm 1/10W	RM73B--0R0K
R352~370	247 0009 985	Carbon chip 10kohm 1/10W	RM73B--103J
R371~385	247 0018 905	Carbon chip 0ohm 1/10W	RM73B--0R0K
R386	247 0009 901	Carbon chip 4.7kohm 1/10W	RM73B--472J
R387~398	247 0018 905	Carbon chip 0ohm 1/10W	RM73B--0R0K
R399	247 0005 905	Carbon chip 100ohm 1/10W	RM73B--101J
R400~403	247 0009 901	Carbon chip 4.7kohm 1/10W	RM73B--472J
R404	247 0018 905	Carbon chip 0ohm 1/10W	RM73B--0R0K

R405	247 0010 903	Carbon chip 12kohm 1/10W	RM73B--123J
R406	247 0018 905	Carbon chip 0ohm 1/10W	RM73B--0R0K
R408,409	247 0018 905	Carbon chip 0ohm 1/10W	RM73B--0R0K
R410,411	247 0008 915	Carbon chip 2kohm 1/10W	RM73B--202J
R412~416	247 0004 922	Carbon chip 47ohm 1/10W	RM73B--470J
R417~422	247 0012 927	Carbon chip 100kohm 1/10W	RM73B--104J
R425	247 0011 944	Carbon chip 47kohm 1/10W	RM73B--473J
R428~431	247 0018 905	Carbon chip 0ohm 1/10W	RM73B--0R0K
R432	247 0010 958	Carbon chip 20kohm 1/10W	RM73B--203J
R433	247 0005 905	Carbon chip 100ohm 1/10W	RM73B--101J
R434	247 0009 901	Carbon chip 4.7kohm 1/10W	RM73B--472J
R435	247 0009 985	Carbon chip 10kohm 1/10W	RM73B--103J
R437,438	247 0007 945	Carbon chip 1kohm 1/10W	RM73B--102J
R439,440	247 0008 960	Carbon chip 3.3kohm 1/10W	RM73B--332J
R441,442	247 0007 945	Carbon chip 1kohm 1/10W	RM73B--102J
R443,444	247 0008 960	Carbon chip 3.3kohm 1/10W	RM73B--332J
R445,446	247 0007 945	Carbon chip 1kohm 1/10W	RM73B--102J
R447,448	247 0008 960	Carbon chip 3.3kohm 1/10W	RM73B--332J
R449,450	247 0018 905	Carbon chip 0ohm 1/10W	RM73B--0R0K
R462,463	247 0012 927	Carbon chip 100kohm 1/10W	RM73B--104J
R467~469	247 0018 905	Carbon chip 0ohm 1/10W	RM73B--0R0K
R471	247 0018 905	Carbon chip 0ohm 1/10W	RM73B--0R0K
R477~480	247 0009 901	Carbon chip 4.7kohm 1/10W	RM73B--472J
R481,482	247 0011 944	Carbon chip 47kohm 1/10W	RM73B--473J
R483~486	247 0009 998	Carbon chip 11kohm 1/10W	RM73B--113J
R487~490	247 0009 901	Carbon chip 4.7kohm 1/10W	RM73B--472J
R491~494	247 0006 920	Carbon chip 330ohm 1/10W	RM73B--331J
R496	247 0018 905	Carbon chip 0ohm 1/10W	RM73B--0R0K
R497	247 0009 985	Carbon chip 10kohm 1/10W	RM73B--103J
R498~500	247 0005 905	Carbon chip 100ohm 1/10W	RM73B--101J
R501~503	247 0018 905	Carbon chip 0ohm 1/10W	RM73B--0R0K
R504~518	247 0006 920	Carbon chip 330ohm 1/10W	RM73B--331J
R520	247 0018 905	Carbon chip 0ohm 1/10W	RM73B--0R0K
R521,522	247 0007 961	Carbon chip 1.2kohm 1/10W	RM73B--122J
R523,524	247 0006 988	Carbon chip 560ohm 1/10W	RM73B--561J
R525~528	247 0009 943	Carbon chip 6.8kohm 1/10W	RM73B--682J
R529,530	247 0012 927	Carbon chip 100kohm 1/10W	RM73B--104J
R531,532	247 0008 944	Carbon chip 2.7kohm 1/10W	RM73B--272J
R533,534	247 0009 901	Carbon chip 4.7kohm 1/10W	RM73B--472J
R535,536	247 0009 901	Carbon chip 4.7kohm 1/10W	RM73B--472J
R537,538	247 0009 901	Carbon chip 4.7kohm 1/10W	RM73B--472J
R539,540	247 0005 989	Carbon chip 220ohm 1/10W	RM73B--221J
R541,542	247 0008 960	Carbon chip 3.3kohm 1/10W	RM73B--332J
R543,544	247 0012 927	Carbon chip 100kohm 1/10W	RM73B--104J
R545,546	247 0007 961	Carbon chip 1.2kohm 1/10W	RM73B--122J
R547,548	247 0006 988	Carbon chip 560ohm 1/10W	RM73B--561J
R549	247 0009 914	Carbon chip 5.1kohm 1/10W	RM73B--512J
R550	247 0009 943	Carbon chip 6.8kohm 1/10W	RM73B--682J
R551	247 0009 914	Carbon chip 5.1kohm 1/10W	RM73B--512J
R552	247 0009 943	Carbon chip 6.8kohm 1/10W	RM73B--682J
R553,554	247 0012 927	Carbon chip 100kohm 1/10W	RM73B--104J



Ref. No.	Part No.	Part Name	Remarks
R555,556	247 0008 944	Carbon chip 2.7kohm 1/10W	RM73B--272J
R557	247 0009 901	Carbon chip 4.7kohm 1/10W	RM73B--472J
R558	247 0009 943	Carbon chip 6.8kohm 1/10W	RM73B--682J
R560	247 0009 901	Carbon chip 4.7kohm 1/10W	RM73B--472J
R561	247 0018 905	Carbon chip 0ohm 1/10W	RM73B--0R0K
R562	247 0009 901	Carbon chip 4.7kohm 1/10W	RM73B--472J
R563,564	247 0005 989	Carbon chip 220ohm 1/10W	RM73B--221J
R565,566	247 0012 927	Carbon chip 100kohm 1/10W	RM73B--104J
R567,568	247 0007 961	Carbon chip 1.2kohm 1/10W	RM73B--122J
R569,570	247 0006 988	Carbon chip 560ohm 1/10W	RM73B--561J
R571-574	247 0009 914	Carbon chip 5.1kohm 1/10W	RM73B--512J
R575,576	247 0012 927	Carbon chip 100kohm 1/10W	RM73B--104J
R577,578	247 0008 944	Carbon chip 2.7kohm 1/10W	RM73B--272J
R579,580	247 0009 901	Carbon chip 4.7kohm 1/10W	RM73B--472J
R583,584	247 0018 905	Carbon chip 0ohm 1/10W	RM73B--0R0K
R585,586	247 0005 989	Carbon chip 220ohm 1/10W	RM73B--221J
R587,588	247 0012 927	Carbon chip 100kohm 1/10W	RM73B--104J
R592	247 0005 905	Carbon chip 100ohm 1/10W	RM73B--101J
R593-596	247 0008 960	Carbon chip 3.3kohm 1/10W	RM73B--332J
R601,602	247 0018 905	Carbon chip 0ohm 1/10W	RM73B--0R0K
R603,604	247 0006 946	Carbon chip 390ohm 1/10W	RM73B--391J
R605,606	247 0011 986	Carbon chip 68kohm 1/10W	RM73B--683J
R607,608	247 0012 969	Carbon chip 150kohm 1/10W	RM73B--154J
R609,610	247 0004 922	Carbon chip 47ohm 1/10W	RM73B--470J
R611,612	247 0005 992	Carbon chip 240ohm 1/10W	RM73B--241J
R613,614	247 0012 956	Carbon chip 130kohm 1/10W	RM73B--134J
R615,616	247 0009 998	Carbon chip 11kohm 1/10W	RM73B--113J
R617,618	247 0003 949	Carbon chip 22ohm 1/10W	RM73B--220J
R619,620	247 0005 905	Carbon chip 100ohm 1/10W	RM73B--101J
R621,622	247 0011 944	Carbon chip 47kohm 1/10W	RM73B--473J
R623-632	247 0015 966	Carbon chip 2.7Mohm 1/10W	RM73B--275J
R633-642	247 0006 962	Carbon chip 470ohm 1/10W	RM73B--471J
R643,644	247 0012 998	Carbon chip 200kohm 1/10W	RM73B--204J
R645,646	247 0006 962	Carbon chip 470ohm 1/10W	RM73B--471J
R647,648	247 0005 905	Carbon chip 100ohm 1/10W	RM73B--101J
R649,650	247 0011 944	Carbon chip 47kohm 1/10W	RM73B--473J
R651-654	247 0012 927	Carbon chip 100kohm 1/10W	RM73B--104J
R655-658	247 0005 905	Carbon chip 100ohm 1/10W	RM73B--101J
R659,660	247 0006 962	Carbon chip 470ohm 1/10W	RM73B--471J
R663,664	247 0005 905	Carbon chip 100ohm 1/10W	RM73B--101J
R665,666	247 0012 927	Carbon chip 100kohm 1/10W	RM73B--104J
R667-672	247 0009 985	Carbon chip 10kohm 1/10W	RM73B--103J
R673,674	247 0018 905	Carbon chip 0ohm 1/10W	RM73B--0R0K
R677,678	247 0005 905	Carbon chip 100ohm 1/10W	RM73B--101J
R679,680	247 0012 927	Carbon chip 100kohm 1/10W	RM73B--104J
R681	247 0011 944	Carbon chip 47kohm 1/10W	RM73B--473J
R683-686	247 0006 962	Carbon chip 470ohm 1/10W	RM73B--471J
R687-690	247 0015 966	Carbon chip 2.7Mohm 1/10W	RM73B--275J
R691,692	247 0005 905	Carbon chip 100ohm 1/10W	RM73B--101J
R693-695	247 0018 905	Carbon chip 0ohm 1/10W	RM73B--0R0K

Ref. No.	Part No.	Part Name	Remarks
R701,702	247 0011 973	Carbon chip 62kohm 1/10W	RM73B--623J
R703,704	247 0012 998	Carbon chip 200kohm 1/10W	RM73B--204J
R705,706	247 0006 962	Carbon chip 470ohm 1/10W	RM73B--471J
R709,710	247 0018 905	Carbon chip 0ohm 1/10W	RM73B--0R0K
R711,712	247 0005 905	Carbon chip 100ohm 1/10W	RM73B--101J
R713,714	247 0012 927	Carbon chip 100kohm 1/10W	RM73B--104J
R717,718	247 0011 973	Carbon chip 62kohm 1/10W	RM73B--623J
R719,720	247 0012 998	Carbon chip 200kohm 1/10W	RM73B--204J
R721,722	247 0006 962	Carbon chip 470ohm 1/10W	RM73B--471J
R725,726	247 0018 905	Carbon chip 0ohm 1/10W	RM73B--0R0K
R727	247 0007 945	Carbon chip 1kohm 1/10W	RM73B--102J
R728	247 0005 905	Carbon chip 100ohm 1/10W	RM73B--101J
R729	247 0008 986	Carbon chip 3.9kohm 1/10W	RM73B--392J
R730	247 0012 927	Carbon chip 100kohm 1/10W	RM73B--104J
R733,734	247 0011 973	Carbon chip 62kohm 1/10W	RM73B--623J
R735,736	247 0012 998	Carbon chip 200kohm 1/10W	RM73B--204J
R737,738	247 0006 962	Carbon chip 470ohm 1/10W	RM73B--471J
R741,742	247 0018 905	Carbon chip 0ohm 1/10W	RM73B--0R0K
R743,744	247 0005 905	Carbon chip 100ohm 1/10W	RM73B--101J
R745,746	247 0012 927	Carbon chip 100kohm 1/10W	RM73B--104J
R747-752	247 0018 905	Carbon chip 0ohm 1/10W	RM73B--0R0K
R791,792	247 0018 905	Carbon chip 0ohm 1/10W	RM73B--0R0K
R801,802	247 0010 961	Carbon chip 22kohm 1/10W	RM73B--223J
R803,804	247 0010 932	Carbon chip 16kohm 1/10W	RM73B--163J
R805-808	247 0009 901	Carbon chip 4.7kohm 1/10W	RM73B--472J
R809,810	247 0007 932	Carbon chip 910ohm 1/10W	RM73B--911J
R811,812	247 0007 945	Carbon chip 1kohm 1/10W	RM73B--102J
R813,814	247 0009 943	Carbon chip 6.8kohm 1/10W	RM73B--682J
R815,816	247 0009 901	Carbon chip 4.7kohm 1/10W	RM73B--472J
R819,820	247 0008 986	Carbon chip 3.9kohm 1/10W	RM73B--392J
R829,830	247 0005 905	Carbon chip 100ohm 1/10W	RM73B--101J
R831,832	247 0012 927	Carbon chip 100kohm 1/10W	RM73B--104J
R833,834	247 0009 901	Carbon chip 4.7kohm 1/10W	RM73B--472J
R835,836	247 0008 928	Carbon chip 2.2kohm 1/10W	RM73B--222J
R837	247 0009 927	Carbon chip 5.6kohm 1/10W	RM73B--562J
R839,840	247 0009 901	Carbon chip 4.7kohm 1/10W	RM73B--472J
R842	247 0009 969	Carbon chip 8.2kohm 1/10W	RM73B--822J
R846	247 0005 905	Carbon chip 100ohm 1/10W	RM73B--101J
R850	247 0012 927	Carbon chip 100kohm 1/10W	RM73B--104J
R869	247 0011 944	Carbon chip 47kohm 1/10W	RM73B--473J
R901-906	247 0007 945	Carbon chip 1kohm 1/10W	RM73B--102J
CAPACITORS GROUP			
C301	257 0014 935	Ceramic chip 0.1µF/25V	CK73F1E104Z
C302	254 4254 938	Electrolytic 47µF/16V	CE04W1C470M
C303	257 0004 961	Ceramic chip 100pF/50V	CC73SL1H101J
C304	254 4256 923	Electrolytic 33µF/25V	CE04W1E330M
C305	257 0012 966	Ceramic chip 0.01µF/50V	CK73F1H103Z
C306	257 0003 904	Ceramic chip 22pF/50V	CC73SL1H220J

Ref. No.	Part No.	Part Name	Remarks
C307	257 0012 966	Ceramic chip 0.01μF/50V	CK73F1H103Z
C308	254 4254 909	Electrolytic 10μF/16V	CE04W1C100M
C309,310	257 0012 966	Ceramic chip 0.01μF/50V	CK73F1H103Z
C311	257 0004 961	Ceramic chip 100pF/50V	CC73SL1H101J
C312	257 0011 941	Ceramic chip 0.022μF/25V	CK73B1E223K
C313-315	257 0014 935	Ceramic chip 0.1μF/25V	CK73F1E104Z
C316	254 4254 909	Electrolytic 10μF/16V	CE04W1C100M
C317	257 0014 935	Ceramic chip 0.1μF/25V	CK73F1E104Z
C318	254 4254 909	Electrolytic 10μF/16V	CE04W1C100M
C319	257 0004 932	Ceramic chip 75pF/50V	CC73SL1H750J
C320	257 0014 935	Ceramic chip 0.1μF/25V	CK73F1E104Z
C321	257 0011 996	Ceramic chip 0.1μF/25V	CK73B1E104K
C322	257 0010 900	Ceramic chip 0.01μF/50V	CK73B1H103K
C323	257 0014 935	Ceramic chip 0.1μF/25V	CK73F1E104Z
C325	257 0008 983	Ceramic chip 1000pF/50V	CK73B1H102K
C326	254 3061 902	Electrolytic 1μF/50V	CE04D1H010MTBP (SRE)
C327	257 0014 935	Ceramic chip 0.1μF/25V	CK73F1E104Z
C328	254 4254 909	Electrolytic 10μF/16V	CE04W1C100M
C329	254 3061 902	Electrolytic 1μF/50V	CE04D1H010MTBP (SRE)
C330	257 0014 935	Ceramic chip 0.1μF/25V	CK73F1E104Z
C331	254 4254 909	Electrolytic 10μF/16V	CE04W1C100M
C332-334	257 0014 935	Ceramic chip 0.1μF/25V	CK73F1E104Z
C335	254 3053 936	Electrolytic 47μF/16V	CE04D1C470MBP
C336	257 0014 935	Ceramic chip 0.1μF/25V	CK73F1E104Z
C337	254 4252 930	Electrolytic 100μF/10V	CE04W1A101M
C338	257 0002 989	Ceramic chip 18pF/50V	CC73SL1H180J
C339	257 0001 922	Ceramic chip 1 pF/50V	CC73SL1H010C
C340,341	257 0010 900	Ceramic chip 0.01μF/50V	CK73B1H103K
C342	257 0014 935	Ceramic chip 0.1μF/25V	CK73F1E104Z
C343	257 0012 966	Ceramic chip 0.01μF/50V	CK73F1H103Z
C344	257 0014 935	Ceramic chip 0.1μF/25V	CK73F1E104Z
C345	257 0012 966	Ceramic chip 0.01μF/50V	CK73F1H103Z
C346	257 0014 935	Ceramic chip 0.1μF/25V	CK73F1E104Z
C347	257 0012 966	Ceramic chip 0.01μF/50V	CK73F1H103Z
C348	254 4254 909	Electrolytic 10μF/16V	CE04W1C100M
C349	257 0014 935	Ceramic chip 0.1μF/25V	CK73F1E104Z
C350	257 0012 966	Ceramic chip 0.01μF/50V	CK73F1H103Z
C351	257 0014 935	Ceramic chip 0.1μF/25V	CK73F1E104Z
C352	254 4254 909	Electrolytic 10μF/16V	CE04W1C100M
C353	257 0014 935	Ceramic chip 0.1μF/25V	CK73F1E104Z
C358	257 0012 966	Ceramic chip 0.01μF/50V	CK73F1H103Z
C360	257 0012 966	Ceramic chip 0.01μF/50V	CK73F1H103Z
C361	257 0011 996	Ceramic chip 0.1μF/25V	CK73B1E104Z
C362,363	257 0012 966	Ceramic chip 0.01μF/50V	CK73F1H103Z
C377,378	257 0004 903	Ceramic chip 56pF/50V	CC73SL1H560J
C382	257 0008 983	Ceramic chip 1000pF/50V	CK73B1H102K
C383	257 0005 944	Ceramic chip 220pF/50V	CK73B1H221J
C384,385	257 0008 983	Ceramic chip 1000pF/50V	CK73B1H102K
C387	257 0008 983	Ceramic chip 1000pF/50V	CK73B1H102K
C388	257 0012 966	Ceramic chip 0.01μF/50V	CK73F1H103Z

Ref. No.	Part No.	Part Name	Remarks
C407	254 4196 944	Electrolytic 1μF/50V	CE04W1H010M (SRA)
C425	257 0012 966	Ceramic chip 0.01μF/50V	CK73F1H103Z
C431,432	254 4196 944	Electrolytic 1μF/50V	CE04W1H010M (SRA)
C434	257 0008 983	Ceramic chip 1000pF/50V	CK73B1H102K
C435	257 0012 966	Ceramic chip 0.01μF/50V	CK73F1H103Z
C436	256 1034 979	Metalized 0.1μF/50V	CF93A1H104J
C437,438	257 0014 935	Ceramic chip 0.1μF/25V	CK73F1E104Z
C441	257 0012 966	Ceramic chip 0.01μF/50V	CK73F1H103Z
C443	254 4254 909	Electrolytic 10μF/16V	CE04W1C100M
C444	254 4260 948	Electrolytic 1μF/50V	CE04W1H010M
C445,446	257 0012 966	Ceramic chip 0.01μF/50V	CK73F1H103Z
C448	257 0008 983	Ceramic chip 1000pF/50V	CK73B1H102K
C461,462	257 0012 966	Ceramic chip 0.01μF/50V	CK73F1H103Z
C463,464	254 4260 935	Electrolytic 0.47μF/50V	CE04W1HR47M
C465-467	257 0012 966	Ceramic chip 0.01μF/50V	CK73F1H103Z
C468	257 0011 983	Ceramic chip 0.047μF/25V	CK73B1E473K
C469	257 0012 966	Ceramic chip 0.01μF/50V	CK73F1H103Z
C470,471	257 0014 935	Ceramic chip 0.1μF/25V	CK73F1E104Z
C472	257 0012 966	Ceramic chip 0.01μF/50V	CK73F1H103Z
C473	257 0007 900	Ceramic chip 1000pF/50V	CC73SL1H102J
C474	257 0012 966	Ceramic chip 0.01μF/50V	CK73F1H103Z
C475	257 0014 935	Ceramic chip 0.1μF/25V	CK73F1E104Z
C476	257 0012 966	Ceramic chip 0.01μF/50V	CK73F1H103Z
C478	257 0012 966	Ceramic chip 0.01μF/50V	CK73F1H103Z
C479	257 0007 900	Ceramic chip 1000pF/50V	CC73SL1H102J
C480	257 0012 966	Ceramic chip 0.01μF/50V	CK73F1H103Z
C481,482	257 0014 935	Ceramic chip 0.1μF/25V	CK73F1E104Z
C483,484	254 4193 905	Electrolytic 10μF/16V	CE04W1C100M(SRA)
C485,486	254 4196 944	Electrolytic 1μF/50V	CE04W1H010M(SRA)
C487,488	254 4193 905	Electrolytic 10μF/16V	CE04W1C100M(SRA)
C489,490	255 1264 924	Mylar film 1500pF/50V	CQ93M1H152J(B)
C492	257 0014 935	Ceramic chip 0.1μF/25V	CK73F1E104Z
C494	254 4193 905	Electrolytic 10μF/16V	CE04W1C100M(SRA)
C495	257 0014 935	Ceramic chip 0.1μF/25V	CK73F1E104Z
C496	257 0008 983	Ceramic chip 1000pF/50V	CK73B1H102K
C497,498	254 4193 905	Electrolytic 10μF/16V	CE04W1C100M(SRA)
C499	257 0008 983	Ceramic chip 1000pF/50V	CK73B1H102K
C500	257 0012 966	Ceramic chip 0.01μF/50V	CK73F1H103Z
C501	254 4193 905	Electrolytic 10μF/16V	CE04W1C100M(SRA)
C502	257 0012 966	Ceramic chip 0.01μF/50V	CK73F1H103Z
C503	254 4193 905	Electrolytic 10μF/16V	CE04W1C100M(SRA)
C504	257 0012 966	Ceramic chip 0.01μF/50V	CK73F1H103Z
C505	254 4193 905	Electrolytic 10μF/16V	CE04W1C100M(SRA)
C506	257 0012 966	Ceramic chip 0.01μF/50V	CK73F1H103Z
C507	254 4193 905	Electrolytic 10μF/16V	CE04W1C100M(SRA)
C508	257 0012 966	Ceramic chip 0.01μF/50V	CK73F1H103Z
C509	254 4193 905	Electrolytic 10μF/16V	CE04W1C100M(SRA)
C510	257 0012 966	Ceramic chip 0.01μF/50V	CK73F1H103Z
C511	254 4193 905	Electrolytic 10μF/16V	CE04W1C100M(SRA)

Ref. No.	Part No.	Part Name	Remarks	Ref. No.	Part No.	Part Name	Remarks	
C512-515	257 0012 966	Ceramic chip 0.01 $\mu$ F/50V	CK73F1H103Z	C641	254 4260 980	Electrolytic 10 $\mu$ F/50V	CE04W1H100M	
C516,517	254 4252 930	Electrolytic 100 $\mu$ F/10V	CE04W1A101M	C642	254 4260 948	Electrolytic 1 $\mu$ F/50V	CE04W1H010M	
C518	254 4193 905	Electrolytic 10 $\mu$ F/16V	CE04W1C100M(SRA)	C643	254 4260 980	Electrolytic 10 $\mu$ F/50V	CE04W1H100M	
C519,520	254 4252 930	Electrolytic 100 $\mu$ F/10V	CE04W1A101M	C644	254 4260 948	Electrolytic 1 $\mu$ F/50V	CE04W1H010M	
C521	254 4193 905	Electrolytic 10 $\mu$ F/16V	CE04W1C100M(SRA)	C645,646	254 4260 951	Electrolytic 2.2 $\mu$ F/50V	CE04W1H2R2M	
C522,523	254 4252 930	Electrolytic 100 $\mu$ F/10V	CE04W1A101M	C647,648	257 0005 944	Ceramic chip 220pF/50V	CC73SL1H221J	
C524	254 4193 905	Electrolytic 10 $\mu$ F/16V	CE04W1C100M(SRA)	C651,652	254 4260 948	Electrolytic 1 $\mu$ F/50V	CE04W1H010M	
C525,526	257 0012 966	Ceramic chip 0.01 $\mu$ F/50V	CK73F1H103Z	C655,656	254 4254 909	Electrolytic 10 $\mu$ F/16V	CE04W1C100M	
C527,528	254 4252 930	Electrolytic 100 $\mu$ F/10V	CE04W1A101M	C657,658	254 4260 948	Electrolytic 1 $\mu$ F/50V	CE04W1H010M	
C529-532	257 0004 961	Ceramic chip 100pF/50V	CC73SL1H101J	C661-664	257 0004 961	Ceramic chip 100pF/50V	CC73SL1H101J	
C533,534	254 4193 905	Electrolytic 10 $\mu$ F/16V	CE04W1C100M(SRA)	C665-667	257 0012 966	Ceramic chip 0.01 $\mu$ F/50V	CK73F1H103Z	
C535,536	255 4201 968	Polypropylene film 470pF/50V	CQ93P1H471J	C671,672	254 4254 909	Electrolytic 10 $\mu$ F/16V	CE04W1C100M	
C537,538	255 4201 984	Polypropylene film 560pF/50V	CQ93P1H561J	C703,704	254 4254 909	Electrolytic 10 $\mu$ F/16V	CE04W1C100M	
C539,540	257 0014 935	Ceramic chip 0.1 $\mu$ F/25V	CK73F1E104Z	C705,706	257 0004 961	Ceramic chip 100pF/50V	CC73SL1H101J	
C541,542	255 1265 907	Mylar film 6800pF/50V	CQ93M1H682J(B)	C709,710	254 4254 909	Electrolytic 10 $\mu$ F/16V	CE04W1C100M	
C543,544	254 4193 905	Electrolytic 10 $\mu$ F/16V	CE04W1C100M(SRA)	C711,712	254 4260 948	Electrolytic 1 $\mu$ F/50V	CE04W1H010M	
C545,546	254 4252 930	Electrolytic 100 $\mu$ F/10V	CE04W1A101M	C717,718	254 4254 909	Electrolytic 10 $\mu$ F/16V	CE04W1C100M	
C547-550	257 0004 961	Ceramic chip 100pF/50V	CC73SL1H101J	C719,720	257 0004 961	Ceramic chip 100pF/50V	CC73SL1H101J	
C551,552	254 4193 905	Electrolytic 10 $\mu$ F/16V	CE04W1C100M(SRA)	C723	254 4254 941	Electrolytic 100 $\mu$ F/16V	CE04W1C101M	
C553	255 4202 925	Polypropylene film 820pF/50V	CQ93P1H821J	C724	254 4254 909	Electrolytic 10 $\mu$ F/16V	CE04W1C100M	
C555	255 4201 926	Polypropylene film 330pF/50V	CQ93P1H331J	C725,726	254 4260 948	Electrolytic 1 $\mu$ F/50V	CE04W1H010M	
C556	256 1034 979	Metalized 0.1 $\mu$ F/50V	CF93A1H104J	C731,732	254 4254 909	Electrolytic 10 $\mu$ F/16V	CE04W1C100M	
C557,558	257 0014 935	Ceramic chip 0.1 $\mu$ F/25V	CK73F1E104Z	C733,734	257 0004 961	Ceramic chip 100pF/50V	CC73SL1H101J	
C559,560	255 1265 907	Mylar film 6800pF/50V	CQ93M1H682J(B)	C737,738	254 4254 909	Electrolytic 10 $\mu$ F/16V	CE04W1C100M	
C561,562	254 4193 905	Electrolytic 10 $\mu$ F/16V	CE04W1C100M(SRA)	C739,740	254 4260 948	Electrolytic 1 $\mu$ F/50V	CE04W1H010M	
C563,564	254 4252 930	Electrolytic 100 $\mu$ F/10V	CE04W1A101M	C743,744	257 0012 982	Ceramic chip 0.022 $\mu$ F/50V	CK73F1H223Z	
C565-568	257 0004 961	Ceramic chip 100pF/50V	CC73SL1H101J	C745,746	254 4260 948	Electrolytic 1 $\mu$ F/50V	CE04W1H010M	
C569,570	254 4193 905	Electrolytic 10 $\mu$ F/16V	CE04W1C100M(SRA)	C747	253 1116 908	Ceramic chip 2200pF/50V	CK45B1H222K	
C571,572	255 4202 925	Polypropylene film 820pF/50V	CQ93P1H821J	C801,802	256 1034 966	Metalized 0.082 $\mu$ F/50V	CF93A1H823J	
C573,574	255 4201 926	Polypropylene film 330pF/50V	CQ93P1H331J	C803,804	256 1034 982	Metalized 0.12 $\mu$ F/50V	CF93A1H124J	
C575,576	257 0014 935	Ceramic chip 0.1 $\mu$ F/25V	CK73F1E104Z	C805,806	254 4193 905	Electrolytic 10 $\mu$ F/16V	CE04W1C100M(SRA)	
C577,578	255 1265 907	Mylar film 6800pF/50V	CQ93M1H682J(B)	C811,812	254 4254 909	Electrolytic 10 $\mu$ F/16V	CE04W1C100M	
C579,580	254 4193 905	Electrolytic 10 $\mu$ F/16V	CE04W1C100M(SRA)	C813,814	257 0014 935	Ceramic chip 0.1 $\mu$ F/25V	CK73F1E104Z	
C581,582	257 0012 966	Ceramic chip 0.01 $\mu$ F/50V	CK73F1H103Z	C820	254 4254 909	Electrolytic 10 $\mu$ F/16V	CE04W1C100M	
C583-588	254 4193 905	Electrolytic 10 $\mu$ F/16V	CE04W1C100M(SRA)	C823,824	254 4260 948	Electrolytic 1 $\mu$ F/50V	CE04W1H010M	
C589	257 0008 983	Ceramic chip 1000pF/50V	CK73B1H102K	C835,836	254 4260 948	Electrolytic 1 $\mu$ F/50V	CE04W1H010M	
C591	257 0014 935	Ceramic chip 0.1 $\mu$ F/25V	CK73F1E104Z	C837	257 0012 966	Ceramic chip 0.01 $\mu$ F/50V	CK73F1H103Z	
C595	257 0008 983	Ceramic chip 1000pF/50V	CK73B1H102K	C843	254 4260 948	Electrolytic 1 $\mu$ F/50V	CE04W1H010M	
C598	257 0008 983	Ceramic chip 1000pF/50V	CK73B1H102K					
C601,602	257 0005 944	Ceramic chip 220pF/50V	CC73SL1H221J	<b>OTHER PARTS GROUP</b>				<b>Q'ty</b>
C603,604	254 4254 909	Electrolytic 10 $\mu$ F/16V	CE04W1C100M	CW071	205 0942 022	7P connector socket(TUC-P)	1	
C605,606	257 0004 961	Ceramic chip 100pF/50V	CC73SL1H101J	CW091	205 0885 037	9P connector socket (TUC-P)	1	
C607,608	254 4250 932	Electrolytic 220 $\mu$ F/6.3V	CE04W0J221M	CW102	205 0885 053	10P connector socket (TUC-P)	1	
C609,610	255 4199 999	Mylar film 0.024 $\mu$ F/50V	CQ92M1H243J(MRZ)	CW103	205 0986 059	10P connector plug (TKC-A)	1	
C611,612	255 1265 907	Mylar film 6800pF/50V	CQ93M1H682J(B)	CW112	205 0885 066	11P connector socket (TUC-P)	1	
C613,614	254 4254 938	Electrolytic 47 $\mu$ F/16V	CE04W1C470M	CW151,152	205 0885 040	15P connector socket (TUC-P)	2	
C615,616	257 0012 982	Ceramic chip 0.022 $\mu$ F/50V	CK73F1H223Z	CW154	205 0885 040	15P connector socket (TUC-P)	1	
C627,628	257 0004 961	Ceramic chip 100pF/50V	CC73SL1H101J	CX103	205 0985 018	10P connector socket(TKC-A)	1	
C629,930	254 4254 909	Electrolytic 10 $\mu$ F/16V	CE04W1C100M					
C633,634	254 4254 938	Electrolytic 47 $\mu$ F/16V	CE04W1C470M					
C635-640	257 0012 982	Ceramic chip 0.022 $\mu$ F/50V	CK73F1H223Z					

1U-3006 E. VOL UNIT

Ref. No.	Part No.	Part Name	Remarks	Q'ty	Ref. No.	Part No.	Part Name	Remarks
FB301	235 0106 908	Chip emifil (21A05)		1	<b>SEMICONDUCTORS GROUP</b>			
FB307~310	235 0049 900	Beads inductor		4	IC101	262 2214 007	IC LC7536	
FB321~323	235 0049 900	Beads inductor		3	IC103	263 0615 902	IC BA15218F	
FB350~358	235 0106 908	Chip emifil (21A05)		9	IC104	263 0896 909	IC NJM2068MD	
FB501	235 0049 900	Beads inductor		1	IC105,106	263 0615 902	IC BA15218F	
FB503~506	235 0049 900	Beads inductor		4	IC107,108	262 2214 007	IC LC7536	
FB508,509	235 0049 900	Beads inductor		2	IC109,110	263 0615 902	IC BA15218F	
FB510~520	235 0106 908	Chip emifil (21A05)		11	TR171,172	275 0075 901	FET 2SK209-Y/GR	
FB521~524	235 0049 900	Beads inductor		4	TR173	269 0055 900	Transistor DTA144EK	
FB526~528	235 0049 900	Beads inductor		3	TR174	269 0054 901	Transistor DTC144EK	
FB530,531	235 0049 900	Beads inductor		2	TR175	275 0075 901	FET 2SK209-Y/GR	
FB601	235 0106 908	Chip emifil (21A05)		1	D171~173	276 0438 910	Diode MA151A	
FB603	235 0106 908	Chip emifil (21A05)		1	<b>RESISTORS GROUP</b>			
FB701	235 0106 908	Chip emifil (21A05)		1	R111,112	247 0011 944	Carbon chip 47kohm 1/10W	RM73B--473J
JK301	204 8561 004	2P pin jack (NI)		1	R113,114	247 0013 984	Carbon chip 470kohm 1/10W	RM73B--474J
JK601,602	204 8543 006	6 P pin jack		2	R115,116	247 0011 944	Carbon chip 47kohm 1/10W	RM73B--473J
JK603	204 8540 009	4 P pin jack		1	R117,118	247 0005 905	Carbon chip 100ohm 1/10W	RM73B--101J
JK701	204 8543 006	6 P pin jack		1	R119,120	247 0012 927	Carbon chip 100kohm 1/10W	RM73B--104J
L301	235 0060 918	Inductor 4.7μH		1	R121,122	247 0005 905	Carbon chip 100ohm 1/10W	RM73B--101J
L303	235 0060 905	Inductor 2.2μH		1	R123~126	247 0007 945	Carbon chip 1kohm 1/10W	RM73B--102J
L304	235 0070 953	Inductor 68μH		1	R127,128	247 0007 945	Carbon chip 1kohm 1/10W	RM73B--102J
L401	235 0060 950	Inductor 10μH		1	R129,130	247 0010 961	Carbon chip 22kohm 1/10W	RM73B--223J
L402	235 0049 900	Beads Inductor		1	R131,132	247 0013 900	Carbon chip 220kohm 1/10W	RM73B--224J
LF301	261 0152 003	2.88M band pass filter	2.88M BPF(5VLT)	1	R133,134	247 0005 905	Carbon chip 100ohm 1/10W	RM73B--101J
X301	399 0402 003	Crystal 18.432 MHz		1	R135,136	247 0012 927	Carbon chip 100kohm 1/10W	RM73B--104J
X302	399 0191 903	Ceramic resonator	CST4.00MGW-TF01	1	R137,138	247 0005 905	Carbon chip 100ohm 1/10W	RM73B--101J
					R139,140	247 0007 916	Carbon chip 750ohm 1/10W	RM73B--751J
					R141	247 0009 901	Carbon chip 4.7kohm 1/10W	RM73B--472J
					R142	247 0009 943	Carbon chip 6.8kohm 1/10W	RM73B--682J
					R143	247 0005 905	Carbon chip 100ohm 1/10W	RM73B--101J
					R144	247 0006 962	Carbon chip 470ohm 1/10W	RM73B--471J
					R145,146	247 0012 927	Carbon chip 100kohm 1/10W	RM73B--104J
					R147,148	247 0010 961	Carbon chip 22kohm 1/10W	RM73B--223J
					R149,150	247 0013 900	Carbon chip 220kohm 1/10W	RM73B--224J
					R151,152	247 0011 944	Carbon chip 47kohm 1/10W	RM73B--473J
					R153,154	247 0005 905	Carbon chip 100ohm 1/10W	RM73B--101J
					R155,156	247 0012 927	Carbon chip 100kohm 1/10W	RM73B--104J
					R157,158	247 0005 905	Carbon chip 100ohm 1/10W	RM73B--101J
					R159,160	247 0007 916	Carbon chip 750ohm 1/10W	RM73B--751J
					R161,162	247 0009 901	Carbon chip 4.7kohm 1/10W	RM73B--472J
					R163,164	247 0005 905	Carbon chip 100ohm 1/10W	RM73B--101J
					R165,166	247 0012 927	Carbon chip 100kohm 1/10W	RM73B--104J
					R167,168	247 0011 944	Carbon chip 47kohm 1/10W	RM73B--473J
					R171,172	247 0006 920	Carbon chip 330ohm 1/10W	RM73B--331J
					R173	247 0009 943	Carbon chip 6.8kohm 1/10W	RM73B--682J
					R174~177	247 0011 944	Carbon chip 47kohm 1/10W	RM73B--473J

Ref. No.	Part No.	Part Name	Remarks
<b>CAPACITORS GROUP</b>			
C103,104	254 4260 948	Electrolytic 1 $\mu$ F/50V	CE04W1H010M
C105,106	254 4254 938	Electrolytic 47 $\mu$ F/16V	CE04W1C470M
C107,108	257 0012 982	Ceramic chip 0.022 $\mu$ F/50V	CK73F1H223Z
C109-112	254 4254 909	Electrolytic 10 $\mu$ F/16V	CE04W1C100M
C114	257 0012 966	Ceramic chip 0.01 $\mu$ F/50V	CK73F1H103Z
C115,116	254 4260 948	Electrolytic 1 $\mu$ F/50V	CE04W1H010M
C117,118	254 4254 912	Electrolytic 22 $\mu$ F/16V	CE04W1C220M
C119,120	257 0004 961	Ceramic chip 100pF/50V	CC73SL1H101J
C121,122	254 4254 909	Electrolytic 10 $\mu$ F/16V	CE04W1C100M
C123,124	257 0012 982	Ceramic chip 0.022 $\mu$ F/50V	CK73F1H223Z
C125,126	254 4260 948	Electrolytic 1 $\mu$ F/50V	CE04W1H010M
C127,128	254 4254 909	Electrolytic 10 $\mu$ F/16V	CE04W1C100M
C131,132	254 4254 909	Electrolytic 10 $\mu$ F/16V	CE04W1C100M
C134	257 0012 966	Ceramic chip 0.01 $\mu$ F/50V	CK73F1H103Z
C135,136	254 4260 948	Electrolytic 1 $\mu$ F/50V	CE04W1H010M
C137,138	254 4254 909	Electrolytic 10 $\mu$ F/16V	CE04W1C100M
C141,142	257 0004 961	Ceramic chip 100pF/50V	CC73SL1H101J
C143,144	254 4254 909	Electrolytic 10 $\mu$ F/16V	CE04W1C100M
C145,146	257 0012 982	Ceramic chip 0.022 $\mu$ F/50V	CK73F1H223Z
C147,148	254 4260 948	Electrolytic 1 $\mu$ F/50V	CE04W1H010M
C149,150	254 4254 909	Electrolytic 10 $\mu$ F/16V	CE04W1C100M
C153,154	254 4254 909	Electrolytic 10 $\mu$ F/16V	CE04W1C100M
C156	257 0012 966	Ceramic chip 0.01 $\mu$ F/50V	CK73F1H103Z
C157,158	254 4260 948	Electrolytic 1 $\mu$ F/50V	CE04W1H010M
C159,160	254 4254 909	Electrolytic 10 $\mu$ F/16V	CE04W1C100M
C163,164	257 0004 961	Ceramic chip 100pF/50V	CC73SL1H101J
C171,172	256 1034 953	Metalized 0.068 $\mu$ F/50V	CF93A1H683J
C173	255 1265 923	Mylar film 8200pF/50V	CQ93M1H822J(B)
<b>OTHER PARTS GROUP</b>			
			<b>Q'ty</b>
CW104	205 0885 053	10P connector socket (TUC-P)	1
CW144	205 0885 011	14P connector socket (TUC-P)	1
CX054	205 0343 058	5P connector base(KR-PH)	1
CY072	205 0343 074	7P connector base(KR-PH)	1
ST101	205 0452 017	Style pin	1
W702	205 1005 007	1P terminal	1

**PARTS LIST OF EXPLODED VIEW**

Ref. No.	Part No.	Part Name	Remarks	Q'ty	Ref. No.	Part No.	Part Name	Remarks	Q'ty
1	1U-2994	Main P.W.B. unit ass'y		1	37	477 0018 001	Washer (P-87)		1
2	1U-2995	Power amp. P.W.B. unit ass'y		1	38	205 0071 016	Terminal ass'y		1
2-1	1U-2995-1	Power supply-1 P.W.B. unit			39	146 1669 306	Inner panel ass'y		1
2-2	1U-2995-2	Front amp. P.W.B. unit			40	412 4249 002	PWB bracket (E)		1
2-3	1U-2995-3	Surround amp. P.W.B. unit			41	113 1804 006	Tuning knob		1
2-4	1U-2995-4	Reg.-1 P.W.B. unit			42	113 1805 005	Function knob		2
2-5	1U-2995-5	Reg.-2 P.W.B. unit			43	412 4163 007	Switch bracket		1
2-6	1U-2995-6	Reg.-3 P.W.B. unit			44	445 0048 003	Cord holder (L76)		4
2-7	1U-2995-7	Reg.-4 P.W.B. unit			45	411 1365 106	Shield plate		1
2-8	1U-2995-8	Reg.-5 P.W.B. unit			46	445 8004 007	Wire clasper		10
3	1U-2996	Video & display P.W.B. unit ass'y		1	47	461 0386 068	Rubber sheet		2
3-1	1U-2996-1	Display P.W.B. unit			48	461 9001 001	Rubber sheet	30X8X5	1
3-2	1U-2996-2	C-video P.W.B. unit			49	112 0744 038	VR. knob ass'y		1
3-3	1U-2996-3	S-video P.W.B. unit			50	112 0685 100	Knob (MARU)		2
3-4	1U-2996-4	LED P.W.B. unit			51	113 9213 000	P- knob (P) ass'y		1
3-5	1U-2996-5	Reg. P.W.B. unit			52	102 0583 001	Top cover		1
4	1U-2997	Tuner P.W.B. unit ass'y		1	53	461 0386 071	Rubber sheet		1
4-1	1U-2997-1	Tuner P.W.B. unit			54	414 0819 005	Earth plate		1
4-2	1U-2997-2	Power supply-2 P.W.B. unit			<b>SCREWS</b>				
4-3	1U-2997-3	H/P P.W.B. unit			101	471 3303 016	Screw 3X6 CBS-Z		2
4-4	1U-2997-4	Power switch P.W.B. unit			102	473 7002 018	Screw 3X8 CBTS(S)-Z		45
4-5	1U-2997-5	Pre out P.W.B. unit			103	473 7005 002	Screw 3X10 CBTS(S)-Z		8
5	1U-2998	Audio & DSP P.W.B. unit ass'y		1	104	473 7004 016	Screw 4X6 CBTS(S)-Z		10
5-1	1U-2998-1	DSP P.W.B. unit			105	473 7015 018	Screw 3X8 CBTS(S)-B		18
5-2	1U-2998-2	Audio in P.W.B. unit			106	473 7500 015	Screw 3X8 CBTS(P)-Z		12
5-3	1U-2998-3	6ch. external in P.W.B. unit			107	473 7505 007	Screw 2.6X8 CBTS(P)-Z		2
6	1U-3006	E.vol. P.W.B. unit ass'y		1	108	473 7508 017	Screw 3X10 CBTS(P)-B		5
7	411 1358 304	Main chassis		1	109	473 8007 009	Cup screw 3X12		11
8	412 4204 209	Trans. bracket		1	110	473 8063 014	Screw 4X8 CBTS (B)-B		6
9	412 4210 002	Bracket		5	111	477 0064 107	Fixing screw		23
10	104 0194 205	Foot ass'y		4	112	477 0262 006	Special screw		1
11	412 4205 004	PWB bracket (A)		1	<b>PACKING &amp; ACCESORIES (Not included EXPLODED VIEW)</b>				
12	513 2706 002	Caution label	R	1	151	505 8092 007	Laminate envelope		1
13	513 2706 015	Caution label	L	1	152	503 1236 000	Cushion		1
14	417 0546 209	Radiator		1	153	505 8006 019	Envelope		1
15	415 0234 007	Insulating sheet		11	154	511 3081 005	Instruction manual		1
16	271 0276 009	Transistor 2SA1633F31(E/F)		1	155	231 0922 009	Loop antenna		1
17	412 4207 002	Radiator bracket (A)		1	156	395 0023 008	FM ant. ass'y		1
18	412 4208 001	Radiator bracket (B)		1	157	399 0355 008	Remocon RC-825		1
19	412 4259 005	Tuner bracket		1	158		Battery		2
20	412 2814 044	Card spacer (L=6)		1	159	515 0671 504	S.S. list (EX)		1
21	477 0288 006	Push rivet		2	160	529 0079 008	FM ant. adapter		1
22	105 1225 202	Back panel		1	161	501 1954 001	Carton case		1
23	412 4203 006	Radiator support (R)		1	162	513 1389 006	Control card base		1
24	412 2814 028	Card spacer (L=10)		4	163	513 1349 004	Thermal carbon film		1
25	417 0544 308	Power radiator		1	164	515 0690 103	DEL warranty home		1
26	273 0389 031	Transistor 2SC3855 LB (O/P/Y)(Z)		5	165	517 0107 087	UPC label		1
27	271 0240 035	Transistor 2SA1491 LB (O/P/Y)(Z)		5					
28	412 4247 004	PWB bracket (C)		1					
29	412 4212 107	Radiator bracket (R)		1					
30	412 4211 108	Radiator bracket (F)		1					
31	412 4248 003	PWB bracket (D)		2					
32	412 4201 105	PWB bracket		1					
33	233 6220 002	Power trans. (EU/EC)		1					
34	412 4209 301	PWB support		1					
35	208 2060 002	AC cord (POLARIZED)		1					
36	445 0056 008	Cord bush		1					

# EXPLODED VIEW OF CHASSIS AND CABINET

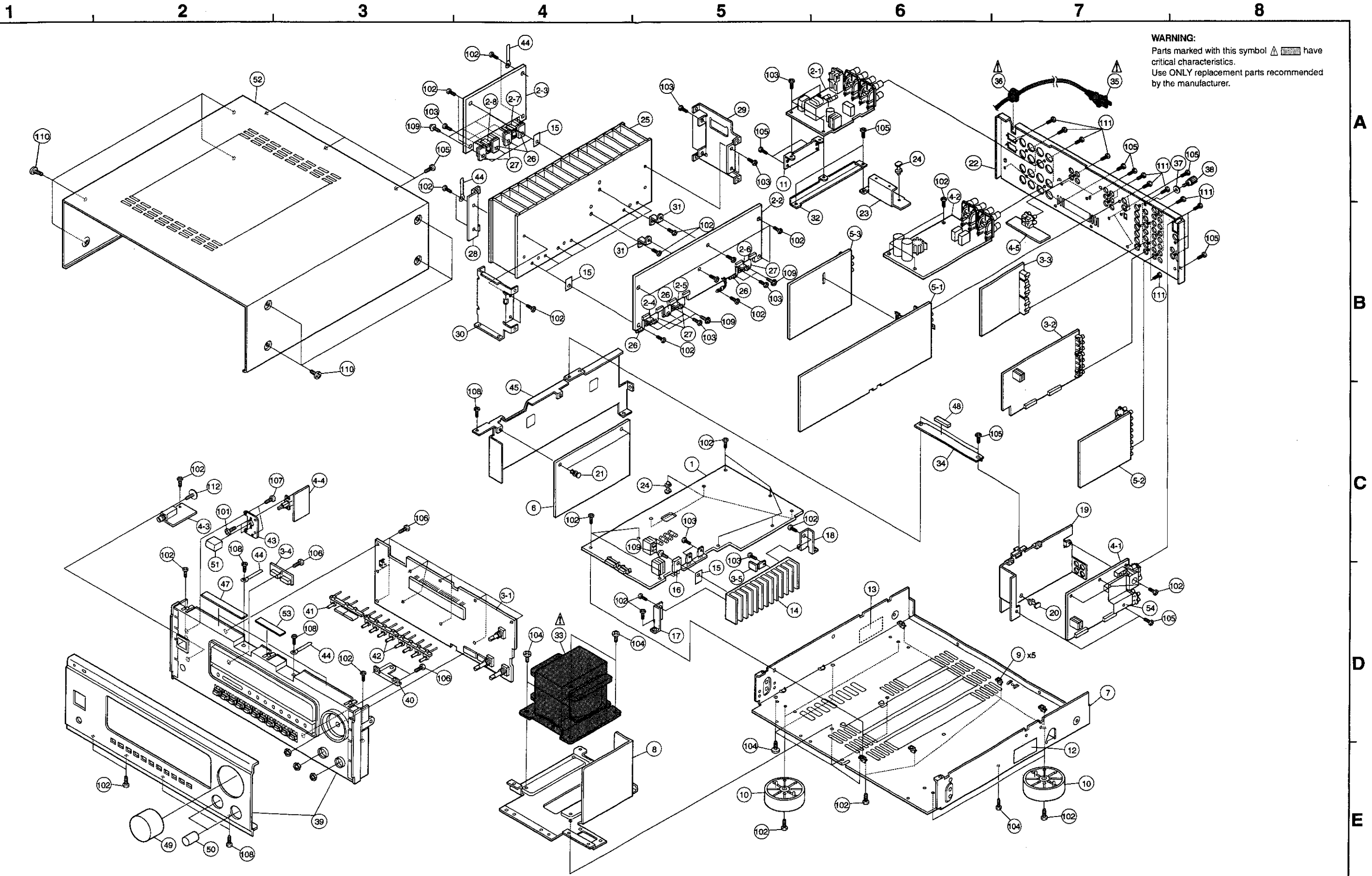

**WARNING:**  
Parts marked with this symbol  have critical characteristics. Use **ONLY** replacement parts recommended by the manufacturer.

A  
B  
C  
D  
E

BLOCK DIAGRAM

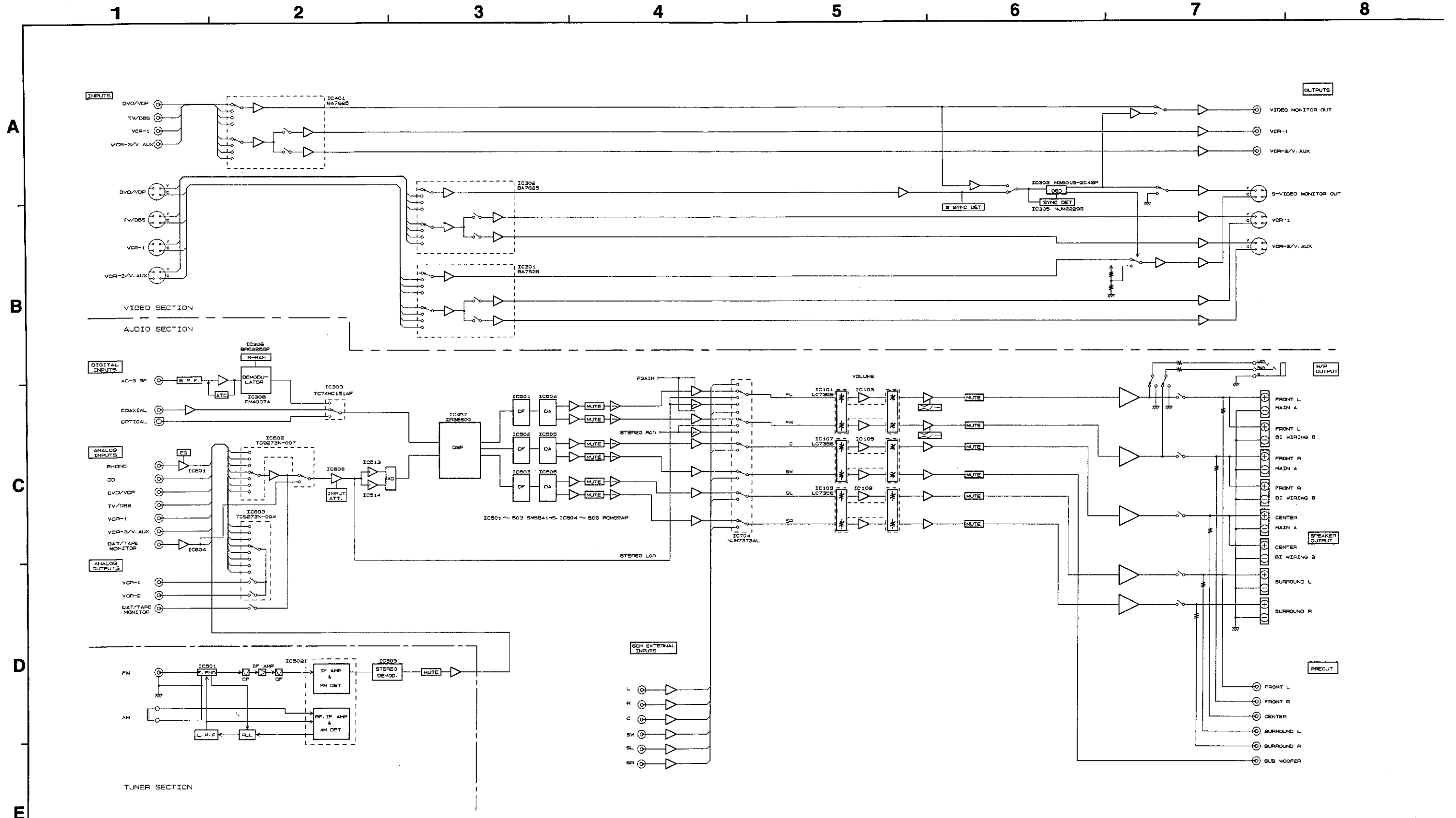



# BLOCK LEVEL DIAGRAM

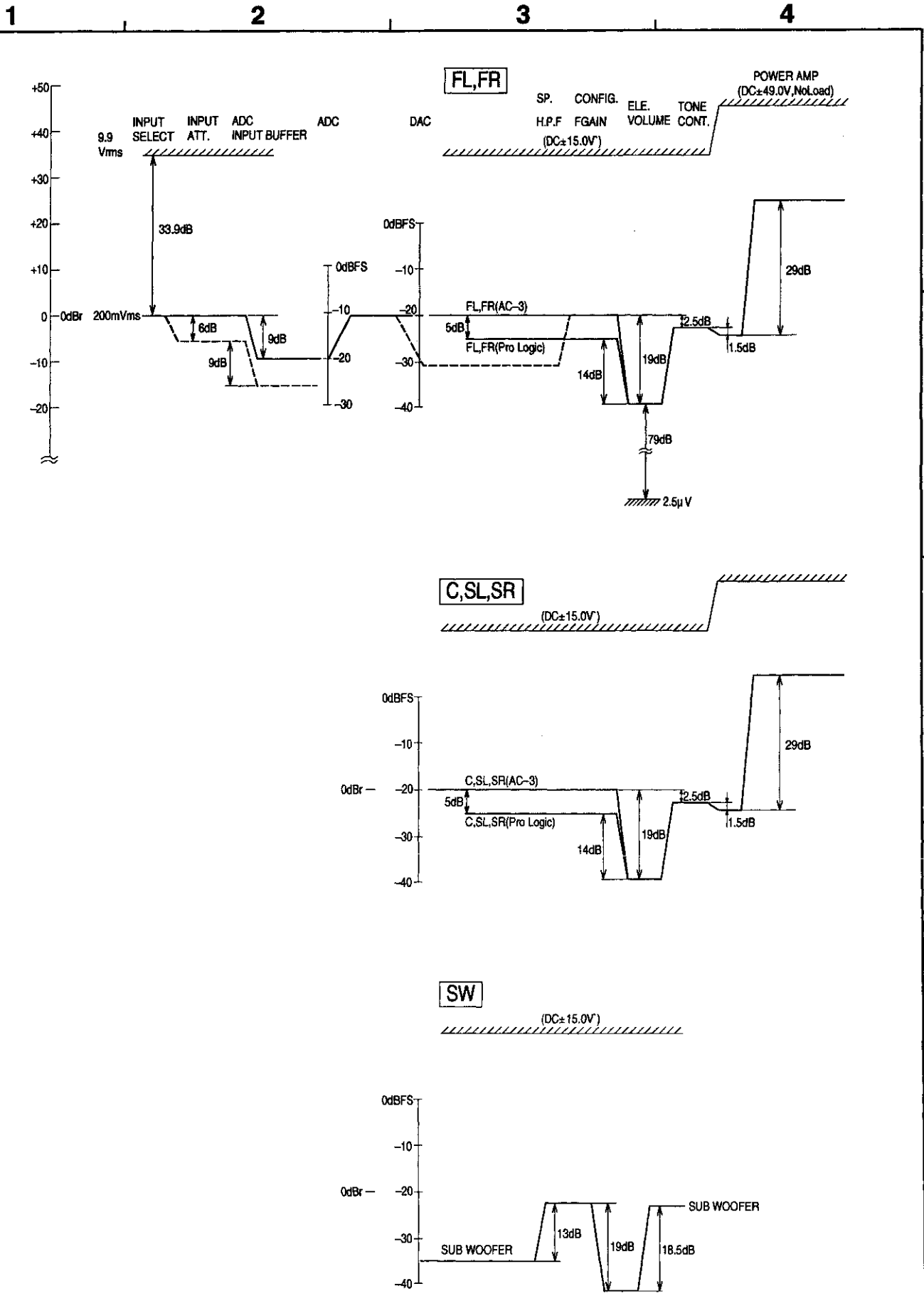

**A**

**B**

**C**

**D**

**E**

MEMO:

# WIRING DIAGRAM

1

2

3

4

5

6

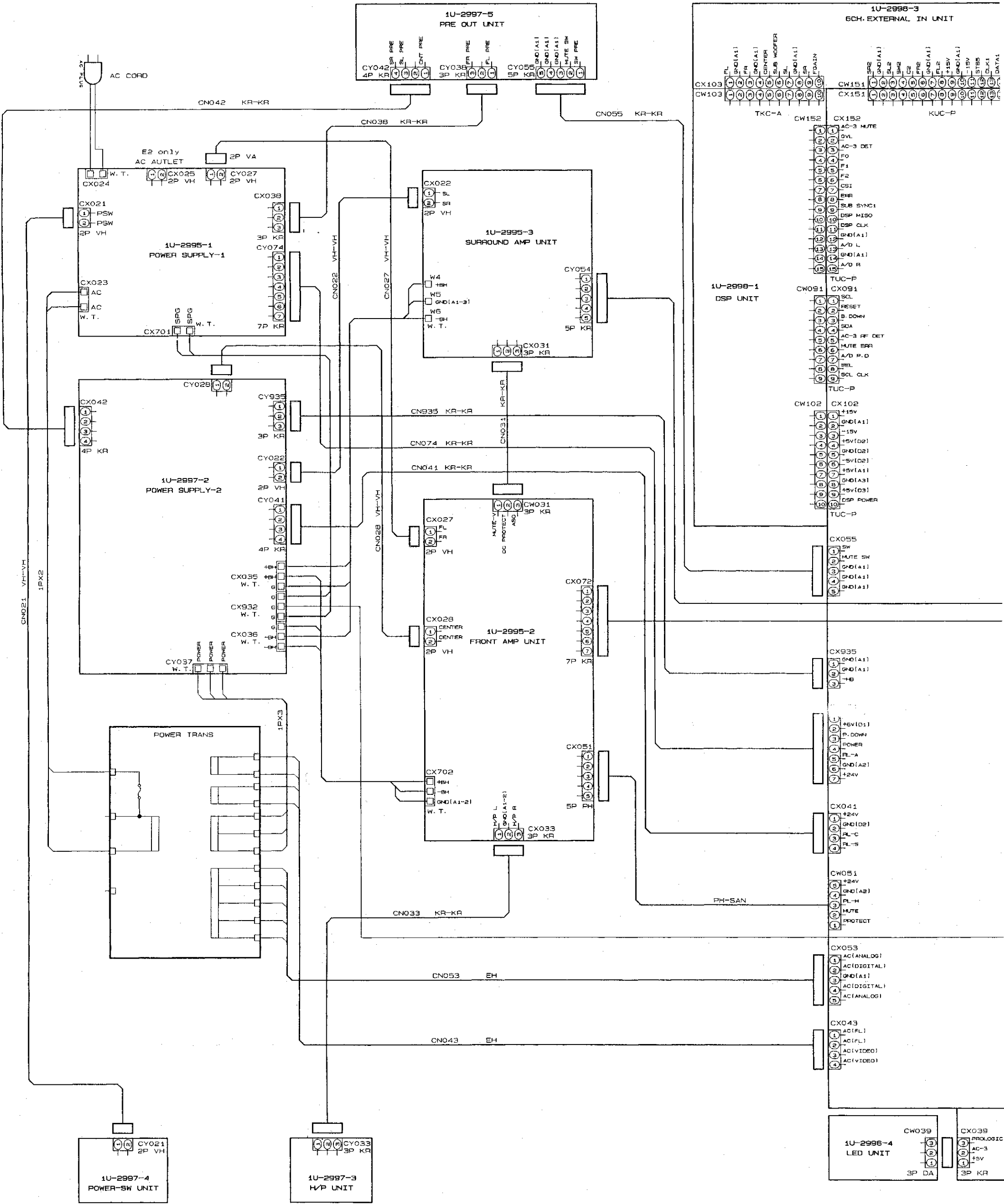

6

7

8

9

10

11

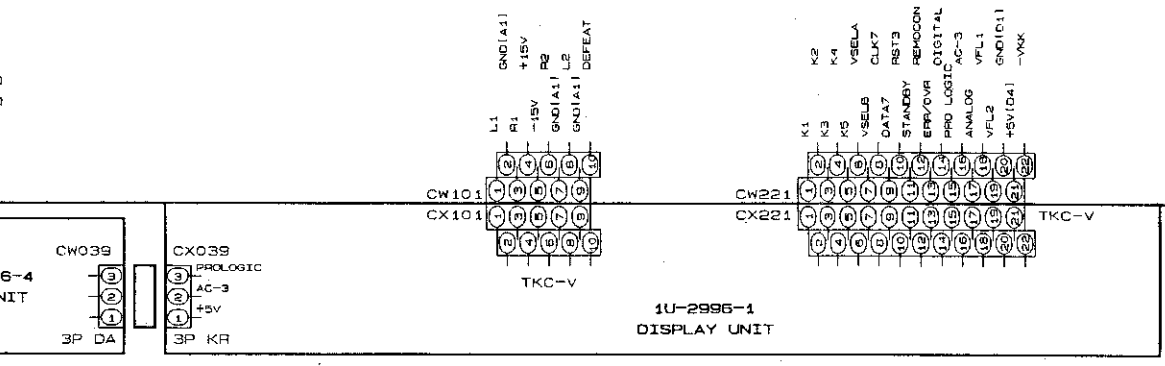
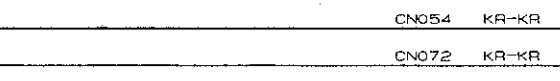
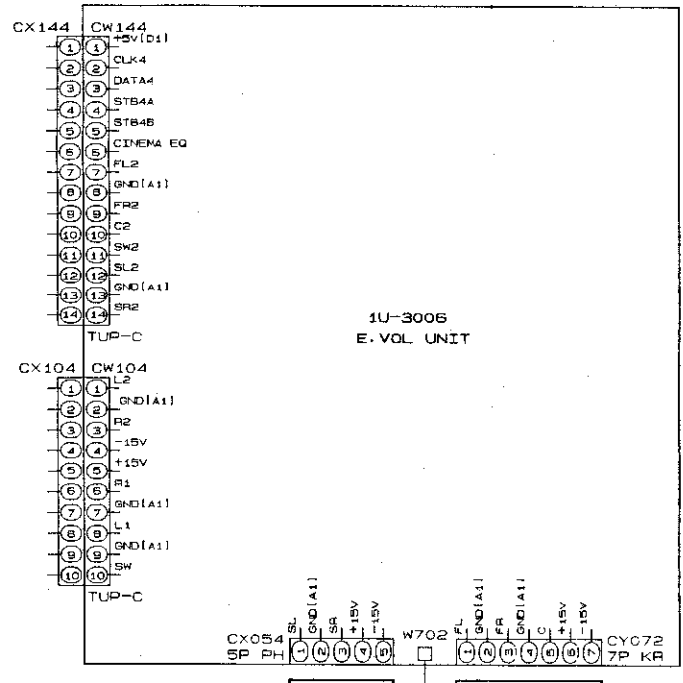
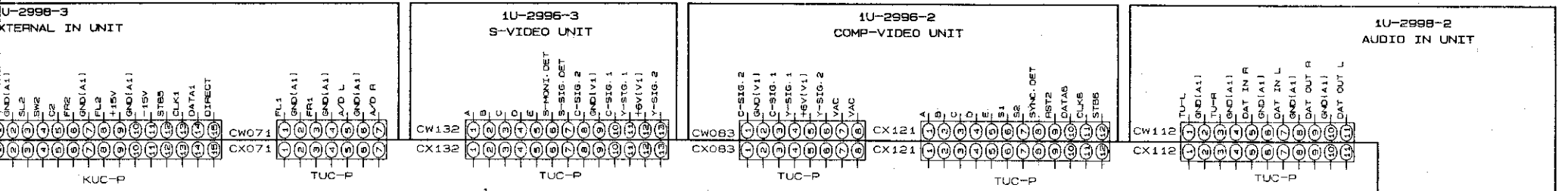

A  
B  
C  
D  
E  
F  
G  
H

SCHMATIC DIAGRAM (1/11)

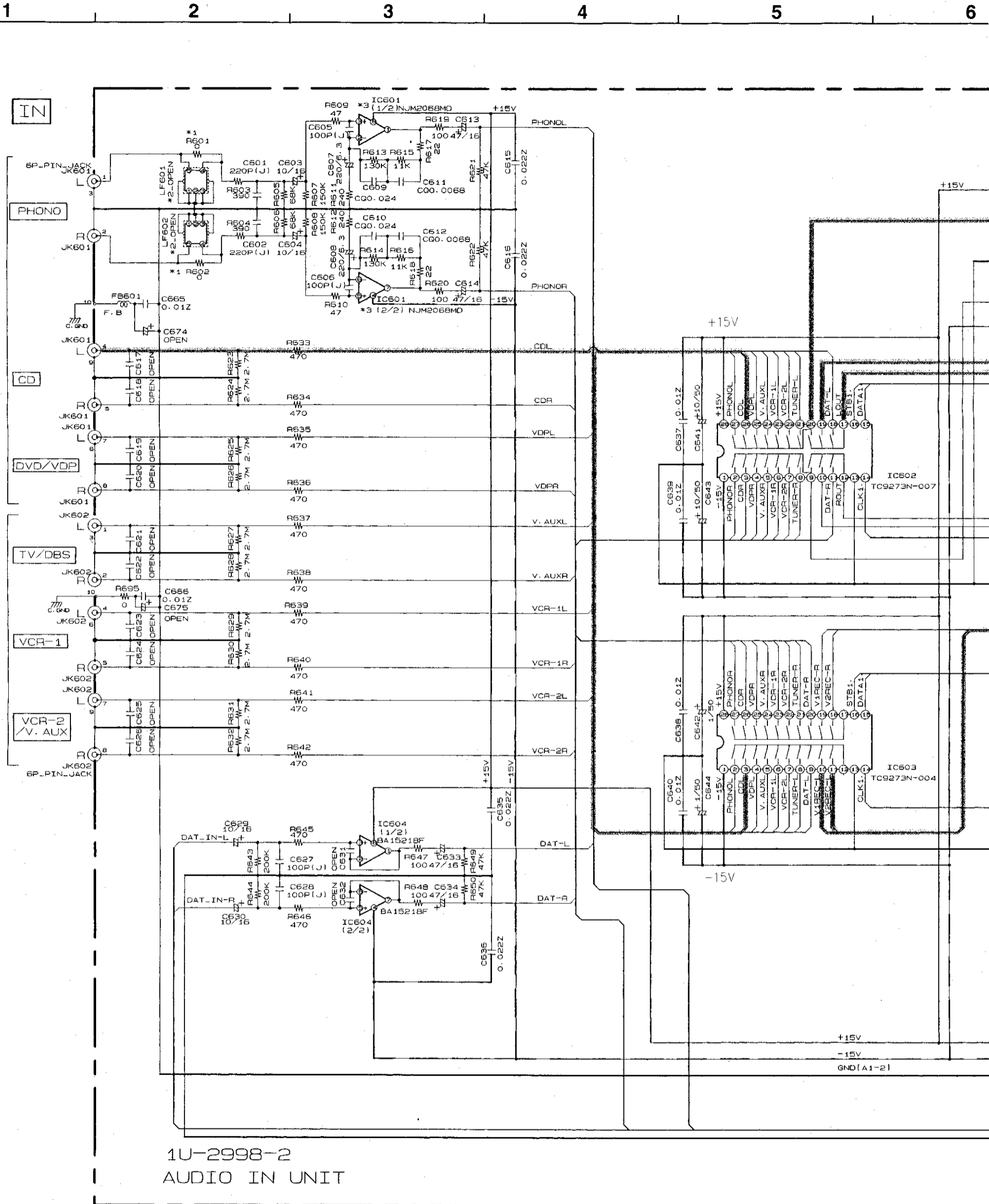

1U-2998-2  
AUDIO IN UNIT

**NOTES**  
ALL RESISTANCE VALUES IN OHM. k=1,000 OHM, M=1,000,000 OHM  
ALL CAPACITANCE VALUES IN MICRO FARAD. P-MICRO-MICRO FARAD  
EACH VOLTAGE AND CURRENT ARE MEASURED AT NO SIGNAL INPUT CONDITION.  
CIRCUIT AND PARTS ARE SUBJECT TO CHANGE WITHOUT PRIOR NOTICE.

**WARNING:**  
Parts marked with this symbol have critical characteristics. Use ONLY replacement parts recommended by the manufacturer.

**CAUTION:**  
Before returning the unit to the customer, make sure you make either (1) a leakage current check or (2) a line to chassis resistance check. If the leakage current exceeds 0.5 milliamps, or if the resistance from chassis to either side of the power cord is less than 240 kohms, the unit is defective.

**WARNING:**  
DO NOT return the unit to the customer until the problem is located and corrected.

	*1 R501, 602	*2 LF501, 502	*3 IC601
* USA CANADA	0	---	NJM2068MD
ASIA	1.3K	L. P. F	NJM2068MD
EUROPE	1.3K	L. P. F	NJM2068MD
JAPAN	0	---	NJM2068MD

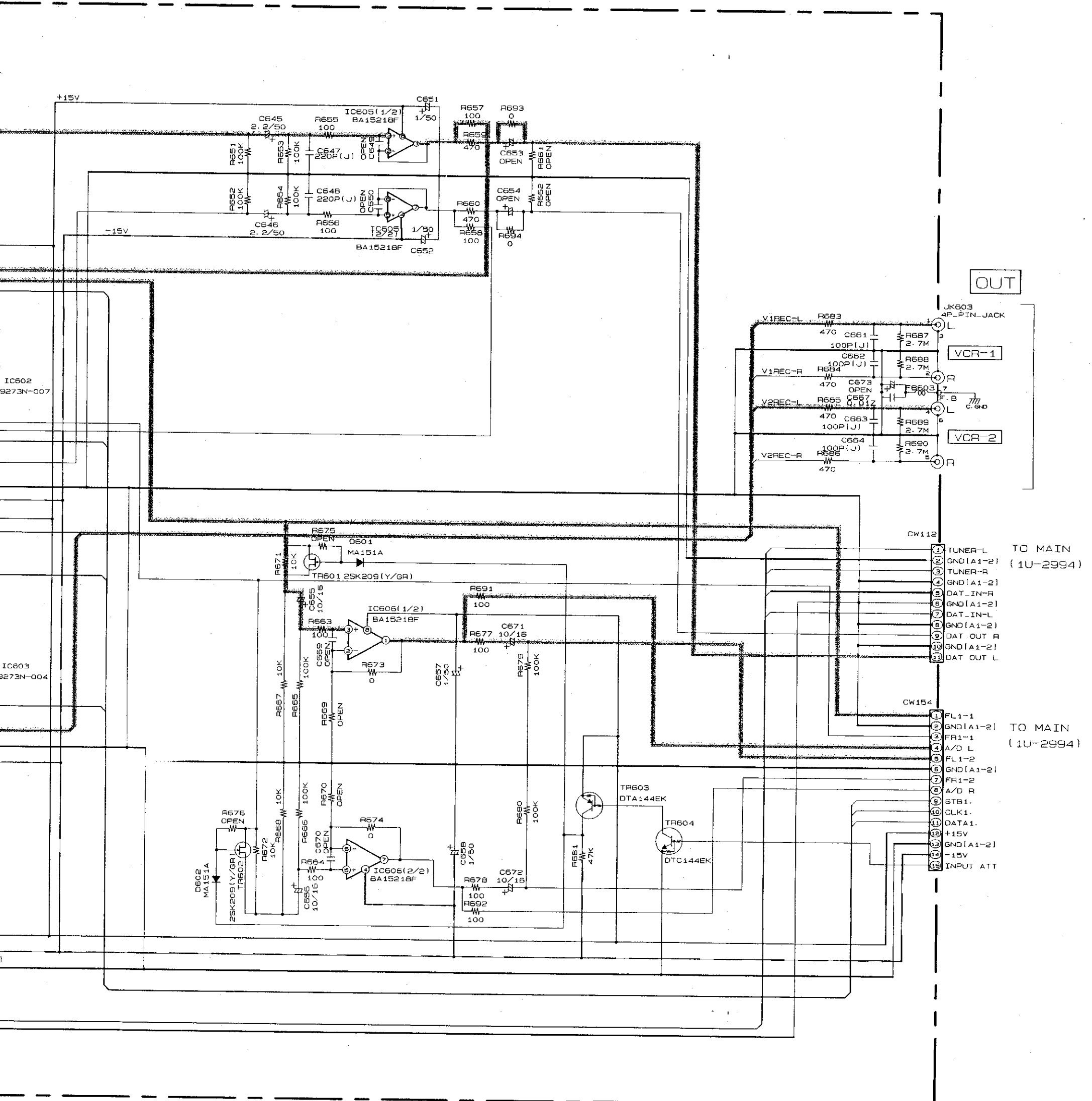

*3	IC601
602	IC601
	NUM2068MD
F	NUM2068MD
F	NUM2068MD
	NUM2068MD

\_\_\_\_\_ +B LINE  
 - - - - - -B LINE  
 \_\_\_\_\_ SIGNAL LINE

# SCHEMATIC DIAGRAM (2/11)

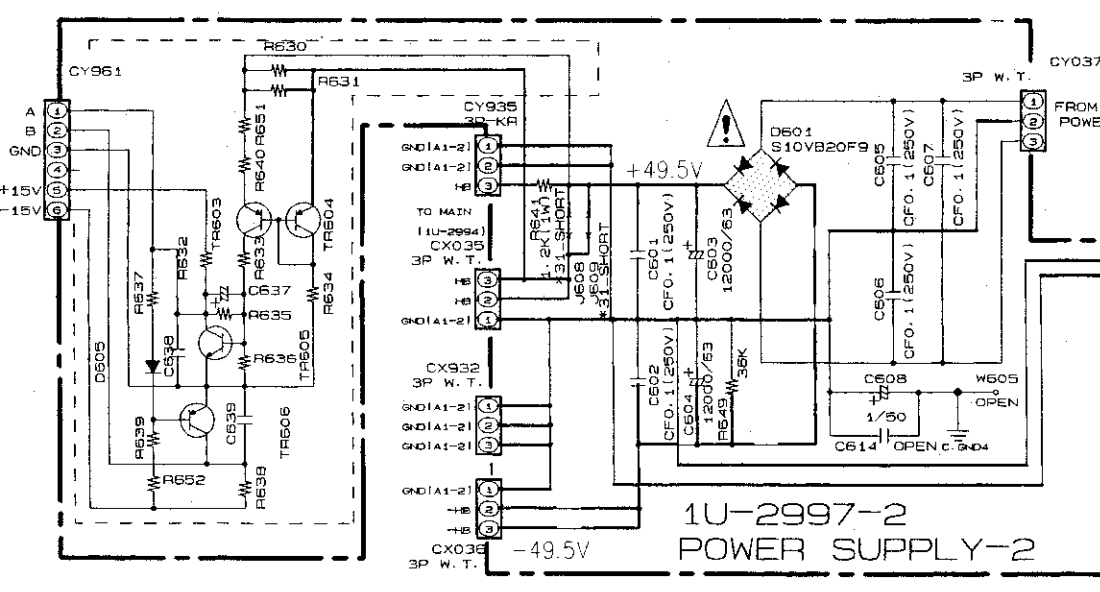
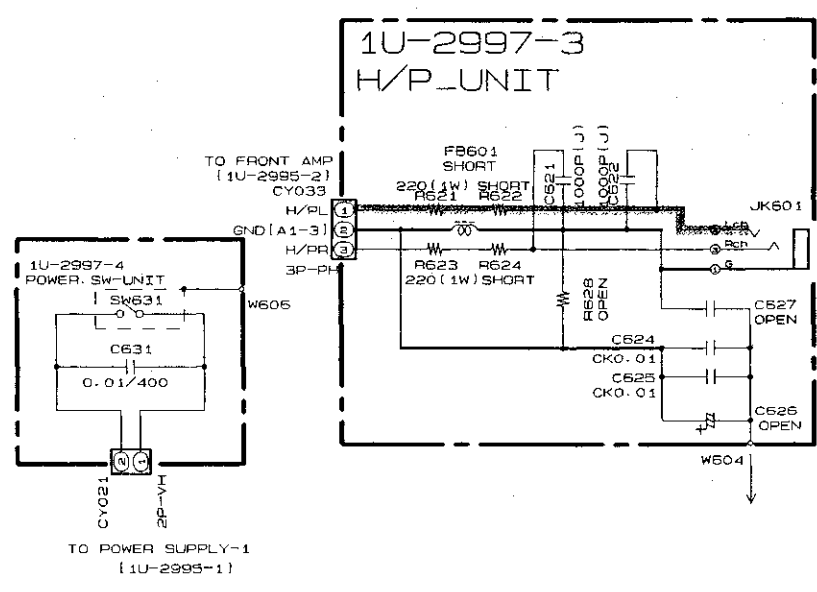
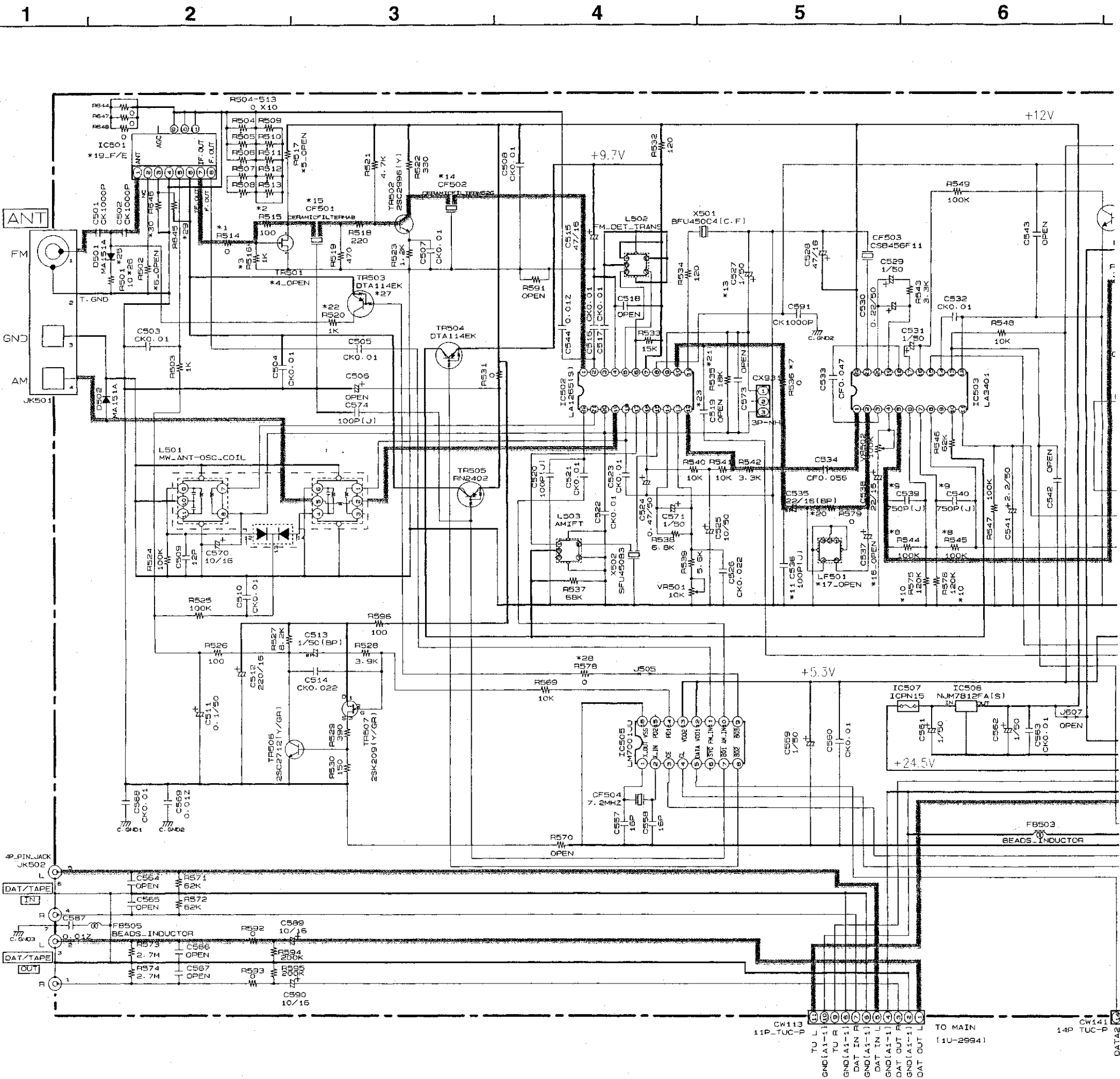

6 7 8 9 10 11

A  
B  
C  
D  
E  
F  
G  
H

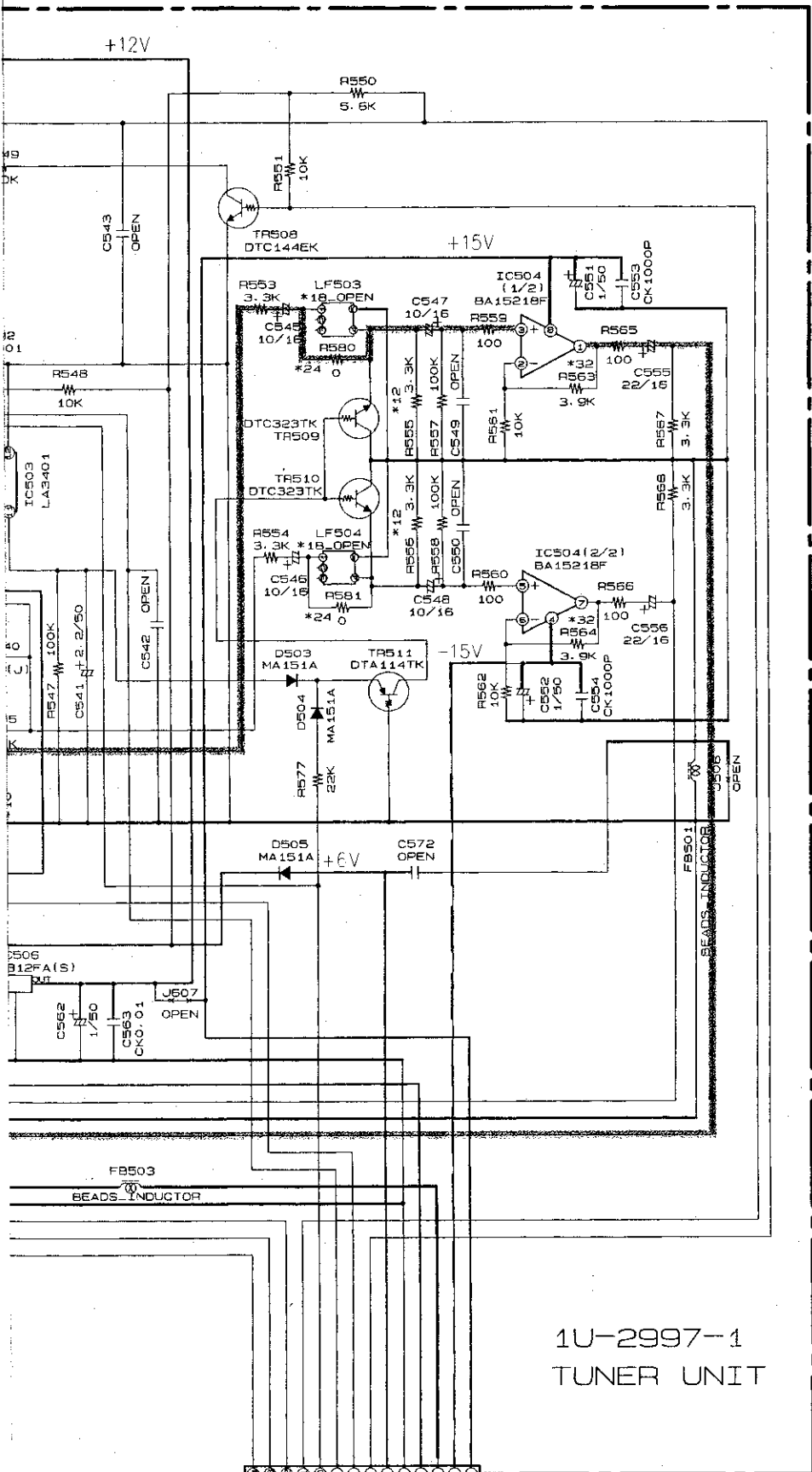

1U-2997-1  
TUNER UNIT

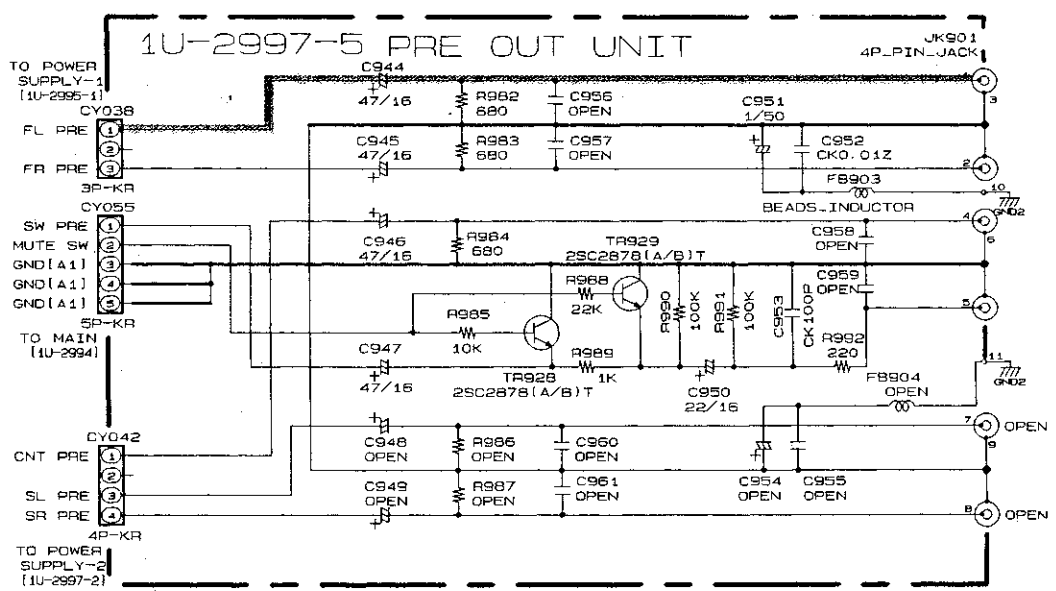

* NO	* USA CANADA	ASIA	EUROPE	JAPAN	* NO	* USA CANADA	ASIA	EUROPE	JAPAN
1 R514	0		0	0	20 R579	0			0
2 R515	100			100	21 R535	18K	39K		18K
3 R516	1K		330	330	22 R520	1K	1K		
4 TR501		29K161(6R)TP4			23 C519		CK100p		
5 R517			330		24 R580-581	0			
6 R502			0		25 D501	MA151A	MA151A		
7 R536	0		1.2K	0	26 R501	10	10		
8 R544-545	100K		100K	100K	27 TR503	DTA114EK	DTA114EK		
9 C539-540	750p		510p	510p	28 R578	0	0		
10 R575-576	120K		120K	120K	29 R645		10K		
11 C536	100p				30 R646		5.6K		
12 R555-556	3.3K			3.3K	31 J608-609	SHORT	SHORT		OPEN
13 C527	1/50		0.33/50	0.33/50	32 R563-564	3.9K	3.9K	13K	3.9K
14 CF502	SFE 10.7MS2G	SFT	10.7MS2	SFE 10.7MS2G					
15 CF501	SFE 10.7MA8	SFT	10.7MS2	SFE 10.7MA8					
16 C537			22/16						
17 LF501		ANTI BIRDIE FILTER							
18 LF503-504		LPF	LPF	LPF 23200B5004					
19 IC501	F/E 2160102008	F/E 2169013004	F/E	2169012005					

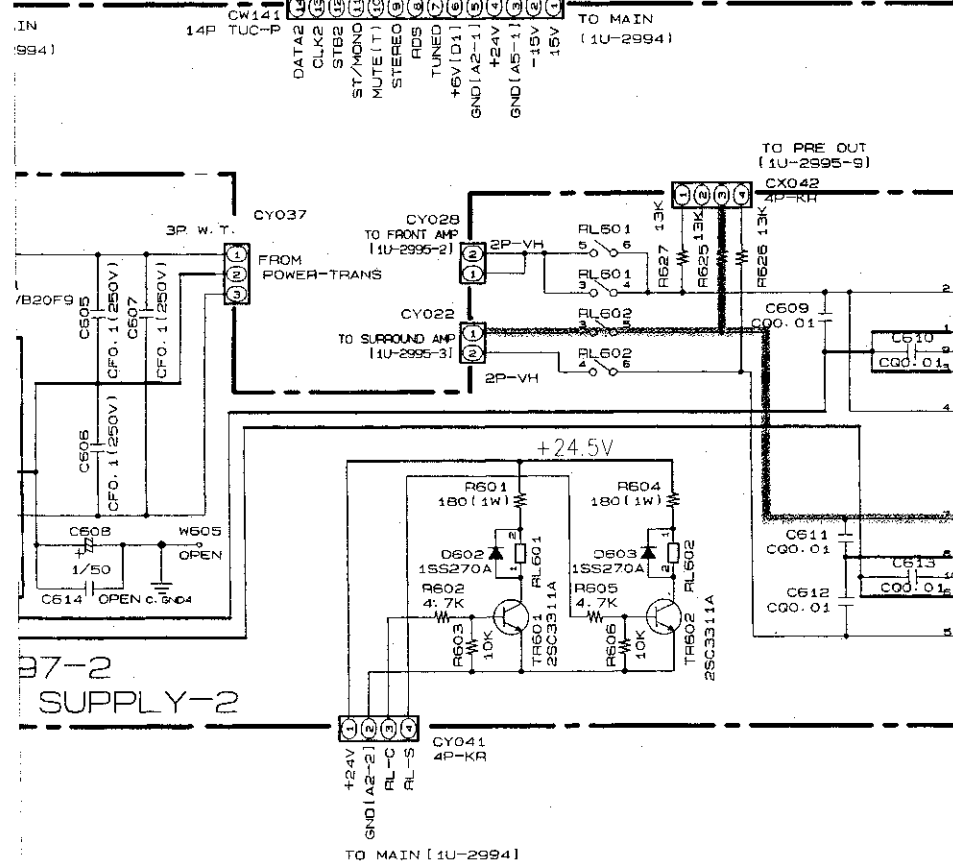

1U-2997-2  
SUPPLY-2

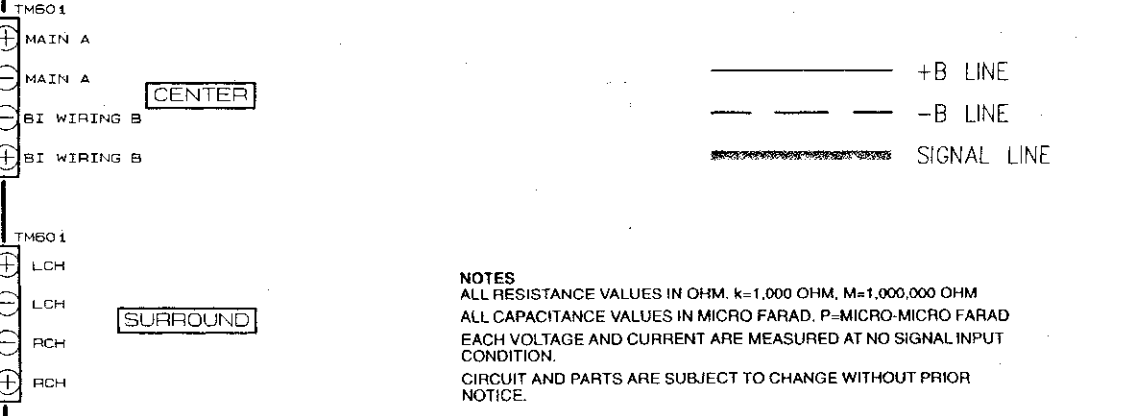

NOTES  
ALL RESISTANCE VALUES IN OHM. k=1,000 OHM, M=1,000,000 OHM  
ALL CAPACITANCE VALUES IN MICRO FARAD. P=MICRO-MICRO FARAD  
EACH VOLTAGE AND CURRENT ARE MEASURED AT NO SIGNAL INPUT CONDITION.  
CIRCUIT AND PARTS ARE SUBJECT TO CHANGE WITHOUT PRIOR NOTICE.

WARNING:  
Parts marked with this symbol have critical characteristics. Use ONLY replacement parts recommended by the manufacturer.

CAUTION:  
Before returning the unit to the customer, make sure you make either (1) a leakage current check or (2) a line to chassis resistance check. If the leakage current exceeds 0.5 milliamps, or if the resistance from chassis to either side of the power cord is less than 240 kohms, the unit is defective.

WARNING:  
DO NOT return the unit to the customer until the problem is located and corrected.



SCHEMATIC DIAGRAM (3/11)

1 2 3 4 5 6

A

B

C

D

E

F

G

H

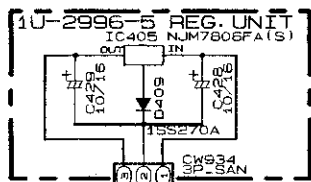

TO COMP-VIDEO (1U-2996-2)

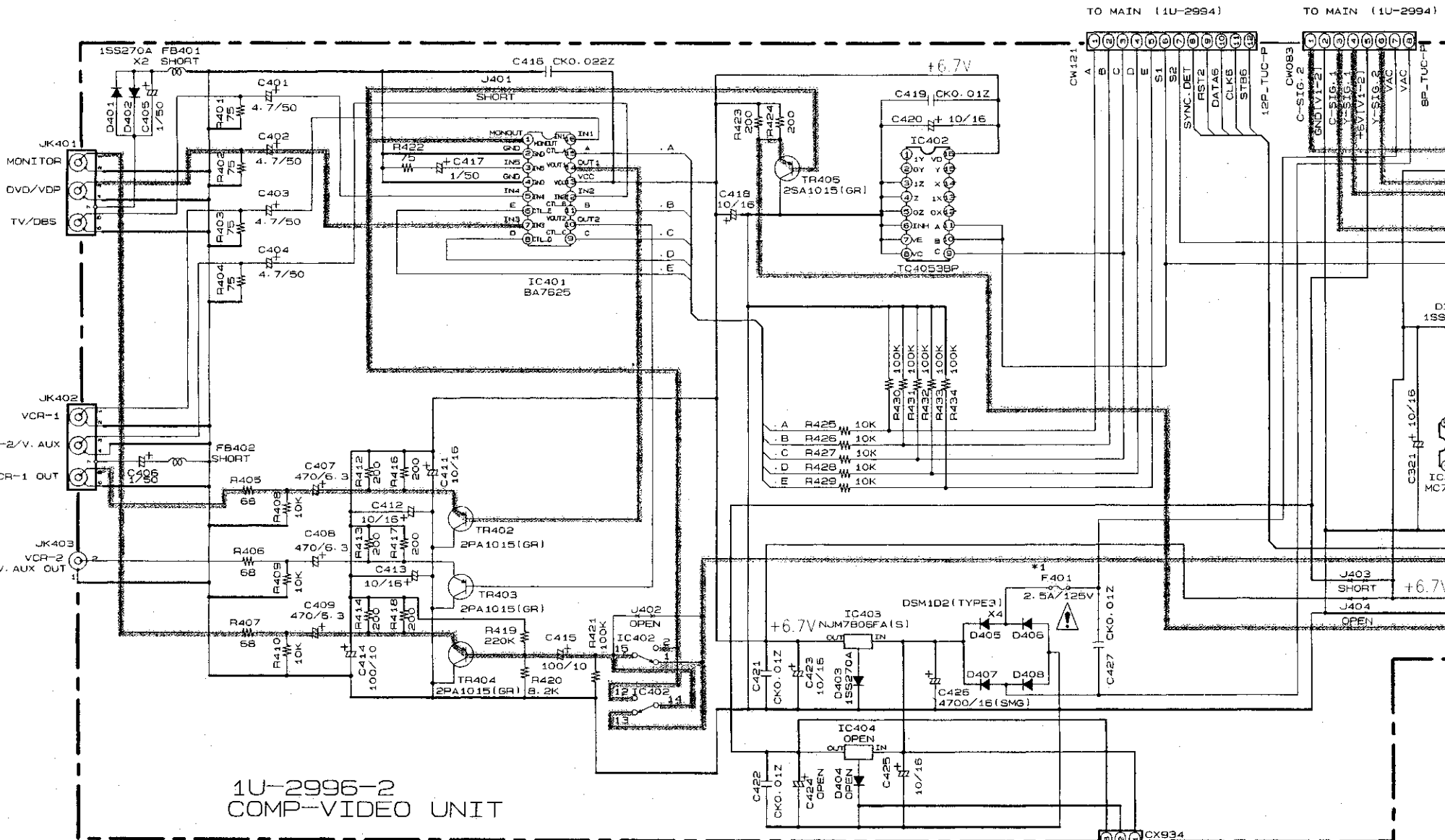
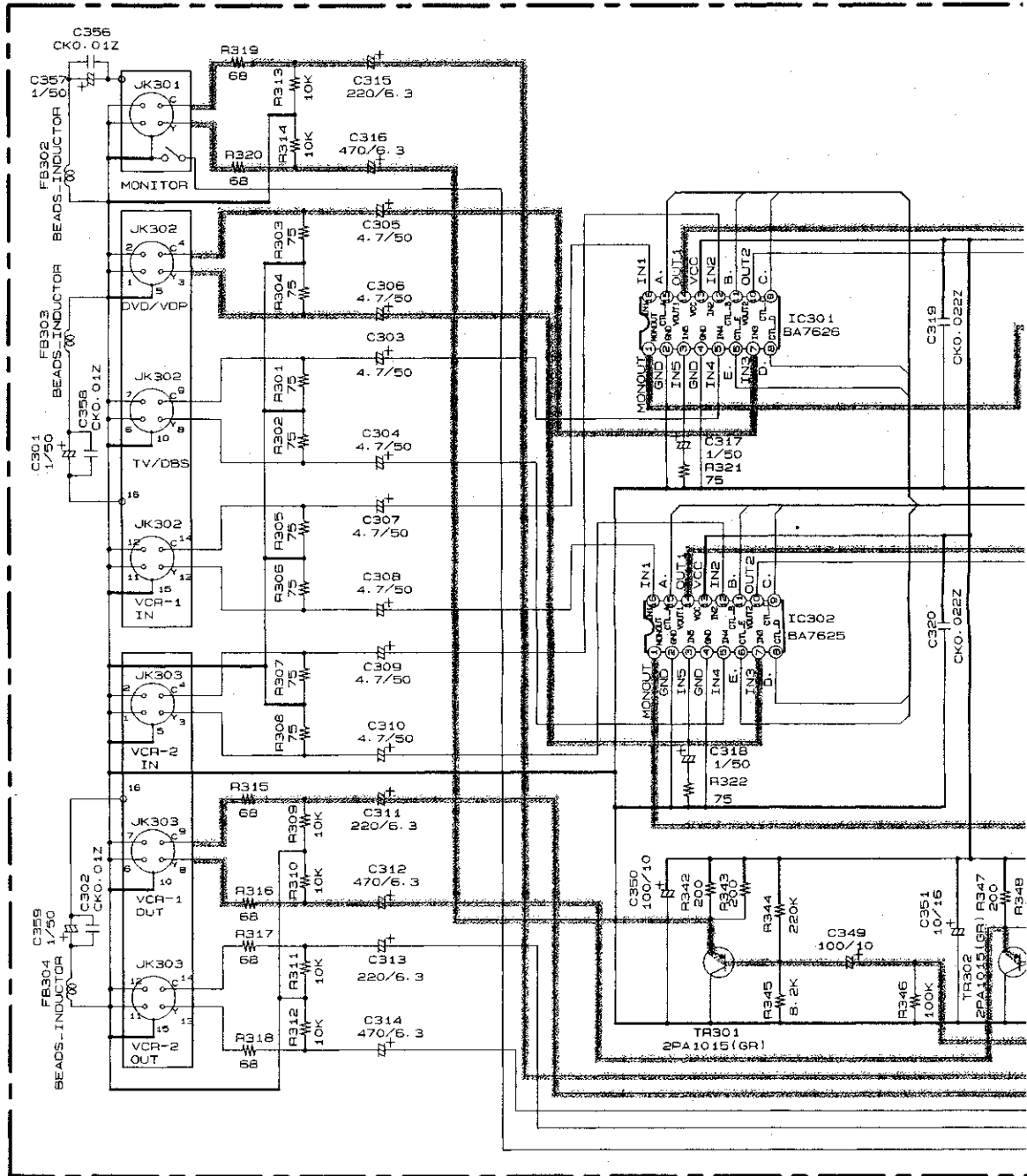

1U-2996-2  
COMP-VIDEO UNIT

TO REG. UNIT (1U-2996-5)

# 1U-2996-3 S-VIDEO UNIT

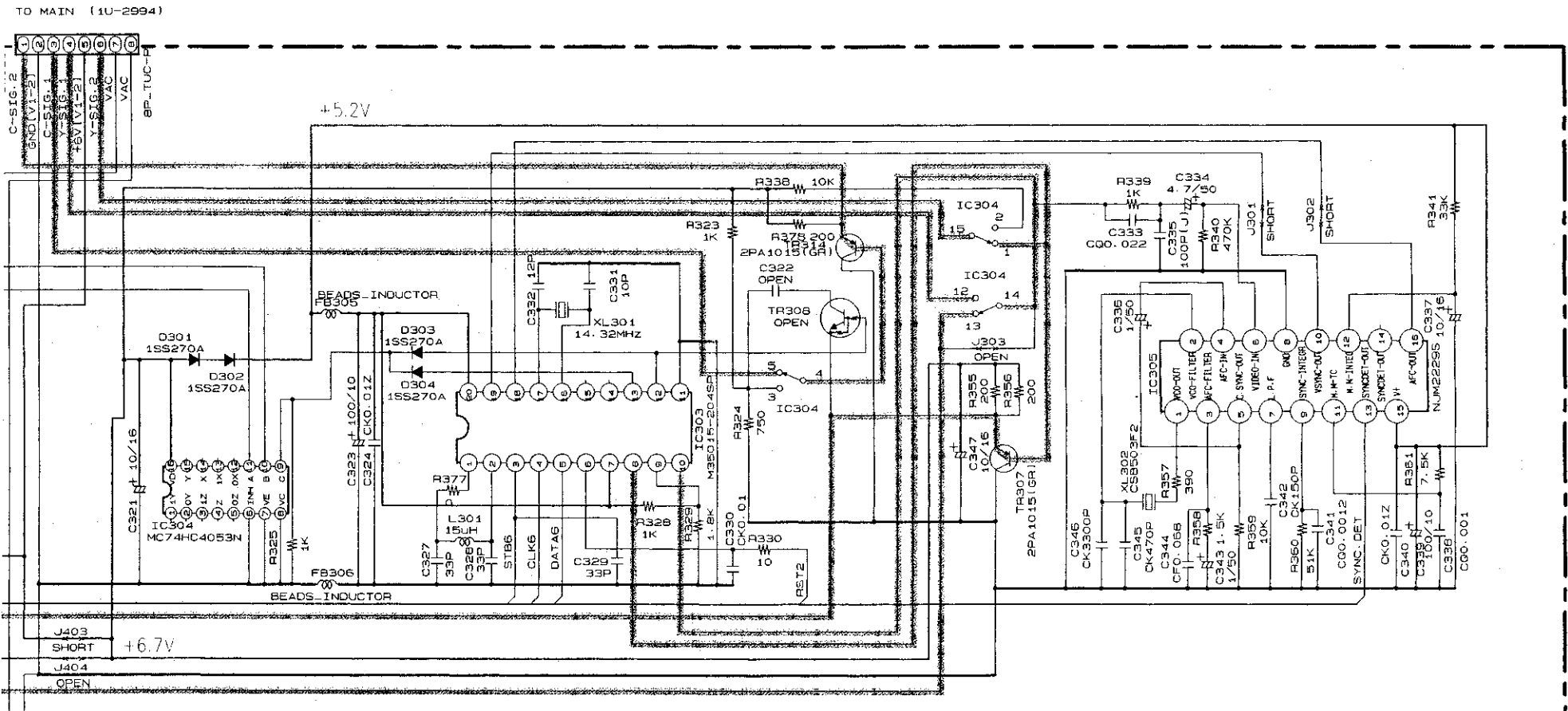
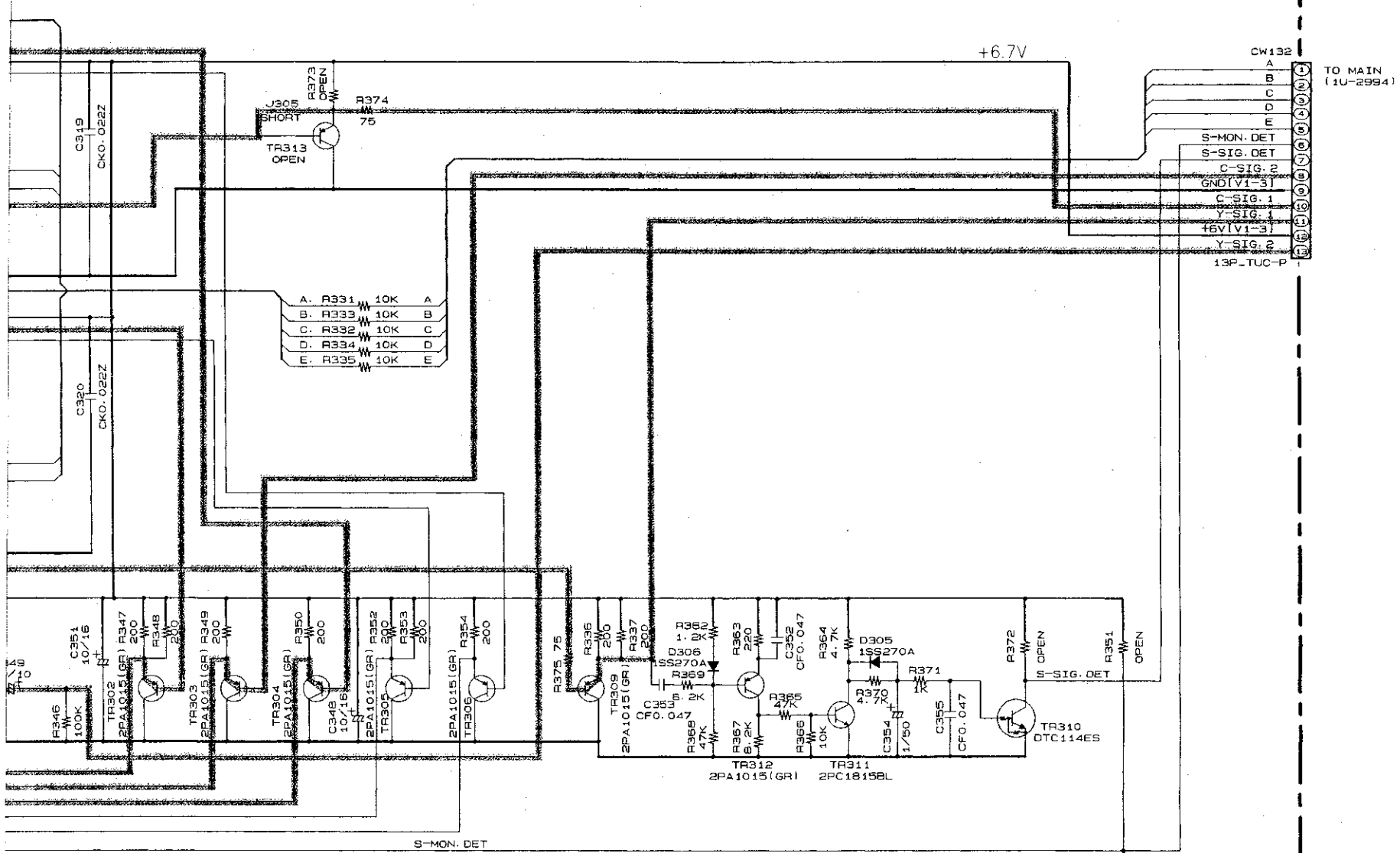

	*1
	F401
* USA	2.5A/125V
CANADA	2051039076
ASIA	2.5A/250V
	2051015032
EUROPE	2.5A/250V
	2051015032
JAPAN	2.5A/125V
	2051035067

**NOTES**  
 ALL RESISTANCE VALUES IN OHM. K=1,000 OHM, M=1,000,000 OHM  
 ALL CAPACITANCE VALUES IN MICRO FARAD. P=MICRO-MICRO FARAD  
 EACH VOLTAGE AND CURRENT ARE MEASURED AT NO SIGNAL INPUT CONDITION.  
 CIRCUIT AND PARTS ARE SUBJECT TO CHANGE WITHOUT PRIOR NOTICE.

—+B LINE  
 — SIGNAL LINE

**WARNING:**  
 Parts marked with this symbol have critical characteristics. Use ONLY replacement parts recommended by the manufacturer.

**CAUTION:**  
 Before returning the unit to the customer, make sure you make either (1) a leakage current check or (2) a line to chassis resistance check. If the leakage current exceeds 0.5 milliamps, or if the resistance from chassis to either side of the power cord is less than 240 kohms, the unit is defective.

**WARNING:**  
 DO NOT return the unit to the customer until the problem is located and corrected.

# SCHEMATIC DIAGRAM (4/11)

1                      2                      3                      4                      5                      6

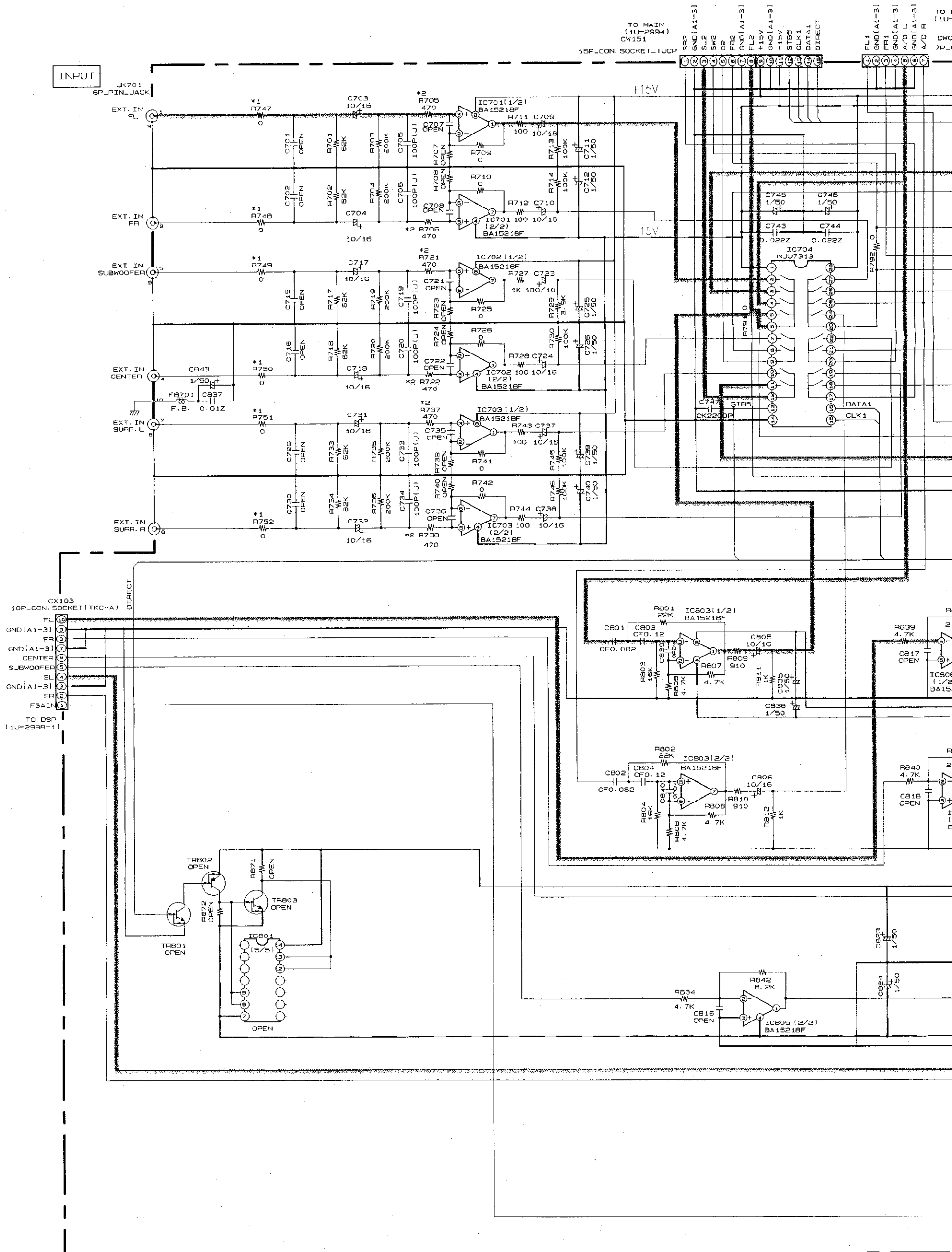

NOTES  
 ALL RESISTANCE VALUES IN OHM, K, M.  
 ALL CAPACITANCE VALUES IN MICRO.  
 EACH VOLTAGE AND CURRENT ARE IN  
 CONDITION.  
 CIRCUIT AND PARTS ARE SUBJECT TO  
 NOTICE.

6 7 8 9 10 11

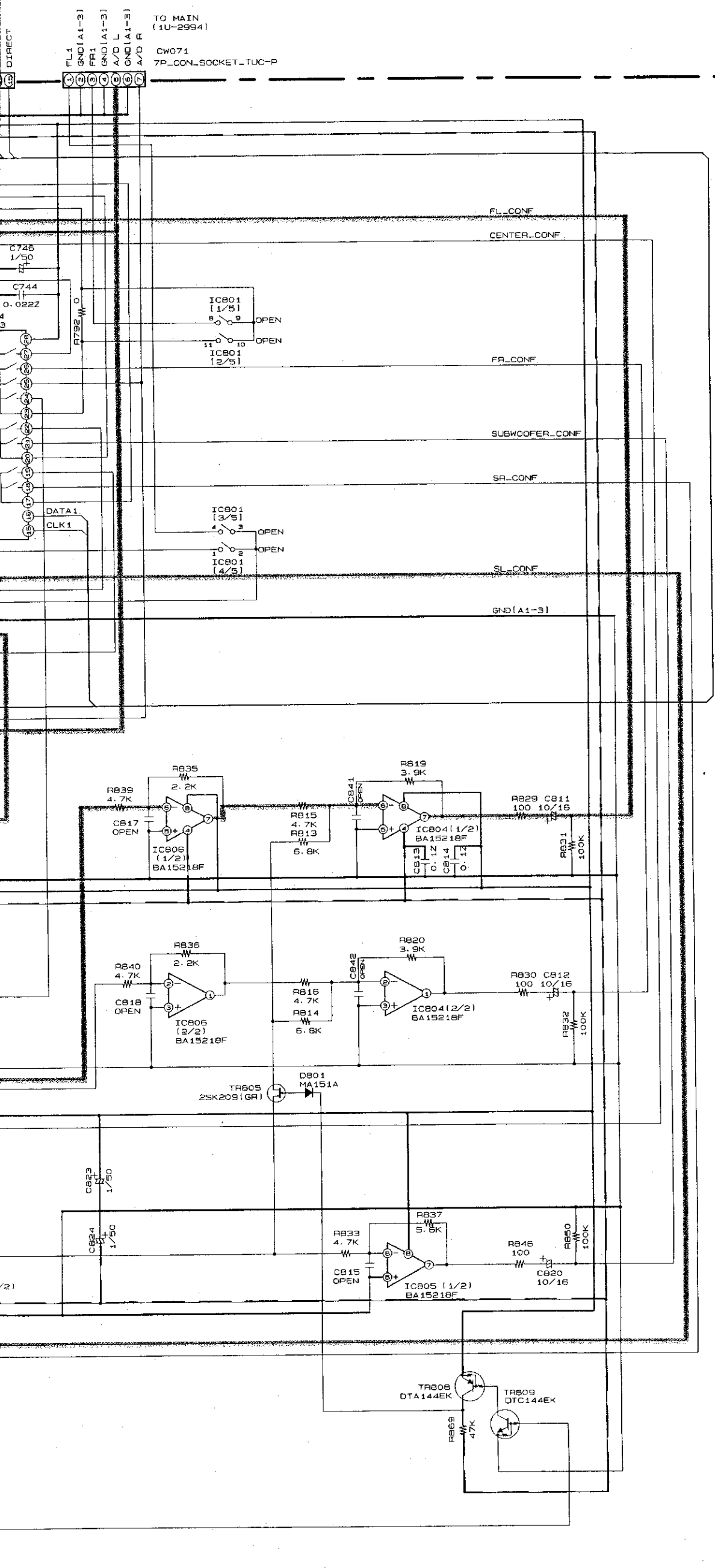

	*1	*2
	R747, 748 R749, 750 R751, 752	R705, 706 R721, 722 R737, 738
* USA CANADA	0	470
ASIA	470	100
EUROPE	470	100
JAPAN	0	470

1U-2998-3  
6CH. EXTERNAL\_IN UNIT

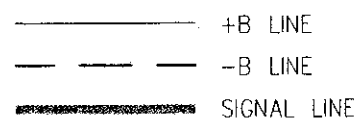

**NOTES**  
 ALL RESISTANCE VALUES IN OHM. K=1,000 OHM, M=1,000,000 OHM  
 ALL CAPACITANCE VALUES IN MICRO FARAD. P=MICRO-MICRO FARAD  
 EACH VOLTAGE AND CURRENT ARE MEASURED AT NO SIGNAL INPUT CONDITION.  
 CIRCUIT AND PARTS ARE SUBJECT TO CHANGE WITHOUT PRIOR NOTICE.

**WARNING:**  
 Parts marked with this symbol have critical characteristics. Use ONLY replacement parts recommended by the manufacturer.

**CAUTION:**  
 Before returning the unit to the customer, make sure you make either (1) a leakage current check or (2) a line to chassis resistance check. If the leakage current exceeds 0.5 milliamps, or if the resistance from chassis to either side of the power cord is less than 240 kohms, the unit is defective.

**WARNING:**  
 DO NOT return the unit to the customer until the problem is located and corrected.

A  
B  
C  
D  
E  
F  
G  
H

SCHEMATIC DIAGRAM (5/11)

1 2 3 4 5 6

A

B

C

D

E

F

G

H

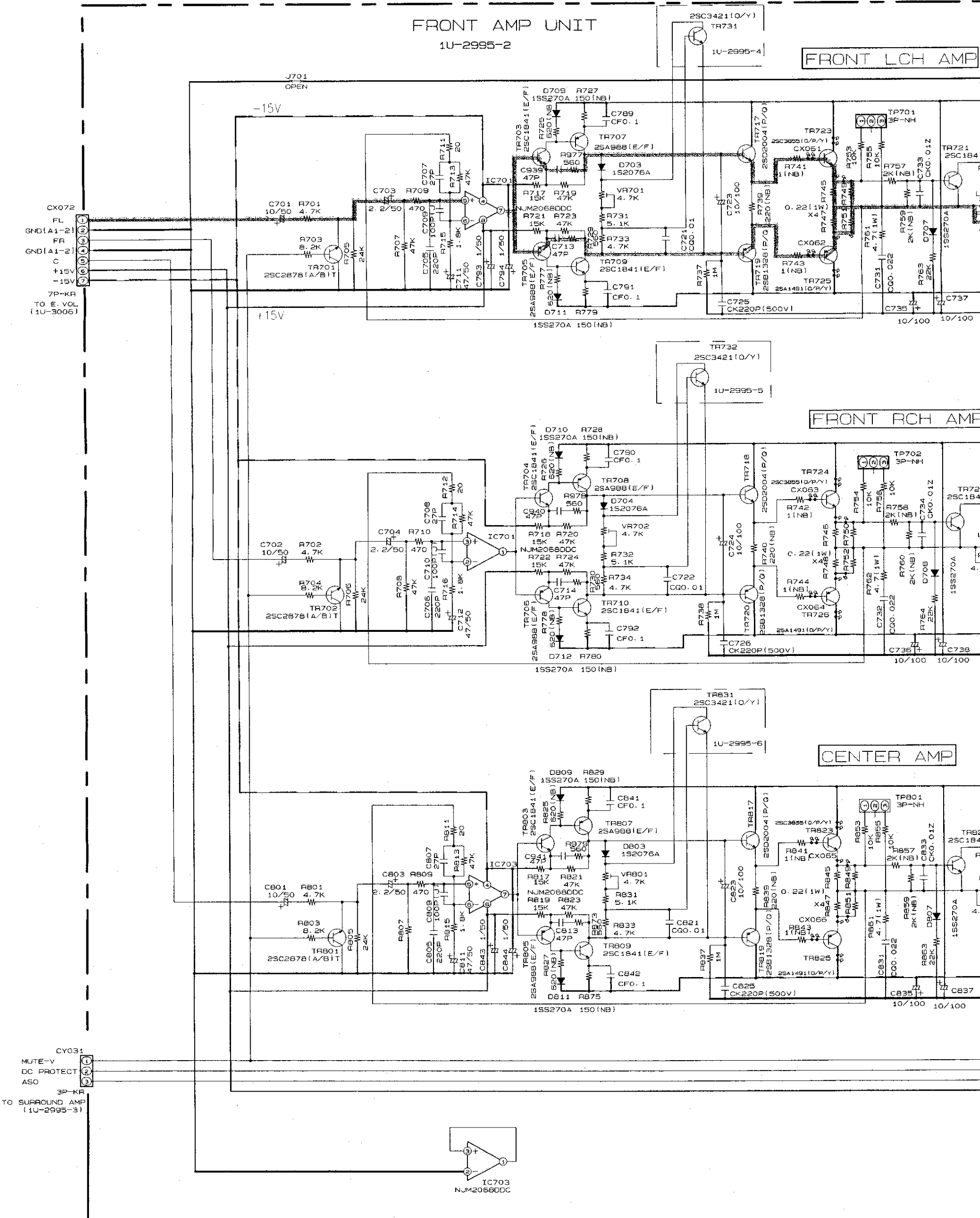

TO POWER SUPPLY-2  
(1U-2997-2)

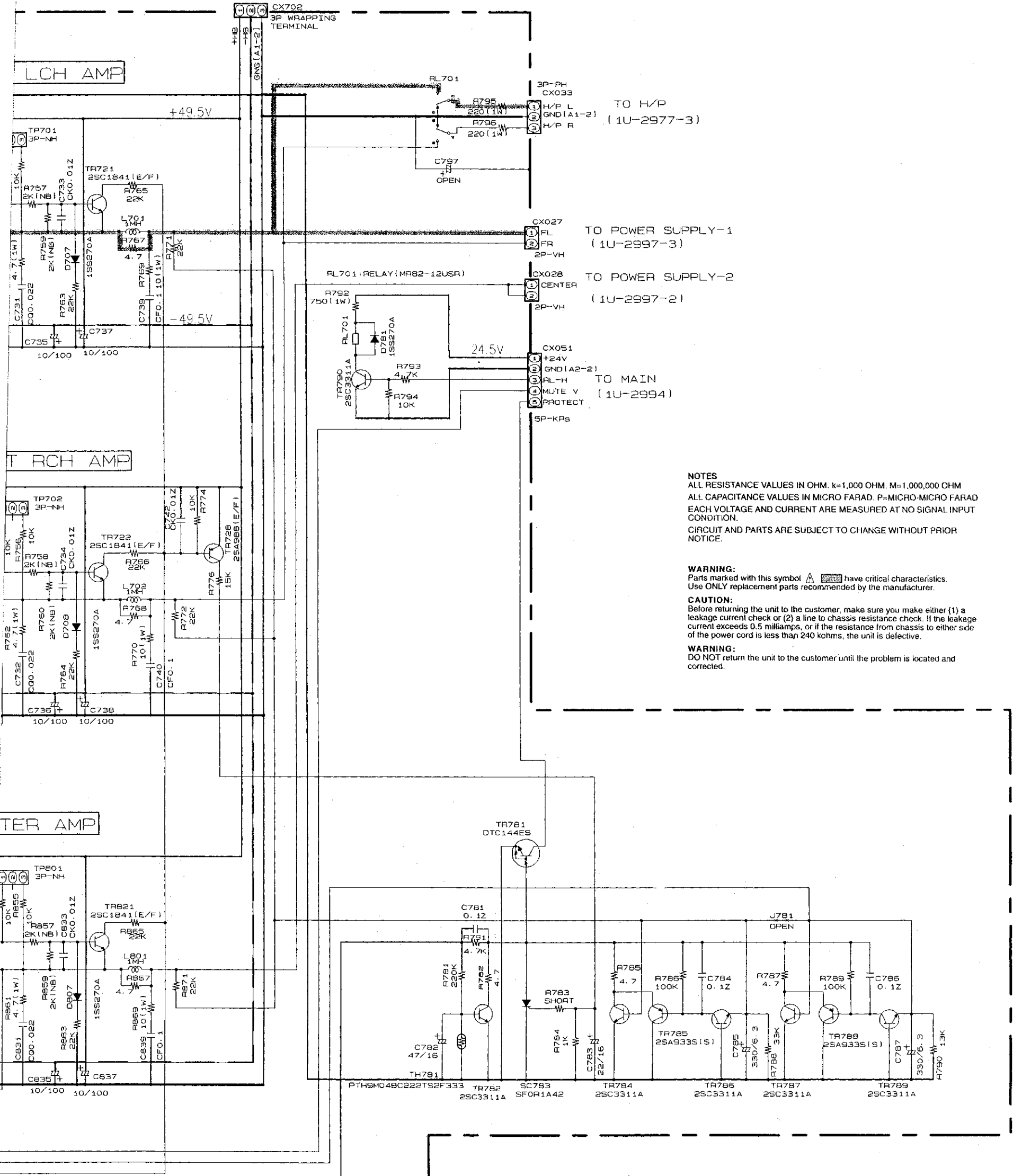

TO H/P  
(1U-2977-3)

TO POWER SUPPLY-1  
(1U-2997-3)

TO POWER SUPPLY-2  
(1U-2997-2)

TO MAIN  
(1U-2994)

**NOTES**  
 ALL RESISTANCE VALUES IN OHM. k=1,000 OHM, M=1,000,000 OHM  
 ALL CAPACITANCE VALUES IN MICRO FARAD. P=MICRO-MICRO FARAD  
 EACH VOLTAGE AND CURRENT ARE MEASURED AT NO SIGNAL INPUT CONDITION.  
 CIRCUIT AND PARTS ARE SUBJECT TO CHANGE WITHOUT PRIOR NOTICE.

**WARNING:**  
 Parts marked with this symbol have critical characteristics. Use ONLY replacement parts recommended by the manufacturer.

**CAUTION:**  
 Before returning the unit to the customer, make sure you make either (1) a leakage current check or (2) a line to chassis resistance check. If the leakage current exceeds 0.5 milliamps, or if the resistance from chassis to either side of the power cord is less than 240 kohms, the unit is defective.

**WARNING:**  
 DO NOT return the unit to the customer until the problem is located and corrected.

— +B LINE  
 - - - -B LINE  
 ~~~~~ SIGNAL LINE







SCHMATIC DIAGRAM (7/11)

1 2 3 4 5 6

A

B

C

D

E

F

G

H

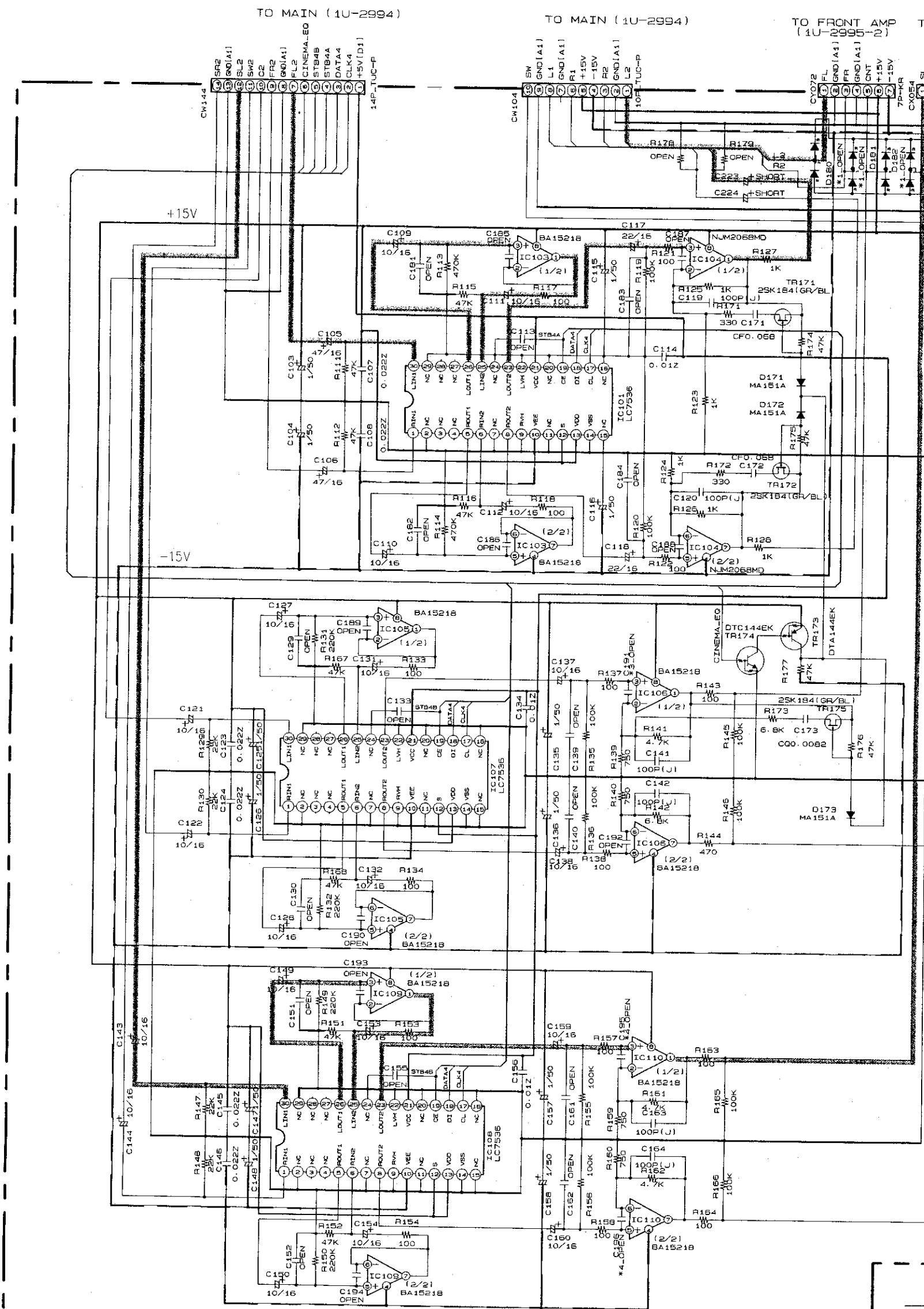

1U-3006  
E. VOL UNIT

|                | *1<br>D180 ~ 185 | *2<br>CX961 | *3<br>C191 | *4<br>C195, 196 |
|----------------|------------------|-------------|------------|-----------------|
| * USA / CANADA | ---              | ---         | ---        | ---             |
| ASIA / EUROPE  | ---              | ---         | 100P       | 100P            |
| JAPAN          | MA157A-TX        | 6P KR       | ---        | ---             |



# SCHEMATIC DIAGRAM (8/11)

1

2

3

4

5

6

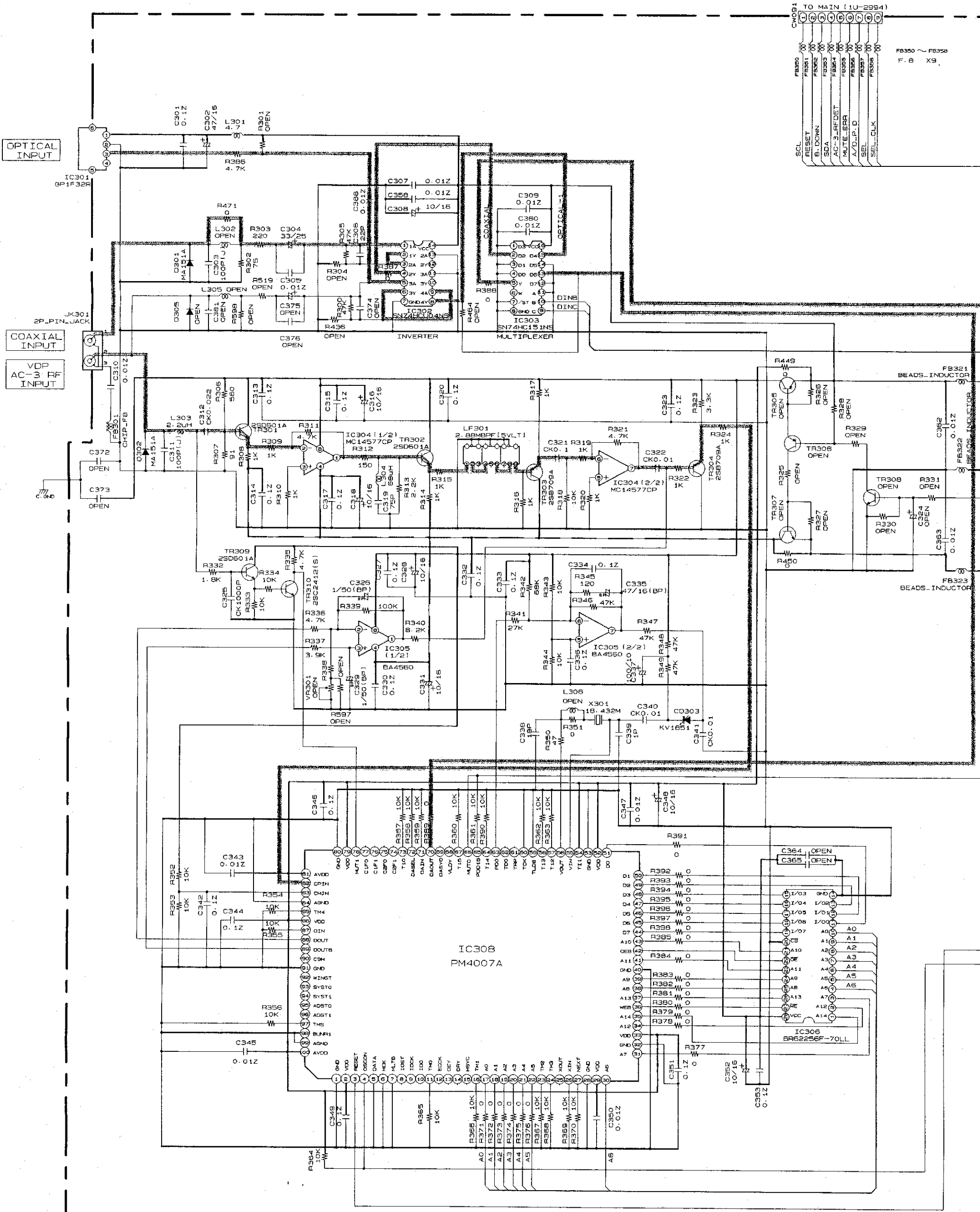

6 7 8 9 10 11

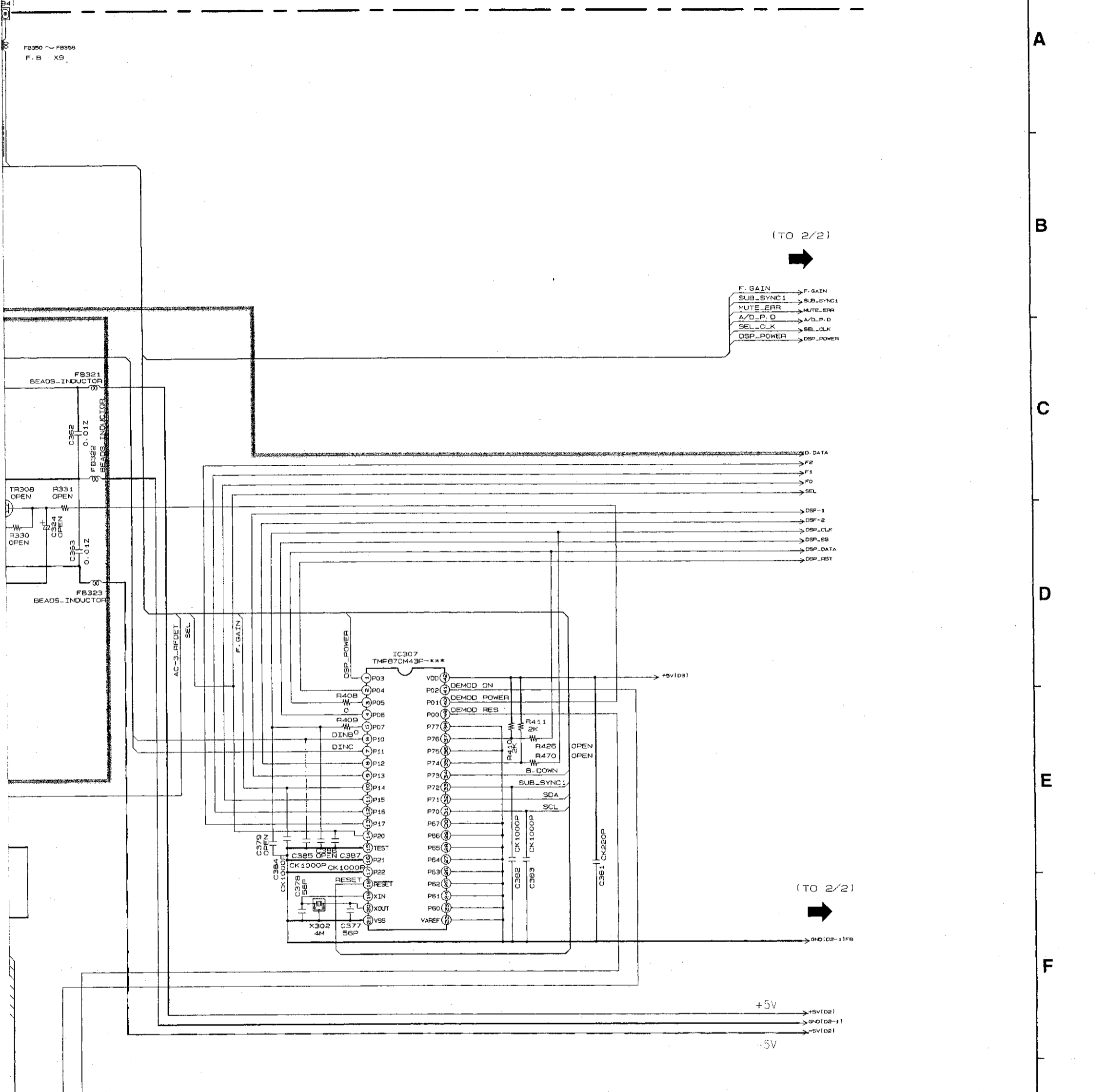

DSP\_UNIT  
1U-2998-1 (1/2)

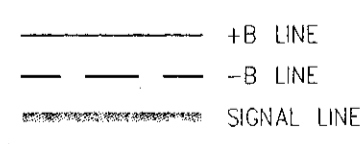

NOTES  
 ALL RESISTANCE VALUES IN OHM. k=1,000 OHM, M=1,000,000 OHM  
 ALL CAPACITANCE VALUES IN MICRO FARAD. P=MICRO-MICRO FARAD  
 EACH VOLTAGE AND CURRENT ARE MEASURED AT NO SIGNAL INPUT CONDITION.  
 CIRCUIT AND PARTS ARE SUBJECT TO CHANGE WITHOUT PRIOR NOTICE.

**WARNING:**  
 Parts marked with this symbol have critical characteristics. Use ONLY replacement parts recommended by the manufacturer.

**CAUTION:**  
 Before returning the unit to the customer, make sure you make either (1) a leakage current check or (2) a line to chassis resistance check. If the leakage current exceeds 0.5 milliamps, or if the resistance from chassis to either side of the power cord is less than 240 kohms, the unit is defective.

**WARNING:**  
 DO NOT return the unit to the customer until the problem is located and corrected.

A  
B  
C  
D  
E  
F  
G  
H

# SCHEMATIC DIAGRAM (9/11)

1 2 3 4 5 6

A  
B  
C  
D  
E  
F  
G  
H

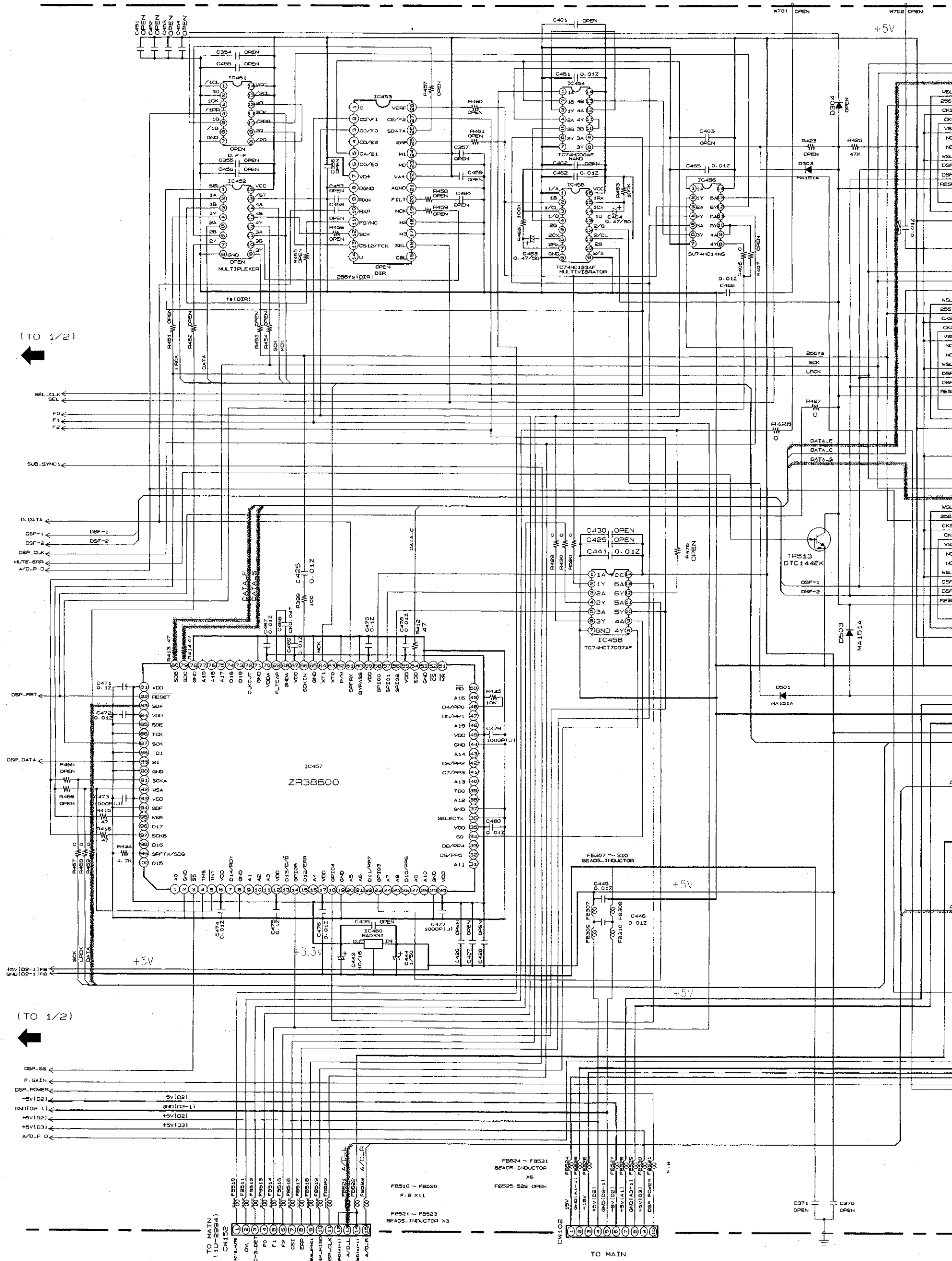

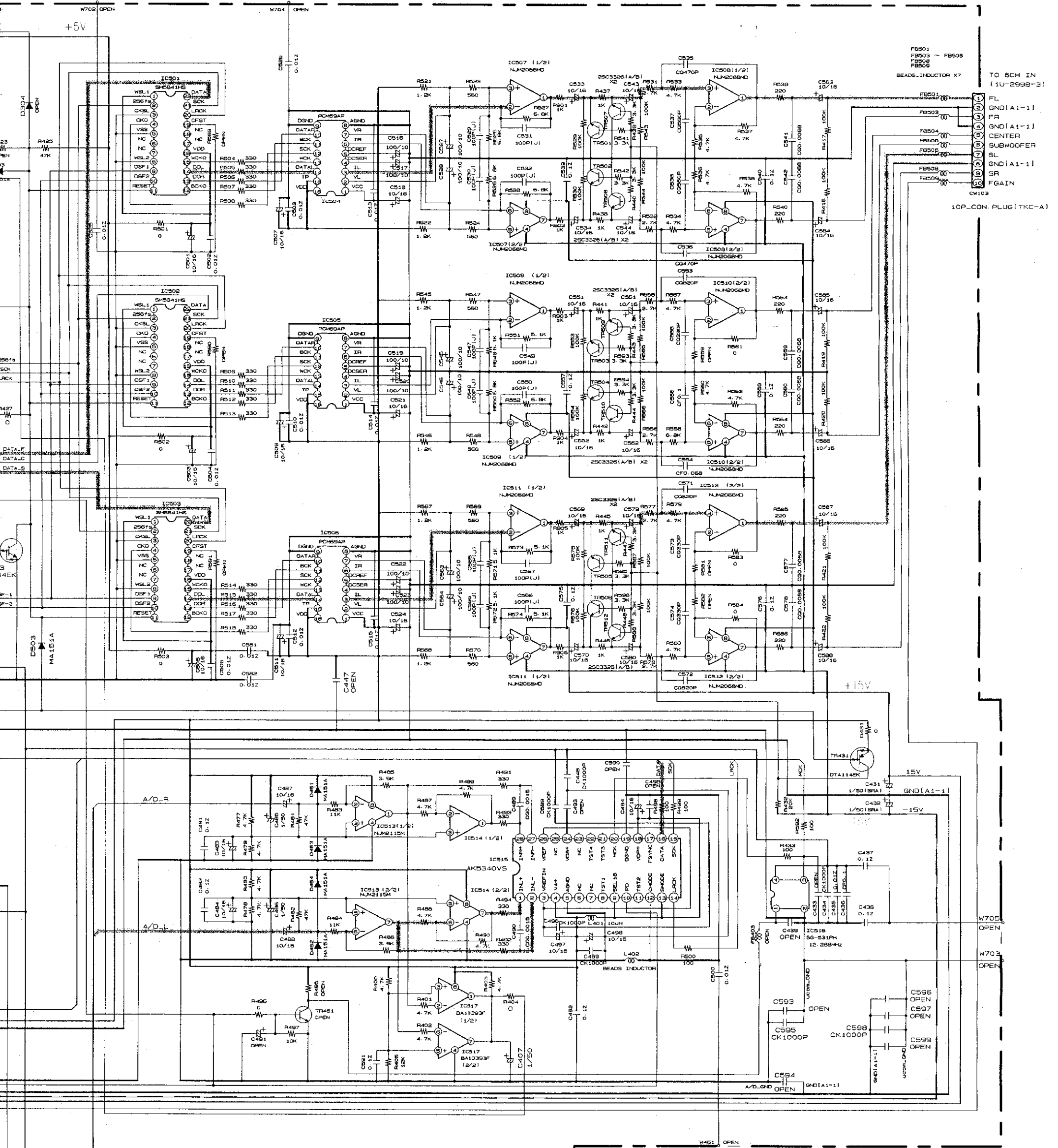

DSP\_UNIT  
1U-2998-1 (2/2)

— +B LINE  
— -B LINE  
— SIGNAL LINE

**NOTES**  
ALL RESISTANCE VALUES IN OHM. K=1,000 OHM, M=1,000,000 OHM  
ALL CAPACITANCE VALUES IN MICRO FARAD. P-MICRO-MICRO FARAD  
EACH VOLTAGE AND CURRENT ARE MEASURED AT NO SIGNAL INPUT CONDITION.  
CIRCUIT AND PARTS ARE SUBJECT TO CHANGE WITHOUT PRIOR NOTICE.

**WARNING:**  
Parts marked with this symbol have critical characteristics. Use ONLY replacement parts recommended by the manufacturer.

**CAUTION:**  
Before returning the unit to the customer, make sure you make either (1) a leakage current check or (2) a line to chassis resistance check. If the leakage current exceeds 0.5 milliamps, or if the resistance from chassis to either side of the power cord is less than 240 kohms, the unit is defective.

**WARNING:**  
DO NOT return the unit to the customer until the problem is located and corrected.

SCHEMATIC DIAGRAM (10/11)

1 2 3 4 5 6

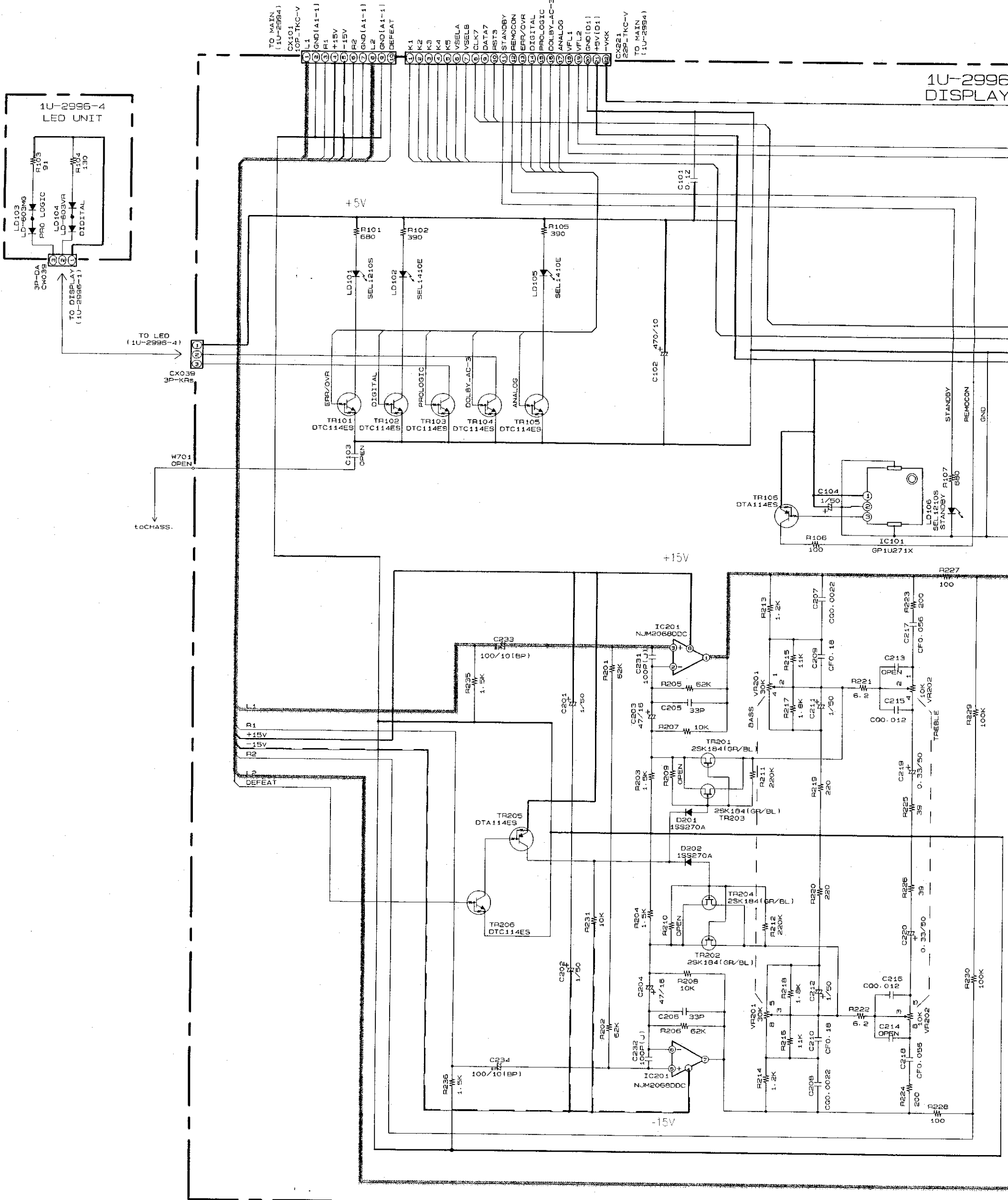

6 7 8 9 10 11

1U-2996-1  
DISPLAY UNIT -32V

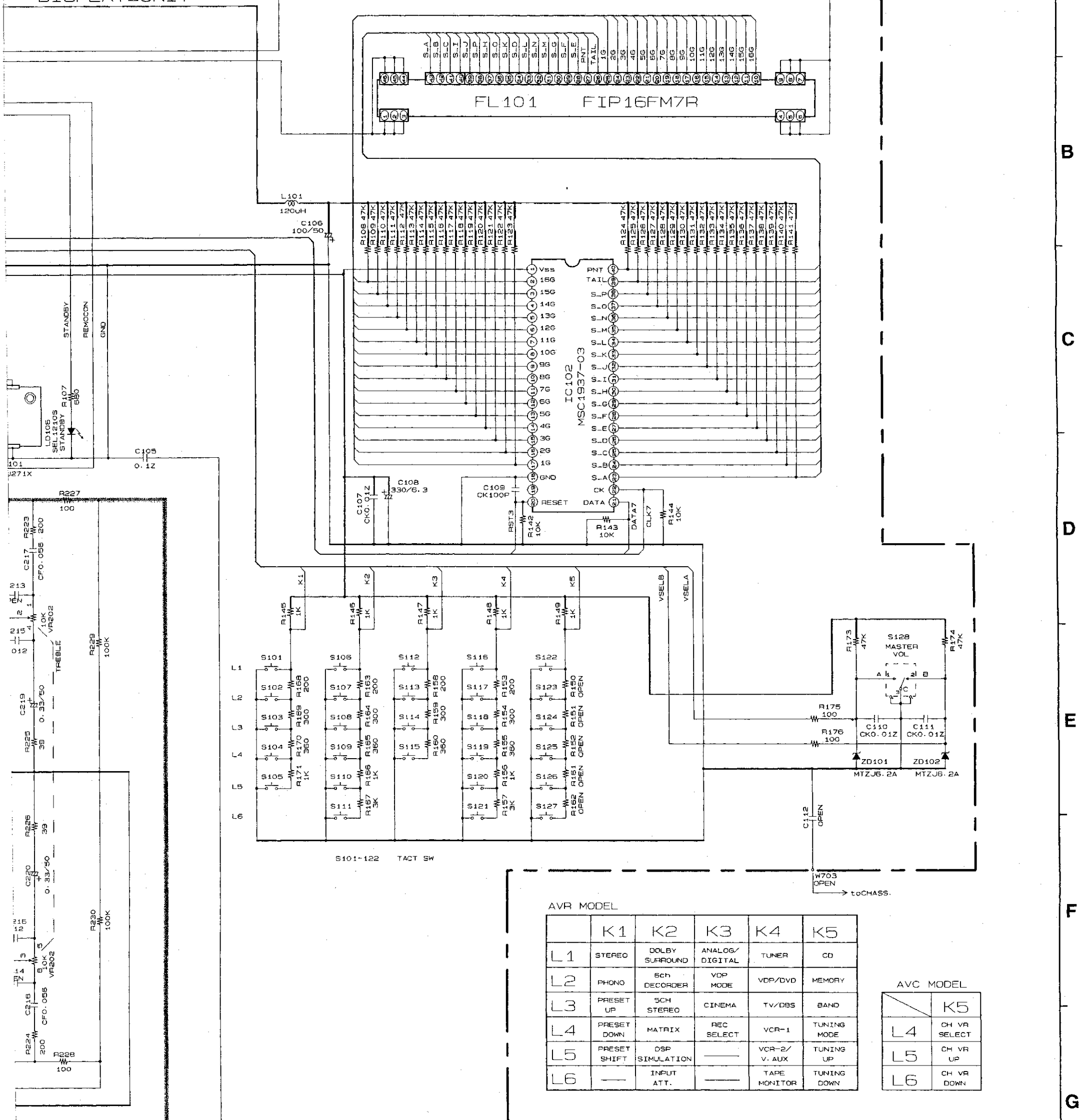

AVR MODEL

|    | K1           | K2             | K3             | K4           | K5          |
|----|--------------|----------------|----------------|--------------|-------------|
| L1 | STEREO       | DOLBY SURROUND | ANALOG/DIGITAL | TUNER        | CD          |
| L2 | PHONO        | SCH DECODER    | VDP MODE       | VDP/DVD      | MEMORY      |
| L3 | PRESET UP    | SCH STEREO     | CINEMA         | TV/DBS       | BAND        |
| L4 | PRESET DOWN  | MATRIX         | REC SELECT     | VCR-1        | TUNING MODE |
| L5 | PRESET SHIFT | DSP SIMULATION |                | VCR-2/V.AUX  | TUNING UP   |
| L6 |              | INPUT ATT.     |                | TAPE MONITOR | TUNING DOWN |

AVC MODEL

|    | K5           |
|----|--------------|
| L4 | CH VR SELECT |
| L5 | CH VR UP     |
| L6 | CH VR DOWN   |

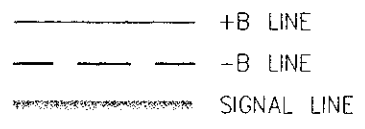

**NOTES**  
 ALL RESISTANCE VALUES IN OHM. k=1,000 OHM, M=1,000,000 OHM  
 ALL CAPACITANCE VALUES IN MICRO FARAD. P=MICRO-MICRO FARAD  
 EACH VOLTAGE AND CURRENT ARE MEASURED AT NO SIGNAL INPUT CONDITION.  
 CIRCUIT AND PARTS ARE SUBJECT TO CHANGE WITHOUT PRIOR NOTICE.

**WARNING:**  
 Parts marked with this symbol have critical characteristics. Use ONLY replacement parts recommended by the manufacturer.

**CAUTION:**  
 Before returning the unit to the customer, make sure you make either (1) a leakage current check or (2) a line to chassis resistance check. If the leakage current exceeds 0.5 milliamperes, or if the resistance from chassis to either side of the power cord is less than 240 kohms, the unit is defective.

**WARNING:**  
 DO NOT return the unit to the customer until the problem is located and corrected.

A  
B  
C  
D  
E  
F  
G  
H



**SCHEMATIC DIAGRAM (11/11)**

1 2 3 4 5 6

A

B

C

D

E

F

G

H

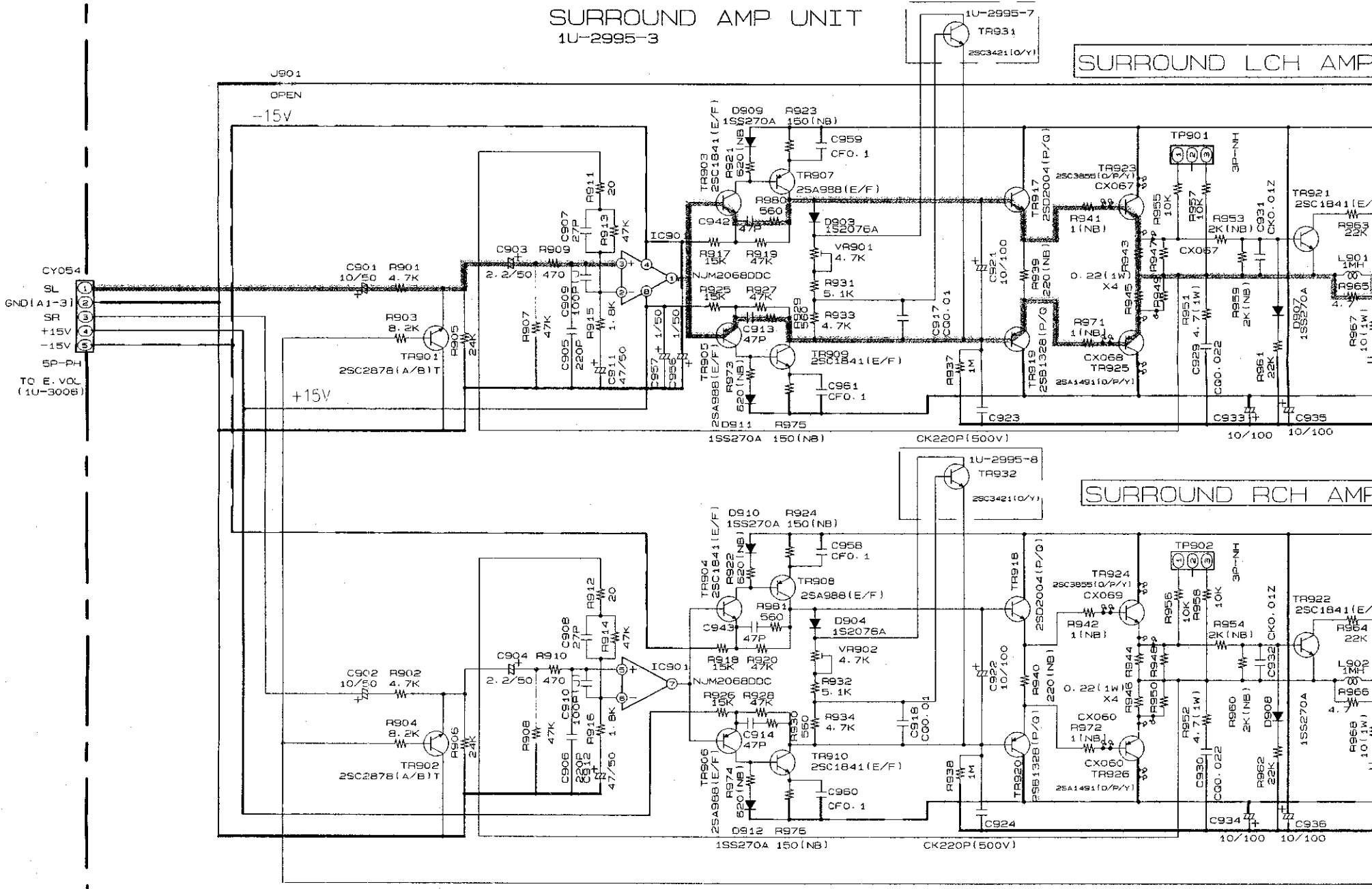

**NOTES**  
 ALL RESISTANCE VALUES IN OHM. k=1,000 OHM, M=1,000,000 OHM  
 ALL CAPACITANCE VALUES IN MICRO FARAD. P=MICRO-MICRO FARAD  
 EACH VOLTAGE AND CURRENT ARE MEASURED AT NO SIGNAL INPUT CONDITION.  
 CIRCUIT AND PARTS ARE SUBJECT TO CHANGE WITHOUT PRIOR NOTICE.

**WARNING:**  
 Parts marked with this symbol  have critical characteristics. Use ONLY replacement parts recommended by the manufacturer.

**CAUTION:**  
 Before returning the unit to the customer, make sure you make either (1) a leakage current check or (2) a line to chassis resistance check. If the leakage current exceeds 0.5 milliamps, or if the resistance from chassis to either side of the power cord is less than 240 kohms, the unit is defective.

**WARNING:**  
 DO NOT return the unit to the customer until the problem is located and corrected.

TO MAIN (1U-2994)

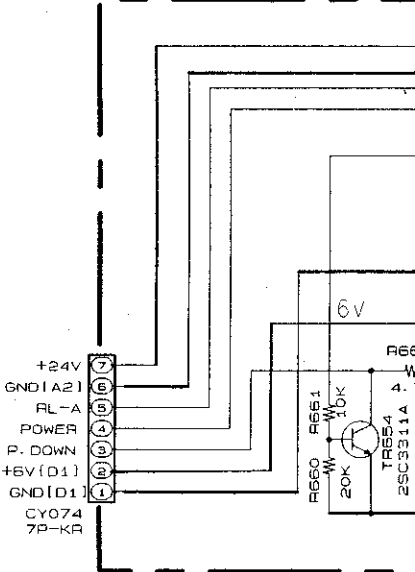

|        | *1         | *2         | * |
|--------|------------|------------|---|
|        | F1         | F8         |   |
| * USA  | 8A/125V    | 8A/125V    |   |
| CANADA | 20A1046014 | 20A1046014 | 2 |
| ASIA   | 4A/250V    | 2.5A/250V  | 2 |
|        | 20A1015087 | 20A1015032 |   |
| EUROPE | 4A/250V    | 2.5A/250V  | 2 |
|        | 20A1015087 | 20A1015032 |   |
| JAPAN  | 8A/125V    | 8A/125V    | 2 |
|        | 20A1052008 | 20A1052008 |   |

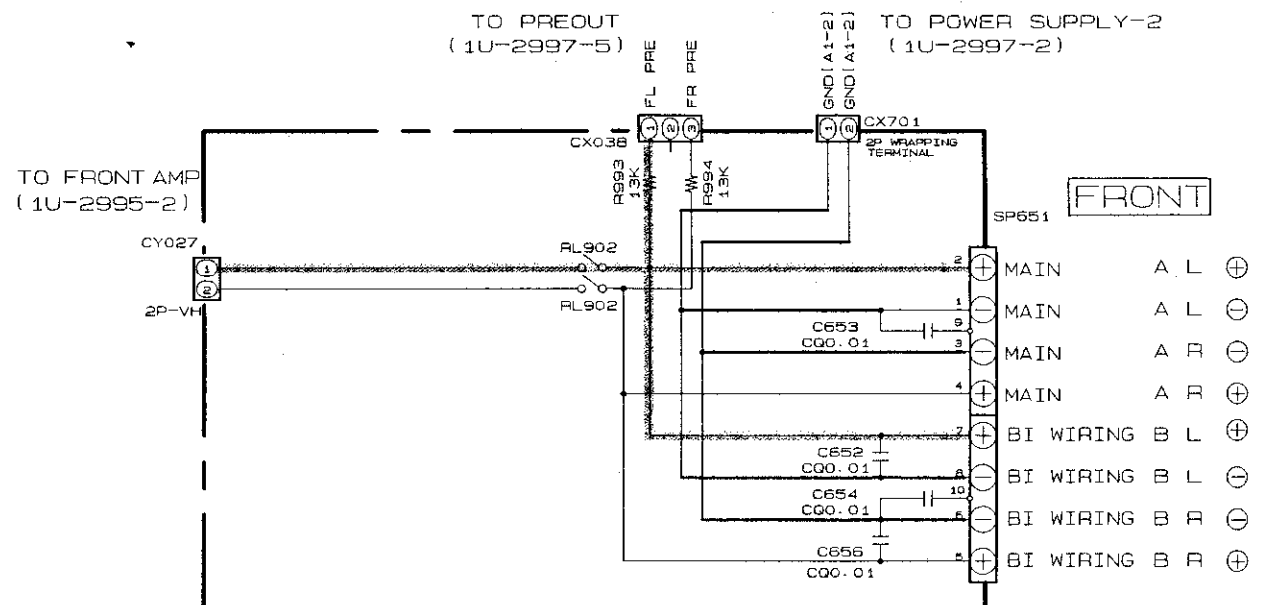
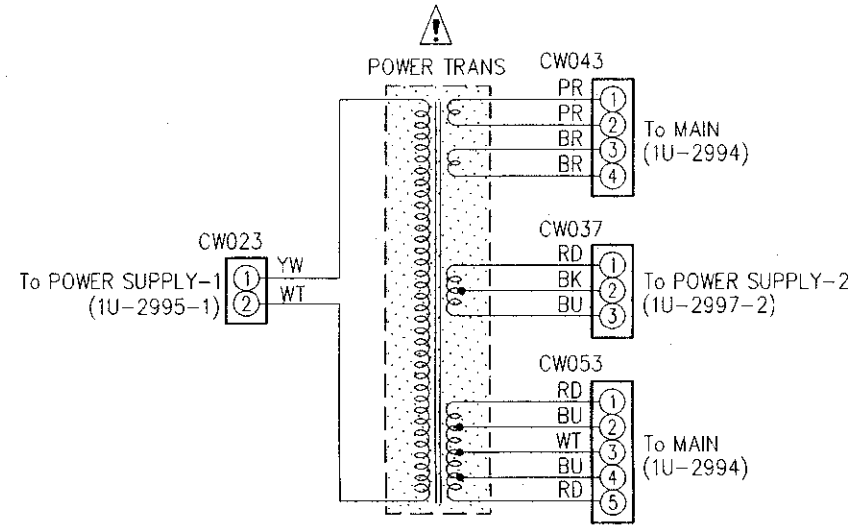
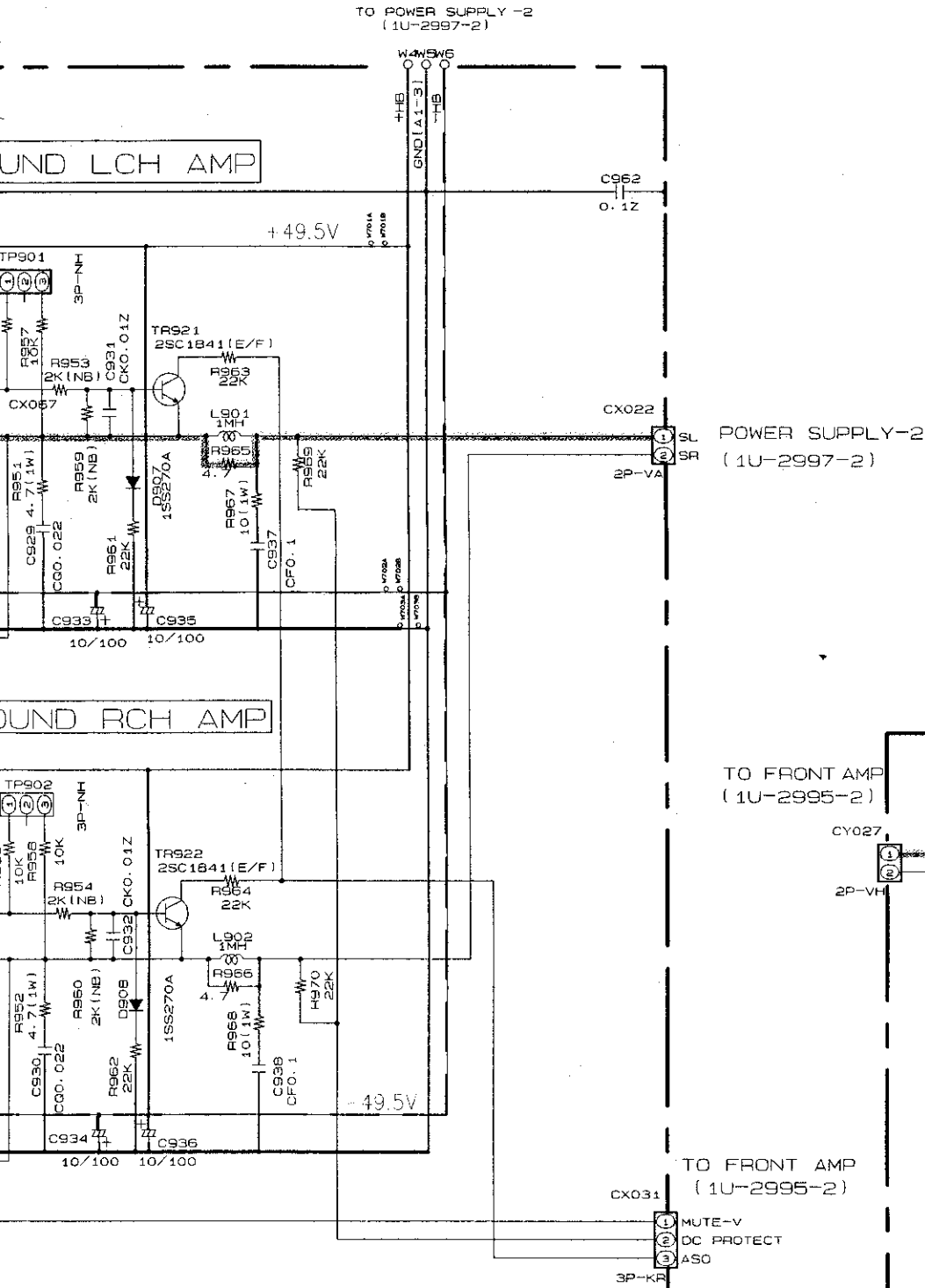

**POWER SUPPLY-1 UNIT**  
1U-2995-1

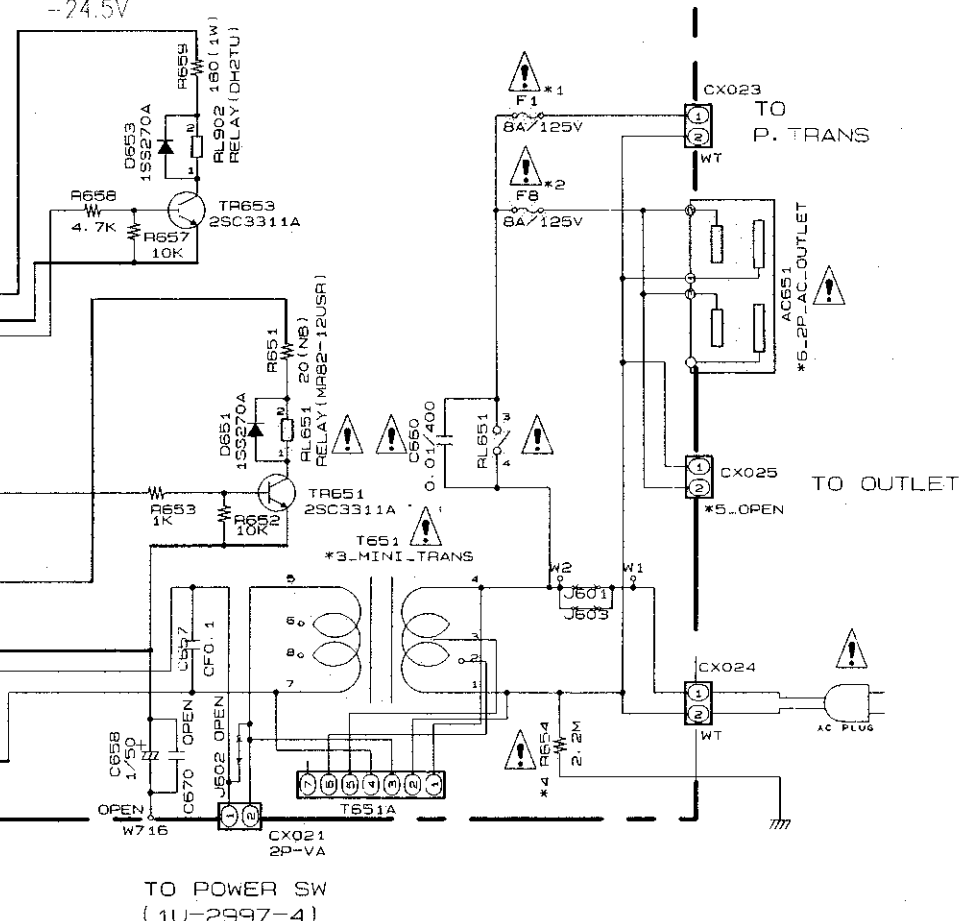

| *1                    | *2                      | *3         | *4   | *5    | *6              |
|-----------------------|-------------------------|------------|------|-------|-----------------|
| F1                    | FB                      | T651       | R654 | CX025 | AC651           |
| 8A/125V<br>2041046014 | 8A/125V<br>2061046014   | 2335818004 | 2.2M | —     | 2P AC<br>OUTLET |
| 4A/250V<br>2061015087 | 2.5A/250V<br>2061015032 | 2336074009 | —    | 2P-VH | —               |
| 4A/250V<br>2061015087 | 2.5A/250V<br>2061015032 | 2336074009 | —    | 2P-VH | —               |
| 8A/125V<br>2061052008 | 8A/125V<br>2061052008   | 2330362005 | —    | —     | 2P AC<br>OUTLET |

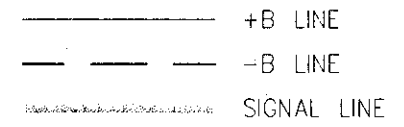

# REMOTE CONTROL UNIT (RC-825)

1 2 3 4 5 6 7 8

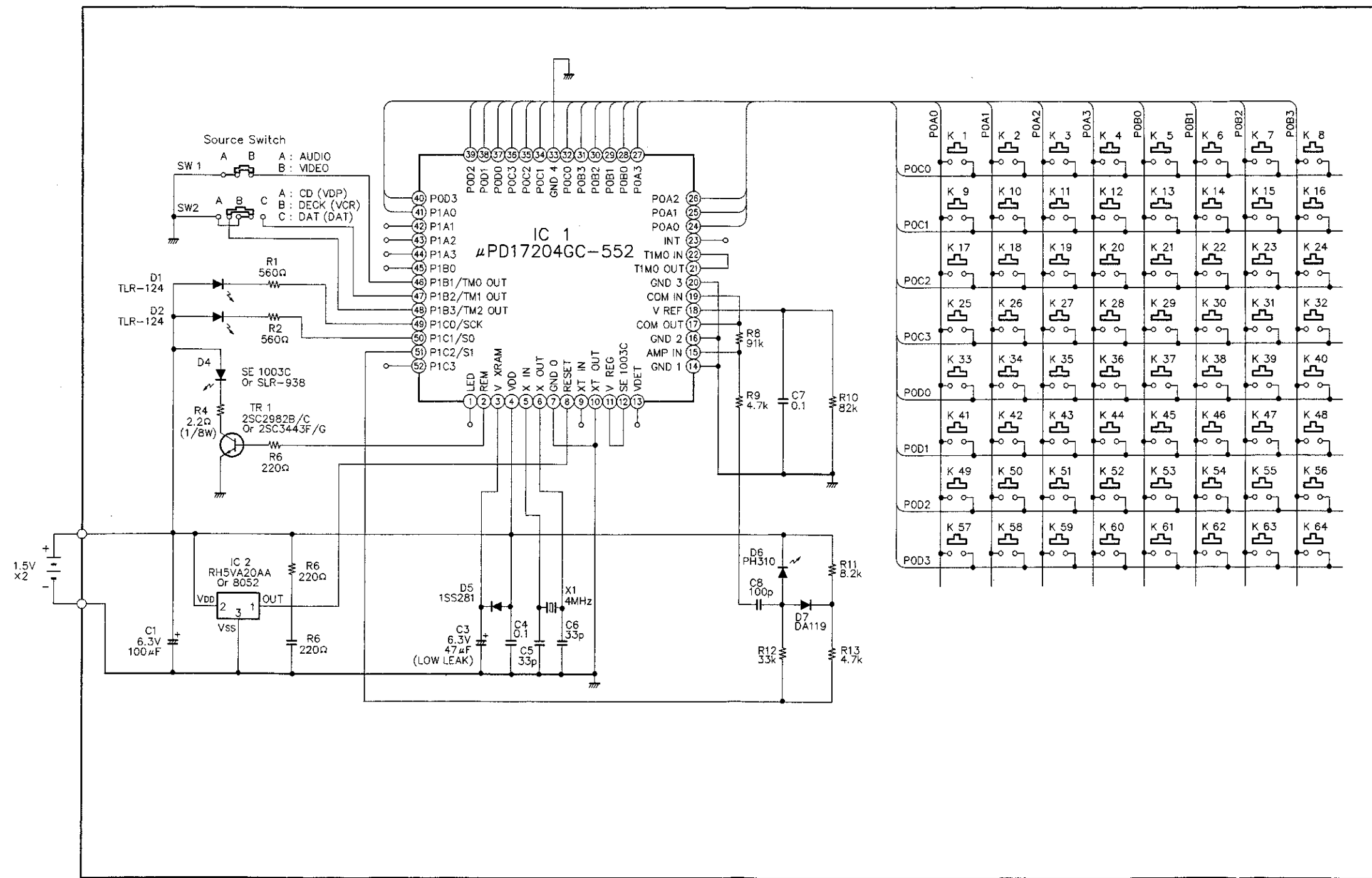

A  
B  
C  
D  
E

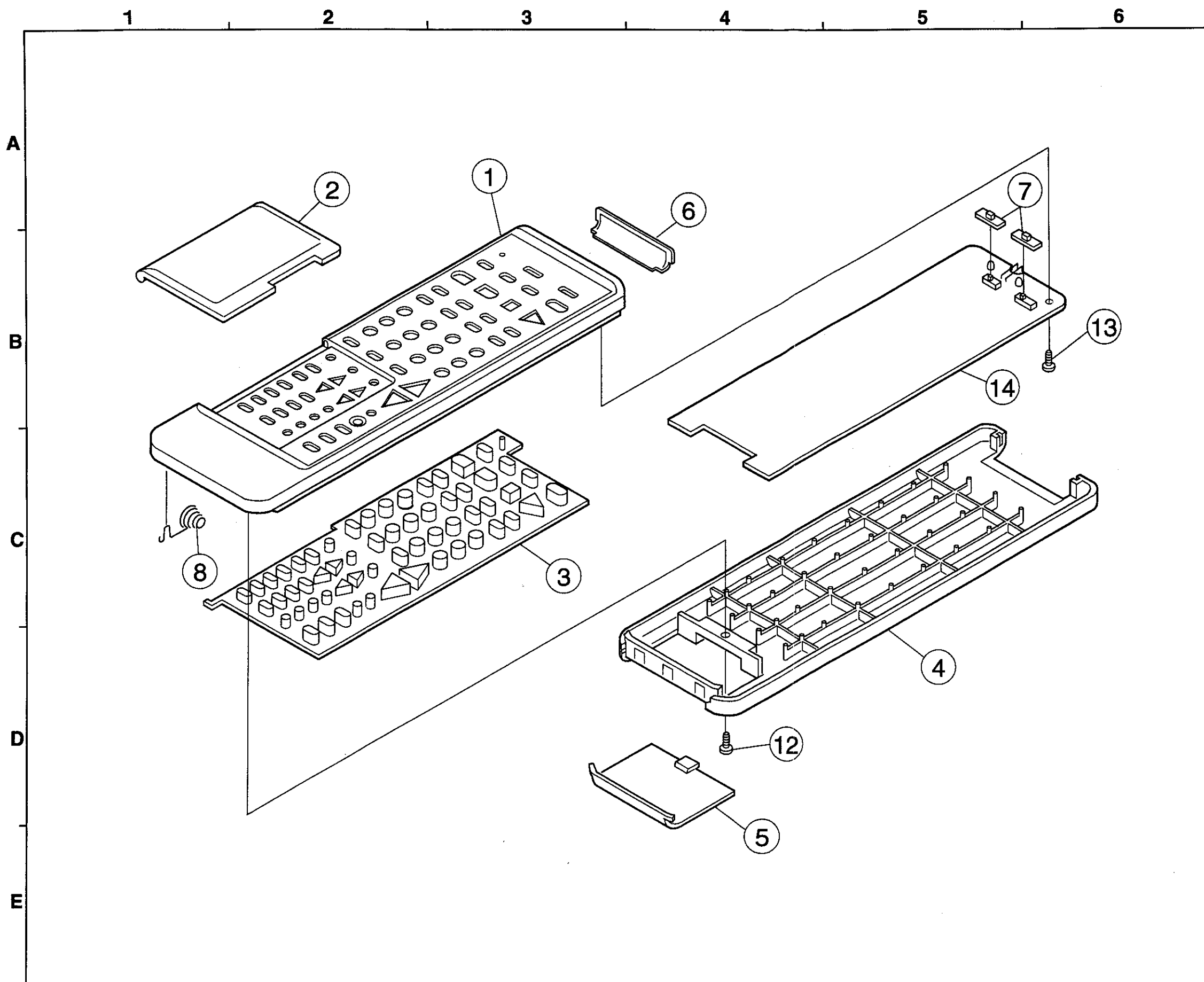

**PARTS LIST OF REMOTE CONTROL UNIT (RC-825)**

| Ref. No. | Part No.     | Part Name                     | Remarks       | Q'ty |
|----------|--------------|-------------------------------|---------------|------|
| ⊙ 1      | 9H3 1000 164 | Top Case (RC825) Assy         |               | 1s   |
| ⊙ 2      | 9H3 1000 168 | Cover                         |               | 1    |
| ⊙ 3      | 9H3 1000 169 | Switch Rubber                 |               | 1    |
| ⊙ 4      | 9H3 1000 166 | Bottom Case                   |               | 1    |
| ⊙ 5      | 9H3 1000 167 | Battery Cover                 |               | 1    |
| ⊙ 6      | 9H3 1000 148 | Filter                        |               | 1    |
| 7        | 9H3 1000 150 | Slide Knob                    |               | 2    |
| 8        | 9H3 1000 152 | Coil Spring                   |               | 1    |
| 9        | —            | —                             |               |      |
| 10       | —            | —                             |               |      |
| 11       | —            | —                             |               |      |
| 12       | 9H3 1000 154 | Tapping Screw 2x6             |               | 1    |
| 13       | 9H3 1000 107 | Tapping Screw 2x5             |               | 1    |
| 14       | 9H3 1000 161 | Main P.W.B. Assy              |               | 1s   |
| IC1      | 9H3 1000 162 | IC $\mu$ PD17204GC-552        | $\mu$ -Com    | 1    |
| IC2      | 9H3 1000 158 | IC RH5VA10AA                  | vol. Detector | 1    |
| Q1       | 9H3 1000 070 | Transistor 2SC2982            | Chip          | 1    |
| D1,2     | 9H3 1000 028 | LED TLR124                    | Visible-Red   | 2    |
| D4       | 9H3 1000 131 | LED SE1003-C                  | Infrared      | 1    |
| D5       | 9H3 1000 087 | Diode 1SS2B1                  |               | 1    |
| D6       | 9H3 1000 029 | Diode PH310                   | Photo-PIN     | 1    |
| D7       | 9H3 1000 071 | Diode DA119                   | Chip          | 1    |
| X1       | 9H3 1000 088 | Ceramic Resonator             | KBR4, 0M503   | 1    |
| SW1      | 9H3 1000 089 | Slide Switch                  |               | 1    |
| SW2      | 9H3 1000 074 | Slide Switch                  |               | 1    |
| C1       | 254 4213 034 | Electrolytic 100 $\mu$ F/6.3V | CE04W0J101M   | 1    |
| C3       | 254 4213 021 | Electrolytic 47 $\mu$ F/6.3V  | CE04W0J470M   | 1    |

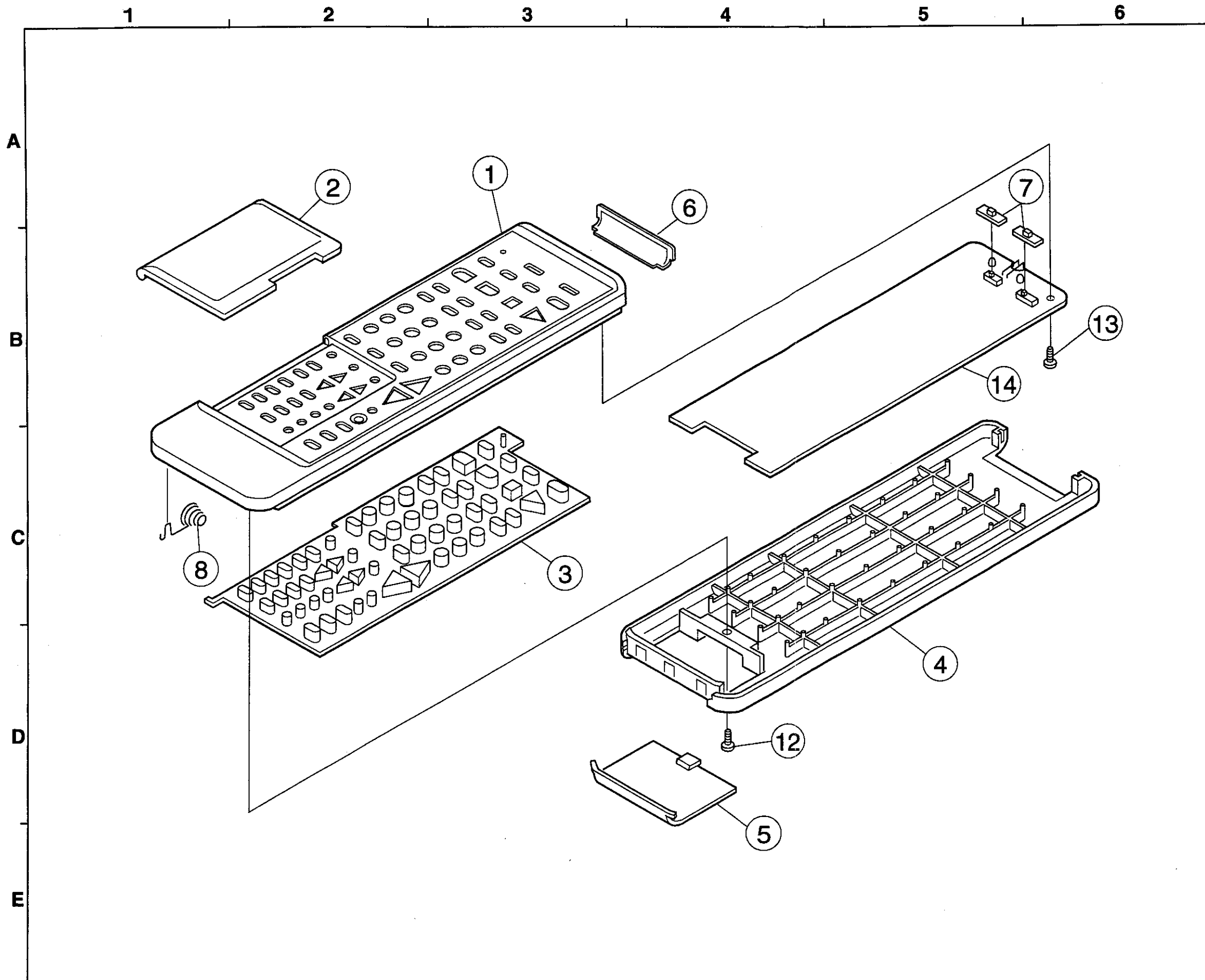

**PARTS LIST OF REMOTE CONTROL UNIT (RC-825)**

| Ref. No. | Part No.     | Part Name                     | Remarks       | Q'ty |
|----------|--------------|-------------------------------|---------------|------|
| ⊙ 1      | 9H3 1000 164 | Top Case (RC825) Ass'y        |               | 1s   |
| ⊙ 2      | 9H3 1000 168 | Cover                         |               | 1    |
| ⊙ 3      | 9H3 1000 169 | Switch Rubber                 |               | 1    |
| ⊙ 4      | 9H3 1000 166 | Bottom Case                   |               | 1    |
| ⊙ 5      | 9H3 1000 167 | Battery Cover                 |               | 1    |
| ⊙ 6      | 9H3 1000 148 | Filter                        |               | 1    |
| 7        | 9H3 1000 150 | Slide Knob                    |               | 2    |
| 8        | 9H3 1000 152 | Coil Spring                   |               | 1    |
| 9        | —            | —                             |               |      |
| 10       | —            | —                             |               |      |
| 11       | —            | —                             |               |      |
| 12       | 9H3 1000 154 | Tapping Screw 2x6             |               | 1    |
| 13       | 9H3 1000 107 | Tapping Screw 2x5             |               | 1    |
| 14       | 9H3 1000 161 | Main P.W.B. Ass'y             |               | 1s   |
| IC1      | 9H3 1000 162 | IC $\mu$ PD17204GC-552        | $\mu$ -Com    | 1    |
| IC2      | 9H3 1000 158 | IC RH5VA10AA                  | vol. Detector | 1    |
| Q1       | 9H3 1000 070 | Transistor 2SC2982            | Chip          | 1    |
| D1,2     | 9H3 1000 028 | LED TLR124                    | Visible-Red   | 2    |
| D4       | 9H3 1000 131 | LED SE1003-C                  | Infrared      | 1    |
| D5       | 9H3 1000 087 | Diode 1SS2B1                  |               | 1    |
| D6       | 9H3 1000 029 | Diode PH310                   | Photo-PIN     | 1    |
| D7       | 9H3 1000 071 | Diode DA119                   | Chip          | 1    |
| X1       | 9H3 1000 088 | Ceramic Resonator             | KBR4, 0M503   | 1    |
| SW1      | 9H3 1000 089 | Slide Switch                  |               | 1    |
| SW2      | 9H3 1000 074 | Slide Switch                  |               | 1    |
| C1       | 254 4213 034 | Electrolytic 100 $\mu$ F/6.3V | CE04W0J101M   | 1    |
| C3       | 254 4213 021 | Electrolytic 47 $\mu$ F/6.3V  | CE04W0J470M   | 1    |

# DENON

|                                                                        |                                                          |
|------------------------------------------------------------------------|----------------------------------------------------------|
| <b>DENON</b> ORIGINAL ERSATZTEILE<br>ORIGINAL SPAREPARTS               |                                                          |
| Lagerort / Warehouse Location<br><b>E018C04C</b>                       | Lieferschein-Nr. / Delivery Note No<br><b>0250412708</b> |
| Menge / Quantity<br><b>1</b>                                           |                                                          |
| Ihre Ref.-Nr. / Your Ref. No<br><b>055201000</b>                       | Datum / Date<br><b>24.05.2006</b>                        |
| Artikel / Article<br><b>SERVICE MANUAL AVR3200</b><br><b>SMAVR3200</b> |                                                          |

## **NIPPON COLUMBIA CO. LTD.**

14-14, AKASAKA 4-CHOME, MINATO-KU, TOKYO 107-11 JAPAN  
Telephone: 03 (3584) 8111  
Cable: NIPPON COLUMBIA TOKYO Telex: JAPANOLA J22591

# DENON

Hi-Fi AV Surround Receiver

**For Europe and Asia Models**

## SERVICE MANUAL

# MODEL AVR-3200/3200G

## AV SURROUND RECEIVER

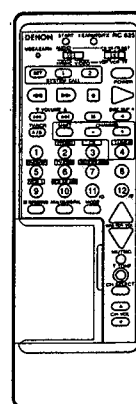
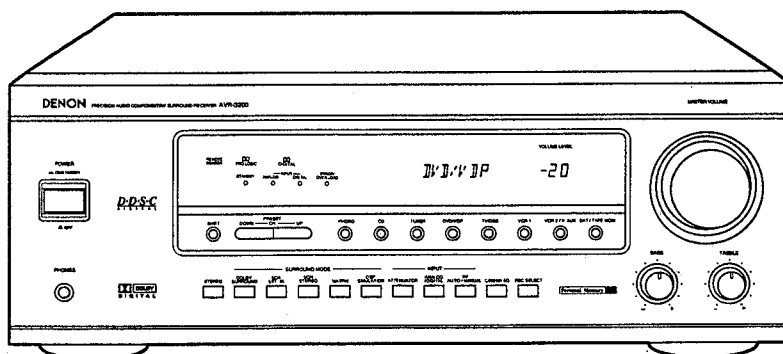

AVR-3200G has the accessories with wood board.

This service manual is supplement for Europe and Asia models. For servicing, refer to the service manual of AVR-3200 (For U.S.A./Canada model) already issued at the same time.

### — TABLE OF CONTENTS —

|                                                   |      |
|---------------------------------------------------|------|
| ADDENDUM PARTS LIST OF EXPLODED VIEW .....        | 2    |
| EXPLODED VIEW .....                               | 3    |
| ADDENDUM PARTS LIST OF PRINTED WIRING BOARD ..... | 4-6  |
| SCHEMATIC DIAGRAM .....                           | 7-11 |

● In order to explain clearly, some illustrations using in this service manual may be slightly different from the actual set.

# NIPPON COLUMBIA CO., LTD.

## ADDENDUM PARTS LIST OF EXPLODED VIEW

| Ref No. | Part Name             | Part No.     |              |                  |                 |
|---------|-----------------------|--------------|--------------|------------------|-----------------|
|         |                       | U.S.A. Model | Europe Model | Asia Black Model | Asia Gold Model |
| 22      | Back panel            | 105 1225 202 | 105 1225 228 | 105 1225 228     | 105 1225 231    |
| 33      | Power trans.          | 233 6220 002 | 233 6224 008 | 233 6224 008     | 233 6224 008    |
| 35      | AC cord               | 206 2060 002 | 206 2063 009 | 206 2063 009     | 206 2063 009    |
| 39      | Inner panel Ass'y     | 146 1669 209 | 146 1669 225 | 146 1669 225     | 146 1669 335    |
| 41      | Tuning knob           | 113 1804 006 | 113 1804 006 | 113 1804 006     | 113 1804 019    |
| 42      | Function knob         | 113 1805 005 | 113 1805 005 | 113 1805 005     | 113 1805 018    |
| 49      | VR. knob Ass'y        | 112 0744 038 | 112 0744 038 | 112 0744 038     | 112 0744 041    |
| 50      | Knob (MARU)           | 112 0685 100 | 112 0685 100 | 112 0685 100     | 112 0685 113    |
| 51      | P. knob (P) Ass'y     | 113 9213 000 | 113 9213 000 | 113 9213 000     | 113 9213 039    |
| 52      | Top cover             | 102 0583 001 | 102 0583 001 | 102 0583 001     | 102 0583 014    |
| 54      | Earth plate           | 414 0819 005 | —            | —                | —               |
| 61      | AC outlet (E2)        | —            | 203 3942 007 | 203 3942 007     | 203 3942 007    |
| 62      | UL tube               | —            | 415 0364 016 | 415 0364 016     | 415 0364 016    |
| 63      | Wood board (L)        | —            | —            | —                | 101 2491 046    |
| 64      | Wood board (R)        | —            | —            | —                | 101 2492 045    |
| 65      | Felt sheet            | —            | —            | —                | 124 0032 015    |
| 121     | Screw 4x20 CBTS (S)-B | —            | —            | —                | 473 7007 039    |
|         | Screw 4x8 CBTS (B)-B  | 473 8063 014 | 473 8063 014 | 473 8063 014     | —               |
| 122     | Screw 4x25 CBTS       | —            | —            | —                | 473 3809 011    |
| 123     | 5 W (Washer)          | —            | —            | —                | 475 1006 016    |
| 152     | Cushion Ass'y         | 503 1236 000 | 503 1236 000 | 503 1236 000     | 503 1252 000    |
| 154     | Instruction manual    | 511 3081 005 | 511 3115 007 | 511 3115 007     | 511 3115 007    |
| 157     | RC-827 remocon        | —            | 399 0355 011 | 399 0355 011     | 399 0355 011    |
|         | RC-825 remocon        | 399 0355 008 | —            | —                | —               |
| 166     | Side pad              | —            | —            | —                | 504 0159 013    |



# EXPLODED VIEW

**WARNING:**  
Parts marked with this symbol  have critical characteristics.  
Use **ONLY** replacement parts recommended by the manufacturer.

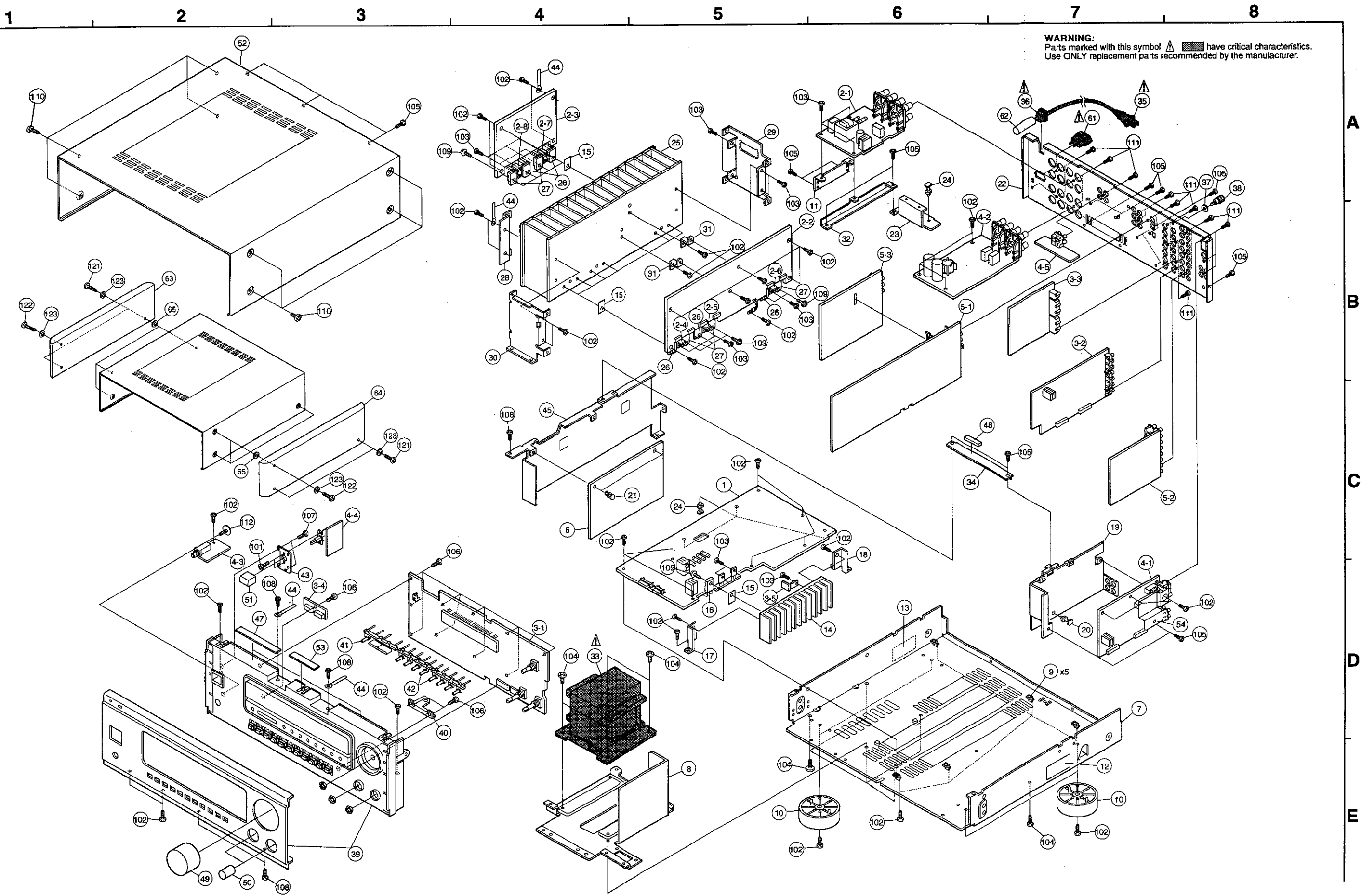

**NOTE FOR PARTS LIST**

- Part indicated with the mark "⊙" are not always in stock and possibly to take a long period of time for supplying, or in some case supplying of part may be refused.
- When ordering of part, clearly indicate "1" and "I" (i) to avoid mis-supplying.
- Ordering part without stating its part number can not be supplied.
- Part indicated with the mark "★" is not illustrated in the exploded view.
- Not including Carbon Film ±5%, 1/4W Type in the P.W.Board parts list. (Refer to the Schematic Diagram for those parts.)

**WARNING:**  
Parts marked with this symbol  have critical characteristics.  
Use ONLY replacement parts recommended by the manufacturer.

**● Resistors**

Ex.: RN 14K 2E 182 G FR  
Type Shape Power Resist- Allowable Others  
and per- ance error Others  
formance

|                       |           |          |                          |
|-----------------------|-----------|----------|--------------------------|
| RD : Carbon           | 2B : 1/8W | F : ±1%  | P : Pulse-resistant type |
| RC : Composition      | 2E : 1/4W | G : ±2%  | NL : Low noise type      |
| RS : Metal oxide film | 2H : 1/2W | J : ±5%  | NB : Non-burning type    |
| RW : Winding          | 3A : 1W   | K : ±10% | FR : Fuse-resistor       |
| RN : Metal film       | 3D : 2W   | M : ±20% | F : Lead wire forming    |
| RK : Metal mixture    | 3F : 3W   |          |                          |
|                       | 3H : 5W   |          |                          |

**\* Resistance**  
1 8 2 ⇒ 1800 ohm = 1.8 kohm  
Indicates number of zeros after effective number.  
2-digit effective number.  
• Units: ohm

1 R 2 ⇒ 1.2 ohm  
1-digit effective number.  
2-digit effective number, decimal point indicated by R.  
• Units: ohm

**● Capacitors**

Ex.: CE 04W 1H 2R2 M BP  
Type Shape Dielectric Capacity Allowable Others  
and per- strength error Others  
formance

|                                  |           |             |                                  |
|----------------------------------|-----------|-------------|----------------------------------|
| CE : Aluminum foil electrolytic  | 0J : 6.3V | F : ±1%     | HS : High stability type         |
| CA : Aluminum solid electrolytic | 1A : 10V  | G : ±2%     | BP : Non-polar type              |
| CS : Tantalum electrolytic       | 1C : 16V  | J : ±5%     | HR : Ripple-resistant type       |
| CO : Film                        | 1E : 25V  | K : ±10%    | DL : For charge and discharge    |
| CK : Ceramic                     | 1V : 35V  | M : ±20%    | HF : For assuring high frequency |
| CG : Ceramic                     | 1H : 50V  | Z : +80%    | U : UL part                      |
| CP : Oil                         | 2A : 100V | -20%        | C : CSA part                     |
| CM : Mica                        | 2B : 125V | P : +100%   | W : UL-CSA type                  |
| CF : Metallized                  | 2C : 160V | -0%         | F : Lead wire forming            |
| CH : Metallized                  | 2D : 200V | C : ±0.25pF |                                  |
|                                  | 2E : 250V | D : ±0.5pF  |                                  |
|                                  | 2H : 500V | = : Others  |                                  |
|                                  | 2J : 630V |             |                                  |

**\* Capacity (electrolyte only)**  
2 2 2 ⇒ 2200µF  
Indicates number of zeros after effective number.  
2-digit effective number.  
• Units: µF

2 R 2 ⇒ 2.2µF  
1-digit effective number.  
2-digit effective number, decimal point indicated by R.  
• Units: µF

**\* Capacity (except electrolyte)**  
2 2 2 ⇒ 2200pF=0.0022µF  
(More than 2) — Indicates number of zeros after effective number.  
2-digit effective number.  
• Units: µF

2 2 1 ⇒ 220pF  
(0 or 1) — Indicates number of zeros after effective number.  
2-digit effective number.  
• Units: pF

• When the dielectric strength is indicated in AC, "AC" is included after the dielectric strength value.

**ADDENDUM PARTS LIST OF P.W.BOARD**

**1U-2994 MAIN P.W.B. UNIT**

| Ref No.  | U.S.A. Model |                                 | Europe Model |                                      | Asia Model   |                                      | Remarks      |
|----------|--------------|---------------------------------|--------------|--------------------------------------|--------------|--------------------------------------|--------------|
|          | Part No.     | Part Name                       | Part No.     | Part Name                            | Part No.     | Part Name                            |              |
| C142     | 257 0008 983 | Ceramic chip<br>1000pF/50V ±10% | —            | —                                    | —            | —                                    |              |
| C165,166 | —            | —                               | 257 0003 920 | Ceramic chip 27pF/50V ±5%            | 257 0003 920 | Ceramic chip 27pF/50V ±5%            |              |
| C167     | —            | —                               | 254 4260 951 | Electrolytic 2.2µF/50V               | 254 4260 951 | Electrolytic 2.2µF/50V               |              |
| C168     | —            | —                               | 254 4254 909 | Electrolytic 10µF/16V                | 254 4254 909 | Electrolytic 10µF/16V                |              |
| C169     | —            | —                               | 257 0006 943 | Ceramic chip 560pF/50V ±5%           | 257 0006 943 | Ceramic chip 560pF/50V ±5%           |              |
| C170     | —            | —                               | 257 0012 966 | Ceramic chip<br>0.01µF/50V +80, -20% | 257 0012 966 | Ceramic chip<br>0.01µF/50V +80, -20% |              |
| C171     | —            | —                               | 254 4254 909 | Electrolytic 10µF/16V                | 254 4254 909 | Electrolytic 10µF/16V                |              |
| D101     | —            | —                               | 276 0432 903 | Diode 1SS270A                        | 276 0432 903 | Diode 1SS270A                        |              |
| F101~104 | 206 1039 076 | Fuse 2.5A                       | 206 1015 032 | Fuse 2.5A                            | 206 1015 032 | Fuse 2.5A                            |              |
| FB110    | 235 0049 900 | Beads inductor                  | —            | (Jumper)                             | —            | (Jumper)                             |              |
| IC111    | —            | —                               | 262 1701 906 | IC SAA6579T                          | 262 1701 906 | IC SAA6579T                          |              |
| IC112    | —            | —                               | 262 1929 908 | IC LC7074M-TE-R                      | 262 1929 908 | IC LC7074M-TE-R                      |              |
| R196     | 247 0018 905 | Carbon chip 0ohm 1/10W ±10%     | —            | —                                    | —            | —                                    |              |
| R197     | —            | —                               | 247 0009 985 | Carbon chip<br>10kohm 1/10W ±5%      | 247 0009 985 | Carbon chip<br>10kohm 1/10W ±5%      |              |
| X101     | —            | —                               | 399 0178 007 | Crystal 4.332MHz                     | 399 0178 007 | Crystal 4.332MHz                     |              |
| X102     | —            | —                               | 399 0191 903 | Ceramic resonator<br>CST4.00MGW-TF01 | 399 0191 903 | Ceramic resonator<br>CST4.00MGW-TF01 |              |
| —        | —            | —                               | 513 2585 074 | Fuse label                           | 513 2585 074 | Fuse label                           | for F101~104 |

**1U-2995 POWER AMP. P.W.B. UNIT**

| Ref No. | U.S.A. Model |                                   | Europe Model |                         | Asia Model   |                         | Remarks  |
|---------|--------------|-----------------------------------|--------------|-------------------------|--------------|-------------------------|----------|
|         | Part No.     | Part Name                         | Part No.     | Part Name               | Part No.     | Part Name               |          |
| AC651   | 203 3976 002 | AC outlet (2P)                    | —            | —                       | —            | —                       |          |
| CX025   | —            | —                                 | 205 0581 001 | 2P VH connector base    | 205 0581 001 | 2P VH connector base    |          |
| F001    | 206 1046 014 | Fuse 8A                           | 206 1015 087 | Fuse 4A                 | 206 1015 087 | Fuse 4A                 |          |
| F008    | 206 1046 014 | Fuse 8A                           | 206 1015 032 | Fuse 2.5A               | 206 1015 032 | Fuse 2.5A               |          |
| R654    | 242 0073 000 | Composition<br>2.2M ohm 1/2W ±10% | —            | —                       | —            | —                       |          |
| T651    | 233 5818 004 | Power trans. (Mini)-EU            | 233 6074 009 | Power trans. (Mini) -ES | 233 6074 009 | Power trans. (Mini) -ES |          |
| —       | —            | —                                 | 415 0299 000 | Condenser cover         | 415 0299 000 | Condenser cover         | for C660 |
| —       | —            | —                                 | 513 2585 074 | Fuse label              | 513 2585 074 | Fuse label              | for F008 |
| —       | —            | —                                 | 513 2585 058 | Fuse label              | 513 2585 058 | Fuse label              | for F001 |

**1U-2996 VIDEO & DISPLAY P.W.B. UNIT**

| Ref No. | U.S.A. Model |           | Europe Model |            | Asia Model   |            | Remarks  |
|---------|--------------|-----------|--------------|------------|--------------|------------|----------|
|         | Part No.     | Part Name | Part No.     | Part Name  | Part No.     | Part Name  |          |
| F401    | 206 1039 076 | Fuse 2.5A | 206 1015 032 | Fuse 2.5A  | 206 1015 032 | Fuse 2.5A  |          |
| —       | —            | —         | 513 2585 074 | Fuse label | 513 2585 074 | Fuse label | for F401 |

## 1U-2997 TUNER P.W.B. UNIT

| Ref No.   | U.S.A. Model |                                 | Europe Model |                                  | Asia Model   |                                  | Remarks |
|-----------|--------------|---------------------------------|--------------|----------------------------------|--------------|----------------------------------|---------|
|           | Part No.     | Part Name                       | Part No.     | Part Name                        | Part No.     | Part Name                        |         |
| C519      | —            | —                               | 257 0004 961 | Ceramic chip 100pF/50V ±5%       | 257 0004 961 | Ceramic chip 100pF/50V ±5%       |         |
| C527      | 254 4260 948 | Electrolytic 1μF/50V            | 254 4260 922 | Electrolytic 0.33μF/50V          | 254 4260 922 | Electrolytic 0.33μF/50V          |         |
| C536      | 257 0004 961 | Ceramic chip 100pF/50V ±5%      | —            | —                                | —            | —                                |         |
| C537      | —            | —                               | 254 4254 912 | Electrolytic 22μF/16V            | 254 4254 912 | Electrolytic 22μF/16V            |         |
| C539,540  | 257 0006 972 | Ceramic chip 750pF/50V ±5%      | 257 0006 930 | Ceramic chip 510pF/50V ±5%       | 257 0006 930 | Ceramic chip 510pF/50V ±5%       |         |
| C568      | 257 0010 900 | Ceramic chip<br>0.01μF/50V ±10% | 257 0008 983 | Ceramic chip<br>1000pF/50V ±10%  | —            | —                                |         |
| C564,565  | —            | —                               | —            | —                                | 257 0005 986 | Ceramic chip 330pF/50V ±5%       |         |
| C591      | 257 0008 983 | Ceramic chip 1000pF/50V ±5%     | —            | —                                | —            | —                                |         |
| CF501,502 | —            | —                               | 261 0146 006 | FMCF5K107M2-A                    | 261 0146 006 | FMCF5K107M2-A                    |         |
| IC501     | 216 0102 008 | Front end                       | 216 9013 004 | FM front end (U) S               | 216 9013 004 | FM front end (U) S               |         |
| JK601     | 204 8264 013 | Headphone jack (NI)             | 204 8264 013 | Headphone jack (NI)              | 204 8264 071 | Headphone jack (gold)            |         |
| LF501     | —            | —                               | 232 9010 009 | Antibirdie filter                | 232 9010 009 | Antibirdie filter                |         |
| LF503,504 | —            | —                               | 232 0085 004 | LPF                              | 232 0085 004 | LPF                              |         |
| R502      | —            | —                               | 247 0018 905 | Carbon chip 0ohm 1/10W ±10%      | 247 0018 905 | Carbon chip 0ohm 1/10W ±10%      |         |
| R514      | 247 0018 905 | Carbon chip<br>0ohm 1/10W ±10%  | 247 0005 905 | Carbon chip<br>100ohm 1/10W ±5%  | 247 0005 905 | Carbon chip<br>100ohm 1/10W ±5%  |         |
| R515      | 247 0005 905 | Carbon chip<br>100ohm 1/10W ±5% | —            | —                                | —            | —                                |         |
| R516      | 247 0007 945 | Carbon chip 1kohm 1/10W ±5%     | 247 0006 920 | Carbon chip<br>330ohm 1/10W ±5%  | 247 0006 920 | Carbon chip<br>330ohm 1/10W ±5%  |         |
| R517      | —            | —                               | 247 0006 920 | Carbon chip<br>330ohm 1/10W ±5%  | 247 0006 920 | Carbon chip<br>330ohm 1/10W ±5%  |         |
| R535      | 247 0010 945 | Carbon chip<br>18kohm 1/10W ±5% | 247 0011 928 | Carbon chip<br>39kohm 1/10W ±5%  | 247 0011 928 | Carbon chip<br>39kohm 1/10W ±5%  |         |
| R536      | 247 0018 905 | Carbon chip 0ohm 1/10W ±10%     | 247 0008 944 | Carbon chip<br>2.7kohm 1/10W ±5% | 247 0008 944 | Carbon chip<br>2.7kohm 1/10W ±5% |         |
| R563,564  | 247 0010 916 | Carbon chip<br>13kohm 1/10W ±5% | 247 0010 929 | Carbon chip<br>15kohm 1/10W ±5%  | 247 0010 929 | Carbon chip<br>15kohm 1/10W ±5%  |         |
| R579,580  | 247 0018 905 | Carbon chip 0ohm 1/10W ±10%     | —            | —                                | —            | —                                |         |
| R581      | 247 0018 905 | Carbon chip 0ohm 1/10W ±10%     | —            | —                                | —            | —                                |         |
| R592,593  | 247 0018 905 | Carbon chip 0ohm 1/10W ±10%     | 247 0005 905 | Carbon chip<br>100ohm 1/10W ±5%  | 247 0018 905 | Carbon chip 0ohm 1/10W ±10%      |         |
| R597,598  | 247 0018 905 | Carbon chip 0ohm 1/10W ±10%     | 247 0006 962 | Carbon chip<br>470ohm 1/10W ±5%  | 247 0018 905 | Carbon chip 0ohm 1/10W ±10%      |         |
| R645      | —            | —                               | 247 0009 985 | Carbon chip<br>10kohm 1/10W ±5%  | 247 0009 985 | Carbon chip<br>10kohm 1/10W ±5%  |         |
| R646      | —            | —                               | 247 0009 927 | Carbon chip<br>5.6kohm 1/10W ±5% | 247 0009 927 | Carbon chip<br>5.6kohm 1/10W ±5% |         |
| TR501     | —            | —                               | 275 0074 902 | FET 2SK211-Y/GR                  | 275 0074 902 | FET 2SK211-Y/GR                  |         |
| C592      | —            | —                               | 253 1180 921 | Ceramic cap.1000pF/50V ±10%      | 253 1180 921 | Ceramic cap.1000pF/50V ±10%      |         |

1U-2998 AUDIO & DSP P.W.B. UNIT

| Ref No.   | U.S.A. Model |                                 | Europe Model               |                                 | Asia Model   |                                 | Remarks |
|-----------|--------------|---------------------------------|----------------------------|---------------------------------|--------------|---------------------------------|---------|
|           | Part No.     | Part Name                       | Part No.                   | Part Name                       | Part No.     | Part Name                       |         |
|           | C303         | 257 0004 961                    | Ceramic chip 100pF/50V ±5% | —                               | —            | 257 0004 961                    |         |
| C311      | 257 0004 961 | Ceramic chip 100pF/50V ±5%      | —                          | —                               | 257 0004 961 | Ceramic chip 100pF/50V ±5%      |         |
| C447      | —            | —                               | 257 0008 983               | Ceramic chip<br>1000pF/50V ±10% | 257 0008 983 | Ceramic chip<br>1000pF/50V ±10% |         |
| C617-626  | —            | —                               | 257 0005 986               | Ceramic chip 330pF/50V ±5%      | 257 0005 986 | Ceramic chip 330pF/50V ±5%      |         |
| C627,628  | —            | —                               | 257 0006 927               | Ceramic chip 470pF/50V ±5%      | 257 0004 961 | Ceramic chip 100pF/50V ±5%      |         |
| C631,632  | —            | —                               | 257 0004 961               | Ceramic chip 100pF/50V ±5%      | 257 0004 961 | Ceramic chip 100pF/50V ±5%      |         |
| C649,650  | —            | —                               | 257 0005 986               | Ceramic chip 330pF/50V ±5%      | 257 0005 986 | Ceramic chip 330pF/50V ±5%      |         |
| C701,702  | —            | —                               | 257 0004 961               | Ceramic chip 100pF/50V ±5%      | 257 0004 961 | Ceramic chip 100pF/50V ±5%      |         |
| C715,716  | —            | —                               | 257 0005 986               | Ceramic chip 330pF/50V ±5%      | 257 0005 986 | Ceramic chip 330pF/50V ±5%      |         |
| C721,722  | —            | —                               | 257 0004 961               | Ceramic chip 100pF/50V ±5%      | 257 0004 961 | Ceramic chip 100pF/50V ±5%      |         |
| C729,730  | —            | —                               | 257 0005 986               | Ceramic chip 330pF/50V ±5%      | 257 0005 986 | Ceramic chip 330pF/50V ±5%      |         |
| C735,736  | —            | —                               | 257 0004 961               | Ceramic chip 100pF/50V ±5%      | 257 0004 961 | Ceramic chip 100pF/50V ±5%      |         |
| FB301     | 235 0106 908 | Chip emifil (21A05)             | 247 0018 905               | Carbon chip 0ohm 1/10W ±10%     | 235 0106 908 | Chip emifil (21A05)             |         |
| LF601,602 | —            | —                               | 235 9003 002               | FTZ choke coil                  | 235 9003 002 | FTZ choke coil                  |         |
| R601,602  | 247 0018 905 | Carbon chip<br>0ohm 1/10W ±10%  | 247 0007 974               | Carbon chip<br>1.3kohm 1/10W±5% | 247 0007 974 | Carbon chip<br>1.3kohm 1/10W±5% |         |
| R645,646  | 247 0006 962 | Carbon chip<br>470ohm 1/10W ±5% | 247 0005 905               | Carbon chip<br>100ohm 1/10W ±5% | 247 0006 962 | Carbon chip<br>470ohm 1/10W ±5% |         |
| R705,706  | 247 0006 962 | Carbon chip<br>470ohm 1/10W ±5% | 247 0005 905               | Carbon chip<br>100ohm 1/10W ±5% | 247 0005 905 | Carbon chip<br>100ohm 1/10W ±5% |         |
| R721,722  | 247 0006 962 | Carbon chip<br>470ohm 1/10W ±5% | 247 0005 905               | Carbon chip<br>100ohm 1/10W ±5% | 247 0005 905 | Carbon chip<br>100ohm 1/10W ±5% |         |
| R737,738  | 247 0006 962 | Carbon chip<br>470ohm 1/10W ±5% | 247 0005 905               | Carbon chip<br>100ohm 1/10W ±5% | 247 0005 905 | Carbon chip<br>100ohm 1/10W ±5% |         |
| R747-750  | 247 0018 905 | Carbon chip<br>0ohm 1/10W ±10%  | 247 0006 962               | Carbon chip<br>470ohm 1/10W ±5% | 247 0006 962 | Carbon chip<br>470ohm 1/10W ±5% |         |
| R751,752  | 247 0018 905 | Carbon chip<br>0ohm 1/10W ±10%  | 247 0006 962               | Carbon chip<br>470ohm 1/10W ±5% | 247 0006 962 | Carbon chip<br>470ohm 1/10W ±5% |         |

1U-3006 E. VOL. P.W.B. UNIT

| Ref No.  | U.S.A. Model |           | Europe Model |                            | Asia Model                 |                            | Remarks |
|----------|--------------|-----------|--------------|----------------------------|----------------------------|----------------------------|---------|
|          | Part No.     | Part Name | Part No.     | Part Name                  | Part No.                   | Part Name                  |         |
|          | C191         | —         | —            | 257 0004 961               | Ceramic chip 100pF/50V ±5% | 257 0004 961               |         |
| C195,196 | —            | —         | 257 0004 961 | Ceramic chip 100pF/50V ±5% | 257 0004 961               | Ceramic chip 100pF/50V ±5% |         |
| C199     | —            | —         | 253 1180 921 | Ceramic 1000pF/50V ±10%    | 253 1180 921               | Ceramic 1000pF/50V ±10%    |         |
| —        | —            | —         | 203 0318 045 | Earth wire (UL1430)        | 203 0318 045               | Earth wire (UL1430)        |         |

SCHEMATIC DIAGRAM (1/5)

1 2 3 4 5 6

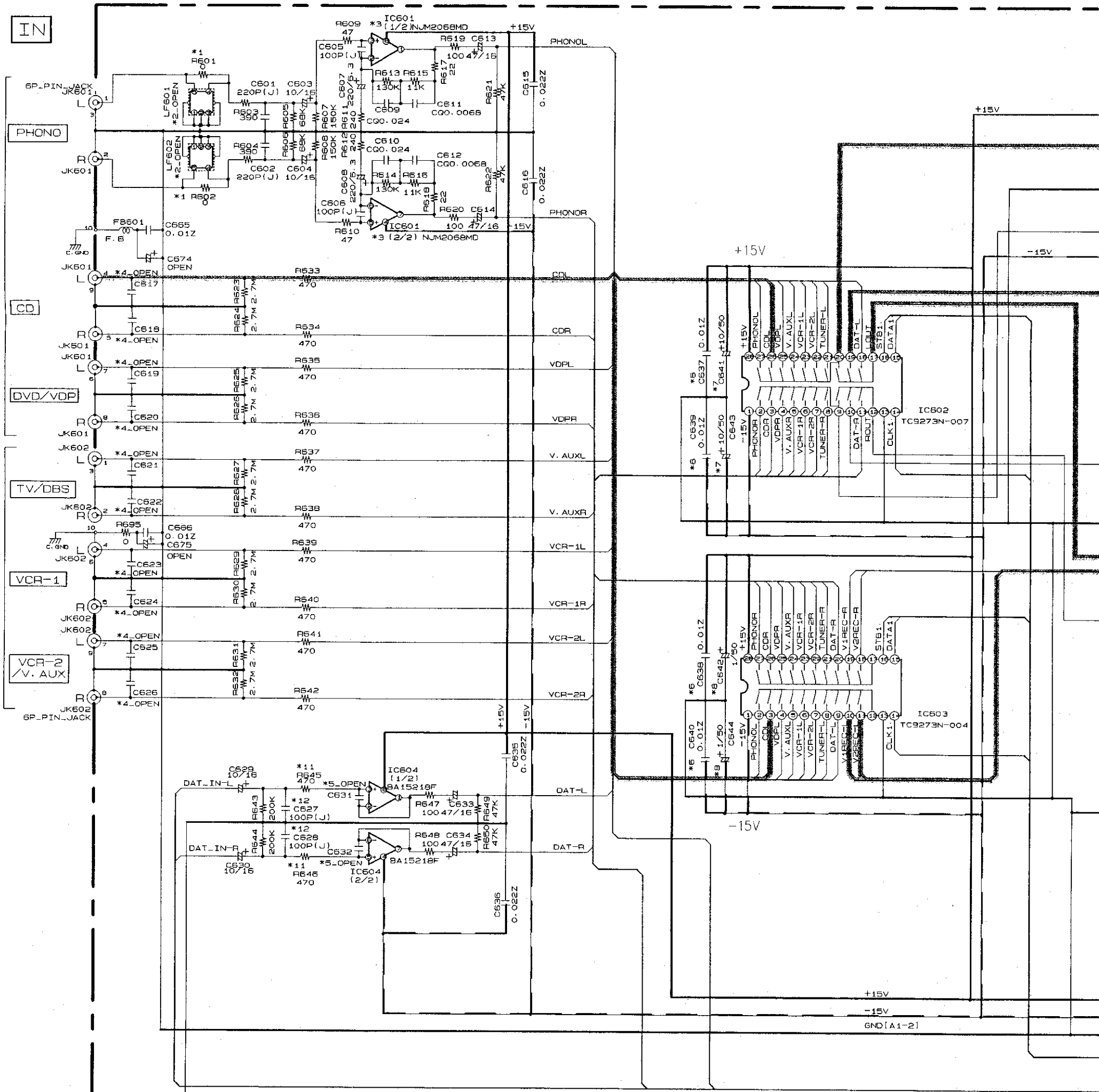

1U-2998-2  
AUDIO IN UNIT

|                                    | *1        | *2         | *3        | *4         | *5        | *6         | *7          | *8                           | *9                           | *10          | *11              | *12              | *13         |
|------------------------------------|-----------|------------|-----------|------------|-----------|------------|-------------|------------------------------|------------------------------|--------------|------------------|------------------|-------------|
|                                    | R501, 602 | LF601, 602 | IC601     | C617 ~ 626 | C631, 632 | C637 ~ 640 | C641, 643   | *8<br>C642, 644<br>C657, 658 | *9<br>C655, 656<br>C671, 672 | *10<br>IC605 | *11<br>R645, 646 | *12<br>C627, 628 | *13<br>C649 |
| * USA<br>CANADA<br>TAIWAN R. O. C. | 0         | —          | NJM2068MD | —          | —         | 0.01Z      | 10/50       | 1/50                         | 10/16                        | BA15218      | 470              | 100P             | —           |
| ASIA                               | 1.3K      | L. P. F    | NJM2068MD | 330P       | 100P      | 0.01Z      | 10/50       | 1/50                         | 10/16                        | BA15218      | 470              | 100P             | —           |
| EUROPE                             | 1.3K      | L. P. F    | NJM2068MD | 330P       | —         | 0.01Z      | 10/50       | 1/50                         | 10/16                        | BA15218      | 100              | 470P             | 10          |
| JAPAN                              | 0         | —          | NJM2068MD | —          | —         | —          | 10/50 (ASF) | 1/50 (ASF)                   | 10/50 (ASF)                  | NJM5532MD    | 470              | 100P             | —           |

6

7

8

9

10

11

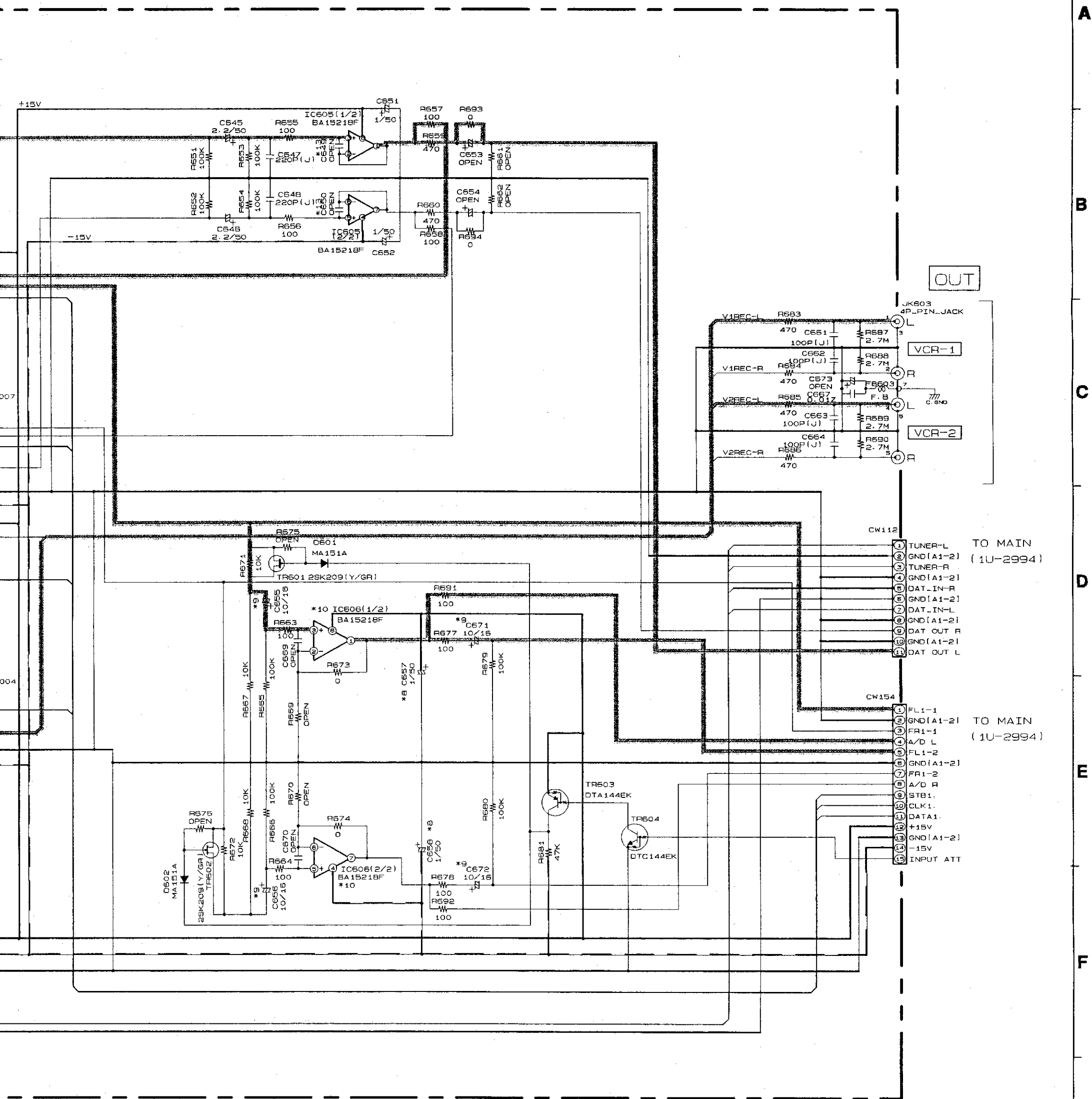

|        |                 |                 |
|--------|-----------------|-----------------|
| 15-646 | *12<br>C627-628 | *13<br>C649-650 |
| 470    | 100P            | —               |
| 470    | 100P            | —               |
| 100    | 470P            | 100P            |
| 470    | 100P            | —               |

**NOTICE**  
 ALL RESISTANCE VALUES IN OHM. k=1,000 OHM M=1,000,000 OHM  
 ALL CAPACITANCE VALUES IN MICRO FARAD. P=MICRO-MICRO FARAD  
 EACH VOLTAGE AND CURRENT ARE MEASURED AT NO SIGNAL INPUT  
 CONDITION.  
 CIRCUIT AND PARTS ARE SUBJECT TO CHANGE WITHOUT PRIOR  
 NOTICE.

**WARNING:**  
 Parts marked with this symbol have critical characteristics.  
 Use ONLY replacement parts recommended by the manufacturer.

**CAUTION:**  
 Before returning the unit to the customer, make sure you make either (1) a  
 leakage current check or (2) a line to chassis resistance check. If the leakage  
 current exceeds 0.5 milliamperes, or if the resistance from chassis to either side  
 of the power cord is less than 240 kohms, the unit is defective.

**WARNING:**  
 DO NOT return the unit to the customer until the problem is located and  
 corrected.

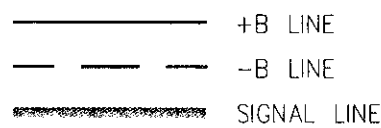

A

B

C

D

E

F

G

H

SCHEMATIC DIAGRAM (2/5)

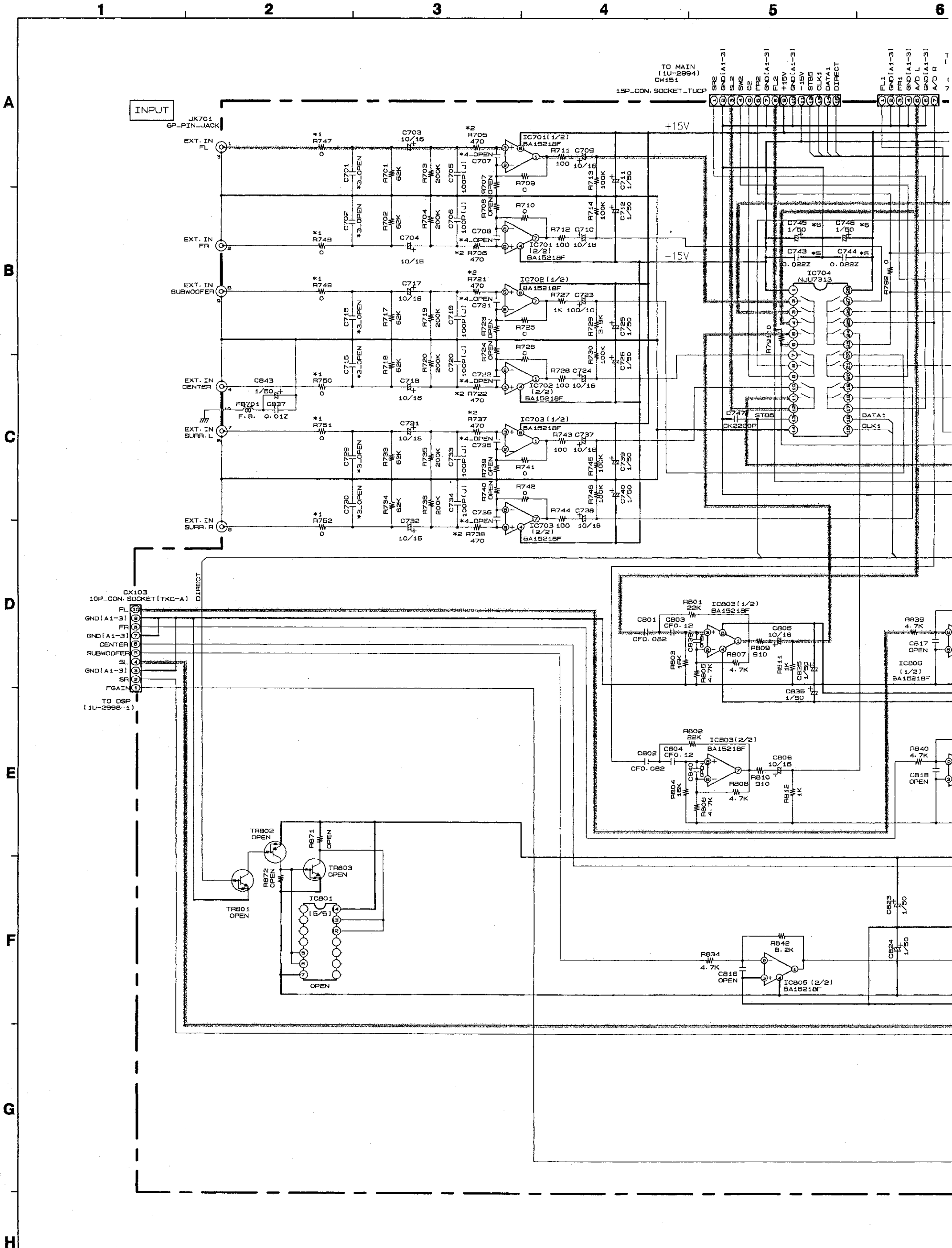

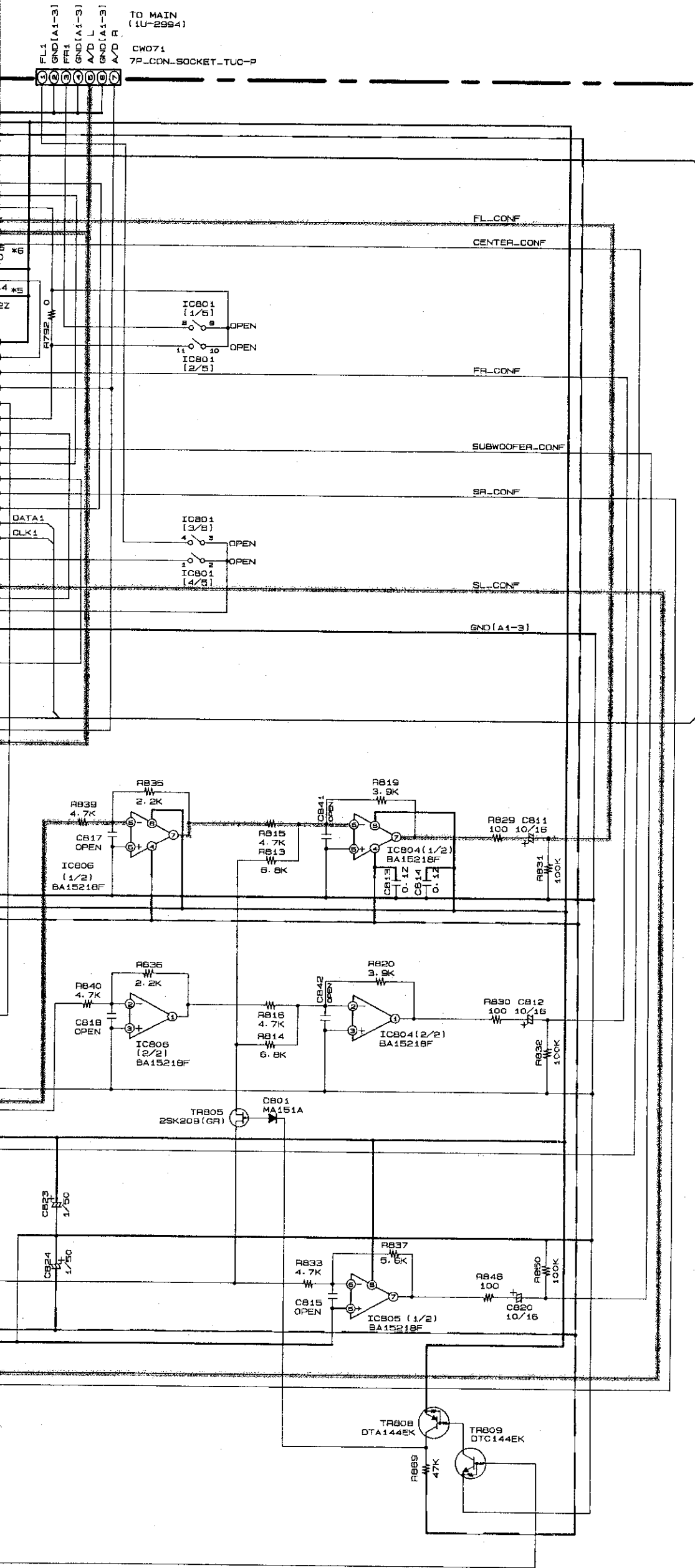

|                                      | *1                                  | *2                                  | *3                                  | *4                                  |
|--------------------------------------|-------------------------------------|-------------------------------------|-------------------------------------|-------------------------------------|
|                                      | R747, 748<br>R749, 750<br>R751, 752 | R705, 706<br>R721, 722<br>R737, 738 | C701, 702<br>C715, 716<br>C729, 730 | C707, 708<br>C721, 722<br>C735, 736 |
| * USA<br>CANADA<br>TAIWAN<br>R. O. C | 0                                   | 470                                 | —                                   | —                                   |
| ASIA                                 | 470                                 | 100                                 | 330P                                | 100P                                |
| EUROPE                               | 470                                 | 100                                 | 330P                                | 100P                                |
| JAPAN                                | 0                                   | 470                                 | —                                   | —                                   |

|                                      | *5        | *6         |
|--------------------------------------|-----------|------------|
|                                      | C743, 744 | C745, 746  |
| * USA<br>CANADA<br>TAIWAN<br>R. O. C | 0.022Z    | 1/50       |
| ASIA                                 | 0.022Z    | 1/50       |
| EUROPE                               | 0.022Z    | 1/50       |
| JAPAN                                | —         | 1/50 (ASF) |

1U-2998-3  
6CH. EXTERNAL\_IN\_UNIT

**NOTICE**  
ALL RESISTANCE VALUES IN OHM. k=1,000 OHM M=1,000,000 OHM  
ALL CAPACITANCE VALUES IN MICRO FARAD. P=MICRO-MICRO FARAD  
EACH VOLTAGE AND CURRENT ARE MEASURED AT NO SIGNAL INPUT  
CONDITION.  
CIRCUIT AND PARTS ARE SUBJECT TO CHANGE WITHOUT PRIOR  
NOTICE.

**WARNING:**  
Parts marked with this symbol have critical characteristics.  
Use ONLY replacement parts recommended by the manufacturer.

**CAUTION:**  
Before returning the unit to the customer, make sure you make either (1) a  
leakage current check or (2) a line to chassis resistance check. If the leakage  
current exceeds 0.5 milliamps, or if the resistance from chassis to either side  
of the power cord is less than 240 kohms, the unit is defective.

**WARNING:**  
DO NOT return the unit to the customer unit the problem is located and  
corrected.

— +B LINE  
- - - -B LINE  
--- SIGNAL LINE



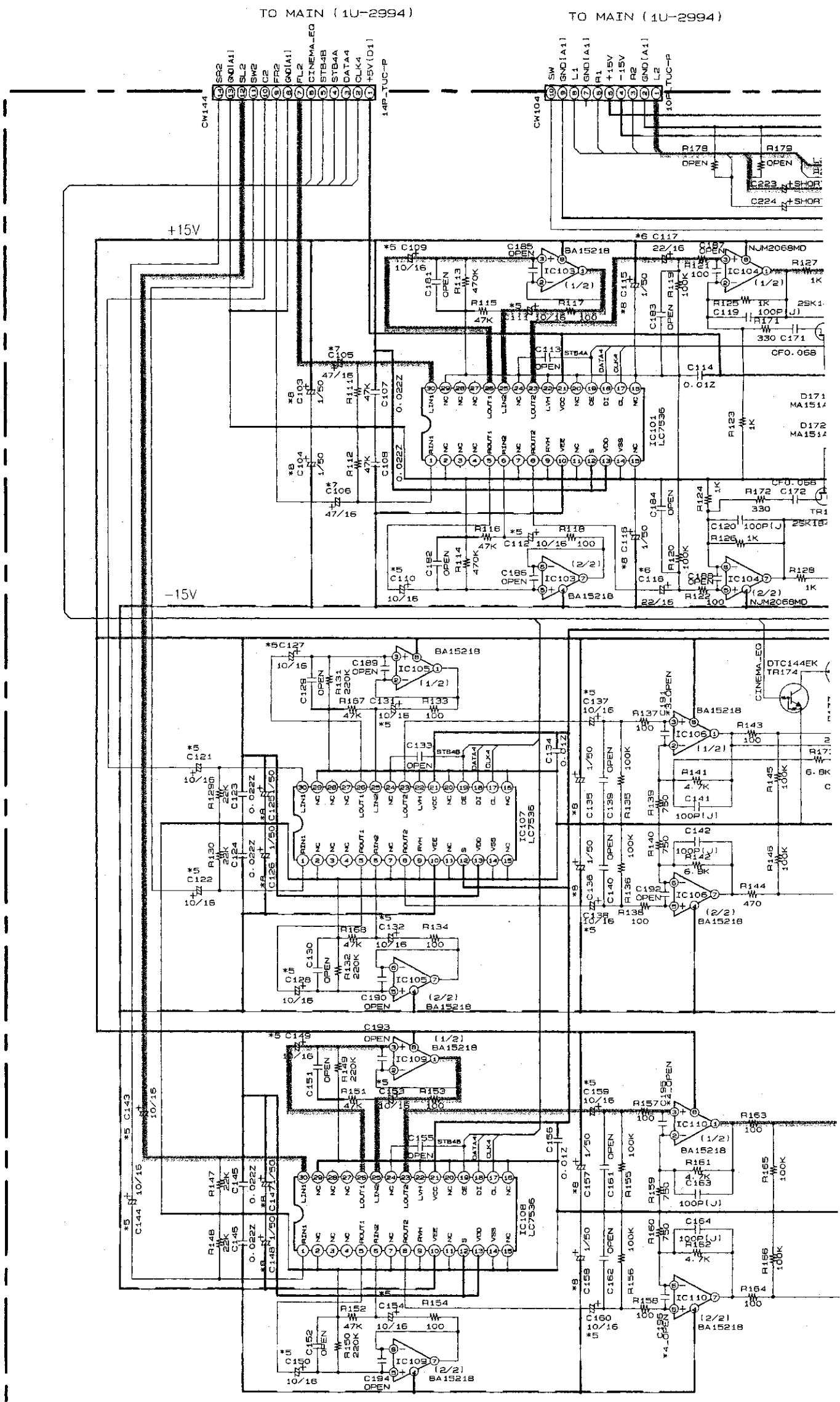

1U-3006  
E. VOL UNIT

|                                | *1         | *2    | *3   | *4       | *5                                                                                                | *6          | *7          | *8                                         |
|--------------------------------|------------|-------|------|----------|---------------------------------------------------------------------------------------------------|-------------|-------------|--------------------------------------------|
|                                | D180 ~ 185 | CX951 | C191 | C195-196 | C109 ~ C112, 121, 122, 127, 128<br>C131, 132, 137, 138, 143, 144, 149, 150<br>C153, 154, 159, 160 | C117, 118   | C105, 106   | C103, 104, 115, 116<br>C135, 136, 147, 148 |
| * USA / CANADA<br>TAIWAN R.O.C | ---        | ---   | ---  | ---      | 10/16                                                                                             | 22/15       | 47/15       | 1/50                                       |
| ASIA / EUROPE                  | ---        | ---   | 100P | 100P     | 10/16                                                                                             | 22/15       | 47/15       | 1/50                                       |
| JAPAN                          | MA157A-TX  | 6P KR | ---  | ---      | 10/50 (ASF)                                                                                       | 22/50 (ASF) | 47/50 (ASF) | 1/50 (ASF)                                 |

6 7 8 9 10 11

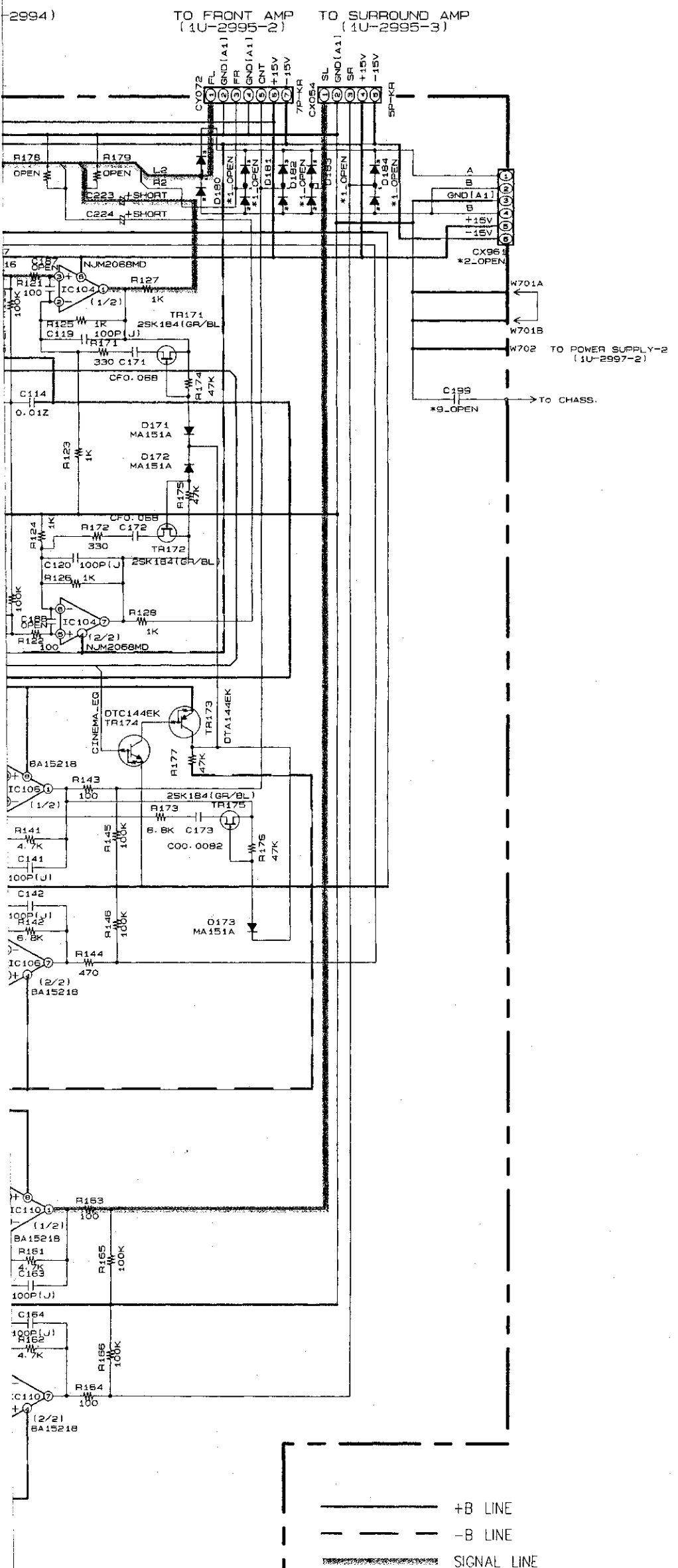

**NOTICE**  
 ALL RESISTANCE VALUES IN OHM. k=1,000 OHM M=1,000,000 OHM  
 ALL CAPACITANCE VALUES IN MICRO FARAD. P=MICRO-MICRO FARAD  
 EACH VOLTAGE AND CURRENT ARE MEASURED AT NO SIGNAL INPUT  
 CONDITION.  
 CIRCUIT AND PARTS ARE SUBJECT TO CHANGE WITHOUT PRIOR  
 NOTICE.

**WARNING:**  
 Parts marked with this symbol have critical characteristics.  
 Use ONLY replacement parts recommended by the manufacturer.

**CAUTION:**  
 Before returning the unit to the customer, make sure you make either (1) a  
 leakage current check or (2) a line to chassis resistance check. If the leakage  
 current exceeds 0.5 milliamps, or if the resistance from chassis to either side  
 of the power cord is less than 240 kohms, the unit is defective.

**WARNING:**  
 DO NOT return the unit to the customer unit the problem is located and  
 corrected.

|            |                                                                      |            |
|------------|----------------------------------------------------------------------|------------|
| 105, 105   | *8<br>C193, 104, 115, 116, 125, 126<br>C135, 136, 147, 148, 157, 159 | *9<br>C199 |
| 47/16      | 1/50                                                                 | ----       |
| 47/15      | 1/50                                                                 | 1000P      |
| 1/50 (ASF) | 1/50 (ASF)                                                           | ----       |

A  
B  
C  
D  
E  
F  
G  
H

6 7 8 9 10 11

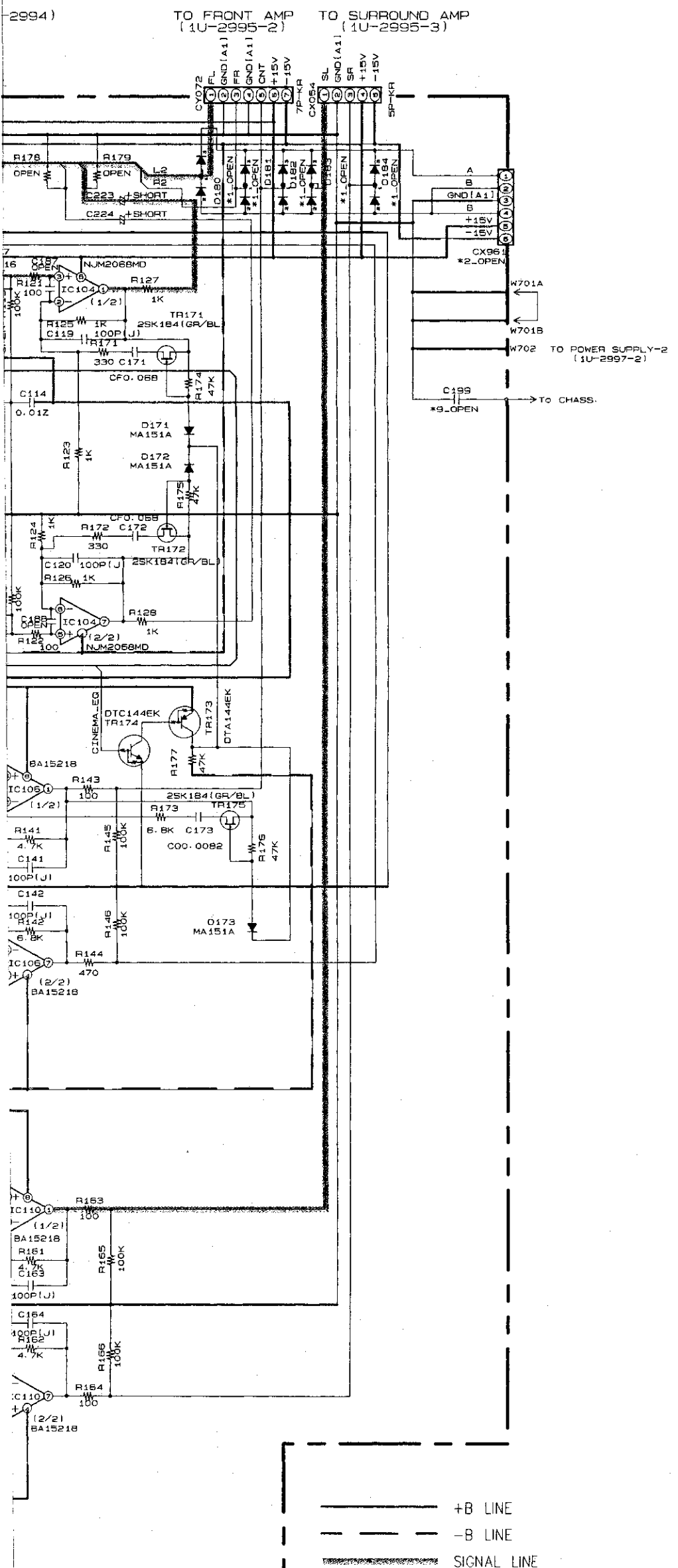

**NOTICE**  
 ALL RESISTANCE VALUES IN OHM. k=1,000 OHM M=1,000,000 OHM  
 ALL CAPACITANCE VALUES IN MICRO FARAD. P=MICRO-MICRO FARAD  
 EACH VOLTAGE AND CURRENT ARE MEASURED AT NO SIGNAL INPUT  
 CONDITION.  
 CIRCUIT AND PARTS ARE SUBJECT TO CHANGE WITHOUT PRIOR  
 NOTICE.

**WARNING:**  
 Parts marked with this symbol have critical characteristics.  
 Use ONLY replacement parts recommended by the manufacturer.

**CAUTION:**  
 Before returning the unit to the customer, make sure you make either (1) a  
 leakage current check or (2) a line to chassis resistance check. If the leakage  
 current exceeds 0.5 milliamps, or if the resistance from chassis to either side  
 of the power cord is less than 240 kohms, the unit is defective.

**WARNING:**  
 DO NOT return the unit to the customer until the problem is located and  
 corrected.

|            |                                                                |       |
|------------|----------------------------------------------------------------|-------|
| 7          | *8                                                             | *9    |
| 105, 106   | C103, 104, 115, 116, 125, 126<br>C135, 136, 147, 148, 157, 158 | C199  |
| 47/16      | 1/50                                                           | ---   |
| 47/15      | 1/50                                                           | 1000P |
| 1/50 (ASF) | 1/50 (ASF)                                                     | ---   |

A  
B  
C  
D  
E  
F  
G  
H

SCHEMATIC DIAGRAM (4/5)

1 2 3 4 5

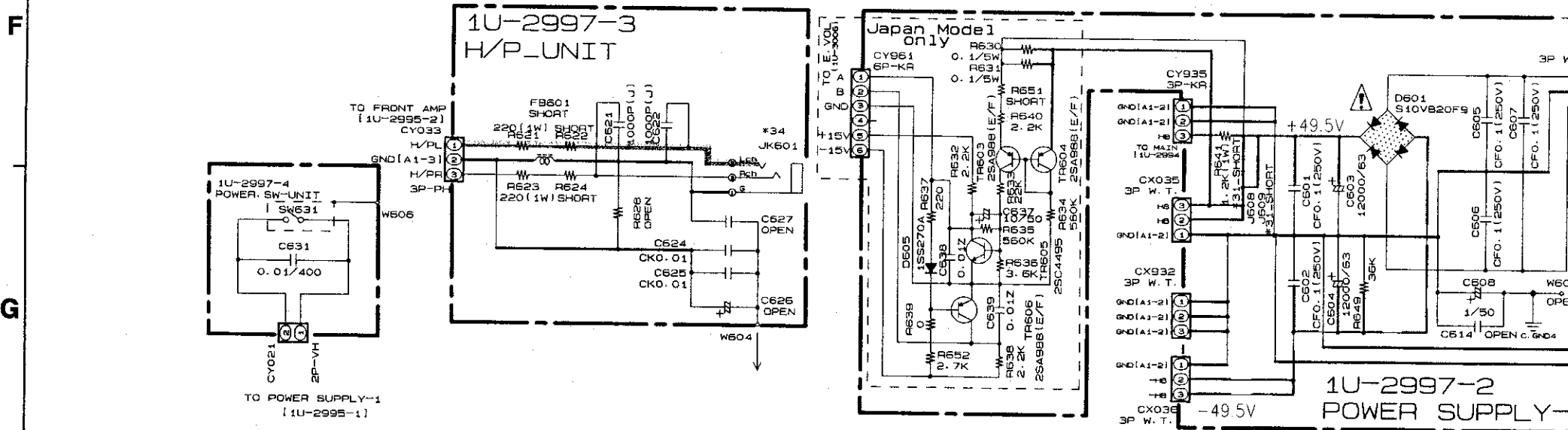
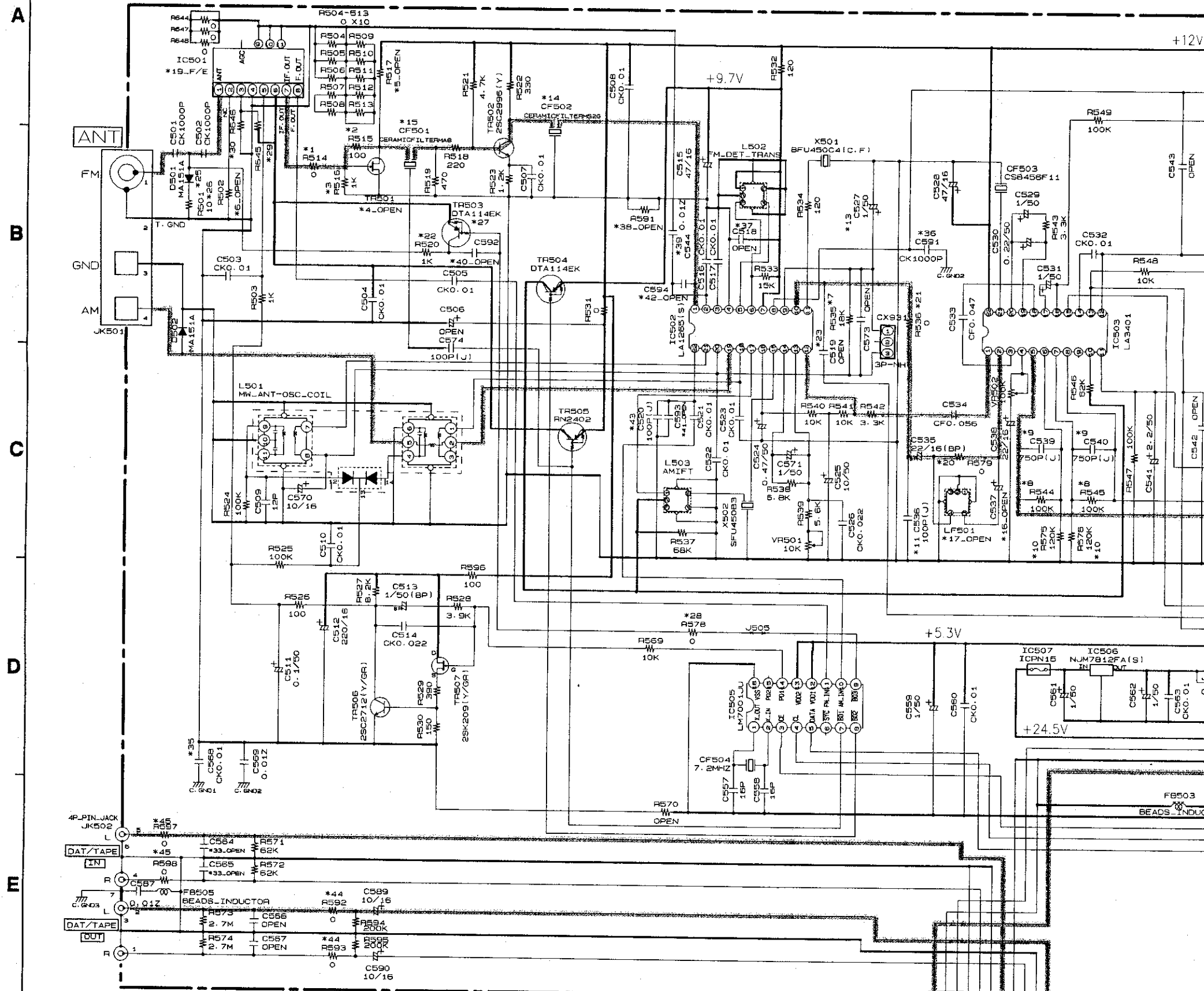

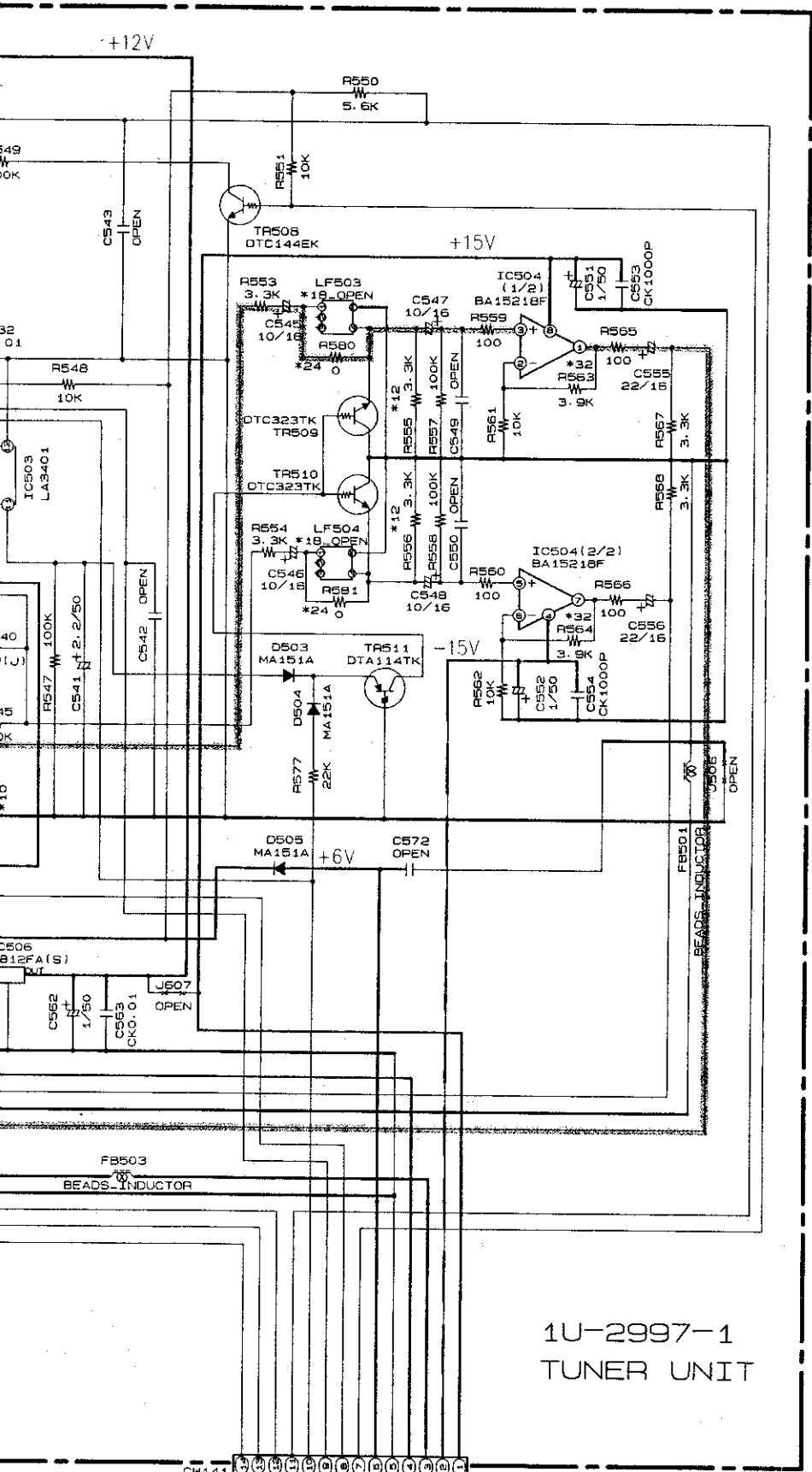

1U-2997-1  
TUNER UNIT

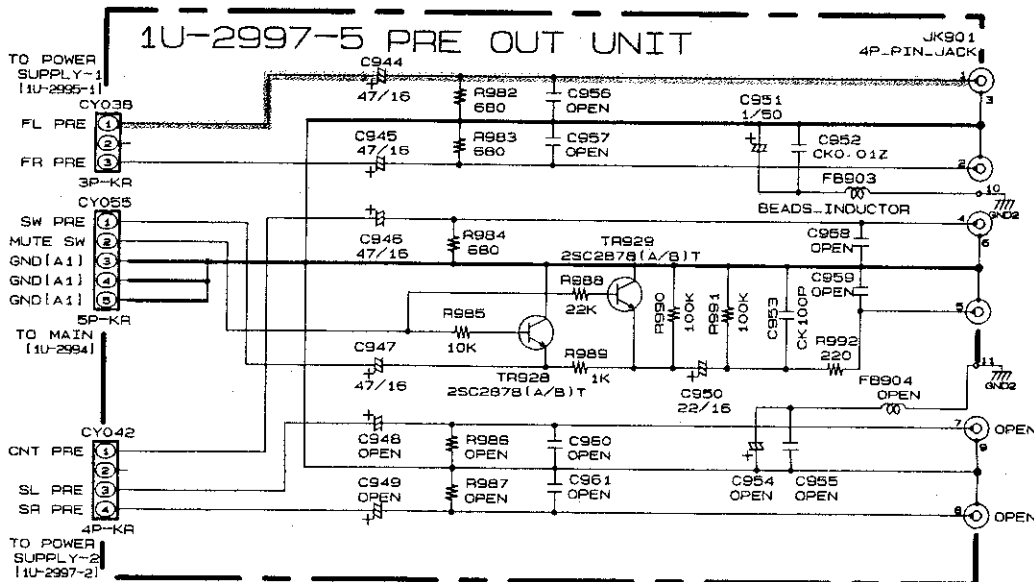

1U-2997-5 PRE OUT UNIT

| * NO | USA CANADA | TAIWAN R.O.C   | ASIA       | EUROPE             | JAPAN          |
|------|------------|----------------|------------|--------------------|----------------|
| 1    | R514       | 0              |            | 100                | 0              |
| 2    | R515       | 100            |            |                    | 100            |
| 3    | R516       | 1K             |            | 330                | 330            |
| 4    | TR501      |                | 29K211(GR) |                    |                |
| 5    | R517       |                |            | 330                |                |
| 6    | R502       |                |            | 0                  |                |
| 7    | R535       | 18K            | 39K        | 39K                | 18K            |
| 8    | R544, 545  | 100K           |            | 100K               | 100K           |
| 9    | C539, 540  | 750p           | 510p       | 510p               | 510p           |
| 10   | R575, 576  | 120K           |            | 120K               | 120K           |
| 11   | C536       | 100p           |            |                    |                |
| 12   | R555, 556  | 3.3K           |            | 3.3K               | 3.3K           |
| 13   | C527       | 1/50           | 0.33/50    | 0.33/50            | 0.33/50        |
| 14   | CF502      | SFE 10.7MS2G   |            | SFT 10.7MS2        | SFE 10.7MS2G   |
| 15   | CF501      | SFE 10.7MA8    |            | SFT 10.7MS2        | SFE 10.7MA8    |
| 16   | C537       |                |            | 22/16              |                |
| 17   | LF501      |                |            | ANTI BIRDIE FILTER |                |
| 18   | LF503, 504 |                |            | LPF 2320085004     | LPF 2320085004 |
| 19   | IC501      | F/E 2160102008 |            | F/E 2169013004     | F/E 2169012005 |

| * NO | USA CANADA TAIWAN R.O.C | ASIA     | EUROPE | JAPAN    |         |
|------|-------------------------|----------|--------|----------|---------|
| 20   | R579                    | 0        |        |          | 0       |
| 21   | R536                    | 0        | 2.7K   |          | 0       |
| 22   | R520                    | 1K       |        | 1K       |         |
| 23   | C519                    |          |        | CK100p   |         |
| 24   | R580, 581               | 0        |        |          |         |
| 25   | D501                    | MA151A   |        | MA151A   |         |
| 26   | R501                    | 10       |        | 10       |         |
| 27   | TR503                   | DTA114EK |        | DTA114EK |         |
| 28   | R578                    | 0        |        | 0        |         |
| 29   | R645                    |          |        | 10K      |         |
| 30   | R646                    |          |        | 5.6K     |         |
| 31   | J608, 609               | SHORT    |        | SHORT    | OPEN    |
| 32   | R563, 564               | 3.9K     |        | 15K      | 3.9K    |
| 33   | C564, 565               |          |        | 330p     |         |
| 34   | JK501                   | N1       | AU     | N1       | N1      |
| 35   | C568                    | CK0.01   |        | CK1000p  |         |
| 36   | C591                    | CK1000p  |        |          |         |
| 37   | C518                    |          |        |          | CK0.01Z |
| 38   | R591                    |          |        |          | 0       |
| 39   | C544                    | 0.01Z    |        | 0.01Z    |         |
| 40   | C592                    |          |        | CK1000p  |         |
| 41   | C593                    |          |        |          | 100p    |
| 42   | C594                    |          |        |          | 100p    |
| 43   | C520                    | 100p     |        | 100p     |         |
| 44   | R592, 593               | 0        | 0      | 100      | 0       |
| 45   | R597, 598               | 0        | 0      | 470      | 0       |

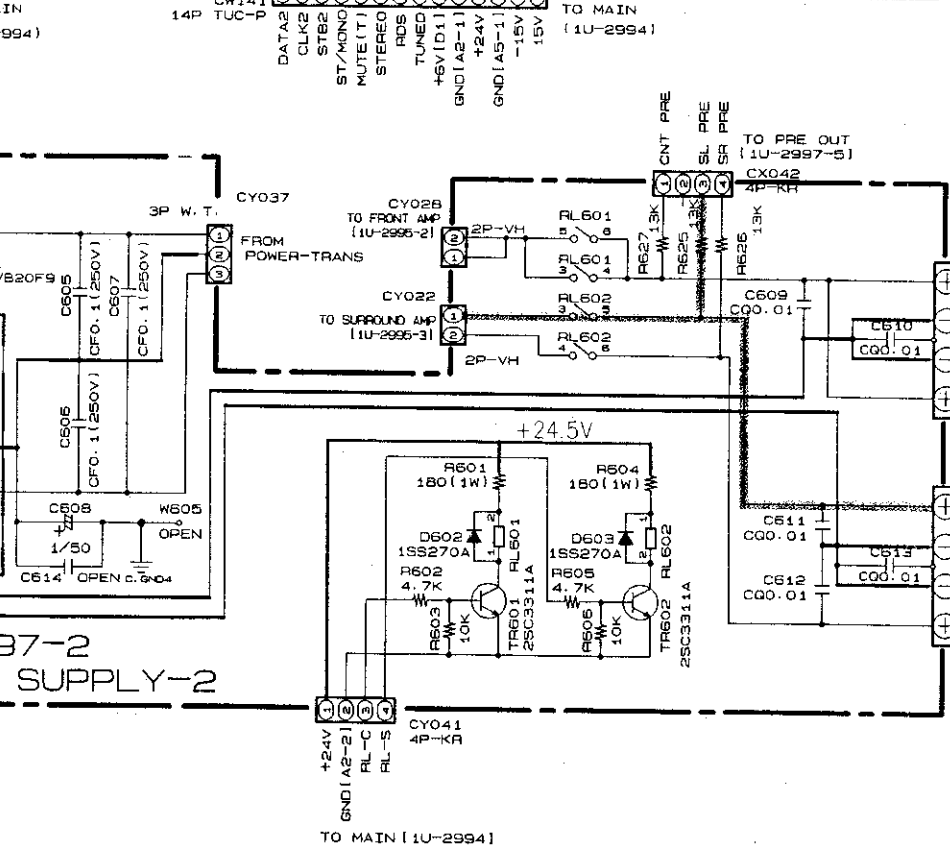

1U-2997-2  
SUPPLY-2

CENTER

SURROUND

— +B LINE  
- - - -B LINE  
— SIGNAL LINE

**NOTICE**

ALL RESISTANCE VALUES IN OHM. k=1,000 OHM M=1,000,000 OHM  
ALL CAPACITANCE VALUES IN MICRO FARAD. P=MICRO-MICRO FARAD  
EACH VOLTAGE AND CURRENT ARE MEASURED AT NO SIGNAL INPUT CONDITION.  
CIRCUIT AND PARTS ARE SUBJECT TO CHANGE WITHOUT PRIOR NOTICE.

**WARNING:**

Parts marked with this symbol  have critical characteristics. Use ONLY replacement parts recommended by the manufacturer.

**CAUTION:**

Before returning the unit to the customer, make sure you make either (1) a leakage current check or (2) a line to chassis resistance check. If the leakage current exceeds 0.5 millamps, or if the resistance from chassis to either side of the power cord is less than 240 kohms, the unit is defective.

**WARNING:**

DO NOT return the unit to the customer until the problem is located and corrected.

SCHEMATIC DIAGRAM (5/5)

1

2

3

4

5

6

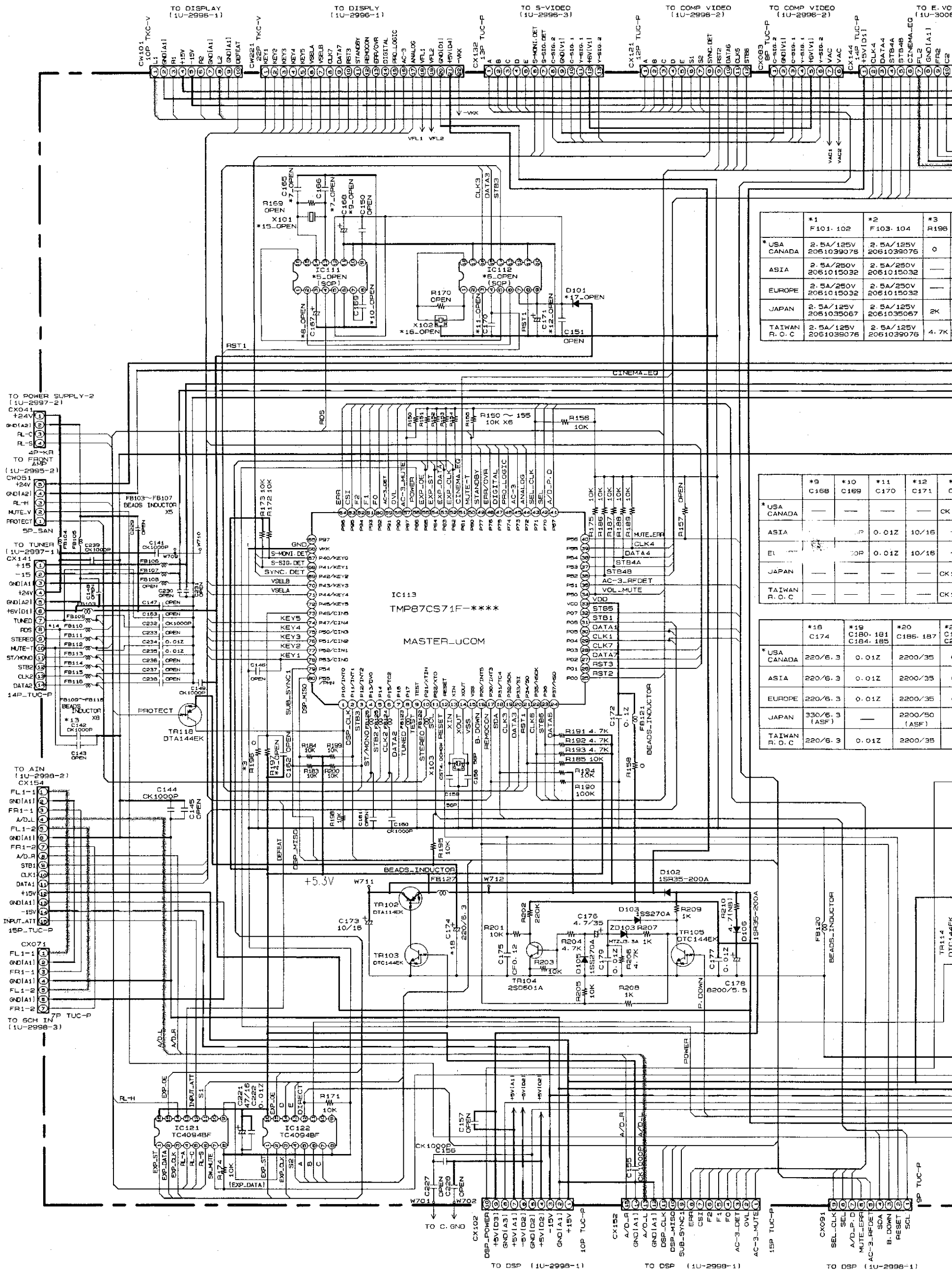

|          |            |            |      |
|----------|------------|------------|------|
|          | *1         | *2         | *3   |
|          | F101, 102  | F103, 104  | R196 |
| * USA    | 2.5A/125V  | 2.5A/125V  | 0    |
| CANADA   | 2061039076 | 2061039076 |      |
| ASIA     | 2.5A/250V  | 2.5A/250V  |      |
|          | 2061015032 | 2061015032 |      |
| EUROPE   | 2.5A/250V  | 2.5A/250V  |      |
|          | 2061015032 | 2061015032 |      |
| JAPAN    | 2.5A/125V  | 2.5A/125V  | 2K   |
|          | 2061035067 | 2061035067 |      |
| TAIWAN   | 2.5A/125V  | 2.5A/125V  | 4.7K |
| R. O. C. | 2061039076 | 2061039076 |      |

|          |      |       |       |      |     |
|----------|------|-------|-------|------|-----|
|          | *9   | *10   | *11   | *12  | *   |
|          | C168 | C169  | C170  | C171 | C   |
| * USA    |      |       |       |      | CK1 |
| CANADA   |      |       |       |      |     |
| ASIA     |      | 0.01Z | 10/15 |      |     |
| EUROPE   |      | 0.01Z | 10/15 |      |     |
| JAPAN    |      |       |       |      | CK1 |
| TAIWAN   |      |       |       |      | CK1 |
| R. O. C. |      |       |       |      |     |

|          |         |           |           |     |
|----------|---------|-----------|-----------|-----|
|          | *18     | *19       | *20       | *21 |
|          | C174    | C180, 181 | C185, 187 | C1  |
| * USA    | 220/6.3 | 0.01Z     | 2200/35   | C   |
| CANADA   |         |           |           |     |
| ASIA     | 220/6.3 | 0.01Z     | 2200/35   | C   |
| EUROPE   | 220/6.3 | 0.01Z     | 2200/35   | C   |
| JAPAN    | 330/6.3 | (ASF)     | 2200/50   | C   |
| TAIWAN   | 220/6.3 | 0.01Z     | 2200/35   | C   |
| R. O. C. |         |           |           |     |

TO DSP (1U-2998-1)      TO DSP (1U-2998-1)      TO DSP (1U-2998-1)

6 7 8 9 10 11

A  
B  
C  
D  
E  
F  
G  
H

# 1U-2994 MAIN UNIT

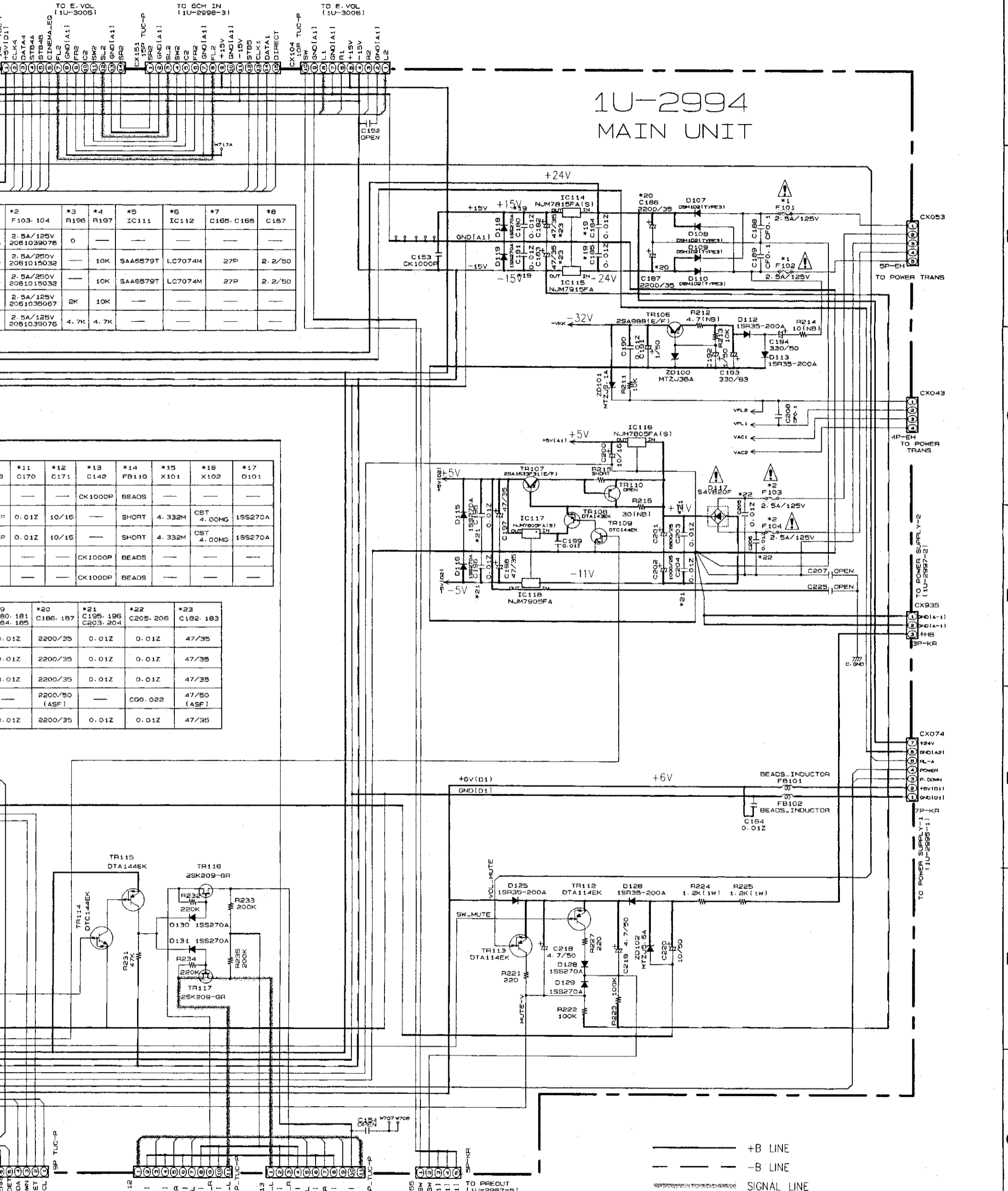

| *2                      | *3   | *4   | *5       | *6      | *7        | *8     |
|-------------------------|------|------|----------|---------|-----------|--------|
| F103-104                | R196 | R197 | IC111    | IC112   | C165-C168 | C167   |
| 2.5A/125V<br>2061039076 | 0    | 10K  | SAA6579T | LC7074M | 27P       | 2.2/50 |
| 2.5A/250V<br>2061015032 | —    | 10K  | SAA6579T | LC7074M | 27P       | 2.2/50 |
| 2.5A/250V<br>2061015032 | —    | 10K  | SAA6579T | LC7074M | 27P       | 2.2/50 |
| 2.5A/125V<br>2061035067 | 2K   | 10K  | —        | —       | —         | —      |
| 2.5A/125V<br>2061039076 | 4.7K | 4.7K | —        | —       | —         | —      |

| *9    | *11   | *12     | *13   | *14    | *15           | *16     | *17 |
|-------|-------|---------|-------|--------|---------------|---------|-----|
| C170  | C171  | C142    | FB110 | X101   | X102          | D101    |     |
| —     | —     | CK1000P | BEADS | —      | —             | —       | —   |
| 0.01Z | 10/16 | —       | SHORT | 4.332M | CST<br>4.00MG | 1S5270A | —   |
| 0.01Z | 10/16 | —       | SHORT | 4.332M | CST<br>4.00MG | 1S5270A | —   |
| —     | —     | CK1000P | BEADS | —      | —             | —       | —   |

| *19                  | *20              | *21                  | *22      | *23            |
|----------------------|------------------|----------------------|----------|----------------|
| C180-181<br>C184-185 | C186-187         | C195-196<br>C203-204 | C205-206 | C182-183       |
| 0.01Z                | 2200/35          | 0.01Z                | 0.01Z    | 47/35          |
| 0.01Z                | 2200/35          | 0.01Z                | 0.01Z    | 47/35          |
| 0.01Z                | 2200/35          | 0.01Z                | 0.01Z    | 47/35          |
| —                    | 2200/50<br>(ASF) | —                    | C00-022  | 47/50<br>(ASF) |
| 0.01Z                | 2200/35          | 0.01Z                | 0.01Z    | 47/35          |

**NOTICE**  
 ALL RESISTANCE VALUES IN OHM. k=1,000 OHM M=1,000,000 OHM  
 ALL CAPACITANCE VALUES IN MICRO FARAD. P=MICRO-MICRO FARAD  
 EACH VOLTAGE AND CURRENT ARE MEASURED AT NO SIGNAL INPUT  
 CONDITION.  
 CIRCUIT AND PARTS ARE SUBJECT TO CHANGE WITHOUT PRIOR  
 NOTICE.

**WARNING:**  
 Parts marked with this symbol have critical characteristics.  
 Use ONLY replacement parts recommended by the manufacturer.

**CAUTION:**  
 Before returning the unit to the customer, make sure you make either (1) a  
 leakage current check or (2) a line to chassis resistance check. If the leakage  
 current exceeds 0.5 milliamps, or if the resistance from chassis to either side  
 of the power cord is less than 240 kohms, the unit is defective.

**WARNING:**  
 DO NOT return the unit to the customer unit the problem is located and  
 corrected.