

DENON

Hi-Fi Component

SERVICE MANUAL MODEL AVR-3300 AV SURROUND RECEIVER

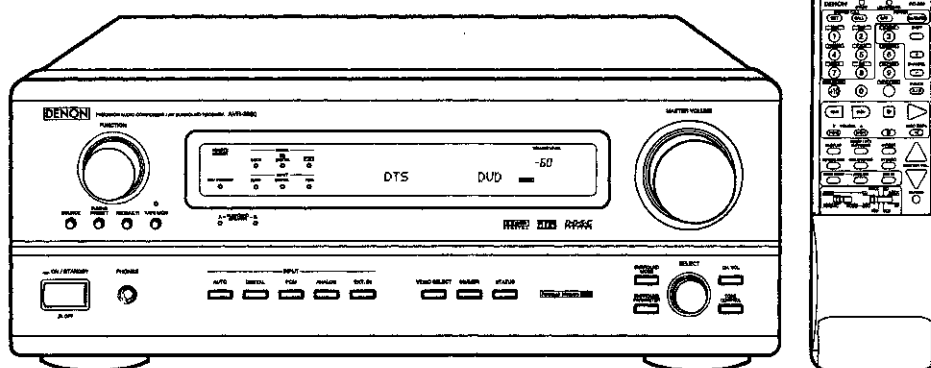

— TABLE OF CONTENTS —

SAFETY PRECAUTIONS	2	SCHMATIC DIAGRAM	73-86
SPECIFICATIONS	2	(1/14) 1U-3215-1 AUDIO/DSP UNIT	73
WIRE ARRANGEMENT	3	(2/14) 1U-3215-1 AUDIO/DSP UNIT	74
DISASSEMBLY	4-6	(3/14) 1U-3215-1 AUDIO/DSP UNIT	75
LEVEL DIAGRAMS	7,8	(4/14) 1U-3215-1 AUDIO/DSP UNIT	76
CLOCK FLOW & WAVE FORM IN DIGITAL BLOCK .	9,10	(5/14) 1U-3199-1 EXT IN VR UNIT	77
ADJUSTMENT	11-13	(6/14) 1U-3200-2 CONNECT UNIT	78
SEMICONDUCTORS	14-37	(7/14) 1U-3201-1 REGULATOR UNIT	79
PRINTED WIRING BOARDS	38-43	1U-3201-2 AMP UNIT	79
NOTE FOR PARTS LIST	44	1U-3201-3 H/P & P.SW UNIT	79
PARTS LIST OF P.W.B UNIT	44-61	1U-3201-4 FRONT UNIT	79
ADDENDUM PARTS LIST OF P.W.B. UNIT ASS'Y	62-67	(8/14) 1U-3198-1 POWER UNIT	80
EXPLODED VIEW	68	(9/14) 1U-3200-3 PRE OUT UNIT	81
PARTS LIST OF EXPLODED VIEW	69	1U-3200-4 DIGITAL INPUT UNIT	81
ADDENDUM PARTS LIST OF EXPLODED VIEW	69	1U-3223-1/1U-3223-2 VOLTAGE SELECT UNIT ...	81
BLOCK DIAGRAM	71	1U-3223-3 RF-5V UNIT	81
WIRING DIAGRAMS	72	(10/14) 1U-3198-3 COMP-VIDEO UNIT	82
		1U-3244-2 C. VIDEO UNIT	82
		(11/14) 1U-3244-1 S-VIDEO UNIT	83
		(12/14) 1U-3199-2 DISPLAY UNIT	84
		1U-3199-3 VOL. UNIT	84
		(13/14) 1U-3200-1 CONTROL UNIT	85
		(14/14) 1U-3201-5 TUNER UNIT	86

● Some illustrations using in this service manual are slightly different from the actual set.

NIPPON COLUMBIA CO., LTD.

SAFETY PRECAUTIONS

The following check should be performed for the continued protection of the customer and service technician.

LEAKAGE CURRENT CHECK

Before returning the unit to the customer, make sure you make either (1) a leakage current check or (2) a line to chassis resistance check. If the leakage current exceeds 0.5 milliamps, or if the resistance from chassis to either side of the power cord is less than 460 kohms, the unit is defective.

SPECIFICATIONS

AUDIO SECTION

(Power Amplifier)

Rated output:

Front:	105 W + 105 W	(8 Ω/ohms, 20 Hz ~ 20 kHz with 0.05 % T.H.D.)
	140 W + 140 W	(6 Ω/ohms, 1 kHz with 0.7 % T.H.D.)
Center:	105 W	(8 Ω/ohms, 20 Hz ~ 20 kHz with 0.05 % T.H.D.)
	140 W	(6 Ω/ohms, 1 kHz with 0.7 % T.H.D.)
Surround:	105 W + 105 W	(8 Ω/ohms, 20 Hz ~ 20 kHz with 0.05 % T.H.D.)
	140 W + 140 W	(6 Ω/ohms, 1 kHz with 0.7 % T.H.D.)
Front:	170 W + 170 W	(6 Ω/ohms, EIAJ)
Center:	170 W	(6 Ω/ohms, EIAJ)
Surround:	170 W + 170 W	(6 Ω/ohms, EIAJ)
Dynamic power:	140 W × 2 ch	(8 Ω/ohms)
	210 W × 2 ch	(4 Ω/ohms)
	240 W × 2 ch	(2 Ω/ohms)
Output terminals:	Front/Center:	6 - 16 Ω/ohms
	Surround:	A or B 6 - 16 Ω/ohms
		A + B 8 - 16 Ω/ohms

(for multiple voltage and Taiwan R.O.C. models)

(Analog)

Input sensitivity/input impedance:
Frequency response:
S/N:
Distortion:
Rated output/maximum output:

200 mV/47 kΩ/kohms
10 Hz ~ 50 kHz: +0, -3 dB (DIRECT mode)
102 dB (DIRECT mode)
0.01 % (20 Hz ~ 20 kHz) (DIRECT mode)
1.2 V/8 V

(Digital)

D/A output:

Rated output - 2 V (at 0 dB playback)
Total harmonic distortion - 0.008% (1 kHz, at 0 dB)
S/N ratio - 102 dB
Dynamic range - 96 dB
Format - Digital audio interface

Digital input:

(Phono equalizer (PHONO input-REC OUT))

Input sensitivity:
RIAA deviation:
Signal-to-noise ratio:
Rated output/Maximum output:
Distortion factor:

2.5 mV
±1 dB (20 Hz to 20 kHz)
74 dB (A weighting, with 5 mV input)
150 mV/8 V
0.03% (1 kHz, 3 V)

VIDEO SECTION

(Standard Video Jacks)

Input/output level and impedance:
Frequency response:

1 V p-p, 75 Ω/ohms
5 Hz ~ 10 MHz - +0, -3 dB

(S-video jacks)

Input/output level and impedance:

Y (brightness) signal - 1 V p-p; 75Ω/ohms
C (color) signal - 0.286 V p-p, 75Ω/ohms
5 Hz ~ 10 MHz - +0, -3 dB

Frequency response:

(Color component video jacks)

Input/output level and impedance:

Y (brightness) signal - 1 V p-p; 75Ω/ohms
Cb (blue) signal - 0.7 V p-p; 75Ω/ohms
Cr (red) signal - 0.7 V p-p; 75Ω/ohms
5 Hz ~ 20 MHz - +0, -3 dB

Frequency response:

TUNER SECTION

Receiving range:

[FM] (Note: μV at 75 Ω/ohms, 0 dBf = 1 × 10⁻¹⁵ W)
87.50 MHz ~ 107.90 MHz
(for North America model)
87.50 MHz ~ 108.00 MHz
(for Multiple voltage, Taiwan R.O.C. and Europe models)

[AM]
520 kHz ~ 1710 kHz
(for North America model)
522 kHz ~ 1611 kHz
(for Multiple voltage, Taiwan R.O.C. and Europe models)
18 μV

Usable sensitivity:

50 dB quieting sensitivity:

1.0 μV (11.2 dBf)
MONO 1.6 μV (15.3 dBf)
STEREO 23 μV (38.5 dBf)

S/N ratio:

MONO 80 dB
STEREO 75 dB
MONO 0.15 %
STEREO 0.3 %

Total harmonic distortion:

GENERAL

Power supply:

AC120 V, 60 Hz (for North America model)
AC115/230 V, 50/60 Hz (for Multiple voltage and Taiwan R.O.C.)
AC230 V, 50 Hz (Europe model)

Power consumption:

5.6 A (for North America model)
320 W (for Multiple voltage, Taiwan R.O.C. and Europe models)

Maximum external dimensions:

Weight:

434 (W) × 171 (H) × 416 (D) mm (17-3/32" × 6-11/32" × 16-3/8")
15.0 kg (33 lbs. 2 oz.)

REMOTE CONTROL UNIT (RC-860: North America, Multiple voltage, Taiwan R.O.C. models) (RC-864: Europe model)

Batteries:

External dimensions:

Weight:

R6P/AA Type (two batteries)
70 (W) × 215 (H) × 24 (D) mm (2-3/4" × 8-15/32" × 15/16")
200 g (Approx. 7 oz.) (including batteries)

WIRE ARRANGEMENT

If wire bundles are untied or moved to perform adjustment or parts replacement etc., be sure to rearrange them neatly as they were originally bundled or placed afterward. Otherwise, incorrect arrangement can be a cause of noise generation.

Wire arrangement viewed from the top

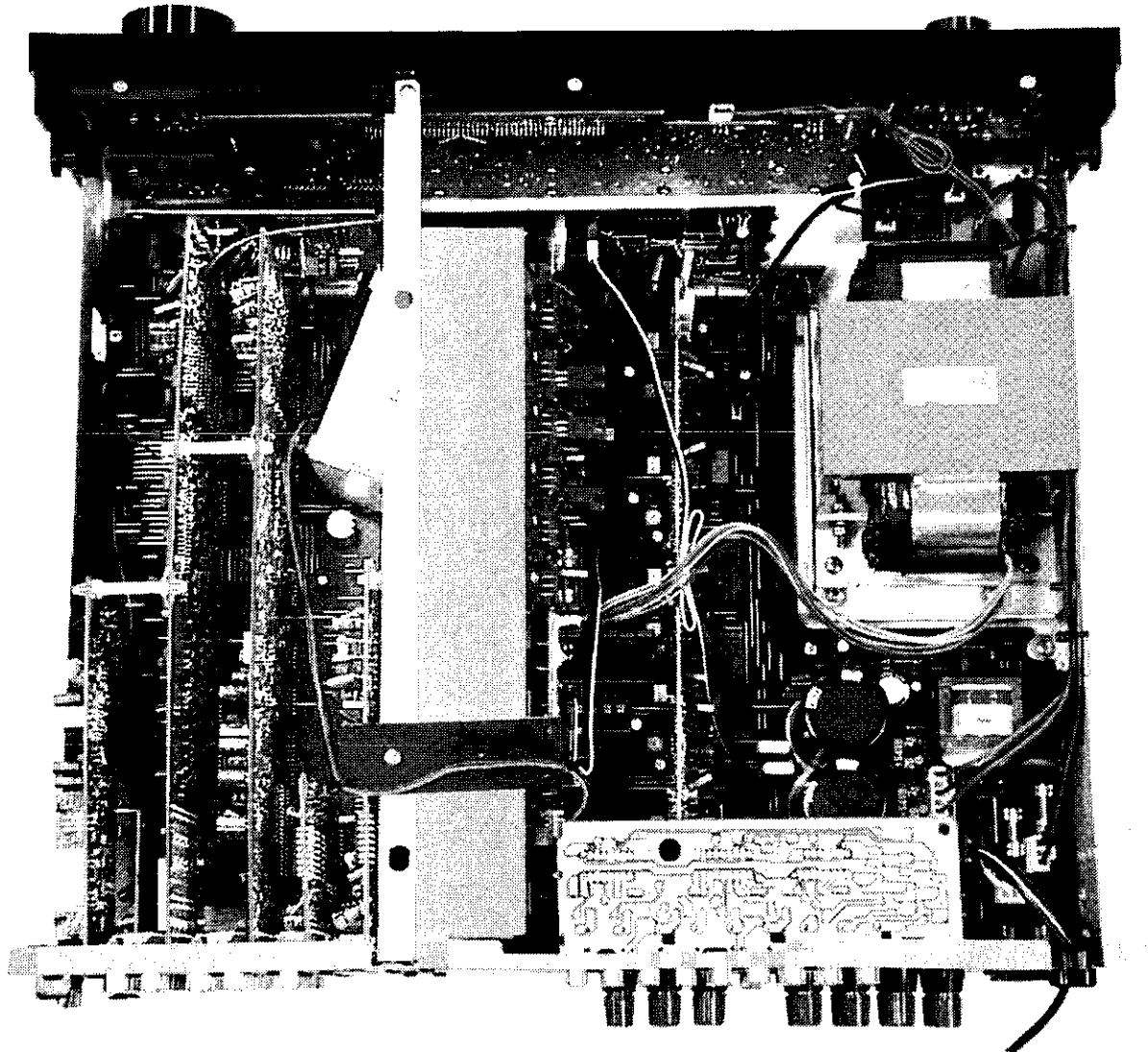

DISASSEMBLY

(Follow the procedure below in reverse order when reassembling)

1. Top Cover

Remove 3 screws ① on the rear and 6 screws ② on both sides to detach the Top Cover as shown in the arrow direction.

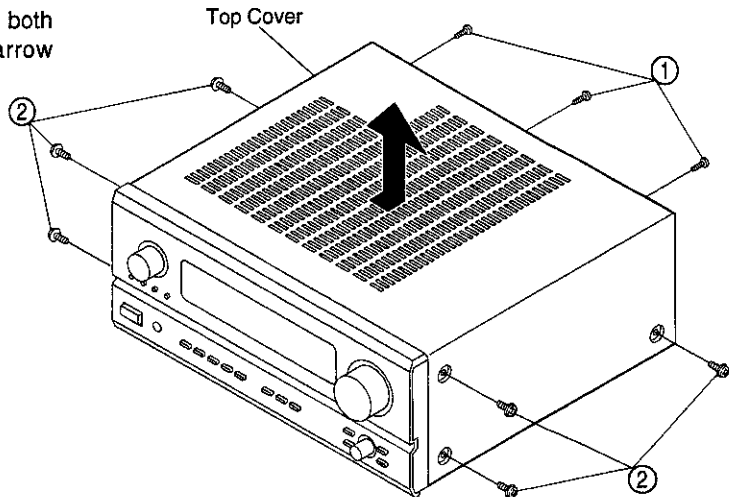

2. Front Panel

(1) Remove 7 screws ③ from the top and bottom edges of the Front Panel.

(2) Release 4 top and bottom hooks, then detach the Front Panel as shown in the arrow direction.

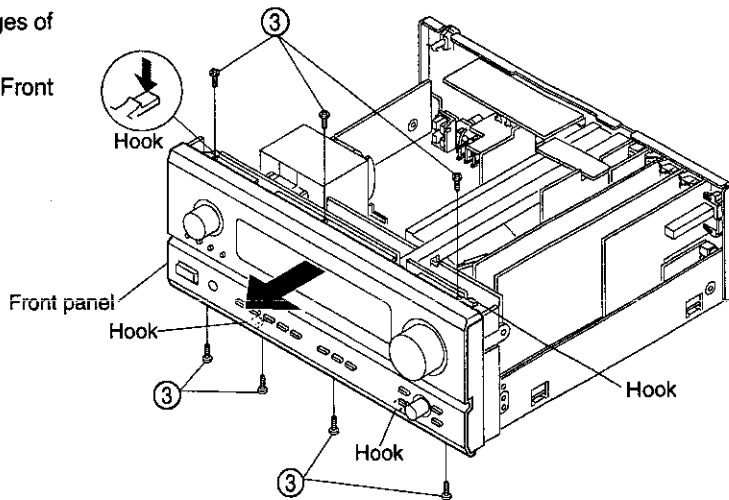

3. Inner Panel

Pull out the Inner Panel in the arrow direction after removing 3 screws ④.

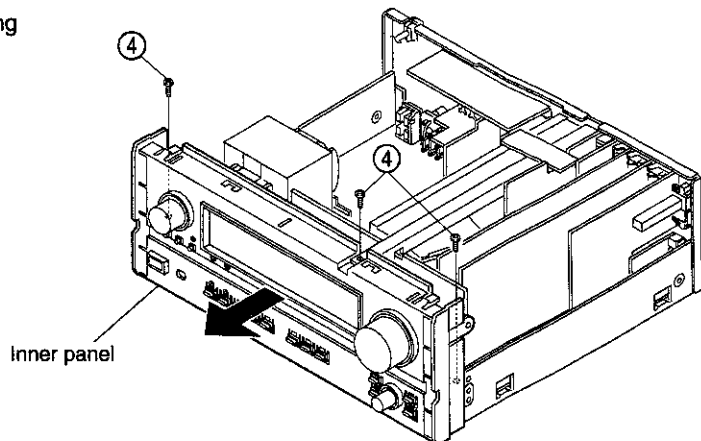

4. Inner Panel Ass'y

- (1) Remove 3 round and 1 square knobs, and unscrew 4 nuts.
- (2) Remove 19 screws (5) fixing each P.W.B.

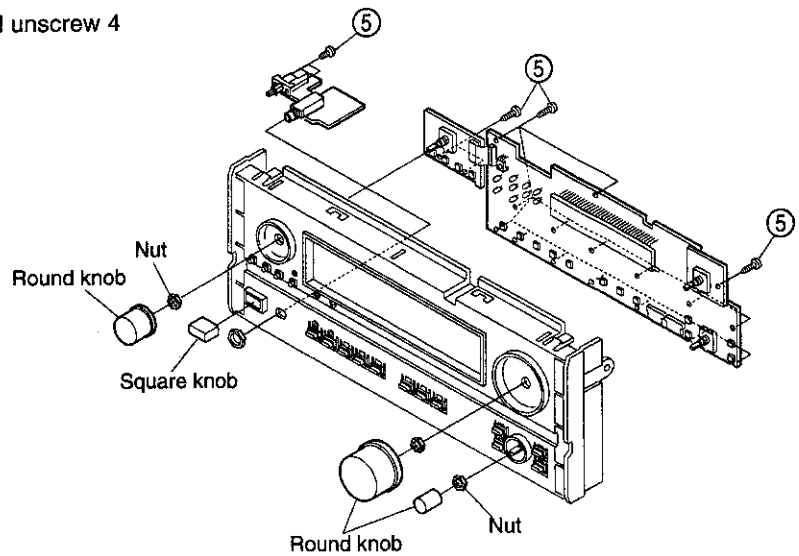

5. Amp Unit

- (1) Remove 8 screws (6) to detach Component Video Unit (7) and Pre-out Unit (8).
- (2) Take off the Amp Unit (9) as shown in the arrow direction after removing 1 screw (10).

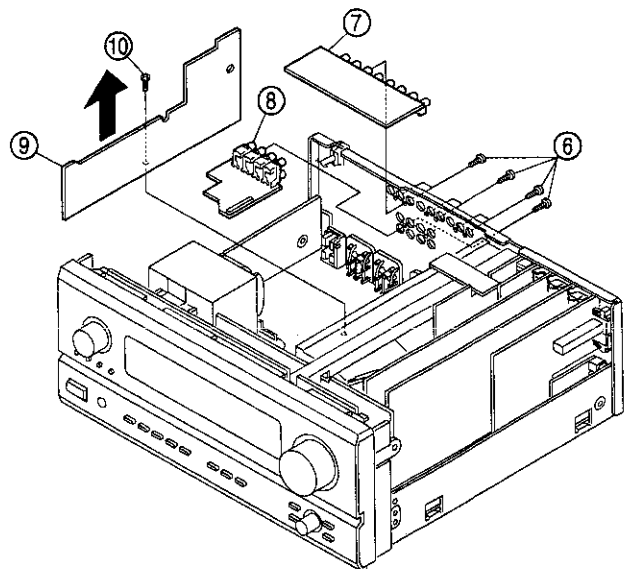

6. Regulator Unit

Take off the Regulator Unit (11) as shown in the arrow direction after removing 8 screws (12).

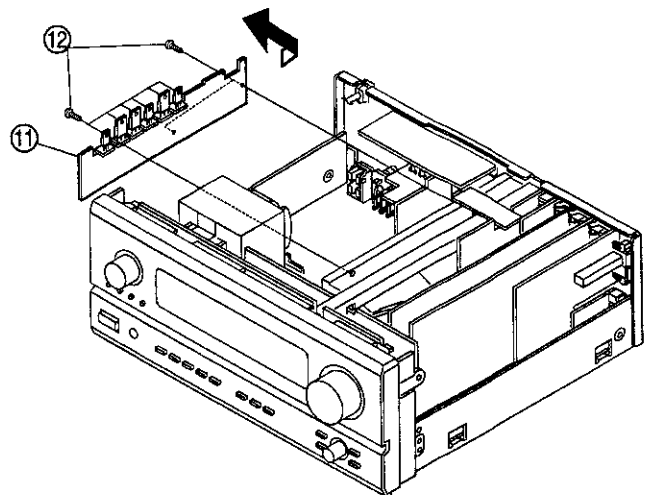

7. S-Video / C-video / Audio-in & DSP / Ext-in & VR / Digital-in / Tuner Unit

- (1) Remove 37 screws (13) to detach the Rear Panel.
- (2) Take off the objective P.W.B. upward.

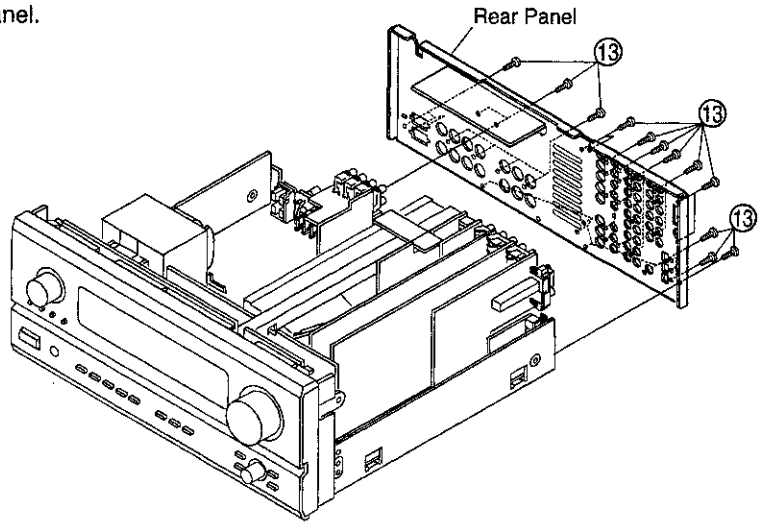

8. How to Check Power Amp / μ -com Unit with Power-on

- (1) Remove 12 screws (14), 1 screw (15), and 4 screws (16) fixing to the Chassis.
- (2) Pull up the Unit to separate from the Chassis.

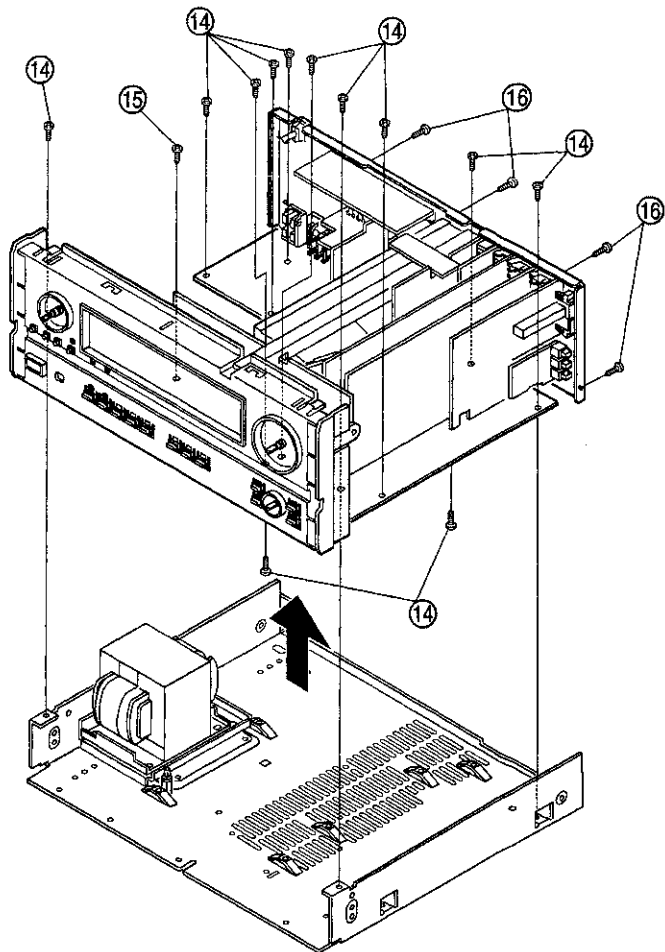

LEVEL DIAGRAM

FRONT

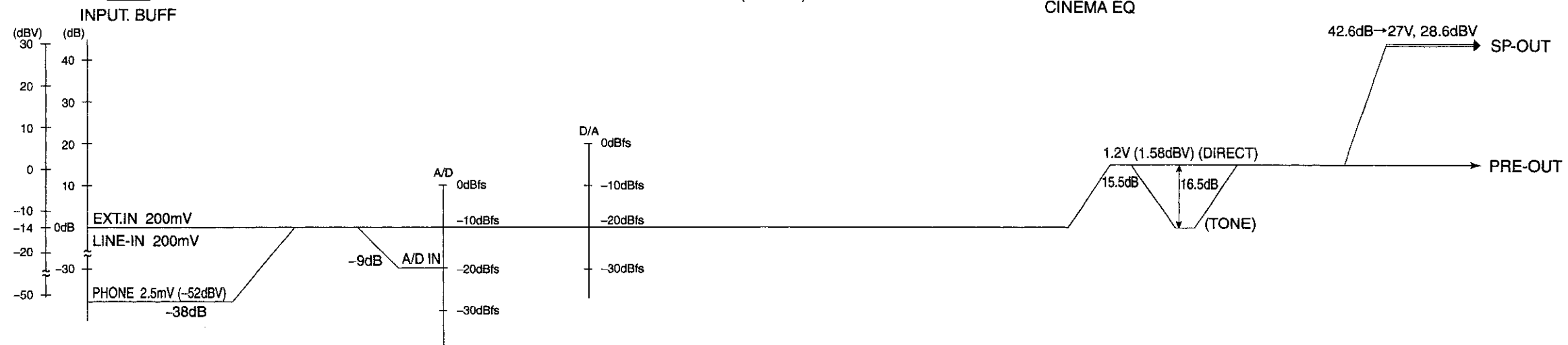
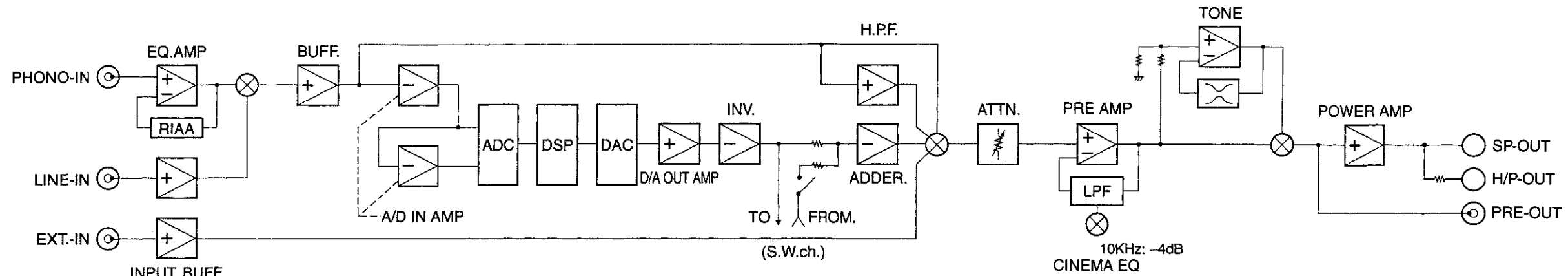

CENTER SURROUND

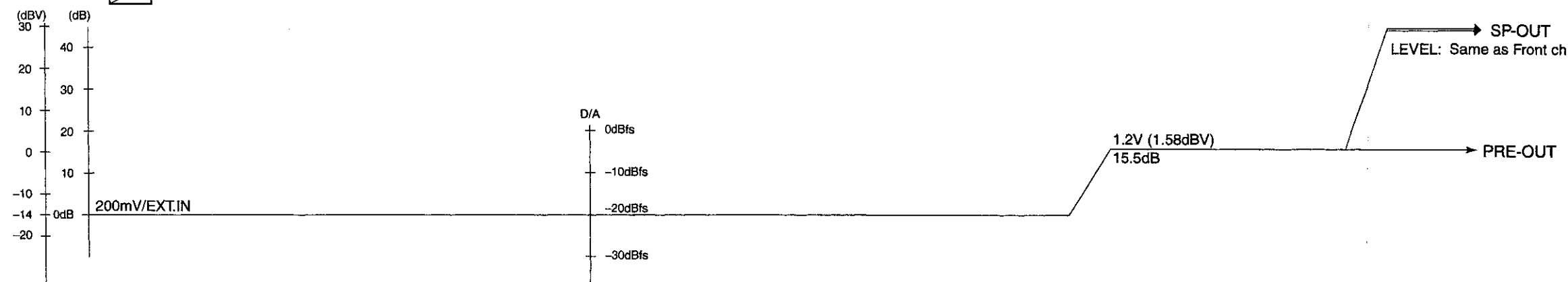
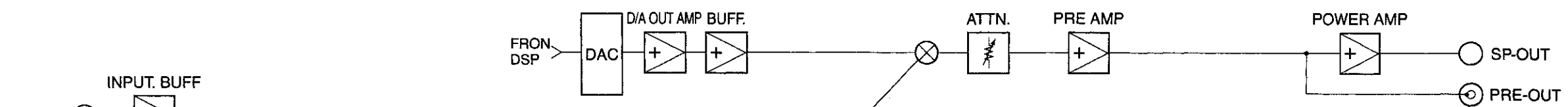

A
B
C
D
E

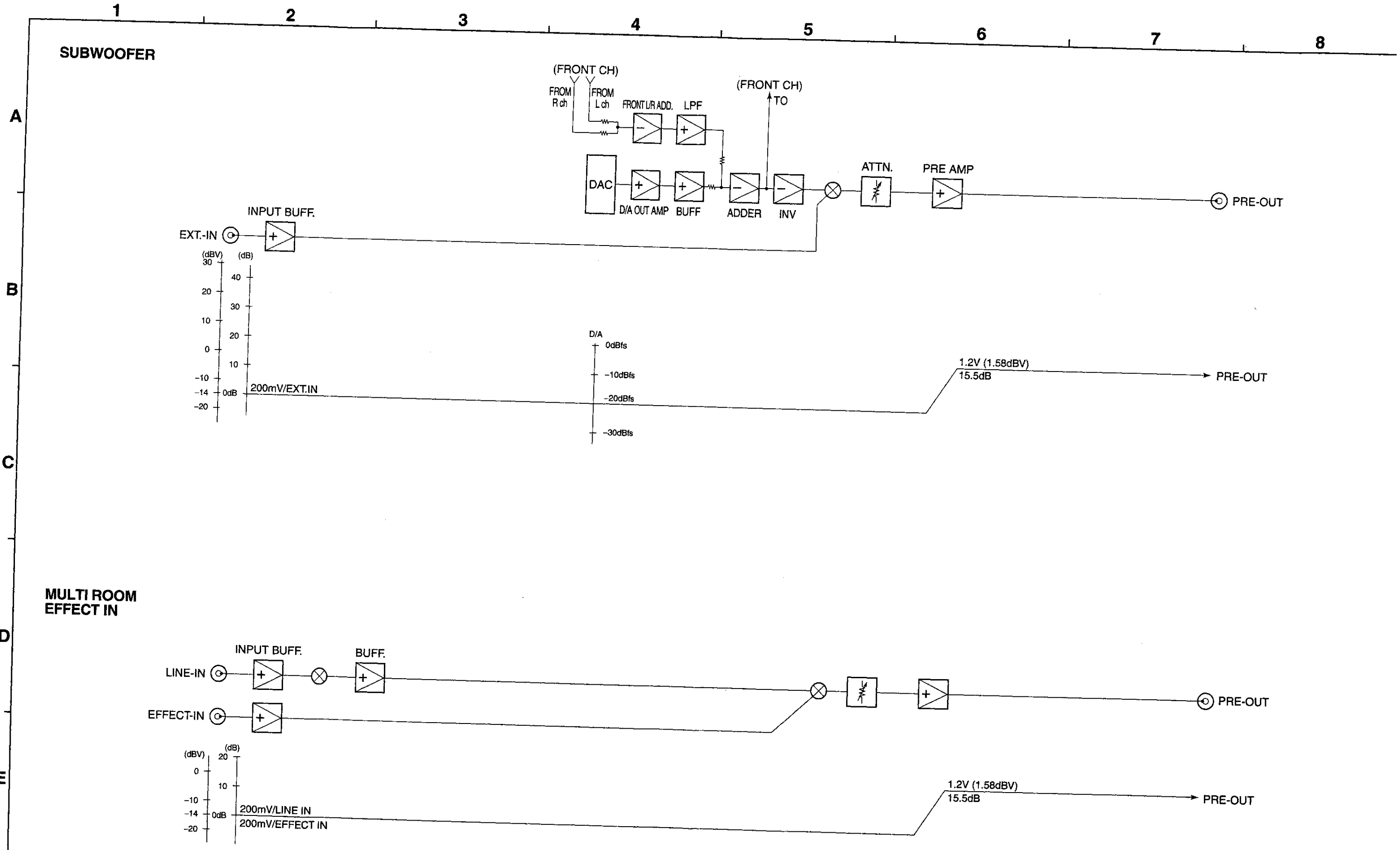

CLOCK FLOW & WAVE FORM IN DIGITAL BLOCK

Wave Form

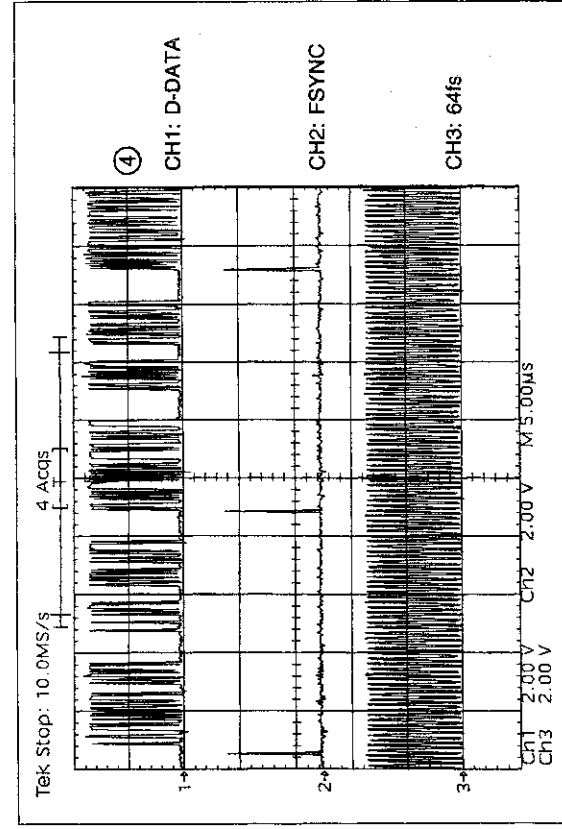
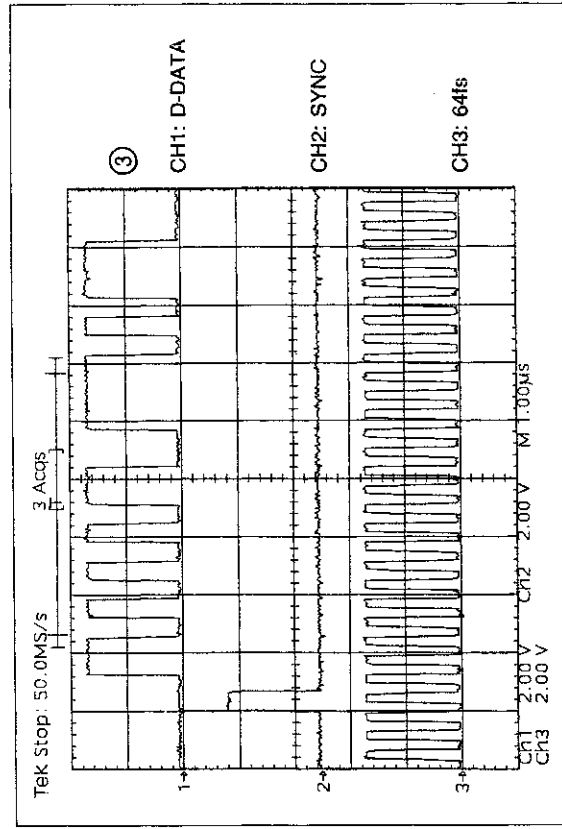
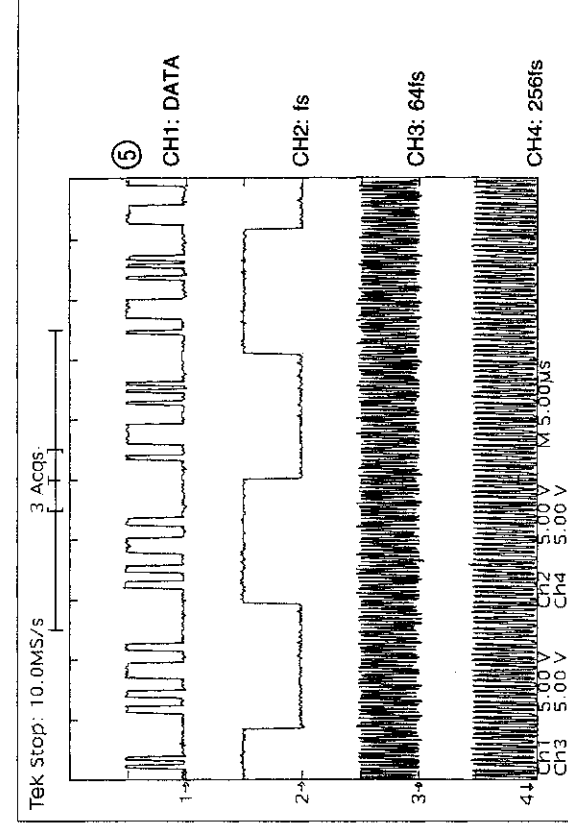
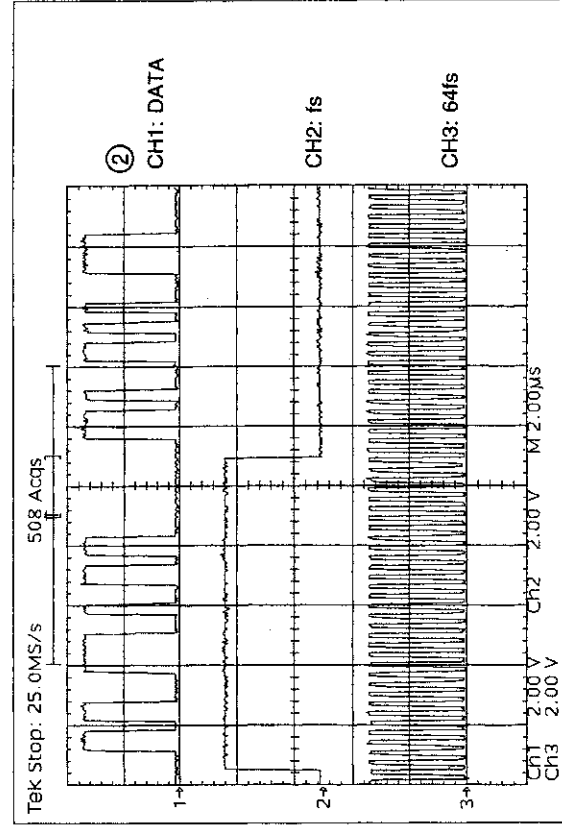
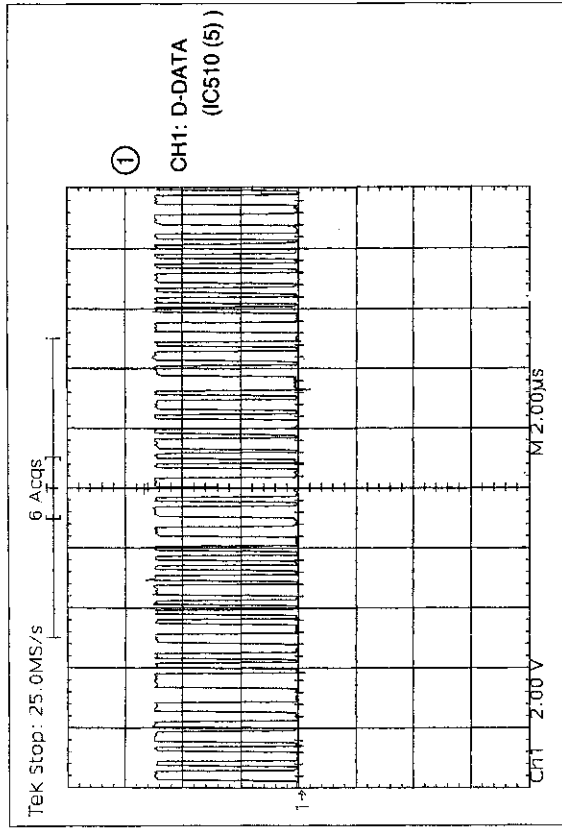

Clock Flow

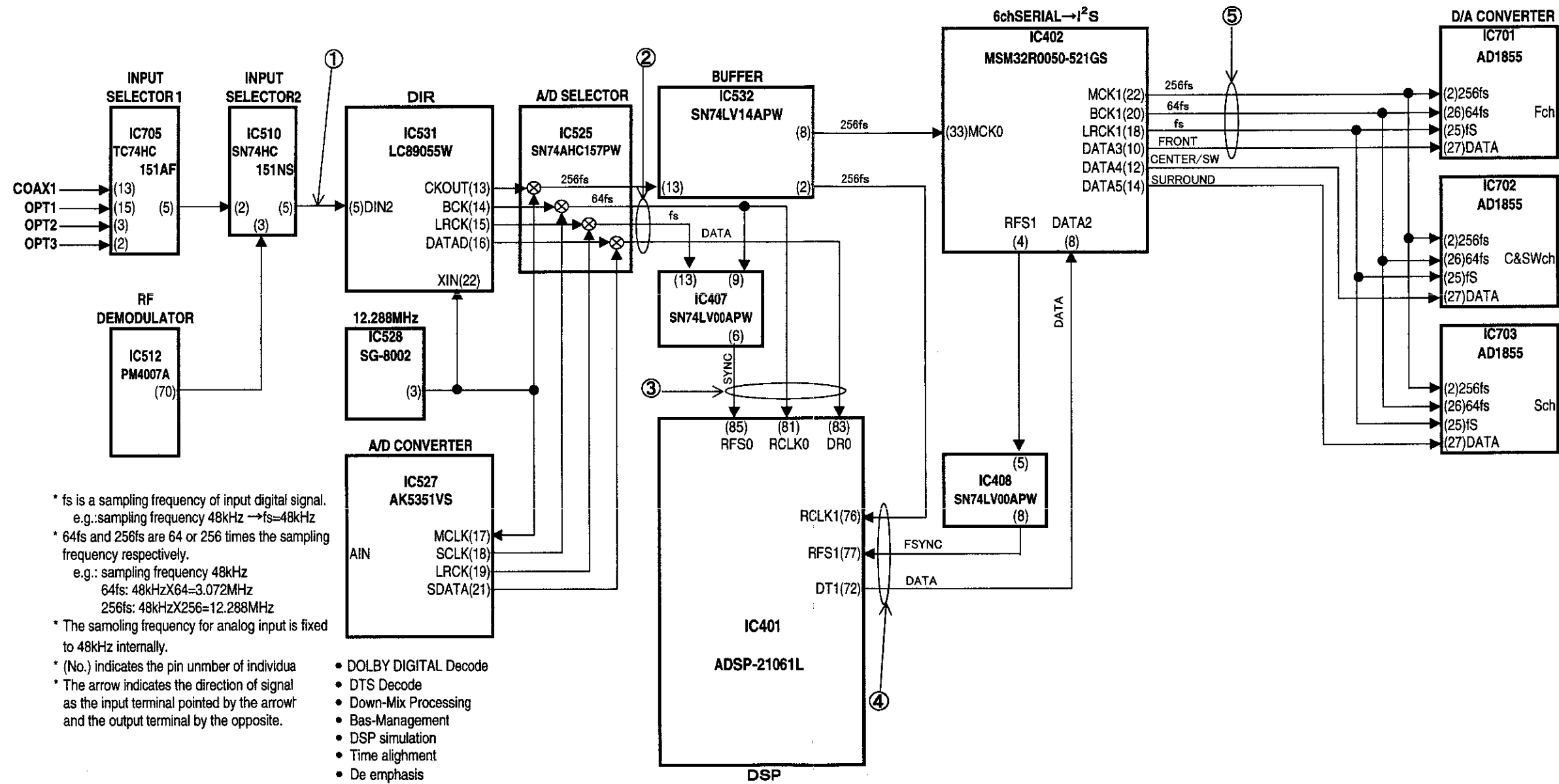

ADJUSTMENT

Tuner Section

CONNECTION DIAGRAM OF MEASURING INSTRUMENTS

● FM

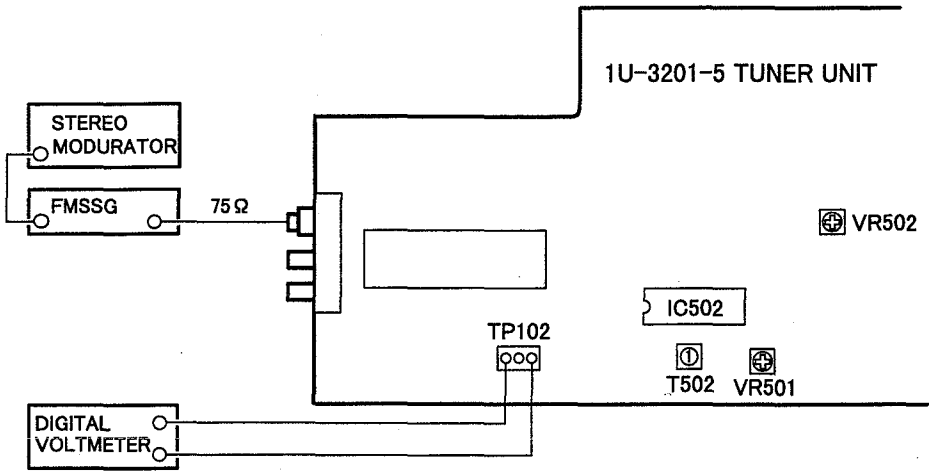

● AM

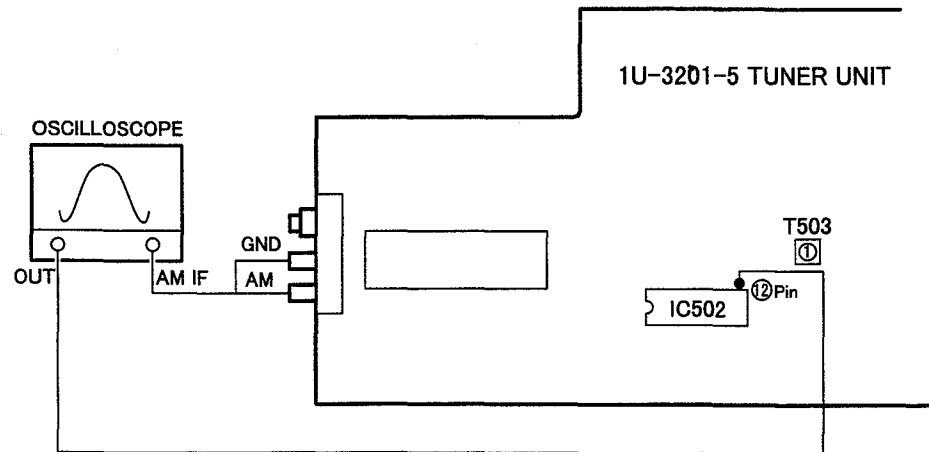

FM/MPX ALIGNMENT

Step	Alignment Item	Tuning Frequency Setting	Input			Modulation	Coupling	Output		Adjust		Remarks
			Type	Frequency	Input Level			Type	Connect to	Points	Adjust to	
1	Tuning Center	98.1 MHz	FM SSG	98.1 MHz	60 dB μ i	None	Antenna Terminal	Digital Voltmeter	TP102	T502	\pm 50mV	Function : FM Mode : Auto
2	Separation	98.1 MHz	FM SSG	98.1 MHz	60 dB μ i	Stereo (L) 1KHz 100%	Antenna Terminal	AC Voltmeter	AUDIO OUT Terminal (R)	VR502	Maximum Separation	—
3	Signal Level	98.1 MHz	FM SSG	98.1 MHz	20 dB μ i	Off	Antenna Terminal	—	—	VR501	Light "TUNED" FLD Character	—

AM ALIGNMENT

Step	Alignment Item	Frequency	Input	Output		Remarks
				Type	Connect to	
1	IF	—	IF SWEEP (Input level is not over to work A.G.C.)	Oscilloscope	IC502 12Pin	Maximum height and best symmetry curve
					T503	

Audio Section

Idling Current (1U-3198-1)

Required measurement equipment : DC Voltmeter

Preparation

- (1) Avoid direct blow from an air conditioner or an electric fan, and adjust the unit at normal room temperature 15 °C ~ 30 °C (59 °F ~ 86 °F).
- (2) Presetting
 - POWER (Power source switch) → OFF
 - SPEAKER (Speaker terminal) → No load (Do not connect speaker, dummy resistor, etc.)

Adjustment

- (1) Remove top cover and set VR501, VR502, VR503, VR504, VR505, on 1U-3198-1 (Power Unit) at counterclockwise (\circlearrowleft) fully.
- (2) Connect DC Voltmeter to test points (FRONT-Lch: TP501, FRONT-Rch: TP502, CENTER ch: TP505, SURROUND-Lch: TP503, SURROUND-Rch: TP504).
- (3) Connect power cord to AC Line, and turn power switch "ON".
- (4) Presetting.
 - MASTER VOLUME : "---" counterclockwise (\circlearrowleft min.)
 - MODE : 5CH STEREO
 - FUNCTION : CD
- (5) Allow 2 minutes, and turn VR501 clockwise (\circlearrowright) and adjust the TEST POINT voltage to 1.5 mV \pm 0.5 mV DC.
- (6) After 10 minutes from preset, turn VR501 to set the voltage to 3 mV \pm 0.5 mV DC.
- (7) Adjust the Variable Resistors of other channels in the same way.
- (8) After 5 minutes from (6), turn VR501 to set the voltage to 3 mV \pm 0.5 mV DC.
- (9) Adjust the Variable Resistors of other channels in the same way.

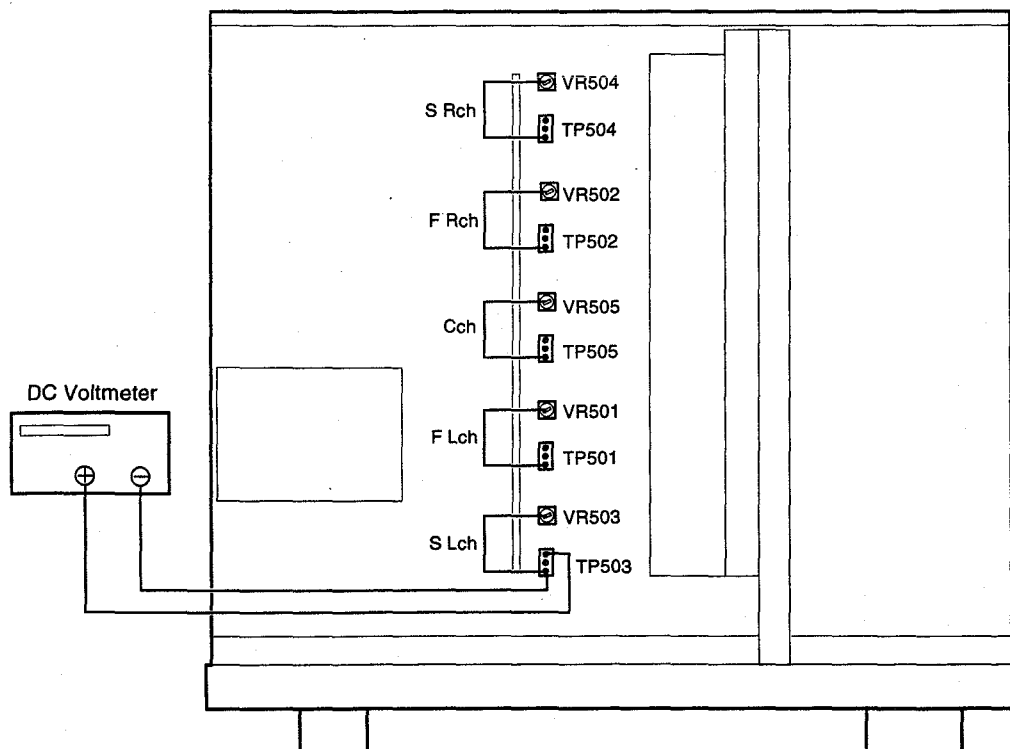

SEMICONDUCTORS

● IC's

Note: Abbreviation ahead of IC No. indicates the name of P.W.B.

- PO: Power P.W.B. RE: Regulator P.W.B.
- EX: Exit in P.W.B. AU: Audio/DSP P.W.B.
- CO: Control P.W.B. VI: Video P.W.B.

TMP88CU74F (CO: IC303)

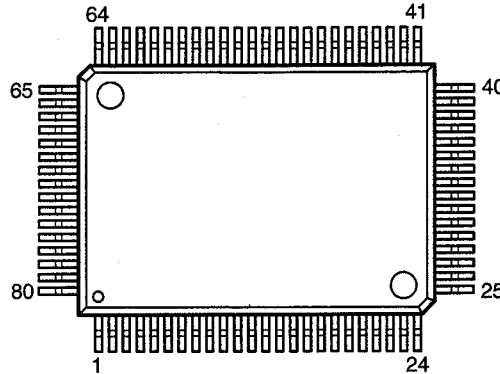

TMP88CU74F Terminal Function

Pin No.	Name	Symbol	I/O	Type	Op	Det	Res	Init	Function
1	P02/S01	RDS RESET	O	C	—	—	Z	L	RDS reset output (LC7074)
2	P03	OSD RST	O	C	—	—	Z	H	OSD control output (M35015)
3	P04	ST/MONO	O	C	—	—	Z	L	STEREO/MONO control signal, L: STEREO
4	P05	PLFL DATA	O	C	—	—	Z	L	PLL, FL control terminal (LC72131 & LC75721NE)
5	P06	PLL STB	O	C	—	—	Z	L	PLL control terminal (LC72131)
6	P07	PLFL CLK	O	C	—	—	Z	L	PLL, FL control terminal (LC72131 & LC75721NE)
7	Vss	Vss	I	—	GND	—	—	L	GND
8	Xout	Xout	O	—	—	—	—	—	XTAL
9	Xin	Xin	I	—	—	—	—	—	XTAL
10	RESET_	RESET_	I	—	Eu	Lv	L	—	Reset input
11	P22/XTOUT	TUNED_	I	—	Eu	Lv	Z	—	Tuning detect, L: Tuned
12	P21/XTIN	STEREO_	I	—	Eu	Lv	Z	—	L: At stereo receive
13	TEST	TEST	I	—	GND	S	—	—	Connect to GND
14	P20/INT5	B.DOWN_	I	—	Eu	Lv	Z	—	Power down detect, L: Power down
15	P10/INT0_	PROTECT_	I	—	Ed	E&L	Z	—	PROTECTION detect input, H: Detect
16	P11/INT1	RDS START	I	—	—	—	Z	L	RDS data input (LC7074)
17	P12	OSD CLK	O	C	—	—	Z	H	OSD control output (M35015)
18	P13	OSD CS	O	C	—	—	Z	H	OSD control output (M35015)
19	P14	OSDDATA	O	C	—	—	Z	L	OSD control output (M35015)
20	P15/INT3	REMOCON	I	—	Ed	E&L	Z	—	Remote control signal input
21	P16/INT2	ACK	O	C	—	—	Z	L	MAIN-SUB CPU comm. control terminal
22	P17/INT4	REQ	I	—	Eu	—	Z	L	MAIN-SUB CPU comm. control terminal
23	P30/SCL	SI	I	—	—	—	—	—	MAIN-SUB CPU comm. control terminal
24	P31/SDA	SO	O	C	—	—	—	—	MAIN-SUB CPU comm. control terminal
25	P32/SCK0_	CLK	O	C	—	—	—	—	MAIN-SUB CPU comm. control terminal
26	P40/AIN0	MODE	I	—	Eu	Lv	Z	—	Destination switching input
27	P41/AIN1	KEY1	I	—	Eu	Lv	Z	—	Button input 1
28	P42/AIN2	KEY2	I	—	Eu	Lv	Z	—	Button input 2
29	P43/AIN3	KEY3	I	—	Eu	Lv	Z	—	Button input 3
30	P44/AIN4	FUNC STB1	O	C	—	—	Z	—	Function control output (TC9274N), INPUT
31	P45/AIN5	FUNC/T. CON CLK	O	C	—	—	Z	L	Function control output (TC9274N, TC9273), TONE control output (TC9184P)
32	P46/AIN6	FUNC/T. CON DATA	O	C	—	—	Z	L	Function control output (TC9274N, TC9273), TONE control output (TC9184P)
33	P47/AIN7	FUNC STB2	O	C	—	—	Z	L	Function control output (TC9274N), 6CH/8CH EXT.IN
34	P50/AIN8	E.VOL STB	O	C	—	—	L	L	Elect. volume control output (TC9459)
35	P51/AIN9	TONE STB	O	C	—	—	L	L	TONE control output (TC9184P)
36	P52/AIN10	E.VOL DATA	O	C	—	—	L	H	Elect. volume control output (TC9459)
37	P53/AIN11	E.VOL CLK	O	C	—	—	L	H	Elect. volume control output (TC9459)

Pin No.	Name	Symbol	I/O	Type	Op	Det	Res	Init	Function
38	VASS	VASS	I						Ref. volt (GND)
39	VAREF	VAREF	I						Ref. volt (VDD)
40	VDD	VDD	I						Power supply
41	P60	FL CE	O	P	Ed	S	L	H	FL display control output (LC75712NE)
42	P61	FL RES	O	P	Ed	S	L	H	FL display control output (LC75712NE)
43	P62	FUNC STB3	O	P	Ed	—	Z	L	Function control output (TC9273), REC OUT
44	P63	SA-RELAY	O	P	Id	—	L	L	Surround SP relay A control terminal, L: Mute
45	P64	SB-RELAY	O	P	Id	—	L	L	Surround SP relay B control terminal, L: Mute
46	P65	C-RELAY	O	P	Id	—	L	L	Center SP relay control terminal, L: Mute
47	P66	F-RELAY	O	P	Id	—	L	H	Front SP relay control terminal, L: Mute
48	P67	PRE F MUTE	O	P	Ed	—	L	H	Front PRE OUT mute control terminal, L: Mute
49	P70	PRE C MUTE	O	P	Ed	—	L	L	Center PRE OUT mute control terminal, L: Mute
50	P71	PRE S MUTE	O	P	Ed	—	L	L	Surround PRE OUT mute control terminal, L: Mute
51	P72	SUB WOOFER MUTE	O	P	Ed	—	L	H	Sub-woofer PRE OUT mute control terminal, L: Mute
52	P73	H/P RELAY	O	P	Id	—	L	H	H/P OUT relay control terminal, L: Mute
53	P74	EXP OE	O	P	Ed	—	L	H	Port expander control terminal (TC4094B)
54	P75	EXP CLK	O	P	Ed	—	L	L	Port expander control terminal (TC4094B)
55	P76	EXPDATA	O	P	Ed	—	L	L	Port expander control terminal (TC4094B)
56	P77	EXP STB	O	P	Ed	—	L	L	Port expander control terminal (TC4094B)
57	P80	POWER	O	P	Id	—	L	H	Power relay control output, H: ON
58	P81	RESET2	O	P	Id	—	L	L	Reset signal output to sub-CPU, H: Reset
59	P82	SUB-CPU-B-DOWN	O	P	Id	—	L	L	B-DOWN signal output to sub-CPU
60	P83	TAPE MON. LED	O	P	Id	—	L	L	TAPE MONITOR LED indicator control, H: MONITOR
61	P84	STANDBY	O	P	Id	—	L	H	Standby LED drive output H: Light
62	P85	DIRECT	O	P	Id	—	L	L	DIRECT relay control, H: DIRECT
63	P86	S1	O	P	Id	—	L	—	Video signal switching control output
64	P87	S2	O	P	Id	—	L	—	Video signal switching control output
65	P90	TUNER MUTE	O	P	Ed	—	L	H	TUNER mute control terminal, H: Mute
66	P91	MULTI/EFFECT MUTE	O	P	Id	—	L	H	MULTI/EFFECT PREOUT mute control terminal, H: Mute.
67	P92	S MONI DET	I	—	Eu	Lv	Z	—	S monitor connection detect input, L: Connected
68	P93	S SIG DET	I	—	Eu	Lv	Z	—	S signal detect input, H: Detected
69	P94	SYNC DET.	I	—	Eu	Lv	Z	—	Sync detect input, H: Ext. sync
70	P95	SEL A (M)	I	—	Eu	Lv	Z	—	Master volume rotation detect input (rotary encoder)
71	P96	SEL B (M)	I	—	Eu	Lv	Z	—	Master volume rotation detect input (rotary encoder)
72	P97	CINEMA EQ	O	P	Eu	Lv	Z	L	CINEMA EQ control output, H: ON
73	PD0	VOL MUTE	O	P	Ed	—	L	L	Master volume minimum control, L: Min.
74	PD1	SEL C (S)	I	—	Eu	Lv	Z	—	Surround mode rotation detect input (rotary encoder)
75	PD2	SEL D (S)	I	—	Eu	Lv	Z	—	Surround mode rotation detect input (rotary encoder)
76	PD3	SEL E (F)	I	—	Eu	Lv	Z	—	Input selector switch rotation detect input (rotary encoder)
77	PD4	SEL F (F)	I	—	Eu	Lv	Z	—	Input selector switch rotation detect input (rotary encoder)
78	Vkk	Vkk	—	—	—	—	—	—	GND fixed
79	P00/SCK1_	RDS CLK	I	—	—	S	Z	—	RDS clock input (LC7074)
80	P01/SI1	RDS DATA	I	—	—	S	Z	—	RDS data input (LC7074)

NOTE:

Pin No. : Terminal number of microcomputer.

Port Name : The name entered in the data sheet of microcomputer.

Symbol : Symbolized interface function.

I/O : Input or out of part.

"I" = Input port

"O" = Output port

Type : Composition of port in case of output port.

"C" = CMOS output

"N" = NMOS open drain output

"P" = PMOS open drain output

Op : Pull up/Pull down selection information.

"Iu" = Inner microcomputer pull up

"Id" = Inner microcomputer pull down

"Eu" = External microcomputer pull up

"Ed" = External microcomputer pull down

Det : Indicates judging state of input port. Level detection is "Lv"; Edge detection is "Ed"; Detection by both shifting is "E&L"; Serial data detection is "S" (Serial data output is also "S").

Res : State at reset.

"H" = Outputs High Level at reset

"L" = Outputs Low Level at reset

"Z" = Becomes High impedance mode at reset

Ini : Initial output state.

Function : Function and logical level explanation of signals to be interface.

TMP93CS41F (AU: IC301)

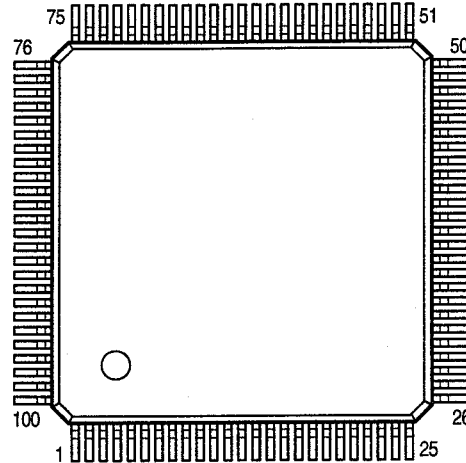

TMP93CS41F Terminal Function

Pin No.	Name	Symbol	I/O	Type	Op	Det	Res	Init	Function
1	V REFL		—	—	—	—	—	—	A/D ref. GND
2	A Vss	←	—	—	—	—	—	—	A/D GND
3	A Vcc	←	—	—	—	—	—	—	AD +5V
4	_NMI		I	—	—	—	—	—	Not used (fixed to H)
5	P70/TI0	_DEMOD RESET	O	C	Ed	—	L	L	Demodulator reset output (L: Reset)
6	P71/TO1	DEMOD ON	O	C	Ed	—	L	L	Demodulator osc. control output (H: Osc.)
7	P72/TO2	FAN1	O	C	Ed	—	L	L	FAN control output (H: ON, L: OFF)
8	P73/TO3	FAN2	O	C	Ed	—	L	L	FAN control output (H: Hi, L: Low & off)
9	P80/INT4/TI4	B.DOWN_	I	—	Eu	E↓&L	Z	—	Power down detect (L: Detected)
10	P81/INT5/TI5	DSP ACK	I	—	—	E↑&L	—	—	Host I/F comm. response input (L: OK)
11	P82/TO4	AC-3 RF DET	I	—	—	E↓&L	—	—	AC-3 RF signal judge input (L: AC-3 data input)
12	P83/TO5	_REQ	O	C	Eu	—	H	L	MAIN-SUB CPU comm. control output (L: Comm. request from sub)
13	P84/INT6/TI6	_ACK	I	—	Eu	E↓&L	—	—	MAIN-SUB CPU comm. control input (L: Ack. return from main)
14	P85/INT7/TI7	ERR	I	—	—	E↑&L	—	—	DIR control input terminal (LC89055Q)(H: ERR)
15	P86/TO6	_DSP RESET	O	C	Ed	—	L	L	DSP reset output terminal (L: Reset)
16	P97/INT0	_CS	I	—	Ed	E↑&L	—	—	DIR control input terminal (LC89055Q), when CH status change L→H
17	P90/TXD0	SI	O	C					MAIN-SUB CPU comm. control terminal (data output)
18	P91/RXD0	SO	I	—					MAIN-SUB CPU comm. control terminal (data input)
19	P92/_CTS0/SCLK0	CLK	I/O	C					MAIN-SUB CPU comm. control terminal (I2C clock in/output)
20	P93/TXD1		O	C	—	—	Z	L	
21	P94/RXD1	DIR MISO	I	—	—	Lv	—	—	DIR control input terminal (LC89055Q) control data input
22	P95/SCLK1	DIR CLK	O	C	—	—	Z	L	DIR control terminal (LC89055Q) control clock output
23	AM8/_16	←	—	—	—	—	—	—	Fixed to +5V
24	CLK		O	C	Eu	—	—	—	
25	Vcc	←	—	—	—	—	—	—	+5V
26	Vss	I/O1	—	—	—	—	—	—	GND
27	X1	Xin	I	—	—	—	—	—	X'tal connection
28	X2	Xout	O	—	—	—	—	—	X'tal connection
29	_EA	←	—	—	—	—	—	—	Fixed to +5V
30	_RESET	RESET2_	I	—	Eu	Lv	L	—	Reset input (controlled by main CPU)
31	P96/XT1	A/D RESET	O	N	Eu	—	H	H	A/D control terminal (L: Reset)
32	P97/XT2	ASIC-RESET	O	N	Eu	—	H	H	ASIC control terminal (L: Reset)
33	TEST1	←	I	—	—	—	—	—	Connected to TEST2
34	TEST2	←	I	—	—	—	—	—	Connected to TEST1
35	PA0	DINA	O	C	Ed	—	L	L	Digital input switching control output
36	PA1	DINB	O	C	Ed	—	L	L	Digital input switching control output
37	PA2	DINC	O	C	Ed	—	L	L	Digital input switching control output
38	PA3	DIND	O	C	Ed	—	L	L	Digital input switching control output
39	PA4	DINE	O	C	Ed	—	L	L	
40	PA5		O	C	Ed	—	L	L	

Pin No.	Name	Symbol	I/O	Type	Op	Det	Res	Init	Function
41	PA6		O	C	Ed	—	L	L	
42	PA7/SCOUT	96k-DAC	O	C	Ed	—	L	L	DAC control terminal (H: Sample frequency 96kHz)
43	ALE	←	O	C	—	—	L	L	Address latch enable
44	Vcc		—	—	—	—	—	—	+5V
45	P00/AD0	AD0	I/O	C	—	—	Z	L	EPROM data in D0 / address out A0
46	P01/AD1	AD1	I/O	C	—	—	Z	L	EPROM data in D1 / address out A1
47	P02/AD2	AD2	I/O	C	—	—	Z	L	EPROM data in D2 / address out A2
48	P03/AD3	AD3	I/O	C	—	—	Z	L	EPROM data in D3 / address out A3
49	P04/AD4	AD4	I/O	C	—	—	Z	L	EPROM data in D4 / address out A4
50	P05/AD5	AD5	I/O	C	—	—	Z	L	EPROM data in D5 / address out A5
51	P06/AD6	AD6	I/O	C	—	—	Z	L	EPROM data in D6 / address out A6
52	P07/AD7	AD7	I/O	C	—	—	Z	L	EPROM data in D7 / address out A7
53	P10/AD8/A8	A8	O	C	—	—	Z	L	EPROM address out A8
54	P11/AD9/A9	A9	O	C	—	—	Z	L	EPROM address out A9
55	P12/AD10/A10	A10	O	C	—	—	Z	L	EPROM address out A10
56	P13/AD11/A11	A11	O	C	—	—	Z	L	EPROM address out A11
57	P14/AD12/A12	A12	O	C	—	—	Z	L	EPROM address out A12
58	P15/AD13/A13	A13	O	C	—	—	Z	L	EPROM address out A13
59	P16/AD14/A14	A14	O	C	—	—	Z	L	EPROM address out A14
60	P17/AD15/A15	A15	O	C	—	—	Z	L	EPROM address out A15
61	_WDTOUT	←	O	C	—	—	Z	H	Watch dog output
62	Vss	←	—	—	—	—	—	—	GND
63	Vcc	←	—	—	—	—	—	—	+5V
64	P20/A0/A16	A16	O	C	—	—	Z	L	EPROM address out A16
65	P21/A1/A17		O	C	—	—	Z	L	
66	P22/A2/A18	DIRCE	O	C	—	—	Z	L	DIR control terminal (LC89055Q) control chip enable output
67	P23/A3/A19	DIR MOSI	O	C	—	—	Z	L	DIR control terminal (LC89055Q) control data output
68	P24/A4/A20		O	C	—	—	Z	L	
69	P25/A5/A21	SW-SUM	O	C	Ed	—	L	L	
70	P26/A6/A22	DAC-RESET	O	C	Ed	—	L	L	DAC control terminal (L: Power down mode, ↑ (rising edge) Reset)
71	P27/A7/A23	SEL CK	O	C	Ed	—	Z	L	ADC/DIR data clock switching control terminal (L: ADC)
72	P30/_RD	_RD	O	C	Ed	—	Z	L	Flash memory control terminal
73	P31/_WR	_WR	O	C	Ed	—	Z	L	Flash memory control terminal
74	P32/_HWR	CSI	I	—	Ed	Lv	—	—	DIR control input terminal (L: PCM)
75	P33/_WAIT	ERR MUTE_	O	C	Ed	—	L	L	Pop noise preventive mute control output (L: Mute)
76	P34/_BUSRQ	_DSP REQUEST	O	C	Ed	—	Z	L	(ADSP21061L-A:IRQ1_) host I/F interrupt request output (L: REQ)
77	P35/_BUSRQ	DIG.(AC39 MUTE	O	C	Ed	—	Z	L	Digital mute control output (L: AC-3 or DTS decode enable)
78	P36/_RW	WRITE	O	C	—	—	Z	L	DSP comm. control terminal (H: Data write)
79	P37/_RAS	DIR RESET	O	C	—	—	Z	L	DIR control output (LC89055Q) (L: Reset)
80	P40/_CS0/_CAS0		O	C	—	—	Z	L	
81	P41/_CS1/_CAS1		O	C	—	—	Z	L	
82	P42/_CS2/_CAS2	_CS0	O	C	—	—	Z	L	Flash memory control terminal
83	P60/PG00	I/01	I/O	C	—	—	Z	L	DSP comm. terminal (ADSP21061L: D16)
84	P61/PG01	I/02	I/O	C	—	—	Z	L	DSP comm. terminal (ADSP21061L: D17)
85	P62/PG02	I/03	I/O	C	—	—	Z	L	DSP comm. terminal (ADSP21061L: D18)
86	P63/PG03	I/04	I/O	C	—	—	Z	L	DSP comm. terminal (ADSP21061L: D19)
87	P64/PG10	I/05	I/O	C	—	—	Z	L	DSP comm. terminal (ADSP21061L: D20)
88	P65/PG11	I/06	I/O	C	—	—	Z	L	DSP comm. terminal (ADSP21061L: D21)
89	P66/PG12	I/07	I/O	C	—	—	Z	L	DSP comm. terminal (ADSP21061L: D22)
90	P67/PG13	I/08	I/O	C	—	—	Z	L	DSP comm. terminal (ADSP21061L: D23)
91	Vss	←	—	—	—	—	—	—	GND
92	P50/AN0	AUDIO LEVEL	I	—	Eu	Lv	Z	—	Signal level detect, set to A/D input
93	P51/AN1	POSI (FAN)	I	—	Eu	Lv	Z	—	Temperature detect, set to A/D input
94	P52/AN2	EMP	I	—	—	Lv	—	—	H: EMP on
95	P53/AN3	96K DET	I	—	—	Lv	—	—	96k signal detect input, H: 96k
96	P54/AN4	BUSY1	I	—	—	Lv	—	—	(ADSP21061L-A:FLAG2A)
97	P55/AN5	FLAG 3A	I	—	—	Lv	—	—	(ADSP21061L-A:FLAG3A)
98	P56/AN6		I	—	—	Lv	—	—	
99	P57/AN7		I	—	—	Lv	—	—	
100	V REFH	←	—	—	—	—	—	—	AD ref. +5V

ADSP-21061L (AU: IC401)

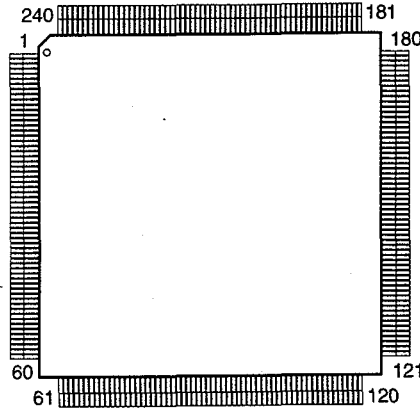

ADSP-21061L Terminal Function

Pin No.	Pin Name	Pin No.	Pin Name	Pin No.	Pin Name	Pin No.	Pin Name	Pin No.	Pin Name	Pin No.	Pin Name
1	TDI	41	ADDR20	81	TCLK0	121	DATA41	161	DATA14	201	NC
2	TRST	42	ADDR21	82	TFS0	122	DATA40	162	DATA13	202	NC
3	VDD	43	GND	83	DR0	123	DATA39	163	DATA12	203	NC
4	TDO	44	ADDR22	84	RCLK0	124	VDD	164	GND	204	NC
5	TIMEXP	45	ADDR23	85	RFS0	125	DATA38	165	DATA11	205	VDD
6	EMU	46	ADDR24	86	VDD	126	DATA37	166	DATA10	206	NC
7	ICSA	47	VDD	87	VDD	127	DATA36	167	DATA9	207	NC
8	FLAG3	48	GND	88	GND	128	GND	168	VDD	208	NC
9	FLAG2	49	VDD	89	ADRCLK	129	NC	169	DATA8	209	NC
10	FLAG1	50	ADDR25	90	REDY	130	DATA35	170	DATA7	210	NC
11	FLAG0	51	ADDR26	91	H $\overline{\text{B}}\text{G}$	131	DATA34	171	DATA6	211	NC
12	GND	52	ADDR27	92	C $\overline{\text{S}}$	132	DATA33	172	GND	212	GND
13	ADDR0	53	EGND	93	R $\overline{\text{D}}$	133	VDD	173	DATA5	213	NC
14	ADDR1	54	MS3	94	WR	134	VDD	174	DATA4	214	NC
15	VDD	55	MS2	95	GND	135	GND	175	DATA3	215	NC
16	ADDR2	56	MS1	96	VDD	136	DATA32	176	VDD	216	NC
17	ADDR3	57	MS0	97	GND	137	DATA31	177	DATA2	217	NC
18	ADDR4	58	SW	98	CLKIN	138	DATA30	178	DATA1	218	NC
19	GND	59	BMS	99	ACK	139	GND	179	DATA0	219	VDD
20	ADDR5	60	ADDR28	100	DMAG2	140	DATA29	180	GND	220	GND
21	ADDR6	61	GND	101	DMAG1	141	DATA28	181	GND	221	VDD
22	ADDR7	62	VDD	102	PAGE	142	DATA27	182	NC	222	NC
23	VDD	63	VDD	103	VDD	143	VDD	183	NC	223	NC
24	ADDR8	64	ADDR29	104	BR6	144	VDD	184	NC	224	NC
25	ADDR9	65	ADDR30	105	BR5	145	DATA26	185	NC	225	NC
26	ADDR10	66	ADDR31	106	BR4	146	DATA25	186	NC	226	NC
27	GND	67	GND	107	BR3	147	DATA24	187	NC	227	NC
28	ADDR11	68	SBTS	108	BR2	148	GND	188	VDD	228	GND
29	ADDR12	69	DMAR2	109	BR1	149	DATA23	189	NC	229	ID2
30	ADDR13	70	DMAR1	110	GND	150	DATA22	190	NC	230	ID1
31	VDD	71	HBR	111	VDD	151	DATA21	191	NC	231	ID0
32	ADDR14	72	DT1	112	GND	152	VDD	192	NC	232	LBOOT
33	ADDR15	73	TCLK1	113	DATA47	153	DATA20	193	NC	233	RPBA
34	GND	74	TFS1	114	DATA46	154	DATA19	194	NC	234	RESET
35	ADDR16	75	DR1	115	DATA45	155	DATA18	195	GND	235	EBOOT
36	ADDR17	76	RCLK1	116	VDD	156	GND	196	GND	236	IRQ2
37	ADDR18	77	RFS1	117	DATA44	157	DATA17	197	VDD	237	IRQ1
38	VDD	78	GND	118	DATA43	158	DATA16	198	NC	238	IRQ0
39	VDD	79	CPA	119	DATA42	159	DATA15	199	NC	239	TCK
40	ADDR19	80	DT0	120	GND	160	VDD	200	NC	240	TMS

MSM32R0050-521GS
(AU:IC402)

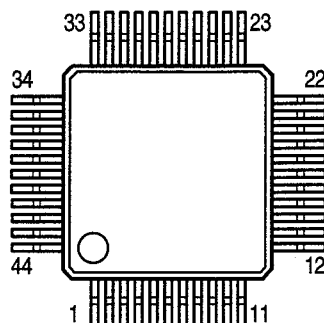

MSM32R0050-521GS Terminal Function

Pin No.	Name	Symbol	Function	Pin No.	Name	Symbol	Function
1	Vcc	Vcc		23	GND	I/O	
2	RFS0	I/O	RFS for DSP (64fs)	24	N.C.	I/O	
3	GND	GND		25	N.C.	I/O	
4	RFS1	I/O	RFS for DSP (256fs)	26	Vcc	Vcc	
5	GND	I/O		27	N.C.	I/O	
6	RFS1A	I/O	Same as RFS1	28	GND	GND	
7	GND	I/O		29	N.C.	I/O	
8	DATA2	I/O	Output data from DSP	30	N.C.	I/O	
9	GND	I/O		31	N.C.	I/O	
10	DATA3	I/O	Data for L/R DAC	32	N.C.	I/O	
11	GND	I/O		33	MCK0	I/O	MCK for RFS1 generation
12	DATA4	I/O	Data for C/SW DAC	34	GND	GND	
13	GND	I/O		35	LRCK0	I/O	LRCK for RFS0 generation
14	DATA5	I/O	Data for SL/SR DAC	36	GND	I/O	
15	GND	I/O		37	BCK0	I/O	BCK for RFS0 generation
16	DATA6	I/O	Data for reserve DAC	38	GND	I/O	
17	GND	I/O		39	GND	I/O	
18	LRCK1	I/O	LRCK for all DAC	40	Vcc	Vcc	
19	Vcc			41	/SRESET	RESET	System reset (L: Reset)
20	BCK1	I/O	BCK for all DAC	42	/CRESET	I/O	Clock reset (L: Reset)
21	GND	I/O		43	GND	I/O	
22	MCK1	I/O	MCK for all DAC	44	/D_MUTE	I/O	DAC mute (L: Mute)

M35015-204SP (VI: IC308)

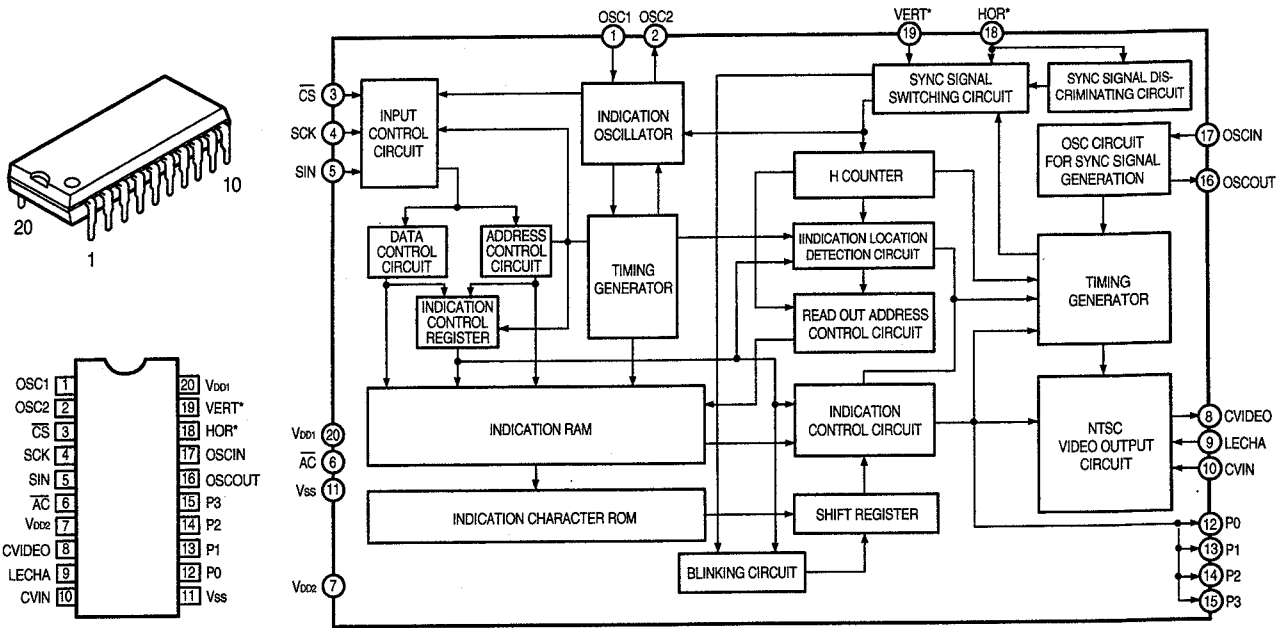

M35015-204SP Terminal Function

Pin No.	Symbol	Name	I/O	Function
1	OSC1	Osc. circuit ext. terminal.	I	External terminal for indication oscillator circuit. Standard OSC. freq. is approx. 7MHz. With this OSC. freq., decides horizontal indicatin and character width.
2	OSC2		O	
3	CS	Chip select input	I	Chip select terminal and turns to "L" when transfer serial data. Hysteresis input. Pull up resistor is built-in.
4	SCK	Serial clock input	I	Takes in serial data of SIN at SCK rise when CS terminal is in "L". Hysteresis input. Pull up rersist is built-in.
5	SIN	Serial data input	I	Serial input of register for indication control and data, and address for indication data memory. Hysteresis input. Pull up rersistor is built-in.
6	AC	Auto-clear input	I	Resets internal circuit of IC at "L" mode. Hysteresi input. Pull up resistor is built-in.
7	VDD2	Power supply	—	Power supply terminal of analog system. Connect to +5V.
8	CVIDEO	Combined video output	O	Output terminal of combined video signal. Outputs 2Vp-p combined signal. Character output, etc. Overlap CVIN signal and outputs at superimpose.
9	LECHA	Character level input	I	Input terminal deciding character output level in combined video signal. color of character is white.
10	CVIN	Combined video input	I	Input terminal of external combined video signal. Character output etc. overlap this external combined video signal.
11	VSS	Ground	—	Ground terminal. Connect to GND.
12	P0	Output port p0	O	General output or character background signal BL NK1* output is switchable. Polarity can be selected at ROM mask.
13	P1	Output port P1	O	General output or character background signal CO1* output is switchable. Polarity can be selected at ROM mask.
14	P2	Output port P2	O	General output or character background signal BLNK2* output is switchable. Polarity can be selected at ROM mask.
15	P3	Output port P3	O	General output or character background signal CO2* output is switchable. Polarity can be selected at ROM mask.
16	OSCOUT	Ext. terminal for sync sig. OSC. Circuit	O	Terminal for external use of sync signal OSC. circuit. Use the freq.: 14.32MHz at NTSC system, 17.73MHz at PAL. system, 14.30MHz at MPAL system.
17	OSCIN		I	
18	HOR*	Horizontal sync signal	I	Inputs horizontal sync signal. Hysteresis input.
19	VERT*	Vertical sync signal	—	Input vertical sync signal. Hysteresis input. Polarity can be selected at ROM mask.
20	VDD1	Power supply	I	Power supply terminal of digital system. Connect to +5V.

LC89055W (AU: IC531)

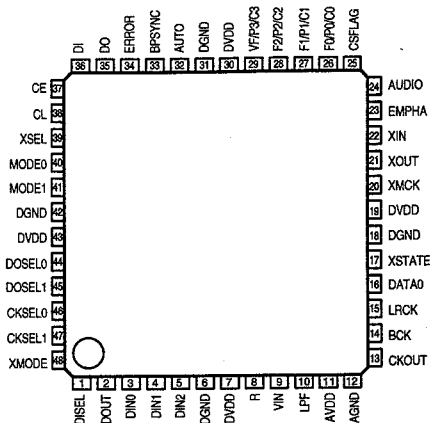

LC89055W Terminal Function

Pin No.	Pin Name	I/O	Function
1	DISEL	I	Data input terminal (select input pin of DINO, DIN1)
2	DOUT	O	Input bi-phase data through output terminal
3	DINO	I	Amp built-in coaxial/optical input correspond data input terminal
4	DIN1	I	Amp built-in coaxial/optical input correspond data input terminal
5	DIN2	I	Optical input correspond data input terminal
6	DGND		Digital GND
7	DVDD		Digital power supply
8	R	I	VCO gain control input terminal
9	VIN	I	VCO free-run frequency setting input terminal
10	LPF	O	PLL loop filter setting terminal
11	AVDD		Analog power supply
12	AGND		Analog GND
13	CKOUT	O	Clock output terminal (256fs, 384fs, 512fs, X'tal osc., VCO free-run osc.)
14	BCK	O	64fs clock output terminal
15	LRCK	O	fs clock output terminal (L: Rch, H: Lch, I2S: Reverse)
16	DATA0	O	Data output terminal
17	XSTATE	O	Input data detecting result output terminal
18	DGND		Digital GND
19	DVDD		Digital power supply
20	XMCK	O	X'tal osc. clock output terminal (24.576MHz or 12.288MHz)
21	XOUT	O	X'tal osc. connection output terminal
22	XIN	I	X'tal osc. connection output terminal
23	EMPHA	O	Emphasis information output terminal of channel status
24	AUDIO	O	Bit1 output terminal of channel status
25	CSFLAG	O	Top 40bit revise flag output terminal of channel status
26	F0/P0/C0	O	Input fs cal. sig. out / data type out / input word inf. output terminal
27	F1/P1/C1	O	Input fs cal. sig. out / data type out / input word inf. output terminal
28	F2/P2/C2	O	Input fs cal. sig. out / data type out / input word inf. output terminal
29	VF/P3/C3	O	Validity flag out / data type out / input word inf. output terminal
30	DVDD		Digital power supply
31	DGND		Digital GND
32	AUTO	O	Non PCM burst data transfer detect sig. output terminal
33	BPSYNC	O	Non PCM burst data preamble Pa, Pb, Pc, Pd sync sig. output terminal
34	ERROR	O	PLL lock error, data error flag output terminal
35	DO	O	CPU I/F read data output terminal
36	DI	I	CPU I/F write data input terminal
37	CE	I	CPU I/F chip enable input terminal
38	CL	I	CPU I/F clock input terminal
39	XSEL	I	Frequency select input pin of XIN X'tal osc. (24.576MHz or 12.288MHz)
40	MODE0	I	Mode setting input terminal
41	MODE1	I	Mode setting input terminal
42	DGND		Digital GND
43	DVDD		Digital power supply
44	DOSEL0	I	Data output format select input terminal
45	DOSEL1	I	Data output format select input terminal
46	CKSEL0	I	Output clock select input terminal
47	CKSEL1	I	Output clock select input terminal
48	XMODE	I	Reset input terminal

* For latch-up countermeasure, set digital (DVDD) and analog (AVDD) power on/off in the same timing.

LC75721NE (EX: IC101)

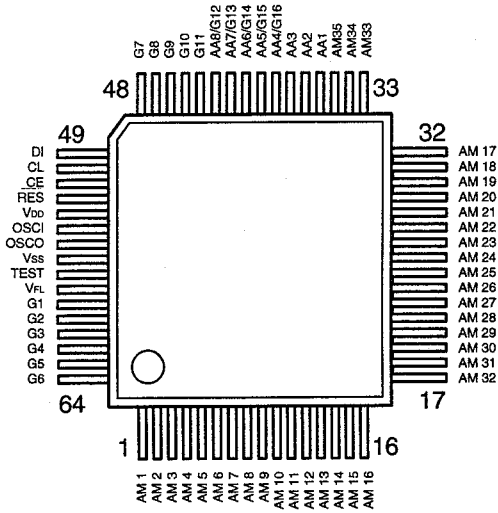

Symbol	Function
V _{DD}	Power terminal +5V
V _{SS}	Power terminal GND
V _{FL}	Power terminal FL drive
DI CL CE	Serial data transfer terminal DI: Data CL: Clock CE: Chip enable
OSCI OSCO	External CR connecting terminal
RES	System reset terminal
AM1~AM35 AA1~AA3	Anode output terminal
AA4/G16 AA5/G15 AA6/G14 AA7/G13 AA8/G12	Anode/Grid output terminal
G1~G11	Grid output terminal
TEST	LSI test terminal

AD1855 (AU: IC701, 702, 703)

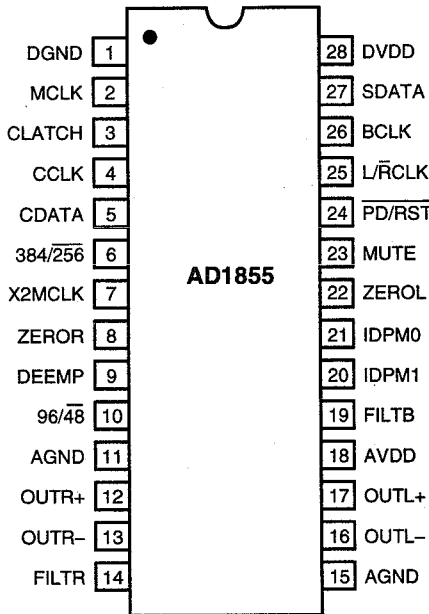

Pin No.	Name	I/O	Description
1	DGND	I	Digital Ground.
2	MCLK	I	Master Clock Input.
3	CLATCH	I	Latch input for control data.
4	CCLK	I	Control clock input for control data.
5	CDATA	I	Serial control input.
6	384/256	I	Selects the master clock mode.
7	X2MCLK	I	Selects internal clock doubler (LO) or internal clock=MCLK (HI).
8	ZEROR	O	Right Channel Zero Flag Output.
9	DEEMP	I	De-Emphasis.
10	96/48	I	Selects 48 kHz (LO) or 96 kHz Sample Frequency Control.
11,15	AGND	I	Analog Ground.
12	OUTR+	O	Right Channel Positive line level analog output.
13	OUTR-	O	Right Channel Negative line level analog output.
14	FILTR	O	Voltage Reference Filter Capacitor Connection.
16	OUTL-	O	Left Channel Negative line level analog output.
17	OUTL+	O	Left Channel Positive line level analog output.
18	AVDD	I	Analog Power supply.
19	FILTB	O	Filter Capacitor connection.
20	IDPM1	I	Input serial data port mode control one.
21	IDPM0	I	Input serial data port mode control zero.
22	ZEROL	O	Left Channel Zero Flag output.
23	MUTE	I	Mute. Assert HI to mute both stereo analog outputs.
24	PD/RST	I	Power-Down/Reset.
25	L/RCLK	I	Left/Right clock input for input data.
26	BCLK	I	Bit clock input for input data.
27	SDATA	I	Serial input.
28	DVDD	I	Digital Power Supply.

AK5351 (AU: IC527)

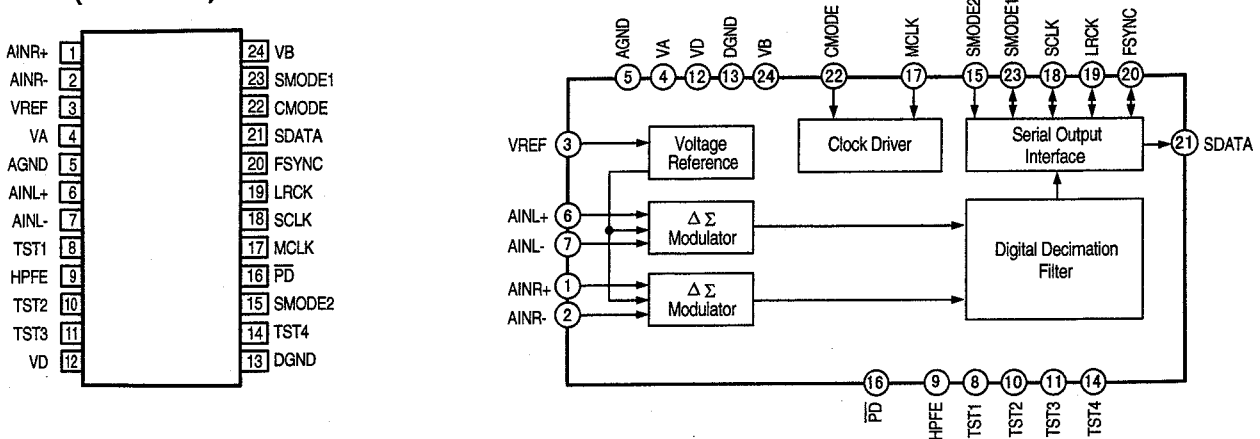

AK5351 Terminal Function

Pin No.	Symbol	I/O	Function
1	AINR+	I	Rch analog non-inverted input pin.
2	AINR-	I	Rch analog inverted input pin
3	VREF	O	Vref. output pin (VA-2.6V)
4	VA	—	Analog part power supply pin (+5V)
5	AGND	—	Analog ground pin
6	AINL+	I	Lch analog non-inverted input pin
7	AINL-	I	Lch analog inverted input pin
8	TST1		Test pin
9	HPFE	I	Hi-pass filter enable pin, "H": ON, "L": OFF
10	TST2		Test pin
11	TST3		Test pin
12	VD	—	Digital part power supply pin (+5V)
13	DGND	—	Digital ground pin
14	TST4		Test pin
15	SMODE2	I	Interface clock select pin
16	PD	I	Power down pin, "L": power down mode
17	MCLK	I	Master clock input pin, CMODE="H": 384fs, "L": 256fs
18	SCLK	I/O	Serial data clock pin
19	LRCK	I/O	Input channel select pin
20	FSYNC	I/O	Frame sync clock pin
21	SDATA	O	Serial data output pin
22	CMODE	I	Master clock select pin, "H": MCLK=384fs, "L": 256fs
23	SMODE1	I	Interface clock select pin
24	VB	—	Bulk power supply pin (+5V)

NJM2229S (VI: IC305)

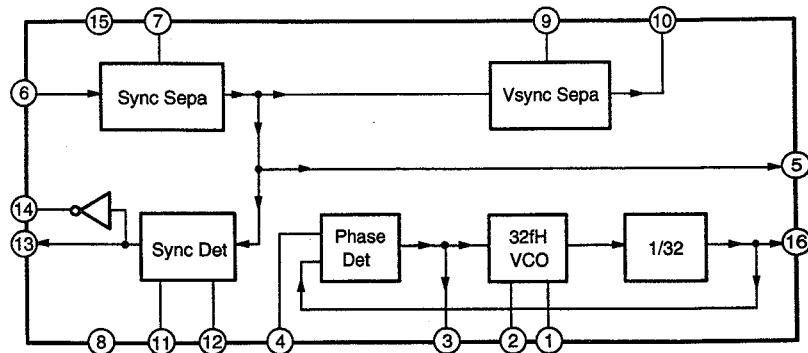
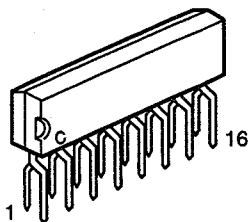

TC4094BF (CO: IC304, EX: IC103)

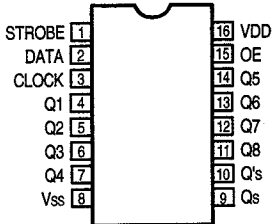
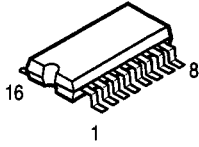

CO: IC304

Port	Symbol	Function
Q1	A	Video input switching
Q2	B	Video input switching
Q3	C	Video input switching
Q4	D	Video output switching
Q5	E	Video output switching
Q6	F	Video output switching (DVD/TV)
Q7	G	Video output switching (DVD/TV)
Q8	Not Used	

EX: IC103

Port	Symbol	Function
Q1	LOCK LED	"LOCK" LED drive output (H: Lock)
Q2	DOLBY DIGITAL LED	"DOLBY DIGITAL" LED drive output (H: D.Digital)
Q3	dts LED	"dts" LED drive output (H: dts)
Q4	AUTO LED	"AUTO" LED drive output (H: input mode "AUTO")
Q5	DTS LED	"DTS" LED drive output (H: input mode "DTS")
Q6	PCM LED	"PCM" LED drive output (H: input mode "PCM")
Q7	SURROUND SP-A LED	"SURROUND SPEAKER A" LED drive output
Q8	SURROUND SP-B LED	"SURROUND SPEAKER B" LED drive output

TC9273N-004 (AU: IC108)

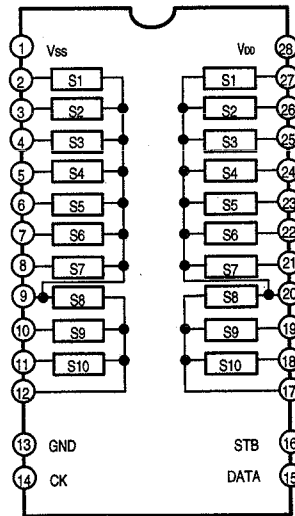
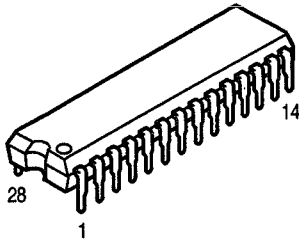

TC9273N Terminal Function

Pin No.	Symbol	Name	Function	Note
1	Vss	-Power Terminal	Dual Power Use: VDD = 8.0~17 V GND = 0V Vss = -8.0~17V Single Power Use: VDD = 8.0~18V Vss = GND = 0V	—
13	GND	Digital Ground		
28	VDD	+Power Terminal		
2~12 17~27	S1~11	I/O Terminal	Input terminal of analog switch.	—
14	CK	Clock Input	Clock input for data transfer.	Low level Border Input Terminal
15	DATA	Data Input	Serial input for switch setting.	
16	STB	Strobe Input	Strobe input for data writing.	

Asia model only
PM4007A (AU: IC512)

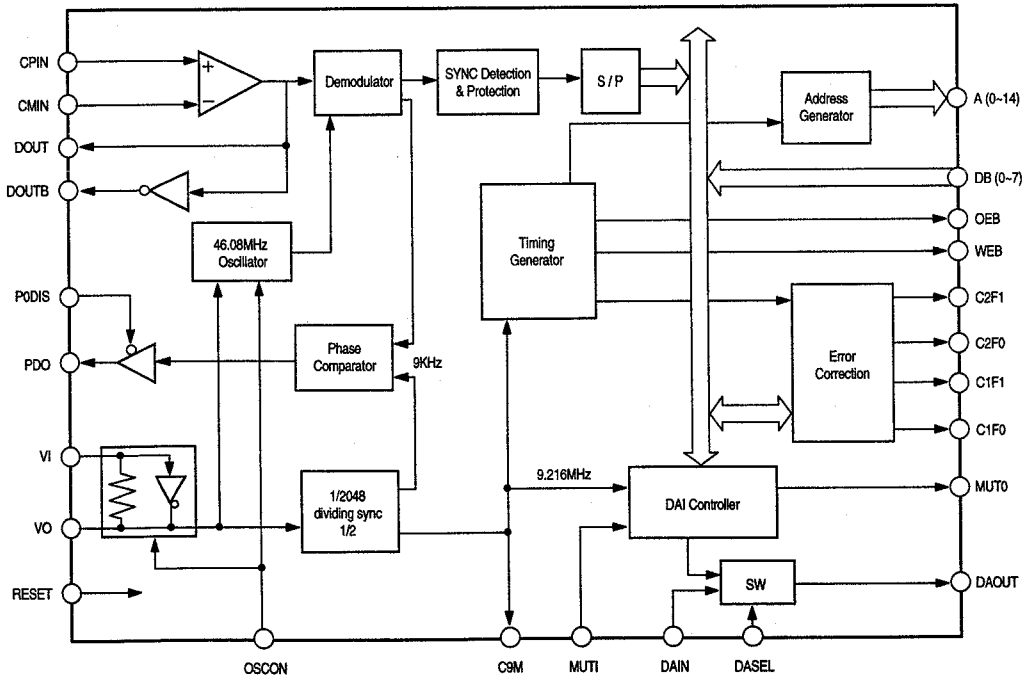
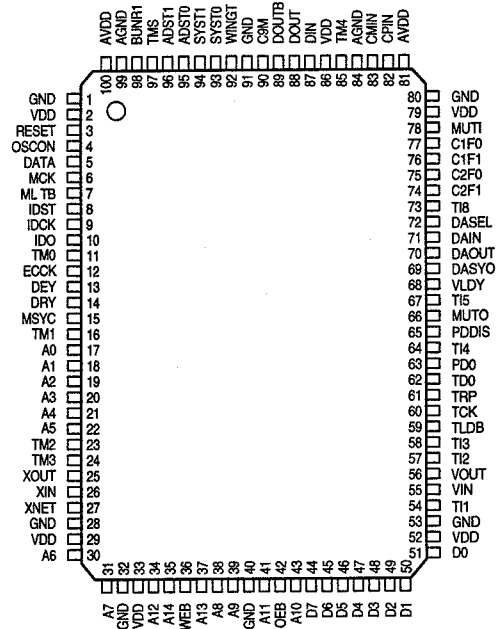
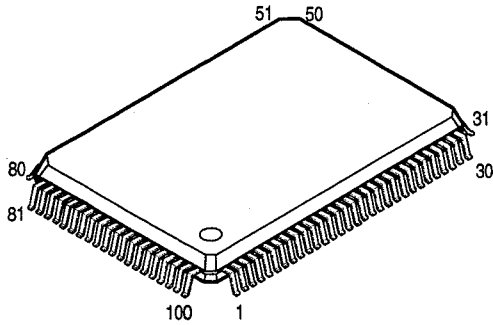

Asia model only
BR62256F-70LL (AU: IC516)

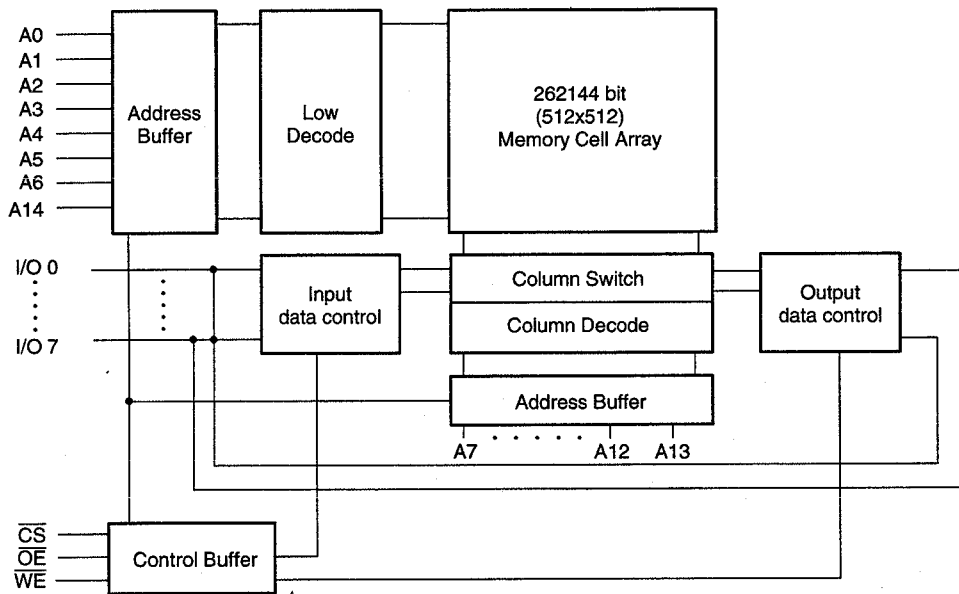
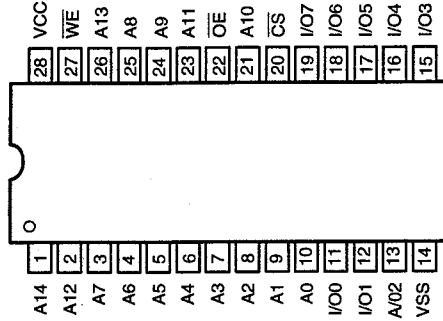
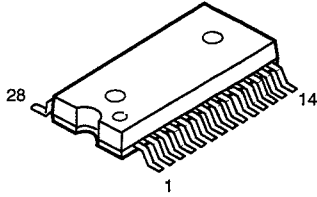

BR62256F-70LL Terminal Function

Pin No.	Symbol	I/O	Function
1-10	A0-A9	I	32K byte memory address input.
11-13,	I/O0-I/O2	I/O	8 bit data input/output.
14	Vss	—	GND
15-19	I/O3-I/O7	I/O	8 bit data input/output.
20	CS	I	Chip select control input.
21	A10	I	32K byte memory address input.
22	OE	I	Output enable control input.
23-26	A11-A14	I	32K byte memory address input.
27	WE	I	Write enable control input.
28	Vcc	—	+5V power supply.

TC9274N-012 (EX: IC312)

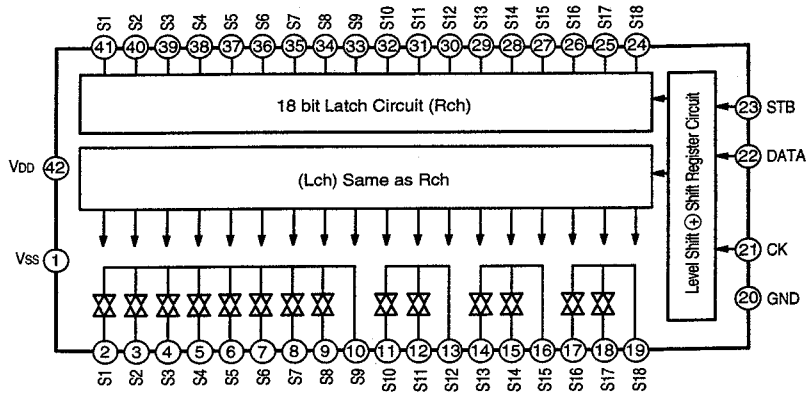
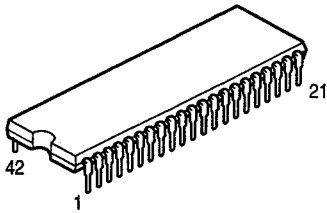

TC9274N-011 (AU: IC107)

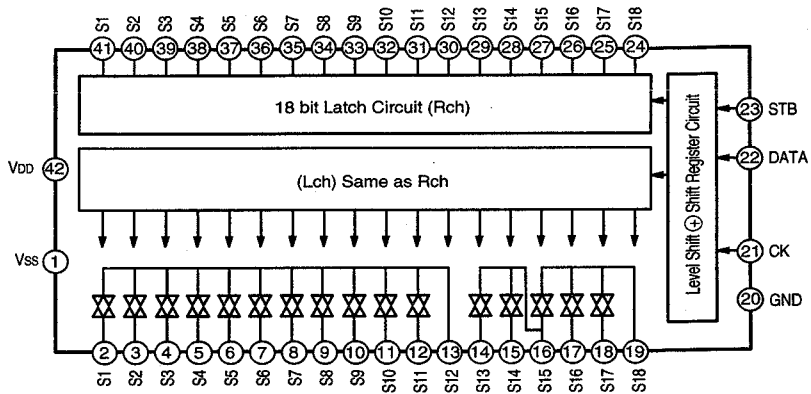
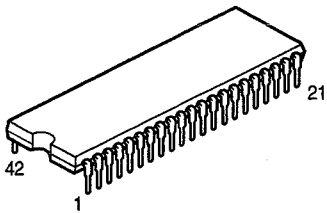

MC74HC4053N (VI: IC304)

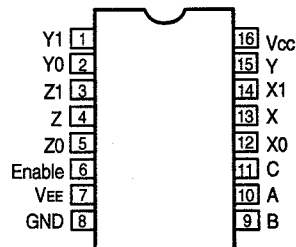
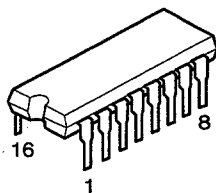

		Control Inputs			ON Switches		
		Select					
Enable		C	B	A			
		L	L	L	L	Z0	Y0
L	L	L	H	Z0	Y0	X1	
L	L	H	L	Z0	Y1	X0	
L	L	H	H	Z0	Y1	X1	
L	H	L	L	Z1	Y0	X0	
L	H	L	H	Z1	Y0	X1	
L	H	H	L	Z1	Y1	X0	
L	H	H	H	Z1	Y1	X1	
H	X	X	X	None			

TC9184AP (CO: IC102)

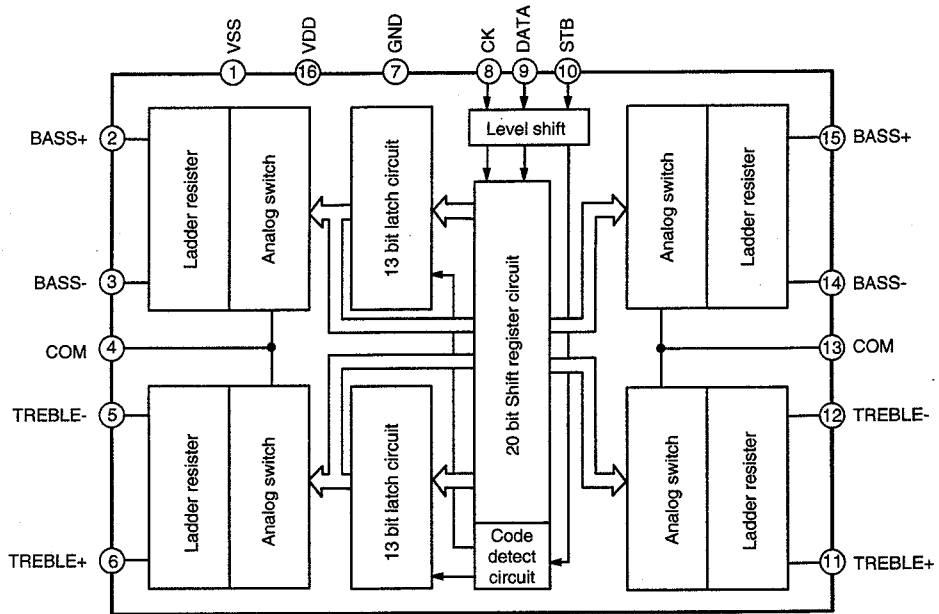
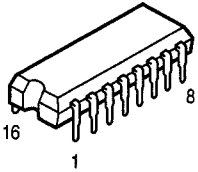

LA1265 (S)
(RE: IC502)

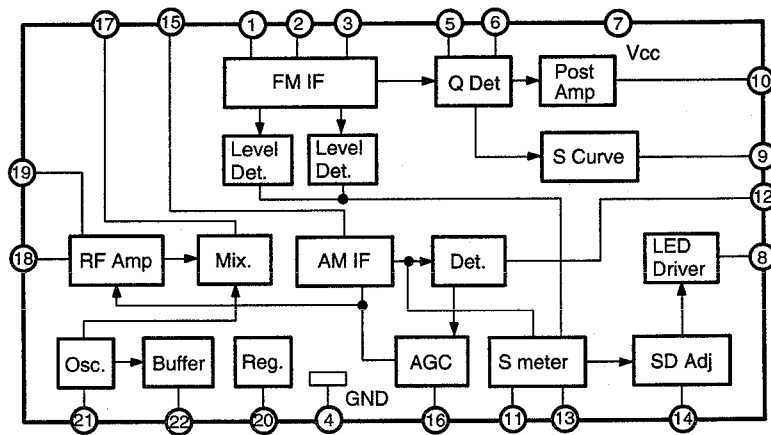
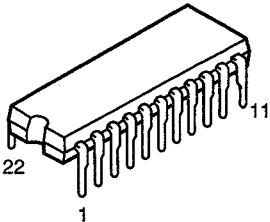

TC55V1664BFT-12 (AU: IC404, 405)

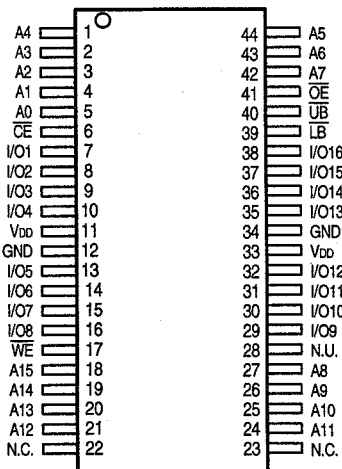

Terminal Function

Symbol	Function Name
A0-A15	Address input
I/O1-I/O16	Data in/output
\overline{CE}	Chip enable input
\overline{WE}	Write enable input
\overline{OE}	Output buffer control input
LB, UB	Data byte control input
VDD	Power terminal (+3.3V)
GND	GND
N.C.	No connection
N.U.	Unusable (input)

SN74AHCT573PW (AU: IC411)
 SN74LV573ANS (AU: IC302, 412)

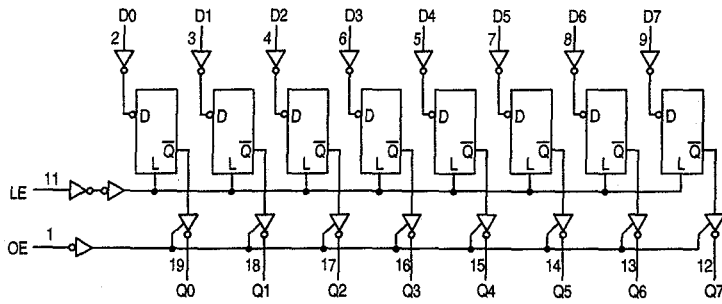
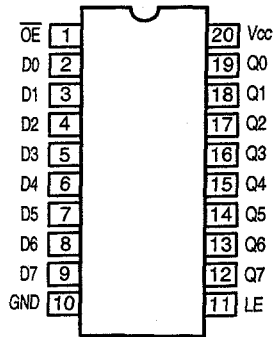

LA3401 (RE: IC503)

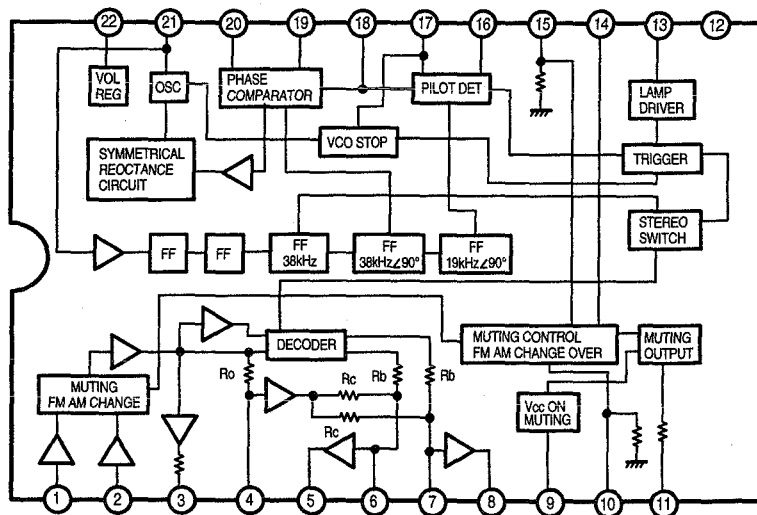
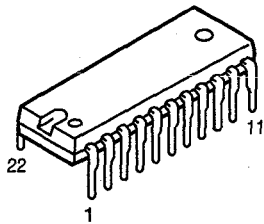

NJM2068MD
 (AU: IC106, 109, 112, 731-733)
 (CO: IC103, 104, 952)
 (EX: IC301, 303, 304, 308, 309, 310, 701, 801-804)
 BA4510F (AU: IC651, 652)
 NJM2082MD (CO: IC951)

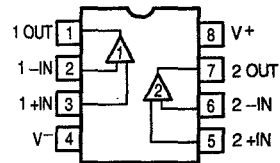
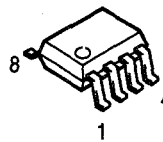

SN74LV14APW (AU: IC530, 532)
 SN74LV00APW (AU: IC407, 408, 524, 529)
 TC74VHC02FT (AU: IC410)
 TC74HCU04AF (CO: IC704)
 SN74LV74APW (AU: IC409)

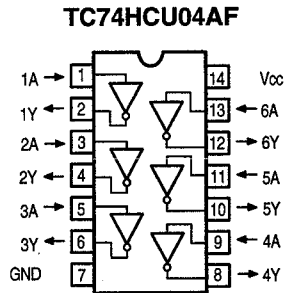
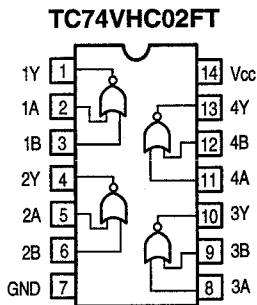
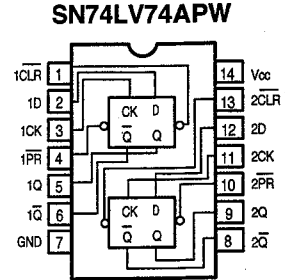
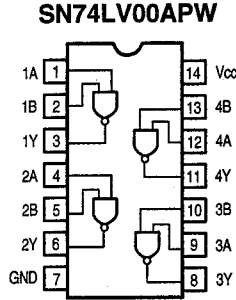
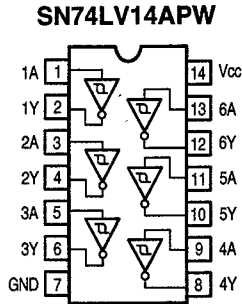
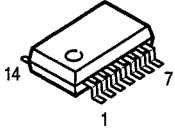

BA7625 (VI: IC302, 376, 377, 402, 450)
 BA7626 (VI: IC301, 451~453)

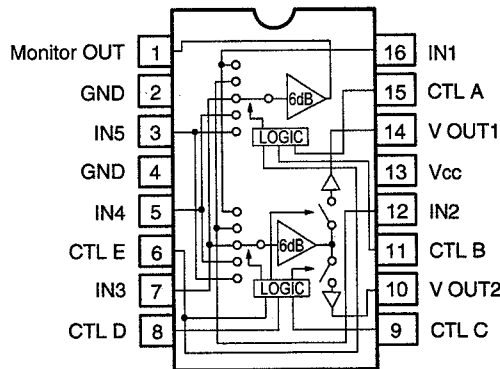
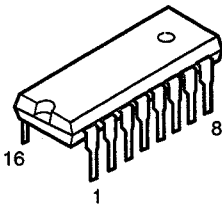

A	B	E	MONITOR OUT
L	L	*	IN 1
H	L	*	IN 2
L	H	*	IN 3
H	H	L	IN 4
H	H	H	IN 5

C	D	E	V OUT 1
L	L	*	—
H	L	*	IN 2
L	H	*	IN 3
H	H	L	IN 4
H	H	H	IN 5

C	D	E	V OUT 2
L	L	*	IN 1
H	L	*	—
L	H	*	IN 3
H	H	L	IN 4
H	H	H	IN 5

Note 1: * mark means that feasible for either H or L.
 Note 2: Each input terminal is provided with sink chip clamp (BA7625).
 Each input terminal takes 20kohm at the end (BA7626).

LC72131M (RE: IC507)

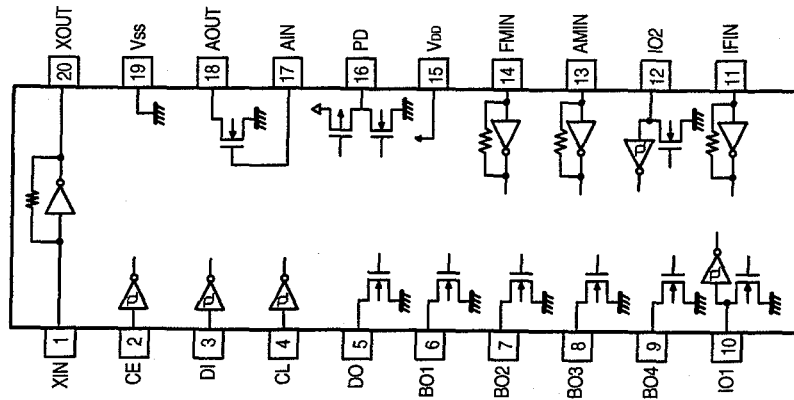
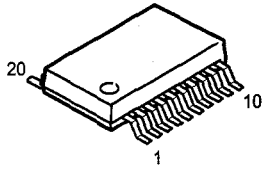

TC9459N (EX: IC805~808)

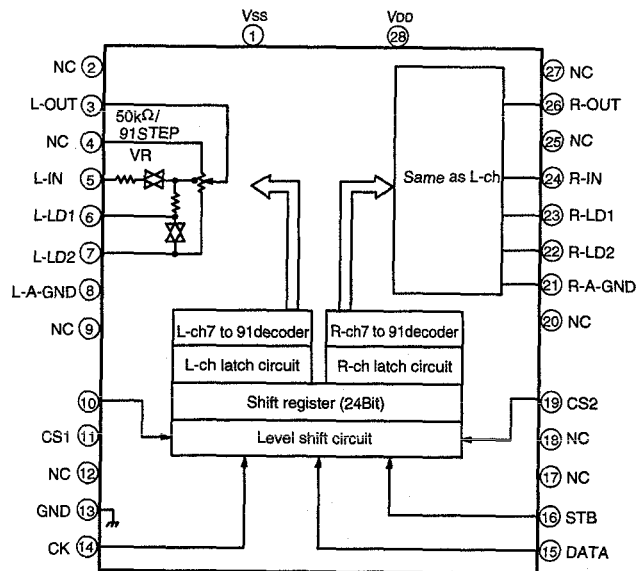
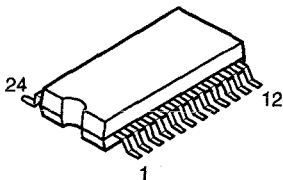

TC4053BP (VI: IC403)

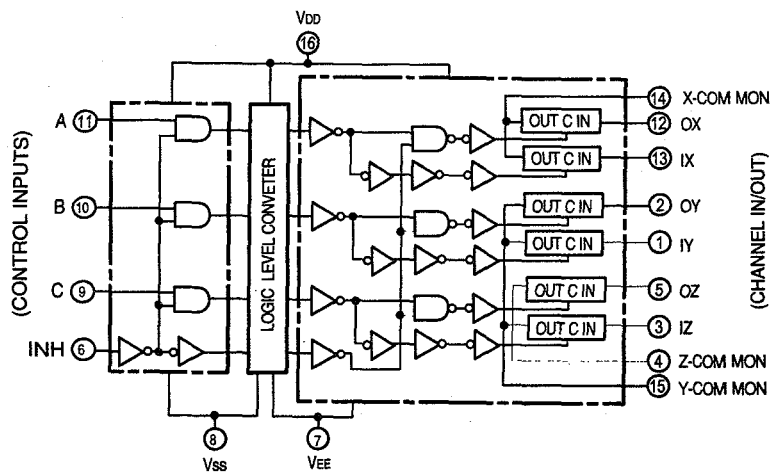
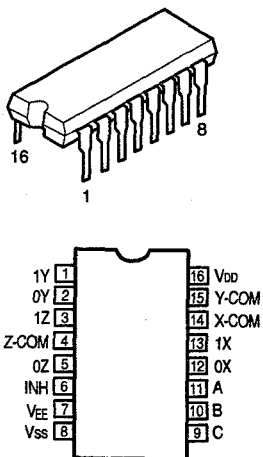

SN74AHC157PW
 (AU: IC525)
 TC74VHC123FT
 (AU: IC517, 523)
 TC74HC151AF
 (CO: IC705)
 SN74HC151NS
 (AU: IC510)

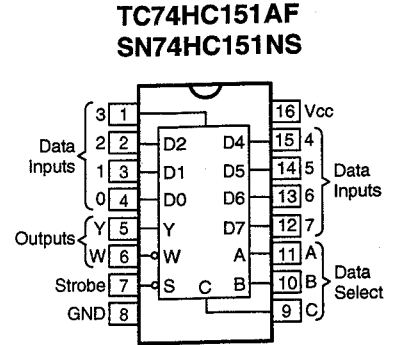
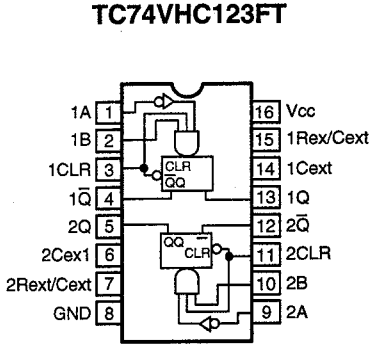
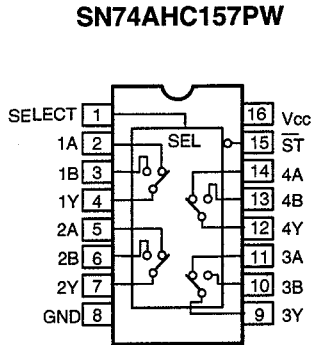
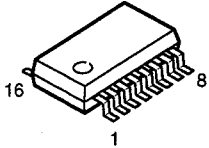

W29EE011P-90 (AU: IC303)

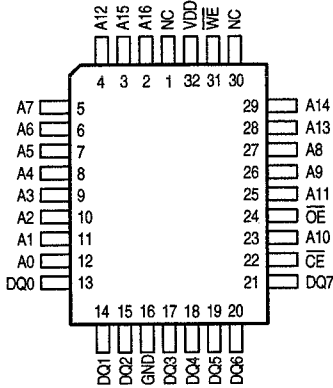

Terminal Function

Name	Function
A0 - A16	Address input
DQ0 - DQ7	Data in/output
CE	Chip enable
OE	Output enable
WE	Write enable
V _{DD}	Power terminal
GND	GND
NC	No connection

TC58FVT800FT-12 (AU: IC403)

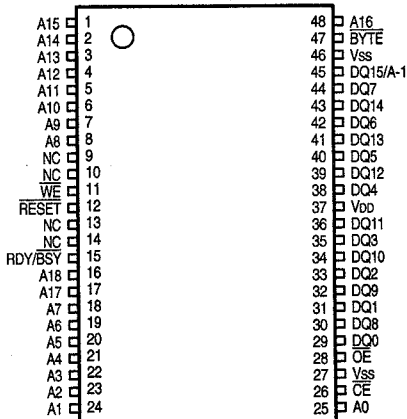

Terminal Function

Symbol	Function Name
A0-A18	Address input
DQ0-DQ14	Data in/output
DQ15/A-1	Data in/output/Address input
CE	Chip enable input
OE	Output enable input
BYTE	Word/bute select input
WE	Write enable input
RDY/BSY	Ready/busy output
RESET	Hardware reset input
NC	No connection
VDD	Power
Vss	GND

SN74AHCT1G08DBV (AU: IC415~420)

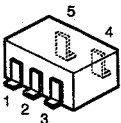

1: A
 2: B
 3: GND
 4: Y
 5: Vcc

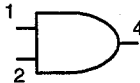

Europe model only
SAA6579T (CO: IC301)

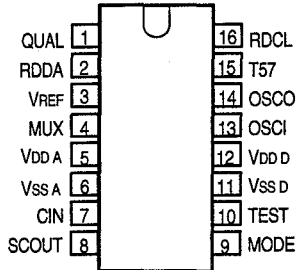
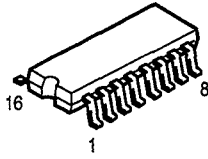

SAA6579T Terminal Function

Pin No.	Symbol	Function
1	QUAL	Quality indication output.
2	RDDA	RDS data output.
3	VREF	Reference voltage output (0.5 VDD A).
4	MUX	Multiplex signal input.
5	VDD A	+5V power supply for analog part.
6	VSS A	Ground for analog part (0V).
7	CIN	Subcarrier input to comparator.
8	SCOUT	Subcarrier output of reconstruction filter.
9	MODE	Oscillation mode/test control input.
10	TEST	Test enable input.
11	VSS D	Ground for digital part (0V).
12	VDD D	+5V power supply for digital part.
13	OSCI	Oscillator input.
14	OSCO	Oscillator output.
15	T57	57kHz clock signal output.
16	RDCL	RDS clock output.

Europe model only
LC7074M (CO: IC302)

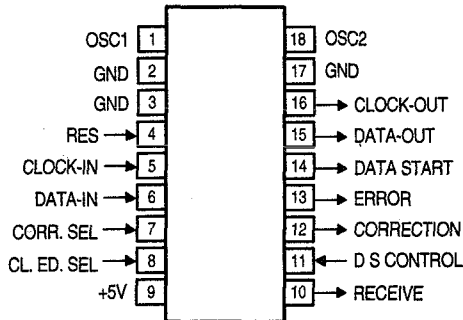
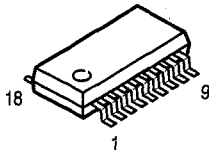

TC74HC4052 (VI: IC371, 375, 401)

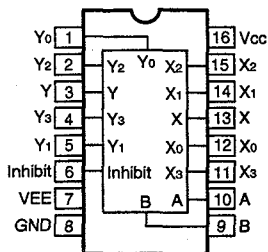

TC74VHC541FT (AU: IC413)
TC74VHCT541AFT (AU: IC414)

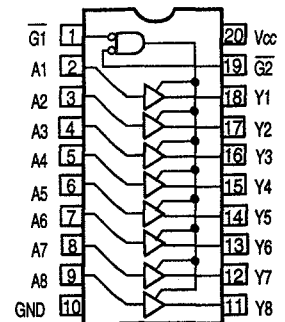
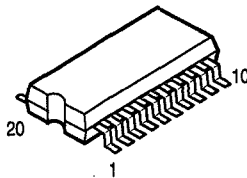

NJM7805FA (S) (RE: IC902, 903)
 NJM7806FA (S)
 (PO: IC502)
 (RE: IC904)
 NJM7812FA (S) (RE: IC905, 906)
 BA033T (AU: 601)

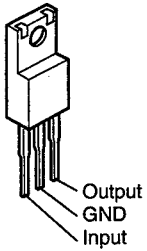

NJM7912FA (RE: IC907)

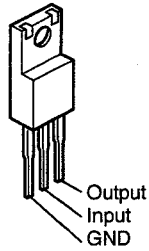

SG-8002DCPT (12.288MHz)
 (AU: IC528)

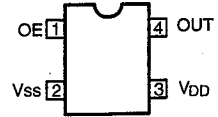
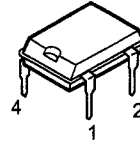

● IC PROTECTOR

ICP-N15 (PO: IC501)

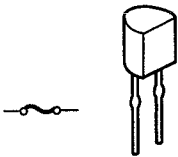

● OPTICAL

INPUT
 GP1F37R1 (CO: IC701~703)

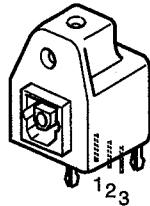

1. Vcc
 2. GND
 3. Vout

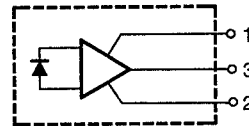

● OTHERS

GP1U271X (Remote Control Sensor)
 (EX: IC102)

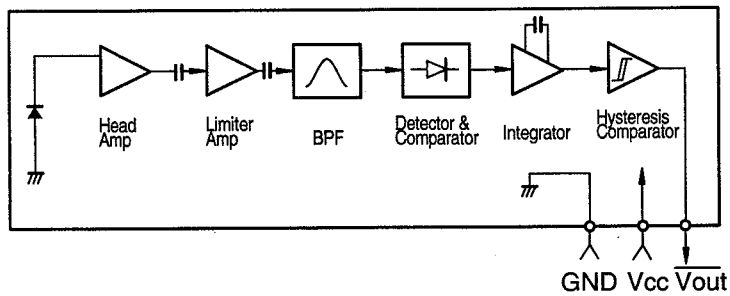
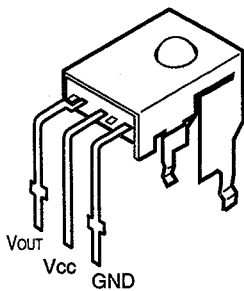

HG-8002JA (X'tal Oscillator)
 (AU: IC406)

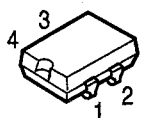

1. OE or ST
 2. GND
 3. OUT
 4: VDD

● TRANSISTORS

2SA970 (BL)
2PA1015GR
2SA988 (E/F)
2SC1841 (E/F)
2SC2878 (A/B)
2PC1815 (BL)

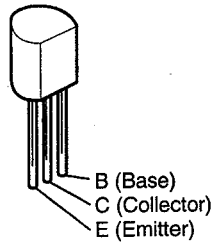

2SK373

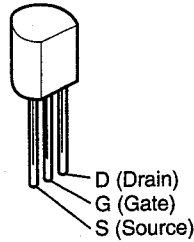

2SC2705 (O) / (Y)

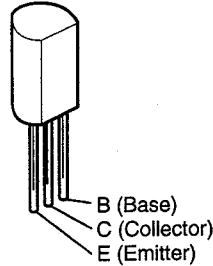

2SA1491
2SC3855

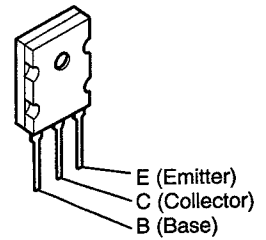

2SB1186A (D)
2SD1763A (D)

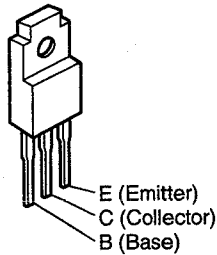

2SA1670 (O/P/Y)

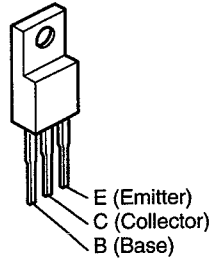

2SC4495

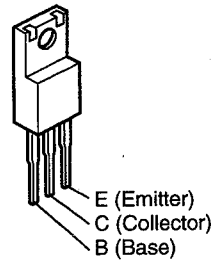

DTA114TK
DTA114EK
DTA144EK
DTC114EK
DTC144EK
DTC323TK
RN2402

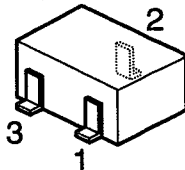

1: GND/Emitter
2: Out/Collector
3: In/Base

DTA114TK
DTA114EK
DTA144EK
RN2402

PNP Type

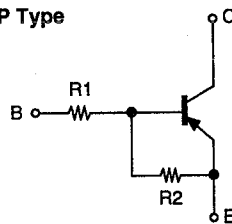

	R1	R2
DTA114TK	10kohm	-
DTA114EK	10kohm	10kohm
DTA144EK	47kohm	47kohm
RN2402	10kohm	10kohm

DTC114EK
DTC144EK
DTC323TK

NPN Type

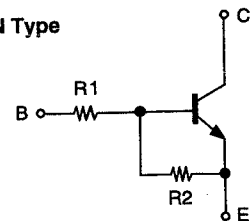

	R1	R2
DTC114EK	10kohm	10kohm
DTC144EK	47kohm	47kohm
DTC323TK	2.2kohm	-

2SA933S (S)
2SC3311A
2SC1645S (B)

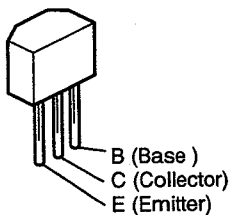

2SK209 (GR)

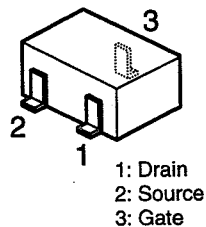

1: Drain
2: Source
3: Gate

2SA1182 Y/O
2SC2996 (Y)
2SC3326 (A/B)
2SD601A

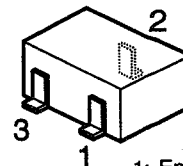

1: Emitter
2: Collector
3: Base

● DIODES (included LED)

1SS270A

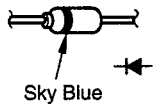

MTZJ3.3A MTZJ9.1A
 MTZJ5.6A MTZJ12A
 MTZJ6.2A MTZJ36A
 MTZJ7.5A

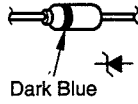

1SR35-200A

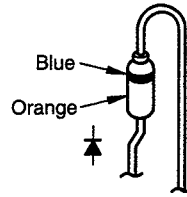

S4VB20

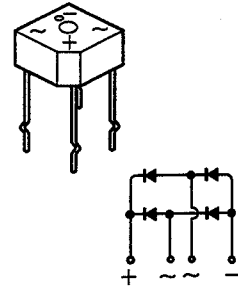

SEL1210S (Red)
 SEL1410E (Green)
 SEL4214S

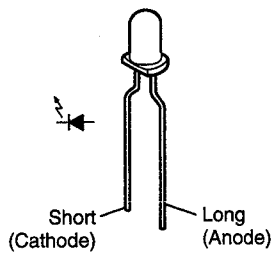

MA151WK

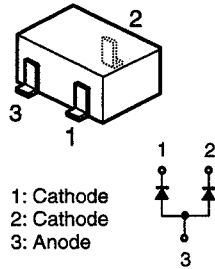

MA151A

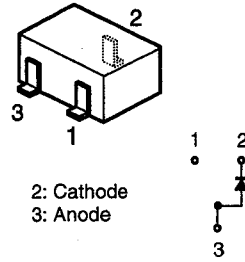

NOTE FOR PARTS LIST

- Part indicated with the mark "⊙" are not always in stock and possibly to take a long period of time for supplying, or in some case supplying of part may be refused.
- When ordering of part, clearly indicate "1" and "I" (i) to avoid mis-supplying.
- Ordering part without stating its part number can not be supplied.
- Part indicated with the mark "★" is not illustrated in the exploded view.
- Not including Carbon Film ±5%, 1/4W Type in the P.W.Board parts list. (Refer to the Schematic Diagram for those parts.)

WARNING:

Parts marked with this symbol  have critical characteristics. Use ONLY replacement parts recommended by the manufacturer.

● **Resistors**

Ex.: RN 14K 2E 182 G FR
 Type Shape Power Resist- Allowable FR Others
 and performance ance error

RD : Carbon	2B : 1/8W	F : ±1%	P : Pulse-resistant type
RC : Composition	2E : 1/4W	G : ±2%	NL : Low noise type
RS : Metal oxide film	2H : 1/2W	J : ±5%	NB : Non-burning type
RW : Winding	3A : 1W	K : ±10%	FR : Fuse-resistor
RN : Metal film	3D : 2W	M : ±20%	F : Lead wire forming
RK : Metal mixture	3F : 3W		
	3H : 5W		

* **Resistance**

1 8 2 ⇒ 1800 ohm = 1.8 kohm
 ↑ ↑ ↑
 Indicates number of zeros after effective number.
 2-digit effective number.

• Units: ohm

1 R 2 ⇒ 1.2 ohm
 ↑ ↑ ↑
 1-digit effective number.
 2-digit effective number, decimal point indicated by R.

• Units: ohm

● **Capacitors**

Ex.: CE 04W 1H 2R2 M BP
 Type Shape Dielectric Capacity Allowable M BP Others
 and per- strength error

CE : Aluminum foil electrolytic	0J : 6.3V	F : ±1%	HS : High stability type
CA : Aluminum solid electrolytic	1A : 10V	G : ±2%	BP : Non-polar type
CS : Tantalum electrolytic	1C : 16V	J : ±5%	HR : Ripple-resistant type
CQ : Film	1E : 25V	K : ±10%	DL : For charge and discharge
CK : Ceramic	1V : 35V	M : ±20%	HF : For assuring high frequency
CC : Ceramic	1H : 50V	Z : +80%	U : UL part
CP : Oil	2A : 100V	-20%	C : CSA part
CM : Mica	2B : 125V	P : +100%	W : UL-CSA type
CF : Metallized	2C : 160V	-0%	F : Lead wire forming
CH : Metallized	2D : 200V	C : ±0.25pF	
	2E : 250V	D : ±0.5pF	
	2H : 500V	= : Others	
	2J : 630V		

* **Capacity (electrolyte only)**

2 2 2 ⇒ 2200µF
 ↑ ↑ ↑
 Indicates number of zeros after effective number.
 2-digit effective number.

• Units: µF.

2 R 2 ⇒ 2.2µF
 ↑ ↑ ↑
 1-digit effective number.
 2-digit effective number, decimal point indicated by R.

• Units: µF.

* **Capacity (except electrolyte)**

2 2 2 ⇒ 2200pF=0.0022µF
 ↑ ↑ ↑ (More than 2) — Indicates number of zeros after effective number.
 2-digit effective number.

• Units: µF.

2 2 1 ⇒ 220pF
 ↑ ↑ ↑ (0 or 1) — Indicates number of zeros after effective number.
 2-digit effective number.

• Units: pF.

• When the dielectric strength is indicated in AC, "AC" is included after the dielectric strength value.

PARTS LIST OF P.W.B. UNIT 1U-3198 POWER UNIT ASS'Y

Ref. No.	Part No.	Part Name	Remarks	Ref. No.	Part No.	Part Name	Remarks
SEMICONDUCTORS GROUP							
IC451-453	263 0857 003	IC BA7626		R605-608	244 2052 957	Metal oxide 5.6 kohm 1W	RS14B3A562JNBS(S)
IC501	268 0073 905	IC ICP-N15T		R619,620	241 2378 962	Carbon film 330 ohm 1/4W(NB)	RD14B2E331JNBS
IC502	263 0793 002	IC NJM7806FA(S)		R621-624	241 2387 908	Carbon film 1 ohm 1/4W(NB)	RD14B2E010JNBS
TR451-453	271 0290 904	Transistor 2PA1015GR		R625-632	244 2043 982	Metal oxide 0.22 ohm 1W	RS14B3AR22JNBS(S)
TR507,508	273 0454 908	Transistor 2SC1645S(B)		R633,634	241 2387 908	Carbon film 1 kohm 1/4W(NB)	RD14B2E102JNBS
TR511,512	274 0158 003	Transistor 2SD1763A(D)		R639-642	244 2043 937	Metal oxide 10 ohm 1W	RS14B3A100JNBS(S)
TR513,514	272 0115 008	Transistor 2SB1186A(D)		R647,648	244 2043 937	Metal oxide 10 ohm 1W	RS14B3A100JNBS(S)
TR519,520	273 0235 923	Transistor 2SC1841(E/F)		R672,673	244 2052 957	Metal oxide 5.6 kohm 1W	RS14B3A562JNBS(S)
TR527,528	273 0454 908	Transistor 2SC1645S(B)		R679	241 2378 962	Carbon film 330 ohm 1/4W(NB)	RD14B2E331JNBS
TR531,532	274 0158 003	Transistor 2SD1763A(D)		R680,681	241 2387 908	Carbon film 1 ohm 1/4W(NB)	RD14B2E010JNBS
TR533,534	272 0115 008	Transistor 2SB1186A(D)		R682-685	244 2043 982	Metal oxide 0.22 ohm 1W	RS14B3AR22JNBS(S)
TR539,540	273 0235 923	Transistor 2SC1841(E/F)		R686	241 2387 908	Carbon film 1 kohm 1/4W(NB)	RD14B2E102JNBS
TR544	273 0454 908	Transistor 2SC1645S(B)		R690	244 2043 937	Metal oxide 10 ohm 1W	RS14B3A100JNBS(S)
TR546	274 0158 003	Transistor 2SD1763A(D)		R694	244 2043 937	Metal oxide 10 ohm 1W	RS14B3A100JNBS(S)
TR547	272 0115 008	Transistor 2SB1186A(D)		R714,715	243 2039 032	Winding 0.1 ohm 5W	RW99=3H0R1K
TR550	273 0235 923	Transistor 2SC1841(E/F)		R734	Note	Note	
TR551	271 0131 924	Transistor 2SA988(E/F)		R757,758	244 2052 960	Metal oxide 220 ohm 1W	RS14B3A221JNBS(S)
TR554	273 0429 904	Transistor 2SC3311A		VR501-505	211 6132 909	Semi fixed resistor 4.7 kohm	V06PB472
TR555	271 0192 905	Transistor 2SA933S(S)		CAPACITORS GROUP			
TR556,557	273 0429 904	Transistor 2SC3311A		C451-453	253 9039 906	Ceramic 0.1 µF/25V	CK45=1E104Z
TR558	271 0192 905	Transistor 2SA933S(S)		C454-456	254 4524 943	Electrolytic 1 µF/50V	CE04W1H010M SMG/RE3
TR559	273 0429 904	Transistor 2SC3311A		C457-459	254 4533 950	Electrolytic 470 µF/6.3V	CE04W0J471M SMG/RE3
TR560-566	273 0429 904	Transistor 2SC3311A		C460-462	254 4524 943	Electrolytic 1 µF/50V	CE04W1H010M SMG/RE3
D451,452	276 0432 903	Diode 1SS270A		C463-465	253 1181 917	Ceramic 0.022 µF/50V	CK45F1H223Z
D501-505	276 0432 903	Diode 1SS270A		C466-471	254 4524 972	Electrolytic 4.7 µF/50V	CE04W1H4R7M SMG/RE3
D507-512	276 0553 905	Diode 1SR35-200A		C472-475	254 4538 942	Electrolytic 100 µF/16V	CE04W1C101M SMG/RE3
D513-517	276 0432 903	Diode 1SS270A		C501,502	253 4543 905	Ceramic 220 pF/500V	CC45SL2H221J
D518,519	276 0305 001	Diode S4VB20		C505,506	253 4543 905	Ceramic 220 pF/500V	CC45SL2H221J
D520	276 0432 903	Diode 1SS270A		C509	253 4543 905	Ceramic 220 pF/500V	CC45SL2H221J
D526-535	276 0432 903	Diode 1SS270A		C513,514	254 4525 913	Electrolytic 47 µF/50V	CE04W1H470M SMG/RE3
ZD501	276 0644 911	Zener diode MTZJ7.5A		C515,516	254 4527 982	Electrolytic 10 µF/100V	CE04W2A100M SMG/RE3
ZD502-511	276 0634 905	Zener diode MTZJ3.3A		C521,522	256 1058 971	Metalized 0.1 µF/50V	CF93A1H104J (JL)
SC501	279 0016 904	Thyristor SF0R1A42		C525,526	Note	Note	
RESISTORS GROUP							
R551,552	241 2387 908	Carbon film 1 kohm 1/4W(NB)	RD14B2E102JNBS	C541,542	254 4525 913	Electrolytic 47 µF/50V	CE04W1H470M SMG/RE3
R525-528	244 2052 957	Metal oxide 5.6 kohm 1W	RS14B3A562JNBS(S)	C545,546	254 4527 982	Electrolytic 10 µF/100V	CE04W2A100M SMG/RE3
R537,538	241 2378 962	Carbon film 330 ohm 1/4W(NB)	RD14B2E331JNBS	C549,550	256 1058 971	Metalized 0.1 µF/50V	CF93A1H104J (JL)
R539-542	241 2387 908	Carbon film 1 ohm 1/4W(NB)	RD14B2E010JNBS	C553,554	Note	Note	
R543-550	244 2043 982	Metal oxide 0.22 ohm 1W	RS14B3AR22JNBS(S)	C566	254 4525 913	Electrolytic 47 µF/50V	CE04W1H470M SMG/RE3
R557,558	244 2043 937	Metal oxide 10 ohm 1W	RS14B3A100JNBS(S)	C567	254 4527 982	Electrolytic 10 µF/100V	CE04W2A100M SMG/RE3
R567,568	244 2043 937	Metal oxide 10 ohm 1W	RS14B3A100JNBS(S)	C570	256 1058 971	Metalized 0.1 µF/50V	CF93A1H104J (JL)
R571	244 2043 937	Metal oxide 10 ohm 1W	RS14B3A100JNBS(S)	C572	Note	Note	
				C573	253 1181 904	Ceramic 0.01 µF/50V	CK45F1H103Z
				C583	254 4538 900	Electrolytic 10 µF/16V	CE04W1C100M SMG/RE3
				C584	253 9039 906	Ceramic 0.1 µF/25V	CK45=1E104Z
				C585	254 4300 989	Electrolytic 330 µF/6.3V	CE04W0J331M SRE
				C586	253 9039 906	Ceramic 0.1 µF/25V	CK45=1E104Z
				C587	254 4533 947	Electrolytic 330 µF/6.3V	CE04W0J331M SMG/RE3
				C588	253 1181 904	Ceramic 0.01 µF/50V	CK45F1H103Z

1 2 3 4 5 6 7 8

1U-3223 VOLTAGE SELECT UNIT ASS'Y (Asia model & Taiwan model only)
1U-3244 VIDEO UNIT ASS'Y

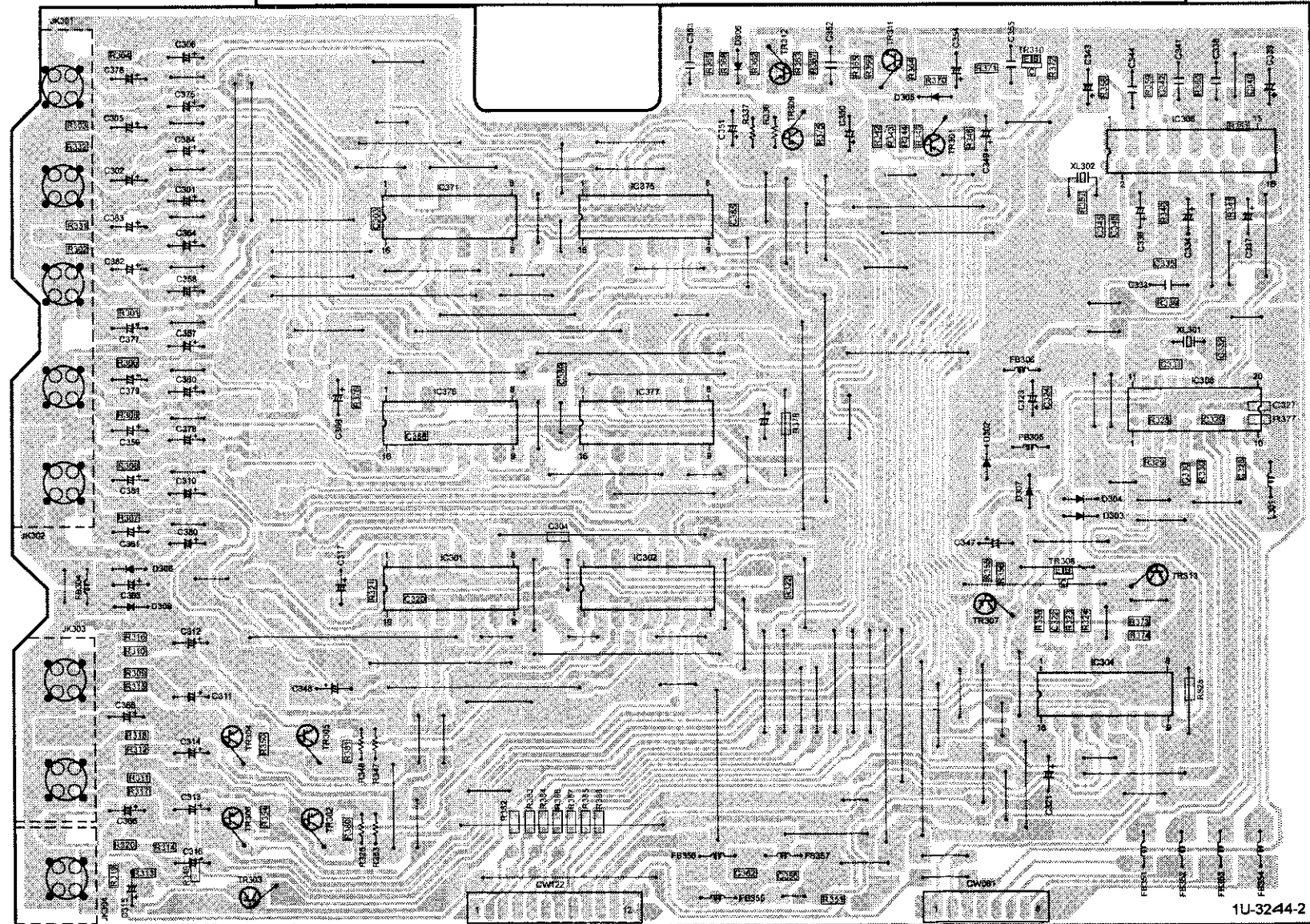
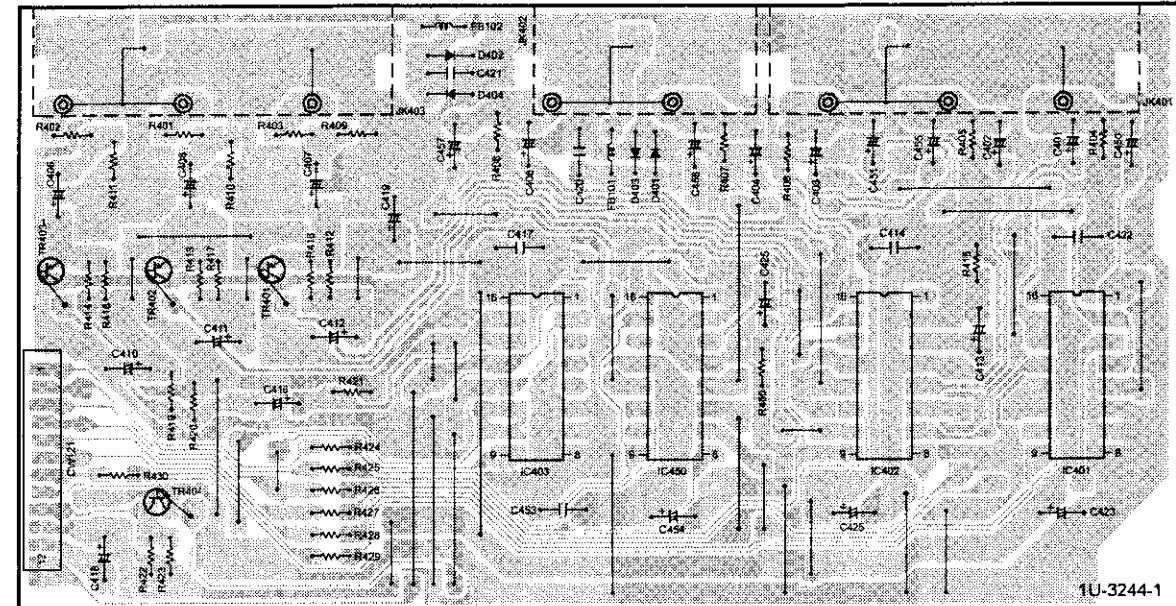
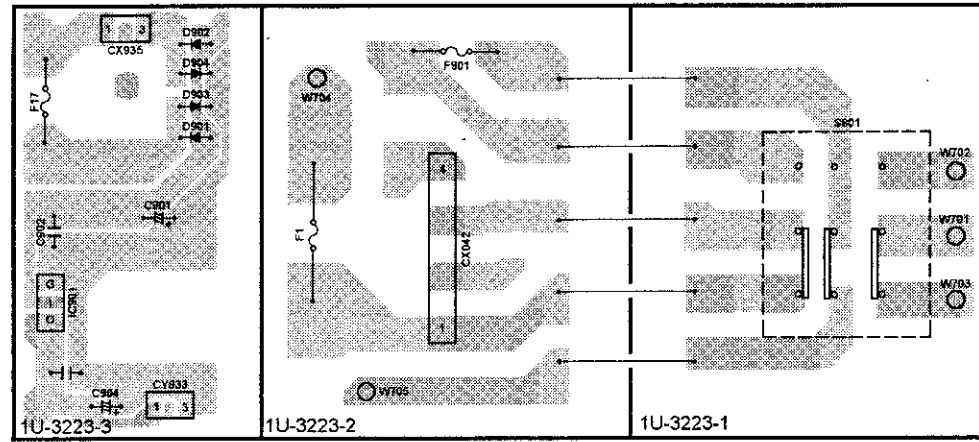

A
B
C
D
E

1 2 3 4 5 6 7 8

1U-3215 AUDIO / DSP UNIT ASS'Y

A

B

C

D

E

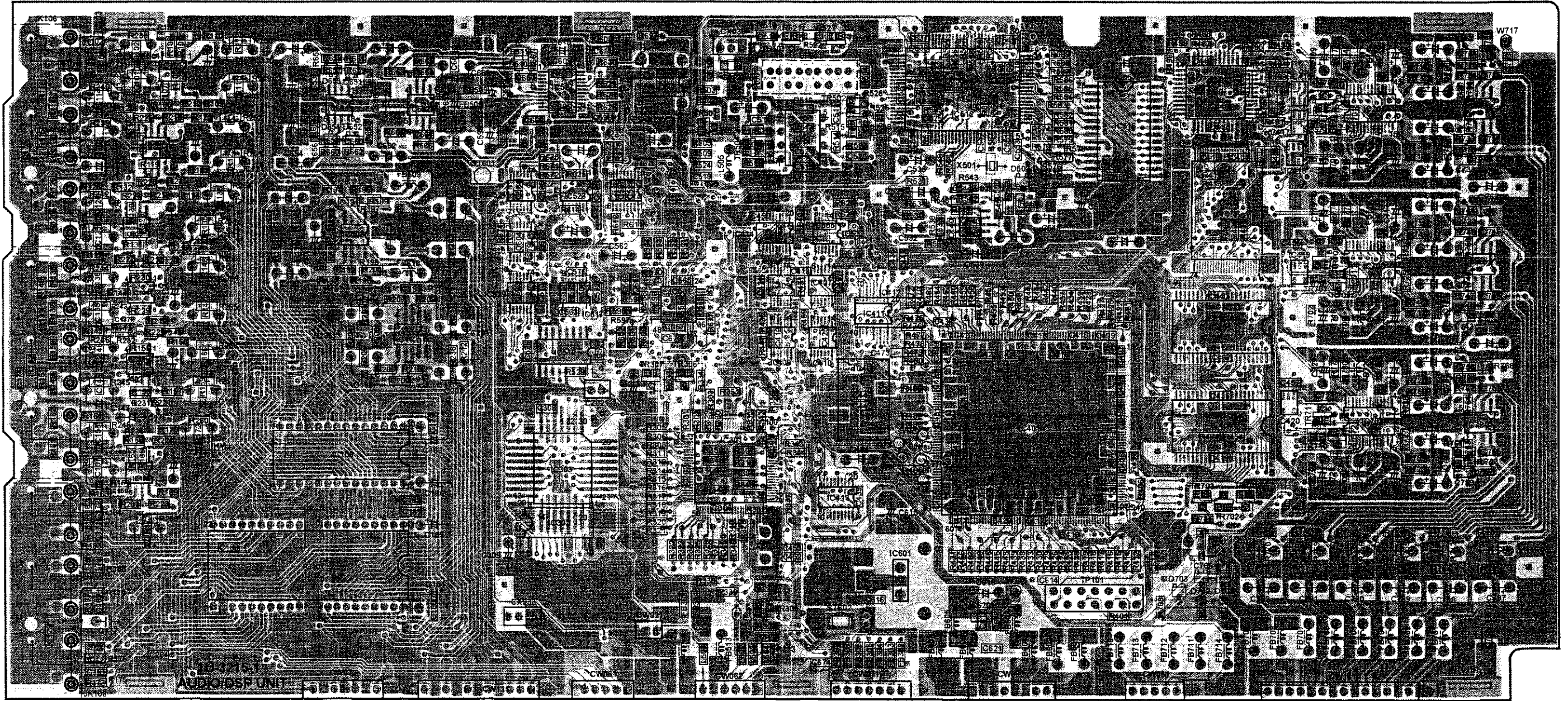

1 2 3 4 5 6 7 8

1U-3200 CONTROL UNIT ASS'Y

A

B

C

D

E

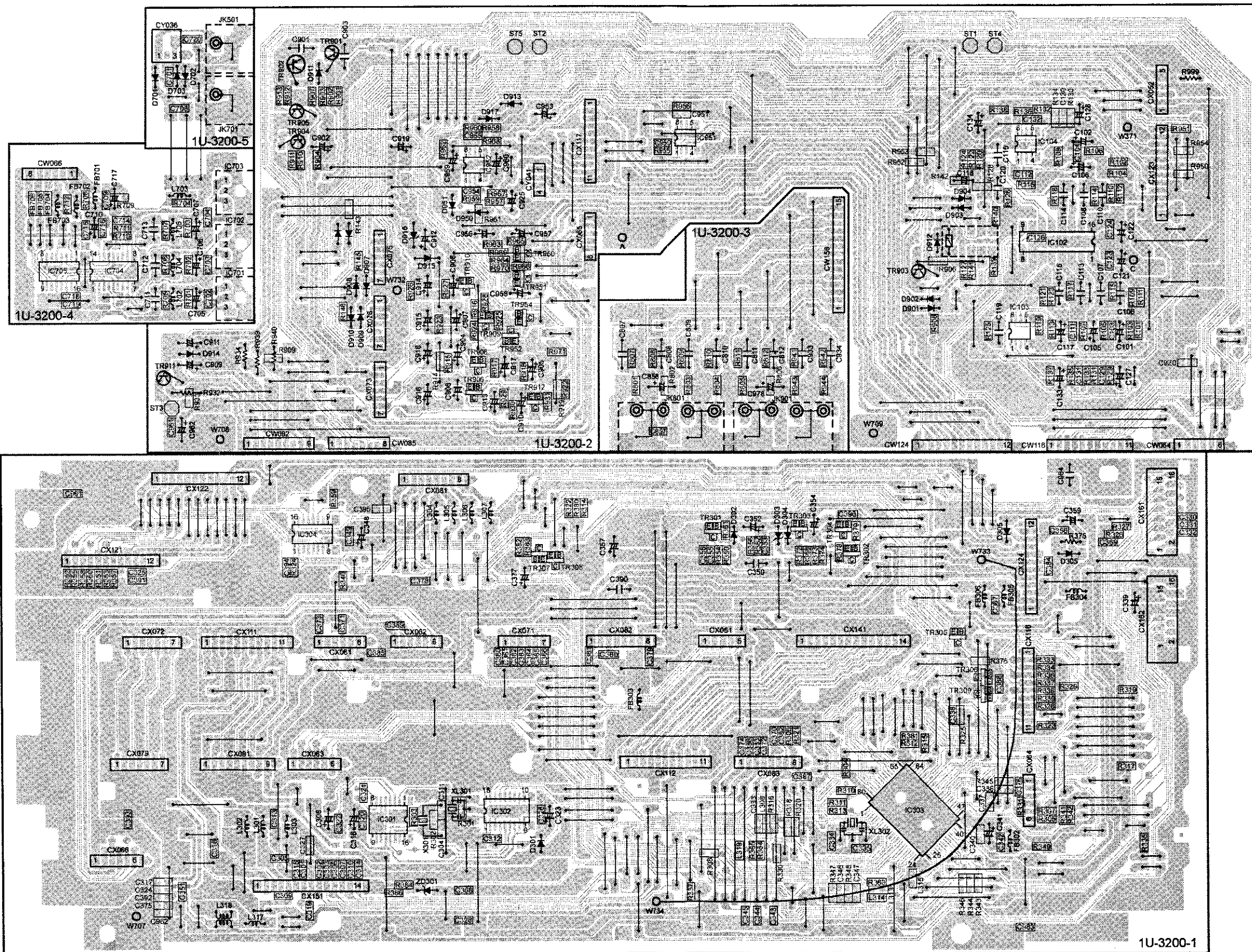

FL DISPLAY CM1690C (EX: FL101)

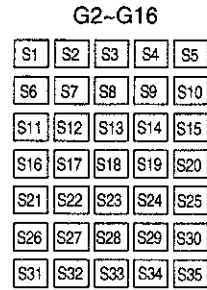
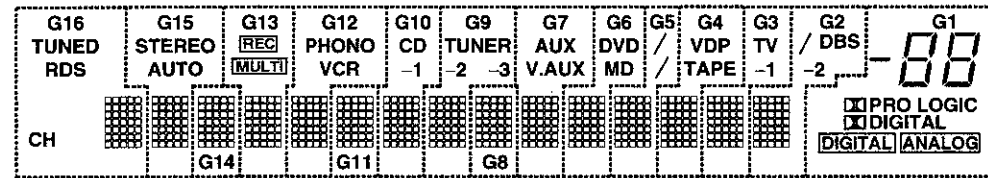
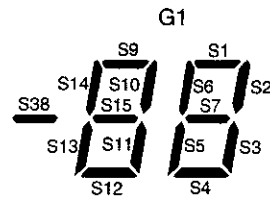
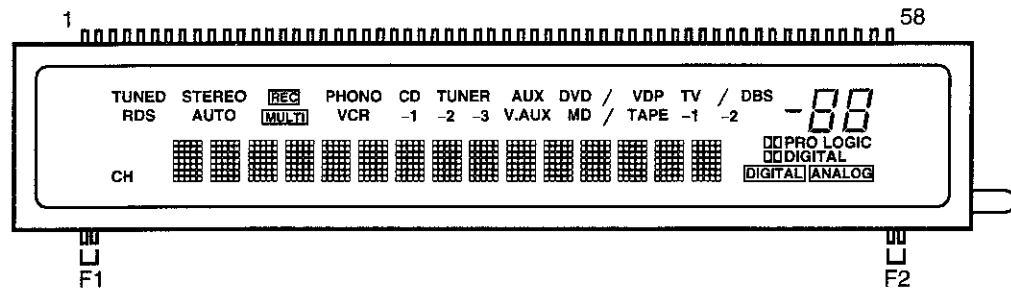

Pin Assignment

PIN NO.	1	2	3	4	5	6	7	8	9	10	11	12	13	14	15	16	17	18	19	20
CONNECTION	F1	F1	S1	S2	S3	S4	S5	S6	S7	S8	S9	S10	S11	S12	S13	S14	S15	S16	S17	S18
PIN NO.	21	22	23	24	25	26	27	28	29	30	31	32	33	34	35	36	37	38	39	40
CONNECTION	S19	S20	S21	S22	S23	S24	S25	S26	S27	S28	S29	S30	S31	S32	S33	S34	S35	S36	S37	S38
PIN NO.	41	42	43	44	45	46	47	48	49	50	51	52	53	54	55	56	57	58		
CONNECTION	G16	G15	G14	G13	G12	G11	G10	G9	G8	G7	G6	G5	G4	G3	G2	G1	F2	F2		

F1,F2 : Filament
 G1-G16 : Grid
 S1-S38 : Anode

Anode & Grid Assignment

	G1	G2-G16		G1	G2-G16		G1	G2-G16		G1	G2-G16
S1	S1	S1	S10	S10	S10	S19	---	S19	S28	---	S28
S2	S2	S2	S11	S11	S11	S20	---	S20	S29	---	S29
S3	S3	S3	S12	S12	S12	S21	---	S21	S30	---	S30
S4	S4	S4	S13	S13	S13	S22	---	S22	S31	---	S31
S5	S5	S5	S14	S14	S14	S23	---	S23	S32	---	S32
S6	S6	S6	S15	S15	S15	S24	---	S24	S33	---	S33
S7	S7	S7	S16	---	S16	S25	---	S25	S34	---	S34
S8	---	S8	S17	DIGITAL	S17	S26	---	S26	S35	---	S35
S9	S9	S9	S18	PRO LOGIC	S18	S27	---	S27			

	G1	G2	G3	G4	G5	G6	G7	G8	G9	G10	G11	G12	G13	G14	G15	G16
S36	DIGITAL	/	TV	VDP	/(DVD)	DVD	AUX	---	TUNER	CD	---	PHONO	REC	---	STEREO	TUNED
S37	ANALOG	-2	-1	TAPE	/(MD)	MD	V.MAX	---	-2	-1	---	VCR	MULTI	---	AUTO	RDS
S38	S38	DBS	---	---	---	---	---	---	-3	---	---	---	---	---	---	CH

Ref. No.	Part No.	Part Name	Remarks	Ref. No.	Part No.	Part Name	Remarks	Q'ty
C589	254 4538 900	Electrolytic 10 μ F/16V	CE04W1C100M SMG/RE3	RL502-505	214 0195 006	Relay FTR-F1		4
C590	254 4524 943	Electrolytic 1 μ F/50V	CE04W1H010M SMG/RE3	RL506	214 0188 000	Relay VS-12MBNR-SM2(TV-8)		1
C591~593	253 1181 904	Ceramic 0.01 μ F/50V	CK45F1H103Z	Δ RL501	Note	Note		1
C594	254 4256 790	Electrolytic 2200 μ F/25V	CE04W1E222MC					
C595	254 4524 943	Electrolytic 1 μ F/50V	CE04W1H010M SMG/RE3					
C599	256 1058 971	Metalized 0.1 μ F/50V	CF93A1H104J (JL)	TP501-505	205 0190 036	3P NH Connector base		5
				TP510	205 0190 036	3P NH Connector base		1
C601	254 4524 943	Electrolytic 1 μ F/50V	CE04W1H010M SMG/RE3		Note	Fuse label		1
C602	254 6211 005	Electrolytic 12000 μ F/63V	CE68W1J123M(DL)		Note	Fuse label		1
C603,604	256 1042 903	Metalized 0.1 μ F/250V	CF93A2E104K					
C605	254 6211 005	Electrolytic 12000 μ F/63V	CE68W1J123M(DL)					
C606-608	256 1042 903	Metalized 0.1 μ F/250V	CF93A2E104K					
C609-612	255 1265 936	Mylar film 0.01 μ F/50V	CQ93M1H103J(B)					
C613-616	Note	Note						
C617,618	Note	Note						
C631,632	Note	Note						
C646	254 4262 784	Electrolytic 470 μ F/63V	CE04W1J471MC					
C648	253 8014 702	Ceramic 0.01 μ F/400V(AC)	CK45F2GAC103MC					
C649	Note	Note						
OTHER PARTS								Q'ty
AC501	Note	Note						1
CW121	205 1125 026	12P Connector socket						1
CX021	Note	Note						
CX022	205 0581 001	2P VH Connector base						1
CX023	Note	Note						
CX024	205 1119 029	2P Connector base(35328)						1
CX031	205 1126 038	3P Connector base						1
CX032	Note	Note						
CX033	205 0653 036	3P Connector base(35328)						1
CX041	205 0343 045	4P Connector base (KR-PH)						1
CX054-057	205 1122 058	5P Connector base						4
CX074	205 1122 074	7P Connector base						1
CX085	205 0884 096	8P Connector base						1
CX092	205 0884 038	9P Connector base						1
CX960-969	205 1064 064	6P Pin header						10
Δ F001	Note	Note						1
Δ F008	Note	Note						1
FF501,502	202 0040 909	Fuse clip						2
FH501,502	202 0040 909	Fuse clip						2
JK451~453	204 8581 000	3P Pin jack (NI-COM.V)						3
JK601	205 0472 013	8P SP Terminal (EAEK)						1
JK603	205 1108 001	6P SP Terminal (E3)						1
RL501	214 0200 001	Relay (EC2-12N35)						1

1U-3199 EXT.IN UNIT ASS'Y

Ref. No.	Part No.	Part Name	Remarks	Ref. No.	Part No.	Part Name	Remarks
SEMICONDUCTORS GROUP							
IC101	262 2549 002	IC LC75721E		R114	247 0006 917	Carbon chip 300 ohm 1/10W	RM73B--301J
IC102	499 0290 007	IC GP1U271X		R115	247 0006 975	Carbon chip 510 ohm 1/10W	RM73B--511J
IC103	262 2375 904	IC TC4094BF		R116	247 0007 945	Carbon chip 1 kohm 1/10W	RM73B--102J
				R117-119	247 0008 957	Carbon chip 3 kohm 1/10W	RM73B--302J
IC301	263 0896 909	IC NJM2068MD		R124	247 0009 985	Carbon chip 10 kohm 1/10W	RM73B--103J
IC303,304	263 0896 909	IC NJM2068MD		R125	247 0007 945	Carbon chip 1 kohm 1/10W	RM73B--102J
IC308-310	263 0896 909	IC NJM2068MD		R126	247 0005 976	Carbon chip 200 ohm 1/10W	RM73B--201J
IC312	262 2667 007	IC TC9274N-***		R127	247 0006 917	Carbon chip 300 ohm 1/10W	RM73B--301J
				R128	247 0006 975	Carbon chip 510 ohm 1/10W	RM73B--511J
IC701	263 0896 909	IC NJM2068MD		R129	247 0007 945	Carbon chip 1 kohm 1/10W	RM73B--102J
				R137,138	241 2387 940	Carbon film 4.7 ohm 1/4W(NB)	RD14B2E4R7JNBS
IC801-804	263 0896 909	IC NJM2068MD		R139	247 0007 945	Carbon chip 1 kohm 1/10W	RM73B--102J
IC805-808	262 2662 002	IC TC9459N		R140	247 0005 905	Carbon chip 100 ohm 1/10W	RM73B--101J
				R141,142	247 0009 901	Carbon chip 4.7 kohm 1/10W	RM73B--472J
TR102-110	269 0082 902	Transistor DTC114EK		R153-155	247 0011 986	Carbon chip 68 kohm 1/10W	RM73B--683J
TR111	269 0083 901	Transistor DTA114EK		R156,157	247 0005 905	Carbon chip 100 ohm 1/10W	RM73B--101J
TR112	269 0055 900	Transistor DTA144EK		R158,159	247 0011 986	Carbon chip 68 kohm 1/10W	RM73B--683J
TR113-115	269 0054 901	Transistor DTC144EK		R160	247 0009 901	Carbon chip 4.7 kohm 1/10W	RM73B--472J
TR116,117	269 0055 900	Transistor DTA144EK		R162-170	247 0011 986	Carbon chip 68 kohm 1/10W	RM73B--683J
TR130	269 0055 900	Transistor DTA144EK		R171	247 0009 901	Carbon chip 4.7 kohm 1/10W	RM73B--472J
				R173,174	247 0011 986	Carbon chip 68 kohm 1/10W	RM73B--683J
TR301-304	273 0414 906	Transistor 2SC3326(A/B)		R175,176	247 0011 944	Carbon chip 47 kohm 1/10W	RM73B--473J
TR311-315	273 0414 906	Transistor 2SC3326(A/B)		R177-181	247 0011 986	Carbon chip 68 kohm 1/10W	RM73B--683J
TR323-326	273 0414 906	Transistor 2SC3326(A/B)		R182	247 0009 985	Carbon chip 10 kohm 1/10W	RM73B--103J
TR327,328	275 0094 908	Transistor 2SK209-GR		R183-212	247 0011 986	Carbon chip 68 kohm 1/10W	RM73B--683J
TR329	269 0054 901	Transistor DTC144EK					
				R213	247 0011 944	Carbon chip 47 kohm 1/10W	RM73B--473J
TR801-803	275 0094 908	Transistor 2SK209-GR		R301-304	247 0005 976	Carbon chip 200 ohm 1/10W	RM73B--201J
TR805	269 0083 901	Transistor DTA114EK		R305-308	247 0011 902	Carbon chip 33 kohm 1/10W	RM73B--333J
TR807	269 0054 901	Transistor DTC144EK		R309,310	247 0012 927	Carbon chip 100 kohm 1/10W	RM73B--104J
				R311,312	247 0005 905	Carbon chip 100 ohm 1/10W	RM73B--101J
D101,102	276 0637 902	Diode MTZJ6.2A		R313,314	247 0018 905	Carbon chip 0 ohm 1/10W	RM73B--0R0K
D104	276 0644 937	Diode MTZJ9.1A		R315,316	247 0005 905	Carbon chip 100 ohm 1/10W	RM73B--101J
D105	276 0637 902	Diode MTZJ6.2A		R317,318	247 0012 927	Carbon chip 100 kohm 1/10W	RM73B--104J
D107	276 0637 902	Diode MTZJ6.2A		R326	247 0011 944	Carbon chip 47 kohm 1/10W	RM73B--473J
D109	276 0432 903	Diode 1SS270A		R328,329	247 0011 944	Carbon chip 47 kohm 1/10W	RM73B--473J
D110,111	276 0438 910	Diode MA151A		R337-342	247 0005 976	Carbon chip 200 ohm 1/10W	RM73B--201J
				R343-346	247 0011 902	Carbon chip 33 kohm 1/10W	RM73B--333J
D323,324	276 0432 903	Diode 1SS270A		R347,348	247 0012 927	Carbon chip 100 kohm 1/10W	RM73B--104J
D801-803	276 0432 903	Diode 1SS270A		R349,350	247 0005 905	Carbon chip 100 ohm 1/10W	RM73B--101J
				R352	247 0009 901	Carbon chip 4.7 kohm 1/10W	RM73B--472J
LD104-110	393 9434 906	LED SEL1210S		R354	247 0009 914	Carbon chip 5.1 kohm 1/10W	RM73B--512J
LD111,112	393 9452 904	LED SEL1410E		R355	247 0018 905	Carbon chip 0 ohm 1/10W	RM73B--0R0K
				R357,358	247 0005 905	Carbon chip 100 ohm 1/10W	RM73B--101J
				R359,360	247 0012 927	Carbon chip 100 kohm 1/10W	RM73B--104J
				R361-364	247 0005 976	Carbon chip 200 ohm 1/10W	RM73B--201J
				R365,366	247 0007 990	Carbon chip 1.6 kohm 1/10W	RM73B--162J
				R367-370	247 0011 902	Carbon chip 33 kohm 1/10W	RM73B--333J
				R371,372	247 0012 927	Carbon chip 100 kohm 1/10W	RM73B--104J
				R373,374	247 0005 905	Carbon chip 100 ohm 1/10W	RM73B--101J
				R378,379	247 0018 905	Carbon chip 0 ohm 1/10W	RM73B--0R0K
RESISTORS GROUP							
R101	247 0005 905	Carbon chip 100 ohm 1/10W	RM73B--101J				
R102-110	247 0007 903	Carbon chip 680 ohm 1/10W	RM73B--681J				
R111	247 0005 905	Carbon chip 100 ohm 1/10W	RM73B--101J				
R112	247 0007 945	Carbon chip 1 kohm 1/10W	RM73B--102J				
R113	247 0005 976	Carbon chip 200 ohm 1/10W	RM73B--201J				

Ref. No.	Part No.	Part Name	Remarks	Ref. No.	Part No.	Part Name	Remarks
R381,382	247 0005 905	Carbon chip 100 ohm 1/10W	RM73B--101J	R725,726	247 0015 966	Carbon chip 2.7 Mohm 1/10W	RM73B--275J
R383,384	247 0012 927	Carbon chip 100 kohm 1/10W	RM73B--104J	R729~732	247 0018 905	Carbon chip 0 ohm 1/10W	RM73B--0R0K
R385,386	Note	Note		R801,802	247 0012 927	Carbon chip 100 kohm 1/10W	RM73B--104J
R387,388	247 0015 966	Carbon chip 2.7 Mohm 1/10W	RM73B--275J	R803,804	247 0005 905	Carbon chip 100 ohm 1/10W	RM73B--101J
R391,392	247 0018 905	Carbon chip 0 ohm 1/10W	RM73B--0R0K	R805,806	247 0007 916	Carbon chip 750 ohm 1/10W	RM73B--751J
R395~398	247 0018 905	Carbon chip 0 ohm 1/10W	RM73B--0R0K	R807,808	247 0009 943	Carbon chip 6.8 kohm 1/10W	RM73B--682J
R401,402	Note	Note		R809,810	247 0009 901	Carbon chip 4.7 kohm 1/10W	RM73B--472J
R403,404	247 0015 966	Carbon chip 2.7 Mohm 1/10W	RM73B--275J	R811,812	247 0011 944	Carbon chip 47 kohm 1/10W	RM73B--473J
R407,408	247 0018 905	Carbon chip 0 ohm 1/10W	RM73B--0R0K	R813,814	247 0005 905	Carbon chip 100 ohm 1/10W	RM73B--101J
R411~414	247 0018 905	Carbon chip 0 ohm 1/10W	RM73B--0R0K	R815~818	247 0012 927	Carbon chip 100 kohm 1/10W	RM73B--104J
R417,418	Note	Note		R819,820	247 0005 905	Carbon chip 100 ohm 1/10W	RM73B--101J
R419,420	247 0015 966	Carbon chip 2.7 Mohm 1/10W	RM73B--275J	R821,822	247 0007 916	Carbon chip 750 ohm 1/10W	RM73B--751J
R423,424	247 0018 905	Carbon chip 0 ohm 1/10W	RM73B--0R0K	R823	247 0009 943	Carbon chip 6.8 kohm 1/10W	RM73B--682J
R427~430	247 0018 905	Carbon chip 0 ohm 1/10W	RM73B--0R0K	R824	247 0009 969	Carbon chip 8.2 kohm 1/10W	RM73B--822J
R433~438	247 0011 928	Carbon chip 39 kohm 1/10W	RM73B--393J	R825	247 0009 901	Carbon chip 4.7 kohm 1/10W	RM73B--472J
R439,440	247 0004 922	Carbon chip 47 ohm 1/10W	RM73B--470J	R827,828	247 0005 905	Carbon chip 100 ohm 1/10W	RM73B--101J
R441,442	247 0012 927	Carbon chip 100 kohm 1/10W	RM73B--104J	R829	247 0011 944	Carbon chip 47 kohm 1/10W	RM73B--473J
R445	247 0009 901	Carbon chip 4.7 kohm 1/10W	RM73B--472J	R831~834	247 0012 927	Carbon chip 100 kohm 1/10W	RM73B--104J
R446,447	247 0008 960	Carbon chip 3.3 kohm 1/10W	RM73B--332J	R835,836	247 0005 905	Carbon chip 100 ohm 1/10W	RM73B--101J
R448~450	247 0009 901	Carbon chip 4.7 kohm 1/10W	RM73B--472J	R837,838	247 0007 916	Carbon chip 750 ohm 1/10W	RM73B--751J
R451,452	247 0005 905	Carbon chip 100 ohm 1/10W	RM73B--101J	R839,840	247 0009 901	Carbon chip 4.7 kohm 1/10W	RM73B--472J
R453,454	247 0012 927	Carbon chip 100 kohm 1/10W	RM73B--104J	R841,842	247 0005 905	Carbon chip 100 ohm 1/10W	RM73B--101J
R455	247 0011 944	Carbon chip 47 kohm 1/10W	RM73B--473J	R843~846	247 0012 927	Carbon chip 100 kohm 1/10W	RM73B--104J
R456	247 0018 905	Carbon chip 0 ohm 1/10W	RM73B--0R0K	R847,848	247 0005 905	Carbon chip 100 ohm 1/10W	RM73B--101J
R458	247 0009 901	Carbon chip 4.7 kohm 1/10W	RM73B--472J	R849,850	247 0007 916	Carbon chip 750 ohm 1/10W	RM73B--751J
R459	247 0009 927	Carbon chip 5.6 kohm 1/10W	RM73B--562J	R851,852	247 0008 999	Carbon chip 4.3 kohm 1/10W	RM73B--432J
R460	247 0009 901	Carbon chip 4.7 kohm 1/10W	RM73B--472J	R853,854	247 0005 905	Carbon chip 100 ohm 1/10W	RM73B--101J
R461	247 0009 930	Carbon chip 6.2 kohm 1/10W	RM73B--622J	R855,856	247 0012 927	Carbon chip 100 kohm 1/10W	RM73B--104J
R462	247 0005 905	Carbon chip 100 ohm 1/10W	RM73B--101J	R857	247 0009 985	Carbon chip 10 kohm 1/10W	RM73B--103J
R463	247 0012 927	Carbon chip 100 kohm 1/10W	RM73B--104J	R858	247 0007 945	Carbon chip 1 kohm 1/10W	RM73B--102J
R465,466	Note	Note		R859~866	247 0011 944	Carbon chip 47 kohm 1/10W	RM73B--473J
R467,468	247 0015 966	Carbon chip 2.7 Mohm 1/10W	RM73B--275J	R867~869	247 0012 927	Carbon chip 100 kohm 1/10W	RM73B--104J
R471,472	247 0018 905	Carbon chip 0 ohm 1/10W	RM73B--0R0K	R871,872	247 0012 927	Carbon chip 100 kohm 1/10W	RM73B--104J
R475~478	247 0018 905	Carbon chip 0 ohm 1/10W	RM73B--0R0K	CAPACITORS GROUP			
R481,482	247 0018 905	Carbon chip 0 ohm 1/10W	RM73B--0R0K	C102	257 0014 935	Ceramic chip 0.1 μ F/25V	CK73F1E104Z
R483	247 0007 945	Carbon chip 1 kohm 1/10W	RM73B--102J	C103	254 4299 906	Electrolytic 10 μ F/16V	CE04W1C100M(SRE)
R484~492	247 0018 905	Carbon chip 0 ohm 1/10W	RM73B--0R0K	C104	254 4305 968	Electrolytic 1 μ F/50V	CE04W1H010M(SRE)
R493~498	247 0012 927	Carbon chip 100 kohm 1/10W	RM73B--104J	C107	256 1058 971	Metalized 0.1 μ F/50V	CF93A1H104J (JL)
R701,702	Note	Note		C109	254 4196 999	Electrolytic 22 μ F/50V	CE04W1H220M (SRA)
R703,704	247 0006 946	Carbon chip 390 ohm 1/10W	RM73B--391J	C110~113	257 0012 966	Ceramic chip 0.01 μ F/50V	CK73F1H103Z
R705,706	247 0011 986	Carbon chip 68 kohm 1/10W	RM73B--683J	C115	257 0012 966	Ceramic chip 0.01 μ F/50V	CK73F1H103Z
R707,708	247 0012 969	Carbon chip 150 kohm 1/10W	RM73B--154J	C116	254 4300 989	Electrolytic 330 μ F/6.3V	CE04W0J331M(SRE)
R709,710	247 0004 922	Carbon chip 47 ohm 1/10W	RM73B--470J	C117	257 0008 983	Ceramic chip 1000 pF/50V	CK73B1H102K
R711,712	247 0005 992	Carbon chip 240 ohm 1/10W	RM73B--241J	C120	257 0003 933	Ceramic chip 30 pF/50V	CC73SL1H300J
R713,714	247 0012 956	Carbon chip 130 kohm 1/10W	RM73B--134J	C121	254 4299 906	Electrolytic 10 μ F/16V	CE04W1C100M(SRE)
R715,716	247 0009 998	Carbon chip 11 kohm 1/10W	RM73B--113J	C122	257 0012 982	Ceramic chip 0.022 μ F/50V	CK73F1H223Z
R717,718	247 0003 949	Carbon chip 22 ohm 1/10W	RM73B--220J	C126	257 0008 983	Ceramic chip 1000 pF/50V	CK73B1H102K
R719,720	247 0004 922	Carbon chip 47 ohm 1/10W	RM73B--470J	C301,302	254 4538 900	Electrolytic 10 μ F/16V	CE04W1C100M SMG/RE3
R721,722	247 0011 944	Carbon chip 47 kohm 1/10W	RM73B--473J	C307,308	254 4538 900	Electrolytic 10 μ F/16V	CE04W1C100M SMG/RE3
R723,724	Note	Note					

Ref. No.	Part No.	Part Name	Remarks	Ref. No.	Part No.	Part Name	Remarks	
C309	257 0008 983	Ceramic chip 1000 pF/50V	CK73B1H102K	C815,816	254 4538 900	Electrolytic 10 µF/16V	CE04W1C100M SMG/RE3	
C311,312	254 4538 900	Electrolytic 10 µF/16V	CE04W1C100M SMG/RE3	C817,818	257 0003 988	Ceramic chip 47 pF/50V	CC73SL1H470J	
C321,322	Note	Note		C821,822	257 0004 961	Ceramic chip 100 pF/50V	CC73SL1H101J	
C323,324	254 4538 900	Electrolytic 10 µF/16V	CE04W1C100M SMG/RE3	C823	255 1265 923	Mylar film 8200 pF/50V	CQ93M1H822J(B)	
C325,326	257 0004 961	Ceramic chip 100 pF/50V	CC73SL1H101J	C825,826	254 4524 943	Electrolytic 1 µF/50V	CE04W1H010M SMG/RE3	
C327,328	254 4538 900	Electrolytic 10 µF/16V	CE04W1C100M SMG/RE3	C827,828	257 0012 982	Ceramic chip 0.022 µF/50V	CK73F1H223Z	
C331~334	254 4538 900	Electrolytic 10 µF/16V	CE04W1C100M SMG/RE3	C829,830	254 4538 900	Electrolytic 10 µF/16V	CE04W1C100M SMG/RE3	
C335,336	257 0004 961	Ceramic chip 100 pF/50V	CC73SL1H101J	C831,832	257 0003 988	Ceramic chip 47 pF/50V	CC73SL1H470J	
C337,338	254 4538 900	Electrolytic 10 µF/16V	CE04W1C100M SMG/RE3	C835,836	257 0004 961	Ceramic chip 100 pF/50V	CC73SL1H101J	
C341,342	254 4538 900	Electrolytic 10 µF/16V	CE04W1C100M SMG/RE3	C837,838	254 4524 943	Electrolytic 1 µF/50V	CE04W1H010M SMG/RE3	
C343,344	Note	Note		C839,840	257 0012 982	Ceramic chip 0.022 µF/50V	CK73F1H223Z	
C355,356	Note	Note		C841,842	254 4538 900	Electrolytic 10 µF/16V	CE04W1C100M SMG/RE3	
C367,368	Note	Note		C843,844	257 0003 988	Ceramic chip 47 pF/50V	CC73SL1H470J	
C379~382	256 1058 955	Metalized 0.068 µF/50V	CF93A1H683J (JL)	C847,848	257 0004 961	Ceramic chip 100 pF/50V	CC73SL1H101J	
C385,386	254 4524 943	Electrolytic 1 µF/50V	CE04W1H010M SMG/RE3	C849,850	254 4524 943	Electrolytic 1 µF/50V	CE04W1H010M SMG/RE3	
C387,388	254 4538 900	Electrolytic 10 µF/16V	CE04W1C100M SMG/RE3	C851,852	257 0012 982	Ceramic chip 0.022 µF/50V	CK73F1H223Z	
C389,390	254 4524 943	Electrolytic 1 µF/50V	CE04W1H010M SMG/RE3	C860	254 4524 943	Electrolytic 1 µF/50V	CE04W1H010M SMG/RE3	
C395,396	257 0004 961	Ceramic chip 100 pF/50V	CC73SL1H101J	C861~868	254 4538 900	Electrolytic 10 µF/16V	CE04W1C100M SMG/RE3	
C397,398	254 4538 900	Electrolytic 10 µF/16V	CE04W1C100M SMG/RE3	C869~871	254 4524 969	Electrolytic 3.3 µF/50V	CE04W1H3R3M SMG/RE3	
C399,400	257 0012 966	Ceramic chip 0.01 µF/50V	CK73F1H103Z	C873,874	254 4524 969	Electrolytic 3.3 µF/50V	CE04W1H3R3M SMG/RE3	
C401,402	254 4524 943	Electrolytic 1 µF/50V	CE04W1H010M SMG/RE3	OTHER PARTS				Q'ty
C403	257 0008 983	Ceramic chip 1000 pF/50V	CK73B1H102K	CW052	205 1124 056	5P Connector socket		1
C405	257 0004 961	Ceramic chip 100 pF/50V	CC73SL1H101J	CW063	205 1124 069	6P Connector socket		1
C407	257 0004 961	Ceramic chip 100 pF/50V	CC73SL1H101J	CW079	205 1124 072	7P Connector socket		1
C408	254 4538 900	Electrolytic 10 µF/16V	CE04W1C100M SMG/RE3	CW083	205 1124 085	8P Connector socket		1
C409	257 0014 935	Ceramic chip 0.1 µF/25V	CK73F1E104Z	CW091	205 1124 098	9P Connector socket		1
C417	257 0014 935	Ceramic chip 0.1 µF/25V	CK73F1E104Z	CW101	205 1000 002	10P FJ Connector plug		1
C415,416	257 0014 935	Ceramic chip 0.1 µF/25V	CK73F1E104Z	CW112	205 1125 013	11P Connector socket		1
C459~461	254 4524 901	Electrolytic 0.1 µF/50V	CE04W1H0R1M SMG/RE3	CW123	205 1125 026	12P Connector socket		1
C462,463	257 0004 961	Ceramic chip 100 pF/50V	CC73SL1H101J	CW161,162	205 1055 028	16P Connector base (TKC-V)		2
C703,704	257 0005 944	Ceramic chip 220 pF/50V	CC73SL1H221J	CX932	205 1121 033	3P Connector base-L(5268)		1
C705,706	254 4538 900	Electrolytic 10 µF/16V	CE04W1C100M SMG/RE3	CY021	Note	Note		1
C707,708	257 0004 961	Ceramic chip 100 pF/50V	CC73SL1H101J	FB101	235 0049 900	Beads inductor		1
C709,710	254 4533 934	Electrolytic 220 µF/6.3V	CE04W0J221M SMG/RE3	FB401	235 0106 908	Chip emifil (21A05)		1
C711,712	255 4199 999	Polypropylene film 0.024 µF/50V	CQ92M1H243J(MRZ)	FB704	247 0018 905	Carbon chip 0 ohm 1/10W	RM73B--0R0K	1
C713,714	255 1265 907	Mylar film 6800 pF/50V	CQ93M1H682J(B)	FL101	393 8033 007	FLD (CM1690C)		1
C715,716	254 4538 900	Electrolytic 10 µF/16V	CE04W1C100M SMG/RE3	JK301	204 8513 010	6P Pin jack (S-GND)		1
C717,718	257 0012 982	Ceramic chip 0.022 µF/50V	CK73F1H223Z	JK303	204 8513 010	6P Pin jack (S-GND)		1
C719,720	Note	Note		L301~304	235 0049 900	Beads inductor		4
C725,726	247 0018 905	Carbon chip 0 ohm 1/10W	RM73B--0R0K	L701,702	Note	Note		2
C729,730	254 4524 943	Electrolytic 1 µF/50V	CE04W1H010M SMG/RE3	S101~110	212 5609 902	Tact switch		10
C741	257 0014 935	Ceramic chip 0.1 µF/25V	CK73F1E104Z	S112	212 5609 902	Tact switch		1
C742	257 0014 935	Ceramic chip 0.1 µF/25V	CK73F1E104Z	S113	212 0373 000	Rotary encoder EC16B		1
C801,802	254 4538 900	Electrolytic 10 µF/16V	CE04W1C100M SMG/RE3	S114	212 0419 003	Rotary encoder		1
C803,804	257 0003 988	Ceramic chip 47 pF/50V	CC73SL1H470J	S115	212 5609 902	Tact switch		1
C807,808	257 0004 961	Ceramic chip 100 pF/50V	CC73SL1H101J	S901	Note	Note		1
C809,810	255 1265 923	Mylar film 8200 pF/50V	CQ93M1H822J(B)		414 0799 109	Shield plate		1
C811,812	254 4524 943	Electrolytic 1 µF/50V	CE04W1H010M SMG/RE3		203 0525 029	1P SIN Cord ass'y	L=210	1
C813,814	257 0012 982	Ceramic chip 0.022 µF/50V	CK73F1H223Z					

1U-3200 CONTROL UNIT ASS'Y

Ref. No.	Part No.	Part Name	Remarks	Ref. No.	Part No.	Part Name	Remarks
SEMICONDUCTORS GROUP				RESISTORS GROUP			
IC102	262 2616 003	IC TC9184AP		R101,102	247 0008 928	Carbon chip 2.2 kohm 1/10W	RM73B--222J
IC103,104	263 0896 909	IC NJM2068MD		R103,104	247 0006 946	Carbon chip 390 ohm 1/10W	RM73B--391J
IC301	Note	Note		R105,106	247 0013 984	Carbon chip 470 kohm 1/10W	RM73B--474J
IC302	Note	Note		R107,108	247 0005 905	Carbon chip 100 ohm 1/10W	RM73B--101J
IC303	262 2702 108	IC TMP88CU74F-****		R109,110	247 0012 901	Carbon chip 82 kohm 1/10W	RM73B--823J
IC304	262 2375 904	IC TC4094BF		R111,112	247 0009 901	Carbon chip 4.7 kohm 1/10W	RM73B--472J
IC701-703	269 0178 007	IC GP1F37R1		R113	247 0013 984	Carbon chip 470 kohm 1/10W	RM73B--474J
IC704	262 1205 907	IC TC74HCU04AF		R114,115	247 0011 928	Carbon chip 39 kohm 1/10W	RM73B--393J
IC705	262 2213 901	IC TC74HC151AF		R116	247 0013 984	Carbon chip 470 kohm 1/10W	RM73B--474J
IC951	263 0892 903	IC NJM2082M		R117,118	247 0014 909	Carbon chip 560 kohm 1/10W	RM73B--564J
IC952	263 0896 909	IC NJM2068MD		R119,120	247 0004 922	Carbon chip 47 ohm 1/10W	RM73B--470J
TR301	274 0163 904	Transistor 2SD601A		R121,122	247 0009 927	Carbon chip 5.6 kohm 1/10W	RM73B--562J
TR302	271 0291 903	Transistor 2SA1182Y/O		R123,124	247 0010 987	Carbon chip 27 kohm 1/10W	RM73B--273J
TR303	269 0054 901	Transistor DTC144EK		R125,126	247 0007 945	Carbon chip 1 kohm 1/10W	RM73B--102J
TR304	269 0082 902	Transistor DTC114EK		R127,128	247 0012 927	Carbon chip 100 kohm 1/10W	RM73B--104J
TR305	269 0055 900	Transistor DTA144EK		R129-132	247 0018 905	Carbon chip 0 ohm 1/10W	RM73B--0R0K
TR306	269 0054 901	Transistor DTC144EK		R135,136	247 0018 905	Carbon chip 0 ohm 1/10W	RM73B--0R0K
TR307	269 0083 901	Transistor DTA114EK		R141-143	247 0005 905	Carbon chip 100 ohm 1/10W	RM73B--101J
TR308,309	269 0054 901	Transistor DTC144EK		R145,146	247 0005 905	Carbon chip 100 ohm 1/10W	RM73B--101J
TR901	271 0131 924	Transistor 2SA988(E/F)		R303	Note	Note	
TR902	273 0445 001	Transistor 2SC4495		R304-307	247 0009 985	Carbon chip 10 kohm 1/10W	RM73B--103J
TR903	273 0429 904	Transistor 2SC3311A		R308	247 0005 905	Carbon chip 100 ohm 1/10W	RM73B--101J
TR904,905	271 0131 924	Transistor 2SA988(E/F)		R310,311	247 0007 945	Carbon chip 1 kohm 1/10W	RM73B--102J
TR906-910	269 0083 901	Transistor DTA114EK		R312	247 0009 985	Carbon chip 10 kohm 1/10W	RM73B--103J
TR911	271 0131 924	Transistor 2SA988(E/F)		R313	247 0007 945	Carbon chip 1 kohm 1/10W	RM73B--102J
TR912	269 0083 901	Transistor DTA114EK		R314	247 0009 985	Carbon chip 10 kohm 1/10W	RM73B--103J
TR950-952	269 0082 902	Transistor DTC114EK		R315	247 0018 905	Carbon chip 0 ohm 1/10W	RM73B--0R0K
TR953	269 0083 901	Transistor DTA114EK		R316	247 0005 905	Carbon chip 100 ohm 1/10W	RM73B--101J
TR954,955	269 0082 902	Transistor DTC114EK		R318	247 0005 905	Carbon chip 100 ohm 1/10W	RM73B--101J
D301	Note	Note		R320	247 0005 905	Carbon chip 100 ohm 1/10W	RM73B--101J
D302	276 0432 903	Diode 1SS270A		R324-326	247 0009 901	Carbon chip 4.7 kohm 1/10W	RM73B--472J
D303	276 0634 905	Diode MTZJ3.3A		R327	247 0009 985	Carbon chip 10 kohm 1/10W	RM73B--103J
D304	276 0432 903	Diode 1SS270A		R329	247 0009 985	Carbon chip 10 kohm 1/10W	RM73B--103J
D305,306	276 0553 905	Diode 1SR35-200A		R330	247 0005 905	Carbon chip 100 ohm 1/10W	RM73B--101J
D701	276 0432 903	Diode 1SS270A		R331	247 0009 985	Carbon chip 10 kohm 1/10W	RM73B--103J
D901-912	276 0432 903	Diode 1SS270A		R333,334	247 0009 985	Carbon chip 10 kohm 1/10W	RM73B--103J
D913	276 0553 905	Diode 1SR35-200A		R335	247 0011 944	Carbon chip 47 kohm 1/10W	RM73B--473J
D914	276 0645 978	Diode MTZJ36A		R340-342	247 0009 985	Carbon chip 10 kohm 1/10W	RM73B--103J
D915	276 0553 905	Diode 1SR35-200A		R343,344	247 0005 905	Carbon chip 100 ohm 1/10W	RM73B--101J
D916	276 0643 996	Diode MTZJ5.6A		R345	247 0018 905	Carbon chip 0 ohm 1/10W	RM73B--0R0K
D917	276 0553 905	Diode 1SR35-200A		R346	247 0005 905	Carbon chip 100 ohm 1/10W	RM73B--101J
D950,951	276 0553 905	Diode 1SR35-200A		R347,348	Note	Note	Note
				R349	247 0018 905	Carbon chip 0 ohm 1/10W	RM73B--0R0K
				R350	247 0009 985	Carbon chip 10 kohm 1/10W	RM73B--103J
				R351-353	247 0012 927	Carbon chip 100 kohm 1/10W	RM73B--104J
				R354	247 0013 900	Carbon chip 220 kohm 1/10W	RM73B--224J
				R355	247 0012 927	Carbon chip 100 kohm 1/10W	RM73B--104J
				R356	247 0009 985	Carbon chip 10 kohm 1/10W	RM73B--103J
				R357-360	247 0012 927	Carbon chip 100 kohm 1/10W	RM73B--104J
				R361,362	247 0009 901	Carbon chip 4.7 kohm 1/10W	RM73B--472J

Ref. No.	Part No.	Part Name	Remarks
R363-365	247 0005 905	Carbon chip 100 ohm 1/10W	RM73B--101J
R366	Note	Note	
R368	247 0007 945	Carbon chip 1 kohm 1/10W	RM73B--102J
R372,373	247 0007 945	Carbon chip 1 kohm 1/10W	RM73B--102J
R374	247 0009 985	Carbon chip 10 kohm 1/10W	RM73B--103J
R375	241 2387 940	Carbon film 4.7 ohm 1/4W(NB)	RD14B2E4R7JNBS
R376	247 0009 985	Carbon chip 10 kohm 1/10W	RM73B--103J
R377	Note	Note	
R378-383	247 0009 985	Carbon chip 10 kohm 1/10W	RM73B--103J
R384	Note	Note	
R701-703	247 0018 905	Carbon chip 0 ohm 1/10W	RM73B--0R0K
R705-707	247 0009 901	Carbon chip 4.7 kohm 1/10W	RM73B--472J
R708	247 0004 977	Carbon chip 75 ohm 1/10W	RM73B--750J
R709	247 0005 905	Carbon chip 100 ohm 1/10W	RM73B--101J
R710	247 0008 928	Carbon chip 2.2 kohm 1/10W	RM73B--222J
R711	247 0011 944	Carbon chip 47 kohm 1/10W	RM73B--473J
R712	247 0018 905	Carbon chip 0 ohm 1/10W	RM73B--0R0K
R801-806	247 0005 989	Carbon chip 220 ohm 1/10W	RM73B--221J
R807-812	247 0012 927	Carbon chip 100 kohm 1/10W	RM73B--104J
R901	247 0008 928	Carbon chip 2.2 kohm 1/10W	RM73B--222J
R902	247 0008 957	Carbon chip 3 kohm 1/10W	RM73B--302J
R903,904	247 0008 928	Carbon chip 2.2 kohm 1/10W	RM73B--222J
R906	247 0009 985	Carbon chip 10 kohm 1/10W	RM73B--103J
R907	247 0014 909	Carbon chip 560 kohm 1/10W	RM73B--564J
R908	247 0009 901	Carbon chip 4.7 kohm 1/10W	RM73B--472J
R909	247 0005 992	Carbon chip 240 ohm 1/10W	RM73B--241J
R910	247 0008 928	Carbon chip 2.2 kohm 1/10W	RM73B--222J
R911	247 0010 961	Carbon chip 22 kohm 1/10W	RM73B--223J
R912	247 0008 973	Carbon chip 3.6 kohm 1/10W	RM73B--362J
R913	247 0014 909	Carbon chip 560 kohm 1/10W	RM73B--564J
R914	247 0013 984	Carbon chip 470 kohm 1/10W	RM73B--474J
R915	247 0007 945	Carbon chip 1 kohm 1/10W	RM73B--102J
R916	247 0009 985	Carbon chip 10 kohm 1/10W	RM73B--103J
R917	247 0013 984	Carbon chip 470 kohm 1/10W	RM73B--474J
R918	247 0007 945	Carbon chip 1 kohm 1/10W	RM73B--102J
R919	247 0009 985	Carbon chip 10 kohm 1/10W	RM73B--103J
R920	247 0013 984	Carbon chip 470 kohm 1/10W	RM73B--474J
R921	247 0007 945	Carbon chip 1 kohm 1/10W	RM73B--102J
R922	247 0009 985	Carbon chip 10 kohm 1/10W	RM73B--103J
R923	247 0013 984	Carbon chip 470 kohm 1/10W	RM73B--474J
R924	247 0007 945	Carbon chip 1 kohm 1/10W	RM73B--102J
R925	247 0009 985	Carbon chip 10 kohm 1/10W	RM73B--103J
R926	247 0013 984	Carbon chip 470 kohm 1/10W	RM73B--474J
R927	247 0007 945	Carbon chip 1 kohm 1/10W	RM73B--102J
R928	247 0009 985	Carbon chip 10 kohm 1/10W	RM73B--103J
R929	247 0013 984	Carbon chip 470 kohm 1/10W	RM73B--474J
R930	247 0007 945	Carbon chip 1 kohm 1/10W	RM73B--102J
R931	247 0009 985	Carbon chip 10 kohm 1/10W	RM73B--103J
R932	241 2387 940	Carbon film 4.7 ohm 1/4W(NB)	RD14B2E4R7JNBS

Ref. No.	Part No.	Part Name	Remarks
R933	247 0009 985	Carbon chip 10 kohm 1/10W	RM73B--103J
R934	244 2055 996	Metal oxide 1.2 kohm 1W	RS14B3A122JNBS(S)
R939,940	244 2055 996	Metal oxide 1.2 kohm 1W	RS14B3A122JNBS(S)
R941,942	247 0012 927	Carbon chip 100 kohm 1/10W	RM73B--104J
R943,944	247 0005 989	Carbon chip 220 ohm 1/10W	RM73B--221J
R950-956	247 0015 966	Carbon chip 2.7 Mohm 1/10W	RM73B--275J
R957,958	247 0009 901	Carbon chip 4.7 kohm 1/10W	RM73B--472J
R959,960	247 0011 944	Carbon chip 47 kohm 1/10W	RM73B--473J
R961,962	247 0005 905	Carbon chip 100 ohm 1/10W	RM73B--101J
R963,964	247 0009 901	Carbon chip 4.7 kohm 1/10W	RM73B--472J
R965	247 0013 900	Carbon chip 220 kohm 1/10W	RM73B--224J
R966	247 0009 901	Carbon chip 4.7 kohm 1/10W	RM73B--472J
R967,968	247 0011 944	Carbon chip 47 kohm 1/10W	RM73B--473J
R970	247 0002 966	Carbon chip 10 ohm 1/10W	RM73B--100J
R971	247 0009 985	Carbon chip 10 kohm 1/10W	RM73B--103J

CAPACITORS GROUP

Ref. No.	Part No.	Part Name	Remarks
C101,102	254 4524 956	Electrolytic 2.2 μ F/50V	CE04W1H2R2M SMG/RE3
C103,104	257 0004 961	Ceramic chip 100 pF/50V	CC73SL1H101J
C105,106	254 4524 969	Electrolytic 3.3 μ F/50V	CE04W1H3R3M SMG/RE3
C107,108	256 1058 942	Metalized 0.056 μ F/50V	CF93A1H563J (JL)
C109,110	255 1265 907	Mylar film 6800 pF/50V	CQ93M1H682J(B)
C111,112	257 0004 961	Ceramic chip 100 pF/50V	CC73SL1H101J
C113,114	255 1265 949	Mylar film 0.012 μ F/50V	CQ93M1H123J(B)
C115,116	255 1264 953	Mylar film 2700 pF/50V	CQ93M1H272J(B)
C117,118	254 4524 972	Electrolytic 4.7 μ F/50V	CE04W1H4R7M SMG/RE3
C119,120	255 1265 978	Mylar film 0.022 μ F/50V	CQ93M1H223J(B)
C121,122	254 4524 972	Electrolytic 4.7 μ F/50V	CE04W1H4R7M SMG/RE3
C123,124	257 0014 935	Ceramic chip 0.1 μ F/25V	CK73F1E104Z
C304	Note	Note	
C305	Note	Note	
C308	Note	Note	
C309	Note	Note	
C310	257 0008 983	Ceramic chip 1000 pF/50V	CK73B1H102K
C311	Note	Note	
C312	Note	Note	
C314	257 0008 983	Ceramic chip 1000 pF/50V	CK73B1H102K
C315	Note	Note	
C316	Note	Note	
C317	257 0008 983	Ceramic chip 1000 pF/50V	CK73B1H102K
C321	Note	Note	
C322	Note	Note	
C323	Note	Note	
C324	Note	Note	
C325	257 0008 983	Ceramic chip 1000 pF/50V	CK73B1H102K
C327	Note	Note	
C333	257 0008 983	Ceramic chip 1000 pF/50V	CK73B1H102K

Ref. No.	Part No.	Part Name	Remarks	Ref. No.	Part No.	Part Name	Remarks	Q'ty	
C339	254 4536 957	Electrolytic 470 μ F/10V	CE04W1A471MT SMG/RE3	C956	254 4538 900	Electrolytic 10 μ F/16V	CE04W1C100M SMG/RE3		
C340	257 0014 935	Ceramic chip 0.1 μ F/25V	CK73F1E104Z	C957-960	254 4524 943	Electrolytic 1 μ F/50V	CE04W1H010M SMG/RE3		
C341	254 4538 939	Electrolytic 47 μ F/16V	CE04W1C470M SMG/RE3	C961	257 0012 966	Ceramic chip 0.01 μ F/50V	CK73F1H103Z		
C342	257 0010 984	Ceramic chip 0.047 μ F/50V	CK73B1H473K	C962	254 4524 943	Electrolytic 1 μ F/50V	CE04W1H010M SMG/RE3		
C348	254 4538 939	Electrolytic 47 μ F/16V	CE04W1C470M SMG/RE3	C981	Note	Note			
C349	257 0012 966	Ceramic chip 0.01 μ F/50V	CK73F1H103Z	C983	Note	Note			
C350	256 1058 984	Metalized 0.12 μ F/50V	CF93A1H124J (JL)	C984	Note	Note			
C352	254 4304 927	Electrolytic 4.7 μ F/35V	CE04W1V4R7M(SRE)	OTHER PARTS					
C353	257 0012 966	Ceramic chip 0.01 μ F/50V	CK73F1H103Z	CW064	205 1124 069	6P Connector socket		1	
C354	254 4300 963	Electrolytic 100 μ F/6.3V	CE04W0J101M(SRE)	CW066	205 1124 069	6P Connector socket		1	
C355	257 0012 966	Ceramic chip 0.01 μ F/50V	CK73F1H103Z	CW085	205 0885 095	8P Connector socket		1	
C356	257 0008 983	Ceramic chip 1000 pF/50V	CK73B1H102K	CW092	205 0885 037	9P Connector socket		1	
C357	259 0007 702	Back up cap. 8200 μ F/5.5V	SB CAP==822=C	CW116	205 0885 066	11P Connector socket		1	
C358	257 0008 983	Ceramic chip 1000 pF/50V	CK73B1H102K	CW124	205 0885 079	12P Connector socket		1	
C359	254 4533 934	Electrolytic 220 μ F/6.3V	CE04W0J221M SMG/RE3	CW156	205 1125 055	15P Connector socket		1	
C367	257 0012 966	Ceramic chip 0.01 μ F/50V	CK73F1H103Z	CX051,052	205 1122 058	5P Connector base		2	
C368	Note	Note		CX061-063	205 1122 061	6P Connector base		3	
C376	Note	Note		CX064,065	205 1122 061	6P Connector base		2	
C377	254 4538 900	Electrolytic 10 μ F/16V	CE04W1C100M SMG/RE3	CX066	205 1122 061	6P Connector base		1	
C379	257 0008 983	Ceramic chip 1000 pF/50V	CK73B1H102K	CX071,072	205 0943 021	7P Connector base		2	
C382	Note	Note		CX073	205 1000 015	7P FJ Connector plug		1	
C384	Note	Note		CX075,076	205 1000 015	7P FJ Connector plug		2	
C386	Note	Note		CX079	205 1122 074	7P Connector base		1	
C389	Note	Note		CX081-083	205 1122 087	8P Connector base		3	
C390	Note	Note		CX091	205 1122 090	9P Connector base		1	
C391	Note	Note		CX111,112	205 1123 015	11P Connector base		2	
C393	257 0008 983	Ceramic chip 1000 pF/50V	CK73B1H102K	CX116,117	205 1123 015	11P Connector base		2	
C394-396	Note	Note		CX121-123	205 1123 028	12P Connector base		3	
C701-704	257 0014 935	Ceramic chip 0.1 μ F/25V	CK73F1E104Z	CX124	205 0884 070	12P Connector base		1	
C705-707	254 4538 939	Electrolytic 47 μ F/16V	CE04W1C470M SMG/RE3	CX141	205 1123 044	14P Connector base		1	
C709	257 0014 935	Ceramic chip 0.1 μ F/25V	CK73F1E104Z	CX151	205 1123 057	15P Connector base		1	
C710	254 4524 969	Electrolytic 3.3 μ F/50V	CE04W1H3R3M SMG/RE3	CX161,162	205 1056 027	16P Connector socket TKC-V		2	
C714	257 0003 904	Ceramic chip 22 pF/50V	CC73SL1H220J	CY036	Note	Note		1	
C715,716	257 0012 966	Ceramic chip 0.01 μ F/50V	CK73F1H103Z	CY401	205 1126 041	4P Connector base		1	
C717	254 4538 900	Electrolytic 10 μ F/16V	CE04W1C100M SMG/RE3	FB302	235 0049 900	Beads inductor		1	
C718,719	257 0012 966	Ceramic chip 0.01 μ F/50V	CK73F1H103Z	FB304,305	235 0049 900	Beads inductor		2	
C720	Note	Note		FB306	235 0049 900	Beads inductor		1	
C857	257 0012 966	Ceramic chip 0.01 μ F/50V	CK73F1H103Z	FB704-706	247 0018 905	Carbon chip 0 ohm 1/10W	RM73B-OROKT	3	
C858	254 4524 943	Electrolytic 1 μ F/50V	CE04W1H010M SMG/RE3	JK501	Note	Note		1	
C901	253 1181 904	Ceramic 0.01 μ F/50V	CK45F1H103Z	JK801	204 8540 009	4P Pin jack		1	
C902	254 4524 956	Electrolytic 2.2 μ F/50V	CE04W1H2R2M SMG/RE3	JK901	204 8540 009	4P Pin jack		1	
C903	253 1181 904	Ceramic 0.01 μ F/50V	CK45F1H103Z	JK701	204 8551 014	1P Pin jack (OR)		1	
C909	254 4524 943	Electrolytic 1 μ F/50V	CE04W1H010M SMG/RE3	L303	235 0070 908	Inductor 120mH		1	
C911	254 4527 908	Electrolytic 0.1 μ F/100V	CE04W2A0R1M SMG/RE3	L308	235 0131 902	Chip emifil (BLM21B272S)		1	
C912	254 4524 985	Electrolytic 10 μ F/50V	CE04W1H100M SMG/RE3	L313-315	235 0131 902	Chip emifil (BLM21B272S)		3	
C913-918	254 4524 901	Electrolytic 0.1 μ F/50V	CE04W1H0R1M SMG/RE3						
C919	254 4522 958	Electrolytic 100 μ F/35V	CE04W1V101M SMG/RE3						
C952,953	254 4538 900	Electrolytic 10 μ F/16V	CE04W1C100M SMG/RE3						
C954,955	257 0004 961	Ceramic chip 100 pF/50V	CC73SL1H101J						

1U-3201 REGULATOR UNIT ASS'Y

Ref. No.	Part No.	Part Name	Remarks	Q'ty	Ref. No.	Part No.	Part Name	Remarks
L317	235 0049 900	Beads inductor		1	SEMICONDUCTORS GROUP			
L318	231 0083 003	Low volt line filter		1	IC501	Note	Note	
L319	235 0131 902	Chip emifil (BLM21B272S)		1	IC502	263 0891 001	IC LA1265(S)	
L702	235 0060 918	Inductor 4.7mH		1	IC503	263 0439 007	IC LA3401	
L703	235 0060 905	Inductor 2.2mH		1	IC507	262 2450 900	IC LC72131M	
L704,705	235 0060 918	Inductor 4.7mH		2	IC902,903	263 0809 006	IC NJM7805FA(S)	
RL901	214 0200 001	Relay (EC2-12N35)		1	IC904	263 0793 002	IC NJM7806FA(S)	
W708,709	205 1034 010	M3 Screw teaminal		2	IC905,906	263 0801 004	IC NJM7812FA(S)	
X301	Note	Note		1	IC907	263 0641 002	IC NJM7912FA	
XL301	Note	Note		1	TR501	Note	Note	
XL302	399 0532 902	Crystal CST12.5MTW		1	TR502	273 0411 909	Transistor 2SC2996-Y	
	203 0525 029	1P SIN Cord ass'y	L=210	1	TR503,504	269 0083 901	Transistor DTA114EK	
	203 0463 000	1P SIN Connector ass'y	L=280	1	TR505	269 0114 906	Transistor RN2402	
					TR508	269 0054 901	Transistor DTC144EK	
					TR509,510	269 0066 902	Transistor DTC323TK	
					TR511	269 0086 908	Transistor DTA114TK	
					TR801-814	273 0253 918	Transistor 2SC2878(A/B)	
					TR815-818	271 0094 919	Transistor 2SA970(BL)	
					TR819,820	273 0281 906	Transistor 2SC2705 (O)/(Y)	
					TR821,822	273 0253 918	Transistor 2SC2878(A/B)	
					TR823-826	271 0094 919	Transistor 2SA970(BL)	
					TR827,828	273 0281 906	Transistor 2SC2705 (O)/(Y)	
					TR829	273 0253 918	Transistor 2SC2878(A/B)	
					TR830,831	271 0094 919	Transistor 2SA970(BL)	
					TR832	273 0281 906	Transistor 2SC2705 (O)/(Y)	
					TR911	269 0082 902	Transistor DTC114EK	
					TR913-915	273 0253 918	Transistor 2SC2878(A/B)	
					TR916	273 0253 918	Transistor 2SC2878(A/B)	
					TR918-920	271 0262 000	Transistor 2SA1670(O/P/Y)	
					TR921	274 0158 003	Transistor 2SD1763A(D)	
					TR922	269 0082 902	Transistor DTC114EK	
					TR924	272 0115 008	Transistor 2SB1186A(D)	
					TR926	275 0042 905	Transistor 2SK373(Y)	
					TR927	269 0082 902	Transistor DTC114EK	
					D501	276 0432 903	Diode 1SS270A	
					D503-505	276 0432 903	Diode 1SS270A	
					D911-913	276 0432 903	Diode 1SS270A	
					D914,915	276 0553 905	Diode 1SR35-200A	
					D916	276 0305 001	Diode S4VB20	
					D918,919	276 0553 905	Diode 1SR35-200A	
					D922	276 0305 001	Diode S4VB20	
					D923	276 0553 905	Diode 1SR35-200A	
					ZD502	276 0644 937	Zener diode MTZJ9.1A	

Ref. No.	Part No.	Part Name	Remarks
ZD901	276 0644 966	Zener diode MTZJ12A	
ZD917,918	276 0637 902	Zener diode MTZJ6.2A	
PT901	279 0034 054	Posistor PTH9M04BC222TS2F333	
PT902	279 0034 012	Posistor PTH9M04BG222TS2F333	

RESISTORS GROUP

R501	247 0002 966	Carbon chip 10 ohm 1/10W	RM73B--100J
R502	Note	Note	
R503	247 0007 945	Carbon chip 1 kohm 1/10W	RM73B--102J
R504-512	247 0018 905	Carbon chip 0 ohm 1/10W	RM73B--0R0K
R514	247 0005 905	Carbon chip 100 ohm 1/10W	RM73B--101J
R515	Note	Note	
R516	Note	Note	
R517	Note	Note	
R518	247 0005 989	Carbon chip 220 ohm 1/10W	RM73B--221J
R519	247 0006 962	Carbon chip 470 ohm 1/10W	RM73B--471J
R520	247 0007 945	Carbon chip 1 kohm 1/10W	RM73B--102J
R521	247 0009 901	Carbon chip 4.7 kohm 1/10W	RM73B--472J
R522	247 0006 920	Carbon chip 330 ohm 1/10W	RM73B--331J
R523	247 0007 961	Carbon chip 1.2 kohm 1/10W	RM73B--122J
R524	247 0012 927	Carbon chip 100 kohm 1/10W	RM73B--104J
R525	247 0007 945	Carbon chip 1 kohm 1/10W	RM73B--102J
R526	247 0009 927	Carbon chip 5.6 kohm 1/10W	RM73B--562J
R527-529	247 0007 945	Carbon chip 1 kohm 1/10W	RM73B--102J
R531,532	247 0018 905	Carbon chip 0 ohm 1/10W	RM73B--0R0K
R533	Note	Note	
R534	247 0005 921	Carbon chip 120 ohm 1/10W	RM73B--121J
R535	Note	Note	
R536	Note	Note	
R537	247 0011 986	Carbon chip 68 kohm 1/10W	RM73B--683J
R538	247 0009 943	Carbon chip 6.8 kohm 1/10W	RM73B--682J
R539	247 0009 927	Carbon chip 5.6 kohm 1/10W	RM73B--562J
R540,541	247 0009 985	Carbon chip 10 kohm 1/10W	RM73B--103J
R542,543	247 0008 960	Carbon chip 3.3 kohm 1/10W	RM73B--332J
R544,545	Note	Note	
R546	247 0011 928	Carbon chip 39 kohm 1/10W	RM73B--393J
R547	247 0012 927	Carbon chip 100 kohm 1/10W	RM73B--104J
R548	247 0009 985	Carbon chip 10 kohm 1/10W	RM73B--103J
R549	247 0012 927	Carbon chip 100 kohm 1/10W	RM73B--104J
R550	247 0009 927	Carbon chip 5.6 kohm 1/10W	RM73B--562J
R551	247 0009 985	Carbon chip 10 kohm 1/10W	RM73B--103J
R553,554	247 0008 960	Carbon chip 3.3 kohm 1/10W	RM73B--332J
R555,556	Note	Note	
R569	Note	Note	
R570	Note	Note	
R571-574	247 0018 905	Carbon chip 0 ohm 1/10W	RM73B--0R0K
R575,576	Note	Note	
R577	247 0010 961	Carbon chip 22 kohm 1/10W	RM73B--223J
R578	247 0018 905	Carbon chip 0 ohm 1/10W	RM73B--0R0K
R579-581	Note	Note	

Ref. No.	Part No.	Part Name	Remarks	Q'ty
R582	247 0018 905	Carbon chip 0 ohm 1/10W	RM73B--0R0K	
R595	247 0018 905	Carbon chip 0 ohm 1/10W	RM73B--0R0K	
R713,714	244 2052 960	Metal oxide 220 ohm 1W	RS14B3A221JNBS(S)	
R861,862	241 2376 964	Carbon film 47 ohm 1/4W(NB)	RD14B2E470JNBS	
R887,888	241 2376 964	Carbon film 47 ohm 1/4W(NB)	RD14B2E470JNBS	
R901	241 2376 964	Carbon film 47 ohm 1/4W(NB)	RD14B2E470JNBS	
R911	247 0006 917	Carbon chip 300 ohm 1/10W	RM73B--301J	
R912,913	247 0006 975	Carbon chip 510 ohm 1/10W	RM73B--511J	
R914	247 0007 903	Carbon chip 680 ohm 1/10W	RM73B--681J	
R917	247 0005 976	Carbon chip 200 ohm 1/10W	RM73B--201J	
R941,942	247 0005 905	Carbon chip 100 ohm 1/10W	RM73B--101J	
R943,944	247 0009 901	Carbon chip 4.7 kohm 1/10W	RM73B--472J	
R949-951	241 2376 919	Carbon film 30 ohm 1/4W(NB)	RD14B2E300JNBS	
R958,959	241 2376 964	Carbon film 47 ohm 1/4W(NB)	RD14B2E470JNBS	
R963	241 2375 907	Carbon film 10 ohm 1/4W(NB)	RD14B2E100JNBS	
VR501	211 6132 925	Semi fixed resistor 10 kohm	V06PB103	
VR502	211 6132 983	Semi fixed resistor 100 kohm	V06PB104	

CAPACITORS GROUP

C501,502	257 0008 983	Ceramic chip 1000 pF/50V	CK73B1H102K
C503-505	257 0010 900	Ceramic chip 0.01 μF/50V	CK73B1H103K
C507,508	257 0010 900	Ceramic chip 0.01 μF/50V	CK73B1H103K
C509	257 0002 947	Ceramic chip 12 pF/50V	CC73SL1H120J
C510	257 0010 900	Ceramic chip 0.01 μF/50V	CK73B1H103K
C511	254 4538 939	Electrolytic 47 μF/16V	CE04W1C470M SMG/RE3
C512	257 0010 900	Ceramic chip 0.01 μF/50V	CK73B1H103K
C513	254 4524 943	Electrolytic 1 μF/50V	CE04W1H010M SMG/RE3
C514	257 0012 966	Ceramic chip 0.01 μF/50V	CK73F1H103Z
C515	254 4538 939	Electrolytic 47 μF/16V	CE04W1C470M SMG/RE3
C516,517	257 0010 900	Ceramic chip 0.01 μF/50V	CK73B1H103K
C518	257 0010 984	Ceramic chip 0.047 μF/50V	CK73B1H473K
C519	Note	Note	
C520	257 0004 961	Ceramic chip 100 pF/50V	CC73SL1H101J
C521-523	257 0010 900	Ceramic chip 0.01 μF/50V	CK73B1H103K
C524	254 4524 930	Electrolytic 47 μF/50V	CE04W1HR47M SMG/RE3
C525	254 4524 985	Electrolytic 10 μF/50V	CE04W1H100M SMG/RE3
C526	257 0010 942	Ceramic chip 0.022 μF/50V	CK73B1H223K
C527	Note	Note	
C528	254 4538 939	Electrolytic 47 μF/16V	CE04W1C470M SMG/RE3
C529	254 4524 943	Electrolytic 1 μF/50V	CE04W1H010M SMG/RE3
C530	254 4524 914	Electrolytic 0.22 μF/50V	CE04W1HR22M SMG/RE3
C531	254 4524 943	Electrolytic 1 μF/50V	CE04W1H010M SMG/RE3
C532	257 0010 900	Ceramic chip 0.01 μF/50V	CK73B1H103K
C533	256 1058 939	Metalized 0.047 μF/50V	CF93A1H473J (JL)
C535	254 3053 910	Electrolytic 22 μF/16V	CE04D1C220MBP
C536	Note	Note	

Ref. No.	Part No.	Part Name	Remarks	Ref. No.	Part No.	Part Name	Remarks	Q'ty
C537	Note	Note		C963	254 4257 702	Electrolytic 3300 µF/25V	CE04W1E332MC	
C538	254 4538 913	Electrolytic 22 µF/16V	CE04W1C220M SMG/RE3	C965-968	256 1058 971	Metalized 0.1 µF/50V	CF93A1H104J (JL)	
C539,540	Note	Note		C969,970	254 4524 943	Electrolytic 1 µF/50V	CE04W1H010M SMG/RE3	
C541	254 4524 956	Electrolytic 2.2 µF/50V	CE04W1H2R2M SMG/RE3	C975,976	254 4524 943	Electrolytic 1 µF/50V	CE04W1H010M SMG/RE3	
C544	257 0010 900	Ceramic chip 0.01 µF/50V	CK73B1H103K	C977,978	254 4524 985	Electrolytic 10 µF/50V	CE04W1H100M SMG/RE3	
C545,546	254 4538 900	Electrolytic 10 µF/16V	CE04W1C100M SMG/RE3	C979	254 4524 985	Electrolytic 10 µF/50V	CE04W1H100M SMG/RE3	
C557,558	257 0002 963	Ceramic chip 15 pF/50V	CC73SL1H150J	OTHER PARTS				
C559	254 4524 943	Electrolytic 1 µF/50V	CE04W1H010M SMG/RE3	CF501	Note	Note		1
C561	257 0012 966	Ceramic chip 0.01 µF/50V	CK73F1H103Z	CF502	Note	Note		1
C562	257 0014 935	Ceramic chip 0.1 µF/25V	CK73F1E104Z	CF503	261 0079 005	Ceramic resonator CSB456F11		1
C570	254 4538 900	Electrolytic 10 µF/16V	CE04W1C100M SMG/RE3	CF504	261 0031 001	Ceramic filter BFU450C4		1
C571	254 4524 943	Electrolytic 1 µF/50V	CE04W1H010M SMG/RE3	CF505	261 0116 007	Ceramic filter SFU450B3		1
C574	254 0004 961	Ceramic chip 100 pF/50V	CC73SL1H101J	CW054-057	205 1124 056	5P Connector socket		4
C575	257 0012 966	Ceramic chip 0.01 µF/50V	CK73F1H103Z	CW065	205 1124 069	6P Connector socket		1
C721,722	255 1264 908	Mylar film 1000 pF/50V	CQ93M1H102J(B)	CW073	205 1081 018	7P FJ Connector base		1
C723	253 9039 906	Ceramic 0.1 µF/25V	CK45=1E104Z	CW074	205 1124 072	7P Connector socket		1
C813-826	254 4538 913	Electrolytic 22 µF/16V	CE04W1C220M SMG/RE3	CW075,076	205 1081 018	7P FJ Conenctor base		2
C829,830	254 4524 985	Electrolytic 10 µF/50V	CE04W1H100M SMG/RE3	CW081	205 1124 085	8P Connector socket		1
C831,832	253 1179 945	Ceramic 220 pF/50V	CK45B1H221K	CW117	205 1125 013	11P Connector socket		1
C835,836	254 4538 939	Electrolytic 47 µF/16V	CE04W1C470M SMG/RE3	CW122	205 1125 026	12P Connector socket		1
C837,838	255 1264 966	Mylar film 3300 pF/50V	CQ93M1H332J(B)	CW151	205 1125 055	15P Connector socket		1
C839,840	253 4482 901	Ceramic 33 pF/500V	CC45SL2H330J	CX021,022	205 0185 025	2P Wire holder		2
C841,842	254 4538 913	Electrolytic 22 µF/16V	CE04W1C220M SMG/RE3	CX034	205 1121 033	3P Connector base-L(5268)		1
C845,846	254 4524 985	Electrolytic 10 µF/50V	CE04W1H100M SMG/RE3	CX037-039	205 1126 038	3P Connector base(53014)		3
C847,848	253 1179 945	Ceramic 220 pF/50V	CK45B1H221K	CX087	205 1121 088	8P Connector base(5268)		1
C851,852	254 4538 939	Electrolytic 47 µF/16V	CE04W1C470M SMG/RE3	CX101	205 1081 005	10P FJ Connector base		1
C853,854	255 1264 966	Mylar film 3300 pF/50V	CQ93M1H332J(B)	CX156	205 1123 057	15P Connector base		1
C855,856	253 4482 901	Ceramic 33 pF/500V	CC45SL2H330J	CY031	205 1126 038	3P Connector base(53014)		1
C859	254 4524 985	Electrolytic 10 µF/50V	CE04W1H100M SMG/RE3	CY037	205 1126 038	3P Connector base(53014)		1
C860	254 4538 913	Electrolytic 22 µF/16V	CE04W1C220M SMG/RE3	CY038,039	205 1127 037	3P Connector base-L(53015)		2
C862	254 4524 985	Electrolytic 10 µF/50V	CE04W1H100M SMG/RE3	TP102	205 0190 036	3P NH Connector base		1
C863	253 1179 945	Ceramic 220 pF/50V	CK45B1H221K	Δ F011-013	Note	Note		3
C864	253 1179 945	Ceramic 220 pF/50V	CK45B1H221K	Δ F014	Note	Note		1
C865	254 4538 939	Electrolytic 47 µF/16V	CE04W1C470M SMG/RE3	FB501	235 0049 900	Beads inductor		1
C866	255 1264 966	Mylar film 3300 pF/50V	CQ93M1H332J(B)	FF901-904	202 0040 909	Fuse clip		4
C867	253 4482 901	Ceramic 33 pF/500V	CC45SL2H330J	FH901-904	202 0040 909	Fuse cliip		4
C914	253 1181 904	Ceramic 0.01 µF/50V	CK45F1H103Z	JK501	205 0847 004	3P antenna terminal (PAL/F)		1
C915	253 1181 904	Ceramic 0.01 µF/50V	CK45F1H103Z	JK702	204 8580 001	Headphone jack		1
C929-932	254 4538 913	Electrolytic 22 µF/16V	CE04W1C220M SMG/RE3	L301	235 0060 963	Inductor 15\$\$\$H		1
C937	254 4538 939	Electrolytic 47 µF/16V	CE04W1C470M SMG/RE3	L504	235 0060 905	Inductor 2.2\$\$\$H		1
C938	253 9039 906	Ceramic 0.1 µF/25V	CK45=1E104Z					
C939-944	253 1181 904	Ceramic 0.01 µF/50V	CK45F1H103Z					
C945-950	254 4541 939	Electrolytic 47 µF/25V	CE04W1E470M SMG/RE3					
C951,952	254 4524 943	Electrolytic 1 µF/50V	CE04W1H010M SMG/RE3					
C954-956	254 4524 943	Electrolytic 1 µF/50V	CE04W1H010M SMG/RE3					
C957,958	254 4406 702	Electrolytic 3300 µF/16V	CE04W1C332MC(SMG)					
C959	254 4524 943	Electrolytic 1 µF/50V	CE04W1H010M SMG/RE3					
C960,961	253 1181 904	Ceramic 0.01 µF/50V	CK45F1H103Z					
C962	254 4403 747	Electrolytic 10000 µF/25V	CE04W1E103MC(SMG)					

1U-3215 AUDIO/DSP UNIT ASS'Y

Ref. No.	Part No.	Part Name	Remarks	Q'ty	Ref. No.	Part No.	Part Name	Remarks
LF501	Note	Note		1	SEMICONDUCTORS GROUP			
LF503,504	Note	Note		2	IC106	263 0896 909	IC NJM2068MD	
S501	Note	Note		1	IC107	262 2545 006	IC TC9274N-011	
S901	212 0373 000	Rotary encoder EC16B		1	IC108	262 2033 000	IC TC9273N-004	
S902-905	212 5609 902	Tact switch		4	IC109	263 0896 909	IC NJM2068MD	
SW901	212 0420 005	1P Push switch (NON LOCK)		1	IC112	263 0896 909	IC NJM2068MD	
T501	231 2096 001	MW ant.-osc. coil		1	IC301	262 2615 004	IC TMP93CS41F	
T502	231 2085 009	FM DET trans.		1	IC302	262 2682 901	IC SN74LV573ANS-EL2	
T503	231 1138 009	AM IFT		1	IC303	262 2710 006	IC W29EE011P-90 (33)	
TP101	205 0190 036	3P NH Connector base		1	IC401	262 2673 004	IC ADSST-21061LKS-176	
W075	205 1034 010	M3 Screw terminal		1	IC402	262 2630 005	IC MSM32R0050-521GS	
XL503	399 0075 003	Crystal 7.2 MHz		1	IC403	262 2703 000	IC TC58FVT800FT-12 (33)	
	513 2585 045	Fuse label		3	IC404,405	262 2611 008	IC TC55V1664BFT-12	
	513 2585 074	Fuse label		1	IC406	262 2671 909	IC HG-8002JA44MHZPCCX	
					IC407,408	262 2519 906	IC SN74LV00APW-EL2	
					IC409	262 2518 907	IC SN74LV74APW-EL2	
					IC410	262 2504 908	IC TC74VHC02FT	
					IC411	262 2606 903	IC SN74AHCT573PW	
					IC412	262 2682 901	IC SN74LV573ANS-EL2	
					IC413	262 2520 908	IC TC74VHC541FT	
					IC414	262 2503 909	IC TC74VHCT541AFT	
					IC415,416	262 2685 908	IC SN74AHCT1G08DBV	
					IC417,418	262 2685 908	IC SN74AHCT1G08DBV	
					IC419,420	262 2685 908	IC SN74AHCT1G08DBV	
					IC507	Note	Note	
					IC510	262 2386 906	IC SN74HC151NS	
					IC511	Note	Note	
					IC512	Note	Note	
					IC516	Note	Note	
					IC517	262 2608 901	IC TC74VHC123AF	
					IC523	262 2608 901	IC TC74VHC123AF	
					IC524	262 2519 906	IC SN74LV00APW-EL2	
					IC525	262 2609 900	IC SN74AHC157PW	
					IC527	262 2426 905	IC AK5351-VF	
					IC528	399 0515 000	IC SG-8002DCPT(12.288M)	
					IC529	262 2519 906	IC SN74LV00APW-EL2	
					IC530	262 2557 900	IC SN74LV14APW-EL2	
					IC531	262 2675 002	IC LC89055W(ES4)	
					IC532	262 2557 900	IC SN74LV14APW-EL2	
					IC601	263 1048 002	IC BA033T	
					IC651,652	263 0934 900	IC BA4510F-E2	
					IC701~703	262 2674 906	IC AD1855JRSRL	
					IC731~733	263 0896 909	IC NJM2068MD	
					TR305	269 0082 902	Transistor DTC114EK	
					TR501	Note	Note	

Ref. No.	Part No.	Part Name	Remarks
TR502	Note	Note	
TR503,504	Note	Note	
TR505	Note	Note	
TR506	Note	Note	
TR701	269 0083 901	Transistor DTA114EK	
TR702	269 0082 902	Transistor DTC114EK	
TR703-712	269 0083 901	Transistor DTA114EK	
D501	Note	Note	
D502	Note	Note	
D701-703	276 0438 949	Diode MA151WK	

RESISTORS GROUP

R101,102	Note	Note	
R103,104	247 0015 966	Carbon chip 2.7 Mohm 1/10W	RM73B-275J
R107-110	247 0018 905	Carbon chip 0 ohm 1/10W	RM73B-0R0K
R113,114	Note	Note	
R115,116	247 0015 966	Carbon chip 2.7 Mohm 1/10W	RM73B-275J
R119-122	247 0018 905	Carbon chip 0 ohm 1/10W	RM73B-0R0K
R125,126	Note	Note	
R127,128	247 0015 966	Carbon chip 2.7 Mohm 1/10W	RM73B-275J
R131-134	247 0018 905	Carbon chip 0 ohm 1/10W	RM73B-0R0K
R137,138	Note	Note	
R139,140	247 0015 966	Carbon chip 2.7 Mohm 1/10W	RM73B-275J
R143-146	247 0018 905	Carbon chip 0 ohm 1/10W	RM73B-0R0K
R149,150	Note	Note	
R151,152	247 0015 966	Carbon chip 2.7 Mohm 1/10W	RM73B-275J
R155-158	247 0018 905	Carbon chip 0 ohm 1/10W	RM73B-0R0K
R161,162	Note	Note	
R163-166	247 0012 927	Carbon chip 100 kohm 1/10W	RM73B-104J
R167,168	247 0006 962	Carbon chip 470 ohm 1/10W	RM73B-471J
R169,170	247 0004 922	Carbon chip 47 ohm 1/10W	RM73B-470J
R171,172	247 0012 927	Carbon chip 100 kohm 1/10W	RM73B-104J
R173,174	247 0015 966	Carbon chip 2.7 Mohm 1/10W	RM73B-275J
R175,176	247 0006 962	Carbon chip 470 ohm 1/10W	RM73B-471J
R177,178	247 0015 966	Carbon chip 2.7 Mohm 1/10W	RM73B-275J
R179,180	247 0006 962	Carbon chip 470 ohm 1/10W	RM73B-471J
R181,182	247 0015 966	Carbon chip 2.7 Mohm 1/10W	RM73B-275J
R183,184	247 0006 962	Carbon chip 470 ohm 1/10W	RM73B-471J
R185,186	247 0018 905	Carbon chip 0 ohm 1/10W	RM73B-0R0K
R187-190	247 0012 998	Carbon chip 200 kohm 1/10W	RM73B-204J
R191,192	247 0005 905	Carbon chip 100 ohm 1/10W	RM73B-101J
R195,196	247 0018 905	Carbon chip 0 ohm 1/10W	RM73B-0R0K
R197-200	247 0005 905	Carbon chip 100 ohm 1/10W	RM73B-101J
R201,202	247 0012 927	Carbon chip 100 kohm 1/10W	RM73B-104J
R203-206	247 0012 998	Carbon chip 200 kohm 1/10W	RM73B-204J
R207,208	247 0006 962	Carbon chip 470 ohm 1/10W	RM73B-471J
R209,210	247 0004 922	Carbon chip 47 ohm 1/10W	RM73B-470J

Ref. No.	Part No.	Part Name	Remarks
R211,212	247 0011 944	Carbon chip 47 kohm 1/10W	RM73B-473J
R213-222	247 0018 905	Carbon chip 0 ohm 1/10W	RM73B-0R0K
R223,224	247 0018 905	Carbon chip 0 ohm 1/10W	RM73B-0R0K
R225-232	247 0018 905	Carbon chip 0 ohm 1/10W	RM73B-0R0K
R235,236	247 0018 905	Carbon chip 0 ohm 1/10W	RM73B-0R0K
R237-246	247 2018 903	Carbon chip 0 ohm 1/16W	RM73B-0R0K
R249-258	247 2018 903	Carbon chip 0 ohm 1/16W	RM73B-0R0K
R301,302	247 0009 985	Carbon chip 10 kohm 1/10W	RM73B-103J
R303	247 2003 989	Carbon chip 33 ohm 1/16W	RM73B-330J
R304	247 0009 901	Carbon chip 4.7 kohm 1/10W	RM73B-472J
R305,306	247 2003 989	Carbon chip 33 ohm 1/16W	RM73B-330J
R307	247 0009 985	Carbon chip 10 kohm 1/10W	RM73B-103J
R308	247 2003 989	Carbon chip 33 ohm 1/16W	RM73B-330J
R309	247 0009 985	Carbon chip 10 kohm 1/10W	RM73B-103J
R311,312	247 2003 989	Carbon chip 33 ohm 1/16W	RM73B-330J
R313	247 0009 985	Carbon chip 10 kohm 1/10W	RM73B-103J
R314-327	247 2003 989	Carbon chip 33 ohm 1/16W	RM73B-330J
R328	247 0018 905	Carbon chip 0 ohm 1/10W	RM73B-0R0K
R332	247 2018 903	Carbon chip 0 ohm 1/16W	RM73B-0R0K
R334	247 0018 905	Carbon chip 0 ohm 1/10W	RM73B-0R0K
R335,336	247 0009 985	Carbon chip 10 kohm 1/10W	RM73B-103J
R337	247 2011 942	Carbon chip 47 kohm 1/16W	RM73B-473J
R338	247 0009 985	Carbon chip 10 kohm 1/10W	RM73B-103J
R340	247 0009 985	Carbon chip 10 kohm 1/10W	RM73B-103J
R341	247 0009 901	Carbon chip 4.7 kohm 1/10W	RM73B-472J
R342	247 0009 985	Carbon chip 10 kohm 1/10W	RM73B-103J
R345,346	247 0018 905	Carbon chip 0 ohm 1/10W	RM73B-0R0K
R348-351	247 0009 985	Carbon chip 10 kohm 1/10W	RM73B-103J
R401	247 0009 985	Carbon chip 10 kohm 1/10W	RM73B-103J
R402,403	247 2009 983	Carbon chip 16 kohm 1/16W	RM73B-103J
R404-407	247 2018 903	Carbon chip 0 ohm 1/16W	RM73B-0R0K
R408-411	247 2009 983	Carbon chip 10 kohm 1/16W	RM73B-103J
R412	247 2003 989	Carbon chip 33 ohm 1/16W	RM73B-330J
R413	247 2009 983	Carbon chip 10 kohm 1/16W	RM73B-103J
R414-430	247 2003 989	Carbon chip 33 ohm 1/16W	RM73B-330J
R431	247 2018 903	Carbon chip 0 ohm 1/16W	RM73B-0R0K
R432-434	247 2003 989	Carbon chip 33 ohm 1/16W	RM73B-330J
R435	247 2004 920	Carbon chip 47 ohm 1/16W	RM73B-470J
R437-440	247 2003 989	Carbon chip 33 ohm 1/16W	RM73B-330J
R442-450	247 2003 989	Carbon chip 33 ohm 1/16W	RM73B-330J
R453	247 2003 989	Carbon chip 33 ohm 1/16W	RM73B-330J
R454	247 2009 983	Carbon chip 10 kohm 1/16W	RM73B-103J
R455-460	247 2003 989	Carbon chip 33 ohm 1/16W	RM73B-330J
R462-464	247 2003 989	Carbon chip 33 ohm 1/16W	RM73B-330J
R466,467	247 2003 989	Carbon chip 33 ohm 1/16W	RM73B-330J
R469	247 2009 983	Carbon chip 10 kohm 1/16W	RM73B-103J
R470-472	247 2003 989	Carbon chip 33 ohm 1/16W	RM73B-330J
R473,474	247 2009 983	Carbon chip 10 kohm 1/16W	RM73B-103J
R475-480	247 2003 989	Carbon chip 33 ohm 1/16W	RM73B-330J
R482,483	247 2003 989	Carbon chip 33 ohm 1/16W	RM73B-330J

Ref. No.	Part No.	Part Name	Remarks	Ref. No.	Part No.	Part Name	Remarks
R484,485	247 2004 920	Carbon chip 47 ohm 1/16W	RM73B-470J	R719,720	247 0008 902	Carbon chip 1.8 kohm 1/10W	RM73B--182J
R486	247 0004 922	Carbon chip 47 ohm 1/10W	RM73B-470J	R721,722	247 0008 986	Carbon chip 3.9 kohm 1/10W	RM73B--392J
R488	247 2004 920	Carbon chip 47 ohm 1/16W	RM73B-470J	R723,724	247 0008 902	Carbon chip 1.8 kohm 1/10W	RM73B--182J
R489	247 0018 905	Carbon chip 0 ohm 1/10W	RM73B-0R0K	R731,732	247 0008 986	Carbon chip 3.9 kohm 1/10W	RM73B--392J
R491-495	247 2004 920	Carbon chip 47 ohm 1/16W	RM73B-470J	R733,734	247 0008 902	Carbon chip 1.8 kohm 1/10W	RM73B--182J
R497,498	247 2009 983	Carbon chip 10 kohm 1/16W	RM73B--103J	R735,736	247 0009 914	Carbon chip 5.1 kohm 1/10W	RM73B--512J
R501-506	Note	Note		R739,740	247 0009 914	Carbon chip 5.1 kohm 1/10W	RM73B--512J
R512-528	Note	Note		R741,742	247 0006 988	Carbon chip 560 ohm 1/10W	RM73B--561J
R529	247 0004 922	Carbon chip 47 ohm 1/10W	RM73B--470J	R743,744	247 0007 990	Carbon chip 1.6 kohm 1/10W	RM73B--162J
R530-533	Note	Note		R745,746	247 0008 986	Carbon chip 3.9 kohm 1/10W	RM73B--392J
R535-589	Note	Note		R747,748	247 0008 902	Carbon chip 1.8 kohm 1/10W	RM73B--182J
R591-594	247 0004 922	Carbon chip 47 ohm 1/10W	RM73B-470J	R749,750	247 0009 914	Carbon chip 5.1 kohm 1/10W	RM73B--512J
R595	247 0014 967	Carbon chip 1 Mohm 1/10W	RM73B--105J	R753,754	247 0009 914	Carbon chip 5.1 kohm 1/10W	RM73B--512J
R596	247 0009 969	Carbon chip 8.2 kohm 1/10W	RM73B--822J	R755,756	247 0006 988	Carbon chip 560 ohm 1/10W	RM73B--561J
R597	247 0008 957	Carbon chip 3 kohm 1/10W	RM73B--302J	R757,758	247 0007 990	Carbon chip 1.6 kohm 1/10W	RM73B--162J
R598	247 0009 914	Carbon chip 5.1 kohm 1/10W	RM73B--512J	R759,760	247 0008 986	Carbon chip 3.9 kohm 1/10W	RM73B--392J
R599	247 0004 977	Carbon chip 75 ohm 1/10W	RM73B--750J	R761,762	247 0008 902	Carbon chip 1.8 kohm 1/10W	RM73B--182J
R602	247 0018 905	Carbon chip 0 ohm 1/10W	RM73B-0R0K	R763,764	247 0009 914	Carbon chip 5.1 kohm 1/10W	RM73B--512J
R606	247 0011 902	Carbon chip 33 kohm 1/10W	RM73B--333J	R767,768	247 0009 914	Carbon chip 5.1 kohm 1/10W	RM73B--512J
R611	247 0004 922	Carbon chip 47 ohm 1/10W	RM73B-470J	R769,770	247 0006 988	Carbon chip 560 ohm 1/10W	RM73B--561J
R612	247 2004 920	Carbon chip 47 ohm 1/16W	RM73B-470J	R771,772	247 0007 990	Carbon chip 1.6 kohm 1/10W	RM73B--162J
R613	247 0004 922	Carbon chip 47 ohm 1/10W	RM73B-470J	R773-781	247 0009 985	Carbon chip 10 kohm 1/10W	RM73B--103J
R614	247 0012 927	Carbon chip 100 kohm 1/10W	RM73B--104J	CAPACITORS GROUP			
R621	Note	Note		C101,102	Note	Note	
R622-624	247 2004 920	Carbon chip 47 ohm 1/16W	RM73B-470J	C113,114	Note	Note	
R625	247 0012 927	Carbon chip 100 kohm 1/10W	RM73B--104J	C123,124	Note	Note	
R626	247 0004 922	Carbon chip 47 ohm 1/10W	RM73B-470J	C135,136	Note	Note	
R627	Note	Note		C145,146	Note	Note	
R628, 629	247 0004 922	Carbon chip 47 ohm 1/10W	RM73B--470J	C157,158	Note	Note	
R630	Note	Note		C159,160	254 4524 985	Electrolytic 10 μ F/50V	CE04W1H100M SMG/RE3
R631	247 0018 905	Carbon chip 0 ohm 1/10W	RM73B-0R0K	C165,166	254 4524 985	Electrolytic 10 μ F/50V	CE04W1H100M SMG/RE3
R651-654	247 0009 901	Carbon chip 4.7 kohm 1/10W	RM73B-472J	C167-172	257 0004 961	Ceramic chip 100 pF/50V	CC73SL1H101J
R655,656	247 0011 944	Carbon chip 47 kohm 1/10W	RM73B-473J	C173,174	257 0012 966	Ceramic chip 0.01 μ F/50V	CK73F1H103Z
R657,658	247 0009 998	Carbon chip 11 kohm 1/10W	RM73B--113J	C177	256 1058 939	Metalized 0.047 μ F/50V	CF93A1H473J (JL)
R659,660	247 0012 972	Carbon chip 100 kohm 1/10W	RM73B--104J	C178-182	257 0012 966	Ceramic chip 0.01 μ F/50V	CK73F1H103Z
R661,662	247 0008 986	Carbon chip 3.9 kohm 1/10W	RM73B--392J	C183-186	254 4524 943	Electrolytic 1 μ F/50V	CE04W1H010M SMG/RE3
R663-666	247 0009 901	Carbon chip 4.7 kohm 1/10W	RM73B-472J	C188	257 0008 983	Ceramic chip 1000 pF/50V	CK73B1H102K
R667-670	247 0006 920	Carbon chip 330 ohm 1/10W	RM73B--331J	C189,190	254 4538 900	Electrolytic 10 μ F/16V	CE04W1C100M SMG/RE3
R671-673	247 2018 903	Carbon chip 0 ohm 1/16W	RM73B-0R0K	C193,194	254 4524 943	Electrolytic 1 μ F/50V	CE04W1H010M SMG/RE3
R676	247 2004 920	Carbon chip 47 ohm 1/16W	RM73B-470J	C195-198	254 4538 900	Electrolytic 10 μ F/16V	CE04W1C100M SMG/RE3
R677	247 2009 983	Carbon chip 10 kohm 1/16W	RM73B--103J	C201,202	254 4524 943	Electrolytic 1 μ F/50V	CE04W1H010M SMG/RE3
R678	247 2004 920	Carbon chip 47 ohm 1/16W	RM73B-470J	C301,302	257 0014 935	Ceramic chip 0.1 μ F/25V	CK73F1E104Z
R679	247 2018 903	Carbon chip 0 ohm 1/16W	RM73B-0R0K	C305	257 0012 966	Ceramic chip 0.01 μ F/50V	CK73F1H103Z
R705-707	247 0009 985	Carbon chip 10 kohm 1/10W	RM73B--103J	C306	257 0014 935	Ceramic chip 0.1 μ F/25V	CK73F1E104Z
R708-710	247 0007 945	Carbon chip 1 kohm 1/10W	RM73B--102J	C307	254 4524 943	Electrolytic 1 μ F/50V	CE04W1H010M SMG/RE3
R711	247 0018 905	Carbon chip 0 ohm 1/10W	RM73B-0R0K	C308	257 0014 935	Ceramic chip 0.1 μ F/25V	CK73F1E104Z
R713,714	247 0008 986	Carbon chip 3.9 kohm 1/10W	RM73B--392J	C309	254 4524 943	Electrolytic 1 μ F/50V	CE04W1H010M SMG/RE3
R715,716	247 0008 944	Carbon chip 2.7 kohm 1/10W	RM73B--272J	C311	257 0012 966	Ceramic chip 0.01 μ F/50V	CK73F1H103Z
R717,718	247 0008 902	Carbon chip 1.8 kohm 1/10W	RM73B--182J				

Ref. No.	Part No.	Part Name	Remarks
C401	257 0014 935	Ceramic chip 0.1 μF/25V	CK73F1E104Z
C402	257 0008 983	Ceramic chip 1000 pF/50V	CK73B1H102K
C403	257 0014 935	Ceramic chip 0.1 μF/25V	CK73F1E104Z
C404	257 0012 966	Ceramic chip 0.01 μF/50V	CK73F1H103Z
C405	257 0008 983	Ceramic chip 1000 pF/50V	CK73B1H102K
C406	257 0014 935	Ceramic chip 0.1 μF/25V	CK73F1E104Z
C407	257 0012 966	Ceramic chip 0.01 μF/50V	CK73F1H103Z
C408	257 0014 935	Ceramic chip 0.1 μF/25V	CK73F1E104Z
C409	257 0012 966	Ceramic chip 0.01 μF/50V	CK73F1H103Z
C410	257 0014 935	Ceramic chip 0.1 μF/25V	CK73F1E104Z
C411-414	257 0012 966	Ceramic chip 0.01 μF/50V	CK73F1H103Z
C415	257 0014 935	Ceramic chip 0.1 μF/25V	CK73F1E104Z
C416,417	257 0008 983	Ceramic chip 1000 pF/50V	CK73B1H102K
C418	257 0012 966	Ceramic chip 0.01 μF/50V	CK73F1H103Z
C419-421	257 0014 935	Ceramic chip 0.1 μF/25V	CK73F1E104Z
C422	257 0012 966	Ceramic chip 0.01 μF/50V	CK73F1H103Z
C423,424	257 0008 983	Ceramic chip 1000 pF/50V	CK73B1H102K
C425	257 0012 966	Ceramic chip 0.01 μF/50V	CK73F1H103Z
C426	257 0014 935	Ceramic chip 0.1 μF/25V	CK73F1E104Z
C427	257 0012 966	Ceramic chip 0.01 μF/50V	CK73F1H103Z
C428	257 0014 935	Ceramic chip 0.1 μF/25V	CK73F1E104Z
C429	257 0008 983	Ceramic chip 1000 pF/50V	CK73B1H102K
C430	257 0012 966	Ceramic chip 0.01 μF/50V	CK73F1H103Z
C431	257 0014 935	Ceramic chip 0.1 μF/25V	CK73F1E104Z
C432	257 0008 983	Ceramic chip 1000 pF/50V	CK73B1H102K
C433	257 0012 966	Ceramic chip 0.01 μF/50V	CK73F1H103Z
C434	254 4533 950	Electrolytic 470 μF/6.3V	CE04W0J471M SMG/RE3
C435	257 0012 966	Ceramic chip 0.01 μF/50V	CK73F1H103Z
C436,437	257 0014 935	Ceramic chip 0.1 μF/25V	CK73F1E104Z
C438,439	257 0012 966	Ceramic chip 0.01 μF/50V	CK73F1H103Z
C440	257 0014 935	Ceramic chip 0.1 μF/25V	CK73F1E104Z
C441,442	257 0012 966	Ceramic chip 0.01 μF/50V	CK73F1H103Z
C443	257 0008 983	Ceramic chip 1000 pF/50V	CK73B1H102K
C444	254 4533 921	Electrolytic 100 μF/6.3V	CE04W0J101M SMG/RE3
C445-448	257 0014 935	Ceramic chip 0.1 μF/25V	CK73F1E104Z
C454-457	257 0012 966	Ceramic chip 0.01 μF/50V	CK73F1H103Z
C509-522	Note	Note	
C525	Note	Note	
C526,527	257 0012 966	Ceramic chip 0.01 μF/50V	CK73F1H103Z
C528-540	Note	Note	
C543-549	Note	Note	
C551,552	Note	Note	
C554	Note	Note	
C555,556	Note	Note	
C557	Note	Note	
C562	254 4524 943	Electrolytic 1 μF/50V	CE04W1H010M SMG/RE3
C563	257 0008 983	Ceramic chip 1000 pF/50V	CK73B1H102K
C564-567	257 0014 935	Ceramic chip 0.1 μF/25V	CK73F1E104Z
C568	257 0010 900	Ceramic chip 0.01 μF/50V	CK73B1H103K
C569	257 0011 996	Ceramic chip 0.1 μF/25V	CK73B1E104K
C570	257 0014 935	Ceramic chip 0.1 μF/25V	CK73F1E104Z

Ref. No.	Part No.	Part Name	Remarks
C572,573	257 0012 966	Ceramic chip 0.01 μF/50V	CK73F1H103Z
C576	257 0005 986	Ceramic chip 330 pF/50V	CC73SL1H331J
C581	254 4524 930	Electrolytic 47 μF/50V	CE04W1HR47M SMG/RE3
C584-589	257 0012 966	Ceramic chip 0.01 μF/50V	CK73F1H103Z
C594	254 4524 930	Electrolytic 0.47 μF/50V	CE04W1HR47M SMG/RE3
C595	257 0014 935	Ceramic chip 0.1 μF/25V	CK73F1E104Z
C596	257 0004 961	Ceramic chip 100 pF/50V	CC73SL1H101J
C597	257 0014 935	Ceramic chip 0.1 μF/25V	CK73F1E104Z
C598	254 4538 900	Electrolytic 10 μF/16V	CE04W1C100M SMG/RE3
C599	257 0014 935	Ceramic chip 0.1 μF/25V	CK73F1E104Z
C600	254 4538 900	Electrolytic 10 μF/16V	CE04W1C100M SMG/RE3
C601	257 0014 935	Ceramic chip 0.1 μF/25V	CK73F1E104Z
C602-604	257 0012 966	Ceramic chip 0.01 μF/50V	CK73F1H103Z
C605	257 0008 983	Ceramic chip 1000 pF/50V	CK73B1H102K
C606	257 0012 966	Ceramic chip 0.01 μF/50V	CK73F1H103Z
C607	254 4533 921	Electrolytic 100 μF/6.3V	CE04W0J101M SMG/RE3
C609	257 0014 935	Ceramic chip 0.1 μF/25V	CK73F1E104Z
C610	254 4538 900	Electrolytic 10 μF/16V	CE04W1C100M SMG/RE3
C611	257 0008 983	Ceramic chip 1000 pF/50V	CK73B1H102K
C612-614	257 0012 966	Ceramic chip 0.01 μF/50V	CK73F1H103Z
C615	254 4538 900	Electrolytic 10 μF/16V	CE04W1C100M SMG/RE3
C619	254 4524 943	Electrolytic 1 μF/50V	CE04W1H010M SMG/RE3
C620,621	257 0012 966	Ceramic chip 0.01 μF/50V	CK73F1H103Z
C651,652	257 0014 935	Ceramic chip 0.1 μF/25V	CK73F1E104Z
C653-656	254 4538 900	Electrolytic 10 μF/16V	CE04W1C100M SMG/RE3
C657,658	254 4538 942	Electrolytic 100 μF/16V	CE04W1C101M SMG/RE3
C659,660	257 0004 961	Ceramic chip 100 pF/50V	CC73SL1H101J
C661,662	254 4538 900	Electrolytic 10 μF/16V	CE04W1C100M SMG/RE3
C663,664	257 0004 961	Ceramic chip 100 pF/50V	CC73SL1H101J
C665,666	254 4538 900	Electrolytic 10 μF/16V	CE04W1C100M SMG/RE3
C667,668	257 0007 942	Ceramic chip 1500 pF/50V	CC73SL1H152J
C669	257 0011 909	Ceramic chip 0.01 μF/25V	CK73B1E103K
C670	257 0014 935	Ceramic chip 0.1 μF/25V	CK73F1E104Z
C701	257 0014 935	Ceramic chip 0.1 μF/25V	CK73F1E104Z
C703	257 0010 984	Ceramic chip 0.047 μF/25V	CK73B1H473K
C704	254 4538 900	Electrolytic 10 μF/16V	CE04W1C100M SMG/RE3
C705,706	257 0014 935	Ceramic chip 0.1 μF/25V	CK73F1E104Z
C707-709	254 4538 900	Electrolytic 10 μF/16V	CE04W1C100M SMG/RE3
C711	257 0014 935	Ceramic chip 0.1 μF/25V	CK73F1E104Z
C713	257 0010 984	Ceramic chip 0.047 μF/25V	CK73B1H473K
C714	254 4538 900	Electrolytic 10 μF/16V	CE04W1C100M SMG/RE3
C715,716	257 0014 935	Ceramic chip 0.1 μF/25V	CK73F1E104Z
C717-719	254 4538 900	Electrolytic 10 μF/16V	CE04W1C100M SMG/RE3
C721	257 0014 935	Ceramic chip 0.1 μF/25V	CK73F1E104Z
C723	257 0010 984	Ceramic chip 0.047 μF/25V	CK73B1H473K
C724	254 4538 900	Electrolytic 10 μF/16V	CE04W1C100M SMG/RE3
C725,726	257 0014 935	Ceramic chip 0.1 μF/25V	CK73F1E104Z
C727-729	254 4538 900	Electrolytic 10 μF/16V	CE04W1C100M SMG/RE3
C731,732	254 4538 926	Electrolytic 33 μF/16V	CE04W1C330M SMG/RE3
C733-736	257 0005 928	Ceramic chip 180 pF/50V	CC73SL1H181J

1U-3223 VOLTAGE SELECT UNIT ASS'Y

(Asia model & Taiwan model only)

Ref. No.	Part No.	Part Name	Remarks	Ref. No.	Part No.	Part Name	Remarks	Q'ty
C737,738	255 1264 940	Mylar film 2200 pF/50V	CQ93M1H222J(B)	IC901	263 0554 005	IC NJM7905FA		
C741,742	254 4538 926	Electrolytic 33 μF/16V	CE04W1C330M SMG/RE3	D901-904	276 0553 905	Diode 1SR35-200A		
C743-746	257 0005 928	Ceramic chip 180 pF/50V	CC73SL1H181J	C901	254 4261 772	Electrolytic 2200 μF/50V		
C747,748	255 1264 940	Mylar film 2200 pF/50V	CQ93M1H222J(B)	C902,903	253 1181 904	Ceramic chip 0.01 μF/50V		
C751,752	254 4538 926	Electrolytic 33 μF/16V	CE04W1C330M SMG/RE3	C904	254 4524 985	Electrolytic 10 μF/50V		
C753-756	257 0005 928	Ceramic chip 180 pF/50V	CC73SL1H181J	CX935	205 0233 032	3P EH Connector base		1
C757,758	255 1264 940	Mylar film 2200 pF/50V	CQ93M1H222J(B)	CY022	205 0581 001	2P VH Connector base		1
C761,762	254 4538 900	Electrolytic 10 μF/16V	CE04W1C100M SMG/RE3	CY032	205 0653 036	3P VH Connector base		1
C763,764	257 0014 935	Ceramic chip 0.1 μF/25V	CK73F1E104Z	CY042	205 0653 049	4P VH Connector base		1
C767,768	254 4538 926	Electrolytic 33 μF/16V	CE04W1C330M SMG/RE3	CY933	205 0653 036	3P Connector base (35328)		1
C769,770	257 0006 943	Ceramic chip 560 pF/50V	CC73SL1H561J	Δ F017	206 1083 006	Fuse (2.5A)		1
C771,772	254 4538 926	Electrolytic 33 μF/16V	CE04W1C330M SMG/RE3	Δ F901	206 1083 019	Fuse (3.15A)		1
C773,774	257 0006 943	Ceramic chip 560 pF/50V	CC73SL1H561J	FF017	202 0040 909	Fuse clip		1
C775,776	254 4538 926	Electrolytic 33 μF/16V	CE04W1C330M SMG/RE3	FF901	202 0040 909	Fuse clip		1
C777-784	257 0006 943	Ceramic chip 560 pF/50V	CC73SL1H561J	FH017	202 0040 909	Fuse clip		1
C787-792	254 4538 900	Electrolytic 10 μF/16V	CE04W1C100M SMG/RE3	FH901	202 0040 909	Fuse clip		1
OTHER PARTS					S801	212 4810 006	Slide switch	1
BF201	Note	Note						1
CX036	Note	Note						1
CX933	Note	Note						1
CW051	205 1124 056	5P Connector socket						1
CW061,062	205 1124 069	6P Connector socket						2
CW071,072	205 1124 072	7P Connector socket						2
CW082	205 1124 085	8P Connector socket						1
CW111	205 1124 098	11P Connector socket						1
CW141	205 1125 042	14P Connector socket						1
FB302-308	235 0106 908	Chip emifil (21A05)						7
FB309	235 0106 908	Chip emifil (21A05)						1
FB311	235 0106 908	Chip emifil (21A05)						1
FB403	235 0106 908	Chip emifil (21A05)						1
FB508	235 0106 908	Chip emifil (21A05)						1
FB509-511	235 0106 908	Chip emifil (21A05)						3
FB512,513	235 0049 900	Beads inductor						2
FB601,602	235 0049 900	Beads inductor						2
FB603-607	235 0049 900	Beads inductor						5
FB609,610	235 0049 900	Beads inductor						2
FB701,702	235 0049 900	Beads inductor						2
FB704	235 0049 900	Beads inductor						1
FB705-720	235 0049 900	Beads inductor						16
JK106-108	204 8513 010	6P Pin jack (S-GND)						3
L501-504	235 0106 908	Chip emifil (21A05)						4
L505	Note	Note						1
X302	399 0532 902	Ceramic 12.5MHz	GST12.5MTW					1
X501	Note	Note						1
	207 0020 005	IC Sokeet	IC403					1
	207 0021 004	IC Sokeet	IC303					1

1U-3244 VIDEO UNIT ASS'Y

Ref. No.	Part No.	Part Name	Remarks
SEMICONDUCTORS GROUP			
IC301	263 0857 003	IC BA7626	
IC302	263 0856 004	IC BA7625	
IC304	262 2067 005	IC MC74HC4053N	
IC305	263 0682 003	IC NJM2229S	
IC308	262 2311 007	IC M35015-***SP	
IC371	262 1151 006	IC TC74HC4052AP	
IC375	262 1151 006	IC TC74HC4052AP	
IC376	263 0856 004	IC BA7625	
IC377	263 0857 003	IC BA7626	
IC401	262 1151 006	IC TC74HC4052AP	
IC402	263 0856 004	IC BA7625	
IC403	262 0522 005	IC TC4053BP	
IC450	263 0856 004	IC BA7625	
TR301-307	271 0290 904	Transistor 2PA1015GR	
TR309	271 0290 904	Transistor 2PA1015GR	
TR310	269 0082 902	Transistor DTC114EK	
TR311	273 0446 903	Transistor 2PC1815BL	
TR312,313	271 0290 904	Transistor 2PA1015GR	
TR401-404	271 0290 904	Transistor 2PA1015GR	
D302-309	276 0432 903	Diode 1SS270A	
D401-404	276 0432 903	Diode 1SS270A	
RESISTORS GROUP			
R301-308	247 0004 977	Carbon chip 75 ohm 1/10W	RM73B--750J
R309-314	247 0009 985	Carbon chip 10 kohm 1/10W	RM73B--103J
R315-320	247 0004 964	Carbon chip 68 ohm 1/10W	RM73B--680J
R321,322	247 0004 977	Carbon chip 75 ohm 1/10W	RM73B--750J
R323	247 0007 945	Carbon chip 1 kohm 1/10W	RM73B--102J
R324	247 0007 916	Carbon chip 750 ohm 1/10W	RM73B--751J
R325	247 0007 945	Carbon chip 1 kohm 1/10W	RM73B--102J
R328	247 0007 945	Carbon chip 1 kohm 1/10W	RM73B--102J
R329	247 0008 902	Carbon chip 1.8 kohm 1/10W	RM73B--182J
R330	247 0002 966	Carbon chip 10 ohm 1/10W	RM73B--100J
R331,332	247 0004 977	Carbon chip 75 ohm 1/10W	RM73B--750J
R338	247 0009 985	Carbon chip 10 kohm 1/10W	RM73B--103J
R339	247 0007 945	Carbon chip 1 kohm 1/10W	RM73B--102J
R340	247 0013 984	Carbon chip 470 kohm 1/10W	RM73B--474J
R341	247 0011 902	Carbon chip 33 kohm 1/10W	RM73B--333J
R342,343	247 0005 976	Carbon chip 200 ohm 1/10W	RM73B--201J
R344	247 0013 900	Carbon chip 220 kohm 1/10W	RM73B--224J
R345	247 0009 969	Carbon chip 8.2 kohm 1/10W	RM73B--822J
R346	247 0012 927	Carbon chip 100 kohm 1/10W	RM73B--104J
R349,350	247 0005 976	Carbon chip 200 ohm 1/10W	RM73B--201J
R354-356	247 0005 976	Carbon chip 200 ohm 1/10W	RM73B--201J
R357	247 0006 946	Carbon chip 390 ohm 1/10W	RM73B--391J
R358	247 0007 987	Carbon chip 1.5 kohm 1/10W	RM73B--152J
R359	247 0009 985	Carbon chip 10 kohm 1/10W	RM73B--103J
R360	247 0011 957	Carbon chip 51 kohm 1/10W	RM73B--513J

Ref. No.	Part No.	Part Name	Remarks
R361	247 0009 956	Carbon chip 7.5 kohm 1/10W	RM73B--752J
R362	247 0007 961	Carbon chip 1.2 kohm 1/10W	RM73B--122J
R363	247 0005 989	Carbon chip 220 ohm 1/10W	RM73B--221J
R364	247 0009 901	Carbon chip 4.7 kohm 1/10W	RM73B--472J
R365	247 0011 944	Carbon chip 47 kohm 1/10W	RM73B--473J
R366	247 0009 985	Carbon chip 10 kohm 1/10W	RM73B--103J
R367	247 0009 969	Carbon chip 8.2 kohm 1/10W	RM73B--822J
R368	247 0011 944	Carbon chip 47 kohm 1/10W	RM73B--473J
R369	247 0009 969	Carbon chip 8.2 kohm 1/10W	RM73B--822J
R370	247 0009 901	Carbon chip 4.7 kohm 1/10W	RM73B--472J
R371	247 0007 945	Carbon chip 1 kohm 1/10W	RM73B--102J
R373	247 0005 976	Carbon chip 200 ohm 1/10W	RM73B--201J
R374,375	247 0004 977	Carbon chip 75 ohm 1/10W	RM73B--750J
R376	247 0004 977	Carbon chip 75 ohm 1/10W	RM73B--750J
R377	247 0018 905	Carbon chip 0 ohm 1/10W	RM73B--0R0K
R378	247 0004 977	Carbon chip 75 ohm 1/10W	RM73B--750J
R380,381	247 0005 905	Carbon chip 100 ohm 1/10W	RM73B--101J
R382-388	247 0009 985	Carbon chip 10 kohm 1/10W	RM73B--103J

CAPACITORS GROUP			
C301,302	254 4524 972	Electrolytic 4.7 μ F/50V	CE04W1H4R7M SMG/RE3
C303,304	257 0012 982	Ceramic chip 0.022 μ F/50V	CK73F1H223Z
C305,306	254 4524 972	Electrolytic 4.7 μ F/50V	CE04W1H4R7M SMG/RE3
C310	254 4524 972	Electrolytic 4.7 μ F/50V	CE04W1H4R7M SMG/RE3
C311	254 4533 934	Electrolytic 220 μ F/6.3V	CE04W0J221M SMG/RE3
C312	254 4533 950	Electrolytic 470 μ F/6.3V	CE04W0J471M SMG/RE3
C313	254 4533 934	Electrolytic 220 μ F/6.3V	CE04W0J221M SMG/RE3
C314	254 4533 950	Electrolytic 470 μ F/6.3V	CE04W0J471M SMG/RE3
C315	254 4533 934	Electrolytic 220 μ F/6.3V	CE04W0J221M SMG/RE3
C316	254 4533 950	Electrolytic 470 μ F/6.3V	CE04W0J471M SMG/RE3
C317,318	254 4524 943	Electrolytic 1 μ F/50V	CE04W1H010M SMG/RE3
C320	257 0012 982	Ceramic chip 0.022 μ F/50V	CK73F1H223Z
C321	254 4538 900	Electrolytic 10 μ F/16V	CE04W1C100M SMG/RE3
C323	254 4536 928	Electrolytic 100 μ F/10V	CE04W1A101M SMG/RE3
C324	257 0012 966	Ceramic chip 0.01 μ F/50V	CK73F1H103Z
C327-329	257 0003 946	Ceramic chip 33 pF/50V	CC73SL1H330J
C330	257 0010 900	Ceramic chip 0.01 μ F/50V	CK73B1H103K
C331	257 0002 921	Ceramic chip 10 pF/50V	CC73SL1H100D
C332	257 0002 947	Ceramic chip 12 pF/50V	CC73SL1H120J
C333	255 1265 978	Mylar film 0.022 μ F/50V	CQ93M1H223J(B)
C334	254 4524 972	Electrolytic 4.7 μ F/50V	CE04W1H4R7M SMG/RE3
C335	257 0004 961	Ceramic chip 100 pF/50V	CC73SL1H101J
C336	254 4524 943	Electrolytic 1 μ F/50V	CE04W1H010M SMG/RE3
C337	254 4538 900	Electrolytic 10 μ F/16V	CE04W1C100M SMG/RE3
C338	255 1264 908	Mylar film 1000 pF/50V	CQ93M1H102J(B)
C339	254 4536 928	Electrolytic 100 μ F/10V	CE04W1A101M SMG/RE3
C340	257 0012 966	Ceramic chip 0.01 μ F/50V	CK73F1H103Z
C341	255 1264 911	Mylar film 1200 pF/50V	CQ93M1H122J(B)
C342	257 0005 902	Ceramic chip 150 pF/50V	CC73SL1H151J
C343	254 4524 943	Electrolytic 1 μ F/50V	CE04W1H010M SMG/RE3

Ref. No.	Part No.	Part Name	Remarks	
C344	256 1058 955	Metalized 0.068 μ F/50V	CF93A1H683J (JL)	
C345	257 0008 941	Ceramic chip 470 pF/50V	CK73B1H471K	
C346	257 0009 940	Ceramic chip 3300 pF/50V	CK73B1H332K	
C347	254 4538 900	Electrolytic 10 μ F/16V	CE04W1C100M SMG/RE3	
C348	254 4538 942	Electrolytic 100 μ F/16V	CE04W1C101M SMG/RE3	
C349,350	254 4536 928	Electrolytic 100 μ F/10V	CE04W1A101M SMG/RE3	
C351	254 4538 942	Electrolytic 100 μ F/16V	CE04W1C101M SMG/RE3	
C352,353	256 1058 939	Metalized 0.047 μ F/50V	CF93A1H473J (JL)	
C354	254 4524 943	Electrolytic 1 μ F/50V	CE04W1H010M SMG/RE3	
C355	256 1058 939	Metalized 0.047 μ F/50V	CF93A1H473J (JL)	
C356	257 0012 966	Ceramic chip 0.01 μ F/50V	CK73F1H103Z	
C357-361	254 4524 972	Electrolytic 4.7 μ F/50V	CE04W1H4R7M SMG/RE3	
C362	257 0012 966	Ceramic chip 0.01 μ F/50V	CK73F1H103Z	
C363-366	253 1180 921	Ceramic chip 1000 pF/50V	CK45B1H102K	
C375-384	254 4524 972	Electrolytic 4.7 μ F/50V	CE04W1H4R7M SMG/RE3	
C385	257 0012 982	Ceramic chip 0.022 μ F/50V	CK73F1H223Z	
C386,387	254 4524 943	Electrolytic 1 μ F/50V	CE04W1H010M SMG/RE3	
C388,389	257 0012 982	Ceramic chip 0.022 μ F/50V	CK73F1H223Z	
C401-405	254 4306 909	Electrolytic 4.7 μ F/50V	CE04W1H4R7M(SRE)	
C406-408	254 4300 989	Electrolytic 330 μ F/6.3V	CE04W0J331M(SRE)	
C410	254 4302 974	Electrolytic 100 μ F/10V	CE04W1A101M(SRE)	
C411,412	254 4299 906	Electrolytic 10 μ F/16V	CE04W1C100M(SRE)	
C413	254 4305 968	Electrolytic 1 μ F/50V	CE04W1H010M(SRE)	
C414	253 1181 917	Ceramic 0.022 μ F/50V	CK45F1H223Z	
C415	254 4299 906	Electrolytic 10 μ F/16V	CE04W1C100M(SRE)	
C416	254 4302 974	Electrolytic 100 μ F/10V	CE04W1A101M(SRE)	
C417	253 1181 904	Ceramic 0.01 μ F/50V	CK45F1H103Z	
C418,419	254 4299 906	Electrolytic 10 μ F/16V	CE04W1C100M(SRE)	
C420,421	253 1181 904	Ceramic 0.01 μ F/50V	CK45F1H103Z	
C422	253 1181 917	Ceramic 0.022 μ F/50V	CK45F1H223Z	
C423	254 4299 906	Electrolytic 10 μ F/16V	CE04W1C100M(SRE)	
C450,451	254 4306 909	Electrolytic 4.7 μ F/50V	CE04W1H4R7M(SRE)	
C452	254 4305 968	Electrolytic 1 μ F/50V	CE04W1H010M(SRE)	
C453	253 1181 917	Ceramic 0.022 μ F/50V	CK45F1H223Z	
C454	254 4299 906	Electrolytic 10 μ F/16V	CE04W1C100M(SRE)	
C455-457	254 4306 909	Electrolytic 4.7 μ F/50V	CE04W1H4R7M(SRE)	
OTHER PARTS				Q'ty
FB304-306	235 0049 900	Beads inductor		3
FB355-357	235 0049 900	Beads inductor		3
JK301	204 8415 011	3P S-Terminal		1
JK302,303	204 8414 012	2P S-Terminal		2
JK304	205 0902 004	1P S-Terminal (SW)		1
JK401	204 8516 017	3P Pin jack		1
JK402	204 8583 008	2P Pin jack (VIDEO)		1
JK403	204 8516 017	3P Pin jack		1
XL301	399 0153 006	Crystal 14.32MHZ-12PF		1
XL302	399 0105 009	Ceramic resonator CSB503F2		1
CW081	205 1124 085	8P Connector socket		1
CW121,122	205 1125 026	12P Connector socket		2

**ADDENDUM PARTS LIST OF P.W.B. UNIT ASS'Y
1U-3198 POWER UNIT ASS'Y**

Ref. No.	EUROPE MODEL		ASIA MODEL		TAIWAN MODEL		U.S.A./CANADA MODELS	
	Part No.	Part Name	Part No.	Part Name	Part No.	Part Name	Part No.	Part Name
R734	—	—	—	—	—	—	242 2009 001	Composition 2.2 Mohm 1/2W
C525,526	256 1058 939	Metalized 0.047 μ F/50V	256 1058 939	Metalized 0.047 μ F/50V	256 1058 939	Metalized 0.047 μ F/50V	255 1265 978	Mylar film 0.022 μ F/50V
C617,618	256 1058 939	Metalized 0.047 μ F/50V	256 1058 939	Metalized 0.047 μ F/50V	256 1058 939	Metalized 0.047 μ F/50V	255 1265 978	Mylar film 0.022 μ F/50V
C553,554	256 1058 939	Metalized 0.047 μ F/50V	256 1058 939	Metalized 0.047 μ F/50V	256 1058 939	Metalized 0.047 μ F/50V	255 1265 978	Mylar film 0.022 μ F/50V
C572	256 1058 939	Metalized 0.047 μ F/50V	256 1058 939	Metalized 0.047 μ F/50V	256 1058 939	Metalized 0.047 μ F/50V	255 1265 978	Mylar film 0.022 μ F/50V
C613-616	255 1265 936	Mylar film 0.01 μ F/50V	255 1265 936	Mylar film 0.01 μ F/50V	255 1265 936	Mylar film 0.01 μ F/50V	—	—
C631,632	255 1265 936	Mylar film 0.01 μ F/50V	255 1265 936	Mylar film 0.01 μ F/50V	255 1265 936	Mylar film 0.01 μ F/50V	—	—
C649	255 1265 936	Mylar film 0.01 μ F/50V	255 1265 936	Mylar film 0.01 μ F/50V	255 1265 936	Mylar film 0.01 μ F/50V	—	—
CX021	205 0581 001	2P VH Connector base	205 0581 001	2P VH Connector base	205 0581 001	2P VH Connector base	—	—
CX023	205 0581 001	2P VH Connector base	205 0581 001	2P VH Connector base	205 0581 001	2P VH Connector base	—	—
CX032	—	—	205 0653 036	3P VH Connector base	205 0653 036	3P VH Connector base	—	—
△ F001	206 1083 019	Fuse (3.15A)	206 1083 035	Fuse (0.3V)	206 1083 035	Fuse (6.3V)	206 1046 043	Fuse 10A
△ F008	206 1083 006	Fuse (2.5A)	206 1083 036	Fuse (2.5A)	206 1083 036	Fuse (2.5A)	206 1046 014	Fuse 8A
T501	233 6058 025	Power trans (mini)	233 6278 009	Power trans (mini)	233 6278 009	Power trans (mini)	233 6073 000	Power trans (mini)
AC501	—	—	—	—	—	—	203 3976 002	AC Outlet (2P)
	513 2585 045	Fuse label	513 2654 057	Fuse label	513 2654 057	Fuse label	—	—
	513 2585 074	Fuse label	513 2585 074	Fuse label	513 2585 074	Fuse label	—	—

1U-3199 EXT. IN UNIT ASS'Y

Ref. No.	EUROPE MODEL		ASIA MODEL		TAIWAN MODEL		U.S.A./CANADA MODELS	
	Part No.	Part Name	Part No.	Part Name	Part No.	Part Name	Part No.	Part Name
R385,386	247 0006 962	Carbon chip 470 ohm 1/10W	247 0006 962	Carbon chip 470 ohm 1/10W	247 0006 962	Carbon chip 470 ohm 1/10W	247 0005 905	Carbon chip 100 ohm 1/10W
R401,402	247 0006 962	Carbon chip 470 ohm 1/10W	247 0006 962	Carbon chip 470 ohm 1/10W	247 0006 962	Carbon chip 470 ohm 1/10W	247 0005 905	Carbon chip 100 ohm 1/10W
R417,418	247 0006 962	Carbon chip 470 ohm 1/10W	247 0006 962	Carbon chip 470 ohm 1/10W	247 0006 962	Carbon chip 470 ohm 1/10W	247 0005 905	Carbon chip 100 ohm 1/10W
R465,466	247 0006 962	Carbon chip 470 ohm 1/10W	247 0006 962	Carbon chip 470 ohm 1/10W	247 0006 962	Carbon chip 470 ohm 1/10W	247 0005 905	Carbon chip 100 ohm 1/10W
R701,702	247 0007 974	Carbon chip 1.3 kohm 1/10W	247 0007 974	Carbon chip 1.3 kohm 1/10W	247 0007 974	Carbon chip 1.3 kohm 1/10W	247 0018 905	Carbon chip 0 ohm 1/10W
R723,724	247 0006 962	Carbon chip 470 ohm 1/10W	247 0006 962	Carbon chip 470 ohm 1/10W	247 0006 962	Carbon chip 470 ohm 1/10W	247 0005 905	Carbon chip 100 ohm 1/10W
C321,322	257 0005 986	Ceramic chip 330 pF/50V	257 0005 986	Ceramic chip 330 pF/50V	257 0005 986	Ceramic chip 330 pF/50V	—	—
C343,344	257 0005 986	Ceramic chip 330 pF/50V	257 0005 986	Ceramic chip 330 pF/50V	257 0005 986	Ceramic chip 330 pF/50V	—	—
C355,356	257 0005 986	Ceramic chip 330 pF/50V	257 0005 986	Ceramic chip 330 pF/50V	257 0005 986	Ceramic chip 330 pF/50V	—	—
C367,368	257 0005 986	Ceramic chip 330 pF/50V	257 0005 986	Ceramic chip 330 pF/50V	257 0005 986	Ceramic chip 330 pF/50V	—	—
C719,720	257 0005 986	Ceramic chip 330 pF/50V	257 0005 986	Ceramic chip 330 pF/50V	257 0005 986	Ceramic chip 330 pF/50V	—	—
CY021	205 0581 001	2P VH Connector base	205 0581 001	2P VH Connector base	205 0581 001	2P VH Connector base	—	—
L701,702	235 9003 002	FTZ choke coil	235 9003 002	FTZ choke coil	235 9003 002	FTZ choke coil	—	—
S901	212 1030 009	Power switch (TV-5)	212 1030 009	Power switch (TV-5)	212 1030 009	Power switch (TV-5)	—	—

1U-3200 CONTROL P.W.B. UNIT ASS'Y

Ref. No.	EUROPE MODEL		ASIA MODEL		TAIWAN MODEL		U.S.A./CANADA MODELS	
	Part No.	Part Name	Part No.	Part Name	Part No.	Part Name	Part No.	Part Name
IC301	262 1701 906	IC SAA6579T	—	—	—	—	—	—
IC302	262 1929 908	IC LC7074M-R	—	—	—	—	—	—
D301	276 0432 903	Diode 1SS270A	—	—	—	—	—	—
R303	247 0018 905	Carbon chip 0 ohm 1/10W	—	—	—	—	—	—
R347	247 0018 905	Carbon chip 0 ohm 1/10W	247 0007 945	Carbon chip 1 kohm 1/10W	247 0007 945	Carbon chip 1 kohm 1/10W	—	—
R348	—	—	247 0009 914	Carbon chip 5.1 kohm 1/10W	247 0009 914	Carbon chip 5.1 kohm 1/10W	247 0018 905	Carbon chip 0 ohm 1/10W
R366	—	—	247 0018 905	Carbon chip 0 ohm 1/10W	247 0018 905	Carbon chip 0 ohm 1/10W	—	—
R377	247 0009 985	Carbon chip 10 kohm 1/10W	—	—	—	—	—	—
R384	—	—	247 0007 974	Carbon chip 1.3 kohm 1/10W	247 0007 974	Carbon chip 1.3 kohm 1/10W	—	—
C304	257 0003 946	Ceramic chip 33 pF/50V	—	—	—	—	—	—
C305	257 0010 984	Ceramic chip 0.047 μ F/50V	257 0010 984	Ceramic chip 0.047 μ F/50V	257 0010 984	Ceramic chip 0.047 μ F/50V	257 0008 983	Ceramic chip 1000 pF/50V
C308	254 4260 951	Electrolytic 2.2 μ F/50V	—	—	—	—	—	—
C309	—	—	—	—	—	—	257 0008 983	Ceramic chip 1000 pF/50V
C311	257 0003 946	Ceramic chip 33 pF/50V	—	—	—	—	—	—
C312	257 0012 966	Ceramic chip 0.01 μ F/50V	—	—	—	—	—	—
C315	—	—	—	—	—	—	257 0008 983	Ceramic chip 1000 pF/50V
C316	254 4538 900	Electrolytic 10 μ F/16V	—	—	—	—	—	—
C321	257 0006 943	Ceramic chip 560 pF/50V	—	—	—	—	—	—
C322	—	—	—	—	—	—	257 0008 983	Ceramic chip 1000 pF/50V
C323	254 4538 900	Electrolytic 10 μ F/16V	—	—	—	—	—	—
C324	—	—	—	—	—	—	257 0008 983	Ceramic chip 1000 pF/50V
C327	—	—	257 0008 983	Ceramic chip 1000 pF/50V	257 0008 983	Ceramic chip 1000 pF/50V	257 0008 983	Ceramic chip 1000 pF/50V
C368	—	—	—	—	—	—	257 0008 983	Ceramic chip 1000 pF/50V
C376	—	—	—	—	—	—	257 0008 983	Ceramic chip 1000 pF/50V
C382	—	—	—	—	—	—	257 0008 983	Ceramic chip 1000 pF/50V
C384	—	—	—	—	—	—	257 0008 983	Ceramic chip 1000 pF/50V
C386	—	—	—	—	—	—	257 0008 983	Ceramic chip 1000 pF/50V
C389	—	—	—	—	—	—	257 0012 982	Ceramic chip 0.022 μ F/50V
C390	—	—	—	—	—	—	256 1058 971	Metalized 0.1 μ F/50V
C391	—	—	—	—	—	—	257 0008 983	Ceramic chip 1000 pF/50V
C394-396	257 0008 983	Ceramic chip 1000 pF/50V	257 0008 983	Ceramic chip 1000 pF/50V	257 0008 983	Ceramic chip 1000 pF/50V	—	—
C720	—	—	257 0014 935	Ceramic chip 0.1 μ F/25V	257 0014 935	Ceramic chip 0.1 μ F/25V	—	—
C981	—	—	257 0008 983	Ceramic chip 1000 pF/50V	257 0008 983	Ceramic chip 1000 pF/50V	—	—
C983	257 0008 983	Ceramic chip 1000 pF/50V	—	—	—	—	257 0008 983	Ceramic chip 1000 pF/50V
C984	257 0008 983	Ceramic chip 1000 pF/50V	—	—	—	—	—	—
CY036	—	—	205 1127 037	3P Connector base-L (53015)	205 1127 037	3P Connector base-L (53015)	—	—
JK501	—	—	204 8551 027	1P Pin jack (BK)	204 8551 027	1P Pin jack (BK)	—	—
X301	399 0178 007	Crystal 4.332 MHz	—	—	—	—	—	—
XL301	399 0191 903	Ceramic 4.00 MHz	—	—	—	—	—	—

1U-3201 REGULATOR P.W.B. UNIT ASS'Y

Ref. No.	EUROPE MODEL		ASIA MODEL		TAIWAN MODEL		U.S.A./CANADA MODELS	
	Part No.	Part Name	Part No.	Part Name	Part No.	Part Name	Part No.	Part Name
IC501	216 9013 004	FM FRONT END (U) S	216 0102 008	FRONT END	216 0102 008	FRONT END	216 0102 008	FRONT END
TR501	275 0074 902	Transistor 2SK211-Y/GR	—	—	—	—	—	—
R502	247 0018 905	Carbon chip 0 ohm 1/10W	—	—	—	—	—	—
R515	—	—	247 0005 905	Carbon chip 100 ohm 1/10W	247 0005 905	Carbon chip 100 ohm 1/10W	247 0005 905	Carbon chip 100 ohm 1/10W
R516	247 0006 920	Carbon chip 330 ohm 1/10W	247 0007 945	Carbon chip 1 kohm 1/10W	247 0007 945	Carbon chip 1 kohm 1/10W	247 0007 945	Carbon chip 1 kohm 1/10W
R517	247 0006 920	Carbon chip 330 ohm 1/10W	—	—	—	—	—	—
R533	247 0009 901	Carbon chip 4.7 kohm 1/10W	247 0009 901	Carbon chip 4.7 kohm 1/10W	247 0009 901	Carbon chip 4.7 kohm 1/10W	247 0008 999	Carbon chip 4.3 kohm 1/10W
R535	247 0010 990	Carbon chip 30 kohm 1/10W	247 0010 990	Carbon chip 30 kohm 1/10W	247 0010 990	Carbon chip 30 kohm 1/10W	247 0010 945	Carbon chip 18 kohm 1/10W
R536	247 0008 944	Carbon chip 2.7 kohm 1/10W	247 0018 905	Carbon chip 0 kohm 1/10W	247 0018 905	Carbon chip 0 kohm 1/10W	247 0018 905	Carbon chip 0 ohm 1/10W
R544,545	247 0012 969	Carbon chip 150 kohm 1/10W	247 0012 927	Carbon chip 100 kohm 1/10W	247 0012 927	Carbon chip 100 kohm 1/10W	247 0012 927	Carbon chip 100 kohm 1/10W
R555,556	247 0008 960	Carbon chip 3.3 kohm 1/10W	247 0009 927	Carbon chip 5.6 kohm 1/10W	247 0009 927	Carbon chip 5.6 kohm 1/10W	247 0009 927	Carbon chip 5.6 kohm 1/10W
R569	247 0009 927	Carbon chip 5.6 kohm 1/10W	—	—	—	—	—	—
R570	247 0009 985	Carbon chip 10 kohm 1/10W	—	—	—	—	—	—
R575,576	247 0012 998	Carbon chip 200 kohm 1/10W	247 0012 943	Carbon chip 120 kohm 1/10W	247 0012 943	Carbon chip 120 kohm 1/10W	247 0012 943	Carbon chip 120 kohm 1/10W
R579	—	—	247 0018 905	Carbon chip 0 kohm 1/10W	247 0018 905	Carbon chip 0 kohm 1/10W	247 0018 905	Carbon chip 0 kohm 1/10W
R580,581	—	—	247 0018 905	Carbon chip 0 kohm 1/10W	247 0018 905	Carbon chip 0 kohm 1/10W	247 0018 905	Carbon chip 0 kohm 1/10W
R655,856	241 2397 943	Carbon film 330 ohm 1/4W	241 2397 943	Carbon film 330 ohm 1/4W	241 2397 943	Carbon film 330 ohm 1/4W	241 2397 971	Carbon film 470 ohm 1/4W
R881,882	241 2397 943	Carbon film 330 ohm 1/4W	241 2397 943	Carbon film 330 ohm 1/4W	241 2397 943	Carbon film 330 ohm 1/4W	241 2397 971	Carbon film 470 ohm 1/4W
R898	241 2397 943	Carbon film 330 ohm 1/4W	241 2397 943	Carbon film 330 ohm 1/4W	241 2397 943	Carbon film 330 ohm 1/4W	241 2397 971	Carbon film 470 ohm 1/4W
C519	—	—	257 0004 961	Ceramic chip 100 pF/50V	257 0004 961	Ceramic chip 100 pF/50V	—	—
C527	254 4260 922	Electrolytic 0.33 μF/50V	254 4260 922	Electrolytic 0.33 μF/50V	254 4260 922	Electrolytic 0.33 μF/50V	254 4524 943	Electrolytic 1 μF/50V
C536	—	—	257 0004 961	Ceramic chip 100 pF/50V	257 0004 961	Ceramic chip 100 pF/50V	257 0004 961	Ceramic chip 100 pF/50V
C537	254 4538 913	Electrolytic 22 μF/16V	—	—	—	—	—	—
C539,540	257 0005 973	Ceramic chip 300 pF/50V	257 0006 930	Ceramic chip 510 pF/50V	257 0006 930	Ceramic chip 510 pF/50V	257 0006 972	Ceramic chip 750 pF/50V
CF501	267 0146 006	Ceramic filter FMCF5K107MS-A	261 0135 907	Ceramic filter MA8	261 0135 907	Ceramic filter MA8	261 0135 907	Ceramic filter MA8
CF502	261 0146 006	Ceramic filter FMCF5K107MS-A	261 0136 906	Ceramic filter MS2G	261 0136 906	Ceramic filter MS2G	261 0136 906	Ceramic filter MS2G
△ F011-013	206 1083 019	Fuse (3.15A)	206 1083 019	Fuse (3.15A)	206 1083 019	Fuse (3.15A)	206 1082 010	Fuse 3.15A
△ F014	2026 1083 008	Fuse (2.5A)	206 1083 006	Fuse (2.5A)	206 1083 006	Fuse (2.5A)	206 1082 007	Fuse 2.5A
LF501	232 9010 009	Antibirdie filter	—	—	—	—	—	—
LF503,504	232 0085 004	Low pass filter	—	—	—	—	—	—
S501	—	—	212 0408 001	Slide switch	212 0408 001	Slide switch	—	—

1U-3215 AUDIO/DSP P.W.B. UNIT ASS'Y

Ref. No.	EUROPE MODEL		ASIA MODEL		TAIWAN MODEL		U.S.A./CANADA MODELS	
	Part No.	Part Name	Part No.	Part Name	Part No.	Part Name	Part No.	Part Name
IC507	—	—	263 1018 003	IC MC14577CP	263 1018 003	IC MC14577CP	—	—
IC511	—	—	263 0687 901	IC BA4560F-E2	263 0687 901	IC BA4560F-E2	—	—
IC512	—	—	262 2372 004	IC PM4007A262 2372 004	IC PM4007A	—	—	—
IC516	—	—	262 2371 908	IC BR62256F-70LL	262 2371 908	IC BR62256F-70LL	—	—
TR501	—	—	274 0163 904	Transistor 2SD601A	274 0163 904	Transistor 2SD601A	—	—
TR502	—	—	271 0238 908	Transistor 2SA1037K(S/R)	271 0238 908	Transistor 2SA1037K(S/R)	—	—
TR503,504	—	—	274 0163 904	Transistor 2SD601A	274 0163 904	Transistor 2SD601A	—	—
TR505	—	—	272 0125 904	Transistor 2SB709A	272 0125 904	Transistor 2SB709A	—	—
TR506	—	—	273 0384 900	Transistor 2SC2412K	273 0384 900	Transistor 2SC2412K	—	—
D501	—	—	276 0438 910	Diode MA151A	276 0438 910	Diode MA151A	—	—
D502	—	—	276 0663 905	Diode KV1851	276 0663 905	Diode KV1851	—	—
R101,102	247 0006 962	Carbon chip 470 ohm 1/10W	247 0006 962	Carbon chip 470 ohm 1/10W	247 0006 962	Carbon chip 470 ohm 1/10W	247 0005 905	Carbon chip 100 ohm 1/10W
R113,114	247 0006 962	Carbon chip 470 ohm 1/10W	247 0006 962	Carbon chip 470 ohm 1/10W	247 0006 962	Carbon chip 470 ohm 1/10W	247 0005 905	Carbon chip 100 ohm 1/10W
R125,126	247 0006 962	Carbon chip 470 ohm 1/10W	247 0006 962	Carbon chip 470 ohm 1/10W	247 0006 962	Carbon chip 470 ohm 1/10W	247 0005 905	Carbon chip 100 ohm 1/10W
R137,138	247 0006 962	Carbon chip 470 ohm 1/10W	247 0006 962	Carbon chip 470 ohm 1/10W	247 0006 962	Carbon chip 470 ohm 1/10W	247 0005 905	Carbon chip 100 ohm 1/10W
R149,150	247 0006 962	Carbon chip 470 ohm 1/10W	247 0006 962	Carbon chip 470 ohm 1/10W	247 0006 962	Carbon chip 470 ohm 1/10W	247 0005 905	Carbon chip 100 ohm 1/10W
R161,162	247 0006 962	Carbon chip 470 ohm 1/10W	247 0006 962	Carbon chip 470 ohm 1/10W	247 0006 962	Carbon chip 470 ohm 1/10W	247 0005 905	Carbon chip 100 ohm 1/10W
R501	—	—	247 0007 945	Carbon chip 1 kohm 1/10W	247 0007 945	Carbon chip 1 kohm 1/10W	—	—
R502	—	—	247 0006 988	Carbon chip 560 ohm 1/10W	247 0006 988	Carbon chip 560 ohm 1/10W	—	—
R503	—	—	247 0004 993	Carbon chip 91 ohm 1/10W	247 0004 993	Carbon chip 91 ohm 1/10W	—	—
R504-506	—	—	247 0007 945	Carbon chip 1 kohm 1/10W	247 0007 945	Carbon chip 1 kohm 1/10W	—	—
R512	—	—	247 0007 945	Carbon chip 1 kohm 1/10W	247 0007 945	Carbon chip 1 kohm 1/10W	—	—
R513	—	—	247 0009 985	Carbon chip 10 kohm 1/10W	247 0009 985	Carbon chip 10 kohm 1/10W	—	—
R514,515	—	—	247 0007 945	Carbon chip 1 kohm 1/10W	247 0007 945	Carbon chip 1 kohm 1/10W	—	—
R516	—	—	247 0009 901	Carbon chip 4.7 kohm 1/10W	247 0009 901	Carbon chip 4.7 kohm 1/10W	—	—
R517	—	—	247 0008 902	Carbon chip 1.8 kohm 1/10W	247 0008 902	Carbon chip 1.8 kohm 1/10W	—	—
R518	—	—	247 0007 945	Carbon chip 1 kohm 1/10W	247 0007 945	Carbon chip 1 kohm 1/10W	—	—
R519	—	—	247 0005 947	Carbon chip 150 ohm 1/10W	247 0005 947	Carbon chip 150 ohm 1/10W	—	—
R520	—	—	247 0009 901	Carbon chip 4.7 kohm 1/10W	247 0009 901	Carbon chip 4.7 kohm 1/10W	—	—
R521,522	—	—	247 0009 985	Carbon chip 10 kohm 1/10W	247 0009 985	Carbon chip 10 kohm 1/10W	—	—
R523	—	—	247 0007 945	Carbon chip 1 kohm 1/10W	247 0007 945	Carbon chip 1 kohm 1/10W	—	—
R524	—	—	247 0008 928	Carbon chip 2.2 kohm 1/10W	247 0008 928	Carbon chip 2.2 kohm 1/10W	—	—
R525	—	—	247 0007 945	Carbon chip 1 kohm 1/10W	247 0007 945	Carbon chip 1 kohm 1/10W	—	—
R526	—	—	247 0008 960	Carbon chip 3.3 kohm 1/10W	247 0008 960	Carbon chip 3.3 kohm 1/10W	—	—
R527	—	—	247 0009 901	Carbon chip 4.7 kohm 1/10W	247 0009 901	Carbon chip 4.7 kohm 1/10W	—	—
R528	—	—	247 0007 945	Carbon chip 1 kohm 1/10W	247 0007 945	Carbon chip 1 kohm 1/10W	—	—
R530	—	—	247 0009 901	Carbon chip 4.7 kohm 1/10W	247 0009 901	Carbon chip 4.7 kohm 1/10W	—	—
R531	—	—	247 0008 986	Carbon chip 3.9 kohm 1/10W	247 0008 986	Carbon chip 3.9 kohm 1/10W	—	—
R532,533	—	—	247 2009 983	Carbon chip 10 kohm 1/16W	247 2009 983	Carbon chip 10 kohm 1/16W	—	—
R535-537	—	—	247 2009 983	Carbon chip 10 kohm 1/16W	247 2009 983	Carbon chip 10 kohm 1/16W	—	—
R538	—	—	247 0012 927	Carbon chip 100 kohm 1/10W	247 0012 927	Carbon chip 100 kohm 1/10W	—	—
R539	—	—	247 0009 969	Carbon chip 8.2 kohm 1/10W	247 0009 969	Carbon chip 8.2 kohm 1/10W	—	—
R540	—	—	247 2009 983	Carbon chip 10 kohm 1/16W	247 2009 983	Carbon chip 10 kohm 1/16W	—	—
R541	—	—	247 2009 983	Carbon chip 10 kohm 1/16W	247 2009 983	Carbon chip 10 kohm 1/16W	—	—
R542	—	—	247 0011 986	Carbon chip 68 kohm 1/10W	247 0011 986	Carbon chip 68 kohm 1/10W	—	—
R543	—	—	247 0010 987	Carbon chip 27 kohm 1/10W	247 0010 987	Carbon chip 27 kohm 1/10W	—	—
R544	—	—	247 2009 983	Carbon chip 10 kohm 1/16W	247 2009 983	Carbon chip 10 kohm 1/16W	—	—
R545	—	—	247 2018 903	Carbon chip 0 ohm 1/16W	247 2018 903	Carbon chip 0 ohm 1/16W	—	—

Ref. No.	EUROPE MODEL		ASIA MODEL		TAIWAN MODEL		U.S.A./CANADA MODELS	
	Part No.	Part Name	Part No.	Part Name	Part No.	Part Name	Part No.	Part Name
R546	—	—	247 2009 983	Carbon chip 10 kohm 1/16W	247 2009 983	Carbon chip 10 kohm 1/16W	—	—
R547,548	—	—	247 0009 985	Carbon chip 10 kohm 1/10W	247 0009 985	Carbon chip 10 kohm 1/10W	—	—
R549	—	—	247 2009 983	Carbon chip 10 kohm 1/16W	247 2009 983	Carbon chip 10 kohm 1/16W	—	—
R550	—	—	247 0005 921	Carbon chip 120 ohm 1/10W	247 0005 921	Carbon chip 120 ohm 1/10W	—	—
R550	—	—	257 0010 900	Ceramic chip 0.01 μ F/50V	257 0010 900	Ceramic chip 0.01 μ F/50V	—	—
R551-553	—	—	247 2009 983	Carbon chip 10 kohm 1/16W	247 2009 983	Carbon chip 10 kohm 1/16W	—	—
R553	—	—	257 0010 900	Ceramic chip 0.01 μ F/50V	257 0010 900	Ceramic chip 0.01 μ F/50V	—	—
R554	—	—	247 2018 903	Carbon chip 0 ohm 1/16W	247 2018 903	Carbon chip 0 ohm 1/16W	—	—
R555	—	—	247 0011 944	Carbon chip 47 kohm 1/10W	247 0011 944	Carbon chip 47 kohm 1/10W	—	—
R556-560	—	—	247 2018 903	Carbon chip 0 ohm 1/16W	247 2018 903	Carbon chip 0 ohm 1/16W	—	—
R561,562	—	—	247 2009 983	Carbon chip 10 kohm 1/16W	247 2009 983	Carbon chip 10 kohm 1/16W	—	—
R563	—	—	247 0011 944	Carbon chip 47 kohm 1/10W	247 0011 944	Carbon chip 47 kohm 1/10W	—	—
R564	—	—	247 2009 983	Carbon chip 10 kohm 1/16W	247 2009 983	Carbon chip 10 kohm 1/16W	—	—
R565	—	—	247 2009 983	Carbon chip 10 kohm 1/16W	247 2009 983	Carbon chip 10 kohm 1/16W	—	—
R566	—	—	247 0011 944	Carbon chip 47 kohm 1/10W	247 0011 944	Carbon chip 47 kohm 1/10W	—	—
R567	—	—	247 2004 920	Carbon chip 47 ohm 1/16W	247 2004 920	Carbon chip 47 ohm 1/16W	—	—
R568	—	—	247 2009 983	Carbon chip 10 kohm 1/16W	247 2009 983	Carbon chip 10 kohm 1/16W	—	—
R569	—	—	247 0011 944	Carbon chip 47 kohm 1/10W	247 0011 944	Carbon chip 47 kohm 1/10W	—	—
R570	—	—	247 2009 983	Carbon chip 10 kohm 1/16W	247 2009 983	Carbon chip 10 kohm 1/16W	—	—
R571-589	—	—	247 2018 903	Carbon chip 0 ohm 1/16W	247 2018 903	Carbon chip 0 ohm 1/16W	—	—
R621	247 0004 906	Carbon chip 39 ohm 1/10W	247 0004 906	Carbon chip 39 ohm 1/10W	247 0004 906	Carbon chip 39 ohm 1/10W	247 0018 905	Carbon chip 0 ohm 1/10W
R627	247 0005 905	Carbon chip 100 ohm 1/10W	247 0005 905	Carbon chip 100 ohm 1/10W	247 0005 905	Carbon chip 100 ohm 1/10W	247 0004 922	Carbon chip 47 ohm 1/10W
R630	247 0005 905	Carbon chip 100 ohm 1/10W	247 0005 905	Carbon chip 100 ohm 1/10W	247 0005 905	Carbon chip 100 ohm 1/10W	247 0003 981	Carbon chip 33 ohm 1/10W
C101,102	257 0005 986	Ceramic chip 330 pF/50V	257 0005 986	Ceramic chip 330 pF/50V	257 0005 986	Ceramic chip 330 pF/50V	—	—
C113,114	257 0005 986	Ceramic chip 330 pF/50V	257 0005 986	Ceramic chip 330 pF/50V	257 0005 986	Ceramic chip 330 pF/50V	—	—
C123,124	257 0005 986	Ceramic chip 330 pF/50V	257 0005 986	Ceramic chip 330 pF/50V	257 0005 986	Ceramic chip 330 pF/50V	—	—
C135,136	257 0005 986	Ceramic chip 330 pF/50V	257 0005 986	Ceramic chip 330 pF/50V	257 0005 986	Ceramic chip 330 pF/50V	—	—
C145,146	257 0005 986	Ceramic chip 330 pF/50V	257 0005 986	Ceramic chip 330 pF/50V	257 0005 986	Ceramic chip 330 pF/50V	—	—
C157,158	257 0005 986	Ceramic chip 330 pF/50V	257 0005 986	Ceramic chip 330 pF/50V	257 0005 986	Ceramic chip 330 pF/50V	—	—
C509	—	—	257 0014 935	Ceramic chip 0.1 μ F/25V	257 0014 935	Ceramic chip 0.1 μ F/25V	—	—
C510	—	—	257 0011 941	Ceramic chip 0.022 μ F/25V	257 0011 941	Ceramic chip 0.022 μ F/25V	—	—
C511	—	—	257 0011 996	Ceramic chip 0.1 μ F/25V	257 0011 996	Ceramic chip 0.1 μ F/25V	—	—
C512	—	—	257 0004 961	Ceramic chip 100 pF/50V	257 0004 961	Ceramic chip 100 pF/50V	—	—
C513-515	—	—	257 0014 935	Ceramic chip 0.1 μ F/25V	257 0014 935	Ceramic chip 0.1 μ F/25V	—	—
C516	—	—	257 0008 983	Ceramic chip 1000 pF/50V	257 0008 983	Ceramic chip 1000 pF/50V	—	—
C517,518	—	—	254 4299 906	Electrolytic 10 μ F/16V	254 4299 906	Electrolytic 10 μ F/16V	—	—
C519	—	—	257 0004 932	Ceramic chip 75 pF/50V	257 0004 932	Ceramic chip 75 pF/50V	—	—
C520	—	—	257 0010 900	Ceramic chip 0.01 μ F/50V	257 0010 900	Ceramic chip 0.01 μ F/50V	—	—
C521,522	—	—	257 0014 935	Ceramic chip 0.1 μ F/25V	257 0014 935	Ceramic chip 0.1 μ F/25V	—	—
C525	—	—	257 0014 935	Ceramic chip 0.1 μ F/25V	257 0014 935	Ceramic chip 0.1 μ F/25V	—	—
C528	—	—	257 0012 966	Ceramic chip 0.01 μ F/50V	257 0012 966	Ceramic chip 0.01 μ F/50V	—	—
C529	—	—	254 3056 917	Electrolytic 1 μ F/50V	254 3056 917	Electrolytic 1 μ F/50V	—	—
C530	—	—	257 0012 966	Ceramic chip 0.01 μ F/50V	257 0012 966	Ceramic chip 0.01 μ F/50V	—	—
C531	—	—	257 0014 935	Ceramic chip 0.1 μ F/25V	257 0014 935	Ceramic chip 0.1 μ F/25V	—	—
C532	—	—	254 3056 917	Electrolytic 1 μ F/50V	254 3056 917	Electrolytic 1 μ F/50V	—	—
C533,534	—	—	257 0014 935	Ceramic chip 0.1 μ F/25V	257 0014 935	Ceramic chip 0.1 μ F/25V	—	—
C535	—	—	254 4299 906	Electrolytic 10 μ F/16V	254 4299 906	Electrolytic 10 μ F/16V	—	—
C536,537	—	—	257 0014 935	Ceramic chip 0.1 μ F/25V	257 0014 935	Ceramic chip 0.1 μ F/25V	—	—
C538	—	—	257 0012 982	Ceramic chip 0.022 μ F/50V	257 0012 982	Ceramic chip 0.022 μ F/50V	—	—
C539	—	—	254 4299 906	Electrolytic 10 μ F/16V	254 4299 906	Electrolytic 10 μ F/16V	—	—

Ref. No.	EUROPE MODEL		ASIA MODEL		TAIWAN MODEL		U.S.A./CANADA MODELS	
	Part No.	Part Name	Part No.	Part Name	Part No.	Part Name	Part No.	Part Name
C540	—	—	257 0014 935	Ceramic chip 0.1 μ F/25V	257 0014 935	Ceramic chip 0.1 μ F/25V	—	—
C543-545	—	—	257 0014 935	Ceramic chip 0.1 μ F/25V	257 0014 935	Ceramic chip 0.1 μ F/25V	—	—
C546	—	—	254 3053 936	Electrolytic 47 μ F/16V	254 3053 936	Electrolytic 47 μ F/16V	—	—
C547	—	—	257 0002 989	Ceramic chip 18 pF/50V	257 0002 989	Ceramic chip 18 pF/50V	—	—
C548	—	—	254 4302 974	Electrolytic 100 μ F/10V	254 4302 974	Electrolytic 100 μ F/10V	—	—
C549	—	—	257 0012 966	Ceramic chip 0.01 μ F/50V	257 0012 966	Ceramic chip 0.01 μ F/50V	—	—
C551	—	—	257 0001 922	Ceramic chip 1 pF/50V	257 0001 922	Ceramic chip 1 pF/50V	—	—
C552	—	—	257 0012 966	Ceramic chip 0.01 μ F/50V	257 0012 966	Ceramic chip 0.01 μ F/50V	—	—
C554	—	—	257 0014 935	Ceramic chip 0.1 μ F/25V	257 0014 935	Ceramic chip 0.1 μ F/25V	—	—
C555,556	—	—	254 4299 906	Electrolytic 10 μ F/16V	254 4299 906	Electrolytic 10 μ F/16V	—	—
C557	—	—	257 0014 935	Ceramic chip 0.1 μ F/25V	257 0014 935	Ceramic chip 0.1 μ F/25V	—	—
BF201	—	—	261 0152 003	2.88M band pass filter	261 0152 003	2.88M band pass filter	—	—
CX036	—	—	205 0653 036	3P Connector base (35328)	205 0653 036	3P Connector base (35328)	—	—
CX933	—	—	205 0653 036	3P Connector base (35328)	205 0653 036	3P Connector base (35328)	—	—
L505	—	—	235 0070 953	Inductor 68 μ H	235 0070 953	Inductor 68 μ H	—	—
X501	—	—	399 0402 003	Crystal 18.432 MHz	399 0402 003	Crystal 18.432 MHz	—	—

EXPLODED VIEW

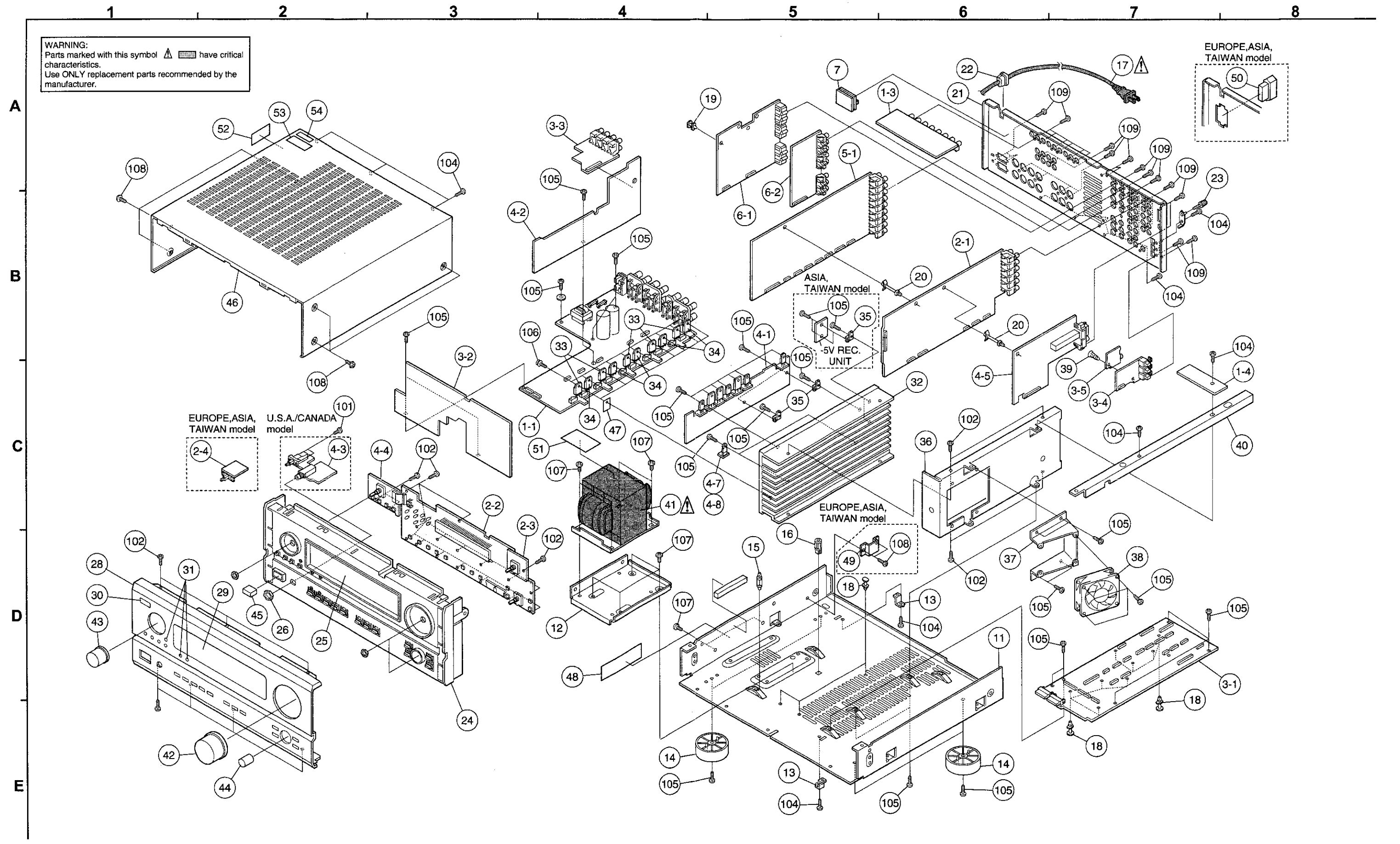

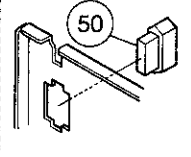

WARNING:
 Parts marked with this symbol  have critical characteristics.
 Use **ONLY** replacement parts recommended by the manufacturer.

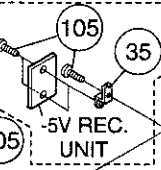
EUROPE, ASIA,
 TAIWAN model

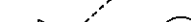
ASIA,
 TAIWAN model

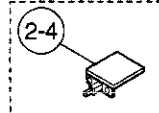
 -5V REC.
 UNIT

EUROPE, ASIA,
 TAIWAN model

EUROPE, ASIA,
 TAIWAN model

 U.S.A./CANADA
 model

A
B
C
D
E

1 2 3 4 5 6 7 8

PARTS LIST OF EXPLODED VIEW

Ref. No.	Part No.	Part Name	Remarks	Q'ty
1	1U-3198	Power unit ass'y		1
1-1	1U-3198-1	Power unit		1
1-3	1U-3198-3	Component video unit		1
1-4	1U-3198-4	Wiring unit		1
2	1U-3199	EXT. IN unit ass'y		1
2-1	1U-3199-1	EXT. IN / VR. unit		1
2-2	1U-3199-2	Display unit		1
2-3	1U-3199-3	VOL. unit		1
2-4	1U-3199-4	P.SW. unit	Europe, Asia, Taiwan model	1
3	1U-3200	Control unit ass'y		1
3-1	1U-3200-1	Control unit		1
3-2	1U-3200-2	Connect unit		1
3-3	1U-3200-3	PRE OUT unit		1
3-4	1U-3200-4	Digital in unit		1
3-5	1U-3200-5	Digital in-2 unit		1
4	1U-3201	Regulator unit ass'y		1
4-1	1U-3201-1	Regulator unit		1
4-2	1U-3201-2	AMP unit		1
4-3	1U-3201-3	H/P & P. SW unit		1
4-4	1U-3201-4	Front unit		1
4-5	1U-3201-5	Tuner unit		1
4-7	1U-3201-7	Posistor unit		1
4-8	1U-3201-8	Posistor unit		1
5	1U-3215	Audio / DSP unit		1
5-1	1U-3215-1	Audio / DSP unit ass'y		1
6	1U-3244	Video unit ass'y		1
6-1	1U-3244-1	S-video unit		1
6-2	1U-3244-2	C-video unit		1
7	1U-3223B	Voltage select unit	Asia & Taiwan model only	1
11	411 1372 526	Main chassis		1
12	412 4522 004	Trans bracket		1
13	412 4210 002	Bracket		2
14	104 0194 205	Foot ass'y		4
15	449 0133 017	PWB Holder		1
16	412 3548 005	PWB Catcher		1
17	Note	AC Cord		1
18	412 2814 028	Card spacer	L=10	11
19	412 2814 031	Card spacer	L=4	1
20	409 0052 019	Holder (A)		2
21	Note	Back panel		1
22	445 0056 008	Cord bush		1
23	205 1116 006	Terminal ass'y		1
24	Note	Inner panel		1
25	Note	Display sheet		1
26	475 6124 003	12 NUT		1
28	Note	Front panel		1
29	143 1064 009	Window		1
30	Note	DENON mark		1
31	143 1011 007	Lens (S)		3
32	417 0585 202	Radiator		1
33	273 0413 004	Transistor 2SC3855LB4(O/P/Y)(Z)		5
34	271 0263 009	Transistor 2SA1491LB4(O/P/Y)(Z)		5

Ref. No.	Part No.	Part Name	Remarks	Q'ty
35	412 4127 001	PWB Bracket (B)		2
36	412 4525 001	Fan bracket		1
37	412 4527 009	Fan cover		1
38	421 0749 005	Fan (80x80)24V		1
39	412 2741 007	PWB Holder		1
40	412 4296 107	Radiator bracket		1
41	Note	Power trans		1
42	Note	Knob (M) ass'y		1
43	Note	Knob (F) ass'y		1
44	Note	Knob (S) ass'y		1
45	Note	Push knob		1
46	Note	Top cover		1
47	415 0234 007	Insulating sheet		10
48	513 3309 000	Caution label	USA/CANADA model only	1
★	203 4871 067	3P KR-KR Connector	CN31	1
★	203 4871 067	3P KR-KR Connector	CN37	1
★	203 4871 083	3P KR-KR Connector	CN38	1
★	203 4871 067	3P KR-KR Connector	CN39	1
★	203 6386 026	4P KR-KR Connector	CN41	1
49	412 2955 107	Side bracket		1
50	203 3942 007	AC Outret		1
51	513 3333 005	Label (Trans)		1
SCREWS				
101	4737500015	Screw 3x8 CBTS (P)-Z		19
102	4737501001	Screw 3x10 CBTS (P)-Z		11
103	4737501030	Screw 3x20 CBTS (P)-Z		1
104	4737015018	Screw 3x8 CBTS (S)-B		13
105	4737005002	Screw 3x10 CBTS (S)-Z		37
106	4738007009	Screw 3x12 CUP SCREW		10
107	4737004003	Screw 4x8 CBTS (S)-Z		10
108	4738064000	Screw 4x8 CBTS(B)-B-3P		6
109	4770064107	FIXING SCREW		36
110	473 8064 013	Screw 4x8 CBTS(B)-N-3P	Gold model only	6
PACKING & ACCESSORIES (Not included EXPLODED VIEW)				
201	503 1325 005	Cushion ass'y		1
202	503 1326 004	Cushion (Front)		1
203	503 1327 003	Cushion (Rear)		1
204	505 8006 019	Envelope		1
205	Note	Inst manual		1
206	231 0922 009	Loop antenna		1
207	395 0023 008	*FM Antenna ass'y		1
208	529 0079 008	FM Antenna adapter		1
209	Note	Remote control		1
210	515 0671 708	Service station list		1
211	501 2045 003	Carton case		1
212	513 1389 006	Control card base		1
213	513 1349 004	Thermal carbon film		1
214	515 0690 307	DEL Warranty home		1
215	Note	Color label (Gold)		1
216	Note	Preset label		1
217	504 0189 009	Cabinet sheet		1
★	218	Note	AC Adapter (4.8)	Asia, Taiwan model

ADDENDUM PARTS LIST OF EXPLODED VIEW

G Mark: Gold model B Mark: Black model

Ref. No.	EUROPE MODEL		ASIA MODEL		TAIWAN MODEL		U.S.A./CANADA MODELS	
	Part No.	Part Name	Part No.	Part Name	Part No.	Part Name	Part No.	Part Name
17	206 2171 001	AC Cord	206 2173 009	AC Cord	206 2173 009	AC Cord	206 2161 008	AC Cord
21	105 1316 124	Back panel	105 1316 137	Back panel	105 1316 137	Back panel	105 1316 108	Back panel
24	146 2139 013	Inner panel	G 146 2139 013	Inner panel	G 146 2139 013	Inner panel	G 146 2139 107	Inner panel
25	143 1065 118	Display sheet	G 143 1065 011	Display sheet	G 143 1065 011	Display sheet	G 143 1065 008	Display sheet
28	144 2668 041	Front panel	G 144 2668 054	Front panel	G 144 2668 054	Front panel	G —	—
	144 2668 025	Front panel	B 144 2668 038	Front panel	B 144 2668 038	Front panel	B 144 2668 009	Front panel
30	131 9004 068	DENON mark	G 131 9004 068	DENON mark	G 131 9004 068	DENON mark	G —	—
	131 9004 013	DENON mark	B 131 9004 013	DENON mark	B 131 9004 013	DENON mark	B 131 9004 013	DENON mark
41	233 6300 003	Power trans (Main)	233 6301 002	Power trans (Main)	233 6301 002	Power trans (Main)	233 6295 008	Power trans (Main)
42	112 0839 011	Knob (M) ass'y	G 112 0839 011	Knob (M) ass'y	G 112 0839 011	Knob (M) ass'y	G —	—
	112 0839 008	Knob (M) ass'y	B 112 0839 008	Knob (M) ass'y	B 112 0839 008	Knob (M) ass'y	B 112 0839 008	Knob (M) ass'y
43	112 0837 013	Knob (F) ass'y	G 112 0837 013	Knob (F) ass'y	G 112 0837 013	Knob (F) ass'y	G —	—
	112 0837 000	Knob (F) ass'y	B 112 0837 000	Knob (F) ass'y	B 112 0837 000	Knob (F) ass'y	B 112 0837 000	Knob (F) ass'y
44	112 0835 015	Knob (S) ass'y	G 112 0835 015	Knob (S) ass'y	G 112 0835 015	Knob (S) ass'y	G —	—
	112 0835 002	Knob (S) ass'y	B 112 0835 002	Knob (S) ass'y	B 112 0835 002	Knob (S) ass'y	B 112 0835 002	Knob (S) ass'y
45	113 1873 011	Push knob	G 113 1873 011	Push knob	G 113 1873 011	Push knob	G —	—
	113 1873 008	Push knob	B 113 1873 008	Push knob	B 113 1873 008	Push knob	B 113 1873 008	Push knob
46	102 0603 017	Top cover	G 102 0603 017	Top cover	G 102 0603 017	Top cover	G —	—
	102 0603 004	Top cover	B 102 0603 004	Top cover	B 102 0603 004	Top cover	B 102 0603 004	Top cover
52	—	—	513 3331 007	Label (DTS)	513 3331 007	Label (DTS)	—	—
53	—	—	—	—	513 2482 009	Caution Label (T)	—	—
54	—	—	—	—	513 2481 000	Serial No. Sheet (T)	—	—
205	511 3501 006	Inst manual	511 3459 006	Inst manual	511 3459 006	Inst manual	511 3459 006	Inst manual
209	399 0546 011	Remote control (RC-864)	399 0546 008	Remote control (RC-860)	399 0546 008	Remote control (RC-860)	399 0546 008	Remote control (RC-860)
215	513 9111 001	Color label (Gold)	513 9111 001	Color label (Gold)	513 9111 001	Color label (Gold)	—	—
216	—	—	515 8030 040	Preset label	515 8030 040	Preset label	—	—

BLOCK DIAGRAM

1

2

3

4

5

6

C-VIDEO

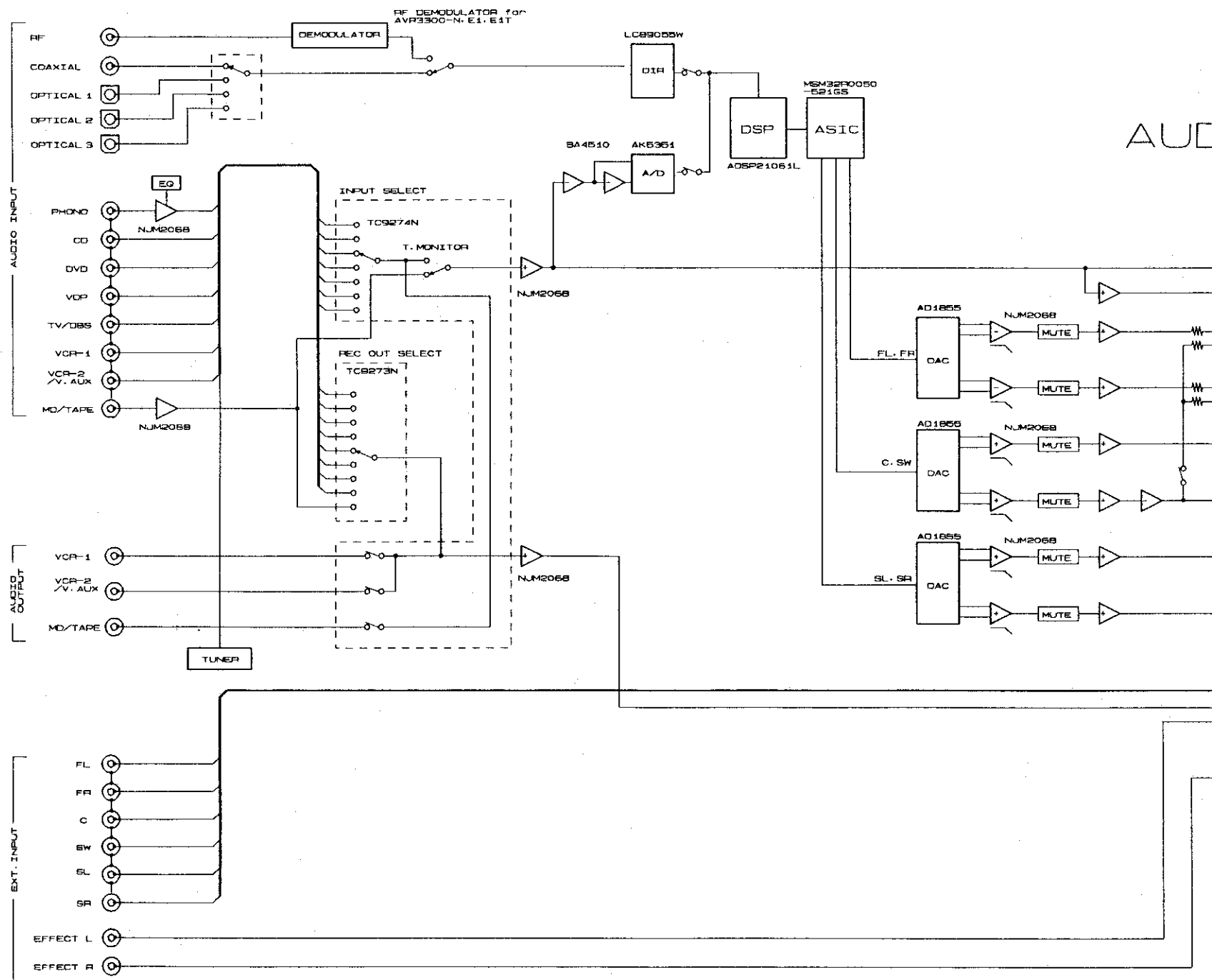
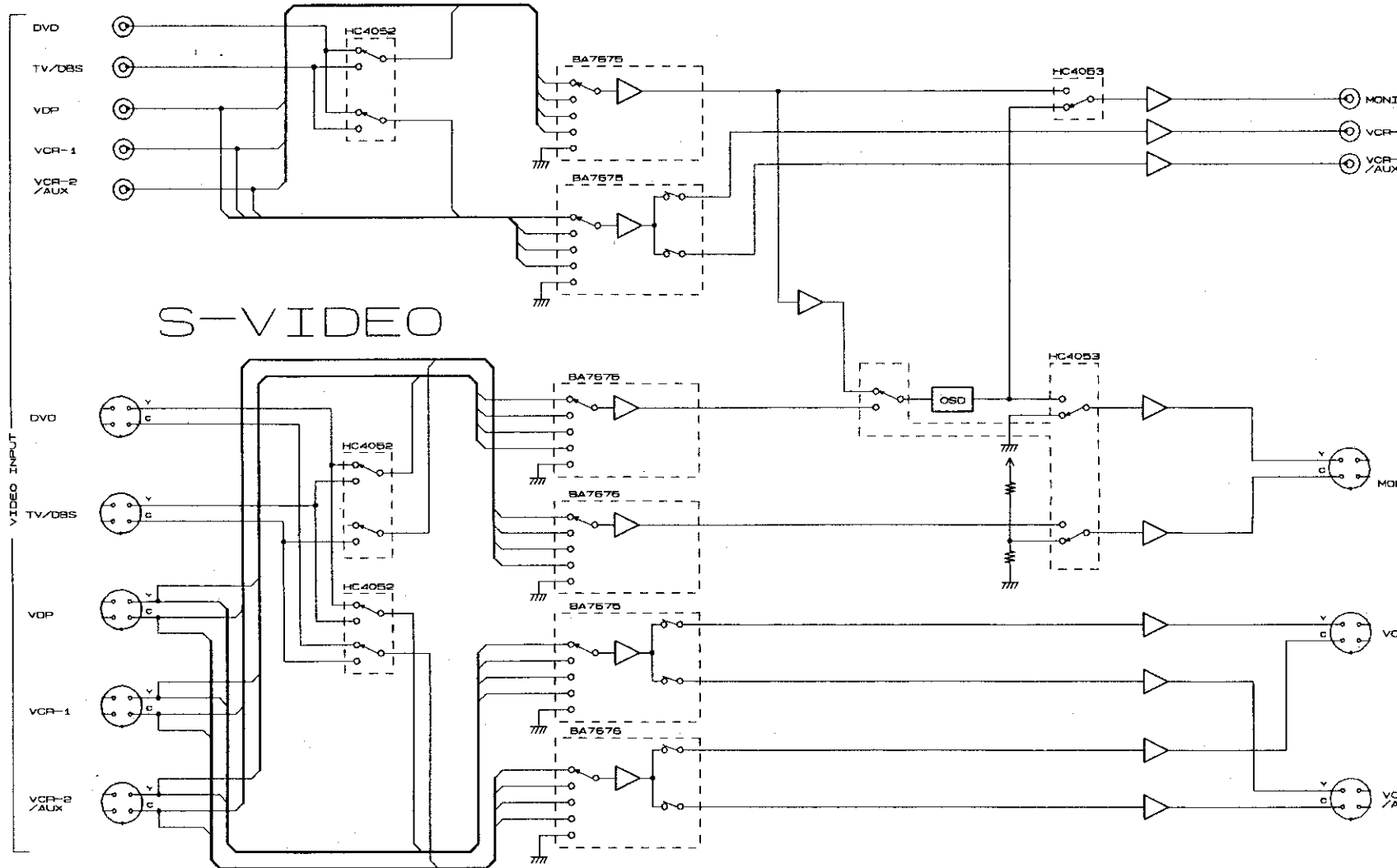

6

7

8

9

10

11

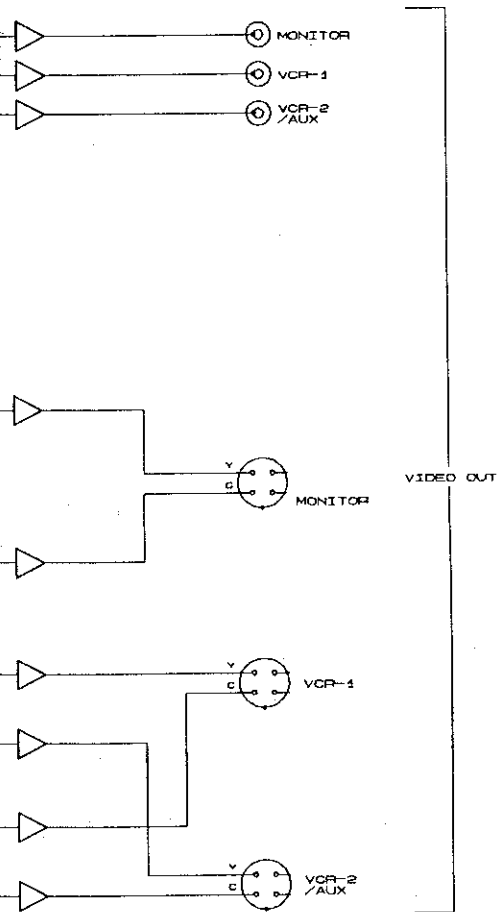

COMPONENT VIDEO

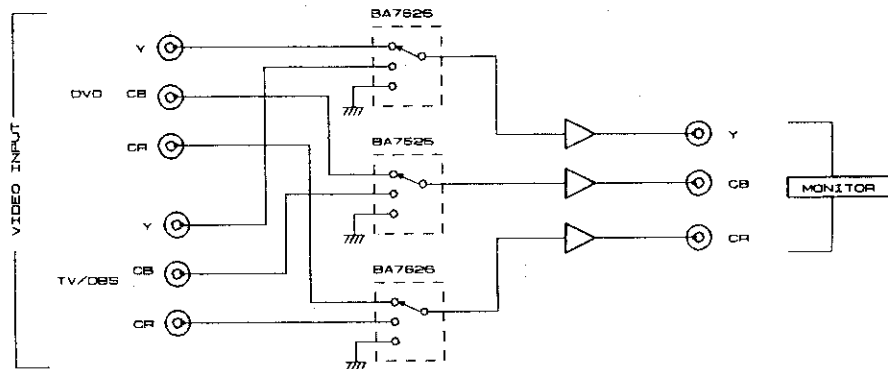

AUDIO SIGNAL

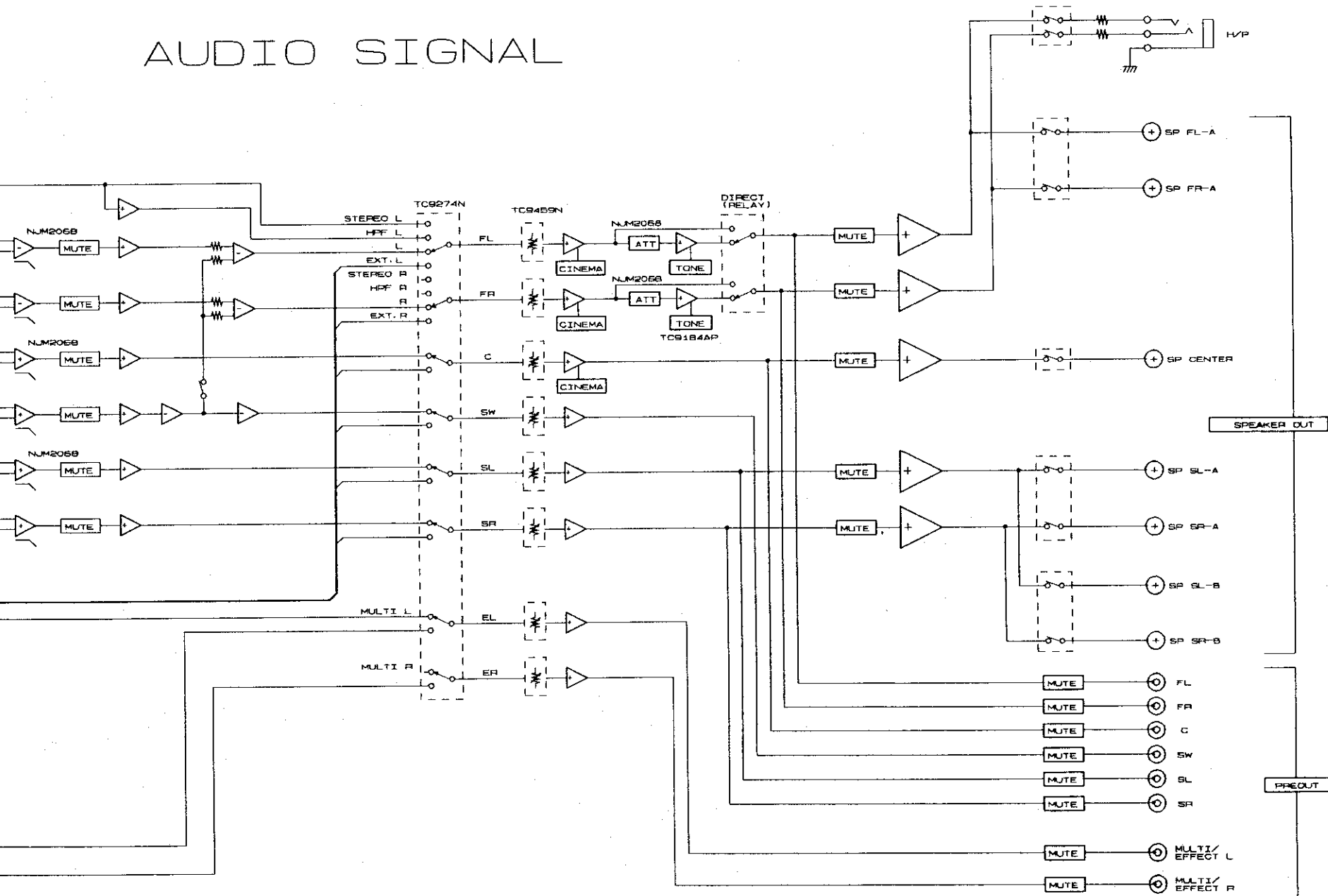

WIRING DIAGRAM

1 2 3 4 5 6

A

B

C

D

E

F

G

H

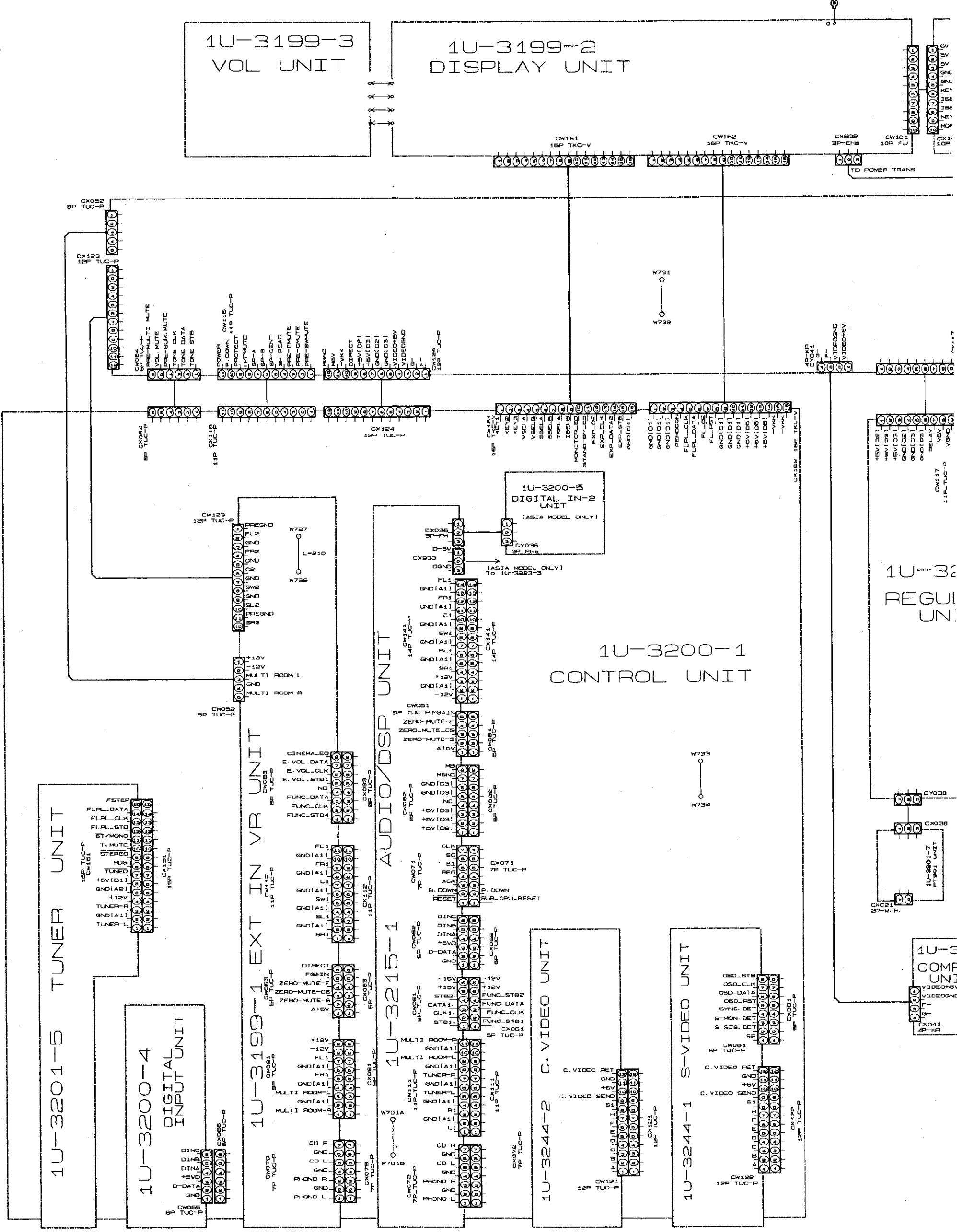

1U-3200-7 REGUL UNIT

1U-3200-8 COMP UNIT

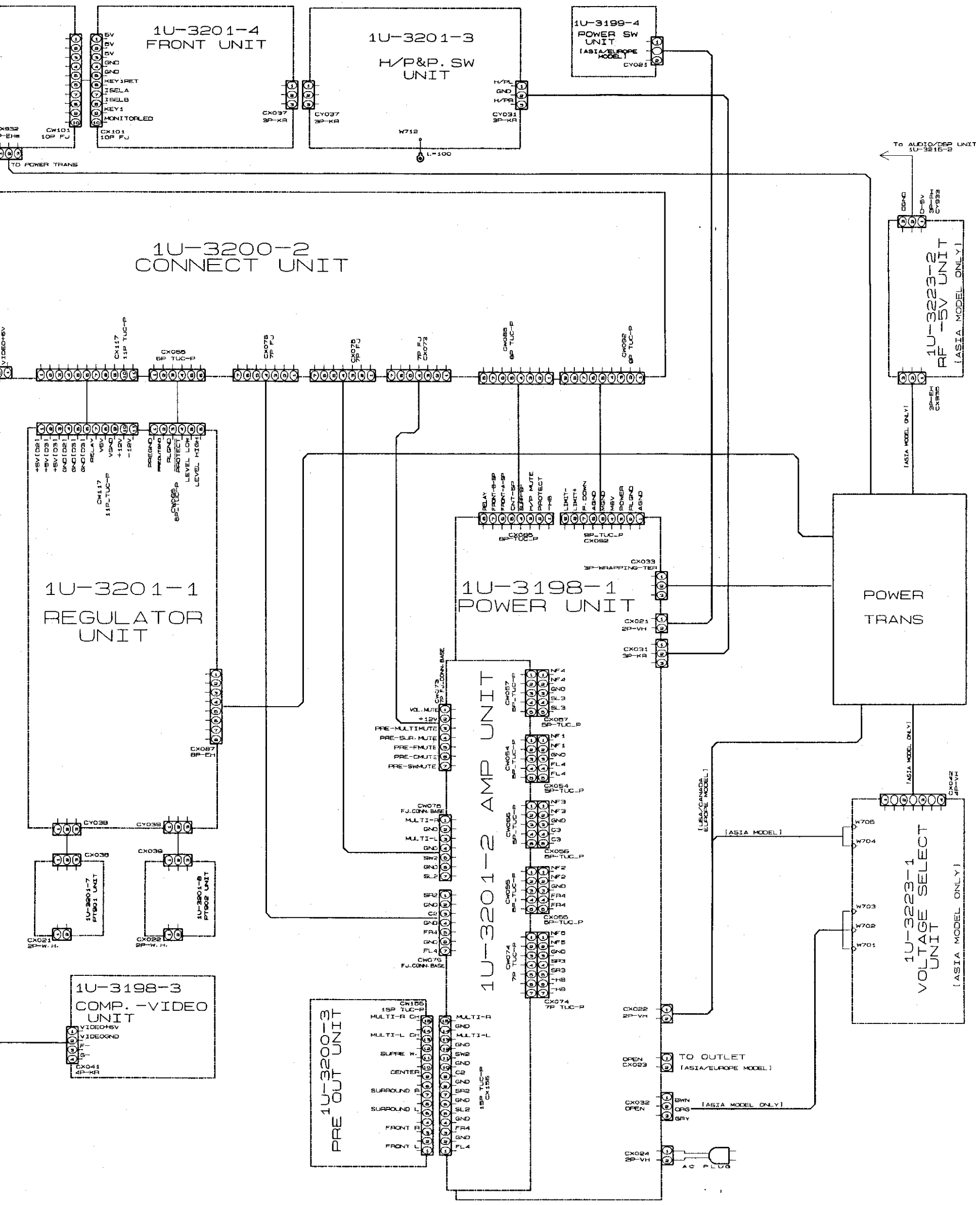

SCHEMATIC DIAGRAMS (1/14)

1

2

3

4

5

6

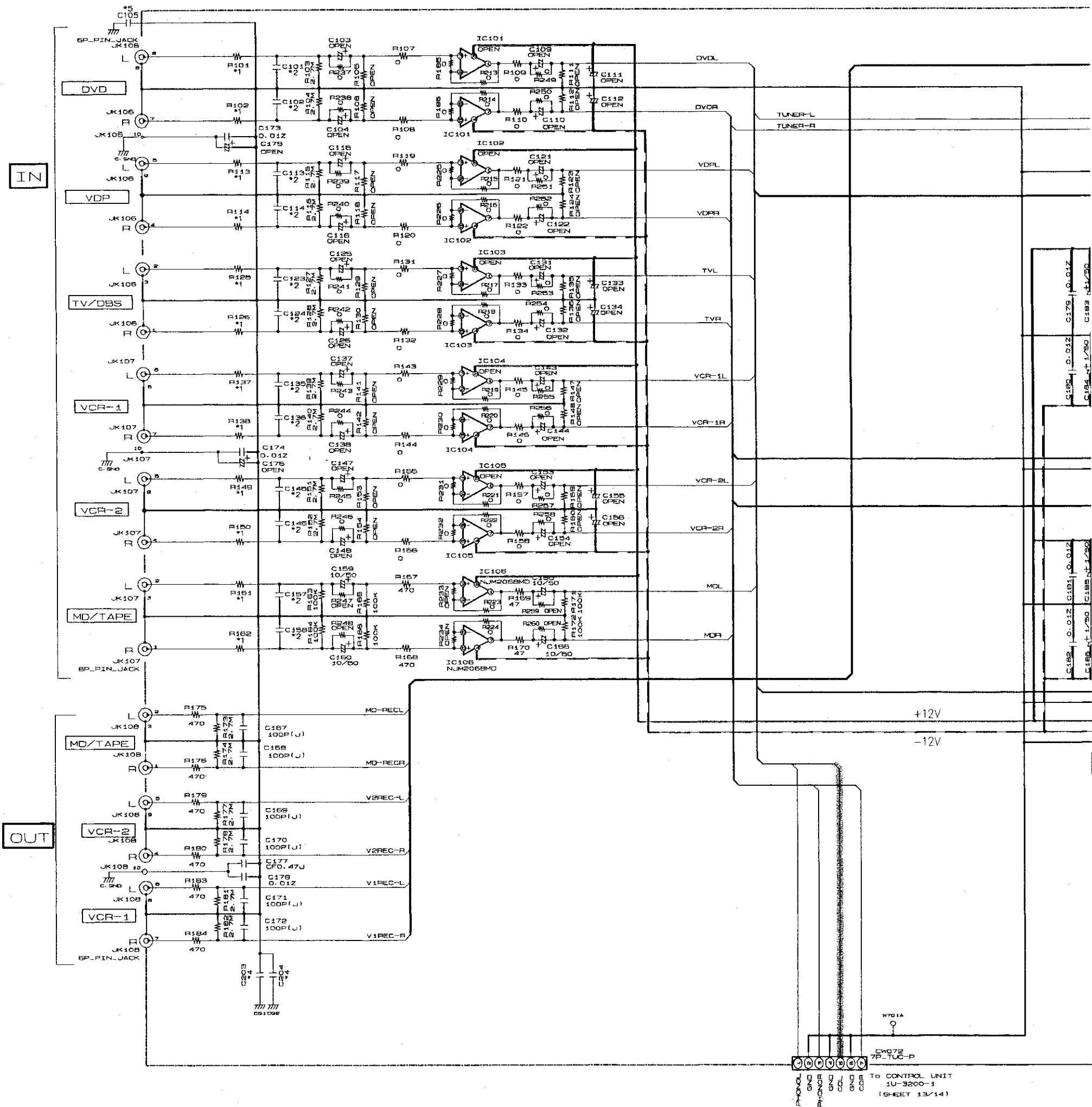

	*1	*2	*3	*4	*5
	R101,102,113,114,125,126 R137,138,149,150,161,162	C101,102,113,114,123,124 C135,136,145,146,157,158	C195,196	C203,204	C105
USA	100	OPEN	10/16	OPEN	OPEN
CANADA	100	OPEN	10/16	OPEN	OPEN
EUROPE	470	CK330P	100/16	CK473K	CK0.022Z
ASIA	470	CK330P	10/16	OPEN	OPEN

NOTICE
ALL RESISTANCE VALUES IN
ALL CAPACITANCE VALUES IN
EACH VOLTAGE AND CURRENT
CONDITION.
CIRCUIT AND PARTS ARE SUBJECT TO
CHANGE WITHOUT NOTICE.

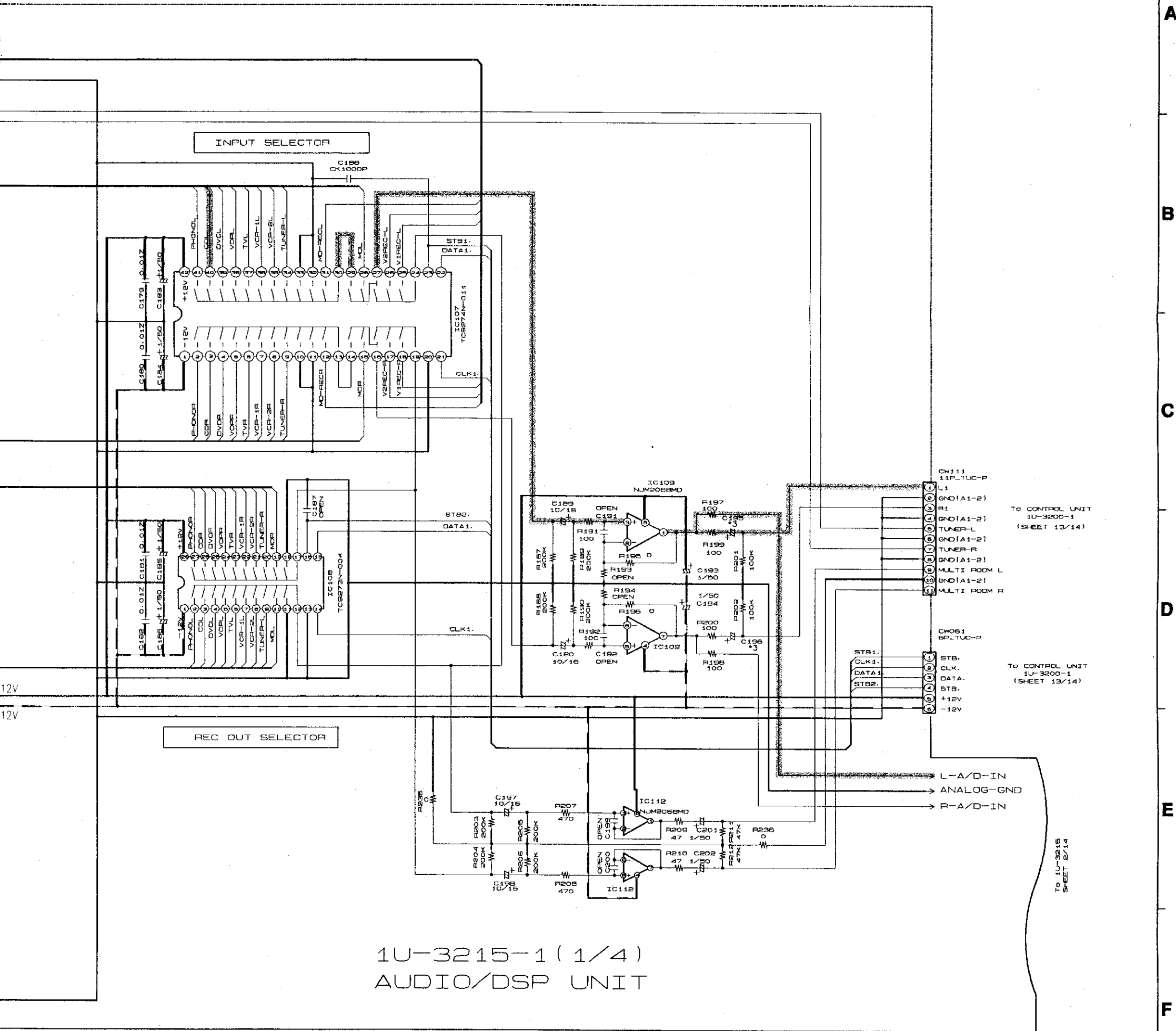

1U-3215-1 (1/4)
AUDIO/DSP UNIT

————— +B LINE
 - - - - - -B LINE
 SIGNAL LINE

NOTICE
 ALL RESISTANCE VALUES IN OHM. k=1,000 OHM M=1,000,000 OHM
 ALL CAPACITANCE VALUES IN MICRO FARAD. P=MICRO-MICRO FARAD
 EACH VOLTAGE AND CURRENT ARE MEASURED AT NO SIGNAL INPUT
 CONDITION.
 CIRCUIT AND PARTS ARE SUBJECT TO CHANGE WITHOUT PRIOR
 NOTICE.

WARNING:
 Parts marked with this symbol have critical characteristics.
 Use ONLY replacement parts recommended by the manufacturer.

CAUTION:
 Before returning the unit to the customer, make sure you make either (1) a
 leakage current check or (2) a line to chassis resistance check. If the leakage
 current exceeds 0.5 milliamps, or if the resistance from chassis to either side
 of the power cord is less than 460 kohms, the unit is defective.

WARNING:
 DO NOT return the unit to the customer until the problem is located and
 corrected.

SCHEMATIC DIAGRAMS (2/14)

1 2 3 4 5 6

A

B

C

D

E

F

G

H

1U-3215-1 (2/4)
AUDIO/DSP UNIT

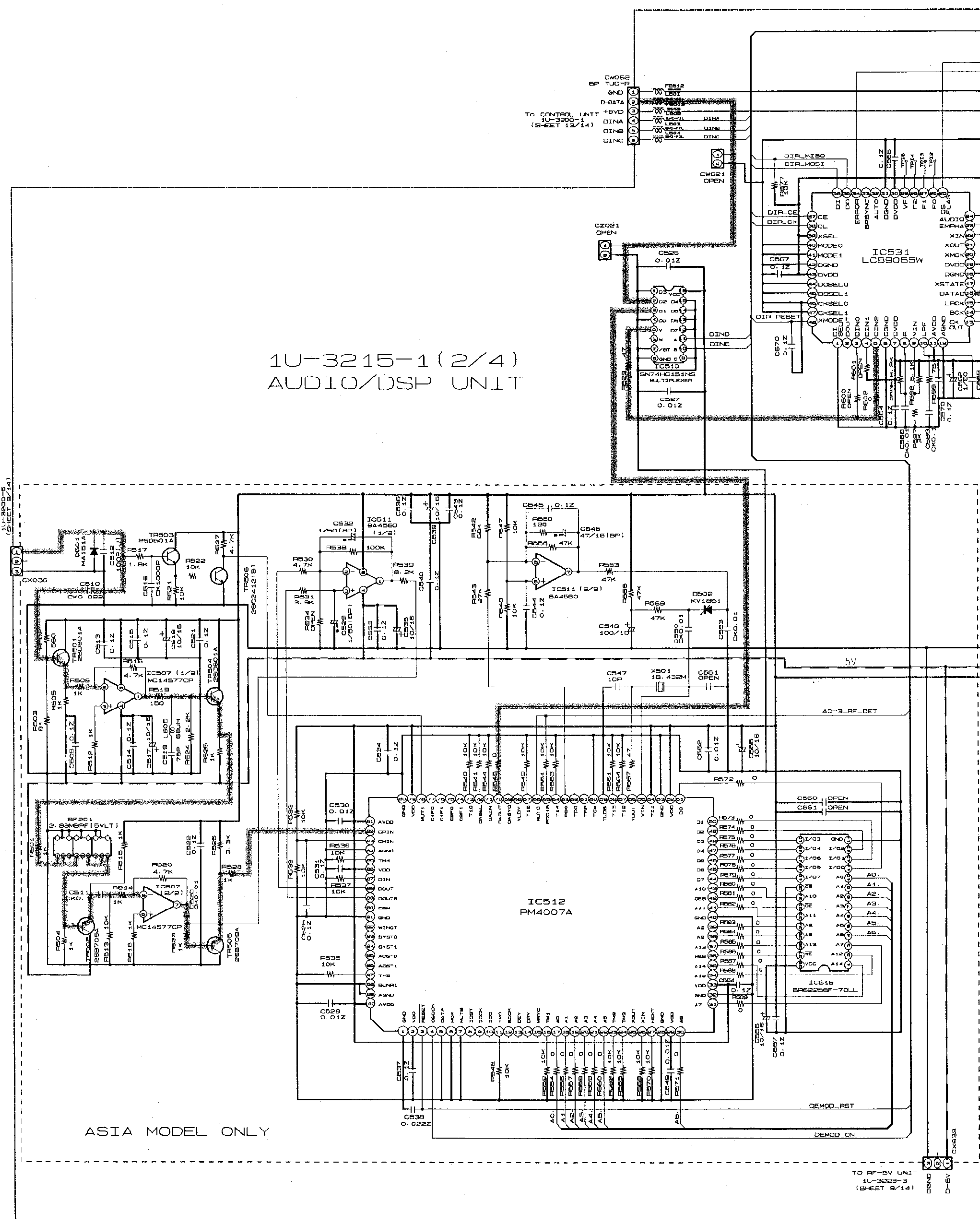

NOTICE
 ALL RESISTANCE VALUES IN OHM. k=1,000 OHM M=1,000,000 OHM
 ALL CAPACITANCE VALUES IN MICRO FARAD. P=MICRO-MICRO FARAD
 EACH VOLTAGE AND CURRENT ARE MEASURED AT NO SIGNAL INPUT
 CONDITION.
 CIRCUIT AND PARTS ARE SUBJECT TO CHANGE WITHOUT PRIOR
 NOTICE.

WARNING:
 Parts marked with this symbol  have critical characteristics.
 Use ONLY replacement parts recommended by the manufacturer.

CAUTION:
 Before returning the unit to the customer, make sure you make either (1) a
 leakage current check or (2) a line to chassis resistance check. If the leakage
 current exceeds 0.5 milliamps, or if the resistance from chassis to either side
 of the power cord is less than 460 kohms, the unit is defective.

WARNING:
 DO NOT return the unit to the customer until the problem is located and
 corrected.

To SHEET 1/14
 L-A/D-IN
 ANALOG-GND
 R-A/D-IN

SCHEMATIC DIAGRAMS (2/14)

1 2 3 4 5 6

A

B

C

D

E

F

G

H

1U-3215-1(2/4)
AUDIO/DSP UNIT

TO DIGITAL UNIT
1U-3200-3
(SHEET 2/14)

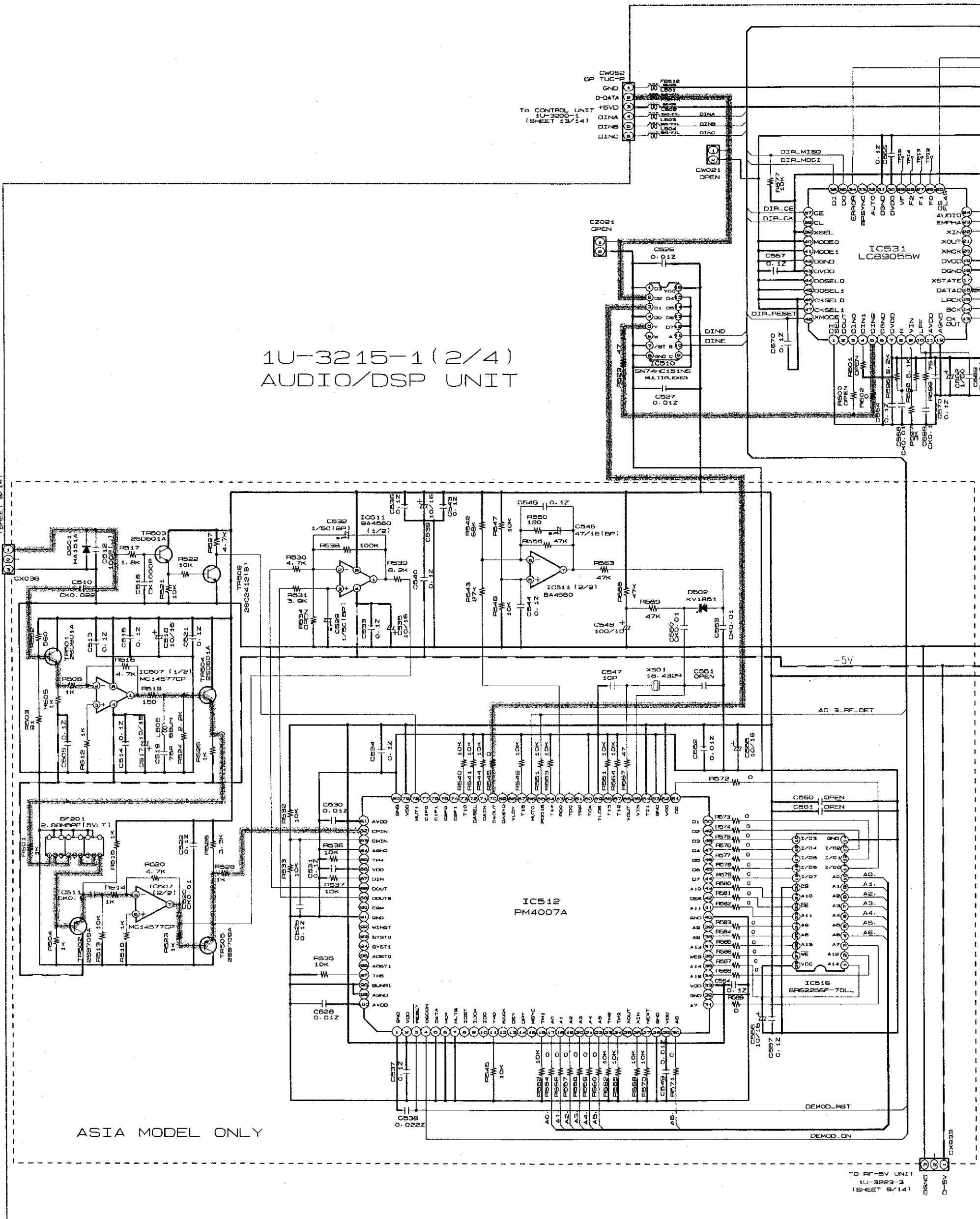

ASIA MODEL ONLY

NOTICE
 ALL RESISTANCE VALUES IN OHM, k=1,000 OHM M=1,000,000 OHM
 ALL CAPACITANCE VALUES IN MICRO FARAD. P=MICRO-MICRO FARAD
 EACH VOLTAGE AND CURRENT ARE MEASURED AT NO SIGNAL INPUT
 CONDITION.
 CIRCUIT AND PARTS ARE SUBJECT TO CHANGE WITHOUT PRIOR
 NOTICE.

WARNING:
 Parts marked with this symbol  have critical characteristics.
 Use ONLY replacement parts recommended by the manufacturer.

CAUTION:
 Before returning the unit to the customer, make sure you make either (1) a
 leakage current check or (2) a line to chassis resistance check. If the leakage
 current exceeds 0.5 milliamps, or if the resistance from chassis to either side
 of the power cord is less than 460 kohms, the unit is defective.

WARNING:
 DO NOT return the unit to the customer until the problem is located and
 corrected.

To SHEET 1/14

L-A/D-IN
 ANALOG-GND
 R-A/D-IN

TO RF-BV UNIT
 1U-3223-3
 (SHEET 9/14)

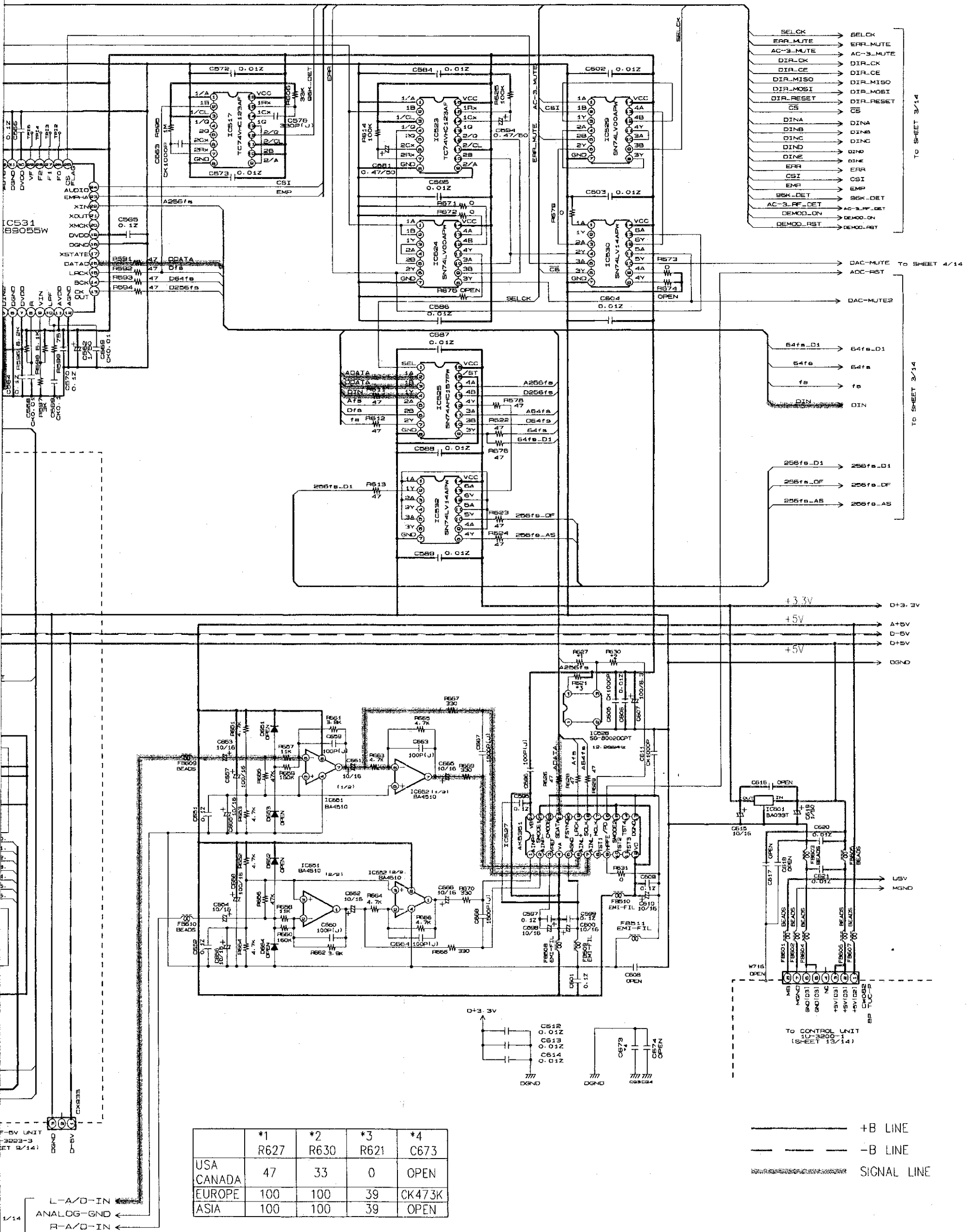

- SELCK → SELCK
- ERR_MUTE → ERR_MUTE
- AC-3_MUTE → AC-3_MUTE
- DIR_CHK → DIR_CHK
- DIR_CE → DIR_CE
- DIR_MISO → DIR_MISO
- DIR_MOSI → DIR_MOSI
- DIR_RESET → DIR_RESET
- CS → CS
- DINA → DINA
- DINB → DINB
- DINC → DINC
- DIND → DIND
- DINE → DINE
- DIR → DIR
- CSI → CSI
- EMP → EMP
- 9SK_DET → 9SK_DET
- AC-3_FF_DET → AC-3_FF_DET
- DEMOD_ON → DEMOD_ON
- DEMOD_RST → DEMOD_RST

- DAC-MUTE → DAC-MUTE
- ACC-RST → ACC-RST
- DAC-MUTE2 → DAC-MUTE2

- 64fs_D1 → 64fs_D1
- 64fs → 64fs
- fs → fs
- DIN → DIN

- 256fs_D1 → 256fs_D1
- 256fs_OF → 256fs_OF
- 256fs_AS → 256fs_AS

- +3.3V → +3.3V
- +5V → +5V
- 5V → -5V
- +5V → +5V
- GND → GND

- USV → USV
- MSGND → MSGND

TO CONTROL UNIT
(SHEET 13/14)

	*1	*2	*3	*4
USA	R627	R630	R621	C673
CANADA	47	33	0	OPEN
EUROPE	100	100	39	CK473K
ASIA	100	100	39	OPEN

- +B LINE
- -B LINE
- SIGNAL LINE

SCHEMATIC DIAGRAMS (3/14)

1

2

3

4

5

6

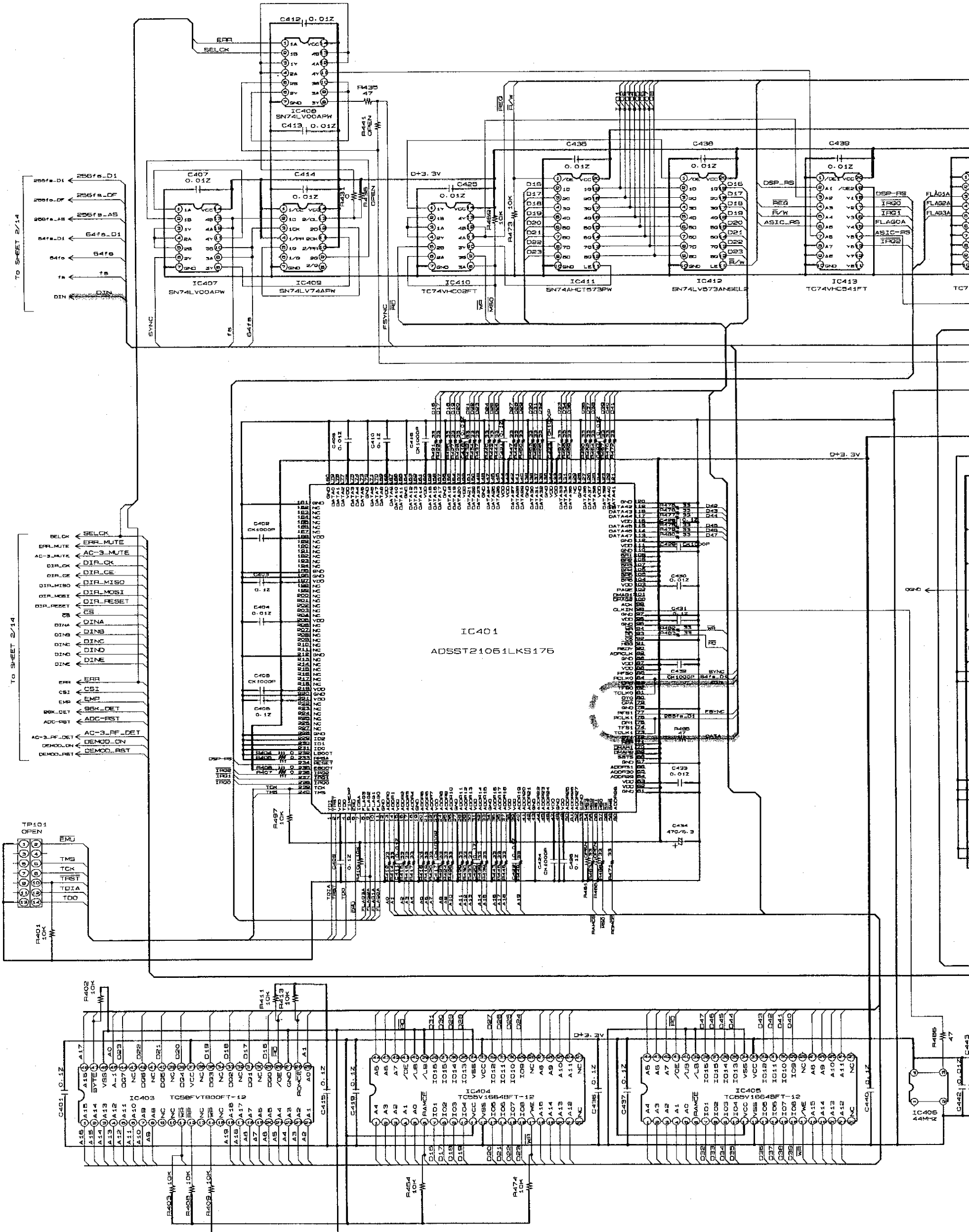

NOTICE
 ALL RESISTANCE VALUES IN
 ALL CAPACITANCE VALUES IN
 EACH VOLTAGE AND CURRENT
 CONDITION.
 CIRCUIT AND PARTS ARE SUBJECT TO
 NOTICE.

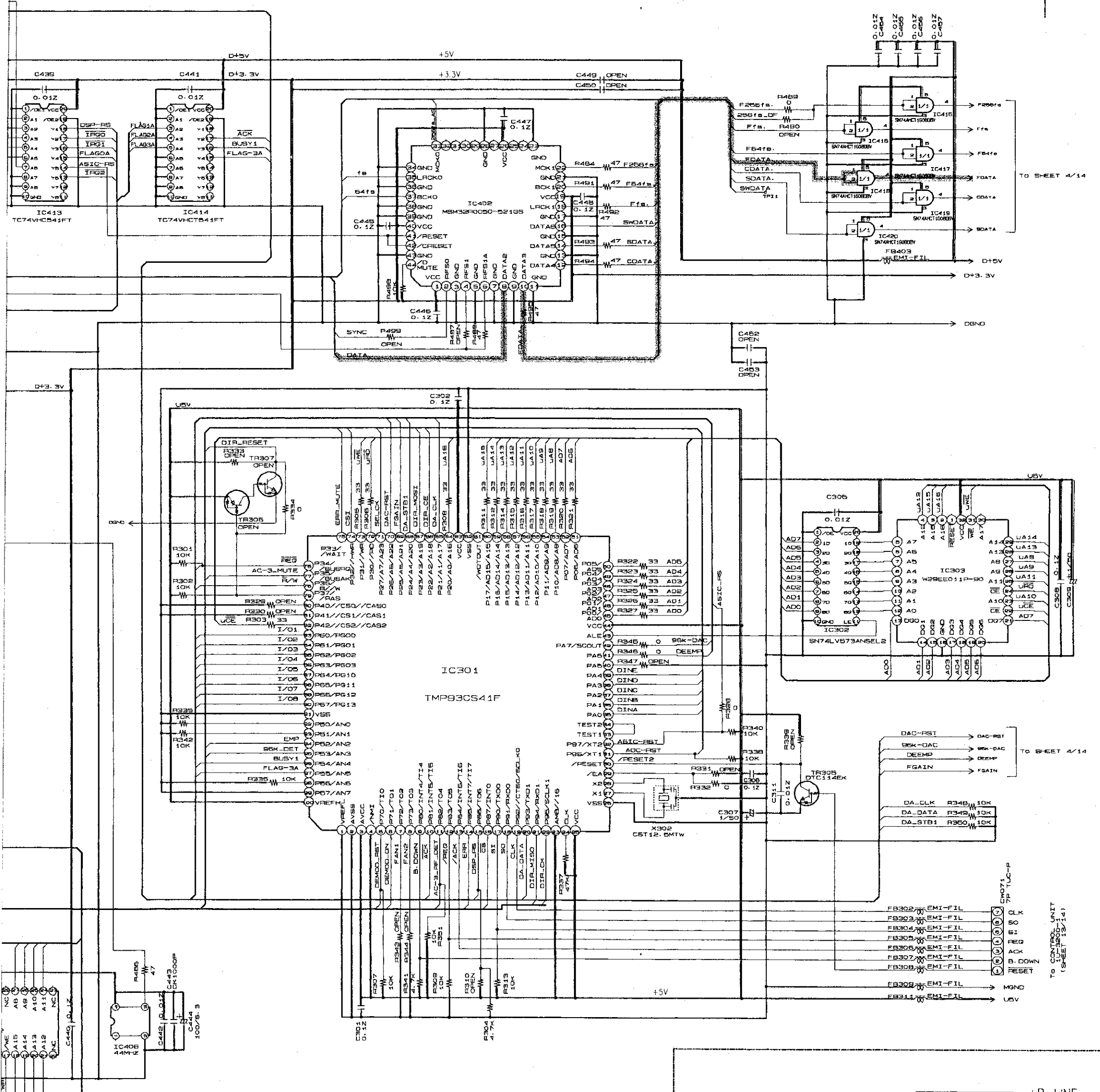

1U-3215-1 (3/4)
AUDIO/DSP UNIT

— +B LINE
 - - - - - SIGNAL LINE

NOTICE
 ALL RESISTANCE VALUES IN OHM, k=1,000 OHM M=1,000,000 OHM
 ALL CAPACITANCE VALUES IN MICRO FARAD. P=MICRO-MICRO FARAD
 EACH VOLTAGE AND CURRENT ARE MEASURED AT NO SIGNAL INPUT
 CONDITION.
 CIRCUIT AND PARTS ARE SUBJECT TO CHANGE WITHOUT PRIOR
 NOTICE.

WARNING:
 Parts marked with this symbol Δ have critical characteristics.
 Use ONLY replacement parts recommended by the manufacturer.

CAUTION:
 Before returning the unit to the customer, make sure you make either (1) a
 leakage current check or (2) a line to chassis resistance check. If the leakage
 current exceeds 0.5 milliamps, or if the resistance from chassis to either side
 of the power cord is less than 460 kohms, the unit is defective.

WARNING:
 DO NOT return the unit to the customer until the problem is located and
 corrected.

SCHEMATIC DIAGRAMS (3/14)
1U-3215-1 AUDIO / DSP UNIT

TO SHEET 4/14
 TO SHEET 4/14
 TO CONTROL UNIT
 (SHEET 13-14)

SCHEMATIC DIAGRAMS (4/14)

1 2 3 4 5 6

A
B
C
D
E
F
G
H

1U-3215
AUDIO/D

To SHEET 2/14

To SHEET 3/14

To SHEET 3/14

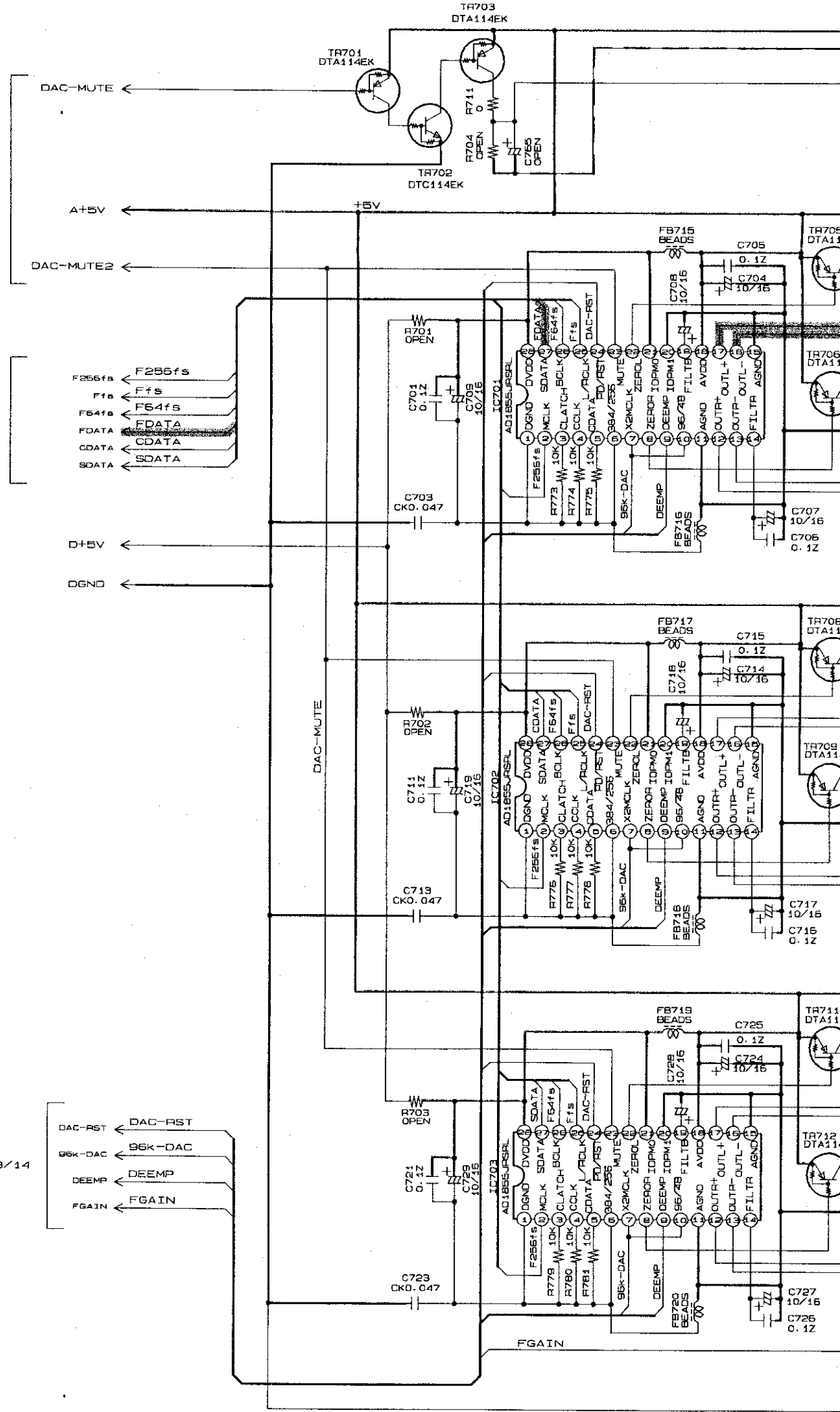

	*1
	C702
USA	OPEN
CANADA	OPEN
EUROPE	CK1000P
ASIA	OPEN

NOTICE
ALL RESISTANCE VALUES IN OHM. k=1,000 OHM M=1,000,000 OHM
ALL CAPACITANCE VALUES IN MICRO FARAD. P=MICRO-MICRO FARAD
EACH VOLTAGE AND CURRENT ARE MEASURED AT NO SIGNAL INPUT
CONDITION.
CIRCUIT AND PARTS ARE SUBJECT TO CHANGE WITHOUT PRIOR
NOTICE.

1U-3215-1 (4/4) AUDIO/DSP UNIT

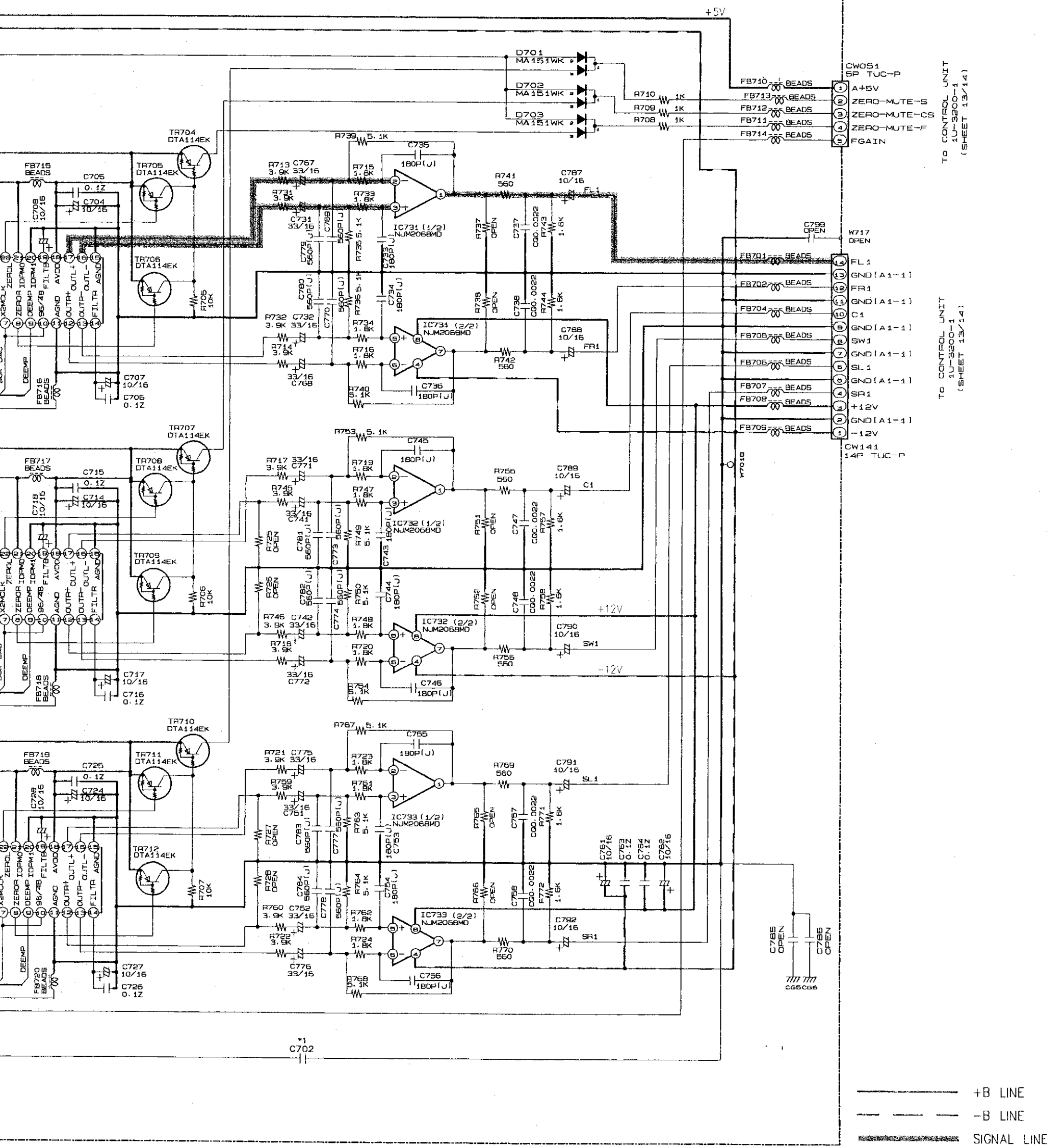

_____ +B LINE
 _____ -B LINE
 _____ SIGNAL LINE

WARNING:
Parts marked with this symbol have critical characteristics. Use ONLY replacement parts recommended by the manufacturer.

CAUTION:
Before returning the unit to the customer, make sure you make either (1) a leakage current check or (2) a line to chassis resistance check. If the leakage current exceeds 0.5 millamps, or if the resistance from chassis to either side of the power cord is less than 460 kohms, the unit is defective.

WARNING:
DO NOT return the unit to the customer until the problem is located and corrected.

SCHEMATIC DIAGRAMS (4/14) 1U-3215-1 AUDIO / DSP UNIT

IN OHM, k=1,000 OHM, M=1,000,000 OHM
S IN MICRO FARAD, P=MICRO-MICRO FARAD
RESISTANCE ARE MEASURED AT NO SIGNAL INPUT

SUBJECT TO CHANGE WITHOUT PRIOR

TO CONTROL UNIT
1U-3200-1
(SHEET 13/14)

TO CONTROL UNIT
1U-3200-1
(SHEET 13/14)

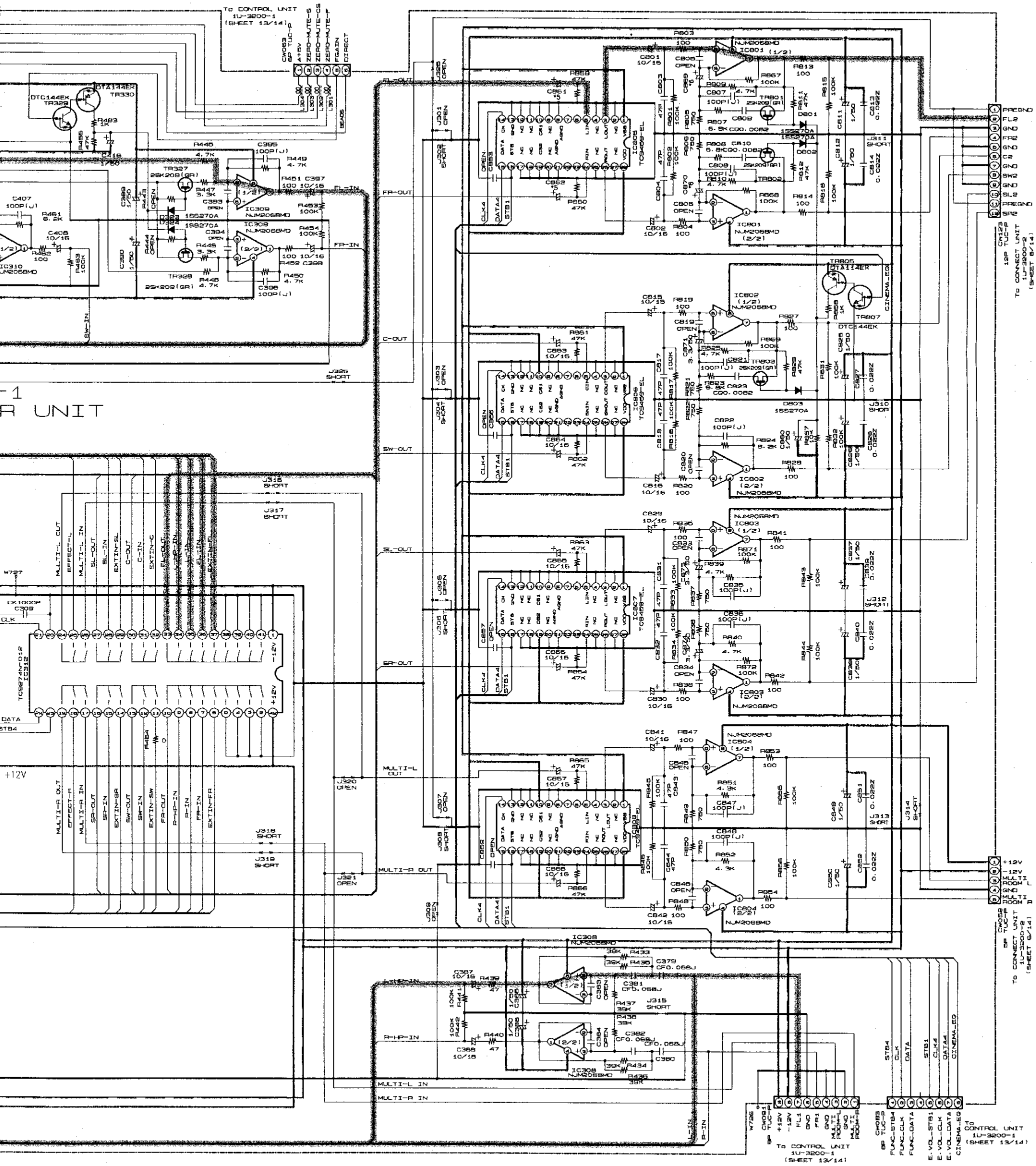

M. k=1,000 OHM M=1,000,000 OHM
 MICRO FARAD. P=MICRO-MICRO FARAD
 ARE MEASURED AT NO SIGNAL INPUT

CT TO CHANGE WITHOUT PRIOR

WARNING:
 Parts marked with this symbol Δ have critical characteristics.
 Use ONLY replacement parts recommended by the manufacturer.

CAUTION:
 Before returning the unit to the customer, make sure you make either (1) a leakage current check or (2) a line to chassis resistance check. If the leakage current exceeds 0.5 millamps, or if the resistance from chassis to either side of the power cord is less than 460 kohms, the unit is defective.

WARNING:
 DO NOT return the unit to the customer until the problem is located and corrected.

— +B LINE
 - - - -B LINE
 ~~~~~ SIGNAL LINE

**SCHEMATIC DIAGRAMS (5/14)**  
**1U-3199-1 EXT IN VR UNIT**





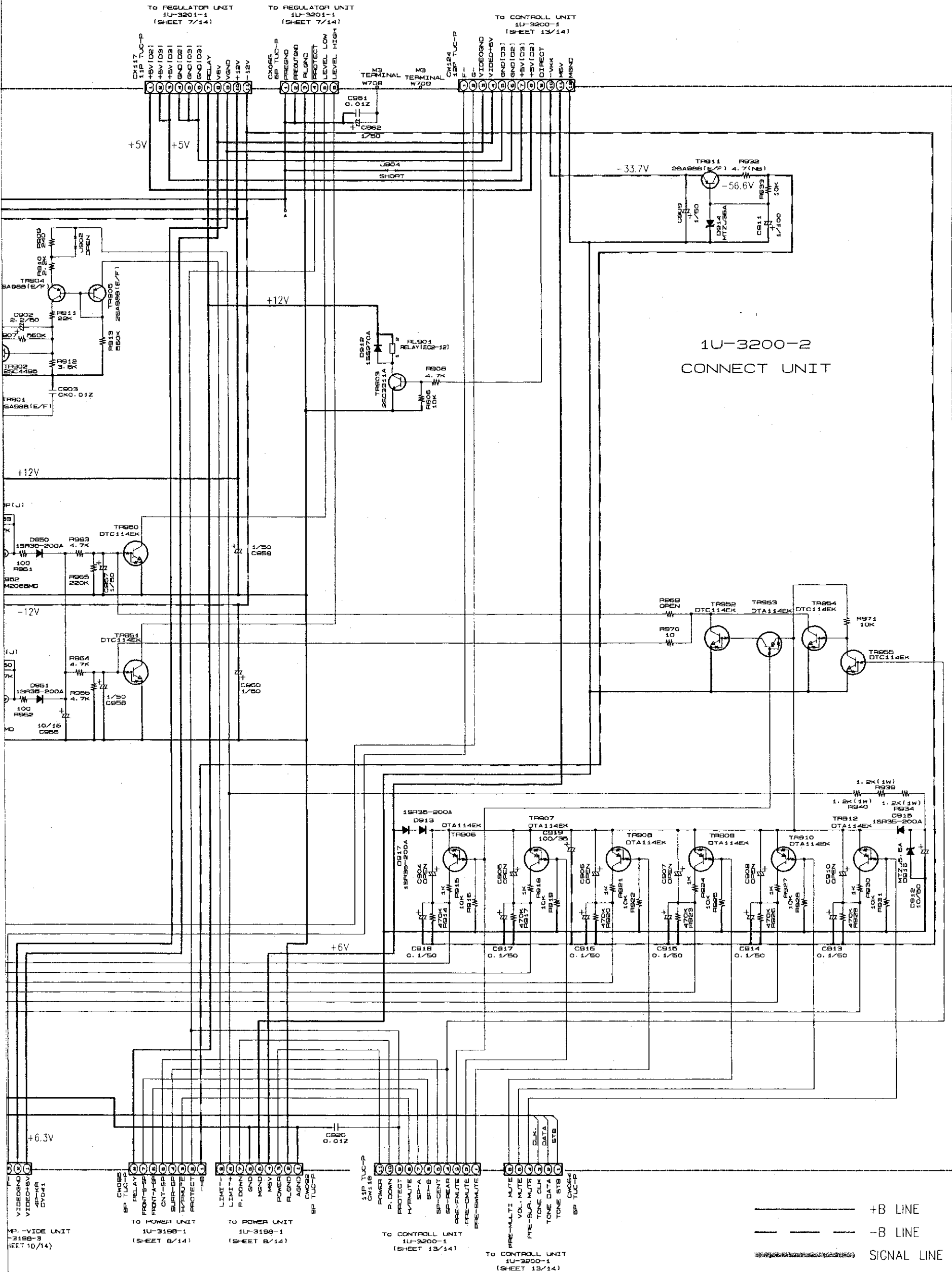

\_\_\_\_\_ +B LINE  
 \_\_\_\_\_ -B LINE  
 \_\_\_\_\_ SIGNAL LINE

**WARNING:**  
Parts marked with this symbol have critical characteristics. Use ONLY replacement parts recommended by the manufacturer.

**CAUTION:**  
Before returning the unit to the customer, make sure you make either (1) a leakage current check or (2) a line to chassis resistance check. If the leakage current exceeds 0.5 milliamperes, or if the resistance from chassis to either side of the power cord is less than 460 kohms, the unit is defective.

**WARNING:**  
DO NOT return the unit to the customer until the problem is located and corrected.

**SCHEMATIC DIAGRAMS (6/14)**  
**1U-3200-2 CONNECT UNIT**

OHM, K=1,000 OHM M=1,000,000 OHM  
MICRO FARAD, P=MICRO-MICRO FARAD  
ARE MEASURED AT NO SIGNAL INPUT

JECT TO CHANGE WITHOUT PRIOR





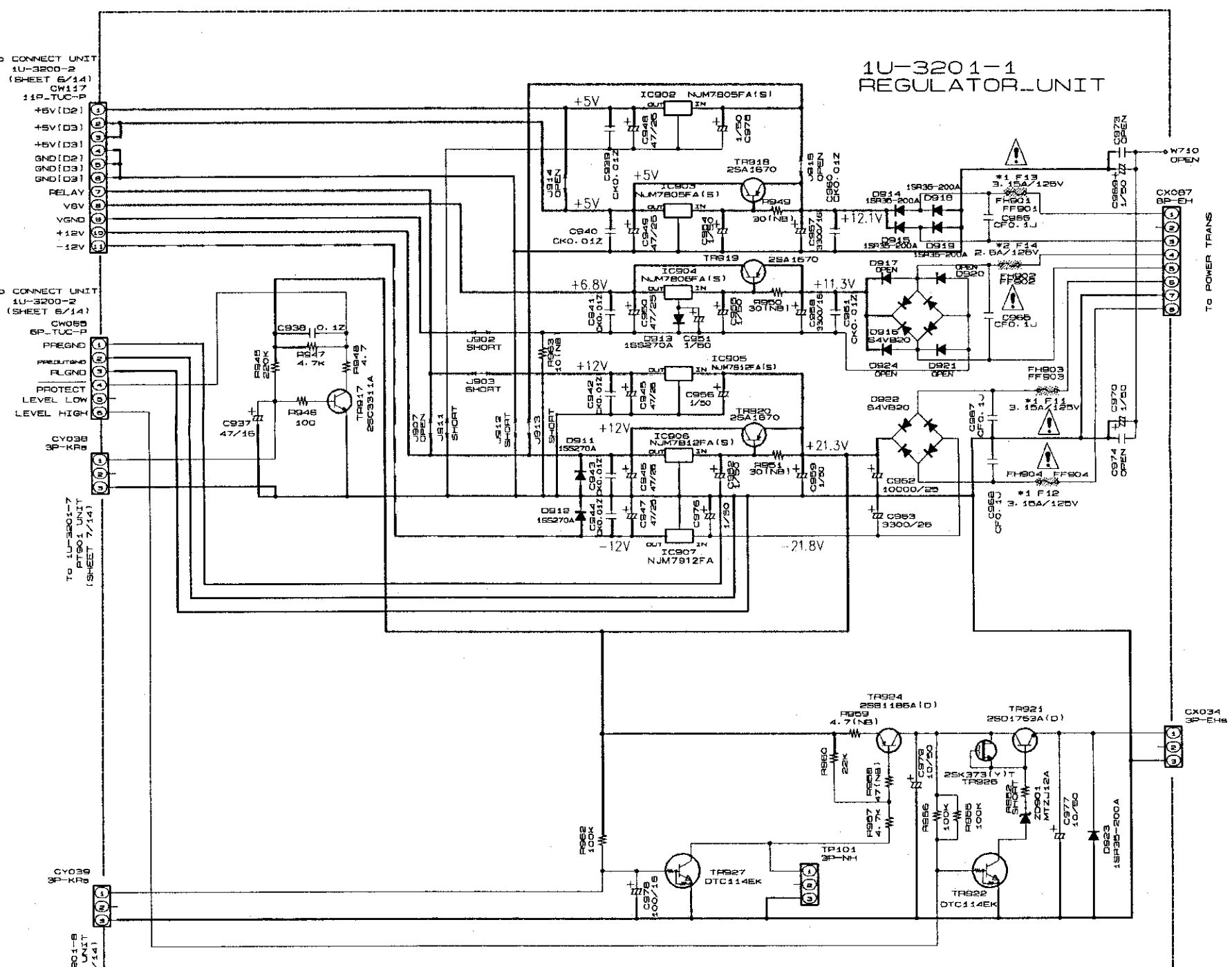
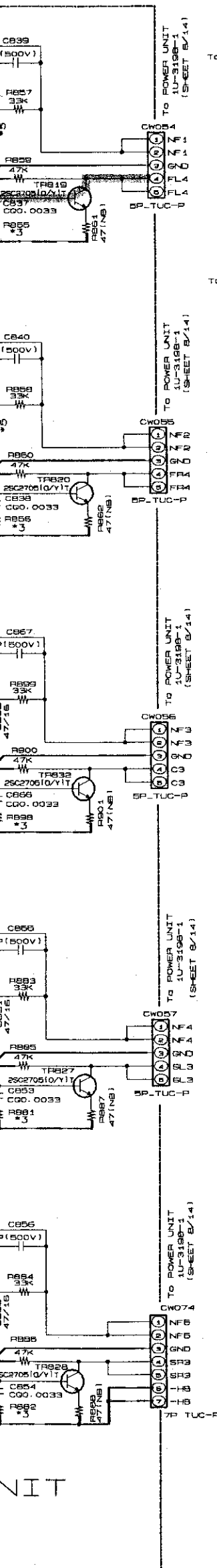

| K1 |                 |
|----|-----------------|
| L2 | SOURCE          |
| L3 | TUNER/PRESET    |
| L4 | REC/MULTI       |
| L5 | NO TAPE MONITOR |

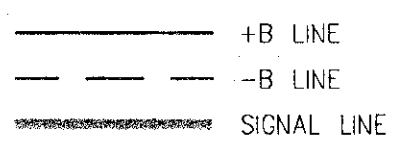
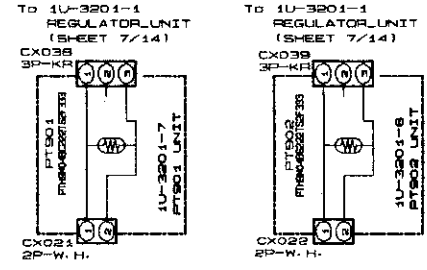
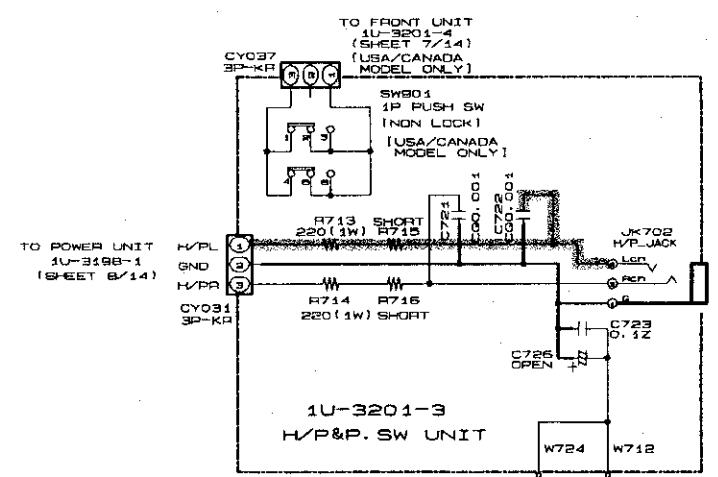
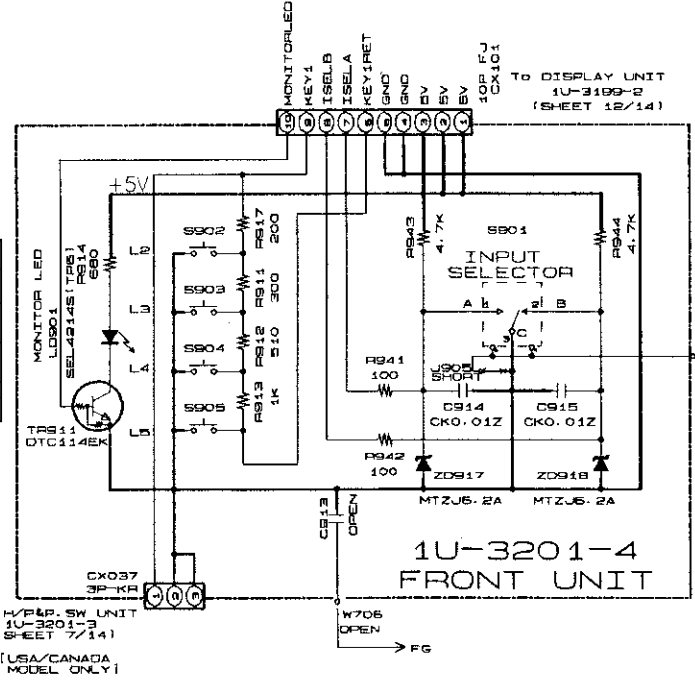

**WARNING:**  
Parts marked with this symbol have critical characteristics. Use ONLY replacement parts recommended by the manufacturer.

**CAUTION:**  
Before returning the unit to the customer, make sure you make either (1) a leakage current check or (2) a line to chassis resistance check. If the leakage current exceeds 0.5 milliamperes, or if the resistance from chassis to either side of the power cord is less than 460 kohms, the unit is defective.

**WARNING:**  
DO NOT return the unit to the customer until the problem is located and corrected.

**SCHEMATIC DIAGRAMS (7/14)**  
**1U-3201-1 REGULATOR UNIT / 1U-3201-2 AMP UNIT**  
**1U-3201-3 H/P & P.S.W UNIT / 1U-3201-4 FRONT UNIT**



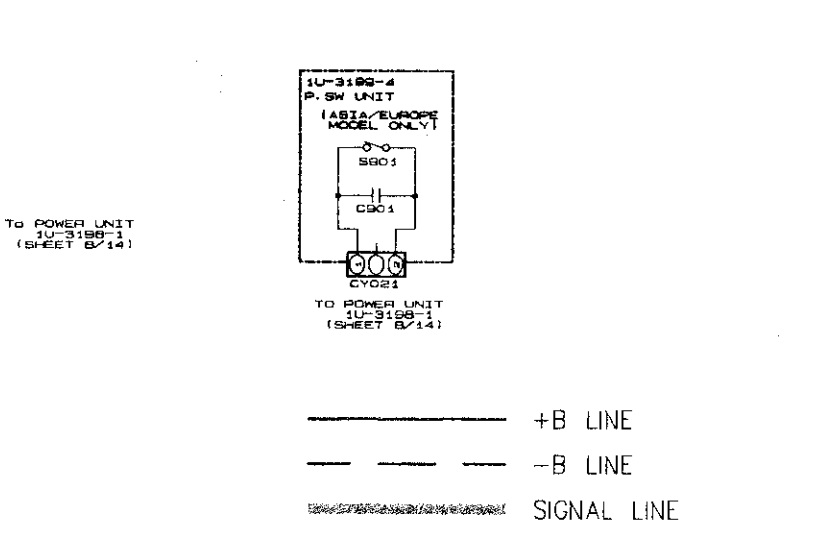
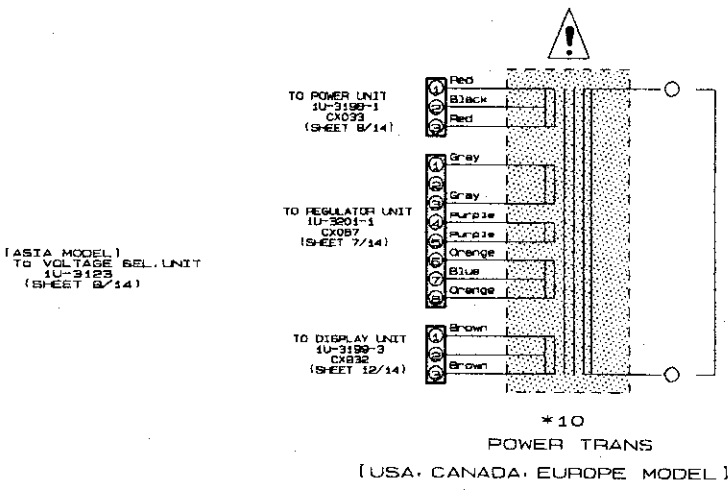
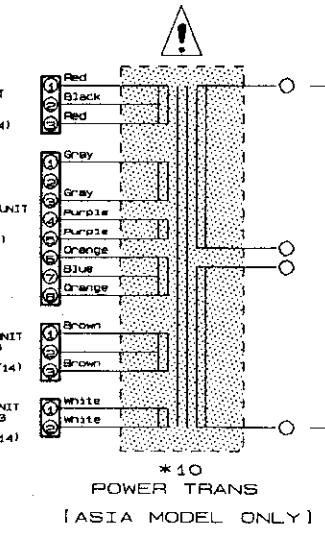
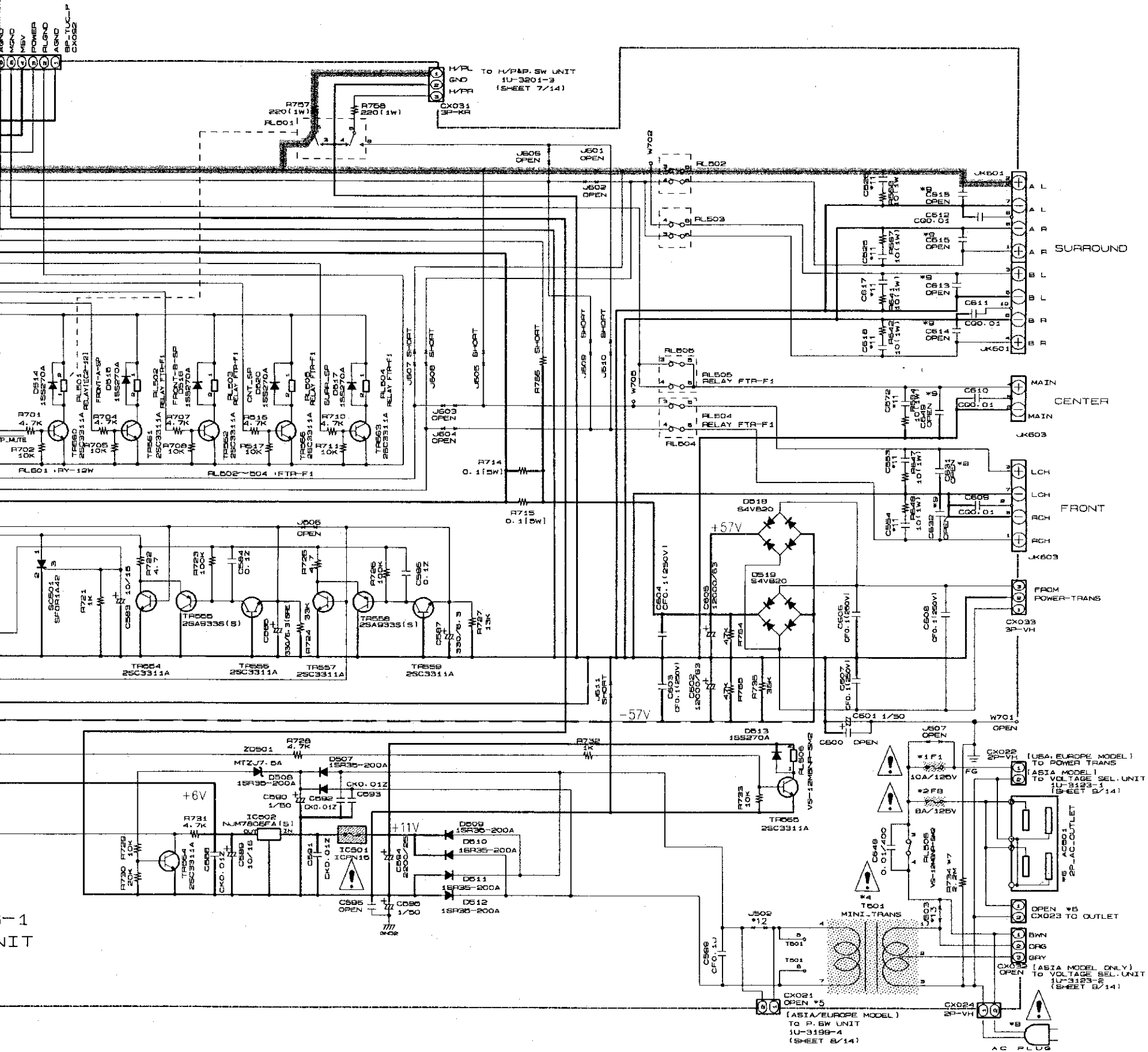

RESISTANCE VALUES IN OHM. k=1,000 OHM M=1,000,000 OHM  
 CAPACITANCE VALUES IN MICRO FARAD. P=MICRO-MICRO FARAD  
 VOLTAGE AND CURRENT ARE MEASURED AT NO SIGNAL INPUT  
 PARTS ARE SUBJECT TO CHANGE WITHOUT PRIOR NOTICE

**WARNING:**  
 Parts marked with this symbol have critical characteristics. Use ONLY replacement parts recommended by the manufacturer.

**CAUTION:**  
 Before returning the unit to the customer, make sure you make either (1) a leakage current check or (2) a line to chassis resistance check. If the leakage current exceeds 0.5 milliamps, or if the resistance from chassis to either side of the power cord is less than 460 kohms, the unit is defective.

**WARNING:**  
 DO NOT return the unit to the customer until the problem is located and corrected.

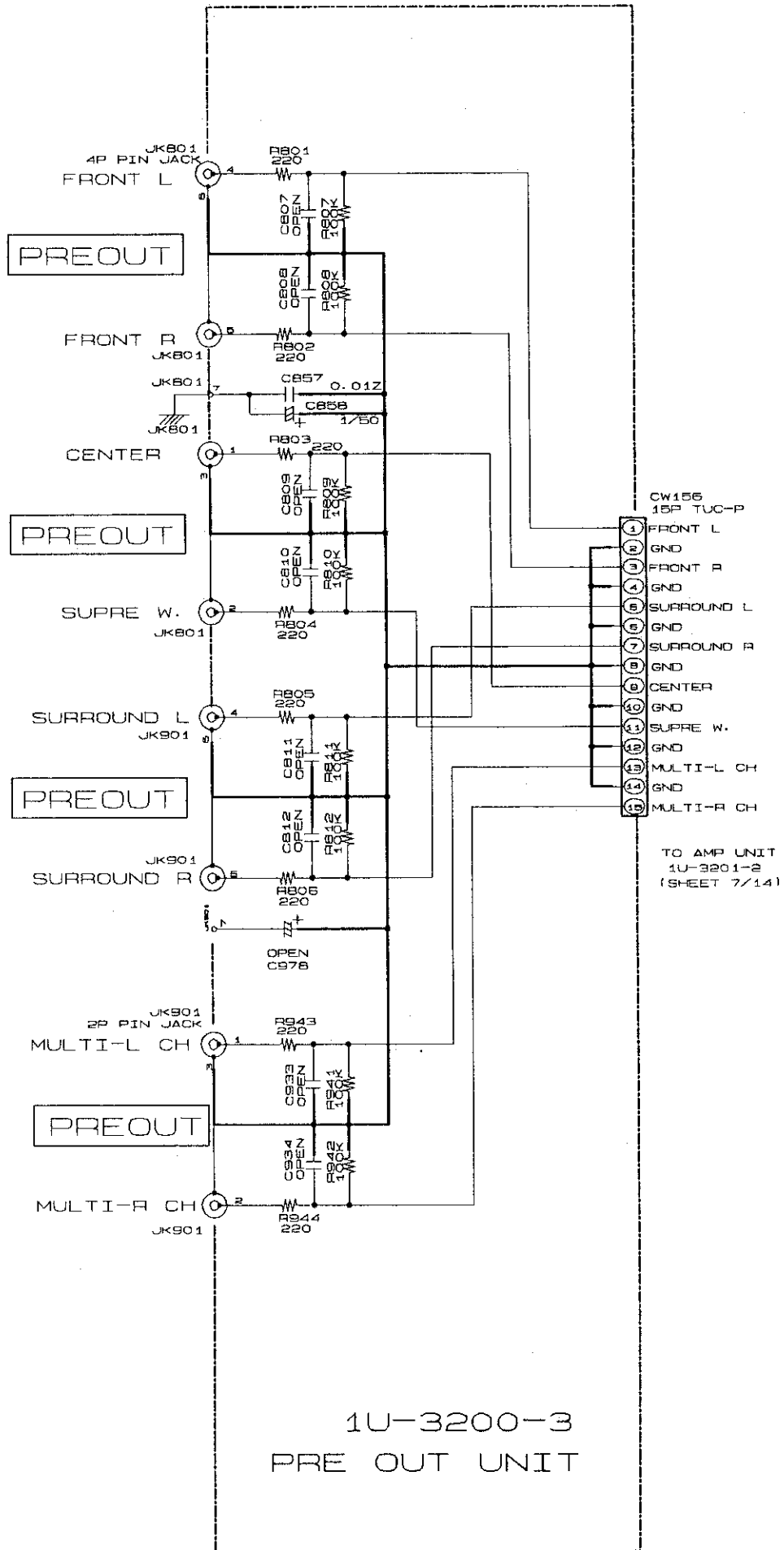

1U-3200-3  
PRE OUT UNIT

|        | *1          | *2    | *3    |
|--------|-------------|-------|-------|
|        | JK501       | C720  | CY036 |
| USA    | OPEN        | OPEN  | OPEN  |
| CANADA | OPEN        | OPEN  | OPEN  |
| EUROPE | OPEN        | OPEN  | OPEN  |
| ASIA   | 1P PIN JACK | CK0.1 | 3P KR |

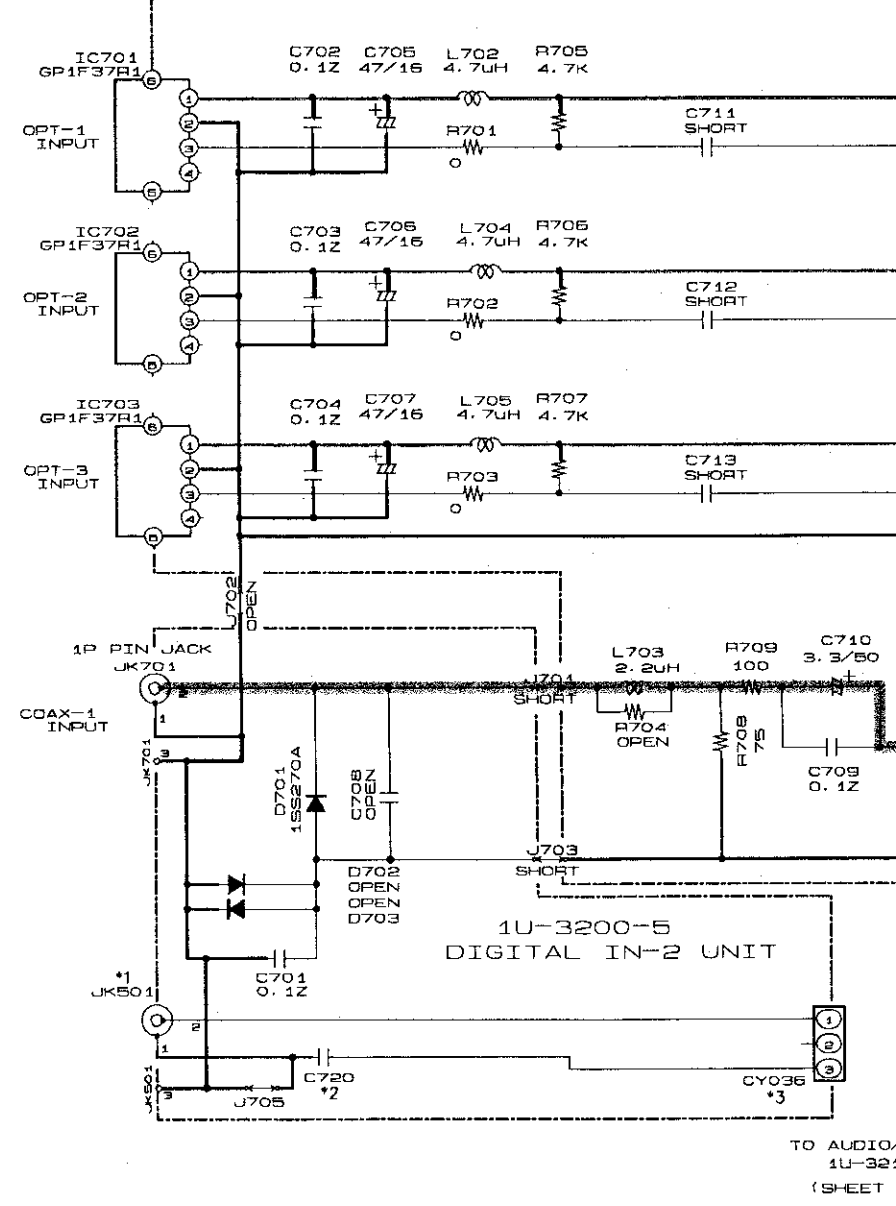

1U-3200-5  
DIGITAL IN-2 UNIT

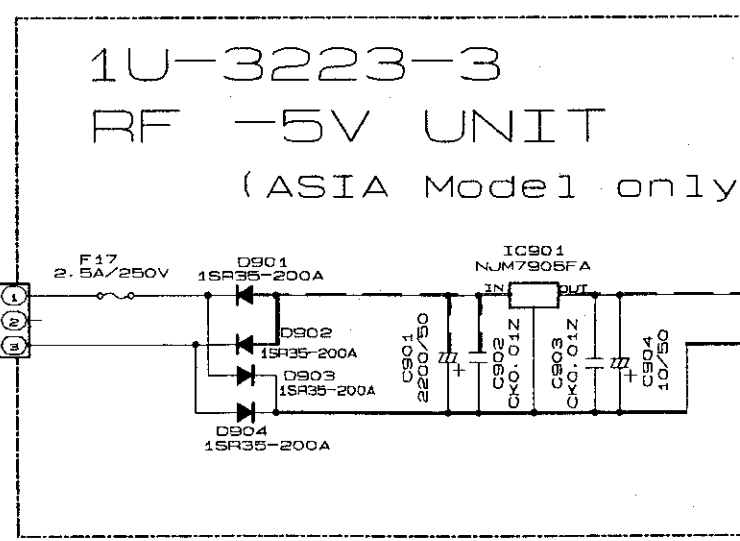

**NOTICE**  
ALL RESISTANCE VALUES IN OHM. k=1,000 OHM M=1,000,000 OHM  
ALL CAPACITANCE VALUES IN MICRO FARAD. P=MICRO-MICRO FARAD  
EACH VOLTAGE AND CURRENT ARE MEASURED AT NO SIGNAL INPUT  
CONDITION.  
CIRCUIT AND PARTS ARE SUBJECT TO CHANGE WITHOUT PRIOR  
NOTICE.

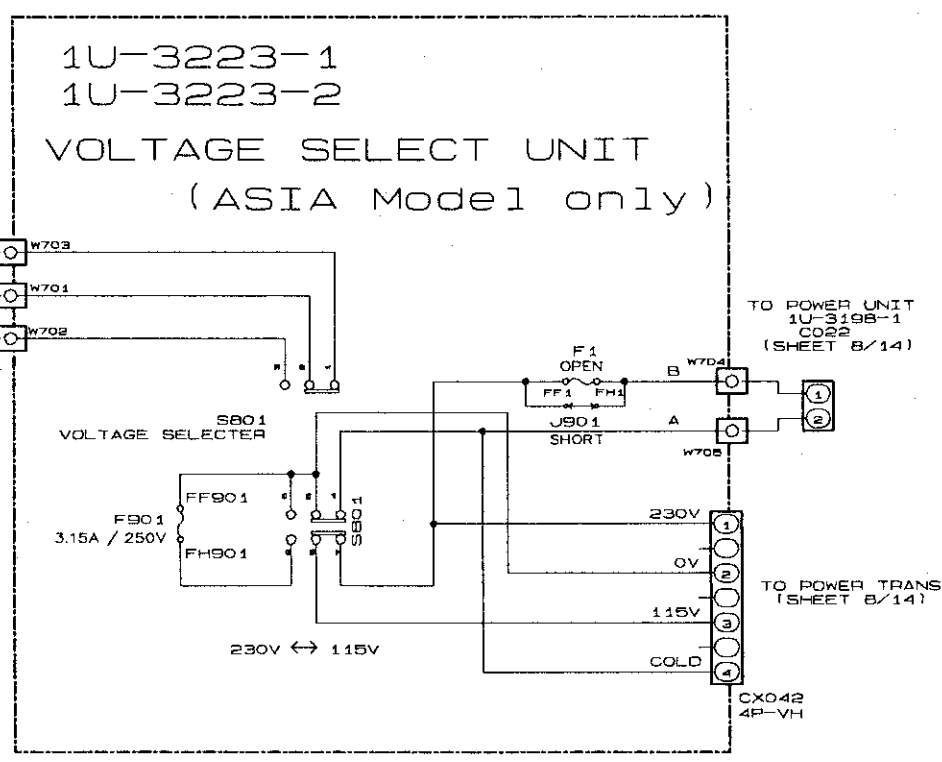
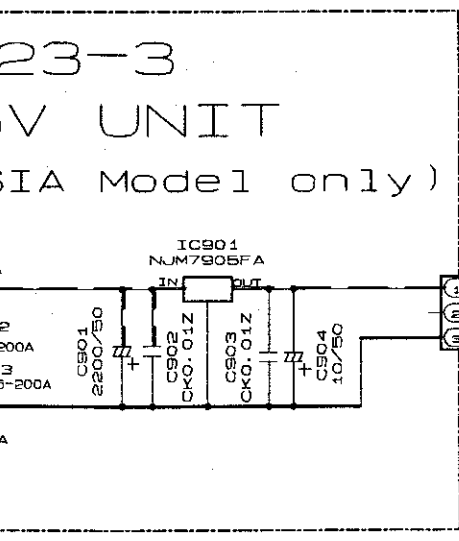
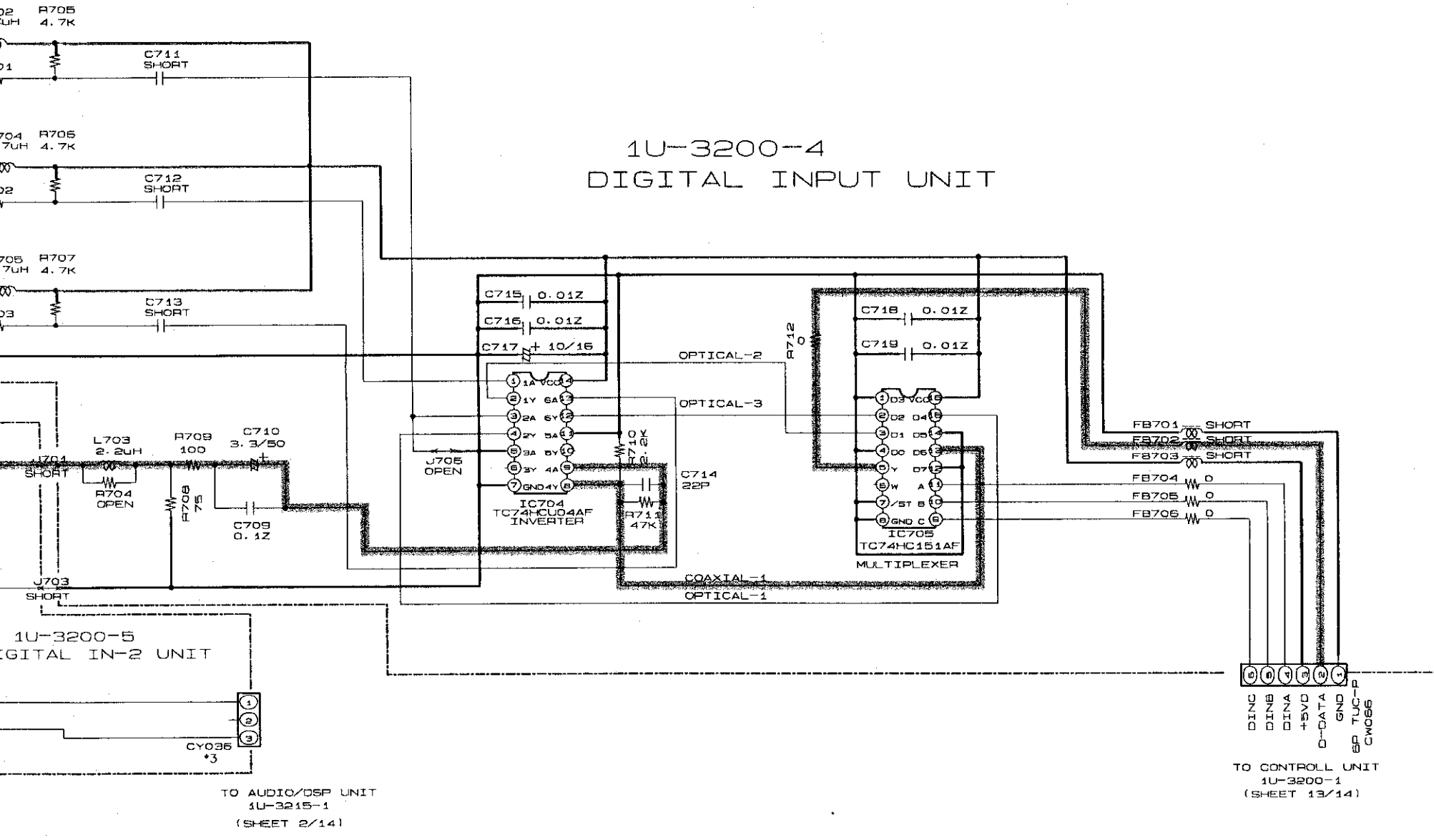

OHM, k=1,000 OHM M=1,000,000 OHM  
IN MICRO FARAD, P=MICRO-MICRO FARAD  
NT ARE MEASURED AT NO SIGNAL INPUT  
SUBJECT TO CHANGE WITHOUT PRIOR

**WARNING:**  
Parts marked with this symbol have critical characteristics. Use ONLY replacement parts recommended by the manufacturer.

**CAUTION:**  
Before returning the unit to the customer, make sure you make either (1) a leakage current check or (2) a line to chassis resistance check. If the leakage current exceeds 0.5 milliamps, or if the resistance from chassis to either side of the power cord is less than 460 kohms, the unit is defective.

**WARNING:**  
DO NOT return the unit to the customer until the problem is located and corrected.

————— +B LINE  
- - - - - -B LINE  
————— SIGNAL LINE

SCHEMATIC DIAGRAMS (10/14)

1 2 3 4 5 6

A

B

C

D

E

F

G

H

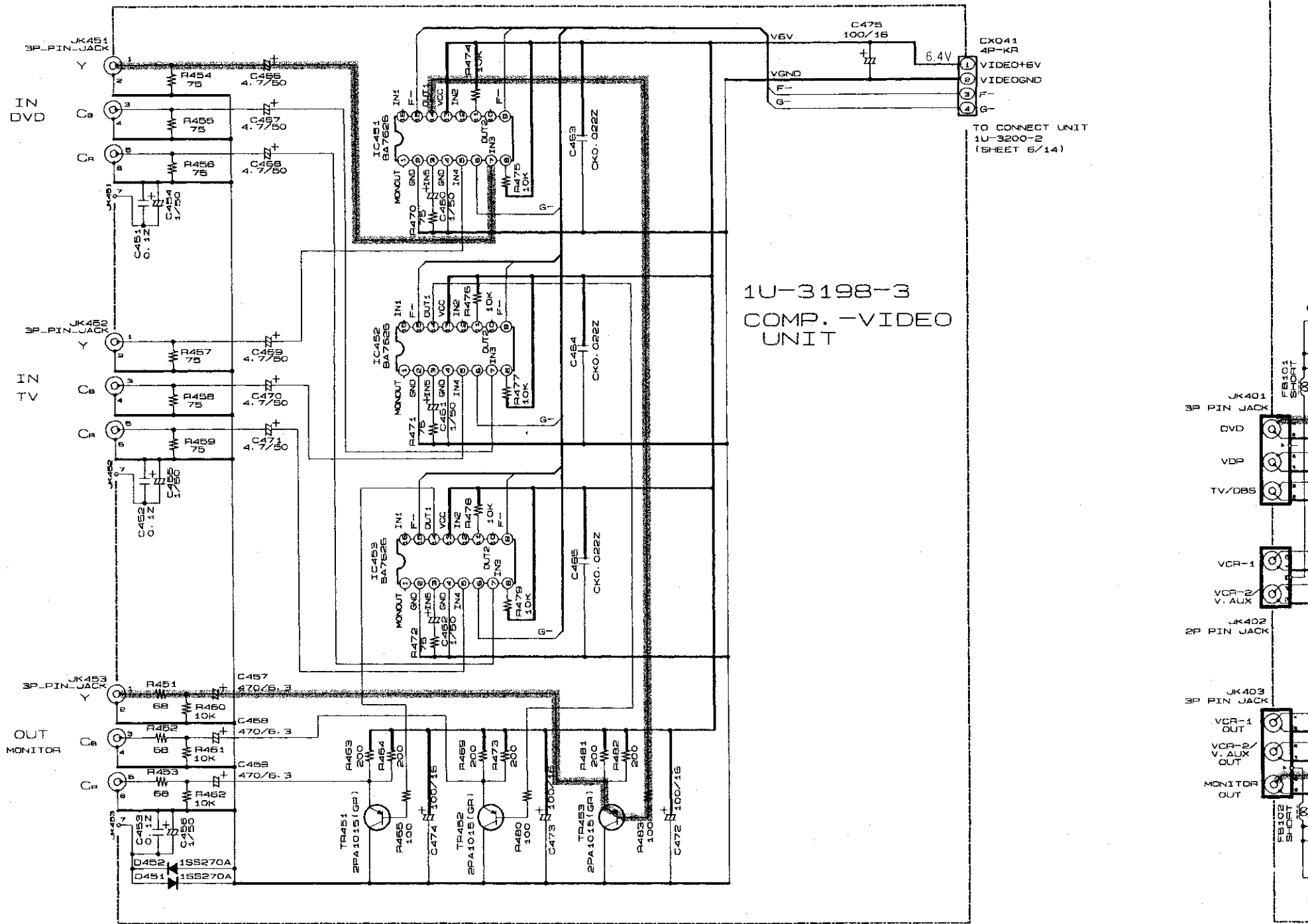

**NOTICE**

ALL RESISTANCE VALUES IN OHM. k=1,000 OHM M=1,000,000 OHM  
ALL CAPACITANCE VALUES IN MICRO FARAD. P=MICRO-MICRO FARAD  
EACH VOLTAGE AND CURRENT ARE MEASURED AT NO SIGNAL INPUT  
CONDITION.  
CIRCUIT AND PARTS ARE SUBJECT TO CHANGE WITHOUT PRIOR  
NOTICE.

**WARNING:**

Parts marked with this symbol have critical characteristics.  
Use ONLY replacement parts recommended by the manufacturer.

**CAUTION:**

Before returning the unit to the customer, make sure you make either (1) a leakage current check or (2) a line to chassis resistance check. If the leakage current exceeds 0.5 millamps, or if the resistance from chassis to either side of the power cord is less than 460 kohms, the unit is defective.

**WARNING:**

DO NOT return the unit to the customer until the problem is located and corrected.

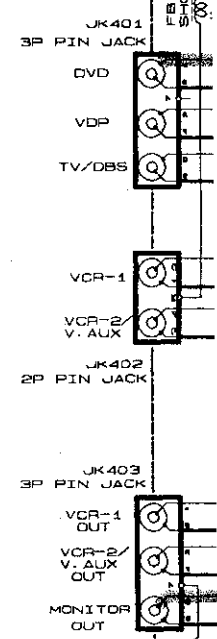

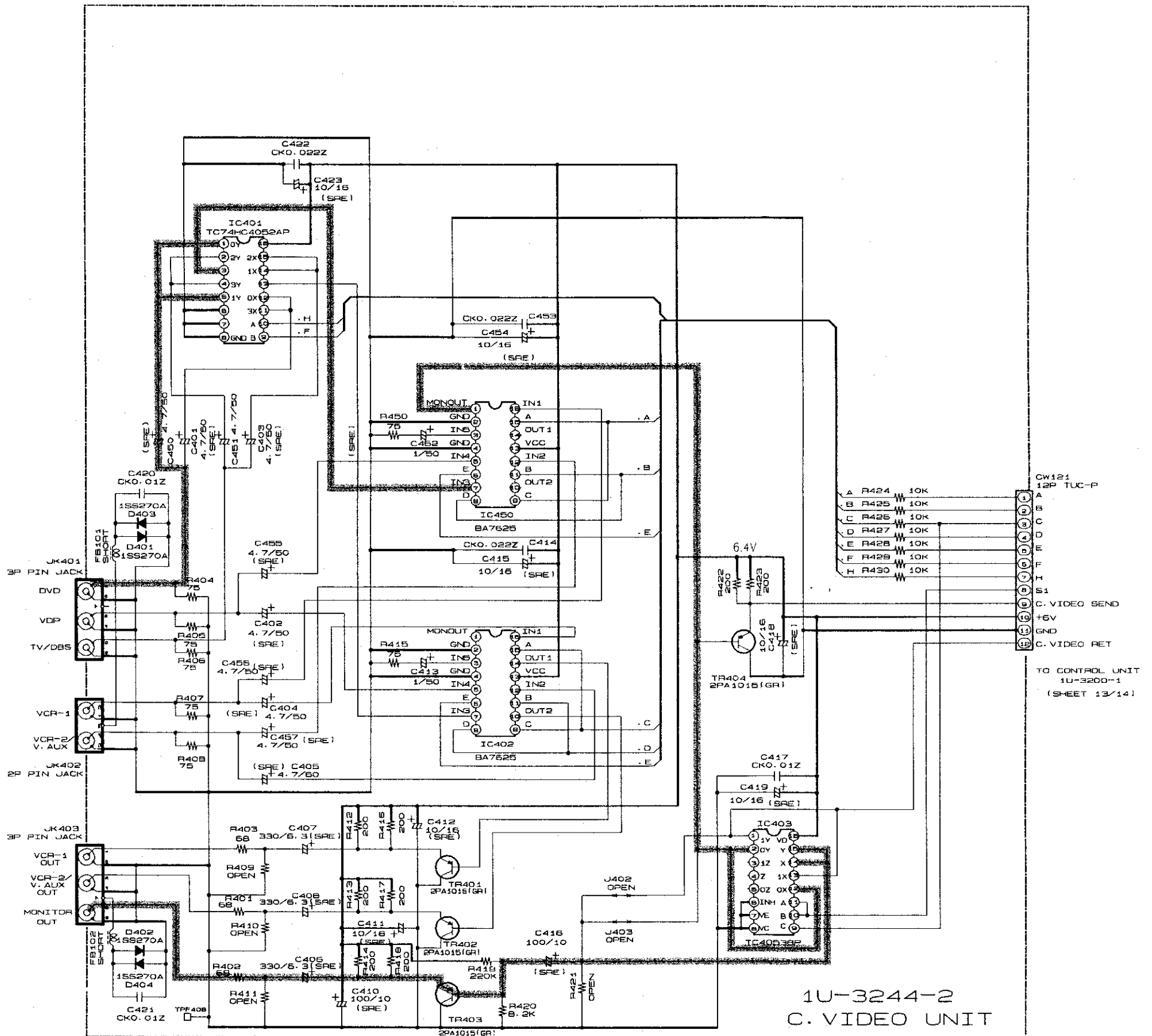

1U-3244-2  
C. VIDEO UNIT

————— +B LINE  
 - - - - - SIGNAL LINE

either (1) a  
 if the leakage  
 to either side

oted and



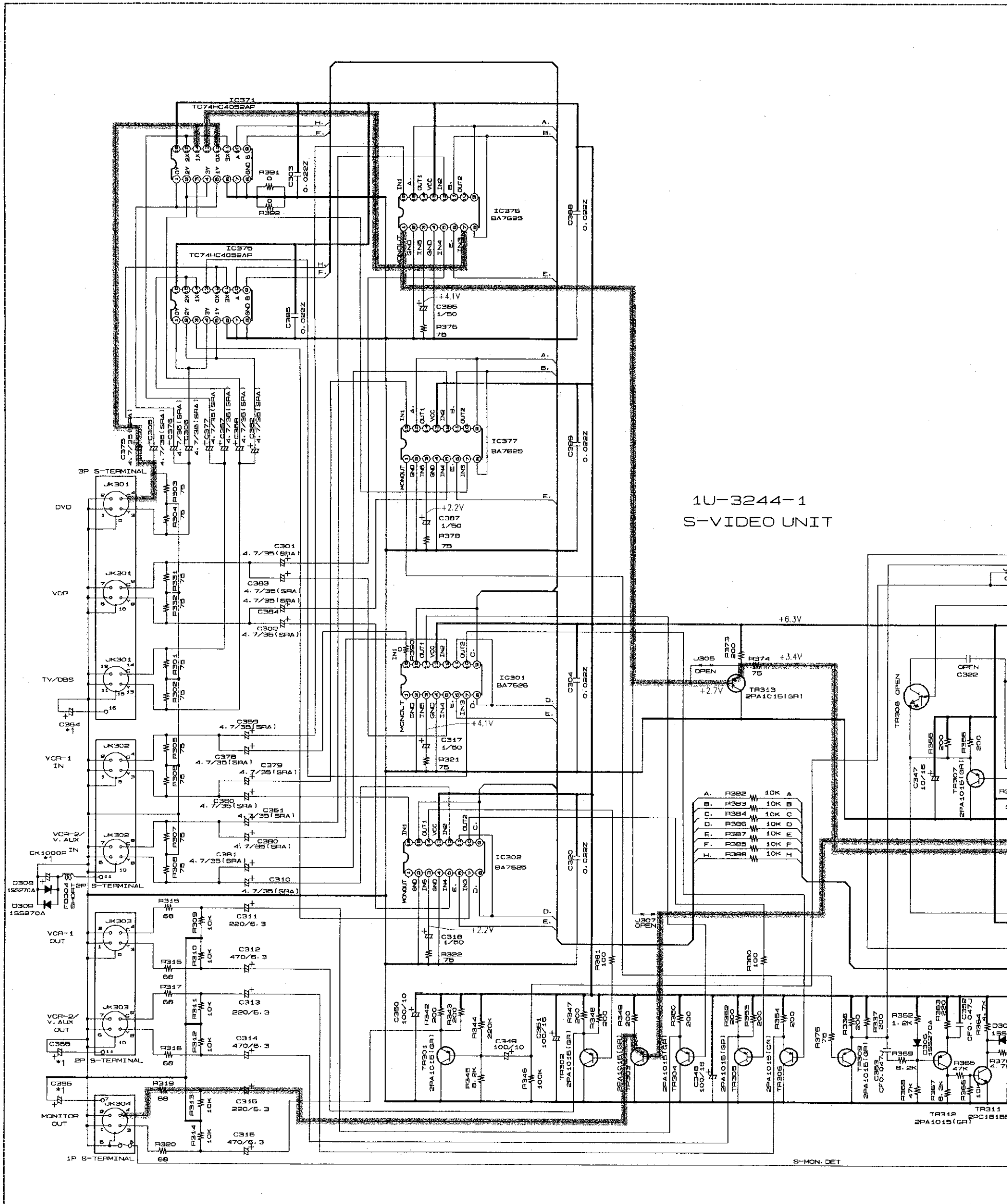

1U-3244-1  
S-VIDEO UNIT

+6.3V

+3.4V

+2.7V

+4.1V

+2.2V

10K A

10K B

10K C

10K D

10K E

10K F

10K G

10K H

S-MON. DET

|        |                  |
|--------|------------------|
|        | #1               |
|        | C363,364,365,366 |
| USA    | CK1000P          |
| CANADA |                  |
| EUROPE | OPEN             |
| ASIA   | OPEN             |

**NOTICE**  
ALL RESISTANCE VALUES IN OHM. K=1,000 OHM M=1,000,000.  
ALL CAPACITANCE VALUES IN MICRO FARAD. P=MICRO-MICRO.  
EACH VOLTAGE AND CURRENT ARE MEASURED AT NO SIGNAL CONDITION.  
CIRCUIT AND PARTS ARE SUBJECT TO CHANGE WITHOUT NOTICE.

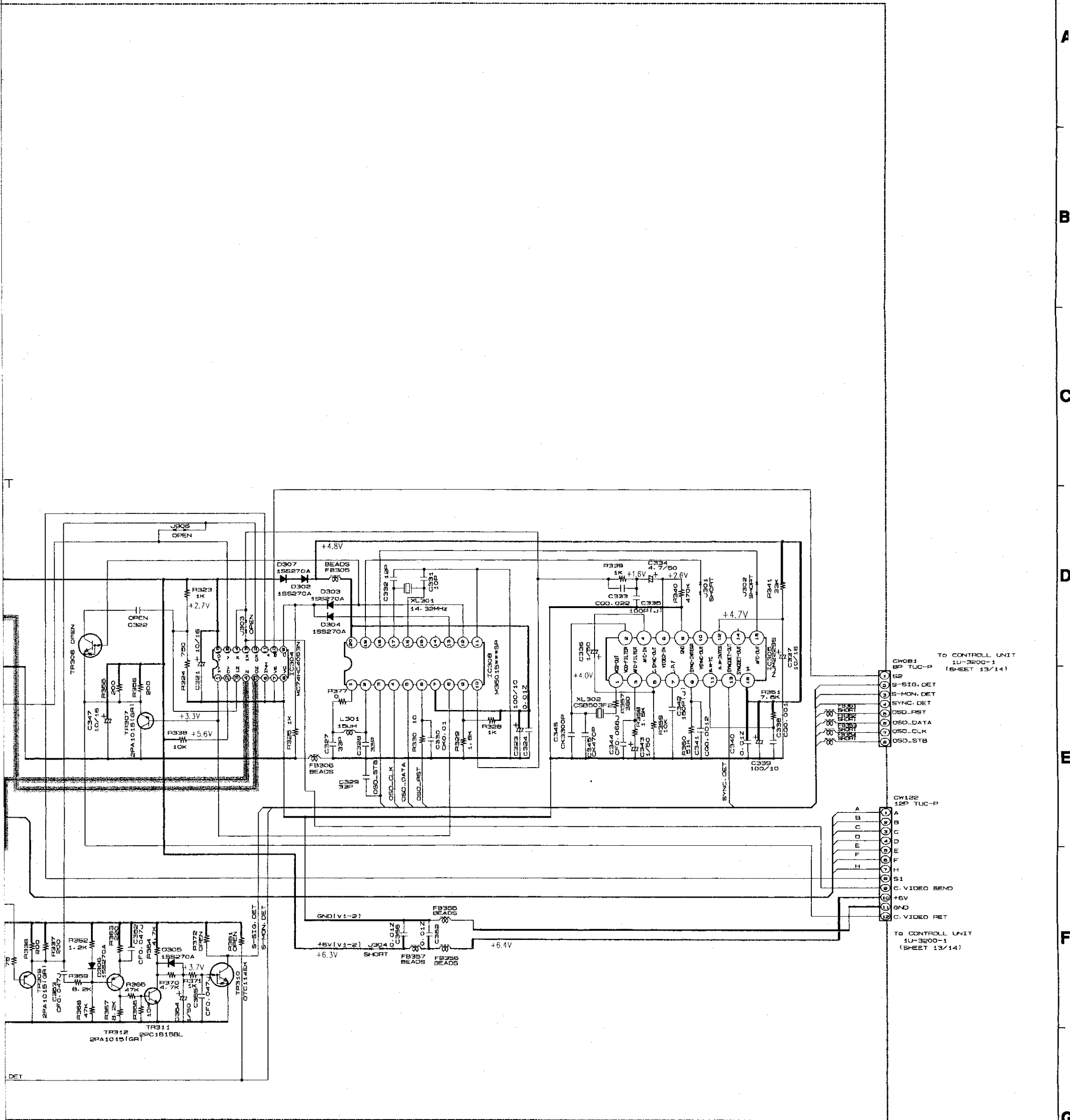

**WARNING:**

Parts marked with this symbol  have critical characteristics. Use ONLY replacement parts recommended by the manufacturer.

**CAUTION:**

Before returning the unit to the customer, make sure you make either (1) a leakage current check or (2) a line to chassis resistance check. If the leakage current exceeds 0.5 milliamps, or if the resistance from chassis to either side of the power cord is less than 460 kohms, the unit is defective.

**WARNING:**

DO NOT return the unit to the customer until the problem is located and corrected.

————— +B LINE

————— SIGNAL LINE

VALUES IN OHM. k=1,000 OHM M=1,000,000 OHM  
VALUES IN MICRO FARAD. P=MICRO-MICRO FARAD  
CURRENT ARE MEASURED AT NO SIGNAL INPUT

ARE SUBJECT TO CHANGE WITHOUT PRIOR

SCHEMATIC DIAGRAMS (12/14)

1 2 3 4 5 6

A  
B  
C  
D  
E  
F  
G  
H

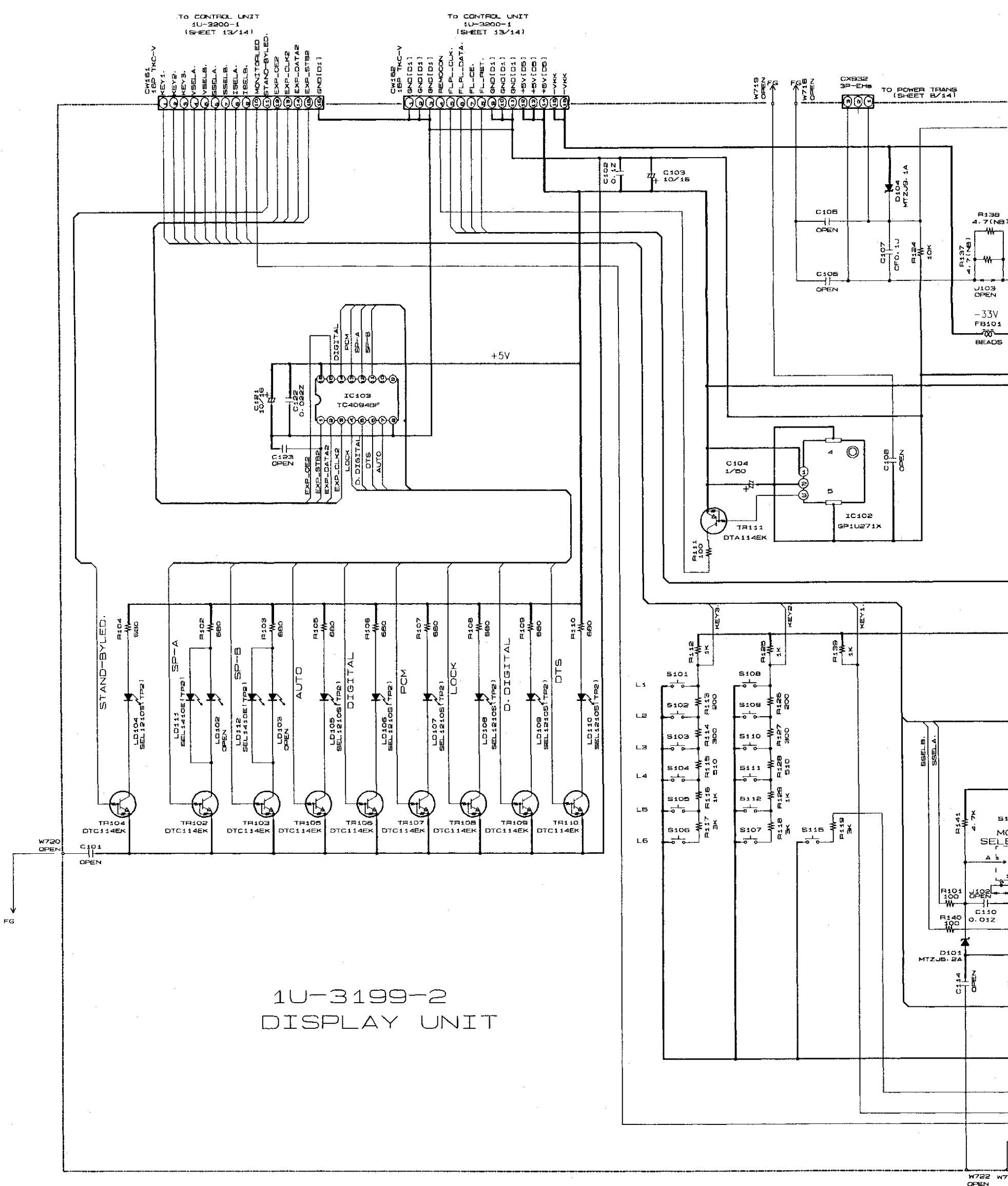

**NOTICE**  
ALL RESISTANCE VALUES IN OHM. k=1,000 OHM M=1,000,000 OHM  
ALL CAPACITANCE VALUES IN MICRO FARAD. P=MICRO-MICRO FARAD  
EACH VOLTAGE AND CURRENT ARE MEASURED AT NO SIGNAL INPUT  
CONDITION.  
CIRCUIT AND PARTS ARE SUBJECT TO CHANGE WITHOUT PRIOR  
NOTICE.

**WARNING:**  
Parts marked with this symbol have critical characteristics.  
Use ONLY replacement parts recommended by the manufacturer.

**CAUTION:**  
Before returning the unit to the customer, make sure you make either (1) a leakage current check or (2) a line to chassis resistance check. If the leakage current exceeds 0.5 milliamps, or if the resistance from chassis to either side of the power cord is less than 460 kohms, the unit is defective.

**WARNING:**  
DO NOT return the unit to the customer until the problem is located and corrected.



# SCHEMATIC DIAGRAMS (13/14)

1

2

3

4

5

6

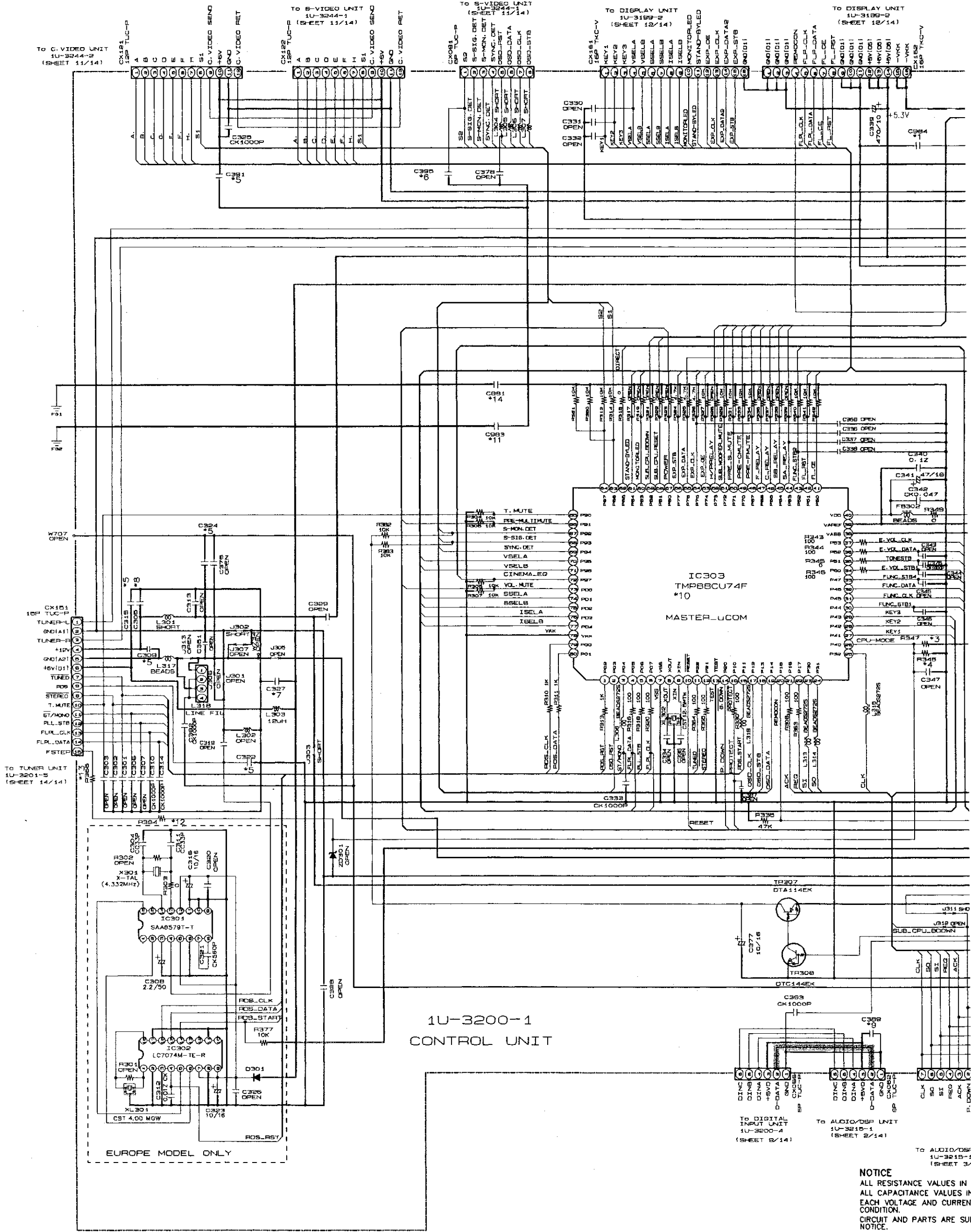

|               | *1<br>C984 | *2<br>C390 | *3<br>R347 | *4<br>R348 | *5<br>C309,315,324,382,391,<br>C384,386,322,368,376 | *6<br>C394,395,,396 | *7<br>C327 | *8<br>C305 | *9<br>C389 | *10<br>IC303 | *11<br>C983 | *12<br>R384 | *13<br>R366 |
|---------------|------------|------------|------------|------------|-----------------------------------------------------|---------------------|------------|------------|------------|--------------|-------------|-------------|-------------|
| USA<br>CANADA | OPEN       | CF0.1J     | OPEN       | 0          | CK1000P                                             | OPEN                | CK1000P    | CK1000P    | CK0.022Z   | 262 2613 019 | CK1000P     | OPEN        | OPEN        |
| EUROPE        | CK1000pF   | OPEN       | 0          | OPEN       | OPEN                                                | CK1000P             | OPEN       | CK0.047    | OPEN       | 262 2711 005 | CK1000P     | OPEN        | OPEN        |
| ASIA          | OPEN       | OPEN       | 1K         | 5.1K       | OPEN                                                | CK1000P             | CK1000P    | CK0.047    | OPEN       | 262 2613 019 | OPEN        | 1.3K        | 0           |

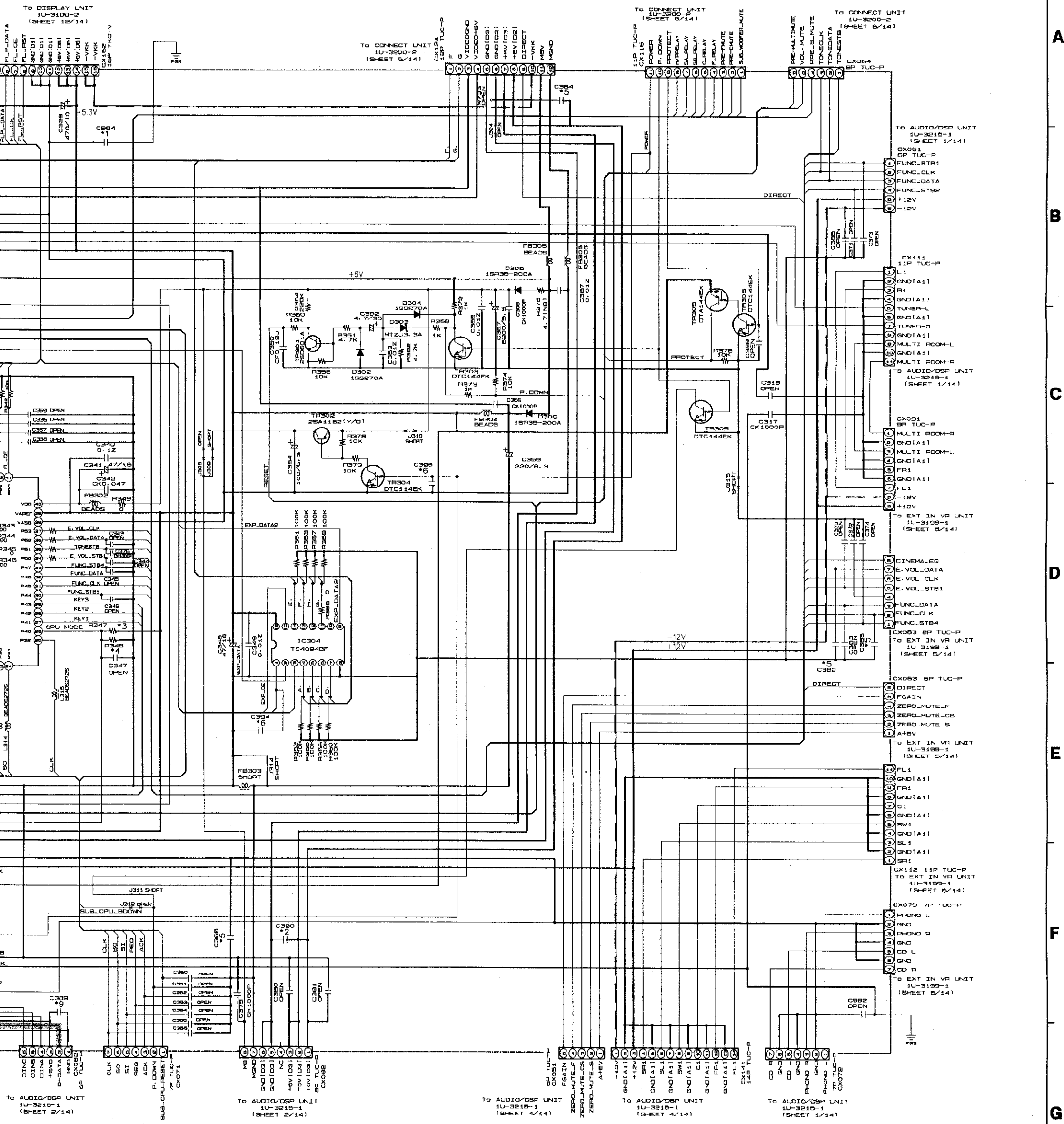

NOTICE

ALL RESISTANCE VALUES IN OHM. K=1,000 OHM M=1,000,000 OHM  
 ALL CAPACITANCE VALUES IN MICRO FARAD. P=MICRO-MICRO FARAD  
 EACH VOLTAGE AND CURRENT ARE MEASURED AT NO SIGNAL INPUT  
 CONDITION.  
 CIRCUIT AND PARTS ARE SUBJECT TO CHANGE WITHOUT PRIOR  
 NOTICE.

WARNING:

Parts marked with this symbol have critical characteristics.  
 Use ONLY replacement parts recommended by the manufacturer.

CAUTION:

Before returning the unit to the customer, make sure you make either (1) a leakage current check or (2) a line to chassis resistance check. If the leakage current exceeds 0.5 millamps, or if the resistance from chassis to either side of the power cord is less than 460 kohms, the unit is defective.

WARNING:

DO NOT return the unit to the customer until the problem is located and corrected.

|         |      |      |         |
|---------|------|------|---------|
| *11     | *12  | *13  | *14     |
| C983    | R384 | R366 | C981    |
| CK1000P | OPEN | OPEN | OPEN    |
| CK1000P | OPEN | OPEN | OPEN    |
| OPEN    | 1.3K | 0    | CK1000P |

**SCHEMATIC DIAGRAMS (13/14)**  
**1U-3200-1 CONTROL UNIT**

A

B

C

D

E

F

G

H

SCHEMATIC DIAGRAMS (14/14)

1 2 3 4 5 6

A

B

C

D

E

F

G

H

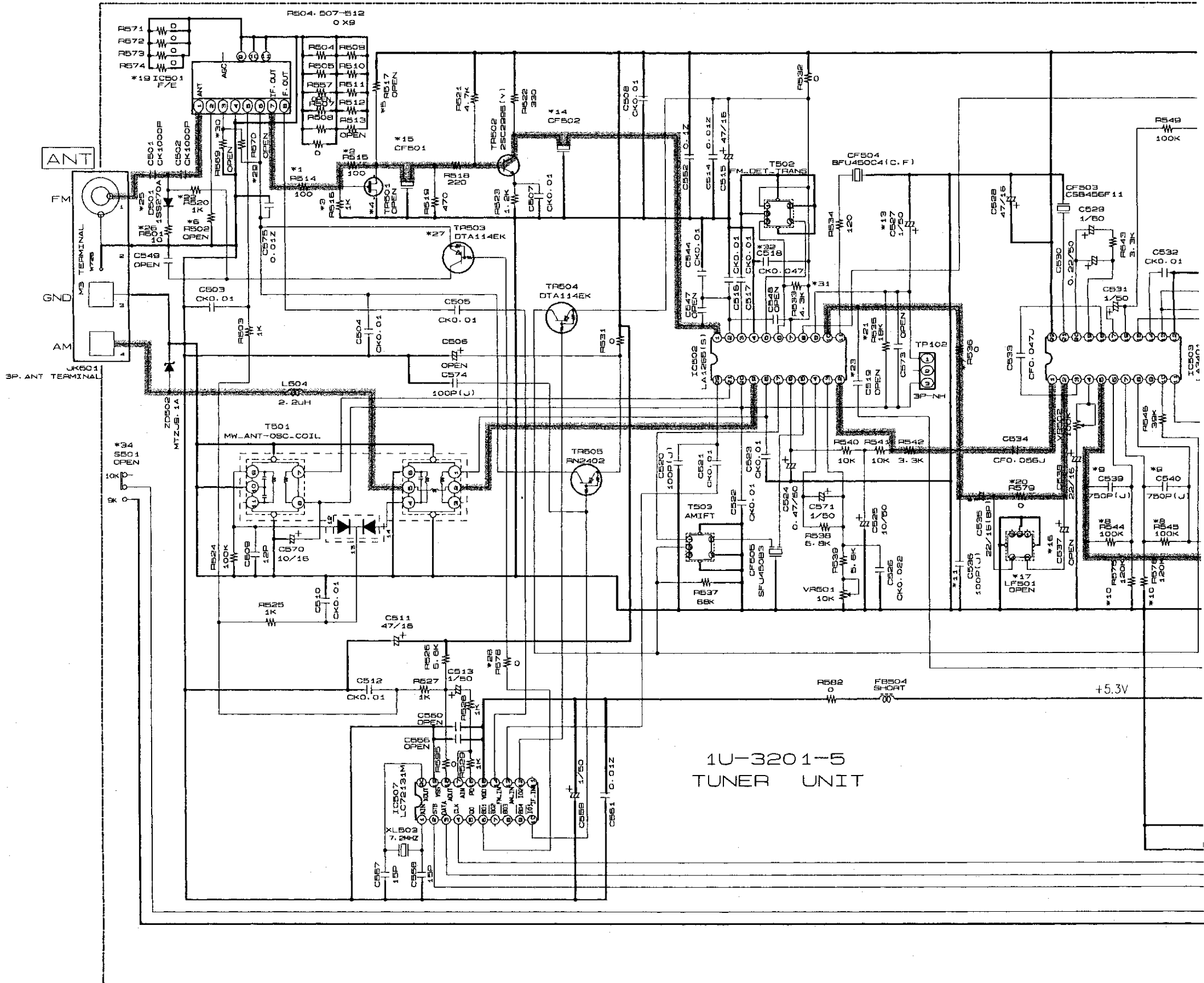

1U-3201-5  
TUNER UNIT

**NOTICE**  
 ALL RESISTANCE VALUES IN OHM. k=1,000 OHM M=1,000,000 OHM  
 ALL CAPACITANCE VALUES IN MICRO FARAD. P=MICRO-MICRO FARAD  
 EACH VOLTAGE AND CURRENT ARE MEASURED AT NO SIGNAL INPUT  
 CONDITION.  
 CIRCUIT AND PARTS ARE SUBJECT TO CHANGE WITHOUT PRIOR  
 NOTICE.

**WARNING:**  
 Parts marked with this symbol  $\Delta$  have critical characteristics.  
 Use ONLY replacement parts recommended by the manufacturer.

**CAUTION:**  
 Before returning the unit to the customer, make sure you make either (1) a  
 leakage current check or (2) a line to chassis resistance check. If the leakage  
 current exceeds 0.5 milliamps, or if the resistance from chassis to either side  
 of the power cord is less than 460 kohms, the unit is defective.

**WARNING:**  
 DO NOT return the unit to the customer until the problem is located and  
 corrected.

