

DENON

Hi-Fi Stereo Amplifier

SERVICE MANUAL

MODEL DCA-3500 DCA-3400

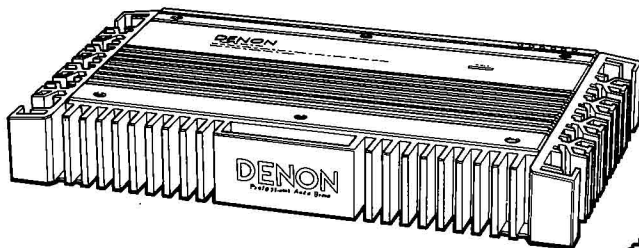

DCA-3500

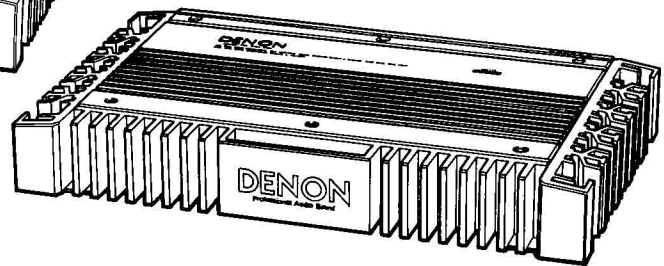

DCA-3400

CONTENTS

FEATURES	2
SPECIFICATIONS	2
CONNECTIONS	3
CIRCUIT DESCRIPTIONS	4,5
BLOCK DIAGRAM	6
METHOD OF ADJUSTMENTS	7
PRINTED WIRING BOARD AND PARTS LIST	8~17
WIRING DIAGRAM	18,19
EXPLODED VIEW AND PARTS LIST	20~23
SEMICONDUCTORS	24
SCHEMATIC DIAGRAM	25,26
REMOVAL OF EACH SECTIONS	27,28

NIPPON COLUMBIA CO., LTD.

FEATURES

● DCA-3500

- 3/5 Channel Power Amplifier with Built-in Subwoofer Drive.
Maximum Power Output
5 Channel 40 W x 4 + 80 W (Subwoofer)
(1 kHz/4 ohms, T.H.D. 1%)
3 Channel 80 W x 2 + 80 W (Subwoofer)
(1 kHz/4 ohms, T.H.D. 1%)
- Non-Negative Feedback Amplification.
- Non-Switching Class-A Amplification.
- Subwoofer Amplifier with Crossover Network.
- "Compact Star"™ Convection Cooling Heatsinks
- DC Power Terminal Block connections are quick and secure.
- Pulse Regulated Power Supply
- Ground Isolation Amplifier
- Remote Power On/Off
- Variable Input Sensitivity
- Convenient Power Indicator
- Built-in Protector
- Gold-Plated RCA-type Inputs.

● DCA-3400

- 2/4 Channel Power Amplifier
Maximum Power Output
4 Channel 40 W x 4 (1 kHz/4 ohms, T.H.D. 1%)
2 Channel 80 W x 2 (1 kHz/4 ohms, T.H.D. 1%)
- Non-Negative Feedback Amplification.
- Non-Switching Class-A Amplification.
- "Compact Star"™ Convection Cooling Heatsinks.
- DC Power Terminal Block connections are quick and secure.
- Pulse Regulated Power Supply.
- Ground Isolation Amplifier.
- Remote Power On/Off
- Variable Input Sensitivity.
- Convenient Power Indicator.
- Built-in Protector
- Gold-Plated RCA-type Inputs.

SPECIFICATIONS

Power Output

5-Channel	40 W x 4 + 80 W in to 4 ohms, 1 kHz at 1% T.H.D.
3-Channel	80 W x 2 + 80 W in to 4 ohms, 1 kHz at 1% T.H.D.

Power Output

5-Channel	28 W x 4 + 60 W from 20 Hz to 20 kHz with 0.05% T.H.D.
------------------	---

Frequency Response

5 Hz — 200 kHz (—3 dB)

Subwoofer Crossover

80 Hz/120 Hz Selectable
High cut —18 dB/oct
Low cut —12 dB/oct

Signal to Noise Ratio

90 dB (IHF A Weighted)

Input Sensitivity/Impedance

200 mV — 2 V (Variable)/10 k ohms

Speaker Impedance

4 ohms

Dimensions (W x H x D)

400 mm x 53 mm x 214 mm
(15-3/4" x 2-3/32" x 8-27/64")

Weight

4.5 kg (9 lbs 15 oz)

Power Output

4-Channel	40 W x 4 into 4 ohms, 1 kHz at 1% T.H.D.
2-Channel	80 W x 2 into 4 ohms, 1 kHz at 1% T.H.D.

Power Output

4-Channel	28 W x 4 from 20 Hz to 20 kHz with 0.05% T.H.D.
------------------	--

Frequency Response

5 Hz — 200 kHz (—3 dB)

Signal to Noise Ratio

90 dB (IHF A Weighted)

Input Sensitivity/Impedance

200 mV — 2 V (Variable)/10 k ohms

Speaker Impedance

4 ohms

Dimensions (W x H x D)

365 mm x 53 mm x 214 mm
(14-3/8" x 2-3/32" x 8-27/64")

Weight

3.9 kg (8 lbs 10 oz)

Design and Specifications are subject to change for improvement without prior notice.

After the DENON Power Amplifier DCA-3500 and 3400 is securely installed, make the connections as follows.

* Remove the ground cable (—) from the battery before installation to prevent damage to unit or the automobile's electrical system by miss-connection.

1) Connect the pre-out from your component to the input of DCA-3500 and 3400.

2) Connect the speaker wires to the speaker terminals of DCA-3500 and 3400.

* Make sure the polarity of left and right speaker line is observed.

* Never connect the negative (—) sides of each speaker together.

* Never make the plus and minus wire short-circuit.

* Never connect the negative (—) side to the car chassis.

3) Secure the ground wire to a clean bare metal spot on the car chassis. Make sure paint or coating is scraped away for best connection.

(The wire gauge should be 10 ~ 12AWG.)

4) Connect the remote cord to the remote control terminal of your indash player.

(The wire gauge should be 18AWG.)

5) Connect the ACC cord to the ignition terminal.

(The wire gauge should be 18AWG.)

6) Connect the battery cord directly to the positive (+) terminal of battery.

(The wire gauge should be 10 ~ 12AWG.)

* Connect both battery cords (BATT 1, BATT 2) and both ground cords (GND 1, GND 2).

* Make all connections securely to prevent noise. Bind up the cords by tape after connection.

* Confirm again that your connection follows this instruction manual, re-install the parts of your automobile as they were and re-connect the negative (—) cable to the negative (—) terminal of the battery.

* If your indash player does not have a remote terminal, consult your DENON Dealer for alternate hook up.

* Filter select switch (DCA-3500 only)

The FILTER select switch permits the cutoff frequency of the Crossover Network to be switched from 80 Hz to 120 Hz or OFF. Set the switch in the desired position. If the system is used with the filter select switch set in the OFF position, then reverse the polarity of the subwoofer speaker connection.

DENON

Hi-Fi Stereo Amplifier

SUPPLEMENT

MODEL DCA-3500 DCA-3400

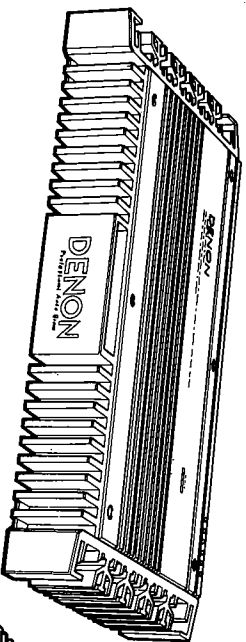

DCA-3500

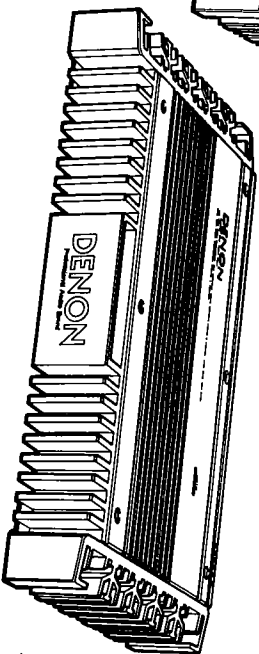

DCA-3400

The name of model appears on the cover of this service manual will make a change purposing further improvements.
Please prepare this sheet and the original service manual (Service Manual No. 0056) at the time of servicing.
Serial No. 7032600001~

BLOCK DIAGRAM

- DCA-3400

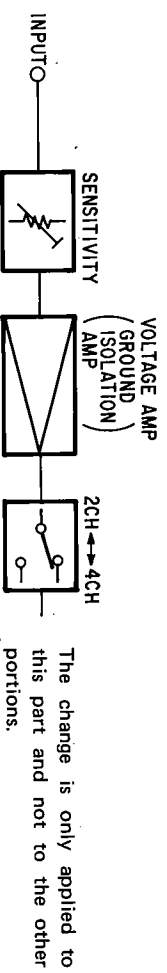

NIPPON COLUMBIA CO., LTD.

• DCA-3500

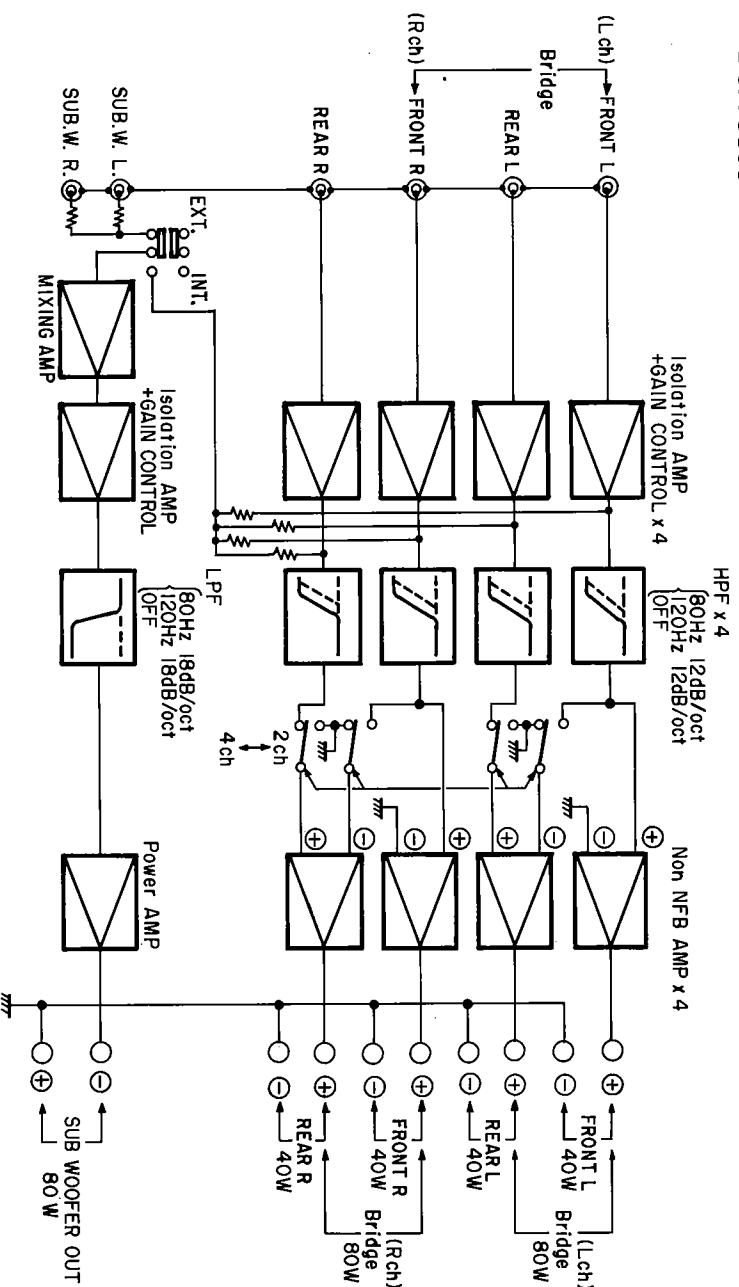

The Changing Parts in the Parts List (DCA-3500)

1U-1453 POWER AMP. UNIT PARTS LIST

Ref. No.	Part No.	Part Name & Descriptions	Ref. No.	Part No.	Part Name & Descriptions
RESISTORS					
R618,619	2412401075	22 kohm ±5% 1/4W Carbon (Delete)	C611,612	2544256004	10μF ±20% 25V Electrolytic (Delete)
R670~673	2412405000	510 kohm ±5% 1/4W Carbon (Add)	C612	2544256004	10μF ±20% 25V Electrolytic (Add)
			C402	2544252037	100μF ±20% 10V Electrolytic (Add)
CAPACITORS					

1U-1432 P. SUPPLY UNIT PARTS LIST

Ref. No.	Part No.	Part Name & Descriptions
RESISTORS		
R451	2412400050	6.8 kohm ±5% 1/4W Carbon (Add)

NIPPON COLUMBIA CO., LTD.
14-14, 4CHOME AKASAKA,
MINATO-KU, TOKYO 107 JAPAN

TEL: 03-584-8111
TLX: JAPANOLA J22591
CABLE: NIPPONCOLUMBIA TOKYO

SCHEMATIC DIAGRAM (DCA-3500)

IC	IC503	IC504	IC505	IC506	IC507	IC508	IC509	IC510	IC511	IC512	IC513	IC514	IC515	IC516	IC517	IC518	IC519	IC520	IC521	IC522	IC523	IC524	IC525	IC526	IC527	IC528	IC529	IC530	IC531	IC532	IC533	IC534	IC535	IC536	IC537	IC538	IC539	IC540		
Transistor	2N4001	2N4002	2N4003	2N4004	2N4005	2N4006	2N4007	2N4008	2N4009	2N4010	2N4011	2N4012	2N4013	2N4014	2N4015	2N4016	2N4017	2N4018	2N4019	2N4020	2N4021	2N4022	2N4023	2N4024	2N4025	2N4026	2N4027	2N4028	2N4029	2N4030	2N4031	2N4032	2N4033	2N4034	2N4035	2N4036	2N4037	2N4038	2N4039	2N4040
Diode	1N4001	1N4002	1N4003	1N4004	1N4005	1N4006	1N4007	1N4008	1N4009	1N4010	1N4011	1N4012	1N4013	1N4014	1N4015	1N4016	1N4017	1N4018	1N4019	1N4020	1N4021	1N4022	1N4023	1N4024	1N4025	1N4026	1N4027	1N4028	1N4029	1N4030	1N4031	1N4032	1N4033	1N4034	1N4035	1N4036	1N4037	1N4038	1N4039	1N4040
Resistor	100K	200K	300K	400K	500K	600K	700K	800K	900K	1M	2M	3M	4M	5M	6M	7M	8M	9M	10M	15M	20M	30M	40M	50M	60M	70M	80M	90M	100M	150M	200M	300M	400M	500M	600M	700M	800M	900M	1000M	
Capacitor	100P	200P	300P	400P	500P	600P	700P	800P	900P	1000P	100N	200N	300N	400N	500N	600N	700N	800N	900N	1000N	100U	200U	300U	400U	500U	600U	700U	800U	900U	1000U	100M	200M	300M	400M	500M	600M	700M	800M	900M	1000M

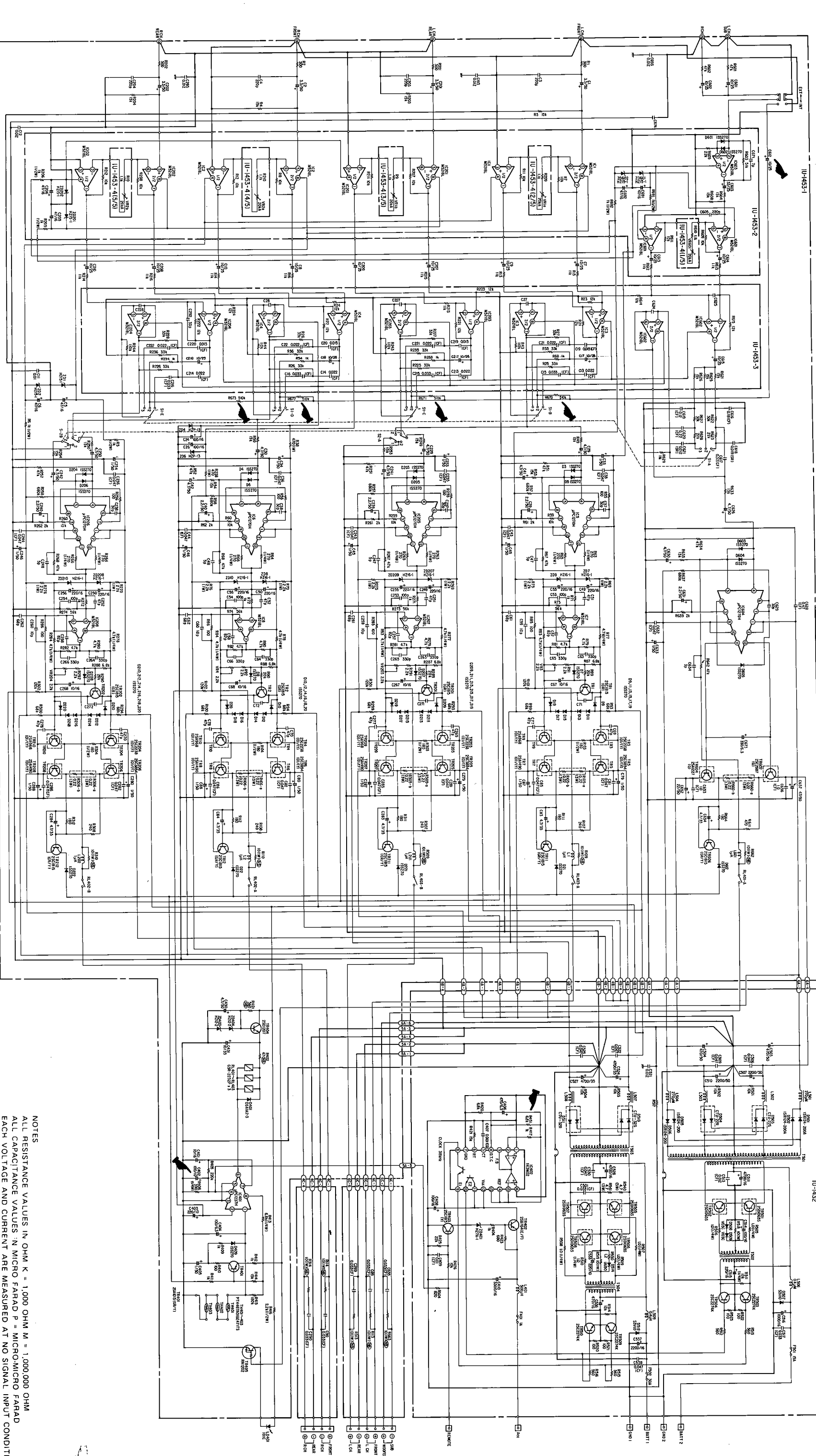

NOTES
 ALL RESISTANCE VALUES IN OHM K = 1,000 OHM M = 1,000,000 OHM
 ALL CAPACITANCE VALUES IN MICRO FARAD P = MICRO-MICRO FARAD
 EACH VOLTAGE AND CURRENT ARE MEASURED AT NO SIGNAL INPUT CONDITION.
 CIRCUIT AND PARTS ARE SUBJECT TO CHANGE WITHOUT PRIOR NOTICE.

CONNECTIONS

• DCA-3500

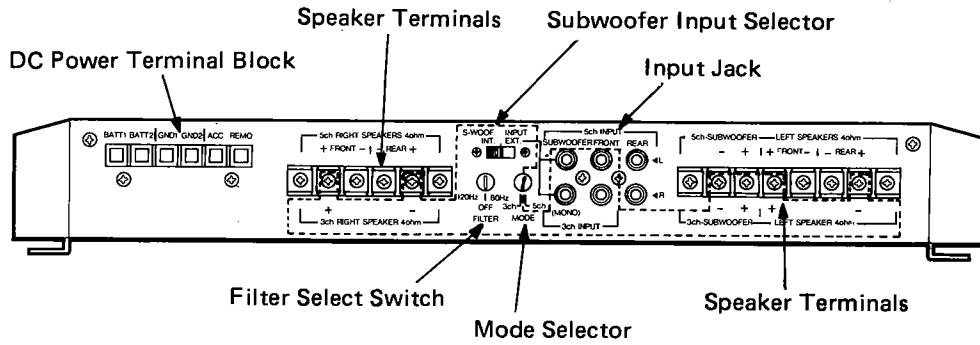

• DCA-3400

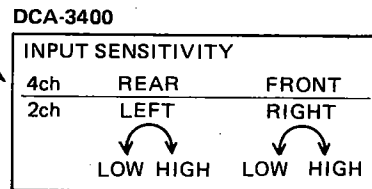
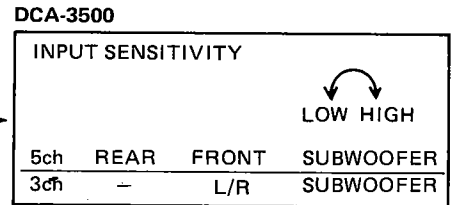
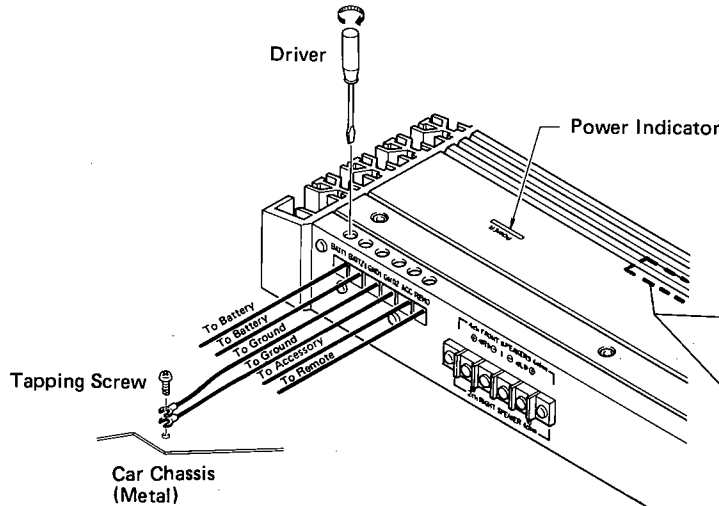
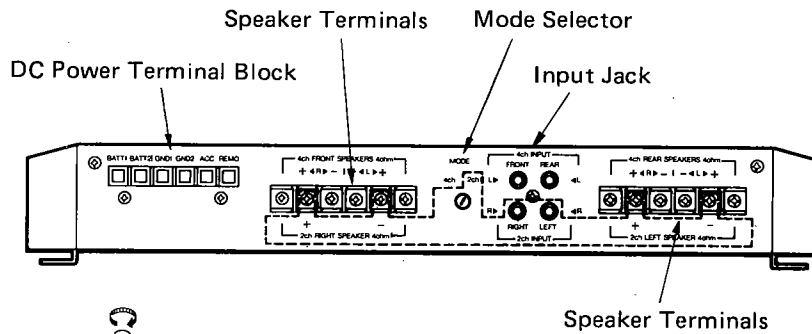

Please use the optional cord kit AK-110 or AK-140, available from your dealer.

	AK-110	AK-140
2P RCA PIN-PIN CORD	1.5 m	5 m (GOLD PLATE)
ACC CORD	1.5 m	5 m
BATTERY CORD	2 m	6 m
REMOTE CORD	1.5 m	5 m
Y TYPE REMOTE CORD	0.1 m	0.1 m

Tighten the GROUND, BATTERY and REMOTE wires securely by inserting a supplied screwdriver in the round holes on the top of the panel. 5 mm is appropriate for the length of the inner, stripped wire.

CIRCUIT DESCRIPTION

• DCA-3500

1. Ground Isolation Amplifier

DCA-3500 utilizes a ground isolation amplifier intended to eliminate ignition and alternator noises of vehicle that are coming in to the power amplifier with the input signal and the ground line.

This circuit is shown in the following figure.

Only the case when it becomes $Z_1 = Z_2$, $Z_1 f = Z_2 f$ in this circuit, the output will become $e_o = Z_1 f / Z_1 e_i$, thus no noise "e_n" contained in the output.

Since DCA-3500 selecting the input sensitivity by the voltage amplifier, Z_1 and Z_2 values can be changed by the switch.

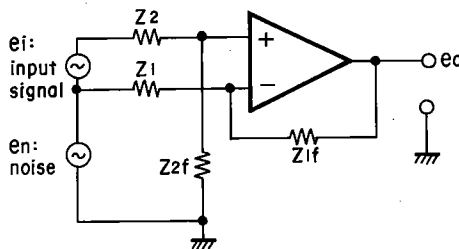

2. DC-DC Converter

When the REMOTE and ACCESSORY terminal of DCA-3500 is applied a voltage, a voltage will be applied to pin 11 and 12 of IC402. The output of a square wave oscillated by C407 and R421 connected at pins 5 and 6 will be conveyed to pin 9 and 10 to switch TR503, TR504, TR509 and TR510. This output will go through the primary of T502 and T504 to power stage (TR501, TR502, TR505, TR506, TR507 and TR508) in the secondary side of T502 and T504. After amplification, it will pass through the primary of T501 and T503 and be applied to a rectifying circuit in the secondary side to get DC power voltage. This power voltage is $\pm 28V$ and $\pm 30V$.

3. Protector

DCA-3500 employs a built-in protector to protect the amplifier and speaker against damage in an abnormal condition. This protector works in the following three abnormal conditions.

1. Excessive current flow at speaker terminal due to terminal short.
2. Extraordinary voltage rise at speaker terminal.
3. Excessive temperature rise of heat sink.

For protection, IC101 is used. A voltage applied to pin 1 or 2 of IC401 rises and exceeds the detecting value, the relay driver stage in IC turns OFF and breaks the relay of power amplifier output point, accordingly to cut the output power to speaker.

When the amplifier returns to normal condition and a voltage at pin 1 and 2 of IC401 becomes lower than the detecting value, the relay driver stage in IC automatically turns ON and energizes the relay of power amplifier output point, thus delivering the output power to speaker.

a) Overload Detector

When excessive current flows at speaker terminal, a voltage applied to the emitter resistor of the power transistor in the last stage will go up and turns ON TR606 or TR11 or TR221 or TR12. Then TR212 will turn ON, and a voltage at pin 1 of IC401 rises and exceeds the detecting value, causing to cut the output power to speaker.

b) DC Detector

If there is existing a DC voltage at + or - speaker terminal of either channel, a voltage divided by R418, R419 and R420 will apply to pin 2 of protecting IC. At the same time, the other channel speaker terminal is imaginarily grounded. Meanwhile, if a voltage at pin 2 exceeds the detecting value, the output power will not be delivered to speaker terminal.

c) Thermal Detector

A voltage divided by R415, posistor TH401, TH402, TH403 and TH404 is applied to pin 1 of IC401 through D411. In normal temperature, the resistance value of the posistor is lesser, but when the temperature rises and exceeds to a certain extent, the value rapidly turns to great. For this reason, when the temperature goes up, the voltage at pin 1 will increase and at a certain temperature, the voltage exceeds the detecting value of pin 1 and the output to speaker will be cut.

4. ON/OFF Mute

DCA-3500 employs a function to detect a pop originating power on/off and cuts the output power to speaker terminal by the relay. This function is also performed by IC401.

At the time of turning on the power, the time constant of R405 and C401 causes to delay voltage rise at pin 7. When it rises to the detecting value, the relay will activate to prevent producing pop.

At the time of turning off the power, pin 4 detects a pop from REMO terminal through R404 and de-activates the relay to prevent producing pop prior to the discharge of big capacitors C507, C510, C524 and C527 in the power source.

• DCA-3400

1. Ground Isolation Amplifier

DCA-3400 utilizes a ground isolation amplifier intended to eliminate ignition and alternator noises of vehicle that are coming in to the power amplifier with the input signal and the ground line.

This circuit is shown in the following figure.

Only the case when it becomes $Z_1 = Z_2$, $Z_{1f} = Z_{2f}$ in this circuit, the output will become $e_o = Z_{1f}/Z_1 e_i$, thus no noise "e_n" contained in the output.

Since DCA-3400 selecting the input sensitivity by the voltage amplifier, Z_1 and Z_2 values can be changed by the switch.

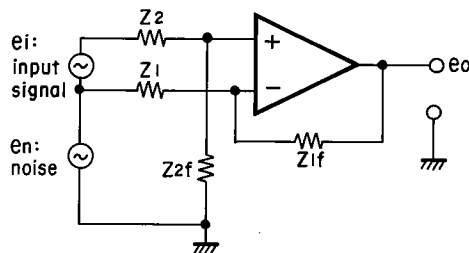

2. DC-DC Converter

When the REMOTE and ACCESSORY terminal of DCA-3400 is applied a voltage, a voltage will applied to pin 11 and 12 of IC301. The output of a square wave oscillated by C332 and R320 connected at pins 5 and 6 will conveyed to pin 9 and 10 to switch TR301, TR306, TR353 and TR354. This output will go through the primary of T301 and T351 to power stage (TR301, TR302, TR351 and TR352) in the secondary side of T301 and T351. After amplified, it will pass through the primary of T302 and T352 and applied to rectifying circuit in the secondary side to get DC power voltage. This power voltages is $\pm 28V$.

3. Protector

DCA-3400 employs a built-in protector to protect amplifier and speaker against damaging in an abnormal condition. This protector works in the following three abnormal conditions.

1. Excessive current flow at speaker terminal due to terminal short.
2. Extraordinary voltage rise at speaker terminal.
3. Excessive temperature rise of heat sink.

For the protection, IC201 is used. A voltage applied to pin 1 or 2 of IC201 rises and exceed the detecting value, the relay drive stage in IC turns to OFF and breaks the relay of power amplifier output point, accordingly to cut the output power to speaker.

When the amplifier return to normal condition and a voltage at pin 1 and 2 of IC201 becomes lower than the detecting value, the relay driver stage in IC automatically turned ON and energize the relay of power amplifier output point, thus delivers the output power to speaker.

a) Overload Detector

When excessive current flows at speaker terminal, a voltage applied to emitter resistor of power transistor in last stage will go up and turns ON TR11 or TR111 or TR12 or TR112. Then TR201 will turn ON, and a voltage at pin 1 of IC201 rises and exceed the detecting value causing to cut the output power to speaker.

b) DC Detector

If there existing a DC voltage at + or - speaker terminal of either channel, a voltage divided by R61, R161, R62, R162 and R209 will apply to pin 2 of protecting IC. At the same time, the other channel speaker terminal is imaginary grounded. Meanwhile if a voltage at pin 2 exceeds detecting value the output power will not be delivered to speaker terminal.

c) Thermal Detector

A voltage divided by R207, posistor TH201, TH202 and TH203 is applied to pin 1 of IC201 through D201. In normal temperature the resistance value of posistor is lesser, but when the temperature rises and exceeds to a certain extent, the value rapidly turns to great. For this reason, when the temperature goes up, the voltage at pin 1 will increase and at a certain temperature, the voltage exceeds the detecting value of pin 1 and the output to speaker will be cut.

4. ON/OFF Mute

DCA-3400 employs a function to detect a pop originating power on/off and cuts the output power to speaker terminal by the relay. This function is also performed by IC201.

At the time of turning on the power, the time constant of R210 and C205 causes to delay voltage rise at pin 7. When it rises to the detecting value, the relay will activate to prevent producing pop.

At the time of turning off the power, pin 4 detects a pop from REMO terminal through R211 and de-activate the relay to prevent producing pop prior to the discharge of big capacitors C311, C315, C363 and C366 in the power source.

BLOCK DIAGRAM

• DCA-3500

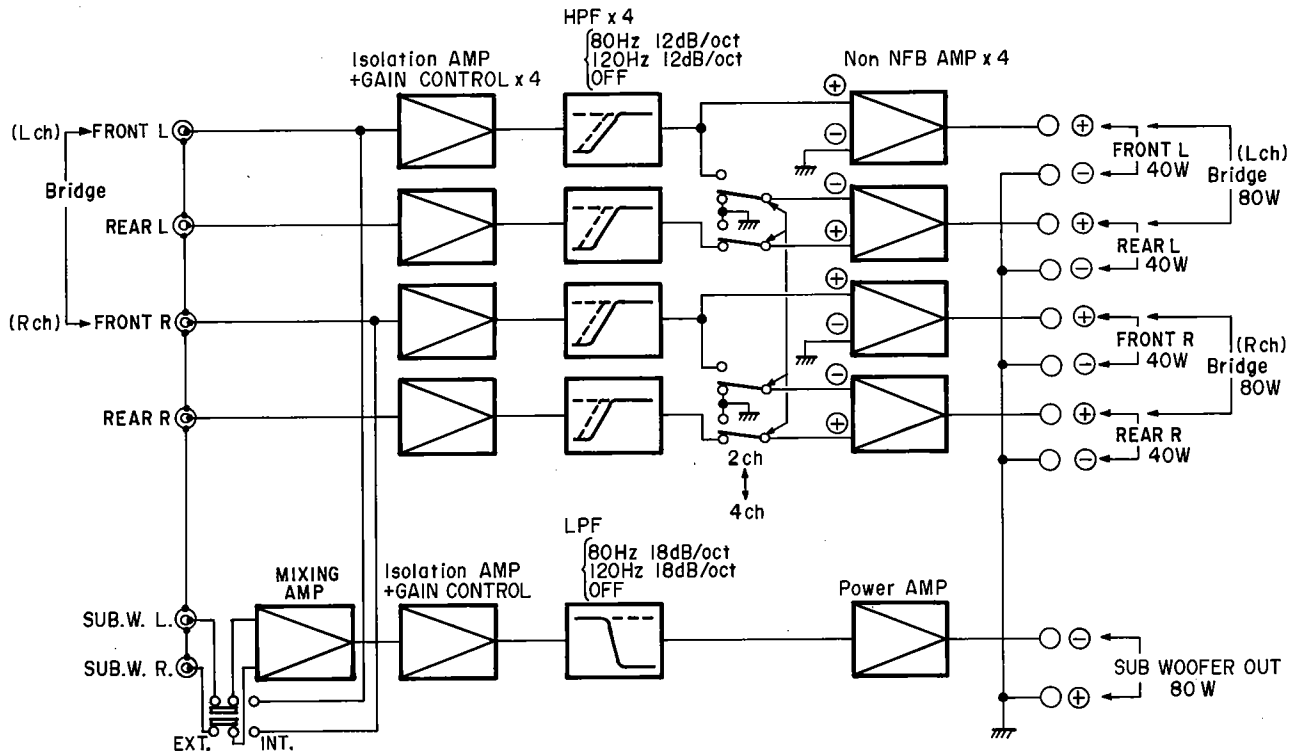

• DCA-3400

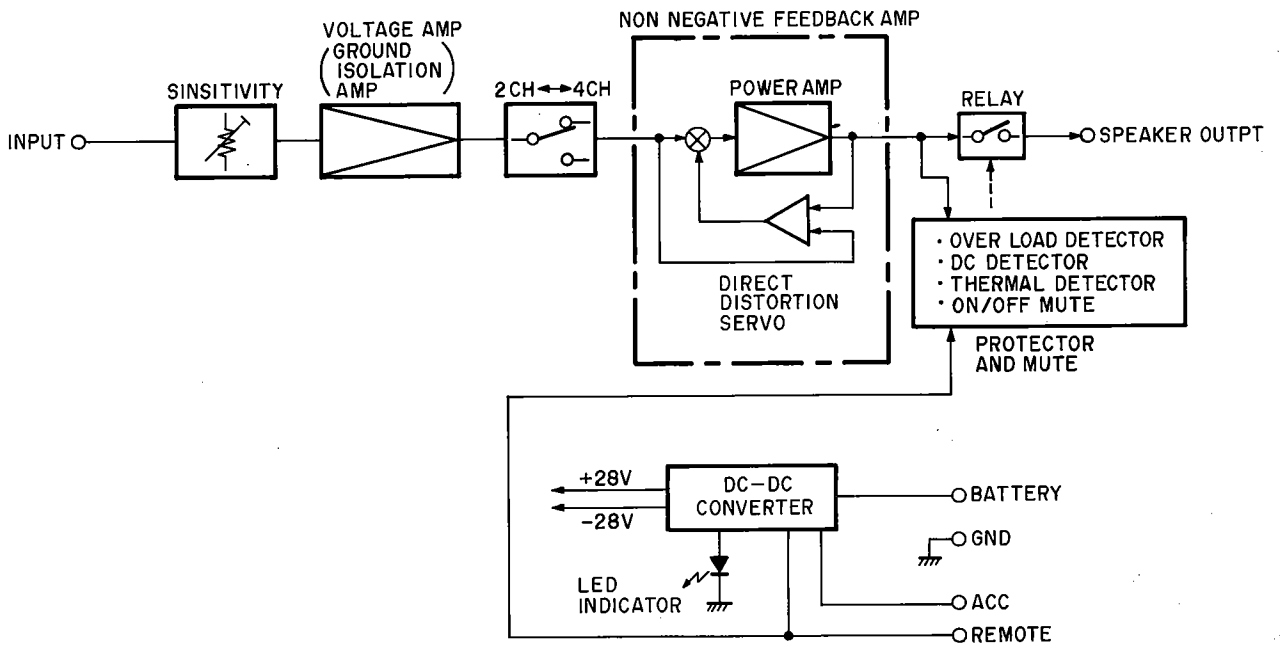

METHOD OF ADJUSTMENTS

When making adjustments, be sure the power supply is at the rated voltage and the room air is in normal condition with respect to temperature and humidity.

Idle Current Adjustment

• DCA-3500

Turn on the power and warm up more than five minutes. Obtain 22 mV DC across the emitter resistor (R105, R106, R305 and R306) of last stage power transistors by means of adjusting VR003, VR004, VR203 and VR204. The idle current at this time is 50 mV DC.

The top panel acts as cooling body. Therefore, when turn the power supply on without equipment of the top panel in adjusting idle current case, take care not to supply current more than 3 minutes to avoid the transistor being broken by the overheated. And you could supply power current after the inner cooling body came down as much as normal temperature.

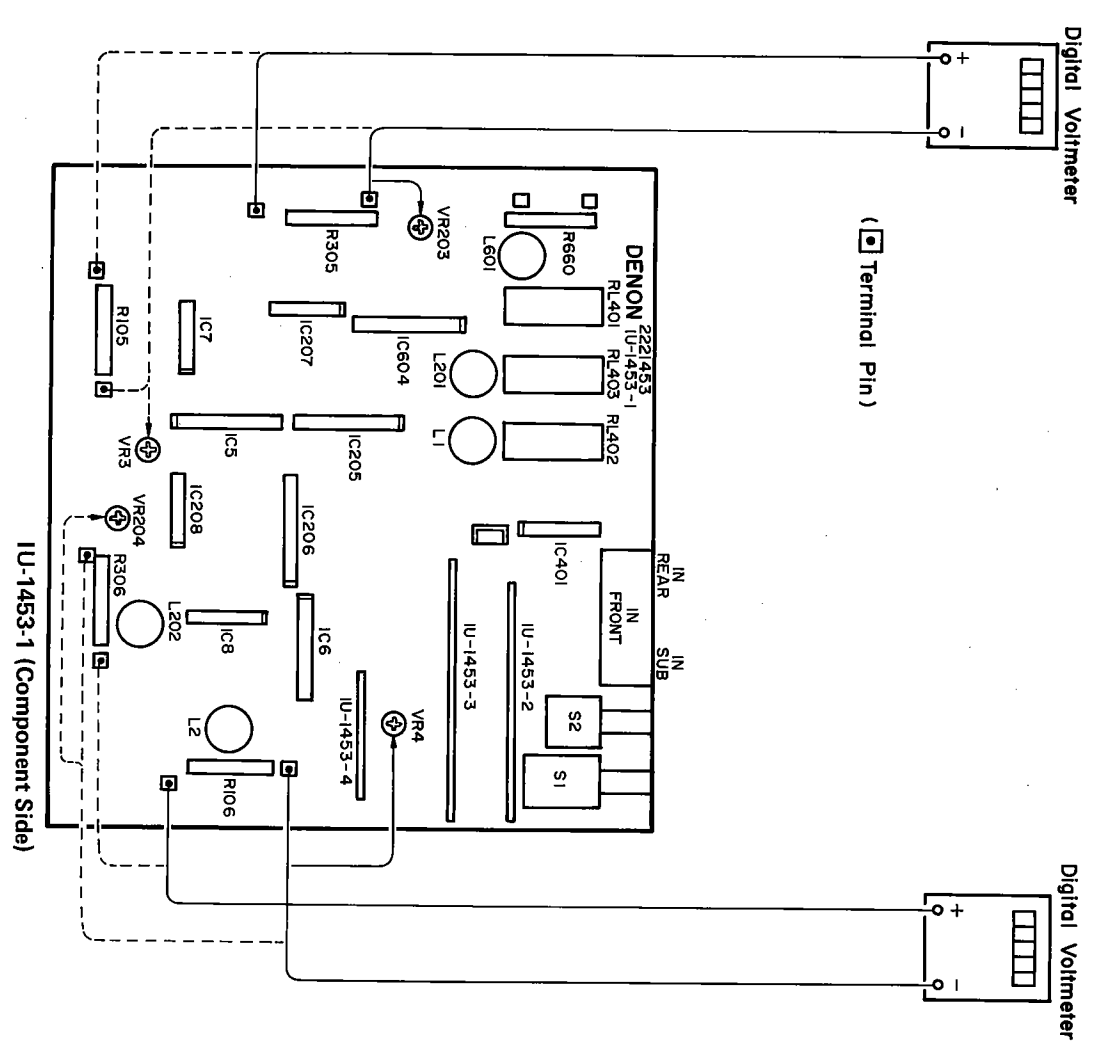

Idle Current Adjustment

• DCA-3400

Turn on the power and warm up more than five minutes. Obtain 22 mV DC across the emitter resistor (R65, R66, R165 and R166) of last stage power transistors by means of adjusting VR1, VR2, VR101 and VR102. The idle current at this time is 50 mV DC.

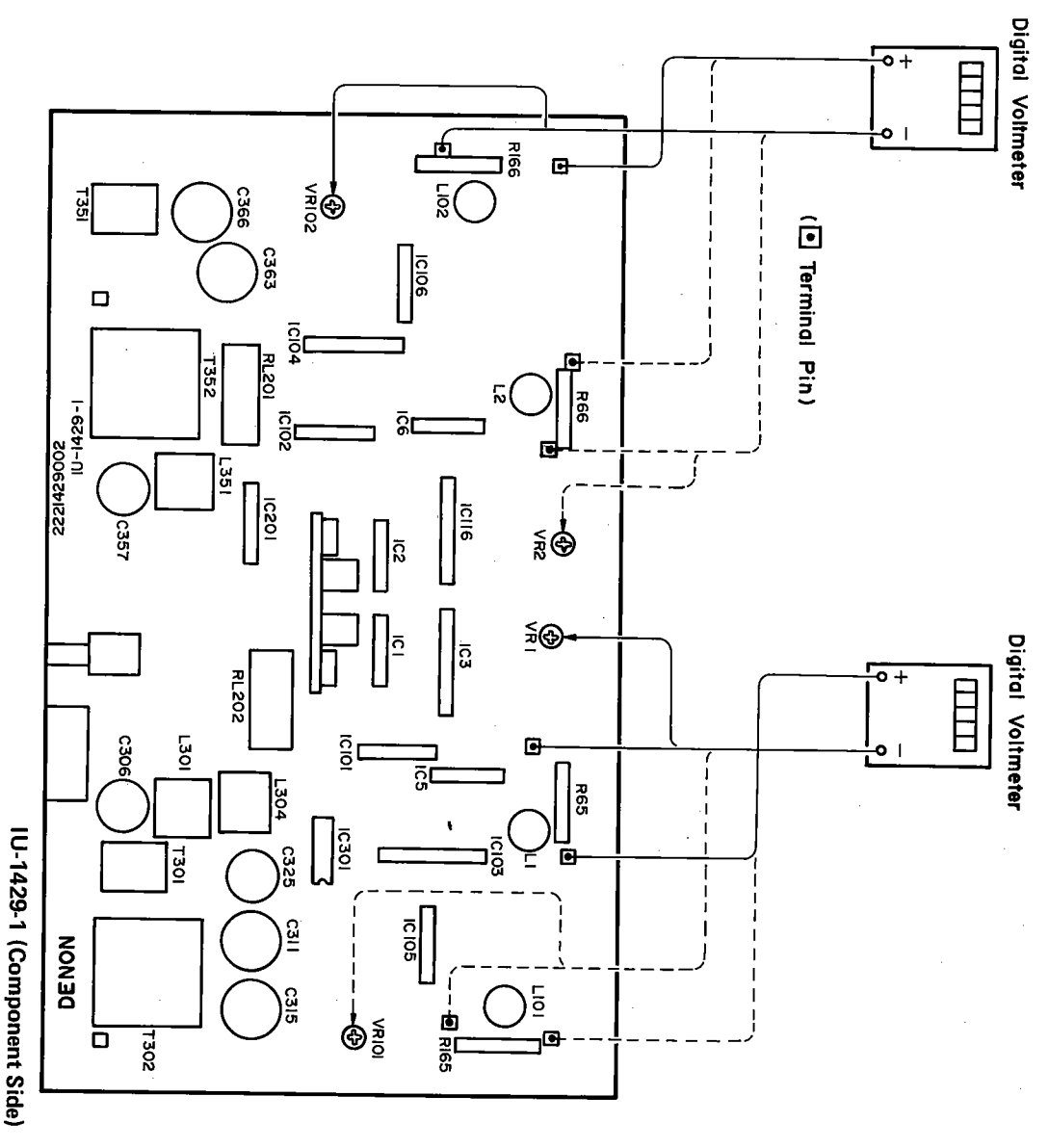

1U-1453 POWER AMP. UNIT (for DCA-3500)

Pattern Side 1

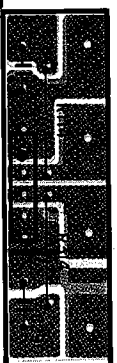

2

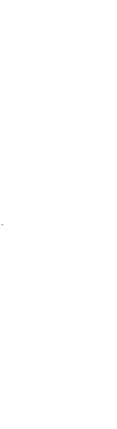

3



4

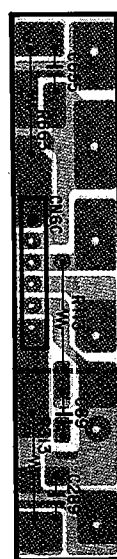

5



6



7



8

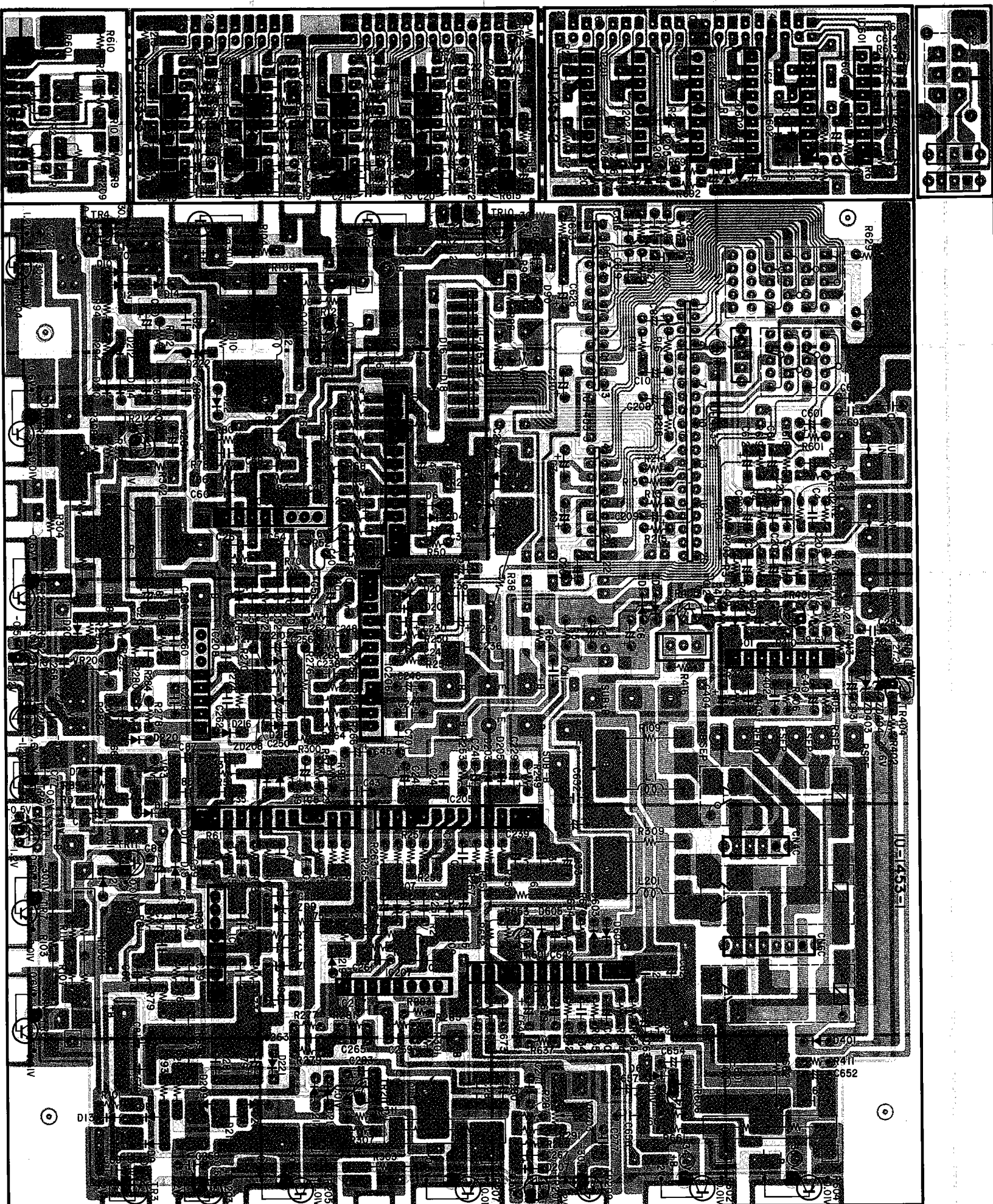

Pin	IC5	IC6	IC205	IC206
1	30.1V	30.1V	30.1V	30.1V
2	—	—	—	—
3	24.1V	24.1V	24.1V	24.1V
4	0.1V	0.1V	0.1V	0.1V
5	0.1V	0.1V	0.1V	0.1V
6	-28.3V	-28.3V	-28.3V	-28.3V
7	-0.5V	-0.5V	-0.5V	-0.5V
8	-0.1V	-0.1V	-0.1V	-0.1V
9	-30.1V	-30.1V	-30.1V	-30.1V
10	30.1V	30.1V	30.1V	30.1V
11	-0.1V	-0.1V	-0.1V	-0.1V
12	0.1V	0.1V	0.1V	0.1V

IC401	Pin	Value
IC401	1	0.03V
	2	0.02V
	3	—
	4	4.3V
	5	—
	6	0.9V
	7	2.3V
	8	3.4V
	9	—
	10	—
	11	—
	12	—

Pin	IC7	IC8	IC207	IC208
1	—	—	—	—
2	—	—	—	—
3	—	—	—	—
4	-5.9V	-5.9V	-5.9V	-5.9V
5	0.1V	0.1V	0.1V	0.1V
6	0.1V	0.1V	0.1V	0.1V
7	0.2V	0.2V	0.2V	0.2V
8	15.5V	15.5V	15.5V	15.5V

IC604	Pin	Value
IC604	1	0.1V
	2	0.1V
	3	33.6V
	4	0.1V
	5	0.1V
	6	0.4V
	7	39.6V
	8	0.2V
	9	-39.8V
	10	-39.8V
	11	-0.1V
	12	—

Pin	1	2	3	4	5	6	7	8
IC1	0V	—	—	—	—	—	—	0V
IC2	0V	—	—	—	—	—	—	0V
IC3	0V	—	—	—	—	—	—	0V
IC4	0V	—	—	—	—	—	—	0V
IC201	0V	—	—	—	—	—	—	0V
IC202	0V	—	—	—	—	—	—	0V
IC203	0V	—	—	—	—	—	—	0V
IC204	0V	—	—	—	—	—	—	0V
IC601	0V	—	—	—	—	—	—	0V
IC602	0V	—	—	—	—	—	—	0V
IC603	0V	—	—	—	—	—	—	0V

Component Side

A

B

C

D

E

2

3

4

5

6

7

8

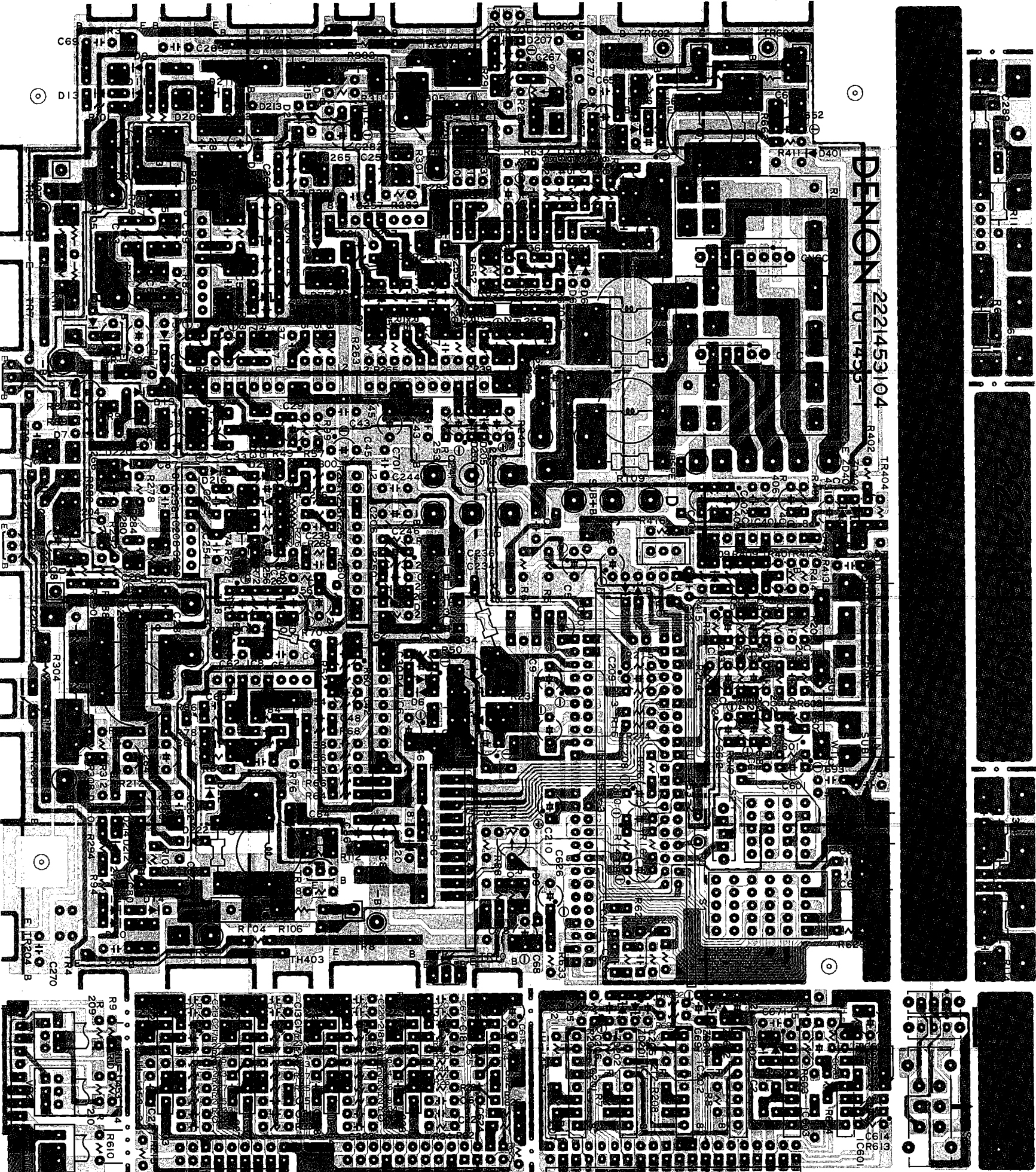

1U-1432 POWER SUPPLY (for DCA-3500)

Pattern Side 1

2

3

4

5

6

7

8

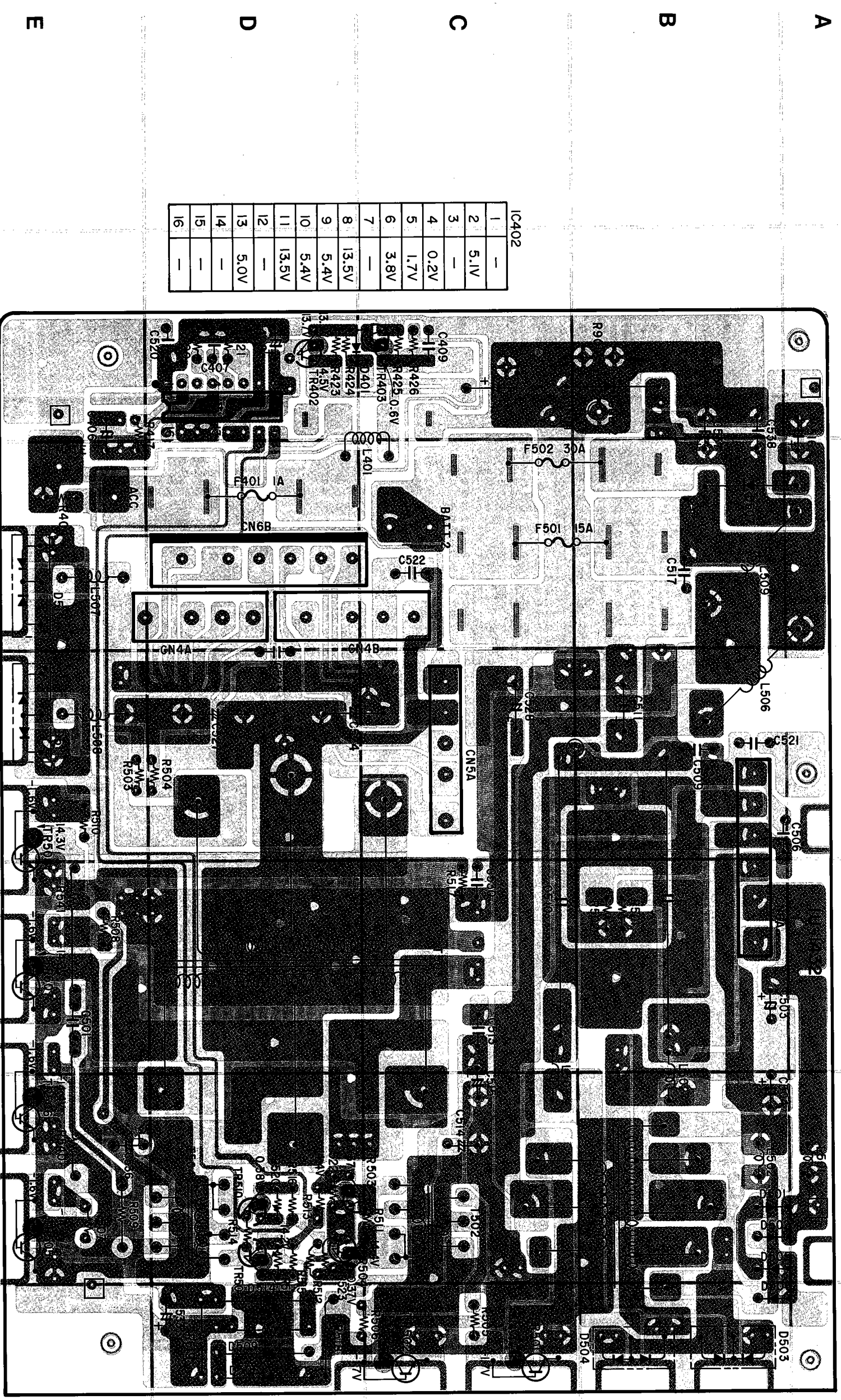

IC402	
1	—
2	5.1V
3	—
4	0.2V
5	1.7V
6	3.8V
7	—
8	13.5V
9	5.4V
10	5.4V
11	13.5V
12	—
13	5.0V
14	—
15	—
16	—

1
Component Side

2

3

4

5

6

7

8

A

B

C

D

E

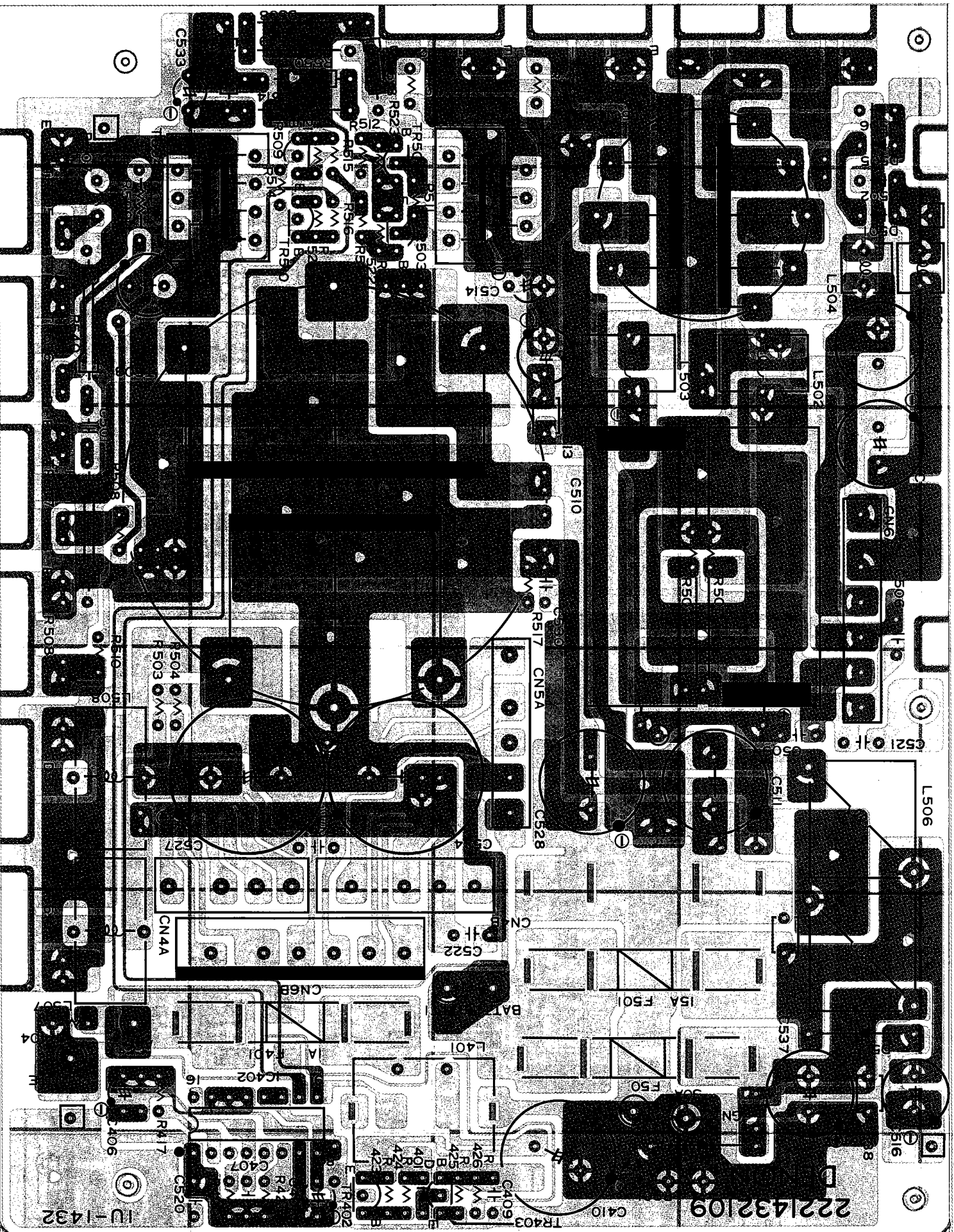

1U-1429 AMP. UNIT (for DCA-3400)

Pattern Side 1

2

3

4

5

6

7

8

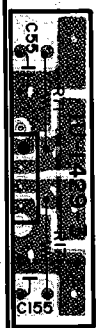
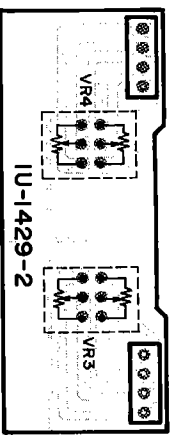
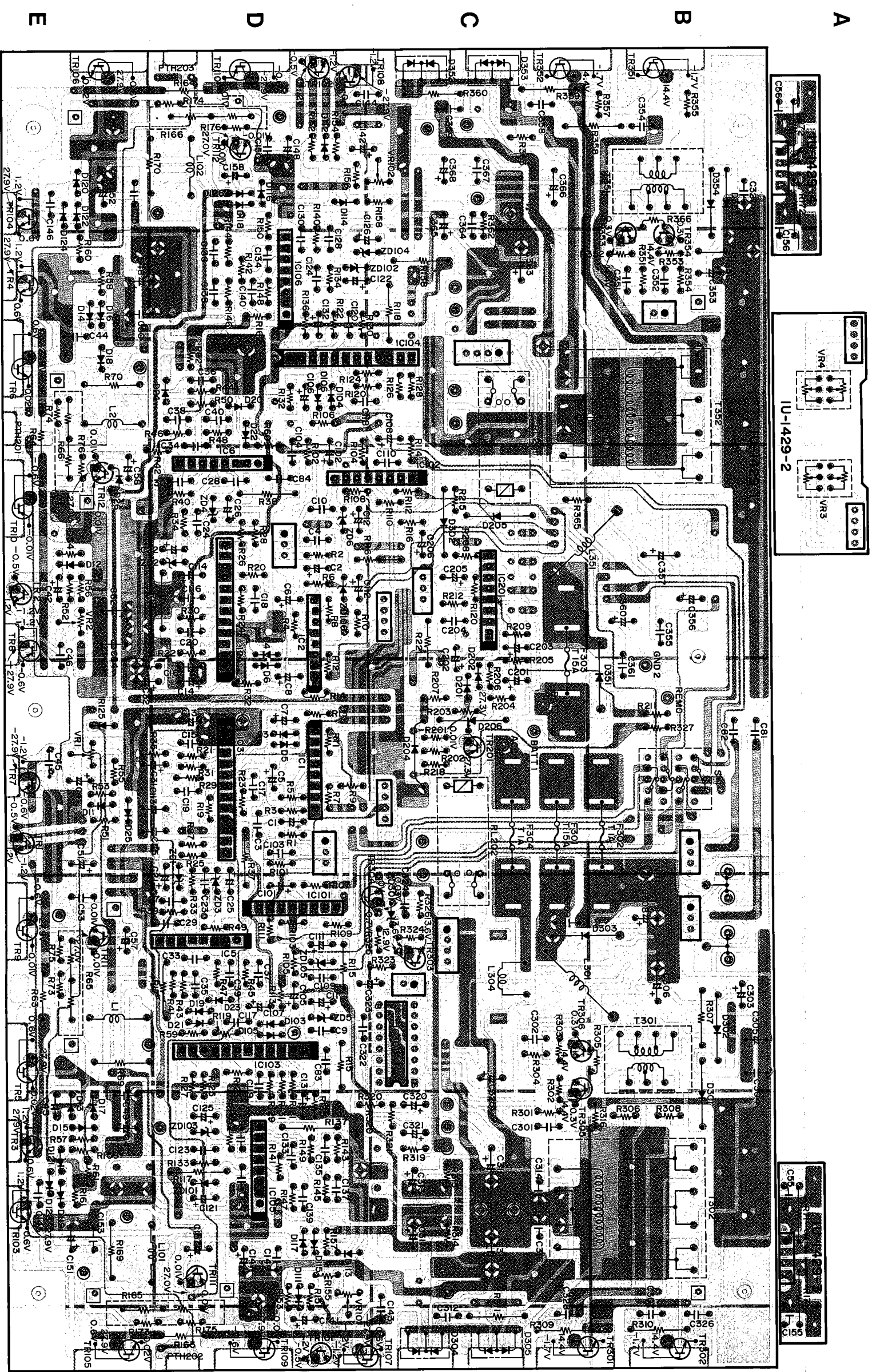

Pin	IC3	IC4	IC103	IC104
1	27.9V	27.9V	27.9V	27.9V
2	27.9V	27.9V	27.9V	27.9V
3	21.8V	21.8V	21.8V	21.8V
4	0.2V	0.2V	0.2V	0.2V
5	0.2V	0.2V	0.2V	0.2V
6	-26.2V	-26.2V	-26.2V	-26.2V
7	0.5V	0.5V	0.5V	0.5V
8	0.05V	0.05V	0.05V	0.05V
9	-27.9V	-27.9V	-27.9V	-27.9V
10	-27.9V	-27.9V	-27.9V	-27.9V
11	-0.04V	-0.04V	-0.04V	-0.04V
12	0.06V	0.06V	0.06V	0.06V

Pin	IC301
1	0V
2	5.0V
3	—
4	0.2V
5	1.7V
6	3.7V
7	—
8	13.6V
9	5.0V
10	5.0V
11	13.6V
12	—
13	—
14	5.0V
15	—
16	0V

Pin	IC1	IC2	IC101	IC102
1	0.003V/0.003V	0.003V/0.003V	0.003V	0.003V
2	0.007V/0.007V	0.007V/0.007V	0.007V	0.007V
3	0.006V/0.006V	0.006V/0.006V	0.006V	0.006V
4	-14.7V	-14.7V	-14.7V	-14.7V
5	0.007V/0.007V	0.007V/0.007V	0.007V	0.007V
6	0.007V/0.007V	0.007V/0.007V	0.007V	0.007V
7	0.008V/0.008V	0.008V/0.008V	0.008V	0.008V
8	14.7V	14.7V	14.7V	14.7V

Pin	IC201
1	0.01V
2	0.01V
3	—
4	4.3V
5	—
6	0.8V
7	2.2V
8	3.3V

Pin	IC5	IC6	IC105	IC106
1	—	—	—	—
2	—	—	—	—
3	—	—	—	—
4	-15.4V	-15.4V	-15.4V	-15.4V
5	0.01V	0.01V	0.01V	0.01V
6	0.01V	0.01V	0.01V	0.01V
7	0.04V	0.04V	0.04V	0.04V
8	15.4V	15.4V	15.4V	15.4V

Component Side

1 2 3 4 5 6 7 8

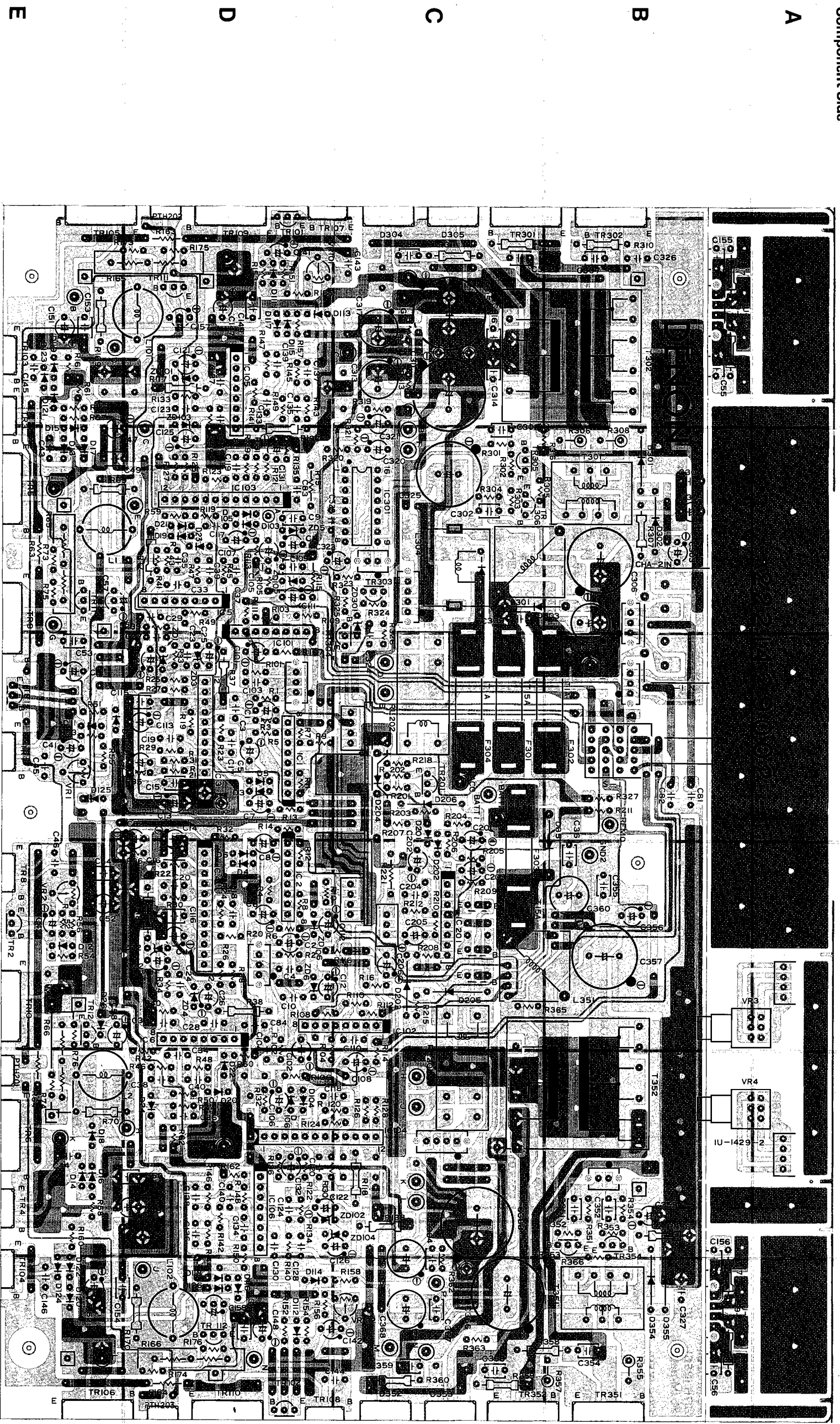

1U-1453 POWER AMP. UNIT PARTS LIST (for DCA-3500)

Ref. No.	Part No.	Part Name & Descriptions	Ref. No.	Part No.	Part Name & Descriptions	Ref. No.	Part No.	Part Name & Descriptions	Ref. No.	Part No.	Part Name & Descriptions	Q'ty	
SEMICONDUCTORS													
IC001	2360189001	M5218L (Mitsubishi)	R660	2432026032	0.22/0.22 ohm ±10% 3W Wire Wound	C241,242	2544260074	4.7µF ±20% 50V Electrolytic	L001,002	2350007007	Inductor	1	
IC005,006	2630394003	µPC1270H (NEC)	R662,663	2442043034	10 ohm ±5% 1W Metal Oxide (S)	C243,244	2561034034	0.047µF ±5% 50V Metallized	L201,202	2350007007	Inductor	1	
IC007,008	2630189001	M5218L (Mitsubishi)	VR001	2110491002	Variable Volume 20 kohm	C245,246	2544260045	1µF ±20% 50V Electrolytic	L601	2350007007	Inductor	1	
IC201	2630189001	M5218L (Mitsubishi)	VR003,004	2116048048	Semi Fixed Resistor 2.2 kohm	C247,248	—	—	RL401	2149003005	Relay	1	
IC205,206	2630394003	µPC1270H (NEC)	VR201	2110491002	Variable Volume 20 kohm	C249,250	2544254051	220µF ±20% 16V Electrolytic	~403	—	—	—	
IC207,208	2630189001	M5218L (Mitsubishi)	VR203,204	2116048048	Semi Fixed Resistor 2.2 kohm	C251,252	2533619005	475F ±5% 50V Ceramic	E.U.P.				
IC601	2630189001	M5218L (Mitsubishi)	VR601	2110490003	Variable Volume 20 kohm	C253,254	2531055069	1000P ±10% 50V Ceramic					
IC604	2630394003	µPC1270H (NEC)					C255,256	2544254051					220µF ±20% 16V Electrolytic
TR001,002	2730198028	2SC1815(GR)					C257,258	2533625002					825F ±5% 50V Ceramic
TR011,012	2730198044	2SC1815(Y/GR)					C259,260	2533630308					100F ±0.5pF 50V Ceramic
TR201,202	2730198028	2SC1815(GR)					C261,262	2533623004					680F ±5% 50V Ceramic
TR211,212	2730198044	2SC1815(Y/GR)					C263~266	2531001000					330pF ±10% 50V Ceramic
TR401	2710102034	2SA1015(GR/Y)					C267,268	2544254006					10µF ±20% 16V Electrolytic
TR404	2740097009	2SD1207(T/S)					C269,270	2533619005					475F ±5% 50V Ceramic
TR405	2690025008	RN1202/10K-10K)					C277,278	2533619005					475F ±5% 50V Ceramic
TR601	2730198015	2SC1815(BL)					C279,280	2544260045	1µF ±20% 50V Electrolytic				
TR606	2730198044	2SC1815(Y/GR)					C281,282	2561034034	0.047µF ±5% 50V Metallized				
D003~022	2760417009	1SS270					C283,284	2544258002	4.7µF ±20% 35V Electrolytic				
D003	2760417009	1SS270					C285,286	2561034034	0.047µF ±5% 50V Metallized				
D401	2760427015	1SS270					C287,288	2544260045	1µF ±20% 50V Electrolytic				
D411	2760417009	1SS270					C289,290	2561034018	0.033µF ±5% 50V Metallized				
D601~605	2760417009	1SS270					C401	2551121025	10µF ±20% 16V Electrolytic				
D612	2760417009	1SS270					C403	2544252037	100µF ±20% 10V Electrolytic				
ZD001,002	2760476008	HZS15-1 TD					C404	2544252037	100µF ±20% 6.3V Electrolytic				
ZD004	2760494006	HZP-13					C430	2544260045	1µF ±20% 50V Electrolytic				
ZD006	2760494006	HZP-13					C431	2544258015	10µF ±20% 35V Electrolytic				
ZD007	2760477007	HZS16-1 TD					C601,602	2544258002	33µF ±20% 25V Electrolytic				
ZD403,404	2760475009	HZS15-1 TD					C603	2544256020	33µF ±20% 25V Electrolytic				
ZD601,602	2760476008	HZS15-1 TD					C604	—	—				
CAPACITORS													
C001,002	2544260061	3.3µF ±20% 50V Electrolytic	C605	2531055069	100pF ±10% 50V Ceramic	C606~608	—	—	C609	—	—	—	
C003,004	2531055056	220pF ±10% 50V Ceramic	C005,006	2544254035	47µF ±20% 16V Electrolytic	C611,612	2544258002	4.7µF ±20% 35V Electrolytic	C619	2561034034	0.12µF ±5% 50V Metallized	1	
C007~010	2544256004	10µF ±20% 25V Electrolytic	C011,012	2531024003	0.01µF ±80~20% 50V Ceramic	C613~615	2544260074	0.18µF ±20% 25V Metallized	C620	2561035017	0.22µF ±5% 50V Metallized	1	
C013,014	2551121067	0.022µF ±5% 50V Plastic Film	C015,016	2561034018	0.033µF ±5% 50V Metallized	C616	2561035004	0.18µF ±20% 25V Metallized	C621	2539035007	0.012µF ±10% 25V Ceramic	1	
C017,018	2544256004	0.033µF ±5% 50V Metallized	C019,020	2551121041	0.015µF ±5% 50V Plastic Film	C617	2561035033	0.33µF ±5% 50V Metallized	C622,623	—	—	—	
C021,022	2551121067	0.022µF ±5% 50V Plastic Film	C024	2544254048	100µF ±20% 16V Electrolytic	C618	2539035010	0.018µF ±10% 25V Ceramic	C627	2561035059	0.47µF ±5% 50V Metallized	1	
C026	2544254048	4.7µF ±20% 16V Electrolytic	C029,030	2544260074	1µF ±20% 50V Electrolytic	C628	2533614000	30pF ±5% 50V Ceramic	C629	2544260074	4.7µF ±20% 50V Electrolytic	1	
C033,034	2544260045	1µF ±20% 50V Electrolytic	C035,036	2561034034	0.047µF ±5% 50V Metallized	C630	2544260058	2.2µF ±20% 50V Electrolytic	C631	2561034034	0.047µF ±5% 50V Metallized	1	
C037,038	2533614000	30pF ±5% 50V Ceramic	C039,040	2544260058	2.2µF ±20% 50V Electrolytic	C632	2561034034	0.047µF ±5% 50V Metallized	C633	2561034034	0.047µF ±5% 50V Metallized	1	
C055,056	2544254051	220µF ±20% 16V Electrolytic	C057,058	2533625002	825F ±5% 50V Ceramic	C634	2544260045	1µF ±20% 50V Electrolytic	C642	—	—	—	
C059,060	2533630308	68pF ±5% 50V Ceramic	C061,062	2533623004	330pF ±10% 50V Ceramic	C645	—	—	C652	2544260090	22µF ±20% 50V Electrolytic	1	
C063~066	2531001000	10µF ±20% 16V Electrolytic	C067,068	2544254006	47pF ±5% 50V Ceramic	C653	2561035017	0.22µF ±5% 50V Metallized	C654	2561035091	1µF ±5% 50V Metallized	1	
C069,070	2533619005	47pF ±5% 50V Ceramic	C077,078	2533619005	47pF ±5% 50V Ceramic	C655,656	2561035091	1µF ±5% 50V Metallized	C657	2544261015	47µF ±20% 50V Electrolytic	1	
C079,080	2544260045	1µF ±20% 50V Electrolytic	C081,082	2544260045	1µF ±20% 50V Electrolytic	C659,692	2544254035	47µF ±20% 16V Electrolytic					
C083,084	2544258002	4.7µF ±20% 35V Electrolytic	C085,086	2561034034	0.047µF ±5% 50V Metallized								
C087,088	2544260045	1µF ±20% 50V Metallized	C089,090	2561034018	0.033µF ±5% 50V Metallized								
C193	2531024003	3.3µF ±20% 50V Electrolytic	C201,202	2544260061	3.3µF ±20% 50V Electrolytic								
C203,204	2531055056	220pF ±10% 50V Ceramic	C205,206	2544254035	47µF ±20% 16V Electrolytic								
C215,216	2561034018	0.033µF ±5% 50V Metallized	C217,218	2544256004	10µF ±20% 25V Electrolytic								
C219,220	2551121041	0.015µF ±5% 50V Plastic Film	C221,222	2551121067	0.022µF ±5% 50V Plastic Film								
C229,230	2544260074	4.7µF ±20% 50V Electrolytic	C233,234	2544260045	1µF ±20% 50V Electrolytic								
C235,236	2561034034	0.047µF ±5% 50V Metallized	C237,238	2533614000	30pF ±5% 50V Ceramic								
C239,240	2544260058	2.2µF ±20% 50V Electrolytic											
OTHER PARTS													
SW001	2124642009	Rotary Switch	SW002	2124641000	Rotary Switch	SW601	2124091003	Slide Switch					
									2050391107	6P Pin Jack (T5916)	1		
									2050389106	6P Speaker Terminal	1		
COIL, TRANS													
OTHER PARTS													
(P.W. Board)													
Terminal Pin													
EP-5667H1													
2050185067													
2050185041													
2050233032													
2050234060													
2050402009													
2050401013													
2050401026													
2050401026													
2046198007													
2040191003													
2038187003													
2036199006													
2040192002													
2036193015													
2030299054													
2030299083													
2030299096													

1U-1432 POWER SUPPLY UNIT PARTS LIST (for DCA-3500)

Ref. No.	Part No.	Part Name & Descriptions		Ref. No.	Part No.	Part Name & Descriptions	Q'ty
SEMICONDUCTORS				E.U.P.			
IC402	2620720001	IR3M02 (Sharp)	IC	F401	2061025035	Fuse 1A (LC)	1
TR402	2720078006	2SB764(E/F)	Transistor	F501	2061017030	Fuse 15A	1
TR403	2730198002	2SC1815(Y)	Transistor	F502	2061017056	Fuse (30.0A)	1
TR503, 504	2730327019	2SC2274K(E/F)AA	Transistor		EP-5870	Fuse Holder	6
TR509, 510	2730327019	2SC2274K(E/F)AA	Transistor	OTHER PARTS			
D501,502	2760442003	1SR124-200AT93	Diode	221432109	(P.W. Board)		1
D505,506	2760442003	1SR124-200AT93	Diode	EP-5667H1	Terminal Pin		4
D507	2760398018	S3V10F(04P15)	Diode	2050122062	6P Connector Pin Ass'y		1
D508,509	2760055005	V03C	Diode	2050122059	5P Connector Pin Ass'y		1
D512	2760398018	S3V10F(04P15)	Diode	2050122046	4P Connector Pin Ass'y		1
D514	2760113002	U05C	Diode	2050217061	6P Connector Base (ULTR)		1
ZD401	2760464007	HZS7A-1 TD	Zener	2050217045	4P Connector Base (ULTR)		1
RESISTORS (not including Carbon Film $\pm 5\%$, 1/6W, 1/4W Type)				2030305074	1P Sin Connector Ass'y		1
Δ R505~510	2412369010	1 ohm $\pm 5\%$	1/4W Carbon Film (NBF)	2030289080	1P Contact Ass'y		1
Δ R518,519	2442043034	10 ohm $\pm 5\%$	1W Metal Oxide (S)	2030300024	1P Sin Connector Ass'y		1
Δ R550	2440006015	1.2 ohm $\pm 5\%$	1W Metal Oxide (NBF)	2030300037	1P Sin Connector Ass'y		1
CAPACITORS				2030305045	1P Sin Connector Ass'y		1
C406	2544254048	100 μ F $\pm 20\%$	16V Electrolytic	2030305058	1P Sin Connector Ass'y		1
C407	2551120000	0.001 μ F $\pm 5\%$	50V Plastic Film	2030305061	1P Sin Connector Ass'y		1
C408	2544254048	100 μ F $\pm 20\%$	16V Electrolytic				
C409	2551121025	0.01 μ F $\pm 5\%$	50V Plastic Film				
C410	2544255005	3300 μ F $\pm 20\%$	16V Electrolytic				
C501	2561034018	0.033 μ F $\pm 5\%$	50V Metalized				
C503,504	2544220027	470 μ F	50V Electrolytic				
C506	2561034034	0.047 μ F $\pm 5\%$	50V Metalized				
C507	2542083004	2200 μ F $\pm 20\%$	50V Electrolytic				
C509	2561034034	0.047 μ F $\pm 5\%$	50V Metalized				
C510	2542083004	2200 μ F $\pm 20\%$	50V Electrolytic				
C511	2544255018	4700 μ F $\pm 20\%$	16V Electrolytic				
C513	2551121025	0.01 μ F $\pm 5\%$	50V Plastic Film				
C514	2544279007	100 μ F $\pm 20\%$	10V Electrolytic				
C515	2544274002	220 μ F $\pm 20\%$	16V Electrolytic				
C516	2544254080	1000 μ F $\pm 20\%$	16V Electrolytic				
C517	2561034018	0.033 μ F $\pm 5\%$	50V Metalized				
C520,521	2531024003	0.01 μ F $\pm 80,-20\%$	50V Ceramic				
C522	2561034034	0.047 μ F $\pm 5\%$	50V Metalized				
C524	2544259027	4700 μ F $\pm 20\%$	35V Electrolytic				
C525	2561034034	0.047 μ F $\pm 5\%$	50V Metalized				
C527	2544259027	4700 μ F $\pm 20\%$	35V Electrolytic				
C528	2544255018	4700 μ F $\pm 20\%$	16V Electrolytic				
C530	2561034034	0.047 μ F $\pm 5\%$	50V Metalized				
C533	2544279010	220 μ F	10V Electrolytic				
C536	2544274031	470 μ F	16V Electrolytic				
C537	2544254093	2200 μ F $\pm 20\%$	16V Electrolytic				
C538	2561034034	0.047 μ F $\pm 5\%$	50V Metalized				
COIL, TRANS							
L401	2350037006	Inductor					
L501	2350028002	Coil (270 μ H)					
L502,503	2350039004	Inductor					
L504	2350028002	Coil (270 μ H)					
L506	2320093106	Choke Coil					
L507,508	2350040006	Inductor					
L509	2320093106	Choke Coil					
T501	2330291008	Pulse Trans					
T502	2330273000	Driver Trans					
T503	2330293006	Pulse Trans					
T504	2330273000	Driver Trans					

1U-1429 AMP. UNIT PARTS LIST (for DCA-3400)

Ref. No.	Part No.	Part Name & Descriptions	
SEMICONDUCTORS			
IC001,002	2630189001	M5218L (Mitsubishi)	IC
IC003,004	2630394003	μ PC1270H (NEC)	IC
IC005,006	2630189001	M5218L (Mitsubishi)	IC
IC101,102	2630189001	M5218L (Mitsubishi)	IC
IC103,104	2630394003	μ PC1270H (NEC)	IC
IC105,106	2630189001	M5218L (Mitsubishi)	IC
IC201	2630209004	μ PC1237H (NEC)	IC
IC301	2620832009	μ PC494C (NEC)	IC
TR001,002	2730198028	2SC1815(GR)	Transistor
TR011,012	2730198044	2SC1815(Y/GR)	Transistor
TR101,102	2730198028	2SC1815(GR)	Transistor
TR111,112	2730198044	2SC1815(Y/GR)	Transistor
TR201	2710102034	2SA1015(GR/Y)	Transistor
TR202	-	-	-
TR203,204	-	-	-
TR303	2720067004	2SB647(D)	Transistor
TR304	2730198002	2SC1815(Y)	Transistor
TR305,306	2730327019	2SC2274K (E/F)	Transistor
TR353,354	2730327019	2SC2274K (E/F)	Transistor
D003~006	2760417009	1SS270	Diode
D011~026	2760417009	1SS270	Diode
D103~106	2760417009	1SS270	Diode
D111~126	2760417009	1SS270	Diode
D201,202	2760417009	1SS270	Diode
D203~206	2760433009	DSM1A2	Diode
D301	2760055005	V03C	Diode
D303	2760398018	S3V10F(04P15)	Diode
D306	-	-	-
D351	2760398018	S3V10F(04P15)	Diode
D354	2760055005	V03C	Diode
ZD001~004	2760477007	HZS16-1	Zener
ZD005,006	2760476008	HZS15-1	Zener
ZD101~104	2760477007	HZS16-1	Zener
ZD105,106	2760476008	HZS15-1	Zener
ZD301	2760464007	HZS7A-1	Zener
RESISTORS (not including Carbon Film \pm5%, 1/6W, 1/4W Type)			
R015,016	2410185005	1 kohm \pm 5% 1/2W	Carbon Film
R017,018	2442043047	2.2 kohm \pm 5% 1W	Metal Oxide (S)
R037,038	2442043047	2.2 kohm \pm 5% 1W	Metal Oxide (S)
R063,064	2410167007	180 ohm \pm 5% 1/2W	Carbon Film
R065,066	2432026032	0.22/0.22 ohm \pm 10% 3W	Wire Wound
R069~072	2442043034	10 ohm \pm 5% 1W	Metal Oxide (S)
R115,116	2410185005	1 kohm \pm 5% 1/2W	Carbon Film
R117,118	2442043047	2.2 kohm \pm 5% 1W	Metal Oxide (S)
R137,138	2442043047	2.2 kohm \pm 5% 1W	Metal Oxide (S)
R163,164	2410167007	180 ohm \pm 5% 1/2W	Carbon Film
R165,166	2432026032	0.22/0.22 ohm \pm 10% 3W	Wire Wound
R169~172	2442043034	10 ohm \pm 5% 1W	Metal Oxide (S)
R221	2410193000	2.2 kohm \pm 5% 1/2W	Carbon Film
R306	2412387005	1 ohm \pm 5% 1/4W	Carbon Film (NBS)
R307	2442043034	10 ohm \pm 5% 1W	Metal Oxide (S)
R308	2412387005	1 ohm \pm 5% 1/4W	Carbon Film (NBS)
R355	2412387005	1 ohm \pm 5% 1/4W	Carbon Film (NBS)
R356	2442043034	10 ohm \pm 5% 1W	Metal Oxide (S)

Ref. No.	Part No.	Part Name & Descriptions	
R357	2412387005	1 ohm \pm 5% 1/4W	Carbon Film (NBS)
R367,368	2440010027	2.7 ohm \pm 5% 1W	Metal Oxide (NBF)
VR001,002	2116048048	Semi Fixed Resistor 2.2 kohm	
VR003,004	2110491002	Variable Volume 20 kohm	
VR101,102	2116048048	Semi Fixed Resistor 2.2 kohm	
CAPACITORS			
C001,002	2544260061	3.3 μ F \pm 20% 50V	Electrolytic
C003,004	2531055056	220pF \pm 10% 50V	Ceramic
C005~008	2544260061	3.3 μ F \pm 20% 50V	Electrolytic
C009,010	2531024003	0.01 μ F \pm 80,-20% 50V	Ceramic
C011,012	2544254048	100 μ F \pm 20% 16V	Electrolytic
C013,014	2544260045	1 μ F \pm 20% 50V	Electrolytic
C015,016	2561034034	0.047 μ F \pm 5% 50V	Metalized
C017,018	2533614000	30pF \pm 5% 50V	Ceramic
C019,020	2534342041	5pF \pm 0.25pF 50V	Ceramic
C021,022	2544254051	220 μ F \pm 20% 16V	Electrolytic
C023,024	2533619005	47pF \pm 5% 50V	Ceramic
C025,026	2544254051	220 μ F \pm 20% 16V	Electrolytic
C027,028	2531055069	100pF \pm 10% 50V	Ceramic
C029,030	2533623004	68pF \pm 5% 50V	Ceramic
C031,032	2544260058	2.2 μ F \pm 20% 50V	Electrolytic
C033,034	2533625002	82pF \pm 5% 50V	Ceramic
C035~038	2531001000	330pF \pm 10% 50V	Ceramic
C039,040	2533603008	10pF \pm 0.5pF 50V	Ceramic
C041,042	2544254006	10 μ F \pm 20% 16V	Electrolytic
C043~046	2533619005	47pF \pm 5% 50V	Ceramic
C047,048	2544260045	1 μ F \pm 20% 50V	Electrolytic
C049,050	2561034034	0.047 μ F \pm 5% 50V	Metalized
C051,052	2544260045	1 μ F \pm 20% 50V	Electrolytic
C053,054	2561034034	0.047 μ F \pm 5% 50V	Metalized
C055,056	2561034018	0.033 μ F \pm 5% 50V	Metalized
C057,058	2544258002	4.7 μ F \pm 20% 35V	Electrolytic
C081~084	2531024003	0.01 μ F \pm 80,-20% 50V	Ceramic
C101,102	2544260061	3.3 μ F \pm 20% 50V	Electrolytic
C103,104	2531055056	220pF \pm 10% 50V	Ceramic
C105~108	2544260061	3.3 μ F \pm 20% 50V	Electrolytic
C109,110	2531024003	0.01 μ F \pm 80,-20% 50V	Ceramic
C111,112	2544254048	100 μ F \pm 20% 16V	Electrolytic
C113,114	2544260045	1 μ F \pm 20% 50V	Electrolytic
C115,116	2561034034	0.047 μ F \pm 5% 50V	Metalized
C117,118	2533614000	30pF \pm 5% 50V	Ceramic
C119,120	2534342041	5pF \pm 0.25pF 50V	Ceramic
C121,122	2544254051	220 μ F \pm 20% 16V	Electrolytic
C123,124	2533619005	47pF \pm 5% 50V	Ceramic
C125,126	2544254051	220 μ F \pm 20% 16V	Electrolytic
C127,128	2531055069	100pF \pm 10% 50V	Ceramic
C129,130	2533623004	68pF \pm 5% 50V	Ceramic
C131,132	2544260058	2.2 μ F \pm 20% 50V	Electrolytic
C133,134	2533625002	82pF \pm 5% 50V	Ceramic
C135~138	2531001000	330pF \pm 10% 50V	Ceramic
C139,140	2533603008	10pF \pm 0.5pF 50V	Ceramic
C141,142	2544254006	10 μ F \pm 20% 16V	Electrolytic
C143~146	2533619005	47pF \pm 5% 50V	Ceramic
C147,148	2544260045	1 μ F \pm 20% 50V	Electrolytic
C149,150	2561034034	0.047 μ F \pm 5% 50V	Metalized
C151,152	2544260045	1 μ F \pm 20% 50V	Electrolytic
C153,154	2561034034	0.047 μ F \pm 5% 50V	Metalized
C155,156	2561034018	0.033 μ F \pm 5% 50V	Metalized
C157,158	2544258002	4.7 μ F \pm 20% 35V	Electrolytic
C201	2544260045	1 μ F \pm 20% 50V	Electrolytic
C202	2544252037	100 μ F \pm 20% 10V	Electrolytic
C203	2544252037	100 μ F \pm 20% 10V	Electrolytic
C204	2531024003	0.01 μ F \pm 80,-20% 50V	Ceramic
C205	2544254006	10 μ F \pm 20% 16V	Electrolytic

Ref. No.	Part No.	Part Name & Descriptions	Q'ty
C206	2544258057	100μF ±20% 35V Electrolytic	2
C301,302	2561034034	0.047μF ±5% 50V Metallized	2
C303	2544252037	100μF ±20% 10V Electrolytic	1
C304	2531024003	0.01μF +80,-20% 50V Ceramic	1
C305	2544260045	1μF ±20% 50V Electrolytic	1
C306	2544255018	4700μF ±20% 16V Electrolytic	1
C307	—	—	1
C308	2544254080	1000μF ±20% 16V Electrolytic	1
C309	2561034018	0.033μF ±5% 50V Metallized	1
C310	—	—	1
C311	2544259014	3300μF ±20% 35V Electrolytic	1
C312	—	—	1
C313	2544258060	220μF ±20% 35V Electrolytic	1
C314	2561034034	0.047μF ±5% 50V Metallized	1
C315	2544259014	3300μF ±20% 35V Electrolytic	1
C316	2561034034	0.047μF ±5% 50V Metallized	1
C317	2544258060	220μF ±20% 35V Electrolytic	1
C318	—	—	1
C320	2544254048	100μF ±20% 16V Electrolytic	1
C321	2544254051	220μF ±20% 16V Electrolytic	1
C322	2551120000	0.001μF ±5% 50V Plastic Film	4
C323	2544254048	100μF ±20% 16V Electrolytic	1
C324	2531024003	0.01μF +80,-20% 50V Ceramic	1
C325	2544255005	3300μF ±20% 16V Electrolytic	1
C326,327	2561034034	0.047μF ±5% 50V Metallized	2
C328	—	—	1
C351,352	2561034034	0.047μF ±5% 50V Metallized	1
C353	2544252037	100μF ±20% 10V Electrolytic	1
C354	—	—	1
C355	2531024003	0.01μF +80,-20% 50V Ceramic	1
C356	2544260045	1μF ±20% 50V Electrolytic	1
C357	2544255018	4700μF ±20% 16V Electrolytic	1
C358	—	—	1
C359	—	—	1
C360	2544254080	1000μF ±20% 16V Electrolytic	1
C361	2561034018	0.033μF ±5% 50V Metallized	1
C362	—	—	1
C363	2544259014	3300μF ±20% 35V Electrolytic	1
C364	2561034034	0.047μF ±5% 50V Metallized	1
C365	2544258060	220μF ±20% 35V Electrolytic	1
C366	2544259014	3300μF ±20% 35V Electrolytic	1
C367	2561034034	0.047μF ±5% 50V Metallized	1
C368	2544258060	220μF ±20% 35V Electrolytic	1

COIL, TRANS

Ref. No.	Part No.	Part Name & Descriptions	Q'ty
L001,002	2350007007	Inductor	2
L101,102	2350007000	Inductor	2
L301	2320093106	Choke Coil	1
L304	2350037006	Inductor	1
L305	2320093106	Choke Coil	1
T301	2330273000	Driver Trans	1
T302	2330272108	Pulse Trans	1
T351	2330273000	Driver Trans	1
T352	2330272108	Pulse Trans	1
RL201, 202	2149003005	Relay	2

Ref. No.	Part No.	Part Name & Descriptions	Q'ty
E.U.P.			
SW001	2124641000	Rotary Switch	1
	2050391107	4P Speaker Terminal	2
	2048229003	4P Pin Jack	1
	EP-5870	Fuse Holder	8
F301	2061017030	Fuse 15A	1
F302	2061025035	Fuse 1A (LC)	1
F303	2061017030	Fuse 15A	1
F304	2061025035	Fuse 1A (LC)	1

OTHER PARTS

Ref. No.	Part No.	Part Name & Descriptions	Q'ty
	2221429109	P.W. Board	1
	2090008146	Jumper Wire P=5mm	1
	EP-5667H1	Terminal Pin	4
	2050154043	4P NH Connector Base	2
	2050190036	3P NH Connector Base	1
	2050185038	3P Wire Holder	1
	2050185041	4P Wire Holder	2
	2030289077	1P Contact Ass'y	1
	2030299009	1P SIN. Con. Ass'y	1
	2030299012	1P SIN. Con. Ass'y	1
	2030299025	1P SIN. Con. Ass'y	2
	2030299038	1P SIN. Con. Ass'y	4
	2030299041	1P SIN. Con. Ass'y	4
	2030299054	1P SIN. Con. Ass'y	2
	2030299067	1P SIN. Con. Ass'y	2
	2030300008	1P SIN. Con. Ass'y	1
	2030300011	1P SIN. Con. Ass'y	1
	2036193002	4P EH Con. Cord	1
	2030305003	1P SIN. Con. Ass'y	2
	2030305016	1P SIN. Con. Ass'y	1
	2030305029	1P SIN. Con. Ass'y	1
	2030305032	1P SIN. Con. Ass'y	1
	2090196003	2C Shield Wire	1
	2090196016	2C Shield Wire	1
	2050233045	4P EH Connector Base	2
	4150395001	UL Tube(4.7) Black	2
	4150309042	P.V.C. Tube	2
	4450033005	Wire Clamp Band	4
	4150396000	Glass Tube	1

WIRING DIAGRAM (for DCA-3500)

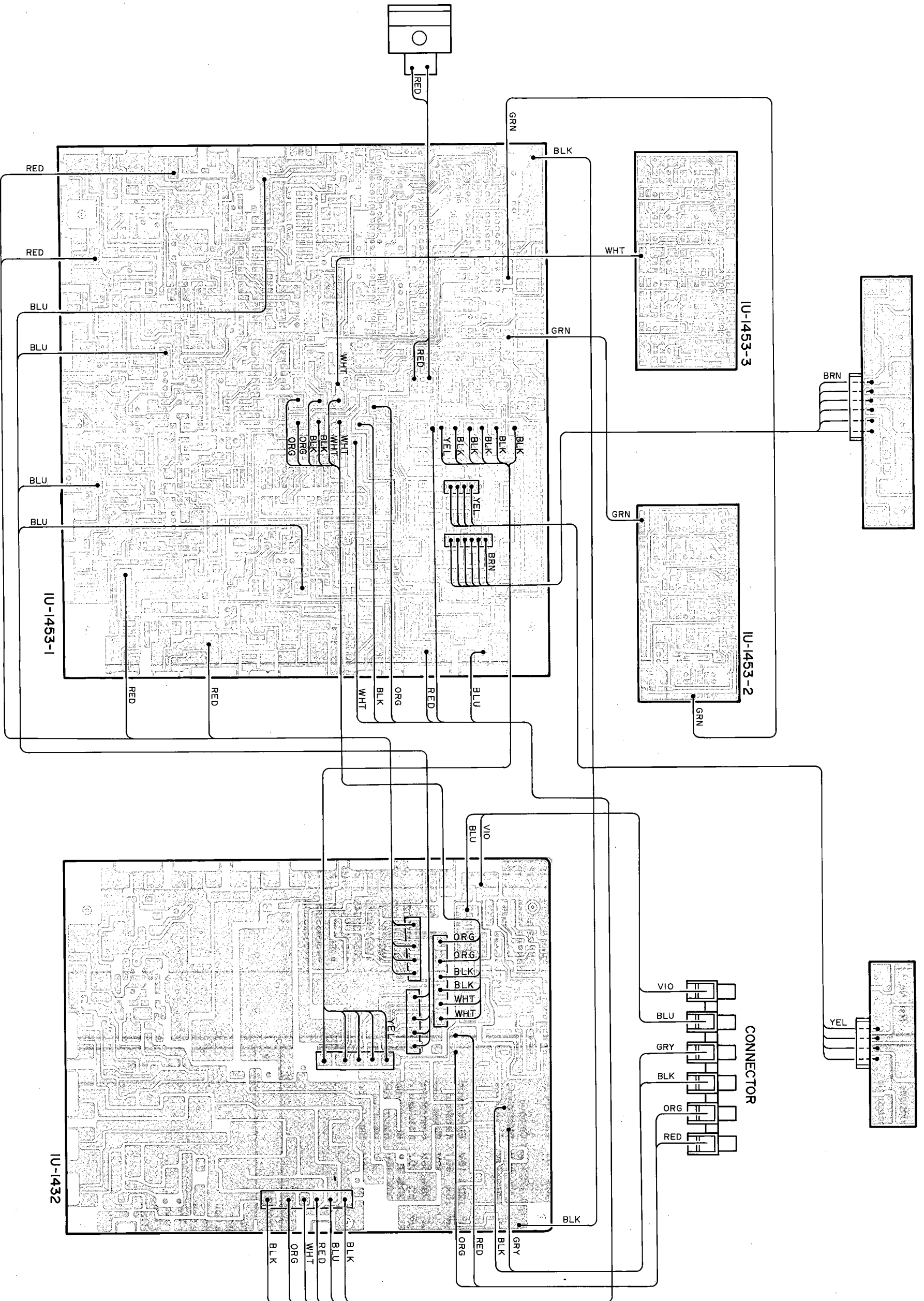

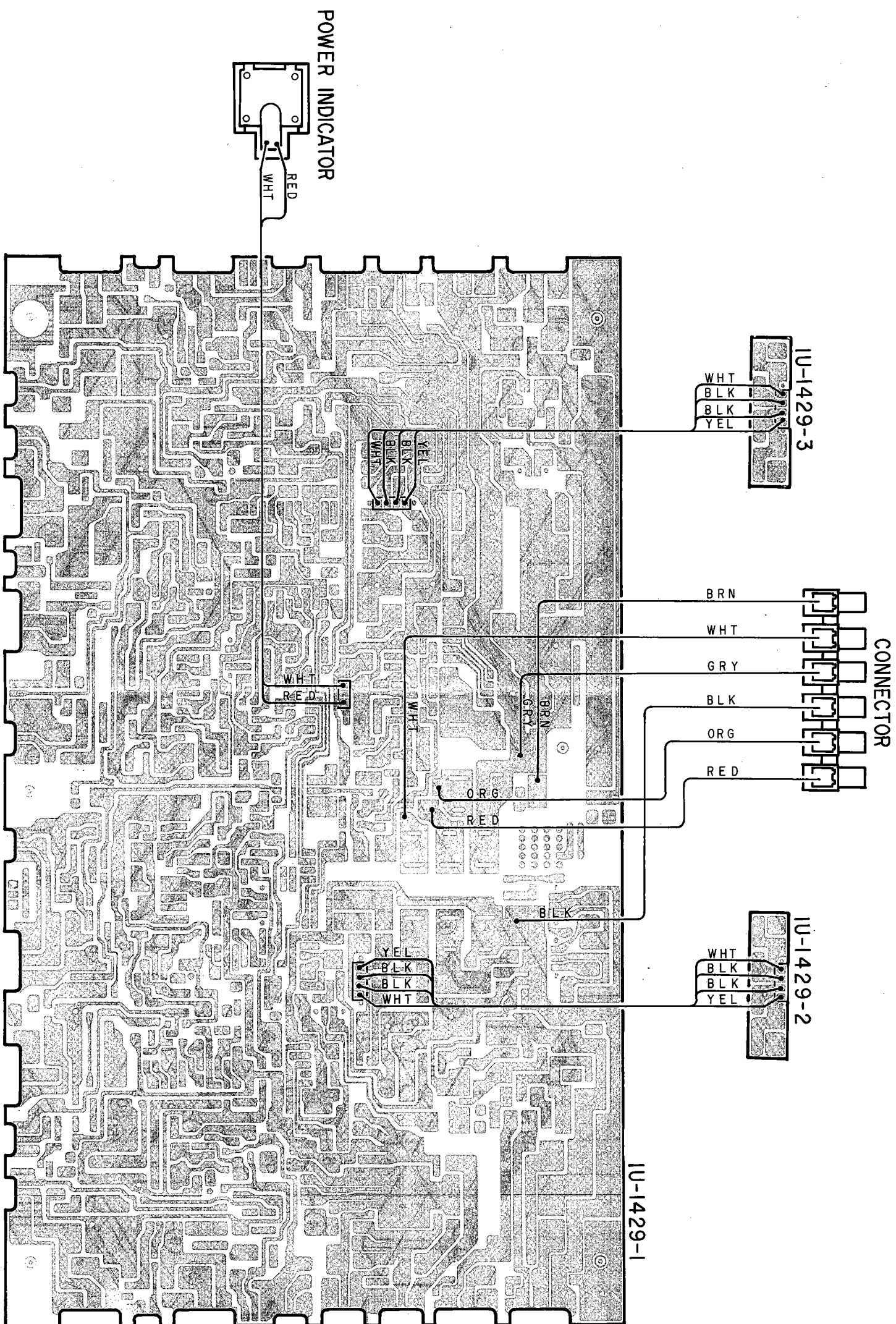

EXPLODED VIEW (for DCA-3500)

- 1
- 2
- 3
- 4
- 5
- 6
- 7
- 8

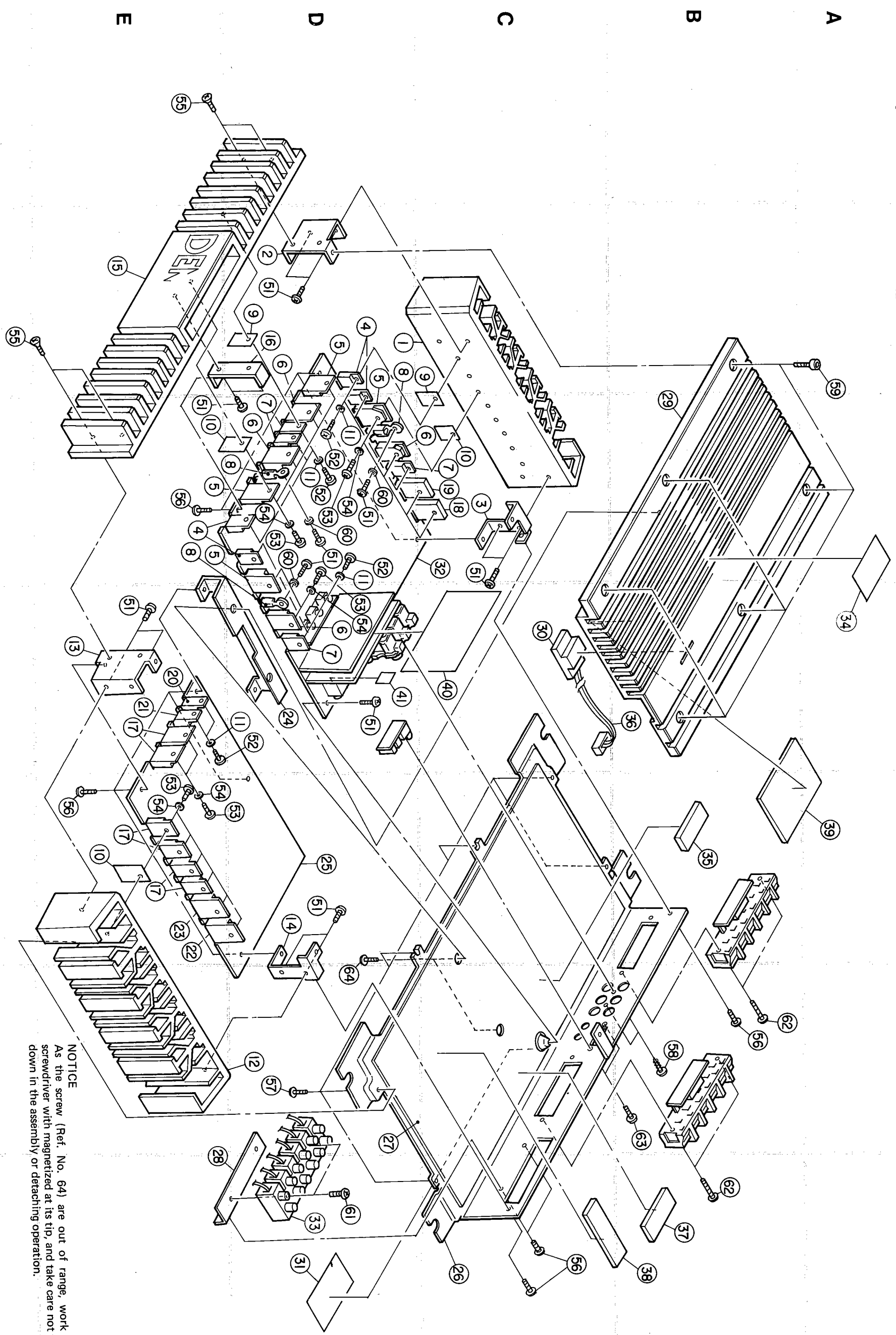

NOTICE
As the screw (Ref. No. 64) are out of range, work by ⊕
screwdriver with magnetized at its tip, and take care not to fall
down in the assembly or detaching operation.

EXPLODED VIEW OF PARTS LIST (for DCA-3500)

Ref. No.	Address	Part No.	Part Name & Descriptions	Q'ty
1	2-D	4170290005	HEAT SINK L	1
2	2-D	4122133000	STAY A	1
3	3-C	4122158001	STAY C	1
4	2-D	2730240028	TRANSISTOR 2SC2238(Y)/(O)LB110A	4
5	2-D	2730336013	TRANSISTOR 2SC3854(O)/(Y)LB	4
6	2-D	2710204013	TRANSISTOR 2SA1490(O)/(Y)LB	4
7	3-C	2710140025	TRANSISTOR 2SA968(Y)/(O)LB110A	4
8	2-D	2760416000	POSITOR PTH487A01BC471TS	3
9	2-C	4150347004	INSULATING SHEET	10
10	3-C	4150234007	INSULATING SHEET	18
11	3-D	4150181008	WASHER (B-17)	10
12	6-D	4170291004	HEAT SINK R	1
13	4-E	4122134009	STAY B	1
14	5-D	4122159000	STAY D	1
15	2-E	4170286103	HEAT SINK F	1
16	2-D	4122135008	FRONT STAY	1
17	4-E	2740113019	TRANSISTOR 2SD1065(S)LB	6
18	3-C	2710219008	TRANSISTOR 2SA1227A(Q)IL	1
19	3-C	2730353009	TRANSISTOR 2SC2987A(Q)IL	1
20	4-E	2760415001	DIODE CTU-22S LB	1
21	4-E	2760415014	DIODE CTU-22R LB	1
22	5-E	2760487000	DIODE CUT-32S LB	1
23	5-E	2760488009	DIODE CTU-32R LB	1
24	4-D	4170287102	RADIATOR	1
25	5-D	1U-1432	POWER SUPPLY UNIT	1s
26	7-C	4110649108	BOTTOM PLATE	1
27	6-D	4150372008	INSULATING SHEET	1
28	6-E	4410790003	TERMINAL BRACKET	1
29	3-B	1441609001	TOP PANEL ASS'Y	1
30	4-C	3939281007	SLF-101C LED	1
31	7-D	5131240022	RATING SHEET	1
32	3-C	1U-1453	POWER AMP UNIT	1s
33	7-D	2050393008	6P TERMINAL BLOCK	1
34	4-A	5131269003	ADJUSTMENT SHEET	1
35	5-B	4610329038	RUBBER SHEET	1
36	4-B	2034313075	3P EH CONNECTOR CORD	1
37	7-B	4610329041	RUBBER SHEET	1
38	7-B	4610329054	RUBBER SHEET	1
39	5-A	4610329067	RUBBER SHEET	1
40	4-C	4150398008	INSULATING SHEET	1
41	4-D	4150401105	INSULATING SHEET	1
SCREWS				
51	2-D	4737005073	TAPPING SCREW (S) 3x5	14
52	3-D	4700010008	PAN SCREW WITH S.W 3x8	10
53	3-D	4737005002	TAPPING SCREW (S) 3x10	18
54	3-D	4752003005	SPRING WASHER φ3	18
55	1-E	4712305028	F. HEAD SCREW 3x10 BLACK	4
56	3-E	4737002034	TAPPING SCREW (S) 3x6	11
57	6-D	4770064107	FIXING SCREW	6
58	6-B	4737500044	TAPPING SCREW (P) 3x8 BLACK	2
59	2-A	4755109003	HEX. SCREW 4x6	6
60	3-D	4751003006	WASHER φ3	3
61	7-D	4737005028	TAPPING SCREW (S) 3x14	2
62	6-B	4737007026	TAPPING SCREW (S) 4x16 BLACK	4
63	6-B	4713201024	BIND SCREW 2.6x4	2
64	6-D	4737500002	TAPPING SCREW (P) 3x6	2

Ref. No.	Address	Part No.	Part Name & Descriptions	Q'ty
PACKING & ACCESSORIES (not including EXPLODED VIEW)				
101		5050061007	ENVELOPE	1
102		5111500009	INST. MANUAL	1
103		5150333004	GUARANTEE CARD	1
104		5150337107	CUSTOM CARD	1
105		5050076115	POLYCOVER	1
106		4700022009	PAN SCREW WITH SW 4x16	4
107		4751005004	WASHER φ4	4
108		SC-1050H	NUT	4
109		4718006004	TAPPING SCREW (1) 4x12	4
110		5050099040	POLY COVER	1
111		5030596000	CUSHION	2
112		5011158001	INDIVIDUAL CARTON	1
113		5011159000	MASTER CARTON	1/3

Note: Parts with * marks are not shown in the exploded view.

EXPLODED VIEW OF PARTS LIST (for DCA-3400)

Ref. No.	Address	Part No.	Part Name & Descriptions	Q'ty
1	3-B	4170282000	HEAT SINK L	1
2	2-D	4122133000	STAY A	1
3	3-D	2730240028	TRANSISTOR 2SC2238(Y)/(O)LB110A	4
4	3-D	2730336013	TRANSISTOR 2SC3854(O)/(Y)LB	4
5	3-C	2710204013	TRANSISTOR 2SA1490(O)/(Y)LB	4
6	3-C	2710140025	TRANSISTOR 2SA968(Y)/(O)LB110A	4
7	3-C	4150347004	INSULATING SHEET	12
8	3-C	4150234007	INSULATING SHEET	12
9	4-D	4150181008	WASHER (B-17)	12
10	6-D	4170283009	HEAT SINK R	1
11	3-E	4122134009	STAY B	1
12	2-E	4120284105	HEAT SINK F	1
13	2-D	4122135008	FRONT STAY	1
14	3-C	2740113019	TRANSISTOR 2SD1065(S)LB	4
15	3-C	2760415001	DIODE CTU-22S LB	2
16	3-C	2760415014	DIODE CTU-22R LB	2
17	5-D	1U-1429	AMP UNIT	1s
18	7-E	4410790003	TERMINAL BRACKET	1
19	6-D	4110640107	BOTTOM PLATE	1
20	7-D	4150367000	INSULATING SHEET	1
21	3-B	1441589008	TOP PANEL ASS'Y	1
22	4-C	3939281007	SLF-101C LED	1
23	7-D	5131240019	RATING SHEET	1
24	4-C	4122158001	STAY C	1
25	5-D	4122159000	STAY D	1
26	3-D	2760416000	POSISTOR PTH487A01BC471TS	3
27	7-D	2050393008	6P TERMINAL BLOCK	1
28	4-A	5131256003	ADJUSTMENT SHEET	1
29	4-A	4610329009	RUBBER SHEET	2
30	4-D	4610329012	RUBBER SHEET(for TL202 UP)	1
31	4-D	4610329025	RUBBER SHEET(for TL201 UP)	1
32	5-B	2034308022	3P CONNECTOR CORD	1
33	7-C	4610329038	RUBBER SHEET	2
SCREWS				
51	2-D	4737005073	TAPPING SCREW (S) 3x5	14
52	4-D	4700010008	PAN SCREW WITH S.W 3x8	12
53	3-D	4737005002	TAPPING SCREW (S) 3x10	12
54	3-D	4752003005	SPRING W. ϕ 3	12
55	4-E	4737002018	TAPPING SCREW (2) 3x8	5
56	1-E	4712305028	F. SCREW 3x10 B	4
57	6-B	4737500044	TAPPING SCREW (P) 3x8 B	1
58	3-A	4755109003	HEX. SCREW 4x6	6
59	3-D	4751003006	WASHER ϕ 3	3
60	7-D	4737005028	TAPPING SCREW (S) 3x14	2
61	6-B	4737002034	TAPPING SCREW (S) 3x6-B	4
62	6-B	4737007026	TAPPING SCREW (S) 4x16-B	4
63	6-D	4770064107	FIXING SCREW	6
64	2-D	4751003019	WASHER ϕ 3-B	2
PACKING & ACCESSORIES (not including EXPLODED VIEW)				
101		5050061007	ENVELOPE	1
102		5111497002	INST. MANUAL	1
103		5150333004	GUARANTEE CARD	1
104		5150337107	CUSTOM CARD	1
105		5050076115	POLYCOVER	1
106		4700022009	PAN SCREW 4x16	4
107		4751005004	WASHER ϕ 4	4
108		SC-1050H	NUT	4
109		4718006004	TAPPING SCREW (1) 4x12	4
110		5050099040	POLYCOVER	1
111		5030596000	CUSHION	2
112		5011156003	INDIVIDUAL CARTON	1
113		5011157002	MASTER CARTON	1/3
114		5290044004	MINI DRIVER	1
115				

Note: Parts with * marks are not shown in the exploded view.

1

2

3

4

5

6

7

8

A

B

C

D

E

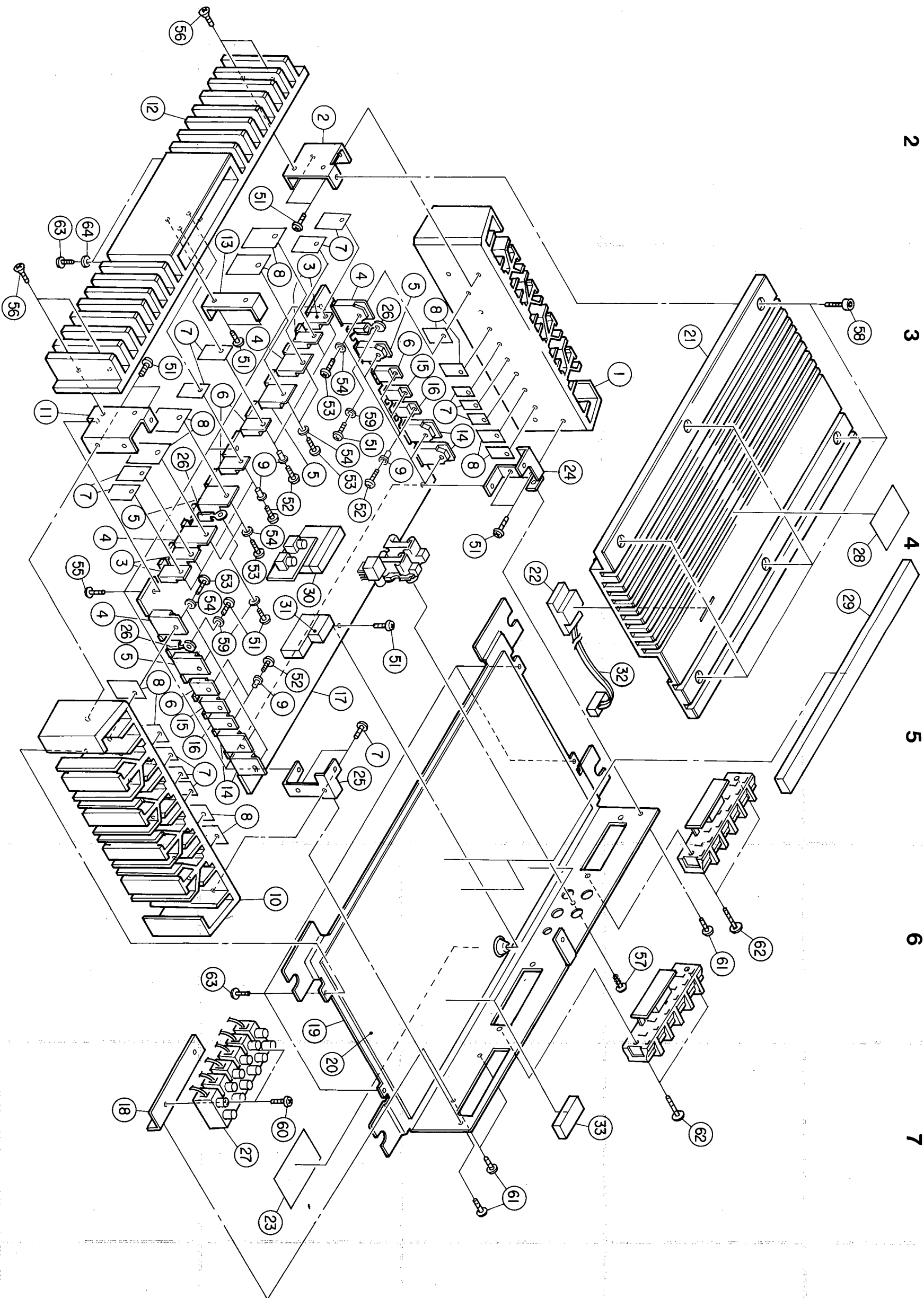

SEMICONDUCTORS

• IC's

MS218L
(Mitsubishi)

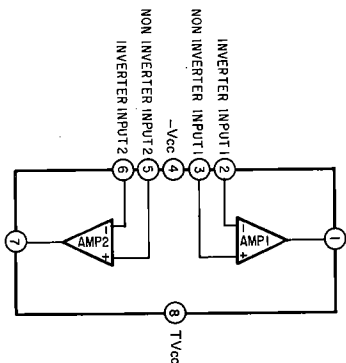
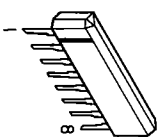

μPC494C
(NEC)

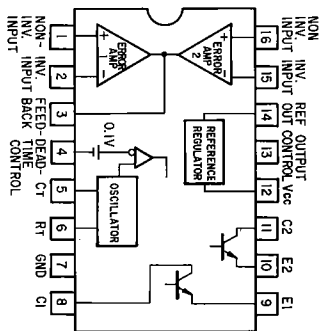
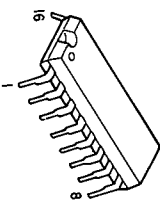

μPC1270H
(NEC)

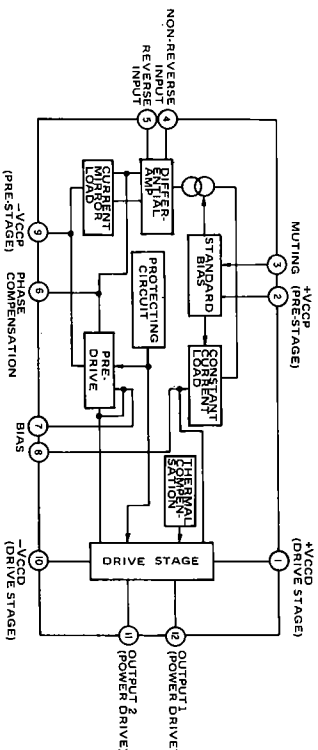
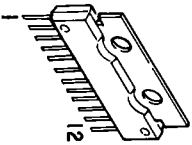

μPC1237H
(NEC)

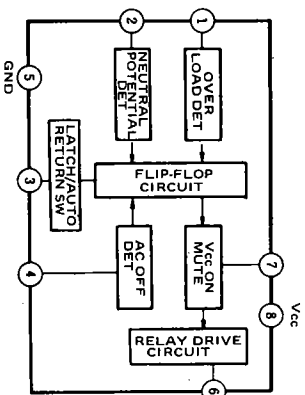

IR3M02
(Sharp)

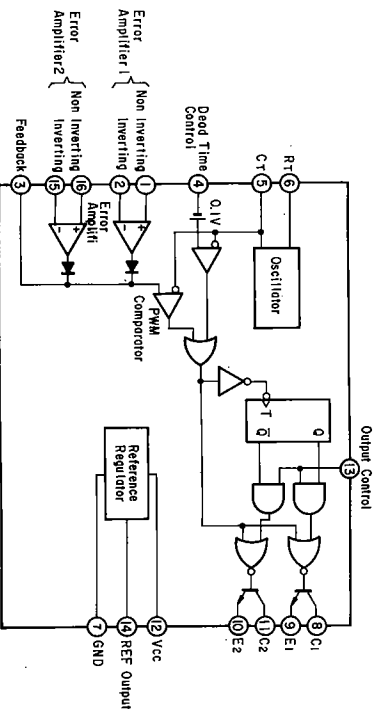
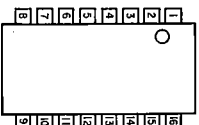

• TRANSISTORS

2SC1815(GR), (Y/GR), (Y), (BL)
2SC2274K(E/E)
2SA1015(GR/Y)

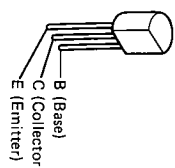

2SA968(Y)/(O)LB110A
2SC2238(Y)/(O)LB110A

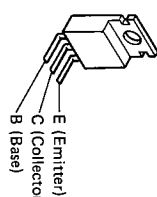

2SA1490(O)/(Y)LB
2SC3854(O)/(Y)LB
2SD1065(S)LB

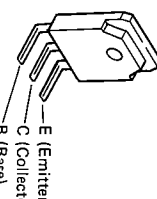

2SB647(D)
2SB764(E/F)
2SD1207(T/S)

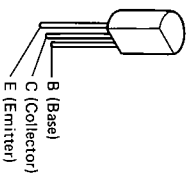

2SA1227A(O)IL } DCA-3500 only
2SC2987A(O)IL

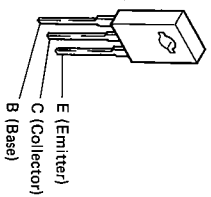

RN1202(10K-10K)
RN2202(10K-10K)

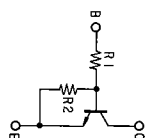
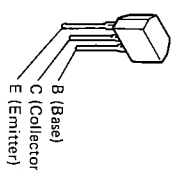

• DIODES (Including LED)

V03C



HZS7A-1
HZS12C-1
HZS15-1
HZS16-1

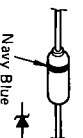

1SS270



CTU-22S LB

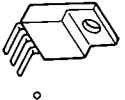

CTU-22R LB

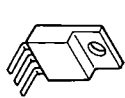

(Posistor)
PTH487A
01BC47TTS

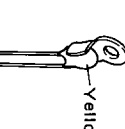

(LED)
SLF-101C

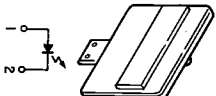

DSA1A2
DCA-3500 only

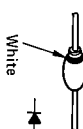

S3V10F (04P15)

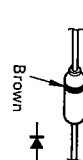

CTU-32S-LB
(DCA-3500 only)

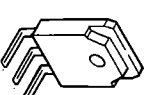

CTU-32R LB

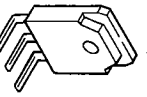

U05C
DCA-3500 only

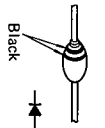

DSM1A2

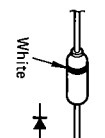

1SR124-200AT
DCA-3500 only

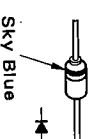

REMOVAL OF EACH SECTIONS

• DCA-3500

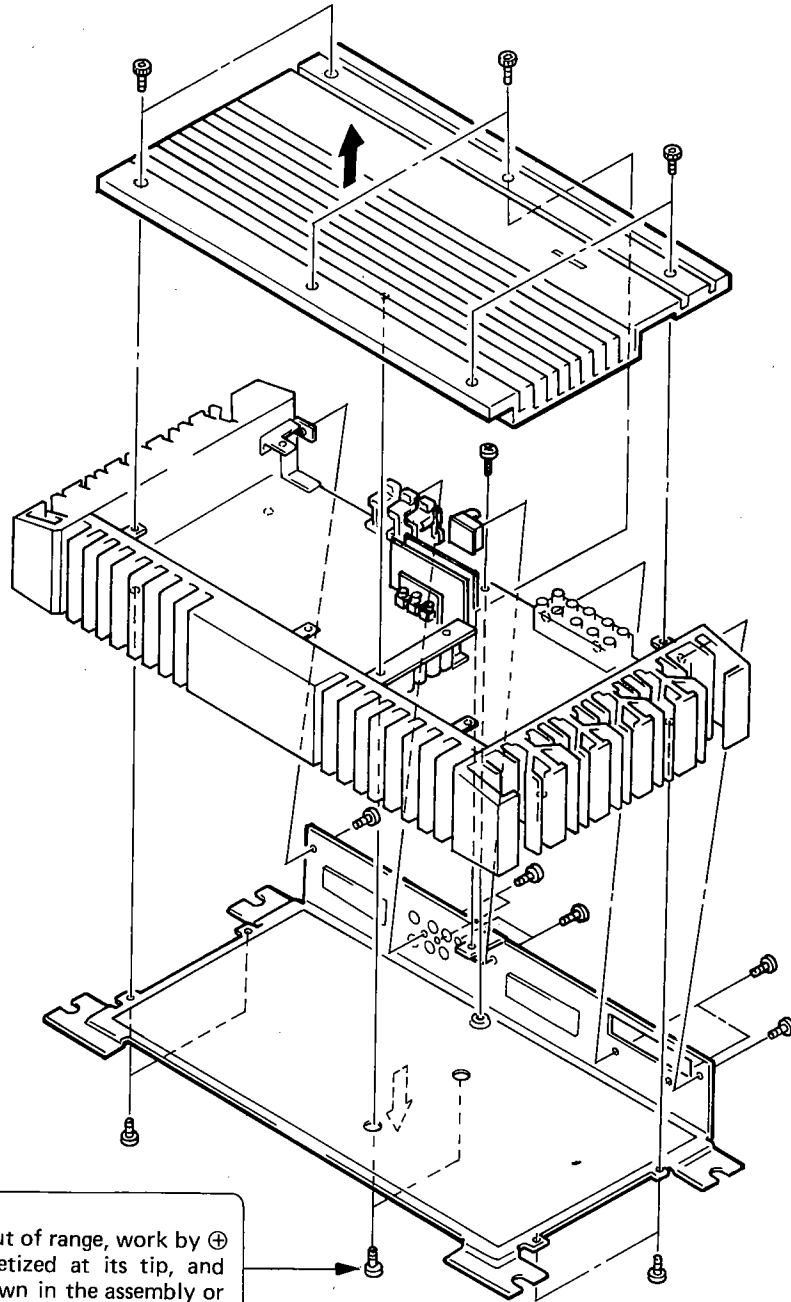
**NOTICE**

As these 2 screws are out of range, work by ⊕ screwdriver with magnetized at its tip, and take care not to fall down in the assembly or detaching operation.

PRECAUTIONS

1. DENON Power Amplifier DCA-3500 and 3400 is only available for use in negative (−) ground automobiles. It cannot be used positive (+) ground automobiles.
2. DENON Power Amplifier DCA-3500 and 3400 will operate properly with 14.4 V (11 V–16 V) car batteries. You cannot use it for 24 V or other types of car batteries.
3. For fuse replacement, replace only with same amperage as old one. Improper fuses can lead to serious damage to the unit. (Accessible by removing the top panel.)
4. Do not allow any liquid or small objects to get inside the unit.

DENON

• DCA-3400

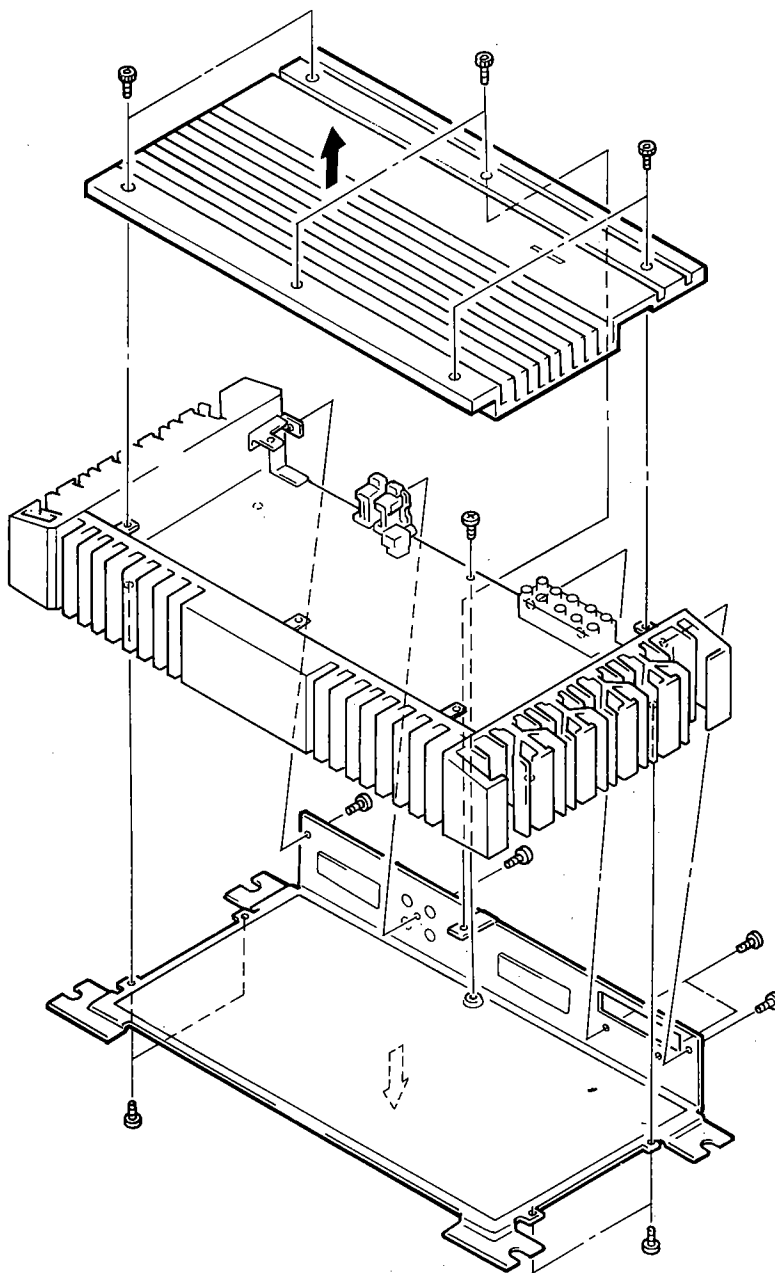

NIPPON COLUMBIA CO., LTD.
14-14, 4-CHOME AKASAKA,
MINATO-KU, TOKYO 107 JAPAN

TEL: 03-584-8111
TLX: JAPANOLA J22591
CABLE: NIPPONCOLUMBIA TOKYO

Printed in Japan 703 **BU** 0056

SCHEMATIC DIAGRAM (DCA-3500)

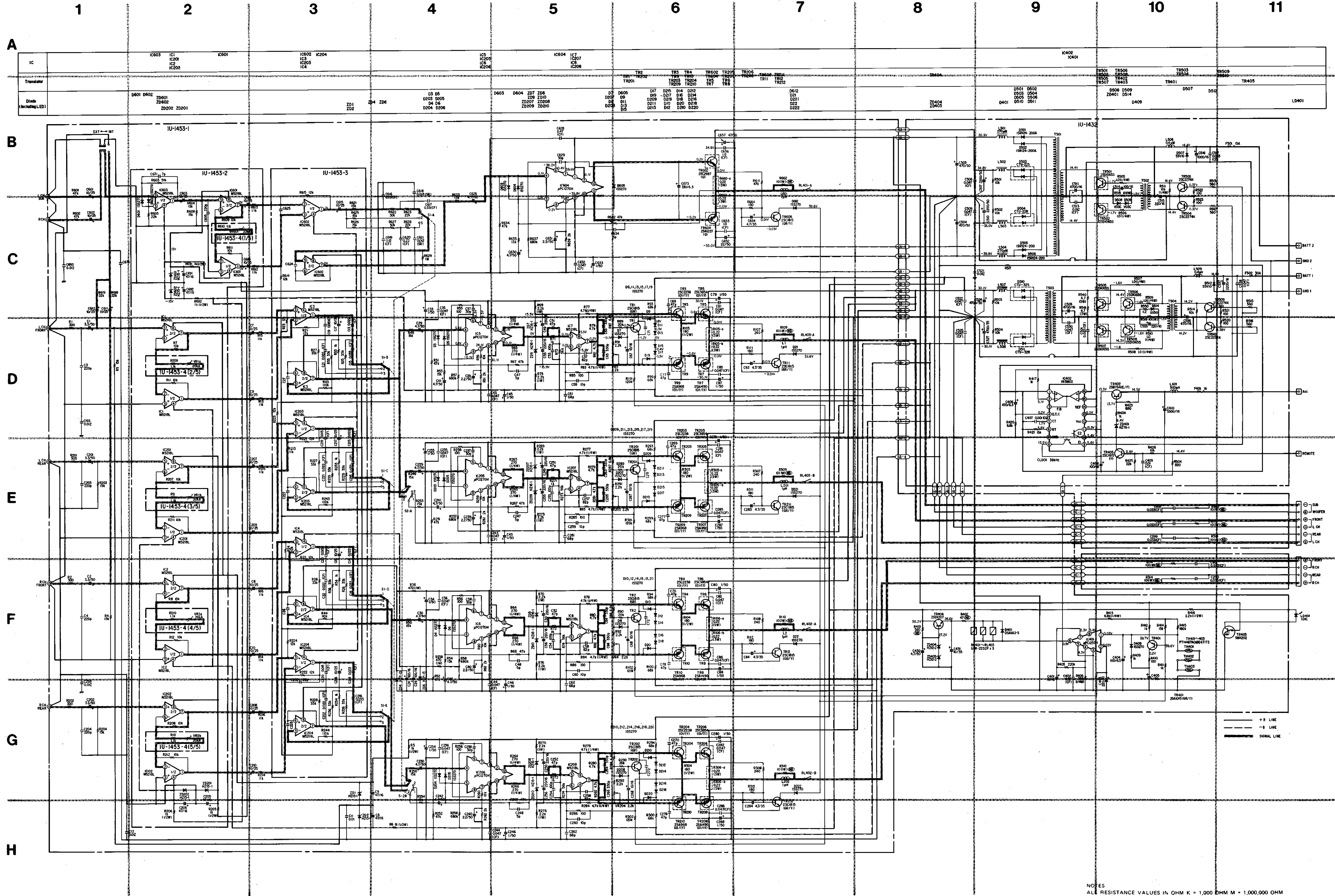

NOTES
 ALL RESISTANCE VALUES IN OHM K = 1,000 OHM M = 1,000,000 OHM
 ALL CAPACITANCE VALUES IN MICRO FARAD P = MICRO-MICRO FARAD
 EACH VOLTAGE AND CURRENT ARE MEASURED AT NO SIGNAL INPUT CONDITION.
 CIRCUIT AND PARTS ARE SUBJECT TO CHANGE WITHOUT PRIOR NOTICE.

SCHEMATIC DIAGRAM (DCA-3400)

	1	2	3	4	5	6	7	8	9	10	11
A	IC	IC1 IC101 IC2 IC102	IC3 IC103 IC4 IC104	IC5 IC6 IC201							
	Transistor		TR201		TR1 TR101 TR2 TR102	TR3 TR7 TR9 TR107 TR103 TR105 TR4 TR6 TR8 TR10 TR108 TR104 TR106	TR11 TR111 TR12 TR112	TR305 TR306 TR302	TR301 TR352	TR305 TR304	
B	Diode (Including LED)		Z05 D3 D5 D103 D105 ZD105 ZD6 D4 D6 D104 D106 ZD106	Z01 Z03 ZD101 ZD103 ZD2 ZD4 ZD102 ZD104 D201 D202	D11 D111 D12 D112	D13 D15 D17 D19 D21 D23 D15 D17 D19 D21 D23 D4 D6 D18 D20 D22 D24 D14 D16 D18 D20 D22 D24	D25 D26 D26 D203 D204 D205 D206	D301 D354	D303 D304 D305 D351 D352 D353		

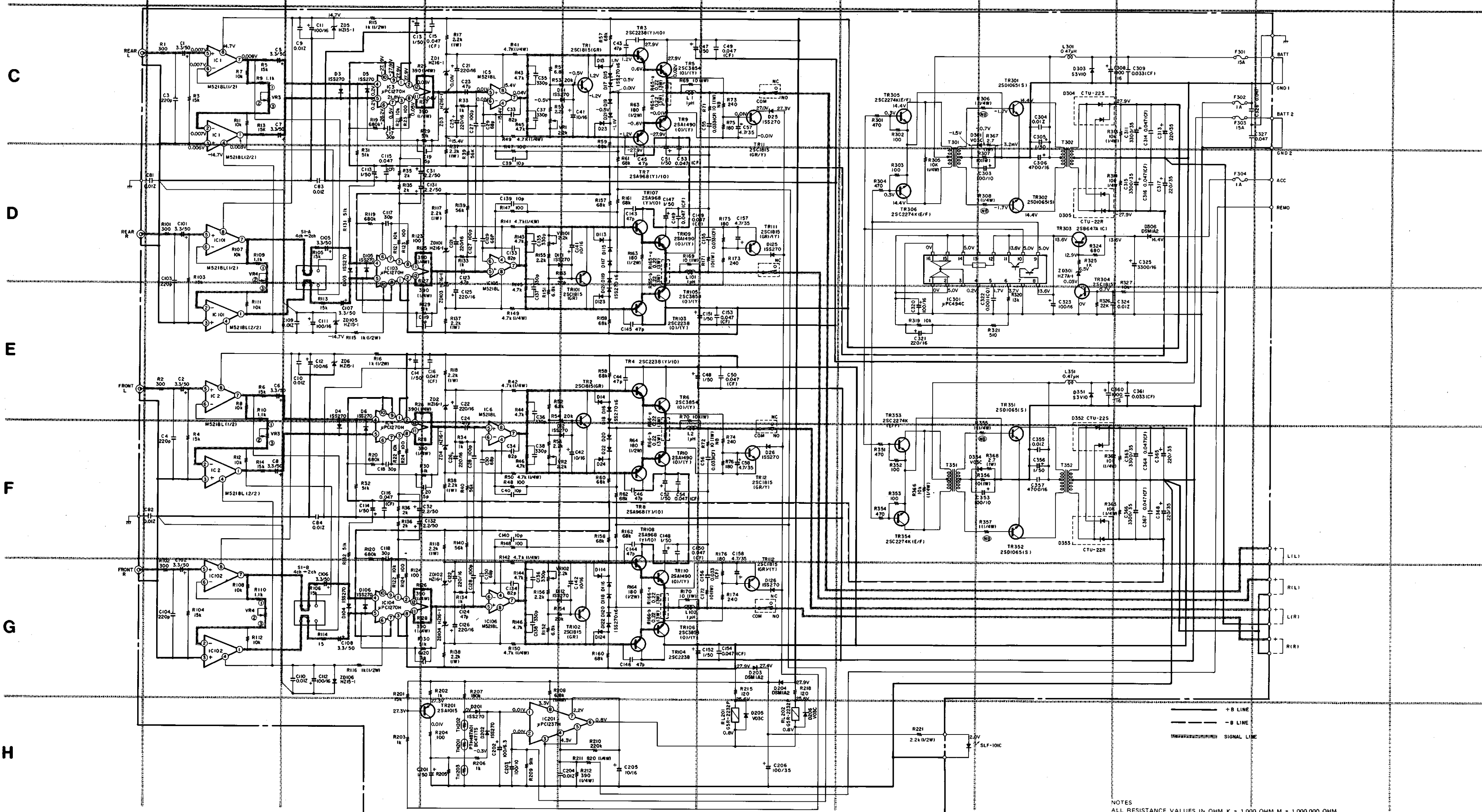

--- +B LINE
 --- -B LINE
 SIGNAL LINE

NOTES
 ALL RESISTANCE VALUES IN OHM K = 1,000 OHM M = 1,000,000 OHM
 ALL CAPACITANCE VALUES IN MICRO FARAD P = MICRO-MICRO FARAD
 EACH VOLTAGE AND CURRENT ARE MEASURED AT NO SIGNAL INPUT CONDITION.
 CIRCUIT AND PARTS ARE SUBJECT TO CHANGE WITHOUT PRIOR NOTICE.