

DENON

For Europe & U.K. model

Hi-Fi Component

SERVICE MANUAL MODEL DCD-201SA STEREO CD PLAYER

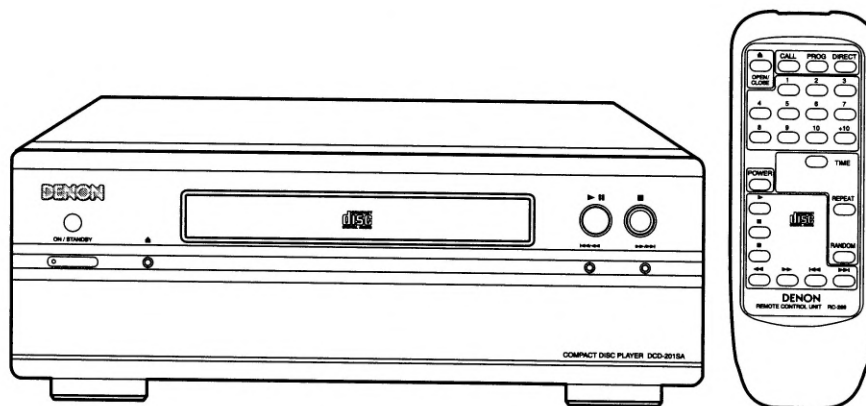

— TABLE OF CONTENTS —

SAFETY PRECAUTIONS	2	PARTS LIST OF PRINTED WIRING BOARD ...	19~22
SPECIFICATIONS	2	EXPLODED VIEW	23
DISASSEMBLY	3,4	PARTS LIST OF EXPLODED VIEW	24
CD TEST MODE	5,6	EXPLODED VIEW OF CD MECHANISM UNIT	25
WAVE FORMS OF EACH POINT	7	PARTS LIST OF CD MECHANISM UNIT	25
BLOCK DIAGRAM	8	PACKING VIEW	26
SEMICONDUCTORS	9~15	PARTS LIST OF PACKING & ACCESSORIES	26
PRINTED WIRING BOARD	16,17	FORMING CUSHIONS	27
NOTE FOR PARTS LIST	18	SCHEMATIC DIAGRAM	28

• Some illustrations using in this service manual are slightly different from the actual set.

NIPPON COLUMBIA CO., LTD.

14-14, AKASAKA 4-CHOME, MINATO-KU, TOKYO 107-8011 JAPAN
Telephone: 03 (3584) 8111

SAFETY PRECAUTIONS

The following check should be performed for the continued protection of the customer and service technician.

LEAKAGE CURRENT CHECK

Before returning the unit to the customer, make sure you make either (1) a leakage current check or (2) a line to chassis resistance check. If the leakage current exceeds 0.5 milliamps, or if the resistance from chassis to either side of the power cord is less than 460 kohms, the unit is defective.

SPECIFICATIONS

• AUDIO

Number of Channels:	2 channels
Frequency Response:	2 ~ 20,000 Hz
Dynamic Range:	100 dB
Signal-to-noise Ratio:	105 dB
Harmonic Distortion:	0.003 % (1 kHz)
Separation:	100 dB (1 kHz)
Wow and Flutter:	Below measurable limit: (±0.001 % W. peak)
Output Voltage:	1.8 V

• DISCS

Compact Disc format

• GENERAL CHARACTERISTICS

Power Supply:	AC 230 V, 50 Hz
Power Consumption:	10 W (Approx. 1 W in standby mode)
Dimensions:	250 (W) × 90 (H) × 346 (D) mm
Mass:	3.3 kg

• REMOTE CONTROL UNIT (RC-268)

Remote Control System:	Infrared pulse system
Power Supply:	3 V DC, Two R6P (standard size "AA") dry cell batteries
External Dimensions:	54.5 (W) × 150 (H) × 24.8 (D) mm
Mass:	90 g including batteries

* Design and specifications are subject to change without notice in the course of product improvement.

DISASSEMBLY

(Follow the procedure below in reverse order when reassembling)

1. Top Cover

- 1) Remove 4 screws ① on both sides.
- 2) Remove 5 screws ② and detach the Top Cover as shown in the arrow direction.

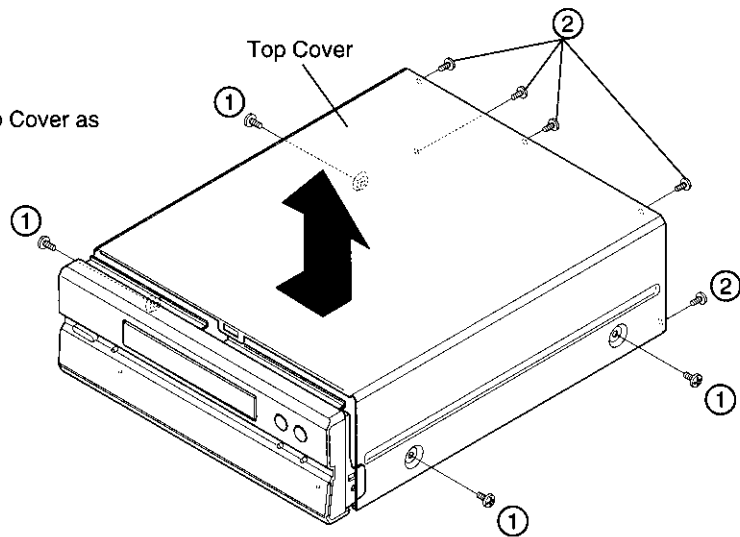

2. Front Panel

- 1) Turn the unit power on, and open the Tray of the CD Mecha.
- 2) Remove the Loader Panel, close the Tray, and turn off the power.
- 3) Disconnect 2 wire connectors coming out of the Front Panel.
- 4) Remove 4 screws ③ and 2 screws ④, and detach the Front Panel as shown.

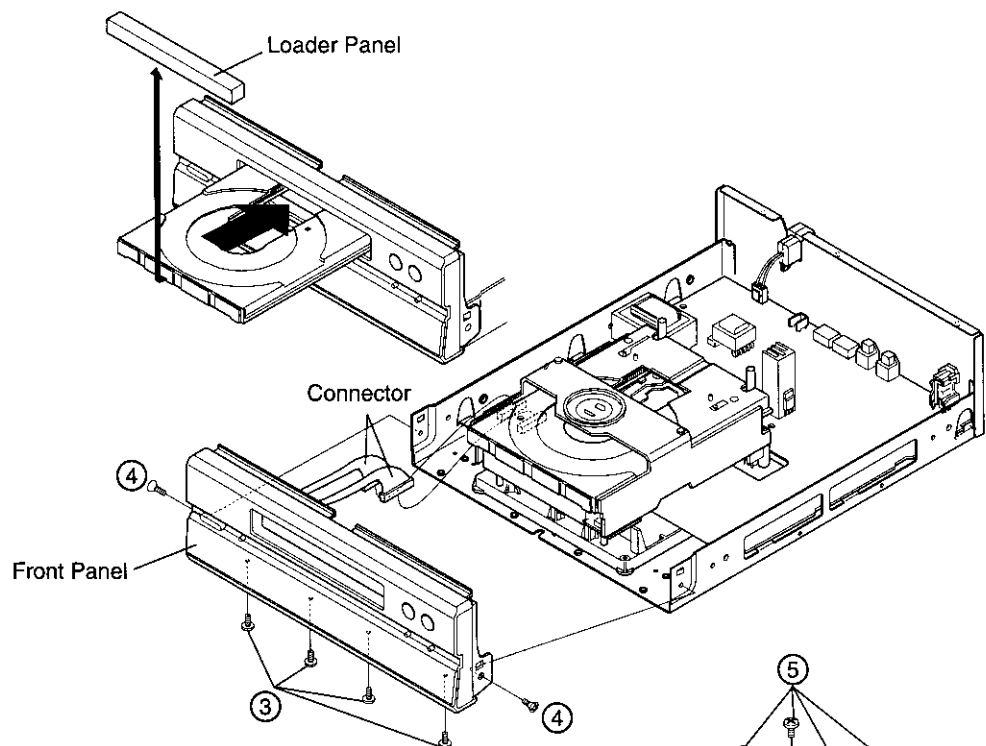

3. Display PWB

- 1) Remove 8 screws ⑤ and detach the Display P.W.B..

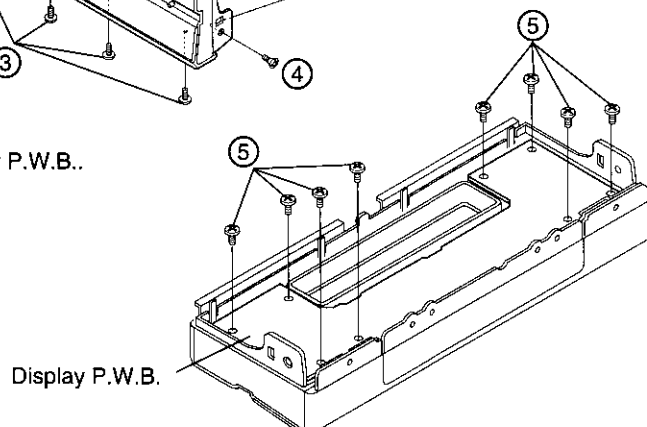

4. CD Mecha. Unit

- 1) Open the Tray completely by turning the gear under the Mecha. Unit counterclockwise.
- 2) Remove 2 screws (6) on the Tray.
- 3) Remove 2 rear screws (7) fixing the CD Mecha.
- 4) Detach the CD Mecha. in the arrow direction.
- 5) Lift the CD Mecha., and disconnect FFC and connectors.

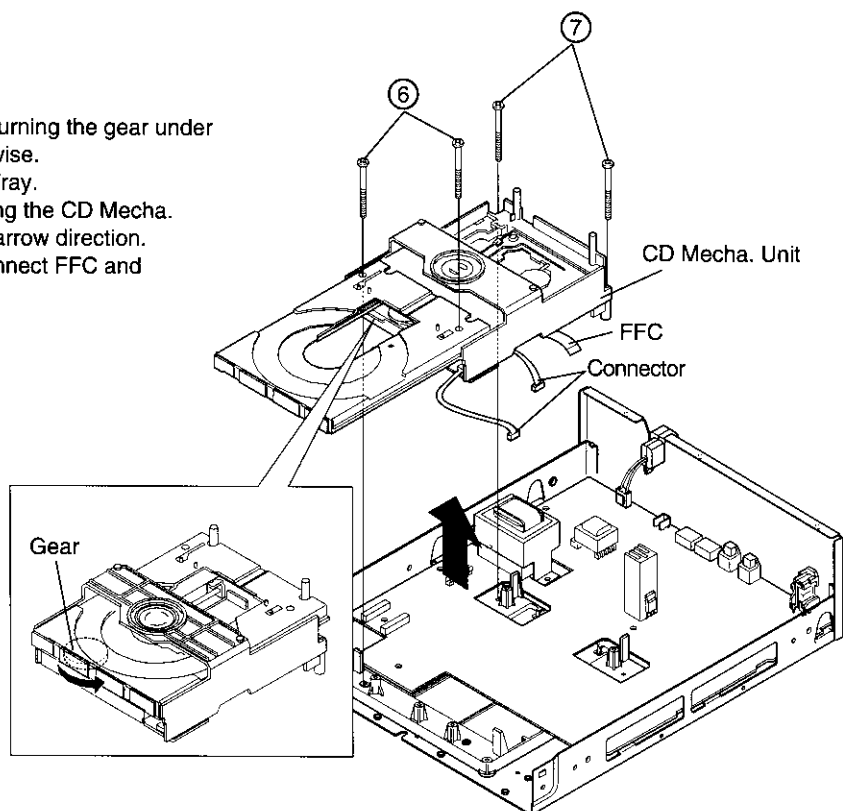

5. Main P.W.B.

- 1) Remove 5 screws (8), 2 screws (9), 1 screw (10) on the Main P.W.B., and 4 screws (11) on the Rear Panel.
- 2) Release 1 P.W.B. holder and detach the Main P.W.B..

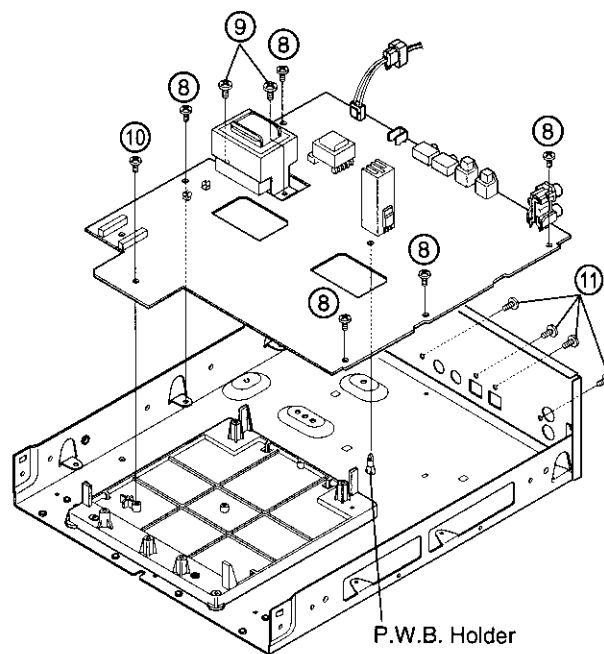

• Caution

When inserting the FFC coming out of the CD Mecha. to the connector base, +B and GND may be short-circuited if the wires are bent. Connect or disconnect the wires as straight as possible by holding the FFC with both hands when connecting or disconnecting the FFC.

CD TEST MODE

● Setting of the test mode

How to start the test mode: Turn on the power in the condition that CLSW (Test Point) and OPSW (Test Point) are being shorted. ("01" is indicated on the DISPLAY)
 To exit from the test mode, turn off the power. (Refer to Fig. 1 "Test Point Layout")

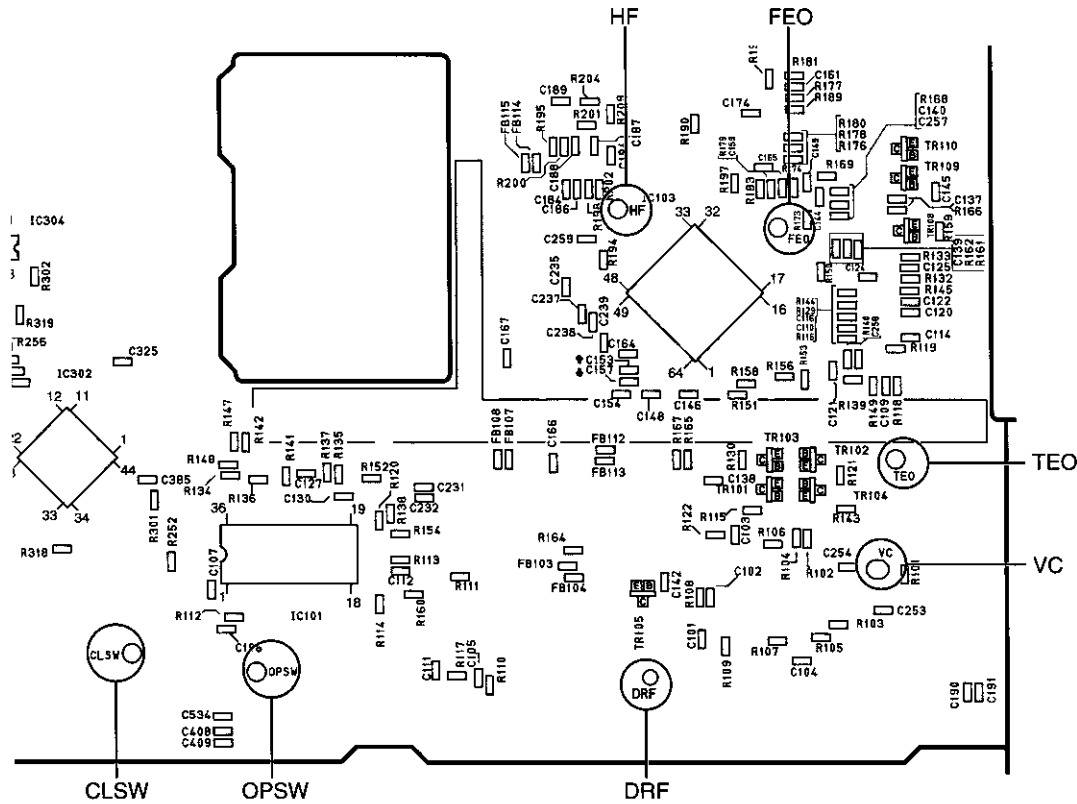

Fig. 1 "Test Point" Layout

- * Laser light of the pickup is always emitted regardless of DISC loading in the test mode. You may lose your eyesight if you look into the laser directly. So be careful enough when operating in the test mode.

● Used DISC: A-BEX TCD784

● Explanation of each button

- * Use only the buttons described below for operations while in the test mode, and don't push any other buttons.

Name of buttons	Operation
OPEN / CLOSE	<ul style="list-style-type: none"> • Loads or unloads DISC
PLAY/ PAUSE	<ul style="list-style-type: none"> • Emits laser light • Repeats search operation (No DISC condition: While it's pressed) • Actuates focus servo (In case of DISC loaded) • Actuates tracking servo
STOP	<ul style="list-style-type: none"> • Stops operation
AUTO/MANUAL SEARCH FORWARD	<ul style="list-style-type: none"> • Moves pickup (Forward) (With pushing the button more than 0.5 sec.) • Performs auto adjustment (With pushing the button less than 0.5 sec.)
AUTO/MANUAL SEARCH REVERSE	<ul style="list-style-type: none"> • Moves pickup (Reverse) (With pushing the button more than 0.5 sec.)

● How to check the test mode

(1) DISC discrimination, adjustment

- * Insert DISC, and press the AUTO/MANUAL SEARCH REVERSE button (With pushing the button less than 0.5 sec.)
- * "06 Adj" is displayed, and discrimination of DISC size 8 cm/12 cm, discrimination of DISC reflectance (CD, CD-R/CD-RW), adjustment of focus, tracking offset, and EF balance will be performed. (Adjusted values are not displayed: Refer to Fig. 2, 3)

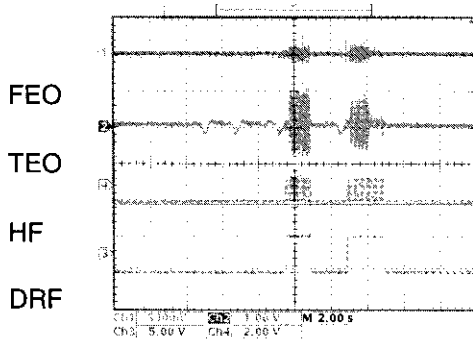

Fig. 2 DISC discrimination, adjustment (Case of CD-RW)

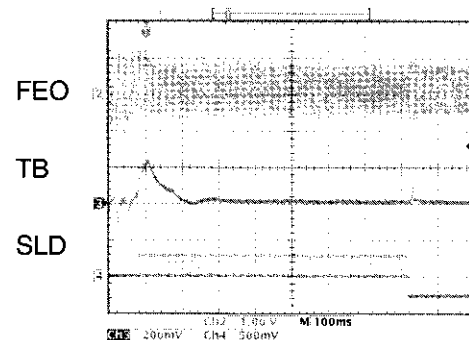

Fig. 3 Adjustment of EF balance

- * After completing the discrimination and adjustment, it becomes stop condition.
- * Once discrimination of DISC has been carried out in the "06 Adj" mode, discrimination of size and reflectance is no longer made, and only adjustment will be performed.

(2) Checking of servo state

- * Press the PLAY button after performing above (1) "DISC discrimination, adjustment".
- * "02 L on" is displayed, and the laser will start to light. (The pickup may vibrate with a rattling noise if DISC has been loaded, but this is not abnormal.)
- * Press the PLAY button again.
- * "03 F on" is displayed. DISC starts turning, and focus servo will be actuated. (Refer to Fig. 4, 5)

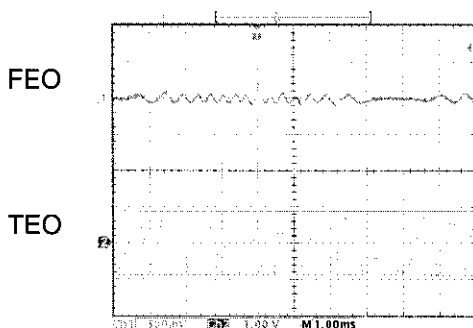

Fig. 4 In "03 F on"

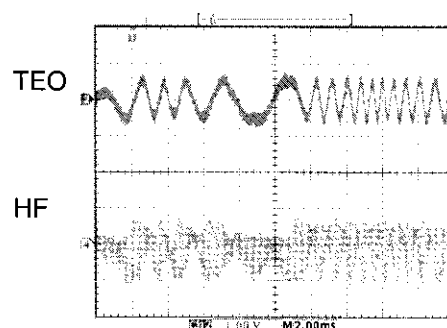

Fig. 5 In "03 F on"

- * Press the PLAY button again.
- * "04 t on" is displayed. Tracking, CLV, and slide servo will be actuated.
- * Monitor HF signal using the Test Point, HF point and VC point. Check that the signal's amplitude is $1.5V \pm 0.3V_{p-p}$. (Refer to Fig. 6)

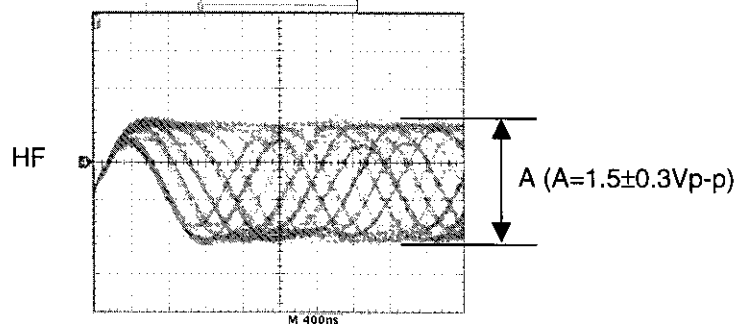
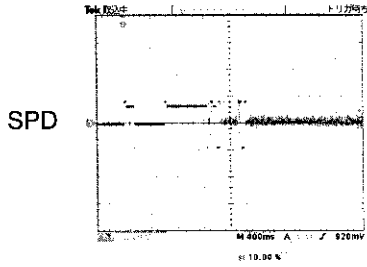
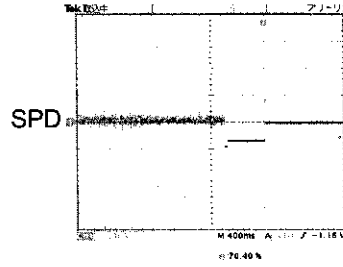

Fig. 6 In "04 t on"

WAVE-FORMS OF EACH POINT



When 12 cm DISC start



When 12 cm DISC stop

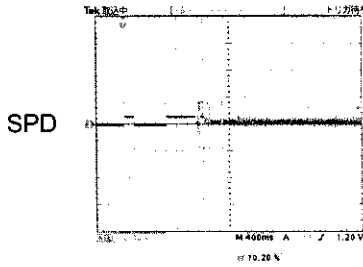

When 8 cm DISC start

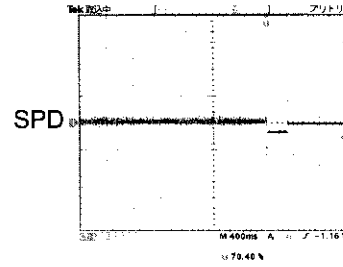

When 8 cm DISC stop

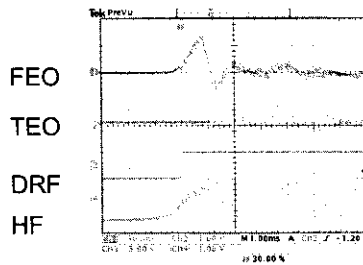

When focus servo on

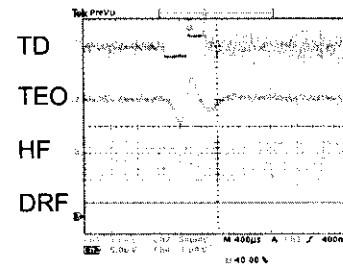

During PAUSE

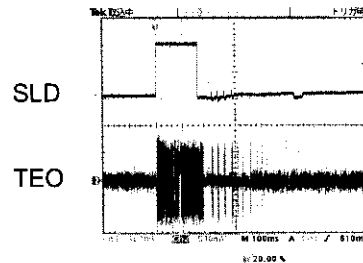

Track search (when forward)

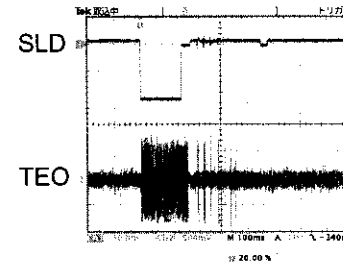

Track search (when reverse)

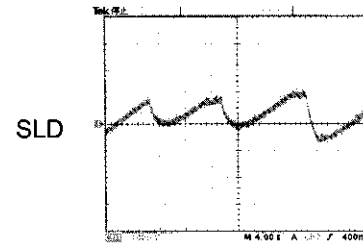

During PLAY

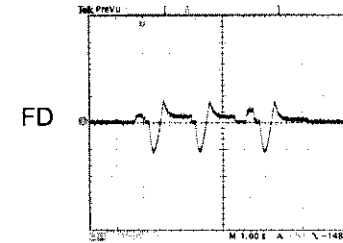

Focus search (no DISC)

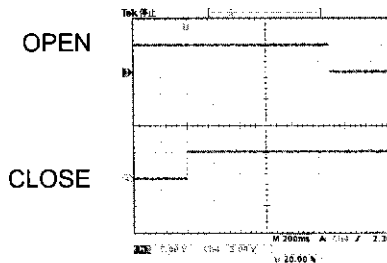

When the tray OPEN

BLOCK DIAGRAM

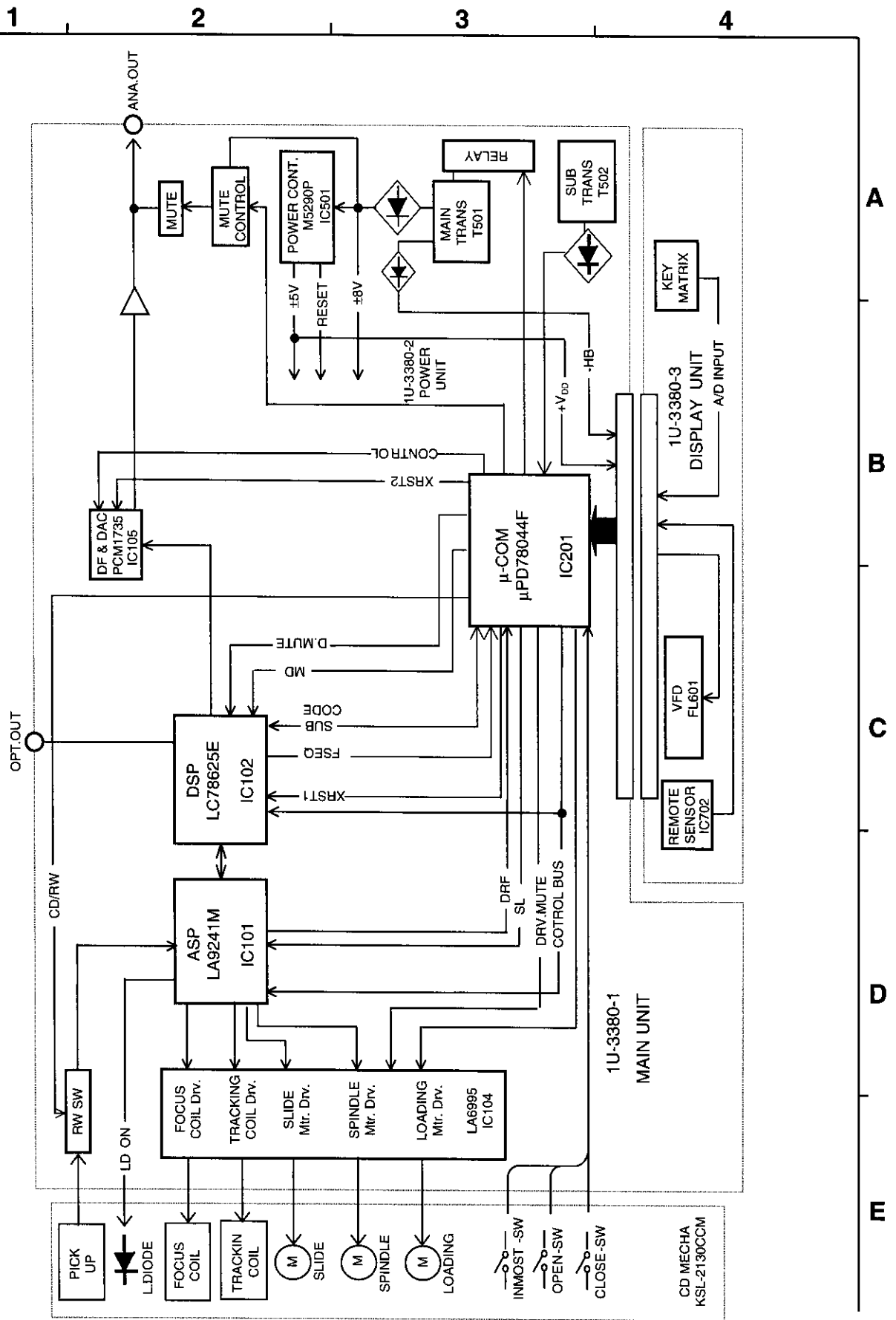

A
B
C
D
E

SEMICONDUCTORS

● IC's

μPD78044FGF-196-3B9 (IC601)

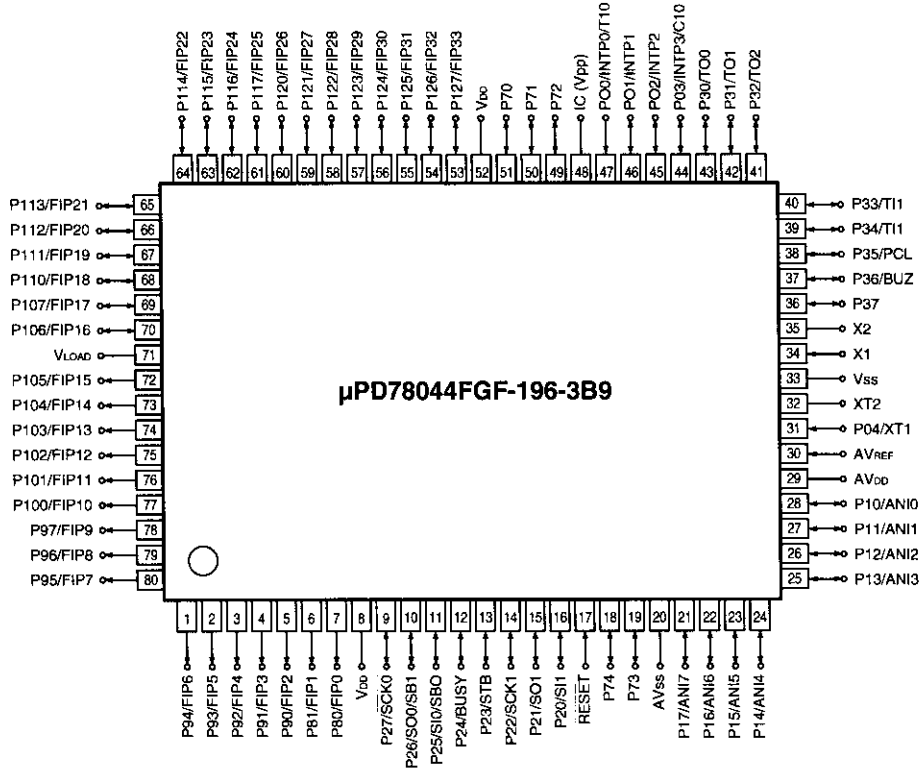

μPD78044FGF-196-3B9 Terminal Function

Pin No.	Pin Name	Port	I/O	Typ	Act	Stby	Ext	Function
1	P94	G7	O	C		Z	PD	FL display drive
2	FIP5	G6	O	C		Z	PD	FL display drive
3	FIP4	G5	O	C		Z	PD	FL display drive
4	FIP3	G4	O	C		Z	PD	FL display drive
5	FIP2	G3	O	C		Z	PD	FL display drive
6	FIP1	G2	O	C		Z	PD	FL display drive
7	FIP0	G1	O	C		Z	PD	FL display drive
8	V _{DD}	[5V]	—	—	—	—	—	Positive power
9	SCK0	SCICLK	I	B		I	PD	DENON bus
10	SO0	SCIDOUT	O	B		O	PD	DENON bus
11	SI0	SCIDIN	I	B		I	PD	DENON bus
12	P24	—	I	B		I	PD	GND
13	P23	ML	O	B		I	PD	Digital filter control
14	SCK1	CQCK	O	B		I	PD	Clock output terminal for serial comm. with CD DSP
15	SO1	COIN	O	B		I	PD	Data output terminal for serial comm. with CD DSP
16	SI1	SQOUT	I	B		I	PD	Data input terminal for serial comm. with CD DSP
17	RESET	RESET	I	—		I	—	System reset input
18	P74	—	I	B		—	PU	GND
19	P73	ALPHA	I	B		I	PU	Special mode
20	AV _{SS}	[GND]	—	—		—	—	GND potential of A/D converter, connect to V _{SS}
21	P17	DSP_XRST1	O	B		I	PD	DSP reset output terminal
22	P16	DA_XRST	O	B		I	PD	DA reset output terminal
23	P15	ON/OFF	O	B		I	PU	Power control
24	P14	POWER	O	B		I	PU	Power monitor
25	ANI3	TEST1	O	B		I	PD	Test mode terminal
26	ANI2	TEST2	O	B		I	PD	Test mode terminal

Pin No.	Pin Name	Port	I/O	Typ	Act	Stby	Ext	Function
27	ANI1	AD1	O	B		I	PU	Key input terminal
28	ANI0	AD2	O	B		I	PU	Key input terminal
29	AVDD	[5V]	—	—		—	—	Analog power of A/D converter, connect to VDD
30	AVREF	[5V]	I	—		—	—	Ref. V input for A/D converter
31	PO4	—	I	A		—	VSS	GND
32	XT2	—	—	—		—	OPEN	Open
33	Vss	[GND]	—	—		—	VSS	GND
34	X1	XTAL	I	A		I	—	X'tal connection for main system clock oscillation
35	X2	XTAL	—	—		—	—	X'tal connection for main system clock oscillation
36	P37	MDATA	O	B	L	I	PD	Digital filter control
37	P36	MCLK	O	B	L	I	PD	Digital filter control
38	P35	RWC	O	B	H	I	PD	DSP control
39	P34	SL+	O	B	H	I	PD	Slide operation control terminal
40	P33	SL-	O	B		I	PD	Slide operation control terminal
41	P32	—	I	B		—	PD	GND
42	P31	CD/RW	O	B		I	PD	CD/RW gain switch control terminal
43	P30	SEARCH	O	B		I	PD	Servo control, search operation control
44	INPT3	REMOTE	I	B	H	I	PU	Remote control signal input terminal
45	INPT2	WRQ	I	B	H	I	PD	For DSP control
46	INPT1	DRF	I	B	H	I	PD	Disc reflection check
47	INPT0	SCIDIN	I	A		I	PD	DENON bus interrupt monitor input terminal
48	IC	—	—	—		—	—	Internal connection, connect to Vss directly
49	P72	FSEQ	I	B		I	PU	Serve status check input terminal
50	P71	A_MUTE	O	B		I	PU	Audio mute control terminal
51	P70	DRV_MUTE	O	B		I	PU	Motor driver mute control terminal
52	VDD	[5V]	—	—		—	—	Positive power
53	P127	OPSW	I	C	L	I	PU	Tray open switch (test mode on)
54	P126	CLSW	I	C	L	I	PU	Tray close switch (test mode on)
55	P125	INSW	I	C	L	I	PU	Inner SW
56	P124	OPEN	O	C	H	I	PD	Loader control terminal
57	P123	CLOSE	O	C	H	I	PD	Loader control terminal
58	P122	MODEL	I	C		I	PU	Model discri. input terminal (H: Domestic, L: Overseas)
59	P121	—	O	C		L	PD	—
60	P120	—	O	C		L	PD	—
61	FIP25	—	O	C		L	PD	—
62	FIP24	HS	O	C		L	PD	High speed control output
63	FIP23	LED_G	O	C		L	PD	LED green
64	FIP22	LED_R	O	C		L	PD	LED red
65	FIP21	—	O	C		L	PD	Open
66	FIP20	P8	O	C		L	PD	FL display drive
67	FIP19	P9	O	C		L	PD	FL display drive
68	FIP18	P10	O	C		L	PD	FL display drive
69	FIP17	P9	O	C		Z	PD	FL display drive
70	FIP16	P11	O	C		Z	PD	FL display drive
71	VLOAD	[-HB]	—	C		—	—	FIP driver pull-down R connection
72	FIP15	P2	O	C		Z	PD	FL display drive
73	FIP14	P3	O	C		Z	PD	FL display drive
74	FIP13	P4	O	C		Z	PD	FL display drive
75	FIP12	P5	O	C		Z	PD	FL display drive
76	FIP11	P6	O	C		Z	PD	FL display drive
77	FIP10	P7	O	C		Z	PD	FL display drive
78	P97	—	O	C		Z	PD	FL display drive
79	P96	—	O	C		Z	PD	FL display drive
80	P95	G8	O	C		Z	PD	FL display drive

Type A: Standard input port
 B: Standard in/output port
 C: Hi-voltage proof in/output port
 D: P-ch open drain hi-voltage proof

Note) PD: Pull-down to VDISP
 PDG: Pull-down to GND

LC78625E (IC106)

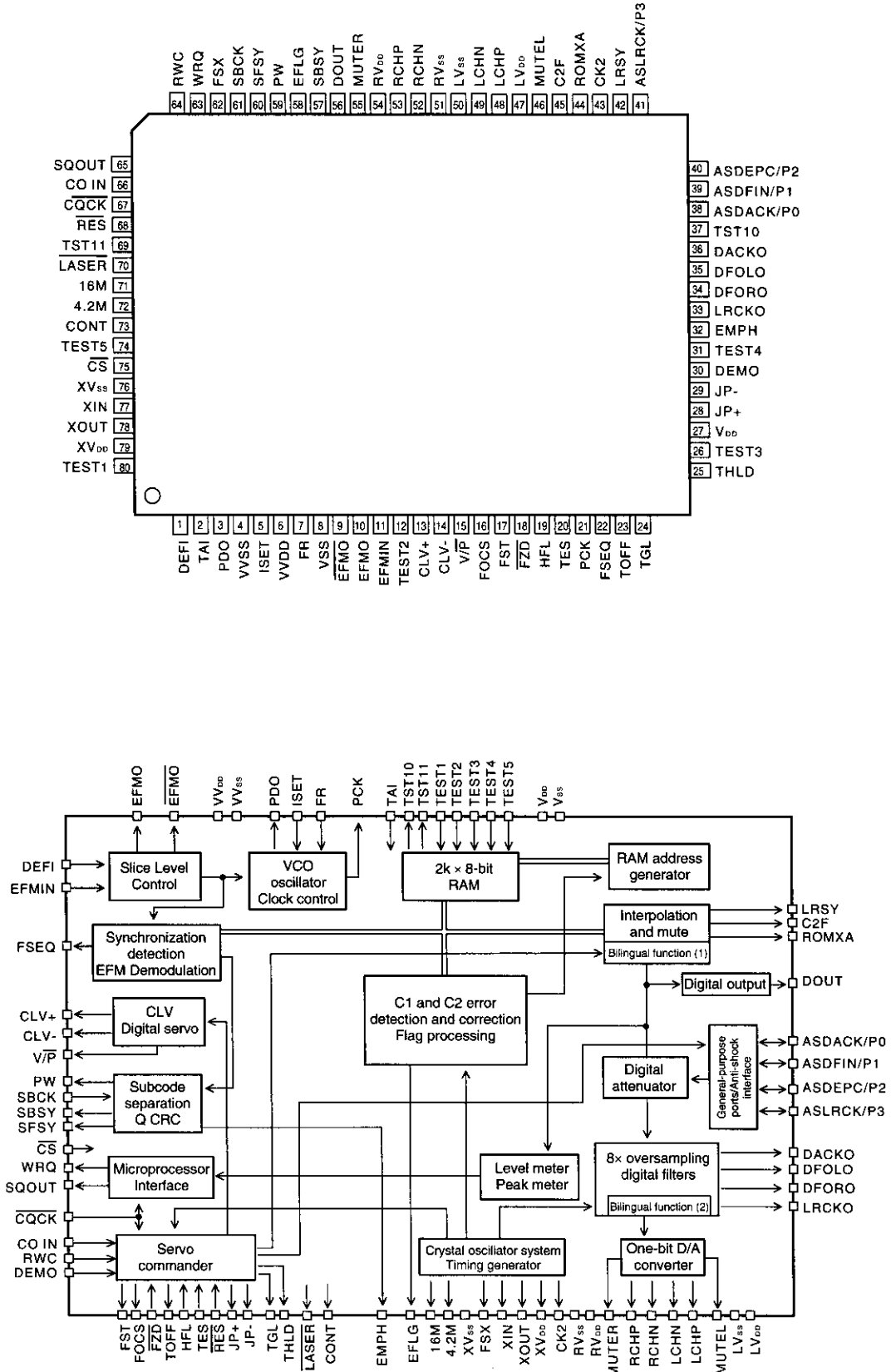

LA6559 (IC101)

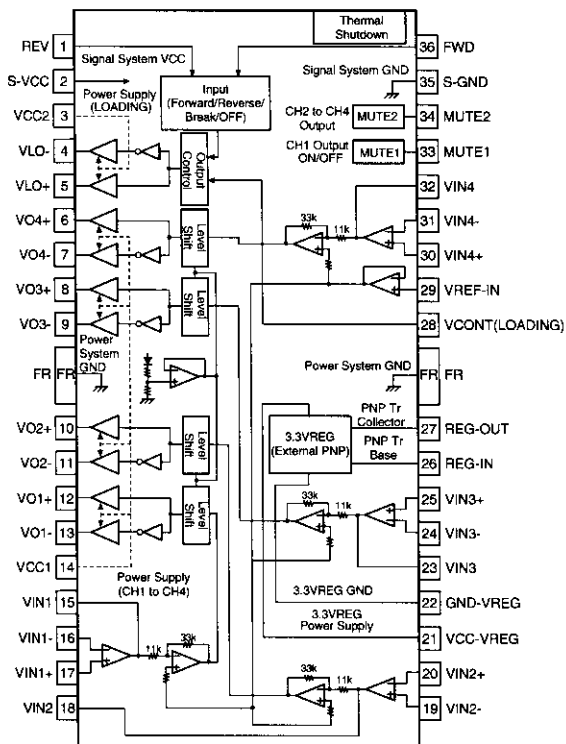

Pin No.	Name	Function
1	REV	5CH output change terminal, logic input of loading block
2	S-Vcc	signal system power supply (BTL-AMP:CH1~4)
3	Vcc2	Power supply for loading block
4	VL0-	Loading output (-)
5	VL0+	Loading output (+)
6	VO4+	Output terminal (+) for channel 4
7	VO4-	Output terminal (-) for channel 4
8	VO3+	Output terminal (+) for channel 3
9	VO3-	Output terminal (-) for channel 3
10	VO2+	Output terminal (+) for channel 2
11	VO2-	Output terminal (-) for channel 2
12	VO1+	Output terminal (+) for channel 1
13	VO1-	Output terminal (-) for channel 1
14	Vcc1	CH1~CH4(BTL-AMP) output stage power supply
15	VIN1	Input terminal for channel 1
16	VIN1-	OP-AMP input AMP-A input terminal (-)
17	VIN1+	OP-AMP input AMP-A input terminal (+)
18	VIN2	Input terminal for channel 2, input AMP output
19	VIN2-	Input terminal (-) for channel 2
20	VIN2+	Input terminal (+) for channel 2
21	Vcc-VREG	3.3VREG power supply
22	GND-VREG	3.3VREG GND
23	VIN3	Input terminal for channel 3, input AMP output
24	VIN3-	Input terminal (-) for channel 3
25	VIN3+	Input terminal (+) for channel 3
26	REG-IN	PNP transistor base connected
27	REG-OUT	3.3V power output to which the PNP transistor collector connected
28	VCONT	Loading output voltage set terminal
29	VREF-IN	Reference voltage applied terminal
30	VIN4+	Input terminal (+) for channel 4
31	VIN4-	Input terminal (-) for channel 4
32	VIN4	Input terminal for channel 4, input AMP output
33	MUTE1	Output ON/OFF for channel 1 (BTL AMP)
34	MUTE2	Output ON/OFF for channel 2 to 4 (BTL AMP)
35	S-GND	Signal system GND
36	FWD	Output change terminal (FWD) for loading output (VLO+), logic input of loading block

LA9241M (IC103)

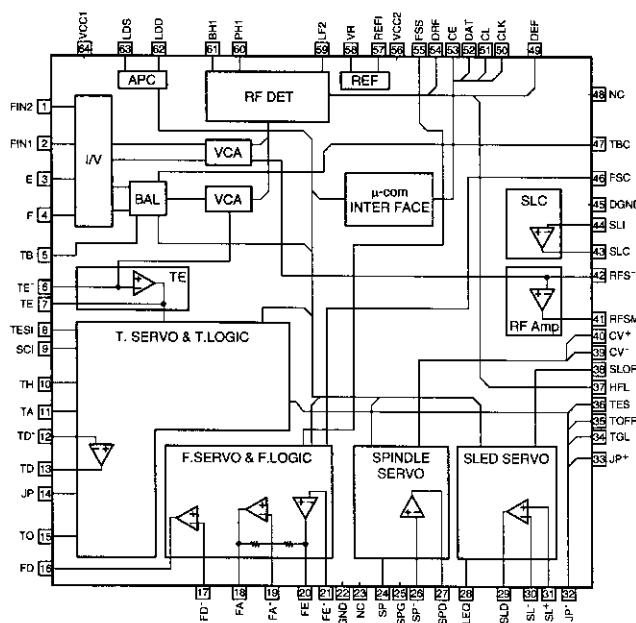
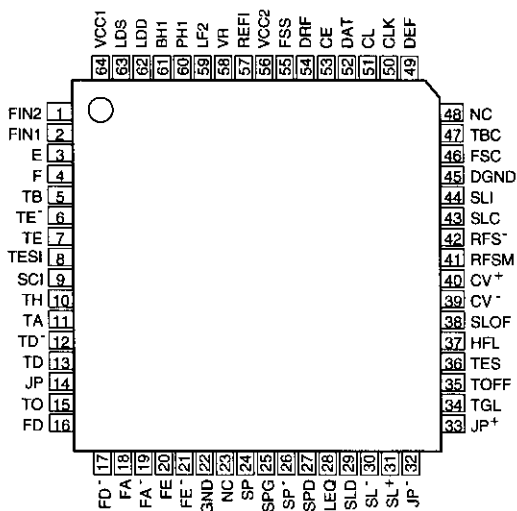

PCM1735E (IC301)

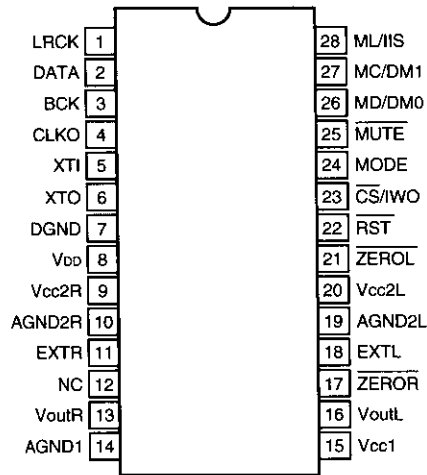

PCM1735E Terminal Function

Pin No.	Name	I/O	Function
1	LRCK	I	LRCK clock input (fs)
2	DATA	I	Data input
3	BCK	I	Bit clock input for data
4	CLKO	O	System clock, buffer output
5	XTI	I	X'tal oscillator connect or ext. clock input
6	XTO	O	X'tal oscillator connect
7	DGND	-	Digital GND
8	VDD	-	Digital power supply +5V
9	VCC2R	-	Analog power supply +5V
10	AGND2R	-	Analog GND
11	EXTR	O	Rch analog out amp, common
12	NC	-	NC
13	VoutR	O	Rch analog V-out
14	AGND1	-	Analog GND
15	VCC1	-	Analog power supply +5V
16	VoutL	O	Lch analog V-out
17	ZEROR	O	Rch zero-data flag (open drain)
18	EXTL	O	Lch analog out amp, common
19	AGND2L	-	Analog GND
20	VCC2L	-	Analog power supply +5V
21	ZEROL	O	Lch zero-data flag (open drain)
22	RST	I	Reset, L:DF and D-S modulator reset
23	CS/IWO	I	Chip select/Input format select
24	MODE	I	Mode control select (H: Soft, L: Hard)
25	MUTE	I	Mute control
26	MD/DM0	I	Mode cont. data/De-emphasis select 1
27	MC/DM1	I	Mode cont. BCK/De-emphasis select 2
28	ML/IIS	I	Mode cont. latch/Input format select

OP725GSR (IC303)

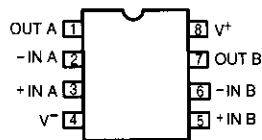

TC7WU04F (IC107)

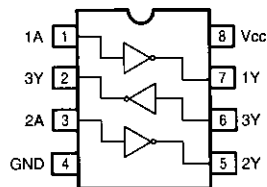

**BA05ST (IC501)
NJM7806FA (S) (IC505)**

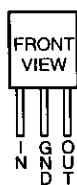

**ICP-N15 (IC504)
ICP-N20 (IC503)**

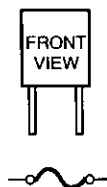

PST600C (IC603)

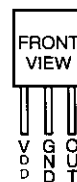

M5290P (IC502)

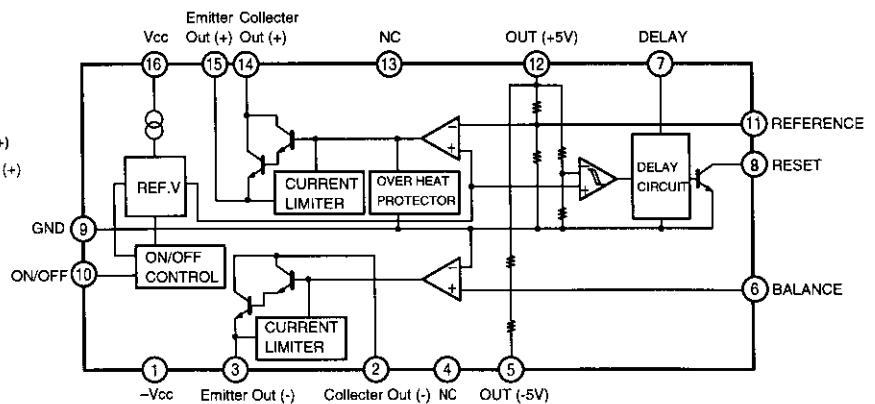
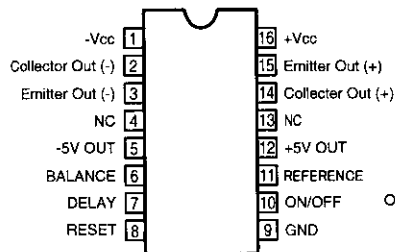

● TRANSISTORS

2SA1037K
 2SC3326(A/B)
 DTA144EK
 DTA124XK
 DTC114EK
 DTC124EK
 DTC144EK
 DTC144TK

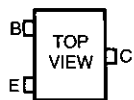

DTA Series

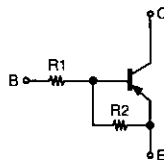

	R1	R2
DTA144EK	47kohm / Ω	47kohm / Ω
DTA124XK	22kohm / Ω	47kohm / Ω

DTC Series

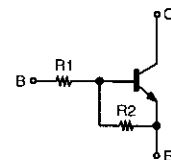

	R1	R2
DTC114EK	10kohm / Ω	10kohm / Ω
DTC124EK	22kohm / Ω	22kohm / Ω
DTC144EK	47kohm / Ω	47kohm / Ω
DTC144TK	47kohm / Ω	—

2SA933S(S)
 2SC1740S(S)
 2SB562(C)
 2SD468(C)

2SB1185(E/F)

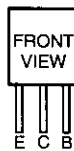

● DIODES (Including LED)

1SS270A
 1SR35-400A

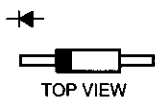

MTZJ6.2A
 MTZJ6.8A
 MTZJ18A
 MTZJ36A

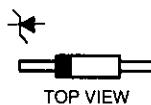

SLR-9335DS-91 (Green/Red)

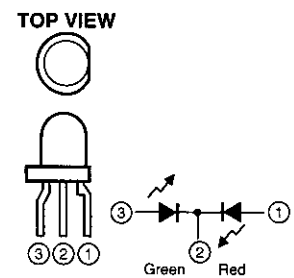

● IR SENSOR

RPM6938-V4 (IC701)

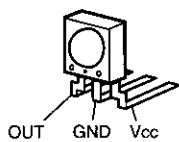

● OPTICAL

OUTPUT
 GP1FA551TZ (JK101, 102)

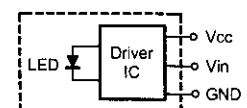

● FL DISPLAY

8-BT-226GNK (FL701)
 (Part No. 393 8055 001)

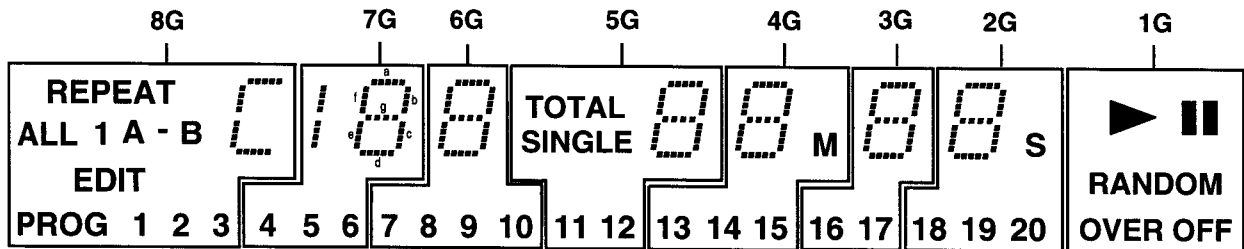

Pin Connection

Pin No.	1	2	3	4	5	6	7	8	9	10	11	12	13	14	15	16	17	18	19	20	21	22	23	24
Connection	F1	F1	NP	NP	1G	2G	3G	4G	5G	6G	7G	8G	NC	NC	NC	NC	NC	NC	NC	NC	NC	NC	NC	NC

Pin No.	25	26	27	28	29	30	31	32	33	34	35	36	37	38	39	40	41	42	43	44	45	46	47
Connection	NC	NC	NC	NC	NC	NC	NC	NC	P11	P10	P9	P8	P7	P6	P5	P4	P3	P2	P1	NP	NP	F2	F2

- NOTE 1) F1,F2 : Filament
 2) NP : No Pin
 3) NC : No connection
 4) 1G~11G : Grid

Anode Connection

	8G	7G	6G	5G	4G	3G	2G	1G
P1	REPEAT	a	a	a	a	a	a	▶
P2	[b	b	b	b	b	b	
P3	ALL	c	c	c	c	c	c	RANDOM
P4	1	d	d	d	d	d	d	OVER
P5	A -	e	e	e	e	e	e	OFF
P6	B	f	f	f	f	f	f	-
P7	EDIT	g	g	g	g	g	g	-
P8	PROG	/	7	TOTAL	M	16	S	-
P9	1	4	8	SINGLE	13	17	18	-
P10	2	5	9	11	14	-	19	-
P11	3	6	10	12	15	-	20	-

PRINTED WIRING BOARD

1U-3380 CD P.W.B. UNIT Ass'y

1 2 3 4 5 6 7 8

A
B
C
D
E

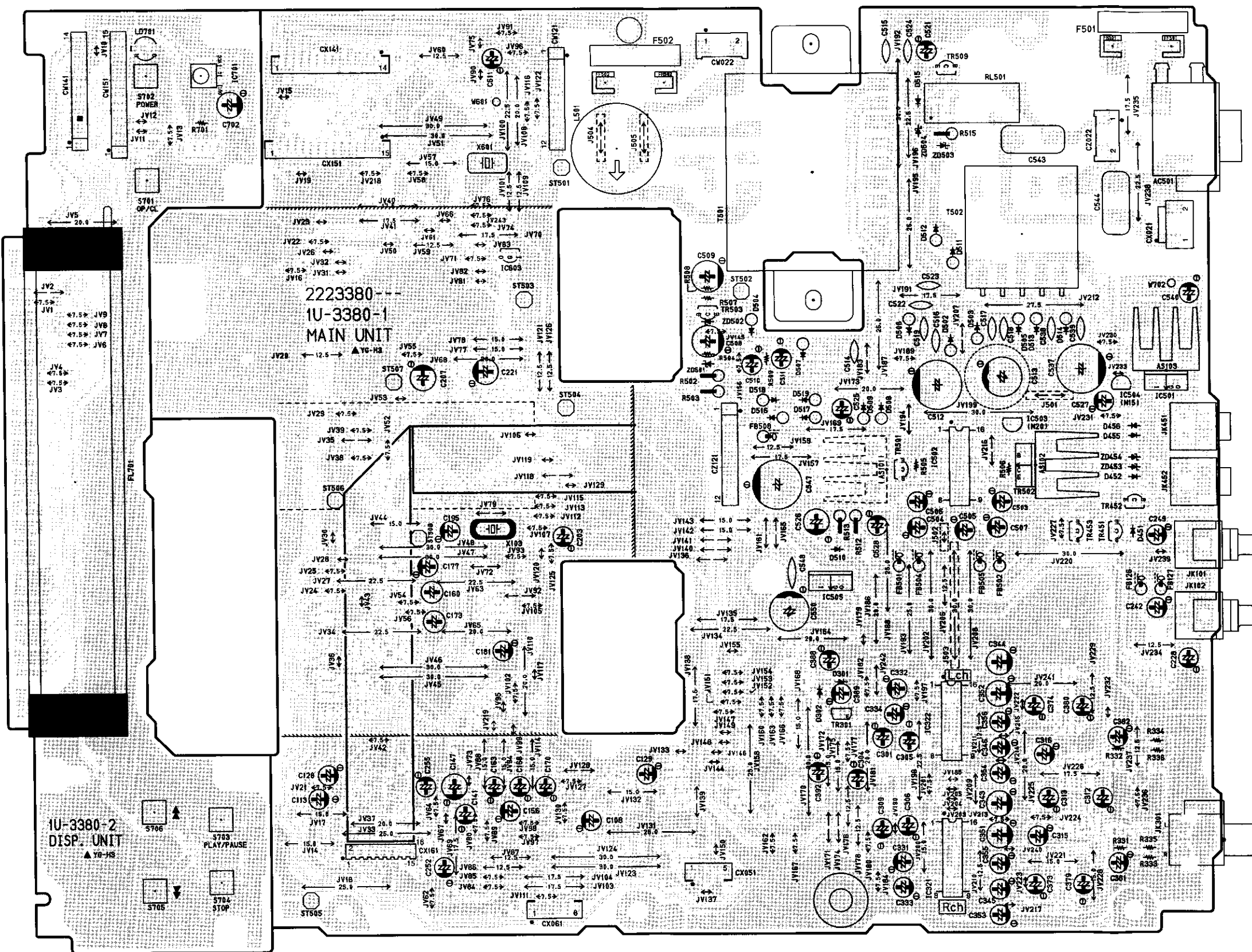

COMPONENT SIDE

1U-3380 CD P.W.B. UNIT Ass'y

1 2 3 4 5 6 7 8

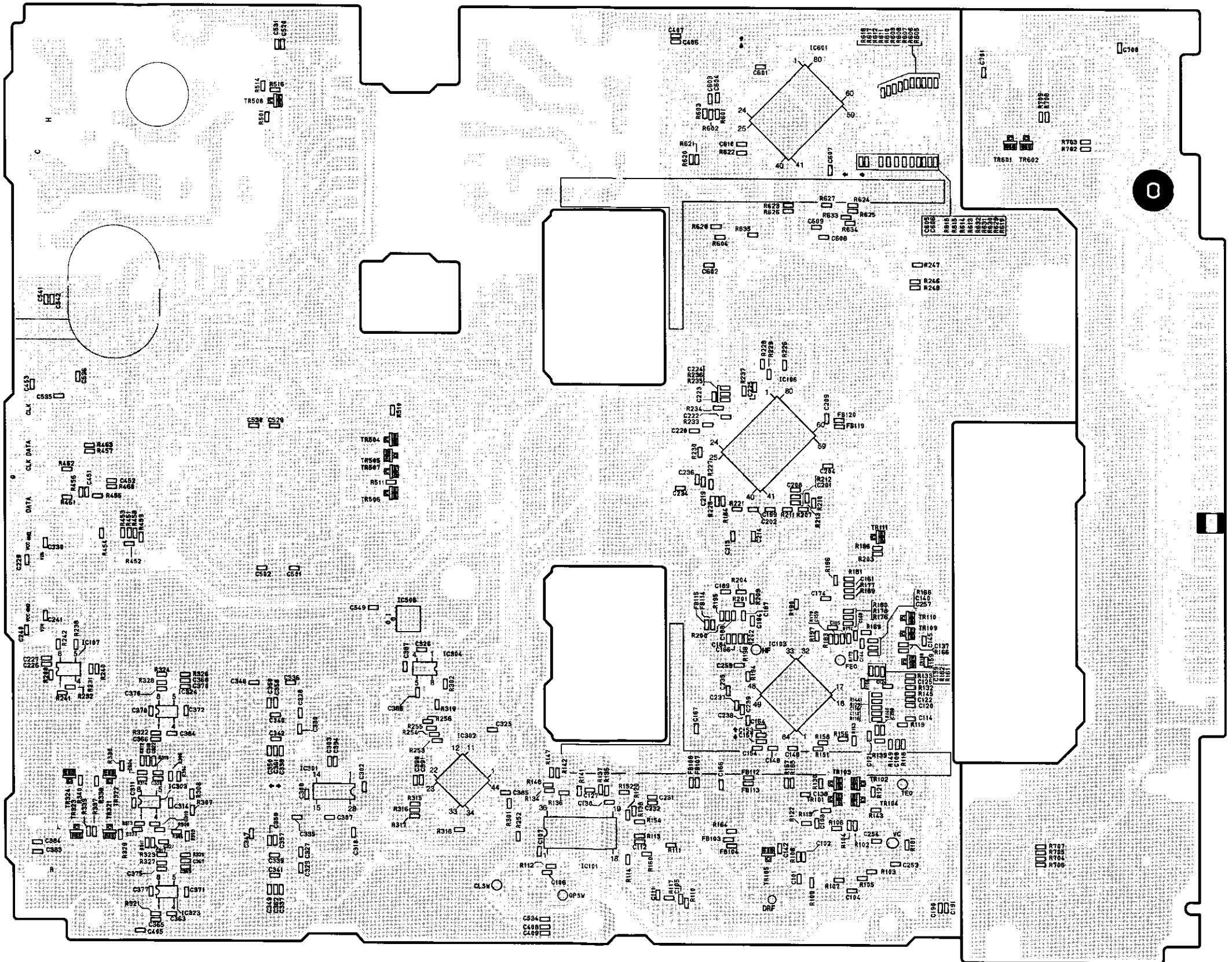

A
B
C
D
E

FOIL SIDE

NOTE FOR PARTS LIST

- Part indicated with the mark "⊙" are not always in stock and possibly to take a long period of time for supplying, or in some case supplying of part may be refused.
- When ordering of part, clearly indicate "1" and "I" (i) to avoid mis-supplying.
- Ordering part without stating its part number can not be supplied.
- Part indicated with the mark "★" is not illustrated in the exploded view.
- Not including Carbon Film ±5%, 1/4W Type in the P.W.Board parts list. (Refer to the Schematic Diagram for those parts.)

WARNING:

Parts marked with this symbol  have critical characteristics.
Use ONLY replacement parts recommended by the manufacturer.

● Resistors

Ex.: RN 14K 2E 182 G FR
 Type Shape Power Resist- Allowable Others
 and performance ance error

RD : Carbon	2B : 1/8W	F : ±1%	P : Pulse-resistant type
RC : Composition	2E : 1/4W	G : ±2%	NL : Low noise type
RS : Metal oxide film	2H : 1/2W	J : ±5%	NB : Non-burning type
RW : Winding	3A : 1W	K : ±10%	FR : Fuse-resistor
RN : Metal film	3D : 2W	M : ±20%	F : Lead wire forming
RK : Metal mixture	3F : 3W		
	3H : 5W		

*** Resistance**

$\overset{1}{\text{R}} \overset{8}{\text{2}} \Rightarrow 1800 \text{ ohm} = 1.8 \text{ kohm}$
 Indicates number of zeros after effective number.
 2-digit effective number.

• Units: ohm

$\overset{1}{\text{R}} \overset{2}{\text{2}} \Rightarrow 1.2 \text{ ohm}$
 1-digit effective number.
 2-digit effective number, decimal point indicated by R.

• Units: ohm

● Capacitors

Ex.: CE 04W 1H 2R2 M BP
 Type Shape Dielectric Capacity Allowable Others
 and per- strength error

CE : Aluminum foil electrolytic	0J : 6.3V	F : ±1%	HS : High stability type
CA : Aluminum solid electrolytic	1A : 10V	G : ±2%	BP : Non-polar type
CS : Tantalum electrolytic	1C : 16V	J : ±5%	HR : Ripple-resistant type
CQ : Film	1E : 25V	K : ±10%	DL : For change and discharge
CK : Ceramic	1V : 35V	M : ±20%	HF : For assuring high frequency
CC : Ceramic	1H : 50V	Z : +80%	U : UL part
CP : Oil	2A : 100V	-20%	C : CSA part
CM : Mica	2B : 125V	P : +100%	W : UL-CSA type
CF : Metallized	2C : 160V	-0%	F : Lead wire forming
CH : Metallized	2D : 200V	C : ±0.25pF	
	2E : 250V	D : ±0.5pF	
	2H : 500V	= : Others	
	2J : 630V		

*** Capacity (electrolyte only)**

$\overset{2}{\text{2}} \overset{2}{\text{2}} \Rightarrow 2200\mu\text{F}$
 Indicates number of zeros after effective number.
 2-digit effective number.

• Units: μF.

$\overset{2}{\text{R}} \overset{2}{\text{2}} \Rightarrow 2.2\mu\text{F}$
 1-digit effective number.
 2-digit effective number, decimal point indicated by R.

• Units: μF.

*** Capacity (except electrolyte)**

$\overset{2}{\text{2}} \overset{2}{\text{2}} \Rightarrow 2200\text{pF} = 0.0022\mu\text{F}$
 (More than 2) — Indicates number of zeros after effective number.
 2-digit effective number.

• Units: pF.

$\overset{2}{\text{2}} \overset{1}{\text{2}} \Rightarrow 220\text{pF}$
 (0 or 1) — Indicates number of zeros after effective number.
 2-digit effective number.

• Units: pF.

• When the dielectric strength is indicated in AC, "AC" is included after the dielectric strength value.

PARTS LIST OF P.W.B. UNIT

1U-3380E2 CD P.W.B. UNIT ASS'Y

Ref. No.	Part No.	Part Name	Remarks	Ref. No.	Part No.	Part Name	Remarks
SEMICONDUCTORS GROUP				RESISTORS GROUP			
IC101	263 1091 907	IC LA6559		ZD501	276 0644 908	Zener diode MTZJ6.8A	
IC103	263 1090 005	IC LA9241M		ZD502	276 0645 978	Zener diode MTZJ36A	
IC106	262 2903 004	IC LC78625E		ZD503	276 0645 907	Zener diode MTZJ18A	
IC107	262 1953 903	IC TC7WU04F		LD701	393 9594 008	LED SLR-9335DS-91	Green/Red
IC301	262 2846 909	IC PCM1735E		RESISTORS GROUP			
IC303	263 1074 908	IC OP275GSR		R101	247 2011 900	Carbon chip 33kohm 1/16W	RM73B--333J
IC501	263 1092 003	IC BA05T		R102-105	247 2010 927	Carbon chip 15kohm 1/16W	RM73B--153J
IC502	263 0693 005	IC M5290P		R106	247 2011 900	Carbon chip 33kohm 1/16W	RM73B--333J
IC503	268 0074 904	IC ICP-N20		R107	247 2018 903	Carbon chip 0ohm 1/16W	RM73B--0R0K
IC504	268 0073 905	IC ICP-N15		R108-110	247 2004 920	Carbon chip 47ohm 1/16W	RM73B--470J
IC505	263 0793 002	IC NJM7806FA (S)		R111	247 2010 969	Carbon chip 22kohm 1/16W	RM73B--223J
IC601	262 2999 005	IC UPD78044FGF-196-3B9		R112	247 2004 920	Carbon chip 47ohm 1/16W	RM73B--470J
IC603	263 0913 905	IC PST600C		R113	247 2012 925	Carbon chip 100kohm 1/16W	RM73B--104J
IC701	499 0301 006	Remocon sensor RPM6938-V4		R114	247 2010 972	Carbon chip 24kohm 1/16W	RM73B--243J
TR101-104	269 0054 901	Transistor DTC144EK		R115	247 2009 925	Carbon chip 5.6kohm 1/16W	RM73B--562J
TR105	271 0238 908	Transistor 2SA1037K (S/R)		R116	247 2008 926	Carbon chip 2.2kohm 1/16W	RM73B--222J
TR108,109	269 0085 909	Transistor DTC144TK		R117	247 2004 920	Carbon chip 47ohm 1/16W	RM73B--470J
TR323,324	273 0414 906	Transistor 2SC3326 (A/B)		R118	247 2011 984	Carbon chip 68kohm 1/16W	RM73B--683J
TR451	271 0192 905	Transistor 2SA933S (S)		R119	247 2010 914	Carbon chip 13kohm 1/16W	RM73B--133J
TR452	273 0303 910	Transistor 2SC1740S (S)		R120	247 2010 956	Carbon chip 20kohm 1/16W	RM73B--203J
TR453	271 0192 905	Transistor 2SA933S (S)		R121	247 2009 925	Carbon chip 5.6kohm 1/16W	RM73B--562J
TR501	274 0036 905	Transistor 2SD468 (C)		R122	247 2009 983	Carbon chip 10kohm 1/16W	RM73B--103J
TR502	272 0083 004	Transistor 2SB1185 (E/F)		R129	247 2010 927	Carbon chip 15kohm 1/16W	RM73B--153J
TR503	272 0025 907	Transistor 2SB562 (C)		R130	247 2007 943	Carbon chip 1kohm 1/16W	RM73B--102J
TR504	269 0055 900	Transistor DTA144EK		R132	247 2010 927	Carbon chip 15kohm 1/16W	RM73B--153J
TR505	269 0082 902	Transistor DTC114EK		R133	247 2006 999	Carbon chip 620ohm 1/16W	RM73B--621J
TR506	269 0156 906	Transistor DTA124XK		R134	247 2010 927	Carbon chip 15kohm 1/16W	RM73B--153J
TR507,508	269 0082 902	Transistor DTC114EK		R135	247 2010 972	Carbon chip 24kohm 1/16W	RM73B--243J
TR509	273 0303 910	Transistor 2SC1740S (S)		R136-138	247 2010 969	Carbon chip 22kohm 1/16W	RM73B--223J
TR601,602	269 0102 905	Transistor DTC124EK		R139	247 2013 908	Carbon chip 220kohm 1/16W	RM73B--224J
D451,452	276 0432 903	Diode 1SS270A		R140	247 2010 956	Carbon chip 20kohm 1/16W	RM73B--203J
D455,456	276 0432 903	Diode 1SS270A		R141,142	247 2010 969	Carbon chip 22kohm 1/16W	RM73B--223J
D502-509	276 0704 903	Diode 1SR35-400A		R143	247 2007 943	Carbon chip 1kohm 1/16W	RM73B--102J
D510	276 0432 903	Diode 1SS270A		R144	247 2012 983	Carbon chip 180kohm 1/16W	RM73B--184J
D511-514	276 0704 903	Diode 1SR35-400A		R145	247 2011 900	Carbon chip 33kohm 1/16W	RM73B--333J
D515	276 0432 903	Diode 1SS270A		R147	247 2018 903	Carbon chip 0ohm 1/16W	RM73B--0R0K
D516-519	276 0704 903	Diode 1SR35-400A		R148	247 2011 955	Carbon chip 51kohm 1/16W	RM73B--513J
ZD453,454	276 0637 902	Zener diode MTZJ6.2A		R149	247 2010 943	Carbon chip 18kohm 1/16W	RM73B--183J
				R150	247 2008 926	Carbon chip 2.2kohm 1/16W	RM73B--222J
				R151	247 2010 985	Carbon chip 27kohm 1/16W	RM73B--273J
				R152	247 2010 998	Carbon chip 30kohm 1/16W	RM73B--303J
				R153	247 2010 985	Carbon chip 27kohm 1/16W	RM73B--273J
				R154	247 2011 942	Carbon chip 47kohm 1/16W	RM73B--473J
				R156	247 2009 983	Carbon chip 10kohm 1/16W	RM73B--103J
				R158	247 2009 983	Carbon chip 10kohm 1/16W	RM73B--103J
				R159	247 2018 903	Carbon chip 0ohm 1/16W	RM73B--0R0K
				R160	247 2011 971	Carbon chip 62kohm 1/16W	RM73B--623J
				R161	247 2010 985	Carbon chip 27kohm 1/16W	RM73B--273J
				R162	247 2010 972	Carbon chip 24kohm 1/16W	RM73B--243J
				R164	247 2002 964	Carbon chip 10ohm 1/16W	RM73B--100J

Ref. No.	Part No.	Part Name	Remarks	Ref. No.	Part No.	Part Name	Remarks
R165	247 2004 991	Carbon chip 91ohm 1/16W	RM73B--910J	R335,336	241 2422 902	Carbon film 680ohm 1/4W	RD14B2E681J (PSNB)
R166	247 2011 942	Carbon chip 47kohm 1/16W	RM73B--473J	R339,340	247 2007 943	Carbon chip 1kohm 1/16W	RM73B--102J
R167	247 2004 991	Carbon chip 91ohm 1/16W	RM73B--910J	R451	247 2009 983	Carbon chip 10kohm 1/16W	RM73B--103J
R168	247 2010 943	Carbon chip 18kohm 1/16W	RM73B--183J	R452,453	247 2010 969	Carbon chip 22kohm 1/16W	RM73B--223J
R169	247 2011 900	Carbon chip 33kohm 1/16W	RM73B--333J	R454	247 2009 983	Carbon chip 10kohm 1/16W	RM73B--103J
R173	247 2008 926	Carbon chip 2.2kohm 1/16W	RM73B--222J	R455,456	247 2010 969	Carbon chip 22kohm 1/16W	RM73B--223J
R174	247 2010 985	Carbon chip 27kohm 1/16W	RM73B--273J	R457	247 2011 942	Carbon chip 47kohm 1/16W	RM73B--473J
R176	247 2010 998	Carbon chip 30kohm 1/16W	RM73B--303J	R458	247 2007 943	Carbon chip 1kohm 1/16W	RM73B--102J
R177	247 2006 931	Carbon chip 360ohm 1/16W	RM73B--361J	R459,460	247 2010 969	Carbon chip 22kohm 1/16W	RM73B--223J
R178	247 2011 913	Carbon chip 36kohm 1/16W	RM73B--363J	R461	247 2005 987	Carbon chip 220ohm 1/16W	RM73B--221J
R179	247 2012 954	Carbon chip 130kohm 1/16W	RM73B--134J	R462	247 2005 903	Carbon chip 100ohm 1/16W	RM73B--101J
R180,181	247 2018 903	Carbon chip 0ohm 1/16W	RM73B--0R0K	R501	247 2008 900	Carbon chip 1.8kohm 1/16W	RM73B--182J
R183	247 2011 984	Carbon chip 68kohm 1/16W	RM73B--683J	R502,503	241 2377 947	Carbon film 100ohm 1/4W (NB)	RD14B2E101JNBS
R184	247 2018 903	Carbon chip 0ohm 1/16W	RM73B--0R0K	R510	247 2009 983	Carbon chip 10kohm 1/16W	RM73B--103J
R186	247 2018 903	Carbon chip 0ohm 1/16W	RM73B--0R0K	R511	247 2012 996	Carbon chip 200kohm 1/16W	RM73B--204J
R189	247 2010 901	Carbon chip 12kohm 1/16W	RM73B--123J	R512	244 2051 974	Metal oxide 1kohm 1W (NB)	RS14B3A102JNBS (S)
R190	247 2008 968	Carbon chip 3.3kohm 1/16W	RM73B--332J	R513	241 2377 934	Carbon film 91ohm 1/4W (NB)	RD14B2E910JNBS
R194	247 2009 909	Carbon chip 4.7kohm 1/16W	RM73B--472J	R514	247 2007 943	Carbon chip 1kohm 1/16W	RM73B--102J
R195	247 2013 924	Carbon chip 270kohm 1/16W	RM73B--274J	R515	244 2043 937	Metal oxide 10ohm 1W (NB)	RS14B3A100JNBS (S)
R196,197	247 2012 996	Carbon chip 200kohm 1/16W	RM73B--204J	R516	247 2011 942	Carbon chip 47kohm 1/16W	RM73B--473J
R198	247 2011 955	Carbon chip 51kohm 1/16W	RM73B--513J	R517	247 2009 983	Carbon chip 10kohm 1/16W	RM73B--103J
R200	247 2009 983	Carbon chip 10kohm 1/16W	RM73B--103J	R601,602	247 2012 925	Carbon chip 100kohm 1/16W	RM73B--104J
R201	247 2011 926	Carbon chip 39kohm 1/16W	RM73B--393J	R603	247 2004 975	Carbon chip 75ohm 1/16W	RM73B--750J
R202	247 2010 969	Carbon chip 22kohm 1/16W	RM73B--223J	R604	247 2011 942	Carbon chip 47kohm 1/16W	RM73B--473J
R204	247 2009 983	Carbon chip 10kohm 1/16W	RM73B--103J	R605-619	247 2012 925	Carbon chip 100kohm 1/16W	RM73B--104J
R207	247 2015 906	Carbon chip 1.5Mohm 1/16W	RM73B--155K	R620,621	247 2007 943	Carbon chip 1kohm 1/16W	RM73B--102J
R208	247 2011 942	Carbon chip 47kohm 1/16W	RM73B--473J	R622	247 2014 965	Carbon chip 1Mohm 1/16W	RM73B--105J
R209	247 2006 902	Carbon chip 330ohm 1/16W	RM73B--331J	R623	247 2009 912	Carbon chip 5.1kohm 1/16W	RM73B--512J
R210	247 2011 900	Carbon chip 33kohm 1/16W	RM73B--333J	R624	247 2018 903	Carbon chip 0ohm 1/16W	RM73B--0R0K
R211	247 2007 901	Carbon chip 680ohm 1/16W	RM73B--681J	R626	247 2009 912	Carbon chip 5.1kohm 1/16W	RM73B--512J
R212	247 2011 900	Carbon chip 33kohm 1/16W	RM73B--333J	R627-634	247 2012 925	Carbon chip 100kohm 1/16W	RM73B--104J
R213	247 2007 969	Carbon chip 1.2kohm 1/16W	RM73B--122J	R635	247 2018 903	Carbon chip 0ohm 1/16W	RM73B--0R0K
R225-230	247 2003 947	Carbon chip 22ohm 1/16W	RM73B--220J	R702,703	247 2007 943	Carbon chip 1kohm 1/16W	RM73B--102J
R231	247 2011 942	Carbon chip 47kohm 1/16W	RM73B--473J	R704,705	247 2005 945	Carbon chip 150ohm 1/16W	RM73B--151J
R232	247 2006 960	Carbon chip 470ohm 1/16W	RM73B--471J	R706,707	247 2005 961	Carbon chip 180ohm 1/16W	RM73B--181J
R233	247 2004 920	Carbon chip 47ohm 1/16W	RM73B--470J	R708	247 2005 987	Carbon chip 220ohm 1/16W	RM73B--221J
R234-237	247 2009 967	Carbon chip 8.2kohm 1/16W	RM73B--822J	R709	247 2006 902	Carbon chip 330ohm 1/16W	RM73B--331J
R238	247 2005 903	Carbon chip 100ohm 1/16W	RM73B--101J	CAPACITORS GROUP			
R240	247 2011 942	Carbon chip 47kohm 1/16W	RM73B--473J	C101-107	257 0512 903	Ceramic chip 0.1uF/25V	CK73F1E104Z
R241	247 2006 960	Carbon chip 470ohm 1/16W	RM73B--471J	C108	254 4538 942	Electrolytic 100uF/16V	CE04W1C101M (SMG/RE3)
R242	247 2005 903	Carbon chip 100ohm 1/16W	RM73B--101J	C109	257 0516 925	Ceramic chip 0.033uF/25V	CK73B1E333K
R246-248	247 2012 925	Carbon chip 100kohm 1/16W	RM73B--104J	C110	257 0507 976	Ceramic chip 330pF/50V	CC73CH1H331J
R252-256	247 2018 903	Carbon chip 0ohm 1/16W	RM73B--0R0K	C111,112	257 0512 903	Ceramic chip 0.1uF/25V	CK73F1E104Z
R303,304	247 2011 942	Carbon chip 47kohm 1/16W	RM73B--473J	C113	254 4524 927	Electrolytic 0.33uF/50V	CE04W1HR33M (SMG/RE3)
R305,306	247 2008 971	Carbon chip 3.6kohm 1/16W	RM73B--362J	C114	257 0501 927	Ceramic chip 0.015uF/50V	CK73B1H153K
R307,308	247 2011 942	Carbon chip 47kohm 1/16W	RM73B--473J	C116	257 0517 908	Ceramic chip 0.047uF/16V	CK73B1C473K
R309,310	247 2008 971	Carbon chip 3.6kohm 1/16W	RM73B--362J	C120	257 0506 993	Ceramic chip 150pF/50V	CC73CH1H151J
R311,312	247 2009 983	Carbon chip 10kohm 1/16W	RM73B--103J				
R313,314	247 2009 941	Carbon chip 6.8kohm 1/16W	RM73B--682J				
R329,330	247 2010 998	Carbon chip 30kohm 1/16W	RM73B--303J				

Ref. No.	Part No.	Part Name	Remarks	Ref. No.	Part No.	Part Name	Remarks
C121	257 0512 903	Ceramic chip 0.1uF/25V	CK73F1E104Z	C226	257 0509 929	Ceramic chip 1000pF/50V	CK73B1H102K
C122	257 0517 908	Ceramic chip 0.047uF/16V	CK73B1C473K	C227	257 0512 903	Ceramic chip 0.1uF/25V	CK73F1E104Z
C124,125	257 0517 908	Ceramic chip 0.047uF/16V	CK73B1C473K	C228	254 4538 900	Electrolytic 10uF/16V	CE04W1C100M (SMG/RE3)
C127	257 0512 903	Ceramic chip 0.1uF/25V	CK73F1E104Z	C229	257 0504 940	Ceramic chip 33pF/50V	CC73CH1H330J
C128	254 4538 942	Electrolytic 100uF/16V	CE04W1C101M (SMG/RE3)	C230,231	257 0512 903	Ceramic chip 0.1uF/25V	CK73F1E104Z
C130	257 0512 903	Ceramic chip 0.1uF/25V	CK73F1E104Z	C232	257 0501 901	Ceramic chip 0.01uF/50V	CK73B1H103K
C137,138	257 0501 901	Ceramic chip 0.01uF/50V	CK73B1H103K	C234	257 0506 951	Ceramic chip 100pF/50V	CC73CH1H101J
C139	257 0509 929	Ceramic chip 1000pF/50V	CK73B1H102K	C236-239	257 0506 951	Ceramic chip 100pF/50V	CC73CH1H101J
C140	257 0512 903	Ceramic chip 0.1uF/25V	CK73F1E104Z	C240	257 0504 940	Ceramic chip 33pF/50V	CC73CH1H330J
C141	254 4538 939	Electrolytic 47uF/16V	CE04W1C470M (SMG/RE3)	C241	257 0512 903	Ceramic chip 0.1uF/25V	CK73F1E104Z
C142	257 0509 929	Ceramic chip 1000pF/50V	CK73B1H102K	C242	254 4538 900	Electrolytic 10uF/16V	CE04W1C100M (SMG/RE3)
C144	257 0512 903	Ceramic chip 0.1uF/25V	CK73F1E104Z	C249	254 4538 900	Electrolytic 10uF/16V	CE04W1C100M (SMG/RE3)
C145	257 0507 934	Ceramic chip 220pF/50V	CC73CH1H221J	C252	254 4538 942	Electrolytic 100uF/16V	CE04W1C101M (SMG/RE3)
C146	257 0509 929	Ceramic chip 1000pF/50V	CK73B1H102K	C253,254	257 0501 901	Ceramic chip 0.01uF/50V	CK73B1H103K
C147	254 4538 955	Electrolytic 220uF/16V	CE04W1C221M (SMG/RE3)	C255	254 4538 942	Electrolytic 100uF/16V	CE04W1C101M (SMG/RE3)
C148	257 0514 901	Ceramic chip 0.33uF/16V	CK73F1C334Z	C301	254 4583 971	Electrolytic 47uF/50V	CE04W1H470M (ROB)
C149	257 0501 901	Ceramic chip 0.01uF/50V	CK73B1H103K	C302	257 0512 903	Ceramic chip 0.1uF/25V	CK73F1E104Z
C153	257 0512 903	Ceramic chip 0.1uF/25V	CK73F1E104Z	C304	254 4368 934	Electrolytic 100uF/25V	CE04W1E101M (ASF)
C154	257 0517 908	Ceramic chip 0.047uF/16V	CK73B1C473K	C306	254 4580 712	Electrolytic 100uF/50V	CE04W1H101M (ROB)
C156	254 4538 942	Electrolytic 100uF/16V	CE04W1C101M (SMG/RE3)	C309	254 4583 971	Electrolytic 47uF/50V	CE04W1H470M (ROB)
C157	257 0501 901	Ceramic chip 0.01uF/50V	CK73B1H103K	C310	257 0512 903	Ceramic chip 0.1uF/25V	CK73F1E104Z
C159	257 0510 918	Ceramic chip 3300pF/50V	CK73B1H332K	C312,313	254 4580 712	Electrolytic 100uF/50V	CE04W1H101M (ROB)
C160	254 3056 917	Electrolytic 1uF/50V	CE04D1H010MBP	C315,316	254 4557 936	Electrolytic 10uF/50V	CE04W1H100M (RFS)
C163	254 4538 900	Electrolytic 10uF/16V	CE04W1C100M (SMG/RE3)	C317,318	255 4232 937	Polypropylene film 1000pF/100V	CQ93P2A102J (NH)
C164	257 0512 903	Ceramic chip 0.1uF/25V	CK73F1E104Z	C321,322	255 4232 937	Polypropylene film 1000pF/100V	CQ93P2A102J (NH)
C165	257 0506 951	Ceramic chip 100pF/50V	CC73CH1H101J	C381,382	254 4445 750	Electrolytic 100uF/50V	CE04W1H101M (ARSG)
C166,167	257 0512 903	Ceramic chip 0.1uF/25V	CK73F1E104Z	C394	257 0512 903	Ceramic chip 0.1uF/25V	CK73F1E104Z
C168	254 4538 942	Electrolytic 100uF/16V	CE04W1C101M (SMG/RE3)	C406	257 0501 901	Ceramic chip 0.01uF/50V	CK73B1H103K
C170	254 4538 942	Electrolytic 100uF/16V	CE04W1C101M (SMG/RE3)	C407	257 0512 903	Ceramic chip 0.1uF/25V	CK73F1E104Z
C173	254 3056 917	Electrolytic 1uF/50V	CE04D1H010MBP	C408	257 0501 901	Ceramic chip 0.01uF/50V	CK73B1H103K
C174	257 0510 918	Ceramic chip 3300pF/50V	CK73B1H332K	C409	257 0512 903	Ceramic chip 0.1uF/25V	CK73F1E104Z
C177	254 4538 939	Electrolytic 47uF/16V	CE04W1C470M (SMG/RE3)	C451,452	257 0509 929	Ceramic chip 1000pF/50V	CK73B1H102K
C181	254 4522 903	Electrolytic 4.7uF/35V	CE04W1V4R7M (SMG/RE3)	C453	257 0501 901	Ceramic chip 0.01uF/50V	CK73B1H103K
C184	257 0512 903	Ceramic chip 0.1uF/25V	CK73F1E104Z	C503	254 4524 943	Electrolytic 1uF/50V	CE04W1H010M (SMG/RE3)
C186	257 0509 929	Ceramic chip 1000pF/50V	CK73B1H102K	C504	254 4538 900	Electrolytic 10uF/16V	CE04W1C100M (SMG/RE3)
C189	257 0503 941	Ceramic chip 12pF/50V	CC73CH1H120J	C505	254 4580 712	Electrolytic 100uF/50V	CE04W1H101M (ROB)
C194	257 0501 901	Ceramic chip 0.01uF/50V	CK73B1H103K	C506	254 4524 943	Electrolytic 1uF/50V	CE04W1H010M (SMG/RE3)
C195	254 4524 972	Electrolytic 4.7uF/50V	CE04W1H4R7M (SMG/RE3)	C507	254 4524 969	Electrolytic 3.3uF/50V	CE04W1H3R3M (SMG/RE3)
C199	257 0517 908	Ceramic chip 0.047uF/16V	CK73B1C473K	C508,509	254 4525 926	Electrolytic 100uF/50V	CE04W1H101M (SMG/RE3)
C201,202	257 0512 903	Ceramic chip 0.1uF/25V	CK73F1E104Z	C510,511	254 4525 900	Electrolytic 33uF/50V	CE04W1H330M (SMG/RE3)
C203	254 4538 942	Electrolytic 100uF/16V	CE04W1C101M (SMG/RE3)	C512	254 4452 714	Electrolytic 2200uF/16V	CE04W1C222M (ASF)
C204	257 0506 951	Ceramic chip 100pF/50V	CC73CH1H101J	C513	254 4319 789	Electrolytic 3300uF/25V	CE04W1E332M (ASF)
C207	254 4538 942	Electrolytic 100uF/16V	CE04W1C101M (SMG/RE3)	C515	253 1146 907	Ceramic 0.01uF/50V	CK45F1H103Z
C208,209	257 0512 903	Ceramic chip 0.1uF/25V	CK73F1E104Z	C520	257 0501 901	Ceramic chip 0.01uF/50V	CK73B1H103K
C214,215	257 0503 941	Ceramic chip 12pF/50V	CC73CH1H120J	C522,523	253 9030 950	Ceramic 6800pF/25V	CK45=1E682K
C219	257 0512 903	Ceramic chip 0.1uF/25V	CK73F1E104Z	C524	253 1146 907	Ceramic 0.01uF/50V	CK45F1H103Z
C220	257 0511 917	Ceramic chip 0.022uF/50V	CK73F1H223Z	C525	254 4524 943	Electrolytic 1uF/50V	CE04W1H010M (SMG/RE3)
C221	254 4538 942	Electrolytic 100uF/16V	CE04W1C101M (SMG/RE3)	C526	254 4538 955	Electrolytic 220uF/16V	CE04W1C221M (SMG/RE3)
C222	257 0512 903	Ceramic chip 0.1uF/25V	CK73F1E104Z	C527	254 4538 900	Electrolytic 10uF/16V	CE04W1C100M (SMG/RE3)
C223,224	257 0507 989	Ceramic chip 360pF/50V	CC73CH1H361J				
C225	257 0512 903	Ceramic chip 0.1uF/25V	CK73F1E104Z				

Ref. No.	Part No.	Part Name	Remarks	Ref. No.	Part No.	Part Name	Remarks	Q'ty	
C529	257 0512 903	Ceramic chip 0.1uF/25V	CK73F1E104Z	OTHER PARTS GROUP					
C530	254 4580 712	Electrolytic 100uF/50V	CE04W1H101M (ROB)	AS104	449 0172 007	Sensor holder		1	
C530,531	257 0512 903	Ceramic chip 0.1uF/25V	CK73F1E104Z	AS505	417 0476 049	Radiator		1	
C534-536	257 0512 903	Ceramic chip 0.1uF/25V	CK73F1E104Z	AS555	471 3304 015	Screw 3x8 CBS-Z		1	
C537	254 4539 718	Electrolytic 2200uF/16V	CE04W1C222M (SMG/RE3)	AS701,702	461 1110 000	FL spacer		2	
C538,539	253 1181 904	Ceramic 0.01uF/50V	CK45F1H103Z	CW022	203 5042 015	3P SDN-SDN connector cord		1	
C540	254 4524 943	Electrolytic 1uF/50V	CE04W1H010M (SMG/RE3)	CW121	204 6302 003	12P DA-DA connector cord		1	
△ C543	253 8026 703	Ceramic 4700pF/250V (AC)	CK45E2EAC472M	CW141	204 6211 013	14P KR-DA connector cord		1	
C547	254 4403 721	Electrolytic 2200uF/25V	CE04W1E222M (SMG)	CW151	204 6335 038	15P KR-DA connector cord		1	
C548	253 9039 906	Ceramic 0.1uF/25V	CK45=1E104Z	CX021	205 0581 001	2P VH connector base		1	
C549	257 0512 903	Ceramic chip 0.1uF/25V	CK73F1E104Z	CX051	205 0343 058	5P connector base (KR-PH)		1	
C550	254 4538 942	Electrolytic 100uF/16V	CE04W1C101M (SMG/RE3)	CX061	205 0343 061	6P connector base (KR-PH)		1	
C601-603	257 0512 903	Ceramic chip 0.1uF/25V	CK73F1E104Z	CX141	205 0375 042	14P connector base (KR-PH)		1	
C604-606	257 0506 951	Ceramic chip 100pF/50V	CC73CH1H101J	CX151	205 0375 055	15P connector base (KR-PH)		1	
C607	257 0512 903	Ceramic chip 0.1uF/25V	CK73F1E104Z	CX161	205 0892 033	16P FFC connector base		1	
C609	257 0506 951	Ceramic chip 100pF/50V	CC73CH1H101J	FB103,104	235 0129 901	EMI filter		2	
C610	257 0512 903	Ceramic chip 0.1uF/25V	CK73F1E104Z	FB107,108	235 0129 901	EMI filter		2	
C611	254 4538 900	Electrolytic 10uF/16V	CE04W1C100M (SMG/RE3)	FB112-115	235 0129 901	EMI filter		4	
C612	257 0512 903	Ceramic chip 0.1uF/25V	CK73F1E104Z	FB119,120	235 0129 901	EMI filter		2	
C700,701	257 0501 901	Ceramic chip 0.01uF/50V	CK73B1H103K	FB126,127	235 0049 900	Beads inductor		2	
C702	254 4302 974	Electrolytic 100uF/10V	CE04W1A101M (SRE)	FL701	393 8055 001	FLD (8-BT-226GNK)		1	
				JK101,102	269 0187 001	Optical digital output	GP1FA551TZ	2	
				JK301	204 8639 004	2P pin jack (C-GND)		1	
				JK451,452	204 8637 006	Mini jack		2	
				△ RL501	214 0214 000	Relay (SDT-S-109LMR)		1	
				S701-706	212 5604 910	Tact switch		6	
				ST504,505	205 0452 017	Style pin		2	
				ST508	205 0452 017	Style pin		1	
				△ T502	233 6397 003	Power trans. (Sub)		1	
				TM101	412 9483 009	Earth plate		1	
				X103	399 0165 007	Crystal 16.9344MHz		1	
				X601	399 0111 909	Ceramic resonator	CST4.23MGW	1	

EXPLODED VIEW

1 2 3 4 5 6 7 8

WARNING:
 Parts marked with this symbol  have critical characteristics.
 Use **ONLY** replacement parts recommended by the manufacturer.

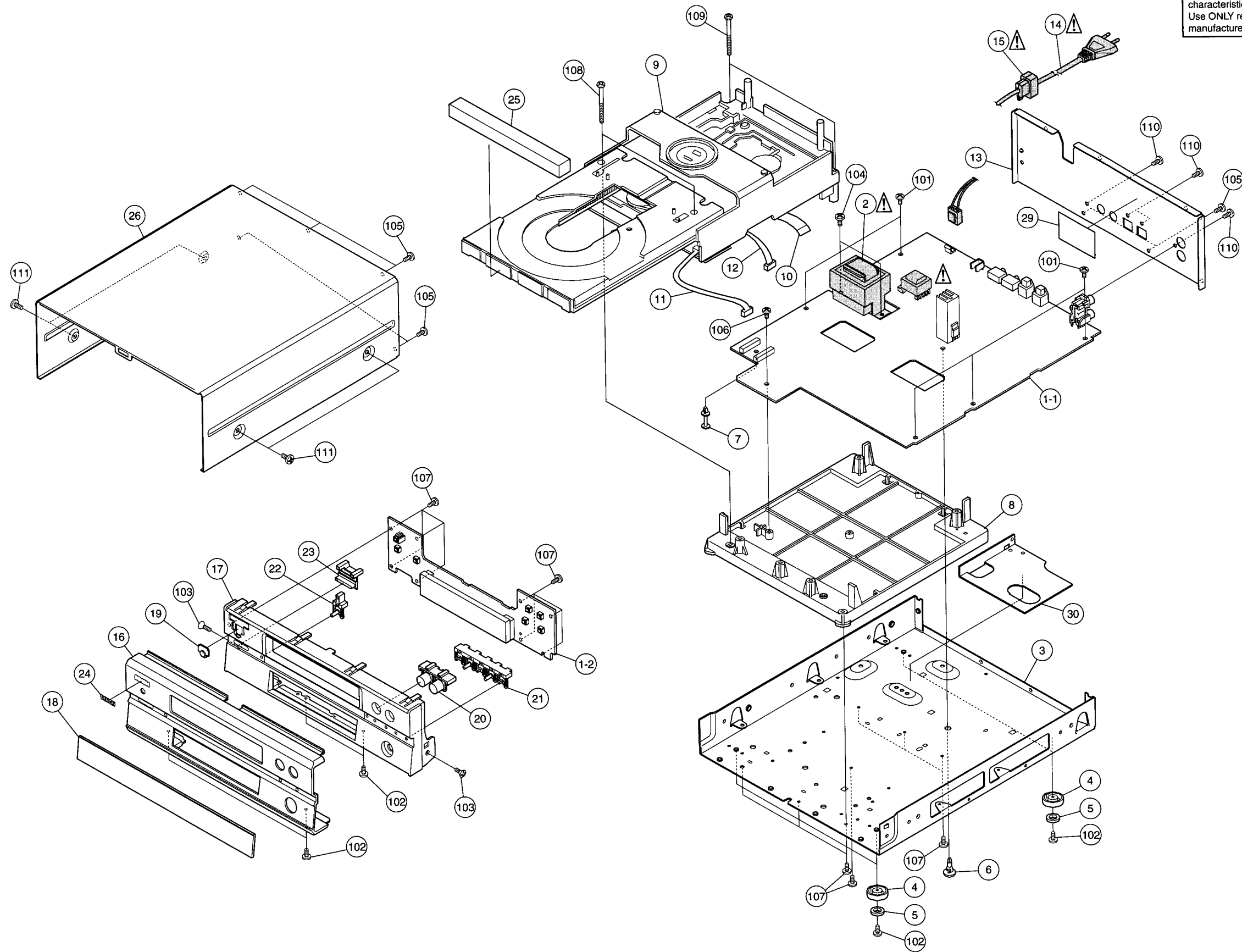

PARTS LIST OF EXPLODED VIEW

Note: The symbols in the column "Remarks" indicate the following destinations.
 E2: Europe model
 EK: U.K. model

Ref. No.	Part No.	Part Name	Remarks	Q'ty
1	1U-3380E2	CD P.W.B. unit Ass'y		1
1-1		Main unit		
1-2		Display unit		
△	2	233 6396 004 Power trans.	T501	1
	3	411 1993 206 Main chassis		1
	4	104 0324 004 Foot		4
	5	461 1066 002 Felt		4
	6	412 2741 036 P.W.B. holder (H=10)		1
	7	412 2814 028 Card spacer (L=10)		2
	8	412 4829 105 Mecha base		1
	9	337 0100 006 CD mecha. unit (CD11FTA3N)		1
	10	009 0159 039 16P FFC cable	CW161	1
	11	203 8299 069 5P KR-KR connector cord	CW051	1
	12	204 0374 011 6P PH-PH connector cord	CW061	1
	13	105 1386 141 Back panel		1
△	14	206 2089 106 AC cord (E2)	for E2	1
△	14	206 2128 009 AC cord (EK)	for EK	1
△	15	445 0056 008 Cord bush		1
	16	144 2778 009 Front panel		1
	17	146 2253 009 Inner panel		1
	18	143 1130 001 Window		1
	19	143 1131 000 Remocon filter		1
	20	113 1910 000 2P knob		1
	21	113 1912 008 5P knob		1
	22	113 1914 006 1P knob		1
	23	113 1917 100 Power knob		1
	24	131 0156 009 DENON badge		1
	25	146 2256 006 Loader panel		1
	26	102 0653 012 Top cover		1
★	27	001 9002 031 Vinyl wire (UL1430 AWG24)	JV216-JV214	1
★	28	001 9002 057 Vinyl wire (UL1430 AWG24)	JV194-JV225	1
	29	513 2065 002 E2 laser caution		1
	30	415 0873 002 PVC sheet		1
SCREWS				
	101	473 7002 005 Screw 3x6 CBTS (S)-Z		5
	102	473 7002 021 Screw 3x8 CBTS (S)-B		8
	103	473 7003 017 Screw 3x8 CFTS (S)-B		2
	104	473 7004 016 Screw 4x6 CBTS (S)-Z		2
	105	473 7015 005 Screw 3x6 CBTS (S)-B		7
	106	473 7500 015 Screw 3x8 CBTS (P)-Z		1
	107	473 7500 044 Screw 3x8 CBTS (P)-B		15
	108	473 8079 008 Special screw		2
	109	473 8079 024 Special screw		2
	110	477 0064 107 Fixing screw		7
	111	477 0263 018 3P. swelling screw		4

EXPLODED VIEW OF CD MECHANISM UNIT (CD11FTA3N)

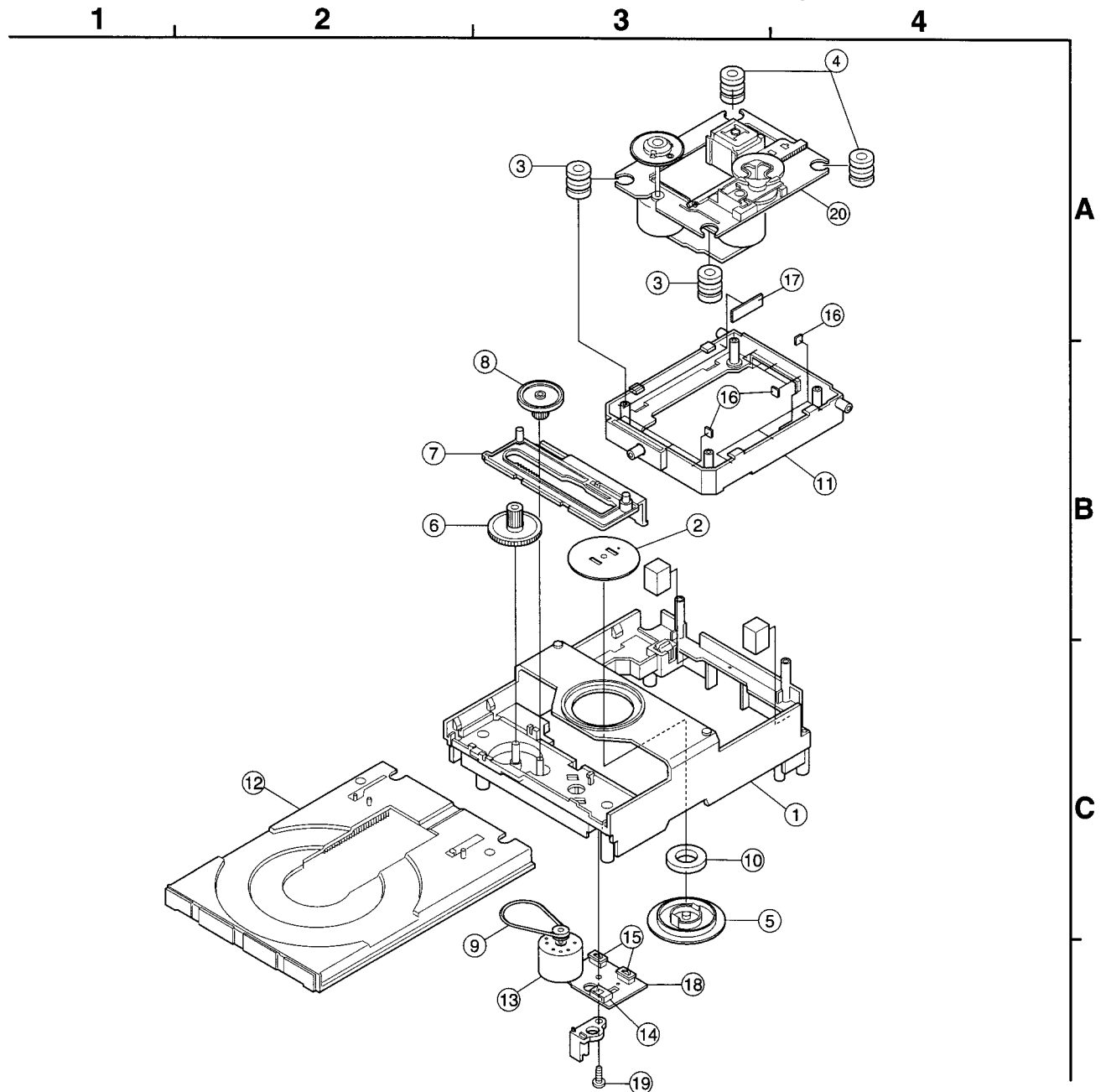

PARTS LIST OF CD MECHANISM UNIT

Ref. No.	Part No.	Part Name	Remarks	Q'ty	Ref. No.	Part No.	Part Name	Remarks	Q'ty
1	964 0009 006	Frame chassis		1	11	964 0010 008	Mecha lifter		1
2	964 0009 103	Magnet plate		1	12	964 0010 105	Loading table		1
3	964 0009 200	Rubber cushion		2	13	964 0010 901	Loading motor		1
4	964 0009 307	Rubber cushion		2	14	964 0010 202	5P Plug		1
5	964 0009 404	Magnet holder		1	15	964 0010 309	Push switch 2-1		2
6	964 0009 501	Drive gear		1	16	964 0010 406	Cushion		9
7	964 0009 608	Slide gear		1	17	964 0010 503	Cushion		2
8	964 0009 705	Pulley gear		1	18	964 0010 600	Motor P.W.B.		2
9	964 0009 802	Square belt		1	19	964 0010 707	Screw 3x8 SCR S-TPG BIN		1
10	964 0009 909	Magnet		1	20	964 0011 007	Mecha DA11T3CN		1

PACKING VIEW

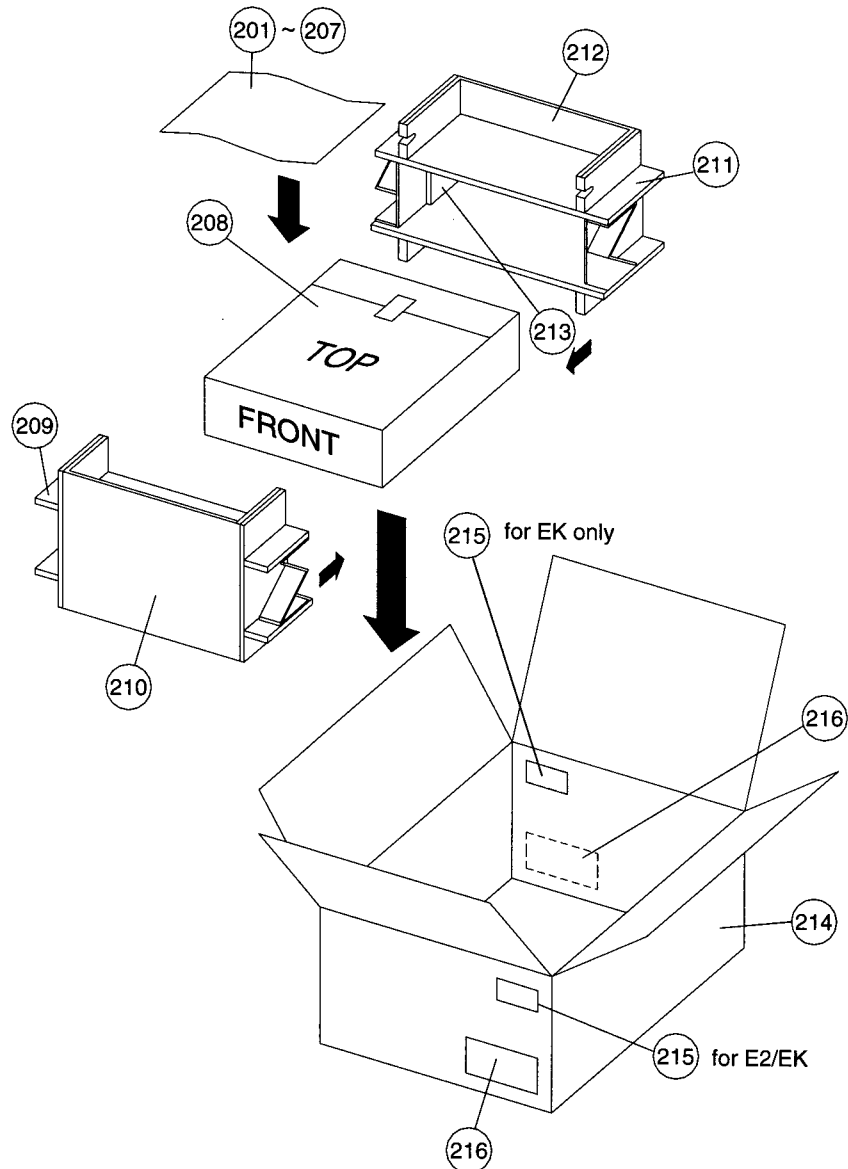

PARTS LIST OF PACKING & ACCESSORIES

Note: The symbols in the column "Remarks" indicate the following destinations.
 E2: Europe model
 EK: U.K. model

Ref. No.	Part No.	Part Name	Remarks	Q'ty	Ref. No.	Part No.	Part Name	Remarks	Q'ty
201	505 0038 030	Poly. cover		1	212	502 0972 003	Cushion (Rear-B)		1
202	511 3821 003	Instruction manual		1	213	502 0973 002	Cushion pad		1
203	515 0867 101	Service station list (EX)		1	214	501 2158 000	Carton case		1
204	399 0463 000	Remote controller	RC-268	1	215	517 1453 002	E2 POS label	for E2	1
205	—	Battery (R6Px2)		1	215	517 1455 000	EK POS label	for EK	2
206	203 0704 002	Stereo miniplug cord		1	216	—	Control card		1
207	203 0705 001	2P pin cord		1	★ 217	513 1642 002	No. sheet		1
208	505 0335 005	Cabinet cover		1					
209	502 0969 003	Cushion (Front-A)		1					
210	502 0970 005	Cushion (Front-B)		1					
211	502 0971 004	Cushion (Rear-A)		1					

FORMING CUSHIONS

Cushion (F) Ass'y

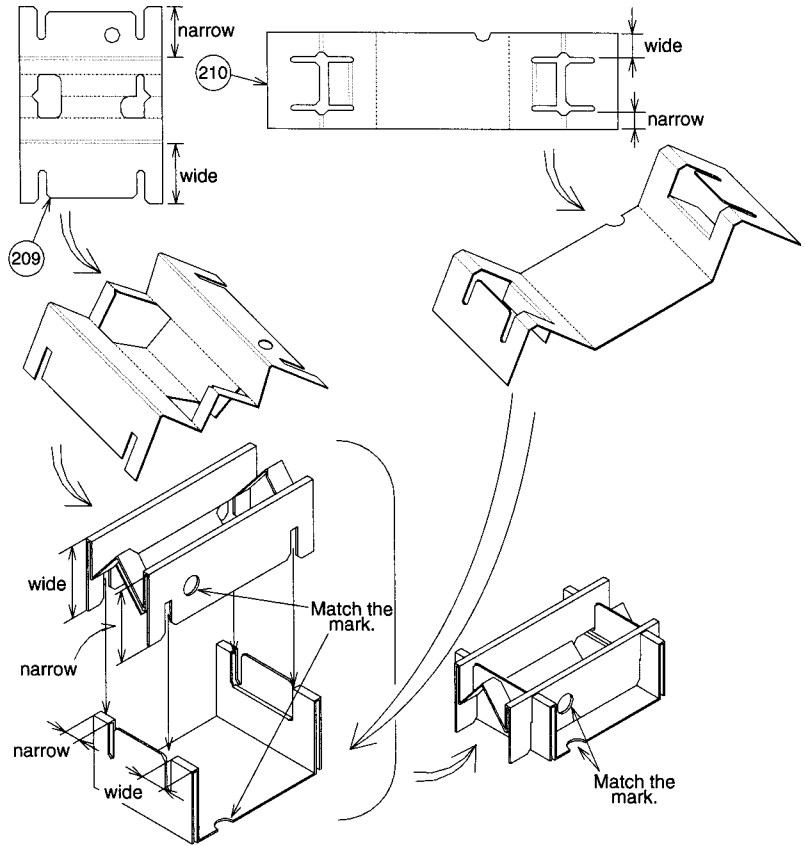

Cushion (R) Ass'y

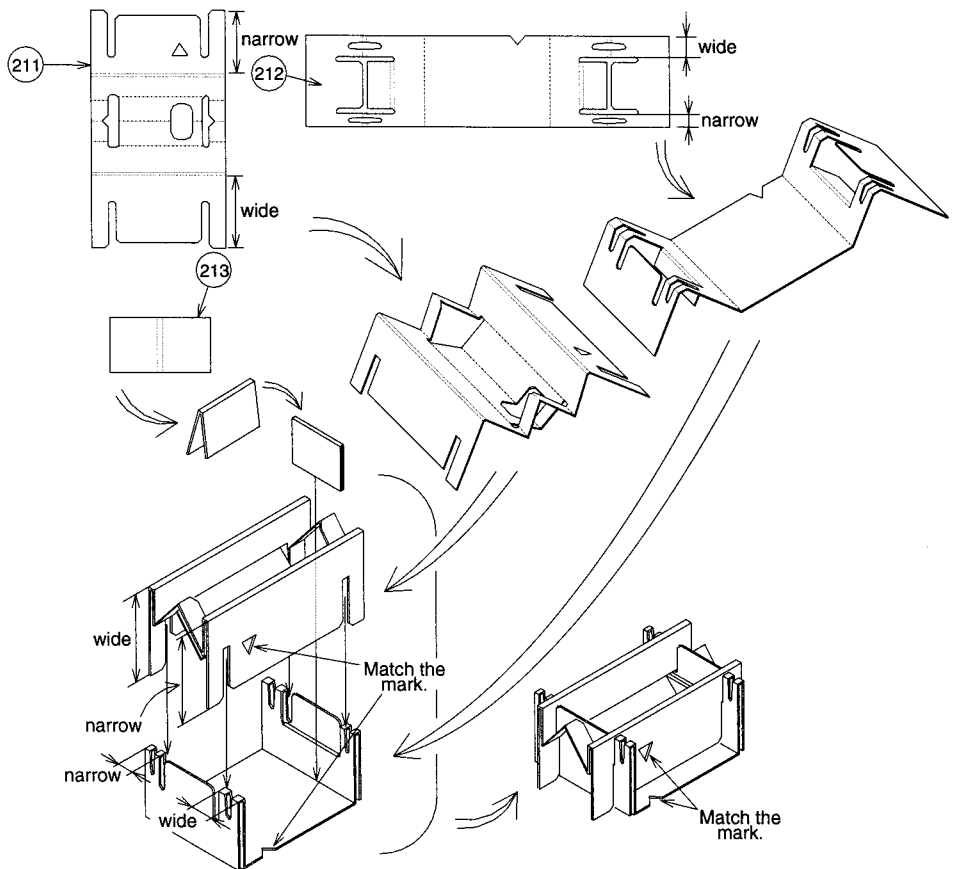

SCHEMATIC DIAGRAM

1

2

3

4

5

6

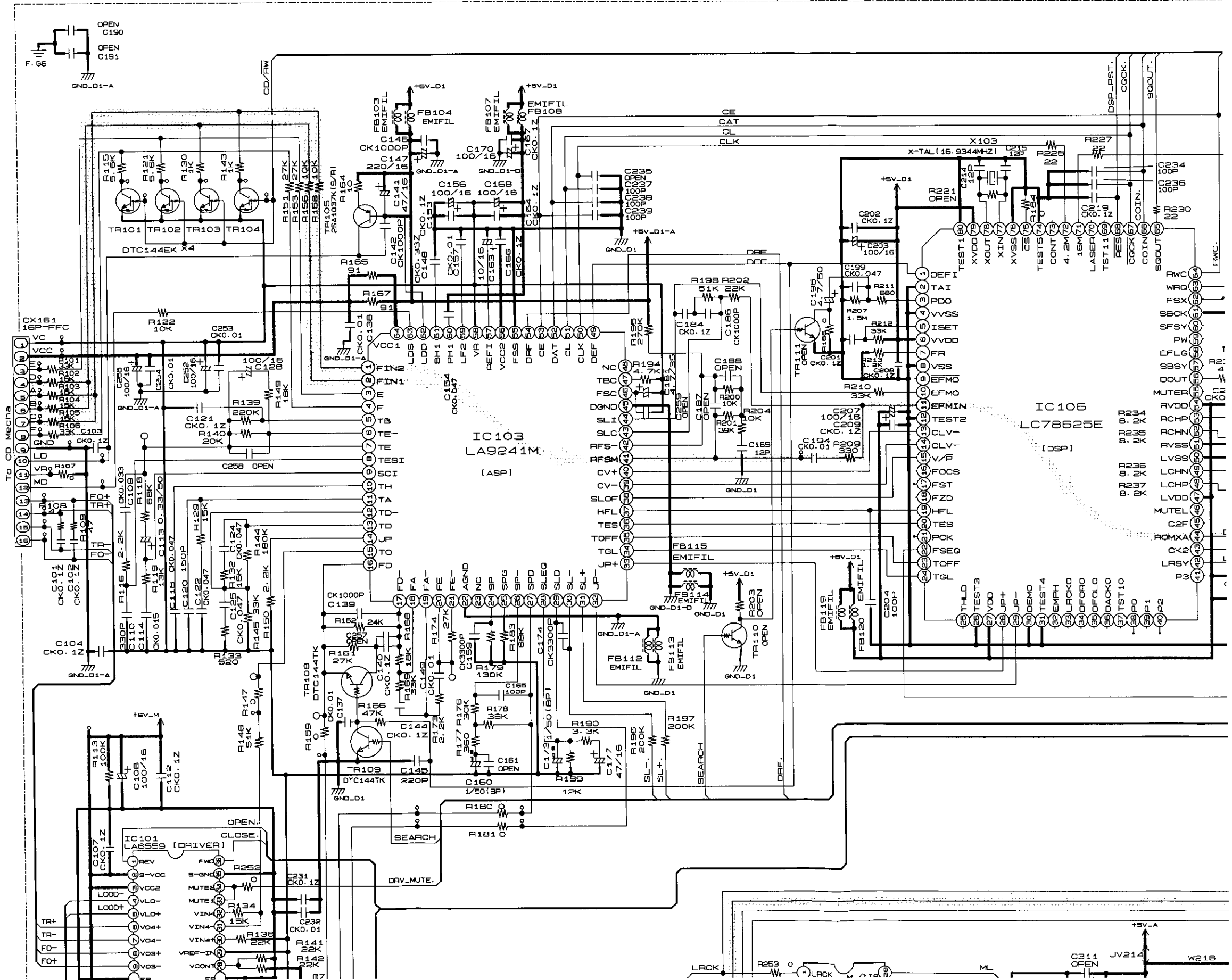

6

7

8

9

10

11

A

B

C

D

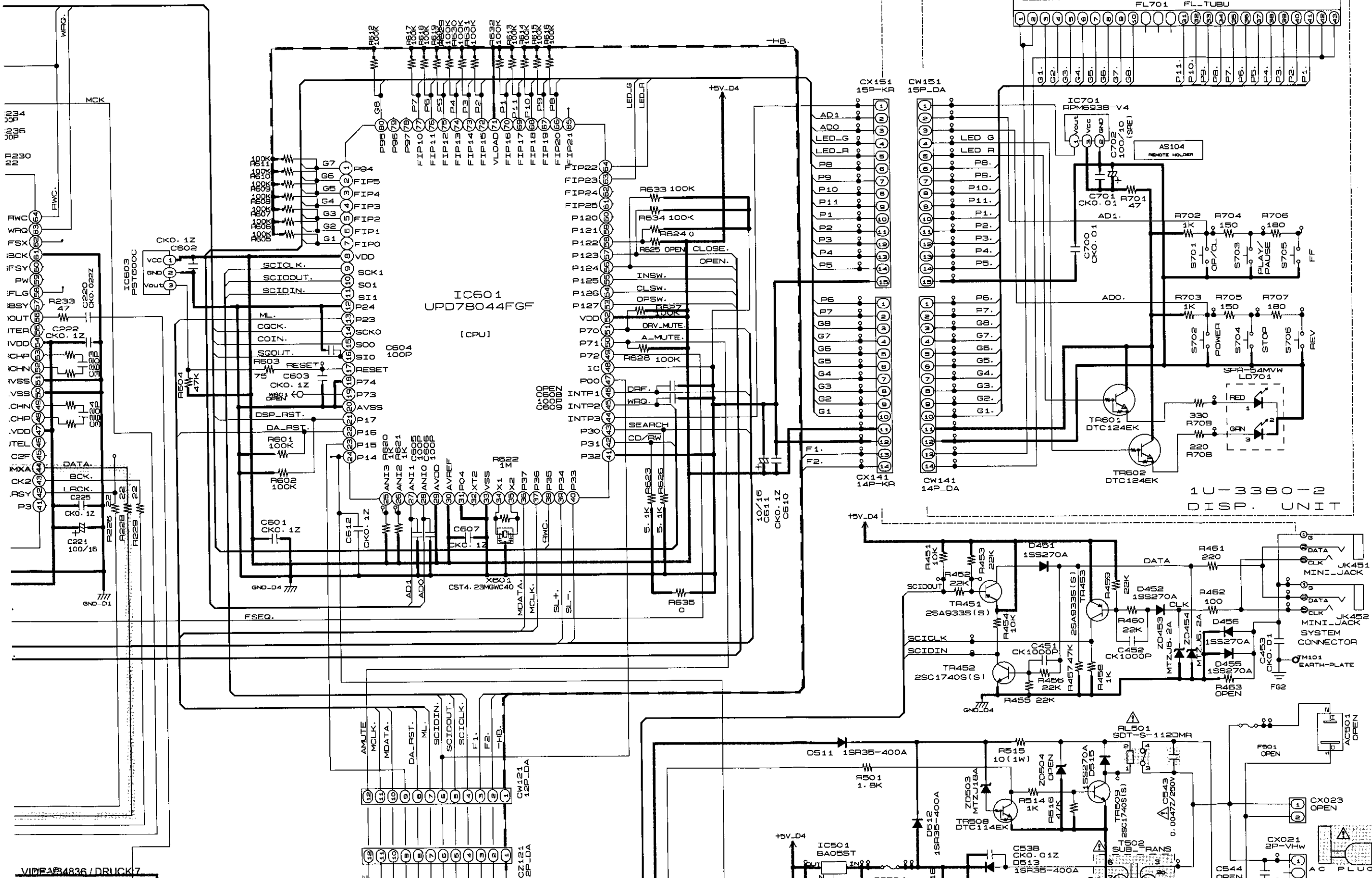

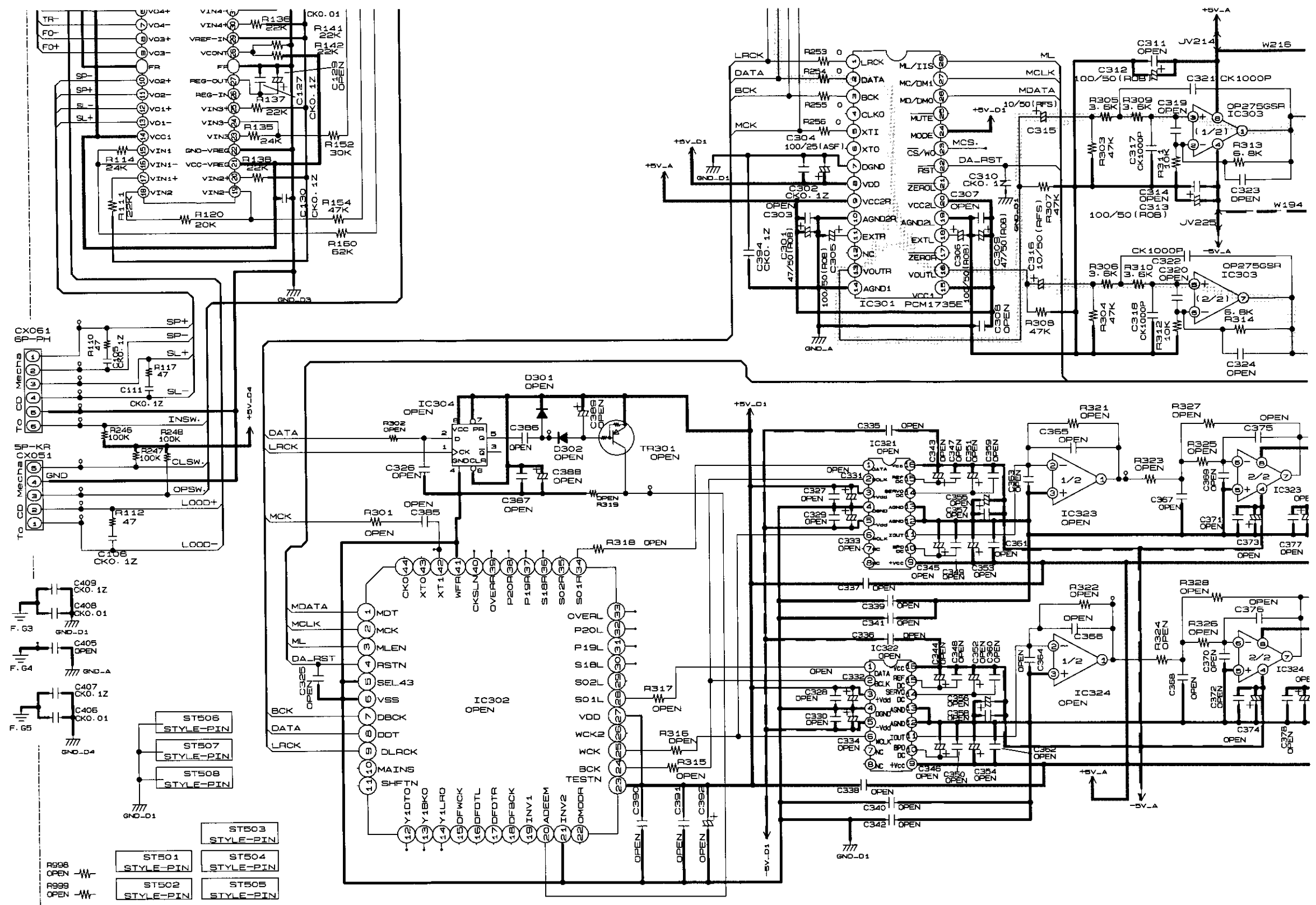

NOTICE
 ALL RESISTANCE VALUES IN OHM
 ALL CAPACITANCE VALUES IN MIC
 EACH VOLTAGE AND CURRENT AT
 CONDITION.
 CIRCUIT AND PARTS ARE SUBJEC
 NOTICE.

JV214	SHORT	E2/EK
JV225	SHORT	OPEN
W194	OPEN	1P WIRE (001 9002 057)
W216	OPEN	1P WIRE (001 9002 031)

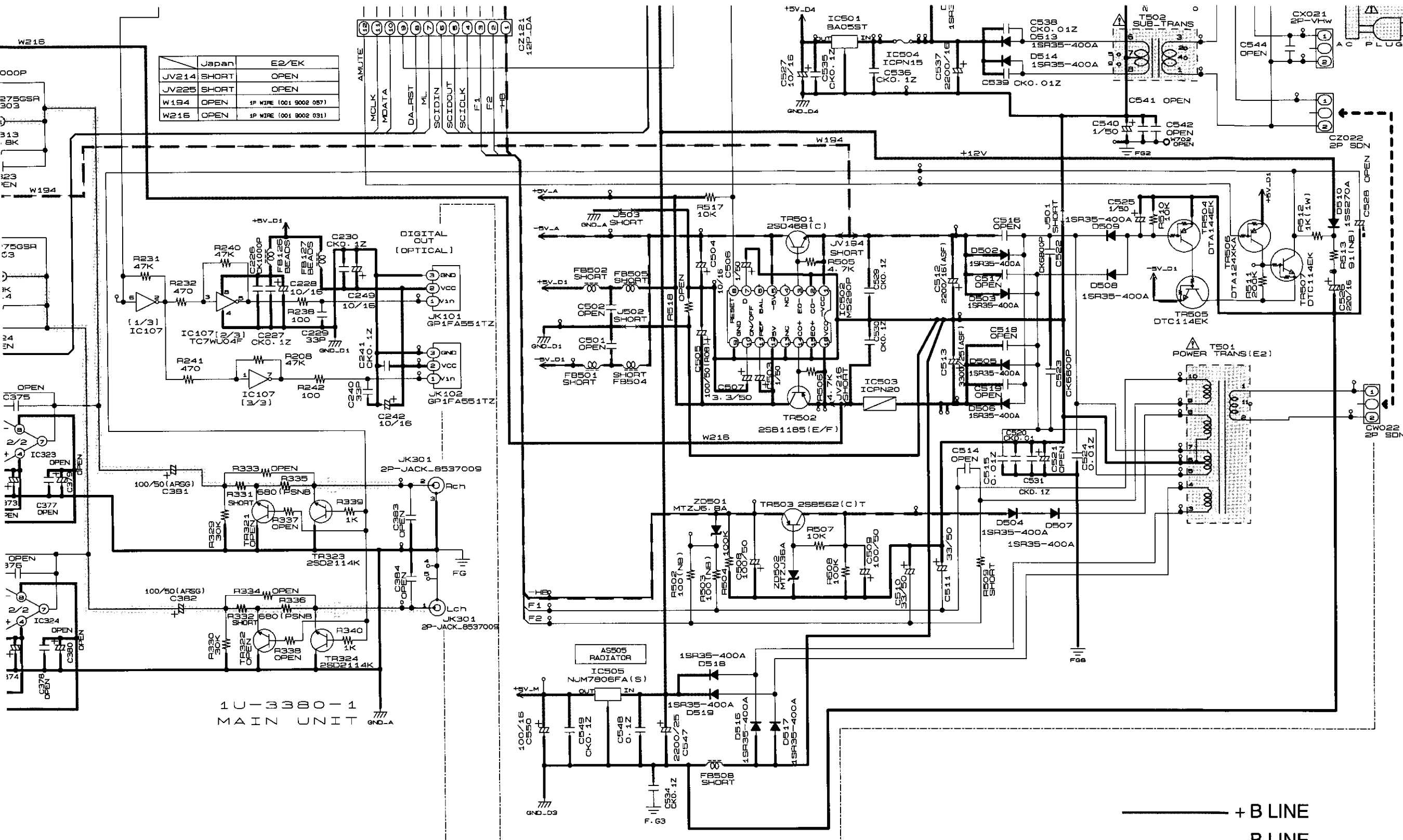

1U-3380-1
MAIN UNIT

WARNING:

Parts marked with this symbol  have critical characteristics. Use ONLY replacement parts recommended by the manufacture.

CAUTION:

Before returning the unit to the customer, make sure you make either (1) a leakage current check or (2) a line to chassis resistance check. If the leakage current exceeds 0.5 milliamps, or if the resistance from chassis to either side of the power card is less than 460kohms, the unit is defective.

WARNING:

DO NOT return the unit to the customer until the problem is located and corrected.

SCHEMATIC DIAGRAM
1U-3380-1 MAIN UNIT
1U-3380-2 DISP. UNIT

— + B LINE
- - - - - B LINE
..... SIGNAL LINE

Ω IN OHM. k=1,000 OHM M=1,000,000 OHM
μS IN MICRO FARAD. P=MICRO-MICRO FARAD
R ENT ARE MEASURED AT MO SIGNAL INPUT

SUBJECT TO CHANGE WITHOUT PRIOR