

DENON

Hi-Fi Component

SERVICE MANUAL

STEREO CD PLAYER

MODEL DCD-860/660



(Photo: DCD-860)

TABLE OF CONTENTS

OPERATING INSTRUCTIONS	2 ~ 12
SPECIFICATIONS	13
NOTE FOR HANDLING OF LASER PICK-UP	14 ~ 16
DISASSEMBLY	17
ADJUSTMENT	18 ~ 22
HEAT RUN MODE FUNCTION	23
IC TERMINAL FUNCTION	24 ~ 29
PARTS LIST OF P.W.BOARD	30, 31
PARTS LIST OF PACKING & ACCESSORIES	31
PARTS LIST OF EXPLODED VIEW	32
EXPLODED VIEW	33
PARTS LIST OF FG-415/416 MECHANISM UNIT	34
EXPLODED VIEW OF FG-415/416 MECHANISM UNIT	34
P.W.BOARD	35 ~ 37
WIRING DIAGRAM	38, 39
SEMICONDUCTORS	40
SCHEMATIC DIAGRAM	41, 42

NIPPON COLUMBIA CO., LTD.

IMPORTANT TO SAFETY

WARNING:

TO PREVENT FIRE OR SHOCK HAZARD, DO NOT EXPOSE THIS APPLIANCE TO RAIN OR MOISTURE.

CAUTION:

1. **Handle the power supply cord carefully**
Do not damage or deform the power supply cord. If it is damaged or deformed, it may cause electric shock or malfunction when used. When removing from wall outlet, be sure to remove by holding the plug attachment and not by pulling the cord.
2. **Do not open the top cover**
In order to prevent electric shock, do not open the top cover. If problems occur, contact your DENON DEALER.
3. **Do not place anything inside**
Do not place metal objects or spill liquid inside the CD player. Electric shock or malfunction may result.



CAUTION
RISK OF ELECTRIC SHOCK
DO NOT OPEN



CAUTION: TO REDUCE THE RISK OF ELECTRIC SHOCK, DO NOT REMOVE COVER (OR BACK). NO USER SERVICEABLE PARTS INSIDE. REFER SERVICING TO QUALIFIED SERVICE PERSONNEL.



The lightning flash with arrowhead symbol within an equilateral triangle is intended to alert the user of the presence of uninsulated "dangerous voltage" within the product's enclosure that may be of sufficient magnitude to constitute a risk of electric shock to persons.



The exclamation point within an equilateral triangle is intended to alert the user of the presence of important operating and maintenance (servicing) instruction in the literature accompanying the appliance.

IMPORTANT (BRITISH MODEL ONLY)

The wires in this mains lead are coloured in accordance with the following code:

Blue: Neutral Brown: Live

The colours of the wires in the mains lead of this apparatus may not correspond with the coloured markings identifying the terminals in your plug proceed as follows.

The wire which is coloured blue must be connected to the terminal which is marked with the letter N or coloured black.

The wire which is coloured brown must be connected to the terminal which is marked with the letter L or coloured red.

NOTE:

This CD player uses the semiconductor laser. To allow you to enjoy music at a stable operation, it is recommended to use this in a room of 5°C (41°F) – 35°C (95°F).

LABELS (for U.S.A. model only)

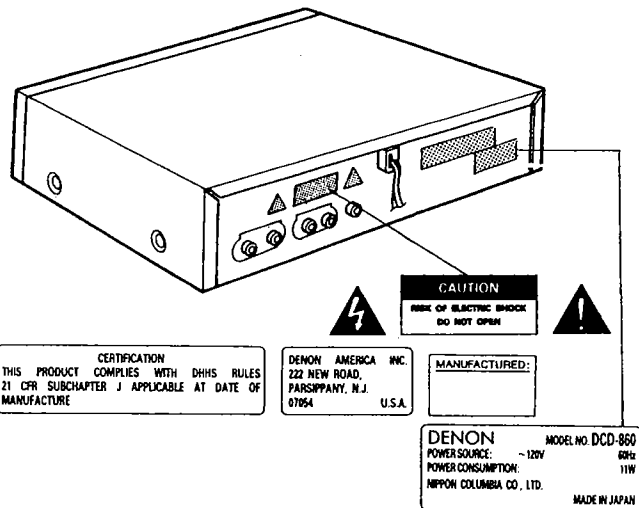

CAUTION:
USE OF CONTROLS OR ADJUSTMENTS OR REPERMANCE OF PROCEDURES OTHER THAN THOSE SPECIFIED HEREIN MAY RESULT IN HAZARDOUS RADIATION EXPOSURE.

THE COMPACT DISC PLAYER SHOULD NOT BE ADJUSTED OR REPAIRED BY ANYONE EXCEPT PROPERLY QUALIFIED SERVICE PERSONNEL.

NOTE:

This unit may cause interference to radio and television reception if you do not operate it in strict accordance with this OPERATING INSTRUCTIONS.

This unit complies with Class B computing device rules in accordance with the specifications in Sub-part J or Part 15 of the FCC Rules, which are designed to provide reasonable protection against such interference in a residential installation. If the unit does cause interference to any radio or television reception, try to reduce it by one or more of the following means:

- a) Turn the other unit to improve reception
- b) Move this unit
- c) Move this unit away from others
- d) Plug this unit respectively into a different AC outlet

* This is note in accordance with Section 15.838 of the FCC Rules.

Thank you for purchasing this DENON Compact Disc Player. Please read the operating instructions thoroughly in order to acquaint yourself with the CD player and achieve maximum satisfaction from it.

— TABLE OF CONTENTS —

FEATURES	3
NAMES AND FUNCTIONS OF PARTS	4, 5
CONNECTION	6
OPENING AND CLOSING THE DISC HOLDER AND LOADING A DISC	6
NORMAL CD PLAYBACK	6
ADVANCED CD PLAYBACK	7 ~ 11
TIMER-CONTROLLED PLAYBACK	11
THE COMPACT DISC	11
PLAYBACK USING THE REMOTE CONTROL UNIT	12

Please check to make sure the following items are included with the main unit in the carton:

- | | |
|-----------------------------------|---|
| (1) Operating Instructions | 1 |
| (2) Connection Cord | 1 |
| (3) Remote Control Unit | 1 |
| (4) R6P AA Dry Cell Battery | 2 |

VAROITUS: SUOJAKOTELOA EI SAA AVATA. LAITE SISÄLTÄÄ LASERDIODIN, JOKA LÄHETTÄÄ NÄKYMÄTÖNTÄ SILMILLE VAARALLISTA LASERSÄTEILYÄ.

ADVARSEL: USYNLIG LASERSTRÅLING VED ÅBNING NÅR SIKKERHEDSAFBRYDERE ER UDE AF FUNKTION. UNDGÅ UDSAETTELSE FOR STRÅLING.

WARNING: OSYNLIG LASERSTRÅLNING VID AVLÄGSNANDE AV APPARATENS HÖLJE. UNDVIK EXPONERING AV LASERSTRÅLNING.



"CLASS 1
LASER PRODUCT"

FEATURES

This Compact Disc Player incorporates DENON's Super Linear Converter which prevents deterioration of sound quality in PCM playback systems. This assures accurate reproduction of the digital signals recorded on compact discs no matter whether they are pure studio recordings or "live" performance recordings. All parts making up this CD player have selected with the greatest care in order to produce high quality realistic playback of the full musical content on compact discs.

(1) Double Super Linear Converter

The use of Denon's unique system and D/A converters with excellent resolution to prevent zero cross distortion, the main cause of reduced sound quality in the PCM playback system, make for sound field reproduction with rich musical expression.

(2) High Performance Digital Filter

This player uses independent D/A converters for the left and right channels and an 8x oversampling high precision digital filter to bring out the best of the analog filter and offer clear, crisp sound.

(3) Digital Output [DCD-860 Only]

The data on the compact disc is output in digital format, so the music can be reproduced on an external digital processor or D/A unit.

(4) Simple Playback of 8cm CD Singles

8cm CD singles can be played without using an adaptor.

• Line Voltage Selection (for multiple voltage model only)

- * The desired voltage may be set with the VOLTAGE SELECTOR knob on the rear panel, using a screwdriver.
- * Do not twist the VOLTAGE SELECTOR knob with excessive force as this may cause damage.
- * If the VOLTAGE SELECTOR knob does not turn smoothly, please contact a qualified serviceman.

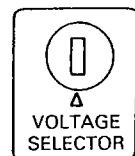

NAMES AND FUNCTIONS OF PARTS

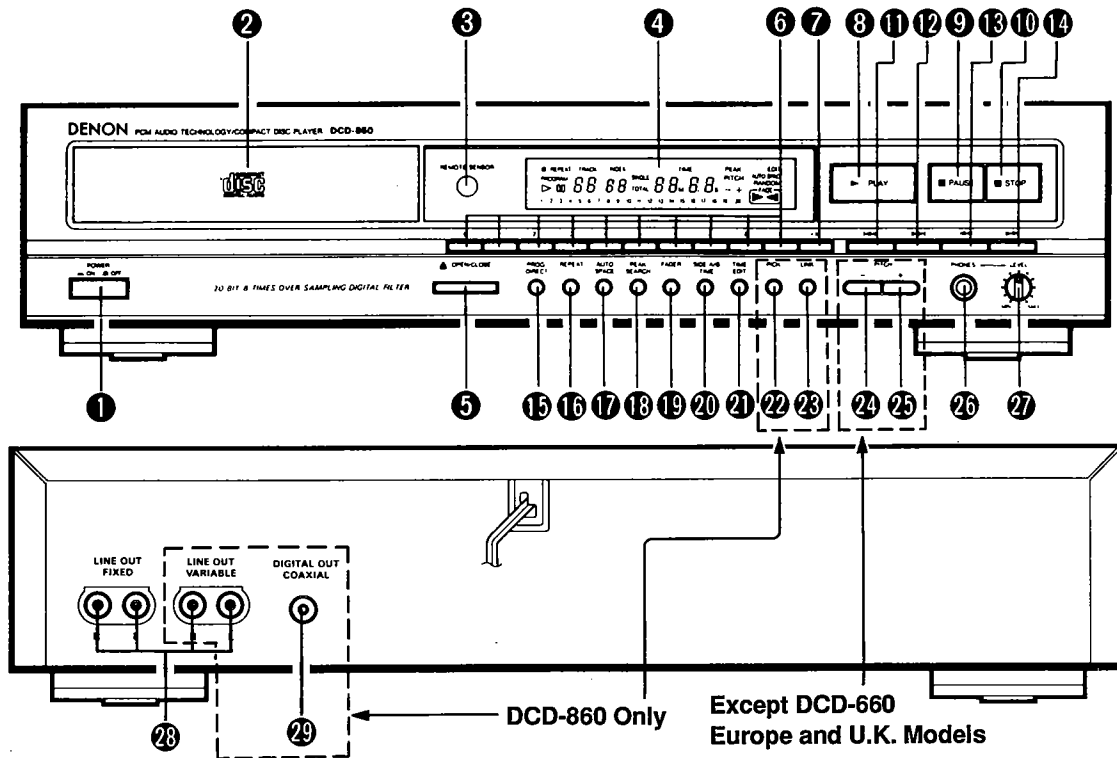

1 Power Switch (POWER)

- When the power is turned on, "(-20)" appears on the TIME display, and if no disc is loaded, "(0000000)" appears on the digital display.
- If the power is turned on with a disc already loaded, the total number of tracks on the disc is displayed on the TRACK NO. display, the total time is displayed on the TIME display, the numbers on the music calendar light up to the number of tracks on the disc, and playback begins.
- When the power is turned off, the unit is set to the standby mode.

2 Disc Holder

- Place the disc on the disc holder with the label facing up.
- Use the open/close button (▲ OPEN/CLOSE) 5 to open and close the disc holder.
- The disc holder may also be closed by pressing the play button (▶ PLAY) 8 or pause button (⏸ PAUSE) 9.

3 Remote Control Sensor (REMOTE SENSOR)

- This sensor receives the infrared light transmitted from the wireless remote control unit.
- For remote control, point the supplied remote control unit towards this sensor.
- When a signal is transmitted from the remote control unit, the remote control indicator in the display 4 will light up briefly.

4 Display

- The digital display is divided into sections, such as displays for track number, index, playback time and calendar, as shown below.

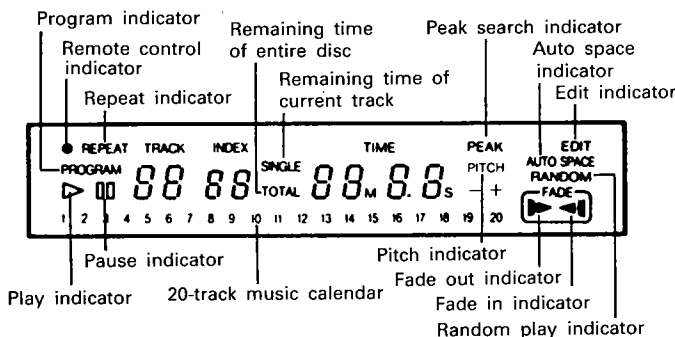

5 Open/Close Button (▲ OPEN/CLOSE)

- The disc holder is opened and closed by pressing this button.
- Press this button once to open the disc holder, and once again to close it.
- When the disc holder is closed with a disc loaded, the disc will rotate for a couple of seconds while the disc contents are read. The number of tracks and total playback time on the disc are then displayed on the digital display 4.

6 Number Buttons (0, 1, 2, 3, 4, 5, 6, 7, 8, and 9)

- Use these buttons for the direct search and program memory functions.
- For direct search, press for example button 3 if you want to hear track number 3. For track number 12, press [+10] then 2. To program tracks, press the PROG/DIRECT button 16 to set to the program mode.

7 +10 Button (+10)

- Press this button first when selecting track numbers over 10. Use it together with the number buttons 6. For example, to select track number 15, press [+10] then 5. For track number 33, press [+10] three times, then press 3.

8 Play Button (▶ PLAY)

- Press this button to start playback of a disc.
- When this button is pressed, ▶ is displayed, and the track number being played is displayed together with the elapsed playback time of the track.
- Tracks are shown on the calendar display. Once a track has been played, the corresponding track number goes out on the calendar display.

9 Pause Button (⏸ PAUSE)

- Press this button to stop playback temporarily.
- If this button is pressed during playback, playback is stopped temporarily, the ▶ indicator goes out and the ⏸ indicator temporarily.
- Press this button or the play button (▶ PLAY) again to continue playback.

- 10 Stop Button (■ STOP)**
- Press this button to stop playback. The disc will stop rotating, and the number of tracks and total playing time of the disc are displayed on the TRACK NO. and TIME displays, respectively.
 - In case programmed playback is engaged when this button is pressed, the number of tracks and total playing time of the program are displayed.
- 11 Automatic Search Reverse Button (⏮)**
- Press this button to return the pickup to the beginning of the present track. Press again to return to other tracks.
 - By pressing the button a number of times, the pickup will move back the corresponding number of tracks.
- 12 Automatic Search Forward Button (⏭)**
- Press this button to move the pickup forward to the beginning of the next track. Press again to move ahead to other tracks.
 - By pressing the button a number of times, the pickup will advance the corresponding number of tracks.
- 13 Manual Search Reverse Button (⏪)**
- Press this button during playback for fast reverse search. As long as the button is kept pressed, music signals are played back faster than normal.
 - Pressing this button when the pause mode is engaged, you can quickly reverse the pickup to a desired position, three times faster compared to manual reverse search during playback. During this time, no sound is heard.
- 14 Manual Search Forward Button (⏩)**
- Press this button during playback for fast forward search. As long as the button is kept pressed, music signals are played back faster than normal.
 - Pressing this button when the pause mode is engaged, you can quickly forward the pickup to a desired position, three times faster compared to manual forward search during playback. During this time, no sound is heard.
- 15 Program/Direct Button (PROG/DIRECT)**
- Press this button when you want to enter tracks for programmed playback. (Refer to page 7 for details.)
- 16 Repeat Button (REPEAT)**
- Press this button to repeat playback of all tracks.
 - When this button is pressed, **REPEAT** lights on the display and all tracks on the disc or in a program will be repeatedly played back. Press this button once more to disengage the Repeat All function.
- 17 Auto Space Button (AUTO SPACE)**
- Pressing this button will cause the **AUTO SPACE** indicator to light and a blank space of approximately 4 seconds is inserted between tracks during CD playback. Pressing the button once more, the **AUTO SPACE** indicator goes out and the Auto Space feature is cancelled.
 - When one of the track search buttons (⏮ or ⏭) is pressed, the Auto Space function will not operate.
 - The Auto Space function will work during normal playback as well as programmed playback.
 - Although 4-second blanks are inserted between tracks, this additional time is not reflected by the indication on the time remaining display or time display when the Auto Edit function is engaged.
- 18 Peak Search Button (PEAK SEARCH)**
- Press this button to search for the peak level. (Refer to Page 10, 11)
- 19 Fader Button (FADER)**
- Press this button to perform fade out or fade in. (Refer to Page 10.)
- 20 Side A/B and Time Mode Button (SIDE A/B TIME)**
- Press this button to switch between the display of side A and side B of the tape during the time edit operation. (Only when stopped.)
 - This button is used to select the desired indication on the TIME display. The indication on this display will change each time the button is pressed. Normally, the elapsed playback time of the current track is displayed. Pressing the button once, **SINGLE** is displayed and the remaining time of the current track is displayed. Pressing once more, **TOTAL** is displayed, and total playing time of remaining tracks is displayed. However, when programmed play is in progress, the total remaining time of the program is displayed. Press the button once again to return to the normal display of the elapsed playback time of the current track.
- 21 Time Edit Button (TIME EDIT)**
- Press this button to edit in conjunction with the tape time. (Refer to Page 9.)
- 22 Pick Button (PICK) [DCD-860 Only]**
- Press this button when substituting a track with the time edit. (Refer to Page 9, 10.)
- 23 Link Button (LINK) [DCD-860 Only]**
- Press this button when editing spans a number of discs. (Refer to Page 10.)
- 24 Pitch - Button (PITCH -)**
[Except DCD-660 Europe and U.K. Models]
- Press this button to slow down the playing speed. (Refer to Page 11.)
- 25 Pitch + Button (PITCH +)**
[Except DCD-660 Europe and U.K. Models]
- Press this button to make the playing speed faster. (Refer to Page 11.)
- 26 Headphones Jack (PHONES)**
- For private listening, you can connect your headphones to this jack. Do not raise the volume level too much when listening through headphones. (Headphones are sold separately.)
- 27 Volume Control (PHONES LEVEL)**
- Use this to adjust the output level (VOLUME) of the headphones.
- 28 Output Terminal (FIX-VARIABLE)**
[VARIABLE: DCD-860 Only]
- Connect these jacks to the input jacks on your amplifier. (Refer to page 6 for details on the connections.)
- 29 Digital Output Jack (COAXIAL) [DCD-860 Only]**
- This jack outputs digital data.
 - We recommend using a 75-ohm pin cord (available in stores) for connections.

Continuous Operation

If the automatic search reverse button ①, the automatic search forward button ②, the pitch - button ④, the pitch + button ⑤ or the +10 button ⑦ are held in, the function of that button will be repeated.

CONNECTION

(1) Connecting the Output Terminal (FIX-VARIABLE) [VARIABLE: DCD-860 Only]

Use the included pin cords to connect the left (L) and right (R) output terminal (FIX-VARIABLE) of this player to the CD, AUX, or TAPE PLAY left (L) and right (R) input jacks of the amplifier. There are two types of output jacks, one of the variable type and one of the fixed type. Be sure to use the variable outputs if you want to be able to control the output level from this player.

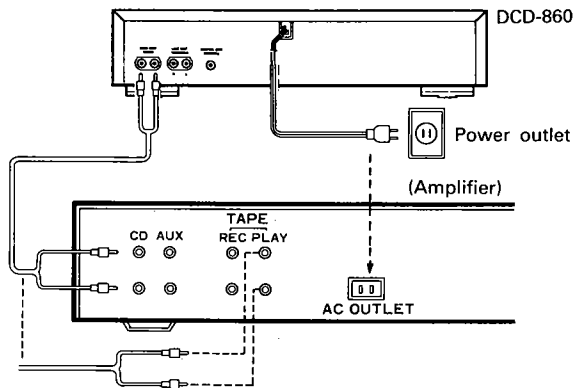

(2) Connecting the Digital Output Jack (COAXIAL) [DCD-860 Only]

Use a 75-ohm pin cord to connect the digital output jack (COAXIAL) of the DCD-860 to the digital input jack (COAXIAL) on a digital processor or D/A unit, available in stores.

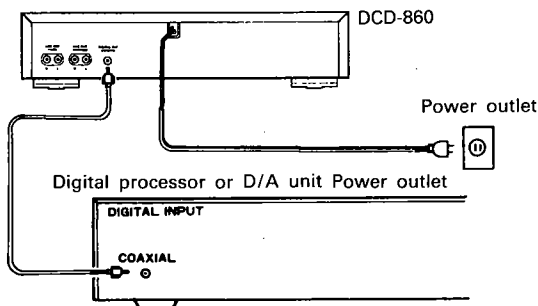

Connection Precautions

- Before proceeding with connections or disconnections of cables and power cords, be sure to turn all system components off.
- Ensure that all cables are connected properly to the L (left) and R (right) jacks.
- Insert plugs fully into the terminals.
- Connect the output jacks to the amplifier CD, AUX or TAPE PLAY input jacks.

OPENING AND CLOSING THE DISC HOLDER AND LOADING A DISC

Opening and closing the disc holder (This operation only works while the power is on.)

1. Press the power switch (POWER) to turn on the power.
2. Press the open/close button (▲ OPEN/CLOSE).

How to load a disc

- Make sure the disc holder is completely open.
- Hold the disc by the edges and place it on the disc tray. (Do not touch the signal surface, i.e., the glossy side.)
- When using 12 cm. diameter discs, make sure the outer edge matches the tray guide circumference (Fig. 1), and when using CD singles (8 cm. diameter) match the outer edge with the inner tray guide circumference. (Fig. 2)
- Press the open/close button (▲ OPEN/CLOSE) to close the disc holder.
- When the disc holder is closed, the disc is read and after a few seconds the number of tracks and total playing time are displayed on the TRACK NO. and TIME displays, respectively.

- When the disc holder is open and a disc is loaded, you may also press the play (▶ PLAY) or pause (⏸ PAUSE) button to close the disc holder. (If the play button (▶ PLAY) is pressed, playback will start immediately upon the disc contents having been read.)

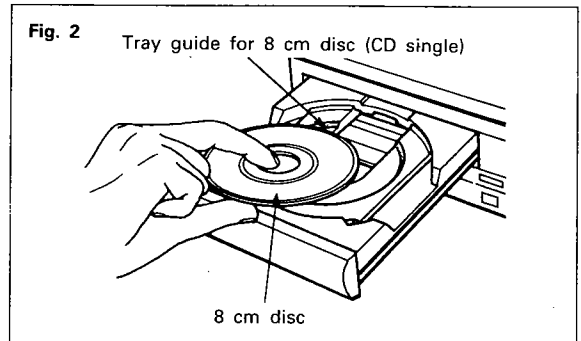
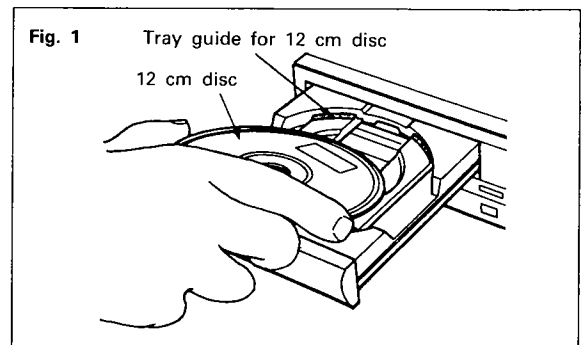

Caution:

- If your finger should get caught in the disc holder when it closes, press the open/close button (▲ OPEN/CLOSE).
- Do not place any foreign objects on the disc tray, and do not place more than one disc on the tray at a time. Otherwise malfunction may occur.
- Do not push in the disc tray manually when the power is off as this may cause malfunction and damage the CD player.

NORMAL CD PLAYBACK

(1) Starting Playback

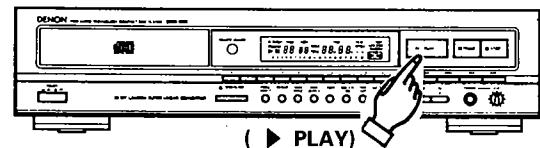

1. Press the power switch (POWER) to turn on the power.
2. Load the disc you want to play.
 - When the disc holder is closed, the disc is read and the number of tracks and total playing time of the disc are displayed.
3. Press the play button (▶ PLAY).

(2) Stopping Playback

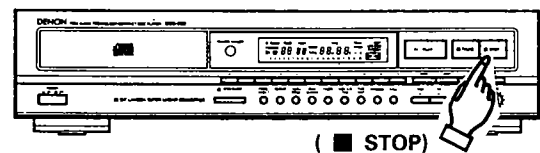

1. Press the stop button (■ STOP).
- When all tracks have been played on a disc, playback will stop by itself.

Precautions:

- If no disc has been loaded or the disc has been placed upside down, all indicators will light.
- When the information on the disc cannot be read correctly, for example due to dust or dirt on the disc, the indicators will read as shown below. Nothing will be shown on the TRACK NO. and TIME displays, and it may take quite a while to read the disc.

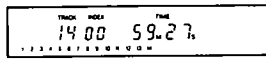

Normal display

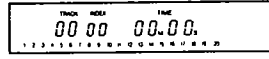

Improper display

ADVANCED CD PLAYBACK

1 Playing a Specific Track Direct Search

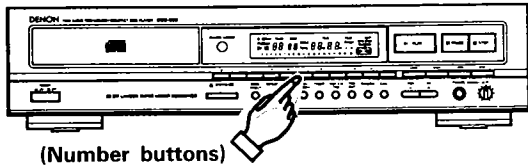

- Use the number buttons and the +10 button to input the number of the desired track.
- For example, to play track number 4, press **[4]**, and to play track number 12, press **[+10]** and **[2]**. Playback will begin from that track.

2 Advancing to the next track during playback Automatic Search

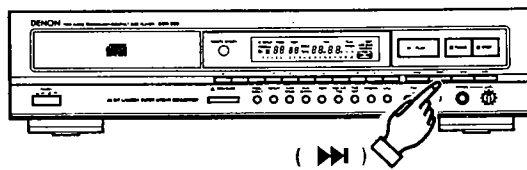

- Press the Automatic search forward button (▶▶) during playback.
- The pickup will advance to the beginning of the next track and playback will continue. Pressing the button several times will forward the pickup the corresponding number tracks.

3 Returning to the beginning of the current track during playback Automatic Search

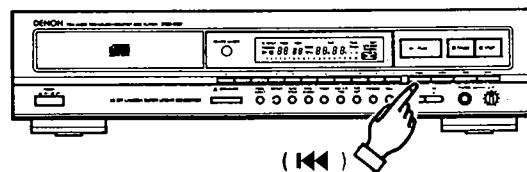

- Press the Automatic search reverse button (◀◀) during playback.
- The pickup will return to the beginning of the current track and playback will continue. Pressing the button several times will return the pickup the corresponding number tracks.

4 Playing Specific Tracks in a Specific Order Programmed Play

- With this function, you can choose any of the tracks on the disc and program them to play in any order.
- Programming is possible with the disc holder open.
- Up to 20 tracks can be programmed.
- The programmed tracks are shown on the calendar.

(1) Programming

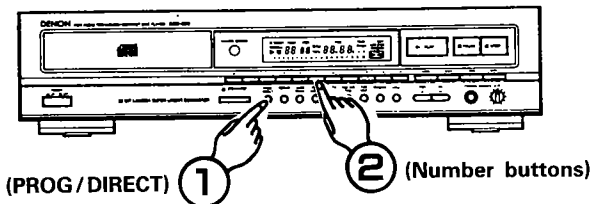

- Press the PROG/DIRECT button so that the **PROGRAM** indicator lights, then use the number buttons and the +10 button to program the tracks.
- For example, to program tracks 3, 12, and 7, press **[PROG/DIRECT]**, **[3]**, **[+10]**, **[2]**, and **[7]**.
- The corresponding track number lights on the calendar each time a track is programmed, the track number is displayed on the TRACK NO. display, and the total playing time of the programmed tracks is displayed on the TIME display. A few seconds after the last track has been programmed, the total number of tracks programmed is displayed on the TRACK NO. display and the total playing time of the programmed tracks is displayed on the TIME display.

(2) Checking the Programmed Tracks (Remote control only)

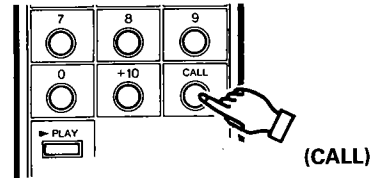

- Press the CALL button.
- The programmed tracks are displayed in order on the TRACK NO. display each time the CALL button is pressed.

(3) Playing the Programmed Tracks

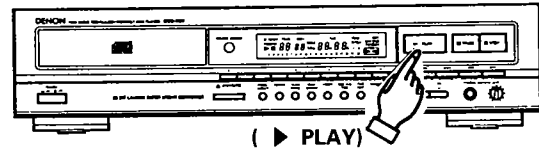

- Press the (▶ PLAY) button to play the tracks in the programmed order.

(4) Clearing the Program

- The entire program is cleared when the PROG/DIRECT button is pressed again. The program is also cleared when the (▲ OPEN/CLOSE) button is pressed.
- If the PROG/DIRECT button is pressed during programmed play, the program is cleared and playback continues normally through to the last track on the disc.

NOTES

- If programming is done in the play or pause mode, the track currently playing is programmed at the first position. Other tracks can be added to the program, but the number of programmed tracks and the playing time will not be displayed.
- Direct search is not possible during programmed play. If the number buttons are pressed, that track is added to the end of the program.
- Programming is possible with the disc holder open. Track numbers greater than the number of tracks recorded on the disc can be programmed, but will be automatically cleared before playback begins.
- The remaining time per track will only be displayed for track numbers 1 through 20.
- The total program time and remaining program time are not displayed if tracks greater than track number 20 are programmed.

5 Repeating playback Repeat

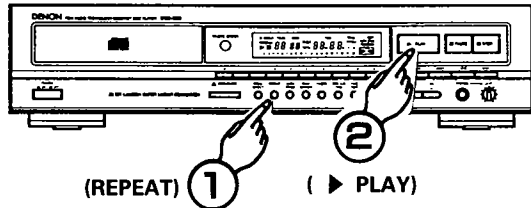

- ① Press the repeat button (REPEAT).
- ② Press the play button (▶ PLAY).
 - Pressing the repeat all tracks button (REPEAT), [REPEAT] is displayed.
 - Steps ① and ② above may be reversed.
 - To cancel repeat playback of all tracks, press the repeat button (REPEAT) once more.
 - Pressing the repeat button (REPEAT) during programmed playback, playback of the tracks entered into the memory will be repeated.

6 Pausing playback at any point Pause

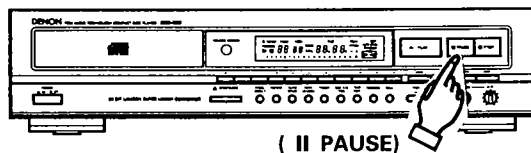

- Playback can be temporarily halted and then continued from the same point in the track.
1. Press the pause button (|| PAUSE) during playback.
 2. To continue playback, press the play button (▶ PLAY) or the pause button (|| PAUSE) once more.

7 Audible quick search Manual Search

- Using this function, you can cue to a desired point within a track, either in the forward or reverse direction.
- Release the manual search button (◀◀ or ▶▶) when the desired point has been reached. Normal playback then continues.

(1) Manual Search Forward

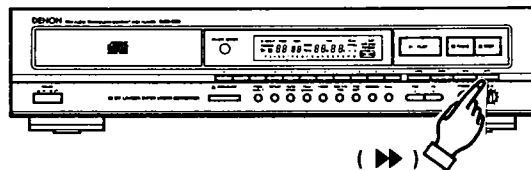

1. Press the manual search forward button (▶▶) during playback. Playback of the track is sped up.
- As a reference, the current track number and elapsed playback time within the track are displayed.
- Manual search forward is approximately three times faster when engaged during the pause state compared to playback. In this case, no sound is heard however.
- If the manual search forward button (▶▶) is kept pressed after the end of the final track on the disc is reached, [JJ] is displayed and manual search stops. To return to another point, press the manual search reverse button (◀◀) until [JJ] disappears.

(2) Manual Search in Reverse

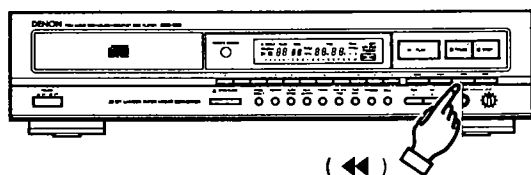

1. Press the manual search reverse button (◀◀) during playback. Reverse playback of the track is sped up.
 - As a reference, the current track number and elapsed playback time within the track are displayed.
 - Manual search in reverse is approximately three times faster when engaged during the pause state compared to playback. In this case, no sound is heard however.
 - If the manual search reverse button (◀◀) is kept pressed after the beginning of the first track on the disc is reached, [LL] is displayed and manual search stops. To return to another point, press the manual search forward button (▶▶) until [LL] disappears.

8 Inserting blanks between tracks Auto Space

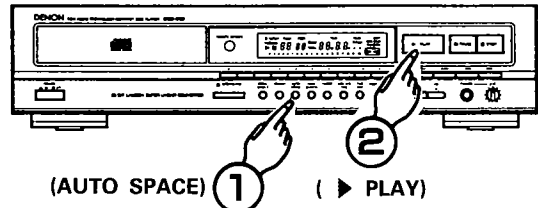

- This is convenient feature that will insert 4-second blanks between tracks, which can be used when recording compact discs on tape.

1. Pressing the auto space button (AUTO SPACE) will cause the [AUTO SPACE] indicator to light.
2. Press the play button (▶ PLAY) to start playback. When a track has been played to its end, a 4-second silence is made before the next track starts playing.
3. Press the auto space button (AUTO SPACE) again to cancel the function.

9 Searching and Pausing at the Beginning of the Track Pause

(1) With Direct Search

- In this case, the set pauses at the beginning of the track found with the direct search operation.

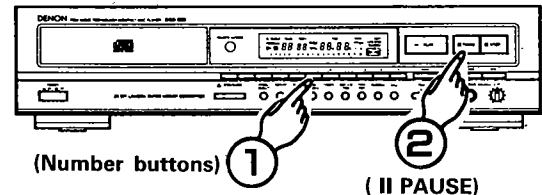

1. Press the number button(s) for the desired track.
2. Press the (|| PAUSE) button.
 - To start playback, press the (▶ PLAY) or (|| PAUSE) button.

(2) With Program Search

- Press the (|| PAUSE) button after the program search operation is completed. The set will pause at the beginning of the first programmed track.

10 Playing in Random Order **Random Play**

(Remote control only)

- With this function, the tracks recorded on the disc can be played in a completely random order.

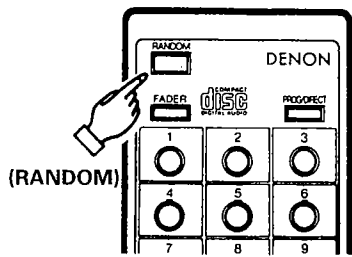

(RC-226/227)

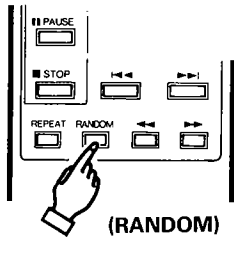

(RC-223/224)

- When the RANDOM button is pressed, the **RANDOM** indicator lights and random play begins automatically.
- If the RANDOM button is pressed when tracks have been programmed, only the programmed tracks will be played, in random order.
- If the RANDOM button is pressed when the repeat function is set, the tracks will be played through once in random order, then played through again in a different order, etc.
- During random play, all of the tracks on the disc are displayed rapidly on the TRACK NO. display, and the track which will be played next cannot be known until playback starts.

NOTE:

- The remaining time in the total mode cannot be displayed during random play.
- If the RANDOM button is pressed when in the time edit mode, the time edit mode is cleared.

11 Edit Recording on Sides A and B of the Tape **Edit Function**

(1) Editing by Tape Time Specification (TIME EDIT)

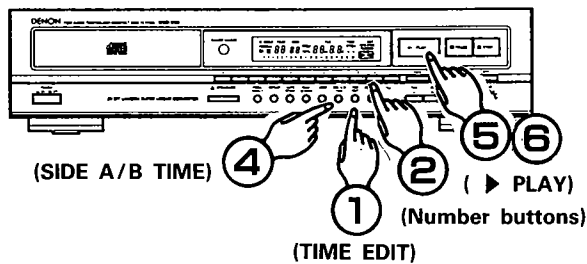

The time edit function permits highly efficient editing in conjunction with the length (tape time) of the cassette tape to be recorded.

- ① When the TIME EDIT button is pressed, (⌂-...) will appear and the player will wait for the tape time to be input. **EDIT** will light up.

Example of tracks being placed in the blank spaces

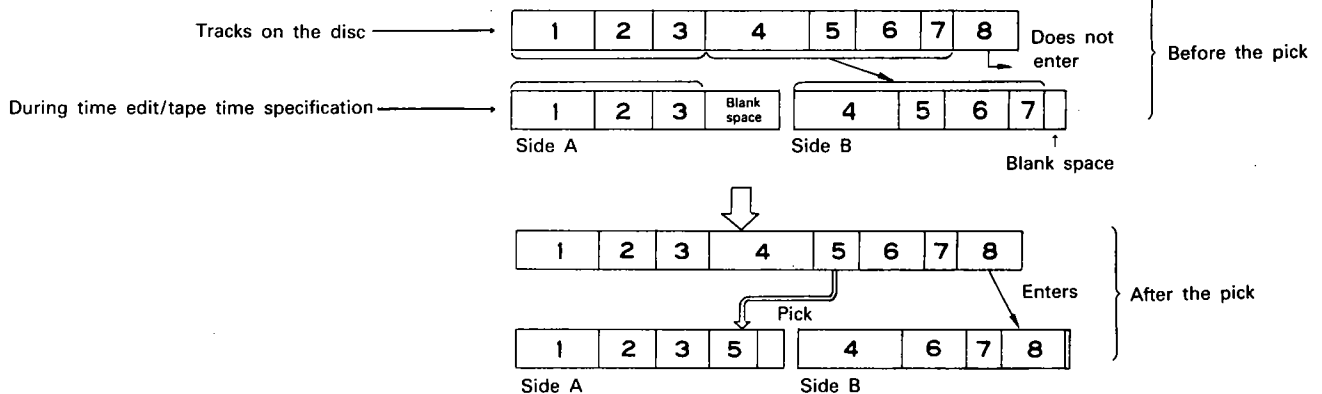

- ② Input the tape time with the number buttons. (The tape time is the total time of sides A and B.)
Example: For a 46-minute tape, press 4 and 6.
- ③ When the tape time has been specified, the tracks of side A that can be recorded are displayed on the calendar and the blank time of tape side A is displayed at TIME. (B -) is displayed at TRACK NO. and the number of tracks that can be recorded are displayed at INDEX.
- ④ Pressing the SIDE A/B TIME button permits a check of the calendar display of the tracks that can be recorded on side B and the blank time. (b -) is displayed at TRACK NO. and the number of tracks that can be recorded are displayed at INDEX. Each press of this button alternately displays side A and side B.
- ⑤ Pressing the play button (▶ PLAY) starts the play from the first track of side A. When side A has finished playing, the player will automatically pause at the beginning of the first track of side B.
- ⑥ Pressing the play button (▶ PLAY) or the pause button (|| PAUSE) again will start the play mode. When side B has finished playing, the player automatically stop.

When a mistake has been made in the time specification and the play button (▶ PLAY) has not yet been pressed, pressing the TIME EDIT button will return the settings to the condition of Step ①. This can be done any number of times.

- ⑦ The time edit function also works in the program track selection mode (Page 7). In this mode, sides A and B can be divided according to the program order. When the auto space function has been turned on, 4 seconds will be added to the play time of each track.

NOTE:

- The time edit function will not work for discs containing more than 20 tracks.
- The automatic search buttons (⏪ , ⏩) and the manual search buttons (⏴ , ⏵) do not function during the time edit operation.
- Pressing the stop button (■ STOP) or the open/close button (▲ OPEN/CLOSE) (except for at the time of the link operation) will cancel the time edit operation.

(2) Pick Function (PICK) [DCD-860 Only]

In (1) time edit, the tracks are ordered from the first track or in the programmed order so that a large blank space might remain at the end of the tape. The pick function is used to shorten this blank space and effectively use the time of the specified tape.

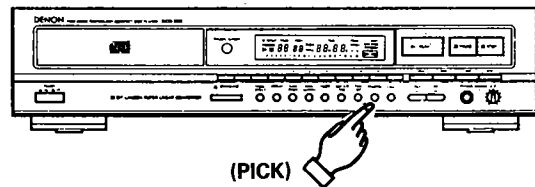

- ① In (1) time edit, press the pick button (PICK) following the tape time specification and before pressing the play button (▶ PLAY).
- ② When the display is showing side A, pick is executed from among the tracks other than those fixed on side A (in the blank portion of side A). When the display is showing side B, pick is executed from among the unfixed tracks (in the blank portion of side B).

- ③ When there are no tracks that can be picked in the blank portion of side A (side B), cancel the last track of side A (side B), increase the blank portion, and pick an available track in the new blank portion. At this time the tracks cancelled from side A are automatically fixed on side B.
- When there are no tracks that can be picked even though the last track of side A (side B) has been cancelled, the setting will remain the same even if the cancellation is suspended.

Example of tracks not being placed in the blank spaces

When tracks are not placed in blank spaces as shown in the diagram to the right, the last track (track 3 in the example) is cancelled and substituted with a track from side B.

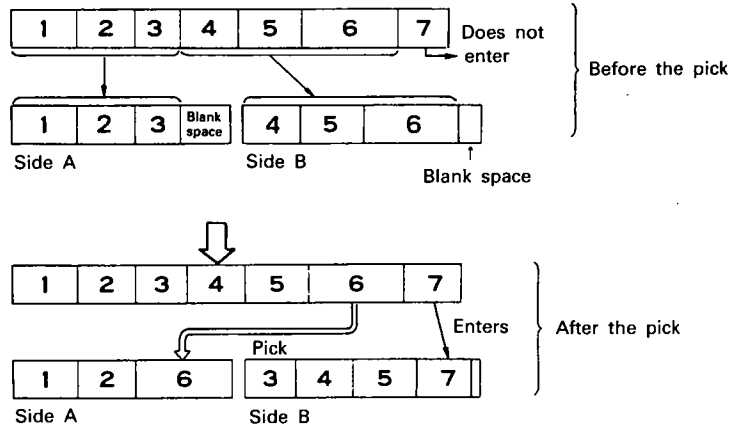

(3) Link Function (LINK) [DCD-860 Only]

The link function provides the convenience of editing a number of discs in succession.

The link operation is used following the tape time specification of the time edit function and before the end of playback.

- ① When the link button (LINK) is pressed, [EDIT] will start flashing.
- ② After the tracks have been played, the player will stop automatically. The blank time of the tape will be displayed at this time.
- ③ Press the open/close button (▲ OPEN/CLOSE) of the disc holder and change the disc.
- ④ Pressing the time edit (TIME EDIT) button will permit editing using the blank time of the tape in Step ②.

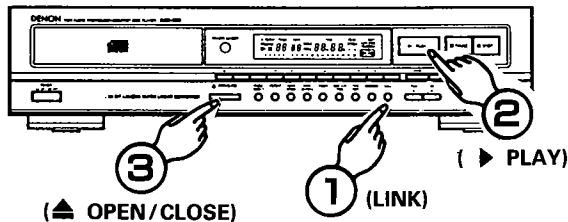

NOTE:

- The link operation is cancelled by the stop button (■ STOP). It will also be cancelled if the disc holder is opened during play.
- When editing has not been performed as far as side B with the time edit (i.e., only for part of side A), editing will be done within the blank time of side A and the blank time of side B.
- When editing has been performed as far as side B with the time edit, the blank time of side B will be used for editing.

⑫ Fading Out or Fading In at the Desired Location Fader Function (Analog output only)

(1) Fading out and fading in is possible at the desired position during play Manual Fader

- ① **Fade Out**
When the fader button (FADER) is pressed during play, fade out will be provided for about 5 seconds. (FADE) will light up during the operation and (▶) will flash. When fade out is completed the player will automatically pause.
- ② **Fade In**
When the fader button (FADER) is pressed in the pause mode, the player will start playing and fade in will be provided for about 3 seconds. (FADE) will light up during the operation and (◀) will flash.

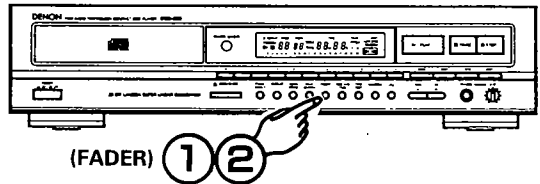

(2) Setting the Fade Out Time in Advance (TIME FADE)

- ① When the fader button (FADER) is pressed in the stop mode, the FADE indicator (FADE) will light up, TIME will appear as —M—S, and the player will wait for the input of the fade out time.
- ② Input the fade out time with the (0~9) number buttons.
- ③ Pressing the play button (▶ PLAY) will start the playback and the FADE indicator (FADE) will light up.
- ④ The (▶) indication will start flashing 5 seconds before the specified fade out time and then the fade out will begin. The fade out will end at the specified time and the player will automatically pause.

The time fade function will be cancelled if an auto search or manual search is performed during playback.

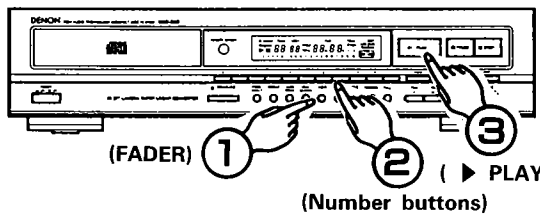

⑬ To Search for the Peak Level of the Disc Peak Search

- The player searches for the peak portion and plays a few seconds either side of this point repeatedly. This is convenient for making recording adjustments on the tape recorder.

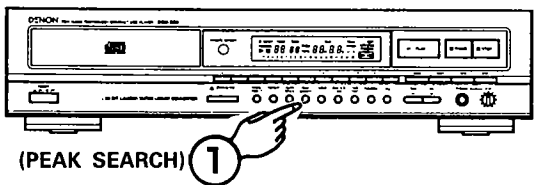

- ① When the peak search button (PEAK SEARCH) is pressed in the stop mode, the PEAK indicator will flash and the player will search for the portion having the peak level.

- ② After the search, the PEAK indicator lights up and a few seconds either side of the peak level point are played back repeatedly. This is convenient for making recording adjustments on the tape recorder.
- ③ To cancel the peak search, press the stop (■ STOP) button.
- ④ When the play button (▶ PLAY) or the pause button (⏸ PAUSE) is pressed during peak search or while playing the peak portion back repeatedly, the player will go to the beginning of the first track (the first track of the program for program playback, or the track that was first selected in the time edit) and begin playback from here if the play button was pressed or enter the pause mode if the pause button was pressed.

NOTE:

- The peak search function reads the level of the disc from the beginning of the disc to the end at a fixed interval and regards the maximum value that was read as the peak. Peak search takes a little time for this reason.
- The peak portion may change each time the disc is read and there may be a slight difference in the actual peak level, but since this difference ever so slight there will be no adverse affects on the adjustment of the recording level.
- The time fade function is cancelled when the peak search operation is performed. To use the time fade function, set to the stop mode then reset the function.
- Buttons other than the open/close button (▲ OPEN/CLOSE), play button (▶ PLAY), pause button (⏸ PAUSE), and stop (■ STOP) button will not function during peak search or repeat play of the peak portion.

14 Changing the Speed of Playback Pitch Control
 [Except DCD-660 Europe and U.K. Models]

- Playback can be speeded up or slowed down.

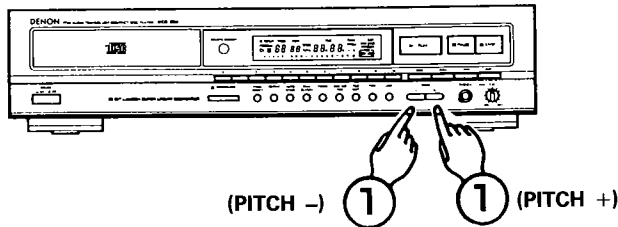

- ① Press the PITCH + or PITCH - button during the play or pause mode to change the speed of playback.
- ② When one of the PITCH buttons is pressed, the amount of the speed change appears on the seconds section ("S") of the TIME display for approximately 2 seconds. "PITCH -" appears when the speed is slower than normal, "PITCH +" when the speed is faster than normal. The speed can be changed in steps of 0.1% from -9.9% to +9.9%.
- ③ Press the PLAY button (▶ PLAY) during playback with a different speed to return to normal speed playback. Also, the speed setting is cancelled if the stop mode is set during playback at a different speed.

NOTES

- No data is output from the digital output jack (COAXIAL) during playback with a different speed (when "PITCH" is lit). If you want to output data, press the PLAY button (▶ PLAY) to return to normal speed playback.
- The pitch also changes when the speed is changed.
- If the speed is changed during the time edit operation, the total playing time changes, so the time of the blank space is not calculated accurately.
- The time display (elapsed playback time, remaining time per track, or total remaining time) will not be accurate during playback with a different speed.
- A maximum of 1 second is required to return to the normal speed when the PLAY button (▶ PLAY) is pressed during playback with a different speed. During this time, only the OPEN/CLOSE (▲ OPEN/CLOSE) and STOP buttons (■ STOP) will function.

TIMER-CONTROLLED PLAYBACK

■ **Operation**

1. Turn on the power of all system components.
2. Set the input selector on the amplifier to correspond to the inputs the CD player is connected to.
3. Make sure a disc has been loaded in the disc holder.
4. Check the time on the timer and then set the desired turn-on time.
5. Turn the audio timer ON.
Power is turned off automatically in all components connected to the timer.
6. When the preset turn-on time is reached, power is turned on in the system components, and CD playback starts from the first track.

■ **Connection**

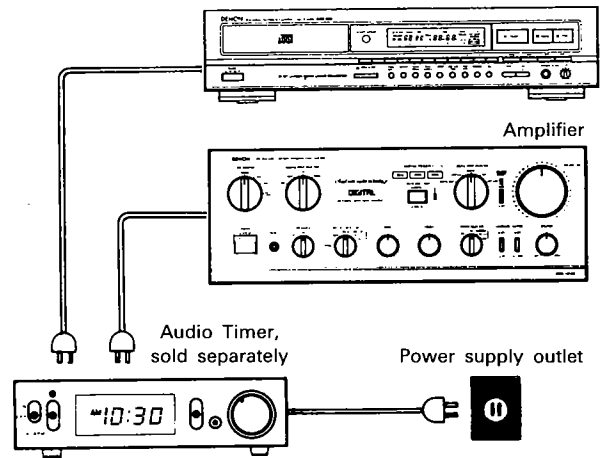

THE COMPACT DISC

1. **Precautions on handling compact discs**

- Do not allow fingerprints, oil or dust on the surface of the compact disc. If the signal surface is dirty, wipe it off with a soft, dry cloth. Wipe in circular motions from the center and out. Use of DENON's AMC-20/21 CD cleaner is recommended.
- Do not use water, benzene, thinner, record sprays, electrostatic proof chemicals, or silicone-treated cloth to clean discs.
- Always use care when handling discs to prevent damaging the surface, in particular when removing a disc from the case and returning it.
- Do not bend compact discs.
- Do not apply heat to compact discs.
- Do not enlarge the hole in the center of the disc.
- Do not write on the disc and do not attach any labels.
- Condensation will form on the disc surface if it is brought into a warm room from a cold area, such as outdoors during winter. Wait until the condensation disappears. Never dry discs with hair dryers, etc.

2. **Precautions on storage**

- After playing a disc, always return it to its case.
- Keep discs in the cases when they are not to be played. This will protect them from dust and dirt and prolong their service life.
- Do not store discs in the following places:
 - 1) Places exposed to direct sunlight for a considerable time.
 - 2) Places subject to accumulation of dust or high humidity.
 - 3) Places exposed to high temperatures, such as close to heater outlets.

PLAYBACK USING THE REMOTE CONTROL UNIT

The accessory remote control unit can be used to control the CD player from a convenient distance.

(1) Inserting the dry cell batteries

1. Remove the battery cover on the back of the remote control unit.

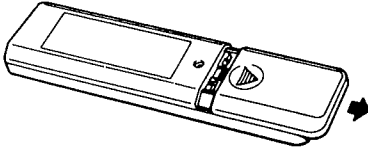

2. Insert two R6P (standard size AA) dry cell batteries with correct polarity as indicated inside the battery compartment.

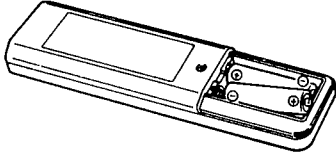

3. Replace the battery cover.

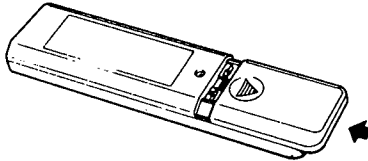

Notes on the Batteries

- The remote control unit uses standard size AA dry cell batteries.
- The batteries will need to be replaced approximately once a year. Replacement may be necessary earlier depending on how much the remote control unit is used.
- If, in less than a year from the time new batteries were inserted, the remote control fails to operate the CD player from a near-by position, it is time to replace the batteries.

- Insert the batteries properly, following the polarity diagram inside the battery compartment, in other words make sure (+) and (-) terminals are properly aligned.
- Batteries are prone to damage and leakage.

Therefore:

- Do not combine new batteries with used ones.
- Do not combine different types of batteries.
- Do not jumper opposite poles of the batteries, expose them to heat, break them open nor expose of them in open fire.
- If the remote control unit is not to be used for a long period of time, remove the batteries from the unit.
- If the batteries have leaked, remove any traces of battery fluid from the battery compartment, wiping thoroughly with a dry cloth. Then insert new batteries.

(2) Directions for Use

- Operate the remote control unit while pointing it towards the remote control sensor on the CD player (see below).

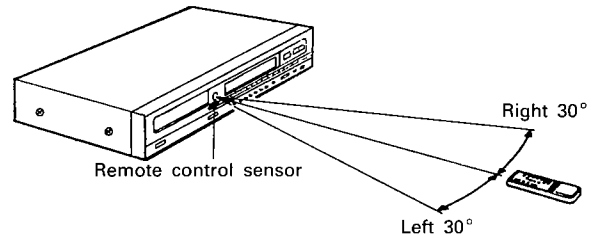

When a remote control signal is received, the remote control indicator on front of the CD player lights briefly.

- The remote control unit can be used at a distance up to 8 meters in a straight line from the CD player. This distance decreases if there are obstructions blocking the signal path or when the remote control unit is operated at an angle from the remote control sensor.
- The buttons on the remote control unit have identical functions with those on the CD player. However, the following functions cannot be remote controlled: Power ON/OFF.

REMOTE CONTROL UNIT RC-224/223/226/227

Disc Holder Open/Close Button (▲ OPEN/CLOSE)
(RC-223/224)

Fader Button (FADER)

Random Button (RANDOM)
(RC-226/227)

Numerical Keypad (0 ~ 9)

Play Button (▶ PLAY)

Pause Button (⏸ PAUSE)

Stop Button (■ STOP)

Repeat Button (REPEAT)

Random button (RANDOM)
(RC-223/224)

Pitch - Button (PITCH -)

Pitch + Button (PITCH +)
(RC-226/227)

Program/Direct Button (PROG/DIRECT)

+10 Button

Call Button (CALL)

Volume Buttons (+)

Volume Buttons (-)

Automatic Search Forward Button (▶▶)

Automatic Search Reverse Button (◀◀)

Manual Search Forward Button (▶▶)

Manual Search Reverse Button (◀◀)

Setting to the Program Mode

- For program search, press the PROG/DIRECT button then the number buttons (0 through 9 and +10).
- The remote control unit is normally set to the direct mode.

RC-224/227 Only

The level of the Variable Output Terminal output can be varied. Pressing the (+) button increases the volume and pressing the (-) button decreases the volume.

Track Selection

Use the numeric track buttons (0 ~ 9 and +10) while programming and to access a desired track almost instantly. The track search buttons (◀◀ and ▶▶) are best used to advance or return from the current track to the next track.

SPECIFICATIONS

	<u>DCD-860</u>	<u>DCD-660</u>
AUDIO		
No. of Channels:	2 channels	
Frequency Response:	2 ~ 20,000 Hz	
Dynamic Range:	97 dB	96 dB
Signal-to-Noise Ratio:	105 dB	103 dB
Harmonic Distortion:	0.003% (1 kHz)	0.004% (1 kHz)
Separation:	100 dB (1 kHz)	99 dB (1 kHz)
Wow & Flutter:	Below measurable limit: ($\pm 0.001\%$ W. peak)	
Output Voltage:	FIX. 2.0 V, VARIABLE 0 ~ 2.0 V	FIX. 2.0 V
DISCS		
	Compact Disc format	
GENERAL CHARACTERISTICS		
Power Supply:	50/60 Hz, Voltage is shown on rating label.	
Power Consumption:	11W	10W
Dimensions:	434 (17.1 in) W x 105 (4.2 in) H x 280 (11.0 in) D mm	
Weight:	4.0 kg	3.8 kg
FUNCTIONS AND DISPLAY		
Functions:	Direct selection, automatic search, programmed playback, repeat playback, manual search, auto space, time mode, time edit, pitch control, peak search, emphasis feature	
Display:	Track number, time, music calendar, and engaged modes	
Others:	Headphones jack	
REMOTE CONTROL UNIT		
	RC-227 (U.S.A., Canada, Australia, and Asia models)	RC-226 (U.S.A., Canada, Australia and Asia models)
	RC-224 (Europe and U.K. models)	RC-223 (Europe and U.K. models)
Remote Control System:	Infrared pulse system	
Power Supply:	3 V DC; two R6P (standard size AA) dry cell batteries	
External Dimensions:	48 (1.9 in.) W x 177 (7.0 in.) H x 18 (0.7 in.) D mm	
Weight:	100 g (including batteries)	
SUPPLIED ACCESSORIES		
	Pin-plug connection cord	

* Design and specifications are subject to change without notice in the course of product improvement.

NOTE FOR HANDLING OF LASER PICK-UP

DESCRIPTION OF THE COMPONENTS

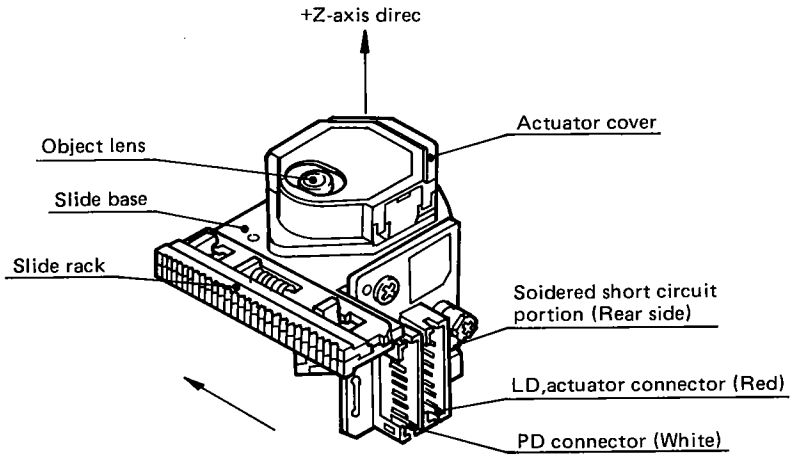

Label

1. Serial number

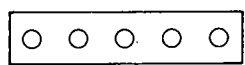

This denotes the serial number used for quality control in the manufacturing plant.

Note: The numbers of figures in English numerals may be changed.

2. Label

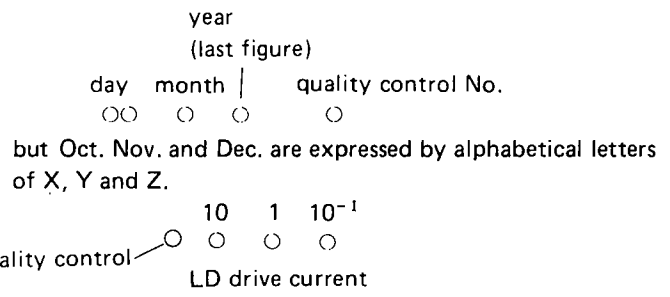
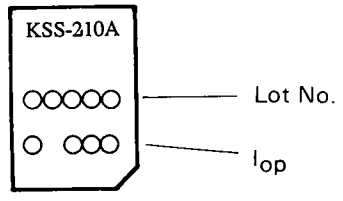

3. Position of the labels

The expressed unit is by mA, with omission of the decimal point as for example, 56.5 mA will be expressed as 565, but the head of English letter means the control in the manufacturing plant.

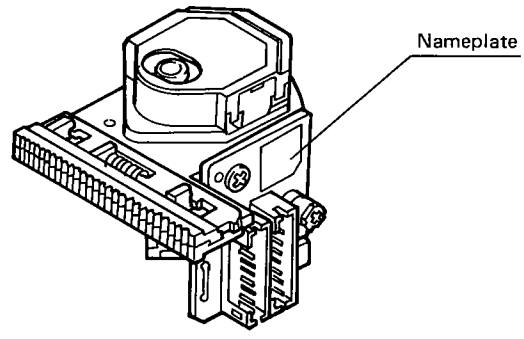

ELECTRICAL PIN CONNECTION

1. PD connector (JAPAN SOLDERLESS TERMINAL MFG CO. LTD "PH series" 8 pin)

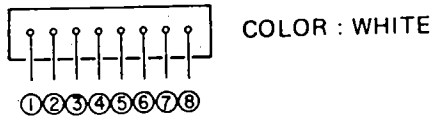

Pin No.	PD element
①	F
②	E
③	K
④	GND
⑤	A
⑥	B
⑦	C
⑧	D

PC Circuit Diagram

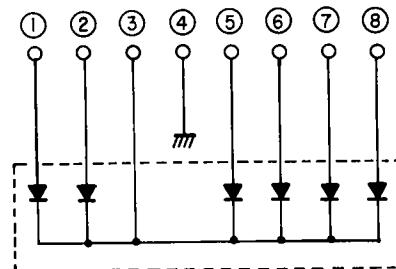

2. Actuator & LD connector (JAPN SOLDERLESS TERMINAL, MFG CO. LTD "PH series" 8 pin)

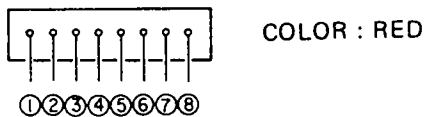

Pin No.	description
①	Laser
②	GND
③	monitor
④	reference
⑤	Fo (-)
⑥	Tr (+)
⑦	Tr (-)
⑧	Fo (+)

LD • Actuator Circuit Diagram

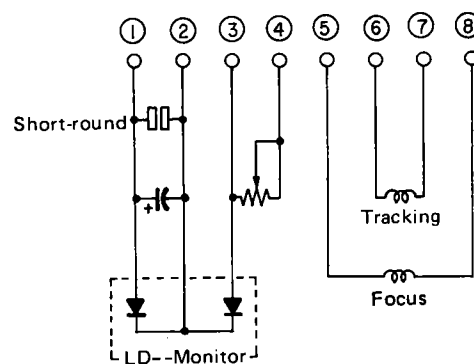

Caution for Handling the Laser Pick-up

The laser pick-up KSS-150A is assembled and precisely adjusted using a sophisticated manufacturing process in our plant. Do not disassemble or attempt to readjust it. Please keep the following instructions carefully in handling pick-up.

1. Handle with Care

(1) Storage

Do not store the pick-up in dusty, high-temperature or high-humidity environments.

(2) Please take care for preventing from shock by falling down or careless handling.

2. Laser Diode (LD)

(1) Protect your eyes

The laser beam may damage the human eye, since the intensity of the focused spot may reach $7 \times 10^3 \text{ W/cm}^2$ even if the intensity at the objective lens is $400 \mu\text{W}$ maximum. As the light beam spreads after focused through the objective lens, it does not effect you in the place as far as more than 30 cms. However, do not look at the laser light beam either through the objective lens directly nor another lens or a mirror.

(2) Poison of As

Since the LD chip contains As (Arsenic), as GaAs + GaAlAs, as known as the poison, although the poison is relatively weak, in comparing with others, e.g. As_2O_3 , AsCl_3 etc., and the amount is small, avoid putting the chip in acid or an alkali solution, heating it over 200°C or putting it into your mouth.

(3) Avoid surge current or electrostatic discharge

The LD may be damaged or deteriorated by its own strong light if a large current is supplied to it, even if only a short pulse.

Make sure that there is no surge current in the LD driving circuit by switches or else. Be careful to handle pick-up as it may be damaged in a moment by human electrostatic discharge. The pins of the LD are short-circuited by solder for protection during shipment.

For safety handling of an LD, grounding the human body, measuring equipments and jig is strongly recommended. And still it is further desirable to make use of mat on the platform and floor for handling the LD.

To open the short circuit, remove the soldering quickly with a soldering iron whose metal part is grounded.

The temperature of the soldering iron should be less than 320°C (30W).

3. Actuator

(1) The performance of the actuator may be effected if magnetic material is located nearby, since the actuator has a strong magnetic circuit. Do not permit dust to enter through the clearance of the cover.

(2) Cleaning the lens

It may change the specifications by attaching dust or ash on the object lens. Clean the lens with a cleaning paper dampened with a little water, not pressing lens with so much strength by the cleaning paper.

4. Metal Bearing

As the metal bearing of Cu-compound sintered alloy is impregnated with FROIL946P (*Part No. 529 0054 007), never fail to supply the bushing with the same lubricant at the time of replacing the pick-up.

5. Handling

Please handle the laser pick-up with holding the side base (rosin molded part).

When either a part of human body or some other things may happen to touch directly with the circuit part of P.W.Board, it may cause deterioration, take careful attention in handling this base.

6. Deterioration

When difficulty occurs either in focus or tracking adjustment nor able to adjust the focus or tracking, it seems that the laser pick-up is deteriorated. In these cases, check a value of laser diode current and give a decision for deterioration.

7. Fundamental Deterioration Decision of Laser Pick-up

(1) If a voltage value in between J2 and J10 of TP102 of the servo and signal processor unit, the value of laser diode current "iop" can be found by a formula

$$\text{"iop 1"} = \frac{V1}{22}$$

(2) If an "iop" exceeds $\pm 10\%$ compared with the IOP indication on the laser pick-up nameplate, there is a fair chance for deterioration when it is checked under a circumambient temperature 23°C .

(3) When the circumambient temperature changes $\pm 10^\circ\text{C}$, "iop 1" will change $\pm 5\%$. The "iop 1" will also be changed by the passage of time.

(4) In case of the above conditions taking into consideration and performed the adjustment in proper way, if the HF leve at H.F (Terminal Pin) on Main unit, and in between GND (Terminal Pin) becomes 1V or lesser values; or a jitter occurs great, the laser pick-up may be deteriorated.

DISASSEMBLY

● Top Cover

Remove 4 screws from both sides and 1 screw from Back Panel.

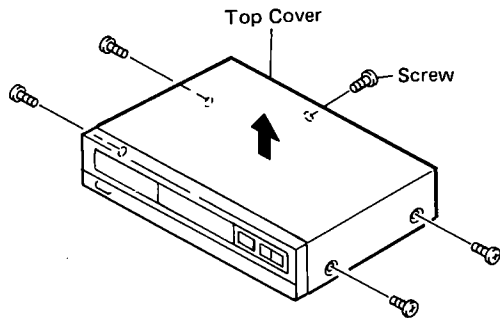

● Mechanism Unit

Remove 4 upper screws.

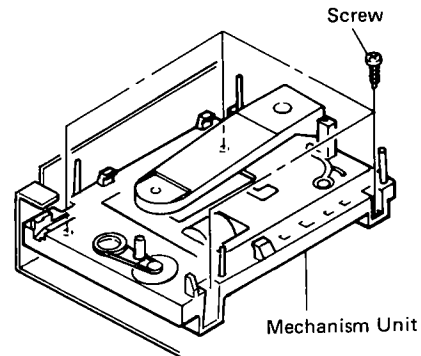

● Front Panel

1. Pull Loader frame frontward, and remove loader panel.
2. Remove 2 front panel upper screws.
3. Undo 2 front panel upper hooks.
4. Pull front panel and undo 3 lower hooks.

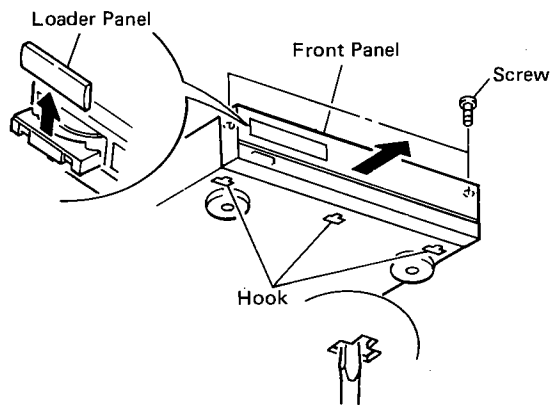

● Clamper Arm

Remove hook as arrow direction.

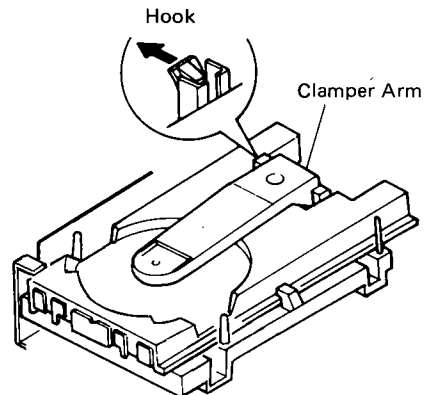

● Loader

1. Pull loader frame frontward.
2. While removing hook out of mecha base, pull out loader frame.

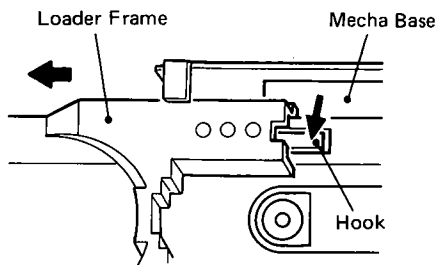

ADJUSTMENT

Microcomputer built in the unit, comprises service program to facilitate servo adjustment by pushing operation button.

1. Start service program

- (1) Turn power switch OFF.
- (2) Shortcircuit J6 (SWOP) and J8 (SWCL) of TP102 on P.W.B. (Main Unit)
(Caution) Do not touch other jumper wires.
- (3) Turn power switch ON.
(Service program starts, and displays track number 01)

(Caution)

- When service program started normal operation of buttons will be defeated.

2. Service program function

Button	Function	Description
▲ OPEN/CLOSE	Opens or closes the disc holder.	<ul style="list-style-type: none"> ● Opens or closes only when disc is stopped. ● Operate other keys after open or close.
■ STOP	Stops system function.	<ul style="list-style-type: none"> ● Displays track number 01. ● Push when adjustment completed, or do it again.
▶ PLAY	Starts focus servo and disc turns.	<ul style="list-style-type: none"> ● Push when adjust tracking offset. ● When completed, displays track number 02.
PAUSE	Starts focus servo, tracking servo, slide servo, spindle servo.	<ul style="list-style-type: none"> ● When PLAY button is pushed, starts tracking servo and slide servo. ● When completed, track number 03.
Other button	No normal operation.	<ul style="list-style-type: none"> ● Do not operate buttons other than above. ● If misoperated, immediately turn power switch OFF.

(Caution)

- Do not use remote control during service program mode.

3. Adjustment

(1) Necessary equipment for adjustment

1. Dual trace oscilloscope
2. Reference disc (CA-1094) 富田靖子
3. Oscillator (10 Hz ~ 10 kHz, 0 ~ 3 Vp-p)
4. Frequency counter (readable more than 5 KHz)

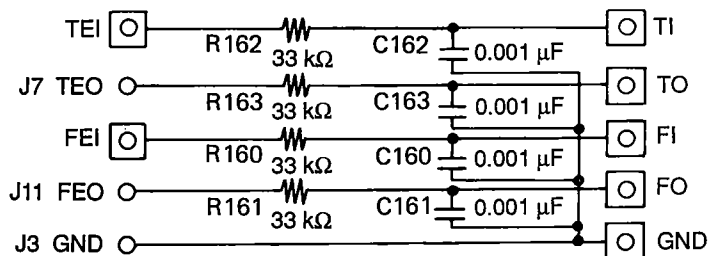

(Filter for measurement in Main Unit)

"□" is Terminal Pin on Main Unit.

(2) Location

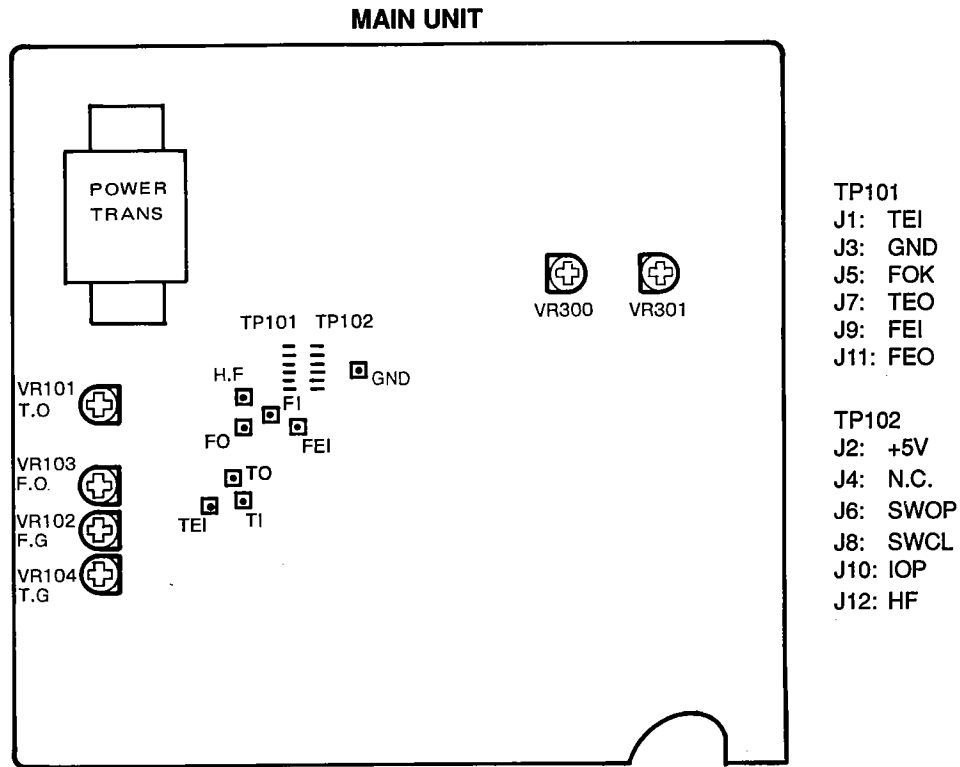

(Caution)
VR300, 301 are adjusted at the time of shipment; readjustment is not needed.

↓
FRONT PANEL

(3) Preset

1.	Start service program.	
2.	Preset VR101 ~ 104 as per left figure.	<p>VR101 (T-OFFSET) 3 O'clock</p> <p>VR103 (F-OFFSET) 3 O'clock</p> <p>VR102 (F-GAIN) 3 O'clock</p> <p>VR104 (T-GAIN) 3 O'clock</p>
3.	Step.	<p>1. Tracking offset (VR101)</p> <p>2. Focus gain (VR102)</p> <p>3. Focus offset (VR103)</p> <p>4. Tracking gain (VR104)</p> <p>5. Tracking offset recheck. (VR101)</p>

4. Tracking offset

Connection					
Oscilloscope (DC range)		Adjust	Check	Step	
V	H	(Volume)	(Oscilloscope)		
0.1V/div	1~2 ms/div	VR101		<ol style="list-style-type: none"> 1. Push ▲ OPEN/CLOSE and load disc holder reference disk. 2. Push ▲ OPEN/CLOSE and close disc holder. 3. Push ▶ PLAY to turn disc. (Displays track number 02) 4. Short (+) (-) of oscilloscope and check the base line. 5. Adjust VR101 [T-OFFSET] to equalize upper and lower amplitude of the waveform. 	

5. Focus gain

Connection						
Oscillator	Counter	Oscilloscope		Adjust	Check	Step
		V	H	(Volume)	(Oscilloscope)	
750 Hz 1 Vp-p (±0.1 V)	750 Hz	<ul style="list-style-type: none"> ● DC range ● X-Y mode 		VR102	<p>Y axis</p> <p>X axis</p> <p>Phase 90°</p> <p>Waveform not right</p> <p>X axis</p> <p>Y axis</p>	<ol style="list-style-type: none"> 1. Push PAUSE (Displays track number 03) 2. Set oscillator to 750 Hz/1 Vp-p. 3. Switch oscilloscope input to X-Y mode. 4. Adjust VR102 [F-GAIN] to symmetrize Lissajous figures to X and Y axes.

6. Focus offset

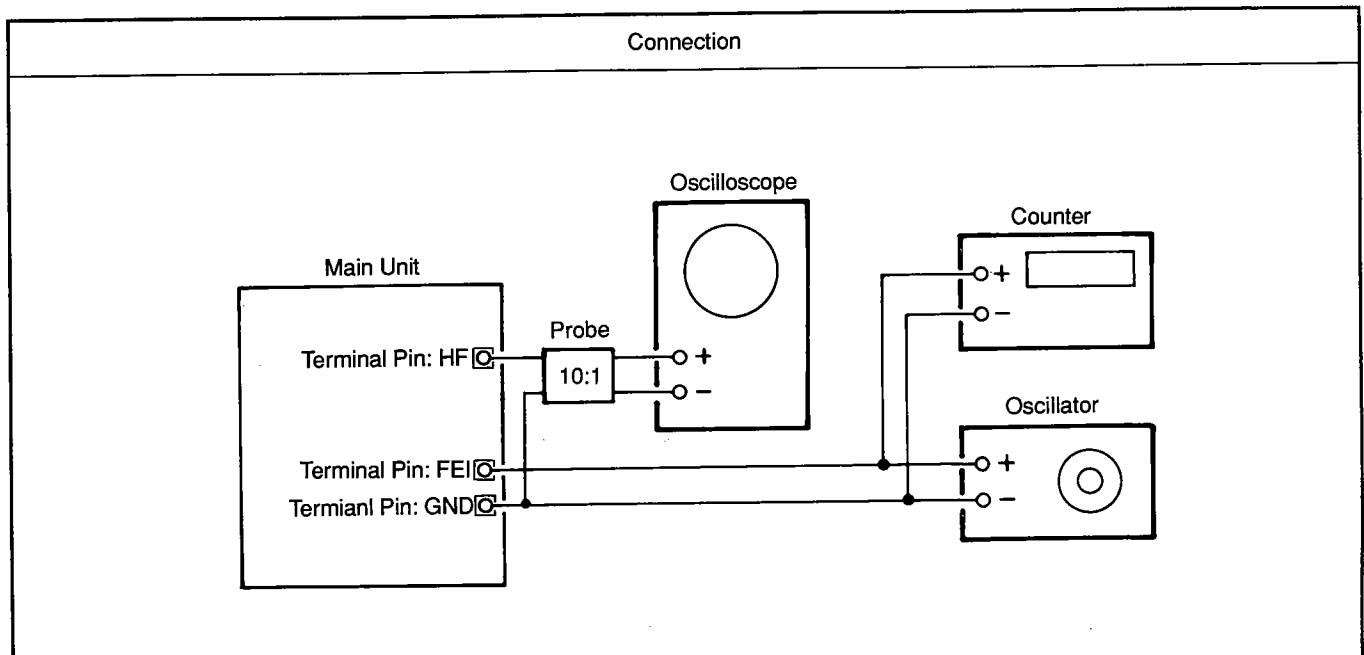

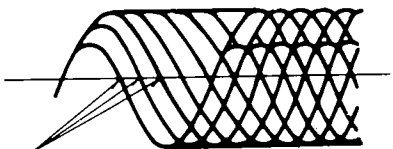
Oscillator	Counter	Oscilloscope		Adjust	Check
		V	H	(Volume)	(Oscilloscope)
750 Hz 1 Vp-p (±0.1V)	750 Hz	50 mV/div or 20 mV/div	0.2 μs/div or 0.5 μs/div	VR103	 Adjust to minimize pattern jitter.
		● Set input mode to ALTERNATE or CHOPPER .			

Step

1. Push **PAUSE**.
2. Set oscillator to 750 Hz, 1 Vp-p (±0.1 V).
3. VR103 [F-OFFSET] to minimize pattern jitter.

7. Tracking gain

Connection

• Caution: Connect oscillator after **|| PAUSE** pushed and servo function started.

Oscillator	Counter	Oscilloscope	Adjust	Check	Step				
<ul style="list-style-type: none"> ● 2.2 kHz (±120 Hz) ● 3 Vp-p (±0.1V) 	2.2 kHz (±120 Hz)	<table border="1"> <tr> <td>V</td> <td>H</td> </tr> <tr> <td colspan="2"> <ul style="list-style-type: none"> ● DC range ● X-Y mode </td> </tr> </table>	V	H	<ul style="list-style-type: none"> ● DC range ● X-Y mode 		(Volume) VR104	(Oscilloscope) Waveform not right 	<ol style="list-style-type: none"> 1. Push PAUSE. (Displays track number 03) 2. Connect oscillator. 3. Set oscillator to 2.2 kHz/3 Vp-p. 4. Switch oscilloscope input to X-Y mode. 5. Adjust VR104 [T-GAIN] to symmetrize Lissajous figures to X-Y axes.
V	H								
<ul style="list-style-type: none"> ● DC range ● X-Y mode 									

8. Tracking offset adjustment check

(1) Adjust tracking offset again.

(2) Push **■ STOP** and stop disc.

(3) Push **▶ PLAY** and check disc turns.

Note: If disc does not turn, push **▶ PLAY** again and check track number **02** is displayed.

(4) Check oscilloscope waveform upper and lower amplitude are same to base line.

(5) Push **■ STOP** and stop disc.

(6) Push **▲ OPEN/CLOSE** and remove the reference disc.

HEAT RUN MODE FUNCTION

Heat Run Mode

1) To activate

While hold pushing ►► , ◀◀ , ►► and ◀◀ keys simultaneously, turn the unit power on. The remote control sensor indicator will light to show that the unit is shifted in Heat Run mode.

Be sure to load the disc previously.

Press the disc holder open/close button (▲ OPEN/CLOSE) to cancel Heat Run mode.

★ This mode functions only for a disc with 21 pieces of music or more. For a disc with 20 pieces of music or lesser, please do not use.

2) Operation

During the Heat Run mode to shift the unit in Play mode makes the unit replays from the first music after opens the loader once and re-closes it when finish playing the last track (comes into lead out).

Hereafter, operates open/close of loader, servo on, reading of TOC, and playing repeatedly, and repeats playing the two tracks; the first and the last ones.

3) Error Message

When the system error occurs while in Heat Run mode, the following error message will display on the Track No. indicator and stops operation.

1. E1

At the time of Focus Servo does not activate.

2. E2

When unable to detect synchronous pattern however the disc is in rotating. (GFS does not drive.)

3. E3

No synchronous pattern can be detected while in Play mode. (No GFS drives.)

4. E4

When TOC is unreadable in despite of servo is activated.

5. E5

In case of loader malfunctions. (Unable to turn on the switch.)

6. E6

The inner circle switch of Pick-up does not turn off.

7. E7

The inner circle switch of Pick-up does not turn on.

★ The number of operation up to the stop will be displayed on the minute and second portion of the indicator.

IC TERMINAL FUNCTION LIST

CXA1081S

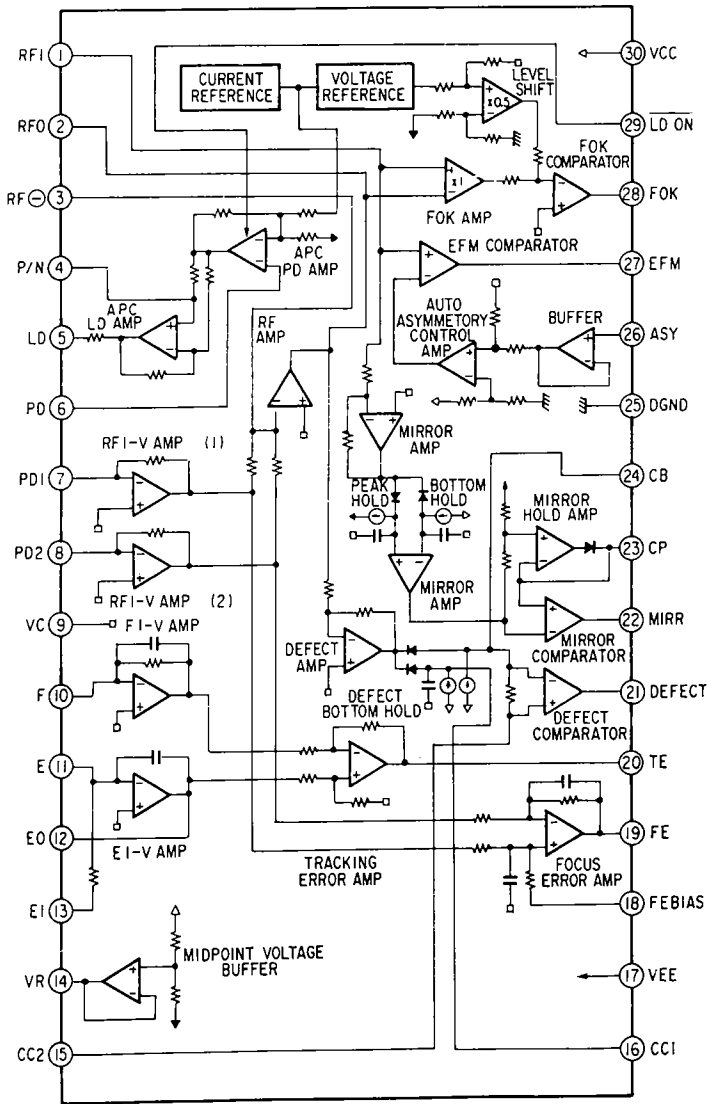

CXA1081S Terminal Function

Terminal No.	Terminal Symbol	I/O	DC voltage (V)	Terminal Function
1	RFI	I	0	Input terminal of capacitance coupled RF summing amplifier output.
2	RFO	O	V _{RFO}	Terminal for RF summing amplifier output. Check point of Eye pattern.
3	RF(-)	I	0	Feedback input terminal of RF summing amplifier.
4	P/N	I	0 (VC)	P-sub/N-sub shifting terminal for Laser Diode (LD). (DC voltage: at N-sub.)
5	LD	O	-1.8	Output terminal of APC (Automatic Power Control) LD amplifier. (DC voltage: at N-sub, PD opened.)
6	PD	I	0	Input terminal of APC (Automatic Power Control) PD amplifier. (DC voltage: opened.)
7	PD1	I	0	Reverse input terminal of RF I-V amplifier (1). Receives an input current through A + C terminals of photo diode.
8	PD2	I	0	Reverse input terminal of RF I-V amplifier (2). Receives an input current through B + D terminals of photo diode.
9	VC	—	0	At ± dual-power supply: Becomes GND. At mono-power supply: Becomes VR. (connect to pin 14.)
10	F	I	0	Reverse input terminal of F I-V amplifier. Receives an input current through F terminal of photo diode.
11	E	I	0	Reverse input terminal of E I-V amplifier. Receives an input current through E terminal of photo diode.
12	EO	O	0	Output terminal of E I-V amplifier.
13	EI	I	0	Feedback input terminal of E I-V amplifier. For gain controlling of E I-V amplifier.
14	VR	O	V _{CC} + V _{EE} /2.	Output terminal of DC voltages (V _{CC} + V _{EE})/2.
15	CC2	I	1.0	Input terminal of capacitance coupled detect bottom hold output.
16	CC1	O	1.2	Output terminal of defect bottom hold.
17	V _{EE}	—	-2.5	At ± dual-power supply: Becomes negative power supply terminal. At mono-power supply: Becomes GND.
18	FE BIAS	I	0	Bias terminal for non-reverse side of focus error amplifier. For CMR controlling of focus error amplifier.
19	FE	O	V _{FE0}	Output terminal of focus error amplifier.
20	TE	O	V _{TE0}	Output terminal of tracking error amplifier.
21	DEFECT	O	V _{DFCTL}	Output terminal of defect comparator. (DC voltage: Connect a 10 kΩ load resistance.)
22	MIRR	O	V _{MIRL}	Output terminal of MIRR comparator. (DC voltage: Connect a 10 kΩ load resistance.)
23	CP	I	-1.3	Connecting terminal for MIRR hold capacitor. Non-reverse input terminal of MIRR comparator.
24	CB	I	0	Connecting terminal for defect bottom hold capacitor.
25	D GND	—	-2.5	At ± dual-power supply: GND. At mono-power supply: GND (V _{EE}).
26	ASY	I	—	Input terminal of auto-asymmetry control.
27	EFM	O	V _{EFMH}	Output terminal of EFM comparator. (DC voltage: Connect a 10 kΩ load resistance.)
28	FOK	O	V _{FOKL}	Output terminal of focus OK comparator. (DC voltage: Connect a 10 kΩ load resistance.)
29	LD ON	I	-2.5 (D GND)	ON/OFF shifting terminal for laser diode (LD). (DC voltage: At LD ON.)
30	V _{CC}	—	2.5	Positive power supply terminal.

CXD2500Q Terminal Function

Terminal No.	Symbol	I/O	Terminal Function
1	FOK	I	Input terminal for OK focussing. Use for Servo-autosequencer.
2	FSW	O	Output to shift time constant of output filter for spindle motor.
3	MON	O	ON/OFF control output for spindle motor.
4	MDP	O	Servo control for spindle motor.
5	MDS	O	Servo control for spindle motor.
6	LOCK	O	Sampling GFS by 460 Hz and if it is "H", delivers "H" ; if it is continuously "L" 8 times, delivers "L".
7	NC	—	
8	VCOO	O	Oscillation current output for analog EFM PLL.
9	VCOI	I	Oscillation current output for analog EFM PLL. f LOCK=8.6436MHz.
10	TEST	I	TEST output. Normally GND.
11	PDO	O	Charge pump output for analog EFM PLL.
12	Vss		GND.
13	NC	—	
14	NC	—	
15	NC	—	
16	VPCO	O	Charge pump output for variable pitch PLL.
17	VCKI	O	Clock input from external VCO for variable pitch. fc center=16.9344MHz.
18	FILO	O	Filter output for master PLL. (slave=digital PLL)
19	FILI	I	Filter input for master PLL.
20	PCO	O	Charge pump output for master PLL.
21	AVss		Analog GND.
22	CLTV	I	Control voltage output for master VCO.
23	AVDD		Analog power supply (+5V).
24	RF	I	EFM signal input.
25	TEST2	I	Put to GND.
26	TEST3	I	Put to GND.
27	ASYO	O	Full swing output for EFM. (L=Vss, H=VDD).
28	TEST4	I	Put to GND.
29	NC	—	
30	PSSL	I	Input to shift output mode of audio data. Serial output at L; parallel output at H.
31	WDCK	O	D/A Interface for 48 bit slot. Word-clock f=2 Fs.
32	LRCK	O	D/A Interface for 48 bit slot. LR-clock f= Fs.
33	VDD		Power supply (+5V).
34	DA16	O	At PSSL=1 for DA16 (MBS) output; PSSL=0 for serial data of 48 bit slot. (2s'COMP, MSB first).
35	DA15	O	At PSSL=1 for DA15 output; PSSL=0 for bit clock of 48 bit slot.
36	DA14	O	At PSSL=1 for DA14 output; PSSL=0 for serial data of 64 bit slot. (2s'COMP, LSB first).
37	DA13	O	At PSSL=1 for DA13 output; PSSL=0 for bit clock of 64 bit slot.
38	DA12	O	At PSSL=1 for DA12 output; PSSL=0 for LR clock of 64 bit slot.
39	DA11	O	At PSSL=1 for DA11 output; PSSL=0 for GTOP output.
40	DA10	O	At PSSL=1 for DA10 output; PSSL=0 for XUGF output.
41	DA09	O	At PSSL=1 for DA09 output; PSSL=0 for XPLCK output.
42	DA08	O	At PSSL=1 for DA08 output; PSSL=0 for GFS output.
43	DA07	O	At PSSL=1 for DA07 output; PSSL=0 for RFCK output.
44	DA06	O	At PSSL=1 for DA06 output; PSSL=0 for C2PO output.
45	DA05	O	At PSSL=1 for DA05 output; PSSL=0 for XRAOF output.
46	DA04	O	At PSSL=1 for DA04 output; PSSL=0 for MNT3 output.
47	DA03	O	At PSSL=1 for DA03 output; PSSL=0 for MNT2 output.
48	DA02	O	At PSSL=1 for DA02 output; PSSL=0 for MNT1 output.
49	DA01	O	At PSSL=1 for DA01 output; PSSL=0 for MNT0 output.
50	APTR	O	Control output for aperture compensation. In H for R-ch.
51	APTL	O	Control output for aperture compensation. In H for L-ch.

Terminal No.	Symbol	I/O	Terminal Function
52	Vss		GND.
53	XTAI	I	X'tal oscillation circuit input. By selecting of mode, f=16.9344MHz or 33.8688MHz.
54	XTAO	O	X'tal oscillation circuit input. f=16.9344MHz.
55	XTSL	I	Selection input terminal of X'tal. "L" for X'tal 16.9344MHz; H for 33.8688MHz.
56	FSTT	O	2/3 Dividing output of 53 and 54 terminal. No change by variable pitch.
57	C4M	O	4.2336MHz output. When variable pitched, simultaneously changes.
58	C16M	O	16.9344MHz output. When variable pitched, simultaneously changes.
59	MD2	I	Digital-out ON/OFF control. ON at H; OFF at L.
60	DOUT	O	Digital-out output terminal.
61	EMPH	O	When playback disc emphasized, outputs H; otherwise outputs L.
62	WFCK	O	WFCK (Write Flame Clock) output.
63	SCOR	O	Output of subcode sync. S0+S1. H output when either one detected.
64	SBSO	O	Serial output of Sub P-W.
65	EXCK	I	Clock input for SBSO read-out.
66	SQSO	O	Output for Sub Q 80 bits and PCM peak level 16 bits.
67	SQCK	I	Clock input for SQSO read-out.
68	MUTE	I	Mute at H; remove mute at L.
69	SENS	—	SENS output. Outputs to CPU.
70	XRST	I	System reset input. Resets at "L".
71	DATA	I	Input of serial data from CPU.
72	XLAT	I	Input for latch from CPU. Latches serial data at release.
73	Vdd		Power supply (+5V).
74	CLOK	I	Serial data transfer clock input from CPU.
75	SEIN	I	SENS input from SSP.
76	CNIN	I	Input of tracking pulse.
77	DATO	O	Serial data output to SSP.
78	XLTO	O	Serial data latch output to SSP.
79	CLKO	O	Serial data transfer clock output to SSP.
80	MIRR	I	Mirror signal input. Use for track jump for over 128 tracks, using autosequencer.

CXD2500Q

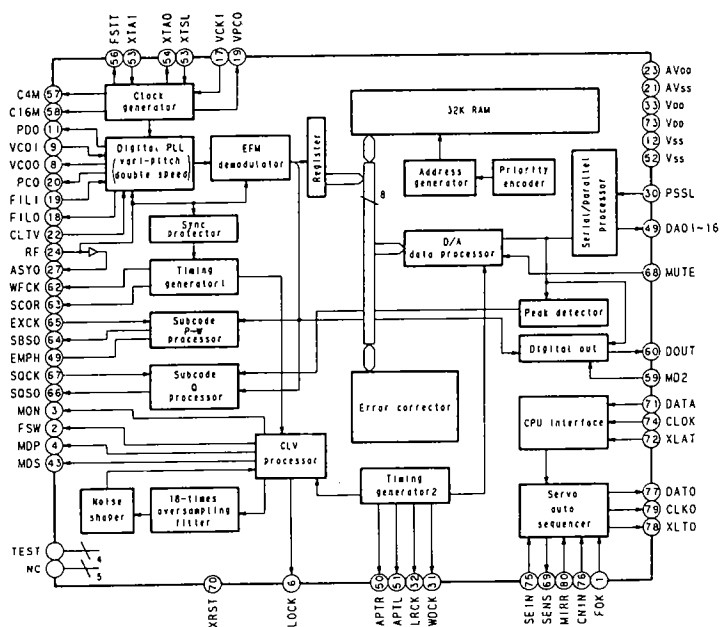

CXA1372S Terminal Function

Terminal No.	Symbol	I/O	Terminal Function
1	TE	I	Tracking error signal input terminal.
2	TDFCT	I	Capacitor connecting terminal for time constant at the time of defect.
3	ATSC	I	Input terminal of ATSC detecting window comparator.
4	FZC	I	Input terminal of focus zero-cross comparator.
5	FE	I	Focus error signal input terminal.
6	FDFCT	I	Capacitor connecting terminal for time constant at the time of defect.
7	Vc	I	Mid-point voltage input terminal.
8	FGD	I	In case of reducing higher range gain of focus servo, connect a capacitor between this terminal and terminal number (9).
9	FS3	I	Shifts higher range gain of focus servo by FS3 ON/OFF.
10	FLB	I	Terminal for external time constant to increase lower range of focus servo.
11	FEO	O	Focus drive output.
12	FE-	I	Reverse input terminal for focus amplifier.
13	SRCH	I	Terminal for external time constant to make focus search waveform.
14	TGU	I	Terminal for external time constant to shift higher range gain of tracking.
15	TG2	I	Terminal for external time constant to shift higher range gain of tracking.
17	TAO	O	Tracking drive output.
18	TA-	I	Reverse input terminal for tracking amplifier.
19	SL+	I	Non-reverse input terminal for sled amplifier.
20	SLO	O	Sled drive output.
21	SL-	I	Reverse input terminal for sled amplifier.
22	FSET	I	Terminal to compensate peak in focus/tracking phase.
23	ISET	I	Delivers a current to set the height of focus search, track jump, and sled kick.
24	SSTOP	I	Terminal for limit switch ON/OFF to detect disc innermost circle.
26	DIRC	I	Terminal is used at the time of 1 track jump. A 47 kohm pull up resistor is included.
27	LOCK	I	Reckless drive protection circuit of sled; activates at "L". A 47k ohm pull up resistor is included.
28	CLK	I	Serial data transfer clock input from CPU.
29	XLT	I	Latch input from CPU.
30	DATA	I	Serial data input from CPU.
31	XRST	I	Reset input terminal. Resets at "L".
32	C.OUT	O	Terminal to output signal for track number count.
33	SENS	O	Terminal to output FZC, AS, TZC, SSTOP by command from CPU.
35	MIRR	O	Output terminal for MIRR comparator.
36	DFCT	O	Output terminal for DEFECT comparator.
37	ASY	I	Input terminal for auto-symmetric control.
38	EFM	O	Output terminal for EFM comparator.
39	FOK	O	Output terminal for focus OK (FOK) comparator.
40	CC1	O	DEFECT bottom hold output terminal.
41	CC2	I	Input terminal to input DEFECT bottom hold output by capacitance combination.
43	CB	I	Capacitor connecting terminal for DEFECT bottom hold.
44	CP	I	MIRR hold capacitor connecting terminal. A non-reverse input terminal for MIRR comparator.
45	RFI	I	Input terminal to input RF summing amplifier output by capacitance combination.
46	RFO	O	Output terminal for RF summing amplifier. Check point for eye pattern.
48	TZC	I	Tracking zero-cross comparator input terminal.

CXA1372S

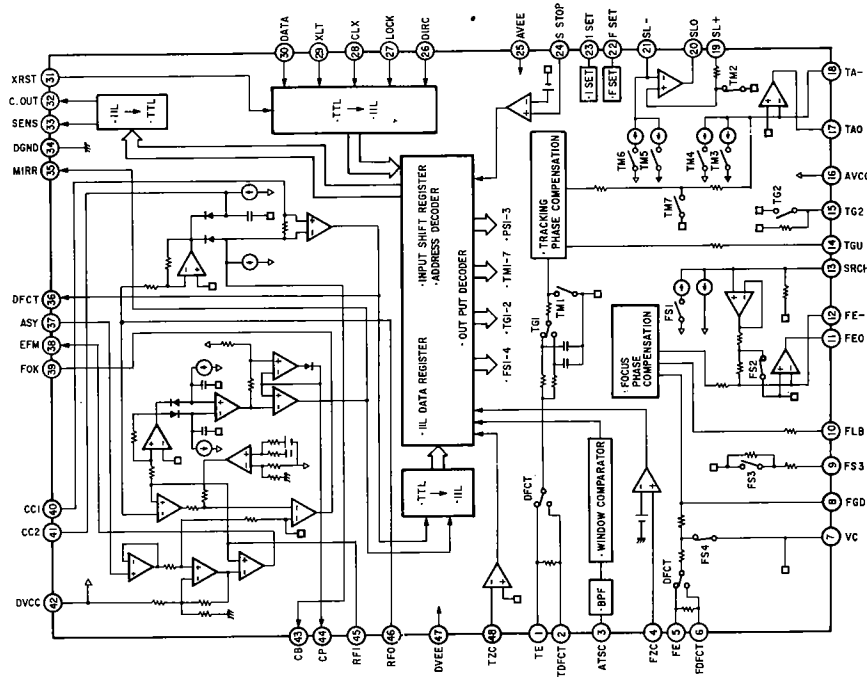

NOTE ON PARTS LIST

- Part indicated with the mark "⊙" are not always in stock and possibly to take a long period of time for supplying, or in some case supplying of part may be refused.
- When ordering of part, clearly indicate "1" and "I" (i) to avoid mis-supplying.
- Ordering part without stating its part number can not be supplied.
- Part indicated with the mark "★" is not illustrated in the exploded view.

WARNING:

Parts marked with this symbol have critical characteristics. Use ONLY replacement parts recommended by the manufacturer.

● **Resistors**

Ex.: RN 14K 2E 182 G FR
 Type Shape and performance Power Resistance Allowable error Others

RD : Carbon	2B : 1/4W	F : ±1%	P : Pulse-resistant type
RC : Fixed	2E : 1/2W	G : ±2%	NL : Low noise type
RS : Metallic film	2H : 3/4W	J : ±5%	NB : Non-burning type
RW : Winding	3A : 1W	K : ±10%	FR : Fuse resistor
RN : Metal film	3D : 2W	M : ±20%	F : Lead wire forming
RK : Metal mixture	3F : 3W		
	3H : 5W		

★ **Resistance**

1 8 2 ⇒ 1800Ω = 1.8kΩ
 Indicates number of zeros after effective number
 2-digit effective number, decimal point indicated by R.
 • Units: Ω

● **Capacitors**

Ex.: CE 04W 1H 2R2 M BP
 Type Shape and performance Dielectric strength Capacity Allowable error Others

CE : Aluminum foil electrolyte	0J : 6.3V	F : ±1%	HS : High stability type
CA : Aluminum solid electrolyte	1A : 10V	G : ±2%	BP : Non-polar type
CS : Tantalum electrolyte	1C : 16V	J : ±5%	HR : Ripple-resistant type
CO : Film	1E : 25V	K : ±10%	DL : For charge and discharge
CQ : Ceramic	1V : 35V	M : ±20%	HF : For assuring high frequency
CC : Ceramic	1H : 50V	Z : +80%	U : UL part
CP : Oil	2A : 100V	-20%	C : CSA part
CM : Mica	2B : 125V	P : +100%	W : UL-CSA type
CF : Metallized	2C : 160V	-0%	F : Lead wire forming
CH : Metallized	2D : 200V	C : ±0.25pF	
	2E : 250V	D : ±0.5pF	
	2H : 500V	= : Others	
	2J : 630V		

★ **Capacity**

2 R 2 ⇒ 2.2 μF
 1-digit effective number, decimal point indicated by R.
 2-digit effective number, decimal point indicated by R.

- Units: μF, (for P, pF (μ pF))
- When the dielectric strength is indicated in AC, "AC" is included after the dielectric strength value.

PARTS LIST OF P.W.BOARD

2U-2081/2082 MAIN UNIT

Ref. No.	Part No.	Part Name	Remarks	
SEMICONDUCTOR GROUP				
[U.S.A., Canada, Australia and Asia Models]				
IC101	262 0842 002	CXA1081S	(DCD-860 only)	
IC102	262 1305 001	CXA1372S		
IC103,104	263 0565 007	BA15218		
IC201				
IC202	262 1304 002	CX2500Q (80P-QFP)		
IC203	262 0824 004	SN74LS624N		
IC204	262 1352 009	TC74HCT04AP		
IC300	262 1339 006	CXD2551P		
IC301	262 1265 002	TC74HCU04AP		
IC302,303	262 1171 002	PCM61P		
IC501	263 0693 005	M5290P		
IC502-505	268 0073 905	ICP-N15T		
IC701	262 0591 007	HD74HC00P		
IC702,703	263 0565 007	BA15218		
IC704	262 0640 000	MN6632A		
IC705	263 0198 005	NJM4556D		
IC706	263 0712 009	:4558P		
◆	263 0565 007	BA15218		
TR101	272 0101 902	:BC369		
◆	272 0025 907	2SB562 (C)		
TR103	274 0145 003	:BD935F		
◆	274 0136 009	2SD1913		
TR104	272 0101 902	:BC369		
◆	272 0025 907	2SB562 (C)		
TR105	274 0144 907	:BC368		
◆	274 0036 905	2SD468 (C)		
TR106	272 0101 902	:BC369		
◆	272 0025 907	2SB562 (C)		
TR107	274 0144 907	:BC368		
◆	274 0036 905	2SD468 (C)		
TR108	272 0101 902	:BC369		
◆	272 0025 907	2SB562 (C)		
TR109	274 0144 907	:BC368		
◆	274 0036 905	2SD468 (C)		
TR110	272 0101 902	:BC369		
◆	272 0025 907	2SB562 (C)		
TR111	274 0144 907	:BC368		
◆	274 0036 905	2SD468 (C)		
TR112	272 0101 902	:BC369		
◆	272 0025 907	2SB562 (C)		
TR501	274 0036 905	2SD468 (C)		
TR502	272 0093 007	2SB1274		
TR503,504	271 0101 925	2SA933 (Q) T-70		
TR702	269 0014 909	DTA124XS (22K-47K)		
TR703	269 0025 901	RN1202(10K-10K)		
TR706,707	274 0124 901	2SD1504 (E/F) TPE2		
710,711				
D201-203	276 0432 903	1SS270ATE		
D501-506	276 0550 908	1SR139-200T-62		
D507	276 0484 919	HZS33-2TD		
D508	276 0465 912	HZS7B-2TD		
D701-703	276 0432 903	1SS270ATE		
SEMICONDUCTOR GROUP				
[Europe, and U.K. Models]				
IC101	262 0842 002	CXA1081S	(DCD-860 only)	
IC102	262 1305 001	CXA1372S		
IC103,104	263 0712 009	:4558P		
◆	263 0565 007	BA15218		
IC201				
IC202	262 1304 002	CXD2500Q (80P-QFP)		
IC203	262 0824 004	SN74LS624N		
IC204	262 1355 006	:PC74HCT04P		
◆	262 1352 009	TC74HCT04AP		
IC300	262 1339 006	CXD2551P		
IC301	262 1354 007	:PC74HCU04P		
◆	262 1265 002	TC74HCU04AP		
RESISTOR GROUP				
VR101,102	211 6047 049	V06PB223		22kΩ
VR103	211 6047 036	V06PB103		10kΩ
VR104	211 6047 049	V06PB223		22kΩ
VR300,301	211 6047 078	V06PB104		100kΩ

• Part indicated with the mark "◆" is substitute in Japan.

PARTS LIST OF EXPLODED VIEW

DCD-860

Ref. No.	Part No.	Part Name	Remarks
⊙ 1	2U-2065	KEY DISPLAY UNIT	U.S.A., CANADA, AUSTRALIA, ASIA EUROPE, U.K.
⊙	2U-2066	KEY DISPLAY UNIT	
2	204 8354 017	HEADPHONE JACK	
3	393 4095 007	FL TUBE	
4	212 1039 000	1P PUSH SWITCH (POWER)	
5	211 0661 007	V0920P07FC202 (H/P VR.)	
6	FG-416	CD MECHA UNIT	U.S.A., CANADA, AUSTRALIA, ASIA EUROPE, U.K.
8	FG-415 GEN 0198 H1	CD MECHA UNIT LOADER FRAME SUB ASS'Y	
9	144 2006 153	FRONT PANEL	(Gold)
10	144 2006 179	FRONT PANEL	
	146 1161 325	SUB PANEL ASS'Y	U.S.A., CANADA AUSTRALIA, ASIA EUROPE, U.K.
	146 1161 309	SUB PANEL ASS'Y	
	146 1155 205	SUB PANEL ASS'Y	(Gold)
	146 1155 218	SUB PANEL ASS'Y	
11	113 1350 204	SERIES KNOB	(Gold)
	113 1350 220	SERIES KNOB	
12	113 1351 009	TENKEY	
	113 1351 025	TENKEY	(Gold)
13	113 1352 105	FUNCTION KNOB	
	113 1352 121	FUNCTION KNOB	(Gold)
⊙ 14	441 1204 006	BRACKET	
15	009 0043 006	35P FFC	
⊙ 16	412 3072 005	PANEL BRACKET	
17	113 1357 207	P. SWITCH KNOB	(Gold)
	113 1357 223	P. SWITCH KNOB	U.S.A., CANADA, AUSTRALIA, ASIA EUROPE, U.K.
18	146 1149 101	LOADER PANEL	
	146 1148 102	LOADER PANEL	(Gold)
19	112 0645 108	HEADPHONE KNOB	
	112 0645 124	HEADPHONE KNOB	(Gold)
⊙ 20	122 0187 113	TOP COVER SPACER	U.S.A., CANADA AUSTRALIA, ASIA EUROPE, U.K.
⊙	122 0187 100	TOP COVER SPACER	
21	473 7508 017	3x10 CBTS(P)-B	
22	473 7002 021	3x8 CBTS(S)-B	
24	473 7002 005	3x6 CBTS(S)-Z	
25	473 7007 000	4x8 CBTS(S)-B	
	473 4801 005	4x8 CTTS	(Gold)
30	411 0962 209	CHASSIS	U.S.A., CANADA, AUSTRALIA, ASIA EUROPE, U.K.
31	411 0959 306	CHASSIS	
	105 0905 251	BACK PANEL	U.S.A.
	105 0905 293	BACK PANEL	CANADA
	105 0905 277	BACK PANEL	ASIA
	105 0905 264	BACK PANEL	AUSTRALIA
	105 0902 115	BACK PANEL	EUROPE
	105 0902 144	BACK PANEL	U.K.
32	104 0208 007	FOOT ASS'Y	U.S.A., CANADA, AUSTRALIA, ASIA EUROPE, U.K.
⊙ 33	104 0230 004	FOOT ASS'Y	
⊙ 34	441 1132 107	BOTTOM PLATE	
	443 0518 003	PCB HOLDER	U.S.A., CANADA, AUSTRALIA, ASIA EUROPE, U.K.
⊙	443 1003 009	PCB SPACER	
⊙ 35	2U-2081	MAIN P.W.B. UNIT	U.S.A., CANADA
⊙	2U-2081 B	MAIN P.W.B. UNIT	ASIA
⊙	2U-2081 C	MAIN P.W.B. UNIT	AUSTRALIA
⊙	2U-2082	MAIN P.W.B. UNIT	EUROPE
⊙	2U-2082 A	MAIN P.W.B. UNIT	U.K.

PARTS LIST OF EXPLODED VIEW

DCD-660

Ref. No.	Part No.	Part Name	Remarks
⊙ 1	2U-2067 A	KEY DISPLAY UNIT	U.S.A., CANADA, AUSTRALIA, ASIA EUROPE, U.K.
⊙	2U-2084	KEY DISPLAY UNIT	
2	204 8354 017	HEADPHONE JACK	
3	393 4101 001	FL TUBE	
4	212 1039 000	1P PUSH SWITCH	
5	211 0661 007	V0920P07FC202	POWER SWITCH HEADPHONE VR
6	FG-416	CD MECHA UNIT	U.S.A., CANADA
	FG-415	CD MECHA UNIT	EUROPE, U.K.
8	GEN 0198 H1	LOADER FRAME SUB ASS'Y	
9	144 2040 009	FRONT PANEL	U.S.A., CANADA, AUSTRALIA, ASIA EUROPE, U.K.
	144 2006 182	FRONT PANEL	(Gold)
	144 2006 195	FRONT PANEL	
10	146 1161 338	SUB PANEL ASS'Y	U.S.A., CANADA AUSTRALIA, ASIA EUROPE, U.K.
	146 1161 312	SUB PANEL ASS'Y	
	146 1155 221	SUB PANEL ASS'Y	(Gold)
	146 1155 234	SUB PANEL ASS'Y	
11	113 1350 233	SERIES KNOB	U.S.A., CANADA, AUSTRALIA, ASIA EUROPE, U.K.
	113 1350 246	SERIES KNOB	(Gold)
	113 1350 259	SERIES KNOB	
12	113 1351 009	TEN KEY	
	113 1351 025	TEN KEY	(Gold)
13	113 1352 105	FUNCTION KNOB	
	113 1352 121	FUNCTION KNOB	(Gold)
⊙ 14	441 1204 006	BRACKET	
15	009 0043 006	35P FFC	
⊙ 16	412 3072 005	PANEL BRACKET	
17	113 1357 207	POWER SWITCH KNOB	(Gold)
	113 1357 223	POWER SWITCH KNOB	U.S.A., CANADA, AUSTRALIA, ASIA EUROPE, U.K.
18	146 1149 101	LOADER PANEL	
	146 1148 102	LOADER PANEL	(Gold)
19	112 0645 108	HEADPHONE KNOB	
	112 0645 124	HEADPHONE KNOB	(Gold)
⊙ 20	122 0187 113	TOP COVER SPACER	U.S.A., CANADA AUSTRALIA, ASIA EUROPE, U.K.
⊙	122 0187 100	TOP COVER SPACER	
21	473 7508 017	3x10 CBTS(P)-B	
22	473 7002 021	3x8 CBTS(S)-B	
24	473 7002 005	3x6 CBTS(S)-Z	
25	473 7007 000	4x8 CBTS(S)-B	
	473 4801 005	4x8 CTTS	(Gold)
⊙ 30	411 0962 306	CHASSIS	U.S.A., CANADA, AUSTRALIA, ASIA EUROPE, U.K.
⊙	411 0959 306	CHASSIS	
31	105 0920 003	BACK PANEL	U.S.A.
	105 0920 016	BACK PANEL	CANADA
	105 0920 032	BACK PANEL	ASIA
	105 0920 029	BACK PANEL	AUSTRALIA
	105 0902 128	BACK PANEL	EUROPE
	105 0902 157	BACK PANEL	U.K.
32	104 0208 007	FOOT ASS'Y	U.S.A., CANADA, AUSTRALIA, ASIA EUROPE, U.K.
⊙ 33	104 0230 004	FOOT ASS'Y	
⊙ 34	441 1132 107	BOTTOM PLATE	
	443 0518 003	P.C.B. HOLDER	U.S.A., CANADA, AUSTRALIA, ASIA EUROPE, U.K.
⊙	443 1003 009	P.C.B. SPACER	
⊙ 35	2U-2081 A	MAIN UNIT	U.S.A., CANADA
⊙	2U-2081 F	MAIN UNIT	ASIA
⊙	2U-2081 E	MAIN UNIT	AUSTRALIA

Ref. No.	Part No.	Part Name	Remarks
⊙	2U-2082 B	MAIN UNIT	EUROPE
⊙	2U-2082 C	MAIN UNIT	U.K.
37	204 8311 021	2P PIN JACK	
△ 38	233 5820 005	POWER TRANS. (EU)	U.S.A., CANADA
△	233 5822 003	POWER TRANS. (E1)	ASIA
△	233 5821 004	POWER TRANS. (EA)	AUSTRALIA
△	233 5823 002	POWER TRANS. (E2)	EUROPE, U.K.
⊙ 39	412 3071 006	TRANS. EARTH	
△ 40	206 2086 002	AC CORD W/CONN. (EU)	U.S.A., CANADA
△	206 2088 000	AC CORD W/CONN. (E1)	ASIA
△	206 2091 000	AC CORD W/CONN. (E2)	EUROPE
△	206 2092 009	AC CORD W/CONN. (EK)	U.K.
△	445 0056 008	CORD BUSH	
43	102 0425 101	TOP COVER	U.S.A., CANADA, AUSTRALIA, ASIA EUROPE, U.K.
	102 0424 005	TOP COVER	
	102 0424 018	TOP COVER	(Gold)
⊙ 44	412 3100 003	P.W.B. EARTH	
	412 3100 003	P.W.B. EARTH	(Gold)

- Parts marked with △ and/or shading have special characteristics important to safety. Be sure to use the specified parts for replacement.
- Part indicated with the mark " ⊙ " are not always in stock and possibly to take a long period of time for supplying, or in some case supplying of part may be refused.
- (Gold) in the Remarks column refers with gold front panels.

EXPLODED VIEW

1 2 3 4 5 6 7 8

WARNING:
Parts marked with this symbol  have critical characteristics.
Use **ONLY** replacement parts recommended by the manufacturer.

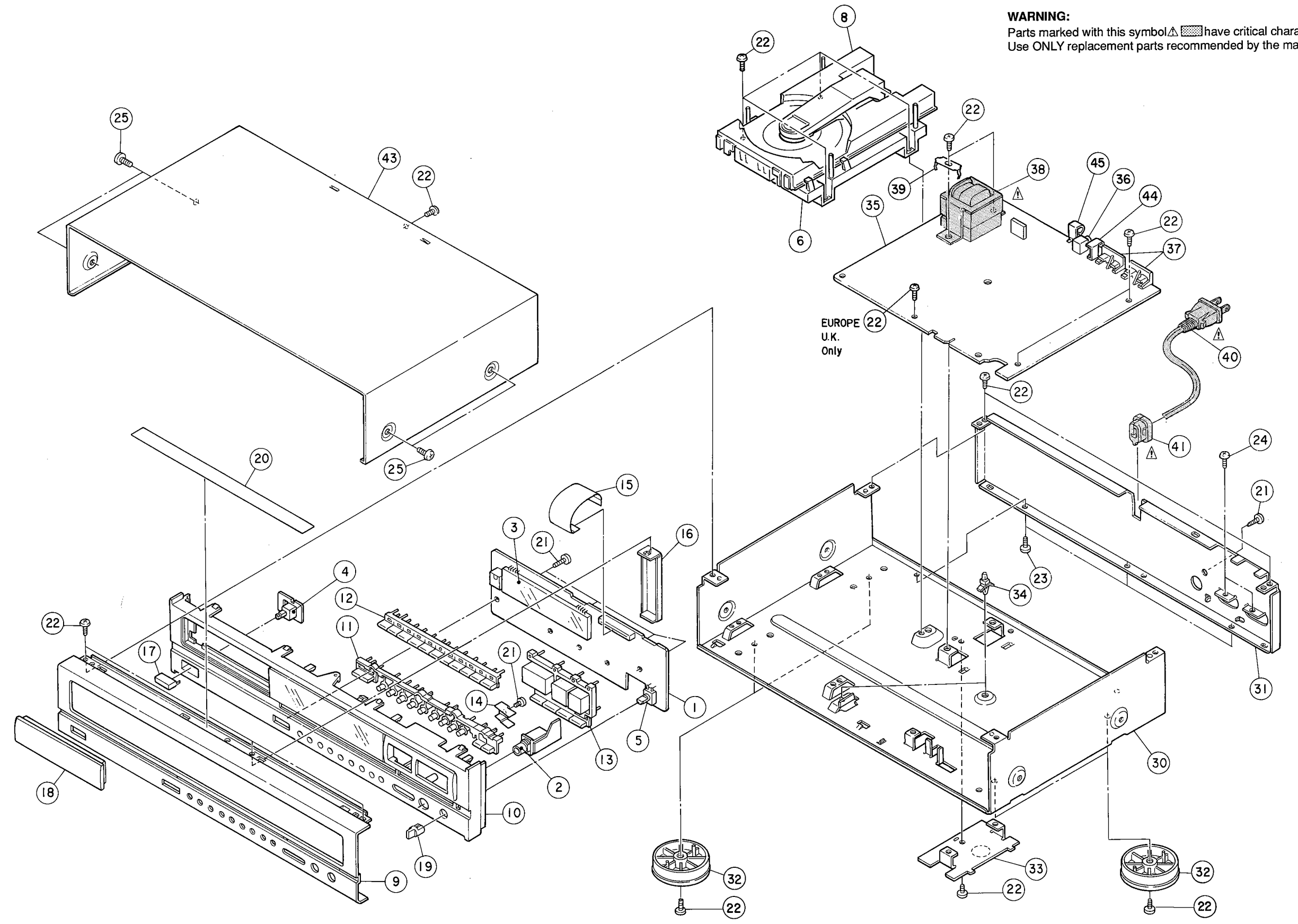

A
B
C
D
E

PARTS LIST OF FG-415/416 MECHANISM UNIT

Ref. No.	Part No.	Part Name	Remarks
①	411 0783 514	P.U. MECHA BASE	
2	431 0262 000	P.U. SLIDE SHAFT	
3	499 0100 003	LASER P.U.	FG416 (KSS-210A)
3	499 0162 009	LASER P.U.	FG415 (KSS-210A)
4	GEN0702	SPINDLE M. SUB ASS'Y	
5	PSO2A09	SLIDE M. SUB ASS'Y	
6	424 0127 105	HELICAL GEAR	
7	433 0505 310	CLAMP ARM ASS'Y	
8	424 0129 404	CLAMPER CAM	
9	212 4696 000	LEAF SW (P.U.)	
10	462 0078 104	DAMPER	
①①	411 0789 518	MECHA BASE	
12	PLO1A49	LOADING MOTOR SUB ASS'Y	
13	477 0262 006	SPECIAL SCREW	
14	424 0130 008	PULLEY GEAR	
15	424 0131 007	GEAR	
①⑥	443 0799 000	COLLAR	
17	423 0050 004	BELT	
18	212 4613 009	LEAF SW (O/C)	
19	431 0264 613	LOADER FRAME	
20	431 0284 130	DISC TRAY ASS'Y	
21	463 0574 009	DISC TRAY SPRING	
22	435 0110 303	RACK	
23	463 0585 001	CL.C. SPRING	
①④	129 0133 003	SHOCK SHEET	
25	463 0583 100	SPRING (F)	
①⑥	463 0584 002	SPRING PLATE	
27	463 0573 000	CLAMPER SPRING	
31	471 3801 039	2x3 CBS-Z	
34	473 3808 009	3x25 CBTS (I)	
35	473 7508 017	3x10 CBTS(P)-B	
36	204 2159 069	8P PH CONNE WIRE	P.U. WIRE
37	204 2282 004	8P-4P 4P, PH CORD	P.U. WIRE (RED) (4px2)
①⑧	461 0448 003	DAMP SHEET	
①④	441 1210 003	P.U. DAMPER	
①④	122 0164 013	HIMERON SHEET	
①④	122 0165 119	HIMERON SHEET	

EXPLODED VIEW OF FG-415/416 MECHANISM UNIT

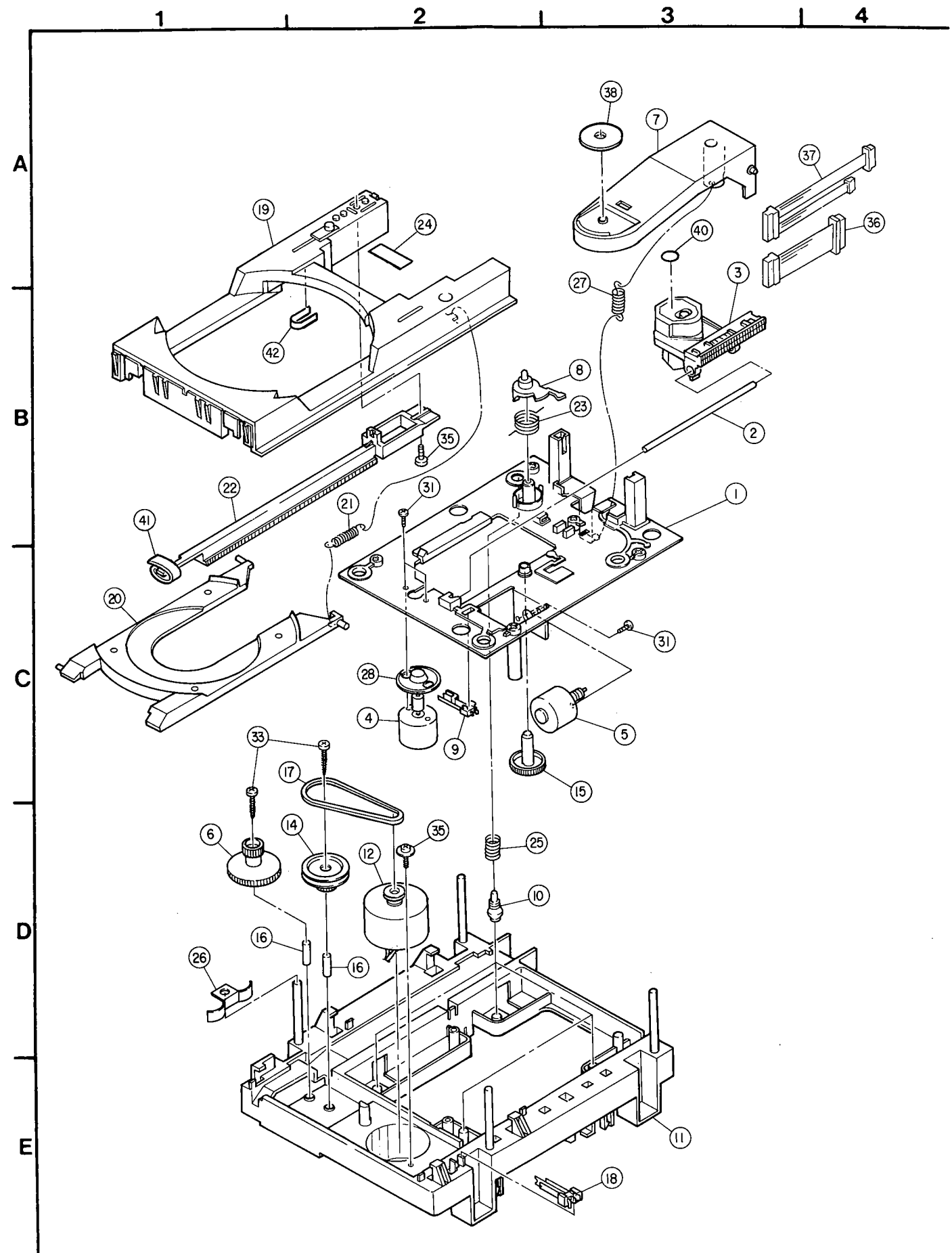

P.W.BOARD

MAIN UNIT (2U-2081/2081A/2081B/2081C/2081E/2081F)

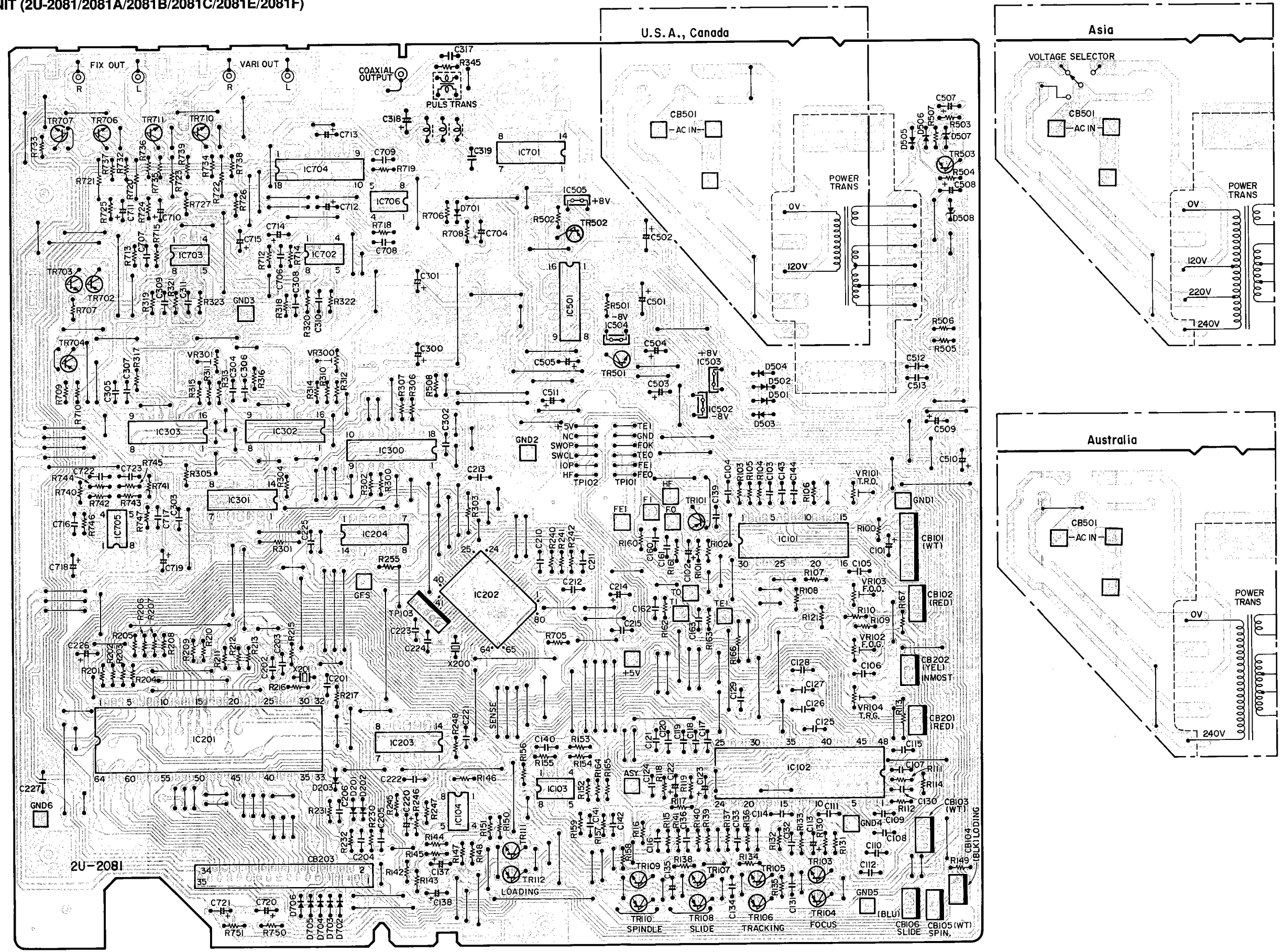

U.S.A., Canada

Asia

Australia

2U-2081

MAIN UNIT (2U-2082/2082A/2082B/2082C)

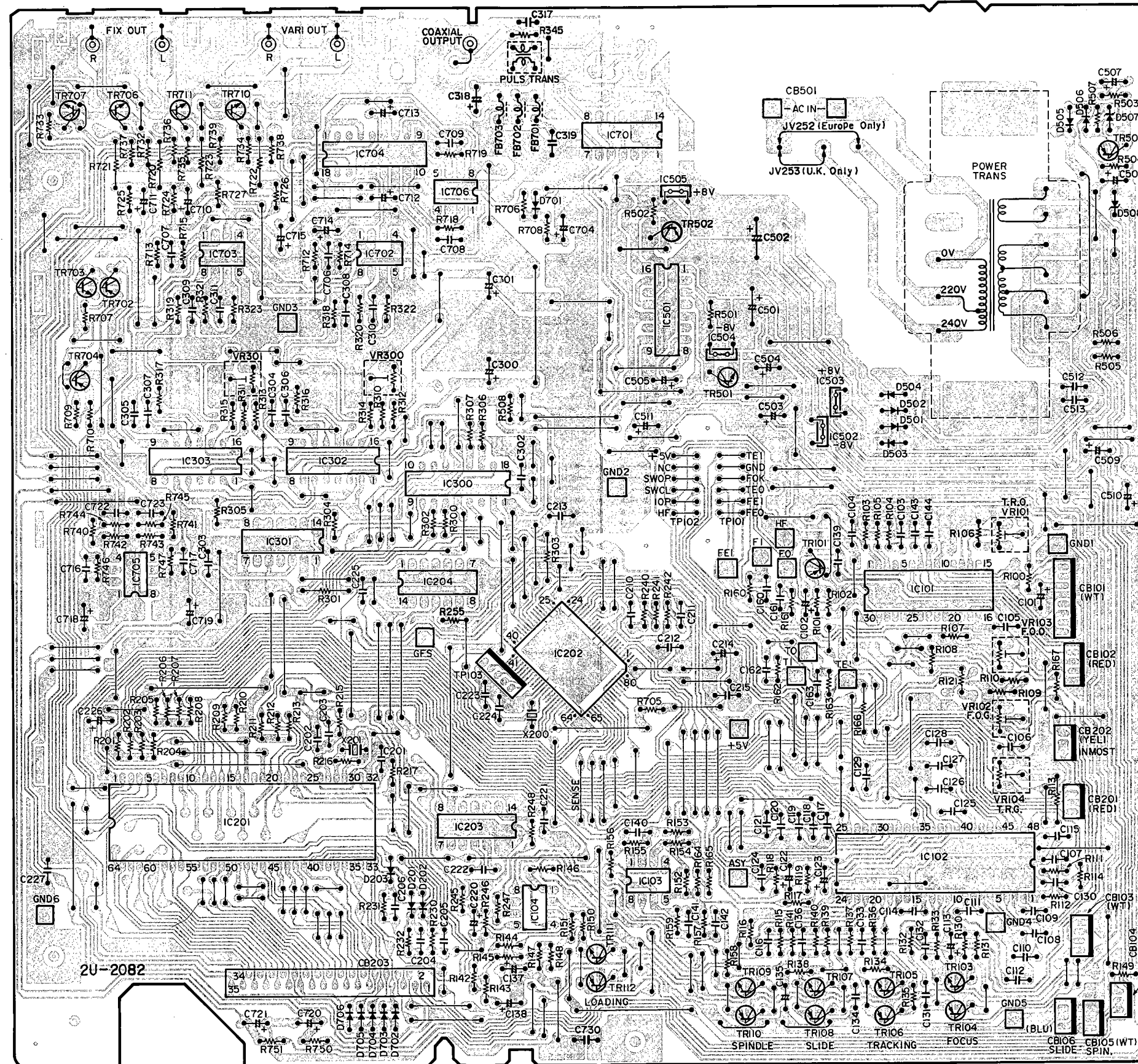

**DCD-860
KEY DISPLAY UNIT (2U-2065)**

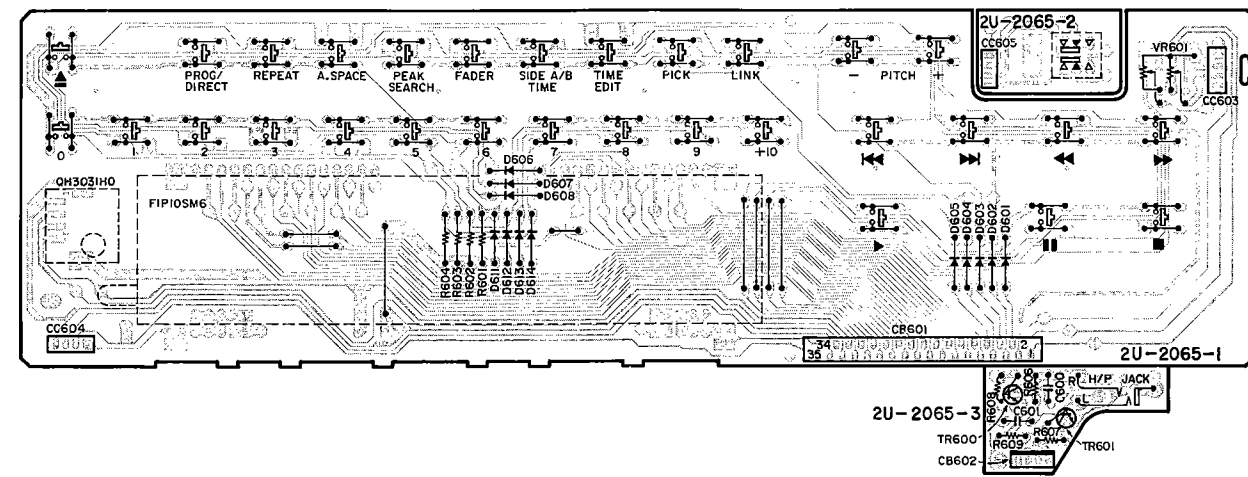

**DCD-660
KEY DISPLAY UNIT (2U-2067A)**

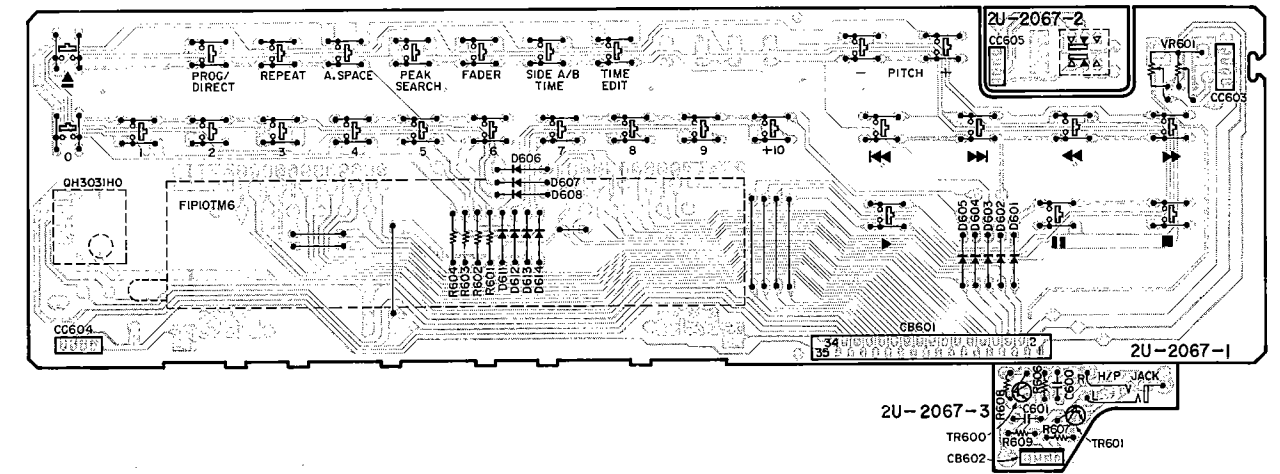

**DCD-860
KEY DISPLAY UNIT (2U-2066)**

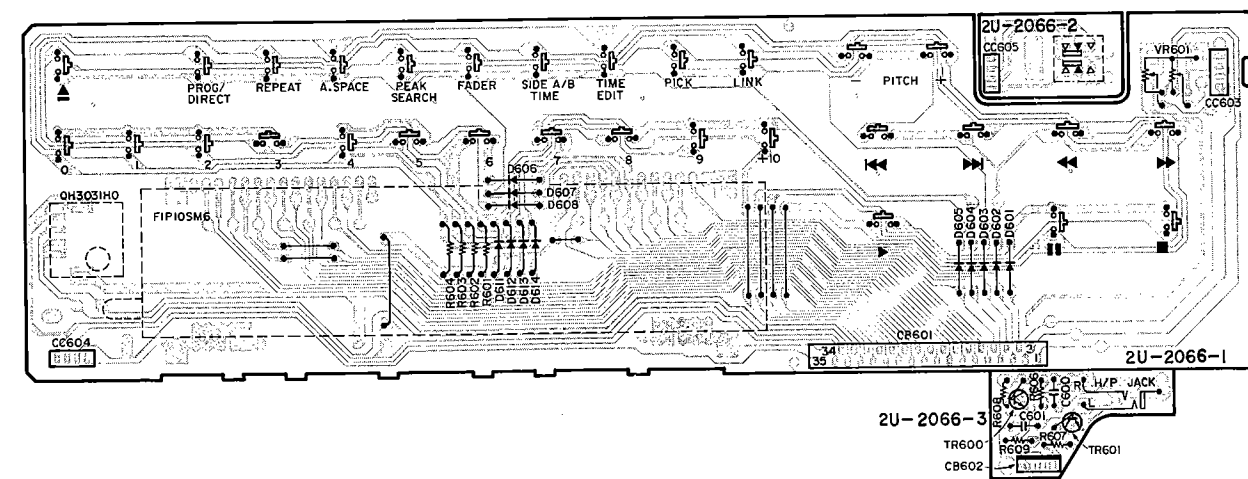

**DCD-660
KEY DISPLAY UNIT (2U-2084)**

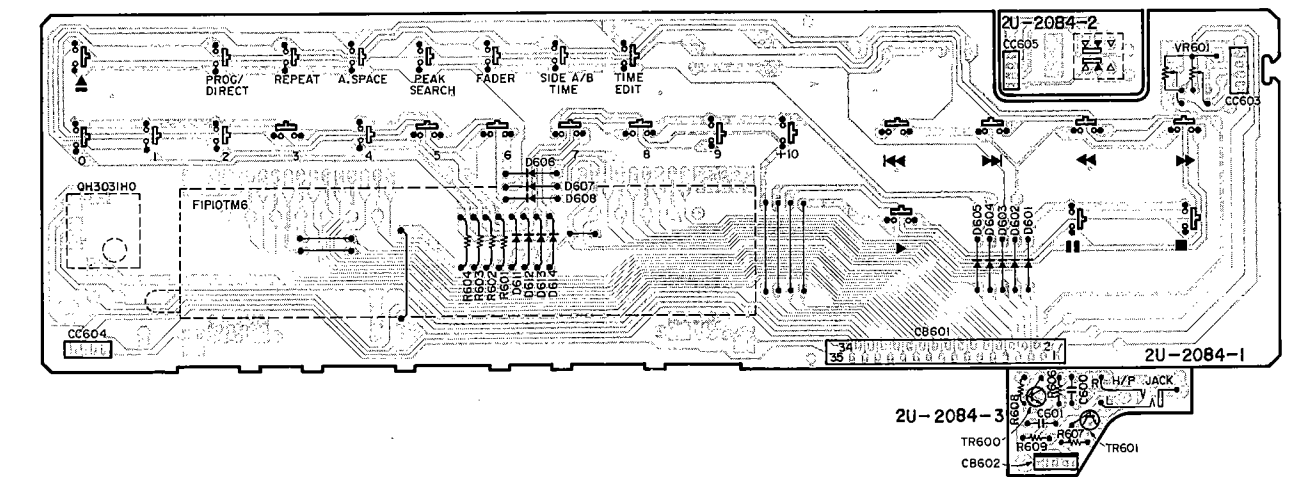

WIRING DIAGRAM

DCD-860

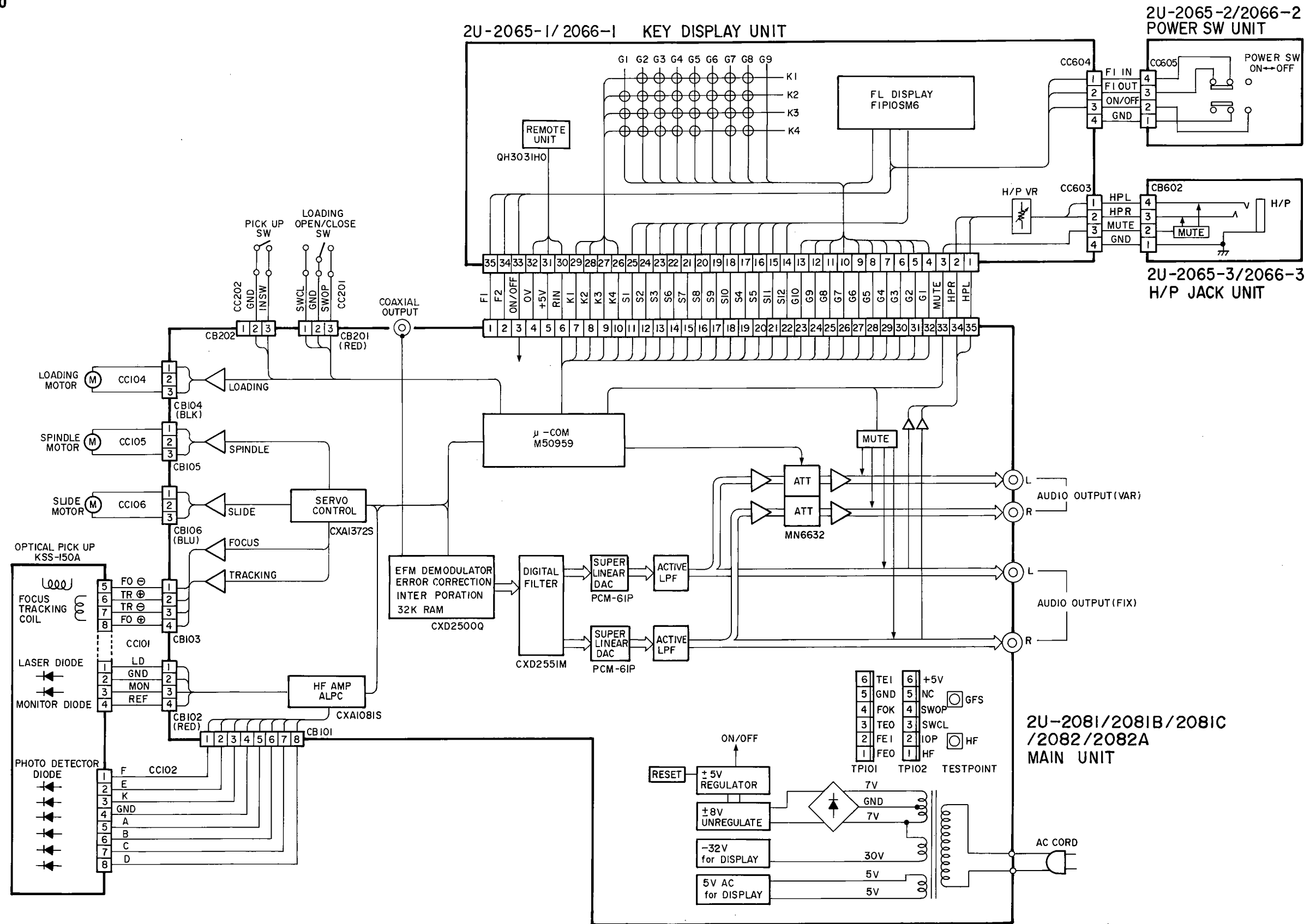

WIRING DIAGRAM

DCD-660

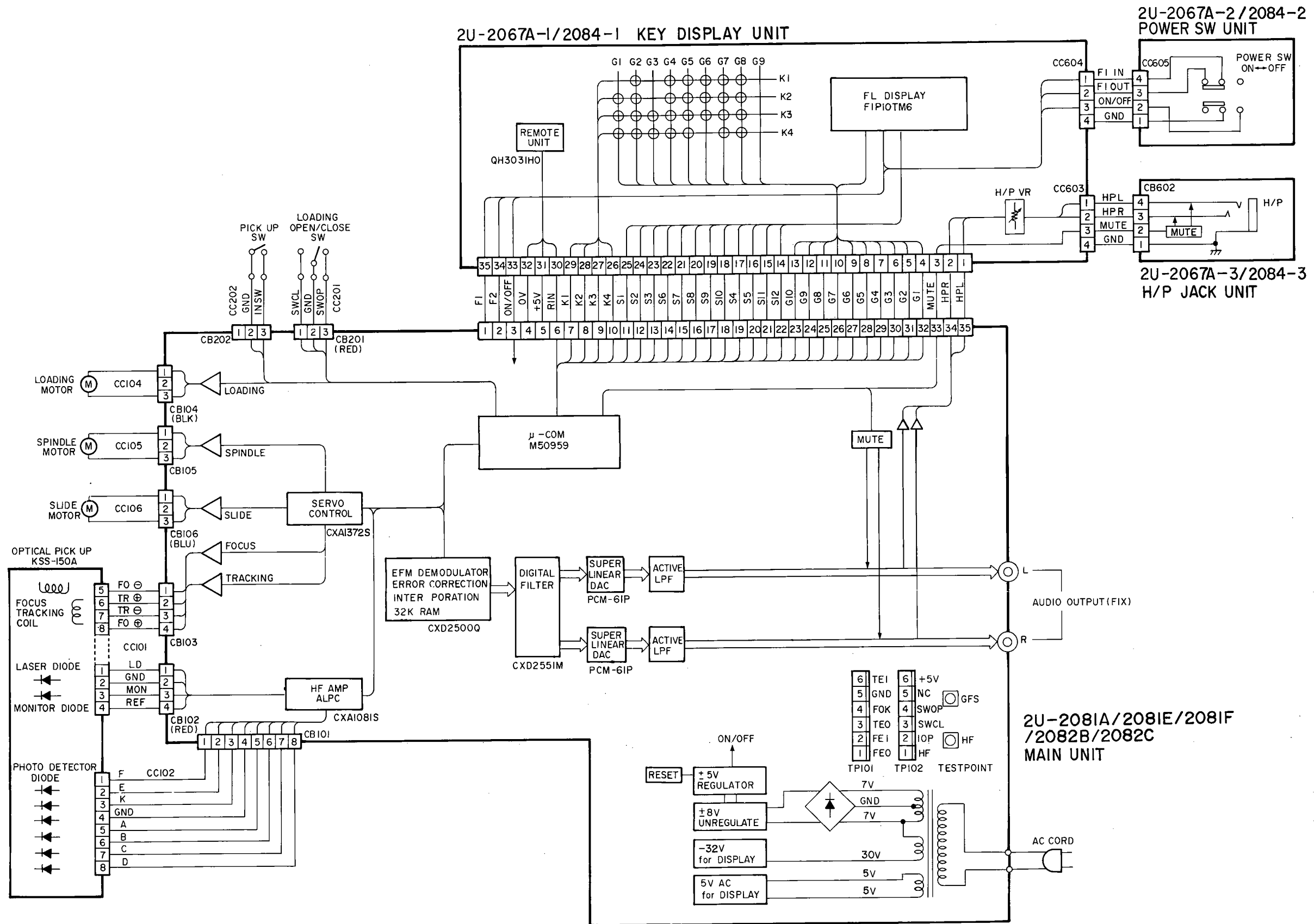

SEMICONDUCTORS

● IC's

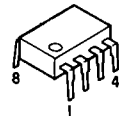

**NJM4556D
BA15218
:RC4558P**

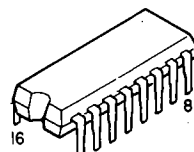
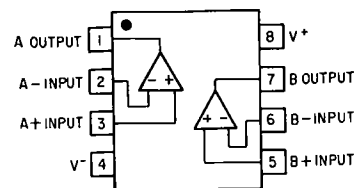

**PCM61P
M5290P**

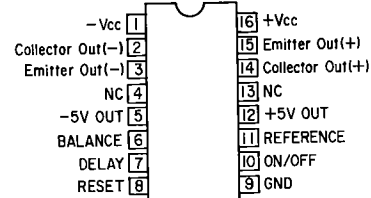

M5290P

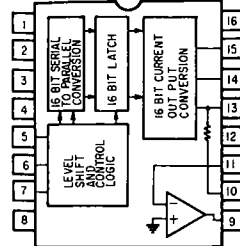

PCM61P

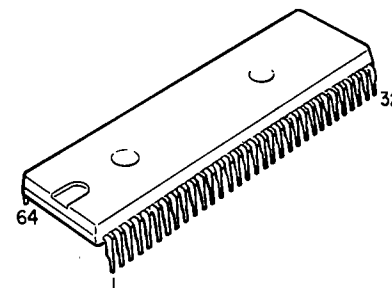

M50959

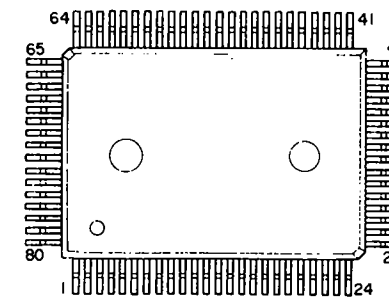

CXD2500Q

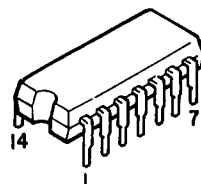

**HD74HC00P
TC74HCU04AP
SN74LS624
TC74HCT04AP
:PC74HC00P
:PC74HCT04P
:PC74HCU04P**

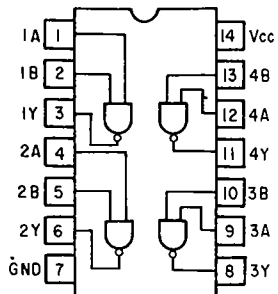

**HD74HC00P
:PC74HC00P**

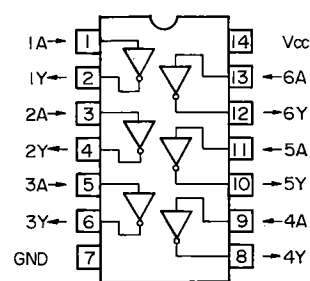

**TC74HCU04AP
TC74HCT04AP
:PC74HCU04P
:PC74HCT04P**

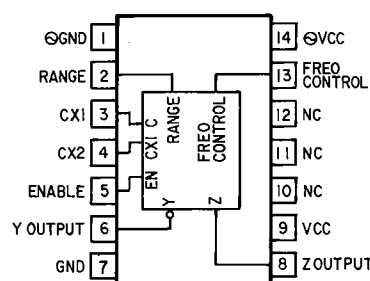

SN74LS624

● IC PROTECTOR

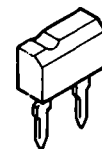

ICP-F15

or



ICP-N15

● DIODES

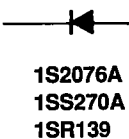

**1S2076A
1SS270A
1SR139**

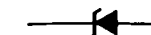

**HZS7B-2
HZS33-2**

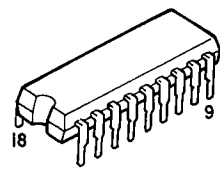

**MN6632A
CXD2551M**

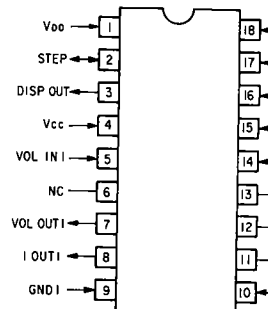

MN6632A

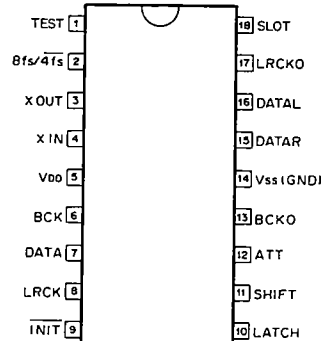

CXD2551M

● TRANSISTORS

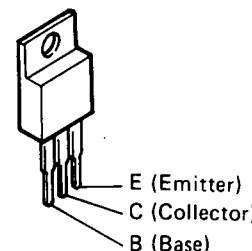

**2SD1913
2SB1274
:BC935F
:BD936F**



**2SA933(Q)
2SD1504(E/F)
:JC557A/B**



**2SB562
2SD468(C)
:BC369
:BC368**



**RN1202(10K-10K)NPN
DTA124XS(22K-47K)**

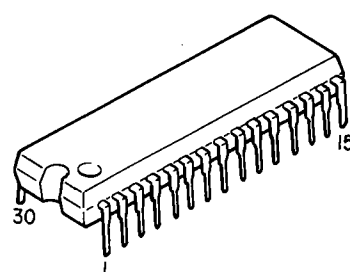
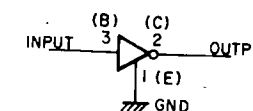

CXA1081S

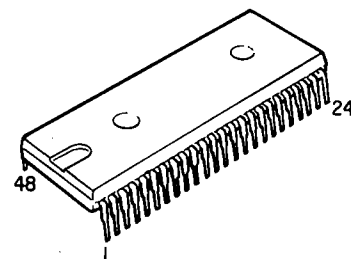
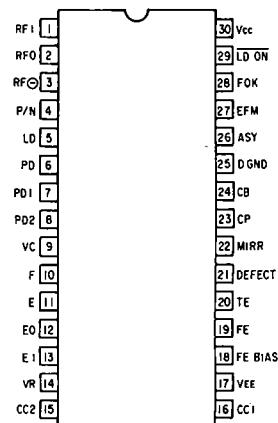

CXA1372S

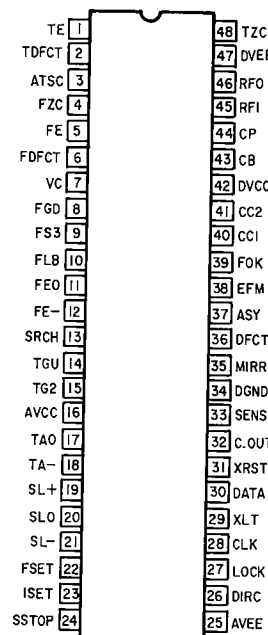

A
B
C
D
E
F
G
H

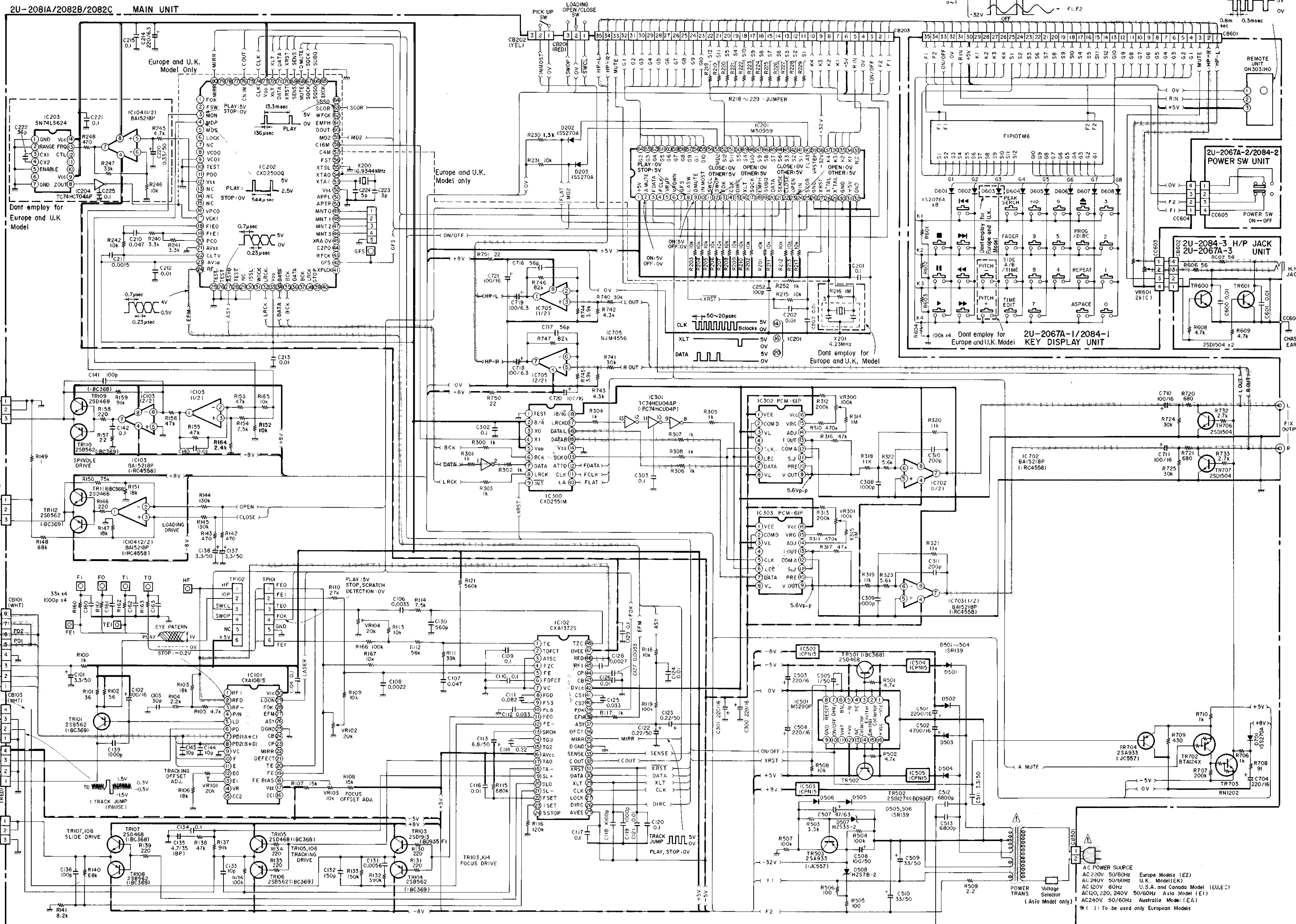

NOTES
 ALL RESISTANCE VALUES IN OHM, k=1,000 OHM, M=1,000,000 OHM
 ALL CAPACITANCE VALUES IN MICRO FARAD, P=MICRO-MICRO FARAD
 EACH VOLTAGE AND CURRENT ARE MEASURED AT NO SIGNAL INPUT CONDITION.
 CIRCUIT AND PARTS ARE SUBJECT TO CHANGE WITHOUT PRIOR NOTICE.

2U-2081/2082/2082A MAIN UNIT

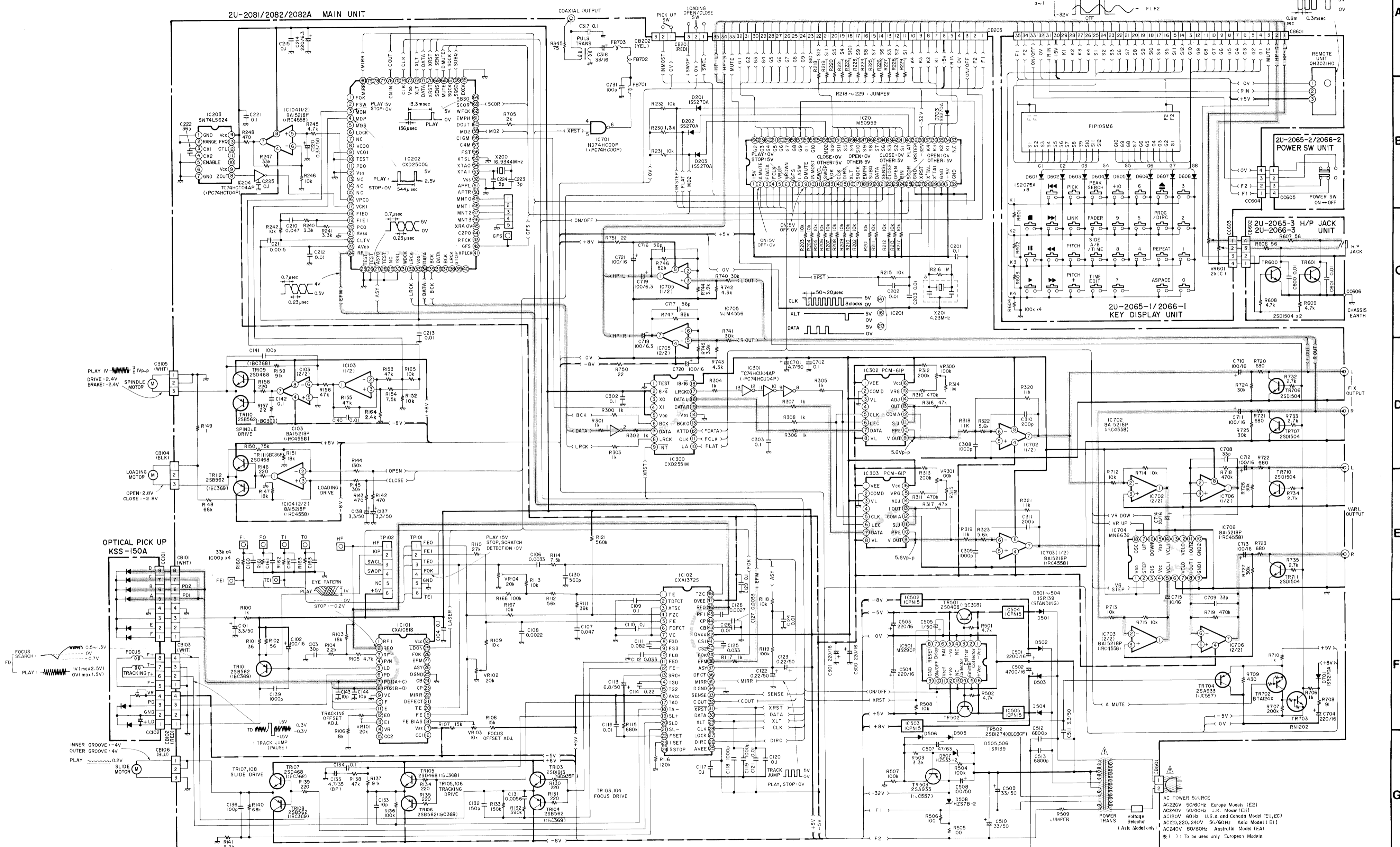

NOTES
 ALL RESISTANCE VALUES IN OHM, k=1,000 OHM, M=1,000,000 OHM
 ALL CAPACITANCE VALUES IN MICRO FARAD. P=MICRO MICRO FARAD
 EACH VOLTAGE AND CURRENT ARE MEASURED AT NO SIGNAL INPUT CONDITION.
 CIRCUIT AND PARTS ARE SUBJECT TO CHANGE WITHOUT PRIOR NOTICE.

A
B
C
D
E
F
G
H