

DENON

Hi-Fi Component

SERVICE MANUAL

STEREO CD PLAYER

MODEL DCD-1500

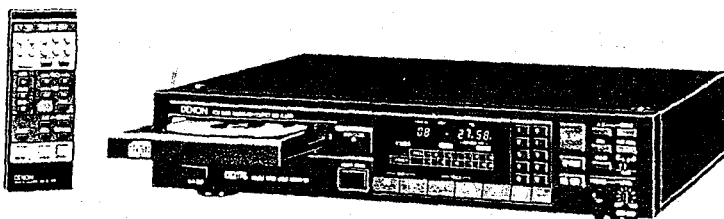

NIPPON COLUMBIA CO., LTD.

TABLE OF CONTENTS

FEATURES	2
SPECIFICATIONS	3
NAMES AND FUNCTIONS OF PARTS	4 ~ 6
NOTE FOR HANDLING OF LASER PIC-UP	7 ~ 8
HANDLING CONNECTION AND SAFETY INFORMATION FOR THE KSS-121A	
OPTICAL PICK-UP	9
DISASSEMBLY	10 ~ 12
ADJUSTMENT OF MECHANISM UNIT	13
MAINTENANCE AND ADJUSTMENT PROCEDURE	13 ~ 20
FUNCTION OF IC TERMINAL	21
FUNCTION OF SUB CODE OUTPUT TERMINAL	22
TROUBLESHOOTING	23 ~ 27
PARTS LIST OF P.W. BOARD	28 ~ 31
PARTS LIST OF EXPLODED VIEW	32
EXPLODED VIEW	33
EXPLODED VIEW OF FG-500 MECHANISM UNIT	34
P.W. BOARD	35 ~ 37
WIRING DIAGRAM	38
SEMICONDUCTORS	39
WAVEFORM IN THE CIRCUIT	40
SCHEMATIC DIAGRAM	41

FEATURES

The DCD-1500 compact laser disc player utilizes a unique DENON Double Super Linear Converter which prevents deterioration of sound quality in the PCM playback system, assuring accurate reproduction of sound recorded on compact laser discs, in the studio or in live sound production areas. The parts for this high performance disc player have been selected with careful discrimination, to produce realistic playback of the full musical production.

SPECIFICATIONS

AUDIO

No. of channels:	2 channels
Frequency response:	5 ~ 20,000 \pm 0.3 dB
Dynamic range:	Above 96 dB
Signal-to-noise ratio:	Above 96 dB
Harmonic distortion:	0.0025% (1 kHz)
Separation:	95 dB (1 kHz)
Wow and flutter:	Less than the measuring limit (\pm 0.001% W. peak)
Output voltage:	2.0 V

DISCS

Playing time:	Compact discs are used. 60 min/singel side (Maximum 79.8 min/single side)
Diameter:	120 mm

SIGNAL FORMAT

Sampling frequency:	44.1 kHz over sampling
Quantization:	16 bit linear/channel
Transmission bit rate:	4.3218 M bits/sec

PICKUP

System:	Objective lens drive system, laser pickup
Lens drive system:	Two-dimensional parallel drive
Light source:	Semiconductor laser
Wavelength:	780 nm

GENERAL CHARACTERISTICS

Power supply:	50/60 Hz, Voltage is shown on rating label.
Power consumption:	17 W
Dimensions:	434 (17.1 in) W x 89 (3.5 in) H x 350 (13.8 in) D mm
Weight:	6.0 kg

FUNCTIONS AND DISPLAY

Functions:	Direct selection, quick selection, programmed selection, repeat playback pause, skip monitor, index search, A-B repeat
Display:	Track number, index number, time, and program
Other functions:	Headphone jack (variable level), Variable level/fixed level output terminal

REMOTE CONTROL UNIT

Remote control system:	RC-1500 Infrared pulse system
Power supply:	3 V!DC Two SUM-4 (standard size four) dry cell batteries
External dimensions:	60 (2.4 in) W x 150 (5.9 in) H x 17 (0.7 in) D mm
Weight:	98 g (Includes batteries)

ACCESSOREIS

Connecting pin cord

* Design and specifications are subject to change without notice in the course of product improvement.

VAROITUS: SUOJAKOTELOA EI SAA AVATA. LAITE SISÄLTÄÄ LASER-DIODIN, JOKA LÄHETTÄÄ SILMÄLLE VAARALLISTA LASER-SATEILYÄ.
ADVARSEL: USYNLIG LASERSTRALING VED ABNING NAR SIKKERHEDSAFBRYDERE ER UDE AF FUNKTION.
UNDGA UDSÆTTELSE FOR STRALING.
"CLASS I LASER PRODUCT"



NAMES AND FUNCTIONS OF PARTS

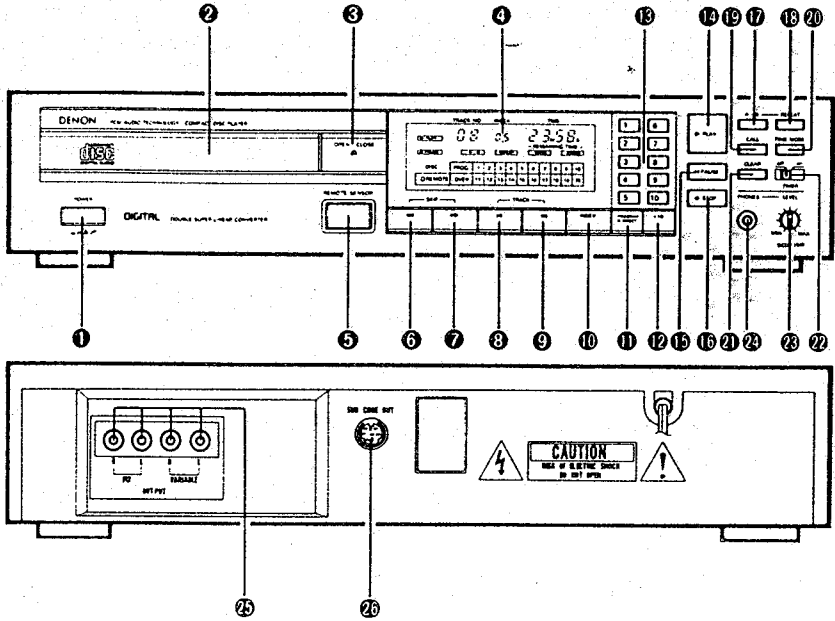

1 Power Switch (POWER)

- Press this switch to turn the power source ON.
- When the power is turned ON, (DD) will light up in the TRACK NO section of the display 4. If no disc is loaded at this time, (----) will be displayed after several seconds.
- If a disc is loaded, the DISC indicator will light, the total number of tracks on the disc will be displayed in the TRACK NO. section of the display, and the total playback time will be displayed under the TIME section. The calendar will light up to display the total number of tracks.

2 Disc Holder

- The disc is loaded into the disc holder for play.
- The disc holder is opened and closed by pressing the disc holder open/close button (▲ OPEN/CLOSE) 3.
- It can also be closed by pressing the play button (▶ PLAY) 10.

3 Disc Holder Open/Close Button (▲ OPEN/CLOSE)

- The disc holder 2 is opened and closed by pressing this button.
- Press the button once to eject the disc holder 2 forward. Press it again to close the holder.

- If the disc holder is closed and a disc has been loaded, the disc is rotated for several seconds, and then the machine enters STOP state. The total number of tracks on the disc and the total playback time are then displayed on the digital display 4.

4 Display

- The display area consists of sections for the track number, the index, the playback time, and the calendar.

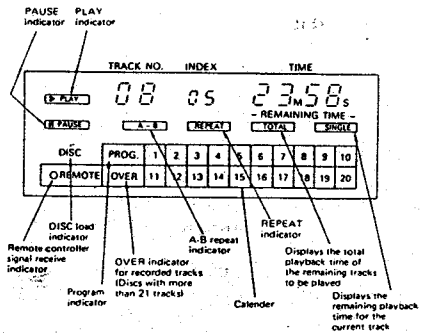

25

6 Remote Control Photosensitive Window

- This window receives the light transmitted from the wireless remote control unit.
- The RC-1500 wireless remote control unit should be operated while it is pointed in the direction of the photosensitive window.
- When the remote control is operated, the remote control sensor indicator lamp will light in the display area 4.

6 Fast Reverse Skip Button (◀◀)

- Press this button to move playback in fast reverse.
- When the machine is in play, sound will be produced during the time that the button is being pressed and the fast reverse is operating.
- If the button is pressed while the machine is in the pause state, the fast reverse will operate three times faster than the reverse speed when the machine is in the play state. No sound will be produced.

7 Fast Forward Skip Button (▶▶)

- Press this button to move playback in forward.
- When the machine is in play, sound will be produced during the time that the button is being pressed and the fast forward is operating.
- If the button is pressed while the machine is in the pause state, the fast forward will operate three times faster than the fast forward speed when the machine is in the play state. No sound will be produced.

8 Track Button (K)

- Press this button to move the pickup forward and advance to the beginning of the desired track.
- If the TRACK button is pressed during playback or pause, the pickup moves forward to the beginning of the track that corresponds to the number of times the button was pressed.

9 Track Button (◀)

- Press this button to move the pickup backward, to return to the beginning of the desired track.
- If the TRACK button is pressed during playback or pause, the pickup moves back to the beginning of the track that corresponds to the number of times the button was pressed.

10 Index Button (INDEX)

- Press this button to begin playback at an index number within a track.
- Select the desired index number by using the ten-key pad.

11 Program and Direct Button (PROGRAM & DIRECT)

- Press this button to select the memory program function or direct track selection function.

12 +10 Button (+10)

- Press this button to select a track number that is larger than 11.
- The +10 button is used in conjunction with the ten-key pad 13. For example, to select track number 15, press the +10 button and then 5 on the ten-key pad.
- Similarly, to select track number 32, press +10, +10, +10 and then press 2.

13 Ten-key Pad

- These buttons are pressed for direct track selection or to program a selection into memory. For example, to play back the third track using the direct selection function, press 3 on the key pad. Track number 3 will then start to play. To play track number 12, press +10 and then 2.
- To use the keypad in program mode, first press the PROGRAM & DIRECT button to enter the correct mode.

14 Play Button (▶ PLAY)

- Press this button to play a disc.
- When the PLAY button is pressed, the ▶ PLAY indicator lights, and the number of the track being played, the index number, and the elapsed playback time for that track are displayed. The calendar lights to display the all of the playback tracks. The displayed tracks then go out in order as each finishes playing.
- When playback of the last track has finished, the ▶ PLAY indicator goes out, and the machine enters stop state.
- It is also possible to use the PLAY button to close the disc holder after a disc has been inserted. Playback then begins.

15 Pause Button (|| PAUSE)

- Press this button to stop the playback temporarily.
- If the PAUSE button is pressed during playback, the play is stopped temporarily, the PLAY lamp goes out, and the PAUSE lamp lights.
- To end the pause, push the PLAY key 14.

16 Stop Button (■ STOP)

- Press this button to stop the playback.
- The rotation of the disc stops, and the total number of tracks and the total playback time are read out on the TRACK NO, and TIME sections of the display.
- During programmed playback, the total number of tracks programmed in memory and the total programmed performance time are displayed.

17 A-B Repeat Button (A — B)

- Press this button to perform repeated playback of a desired section between two specified points.

18 Repeat Button (REPEAT)

- Press this button to repeat playback.
- When the REPEAT button is pressed, the **REPEAT** indicator lights and repeated playback is performed for all of the tracks on the disc. During programmed playback, all of the tracks programmed into memory are played repeatedly.
Press the REPEAT button again to cancel the repeat operation.

19 Call Button (CALL)

- Press this button to verify the track numbers that have been programmed into memory.

20 Time Mode Button (TIME MODE)

- This button is used to select the type of information to be read out under the TIME section of the display. Either the elapsed playback time of the current track, the remaining playback time for that track, or the playback time for the remaining tracks on the disc can be selected.

Normally the elapsed playback time of the current track is displayed. If the button is pressed once, the **SINGLE** indicator lights and the remaining time left to play on the track is displayed. If the button is pressed again, the **SINGLE** indicator goes on, and the **TOTAL** indicator goes on, and the playback time for the remaining tracks left on the disc is displayed. If the button is pressed once more, the **TOTAL** indicator goes out and the display returns to the elapsed playback time for that track.

If the button is pressed so that the **TOTAL** indicator lights during programmed playback, the playback time for all of the remaining programmed tracks is displayed.

21 Clear Button (CLEAR)

- Press this button to correct the programmed contents of memory.

22 Timer Button (TIMER)

- This button is used in conjunction with an audio timer to perform timer playback at the specified time.

23 Volume adjustment knob

- This knob is used to adjust the output level (volume) of the headphone jack.

24 Headphone Jack (PHONES)

- When using headphones, please listen to them at an appropriate volume.
(Headphones are sold separately.)

25 Output terminal (OUTPUT)

- Connect the output terminal to the input terminal of the amp.

26 Sub code output terminal (SUB CODE OUT)

- This output terminal will enable the more effective use of the compact disc player in the future.

NOTE FOR HANDLING OF LASER PICK-UP

DESCRIPTION OF THE COMPONENTS

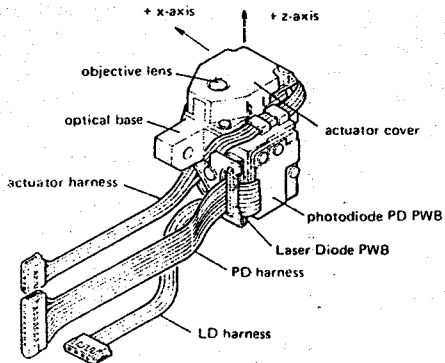

CROSS-SECTIONAL DRAWING OF THE OPTICAL PICK-UP

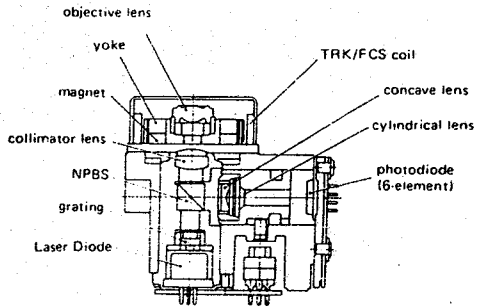

7. Label

7-1. Serial number

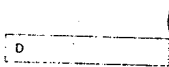

This denotes the serial number used for quality control in the manufacturing plant.

7-2. Label



Lot No.
Top

year
(last figure)
day month | quality control No.
00 0 0
10 1 10⁻¹
0 0 0

For example, 56.5 mA will be expressed as 565.

7-3. Position of the labels

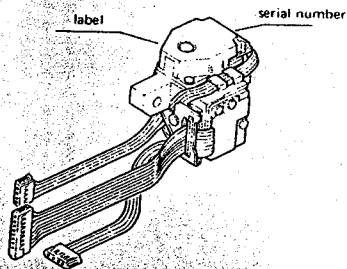

ELECTRICAL PIN CONNECTION

1. PD harness

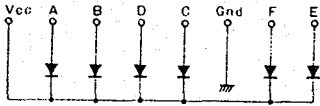

Pin No.	PD element
1	VCC
2	A
3	B
4	D
5	C
6	GND
7	F
8	E

1	2	3	4	5	6	7	8
JST							
YEL							

2. Actuator harness

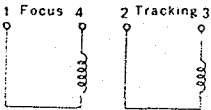

Pin No.	description
1	FCS +
2	TRK +
3	TRK -
4	FSC -

1	2	3	4
JST			
YEL			

FCS + : Lens moves toward the disc
 TRK + : Lens moves toward the center of the disc

3. LD harness

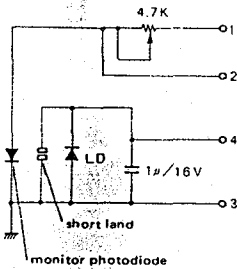

Pin No.	description
1	reference
2	monitor
3	GND
4	laser

1	2	3	4
JST			
BLK			

HANDLING, CONNECT AND SAFETY INFORMATION FOR THE KSS-121A OPTICAL PICK-UP

1. Handling Instructions

Please read the following instructions carefully before handling pick-ups.

1) Handle with care

The pick-up KSS-121A is assembled and precisely adjusted using a sophisticated manufacturing process in our plant. Keep the pick-up protected from vibration and impact. Do not disassemble or attempt to re-adjust it. Hold the optical base (aluminum diecast) when handling it. Do not touch the PD and LD PWB (Printed Wiring Board).

2) Storage

Do not store the pick-up in dusty, high-temperature or high-humidity environments.

3) Laser Diode

Protect Your Eyes

Do not look at the laser light beam through the objective lens directly nor another lens or a mirror. The laser beam may damage the human eye, since the intensity of the focusd spot may reach 1.3×10^4 W/cm² even if the intensity at the objective lens is 400 μ W maximum.

Poison

The LD chip contains As (arsenic), a poison. Although the poison is relatively weak and the amount is small, avoid putting the chip in acid or an alkali solution, heating it over 200°C or putting it into your mouth.

Avoid surge current or electrostatic discharge

The LD may be damaged if a large current is applied to it, even if only a short pulse. For safe handling of an LD, grounding the human body and measuring equipment is strongly recommended. Make sure that there is no surge current in the LD driving circuit. The PINs of the LD are short-circuited for protection during shipment.

To open the short circuit, remove the soldering quickly with a soldering iron whose insulation resistance is larger than 10 M Ω after connection to a suitable *APC circuit. The temperature of the soldering iron should be less than 320°C.

Note: *APC (Auto Power Control)

4) Actuator

The performance of the actuator may be effected if magnetic material is located nearby, since the actuator has a strong magnetic circuit.

Do not permit dust to enter through the gap of the cover.

Cleaning the lens:

Lens-cleaning paper with 50 : 50 mixed solvent of IPA (Isopropyl alcohol) and Freon (freon 113 CCl₂F₂CClF) is recommended.

2. Connections

1) How to mount the pick-up

Use the reference plane as shown in the assembly drawing when mounting the pick-up in the transportation mechanism. No special adjustment such as skew adjustment or grating angle adjustment is required. The metal bearing of Cu-compound sintered alloy is impregnated with oil. You do not normally need to lubricate the bushing. If you need to lubricate, use Hydrofluid EP-56 (Mitsubishi Oil).

2) Harness and connector

Use the specified connector housings for electrical connections. Care should be taken to see that the connector of the LD harness is clamped tightly, since a loose connection may cause a serious damage to the LD. There may be a deterioration in the eye pattern if a digital noise source such as a microcomputer is positioned near the PD harness.

3) Safety regulations

This pick-up is designed to meet general safety regulations. For the pick-up as installed in a set to be certified as meeting the safety regulations of a particular country, however, application will have to be made to the proper authorities.

DISASSEMBLY

• Removal of Top Cover

Remove two screws on the front and two screws on the rear of Top Cover (24) and detach the Top Cover by means of lifting it.

• Removal of Front Panel

1 Remove three screws (38) and three screws (31) securing Front Panel. (Figure 1)

2 Push three hooks on the bottom of the Front Panel with a (+) screwdriver, and draw the Panel forward releases hooks to detach the Front Panel from the chassis. Further, the Front Panel and the P.W.B.'s are linked with connectors, remove them as necessary. (Figure 1)

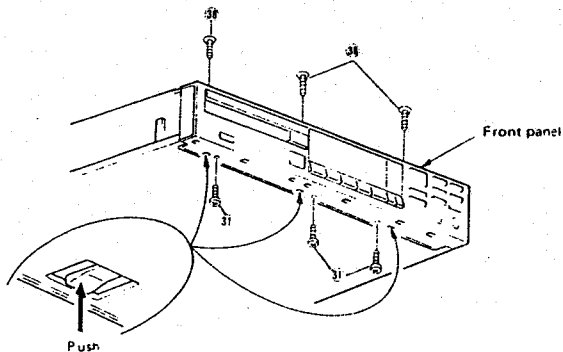

Fig. 1

3 To remove the Front Panel entirely from the chassis, unlink the connectors between the chassis and the display P.W.B. mounted on the Front Panel. (Figure 2)

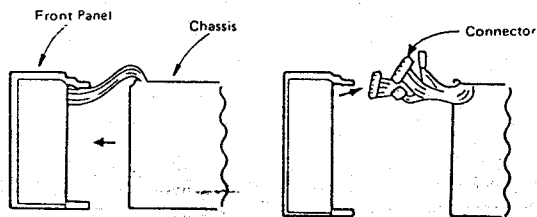

Fig. 2

• Removal of Display P.W.B from the Front Panel

1 Remove eight screws (31) and (32) - 6 each 3 x 10 mm CBTS(P); 2 each 3 x 6 mm CBTS(S) holding the P.W.B.

2 Detach the P.W.B. employing FL tube, then push the snap-fit in the direction arrow shows to remove Display P.W.B. (KU-5770). (Figure 3)

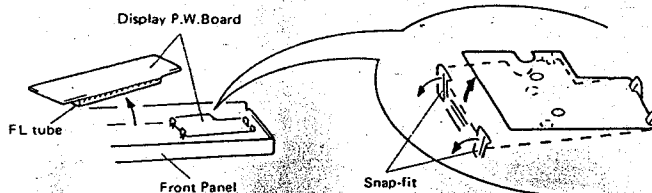

Fig. 3

• **Removal of Panel Base (B) ⑩**

- 1 Remove screw ③① securing the Panel Base (B).
- 2 Unfasten screw ③① mounting the prop and remove prop.

- 3 Detach the Panel Base (B) by following the steps as explained in the Figure. (Figure 4)

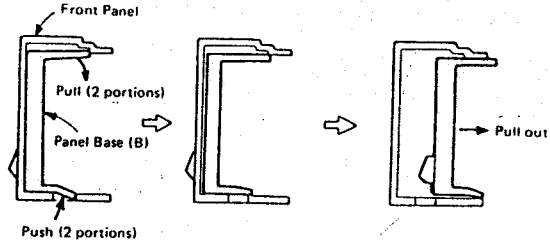

Fig. 4

• **Removal of Panel Base (A) ⑧**

- 1 Pull three pawls catching the upper side of Front Panel inward and release. For steps to detach the Panel Base A, refer to the illustration. (Figure 5)

• **Removal of Knob Frame ⑨**

- 1 Same as to "Removal of Panel Base (A)", pull two pawls catching the upper side of Front Panel inward and release. Then pull out the Knob Frame. (Figure 5)

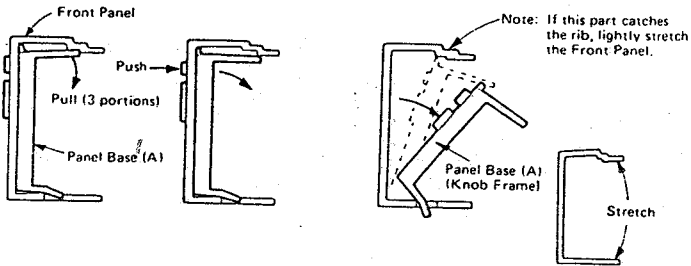
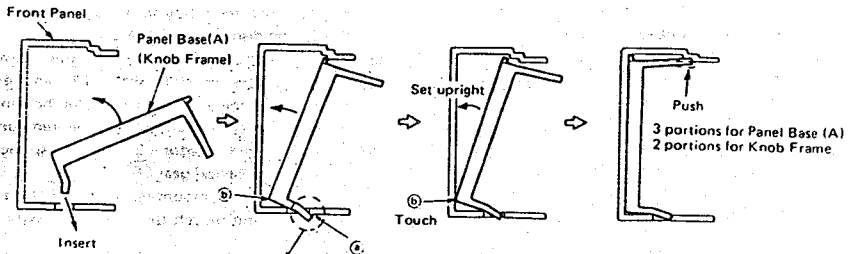

Fig. 5

• **Reassembling of Panel Base (A) and Knob Frame**

- 1 Attach the Panel Base (A) and the Knob Frame to the Front Panel as illustrated in the Figure. (Figure 6)



Note: In this condition the Panel Base (A) will not be set upright as pawl hitches part ⑧. Make part ⑥ touch the inner surface of Front panel to set the Panel Base (A) upright.

Fig. 6

- 2 After attached the Panel Base (A), pull it to the arrow direction as in the Figure until it stops (approx. 1 mm). Follow the same procedure to complete attaching the Knob Frame. (Figure 7)

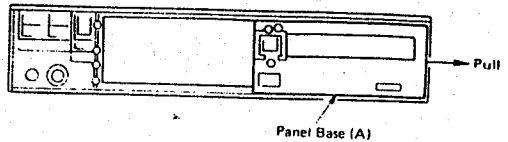

Fig. 7

• Reassembling of Panel Base (B) ⑩

- 1 Using two screws at the places indicated with arrow in the Figure to mount the Panel Base (B).

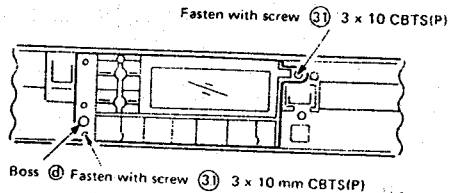
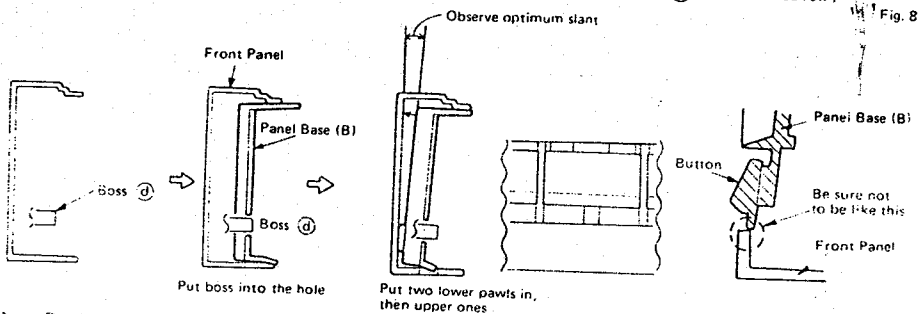

Fig. 8

- 2 Mounting hints. (Figure 9)



Note Do not excessively slant the Panel Base (B) as this may result in setting of the Button onto the bottom of Front Panel. Be sure to observe carefully.

Fig. 9

• Removal of Mechanism Unit (Refer to page 34.)

The Mechanism Unit can be removed after removing the Front Panel.

- (1) Remove screw ⑤⑨ on the rear of loader and disassemble the loader stopper ④①.
- (2) Unfasten screw ⑥④ securing the leaf switch ④⑦ on the right hand side of Mechanism Unit to detach.
- (3) Draw loader unit frontward to detach.
- (4) Remove four screws ⑤① tightening Mechanism Unit. Hold the rear of the Unit and pull it out diagonally to rear to dismantle.

• Removal of Mechanism Unit Parts (Refer to page 34.)

Refer to the exploded view of Mechanism Unit and the following instructions, replace pick-up, slide motor, and spindle motor.

- (1) Remove 2 mounting screws ⑥⑤ for the housing ⑧ and detach the housing from the mechanism plate ①.
- (2) Unfasten two mounting screws ③④, ⑥③ for the servo P.W.B. and dismantle the P.W.B.
- (3) To replace pick-up ⑩, remove four screws ⑤④ on the both sides of slide shaft ⑫, and disassemble pick-up with the slide shaft from the housing ⑧. Do not over tighten the screws ⑤④ when remounting.
- (4) To replace slide motor ③, remove spring ⑦, 3-E ring ⑤②, and helical gear ⑥.
- (5) Next, remove 2 mounting screws ⑤① of the slide motor ③ and detach the slide motor with the worm gear ④.
- (6) To replace spindle motor ⑨, unfasten a mounting screw ⑥① for the turntable ⑬.
- (7) Next, remove 2 mounting screws ⑤③ for the spindle motor and detach the spindle motor from the housing. In addition when remounting the turntable, refer to the "Turntable Height Adjustment" and adjust it properly.

ADJUSTMENT OF MECHANISM UNIT

• Turntable Height Adjustment

- ① Attach the turntable to the spindle motor.
- ② To adjust the height in 2 mm, insert "A" part of the jig between the upper surface of the housing and the lower surface of the turntable.
- ③ When it is adjusted to 2 mm, tighten the set screw.

About the height adjustment jig

As illustration shows, the jig to be used for the height adjustment is prepared. The part indicated "A" for turntable height and "B" for clamper arm height adjustment. In order easier for the adjustment, place the laser pick-up away from the housing and the turntable and insert the jig between the housing and the turntable before attempting the adjustment.

• Clamper Arm Height Adjustment

- ① Load a disc onto the turntable.
- ② To adjust the height between the disc and disc clamper in 2.5 mm, insert "B" part of the jig into the portion indicated in the illustration.
- ③ After adjusting it to 2.5 mm, fasten the clamper height adjustment screw.

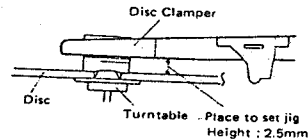
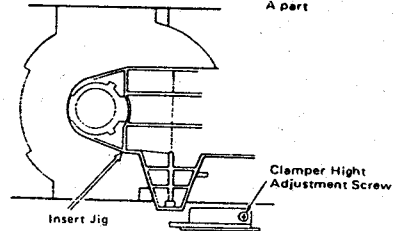
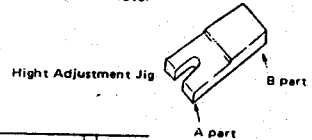
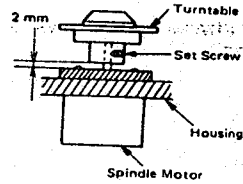

MAINTENANCE AND ADJUSTMENT PROCEDURE

For necessary operations to perform part replacement, repairing, and adjustment, it is feasible by using of operation buttons normally used for playing to adjust tracking, focus, etc. of the laser pick-up. because of a service software (service mode) is programmed to a microcomputer employed in this model.

Hereafter the adjustment procedures for each circuit checking and servo system adjustment are explained as the unit is set to service mode condition except for specified case.

1. Setting of Service Mode

- Turn off the power (do not load a disc).
- Remove top cover for confirming of inside.
- Short-circuit pins ① and ③, TP-204 of signal processing P.W.B. (KU-5760). It is convenient to use a connector like one the illustration shows.

Note: Never short-circuit TP-204 after the power turned on.

- By turning on the power, "00" blinks on the indication window showing service mode.
- On this state, all buttons' functions for normal playing are inoperative and the disc tray can not be opened or closed.

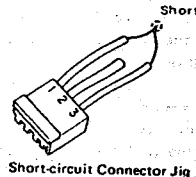

2. NOTES ON OPERATION BUTTONS IN SERVICE MODE

(1) Play Button (▶ PLAY)

Each push of the button to actuate the following servo circuit operation in consecutive order. Pushing it four times actuates all servo operations.

- Push it once : Actuate focus servo circuit ("1" appears on the calendar.)
- Push it twice : Actuate spindle servo circuit ("2" appears on the calendar.)
- Push it three times : Actuate tracking servo circuit ("3" appears on the calendar.)
- Push it four times : Actuate slide servo circuit ("4" appears on the calendar.)

When focus servo operation is defective, it will not go to the next step however the button is pressed.

(2) Stop Button (■ STOP)

Pushing the button to cancel all circuit operations. To check servo circuit again or recheck from the beginning, put it.

(3) Track Button (◀ ▶)

In service mode, this button has two functions.

- ① In stop state (include the condition after the power is turned on):

The pick-up slides.

While pushing "◀" side, pick-up moves to disc center; while pushing "▶" side, it moves to disc outer circle.

- ② In the state when play button (▶ PLAY) is pressed four times and all servo circuits are activated:

Performs track jump.

There are three types of track jump (1, 10, 100 tracks) and are switchable by pause button (|| PAUSE).

- Except for the above two conditions, this button will not function even if it is pressed.

(An example: In such a case when the play button is pressed three times and the servos are activated up to tracking.)

- Pushing the track button (◀ ▶) while all servo circuits are activated makes the tracking servo gain lowered.

Note that the adjustment of tracking servo explained later must be performed under the tracking servo is in high gain. To put it in high gain condition, turn off the power once and turn on again, then activate all servo circuits.

(4) Pause Button (|| PAUSE)

Switches track jump mode.

It is always reverted to 1 track jump mode whenever the power is turned on.

Each push of the button shifts the mode to 10-track,

100-track, 1-track . . . In 1-track jump "00",

10-track jump "01"; 100-track jump "02" blinks on the display to show respective mode.

Confirmation of track jump mode can be obtained by the time width of tracking error signal.

3. CHECKING OF FOCUS, SPINDLE, TRACKING, AND SLIDE SERVO OPERATIONS

- Be sure to observe the preceding "Turntable Height Adjustment" at the time removed the turntable or in case of disc hit the tray.

Also when replaced the parts, be sure to do the following servo system adjustments prior to these adjustments.

- (1) Turn off the power and disconnect the jumper to pins ① and ③ of TP-204. Then turn on the power and operate disc holder open-close button (▲ OPEN/CLOSE) to load the standard disc.

Note: When TP-204 is shorted, disc holder can not be opened or closed even though the disc holder open/close button is pressed. Displace the lock arm from the lock point, enables loading of disc by drawing the disc holder frontward manually. In this case, turning on and off the power is not essential.

- (2) Short-circuit pins ① and ③ of TP-204 and turn on the power. Check to see that "00" blinks on the indication window.

(3) Checking of Focus Servo Operation.

Pushing the play button (▶ PLAY) starts focus search. When the disc is loaded, by detecting of a focusing point of the laser beam on the disc surface to activate focus servo.

When the disc is not loaded, repeats focus search three times and the returns to the former state (the condition before pushing the button).

When the button is continuously pushed, repeats focus search with or without loading of the disc. When the button is released, starts detecting a focusing point within the three times of search operation. In case of focus servo is properly worked, the position of object lens of laser pick-up becomes approximately the same height as actuator cover.

Confirmation of the proper focus servo operation can be checked by a "squeak" sound reproduced when turning the disc clockwise or counterclockwise with the hand lightly.

This sound derives from the movement of actuator for focus servo, so checking of this sound namely to confirm proper operation of focus servo.

Note: Confirming up and down movements of object lens enables checking of focus search operation. Remove the disc and detach the disc clasper so as to look object lens movement more easily, then push play button (▶ PLAY). The object lens repeats moving three times up and down then stops. Through this movement the operation of actuator for focus control can be checked.

(4) Checking of Spindle Servo

After checking the focus servo, push-play button. (▶ PLAY) again. The disc starts to run. With this revolution of disc, the servo operation can be confirmed. (Confirm that "2" indicates on the calendar.)

Note: If the disc does not run due to spindle servo malfunction or runs fast, the following "Checking of Tracking Servo" will be impossible.

(5) Checking of Tracking Servo

Push play button (▶ PLAY) again. When tracking servo is properly operated, a "Sizzle" sound from the operation of tracking actuator of laser pick-up will be produced. (Confirm that "3" indicates on the calendar.)

Note: Same as previous column, if it is not properly operated the following checking will be impossible.

(6) Checking of Slide Servo

Note: Before checking, prepare and insert a headphone into the headphone jack with a volume adjusted to adequate level. Push play button (▶ PLAY) again. When slide servo is properly operated, the sound will be heard through the headphone. This sound not always be heard normally, for many instances it will be heard as if it is muted. (Confirm that "4" indicates on the calendar.)

Note: If there is no sound, the laser pick-up may be set at disc's lead-in or lead-out position. For this case, move the laser pick-up to the program are referring to the column 4.(5) ②.

(7) Checking of Playback Sound

• Connect the line-out of this unit to an appropriate amplifier so that the playback sound can be checked. Push either side of track button (◀▶). In this state tracking servo becomes low gain and the unit becomes normal playing condition.

(8) Checking of General Functions

Turn off the power and disconnect the jumper to pins ① and ③ of TP-204. Turn on the power and check all playing controls for proper functions.

Note: Because of a timing of the microcomputer employed in the unit, occasionally it does not accept a command from the button. In this case do not judge it for defective, repeat the same check for several times.

4. ADJUSTMENT

(1) Before Adjustment.

Adjustment order is, first to adjust turntable height, etc. at the time complete assembling, secondly to adjust electrical adjustments for laser pick-up system and spindle motor system to complete. The adjustment of the super-linear converter employed in this unit aiming to reduce a distortion at the time of D/A conversion is unnecessary except for special occasion.

(2) Measuring Equipments and Implements for Adjustment

- ① Dual-mode oscilloscope
- ② Specified disc for adjustment
- ③ Measuring filter

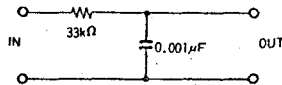

- ④ Audio frequency oscillator
10 kHz, 3 Vp-p output maximum
- ⑤ Frequency counter
Count up to 5 MHz minimum
- ⑥ Connector with wires for signal pick-up
6p 1 each
3p 2 each
- ⑦ Headphones
Checking of playback sound

(3) Preparation

Signal Processing PWB Location of Terminal for Adjustment

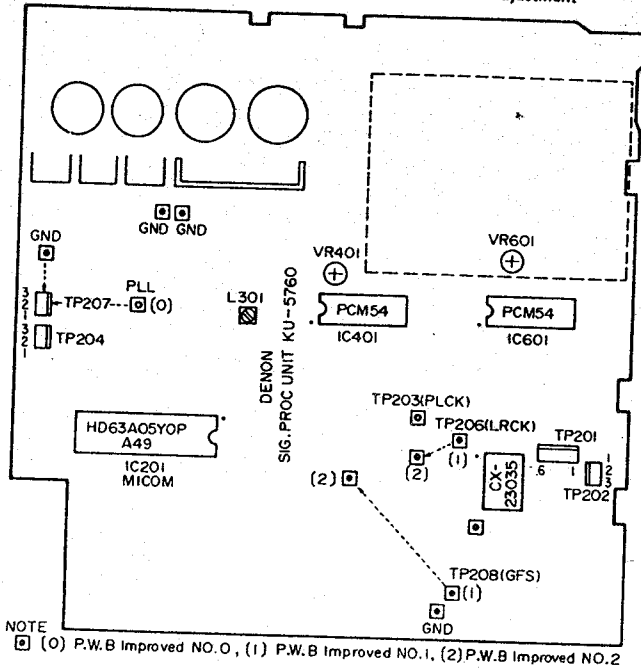

- ① Be sure that the power is off state.
Short-circuit pins ① and ③, TP-204 of signal processing P.W.B. (KU-5760) and set the unit to service mode.
- ② Remove disc clamber by means of drawing the disc holder of mechanism unit frontward.
(Manually move the lock arm fitted with side of the disc holder, release the lock of tray, and draw the disc holder frontward.)
- ③ Connect the wires of signal pick-up connectors to TP-101 (6P) and TP-102 (3P).
- ④ Mount the disc clamber removed in step 2. Leave the disc holder drawn frontward.
- ⑤ Set the adjustment VRs on the servo P.W.B. (KU-5720) of mechanism unit at the following positions. Observe the marking of VR and set them to preset positions.

VR101 (330 kΩ)	→ 12 O'clock
VR102 (47 kΩ)	→ 12 O'clock
VR103 (10 kΩ)	→ 11 O'clock
VR104 (10 kΩ)	→ 10 O'clock
- ⑥ That is all to complete preparations. Following is the adjustment order.
 1. PLL
 2. Tracking offset
 3. Focus gain
 4. Focus offset
 5. Tracking gain
 6. Tracking offset recheck

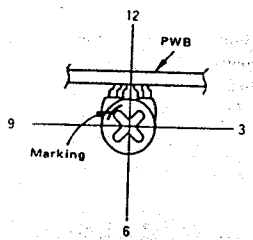
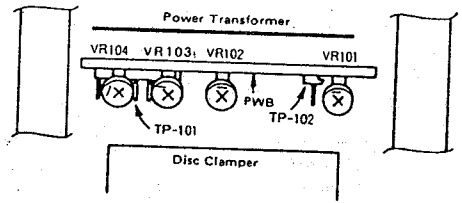

(4) Adjustment of PLL

① Preparation

- Turn the power off.
- Do not load the adjustment disc.
- Check to see that the laser pick-up is set at inner circle of program area (To move pick-up, refer to (5) ②).
- Check to see that the unit is in service mode (Short-circuit pins ① and ③, TP-204 of signal processing P.W.B.).
- Short-circuit pins ① and ②, or ② and ③, TP-202 (3P) of signal processing P.W.B. (KU-5760).
- Short-circuit pins ② and ③, TP-207 (3P) of signal processing P.W.B.
- Turn the power on.
- Confirm that "UU" blinks on the indication window.

② Connection of measuring equipment.

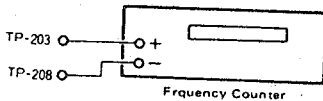

- Connect positive (+) side of the frequency counter to TP-203 and negative (-) side to TP-208.

③ Adjustment

- Rotate L-301 with a non-magnetic screwdriver and obtain $4.32 \text{ MHz} \pm 20 \text{ kHz}$ PLL frequency on the frequency counter ($4.30 \text{ MHz} \sim 4.34 \text{ MHz}$).

④ End of adjustment

- Turn off the power.
- Remove the short circuit at TP-207 (remove shorting connector).

Note: Do not remove the short circuit at TP-202 as this is required in next servo system adjustment.

(5) Adjustment of Tracking Offset

① Connection of measuring equipment

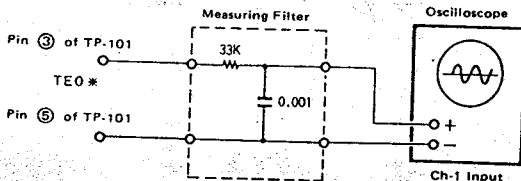

* TEO: Track error out

② Use track button (H H) to move the laser pick-up close to turntable and place it to program area (recorded portion) near turntable side by the eye.

Note: All adjustments hereafter require the pick-up position set in the program area (recorded portion) however, recommend the pick-up be set at inner circle of disc to avoid increasing of effects due to warp and eccentricity in the outer circle of disc.

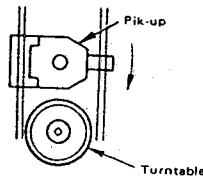

③ Load the adjustment disc and close the disc holder manually.

- Check to see that the power is turned on and the unit is in service mode.

④ Adjustment

With a sufficient time interval in between, push play button (▶ PLAY) twice and make the focus servo and spindle servo activated. Disc starts to run and confirm that "2" indicates on the calendar (Refer to 2.(1) and 3. (3)~(6)).

- Terminate the input terminal of oscilloscope to the ground and set the horizontal base line to the center of oscilloscope scale. When it is set, select the input of oscilloscope to DC range.

- Observe a waveform by setting the oscilloscope:—

Input 0.1 V (use 10:1 probe)

Sweep time 1 msec. or 2 msec.

Adjust VR101 so as to obtain the height of waveform A and B becomes even as shown in illustration.

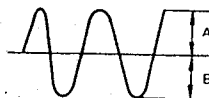

(6) Adjustment of Focus Gain

- 1 With a sufficient interval of time in between, push play button (▶ PLAY) twice to activate tracking servo and spindle servo.
- 2 Plug in the headphone and make sure the playback sound is heard prior to the adjustment.

- 3 Connect of measuring equipment.
Connect the measuring equipments as per illustration.
Note: Before connecting the oscillator check the operation of servo (produce sound).

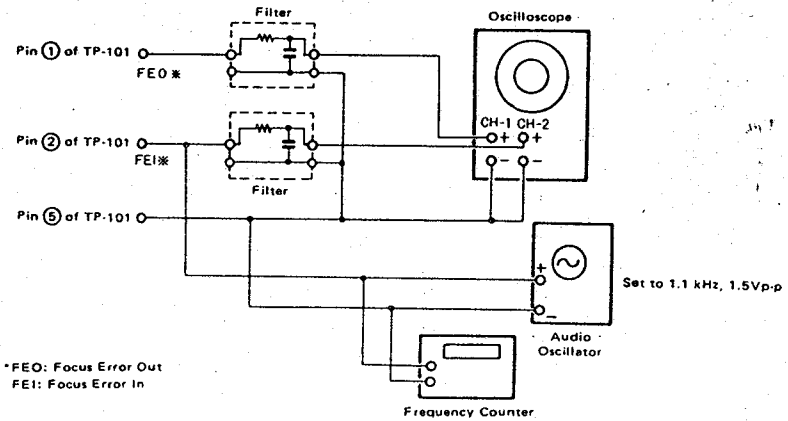

*FEO: Focus Error Out
FEI: Focus Error In

④ Adjustment

- Set the output of audio oscillator to 1.1 kHz, 1.5 Vp-p (± 0.1 V).
- Prepare and connect two filters as per illustration.
- Select oscilloscope input so to observe Lissajous figure. (Select DC range both X and Y inputs.)

- Adjust VR-103 and obtain Lissajous figure symmetric to X and Y axes. (Adjust the phase of two inputs to 90° .)

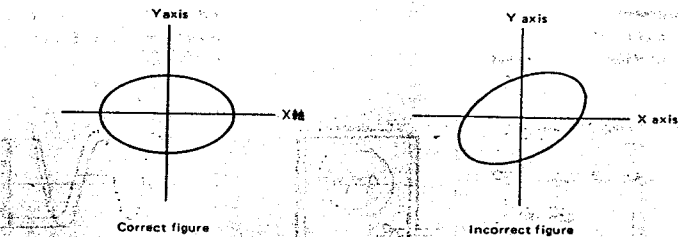

(7) Adjustment of Focus Offset

- ① Adjust it in the same condition as to focus gain except the measuring equipment connections.
- ② Connection of measuring equipment

Note: Audio oscillator should be connected during the servo operation.

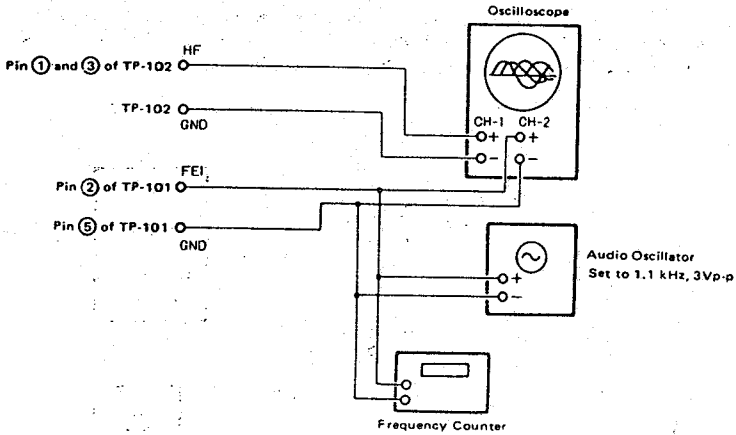

③ Adjustment

- Set the output of audio oscillator to 1.1 kHz, 3.0 V_{p-p} (± 0.1 V).
- Select oscilloscope input mode at "ALTER-NATE" or "CHOPPER" and set it to 50 mV/DIV or 20 mV/DIV (use 10:1 probe).
Observe by setting the sweep time to 0.2 or 0.5 μ s range.

- A waveform to observe in this time called "Eye Pattern".
- Adjust VR-102 for a minimum jitter amount.

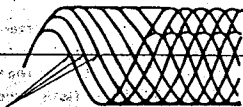

Adjust A portion for most fine waveform.

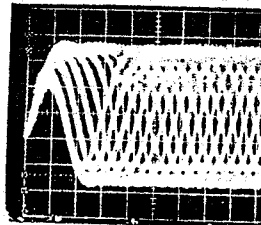

(8) Adjustment of Tracking Gain

- ① Adjust it in the same condition as to focus gain except the measuring equipment connections.
- ② Audio oscillator should be connected while the servo is in operation.
If the connection is made before servo operation, causing mis-operation.
If the connection is made in failure, disconnect oscillator, push stop button (■ STOP) to stop all operations, and follow the steps from the beginning.
- ③ Connection of measuring equipment.

④ Adjustment

- Set the output of audio oscillator to 2.25 kHz ± 120 Hz 2 Vp-p ± 0.1 V.
- Connect two filters as per illustration.
- Select oscilloscope input so to observe Lissajous waveform. (Select DC range both X and Y inputs.)
- Adjust VR-104 and obtain Lissajous waveform symmetric to X and Y axes. The waveform is the same as focus gain adjustment.

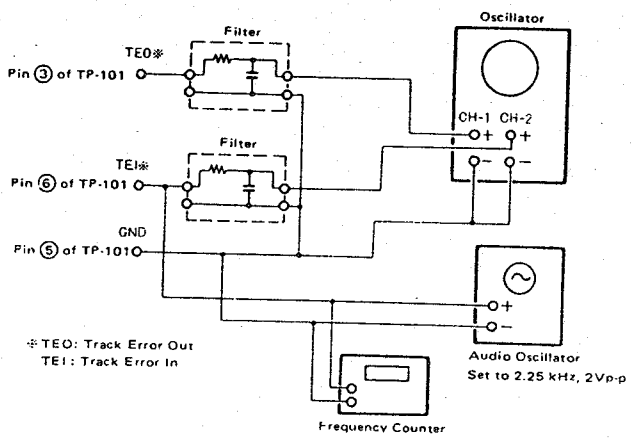

* TEO: Track Error Out
* TEI: Track Error In

(9) Checking of Tracking Offset

- ① Check the adjustment performed in the previous column (5).
 - Push stop button (■ STOP) to stop disc revolution.
 - With a sufficient interval of time in between, push play button (▶ PLAY) twice and check that the disc starts to run.

Note: The microcomputer employed in the unit sometimes does not accept button operation. If so, push the button again.

- ② That is all to complete adjustments.
 - Remove the signal pick-up connector with wires from TP-101, 102 on the mechanism unit P.W.B. (KU-5720). (It is necessary to pull out the disc holder and remove the disc clasper. Refer to column (3).)

FUNCTION OF IC TERMINAL

• Remote Control IC LU59001

Terminal No.	Function	Terminal No.	Function
1	Data output.	11	Remote control code input.
2	Data output.		Receivers code from RM557.
3	Data output.	12	System address, ground.
4	Data output.	13	System address, ground.
5	Data output.	14	System address, ground.
6	455 kHz osc.	15	System address, ground.
7	455 kHz osc.	16	Data output.
8	Ground.	17	Data output.
9	ACL (Auto Clear). Receivers High (+5V) from IC201 for 15 msec. at the time of turning the power on, normally Low (0V).	18	System address, +5V.
		19	Break in signal to main microcomputer (HD6305X0A53) IC201.
10.	Ground	20	VDD. +5V

• Table of LU59001 Date output

Date of LU59001 when "KEY IN" by remote control.

Note: 0 : 0V
1 : 5V

Key of Remote Control (RC-1500)		Terminal No. of LU59001												
		System Address					Date				Expand Date			
		C 1	C 2	C 3	C 4	C 5	C 6	C 7	C 8	C 9	C 10	C 11	C 12	C 13
1	1	0	0	0	1	0	0	1	0	0	0	1	0	
2	2						1	1	0	0	0			
3	3						0	0	1	0	0	0		
4	4						1	0	1	0	0	0		
5	5						0	1	1	0	0	0		
6	6						1	1	1	0	0	0		
7	7						0	0	0	1	0	0		
8	8						1	0	0	1	0	0		
9	9						0	1	0	1	0	0		
10	0						1	1	0	1	0	0		
11	+10						0	0	1	1	0	0		
12	PROGRAM						1	0	1	1	0	0		
13	VOLUME+						0	1	1	1	0	0		
14	VOLUME-						1	1	1	1	0	0		
15	OPEN/CLOSE						0	0	0	0	1	0		
16	CLEAR						1	0	0	0	1	0		
17	CALL						0	1	0	0	1	0		
18	DISPLAY						1	1	0	0	1	0		
19	REPEAT	0	0	0	1	0	0	0	1	0	1	0	1	0
20	A-B						1	0	1	0	1	0		
21	INDEX						0	1	1	0	1	0		
22	DIRECT						1	1	1	0	1	0		
23	TRACK ←						0	0	0	1	1	0		
24	TRACK →						1	0	0	1	1	0		
25	SKIP →→						0	1	0	1	1	0		
26	←←SKIP						1	1	0	1	1	0		
27	PLAY						0	0	1	1	1	0		
28	PAUSE						1	0	1	1	1	0		
29	STOP						0	1	1	1	1	0		

Input

Output

FUNCTION OF SUB CODE OUTPUT TERMINAL

• Sub-code Output Terminals

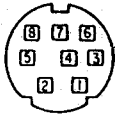

1. EXCK
2. SBSO
3. SUBO
4. SCOR
5. WFCK
6. CRCF
7. NC
8. MUTE

⑤ WFCK Waveform

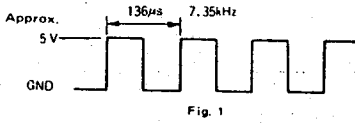

④ SCOR

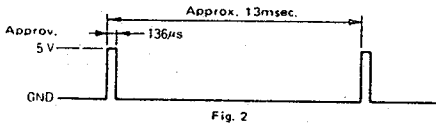

② SBSO

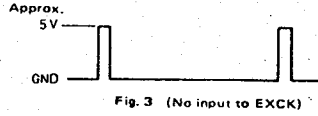

The waveform at SBSO terminal changes from Figure 3 to Figure 4 when applying WFCK signal to EXCK terminal.



③ MUTE

Low (0V) at PLAY, others High (5V).

TROUBLESHOOTING

0320127-1

1. LOADER FRAME DOES NOT OPEN OR CLOSE

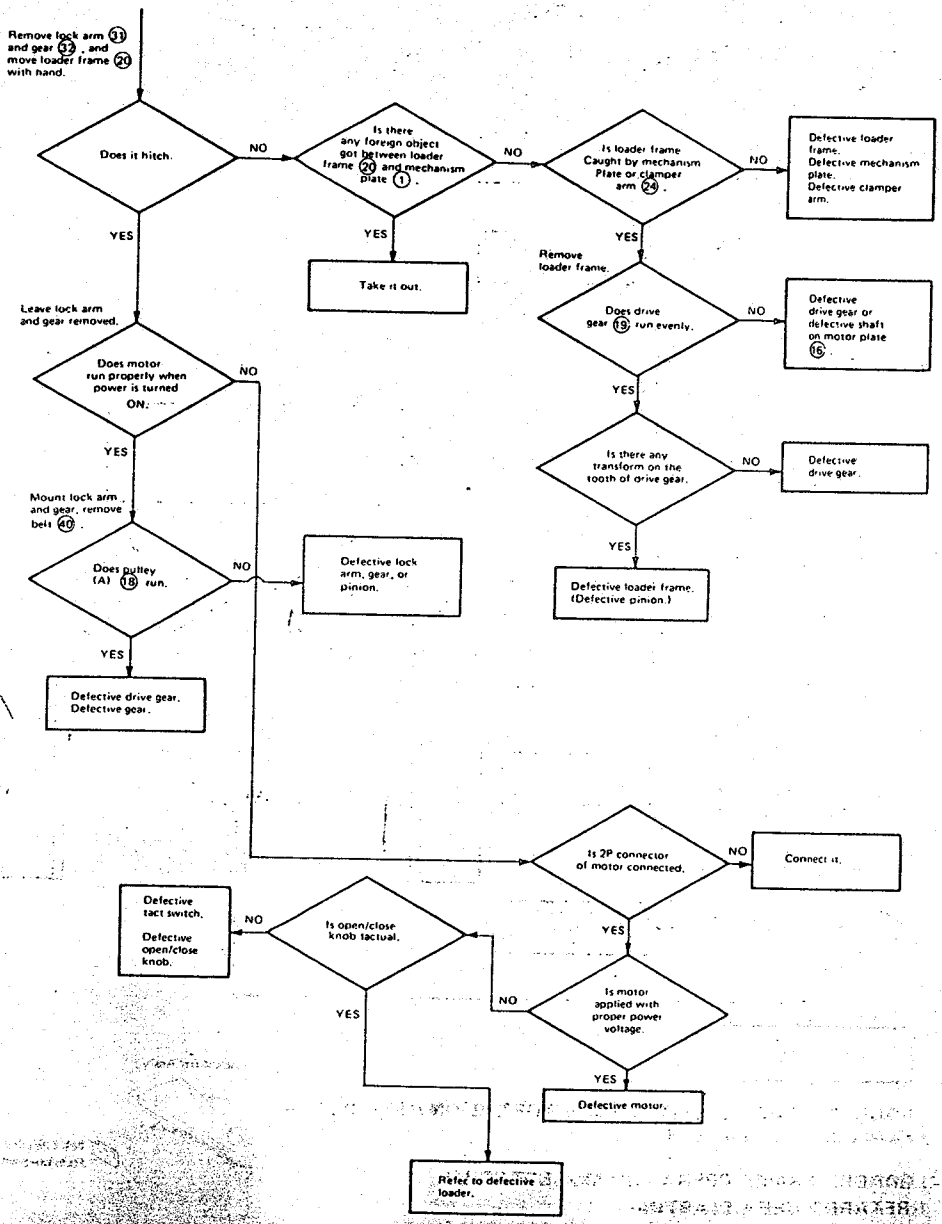

2. LOADER FRAME NOT LOCKS WHEN IT CLOSED

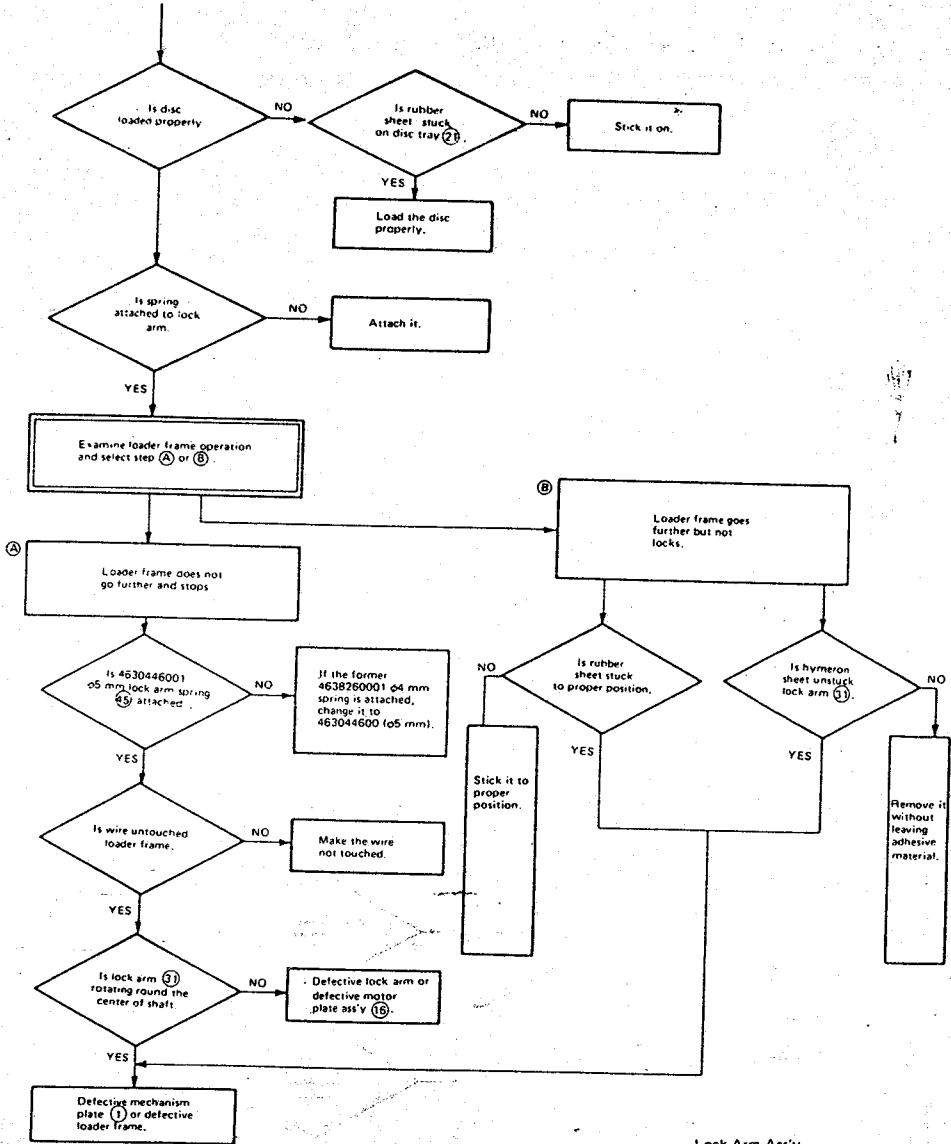

3. LOADER FRAME UNLOCKS WHEN TURNING ON THE POWER
Follow the instruction 2. (B).

4. LOADER FRAME OPERATION MOMENTARILY
RETARDS WHEN STARTING

Stick 461026607 rubber sheet on the lock arm ass'y as per illustration.

Lock Arm Ass'y

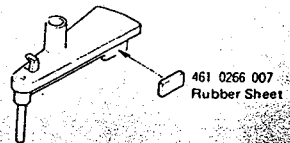

DEFECTIVE INITIAL OPERATION AT THE TIME OF DISC SETTING (1/2)

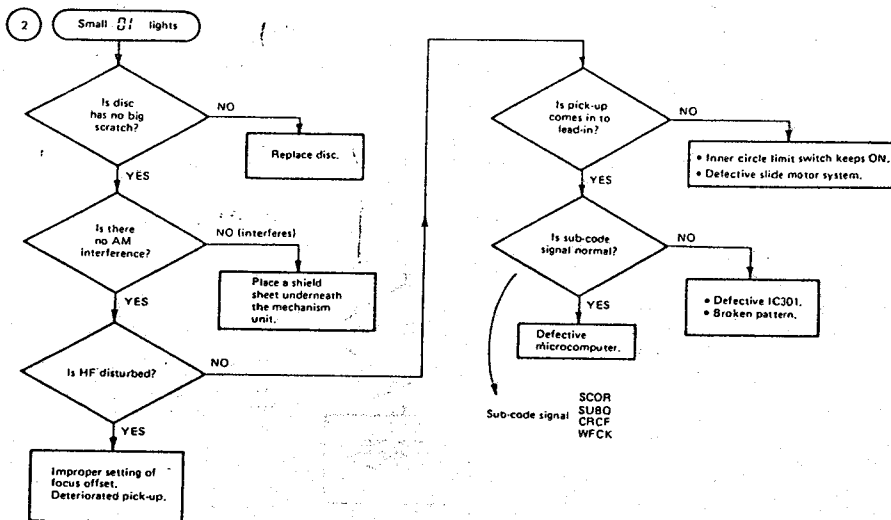
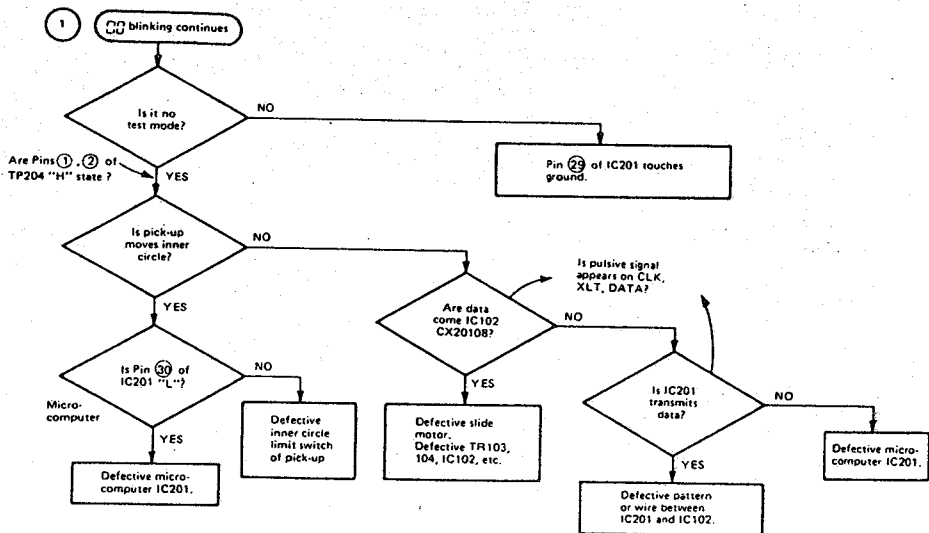

DEFECTIVE INITIAL OPERATION AT THE TIME OF DISC SETTING (2/2)

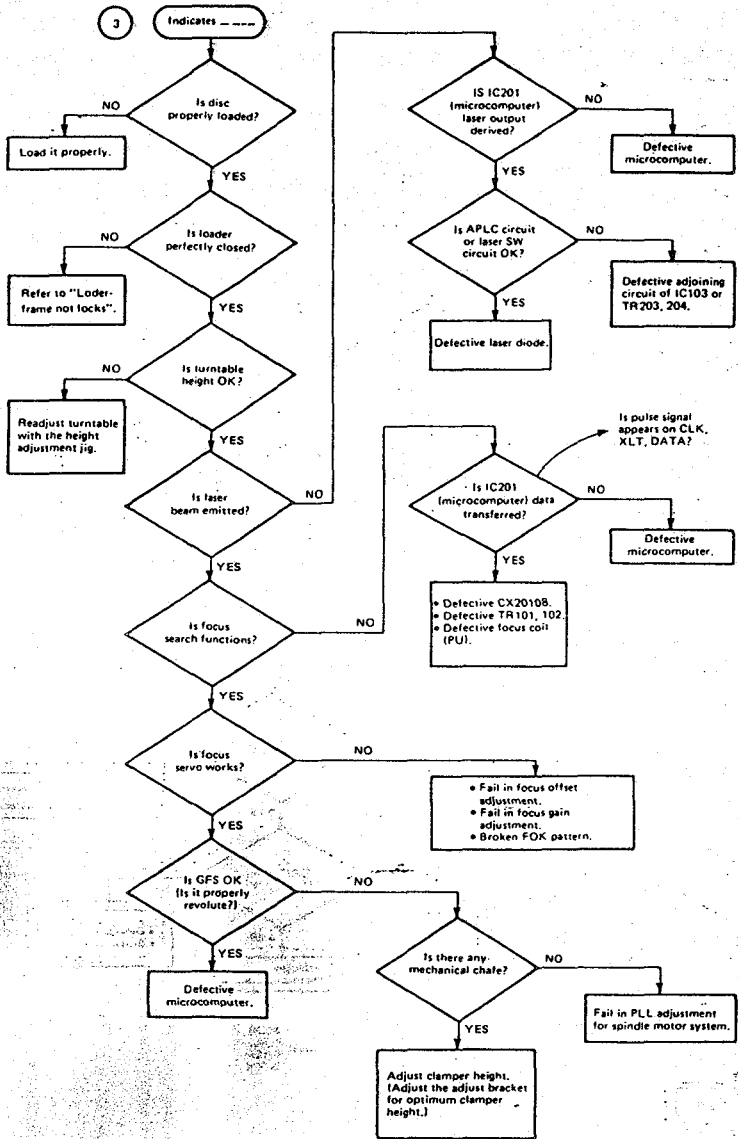

DOES NOT SEARCH (INCLUDING TAKES TIME TO SEARCH)

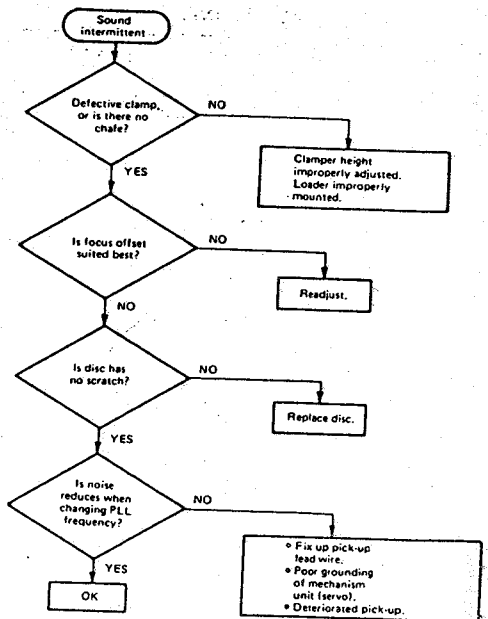
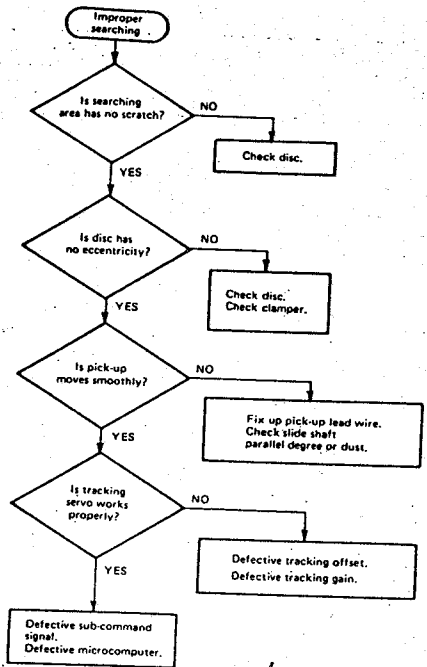

SOUND INTERMITTENT, LOADER IMPROPERLY WORKS

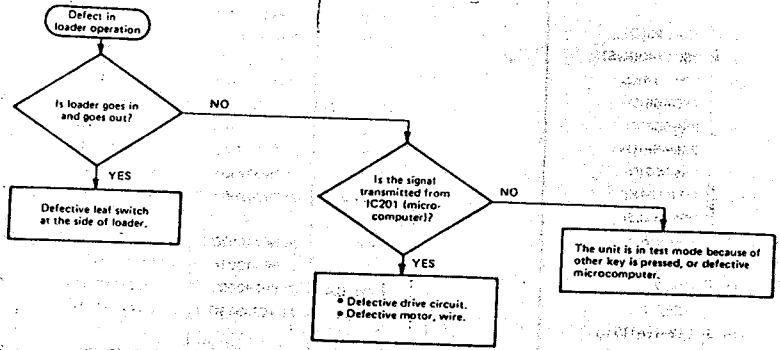

PARTS LIST OF P.W. BOARD

KU-5760 SIG. PROC AUDIO UNIT

Ref. No.	Part No.	Part Name	Remarks
SEMICONDUCTOR GROUP			
IC201	2620637000	HD63A05Y0-A49P	
IC202	2620635002	LU59001	
IC203	2620512002	HD-74LS-154P	
IC205	2620517007	MSL-917RS	
IC206,207	2630298002	LB1240	
IC300	2620614007	CX23035	
IC301	2620554002	HM-6116P-4	
IC302,303	2630244001	NJM082D	
IC401	2620638009	PCM54KP	
IC402	2620419008	HD140538P	
IC403	2630285002	LF-356N	
IC404	2630360008	NE5532	
IC405	2620419008	HD140538P	
IC406	2630118001	NJM4560D	
IC501	2630286001	HA-178-05	
IC502	2630160004	μPC7905H	
IC503	2630254004	NJM78M05A	
IC504	2630167007	μPC7812H	
IC505	2630168006	μPC7912H	
IC506	2620640000	MN6632A	
IC507	2620536004	TL7705CP-B	
IC601	2620638009	PCM54KP	
IC602	2620419008	HD140538P	
IC603	2630285002	LF-356N	
IC604	2630360008	NE5532	
IC605	2620419008	HD140538P	
IC606	2630118001	NJM4560D	
IC701	2630198005	NJM4556D	
IC901	2630198005	NJM4556D	
IC400	2620639008	SM5801	
IC600	2620639008	SM5801	
TR201	2730178022	2SC1740(R/S)	
~203			
TR204	2710101022	2SA993(I)	
TR205	2730178022	2SC1740(R/S)	
TR206	2690015005	DTC124XS	
TR301	2740036002	2SD468(D)	
TR302	2720025004	2SB562(C)	
TR303	2740036002	2SD468(D)	
TR304	2740025004	2SB562(C)	
TR305	2690015005	DTC124XS	
TR501	2720025004	2SB562(C)	
D202	2760185027	HZ4B-2	
D203,204	2760049008	1S2076	
D301	2760399004	KV1236	
D401,402	2760236031	HZ5C-1	
D501,502	2760405008	SIWB(A)10	
D503	2760173084	HZ6C-1	
D504	2760237001	RV06	
D505	2760224014	HZ30-2	
D506,507	2760049008	1S2076	
D508	2760370007	1SS106	
D509,510	2760049008	1S2076	
D601,602	2760236031	HZ5C-1	

Ref. No.	Part No.	Part Name	Remarks
RESISTOR GROUP			
VR401,601	EP-5462H19	SOLID VR (104)	100kΩ
VR701	2110459002	V1220Q25FA103	10kΩ
R441,641	2440017020	RS1483A100JNBF	10Ω 1W
CAPACITOR GROUP			
C201,202	2533614000	CC45SL1H300J	30pF 50V
C203	2544140000	CE04W1V4R7=	4.7μF 35V
C206	2544140000	CE04W1V4R7=	4.7μF 35V
C220,221	2533635005	CC45SL1H221J	220pF 50V
C223	2544145005	CE04W1HR47=	0.47μF 50V
C225	2539002001	CK45=1E104Z	0.1μF 25V
~227			
C228	2544132005	CE04W1C100=	10μF 16V
C301,302	2533610004	CC45SL1H200J	20pF 50V
C303	2544132005	CE04W1C100=	10μF 16V
C304	2539002001	CK45=1E104Z	0.1μF 25V
C305	2533617007	CC45SL1H390J	39pF 50V
C306	2551120042	CO93M1H222J	2200pF 50V
C307	2533616008	CC45SL1H360J	36pF 50V
C308	2533633007	CC45SL1H181J	180pF 50V
C309	2551120042	CO93M1H222J	2200pF 50V
C310	2544146004	CE04W1H010=	1μF 50V
C311	2544162020	CE04W1A471M	470pF 10V
C321,322	2551120084	CO93M1H472J	4700pF 50V
C323	2561034050	CF93A1H683J	0.068μF 50V
C324	2544146004	CE04W1H010=	1μF 50V
C330	2544132005	CE04W1C100=	10μF 16V
C331	2539002001	CK45=1E104Z	0.1μF 25V
C332	2539002001	CK45=1E104Z	0.1μF 25V
C400	2539002001	CK45=1E104Z	0.1μF 25V
C401	2544217014	CE04W1E101M (NXD)	100μF 25V
C402	2544146004	CE04W1H010=	1μF 50V
C406	2554210069	CO09P1H331J	330pF 50V
C408	2554210043	CO09P1H152J	1500pF 50V
C411	2561026042	CF93A2B224K	0.22μF 125V
C412	2561026000	CF93A2B105K	1μF 125V
C413,414	2544201017	CE04W1E101=(SL)	100μF 25V
C422	2533615009	CC45SL1H330J	33pF 50V
C426	2539002001	CK45=1E104Z	0.1μF 25V
C442	2539002001	CK45=1E104Z	0.1μF 25V
C450,452,453	2539002001	CK45=1E104Z	0.1μF 25V
C456	2554210072	CO09P1H431J	430pF 50V
C455	2554210014	CO09P1H122	1200pF 50V
C456,458	2554210001	CO09P1H861J	860pF 50V
C460	2544088010	CE04W1C101M	100μF 16V
~462			
C457	2554210001	CO09P1H861J	860pF 50V
C502,503	2544202003	CE04W1C682M	6800μF 16V
C504	2539002001	CK45=1E104Z	0.1μF 25V
~506			
C507	2544007004	CE04W01102=	1000μF 6.3V
~509			

Ref. No.	Part Name	Part Name	Remarks
C510	2544166039	CE04W1H102M	1000 μ F 50V
C511	2544146004	CE04W1H010=	1 μ F 50V
C515,516	2539002001	CK45=1E104Z	0.1 μ F 25V
C517,518	2544146004	CE04W1H010=	1 μ F 50V
C523	2544163003	CE04W1C221M	220 μ F 16V
C524	2539002001	CK45=1E104Z	0.1 μ F 25V
C525	2590002008	EECF5R5V473	
C600	2539002001	CK45=1E104Z	0.1 μ F 25V
C601	2544217014	CE04W1E101M (NXD)	100 μ F 25V
C602	2544146004	CE04W1H010=	1 μ F 50V
C606	2554210069	CQ09P1H331J	330pF 50V
C608	2554210043	CQ09P1H152J	1500pF 50V
C611	2561026042	CF93A2B224K	0.27 μ F 125V
C612	2561026000	CF93A2B105K	1 μ F 125V
C613,614	2544201017	CE04W1E101=(SL)	100 μ F 25V
C622	2533615009	CC45SL1H330J	33pF 50V
C626,642, 650	2539002001	CK45=1E104Z	0.1 μ F 25V
C652,653	2539002001	CK45=1E104Z	0.1 μ F 25V
C656	2554210072	CQ09P1H431J	430pF 50V
C660	2544088010	CE04W1C101M	100 μ F 16V
~662			
C655	2554210014	CQ09P1H122J	1200pF 50V
C656	2554210001	CQ09P1H861J	860pF 50V
~658			
C701,702	2544134003	CE04W1C330=	33 μ F 16V
C703	2539002001	CK45=1E104Z	0.1 μ F 25V
C517,518	2544089006	CE04W1H010M	1 μ F 50V
C513,514	2544188017	CE04W1E472=	4700 μ F 25V

OTHER PARTS GROUP

	4170253000	RADIATOR	
	4178028101	HEAT SINK	
	4150307002	INSULATING SHEET	
	4150308001	BUSH	
X201	3990032004	FCR6.0M2S	
X202	2610037005	CSB455E	
X301	3990029004	X'TAL (8.4672MHz)	8.4672MHz
L301	2350017000	INDUCTOR (7 μ H)	7 μ H
L401,601	2140020003	REED RELAY L23(M)	L23(M)
L401,601	2350018009	LPF COIL	42.8 μ H
L402,602	2350018012	LPF COIL	81.2 μ H
L403,603	2350018025	LPF COIL	44.2 μ H
L404,604	2350018038	LPF COIL	60.0 μ H
L405,605	2350018041	LPF COIL	35.7 μ H
	2048114011	4P PIN JACK	
	2048198008	H/P JACK	
	4121934006	SHIELD COVER	
	2050185054	5P WIRE HOLDER	
	2050185038	3P WIRE HOLDER	
TP201	2050190065	4P NH CONNECTOR BASE	

Ref. No.	Part No.	Part Name	Remarks
TP202,	2050190036	3P NH	
207		CONNECTOR BASE	
CB211,	2050233032	3P EH	
213,215,		CONNECTOR BASE	
217,218,			
210,204,			
205,208,			
401,402,			
601,602,			
CB213,	2050233045	4P EH	
216		CONNECTOR BASE	
CB214,	2050233058	5P EH	
216,708		CONNECTOR BASE	
CB203	2050233061	6P EH	
		CONNECTOR BASE	
CB201,	2050233074	7P EH	
202		CONNECTOR BASE	
CB212,	2050233087	8P EH	
213		CONNECTOR BASE	
CB250	2050233090	9P EH	
		CONNECTOR BASE	
CB206	2050190065	6P NH	
		CONNECTOR BASE	
CB207	2050190049	4P NH	
		CONNECTOR BASE	
CC501	2035696005	3P-3P SCN WIRE	
CC208	2038152009	5P EH CON. CORD	
CC401	2034294000	3P EH CON. CORD (S)	
CC402	2034294013	3P EH CON. CORD (S)	
CC601	2034294026	3P EH CON. CORD (S)	
CC602	2034294039	3P EH CON. CORD (S)	

KU-5720 SERVO AMP UNIT

Ref. No.	Part No.	Part Name	Remarks
SEMICONDUCTORS GROUP			
IC101	2620613008	CX20109	
IC102	2620612009	CX20108	
IC103	2630257001	M-5218P	
TR101	2740036002	2SD468(C)	
TR102	2720025004	2SB562(C)	
TR103	2740036002	2SD468(C)	
TR104	2720025004	2SB562(C)	
TR105	2740036002	2SD468(C)	
TR106	2720025004	2SB562(C)	
TR107	2740036002	2SD468(C)	
D101	2760049008	1S2076	
D102	2760236057	HZ5C-3	
D103	2760049008	1S2076	
RESISTOR GROUP			
R161	2452191002	RN14K2E222G	2.2k Ω 1/4W
R162	2452175002	RN14K2E471G	470 Ω 1/4W
R163	2452207006	RN14K2E103G	10k Ω 1/4W
R164	2452211005	RN14K2E153G	15k Ω 1/4W
R168	2452146002	RN14K2E360G	36 Ω 1/4W
R169	2452153008	RN14K2E560G	56 Ω 1/4W
VR101	2116046037	V06QB334	330k Ω
VR102	2116046011	V06QB473	47k Ω
VR103	2116046008	V06QB103	10k Ω
VR104	2116046008	V06QB103	10k Ω
CAPACITOR GROUP			
C101	2544146004	CE04W1H010	1 μ F/50V
C102	2551121038	CQ93M1H123J	0.012 μ F/50V
C103,104	2533611003	CC45SL1H220J	22pF/50V
C105,106	2533615009	CC45SL1H330J	33pF/50V
C107	2561034018	CF93A1H333J	0.033 μ F/50V
C108	2551121025	CQ93M1H103J	0.01 μ F/50V
C109	2544145005	CE04W1HR47-	0.47 μ F/50V
C110	2544129005	CE04W1A470-	47 μ F/10V
C111	2544146004	CE04W1H010-	1 μ F/50V
C112,113	2544130007	CE04W1A101-	100 μ F/10V
C121	2551120042	CQ93M1H222J	2200pF/50V
C122	2533643000	CC45SL1H471J	470pF/50V
C123	2544132005	CE04W1C100-	10 μ F/16V
C124	2544140000	CE04W1V4R7-	4.7 μ F/35V
C125	2533639001	CC45SL1H331J	330pF/50V
C126	2561034063	CF93A1H823J	0.082 μ F/50V
C127,128	2533627000	CC45SL1H101J	100pF/50V
C129	2561034076	CF93A1H104J	0.1 μ F/50V
C130,131	2544132005	CE04W1C100-	10 μ F/16V
C132	2551121038	CQ93M1H123J	0.012 μ F/50V
C133	2551121012	CQ93M1H822J	8200pF/50V
C134	2561035020	CF93A1H274J	0.27 μ F/50V
C135	2544162020	CE04W1A471M	470 μ F/10V
C137	2561035004	CF93A1H184J	0.18 μ F/50V
C161-163	2544130007	CE04W1A101-	100 μ F/10V
C164	2531024003	CK45F1H103Z	0.01 μ F/50V
C170	2544146004	CE04W1H010-	1 μ F/50V

Ref. No.	Part No.	Part Name	Remarks
OTHER PARTS GROUP			
	2052033032	3P EH CONNECTOR BASE	
	2050233061	6P EH CONNECTOR BASE	
	2050233074	7P EH CONNECTOR BASE	
	2050234044	4P EH SID CONN. BASE	
	2050234086	8P EH SID CONN. BASE	
	2050190036	3P NH CONNECTOR BASE	
	2050190065	6P NH CONNECTOR BASE	

KU-5770 KEY DISPLAY UNIT

Ref. No.	Part No.	Part Name	Remarks
SEMICONDUCTOR GROUP			
IC801	2620642008	HD74LS241	
D304	2760370007	1SS106	
~310			
CAPACITOR GROUP			
C801	2539036006	CK45+1E104Z	0.1 μ F 25V
OTHER PARTS GROUP			
SW301	2124388004	TACT-SWITCH	
~308			
SW309	2123333005	TACT-SWITCH	
~326			
SW327	2120258002	SLIDE SWITCH	
	3934017001	F1P9HMG 300AL	
	4990040008	FRM-557	
	2048190006	BRP-DIN	
		CONNECTOR	

* The carbon resistors rated at 1/4W are not listed herein.

KU-5781 LINE FILTER UNIT (E2)

Ref. No.	Part No.	Part Name	Remarks
A1802	242164008	RD14B2E106J	1MΩ 1/4W
A1852	2538010007	CK45-2GAC103P	0.01μF 400VAC
A18501	2398018002	LINE FILTER COIL	
	2123336002	POWER SW	
	2040090010	6P CONNECTOR CORD	
	2050185067	6P WIRE HOLDER	
	2036105016	4P CONNECTOR CORD	
	2050185041	4P WIRE HOLDER	
	4150299000	CONDENSER COVER	
		FUSE	(0.16A)
		FUSE HOLDER	(0.16A)
		FUSE LABEL	(500mA)
	5138254037	FUSE LABEL	(500mA)

KU-5874 LINE FILTER UNIT (EA)

Ref. No.	Part No.	Part Name	Remarks
A1802	242164008	RD14B2E106J	1MΩ 1/4W
A1852	2538010007	CK45-2GAC103P	0.01μF 400VAC
A18501	2398018002	LINE FILTER COIL	
	2123336002	POWER SW	
	2040090010	6P CONNECTOR CORD	
	2050185067	6P WIRE HOLDER	
	2036105016	4P CONNECTOR CORD	
	2050185041	4P WIRE HOLDER	
	4150299000	CONDENSER COVER	
		FUSE	(0.16A)
		FUSE HOLDER	(0.16A)
		FUSE LABEL	(500mA)
	5138254037	FUSE LABEL	(500mA)

KU-5782 LINE FILTER UNIT (EC, EU)

Ref. No.	Part No.	Part Name	Remarks
A1802	242164008	RD14B2E106J	1MΩ 1/4W
A1852	2538010007	CK45-2GAC103P	0.01μF 400VAC
A18501	2398018002	LINE FILTER COIL	
	2123336002	POWER SW	
	2040090010	6P CONNECTOR CORD	
	2050185067	6P WIRE HOLDER	
	2036105016	4P CONNECTOR CORD	
	2050185041	4P WIRE HOLDER	

KU-5785 LINE FILTER UNIT (EK)

Ref. No.	Part No.	Part Name	Remarks
A1802	242164008	RD14B2E106J	1MΩ 1/4W
A1852	2538010007	CK45-2GAC103P	0.01μF 400VAC
A18501	2398018002	LINE FILTER COIL	
	2123336002	POWER SW	
	2040090010	6P CONNECTOR CORD	
	2050185067	6P WIRE HOLDER	
	2036105016	4P CONNECTOR CORD	
	2050185041	4P WIRE HOLDER	
		FUSE	(0.16A)
		FUSE HOLDER	(0.16A)
	5138254011	FUSE LABEL	(0.16A)
		FUSE LABEL	(500mA)

KU-5783 LINE FILTER UNIT (E1)

Ref. No.	Part No.	Part Name	Remarks
A1802	242164008	RD14B2E106J	1MΩ 1/4W
A1852	2538010007	CK45-2GAC103P	0.01μF 400VAC
A18501	2398018002	LINE FILTER COIL	
	2123336002	POWER SW	
	2040090010	6P CONNECTOR CORD	
	2050185067	6P WIRE HOLDER	
	2036105016	4P CONNECTOR CORD	
	2050185041	4P WIRE HOLDER	
		FUSE	(0.16A)
		FUSE HOLDER	(0.16A)
	5138254037	FUSE LABEL	(500mA)
	2050217045	4P CON. BASE (ULTR)	

WARNING:
Parts marked with Δ and/or shading have special characteristics important to safety.

Be sure to use the specified parts for replacement.

Remarks symbols in the parts list refer to the following countries and areas.

- EA: Australia
- EC: Canada
- E1: Multiple voltage model
- EU: U.S.A.
- E2: European continent
- EK: United Kingdom

PARTS LIST OF EXPLODED VIEW

Ref. No.	Part No.	Part Name	Remarks
1	1030830618	CHASSIS	
1	1030830634	CHASSIS	E1 only
2	1020212107	BOTTOM COVER	
3	4610162004	FELT PAD	
4	4121874001	EARTH PLATE	
5	KU-5760	SIG. PROC. AUDIO UNIT	
6	PF01A13	FRONT PANEL SUB	
7	1430398006	REMOTE SENSOR WINDOW	
8	1460768004	PANEL BASE (A) ASS'Y	
9	1460770005	KNOB FRAME ASS'Y	
10	1460769003	PANEL BASE (B) ASS'Y	
11	1430426101	MARK PLATE	
12	1430429001	WINDOW	
13	1430430100	FILTER	
14	1130754002	RUBBER KEY BOARD	
15	1140097105	10 KEY FRAME	
16	KU-5770	KEY DISPLAY UNIT	
17	1130753006	SLIDE KNOB	
18	4121873219	TRANS BRACKET	
18	4121873109	TRANS BRACKET	E1 only
▲ 19	2335519002	POWER TRANS	E1, E2
▲ 19	2335518003	POWER TRANS	EC, EU
▲ 19	2335520004	POWER TRANS	E1
▲ 20	KU-5781	LINE FILTER UNIT	E2
▲ 20	KU-5782	LINE FILTER UNIT	EC, EU
▲ 20	KU-5783	LINE FILTER UNIT	E1
▲ 20	KU-5784	LINE FILTER UNIT	EA
▲ 20	KU-5785	LINE FILTER UNIT	EK
▲ 21	2006019310	AS 3P AC CORD	EA
▲ 21	2062031002	AC CORD	EC, EU
▲ 21	2062024006	AC CORD WITH LABEL	EK
▲ 21	2006031026	AC CORD	E1
▲ 21	2062002031	AC CORD WITH PLUG	E2
▲ 22	MD-3802	BUSHING	E1, E2
▲ 22	MD-2982H	CORD BUSH	EA
▲ 22	4450020005	CORD BUSH	EC, E, K, EU, E2
23	1130734009	P.S.W. LEVER ASS'Y	
24	1020211111	TOP COVER	
25	1460772003	TOP COVER WASHER	
26	FG-500	CD MECHA UNIT	
27	1220121001	SHEET	
28	5040619003	SHEET	
29	1250024000	MASKING SHEET	
30	1220475006	H/P KNOB	
31	4737508017	3x10 CBTS(P)-B	
32	4737507005	2x8 CBTS(P)-B	
33	4737002018	3x8 CBTS(S)-Z	
34	4737002005	3x6 CBTS(S)-Z	
35	4737514001	SPECIAL SCREW	
36	4737005002	3x10 CBTS(S)-Z	

Ref. No.	Part No.	Part Name	Remarks
37	4737508020	3x12 CBTS(P)-B	
38	4737511004	3x10 CBTS(P)-Z	
39	4110510004	PROP	
41	1040034006	STOPPER	
42	4737501027	3x16 CBTS(P)-B	E1 only

PACKING & ACCESSORIES GROUP

Ref. No.	Part No.	Part Name	Remarks
	2036149001	4P CONNECTOR CORD	E1 only
	2033667007	PLUG ADAPTER	E1 only
	5058092036	LAMINATE ENVELOPE	
	5030519003	PACKING CARTON CASE	
	5011070231	CARTON CASE	
	5050061007	ENVELOPE	
	2032173000	2P PIN CORD	
	5111367006	INST. MANUAL	
	5111366007	INST. MANUAL	EU only
	4990046002	RC1500	

WARNING:
 Parts marked with ▲ and/or shading have special characteristics important to safety.
 Be sure to use the specified parts for replacement.

Remarks symbols in the parts list refer to the following countries and areas:
 EA: Australia EC: Canada
 E1: Multiple voltage model EU: U.S.A.
 E2: European continent EK: United Kingdom

EXPLODED VIEW

8 7 6 5 4 3 2 1

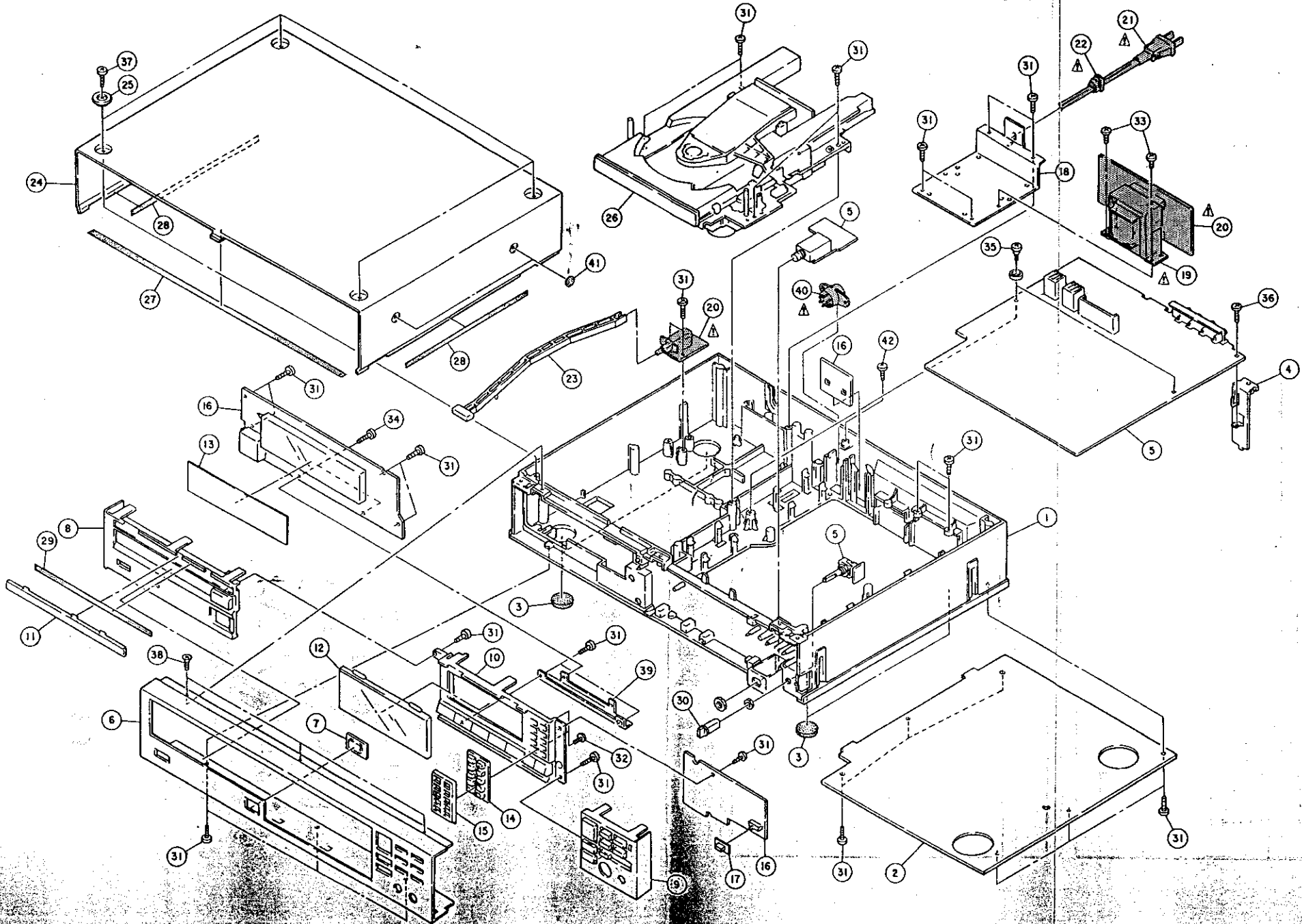

PARTS LIST OF FG-500 CD MECHA UNIT

Ref. No.	Part No.	Part Name	Remarks
1	4110480309	MECHA PLATE	
2	4121862204	MOTOR BRACKET ASS'Y	
3	2170140005	SLIDE MOTOR	
4	4240093006	WORM GEAR ASS'Y	
5	4121863009	SPRING PLATE	
6	4240089308	HELICAL GEAR	
7	4638225004	SPRING (GEAR)	
8	3150329308	HOUSING	
9	2170139003	SPINDLE MOTOR	
10	4990044004	KSS121A	2170154001
11	4250169205	RACK	
12	4310192002	SLIDE SHAFT	
13	4210338209	TURNTABLE	
14	KU-5710-2		
15	4250170003	SLIDER ROLLER	
16	4121939001	MOTOR PLATE ASS'Y	
17	2170142003	LOADING MOTOR	
18	4210366006	PULLEY (A)	
19	4240090106	DRIVE GEAR	
20	4310191207	LOADER FRAME	
21	4310190208	DISC TRAY	
22	4630435106	DISC TRAY SPRING	
23	4250171206	LOADER PANEL	
24	4330426208	CLAMPER ARM	
25	4210336308	CLAMPER PRESS	
26	4310194000	CLAMP MAGNET	
27	4630441006	CLAMPER SPRING	
28	4610162020	FELT PAD	
29	4121877105	ADJUST BRACKET ASS'Y	
30	4638231105	SPRING	
31	4210340103	LOCK ARM ASS'Y	
32	4240091202	GEAR	
33	KU-5720	SERVO AMP UNIT	
34	4770096007	PUSH RIVET	
35	4630440007	COIL SPRING	
36	4630440010	COIL SPRING	
37	4620062000	DAMPER (A)	
38	4620063009	DAMPER (B)	
39	4240100009	GEAR (P)	
40	4230043008	BELT	
41	4121890108	LOADER STOPPER	
42	1220117015	HYMERON SHEET	
43	4610259001	RUBBER PAD	
44	4410597002	DAMPER PLATE	
45	4638260001	SPRING	
46	2123335003	MICRO-SW	(SCL-101P)
47	2124575008	LEAF-SW	(MSW-1585)
48	4430458008	COLLAR	
49	4430468001	COLLAR (S)	

EXPLODED VIEW OF FG-500 MECHA UNIT

Ref. No.	Part No.	Part Name	Remarks
51	4713201011	2.6x4 CBS	
52	4761003009	3E RING	
53	4713102013	2x5 CBS-Z	
54	4737500002	3x6 CBTS(P)-Z	
55	WA-0107H4	WASHER	
56	4737508017	3x10 CBTS(P)-B	
57	4751106000	WASHER	
58	4713303016	3x6 CBS-Z	
59	4744306008	3x10 BSS	
60	4713204018	2.6x8 CBS-Z	
61	4714300004	2.6x4 BBS(A)	
62	4737002005	3x6 CBTS(S)-Z	
63	4753001006	3T WA	
64	4737505023	2.6x10 CBTS-Z	
65	4711807006	3x18 CPS	

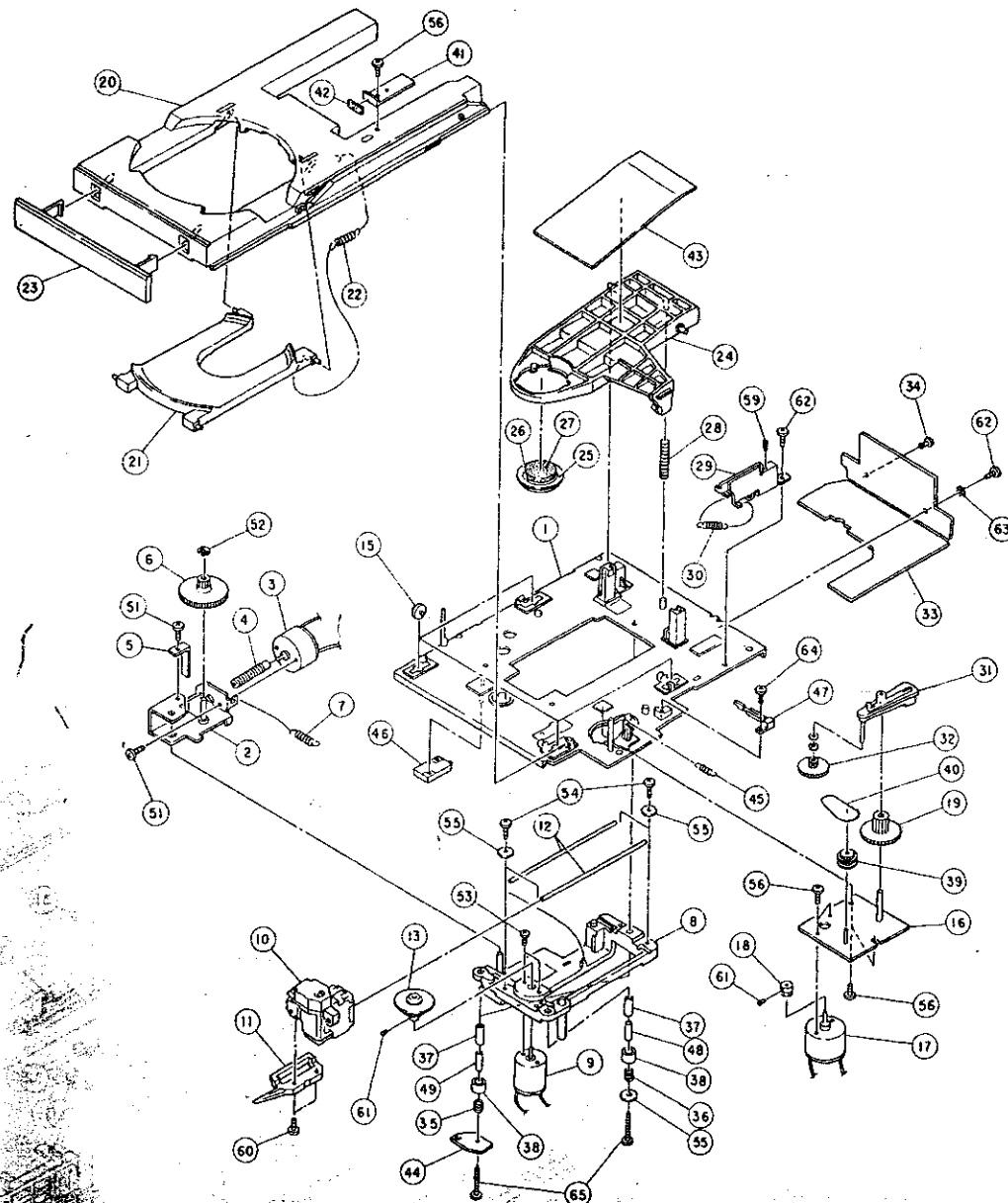

P.W. BOARD

KU-5760 SIG. PROC AUDIO

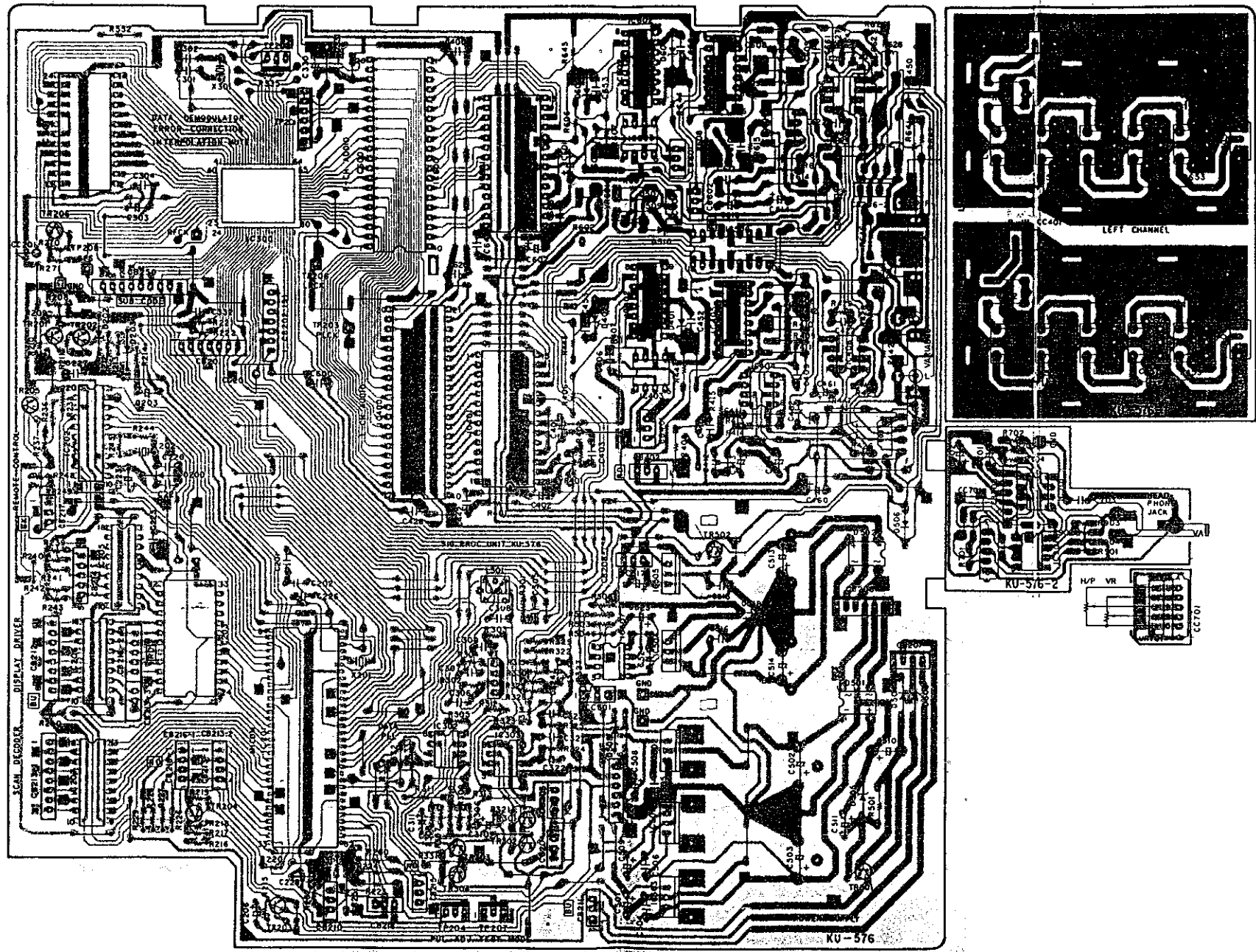

KU-5720 SERVO AMP UNIT

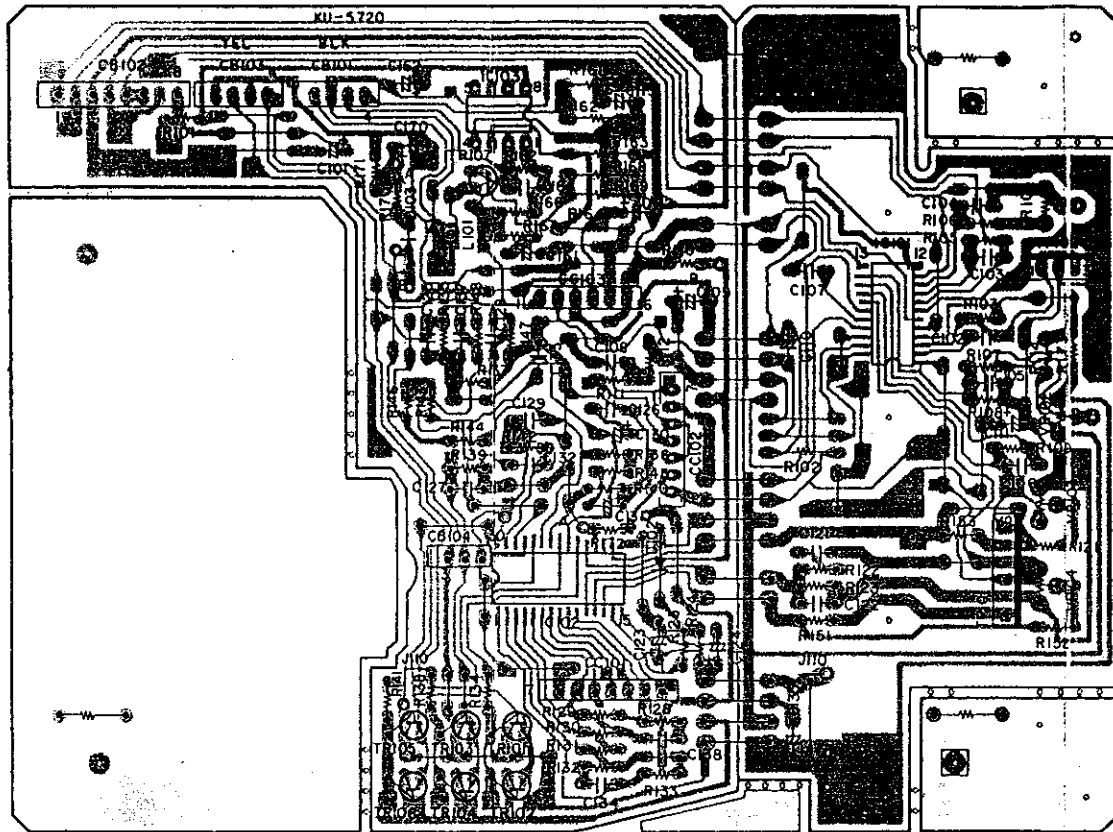

KU-5770-KEY DISPLAY UNIT

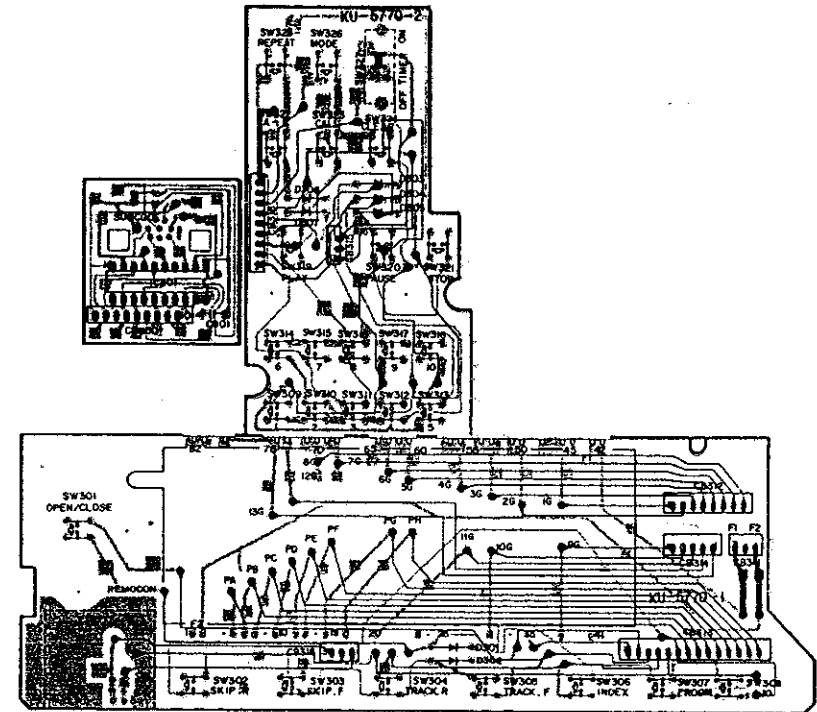

KU-5781 LINE FILTER UNIT (E2)

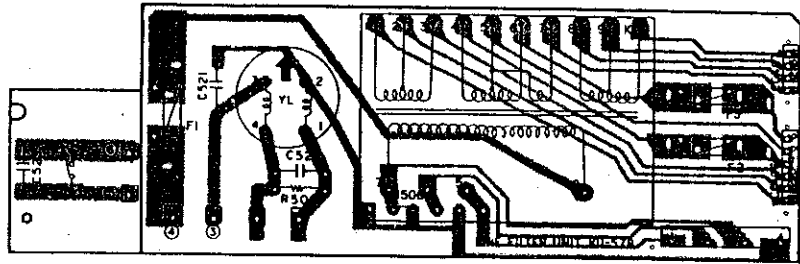

KU-5784 LINE FILTER UNIT (EA)

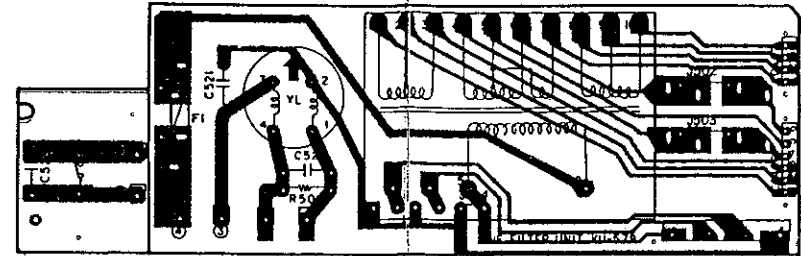

KU-5782 LINE FILTER UNIT (EU, EG)

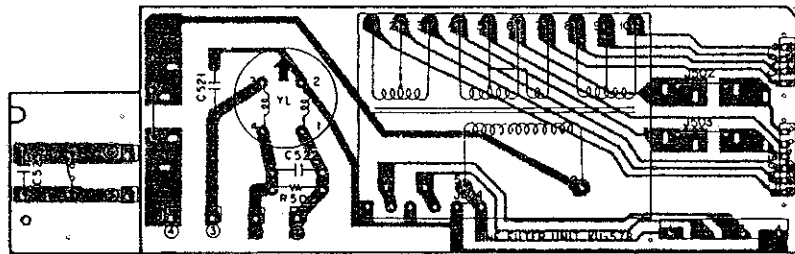

KU-5785 LINE FILTER UNIT (EK)

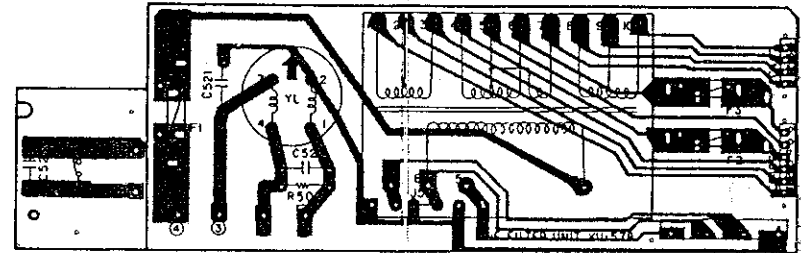

KU-5783 LINE FILTER UNIT (E1)

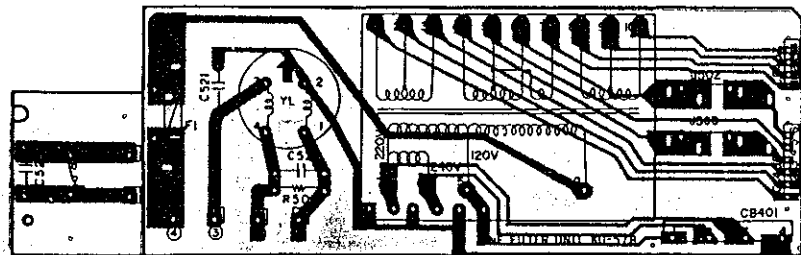

WIRING DIAGRAM

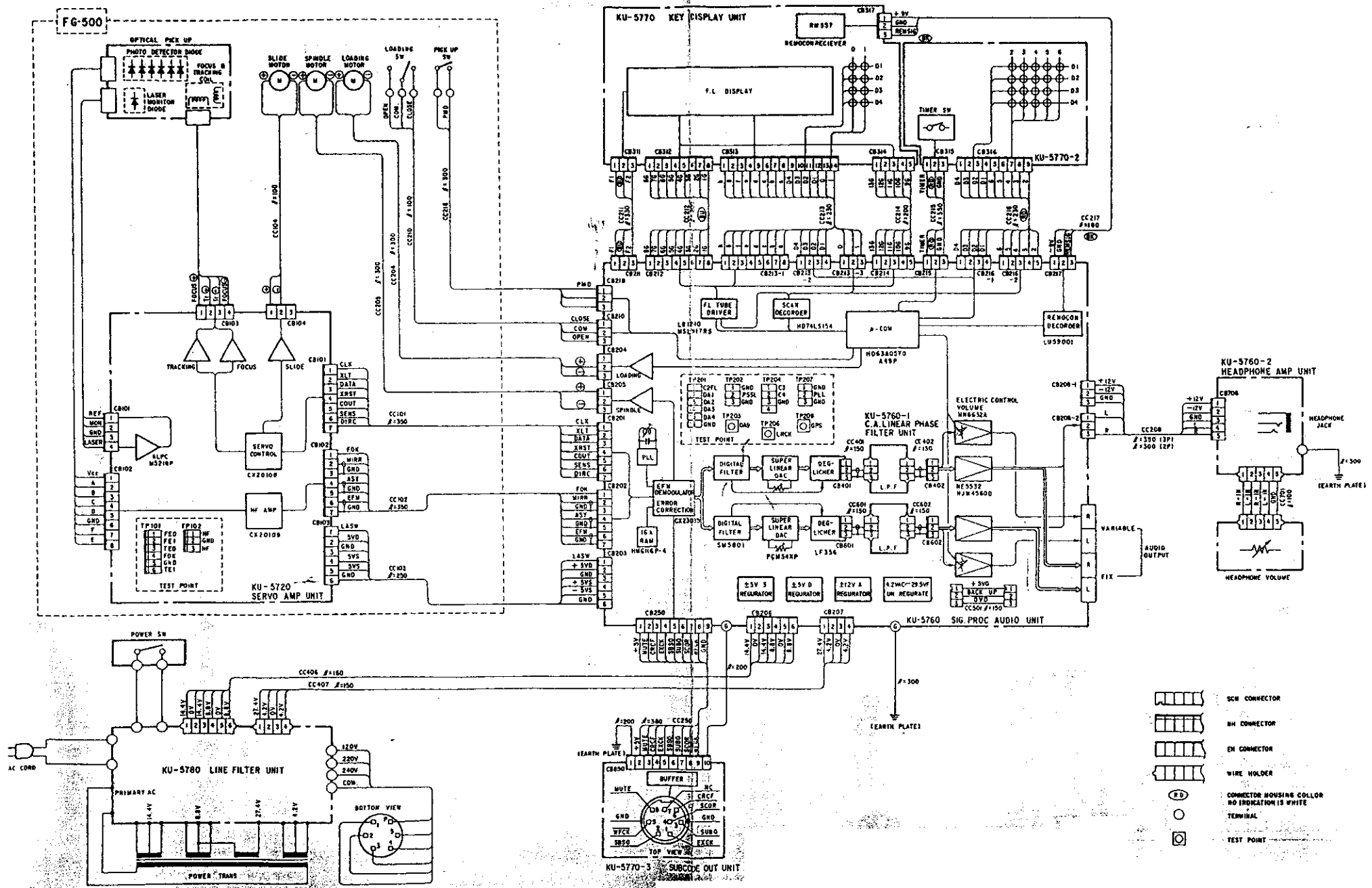

- SCW CONNECTOR
- NH CONNECTOR
- EH CONNECTOR
- WIRE HOLDER
- CONNECTOR HOUSING COLLAR
NO INDICATION IS WHITE
- TERMINAL
- TEST POINT

FOR MULTI TRANS
LET ONLY

SEMICONDUCTORS

• IC



NJM082D
NE5532
M5218P
NJM4556D
LF356N
NJM4560D
TL7705CP-8

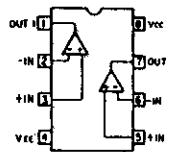

NJM082D
NE5532
M5218P
NJM4556D
NJM4560D

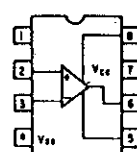

LF356N

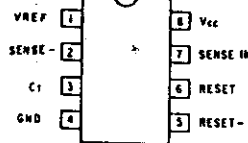

TL7705CP-8

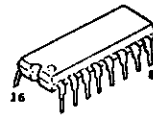

HD-140538P

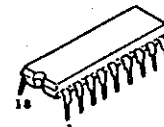
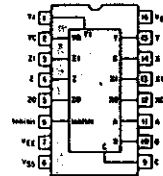

LB1240
MSL-917RS
MN6632A

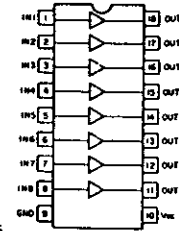

LB1240

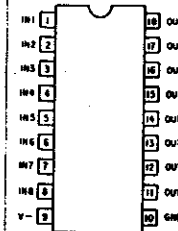

MSL-917RS

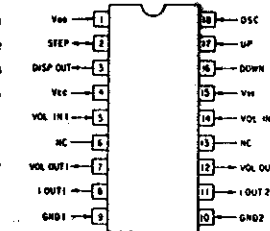

MN6632A

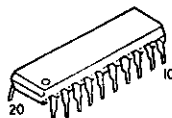

LU59001
HD74LS241

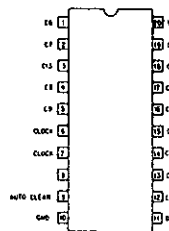

LU59001

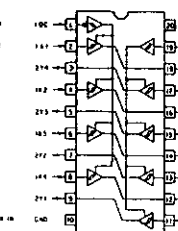

HD74LS241

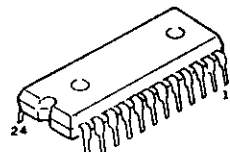

HM6116P-4
HD74LS154P

Fig. 7

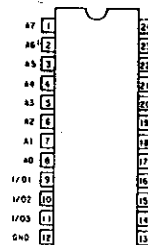

HM6116P-4

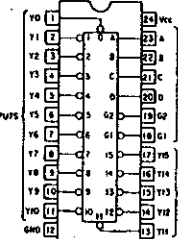

HD74LS154P

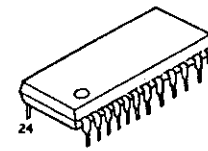

CX20109

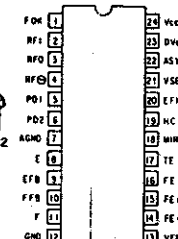

NJM78M05A
HA178-05
μPC7912H



μPC7905
μPC7912

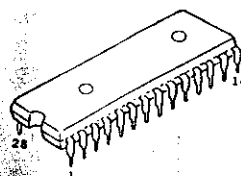

PCM54KP

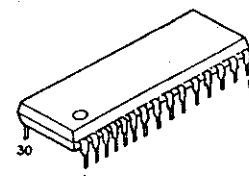
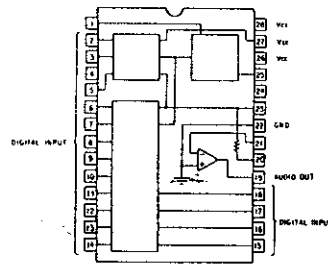

CX20108

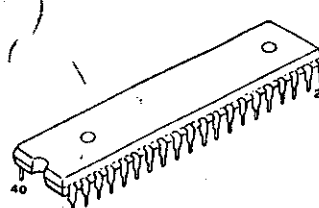
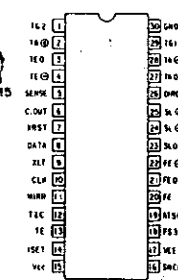

SM5801

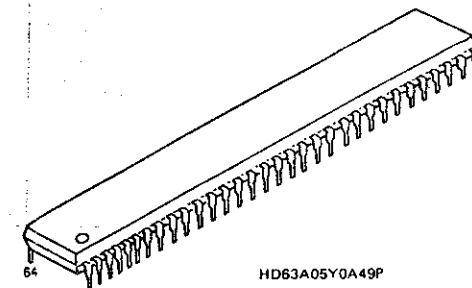

HD63A05Y0A49P

• TRANSISTORS



2SA933(Q)
2SC1740(K/S)



2SB562(C)
2SD468(C)



DTC 24XS

• DIODES

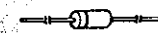

IS2076
RV06
ISS106

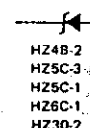

HZ4B-2
HZ5C-3
HZ5C-1
HZ6C-1
HZ30-2



KV1236



S1WB

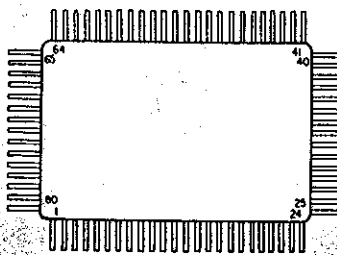
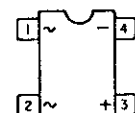

CX23035

WAVEFORM IN THE CIRCUIT

(1) HF Output Waveform
0.5V/DIV, 5ms/DIV

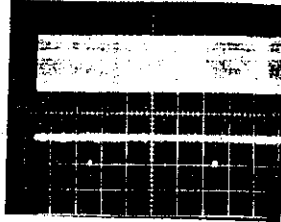

(2) GFS Output Waveform
5V/DIV, 5ms/DIV

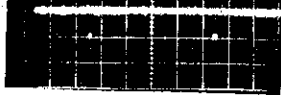

(3) MDS Output Waveform
5V/DIV, 200μs/DIV

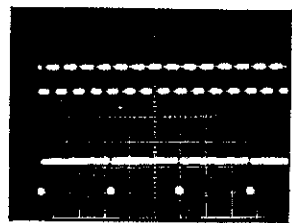

(4) MDP Output Waveform
2V/DIV, 200μs/DIV



(5) RM557 Output (LU59001 pin 1)

Play button operated by remote control

2V/DIV, 10msec/DIV

GND

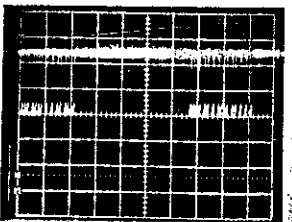

(6) LRCK

5 μsec/DIV, 5V/sec

GND

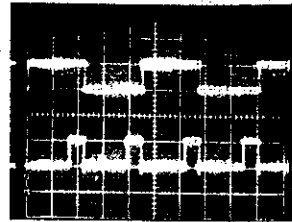

(7) DG

5 μsec/DIV, 5V/sec

GND



(8) Electronic VR IC506

UP (pin 1)

10msec/DIV, 5V/DIV

GND

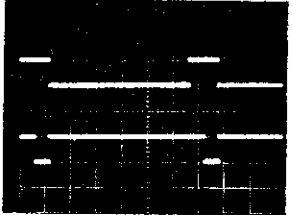

(9) IC506

STEP (pin 2)

10msec/DIV, 5V/DIV

GND



(10) Electronic VR IC506

DOWN (pin 19)

10msec/DIV, 5V/DIV

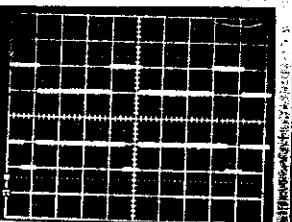

(9) IC506

STEP

10msec/DIV, 5V/DIV

(11) Focus, Drive Waveform



Oscilloscope 1 ms/div

(12) Tracking Waveform

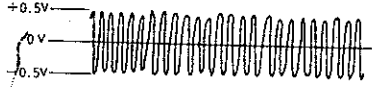

Oscilloscope 1 nS/div

(13) Slide Drive Waveform

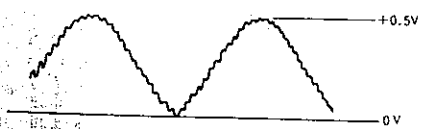

Few seconds cycle

Dynamic Driver Phase

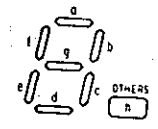
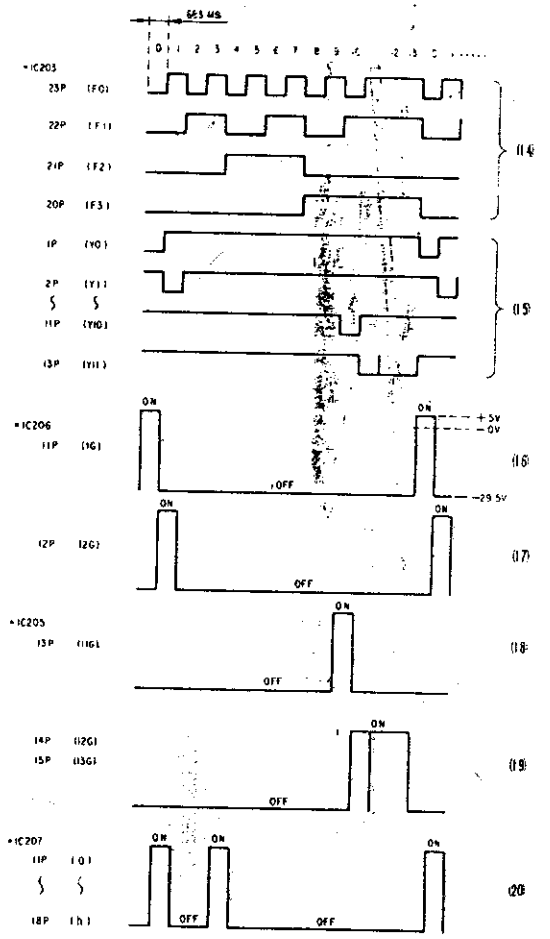

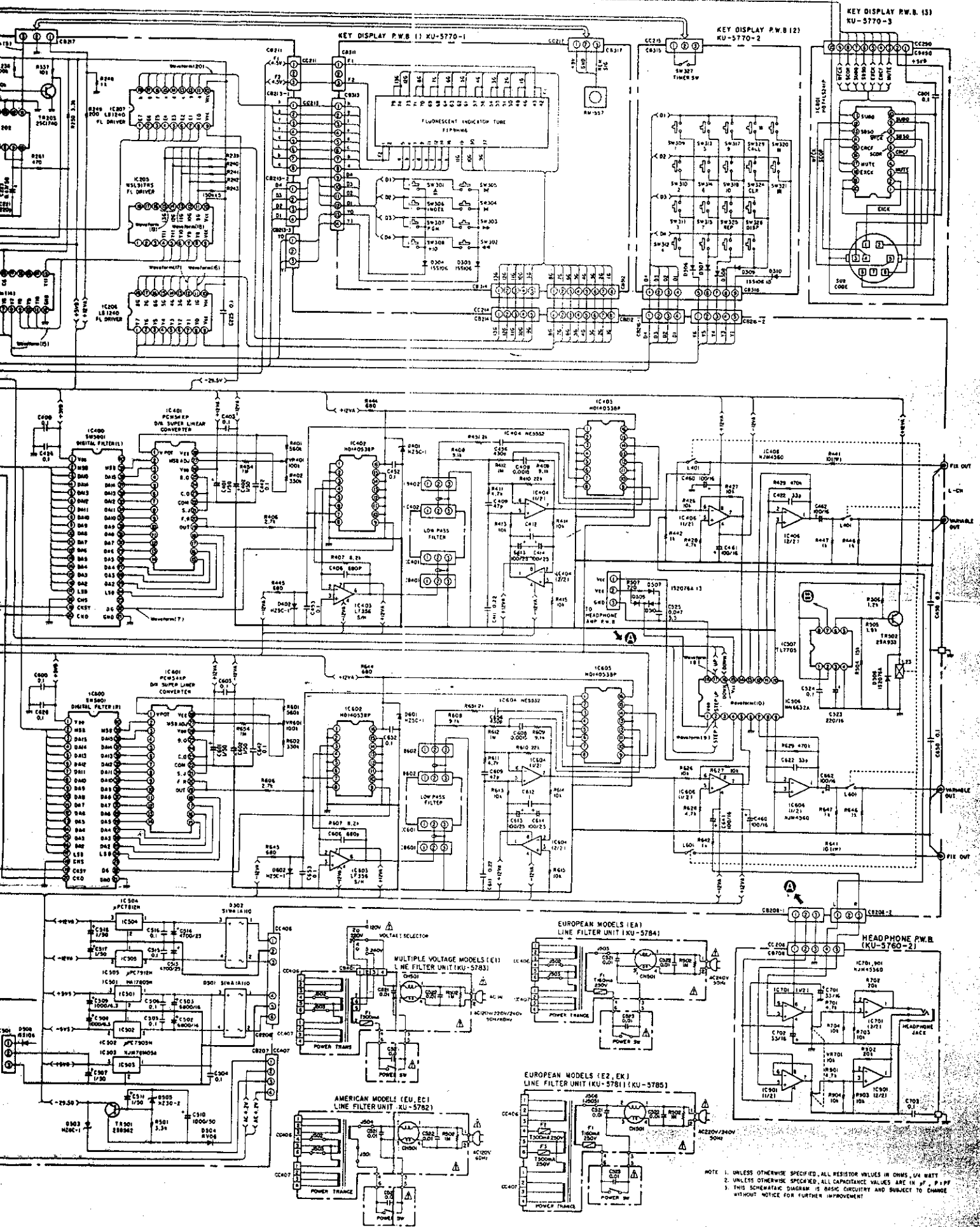

KEY DISPLAY P.W.B. (3) KU-5770-3

KEY DISPLAY P.W.B. (1) KU-5770-1

KEY DISPLAY P.W.B. (2) KU-5770-2

HEADPHONE P.W.B. (KU-5760-2)

EUROPEAN MODELS (EA) LINE FILTER UNIT (KU-5781)

EUROPEAN MODELS (EK) LINE FILTER UNIT (KU-5785)

AMERICAN MODELS (EU, EC) LINE FILTER UNIT (KU-5782)

NOTE 1. UNLESS OTHERWISE SPECIFIED, ALL RESISTOR VALUES IN OHMS, Ω OR M Ω .
 2. UNLESS OTHERWISE SPECIFIED, ALL CAPACITANCE VALUES ARE IN P.F., P.F.F.
 3. THIS SCHEMATIC DIAGRAM IS BASIC CIRCUITRY AND SUBJECT TO CHANGE WITHOUT NOTICE FOR FURTHER IMPROVEMENT.

