

DENON

FM AM Receiver/CD Player

SERVICE MANUAL MODEL DCT-950R FM AM RECEIVER/CD PLAYER

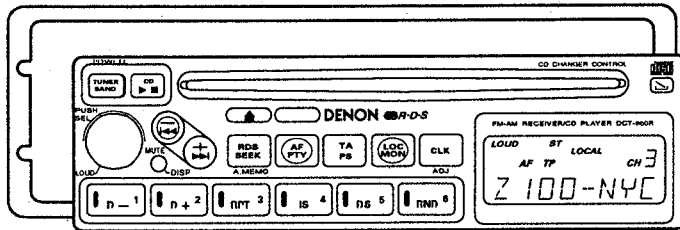

U.S.A. Version

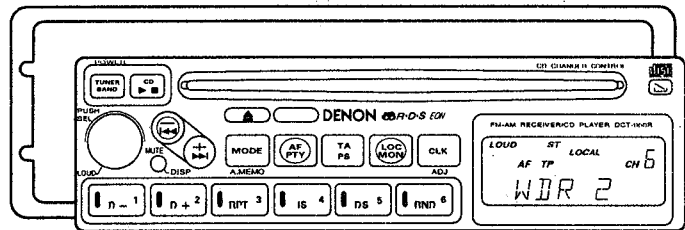

Europe Version

CONTENTS







OPERATING INSTRUCTIONS (U.S.A. Version)	2 ~ 15
OPERATING INSTRUCTIONS (Europe Version)	16 ~ 29
CIRCUIT DESCRIPTIONS	30 ~ 32
REMOVAL OF EACH SECTION	33
SPECIFICATIONS FOR ADJUSTMENT	34 ~ 38
SERVICE NOTE FOR CD SECTION	39
BLOCK DIAGRAM -1/3, 2/3, 3/3	40 ~ 42
SEMICONDUCTORS	43 ~ 59
PRINTED WIRING BOARD	
MAIN UNIT	60, 61
MD SECTION UNIT	62, 63
WIRING DIAGRAM	64
IC'S AND TRANSISTORS VOLTAGE VALUES	65, 66
SCHEMATIC DIAGRAM -1/3, 2/3, 3/3	67 ~ 69
EXPLODED VIEW OF CHASSIS AND CABINET, PARTS LIST	70, 71
DISASSEMBLY OF CD MECHANISM	72, 73
PRINTED WIRING BOARD PARTS LIST	74 ~ 79



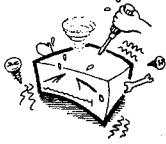

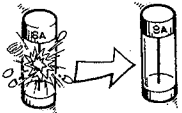
NIPPON COLUMBIA CO., LTD.

(U.S.A. Version)

For safety, heed the following cautions. Failure to do so can lead to accidents and damage to the unit:

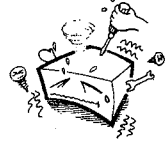
Pour votre sécurité, veuillez prendre les précautions suivantes. La négligence de respecter ces points peut entraîner des accidents et l'endommagement de l'appareil.

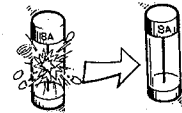
<p>Do not disassemble.</p> 	<p>Do not subject to strong shocks.</p> 
<p>Replace the fuse with a fuse of the same amperage.</p> 	<p>Keep away from strong magnetic forces.</p> 
<p>Do not let the unit get wet.</p> 	<p>Do not wipe with benzene or thinner.</p> 

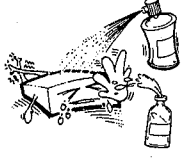
<p>Ne pas démonter.</p> 	<p>Ne pas exposer à des chocs violents.</p> 
<p>Remplacer le fusible par un fusible du même ampérage.</p> 	<p>Conserver à l'abri de puissantes sources magnétiques.</p> 
<p>Veiller à ce que l'appareil ne se mouille pas.</p> 	<p>Ne pas nettoyer avec de la benzène ou un diluant.</p> 

CONTROL & INDICATORS/COMMANDES ET INDICATEURS

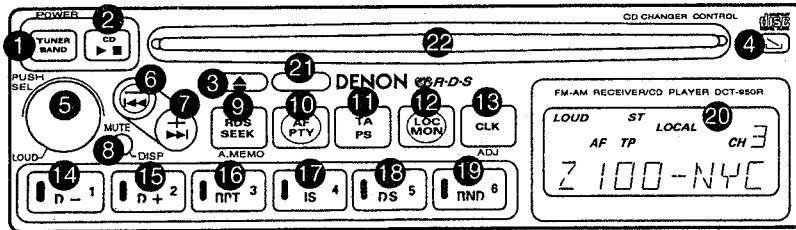

- MUTE IN WIRE (PINK/WHITE)
- FLL D'ENTRÉE DE SOURDINE (ROSE/BLANC)

- 1 TUNER/BAND/POWER ON/• POWER OFF button
 - 2 CD button
 - 3 Eject button
 - 4 Detach button
 - 5 Control Knob (Volume/Bass/Treble/Fader/Balance) Control Select/• Loudness button
 - 6 7 Seek/• Manual up/down and Auto/• Manual search
 - 8 Muting/• Display button
 - 9 RDS Seek/• Automatic Memory button
 - 10 AF/PTY/• AF Level Adj./• PTY Select button
 - 11 TA/• Preset Scan button
 - 12 Local/• Mono button
 - 13 Clock button/• Clock ADJ button
 - 14 Preset/• Preset Memory/disc change button
 - 15 Preset/• Preset Memory/disc change button
 - 16 Preset/• Preset Memory/Repeat button
 - 17 Preset/• Preset Memory/Intro Scan button
 - 18 Preset/• Preset Memory/Disc Scan button
 - 19 Preset/• Preset Memory/Random button
 - 20 LCD display
 - 21 Remote Sensor
 - 22 Compact Disc Slot
 - 23 Mute in
- To use the functions marked "•", press the button for over two seconds.

- 1 Touche de tuner/gamme/mise sous tension/• mise hors circuit (TUNER/BAND/POWER ON/• POWER OFF)
 - 2 Touche CD
 - 3 Touche d'éjection
 - 4 Touche de détachement
 - 5 Commande de volume (Volume/graves/aiguës/fader/équilibre) Sélecteur de contrôle/• touche de compensation physiologique
 - 6 7 Touche de recherche/• de syntonisation manuelle Haut/Bas et automatique/• de recherche manuelle
 - 8 Touche de sourdine/• d'affichage
 - 9 Touche de recherche RDS/• de mémoire automatique
 - 10 Touche AF/PTY/• de réglage de niveau AF./• de sélection PTY
 - 11 Touche TA/• de balayage
 - 12 Touche local/• mono
 - 13 Touche d'horloge/• de réglage d'horloge (ADJ)
 - 14 Touche de présélection/• de mémoire présélectionnée/changement de disque
 - 15 Touche de présélection/• de mémoire présélectionnée/changement de disque
 - 16 Touche de présélection/• de mémoire présélectionnée/répétition
 - 17 Touche de présélection/• de mémoire présélectionnée/balayage des introductions
 - 18 Touche de présélection/• de mémoire présélectionnée/balayage de disque
 - 19 Touche de présélection/• de mémoire présélectionnée/aléatoire
 - 20 Affichage à cristaux liquides (LCD)
 - 21 Détecteur de télécommande
 - 22 Fente de disque compact
 - 23 Entrée de sourdine
- Pour utiliser les fonctions marquées "•", appuyer sur la touche pendant plus de deux secondes.

[U.S.A. Version]

Precautions on storage

- After playing a disc, always unload it from the player.
- Always return a disc to its proper case to prevent it from becoming dirty or damaged.
- Do not place discs in the following types of areas:
 - 1) Areas exposed to direct sunlight for a considerable time.
 - 2) Areas subject to accumulation of dust or high humidity.
 - 3) Locations near the path of hot air from the heater vent.

Précautions de stockage

- Après la lecture d'un disque, retirer toujours le disque du lecteur.
- Retourner toujours un disque dans son propre étui afin d'éviter de le salir ou de l'endommager.
- Ne pas placer les disques dans les endroits suivants:
 - 1) Endroits exposés en plein soleil pendant une longue période.
 - 2) Endroits où il y a une accumulation de poussière et où règne un taux d'humidité élevé.
 - 3) Endroits près du passage d'air chaud d'un radiateur.

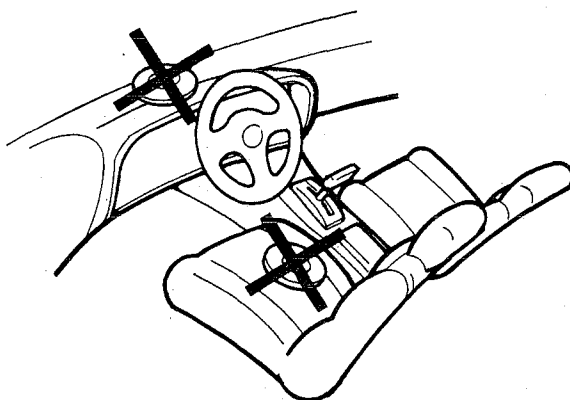

4

COMPACT DISC

1. Precautions on handling compact discs	
Do not let fingerprints, dust or oil on the disc! If the disc is dirty, wipe it clean with a clean, dry cloth.	Do not bend.
Do not use benzene, thinner, water, record spray, electrostatic proof chemicals, or silicone-treated cloths to wipe discs.	Do not apply heat!
Do not enlarge the hole in the center of the disc.	Do not attempt to play a CD-ROM Disc and 8cm CD.
Do not write on the disc with a hard tipped implement such as a pencil or ball-point pen.	When condensation form, do not attempt to dry the disc with a hair dryer, etc.

DISQUE COMPACT

1. Précautions de manipulation de disques compacts	
Ne pas laisser des traces de doigt, de la poussière ou de la graisse sur les disques! Si le disque est sale, l'essuyer avec un chiffon propre et sec.	Ne pas plier.
Ne pas utiliser du benzène, un diluant, de l'eau, un aérosol pour disque, des produits chimiques électrostatiques, ou des tissus traités au silicone pour essuyer les disques.	Ne pas appliquer de la chaleur!
Ne pas élargir le trou au centre du disque.	Ne pas essayer de lire un disque CD-ROM et 8cm CD.
Ne pas écrire sur l'étiquette (face imprimée) avec un objet à pointe dure comme un crayon ou un stylo.	Lorsque de la condensation se forme, ne pas essayer de sécher le disque avec un sèche-cheveux, etc.

5

(U.S.A. Version)

Please carefully read all safety and operating instructions before installation and use.

It will help you to obtain the best performances from your new FM-AM Receiver/CD Player.

FEATURES

- Power: (Both Channels Driven)
 20 W x 4 ch 1 kHz/4 ohms (MAX)
 14 W x 4 ch 1 kHz/4 ohms 10% THD
 10 W x 4 ch 20 Hz - 20 kHz/4 ohms 0.8% THD
- HIGH POWER PRE-OUTPUT 2.2V/10 kohms
 - 20 bit digital filter with 8-times oversampling and noise shaper.
 - Dual 18-bit D/A converter.
 - 3-Beam laser pickup servo.
 - Detachable Front Panel.
 - RDS (PS, PTY, AF, PI, TA, TP, CT).
 - 30 Station-presets (18 FM - 12 AM).
 - Automatic Memory System.
 - Denon Optimum Reception System IV (FM circuitry-Auto high blend and FM pulse noise canceller).
 - Stereo/mono (FM), local switches.
 - CD changer control.
 Disc/Intro Scan
 Repeat play (Disc & Track)
 2-Mode random play
 Automatic/Manual search
 - Wireless Remote Control (Option)
 - Flexible fader-internal front amp to rear amp and/or internal front amp to internal rear amp.
 - DIN "E" & ISO mount.
 - Night illumination with dash light dimmer lead.

- Quartz Clock
- Muting Switch
- Telephone Mute

CERTIFICATION
 • Certified only to Canadian Electrical Code.
 • Certifie en vertu du code Canadien de l'electricite seulement.

CERTIFICATION
 This product complies with DHHS rules 21 CFR subchapter J applicable at date of manufacture.

CAUTION - Use of controls or adjustments or performance of procedures other than those specified herein may result in hazardous radiation exposure.

The Compact Disc Player should not be adjusted or repaired by anyone except properly qualified service personnel.

FOR YOUR RECORDS

Please record the serial number of your unit in the space provided below and keep it as a permanent record. The serial number is indicated on the top of the unit.
 You will need the serial number, if the need for service should arise.

Model DCT-950R
 Serial Number _____

6

CONNECTIONS

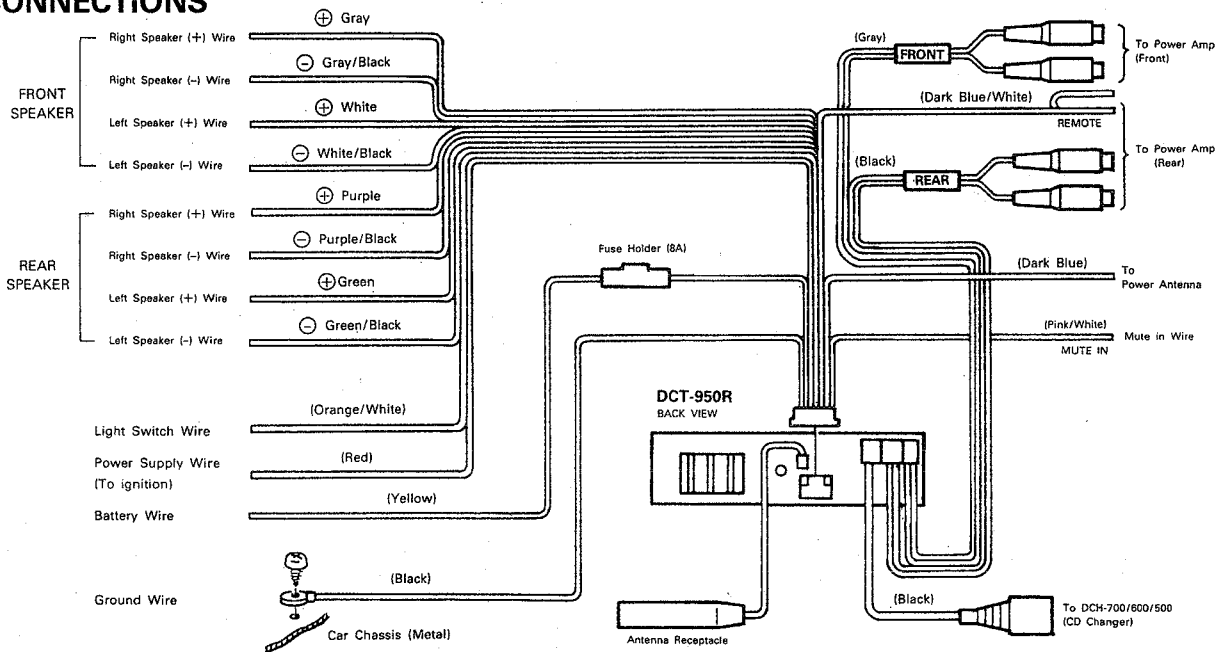

DENON Compact Disc Player DCT-950R will operate properly with 14.4 V (11-16 V) car batteries. You cannot use it for 24 V or other types or car batteries.

Maximum rated current capacity from Remote output and the Power antenna output is 300mA

* Do not use the remote output as the power supply for other sets (for example, power amplifiers, RF modulators, etc.). Connect the remote output to the power amplifier's control terminal (remote).

** When connecting two power amplifiers, divide the remote output in two.

CAUTION! - To prevent damage to the unit. BE SURE to connect the color coded leads correctly according to the diagram. Otherwise malfunctioning of the unit and/or damage to the vehicle may occur.

DO NOT connect the (-) (negative) loudspeaker lead to the ground (chassis) or to any other (-) loudspeaker lead from this unit.

* Only connect the set after connecting all the connector wires.

** Be sure to insulate the wires after connecting them.

7

(U.S.A. Version)

INSTALLATION

- Use screws supplied as accessories when installing the unit.

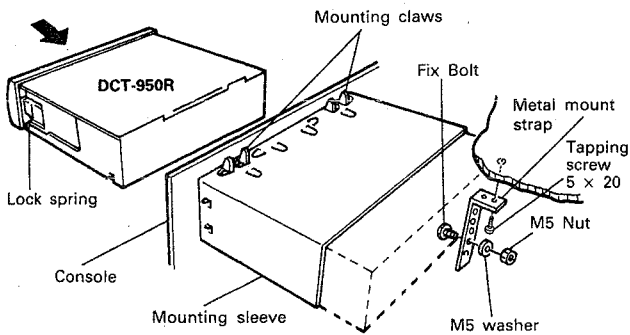

1. Insert the mounting sleeve in the console or dashboard then fasten it to the console with the mounting claws.
2. Insert the unit into the mounting sleeve then check that it is fastened to the mounting sleeve with the lock springs on either side.
3. Fasten the back of the unit to part of the vehicle using the metal mounting strap.

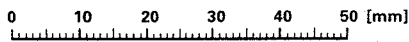

ACCESSORIES

No.	Part name	Q'ty
①	Hook Bar	2
②	M5 Washer	1
③	Tapping Screw 5×20	1
④	M5 Nut	1
⑤	Fix. Bolt	1
⑥	Metal Mount Strap	1
⑦	16P-Wire Ass'y	1
⑧	Carry Case	1

- To remove the unit

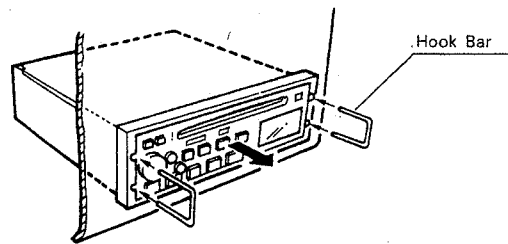

1. Remove the metal mounting strap fastening the back of the unit from the unit.
2. Insert the Hook Bar into the hole in the panel and pull the unit out.

8

Using the Removable Front Panel

The front panel of this unit can be removed to prevent theft.

Detaching the Front Panel

1. Press button , and the right-hand side of the panel will eject.

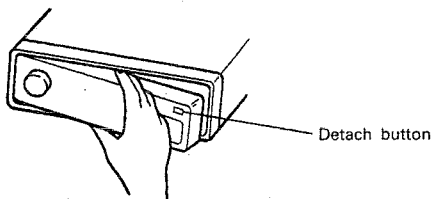

2. Enclose the front panel in the supplied carry case for safe-keeping.

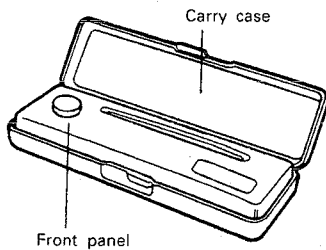

- Take care not to put pressure on the display or drop the front panel.
- Do not leave the front panel in any area exposed to high temperatures or direct sunlight.

Replacing the Front Panel

Insert the panel as shown on steps ① and ② on the diagram below.

- When replacing the front panel, do not put pressure on the display or control buttons.

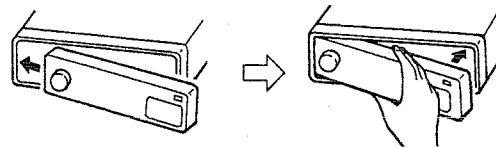

- ① Fasten the hook on the left side.
- ② Push in the right side to insert the panel.

- Note that if the front panel is not attached correctly, pushing button  may not release the panel, and the other control buttons may not function.

Precautions

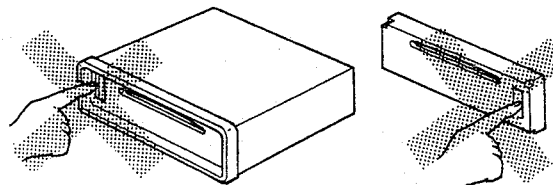

- Do not touch the contacts on the front panel or on the unit body, since this may result in poor electrical contact. If dirt or other foreign substances get on the contacts, wipe them with a clean, dry cloth.





9





(U.S.A. Version)

Power Off/Power On Functions

<Power Off>
 When the **1**  button is pressed for over 2 seconds while the set is operating, the power turns off and the display and back light turn off.
 When the power is off, the clock can be adjusted by pressing the **16**  button for over 2 seconds. For details, see page 23.

<Power On>
 When the power is off, it press the **1**  button to turn the power on and tuner on, and it press the **2**  button to turn the power on and CD play.

Switching the Mode

- 1 Press the **2**  button while listening to the tuner to play a CD.
- 2 Press the **1**  button while playing a CD to listen to the tuner.
- 3 To switch from a single CD to the changer, press the **16**  or **16**  button.

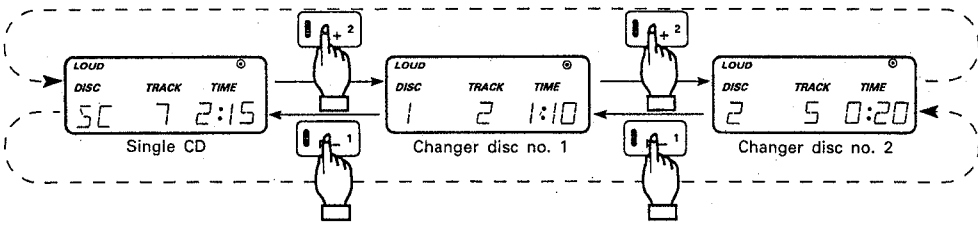

10

Control knob operation

- The **5** control knob normally adjusts the volume when turned. Press the **5** control knob to switch the adjustment mode in the following order:
- The control knob returns to the volume adjust mode five seconds after the last adjustment has been made.

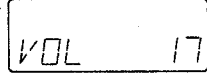
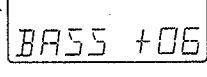
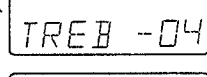
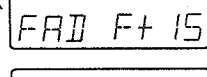
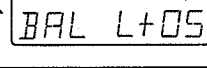
Example of LCD display	Mode	Operation
	Volume	• Turn the knob clockwise to increase the volume, counterclockwise to decrease the volume.
	Bass	• Turn the knob clockwise to increase the bass, counterclockwise to decrease the bass.
	Treble	• Turn the knob clockwise to increase the treble, counterclockwise to decrease the treble.
	Fader	• Turn the knob clockwise to shift the balance to the front side, counterclockwise to shift the balance to the rear side.
	Balance	• Turn the knob clockwise to shift the balance to the right side, counterclockwise to shift the balance to the left side.

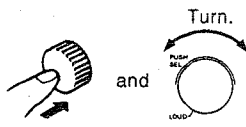

Loudness Function

When **5** control knob is pressed for more than 2 seconds, the bass and treble are emphasized, making for a more powerful sound. This can be used to make the sound more listenable at low volume levels.

Mute Function

Press the **8**  button causes muting, reducing the sound volume, "MUTE" flashes on the display. Pressing the button again cancels the display.

(U.S.A. Version)

Listening to the Radio

- Press button to turn the tuner on.
- Press the button to select one of the FM or AM bands.

→ FM1 → FM2 → FM3 → AM1 → AM2 →

- Use the seek buttons to set the desired frequency. There are two ways to adjust the frequency, as explained below.

"ST" appears on the display when a stereo broadcast is received.

(1) Seek Tuning

Press this button to move to lower frequencies. Tuning stops automatically when a station is found.

Press this button to move to higher frequencies. Tuning stops automatically when a station is found.

Tuning will not stop at stations whose signals are weak. To tune in such stations, use manual tuning.

- Press the button to search for only stations with strong signals when tuning in the seek mode.

(2) Manual Tuning

Press the or button for at least two seconds to begin manual tuning.

The frequency decreases in steps of 200 kHz for FM and 10 kHz for AM each time this button is pressed.

The frequency increases in steps of 200 kHz for FM and 10 kHz for AM each time this button is pressed.

Presetting of 18 FM Stations and 12 AM Station

18 FM stations, and 12 AM stations can be preset at buttons 1 to 6 then tuned in directly.

Example: Preset 102.5MHz at preset button 1 for FM1:

- Tune in FM1 102.5MHz using the seek tuning or manual tuning method.
- Press preset button 1 () and hold it in for at least two seconds.
- After about two seconds, a "beep" is heard.
- "CH1" appears on the display. The station is now preset in the memory.

Use this procedure to store other stations. To tune in preset stations directly, simply press the button at which the station was stored.

12

Using the Automatic Memory System

Use this function in areas where you do not know the frequencies of stations to automatically find stations and store them at the preset buttons.

The stations are automatically stored at the FM3 and AM2 bands, so if you store the stations you normally listen to at the FM1, FM2 and AM1 bands, this function lets you quickly find stations in different areas without clearing the stations you normally listen to.

- Use the and buttons to select the frequency from which you want to start searching.
- Press the button and hold it in for at least 2 seconds.
- "A.MEMO" appears on the display. The band automatically switches to FM3 for FM, AM2 for AM, and the stations with the best reception are stored in order at preset buttons 1 to 6.
- Once the stations with the best reception are stored for the FM3 (AM2) band, the "A.MEMO" indicator turns off.
- Use the button to switch back to the FM1, FM2 or AM1 band.

NOTE:

- Stations can also be stored manually for the FM3 and AM2 bands. However, when the automatic memory function is used, these stations are replaced by the new stations with the best reception.
- If there are fewer than six stations with good reception, the number of the first preset button at which a station was stored is indicated on the display.
- In rare cases, it may happen that no stations are stored when the automatic memory function is used, due to poor reception conditions, etc.

Presetting Scanning

This function lets you check the stations stored at preset buttons 1 to 6.

Press the button for at least 2 seconds. The stations are received in order for 5 seconds each.

Mono Function (Auto/Mono Selection)

This function is used at the time of FM reception when the stereo broadcast is hard to hear or when there is noise interference. It changes the stereo reception to monaural.

Press the button for more than 2 seconds.

- Even when this function is used, there are occasions when the sound is not improved, depending on the reception conditions.

(U.S.A. Version)

Using the RDS (Radio Data System)

- The RDS functions are for the FM band only, and will only work on stations that are broadcasting with the RDS service.
- Not all RDS stations offer all the RDS services listed on the previous page. Some RDS stations may only provide some of the RDS services.
- The RDS functions may not work properly when the reception is poor.

RDS Search

Use this function to automatically tune in stations with RDS broadcasts.

- 1 Press the **FM BAND** button and select the FM1, FM2 or FM3 band.
- 2 Press the **RDS SEEK** button to automatically search for stations with RDS broadcasts. When an RDS station is tuned in, the station's name appears on the display.

<Notes on RDS Search Function>

This button has a slightly different function if the PTY or TA function is switched on.

PS (Program Service Name) Function

Displaying the PS (Program Service Name) on the LCD

- 1 Tune in the desired RDS station.
- 2 After the frequency of the station being received appears on the display, the display switches to the PS (Program Service Name).

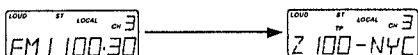

- 3 To check the frequency of the station being received, press the **MUTE/DISP** button and hold it in for two seconds. The display changes to the frequency. Three seconds later, the PTY code appears, and three seconds later, the PS reappears.

<Notes on Using the PS Function>

- The PS (Program Service Name) is not displayed if the station being received is not an RDS station or if its signals are weak.

14

PTY (Program Type) Function

Use this function to automatically tune an RDS station broadcasting a certain type of program.

- 1 Press the **FM BAND** button and select the FM1, FM2 or FM3.
- 2 Press the **PTY** button twice, and check that the "PTY" indicator has appeared on the display.
- 3 Press the **PTY** button for at least two seconds and check that the indicator on the display has started to flash. (The program type mode is selected.)



- 4 Press the **PREV** or **NEXT** button to select the type of program.

- The program type changes each time the **PREV** or **NEXT** button is pressed.
- See the list of the program types which can be selected.
- 5 Press the **RDS SEEK** button.
- 6 An RDS station of the type you have selected is automatically tuned in.
- "PTY SEEK" and the selected program type are displayed alternately while a station is being tuned in.
- It is not possible to tune in stations broadcasting the type of program you have selected but not offering RDS services, or RDS stations which do not offer the PTY service. At this moment a "beep" sound is heard.

List of PTY Program Types

DISPLAY	PROGRAM TYPE	DISPLAY	PROGRAM TYPE	DISPLAY	PROGRAM TYPE
NEWS	News	COUNTRY	Country	SOFT R+B	Soft R&B
INFORM	Information	OLDIES	Oldies	LANGUAGE	Language
SPORTS	Sports	SOFT	Soft	REL MUSC	Religious Music
TALK	Talk	NOSTALGA	Nostalgia	REL TALK	Religious Talk
ROCK	Rock	JAZZ	Jazz	PERSONLTY	Personality
CLS ROCK	Classic Rock	CLASSICL	Classical	PUBLIC	Public
ADLT HIT	Adult Hits	R+B	R&B	NO RDS*	No Program type**
SOFT RCK	Soft Rock			NO PTY*	No Program type
TOP 40	Top 40				

*Cannot be selected in the program type selection mode.
**The station being received is not an RDS station or its signals are weak.

(U.S.A. Version)

PTY (Program Type) Function

- **Tuning in RDS stations broadcasting a certain type of program using the preset buttons:**
If you have already entered an RDS station in a preset memory, the unit will remember what the PTY of this station is, and will allow you to tune in another RDS station broadcasting the same PTY code.
Example: If you already have a "NEWS" station entered in preset 4, and you want to find another "NEWS" station:

- 1) Push button.
- 2) Make sure that PTY mode is selected and shows on the display. (If it is not, push the button until "PTY" is shown on the display)



- 3) Push the preset 4 button to tune in a "NEWS" stations.
- 4) Then push the button. The unit will search for another RDS station with the "NEWS" PTY code.

Emergency Program Reception Function

If the unit receives an Emergency code, "ALERT" appears on the display and beep tone is heard.
During an emergency broadcast, the volume on the unit will turn up even if the volume knob is set to the minimum. Also, if the unit is in the CD mode, the unit will automatically switch to the radio, indicating an emergency. Follow the instructions being broadcast.

- This function will only work when receiving RDS stations (stations with program service names). In addition, it may not work properly if the signals of the station being received are weak.
- This function will only work during actual emergency broadcasts, and will not work during tests of the emergency broadcast system.

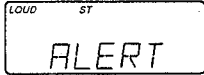

RDS Emergency Alert Feature

The RDS Emergency Alert Feature is activated by a signal sent at the sole discretion of the RDS broadcaster. The RDS Emergency Alert Feature is included in this product for the convenience of the consumer, and is not intended to augment or replace the Official Emergency Broadcast System as administered by the Federal Communications Commission. For this reason, Nippon Columbia Co. and its Subsidiaries, including but not limited to DENON ELECTRONICS and DENON Canada, Inc., refuse all Warranties, claims of merchantability or fitness, or liabilities, whether incidental, consequential or otherwise, related to, either directly or indirectly, the operation or lack of operation of this feature. This exclusion applies to any and/or all Nippon Columbia Co. Products, whether present or future, that implement, in any form or variation, the RDS Emergency Alert Feature.

AF (Alternative Frequency) Function

To constantly receive RDS stations broadcasting the same program on multiple frequencies

- 1) Tune in the desired RDS station.
- 2) Press the button until "AF" appears on the display.

- When the signal strength of the station being received becomes weak, "AF" flashes on the display, and the unit searches for another station that is broadcasting the same program based on the AF code list.
- The frequency changes if another station broadcasting the same program is found.

Storing the AF lists and PI codes in the preset memory

- 1) Tune in the desired RDS station.
- 2) Press the preset memory button (M1 to M6) at which you want to store that station and hold it in for at least 2 seconds.
- 3) Press the button until "AF" appears on the display.
- 4) When a preset button at which the AF list or PI codes was stored is pressed, the AF or PI search operation is performed automatically. The stored broadcast stations and broadcast stations carrying the same content are searched for based on the AF list.

<Notes on Using the AF Function>

- 1) With the AF function, the AF button is pressed and stations broadcasting the same program as the station currently being received are searched for based on the AF list. The AF list includes stations broadcasting the same program. If no receivable station is found when the list is checked through 10 times, stations are searched for using the PI codes (codes for stations broadcasting the same program) and a beep tone is sounded. This operation is then repeated. Thus, in areas far from the broadcasting stations, the alternative frequency function may not work.

- 2) When presetting, both the program name, PI codes, AF list and PTY code are stored along with the station's frequency for buttons M1 to M6 on the FM band.
- 3) The sound may be interrupted once ever 10 seconds after the button is pressed while the station with the best reception is being searched for based on the AF list. This is not a malfunction.
- 4) "AF LEV n" (n = 0 to 7) appears on the display if the button is pressed for over 2 seconds. Now use the and buttons to change the value of "n" and the strength of the signals at which the alternative frequency function will begin operating.
The lower the value of "n", the weaker the signals of the station being received must be before the AF function begins operating.



(U.S.A. Version)

AF (Alternative Frequency) Function



- 5) "AF" flashes on the display if the signals of the station being received become weak and the data cannot be identified.
- 6) The AF function may not work properly for RDS stations which do not transmit AF lists.

TA (Traffic Announcement) Function

Searching for TP (Traffic Program) broadcast stations automatically



- 1 Press the  button and select FM1, FM2 or FM3.
- 2 Press the  button. "TA" appears on the display.
- 3 Press the  button.
- 4 Tuning automatically stops at an RDS station broadcasting traffic information. "TP" appears on the display and the TP station is received.

Setting the volume when a TA (traffic information announcement) starts while in standby (on FM1, FM2 or FM3)



- 1 Press the  button and select FM1, FM2 or FM3.
- 2 Press the  button. "TA" appears on the display.
- 3 Press the  button.
- 4 Tuning automatically stops at an RDS station broadcasting traffic information and that station is received.
- 5 When a traffic announcement begins, the volume is set to the level at which it was set the last time a traffic announcement was received (the TA level). "TA VOL" appears on the display if the volume is adjusted at this time.
- 6 The TA level can be changed by changing the volume when traffic information is being broadcast. Also, when the next traffic information is tuned in, it is played at the previously set volume level.
- 7 The volume returns to the original level once the traffic announcement is over.

TA (Traffic Announcement) Function

Automatically listening to traffic information announcements while playing a CD.

- 1 Press the  button. "TA" appears on the display.
 - 2 Press the  button to tune in the desired TP station.
 - 3 Insert CD or press the  button and start playing CD.
 - 4 Use the control knob to adjust the volume of the CD.
- When the traffic information announcement starts, CD play is set to the pause condition and the set automatically switches to the traffic information.

<Notes on Using the TA Function>

- 1) With the TA function, the TA button is pressed and stations broadcasting the same program as the station currently being received are searched for based on the AF list. The AF list includes stations broadcasting the same program. Thus, in areas far from the broadcasting stations, the alternative frequency function may not work.
- 2) A beep tone is sounded if there is no station broadcasting a Traffic Program or if its signals are weak. If this happens, press the  button again so that "TA" disappears from so that "TA" disappears from the display, then wait until entering an area in which a station broadcasting TPs can be received and press the  button again, then press the  button to tune in a traffic information station.
- 3) "TA" flashes on the display if the signals of the station being received become weak and the data cannot be identified.
- 4) Some stations broadcast TA (traffic announcement) signals even when they are not broadcasting traffic information announcements. In such cases, the TA function will not work properly.

(U.S.A. Version)

Listening to Compact Disc (Single CD or CD changer)

- 1 Load the CD from ②.
 - 2 Button
Pushing this button will start the CD play.
The "▶" sign and the currently playing disc number, track number and track time will be displayed on the display.
Pushing this button once again will stop the CD play.
 - 3 The CD is ejected from ② when the button is pressed.
- When a disc is loaded in the set, the "●" mark appears on the display.

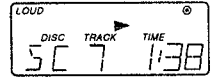

- Disc Change (Please connect DCH-700/600/500)**
- 4 Pushing the button will advance the unit to the next disc and start the play from the first track.
 - 5 Pushing the button will return the unit to the previous disc and start the play from the first track. The number of the changed disc is displayed on the display.
- See page 10 for instructions on switching from a single CD to the changer and a description of the display.

Searching for the Desired Track

(1) Automatic Search

- 1 Pushing the button will find the beginning of the next song and resume play.
 - 2 Pushing the button will return to the beginning of the song in play, and resume play.
- The track numbers of the songs being searched will be displayed on the display.
 - Note that the manual search mode is set if the or button is pressed for more than two seconds.

(2) Manual Search

- 1 Continuing to push the up button for more than 2 seconds, will fast forward the disc.
 - 2 Continuing to push the down button for more than 2 seconds, will fast reverse the disc.
- At this time the sound can be heard at a lower volume than during regular playback.

Repeat Play

(1) One track

- 1 Press the button once. "RPT 1" appears on the display, and the track which is currently playing is played repeatedly.
Use this to play a single track repeatedly.
- To cancel the repeat function, either press the button twice, or press another CD control button.

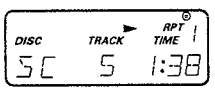

(2) One disc (Please connect CD Changer)

- 1 Press the button twice. "RPT A" appears on the display, and the entire disc which is currently playing is played repeatedly.
Use this to play one CD repeatedly.
- To cancel the repeat function, either press the button once, or press another CD control button.
 - If no CD changer is connected, the same disc is played repeatedly when the repeat button is pressed.



Intro Scan

- 1 Press the button. "IS" appears on the display, and the first 10 seconds of each track is played.
Use this to search for a certain track.
- To stop the intro scan function, either press the button again, or press another CD control button.



- With this function, only the disc currently playing is scanned.

Disc Scan (Please connect CD Changer)

- 1 Press the button. "DS" appears on the display, and the first 10 seconds of each disc (the first track) is played.
Use this to search for a certain disc.
- To stop the disc scan function, either press the button again, or press another CD control button.



- With this function, the in-dash CD single disc and the discs in the CD changer are scanned in order.

(U.S.A. Version)

Random Play

(1) One disc

- 1 Press the button once. "RND 1" appears on the display, and the tracks on the disc which is currently playing are played in random order.
- 2 When the button is pressed, a track selected randomly starts playing.
 - To cancel the random play function, either press the button twice, or press another CD control button.
 - "RND" is displayed if no changer is connected.



(2) All discs (Please connect CD Changer)

- 1 Press the button twice. "RND 2" appears on the display, and all the tracks on all the discs are played in random order.
- 2 When the button is pressed, a randomly selected track on a randomly selected disc starts playing.
 - To cancel the random play function, either press the button until "RND 1", or "RND 2" disappears, or press another CD control button.



- With this function, only the tracks on the discs in the CD changer are played at random.

Error Displays

If any of the following error displays are shown on the display when the unit is operated, carry out the measure indicated in the table.

Error display	Cause of error	Measure
NO MAG.	The disc magazine is not inserted in the changer.	Insert a disc magazine that has been loaded with discs into the changer.
NO DISC	Discs are not loaded in the disc magazine.	Remove the disc magazine and load the discs.
ERROR	Troubleshooting	Push the DCT-950R reset switch.
HOT	The temperature protection circuit of the DCH-700/600/500 has operated.	Wait until the temperature drops.
DISC REV	All of the discs in the magazine are upside-down or dirty.	Set the discs properly or wipe off the dirt.
SC HOT	The temperature protection circuit of the CD Mechanism has operated.	Wait until the temperature drops.

22

Time Adjustment

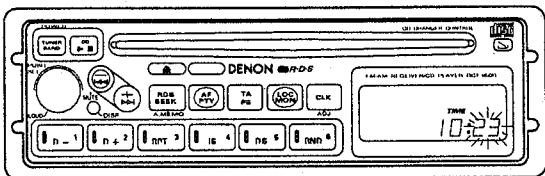

Time display: Pressing the button provides a time display for about 5 seconds.

1. Automatic adjustment

- The clock is automatically adjusted by the RDS CT (Clock Time) function.
- If the button is pressed after the clock has been adjusted with the CT function, "CT" is displayed in front of the time display.

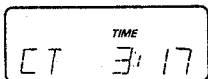

- The clock may not be properly adjusted when receiving stations from areas in different time zones.
- Some RDS stations do not offer the CT service.
- Automatic adjustment may not be possible when reception is poor due to the inability to receive the CT code.
- To use the automatic clock adjustment function, the unit has to be tuned to an RDS radio station for an average of 30 seconds before using this feature.

2. Manual adjustment (only operates in the OFF mode)

- 1) When the button is pressed for more than 2 seconds, the back light and display turn on.
- 2) Adjust the Hour setting with the or buttons.
- 3) Press the button. The Minute display will flash and the minute adjustment mode will be set.
- 4) Adjust the Minute setting with the or buttons.
- 5) Press the button again. The time will start advancing from the adjusted time setting.

Note:

- The time is displayed with a 12-hour display; there is no A.M. or P.M. indication.
- The time cannot be adjusted manually when the set is operating.

Telephone Mute

1. When a car telephone is connected to terminal , the volume automatically decreases when a telephone call is received.
 - "TEL MUTE" appears on the LCD.
 - The volume and display are restored to their original settings when the telephone is hung up.

Note: There is a possibility that the telephone mute function will not operate with the telephone that is used. In view of this, please be sure to discuss this matter with the installer or the service representative when you have decided to install a telephone.

23

(U.S.A. Version)

Reset Switch

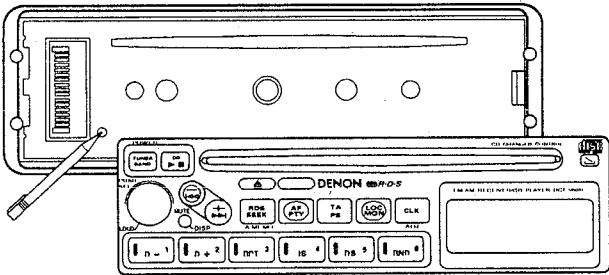

1 Reset Function

Press the release button and remove the panel. Press the reset switch using the tip of a ball-point pen, etc., when the power supply is first connected or when the display malfunctions due to external interference.

NOTES:

- Everything stored in the memory, including the stations stored at preset channels M1 to M6, is cleared when the reset switch is pressed. The time is also reset to 12:00.
- Do not press the reset switch with a sharp object, such as a metal pin.
- If the problem persists after the reset switch is pressed, contact your Denon dealer or a local Denon service center.

24

Cleaning

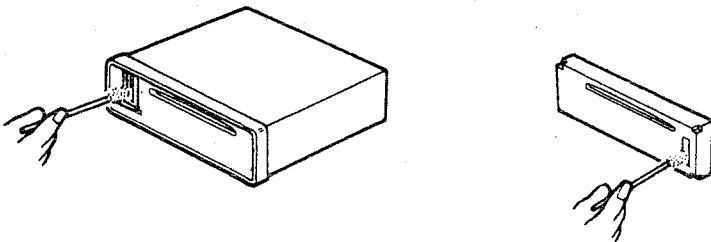

There may be a poor connection at the connector on the panel or on the set if the unit is frequently detached. Periodically wipe the connectors with a cotton swab moistened with alcohol.

* Always turn the car's accessory power supply off when cleaning.

25

(U.S.A. Version)

• WIRELESS REMOTE CONTROL (OPTION)

The accessory remote control unit RC-436 is used to control DCT-950R from a distance.

1. Loading the Dry Cell Batteries

(1) Remove the rear cover on the remote control unit.

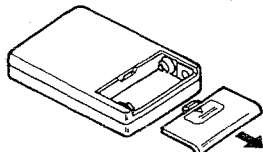

(2) Load two R03 (standard size AAA) dry cell batteries as shown in the diagram inside the battery compartment.

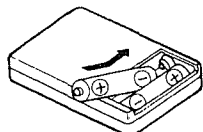

(3) Replace the rear cover.

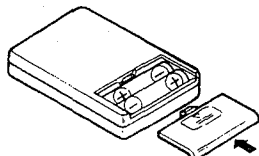

Battery Precautions

- The remote control unit uses R03 (standard size AAA) dry cell batteries.
- The batteries will need to be replaced approximately once a year. This will depend upon how often the remote control is used.
- If the remote control will not operate the In-dash player even if held at very close distance, exhausted batteries may be suspected. Replace the batteries with new ones.
- Load the batteries properly according to the illustration inside the battery compartment. Align the battery polarity (+ and -) correctly.
- Batteries are prone to damage and may start to leak. Therefore:
 - Do not combine new batteries with used ones.
 - Do not combine different types of batteries.
 - Do not jumper the opposite poles of the batteries, expose them to heat or break them open.
 - Do not dispose of used batteries in open fire. Obey local regulations on battery disposal.
- When the remote control is not to be used for a long period of time, remove the batteries from the unit.
- If the batteries have leaked, remove any battery fluid from the inside the battery compartment by wiping it out thoroughly. Then load new batteries.

26

2. Directions for use

- Operate the remote control unit while pointing it at the remote sensor on DCT-950R, as shown in the diagram below.

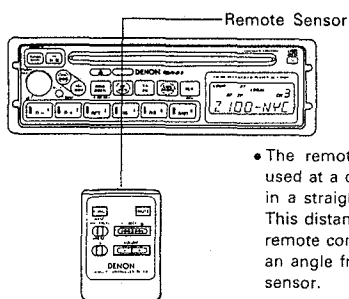

• The remote control unit can be used at a distance up to 6 meters in a straight line from DCT-950R. This distance decreases when the remote control unit is operated at an angle from the remote control sensor.

- Point the remote control unit at the remote control sensor when operating it. DCT-950R may not function if there are obstacles between remote control unit and the remote control sensor, so operate the remote control unit from directly in front of DCT-950R.

Operation Precautions

- Do not press the operation buttons on DCT-950R and the remote control at the same time. This will cause miss operation.
- Remote control operation may be impaired if the Remote Sensor on DCT-950R player is exposed to strong light (for example, direct sunlight)

3. CONTROLS

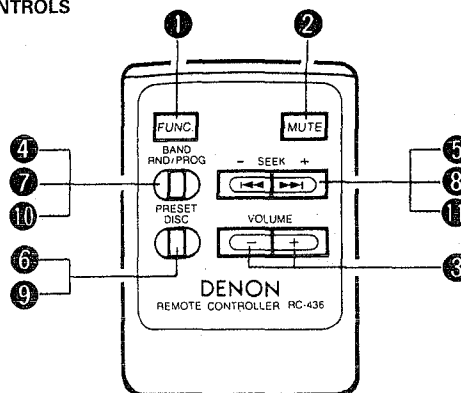

• MAIN CONTROL

① FUNCTION button

This button permits switching between tuner and CD.

TUNER ⇄ CD

Pressing this button when DCT-950R is off will switch on the tuner. This switch does not have an off function.

② MUTE button

Pressing this switch causes muting, reducing the sound volume. "MUTE" flashes on the display when the MUTE button is pressed. Pressing the button again cancels the display.

③ VOLUME button

Press the button to increase the volume.

Press the button to decrease the volume.



(U.S.A. Version)

● RADIO CONTROL

④ BAND SELECT button

This button changes the band. (See Page 12.)

⑤ SEEK TUNING button

 button and  button provide seek tuning in the direction of a higher frequency and a lower frequency, respectively. (See Page 12.)

⑥ PRESET button

This button changes the channels (CH) of the preset memory. This button changes the channels in the order of CH 1 → CH 2 → CH 3...

● CD CONTROL

⑦ RANDOM button

Pressing this button provides random playback.



1) For single CDs

When this button is pressed, the mode switches between *random* and *normal play (off)*.

2) For a changer

Each press of this button advances the changer in the sequence of RND 1 → RND 2 → Normal Play (OFF). (See Page 22.)

⑧ AUTOMATIC SEARCH button

Pressing the  button provides an automatic search to the next track, whereas pressing the  button provides an automatic search to the beginning of the track currently being played. (See page 20)

⑨ DISC CHANGE button

Pressing this button changes the disc in the direction of a larger disc number. (See page 20)

Notes:

- The remote control unit will function from a distance of approximately 6 meters directly in front of the remote sensor.
- The distance from which the remote control unit will function will decrease if it is operated from an angle.
- The remote control unit may not function if there is an obstacle between it and the remote sensor.
- The distance from which the remote control unit will function will decrease if the batteries are worn.
- The DCT-950R does not include a programming function.

28

SPECIFICATIONS

FM TUNER

- Mono Usable Sensitivity 11.4 dBf 1 μ V (75 ohms)
- 50 dB Quietening Sensitivity 20.3 dBf 2.8 μ V (75 ohms)
- Alternate Channel Selectivity 100 dB
- S/N (Signal to Noise Ratio) 70 dB
- Stereo Separation 40 dB at 1 kHz
- Capture Ratio 2.5 dB

AM TUNER

- Sensitivity 30 μ V (S/N 20 dB)

CD

- Frequency Response 5 Hz ~ 20 kHz \pm 1.0 dB
- Dynamic Range 96 dB
- Signal to Noise Ratio 96 dB
- Harmonic Distortion 0.005%
- Wow and Flutter Below a Measurable level

DISC

- Applicable Disc Compact Disc

SIGNAL FORMAT

- Sampling Frequency 44.1 kHz
- Quantization 16 Bit Linear
- Transfer Bit Rate 4.3218 Megabits/sec.

GENERAL

- Power Output *1 14 W \times 4 ch at 1 kHz with 10% THD
- Power Output *2 10 W \times 4 ch from 20 Hz to 20 kHz with 0.8% THD
- Output Voltage – Pre-amp level 2.2 V/10 k ohms
- Bass \pm 12 dB at 40 Hz
- Treble \pm 12 dB at 15 kHz
- Loudness (Vol. –30 dB) +8 dB at 100 Hz
+8 dB at 10 kHz
- Remote Output 12V 300 mA max.
- Power Antenna Output 12V 300 mA max.
- Chassis Size (W \times H \times D) 178 mm \times 50 mm \times 172 mm
(7-1/64" \times 2" \times 6-25/32")
- Panel Size (W \times H \times D) 187 mm \times 59 mm \times 23 mm
(7-23/64" \times 2-21/64" \times 29/32")
- Weight 2.0 kg (4 lbs 6 oz)

*1 Power Output is per channel minimum continuous average power into 4 ohms, both channels driven, at 1 kHz, with no more than 10% total harmonic distortion.

*2 Power Output is per channel minimum continuous average power into 4 ohms, both channels driven from 20 Hz to 20 kHz, with no more than 0.8% total harmonic distortion.

Design and specifications are subject to change for improvement without prior notice.

29

15

(Europe Version)

For safety, heed the following cautions. Failure to do so can lead to accidents and damage to the unit:

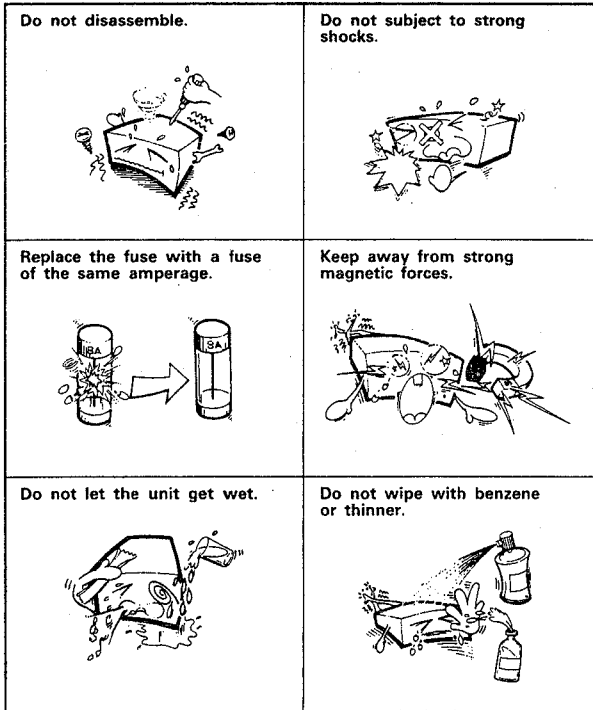

Halten Sie sich aus Sicherheitsgründen bitte an die folgenden Hinweise. Bei Zuwiderhandlungen können Unfälle mit Personenschaden oder Beschädigungen am Gerät auftreten.



CONTROL & INDICATORS/BEDIENUNGSELEMENTE & ANZEIGEN

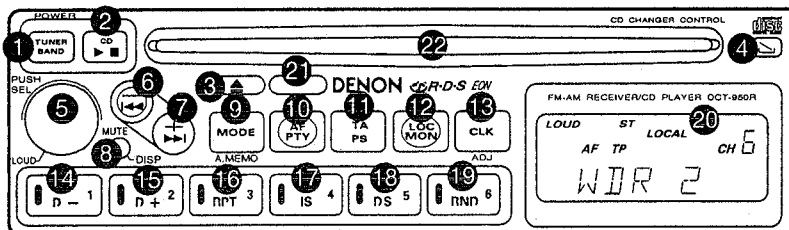

MUTE IN WIRE (PINK/WHITE) KABEL FÜR STUMMSCHALTUNGS-EINGANG (ROSE/WEIß)









- 1 TUNER/BAND/POWER ON/• POWER OFF button
- 2 CD button
- 3 Eject button
- 4 Detach button
- 5 Control Knob (Volume/Bass/Treble/Fader/Balance)
- 6 Control Select/• Loudness button
- 7 Seek/• Manual up/down and Auto/• Manual search
- 8 Muting/• Display button
- 9 Seek/Manual and Search on/off button • Automatic Memory button
- 10 AF/PTY/• AF Level Adj./• PTY Select button
- 11 TA/• Preset Scan button
- 12 Local/• Mono button
- 13 Clock button/• Clock ADJ button
- 14 Preset/• Preset Memory/disc change button
- 15 Preset/• Preset Memory/disc change button
- 16 Preset/• Preset Memory/Repeat button
- 17 Preset/• Preset Memory/Intro Scan button
- 18 Preset/• Preset Memory/Disc Scan button
- 19 Preset/• Preset Memory/Random button
- 20 LCD display
- 21 Remote Sensor
- 22 Compact Disc Slot
- 23 Mute in

To use the functions marked "•", press the button for over two seconds.





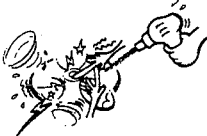
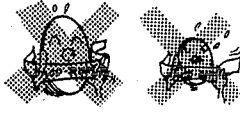



- 1 TUNER-/Frequenzbereich-/NetztaSte Ein/Aus (TUNER/BAND/POWER ON/OFF)
 - 2 CD-Taste
 - 3 Auswurf-taste
 - 4 Abnehm-taste
 - 5 Regler (Lautstärke/Tiefen/Höhen/Fader/Balance) Wähler/• Loudness-Taste
 - 6 7 Sendersuchlauf/Manueller Suchlauf Auf/Ab/ und automatischer/manueller Suchlauf
 - 8 Stummschalt-/Display-Taste
 - 9 Sendersuchlauf/Ein-/Aus-Taste für manuellen und automatischen Suchlauf/Automatik-Speicher-Taste
 - 10 AF/PTY-/• AF-Pegel-Einstell-taste/• PTY-Wahl-taste
 - 11 TA-/• Speichersuchlauf-Taste
 - 12 Lokal-/• Mono-Taste
 - 13 Uhr-Taste/• Uhr-Einstell-taste (ADJ)
 - 14 Vorwahl-/• Vorwahlspeicher-/CD-Wechsler-taste
 - 15 Vorwahl-/• Vorwahlspeicher-/CD-Wechsler-taste
 - 16 Vorwahl-/• Vorwahlspeicher-/Wiederholungstaste
 - 17 Vorwahl-/• Vorwahlspeicher-/Titelanspieltaste
 - 18 Vorwahl-/• Vorwahlspeicher-/CD-Suchlauf-taste
 - 19 Vorwahl-/• Vorwahlspeicher-/Zufallswiedergabe-Taste
 - 20 LCD-Display
 - 21 Fernbedienungssensor
 - 22 CD-Fach
 - 23 Stummschaltungs-Eingang
- Um die mit "•" markierten Funktionen anzuwenden, müssen Sie die Taste für länger als zwei Sekunden drücken.

(Europe Version)

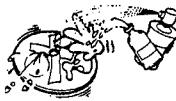
COMPACT DISC

1. Precautions on handling compact discs	
Do not let fingerprints, dust or oil on the disc! If the disc is dirty, wipe it clean with a clean, dry cloth.	Do not bend.
	
Do not use benzene, thinner, water, record spray, electrostatic proof chemicals, or silicone-treated cloths to wipe discs.	Do not apply heat!
	
Do not enlarge the hole in the center of the disc.	Do not attempt to play a CD-ROM Disc and 8cm CD.
	
Do not write on the disc with a hard tipped implement such as a pencil or ball-point pen.	When condensation forms, do not attempt to dry the disc with a hair dryer, etc.
	

CD-PLATTEN

1. Vorsichtsmaßnahmen zur Handhabung von CD-Platten	
Die Oberfläche der CD-Platten darf nicht mit den Fingern berührt werden bzw. mit Öl oder Staub in Berührung kommen! Die Oberfläche kann im Bedarfsfall mit einem weichen, trockenen Tuch saubergewischt werden.	CD-Platten dürfen nicht gebogen werden.
	
Zur Reinigung von CD-Platten dürfen weder Benzin, Verdünner, Wasser, herkömmliche Schallplattenreiniger, Antistatikmittel noch silikonbehandelte Tücher verwendet werden.	CD-Platten dürfen nicht größerer Wärmeeinwirkung ausgesetzt werden.
	
Das Loch in der Mitte einer CD-Platte darf nicht vergrößert bzw. erweitert werden.	Eine CD-ROM-Platte darf nicht abgespielt werden.
	
CD-Platten dürfen (auf der beschrifteten Seite) nicht mit einem Bleistift oder Kugelschreiber o.ä. beschrieben werden.	Schlägt sich Feuchtigkeit auf den Platten nieder, warten Sie bitte, bis sich die Feuchtigkeit von allein verflüchtigt hat. Es darf keinesfalls versucht werden, die CD-Platten mit einem Haartrockner o.ä. zu trocknen.
	

6

2. Precautions on storage

- After playing a disc, always unload it from the player.
- Always return a disc to its proper case to prevent it from becoming dirty or damaged.
- Do not place discs in the following types of areas:
 - 1) Areas exposed to direct sunlight for a considerable time.
 - 2) Areas subject to accumulation of dust or high humidity.
 - 3) Locations near the path of hot air from the heater vent.

2. Vorsichtsmaßnahmen zur Aufbewahrung von CD-Platten

- Nach dem Abspielen einer CD-Platte sollte diese aus dem CD-Spieler herausgenommen werden.
- CD-Platten sollten immer in der dazugehörigen Box aufbewahrt werden. Damit wird einem Verstauben und einer Verschmutzung der CD-Platten vorgebeugt und damit die Lebenszeit der Platten verlängert.
- CD-Platten dürfen an folgenden Stellen nicht aufbewahrt werden:
 - 1) an Stellen, wo sie für längere Zeit direkter Sonneneinstrahlung ausgesetzt sind,
 - 2) an staubigen oder feuchten Stellen,
 - 3) an Stellen, wo sie starker Wärmeeinwirkung ausgesetzt sind, z.B. in der Nähe von Heizkörpern usw.

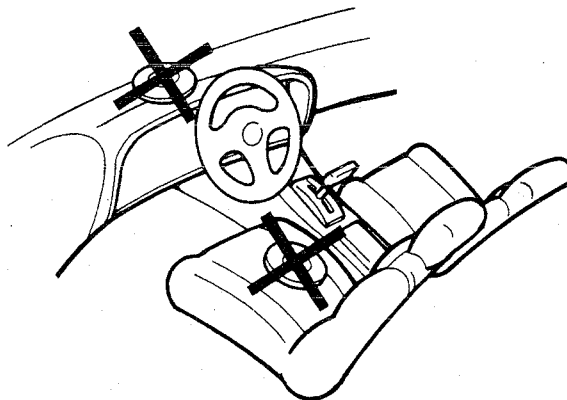

8

(Europe Version)

Please carefully read all safety and operating instructions before installation and use. It will help you to obtain the best performances from your new FM-AM Receiver/CD Player.

FEATURES

- Power: (Both Channels Driven)
 20 W x 4 ch 1 kHz/4 ohms (MAX)
 14 W x 4 ch 1 kHz/4 ohms 10% THD
 10 W x 4 ch 20 Hz - 20 kHz/4 ohms 0.8% THD
- HIGH POWER PRE-OUTPUT 2.2V/10 kohms
 - 20 bit digital filter with 8-times oversampling and noise shaper.
 - Dual 18-bit D/A converter.
 - 3-Beam laser pickup servo.
 - Detachable Front Panel.
 - RDS (PS, PTY, AF, PI, TA, TP, CT).
 - 30 Station-presets (18 FM - 12 MW).
 - Automatic Memory System.
 - Denon Optimum Reception System IV (FM circuitry-Auto high blend and FM pulse noise canceller).
 - Stereo/mono (FM), local switches.
 - CD changer control.
 Disc/Intro Scan
 Repeat play (Disc & Track)
 2-Mode random play
 Automatic/Manual search
 - Wireless Remote Control (Option)
 - Flexible fader-internal front amp to rear amp and/or internal front amp to internal rear amp.
 - DIN "E" & ISO mount.
 - Night illumination with dash light dimmer lead.

- Quartz Clock
- Muting Switch
- Telephone Mute

CAUTION
 The use of optical instruments with this product will increase eye hazard.

CAUTION - Use of controls or adjustments or performance of procedures other than those specified herein may result in hazardous radiation exposure.

The Compact Disc Player should not be adjusted or repaired by anyone except properly qualified service personnel.

FOR YOUR RECORDS

Please record the serial number of your unit in the space provided below and keep it as a permanent record. The serial number is indicated on the top of the unit. You will need the serial number, if the need for service should arise.

Model DCT-950R
 Serial Number _____

10

CONNECTIONS

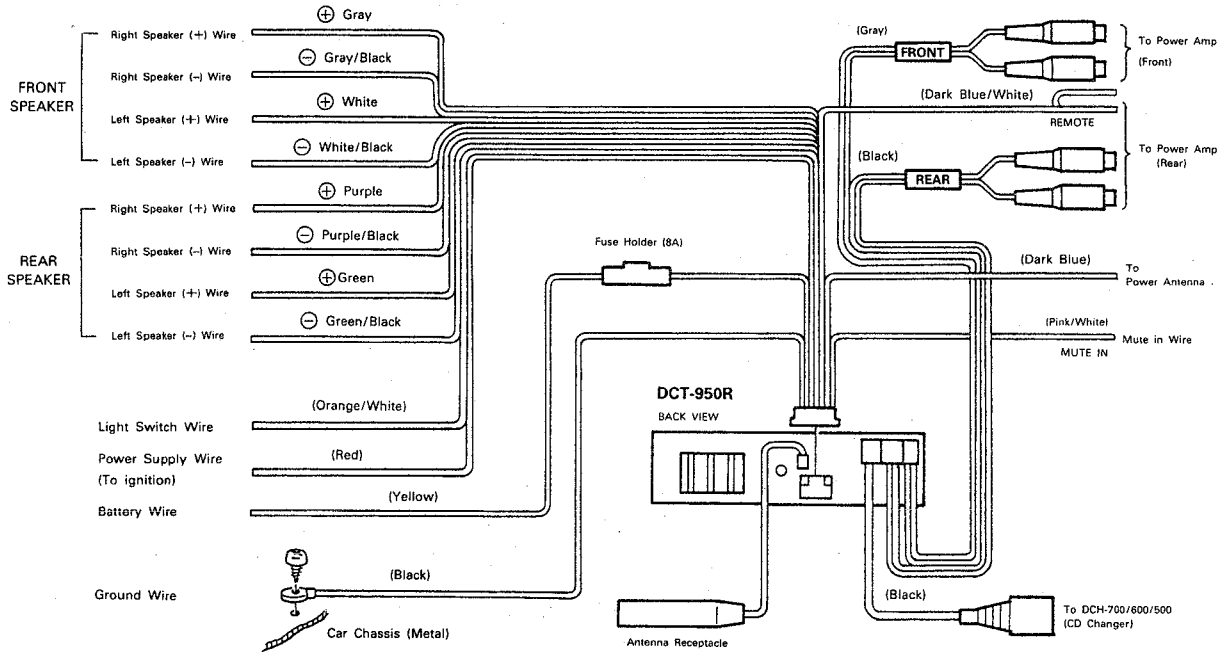

DENON Compact Disc Player DCT-950R will operate properly with 14.4 V (11-16 V) car batteries. You cannot use it for 24 V or other types or car batteries. Maximum rated current capacity from Remote output and the Power antenna output is 300 mA.
 * Do not use the remote output as the power supply for other sets (for example, power amplifiers, RF modulators, etc.). Connect the remote output to the power amplifier's control terminal (remote).
 ** When connecting two power amplifiers, divide the remote output in two.

CAUTION! - To prevent damage to the unit. BE SURE to connect the color coded leads correctly according to the diagram. Otherwise malfunctioning of the unit and/or damage to the vehicle may occur. DO NOT connect the (-) (negative) loudspeaker lead to the ground (chassis) or to any other (-) loudspeaker lead from this unit.
 * Only connect the set after connecting all the connector wires.
 ** Be sure to insulate the wires after connecting them.

(Europe Version)

INSTALLATION

- Use screws supplied as accessories when installing the unit.

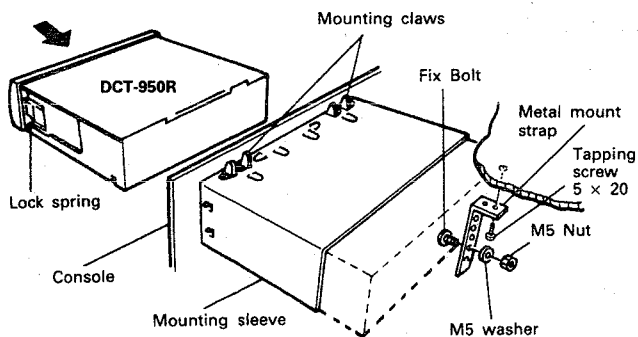

1. Insert the mounting sleeve in the console or dashboard then fasten it to the console with the mounting claws.
2. Insert the unit into the mounting sleeve then check that it is fastened to the mounting sleeve with the lock springs on either side.
3. Fasten the back of the unit to part of the vehicle using the metal mounting strap.

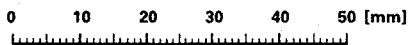

ACCESSORIES

No.	Part name	Q'ty
①	Hook Bar	2
②	M5 Washer	1
③	Tapping Screw 5×20	1
④	M5 Nut	1
⑤	Fix. Bolt	1
⑥	Metal Mount Strap	1
⑦	16P-Wire Ass'y	1
⑧	Carry Case	1

- To remove the unit

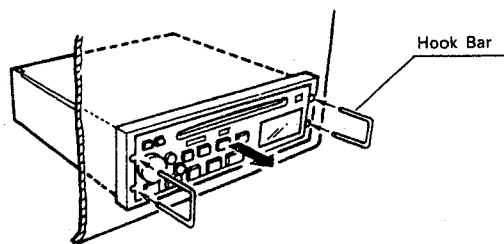



1. Remove the metal mounting strap fastening the back of the unit from the unit.
2. Insert the Hook Bar into the hole in the panel and pull the unit out.

12

Using the Removable Front Panel

The front panel of this unit can be removed to prevent theft.

Detaching the Front Panel

1. Press button  , and the right-hand side of the panel will eject.

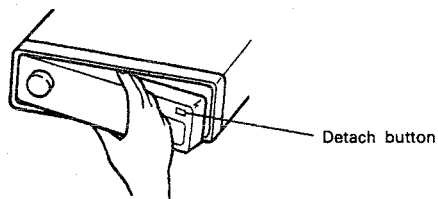

2. Enclose the front panel in the supplied carry case for safekeeping.

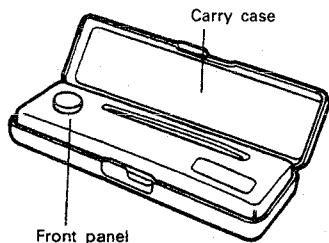

- Take care not to put pressure on the display or drop the front panel.
- Do not leave the front panel in any area exposed to high temperatures or direct sunlight.

Replacing the Front Panel

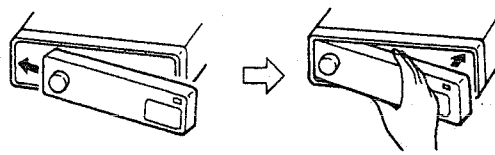

Insert the panel as shown on steps ① and ② on the diagram below.

- When replacing the front panel, do not put pressure on the display or control buttons.



① Fasten the hook on the left side.

② Push in the right side to insert the panel.

- Note that if the front panel is not attached correctly, pushing button   may not release the panel, and the other control buttons may not function.

Precautions

- Do not touch the contacts on the front panel or on the unit body, since this may result in poor electrical contact. If dirt or other foreign substances get on the contacts, wipe them with a clean, dry cloth.

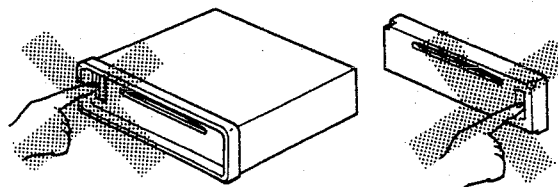

13

19

(Europe Version)

Power Off/Power On Functions

<Power Off>

When the **[TUNER BAND]** button is pressed for over 2 seconds while the set is operating, the power turns off and the display and back light turn off.

When the power is off, the clock can be adjusted by pressing the **[CLK ADJ]** button for over 2 seconds. For details, see page 27.

<Power On>

When the power is off, if press the **[TUNER BAND]** button to turn the power on and tuner on, and if press the **[CD]** button to turn the power on and CD play.

Switching the Mode

- 1 Press the **[CD]** button while listening to the tuner to play a CD.
- 2 Press the **[TUNER BAND]** button while playing a CD to listen to the tuner.
- 3 To switch from a single CD to the changer, press the **[n-1]** or **[n+2]** button.

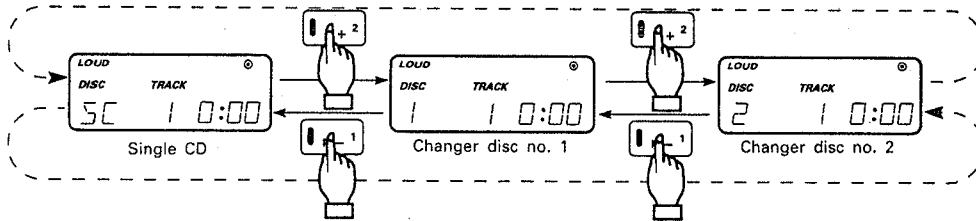

14

Control knob operation

- The **[KNOB]** control knob normally adjusts the volume when turned. Press the **[KNOB]** control knob to switch the adjustment mode in the following order:
- The control knob returns to the volume adjust mode five seconds after the last adjustment has been made.

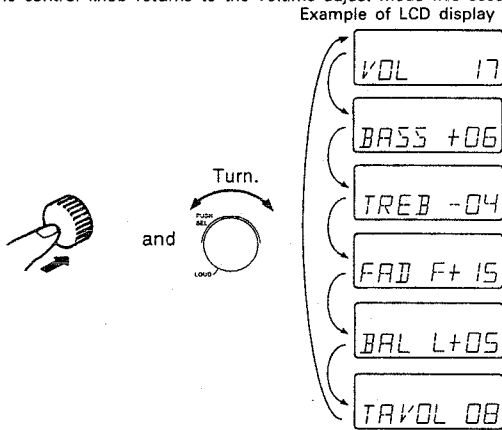

Mode	Operation
Volume	• Turn the knob clockwise to increase the volume, counterclockwise to decrease the volume.
Bass	• Turn the knob clockwise to increase the bass, counterclockwise to decrease the bass.
Treble	• Turn the knob clockwise to increase the treble, counterclockwise to decrease the treble.
Fader	• Turn the knob clockwise to shift the balance to the front side, counterclockwise to shift the balance to the rear side.
Balance	• Turn the knob clockwise to shift the balance to the right side, counterclockwise to shift the balance to the left side.
TA level	In the TA mode: <ul style="list-style-type: none"> • The volume level when traffic announcements are received switches to the level set with the "TA VOL" setting. (See Page 22.) • Turn the knob clockwise to increase the "TA VOL" setting, counterclockwise to decrease it. • The current volume level does not change when the "TA VOL" setting is adjusted, except while receiving a traffic announcement.

Loudness Function

When **[KNOB]** control knob is pressed for more than 2 seconds, the bass and treble are emphasized, making for a more powerful sound. This can be used to make the sound more listenable at low volume levels.

Mute Function

Press the **[MUTE]** button causes muting, reducing the sound volume, "MUTE" flashes on the display. Pressing the button again cancels the display.

15

(Europe Version)

Listening to the Radio

1 Press button to turn the tuner on.
 2 Press the button to select one of the FM or MW bands.

→ FM1 → FM2 → FM3 → MW1 → MW2 →

3 Use the seek buttons to set the desired frequency. There are two ways to adjust the frequency, as explained below.

"ST" appears on the display when a stereo broadcast is received.

(1) Seek Tuning
 Press the button and check that "SEEK" has appeared on the display.

Press this button to move to lower frequencies. Tuning stops automatically when a station is found.
 Press this button to move to higher frequencies. Tuning stops automatically when a station is found.

Tuning will not stop at stations whose signals are weak. To tune in such stations, use manual tuning.

- Press the button to search for only stations with strong signals when tuning in the seek mode.

(2) Manual Tuning
 If "SEEK" is displayed on the display, press the button to turn it off.

The frequency decreases in steps of 50 kHz for FM and 9 kHz for MW each time this button is pressed.

The frequency increases in steps of 50 kHz for FM and 9 kHz for MW each time this button is pressed.

Presetting of 18 FM Stations and 12 MW Station

18 FM stations, and 12 MW stations can be preset at buttons 1 to 6 then tuned in directly.

Example: Preset 102.5MHz at preset button 1 for FM1:

1 Tune in FM1 102.5MHz using the seek tuning or manual tuning method.

2 Press preset button 1 () and hold it in for at least two seconds.

3 After about two seconds, a "beep" is heard.

4 "CH1" appears on the display. The station is now preset in the memory.

Use this procedure to store other stations. To tune in preset stations directly, simply press the button at which the station was stored.

16

Using the Automatic Memory System

Use this function in areas where you do not know the frequencies of stations to automatically find stations and store them at the preset buttons.

The stations are automatically stored at the FM3 and MW2 bands, so if you store the stations you normally listen to at the FM1, FM2 and MW1 bands, this function lets you quickly find stations in different areas without clearing the stations you normally listen to.

1 Use the and buttons to select the frequency from which you want to start searching.

2 Press the button and hold it in for at least 2 seconds.

3 "A.MEMO" appears on the display. The band automatically switches to FM3 for FM, MW2 for MW, and the stations are stored in order at preset buttons 1 to 6.

4 Once the stations are stored for the FM3 (MW2) band, the "A.MEMO" indicator turns off.

5 Use the button to switch back to the FM1, FM2 or MW1 band.

NOTE:

- Stations can also be stored manually for the FM3 and MW2 bands. However, when the automatic memory function is used, these stations are replaced by the new stations.
- If there are fewer than six stations with good reception, the number of the last preset button at which a station was stored is indicated on the display.
- In rare cases, it may happen that no stations are stored when the automatic memory function is used, due to poor reception conditions, etc.

Presetting Scanning

This function lets you check the stations stored at preset buttons 1 to 6.

Press the button for at least 2 seconds.
 The stations are received in order for 5 seconds each.

Mono Function (Auto/Mono Selection)

This function is used at the time of FM reception when the stereo broadcast is hard to hear or when there is noise interference. It changes the stereo reception to monaural.

Press the button for more than 2 seconds.

- Even when this function is used, there are occasions when the sound is not improved, depending on the reception conditions.

17

(Europe Version)

Using the RDS (Radio Data System)

- The RDS functions are for the FM band only, and will only work on stations that are broadcasting with the RDS service.
- Not all RDS stations offer all the RDS services listed on the previous page. Some RDS stations may only provide some of the RDS services.
- The RDS functions may not work properly when the reception is poor.

RDS Search

Use this function to automatically tune in stations with RDS broadcasts.

- 1 Press the **1** button and select the FM1, FM2 or FM3 band.
- 2 Press the **6** or **7** button to automatically search for stations with RDS broadcasts. When an RDS station is tuned in, the station's name appears on the display.

<Notes on RDS Search Function>

This button has a slightly different function if the PTY or TA function is switched on.

PS (Program Service Name) Function

Displaying the PS (Program Service Name) on the LCD

- 1 Tune in the disired RDS station.
- 2 After the frequency of the station being received appears on the display, the display switches to the PS (Program Service Name).

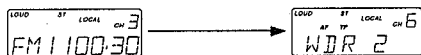

- 3 To check the frequency of the station being received, press the **8** button and hold it in for two seconds. The display changes to the frequency. Three seconds later, the PTY code appears, and another three seconds later, the PS reappears.

<Notes on Using the PS Function>

- The PS (Program Service Name) is not displayed if the station being received is not an RDS station or if its signals are weak.

18

PTY (Program Type) Function

Use this function to automatically tune an RDS station broadcasting a certain type of program.

- 1 Press the **1** button and select the FM1, FM2 or FM3.
- 2 Press the **10** button twice, and check that the "PTY" indicator has appeared on the display.
- 3 Press the **10** button for at least two seconds and check that the indicator on the display has started to flash. (The program type mode is selected.)

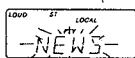

- 4 Press the **11** or **12** button to select the type of program.

- The program type changes each time the **11** or **12** button is pressed.
- See the list of the program types which can be selected.
- 5 Press the **6** or **7** buttons.
- 6 An RDS station of the type you have selected is automatically tuned in.
- "PTY SEEK" and the selected program type are displayed alternately while a station is being tuned in.
- It is not possible to tune in stations broadcasting the type of program you have selected but not offering RDS services, or RDS stations which do not offer the PTY service. At this moment a "beep" sound is heard.

List of PTY Program Types

DISPLAY	PROGRAM TYPE	DISPLAY	PROGRAM TYPE	DISPLAY	PROGRAM TYPE
NEWS	News	CULTURE	Culture	LIGHT M	Light Music
AFFAIRS	Current Affairs	SCIENCE	Science	CLASSICS	Serious Classical
INFO	Information	VARIED	Varied	OTHER M	Other Music
SPORT	Sport	POP M	Pop Music	NO RDS*	No Program type**
EDUCATE	Education	ROCK M	Rock Music	NO PTY*	No Program type*
DRAMA	Drama	M.O.R.M.	M.O.R. Music		

*Cannot be selected in the program type selection mode.
 **The station being received is not an RDS station or its signals are weak.



(Europe Version)

PTY (Program Type) Function



- Tuning in RDS stations broadcasting a certain type of program using the preset buttons:

If you have already entered an RDS stations in a preset memory, the unit will remember what the PTY of this station is, and will allow you to tune in another RDS station broadcasting the same PTY code.

Example: If you already have a "NEWS" station entered in preset 4, and you want to find another "NEWS" station:

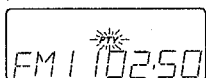
- 1) Push  button.
- 2) Make sure that PTY mode is selected and shows on the display. (If it is not, push the  button until "PTY" is shown on the display)



- 3) Push the preset 4  button to tune in a "NEWS" stations.
- 4) Then push the  or  buttons. The unit will search for another RDS station with the "NEWS" PTY code.

Emergency Program Reception Function

If the unit receives an Emergency code, "ALARM" appears on the display and beep tone is heard.

During an emergency broadcast, the volume on the unit will turn up even if the volume knob is set to the minimum. Also, if the unit is in the CD mode, the unit will automatically switch to the radio, indicating an emergency. Follow the instructions being broadcast.

- This function will only work when receiving RDS stations (stations with program service names). In addition, it may not work properly if the signals of the station being received are weak.
- This function will only work during actual emergency broadcasts, and will not work during tests of the emergency broadcast system.

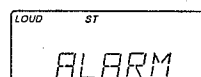
**RDS Emergency Alert Feature**

The RDS Emergency Alert Feature is activated by a signal sent at the sole discretion of the RDS broadcaster. The RDS Emergency Alert Feature is included in this product for the convenience of the consumer, and is not intended to augment or replace the Official Emergency Broadcast System as administered by the Federal Communications Commission. For this reason, Nippon Columbia Co. and its Subsidiaries, refuse all Warranties, claims of mer-

chantability or fitness, or liabilities, whether incidental, consequential or otherwise, related to, either directly or indirectly, the operation or lack of operation of this feature. This exclusion applies to any and/or all Nippon Columbia Co. Products, whether present or future, that implement, in any form or variation, the RDS Emergency Alert Feature.

20

AF (Alternative Frequency) Function

To constantly receive RDS stations broadcasting the same program on multiple frequencies





- 1) Tune in the desired RDS station.
- 2) Press the  button until "AF" appears on the display.
 - When the signal strength of the station being received becomes weak, "AF" flashes on the display, and the unit searches for another station that is broadcasting the same program based on the AF code list.
 - The frequency changes if another station broadcasting the same program is found.

Storing the AF lists and PI codes in the preset memory

- 1) Tune in the desired RDS station.
- 2) Press the preset memory button (M1 to M6) at which you want to store that station and hold it in for at least 2 seconds.
- 3) Press the  button until "AF" appears on the display.
- 4) When a preset button at which the AF list or PI codes was stored is pressed, the AF or PI search operation is performed automatically. The stored broadcast stations and broadcast stations carrying the same content are searched for based on the AF list.

<Notes on Using the AF Function>

- 1) With the AF function, the AF button is pressed and stations broadcasting the same program as the station currently being received are searched for based on the AF list. The AF list includes stations broadcasting the same program. If no receivable station is found when the list is checked through 10 times, stations are searched for using the PI codes (codes for stations broadcasting the same program) and a beep tone is sounded. This operation is then repeated. Thus, in areas far from the broadcasting stations, the alternative frequency function may not work.

- 2) When presetting, both the program name, PI codes, AF list and PTY code are stored along with the station's frequency for buttons M1 to M6 on the FM band.
- 3) The sound may be interrupted once ever 10 seconds after the  button is pressed while the station with the best reception is being searched for based on the AF list. This is not a malfunction.
- 4) "AF LEV n" (n = 0 to 7) appears on the display if the  button is pressed for over 2 seconds. Now use the  and  buttons to change the value of "n" and the strength of the signals at which the alternative frequency function will begin operating. The lower the value of "n", the weaker the signals of the station being received must be before the AF function begins operating.

21

23

(Europe Version)

AF (Alternative Frequency) Function

- 5) "AF" flashes on the display if the signals of the station being received become weak and the data cannot be identified.
- 6) The AF function may not work properly for RDS stations which do not transmit AF lists.

TA (Traffic Announcement) Function

Searching for TP (Traffic Program) broadcast stations automatically

- 1 Press the button and select FM1, FM2 or FM3.
- 2 Press the button. "TA" appears on the display.
- 3 Press the or buttons.
- 4 Tuning automatically stops at an RDS station broadcasting traffic information. "TP" appears on the display and the TP station is received.

<Notes on Using the TA Function>

If the station currently tuned in provides the EON (Enhanced Other Network) service, traffic announcements broadcast by other stations can be heard while listening to current station in the TA mode. (The EON service is not offered in some areas.)

Setting the volume when a TA (traffic information announcement) starts while in standby (on FM1, FM2 or FM3)

- 1 Press the button and select FM1, FM2 or FM3.
- 2 Press the button. "TA" appears on the display.
- 3 Press the or buttons.
- 4 Tuning automatically stops at an RDS station broadcasting traffic information, or a station providing the EON service with which traffic information broadcast on other stations can be heard and that station is received.
- 5 When a traffic announcement begins, the volume is set to the level at which it was set the last time a traffic announcement was received (the TA level). "TA VOL" appears on the display if the volume is adjusted at this time.
- 6 The TA level can be changed by changing the volume when traffic information is being broadcast. Also, when the next traffic information is tuned in, it is played at the previously set volume level.
The TA level can be adjusted even when not receiving a traffic announcement. (See Page 15.)
- 7 The volume returns to the original level once the traffic announcement is over.

TA (Traffic Announcement) Function

Automatically listening to traffic information announcements while playing a CD.

- 1 Press the button. "TA" appears on the display.
 - 2 Press the or buttons to tune in the desired TP station.
 - 3 Insert CD or press the button and start playing CD.
 - 4 Use the control knob to adjust the volume of the CD.
- When the traffic information announcement starts, CD play is set to the pause condition and the set automatically switches to the traffic information.

<NOTE: Cancelling the traffic announcement>



The mode automatically switches when a traffic announcement starts. To cancel the traffic announcement and return to the previous mode, press the button. "TA" disappears and only the traffic announcement is cancelled. A beep tone is sounded once at this time.

<Notes on Using the TA Function>



- 1) With the TA function, the TA button is pressed and stations broadcasting the same program as the station currently being received are searched for based on the AF list. The AF list includes stations broadcasting the same program. Thus, in areas far from the broadcasting stations, the alternative frequency function may not work.
- 2) A beep tone is sounded if there is no station broadcasting a Traffic Program or if its signals are weak. If this happens, press the button again so that "TA" disappears from the display, then wait until entering an area in which a station broadcasting TPs can be received and press the button again, then press the or buttons to tune in a traffic information station, or a station providing the EON service with which traffic information broadcast on other stations can be heard.
- 3) "TA" flashes on the display if the signals of the station being received become weak and the data cannot be identified.
- 4) Some stations broadcast TA (traffic announcement) signals even when they are not broadcasting traffic information announcements. In such cases, the TA function will not work properly.

(Europe Version)

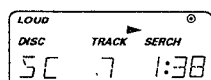

Listening to Compact Disc (Single CD or CD changer)

- 1  Button
Pushing this button will start the CD play.
The "▶" sign and the currently playing disc number, track number and track time will be displayed on the display. Pushing this button once again will stop the CD play.
- 2 When the  button is pressed, the CD is ejected from .
 - If no disc is loaded in the set, "●" appears on the display.



**Disc Change (Please connect CD Changer)**

- 3 Pushing the  button will advance the unit to the next disc and start the play from the first track.
 - 4 Pushing the  button will return the unit to the previous disc and start the play from the first track. The number of the changed disc is displayed on the display.
- See page 14 for instructions on switching from a single CD to the changer and a description of the display.

Searching for the Desired Track**(1) Automatic Search**



- 1 Pushing the  button will display "SEARCH" on the display and set the unit to the automatic search mode.
 - 2 Pushing the  button will find the beginning of the next song and resume play.
 - 3 Pushing the  button will return to the beginning of the song in play, and resume play.
- The track numbers of the songs being searched will be displayed on the display.

(2) Manual Search



- 1 Pushing the  button will set the manual search mode and the "SEARCH" display on the display will go out.
 - 2 Continuing to push the  up button will fast forward the disc.
 - 3 Continuing to push the  down button will fast reverse the disc.
- At this time the sound can be heard at a lower volume than during regular playback.

24

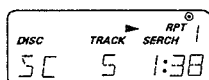

Repeat Play**(1) One track**

- 1 Press the  button once. "RPT 1" appears on the display, and the track which is currently playing is played repeatedly.
Use this to play a single track repeatedly.
- To cancel the repeat function, either press the  button twice, or press another CD control button.

**(2) One disc (Please connect CD Changer)**

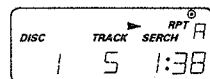
- 1 Press the  button twice. "RPT A" appears on the display, and the entire disc which is currently playing is played repeatedly.
Use this to play one CD repeatedly.
- To cancel the repeat function, either press the  button once, or press another CD control button.
 - If no CD changer is connected, the same disc is played repeatedly even if the repeat button is not pressed.



**Intro Scan**

- 1 Press the  button. "IS" appears on the display, and the first 10 seconds of each track is played.
Use this to search for a certain track.
- To stop the intro scan function, either press the  button again, or press another CD control button.



- This function only scans the currently playing disc.

Disc Scan (Please connect CD Changer)

- 1 Press the  button. "DS" appears on the display, and the first 10 seconds of each disc (the first track) is played.
Use this to search for a certain disc.
- To stop the disc scan function, either press the  button again, or press another CD control button.



- This function scans the in-dash CD single disc and all discs in the CD changer.

25

25

(Europe Version)

Random Play

(1) One disc

- 1 Press the button once. "RND 1" appears on the display, and the tracks on the disc which is currently playing are played in random order.
 - 2 To move to the next track (selected in random order) when in the middle of a track, check that "SEARCH" is displayed on the display, then press the button.
- To cancel the random play function, either press the button twice, or press another CD control button.
 - "RND" is displayed if no changer is connected.



(2) All discs (Please connect CD Changer)

- 1 Press the button twice. "RND 2" appears on the display, and all the tracks on all the discs are played in random order.
 - 2 When the button is pressed, during the automatic search mode (when "SEARCH" is displayed on the display), a randomly selected track on a randomly selected disc starts playing.
- To cancel the random play function, either press the button until "RND 1", or "RND 2" disappears, or press another CD control button.



- With this function, only the discs in the CD changer are played in random order.

Error Displays

If any of the following error displays are shown on the display when the unit is operated, carry out the measure indicated in the table.

Error display	Cause of error	Measure
NO MAG.	The disc magazine is not inserted in the changer.	Insert a disc magazine that has been loaded with discs into the changer.
NO DISC	Discs are not loaded in the disc magazine.	Remove the disc magazine and load the discs.
ERROR	Troubleshooting	Push the DCT-950R reset switch.
HOT	The temperature protection circuit of the DCH-700/600/500 has operated.	Wait until the temperature drops.
DISC REV	All of the discs in the magazine are upside-down or dirty.	Set the discs properly or wipe off the dirt.
SC HOT	The temperature protection circuit of the CD Mechanism has operated.	Wait until the temperature drops.

Time Adjustment

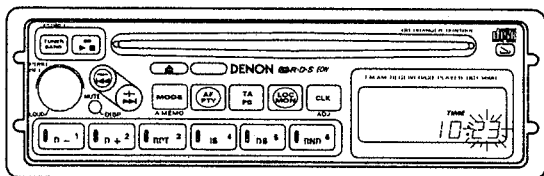

Time display: Pressing the button provides a time display for about 5 seconds.

1. Automatic adjustment

- The clock is automatically adjusted by the RDS CT (Clock Time) function.
- If the button is pressed after the clock has been adjusted with the CT function, "CT" is displayed in front of the time display.

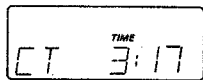

- The clock may not be properly adjusted when receiving stations from areas in different time zones.
- Some RDS stations do not offer the CT service.
- Automatic adjustment may not be possible when reception is poor due to the inability to receive the CT code.
- To use the automatic clock adjustment function, the unit has to be tuned to an RDS radio station for an average of 30 seconds before using this feature.

2. Manual adjustment (only operates in the OFF mode)

- 1) When the button is pressed for more than 2 seconds, the back light and display turn on.
- 2) Adjust the Hour setting with the or buttons.
- 3) Press the button. The Minute display will flash and the minute adjustment mode will be set.
- 4) Adjust the Minute setting with the or buttons.
- 5) Press the button again. The time will start advancing from the adjusted time setting.

Note:

- The time is displayed with a 12-hour display; there is no A.M. or P.M. indication.
- The time cannot be adjusted manually when the set is operating.

Telephone Mute

1. When terminal is connected to a car telephone, the volume is automatically decreased when a call is received.
- "TEL MUTE" appears on the display.
 - The volume returns to the previous level when the telephone is hung up.

Note: There is a possibility that the telephone mute function will not operate with the telephone that is used. In view of this, please be sure to discuss this matter with the installer or the service representative when you have decided to install a telephone.

(Europe Version)

Reset Switch

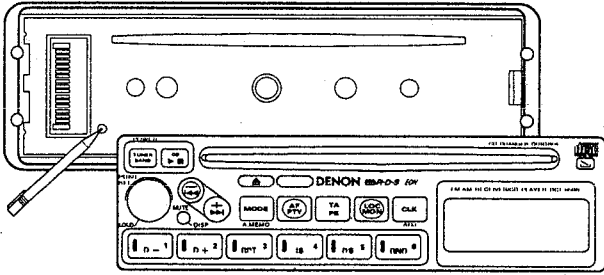

1 Reset Function

Press the release button and remove the panel. Press the reset switch using the tip of a ball-point pen, etc., when the power supply is first connected or when the display malfunctions due to external interference.

NOTES:

- Everything stored in the memory, including the stations stored at preset channels M1 to M6, is cleared when the reset switch is pressed. The time is also reset to 12:00.
- Do not press the reset switch with a sharp object, such as a metal pin.
- If the problem persists after the reset switch is pressed, contact your Denon dealer or a local Denon service center.

28

Cleaning

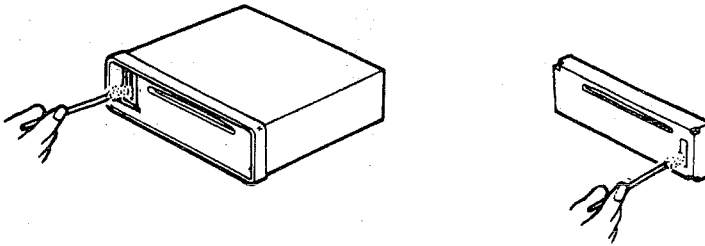

There may be a poor connection at the connector on the panel or on the set if the unit is frequently detached. Periodically wipe the connectors with a cotton swab moistened with alcohol.

* Always turn the car's accessory power supply off when cleaning.

29

27

(Europe Version)

• WIRELESS REMOTE CONTROL (OPTION)

The accessory remote control unit RC-436 is used to control DCT-950R from a distance.

1. Loading the Dry Cell Batteries

(1) Remove the rear cover on the remote control unit.

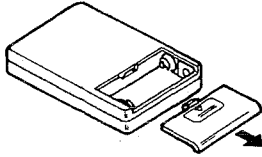

(2) Load two R03 (standard size AAA) dry cell batteries as shown in the diagram inside the battery compartment.

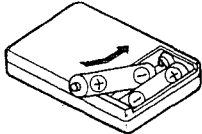

(3) Replace the rear cover.

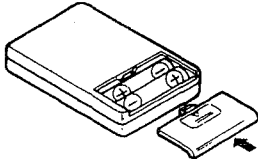

Battery Precautions

- The remote control unit uses R03 (standard size AAA) dry cell batteries.
- The batteries will need to be replaced approximately once a year. This will depend upon how often the remote control is used.
- If the remote control will not operate the In-dash player even if held at very close distance, exhausted batteries may be suspected. Replace the batteries with new ones.
- Load the batteries properly according to the illustration inside the battery compartment. Align the battery polarity (+ and -) correctly.
- Batteries are prone to damage and may start to leak. Therefore:
 - Do not combine new batteries with used ones.
 - Do not combine different types of batteries.
 - Do not jumper the opposite poles of the batteries, expose them to heat or break them open.
 - Do not dispose of used batteries in open fire. Obey local regulations on battery disposal.
- When the remote control is not to be used for a long period of time, remove the batteries from the unit.
- If the batteries have leaked, remove any battery fluid from the inside the battery compartment by wiping it out thoroughly. Then load new batteries.

30

2. Directions for use

- Operate the remote control unit while pointing it at the remote sensor on DCT-950R, as shown in the diagram below.

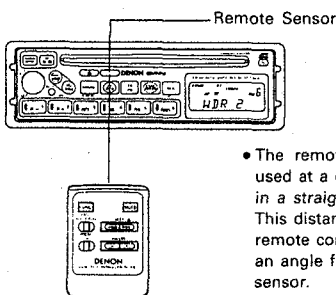

• The remote control unit can be used at a distance up to 6 meters in a straight line from DCT-950R. This distance decreases when the remote control unit is operated at an angle from the remote control sensor.

- Point the remote control unit at the remote control sensor when operating it. DCT-950R may not function if there are obstacles between remote control unit and the remote control sensor, so operate the remote control unit from directly in front of DCT-950R.

Operation Precautions

- Do not press the operation buttons on DCT-950R and the remote control at the same time. This will cause miss operation.
- Remote control operation may be impaired if the Remote Sensor on DCT-950R player is exposed to strong light (for example, direct sunlight)

3. CONTROLS

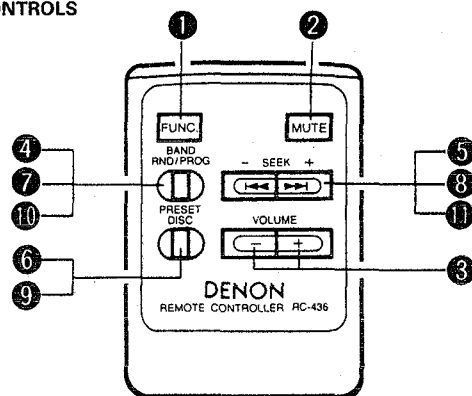

• MAIN CONTROL

① FUNCTION button

This button permits switching between tuner and CD.

TUNER ↔ CD

Pressing this button when DCT-950R is off will switch on the tuner. This switch does not have an off function.

② MUTE button

Pressing this switch causes muting, reducing the sound volume. "MUTE" flashes on the display when the MUTE button is pressed. Pressing the button again cancels the display.

③ VOLUME button

Press the button to increase the volume.

Press the button to decrease the volume.



(Europe Version)

● RADIO CONTROL

④ BAND SELECT button

This button changes the band. (See Page 16.)

⑤ SEEK TUNING button

 button and  button provide seek tuning in the direction of a higher frequency and a lower frequency, respectively. (See Page 16.)

⑥ PRESET button

This button changes the channels (CH) of the preset memory. This button changes the channels in the order of CH 1 → CH 2 → CH 3...

● CD CONTROL

⑦ RANDOM button

Pressing this button provides random playback.



1) For single CDs

When this button is pressed, the mode switches between random and normal play (off).

2) For a changer

Each press of this button advances the changer in the sequence of RND 1 → RND 2 → Normal Play (OFF). (See Page 26.)

⑧ AUTOMATIC SEARCH button

Pressing the  button provides an automatic search to the next track, whereas pressing the  button provides an automatic search to the beginning of the track currently being played. (See page 24)

⑨ DISC CHANGE button

Pressing this button changes the disc in the direction of a larger disc number. (See page 24)

Notes:

- The remote control unit will function from a distance of approximately 6 meters directly in front of the remote sensor.
- The distance from which the remote control unit will function will decrease if it is operated from an angle.
- The remote control unit may not function if there is an obstacle between it and the remote sensor.
- The distance from which the remote control unit will function will decrease if the batteries are worn.
- The DCT-950R does not include a programming function.

32

SPECIFICATIONS

FM TUNER

- Mono Usable Sensitivity 11.4 dBf 1 μV (75 ohms)
- 50 dB Quieting Sensitivity 20.3 dBf 2.8 μV (75 ohms)
- Alternate Channel Selectivity 100 dB
- S/N (Signal to Noise Ratio) 70 dB
- Stereo Separation 40 dB at 1 kHz
- Capture Ratio 2.5 dB

AM TUNER

- Sensitivity 30 μV (S/N 20 dB)

CD

- Frequency Response 5 Hz ~ 20 kHz ± 1.0 dB
- Dynamic Range 96 dB
- Signal to Noise Ratio 96 dB
- Harmonic Distortion 0.005%
- Wow and Flutter Below a Measurable level

DISC

- Applicable Disc Compact Disc

SIGNAL FORMAT

- Sampling Frequency 44.1 kHz
- Quantization 16 Bit Linear
- Transfer Bit Rate 4.3218 Megabits/sec.

GENERAL

- Power Output *1 14 W × 4 ch at 1 kHz with 10% THD
- Power Output *2 10 W × 4 ch from 20 Hz to 20 kHz with 0.8% THD
- Output Voltage – Pre-amp level 2.2 V/10 k ohms
- Bass ±12 dB at 40 Hz
- Treble ±12 dB at 15 kHz
- Loudness (Vol. –30 dB) +8 dB at 100 Hz
+8 dB at 10 kHz
- Remote Output 12 V 300 mA max.
- Power Antenna Output 12 V 300 mA max.
- Chassis Size (W × H × D) 178 mm × 50 mm × 172 mm (7-1/64" × 2" × 6-25/32")
- Panel Size (W × H × D) 187 mm × 59 mm × 23 mm (7-23/64" × 2-21/64" × 29/32")
- Weight 2.0 kg (4 lbs 6 oz)

*1 Power Output is per channel minimum continuous average power into 4 ohms, both channels driven, at 1 kHz, with no more than 10% total harmonic distortion.

*2 Power Output is per channel minimum continuous average power into 4 ohms, both channels driven from 20 Hz to 20 kHz, with no more than 0.8% total harmonic distortion.

Design and specifications are subject to change for improvement without prior notice.

CIRCUIT DESCRIPTIONS

RDS (Radio Data System)

RDS is a new FM-broadcasting system, which is promoted by European Broadcasting Union (EBU) in Europe and by National Radio System Committee (NRSC) in U.S.A.. Inaudible control signals are transmitted with the subcarrier to automatize FM reception and maximize operating ease. With RDS, the tuner can display the call name of the currently received station or search automatically for the strongest transmitter signal with the same or any specified program. These features are highly useful also for receiving traffic information or ensuring optimum reception in a car.

● Main specifications of RDS

Data rate	1,187.5 bps
Signal format	(26,16) modified shortened cyclic code
Baseband signal format	Differential phase shift keying (DPSK)
Subcarrier frequency	57 kHz
Subcarrier frequency modulation	Double Side Band Suppressed Carrier Amplitude Modulation
Maincarrier frequency deviation	±2 kHz

● Data channel

Data channel employs 57 kHz band to minimize interference to programme band. RDS signal is a signal with bit rate of 1,187.5 bps. modulated by differential phase shift keying (DPSK). This signal comprises the composite signal and an additional signal with subcarriers of 57kHz modulated in amplitude by double side band suppressed carriers.

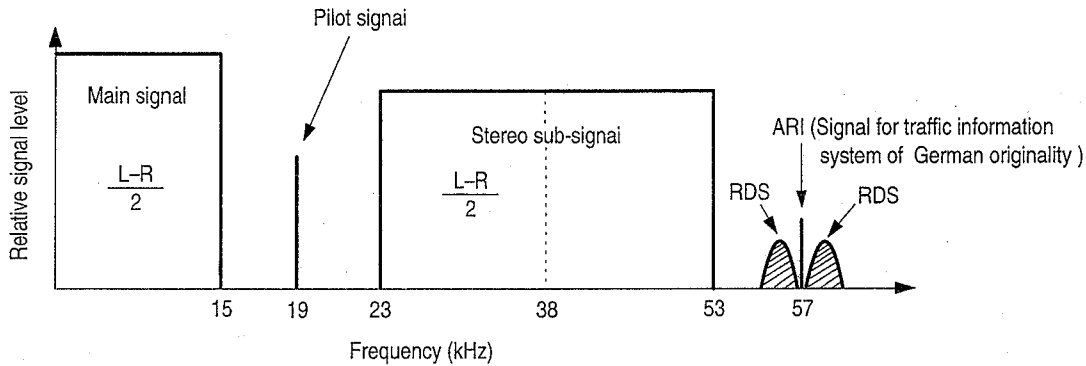

● Data Format

All data are transmitted in a group unit which comprises 104 bit. The 104 bit unit comprises 4 block, which format 26 bit block respectively. Each block comprises 16 bit information words and 10 bit check words. Data in each block are specified depending on the situation: The first 16 bit of the first block is always the program identification (PI) code, the first 5 bit of the second block is a group-type to clarify the group application, the next 1 bit is Traffic Program Identification (TP) code, and the following 5 bit is Program Type (PTY) code. Each contents of data is specified for remainder of the second block, the third and fourth block data respectively. Group type comprises 32 types of 0A-15B, which transmit different contents in each group respectively. Group 0A has a role of basic tuning function, and therefore is transmitted most often.

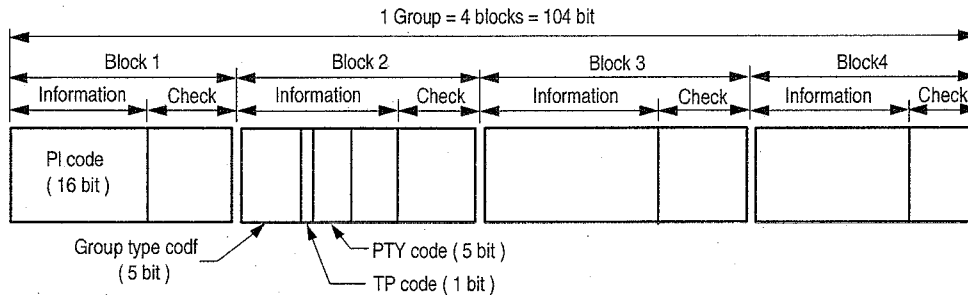

PI: Program Identification Code (Country identification, Area coverage, Programme reference number)
 TP: Traffic Program Identification Code.
 PTY: Program Type Code (News, Sports, Classical, Rock)

RDS Control

1. Signal Flow (Refer to Block Diagram)

Picks up RDS signal from the output of FM IF IC (IC403/LA1862M) through C302 (100P). Inputs this signal to RDS decoder IC301 (SAA6579T) for decoding, further, inputs this signal to synchro correction IC IC302 (LC7074NM) to demodulate RDS data, thus RDS data will be demodulated.

RDS data as in form of serial data consists of RDS START, RDS CLK, and RDS DATA is emitted from IC302 and applied to system control microcomputer IC901 (μ PD78056). This IC901 performs DCT-950R related all controls of LCD indication, control of CD changer, etc. besides control of RDS. RDS data will be memorized in internal RAM of IC901 and in IC903 (LC3517AML) of external RAM.

2. PS Function: Program Service Name

A function to indicate a name of broadcast station being received on the LCD by PS code in BLOCK 4 of Group 0A. Also, functions to indicate on the LCD when PS code is received through the continual check of PS code without relying on "AF/PTY" key or "TA" key if it is FM BAND.

3. AF Function: Alternative Frequencies (frequency list of stations broadcasting the same program)

An automatic searching function, i.e. when reception condition of RDS station being received becomes poor for some reason, or in case a station being received comes into out of service area and makes no reception as receiving is carried out on the moving vehicle, shifts to a station broadcasting the same program. The automatic searching function only performs at the time "AF/PTY" key ON or "TA" key ON state, on the other hand PI code or AF code is continually checked in FM BAND.

4. TA Function: Traffic Announcement

A function at the time TA code of 12th bit in BLOCK 2 of group 0A becomes ON, it automatically shifts the voice to RADIO and listen to traffic announcement even if the voice of cassette or CD changer is in output state. At the same time, sound volume will also be boosted however the volume is set at minimum that can be feasible to listen to the traffic announcement. Note that TA function is only effective in "TA" key ON state.

5. CT Function (Clock time)

CT-code is transmitted using Group 4A. CT-code is generally sent from broadcast station one time per one minute.

When receiving RDS broadcast transmitting CT-code, clock can be automatically adjusted by pressing "CLK" key for 2 seconds.

6. Search Function

1) AF Search

AF search performs automatic search as mentioned in "Paragraph 3. AF Function", also performs the optimum reception searching (to select best receiving condition station among the same PI code broadcast stations) at the time RADIO ON, shifting from AM, to FM BAND, or at preset call, etc.

The latter one is called AF Search (A) and the former one is called AF Search (B).

AF search (B) will function when field strength has reached less than certain level (this level is adjustable by VR 404, or RDS data is unable to receive for 10 seconds (*), or the same PI code is unable to receive for 10 seconds. Also, AF search (B) stops searching when RDS code is enable to receive and at the time searches the same PI code station, then shifts the receiving station. The both AF search (A) and (B) return to the receiving station searching has started when an appropriate station which satisfies the conditions is unable to find in one round search.

(*) When RDS signal is unable to receive for 5 seconds, AF indication will blink in "AF" key ON state, PTY indication will blink in "PTY" key ON state and TA indication will blink in "TA" key ON state.

Note:) When performing AF search, time constants of low pass filter of PLL circuit (TR404, 405, IC401 [TC4S66F]) are changed in order to minimize audio interruption. Thus, the time for PLL circuit to lock can be shortened. (2-mode loop filter circuit)

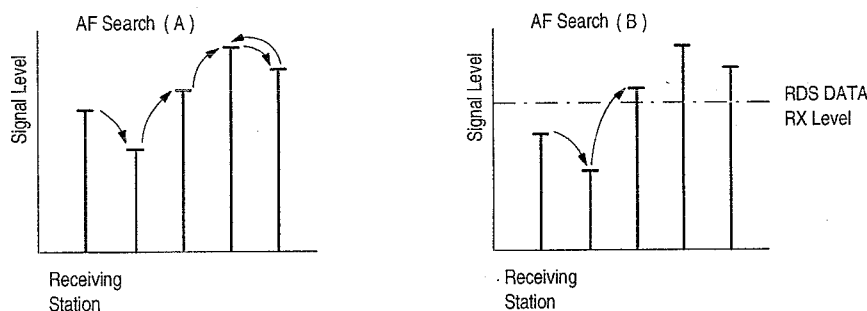



2) PI Search

When performing AF Search (A) and receives no RDS station, (**) performing AF Search (B) consecutively 10 times, and receives no RDS station, or PI code is detected however, AF code can not be read and that the performing of AF search is unable to do, then, PI Search will be performed 15 seconds later. This PI Search is Auto Seek and to search the same PI code station, and to produce a "BEEP" tone at beginning of search and indicates 'PI' preceding to the frequency display on LCD. And, when searching FM BAND for one round and can not find the same PI code station, produces a BEEP" tone gain to finish searching.



(**) For U.S.A. model, PI search cannot be performed in this case.

3) RDS Search

When  key or  key is pressed (only in SEEK mode) (For U.S.A. model, when  key is pressed), it becomes AUTO Seek, RDS Search to stop only at RDS station. At this time, preceding to the frequency display on LCD indicates 'RDS' letter. Also, in "AF" key ON state, when wholly has not received PI code or AF code by the station being received (stores no PI code or AF code in the memory of microcomputer) and RDS data (***) can not be received for 2 seconds causes to produce a "BEEP" tone and automatically performs RDS search.

(***) For U.S.A. model, RDS search cannot be performed in this case.





4) TP Search

When  key or  key is pressed in "TP" key ON state (only in SEEK mode) (For U.S.A. model, when  key is pressed), become AUTO Seek, TP Search to stop only at a station which TP code is ON in BLOCK 2 of all groups. At this time, "TP" letter will be displayed preceding to the frequency indication on LCD.

Or, when TP code can not be detected for 15 seconds in "TA" key ON state when turning ON the RADIO or becomes FM mode from AM mode and can not detect TP code for 2 seconds, or at the time a receiving station is not TP station and to turn ON "TA" key, produces a "BEEP" tone and performs TP Search automatically (For U.S.A. model, does not shift to TP search automatically).

Also, when performs TP Search for 5 rounds in BAND and can not search TP station, continually produces "BEEP" tone. This alarm tone continues until finding TP station or when it becomes "TA" key OFF state, it also continues however shifting to cassette or CD mode if "TA" key ON state remains.

5) PTY Search (Program Type)

PTY-code is transmitting 7 ~ 11 bit of BLOCK 2 of all groups. PTY-code has 16 different types (For U.S.A. model, only 24 types). Press "AF/PTY" key for more than 2 seconds, press  or  key to select desired type; then AUTO Seek can be obtained by  key or  key pressing (For U.S.A. model, when  key is pressed) and can stop at the desired typed station only.

7. EON Function (Enhanced Other Networks information) Europe Model Only

EON data are information data of station other than currently receiving from. Transmitted data are PI, PS, AF, TA, TP, PTY, and etc. of other stations. EON data are sent using Group 14A and Group 14B. By using these EON data, rewriting of contents of preset memory from time to time, and listening to traffic informations other than currently receiving becomes feasible.

8. MODE

DCT-950R has 4 modes: RDS OFF, AF, TA, PTY, and the mode will be cyclically shifted with "AF/PTY" key and "TA" key.

Key In Present Mode	AF/PTY	TA
RDS OFF	AF	TA
AF	PTY	TA
PTY	OFF	TA
TA	AF	RDS OFF

The following is the effective functions for each mode.

	PS	PTY (ONLY 31)	AF Search	PI Search	RDS Search	TP Search	PTY Search
RDS OFF	○	○	×	×	○*	×	×
AF	○	○	○	○	○	×	×
TA	○	○	○	×	×	○	×
PTY	○	○	○	×	×	×	○

*U.S.A. version only

REMOVAL OF EACH SECTION

- 1) Press release button to remove Front Panel Unit.
- 2) Insert a screwdriver into three holes and moving the screwdriver, pull up Top Cover in arrow direction.
- 3) Disassemble the CD Mechanism by means of removing 4 screws and pull out the connector from the P.W.Board.

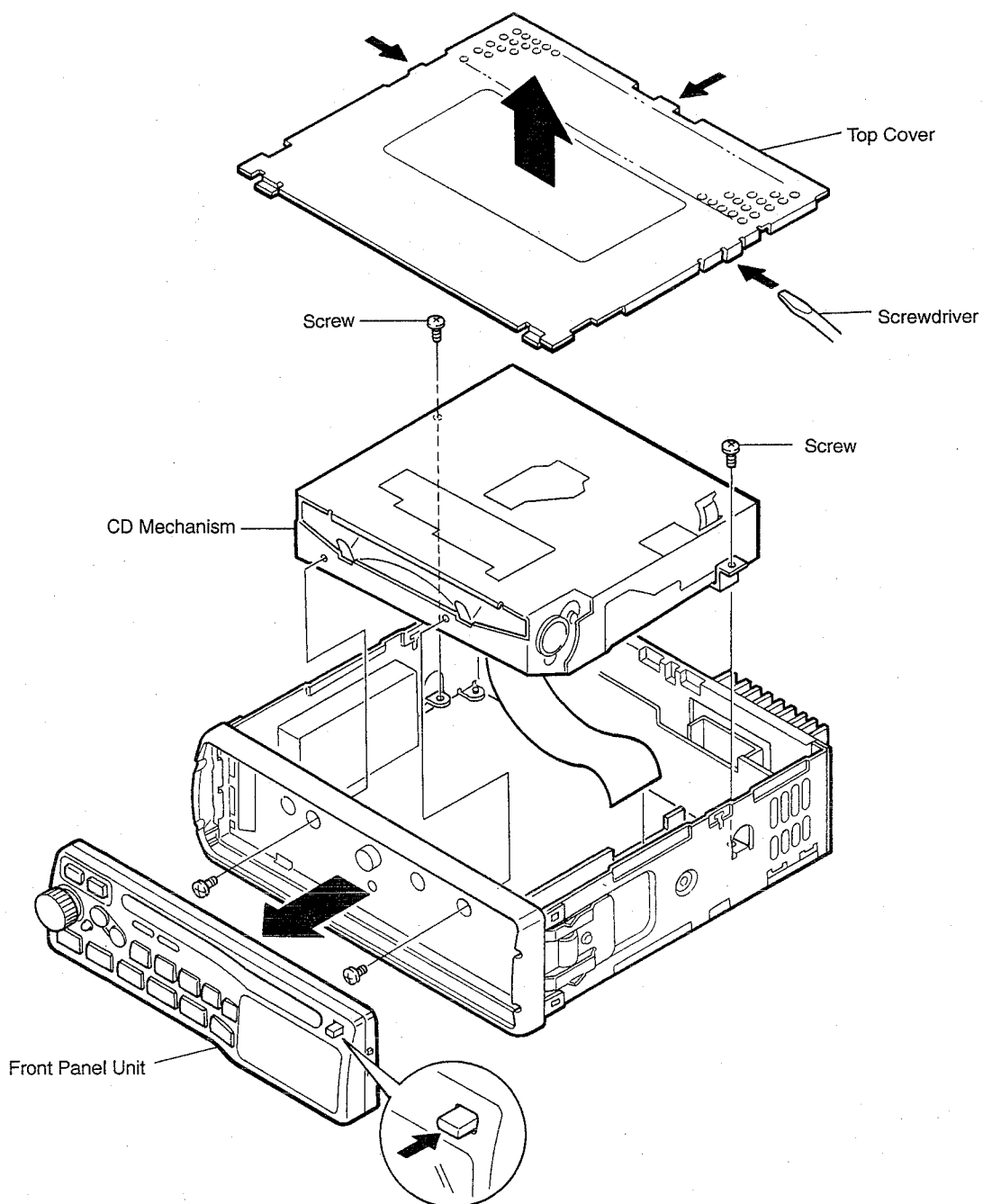

SPECIFICATIONS FOR ADJUSTMENT

● WIRING DIAGRAM

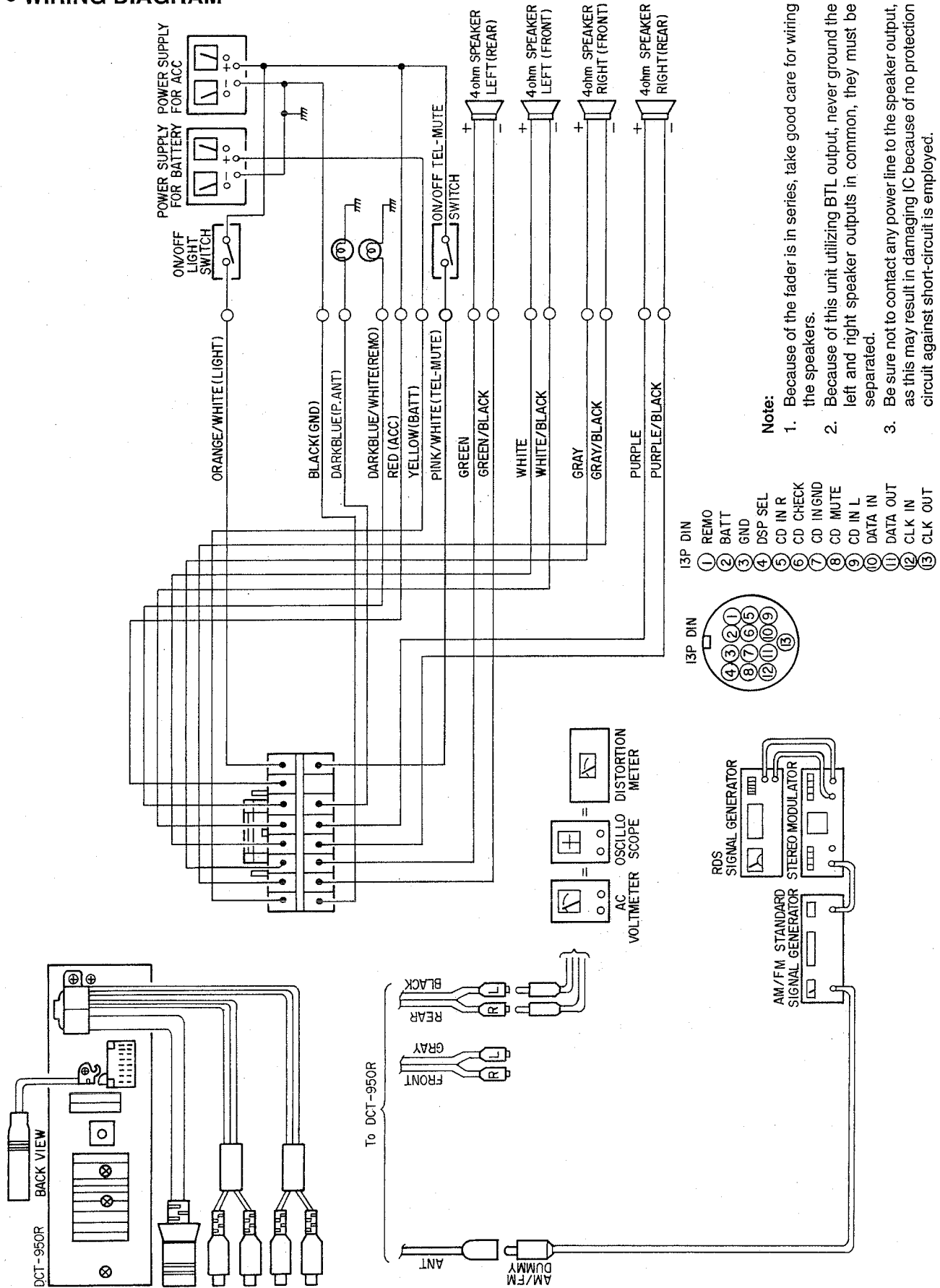

- Note:**
1. Because of the fader is in series, take good care for wiring the speakers.
 2. Because of this unit utilizing BTL output, never ground the left and right speaker outputs in common, they must be separated.
 3. Be sure not to contact any power line to the speaker output, as this may result in damaging IC because of no protection circuit against short-circuit is employed.

1. Conditions for adjustment (adjustment must be done in the following conditions)

- 1-1 Supply voltage 14.4V DC
- 1-2 Temperature Normal temperature
- 1-3 Dummy antenna Use standard dummy antenna

AM standard dummy

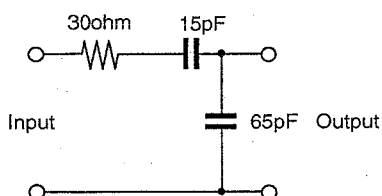

For 50ohm signal generator

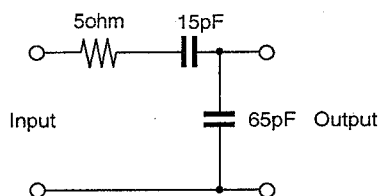

For 75ohm signal generator

Note: Input level should be read at the SG output.

FM standard dummy

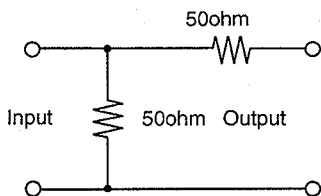

For 50ohm signal generator

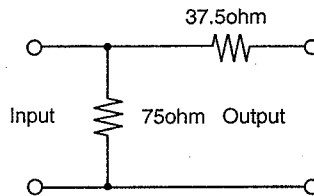

For 75ohm signal generator

Note: Input level should be read at the unit input (antenna input).

2. Setting of controls before adjustment (controls and switches must be set as follows)

2-1 Controls

- Requires semifixed resistors set at mechanical center position.
- Control knob — Set balance and fader to center, bass and treble to 0. Set volume at MAX position.

2-2 Switches

- LOUD, MUTE, MONO, AF, LOCAL, and TA, set to OFF position.

ADJUSTMENT

There is no change except undermentioned FM ALIGNMENT, FM MPX ALIGNMENT and CONFIRMATION ITEMS (Appendix.)

● FM ALIGNMENT (Confirm that the LOCAL is not indicated.)

Table 1

Step	Aligning	SG set	Tune in to	Output Connection	Adjusting Method	Remarks
1	Discriminator (FM Det Coil)	98.1 MHz 1 kHz, 75 kHz dev 60 dB μ (Ant input)	98.1 MHz	CN2A 0-center meter	Adjust T401 and obtain 0-center meter indication at 0V.	Indication should be within $0 \pm 0.05V$.
2	FM IF (Tuner Pack)	98.1 MHz 1 kHz, 75 kHz dev Low level without limiter effect	98.1 MHz	LINE Amp output to AC Voltmeter	(Adjust IFT1 for) maximum output.	Preset by the factory. Adjust only as necessary.
3	Muting	98.1 MHz 1 kHz, 75 kHz dev 60 dB μ (Ant input)	98.1 MHz	LINE Amp output to AC Voltmeter	None	Set the Line output at 0dB. -25dB (Europe Version, -35dB) over noise output by moving the SG frequency from 98.1 to 99.1 MHz.
4	Output level	98.1 MHz 1 kHz, 75 kHz dev 60 dB μ (Ant input)	98.1 MHz	LINE Amp output to AC Voltmeter	None	Set the Volume control at maximum. Confirm that LINE Amp output is within $1.25V \pm 0.25V$ (center 1.25V).
5	Auto-stop level	98.1 MHz 1 kHz 75 kHz dev 17 dB μ (Ant input)	98.1 MHz	None	Adjust VR403 and set to the range.	Select appropriate frequency point and search. Confirm that auto stop functions at $17 \pm 6dB\mu$ ANT input.

● FM MPX ALIGNMENT (Confirm that the MONO is not indicated.)

Table 2

Step	Aligning	SG set	Tune in to	Output Connection	Adjusting Method	Remarks
6	Separation	98.1 MHz 1 kHz, 67.5 kHz dev Pilot 7.5kHz dev 60 dB μ (Ant input)	98.1 MHz	L and R LINE Amp output to AC Voltmeter	Adjust VR401 and set to the range.	L and R separation becomes 25 dB over.
7	D.O.R.S. IV (Auto-blend and Auto high filter)	98.1 MHz 1 kHz, 67.5 kHz dev Pilot 7.5kHz dev 40 dB μ (Ant input)	98.1 MHz	L and R LINE Amp output to AC Voltmeter	Adjust VR402 so that the L and R separation becomes $10 \pm 3dB$.	As input 60dB μ separation occasionally changes for worse when performing adjustment, repeat adjustments Separation and Autoblend for any number of times.
8	AF Start level	98.1 MHz 1 kHz, 60.0 kHz dev Pilot 7.5kHz dev 20dB (Ant input)	98.1 MHz	TP (VSM) to DC Voltmeter	Adjust VR404 to obtain 1.5V on the DC Voltmeter	

● AM (MW) ALIGNMENT

Table 3

Step	Aligning	SG set	Tune in to	Output Connection	Adjusting Point	Adjusting Method	Remarks
9	AM IF	999 kHz (1000 kHz) 400 Hz 30% Level at no AGC effect	999 kHz (1000 kHz)	L and R Line Amp output to AC Voltmeter	IFT2 IFT3	Preset by the factory. Adjust only as necessary.	
10	Tuning Voltage		531 kHz (530 kHz) 1602 kHz (1710 kHz)			Preset by the factory. Adjust only as necessary.	
11	Tracking	603 kHz (600 kHz) 400Hz 30% Low level without limiter effect 1404 kHz (1400 kHz) 400 Hz 30% Low level without limiter effect		L and R Line Amp output to AC Voltmeter	None	Preset by the factory. Adjust only as necessary.	
12	Auto-stop level	999 kHz (1000 kHz) 400 Hz 30%	Select appropriate frequency point and search.		None	None	Indication should be within $35 \pm 8\text{dB}\mu$.
13	Output level	999 kHz (1000 kHz) 400 Hz 90% 74 dB μ (Ant input)	999 kHz (1000 kHz)	L and R Line Amp output to AC Voltmeter	None	None	Set the Volume control at maximum. Confirm that LINE Amp output is within $1.25\text{V} \pm 0.25\text{V}$ (center 1.25V).

() are U.S.A. Model

ADJUSTMENT POINT

● RADIO

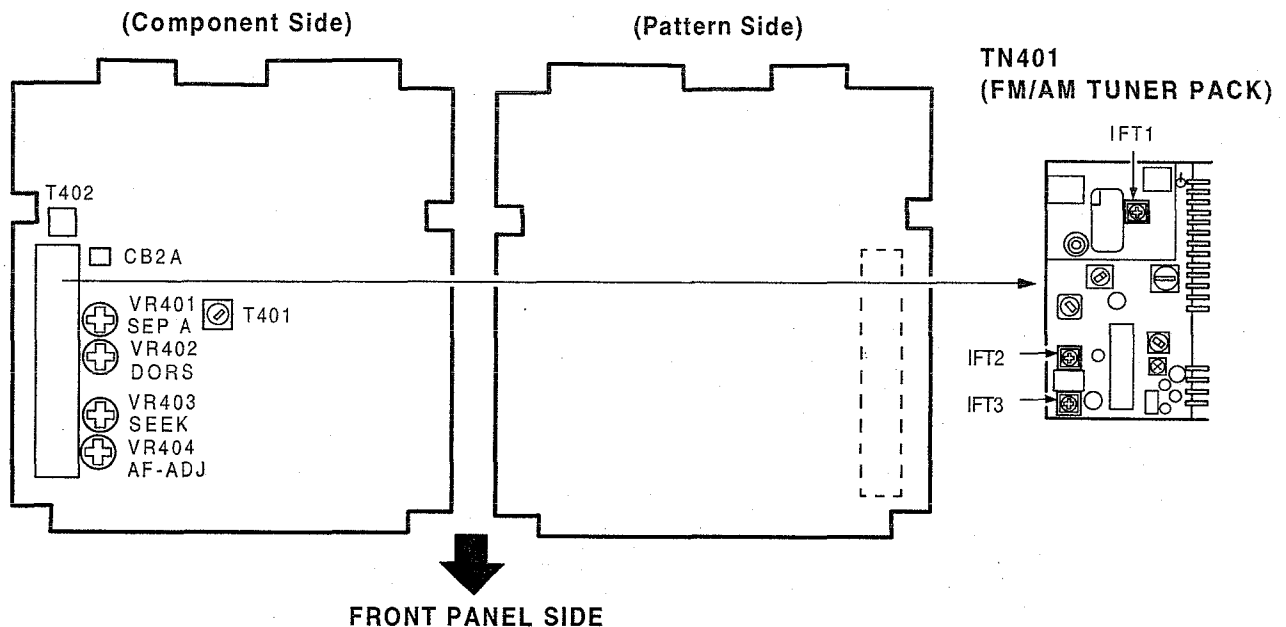

FM/AM TUNER PACK Part No. 216 0091 009

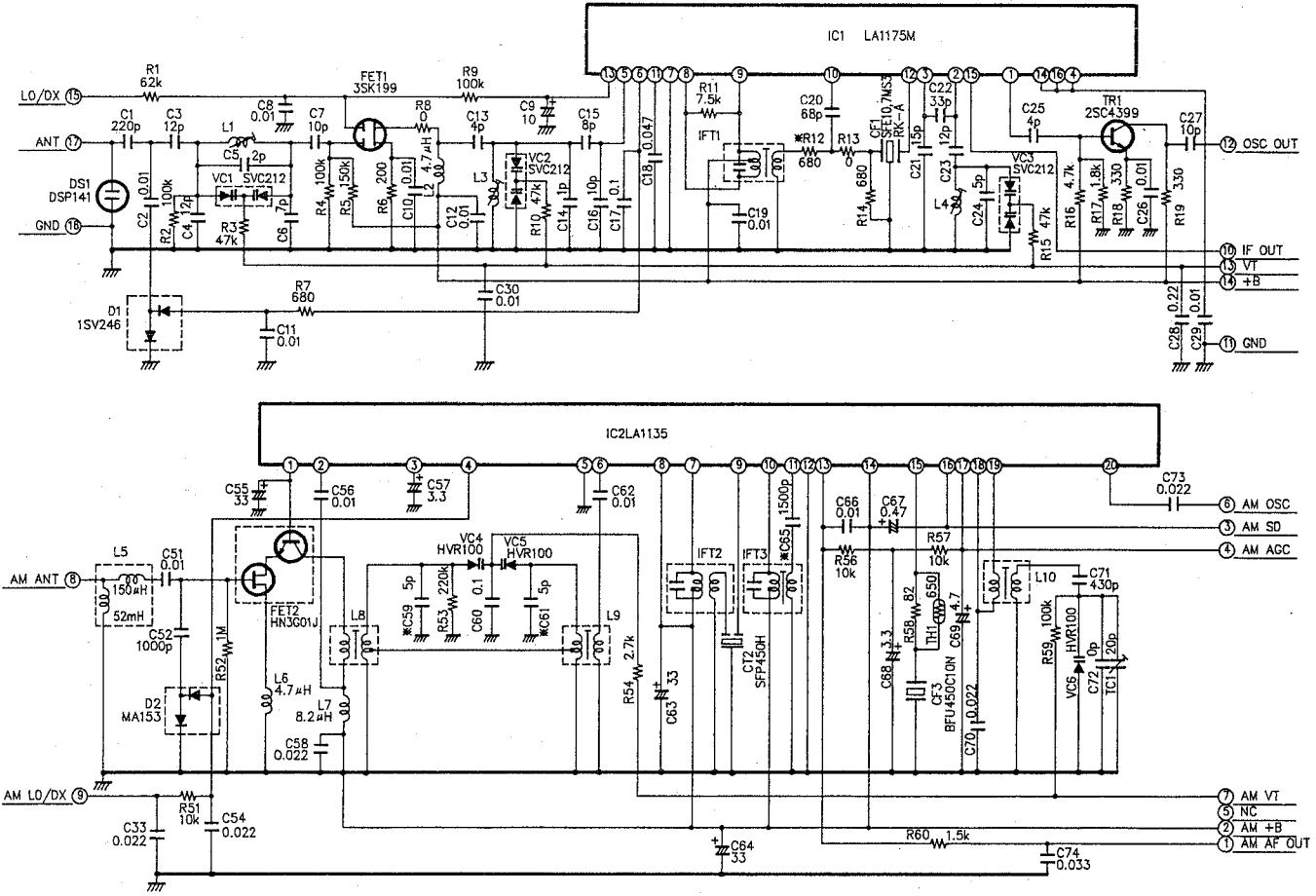

Note:
 1. CV1, 2, 3 SVC-212 (or Equivalent)
 2. Parts with * are adjustable and may be changed.

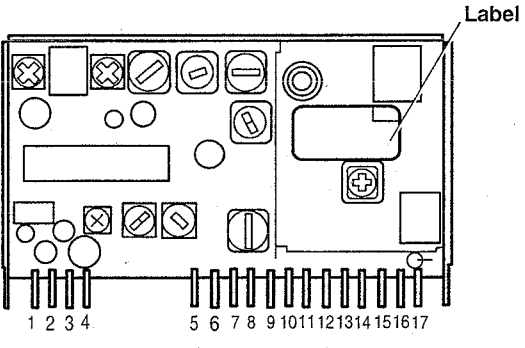



- | | |
|---------------|----------------|
| Terminal No. | |
| 1. AM DET OUT | 10. FM IF OUT |
| 2. AM + B | 11. FM GND |
| 3. AM SD | 12. FM OSC OUT |
| 4. AM AGC | 13. FM TV |
| 5. NC | 14. FM + B |
| 6. AM OSC OUT | 15. FM LO/DX |
| 7. AM VT | 16. FM GND |
| 8. AM. ANT | 17. FM ANT |
| 9. AM LO/DX | |

SERVICE NOTE FOR CD SECTION

● Heat Run Mode

The heat run mode aims to provide reliable checking for the unit as well as performance confirmation. Use this mode as your need.

1) Action the heat run program

- ① Press the 3 keys , , and .
- ② Turn on the power (ACC, BATT).
- ③ When "HEAT RUN" displays on the LCD, the heat run program is actuating.

2) Action of heat run program (8cm CD will not act)

The following 3 actions are possible.

① ALL PLAY mode

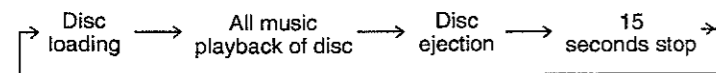

② SEARCH PLAY mode

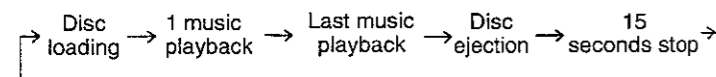

③ CHACKING mode

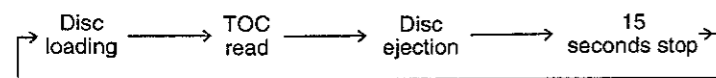

3) Actuating each mode

① ALL PLAY mode

- a. Press PRESET Button 1 while LCD is blinking. "HR A0000" display blinks (*).
- b. Insert a disc and press CD PLAY Button. LCD lights and performs ALL PLAY mode.

② SEARCH PLAY mode

- a. Press PRESET Button 2 while LCD is blinking. "HR S0000" display blinks (*).
- b. Insert a disc and press CD PLAY button. LCD lights and performs SEARCH PLAY mode.

③ CHACKING mode

- a. Press PRESET Button 3 while LCD is blinking. "HR C0000" display blinks (*).
- b. Insert a disc and press CD PLAY Button. LCD lights and performs CHACKING mode.

* In each respective mode, the display indicating number of disc ejection also blinks.

4) LCD display

- ① 4 digit figure: Indicates the number of disc ejection. Each ejection shifts the count 1 by 1. The display will not fail even though the power is turned off.
- ② English letter
 - ER L : Indicates the error when loading will not finish within 15 seconds after start of loading.
 - ER E : Indicates the error when ejection will not finish within 15 seconds after start of ejection.
 - ER T : Indicates the error when TOC is unable to read.
 - ER S : Indicates the error when search is unable to do.
 - ER H : Indicates high temperature.
 - ER C : Indicates low temperature.
 - ER F : Indicates the error when playback is unable to continue (no FOCUS applies during playback).

5) Action at a time error occurrence

When each error occurs, LCD displays the error message in blinking and stops action. Except when the following conditions the actions continue.

- ① "ER H" indication : The action automatically continues when the temperature becomes low.
- ② "ER C" indication : The action automatically continues when the temperature becomes high.
- ③ "ER E" indication : Performs loading and stops. If it still unable to perform, again performs eject, loading eject for up to 2 times, then stops at that point afterward.
- ④ "ER L" indication : Performs ejection and stops. If it still unable to perform, again performs loading, eject, loading for up to 2 times, then stops at that point afterward.

* When error occurred, without pressing PRESET Button 5 to release the error state the unit can not act the CD.

6) Effective button function in heat run program

PRESET Button 1 : Described previously

PRESET Button 2 : Described previously

PRESET Button 3 : Described previously

PRESET Button 5 : Releasing of error state

PRESET Button 6 : Pressing it while indication is blinking resets error and counter to 0.

CD PLAY Button : Pressing it while LCD is lighting intercepts the heat run mode and becomes blinking mode.

EJECT Button : Ejects the CD.

7) Releasing the heat run program





Pressing RESET Button makes releasing.

8) Others

Indications of counter, error and mode remain however ACC is turned OFF and PANEL is turned OFF.

● LCD check mode

Utilize this mode for checking the LCD indication.

- ① Press the keys , , , (for U.S.A. and Canada models ).
- ② Turn on the power (ACC, BATT).
- ③ Repeats turn on/off the lights of all LCD indications with the intervals 0.5 second.

BLOCK DIAGRAM - (1/3)

CD MECH. SECTION

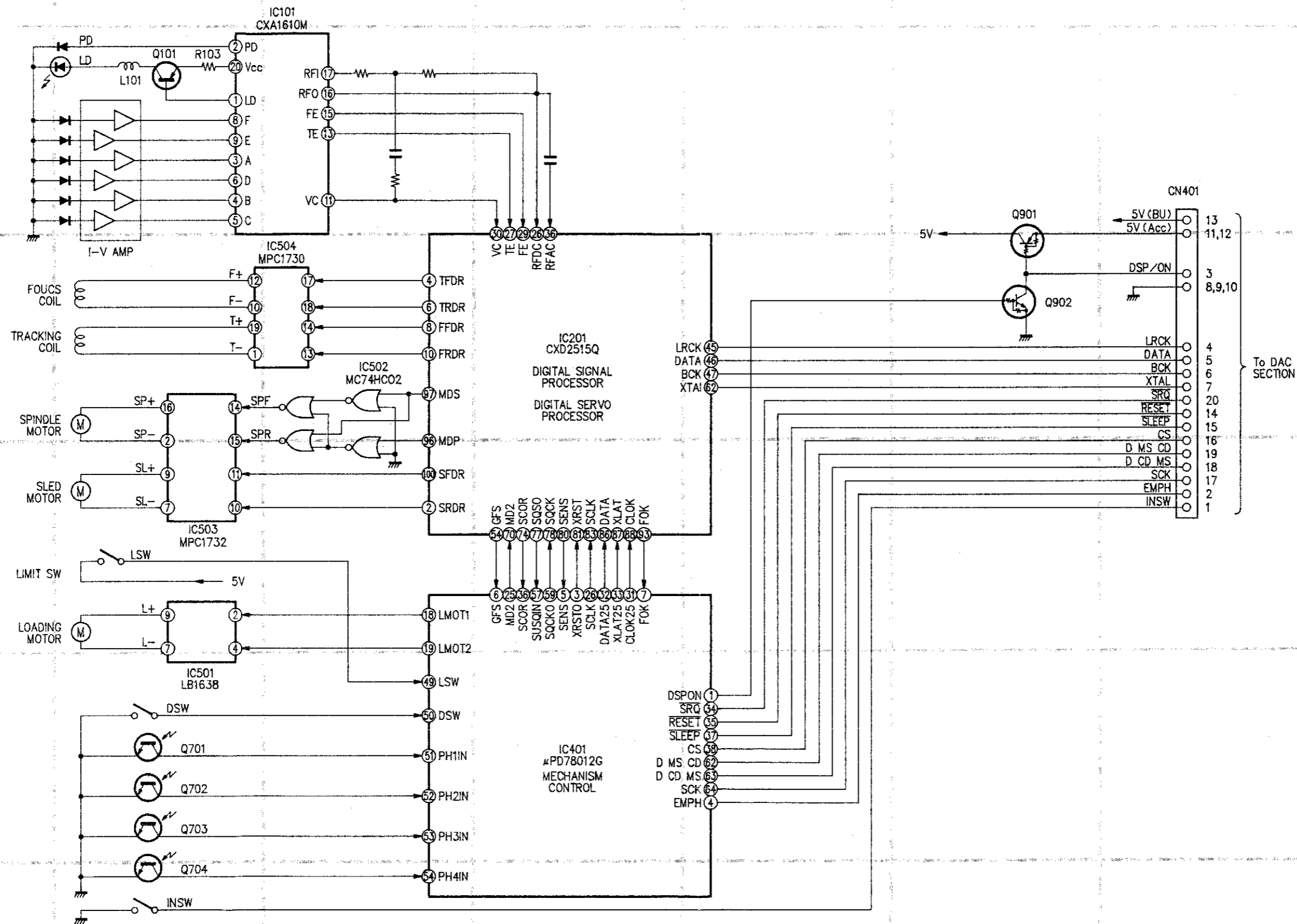

BLOCK DIAGRAM - (2/3)
DAC SECTION

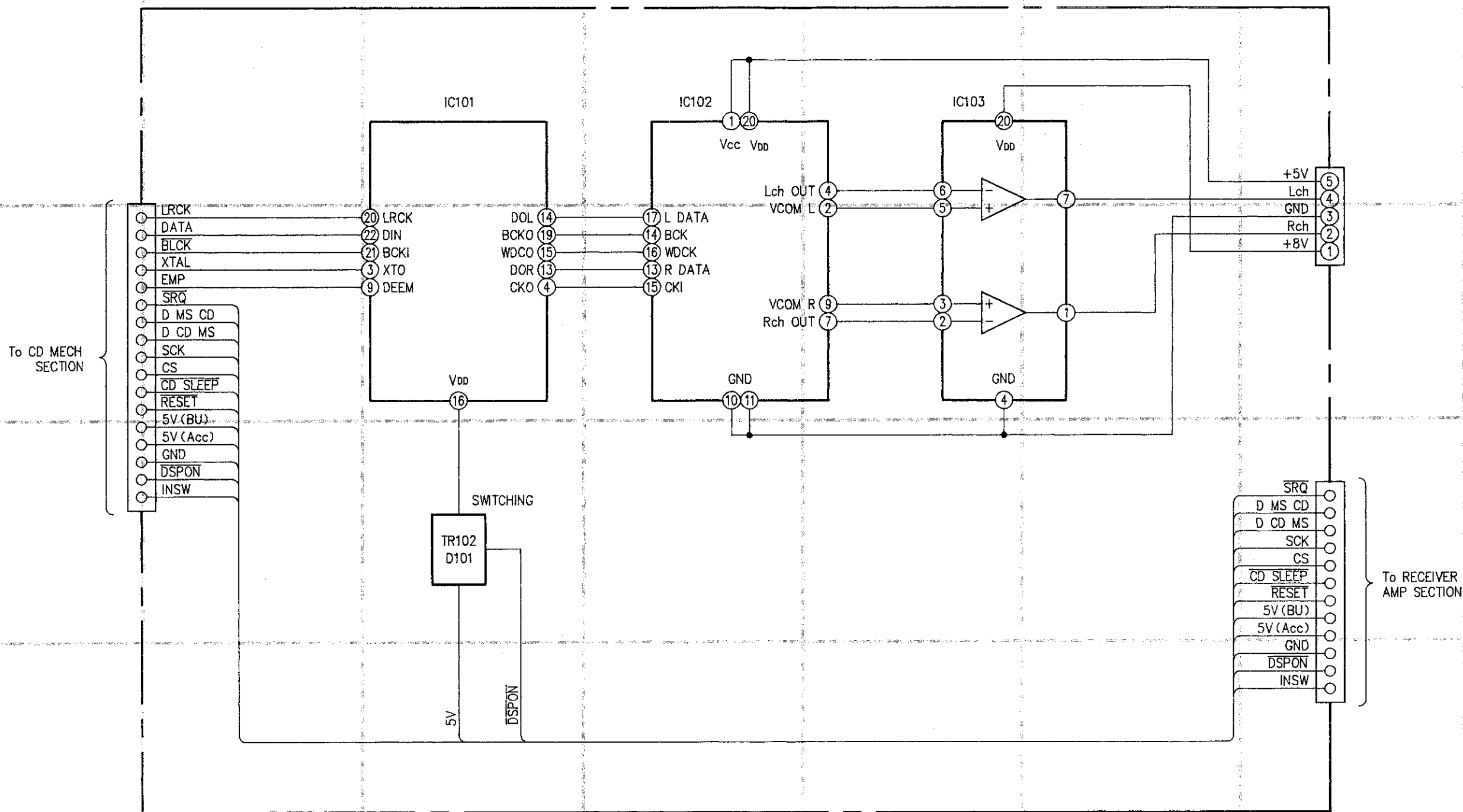

BLOCK DIAGRAM - (3/3) RECEIVER, AMP SECTION

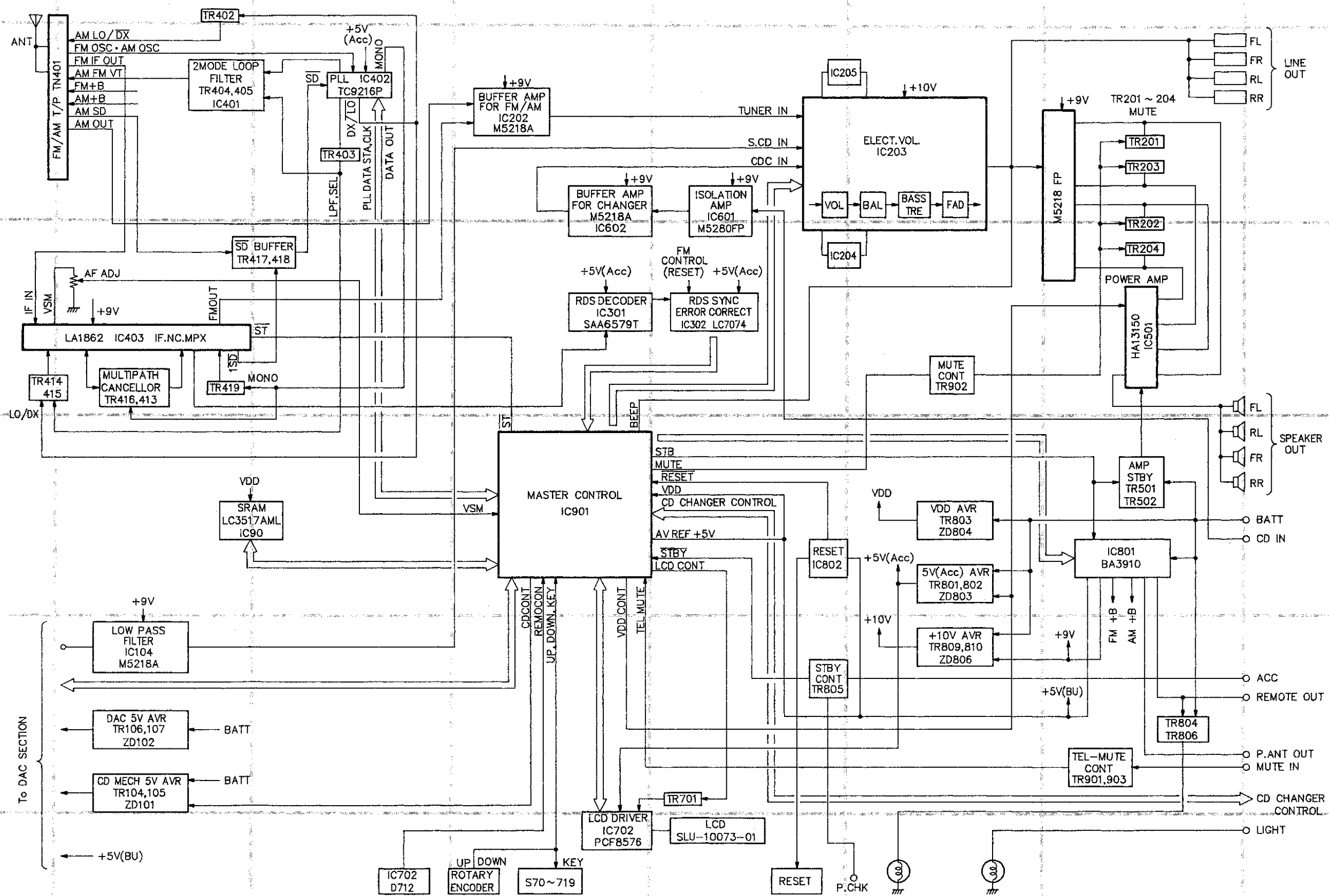

SEMICONDUCTORS

CD Mech. Section

IC's

CXA1610M (IC101)

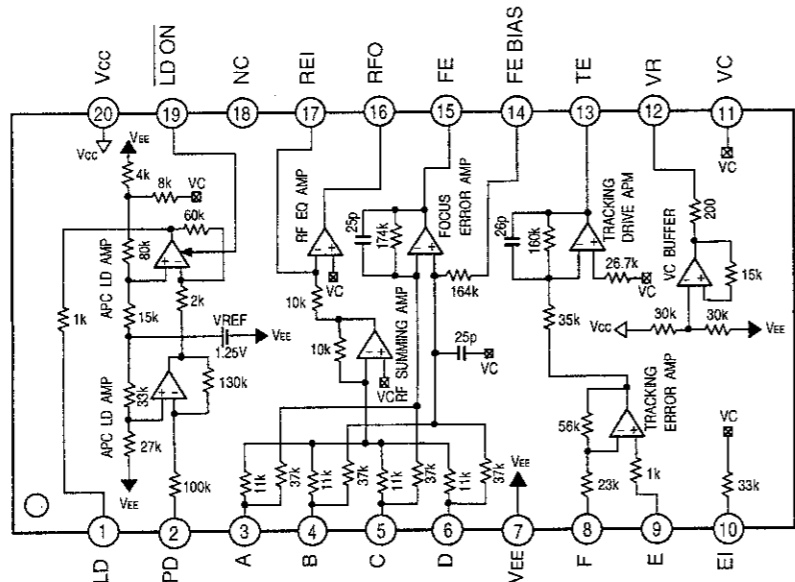
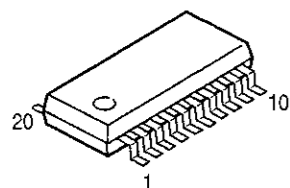

CXA1610M Terminal Function

Pin No.	Symbol	I/O	Function
1	LD	O	Output terminal of APC amplifier.
2	PD	I	Input terminal of APC amplifier.
3	A	I	Terminal numbers 3,4,5,6 are for inputs of RF amplifier and FE amplifier. Terminal number 14 is for adjustment terminal of focus bias.
4	B	I	
5	C	I	
6	D	I	
14	FE BIAS	I	
7	VEE	I	VEE terminal
8	F	I	Input terminal of tracking error amplifier.
9	E	I	
10	EI	—	33 kohm resistor is provided between VC. Connect to TE adjustment VR for using.
11	VC	I	Input terminal for VC center point voltage. For dual ±5V power supply, connect to GND. For single +5V power supply, connect to VR terminal.
12	VR	O	Output terminal of (Vcc + VEE) / 2 DC power supply.
13	TE	O	Output terminal of tracking error amplifier. Emits F-E signal.
15	FE	O	Output terminal of focus error amplifier.
16	RFO	O	Output terminal of RF amplifier.
17	RFI	—	Input terminal of reverse side RF amplifier. A resistor connected between this terminal and RFO terminal decide the gain of RF amplifier.
18	NC	—	Opened on the circuit diagram.
19	LD ON	—	ON/OFF shifting terminal of APC amplifier. GND to ON; Vcc to OFF.
20	Vcc	—	Vcc terminal.

LB1638 (IC501)

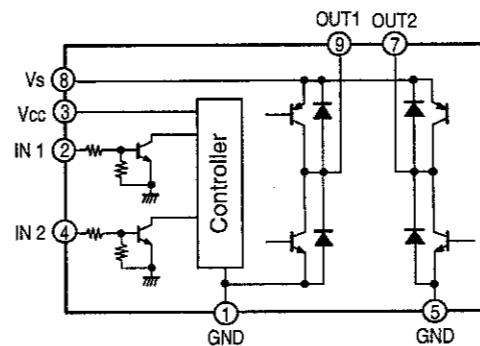
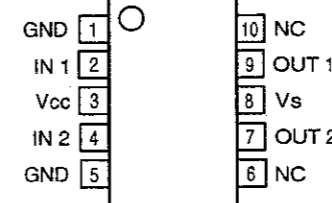
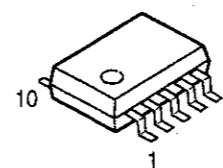

MC74HCD2AF (IC502)

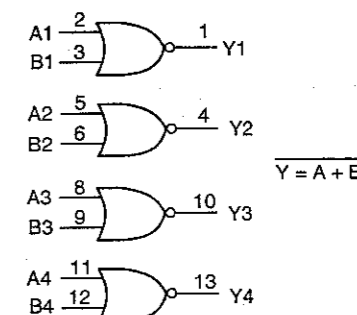
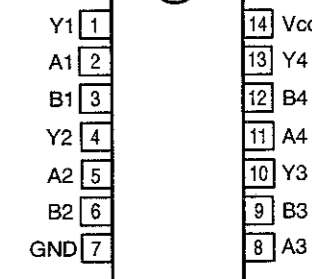
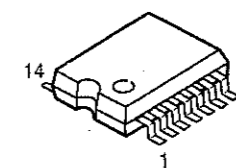

Vcc = 14 Pin
GND = 7 Pin

MPC1730MR2 (IC504)

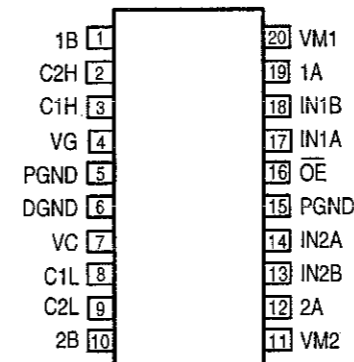
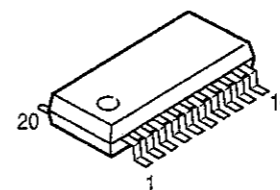

MPC1732MR2 (IC503)

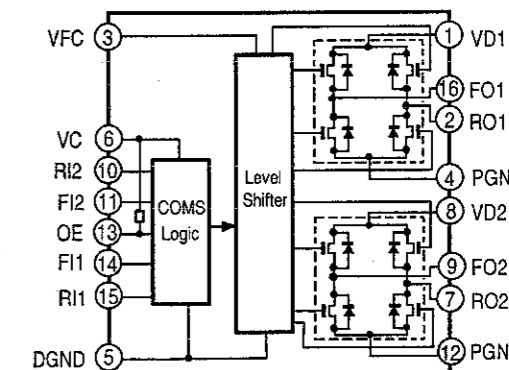
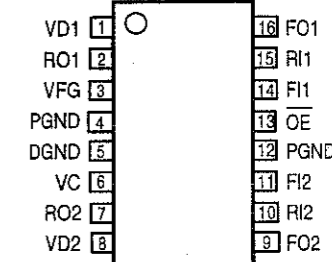
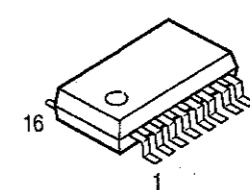

CXD2515Q
(IC201)

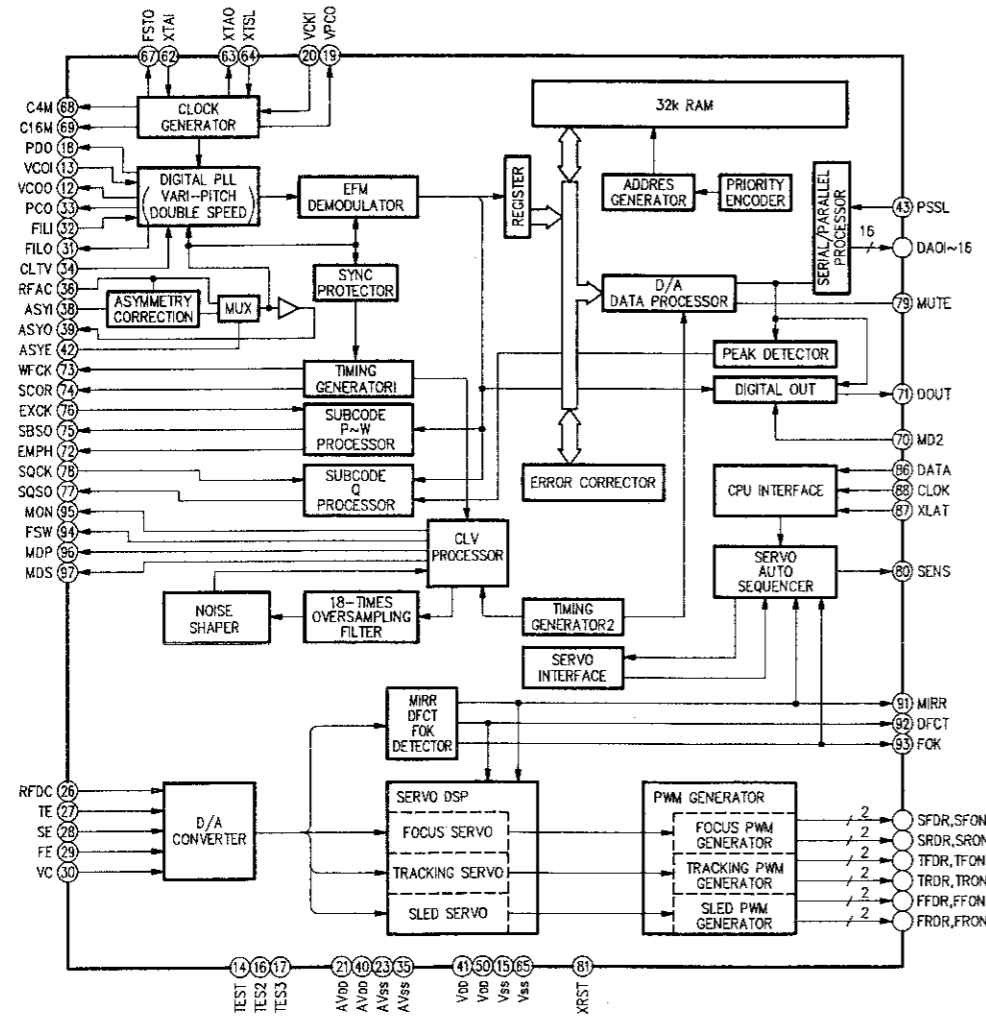
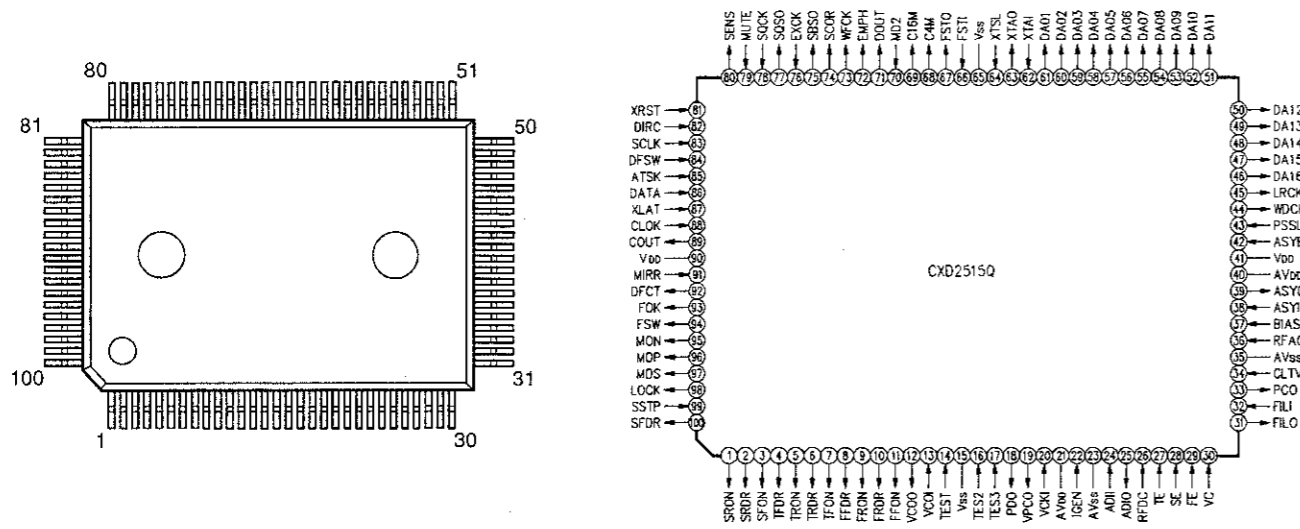

CXD2515Q Terminal Function

Pin No.	Symbol	I/O	Function
1	SRON	O	Sled drive output.
2	SRDR	O	Sled drive output.
3	SFON	O	Sled drive output.
4	TFDR	O	Tracking drive output.
5	TRON	O	Tracking drive output.
6	TRDR	O	Tracking drive output.
7	TFON	O	Tracking drive output.
8	FFDR	O	Focus drive output.
9	FRON	O	Focus drive output.
10	FRDR	O	Focus drive output.
11	FFON	O	Focus drive output.
12	VCOO	O	Oscillation circuit output for analog EFM PLL.
13	VCOI	I	Oscillation circuit input for analog EFM PLL. f _{LOCK} = 8.6436MHz.
14	TEST	I	Test terminal, normally GND.
15	Vss	—	Digital GND.
16	TES2	I	Test terminal, normally GND.
17	TES3	I	Test terminal normally GND.
18	PDO	O	Charge pump output for analog EFM PLL.
19	VPCO	O	PLL charge pump output for variable pitch.
20	VCKI	I	Clock input from external VCO for variable pitch. f _{center} = 16.9344MHz.
21	AV _{DD}	—	Analog power supply.
22	IGEN	I	Connecting terminal of current source reference resistor for OP amplifier.
23	AV _{SS}	—	Analog GND.
24	ADII	I	A/D converter input terminal.
25	ADIO	O	OP amplifier output terminal.
26	RFDC	I	RF signal input. Input range: 2.15V ~ 5.0V (at V _{DD} = AV _{DD} = 5.0V).
27	TE	I	Tracking error signal input. Input range: 2.5V ±1.0V (at V _{DD} = AV _{DD} = 5.0V).
28	SE	I	Sled error signal input. Input range: 2.5V ±1.0V (at V _{DD} = AV _{DD} = 5.0V).
29	FE	I	Focus error signal input. Input range: 2.5V ±1.0V (at V _{DD} = AV _{DD} = 5.0V).
30	VC	I	Center point voltage input terminal.
31	FILO	O	Filter output for master PLL.
32	FILI	I	Filter input for master PLL.
33	PCO	O	Charge pump output for master PLL.
34	CLTV	I	VCO control voltage input for master.
35	AV _{SS}	—	Analog GND.
36	RFAC	I	EFM signal input.
37	BLAS	I	Asymmetry circuit constant current input.
38	ASYI	I	Asymmetry compare voltage input.
39	ASYO	O	EFM full swing output (L = V _{SS} , H = V _{DD}).
40	AV _{DD}	—	Analog power supply.
41	V _{DD}	—	Digital power supply.
42	ASYE	I	Asymmetry circuit ON/OFF (L = OFF, H = ON).
43	PSSL	I	Audio data output mode shifting input. L to serial output, H to parallel output.
44	WDCK	O	48-bit slot D/A interface. Word clock f = 2Fs.
45	LRCK	O	48-bit slot D/A interface. LR clock f = Fs.
46	DA16	O	DA16 output at PSSL = 1. Serial data of 48-bit slot at PSSL = 0.
47	DA15	O	DA15 output at PSSL = 1. Bit clock of 48-bit slot at PSSL = 0.
48	DA14	O	DA14 output at PSSL = 1. Serial data of 64-bit slot at PSSL = 0.
49	DA13	O	DA13 output at PSSL = 1. Bit clock of 64-bit slot at PSSL = 0.
50	DA12	O	DA12 output at PSSL = 1. LR clock of 64-bit slot at PSSL = 0.
51	DA11	O	DA11 output at PSSL = 1. G _{TOP} output at PSSL = 0.
52	DA10	O	DA10 output at PSSL = 1. XUGF output at PSSL = 0.
53	DA09	O	DA09 output at PSSL = 1. XPLCK output at PSSL = 0.
54	DA08	O	DA08 output at PSSL = 1. GFS output at PSSL = 0.
55	DA07	O	DA07 output at PSSL = 1. RFCK output at PSSL = 0.
56	DA06	O	DA06 output at PSSL = 1. C ₂ PO output at PSSL = 0.

Pin No.	Symbol	I/O	Function
57	DA05	O	DA05 output at PSSL = 1. XRAOF output at PSSL = 0.
58	DA04	O	DA04 output at PSSL = 1. MNT3 output at PSSL = 0.
59	DA03	O	DA03 output at PSSL = 1. MNT2 output at PSSL = 0.
60	DA02	O	DA02 output at PSSL = 1. MNT1 output at PSSL = 0.
61	DA01	O	DA01 output at PSSL = 1. MNT0 output at PSSL = 0.
62	XTAI	I	X'tal oscillation circuit input. L at X'tal is 16.9344MHz H at X'tal is 33.8688MHz.
63	XTAO	O	X'tal oscillation circuit output.
64	XTSL	I	X'tal selection input terminal. L at X'tal is 16.9344MHz, H at X'tal is 33.8688MHz.
65	Vss	—	Digital GND.
66	FSTI	I	2/3 divided input of terminals 62, 63.
67	FSTO	O	2/3 divided output. Does not vary with variable pitch.
68	C4M	O	4.2336MHz output. Simultaneously varies when variable pitched.
69	C16M	O	16.9344MHz output. Simultaneously varies when variable pitched.
70	MD2	I	Digital-out ON/OFF control terminal (L = OFF, H = ON).
71	DOUT	O	Digital-out output terminal.
72	EMPH	O	Emphasis mode output of playback disc (L = with emphasis, H = without emphasis).
73	WFCK	O	WFCK output.
74	SCOR	O	Sub-code sync output terminal (H at either of sub-code sync S0 or S1 is detected).
75	SBSO	O	Serial output of sub P - W.
76	EXCK	I	Clock input for SQSO read out.
77	SQSO	O	SubQ 80-bit output. PCM peak data, level data 16-bit output.
78	SQCK	I	Clock input for SQSO read out.
79	MUTE	I	Mute shifting terminal (mute at H).
80	SENS	O	SENS output. Emits to CPU.
81	XRST	I	System reset (reset at L).
82	DIRC	I	Using at 1 track jump.
83	SCLK	I	Clock or SENS serial data read out.
84	DFSW	I	Terminal for DFCT shifting (DFCT measure circuit OFF at H).
85	ATSK	I	Terminal for anti-shock.
86	DATA	I	Serial data input from CPU.
87	XLAT	I	Latch input from CPU.
88	CLOCK	I	Serial data transfer clock input from CPU.
89	COUT	O	Number of track count signal output.
90	V _{DD}	—	Digital power supply.
91	MIRR	O	Mirror signal output.
92	DFCT	O	Defect signal output.
93	FOK	O	Focus OK output.
94	FSW	O	Output filter shifting output of spindle motor.
95	MON	O	ON/OFF control output of spindle motor.
96	MDP	O	Servo control of spindle motor.
97	MDS	O	Servo control of spindle motor.
98	LOCK	O	By sampling GFS with 460Hz and when GFS at H, H output. L output at consecutively L 8 times.
99	SSTP	I	Terminal for disc innermost circle detection signal.
100	SFDR	O	Sled rive output.

Note:

- 64-bit slot is 2's complement output of LSB first, 48-bit slot is 2's complement output.
- CTOP monitors frame sync protection condition (H: sync protection window open).
- XUGF is frame sync possessed from EFM signal and is negative pulse, Signal previous to sync protection.
- XPLCK is reversal of PLL clock. PLL is so made up to coincide rising edge with the varying point of EFM signal.
- GFS signal is a signal to become H when frame sync coincides inserted protection timing.
- RFCK is possessed with X'tal accuracy. Signal of 136 μ s cycle.
- C2PO is a signal indicating data error condition.
- XRAOR is a generating signal when 32kRAM exceeds jitter margin of 28 frame.

μPD78012GC-546-AB8 (IC401)

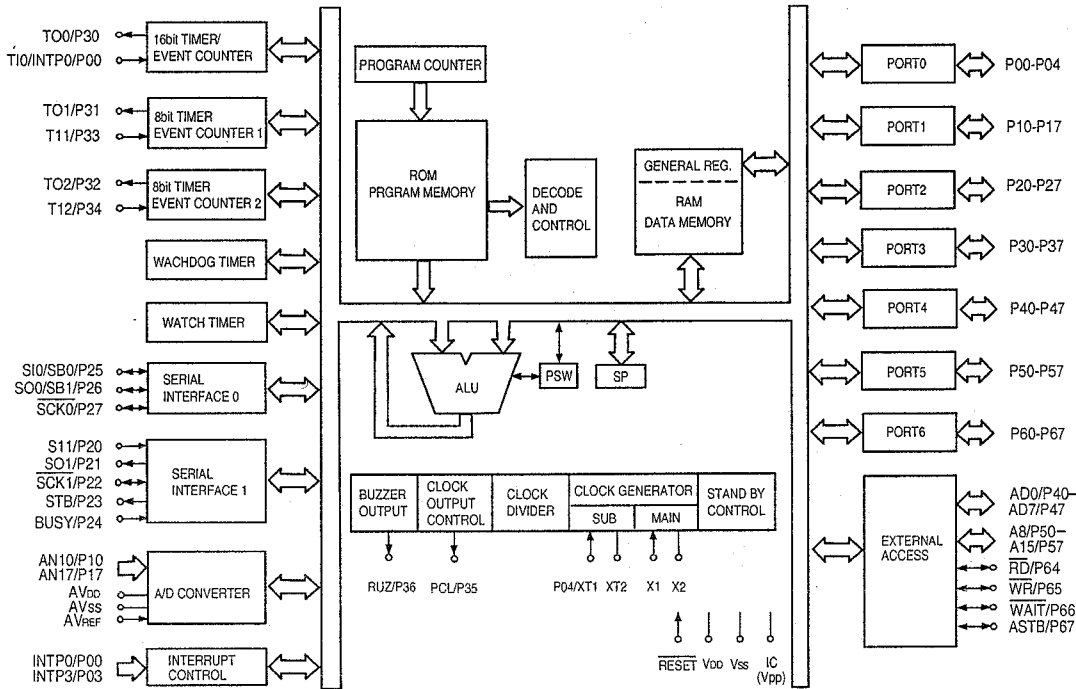
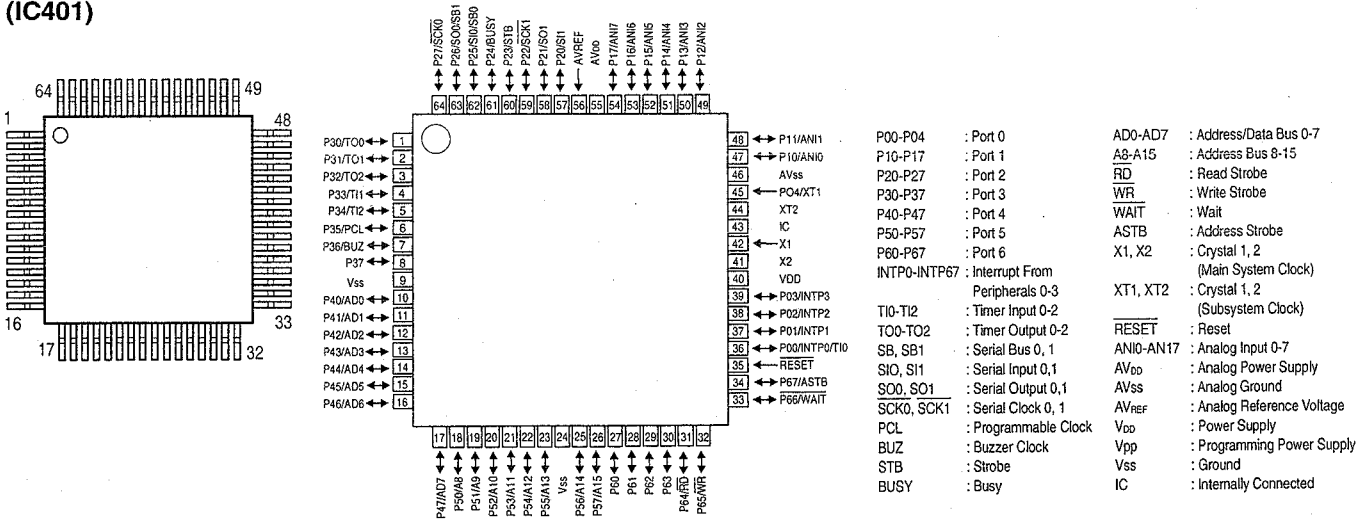

μPD78012 Terminal Function

Pin No.	Symbol	Name	I/O	Function
1	DSPON	P30/TO0	O	Power supply ON/OFF control for CXD-2515, A/D converter, RF amplifier, etc.
2	NC	P31/TO1		Not used.
3	ERSTO	P32/TO2	O	Terminal to reset CXD-2515.
4	EMPH	P33/TI1	O	ON/OFF control of emphasis.
5	SENS	P34/TI2	I	SENS input of CXD-2515.
6	LDON	P35/PCL	O	ON/OFF control of laser diode.
7	FOK	P36/BUZ	I	FOK input of CXD-2515.
8	GFS	P37	I	GFS input of CXD-2515.
9	Vss	Vss	—	Microcomputer GND.
10	TROFF0	P40/AD0	O	0 bit of tracking offset adjustment.

Pin No.	Symbol	Name	I/O	Function																
11	TROFF1	P41/AD1	O	1 bit of tracking offset adjustment.																
12	TROFF2	P42/AD2	O	2 bit of tracking offset adjustment.																
13	TROFF3	P43/AD3	O	3 bit of tracking offset adjustment.																
14	FOBIAS0	P44/AD4	O	0 bit of focus bias adjustment.																
15	FOBIAS1	P45/AD5	O	1 bit of focus bias adjustment.																
16	FOBIAS2	P46/AD6	O	2 bit of focus bias adjustment.																
17	TRLPF	P47/AD7	O	Low pass filter ON/OFF at tracking offset adjustment.																
18	LMOT1	P50/A8	O	Control 1 of loading motor.	<table border="1"> <thead> <tr> <th>LMOT1</th> <th>LMOT2</th> <th>Output</th> </tr> </thead> <tbody> <tr> <td>0</td> <td>0</td> <td>Stop</td> </tr> <tr> <td>1</td> <td>0</td> <td>Right turn</td> </tr> <tr> <td>0</td> <td>1</td> <td>Reverse turn</td> </tr> <tr> <td>1</td> <td>1</td> <td>Brake</td> </tr> </tbody> </table>	LMOT1	LMOT2	Output	0	0	Stop	1	0	Right turn	0	1	Reverse turn	1	1	Brake
LMOT1	LMOT2	Output																		
0	0	Stop																		
1	0	Right turn																		
0	1	Reverse turn																		
1	1	Brake																		
19	LMOT2	P51/A9	O	Control 2 of loading motor.																
20	NC	P52/A10	—	Not used.																
21	OE	P53/A11	O	Enable control of 2 axes driver.																
22	NC	P54/A12	—	Not used.																
23	NC	P55/A13	—	Not used.																
24	Vss	Vss		Microcomputer GND.																
25	MD2	P56/A14	O	Digital out ON/OFF control of CXD-2515.																
26	SCLK	P57/A15	O	Clock output for Serial data read out of CXD-2515.																
27	NC	P60	—	Not used.																
28	NC	P61	—	Not used.																
29	INSW	P62	I	Disc insertion detecting switch input.																
30	NC	P63	—	Not used.																
31	CLOCK25	P64/RD	O	Command clock output to CXD-2515.																
32	DATA25	P65/WR	O	Command data output to CXD-2515.																
33	XLAT25	P66/WAIT	O	Command latch output to CXD-2515.																
34	SRQ	P67/ASTB	O	Mechanism control's communication request output in communication with master microcomputer.																
35	RESET	RESET	I	Reset input of microcomputer.																
36	SCOR	P00/INTP0/TIO	I	Sub-code sync (SCOR) input of CXD-2515.																
37	SLEEP	P01/INTP1	I	Sleep mode control input of microcomputer.																
38	CS	P02/INTP2	I	Master's communication request input in communication with master microcomputer.																
39	NC	P03/INTP3	—	Not used.																
40	V _{DD}	V _{DD}		Microcomputer power supply.																
41	X2	X2		X'tal connection terminal for clock oscillation.																
42	X1	X1		X'tal connection terminal for clock oscillation.																
43	—	IC (V _{pp})		Connect to GND.																
44	—	XT2		Connect to GND.																
45	—	P04/XT1		Connect to GND.																
46	AV _{SS}	AV _{SS}		GND polarity of A/D converter.																
47	HOT	P10/ANI0	I	Upper side input terminal of temperature sensor.																
48	COLD	P11/ANI1	I	Lower side input terminal of temperature sensor.																
49	LSW	P12/ANI2	I	Location detection switch input of optical pick-up inner circle.																
50	DSW	P13/ANI3	I	Disc chacking complete switch input.																
51	PH1 IN	P14/ANI4	I	Disc sensor 1 input.																
52	PH2 IN	P15/ANI5	I	Disc sensor 2 input.																
53	PH3 IN	P16/ANI6	I	Disc sensor 3 input.																
54	PHIN4	P17/ANI7	I	Disc sensor 4 input.																
55	AV _{DD}	AV _{DD}		Analog power supply of A/D converter.																
56	AVREF	AVREF	I	Reference voltage input of A/D converter.																
57	SUBQIN	P20/SI1	I	Sub-Q data read out input of CXD-2515.																
58	NC	P21/SO1	—	Not used.																
59	SQCK	P22/SCK1	O	Clock output for sub-Q data read out of CXD-2515.																
60	NC	P23/STB		Not used.																
61	12CM	P24/BUSY	I	Shifting input of 12cm exclusive or 12/8cm combined used.																
62	D_MS_CD	P25/SI0/SB0	I	Data input from master in communication with master microcomputer.																
63	D_CD_MS	P26/SO0/SB1	O	Data output to master in communication with master microcomputer.																
64	SCK	P27/SCK0	I	Serial clock input in communication with master microcomputer.																

● TRANSISTORS

UMG4 (Chip)

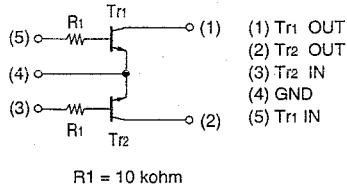
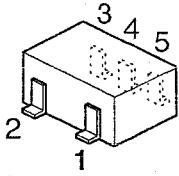

DTB113ZK
 DTC114TU
 DTC124EU
 (Chip)

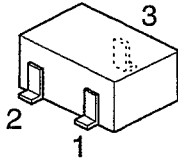

DTBZK Series

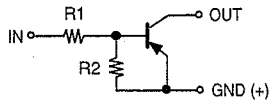

	R1	R2
DTB113ZK	1Kohm	10Kohm

DTCTU, EU Series

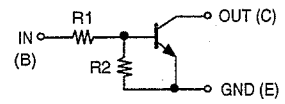

	R1	R2
DTC114TU	10Kohm	—
DTC124EU	22Kohm	22Kohm

2SB624
 (Chip)

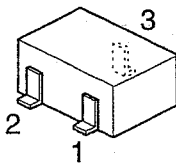

- 1: Emitter
- 2: Base
- 3: Collector

Main, Front, DAC Section

● IC's

PCF8576T
(IC701)

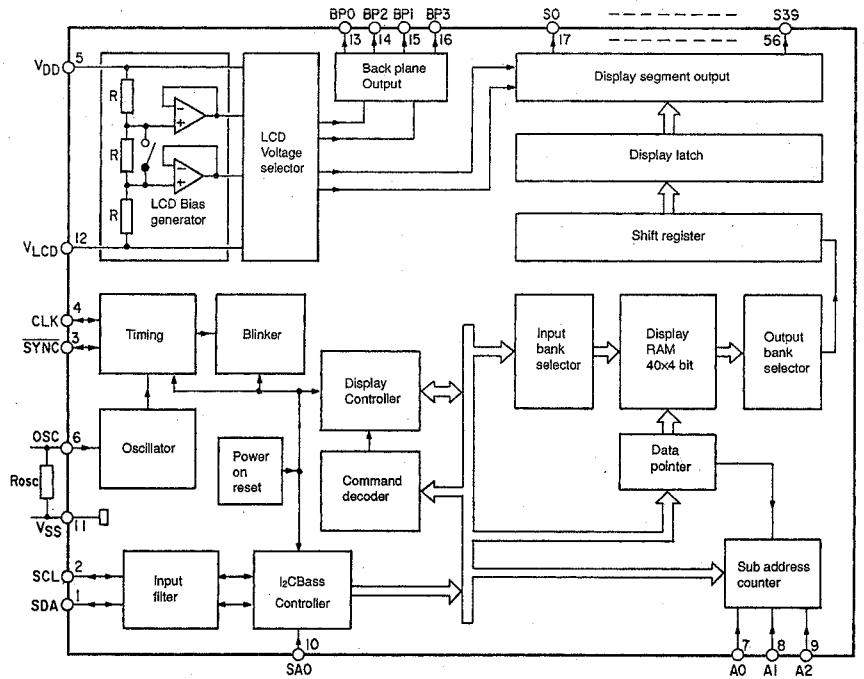
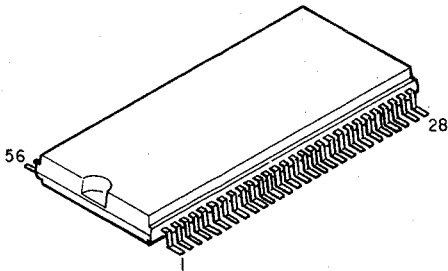

TC9216P
(IC402)

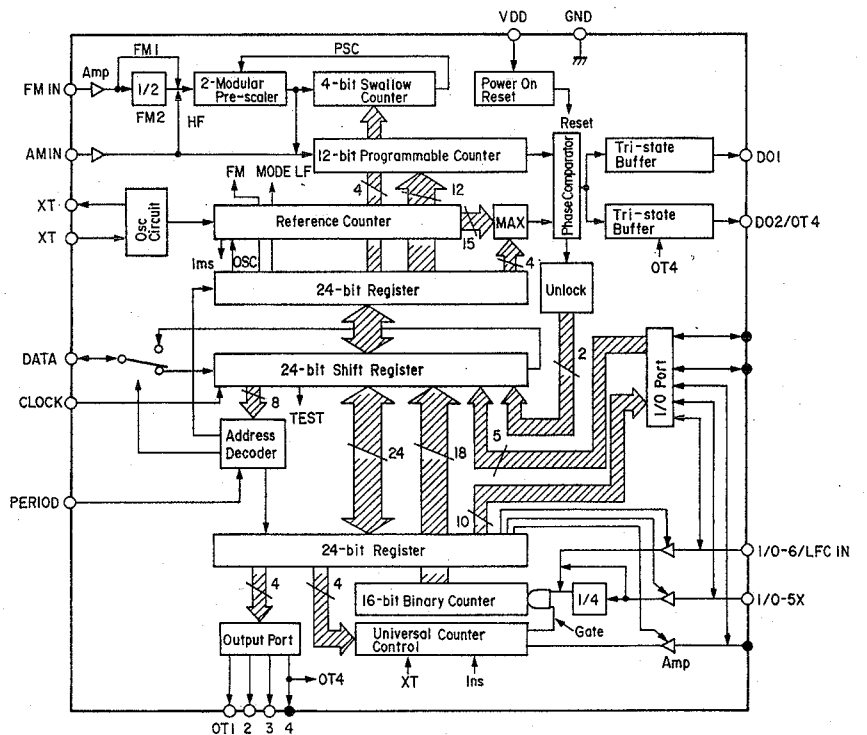
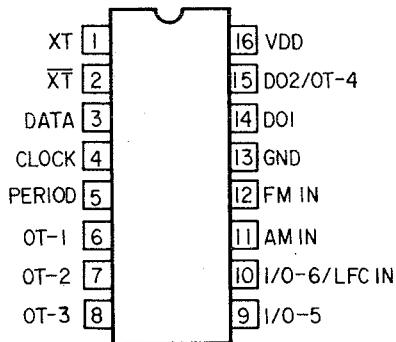
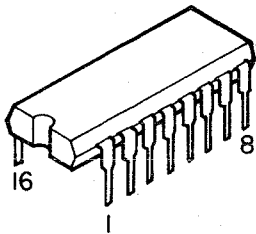

μPD78056GC-018-3B9 (IC901)

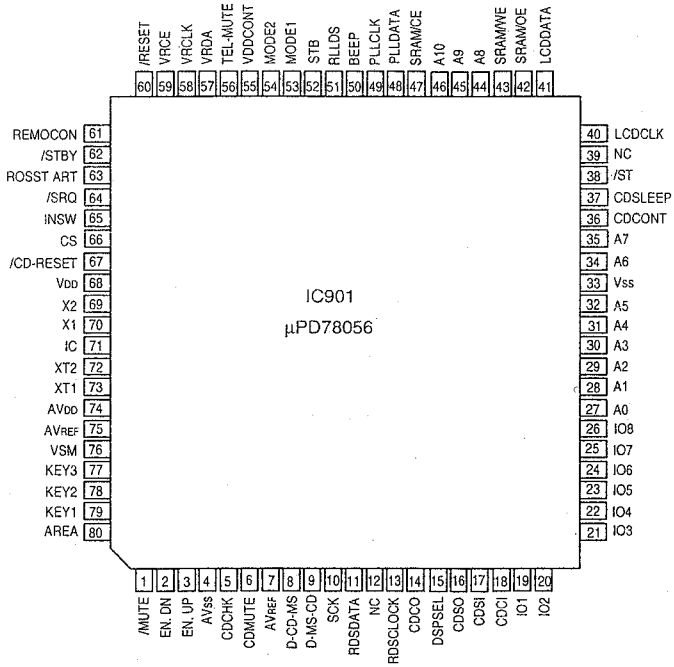
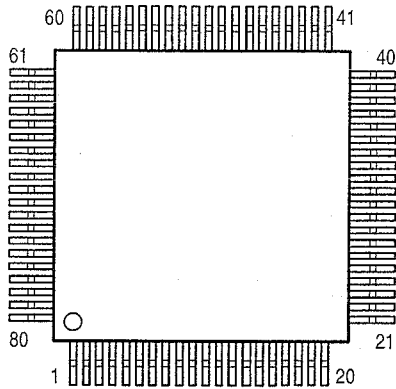

μPD78056GF-0xx-3B9 Terminal Function

Pin No.	Symbol	Name	I/O	Function
1	P15/AN15	MUTE	O	Mute output, L = MUTE ON.
2	P16/AN16	EN UP	I	Pulse encoder input.
3	P17/AN17	EN DOWN	I	Pulse encoder input.
4	AVss	GND	—	
5	P130	CDCHK	I/O	Reset output from CD changer/Detection of existence, H: Exist CDC.
6	P131	CDMUTE	I	MUTE control signal input from CD changer, H: MUTE ON.
7	AVref1		—	
8	P70/SI2	D-CD-MS	I	CD mechanism serial data input.
9	P71/SO2	D-MS-CD	O	CD mechanism serial data output.
10	P72/SCK2	CD SCK	O	CD mechanism serial clock input.
11	P20/SI1	RDS DATA	I	LC7074 serial data input.
12	P21/SO1	N.C.	—	
13	P22/SCK1	RDS CLK	I	LC7074 serial clock input.
14	P23	CD CO	O	CD changer serial clock output.
15	P24	DSPSEL	O	CD changer communication timing signal output.
16	P25/SI0	CD SO	O	CD changer serial data output.
17	P26/SO0	CD SI	I	CD changer serial data input.
18	P27/SCK0	CD CI	I	CD changer serial clock input.
19	P40	IO1	I/O	SRAM data input/output.
20	P41	IO2		SRAM data input/output.
21	P42	IO3		SRAM data input/output.
22	P43	IO4		SRAM data input/output.
23	P44	IO5		SRAM data input/output.
24	P45	IO6		SRAM data input/output.
25	P46	IO7		SRAM data input/output.
26	P47	IO8		SRAM data input/output.
27	P50	A0	O	SRAM address output.
28	P51	A1	O	SRAM address output.
29	P52	A2	O	SRAM address output.
30	P53	A3	O	SRAM address output.
31	P54	A4	O	SRAM address output.
32	P55	A5	O	SRAM address output.
33	Vss	GND	—	
34	P56	A6	O	SRAM address output.
35	P57	A7	O	SRAM address output.

Pin No.	Symbol	Name	I/O	Function
36	P60	CDCONT	O	CD mechanism ACC system 5V power supply control output, H: ON.
37	P61	CD SLEEP	O	CD mechanism lower power consumption mode selection, L: SLEEP.
38	P62	ST	I	ST detection input.
39	P63	N. C.	I	
40	P64	LCD CLK	O	Serial clock input to PCF8576.
41	P65	LCD DATA	I/O	Serial data input/output with PCF8576.
42	P66	SRAM OE	O	SRAM control output, L: ENABLE.
43	P67	SRAM WE	O	SRAM control output, L: ENABLE.
44	P30	A8	O	SRAM address data output.
45	P31	A9	O	SRAM address data output.
46	P32	A10	O	SRAM address data output.
47	P33	SRAM CE	O	SRAM control signal output, L: ENABLE.
48	P34	PLL DATA	I/O	PLL serial data input/output.
49	P35	PLL CLK	O	PLL serial clock output.
50	P36/BUZ	BEEP	O	BEEP tone output terminal.
51	P37	PLL DS	O	PLL communication timing signal output, L: STROVE.
52	P120	STB	O	IC control output for power supply.
53	P121	MODE1	O	IC control output for power supply.
54	P122	MODE2	O	IC control output for power supply.
55	P123	VDD CONT	O	Control output for +B(5V), H: ON.
56	P124	TEL MUTE	I	TELEPHONE MUTE input terminal, H: TEL MUTE IN.
57	P125	VR DI	O	CXA1767Q serial data output.
58	P126	VR CLK	O	CXA1767Q serial clock output.
59	P127	VR CE	O	CXA1767Q communication control signal output.
60	RESET	RESET	I	RESET input.
61	P00/INTP0	REMOCON	I	REMOCON data input.
62	P01/INTP1	STBY	I	ACC/PANEL detection input, L: ACC OFF/PANEL OFF.
63	P02/INTP2	RDSSTART	I	IC7074 communication timing signal input, L: STROVE.
64	P03/INTP3	CD SRQ	I	CD mechanism communication request signal, L: REQUEST.
65	P04/INTP4	CD INSW	I	Disc detection input, H: DISC exists.
66	P05/INTP5	CD CS	O	CD mechanism communication timing signal input, L: ENABLE.
67	P06/INTP6	CD RESET	O	CD mechanism reset output, L: RESET.
68	V _{DD}	V _{DD}	—	
69	X2	X2	—	
70	X1	X1	I	
71	IC	GND	—	
72	XT2	XT2	—	
73	XT1	XT1	I	
74	AV _{DD}	AV _{DD}	—	
75	AVref0	AVref0	—	
76	P10	VSM	I	VSM input (A/D).
77	P11	KEY3	I	KEY input (A/D).
78	P12	KEY2	I	KEY input (A/D).
79	P13	KEY1	I	KEY input (A/D).
80	P14	AREA	I	Forwarding country selection input (A/D).

PCM67U (IC102)

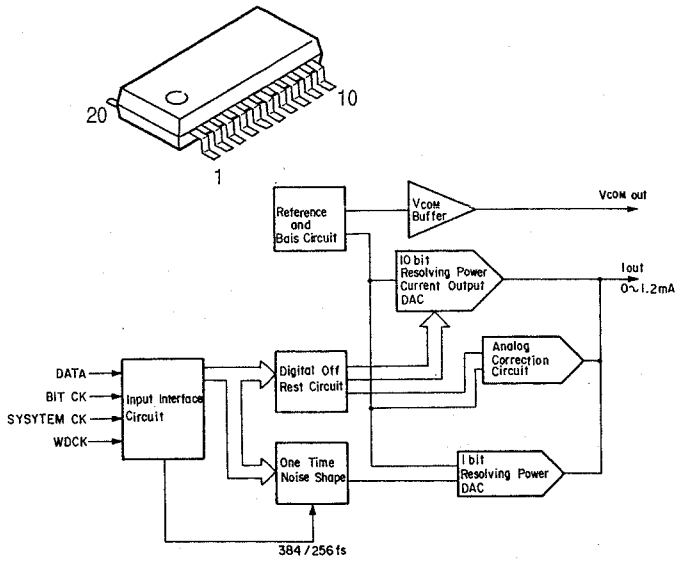

PCM67U Terminal Function

Pin No.	Terminal Function	Pin No.	Terminal Function
1	+ Vcc (Analog Power Supply)	11	D-GND (Digital Common)
2	VCOM, Len	12	TR2
3	N.C	13	DATA Rch
4	Iout, Lch	14	BCK
5	SERVO,DC	15	SYS CLK
6	REF, DC	16	WDCK
7	Iout, Rch	17	DATA Lch
8	N.C	18	RSRVD
9	Vcom, Rch	19	TP1
10	A-GND (Analog Common)	20	+VDD (Digital power supply)

M5218AFP (IC103, 104, 202, 204-207, 602)

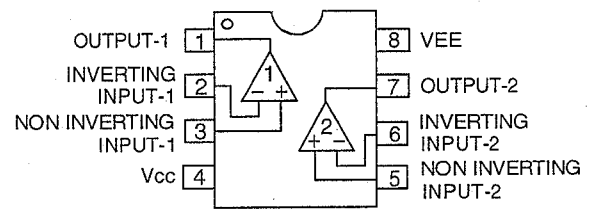
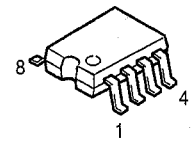

SM5841CS (IC101)

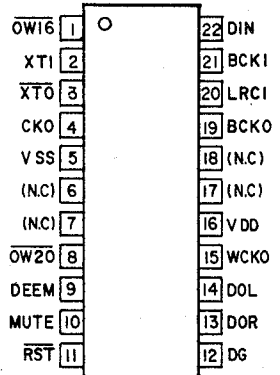
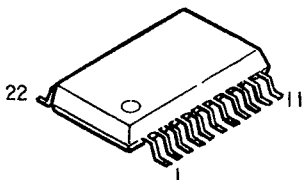

LC3517AML-15 (IC902)

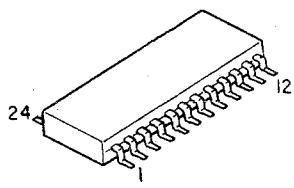

- A0 ~ A10 Address input
- WE Read/Write control input
- OE Output enable input
- CE Chip enable input
- I/O 1 ~ I/O 8 Data input/output
- Vcc/GND Power terminal

TOP VIEW

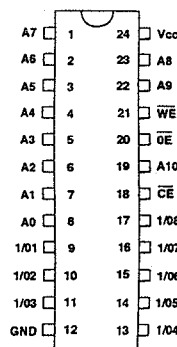

FUNCTION TABLE

Mode	CE	OE	WE	I/O	Power current
Read cycle	L	L	H	Data output	I _{CCA}
Write cycle	L	x	L	Data input	I _{CCA}
Output disable	L	H	x	High impedance	I _{CCA}
Non-selection	H	x	x	High impedance	I _{CCS}

X: H or L

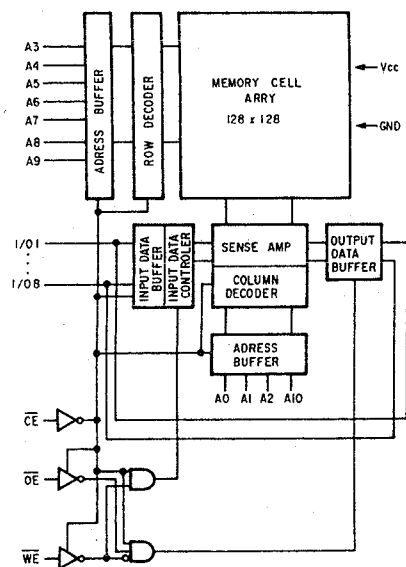

**TC4066BP
(IC602)**

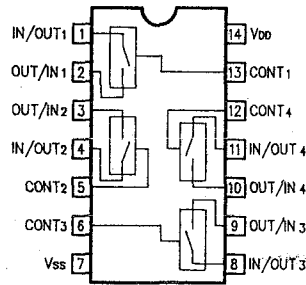
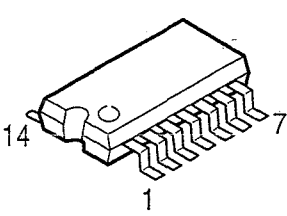

SCHEMATIC DIAGRAM

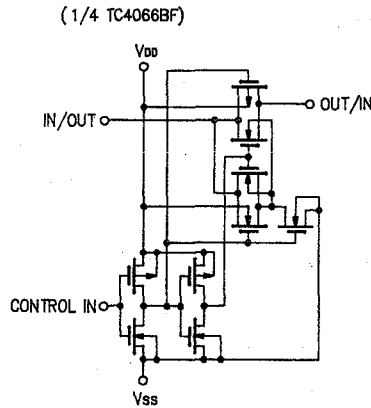

BLOCK DIAGRAM

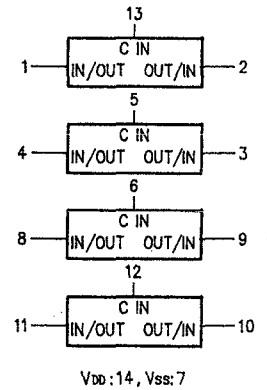

**LC7074NM
(IC302)**

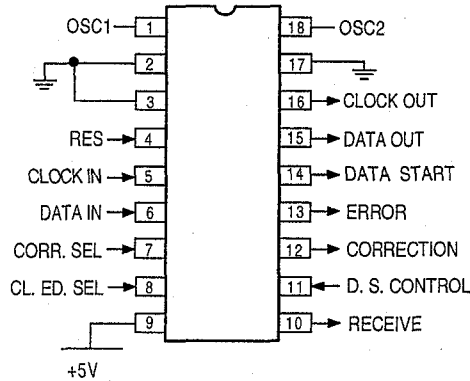
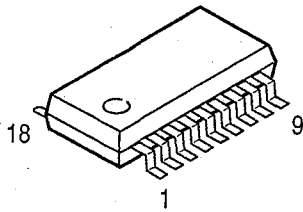

**SAA6579T
(IC301)**

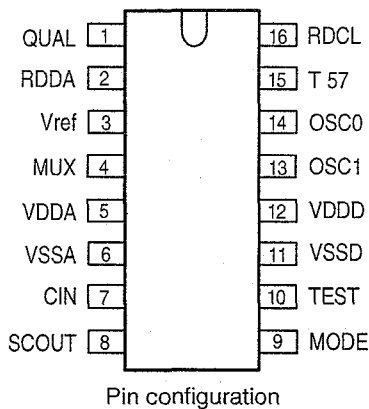
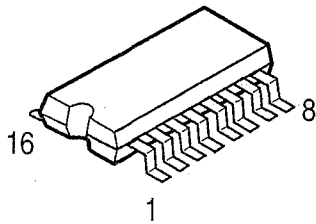

Pin No.	Symbol	Description
1	QUAL	Quality indication output.
2	RDDA	RDS data output.
3	Vref	Reference voltage output (0.5 V _{DDA}).
4	MUX	Multiplex signal input.
5	V _{DDA}	+5V supply voltage for analog part.
6	V _{SSA}	Ground for analog part (0V).
7	CIN	Subcarrier input to comparator.
8	SCOUT	Subcarrier output of reconstruction filter.
9	MODE	Oscillation mode/test control input.
10	TEST	Test enable input.
11	V _{SSD}	Ground for digital part (0V).
12	V _{DDD}	+5V supply voltage for digital part.
13	OSCI	Oscillator input.
14	OSCO	Oscillator output.
15	T57	57kHz clock signal output.
16	RDCL	RDS clock output.

LA1862
(IC403)

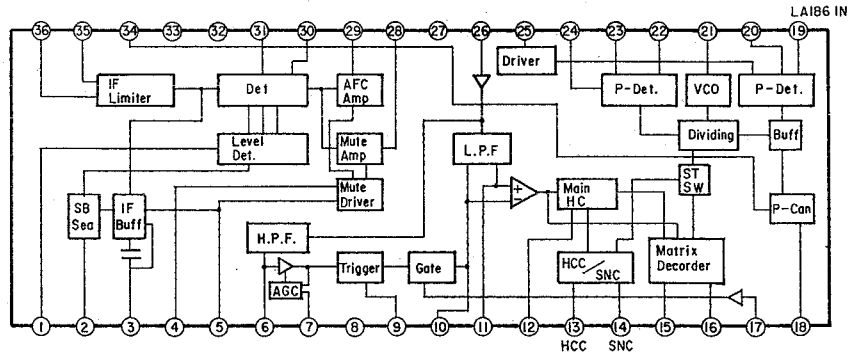
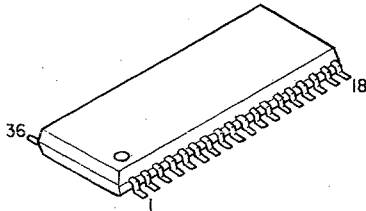

LM1862M Terminal Function

Pin No.	Function	Pin No.	Function
1	S-Meter output terminal.	19	Pilot detector.
2	IF buffer sensitivity control.	20	Pilot detector.
3	IF buffer output terminal.	21	VCO
4	Mute starting point control.	22	Phase detector.
5	Mute drive control terminal.	23	Phase detector.
6	Noise sensitivity control.	24	PLL input terminal.
7	Noise AGC sensitivity control.	25	Stereo indicator lamp terminal.
8	Vcc	26	Noise canceller input.
9	Gate time control terminal.	27	GND.
10	Memory circuit.	28	Muting amp output terminal. (AF output)
11	LFP output.	29	AFC output terminal.
12	High-cut attenuator control.	30	Peak detector input.
13	HCC control input.	31	IF output.
14	SNC control input.	32	Muting attenuator control.
15	MPX left output.	33	Regulator output.
16	MPX right output.	34	Pilot cancel signal detector.
17	Pilot cancel signal input.	35	IF bias.
18	Pilot cancel signal output.	36	IF input.

TC4S66F
(IC401)

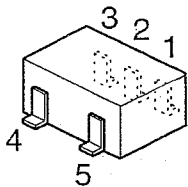

- 1: IN/OUT
- 2: OUT/IN
- 3: Vss
- 4: CONT
- 5: VDD

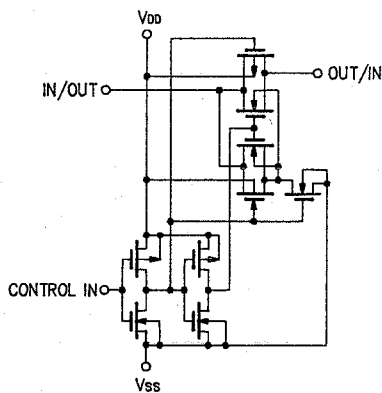

PIN ASSIGNMENT (TOP VIEW)

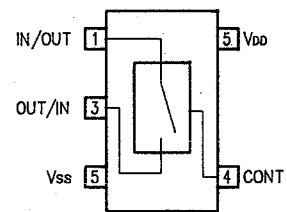

TRUTH VALUE TABLE

CONTROL	Impedance Between IN/OUT-OUT/IN
H	$0.5 \sim 5 \times 10^2$ ohm
L	$>10^9$ ohm

TA8141F
(IC702)

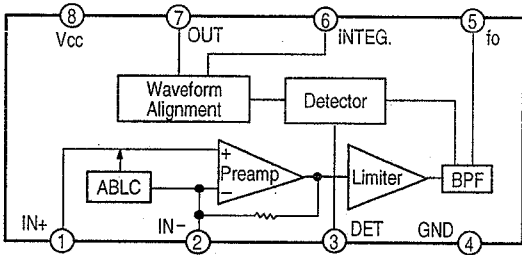
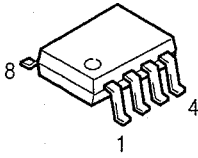

M5280FP
(IC601)

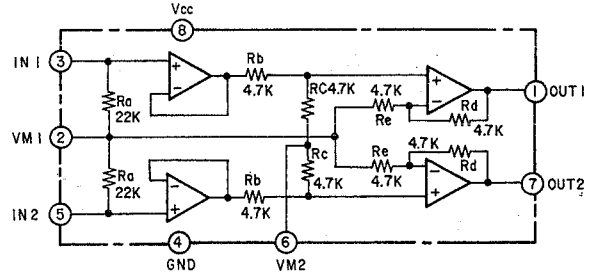
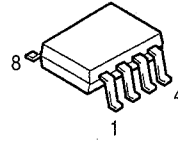

PST529C
(IC802)

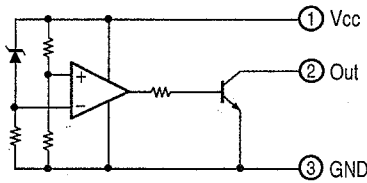

HA13150
(IC501)

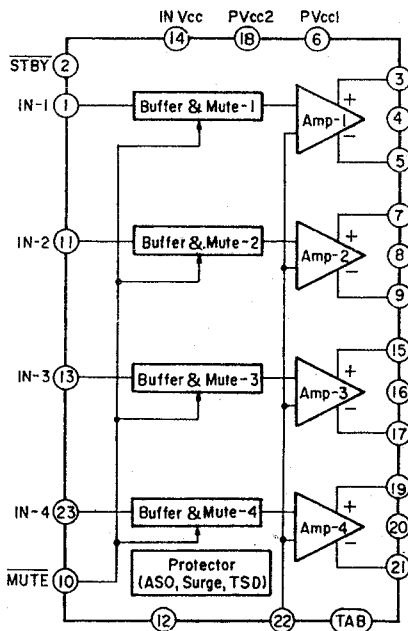
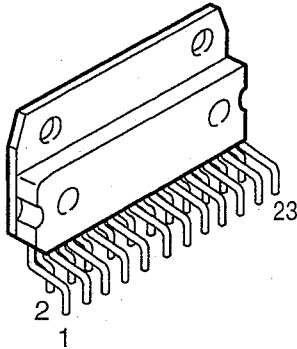

BA3910-V2
(IC801)

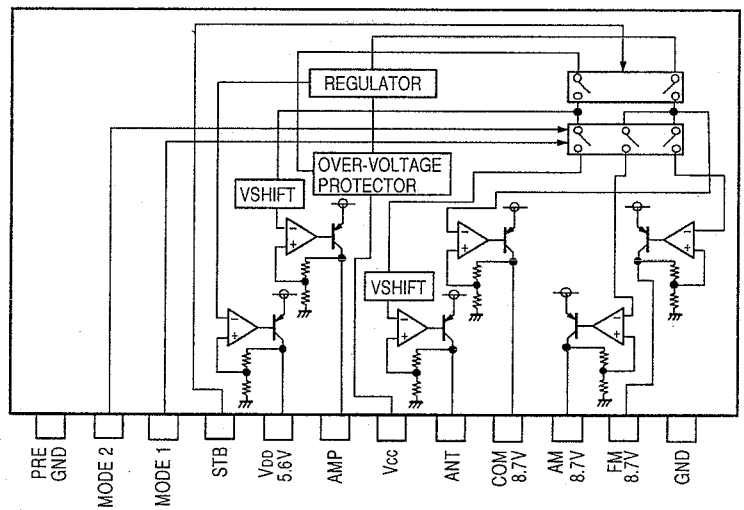
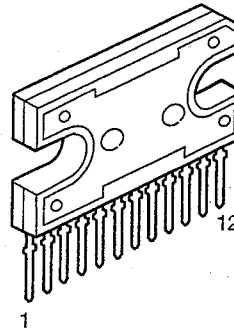

CXA1767Q
(IC203)

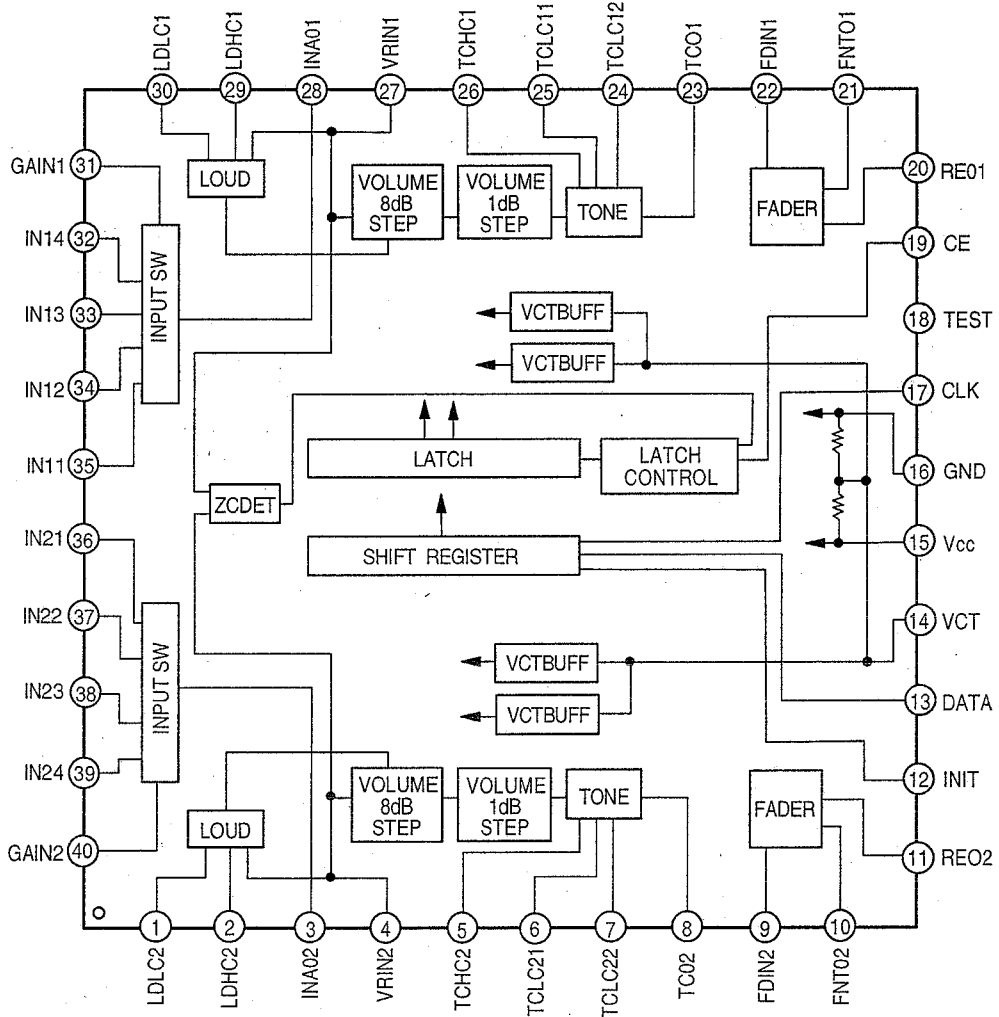
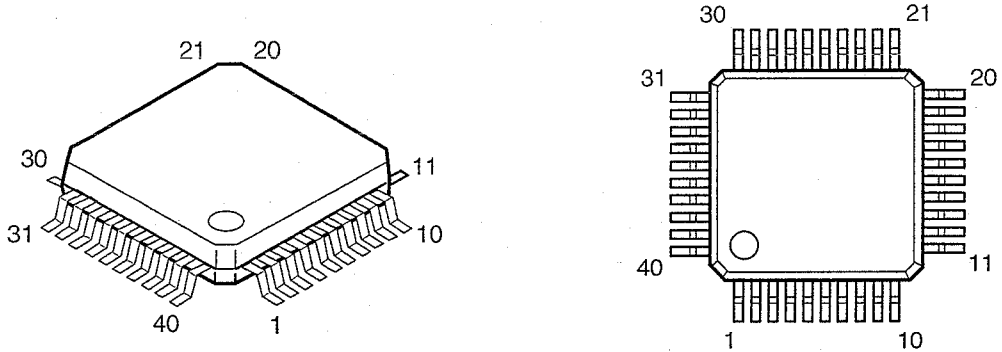

CXA1767Q Terminal Function

Pin No.	Symbol	I/O Resistance Internal Voltage	Function
1 30	LDLC2 LDLC1	5.28 kohm VCT	Setting of loudness lower range cutoff frequency.
2 29	LDHC2 LDHC1	7.97kohm VCT	Setting of loudness higher range cutoff frequency.
3 28	INAO2 INAO1	— VCT	Output of input selector.
4 27	VRIN2 VRIN1	50kohm VCT	Volume input.
5 26	TCHC2 TCHC1	5 kohm VCT	Setting of tone higher range frequency.
6 25	TCLC21 TCLC11	8 kohm VCT	Setting of tone lower range frequency.
7 24	TCLC22 TCLC12	8 kohm VCT	Setting of tone lower range frequency.
8 23	TCO2 TCO1	— VCT	Tone control output.
9 22	FDIN2 FDIN1	24kohm VCT	Fader input.
10 21	FNTO2 FNTO1	— VCT	Front output.
11 20	REO2 REO1	— VCT	Rear output.
12	INIT	—	System reset.
13	DATA	$\approx \infty$ —	Serial data input.
14	VCT	— VCT	Center point potential.
15	Vcc	Vcc	+ Power supply terminal.
16	GND	GND	GND.
17	CLK	$\approx \infty$ —	Serial clock.
18	TEST	—	Terminal for test, must be opened.
19	CE	$\approx \infty$ —	Latch enable.
31 40	GAIN1 GAIN2	10kohm VCT	By connecting to VCT, sets the input amplifier gain at 6db. OPEN: 0db.
32 33 34 35 36 37 38 39	IN14 IN13 IN12 IN11 IN21 IN22 IN23 IN24	50kohm VCT	Signal input.

● TRANSISTORS
Digital Transistors
(Including Resistors)

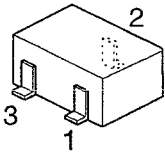

1: GND/Emitter
 2: Out/Collector
 3: In/Base

- DTA115EK
- DTA143EK
- DTC114EK
- DTC143EK
- DTC144EK
- DTC144TK
- DTC314TK

DTA EK Series

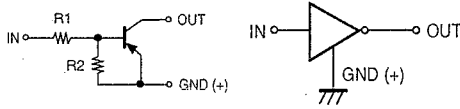

	R1	R2
DTA115EK	100Kohm	100Kohm
DTA143EK	4.7Kohm	4.7Kohm

DTC TK Series

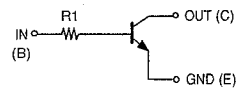

	R1
DTC144TK	47Kohm
DTC314TK	10Kohm

DTC EK Series

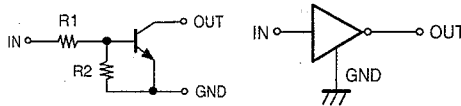

	R1	R2
DTC114EK	10Kohm	10Kohm
DTC143EK	4.7Kohm	4.7Kohm
DTC144EK	47Kohm	47Kohm

2SC2412K (S)

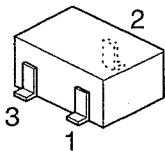

1: Emitter/GND
 2: Collector/OUT
 3: Base/IN

2SB1243 (R)
2SD1858 (Q/R)

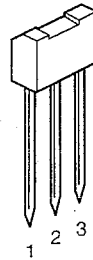

1: Emitter
 2: Collector
 3: Base

2SD1913 (R/S)

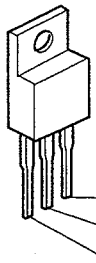

E (Emitter)
 C (Collector)
 B (Base)

FMC3

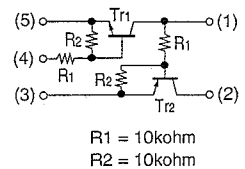
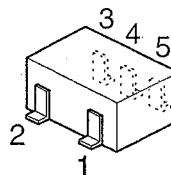

● DIODES (including LED)

HZS2B-1
HZS3A-1
HZS6B-1
HZS7A-1
HZS9C-1
HZS11A-1
HZS24-1

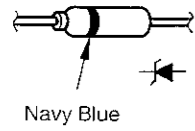

Navy Blue

PD410PI

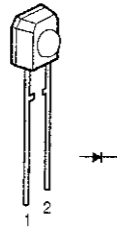

1: Anode
2: Cathode

LTZ-MR15

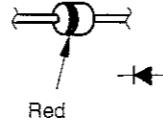

Red

HZM18NB1

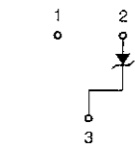
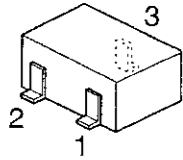

1: Open
2: Anode
3: Cathode

1SS270A

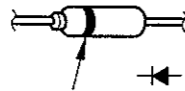

Light Blue

EM2



White

MA151WK
DA204K

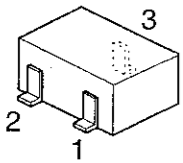

MA151WK

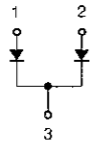

1: Anode
2: Anode
3: Cathode

DA204K

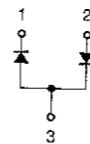

1: Cathode
2: Anode
3: Common

Zener Diode Array (9P)

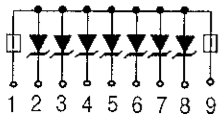
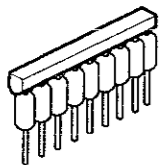

Zener Diode Array (12P)

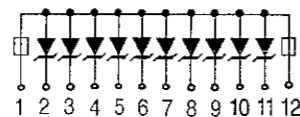
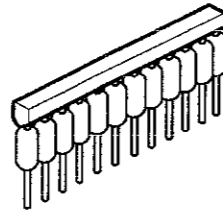

● LCD ASS'Y (SLU-10073-01) LCD1
Parts No. 393 6011 005

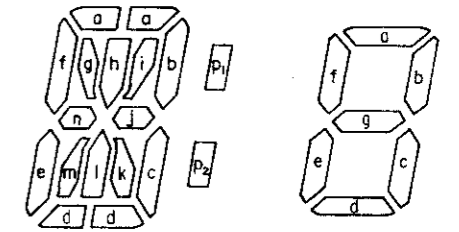
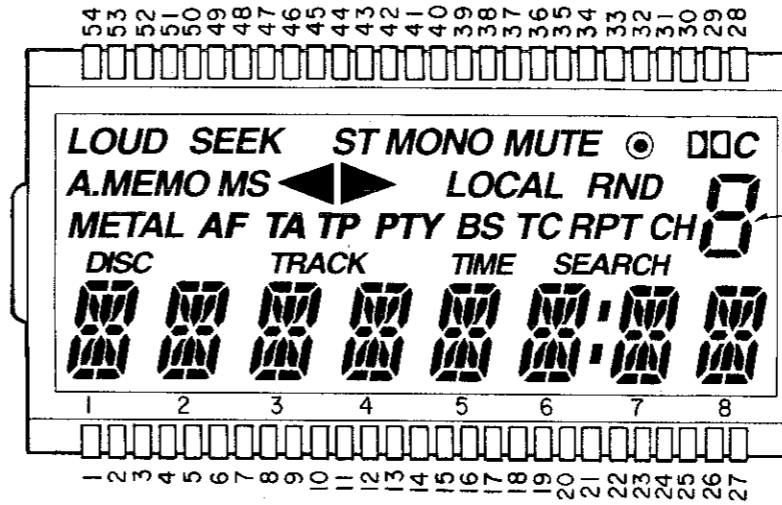

WIRING TABLE

	1	2	3	4	5	6	7	8	9	10	11	12	13	14	15	16	17	18
com1	LOUD	SEEK	1d	1c	DISK	METAL	2d	2c	A.MEMO	AF	3d	3c	MS	TRACK	4d	4c	TA	TP
com2	1e	1m	1l	1k	2e	2m	2l	2k	3e	3m	3l	3k	4e	4m	4l	4k	5e	5m
com3	1n	1g	1h	1j	2n	2g	2h	2j	3n	3g	3h	3j	4n	4g	4h	4j	5n	5g
com4	1f	1a	1i	1b	2f	2a	2i	2b	3f	3a	3i	3b	4f	4a	4i	4b	5f	5a

	19	20	21	22	23	24	25	26	27	28	29	30	31	32	33	34	35	36
com1	5d	5c	TIME	PTY	6d	6c	P2	—	7d	7c	—	—	8d	8c	9a	□□ C	●	MUTE
com2	5l	5k	6e	6m	6l	6k	7e	7m	7l	7k	8e	8m	8l	8k	9b	9f	RND	LOCAL
com3	5h	5j	6n	6g	6h	6j	7n	7g	7h	7j	8n	8g	8h	8j	9c	9g	CH	RPT
com4	5i	5b	6f	6a	6i	6b	7f	7a	7i	7b	8f	8a	8i	8b	9d	9e	SEARCH	P1

	37	38	39	40	41	42	43
com1	ST	▶	◀	—	—	—	com1
com2	MONO	—	—	—	—	com2	—
com3	TC	—	—	—	com3	—	—
com4	BS	—	—	com4	—	—	—

PRINTED WIRING BOARD

1U-2690 MAIN UNIT ASS'Y

Pattern Side

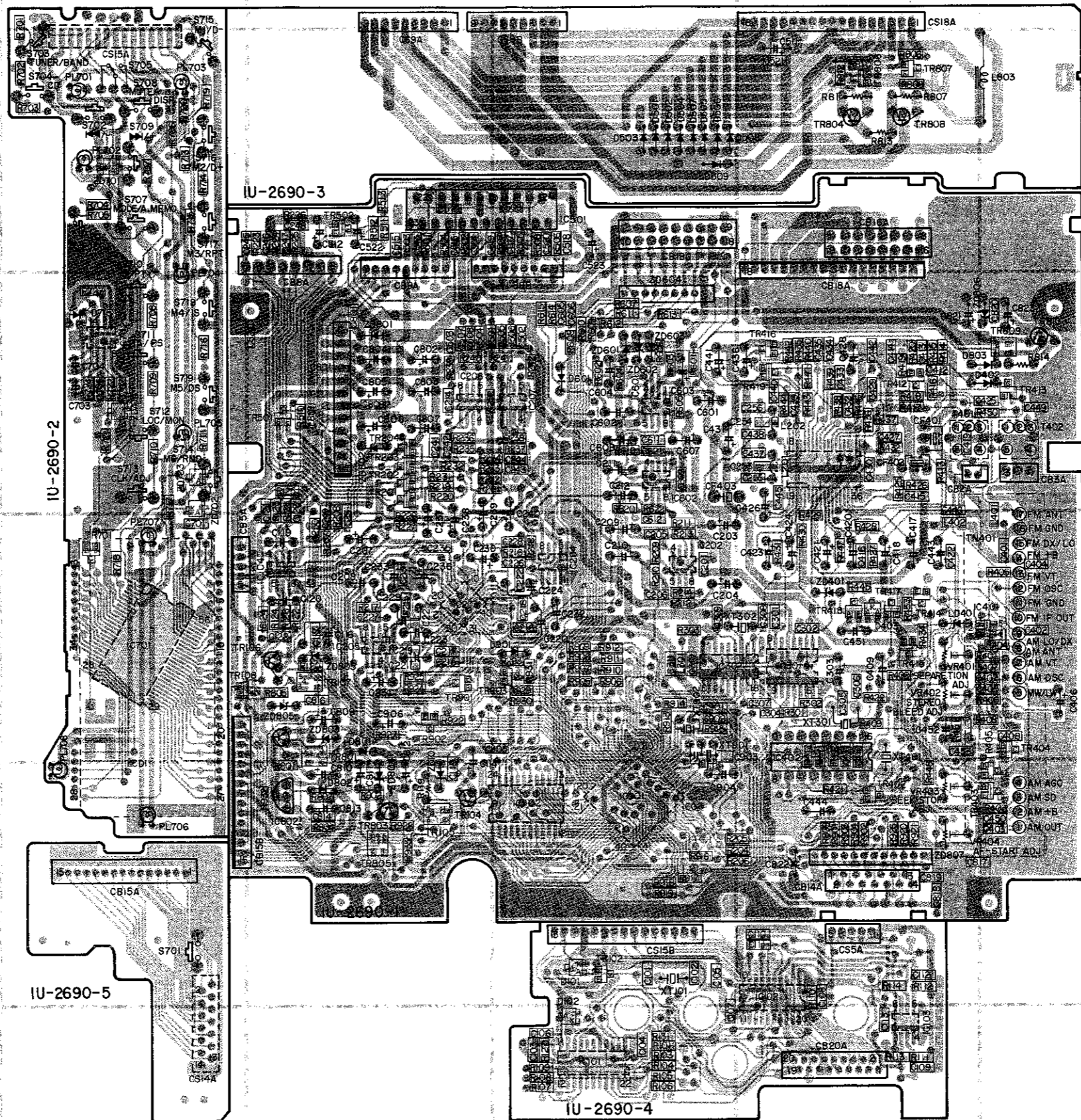

Component Side

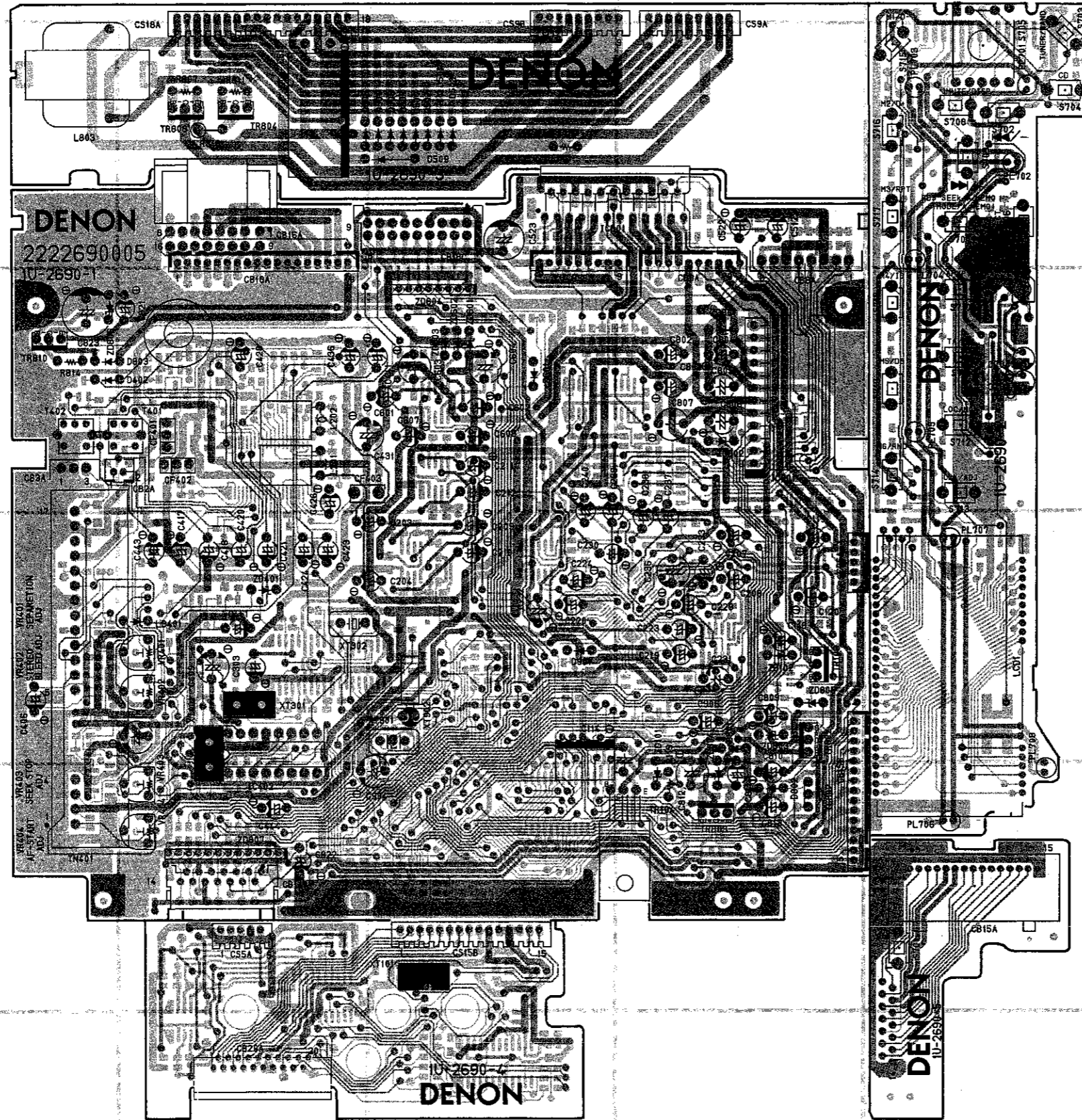

MD SECTION

1-707-396-31 UNIT

Pattern Side

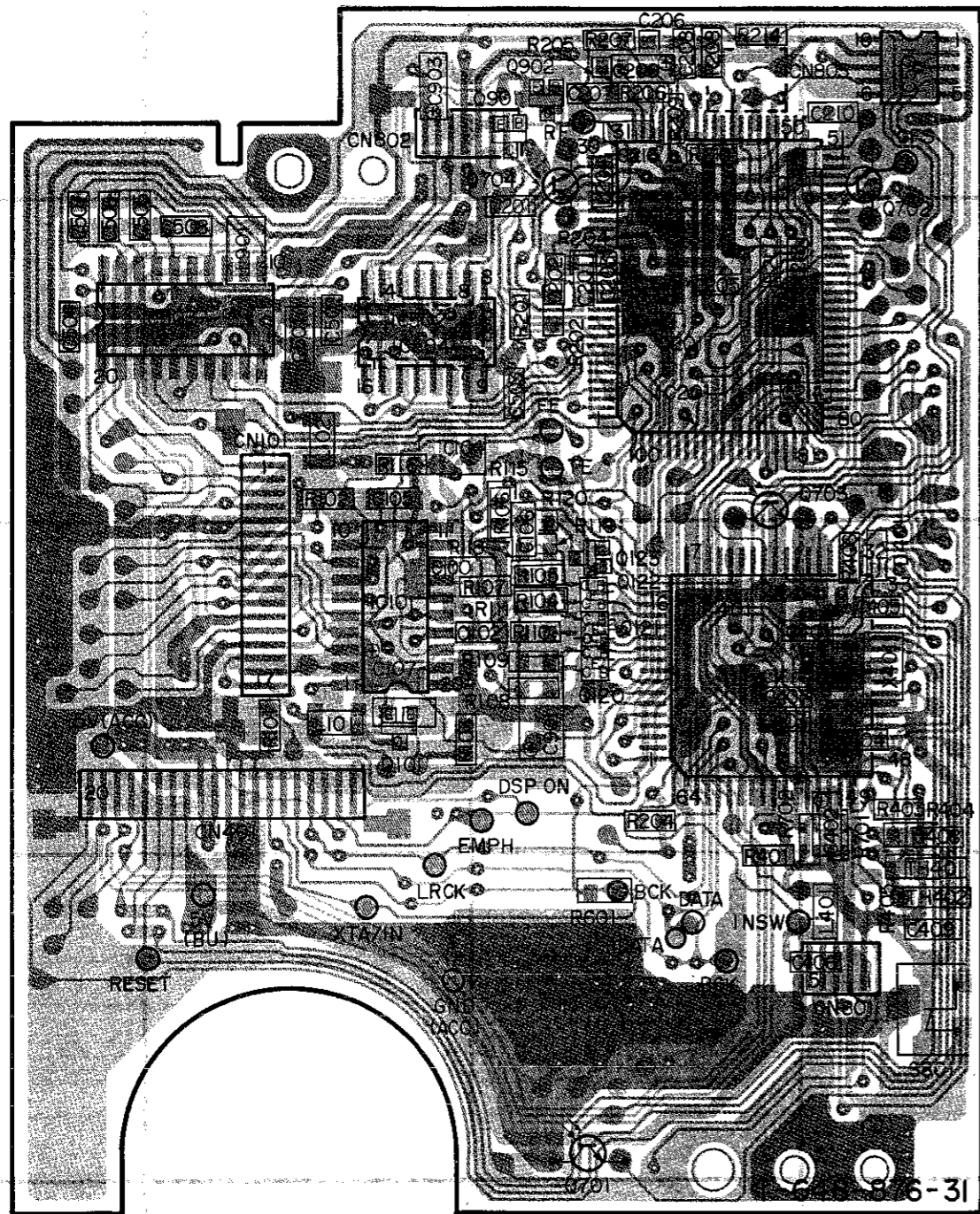

1-650-111-11 and 1-650-144-11 UNITS

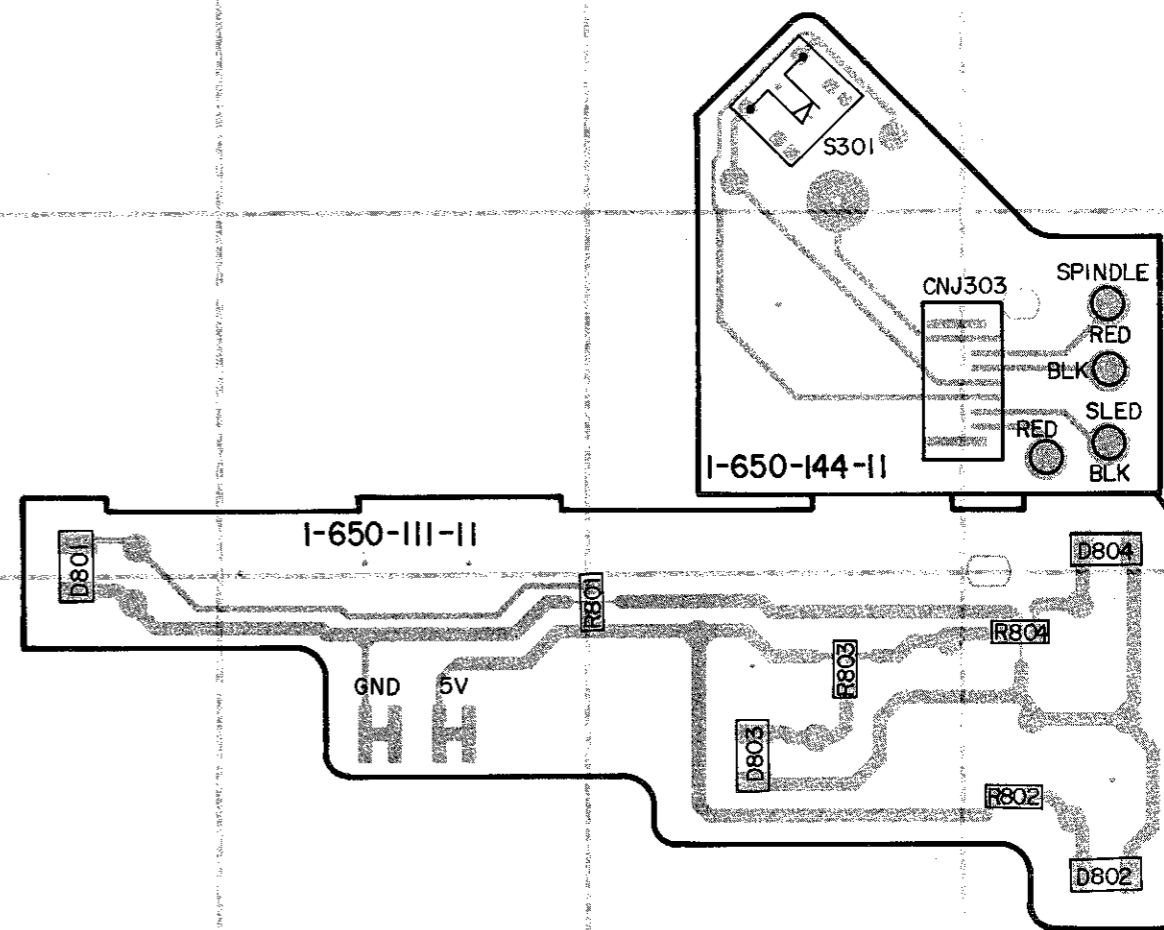

Component Side

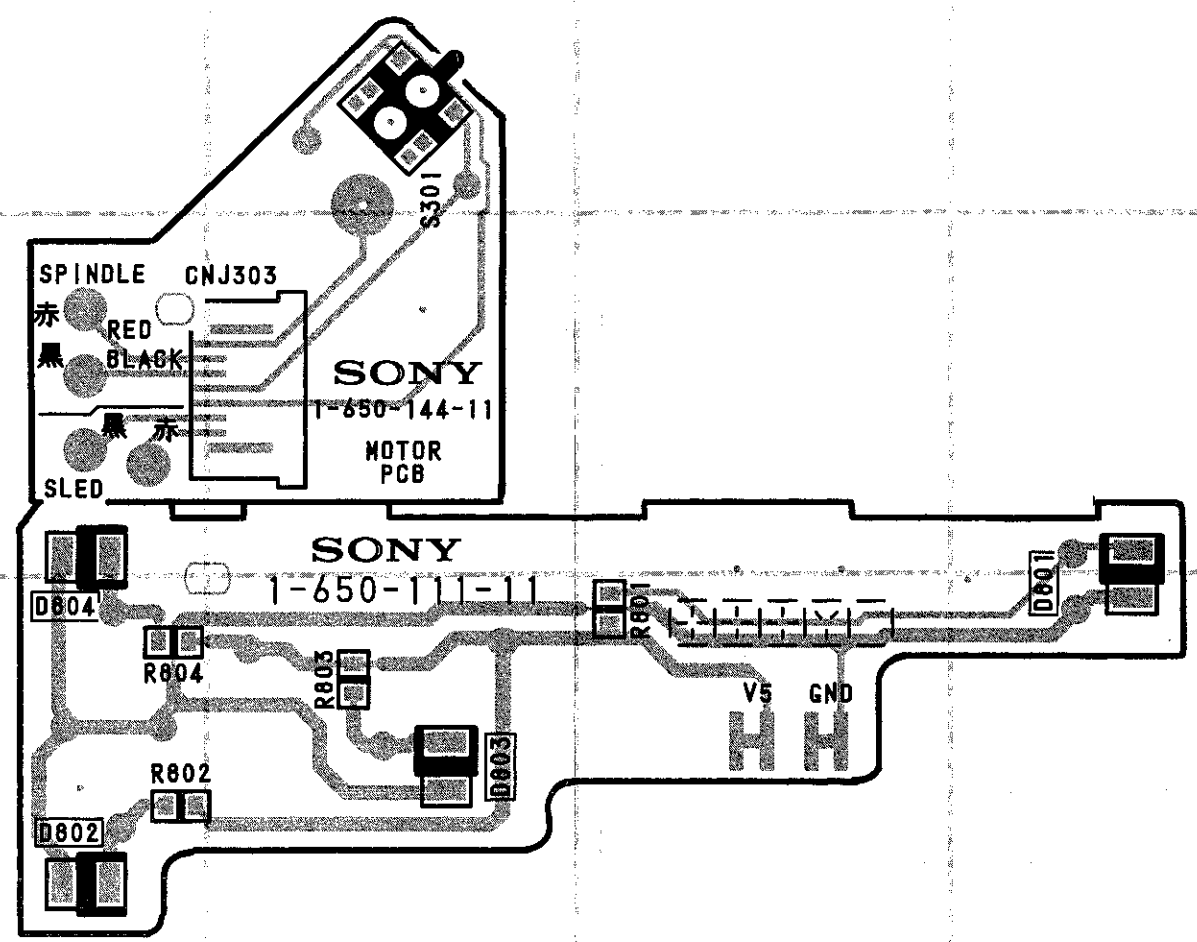
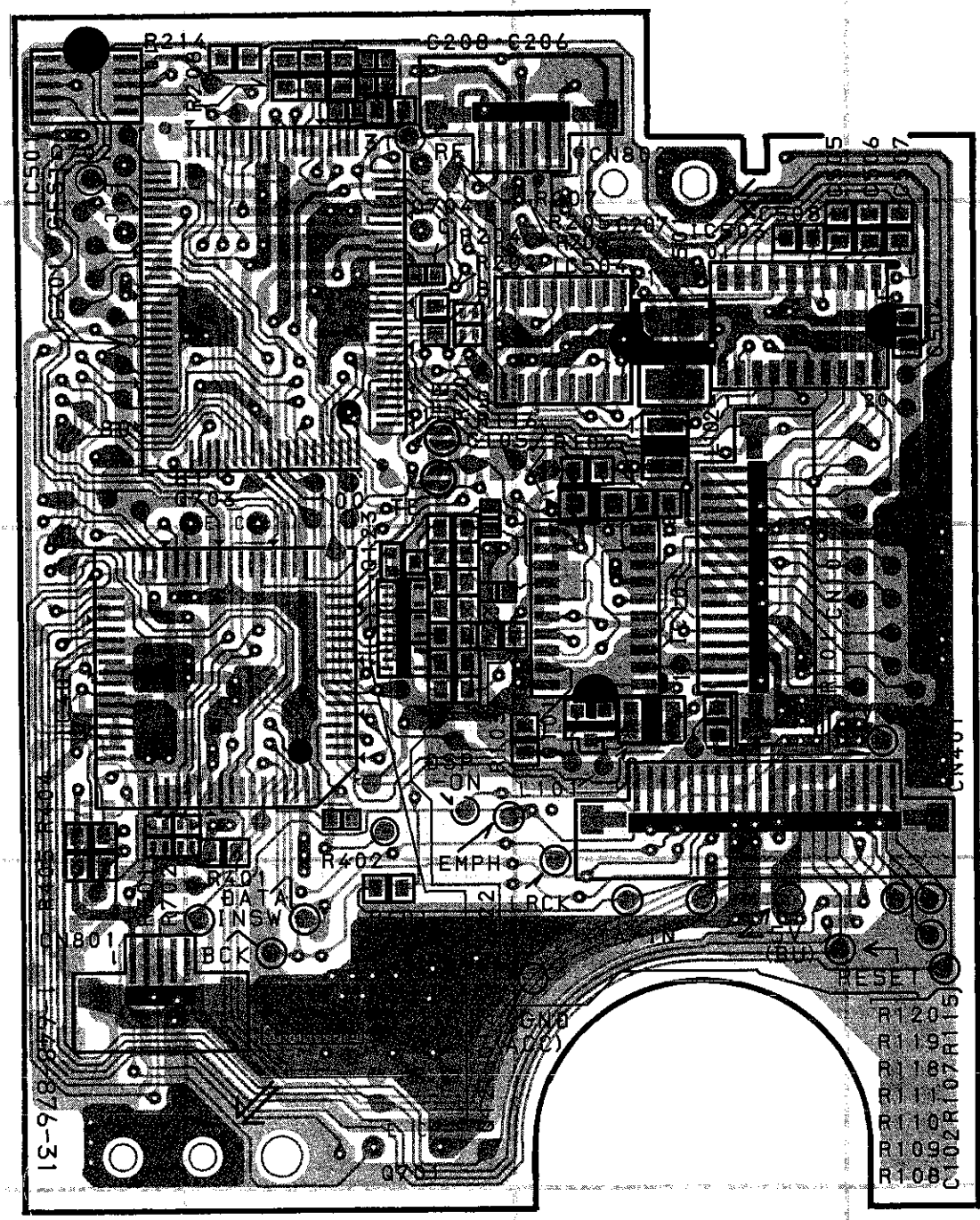

WIRING DIAGRAM

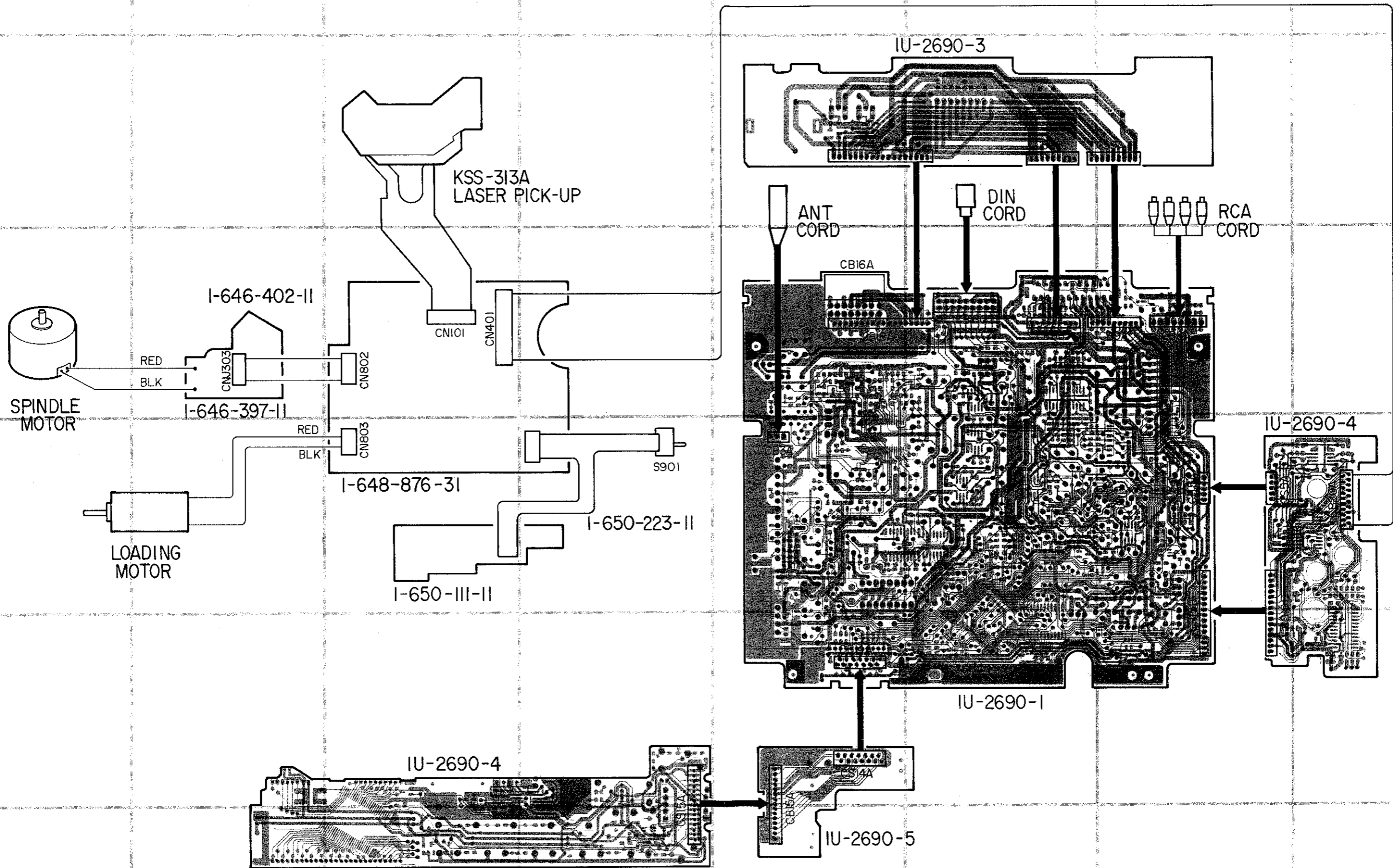

IC's AND TRANSISTORS VOLTAGE VALUES

● MAIN SECTION

IC101 (SM5841CS)

Table for IC101 (SM5841CS) with columns Pin, FM, AM, CD and values for pins 1-22.

IC102 (PCM67U)

Table for IC102 (PCM67U) with columns Pin, FM, AM, CD and values for pins 1-20.

IC103 (M5218AFP)

Table for IC103 (M5218AFP) with columns Pin, FM, AM, CD and values for pins 1-8.

IC104 (M5218AFP)

Table for IC104 (M5218AFP) with columns Pin, FM, AM, CD and values for pins 1-8.

IC202 (M5218AFP)

Table for IC202 (M5218AFP) with columns Pin, FM, AM, CD and values for pins 1-8.

IC203 (CXA1767Q)

Table for IC203 (CXA1767Q) with columns Pin, FM, AM, CD and values for pins 1-40.

IC204 (M5218AFP)

Table for IC204 (M5218AFP) with columns Pin, FM, AM, CD and values for pins 1-8.

IC205 (M5218AFP)

Table for IC205 (M5218AFP) with columns Pin, FM, AM, CD and values for pins 1-8.

IC206 (M5218AFP)

Table for IC206 (M5218AFP) with columns Pin, FM, AM, CD and values for pins 1-8.

IC207 (M5218AFP)

Table for IC207 (M5218AFP) with columns Pin, FM, AM, CD and values for pins 1-8.

IC301 (SAA6579T)

Table for IC301 (SAA6579T) with columns Pin, FM, AM, CD and values for pins 1-16.

IC302 (LC7074NM)

Table for IC302 (LC7074NM) with columns Pin, FM, AM, CD and values for pins 1-36.

IC401 (TC1S66F)

Table for IC401 (TC1S66F) with columns Pin, FM, AM, CD and values for pins 1-5.

IC402 (TC9216P)

Table for IC402 (TC9216P) with columns Pin, FM, AM, CD and values for pins 1-16.

IC403 (LA1862M)

Table for IC403 (LA1862M) with columns Pin, FM, AM and values for pins 1-13.

Table for IC501 (HA13150) with columns Pin, FM, AM, CD and values for pins 1-36.

IC501 (HA13150)

Table for IC501 (HA13150) with columns Pin, FM, AM, CD and values for pins 1-23.

IC601 (M5280FP)

Table for IC601 (M5280FP) with columns Pin, FM, AM, CD and values for pins 1-8.

IC602 (M5218AFP)

Table for IC602 (M5218AFP) with columns Pin, FM, AM, CD and values for pins 1-8.

IC701 (PCF8576T)

Table for IC701 (PCF8576T) with columns Pin, FM, AM, CD and values for pins 1-56.

IC702 (TA8141F)

Table for IC702 (TA8141F) with columns Pin, FM, AM, CD and values for pins 1-8.

IC801 (BA3910B-V2)

Table for IC801 (BA3910B-V2) with columns Pin, FM, AM, CD and values for pins 1-52.

IC802 (PST529C)

Table for IC802 (PST529C) with columns Pin, FM and values for pins 1-3.

IC901 μPD78056GF-xxx-3B9

Table for IC901 μPD78056GF-xxx-3B9 with columns Pin, FM, AM, CD and values for pins 1-60.

Table with columns Pin, FM, AM, CD and values for pins 61-80.

IC902 (LC3517AML-15)

Table for IC902 (LC3517AML-15) with columns Pin, FM, AM, CD and values for pins 1-24.

FM/AM TUNER PACK

- FM 98.1 MHz
• AM 1000 kHz
TN401

Table for FM/AM Tuner Pack with columns Pin, FM, AM and values for pins 1-17.

Large table listing components (Element, Pin, FM, AM, CD) and voltage values for various parts like TR102, DTA143TK, IC104, etc.

SCHEMATIC DIAGRAM - (1/3)

MD SECTION

IC	IC101		IC503		IC504		IC201				
Transistor	Q701	Q702	Q101	Q120	Q121	Q122	Q201	Q123	IC502		
Diode (Including LED)	D801	D802					D803	D804			

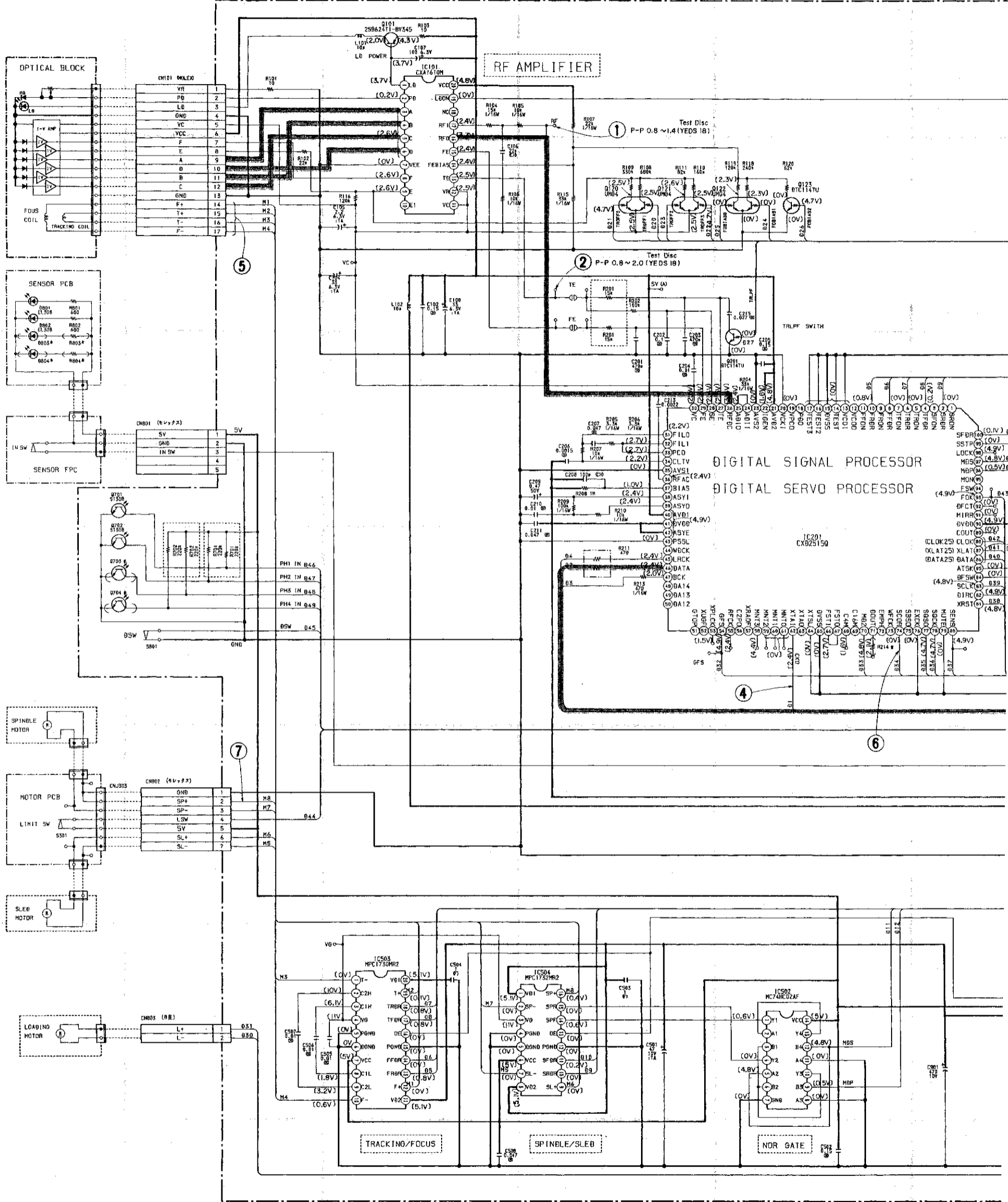

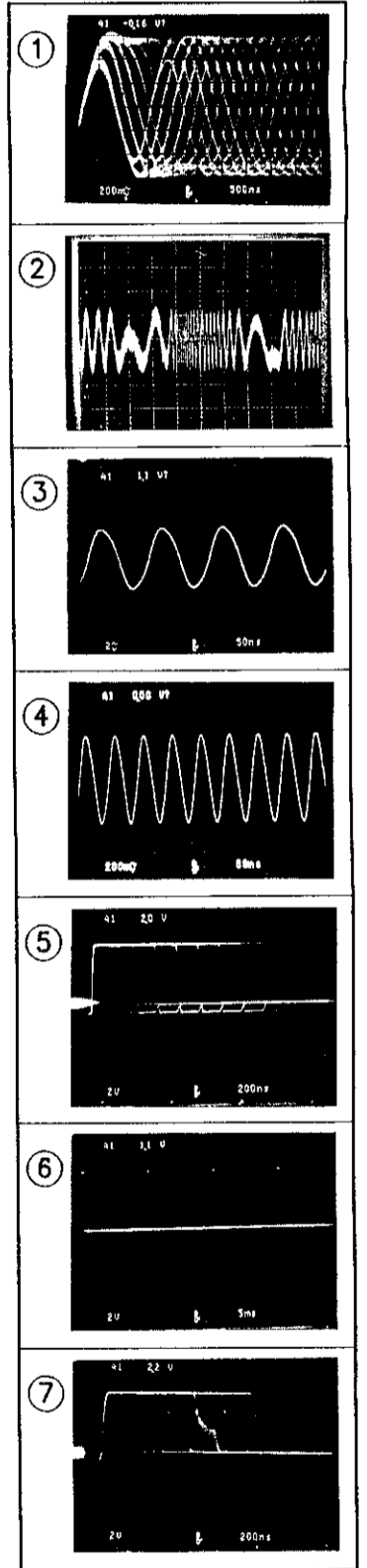
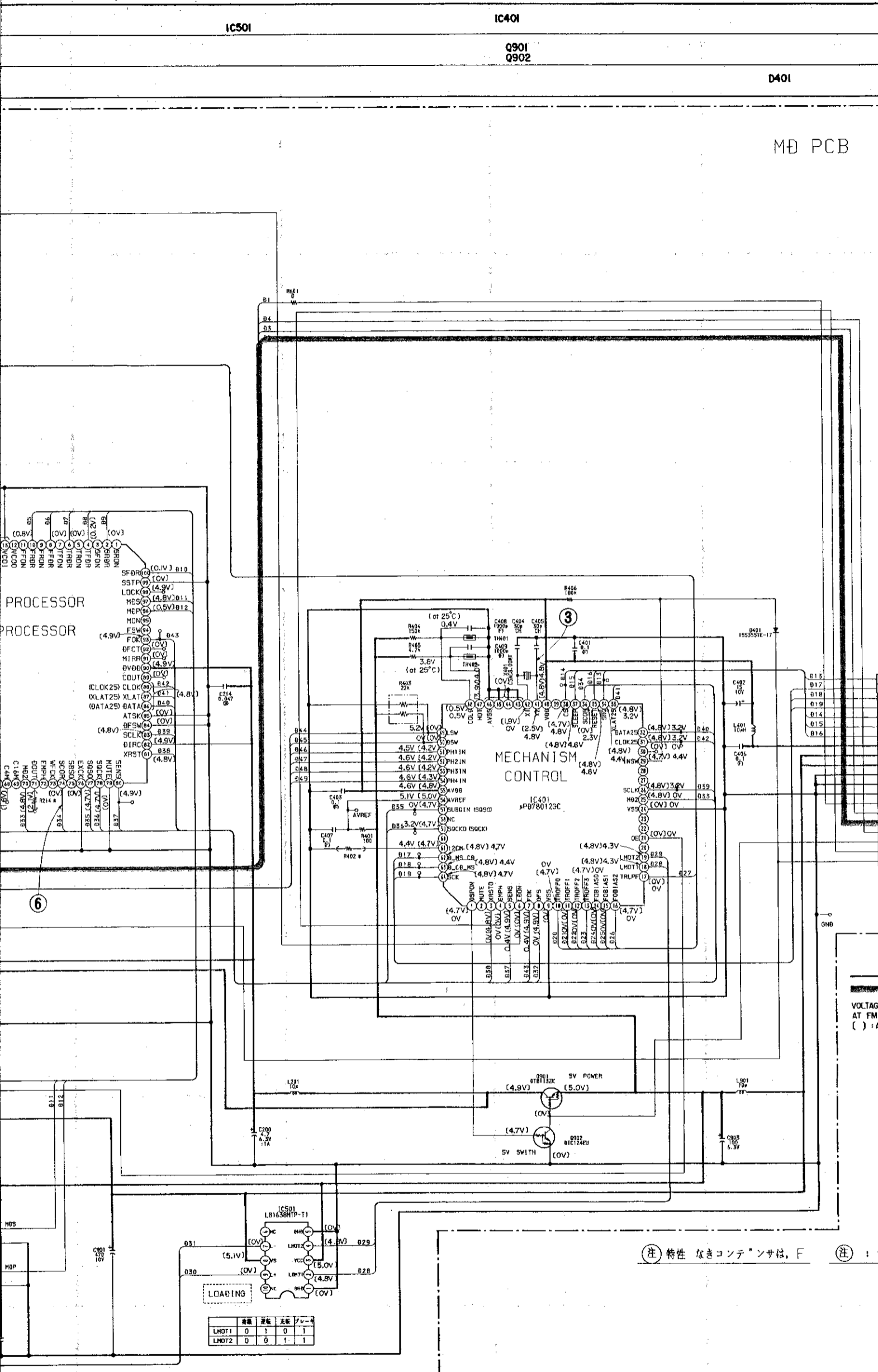

+B LINE
 SIGNAL LINE
 VOLTAGE ARE MEASURED
 AT FM NO SIGNAL
 () : AT CD PLAY (YEDS-18)

注 特性なきコンデンサは、F 注 : # MOUNT 無

WARNING:
Parts marked with this symbol  have critical characteristics. Use ONLY replacement parts recommended by the manufacturer.

CAUTION:
Before returning the unit to the customer, make sure you make either (1) a leakage current check or (2) a line to chassis resistance check. If the leakage current exceeds 0.5 milliamps, or if the resistance from chassis to either side of the power cord is less than 240 kohms, the unit is defective.

WARNING:
DO NOT return the unit to the customer until the problem is located and corrected.

NOTES
ALL RESISTANCE VALUES IN OHM. k=1,000 OHM, M=1,000,000 OHM
ALL CAPACITANCE VALUES IN MICRO FARAD. P=MICRO-MICRO FARAD
EACH VOLTAGE AND CURRENT ARE MEASURED AT NO SIGNAL INPUT CONDITION.
CIRCUIT AND PARTS ARE SUBJECT TO CHANGE WITHOUT PRIOR NOTICE.

SCHEMATICDIAGRAM - (2/3)

MAIN SECTION

IC	IC104	IC401	IC403	IC301	IC402 IC302	IC602 IC601	IC902	IC901	IC202
Transistor	TR104 TR412 TR415	TR105 TR418 TR417	TR106 TR417	TR107 TR405 TR419	TR404	TR402	TR413 TR416		
Diode (including LED)	ZD103 ZD101 ZD401 LD401		ZD102 D403		ZD601 ZD602	ZD603 D402			ZD807

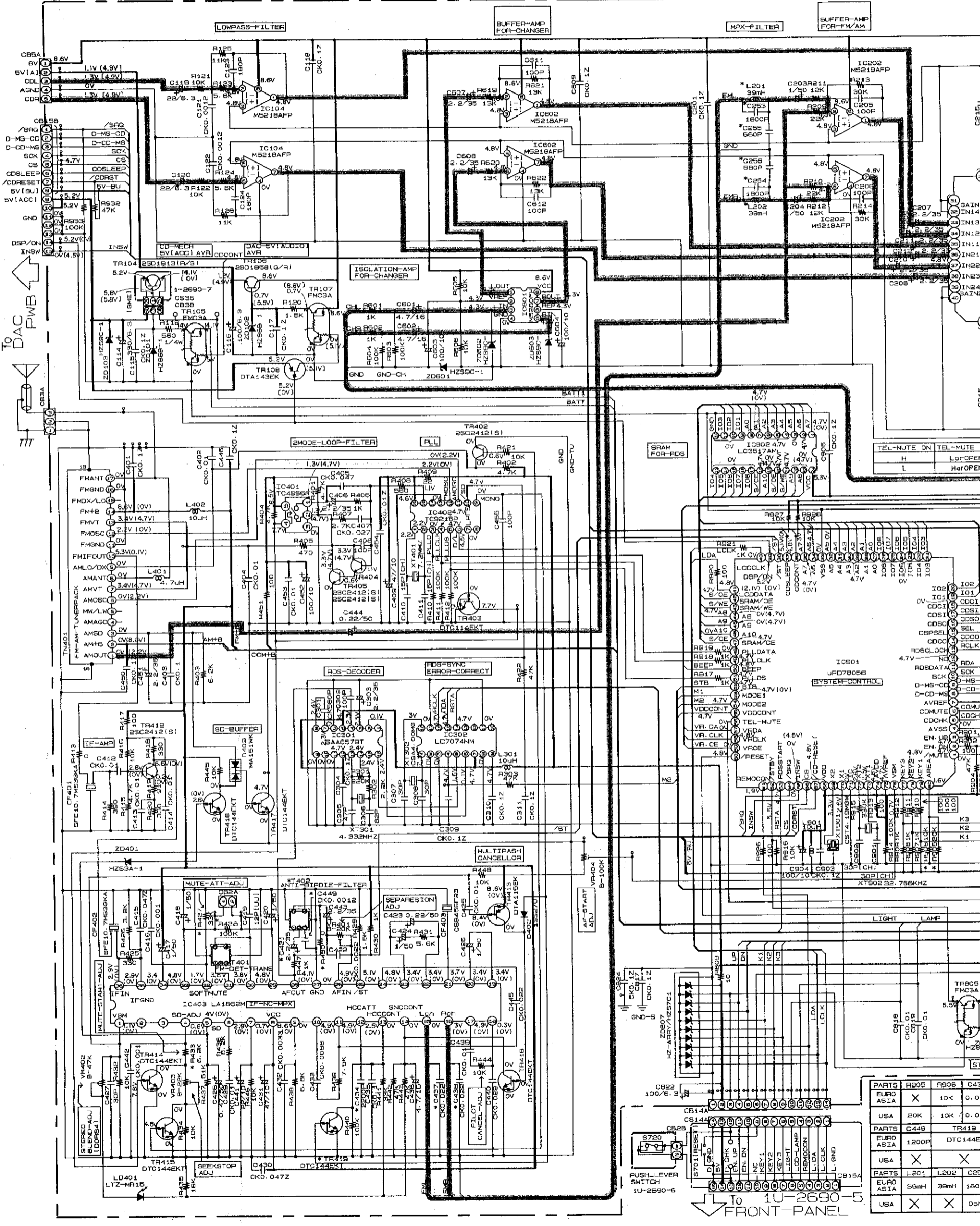

PARTS	R805	R906	C437
EURO ASIA	X	10K	0.02
USA	X	20K	10K
EURO ASIA	X	1200P	DTC144EK
USA	X	X	X
PARTS	L201	L202	C253
EURO ASIA	39MH	39MH	1800P
USA	X	X	0.0m

IC203	IC205	IC206	IC207
IC802	IC204	IC801	IC501
TR901 TR903 TR902	TR810	TR501 TR502 TR803	TR201 TR203 TR202 TR204 TR808 TR807 TR802 TR801
TR805	D804 D901 D801 D805	D803	D505 D506 D507 D508
ZD805	D802 ZD806	ZD804 ZD802 ZD803	D503 D504 D501 D502 ZD801 ZD604

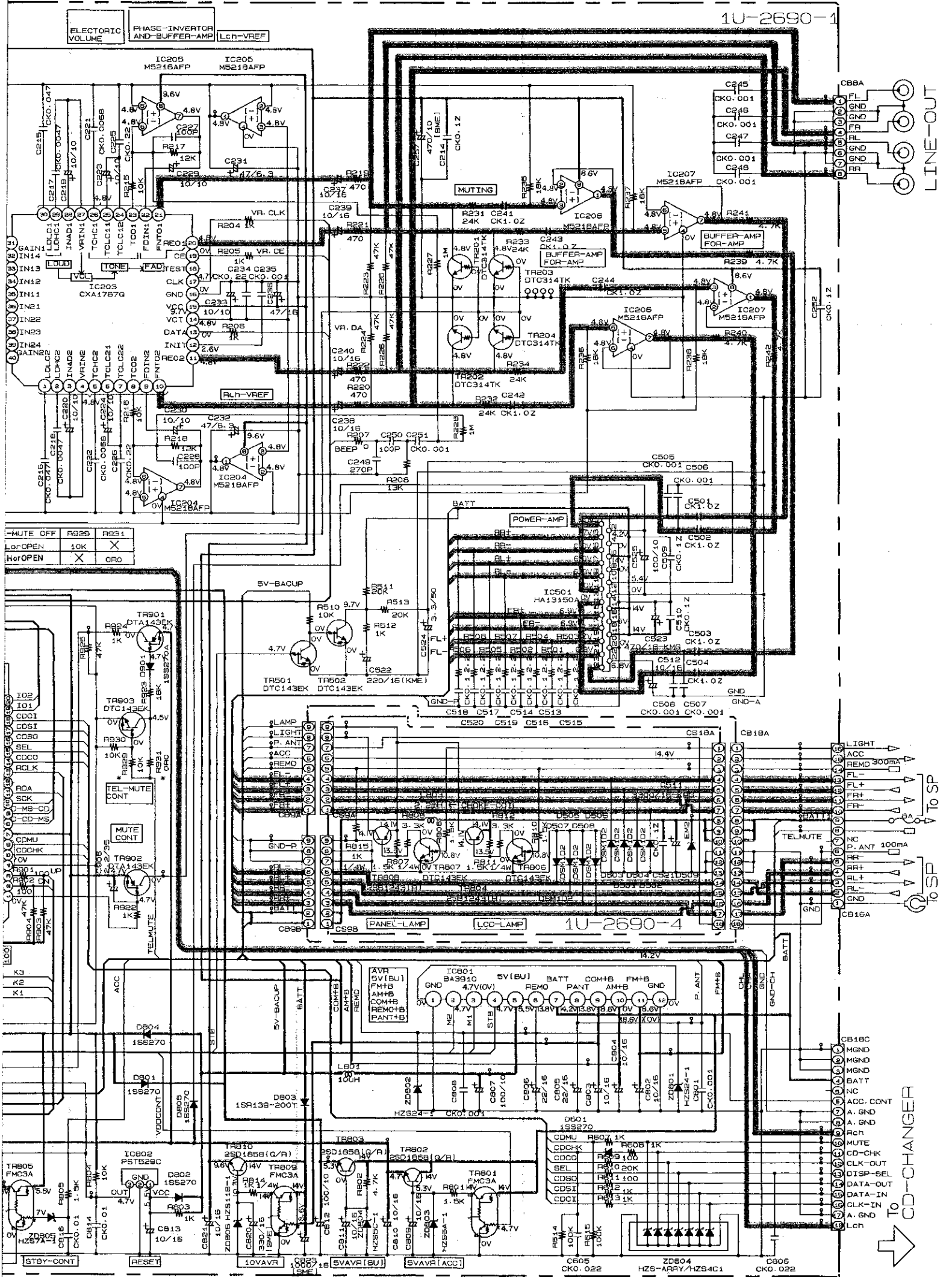

TR805	FMC3A	TR802	2501858(Q/R)	TR803	2501858(Q/R)	TR801	FMC3A
TR805	FMC3A	TR802	2501858(Q/R)	TR803	2501858(Q/R)	TR801	FMC3A
TR805	FMC3A	TR802	2501858(Q/R)	TR803	2501858(Q/R)	TR801	FMC3A
TR805	FMC3A	TR802	2501858(Q/R)	TR803	2501858(Q/R)	TR801	FMC3A

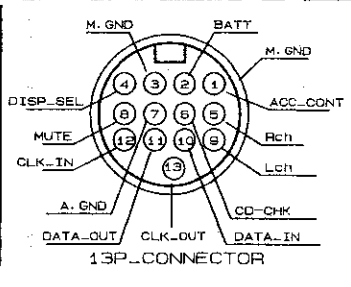

VOLTAGE ARE MEASURED AT FM NO SIGNAL (98.1MHz)
 () : AT AM NO SIGNAL (1000KHz)
 () : AT CD PLAY (YED5-18)

NOTES
 ALL RESISTANCE VALUES IN OHM. k=1,000 OHM, M=1,000,000 OHM
 ALL CAPACITANCE VALUES IN MICRO FARAD.
 P=MICRO-MICRO FARAD
 EACH VOLTAGE AND CURRENT ARE MEASURED AT NO SIGNAL INPUT CONDITION.
 CIRCUIT AND PARTS ARE SUBJECT TO CHANGE WITHOUT PRIOR NOTICE.

WARNING:
 Parts marked with this symbol have critical characteristics.
 Use ONLY replacement parts recommended by the manufacturer.

CAUTION:
 Before returning the unit to the customer, make sure you make either (1) a leakage current check or (2) a line to chassis resistance check. If the leakage current exceeds 0.5 milliamps, or if the resistance from chassis to either side of the power cord is less than 240 kohms, the unit is defective.

WARNING:
 DO NOT return the unit to the customer until the problem is located and corrected.

SCHEMATIC DIAGRAM - (3/3)
LCD DRIVER AND DAC SECTION

IC	IC702		
Transistor	TR701		
Diode (including LED)	ZD701	D715	ZD704 ZD702 ZD703

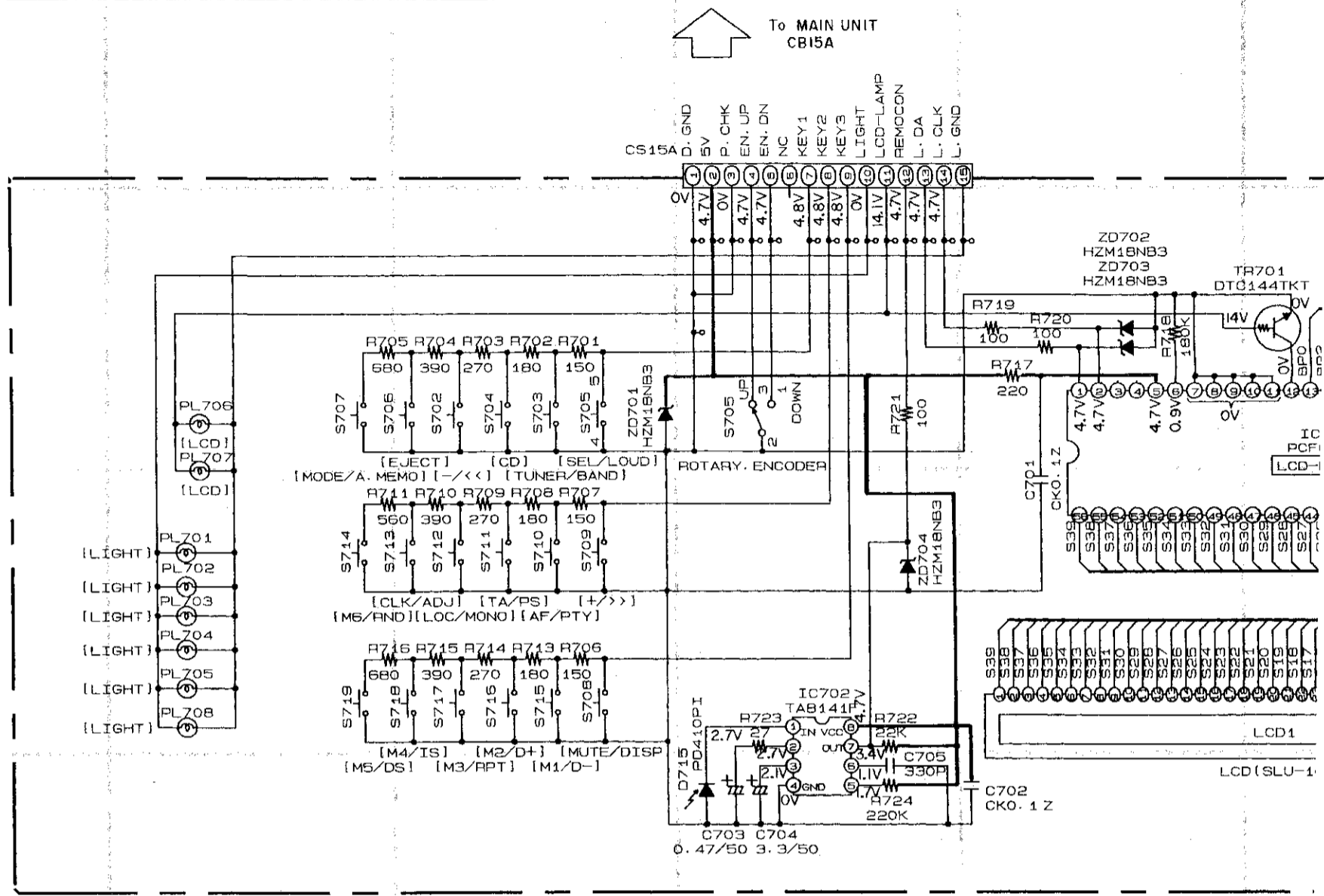

IC	
Transistor	
Diode (including LED)	D102

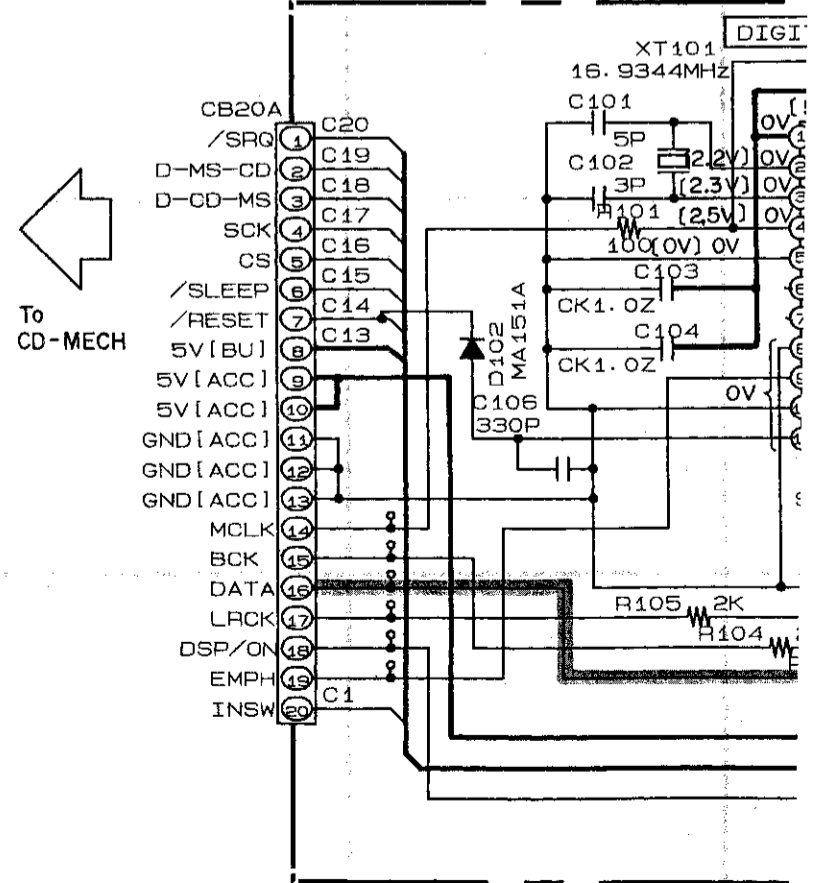

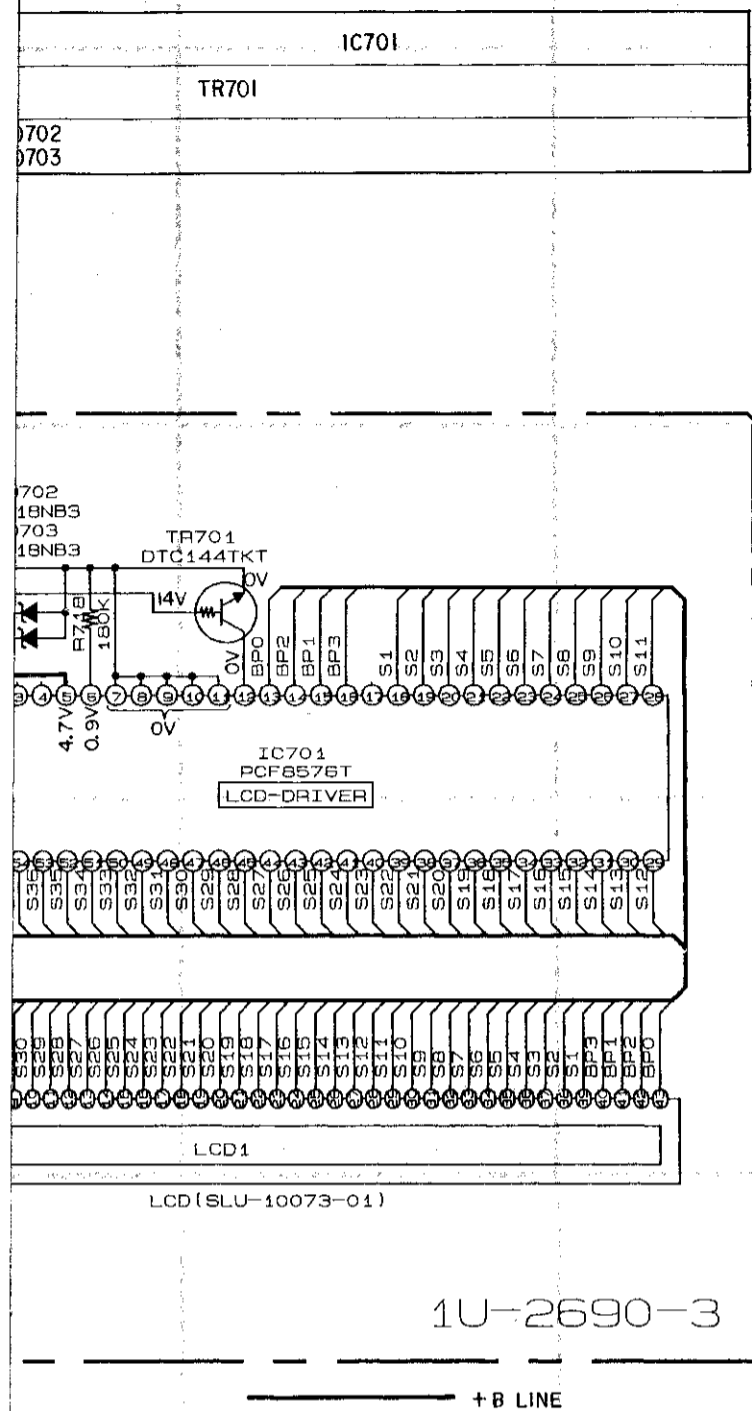

NOTES
 ALL RESISTANCE VALUES IN OHM. k=1,000 OHM, M=1,000,000 OHM
 ALL CAPACITANCE VALUES IN MICRO FARAD. P=MICRO-MICRO FARAD
 EACH VOLTAGE AND CURRENT ARE MEASURED AT NO SIGNAL INPUT
 CONDITION.
 CIRCUIT AND PARTS ARE SUBJECT TO CHANGE WITHOUT PRIOR
 NOTICE.

WARNING:
 Parts marked with this symbol have critical characteristics.
 Use ONLY replacement parts recommended by the manufacturer.

CAUTION:
 Before returning the unit to the customer, make sure you make either (1) a
 leakage current check or (2) a line to chassis resistance check. If the leakage
 current exceeds 0.5 milliamps, or if the resistance from chassis to either side
 of the power cord is less than 240 kohms, the unit is defective.

WARNING:
 DO NOT return the unit to the customer until the problem is located and
 corrected.

1U-2690-3

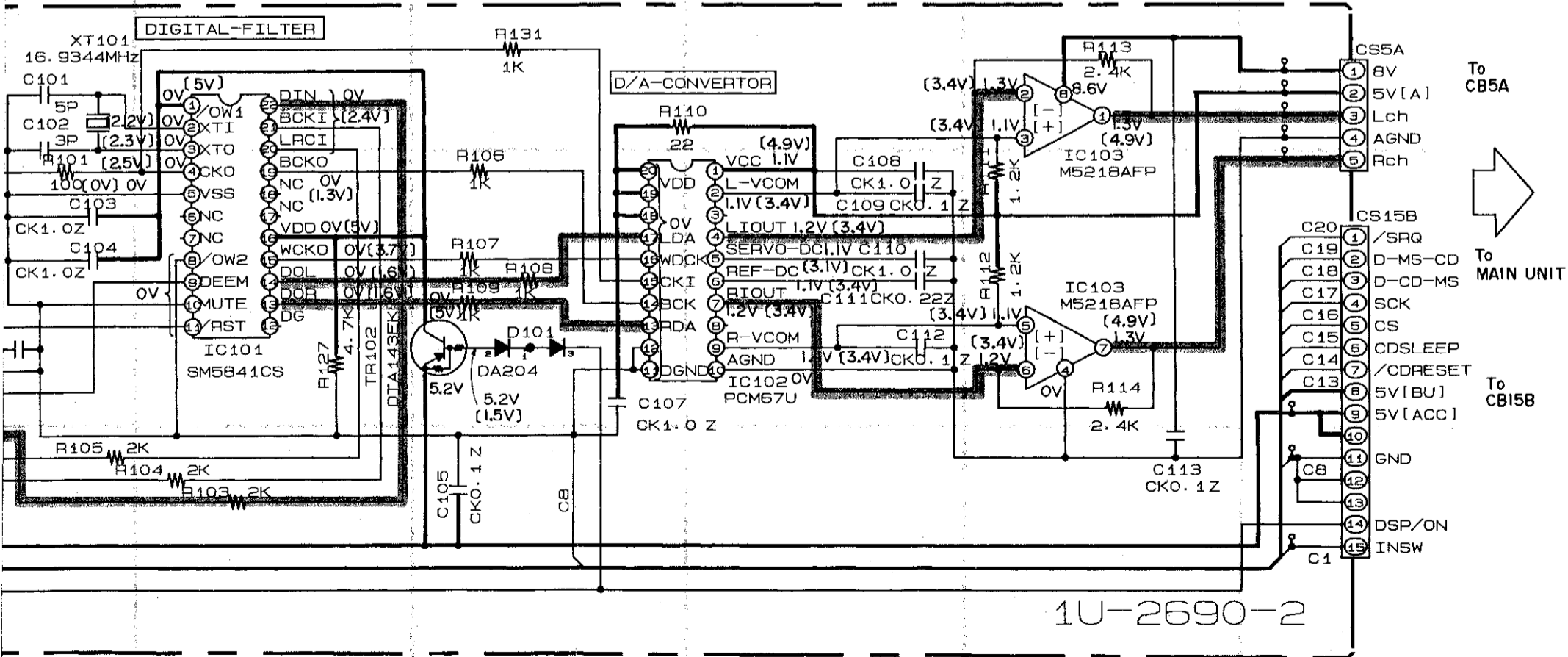
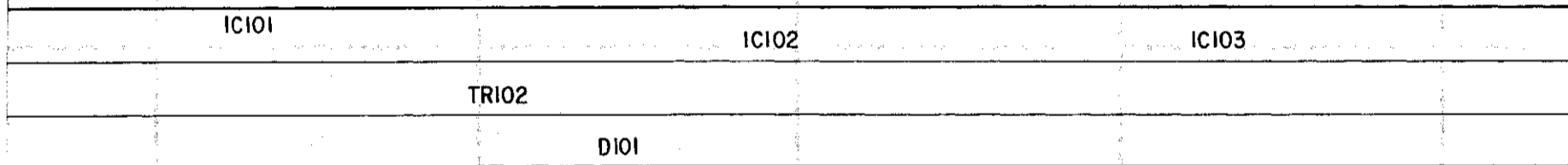

1U-2690-2

+B LINE
SIGNAL LINE
 VOLTAGE ARE MEASURED AT FM NO SIGNAL
 () : AT CD PLAY (YEDS-18)

EXPLODED VIEW OF CHASSIS AND CABINET

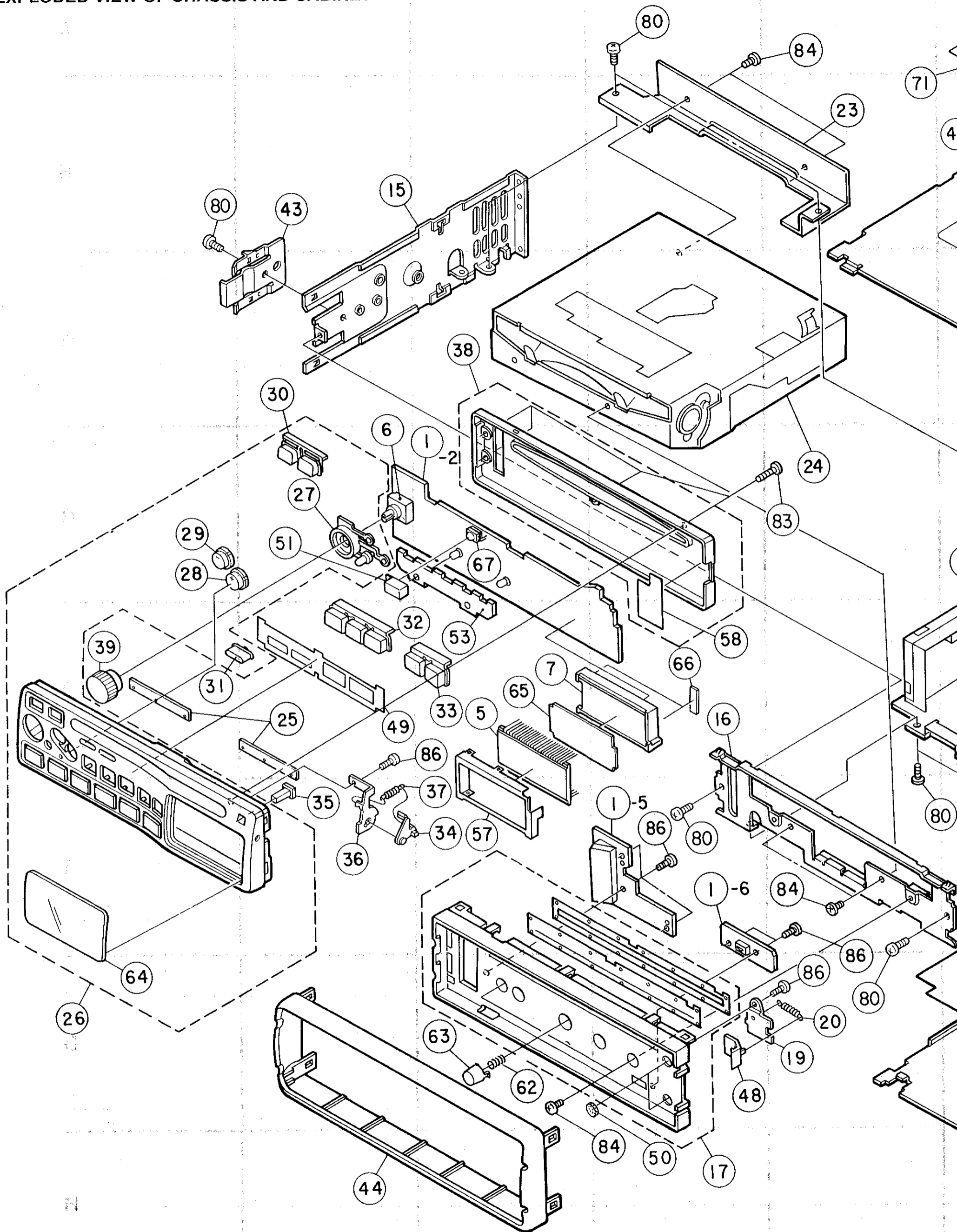

WARNING:
 Parts marked with this symbol  have critical characteristics.
 Use ONLY replacement parts recommended by the manufacturer.

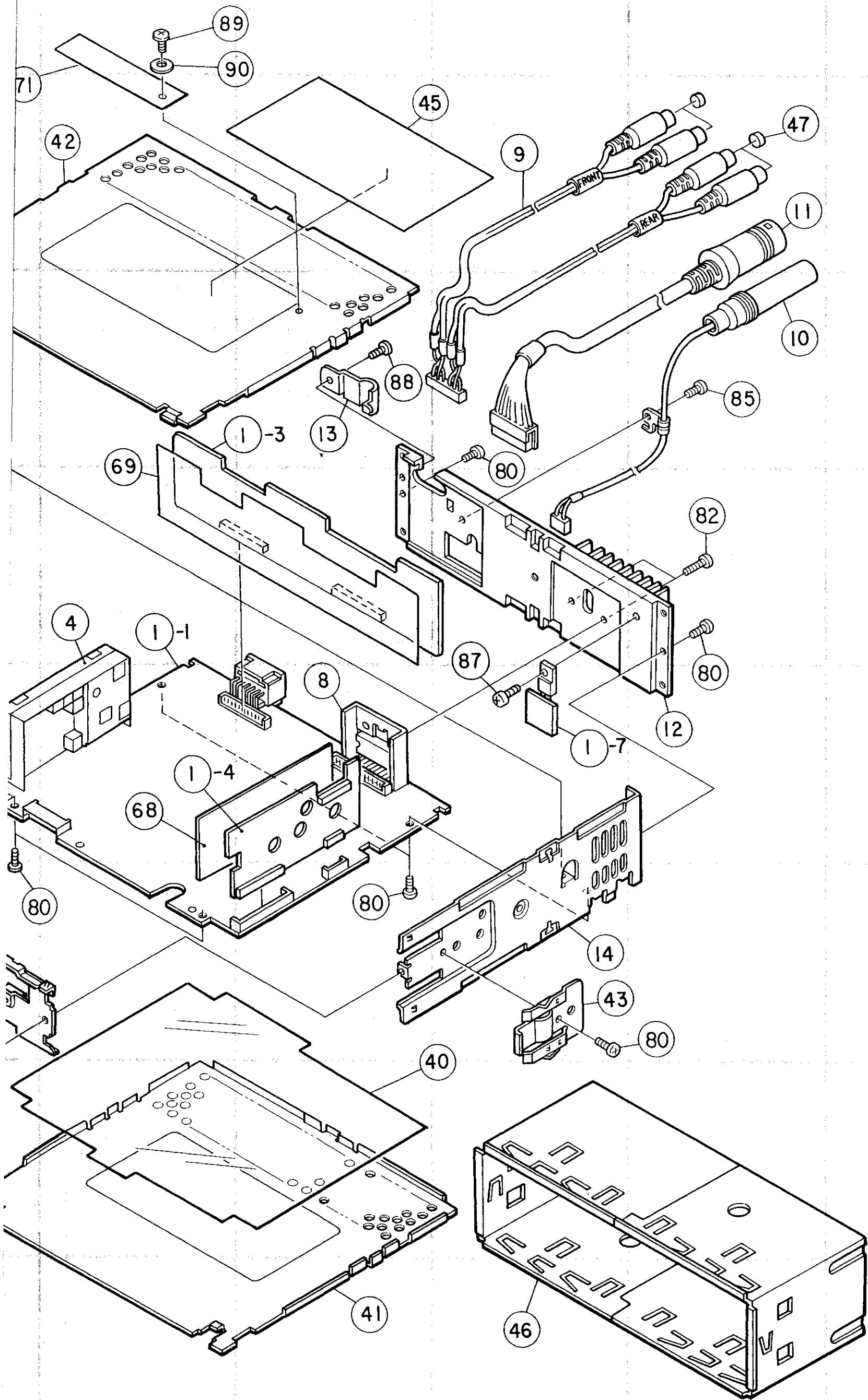

PARTS LIST OF EXPLODED VIEW

Ref. No.	Add.	Part No.	Part Name	Remarks	Q'ty	Ref. No.	Add.	Part No.	Part Name	Remarks	Q'ty
1	—	1U-2690	Main Unit Ass'y	U.S.A. model	1 ^S	48	G-5	431 0355 108	Panel Holder(R)		1
1	—	1U-2690 B	Main Unit Ass'y	Europe model	1 ^S	49	E-3	116 0024 103	Blind Sheet(C)		1
1-1	D-7	—	Main PWB Unit		(1)	50	H-5	461 0613 003	Pad (Round)		2
1-2	D-3	—	Front Panel PWB Unit		(1)	51	D-3	414 0737 006	Shield Cover (A)		1
1-3	C-7	—	SP PWB Unit		(1)	52	—	—	—		—
1-4	E-7	—	DAC PWB Unit		(1)	53	E-4	143 0888 008	Knob Lens		1
1-5	F-4	—	14P Conn. Unit		(1)	★ 54	—	513 2063 004	Laser Caution	Europe model only	1
1-6	F-5	—	SW PWB Unit		—	★ 55	—	513 2275 009	Homologation Sheet	Europe model only	1
1-7	E-9	—	TR PWB Unit		—	★ 56	—	009 0104 000	20P FF Cable		1
★ 2	E-9	254 6177 000	Chemicon 3300μ/16V	C511	1	57	F-4	414 0724 006	LCD Frame		1
3	—	—	—		—	58	E-5	415 0709 008	Insulating Sheet		1
4	D-6	216 0091 009	FWAM Tuner Pack		1	★ 59	—	393 0102 020	Lamp Ass'y(Green)	U.S.A. model PL701-708	8
5	E-4	393 6011 005	LCD(SLU-10073-01) Ass'y	LCD1	1	★ 59	—	393 0102 033	Lamp Ass'y(Orange)	Europe model PL701-708	8
6	D-3	212 0361 009	Rotary Encoder (A)	S705	1	★ 60	—	513 0985 003	Inst. Label	Europe model only	1
7	E-4	143 0885 001	LCD Lens		1	61	—	—	—		—
8	E-8	412 3680 002	IC Holder		1	62	G-4	463 0780 000	Push Spring		1
9	B-9	203 6410 002	4P Pin Jack Cord Ass'y		1	63	G-3	146 1500 009	Push Bar		1
10	C-10	203 5003 009	Ant. Cord Ass'y (A)		1	64	G-2	143 0889 007	LCD Window		1
11	B-10	204 6481 005	13-18P DIN Cord Ass'y	CD Changer	1	65	E-4	143 0880 000	LCD Filter		1
12	E-9	417 0481 115	Radiator		1	66	E-5	414 0701 003	Reflection Sheet		2
13	C-8	412 3684 008	Conn. Bracket		1	67	D-4	461 0852 000	Rubber Sheet		1
14	F-9	411 1238 000	Side Chassis(R)		1	68	E-7	415 0739 007	Insulating Sheet(A)		1
15	B-3	411 1239 009	Side Chassis(L)		1	69	C-7	415 0740 009	Insulating Sheet(B)		1
16	E-5	411 1293 100	Front Chassis		1	★ 70	—	212 1133 003	Push Lever Switch	S720	1
17	H-5	146 1498 205	Front Plate Ass'y		1	71	A-7	515 0698 008	Caution Sheet		1
18	—	146 1499 204	Front Plate		1	SCREWS					
19	G-5	412 3682 204	Lock Bracket		1	80	B-2	473 7001 006	Tapping Screw(S) 2.6x5		14
20	G-6	463 0747 001	Spring A		1	81	—	—	—		—
21	—	415 0728 005	Blind Sheet		1	82	D-10	471 3204 018	Bind Screw 2.6x8		2
22	—	129 0210 007	Enbi. Sheet		1	83	D-5	473 7507 005	Tapping Screw(S) 2x8	Black	4
23	B-6	412 3831 000	Mech. Bracket		1	84	H-4	471 3802 012	Bind Screw 2.6x3		6
24	D-6	337 0033 005	CD Mech. (SCD-205D)		1	85	C-10	473 7505 010	Tapping Screw(P) 2.6x6		1
25	E-3	415 0734 002	Disc Sheet		2	86	E-3	473 7506 006	Tapping Screw(P) 2x5		7
26	G-1	146 1501 202	Front Panel Ass'y	U.S.A. model include 28,29	1 ^S	87	D-8	473 7505 007	Tapping Screw(P) 2.6x8		1
26	G-1	146 1501 215	Front Panel Ass'y	Europe model include 28,29	1 ^S	88	C-8	473 7001 035	Tapping Screw(S) 2.6x6		1
27	—	143 0887 106	Vol. Lens		1	89	A-8	471 3202 013	Bind Screw 2x5		1
28	D-2	113 1604 002	Up Button		(1)	90	A-8	475 1003 006	Washer φ3		1
29	D-2	113 1605 001	Down Button		(1)	PACKING & ACCESSORIES (not included EXPLODED VIEW)					
30	C-3	113 1684 103	Function Button		1	101	—	GEN 2786	Envelope Sub. Ass'y	U.S.A. model	1 ^S
31	E-2	113 1685 005	EJECT Button		1	101	—	GEN 2840	Envelope Sub. Ass'y	Europe model	1 ^S
32	E-3	113 1609 007	Mode Button	U.S.A. model	1	101-1	—	505 0061 007	Envelope		(1)
32	E-3	113 1609 023	Mode Button	Europe model	1	101-2	—	511 2630 101	Inst. Manual(E,F)	U.S.A. model	(1)
33	E-3	113 1610 009	CLK Button		1	101-2	—	511 2642 102	Inst. Manual(E,G,F)	Europe model	(1)
34	F-3	431 0349 305	Release Lever		1	101-2	—	511 2643 101	Inst. Manual(IT,ES,NL,S)	Europe model	(1)
35	F-3	113 1606 000	Release Button		1	101-3	—	515 0689 004	DEL Warranty Car	U.S.A. model only	(1)
36	F-3	412 3683 009	Release Bracket		1	101-4	—	515 0337 301	DEL Custom Card	U.S.A. model only	(1)
37	F-3	463 0748 000	Spring B		1	101-5	—	505 0240 006	Envelope Ass'y		(1)
38	C-4	146 1503 200	Front Cover Ass'y		1	101-5-1	—	505 0099 082	Poly Cover		(1)
39	E-2	112 0730 000	Volume Knob		1	101-5-2	—	475 6010 007	Nut M5		(1)
40	F-8	415 0701 006	Insulating Sheet		1	101-5-3	—	475 1006 003	Washer φ5		(1)
41	H-8	412 3288 116	Cover		1	101-5-4	—	477 0271 000	Special Bolt		(1)
42	B-6	412 3288 129	Cover		1	101-5-5	—	477 0291 006	Hex. Screw 5x20		(1)
43	B-3	461 0704 006	Snap Plate		2	101-6	—	443 1186 007	Hook Bar		(2)
44	H-3	146 1455 109	Frame		1	102	—	204 6486 000	16P Wire Ass'y (B)		1
45	B-8	513 2320 006	Rating Sheet	U.S.A. model	1						
45	B-8	513 2321 005	Rating Sheet	Europe model	1						
46	H-9	412 2870 004	Sleeve Ass'y		1						
47	B-10	415 0453 008	RCA Cap		4						

Ref. No.	Add.	Part No.	Part Name	Remarks	Q'ty
103	—	505 0099 024	Poly Cover	for Set	2
104	—	503 1135 114	Cushion Ass'y		1
105	—	517 0091 070	ITF Label	U.S.A. model only	1/4
106	—	522 0009 006	Carry Case Ass'y		1
107	—	501 1846 009	Ind. Carton	U.S.A. model	1
107	—	501 1846 012	Ind. Carton	Europe model	1
108	—	501 1845 000	Master Carton	U.S.A. model	1/4
108	—	501 1845 013	Master Carton	Europe model	1/4
109	—	412 2036 000	Metal Mount Strap		1
110	—	—	—		—
111	—	515 0480 009	DENON Card	Europe model only	1
112	—	505 0027 009	Poly Cover	Europe model only	1
113	—	513 1542 005	Serial No. Sheet	Europe model only	1
114	—	—	—		—

DISASSEMBLY OF CD MECHANISM

MD SECTION-1

MD SECTION-2

A

B

C

D

E

F

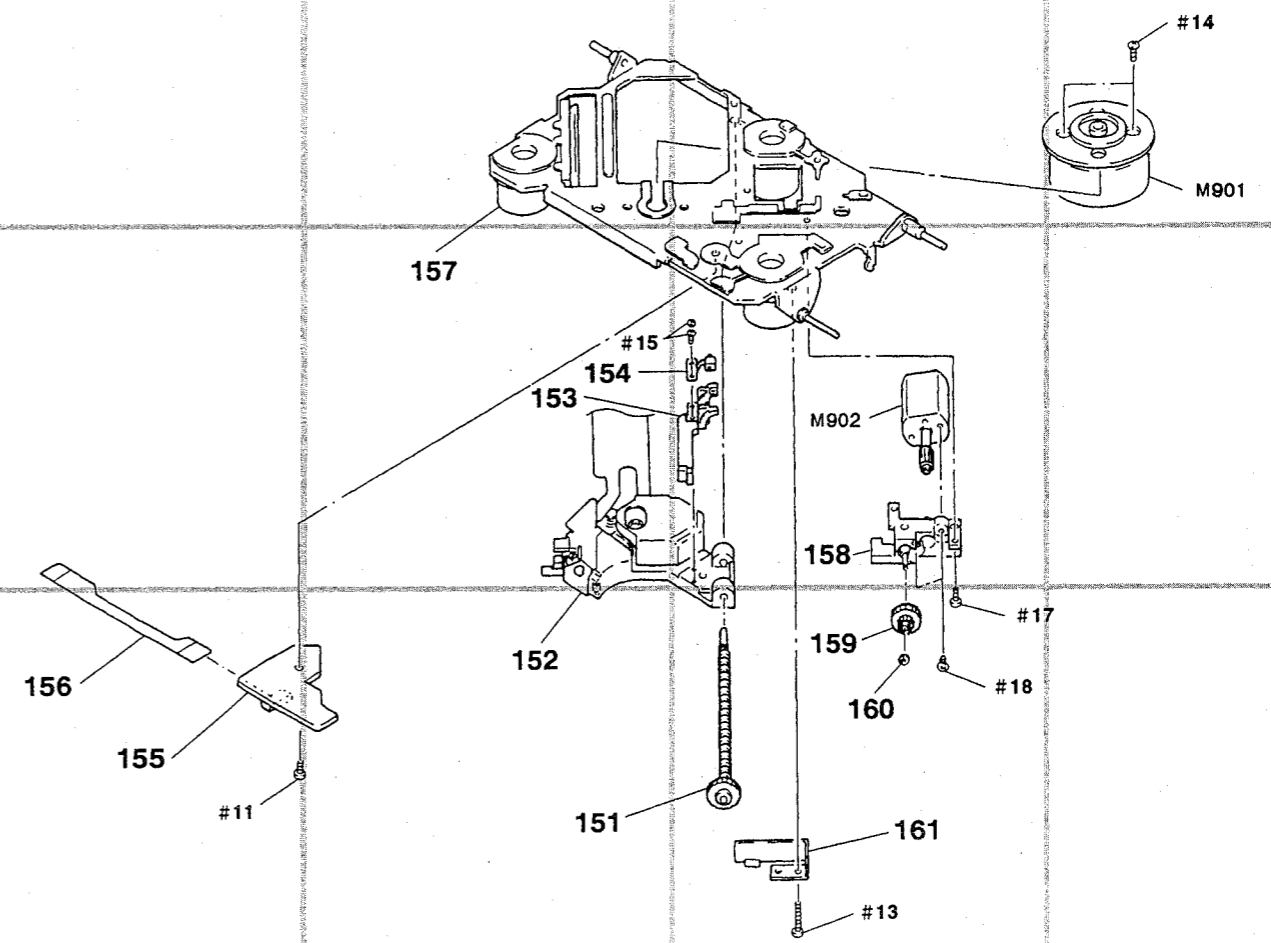
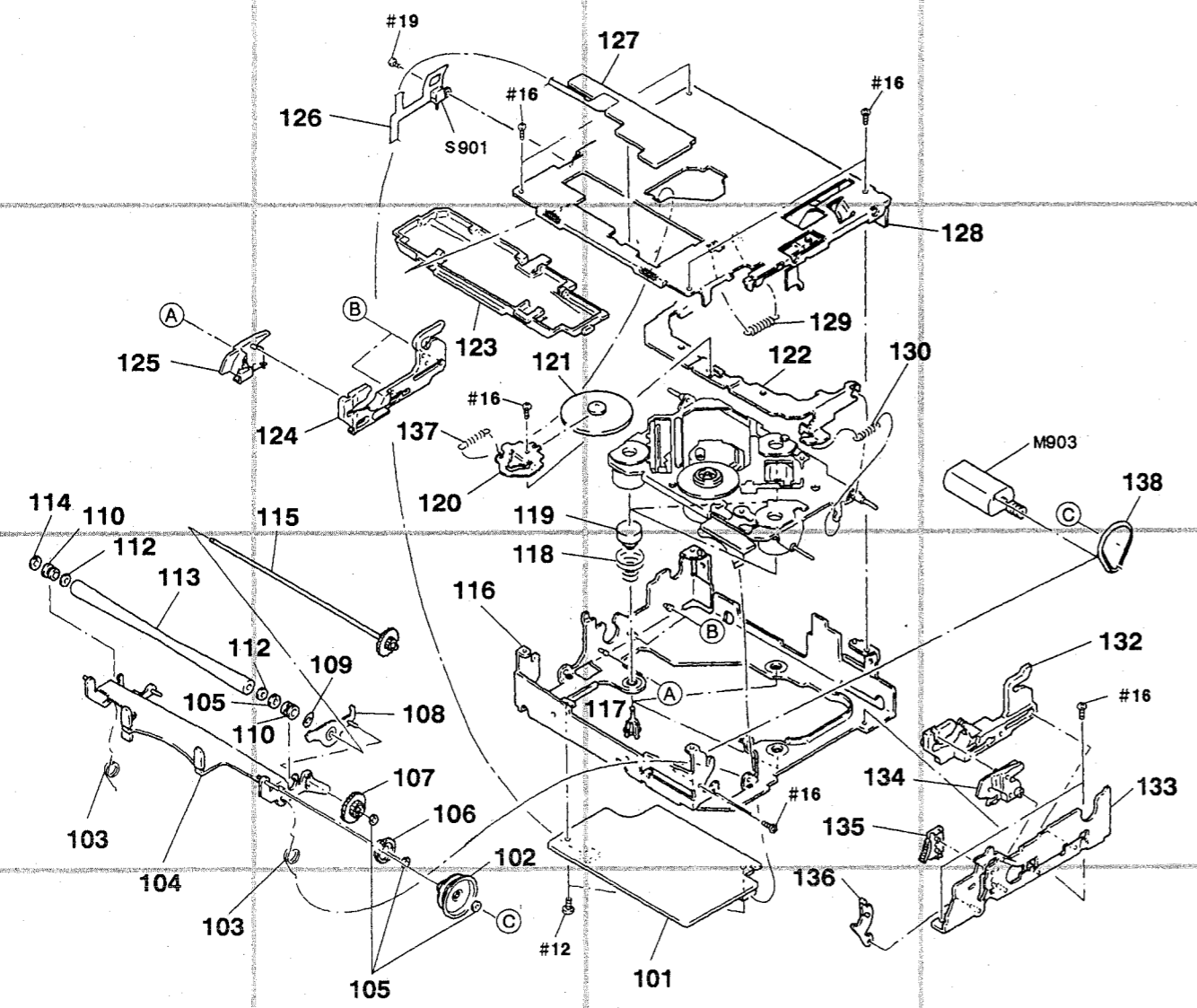

CD MECH. EXPLODED VIEW PARTS LIST

Parts No.:337 0033 005 SCD-205 D Mech.

Ref. No.	Add.	Part No.	Part Name	Remarks	Q'ty	Ref. No.	Add.	Part No.	Part Name	Remarks	Q'ty
● 101	E-3	SA3 2226 34A	MD Board,Complete		1	M902	C-7	SA3 2525 85A	Motor (SL) Ass'y		1
102	D-2	S33 8489 401	Gear (R1)		1	SCREW					
103	D-1	S33 8490 001	Spring (Press)		1	#11	D-5	S76 2177 106	Screw +B2 × 5		
104	E-1	SX3 3678 571	Arm Ass'y, Roller		1	#12	E-2	S76 2177 208	Screw +B2 × 3		
● 105	E-2	S35 7824 211	Washer		1	#13	D-7	S76 2177 260	Screw +B2 × 12		
106	D-2	S33 8489 501	Gear (R2)		1	#14	B-8	S76 2755 207	Screw,Precision +P1.7 × 2.5		
107	D-2	S33 8489 601	Gear (Down)		1	#15	C-6	S76 2755 247	Screw,Precision +P1.7 × 4		
108	D-2	SX3 3668 583	Arm Ass'y,Friction		1	#16	B-2	S76 2755 327	Screw,Precision +P2 × 2.5		
109	D-2	S33 8489 901	Spring (Friction)		1	#17	D-7	S76 2755 337	Screw,Precision +P2 × 3.0		
110	C-1	S33 8489 201	Bearing (Roller)		1	#18	D-7	S76 2755 367	Screw,Precision +P2 × 5		
111	—	—	—			#19	B-2	S76 2755 318	Screw,Precision +P2 × 2		
112	D-1	S37 0143 811	Washer, 2.5		1	#20	—	—	—		
113	D-1	S33 2323 111	Roller (Low)		1						
114	—	—	—								
115	C-2	SA3 2525 91A	Gear Ass'y, Roller		1						
116	D-2	SX3 3668 521	Chassis (M) Ass'y		1						
117	D-3	S33 8492 301	Shaft (Damper)		1						
118	D-2	S33 8491 601	Spring (FL)		1						
119	C-2	S33 8491 401	Damper		1						
● 120	C-2	S33 8491 511	Bracket (CP)		1						
● 121	C-2	S33 8491 801	Retainer (Disc)		1						
● 122	C-3	S33 8490 811	Arm, Chucking		1						
● 123	C-2	S39 0692 303	Guide (Disc)		1						
124	C-2	S33 8488 801	Slider (L)		1						
125	C-1	S33 8488 701	Lever (L)		1						
126	B-2	S16 5022 311	Sensor Flexible Board		1						
● 127	B-3	SA3 2225 25A	Sensor Board, Complete		1						
● 128	C-4	SX3 3668 541	Chassis (T) Ass'y		1						
129	C-3	S33 8488 102	Spring, Tension		1						
● 130	C-3	S33 8491 701	Spring (CH)		1						
131	—	—	—								
132	D-4	SX3 3661 021	Slider (R) Ass'y		1						
● 133	D-4	SX3 3668 531	Chassis (R) Ass'y		1						
134	D-3	S33 8488 901	Lever (R)		1						
135	D-3	S33 8489 701	Gear (Rack)		1						
136	E-3	S33 8489 101	Lever (ST)		1						
137	C-2	S33 8833 101	Spring, Tension		1						
138	C-4	S33 8777 601	Belt (L)		1						
M903	C-4	SA3 2525 80A	Motor (L) Ass'y		1						
S901	B-2	S16 9244 111	Switch, Micro (Disc Det)		1						
151	D-6	SA3 2525 86A	Shaft (SL) Ass'y		1						
▲ 152	D-5	S86 4829 311	Optical Pick-up Block	KSS-313A	1						
153	C-6	S33 8492 201	Gear (SL Feed)		1						
154	C-6	S33 8492 001	Spring (A), Feed		1						
155	D-5	S16 5014 411	Motor Board		1						
156	D-5	S16 4640 211	Motor Flexible Board		1						
● 157	C-6	SX3 3668 551	Chassis (OPT) Ass'y (Outsert)		1						
158	C-7	SX3 3661 001	Base (Driving) Ass'y		1						
159	D-7	S33 8491 201	Gear (K2)		1						
160	D-7	S35 7061 500	Poly-Washer (Dia 1.2)		1						
● 161	D-7	S33 8491 311	Spring (Thrust Retainer)		1						
M901	B-8	SX3 3674 841	Motor (Spring) Ass'y		1						

Note:

The components identified by mark ▲ or dotted line with mark ▲ are critical for safety.
Replace only with part number specified.

Note:

Les composants identifiés par une marque ▲ sont critiques pour la sécurité.
Ne les remplacer que par une pièce portant le numéro spécifié.

NOTE FOR PARTS LIST

- Part indicated with the mark "◎" are not always in stock and possibly to take a long period of time for supplying, or in some case supplying of part may be refused.
- When ordering of part, clearly indicate "1" and "I" (i) to avoid mis-supplying.
- Ordering part without stating its part number can not be supplied.
- Part indicated with the mark "★" is not illustrated in the exploded view.
- Not including Carbon Film ±5%, 1/4W Type in the P.W.Board parts list. (Refer to the Schematic Diagram for those parts.)

WARNING:

Parts marked with this symbol  have critical characteristics.
Use ONLY replacement parts recommended by the manufacturer.

● **Resistors**

Ex.: RN 14K 2E 182 G FR
 Type Shape and performance Power Resistance Allowable error Others

RD : Carbon	2B : 1/8W	F : ±1%	P : Pulse-resistant type
RC : Composition	2E : 1/4W	G : ±2%	NL : Low noise type
RS : Metal oxide film	2H : 1/2W	J : ±5%	NB : Non-burning type
RW : Winding	3A : 1W	K : ±10%	FR : Fuse-resistor
RN : Metal film	3D : 2W	M : ±20%	F : Lead wire forming
RK : Metal mixture	3F : 3W		
	3H : 5W		

* **Resistance**

$\overline{1} \overline{8} \overline{2} \Rightarrow 1800 \text{ ohm} = 1.8 \text{ kohm}$
 Indicates number of zeros after effective number.
 2-digit effective number.

• Units: ohm

$\overline{1} \overline{R} \overline{2} \Rightarrow 1.2 \text{ ohm}$
 1-digit effective number.
 2-digit effective number, decimal point indicated by R.

• Units: ohm

● **Capacitors**

Ex.: CE 04W 1H 2R2 M BP
 Type Shape and performance Dielectric strength Capacity Allowable error Others

CE : Aluminum foil electrolytic	0J : 6.3V	F : ±1%	HS : High stability type
CA : Aluminum solid electrolytic	1A : 10V	G : ±2%	BP : Non-polar type
CS : Tantalum electrolytic	1C : 16V	J : ±5%	HR : Ripple-resistant type
CQ : Film	1E : 25V	K : ±10%	DL : For charge and discharge
CK : Ceramic	1V : 35V	M : ±20%	HF : For assuring high frequency
CC : Ceramic	1H : 50V	Z : +80%	U : UL part
CP : Oil	2A : 100V	-20%	C : CSA part
CM : Mica	2B : 125V	P : +100%	W : UL-CSA type
CF : Metallized	2C : 160V	-0%	F : Lead wire forming
CH : Metallized	2D : 200V	C : ±0.25pF	
	2E : 250V	D : ±0.5pF	
	2H : 500V	= : Others	
	2J : 630V		

* **Capacity (electrolyte only)**

$\overline{2} \overline{2} \overline{2} \Rightarrow 2200\mu\text{F}$
 Indicates number of zeros after effective number.
 2-digit effective number.

• Units: μF.

$\overline{2} \overline{R} \overline{2} \Rightarrow 2.2\mu\text{F}$
 1-digit effective number.
 2-digit effective number, decimal point indicated by R.

• Units: μF.

* **Capacity (except electrolyte)**

$\overline{2} \overline{2} \overline{2} \Rightarrow 2200\text{pF} = 0.0022\mu\text{F}$
 (More than 2) — Indicates number of zeros after effective number.
 2-digit effective number.

• Units: μF.

$\overline{2} \overline{2} \overline{1} \Rightarrow 220\text{pF}$
 (0 or 1) — Indicates number of zeros after effective number.
 2-digit effective number.

• Units: pF.

• When the dielectric strength is indicated in AC, "AC" is included after the dielectric strength value.

P.W.B. ASS'Y PARTS LIST

1U-2690, 1U-2690B MAIN UNIT

Ref. No.	Part No.	Part Name	Remarks	Ref. No.	Part No.	Part Name	Remarks
SEMICONDUCTORS GROUP							
IC101	262 1766 909	IC SM5841CS	D.Filter	D402	276 0432 903	Diode 1SS270A	
IC102	263 0725 902	IC PCM67U	D/A. Con.	D403	276 0438 949	Diode MA151WK	
IC103,104	263 0889 903	IC M5218AFP	OP Amp	D509	276 0598 009	Diode EM2	
IC202	263 0889 903	IC M5218AFP	OP Amp	D601	276 0432 903	Diode 1SS270A	
IC203	263 0928 000	IC CXA1767Q	Electro. Vol.	D715	276 0640 009	Diode PD410PI(FM)	
IC204-207	263 0889 903	IC M5218AFP	OP Amp	D801,802	276 0432 903	Diode 1SS270A	
IC301	262 1701 906	IC :SAA6579T	RDS	D803	276 0552 906	1SR139-200	
IC302	262 1929 908	IC LC7074M	RDS	D804,805	276 0432 903	Diode 1SS270A	
IC401	263 0616 901	IC TC4S66F	2 Mode Loop	D901	276 0432 903	Diode 1SS270A	
IC402	263 0796 009	IC TC9216P		LD401	276 0443 002	Diode LTZ-MR15	
IC403	263 0829 905	IC LA1862M	IF-NC-MPX	ZD101,102	276 0462 902	Zener Diode HZS6B-1	6V
IC501	263 0982 004	IC HA13150A	Power Amp.	ZD103	276 0469 905	Zener Diode HZS9C-1	
IC601	263 0660 902	IC M5280FP		ZD401	276 0452 909	Zener Diode HZS3A-1	3V
IC602	263 0889 903	IC M5218AFP	OP Amp	ZD601-603	276 0469 905	Zener Diode HZS9C-1	9V
IC701	262 1605 905	IC :PCF8576T-T	LCD	ZD604	269 0152 007	Diode Allay 9P	
IC702	263 0933 008	IC TA8141F		ZD701-704	276 0639 913	Zener Diode HZM18NB3	18V
IC801	263 0929 009	IC BA3910B-V2	Power Supply	ZD801,802	276 0481 909	Zener Diode HZS24-1	24V
IC802	263 0652 907	IC PST529C		ZD803	276 0461 903	Zener Diode HZS6A-1	6V
IC901	262 1992 003	IC μ PD78056GC-018-3B9	Main μ -com	ZD804	276 0460 904	Zener Diode HZS5C-1	
IC902	262 1703 904	IC LC3517AML-15	SRAM	ZD805	276 0464 900	Zener Diode HZS7A-1	7V
TR102	269 0047 905	Transistor DTA143EK	Built in Resistor	ZD806	276 0471 906	Zener Diode HZS11B-1	11V
TR104	274 0136 012	Transistor 2SD1913(R/S)		ZD807	269 0151 008	Diode Allay 12 P	
TR105	269 0153 909	Transistor FMC3	Built in Resistor	LCD1	393 6011 005	LCD Assy SLU-10073-01	
TR106	274 0146 905	Transistor 2SD1858(Q/R)		RESISTORS GROUP (Not included Carbon Film $\pm 5\%$ 1/4W.)			
TR107	269 0153 909	Transistor FMC3	Built in Resistor	R101	247 0005 905	Chip Carbon 100ohm 1/10W	RM73B-101J
TR108	269 0047 905	Transistor DTA143EK	Built in Resistor	R103-105	247 0008 915	Chip Carbon 2kohm 1/10W	RM73B-202J
TR201-204	269 0103 904	Transistor DTC314TK	Built in Resistor	R106-109	247 0007 945	Chip Carbon 1kohm 1/10W	RM73B-102J
TR402	273 0384 900	Transistor 2SC2412K(S)		R110	247 0003 949	Chip Carbon 22ohm 1/10W	RM73B-220J
TR403	269 0082 902	Transistor DTC114EK	Built in Resistor	R111,112	247 0007 961	Chip Carbon 1.2kohm 1/10W	RM73B-122J
TR404,405	273 0384 900	Transistor 2SC2412K(S)		R113,114	247 0008 931	Chip Carbon 2.4kohm 1/10W	RM73B-242J
TR412	273 0384 900	Transistor 2SC2412K(S)		R119	241 2397 998	Carbon Film 560ohm 1/4W	RD14B2E561J(5)
TR413	269 0115 905	Transistor DTA115EK	Built in Resistor	R120	247 0007 987	Chip Carbon 1.5kohm 1/10W	RM73B-152J
TR414-418	269 0054 901	Transistor DTC144EK	Built in Resistor	R121,122	247 0009 985	Chip Carbon 10kohm 1/10W	RM73B-103J
TR419	269 0054 901	Transistor DTC144EK	Built in Resistor	R123,124	247 0009 927	Chip Carbon 5.6kohm 1/10W	RM73B-562J
TR501,502	269 0048 904	Transistor DTC143EK	Built in Resistor	R125,126	247 0009 998	Chip Carbon 11kohm 1/10W	RM73B-113J
TR701	269 0085 909	Transistor DTC144TK	Built in Resistor	R127	247 0009 901	Chip Carbon 4.7kohm 1/10W	RM73B-472J
TR801	269 0153 909	Transistor FMC3	Built in Resistor	R131	247 0007 945	Chip Carbon 1kohm 1/10W	RM73B-102J
TR802,803	274 0146 905	Transistor 2SD1858(Q/R)		R204-206	247 0007 945	Chip Carbon 1kohm 1/10W	RM73B-102J
TR804	272 0126 903	Transistor 2SB1243(R)		R207	247 0018 905	Chip Carbon 0ohm 1/10W	RM73B-0R0K
TR805	269 0153 909	Transistor FMC3	Built in Resistor	R208	247 0010 916	Chip Carbon 13kohm 1/10W	RM73B-133J
TR806,807	269 0048 904	Transistor DTC143EK	Built in Resistor	R209,210	247 0010 961	Chip Carbon 22kohm 1/10W	RM73B-223J
TR808	272 0126 903	Transistor 2SB1243(R)	Built in Resistor	R211,212	247 0010 903	Chip Carbon 12kohm 1/10W	RM73B-123J
TR809	269 0153 909	Transistor FMC3	Built in Resistor	R213,214	247 0010 990	Chip Carbon 30kohm 1/10W	RM73B-303J
TR810	274 0146 905	Transistor 2SD1858(Q/R)		R215,216	247 0009 985	Chip Carbon 10kohm 1/10W	RM73B-103J
TR901,902	269 0047 905	Transistor DTA143EK	Built in Resistor	R217,218	247 0010 903	Chip Carbon 12kohm 1/10W	RM73B-123J
TR903	269 0048 904	Transistor DTC143EK	Built in Resistor	R219-222	247 0006 962	Chip Carbon 470ohm 1/10W	RM73B-471J
D101	276 0558 900	Diode DA204K		R223-226	247 0011 944	Chip Carbon 47kohm 1/10W	RM73B-473J
D102	276 0438 910	Diode MA151A		R227,228	247 0014 967	Chip Carbon 1 Mohm 1/10W	RM73B-105J
				R231-234	247 0010 974	Chip Carbon 24kohm 1/10W	RM73B-243J
				R235-238	247 0010 945	Chip Carbon 18kohm 1/10W	RM73B-183J
				R239-242	247 0009 901	Chip Carbon 4.7kohm 1/10W	RM73B-472J

Ref. No.	Part No.	Part Name	Remarks	Ref. No.	Part No.	Part Name	Remarks
R301	247 0013 900	Chip Carbon 220kohm 1/10W	RM73B-224J	R605,606	247 0009 985	Chip Carbon 10kohm 1/10W	RM73B-103J
R302	247 0008 928	Chip Carbon 2.2kohm 1/10W	RM73B-222J	R607,608	247 0007 945	Chip Carbon 1kohm 1/10W	RM73B-102J
R303	247 0011 944	Chip Carbon 47kohm 1/10W	RM73B-473J	R609	247 0005 905	Chip Carbon 100ohm 1/10W	RM73B-101J
R401,402	247 0009 901	Chip Carbon 4.7kohm 1/10W	RM73B-472J	R610	247 0010 958	Chip Carbon 20kohm 1/10W	RM73B-203J
R403	247 0009 930	Chip Carbon 6.2kohm 1/10W	RM73B-622J	R611	247 0005 905	Chip Carbon 100ohm 1/10W	RM73B-101J
R404	247 0009 901	Chip Carbon 4.7kohm 1/10W	RM73B-472J	R612,613	247 0007 945	Chip Carbon 1kohm 1/10W	RM73B-102J
R405	247 0006 962	Chip Carbon 470ohm 1/10W	RM73B-471J	R614,615	247 0012 927	Chip Carbon 100kohm 1/10W	RM73B-104J
R406	247 0007 945	Chip Carbon 1kohm 1/10W	RM73B-102J	R619-622	247 0010 916	Chip Carbon 13kohm 1/10W	RM73B-133J
R407	247 0008 944	Chip Carbon 2.7kohm 1/10W	RM73B-272J	R701	247 0005 947	Chip Carbon 150ohm 1/10W	RM73B-151J
R408	247 0006 988	Chip Carbon 560ohm 1/10W	RM73B-561J	R702	247 0005 963	Chip Carbon 180ohm 1/10W	RM73B-181J
R409	247 0003 949	Chip Carbon 22ohm 1/10W	RM73B-220J	R703	247 0006 904	Chip Carbon 270ohm 1/10W	RM73B-271J
R410-412	247 0012 927	Chip Carbon 100kohm 1/10W	RM73B-104J	R704	247 0006 946	Chip Carbon 390ohm 1/10W	RM73B-391J
R413	247 0018 905	Chip Carbon 0ohm 1/10W	RM73B-0R0K	R705	247 0007 903	Chip Carbon 680ohm 1/10W	RM73B-681J
R414	247 0006 946	Chip Carbon 390ohm 1/10W	RM73B-391J	R706,707	247 0005 947	Chip Carbon 150ohm 1/10W	RM73B-151J
R415	247 0009 901	Chip Carbon 4.7kohm 1/10W	RM73B-472J	R708	247 0005 963	Chip Carbon 180ohm 1/10W	RM73B-181J
R416	247 0009 985	Chip Carbon 10kohm 1/10W	RM73B-103J	R709	247 0006 904	Chip Carbon 270ohm 1/10W	RM73B-271J
R417	247 0005 905	Chip Carbon 100ohm 1/10W	RM73B-101J	R710	247 0006 946	Chip Carbon 390ohm 1/10W	RM73B-391J
R418	247 0006 920	Chip Carbon 330ohm 1/10W	RM73B-331J	R711	247 0006 988	Chip Carbon 560ohm 1/10W	RM73B-561J
R419	247 0004 993	Chip Carbon 91ohm 1/10W	RM73B-910J	R713	247 0005 963	Chip Carbon 180ohm 1/10W	RM73B-181J
R420	247 0006 920	Chip Carbon 330ohm 1/10W	RM73B-331J	R714	247 0006 904	Chip Carbon 270ohm 1/10W	RM73B-271J
R421	247 0009 985	Chip Carbon 10kohm 1/10W	RM73B-103J	R715	247 0006 946	Chip Carbon 390ohm 1/10W	RM73B-391J
R422	247 0011 944	Chip Carbon 47kohm 1/10W	RM73B-473J	R716	247 0007 903	Chip Carbon 680ohm 1/10W	RM73B-681J
R425	247 0006 920	Chip Carbon 330ohm 1/10W	RM73B-331J	R717	247 0005 989	Chip Carbon 220ohm 1/10W	RM73B-221J
R426	247 0008 986	Chip Carbon 3.9kohm 1/10W	RM73B-392J	R718	247 0012 985	Chip Carbon 180kohm 1/10W	RM73B-184J
R427	247 0008 960	Chip Carbon 3.3kohm 1/10W	RM73B-332J	R719-721	247 0005 905	Chip Carbon 100ohm 1/10W	RM73B-101J
R427	247 0011 902	Chip Carbon 33kohm 1/10W	U.S.A. model RM73B-333J Europe model	R722	247 0010 961	Chip Carbon 22kohm 1/10W	RM73B-223J
R428	247 0010 961	Chip Carbon 22kohm 1/10W	RM73B-223J	R723	247 0003 965	Chip Carbon 27ohm 1/10W	RM73B-270J
R428	247 0012 927	Chip Carbon 100kohm 1/10W	U.S.A. model RM73B-104J Europe model	R724	247 0013 900	Chip Carbon 220kohm 1/10W	RM73B-224J
R429	247 0007 987	Chip Carbon 1.5kohm 1/10W	RM73B-152J	R801	247 0007 987	Chip Carbon 1.5kohm 1/10W	RM73B-152J
R430	247 0007 945	Chip Carbon 1kohm 1/10W	RM73B-102J	R802	247 0009 901	Chip Carbon 4.7kohm 1/10W	RM73B-472J
R431	247 0009 927	Chip Carbon 5.6kohm 1/10W	RM73B-562J	R803	247 0007 945	Chip Carbon 1kohm 1/10W	RM73B-102J
R432	247 0009 985	Chip Carbon 10kohm 1/10W	RM73B-103J	R804	247 0009 985	Chip Carbon 10kohm 1/10W	RM73B-103J
R433	247 0008 986	Chip Carbon 3.9kohm 1/10W	RM73B-392J	R805,806	247 0007 987	Chip Carbon 1.5kohm 1/10W	RM73B-152J
R433	247 0009 930	Chip Carbon 6.2kohm 1/10W	U.S.A. model RM73B-622J Europe model	R807	241 2398 997	Carbon Film 1.5kohm 1/4W	RD14B2E152J(5)
R434	247 0009 985	Chip Carbon 10kohm 1/10W	RM73B-103J	R808	247 0008 960	Chip Carbon 3.3kohm 1/10W	RM73B-332J
R435	247 0010 932	Chip Carbon 16kohm 1/10W	RM73B-163J	R809	247 0002 966	Chip Carbon 10ohm 1/10W	RM73B-100J
R436	247 0009 969	Chip Carbon 8.2kohm 1/10W	RM73B-822J	R810	247 0007 987	Chip Carbon 1.5kohm 1/10W	RM73B-152J
R437	247 0011 957	Chip Carbon 51kohm 1/10W	RM73B-513J	R811	241 2398 997	Carbon Film 1.5kohm 1/4W	RD14B2E152J(5)
R438	247 0009 943	Chip Carbon 6.8kohm 1/10W	RM73B-682J	R812	247 0008 960	Chip Carbon 3.3kohm 1/10W	RM73B-332J
R439	247 0009 956	Chip Carbon 7.5kohm 1/10W	U.S.A. model only RM73B-752J	R814,815	241 2398 955	Carbon Film 1kohm 1/4W	RD14B2E102J(5)
R440	247 0012 927	Chip Carbon 100kohm 1/10W	RM73B-104J	R901,902	247 0005 905	Chip Carbon 100ohm 1/10W	RM73B-101J
R441	247 0011 902	Chip Carbon 33kohm 1/10W	RM73B-333J	R903,904	247 0011 944	Chip Carbon 47kohm 1/10W	RM73B-473J
R442,443	247 0011 944	Chip Carbon 47kohm 1/10W	RM73B-473J	R905	247 0010 958	Chip Carbon 20kohm 1/10W	RM73B-203J
R444-446	247 0009 985	Chip Carbon 10kohm 1/10W	RM73B-103J	R906	247 0009 985	Chip Carbon 10kohm 1/10W	RM73B-103J
R447	247 0007 945	Chip Carbon 1kohm 1/10W	RM73B-102J	R907-909	247 0007 945	Chip Carbon 1kohm 1/10W	RM73B-102J
R448	247 0009 985	Chip Carbon 10kohm 1/10W	RM73B-103J	R910-913	247 0005 905	Chip Carbon 100ohm 1/10W	RM73B-101J
R450	247 0018 905	Chip Carbon 0ohm 1/10W	RM73B-0R0K	R914	247 0012 927	Chip Carbon 100kohm 1/10W	RM73B-104J
R451	247 0005 905	Chip Carbon 100ohm 1/10W	U.S.A. model only RM73B-101J	R915	247 0013 942	Chip Carbon 330kohm 1/10W	RM73B-334J
R501-508	247 0001 909	Chip Carbon 2.2ohm 1/10W	RM73B-2R2J	R916	247 0009 985	Chip Carbon 10kohm 1/10W	RM73B-103J
R510	247 0009 985	Chip Carbon 10kohm 1/10W	RM73B-103J	R917-919	247 0007 945	Chip Carbon 1kohm 1/10W	RM73B-102J
R511	247 0010 958	Chip Carbon 20kohm 1/10W	RM73B-203J	R920	247 0009 905	Chip Carbon 100ohm 1/10W	RM73B-101J
R512	247 0007 945	Chip Carbon 1kohm 1/10W	RM73B-102J	R921,922	247 0007 945	Chip Carbon 1kohm 1/10W	RM73B-102J
R513	247 0010 958	Chip Carbon 20kohm 1/10W	RM73B-203J	R923	247 0010 945	Chip Carbon 18kohm 1/10W	RM73B-183J
R601,602	247 0007 945	Chip Carbon 1kohm 1/10W	RM73B-102J	R924	247 0007 945	Chip Carbon 1kohm 1/10W	RM73B-102J
R603,604	247 0012 927	Chip Carbon 100kohm 1/10W	RM73B-104J	R925	247 0011 944	Chip Carbon 47kohm 1/10W	RM73B-473J
				R926	247 0005 905	Chip Carbon 100ohm 1/10W	RM73B-101J
				R927,928	247 0009 985	Chip Carbon 10kohm 1/10W	RM73B-103J
				R930	247 0009 985	Chip Carbon 10kohm 1/10W	RM73B-103J
				R931	247 0018 905	Chip Carbon 0kohm 1/10W	RM73B-0R0K
				R932	247 0011 944	Chip Carbon 47kohm 1/10W	RM73B-473J
				R933	247 0012 927	Chip Carbon 100kohm 1/10W	RM73B-104J

Ref. No.	Part No.	Part Name	Remarks	Q'ty	Ref. No.	Part No.	Part Name	Remarks
(C253,254)	247 0018 905	Chip Carbon 0ohm 1/10W	RM73B-0R0K U.S.A. model only		C309-311	257 0014 935	C.Ceramic 0.1μF/25V	CK73F1E104Z
VR401	211 6077 912	Semi Fixed Resistor 20kohm	V06PB203	1	C401	257 0014 935	C.Ceramic 0.1μF/25V	CK73F1E104Z
VR402	211 6077 983	Semi Fixed Resistor 47kohm	V06PB473	1	C402	257 0011 909	C.Ceramic 0.01μF/25V	CK73B1E103K
VR403	211 6077 954	Semi Fixed Resistor 22kohm	V06PB223	1	C403	257 0011 996	C.Ceramic 0.1μF/25V	CK73B1E104K
VR404	211 6077 938	Semi Fixed Resistor 100kohm	V06PB104	1	C404	257 0011 909	C.Ceramic 0.01μF/25V	CK73B1E103K
CAPACITORS GROUP					C405	257 0011 983	C.Ceramic 0.047μF/25V	CK73B1E473K
C101	257 0001 977	C.Ceramic 5pF/50V	CC73SL1H5R0C		C406	254 4304 901	Electrolytic 2.2μF/35V	CE04W1V2R2M(SRE)
C102	257 0001 951	C.Ceramic 3pF/50V	CC73SL1H3R0C		C407	257 0011 954	C.Ceramic 0.027μF/25V	CK73B1E273K
C103,104	257 0024 909	C.Ceramic 1μF/16V	CK73F1C105Z		C408	257 0004 961	C.Ceramic 100pF/50V	CC73SL1H101J
C105	257 0014 935	C.Ceramic 0.1μF/25V	CK73F1E104Z		C409	254 4302 958	Electrolytic 47μF/10V	CE04W1A470M(SRE)
C106	257 0005 986	C.Ceramic 330pF/50V	CC73SL1H331J		C410,411	257 0016 933	C.Ceramic 15pF/50V	CC73CH1H150J(Temp.)
C107,108	257 0024 909	C.Ceramic 1μF/16V	CK73F1C105Z		C412-414	257 0011 909	C.Ceramic 0.01μF/25V	CK73B1E103K
C109	257 0014 935	C.Ceramic 0.1μF/25V	CK73F1E104Z		C415	257 0014 919	C.Ceramic 0.047μF/25V	CK73F1E473Z
C110	257 0024 909	C.Ceramic 1μF/16V	CK73F1C105Z		C416	257 0008 983	C.Ceramic 100pF/50V	CK73B1H102K
C111	257 0023 900	C.Ceramic 0.22μF/16V	CK73B1C224K		C417,418	254 4305 968	Electrolytic 1μF/50V	CE04W1H010M(SRE)
C112,113	257 0014 935	C.Ceramic 0.1μF/25V	CK73F1E104Z		C419	257 0022 901	C.Ceramic 12pF/50V	CC73UJ1H120J(Temp.)
C114	254 4250 042	Electrolytic 330μF/6.3V	CE04W0J101M(SME)		C420	254 4305 968	Electrolytic 1μF/50V	CE04W1H010M(SRE)
C115	257 0014 935	C.Ceramic 0.1μF/25V	CK73F1E104Z		C421	254 4304 901	Electrolytic 2.2μF/35V	CE04W1V2R2M(SRE)
C116	254 4300 963	Electrolytic 100μF/6.3V	CE04W0J101M(SRE)				Europe model only	CK73B1H222K
C117,118	257 0014 935	C.Ceramic 0.1μF/25V	CK73F1E104Z		C422	257 0009 924	C.Ceramic 2200pF/50V	CK73B1H222K
C119,120	254 4300 934	Electrolytic 22μF/6.3V	CE04W0J220M(SRE)		C423	254 4305 926	Electrolytic 0.22μF/50V	CE04W1HR22M(SRE)
C121,122	257 0008 996	C.Ceramic 1200pF/50V	CK73B1H122K		C424	254 4305 968	Electrolytic 1μF/50V	CE04W1H010M(SRE)
C123,124	257 0005 928	C.Ceramic 180pF/50V	CC73SL1H181J		C425	257 0011 909	C.Ceramic 0.01μF/25V	CK73B1E103K
C201	257 0014 935	C.Ceramic 0.1μF/25V	CK73F1E104Z		C426	254 4305 968	Electrolytic 1μF/50V	CE04W1H010M(SRE)
C203,204	254 4305 968	Electrolytic 1μF/50V	CE04W1H010M(SRE)		C427	257 0003 933	C.Ceramic 30pF/50V	CC73SL1H300J
C205,206	257 0004 961	C.Ceramic 100pF/50V	CC73SL1H101J		C428	254 4305 049	Electrolytic 0.47μF/50V	CE04W1HR47M(SRE)
C207-212	254 4304 901	Electrolytic 2.2μF/35V	CE04W1V2R2M(SRE)		C429	257 0011 909	C.Ceramic 0.01μF/25V	CK73B1E103K
C214	257 0014 935	C.Ceramic 0.1μF/25V	CK73F1E104Z		C430	257 0014 919	C.Ceramic 0.047μF/25V	CK73F1E473Z
C215,216	257 0011 983	C.Ceramic 0.047μF/25V	CK73B1E473K		C431	254 4302 958	Electrolytic 47μF/10V	CE04W1A470M(SRE)
C217,218	257 0009 966	C.Ceramic 4700pF/50V	CK73B1H472K		C432	257 0009 940	C.Ceramic 3300pF/50V	CK73B1H332K
C219,220	254 4302 916	Electrolytic 10μF/10V	CE04W1A100M(SRE)		C433	257 0009 982	C.Ceramic 6800pF/50V	CK73B1H682K
C221,222	257 0009 982	C.Ceramic 6800pF/50V	CK73B1H682K		C434	257 0009 979	C.Ceramic 5600pF/50V	CK73B1H562K
C223,224	254 4302 916	Electrolytic 10μF/10V	CE04W1A100M(SRE)				U.S.A. model	CK73B1H222K
C225,226	257 0023 900	C.Ceramic 0.22μF/16V	CK73B1C224K		C434	257 0009 924	C.Ceramic 2200pF/50V	Europe model
C227,228	257 0004 961	C.Ceramic 100pF/50V	CC73SL1H101J		C435	257 0011 996	C.Ceramic 0.1μF/25V	CK73B1E104K
C229,230	254 4302 916	Electrolytic 10μF/10V	CE04W1A100M(SRE)		C436	254 4299 922	Electrolytic 4.7μF/16V	CE04W1C47M(SRE)
C231,232	254 4300 947	Electrolytic 47μF/6.3V	CE04W0J470M(SRE)		C437,438	257 0011 967	C.Ceramic 0.033μF/25V	CK73B1E333K
C233	254 4302 916	Electrolytic 10μF/10V	CE04W1A100M(SRE)				U.S.A. model	CK73B1E223K
C234	257 0023 900	C.Ceramic 0.22μF/16V	CK73B1C224K		C437,438	257 0011 941	C.Ceramic 0.022μF/25V	Europe model
C235	257 0008 983	C.Ceramic 1000pF/50V	CK73B1H102K		C439	257 0011 909	C.Ceramic 0.01μF/25V	CK73B1E103K
C236	254 4299 964	Electrolytic 47μF/16V	CE04W1C470M(SRE)		C440	257 0011 941	C.Ceramic 0.022μF/25V	CK73B1E223K
C237-240	254 4299 906	Electrolytic 10μF/16V	CE04W1C100M(SRE)		C441	254 4302 932	Electrolytic 22μF/10V	CE04W1A220M(SRE)
C241-244	257 0024 909	C.Ceramic 1μF/16V	CK73F1C105Z		C442	257 0008 983	C.Ceramic 1000pF/50V	CK73B1H102K
C245-248	257 0008 983	C.Ceramic 1000pF/50V	CK73B1H102K		C443	254 4304 901	Electrolytic 2.2μF/35V	CE04W1V2R2M(SRE)
C249	257 0005 960	C.Ceramic 270pF/50V	CC73SL1H271J		C444	254 4305 926	Electrolytic 0.22μF/50V	CE04W1HR22M(SRE)
C250	257 0004 961	C.Ceramic 100pF/50V	CC73SL1H101J		C445	257 0011 941	C.Ceramic 0.022μF/25V	CK73B1E223K
C251	257 0008 983	C.Ceramic 1000pF/50V	CK73B1H102K		C446	257 0014 935	C.Ceramic 0.1μF/25V	CK73F1E104Z
C252	257 0014 935	C.Ceramic 0.1μF/25V	CK73F1E104Z		C449	257 0008 996	C.Ceramic 1200pF/50V	CK73B1H122K
C253,254	257 0009 911	C.Ceramic 1800pF/50V	CK73B1H182K				Europe model only	CK73F1E104Z
			Europe model only		C450	257 0014 935	C.Ceramic 0.1μF/25V	CK73F1E104Z
			Europe model only		C451	254 4304 901	Electrolytic 2.2μF/35V	CE04W1V2R2M(SRE)
C255,256	257 0008 967	C.Ceramic 680pF/50V	CK73B1H681K		C452	254 4302 974	Electrolytic 100μF/10V	CE04W1A101M(SRE)
			Europe model only		C453,454	257 0011 909	C.Ceramic 0.01μF/25V	CK73B1E103K
C257	254 4252 969	Electrolytic 470μF/10V	CE04W1A471M(SME)		C455	257 0004 961	C.Ceramic 100pF/50V	CC73SL1H101J
C301	257 0008 954	C.Ceramic 560pF/50V	CK73B1H561K		C501-504	257 0024 909	C.Ceramic 1μF/16V	CK73F1C105Z
C302	257 0004 961	C.Ceramic 100pF/50V	CC73SL1H101J		C505-508	257 0008 983	C.Ceramic 1000pF/50V	CK73B1H102K
C303	254 4304 901	Electrolytic 2.2μF/35V	CE04W1V2R2M(SRE)		C509,510	257 0014 935	C.Ceramic 0.1μF/25V	CK73F1E104Z
C304	257 0014 935	C.Ceramic 0.1μF/25V	CK73F1E104Z		C511	254 6177 000	Electrolytic 3300μF/16V	CE04W1C332MC(KMG)
C305	257 0003 988	C.Ceramic 47pF/50V	CC73SL1H470J		C512	254 4299 906	Electrolytic 10μF/16V	CE04W1C100M(SRE)
C306	257 0004 945	C.Ceramic 82pF/50V	CC73SL1H820J		C513-520	257 0011 996	C.Ceramic 0.1μF/25V	CK73B1E104K
C307,308	257 0003 933	C.Ceramic 30pF/50V	CC73SL1H300J					

Ref. No.	Part No.	Part Name	Remarks	Ref. No.	Part No.	Part Name	Remarks	Q'ty
C521	257 0014 935	C.Ceramic 0.1μF/25V	CK73F1E104Z	CF401,402	261 0120 006	Ceramic Filter	SFE10.7MS3GK-A	2
C522	254 4388 901	Electrolytic 220μF/16V	CE04W1C221M(KME)	CF403	261 0122 004	Ceramic Filter	CSB456F23	1
C523	254 6177 712	Electrolytic 470μF/16V	CE04W1C471MC(KMG)	S701-704	212 4764 000	Tact Switch		4
C524	254 4402 913	Electrolytic 3.3μF/50V	CE04W1H3R3M(SRE)	S705	212 0361 009	Rotary Encoder (A)		1
C525	254 4302 974	Electrolytic 100μF/10V	CE04W1A101M(SRE)	S706-719	212 4764 000	Tact Switch		14
C601,602	254 4299 922	Electrolytic 4.7μF/16V	CE04W1C4R7M(SRE)	S720	212 1133 003	Push Lever Switch		1
C603,604	254 4302 974	Electrolytic 100μF/10V	CE04W1A101M(SRE)	PL701-708	393 0102 020	Lamp Assy(Green)	U.S.A.model	8
C605,606	257 0011 941	C.Ceramic 0.022μF/25V	CK73B1E223K	PL701-708	393 0102 033	Lamp Assy(Orange)	Europe model	8
C607,608	254 4304 901	Electrolytic 2.2μF/35V	CE04W1V2R2M(SRE)	CB2A	205 0343 029	2P Conn. Base(KR-PH)		1
C609	257 0014 935	C.Ceramic 0.1μF/25V	CK73F1E104Z	CB2B	203 2365 009	2P Conn. Cord		1
C611,612	257 0004 961	C.Ceramic 100pF/50V	CC73SL1H101J	CB3A,3B	205 0233 032	3P EH Conn. Base		2
C701,702	257 0014 935	C.Ceramic 0.1μF/25V	CK73F1E104Z	CB5A	205 0884 009	5P Conn. Base TUC-P		1
C703	254 4305 049	Electrolytic 0.47μF/50V	CE04W1HR47M(SRE)	CB8A	205 0233 087	8P EH Conn. Base		1
C704	254 4305 094	Electrolytic 3.3μF/50V	CE04W1H3R3M(SRE)	CB9A,9B	205 0884 038	9P Conn. Base TUC-P		2
C705	257 0005 986	C.Ceramic 330pF/50V	CC73SL1H331J	CB14A	205 0886 007	14P Conn. Base TKC-F		1
C801	257 0008 983	C.Ceramic 1000pF/50V	CK73B1H102K	CB14B	205 0884 041	15P Conn. Base TUC-P		1
C802-804	254 4299 906	Electrolytic 10μF/16V	CE04W1C100M(SRE)	CB15A	204 6417 008	15P Conn. Socket		1
C805,806	254 4299 919	Electrolytic 22μF/16V	CE04W1C220M(SRE)	CB16A	205 0819 003	16P Conn. Base		1
C807	254 4302 974	Electrolytic 100μF/10V	CE04W1A101M(SRE)	CB18A	205 0884 025	18P Conn. Base TUC-P		1
C808	257 0008 983	C.Ceramic 1000pF/50V	CK73B1H102K	CB18C	205 0820 005	18P Conn. Plug		1
C809-811	254 4299 906	Electrolytic 10μF/16V	CE04W1C100M(SRE)	CB20A	205 0898 008	20P FFC Conn. Base		1
C812	254 4302 974	Electrolytic 100μF/10V	CE04W1A101M(SRE)	CS3B	203 5036 005	3P EH-9073 Conn. Cord		1
C813	254 4299 906	Electrolytic 10μF/16V	CE04W1C100M(SRE)	CS5A	205 0885 008	5P Conn. Socket TUC-P		1
C814	257 0011 909	C.Ceramic 0.01μF/25V	CK73B1E103K	CS9A,9B	205 0885 037	9P Conn. Socket TUC-P		2
C816	257 0011 909	C.Ceramic 0.01μF/25V	CK73B1E103K	CS14A	205 0887 006	14P Conn. Socket TKC-F		1
C817	257 0014 935	C.Ceramic 0.1μF/25V	CK73F1E104Z	CS15A	204 6416 009	15P Conn. Plug		1
C818,819	257 0011 909	C.Ceramic 0.01μF/25V	CK73B1E103K	CS15B	205 0885 040	15P Conn. Socket TUC-P		1
C820	254 4254 967	Electrolytic 330μF/16V	CE04W1C331M	CS18A	205 0885 024	18P Conn. Socket TUC-P		1
C821	254 4299 906	Electrolytic 10μF/16V	CE04W1C100M(SRE)		143 0860 000	LCD Filter		1
C822	254 4300 963	Electrolytic 100μF/6.3V	CE04W0J101M(SRE)		143 0885 001	LCD Lens		1
C823	254 4254 789	Electrolytic 1000μF/16V	CE04W1C102M(SME)		461 0852 000	Rubber Sheet		1
C824	257 0014 935	C.Ceramic 0.1μF/25V	CK73F1E104Z		414 0701 003	Reflection Sheet		2
C901,902	257 0016 988	C.Ceramic 30pF/50V	CC73CH1H300J(Temp.)		412 3680 002	IC Holder		1
C903	257 0014 935	C.Ceramic 0.1μF/25V	CK73F1E104Z					
C904	254 4302 974	Electrolytic 100μF/10V	CE04W1A101M(SRE)					
C905	257 0014 935	C.Ceramic 0.1μF/25V	CK73F1E104Z					
C906	254 4304 901	Electrolytic 2.2μF/35V	CE04W1V2R2M(SRE)					
OTHER GROUP				Q'ty				
	—	(P.W.Board)		(1)				
L201,202	235 0020 990	Inductor 39 mH	Europe model only	2				
L301	235 0088 929	Chip Inductor 10 μH		1				
L401	235 0088 932	Chip Inductor 4.7 μH		1				
L402	235 0088 929	Chip Inductor 10 μH		1				
L801	235 0088 929	Chip Inductor 10 μH		1				
L803	232 0167 100	:Choke Coil		1				
L901	235 0088 929	Chip Inductor 10 μH		1				
T401	231 2088 006	:FM Det. Trans		1				
T402	232 0178 005	:Anti Birdie Filter Coil	Europe model only	1				
TN401	216 0091 009	FM/AM Tuner Pack		1				
XT101	399 0165 007	Crystal(16.9344 MHz)		1				
XT301	399 0151.008	Crystal(4.332 MHz)		1				
XT302	399 0041 008	Ceramic Resonator	CSA4.00MG	1				
XT401	399 0040 009	Crystal(7.2 MHz)		1				
XT901	399 0107 007	Ceramic Resonator	CST4.19MGW	1				
XT902	399 0217 007	Crystal(32.768 kHz)		1				

MD SECTION UNIT

Ref. No.	Part No.	Part Name	Remarks	Ref. No.	Part No.	Part Name	Remarks
SEMICONDUCTORS GROUP				C202	S11 6400 411	C.Ceramic 0.1µF/25V	CK73B1E104K
IC101	S87 5205 930	IC CXA1610M		C203	257 0008 941	C.Ceramic 470 pF/50V	CK73B1H471K
IC201	262 1879 003	IC CXD2515Q		C204	S11 6423 211	C.Ceramic 0.01µF/50V	CK73B1H103K
IC401	S87 5919 851	IC µPD78012GC-546-AB8	µ-com	C205	S11 6449 211	C.Ceramic 0.15µF/16V	CK73B1C154K
IC501	S87 5982 387	IC LB1638M		C206	257 0009 908	C.Ceramic 1500pF/50V	CK73B1H152K
IC502	S87 5992 572	IC SN74HX02ANS		C207	S11 6380 911	C.Ceramic 0.047µF/50V	CK73B1H473K
IC503	S87 5908 753	IC MPC1730MR2		C208	S11 6325 111	C.Ceramic 100 pF/50V	CC73CH1H101J(Temp.)
IC504	S87 5908 755	IC MPC1732MR2		C209	254 4466 904	Electrolytic 0.47µF/50V	CE67C1HR47M
Q101	S82 2914 148	Transistor 2SB624-BV345		C210	S11 6423 211	C.Ceramic 0.01µF/50V	CK73B1H103K
Q120-122	S87 2992 964	Transistor UMG4	Built in Resistor	C211	S11 6380 911	C.Ceramic 0.047µF/25V	CK73B1E473K
Q123	S87 2990 5XX	Transistor DTC114TU	Built in Resistor	C213	S11 6416 111	C.Ceramic 2200pF/50V	CK73F1H222Z
Q201	S87 2990 5XX	Transistor DTC114TU	Built in Resistor	C214	S11 6380 911	C.Ceramic 0.047µF/25V	CK73B1E473K
Q701,702	S87 2901 800	Transistor ST308	Built in Resistor	C215	257 0011 954	C.Ceramic 0.027µF/25V	CK73B1E273K
Q901	S87 2990 460	Transistor DTB113ZK	Built in Resistor	C401	S11 6303 800	C.Ceramic 0.1µF/25V	CK73F1E104Z
Q902	S87 2990 561	Transistor DTC124EU	Built in Resistor	C402	S11 2621 711	Electrolytic 15µF/10V	CE04W1A150M
D401	S87 1998 862	Diode 1SS355		C403	S11 6303 800	C.Ceramic 0.1µF/25V	CK73F1E104Z
D801,802	S87 1904 575	Diode CL-200I		C404,405	257 0016 988	C.Ceramic 30pF/50V	CC73CH1H300J(Temp.)
TH401,402	S18 0671 511	Thermistor		C406,407	S11 6303 800	C.Ceramic 0.1µF/25V	CK73F1E104Z
RESISTORS GROUP (Not included Carbon Film ±5% 1/4W.)				C408,409	257 0008 983	C.Ceramic 1000pF/50V	CK73F1H102Z
R101	S12 1600 100	Chip Carbon 10ohm 1/10W	RM73B--100J	C501	S11 3516 621	C.Tantal 47µF/10V	CS77B1A470M
R102	S12 1608 100	Chip Carbon 22kohm 1/10W	RM73B--223J	C502	S11 6449 211	C.Ceramic 0.15µF/16V	CK73B1C154K
R103	S12 1600 100	Chip Carbon 10ohm 1/10W	RM73B--100J	C503,504	S11 6434 611	C.Ceramic 1µF/16V	CK73F1C105Z
R104	S12 1683 511	Chip Carbon 15kohm 1/16W		C505-507	S11 6423 211	C.Ceramic 0.1µF/50V	CK73B1H104K
R105,106	S12 1683 311	Chip Carbon 10kohm 1/16W		C508	S11 6380 911	C.Ceramic 0.047µF/50V	CK73B1H473K
R107	S12 1683 711	Chip Carbon 22kohm 1/16W		C901	S11 2836 111	Electrolytic 470µF/10V	CE04W1A471M
R108	S12 1611 700	Chip Carbon 680kohm 1/10W	RM73B--684J	C903	254 4464 906	Electrolytic 100µF/6.3V	CE67C0J101M
R109	247 0013 942	Chip Carbon 330kohm 1/10W	RM73B--334J	OTHER GROUP			
R110	247 0012 972	Chip Carbon 160kohm 1/10W	RM73B--164J		—	(P.W.Board)	(1)
R111	S12 1609 500	Chip Carbon 82kohm 1/10W	RM73B--823J	L101,102	S14 1205 811	Chip Inductor 10 µH	2
R115	S12 1683 911	Chip Carbon 33kohm 1/16W		L201	S14 1205 811	Chip Inductor 10 µH	1
R116	S12 1609 900	Chip Carbon 120kohm 1/10W	RM73B--124J	L401	S14 1205 811	Chip Inductor 10 µH	1
R118	247 0013 913	Chip Carbon 240kohm 1/10W	RM73B--244J	L901	S14 1205 811	Chip Inductor 10 µH	1
R119	S12 1609 900	Chip Carbon 120kohm 1/10W	RM73B--124J	X401	S15 7993 821	Ceramic Resonator	CSAC8.00MT 1
R120	247 0011 973	Chip Carbon 62kohm 1/10W	RM73B--623J	CN101	S15 6572 811	17P FPC Conn.	1
R201	S12 3642 611	Resistor Array 15kohm	RK99==153J	CN303	S17 5016 021	7P FPC Conn. Socket	1
R202	S12 1609 700	Chip Carbon 100kohm 1/10W	RM73B--104J	CN401	S15 8080 221	20P Conn. Socket	1
R204	S12 1683 911	Chip Carbon 33kohm 1/16W		CN801	S15 6652 311	5P Conn. Socket	1
R205,206	S12 1682 711	Chip Carbon 3.3kohm 1/16W		CN803	205 0792 926	2P ZH ZR Conn. Base	1
R207	S12 1683 311	Chip Carbon 10kohm 1/16W		S301	S15 7246 721	Push Switch	1
R208	247 0014 967	Chip Carbon 1 Mohm 1/10W	RM73B--105J	S801	S15 7175 431	Push Switch (1key)	1
R209	S12 1684 511	Chip Carbon 100kohm 1/16W		S901	S16 9244 111	Micro Switch	1
R210	S12 1683 311	Chip Carbon 10kohm 1/16W					
R211	S12 3640 811	Resistor Array 470ohm	RK99==471J				
R217	S12 1681 711	Chip Carbon 470ohm 1/16W					
R401	247 0005 905	Chip Carbon 100ohm 1/10W	RM73B--101J				
R403	S12 3642 811	Resistor Array 22kohm 1/10W	RK99==223J				
R404	247 0012 969	Chip Carbon 150kohm 1/10W	RM73B--154J				
R405	247 0009 901	Chip Carbon 4.7kohm 1/10W	RM73B--472J				
R406	S12 1609 700	Chip Carbon 100kohm 1/10W	RM73B--104J				
R601	S12 1629 500	Chip Carbon 0ohm 1/10W	RM73B--0R0K				
R701,702	S12 3644 011	Resistor Array 220kohm	RK99==224J				
R801,802	247 0007 987	Chip Carbon 1.5kohm 1/10W	RM73B--152J				
CAPACITORS GROUP							
C100	S11 3516 221	C.Tantal 33µF/6.3V	CS77B0J330M				
C102	S11 6449 211	C.Ceramic 0.15µF/50V	CS77B1HR15M				
C104	S11 3516 221	C.Tantal 33µF/6.3V	CS77B0J330M				
C105	S11 3514 921	C.Tantal 2.2µF/10V	CS77B1A2R2M				
C106	257 0016 917	C.Ceramic 22pF/50V	CC73CH1H220J(Temp.)				
C107	254 4464 906	Electrolytic 100µF/6.3V	CE67C0J101M				
C200	S11 3518 121	C.Tantal 4.7µF/6.3V	CS77B0J4R7M				
C201	257 0008 941	C.Ceramic 470 pF/50V	CK73B1H471K				