

DENON

Hi-Fi Personal Component System

Europe Model

SERVICE MANUAL

PERSONAL COMPONENT SYSTEM D-F10

- UNIT No. UTU-F10 (AM, FM Stereo Tuner)
- UNIT No. UPA-F10 (Pre-Main Amplifier)
- UNIT No. UCD-F10 (Compact Disc Player)
- UNIT No. UDR-F10 (Cassette Tape Deck)

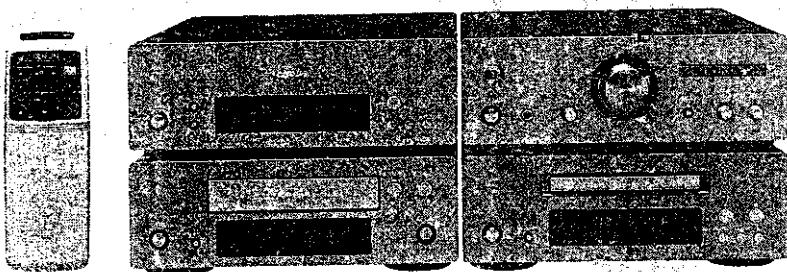

• The D-F10 Personal Component System consists of the following:

AM, FM Stereo Tuner Unit	UTU-F10
Remote Control Unit	RC-172
Pre-Main Amplifier Unit	UPA-F10
CD player Unit	UCD-F10
Cassette Deck Unit	UDR-F10

MAIN FEATURES

DF10

- **RDS compatible**
Compatible with various RDS services, including program service name (PS), program type identification (PTY), traffic program identification (TP) and clock time (CT).
- **Quality power for high quality sound**
55W + 55W (4 ohm DIN) high quality amplifier and terminals for large speakers.
- **High sound quality, multi-function CD player**
Edit function for automatically dividing the tracks on a CD for recording onto sides A and B of a tape. S.L.C for playback with high quality sound.
- **Cassette deck with Dolby B, C and HX-Pro circuits**
For playback and recording of high quality sound.

- **Two types of timers**
Two timer settings can be made - everyday and sleep.
- **Easy-to-use remote control unit**
The most frequently used keys are located on the front, with the remaining keys enclosed under a sliding cover.
- **Auto on function**
The power turns on automatically and playback begins when the play button on the CD player or the cassette deck or the tuner preset up/down buttons on the remote control unit are pressed.

BEFORE USING

- **Moving the system**
To prevent short-circuiting or damage of connection cords, be sure to unplug the power cord and disconnect all connection cords before moving the system.
In addition, always remove CDs before moving the system. If not, the CD may be scratched.
- **Before turning the power on**
Check again that all connections are proper and that the connection cords are not damaged. Always set the power switch to the STANDBY position before disconnecting connection cords.

- Humming may be produced if the system is set near a TV set or other audio component or its connection cords. If this happens, try changing the position of the equipment and connection cords.
- Do not move the system abruptly from a cold place to a warm place, as this may cause dew (water droplets) to form in the set, preventing proper operation. If this happens, wait one hour before using the system.
- **Be sure to keep this manual**
The illustrations used in this manual may differ from the actual system.

Check that the following parts are included in the package aside from the main unit:

- **UPA-F10 (pre-main amplifier unit)**
 - Remote control unit (RC-172) 1
 - R6P/AA batteries 2
 - Operating instructions 1
- **UTU-F10 (AM/FM stereo tuner)**
 - FM antenna 1
 - AM loop antenna 1
 - System connector cable 1
 - RCA pin-plug cord 1
 - AC cord 1
 - Inst. Sheet 1

- **UCD-F10 (compact disc player)**
 - System connector cable 1
 - RCA pin-plug cord 1
 - AC cord 1
 - Inst. Sheet 1
- **UDR-F10 (cassette tape deck)**
 - System connector cable 1
 - RCA pin-plug cord 2
 - Inst. Sheet 1

NIPPON COLUMBIA CO., LTD.

GENERAL SECTION

GENERAL SECTION

TABLE OF CONTENTS

General Section (Page 1 ~ Pages 28)

- Main Features 1
- Before Using 1
- Main Specifications 3
- Operating Instructions 4~28

Tuner Section (Pages 29 ~ Pages 52)

- Block Diagram 29
- Disassembly Procedures 30, 31
- Adjustments 32~34
- Semiconductors 35~41
- Microprocessor Documentation 42, 43
- Printed Wiring Board, Parts List 44~48
- Microprocessor Peripheral Wiring Diagram 49
- Wiring Diagram 50
- Schematic Diagram 51
- Exploded View, Parts List 52

Pre-Main Amplifier Section (Pages 53 ~ Pages 72)

- Remote Control Unit 53
- Block Diagram 54
- Level Diagram 55
- Disassembly Procedures 56, 57
- Adjustments 58
- Semiconductors 59~61
- Microprocessor Documentation 62, 63
- Microprocessor Peripheral Wiring Diagram 64
- Printed Wiring Board, Parts List 65~69
- Wiring Diagram 70
- Schematic Diagram 71
- Exploded View, Parts List 72

CD Player Section (Pages 73 ~ Pages 99)

- Disassembly Procedures 73
- Laser Pickup 74
- Adjustments 75~79
- Semiconductors 80~87
- Microprocessor Documentation 88~90
- Microprocessor Peripheral Wiring Diagram 91
- Printed Wiring Board, Parts List 92~95
- Wiring Diagram 96
- Schematic Diagram 97
- Exploded View, Parts List 98
- Disassembly of CD Mechanism (FG-73) 99

Cassette Deck Section (Pages 100 ~ Pages 121)

- Level Diagram 100
- Block Diagram 100
- Disassembly Procedures 101
- Adjustments 102~105
- Semiconductors 106~109
- Microprocessor Documentation 110
- Microprocessor Peripheral Wiring Diagram 111
- Printed Wiring Board, Parts List 112~115
- Wiring Diagram 116
- Schematic Diagram 117
- Exploded View, Parts List 118
- Cassette Mechanism 119~121

Speaker Section (Pages 122 ~ Pages 123)

- Exploded View, Parts List 122
- Schematic Diagram 122
- Network Ass'y 123
- Wire Forming 123

SPECIFICATIONS

- **Pre-main amplifier (UPA-F10)**
Practical maximum output: 55 W + 55 W (4 ohms DIN)
Low frequency adjustment range: 100 Hz ±8 dB
High frequency adjustment range: 10 kHz ±8 dB
Audio input / output jacks: CD input jacks, tape input/output jacks, tuner input jacks, MD/AUX input/output jacks, processor loop jacks, 6.3mm headphones jack and phono input jacks
AC 230 V, 50 Hz
Power supply: 130 W
Power consumption: 270 (W) × 96 (H) × 342 (D) mm (10-5/8" × 3-25/32" × 13-15/32") (including feet, controls and terminals)
Maximum external dimensions: 4.5 kg (9 lbs. 15 oz)
Weight:
 - **Tuner (UTU-F10)**
Reception frequency band: FM: 87.50 MHz – 108.00 MHz
AM: 522 kHz – 1611 kHz
Reception sensitivity: FM: 1.5 μ/75 ohms
AM: 20 μV
40 dB (1 kHz)
FM stereo separation: AC 230 V, 50 Hz
Power supply: 8 W
Power consumption: 270 (W) × 96 (H) × 318 (D) mm (10-5/8" × 3-25/32" × 12-33/64") (including feet, controls and terminals)
Maximum external dimensions: 2.8 kg (6 lbs. 3 oz)
Weight:
 - **CD player (UCD-F10)**
Wow & flutter: Below measurable limits (±0.001% W. peak)
44.1 kHz
Semiconductor
Optical source: AC 230 V, 50 Hz
Power supply: 8 W
Power consumption: 270 (W) × 96 (H) × 315 (D) mm (10-5/8" × 3-25/32" × 12-13/32") (including feet, controls and terminals)
Maximum external dimensions: 3.3 kg (7 lbs. 5 oz)
Weight:
 - **Cassette deck (UDR-F10)**
Type: Horizontal 4-track 2-channel stereo cassette deck
Heads: 1 hard permalloy recording/playback head
1 double-gap ferrite erasing head
4.75 cm/s
Dolby B and C NR, Dolby HX Pro
Tape speed: Normal, chrome and metal
Included circuits: AC 230 V, 50 Hz
Usable tapes: 13 W
Power supply: 270 (W) × 96 (H) × 313 (D) mm (10-5/8" × 3-25/32" × 12-21/64") (including feet, controls and terminals)
Power consumption: 3.8 kg (8 lbs. 6 oz)
Maximum external dimensions:
Weight:
 - **Remote control unit (RC-172)**
Remote control system: Infrared pulse
Number of buttons: 50
Two DC 1.5 V R6P/AA batteries
Power supply: 57 (W) × 197 (H) × 21 (D) mm (2-1/4" × 7-3/4" × 53/64")
Maximum external dimensions: 130 g (including batteries) (Approx. 4.6 oz)
Weight:
- * Maximum dimensions include controls, jacks, and covers.
(W) = width, (H) = height, (D) = depth
- For improvement purposes, specifications and functions are subject to change without advanced notice.
 - Dolby noise reduction and HX Pro headroom extension manufactured under license from Dolby Laboratories Licensing Corporation. HX Pro originated by Bang & Olufsen.
 - "DOLBY", the double-D symbol  and "HX PRO" are trademarks of Dolby Laboratories Licensing Corporation.

PACKING & ACCESSORIES PARTS LIST

Ref. No.	Part No.	Part Name	Remarks	Qty
1	UTU F10	Tuner Unit	Tuner	1 ^S
2	UPA F10	Pre-Main Amp Unit	Amp.	1 ^S
3	UCDF10	CD Player Unit	CD Player	1 ^S
4	UDR F10	Cassette Deck Unit	Cassette Deck	1 ^S
5	GEN 2740	Envelope Sub. Ass'y-1	included UTU-F10	1 ^S
5-1	505 9125 009	•Poly Cover		(1)
5-2	231 1914 003	•Loop Antenna		(1)
5-3	395 0021 000	•FM Ant. Ass'y		(1)
5-4	203 2310 009	•2P Pin Cord	L=1000	(1)
5-5	203 2315 004	•Stereo Miniplug Cord Ass'y	L=500	(1)
5-6	206 2108 003	•AC Conn. with Plug		(1)
5-7	511 2653 007	•Inst. Sheet		(1)
6	GEN 2738	Envelope Sub Ass'y-2	included UPA-F10	1 ^S
6-1	505 8006 019	•Envelope		(1)
6-2	511 2614 004	•Inst. Manual	E.G.F.IT	(1)
6-3	511 2615 003	•Inst. Manual	ES,NL,S,PO	(1)
6-4	399 0235 005	•Remote Control Unit	RC-172	(1)
6-5	—	•Batteries	R6P/AA/UM-3	(2)

Ref. No.	Part No.	Part Name	Remarks	Qty
7	GEN 2742	Envelope Sub. Ass'y-3	included UCD-F10	1 ^S
7-1	505 9125 009	•Poly Cover		(1)
7-2	203 2310 009	•2P Pin Cord	L=1000	(1)
7-3	203 2315 004	•Stereo Miniplug Cord Ass'y	L=500	(1)
7-4	206 2108 003	•AC Conn. with Plug		(1)
7-5	511 2654 006	•Inst. Sheet		(1)
8	GEN 2744	Envelope Sub. Ass'y-4	included UDR-F10	1 ^S
8-1	505 8006 019	•Envelope		(1)
8-2	203 2223 002	•2P Pin Cord	L=1000	(2)
8-3	203 2315 004	•Stereo Miniplug Cord Ass'y	L=500	(1)
8-4	511 2651 009	•Inst. Sheet		(1)





Ref. No.	Part No.	Part Name	Remarks	Qty
1	SCF 10	Speaker System	Speaker System	1 ^S
2	SCF 1000 119	•Envelope Sub. Ass'y		1 ^S
2-1	SCF 1000 111	•Envelope		(2)
2-2	009 0107 007	•Out Put Cord Ass'y	L=2000	(1)
3	511 2644 003	•Inst. Manual		(1)
4	—	—		(1)

ADVARSEL: USYNLIG LASERSTRÅLING VED ÅBNING, NÅR SIKKERHEDSAFBRYDERE ER UDE AF FUNKTION. UNDGÅ UDSÆTTELSE FOR STRÅLING.

VAROITUS! LAITTEEN KÄYTTÄMINEN MUULLA KUIN TÄSSÄ KÄYTTÖOHJEESSA MAINITULLA TAVALLA SAATTAA ALTISTAA KÄYTTÄJÄN TURVALLISUUSLUOKAN 1 YLITÄVÄLLE NÄKYMÄTTÖMÄLLE LASERSATEILYLLE.

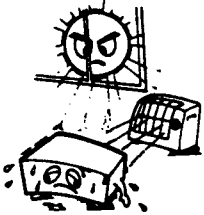
WARNING- OM APPARATEN ANVÄNDS PÅ ANNAT SÄTT ÄN I DENNA BRUKSANVISNING SPECIFICERATS. KAN ANVÄNDAREN UTSÄTTAS FÖR OSYNLIG LASERSTRÅLNING SOM ÖVERSKRIDER GRÄNSEN FÖR LASERKLASS 1.

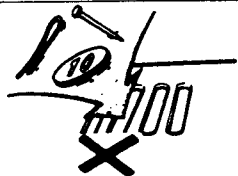
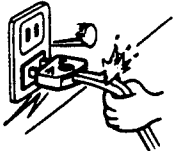
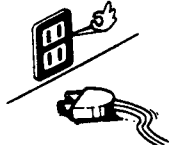
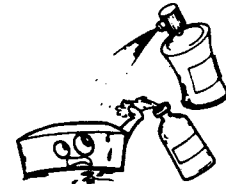
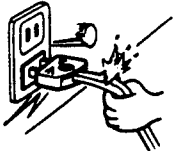
NOTE ON USE/HINWEISE ZUM GEBRAUCH/OBSERVATIONS RELATIVES A L'UTILISATION NOTE SULL'USO

 <ul style="list-style-type: none"> • Avoid high temperatures. Allow for sufficient heat dispersion when installed on a rack. • Vermeiden Sie hohe Temperaturen. Beachten Sie, daß eine ausreichend Luftzirkulation gewährleistet wird, wenn das Gerät auf ein Regal gestellt wird. • Éviter des températures élevées. Tenir compte d'une dispersion de chaleur suffisante lors de l'installation sur une étagère. • Evitare di esporre l'unità a temperature alte. Assicurarsi che ci sia un'adeguata dispersione del calore quando installate l'unità in un mobile per componenti audio. 	 <ul style="list-style-type: none"> • Keep the set free from moisture, water, and dust. • Halten Sie das Gerät von Feuchtigkeit, Wasser und Staub fern. • Protéger l'appareil contre l'humidité, l'eau et la poussière. • Tenete l'unità lontana dall'umidità, dall'acqua e dalla polvere. 	 <ul style="list-style-type: none"> • Do not let foreign objects in the set. • Keine fremden Gegenstände in das Gerät kommen lassen. • Ne pas laisser des objets étrangers dans l'appareil. • E' importante che nessun oggetto è inserito all'interno dell'unità.
 <ul style="list-style-type: none"> • Handle the power cord carefully. Hold the plug when unplugging the cord. • Gehen Sie vorsichtig mit dem Netzkabel um. Halten Sie das Kabel am Stecker, wenn Sie den Stecker herausziehen. • Manipuler le cordon d'alimentation avec précaution. • Tenir la prise lors du débranchement du cordon. • Maneggiare il filo di alimentazione con cura. Agitare per la spina quando scollegate il cavo dalla prese. 	 <ul style="list-style-type: none"> • Unplug the power cord when not using the set for long periods of time. • Wenn das Gerät eine längere Zeit nicht verwendet werden soll, trennen Sie das Netzkabel vom Netzstecker. • Débrancher le cordon d'alimentation lorsque l'appareil n'est pas utilisé pendant de longues périodes. • Disinnestate il filo di alimentazione quando avete l'intenzione di non usare il filo di alimentazione per un lungo periodo di tempo. 	 <ul style="list-style-type: none"> • Do not let insecticides, benzene, and thinner come in contact with the set. • Lassen Sie das Gerät nicht mit Insektiziden, Benzin oder Verdünnungsmitteln in Berührung kommen. • Ne pas mettre en contact des insecticides, du benzène et un diluant avec l'appareil. • Assicurarsi che l'unità non venga in contatto con insetticidi, benzolo o solventi.
 <ul style="list-style-type: none"> • Handle the power cord carefully. Hold the plug when unplugging the cord. • Gehen Sie vorsichtig mit dem Netzkabel um. Halten Sie das Kabel am Stecker, wenn Sie den Stecker herausziehen. • Manipuler le cordon d'alimentation avec précaution. • Tenir la prise lors du débranchement du cordon. • Maneggiare il filo di alimentazione con cura. Agitare per la spina quando scollegate il cavo dalla prese. 	 <p>*(For sets with ventilation holes)</p> <ul style="list-style-type: none"> • Do not obstruct the ventilation holes. • Die Belüftungsöffnungen dürfen nicht verdeckt werden. • Ne pas obstruer les trous d'aération. • Non coprite i fori di ventilazione. 	 <ul style="list-style-type: none"> • Never disassemble or modify the set in any way. • Versuchen Sie niemals das Gerät auseinander zu nehmen oder auf jegliche Art zu verändern. • Ne jamais démonter ou modifier l'appareil d'une manière ou d'une autre. • Non smontate mai, né modificate l'unità in nessun modo.

CAUTION/VORSICHT/ATTENTION/AVVISO

- If the system should smoke or produce strange smells, immediately set the power switch to the STANDBY position, unplug the power cord, and contact your store of purchase.
- Sollte das Gerät Rauch produzieren oder eigenartig riechen, stellen Sie den Netzschalter sofort auf die Position STANDBY (Bereitschaft), ziehen Sie den Netzstecker heraus und kontaktieren Sie Ihren Händler.
- Si de la fumée sort de la chaîne ou des odeurs bizarres, placer l'interrupteur d'alimentation immédiatement sur la position de veille (STANDBY), débrancher le cordon d'alimentation et contacter le distributeur.
- Qualora il sistema dovesse produrre del fumo o degli odori strani, collocare immediatamente l'interruttore di accensione nella posizione STANDBY, disinnestate il filo di alimentazione e rivolgetevi al negozio dell'acquisto.

"SERIAL NO. _____
PLEASE RECORD UNIT SERIAL NUMBER ATTACHED TO THE REAR OF THE
CABINET FOR FUTURE REFERENCE"

SAFETY IMPORTANT

WARNING:

TO PREVENT FIRE OR SHOCK HAZARD, DO NOT EXPOSE THIS APPLIANCE TO RAIN OR MOISTURE.

•NUR FÜR EUROPÄISCHE MODELLE

Konformitätserklärung

Die DENON Electronic GmbH
Halskestraße 32
40880 Ratingen

Erklärt als Hersteller/Importeur, daß das in dieser Bedienungsanleitung beschriebene Gerät den Technischen Vorschriften für Ton- und Fernseh-Rundfunkempfänger nach der Amtsblattverfügung 868/1989 (Amtsblatt des Bundesministers für Post und Telekommunikation vom 31. 8. 1989) entspricht.

CLASS 1 LASER PRODUCT LUOKAN 1 LASERLAITE KLASS 1 LASERAPPARAT

ADVARSEL: USYNLIG LASERSTRÅLING VED ÅBNING. NÅR SIKKERHEDSÅPBEYDRE ER UDE AF FUNKTION. UNDGÅ UDSÆTTELSE FOR STRÅLING.

VAROITUS: LAITTEEN KÄYTTÄMINEN MUULLA KUUN TÄSSÄ KÄYTTÖOHJEISSA MAINITULLA TAVALLA SAATTAA ALTIISTAA KÄYTTÄJÄN TURVALLISUUSLUOKAN 1 YLITÄVÄLLE NÄKYMÄTTÖMÄLLE LASERÄTÄLTYLLE.

VARNING: OM APPARATEN ANVÄNDS PÅ ANNAT SÄTT ÄN I DENNA BRUKANVISNING SPECIFICERATS, KAN ANVÄNDAREN UTEÅTTAS FÖR ÖBYNLIG LASERSTRÅLNING SOM ÖVERSKRIDER GRÄNSEN FÖR LASERKLASS 1.

"CLASS 1
LASER PRODUCT"



FRONT PANEL/FRONTPLATTE/PANNEAU AVANT/PANNELLO ANTERIORE

**PRE-MAIN AMPLIFIER
VORVERSTÄRKER
AMPLIFICATEUR-PRÉAMPLIFICATEUR
PREAMPLIFICATORE PRINCIPALE**

See ENGLISH Page 6
Sehen Sie DEUTSCH Seite 30
Voir FRANÇAIS Page 54
Fate riferimento alla sezione ITALIANO alla pagina 78

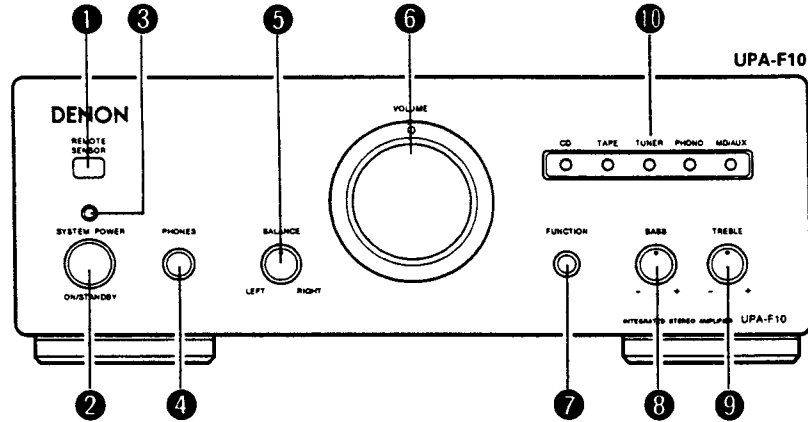

**STEREO TUNER
STEREO EMPFÄNGER
TUNER STÉRÉO
SINTONIZZATORE STEREO**

See ENGLISH Page 6
Sehen Sie DEUTSCH Seite 30
Voir FRANÇAIS Page 54
Fate riferimento alla sezione ITALIANO alla pagina 78

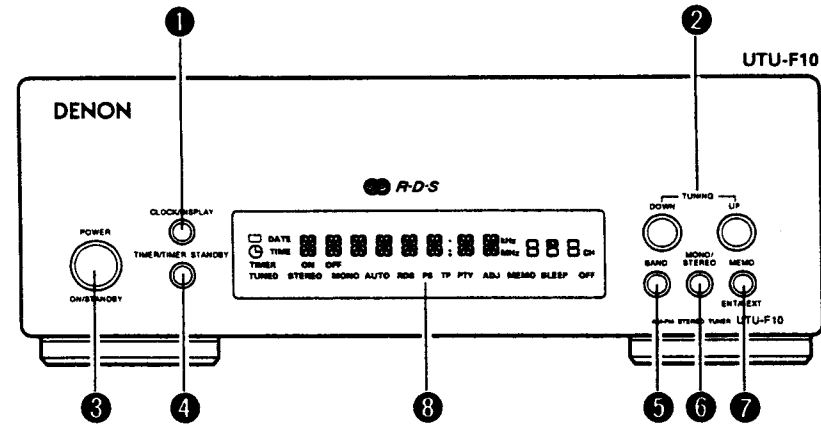

**CD PLAYER
CD-SPIELER
LECTEUR CD
DISPLAY DELLA PIASTRA A CASSETTE**

See ENGLISH Page 7
Sehen Sie DEUTSCH Seite 31
Voir FRANÇAIS Page 55
Fate riferimento alla sezione ITALIANO alla pagina 79

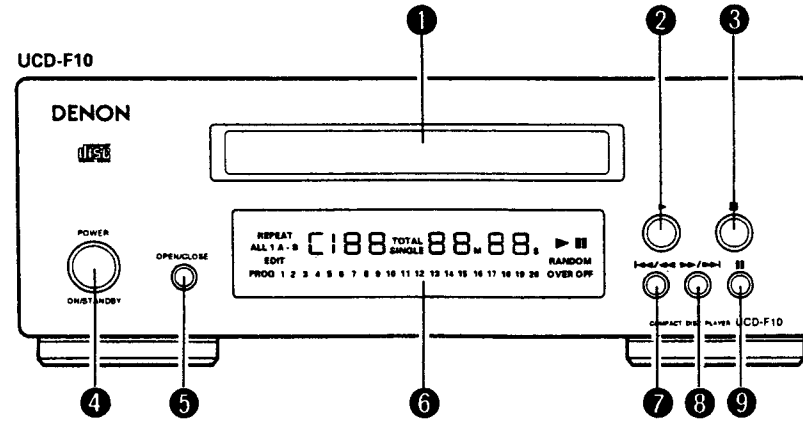

**CASSETTE DECK
CASSETTENECK
PLATINE CASSETTE
PIASTRA A CASSETTE**

See ENGLISH Page 8
Sehen Sie DEUTSCH Seite 32
Voir FRANÇAIS Page 56
Fate riferimento alla sezione ITALIANO alla pagina 80

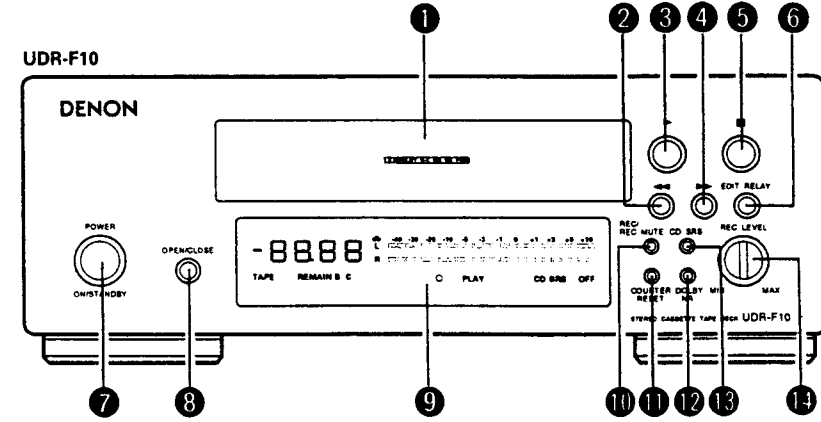

- As an aid to better understanding the operation method, the illustrations used in this manual may differ from the actual system.
- Als Hilfestellung zum besseren Verständnis der Betriebsmethode, erlauben wir uns den Hinweis, daß sich die Abbildungen in dieser Bedienungsanleitung leicht von dem aktuellen System unterscheiden.
- Pour faciliter la compréhension de la méthode de fonctionnement, les illustrations utilisées dans ce manuel peuvent être différentes de celles de la chaîne réelle.
- Per rendere la spiegazione del metodo operativo più facile, le illustrazioni usate in questo libretto delle istruzioni possono differire dal sistema stesso.

5 PART NAMES, FUNCTIONS AND DISPLAYS

PRE-MAIN AMPLIFIER

- 1 **REMOTE SENSOR**
When operating the remote control unit, point it at this sensor.
- 2 **SYSTEM POWER switch**
(This turns the power for the entire system on and off.)
Press this once to turn the power on, then press again to set the power to the standby mode.
- 3 **Power indicator**
This lights when the power cord is plugged into a power outlet, and flashes for 5 seconds after the system power is turned on.
- 4 **PHONES (headphones jack)**
Plug the headphones into this jack.
No sound is produced from the speakers when headphones are plugged in.
- 5 **BALANCE control**
Use this to adjust the balance of the volume between the left and right channels. When set at the center position, the volume is the same for the left and right channels.

TUNER

- 1 **CLOCK/DISPLAY selector button**
This button is used to switch the display between the reception frequency and the clock.
- 2 **TUNING UP and DOWN buttons**
These buttons are used to select AM and FM stations and to set the clock and timer.
- 3 **POWER switch**
Press this button once to turn the tuner's power on, then press again to set the tuner to the standby mode. In the standby mode, "OFF" appears on the display.
- 4 **TIMER/TIMER STANDBY button**
Press this when setting the timer and to turn the timer on so that it operates at the set times.
When the button is pressed after the timer has been set, the timer standby mark ("⌚") appears on the display. Press again to turn the mark off.
The timer will not operate when the "⌚" mark is off.

- 6 **VOLUME control**
Use this to adjust the overall volume.
The volume increases when the control is turned clockwise (↻) and decreases when it is turned counterclockwise (↺).
- 7 **FUNCTION (input) selector button**
Use this to select the input (function).
The input changes in the following order each time this button is pressed: CD, TAPE, TUNER, PHONO, MD/AUX. (The function changes automatically when the system's CD player or cassette deck is played or when a preset channel is recalled on the tuner.)
- 8 **BASS control**
Use this to adjust the volume of the low frequencies.
- 9 **TREBLE control**
Use this to adjust the volume of the high frequencies.
- 10 **Function indicators**
These light to indicate the currently selected function.

- 5 **BAND (AM/FM) selector button**
The band switches between AM and FM each time this button is pressed.
- 6 **MONO/STEREO selector button**
AUTO mode: Use this mode to receive programs in stereo.
The sound and the indicators on the display automatically switch between monaural ("MONO") and stereo ("STEREO") according to whether the program is being broadcast in monaural or stereo.
MONO mode: Use this mode to receive programs in monaural, regardless of whether they are being broadcast in monaural or stereo.
Set this mode if there is much noise or if the signals are weak when receiving stereo programs (when "AUTO" is lit).
- 7 **MEMO ENT/NEXT button**
This button is used to preset AM and FM stations and when setting the timer.
- 8 **Display**

TUNER DISPLAY

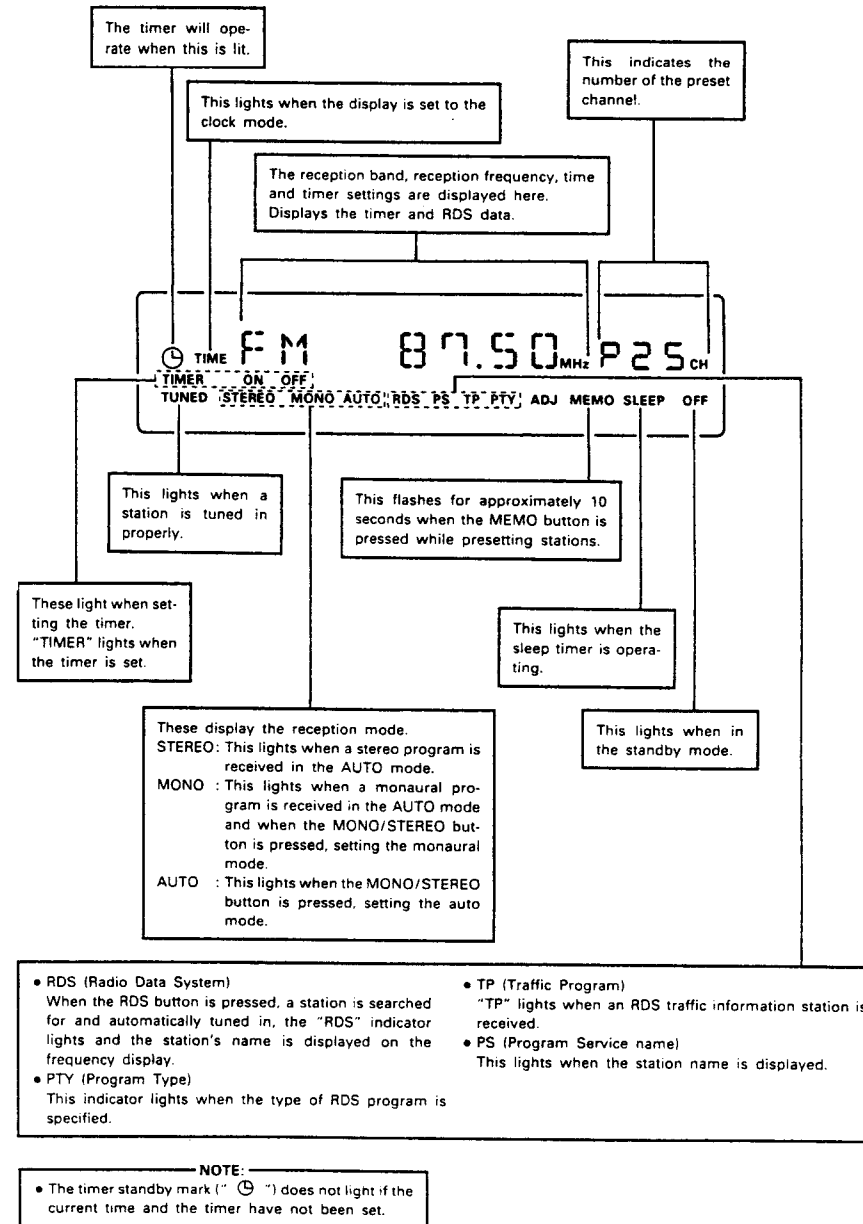

4 CONNECTIONS

NOTE:

This system includes digital circuitry which may cause interference such as color blotching or changes in the color on TVs. If this happens, move the system and the TV as far apart as possible.

Use a record player with an MM cartridge

- Disconnect the ground cord if humming or noise is produced when it is connected.

- For instructions on connection and operation of an optional MD player, refer to the MD player's operating instructions.

MD player, video deck, LD player, etc

Connecting the speaker systems

Connect the speaker system for the left channel (the left side as seen from the front) to the "L" terminals. The speaker system for the right channel to the "R" terminals. Be sure to use speaker systems with an impedance of 4 ohm or greater.

CAUTION:

Whenever the power switch is in the STANDBY position, the unit is still connected on AC line voltage. Please be sure to unplug the cord when you leave home for, say, a vacation.

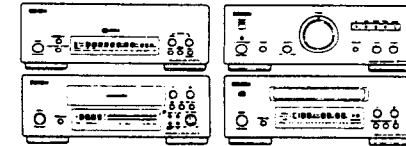

Side by side installation

Install the sets as shown in one of these diagrams. In either case, be sure that the pre-main amplifier's ventilation holes are not obstructed.

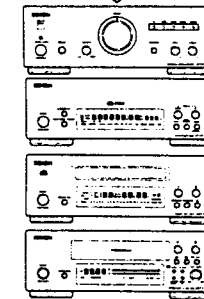

Side by side installation

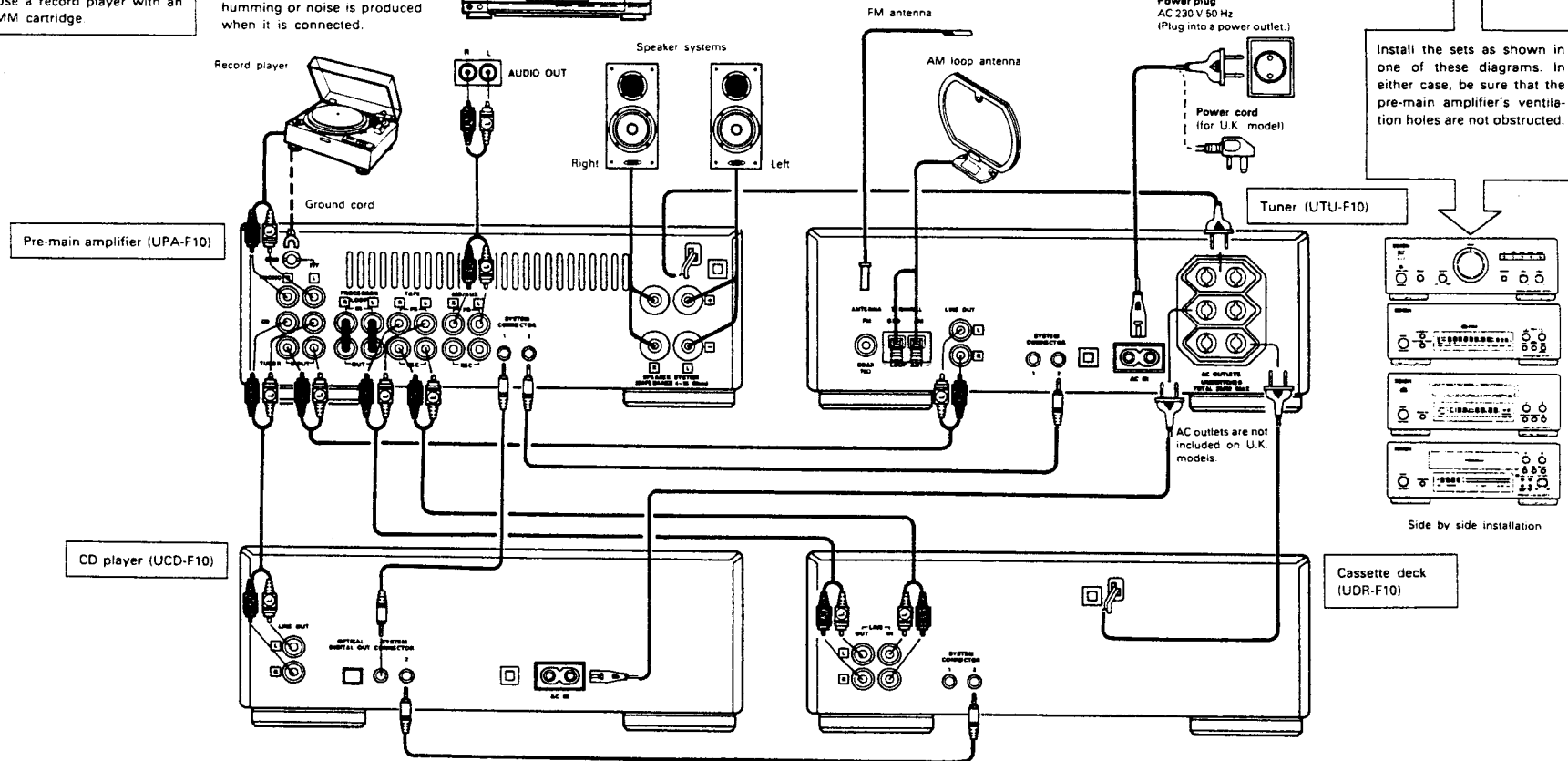

System operations

Such system operations as the timer and the auto on functions, as well as remote control operations cannot be performed unless all the RCA pin-plug cords and system connector cords are connected between the units, so be sure to make all the connections properly as shown in the diagram. Also, disconnecting system connectors while the system is operating may result in malfunction. Be sure to turn unplug the power cord before changing connections.

OPTICAL DIGITAL OUT jack

Digital data is output in optical form from this jack.

PROCESSOR LOOP jacks

The PROCESSOR LOOP jacks on the UPA-F10 are interconnected with short-circuiting pins. Only remove these pins when using these jacks for connection to another component.

NOTES:

- Do not plug the power cord into the power outlet until all connections are completed. Be sure to interconnect the channels (L to L (white) and R to R (red)) properly, as shown on the diagram.
- Insert the plugs securely. Incomplete connections may result in noise.
- Be sure to connect the speaker cords between the speaker terminals and the speaker systems with the same polarities (+ to +, - to -). If the polarities are switched, the sound at the center will be weak, the position of the different instruments will be unclear, and the stereo effect will be lost.
- After unplugging the power cord, wait about 5 seconds before plugging it back in.
- Note that setting the connection cords (pin-plug cords) next to the power cords may result in humming or other noise.

CD PLAYER

- 1 **Disc tray**
Load discs here.
- 2 **(play) button**
Press this button to start playing the disc. Even when the disc tray is open, the disc tray closes and playback begins when this button is pressed. When pressed in the standby mode, the power automatically turns on and playback begins. (Auto on function)
- 3 **(stop) button**
Press this button to stop playback.
- 4 **POWER switch**
Press this once to turn the CD player's power on, then press again to set the CD player to the standby mode. In the standby mode, "OFF" appears on the display.
- 5 **OPEN/CLOSE button**
Press this to open and close the disc tray. When pressed once, the disc tray opens out, and when pressed again, the disc tray closes. If a disc is loaded, the total number of tracks and total playing time of the disc are displayed several seconds after the disc tray is closed. When pressed in the standby mode, the CD player's power turns on.

- 6 **Display**
- 7 **⏮ / ⏪ (automatic/manual search reverse) button**
Use this to move to the beginning of a specific track. When pressed during playback or in the pause mode, the pickup moves backward a number of tracks equal to the number of times the button is pressed.
- 8 **⏩ / ⏭ (automatic/manual search forward) button**
Use this to move to the beginning of a specific track. When pressed during playback or in the pause mode, the pickup moves forward a number of tracks equal to the number of times the button is pressed.
 - The automatic search mode is set if the 7 or 8 button is released within 0.5 seconds, and the manual search mode is set if the button is held for over 0.5 seconds.
- 9 **⏸ (pause) button**
Press this button to stop playback temporarily. Press the play button to cancel the pause mode and resume playback.

CD PLAYER DISPLAY

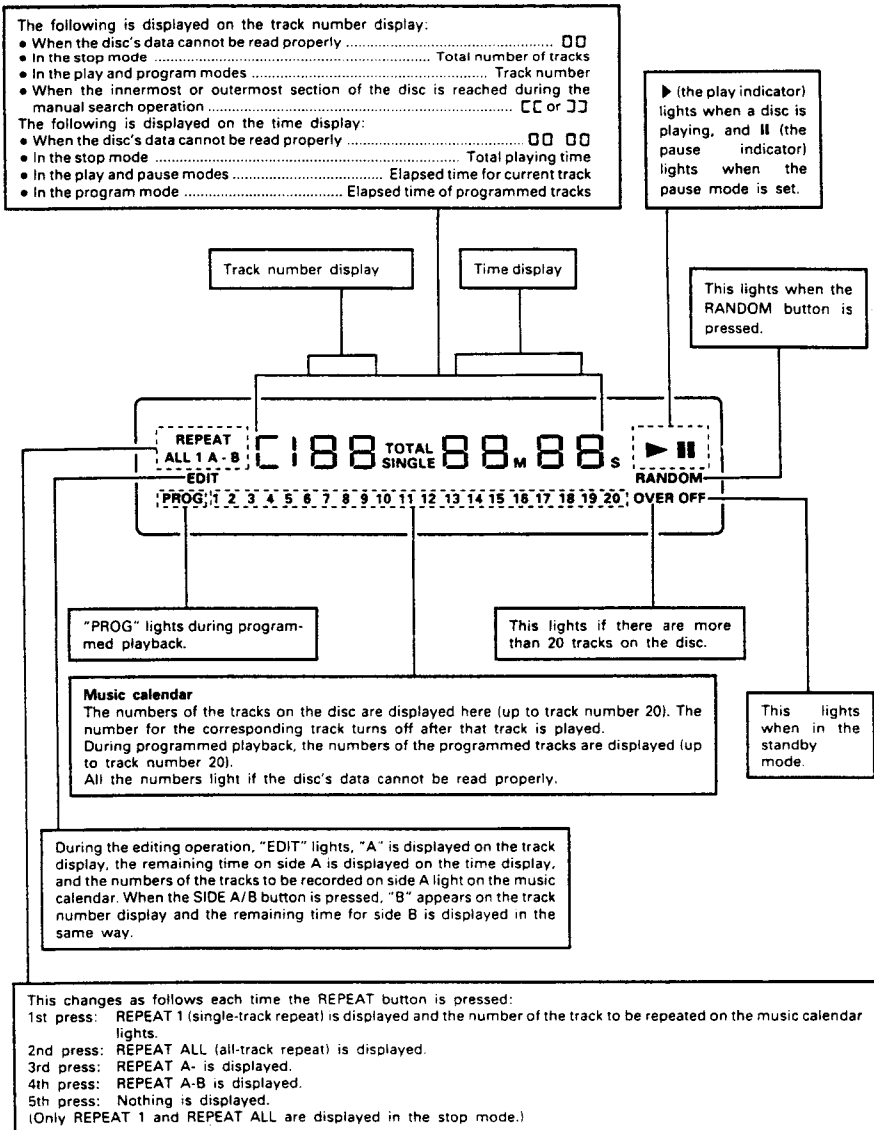

CASSETTE DECK

- 1 **Cassette tray**
The cassette tray opens out when the OPEN/CLOSE button is pressed. Load the cassette tape with the side on which the tape is exposed facing away from you. To close the cassette tray, press the OPEN/CLOSE button again. For details, refer to Page 16.
- 2 **◀ (rewind) button**
Press this button to rewind the tape. Press this button during playback to set the music search mode.
- 3 **▶ (play) button**
Press this button to start playback. When pressed in the standby mode, the power of both the cassette deck and the pre-main amplifier turns on automatically and playback starts. (Auto on function)
- 4 **▶▶ (fast-forward) button**
Press this button to fast-forward the tape. Press this button during playback to set the music search mode.
- 5 **■ (stop) button**
Press this button while the tape is moving to stop the tape.
- 6 **EDIT RELAY button**
The cassette tray opens when all the tracks for side A of the tape have been recorded with the CD edited recording function. To continue recording on side B, turn the tape over then press this button to close the cassette tray and start recording.
- 7 **POWER switch**
Press this once to turn the cassette deck's power on, then press again to set the cassette deck to the standby mode. In the standby mode, "OFF" appears on the display.
- 8 **OPEN/CLOSE button**
Press this to open and close the cassette tray. When pressed in the standby mode, the cassette deck's power turns on.
- 9 **Display**

- 10 **REC/REC MUTE button**
This button is used when recording and when creating blank spaces between selections. If only the REC/REC MUTE button is pressed, the recording pause mode is set.
When REC/REC MUTE button is pressed while in the recording pause mode, the recording mute mode is set for approximately 5 seconds, creating a blank space on the tape, after which the recording pause mode is once again set. When the ▶ (play) button is pressed while in the recording pause mode, recording begins.
The recording pause mode is set when this button is pressed for less than 0.5 seconds while in the recording mode. If it is pressed for over 0.5 seconds while in the recording mode, the recording mute mode is set for approximately 5 seconds, after which the recording pause mode is once again set. Press the ■ (stop) button to cancel the recording pause mode.

NOTE:
• If the play button on the CD player is pressed during the recording pause mode, recording of the CD begins automatically.

- 11 **COUNTER RESET button**
Press this button to reset the tape counter to "00.00".
 - 12 **DOLBY NR mode selector button**
Use this to select the Dolby NR mode (OFF, B or C). When playing a tape, set the Dolby NR mode to the same mode as when the tape was recorded.
-
- 13 **CD-SRS (Synchronized Recording System) button**
Use this button for synchronized recording of CDs. For details, refer to Page 19.
 - 14 **REC LEVEL control**
Use this to set the recording level. For details, refer to Page 19.

CASSETTE DECK DISPLAY

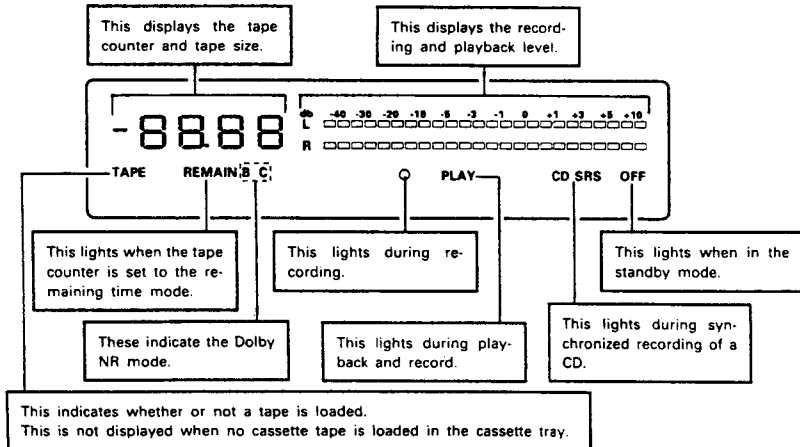

6 REMOTE CONTROL UNIT

The D-F10 comes with a system remote control unit (RC-172).

Inserting the batteries

- NOTES:**
- Use R6P (AA) batteries in this remote control unit.
 - Replace the batteries with new ones approximately once each year, though this depends on how frequently the remote control unit is used.
 - Replace the batteries with new ones earlier if the remote control unit does not operate even from a short distance.
 - Insert the batteries in the proper + and - direction, following the marks in the battery compartment.
 - Remove the batteries when not using the remote control unit for extended periods of time.
 - To avoid damage and leakage:
 - Do not use a new battery with an old one.
 - Do not use two different types of batteries.
 - Do not short-circuit, take apart, heat or dispose of batteries in flames.
 - If the batteries should leak, carefully wipe the fluid out of the battery compartment, then insert new batteries.

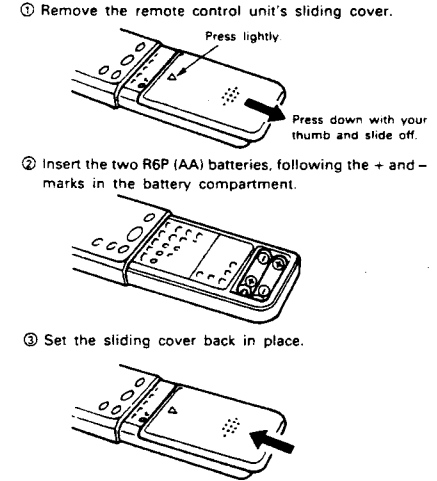

Using the Remote Control Unit

- Cautions on Use**
- The remote control unit may not operate if the remote sensor is exposed to direct sunlight or the strong light from a lighting fixture, or if there is an obstacle between the remote control unit and the remote sensor.
 - Do not press buttons on the remote control unit and on the set at the same time. Doing so could result in malfunction.
 - If the remote control unit is pointed away from the remote sensor during continuous operations (such as when turning the volume up or down), the operation will stop. If this happens, point the remote control unit at the remote sensor and press the button again.

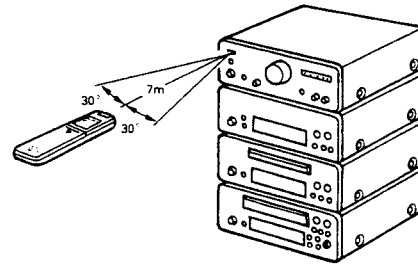

- The remote sensor is located on the pre-main amplifier. Point the remote control unit at the remote sensor as shown on the diagram when operating it.
- The remote control unit will operate from a direct distance of approximately 7 meters, but this distance will be shortened if obstacles are present or if operated at an angle. (The remote control unit will operate at an angle of up to 30° in either direction.)

Remote Control Unit Part Names and Functions

CD operation buttons

- (stop) button
Press this button to stop playback.
- ▶ (play) button
Press this button to start playback.
- ◀ and ▶ (auto search buttons)
Use these buttons to search for the beginning of the desired track.

PRESET buttons

Use these buttons to recall preset stations on the tuner.

Cassette deck operation buttons

- (stop) button
Press this button to stop the tape.
- ▶ (play) button
Press this button to start playback or recording.
- ◀ button
This button does not function.

FUNCTION selector button

Press this button to switch the input (function).
The input changes in the following order each time this button is pressed: CD, TAPE, TUNER, PHONO, MD/AUX.

POWER switch

Use this switch to turn on the power of the entire system or set the power to the standby mode.

VOLUME buttons

Use these to adjust the volume. The volume increases when the ▲ button is pressed and decreases when the ▼ button is pressed.

TUNER button

Press this button to switch the function to the tuner and to recall preset stations from the remote control unit using the number buttons.

Number buttons

Press these buttons after pressing the TUNER button to recall preset stations.
When playing a CD, press these buttons after pressing the DIRECT or PROGRAM button to specify the desired track.

BAND (AM/FM) selector button

TUNING buttons

MEMO button

SLEEP button

Press this button to set the sleep timer.

RDS button

Use this button to automatically tune to stations using the radio data system.
RDS → PTY → TP

PTY button

Press this button after selecting "PTY" with the RDS button to select one of the 15 program types.

CT button

Use this to correct the time of the clock on the UTU-F10. Press this button when the time service of an RDS station is being properly received.
"CT" and "TIME" are displayed for 2 seconds and the UTU-F10's clock is corrected. "NO CT" is displayed if the RDS station does not offer a time service and when the broadcast is not being received properly.

PANEL button

Press this button when receiving RDS stations to select the frequency, PS or PTY display.
Note that this button will not function if the reception is poor.

With this remote control unit, only the most frequently used keys are located on the front. The remaining keys are enclosed under a sliding cover.
To use the buttons under the sliding cover, press lightly on the ▽ mark then press on the ■ part with your thumb and slide the cover down, as shown on the diagram on the previous page.

Cassette deck operation buttons

- REC/REC MUTE button
To start recording from the stop mode, press this button, then press ▶
When this button is pressed, a blank section of approximately 5 seconds is created, after which the recording standby mode is set.
- ◀◀ (rewind) button
Press this button to rewind the tape. Press this button during playback to set the music search mode (to find the beginning of selections).
- ▶▶ (fast-forward) button
Press this button to fast-forward the tape. Press this button during playback to set the music search mode (to find the beginning of selections).
- RESET button
Press this button to reset the tape counter to "00:00"
- REMAIN button
Press this button to display the tape's remaining time on the tape counter.
- TAPE SIZE button
Press this button to select the tape length.
For details, refer to Page 17.
- REV. MODE button
This button does not function.

CD player operation buttons

DIRECT button

Press this button for direct search on the CD player.

◀◀ and ▶▶ (manual search) buttons

Press these buttons during playback to move quickly forward or backward.

REPEAT button

Press this button for repeat playback.

RANDOM button

Press this button to play the tracks in random order.

PROGRAM button

Press this button for programmed playback on the CD player.

CANCEL button

Press this button to clear the last track from the program.

EDIT button

Press this button for edited recording on a tape, dividing the tracks onto sides A and B according to the length of the tape.

TIME/SIDE A/B button

- TIME
Press this button during the play or pause mode to switch the time display.
Normally the elapsed time for the track currently playing is displayed. When this button is pressed, the display switches to the remaining time for that track ("SINGLE" lights), the total remaining time on the disc ("TOTAL" lights), then back to the elapsed time per track.
During programmed playback, the total remaining time display indicates the total remaining time of the programmed tracks.
- SIDE A/B
Press this button during the editing operation to switch the display between sides A and B of the tape.
* The TIME/SIDE A/B button functions as the SIDE A/B button when it is pressed after the EDIT button is pressed and the tracks have been divided between sides A and B and before the play or pause button is pressed (before the recording mode is set).
The TIME/SIDE A/B button functions as the TIME button when it is pressed during the play, pause, or edited recording modes.

7 LISTENING TO RADIO PROGRAMS

(Check the connections on Pages 4 and 5.)
Tuner (UTU-F10)

TUNING

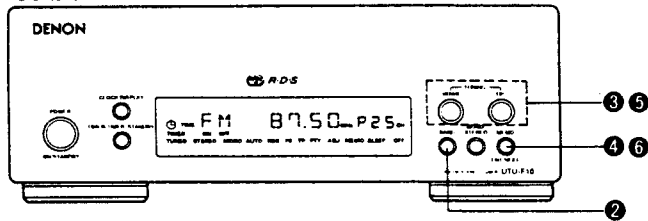

Example: Tuning in FM 87.50 MHz
(AM stations are tuned in using the same procedure.)

1	Set the VOLUME control on the pre-main amplifier to the minimum position, then press the SYSTEM POWER switch to turn on the power.		
2	Press the BAND button on the tuner to select the FM band.		FM 90.00
3	Use the TUNING UP and DOWN buttons to tune the frequency to 87.50. Once the frequency is tuned in, adjust the volume to the desired level using the VOLUME control.		This lights when a station is tuned in. FM 87.50

Auto Tuning

- When one of the TUNING buttons is pressed, the frequency changes in steps of 50kHz in the FM band, 9kHz in the AM band.
- If one of the TUNING buttons is held in for over 1 second, the frequency continues to change when the button is released (auto tuning) and stops when a station is tuned in. Tuning will not stop at stations whose reception is poor.
- To stop the auto tuning function, press the UP or DOWN button once.

Presetting AM and FM Stations

Example: Presetting FM 87.50 (currently tuned in) at preset number 3

4	Press the MEMO ENT/NEXT button. The MEMO indicator flashes for 10 seconds.		Flashes FM 87.50 Flashes
5	Use the UP and DOWN buttons to call out the number at which you want to preset the station (3), or simply press the corresponding number button ③ on the remote control unit.		"P" flashes FM 87.50 P 3 Flashes
6	Press the MEMO ENT/NEXT button while the MEMO indicator is flashing.		"P3" lights FM 87.50 P 3

Up to 30 AM or FM stations can be preset using this procedure.

NOTES:

- In addition to the reception frequency, the reception mode (monaural or auto) is also preset, so check the display when presetting stations.
- If a station is preset at a number where a station is already preset, the previous station is replaced with the new station.
- The preset memory is not cleared immediately when the power cord is unplugged, but is cleared if the cord is left unplugged for an extended period of time. If this happens, preset the stations again.

Listening to Preset Stations

The preset stations can be recalled using the number buttons on the remote control unit. Also, if the following operation is performed when the system power is off, the power automatically turns on and the radio is played. (Auto on function)

Example: Listening to the station preset at number 3
(This operation is only possible from the remote control unit.)

1	Press the TUNER button on the remote control unit.		
2	Press button "3" on the remote control unit.		FM 87.50 P 3





Using the RDS functions

Receiving RDS broadcasts (FM only)

1	Press the BAND button and set the FM band.		FM 87.50
2	Press the RDS button once.		(-RDS-) Flashes "RDS" blinks
3	Press the AUTO TUNING UP or DOWN button.		FM 87.50 Flashes "RDS" displayed
4	The station is tuned in.		"RDS" lights after 5 seconds of flashing. Once the station is tuned in, "RDS" flashes for 5 seconds and the program service name is displayed.

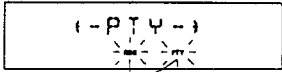

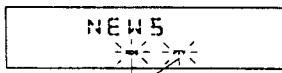
NOTE: If no RDS station is found, "NO PROG" is displayed.

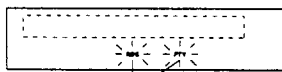
PTY Search

1	Press the RDS button twice.		 <p>Flashes ("PTY" and "RDS" flash, and "-PTY-" is displayed.)</p>
2	Press the PTY button to select the type of program. (One of the 15 types listed below can be selected.)		 <p>Flashes</p>
3	Press the AUTO TUNING UP or DOWN button.		
4	The station is tuned in.		 <p>"PTY" and "RDS" light after 5 seconds of flashing</p> <p>Once the station is tuned in, "RDS" and "PTY" flash for 5 seconds and the program service name is displayed.</p>

NOTE: If no program of the specified type is found, "NO PROG" is displayed.

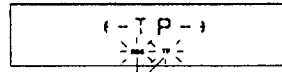
TP Search

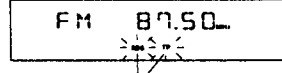
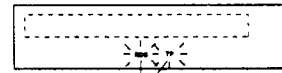
1	Press the RDS button 3 times.		 <p>Flashes</p>
2	Press the UP or DOWN button of AUTO TUNING.		 <p>Flashes</p>
3	Broadcast reception.		 <p>"TP" and "RDS" light</p> <p>Once the station is tuned in, "TP" and "RDS" light and the program service name is displayed.</p>

NOTE: "NO PROG" is displayed when there is no traffic information broadcast station.

Receiving FM programs in stereo

- Press the MONO/STEREO button to turn on the "AUTO" indicator. When a program being broadcast in stereo is received, the "STEREO" indicator lights and the program is received in stereo.
- If reception is poor and there is much noise in the stereo signals, press the MONO/STEREO button to set the monaural mode.

NOTE:

- A humming sound may be heard when using a TV nearby while receiving AM programs. If this happens, move the system as far from the TV as possible.

Programs

NEWS	(News)	VARIED	(Varied)
AFFAIRS	(Current Affairs)	POP M	(Pop Music)
INFO	(Information)	ROCK M	(Rock Music)
SPORT	(Sport)	MOR M	(M.O.R. Music)
EDUCATE	(Education)	LIGHT M	(Light Classics)
DRAMA	(Drama)	CLASSICS	(Serious Classics)
CULTURE	(Culture)	OTHER M	(Other Music)
SCIENCE	(Science)		

8 USING THE TIMER

The time and timer functions are incorporated in the tuner.

Timer Settings

Types of timer operations

- TIMER** : Use this to turn the power on and off at the same times every day.
SLEEP TIMER : Use this to set the power to turn off after 10 to 60 minutes, in steps of 10 minutes (operated from the remote control unit).

Notes on timer settings

- Be sure to set the current time beforehand.
- To listen to or record a radio program ("air check") using the timer, be sure to preset the station beforehand. (Refer to "Presetting AM and FM Stations" on Page 10.)

Power Failures

Should there be a power failure or should the power cord be unplugged, the time display will flash at "00:00". If this happens, reset the current time. Also check the timer and tuner presettings, and reset them if they have been cleared.

Checking the Settings

To check the timer settings, press the **TIMER/TIMER STANDBY** button for at least 3 seconds. (This can also be done when the tuner's power is off.) Next, press the **ENTER/NEXT** button repeatedly to display the timer start mode, the reception band and preset channel number when in the tuner mode, the on time and the off time. Press the **ENTER/NEXT** button once more to return to the current mode display.

Changing the Settings

Repeat the timer setting operation to erase the previous settings and set the new settings.

Clearing the Settings

Press the **TIMER/TIMER STANDBY** button for at least 3 seconds, then press it again while "FUNC" is displayed to clear the timer settings.

Note on Setting the Timer

If the time set with the timer is reached while the system power is on, the operation switches to the operation set by the timer.

Turning the Timer Off

Press the **TIMER/TIMER STANDBY** button to turn the \oplus mark off.

Setting the Current Time

The time is displayed in the 24-hour mode.

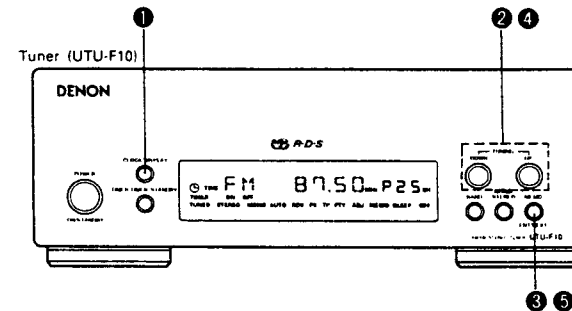

Example: Setting to 19:30 (7:30 p.m.)

1	Press the CLOCK/DISPLAY button for at least 3 seconds.			The hours place flashes. (If the hours have already been set, that number flashes.)
2	Use the UP and DOWN buttons to set the hours.			The hours place flashes.
3	Press the MEMO ENT/NEXT button.			The minutes place flashes. (If the minutes have already been set, that number flashes.)
4	Use the UP and DOWN buttons to set the minutes.			The minutes place flashes.
5	Press the MEMO ENT/NEXT button at the sound of a time service's chime. The time display stops flashing and the clock starts running.			The display stops flashing and the clock starts running from 00 seconds.

- The current time can be set even when the power is off.
- If an RDS station offers a time service, the time can be set by pressing the **CT** button on the remote control unit while that station is tuned in.

Setting the Timer

The power can be set to turn on and off every day at the same time in any of five modes: tuner, CD, cassette deck, MD player (optional) and air check (recording from the radio). (Preset the AM or FM station beforehand.)

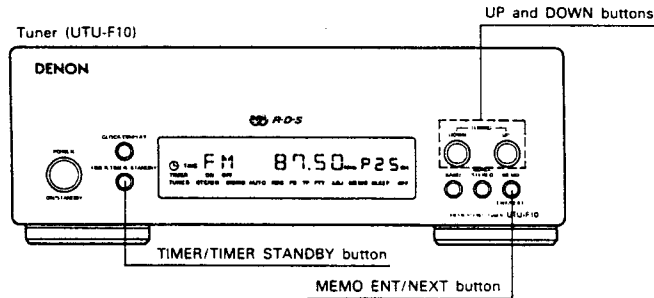

Example: Setting the tuner to turn on at 12:35, off at 12:56 (with FM 87.50 MHz preset at channel "3")

1	Press the SYSTEM POWER switch on the pre-main amplifier to turn on the system's power.		<p>FM 90.00 P 1</p> <p>Say that FM 90.00 MHz is tuned in at preset channel number "1"</p>
2	Press the TIMER/TIMER STANDBY button for at least 3 seconds to set the timer setting mode.		<p>FUNC</p>
3	Use the UP and DOWN buttons to set the "TUNER" mode.		<p>TUNER</p>
4	Press the MEMO ENT/NEXT button.		<p>Flashes</p> <p>87.50 P 3</p>
5	Use the UP and DOWN buttons to set the preset channel number.		<p>87.50 P 3</p>
6	Press the MEMO ENT/NEXT button.		<p>12:00</p> <p>(If the timer has already been set, that number flashes.)</p>
7	Use the UP and DOWN buttons to set the hours for the timer on time.		<p>12:00</p> <p>Flashes</p>

8	Press the MEMO ENT/NEXT button.		<p>12:00</p> <p>Flashes (If the timer has already been set, that number flashes.)</p>
9	Use the UP and DOWN buttons to set the minutes for the timer on time.		<p>12:35</p> <p>Flashes</p>
10	Press the MEMO ENT/NEXT button.		<p>12:00</p> <p>Flashes</p>
11	Use the UP and DOWN buttons to set the hours for the timer off time.		<p>12:00</p> <p>Flashes</p>
12	Press the MEMO ENT/NEXT button.		<p>12:00</p> <p>Flashes (If the timer has already been set, that number flashes.)</p>
13	Use the UP and DOWN buttons to set the minutes for the timer off time.		<p>12:56</p> <p>Flashes (if the timer has already been set, that number flashes.)</p>
14	Press the MEMO ENT/NEXT button.		<p>FM 90.00 P 1</p> <p>The display returns to as it was before the timer setting mode was set.</p>
15	Press the TIMER/TIMER STANDBY button.		<p>Lights</p> <p>FM 90.00 P 1</p>
16	Press the SYSTEM POWER switch on the pre-main amplifier to turn off the system's power.		<p>10.15</p>

If the mark is displayed after the TIMER/TIMER STANDBY button is pressed, the timer will operate at the same times every day. To turn the timer off, press the TIMER/TIMER STANDBY button again to turn the mark off.

NOTES:

- The standby mark ("") will not light if the current time is not set. If this is the case, set the current time, then press the TIMER/TIMER STANDBY button.
- When an optional mini-disc (MD) player is connected, it can be operated with the timer. For instructions, refer to the MD player's operating instructions.

Various Timer Operations

Pre-main amplifier (UPA-F10)

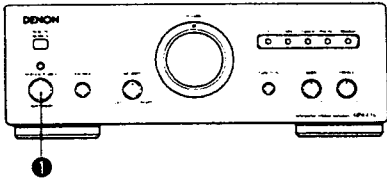

Tuner (UTU-F10)

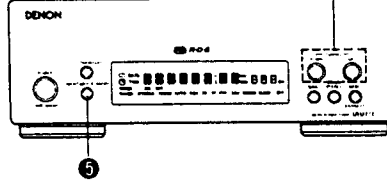

CD player (UCD-F10)

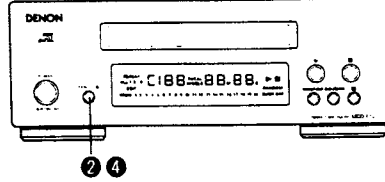

Pre-main amplifier (UPA-F10)

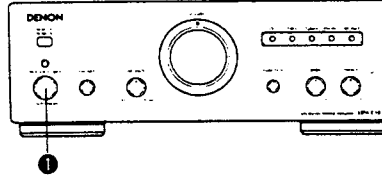

Tuner (UTU-F10)

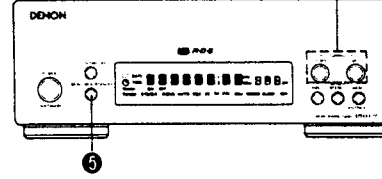

Cassette deck (UDR-F10)

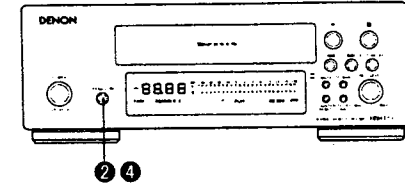

Example 1: Playing a compact disc with the timer

1	Press the SYSTEM POWER switch on the pre-main amplifier to turn on the system's power.		
2	Press the CD player's OPEN/CLOSE button to open the disc tray.		
3	Load the disc in the disc tray. Refer to Page 20.		
4	Press the CD player's OPEN/CLOSE button again to close the disc tray.		
5	Press the tuner's TIMER/TIMER STANDBY button for at least 3 seconds.		
6	Use the tuner's UP and DOWN buttons to set the "CD" mode.		
7	Now follow steps 6 to 16 under "Setting the Timer" on Page 13.		

Example 2: Playing a cassette tape with the timer

1	Press the SYSTEM POWER switch on the pre-main amplifier to turn on the system's power.		
2	Press the cassette deck's OPEN/CLOSE button to open the cassette tray.		
3	Load the cassette tape in the cassette tray. Refer to Page 16.		
4	Press the cassette deck's OPEN/CLOSE button again to close the cassette tray.		
5	Press the tuner's TIMER/TIMER STANDBY button for at least 3 seconds.		
6	Use the tuner's UP and DOWN buttons to set the "TAPE" mode.		
7	Now follow steps 6 to 16 under "Setting the Timer" on Page 13.		

• Check that the cassette deck is set to the desired Dolby NR mode.

Pre-main amplifier (UPA-F10)

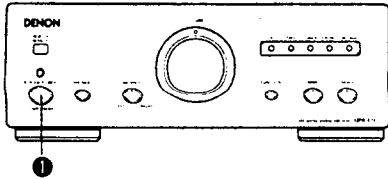

Tuner (UTU-F10)

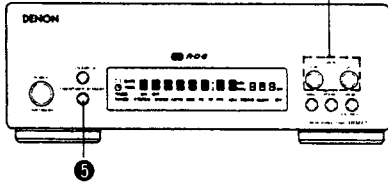

Cassette deck (UDR-F10)

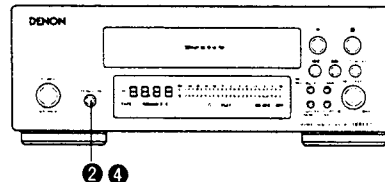

Example 3: Unattended recording of radio programs ("air check")

1	Press the SYSTEM POWER switch on the pre-main amplifier to turn on the system's power.		
2	Press the cassette deck's OPEN/CLOSE button to open the cassette tray.		
3	Load the cassette tape in the cassette tray. Refer to Page 16.		
4	Press the cassette deck's OPEN/CLOSE button again to close the cassette tray.		• For the Dolby NR setting, refer to 2 on Page 19.
5	Press the tuner's TIMER/TIMER STANDBY button for at least 3 seconds.		
6	Use the tuner's UP and DOWN buttons to set the "AIRCH" mode.		
7	Now follow steps 4 to 16 under "Setting the Timer" on Page 13.		

- Recording is not possible on the leader tape at the beginning of the cassette tape, so to avoid missing any of the program, we recommend setting the timer to approximately 1 minute before the program is scheduled to start.
- When an optional mini-disc (MD) player is connected, radio programs can be recorded using the timer. For instructions, refer to the MD player's operating instructions.

Setting the Sleep Timer

With this function, the power can be set to turn off after 10 to 60 minutes, in steps of 10 minutes, using the remote control unit.

Example: Setting the power to turn off in 50 minutes
(This operation is only possible from the remote control unit.)

1	Tuner currently set to FM 87.50 MHz	
2	Press the SLEEP button.	
3	Press the SLEEP button again while the "SLEEP" indicator is flashing.	
4	The previous display reappears after 5 seconds. The "SLEEP" indicator remains lit, indicating that the sleep timer is functioning.	

- The time is reset to "60" (60 minutes) if the SLEEP button is pressed again while the sleep timer is functioning.

Cancelling the Sleep Timer

Press the SLEEP button repeatedly until the "SLEEP" indicator turns off. The sleep timer is also cancelled if the amplifier's SYSTEM POWER switch or the POWER switch on the remote control unit is pressed, turning the system power off.

NOTE:

- If the times set with the sleep and everyday timers overlap, the sleep timer has priority.

Order of priority of the sleep and everyday timers

The sleep timer has priority for the off time. (The system operates as indicated by the bold lines.)

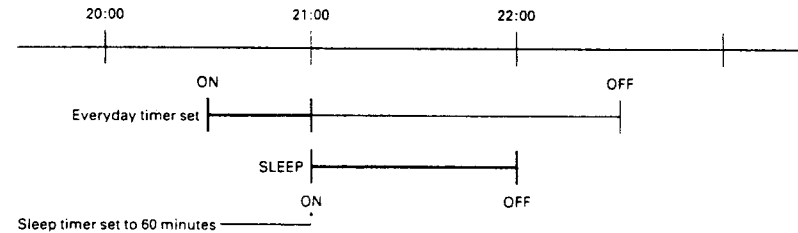

Even when the power was turned on with the timer, the power turns off if the remaining time of the sleep timer reaches "00" before the off time set with the everyday timer is reached. If the everyday timer's on time is reached while the sleep timer is functioning, the everyday timer does not function.

9 BEFORE RECORDING AND PLAYING TAPES

About Cassette Tapes

■ Cautions on handling cassette tapes

- C-120 cassette tapes
 - C-120 (120-minute) cassettes use very thin tape which can easily get caught on the capstans and pinch rollers. We recommend not using C-120 tapes.
 - Tape slack
- If the tape is slack, it may get caught in the mechanism and damaged. Take up any slack in the tape with a pencil, etc., before loading the cassette.

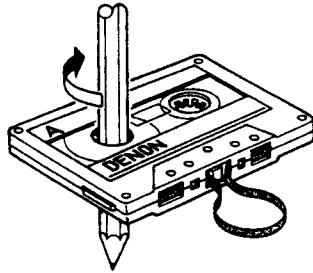

■ Preventing accidental erasure

- Cassette tapes have tabs for preventing accidental erasure. Use a screwdriver, etc., to break off the tabs to prevent recordings from being accidentally erased.
- To record on a tape whose tabs have been broken, place a piece of cellophane tape, etc., over the tab holes.



■ Notes on storing cassette tapes

- Avoid placing cassette tapes in the following types of places:
 - Hot or humid places
 - Dusty places
 - Places exposed to direct sunlight
 - Near magnetic sources (TVs, speakers, etc.)
- Store cassette tapes in cases with stoppers to prevent the tape from getting slack.

Auto Tape Selector Mechanism

The D-F10 is equipped with an auto tape selector mechanism which uses the detection holes in the cassette halves to detect the type of tape and automatically set the most appropriate recording bias and equalization for that type of tape.

- Do not use ferrichrome tapes.
- When an old metal tape with no detection holes is used, the treble will be stressed excessively, so use metal tapes with detection holes.

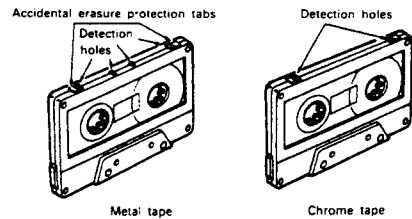

Loading and Unloading Cassette Tape

NOTE:

- Load cassette tapes with the side on which the tape is exposed facing the set. Loading them the other way may result in damage.

■ Loading

- ① Press the OPEN/CLOSE button. The cassette tray opens.
- ② Load the cassette tape in the cassette tray as shown on the diagram below, with the side on which the tape is exposed facing inside.
- ③ Press the OPEN/CLOSE button to close the cassette tray.

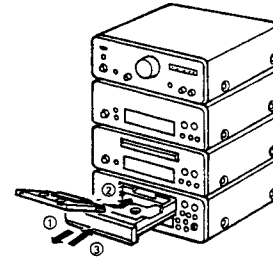

■ Unloading

- ① Press the OPEN/CLOSE button. The cassette tray opens.
- ② Remove the tape.

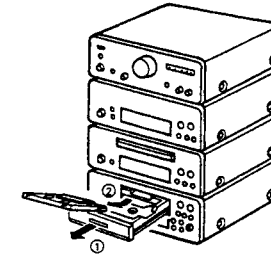

Check the following before recording or playing cassette tapes:

1. Are the heads dirty? The sound quality will be poor if the heads are dirty. Refer to Page 25.
2. Are the accidental erasure protection tabs broken off? Recording is not possible if the accidental erasure protection tabs on the top of the cassette are broken off. Refer to Page 16.

Direction of Tape Playback

The relationship between the operating buttons on the D-F10 and the direction of tape travel is as shown on the diagram at the right.

The side facing the top when the cassette tape is loaded in the cassette tray is played or recorded.

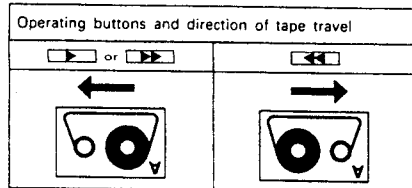

Using the Tape Counter

1. Tape size selector

- When using the tape counter, be sure to set the size of the tape being used.
- Press the TAPE SIZE button on the remote control unit to display the tape size, then press the button again to select the desired tape size. The display changes as follows each time the button is pressed:

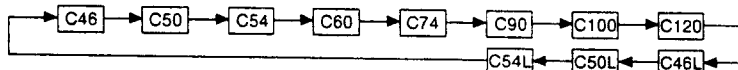

- "C46L", "C50L" and "C54L" are for tapes with large hubs.
- Tape sizes other than the ones indicated above cannot be set.

2. Tape counter

The D-F10's tape counter includes the two modes described below. The mode switches as follows each time the REMAIN button on the remote control unit is pressed:

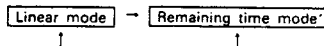

The mode can be changed whether the tape is stopped or moving.

(1) Linear mode

- This indicates the tape's elapsed time in minutes and seconds.

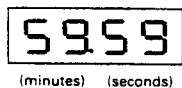

- The counter is reset to "00.00" when a new tape is loaded and when the RESET button is pressed.
- If you make notes on the number on the counter and the recorded content while recording or playing tapes, these notes can be used to easily find the section you want to play or record.

(2) Remaining time mode

- This indicates the remaining time on the tape. When this mode is selected, "REMAIN" appears on the display (①).

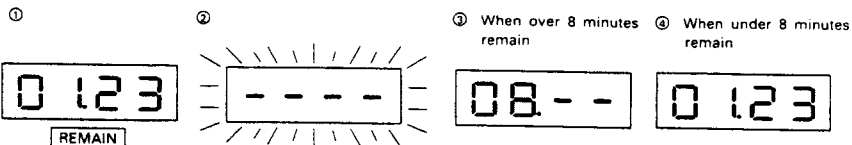

- "----" (②) flashes for approximately 10 seconds after the tape is started while the remaining time is being calculated. After this, only the minutes are displayed if there are more than 8 minutes remaining (③), and both the minutes and seconds are displayed if there are less than 8 minutes remaining (④).
- "----" flashes on the display during the fast-forward and rewind operations.

3. Tape end warning

This "REMAIN" indicator starts flashing to indicate that there is little time remaining on the tape during recording or playback. (There may be a major error in the time at which the "REMAIN" indicator starts flashing if the actual tape and the tape size selector setting do not match, so be sure to set the proper tape size for the tape being used.)

- The "REMAIN" indicator flashes starts approximately 5 minutes before the end of the tape when the counter is set to the linear mode. Press the REMAIN button on the remote control unit as necessary to switch the counter to the remaining time mode to check the remaining time.
- The "REMAIN" indicator remains lit without flashing when the remaining time mode is set.
- The tape end warning is only a rough indicator, and differs according to the thickness of the tape's hubs and the thickness of the tape. In some cases, it may not function.

NOTE:

The D-F10's tape counter and tape end warning are set for use with C46, C50, C54, C60, C74, C90, C100, C120, C46L, C50L or C54L cassette tapes ("L" indicates tapes with large hubs), so they may be off when using tapes of other sizes or when the tape size setting is not the same as the size of the tape being used. When using tapes of other sizes, select the nearest tape size to minimize the error.

The tape counter is not as accurate as a clock, and may be slightly different from the actual time, since the tape thickness differs depending on the type of cassette tape (tape position and time). The counter may also be off due to differences in the hub size (small or large).

- Large hubs are hubs with a diameter of approximately 27mm. Note that there may be a major error in the remaining time display if tapes with larger hubs are used.

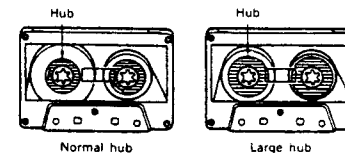

10 PLAYING CASSETTE TAPES

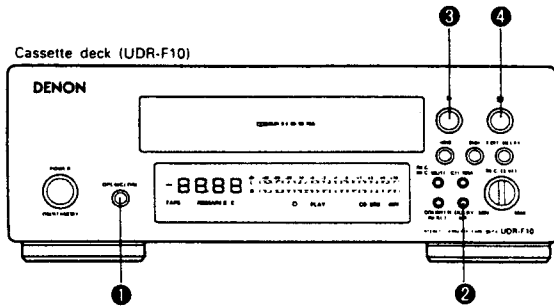

The **[R]** mark indicates operations which can also be performed on the remote control unit.

<p>1 Press the OPEN/CLOSE button and load a recorded tape in the cassette tray. Refer to Page 16.</p>	
<p>2 Press the DOLBY NR button display the Dolby mode. Refer to Page 8.</p>	<p>The mode changes as follows each time the button is pressed:</p> <p>When playing tapes recorded with Dolby NR, set the Dolby mode to the same mode (B or C) as when the tape was recorded.</p>
<p>3 Press the play button (▶).</p>	<p>Playback starts.</p>
<p>4 To stop playback, press the stop button (■).</p>	

Using the Music Search Function (automatically finding the beginning of selections)

- Use this function to move back to the beginning of the current selection or forward to the beginning of the following selection.
- This function can also be used to skip over selections (up to 99 selections in either direction).

<p>1 During playback</p>	<p>To move to the beginning of the current selection: Press once. To move back 5 selections: Press 5 times.</p> <p>To move to the beginning of the following selection: Press once. To move ahead 5 selections: Press 5 times.</p>
--------------------------	--

- To fast-forward or rewind the tape, first press the stop button (■), then press the ▶▶ or ◀◀ button.
- The music search function will only work if there are blank sections of at least 4 seconds between selections.

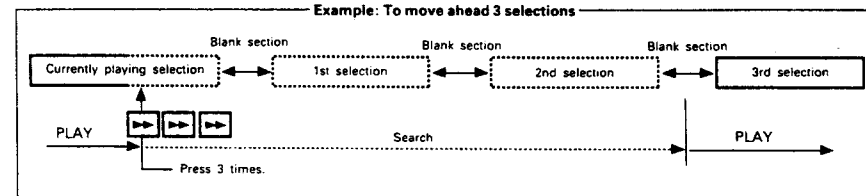

Music Search Display

- When a selection before the current selection is specified:
- When a selection after the current selection is specified:



During the music search function, the number of selections to be skipped is displayed on the tape counter, and decreases each time a blank section is detected. (For example, **[P03]** → **[P02]** → **[P01]** when moving 3 selections ahead.) The tape counter reappears when the operation is completed.

11 RECORDING CASSETTE TAPES

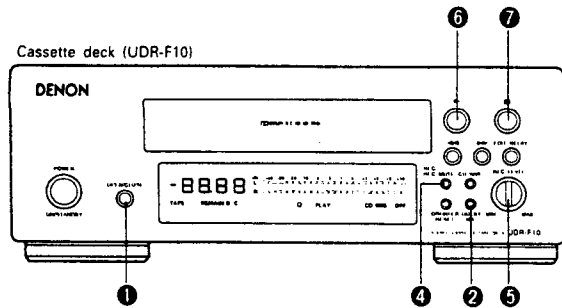

- Before recording on a cassette tape, check that its accidental erasure protection tabs are intact. Recording is not possible if the tabs are broken off.
- The positions of the VOLUME, TREBLE and BASS controls on the pre-main amplifier do not affect the recording.

The mark indicates operations which can also be performed on the remote control unit.

<p>1</p> <p>Press the OPEN/CLOSE button and load the tape onto which you want to record in the cassette tray. Refer to Page 16.</p>	
<p>2</p> <p>Press the DOLBY NR button display the Dolby mode. Refer to Page 8.</p>	<p>The mode changes as follows each time the button is pressed.</p> <p>To record in Dolby NR, set to "B" or "C"</p>

	To record the radio	To record from the component connected to the AUX terminals	To record a CD
3	<p>Press the tuner's BAND selector button.</p> <p>Tune in the station to be recorded. Refer to Page 10.</p>	<p>Press the FUNCTION button on the pre-main amplifier to select "MD/AUX".</p> <p>Starting playback on the MD player, video deck or LD player.</p>	<p>Load the disc in the CD player. Refer to Page 20.</p> <p>Press the CD player's play button to start playback.</p>
4	<p>Press the REC/REC MUTE button.</p>	<p>The recording pause mode is set and the recording indicator (●) appears on the display.</p>	
5	<p>Adjust the recording level.</p>		<p>The recording level of the source being played is displayed on the level meter. Use the REC LEVEL control to adjust the recording level. (Refer to "Adjusting the REC LEVEL Control" below.)</p>
6	<p>Press the play button (▶). (Recording starts.)</p> <p>The recording indicator (●) appears on the display.</p>	<p>6</p> <ul style="list-style-type: none"> • For synchronized recording of CDs Press the stop buttons on the CD player and cassette deck, then press the CD SRS button. <p>"CD SRS" appears on the display. (Recording starts.)</p> <ul style="list-style-type: none"> • When the CD SRS button is pressed, a blank section of 9 seconds is automatically created on the tape before actual recording starts. 	
7	<p>To stop recording, press the stop button (■).</p>		

- If the CD player's play button is pressed in the recording pause mode, recording of the CD begins automatically.
- The CD SRS function will not work if the CD player is set to the random play or program mode.

Adjusting the REC LEVEL Control

The recorded sound will be distorted if the recording level is too high, or there will be much noise if the recording level is too low. It is important to set the recording level to an appropriate setting to achieve a good quality recording.

- Watch how far the level meter lights and adjust the REC LEVEL control accordingly.

Optimum recording input level (approximate)

Type-I (normal) tapes:	Meter lights up to 0dB
Type-II (CrO ₂) tapes:	Meter lights up to +1dB
Type-IV (metal) tapes:	Meter lights up to +3dB

NOTE:
The actual recording level differs depending on the source and the type of tape, so make a trial recording first to check the recording level.

12 PLAYING CDs



Only discs with the mark shown below can be played on the D-F10.

- For CDVs, only the audio part is played. (The video part is not played.)

About Compact Discs

Disc	Remarks
CD	
CDV	Only the audio part is played.
CD singles (8cm discs)	

Removing discs from their cases

As shown on the diagram, grasp the outer edge of the disc with your fingers, insert a finger in the hole in the center, press gently, then lift the disc out of the case.



Loading discs in the disc tray

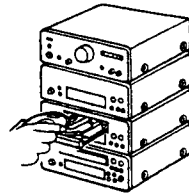

Be sure to load the disc with the labelled side facing up. (Compact discs only play on one side.) For 8cm CDs, set the disc in the sunken section in the center of the tray.

NOTES:

- The disc tray opens when the OPEN/CLOSE button is pressed once and closes when it is pressed again.
- When the disc tray is closed, the disc turns automatically for several seconds, then the total number of tracks and total playing time of that disc appear on the display.
- The disc tray can also be closed by pressing the play button (▶), in which case playback automatically starts from the first track on the disc (or if tracks are programmed, from the first programmed track).

Handling the Disc Tray





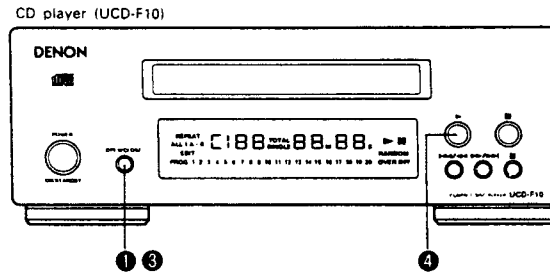

Do not turn off the power, stop the disc tray by hand or pull on it when it is moving. Doing so may damage it. If the headphones' cord or some other object accidentally gets caught in the disc tray while it is closing and the disc tray stops, press the OPEN/CLOSE button again to open the tray and remove the obstacle. Do not set objects other than discs on the disc tray. Doing so may damage it.



Normal Playback

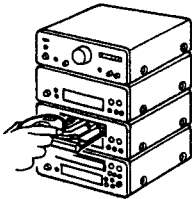

Example: Playing a disc containing 15 tracks and with a playing time of 62 minutes, 03 seconds, starting from the first track

The R mark indicates operations which can also be performed on the remote control unit.		
1	Press the OPEN/CLOSE button to open the disc tray.	 
2	Load the CD in the disc tray.	
3	Press the OPEN/CLOSE button. The disc tray closes. The display appears after several seconds.	 
4	Press the play button (▶).	 

Various Playback Functions

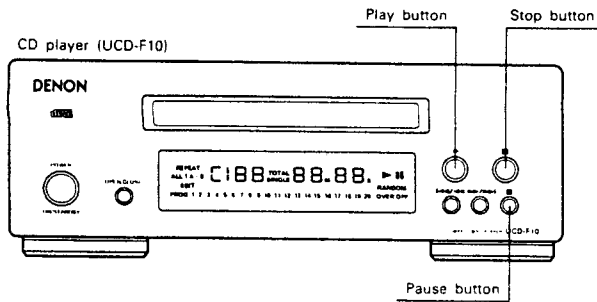

Interrupting playback temporarily

Press the pause button (II).		The "▶" mark turns off and the "II" mark appears on the display, and playback stops at the point where the button was pressed.
------------------------------	--	--

Resuming playback

Press the play button (▶).		The "II" mark turns off and the "▶" mark appears on the display, and playback resumes from the point where the pause button was pressed.
----------------------------	--	--

Stopping playback

Press the stop button (■).		
----------------------------	--	--

• When a disc is loaded, "00" is displayed on the track number display for several seconds while the data on the number of tracks and total playing time is being read from the innermost side of the disc, after which the number of tracks and total playing time appear.

NOTES:

• If no disc is loaded, if the disc is upside-down, or if the data cannot be read properly due to scratches or dirt, the display reads as shown below and the disc will not play.

00 00.00.

In addition to the regular playback, the D-F10 also offers the following playback functions:

① Playing a specific track Direct Search

(Using the remote control unit)
Example: Playing the 8th track

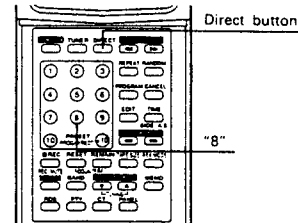

- Press the DIRECT button.
 - Press the button corresponding to the number of the track 8. "8" appears on the track number display and playback of track number 8 begins.
- When the end of the track is reached, playback continues on the next track.
 - To specify a track number of 11 or greater, say track 15, press [+10] then [5], and to specify a track number of 20 or greater, say track 23, press [+10], [+10] then [3]. To play track 20, press [+10] then [10].

② Playing a single track repeatedly Single-track Repeat

(Using the remote control unit)

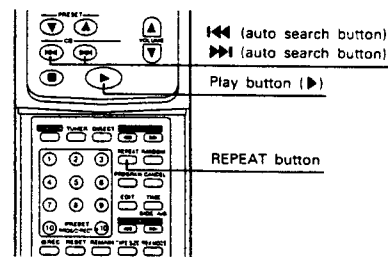

- When the REPEAT button is pressed once, REPEAT 1 appears on the display and the single-track repeat mode is set.
 - Use the ◀◀ and ▶▶ buttons to select the track to be repeated.
 - Press the play button (▶) to start playback.
- When the end of the specified track is reached, playback starts over from the beginning of that track.
 - The single-track repeat mode can also be set by pressing the REPEAT button once during playback.
 - To cancel the single-track repeat mode, press the REPEAT button repeatedly until the "REPEAT" indicator turns off.

③ Playing all the tracks repeatedly All-track Repeat

(Using the remote control unit)

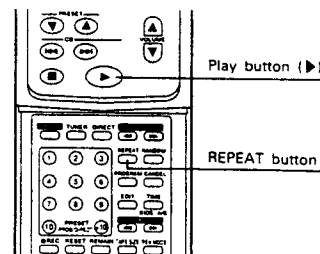





- When the REPEAT button is pressed twice, REPEAT ALL appears on the display and the all-track repeat mode is set.
 - Press the play button (▶) to start playback.
- The all-track repeat mode can also be set by pressing the REPEAT button twice during playback.
 - To cancel the all-track repeat mode, press the REPEAT button to turn the "REPEAT" indicator off.
 - If the REPEAT button is pressed during programmed playback, the tracks are played repeatedly in the programmed order.

Ⓞ Playing a certain section repeatedly

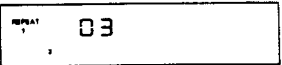
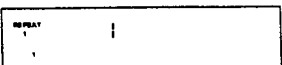
A-B Repeat

Example: Using a CD containing 15 tracks

1st press	(1) When pressed during playback:		The single-track repeat mode is set and that track number is displayed on the music calendar.
	(2) When pressed before playback:		The single-track repeat mode is set and that track number is displayed on the music calendar. Next. ① Press the play button (▶) to play the first track repeatedly. ② If playback is started using the direct search buttons on the remote control unit or the ▶/▶▶ and ◀◀/◀◀ buttons on the CD player, the specified track is played repeatedly.
2nd press	(1) When pressed during playback:		The numbers of all the tracks on the disc are displayed on the music calendar, and the all-track repeat mode is set.
	(2) When pressed before playback:		
3rd press	When pressed during playback:		"REPEAT" and "A" light.
4th press	When pressed during playback:		"REPEAT" and "A-B" light, and the section between points A and B is played repeatedly.
Press the REPEAT button again to return to normal playback.			

Ⓞ Playing the tracks in a certain order

Programmed Playback

(Using the remote control unit)

Example: Programming the 3rd track to play first, the 18th track to play second, using a CD containing 18 tracks and with a playing time of 62 minutes, 03 seconds

Procedure

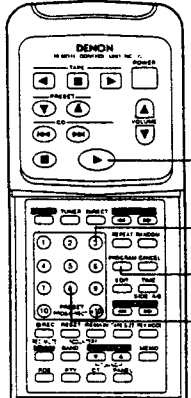
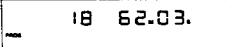
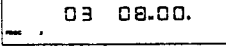
1	Press the PROGRAM button.	
2	Press "3" to set the 3rd track at the first place in the program.	 <p>After 2 seconds □ 1 Display when the 3rd track (8 minutes, 00 seconds long) is set at the first place</p>
3	Press "+10" and "8" to set the 18th track at the second place in the program.	 <p>After 2 seconds □ 2 Display when the 18th track (16 minutes, 05 seconds long) is set at the second place</p>
4	Press the play button (▶).	The tracks are played in the programmed order.

Other operations possible during programmed playback:

Such operations as quick search, pause and skip monitor are also possible during programmed playback. For the quick search function, press the automatic/manual search reverse button (◀◀/◀) to move back to the beginning of the track, then press it again while the time display reads " 00.00. ". To move ahead to the beginning of the next track, press the automatic/manual search forward button (▶/▶▶), regardless of the time display.

NOTES:

- The numbers of the programmed tracks on the music calendar turn off after the tracks have been played.
- If a track with a number of 21 or greater is programmed, the time display will read "--M-S"
- With this CD player, up to 20 tracks with any track number between 1 and 99 can be programmed.
- If a number greater than the total number of tracks on the disc is specified, that number will not be displayed.
- Programming is also possible with the disc tray open. In this case it is possible to program a track number not included on the disc, but when the program is played, that track number will be skipped.
- The entire program is cancelled when the OPEN/CLOSE button is pressed.
- If you make a mistake when programming, press the CANCEL button to cancel the mistake. (The last track in the program is cancelled each time the CANCEL button is pressed.)
- The single-track and A-B repeat functions do not work during programmed playback.
- Set the stop mode when cancelling tracks from the program.

③ Moving ahead to the next track during playback

Quick Search

CD player (UCD-F10)

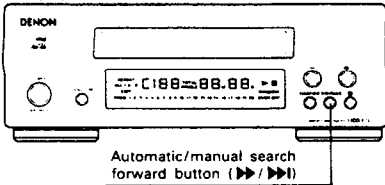

Press the automatic/manual search forward button (▶▶/▶▶).

④ Moving back to the beginning of the track during playback

Quick Search

CD player (UCD-F10)

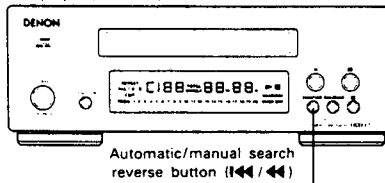

Press the automatic/manual search reverse button (◀◀/◀◀).

⑤ Finding a certain spot on the disc while listening to the sound

Skip Monitor

- Use this function to skip through the disc while listening to the sound.
- When the desired spot is reached using the skip monitor function, release the automatic/manual search forward button (▶▶/▶▶) or automatic/manual search reverse button (◀◀/◀◀) to resume normal playback from that point.

(1) Forward skip monitor

CD player (UCD-F10)

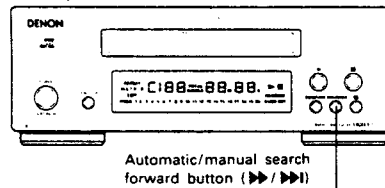

- The track currently being monitored and the elapsed time for that track are indicated on the display.
- If the end of the last track on the disc is reached while pressing the automatic/manual search forward button (▶▶/▶▶), "C" appears on the display and the manual search operation stops. To continue playback, press and hold in the automatic/manual search reverse button (◀◀/◀◀) until a track number appears on the display, then perform the desired operation.

During playback, press and hold in the automatic/manual search forward button (▶▶/▶▶) to skip through the disc in the forward direction while listening to the sound.

(2) Reverse skip monitor

CD player (UCD-F10)

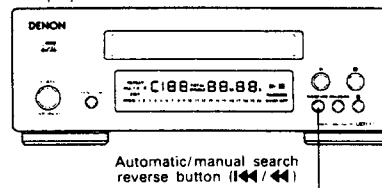

- The track currently being monitored and the elapsed time for that track are indicated on the display.
- If the beginning of the first track on the disc is reached while pressing the automatic/manual search reverse button (◀◀/◀◀), "C" appears on the display and the manual search operation stops. To continue playback, press and hold in the automatic/manual search forward button (▶▶/▶▶) until a track number appears on the display, then perform the desired operation.

During playback, press and hold in the automatic/manual search reverse button (◀◀/◀◀) to skip through the disc in the reverse direction while listening to the sound.

If the automatic/manual search forward or automatic/manual search reverse button is pressed during programmed playback then released at a track not in the program, that track is played to the end, then the next track in the program is played.

⑥ Playing the tracks in random order

Random Playback

(Using the remote control unit)

- Use this function to play all the tracks on the disc once in random order.

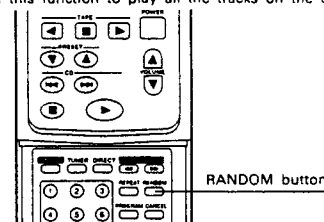

- Press the RANDOM button to turn on the RANDOM indicator, then press the play button to start random playback.
- During playback, simply press the RANDOM button to set the random playback mode.

- The programmed tracks can be played in random order by pressing the RANDOM button when tracks are programmed.
- If the RANDOM button is pressed while the repeat mode is set, the tracks are each played once in random order, then played again in another order, and so on.
- Random playback cannot be set in the single-track or A-B repeat mode.
- While the next track is being searched for, the numbers of all the tracks on the disc are displayed rapidly on the track number display so it is not possible to know which track will be played next.
- The random playback mode is not set when the RANDOM button is pressed during the single-track repeat mode. To set the random playback mode, first cancel the single-track repeat mode.

NOTES:

- The total remaining time cannot be displayed during the random playback mode.
- The random playback mode cannot be set during editing.

25

Edited Recording on Sides A and B of a Tape

This function allows edited recording according to the size of the tape. (This operation is only possible from the remote control unit.)

- Use this function to efficiently edit the tracks on a CD according to the length (time) of the tape onto which you want to record.
- Edited recording is possible with discs containing up to 20 tracks.

NOTES:

- Edited recording is not possible with discs containing more than 20 tracks.
- Load the cassette tape onto which you want to record in the cassette deck with side A on the top before starting the editing procedure. The tape is automatically wound to the beginning before recording starts.
- The editing mode is cancelled when the CD player's stop button is pressed.
- Note that even if the tape is slightly longer than the disc's total playing time, it may not be possible to record all the tracks on sides A and B because of the combination of tracks to be recorded on the different sides of the tape. "OVER" flashes the display if there are tracks which cannot be recorded onto the tape.
- When recording on an already recorded tape, if the tape is longer than the new recording, the previous recording will remain at the end of side B, so erase the tape before starting.
- To protect the recording, do not press the FUNCTION (input selector) button during edited recording.
- During edited recording, only the stop button, POWER switch, and TIME button for the CD player and the TAPE SIZE button, COUNTER button, REMAIN button, stop button, DOLBY NR button, and POWER switch for the cassette deck will function.
- Blank sections of 4 seconds are automatically created between all the selections to make it easier to search for selections on tapes recorded on this system. Since this differs from the actual time between tracks on the CD, the displayed time and the actual remaining time on the tape differ slightly.

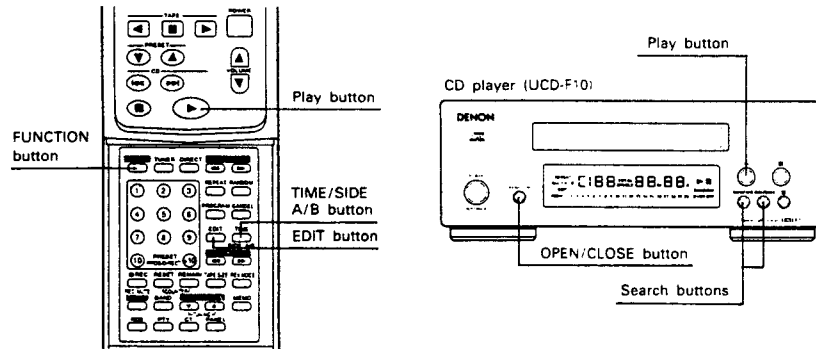

Recording the tracks in the same order as on the disc **Automatic Edited Recording**

Example: Recording a disc containing 18 tracks and a total playing time of 56 minutes on a C-60 cassette tape

1	Press the CD player's OPEN/CLOSE button to open the disc tray. Load the disc in the disc tray.		00 00.00. <small>1 2 3 4 5 6 7 8 9 10 11 12 13 14 15 16 17 18</small>
2	Press the OPEN/CLOSE button to close the disc tray. The display appears after several seconds.		18 56.00. <small>1 2 3 4 5 6 7 8 9 10 11 12 13 14 15 16 17 18</small>

3	Press the FUNCTION button on the remote control unit or the pre-main amplifier to set the CD mode.		
4	Press the EDIT button on the remote control unit to set the length of the tape. (The length is the total for sides A and B.) For a 60-minute (C-60) tape, press the EDIT button 4 times. The display changes as shown below each time the EDIT button is pressed. (If the tape length has already been set once, the display changes starting from that length.)		<p>Example: For a 60-minute tape</p> <div style="text-align: center;"> <p>↓ 2 minutes, 40 seconds remaining on side A</p> <p>Side A display - Tracks 1 to 9 will be recorded on side A.</p> </div>
5	Press the TIME/SIDE A/B button on the remote control unit. The display switches between sides A and B each time the button is pressed.		<p>1 minute, 20 seconds remaining on side B</p> <div style="text-align: center;"> <p>Side B display</p> </div>
6	Press the play button on the remote control unit or the CD player.		<p>Track no. Elapsed time</p> <div style="text-align: center;"> </div>
7	The tape is automatically wound to the beginning on the cassette deck, then recording starts.		
8	When recording on side A is completed, the CD player is set to the pause mode at the first track to be recorded on side B. When the end of side A is reached, the cassette tray opens.		
9	Turn the tape over, then press the EDIT RELAY button.		
10	The cassette tray automatically closes and recording begins on side B.		

Recording the tracks in a specific order **Programmed Edited Recording**

- 1 Program the desired tracks as described in "Programmed Playback" on Page 22.
- 2 Follow steps 4 to 6 for automatic edited recording.

NOTE

Programmed edited recording is not possible with discs containing more than 20 tracks.

13 AUTO ON FUNCTION

- When the play button or OPEN/CLOSE button on the CD player or cassette deck is pressed while the power is set to the standby mode, the power automatically turns on and the play or open/close operation is performed.
- In the same way, when the tuner preset up/down buttons on the remote control unit is pressed, the power turns on and the corresponding station is tuned in.

14 OTHER INFORMATION

Cleaning the Heads

- If the cassette deck's heads are dirty, tapes cannot be played or recorded with good sound quality.
- To take full advantage of all the performance this cassette deck has to offer and ensure good quality sound, clean the heads periodically after approximately 10 hours of use, using a commercially available cleaning cassette.

NOTE

Some commercially available cleaning cassettes are highly abrasive and may damage the heads. Avoid using such cleaning cassettes.

Demagnetizing the Heads

- The heads become magnetized after they have been used for an extended period of time or if they are exposed to a magnetic object. This results in noise or a loss of the treble sound.
- If the heads are magnetized, use a commercially available cassette-type head demagnetizer to demagnetize them.

Cleaning Discs

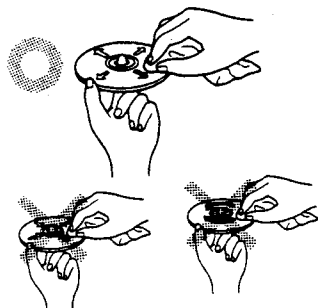

Dust, fingerprints or spit on the disc will result in noise or skipping. If the disc is dirty or if the CD player does not operate properly, use the following procedure to clean the disc:

- Hold the disc with the signal surface (the side opposite the labelled side) facing up, as shown in the diagram.
- Wipe the disc gently from the center towards the edge (in the direction of the arrow) with a soft cloth.

Do not clean discs with the following:

- Benzene, alcohol or other solvents
- Cleaner including an abrasive
- Sprays or cleaners designed for records
- Anti-static

NOTES

- Do not wipe discs in the direction opposite the arrow or in a circular motion as with regular records.
- The disc's signal surface is easily damaged, so do not wipe it with a hard cloth or rub it strongly.

15 SPECIFICATIONS

■ Pre-main amplifier (UPA-F10)

Practical maximum output:
Low frequency adjustment range:
High frequency adjustment range:
Audio input/output jacks:

55W + 55W (4 ohms DIN)
 100Hz ±8dB
 10kHz ±8dB
 CD input jacks, tape input/output jacks, tuner input jacks, MD/AUX input/output jacks, processor loop jacks, 6.3mm headphones jack and phono input jacks
 AC 230V, 50Hz
 130W
 270 (W) × 96 (H) × 342 (D) mm
 (10-5/8" × 3-25/32" × 13-15/32")
 (including feet, controls and terminals)
 4.5kg (9 lbs. 15 oz)

Power supply:
Power consumption:
Maximum external dimensions:

Weight:

■ Tuner (UTU-F10)

Reception frequency band:

FM: 87.50 MHz – 108.00 MHz
 AM: 522 kHz – 1611 kHz
 FM: 1.5 μ/75 ohms
 AM: 20 μV

Reception sensitivity:

FM stereo separation:
Power supply:
Power consumption:
Maximum external dimensions:

40dB (1kHz)
 AC 230V, 50Hz
 8W
 270 (W) × 96 (H) × 318 (D) mm
 (10-5/8" × 3-25/32" × 12-33/64")
 (including feet, controls and terminals)
 2.8kg (6 lbs. 3 oz)

Weight:

■ CD player (UCD-F10)

Wow & flutter:

Below measurable limits
 (±0.001% W, peak)

Sampling frequency:
Optical source:
Power supply:
Power consumption:
Maximum external dimensions:

44.1 kHz
 Semiconductor
 AC 230V, 50Hz
 8W
 270 (W) × 96 (H) × 315 (D) mm
 (10-5/8" × 3-25/32" × 12-13/32")
 (including feet, controls and terminals)
 3.3kg (7 lbs. 5 oz)

Weight:

■ Cassette deck (UDR-F10)

Type:
Heads:

Horizontal 4-track 2-channel stereo cassette deck
 1 hard permalloy recording/playback head
 1 double-gap ferrite erasing head
 4.75 cm/s

Tape speed:
Included circuits:
Usable tapes:
Power supply:
Power consumption:
Maximum external dimensions:

Dolby B and C NR, Dolby HX Pro
 Normal, chrome and metal
 AC 230V, 50Hz
 13W
 270 (W) × 96 (H) × 313 (D) mm
 (10-5/8" × 3-25/32" × 12-21/64")
 (including feet, controls and terminals)
 3.8kg (8 lbs. 6 oz)

Weight:

■ Remote control unit (RC-172)

Remote control system:
Number of buttons:
Power supply:
Maximum external dimensions:

Infrared pulse
 50
 Two DC 1.5V R6P/AA batteries
 57 (W) × 197 (H) × 21 (D) mm
 (2-1/4" × 7-3/4" × 53/64")
 130g (including batteries) (Approx. 4.6 oz)

- Maximum dimensions include controls, jacks, and covers.
 (W) = width, (H) = height, (D) = depth

- For improvement purposes, specifications and functions are subject to change without advanced notice.

■ Dolby noise reduction and HX Pro headroom extension manufactured under license from Dolby Laboratories Licensing Corporation HX Pro originated by Bang & Olufsen.

■ "DOLBY", the double-D symbol  and "HX PRO" are trademarks of Dolby Laboratories Licensing Corporation.

16 TROUBLESHOOTING

Check the following once more before assuming there is a problem with the system.

1. Are connections proper?

2. Is the system being operated as explained in the operating instructions?

If the system does not seem to be operating properly, check as shown on the table below. If none of these checks apply to the problem, the system may be malfunctioning. Disconnect the power cord immediately and contact your store of purchase.

	Symptom	Cause	Countermeasure	Page
General	Power does not turn on when power switch is pressed.	● Power cord is not plugged into a power outlet.	● Plug the power cord securely into an outlet.	5
	No sound is produced from the speakers.	● VOLUME control is turned down. ● Headphones are connected. ● Speaker cords are not securely connected.	● Set the control to an appropriate position. ● Disconnect the headphones. ● Connect securely.	6 6 5
	No treble sound is produced, or the position of the instruments is unclear.	● Speaker polarities (⊕ and ⊖) are inverted.	● Connect the speaker cords properly.	5
	A source other than the desired one is heard.	● Function is not properly set.	● Set the desired function using the FUNCTION button.	6
Cassette deck	Recording does not start when REC/REC MUTE button is pressed.	● No cassette tape is loaded. ● Accidental erasure protection tabs are broken off.	● Load a cassette tape. ● Cover the tab holes with cellophane tape.	16 16
	Sound is broken or no sound is produced during recording and playback.	● Heads are dirty. ● Cassette tape is defective.	● Clean the heads. ● Replace the cassette tape.	25 -
	Humming sound is heard while playing cassette tapes.	● Noise from a TV. ● (Noise may be produced by some types of TVs.)	● Move the TV away from the system. ● Turn the TV off.	4 -
	Wow (shaky sound) is heavy during recording or playback.	● Capstans or pinch rollers are dirty.	● Clean them.	25
Tuner	Hissing sound is heard in FM programs.	● Antenna direction is poor. ● Signals from the broadcast station are weak.	● Change the direction of the antenna. ● Install an outdoor antenna.	4 4
	Hissing sound is heard in AM programs.	● Noise from a TV or interference from a broadcast station.	● Turn the TV off. ● Change the direction of the loop antenna. ● Install an outdoor antenna.	- - 4
	Humming sound is heard in AM programs.	● Signals on the power cord are being modulated by the power source frequency.	● Insert the power cord in the opposite direction. ● Install an outdoor antenna.	- 4
CD player	Total number of tracks not displayed when disc is loaded.	● Disc is loaded upside-down. ● Disc is dirty. ● Disc is not of the specified type.	● Reload the disc. ● Clean the disc. ● Replace with a disc of the specified type.	20 25 -
	Nothing happens when operating buttons are pressed. Disc stops in the middle of a track and will not play properly.	● Disc is loaded upside-down. ● Foreign object on disc tray. ● Disc is dirty. ● Disc is scratched.	● Reload the disc. ● Remove the disc and the foreign object. ● Clean the disc. ● Replace with an unscratched disc.	20 20 25 -
	Sound is broken.	● Dirt, fingerprints, spittle, etc. on disc. ● Disc is scratched. ● Player is in an unstable place and vibrates strongly.	● Clean the disc. ● Replace with an unscratched disc. ● Place the player in a stable place with no vibrations.	25 - -
	Humming sound is heard when disc is played.	● Signals on the power cord are being modulated by the power source frequency.	● Insert the power cord in the opposite direction.	-

● Protector circuit

The UPA-F10 is equipped with a high speed protector circuit.

This circuit protects internal parts from being damaged by strong currents generated in the set should the set be operated when the speaker terminals are incompletely connected or short-circuited.

If this protector circuit is activated, a relay sound is produced, the output to the speakers is interrupted, and the function and power LEDs flash to indicate that there is a problem. If this should happen, unplug the power cord, check the speaker connections, then plug in the power cord and turn the power back on. After several seconds, a relay sound is heard and the set starts operating properly.

- The set may not operate properly due to such external influences as lightning or static electricity. If this happens, either turn off the power with the pre-main amplifier's SYSTEM POWER switch or unplug the power cord, wait approximately 5 seconds, then plug the power cord back in.

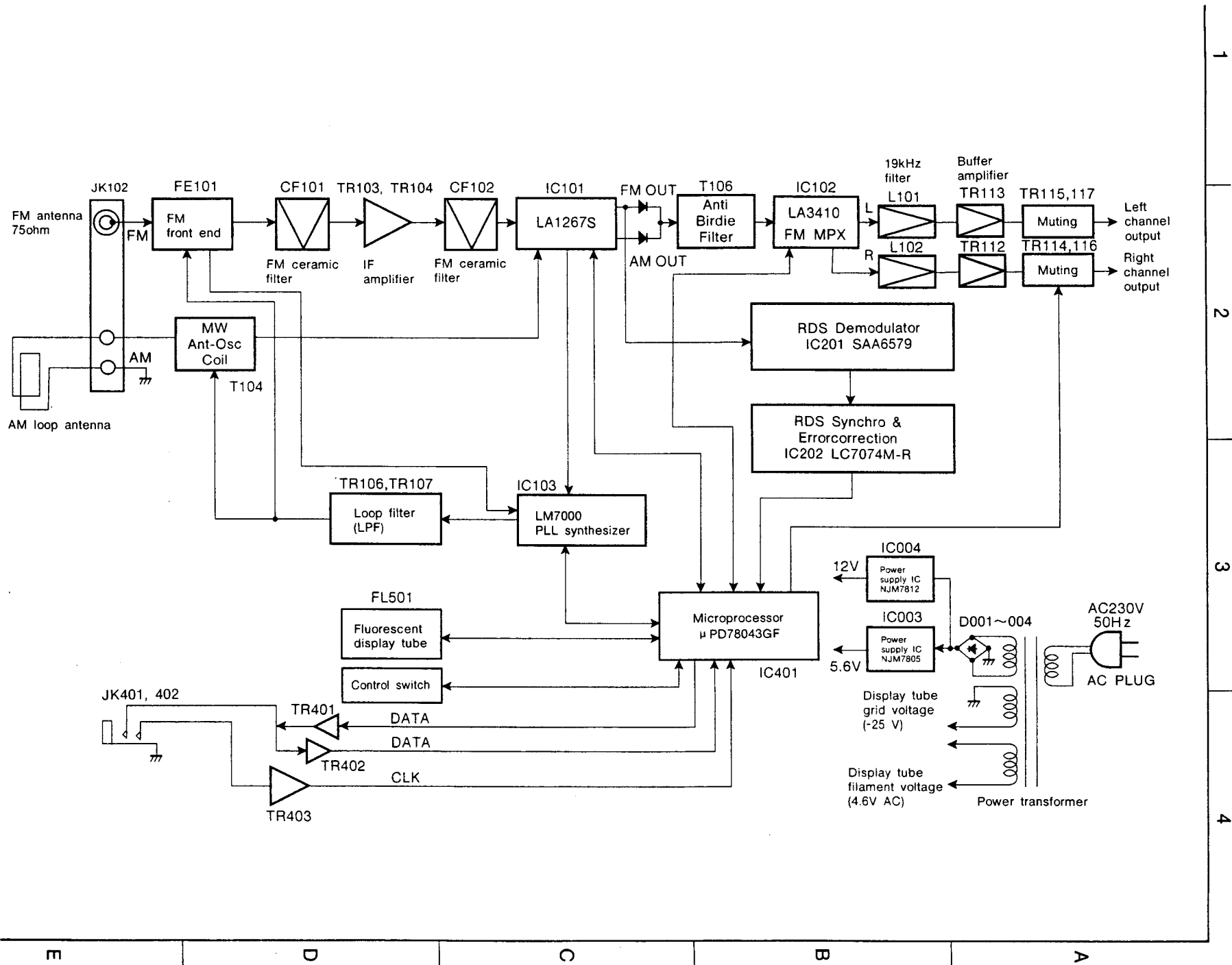

BLOCK DIAGRAM

TUNER SECTION

TUNER SECTION

DISASSEMBLY PROCEDURES

(Assembly is performed in the reverse order.)

1. Removing the Top Cover and the Front Panel

- ① Remove the six screws which fasten the top cover.
- ② Remove the top cover (upward) in the direction of the arrow.

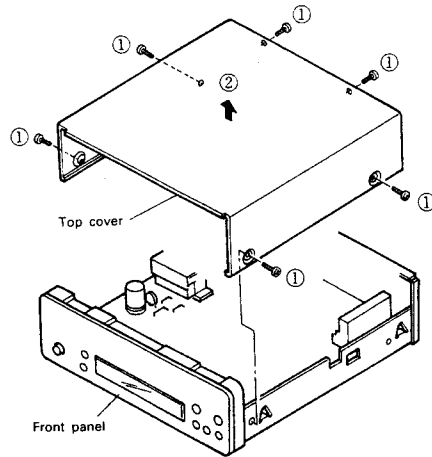

- ③ Remove the two screws which fasten front panel.
- ④ Release the inner panel hooks from the chassis while pulling the panels in the direction of the arrow to remove the inner panel and the front panel as one unit.

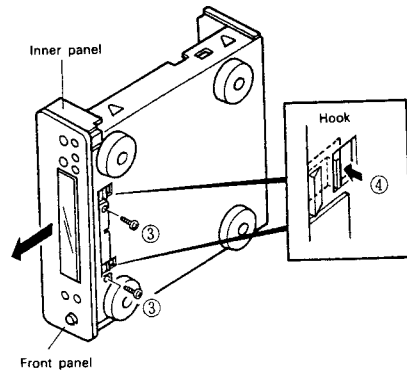

2. Removing the Units

Display Unit (2U-2685B-2)

- ⑤ Remove the six screws which fasten the display unit.

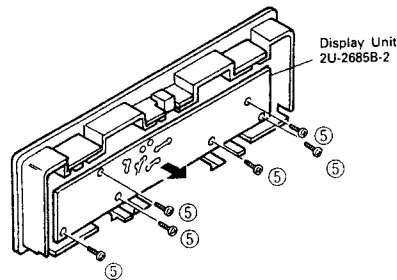

TUNER SECTION

3. Removing the Rear Panel

- ⑥ Remove the three "a" screws and seven "b" screws which fasten the rear panel.
- ⑦ Remove the rear panel in the direction of the arrow.

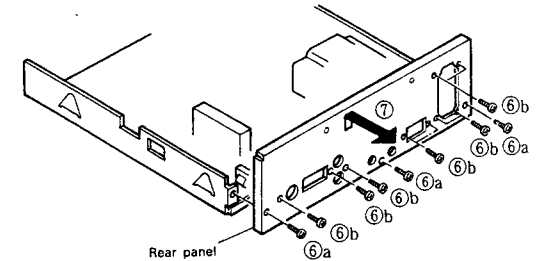

Main Unit (2U-2685B-1)

- ⑧ Remove the two screws which fasten the transformer.
- ⑨ Remove the three screws which fasten the main unit.
- ⑩ Remove the solder of the wire which goes between the chassis ground screw and the front end.

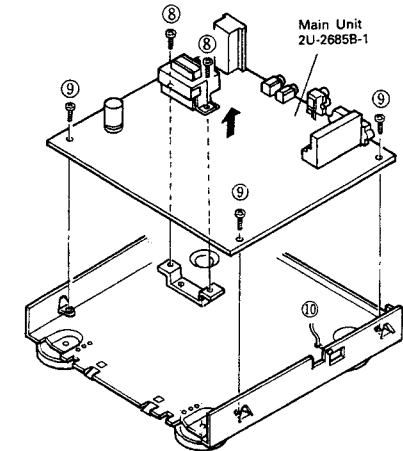

TUNER SECTION

ADJUSTMENTS

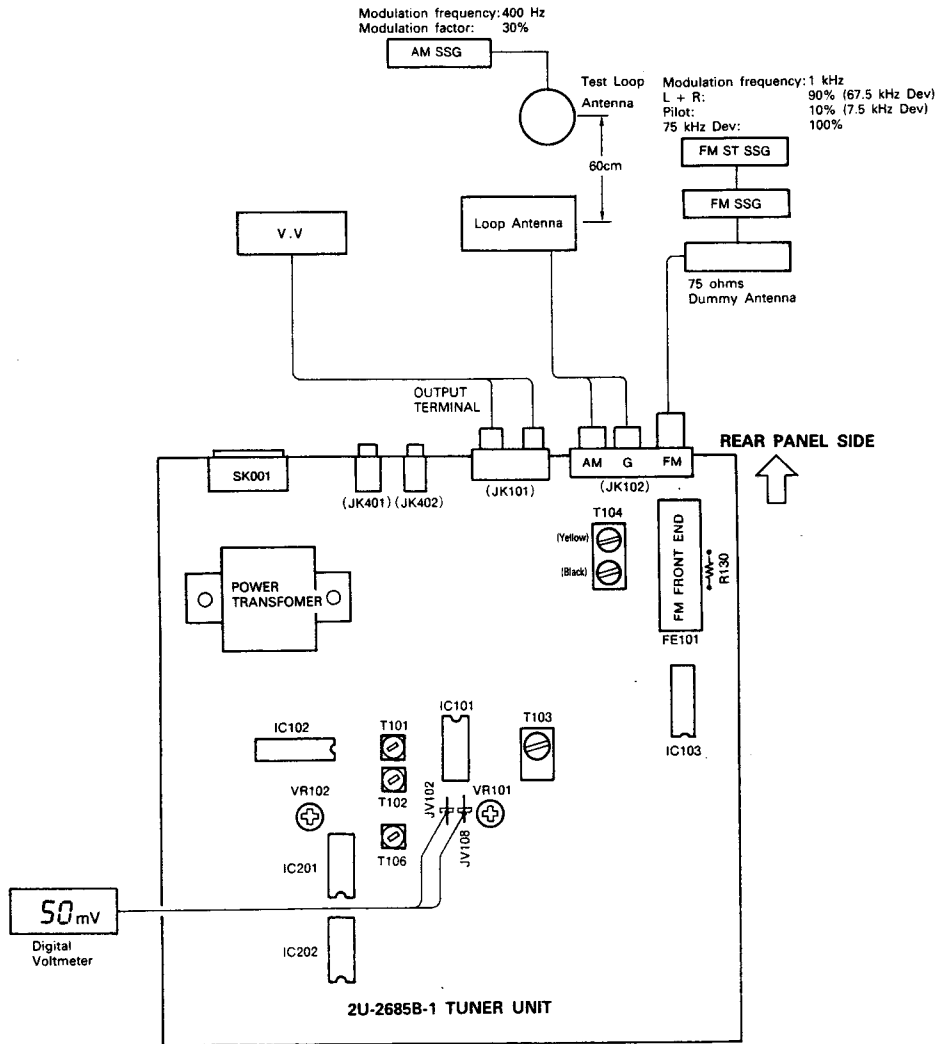

TUNER SECTION

1. FM adjustment (BAND button: FM, MONO/STEREO button: STEREO)

Step	Adjustment item	Tuning point (channel setting)	Input				Output		Adjustment location	Setting value	Notes		
			Measuring instrument	Frequency	Input level	Modulation	Connection location	Measuring instrument				Connection location	
1	FM DC balance	98.00MHz	FM S.G.	98.00MHz	60dB μ	1kHz 75kHz DEV	FM antenna terminal	Digital volt meter	⊕ JV108 ⊖ JV102	T101	0 \pm 50mV	Perform with monaural modulation signal	
2	Distortion	-	-	-	-	-	-	Distortion factor meter	-	Output jack	T102	Minimum distortion	-
3	Repeat Steps 1 and 2												
4	Auto stop level	98.00MHz	FM S.G.	98.00MHz	22dB μ	1kHz 75kHz DEV	FM antenna terminal	-	-	Output jack	VR101	Input level 22dB μ =4dB	(Level at which TUNED lights up) Level at which the output is provided
5	Stereo separation	-	FM stereo modulator FM S.G.	-	60dB μ	1kHz L or R: 67.5kHz DEV Pilot: 7.5kHz DEV	-	VTVM Oscilloscope	-	-	VR102	Minimum R.ch. Output	Perform with L.ch. Input of FM stereo modulator

2. AM adjustment (BAND button: AM)

Step	Adjustment item	Tuning point (channel setting)	Input				Output		Adjustment location	Setting value	Notes		
			Measuring instrument	Frequency	Input level	Modulation	Connection location	Measuring instrument				Connection location	
1	IF	Clear frequency (without a broadcast)	AM IF sweep	-	Level at which -AGC is not applied	-	AM antenna terminal	Oscilloscope	-	Output jack	T103	Waveform maximum and symmetry	-
2	Band edge	52kHz 1611kHz	-	-	-	-	-	Digital voltmeter	⊕ R103 (1kohm) ⊖ G	T104 Black	1.2V \pm 0.2V Approx. 7.6V	Approx. 7.6V	No piece to adjust
3	Tracking	603kHz	AM S.G.	603kHz	Level at which ACG is not applied	400Hz 30%	Loop antenna	VTVM	-	Output terminal	T104 Yellow	Maximum output	-
4	Repeat Steps 2 and 3, and set the output to maximum.												

2U-2685B-1 TUNER MAIN UNIT (Component Side)

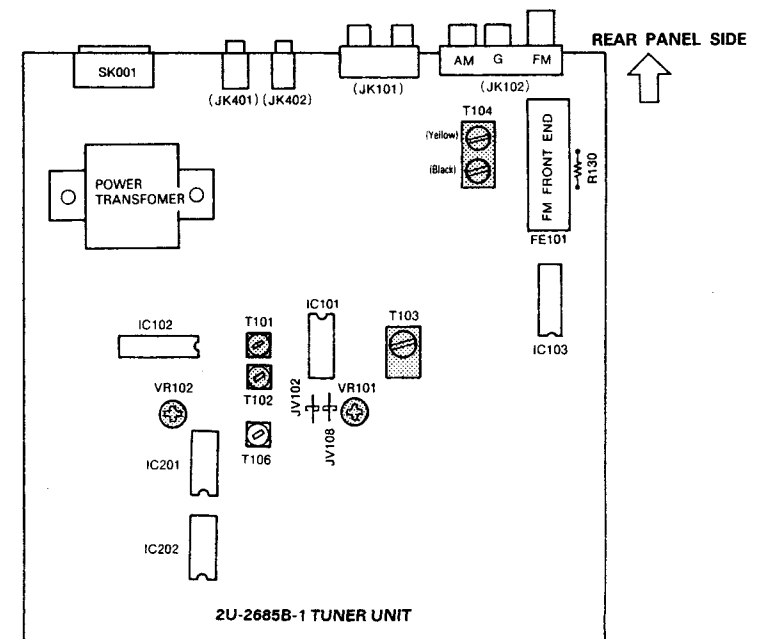

TUNER SECTION

Front End
Part No.: 216 0097 003

No.	Name	No.	Name
1	F. OUT	6	VT
2	GND	7	GND
3	Vcc	8	AGC
4	IF. OUT	9	GND
5	GND	10	ANT

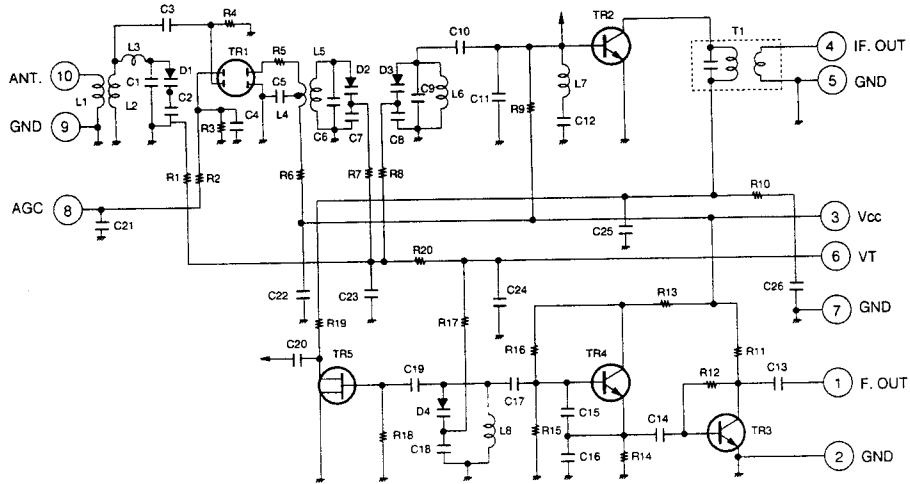
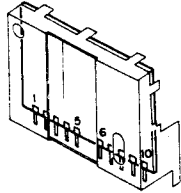

- Note
1. Terminal Number Refer to Overall Appearance
 2. Receiving Frequency 87.5 ~ 108 MHz
 3. Input Impedance ⑨ ~ ⑩ 75 ohm
 4. Output Impedance 300 ohm
 5. Supply Voltage 12 V
 6. Tuning Voltage 1.0 ~ 9.0 V

TUNER SECTION

SEMICONDUCTORS

• IC's

LM7000 (IC103)

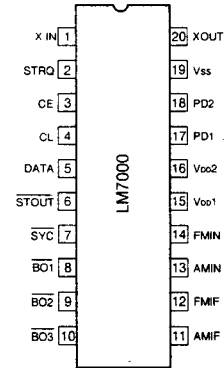
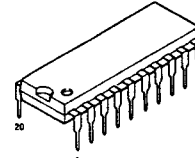

LA1267S (IC101)

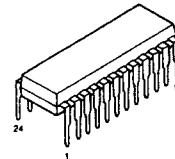

LA3410 (IC102)

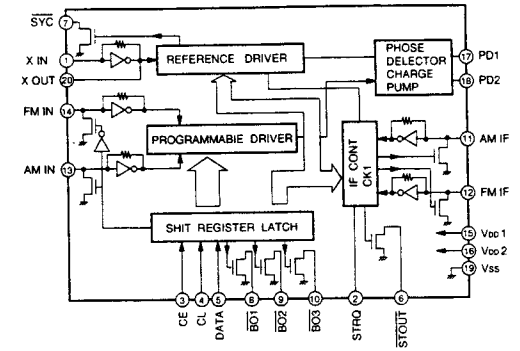
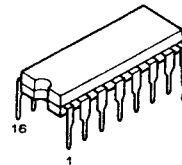

Pin Description

- SYC : Clock (400 kHz) for the controller
- XIN, XOUT : X'tal oscillator (7.2 MHz) with built-in feedback resistor
- FM IN, AM IN : Local oscillator signal input
- CE, CL, DATA : Data input
- BO1, BO2, BO3 : Band data output. BO1 can be set as the time base output (8 Hz).
- STRO : IF counter request input
- STOUT : Auto research stop signal output
- VDD1, VDD2, VSS : Power supply (VDD2 is a back-up power supply)
- AMF, FMIF : IF signal input
- PD1, PD2 : Charge pump output

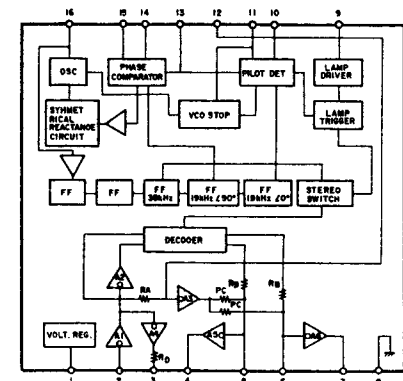
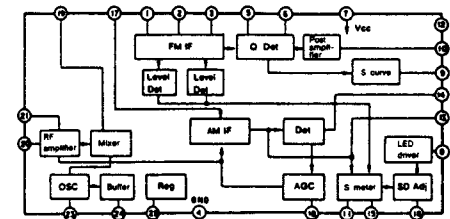

TUNER SECTION

LC7074M-R (IC202)

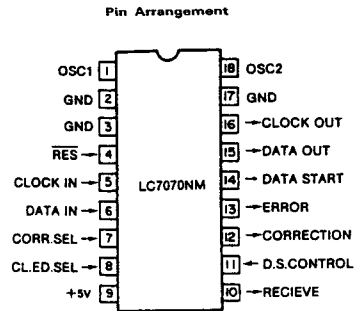
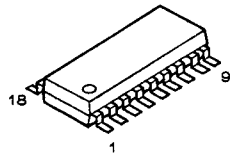

Pin Description

Symbol	Pin No.	I/O	Function/Details	At Time of Reset
OSC1	1	Input	· 4 MHz ceramic oscillator connection.	
OSC2	18	Output		
CLOCK IN	5	Input	· RDS LA2230 series demodulation clock input.	"H" output
DATA IN	6	Input	· RDS LA2230 series demodulation data input.	"H" output
CORR. SEL	7	Input	· Error correction on/off selection input. · Sets the IC to correct errors in the RDS demodulation data or to output the data without correction. When input is 0 : No corrections are made When input is 1 : Corrections are executed	"H" output
CL. ED. SEL	8	Input	· Serial data clock polarity selection input. When input is 0 : Serial data output is enabled at the rise of the output clock. (Serial data output changes at the fall of the output clock.) When input is 1 : Serial data output is enabled at the fall of the output clock. (Serial data output changes at the rise of the output clock.) NOTE: Set at the time of RES input.	"H" output
D.S. CONTROL	11	Input	· Block data start signal control input. When input is 0 : Data start signal is output for all blocks. When input is 1 : Data start signal is output for only the second block.	"H" output
RECEIVE	10 (NC)	Output	· Output during RDS data reception. · After the completion of sync detection, there is a low-level, output while the serial data is being output. There is a high-level output at other times. · Open drain output.	"H" output
CORRECTION	12 (NC)	Output	· Output with or without error correction. · There is a low-level output when the output data of the serial data output have been corrected or when correction is not possible. There is a high-level output when correction has not been applied. · Open drain output.	"H" output
ERROR	13 (NC)	Output	· Presence of error output. · There is a low-level output when the output data of the serial data output has an error and correction is not possible. There is a high-level output when there is no error or when the error has been corrected. · Open drain output.	"H" output
DATA START	14	Output	· Block data start signal of the serial data output. Output with pull-up resistor:	"H" output

TUNER SECTION

Symbol	Pin No.	I/O	Function/Details	At Time of Reset
DATA OUT	15	Output	· Data output of the serial data output. Output with pull-up resistor:	"H" output
CLOCK OUT	16	Output	· Clock output of the serial data output. Output with pull-up resistor:	"H" output
RES	4	Input	· System reset input. · Reset and restart is accomplished by inputting the low level for 4 or more clock cycles.	

Structure of the RDS Data Processing System

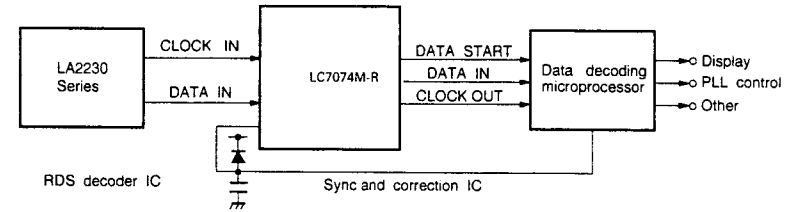

Serial Data Output Timing Chart

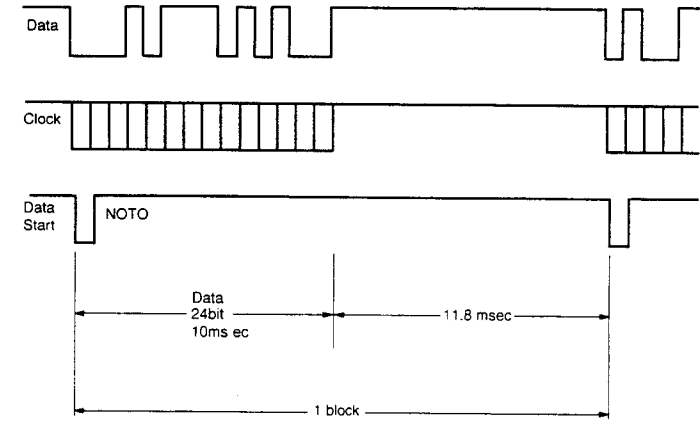

NOTE: Using the D.S. CONTROL input, only the second block among the entire 4 blocks of RDS data can be switched between the data start output and the total blocks' data start output.

TUNER SECTION

SAA8579 (IC201)

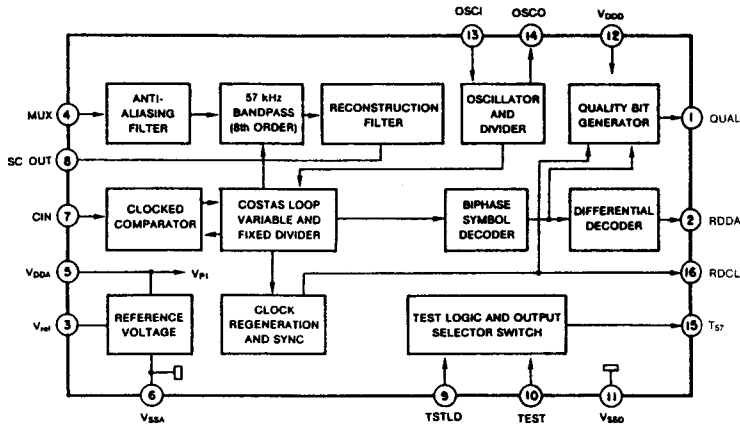

Block diagram and application circuit

Pin Description

SYMBOL	PIN	DESCRIPTION
QUAL	1	quality indication output
RDDA	2	RDS data output
Vref	3	reference voltage output (0.5 V _{DDA})
MUX	4	multiplex signal input
V _{DDA}	5	+5 V supply voltage for analog part
V _{SSA}	6	ground for analog part (0 V)
CIN	7	subcarrier input to comparator
SCOUT	8	subcarrier output of reconstruction filter
TSTLD	9	test control
TEST	10	test enable
V _{SSD}	11	ground for digital part (0 V)
V _{DD}	12	+5 V supply voltage for digital part
OSCI	13	oscillator input
OSCO	14	oscillator output
TST7	15	57 kHz clock signal output
RDCL	16	RDS clock output

Pin configuration

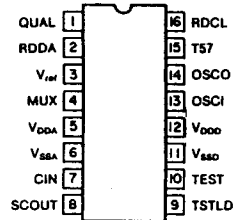

NJN7805FA(S) (IC003)
NJN7812FA(S) (IC004)

• IC PROTECTOR

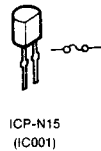
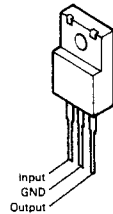

• Transistors

2SA933S (S)
2SC1740S (E)

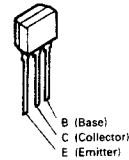

DTA114ES PNP Type
DTC144ES NPN Type
DTC343TS NPN Type

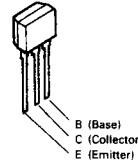

2SA1488 (Y)/(G)

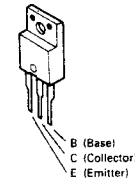

PNP Type
DTA ES Series

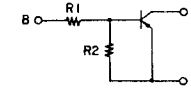

	R1	R2
DTA114ES	10 kohm	10 kom

2SC2410S

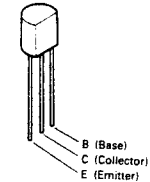

2SK365 (BL/GR)

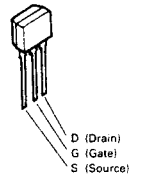

NPN Type
DTC ES/TS Series

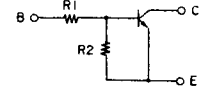

	R1	R2
DTC144ES	47 kohm	47 kom
DTC343TS	4.7 kohm	-

2SK161 (GR)

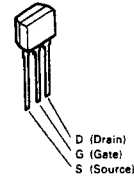

• Diodes

1SS270A

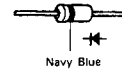

1SR35-200A



HZS4A-1
HZS6A-1
HZS6B-1
HZS9A-1
HZS27-1

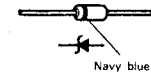

TUNER SECTION

• **Fluorescent Display Tube 11BT27GK**
(Part No.: 393 8012 002)

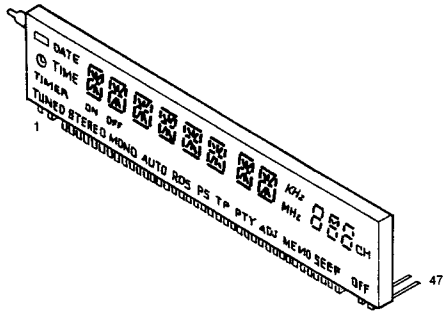

Pin Connections

Pin No.	1	2	3	4	5	6	7	8	9	10	11	12	13	14	15	16	17	18	19	20	21	22	23	24
Connection	F1	F1	NP	NP	1G	2G	3G	4G	5G	6G	7G	8G	9G	10G	11G	NC	NC	NC	NC	NC	NC	NC	NC	NC
Pin No.	25	26	27	28	29	30	31	32	33	34	35	36	37	38	39	40	41	42	43	44	45	46	47	
Connection	NC	NC	NC	P16	P15	P14	P13	P12	P11	P10	P9	P8	P7	P6	P5	P4	P3	P2	P1	NP	NP	F2	F2	

- NOTE**
- 1) F1 and F2: Filaments
 - 2) NP: No pin
 - 3) NC: No connection
 - 4) 1G through 11G: Grid

Pattern Details

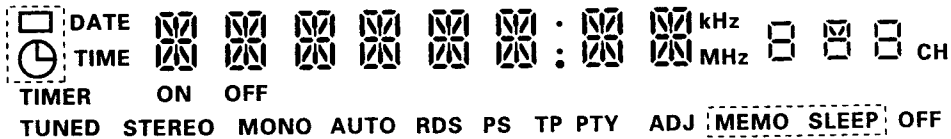

Illumination colors
 Reddish orange (Rsh. O x = 0.645, y = 0.355) portion of above pattern
 Green (G. x = 0.235, y = 0.405) Other portions

TUNER SECTION

GRID ASSIGNMENT

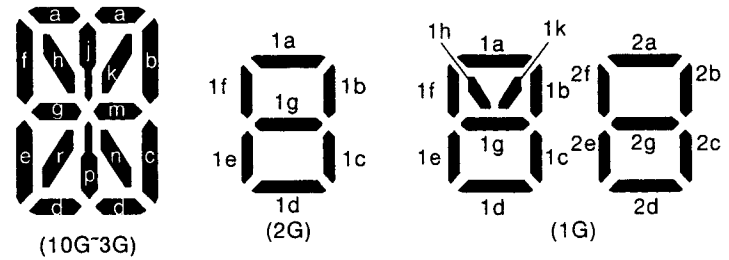
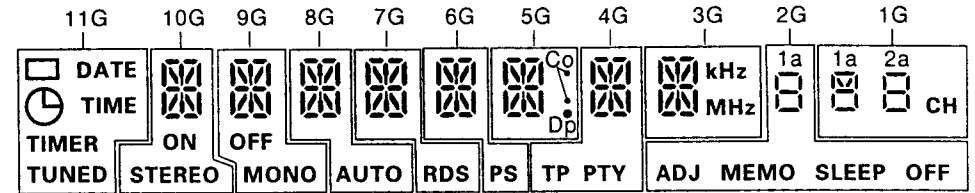

ANODE CONNECTION

	11G	10G	9G	8G	7G	6G	5G	4G	3G	2G	1G
P1	□	a	a	a	a	a	a	a	a	1a	1a
P2	DATE	b	b	b	b	b	b	b	b	1b	1b
P3	⌚	c	c	c	c	c	c	c	c	1c	1c
P4	TIME	d	d	d	d	d	d	d	d	1d	1d
P5	TIMER	e	e	e	e	e	e	e	e	1e	1e
P6	TUNED	f	f	f	f	f	f	f	f	1f	1f
P7	—	g	g	g	g	g	g	g	g	1g	1g
P8	—	h	h	h	h	h	h	h	h	ADJ	1h, 1k
P9	—	j	j	j	j	j	j	j	j	MEMO	2a
P10	—	k	k	k	k	k	k	k	k	SLEEP	2b
P11	—	m	m	m	m	m	m	m	m	OFF	2c
P12	—	n	n	n	n	n	n	n	n	—	2d
P13	—	p	p	p	p	p	p	p	p	—	2e
P14	—	r	r	r	r	r	r	r	r	—	2f
P15	—	ON	OFF	AUTO	RDS	PS	col	TP	KHz	—	2g
P16	—	STEREO	MONO	—	—	—	Dp	PTY	MHz	—	CH

TUNER SECTION

MICROPROCESSOR DOCUMENTATION

μPD78043GF-085-3B9 : 262 1937 204

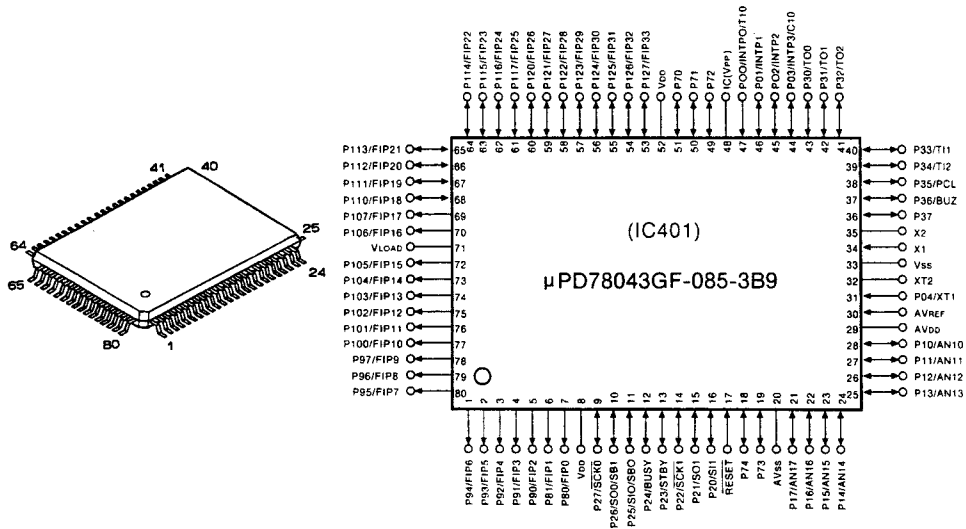

1. Overview

The functions of this microprocessor comprise the following three types.

a. Tuner functions

- Control operations required for receiving FM and AM broadcasts.

b. Timer functions

- These functions count the clock of the 24-hour display.
- These functions perform two types of timer operations, "everyday and sleep."

c. Display functions

- These functions output the drive signals of the fluorescent display tube.

NOTE 1 Plugging the power cord into a power outlet while depressing both the STANDBY and MEMORY buttons will automatically register the frequencies used for tracking adjustments to the preset memory. These frequencies can be used for adjustments and other purposes.

	P1	P2	P3	P4	P5	P6	P7	P8	—	—
AM (kHz)	522	603	846	999	1098	1404	1512	1611		
	P11	P12	P13	P14	P15	—	—	—	—	—
FM (MHz)	87.50	84.00	98.00	100.10	108.00					

※ P9, P10, and P21 through P30 are AM 522 kHz, and P16 through P20 are FM 87.50 MHz.

NOTE 2 Plugging the power cord into a power outlet while depressing both the MEMORY and BAND buttons will initialize all settings including the current time and the contents of the timers and preset memory.

2. Receiving Band Table

Band	Receiving frequency	Local oscillator frequency	IF	Frequency division ratio	Comparison frequency	Step frequency	Other
FM	87.50~108.00MHz	98.20~118.70MHz	10.7MHz	1	25kHz	50kHz	
AM	522~1611kHz	972~2061kHz	450kHz	-	9kHz	9kHz	

3. Signals sent to the LM7000 Programmable Divider

- a. Signals to the programmable divider are sent from 3 sources: CE OUT, CLOCK OUT, and DATA OUT.
- b. The programmable divider takes in DATA at CLOCK $\overline{\text{CLK}}$, when CE equals 1.
- c. The data is a 24-bit serial signal which is taken in to the programmable divider from the LSB. (At the AM setting, D₀ through D₃ are ignored, so that D₄ becomes the LSB.)
- d. The data is made up of the number of frequency divisions data, the band data, and the comparison frequency data. (See diagram below.)

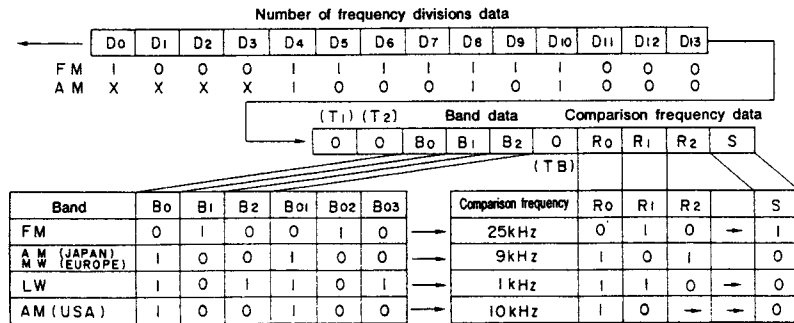

e. Timing for sending
a = 2.5 μsec

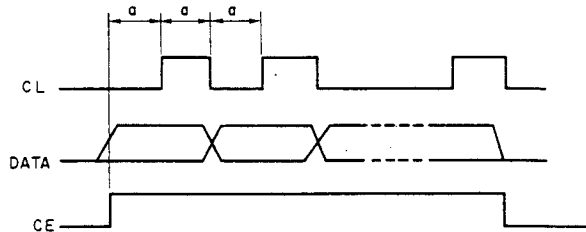

• Pin Description

No.	Port Name	Function Name	I/O	Ini	ACT	Function
1	P94/FIP6	7G	O	L	H	Fluorescent tube digit signal output
2	P93/FIP5	6G	O	L	H	Fluorescent tube digit signal output
3	P92/FIP4	5G	O	L	H	Fluorescent tube digit signal output
4	P91/FIP3	4G	O	L	H	Fluorescent tube digit signal output
5	P90/FIP2	3G	O	L	H	Fluorescent tube digit signal output
6	P81/FIP1	2G	O	L	H	Fluorescent tube digit signal output
7	P80/FIP0	1G	O	L	H	Fluorescent tube digit signal output
8	V _{DD}	5V	-	-	-	+5 V
9	P27/SCK0	SBCLK	O	L	H	DENON BUS clock
10	P28/SQ0/SB1	TXD0	O	L	H	DENON BUS data output
11	P25/SI0/SB0	RXD	I	L	H	DENON BUS data input
12	P24/BUSY	RDS Reset	O	L	L	LC7070 reset output
13	P23/STBY	PLLCE	O	H	H	PLL serial data selection output
14	P22/SCK1	CC lock	I/O	H	-	RDS data fetch clock input and PLL control clock output
15	P21/SQ1	PLL Data	O	H	-	PLL serial data output
16	P20/SI1	RDS Data	I	H	-	RDS serial data input
17	RESET	RESET	I	H	H	Reset
18	P74	PLLSTRO	O	L	L	IF count operation request output
19	P73	SignalIn	I	H	L	RF signal detection signal input
20	AV _{SS}	GND	-	-	-	A/D converter ground
21	P17/ANI7	Tuned in	I	H	-	FM/AM sync signal input
22	P16/ANI6	NC	I	H	-	V _{DD} connection
23	P15/ANI5	NC	I	H	-	V _{DD} connection
24	P14/ANI4	NC	I	H	-	V _{DD} connection
25	P13/ANI3	NC	I	H	-	V _{DD} connection
26	P12/ANI2	NC	I	H	-	V _{DD} connection
27	P11/ANI1	ANI1	I	-	-	Key input *1
28	P10/ANI0	ANI0	I	-	-	Key input *2
29	AV _{DD}	AV _{DD}	-	-	-	Analog 5 V (Common power supply with V _{DD} as a measure against leakage)
30	AV _{REF}	AV _{REF}	-	-	-	+5 V (A/D converter reference voltage)
31	P04/XT1	XT1	I	-	-	32.7 kHz (Xtal input oscillator for the clock)
32	XT2	XT2	O	-	-	32.7 kHz (Xtal output oscillator for the clock)
33	V _{SS}	V _{SS}	-	-	-	Digital ground
34	X1	OSCI	I	-	-	4.19 MHz (Xtal input)
35	X2	OSCO	O	-	-	4.19 MHz (Xtal output)
36	P37	Power ON	O	H	H	Power on/off switching
37	P36/BUZ	NC	O	L	L	Open
38	P35/RPL	XTP	O	-	-	Xtal oscillator output (for frequency adjustments)
39	P34/T12	NC	O	L	L	Open
40	P33/T11	S0/60	I	-	-	AC power supply frequency (50/60 Hz) detection
41	P32/T02	Local/DX	O	L	-	RF signal strength control signal output
42	P31/T01	AUTO/MONO	O	L	-	Stereo (Auto)/Mono switching
43	P30/T00	NC	O	L	L	Open
44	P03/INTP3/C10	RDS Start	I	H	L	RDS signal start detection
45	P02/INTP2	NC	O	L	L	Open
46	P01/INTP1	RXD	I	H	H	DENON BUS data signal input (Transfer start request detection)
47	P00/INTP0/T10	REMOCON	I	-	-	Remote control received data input
48	IC(V _{DD})	V _{DD}	-	-	-	Ground (Set to 5 V when PROM program is used)
49	P72	AM Stereo	I	H	L	AM stereo signal detection
50	P71	Stop In	I	H	L	IF count sync detection
51	P70	Stereo In	I	H	L	FM stereo recovery detection
52	V _{DD}	V _{DD}	-	-	-	5 V
53	P127/FIP33	Mute Out	O	L	L	Mute output
54	P126/FIP32	NC	O	L	L	Open
55	P125/FIP31	NC	O	L	L	Open
56	P124/FIP30	NC	O	L	L	Open
57	P123/FIP29	NC	O	L	L	Open
58	P122/FIP28	Diode In	I	-	L	AM STEREO, EX, RDS, and ADJUST functions selection switch (diode) state detection
59	P121/FIP27	Jumper	I	-	H	Destination (Switch (diode) for USA, Europe, and frequency) state detection
60	P120/FIP26	Seg16	O	L	L	Segment 16 output
61	P117/FIP25	Seg15	O	L	L	Segment 15 output
62	P116/FIP24	Seg14	O	L	L	Segment 14 output
63	P115/FIP23	Seg13	O	L	L	Segment 13 output
64	P114/FIP22	Seg12	O	L	L	Segment 12 output
65	P113/FIP21	Seg11	O	L	L	Segment 11 output
66	P112/FIP20	Seg10	O	L	L	Segment 10 output
67	P111/FIP19	Seg9	O	L	L	Segment 9 output
68	P110/FIP18	Seg8	O	L	L	Segment 8 output
69	P107/FIP17	Seg7	O	L	L	Segment 7 output
70	P106/FIP16	Seg6	O	L	L	Segment 6 output
71	V _{DD}	V _{DD}	-	-	-	High B
72	P105/FIP15	Seg5	O	L	L	Fluorescent tube digit signal output
73	P104/FIP14	Seg4	O	L	L	Fluorescent tube digit signal output
74	P103/FIP13	Seg3	O	L	L	Fluorescent tube digit signal output
75	P102/FIP12	Seg2	O	L	L	Fluorescent tube digit signal output
76	P101/FIP11	Seg1	O	L	L	Fluorescent tube digit signal output
77	P100/FIP10	11G	O	L	L	Fluorescent tube digit signal output
78	P97/FIP9	10G	O	L	L	Fluorescent tube digit signal output
79	P96/FIP8	9G	O	L	L	Fluorescent tube digit signal output
80	P95/FIP7	8G	O	L	L	Fluorescent tube digit signal output

*1: Each of the following buttons CLOCK/DISPLAY, TIMER, BAND, MONO/STEREO, and TUNING up/down
*2: Each of the following buttons PRESET up/down, PANEL, CT, PTY, RDS, MEMO, and DIMMER

1 2 3 4 5 6 7 8

Pattern Side

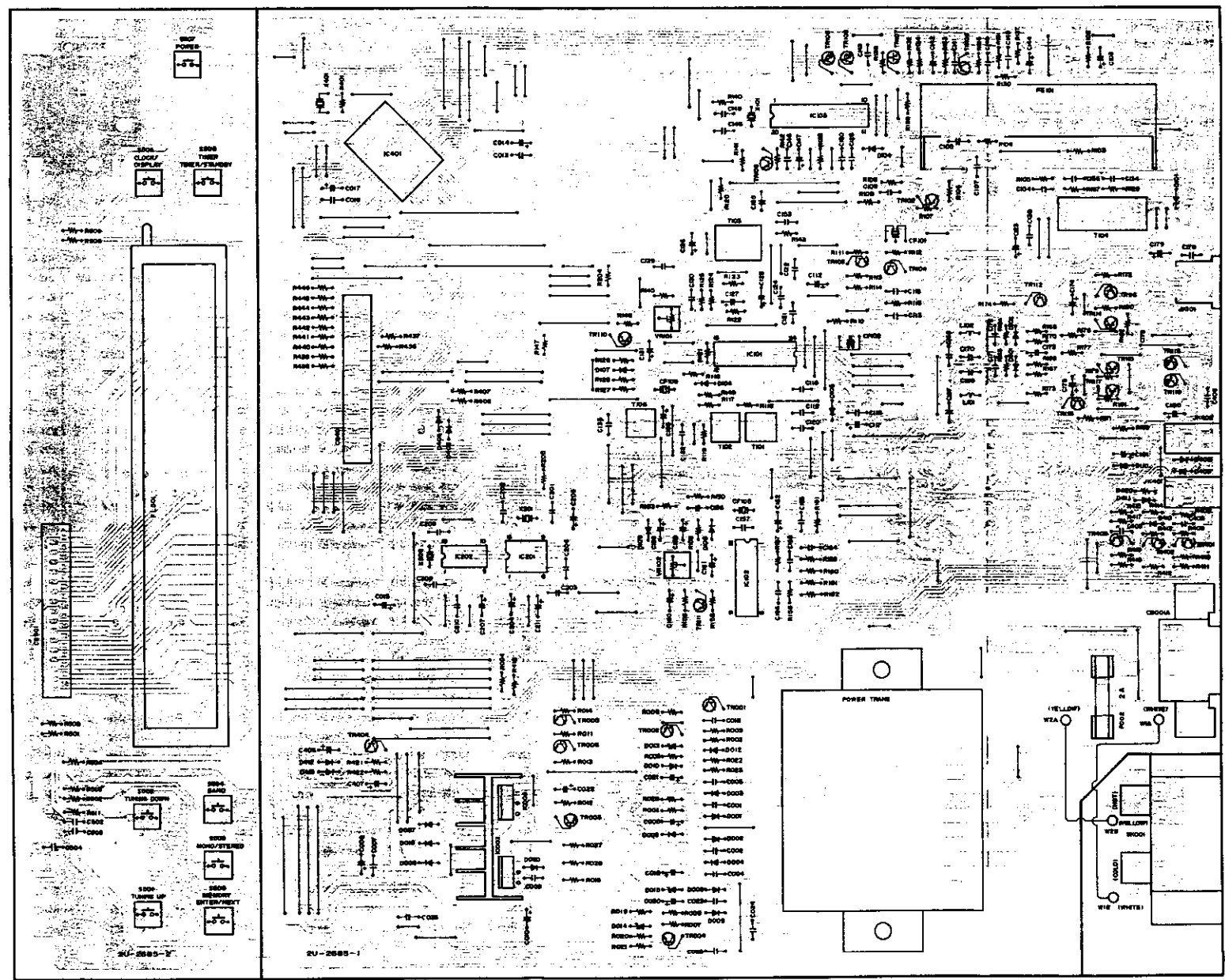

A
B
C
D
E

TUNER SECTION

NOTE ON PARTS LIST

- Part indicated with the mark "⊗" are not always in stock and possibly to take a long period of time for supplying, or in some case supplying of part may be refused.
- When ordering of part, clearly indicate "1" and "I" (i) to avoid mis-supplying.
- Ordering part without stating its part number can not be supplied.
- Part indicated with the mark "★" is not illustrated in the exploded view.
- Not including Carbon Film ±5%, 1/4W Type in the P.W. Board parts list. (Refer to the Schematic Diagram for those parts.)

WARNING:

Parts marked with this symbol Δ \square have critical characteristics. Use ONLY replacement parts recommended by the manufacturer.

Resistors

Ex.: **RN 14K 2E 182 G FR**
 Type Shape Power Resist- Allowable Others
 and per- ance- error
 formance

RD : Carbon Film	2B : 1/8W	F : ±1%	P : Pulse-resistant type
RC : Composition	2E : 1/4W	G : ±2%	NL : Low noise type
RS : Metallic oxide Film	2H : 1/2W	J : ±5%	NB : Non-burning type
RW : Winding	3A : 1W	K : ±10%	FR : Fuse-resistor
RK : Metal film	3D : 2W	M : ±20%	F : Lead wire forming
RL : Metal mixture	3F : 3W		
RM : Carbon chip	3H : 5W		

Resistance

1 8 2 ⇒ 1800 ohm = 1.8 kohm
 Indicates number of zeros after effective number
 2-digit effective number
 • Units: ohm

1 R 2 ⇒ 1.2 ohm
 1-digit effective number.
 2-digit effective number, decimal point indicated by R.
 • Units: ohm

Capacity (electrolyte only)

2 2 2 ⇒ 2200 μF
 Indicates number of zeros after effective number.
 2-digit effective number.
 • Units: μF

2 R 2 ⇒ 2.2 μF
 1-digit effective number.
 2-digit effective number, decimal point indicated by R.
 • Units: μF

Capacitors

Ex.: **CE 04W 1H 2R2 M BP**
 Type Shape Dielectric Capacity Allowable Others
 and per- strength error
 formance

CE : Aluminum foil electrolyte	0J : 6.3V	F : ±1%	HS : High stability type
CA : Aluminum solid electrolyte	1A : 10V	G : ±2%	BP : Non-polar type
CS : Tantalum electrolyte	1C : 16V	J : ±5%	HR : Ripple-resistant type
CO : Film	1E : 25V	K : ±10%	DL : For charge and discharge
CK : Ceramic	1V : 35V	M : ±20%	HF : For assuring high frequency
CC : Ceramic	1H : 50V	Z : +80%	U : UL part
CP : Oil	2A : 100V	-20%	C : CSA part
CM : Mica	2B : 125V	+100%	W : UL-CSA type
CF : Metallized	2C : 160V	-0%	F : Lead wire forming
CH : Metallized	2D : 200V	C : ±0.25pF	
	2E : 250V	D : ±0.5pF	
	2H : 500V	-	
	2J : 630V		

Capacity (except electrolyte)

2 2 2 ⇒ 2200pF = 2200 μF = 0.0022 μF
 (More than 2) Indicates number of zeros after effective number.
 2-digit effective number.
 • Units: pF

2 2 1 ⇒ 220pF
 (0 or 1) Indicates number of zeros after effective number.
 2-digit effective number.
 • Units: pF

• When the dielectric strength is indicated in AC, "AC" is included after the dielectric strength value.

2U-2685B TUNER UNIT ASS'Y PARTS LIST

Ref. No.	Part No.	Part Name	Remarks	Ref. No.	Part No.	Part Name	Remarks
SEMICONDUCTORS GROUP				RESISTORS GROUP (Not included Carbon Film ±5%, 1/4W Type. Refer to the Schematic Diagram for those Parts.)			
IC001	268 0073 905	IC ICP-N15	IC Protector 15V	FL501	393 8012 002	F.L. Tube 11BT27GK	
IC003	263 0809 006	IC NJM7805FA (S)	Regulator +5V	ΔR016	244 2052 928	Metal Oxide 47 ohm 1W (NB)	RS14BSA470JNBS (S)
IC004	263 0801 004	IC NJM7812FA (S)	Regulator +12V	ΔR026	244 2052 928	Metal Oxide 47 ohm 1W (NB)	RS14BSA470JNBS (S)
IC101	263 0831 003	IC LA1267S		ΔR028	241 2378 908	Carbon Film 1 ohm 1/4W (NB)	RD14B2E910JNBS
IC102	263 0584 004	IC LA3410		ΔR138	241 2375 907	Carbon Film 10 ohm 1/4W (NB)	RD14B2E100JNBS
IC103	262 0703 002	IC LM7000		ΔR151	241 2377 947	Carbon Film 100 ohm 1/4W (NB)	RD14B2E101JNBS
IC201	262 1701 906	IC SAA6579		VR101	211 6093 967	Semi Fixed Resist. 47k ohm	V06PB473
IC202	262 1929 204	IC LC7074M-R		VR102	211 6093 970	Semi Fixed Resist. 100k ohm	V06PB104
IC401	262 1937 204	ICμPD78043GF-085-3B9	μ-com	CAPACITORS GROUP			
TR001,002	273 0388 906	Transistor 2SC1740S (E)		C001~004	253 1196 902	Ceramic Cap. 0.01μF/25V	CK14F1E103Z
TR003	271 0206 008	Transistor 2SA1488 (YI/G)		C005	254 4260 948	Electrolytic 1μF/50V	CE04W1H010M
TR004	271 0192 002	Transistor 2SA933S (S)		C006	254 4259 700	Electrolytic 2200μF/35V	CE04W1V222MC
TR005,006	273 0388 906	Transistor 2SC1740S (E)		C007	253 1196 902	Ceramic Cap. 0.01μF/25V	CK14F1E103Z
TR102	275 0051 909	FET 2SK161 (GR)		C008	254 4254 941	Electrolytic 100μF/16V	CE04W1C101M
TR103,104	273 0422 901	Transistor 2SC2410S		C009	253 1196 902	Ceramic Cap. 0.01μF/25V	CK14F1E103Z
TR105	269 0046 003	Transistor DTA114ES	Built in Resistor	C010	254 4252 930	Electrolytic 100μF/10V	CE04W1A101M
TR106	273 0388 906	Transistor 2SC1740S (E)		C013	253 1196 902	Ceramic Cap. 0.01μF/25V	CK14F1E103Z
TR107	275 0053 907	FET 2SK365 (BL/GR)		C014	254 4252 930	Electrolytic 100μF/10V	CE04W1A101M
TR108	273 0422 901	Transistor 2SC2410S		C015	259 0008 002	Backup Cap. 47000pF/5.5V	EES5R5H473
TR109	269 0046 003	Transistor DTA114ES	Built in Resistor	C016	253 1196 902	Ceramic Cap. 0.01μF/25V	CK14F1E103Z
TR110~113	273 0388 906	Transistor 2SC1740S (E)		C017	254 4252 930	Electrolytic 100μF/10V	CE04W1A101M
TR114~117	269 0146 903	Transistor DTC343TS	Built in Resistor	C018	253 1197 914	Ceramic Cap. 0.1μF/25V	CK14F1E104Z
TR118,119	269 0046 003	Transistor DTA114ES	Built in Resistor	C019	254 4261 921	Electrolytic 100μF/50V	CE04W1H101M
TR401	273 0388 906	Transistor 2SC1740S (E)		C020	254 4258 918	Electrolytic 10μF/35V	CE04W1V100M
TR402,403	271 0192 002	Transistor 2SA933S (S)		C021	254 4260 948	Electrolytic 1μF/50V	CE04W1H010M
TR404	269 0040 902	Transistor DTC144ES	Built in Resistor	C022	254 4258 950	Electrolytic 100μF/35V	CE04W1V101M
D001~009	276 0553 905	Diode 1SR35-200A		C023	253 1196 902	Ceramic Cap. 0.01μF/25V	CK14F1E183Z
D010	276 0432 903	Diode 1SS270A		C024	253 1197 914	Ceramic Cap. 0.1μF/25V	CK14F1E104Z
D012	276 0432 903	Diode 1SS270A		C025	253 1196 902	Ceramic Cap. 0.01μF/25V	CK14F1E103Z
D013	276 0467 907	Zener Diode HZS9A-1	9V	C026	253 1197 914	Ceramic Cap. 0.1μF/25V	CK14F1E104Z
D014	276 0461 903	Zener Diode HZS6A-1	6V	C103	254 4254 909	Electrolytic 10μF/16V	CE04W1C100M
D015	276 0482 908	Zener Diode HZS27-1	27V	C104,105	253 1196 902	Ceramic Cap. 0.01μF/25V	CK14F1E103Z
D018	276 0553 905	Diode 1SR35-200A		C107	253 1196 902	Ceramic Cap. 0.01μF/25V	CK14F1E103Z
D020	276 0553 905	Diode 1SR35-200A		C109	253 1196 902	Ceramic Cap. 0.01μF/25V	CK14F1E103Z
D101	276 0455 906	Zener Diode HZS4A-1	4V	C112	254 4254 909	Electrolytic 10μF/16V	CE04W1C100M
D104~110	276 0432 903	Diode 1SS270A		C113	253 1196 902	Ceramic Cap. 0.01μF/25V	CK14F1E103Z
D403	276 0432 903	Diode 1SS270A		C115	253 1196 902	Ceramic Cap. 0.01μF/25V	CK14F1E103Z
D406	276 0432 903	Diode 1SS270A		C116	253 1196 915	Ceramic Cap. 0.022μF/25V	CK14F1E223Z
D408,409	276 0462 902	Zener Diode HZS6B-1	6V	C117	254 4254 909	Electrolytic 10μF/16V	CE04W1C100M
D410~412	276 0432 903	Diode 1SS270A		C118,119	253 1196 915	Ceramic Cap. 0.022μF/25V	CK14F1E223Z
				C120	253 1190 908	Ceramic Cap. 10pF/50V	CK14SL1H100J
				C121	253 1196 902	Ceramic Cap. 0.01μF/25V	CK14F1E103Z
				C122	253 1193 934	Ceramic Cap. 100pF/50V	CK14B1H101K
				C123	254 4254 909	Electrolytic 10μF/16V	CE04W1C100M
				C124	253 1196 915	Ceramic Cap. 0.022μF/25V	CK14F1E223Z

TUNER SECTION

Ref. No.	Part No.	Part Name	Remarks	Ref. No.	Part No.	Part Name	Remarks	Qty
C125	254 4258 905	Electrolytic 4.7uF/35V	CE04W1V47M	C210	254 4252 927	Ceramic Cap. 0.01uF/25V	CK14F1E103Z	
C126	254 4260 964	Electrolytic 3.3uF/50V	CE04W1H3R3M	C211	254 4252 927	Electrolytic 47uF/10V	CE04W1A470M	
C127	254 4254 909	Electrolytic 10uF/16V	CE04W1C100M	C403	253 1194 959	Ceramic Cap. 1000pF/50V	CK14B1H102K	
C128	253 1194 959	Ceramic Cap. 1000pF/50V	CK14B1H102K	C405	253 1194 959	Ceramic Cap. 1000pF/50V	CK14B1H102K	
C129	253 9030 976	BG Ceramic Cap. 0.015uF/25V	CK45-1E153K	C406	253 1196 902	Ceramic Cap. 0.01uF/25V	CK14F1E103Z	
C130	253 1197 914	Ceramic Cap. 0.1uF/25V	CK14F1E104Z	C407	254 4260 948	Electrolytic 1uF/50V	CE04W1H010M	
C131	254 4260 964	Electrolytic 3.3uF/50V	CE04W1H3R3M	C502,503	253 1194 959	Ceramic Cap. 1000pF/50V	CK14B1H102K	
C132	253 1191 923	Ceramic Cap. 33pF/50V	CK14SL1H330J	C504	253 1196 915	Ceramic Cap. 0.022uF/25V	CK14F1E223Z	
C133	255 4201 984	Polypropylene 560pF/50V	CQ93P1H561J	OTHER GROUP				
C134	253 4536 967	Ceramic Cap. 18pF/50V	CC45SL1H180J			(P.W. Board)		(1)
C136	253 1197 901	Ceramic Cap. 0.047uF/50V	CK14F1H473Z	L101,102	235 0020 097	Inductor 39mH		2
C138	253 1196 902	Ceramic Cap. 0.01uF/25V	CK14F1E103Z		212 5604 910	Tact Switch		8
C140	253 1196 902	Ceramic Cap. 0.01uF/25V	CK14F1E103Z	CF101,102	261 0064 007	Ceramic Filter SFT10.7M52		2
C141	253 1196 915	Ceramic Cap. 0.022uF/25V	CK14F1E223Z	CF103	261 0104 009	Ceramic Filter BFU450C4M		1
C142	254 3056 917	Electrolytic 1uF/50V (Bipolar)	CE04D1H010MBP	CF105	261 0103 007	Ceramic Resonator CSB456F11		1
C143	253 1196 902	Ceramic Cap. 0.01uF/25V	CK14F1E103Z	T101	231 2905 008	FM IF DET Trans (A)		1
C144	254 4254 938	Electrolytic 47uF/16V	CE04W1C470M	T102	231 2906 007	FM IF DET Trans (B)		1
C145,146	253 1196 902	Ceramic Cap. 0.01uF/25V	CK14F1E103Z	T103	231 3034 004	AM IFT		1
C147	254 4258 947	Electrolytic 47uF/35V	CE04W1V470M	T104	231 1913 004	MW Ant. -Osc Coil		1
C148	253 3125 900	Ceramic Cap. 15pF/50V	CC45CH1H150J (Temp)	T106	232 0152 005	Ant Birdie Filter		1
C149	253 3127 908	Ceramic Cap. 18pF/50V	CC45CH1H180J (Temp)	FE101	216 0097 003	Front End (U)		1
C150	253 1193 934	Ceramic Cap. 100pF/50V	CK14B1H101K	X101	399 0075 003	Crystal Resonator	7.2MHz	1
C153	253 1196 902	Ceramic Cap. 0.01uF/25V	CK14F1E103Z	X201	399 0178 007	Crystal	4.332MHz	1
C155	254 4260 948	Electrolytic 1uF/50V	CE04W1H010M	X202	399 0041 901	Ceramic Resonator	CSA4.00MG	1
C156	254 3056 917	Electrolytic 1uF/50V (Bipolar)	CE04D1H010MBP	X401	399 0196 908	Ceramic Resonator	EF0EC4194T4	1
C157	253 1197 901	Ceramic Cap. 0.047uF/50V	CK14F1H473Z					
C158	254 4260 964	Electrolytic 3.3uF/50V	CE04W1H3R3M					
C159	254 4260 935	Electrolytic 0.47uF/50V	CE04W1HR47M					
C160	254 4254 909	Electrolytic 10uF/16V	CE04W1C100M					
C161	254 4260 948	Electrolytic 1uF/50V	CE04W1H010M					
C162	254 4254 938	Electrolytic 47uF/16V	CE04W1C470M					
C163	253 1196 902	Ceramic Cap. 0.01uF/25V	CK14F1E103Z					
C164	253 1193 992	Ceramic Cap. 330pF/50V	CK14B1H331K					
C165,166	253 1179 945	Ceramic Cap. 220pF/50V	CK14B1H221K					
C167,168	253 1117 907	Ceramic Cap. 2700pF/50V	CK45B1H272K					
C169,170	253 1115 909	Ceramic Cap. 1800pF/50V	CK45B1H182K					
C171,172	253 1180 934	Ceramic Cap. 1200pF/50V	CK45B1H122K					
C173	254 4254 938	Electrolytic 47uF/16V	CE04W1C470M					
C174,175	254 4260 951	Electrolytic 2.2uF/50V	CE04W1H2R2M					
C178	253 1196 902	Ceramic Cap. 0.01uF/25V	CK14F1E103Z					
C180	254 4252 930	Electrolytic 100uF/10V	CE04W1A101M	Δ	202 0040 909	Fuse Clip		2
C181	254 4254 909	Electrolytic 10uF/16V	CE04W1C100M	ΔSK001A	203 3964 001	3P AC Outlet		1
C185	253 1193 934	Ceramic Cap. 100pF/50V	CK14B1H101K	ΔCB001A	203 2349 009	2P Inlet		1
				ΔPT001	233 6069 003	Power Trans		1
				ΔF002	206 1015 061	Fuse 2A		1
C201,202	253 3131 907	Ceramic Cap. 27pF/50V	CC45CH1H270J (Temp)		513 2024 027	Fuse Label		1
C203	253 1193 934	Ceramic Cap. 100pF/50V	CK14B1H101K					
C204	254 4260 951	Electrolytic 2.2uF/50V	CE04W1H2R2M					
C205	254 4252 927	Electrolytic 47uF/10V	CE04W1A470M	CB401,501	205 0736 005	33P FFC Conn Base		2
C206	253 1194 920	Ceramic Cap. 560pF/50V	CK14B1H561K					
C207	254 4252 927	Electrolytic 47uF/10V	CE04W1A470M		461 0655 009	Rubber Sheet		2
C208,209	253 1191 910	Ceramic Cap. 30pF/50V	CK14SL1H300J		203 0548 022	1P Contact Assy		1

TUNER SECTION

TUNER SECTION

Ref. No.	Part No.	Part Name	Remarks	Qty
	203 0548 035	1P Contact Ass'y		1
	203 0497 021	1P Contact Ass'y		1

MICROPROCESSOR PERIPHERAL WIRING DIAGRAM

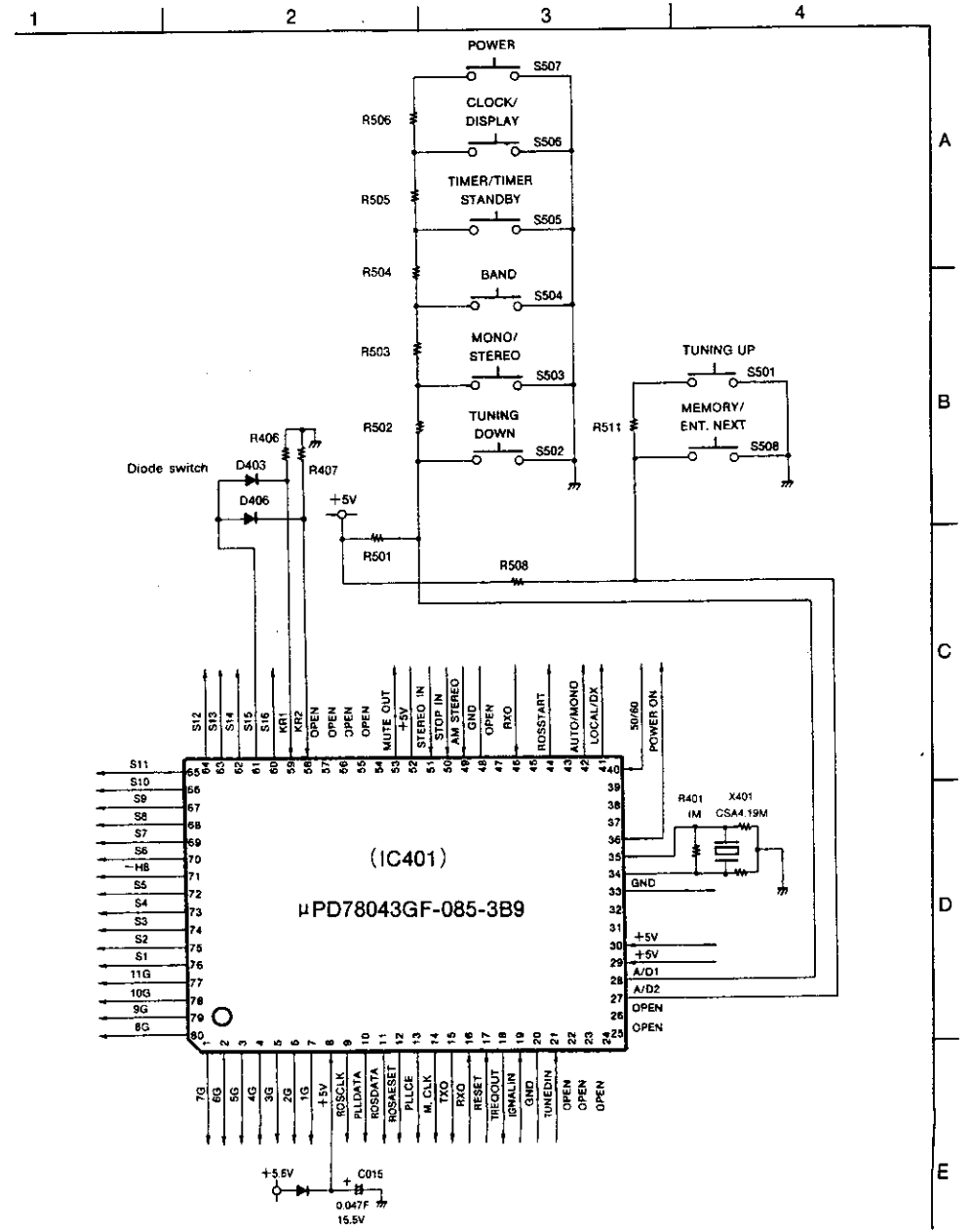

TUNER SECTION

WIRING DIAGRAM

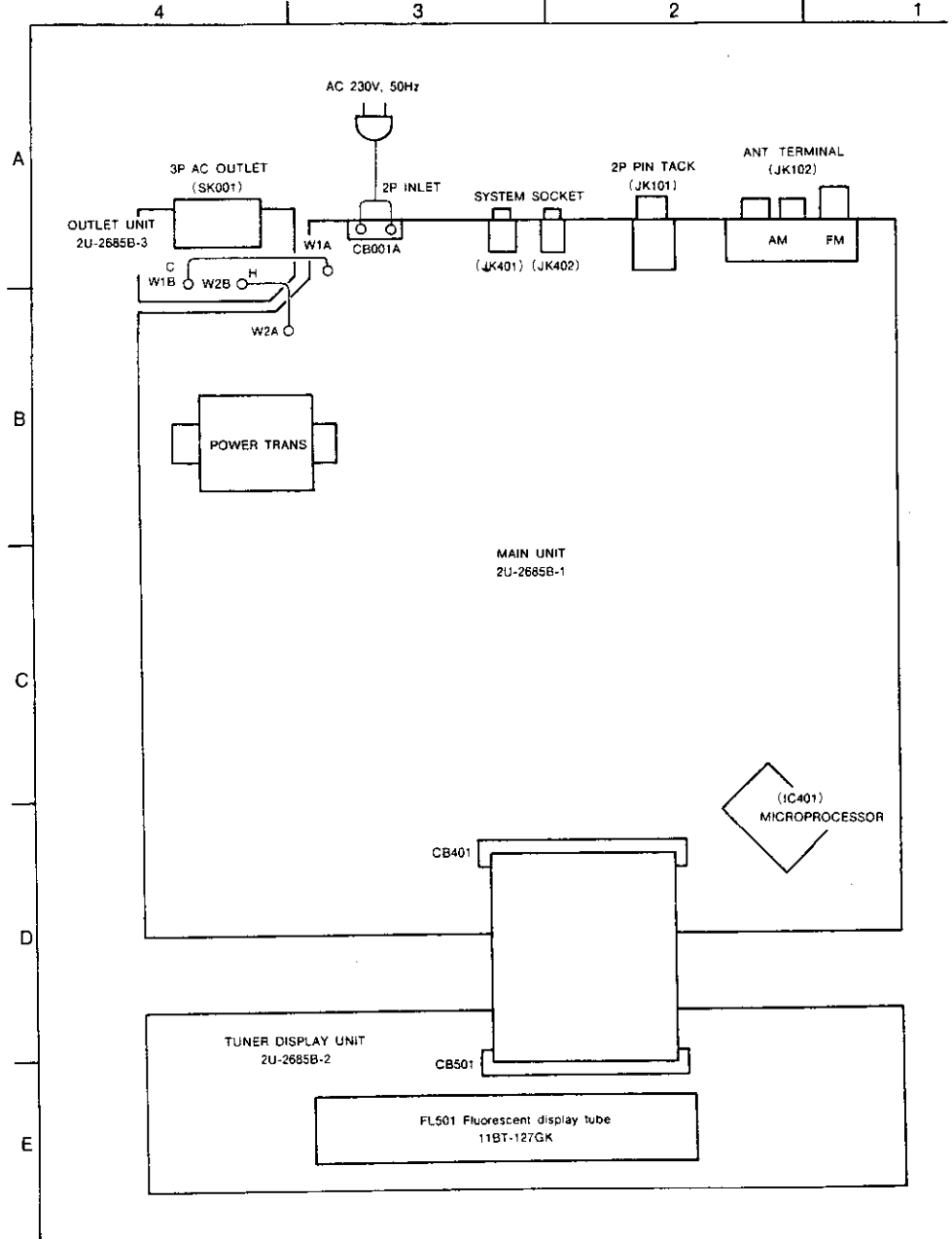

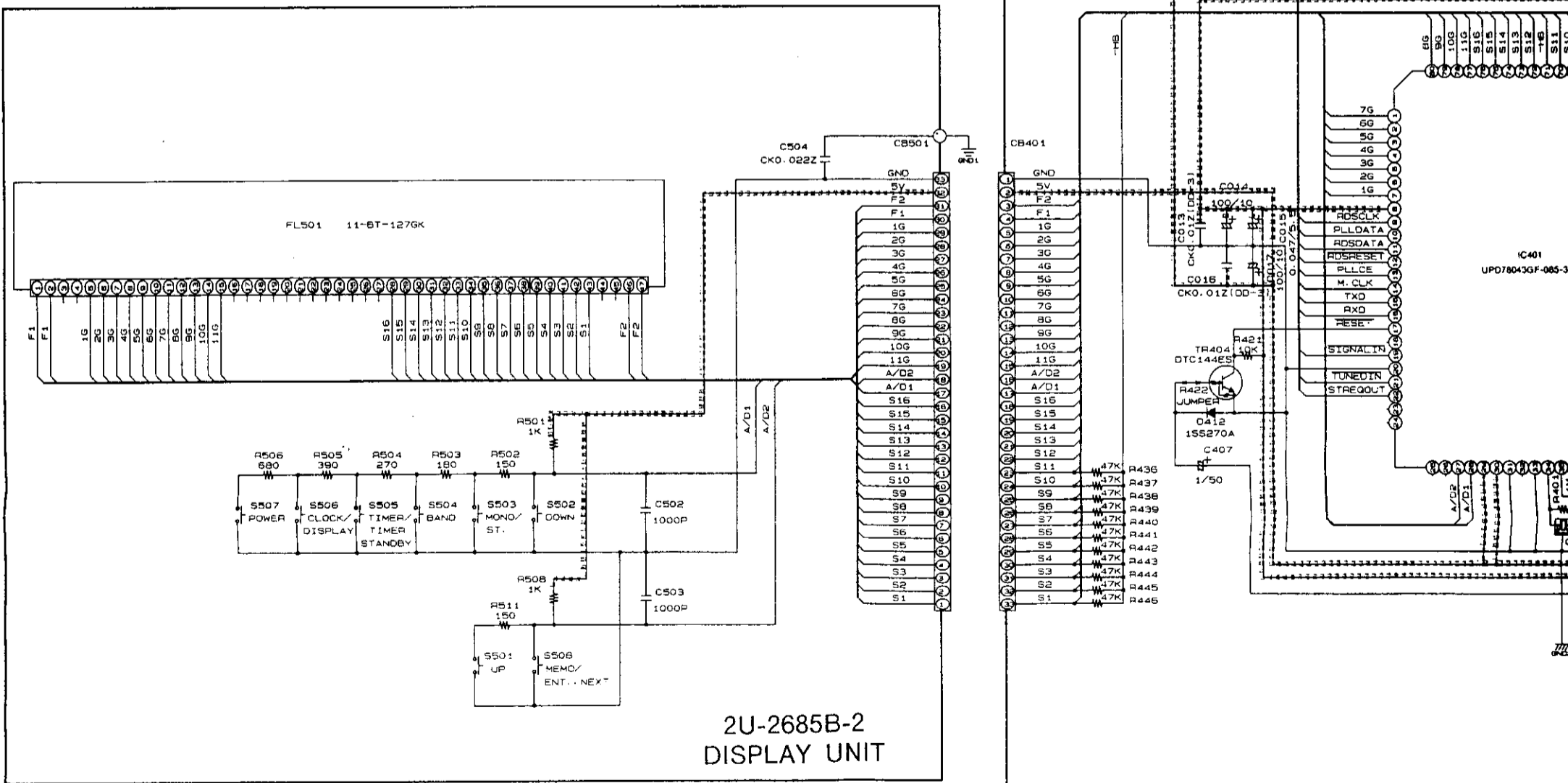
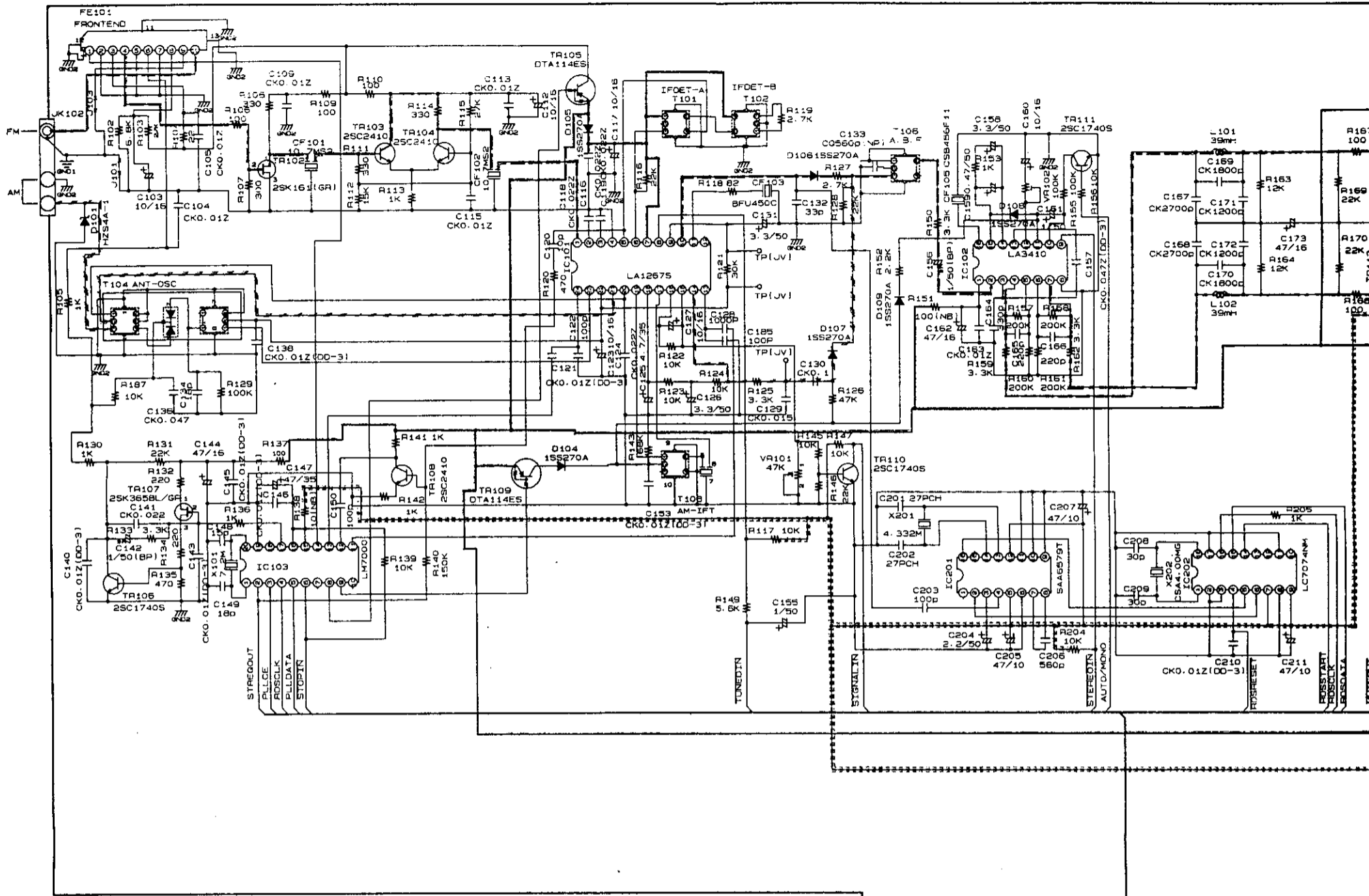

2U-2685B-2
DISPLAY UNIT

- - - - - 12 LINE
 5 LINE
 - - - - - FM Lch SIGNAL LINE
 - - - - - RDS SIGNAL LINE
 - - - - - 100 OHM SIGNAL LINE

CAUTION:
Before returning the unit to the customer, make sure you make either (1) a leakage current check or (2) a line to chassis resistance check. If the leakage current exceeds 0.5 milliamps, or if the resistance from chassis to either side of the power cord is less than 240 Kohms, the unit is defective.

WARNING
DO NOT return the unit to the customer until the problem is located and corrected.

TUNER SECTION

PARTS LIST OF UTU-F10 EXPLODED VIEW

Ref. No.	Part No.	Part Name	Remarks	Qty
1	2U- 2685 B	Tuner Unit Ass'y		1 ^s
1-1	--	Main Unit		(1)
1-2	--	Display Unit		(1)
1-3	--	Outlet Unit		(1)
2	393 8012 002	F.L. Tube 11BT127GK	FL501	1
3	--	--		
4	216 0097 003	Front End (U)	FE101	1
5	254 4259 700	Chemicon 2200μF/35V	C006	1
6	--	--		
7	205 0736 005	33P FFC Conn. Base	CB401,501	2
8	205 0274 004	2P Conn. Base	JK101	1
9	204 8421 005	Mini Jack	JK401,402	2
10	205 0847 004	3P Ant. Terminal (PAL/F)	JK102	1
11	208 9984 001	BP Ant. Outlet	BM001A	1
12	411 9115 251	Main Chassis		1
13	412 3783 213	Trans Bracket		1
14	GEN 2798	Foot Ass'y		4
15	105 1111 112	Rear Panel (Tuner)		1
16	--	--		
17	--	--		
18	--	--		
19	412 2814 028	Card Spacer (L=10)		1
20	233 6096 003	Power Trans		1
21	--	--		
22	144 2363 045	Front Panel (Tuner)		1
23	146 9294 113	Knob Ring (A)		1
24	146 9295 112	Knob Ring (B)		2
25	146 9287 324	Inner Panel (Tuner)		1
26	--	--		
27	143 0872 001	Window		1
28	113 9276 115	Button (5 Key)	4 Gang	1
29	113 1656 018	Tact Button (1 Key)	4 Gang	2
30	113 1654 104	Power Button Ass'y		1
31	009 0106 008	33P FF Cable		1
32	--	--		
33	102 0545 117	Top Cover		1
34	461 0866 009	Rubber Sheet	Put on F.L. Tube	2
35	513 2241 101	Rating Sheet		1
36	203 2349 009	2P Inlet	CB001A	1
37	206 1015 061	Fuse 2A	F002	1
38	461 0859 003	Spacer	for or AC	1
39	--	--		
40	--	--		
SCREWS				
51	473 7004 003	Tapping Screw (S) 4×8		4
52	473 7002 018	Tapping Screw (S) 3×8		8
53	473 7015 018	Tapping Screw (S) 3×8	Black	11
54	477 0064 107	Fixing Screw		7
55	473 7505 007	Tapping Screw (P) 2.6×8		6
56	477 0276 018	Earth Screw		1
57	475 2003 005	Spring Washer φ3	for E. Screw	1
58	473 7500 015	Tapping Screw (P) 3×8		2
59	--	--		
60	--	--		
PACKING & ACCESSORIES (Not included EXPLODED VIEW)				
101	505 0241 005	Cabinet Cover		1
102	503 1091 106	Cushion		1
103	GEN 2740	Envelope Sub. Ass'y		1 ^s
103-1	505 9125 009	:Poly Cover		(1)
103-2	231 1914 003	Loop Antenna		(1)
103-3	395 0021 000	FM Ant. Ass'y		(1)
103-4	203 2310 009	2P Pin Cord	L=1000	(1)
103-5	203 2315 004	Stereo Miniplug Cord	L=500	(1)
103-6	206 2108 003	:AC Conn. with Plug		(1)
103-7	511 2653 007	Inst. Sheet		(1)
104	503 1061 000	:Top Cushion		1
105	501 1781 009	Carton Case		1
106	--	--		
107	--	--		

A
B
C
D
E
F

1 2 3 4 EXPLODED VIEW

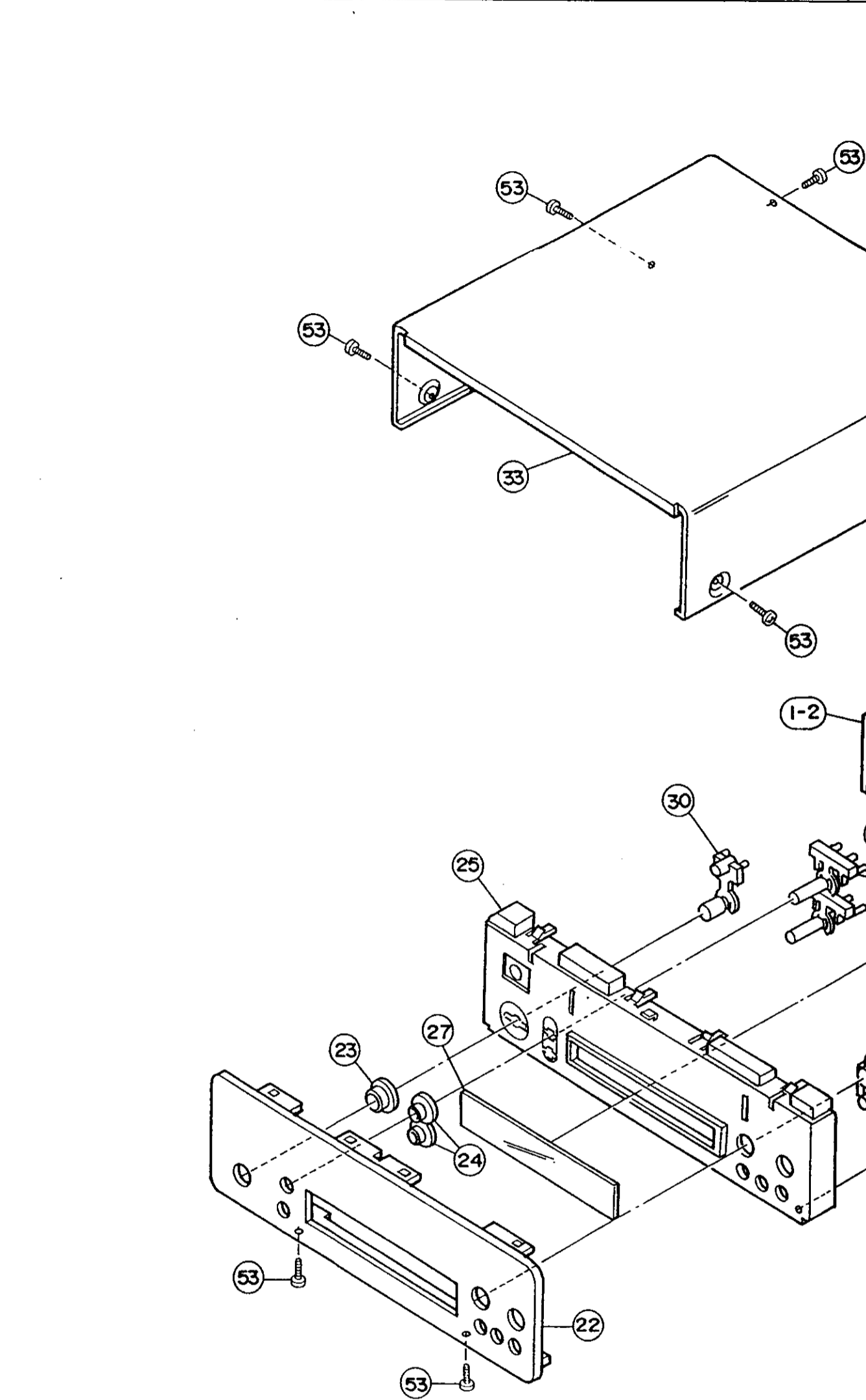

NOTE ON PARTS LIST

- Part indicated with the mark "●" are not always in stock and possibly to take a long period of time for supplying, or in some supplying of part may be refused.
- When ordering of part, clearly indicate "1" and "1" (i) to avoid mis-supplying.
- Ordering part without stating its part number can not be supplied.
- Part indicated with the mark "★" is not illustrated in the exploded view.

WARNING:
Parts marked with this symbol Δ have critical characteristics. Use ONLY replacement parts recommended by the manufacturer.

EXPLODED VIEW

3 4 5 6 7 8

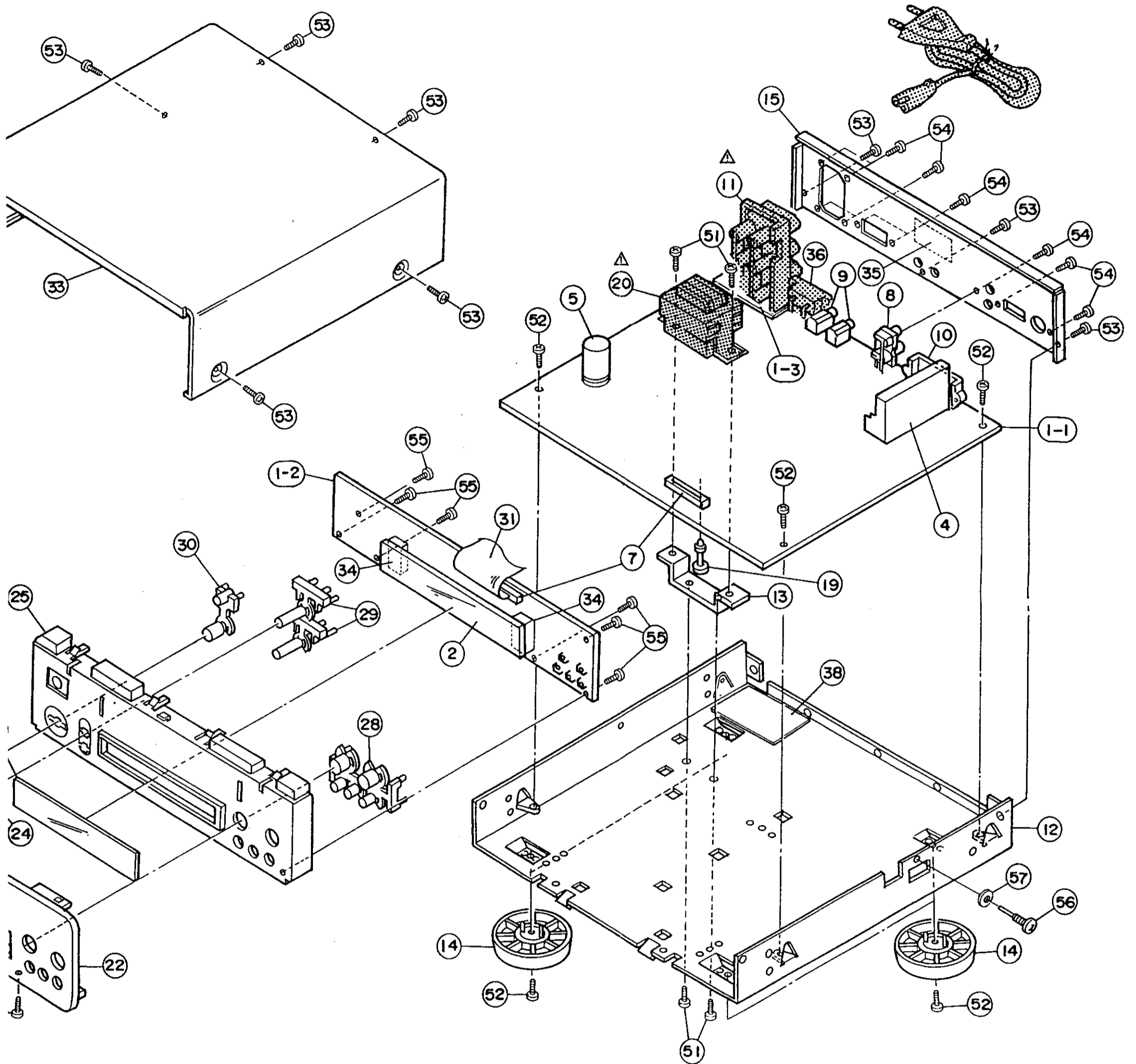

k and possibly to take a long period of time for supplying, or in some case

(i) to avoid mis-supplying.
 ot be supplied.
 n the exploded view.

racteristics.
 nufacturer.

REMOTE CONTROL UNIT (RC-172 : Part No. 399 0235 005)

• Schematic Diagram

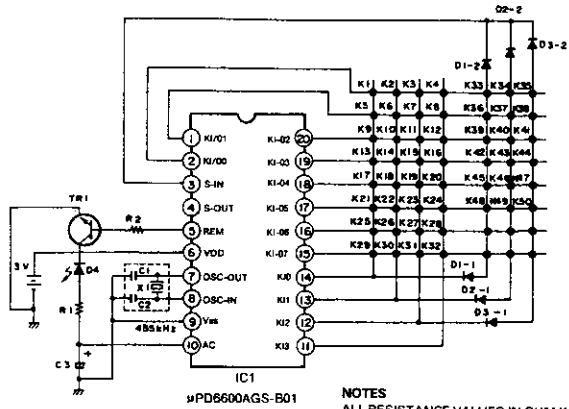

NOTES
 ALL RESISTANCE VALUES IN OHM K-1,000 OHM M-1,000,000 OHM
 ALL CAPACITANCE VALUES IN MICRO FARAD P-MICRO-MICRO FARAD
 EACH VOLTAGE AND CURRENT ARE MEASURED AT NO SIGNAL INPUT CONDITION.
 CIRCUIT AND PARTS ARE SUBJECT TO CHANGE WITHOUT PRIOR NOTICE.

• IC Block Diagram

μPD6600AGS-B01
 Pin Connections Diagram (Top View)

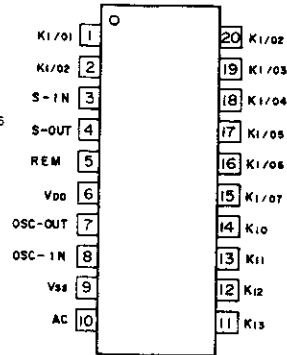

- X1 : CSB455E1
- TR1 : 2SD1781KR or 2SC3265 or 2SD596
- D1 ~ 3 : DAP 202K or MA151WA
- D4 : SE3C3 or LN66
- R1 : 1ohm
- R2 : 220ohms
- C1, C2 : 100PF
- C3 : 100 μF/6.3V
- IC1 : μPF6600AGS

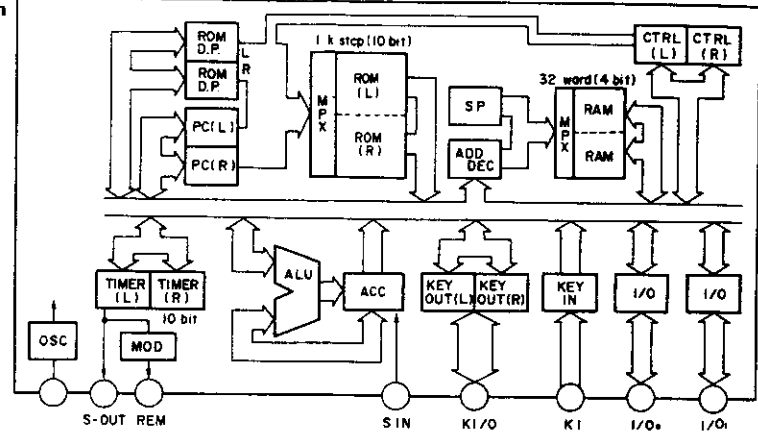

TUNER Mode

After sending the tuner (K5) key and immediately after inserting the batteries, K9 through K19 are to send the tuner number keys and the + number key codes.

Key No.	Address classify	System Address				Data Code					Expansion	Mask	Auto cancel	Registration code	Notes		
		C1	C2	C3	C4	C5	C6	C7	C8	C9						C10	C11
1	RECEIVER	0	0	1	1	0	0	0	0	0	1	0	1	0	0		POWER
2		0	0	1	1	0	1	1	1	1	0	1	0	0	0		FUNCTION (ROTARY)
3		0	0	1	1	0	1	0	1	0	0	1	0	0	0		VOL UP
4		0	0	1	1	0	1	0	1	0	1	0	0	0	0		VOL DOWN
5		0	0	1	1	0	0	1	0	0	1	1	0	0	0		SLEEP
6		0	0	1	1	0	1	1	1	1	0	0	1	0	0		PRESET DOWN
7		0	0	1	1	0	0	1	1	1	0	0	1	0	0		PRESET UP
8		0	0	1	1	0	1	0	0	1	1	0	1	0	0		TUNER
9		0	0	1	1	0	0	1	0	0	0	1	0	0	0		1
10		0	0	1	1	0	1	1	0	0	0	0	1	0	0		2
11		0	0	1	1	0	0	0	1	0	0	0	1	0	0		3
12		0	0	1	1	0	1	0	1	0	0	0	1	0	0		4
13		0	0	1	1	0	1	1	1	0	0	0	1	0	0		5
14		0	0	1	1	0	1	1	1	0	0	0	1	0	0		6
15		0	0	1	1	0	0	0	1	0	0	1	0	0	0		7
16		0	0	1	1	0	1	0	0	1	0	0	1	0	0		8
17		0	0	1	1	0	1	1	0	0	0	1	1	0	0		9
18		0	0	1	1	0	0	1	1	0	0	1	1	0	0		+10
19		0	0	1	1	0	1	1	1	1	0	1	1	0	0		BAND
20	TUNER	0	0	1	1	0	1	1	0	1	0	1	0	0	0		TUNING DOWN
21		0	0	1	1	0	0	1	0	1	1	0	1	1	0		TUNING UP
22		0	0	1	1	0	1	0	0	1	1	0	1	1	0		RDS
23		0	0	1	1	0	0	1	0	0	1	0	1	1	0		PTY
24		0	0	1	1	0	0	1	0	1	0	1	1	1	0		CT (D/T)
25		0	0	1	1	0	1	1	0	0	1	1	1	0	0		PANEL
26		0	0	1	1	0	0	1	1	1	1	1	1	1	0		PRESET MEMORY
27		0	0	1	1	0	1	0	0	0	1	0	1	1	0		DIRECT
28	CD	0	0	0	1	0	1	1	1	1	0	1	0	1	0		PROGRAM
29		0	0	0	1	0	1	0	1	1	0	1	0	0	0		CANCEL (CLEAR)
30		0	0	0	1	0	1	0	0	0	1	0	1	0	0		EDIT (TIME DEIT)
31		0	0	0	1	0	0	0	0	0	1	1	1	0	0		TIME/SIDE A, B
32		0	0	0	1	0	1	1	0	0	1	0	1	0	0		AUTO SEARCH (P)
33		0	0	0	1	0	0	0	0	0	1	0	1	0	0		AUTO SEARCH (R)
34		0	0	0	1	0	1	0	0	1	1	0	1	0	0		MANU SEARCH (P)
35		0	0	0	1	0	0	1	0	1	1	0	1	0	0		MANU SEARCH (R)
36		0	0	0	1	0	1	1	0	1	1	0	1	0	0		PLAY
37		0	0	0	1	0	0	0	1	1	1	1	0	0	0		STOP
38		0	0	0	1	0	0	1	1	1	1	0	1	0	0		REPEAT
39		0	0	0	1	0	0	0	1	0	1	0	1	0	0		RANDOM
40		0	0	0	1	0	0	1	0	1	0	1	1	0	0		

CD Mode

After sending the direct (K28) or program (K29) key, K9 through K19 are to send the CD number keys and the + number key codes.

Key No.	Address classify	System Address				Data Code					Expansion	Mask	Auto cancel	Registration code	Notes		
		C1	C2	C3	C4	C5	C6	C7	C8	C9						C10	C11
41	DECK	0	0	1	0	0	0	0	1	0	1	0	1	0	0		RANDOM
42		0	0	1	0	0	1	1	1	0	1	0	1	0	0		R. PLAY (DECK A)
43		0	0	1	0	0	1	0	1	0	1	1	0	1	0		FF (DECK A)
44		0	0	1	0	0	1	1	0	1	1	0	1	0	0		REW (DECK A)
45		0	0	1	0	0	0	1	1	1	0	1	0	0	0		PLAY (DECK A)
46		0	0	1	0	0	0	1	1	1	1	0	1	0	0		STOP (DECK A)
47		0	0	1	0	0	1	1	1	1	1	0	1	0	0		REC/REC MUTE (A)
48		0	0	1	0	0	0	0	0	0	0	1	1	0	0		TAPE SIZE
49		0	0	1	0	0	0	1	0	0	0	1	1	0	0		REV MODE
50		0	0	1	0	0	0	0	1	0	1	1	1	0	0		REMAIN

• Transistors

- 2SD1781KR
- 2SC3265
- 2SD596



• Diodes

- Infrared LED SE303
- LN66
- DAP202K MA151WA



Cathode (Short) Anode (Long)



PRE-MAIN AMP. SECTION

BLOCK DIAGRAM

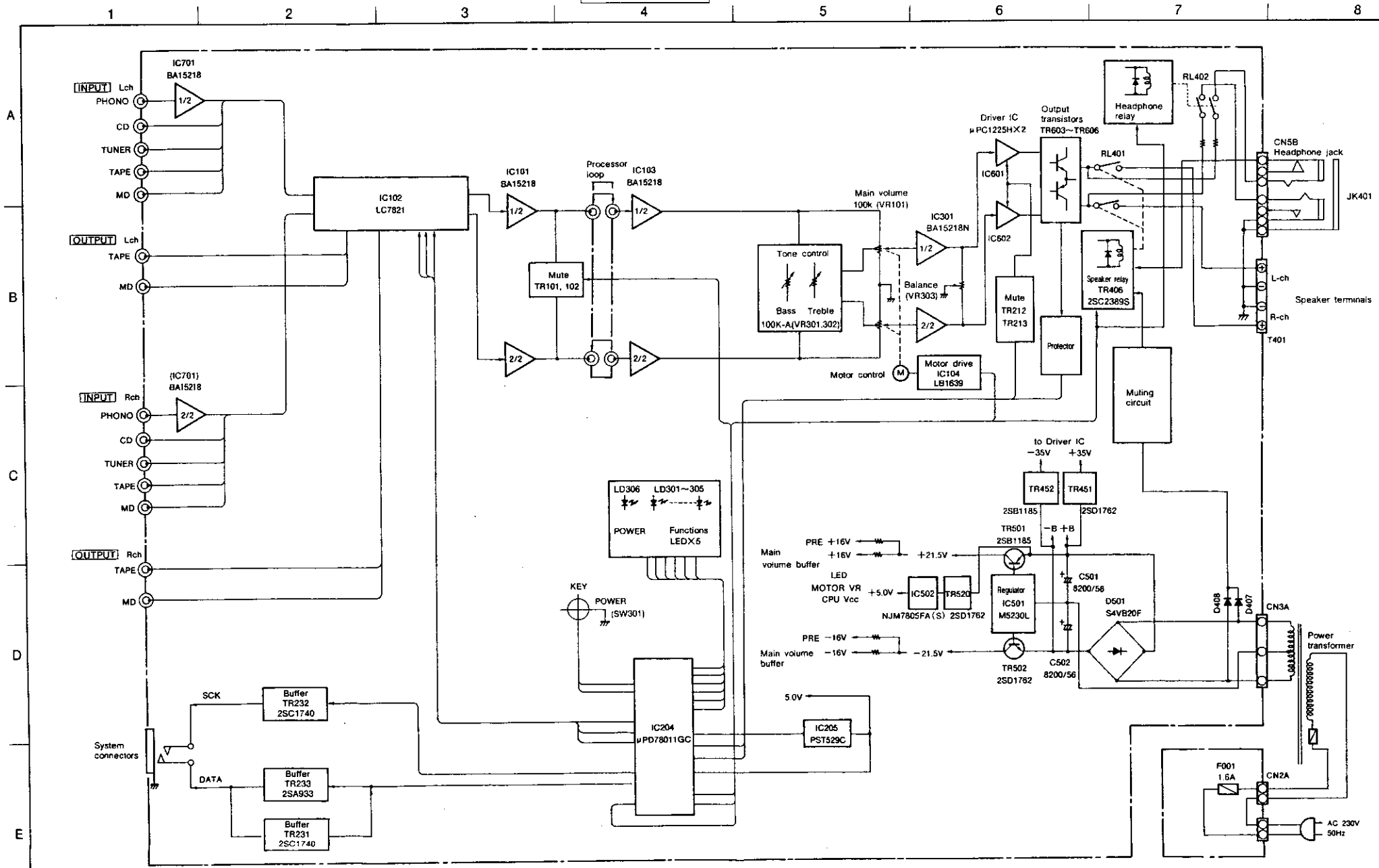

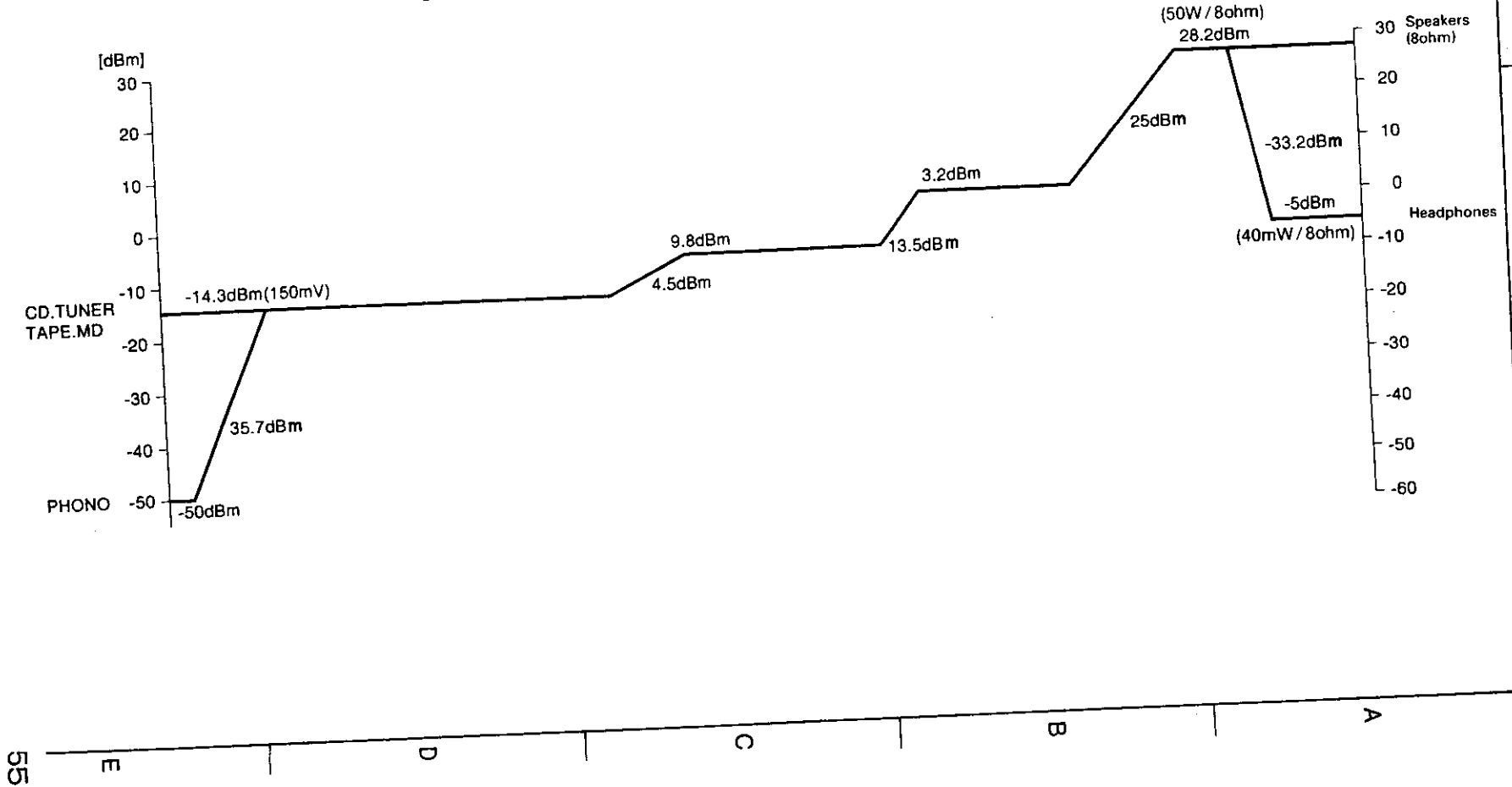
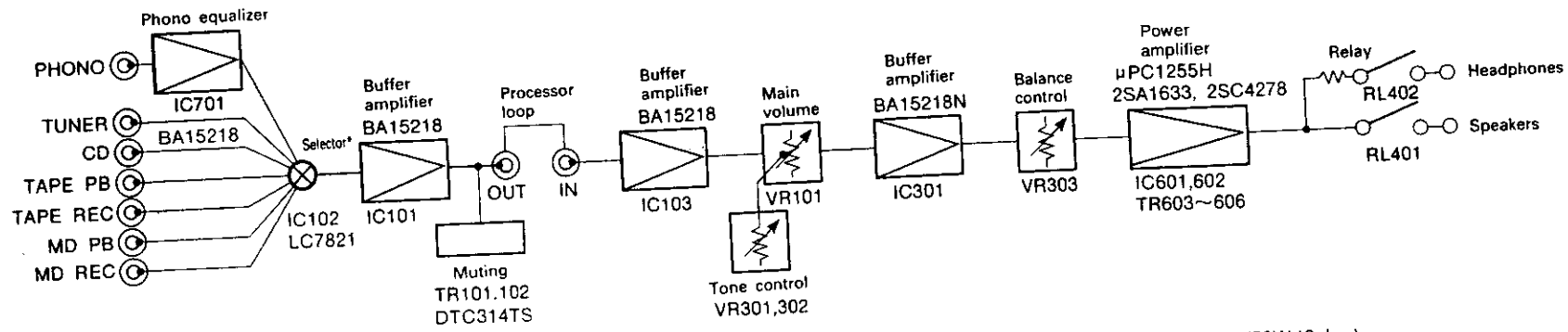

LEVEL DIAGRAM

PRE-MAIN AMP. SECTION

D-F-10

55

PRE-MAIN AMP. SECTION

DISASSEMBLY PROCEDURES

(Assembly is performed in the reverse order.)

1. Removing the Top Cover and the Front Panel

- ① Remove the six screws which fasten the top cover.
- ② Remove the top cover (upward) in the direction of the arrow.

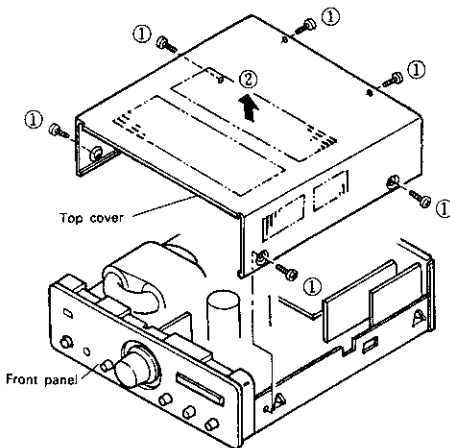

- ③ Remove the two screws which fasten front panel.
- ④ Release the inner panel hooks from the chassis while pulling the panels in the direction of the arrow to remove the inner panel and the front panel as one unit.

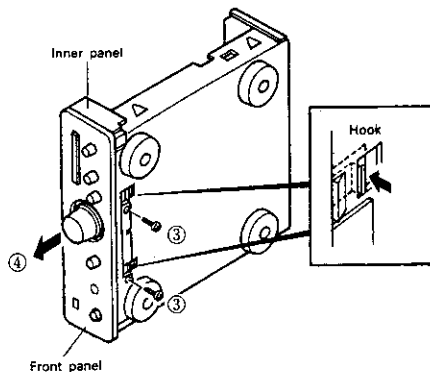

2. Removing the Units

Main Volume Unit (2U-2688B-4)

- ⑤ Remove the main volume control assembly in the direction of the arrow, and remove the nut which fastens the main volume unit.

Switch Unit (1) (2U-2688B-1)

- ⑥ Remove the six screws which fasten switch unit (1).

Headphone Unit (2U-2688B-3)

- ⑦ Remove the screw which fastens the headphone unit.

Remocon Unit (2U-2688B-2) and Switch Unit (2) (2U-2688B-5)

- ⑧ Remove the two screws which fasten remocon unit and switch unit (2).

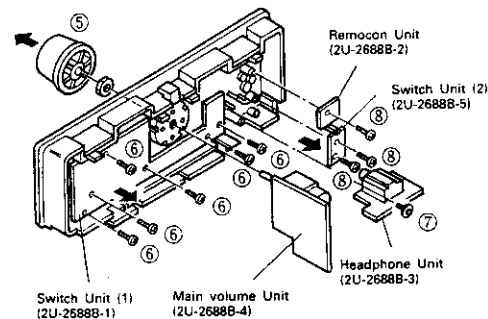

3. Removing the Rear Panel

- ⑨ Remove the cord bush from the rear panel.
- ⑩ Remove the two shorting pins.
- ⑪ Remove the three "a" screws and the nine "b" screws which fasten the rear panel.
- ⑫ Remove the rear panel in the direction of the arrow.

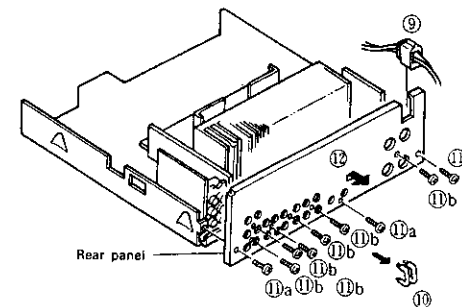

Processor Unit (2U-2687B-3)

- ⑬ Disconnect the processor unit from the connector and remove in the direction of the arrow.

Input Unit (2U-2687B-2)

- ⑭ Disconnect the input unit from the connector and remove in the direction of the arrow.

AC Input Unit (2U-2687B-5)

- ⑮ Disconnect the AC input unit from the connector and remove in the direction of the arrow.

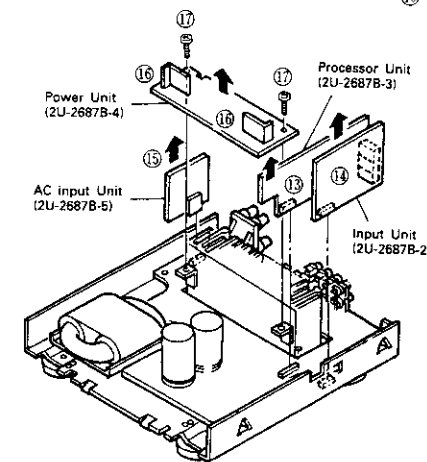

Power Unit (2U-2687B-4)

- ⑯ Remove the solder from the four power transistors.
 - ⑰ Remove the two screws which fasten the power unit.
- NOTE:** Perform this after removing the power radiator.

Main Unit (2U-2687B-1)

- ⑱ Remove the four screws which fasten the power radiator, then remove the power radiator.
- ⑲ Remove the single "a", "b", and "c" screws which fasten the main unit.

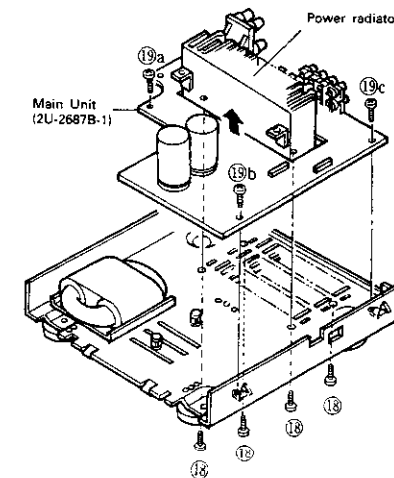

PRE-MAIN AMP. SECTION

ADJUSTMENTS

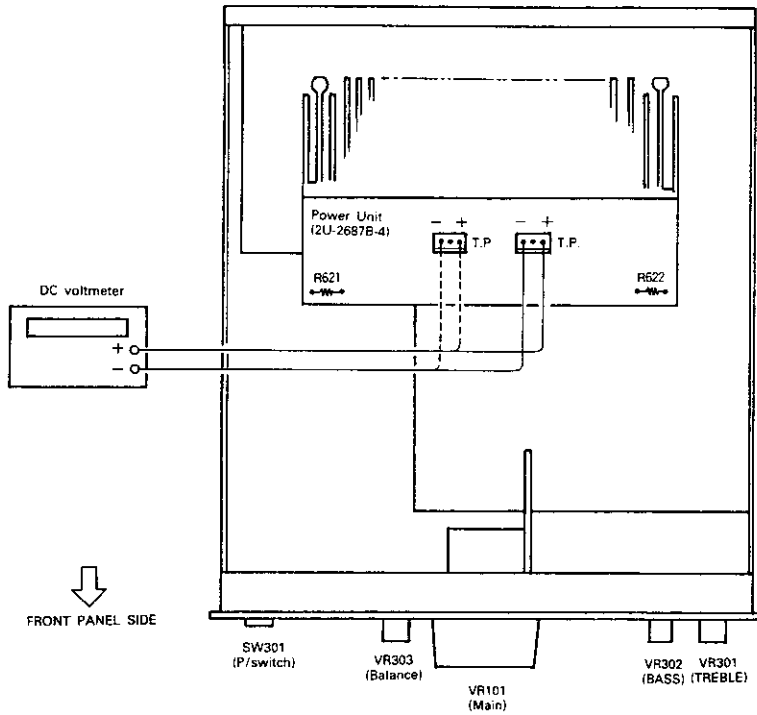

1. Measuring Instruments Required for the Adjustments

- DC voltmeter

2. Preparation

- Place the set in a location having normal usage conditions and avoid places with strong drafts such as near coolers or fans. The operating temperature of the set should be between 15 and 30°C and the humidity should be normal.
- Set the switches of the set as follows:
 - POWER switch → ON (▲)
 - SPEAKER terminals → No load (Do not connect speakers or dummy resistors)
 - INPUT terminals → No input

• Adjustments

- Remove the top cover and connect the DC voltmeter to the test points of the power unit (2U-2687B-4).
- Connect the power cable to a 230 V AC source and set the power switch to "ON (▲)."
- After 10 minutes, read the voltmeter and check that the reading is in the range of 2 mV to 40 mV (DC).
- When the value read from the voltmeter is 2 mV or less, cut R621 and R622 (2 kohm) shown in the above diagram.

SEMICONDUCTORS

PRE-MAIN AMP. SECTION

• IC's

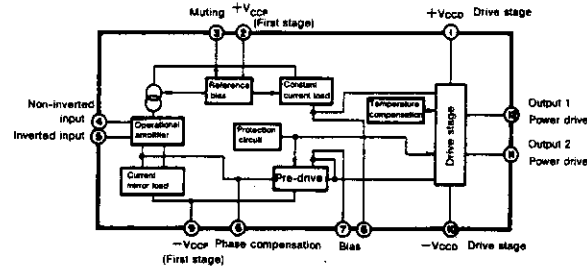
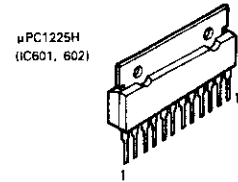

Pin Connections

Pin No.	Connection
1	+V _{CCD} (drive stage power supply)
2	+V _{CCP} (pre-drive stage power supply)
3	MUTING
4	INPUT (non-inverting)
5	NFB (inverting)
6	PHASE COMP
7	BIAS
8	BIAS
9	-V _{CCP} (drive stage power supply)
10	-V _{CCD} (pre-drive stage power supply)
11	LOWER OUTPUT
12	UPPER OUTPUT

LC7821 (IC102)

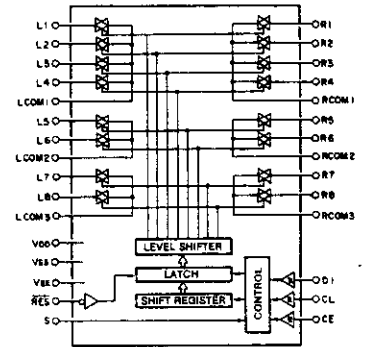
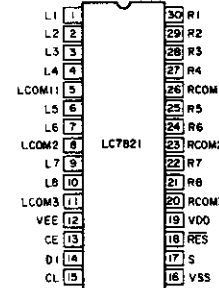
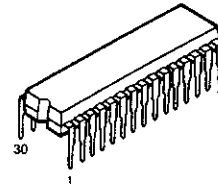

M5230L (IC501)

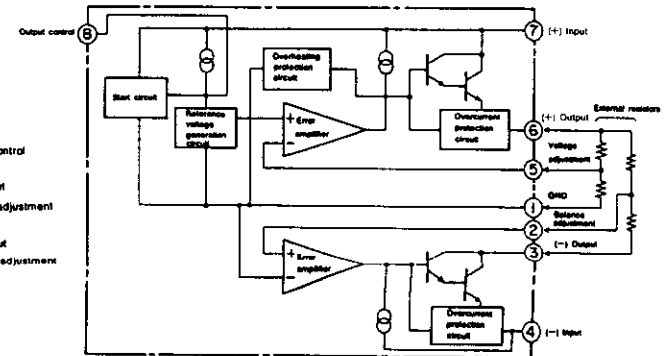
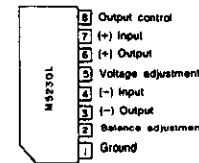

PRE-MAIN AMP. SECTION

PRE-MAIN AMP. SECTION

LB1639
(IC104)

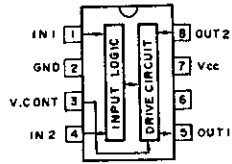
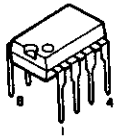

BA15218
(IC101, 103, 701)

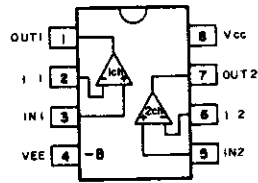
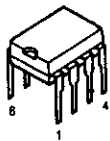

NJM7805FA (S)
(IC502)

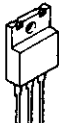

Output
GND
Input

BA15218N
(IC301)

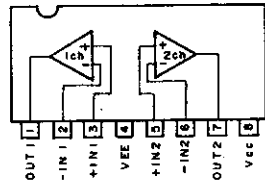
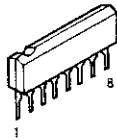

PST529C
(IC205)

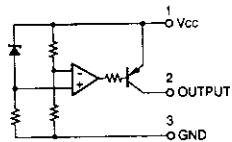

IC Protector

ICP-N15 (IC503, 504, 520)

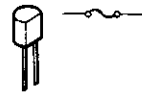

Transistors

2SA1038 (S/E)

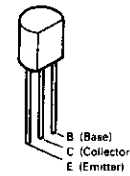

B (Base)
C (Collector)
E (Emitter)

2SA933S (S)
2SC1740S (E)
2SC2389 (S/E)
2SD2144 (U)

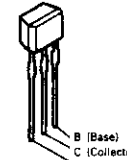

B (Base)
C (Collector)
E (Emitter)

2SB1185 (E/F)
2SD1782 (E/F)

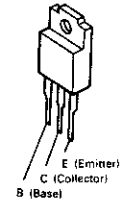

E (Emitter)
C (Collector)
B (Base)

DTA144ES PNP Type
DTC144ES } NPN Type
DTC314TS

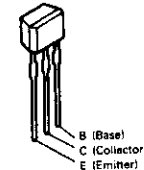

B (Base)
C (Collector)
E (Emitter)

PNP Type

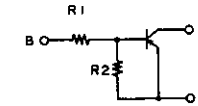

	R1	R2
DTA144ES	47 kohm	47 kohm

NPN Type

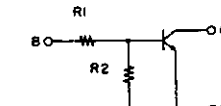

	R1	R2
DTA144ES	47 kohm	47 kohm
DTC314TS	10 kohm	-

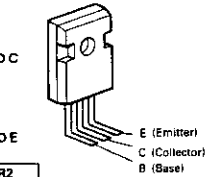

2SA1633 (E/F) (TR605, 606)
2SC4278 (E/F) (TR605, 606)

Diodes (including LED)

1SS252

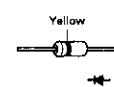

Yellow

HZS8C-1
HZS9B-1
HZS1B-1

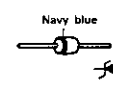

Navy blue

1SR35-200A



Blue

S4VB20F
(D501)

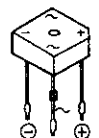

SF0R1A42
(SR401)

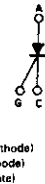
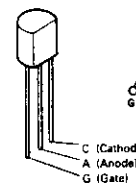

SEL4914D
(LD306)

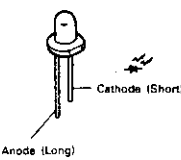

Cathode (Short)
Anode (Long)

SEL4917D
(LD301~305)

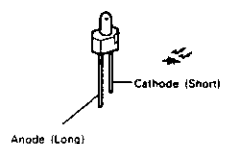

Cathode (Short)
Anode (Long)

Infrared Remote Control Sensor

RPM-638CBB-L
(IC302)

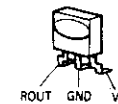

ROUT GND Vcc

PRE-MAIN AMP. SECTION

MICROPROCESSOR DOCUMENTATION

μPD78011GC-625-AB8 : 262 1964 002
(IC204)

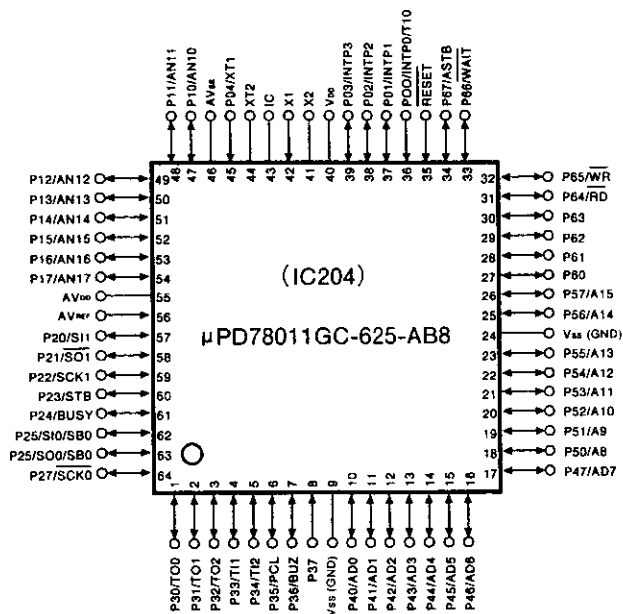
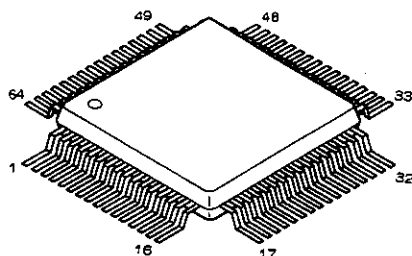

PRE-MAIN AMP. SECTION

• Pin Description (Ini: Initial Condition, ACT: Active)

No.	Port Name	Function Name	I/O	Ini	ACT	Function
1	P30/TO0	NC	O	L	-	Open, fixed at 5 V internally.
2	P31/TO1	NC	O	L	-	Open, fixed at 5 V internally.
3	P32/TO2	NC	O	L	-	Open, fixed at 5 V internally.
4	P33/TO1	NC	O	L	-	Open, fixed at 5 V internally.
5	P34/TO2	NC	O	L	-	Open, fixed at 5 V internally.
6	P35/PCL	NC	O	L	-	Open, fixed at 5 V internally.
7	P36/BUZ	NC	O	L	-	Open, fixed at 5 V internally.
8	P37	NC	O	L	-	Open, fixed at 5 V internally.
9	GND	GND	-	-	-	0 V: digital ground
10	P40/AD0	NC	O	L	-	Open, fixed at 5 V internally.
11	P41/AD1	NC	O	L	-	Open, fixed at 5 V internally.
12	P42/AD2	NC	O	L	-	Open, fixed at 5 V internally.
13	P43/AD3	NC	O	L	-	Open, fixed at 5 V internally.
14	P44/AD4	NC	O	L	-	Open, fixed at 5 V internally.
15	P45/AD5	NC	O	L	-	Open, fixed at 5 V internally.
16	P46/AD6	NC	O	L	-	Open, fixed at 5 V internally.
17	P47	NC	O	L	-	Open, fixed at 5 V internally.
18	P50	NC	O	L	-	Open, fixed at 5 V internally.
19	P51	NC	O	L	-	Open, fixed at 5 V internally.
20	P52	NC	O	L	-	Open, fixed at 5 V internally.
21	P53	NC	O	L	-	Open, fixed at 5 V internally.
22	P54	MDLED	O	H	L	LED lights when MD LED drive is low
23	P55	Phn LED	O	H	L	LED lights when Phono LED drive is low
24	GND	GND	-	-	-	0 V: digital ground
25	P56	Tuner LED	O	H	L	LED lights when Tuner LED drive is low
26	P57	Tape LED	O	H	L	LED lights when Tape LED drive is low
27	P60	CD LED	O	H	L	LED lights when CD LED drive is low
28	P61	Pwr LED	O	H	L	LED lights when Power Indicator LED drive is low
29	P62	VI Down	O	H	L	There is drive when Volume Down is low
30	P63	VI Up	O	H	L	There is drive when Volume Up is low
31	P64	Power Sw	I	H	L	Power On/Off switch: Active low
32	P65	Func Sw	I	-	L	Function switch: Active low
33	P66	TEST	I	-	L	Test mode is set when the level is 0 V immediately after reset cancellation
34	P67	MUTE	O	L	H	Speaker relay is switched off at high level. Sound is muted.
35	RESET	RESET	I	-	L	Reset input
36	PO0/INTP0	REMOCON	I	-	L	Remote control signal input
37	PO1/INTP1	RXD	I	-	L	DENON BUS input signal: Connects in parallel with pin 62
38	PO2/INTP2	PROTECT	I	-	L	Overcurrent detection signal input (Not used with interrupts)
39	PO3/INTP3	NC	O	HZ	-	Fixed at open 0 V.
40	VDD	5 V	-	-	-	Digital 5 V
41	X2	XTAL out	O	-	-	Crystal oscillator output
42	X1	XTAL in	I	-	-	Crystal oscillator input
43	IC	IC	-	-	-	Connected inside microprocessor. Connects to GND.
44	X12	NC	O	-	-	Fixed at open 0 V.
45	PO4/XT1	GND	I	-	-	Connects to GND.
46	AV _{SS}	0 V	-	-	-	0 V: digital ground
47	P10/AN0	NC	I	-	-	Open
48	P11/AN1	NC	I	-	-	Open
49	P12/AN2	NC	I	-	-	Open
50	P13/AN3	NC	I	-	-	Open
51	P14/AN4	NC	I	-	-	Open
52	P15/AN5	NC	I	-	-	Open
53	P16/AN6	FUNC	I	-	-	Open
54	P17/AN7	POWER	I	-	-	Open
55	AV _{DD}	5 V	-	-	-	Digital 5 V
56	AV _{REF}	5 V	-	-	-	Digital 5 V
57	P20/SI1	GND	I	-	-	0 V: digital ground
58	P21/SO1	DT78	O	-	H	Serial output data to IC7821
59	P22/SCK1	CK78	O	H	-	Serial output clock to IC7821
60	P23	CE78	O	L	H	Chip enable to IC7821. A pull-down resistor is attached externally to guarantee the operation at the time of output reset.
61	P24	NC	O	L	L	Fixed at open 0 V.
62	P25/SI0	RXD	O	L	L	DENON BUS communications data input
63	P26/SO0	TXD	O	H	L	DENON BUS communications data output
64	P27/SCK0	SBCLK	O	L	H	DENON BUS communications data clock

PRE-MAIN AMP. SECTION

MICROPROCESSOR PERIPHERAL WIRING DIAGRAM

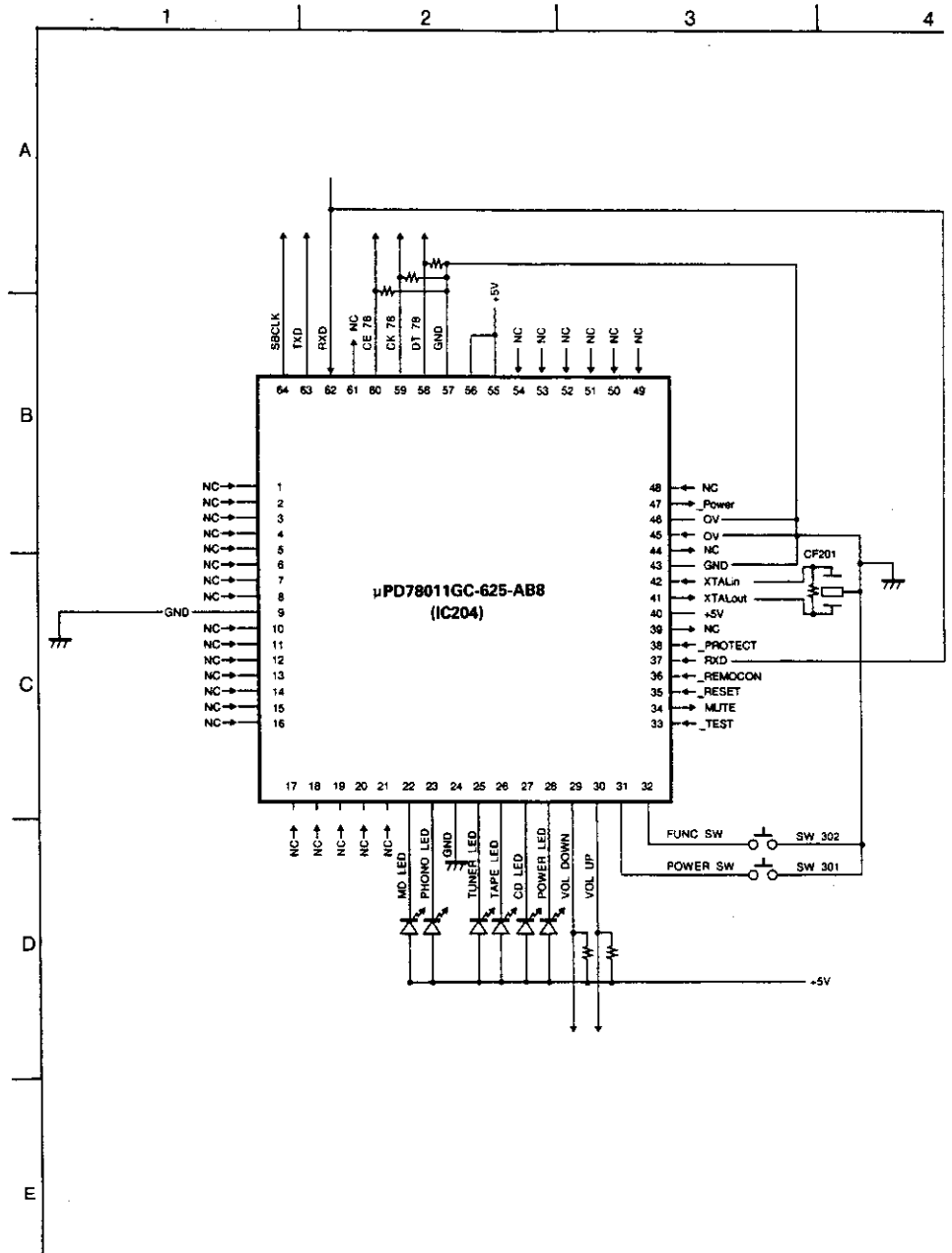

PRINTED WIRING BOARD

PRE-MAIN AMP. SECTION

1 2 3 4 5 6 7 8

UPA-F10 2U-2688B SWITCH UNIT ASS'Y

2U-2688B	
-1	Switch Unit (1)
-2	Remocon Unit
-3	Headphone Unit
-4	Volume Unit
-5	Switch Unit (2)

Component Side

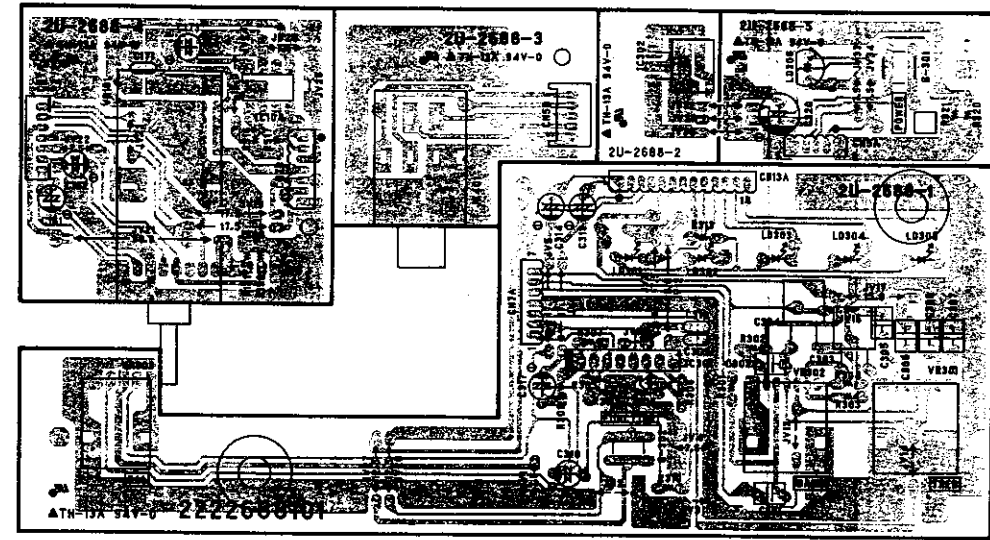

Pattern Side

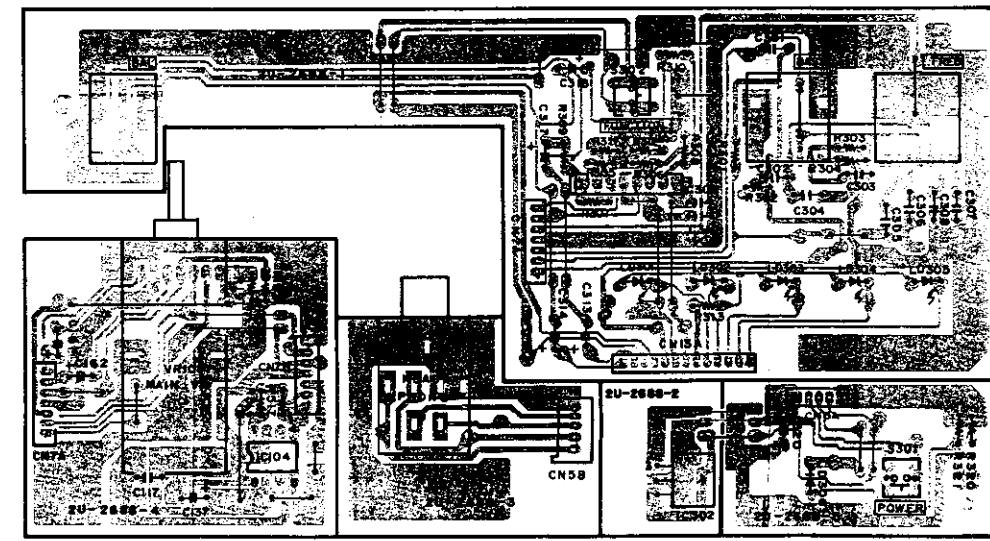

A
B
C
D
E

PRE-MAIN AMP. SECTION

1

2

3

4

5

6

7

8

UPA-F10 2U-2687B MAIN UNIT ASSY

Component Side

2U-2687B	
-1	Main Amp. Unit
-2	Input Unit
-3	Processor Unit
-4	Power Unit
-5	AC Input Unit

A

B

C

D

E

66

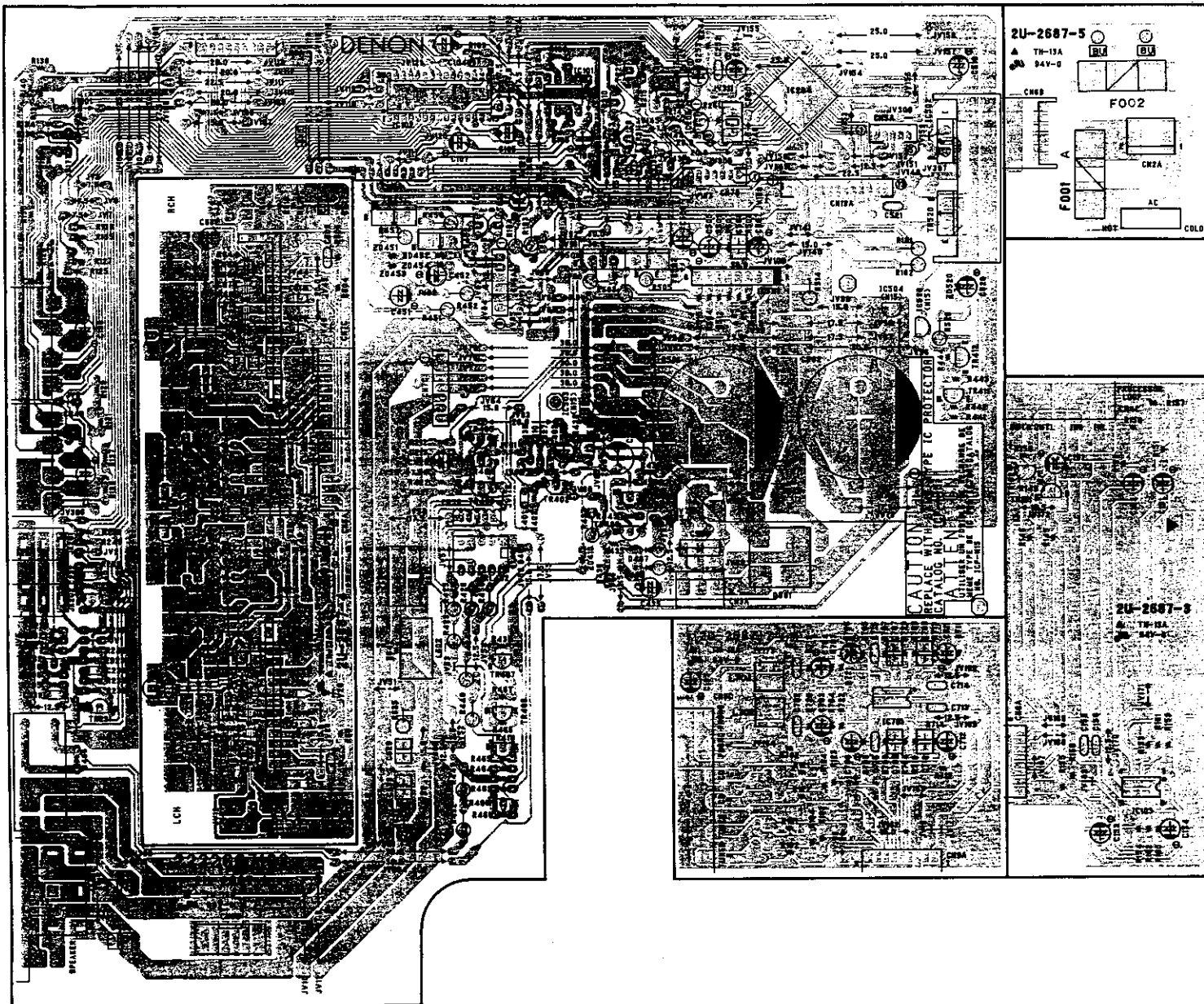

PRE-MAIN AMP. SECTION

Ref. No.	Part No.	Part Name	Remarks	Qty
C435	254 4263 945	Electrolytic 1µF/100V	CE04W2AD10M	2
C451,452	254 4262 917	Electrolytic 10µF/63V	CE04W1J100M	2
C501,502	254 4371 701	Electrolytic 8200µF/56V	CE04W--822MC (DL)	1
C505	254 4260 948	Electrolytic 1µF/50V	CE04W1H010M	1
C506,507	254 4260 980	Electrolytic 10µF/50V	CE04W1H100M	1
C508	255 1264 982	Mylar Film 0.0047µF/50V	CQ93M1H472J (B)	1
C509	256 1043 711	Metalized 0.47µF/250V	CF93B2E474K	1
C510	254 4254 912	Electrolytic 22µF/16V	CE04W1C220M	1
C520	254 4260 964	Electrolytic 3.3µF/50V	CE04W1H3R3M	1
C521	253 1196 902	Ceramic Cap. 0.01µF/25V	CK14F1E103Z	1
C605,606	253 1193 934	Ceramic Cap. 100pF/50V	CK14B1H101K	1
C607,608	254 4470 903	Electrolytic 100µF/6.3V	CE04WQJ101M (KME)	1
C613,614	253 1193 934	Ceramic Cap. 100pF/50V	CK14B1H101K	1
C615,616	253 4536 996	Ceramic Cap. 24pF/50V	CC45SL1H240J	1
C617,618	253 1196 902	Ceramic Cap. 0.01µF/25V	CK14F1E103Z	1
C619,620	254 4274 947	Electrolytic 10µF/16V	CE04W1C100* (KME)	2
C621,622	253 1126 901	Ceramic Cap. 150pF/500V	CK45B2H151K	1
C623,624	255 1265 994	Mylar Film 0.033µF/50V	CQ93M1H333J (B)	1
C625,626	254 4262 917	Electrolytic 10µF/63V	CE04W1J100M	1
C627,628	253 1175 907	Ceramic Cap. 0.022µF/25V	CK14F1E223Z	1
C629,630	256 1034 979	Metalized 0.1µF/50V	CF93A1H104J	1
C631,632	254 4262 917	Electrolytic 10µF/63V	CE04W1J100M	3
C653,654	254 4260 948	Electrolytic 1µF/50V	CE04W1H010M	1
C677,678	253 4535 955	Ceramic Cap. 5pF/50V	CC45SL1H050C	1
C701,702	253 1193 976	Ceramic Cap. 220pF/50V	CK14B1H221K	1
C703,704	254 4254 909	Electrolytic 10µF/16V	CE04W1C100M	1
C705,706	254 4250 932	Electrolytic 220µF/6.3V	CE04WQJ221M	1
C707,708	255 4199 999	Mylar Film 0.024µF/50V	CQ92M1H243J (MRZ)	1
C709,710	255 1265 907	Mylar Film 0.0068µF/50V	CQ93M1H682J (B)	1
C711,712	254 4260 951	Electrolytic 2.2µF/50V	CE04W1H2R2M	1
C713,714	253 1196 902	Ceramic Cap. 0.01µF/25V	CK14F1E103Z	1
C715,716	253 1191 917	Ceramic Cap. 470pF/50V	CK14SL1H471K	1
OTHER GROUP				Qty
		(P.W. Board)		(1)
L601,602	235 0104 007	Inductor 1µH		2
L701,702	235 9003 002	FTZ Choke Coil		2
CF201	399 0243 903	Ceramic Resonator C578.35M1W		1
RL401	214 0154 005	Relay (VB24SMBU)		1
RL402	214 0162 000	Relay (A12W-K)		1
JK101	204 8278 009	6P Pin Jack (S-GND)		1
JK102	204 8286 008	4P Pin Jack (S-GND)		1
JK103,104	204 8457 008	4P Pin Jack (S-GND)		2
JK201,202	204 8421 005	Mini Jack		2
T401	205 0551 002	4P Terminal		1
ΔF001	206 1016 058	Fuse 1.8A	20mm	1
	202 0022 008	Fuse Holder		2
	513 2277 049	Fuse Label		1
	417 0499 000	Heat Sink		2
	473 7002 018	Tapping Screw (S) 3x8		4
	417 0307 066	Heat Sink		1

2U-2688 B SWITCH UNIT ASS'Y PARTS LIST

Ref. No.	Part No.	Part Name	Remarks	Qty
SEMICONDUCTORS GROUP				
IC104	263 0476 002	IC LB1639		1
IC301	263 0606 005	IC BA15218N		1
IC302	499 0281 003	Photocon Sensor RPM-630C88-L		1
LD301~305	393 9420 910	LED SEL4917D	Red	1
LD306	393 9408 945	LED SEL4914D		1
RESISTORS GROUP (Not Included Carbon Film ±5% 1/4W Type. Refer to the Schematic Diagram for these Parts.)				
VR101	211 0825 005	Variable Resistor 100k ohm	Main Vol.	1
VR301,302	211 0822 008	Variable Resistor 100k ohm	Tone Vol.	1
VR303	211 0823 007	Variable Resistor 50k ohm	Balance Vol.	1
CAPACITORS GROUP				
C161,162	254 4260 948	Electrolytic 1µF/50V	CE04W1H010M	1
C171	253 1196 902	Ceramic Cap. 0.01µF/25V	CK14F1E103Z	1
C173	254 4254 938	Electrolytic 47µF/16V	CE04W1C470M	1
C301,302	255 1265 994	Mylar Film 0.033µF/50V	CQ93M1H333J (B)	1
C303,304	256 1035 004	Metalized 0.18µF/50V	CF93A1H184J	1
C305,306	255 1264 995	Mylar Film 0.0056µF/50V	CQ93M1H562J (B)	1
C307,308	255 1265 994	Mylar Film 0.033µF/50V	CQ93M1H333J (B)	1
C309,310	253 1196 902	Ceramic Cap. 0.01µF/25V	CK14F1E103Z	1
C313,314	254 4305 968	Electrolytic 1µF/50V	CE04W1H010M (SRE)	1
C317,318	254 4299 906	Electrolytic 10µF/16V	CE04W1C100M (SRE)	1
C320	254 4299 951	Electrolytic 33µF/16V	CE04W1C330M (SRE)	1
C323,324	253 1194 959	Ceramic Cap. 1000pF/50V	CK14B1H102K	1
OTHER GROUP				
		(P.W. Board)		(1)
S301,302	212 5604 910	Tact Switch		2
JK401	204 8420 006	Headphone Jack (6.5)		1
CN5B	205 0355 059	5P KR Conn. Base (L)		1
CN7A	205 0343 074	7P KR Conn. Base (KR-PH)		1
CN5A	203 8280 065	5P KR-DA Conn. Cord		1
CN7A	204 2513 032	7P KR-DA Conn. Cord		1
CN7B	204 2513 045	7P KR-DA Conn. Cord		1
CN13A	204 6269 049	13P KR-DA Conn. Cord		1
	461 0665 080	Rubber Sheet		1

PRE-MAIN AMP. SECTION

WIRING DIAGRAM

1 2 3 4 5 6 7 8

A

B

C

D

E

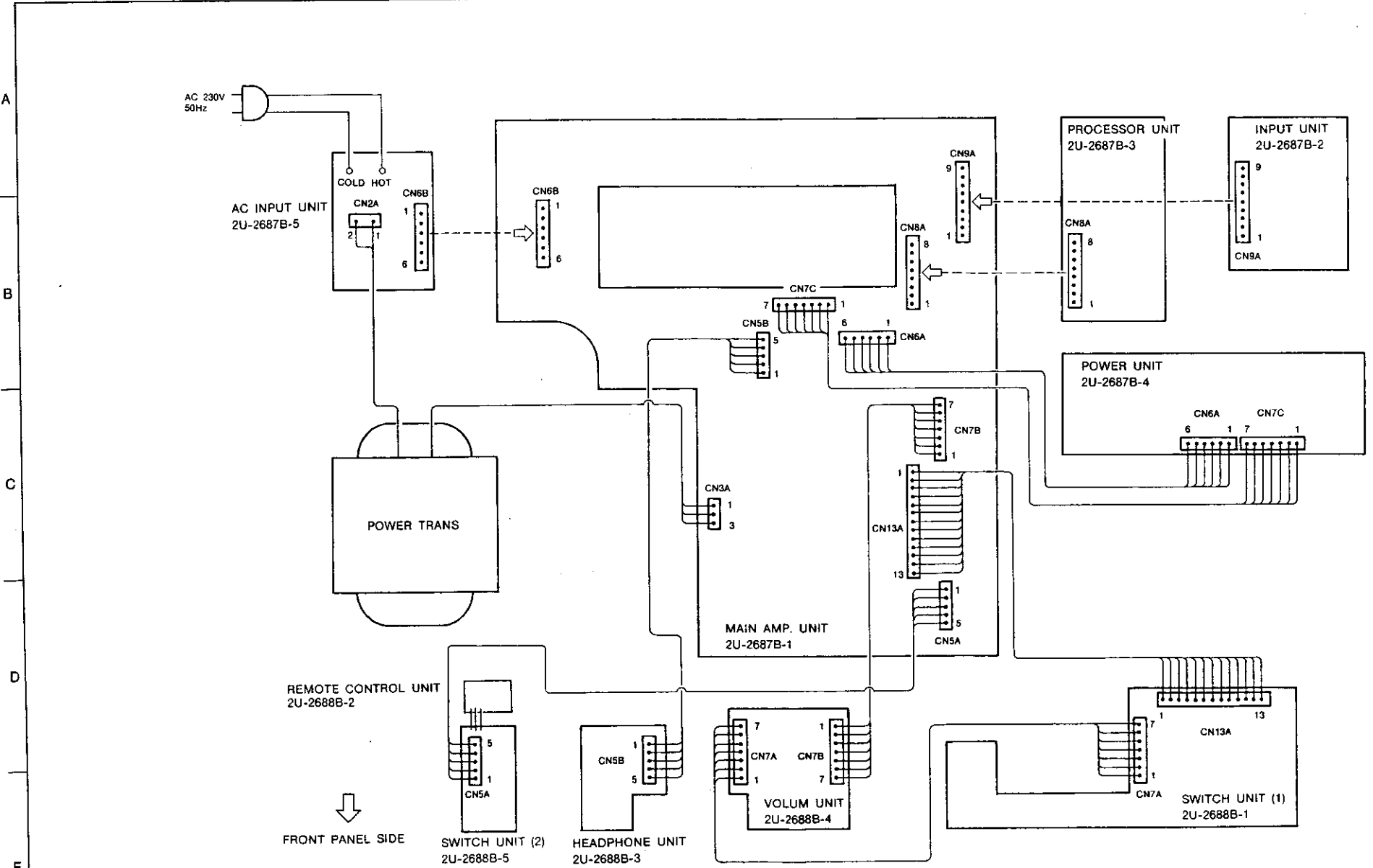

FRONT PANEL SIDE

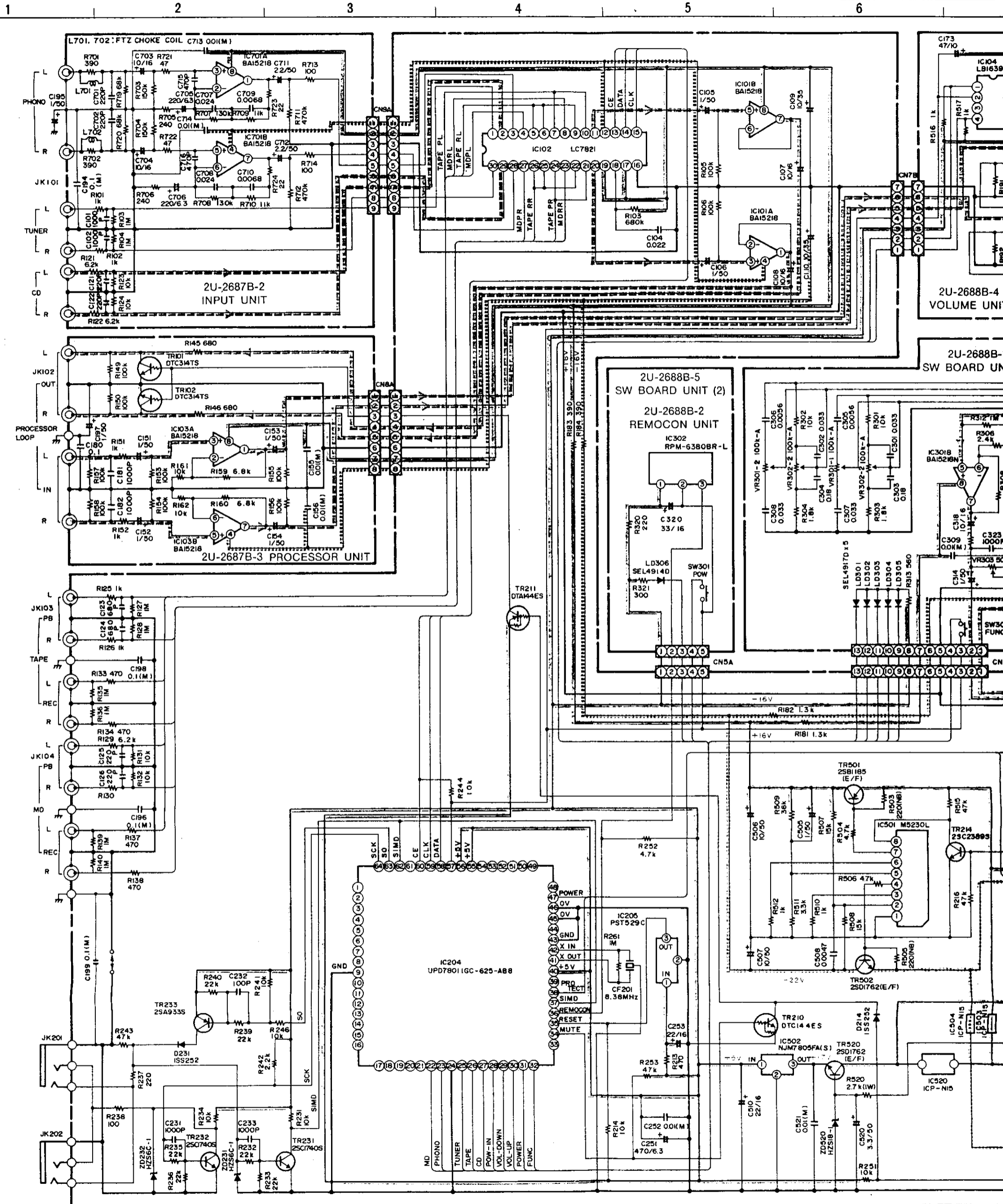

CAUTION:
Before returning the unit to the customer, make sure you make either (1) a leakage current check or (2) a line to chassis leakage current check. If the leakage current exceeds 0.5 milliamps, or if the resistance from chassis to either side of the power cord is less than 100,000 ohms, the unit is defective.

WARNING:
DO NOT return the unit to the customer until the problem is located and corrected.

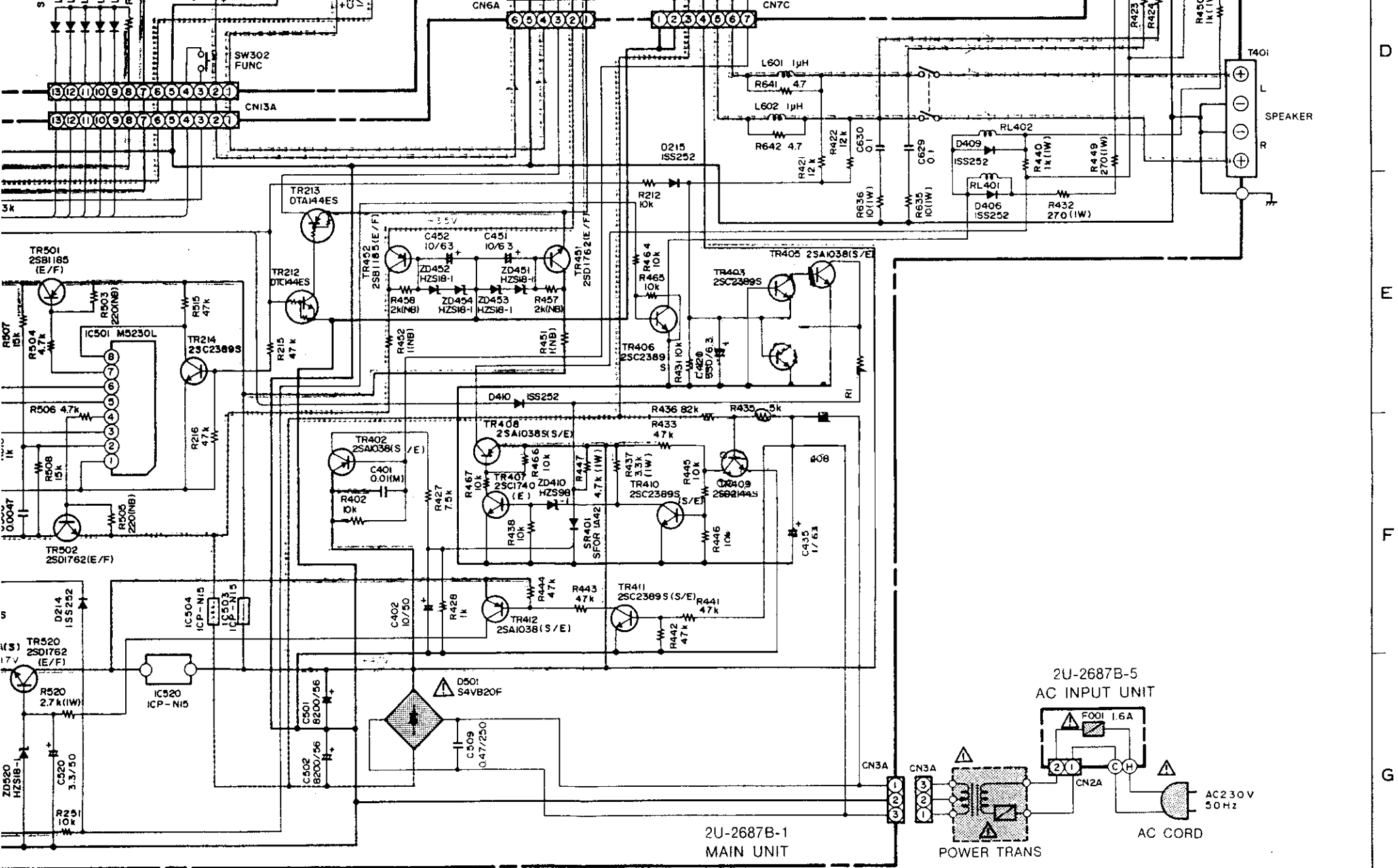

either (1) a leakage current check or (2) a line to chassis resistance check. If the chassis to either side of the power cord is less than 240 Kohms, the unit is

ated and corrected.

WARNING:
 Parts marked with this symbol have critical characteristics. Use ONLY replacement parts recommended by the manufacturer.

NOTES
 ALL RESISTANCE VALUES IN OHM K=1,000 OHM M=1,000,000 OHM
 ALL CAPACITANCE VALUES IN MICRO FARAD P=MICRO-MICRO FARAD
 EACH VOLTAGE AND CURRENT ARE MEASURED AT NO SIGNAL INPUT CONDITION.
 CIRCUIT AND PARTS ARE SUBJECT TO CHANGE WITHOUT PRIOR NOTICE.

D
E
F
G
H

PRE-MAIN AMP. SECTION

EXPLODED VIEW

PARTS LIST OF UPA-F10 EXPLODED VIEW

Ref. No.	Part No.	Part Name	Remarks	Qty
1	2U- 2687 B	Main Unit Assy		1 ^S
1-1	—	Main Unit		(1)
1-2	—	Input Unit		(1)
1-3	—	Processor Unit		(1)
1-4	—	Power Unit		(1)
1-5	—	AC IN Unit		(1)
2	214 0154 005	Relay (VB24SMBU)	RL401	1
3	254 4371 701	Chemicon 8200µF/56V	C501,502	2
4	417 0499 000	Heat Sink		2
5	417 0307 066	Heat Sink		1
6	204 8421 005	Mini Jack	JK201,202	2
7	204 8420 006	Headphone Jack	JK401	1
8	211 0825 005	Variable Resistor 100k ohm	VR101 Main Volume	1
9	204 8266 008	4P Pin Jack (S-GND)	JK102	1
10	204 8457 008	4P Pin Jack (S-GND)	JK103,104	2
11	204 8278 009	6P Pin Jack (S-GND)	JK101	1
12	205 0551 002	4P Terminal	T401	1
13	206 1015 058	Fuse 1.6A	F001	1
14	2U- 2688 B	Switch Unit Assy		1 ^S
14-1	—	Switch Unit (1)		(1)
14-2	—	Remocom Unit		(1)
14-3	—	Headphone Unit		(1)
14-4	—	Volume Unit		(1)
14-5	—	Switch Unit (2)		(1)
15	211 0822 008	Variable Resistor 100k ohm	VR301,302 Tone	2
16	211 0823 007	Variable Resistor 50k ohm	VR303 Balance	1
17	411 1224 315	Main Chassis		1
18	412 3782 007	Trans Bracket		1
19	GEN2798	Foot Ass'y		4
20	412 3548 005	P.W.B. Catcher	H=10	4
21	412 2814 028	Card Spacer (L=10)	H=10	1
22	417 0496 003	Power Radiator		1
23	271 0276 009	Transistor 2SA1633 F31 (E/F)	TR605,606	2
24	273 0430 003	Transistor 2SC4278 F31 (E/F)	TR603,304	2
25	415 0234 007	Insulating Sheet		4
26	412 3829 009	P.W.B. Bracket (A)		2
27	105 1110 016	Rear Panel (Amp.)		1
28	206 2063 009	AC Cord with Plug		1
29	445 0056 008	Cord Bush		1
30	205 0071 016	Terminal Ass'y	GND	1
31	477 0018 001	Washer (P-87)		1
32	233 6094 005	Power Trans		1
33	144 2362 004	Front Panel (Amp.)		1
34	146 1482 208	Knob Ring (C)		1
35	146 9294 100	Knob Ring (A)		1
36	146 9295 109	Knob Ring (B)		1
37	146 1480 404	Inner Panel (Amp.)		1
38	143 0873 107	Lens (5 Gang)		1
39	113 1656 005	Tact Button (1 Key)		1
40	113 1654 104	Power Button Ass'y		1
41	112 0743 000	Knob (Round)		3
42	112 0741 002	Main Volume Kob Ass'y		1
43	445 0033 005	Wire Clamp Band		3
44	205 0752 005	Short Pin		2
45	102 0545 133	Top Cover		1
46	—	—		—
47	499 0281 003	Remocn Sensor	RPM-638CBR-L	1
48	214 0162 000	Relay (A12W-K)	RL402	1
49	143 0874 106	Remocon Window		1
50	146 1483 100	Lens Guide		1
51	143 0876 104	Lens		1
52	513 2240 005	Rating Sheet		1
53	412 3838 003	Headphone Bracket		1
54	414 0725 102	Main VR. Shield		1
55	—	—		—
56	—	—		—
57	—	—		—
SCREWS				
71	473 7004 003	Tapping Screw (S) 4×8		8
72	473 7002 018	Tapping Screw (S) 3×8		7
73	473 7508 046	Tapping Screw (P) 3×16	Black	1
74	473 8007 009	Cup Screw 3×12		4
75	473 7015 018	Tapping Screw (S) 3×8	Black	17
76	477 0064 107	Fixing Screw		6
77	473 7505 007	Tapping Screw (P) 2.6×8		9
78	477 0262 006	Special Screw		2
79	473 7003 020	F.H. Tapping Screw (S) 3×6		2
80	—	—		—
PACKING & ACCESSORIES (Not included EXPLODED VIEW)				
101	505 0102 089	Stylen Paper	700×700	1
102	503 1077 104	Cushion		1
103	GEN2738	Envelope Sub. Ass'y		1 ^S
103-1	505 8006 019	Envelope		(1)
103-2	399 0235 005	Remote Control	RC-172	(1)
103-3	—	Batterise	R06P/AA/UM-3	(2)
103-4	511 2614 004	Inst. Manual	E,G,F,IT	(1)
103-5	511 2615 003	Inst. Manual	ES,NL,S.PO	(1)
104	503 1075 203	Top Cushion		1
105	501 1780 000	Carton Case		1

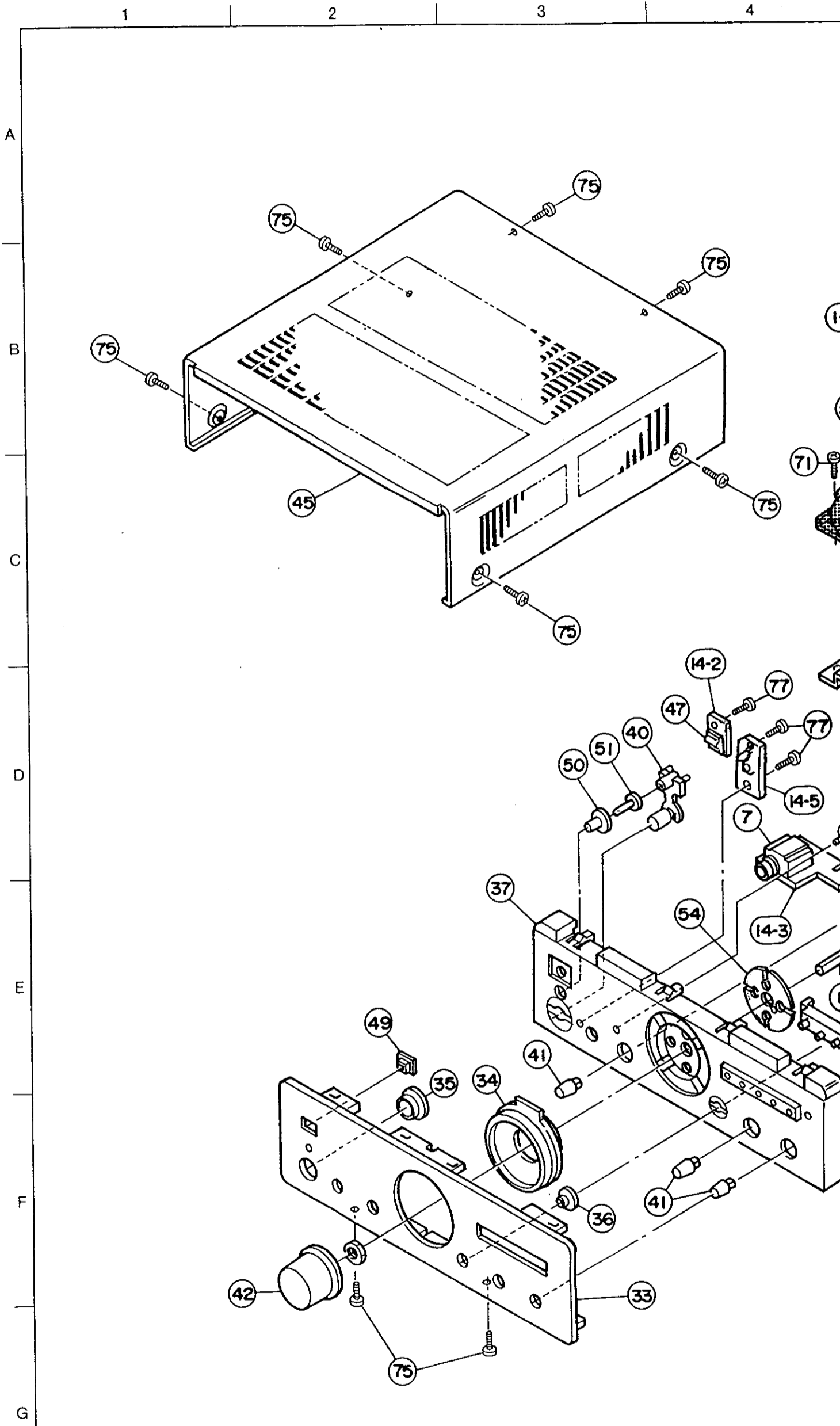

NOTE ON PARTS LIST

- Part indicated with the mark "●" are not always in stock and possibly to take a long period of time for supplying, or in some case supplying of part may be refused.
- When ordering of part, clearly indicate "1" and "1" (i) to avoid mis-supplying.
- Ordering part without stating its part number can not be supplied.
- Part indicated with the mark "★" is not illustrated in the exploded view.

WARNING:

Parts marked with this symbol Δ have critical characteristics. Use ONLY replacement parts recommended by the manufacturer.

EXPLODED VIEW

4

5

6

7

8

9

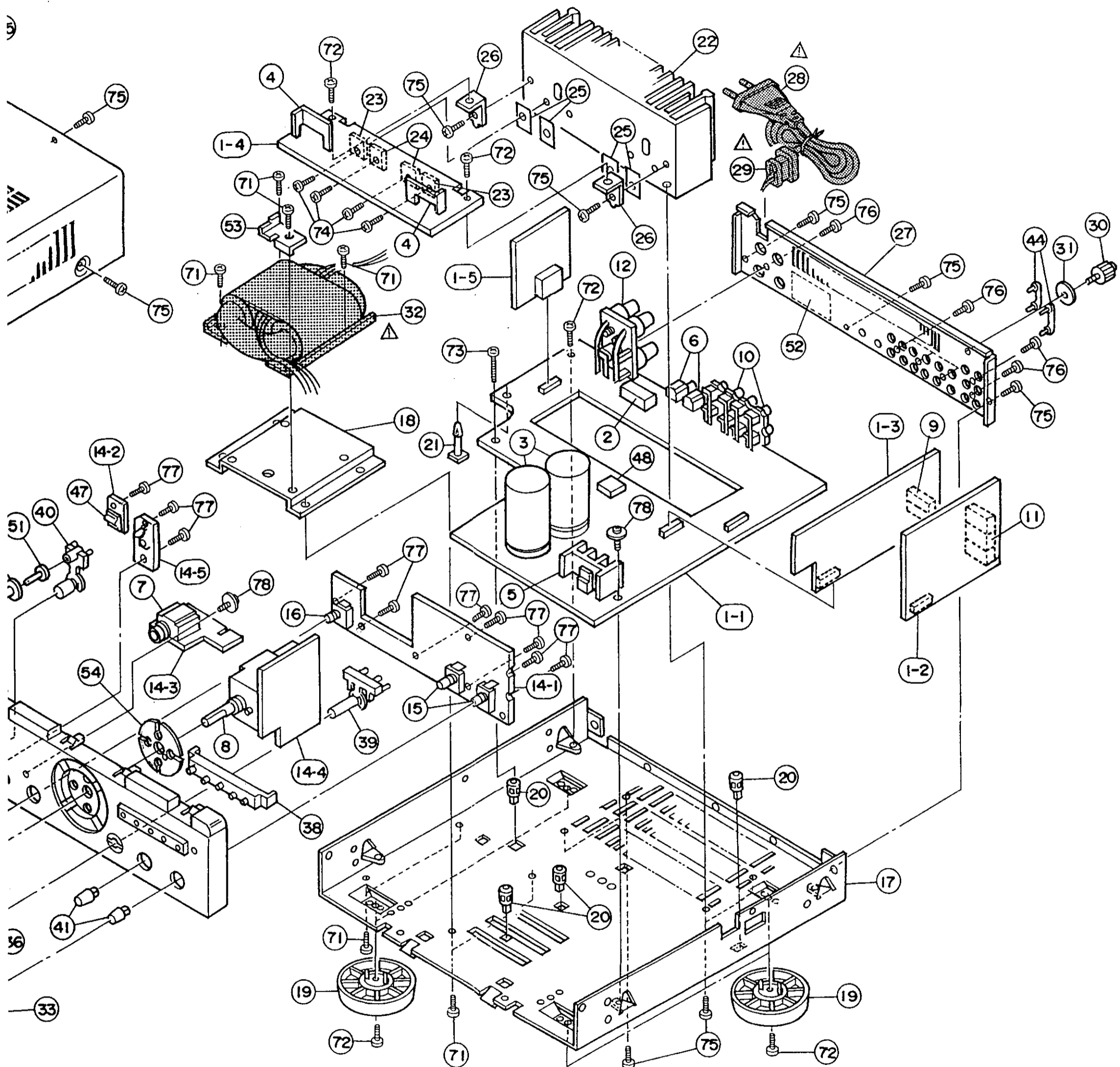

iod of time for suppling, or in some case

CD PLAYER SECTION

DISASSEMBLY PROCEDURES

(Assembly is performed in the reverse order.)

1. Removing the Top Cover and the Front Panel

- ① Remove the six screws which fasten the top cover.
- ② Remove the top cover (upward) in the direction of the arrow.

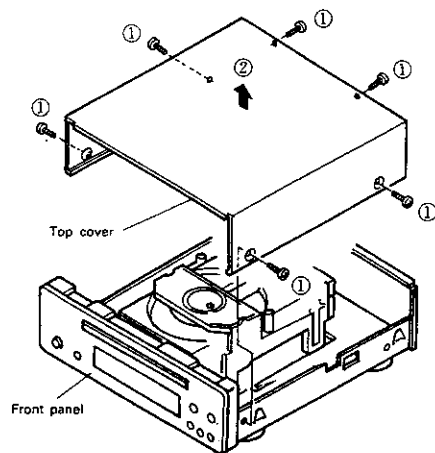

- ③ Remove the two screws which fasten front panel.
- ④ Release the inner panel hooks from the chassis while pulling the panels in the direction of the arrow to remove the inner panel and the front panel as one unit.

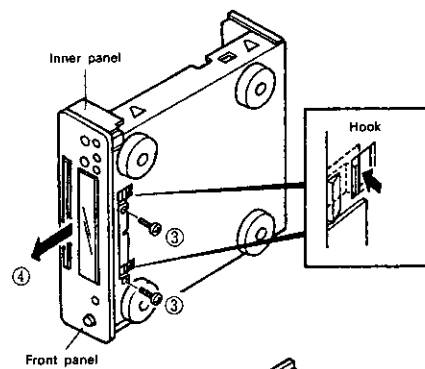

2. Removing the Units

Display Unit (2U-2686B-2)

- ⑤ Remove the six screws which fasten the display units.

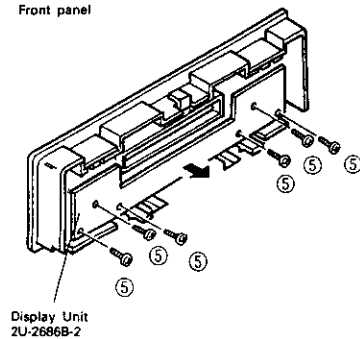

3. Removing the Rear Panel

- ⑦ Remove the three "a" screws and four "b" screws which fasten the rear panel.
- ⑧ Remove the rear panel in the direction of the arrow.

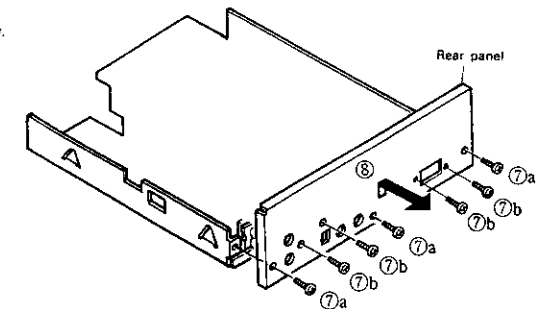

4. Removing the CD Mechanism Unit

- ⑨ Remove the four screws which fasten the CD mechanism unit.
- ⑩ Remove the CD mechanism unit in the direction of the arrow.

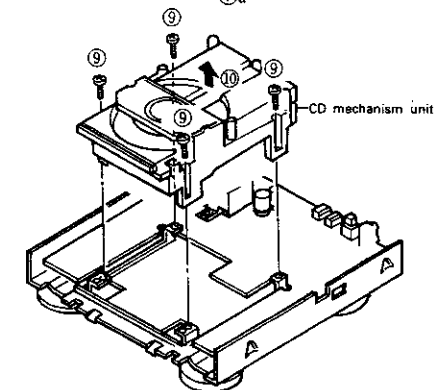

Main Unit (2U-2686B-1)

- ⑪ Remove the two screws which fasten the transformer.
- ⑫ Remove the four screws which fasten the main unit.

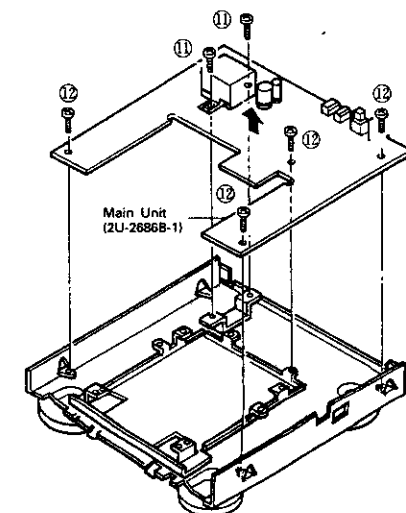

CD PLAYER SECTION

DESCRIPTION OF THE COMPONENTS

LASER PICKUP

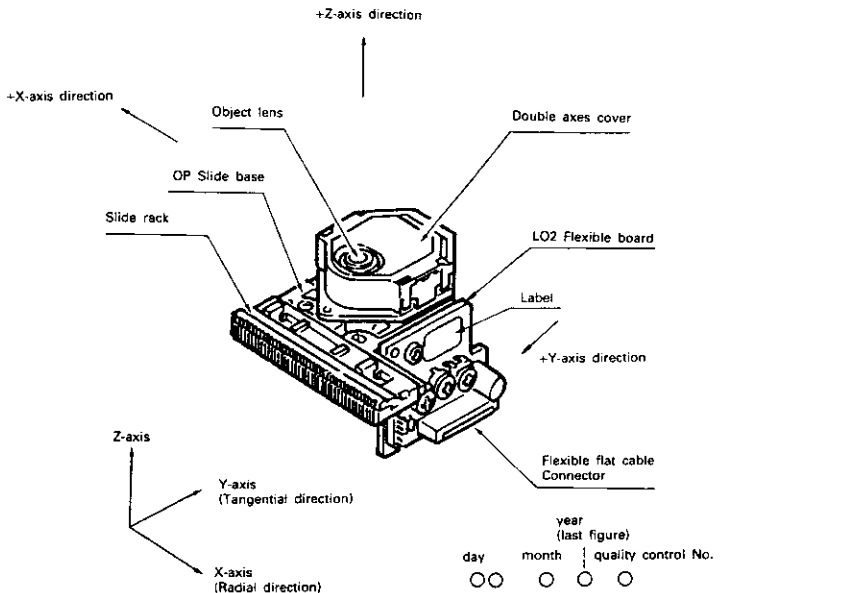

Label

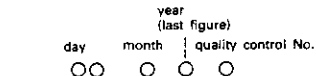
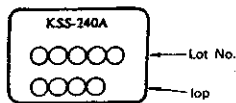

but Oct. Nov. and Dec. are expressed by a alphabetical letters of X, Y and Z.

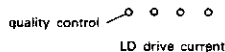

The expressed unit is by mA, with omission of the decimal points as for example, 56.5 mA will be expressed as 565, but the head of English letter means the control in the manufacturing plant.

PIN CONNECTOR

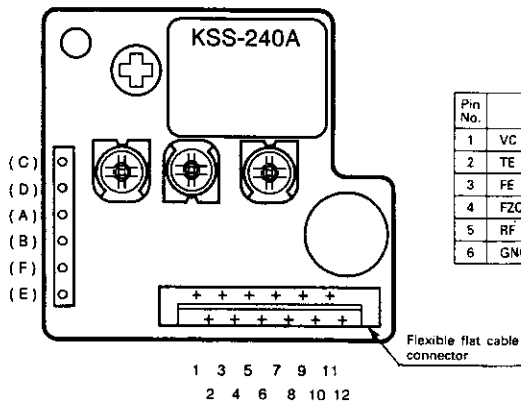

Pin No.	Description	Input/Output	Pin No.	Description	Input/Output
1	VC (+2.5V)	OUT	7	Vcc (+5V)	IN
2	TE (TRK ER signal)	OUT	8	LDC (LD Control)	IN
3	FE (FCS ER signal)	OUT	9	FCS+ (Double axes)	IN
4	FZC (FZS signal)	OUT	10	TRK+ (Double axes)	IN
5	RF (RF signal)	OUT	11	TRK- (Double axes)	IN
6	GND	OUT	12	FCS- (Double axes)	IN

Caution for Handling the Laser Pick-up

The laser pick-up KSS-240A is assembled and precisely adjusted using a sophisticated manufacturing process in our plant. Do not disassemble or attempt to readjust it. Please keep the following instructions carefully in handling pick-up.

1. Handle with Care

- (1) Storage
Do not store the pick-up in dusty, high-temperature or high-humidity environments.
- (2) Please take care for preventing from shock by falling down or careless handling.

2. Laser Diode (LD)

- (1) Protect your eyes
The laser beam may damage the human eye, since the intensity of the focused spot may reach $7 \times 10^3 \text{ W/cm}^2$ even if the intensity at the objective lens is $400 \mu\text{W}$ maximum. As the light beam spreads after focused through the objective lens, it does not effect you in the place as far as more than 30 cms. However, do not look at the laser light beam either through the objective lens directly nor another lens or a mirror.
- (2) Poison of As
Since the LD chip contains As (Arsenic), as GaAs + GaAlAs, as known as the poison, although the poison is relatively weak, in comparing with others, e.g. As_2O_3 , AsCl_3 etc., and the amount is small, avoid putting the chip in acid or an alkali solution, heating it over 200°C or putting it into your mouth.
- (3) Avoid surge current or electrostatic discharge
The LD may be damaged or deteriorated by its own strong light if a large current is supplied to it, even if only a short pulse.

Make sure that there is no surge current in the LD driving circuit by switches or else. Be careful to handle pick-up as it may be damaged in a moment by human electrostatic discharge. The pins of the LD are short-circuited by solder for protection during shipment.

For safety handling of an LD, grounding the human body, measuring equipments and jig is strongly recommended. And still it is further desirable to make use of mat on the platform and floor for handling the LD.

To open the short-circuit, remove the soldering quickly with a soldering iron whose metal part is grounded.

The temperature of the soldering iron should be less than 320°C (30 W).

3. Actuator

- (1) The performance of the actuator may be effected if magnetic material is located nearby, since the actuator has a strong magnetic circuit. Do not permit dust to enter through the clearance of the cover.
- (2) Cleaning the lens
It may change the specifications by attaching dust or ash on the objective lens. Clean the lens with a cleaning paper dampened with a little water, not pressing lens with so much strength by the cleaning paper.

4. Metal Bearing

As the metal bearing of Cu-compound sintered alloy is impregnated with FROIL946P (*Part No. 529 0054 007), never fail to supply the bushing with the same lubricant at the time of replacing the pick-up.

5. Handling

Please handle the laser pick-up with holding the side base (rosin molded prt).

When either a part of human body or some other things may happen to touch directly with the circuit part of P.W. Board, it may cause deterioration, take careful attention in handling this base.

6. Deterioration

As KSS-240A comprises built-in RF Amp and APC circuit, it resists stronger against external electrostatic damages than the former typed pickup. However, there is possibility of pickup deterioration in the following cases.

- (1) Low HF level, or with great numbers of jitters.
- (2) Tracking offset (EF Balance) is out of order (Refer to "Confirmation Method of Adjustment" for confirmation on (1) and (2)).

CD PLAYER SECTION

ADJUSTMENTS

Microcomputer built in the unit, comprises service program to facilitate servo adjustment by pushing operation button.

1. Start service program

Set the UCD-F10 (CD player section) to standby. Then, while short-circuiting TP102 ③ SWCL and ④ SWOP, switch on the power switch. Two to three seconds later, "01" will appear on the display of the UCD-F10 to indicate the service mode setting.

(Caution)

- When service program started normal operation of buttons will be defeated.

2. Service program function

Button	Function	Description
▲ OPEN/CLOSE	Opens or close the disc holder.	<ul style="list-style-type: none"> • Opens or closes only when disc is stopped. • Operate other keys after open or close.
■ STOP	Stops system function.	<ul style="list-style-type: none"> • Displays track number 01. • Push when adjustment completed, or do it again.
▶ PLAY	Starts focus servo and disc turns.	<ul style="list-style-type: none"> • Push when adjust tracking offset. • When completed, displays track number 02.
⏸ PAUSE	Starts focus servo, tracking servo, slide servo, spindle servo.	<ul style="list-style-type: none"> • When PLAY button is pushed, starts tracking servo and slide servo. • When completed, track number 03.
Other buttons	No normal operation.	<ul style="list-style-type: none"> • Do not operate buttons other than the above. • If misoperated, immediately turn power switch OFF.

(Caution)

- Do not use remote control during service program mode.

3. Adjustment method

(1) Location

2U-2686B CD MAIN UNIT (Component Side)

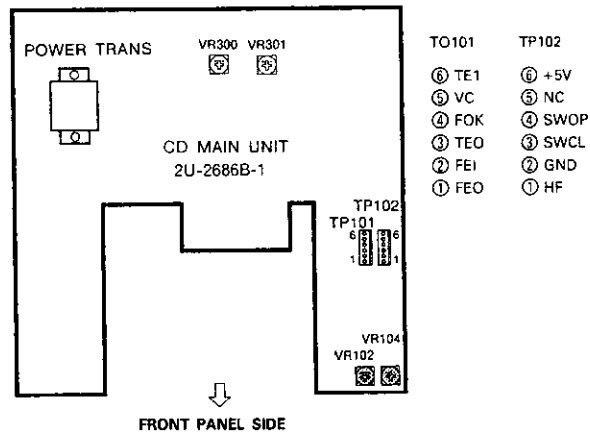

NOTE: VR301 and VR302 have been adjusted before shipping and do not require adjustment.



CD PLAYER SECTION

(2) Necessary equipment for adjustment

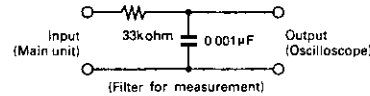
1. Dual trace oscilloscope
2. Reference disc TOMITA YASUKO (CA-1094) or W.A. MOZART (CO-74176)
3. Oscillator (10 Hz ~ 10 kHz, 0 ~ 3 Vp-p)
4. Frequency counter (readable no less than 5 kHz)
5. Filter for measurement





(3) Preset

1.	Start service program.		
2.	Preset VR102, 104 as per right figure.	VR102 (F-GAIN)  12 O'clock VR104 (T-GAIN)  12 O'clock	
3.	Step.	1. Focus gain (VR102) 2. Tracking gain (VR104) 3. Tracking Offset (Confirm) 4. AF Level (Confirm)	

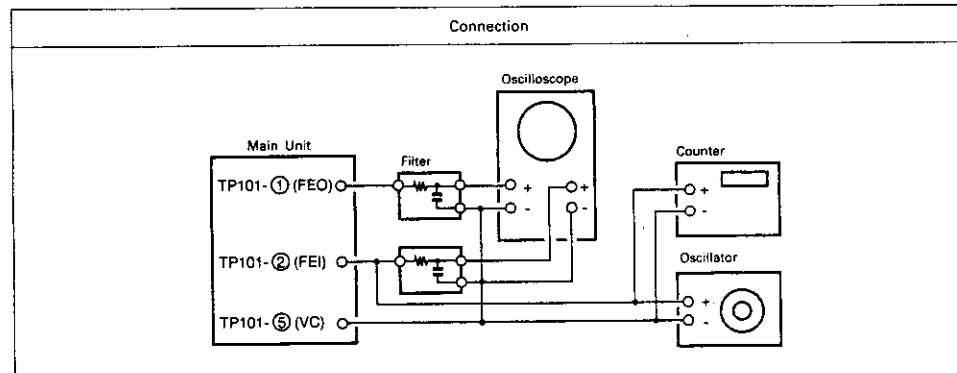
4. Focus gain

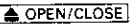

Oscillator	Counter	Oscilloscope	Adjust	Check	Step
(CA-1094) • 930 Hz • 2 Vp-p	930 Hz	V H • DC range • X-Y mode	(Volume) VR102	(Oscilloscope) Y axis X axis Phase 90° Waveform not right Y axis X axis	1. Press the  button and place a disc for adjustment purposes onto the disc holder. 2. Press the  button again and close the disc holder. 3. Push  (Displays track number 03) 4. Set oscillator to 930 Hz/2 Vp-p or 1.1 kHz/2 Vp-p. 5. Switch oscilloscope input to X-Y mode. 6. Adjust VR104 [T-GAIN] to symmetrize Lissajous figures to X-Y axes.
(CO-74176) • 1.1 kHz • 2 Vp-p	1.1 kHz				

CD PLAYER SECTION

5. Tracking gain

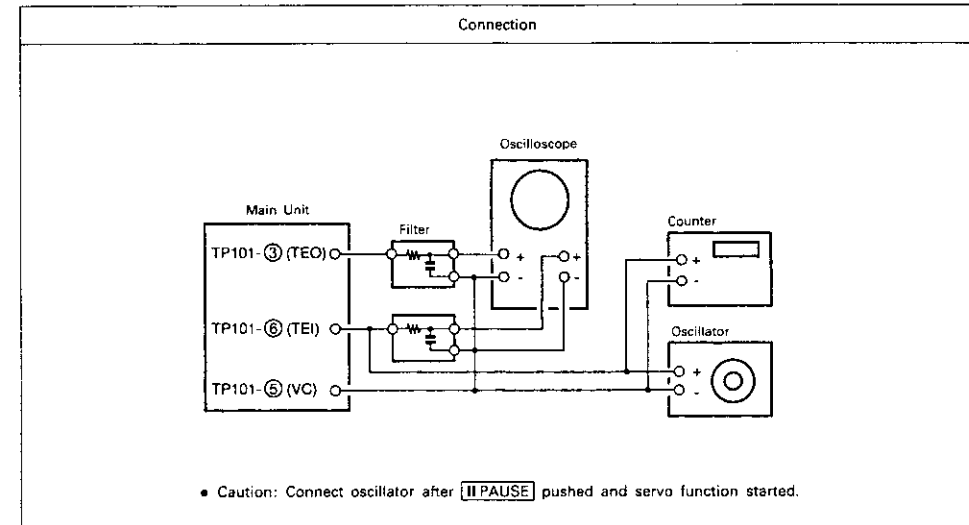

Oscillator	Counter	Oscilloscope	Adjust	Check	Step
(CA-1094) • 2.7 kHz • 0.8 Vp-p	2.7 kHz	V H • DC range • X-Y mode	(Volume) VR104	(Oscilloscope) Y axis X axis Phase 90° Waveform not right Y axis X axis	1. Push  (Displays track number 03) 2. Connect Oscillator 3. Set oscillator to 2.7 kHz/0.8 Vp-p or 3.3 kHz/0.8 Vp-p. 4. Switch oscilloscope input to X-Y mode. 5. Adjust VR104 [T-GAIN] to symmetrize Lissajous figures to X-Y axes.
(CO-74176) • 3.3 kHz • 0.8 Vp-p	3.3 kHz				

CD PLAYER SECTION

6. Tracking offset (E/F Balance) confirm

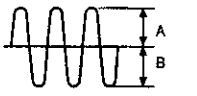
Oscilloscope		Check	Step
V	H	(Oscilloscope)	
0.1V/div	1~2ms/div	 $\frac{A - B}{A + B} \times 100 < 20\%$	1. Push ▶ PLAY to turn disc. (Displays track number 02) 2. Short (+) (-) of oscilloscope and check the base line. 3. Confirm that upper and lower amplitude of the waveform is symmetric against 0 V.

7. HF level confirm

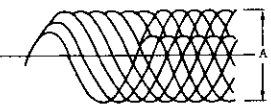
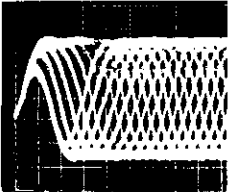
Oscilloscope		Check	Step
V	H	(Oscilloscope)	
50mV/div or 20mV/div	0.2 μV/div or 0.5 μV/div	 $A = 1.36 \pm 0.2V_{p-p}$ 	1. Push ⏸ PAUSE . (Displays track number 03) 2. Check HF level of oscilloscope. 3. Confirm that the waveform is in good shape. (◇ Pattern in center must be able to discriminate clearly.)

• Set input mode to ALTERMATE or CHOPPER.

HEAT RUN MODE FUNCTION

Heat Run Mode

- To activate**
 While hold pushing **▶▶**, **◀◀**, **▶▶▶** and **◀◀◀** keys simultaneously, turn the unit power on. The remote control sensor indicator will light to show that the unit is shifted in Heat Run mode.
 Be sure to load the disc previously.
 Press the disc holder open/close button (**▲ OPEN/CLOSE**) to cancel Heat Run mode.
 ★ This mode functions only for a disc with 21 pieces of music or more. For a disc with 20 pieces of music or lesser, please do not use.
- Operation**
 During the Heat Run mode to shift the unit in Play mode makes the unit replays from the first music after opens the loader once and re-closes it when finish playing the last track (comes into lead out).
 Hereafter, operates open/close of loader, servo on, reading of TOC, and playing repeatedly, and repeats playing the two tracks; the first and the last ones.
- Error Message**
 When the system error occurs while in Heat Run mode, the following error message will display on the Track No. indicator and stops operation.
 - E1
At the time of Focus Servo does not activate.
 - E2
When unable to detect synchronous pattern however the disc is in rotating. (GFS does not drive.)
 - E3
No synchronous pattern can be detected while in Play mode. (No GFS drives.)
 - E4
When TOC is unreadable in despite of servo is activated.
 - E5
In case of loader malfunctions. (Unable to turn on the switch.)
 - E6
The inner circle switch of Pick-up does not turn off.
 - E7
The inner circle switch of Pick-up does not turn on.
★ The number of operation up to the stop will be displayed on the minute and second portion of the indicator.

CD PLAYER SECTION

SEMICONDUCTORS

• IC's

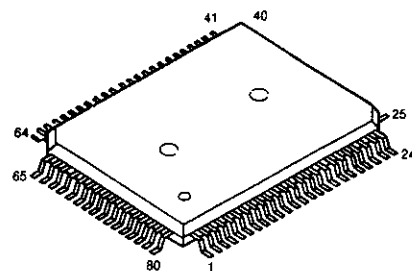

CXD 2500BQ (IC202)

• Pin Function Table

Pin No.	Pin Symbol	I/O	Pin Description
1	FOK	I	Focus OK input pin. Used with SENS output and the servo auto sequencer.
2	FSW	O, Z,0	Output filter switching output of the spindle motor.
3	MON	O, 1,0	On-off control output of the spindle motor.
4	MDP	O, 1,Z,0	Servo control of the spindle motor.
5	MDS	O, 1,Z,0	Servo control of the spindle motor.
6	LOCK	O, 1,0	Samples the GFS at 460 Hz and outputs a high level when GFS is high. Outputs a low level when GFS is continuously low 8 times.
7	NC	-	
8	VCOO	O, 1,0	Oscillator circuit output for analog EFM PLL use.
9	VCOI	O	Oscillator circuit output for analog EFM PLL use. fLOCK = 8.6436 MHz
10	TEST	I	Pin for test purposes, usually grounded.
11	PDO	O, 1,Z,0	Used for the charge pump for analog EFM PLL.
12	V _{SS}		Ground
13	NC	-	
14	NC	-	
15	NC	-	
16	VPCO	O, 1,Z,0	PLL charge pump output for variable pitch.
17	VCKI	O	Clock input center frequency (fcenter) from the external VCO used for variable pitch is 16.9344 MHz.
18	FILO	O, Analog.	Slave (i.e., digital PLL) digital output for the master PLL.
19	FILF	I	Filter input for the master PLL.
20	PCO	O, 1,Z,0	Charge pump output for the master PLL.
21	AV _{SS}		Analog ground
22	CLTV	I	Master VCO control voltage input.
23	AV _{DD}		Analog power supply (+5 V).
24	RF	I	EFM signal input.
25	TEST2	I	Grounded.
26	TEST3	I	Grounded.
27	ASYO	O, 1,0	EFM full-swing output. (V _{SS} at low, V _{DD} at high.)
28	TEST4	I	Grounded.
29	NC	-	
30	PSSI	I	Audio data output mode switching input. Serial output at low level, parallel output at high level.
31	WDCK	O, 1,0	D/A interface for a 48-bit slot. Word clock frequency is 2Fs.
32	LRCK	O, 1,0	D/A interface for a 48-bit slot. LR clock frequency is Fs.
33	V _{DD}		Power supply (+5 V).

CD PLAYER SECTION

Pin No.	Pin Symbol	I/O	Pin Description
34	DA16	O, 1,0	When PSSL equals 1, DA16 (MSB) is output. When PSSL equals 0, the serial data of the 48-bit slot is output. (Two's complement, MSB first.)
35	DA15	O, 1,0	When PSSL equals 1, DA15 is output. When PSSL equals 0, the bit clock of the 48-bit slot is output.
36	DA14	O, 1,0	When PSSL equals 1, DA14 is output. When PSSL equals 0, the serial data of the 48-bit slot is output. (Two's complement, LSB first.)
37	DA13	O, 1,0	When PSSL equals 1, DA13 is output. When PSSL equals 0, the bit clock of the 48-bit slot is output.
38	DA12	O, 1,0	When PSSL equals 1, DA12 is output. When PSSL equals 0, the LR clock of the 48-bit slot is output.
39	DA11	O, 1,0	When PSSL equals 1, DA11 is output. When PSSL equals 0, GTOP is output.
40	DA10	O, 1,0	When PSSL equals 1, DA10 is output. When PSSL equals 0, XUGF is output.
41	DA09	O, 1,0	When PSSL equals 1, DA09 is output. When PSSL equals 0, XPLCK is output.
42	DA08	O, 1,0	When PSSL equals 1, DA08 is output. When PSSL equals 0, GFS is output.
43	DA07	O, 1,0	When PSSL equals 1, DA07 is output. When PSSL equals 0, RFCK is output.
44	DA06	O, 1,0	When PSSL equals 1, DA06 is output. When PSSL equals 0, C2P0 is output.
45	DA05	O, 1,0	When PSSL equals 1, DA05 is output. When PSSL equals 0, XRAOF is output.
46	DA04	O, 1,0	When PSSL equals 1, DA04 is output. When PSSL equals 0, MNT3 is output.
47	DA03	O, 1,0	When PSSL equals 1, DA03 is output. When PSSL equals 0, MNT2 is output.
48	DA02	O, 1,0	When PSSL equals 1, DA02 is output. When PSSL equals 0, MNT1 is output.
49	DA01	O, 1,0	When PSSL equals 1, DA01 is output. When PSSL equals 0, MNT0 is output.
50	APTR	O, 1,0	Aperture correction control output. High level at time of the right channel.
51	APTL	O, 1,0	Aperture correction control output. High level at time of the left channel.
52	V _{SS}		Ground.
53	XTAI	I	16.9344 MHz crystal oscillator circuit input. Or, 33.8688 MHz input.
54	XTAO	O, 1,0	16.9344 MHz crystal oscillator circuit input.
55	XTSL	I	Crystal selection input pin. Set to low level when the crystal is 16.9344 MHz. Set to high level when 33.8688 MHz.
56	FSTT	O, 1,0	Output of 2/3 division of pins 53 and 54. Does not change with variable pitch.
57	C4M	O, 1,0	4.2336 MHz output. Changes simultaneously with variable pitch effects.
58	C16M	O, 1,0	16.9344 MHz output. Changes simultaneously with variable pitch effects.
59	MD2	I	Digital-Out on/off control. On at high level and off at low level.
60	DOU	O, 1,0	Digital-Out output pin.
61	EMPH	O, 1,0	High level output when played disc has emphasis. Low level output when there is no emphasis.
62	WFCK	O, 1,0	WFCK (Write Frame Clock) output.
63	SCOR	O, 1,0	High level is output when either sub code sync S0 or S1 is detected.
64	SBSO	O, 1,0	Serial output of SubP through W.
65	EXCK	I	Clock input for SBSO readout.
66	SQSO	O, 1,0	SubQ 80bit and PCM peak level data 16-bit output.
67	SQCK	I	Clock input for SQSO readout.
68	MUTE	I	Muting at high level, cancellation at low level.
69	SENS	-, 1,Z,0	SENS output. Output to CPU.
70	XRST	I	System set. Reset at low level.
71	DATA	I	Serial data input from the CPU.
72	XLAT	I	Latch input data input from the CPU. Serial data are latched with the trailing edge.
73	V _{DD}		Power supply (+5 V).
74	CLOCK	I	Serial data transfer clock input from the CPU.
75	SEIN	I	Sense input from SSP.
76	CNIN	O, 1,0	Number of track jumps counting signal input.
77	DATO	O, 1,0	Serial data output to SSP.
78	XLTO	O, 1,0	Serial data latch output to SSP. Latched with the trailing edge.
79	CLKP	O, 1,0	Serial data transfer clock output to SSP.
80	MIRR	I	Mirror signal input. Used for jumps of 128 tracks or greater with an auto sequencer.

CD PLAYER SECTION

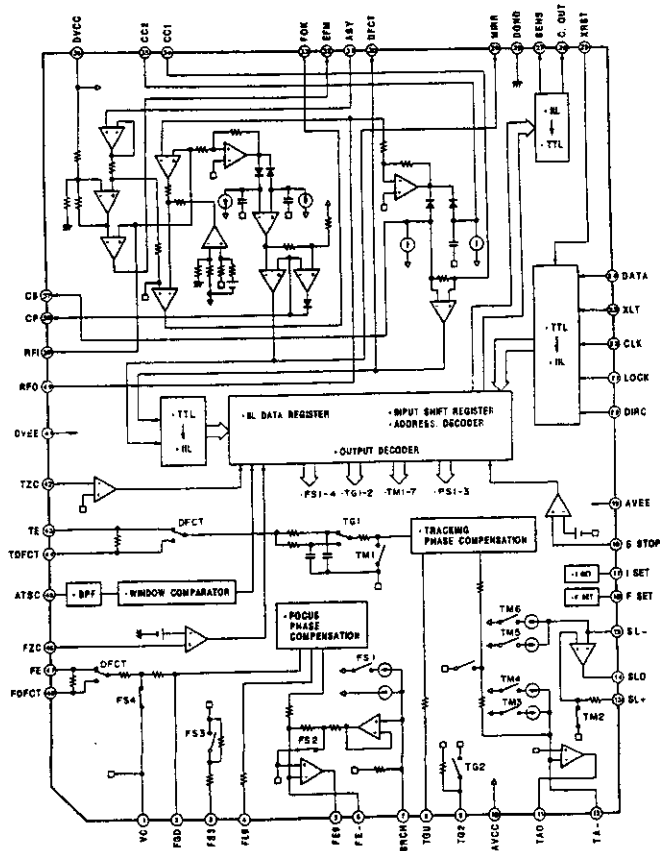
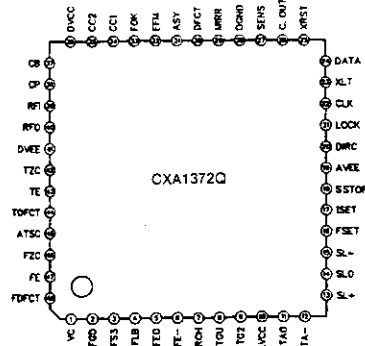
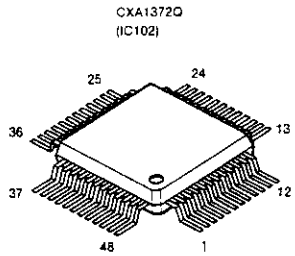

Pin Description Table

Pin No.	Pin Symbol	I/O	Pin Description
1	VC	I	Mid-point voltage input pin. GND with two power supplies. (VCC + GND)/2 with a single power supply.
2	FGD	I	When dropping the high-region gain of the focus servo, insert a capacitor between this pin and pin 3.
3	FS3	I	The on/off state of FS3 switches the high-region gain of the focus servo.
4	FLB	I	This is the time constant external connection pin for the low-region boost of the focus servo.
5	FEO	O	This is the focus drive output.
6	FE-	I	Inverting input pin of the focus amplifier.
7	SRCH	I	Time constant external connection pin for creating the focus search waveform.
8	TGU	I	Time constant external connection pin for switching of the tracking high-region gain.
9	TG2	I	Time constant external connection pin for switching of the tracking high-region gain.
10	—	—	—
11	TAO	O	Tracking drive output.
12	TA-	I	Inverting input pin of the tracking amplifier.
13	SL+	I	Non-inverting input pin of the sled amplifier.
14	SLO	O	Sled drive output.
15	SL-	I	Inverting input pin of the sled amplifier.
16	FSET	I	Pin used for the peak setting of the focus tracking phase correction.
17	ISET	I	Supplies the current which determines the focus search, tracking jump, and sled kick height.
18	SSTOP	I	Pin used for the on/off detection signal of the limit switch which is used for detecting the innermost track of the disc.
19	—	—	—
20	DIRC	I	Used at the time of one tracking jump. Includes a 47 kohm pull-up resistor.
21	LOCK	I	The sled runaway prevention circuit is activated at low level. Includes a 47 kohm pull-up resistor.
22	CLK	I	Serial data transfer clock input from the CPU. (No pull-up resistor.)
23	XLT	I	Latch input from the CPU. (No pull-up resistor.)
24	DATA	I	Serial data input from the CPU. (No pull-up resistor.)
25	XRST	I	Resets with a low level at the reset input pin. (No pull-up resistor.)
26	C.OUT	I	Signal output for the count of the number of tracks.
27	SENS	O	Outputs FZC, AS, TZC, SSTOP and other signals by command from the CPU.
28	—	—	—
29	MIRR	O	Output pin of the MIRR comparator. (DC voltage: 10 kohm load resistor connection)
30	DFCT	O	Output pin of the DEFECT comparator. (DC voltage: 10 kohm load resistor connection)
31	ASY	I	Input pin of the auto symmetry control.
32	EFM	O	Output pin of the EFM comparator. (DC voltage: 10 kohm load resistor connection)
33	FOK	O	Output pin of the focus OK comparator. (DC voltage: 10 kohm load resistor connection)
34	CC1	I	DEFECT bottom hold output pin.
35	CC2	O	Input pin for which the DEFECT bottom hold output is input with capacitive coupling.
36	—	—	—
37	CB	I	Connection pin of the DEFECT bottom hold capacitor.
38	CP	I	Connection pin of the MIRR hold capacitor. This is the non-inverting input pin of the MIRR comparator.
39	RF1	I	Input pin for which the output of the RF summing amplifier is input with capacitive coupling.
40	RFO	O	Output pin of the RF summing amplifier. This is the eye pattern check point.
41	—	—	—
42	TZC	I	Input pin of the tracking zero-cross comparator.
43	TE	I	Tracking error input pin.
44	TDFCT	I	Time-constant capacitor connection pin at time of defects.
45	ATSC	I	Window comparator input pin for ATSC detection.
46	FZC	I	Focus zero-cross comparator input pin.
47	FE	I	Focus error input pin.
48	DFDCT	I	Time-constant capacitor connection pin at time of defects.

CD PLAYER SECTION

PCM61P-L (IC302, 303)

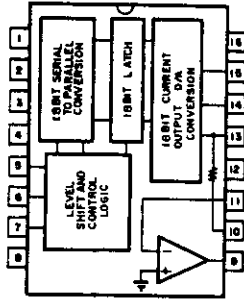
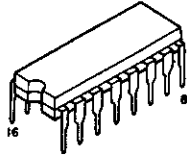

Pin Arrangement

1	-V _{CC}	Analog negative power supply
2	DIG. GND	Digital ground
3	+V _L	Logic positive power supply
4	NC	No connection
5	CLK	Clock input
6	LEC	Latch enable input
7	DATA	Serial data input
8	-V _L	Logic negative power supply
9	V _{OUTA}	Voltage output
10	RF	Feedback resistor
11	S. J	Summing junction
12	ANA. GND	Analog ground
13	I _{OUTJ}	Current output
14	MSB ADJ	MSB adjustment pin
15	V _{POTJ}	MSB trimmer potentiometer pin
16	-V _{CC}	Analog positive power supply

SM5841BS (IC300)

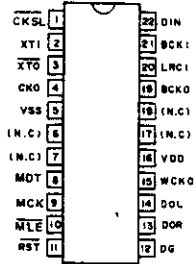
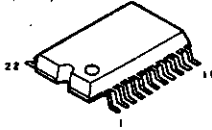

IC Protector
ICP-N15 (IC502, 503)

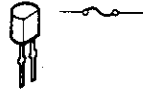

M5290FP (IC501)

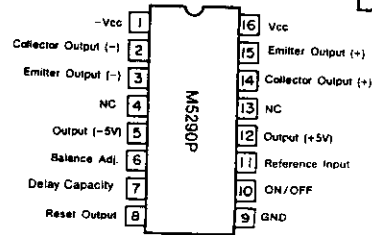
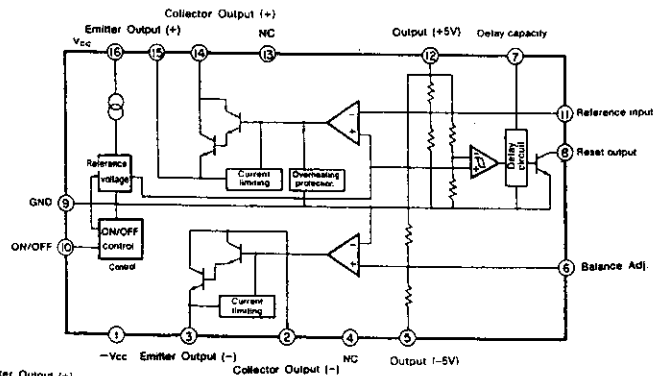
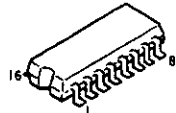

CD PLAYER SECTION

BA15218 (IC103, 105, 106)

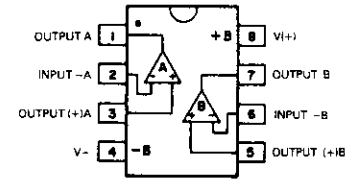
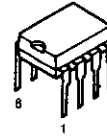

PST529C (IC200)

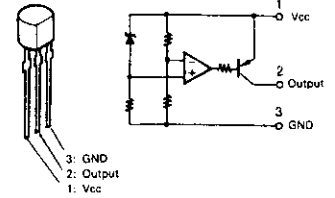

Transistors

- 2SA934 (Q)
- 2SC2060 (Q)

- 2SB1185 (E/F)
- 2SD1762 (E/F)

- 2SA933S (S)
- 2SC1740S (S)
- 2SD2144S

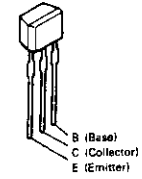
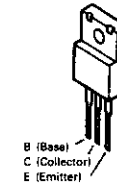
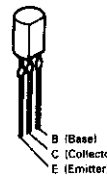

- DTA114ES PNP type
- DTC114ES NPN type

PNP type

NPN type

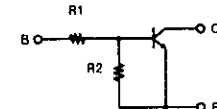
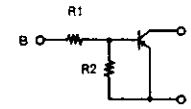
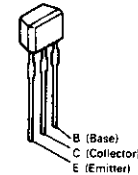

	R1	R2
DTA114ES	10 kohm	10 kom

	R1	R2
DTC114ES	10 kohm	10 kom

Diodes

1SS270A



1SR35-200A

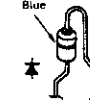

HZS6A-1
HZS6C-1
HZS22-1



Optical out

GP1F32T (JK280)

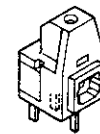

CD PLAYER SECTION

• Fluorescent Display Tube 8BT159GK
(Part No.: 393 8013 001)

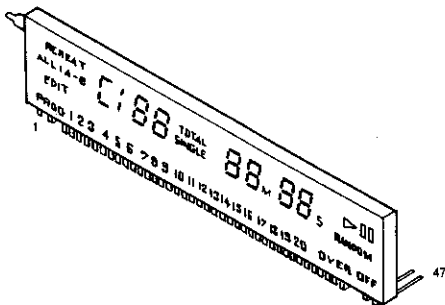

Pin Connections

Pin No.	1	2	3	4	5	6	7	8	9	10	11	12	13	14	15	16	17	18	19	20	21	22	23	24
Connection	F1	F1	NP	NP	1G	2G	3G	4G	5G	6G	7G	8G	NC	NC	NC	NC	NC	NC	NC	NC	NC	NC	NC	NC
Pin No.	25	26	27	28	29	30	31	32	33	34	35	36	37	38	39	40	41	42	43	44	45	46	47	
Connection	NC	NC	NC	NC	NC	NC	NC	NC	P11	P10	P9	P8	P7	P6	P5	P4	P3	P2	P1	NP	NP	F2	F2	

- NOTE**
- 1) F1 and F2: Filaments
 - 2) NP: No pin
 - 3) NC: No connection
 - 4) 1G through 11G: Grid

Pattern Details

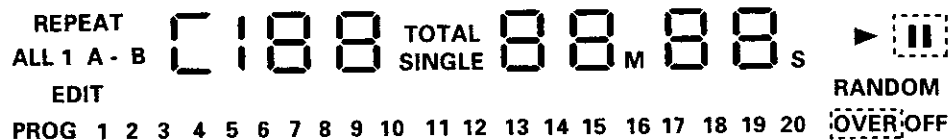

Illumination colors
 Reddish orange: portion of above pattern
 Green: Other portions

CD PLAYER SECTION

GRID ASSIGNMENT

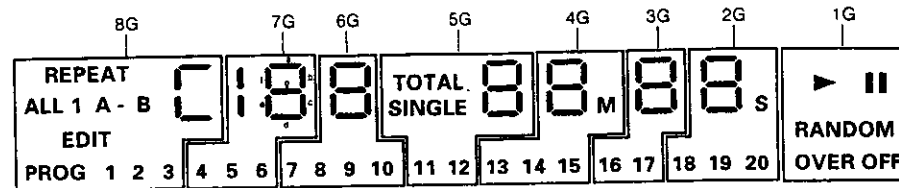

ANODE CONNECTION

	8G	7G	6G	5G	4G	3G	2G	1G
P1	REPEAT	a	a	a	a	a	a	▶
P2	[]	b	b	b	b	b	b	⏸
P3	ALL	c	c	c	c	c	c	RANDOM
P4	1	d	d	d	d	d	d	OVER
P5	A -	e	e	e	e	e	e	OFF
P6	B	f	f	f	f	f	f	—
P7	EDIT	g	g	g	g	g	g	—
P8	PROG	1	7	TOTAL	M	16	S	—
P9	1	4	8	SINGLE	13	17	18	—
P10	2	5	9	11	14	—	19	—
P11	3	6	10	12	15	—	20	—

MICROPROCESSOR DOCUMENTATION

μPD78044GF-085-3B9 : 262 1936 108
(IC201)

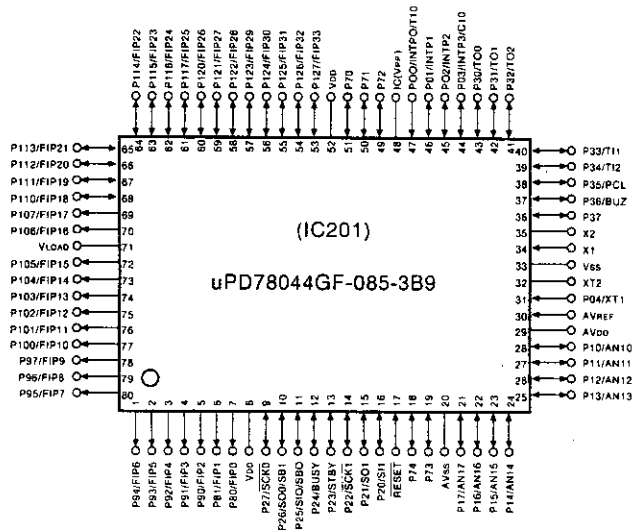
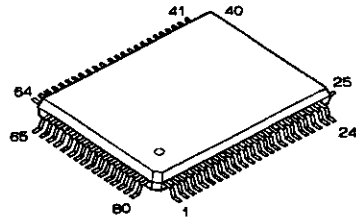

• Pin Description Table

Pin	Port Name	Function Name	I/O	Det	Res	Ext	Ini	Function	Notes
1	P94/FIP6	G7	O	-	-	-	L	Fluorescent tube display grid 7 signal.	O P-open
2	P93/FIP5	G6	O	-	-	-	L	Fluorescent tube display grid 6 signal.	O P-open
3	P92/FIP4	G5	O	-	-	-	L	Fluorescent tube display grid 5 signal.	O P-open
4	P91/FIP3	G4	O	-	-	-	L	Fluorescent tube display grid 4 signal.	O P-open
5	P90/FIP2	G3	O	-	-	-	L	Fluorescent tube display grid 3 signal.	O P-open
6	P81/FIP1	G2	O	-	-	-	L	Fluorescent tube display grid 2 signal.	O P-open
7	P80/FIP0	G1	O	-	-	-	L	Fluorescent tube display grid 1 signal.	O P-open
8	VDD	VDD	-	-	-	-	-	Power supply (Connected to +5 V)	-
9	P27/SCK0	SQCK	O	-	Z	-	H	Subcode input clock signal	IO
10	P26/SO0/SB1	Not used.	O	-	Z	-	H	Not connected.	IO
11	P25/SI0/SB0	SUBQ	I	-	Z	-	-	Subcode input data signal	IO
12	P24/BUSY	Not used.	I	-	Z	-	-	Connected to ground.	IO
13	P23/STB	Not used.	I	-	Z	-	-	Connected to ground.	IO
14	P22/SCK1	FUNCLCK	O	-	Z	-	H	Clock signal for auto functions.	IO
15	P21/SO1	FUNCLCK	O	-	Z	-	H	Data output signal for auto functions.	IO
16	P20/SI1	FUNCLIN	I	-	Z	-	-	Data input signal for auto functions.	IO
17	RESET	RESET	I	Lv	-	-	-	Reset signal input	I.
18	P74	Not used.	I	-	-	-	-	Connected to ground.	IO N-open
19	P73	Not used.	I	-	-	-	-	Connected to ground.	IO N-open
20	AVSS	AVSS	-	-	-	-	-	Ground of A/D converter. (Connected to ground.)	-
21	P17/AN17	XRST	O	-	Z	-	L	Reset signal for DSP.	IO
22	P16/AN16	STANBY	O	-	Z	Pd	L	Power on/off control signal.	IO
23	P15/AN15	Not used.	I	-	Z	-	-	Connected to ground.	IO
24	P14/AN14	Not used.	I	-	Z	-	-	Connected to ground.	IO
25	P13/AN13	Not used.	I	-	Z	-	-	Connected to ground.	IO
26	P12/AN12	Not used.	I	-	Z	-	-	Connected to ground.	IO
27	P11/AN11	K2	I	-	Z	-	-	Key input signal 2. (Analog input)	IO
28	P10/AN10	K1	I	-	Z	-	-	Key input signal 1. (Analog input)	IO
29	AVDD	AVDD	-	-	-	-	-	Analog power supply of the A/D converter. (Connected to +5 V)	-
30	AVREF	AVREF	I	-	-	-	-	Reference voltage input signal of the A/D converter. (Connected to +5 V)	I
31	P04/XT1	Not used.	I	-	-	-	-	Subsystem clock. (Connected to ground.)	I
32	XT2	Not used.	-	-	-	-	-	Subsystem clock. (Not connected.)	-
33	VSS	GND	-	-	-	-	-	Connected to ground.	-
34	X1	X1	I	-	-	-	-	Main system clock.	I
35	X1	X1	I	-	-	-	-	Main system clock.	-
36	P37	CLK	O	-	Z	-	H	Clock	IO
37	P36/BUZ	DATA	O	-	Z	-	H	Data	IO
38	P35/PCL	XLT	O	-	Z	-	H	Latch	IO
39	P34/TI2	LASER	O	-	Z	Pd	L	Laser diode on/off control signal	IO
40	P33/TI1	SENSE	I	L/E	Z	-	-	Servo condition detection signal	IO
41	P32/TO2	FDATA	O	-	Z	-	H	Data for digital filter control.	IO
42	P31/TO1	FCLK	O	-	Z	-	H	Clock for digital filter control.	IO
43	P30/TO0	MLE	O	-	Z	-	H	Latch for digital filter control.	IO
44	P03/INTP3/C10	Not used.	O	Ed	Z	-	-	Connected to ground.	IO
45	P02/INTP1	RESET2	O	Ed	Z	Pu	-	RESET signal input (from M5290).	IO

CD PLAYER SECTION

Pin	Port Name	Function Name	I/O	Det	Res	Ext	Ini	Function	Notes
46	P01/INTP1	SCOR	I	Ed	Z	-	-	Subcode sync signal	IO
47	P00/INTP0/T10	FUNCIN	I	Ed	Z	-	-	Auto function interrupt signal	I
48	IC (VPP)	IC	-	-	-	-	-	Connected to ground.	-
49	P72	DMUTE	O	-	Z	Pu*	H	Digital muting signal	IO N-open
50	P71	AMUTE	O	-	Z	Pu*	H	Analog muting signal	IO N-open
51	P70	DIRC	O	-	Z	Pu*	L	Servo control signal	IO N-open
52	VDD	VDD	-	-	-	-	-	Power supply. (Connected to +5 V)	-
53	P127/FIP33	FOK	I	Lv	Z	-	-	Focus OK signal	IO P-open
54	P126/FIP32	SWOP	I	Lv	Z	Pu	-	Loader open position detection switch	IO P-open
55	P125/FIP31	SWCL	I	Lv	Z	Pu	-	Loader close position detection switch	IO P-open
56	P124/FIP30	INSW	I	Lv	Z	Pu	-	Pickup inner track position detection switch	IO P-open
57	P123/FIP29	GFS	I	Lv	Z	-	-	Rotation sync signal from DSP	IO P-open
58	P122/FIP28	OPEN	O	-	Z	Pd	H	Loader open drive signal	IO P-open
59	P121/FIP27	CLOSE	O	-	Z	Pd	H	Loader close drive signal	IO P-open
60	P120/FIP26	Not used.	O	-	Z	-	L	Not connected.	IO P-open
61	P117/FIP25	Not used.	O	-	Z	-	L	Not connected.	IO P-open
62	P116/FIP24	Not used.	O	-	Z	-	L	Not connected.	IO P-open
63	P115/FIP23	Not used.	O	-	Z	-	L	Not connected.	IO P-open
64	P114/FIP22	Not used.	O	-	Z	-	L	Not connected.	IO P-open
65	P113/FIP21	Not used.	O	-	Z	-	L	Not connected.	IO P-open
66	P112/FIP20	Sh	O	-	Z	Pd	L	Fluorescent tube display segment h signal	IO P-open
67	P111/FIP19	Si	O	-	Z	Pd	L	Fluorescent tube display segment i signal	IO P-open
68	P110/FIP18	Sj	O	-	Z	Pd	L	Fluorescent tube display segment j signal	IO P-open
69	P107/FIP17	Sk	O	-	-	Pd	L	Fluorescent tube display segment k signal	IO P-open
70	P106/FIP16	Sa	O	-	-	Pd	L	Fluorescent tube display segment a signal	IO P-open
71	VLOAD	-HB	-	-	-	-	-	Power supply for the display.	-
72	P105/FIP15	Sb	O	-	-	Pd	L	Fluorescent tube display segment b signal	IO P-open
73	P104/FIP14	Sc	O	-	-	Pd	L	Fluorescent tube display segment c signal	IO P-open
74	P103/FIP13	Sd	O	-	-	Pd	L	Fluorescent tube display segment d signal	IO P-open
75	P102/FIP12	Se	O	-	-	Pd	L	Fluorescent tube display segment e signal	IO P-open
76	P101/FIP11	Sf	O	-	-	Pd	L	Fluorescent tube display segment f signal	IO P-open
77	P100/FIP10	Sg	O	-	-	Pd	L	Fluorescent tube display segment g signal	IO P-open
78	P97/FIP9	Not used.	O	-	-	Pd	L	Not connected.	IO P-open
79	P96/FIP8	Not used.	O	-	-	Pd	L	Not connected.	IO P-open
80	P95/FIP7	G8	O	-	-	Pd	L	Fluorescent tube display grid 8 signal	IO P-open

CD PLAYER SECTION

MICROPROCESSOR PERIPHERAL WIRING DIAGRAM

1 2 3 4 5 6 7 8

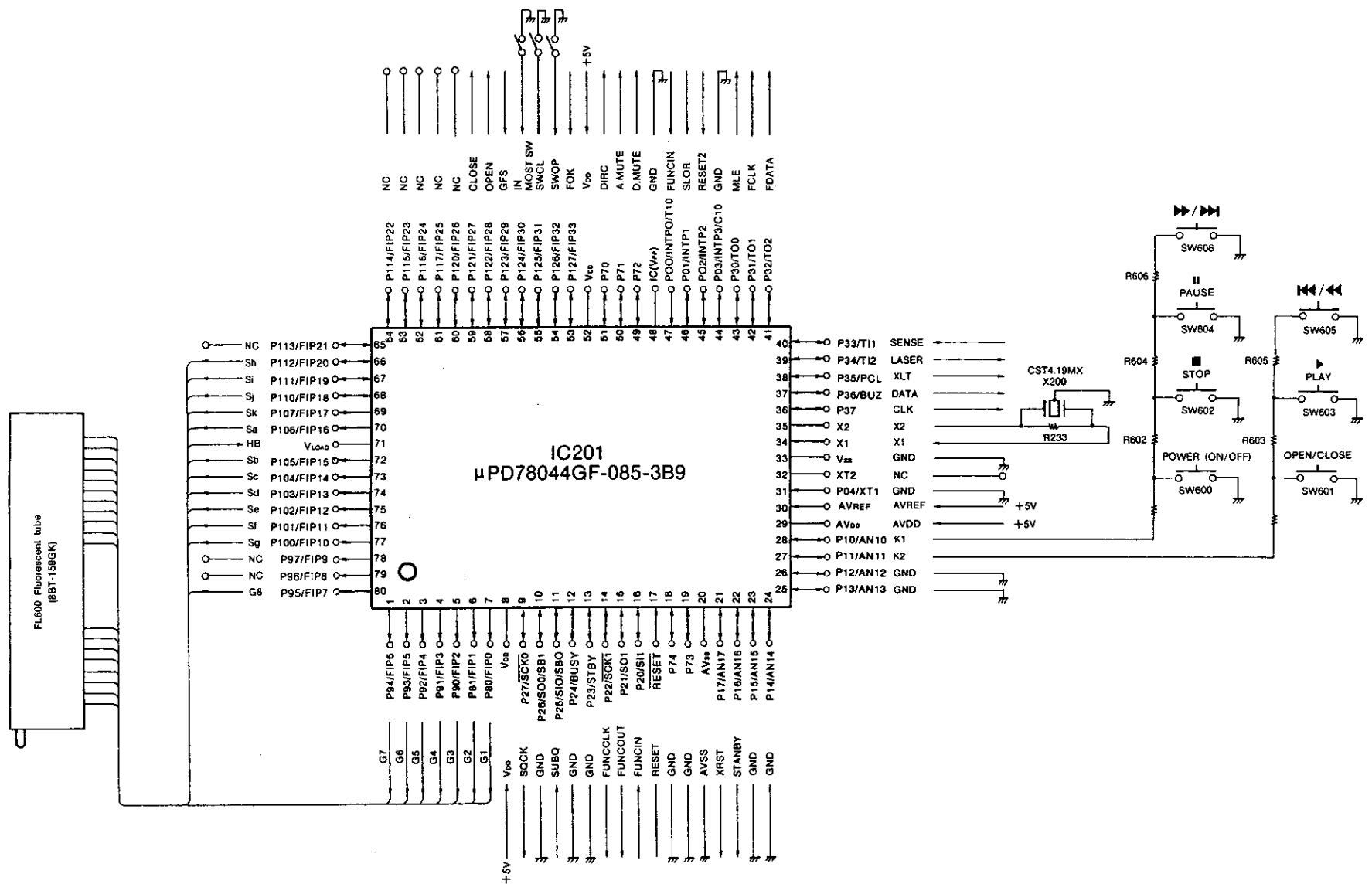

A
B
C
D
E
91

CD PLAYER SECTION

PRINTED WIRING BOARD

1 2 3 4 5 6 7 8

UCD-F10 2U-2686B CD UNIT ASS'Y

Component Side

2U-2686B	
-1	Main Unit
-2	Display Unit

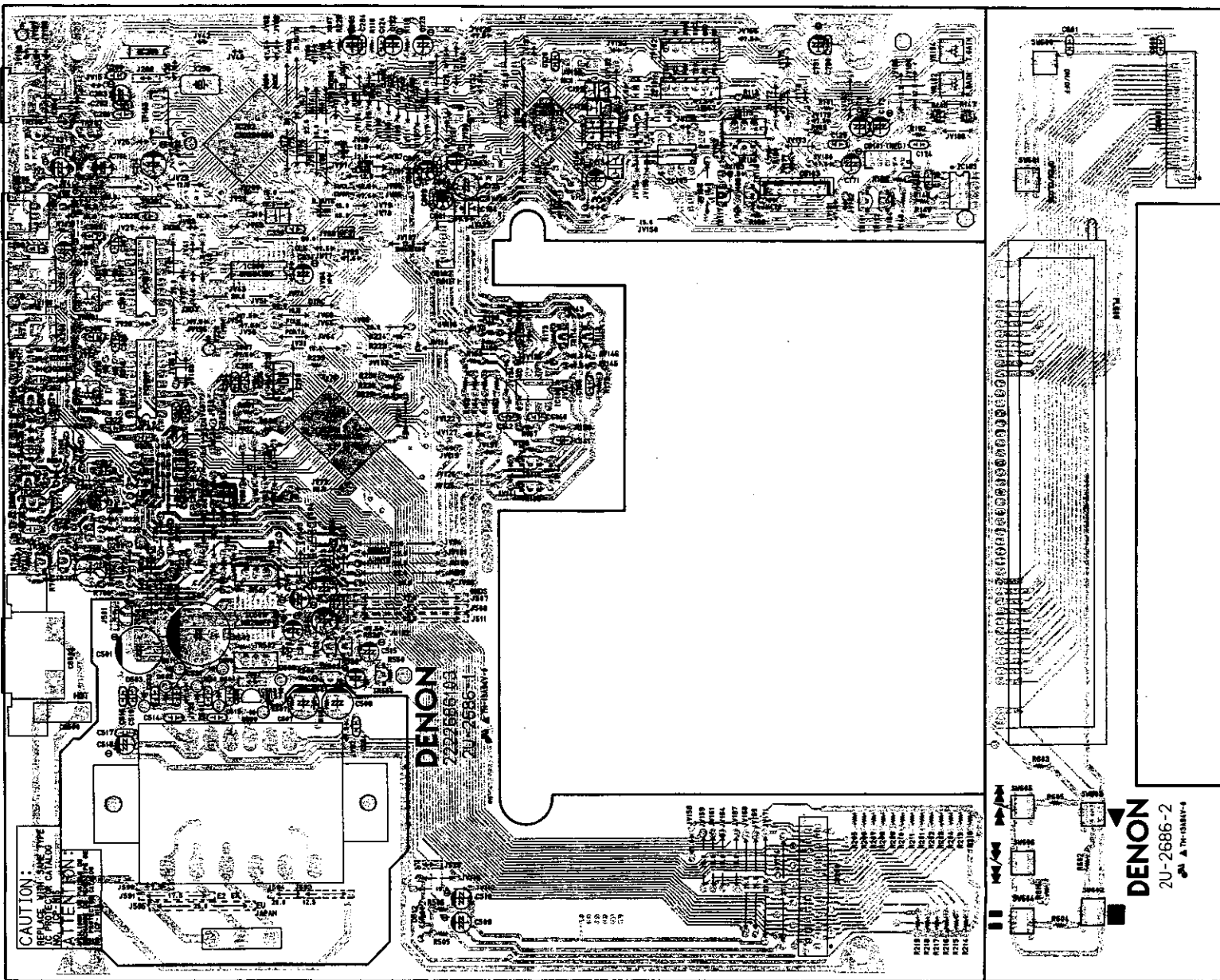

A

B

C

D

E

CD PLAYER SECTION

NOTE ON PARTS LIST

- Part indicated with the mark "⊗" are not always in stock and possibly to take a long period of time for supplying, or in some case supplying of part may be refused.
- When ordering of part, clearly indicate "1" and "1" (i) to avoid mis-supplying.
- Ordering part without stating its part number can not be supplied.
- Part indicated with the mark "★" is not illustrated in the exploded view.
- Not including Carbon Film ±5%, 1/4W Type in the P.W. Board parts list. (Refer to the Schematic Diagram for those parts.)

WARNING:

Parts marked with this symbol \triangle \square have critical characteristics. Use ONLY replacement parts recommended by the manufacturer.

Resistors

Ex.: **RN 14K 2E 182 G FR**
 Type Shape Power Resistance Allowable Others
 and per- error

RD : Carbon Film	2B : 1/8W	F : ±1%	P : Pulse-resistant type
RC : Composition	2E : 1/4W	G : ±2%	NL : Low noise type
RS : Metallic oxide Film	3H : 1/2W	J : ±5%	NB : Non-burning type
RW : Winding	3A : 1W	K : ±10%	FR : Fuse-resistor
RN : Metal film	3D : 2W	M : ±20%	F : Lead wire forming
RK : Metal mixture	3F : 3W		
RM : Carbon chip	3H : 5W		

Resistance
1 8 2 ⇒ 1800 ohm = 1.8 kohm
 ↑ ↑ ↑
 1-digit effective number, 2-digit effective number, decimal point indicated by R.
 • Units: ohm

1 R 2 ⇒ 1.2 ohm
 ↑ ↑ ↑
 1-digit effective number, 2-digit effective number, decimal point indicated by R.
 • Units: ohm

Capacity (electrolyte only)
2 2 2 ⇒ 2200 μF
 ↑ ↑ ↑
 1-digit effective number, 2-digit effective number.
 • Units: μF

2 R 2 ⇒ 2.2 μF
 ↑ ↑ ↑
 1-digit effective number, 2-digit effective number, decimal point indicated by R.
 • Units: μF

Capacitors

Ex.: **CE 04W 1H 2R2 M BP**
 Type Shape Dielectric Capacity Allowable Others
 and per- strength error

CE : Aluminum foil electrolyte	0J : 6.3V	F : ±1%	HS : High stability type
CA : Aluminum solid electrolyte	1A : 10V	G : ±2%	BP : Non-polar type
CS : Tantalum electrolyte	1C : 16V	J : ±5%	HR : Ripple-resistant type
CO : Film	1E : 25V	K : ±10%	DL : For charge and discharge
CK : Ceramic	1V : 35V	M : ±20%	HF : For assuring high frequency
CC : Ceramic	1H : 50V	Z : ±80%	U : UL part
CP : Oil	2A : 100V	-20%	C : CSA part
CM : Mica	2B : 125V	P : ±100%	W : UL-CSA type
CF : Metallized	2C : 160V	-0%	F : Lead wire forming
CH : Metallized	2D : 200V	C : ±0.25pF	
	2E : 250V	D : ±0.5pF	
	2H : 500V	-	
	2J : 630V	-	

Capacity (except electrolyte)
2 2 2 ⇒ 2200pF = 2200 μF = 0.0022 μF
 ↑ ↑ ↑
 (More than 2) — Indicates number of zeros after effective number, 2-digit effective number.
 • Units: μF

2 2 1 ⇒ 220pF
 ↑ ↑ ↑
 (0 or 1) — Indicates number of zeros after effective number, 2-digit effective number.
 • Units: pF

• When the dielectric strength is indicated in AC, "AC" is included after the dielectric strength value.

2U-2686B CD UNIT ASS'Y PARTS LIST

Ref. No.	Part No.	Part Name	Remarks	Ref. No.	Part No.	Part Name	Remarks
SEMICONDUCTORS GROUP							
IC102	262 1342 006	IC CXA1372Q		R114	247 0009 956	Chip Carbon 7.5k ohm 1/10W	RM73B--752J
IC103	263 0565 007	IC BA15218		R115	247 0014 925	Chip Carbon 680k ohm 1/10W	RM73B--684J
IC105.106	263 0565 007	IC BA15218		R116	247 0013 913	Chip Carbon 240k ohm 1/10W	RM73B--244J
IC200	263 0652 907	IC PST529C	u-com	R117	247 0007 945	Chip Carbon 1k ohm 1/10W	RM73B--102J
IC201	262 1936 108	ICμPD78044GF-085-389		R120	247 0009 985	Chip Carbon 10k ohm 1/10W	RM73B--103J
IC202	262 1819 005	IC :CXD2500BQ		R132	247 0013 968	Chip Carbon 390k ohm 1/10W	RM73B--394J
IC300	262 1765 900	IC SM5841BS		R133	247 0012 969	Chip Carbon 150k ohm 1/10W	RM73B--154J
IC302.303	262 1409 004	IC :PCM61P-L		R136	247 0012 927	Chip Carbon 100k ohm 1/10W	RM73B--104J
IC501	263 0916 902	IC M5290FP-600C		R137	247 0012 914	Chip Carbon 91k ohm 1/10W	RM73B--913J
IC502.503	268 0073 905	IC ICP-N15	IC Protector 15V	R138	247 0011 944	Chip Carbon 47k ohm 1/10W	RM73B--473J
TR109	273 0195 005	Transistor 2SC2060 (Q)		R140	247 0011 986	Chip Carbon 68k ohm 1/10W	RM73B--683J
TR110	271 0271 907	Transistor 2SA934 (Q)		R141	247 0009 972	Chip Carbon 91k ohm 1/10W	RM73B--912J
TR111	273 0195 005	Transistor 2SC2060 (Q)		R166	247 0012 927	Chip Carbon 100k ohm 1/10W	RM73B--104J
TR112	271 0271 907	Transistor 2SA934 (Q)		R167	247 0009 985	Chip Carbon 10k ohm 1/10W	RM73B--103J
TR113	273 0195 005	Transistor 2SC2060 (Q)		R174.175	247 0011 944	Chip Carbon 47k ohm 1/10W	RM73B--473J
TR114	271 0271 907	Transistor 2SA934 (Q)		R176.177	247 0012 927	Chip Carbon 100k ohm 1/10W	RM73B--104J
TR115	274 0120 002	Transistor 2SD1762 (E/F)		R179	247 0005 989	Chip Carbon 220 ohm 1/10W	RM73B--221J
TR116	271 0271 907	Transistor 2SA934 (Q)		R181.182	247 0011 944	Chip Carbon 47k ohm 1/10W	RM73B--473J
TR117	273 0195 005	Transistor 2SC2060 (Q)		R183	247 0012 927	Chip Carbon 100k ohm 1/10W	RM73B--104J
TR118	271 0271 907	Transistor 2SA934 (Q)		R185	247 0012 927	Chip Carbon 100k ohm 1/10W	RM73B--104J
TR260	271 0192 002	Transistor 2SA933S (S)		R187	247 0005 989	Chip Carbon 220 ohm 1/10W	RM73B--221J
TR261	273 0303 910	Transistor 2SC1740S (S)		R191	247 0012 969	Chip Carbon 150k ohm 1/10W	RM73B--154J
TR262	271 0192 002	Transistor 2SA933S (S)		R197	247 0012 930	Chip Carbon 110k ohm 1/10W	RM73B--114J
TR501	274 0120 002	Transistor 2SD1762 (E/F)		R240	247 0008 960	Chip Carbon 3.3k ohm 1/10W	RM73B--332J
TR502	272 0083 004	Transistor 2SB1185 (E/F)		R241	247 0009 943	Chip Carbon 6.8k ohm 1/10W	RM73B--682J
TR503	271 0192 002	Transistor 2SA933S (S)		R242	247 0009 985	Chip Carbon 10k ohm 1/10W	RM73B--103J
TR530.531	269 0020 906	Transistor DTC114ES	Built in Resistor	R255	247 0007 945	Chip Carbon 1k ohm 1/10W	RM73B--102J
TR550	273 0195 908	Transistor 2SC2060 (Q)		R305~308	247 0007 945	Chip Carbon 1k ohm 1/10W	RM73B--102J
TR700	269 0020 906	Transistor DTC114ES	Built in Resistor	R310.311	247 0013 984	Chip Carbon 470k ohm 1/10W	RM73B--474J
TR701	269 0046 906	Transistor DTA114ES	Built in Resistor	R312.313	247 0012 996	Chip Carbon 200k ohm 1/10W	RM73B--204J
TR706.707	274 0160 907	Transistor 2SD2144STPU	Built in Resistor	R314.315	247 0014 967	Chip Carbon 1M ohm 1/10W	RM73B--105J
D200	276 0432 903	Diode 1SS270A		R358~360	247 0007 945	Chip Carbon 1K ohm 1/10W	RM73B--102J
D260	276 0432 903	Diode 1SS270A		R705	247 0007 945	Chip Carbon 1k ohm 1/10W	RM73B--102J
D261.262	276 0463 901	Zener Diode HZS6C-1	6V	R720.721	247 0007 903	Chip Carbon 680 ohm 1/10W	RM73B--681J
D263	276 0432 903	Diode 1SS270A		R724.725	247 0010 990	Chip Carbon 30k ohm 1/10W	RM73B--303J
D501~504	276 0553 905	Diode 1SR35-200A		R732.733	247 0008 944	Chip Carbon 2.7k ohm 1/10W	RM73B--272J
D507	276 0480 900	Zener Diode HZS22-1	22V	VR102	211 6093 954	Semi Fixed Resistor 22k ohm	V06PB223
D508.509	276 0553 905	Diode 1SR35-200A		VR104	211 6093 954	Semi Fixed Resistor 22k ohm	V06PB223
D512	276 0461 903	Zener Diode HZS6A-1	6V	VR300.301	211 6093 970	Semi Fixed Resistor 100k ohm	V06PB104
D550	276 0463 901	Zener Diode HZS6C-1	6V	CAPACITORS GROUP			
D700	276 0432 903	Diode 1SS270A		C106	257 0009 940	Chip Ceramic 3300pF/50V	CK73B1H332K
JK280	269 0098 006	Optical Out GP1F32T	OPT. OUT	C107	257 0011 954	Chip Ceramic 0.027μF/25V	CK73B1E273K
FL600	393 8013 001	F.L. Tube 8BT159GK		C108	257 0009 924	Chip Ceramic 2200pF/50V	CK73B1H222K
RESISTORS GROUP (Not included Carbon Film ±5%, 1/4W Type. Refer to the Schematic Diagram for those Parts.)							
R110	247 0012 998	Chip Carbon 200k ohm 1/10W	RM73B--204J	C109~112	256 1034 979	Metallized 0.1μF/50V	CF93A1H104J
R111	247 0011 928	Chip Carbon 39k ohm 1/10W	RM73B--393J	C113	254 4337 910	Electrolytic 6.8μF/50V	CE04W1H6R8M
R112	247 0011 960	Chip Carbon 56k ohm 1/10W	RM73B--563J	C114	256 1035 910	Metallized 0.22μF/50V	CF93A1H224J
				C116	257 0011 909	Chip Ceramic 0.01μF/25V	CK73B1E103K
				C117	253 1197 914	Ceramic Cap. 0.1μF/50V	CK14F1H104Z
				C118.119	257 0007 900	Chip Ceramic 1000pF/50V	CC73SL1H102J
				C120	257 0014 935	Ceramic Cap. 0.1μF/25V	CK73F1E104Z
				C121	257 0012 966	Chip Ceramic 0.01μF/50V	CK73F1H103Z
				C122.123	254 4260 919	Electrolytic 0.22μF/50V	CE04W1HR22M
				C124	253 1198 913	Ceramic Cap. 0.01μF/16V	CK14Y1C103M
				C125	257 0011 967	Chip Ceramic 0.033μF/25V	CK73B1E333K
				C126	253 1198 913	Ceramic Cap. 0.01μF/16V	CK14Y1C103M

CD PLAYER SECTION

WIRING DIAGRAM

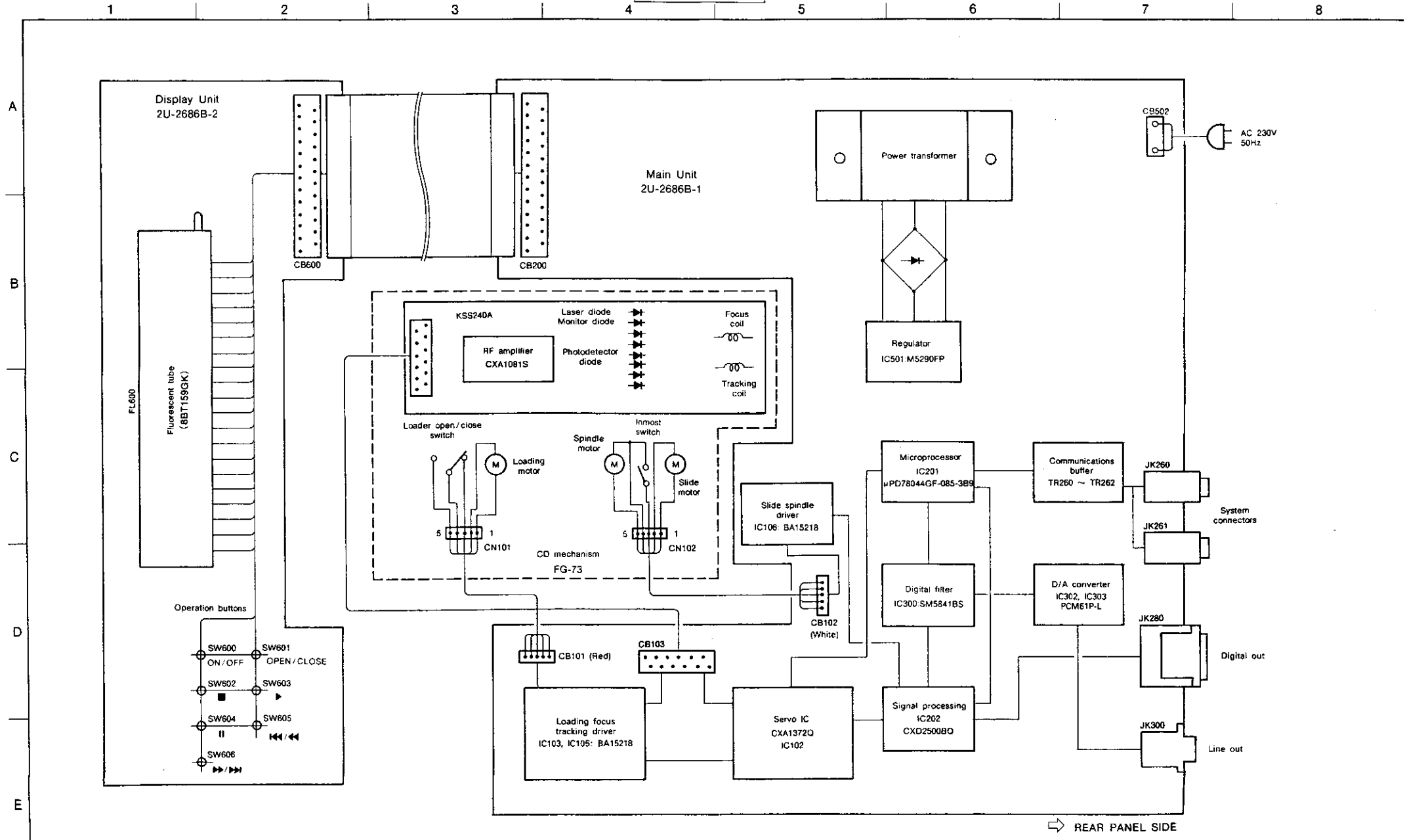

⇨ REAR PANEL SIDE

CD PLAYER SECTION

EXPLODED

PARTS LIST OF UCD-F10 EXPLODED VIEW

Ref. No.	Part No.	Part Name	Remarks	Qty
1	2U- 2686 B	CD Unit Ass'y		1 ^S
1-1	—	Main Unit		(1)
1-2	—	Display Unit		(1)
2	254 4254 792	Chemicon 2200µF/16V	C501	1
3	254 4255 018	Chemicon 4700µF/16V	C502	1
4	205 0736 089	25P FFC Conn. Base	CB200,600	2
5	269 0098 006	Optical Out GP1F32T	JK280	1
6	205 0274 004	2P Conn. Base	JK300	1
7	204 8421 005	Mini Jack	JK260,261	2
8	234 6097 002	Power Trans.		1
9	393 8013 001	F.L. Tube 8BT159GK	FL600	1
10	411 9115 248	Main Chassis		1
11	449 9034 007	Mech. Holder		1
12	412 3783 200	Trans Bracket		1
13	GEN 2798	Foot Ass'y		4
14	105 9237 234	Rear Panel (CD)		1
15	—	—		—
16	—	—		—
17	412 2814 028	Card Spacer (L=10)		2
18	337 0032 006	CD Mech. Ass'y	FG-73	1
19	499 0191 009	Laser Pickup	KSS-240A	1
20	009 0108 006	25P FF Cable Cord		1
21	144 2363 016	Front Panel (CD)		1
22	146 9294 113	Knob Ring (A)		1
23	146 9295 112	Knob Ring (B)		1
24	146 9287 337	Inner Panel (CD)		1
25	143 0872 001	Window		1
26	113 1654 104	Power Button Ass'y		1
27	113 1656 018	Tact Button (1 Key)	OP/CLOSE	1
28	113 9276 115	Button (5 Key)	4 Gang	1
29	146 9289 102	Loader Panel (CD)		1
30	—	—		—
31	102 0545 117	Top Cover		1
32	461 0866 009	Rubber Sheet	Put on F.L. Holder	2
33	513 2242 100	Rating Sheet		1
34	—	—		—
35	203 2349 009	2P Inlet		1
36	513 2066 001	Laser Caution		1
37	513 0985 003	Inst. Label		1
38	461 0859 003	Spacer	for AC 1	1
39	—	—		—
40	—	—		—
SCREWS				
51	473 7015 005	Tapping Screw (S) 3×6	Black	3
52	473 7004 003	Tapping Screw (S) 4×8		4
53	473 7002 018	Tapping Screw (S) 3×8		8
54	477 0064 107	Fixing Screw		4
55	473 7505 007	Tapping Screw (P) 2.6×8		6
56	473 8007 025	Cup Screw 3×8		4
57	473 7015 018	Tapping Screw (S) 3×8	Black	11
58	473 7500 015	Tapping Screw (P) 3×8		2
59	—	—		—
60	—	—		—
PACKING & ACCESSORIES (Not included EXPLODED VIEW)				
101	505 0241 005	Cabinet Cover		1
102	503 1091 106	Cushion		1
103	GEN 2742	Envelope Sub. Ass'y		1 ^S
103-1	505 9125 009	Poly Cover		(1)
103-2	203 2310 009	2P Pin Cord	L=1000	(1)
103-3	203 2315 004	Stereo Miniplug Cord	L=500	(1)
103-4	206 2108 003	AC Conn. with Plug		(1)
103-5	511 2654 006	Inst. Sheet		(1)
104	503 1061 000	Top Cushion		1
105	501 1781 012	Carton Case		1

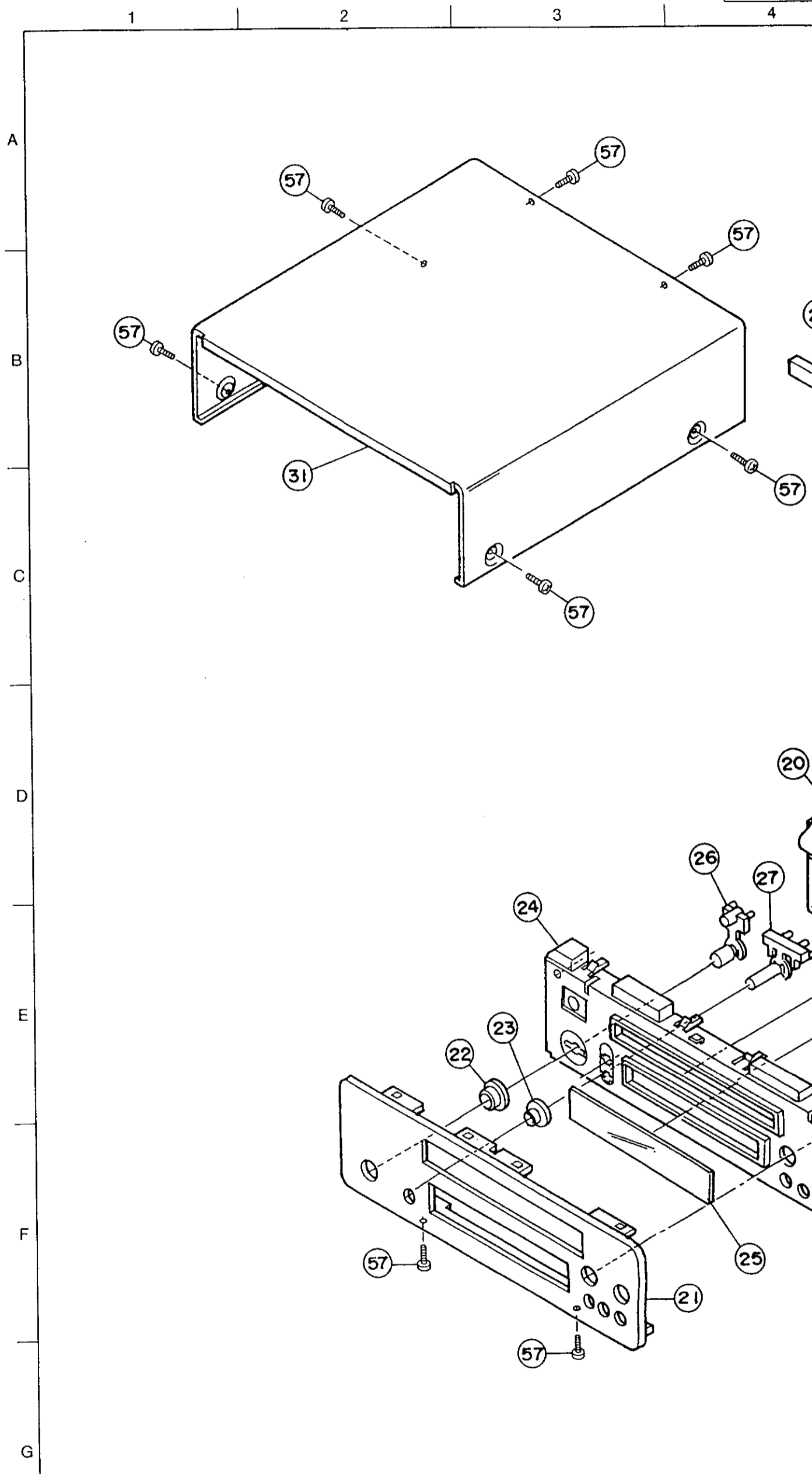

NOTE ON PARTS LIST

- Part indicated with the mark "●" are not always in stock and possibly to take a long period of time for supplying. supplying of part may be refused.
- When ordering of part, clearly indicate "1" and "1" (i) to avoid mis-supplying.
- Ordering part without stating its part number can not be supplied.
- Part indicated with the mark "★" is not illustrated in the exploded view.

WARNING:

Parts marked with this symbol Δ have critical characteristics. Use ONLY replacement parts recommended by the manufacturer.

EXPLODED VIEW

3 4 5 6 7 8 9

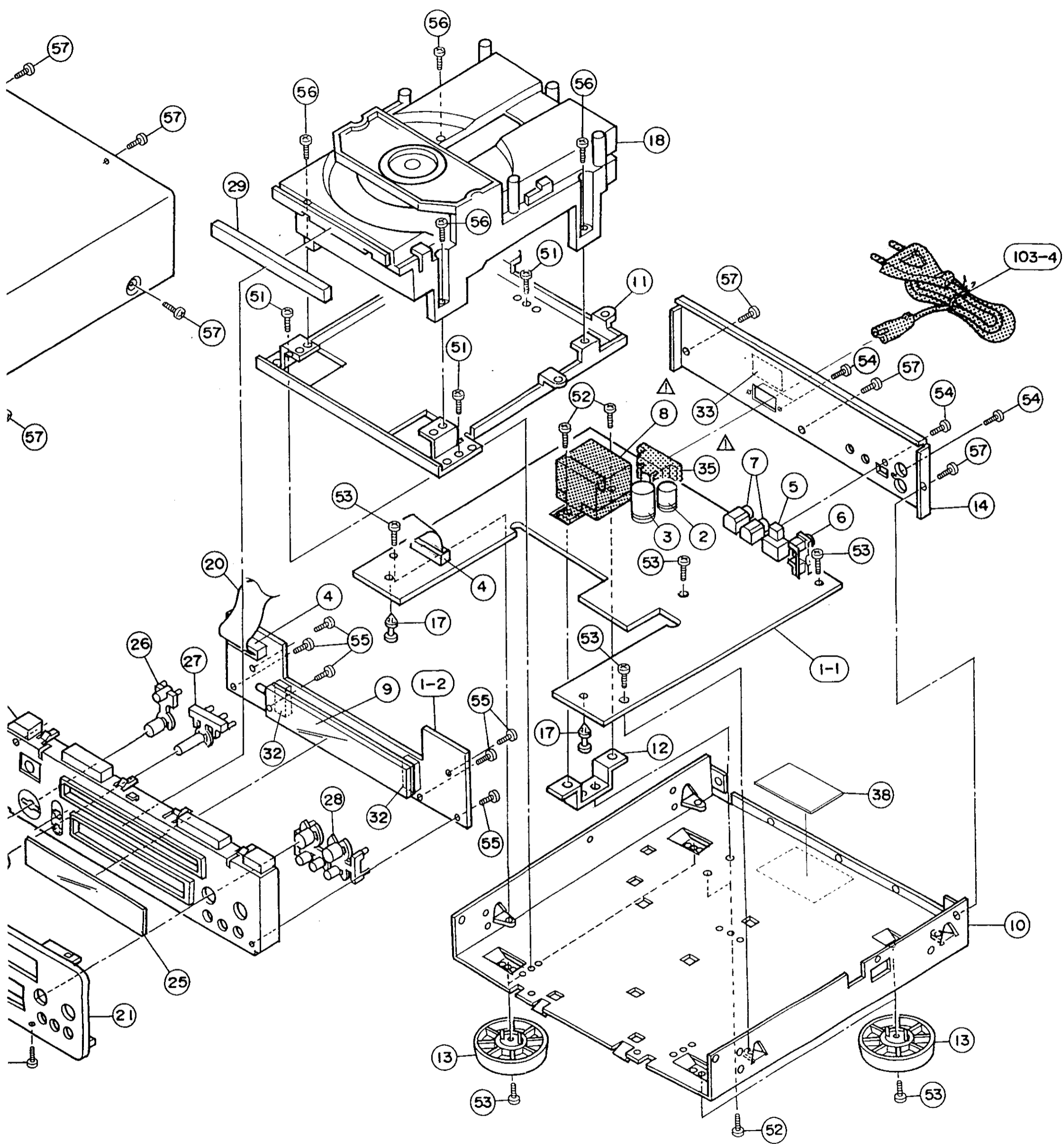

ably to take a long period of time for supplying, or in some case
I mis-supplying.
lied.
oded view.

DISASSEMBLY OF CD MECHANISM (FG-73) Part No. : 337 0032 006

CD PLAYER SECTION

CD MECHANISM (FG-73) PARTS LIST

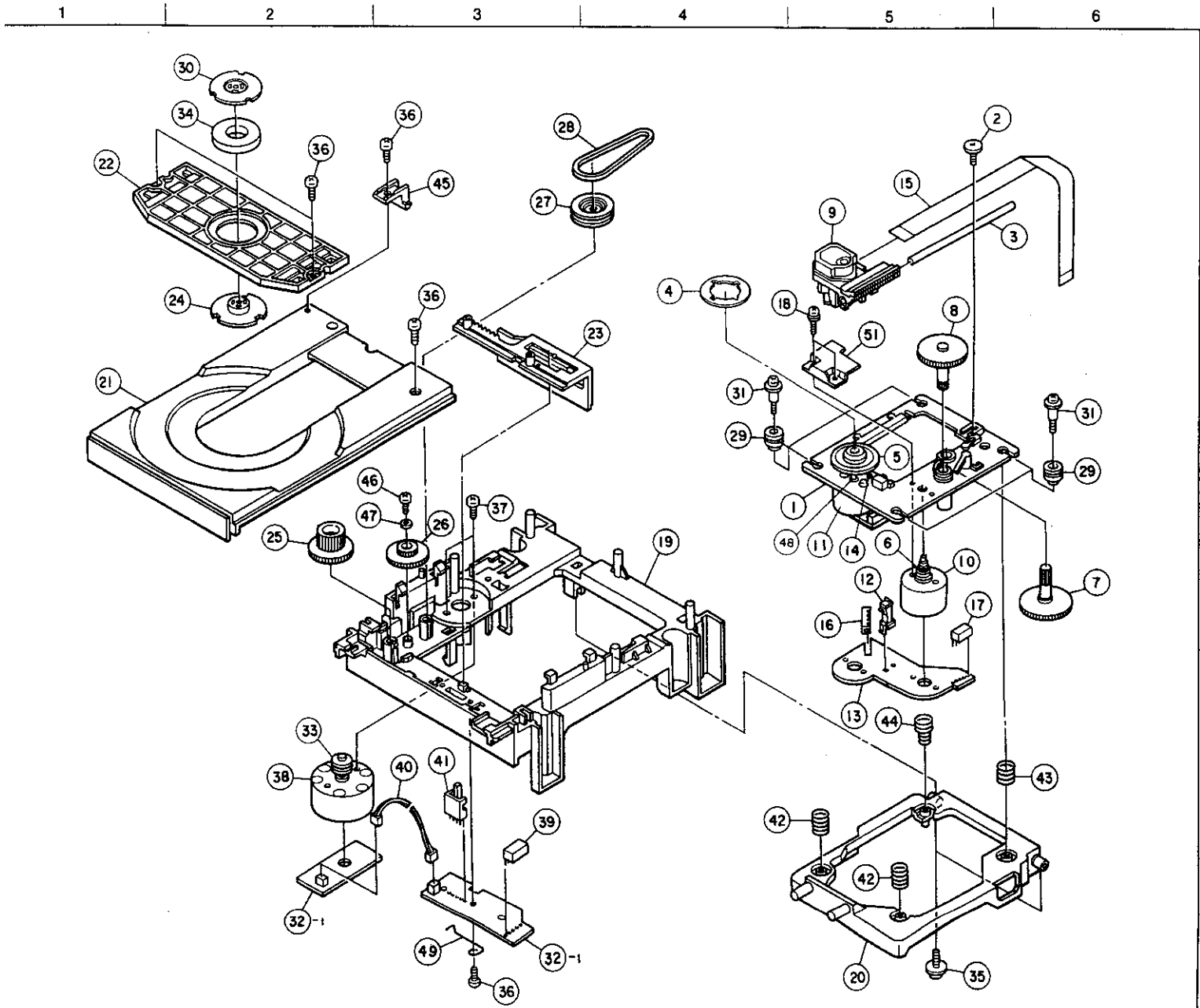

Ref. No.	Part No.	Part Name	Remarks	Qty
1	9KA 85A0 01	FG-40 Base Assy		1 ¹⁾
1-1	9KA 85P0 03	FG-40 Base		(1)
2	9KA 90H0 06	FS Hold Screw		1
3	9KA 90H0 05	Feed Shaft		1
4	9KA 90P0 70	T.T Plate M3A		1
5	9KA 90G1 04	Turn Table M3A		1
6	9KA 85G0 28	Gear Motor FG-40		1
7	9KA 85G0 17	Forward Gear A		1
8	9KA 85G0 18	Forward Gear B		1
9	499 0191 009	Pick Up	KSS240A	1
10	9KM 01T1 36	Motor (Feed)	RF-310T11400-30	1
11	9KM 01T1 31	Motor (Spindle)	RF-310T11400-38	1
12	9KS 01W1 47	Switch	LSA-1121EAU	1
13	9KA 85P0 09	Motor P.W.B. Unit		1
14	9KM 20S0 03	Tams Screw M2×3		2
15	009 0051 001	Flexible P.W.B. Unit	FFC-260-B	1
16	443 1093 006	FFC Bush		1
17	9KA 82G2 53	SP Conn. Base	S5B-PH	1
18	9KM 20S0 04	Tams Screw M2×4		2
19	9KA 85G0 19	Mech. Plate	FL12SA	1
20	9KA 85G0 20	Mech. Frame		1
21	9KA 85G0 25	CD Tray	FL12SA	1
22	9KA 85G0 04	Clamper Frame		1
23	9KA 85G0 22	UD Plate Gear		1
24	9KA 85G0 06	Clamper -F		1
25	9KA 85G0 07	Relay Gear A		1
26	9KA 85G0 08	Relay Gear B		1
27	9KA 85G0 09	Relay Gear C		1
28	9KA 85G0 10	Gear Belt F		1
29	9KA 85G0 30	Dumper		4
30	9KA 85P0 01	Clamper Plate F		1
31	9KA 85H0 01	Screw F		4
32	9KA 85P0 05	Motor Unit Assy		1
32-1	FG7 0000 622	Switch Unit		1
33	9KA 82G0 49	Motor Pulley		1
34	9KA 82G0 57	Magnet 17×27×5		1
35	9KA 91H0 02	Tight Screw M3×8	P light	2
36	9KB 30B0 08	Bind Screw M3×8	B light Black	5
37	9KM 26B0 04	Bind Screw M2.6×4		2
38	9KM 01T1 32	Motor (Loading)	RF500TB14415	1
39	9KA 82G3 08	SP Conn. Base	S5B-PH	1
40	9KA 85G0 27	Connector Cord	CNW2	1
41	9KS 01W1 48	Open/Close Switch		1
42	9KA 85S0 04	Spring D		2
43	9KA 85S0 02	Spring B		1
44	9KA 85S0 03	Spring C		1
45	9KA 85G0 36	Try Stopper		1
46	9KM 20B0 05	Bind Screw M2×5		1
47	9KS 21W6 04	Washer 2.1×6×0.4		1
48	9KB 22G0 29	Oil Seal Washer		1
49	9KA 85S0 05	Hold Spring		1
50	-	-		-
51	9KA 85G0 33	Gear Guide		1
60	9KA 85A0 07	Spindle Motor Assy	Included 1,4,5,11,14,48	1 ⁵⁾
61	9KA 85A0 08	Feed Motor Assy	Included 6,10	1 ⁵⁾
62	9KA 85A0 06	Loading Motor Assy	Included 33,38	1 ⁵⁾

CASSETTE DECK SECTION

LEVEL DIAGRAM

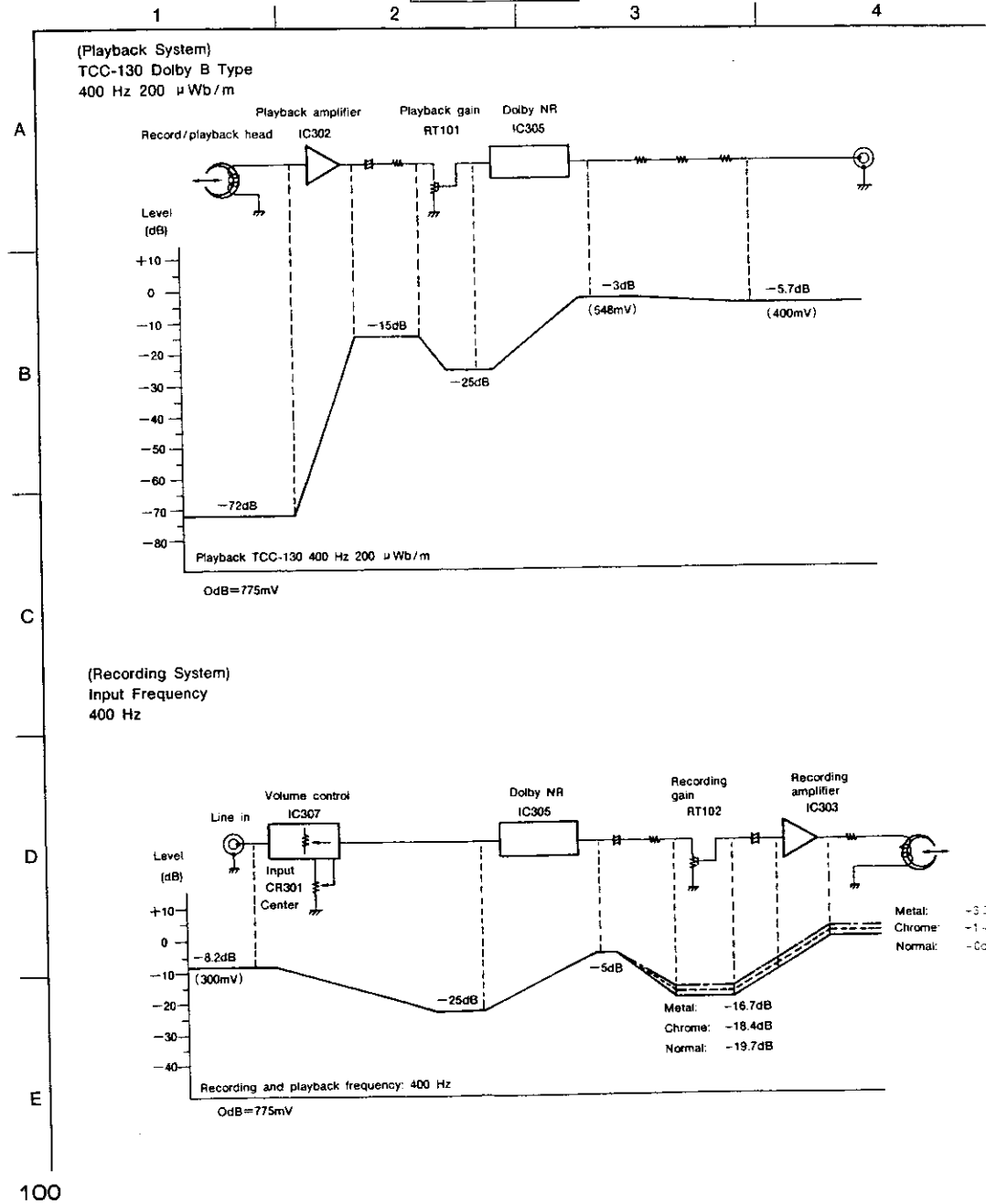

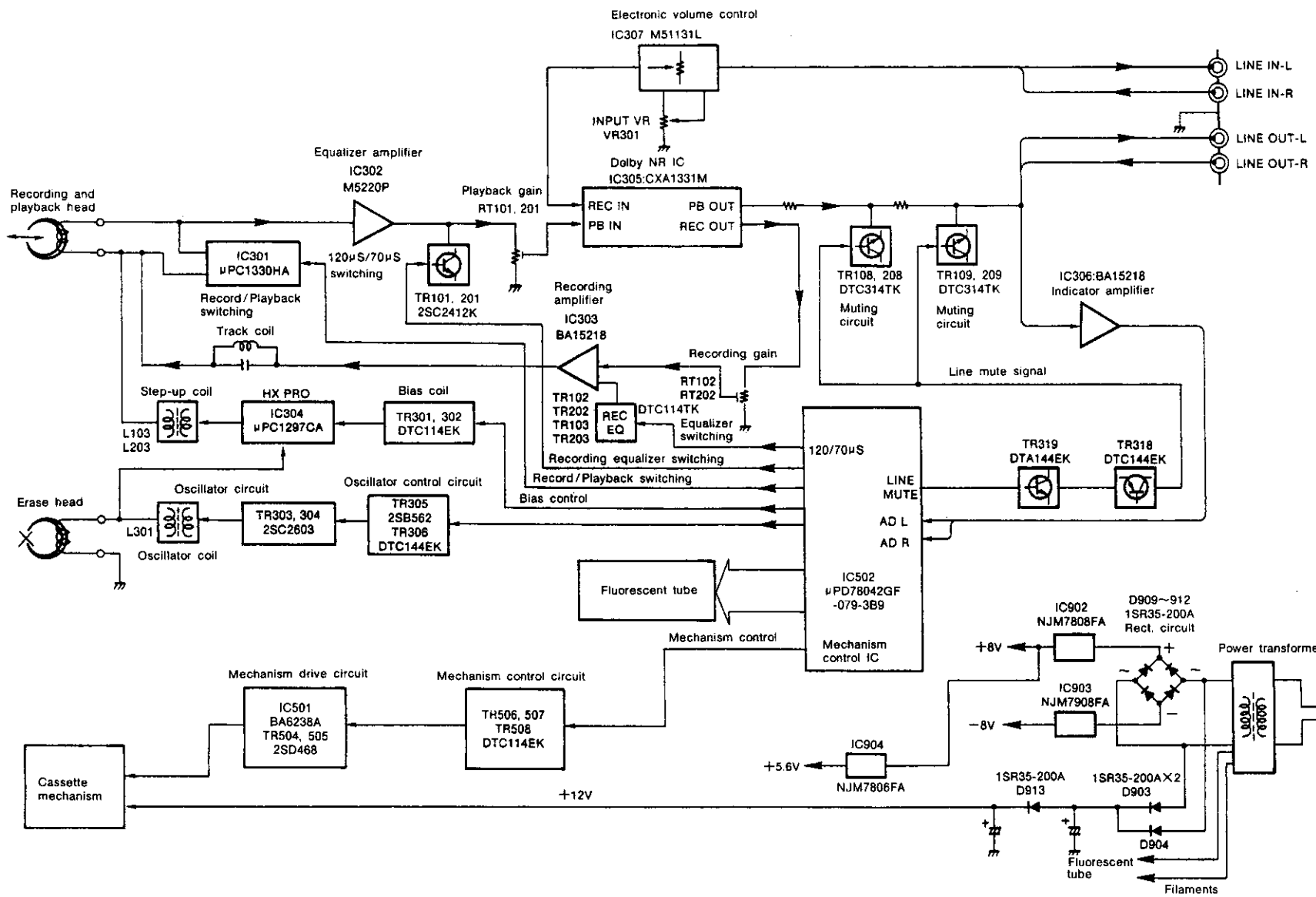

BLOCK DIAGRAM

5
6
7
8

DISASSEMBLY PROCEDURES

(Assembly is performed in the reverse order.)

1. Removing the Top Cover and the Front Panel

- ① Remove the six screws which fasten the top cover.
- ② Remove the top cover (upward) in the direction of the arrow.

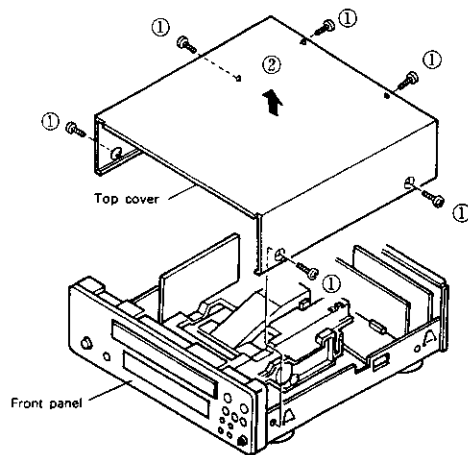

- ③ Remove the two screws which fasten front panel.
- ④ Release the inner panel hooks from the chassis while pulling the panels in the direction of the arrow to remove the inner panel and the front panel as one unit.

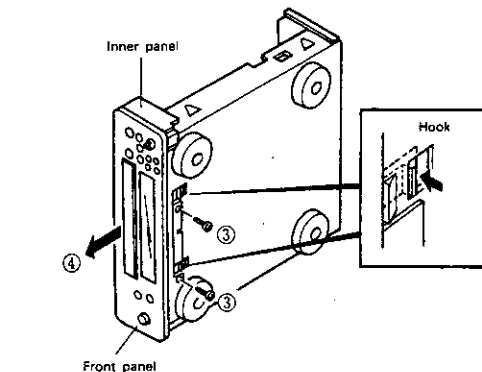
**2. Removing the Units****Display Unit (2U-2700B-5)**

- ⑤ Remove the volume control knob in the direction of the arrow, then remove the eight screws which fasten the display unit.

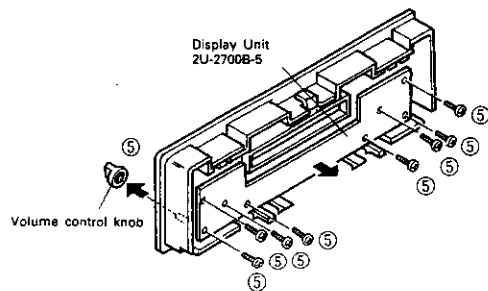
**3. Removing the Rear Panel**

- ⑥ Remove the cord bush from the rear panel.
- ⑦ Remove the six "a" screws and one "b" screw which fasten the rear panel.
- ⑧ Remove the rear panel in the direction of the arrow.

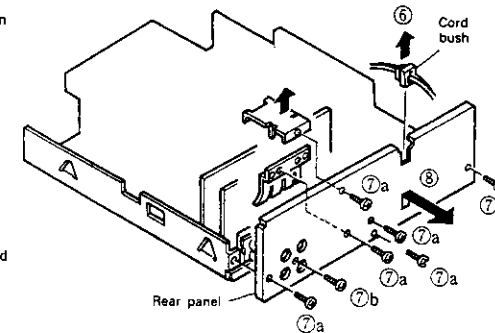
**Microprocessor Unit (2U-2700B-4)**

- ⑨ Disconnect the microprocessor unit from the connector and remove in the direction of the arrow.

R/P Unit (2U-2700B-3)

- ⑩ Disconnect the R/P unit from the connector and remove in the direction of the arrow.

Dolby Unit (2U-2700B-2)

- ⑪ Disconnect the Dolby unit from the connector and remove in the direction of the arrow.

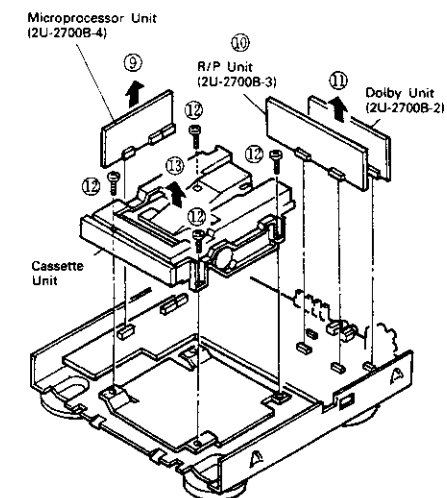
**4. Removing the Cassette Unit**

- ⑫ Remove the five screws which fasten the cassette unit.
- ⑬ Remove the cassette unit in the direction of the arrow.

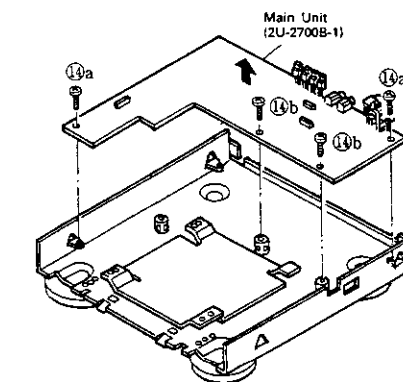
**Main Unit (2U-2700B-1)**

- ⑭ Remove the two "a" screws and 2 "b" screws which fasten the main unit.

CASSETTE DECK SECTION

ADJUSTMENTS

ADJUSTING AND CHECKING THE MECHANISM SECTION

1. Replacement of the pinch roller

Before replacing the pinch roller, clean the tape contact surface of the pinch roller and the tape contact surface of the capstan shaft. After replacement, run a C-90 tape without a pad and check for the presence of tape curl at the tape guide portion of the head.

2. Checking the pinch roller pressure

Set to the playback condition and hook a bar-type spring scale to the bracket above the center line of the pinch roller. Pull the pinch roller away from the capstan shaft, then allow the pinch roller to come into contact with the capstan shaft and check that the reading of the bar-type spring scale is between 250 g and 350 g when the pinch roller starts to rotate. Replace the pinch roller when the value falls outside of the specified range.

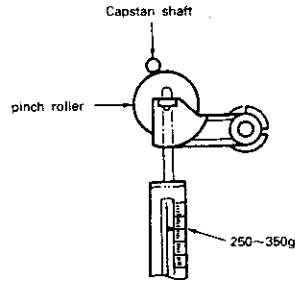

3. Replacement of the recording/playback head assembly

Perform this procedure after removing the front panel.

3-1 Removal of the head assembly

- (1) Remove the 2 head base fastening screws
- (2) Remove the head base from the reed holder and the wire connector.

3-2 Mounting the recording/playback head assembly

Perform by following the steps of Section 3-1 Removal of the head assembly in reverse.

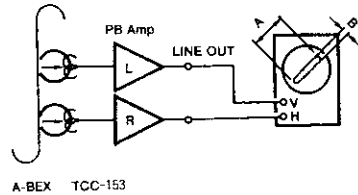

4. Adjustment of the recording/playback head

Azimuth adjustment

Load side A of the A-BEX TCC-153 test tape facing forward, and adjust.

- (1) Play in the FWD direction and turn the azimuth adjustment nut for the FWD side so that the Lissajous's figure becomes maximum at (A) and minimum at (B).
- (2) Apply screw lock to the adjustment locations.

5. Checking the winding torque

Load a cassette type torque meter (Sony TW2111A at the FWD side) and check that the reading of the torque meter during playback is 30 to 70 g-cm at the center value. When outside of the specified value range, check the voltage of the reel motor (approx. 4 V). When the voltage value is low, the torque is weak, and when high, the torque is strong.

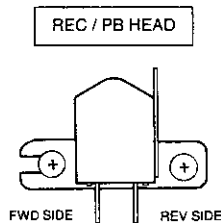

6. Checking the back tension torque at the time of recording and playback

Load a cassette type torque meter (Sony TW2111A at the FWD side) and check that the reading of the torque meter during playback is 2 to 6 g-cm and that there is no unevenness.

7. Checking the FF and REW torque

Load a cassette type torque meter (Sony TW2231) and check that the value indicated by the torque meter for winding and rewinding is between 90 and 180 g-cm.

8. Checking the FF and REW time

Load a DENON HD-X / 60 cassette tape, and check that the time for FF and REW is between 80 and 110 seconds. When outside of the specified range, check Steps 5 and 6.

9. Checking the erroneous erasure prevention, and the metal and chrome switch operations

Check that the detection lever is operating the switch properly depending upon the presence or absence of a hole.

ADJUSTING AND CHECKING THE ELECTRICAL SECTION

Measuring instruments needed for the adjustments

- (1) Low frequency oscillator
- (2) Variable resistance attenuator
- (3) Electronic voltmeter
- (4) Oscilloscope
- (5) Frequency counter
- (6) Adjustment screwdriver
- (7) 4-sided adjustment rod for trap coil adjustments
- (8) Test tapes
(Sony TY224)
(A-BEX TCC-153, TCC-130, TCC-262B/162B)
(DENON HDX-60)
- (9) Mirror cassette for the transport (A-BEX TCC-902)

Adjustment precaution

- (1) Before adjustments, use gauze or a swab moistened with alcohol to wipe the surface of the heads, the capstan shaft, and the pinch roller.
- (2) Demagnetize the record/playback head and the erase head with a head eraser.
- (3) Completely demagnetize the driver to be used for the adjustments.
- (4) Unless otherwise specified, set the various operation controls as indicated below.
Input/output controls: Center
Dolby NR switch: Off

1. Tape transport check

Load the mirror cassette for the transport, and illuminate the area around the fixed guide of the record/playback head with a lamp and observe.

Check that the tape edge is not hitting the tape guide portion. Note that the tape transport is the greatest factor affecting the performance of the cassette deck. Never move the inspection locations without good reason.

For information about replacement and adjustment of the record/playback head, see the section "Adjustment and checking of the mechanism."

2. Azimuth adjustment

- 2-1 After making the tape transport check, load the test tape (A-BEX TCC-153).
- 2-2 Play back the test tape and turn the azimuth adjustment nut so that the Lissajous's figure becomes maximum at (A) and minimum at (B).

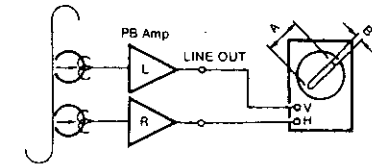

A-BEX TCC-153

3. Tape speed check and adjustment

- 3-1 Connect the frequency counter to the LINE OUT pin and load the test tape (Sony TY-224).
- 3-2 Playback a test tape. At about halfway through the tape, where the tape transport is stable, adjust RT-501 so that the frequency counter will have a reading within the range of $3,000 \text{ Hz} \pm 15 \text{ Hz}$.

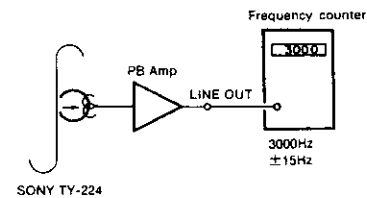

SONY TY-224

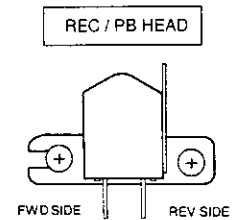

4. Adjustment of the playback system

- 4-1 Playback level
Play back the test tape for the Dolby standard level (A-BEX TCC-130), and adjust RT101 (Left channel) and RT201 (right channel) so that the level of the LINE OUT pin becomes -5.7 dB (400 mV). (Load resistance of 47 kohm)
- 4-2 Checking the playback frequency responses
Play back the test tape (A-BEX TCC-262B/162B), and check that the frequency response satisfies the standard.

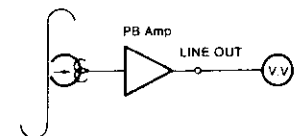

NOTE

After making the azimuth adjustment with the 8 kHz at the start of the A-BEX TCC-262B test tape, perform check of the frequency responses.
Also, after the check make an azimuth adjustment again with A-BEX TCC-153, then apply screw lock.

CASSETTE DECK SECTION

Playback Frequency Response

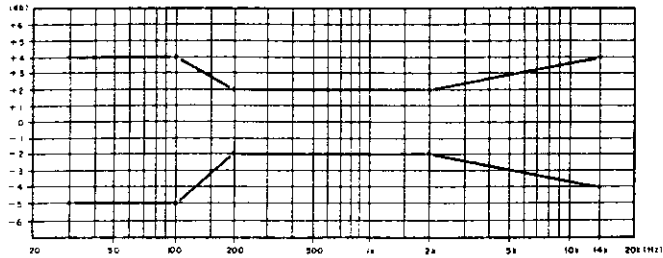

TAPE: A-BEX TCC-262B/162B

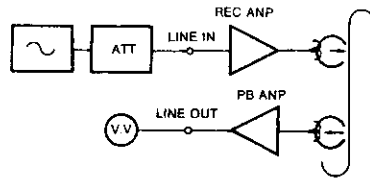

5. Adjustment of the recording system

- 5-1 Adjustment of the recording and playback overall frequency responses
- (1) Load the DENON HD/60 test tape, record a signal of -20 dB 1 kHz input level, and play back.
 - (2) Set the input signal to 10 kHz, record, and play back. Adjust RT103 (left channel) and RT203 (right channel) so that the response specifications of the diagram below are satisfied with respect to the 1 kHz output level.

Recording / Playback Overall Frequency Response

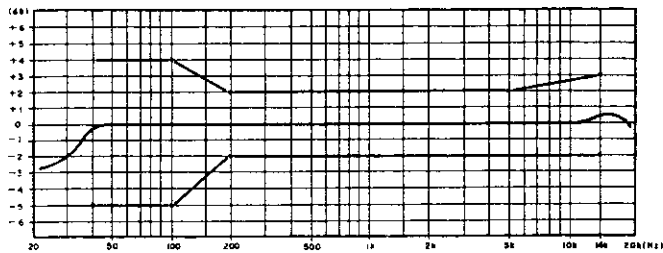

Tape : HD-X/60
Dolby NR : Off
Level : -20 dB From Dolby Level

5-2 Adjustment of the recording/playback level

- (1) Load the DENON HDX/60 test tape, record a signal of 1 kHz (-20 dB), and play back.
- (2) Adjust RT-102 (left channel) and RT-202 (right channel) so that the output of the LINE OUT pin becomes the same as the output at the time of the recording monitor.

Recording / Playback Overall Frequency Response

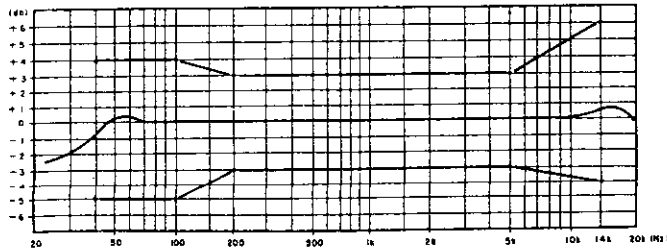

Tape : HD-X/60
Dolby NR : On C
Level : -20 dB From Dolby Level

5-3 Checking the Dolby C recording and playback overall frequency response.

- (1) set the Dolby NR switch to the "C" positions.
- (2) Use the DENON HDX/60 test tape to record and play back according to the outline of Section 5-1, then check that the response specifications have been satisfied.

CASSETTE DECK SECTION

OUTLINE DIAGRAM OF ADJUSTMENT LOCATIONS

2U-2700B-3 PB, REC/PB UNIT ASS'Y (Component Side)

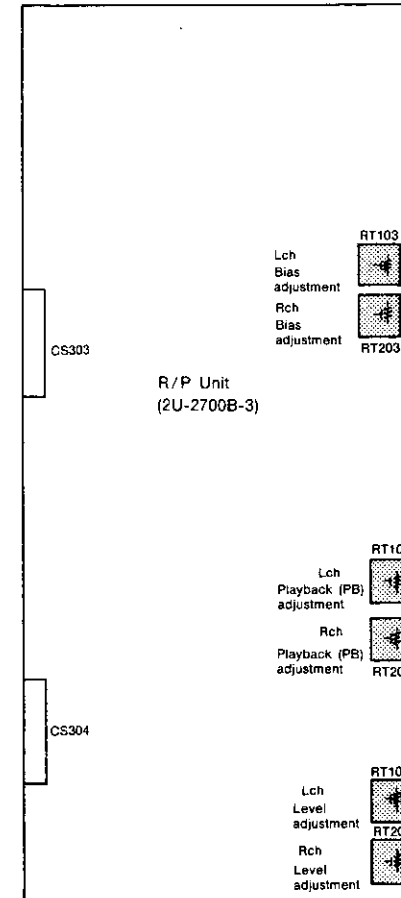

CASSETTE DECK SECTION

CASSETTE DECK SECTION

IC's

CXA1331M (IC305)

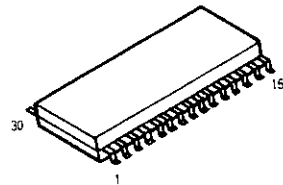

SEMICONDUCTORS

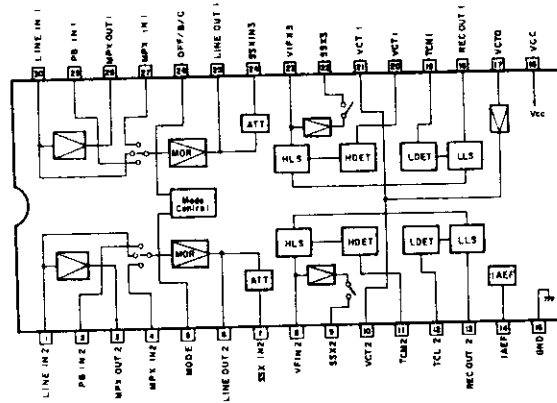

μPC1330HA (IC301)

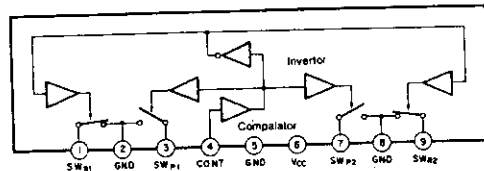
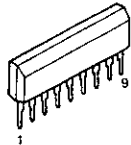

μPC1297CA (IC304)
Dolby HX Pro.

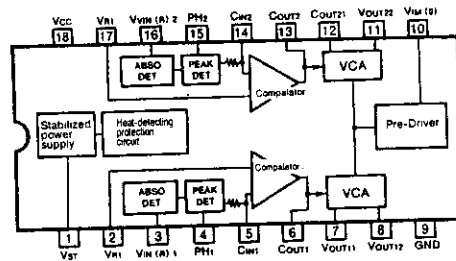
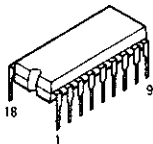

BA6238A (IC501)
Reversible motor driver
(2 circuits built in)

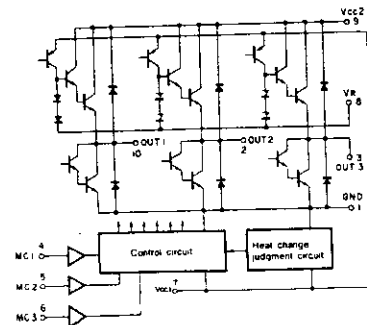
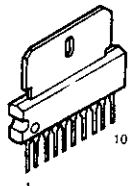

M51131L
(IC307)

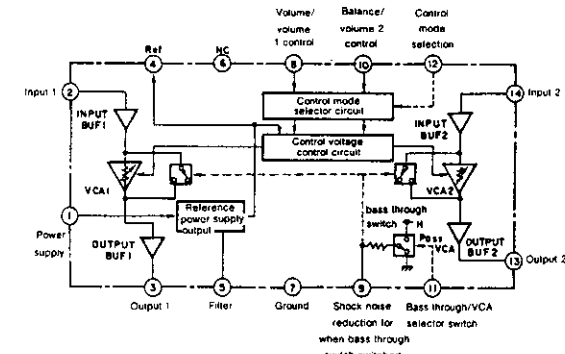
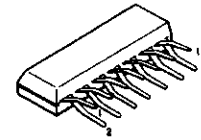

BA15218F
(IC303, 306)

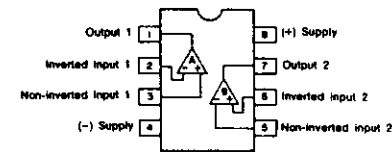
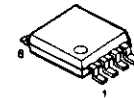

NJM7806FA(S) (IC904)
NJM7808FA(S) (IC902)
(Three-terminal positive
constant voltage power supply)

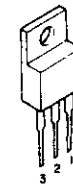

1: Output
2: GND
3: Input

M5220FP
(IC302)

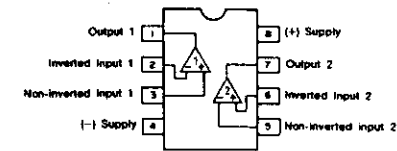
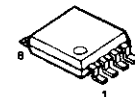

NJM7908FA (IC903)
(Three-terminal negative
constant voltage power supply)



1: Output
2: Input
3: GND

CASSETTE DECK SECTION

• **Transistors**

2SC2603 (E/F)
2SD1111

2SB562 (C)
2SD468 (C)

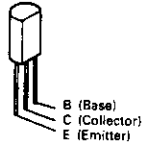
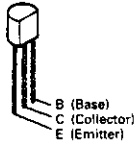

DTA EK series

DTC TK series

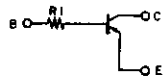
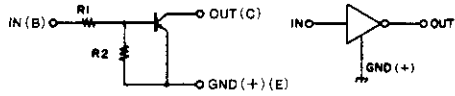
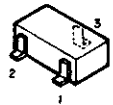

- 1. : GND/Emitter
- 2. : In/Base
- 3. : Out/Collector

	R1	R2
DTA144EK	47 kohm	47 kohm

	R1
DTC114TK	10 kohm
DTC314TK	10 kohm

DTC EK series

- DTA144EK PNP type
- DTC114EK
- DTC124EK
- DTC144EK
- DTC114TK NPN type
- DTC314TK

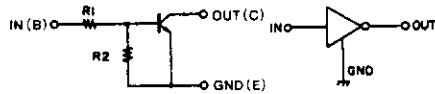

2SA1037K (S/R)
2SC2412K (S)

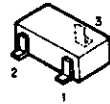

- 1. : Emitter
- 2. : Base
- 3. : Collector

	R1	R2
DTA114EK	10 kohm	10 kohm
DTA124EK	22 kohm	22 kohm
DTA144EK	47 kohm	47 kohm

• **Diodes**

- HZS2C-1
- HZS3C-1
- HZS4C-1
- HZS5C-1
- HZS6A-1
- HZS6C-1
- HZS7B-1
- HZS9B-1
- HZS20-1

1SS252

1SR35-200A



CASSETTE DECK SECTION

• Fluorescent Display Tube BJ239GK
(Part No.: 393 8014 000)

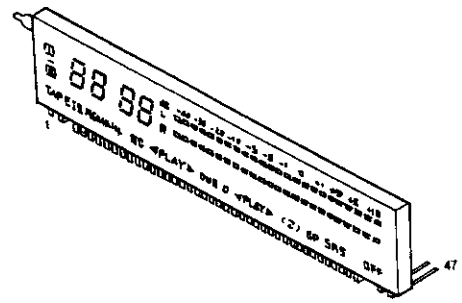

Pin Connections

Pin No.	1	2	3	4	5	6	7	8	9	10	11	12	13	14	15	16	17	18	19	20	21	22	23	24
Connection	F1	F1	NP	NP	1G	2G	3G	4G	5G	NC	NC	NC	NC	NC	NC	NC	NC	NC	NC	NC	NC	NC	NC	NC
Pin No.	25	26	27	28	29	30	31	32	33	34	35	36	37	38	39	40	41	42	43	44	45	46	47	
Connection	NC	NC	P17	P16	P15	P14	P13	P12	P11	P10	P9	P8	P7	P6	P5	P4	P3	P2	P1	NP	NP	F2	F2	

- NOTE
- 1) F1 and F2: Filaments
 - 2) NP: No pin
 - 3) NC: No connection
 - 4) 1G through 5G: Grid

Anode Connection

	5G	4G	3G	2G	1G
P1	TAPE	1a	1a	B1	B1
P2	I	1b	1b	B2	B2
P3	II	1c	1c	B3	B3
P4	REMAIN	1d	1d	B4	B4
P5	B	1e	1e	B5	B5
P6	C	1f	1f	B6	B6
P7	◀ (A)	1g	1g	B7	B7
P8	PLAY (A)	2a	2a	B8	B8
P9	▶ (A)	2b	2b	B9	B9
P10	DUB	2c	2c	B10	B10
P11	○	2d	2d	B11	B11
P12	◀ (B)	2e	2e	B12	B12
P13	PLAY (B)	2f	2f	C	S1
P14	▶ (B)	2g	2g	Σ	—
P15	I	—	Dp	∩	—
P16	—	—	—	CD SRS	—
P17	II	—	—	OFF	—

Grid Assignment

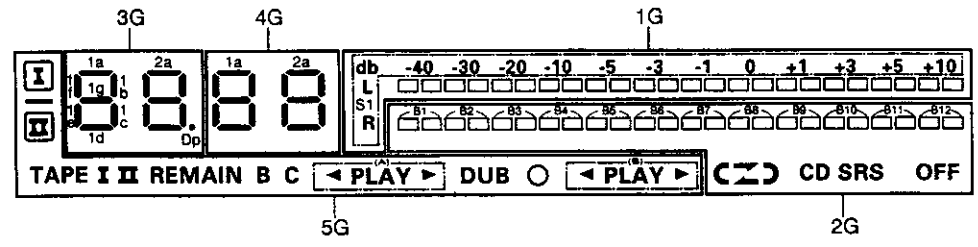

CASSETTE DECK SECTION

MICROPROCESSOR DOCUMENTATION

μPD78042GF-079-3B9 : 262 1938 106
(IC502)

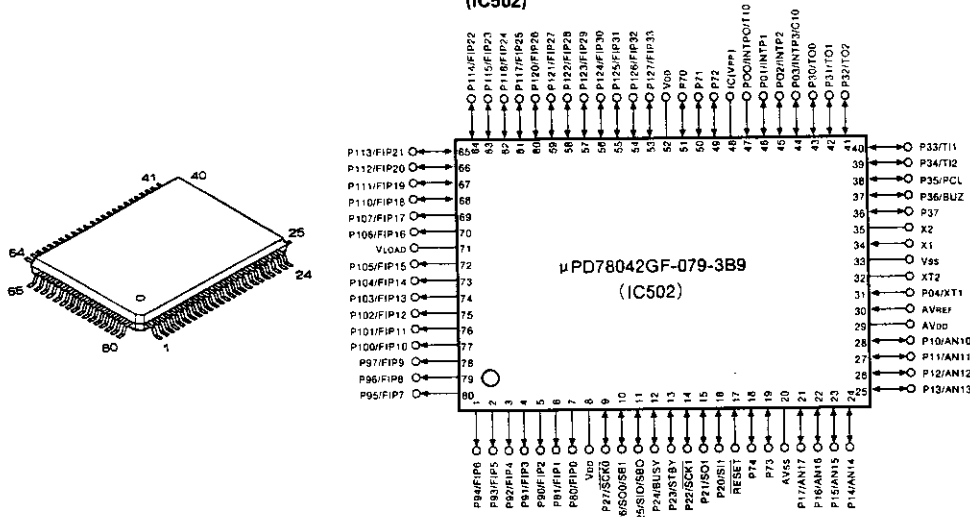

Output logic: H = positive logic, L = negative logic
Initial condition: H = positive potential, L = ground
Output type: P = PMOS, N = NMOS, C = CMOS
Load resistor: None, (PULL) UP, (PULL) DOWN

• Pin Description

Pin	Pin Name	Function Name	I/O	Output Logic	Initial Condition	Output Type	Load Resistor	Details
1	P94	MTCONT2	O	H	Hi-Z	P	External DOWN	PULL-DOWN one time: built in. Mask: optional. Reel, loader motor control
2	P93	MTCONT1	O	H	Hi-Z	P	External DOWN	PULL-DOWN one time: built in. Mask: optional. Reel, loader motor control
3	P92	GRID-5	O	H	Hi-Z	P	Built-in DOWN	PULL-DOWN one time: built in. Mask: optional. Display tube grid control signal
4	P91	GRID-4	O	H	Hi-Z	P	Built-in DOWN	PULL-DOWN one time: built in. Mask: optional. Display tube grid control signal
5	P90	GRID-3	O	H	Hi-Z	P	Built-in DOWN	PULL-DOWN one time: built in. Mask: optional. Display tube grid control signal
6	P81	GRID-2	O	H	Hi-Z	P	Built-in DOWN	PULL-DOWN one time: built in. Mask: optional. Display tube grid control signal
7	P80	GRID-1	O	H	Hi-Z	P	Built-in DOWN	PULL-DOWN one time: built in. Mask: optional. Display tube grid control signal
8	VDD	5[V]						
9	P27	REC-FWD	I	H	Hi-Z	—	External DOWN	Mechanism switch input signal
10	P26	METAL	I	H	Hi-Z	—	External DOWN	Mechanism switch input signal
11	P25	REC-REV	I	H	Hi-Z	—	External DOWN	Mechanism switch input signal
12	P24	PACK	I	H	Hi-Z	—	External DOWN	Mechanism switch input signal
13	P23	CHROME	I	H	Hi-Z	—	External DOWN	Mechanism switch input signal
14	P22	SERCLK	I	EDGE	Hi-Z	—	External UP	Serial communications clock signal
15	P21	SEROUT	O	H	Hi-Z	C	External UP	Serial communications output signal
16	P20	SER-IN	I	H	Hi-Z	—	External UP	Serial communications output signal
17	RESET	RESET	I	L	Hi-Z	—	External UP	Reset input signal
18	P74	R-MUTE	O	H	Hi-Z	N	External UP	Recording mute control signal
19	P73	HEADSW	O	H/L	Hi-Z	N	External UP	Head switching control signal: record at high level and play back at low level
20	AVSS	GND						
21	AN17	KEYIN-3	I	A/D	Hi-Z	—	External UP	Operation button input signal (Not used)
22	AN16	KEYIN-2	I	A/D	Hi-Z	—	External UP	Operation button input signal No. 2
23	AN15	KEYIN-1	I	A/D	Hi-Z	—	External UP	Operation button input signal No. 1
24	AN14	KEYIN-0	I	A/D	Hi-Z	—	External UP	Operation button input signal No. 0
25	AN13	MSREF	I	A/D	Hi-Z	—		Between-track detection reference voltage

Pin	Pin Name	Function Name	I/O	Output Logic	Initial Condition	Output Type	Load Resistor	Details
26	AN12	TEST	I	A/D	Hi-Z	—		
27	AN13	A/D-L	I	A/D	Hi-Z	—	External DOWN	Left channel audio signal
28	AN10	A/D-L	I	A/D	Hi-Z	—	External DOWN	Right channel audio signal
29	AVDD	+5[V]						
30	AVREF	+5[V]						
31	P04	RVS/ONE	I	H/L	Hi-Z	—		Reverse/one-way switching: one-way at low level, reverse at high level
32	XT2	OPEN						
33	VSS	GND						
34	X1	CLOCK						System clock input pin
35	X2	CLOCK						System clock input pin
36	P37	SPD/L	O	H	Hi-Z	C	External DOWN	Loader speed control signal
37	P36	SPD/H	O	H	Hi-Z	C	External DOWN	Loader speed control signal
38	P35	SOL/K	O	H	Hi-Z	C	External DOWN	Solenoid kick control signal
39	P34	SOL/H	O	H	Hi-Z	C	External DOWN	Solenoid kick control signal
40	P33	CAPSTAN	O	H	Hi-Z	C	External DOWN	Capstan control signal
41	P32	LOADSPD	I	H	Hi-Z	—	External DOWN	Loader speed switching input signal
42	P31	LOADOUT	I	H	Hi-Z	—	External DOWN	Loader open input signal
43	P30	LOADIN	I	H	Hi-Z	—	External DOWN	Loader close input signal
44	P03	STANBY	I	H	Hi-Z	—	External UP	Power loss detection signal
45	INTP2	SERINT	I	EDGE	Hi-Z	—	External UP	Serial communications interrupt signal
46	INTP1	TK-PLS	I	EDGE	Hi-Z	—	External UP	Take-up reel pulse input signal
47	INTP0	SP-PLS	I	EDGE	Hi-Z	—	External UP	Supply-reel pulse input signal
48	IC	D-GND						
49	P72	NORMAL	O	H	Hi-Z	N	External DOWN	Tape select switching signal
50	P71	CHROME	O	H	Hi-Z	N	External DOWN	Tape select switching signal
51	P70	METAL	O	H	Hi-Z	N	External DOWN	Tape select switching signal
52	VDD	5[V] HOLD						
53	P127	L-MUTE	O	L	Hi-Z	P	External DOWN	Line mute control signal
54	P126	DOLON/OFF	O	H/L	Hi-Z	P	External DOWN	Dolby on/off switching signal: Off at high level, On at low level
55	P125	DOLB/C	O	H/L	Hi-Z	P	External DOWN	Dolby B/C switching signal: Type-B at high, Type-C at low
56	P124	DOLR/P	O	H/L	Hi-Z	P	External DOWN	Dolby recording/playback switching signal: PB at high, REC at low
57	P123	MPXFL	O	H	Hi-Z	P	External DOWN	MPX filter control signal
58	P122	70/120	O	H/L	Hi-Z	P	External DOWN	Playback equalizer control signal: 70 μ s at high, and 120 μ s at low
59	P121	BIAS	O	H	Hi-Z	P	External DOWN	Bias control signal
60	P120	SEG-17	O	H	Hi-Z	P	Built-in DOWN	PULL-DOWN one time: None. Mask: optional. Display tube segment control signal
61	P117	SEG-01	O	H	Hi-Z	P	Built-in DOWN	PULL-DOWN one time: None. Mask: optional. Display tube segment control signal
62	P116	SEG-02	O	H	Hi-Z	P	Built-in DOWN	PULL-DOWN one time: None. Mask: optional. Display tube segment control signal
63	P115	SEG-03	O	H	Hi-Z	P	Built-in DOWN	PULL-DOWN one time: None. Mask: optional. Display tube segment control signal
64	P114	SEG-04	O	H	Hi-Z	P	Built-in DOWN	PULL-DOWN one time: None. Mask: optional. Display tube segment control signal
65	P113	SEG-05	O	H	Hi-Z	P	Built-in DOWN	PULL-DOWN one time: None. Mask: optional. Display tube segment control signal
66	P112	SEG-06	O	H	Hi-Z	P	Built-in DOWN	PULL-DOWN one time: None. Mask: optional. Display tube segment control signal
67	P111	SEG-07	O	H	Hi-Z	P	Built-in DOWN	PULL-DOWN one time: None. Mask: optional. Display tube segment control signal
68	P110	SEG-08	O	H	Hi-Z	P	Built-in DOWN	PULL-DOWN one time: None. Mask: optional. Display tube segment control signal
69	P107	SEG-09	O	H	Hi-Z	P	Built-in DOWN	PULL-DOWN one time: None. Mask: optional. Display tube segment control signal
70	P106	SEG-10	O	H	Hi-Z	P	Built-in DOWN	PULL-DOWN one time: None. Mask: optional. Display tube segment control signal
71	VLOAD	-2[V]						
72	P105	SEG-11	O	H	Hi-Z	P	Built-in DOWN	PULL-DOWN one time: None. Mask: optional. Display tube segment control signal
73	P104	SEG-12	O	H	Hi-Z	P	Built-in DOWN	PULL-DOWN one time: None. Mask: optional. Display tube segment control signal
74	P103	SEG-13	O	H	Hi-Z	P	Built-in DOWN	PULL-DOWN one time: None. Mask: optional. Display tube segment control signal
75	P102	SEG-14	O	H	Hi-Z	P	Built-in DOWN	PULL-DOWN one time: None. Mask: optional. Display tube segment control signal
76	P101	SEG-15	O	H	Hi-Z	P	Built-in DOWN	PULL-DOWN one time: None. Mask: optional. Display tube segment control signal
77	P100	SEG-16	O	H	Hi-Z	P	Built-in DOWN	PULL-DOWN one time: None. Mask: optional. Display tube segment control signal
78	P97	OPEN						PULL-DOWN one time: Built in. Mask: optional.
79	P96	OPEN						PULL-DOWN one time: Built in. Mask: optional.
80	P95	MTCONT3	O	H	Hi-Z	P	External DOWN	PULL-DOWN one time: Built in. Mask: optional.

CASSETTE DECK SECTION

MICROPROCESSOR PERIPHERAL WIRING DIAGRAM

1 2 3 4 5 6 7 8

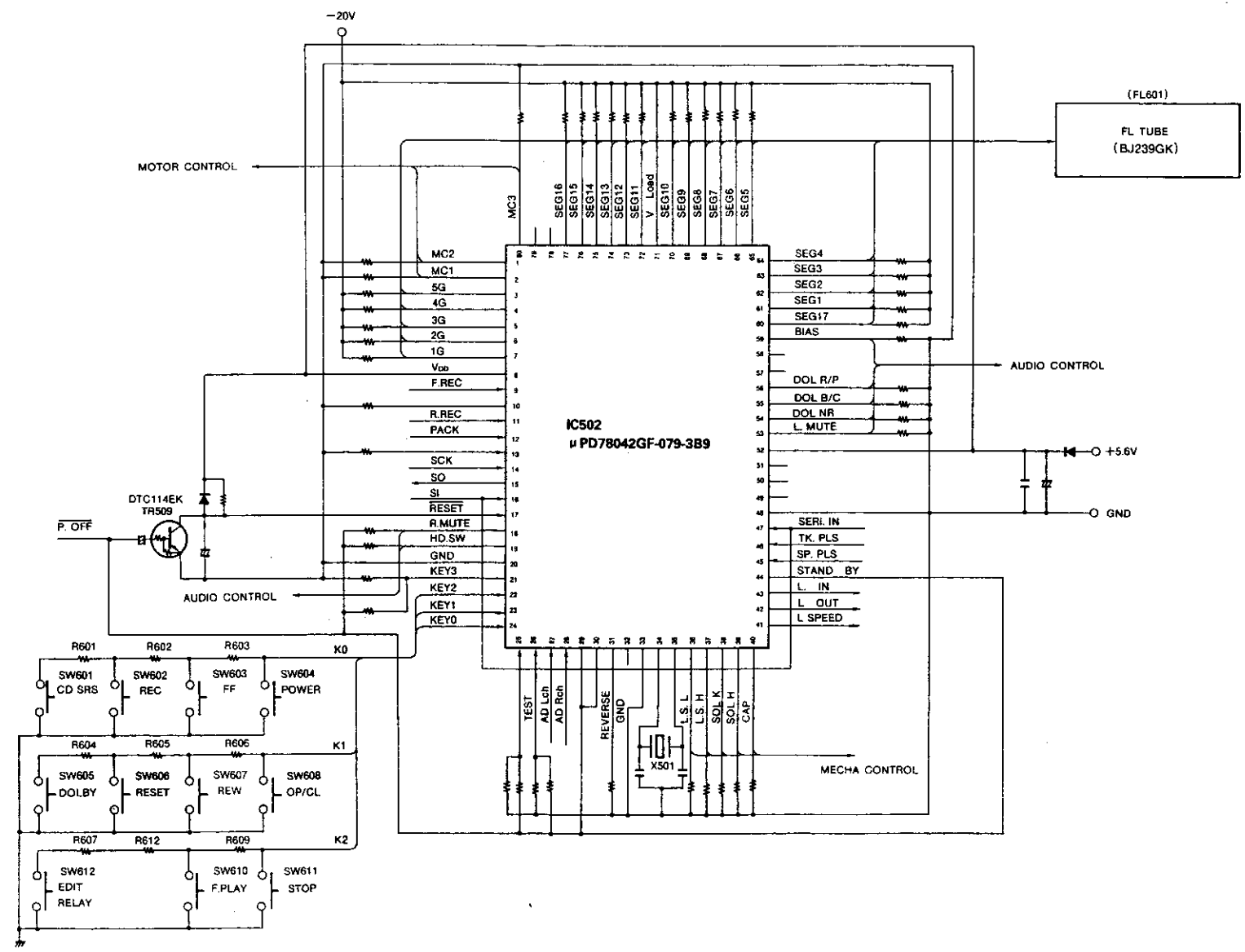

A
B
C
D
E

CASSETTE DECK SECTION

PRINTED WIRING BOARD

1

2

3

4

5

6

7

8

UDR-F10 2U-2700B DECK UNIT ASS'Y

Component Side

A
B
C
D
E

2U-2700B	
-1	Main Unit
-2	Dolby Unit
-3	Rec/PB Unit
-4	Microprocessor Unit
-5	Display Unit

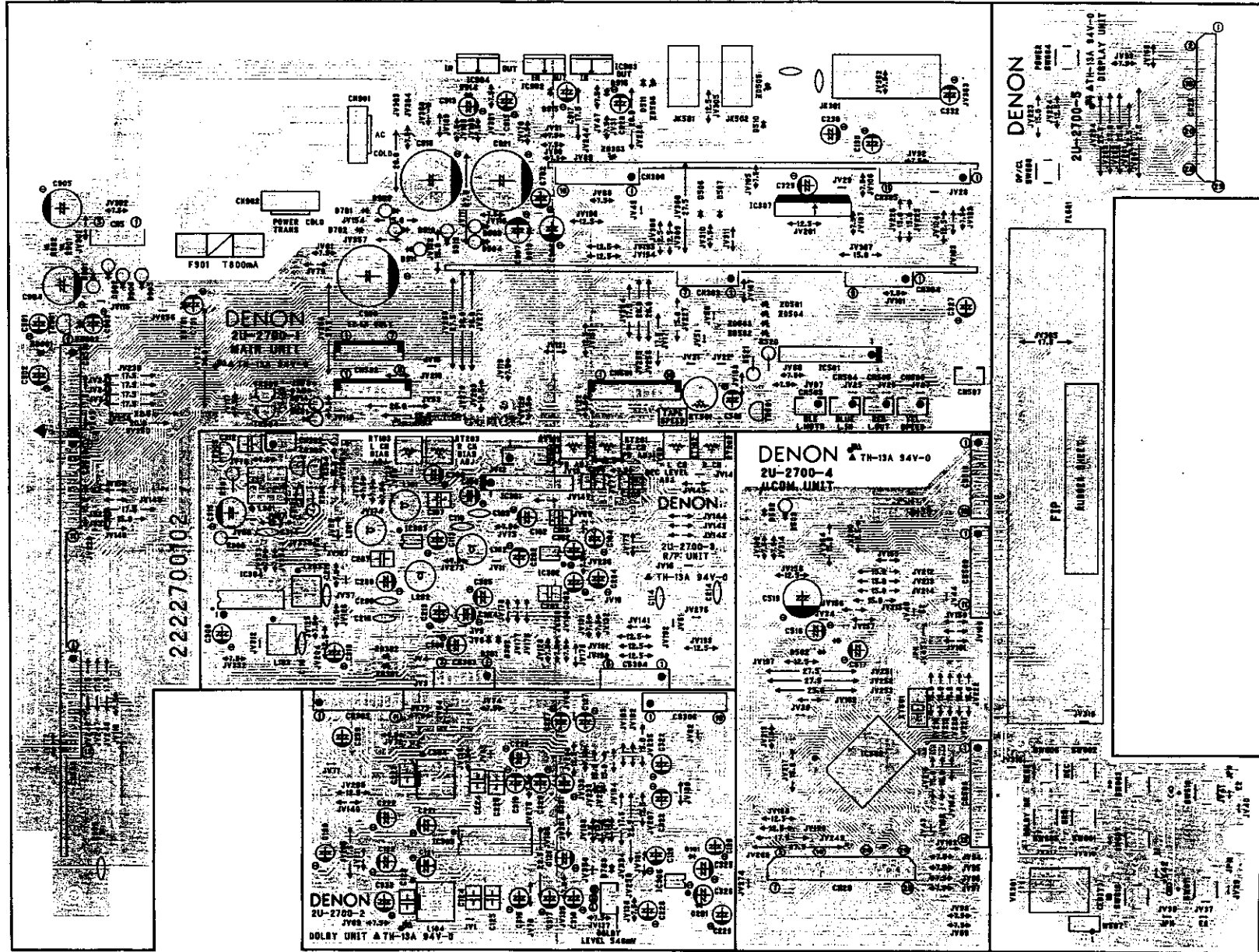

CASSETTE DECK SECTION

1 2 3 4 5 6 7 8

Pattern Side

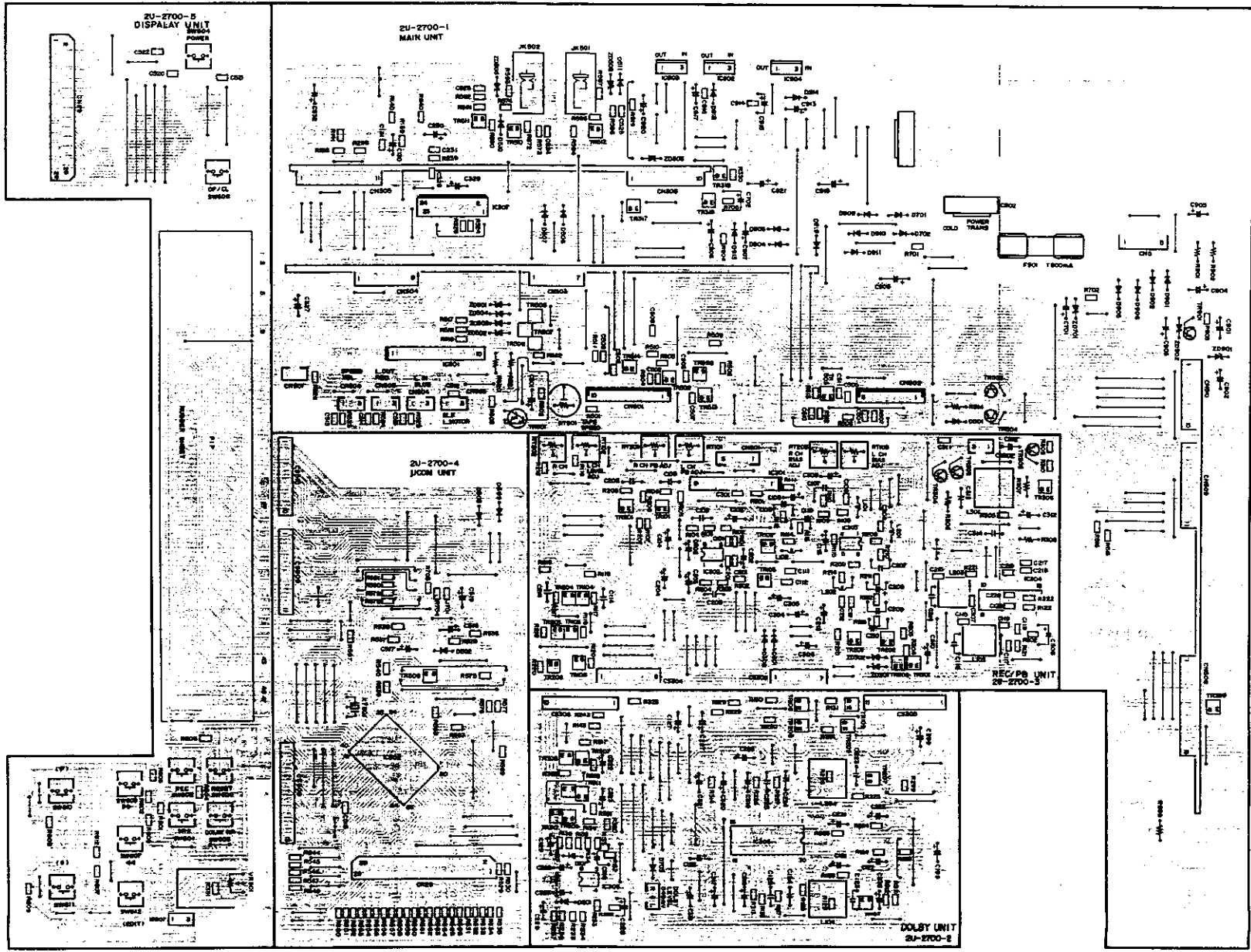

A
B
C
D
E

CASSETTE DECK SECTION

NOTE ON PARTS LIST

- Part indicated with the mark "⊗" are not always in stock and possibly to take a long period of time for supplying, or in some case supplying of part may be refused.
- When ordering of part, clearly indicate "1" and "1" (i) to avoid mis-supplying.
- Ordering part without stating its part number can not be supplied.
- Part indicated with the mark "★" is not illustrated in the exploded view.
- Not including Carbon Film ±5%, 1/4W Type in the P.W. Board parts list. (Refer to the Schematic Diagram for those parts.)

WARNING:

Parts marked with this symbol Δ have critical characteristics. Use ONLY replacement parts recommended by the manufacturer.

Resistors

Ex.: **RN** 14K **2E** 182 **G** **FR**
 Type Shape and performance Power Resistance Allowable Others

RD: Carbon Film	2B: 1/8W	F: ±1%	P: Pulse-resistant type
RC: Composition	2E: 1/4W	G: ±2%	NL: Low noise type
RS: Metallic oxide Film	2H: 1/2W	J: ±5%	NB: Non-burning type
RW: Winding	3A: 1W	K: ±10%	FR: Fuse-resistor
RN: Metal film	3D: 2W	M: ±20%	F: Lead wire forming
RK: Metal mixture	3F: 3W		
RM: Carbon chip	3H: 5W		

Resistance
 $\frac{1}{\text{---}} \frac{8}{\text{---}} \frac{2}{\text{---}}$ ⇒ 1800 ohm = 1.8 kohm
 Indicates number of zeros after effective number
 2-digit effective number
 Units: ohm

$\frac{1}{\text{---}} \frac{R}{\text{---}} \frac{2}{\text{---}}$ ⇒ 1.2 ohm
 1-digit effective number.
 2-digit effective number, decimal point indicated by R.
 Units: ohm

Capacity (electrolyte only)
 $\frac{2}{\text{---}} \frac{2}{\text{---}} \frac{2}{\text{---}}$ ⇒ 2200 μF
 Indicates number of zeros after effective number.
 2-digit effective number.
 Units: μF

$\frac{2}{\text{---}} \frac{R}{\text{---}} \frac{2}{\text{---}}$ ⇒ 2.2 μF
 1-digit effective number.
 2-digit effective number, decimal point indicated by R.
 Units: μF

Capacitors

Ex.: **CE** 04W **1H** **2R2** **M** **BP**
 Type Shape and performance Dielectric strength Capacity Allowable Others

CE: Aluminum foil electrolyte	DJ: 6.3V	F: ±1%	HS: High stability type
CA: Aluminum solid electrolyte	1A: 10V	G: ±2%	BP: Non-polar type
CS: Tantalum electrolyte	1C: 16V	J: ±5%	HR: Ripple-resistant type
CD: Film	1E: 25V	K: ±10%	DL: For charge and discharge
CK: Ceramic	1V: 35V	M: ±20%	DF: For assuring high frequency
CC: Ceramic	1H: 50V	Z: ±80%	U: UL part
CP: Oil	2A: 100V	-: -20%	C: CSA part
CM: Mica	2B: 125V	P: ±100%	W: UL-CSA type
CF: Metallized	2C: 160V	-: -0%	F: Lead wire forming
CH: Metallized	2D: 200V	D: ±0.25pF	
	2E: 250V	C: ±0.5pF	
	2H: 500V	-: -	
	2J: 630V		

Capacity (except electrolyte)
 $\frac{2}{\text{---}} \frac{2}{\text{---}} \frac{2}{\text{---}}$ ⇒ 2200pF = 2200 μF = 0.0022 μF
 (More than 2) Indicates number of zeros after effective number.
 2-digit effective number.
 Units: μF

$\frac{2}{\text{---}} \frac{2}{\text{---}} \frac{1}{\text{---}}$ ⇒ 220pF
 (0 or 1) Indicates number of zeros after effective number.
 2-digit effective number.
 Units: pF

When the dielectric strength is indicated in AC, "AC" is included after the dielectric strength value.

2U-2700B DECK UNIT ASSY PARTS LIST

Ref. No.	Part No.	Part Name	Remarks
SEMICONDUCTORS GROUP			
IC301	263 0590 001	IC μPC1330HA	
IC302	263 0700 901	IC M5220FP	
IC303	263 0615 902	IC BA15218F	SOP
IC304	263 0354 001	IC μPC1297CA	SOP
IC305	262 1267 903	IC CXA1331M	SOP
IC306	263 0615 902	IC BA15218F	SOP
IC307	263 0761 005	IC M51131L	
IC501	262 1362 002	IC BA6238A	
IC502	262 1938 106	IC μPD78042GF-079-3B9	μ-com
IC902	263 0810 008	IC NJM7808FA (S)	Regulator +8V
IC903	263 0503 001	IC NJM7908FA	Regulator -8V
IC904	263 0793 002	IC NJM7806FA (S)	Regulator +6V
TR101	273 0384 900	Transistor 2SC2412K (S)	
TR102~105	269 0088 906	Transistor DTC114TK	Built in resistor
TR106	269 0103 904	Transistor DTC314TK	Built in resistor
TR107	269 0102 905	Transistor DTC124EK	Built in resistor
TR108,109	269 0103 904	Transistor DTC314TK	Built in resistor
TR201	273 0384 900	Transistor 2SC2412K (S)	
TR202~205	269 0088 906	Transistor DTC114TK	Built in resistor
TR206	269 0103 904	Transistor DTC314TK	Built in resistor
TR207	269 0102 905	Transistor DTC124EK	Built in resistor
TR208,209	269 0103 904	Transistor DTC314TK	Built in resistor
TR301,302	269 0082 902	Transistor DTC114EK	Built in resistor
TR303,304	273 0245 023	Transistor 2SC2603 (E/F)	
TR305	272 0025 004	Transistor 2SB562 (C)	
TR306	269 0054 901	Transistor DTC144EK	Built in resistor
TR307	269 0055 900	Transistor DTA144EK	Built in resistor
TR308	269 0054 901	Transistor DTC144EK	Built in resistor
TR309	269 0055 900	Transistor DTA144EK	Built in resistor
TR310,311	269 0054 901	Transistor DTC144EK	Built in resistor
TR312	269 0055 900	Transistor DTA144EK	Built in resistor
TR317	269 0055 900	Transistor DTA144EK	Built in resistor
TR318	269 0054 901	Transistor DTC144EK	Built in resistor
TR319	269 0055 900	Transistor DTA144EK	Built in resistor

Ref. No.	Part No.	Part Name	Remarks	Ref. No.	Part No.	Part Name	Remarks
TR399	269 0054 901	Transistor DTC144EK	Built in resistor	R119	247 0011 928	Chip Carbon 39k ohm 1/10W	RM73B--393J
TR501	274 0111 008	Transistor 2SD1111		R120	247 0010 961	Chip Carbon 22k ohm 1/10W	RM73B--223J
TR502,503	269 0054 901	Transistor DTC144EK	Built in resistor	R121	247 0012 969	Chip Carbon 150k ohm 1/10W	RM73B--154J
TR504,505	274 0036 905	Transistor 2SD468 (C)		R122	247 0010 961	Chip Carbon 22k ohm 1/10W	RM73B--223J
TR506~509	269 0082 902	Transistor DTC114EK	Built in resistor	R123	247 0012 927	Chip Carbon 100k ohm 1/10W	RM73B--104J
TR510	271 0238 908	Transistor 2SA1037K (S/R)		R124	247 0009 956	Chip Carbon 7.5k ohm 1/10W	RM73B--752J
TR511	273 0384 900	Transistor 2SC2412K (S)		R125	247 0008 960	Chip Carbon 3.3k ohm 1/10W	RM73B--332J
TR512	271 0238 908	Transistor 2SA1037K (S/R)		R126	247 0009 943	Chip Carbon 6.8k ohm 1/10W	RM73B--682J
TR513,514	269 0054 901	Transistor DTC144EK	Built in resistor	R127	247 0010 974	Chip Carbon 24k ohm 1/10W	RM73B--243J
TR599	269 0054 901	Transistor DTC144EK	Built in resistor	R128	247 0006 988	Chip Carbon 560 ohm 1/10W	RM73B--561J
				R129	247 0011 944	Chip Carbon 47k ohm 1/10W	RM73B--473J
				R130	247 0008 902	Chip Carbon 1.8k ohm 1/10W	RM73B--182J
TR901	272 0025 004	Transistor 2SB562 (C)		R131,132	247 0007 945	Chip Carbon 1k ohm 1/10W	RM73B--102J
				R133	247 0011 944	Chip Carbon 47k ohm 1/10W	RM73B--473J
D101	276 0616 907	Diode 1SS252		R134	247 0010 974	Chip Carbon 24k ohm 1/10W	RM73B--243J
				R135	247 0010 974	Chip Carbon 27k ohm 1/10W	RM73B--273J
D201	276 0616 907	Diode 1SS252		R136	247 0005 905	Chip Carbon 100 ohm 1/10W	RM73B--101J
				R137	247 0013 984	Chip Carbon 470k ohm 1/10W	RM73B--474J
D301,302	276 0616 907	Diode 1SS252		R139	247 0011 999	Chip Carbon 75k ohm 1/10W	RM73B--753J
				R140	247 0006 962	Chip Carbon 470 ohm 1/10W	RM73B--471J
D501	276 0553 905	Diode 1SR35-200A		R141	247 0008 928	Chip Carbon 2.2k ohm 1/10W	RM73B--222J
D502	276 0616 907	Diode 1SS252		R143	247 0011 944	Chip Carbon 47k ohm 1/10W	RM73B--473J
D503	276 0553 905	Diode 1SR35-200A		R198	247 0009 985	Chip Carbon 10k ohm 1/10W	RM73B--103J
D506,507	276 0616 907	Diode 1SS252		R199	247 0010 974	Chip Carbon 24k ohm 1/10W	RM73B--243J
D510,511	276 0616 907	Diode 1SS252					
D599	276 0616 907	Diode 1SS252		R201	247 0012 998	Chip Carbon 200k ohm 1/10W	RM73B--204J
D701~703	276 0616 907	Diode 1SS252		R202	247 0005 947	Chip Carbon 150 ohm 1/10W	RM73B--151J
				R203	247 0010 974	Chip Carbon 24k ohm 1/10W	RM73B--243J
D801~804	276 0616 907	Diode 1SS252		R204	247 0014 912	Chip Carbon 620k ohm 1/10W	RM73B--624J
				R205	247 0008 960	Chip Carbon 3.3k ohm 1/10W	RM73B--332J
D901~906	276 0553 905	Diode 1SR35-200A		R206	247 0008 986	Chip Carbon 3.9k ohm 1/10W	RM73B--392J
D909~912	276 0553 905	Diode 1SR35-200A		R207	247 0009 943	Chip Carbon 6.8k ohm 1/10W	RM73B--682J
D913~916	276 0616 907	Diode 1SS252		R208	247 0009 956	Chip Carbon 7.5k ohm 1/10W	RM73B--752J
				R209	247 0013 900	Chip Carbon 220k ohm 1/10W	RM73B--224J
JV198,199	276 0616 907	Diode 1SS252		R210	247 0010 990	Chip Carbon 30k ohm 1/10W	RM73B--303J
JV239	276 0616 907	Diode 1SS252		R211	247 0008 957	Chip Carbon 3k ohm 1/10W	RM73B--302J
JV249	276 0616 907	Diode 1SS252		R212	247 0008 928	Chip Carbon 2.2k ohm 1/10W	RM73B--222J
				R213	247 0011 944	Chip Carbon 47k ohm 1/10W	RM73B--473J
				R214	247 0006 917	Chip Carbon 300 ohm 1/10W	RM73B--301J
ZD301,302	276 0468 906	Zener Diode HZS9B-1	9V	R215	247 0010 961	Chip Carbon 22k ohm 1/10W	RM73B--223J
ZD303	276 0457 904	Zener Diode HZS4C-1	4V	R216	247 0008 928	Chip Carbon 2.2k ohm 1/10W	RM73B--222J
				R217	247 0010 945	Chip Carbon 18k ohm 1/10W	RM73B--183J
ZD501	276 0465 909	Zener Diode HZS7B-1	7V	R218	247 0009 985	Chip Carbon 10k ohm 1/10W	RM73B--103J
ZD502	276 0457 904	Zener Diode HZS4C-1	4V	R219	247 0011 928	Chip Carbon 39k ohm 1/10W	RM73B--393J
ZD503	276 0454 907	Zener Diode HZS3C-1	3V	R220	247 0010 961	Chip Carbon 22k ohm 1/10W	RM73B--223J
ZD504	276 0451 900	Zener Diode HZS2C-1	2V	R221	247 0012 969	Chip Carbon 150k ohm 1/10W	RM73B--154J
ZD505,506	276 0463 901	Zener Diode HZS6C-1	6V	R222	247 0010 961	Chip Carbon 22k ohm 1/10W	RM73B--223J
				R223	247 0012 927	Chip Carbon 100k ohm 1/10W	RM73B--104J
ZD701	276 0460 904	Zener Diode HZS5C-1	5V	R224	247 0009 956	Chip Carbon 7.5k ohm 1/10W	RM73B--752J
				R225	247 0008 960	Chip Carbon 3.3k ohm 1/10W	RM73B--332J
ZD901	276 0461 903	Zener Diode HZS6A-1	6V	R226	247 0009 943	Chip Carbon 6.8k ohm 1/10W	RM73B--682J
ZD902	276 0479 908	Zener Diode HZS20-1	20V	R227	247 0010 974	Chip Carbon 24k ohm 1/10W	RM73B--243J
				R228	247 0006 988	Chip Carbon 560 ohm 1/10W	RM73B--561J
FL601	393 8014 000	F.L. Tube BJ239GK		R229	247 0011 944	Chip Carbon 47k ohm 1/10W	RM73B--473J
				R230	247 0008 902	Chip Carbon 1.8k ohm 1/10W	RM73B--182J
				R231,232	247 0007 945	Chip Carbon 1k ohm 1/10W	RM73B--102J
				R233	247 0011 944	Chip Carbon 47k ohm 1/10W	RM73B--473J
RESISTORS GROUP (Not included Carbon Film ±5%, 1/4W Type. Refer to the Schematic Diagram for those Parts.)							
R101	247 0012 998	Chip Carbon 200k ohm 1/10W	RM73B--204J	R234	247 0010 974	Chip Carbon 24k ohm 1/10W	RM73B--243J
R102	247 0005 947	Chip Carbon 150 ohm 1/10W	RM73B--151J	R235	247 0010 987	Chip Carbon 27k ohm 1/10W	RM73B--273J
R103	247 0010 974	Chip Carbon 24k ohm 1/10W	RM73B--243J	R236	247 0005 905	Chip Carbon 100 ohm 1/10W	RM73B--101J
R104	247 0014 912	Chip Carbon 620k ohm 1/10W	RM73B--624J	R237	247 0013 984	Chip Carbon 470k ohm 1/10W	RM73B--474J
R105	247 0008 960	Chip Carbon 3.3k ohm 1/10W	RM73B--332J	R239	247 0011 999	Chip Carbon 75k ohm 1/10W	RM73B--753J
R106	247 0008 986	Chip Carbon 3.9k ohm 1/10W	RM73B--392J	R240	247 0006 962	Chip Carbon 470 ohm 1/10W	RM73B--471J
R107	247 0009 943	Chip Carbon 6.8k ohm 1/10W	RM73B--682J	R241	247 0008 928	Chip Carbon 2.2k ohm 1/10W	RM73B--222J
R108	247 0009 956	Chip Carbon 7.5k ohm 1/10W	RM73B--752J	R242	247 0013 984	Chip Carbon 470k ohm 1/10W	RM73B--474J
R109	247 0013 900	Chip Carbon 220k ohm 1/10W	RM73B--224J	R243	247 0011 944	Chip Carbon 47k ohm 1/10W	RM73B--473J
R110	247 0010 990	Chip Carbon 30k ohm 1/10W	RM73B--303J	R298			

CASSETTE DECK SECTION

Ref. No.	Part No.	Part Name	Remarks	Ref. No.	Part No.	Part Name	Remarks	Ref. No.	Part No.	Part Name	Remarks	Qty				
R309	247 0009 985	Chip Carbon 10k ohm 1/10W	RM73B--103J	R903	247 0009 985	Chip Carbon 10k ohm 1/10W	RM73B--103J	C221,222	254 4260 948	Electrolytic 1µF/50V	CE04W1H010M					
R310	247 0009 901	Chip Carbon 4.7k ohm 1/10W	RM73B--472J	R904	247 0005 905	Chip Carbon 100 ohm 1/10W	RM73B--101J	C223	255 1264 953	Mylar Film 0.0027µF/50V	CQ93M1H272J (B)	L201	235 0020 945	Inductor 15mH	1	
R311	247 0009 985	Chip Carbon 10k ohm 1/10W	RM73B--103J					C224,225	255 1251 911	Mylar Film 0.0022µF/50V	CQ92M1H222J (MRZ)	L202	235 0020 919	Inductor 8.2mH	1	
R312	247 0012 927	Chip Carbon 100k ohm 1/10W	RM73B--104J	ΔR306	241 2313 985	Fusible 4.7 ohm 1/4W (P.W.)	RD14B2E4R7JFRS	C226~228	254 4260 951	Electrolytic 2.2µF/50V	CE04W1V4R7M	L203	239 0100 009	HX Step up Coil	1	
R313	247 0007 945	Chip Carbon 1k ohm 1/10W	RM73B--102J	ΔR307,308	241 2315 925	Fusible 22 ohm 1/4W (P.W.)	RD14B2E20GFRS	C229	254 4260 948	Electrolytic 1µF/50V	CE04W1H010M	L204	232 0109 003	MPX Filter	1	
R314	247 0010 987	Chip Carbon 27k ohm 1/10W	RM73B--273J	ΔR315,316	241 2375 907	Chip Carbon Film 10 ohm 1/4W (N.B.)	RD14B2E100JNBS	C230	254 4258 905	Electrolytic 4.7µF/35V	CE04W1V4R7M					
R317	247 0009 985	Chip Carbon 10k ohm 1/10W	RM73B--103J	ΔR514	244 2055 970	Metal Oxide 56 ohm 1W (N.B.)	RS14B3A560JNBS (S)	C231	257 0004 961	Chip Ceramic 100pF/50V	CC73SL1H101J	L301	232 0135 006	Osc. Coil	1	
R318	247 0011 931	Chip Carbon 43k ohm 1/10W	RM73B--433J	ΔR520,521	244 2051 987	Metal Oxide 4.7 ohm 1W (N.B.)	RS14B3A47JNBS (S)	C239	254 4258 905	Electrolytic 4.7µF/35V	CE04W1V4R7M					
R319	247 0010 961	Chip Carbon 22k ohm 1/10W	RM73B--223J	Δ	241 2315 925	Fusible 22 ohm 1/4W (N.B.)	RD14B2E20GFRS	C301	257 0012 966	Chip Ceramic 0.01µF/50V	CK73F1H103Z					
R320	247 0012 927	Chip Carbon 100k ohm 1/10W	RM73B--104J					C302~305	254 4254 909	Electrolytic 10µF/16V	CE04W1C100M	XT501	399 0107 007	Ceramic Resonator	CST 4.19 MGW	1
R321	247 0010 961	Chip Carbon 22k ohm 1/10W	RM73B--223J	RT101	211 8005 005	Semi Fixed Resistor 47k ohm	V06QB473	C306	254 4280 948	Electrolytic 1µF/50V	CE04W1H010M					
R322	247 0009 985	Chip Carbon 10k ohm 1/10W	RM73B--103J	RT102	211 8070 032	Semi Fixed Resistor 22k ohm	V06QB223	C307	257 1011 982	Chip Ceramic 0.047µF/50V	CK73B1H473K	JK301	204 8266 008	4 P Pin Jack (S-GND)		1
R323	247 0007 945	Chip Carbon 1k ohm 1/10W	RM73B--102J	RT103	211 8005 005	Semi Fixed Resistor 47k ohm	V06QB473	C308	254 4254 909	Electrolytic 10µF/16V	CE04W1C100M	JK501,502	204 8421 005	Mini Jack		2
R324	247 0011 944	Chip Carbon 47k ohm 1/10W	RM73B--473J					C309	254 4256 910	Electrolytic 22µF/25V	CE04W1E220M					
R325	247 0011 928	Chip Carbon 39k ohm 1/10W	RM73B--393J	RT201	211 8005 005	Semi Fixed Resistor 47k ohm	V06QB473	C310	254 4254 909	Electrolytic 10µF/16V	CE04W1C100M	ΔF901	206 1029 002	Fuse (0.2AT)		2
R330	247 0009 985	Chip Carbon 10k ohm 1/10W	RM73B--103J	RT202	211 8070 032	Semi Fixed Resistor 22k ohm	V06QB223	C311	257 0002 921	Chip Ceramic 10pF/50V	CC73SL1H1000		202 0040 909	Fuse Chip		1
R331	247 0011 944	Chip Carbon 47k ohm 1/10W	RM73B--473J	RT203	211 8005 005	Semi Fixed Resistor 47k ohm	V06QB473	C312	255 1253 922	Mylar Film 0.0082µF/200V	CQ92M2D822J		513 9293 013	Fuse Label		1
R501	247 0010 903	Chip Carbon 12k ohm 1/10W	RM73B--123J	RT501	211 6047 007	Semi Fixed Resistor 2.2k ohm	V06PB222	C313	253 9030 989	BC Ceramic Cap 0.033µF/25V	CK45-1E223K					
R502	247 0008 957	Chip Carbon 3k ohm 1/10W	RM73B--302J	VR301	211 0824 006	Variable Resistor 100k ohm	V11P15FB104	C314	253 9031 962	BC Ceramic 2700pF/25V	CK45-1E272K	CN005	205 0233 058	3P EN Conn. Base		1
R503	247 0009 901	Chip Carbon 4.7k ohm 1/10W	RM73B--472J					C315	254 4256 952	Electrolytic 220µF/25V	CE04W1E221M	CN505	205 0321 038	3P Conn. Base (Red)		1
R504	247 0010 961	Chip Carbon 22k ohm 1/10W	RM73B--223J					C316	254 4278 943	Electrolytic 0.56µF/50V	CE04W1HR56M	CN506	205 0343 036	3P Conn. Base (Yellow)		1
R505	247 0009 985	Chip Carbon 10k ohm 1/10W	RM73B--103J					C317	254 4260 922	Electrolytic 0.33µF/50V	CE04W1HR33M	CN504	205 0322 037	3P Conn. Base (Blue)		1
R506	247 0007 945	Chip Carbon 1k ohm 1/10W	RM73B--102J					C318	254 4254 909	Electrolytic 10µF/16V	CE04W1C100M	CN503	205 0323 036	3P Conn. Base (Black)		1
R507,508	247 0012 927	Chip Carbon 100k ohm 1/10W	RM73B--104J					C319	254 4278 943	Electrolytic 0.56µF/50V	CE04W1HR56M	CN302,507	205 0343 032	3P Conn. Base (KR-PH)		2
R509,510	247 0007 945	Chip Carbon 1k ohm 1/10W	RM73B--102J					C320	254 4260 922	Electrolytic 0.33µF/50V	CE04W1HR33M	CN301	205 0343 058	5P Conn. Base (KR-PH)		2
R511	247 0012 927	Chip Carbon 100k ohm 1/10W	RM73B--104J					C321	254 4254 909	Electrolytic 10µF/50V	CE04W1C100M	CN303	205 0535 086	7P Conn. Base		1
R512	247 0010 961	Chip Carbon 22k ohm 1/10W	RM73B--223J					C322,323	254 4260 948	Electrolytic 1µF/50V	CE04W1H010M	CN304	205 0535 002	8P Conn. Base		1
R513	247 0009 985	Chip Carbon 10k ohm 1/10W	RM73B--103J					C325,326	254 4254 909	Electrolytic 10µF/50V	CE04W1C100M	CN508	205 0707 005	13P Conn. Base		1
R515,516	247 0007 945	Chip Carbon 1k ohm 1/10W	RM73B--102J					C327	254 4260 948	Electrolytic 1µF/50V	CE04W1H010M	CN305,509	205 0535 099	11P Conn. Base		2
R517	247 0018 905	Chip Carbon 0 ohm 1/10W	RM73B--0R0K					C328	257 0012 966	Chip Ceramic 0.01µF/50V	CK73F1H103Z	CN306,510	205 0635 057	10P Conn. Base		2
R518,519	247 0009 985	Chip Carbon 10k ohm 1/10W	RM73B--103J					C329	254 4254 912	Electrolytic 22µF/16V	CE04W1C220M	CN501	205 0633 001	10P Trap Conn. Base		1
R522	247 0007 945	Chip Carbon 1k ohm 1/10W	RM73B--102J					C333	254 4260 948	Electrolytic 1µF/50V	CE04W1H010M	CN502	205 0663 072	7P Trap Conn. Base		1
R523~525	247 0012 927	Chip Carbon 100k ohm 1/10W	RM73B--104J													
R526	247 0009 985	Chip Carbon 10k ohm 1/10W	RM73B--103J													
R528	247 0009 985	Chip Carbon 10k ohm 1/10W	RM73B--103J													
R529	247 0012 927	Chip Carbon 100k ohm 1/10W	RM73B--104J													
R530	247 0007 945	Chip Carbon 1k ohm 1/10W	RM73B--102J													
R531~536	247 0012 927	Chip Carbon 100k ohm 1/10W	RM73B--104J													
R537,538	247 0009 901	Chip Carbon 4.7k ohm 1/10W	RM73B--472J													
R539,540	247 0012 927	Chip Carbon 100k ohm 1/10W	RM73B--104J													
R545~547	247 0012 927	Chip Carbon 100k ohm 1/10W	RM73B--104J													
R549~566	247 0012 927	Chip Carbon 100k ohm 1/10W	RM73B--104J													
R567,568	247 0009 985	Chip Carbon 10k ohm 1/10W	RM73B--103J													
R569	247 0012 927	Chip Carbon 100k ohm 1/10W	RM73B--104J													
R572,573	247 0009 985	Chip Carbon 10k ohm 1/10W	RM73B--103J													
R574	247 0005 989	Chip Carbon 220 ohm 1/10W	RM73B--221J													
R575~577	247 0007 945	Chip Carbon 1k ohm 1/10W	RM73B--102J													
R579,580	247 0012 927	Chip Carbon 100k ohm 1/10W	RM73B--104J													
R582~587	247 0012 927	Chip Carbon 100k ohm 1/10W	RM73B--104J													
R590~592	247 0009 985	Chip Carbon 10k ohm 1/10W	RM73B--103J													
R593	247 0011 944	Chip Carbon 47k ohm 1/10W	RM73B--473J													
R594	247 0007 945	Chip Carbon 1k ohm 1/10W	RM73B--102J													
R595,596	247 0010 961	Chip Carbon 22k ohm 1/10W	RM73B--223J													
R597	247 0005 905	Chip Carbon 100 ohm 1/10W	RM73B--101J													
R601	247 0006 917	Chip Carbon 300 ohm 1/10W	RM73B--301J													
R602	247 0005 963	Chip Carbon 180 ohm 1/10W	RM73B--181J													
R603	247 0005 947	Chip Carbon 150 ohm 1/10W	RM73B--151J													
R604	247 0006 917	Chip Carbon 300 ohm 1/10W	RM73B--301J													
R605	247 0005 963	Chip Carbon 180 ohm 1/10W	RM73B--181J													
R606	247 0005 947	Chip Carbon 150 ohm 1/10W	RM73B--151J													
R607	247 0006 917	Chip Carbon 300 ohm 1/10W	RM73B--301J													
R608	247 0005 963	Chip Carbon 180 ohm 1/10W	RM73B--181J													
R609	247 0005 947	Chip Carbon 150 ohm 1/10W	RM73B--151J													
R612	247 0005 963	Chip Carbon 180 ohm 1/10W	RM73B--181J													
R701	247 0009 943	Chip Carbon 5.8k ohm 1/10W	RM73B--582J													
R702	247 0010 945	Chip Carbon 18k ohm 1/10W	RM73B--183J													
R703	247 0009 956	Chip Carbon 7.5k ohm 1/10W	RM73B--752J													
R704	247 0010 903	Chip Carbon 12k ohm 1/10W	RM73B--123J													
R705	247 0012 927	Chip Carbon 100k ohm 1/10W	RM73B--104J													
R710	247 0018 905	Chip Carbon 0 ohm 1/10W	RM73B--0R0K													

CASSETTE DECK SECTION

WIRING DIAGRAM

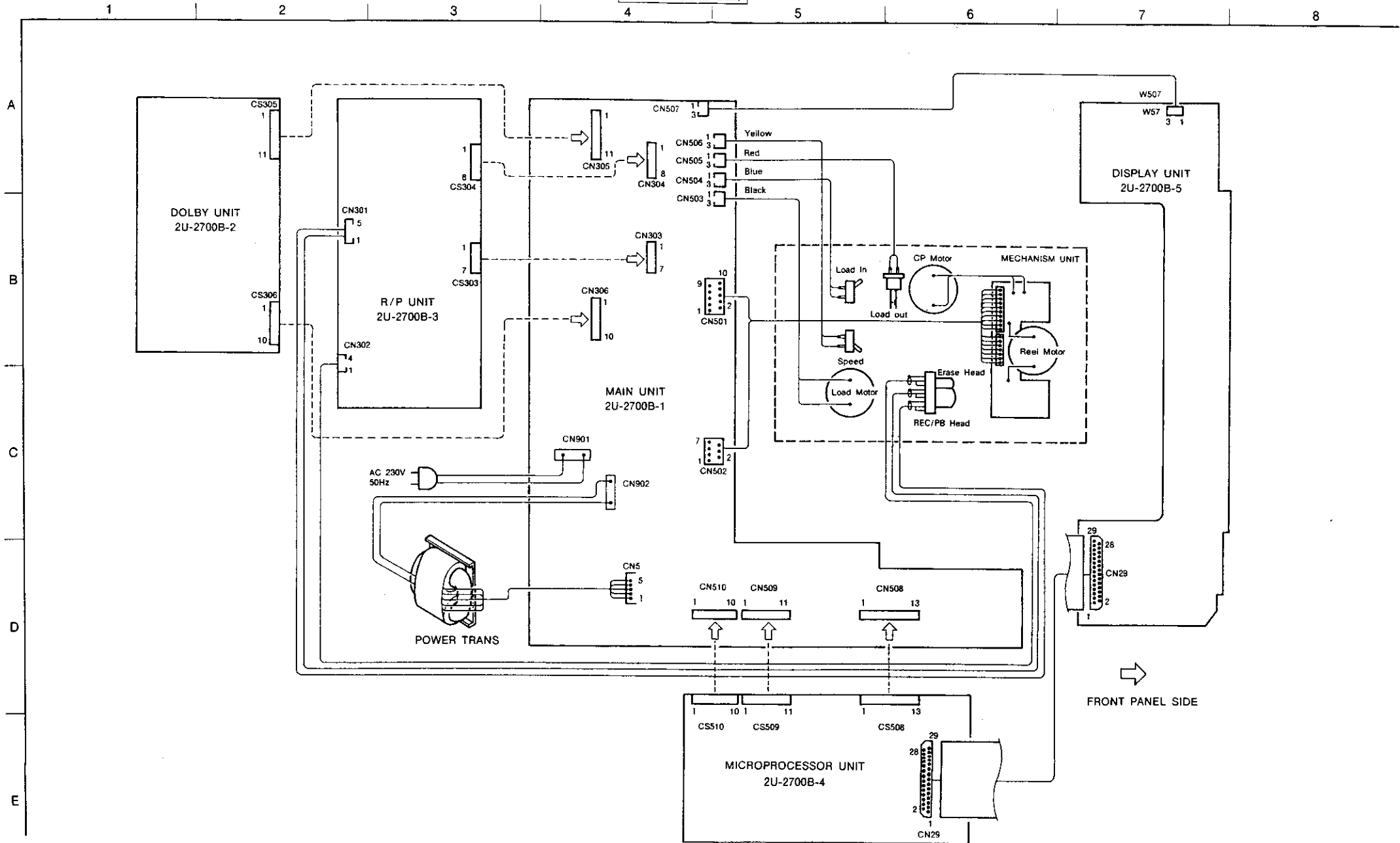



SCHEMATIC DIAGRAM

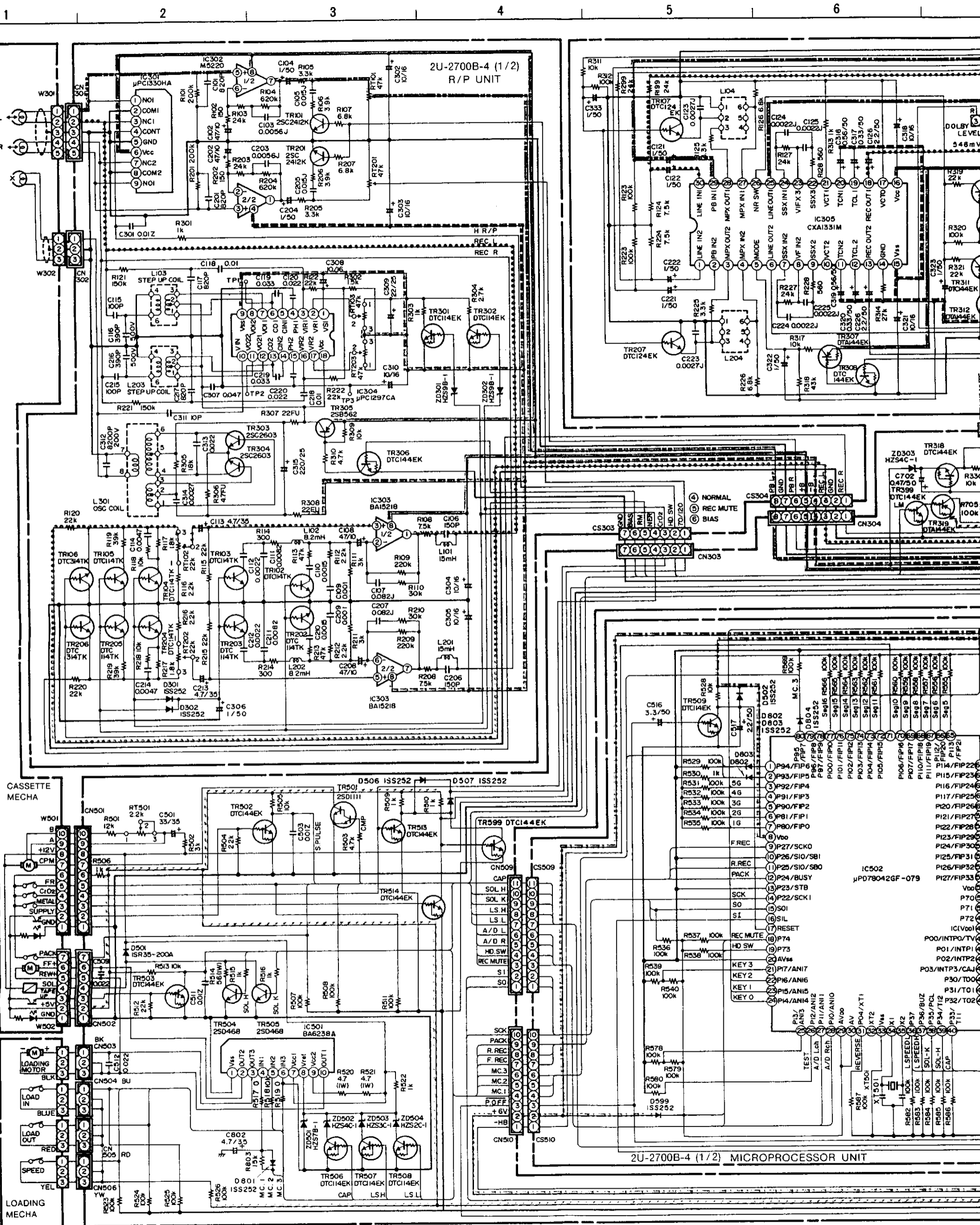

- - - - - PE LINE
 REC MUTE
 - - - - - +5V LINE

CAUTION:
 Before returning the unit to the customer, make sure you make either (1) a leakage current check or (2) a line to chassis resistance check. If the leakage current exceeds 0.5 milliamperes, or if the resistance from chassis to either side of the power cord is less than 240 Kohms, the unit is defective.

* 0Ω is erased only when using the R710 WAITAMU microcomputer. (μP078P044)

WARNING
 DO NOT return the unit to the customer until the problem is located and corrected.

SCHEMATIC DIAGRAM

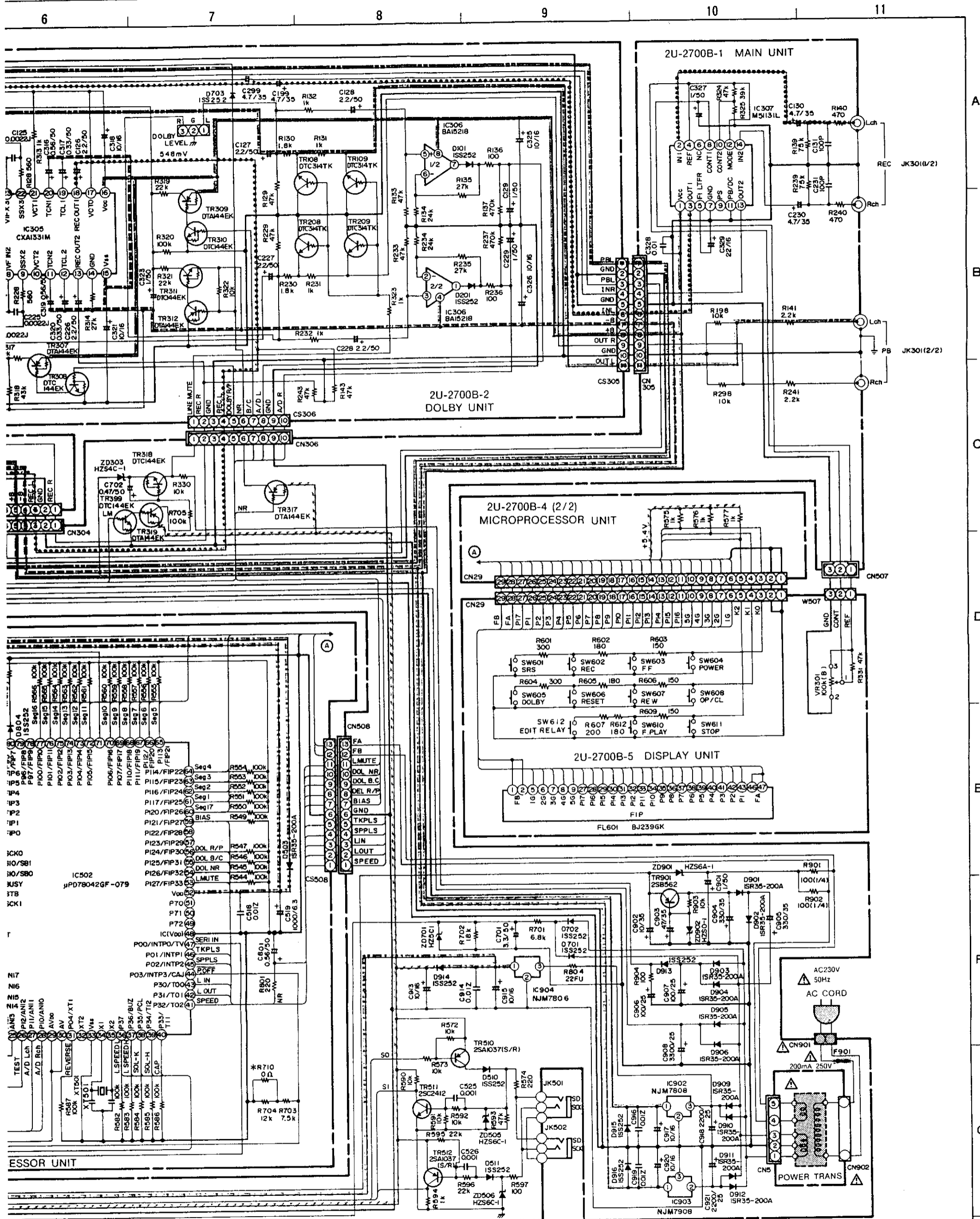

WARNING:
 Parts marked with this symbol Δ have critical characteristics.
 Use ONLY replacement parts recommended by the manufacturer.

NOTES
 ALL RESISTANCE VALUES IN OHM K=1,000 OHM M=1,000,000 OHM
 ALL CAPACITANCE VALUES IN MICRO FARAD P=MICRO-MICRO FARAD
 EACH VOLTAGE AND CURRENT ARE MEASURED AT NO SIGNAL INPUT CONDITION.
 CIRCUIT AND PARTS ARE SUBJECT TO CHANGE WITHOUT PRIOR NOTICE.

1) a leakage current check or (2) a line to chassis resistance check. If the resistance to either side of the power cord is less than 240 Kohms, the unit is defective.

CASSETTE DECK SECTION

EXPLODED

PARTS LIST OF UDR-F10 EXPLODED VIEW

Ref. No.	Part No.	Part Name	Remarks	Qty
1	2U- 2700 B	Deck Unit Assy		1 ^S
1-1	—	Main Unit		(1)
1-2	—	Dolby Unit		(1)
1-3	—	Rec/PB Unit		(1)
1-4	—	Microprocessor Unit		(1)
1-5	—	Display Unit		(1)
2	211 0824 006	Variable Resistor 100k ohm	VR301	1
3	204 8421 005	Mini Jack	JK501,502	2
4	204 8266 008	4P Pin Jack (S-GND)	JK301	1
5	254 4256 091	Chemicon 2200µF/25V	C918,921	2
6	254 4257 003	Chemicon 3300µF/25V	C908	1
7	254 4250 068	Chemicon 1000µF/6.3V	C519	1
8	393 8014 000	F.L. Tube BJ239GK	FL601	1
9	205 0736 034	29P FFC Conn. Base	CN029,029	2
10	411 1224 328	Main Chassis		1
11	412 9373 009	Mech. Holder (Deck)		1
12	GEN 2798	Foot Ass'y		4
13	105 9237 124	Rear Panel (Deck)		1
14	206 2063 009	AC Cord with Plug		1
15	445 0056 008	Cord Bush		1
16	233 6095 004	Power Trans. (Deck)		1
17	412 3548 005	P.W.B. Catcher		3
18	—	—		—
19	412 9371 001	Spring Plate		1
20	412 9372 000	P.W.B. Bracket (A)		1
21	GEN 2862	Cassette Mech. Unit Ass'y		1 ^S
22	144 9188 016	Front Panel (Deck)		1
23	146 9294 100	Knob Ring (A)		2
24	146 9295 109	Knob Ring (B)		1
25	146 9286 309	Inner Panel (Deck)		1
26	143 0872 001	Window		1
27	113 1654 104	Power Button Ass'y		1
28	113 1656 005	Tact Button (1 Key)		1
29	113 9276 102	Button (5 Key)		1
30	113 9277 101	Button (4 Key)		1
31	—	—		—
32	146 9288 006	Loader Panel (Deck)		1
33	112 9100 000	Knob (Fuji)		1
34	445 0033 005	Wire Clamp Band		3
35	102 0545 117	Top Cover		1
36	461 0866 009	Rubber Sheet	Put on Display Unit	2
37	461 0665 035	Rubber Sheet	Put on Top Cover	1
38	513 2243 002	Rating Sheet		1
39	009 0101 003	29P FF Cable		1
40	462 0136 004	Washer	Put on Inner Panel	2
41	415 0730 006	UL Tube (4.8, 3) Black		1
42	461 0861 004	Rubber Sheet	Put on T. cover	1
43	461 0860 005	Spacer	for AC 1	1
44	206 1029 002	Fuse 0.2A T	F90	1
45	—	—		—
46	—	—		—
SCREWS				
51	473 7002 018	Tapping Screw (S) 3×8		11
52	473 7015 018	Tapping Screw (S) 3×8	Black	18
53	473 7508 046	Tapping Screw (P) 3×16	Black	2
54	477 0064 107	Fixing Screw	Black	1
55	473 7505 007	Tapping Screw (P) 2.6×8		8
56	473 7500 015	Tapping Screw (P) 3×8		2
57	473 7007 000	Tapping Screw (S) 4×8	Black	4
58	—	—		—
59	—	—		—
PACKING & ACCESSORIES (Not included EXPLODED VIEW)				
101	505 0102 089	Stylen Paper	700×700	1
102	503 1077 104	Cushion		1
103	GEN 2744	Envelope Sub. Ass'y		1 ^S
103-1	505 8006 019	Envelope		(1)
103-2	203 2223 002	2P Pin Cord	L=1000	(2)
103-3	203 2315 004	Stereo Miniplug Cord	L=500	(1)
103-4	511 2651 009	Inst. Sheet		(1)
104	503 1075 203	Top Cushion		(1)
105	501 1780 013	Carton Case		1

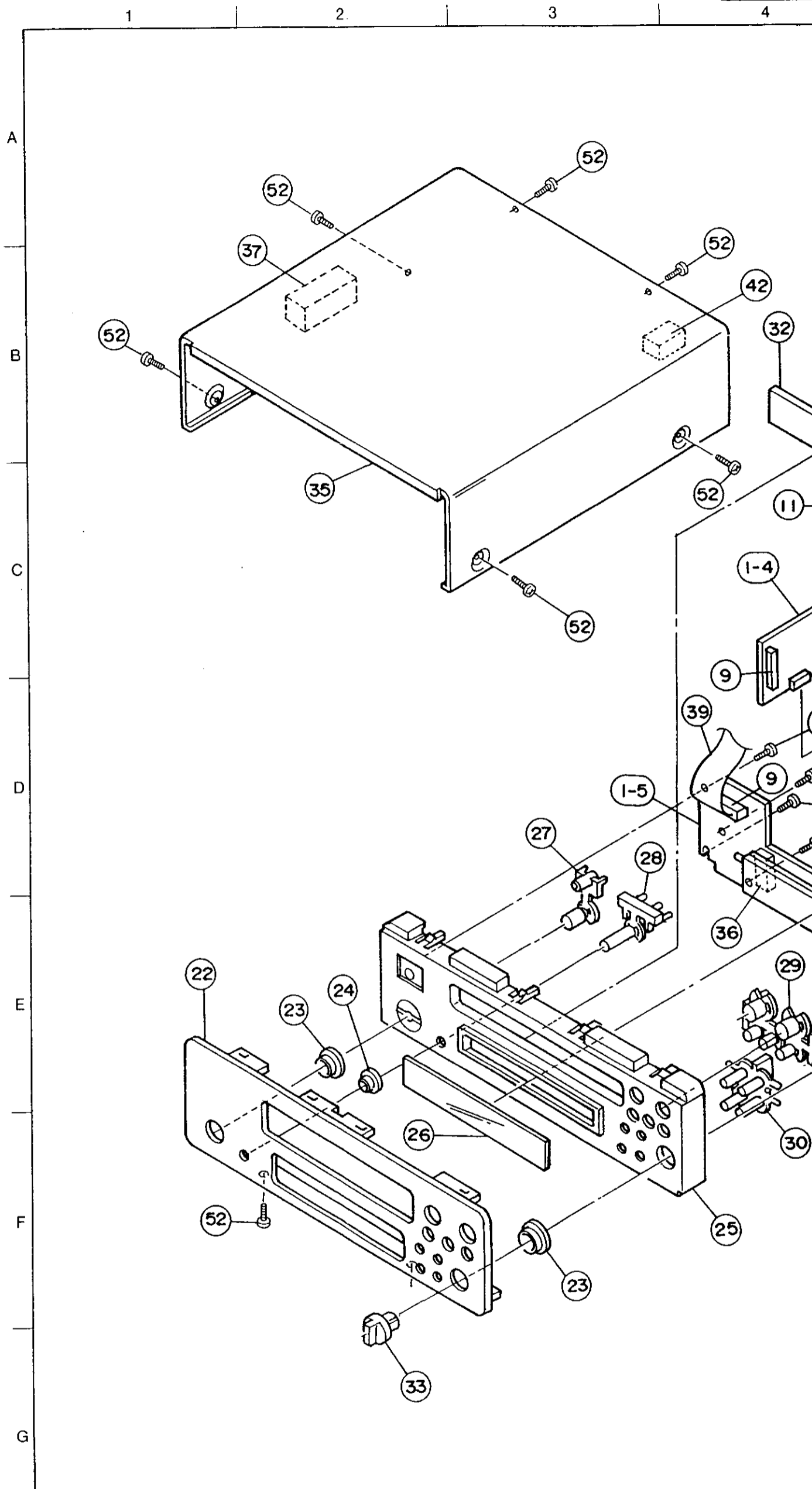

NOTE ON PARTS LIST

- Part indicated with the mark "●" are not always in stock and possibly to take a long period of time for supplying, or in some cases supplying of part may be refused.
- When ordering of part, clearly indicate "1" and "1" (i) to avoid mis-supplying.
- Ordering part without stating its part number can not be supplied.
- Part indicated with the mark "★" is not illustrated in the exploded view.

WARNING:

Parts marked with this symbol Δ have critical characteristics. Use ONLY replacement parts recommended by the manufacturer.

EXPLODED VIEW

3

4

5

6

7

8

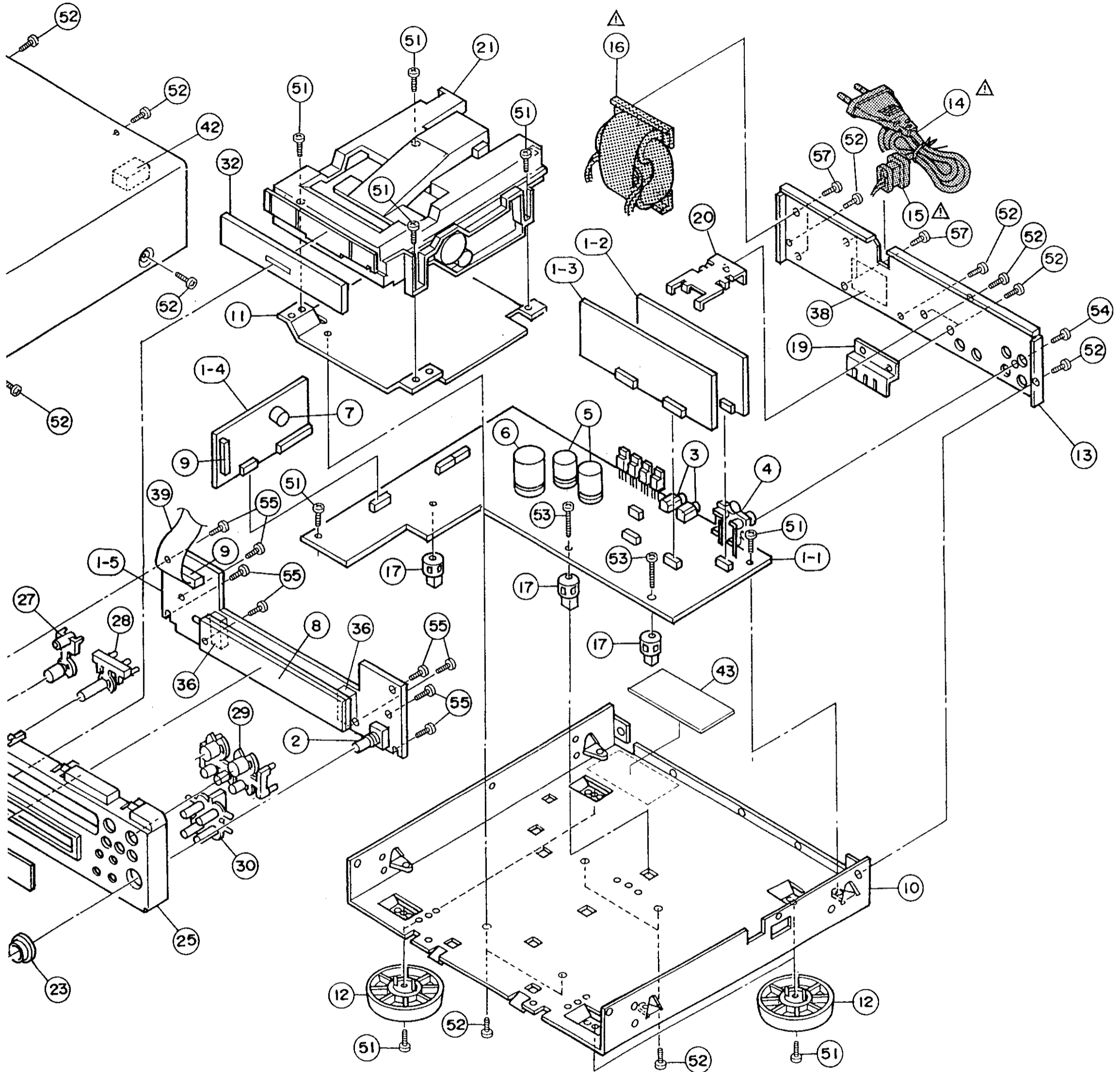

to take a long period of time for supplying, or in some case
mis-supplying.
d.
ed view.

CASSETTE DECK SECTION

DISASSEMBLY PROCEDURE

(Assembly is performed in the reverse order.)

1. Removing the loader frame assembly

- ① Remove the screws attached to the loader frame assembly.
- ② Turn the pulley gear in the direction of the arrow, then pull the loader frame assembly toward you.
- ③ To install the loader frame assembly, the clamp cam must be in the position shown on the diagram.

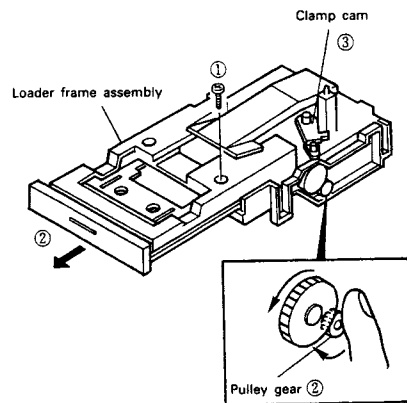

2. Removing the cassette mechanism

- ④ Remove the lever plate spring.
- ⑤ Loosen the pulley gear's screw to the position shown in the diagram.
- ⑥ Remove the four screws attaching the cassette mechanism, then remove the mechanism in the direction of the arrow.

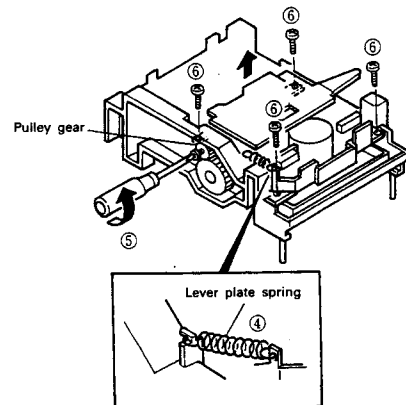

3. Removing the lever plate assembly

- ⑦ Remove the lever plate spring.
- ⑧ Remove the lever plate assembly in the direction of the arrow.

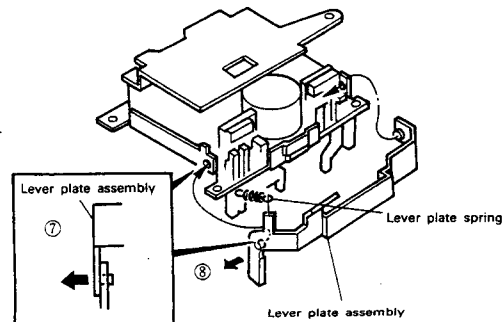

CASSETTE MECHANISM PARTS LIST
(Parts No.: 338 0175 005)

Ref. No.	Part No.	Part Name	Remarks	Qty
2	9DF 5115 99	Chassis Assy		1 ⁵
2- 1	9DF 5170 49	Gear Assy		(1)
2- 4	9DF 6230 37	Reel Base (F) Assy		(1)
2- 5	9DF 6231 27	Reel Base (R) Assy		(1)
2- 8	9DF J111 17	Washer 1.7×0.25		(2)
2-11	9DU J12V 11	W. Poly Washer 2.1×0.25		(2) ⁵
3	9DF 5137 22	Plate HD Assy		1 ⁵
3- 4	9DF 045T 17	Head Base		(1)
3- 5	9DF G137 18	Screw		(1)
3- 7	9DF K21U 11	HB Spring		(1)
3- 8	9DF K26N 14	Spring		(1)
3- 9	9DF U15R 11	Rec/PB Head		(1)
3-10	9DF U192 11	Erase Head		(1)
3-11	9DWH55L 04A	RE/Head Wire Assy		(1)
3-12	9DWH63P 04	E/Head Wire Assy		(1)
4	9DF 5253 00	MTR Main Assy		1 ⁵
5	9DF 5675 52	Control Unit Assy		1 ⁵
5-13	9DA W13G00	Reel Sensor	SG-107F3	(1)
5-17	9DU E16E 11	Push Switch		(5)
8	9DF C52H 61	Cassette Spring		1
12	9DF D45G 21	Play Arm		1
14	9DF D45B 16	Cam Gear (3R)		1
15	9DF D44T 14	REC Sensor Lever		3
16	9DF D46L 11	PACK Sensor Lever		1
17	9DF D44V 12	METAL Sensor Lever		1
18	9DF F17W 31	Main Belt		1
20	9DF J111 30	Poly Washer 2.6×0.25		2
23	9DF J111 14	Poly Washer 2.6×0.5		2
26	9DF K28R 12	Slide Spring		1
29	9DF R23S 12	Fly Wheel Assy		1
30	—	—		—
31	9DF R20L 22	Pinch Roller Assy (R)		1
32	—	—		—
36	9DU G12H 14	Screw 2.6×8		1
39	9DU G13U 15	E Ring		2
40	9DU G20B 11	Screw		1
41	9DF 5642 80	MTR Reel Assy		1
42	9DF G156 11A	Screw 2.6×6.4		2
51	9DF 7652 63	Solenoid Assy		1
52	9DF L39H 12A	Iron Core		1
53	9DF L39K 12	Plunger		1

NOTE ON PARTS LIST

- Part indicated with the mark "⊙" are not always in stock and possibly to take a long period of time for supplying, or in some case supplying of part may be refused.
- When ordering of part, clearly indicate "1" and "1" (i) to avoid mis-supplying.
- Ordering part without stating its part number can not be supplied.
- Part indicated with the mark "★" is not illustrated in the exploded view.

WARNING:

Parts marked with this symbol have critical characteristics. Use ONLY replacement parts recommended by the manufacturer.

CASSETTE MECHANISM

Part No. : 338 0175 005

CASSETTE DECK SECTION

1 2 3 4 5 6 7 8

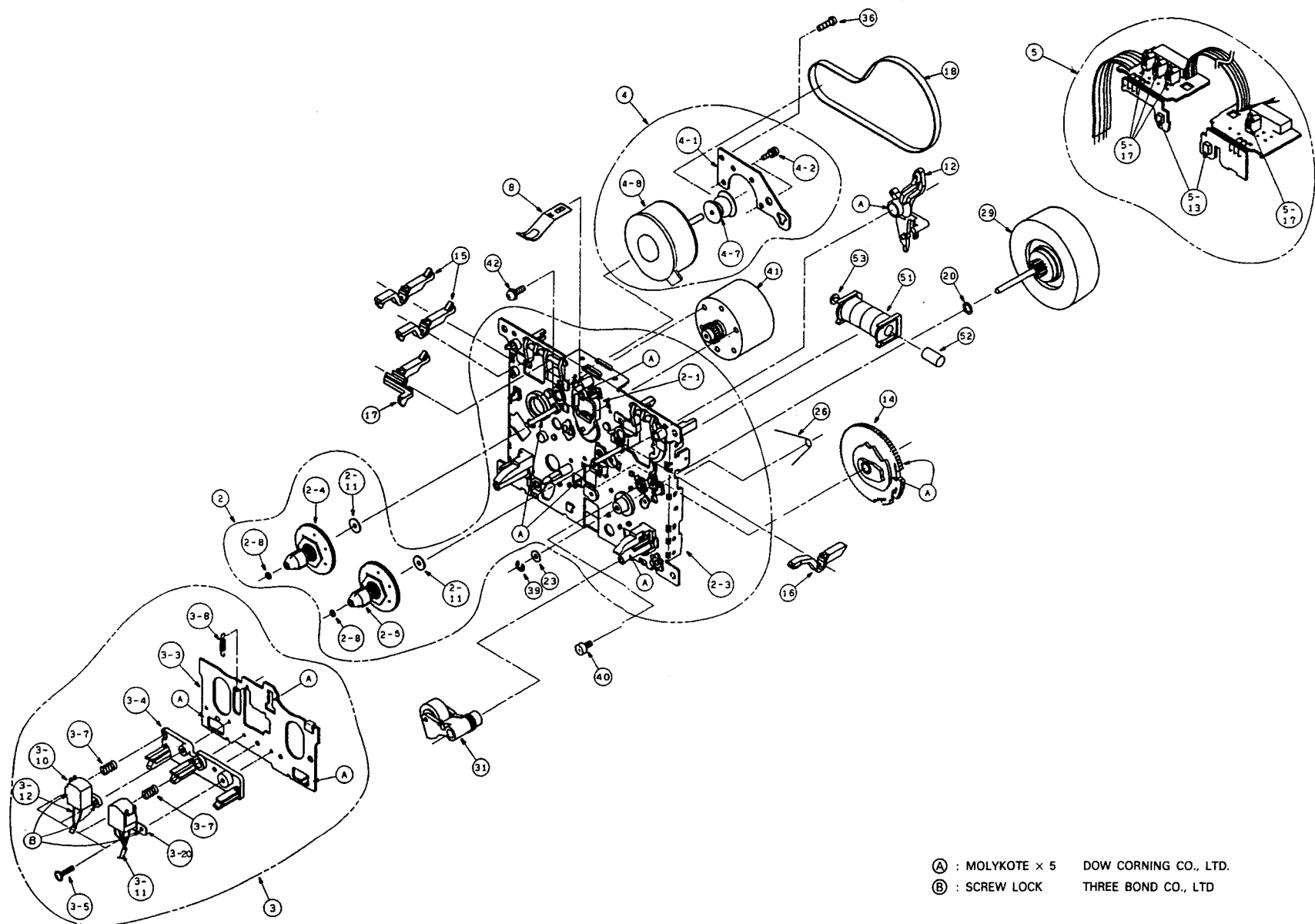

- (A) : MOLYKOTE x 5 DOW CORNING CO., LTD.
- (B) : SCREW LOCK THREE BOND CO., LTD

A
B
C
D
E

SPEAKER SYSTEM

EXPLODED VIEW

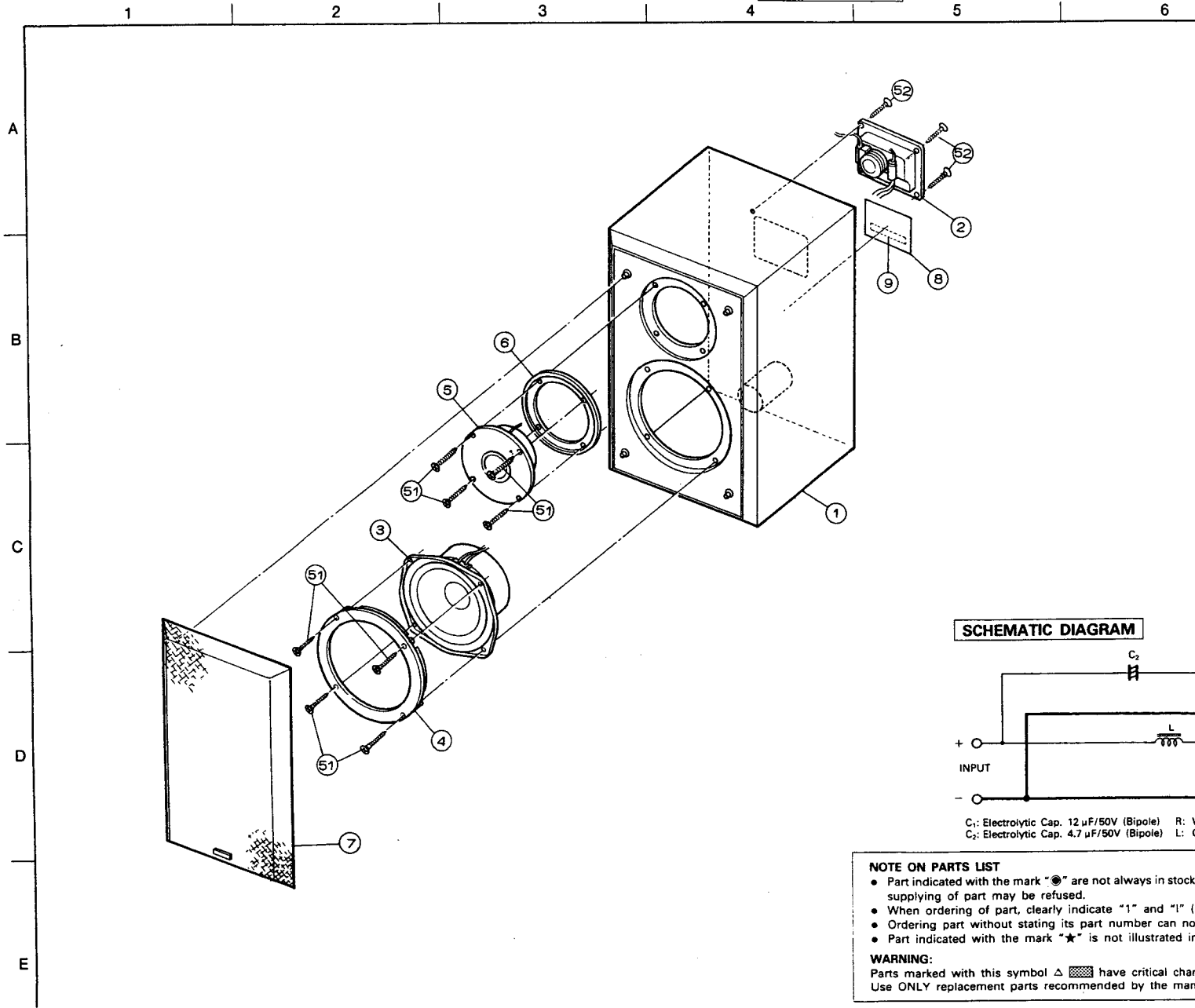

PARTS LIST OF SC-F10 EXPLODED VIEW

Ref. No.	Part No.	Part Name	Remarks	Qty
1	SCF 1000 101	Cabinet Sub. Ass'y		2 ^S
2	SCF 1000 110	:Network Ass'y		2
3	SCF 1000 109	:12RW31 Speaker Ass'y	Woofer	2
4	SCF 1000 103	:Woofer Ring		2
5	SCF 1000 108	:32DT29 Speaker Ass'y	Tweeter	2
6	SCF 1000 104	:Tweeter Ring		8
7	SCF 1000 102	:Grille Board Ass'y		2
8	SCF 1000 118	:Rating Sheet		2
9	SCF 1000 116	:Serial No. Sheet		2
10				
11				
12				
SCREWS				
51	SCF 1000 121	F.H. Tapping Screw		16
52	SCF 1000 122	F.H. Tapping Screw		8
53				
54				
PACKING & ACCESSORIES				
101	SCF 1000 119	Envelope Sub. Ass'y	included S.P. Cord	1 ^S
101-1	SCF 1000 111	:Envelope		(1)
102	SCF 1000 113	:Cabinet Cover		2
103	SCF 1000 114	:Cushion		2
104	SCF 1000 112	:Carton Case		1
105	SCF 1000 116	:Serial No. Sheet		1
106				
NETWORK Ass'y (Parts No.: SCF 1000 110)				
71	—	2P Terminal Ass'y		2
72	—	1C Wire Ass'y (Red)	L=270	2
73	—	1C Wire Ass'y (Black)	L=270	2
74	—	1C Wire Ass'y (Blue)	L=270	2
75	—	1C Wire Ass'y (Green)	L=270	2
76	—	Chemicon 12 μ F/50V	C1 (Bipole)	2
77	—	Choke Coil 0.75mH	L	2
78	—	Resistor 1.5 ohm/5W	R	2
79	—	Chemicon 4.7 μ F/50V	C2 (Bipole)	2
80				2

SCHEMATIC DIAGRAM

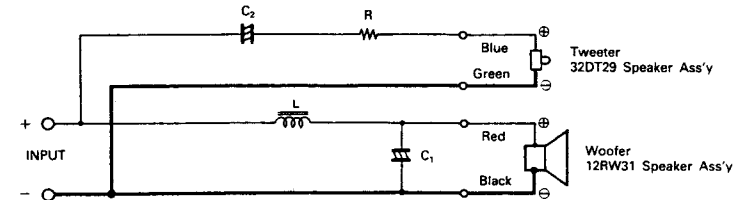

C₁: Electrolytic Cap. 12 μ F/50V (Bipole) R: Wire Wound Resistor 1.5ohm/5W
 C₂: Electrolytic Cap. 4.7 μ F/50V (Bipole) L: Choke Coil 0.75mH

NOTE ON PARTS LIST

- Part indicated with the mark "⊙" are not always in stock and possibly to take a long period of time for supplying, or in some case supplying of part may be refused.
- When ordering of part, clearly indicate "1" and "1" (i) to avoid mis-supplying.
- Ordering part without stating its part number can not be supplied.
- Part indicated with the mark "★" is not illustrated in the exploded view.

WARNING:

Parts marked with this symbol Δ have critical characteristics.
 Use ONLY replacement parts recommended by the manufacturer.

SPEAKER SYSTEM

NETWORK Ass'y
(SCF 1000 110)

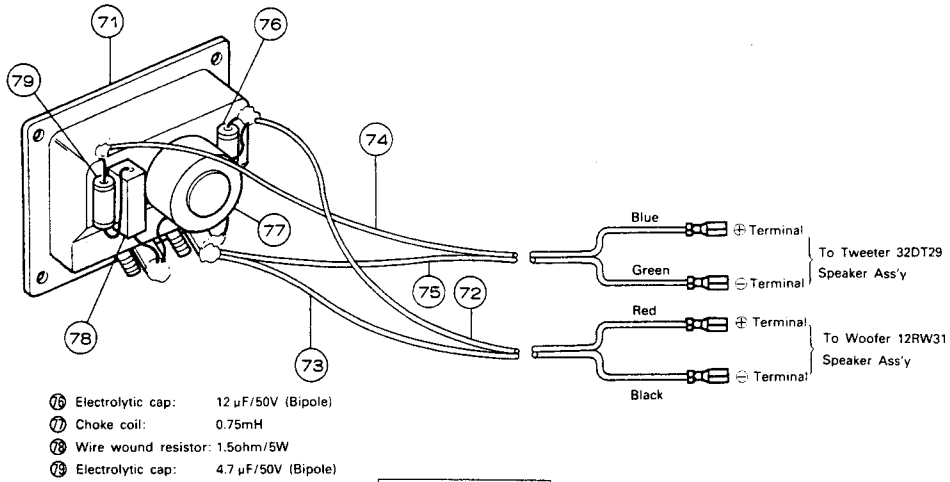

- ⑦⑥ Electrolytic cap: 12 μ F/50V (Bipole)
- ⑦⑦ Choke coil: 0.75mH
- ⑦⑧ Wire wound resistor: 1.5ohm/5W
- ⑦③ Electrolytic cap: 4.7 μ F/50V (Bipole)

WIRE FORMING

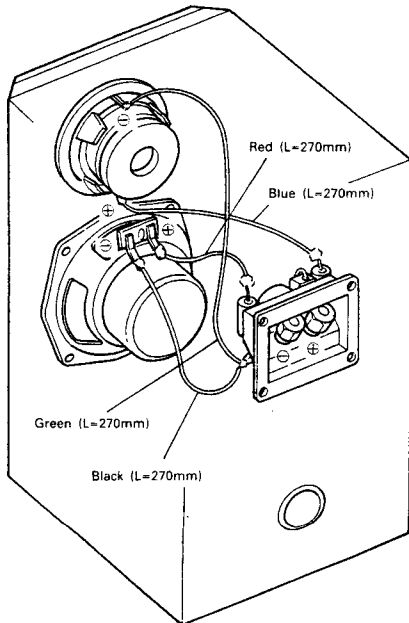

- ① Place so that the network assembly has the Red terminal (+) on the right side, then attach.
- ② For connections to the tweeter, connect the Blue lead to the (+) side (length = 270mm) and the Green lead (length = 270mm) to the (-) side.
- ③ For the connections to the woofer, connect the Red lead (length = 270mm) to the (+) side and the Black lead (length = 270mm) to the (-) side.