

# DENON

Hi-Fi Personal Component System

## SERVICE MANUAL

# MODEL D-F100

### PERSONAL COMPONENT SYSTEM

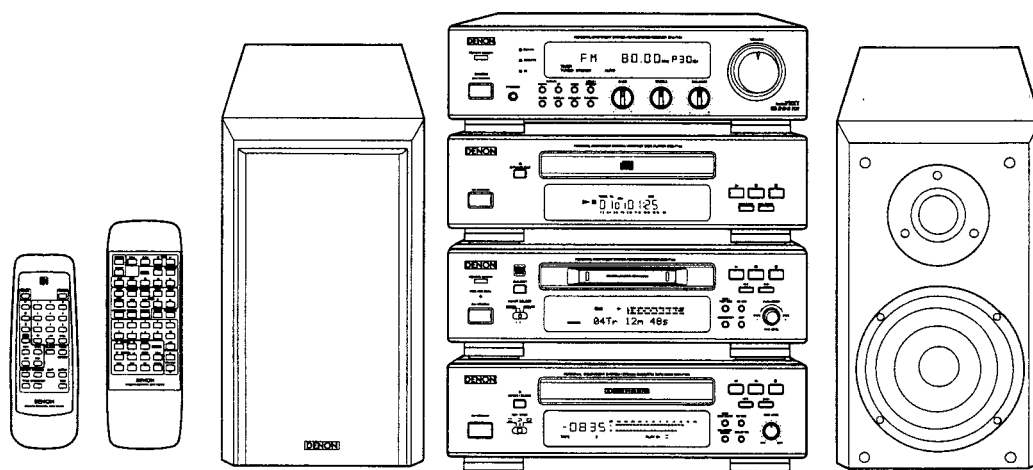

- This Service Manual covers the following components:

**DRA-F100 (AM/FM Stereo Receiver)**  
**DCD-F100 (Compact Disc Player)**  
**DMD-F100 (Mini Disc Recorder)**  
**DRR-F100 (Cassette Tape Deck)**  
**SC-F100 (Speaker System) (Option for Asia model)**

- The D-F100 Personal Component System consists of the following:

AM/FM Stereo Receiver	DRA-F100
Compact Disc Player	DCD-F100
Mini Disc Recorder	DMD-F100
Cassette Tape Deck	DRR-F100
Speaker System	SC-F100 (Option for Asia model)

● Some illustrations using this service manual are slightly different from the actual set.

# NIPPON COLUMBIA CO., LTD.

**GENERAL SECTION****SAFETY PRECAUTIONS**

The following check should be performed for the continued protection of the customer and service technician.

**LEAKAGE CURRENT CHECK**

Before returning the unit to the customer, make sure you make either (1) a leakage current check or (2) a line to chassis resistance check. If the leakage current exceeds 0.5 milliamps, or if the resistance from chassis to either side of the power cord is less than 460 kohms, the unit is defective.

**TABLE OF CONTENTS****GENERAL Section (Page 3 ~ Page 7)**

- SPECIFICATIONS ..... 3
- PACKING VIEW ..... 4~7

**RECEIVER (Page 8 ~ Page 36)**

- BLOCK DIAGRAM ..... 8
- BLOCK AND LEVEL DIAGRAM ..... 9
- DISASSEMBLY ..... 10, 11
- ADJUSTMENTS ..... 12, 13
- SEMICONDUCTORS ..... 14~21
- PRINTED WIRING BOARDS ..... 22~24
- NOTE FOR PARTS LIST ..... 25
- PARTS LIST OF P.W.B. UNIT ..... 26~31
- EXPLODED VIEW ..... 32
- PARTS LIST OF EXPLODED VIEW ..... 33
- WIRING DIAGRAM ..... 34
- SCHEMATIC DIAGRAMS ..... 35, 36
  - (1/2)MAIN/AMP./TONE/VOLUME UNIT ..... 35
  - (2/2)TUNER/FRONT UNIT ..... 36

**CD PLAYER (Page 37 ~ Page 57)**

- BLOCK DIAGRAM ..... 37
- DISASSEMBLY ..... 38, 39
- NOTE FOR HANDLING OF THE LASER ..... 40, 41
- SEMICONDUCTORS ..... 42~45
- PRINTED WIRING BOARDS ..... 46~48
- NOTE FOR PARTS LIST ..... 48
- PARTS LIST OF P.W.B. UNIT ..... 49~51
- WIRING DIAGRAM ..... 51
- EXPLODED VIEW ..... 52
- PARTS LIST OF EXPLODED VIEW ..... 53
- PARTS LIST OF CD MECHANISM UNIT ..... 54
- EXPLODED VIEW OF CD MECHANISM UNIT ..... 55
- SCHEMATIC DIAGRAM ..... 57

**MD RECORDER (Page 59 ~ Page 91)**

- BLOCK DIAGRAM ..... 59
- DISASSEMBLY ..... 60, 61
- DISASSEMBLY OF MD MECHA. .... 62~64
- CONFIRMING THE SERVO ..... 65~70
- SEMICONDUCTORS ..... 71~75
- PRINTED WIRING BOARDS ..... 76, 77
- NOTE FOR PARTS LIST ..... 78
- PARTS LIST OF P.W.B. UNIT ..... 78~80
- WIRING DIAGRAM ..... 81
- PARTS LIST OF EXPLODED VIEW ..... 82
- EXPLODED VIEW ..... 83
- EXPLODED VIEW OF MD MECHANISM UNIT ..... 84
- PARTS LIST OF MD MECHANISM UNIT ..... 85
- PARTS LIST OF MD MECHANISM P.W.B. UNIT ASS'Y ... 86, 87
- PRINTED WIRING BOARD OF MD MECHANISM P.W.B. UNIT ... 88
- SCHEMATIC DIAGRAMS ..... 89~91
  - (1/3)MAIN/FRONT UNIT ..... 89
  - (2/3)MD MECHA. UNIT (1/2) ..... 90
  - (3/3)MD MECHA. UNIT (2/2) ..... 91

**CASSETTE DECK (Page 93 ~ Page 118)**

- BLOCK DIAGRAM ..... 93
- LEVEL DIAGRAM ..... 94
- DISASSEMBLY ..... 95, 96
- ADJUSTMENT ..... 97~101
- SEMICONDUCTORS ..... 102~107
- PRINTED WIRING BOARDS ..... 108, 109
- NOTE FOR PARTS LIST ..... 110
- PARTS LIST OF P.W.B. UNIT ..... 110, 111
- EXPLODED VIEW ..... 112
- PARTS LIST OF EXPLODED VIEW ..... 113
- PARTS LIST OF MECHANISM UNIT ..... 114
- EXPLODED VIEW OF CASSETTE MECHANISM UNIT .... 115
- WIRING DIAGRAM ..... 116
- SCHEMATIC DIAGRAMS ..... 117, 118
  - (1/2)MAIN/AUDIO UNIT ..... 117
  - (2/2)FRONT/MICOM UNIT ..... 118

**SPEAKER SYSTEM (Option for Asia model)  
(Page 119 ~ Page 120)**

- SPECIFICATIONS ..... 119
- SCHEMATIC DIAGRAM ..... 119
- NETWORK ASS'Y ..... 119
- EXPLODED VIEW ..... 120
- PARTS LIST OF EXPLODED VIEW ..... 120
- PACKING & ACCESSORIES ..... 120

## SPECIFICATIONS

### ■ Receiver (DRA-F100)

Practical maximum output:	30W + 30W (4Ω/ohms)
Low frequency adjustment range:	100Hz ±8dB
High frequency adjustment range:	10kHz ±8dB
Audio input/output jacks:	CD input jacks, tape input/output jacks, MD input/output jacks, Aux input jacks. 3.5mm headphones jack and phono input jacks.
Reception frequency band:	FM: 87.50MHz~108.00MHz AM: 522kHz~1611kHz
Reception sensitivity:	FM: 1.5μV/75Ω/ohms AM: 20μV
FM stereo separation:	35dB (1kHz)
Power supply:	AC230V, 50Hz (Europe & U.K. models) AC115/230V, 50/60Hz (Asia model)
Power consumption:	80W
Maximum external dimensions:	270 (W) × 84 (H) × 289 (D) mm (including feet, controls and terminals) (10-5/8" × 3-5/16" × 11-3/8")
Weight:	4.1kg (9lbs. 1 oz)

### ■ CD player (DCD-F100)

Wow & flutter:	Below measurable limits (±0.001% W.peak)
Sampling frequency:	44.1kHz
Optical source:	Semiconductor
Power supply:	AC230V, 50Hz (Europe & U.K. models) AC115/230V, 50/60Hz (Asia model)
Power consumption:	10W
Maximum external dimensions:	270 (W) × 84 (H) × 257 (D) mm (including feet, controls and terminals) (10-5/8" × 3-5/16" × 10-25/64")
Weight:	2.7kg (5 lbs. 15oz)

### Remote control unit (for System) (RC-848: Europe & U.K. models) (RC-829: Asia model)

Remote control method:	Infrared pulse
No. buttons:	52 (Europe & U.K. models) 47 (Asia model)
Power supply:	DC3V using two R6P batteries
Maximum external dimensions:	64 (W) × 195 (H) × 18 (D) mm, (2-1/2" × 7-43/64" × 23/32")
Weight:	130g (Approx. 4.6oz) (including batteries)

### ■ MD recorder (DMD-F100)

Type:	MiniDisc digital audio system
Wow & flutter:	Below measurable limits (±0.001% W.peak or less)
Sampling frequency:	44.1kHz
Recording method:	Magnetic modulation overwriting
Optical source:	Semiconductor
Power supply:	AC230V, 50Hz (Europe & U.K. models) AC115/230V, 50/60Hz (Asia model)
Power consumptions:	11W
Maximum external dimensions:	270 (W) × 84 (H) × 269 (D) mm (including feet, controls and terminals) (10-5/8" × 3-5/16" × 10-19/32")
Weight:	2.9kg (6 lbs. 6oz)

### Remote control unit (RC-267) (for MD)

Remote control method:	Infrared pluse
No. button:	31
Power supply:	DC3V using two R6P batteries
Maximum external dimensions:	54 (W) × 155 (H) × 29 (D) mm, (2-1/8" × 3-7/64" × 1-7/64")
Weight:	100g (3.5oz) (including batteries)

### ■ Cassette deck (DRR-F100)

Type:	Horizontal 4-track 2-channel stereo auto reverse cassette deck
Heads:	1 hard permalloy recording/playback head 1 duple-gap ferrite erasing head
Tape speed:	4.75cm/s
Included circuits:	Dolby B and C NR, Dolby HX Pro
Usable tapes:	Normal, chrome and metal
Power supply:	AC230V, 50Hz (Europe & U.K. models) AC115/230V, 50/60Hz (Asia model)
Power consumption:	14W
Maximum external dimensions:	270 (W) × 84 (H) × 271 (D) mm (including feet, controls and terminals) (10-5/8" × 3-5/16" × 10-43/64")
Weight:	2.9kg (6 lbs. 6oz)

- For improvement purposes, specifications and functions are subject to change without advanced notice.
- Dolby noise reduction and HX pro headroom extension manufactured under license from Dolby Laboratories Licensing Corporation. HX Pro originated by Bang & Olufsen.
- "DOLBY", the double-D symbol  and "HX PRO" are trademarks of Dolby Laboratories Licensing Corporation.

GENERAL SECTION

PACKING VIEW  
Receiver (DRA-F100)

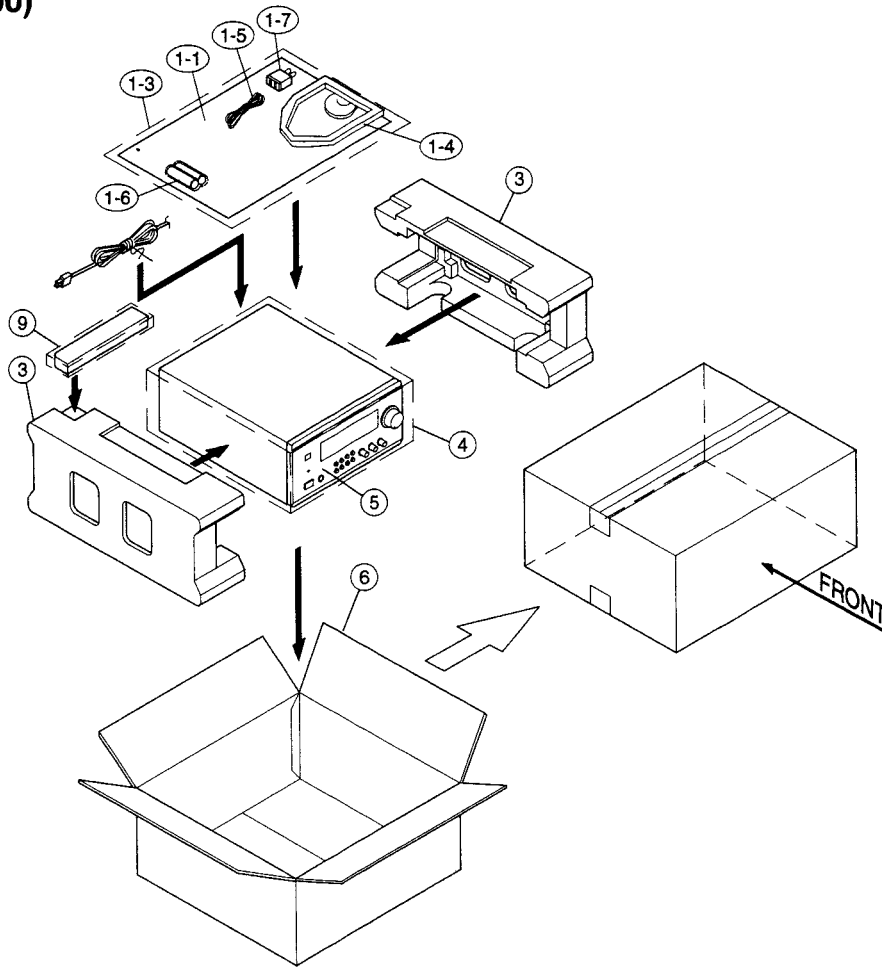

PARTS LIST OF PACKING & ACCESSORIES

Ref. No.	Part No.	Part Name	Remarks	Q'ty	Ref. No.	Part No.	Part Name	Remarks	Q'ty	
★	0-1	960 0092 901	Bar code label	5500014920010	2	4	960 0116 104	Poly bag (set)	6337200029010	1
★	0-2	—	Pos label	5507051630010	2	5		DRA-F100	HK980801	1
				Europe Model					Europe Model	
★	0-2	—	Pos label	5507051630020	2	5		DRA-F100	HK980803	1
				U.K. Model					U.K. Model	
	1-1	960 0115 820	Instruction manual (E2)	5708210010010	1	5		DRA-F100	HK980804	1
				Europe Model					Asia Model	
	1-1	960 0115 833	Instruction manual (EK)	5708210030010	1	6	960 0115 927	Carton case	6007210010010	1
				U.K. Model					Europe Model	
	1-1	960 0115 817	Instruction manual (E1)	5708210040010	1	6	960 0115 930	Carton case	6007210010100?	1
				Asia Model					U.K. Model	
★	1-2	515 0671 708	Service station list (EX)	5777001620010	1	6	960 0115 914	Carton case	6007210010020	1
				Asia Model only					Asia Model	
	1-3	960 0107 809	Poly bag	6337000240010	1	8	960 0142 107	Cushion pad	6240210001400	1
	1-4	960 0004 106	Loop antenna	E601000050000	1				U.K. Model only	
	1-5	960 0004 203	FM antenna	E605000030000	1	9	960 0090 301	Remote controller RC-848	8300012940020	1
	1-6	—	Battery (R6P)	G670001R50010	2				Europe & U.K. Models	
A	1-7	960 0142 204	AC adapter	L109263004100	1	9	960 0081 200	Remote controller RC-829	8300012950010	1
				Asia Model only					Asia Model	
	3	960 0116 007	Cushion	6230210014000	1					

CD Player (DCD-F100)

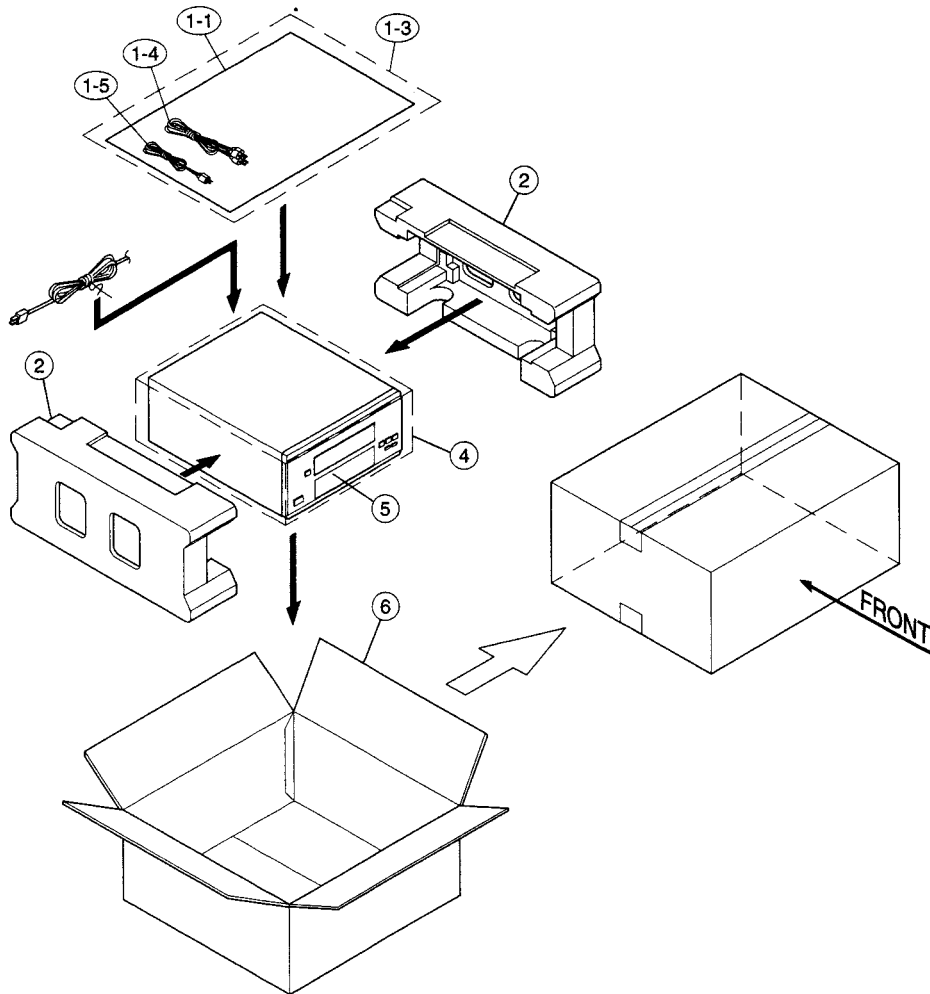

PARTS LIST OF PACKING & ACCESSORIES

Ref. No.	Part No.	Part Name	Remarks	Q'ty	Ref. No.	Part No.	Part Name	Remarks	Q'ty	
★	0-1	960 0092 901	Bar code label	5500014920010	2	1-4	960 0031 108	Pin cord	L063210200000	1
★	0-2	—	Pos label	5507051620010	2	1-5	960 0006 104	Mini plug cord	L063210210040	1
★	0-2	—	Pos label	5507051620020	2	2	960 0122 208	Cushion	6230210024000	1
	1-1	960 0126 822	Instruction manual (E2)	5708210050010	1	4	960 0116 104	Poly bag (set)	6337200029010	1
	1-1	960 0126 835	Instruction manual (EK)	5708210070010	1	5		DCD-F100	HD980501	1
	1-1	960 0126 819	Instruction manual (E1)	5708210080010	1	5		DCD-F100	HD980503	1
★	1-2	515 0671 708	Service station list (EX)	5777001620010	1	5		DCD-F100	HD980504	1
	1-3	960 0107 809	Poly bag	6337000240010	1	6	960 0126 929	Carton case	6007210010040	1
						6	960 0126 916	Carton case	6007210010050	1

**GENERAL SECTION**

**MD Recorder (DMD-F100)**

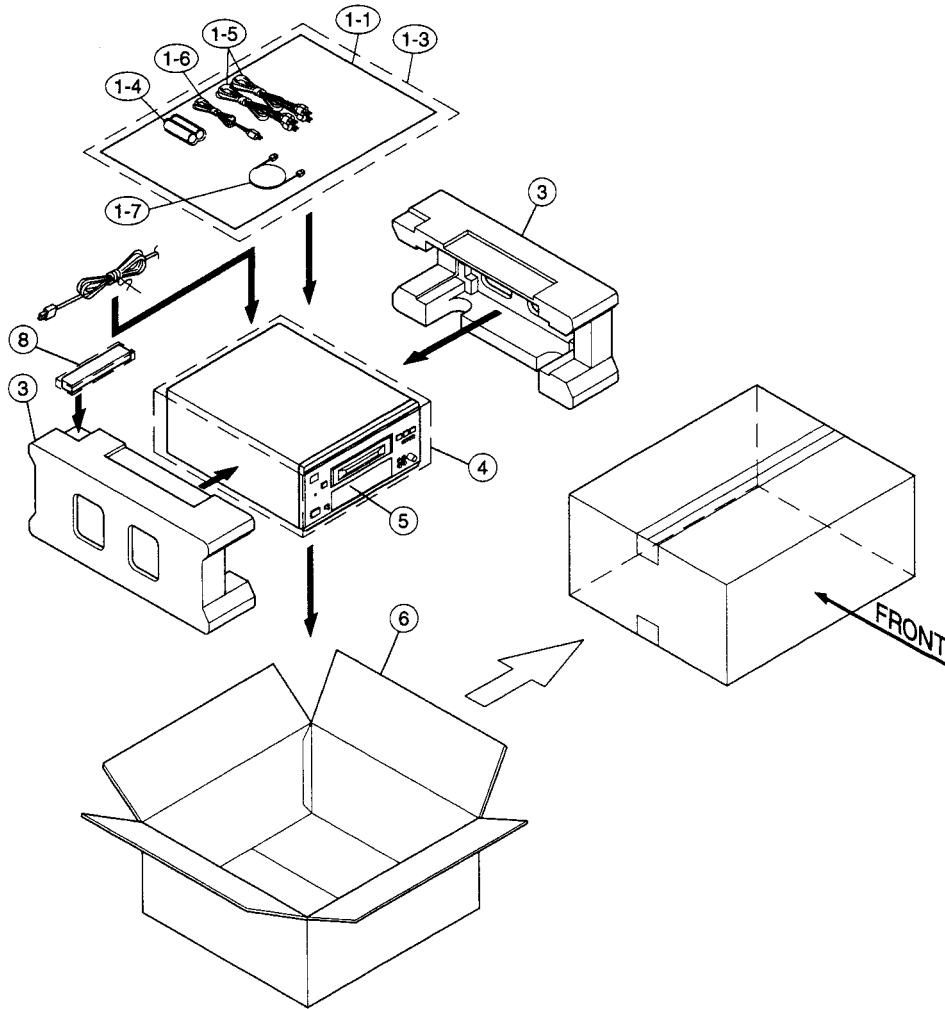

**PARTS LIST OF PACKING & ACCESSORIES**

Ref. No.	Part No.	Part Name	Remarks	Q'ty	Ref. No.	Part No.	Part Name	Remarks	Q'ty	
★	0-1	960 0092 901	Bar code label	5500014920010	2	1-6	960 0006 104	Mini plug cord	L063210210040	1
★	0-2	—	Pos label	5507051610010	2	1-7	960 0132 405	Optical cord	L068601010010	1
				Europe Model		3	960 0122 208	Cushion	6230210024000	1
★	0-2	—	Pos label	5507051610020	2	4	960 0116 104	Poly bag (set)	6337200029010	1
				U.K. Model		5		DMD-F100	HM980201	1
	1-1	960 0122 020	Instruction manual (E2)	5708210130010	1			DMD-F100	HM980203	1
				Europe Model		5		DMD-F100	HM980204	1
	1-1	960 0122 033	Instruction manual (EK)	5708210150010	1			DMD-F100	HM980204	1
				U.K. Model				DMD-F100	HM980204	1
	1-1	960 0122 017	Instruction manual (E1)	5708210160010	1			DMD-F100	HM980204	1
				Asia Model		6	960 0122 127	Carton case	60072100100A0	1
★	1-2	515 0671 708	Service station list (EX)	5777001620010	1			DMD-F100	HM980204	1
				Asia Model only		6	960 0122 114	Carton case	60072100100B0	1
	1-3	960 0107 809	Poly bag	6337000240010	1			DMD-F100	HM980204	1
	1-4	—	Battery (R6P)	G670001R50010	2			DMD-F100	HM980204	1
	1-5	960 0031 108	Pin cord	L063210200000	2	8	960 0135 004	Remote controller RC-267	8300400300010	1

Cassette Deck (DRR-F100)

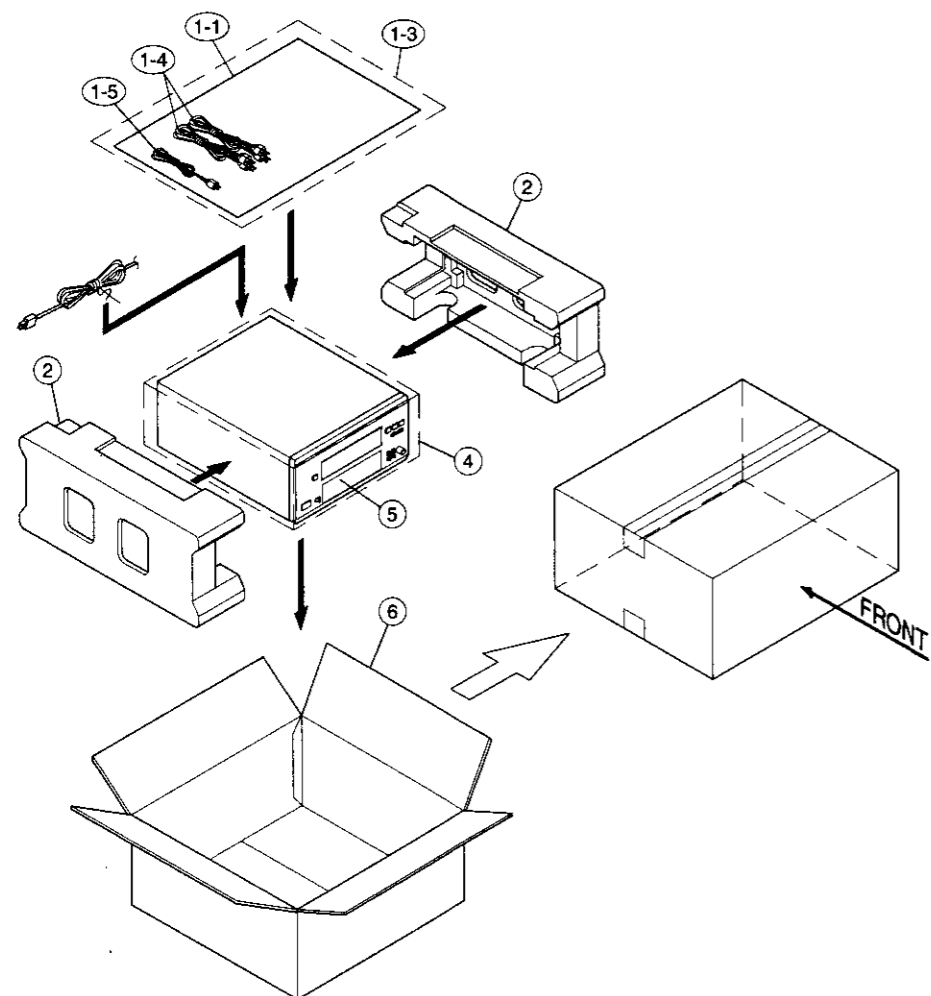

PARTS LIST OF PACKING & ACCESSORIES

Ref. No.	Part No.	Part Name	Remarks	Q'ty	Ref. No.	Part No.	Part Name	Remarks	Q'ty	
★	0-1	960 0092 901	Bar code label	5500014920010	2	1-4	960 0031 108	Pin cord	L063210200000	2
★	0-2	—	Pos label	5507051600010	2	1-5	960 0006 104	Mini plug cord	L063210210040	1
★	0-2	—	Pos label	5507051600020	2	2	960 0122 208	Cushion	6230210024000	1
	1-1	960 0132 324	Instruction manual (E2)	5708210090010	1	4	960 0116 104	Poly bag (set)	6337200029010	1
	1-1	960 0132 337	Instruction manual (EK)	5708210110010	1	5		DRR-F100	HC980401	1
	1-1	960 0132 311	Instruction manual (E1)	5708210120010	1	5		DRR-F100	HC980403	1
★	1-2	515 0671 708	Service station list (EX)	5777001620010	1	5		DRR-F100	HC980404	1
	1-3	960 0107 809	Poly bag	6337000240010	1	6	960 0132 528	Carton case	6007210010070	1
						6	960 0132 515	Carton case	6007210010080	1
								Asia Model		
								Europe & U.K. Models		
								Asia Model		

# RECEIVER BLOCK DIAGRAM

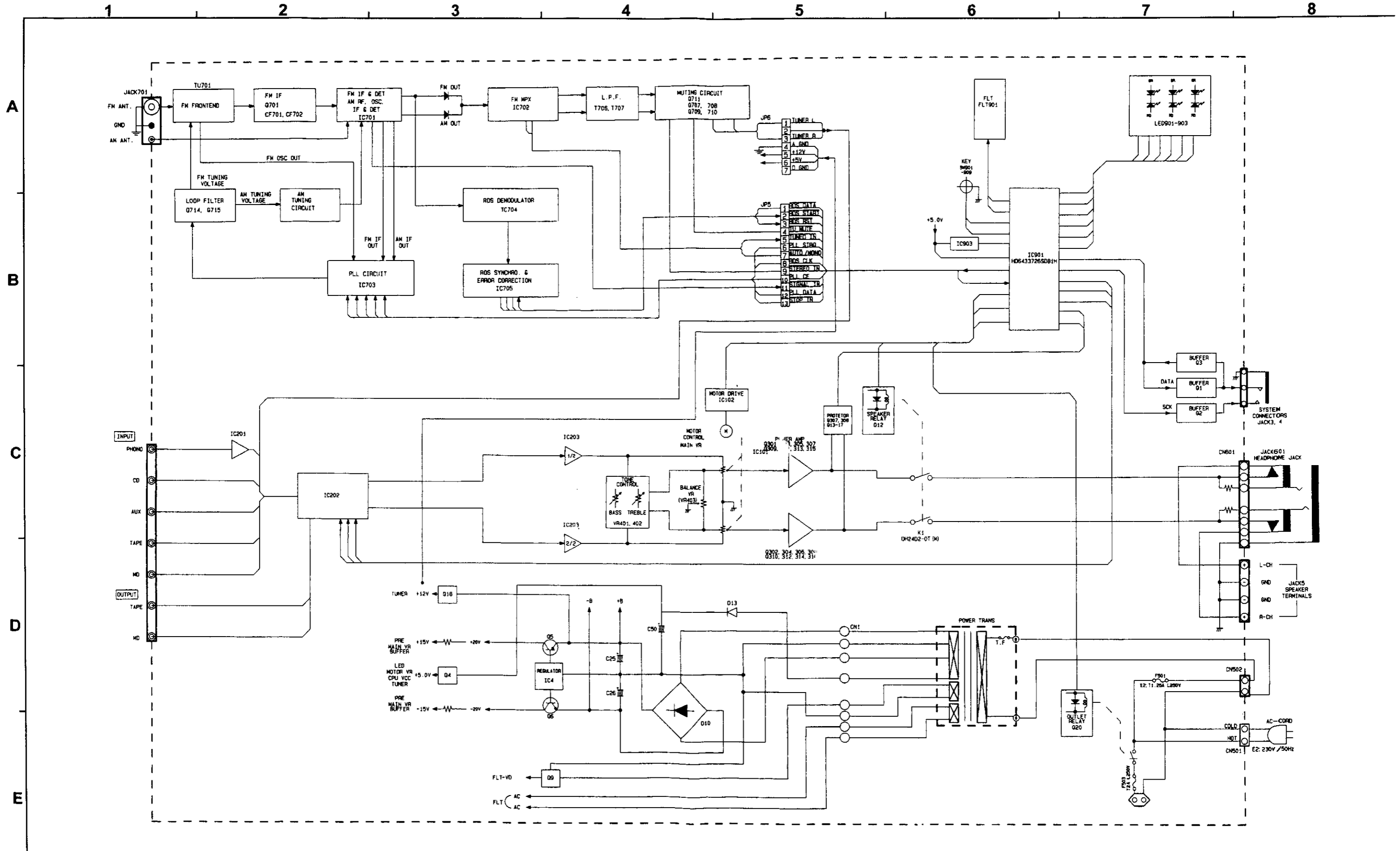



BLOCK & LEVEL DIAGRAM

1

2

3

4

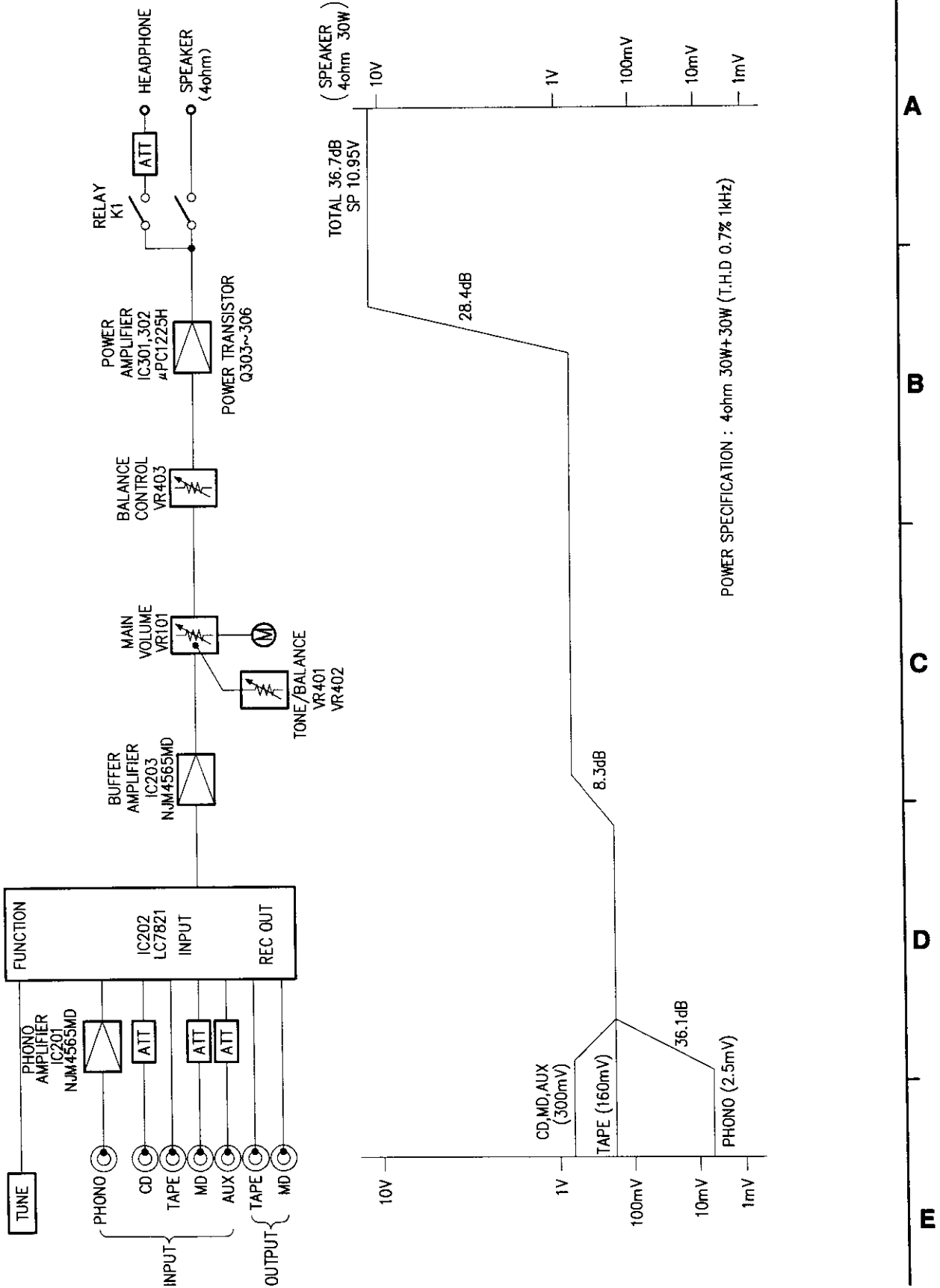

**RECEIVER****DISASSEMBLY**

(Follow the procedure below in reverse order when reassembling)

**1. Top Cover & Front Panel**

- (1) Remove 5 screws ① fixing the Top Cover.
- (2) Detach the Top Cover as shown in the arrow direction.

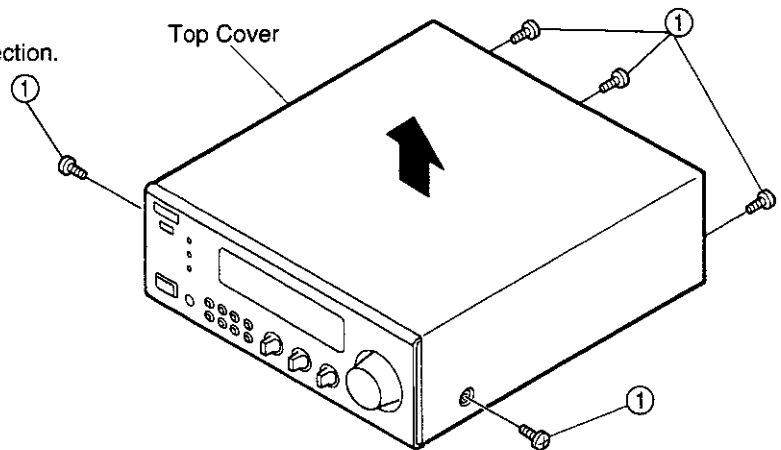

- (3) Remove 4 screws ② on the bottom and both sides.
- (4) Disconnect 16P FFC from its connector base.
- (5) Pull the Front Panel in the arrow direction with releasing Hooks on the Front Frame from the Chassis, and it comes off with the Front Frame.

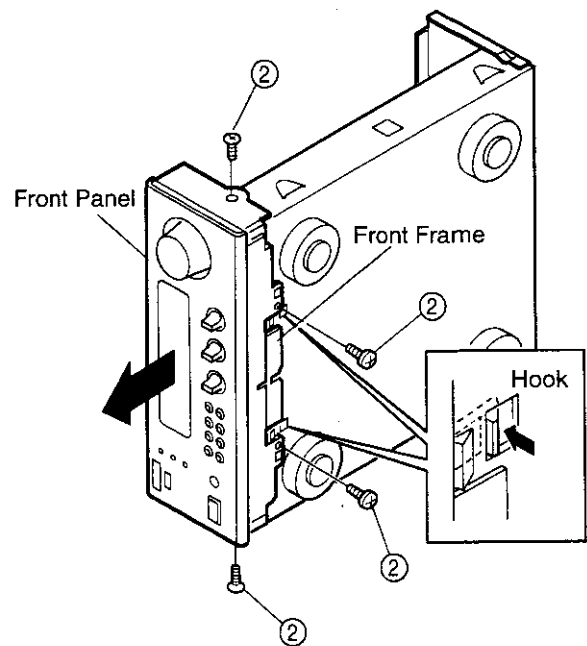
**2. P.W.B.s on Panel****TONE/VOLUME P.W.B.**

- (1) Pull out Knobs (3 Control & 1 Volume) to the arrow direction, and remove 4 Nuts fixing each P.W.B.

**FRONT P.W.B.**

- (2) Remove 2 screws ③.
- (3) Detach the Front P.W.B. with releasing 4 Hooks.

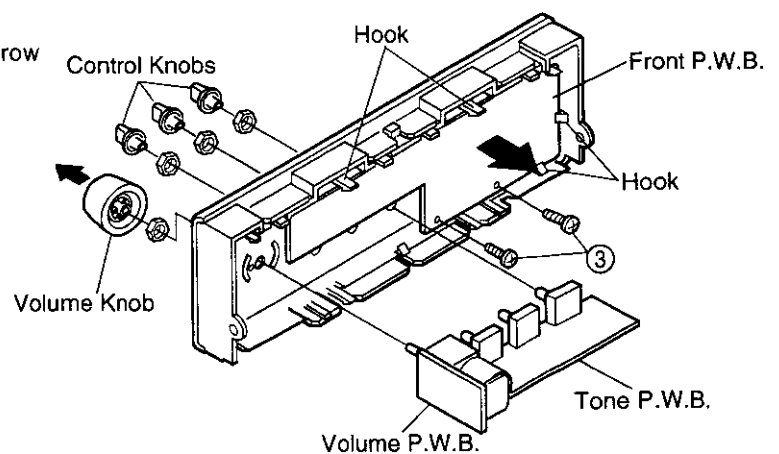

### 3. Back Chassis

- (1) Take off the Cord Stopper from the Back Chassis.
- (2) Remove 10 screws ④ fixing the Back Chassis.
- (3) Detach the Back Chassis to the arrow direction.

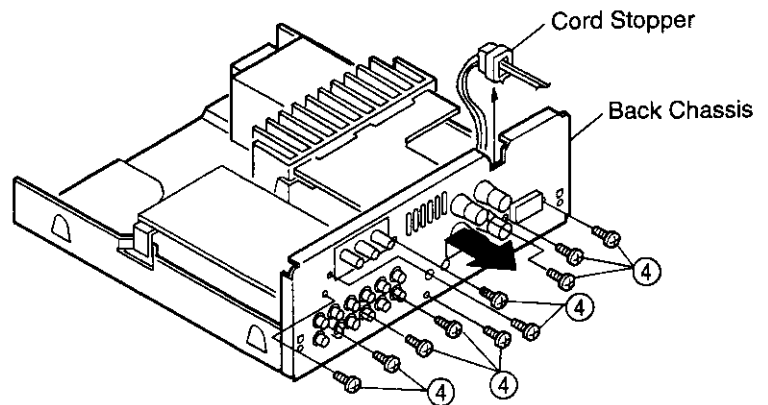

#### TUNER P.W.B.

- (4) Disconnect 13P FFC and 9P Connector Cord from their connector bases.
- (5) Detach the Tuner P.W.B. after removing 1 screw ⑤ and releasing the hook of Locking-fastener.

#### AMP. P.W.B.

- (6) Remove 4 screws ⑥ fixing the Heat Sink Bracket L/R.
- (7) Disconnect 4P and 6P Connector Cord from their connector bases.
- (8) Detach the Amp. P.W.B. with the Main Heat Sink.

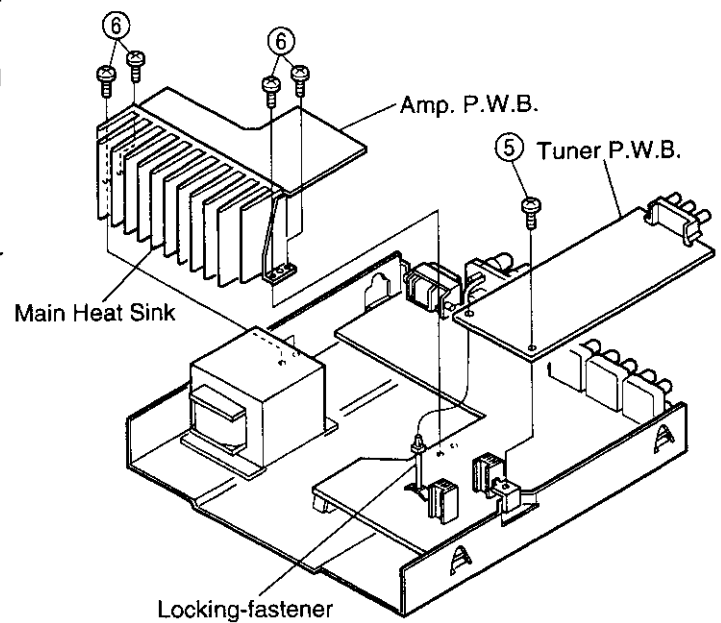

#### MAIN P.W.B.

- (9) Remove 4 screws ⑦, and detach the Main P.W.B. to the arrow direction.

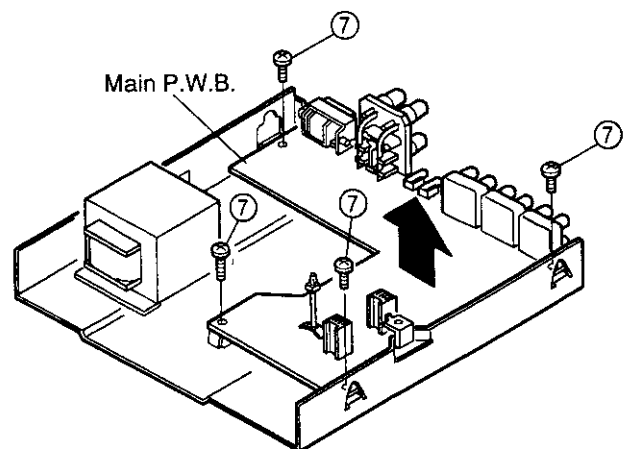

RECEIVER

ADJUSTMENTS

WIRING DIAGRAM

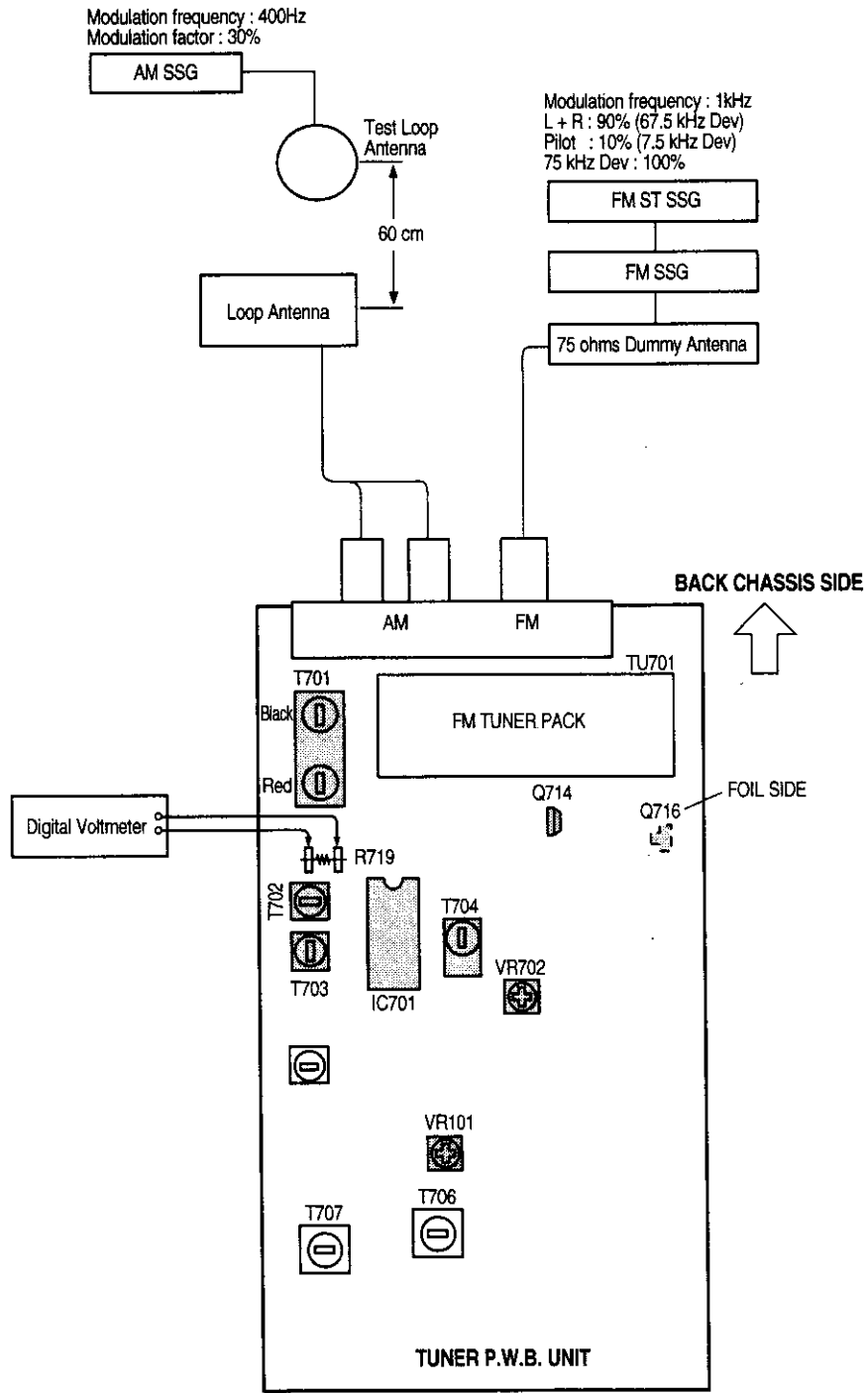

**RECEIVER**

**1. FM adjustment (BAND button: FM, FM MODE button: AUTO (STEREO))**

Step	Adjustment item	Tuning point (channel setting)	Input					Output		Adjustment location	Setting value	Notes
			Measuring instrument	Frequency	Input level	Modulation	Connection location	Measuring instrument	Connection location			
1	FM DC balance	98.00MHz	FM S.G.	98.00MHz	60dB $\mu$	1kHz 75kHz DEV.	FM antenna terminal	Digital volt meter	Both leads of R719	T702	0 $\pm$ 50mV	Perform with monaural modulation signal
2	Distortion	98.00MHz	FM S.G.	98.00MHz	60dB $\mu$	1kHz 75kHz DEV.	FM antenna terminal	Distortion factor meter	Output jack	T703	Minimum distortion	Perform with monaural modulation signal
3	Repeat Steps 1 and 2											
4	Muting level	98.00MHz	FM S.G.	98.00MHz	19dB $\mu$	1kHz 75kHz DEV.	FM antenna terminal	Check for the lighting of TUNED	Output jack	VR702	Input level 22dB $\mu$ $\pm$ 4dB	(Level at which TUNED lights up) Level at which the output is provided
5	Stereo separation	98.00MHz	FM stereo modulator FM S.G.	98.00MHz	60dB $\mu$	1kHz L or R: 67.5kHz DEV. Pilot; 7.5kHz DEV.	FM antenna terminal	VTVM Oscilloscope	Output jack	VR703	Minimum R.ch. Output	Perform with L.ch. Input of FM stereo modulator

**2. AM adjustment (BAND button: AM)**

Step	Adjustment item	Tuning point (channel setting)	Input					Output		Adjustment location	Setting value	Notes
			Measuring instrument	Frequency	Input level	Modulation	Connection location	Measuring instrument	Connection location			
1	IF	Clear frequency (without a broadcast)	AM IF sweep	455kHz	Level at which AGC is not applied	—	AM antenna terminal	Oscilloscope	⊕ IC701 Output terminal Pn⊕ ⊖ Q716 (Base)	T704	Waveform maximum and symmetry	
2	Band edge	522kHz	—	—	—	—	—	Digital voltmeter	⊕ GND (Collector) ⊖ GND	T701(Black)	1.2V $\pm$ 0.2v	
		1611kHz	—	—	—	—	—	—	—	—	Approx. 7.5v	No place to adjust
3	Tracking	603kHz	AM S.G.	603kHz	Level at which AGC is not applied	400Hz 30%	Loop antenna	VTVM	Output terminal	T701(Red)	Maximum output	
4	Repeat Steps 2 and 3, and set the output to maximum.											

RECEIVER

SEMICONDUCTORS

● IC's

HD6433726SE13H (IC901)

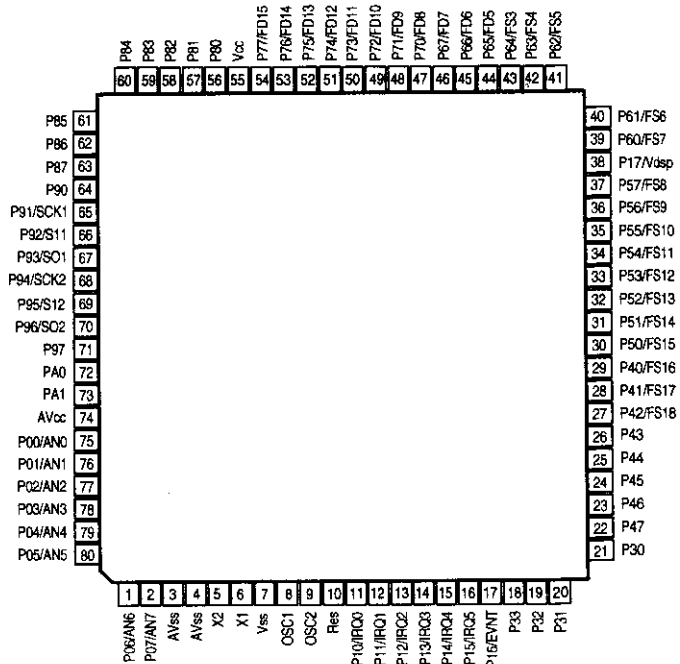
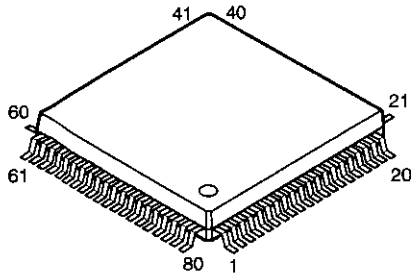

● HD6433726SE13H Terminal Function

Pin No.	Symbol	Port Name	I/O	INI	ACT	Function
1	AM Stereo	P60/AN6	I	—	L	AM stereo signal detection
2	Tuned In	P07/AN7	I	L	H	-FM/AM tuning signal input
3	GND	Avss	—	—	—	Analog GND
4	GND	Test	—	—	—	
5	Sub Xtal	X2	O	—	—	Sub X'tal drive
6	Sub Xtal	X1	I	—	—	Sub X'tal input
7	Vss	Vss	—	—	—	GND
8	OSC1	OSC1	O	—	—	8.38MHz X'tal output
9	OSC2	OSC2	I	—	—	8.38MHz X'tal input
10	Reset	Res	I	—	L	Reset input
11	Remocon	P10/IRQ0	I	—	L	Remote control signal input
12	50/60	P11/IRQ1	I	—	L	50/60Hz AC input
13	Protect	P12/IRQ2	I	—	L	Over-current detect signal input
14	RDS Start	P13/IRQ3	I	—	L	RDS signal start detection
15	RXD	P14/IRQ4	I	—	L	DENON bus data input
16	Mute	P15/IRP5	O	H	L	Speaker relay OFF
17	GND	P16/EVNT	I	—	—	Not used
18	N.C.	P33	O	L	L	No connection
19	RT Gr LED	P32	O	L	H	RT green LED
20	TA Gr LED	P31	O	L	H	TA green LED
21	PTY Gr LED	P30	O	L	H	PTY green LED
22	RT Rd LED	P47	O	L	H	RT red LED
23	TA Rd LED	P46	O	L	H	TA red LED
24	RTY Rd LED	P45	O	L	H	PTY red LED

## RECEIVER

Pin No.	Symbol	Port Name	I/O	INI	ACT	Function
25	Diode 1	P44	I	—	H	Setting recovery input 1
26	Diode 2	P43	I	—	H	Setting recovery input 2
27	Seg 1	P42/FS18	O	L	H	Segment 1 output
28	Seg 2	P41/FS17	O	L	H	Segment 2 output
29	Seg 3	P40/FS16	O	L	H	Segment 3 output
30	Seg 4	P50/FS15	O	L	H	Segment 4 output
31	Seg 5	P51/FS14	O	L	H	Segment 5 output
32	Seg 6	P52/FS13	O	L	H	Segment 6 output
33	Seg 7	P53/FS12	O	L	H	Segment 7 output
34	Seg 8	P54/FS11	O	L	H	Segment 8 output
35	Seg 9	P55/FS10	O	L	H	Segment 9 output
36	Seg 10	P56/FS9	O	L	H	Segment 10 output
37	Seg 11	P57/FS8	O	L	H	Segment 11 output
38	Vdisp	P17/Vdsp	—	—	—	High B voltage
39	Seg 12	P60/FS7	O	L	H	Segment 12 output
40	Seg 13	P61/FS6	O	L	H	Segment 13 output
41	Seg 14	P62/FS5	O	L	H	Segment 14 output
42	Seg 15	P63/FS4	O	L	H	Segment 15 output
43	Seg 16	P64/FS3	O	L	H	Segment 16 output
44	Dig 11	P65/FD5	O	L	H	Digit 11 output
45	Dig 10	P66/FD6	O	L	H	Digit 10 output
46	Dig 9	P67/FD7	O	L	H	Digit 9 output
47	Dig 8	P70/FD8	O	L	H	Digit 8 output
48	Dig 7	P71/FD9	O	L	H	Digit 7 output
49	Dig 6	P72/FD10	O	L	H	Digit 6 output
50	Dig 5	P73/FD11	O	L	H	Digit 5 output
51	Dig 4	P74/FD12	O	L	H	Digit 4 output
52	Dig 3	P75/FD13	O	L	H	Digit 3 output
53	Dig 2	P76/FD14	O	L	H	Digit 2 output
54	Dig 1	P77/FD15	O	L	H	Digit 1 output
55	Vcc	Vcc	—	—	—	5V
56	Volume Dwn	P80	O	H	H	Master VR down
57	Volume Up	P81	O	H	H	Master VR up
58	Power	P82	O	L	L	Amp circuit power ON
59	TU Mute	P83	O	H	L	Tuner audio mute
60	Auto/Mono	P84	O	H	—	FM Auto/Mono setting
61	Ant Sns	P85	O	L	H	ANT sens. attenuation
62	SDB	P86	O	L	H	Super dynamic bass
63	Se1 EEROM	P87	O	L	H	SCI→EEPROM select
64	PLL CE	P90	O	L	H	PLL serial data select output
65	Bus Clock	P91/SCK1	O	H	—	DENON bus clock
66	Bus Data In	P92/SI1	I	—	—	DENON bus data input
67	Bus Data Out	P93/SO1	O	H	—	DENON bus data output
68	RDS Clock	P97/SCK2	O	H	—	RDS data-in clock input, PLL control clock output, LC7821 clock output
69	RDS Data	P95/SI2	I	H	—	RDS serial data input
70	PLL Data	P96/SO2	O	H	—	PLL serial data output, LC7821 serial data output
71	RDS Res	P97	O	H	L	LC7070 reset output
72	PLL STRQ	PA0	O	L	H	IF count operation request output
73	LC7821CE	PA1	O	L	H	LC7821 chip enable
74	AVcc	AVcc	—	—	—	Analog 5V power supply
75	Key AD0	P00/AN0	I	—	—	Analog key input 0
76	Key AD1	P01/AN1	I	—	—	Analog key input 1
77	PWB Test	P02/AN2	I	—	—	5V board check
78	Stereo In	P03/AN3	I	—	L	FM stereo demodulation detect
79	Signal In	P04/AN4	I	—	L	RF signal detect input
80	Stop In	P05/AN5	I	—	L	IF count tuning detect

RECEIVER

LC7074M (IC705)

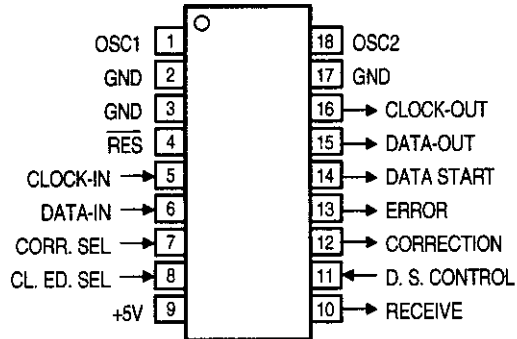
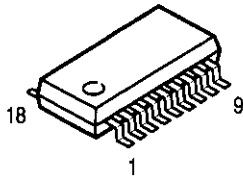

● LC7074M Terminal Function

Pin No.	Symbol	I/O	INI	Function
1	OSC1	I	—	● 4MHz ceramic oscillator connection.
2	GND	—	—	● GND
3	GND	—	—	● GND
4	RES	I	—	● System reset input. ● Reset and restart is accomplished by inputting the low level for 4 or more clock cycles.
5	CLOCK IN	I	H	● RDS LA2230 serial demodulation clock input.
6	DATA IN	I	H	● RDS LA2230 serial demodulation data input.
7	CORR. SEL	I	H	● Error correction on/off selection input. ● Sets the IC to correct errors in the RDS demodulation data or to output the data without correction. When input is 0: No corrections are made When input is 1: Corrections are executed
8	CL. ED. SEL	I	H	● Serial data clock polarity selection input. When input is 0: Serial data output is enabled at the rise of the output clock. (Serial data output changes at the fall of the output clock.) When input is 1: Serial data output is enabled at the fall of the output clock. (Serial data output changes at the rise of the output clock.) <b>Note:</b> Set at the time of RES input.
9	+5V	—	H	● Power supply.
10	RECEIVE (NC)	O	H	● Output during RDS data reception. ● After the completion of sync detection, there is a low-level output while the serial data is being output. There is a high-level output at other times. ● Open drain output.
11	D.S. CONTROL	I	H	● Block data start signal control input. When input is 0: Data start signal is output for all blocks. When input is 1: Data start signal is output for only the second block.
12	CORRECTION (NC)	O	H	● Output without error correction. ● There is a low-level output when the output data of the serial data output have been corrected or when correction is not possible. There is a high-level output when correction has not been applied. ● Open drain output.
13	ERROR (NC)	O	H	● Presence of error output. ● There is a low-level output when the output data of the serial data output has an error and correction is not possible. There is high-level output when there is no error or when the error has been corrected. ● Open drain output.
14	DATA START	O	H	● Block data start signal of the serial data output. Output with pull-up resistor:
15	DATA OUT	O	H	● Data output of the serial data output. Output with pull-up resistor.
16	CLOCK OUT	O	H	● Clock output of the serial data output. Output with pull-up resistor:
17	GND	—	—	● GND
18	OSC2	O	—	● 4MHz ceramic oscillator connection.



RECEIVER

LM7000 (IC703)

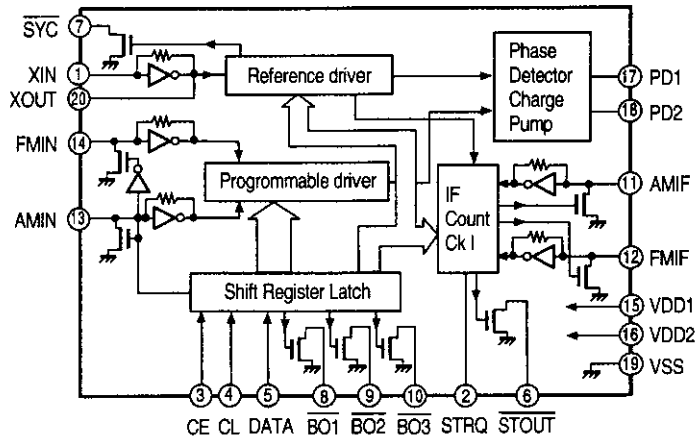
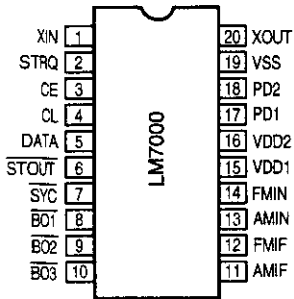
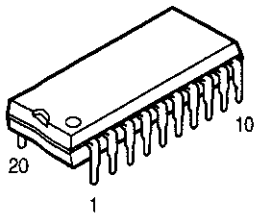

Pin Description

- SYC : Clock (400kHz) for the controller
- XIN, XOUT : X'tal oscillator (7.2MHz) with built-in feedback resistor
- FM IN, AM IN : Local osc. signal input
- CE, CL, DATA : Data input
- B01, B02, B03 : Band data output. B01 can be set as the time base output (8Hz)
- STRQ : IF counter request input
- STOUT : Auto research stop signal output
- VDD1, VDD2, VSS : Power supply (VDD2 is a back-up power supply)
- AMIF, FMIF : IF signal input
- PD1, PD2 : Charge pump output

LA1267 (IC701)

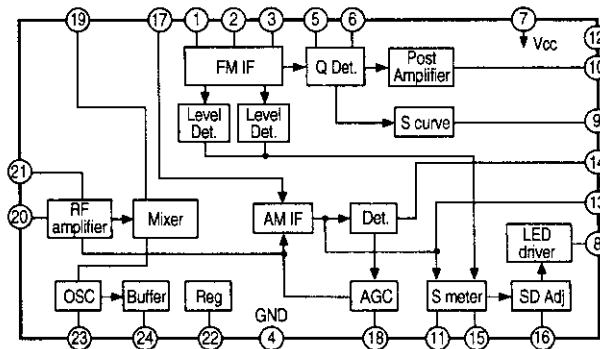
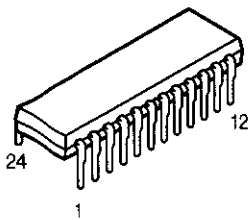

LA3410 (IC702)

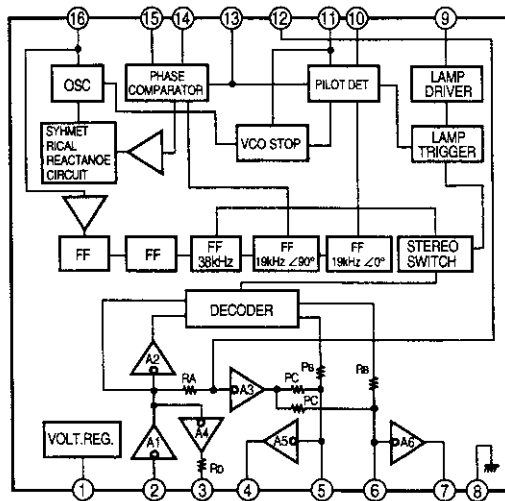
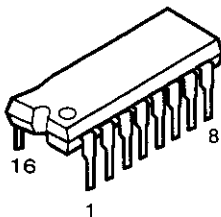

**RECEIVER**

**LC7821 (IC202)**

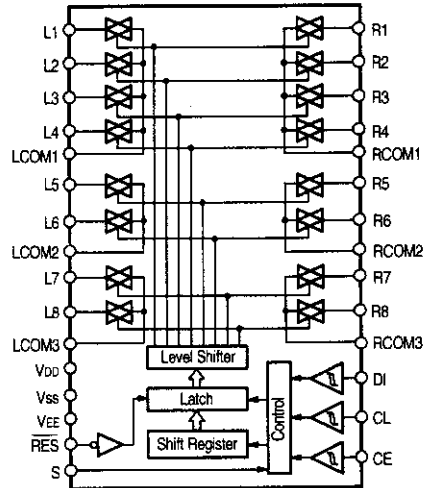
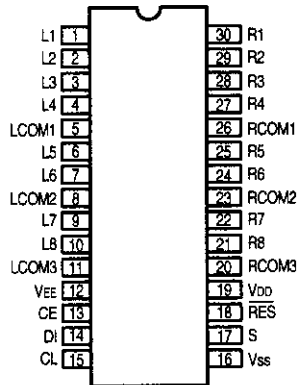
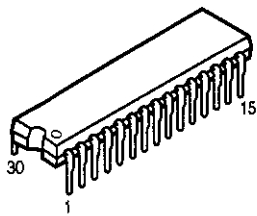

**M5230L (IC401)**

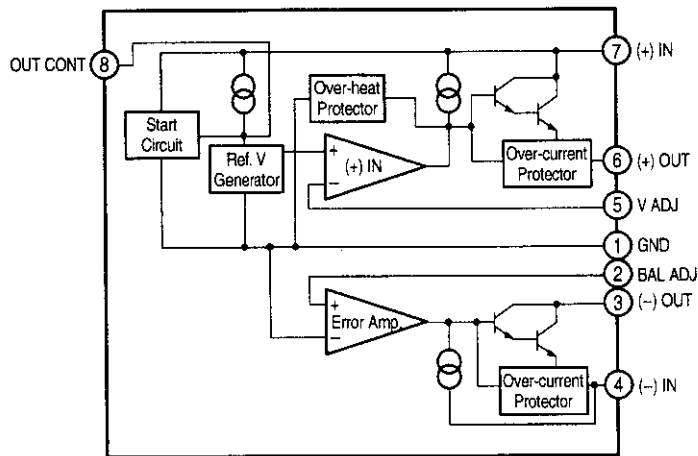
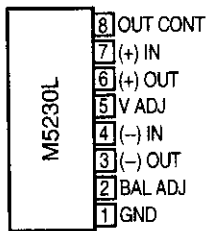
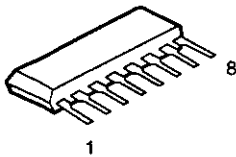

**XL9040F (IC902)**

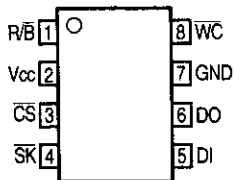
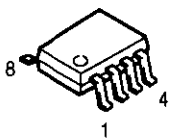

**XL9040F Terminal Function**

Pin No.	Pin Name	I/O	Function
1	R/B	O	READY, BUSY status signal output.
2	Vcc	-	Connect to power supply.
3	CS	I	Chip select input.
4	SK	I	Serial data clock input.
5	DI	I	Ope. code, address, serial data input.
6	DO	O	Serial data output.
7	GND	-	Ref. V for all input/output: OV
8	WC	I	Write control input.

RECEIVER

SAA6579T (IC704)

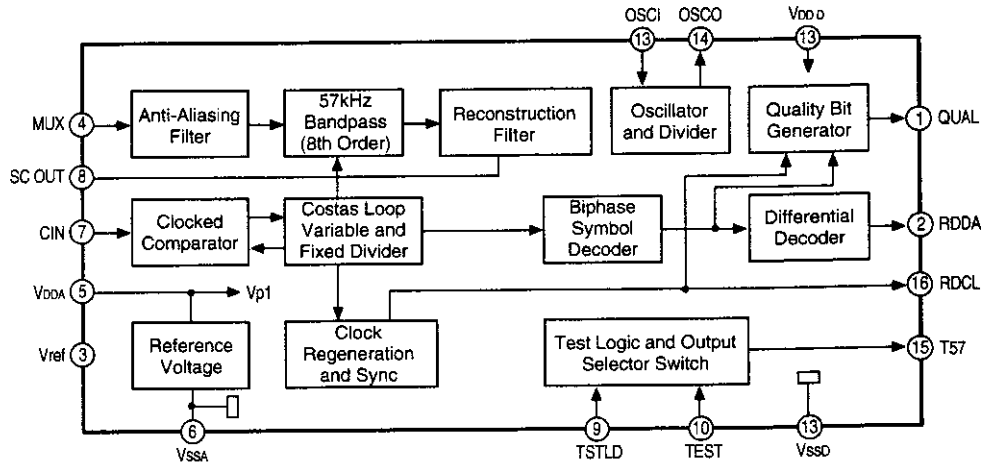
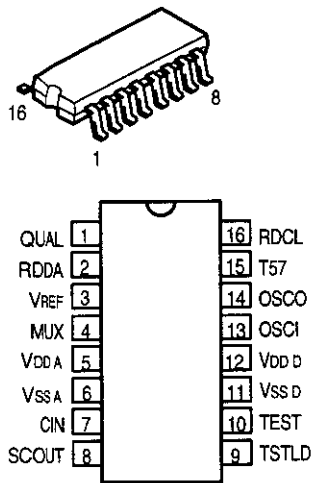

SAA6579T Terminal Function

Pin No.	Symbol	Function
1	QUAL	Quality indication output.
2	RDDA	RDS data output.
3	Vref	Reference voltage output (0.5 VDDA).
4	MUX	Multiplex signal input.
5	VDD A	+5V supply voltage for analog part.
6	VSS A	Ground for analog part (0V).
7	CIN	Subcarrier input to comparator.
8	SCOUT	Subcarrier output of reconstruction filter.
9	TSTLD	Test control.
10	TEST	Test enable.
11	VSS D	Ground for digital part (0V).
12	VDD D	+5V supply voltage for digital part.
13	OSCI	Oscillator input.
14	OSCO	Oscillator output.
15	T57	57kHz clock signal output.
16	RDCL	RDS clock output.

LB1639 (IC102)

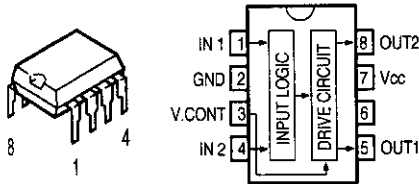

PST600C (IC903)

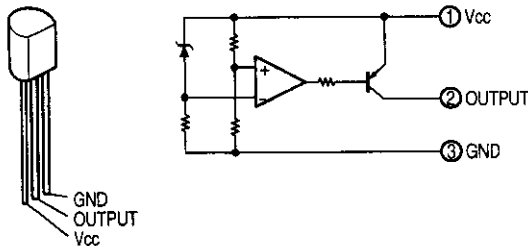

NJM4565MD (IC201, 203)

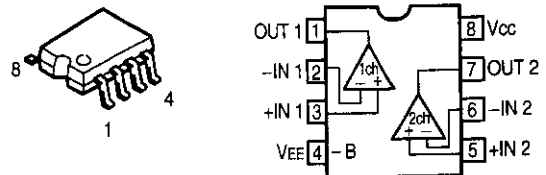

● IC PROTECTOR

ICP-N15(IC1~3)

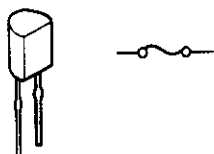

● REMOTE CONTROL SENSOR

PNA4602M00HA(RM901)

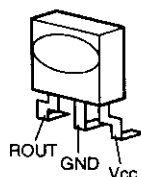

RECEIVER

TRANSISTORS

KSA992 F  
KSC1845 F  
KTA1266  
KTC3198

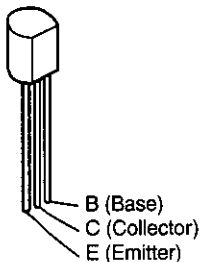

2SA933S  
2SC1740S

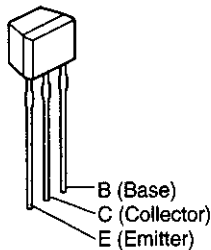

DTC114ES (NPN)  
DTC144ES (NPN)

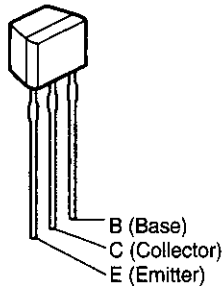

DTC ES Series

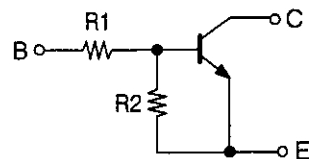

	R1	R2
DTC114ES	10kohm	10kohm
DTC144ES	47kohm	47kohm

2SC4137

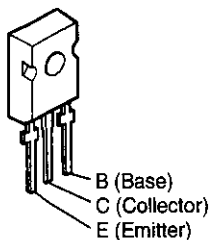

2SB1655  
2SD2576

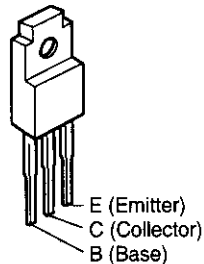

2SB1559  
2SD2389

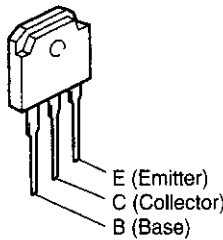

KTC3880

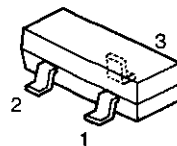

1: E (Emitter)  
2: B (Base)  
3: C (Collector)

2SA1037K  
2SC2412K

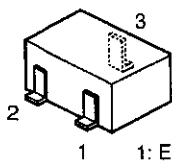

1: E (Emitter)  
2: B (Base)  
3: C (Collector)

DTA114EK  
DTC343TK

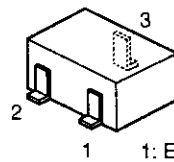

1: E (Emitter)  
2: B (Base)  
3: C (Collector)

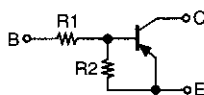

	R1	R2
DTA114EK	10kohm	10kohm

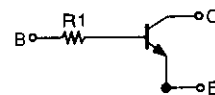

	R1
DTC343TK	4.7kohm

DIODES

1SS133

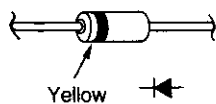

1N4004A

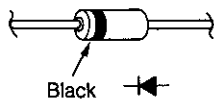

MTZJ13B  
MTZJ27B  
MTZJ5.6B  
MTZJ6.2B

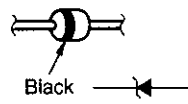

1SS355

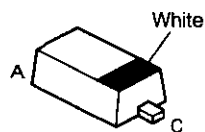

D3SB20

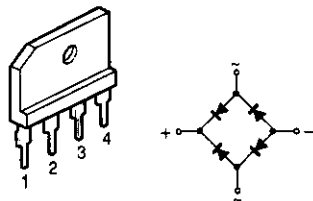

● FL DISPLAY  
11-BT-127GK (FL901)

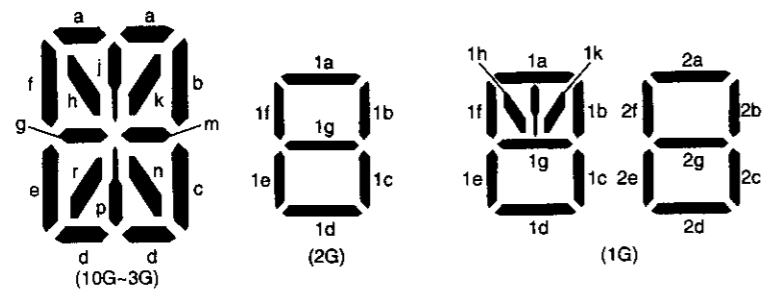
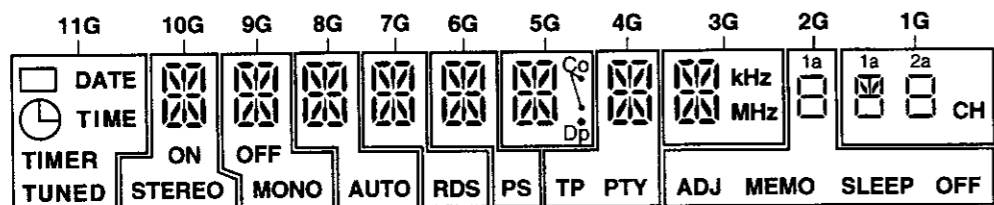
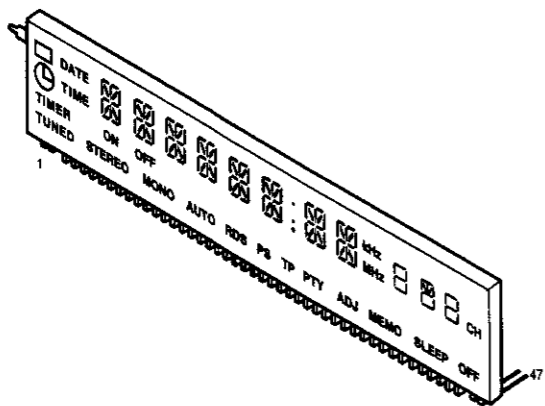

Pin Connection

Pin No.	1	2	3	4	5	6	7	8	9	10	11	12	13	14	15	16	17	18	19	20	21	22	23	24	
Electrode	F1	F1	NP	NP	1G	2G	3G	4G	5G	6G	7G	8G	9G	10G	11G	NC	NC	NC	NC	NC	NC	NC	NC	NC	NC

Pin No.	25	26	27	28	29	30	31	32	33	34	35	36	37	38	39	40	41	42	43	44	45	46	47
Electrode	NC	NC	NC	P16	P15	P14	P13	P12	P11	P10	P9	P8	P7	P6	P5	P4	P3	P2	P1	NP	NP	F2	F2

- Note: 1. F1 and F2: Filaments  
 2. NP: No pin  
 3. NC: No connection  
 4. 1G through 11G: Grid

Anode Connection

	11G	10G	9G	8G	7G	6G	5G	4G	3G	2G	1G
P1	□	a	a	a	a	a	a	a	a	1a	1a
P2	DATE	b	b	b	b	b	b	b	b	1b	1b
P3	⌚	c	c	c	c	c	c	c	c	1c	1c
P4	TIME	d	d	d	d	d	d	d	d	1d	1d
P5	TIMER	e	e	e	e	e	e	e	e	1e	1e
P6	TUNED	f	f	f	f	f	f	f	f	1f	1f
P7	—	g	g	g	g	g	g	g	g	1g	1g
P8	—	h	h	h	h	h	h	h	h	ADJ	1h, 1k
P9	—	j	j	j	j	j	j	j	j	MEMO	2a
P10	—	k	k	k	k	k	k	k	k	SLEEP	2b
P11	—	m	m	m	m	m	m	m	m	OFF	2c
P12	—	n	n	n	n	n	n	n	n	—	2d
P13	—	p	p	p	p	p	p	p	p	—	2e
P14	—	r	r	r	r	r	r	r	r	—	2f
P15	—	ON	OFF	AUTO	RDS	PS	Co	TP	kHz	—	2g
P16	—	STEREO	MONO	—	—	—	Dp	PTY	MHz	—	CH

1 2 3 4 5 6 7 8

A

B

C

D

E

MAIN P.W.B. UNIT ASS'Y

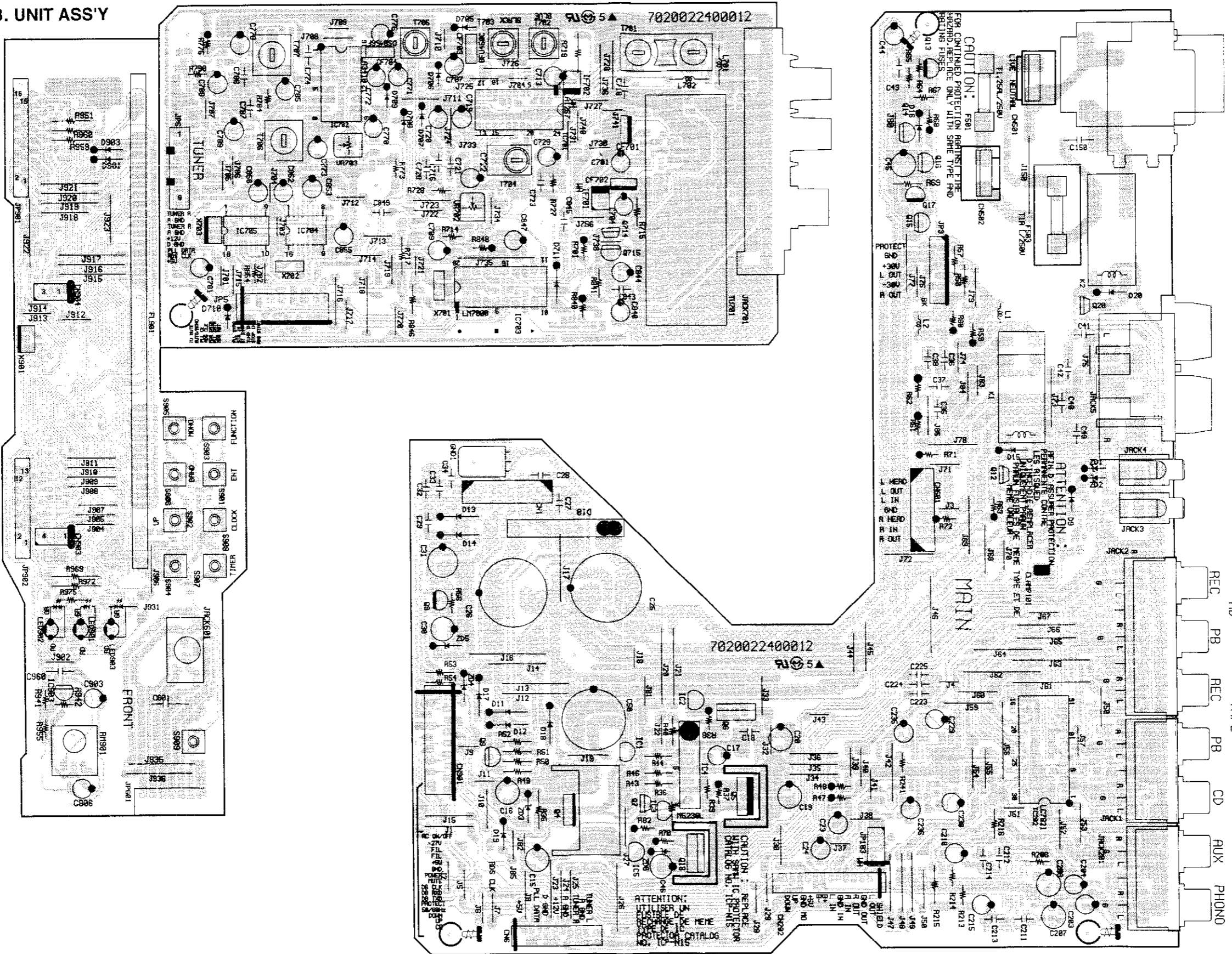

COMPONENT SIDE

1 2 3 4 5 6 7 8

A

B

C

D

E

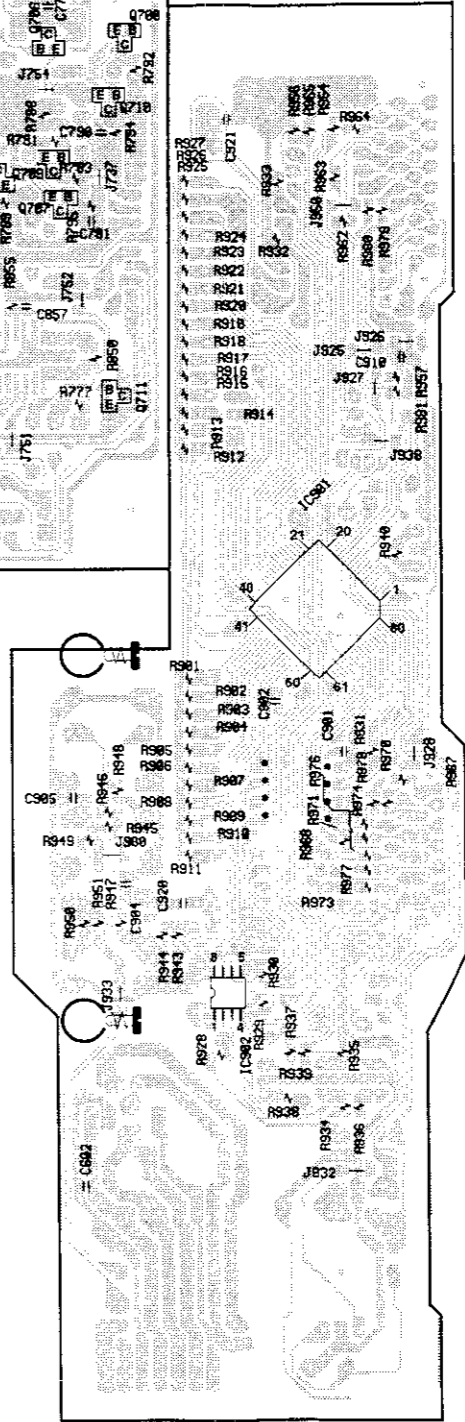
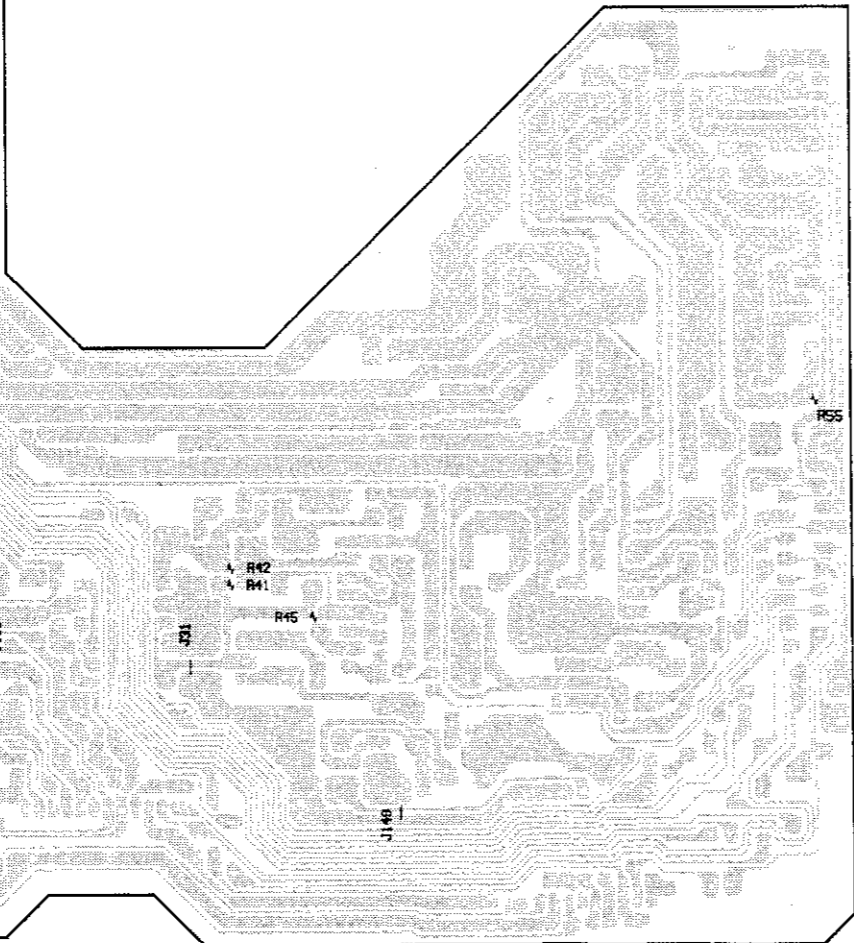
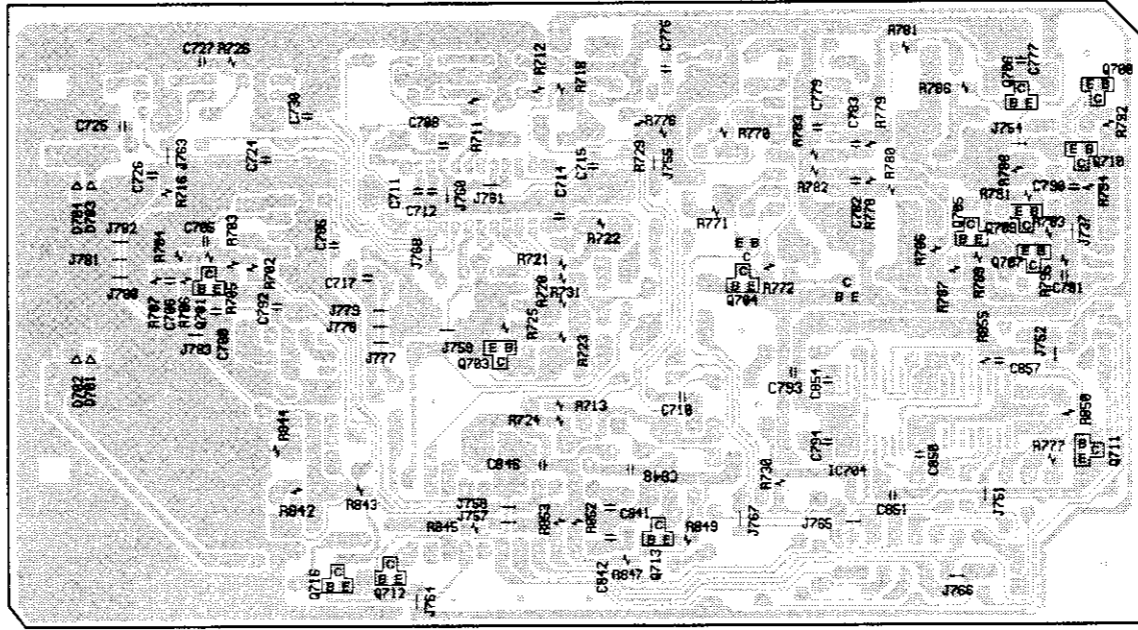
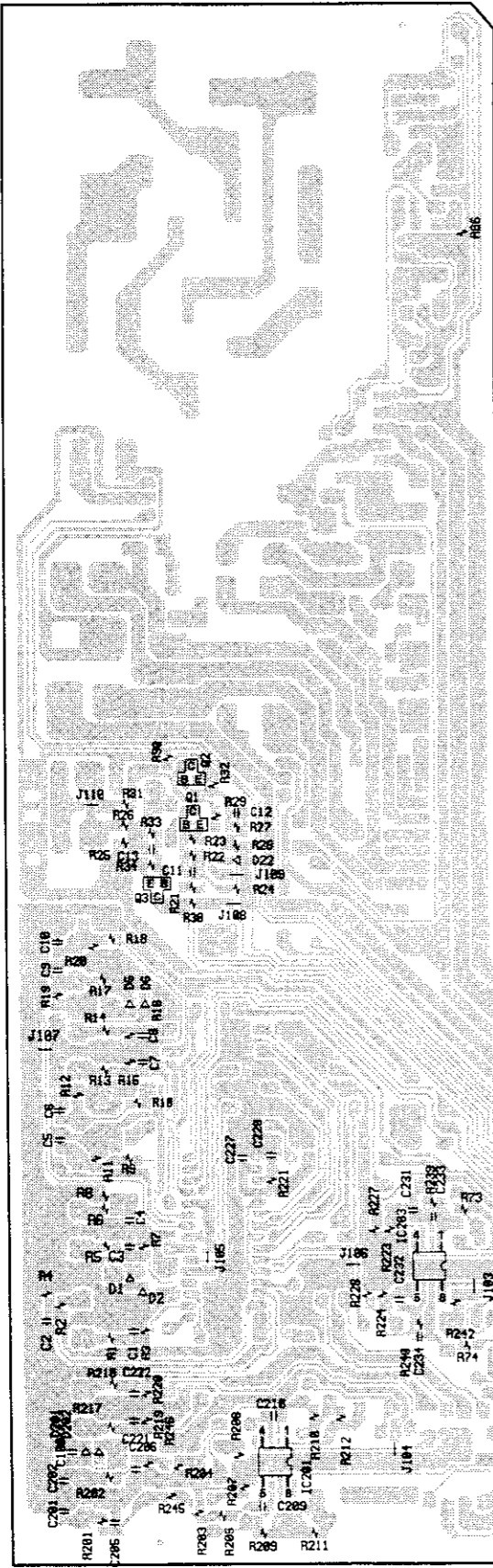

FOIL SIDE

RECEIVER

AMP P.W.B. UNIT ASS'Y

1 2 3 4 5 6 7 8

A

B

C

D

E

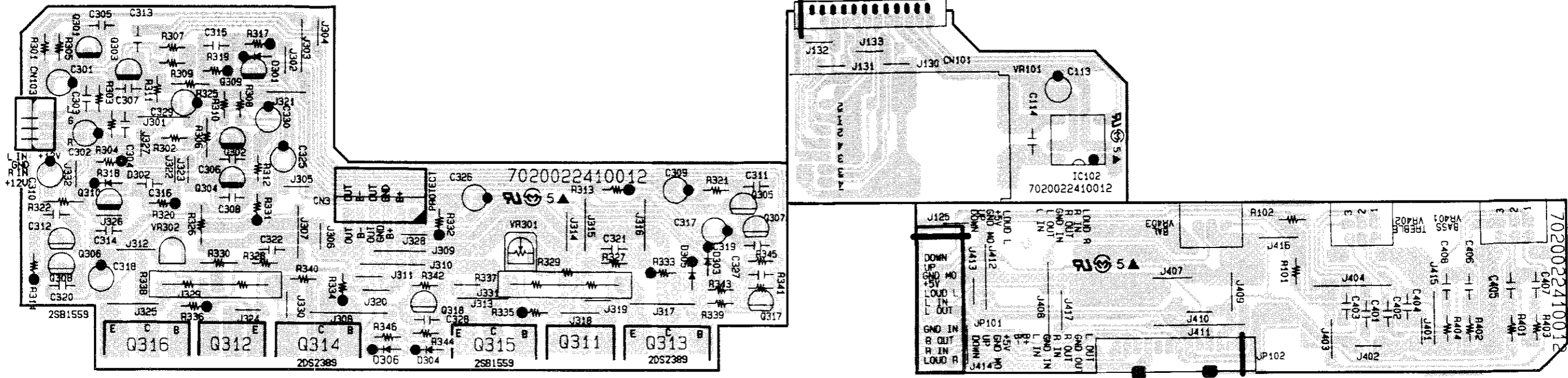

COMPONENT SIDE



# NOTE FOR PARTS LIST

- Part indicated with the mark "⊕" are not always in stock and possibly to take a long period of time for supplying, or in some case supplying of part may be refused.
- When ordering of part, clearly indicate "1" and "1" (i) to avoid mis-supplying.
- Ordering part without stating its part number can not be supplied.
- Part indicated with the mark "★" is not illustrated in the exploded view.
- Not including Carbon Film ±5%, 1/4W Type in the P.W.Board parts list. (Refer to the Schematic Diagram for those parts.)

**WARNING:**

Parts marked with this symbol  have critical characteristics. Use ONLY replacement parts recommended by the manufacturer.

● **Resistors**

Ex.: RN 14K 2E 182 G FR  
 Type Shape Power Resist- Allowable Others  
 and performance ance error

RD : Carbon	2B : 1/8W	F : ±1%	P : Pulse-resistant type
RC : Composition	2E : 1/4W	G : ±2%	NL : Low noise type
RS : Metal oxide film	2H : 1/2W	J : ±5%	NB : Non-burning type
RW : Winding	3A : 1W	K : ±10%	FR : Fuse-resistor
RN : Metal film	3D : 2W	M : ±20%	F : Lead wire forming
RK : Metal mixture	3F : 3W		
	3H : 5W		

\* **Resistance**

$1 \overset{8}{\text{---}} \overset{2}{\text{---}}$  ⇒ 1800 ohm = 1.8 kohm  
 Indicates number of zeros after effective number.  
 2-digit effective number.

• Units: ohm

$1 \overset{R}{\text{---}} \overset{2}{\text{---}}$  ⇒ 1.2 ohm  
 1-digit effective number.  
 2-digit effective number, decimal point indicated by R.

• Units: ohm

● **Capacitors**

Ex.: CE 04W 1H 2R2 M BP  
 Type Shape Dielectric Capacity Allowable Others  
 and performance strength error

CE : Aluminum foil electrolytic	0J : 6.3V	F : ±1%	HS : High stability type
CA : Aluminum solid electrolytic	1A : 10V	G : ±2%	BP : Non-polar type
CS : Tantalum electrolytic	1C : 16V	J : ±5%	HR : Ripple-resistant type
CQ : Film	1E : 25V	K : ±10%	DL : For charge and discharge
CK : Ceramic	1V : 35V	M : ±20%	HF : For assuring high frequency
CC : Ceramic	1H : 50V	Z : -80%	U : UL part
CP : Oil	2A : 100V	-20%	C : CSA part
CM : Mica	2B : 125V	P : +100%	W : UL-CSA type
CF : Metalized	2C : 160V	-0%	F : Lead wire forming
CH : Metalized	2D : 200V	C : ±0.25pF	
	2E : 250V	D : ±0.5pF	
	2H : 500V	= : Others	
	2L : 630V		

\* **Capacity (electrolyte only)**

$2 \overset{2}{\text{---}} \overset{2}{\text{---}}$  ⇒ 2200μF  
 Indicates number of zeros after effective number.  
 2-digit effective number.

• Units: μF.

$2 \overset{R}{\text{---}} \overset{2}{\text{---}}$  ⇒ 2.2μF  
 1-digit effective number.  
 2-digit effective number, decimal point indicated by R.

• Units: μF.

\* **Capacity (except electrolyte)**

$2 \overset{2}{\text{---}} \overset{2}{\text{---}}$  ⇒ 2200pF=0.0022μF  
 (More than 2) Indicates number of zeros after effective number.  
 2-digit effective number.

• Units: μF.

$2 \overset{2}{\text{---}} \overset{1}{\text{---}}$  ⇒ 220pF  
 (0 or 1) Indicates number of zeros after effective number.  
 2-digit effective number.

• Units: pF.

• When the dielectric strength is indicated in AC, "AC" is included after the dielectric strength value.

RECEIVER

PARTS LIST OF P.W.B. UNIT  
MAIN P.W.B. UNIT ASS'Y

Ref. No.	Part No.	Part Name	Remarks
<b>SEMICONDUCTORS GROUP</b>			
IC1-3	268 0073 905	IC ICP-N15	J120001500030
IC4	263 0646 007	IC M5230L	J126523000010
IC201	928 0035 809	IC NJM4565MD	J121456500040
IC202	262 1808 003	IC LC7821	J040782100010
IC203	928 0035 809	IC NJM4565MD	J121456500040
IC701	263 0421 002	IC LA1267	J124126700010
IC702	960 0092 503	IC LA3410	J124341000010
IC703	262 0703 002	IC LM7000	J120700000010
IC704	262 1701 906	IC SAA6579T	J124657900010
IC705	9LC K044 71	IC LC7074M	J120707400010
IC901	960 0119 101	IC HD6433726SD***	J020643372620
IC902	960 0050 503	IC XL9040F	J000904000010
IC903	960 0119 208	IC PST600C	J125600200020
Q1	271 0238 908	Transistor 2SA1037K(S/R)	J5201037K0210
Q2,3	273 0384 900	Transistor 2SC2412K(S)	J5222412K0210
Q4	960 0049 404	Transistor 2SD2576F	J5032576F0010
Q5	9LC F013 21	Transistor 2SB1655E	J5011655E0010
Q6	960 0049 404	Transistor 2SD2576F	J5032576F0010
Q7	269 0040 902	Transistor DTC144ES	J6020144E0010
Q8	960 0005 002	Transistor KTC3198Y	J5023198Y0000
Q9	271 0183 914	Transistor 2SA933S	J5000933S0050
Q12	269 0020 906	Transistor DTC114ES	J6020114E0010
Q13	960 0005 105	Transistor KTA1266Y	J5001266Y0050
Q14-16	960 0005 002	Transistor KTC3198Y	J5023198Y0000
Q17	960 0005 105	Transistor KTA1266Y	J5001266Y0050
Q18	960 0049 404	Transistor 2SD2576F	J5032576F0010
Q20	269 0020 906	Transistor DTC114ES	J6020114E0010 Europe & U.K. Models only
Q701	960 0050 901	Transistor KTC3880O	J5223880O0210
Q703-706	273 0384 900	Transistor 2SC2412K(S)	J5222412K0210
Q707-710	269 0104 903	Transistor DTC343TK	J5220343T0210
Q711,712	269 0083 901	Transistor DTA114EK	J5200114E0210
Q713	960 0050 901	Transistor KTC3880O	J5223880O0210
Q714	273 0178 022	Transistor 2SC1740SR	J5021740S0010
Q715	273 0207 003	Transistor KSC1845F	J5021845F0000
Q716	269 0083 901	Transistor DTA114EK	J5200114E0210
D1,2	960 0117 501	Diode 1SS355	K005035500010
D5,6	960 0117 501	Diode 1SS355	K005035500010
D9	963 0020 309	Diode 1SS133	K000013300520
D10	960 0039 508	Diode D3SB20	K047004000010
D11-14	960 0117 608	Diode 1N4004A	K040400400520
D15,16	963 0020 309	Diode 1SS133	K000013300520
D17,18	960 0117 608	Diode 1N4004A	K040400400520
D20	963 0020 309	Diode 1SS133	K000013300520 Europe & U.K. Models only

Ref. No.	Part No.	Part Name	Remarks
D22	960 0117 501	Diode 1SS355	K005035500010
D201,202	960 0117 501	Diode 1SS355	K005035500010
D701-704	960 0117 501	Diode 1SS355	K005035500010
D705-711	963 0020 309	Diode 1SS133	K000013300520
D901	963 0020 309	Diode 1SS133	K000013300520 Europe & U.K. Models only
D903	963 0020 309	Diode 1SS133	K000013300520
ZD1,2	960 0095 704	Zener diode MTZJ6.2B	K06006R244520
ZD3	960 0095 607	Zener diode MTZJ5.6B	K06005R644520
ZD4	960 0095 704	Zener diode MTZJ6.2B	K06006R244520
ZD5	960 0117 705	Zener diode MTZJ27B	K06027R044520
ZD6	960 0037 209	Zener diode MTZJ13B	K06013R044520
LED901-903	960 0050 202	LED P13-SPR39MVW3	K500032500010 Europe & U.K. Models only
<b>RESISTORS GROUP</b>			
R1,2		Carbon chip 6.2 kohm 1/10W	C200062260200
R3,4		Carbon chip 10 kohm 1/10W	C200010360200
R5,6		Carbon chip 1 kohm 1/10W	C200010260200
R7,8		Carbon chip 1 Mohm 1/10W	C200010560200
R9,10		Carbon chip 470 ohm 1/10W	C200047160200
R11,12		Carbon chip 1 Mohm 1/10W	C200010560200
R13,14		Carbon chip 6.2 kohm 1/10W	C200062260200
R15,16		Carbon chip 10 kohm 1/10W	C200010360200
R17,18		Carbon chip 470 ohm 1/10W	C200047160200
R19,20		Carbon chip 1 Mohm 1/10W	C200010560200
R21		Carbon chip 10 kohm 1/10W	C200010360200
R22,23		Carbon chip 22 kohm 1/10W	C200022360200
R24		Carbon chip 10 kohm 1/10W	C200010360200
R25		Carbon chip 47 kohm 1/10W	C200047360200
R26		Carbon chip 220 ohm 1/10W	C200022160200
R27		Carbon chip 22 kohm 1/10W	C200022360200
R28		Carbon chip 2.2 kohm 1/10W	C200022260200
R29,30		Carbon chip 10 kohm 1/10W	C200010360200
R31		Carbon chip 100 ohm 1/10W	C200010160200
R32-34		Carbon chip 22 kohm 1/10W	C200022360200
R36		Carbon film 47 kohm 1/5W	C00004736P520
R37,38		Metal film 220 ohm 1/4W	C060022163050
R39,40		Carbon film 4.7 kohm 1/5W	C00004726P520
R41,42		Carbon chip 15 kohm 1/10W	C200015360200
R43,44		Carbon film 1 kohm 1/5W	C00001026P520
R45		Carbon chip 33 kohm 1/10W	C200033360200
R46		Carbon film 3.3 kohm 1/5W	C00003326P520
R47,48	244 2055 941	Metal film 330 ohm 1W	C060033165050
R49-52		Carbon film 10 kohm 1/5W	C00001036P520
R53,54		Carbon film 100 ohm 1/5W	C00001016P520
R55		Carbon chip 47 kohm 1/10W	C200047360200
R56		Carbon film 4.7 kohm 1/5W	C00004726P520

## RECEIVER

Ref. No.	Part No.	Part Name	Remarks	Ref. No.	Part No.	Part Name	Remarks
R57,58		Carbon film 33 kohm 1/5W	C00003336P520	R719		Carbon film 30 kohm 1/5W	C00003036P520
R59,60		Metal film 10 ohm 1/4W	C060010063050				Europe & U.K. Models
R63	244 2043 953	Metal film 470 ohm 1W	C060047165050	R719		Carbon film 15 kohm 1/5W	C00001536P520
R64		Carbon film 10 kohm 1/5W	C00001036P520				Asia Model
R65		Carbon film 47 kohm 1/5W	C00004736P520	R720		Carbon chip 3.3 kohm 1/10W	C200033260200
R66		Carbon chip 47 kohm 1/10W	C200047360200	R721-724		Carbon chip 10 kohm 1/10W	C200010360200
R67		Carbon film 4.7 kohm 1/5W	C00004726P520	R725		Carbon chip 22 kohm 1/10W	C200022360200
R68		Carbon film 4.7 ohm 1/5W	C0004R706P520	R726		Carbon chip 100 kohm 1/10W	C200010460200
R68		Metal film 47 ohm 1/4W	C060047063050	R727		Carbon film 68 kohm 1/5W	C00006836P520
R69		Carbon film 10 kohm 1/5W	C00001036P520	R728		Carbon film 47 kohm 1/5W	C00004736P520
R70		Metal film 1.2 kohm 1/4W	C060012263050	R729		Carbon chip 2.7 kohm 1/10W	C200027260200
R71,72	244 2052 973	Metal film 560 ohm 1W	C060056165050	R730,731		Carbon chip 10 kohm 1/10W	C200010360200
R73,74		Carbon chip 2.2 kohm 1/10W	C200022260200	R770		Carbon chip 1 kohm 1/10W	C200010260200
R90		Carbon chip 100 ohm 1/10W	C200010160200	R771		Carbon chip 2.2 kohm 1/10W	C200022260200
				R772		Carbon chip 100 kohm 1/10W	C200010460200
R201,202		Carbon chip 390 ohm 1/10W	C200039160200	R773		Carbon film 10 kohm 1/5W	C00001036P520
R203,204		Carbon chip 150 kohm 1/10W	C200015460200	R775		Metal film 100 ohm 1/4W	C060010163050
R205		Carbon chip 47 ohm 1/10W	C200047060200	R776		Carbon chip 22 kohm 1/10W	C200022360200
R206		Carbon film 47 ohm 1/5W	C00004706P520	R777		Carbon chip 5.6 kohm 1/10W	C200056260200
R207,208		Carbon chip 430 ohm 1/10W	C200043160200	R778,779		Carbon chip 200 kohm 1/10W	C200020460200
R209,210		Carbon chip 270 kohm 1/10W	C200027460200	R780,781		Carbon chip 2.7 kohm 1/10W	C200027260200
R211,212		Carbon chip 22 kohm 1/10W	C200022360200	R782,783		Carbon chip 200 kohm 1/10W	C200020460200
R213,214		Carbon film 470 kohm 1/5W	C00004746P520	R784		Carbon film 3.3 kohm 1/5W	C00003326P520
R216		Carbon film 100 ohm 1/5W	C00001016P520	R785		Carbon chip 3.3 kohm 1/10W	C200033260200
R217,218		Carbon chip 6.2 kohm 1/10W	C200062260200	R786,787		Carbon chip 100 ohm 1/10W	C200010160200
R219,220		Carbon chip 10 kohm 1/10W	C200010360200	R788,789		Carbon chip 5.6 kohm 1/10W	C200056260200
R221		Carbon chip 680 kohm 1/10W	C200068460200	R790		Carbon film 470 ohm 1/5W	C00004716P520
R223,224		Carbon chip 100 kohm 1/10W	C200010460200	R791-793		Carbon chip 470 ohm 1/10W	C200047160200
R227,228		Carbon chip 6.2 kohm 1/10W	C200062260200	R794,795		Carbon chip 10 kohm 1/10W	C200010360200
R239,R240		Carbon chip 10 kohm 1/10W	C200010360200				
R241		Carbon film 100 kohm 1/5W	C00001046P520	R840		Metal film 100 ohm 1/4W	C060010163050
R242		Carbon chip 100 kohm 1/10W	C200010460200	R841		Carbon film 6.2 kohm 1/5W	C00008226P520
R245,246		Carbon chip 68 kohm 1/10W	C200068360200	R842		Carbon chip 1.8 kohm 1/10W	C200018260200
				R843		Carbon chip 10 kohm 1/10W	C200010360200
R701		Metal film 47 ohm 1/4W	C060047063050	R844		Carbon chip 3.3 kohm 1/10W	C200033260200
R702		Carbon chip 100 ohm 1/10W	C200010160200	R845		Carbon chip 10 kohm 1/10W	C200010360200
R703		Carbon chip 3.3 kohm 1/10W	C200033260200	R846		Carbon film 1 kohm 1/5W	C00001026P520
R704		Carbon chip 680 ohm 1/10W	C200068160200	R847		Carbon chip 150 kohm 1/10W	C200015460200
R706		Carbon chip 22 ohm 1/10W	C200022060200	R848		Metal film 10 ohm 1/4W	C060010063050
			Europe & U.K. Models	R849		Carbon film 1 kohm 1/5W	C00001026P520
R706		Carbon chip 56 ohm 1/10W	C200056060200	R850		Carbon chip 1 Mohm 1/10W	C200010560200
			Asia Model				Europe & U.K. Models only
R711		Carbon chip 10 kohm 1/10W	C200010360200				
R712		Carbon chip 5.1 kohm 1/10W	C200051260200	R852,853		Carbon chip 10 kohm 1/10W	C200010360200
R713		Carbon chip 10 kohm 1/10W	C200010360200	R854		Carbon film 10 kohm 1/5W	C00001036P520
R714		Carbon film 5.6 kohm 1/5W	C00005626P520				Europe & U.K. Models only
R715		Carbon film 220 ohm 1/5W	C00002216P520	R855		Carbon chip 10 kohm 1/10W	C200010360200
R716		Carbon chip 10 kohm 1/10W	C200010360200				Europe & U.K. Models only
R717		Carbon film 470 ohm 1/5W	C00004716P520				
R718		Carbon chip 82 ohm 1/10W	C200082060200	R901-927		Carbon chip 47 kohm 1/10W	C200047360200
				R928-930		Carbon chip 10 kohm 1/10W	C200010360200
				R931		Carbon chip 180 ohm 1/10W	C200018160200

RECEIVER

Ref. No.	Part No.	Part Name	Remarks
R932,933		Carbon chip 10 kohm 1/10W	C200010360200
R934		Carbon chip 330 ohm 1/10W	C200033160200 Europe & U.K. Models only
R935		Carbon chip 220 ohm 1/10W	C200022160200 Europe & U.K. Models only
R936		Carbon chip 330 ohm 1/10W	C200033160200 Europe & U.K. Models only
R937		Carbon chip 220 ohm 1/10W	C200022160200 Europe & U.K. Models only
R938		Carbon chip 330 ohm 1/10W	C200033160200 Europe & U.K. Models only
R939		Carbon chip 220 ohm 1/10W	C200022160200 Europe & U.K. Models only
R940		Carbon chip 1 Mohm 1/10W	C200010560200
R941		Carbon film 10 kohm 1/5W	C00001036P520
R942		Carbon film 470 ohm 1/5W	C00004716P520
R943,944		Carbon chip 1 kohm 1/10W	C200010260200
R945		Carbon chip 150 ohm 1/10W	C200015160200
R946		Carbon chip 180 ohm 1/10W	C200018160200
R947		Carbon chip 150 ohm 1/10W	C200015160200
R948		Carbon chip 180 ohm 1/10W	C200018160200
R949		Carbon chip 270 ohm 1/10W	C200027160200
R950		Carbon chip 390 ohm 1/10W	C200039160200
R951		Carbon chip 680 ohm 1/10W	C200068160200
R954		Carbon chip 1 kohm 1/10W	C200010260200
R955		Carbon film 47 ohm 1/5W	C00004706P520
R956,957		Carbon chip 10 kohm 1/10W	C200010360200
R959-961		Carbon film 1 kohm 1/5W	C00001026P520
R962-965		Carbon chip 1 kohm 1/10W	C200010260200
R967,968		Carbon chip 1 kohm 1/10W	C200010260200
R969		Carbon film 1 kohm 1/5W	C00001026P520
R970,971		Carbon chip 1 kohm 1/10W	C200010260200
R972		Carbon film 1 kohm 1/5W	C00001026P520
R973,974		Carbon chip 1 kohm 1/10W	C200010260200
R975		Carbon film 1 kohm 1/5W	C00001026P520
R976-980		Carbon chip 1 kohm 1/10W	C200010260200
R981		Carbon chip 10 kohm 1/10W	C200010360200
VR702	960 0119 907	Semi fixed resistor 22 kohm	C544223015140
VR703	960 0120 006	Semi fixed resistor 220 kohm	C544224015130

CAPACITORS GROUP

C1,2		Ceramic chip 100 pF/50V	D010101167200
C3,4		Ceramic chip 680 pF/50V	D010681167200
C5-11		Ceramic chip 100 pF/50V	D010101167200
C12,13		Ceramic chip 0.001 $\mu$ F/50V	D011102777200
C15	254 4254 019	Electrolytic 22 $\mu$ F/16V	D040220083070
C16	254 4260 061	Electrolytic 3.3 $\mu$ F/50V	D0403R3087100
C17	254 4260 045	Electrolytic 1 $\mu$ F/50V	D040010087070
C18		Film 0.0047 $\mu$ F/100V	D02047206C060
C19,20	254 4256 949	Electrolytic 100 $\mu$ F/25V	D040101084060
C23,24	254 4260 087	Electrolytic 10 $\mu$ F/50V	D040100087050

Ref. No.	Part No.	Part Name	Remarks
C25,26	960 9002 219	Electrolytic 4700 $\mu$ F/50V	D040472087000
<b>▲ C27-29</b>		<b>Ceramic 0.01 <math>\mu</math>F/500V</b>	<b>D00410359D050</b>
C30	254 4260 087	Electrolytic 10 $\mu$ F/50V	D040100087050
C31	254 4261 028	Electrolytic 100 $\mu$ F/50V	D040101087060
C32-34		Ceramic 0.01 $\mu$ F/50V	D004103277050
C35-38		Film 0.0047 $\mu$ F/100V	D02047306C060
C43		Ceramic 0.01 $\mu$ F/50V	D004103277050
C44	254 4260 087	Electrolytic 10 $\mu$ F/50V	D040100087050
C45	254 4250 042	Electrolytic 330 $\mu$ F/6.3V	D040331081050
C46	254 4254 051	Electrolytic 220 $\mu$ F/16V	D040221083090
C50	254 4256 088	Electrolytic 1000 $\mu$ F/25V	D040102084050
<b>▲ C150</b>	<b>963 0020 804</b>	<b>Ceramic 0.0047 <math>\mu</math>F/250V</b>	<b>D008472089000</b> Europe & U.K. Models only
C201,202		Ceramic chip 330 pF/50V	D010331167200
C203,204	254 4260 087	Electrolytic 10 $\mu$ F/50V	D040100087050
C205,206		Ceramic chip 330 pF/50V	D010331167200
C207,208	254 4252 037	Electrolytic 100 $\mu$ F/10V	D040101082060
C209,210		Ceramic chip 0.001 $\mu$ F/50V	D0111102777200
C211,212		Film 0.012 $\mu$ F/100V	D02012306C060
C213,214		Film 0.0033 $\mu$ F/100V	D02033206C060
C215,216	254 4260 058	Electrolytic 2.2 $\mu$ F/50V	D0402R2087100
C221,222		Ceramic chip 100 pF/50V	D010101167200
C223		Ceramic 1000 pF/50V	D004102067060
C224,225		Ceramic 100 pF/50V	D004101067060
C227		Ceramic chip 0.01 $\mu$ F/50V	D011103777200
C228		Ceramic chip 0.022 $\mu$ F/50V	D011223777200
C229,230	254 4260 045	Electrolytic 1 $\mu$ F/50V	D040010087070
C231-234		Ceramic chip 100 pF/50V	D010101167200
C235,236	254 4260 045	Electrolytic 1 $\mu$ F/50V	D040010087070
C701	254 4254 035	Electrolytic 47 $\mu$ F/16V	D040470083080
C704	254 4260 045	Electrolytic 1 $\mu$ F/50V	D040010087050
C705,706		Ceramic chip 0.01 $\mu$ F/50V	D011103597200
C707	254 4260 087	Electrolytic 10 $\mu$ F/50V	D040100087050
C708		Ceramic chip 0.022 $\mu$ F/50V	D011223777200
C709	254 4260 045	Electrolytic 1 $\mu$ F/50V	D040010087050
C710		Ceramic 100 pF/50V	D004101277050
C711,712		Ceramic chip 0.022 $\mu$ F/50V	D011223777200
C713	254 4260 061	Electrolytic 3.3 $\mu$ F/50V	D0403R3087100
C714		Ceramic chip 100 pF/50V	D010101167200
C715		Ceramic chip 33 pF/50V	D010330167200
C716		Ceramic 0.001 $\mu$ F/50V	D004102277050
C717		Ceramic chip 100 pF/50V	D010101167200
C718		Ceramic 22 pF/50V	D000220067050
C719	254 4260 074	Electrolytic 4.7 $\mu$ F/50V	D0404R7087250
C720	254 4260 061	Electrolytic 3.3 $\mu$ F/50V	D0403R3087100
C721		Film 0.015 $\mu$ F/100V	D02015306C060
C722	254 4260 087	Electrolytic 10 $\mu$ F/50V	D040100087050
C723		Ceramic 0.01 $\mu$ F/50V	D004103277050
C724		Ceramic chip 0.01 $\mu$ F/50V	D011103597200

RECEIVER

Ref. No.	Part No.	Part Name	Remarks
C725		Ceramic chip 6 pF/50V	D010060107200
C726		Ceramic chip 0.047 μF/50V	D011473597200
C727		Ceramic chip 15 pF/50V	D010150167200
C728		Ceramic 0.1 μF/25V	D004104594050
C729	254 4260 087	Electrolytic 10 μF/50V	D040100087050
C730		Ceramic 0.022 μF/50V	D004223597050
C770	254 4260 045	Electrolytic 1 μF/50V	D040010087050
C771	254 4260 061	Electrolytic 3.3 μF/50V	D0403R3087100
C772	254 4260 032	Electrolytic 0.47 μF/50V	D040R47087050
C773	254 4260 087	Electrolytic 10 μF/50V	D040100087050
C774		Film 0.047 μF/100V	D02047306C060
C775		Ceramic chip 470 pF/50V	D010471167200
C776	254 4260 061	Electrolytic 3.3 μF/50V	D0403R3087100
C777		Ceramic 0.01 μF/50V	D004103277050
C778	254 4254 035	Electrolytic 47 μF/16V	D040470083080
C779		Ceramic chip 330 pF/50V	D010331167200
C781	254 4260 087	Electrolytic 10 μF/50V	D040100087050
C782,783		Ceramic chip 270 pF/50V	D010271167200
		Europe & U.K. Models	
C782,783		Ceramic chip 470 pF/50V	D010471167200
		Asia Model	
C785	254 4254 035	Electrolytic 47 μF/16V	D040470083080
C786,787		Film 0.0047 μF/100V	D02047206C060
C788,789	254 4260 058	Electrolytic 2.2 μF/50V	D0402R2087100
C790,791		Ceramic chip 0.001 μF/50V	D011102777200
C840	254 4254 035	Electrolytic 47 μF/16V	D040470083080
C841,842		Ceramic chip 22 pF/50V	D010220167200
C843		Film 0.027 μF/100V	D02027306C060
C844	254 4260 045	Electrolytic 1 μF/50V	D040010087050
C845		Ceramic 0.01 μF/50V	D004103277050
C846		Ceramic chip 0.01 μF/50V	D011103597200
C847	254 4254 035	Electrolytic 47 μF/16V	D040470083080
C848		Ceramic chip 100 pF/50V	D010101167200
C849		Ceramic 100 pF/50V	D004101277050
		Europe & U.K. Models only	
C850,851		Ceramic chip 27 pF/50V	D010270167200
		Europe & U.K. Models only	
C852	254 4254 019	Electrolytic 2.2 μF/50V	D0402R2087100
		Europe & U.K. Models only	
C853	254 4254 035	Electrolytic 47 μF/16V	D040470083080
		Europe & U.K. Models only	
C854		Ceramic chip 560 pF/50V	D010561167200
		Europe & U.K. Models only	
C855,856	254 4254 035	Electrolytic 47 μF/16V	D040470083080
		Europe & U.K. Models only	
C857		Ceramic chip 0.01 μF/50V	D011103597200
		Europe & U.K. Models only	
C901,902		Ceramic chip 0.01 μF/50V	D011103777200
C903	254 4254 019	Electrolytic 22 μF/16V	D040220083110
C904,905		Ceramic chip 0.01 μF/50V	D011103777200

Ref. No.	Part No.	Part Name	Remarks
C906	254 4254 035	Electrolytic 47 μF/16V	D040470083070
C960		Ceramic chip 0.01 μF/16V	D005103773530
<b>OTHER PARTS GROUP</b>			
Δ A501	960 0142 301	AC outlet	G435040110000 1
CF701,702	261 0097 003	Ceramic filter SFE10.7MS3GH-A	E430107000150 2 Europe & U.K. Models
CF701,702	261 0120 006	Ceramic filter SFE10.7MS3GK-A	E43010R700510 2 Europe & U.K. Models
CF701,702	960 0043 400	Ceramic filter SFE10.7MA5	E43010R700300 2 Asia Model
CF703	9LB P005 01	Ceramic filter BFU450C4N	E431450000110 1
CF704	261 0079 005	Ceramic resonator CSB456F11	E830456000050 1
CN1	960 0118 801	8P connector base	L102526700800 1
CN6	960 0118 306	9P connector cord	L000101090010 1
CN202	960 0118 607	12P shield cord	L000251120010 1
CN501	960 0118 908	2P connector base	L108039602010 1
CN502	960 0118 908	2P connector base	L108039602010 1 Europe & U.K. Models
CN502	960 0142 408	3P connector base	L108353280310 1 Asia Model
CN601	960 0118 704	7P connector base	L102526700700 1
CN601	960 0119 402	7P connector base	L102526807010 1
CN901	960 0119 004	16P connector base	L140520041610 1
Δ F501	960 0142 505	Fuse 250V 1.25A	G650122251160 1
Δ F502	960 0142 602	Fuse 250V 2.5A	G650252251160 1
			Asia Model only
Δ F503	960 0142 709	Fuse 250V 1A	G650102251160 1
FL901	960 0007 103	FLD (11-BT-127GK)	K530000290010 1
GND1	960 9006 600	GND TERMINAL	3790040876010 1
J101		Carbon chip 0 ohm 1/8W	C200000061300 1
J103-110		Carbon chip 0 ohm 1/8W	C200000061300 8
J149		Carbon chip 0 ohm 1/8W	C200000061300 1
J751		Carbon chip 0 ohm 1/8W	C200000061300 1
			Europe & U.K. Models only
J752		Carbon chip 0 ohm 1/8W	C200000061300 1
J754,755		Carbon chip 0 ohm 1/8W	C200000061300 2
J757-761		Carbon chip 0 ohm 1/8W	C200000061300 5
J763-768		Carbon chip 0 ohm 1/8W	C200000061300 6
J925-928		Carbon chip 0 ohm 1/8W	C200000061300 4
J932,933		Carbon chip 0 ohm 1/8W	C200000061300 2
J938		Carbon chip 0 ohm 1/8W	C200000061300 1

RECEIVER

Ref. No.	Part No.	Part Name	Remarks	Q'ty	Ref. No.	Part No.	Part Name	Remarks	Q'ty
J960		Carbon chip 0 ohm 1/8W	C200000061300	1	X901	399 0243 903	Ceramic 8.38 MHz	E8308R3800010	1
JACK1	960 0004 504	4P pin jack	G602040045000	1		—	Heat sink	2120000400010	1
JACK2	960 0005 406	6P pin jack	G603060046020	1		—	Heat sink	2120000810000	2
JACK3,4	960 0004 407	Mini jack	G401031102010	2		—	Wire clamp	4330000120000	1
JACK5	960 0093 007	4P speaker terminal	G612041037310	1	960 0005 804		Fuse holder	G645000050010, for F501,503	2
JACK201	960 0004 504	4P pin jack	G602040045000	1	960 0117 909		Fuse holder	G646000020010, for F502 Asia Model only	1
JACK601	960 0069 400	Mini jack (G)	G401035180010	1				4070020076010, for FL901	1
JACK701	960 0120 307	Antenna terminal	G59004046000A	1	960 0050 309		FL supporter	B020030081B10	3
JP3	960 0118 403	6P connector cord	L000131060010	1	960 9000 114		Screw 3x8 CBTS(B)-Z		
JP5	960 0120 501	13P connector base	L140520041310	1					
JP101	960 0120 404	9P connector base	L101530140910	1					
JP103	960 0118 500	2P+2P shield cord	L000201040050	1					
JP901	960 0119 606	16P cable holder	L110510161610	1					
JP901	960 0119 703	16P flat cable	L322121162610	1					
JP902	960 0119 509	13P cable holder	L110510161310	1					
JP902	960 0119 800	13P flat cable	L322321132610	1					
JP903	960 0119 305	4P connector cord	L000650040010	1					
K1	960 0091 203	Relay (DH24D2)	G680000220010	1					
Δ K2	960 0118 209	Relay (HR-CR7)	G680000210000	1					
			Europe & U.K. Models only						
L1,2	960 0005 008	Inductor 0.15 μH	D330R15000000	2					
L701	960 0007 365	Inductor 1 μH	D3301R0700520	1					
L702	960 0010 307	Inductor 10 μH	D330100700520	1					
RM901	960 0050 105	Remocon sensor	E940460200010	1					
S901-909	960 0069 206	Tact switch	G180215050010	9					
Δ SW101	963 0027 700	Slide switch	G060040550010	1				Asia Model only	
T701	960 0007 336	MW RF osc. coil	D940209000010	1					
T702	960 0007 349	FM IF coil	D951731561100	1					
T703	960 0007 352	FM IF coil	D951731561200	1					
T704	960 0007 323	MW IF coil	D950209000010	1					
T705	960 0037 607	Antibirdie filter	E403126832410	1					
T706,707	960 0050 600	MPX filter	E401253503100	2					
TU701	960 0092 008	FM tuner pack	E900504000010	1					
X701	960 0120 103	Crystal 7.2 MHz	E8007R2000070	1					
X702	960 0091 805	Crystal 4.332 MHz	E8004R3320050	1				Europe & U.K. Models only	
X703	960 0142 806	Ceramic 4.00MHz	E830400000070	1				Europe & U.K. Models only	

AMP. P.W.B. UNIT ASS'Y

Ref. No.	Part No.	Part Name	Remarks	Ref. No.	Part No.	Part Name	Remarks
<b>SEMICONDUCTORS GROUP</b>				C313,314		Ceramic 8 pF/50V	D000080117060
IC102	263 0476 002	IC LB1639	J127163900010	C315,316		Ceramic 220 pF/50V	D004221277050
Q301-304	271 0111 009	Transistor KSA992F	J5000992F0050	C317,318	254 4260 993	Electrolytic 22 μF/35V	D040220085050
Q305-308	273 0207 003	Transistor KSC1845F	J5021845F0000	<del>C319,320</del>		<del>Ceramic 150 pF/500V</del>	<del>D00015106D050</del>
Q309,310	271 0111 009	Transistor KSA992F	J5000992F0050	C321,322		Ceramic 0.01 μF/50V	D004103277050
Q317,318	273 0207 003	Transistor KSC1845F	J5021845F0000	C325,326	254 4261 015	Electrolytic 47 μF/50V	D040470087060
D301-306	963 0020 309	Diode 1SS133	K000013300520	C327,328		Ceramic 0.022 μF/50V	D004223597050
<b>RESISTORS GROUP</b>				C329,330	254 4252 037	Electrolytic 100 μF/10V	D040101082060
R101,102		Carbon chip 11 kohm 1/10W	C200011360200	C401,402		Film 0.0056 μF/100V	D02056206C060
R301,302		Carbon film 1 kohm 1/5W	C00001026P520	C403-406		Film 0.033 μF/100V	D02033306C060
R303,304		Carbon film 56 kohm 1/5W	C00005636P520	C407,408	256 1035 004	Metalized 0.18 μF/50V	D023184067050
R305,306		Carbon film 7.5 kohm 1/5W	C00007526P520	<b>OTHER PARTS GROUP</b>			
R307-310		Carbon film 2.2 kohm 1/5W	C00002226P520	CN3	960 0116 502	6P connector base	L102526806010
R311,312		Carbon film 1.5 kohm 1/5W	C00001526P520	CN4	960 0117 103	12P connector base	L101352371210
R313,314		Metal film 270 ohm 1/4W	C060027163050	CN103	960 0116 405	4P connector base	L101530150410
R317-320		Metal film 220 ohm 1/4W	C060022163050	J130-134	—	Carbon chip 0 ohm 1/8W	C200000061300
R321,322		Carbon film 15 kohm 1/5W	C00001536P520	JP101	960 0116 900	12P connector base	L101530141210
R325,326		Carbon film 56 kohm 1/5W	C00005636P520	JP102	960 0116 803	12P connector base	L101353361210
R327,328		Carbon film 10 kohm 1/5W	C00001036P520				
R329,330		Carbon film 3.3 kohm 1/5W	C00003326P520				
R331		Metal film 100 ohm 1/4W	C060010163050				
R332-336		Metal film 47 ohm 1/4W	C060047063050				
R337,338	960 0091 504	Winding 0.22 ohm 3W	C145R22077610				
R339,340		Carbon film 1.2 kohm 1/5W	C00001226P520				
R341,342		Carbon film 2.7 kohm 1/5W	C00002726P520				
R343		Carbon film 18 kohm 1/5W	C00001836P520				
R344,345		Carbon film 22 kohm 1/5W	C00002236P520				
R346		Carbon film 18 kohm 1/5W	C00001836P520				
R401,402		Carbon film 10 kohm 1/5W	C00001036P520				
R403,404		Carbon film 1.8 kohm 1/5W	C00001826P520				
VR101	960 0117 006	Variable resistor 100 kohm	C495121400260				
VR301,302	960 0116 308	Semi fixed resistor 1 kohm	C544102015110				
VR401,402	960 0116 706	Variable resistor 100 kohm	C451121400100				
VR403	960 0116 609	Variable resistor 200 kohm	C451112400010				
<b>CAPACITORS GROUP</b>							
C113	254 4260 087	Electrolytic 10 μF/50V	D040100087050				
C114		Ceramic 0.01 μF/50V	D004103277050				
C301,302	254 4263 042	Electrolytic 1 μF/100V	D040010086060				
C303-308		Ceramic 100 pF/50V	D004101277050				
C309,310	254 4263 042	Electrolytic 1 μF/100V	D040010086060				
C311,312		Ceramic 150 pF/50V	D004151277050				

RECEIVER  
EXPLODED VIEW

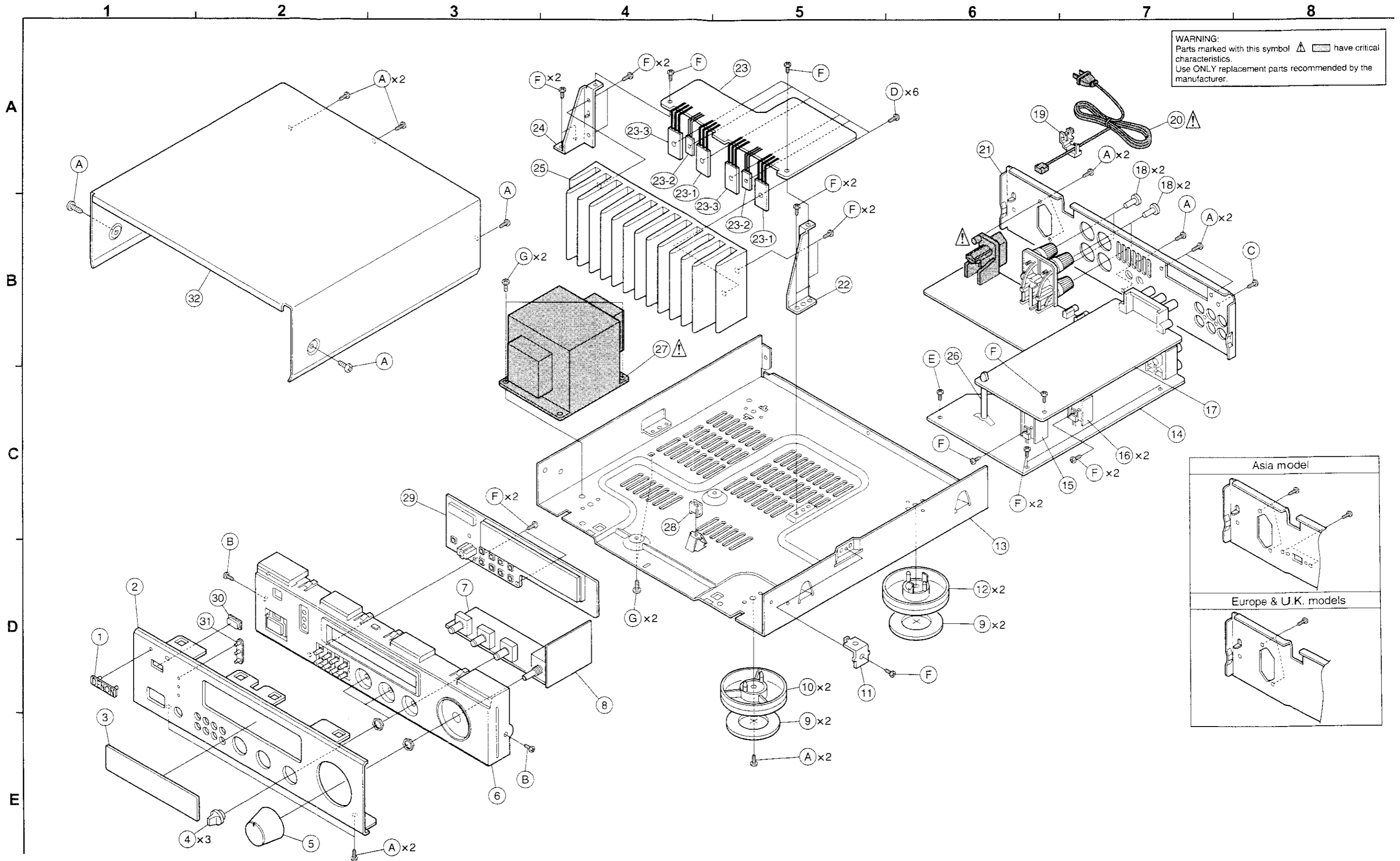

WARNING:  
 Parts marked with this symbol  have critical characteristics.  
 Use ONLY replacement parts recommended by the manufacturer.

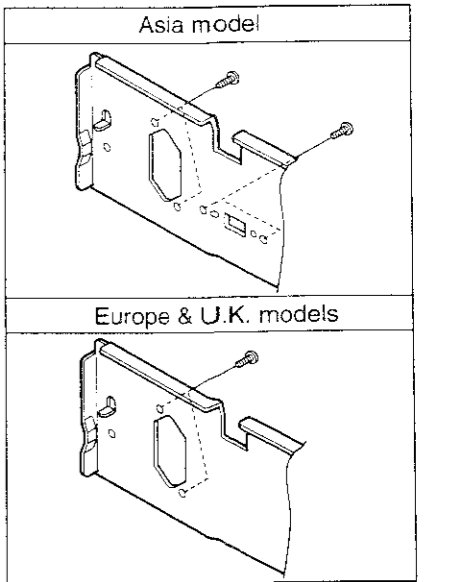



## PARTS LIST OF EXPLODED VIEW

Ref. No.	Part No.	Part Name	Remarks	Q'ty	Ref. No.	Part No.	Part Name	Remarks	Q'ty
	960 0116 201	Amp. P.W.B. unit ass'y	7025HK9808011	1	31	960 0143 106	Function lens	3710210003000 Europe & U.K. Models only	1
7		Tone P.W.B. unit			32	960 0114 407	Top cover	3000210006000	1
8		Volume P.W.B. unit			★ 33	—	Fuse cap	4500020001010, for F503	1
23		Amp. P.W.B. unit			★ 33	—	Fuse cap	4500020001010, Europe & U.K. Models	2
14	960 0117 226	Main P.W.B. unit ass'y	7025HK9808010 Europe & U.K. Models	1	★ 34	960 0120 705	7P connector cord	L000401070010, CN601	1
14	960 0117 213	Main P.W.B. unit ass'y	7025HK9808040 Asia Model	1	<b>SCREWS</b>				
17		Tuner P.W.B. unit			A	960 0108 604	Screw 3×8 CBTS(B)-B	B020030083B10	21
29		Front P.W.B. unit			A	960 0108 604	Screw 3×8 CBTS(B)-B	B020030083B10, for SW101 Asia Model only	2
1	960 0115 707	DENON badge	5630210008000	1	B	960 9000 130	Screw 3×8 CFTS(B)-B	B020030083F10	2
2	960 0142 903	Front panel	3067210028010 Europe & U.K. Models	1	C	960 9000 101	Screw 3×8 CBTS(S)-Ni	B010330084B10	1
2	960 0114 504	Front panel	3067210028020 Asia Model	1	D	960 9000 185	Screw 3×14 CHTS(B) SW W-Z	B018230141H10	6
3	960 0115 309	Display window	5077210043010	1	E	960 9000 156	Screw 3×17 CBTS(B)-Z	B020030171B10	1
4	960 0115 503	Control knob	5087210011010	3	F	960 9000 114	Screw 3×8 CBTS(B)-Z	B020030081B10	16
5	960 0115 406	Volume knob	5080210051000	1	G	960 9000 172	Screw 4×8 CBTS(S) SW W-Z	B028940081B10	4
6	960 0114 601	Front frame	3217210001010	1					
9	960 0003 505	Foot cushion	4050020075010	4					
10	960 0003 408	Foot	4007000061010	2					
11	960 0115 105	P.W.B. bracket	4010210066000	1					
12	960 0115 008	Foot	4000210001000	2					
13	960 0114 902	Main chassis	3200210056000	1					
18	963 0017 707	Terminal bushing	2410040353010	4					
19	960 0135 305	Cord stopper	4380040162010	1					
Δ	20 960 0032 301	AC cord	L061000410010 Europe & U.K. Models	1					
Δ	20 960 0109 205	AC cord	L061000290010 U.K. Model	1					
Δ	20-1 960 0143 009	AC cord ass'y	L068000000040 U.K. Model only	1					
21	960 0114 821	Back chassis	3207210016010 Europe & U.K. Models	1					
21	960 0114 818	Back chassis	3207210016110 Asia Model	1					
22	960 0114 106	Heat sink L bracket	4010210016000	1					
23-1	960 0090 107	Transistor 2SB1559Y	J5011559Y0170, Q315,316	2					
23-2	960 0114 300	Transistor 2SC4137	J5024137V0130, Q311,312	2					
23-3	960 0090 000	Transistor 2SD2389Y	J5032389Y0170, Q313,314	2					
24	960 0114 203	Heat sink R bracket	4010210026000	1					
25	960 0114 009	Main heat sink	2120210028000	1					
26	960 0115 202	Locking fastener	4420200003010	1					
Δ	27 960 0137 507	Power trans.	8200660540010, T101 Europe & U.K. Models	1					
Δ	27 960 0137 604	Power trans.	8200660500020, T101 Asia Model	1					
28	960 0003 301	P.W.B. support	4070001601010	1					
30	960 0114 708	Remocon window	5070210033000	1					

RECEIVER

WIRING DIAGRAM

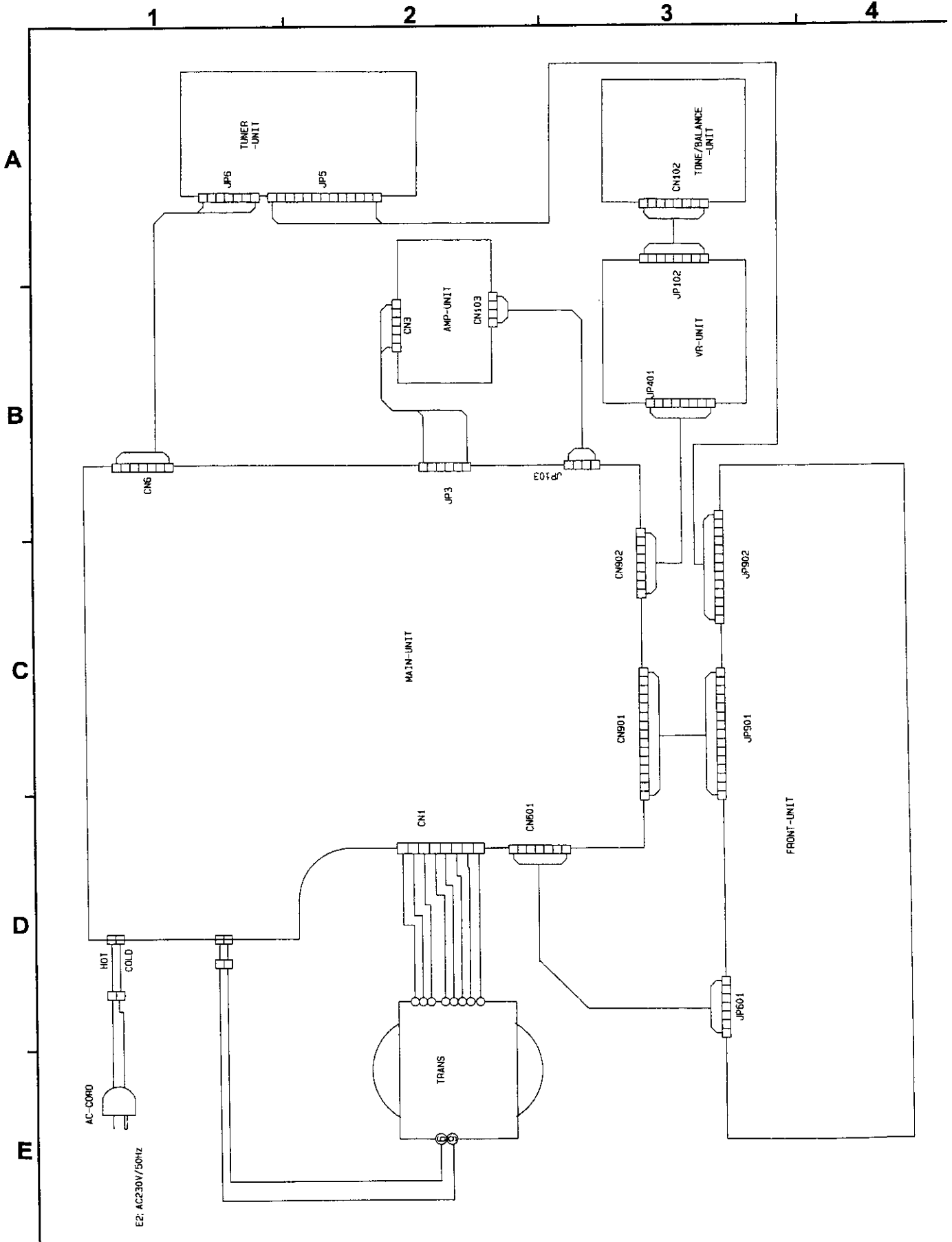

# SCHEMATIC DIAGRAMS (1/2)

1 2 3 4 5

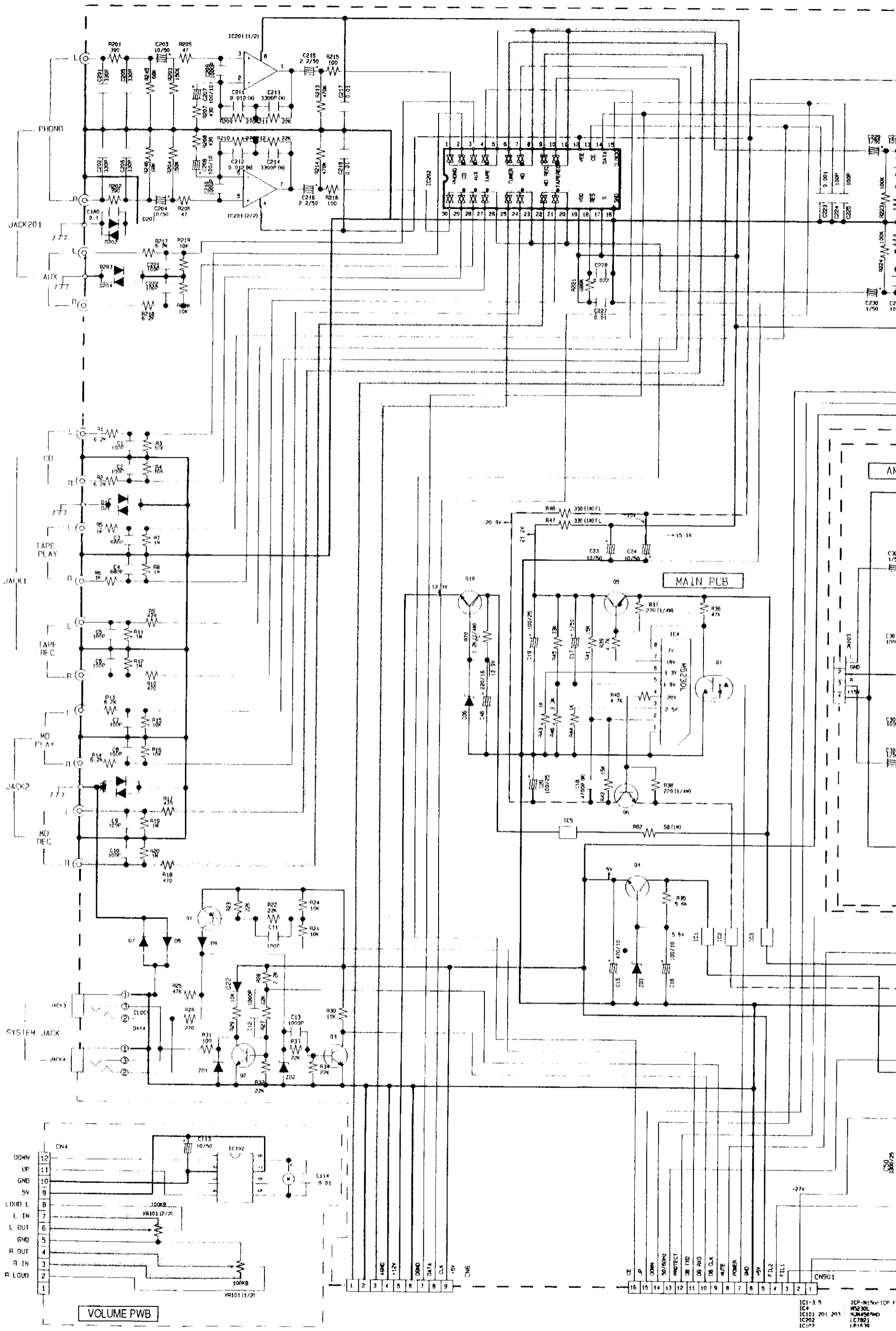

IC1-3 5  
 IC4  
 IC6  
 IC101 201 203  
 IC202  
 IC102  
 ICP-N150P1CP-F  
 MS230L  
 N4M450P40  
 C7821  
 1R16W

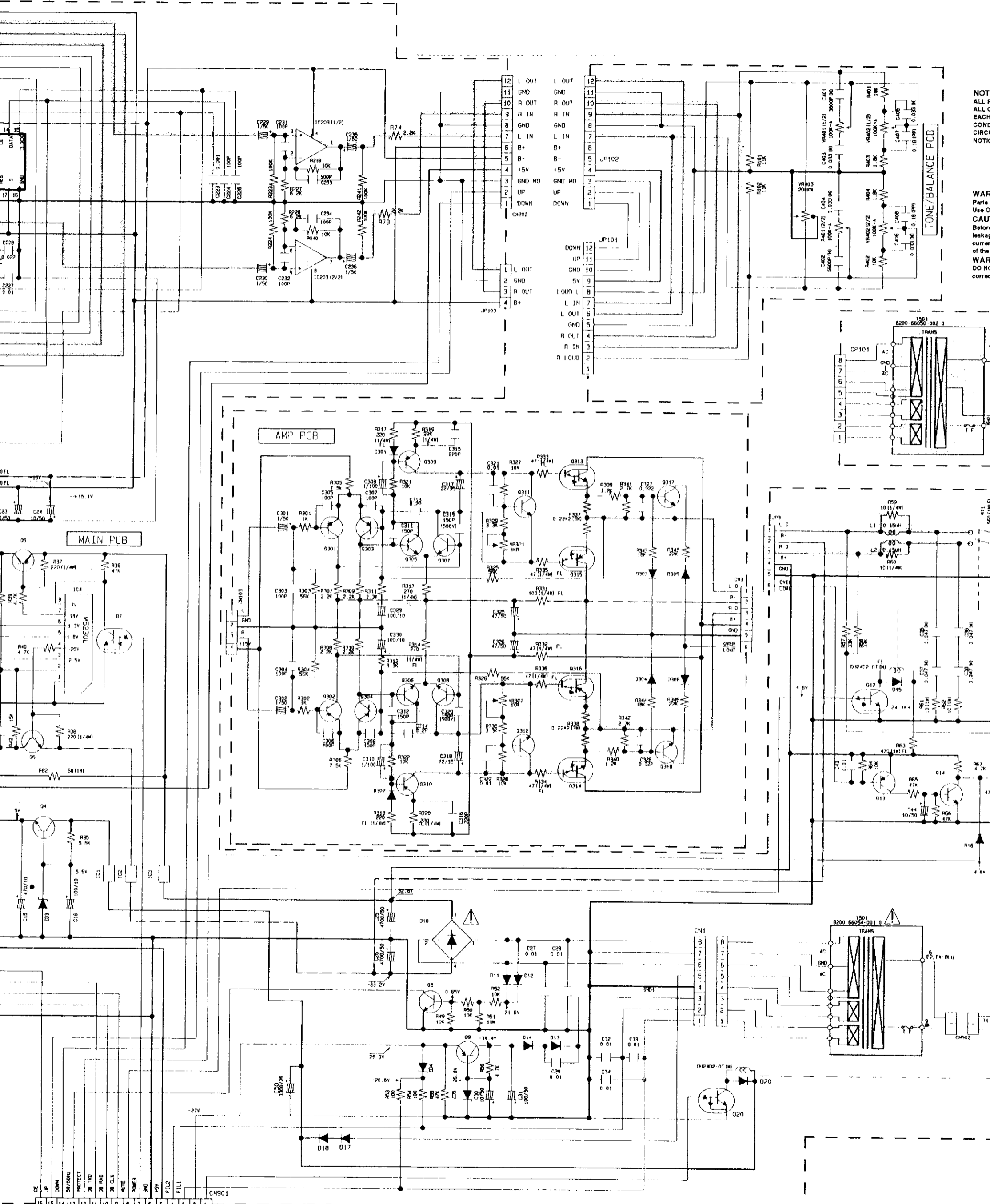

NOT ALL PARTS  
 ALL COMPONENTS  
 EACH COMPONENT  
 COND. CIRCUIT  
 NOTICE

WARNING  
 Parts  
 Use  
 CAUTION  
 Before  
 leakage  
 current  
 of the  
 WARNING  
 DO NOT  
 correct

- |                |                  |                  |           |            |           |                    |              |
|----------------|------------------|------------------|-----------|------------|-----------|--------------------|--------------|
| IC1-3 5        | ICP-N150-ICP-F15 | Q8 15, 16, 20    | 1S51311   | Q1         | 2SA1037K  | Q5                 | 2SB1525 E F1 |
| IC4            | NE230L           | Q11-14, D18, D17 | 144002    | Q2, 3      | 2SC2412K  | Q4, 6, 8           | 2SD2076 E F1 |
| IC101 201, 203 | NE4456*40        | Z01, 2, 4        | NTZ.05.2B | Q1P, Q20   | 01C114ES  | Q301-304, 309, 310 | KS4992F      |
| IC202          | IC7821           | Z05              | NTZ.05.0B | Q7         | 01C144ES  | Q315, 316          | 2SD1550 P-11 |
| IC102          | 1R1K70           | Z06              | NTZ.1.3B  | Q8, 11, 17 | K1A12M61Y | Q313, 314          | 2SD3369 P-11 |
| IC103          |                  | Q19              | 01C12300  | Q9, 14, 16 | K1T1907Y  | Q311, 312          | 2SC4117K     |

7

8

9

10

11

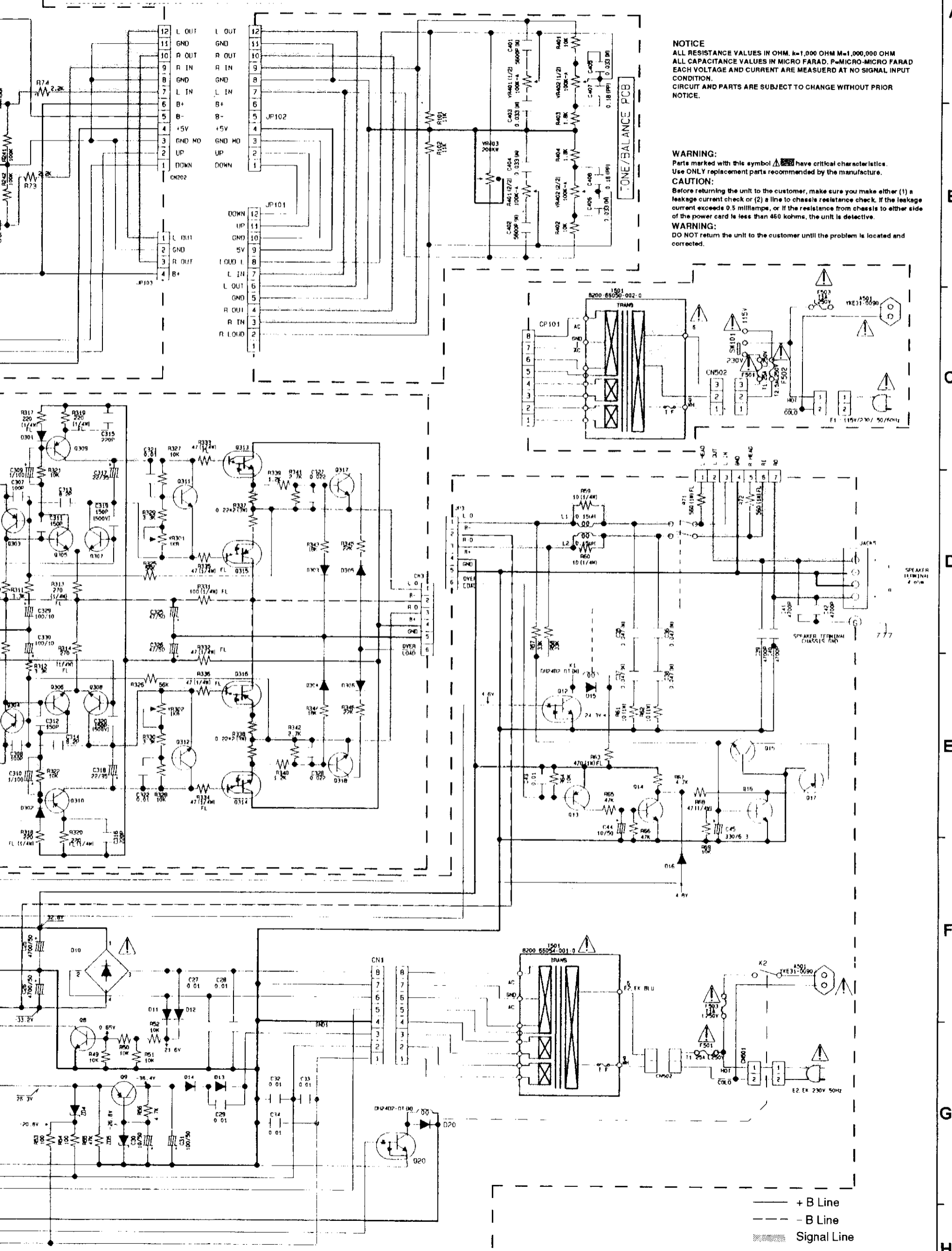

**NOTICE**  
 ALL RESISTANCE VALUES IN OHM, k=1,000 OHM M=1,000,000 OHM  
 ALL CAPACITANCE VALUES IN MICRO FARAD, P=MICRO-MICRO FARAD  
 EACH VOLTAGE AND CURRENT ARE MEASURED AT NO SIGNAL INPUT  
 CONDITION.  
 CIRCUIT AND PARTS ARE SUBJECT TO CHANGE WITHOUT PRIOR  
 NOTICE.

**WARNING:**  
 Parts marked with this symbol have critical characteristics.  
 Use ONLY replacement parts recommended by the manufacturer.

**CAUTION:**  
 Before returning the unit to the customer, make sure you make either (1) a leakage current check or (2) a line to chassis resistance check. If the leakage current exceeds 0.5 millamps, or if the resistance from chassis to either side of the power card is less than 450 kohms, the unit is defective.

**WARNING:**  
 DO NOT return the unit to the customer until the problem is located and corrected.

— + B Line  
 - - - - - B Line  
 ▨ Signal Line

**SCHEMATIC DIAGRAMS (1/2)**  
**MAIN / AMP. / TONE / VOLUME P.W.B. UNIT**

51311	25A1037K	06	25B1655 E F1
114002	25C2412K	04, 8, 18	25D2078 E F1
012 090	01C114E5	0301-304, 309, 310	K3A992F
01	01C144E5	0305-308, 317, 318	K3C1845F
09 13 17	K1A1296(N)	0315 316	25E1560 D P T1
08 14 16	K17119(N)	0313 314	25G2389(N) P T1
01 2 5 6 8 20 21 114 115	K17119(N)	0311 312	25G4137V

SCHEMATIC DIAGRAMS (2/2)

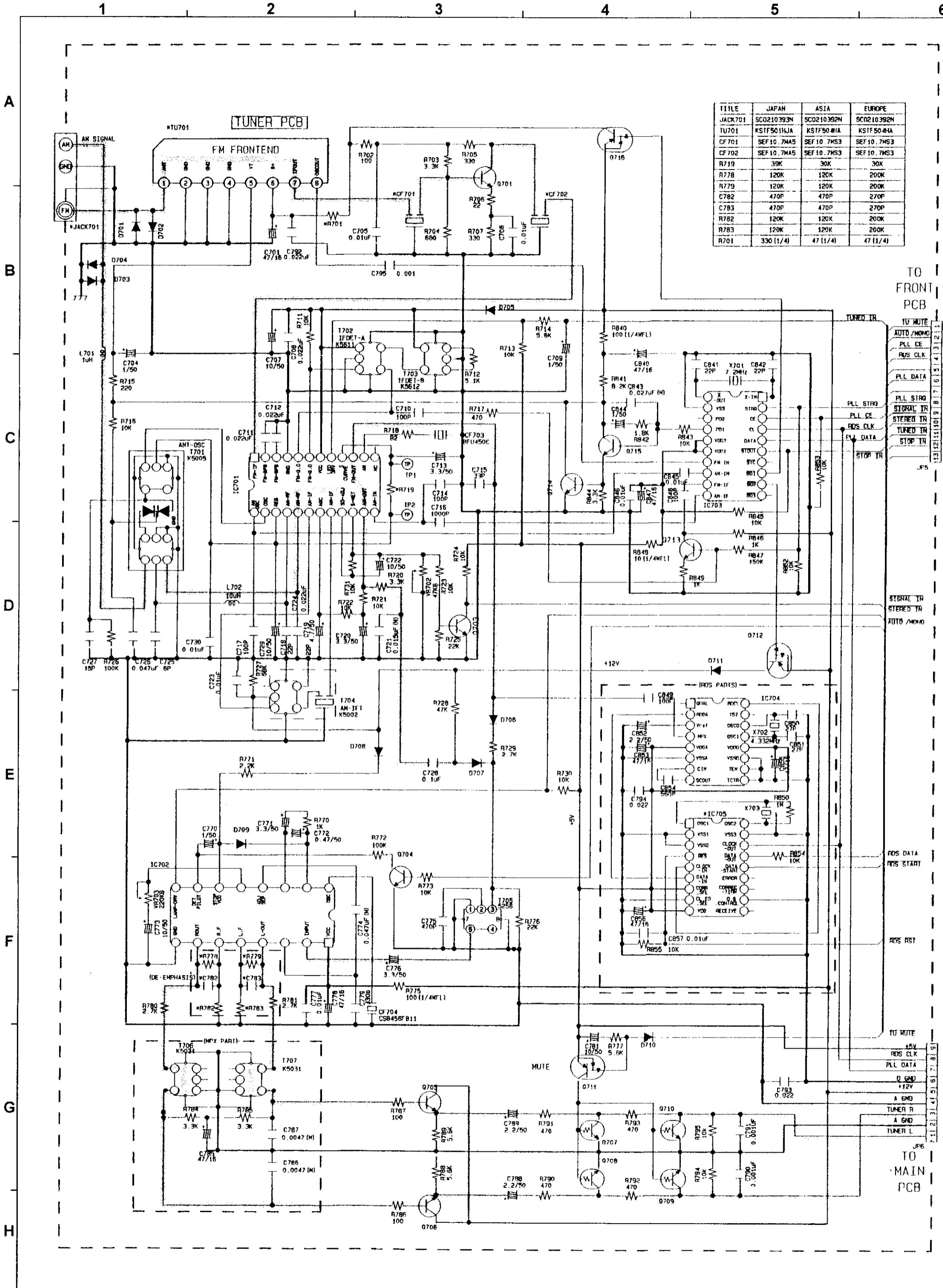

**NOTICE**  
 ALL RESISTANCE VALUES IN OHM, K=1,000 OHM M=1,000,000 OHM  
 ALL CAPACITANCE VALUES IN MICRO FARAD, P=MICRO-MICRO FARAD  
 EACH VOLTAGE AND CURRENT ARE MEASURED AT NO SIGNAL INPUT  
 CONDITION.  
 CIRCUIT AND PARTS ARE SUBJECT TO CHANGE WITHOUT PRIOR  
 NOTICE.

TITLE	JAPAN	ASIA	EUROPE
JACK701	SC0210393N	SC0210392N	SC0210392N
TU701	KSTF501HJA	KSTF504IA	KSTF504IA
CF701	SEF10.7MA5	SEF10.7MS3	SEF10.7MS3
CF702	SEF10.7MA5	SEF10.7MS3	SEF10.7MS3
R719	39K	30K	30K
R778	120K	120K	200K
R779	120K	120K	200K
C782	470P	470P	270P
C783	470P	470P	270P
R782	120K	120K	200K
R783	120K	120K	200K
R701	330 (1/4)	47 (1/4)	47 (1/4)

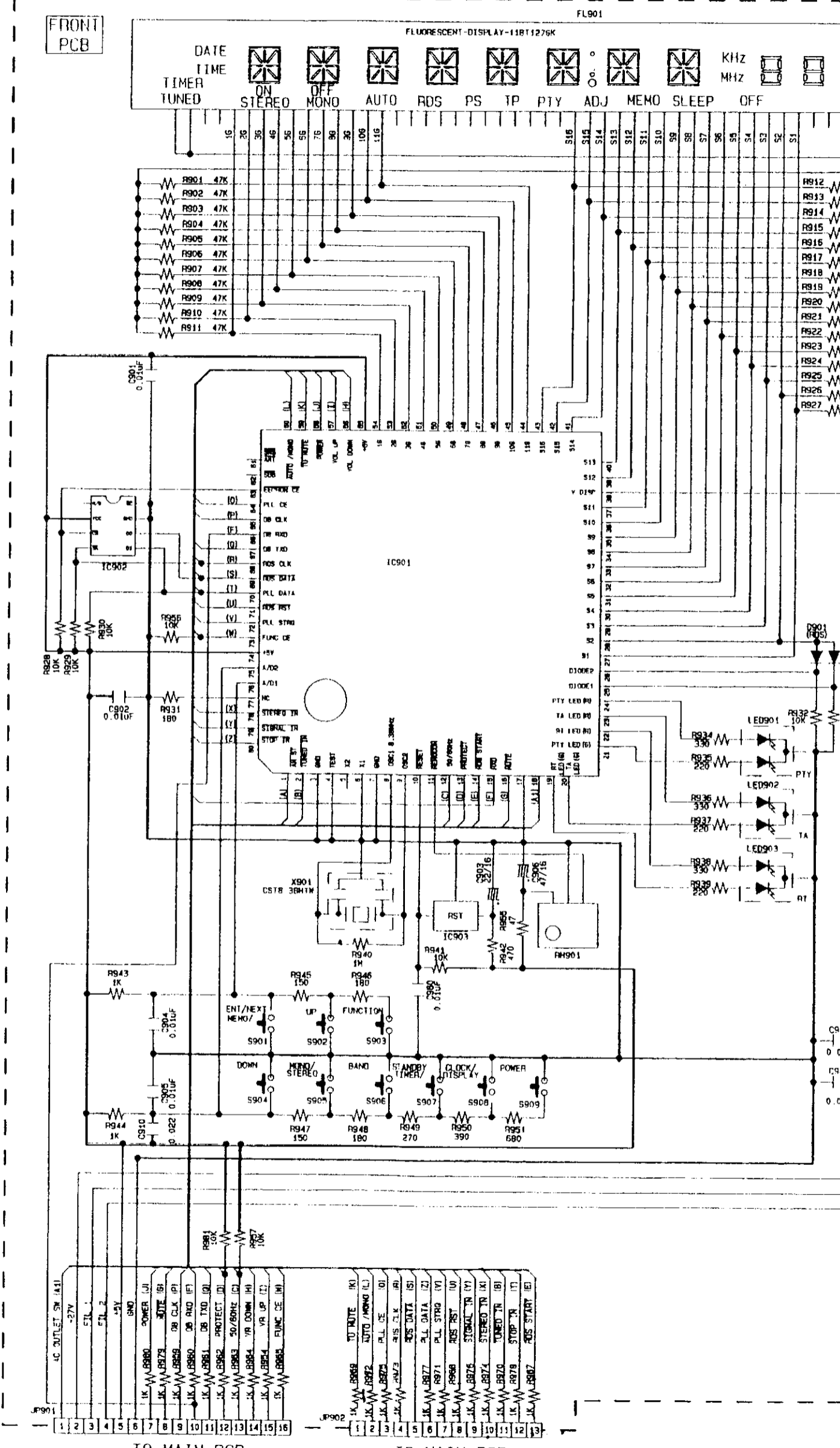
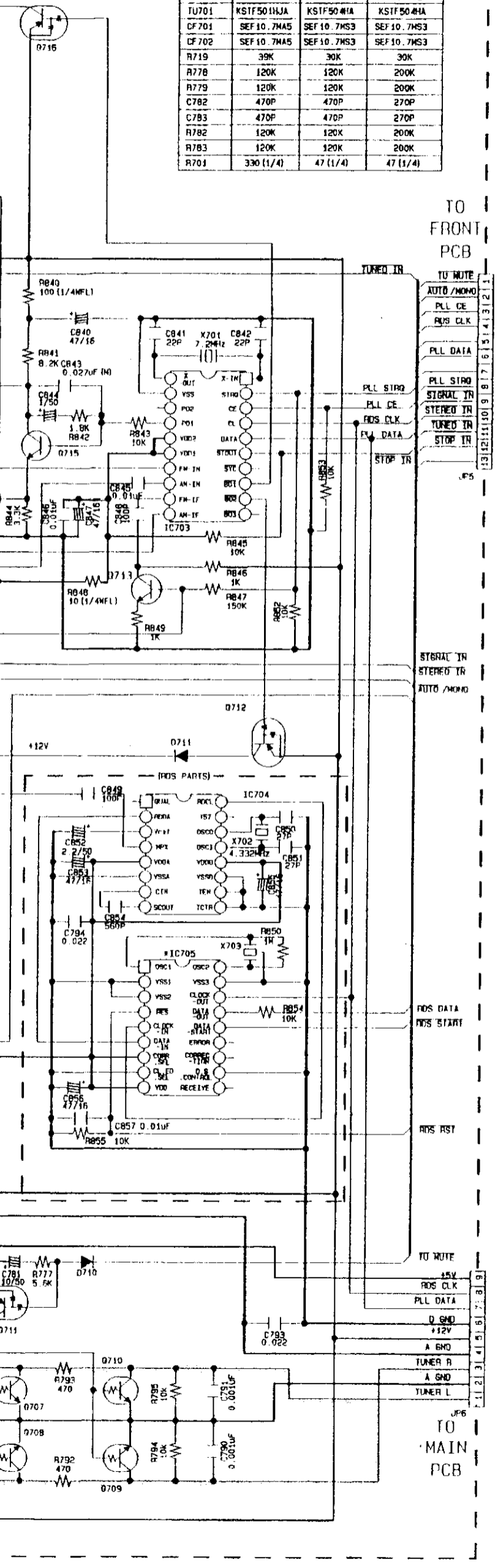

- |                        |                           |                                |
|------------------------|---------------------------|--------------------------------|
| IC701 : LA1267         | 0701, 713 : KTC3980       | D705-D711, D901-D903 : 1SS133T |
| IC702 : LA3410         | 0711, 712, 716 : DTA114EK | LED901-903 : SPR39MYW3         |
| IC703 : LM7000         | 0703-0706 : 2SC2412K      | 0701-D704 : 1SS305             |
| IC704 : SAA6579T       | 0715 : KSC1845F           |                                |
| IC705 : LC7074M        | 0714 : 2SC1740S           |                                |
| IC901 : HD6433726S08TH | 0707-0710 : DIC3431K      |                                |
| IC902 : XL9040F        |                           |                                |
| IC903 : PST800C        |                           |                                |
| IC904 : DTA114EK       |                           |                                |

**SCHEMATIC DIAGRAMS (2/2)**  
**TUNER / FRONT P.W.B. UNIT**

**NOTICE**  
 ALL RESISTANCE VALUES IN OHM, K=1,000 OHM M=1,000,000 OHM  
 ALL CAPACITANCE VALUES IN MICRO FARAD, P=MICRO-MICRO FARAD  
 EACH VOLTAGE AND CURRENT ARE MEASURED AT NO SIGNAL INPUT  
 CONDITION.  
 CIRCUIT AND PARTS ARE SUBJECT TO CHANGE WITHOUT PRIOR  
 NOTICE.

**WARNING:**  
 Parts marked with this symbol  have critical characteristics.  
 Use ONLY replacement parts recommended by the manufacturer.

**CAUTION:**  
 Before returning the unit to the customer, make sure you make either (1) a  
 leakage current check or (2) a line to chassis resistance check. If the leakage  
 current exceeds 0.5 milliamperes, or if the resistance from chassis to either side  
 of the power card is less than 460 kohms, the unit is defective.

**WARNING:**  
 DO NOT return the unit to the customer until the problem is located and  
 corrected.

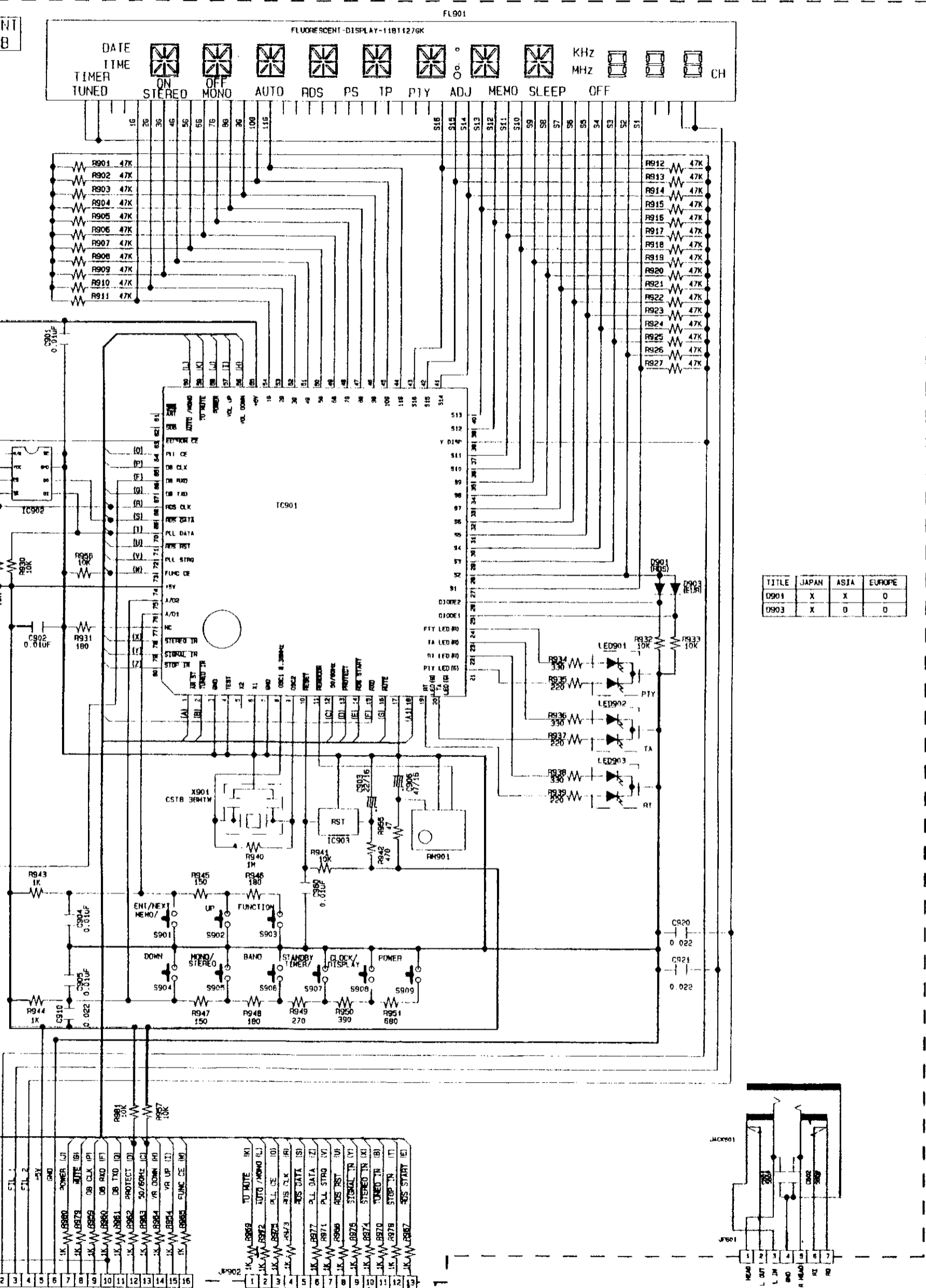

TITLE	JAPAN	ASIA	EUROPE
D901	X	X	0
D903	X	0	0

- TO MAIN PCB**
- IC701 : LA1267
  - IC702 : LA3410
  - IC703 : LM7000
  - IC704 : SAA6579T
  - IC705 : LC7074M
  - IC901 : H0643372680H
  - IC902 : XL9040F
  - IC903 : PST600C
  - D701 : D701
- TO MAIN PCB**
- D701, 713 : K1C3880
  - 0711, 712, 716 : DTA114EK
  - 0703-0706 : 2SC2412K
  - 0715 : KSC1045F
  - 0714 : 2SC1740S
  - 0707-0710 : DTC3431K
  - D705-D711, D901-D903 : 1SS133T
  - LE7901-903 : SFR39MVK3
  - D701, D704 : 1SS355

**SCHEMATIC DIAGRAMS (2/2)**  
**TUNER / FRONT P.W.B. UNIT**

— + B Line  
 Signal Line



BLOCK DIAGRAM

1

2

3

4

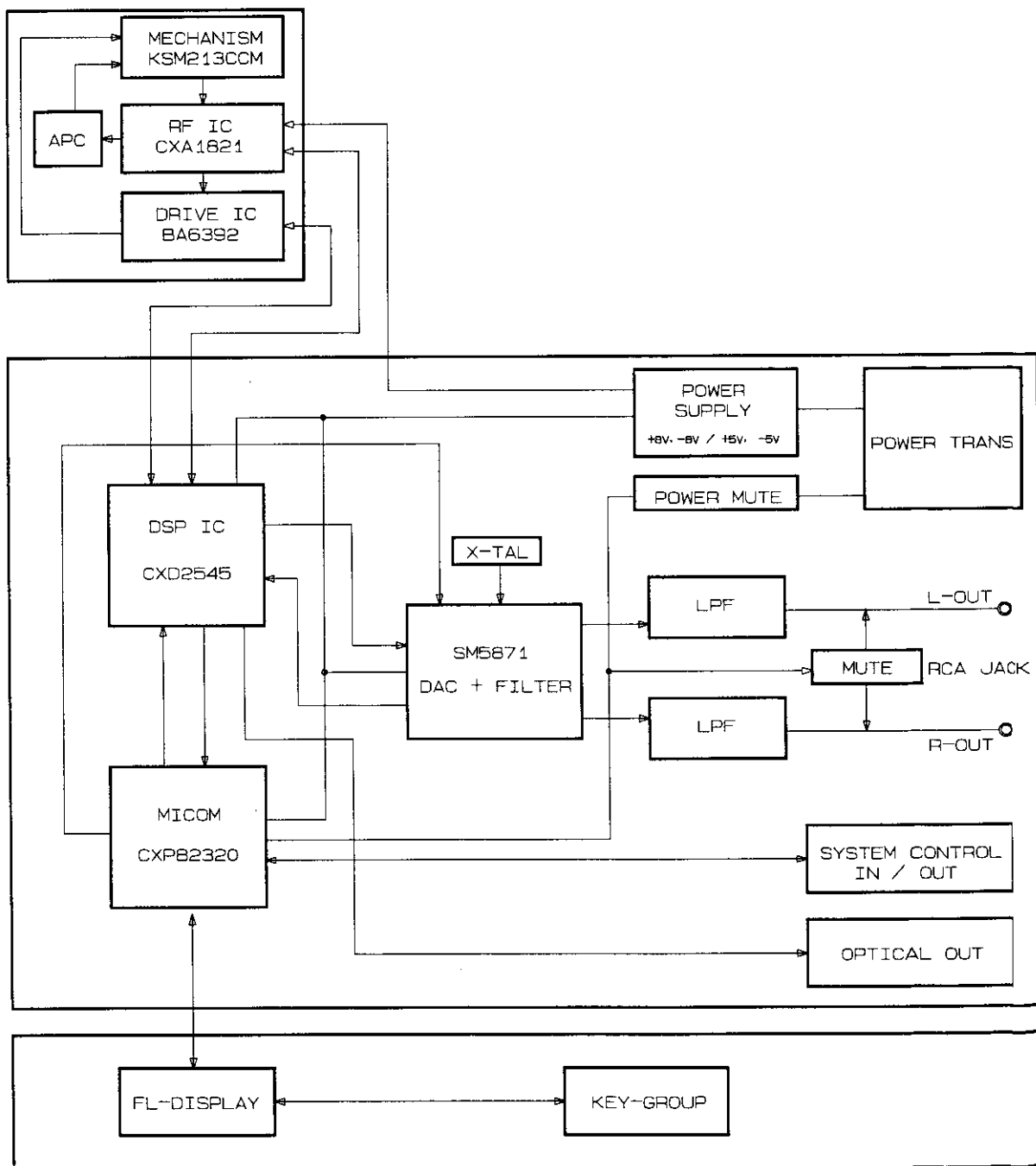

A

B

C

D

E

**CD PLAYER****DISASSEMBLY**

(Follow the procedure below in reverse order when reassembling)

**1. Top Cover & Front Panel**

- (1) Remove 5 screws ① fixing the Top Cover.
- (2) Detach the Top Cover as shown in the arrow direction.

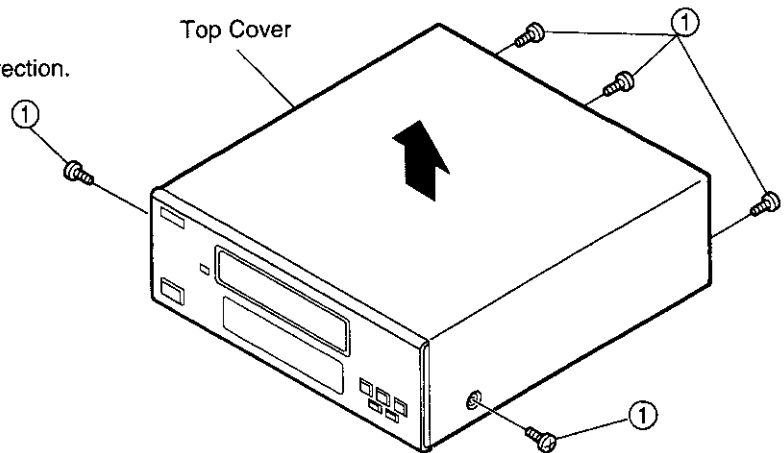

- (3) Remove 4 screws ② on the bottom and both sides.
- (4) Disconnect 29P FPC and 7P flat cable from their connector bases.
- (5) Pull the Front Panel in the arrow direction with releasing Hooks on the Front Frame from the Chassis, and it comes off with the Front Frame.

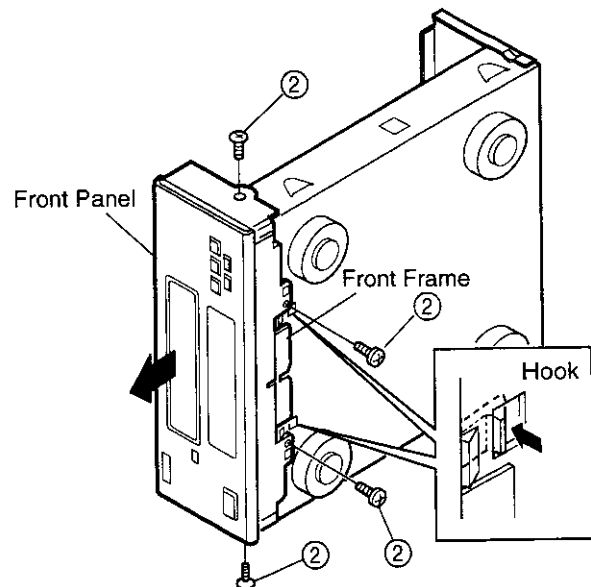
**2. P.W.B. on Panel****FRONT P.W.B.**

Detach the Front P.W.B. to the arrow direction with releasing 6 Hooks.

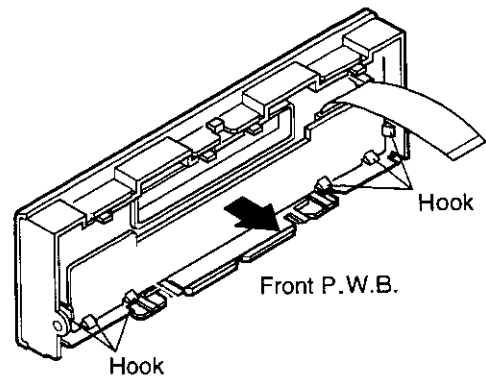

### 3 Back Chassis

- (1) Take off the Cord Stopper from the Back Chassis.
- (2) Remove 5 screws ③, and detach the Back Chassis to the arrow direction.

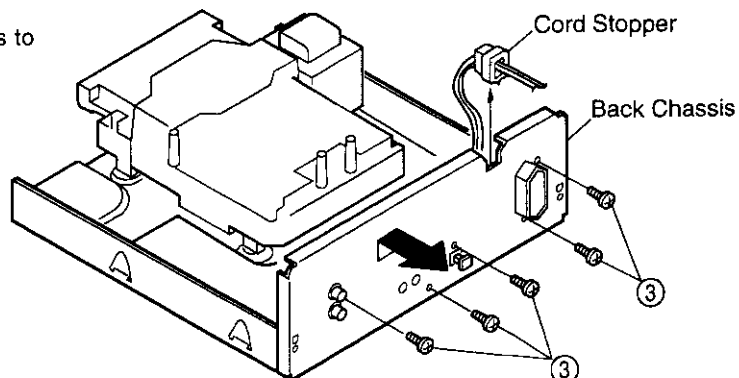

### 4. CD Mecha. Ass'y

- (1) Remove 4 screws ④ fixing the CD Mecha. Ass'y.
- (2) Disconnect 20P FPC and 5P Connector Cord from their connector bases.
- (3) Detach the CD Mecha. Ass'y to the arrow direction.

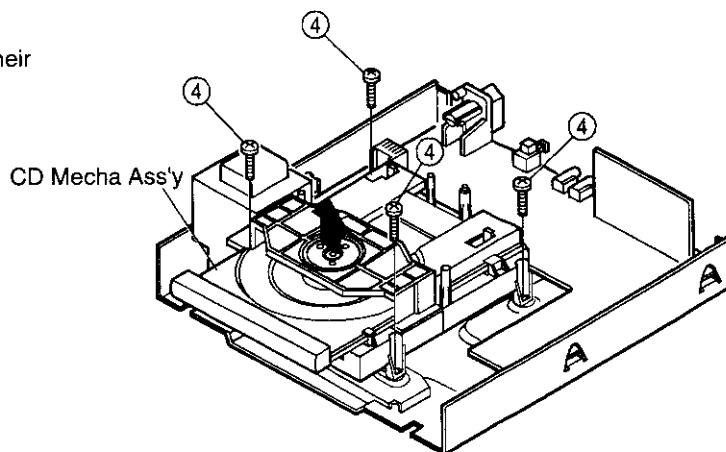

#### AUDIO P.W.B.

- (4) Detach the Audio P.W.B. by disconnecting from its connector as shown in the arrow direction.

#### MAIN P.W.B.

- (5) Remove 4 screws ⑤, and detach the Main P.W.B. to the arrow direction.

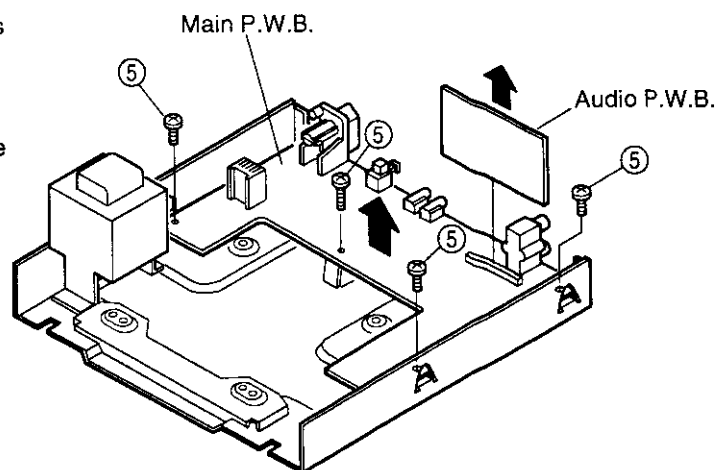

**CD PLAYER**

**NOTE FOR HANDLING OF THE LASER PICK-UP**

**Description of components**

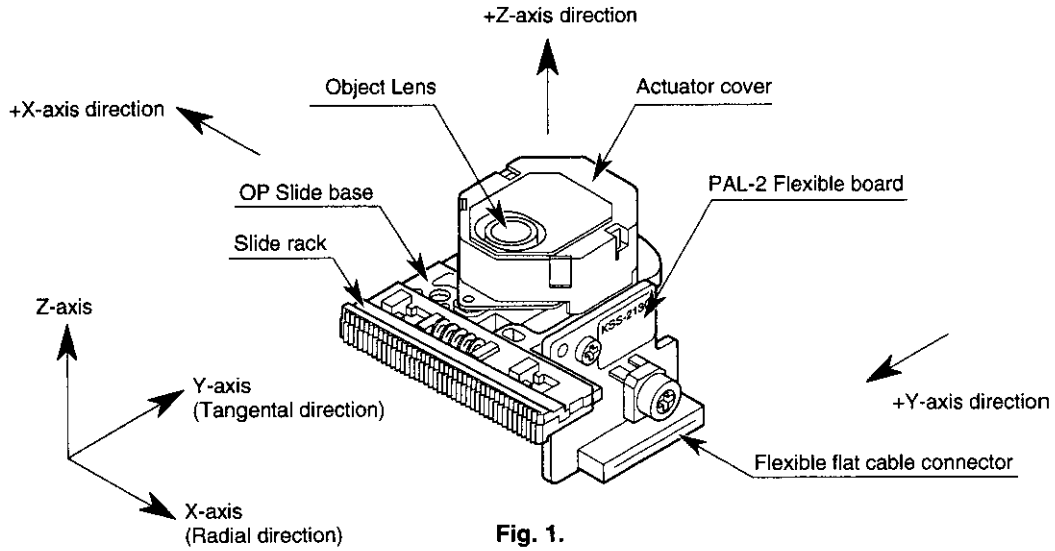

**Fig. 1.**

**Pin connection diagram**

Optical pick-up connector

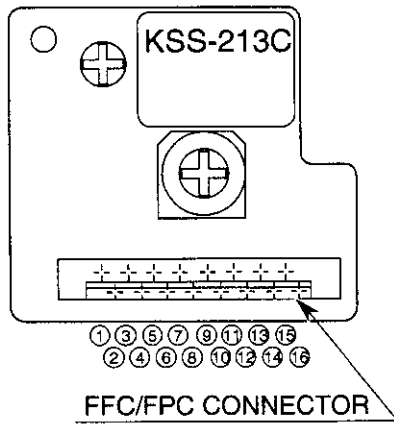

Terminal No.	Name	IN/OUT
1	PD IC Vc	IN
2	Vcc	IN
3	E	OUT
4	D	OUT
5	A	OUT
6	B	OUT
7	C	OUT
8	F	OUT
9	LD PD IC GND	IN
10	LD LD	IN
11	VR	IN
12	PD	OUT
13	FCS (+)	IN
14	TRK (+)	IN
15	TRK (-)	IN
16	FCS (-)	IN

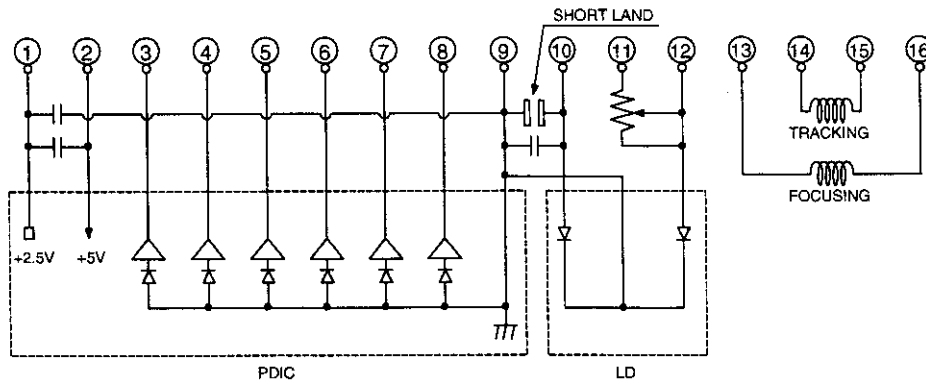

## Handling instructions

This model is assembled and precision adjusted in maker's plant. Never attempt to disassemble or readjust it. Follow the instructions below when handling.

### 1. General

#### (1) Storage

Store and transport this model with the +Z axis pointing up or +Y axis pointing down. (See Fig. 1.)

Avoid storing the KSM-213 series in hot, humid or dusty conditions.

#### (2) Handling

This model is a precision unit. Be careful not to subject it to shocks by dropping or rough handling.

### 2. Laser diode

#### (1) Shield your eyes from the laser beam

The output from the LD is only 400  $\mu$ W maximum after going through the objective lens. However, the intensity of the focused beam reaches about  $0.7 \times 10^4$  W/cm<sup>2</sup>. Never look directly into the LD or observe the laser beam through another lens or mirror. If you need to view the beam, use an infrared viewer or an ITV camera.

#### (2) Toxicity of As

The LD chip is manufactured from GaAs and GaAlAs, which contains toxic As (Arsenic). The toxicity of As in this form is far lower than other As compounds such as As<sub>2</sub>O<sub>3</sub> and AsCl<sub>3</sub>, and the As content of one chip is very small.

However, avoid putting the chip in an acid or alkali solution, heating it over 200°C, or putting it your mouth. Defective LDs from the production line and parts removed in servicing should be disposed of with due care.

#### (3) Avoid current surges and electrostatic discharges

The LD may deteriorate if its output is too high and damage may occur if it is exposed to large currents for even a short time. Protect the LD drive circuit from current surges caused by switches or other sources. An electrostatic discharge from the human body may destroy the LD instantaneously if it is handled carelessly. LD terminals are factory strapped before shipment to protect LD from electrostatic discharges during transportation. For safe handling of the LD, ground your body, measuring equipment, jigs, and tools during installation. Use of a grounding mat on the workbench and floor is recommended. After connector insertion, unstrap the LD terminal with a soldering iron with its metallic tip grounded or whose insulation resistance is 10 megaohms or more (at 500V DC) five minutes after it is tuned on. The temperature of the soldering iron tip must be 320°C or below (30W) and the unstrapping should be performed quickly.

### 3. Actuator

#### (1) Actuator

The performance of the actuator may be affected if a magnetic material is located nearby, since the actuator has a strong magnetic field. Do not allow foreign materials to enter through gap in the cover.

#### (2) Lens cleaning

Dust or dirt on the objective lens has an adverse effect on pick-up performance. Gently wipe the lens using tissue moistened with isopropyl alcohol.

### 4. Lubrication

This drive unit need no lubrication when installed nor during use. Should lubrication become necessary use only grease "G-474B" or "G-474BY" (KANTO KASEI KOGYO) in the feedbearings and in the feed mechanism. Other types of oil or grease must not be used!

### 5. Handling

Hold the diecast chassis when handling the drive unit. Note that the LD and PD may be damaged if you come in contact with any of circuit boards.

## Precautions in use

### 1. APC Circuit

The output laser power must be controlled with the built-in monitor photodiode, since laser power changes with temperature. To prevent the characteristics dispersion of the monitor photodiode, the relation between the potentiometer (VR) attached to the pick-up and the monitor photodiode is factory adjusted so that the RF output will be constant.

### 2. Connections

Use the specified connectors for electrical connections. The eye pattern may deteriorate if a digital noise source such as a microcomputer is positioned near the harness from the photodiode. The laser may deteriorate if the actuator or laser diode connection is poor, securely connect these connectors.

CD PLAYER

SEMICONDUCTORS

● IC's

CXD2545Q (IC103)

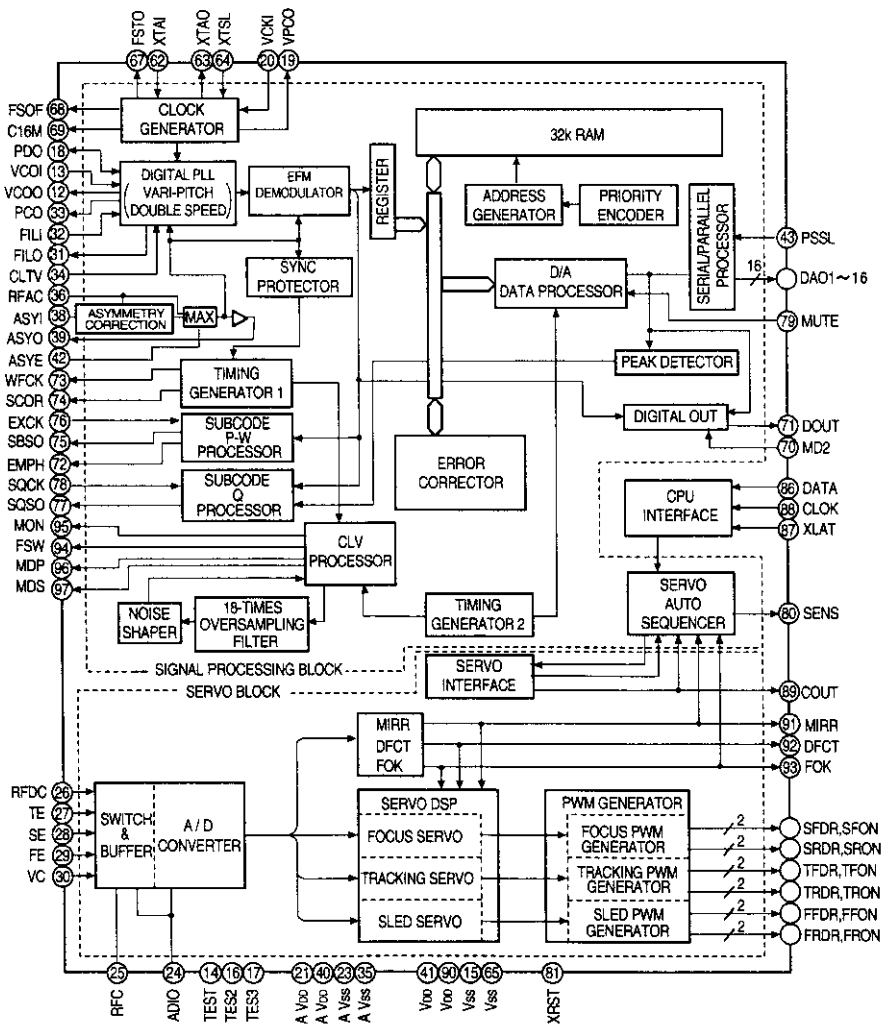
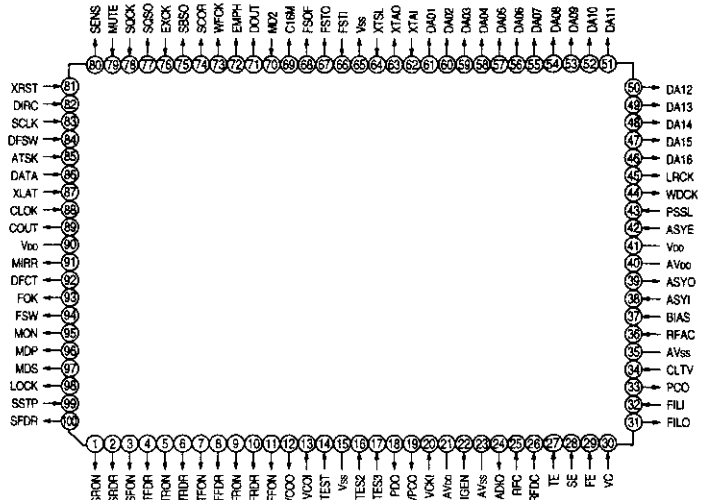
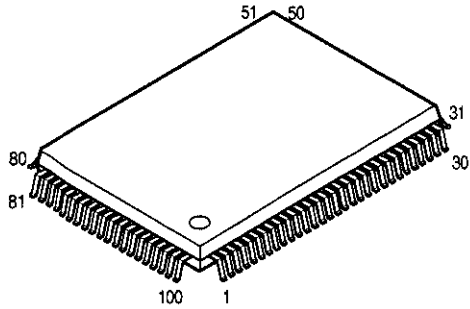

## CXD2545Q Terminal Function

Pin No.	Symbol	I/O	Function
1	SRON	O	Sled drive output signal.
2	SRDR	O	Sled drive output signal.
3	SFON	O	Sled drive output signal.
4	TFDR	O	Tracking drive output signal.
5	TRON	O	Tracking drive output signal.
6	TRDR	O	Tracking drive output signal.
7	TFON	O	Tracking drive output signal.
8	FFDR	O	Focus drive output signal.
9	FRON	O	Focus drive output signal.
10	FRDR	O	Focus drive output signal.
11	FFON	O	Focus drive output signal.
12	VCOO	O	Osc. circuit output for analog EFM PLL.
13	VCOI	I	Osc. circuit input for analog EFM PLL. f <sub>LOCK</sub> =8.6436MHz.
14	TEST	I	Test terminal, normally GND.
15	Vss	—	Digital GND.
16	TES2	I	Test terminal, normally GND.
17	TES3	I	Test terminal, normally GND.
18	PDO	O	Charge pump output for analog EFM PLL.
19	VPCO	O	PLL charge pump output for variable pitch.
20	VCKI	I	Clock input from external VCO for variable pitch. f <sub>center</sub> =16.9344MHz.
21	AVDD	—	Analog power supply.
22	IGEN	I	Op-amp current source ref. R connecting terminal for digital servo.
23	AVss	—	Analog ground.
24	ADIO	O	A/D converter input monitor terminal.
25	RFC	I	Low-pass filter C connecting terminal for RFDC input.
26	RFDC	I	RF signal input. Input range : 2.15V~5.0V (at V <sub>DD</sub> =AV <sub>DD</sub> =5.0V).
27	TE	I	Tracking error signal input. Input range : 2.5V±1.0V (at V <sub>DD</sub> =AV <sub>DD</sub> =5.0V).
28	SE	I	Sled error signal input. Input range : 2.5V±1.0V (at V <sub>DD</sub> =AV <sub>DD</sub> =5.0V).
29	FE	I	Focus error signal input. Input range : 2.5V±1.0V (at V <sub>DD</sub> =AV <sub>DD</sub> =5.0V).
30	VC	I	Center point voltage input terminal.
31	FILO	O	Filter output for master PLL.
32	FILI	I	Filter input for master PLL.
33	PCO	O	Charge pump output for master PLL.
34	CLTV	I	VCO control voltage input for master.
35	AVss	—	Analog ground.
36	RFAC	I	EFM signal input.
37	BIAS	I	Asymmetry circuit constant current input.
38	ASYI	I	Asymmetry comparator voltage input.
39	ASYO	O	EFM full swing output (L=V <sub>ss</sub> , H=V <sub>DD</sub> ).
40	AVDD	—	Analog power supply.
41	VDD	—	Digital power supply.
42	ASYE	I	Asymmetry circuit ON/OFF (L=OFF, H=ON).
43	PSSL	I	Mode shift input of audio data output. L to serial output, H to parallel output.
44	WDCK	O	48 bit slot D/A interface. word clock f=2Fs.
45	LRCK	O	48 bit slot D/A interface. LR clock f=Fs.
46	DA16	O	DA16 output when PSSL=1, 48bit slot serial data when PSSL=0.
47	DA15	O	DA15 output when PSSL=1, 48bit slot bit clock when PSSL=0.
48	DA14	O	DA14 output when PSSL=1, 64bit slot serial data when PSSL=0.
49	DA13	O	DA13 output when PSSL=1, 64bit slot bit clock when PSSL=0.
50	DA12	O	DA12 output when PSSL=1, 64bit slot LR clock when PSSL=0.
51	DA11	O	DA11 output when PSSL=1, GTOP output when PSSL=0.
52	DA10	O	DA10 output when PSSL=1, XUGF output when PSSL=0.
53	DA09	O	DA09 output when PSSL=1, XPLCK output when PSSL=0.
54	DA08	O	DA08 output when PSSL=1, GFS output when PSSL=0.
55	DA07	O	DA07 output when PSSL=1, RFCK output when PSSL=0.
56	DA06	O	DA06 output when PSSL=1, C2PO output when PSSL=0.
57	DA05	O	DA05 output when PSSL=1, XRAOF output when PSSL=0.
58	DA04	O	DA04 output when PSSL=1, MNT3 output when PSSL=0.
59	DA03	O	DA03 output when PSSL=1, MNT2 output when PSSL=0.
60	DA02	O	DA02 output when PSSL=1, MNT1 output when PSSL=0.
61	DA01	O	DA01 output when PSSL=1, MNT0 output when PSSL=0.
62	XTAI	I	X'tal Osc. circuit input. 16.9344MHz or 33.8688MHz.
63	XTAO	O	X'tal Osc. circuit output.

Pin No.	Symbol	I/O	Function
64	XTSL	I	X'tal select input terminal. L at X'tal is 16.9344MHz, H at X'tal is 33.8688MHz. (at normal play)
65	Vss	—	Digital ground.
66	FSTI	I	Ref. clock input terminal for digital servo block.
67	FSTO	O	2/3 cycle output of Pin 62, 63. Does not vary with variable pitch.
68	F5OF	O	1/4 cycle output of Pin 62, 63. Does not vary with variable pitch.
69	C16M	O	16.9344MHz output. Concurrently varies when variable pitched. (at normal play)
70	MD2	I	Digital-Out ON/OFF control terminal (L=OFF, H=ON).
71	DOUT	O	Digital-Out output terminal.
72	EMPH	O	Playback disc emphasis mode output (L=without emphasis, H=with emphasis).
73	WFCK	O	WFCK output.
74	SCOR	O	Sub code sync output terminal (H at either of sub-code sync S0 or S1 is detected).
75	SBSO	O	Sub P-W serial output.
76	EXCK	I	Clock input for SBSO read out.
77	SQSO	O	Sub Q 80 bit output. PCM peak data, level data 16-bit output.
78	SQCK	I	Clock input for SQSO read out.
79	MUTE	I	Mute shift terminal (mute at H).
80	SENS	O	SENS output. Emits to CPU.
81	XRST	I	System reset (reset at L).
82	DIRC	I	Using at 1 track jump. (input V <sub>DD</sub> level when not use)
83	SCLK	I	Clock for SENS serial data read out.
84	DFSW	I	DFCT shift terminal (DFCT measure circuit OFF at H).
85	ATSK	I	Anti-shock terminal.
86	DATA	I	Serial data input from CPU.
87	XLAT	I	Latch input from CPU.
88	CLOK	I	Serial data transfer clock input from CPU.
89	COUT	O	Number of track count signal output.
90	VDD	—	Digital power supply.
91	MIRR	O	Mirror signal output.
92	DFCT	O	Defect signal output.
93	FOK	O	Focus OK output.
94	FSW	O	Output filter shifting output of spindle motor.
95	MON	O	ON/OFF control output of spindle motor.
96	MDP	O	Servo control of spindle motor.
97	MDS	O	Servo control of spindle motor.
98	LOCK	O	By sampling GFS with 460Hz and when GFS at H, H output. L output at consecutively L 8 times.
99	SSTP	I	Terminal for disc innermost circle detection signal.
100	SFDR	O	Sled drive output.

- Note:
- 64bit slot is LSB first 2's complementary output. 48bit slot is MSB first 2's complementary output.
  - GTOP is for monitoring Frame Sync protection. (H: Sync protection window open)
  - XUGF is negative pulse Frame sync gained from EFM signal. Pre-sync-protection signal.
  - XPLCK is reversal of EFM PLL clock. PLL is being made to synchronize falling edge with EFM signal's changing point.
  - GFS signal becomes H when the timing of Frame Sync and interleaf protection are equal.
  - RFCK depends on accuracy of X'tal. It's a signal of 136 μs cycle.
  - C2PO is a signal indicates data error status.
  - XRAOF is a signal generated when the 32k RAM exceeds jitter margin of ±28 frames.

CD PLAYER

SM5871A (IC200)

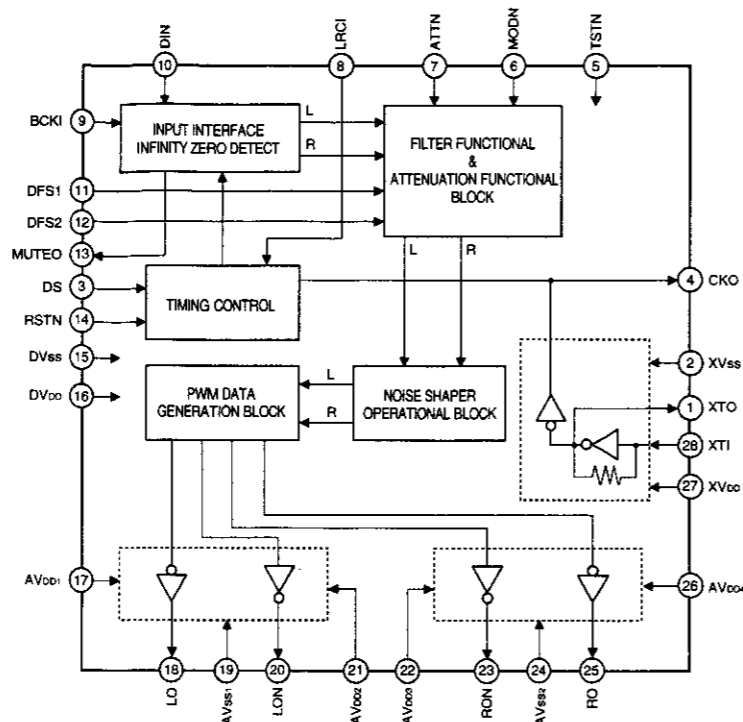
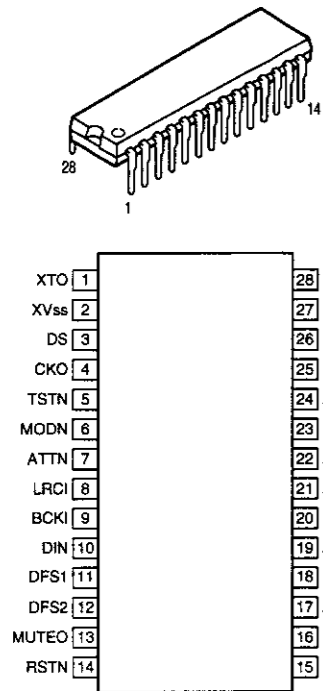

SM5871A Terminal Function

Pin No.	Symbol	i/o	Function
1	XTO	o	Oscillator output.
2	XVss	—	X'tal part GND (0V).
3	DS	ip	Normal/double playback speed select (DS=L: Normal, DS=H: Double).
4	CKO	o	Oscillator output clock (DS=L: 384fs, DS=H: 192fs).
5	TSTN	ip	Test terminal, fixed to H level normally.
6	MODN	ip	Mode control terminal.
7	ATTN	ip	Soft mute control terminal.
8	LRCI	ip	Input data sample rate (fs) clock, H: Lch, L: Rch.
9	BCKI	ip	Input data bit clock..
10	DIN	ip	Input data.
11	DFS1	ip	De-emphasis control terminal 1.
12	DFS2	ip	De-emphasis control terminal 2.
13	MUTE0	o	Infinity zero detect output.
14	RSTN	ip	System reset, H: Normal, L: Reset.
15	DVss	—	Digital GND terminal (0V).
16	DVDD	—	Digital VDD terminal (5V).
17	AVDD1	—	Analog VDD terminal (5V).
18	LO	o	Lch PWM output (+).
19	AVSS1	—	Analog GND terminal 1(0V).
20	LON	o	Lch PWM output (-)
21	AVDD2	—	Analog VDD terminal 2(5V).
22	AVDD3	—	Analog VDD terminal 3(5V).
23	RON	o	Rch PWM output (+)
24	AVSS2	—	Analog GND terminal 2 (0V)
25	RO	o	Rch PWM output (+)
26	AVDD4	—	Analog VDD terminal 4(5V)
27	XVDD	—	X'tal part VDD terminal (5V)
28	XTI	i	Oscillator input terminal (DS=L: 394fs, DS=H: 192fs)

i: input terminal, ip: input terminal w/pull-up resistor, o: output terminal

CXA1821M (IC001)

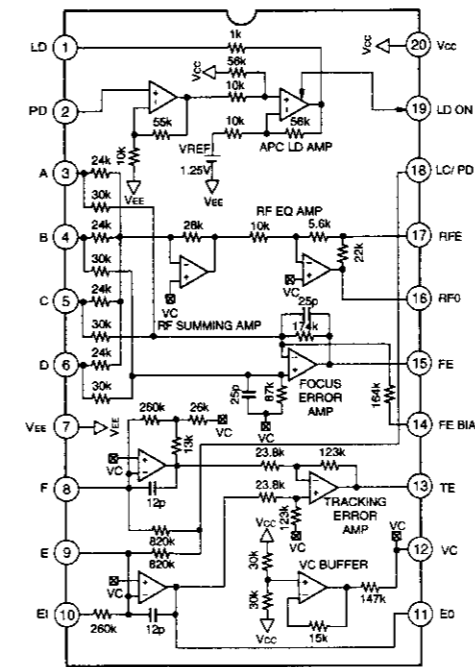
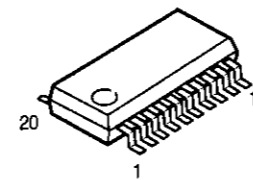

KIA7291S (IC105)

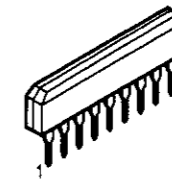

Terminal Function

Pin No.	Symbol	Description
1	IN2	Input terminal
2	Vcc	Power for logic part
3	OUT2	Output terminal
4	NC	No connection
5	GND	GND
6	Vs	Power for output part
7	OUT1	Output terminal
8	Vref	Ref. voltage terminal
9	IN1	Input terminal

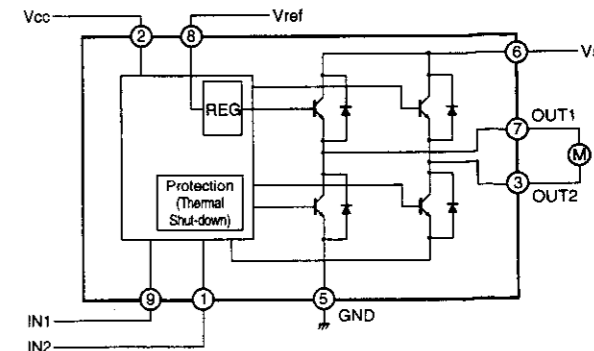

BA6392FP (IC002)

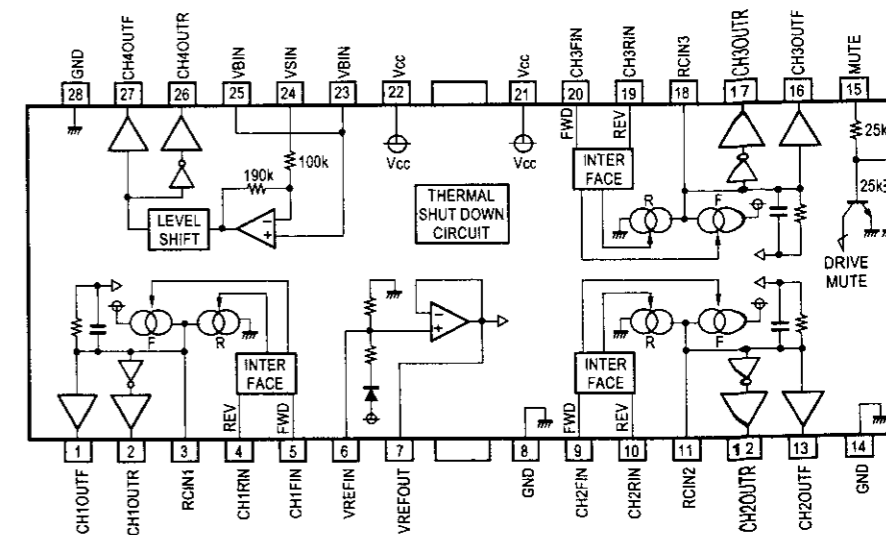
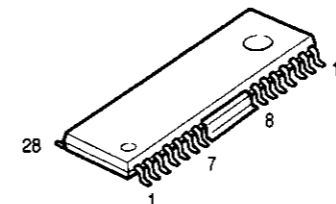

NJM4558DD (IC201, 202)

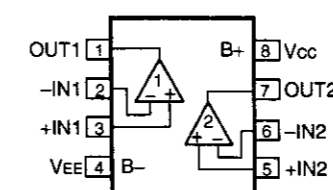
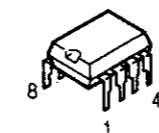

KTD2058 (IC152)

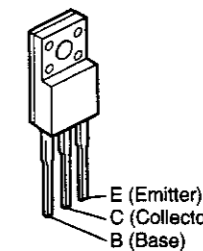

KA7808 (IC101)

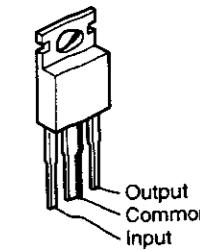



● IC Protector  
ICP-N15 (SF101,102)

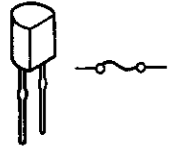

● Optical Output  
GP1F32T (OPTICAL)

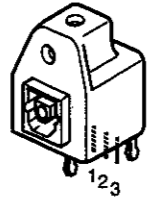

1. Vin  
2. Vcc  
3. GND

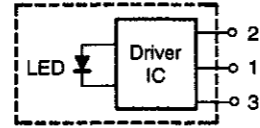

● Transistors

KTA1266  
KTC3198

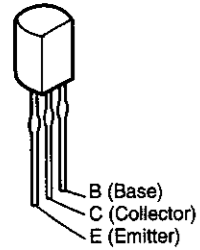

MPSA56

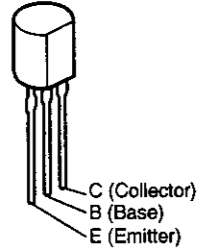

DTC323TS

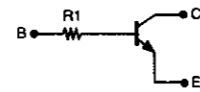
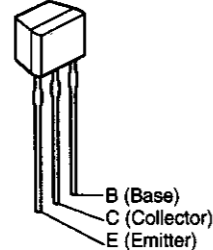

	R1
DTC323TS	2.2kohm

DTA114YS  
DTC114YS

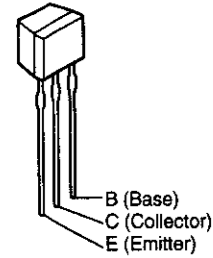

PNP Series

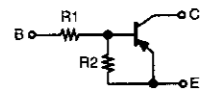

	R1	R2
DTA114YS	10kohm	4.7kohm

NPN Series

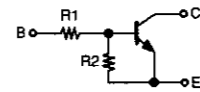

	R1	R2
DTC114YS	10kohm	4.7kohm

● Diodes

KDS226

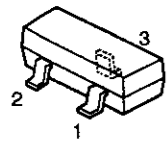

1: Cathode 1  
2: Anode 2  
3: Anode1/Cathode 2

1N4004A

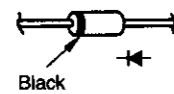

1SS133

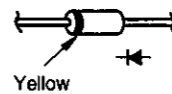

MTZJ3.9B  
MTZJ5.6B  
MTZJ9.1B  
MTZJ24B

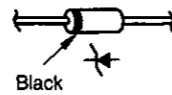

● FL DISPLAY 10-BT-197GK

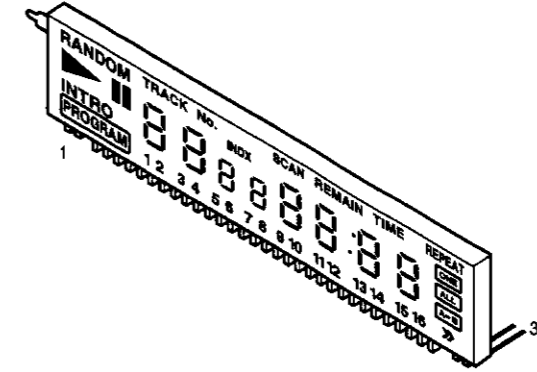

Pin Connection

Pin No.	1	2	3	4	5	6	7	8	9	10	11	12	13	14	15	16	17	18	19	20	21	22	23	24
Connection	F1	F1	NP	10G	9G	8G	7G	6G	5G	4G	3G	2G	1G	NC	NC	NC	NC	NC	a	b	c	d	e	f

Pin No.	25	26	27	28	29	30	31
Connection	g	h	i	j	NP	F2	F2

NOTE 1) F1, F2 . . . . . Filament  
2) NP . . . . . No Pin  
3) NC . . . . . No Connection  
4) 1G~10G . . . . . Grid

Grid Partition

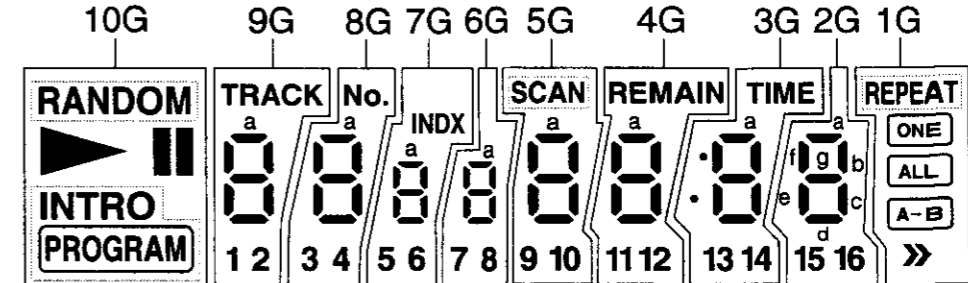

Anode Connection

	10G	9G	8G	7G	6G	5G	4G	3G	2G	1G
P1	RANDOM	a	a	a	a	a	a	a	a	—
P2	▶	b	b	b	b	b	b	b	b	—
P3		c	c	c	c	c	c	c	c	—
P4	—	d	d	d	d	d	d	d	d	REPEAT
P5	—	e	e	e	e	e	e	e	e	ONE
P6	—	f	f	f	f	f	f	f	f	ALL
P7	—	g	g	g	g	g	g	g	g	A→
P8	—	TRACK	NO.	INDX	—	SCAN	REMAIN	TIME	—	B
P9	PROGRAM	1	3	5	7	9	11	13	15	—
P10	INTRO	2	4	6	8	10	12	14	16	»

CD PLAYER  
PRINTED WIRING BOARDS

1 2 3 4 5 6 7 8

MAIN P.W.B. UNIT ASS'Y

A

B

C

D

E

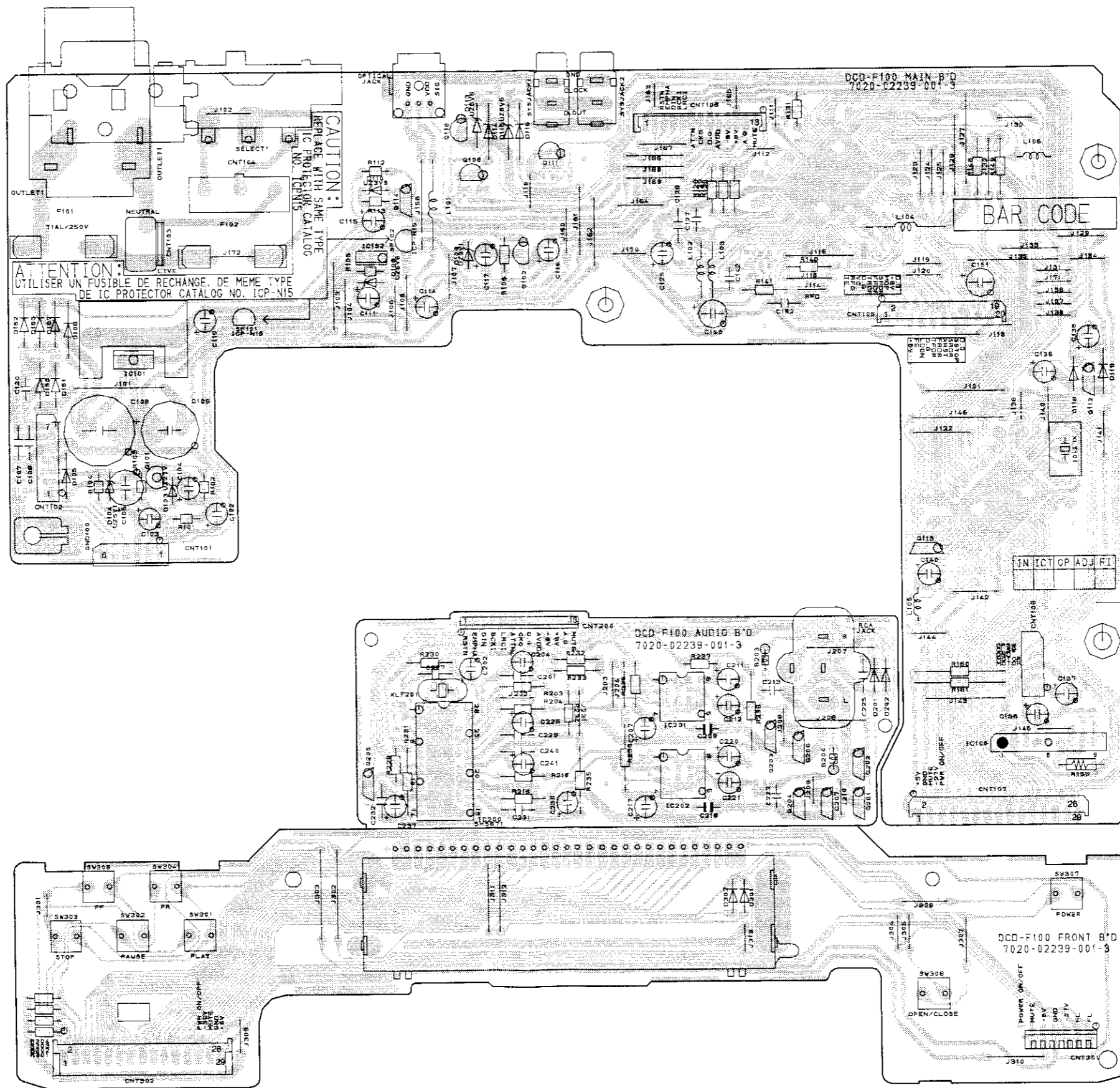

COMPONENT SIDE

1 2 3 4 5 6 7 8

A

B

C

D

E

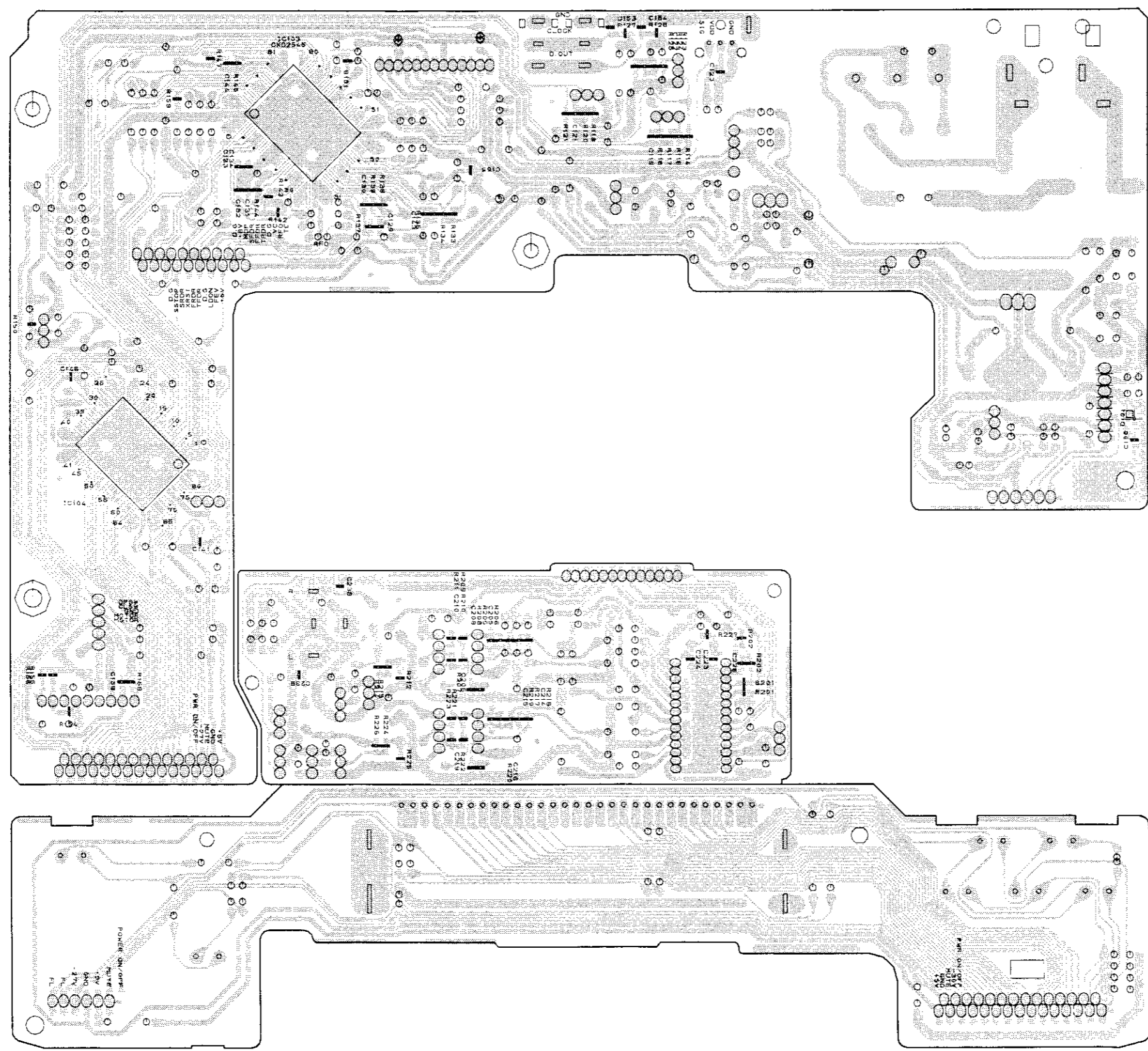

FOIL SIDE

CD PLAYER

RF & DRIVE P.W.B. UNIT ASS'Y

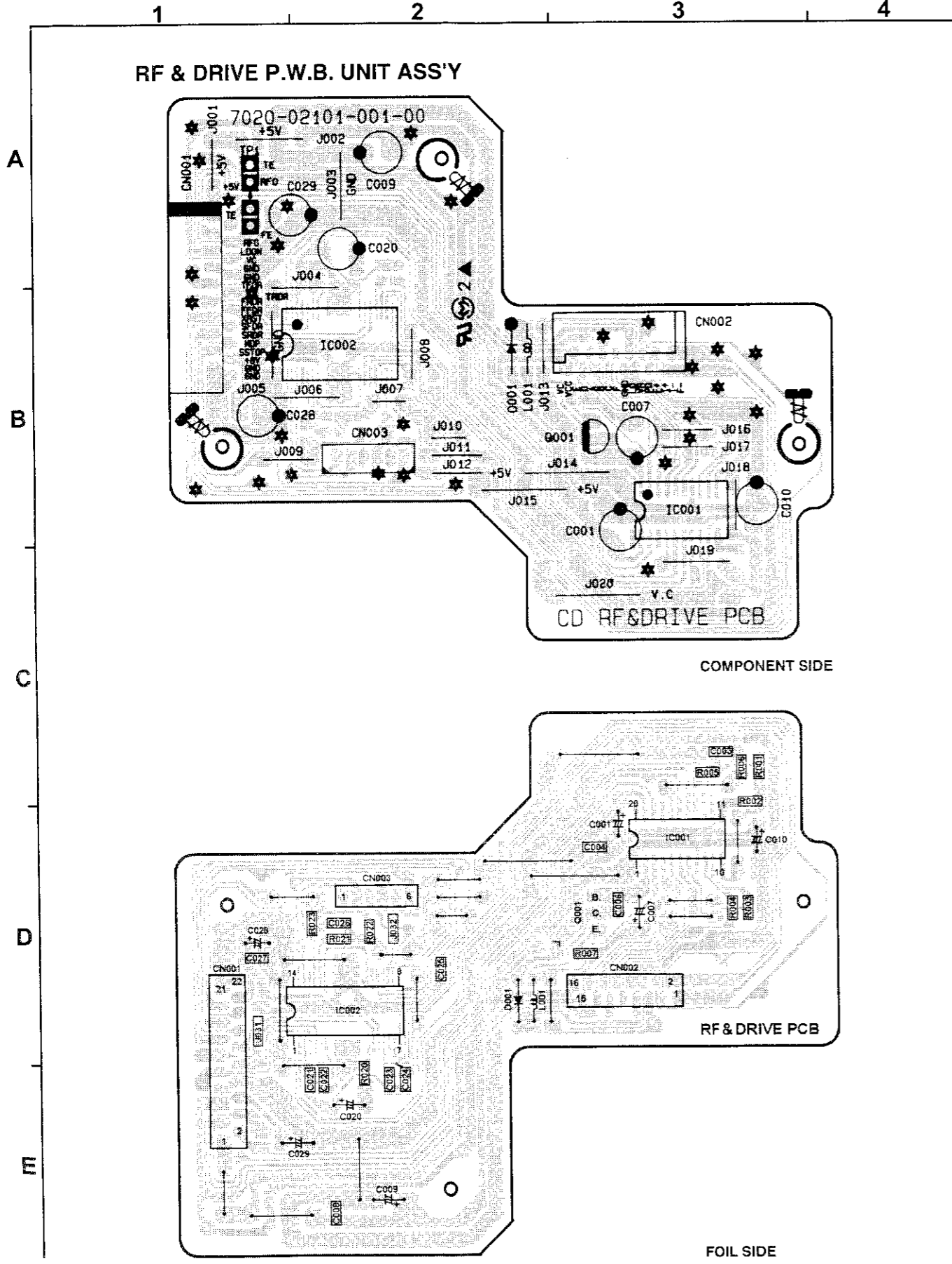

NOTE FOR PARTS LIST

- Part indicated with the mark "⊙" are not always in stock and possibly to take a long period of time for supplying, or in some case supplying of part may be refused.
- When ordering of part, clearly indicate "1" and "1" (i) to avoid mis-supplying.
- Ordering part without stating its part number can not be supplied.
- Part indicated with the mark "★" is not illustrated in the exploded view.
- Not including Carbon Film ±5%, 1/4W Type in the P.W.Board parts list. (Refer to the Schematic Diagram for those parts.)

**WARNING:**  
Parts marked with this symbol have critical characteristics.  
Use ONLY replacement parts recommended by the manufacturer.

● Resistors

Ex.: **RN** 14**K** 2**E** 18**2** **G** **FR**

Type	Shape and performance	Power	Resistance	Allowable error	Others
RD	Carbon	2B : 1/8W	F : ±1%	P	Pulse-resistant type
RC	Composition	2E : 1/4W	G : ±2%	NL	Low noise type
RS	Metal oxide film	2H : 1/2W	J : ±5%	NB	Non-burning type
RW	Winding	3A : 1W	K : ±10%	FR	Fuse-resistor
RN	Metal film	3D : 2W	M : ±20%	F	Lead wire forming
RK	Metal mixture	3F : 3W			
		3H : 5W			

\* Resistance  
 $\overline{182} = 1800 \text{ ohm} = 1.8 \text{ kohm}$   
 Indicates number of zeros after effective number.  
 2-digit effective number.  
 • Units: ohm

$\overline{1R2} = 1.2 \text{ ohm}$   
 1-digit effective number.  
 2-digit effective number, decimal point indicated by R.  
 • Units: ohm

● Capacitors

Ex.: **CE** 04**W** 1**H** 2**R2** **M** **BP**

Type	Shape and performance	Dielectric strength	Capacity	Allowable error	Others
CE	Aluminum foil electrolytic	0J : 6.3V	F : ±1%	HS	High stability type
CA	Aluminum solid electrolytic	1A : 10V	G : ±2%	BP	Non-polar type
CS	Tantalum electrolytic	1C : 16V	J : ±5%	HR	Ripple-resistant type
CQ	Film	1E : 25V	K : ±10%	DL	For charge and discharge
CK	Ceramic	1V : 35V	M : ±20%	HF	For assuring high frequency
CC	Ceramic	1H : 50V	Z : +80%	U	UL part
CP	Oil	2A : 100V	-20%	C	CSA part
CM	Mica	2B : 125V	P : +100%	W	UL-CSA type
CF	Metallized	2C : 160V	-0%	F	Lead wire forming
CH	Metallized	2D : 200V	C : ±0.25pF		
		2E : 250V	D : ±0.5pF		
		2H : 500V	=		
		2J : 630V			

\* Capacity (electrolyte only)  
 $\overline{222} = 2200\mu\text{F}$   
 Indicates number of zeros after effective number.  
 2-digit effective number.  
 • Units:  $\mu\text{F}$ .

$\overline{2R2} = 2.2\mu\text{F}$   
 1-digit effective number.  
 2-digit effective number, decimal point indicated by R.  
 • Units:  $\mu\text{F}$ .

\* Capacity (except electrolyte)  
 $\overline{222} = 2200\text{pF} = 0.0022\mu\text{F}$   
 (More than 2) — Indicates number of zeros after effective number.  
 2-digit effective number.  
 • Units:  $\mu\text{F}$ .

$\overline{221} = 220\text{pF}$   
 (0 or 1) — Indicates number of zeros after effective number.  
 2-digit effective number.  
 • Units: pF.

• When the dielectric strength is indicated in AC, "AC" is included after the dielectric strength value.

**PARTS LIST OF P.W.B. UNIT**  
**CD RF & DRIVE P.W.B. UNIT ASS'Y**

**MAIN P.W.B. UNIT ASS'Y**

Ref. No.	Part No.	Part Name	Remarks
<b>SEMICONDUCTORS GROUP</b>			
IC001	S87 5207 245	IC CXA1821M	J030182100010
IC002	263 0909 906	IC BA6392FP	J127639200010
Q001	960 0005 105	Transistor KTA1266Y	J5001266Y0050
D001	276 0401 905	Diode 1SS133	K000013300520
<b>RESISTORS GROUP</b>			
R001		Carbon chip 47 kohm 1/10W	C200047360200
R002		Carbon chip 22 kohm 1/10W	C200022360200
R003,004		Carbon chip 150 kohm 1/10W	C200015460200
R005		Carbon chip 10 kohm 1/10W	C200010360200
R006		Carbon chip 22 kohm 1/10W	C200022360200
R007		Carbon chip 22 ohm 1/10W	C200022060200
R020		Carbon chip 4.7 ohm 1/10W	C2004R7060200
R021		Carbon chip 150 kohm 1/10W	C200015460200
R022		Carbon chip 56 kohm 1/10W	C200056360200
R023		Carbon chip 150 kohm 1/10W	C200015460200
<b>CAPACITORS GROUP</b>			
C001	254 4252 037	Electrolytic 100 μF/10V	D040101082050
C002		Ceramic chip 0.022 μF/50V	D011223777200
C003		Ceramic chip 15 pF/50V	D010150167200
C004		Ceramic chip 0.022 μF/50V	D011223777200
C006		Ceramic chip 0.001 μF/50V	D011102777200
C007	254 4252 037	Electrolytic 100 μF/10V	D040101082050
C008		Ceramic chip 0.022 μF/50V	D011223777200
C009,010	254 4252 037	Electrolytic 100 μF/10V	D040101082050
C020	254 4260 029	Electrolytic 0.33 μF/50V	D040R33087110
C021		Ceramic chip 27 pF/50V	D010270167200
C022		Ceramic chip 0.1 μF/50V	D011104597200
C023		Ceramic chip 27 pF/50V	D010270167200
C024		Ceramic chip 0.0015 μF/50V	D011152777200
C025		Ceramic chip 0.1 μF/50V	D011104597200
C026		Ceramic chip 0.0068 μF/50V	D011682777200
C027		Ceramic chip 0.022 μF/50V	D011223777200
C028,029	254 4252 037	Electrolytic 100 μF/10V	D040101082050
<b>OTHER PARTS GROUP</b>			
CN001	960 0127 407	20P FPC connector base	L131520442010 1
CN002	960 0127 300	16P FPC connector base	L130528071610 1
CN003	960 0127 203	6P connector base	L101530150610 1
J031,032	—	Carbon chip 0 ohm 1/10W	C200000060200 2
L001	960 0010 307	Inductor 10 μH	D330100700520 1
TP1	—	2P test pin	L421000050000 1

Ref. No.	Part No.	Part Name	Remarks
<b>SEMICONDUCTORS GROUP</b>			
IC101	960 0128 503	IC KA7808	J126780800060
IC103	S87 5236 978	IC CXD2545Q	J031254500010
IC105	960 0129 104	IC TA7291S	J127729100000
IC152	960 0004 902	IC KTD2058Y	J5032058Y0140
IC200	960 0129 609	IC SM5871AP	J042587100020
IC201,202	265 0030 004	IC NJM4558DD	J121455800020
Q101,102	960 0128 309	Transistor MPSA56Y	J5005600Y0050
Q108	960 0005 105	Transistor KTA1266Y	J5001266Y0050
Q110	960 0128 406	Transistor KTC 3198 BL	J5023198B0050
Q111	960 0005 105	Transistor KTA1266Y	J5001266Y0050
Q112	963 0022 006	Transistor DTC114YS	J6020114Y0050
Q113	269 0072 909	Transistor DTC323TS	J602323TS0050
Q114	963 0022 006	Transistor DTC114YS	J6020114Y0050
Q201,202	269 0078 903	Transistor DTA114YS	J6000114Y0010
Q203~207	269 0072 909	Transistor DTC323TS	J602323TS0050
D101	960 0014 206	Diode KDS226S	K005022600010
D103	960 0128 202	Zener diode MTZJ24B	K06024R044520
D104	276 0664 904	Zener diode MTZJ5.6B	K06005R644520
D105	960 0117 608	Diode 1N4004A	K040400400520
D106,107	276 0401 905	Diode 1SS133	K000013300520
D108	276 0664 904	Zener diode MTZJ5.6B	K06005R644520
D109	960 0128 105	Zener diode MTZJ9.1B	K06009R144520
D110	9L2 3480 72M	Zener diode MTZJ3.9B	K06003R944520
D113	276 0664 904	Zener diode MTZJ5.6B	K06005R644520
D114	276 0401 905	Diode 1SS133	K000013300520
D115	276 0664 904	Zener diode MTZJ5.6B	K06005R644520
D116	276 0401 905	Diode 1SS133	K000013300520
D118,119	276 0401 905	Diode 1SS133	K000013300520
D150~153	960 0117 608	Diode 1N4004A	K040400400520
D201,202	276 0401 905	Diode 1SS133	K000013300520
D301,302	276 0401 905	Diode 1SS133	K000013300520
<b>RESISTORS GROUP</b>			
R101		Carbon film 6.8 kohm 1/5W	C00006826P520
R102		Carbon film 47 kohm 1/5W	C00004736P520
R103		Carbon film 3.3 kohm 1/5W	C00003326P520
R104		Carbon film 12 kohm 1/5W	C00001236P520
R105,106		Carbon film 470 ohm 1/5W	C00004716P520
R112		Carbon film 5.6 kohm 1/5W	C00005626P520
R113		Carbon film 47 kohm 1/5W	C00004736P520
R114		Carbon chip 10 kohm 1/10W	C200010360200
R116		Carbon chip 22 kohm 1/10W	C200022360200
R117		Carbon chip 10 kohm 1/10W	C200010360200
R118~120		Carbon chip 22 kohm 1/10W	C200022360200
R121		Carbon chip 10 kohm 1/10W	C200010360200

## CD PLAYER

Ref. No.	Part No.	Part Name	Remarks
R123,124		Carbon chip 22 kohm 1/10W	C200022360200
R125		Carbon chip 47 kohm 1/10W	C200047360200
R126		Carbon chip 220 ohm 1/10W	C200022160200
R127		Carbon chip 100 ohm 1/10W	C200010160200
R128~130		Carbon film 1 kohm 1/5W	C00001026P520
R131		Carbon film 10 kohm 1/5W	C00001036P520
R132		Carbon chip 180 ohm 1/10W	C200018160200
R133		Carbon chip 10 kohm 1/10W	C200010360200
R134		Carbon chip 100 kohm 1/10W	C200010460200
R135		Carbon chip 1 Mohm 1/10W	C200010560200
R137		Carbon chip 10 kohm 1/10W	C200010360200
R138,139		Carbon chip 3.3 kohm 1/10W	C200033260200
R140		Carbon film 15 kohm 1/5W	C00001536P520
R141		Carbon film 100 ohm 1/5W	C00001016P520
R142		Carbon chip 100 kohm 1/10W	C200010460200
R143		Carbon chip 15 kohm 1/10W	C200015360200
R144		Carbon chip 33 kohm 1/10W	C200033360200
R145		Carbon chip 10 kohm 1/10W	C200010360200
R147		Carbon chip 1 kohm 1/10W	C200010260200
R148,149		Carbon film 10 kohm 1/5W	C00001036P520
R150		Carbon chip 47 kohm 1/10W	C200047360200
R153		Carbon chip 1 ohm 1/10W	C200001060200
R154		Carbon chip 2.7 kohm 1/10W	C200027260200
R155		Carbon chip 4.3 kohm 1/10W	C200043260200
R156		Carbon chip 47 kohm 1/10W	C200047360200
R158		Carbon chip 47 kohm 1/10W	C200047360200
R159		Carbon chip 100 kohm 1/10W	C200010460200
R160,161		Carbon film 47 kohm 1/5W	C00004736P520
R201		Carbon chip 22 ohm 1/10W	C200022060200
R202		Carbon chip 180 ohm 1/10W	C200018160200
R203,204		Carbon film 10 kohm 1/5W	C00001036P520
R205,206		Carbon chip 6.8 kohm 1/10W	C200068260200
R207		Carbon chip 22 kohm 1/10W	C200022360200
R208		Carbon chip 24 kohm 1/10W	C200024360200
R209~211		Carbon chip 6.8 kohm 1/10W	C200068260200
R212		Carbon chip 100 kohm 1/10W	C200010460200
R213		Carbon chip 680 ohm 1/10W	C200068160200
R214		Carbon chip 100 ohm 1/10W	C200010160200
R215,216		Carbon film 10 kohm 1/5W	C00001036P520
R217,218		Carbon chip 6.8 kohm 1/10W	C200068260200
R219		Carbon chip 24 kohm 1/10W	C200024360200
R220		Carbon chip 22 kohm 1/10W	C200022360200
R221~223		Carbon chip 6.8 kohm 1/10W	C200068260200
R224		Carbon chip 680 ohm 1/10W	C200068160200
R225		Carbon chip 100 kohm 1/10W	C200010460200
R226		Carbon chip 100 ohm 1/10W	C200010160200
R227		Carbon chip 1 Mohm 1/10W	C200010560200
R228		Carbon film 47 kohm 1/5W	C00004736P520
R230~239		Carbon film 47 ohm 1/5W	C00004706P520
R301~304		Carbon film 47 kohm 1/5W	C00004736P520

Ref. No.	Part No.	Part Name	Remarks
R306~330		Carbon film 100 kohm 1/5W	C00001046P520
<b>CAPACITORS GROUP</b>			
C100		Ceramic chip 0.1 $\mu$ F/50V	D011104177210
C102		Electrolytic 100 $\mu$ F/10V	D040101082060
C103,104		Electrolytic 10 $\mu$ F/50V	D040100087050
C105		Electrolytic 22 $\mu$ F/50V	D040220087060
C106,107		Ceramic 0.1 $\mu$ F/50V	D005104597530
C108		Electrolytic 3300 $\mu$ F/25V	D040332084020
C109		Electrolytic 1000 $\mu$ F/25V	D040102084030
C110,111		Electrolytic 10 $\mu$ F/50V	D040100087050
C114		Electrolytic 100 $\mu$ F/10V	D040101082060
C115		Electrolytic 100 $\mu$ F/25V	D040101084060
C116		Electrolytic 100 $\mu$ F/10V	D040101082060
C117		Electrolytic 10 $\mu$ F/50V	D040100087050
C119		Ceramic chip 0.001 $\mu$ F/50V	D011102177210
C120		Film 0.068 $\mu$ F/63V	D020683078060
C121,122		Ceramic chip 0.001 $\mu$ F/50V	D011102177210
C123		Ceramic chip 0.1 $\mu$ F/50V	D011104177210
C125		Electrolytic 0.1 $\mu$ F/50V	D040R10087070
C126		Ceramic 0.01 $\mu$ F/16V	D005103773530
C127		Film 0.68 $\mu$ F/63V	D020684078060
C129		Ceramic chip 0.0033 $\mu$ F/50V	D011332177210
C130		Ceramic chip 0.047 $\mu$ F	D011473177210
C131		Ceramic chip 0.1 $\mu$ F/50V	D011104177210
C132,133		Ceramic chip 470 pF/50V	D010471167200
C134		Ceramic chip 0.1 $\mu$ F/50V	D011104177210
C135		Electrolytic 3.3 $\mu$ F/50V	D0403R3087100
C136		Electrolytic 1 $\mu$ F/50V	D040010087050
C137,138		Electrolytic 100 $\mu$ F/10V	D040101082060
C137,138		Electrolytic 100 $\mu$ F/10V	D040101082060
C139		Ceramic chip 0.1 $\mu$ F/50V	D011104177210
C140		Electrolytic 100 $\mu$ F/10V	D040101082060
C140		Electrolytic 100 $\mu$ F/10V	D040101082060
C141		Ceramic chip 0.1 $\mu$ F/50V	D011104177210
C142		Film 0.0015 $\mu$ F/100V	D02015206C060
C143		Ceramic chip 100 pF/50V	D010101167200
C144		Ceramic chip 0.1 $\mu$ F/50V	D011104177210
C146		Ceramic chip 0.1 $\mu$ F/50V	D011104177210
C147		Ceramic chip 100 pF/50V	D010101167200
C148		Ceramic 0.1 $\mu$ F/50V	D005104597530
C150,151		Electrolytic 220 $\mu$ F/10V	D040221082050
C152		Ceramic 100 pF/50V	D005101177520
C153,154		Ceramic chip 100 pF/50V	D010101167200
C201		Ceramic 0.047 $\mu$ F/50V	D005473597520
C202		Electrolytic 47 $\mu$ F/16V	D040470083100
C204		Electrolytic 47 $\mu$ F/16V	D040470083100
C205		Ceramic chip 220 pF/50V	D010221167200
C206		Ceramic chip 100 pF/50V	D010101167200
C207		Electrolytic 22 $\mu$ F/16V	D040220083070
C208		Ceramic chip 100 pF/50V	D010101167200

WIRING DIAGRAM

1 2 3 4

Ref. No.	Part No.	Part Name	Remarks	Ref. No.	Part No.	Part Name	Remarks	Q'ty	
C209		Film 0.0022 μF/100V	D02022206C060	RCA1	960 0129 502	2P pin jack	G601201150030	1	
C210		Ceramic chip 220 pF/50V	D010221167200	SF101,102	268 0073 002	IC ICP-N15	J120001500030	2	
C211		Electrolytic 22 μF/16V	D040220083070	SW301-307	960 0069 206	Tact switch	G180215050010	7	
C212		Electrolytic 10 μF/50V	D040100087050	SYSJACK1,2	960 0004 407	Mini jack	G401031102010	2	
C213		Film 0.0022 μF/100V	D02022206C060	XLT101	399 0107 900	Ceramic 4.19MHz	E830419000060	1	
C214		Ceramic chip 220 pF/50V	D010221167200	XLT201	960 0129 405	Crystal 16.9344 MHz	E800169344460	1	
C215,216		Ceramic chip 100 pF/50V	D010101167200		960 0127 708	Heat sink	2120044298010	1	
C217		Electrolytic 22 μF/16V	D040220083070		960 0127 805	Earth plate	4470200016010	1	
C218		Film 0.0022 μF/100V	D02022206C060		960 0005 804	Fuse holder	G645000050010	2	
C219		Ceramic chip 220 pF/50V	D010221167200		960 0005 804	Fuse holder	G645000050010	2	
C220		Electrolytic 22 μF/16V	D040220083070				Asia Model only		
C221		Electrolytic 10 μF/50V	D040100087050		960 0143 300	FL supporter	4070210006000	1	
C222		Film 0.0022 μF/100V	D02022206C060		960 0083 606	FLD (10-BT-197GK)	K530000210010	1	
C223,224		Ceramic chip 27 pF/50V	D010270167200		963 0018 007	Screw 3x8 CBTS(B)-Z	B020030081B10	1	
C225		Ceramic 0.1 μF/50V	D005104597530						
C226		Ceramic chip 27 pF/50V	D010270167200						
C227		Ceramic 0.047 μF/50V	D005473597520						
C228		Electrolytic 47 μF/16V	D040470083100						
C229		Ceramic 0.047 μF/50V	D005473597520						
C231,232		Ceramic 0.047 μF/50V	D005473597520						
C236,237		Electrolytic 47 μF/16V	D040470083100						
C240		Ceramic 0.047 μF/50V	D005473597520						
C241		Electrolytic 47 μF/16V	D040470083100						
<b>OTHER PARTS GROUP</b>				<b>Q'ty</b>					
Δ ISELECT1	963 0027 700	Slide switch	G060040550010 Asia Model only	1					
CNT101	960 0128 804	6P connector base	L102526700600	1					
CNT102	960 0118 704	7P connector base	L102526700700	1					
CNT103	960 0118 908	2P connector base	L108039602010	1					
CNT104	960 0128 901	13P connector base	L104353280300	1					
CNT105	960 0129 007	20P FPC connector base	L131837002000	1					
CNT106	960 0128 707	5P connector base	L102526700500	1					
CNT107	960 0129 201	29P FPC connector base	L131837002900	1					
CNT108	960 0128 600	13P connector base	L101353361310	1					
CNT200	960 0129 706	13P connector base	L101352371310	1					
CNT301	960 0129 900	7P flat cable	L352106183100	1					
CNT302	960 0129 803	29P FPC connector base	L131837002910	1					
Δ F101	960 0142 709	Fuse 250V 1A	G650102251160	1					
Δ F102	960 0142 709	Fuse 250V 1A	G650102251160 Asia Model only	1					
GND100	960 9006 600	GND terminal	3790040876010	1					
L101-106	960 0128 008	Inductor 100 μH	D330101001020	6					
OPTICAL	269 0098 006	Optical connector (GP1F32T)	E100132000010	1					
Δ OUTLET1	960 0142 301	AC outlet	G435040110000	1					

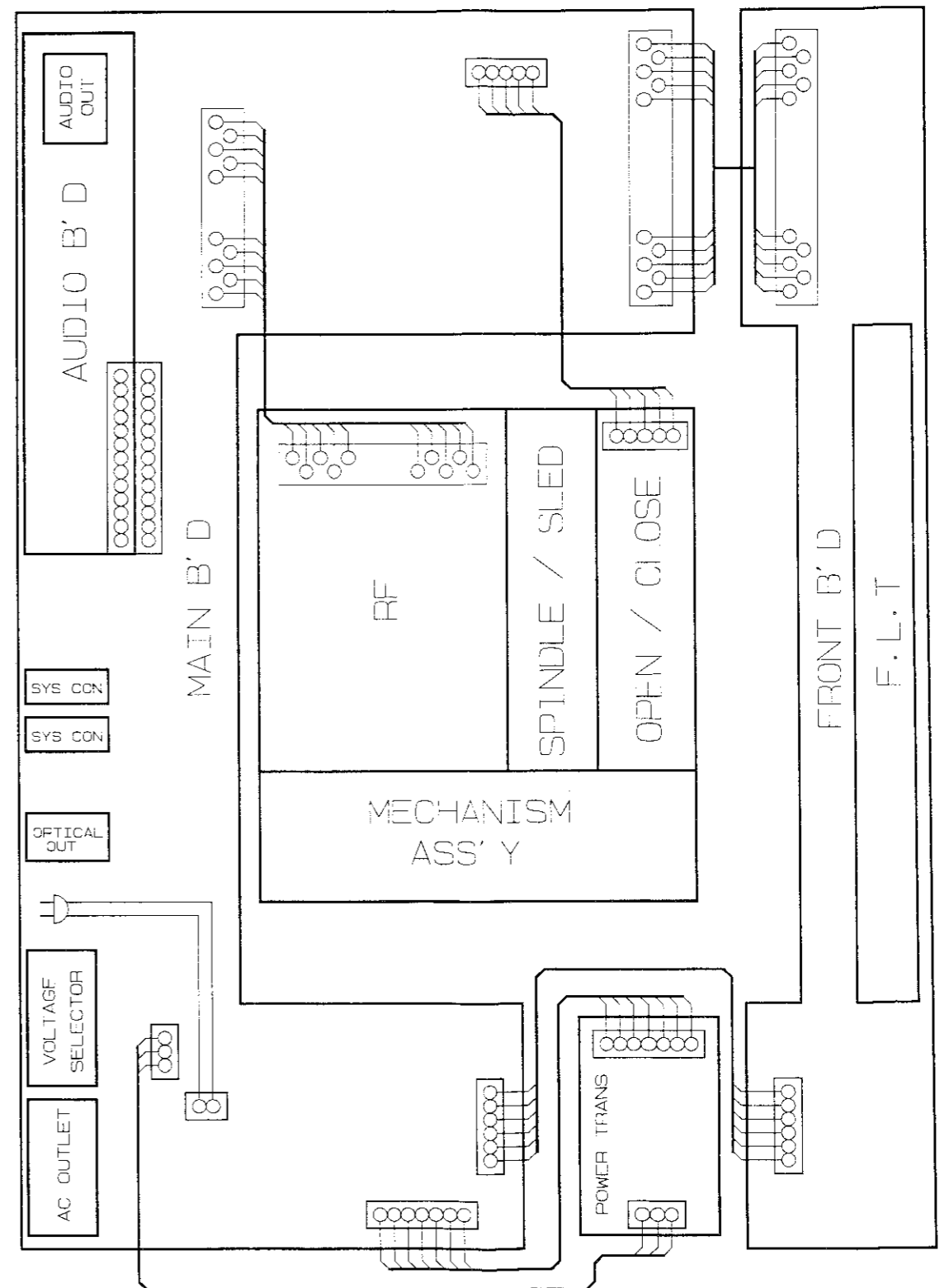

A  
B  
C  
D  
E

EXPLODED VIEW

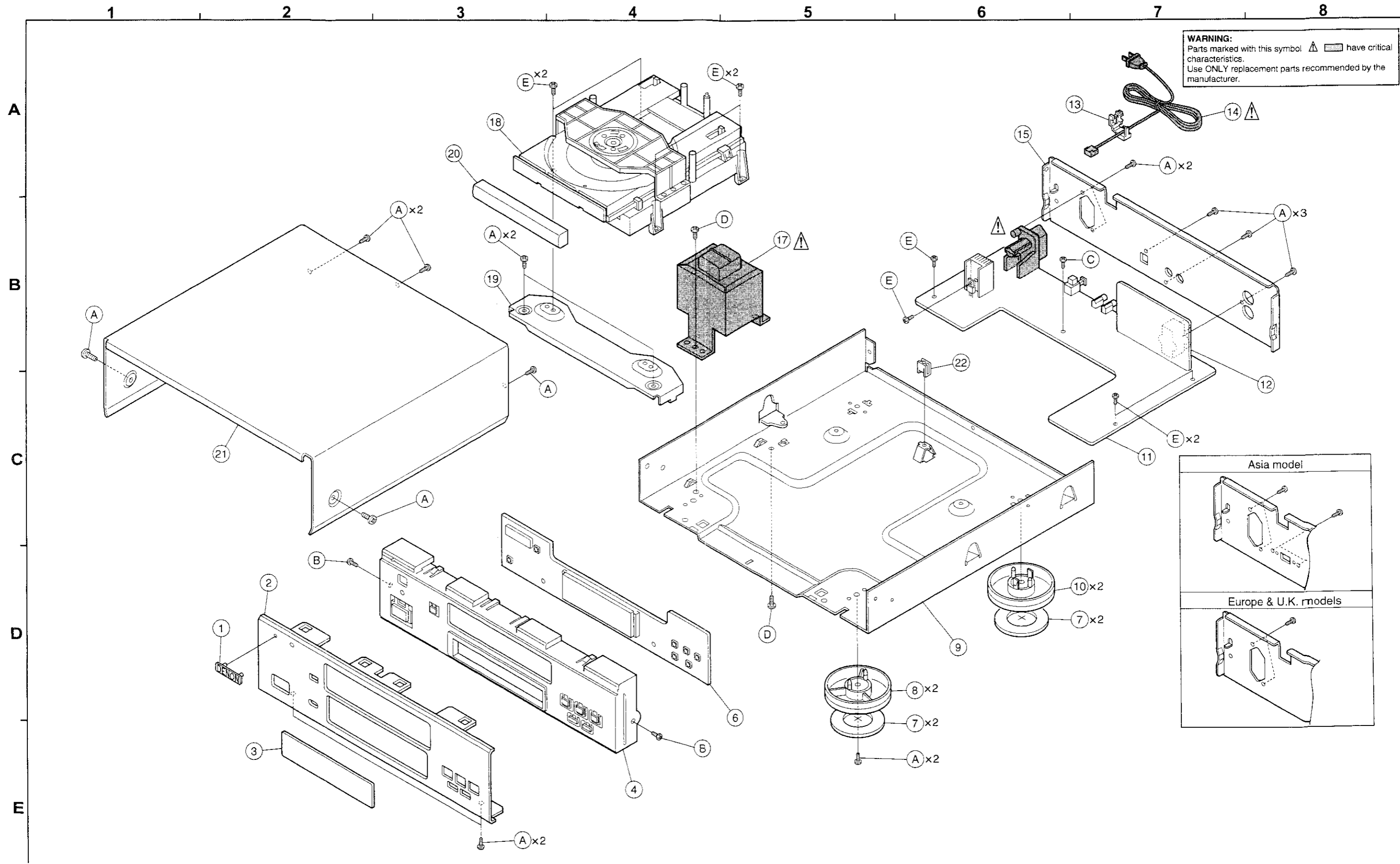



## PARTS LIST OF EXPLODED VIEW

Ref. No.	Part No.	Part Name	Remarks	Q'ty
	960 0138 027	Main P.W.B. unit ass'y	7025HD9805010 Europe & U.K. Models	1
	960 0138 014	Main P.W.B. unit ass'y	7025HD9805040 Asia Model	1
6		Front P.W.B. unit		
11		Main P.W.B. unit		
12		Audio P.W.B. unit		
18-1	960 0127 009	CD RF & drive P.W.B. unit ass'y	7025HD9805011	1
1	960 0115 707	DENON badge	5630210008000	1
2	960 0126 000	Front panel	3067210038010	1
3	960 0126 505	Display window	5077210043020	1
4	960 0126 107	Front frame	3217210011010	1
7	960 0003 505	Foot cushion	4050020075010	4
8	960 0003 408	Foot	4007000061010	2
9	960 0126 301	Main chassis	3200210066000	1
10	960 0115 008	Foot	4000210001000	2
13	960 0135 305	Cord stopper	4380040162010	1
△	960 0032 301	AC cord	L061000410010	1
15	960 0126 220	Back chassis	3207210026010 Europe & U.K. Models	1
15	960 0126 217	Back chassis	3207210026110 Asia Model	1
△	960 0136 304	Power trans.	8200480004010 Europe & U.K. Models	1
△	960 0136 401	Power trans.	8200480004040 Asia Model	1
18	960 0130 203	CD mecha. ass'y	8038000900081	1
19	960 0136 508	Mech. bracket	4010210036000	1
20	960 0126 408	Tray cover	4317210001010	1
21	960 0121 005	Top cover	3000210006100	1
22	960 0003 301	P.W.B. support	4070001601010	1
★	960 0126 709	Caution label	5527067010010	1
★	960 0127 504	20P FPC	L301161200010	1
★	960 0130 106	25P FPC	L301111290010	1
<b>SCREWS</b>				
A	963 0108 604	Screw 3×8 CBTS(B)-B	B020030083B10	16
A	963 0108 604	Screw 3×8 CBTS(B)-B	B020030083B10 for 1SELECT1 Asia Model only	2
B	960 9008 006	Screw 3×8 CFTS(B)-B	B020030083F10	2
C	963 0018 104	Screw 3×17 CBTS(B)-Z	B020030171B10	1
D	960 9003 001	Screw 4×8 CBTS(S)-Z	B020740081B10	2
E	963 0018 007	Screw 3×8 CBTS(B)-Z	B020030081B10	7

## CD PLAYER

## PARTS LIST OF CD MECHANISM UNIT

Ref. No.	Part No.	Part Name	Remarks	Q'ty
<b>LOADER MECHA. SECTION (CD-780MS II)</b>				
1	960 0046 902	Clamper plate	447000406000	1
2	960 0046 106	Flapper	270000036000	1
3	960 0047 202	Magnet core (III)	7600GZ3400L1	1
4	960 0163 306	Clamper	433002004101	1
5	960 0059 504	Guide frame	435002014201	1
6	960 0059 407	Mecha. base	340002002101	1
7	960 0046 407	Rack spring	372000336000	1
8	960 0045 806	Load gear	247000058000	1
9	960 0045 602	Center gear	274000045000	1
10	960 0045 709	Pulley gear	247000046000	1
11	960 0163 403	Tray	460002001102	1
12	960 0045 903	Belt	249000021000	1
13	960 0046 009	Motor pulley	250000008000	1
14	960 0047 105	Motor P.W.B. ass'y	702001087000	1
15	960 0045 408	DC motor	G70000016001	1
16	960 0041 703	Leaf switch	G22000001000	1
17	960 0163 500	5P wire	L000231050010	1
18	960 0163 607	Feed frame	321002010101	1
19	960 0163 704	Switch holder	432000214000	1
20	960 0163 801	6P wire	L00017106280	1
21	960 0163 908	Insulator (green)	124002013501	2
22	960 0164 004	Insulator (red)	124002013502	2
23	960 0164 101	16P flat cable	L30114116001	1
24	960 0046 805	Rubber stopper	438000059000	2
26	960 0173 008	CD RF & drive P.W.B. unit	7028021010020	1
A	960 9000 318	Screw 3 × 10	B020HF6103B1	2
B	960 0164 208	Screw 2.6 × 5	B000HD3051B6	2
C	960 9000 321	Screw 3 × 8 W	1500HZ0780L1	5
D	960 9000 130	Screw 3 × 8	B020HF6083B1	3
W1	9G9 0438 004	Feed mecha. ass'y (KSM-213CCM)	8030040622010	1
<b>TRAVERSE SECTION (KSM-213CCM)</b>				
1	S26 2690 801	Slide shaft		1
7	S88 4837 931	Optical Pick up (KSS-213C)		1
8	S26 2690 701	Gear (A)		1
9	SX2 6258 711	T/T motor chassis ass'y		1
10	SX2 6257 691	Gear motor ass'y		1
11	S16 3967 812	P.W.B. ass'y		1
12	S15 7208 511	Leaf Switch		1
13	S15 6472 211	6P Connector pin		1
14	S76 2125 510	Screw 2 × 3 + P		2

# EXPLODED VIEW OF CD MECHANISM UNIT

1 2 3 4 5 6 7 8

LOADER

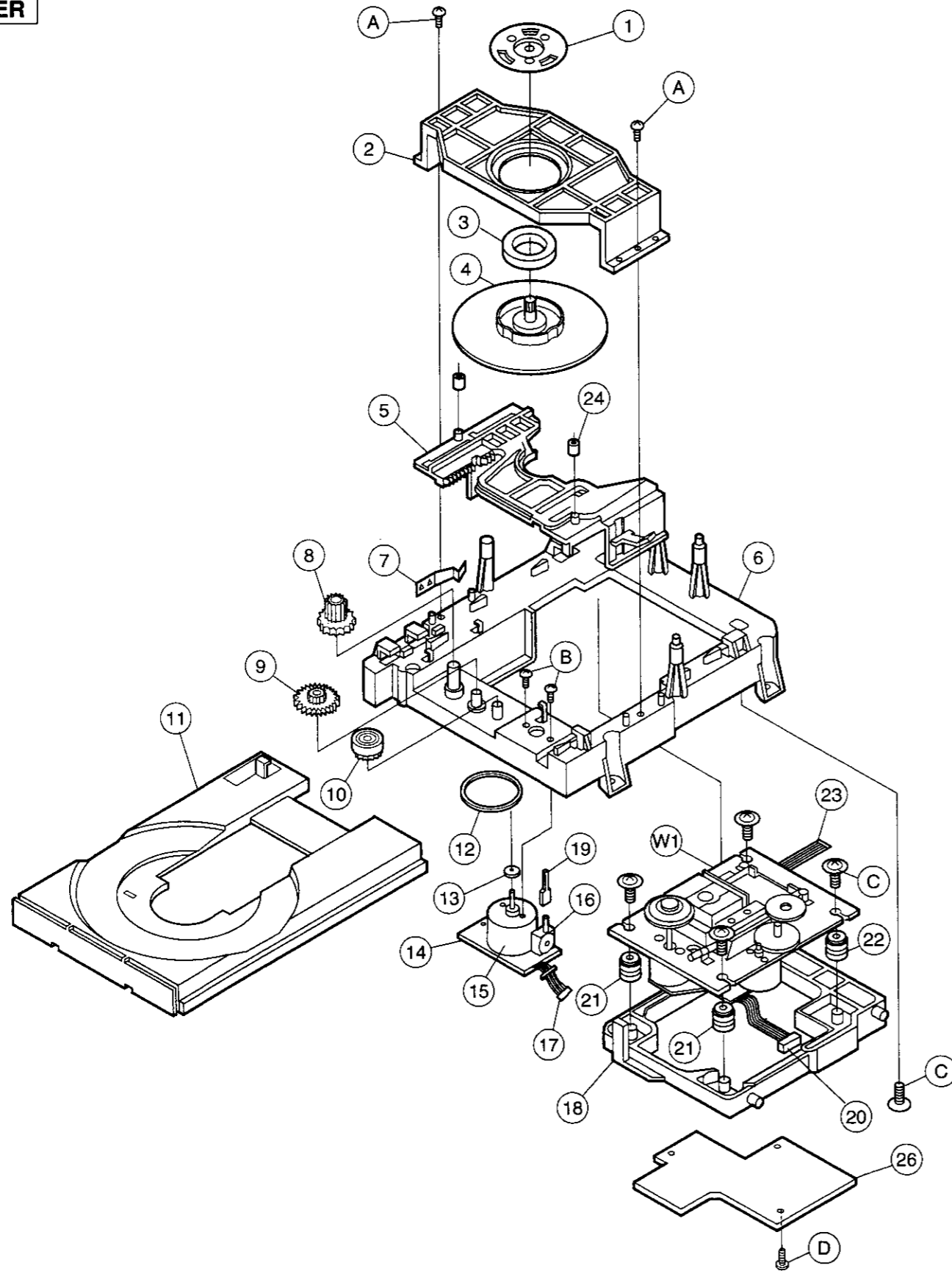

TRAVERSE

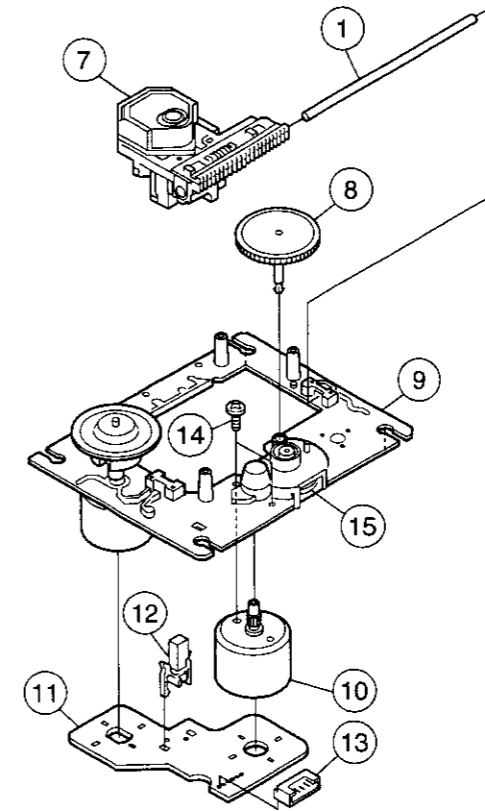

A

B

C

D

E

EXPLODED VIEW OF CD MECHANISM UNIT

1 2 3 4 5 6 7 8

LOADER

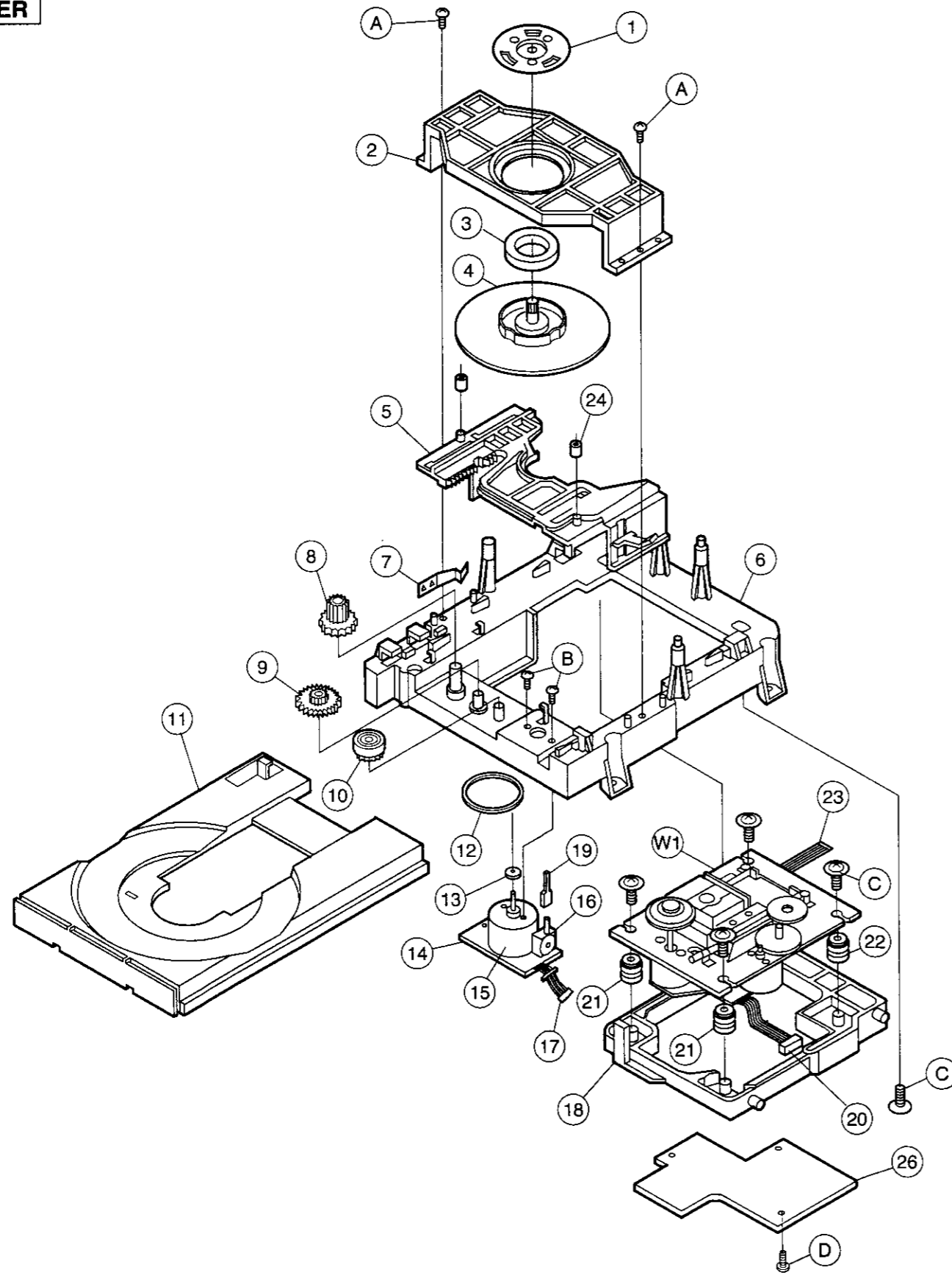

TRAVERSE

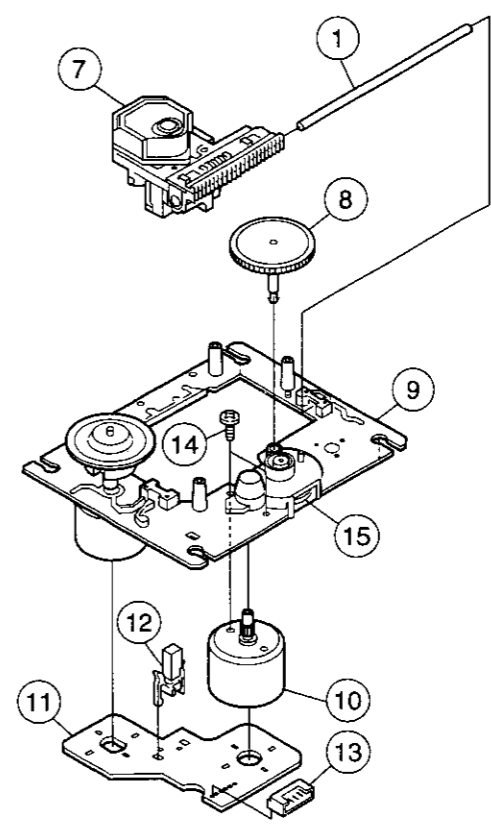

A  
B  
C  
D  
E

CD PLAYER

MEMO:

SCHEMATIC DIAGRAM

1

2

3

4

5

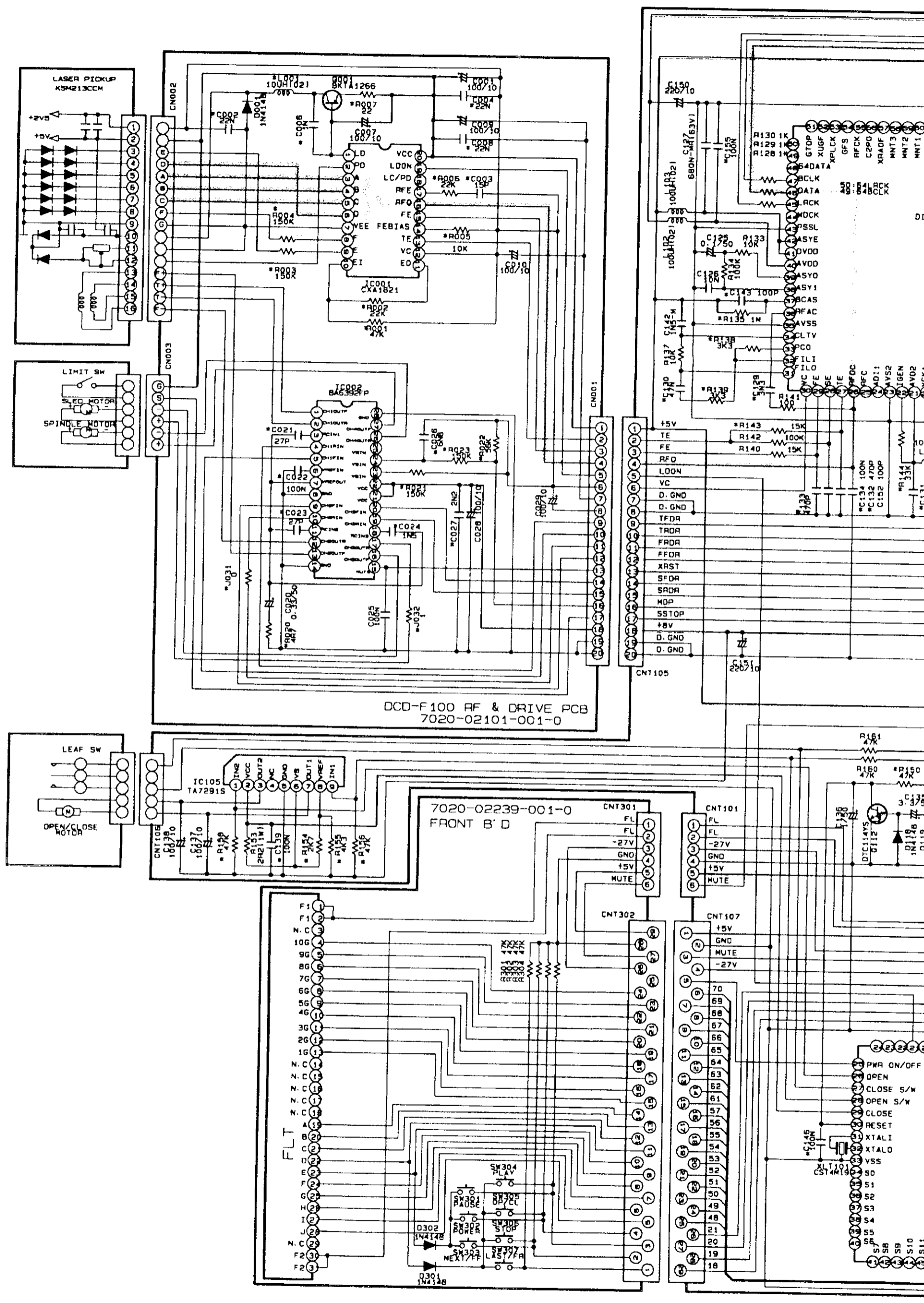

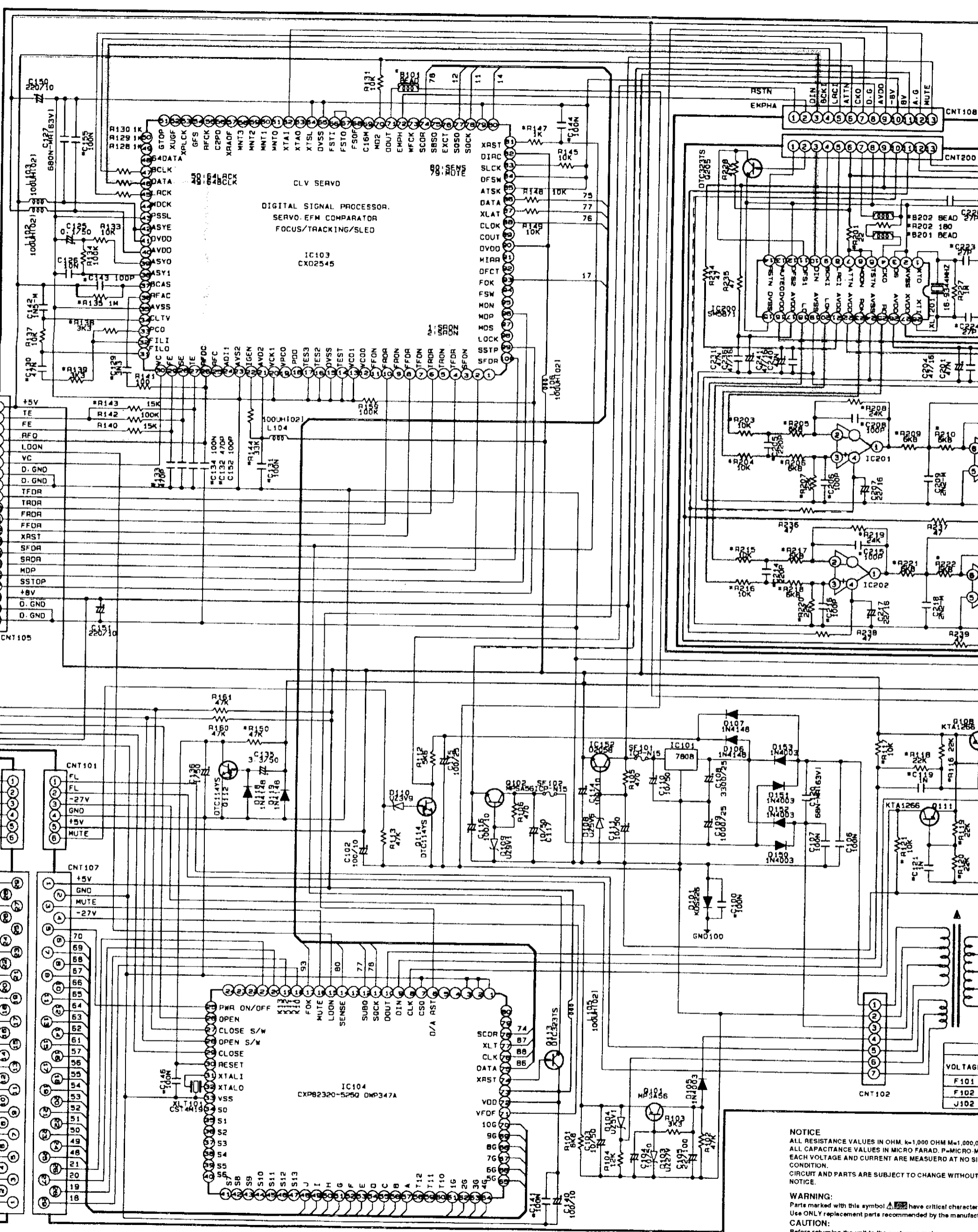

**NOTICE**  
 ALL RESISTANCE VALUES IN OHM. K=1,000 OHM M=1,000,000 OHM  
 ALL CAPACITANCE VALUES IN MICRO FARAD. P-MICRO-MICRO FARAD  
 EACH VOLTAGE AND CURRENT ARE MEASURED AT NO SIGNAL INPUT  
 CONDITION.  
 CIRCUIT AND PARTS ARE SUBJECT TO CHANGE WITHOUT PRIOR NOTICE.

**WARNING:**  
 Parts marked with this symbol  $\Delta$  have critical characteristics.  
 Use ONLY replacement parts recommended by the manufacturer.

**CAUTION:**  
 Before returning the unit to the customer, make sure you make either  
 leakage current check or (2) a line to chassis resistance check. If the  
 current exceeds 0.5 millamps, or if the resistance from chassis to either  
 of the power card is less than 460 kohms, the unit is defective.

**WARNING:**  
 DO NOT return the unit to the customer until the problem is located and  
 corrected.

VOLTAGE	115V/50/60	T1AL/	E
F101	T1AL/		
J102	T1AL/		
			NO

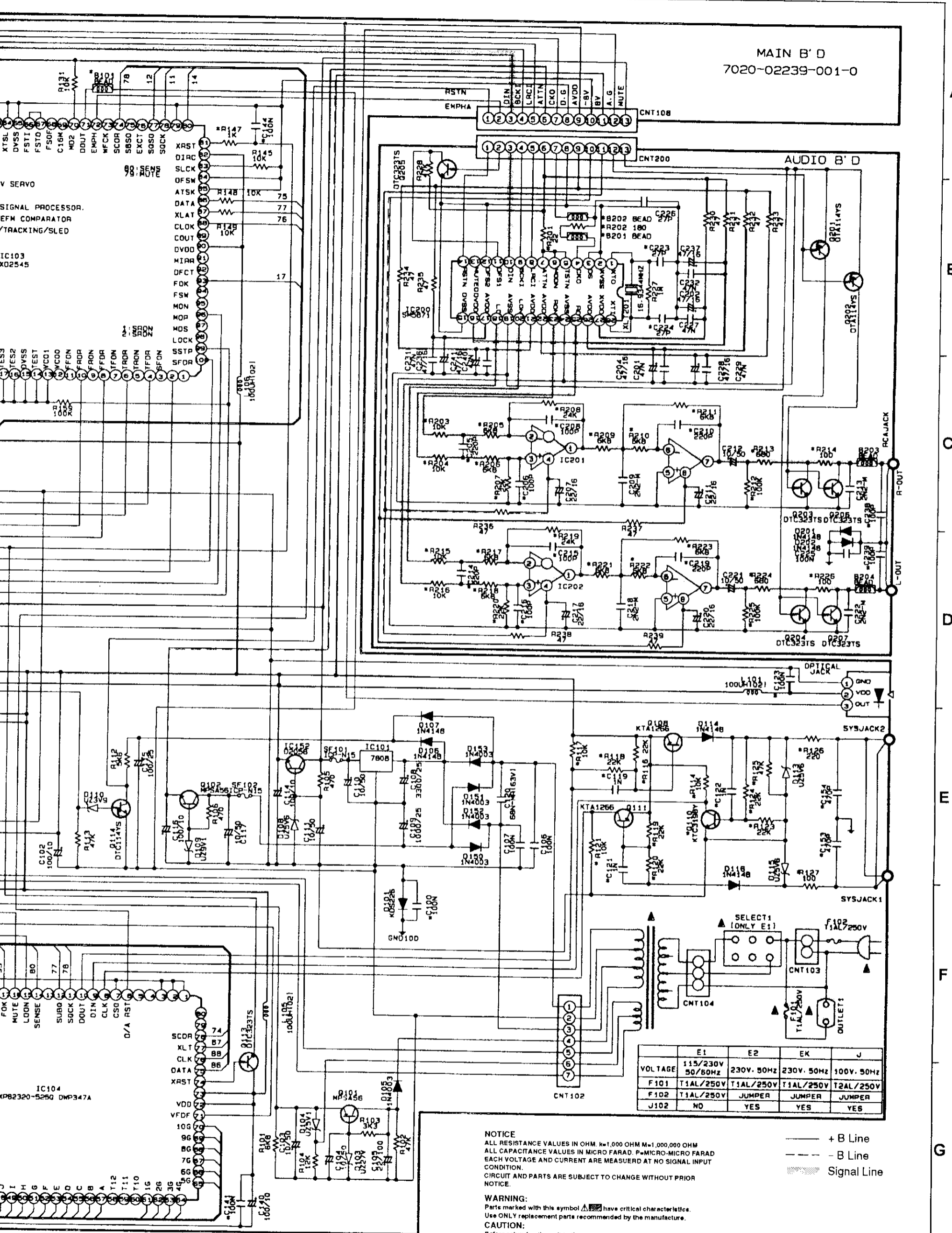

MAIN B'D  
7020-02239-001-0

	E1	E2	EK	J
VOLTAGE	115/230V 50/60Hz	230V, 50Hz	230V, 50Hz	100V, 50Hz
F101	T1A1/250V	T1A1/250V	T1A1/250V	T2A1/250V
F102	T1A1/250V	JUMPER	JUMPER	JUMPER
J102	NO	YES	YES	YES

**NOTICE**  
ALL RESISTANCE VALUES IN OHM, k=1,000 OHM M=1,000,000 OHM  
ALL CAPACITANCE VALUES IN MICRO FARAD, P=MICRO-MICRO FARAD  
EACH VOLTAGE AND CURRENT ARE MEASURED AT NO SIGNAL INPUT  
CONDITION.  
CIRCUIT AND PARTS ARE SUBJECT TO CHANGE WITHOUT PRIOR  
NOTICE.

**WARNING:**  
Parts marked with this symbol have critical characteristics.  
Use ONLY replacement parts recommended by the manufacturer.

**CAUTION:**  
Before returning the unit to the customer, make sure you make either (1) a  
leakage current check or (2) a line to chassis resistance check. If the leakage  
current exceeds 0.5 milliamperes, or if the resistance from chassis to either side  
of the power cord is less than 460 kohms, the unit is defective.

**WARNING:**  
DO NOT return the unit to the customer until the problem is located and  
corrected.

— + B Line  
- - - - B Line  
Signal Line

**SCHEMATIC DIAGRAM  
MAIN P.W.B. UNIT**

A  
B  
C  
D  
E  
F  
G  
H





BLOCK DIAGRAM

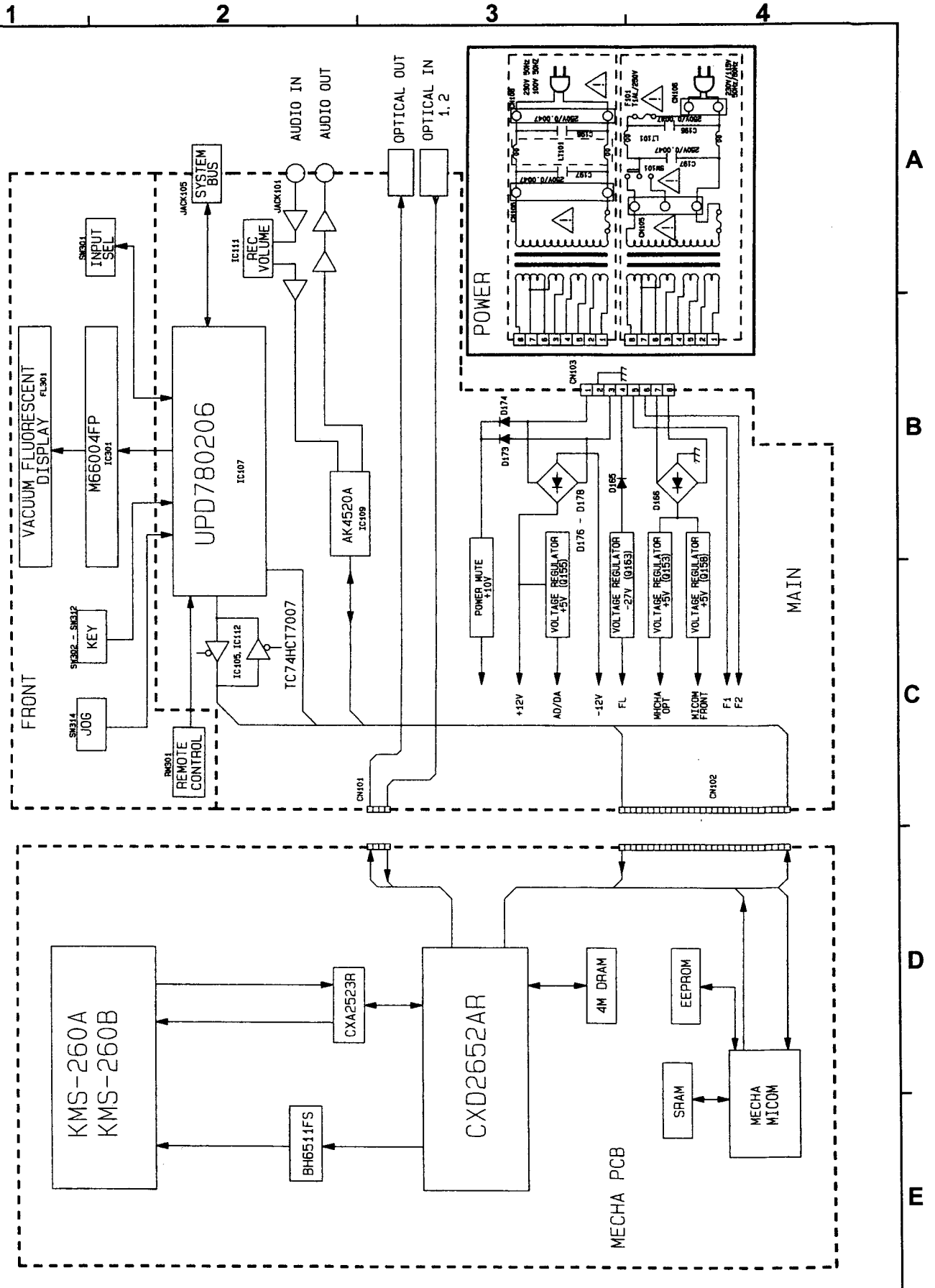

A

B

C

D

E

**MD RECORDER**

**DISASSEMBLY**

(Follow the procedure below in reverse order when reassembling)

**1. Top Cover & Front Panel**

- (1) Remove 5 screws ① fixing the Top Cover.
- (2) Detach the Top Cover as shown in the arrow direction.

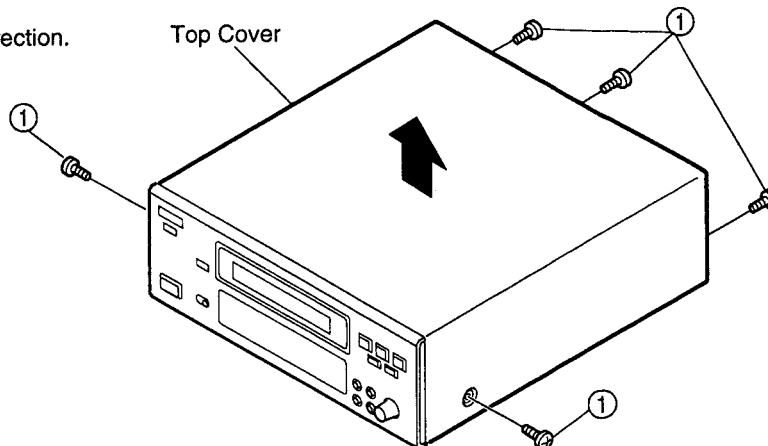

- (3) Remove 4 screws ② on the bottom and both sides.
- (4) Disconnect 19P FPC from its connector base.
- (5) Pull the Front Panel in the arrow direction with releasing Hooks on the Front Frame from the Chassis, and it comes off with the Front Frame.

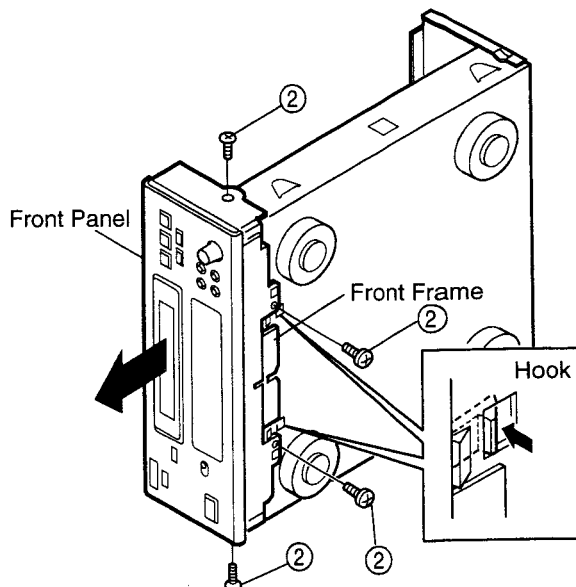

**2. P.W.B. on Panel**

**Front P.W.B.**

- (1) Pull out the Control Knob to the arrow direction, and remove 3 screws ③.
- (2) Detach the Front P.W.B. with releasing 4 Hooks.

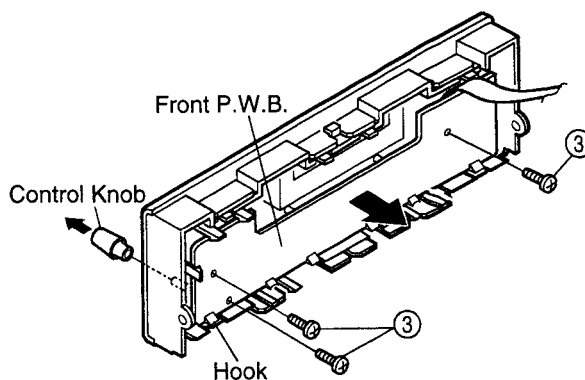

## MD RECORDER

### 3. Back Chassis

- (1) Take off the Cord Stopper from the Back Chassis.
- (2) Remove 7 screws (4), and detach the Back Chassis to the arrow direction.

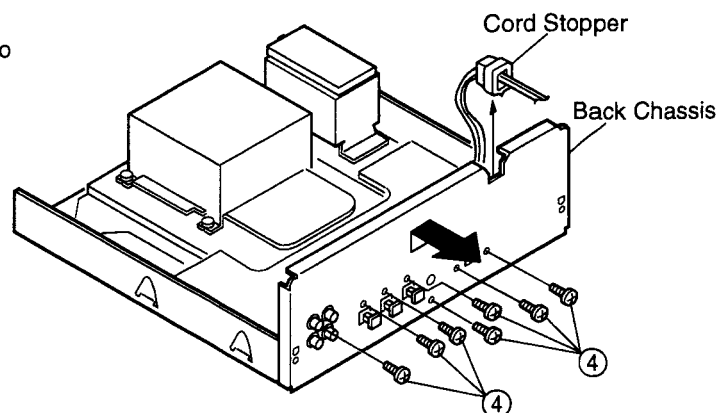

### 4. MD Mecha.

- (1) Remove 4 screws (5) fixing the MD Mecha.
- (2) Remove 1 screw (6) and 1P wire.
- (3) Disconnect 24P FPC and 4P Connector Cord from their connector bases.
- (4) Detach the MD Mecha. to the arrow direction.

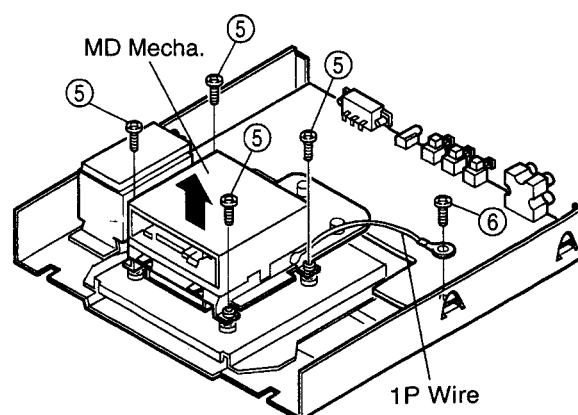

### Main P.W.B.

- (5) Remove 3 screws (7), and detach the Main P.W.B. to the arrow direction.

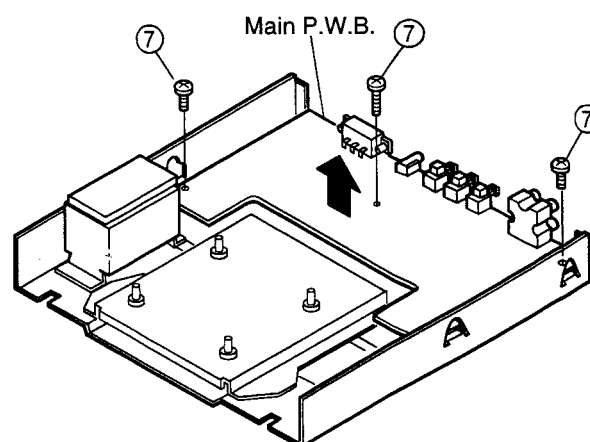

**MD RECORDER**

**DISASSEMBLY OF MD MECHA.**

● **Main Block Disassembly/Reassembly**

The MD Mecha. can be separated into Base Mechanism, Mode Switching Mechanism, Disc Loading Mechanism, and Control Unit.

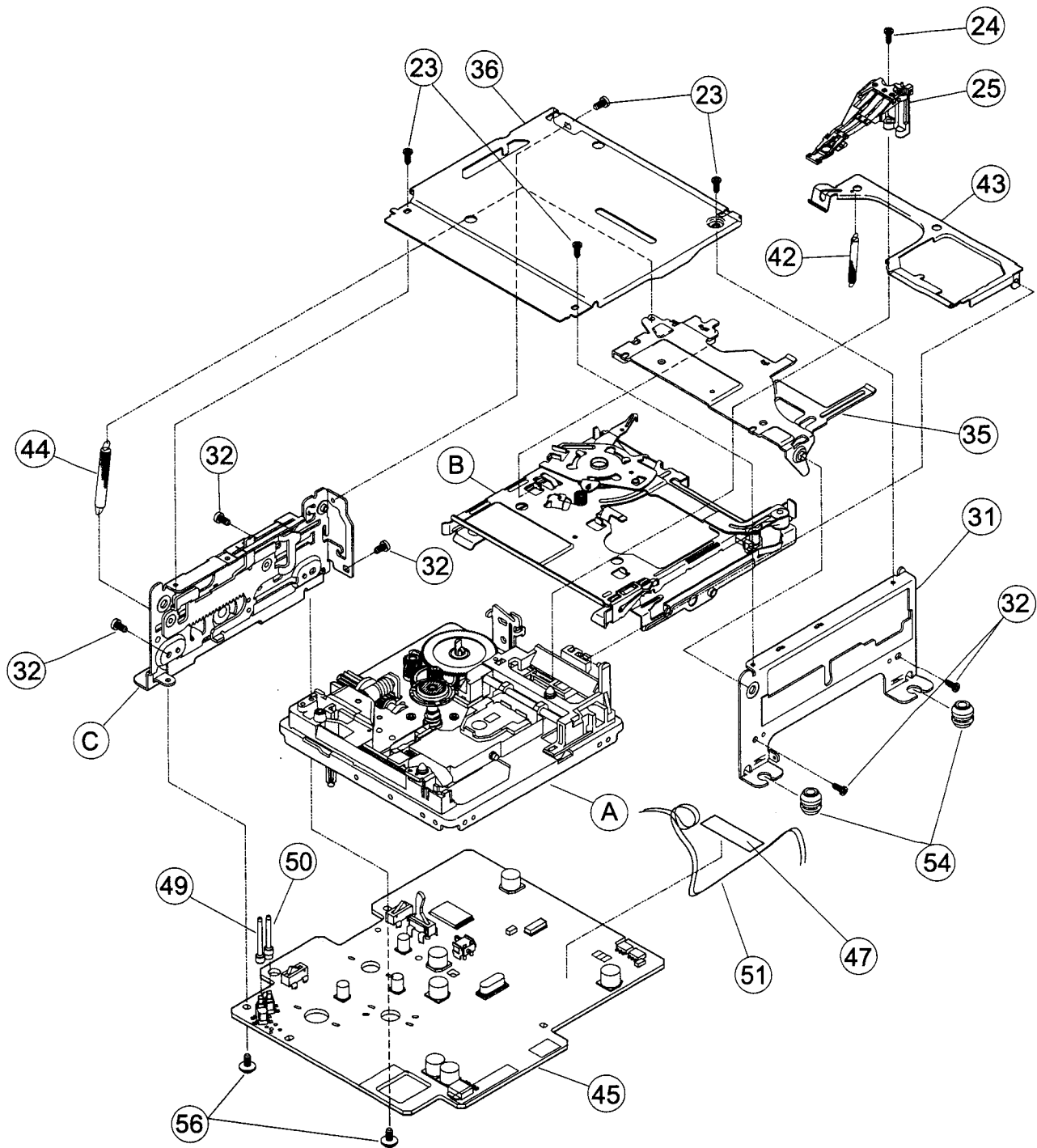

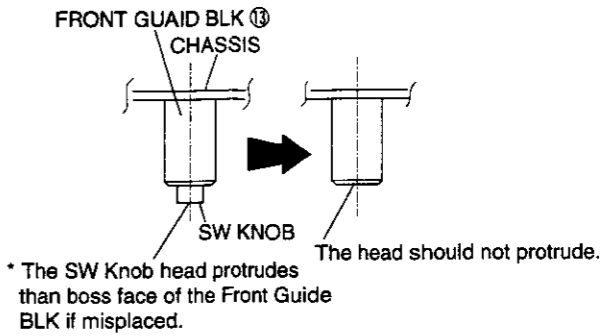
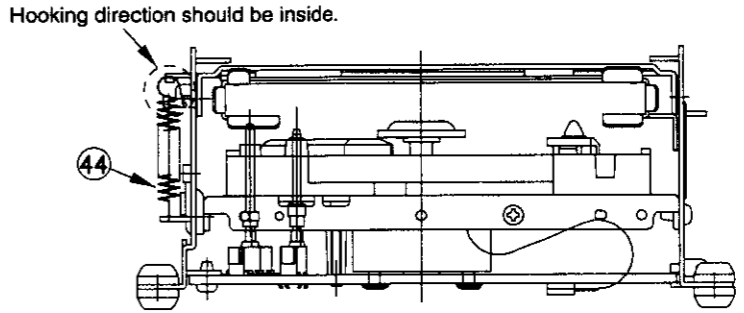
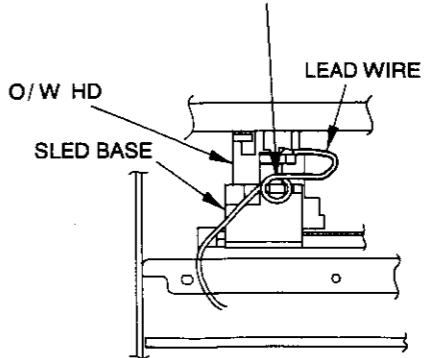
No.	Disassembling Parts	Disassembling Step	Caution
	④⑤ Control Unit ④⑨ SW Knob (L) ⑤⑩ SW Knob (S)	(1) Peel off the Tape ④⑦ for fixing O/W HD Lead Wire. (2) Disconnect the O/W HD Lead Wire ⑤① from the Control Unit ④⑤. (3) Remove solder from 6 motor terminals. (4) Short-circuit the short land of the P/U FFC ④⑧ with solder. (5) Disconnect the P/U FFC ④⑧ from the Control Unit ④⑤. (6) Detach the Control Unit ④⑤ by removing 2 screws ⑤⑥. (7) Remove the SW knob (L) ④⑨ and (S) ⑤⑩.	<ul style="list-style-type: none"> <li>Don't misplace the SW Knob (L) with (S) when reassembling.</li> </ul> 
	③⑥ Top Plate ②⑤ O/W HD ④④ Holder A/SPG ③① Side BLK (R) ⑤④ Insulator ⑧ Disc Loading Mechanism ③⑤ Holder Arm	(1) Detach the Top Plate ③⑥ by removing 4 screws ②③. (2) Detach the O/W HD ②⑤ by removing screw ②④. (3) Remove Holder A/SPG ④④. (4) Detach the Side BLK (R) ③① by removing 2 screws ③②. (5) Remove 2 Insulators ⑤④. (6) Remove the Holder Arm ③⑤. (7) Detach the Disc Loading Mechanism ⑧.	<ul style="list-style-type: none"> <li>Apply screw-lock on the tip of the screw ②④ after assembling the O/W HD.</li> <li>Coil the Lead Wire around the Sled Base ①⑦ by 1-turn after assembling the O/W HD. Also, twist the Lead Wire more than 2-turn.</li> </ul>  <ul style="list-style-type: none"> <li>When assembling the Holder A/SPG ④④, its hooking direction should be as follows.</li> </ul> 
	①③ Mode Switching Mechanism ④② Lifter SPG ④③ HD Lifter	(1) Remove the Lifter SPG ④②. (2) Detach the Mode Switching Mechanism ①③ by removing 3 screws ③②. (3) Remove the HD Lifter ④③.	<ul style="list-style-type: none"> <li>Be careful not to deform the HD Lifter.</li> </ul>

## Assembly

- Follow the procedure in reverse order when reassembling.
- For screw tightening torque and grease/screw-lock apply positions, see Fig. Be careful not to strip the screws when tightening.
- Pay attention to the indication in Caution when reassembling.
- Take necessary anti-static measures when disassembling/reassembling.

Screw-lock: TB1401B ThreeBond  
 Grease: MOLYKOTE YM-103 DOW CORNING

**MD RECORDER**

**● Base Mechanism Disassembly/Reassembly**

The Base Mechanism can be separated into Spindle MTR Ass'y, Sled MTR Ass'y, and P/U Ass'y

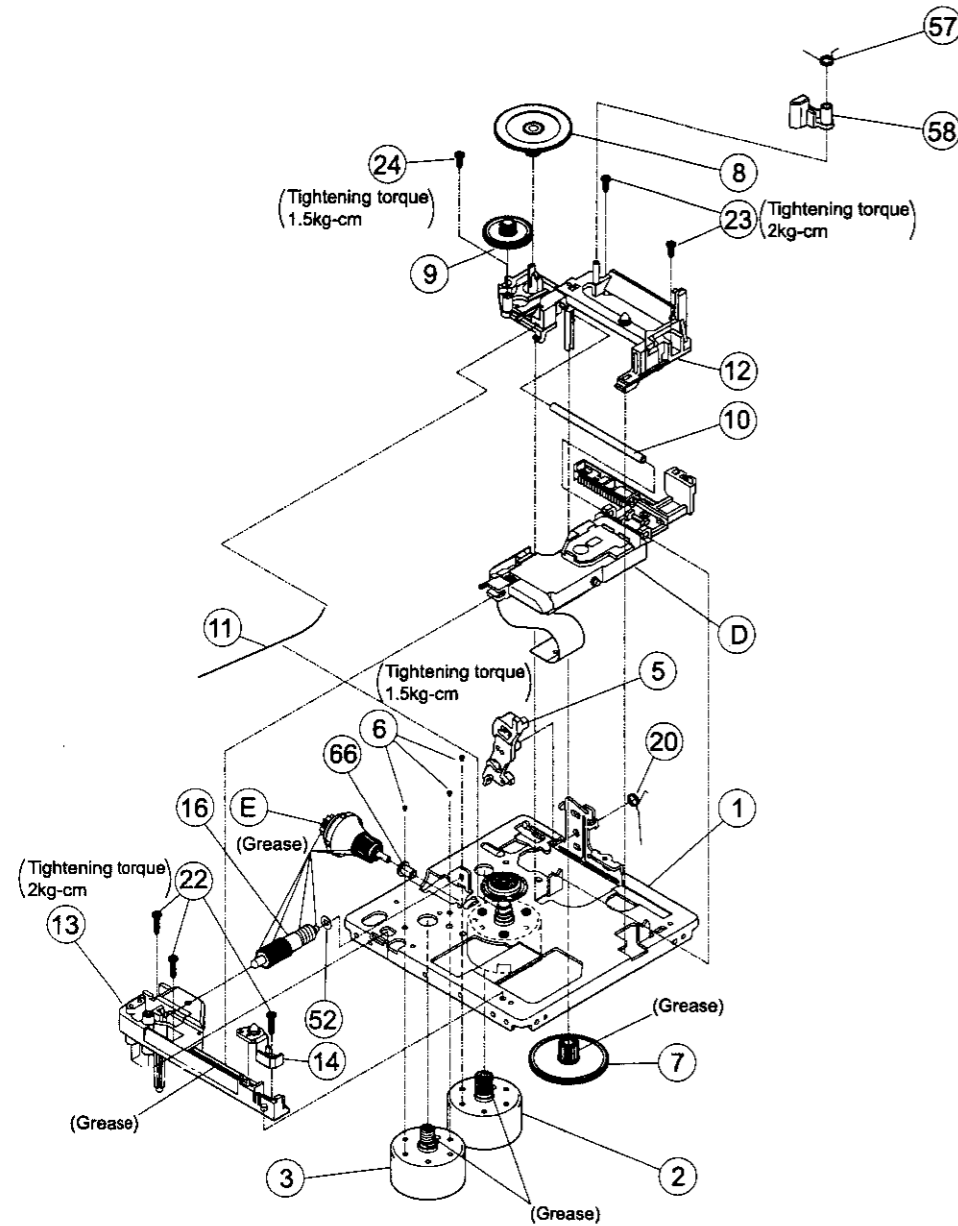

**Assembly**

- Follow the procedure in reverse order when reassembling.
- For screw tightening torque and grease/screw-lock apply positions, see Fig. Be careful not to strip the screws when tightening.
- Pay attention to the indication in Caution when reassembling.
- Take necessary anti-static measures when disassembling/reassembling.

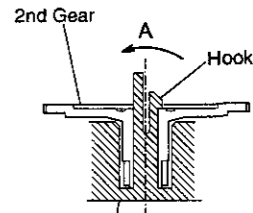
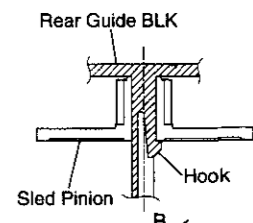
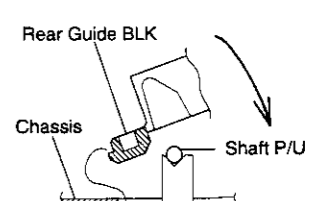
No.	Disassembling Parts	Disassembling Step	Caution
⑧	2nd Gear	(1) Remove the Holder Stopper 58, SPG 59.	<ul style="list-style-type: none"> <li>• Remove the 2nd Gear ⑧ with pressing the hook in the A direction.</li> <li>• Remove the Sled Pinion ⑦ with pressing the hook in the B direction.</li> <li>• When assembling the Rear Guide BLK, hang 2 hooks to the Chassis.</li> <li>• When disassembling/reassembling the Sled or LDG MTR Ass'y with Chassis, be careful not to make any scratch to the gear combined.</li> </ul>   
⑨	1st Gear	(2) Remove the 2nd Gear ⑧.	
⑦	Sled Pinion	(3) Remove the 1st Gear ⑨.	
⑫	Rear Guide	(4) Remove the Sled Pinion ⑦.	
⑩	Shaft P/U	(5) Detach the Rear Guide BLK ⑫ by removing 2 screws ⑳ and 1 screws ㉔.	
⑪	Spindle Stabilizer	(6) Remove the Shaft P/U ⑩, Spindle Stabilizer ⑪.	
⑩	P/U Ass'y	(7) Remove the P/U Ass'y ⑩.	
⑬	Front Guide	(8) Detach the Front Guide ⑬ and Locator ⑭ by removing 3 screws ㉒.	
⑭	Locator	(9) Remove 2nd Worm ⑯, Washer ㉕, then LDG Clutch Ass'y ㉖ and Bush ㉗.	
⑧	2nd Worm	(10) Remove the Sled MTR Ass'y ②, LDG MTR Ass'y ③.	
⑯	LDG Pinion	(11) Remove the SW Lever SPG ㉘.	
②	Sled MTR Ass'y	(12) Remove the SW Lever ⑤.	
③	LDG MTR Ass'y		
㉘	SW Lever SPG		
⑤	SW Lever		

Screw-lock: TB1401B ThreeBond  
Grease: MOLYKOTE YM-103 DOW CORNING

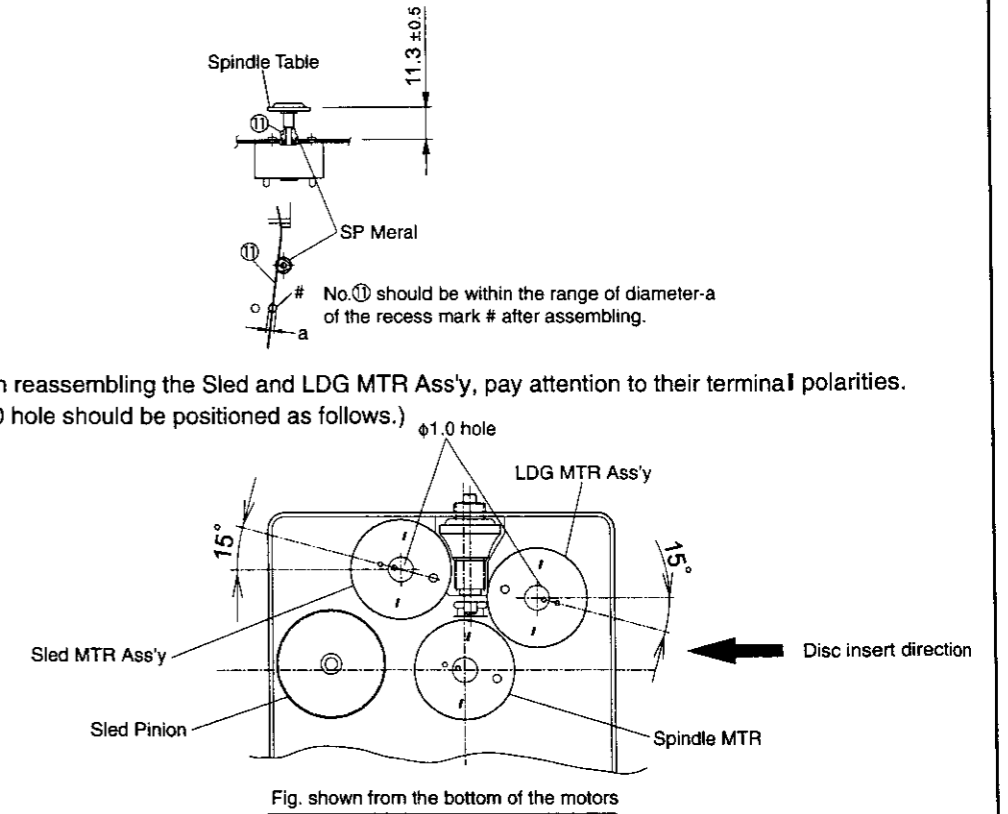

# CONFIRMING THE SERVO

## Service Mode

### Setting Service Mode

While simultaneous pushing PLAY button and STOP button, plug the AC cord to wall socket.

The display shows "TEST MODE".

Turn ◀◀-▶▶ knob to select Service Mode.

Laser power adjustment  
LDPWR Adjust Page 66

Traverse auto adjustment  
AUTO EIAF

Traverse adjustment  
EFBAL Adjust Page 68

Focus bias adjustment  
FBIAS Adjust Page 69

Playback check mode  
C\_Play Mode

Rec. Play check mode  
C\_REC Mode

Nonvolatile memory mode  
EEPROM

**Note:**  
• If you want to cancel the Service Mode, turn off the POWER Switch.

Don't perform this adjustment in normal state.

This mode is not used in service. If you have this mode while servicing, cancel this mode immediately by pressing the STOP button.

The mode switches every time by turning the ◀◀-▶▶ knob.

### Key Functions

Key name	Function
◀◀-▶▶ Knob	Settlement of Parameter, Mode.
ENTER	Proceed forward. Settled. (Push ◀◀-▶▶ )
STOP	Back to previous. Cancelled.
PLAY	Ejecting a disk.

**Note:**  
• In Service Mode, the function of the erase protection knob is not detected. If you press REC key, in Traverse mode or Continuous recording mode, your recorded disk may be erased. Pay attention to your disk used for it.

### Notice of adjustment

When replacing the following parts, adjust and check the items marked with ○.

Adjustment	Optical Pick-up	Mechanism P.W. Board		
		U102	D1	U1, 21, 101
1. Temperature compensation offset adjustment	×	○	○	○
2. Laser power adjustment	○	×	×	○
3. Traverse check	○	○	×	○
4. Focus bias adjustment	○	○	×	○
5. Error rate check	○	○	×	○



**MD RECORDER**

Creating the MO disk of continuous recording

• This disk is used for the focus adjustment bias and the error rate check.  
The following describes how to create the MO disk of continuous recording.

1. Load a MO disk (blank disk) sold in the market.

2. Turn **◀◀◀▶▶▶** knob to display [C\_REC Mode].

3. Press ENTER button to display [C\_REC IN].

4. Turn **◀◀◀▶▶▶** knob to display [C\_REC MID] and push ENTER button.  
Recording will be started. (Display starts from [201:01])

5. Recording will be stop about 3 minutes later. (Display shows [378:01])

6. Press PLAY button to eject the MO disk.

**Note:**

• Do not apply any vibration while performing continuous recording.

Laser Power adjustment  
LDPWR Adjust

**Note:**

• Don't look the emit lighting of the laser diode from just above to prevent you from the loss of eyesight.  
• Pay special attention to handle the laser diode of the optical pick-up, since it is easy to have an electrostatic break.

Connection

• Connect the digital voltmeter to TL1 (IOP) and TL2 (I+3V).

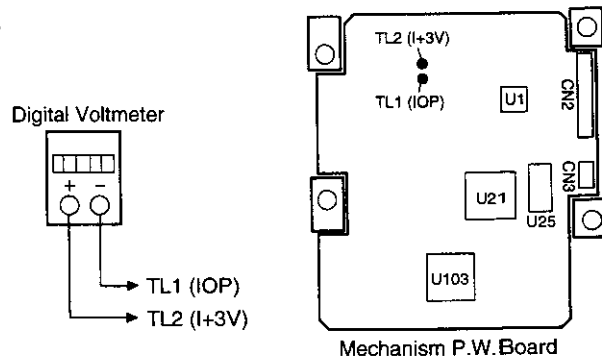

Adjustment Method

1. Set the laser power meter on the object lens of the optical pick-up.  
(The optical pick-up is moved by pressing the manual search key.)

2. Turn **◀◀◀▶▶▶** knob to display [LDPWR Adjust].

3. Press ENTER button to display [LD\$\*\*=+3.4mW]. (\*\*: Adjust setting value)

4. Turn  $\leftarrow \rightarrow$  knob so that the reading of the laser power meter becomes 3.3 to 3.5mW.

5. Press ENTER button to display [LD\$\*\*=6.8mW]. : Writing laser power adjustment

6. Check that the readings of the laser power meter and the digital voltmeter are within specified values below.

### Specification

Reading of the laser power meter:  $6.8 \pm 0.3\text{mW}$

Reading of the digital voltmeter:  $\pm 10\%$  of indicated value on the Optical Pick-up.

(Indication of the optical pick-up)

KMS260A  
X X X X  
D 0 5 2 6

The value with handwriting is lop value.  
The value indicated on the label is rounded off. In case of 52.6mA, the value 52.6 is shown.

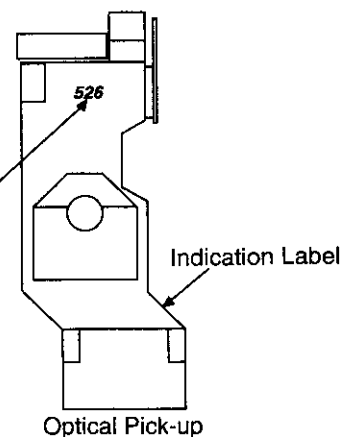

In this example,  $\text{lop} = 52.6\text{mA}$

$\text{lop}(\text{mA}) = \text{The reading}(\text{mV}) \text{ of digital voltmeter} \div 1 (\text{ohm})$

7. Press ENTER button to display [LD\$\*\*=0.87mW].

Adjust  $\leftarrow \rightarrow$  knob and check that the reading of the laser power meter is  $0.87 \pm 0.1\text{mW}$ .

8. Press ENTER button to display [LD\$\*\*=0.68mW].

Adjust  $\leftarrow \rightarrow$  knob and check that the reading of the laser power meter is  $0.68 \pm 0.1\text{mW}$ .

9. Press ENTER button to display [LDPWR Adjust], and stop the laser emit lighting.

### Note:

- Laser power adjustment and check should be performed at the ambient temperature  $22^\circ\text{C} \pm 2^\circ\text{C}$  and humidity  $50\% \pm 5\%$ . (If the ambient condition differs, the deviation values should be corrected.)

**MD RECORDER**

Traverse Adjustment  
EFBAL Adjust

Connection

- Connect the oscilloscope to TL7 (TEO) and TL3 (VC)

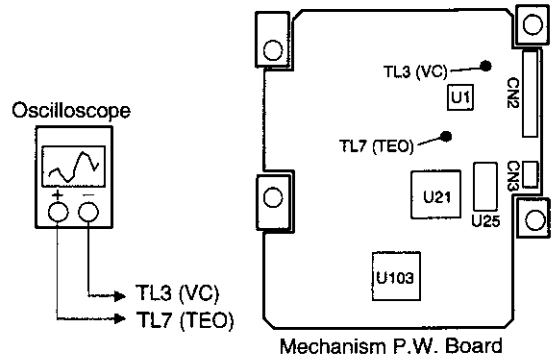

Adjustment Method

1. Load a MO disk sold in the market.

2. Turn  $\lll\text{---}\ggg$  knob to display [EFBAL Adjust].

3. Press ENTER button to display [EFBAL MO\_Writ].

4. Press ENTER button to display [EFB=\$\*\*MO\_W]. (\*\*=Adjust setting value)  
Adjust  $\lll\text{---}\ggg$  knob so that the waveform on the oscilloscope becomes A=B.

(Traverse waveform)

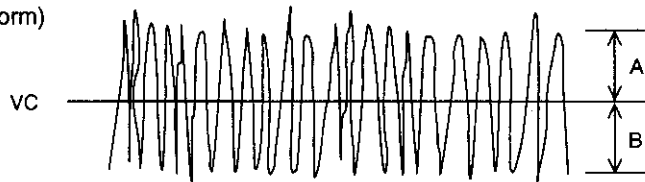

5. Press ENTER button to display [EFB=\$\*\*MO\_G]. (MO groove read power traverse adjustment)

6. Turn  $\lll\text{---}\ggg$  knob so that the waveform on the oscilloscope becomes A=B.  
(It should be adjusted closest to A=B.)

7. Press ENTER button to display [EFBAL MO-Pit].

8. Press ENTER button to display [EFB=\$\*\*MO\_P].  
The optical pick-up moves to the pit portion area automatically, and it is controlled by the servo.

9. Turn  $\lll\text{---}\ggg$  knob so that the waveform on the oscilloscope becomes A=B.  
(It should be adjusted closest to A=B.)

10. Press ENTER button to display [EFBAL CD], then the rotation of the disk automatically stops.

11. Press PLAY button to eject the MO disk.

12. Load the test disk TDYS-1.

13. Press ENTER button to be controlled by the servo. Display shows [FEB=\$\*\*CD].



14. Turn the  $\llcorner\llcorner\llcorner\llcorner\llcorner\llcorner$  knob so that the waveform on the oscilloscope becomes A=B.  
(It should adjusted closest to A=B.)

15. Press ENTER button to display [EFBAL Adjust].

16. Press PLAY button to eject the test disk TDYS-1.

**Note:**

- If the recorded disk is used for this adjustment, the data is erased when writing into the MO disk.
- If the traverse waveform is difficult to see, it becomes better by connecting the filter as shown below.

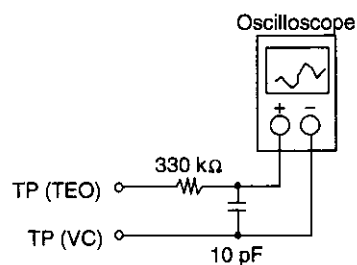

**Focus Bias Adjustment  
FBIAS Adjust**

**Adjustment Method**

1. Load the continuous recorded disk (Refer to "Creating the MO disk of continuous recording").

2. Turn  $\llcorner\llcorner\llcorner\llcorner\llcorner\llcorner$  knob to display [C\_Play Mode].

3. Press ENTER and turn  $\llcorner\llcorner\llcorner\llcorner\llcorner\llcorner$  knob to display [C\_Play MID].

4. Press ENTER button, and after displaying [201= \_c1= \_], push STOP button.

5. Turn  $\llcorner\llcorner\llcorner\llcorner\llcorner\llcorner$  button to display [FBIAS Adjust].

6. Press ENTER button to display [c1=\*\*\* a=\$\*\*].

The first 3 digit numerals show C1 error rate, the numerals after [a=] show the amount of focus bias.

7. Turn  $\llcorner\llcorner\llcorner\llcorner\llcorner\llcorner$  knob clockwise to find the amount of focus bias which has 220 of C1 error rate.

8. Press ENTER button to display [c1=\*\*\* b=\$\*\*].

9. Turn  $\llcorner\llcorner\llcorner\llcorner\llcorner\llcorner$  knob counter-clockwise to find the amount of focus bias which has 220 of C1 error rate.

10. Press PLAY/PAUSE button to display [c1=\*\*\* c=\$\*\*].

11. At that time, check that the C1 error rate is less than 50, then press ENTER button.

## MD RECORDER

12. Press PLAY button to eject the continuous recorded disk.

**Note:**

- The relation between C1 error and the amount of focus bias is shown in the figure below. Find the point a and b in the figure below after adjusting the process described above. The best focus point c can be obtained by calculating automatically from the points a, b.
- Adjust the C1 error rate by reading the average value since it has fluctuation.

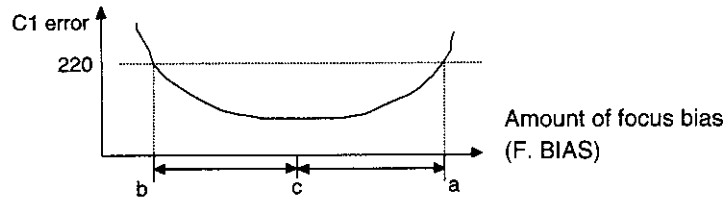

## Checking Error Rate

## Checking CD error rate

## Check Method

1. Load the test disk TDYS-1.

2. Turn  $\llcorner\llcorner\llcorner\llcorner\llcorner\llcorner\llcorner\llcorner$  knob to display [C\_Play Mode].

3. Press ENTER to display [C\_Play IN], and turn  $\llcorner\llcorner\llcorner\llcorner\llcorner\llcorner\llcorner\llcorner$  knob next to display [C\_Play MID], then press ENTER again to display [201:01 c1=\*\*\*].

4. Check that the C1 error rate is less than 20. (\*\*\*:c1 error rate)

5. Press STOP button to stop playing-back, and press PLAY button to eject the test disk.

## Checking MO error rate

## Check Method

1. Load the continuous recorded disk.

2. Turn  $\llcorner\llcorner\llcorner\llcorner\llcorner\llcorner\llcorner\llcorner$  knob to display [C\_Play Mode].

3. Press ENTER to display [C\_Play IN], and turn  $\llcorner\llcorner\llcorner\llcorner\llcorner\llcorner\llcorner\llcorner$  knob next to display [C\_Play MID], then press ENTER again to display [201:01 c1=\*\*\*].

4. Check that the C1 error rate is less than 20. (\*\*\*:c1 error rate)

5. Press STOP button to stop playing-back, and press PLAY to eject the continuous recorded disk.

SEMICONDUCTORS

μPD780206GF (IC107)

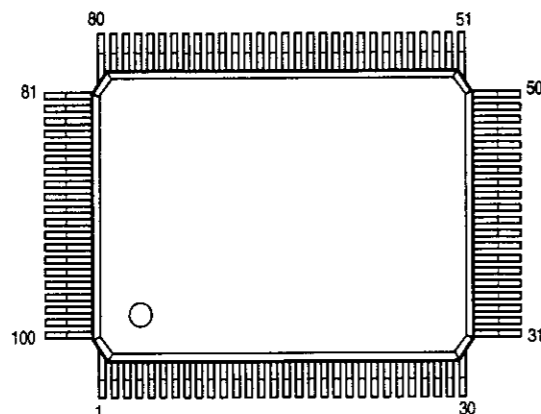

μPD780206GF Terminal Function

Pin No.	Pin Name	Symbol	I/O	Rst	Ini	Act	Ext	Function
1	Vdd	Vdd	—	—	—	—	—	Power supply (+5V)
2	P37	E_VOL_CLK	O	HZ	L	—	P.D	Clock signal output for E. VOL control
3	P36/BUZ	E_VOL_EN	O	HZ	L	—	P.D	Enable signal output for E. VOL control
4	P35/PCL	E_VOL_DAT	O	HZ	L	—	P.D	Data signal output for E. VOL control
5	P34/TI2	NC	I	HZ	L	—	—	Open (not used)
6	P33/TI1	NC	I	HZ	L	—	—	Open (not used)
7	P32/TO2	NC	I	HZ	L	—	—	Open (not used)
8	P31/TO1	NC	I	HZ	L	—	—	Open (not used)
9	P30/TO0	NC	I	HZ	L	—	—	Open (not used)
10	RESET	RESET	I	HZ	H	L	P.UP	Reset signal input
11	X2	X2	—	—	—	—	—	X'tal connect terminal
12	X1	X1	I	—	—	—	—	X'tal connect terminal
13	IC(Vpp)	IC(Vpp)	—	—	—	—	—	GND
14	XT2	XT2	—	—	—	—	—	Open (not used)
15	P04/XT1	NC	I	HZ	L	—	—	Open (not used)
16	Vdd	Vdd	—	—	—	—	—	Power supply (+5V)
17	P27/SCK0	SCK_A	I	HZ	H	—	P.D	Clock signal output for serial comm. (System)
18	P26/SO0/SB1	TXD_A	O	HZ	H	—	P.UP	Data signal output for serial comm. (System)
19	P25/SI0/SB0	RXD_A	I	HZ	H	—	P.UP	Data signal input for serial comm. (System)
20	P24/BUSY	NC	I	HZ	L	—	—	Open (not used)
21	P23/STB	NC	I	HZ	L	—	—	Open (not used)
22	P22/SCK1	M_DSCK	O	HZ	H	—	P.D	Clock signal output for serial comm. (MD Mecha.)
23	P21/SO1	M_KDATA	O	HZ	H	—	P.D	Data signal output for serial comm. (MD Mecha.)
24	P20/SI1	M_MDATA	I	HZ	L	—	—	Data signal input for serial comm. (MD Mecha.)
25	AVss	AVss	—	—	—	—	—	GND
26	P17/ANI7	NC	I	HZ	—	—	—	Open (not used)
27	P16/ANI6	NC	I	HZ	—	—	—	Open (not used)
28	P15/ANI5	BACKUP_CHECK	I	HZ	—	—	P.D	Input for backup power check
29	P14/ANI4	NC	I	HZ	—	—	—	Open (not used)
30	P13/ANI3	REC_INPUT	I	HZ	—	—	P.UP	S/W input for input select
31	P12/ANI2	KEY1	I	HZ	—	—	P.UP	Key input signal
32	P11/ANI1	KEY0	I	HZ	—	—	P.UP	Key input signal
33	P10/ANI0	NC	I	HZ	—	—	—	Open (not used)
34	AVdd	AVdd	—	—	—	—	—	Power supply (+5V)
35	AVREF	AVREF	—	—	—	—	—	Power supply (+5V)
36	P03/INTP3	NC	I	HZ	L	—	—	Open (not used)
37	P02/INTP2	NC	I	HZ	L	—	—	Open (not used)
38	P01/INTP1	M_DSTB	I	HZ	L	L	—	MD Mecha. comm. request signal input
39	P00/INTP0/TI	RMC	I	HZ	L	—	P.UP	Remote control signal input
40	Vss	Vss	—	—	—	—	—	GND
41	P74	NC	I	HZ	L	—	—	Open (not used)
42	P73	NC	I	HZ	L	—	—	Open (not used)

Pin No.	Pin Name	Symbol	I/O	Rst	Ini	Act	Ext	Function
43	P72	NC	I	HZ	L	—	—	Open (not used)
44	P71	ENCODER1_1	I	HZ	L	—	P.UP	Encoder signal input
45	P70	ENCODER1_2	I	HZ	L	—	P.UP	Encoder signal input
46	Vdd	Vdd	—	—	—	—	—	Power supply (+5V)
47	P127/FIP52	NC	I	HZ	L	—	—	Open (not used)
48	P126/FIP51	PICLED	O	HZ	L	—	—	Output signal for LED on/off
49	P125/FIP50	NC	I	HZ	L	—	—	Open (not used)
50	P124/FIP49	NC	I	HZ	L	—	—	Open (not used)
51	P123/FIP48	FLCS_A	O	HZ	H	L	P.D	Chip select output for FL controller
52	P122/FIP47	FLCK_A	O	HZ	H	—	P.D	Clock output for FL controller
53	P121/FIP46	FLDA_A	O	HZ	H	—	P.D	Data output for FL controller
54	P120/FIP45	RESET_A	O	HZ	H	L	P.D	Reset signal output for FL controller
55	P117/FIP44	NC	I	HZ	L	—	—	Open (not used)
56	P116/FIP43	NC	I	HZ	L	—	—	Open (not used)
57	P115/FIP42	NC	I	HZ	L	—	—	Open (not used)
58	P114/FIP41	M_POWN	O	HZ	L	L	P.D	Backup process command terminal
59	P113/FIP40	M_RESET	O	HZ	L	L	P.D	Reset signal output for MD Mecha.
60	P112/FIP39	M_LOADIN	I	HZ	L	L	—	Disc loading signal input, L: Loaded
61	P111/FIP38	M_MUTE	I	HZ	L	L	—	Mute signal input, L: Mute
62	P110/FIP37	M_EMPH.	I	HZ	L	L	—	Emphasis signal input, L: Emphasis
63	P107/FIP36	NC	I	HZ	L	—	—	Open (not used)
64	P106/FIP35	NC	I	HZ	L	—	—	Open (not used)
65	P105/FIP34	NC	I	HZ	L	—	—	Open (not used)
66	P104/FIP33	NC	I	HZ	L	—	—	Open (not used)
67	P103/FIP32	NC	I	HZ	L	—	—	Open (not used)
68	P102/FIP31	NC	I	HZ	L	—	—	Open (not used)
69	P101/FIP30	OPTION1	I	HZ	L	—	—	Option input for area select
70	P100/FIP29	POWER_OFF_DETECT	I	HZ	L	L	P.UP	Input for power off detect
71	P97/FIP28	NC	O	L	L	—	—	Open (not used)
72	P96/FIP27	NC	O	L	L	—	—	Open (not used)
73	P95/FIP26	NC	O	L	L	—	—	Open (not used)
74	P94/FIP25	NC	O	L	L	—	—	Open (not used)
75	P93/FIP24	NC	O	L	L	—	—	Open (not used)
76	P92/FIP23	NC	O	L	L	—	—	Open (not used)
77	P91/FIP22	NC	O	L	L	—	—	Open (not used)
78	P90/FIP21	NC	O	L	L	—	—	Open (not used)
79	VLOAD	VLOAD	—	—	—	—	—	Open (not used)
80	P87/FIP20	M_MICON_ON	O	L	H	—	P.D	Output for backup capacitor on/off, L: On, H: Off
81	P86/FIP19	POWER_OF_CONTROL	O	L	H	—	P.D	Output for MD Mecha. power on/off, L: Off, H: On
82	P85/FIP18	BACKUP_TEST	O	L	L	H	P.D	Output for backup power detect
83	P84/FIP17	DIGITAL_OUT_SELECT	O	L	L	—	P.D	Output for optical input 1/2 switching, L: Opt1, H: Opt2
84	P83/FIP16	OPTICAL_MUTE	O	L	H	L	P.D	Output for optical input mute
85	P82/FIP15	EMPHA_A	O	L	L	L	P.D	Emphasis output signal for D/A control
86	P81/FIP14	ADRESET_A	O	L	L	H	P.D	Reset output signal for D/A control
87	P80/FIP13	AMUTE_A	O	L	L	L	P.D	Output signal for analog output mute
88	FIP12	NC	O	L	L	—	—	Open (not used)
89	FIP11	NC	O	L	L	—	—	Open (not used)
90	FIP10	NC	O	L	L	—	—	Open (not used)
91	FIP9	NC	O	L	L	—	—	Open (not used)
92	FIP8	NC	O	L	L	—	—	Open (not used)
93	FIP7	NC	O	L	L	—	—	Open (not used)
94	FIP6	NC	O	L	L	—	—	Open (not used)
95	FIP5	NC	O	L	L	—	—	Open (not used)
96	FIP4	NC	O	L	L	—	—	Open (not used)
97	FIP3	NC	O	L	L	—	—	Open (not used)
98	FIP2	NC	O	L	L	—	—	Open (not used)
99	FIP1	NC	O	L	L	—	—	Open (not used)
100	FIP0	NC	O	L	L	—	—	Open (not used)

**AK4520-VF  
(IC109)**

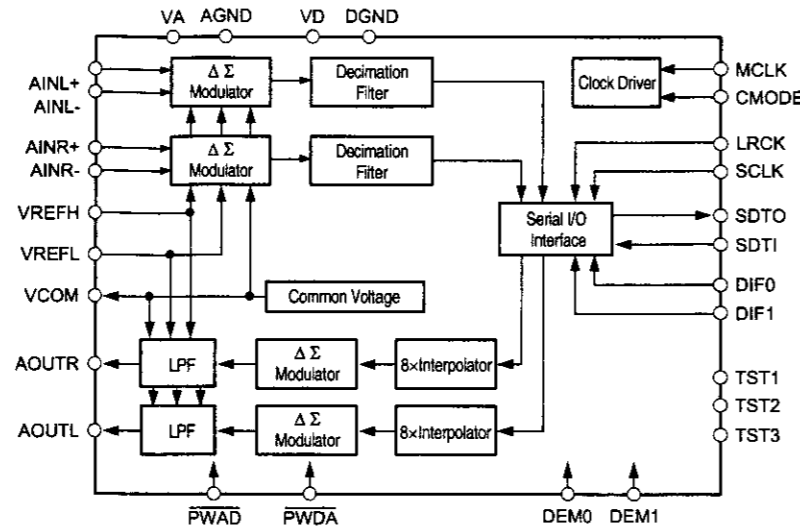
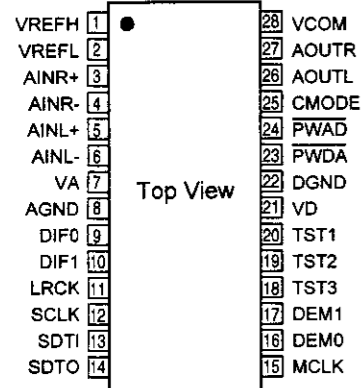
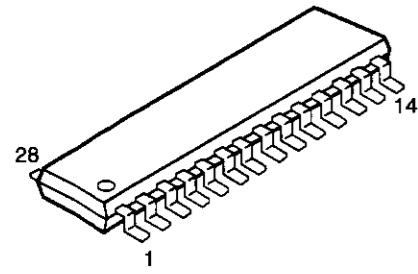

● **AK4520-VF Terminal Function**

Pin No.	Pin Name	I/O	Function
1	VREFH	I	Positive voltage reference input pin, VA. Used with ADC and DAC as positive reference voltage. VREFH is connected to VA, through external filter.
2	VREFL	I	Negative voltage reference input pin, AGND. Used with ADC and DAC as negative reference voltage. VREFL is externally connected to AGND.
3	AINR+	I	Rch analog positive input pin.
4	AINR-	I	Rch analog negative input pin.
5	AINL+	I	Lch analog positive input pin.
6	AINL-	I	Lch analog negative input pin.
7	VA	—	Analog power pin.
8	AGND	---	Analog GND pin.
9	DIF0	I	Audio data exchange format pin.
10	DIF1	I	Audio data exchange format pin.
11	LRCK	I	Input output channel clock pin.
12	SCLK	I	Audio serial data clock pin.
13	SDTI	I	Audio serial data input pin.
14	SDTO	O	Audio serial data output pin.
15	MCLK	I	Master clock input pin.
16	DEM0	I	De-emphasis frequency select pin.
17	DEM1	I	De-emphasis frequency select pin.
18	TST3	I/O	Test pin, connect to DGND or leave open.
19	TST2	I/O	
20	TST1	I	
21	VD	—	Digital power pin.
22	DGND	---	Digital GND pin.
23	PWDA	I	DAC power down mode pin.
24	PWAD	I	ADC power down mode pin.
25	CMODE	I	Master clock select pin. "H" : 384fs, "L" : 256fs
26	AOUTL	O	Lch analog output pin.
27	AOUTR	O	Rch analog output pin.
28	VCOM	O	Common voltage output pin, VA/2.

**M66004FP (IC301)**

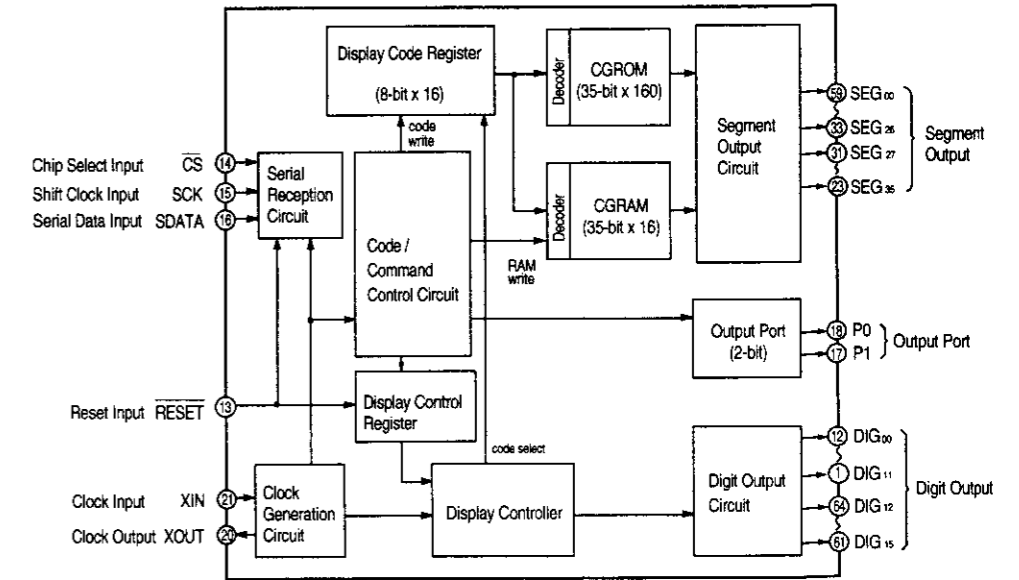
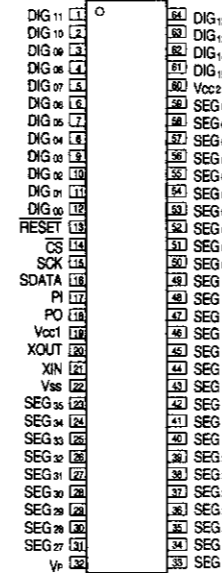
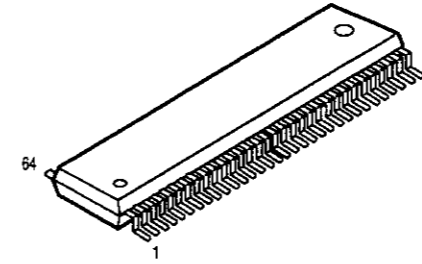

**M66004FP Terminal Function**

Symbol	Name	Function
RESET	Reset Input	Initializes internal state of M66004.
CS	Chip Select Input	Able to communicate with MCU in "L" mode. Command from MCU will be disregarded in "H" mode.
SCK	Shift Clock Input	Shifts input data at rise from "L" to "H".
SDATA	Serial Data Input	Inputs character code or command data needed to display from MSB.
Xin	Clock Input	Sets oscillation frequency by connecting external resistor and capacitor (maximum oscillation frequency fosc (max)=1MHz). Also feasible to apply external clock. In this case, inject external clock to Xin terminal and open Xout terminal.
Xout	Clock Output	
DIG 00 ~ DIG15	Digit Output	Connect to digit terminal of VFD. DIG00~DIG15 correspond to the 1st figure to 16th figure respectively.
SEG 00 ~ SEG 35	Segment Output	Connect to segment terminal of VFD. For corresponding SEG00~SEG35 to segment terminal of VFD, refer to the figure right.
P0, P1		Output port (static operation).
Vcc1		Positive power supply terminal for internal logic.
Vcc2		Positive power supply terminal for high tension output port.
Vss		GND terminal.
Vp		Negative power supply terminal for VFD drive.

(Forwarding connection of segment output terminal.)

□ in the right figure indicates 1 dot of segment, the figure in □ shows the segment output terminal number (00 ~ 35) to be connected.

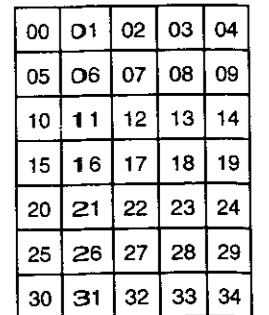

**MD RECORDER**

**PST600C (IC108)**

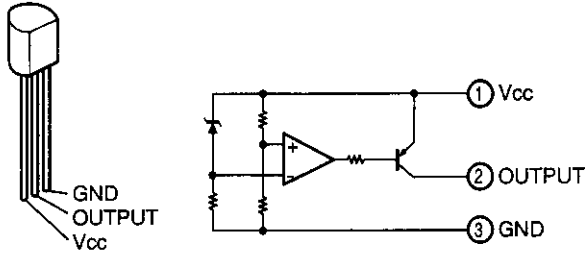

**NJM4565MD (IC 101,102, 110)**

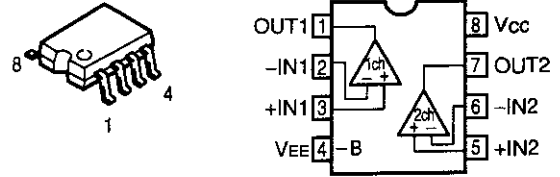

**TC74HC04AF (IC103)**

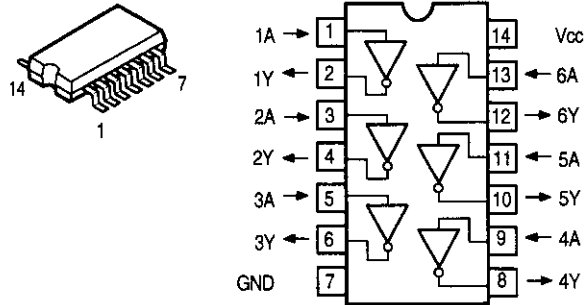

**TC74HC7007AF (IC105,112)**

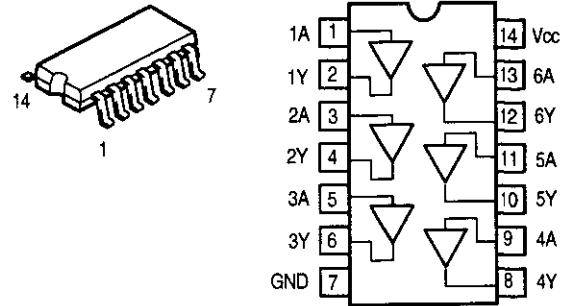

**TC74HC004AF (IC104)**

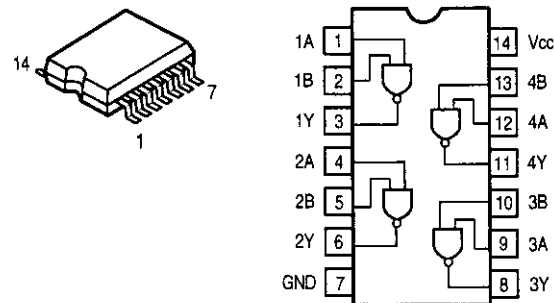

**TL431CLP (IC113)**

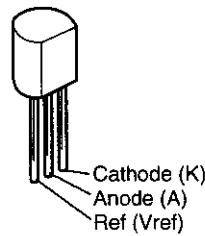

**KIC9459F (IC111)**

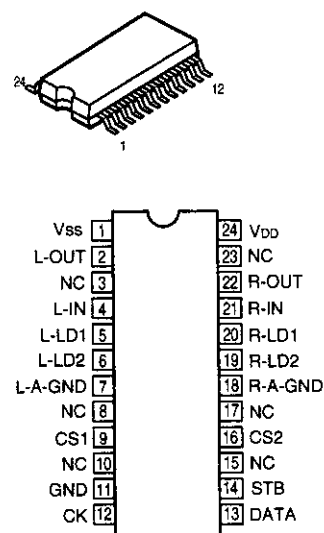

**KIC9459F Terminal Function**

Symbol	Name	Description	Note										
Vss	Power terminal (-)	Dual power use $\begin{cases} VDD=6.0\sim 17v \\ GND=0v \\ VSS=6.0\sim 17v \end{cases}$ Single power use $\begin{cases} VDD=6.0\sim 18v \\ GND=VSS=0v \end{cases}$	—										
VDD	Power terminal (+)												
GND	Digital GND												
L-OUT	Volume output		—										
R-OUT													
L-IN	Volume input												
R-IN													
L-LD1	Tap output for loudness			<table border="1"> <tr> <td></td> <td>LA1</td> <td>LA2</td> </tr> <tr> <td>Loudness "ON"</td> <td>ON</td> <td>OFF</td> </tr> <tr> <td>Loudness "OFF"</td> <td>OFF</td> <td>ON</td> </tr> </table>		LA1	LA2	Loudness "ON"	ON	OFF	Loudness "OFF"	OFF	ON
					LA1	LA2							
Loudness "ON"					ON	OFF							
Loudness "OFF"					OFF	ON							
R-LD1													
L-LD2													
R-LD2													
L-A-GND	Analog common												
R-A-GND													
CS1	Chip select input	Chip select code switching input. Max 4 units can be used simultaneously on ansame bus.											
CS2													
CK	Clock input	Clock input for data transfer											
DATA	Data input	Serial data input for volume setting	Low threshold input terminal										
STB	Strobe input	Strobe input for data write											
NC	No connection												



MD RECORDER

PST600C (IC108)

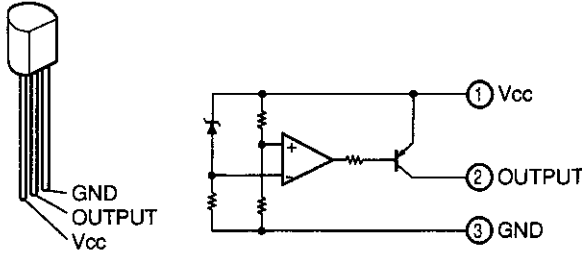

NJM4565MD (IC 101,102, 110)

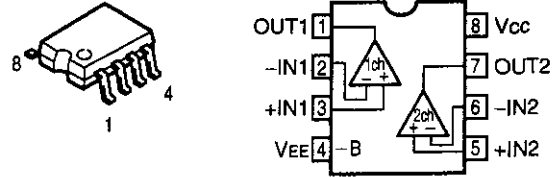

TC74HC04AF (IC103)

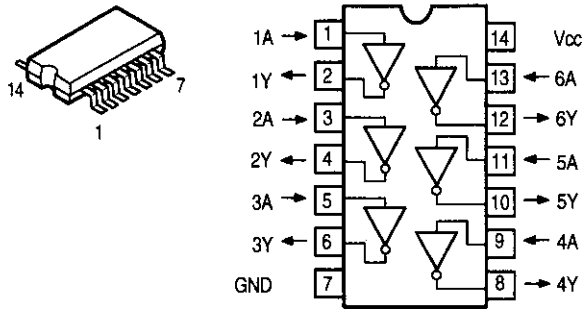

TC74HC7007AF (IC105,112)

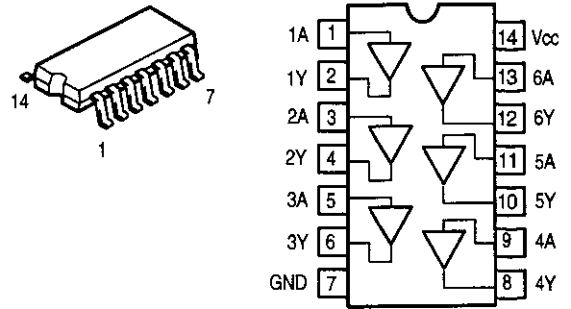

TC74HC004AF (IC104)

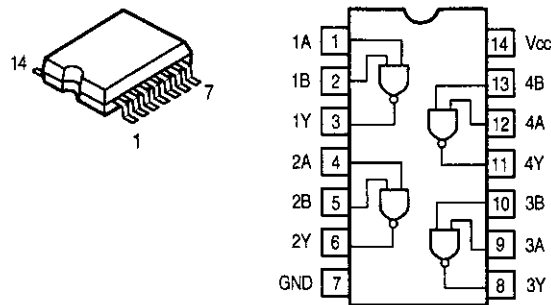

TL431CLP (IC113)

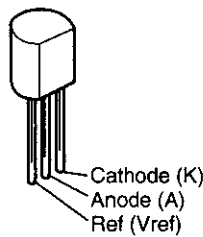

KIC9459F (IC111)

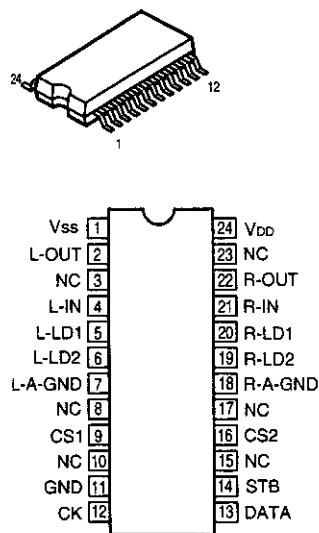

KIC9459F Terminal Function

Symbol	Name	Description	Note									
Vss	Power terminal (-)	Dual power use $V_{DD}=6.0\sim 17v$ $GND=0v$ $V_{SS}=6.0\sim 17v$ Single power use $V_{DD}=6.0\sim 18v$ $GND=V_{SS}=0v$	—									
Vdd	Power terminal (+)											
GND	Digital GND											
L-OUT	Volume output	<table border="1" style="margin-left: auto; margin-right: auto;"> <tr> <td></td> <td>LA1</td> <td>LA2</td> </tr> <tr> <td>Loudness "ON"</td> <td>ON</td> <td>OFF</td> </tr> <tr> <td>Loudness "OFF"</td> <td>OFF</td> <td>ON</td> </tr> </table>		LA1	LA2	Loudness "ON"	ON	OFF	Loudness "OFF"	OFF	ON	—
	LA1		LA2									
Loudness "ON"	ON		OFF									
Loudness "OFF"	OFF		ON									
R-OUT	Volume output											
L-IN	Volume input											
R-IN	Volume input											
L-LD1	Tap output for loudness											
R-LD1												
L-LD2												
R-LD2												
L-A-GND	Analog common											
R-A-GND												
CS1	Chip select input	Chip select code switching input. Max 4 units can be used simultaneously on ansame bus.										
CS2												
CK	Clock input	Clock input for data transfer										
DATA	Data input	Serial data input for volume setting	Low threshold input terminal									
STB	Strobe input	Strobe input for data write										
NC	No connection											

**MD RECORDER**

**● TRANSISTORS**

**2SC1740S**

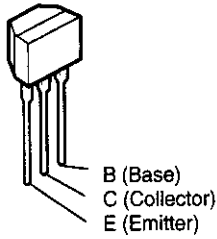

**KSA916**

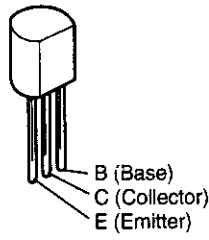

**KTD2058**

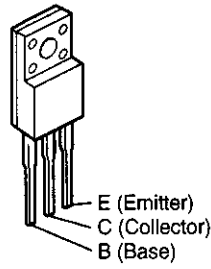

**2SA1037K  
2SC2412K**

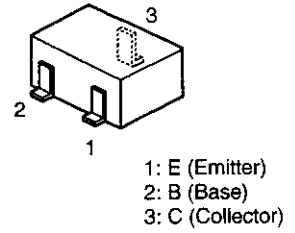

**DTA124EK  
DTC124EK  
DTC343TK**

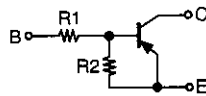
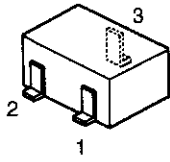

	R1	R2
DTA124EK	22kohm	22kohm

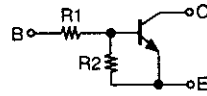

	R1	R2
DTC124EK	22kohm	22kohm

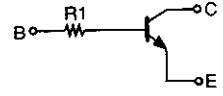

	R1
DTC343TK	4.7kohm

**● DIODES**

**1SS133**

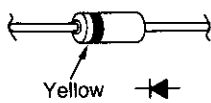

**1N4004A**

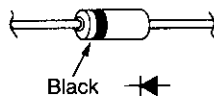

**MTZJ3.6B  
MTZJ4.7B  
MTZJ5.6B  
MTZJ6.2B  
MTZJ7.5B  
MTZJ15B**

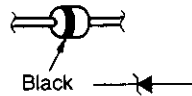

**1SS355**

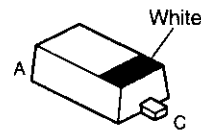

**D2SBA60**

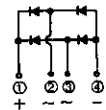
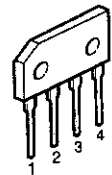

**● IC PROTECTOR**

**ICP-N15/ICP-N25  
(IC120~122)**

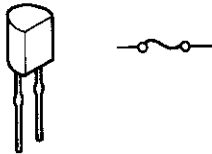

**● OPTICAL INPUT**

**GP1F32R (JACK102,103)**

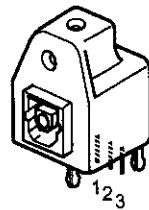

1. Vcc  
2. GND  
3. Out

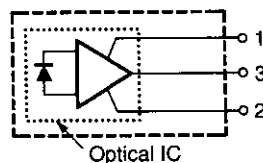

**● OPTICAL OUTPUT**

**GP1F32T (JACK104)**

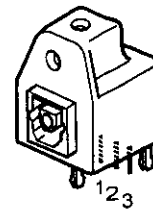

1. Vin  
2. Vcc  
3. GND

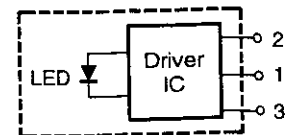

●FL DISPLAY 16-ST-13GK (FL301)

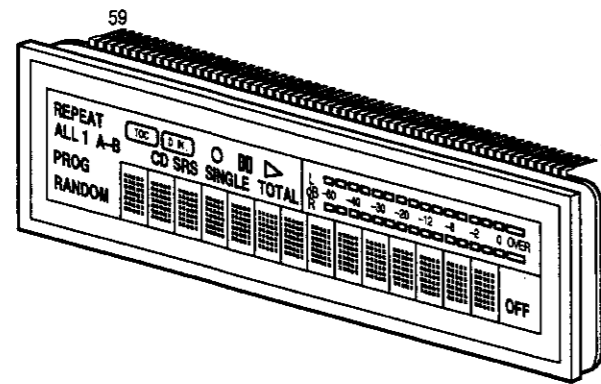

Grid Partition

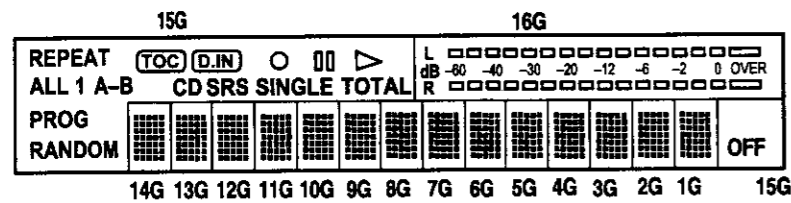

(14G ~ 1G)

Pin Connection

Pin No.	12	11	10	9	8	7	6	5	4	3	2	1
Conection	8G	7G	6G	5G	4G	3G	2G	1G	NP	NP	F1	F1
Pin No.	24	23	22	21	20	19	18	17	16	15	14	13
Conection	P4	P3	P2	P1	16G	15G	14G	13G	12G	11G	10G	9G
Pin No.	36	35	34	33	32	31	30	29	28	27	26	25
Conection	P16	P15	P14	P13	P12	P11	P10	P9	P8	P7	P6	P5
Pin No.	48	47	46	45	44	43	42	41	40	39	38	37
Conection	P28	P27	P26	P25	P24	P23	P22	P21	P20	P19	P18	P17
Pin No.	59	58	57	56	55	54	53	52	51	50	49	
Conection	F2	F2	NP	NP	P35	P34	P33	P32	P31	P30	P29	

- Note: 1. F1, F2 . . . . . Filament  
 2. NP . . . . . No Pin  
 3. DL . . . . . Datum Line  
 4. 1G~16G . . . . . Grid

Anode Connection

	16G	15G	14G ~ 1G
P1	R1	TOTAL	1-1
P2	R2	▷	2-1
P3	R3	SINGLE	3-1
P4	R4	□□	4-1
P5	R5	○	5-1
P6	R6	CD SRS	1-2
P7	R7	D.IN	2-2
P8	R8	(TOC)	3-2
P9	R9	B	4-2
P10	R10	A-	5-2
P11	R11	1	1-3
P12	R12	REPEAT	2-3
P13	R13	ALL	3-3
P14	R14	PROG	4-3
P15	R15	RANDOM	5-3
P16	R16	—	1-4
P17	—	—	2-4
P18	S1	—	3-4
P19	L1	—	4-4
P20	L2	—	5-4
P21	L3	—	1-5
P22	L4	—	2-5
P23	L5	—	3-5
P24	L6	—	4-5
P25	L7	—	5-5
P26	L8	—	1-6
P27	L9	—	2-6
P28	L10	—	3-6
P29	L11	—	4-6
P30	L12	—	5-6
P31	L13	—	1-7
P32	L14	—	2-7
P33	L15	—	3-7
P34	L16	—	4-7
P35	—	OFF	5-7

MD RECORDER  
PRINTED WIRING BOARDS

1 2 3 4 5 6 7 8

MAIN / FRONT P.W.B. UNIT ASS'Y

A

B

C

D

E

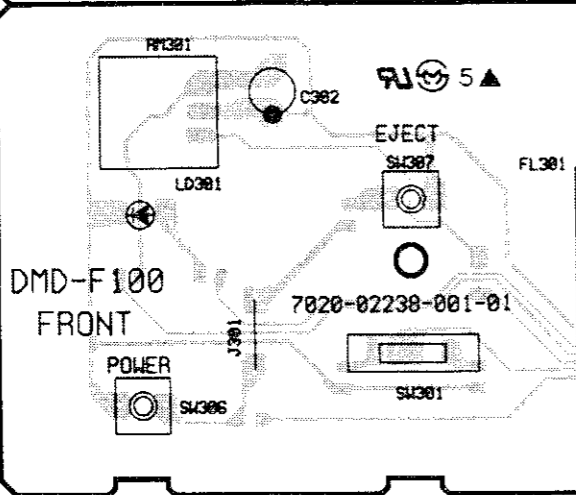
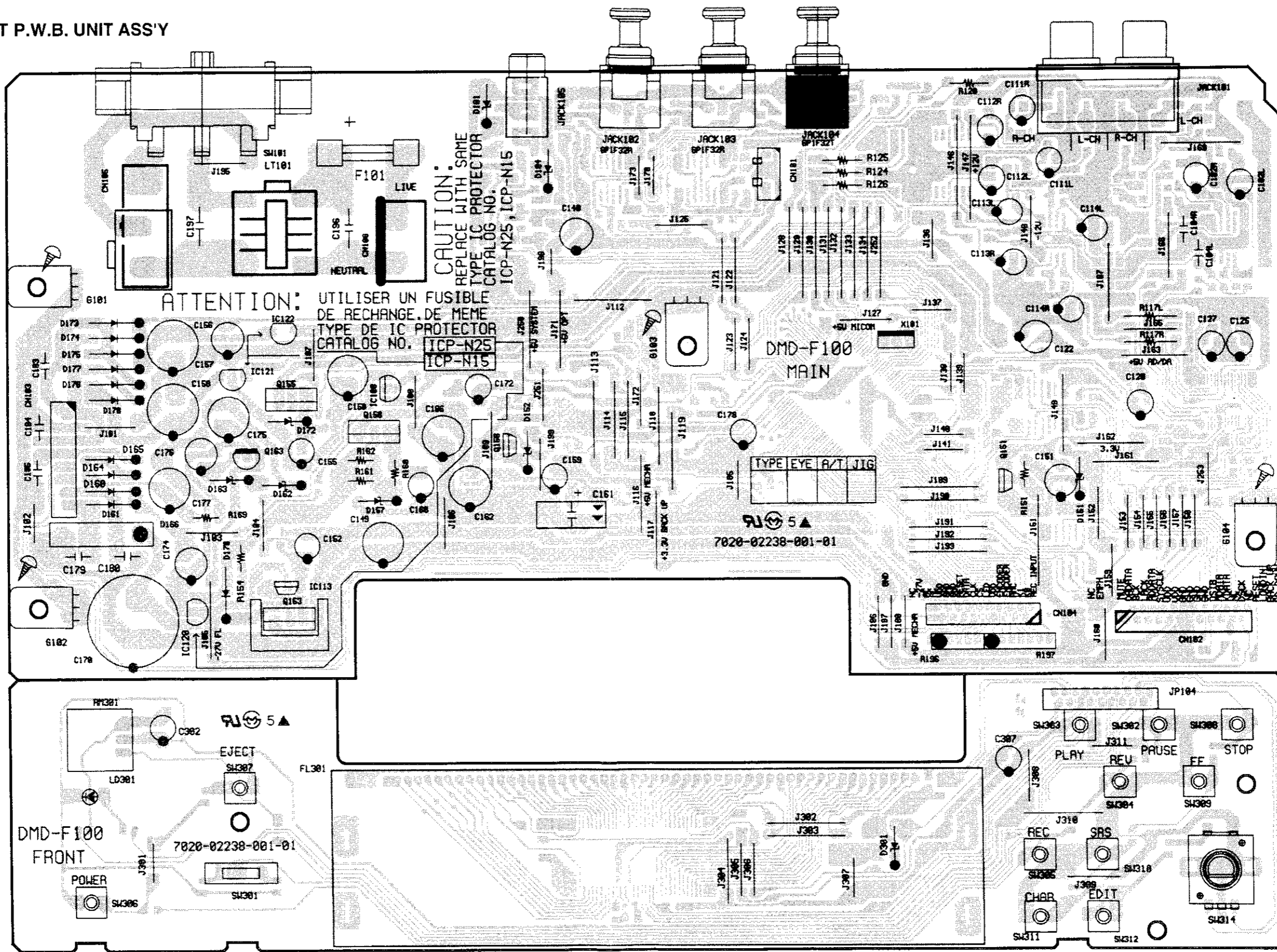

COMPONENT SIDE

1 2 3 4 5 6 7 8

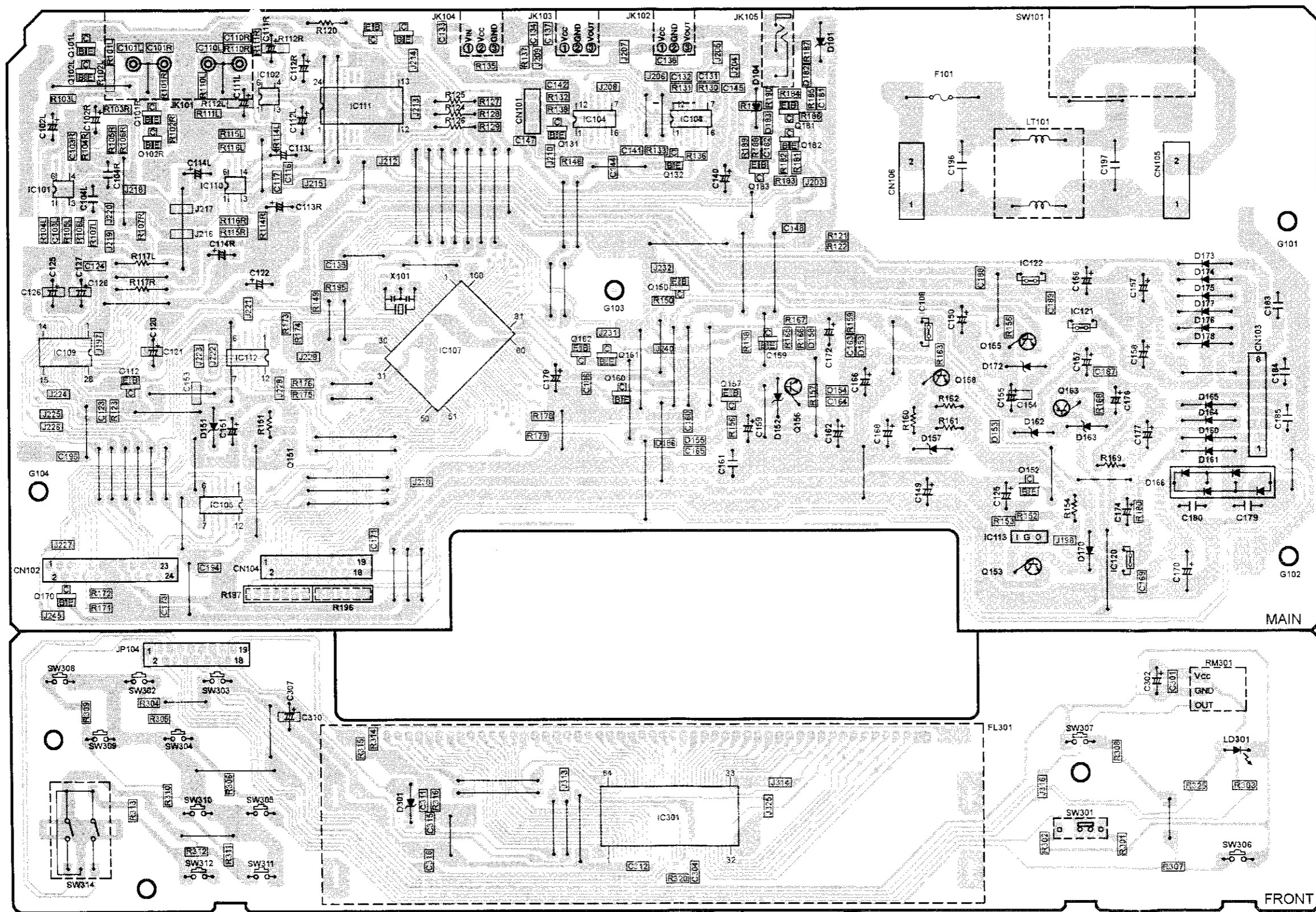

A  
B  
C  
D  
E

FOIL SIDE

MD RECORDER

NOTE FOR PARTS LIST

- Part indicated with the mark "⊙" are not always in stock and possibly to take a long period of time for supplying, or in some case supplying of part may be refused.
- When ordering of part, clearly indicate "1" and "I" (i) to avoid mis-supplying.
- Ordering part without stating its part number can not be supplied.
- Part indicated with the mark "★" is not illustrated in the exploded view.
- Not including Carbon Film ±5%, 1/4W Type in the P.W.Board parts list. (Refer to the Schematic Diagram for those parts.)

WARNING:

Parts marked with this symbol have critical characteristics. Use ONLY replacement parts recommended by the manufacturer.

● Resistors

Ex.: RN 14K 2E 182 G ER  
 Type Shape Power Resist- Allowable Others  
 and per- ance error

RD : Carbon	2B : 1/8W	F : ±1%	P : Pulse-resistant type
RC : Composition	2E : 1/4W	G : ±2%	NL : Low noise type
RS : Metal oxide film	2H : 1/2W	J : ±5%	NB : Non-burning type
RW : Winding	3A : 1W	K : ±10%	FR : Fuse-resistor
RN : Metal film	3D : 2W	M : ±20%	F : Lead wire forming
RK : Metal mixture	3F : 3W		
	3H : 5W		

\* Resistance

$\overset{1}{\text{R}} \overset{2}{\text{R}} \Rightarrow 1800 \text{ ohm} = 1.8 \text{ kohm}$   
 Indicates number of zeros after effective number.  
 2-digit effective number.

• Units: ohm

$\overset{1}{\text{R}} \overset{2}{\text{R}} \Rightarrow 1.2 \text{ ohm}$   
 1-digit effective number.  
 2-digit effective number, decimal point indicated by R.

• Units: ohm

● Capacitors

Ex.: CE 04W 1H 2R2 M BP  
 Type Shape Dielectric Capacity Allowable Others  
 and per- strength error

CE : Aluminum foil electrolytic	0J : 6.3V	F : ±1%	HS : High stability type
CA : Aluminum solid electrolytic	1A : 10V	G : ±2%	BP : Non-polar type
CS : Tantalum electrolytic	1C : 16V	J : ±5%	HR : Ripple-resistant type
CQ : Film	1E : 25V	K : ±10%	DL : For charge and discharge
CK : Ceramic	1V : 35V	M : ±20%	HF : For assuring high frequency
CC : Ceramic	1H : 50V	Z : +80%	U : UL part
CP : Oil	2A : 100V	-20%	C : CSA part
CM : Mica	2B : 125V	P : +100%	W : UL-CSA type
CF : Metallized	2C : 160V	-0%	F : Lead wire forming
CH : Metallized	2D : 200V	C : ±0.25pF	
	2E : 250V	D : ±0.5pF	
	2H : 500V	= : Others	
	2J : 630V		

\* Capacity (electrolyte only)

$\overset{2}{\text{R}} \overset{2}{\text{R}} \Rightarrow 2200 \mu\text{F}$   
 Indicates number of zeros after effective number.  
 2-digit effective number.

• Units: μF.

$\overset{2}{\text{R}} \overset{2}{\text{R}} \Rightarrow 2.2 \mu\text{F}$   
 1-digit effective number.  
 2-digit effective number, decimal point indicated by R.

• Units: μF.

\* Capacity (except electrolyte)

$\overset{2}{\text{R}} \overset{2}{\text{R}} \Rightarrow 2200 \text{pF} = 0.0022 \mu\text{F}$   
 (More than 2) — Indicates number of zeros after effective number.  
 2-digit effective number.

• Units: μF.

$\overset{2}{\text{R}} \overset{2}{\text{R}} \overset{1}{\text{R}} \Rightarrow 220 \text{pF}$   
 (0 or 1) — Indicates number of zeros after effective number.  
 2-digit effective number.

• Units: pF.

• When the dielectric strength is indicated in AC, "AC" is included after the dielectric strength value.

PARTS LIST OF P.W.B. UNIT  
 MAIN P.W.B. UNIT ASS'Y

Ref. No.	Part No.	Part Name	Remarks
<b>SEMICONDUCTORS GROUP</b>			
IC101,C102	928 0035 809	IC NJM4565MD	J121456500040
IC103	262 2229 908	IC TC74HC04AF	J040740400060
IC104	960 0133 200	IC TC74HCOO	J040740000130
IC105	262 2376 903	IC TC74HCT7007AF	J040747007010
IC107	960 0135 923	IC UPD780206GF058-3BA	
IC108	960 0119 208	IC PST600C	J125600200020
IC109	9LC K077 11R	IC AK4520A-VF-E2	J040452000010
IC110	928 0035 809	IC NJM4565MD	J121456500040
IC111	960 0133 307	IC KIC9459F	J084945900010
IC112	262 2376 903	IC TC74HCT7007AF	J040747007010
IC113	960 0133 006	IC TL431CLP	J126431000010
IC120	268 0075 000	IC ICP-N25	J120002500010
IC121,122	268 0073 002	IC ICP-N15	J120001500010
IC301	262 1954 009	IC M66004FP	J127660040010
Q101L,101R	269 0104 903	Transistor DTC343TK	J5220343T0210
Q102L,102R	269 0104 903	Transistor DTC343TK	J5220343T0210
Q110	269 0102 905	Transistor DTC124EK	J5220124E0210
Q111	269 0119 901	Transistor DTA124EK	J5200124E0210
Q112	269 0102 905	Transistor DTC124EK	J5220124E0210
Q131,132	269 0102 905	Transistor DTC124EK	J5220124E0210
Q150	269 0102 905	Transistor DTC124EK	J5220124E0210
Q151	273 0178 022	Transistor 2SC1740SR	J5021740S0010
Q152	269 0102 905	Transistor DTC124EK	J5220124E0210
Q153	960 0004 902	Transistor KTD2058Y	J5032058Y0140
Q154	269 0102 905	Transistor DTC124EK	J5220124E0210
Q155	960 0004 902	Transistor KTD2058Y	J5032058Y0140
Q156	273 0178 022	Transistor 2SC1740SR	J5021740S0010
Q157	271 0238 908	Transistor 2SA1037K(S/R)	J5201037K0210
Q158	960 0004 902	Transistor KTD2058Y	J5032058Y0140
Q159	273 0384 900	Transistor 2SC2412K(S)	J5222412K0210
Q160	269 0102 905	Transistor DTC124EK	J5220124E0210
Q161	271 0238 908	Transistor 2SA1037K(S/R)	J5201037K0210
Q162	269 0102 905	Transistor DTC124EK	J5220124E0210
Q163	960 0133 103	Transistor KSA916Y	J5000916Y0050
Q170	269 0102 905	Transistor DTC124EK	J5220124E0210
Q181,182	271 0238 908	Transistor 2SA1037K(S/R)	J5201037K0210
Q183	273 0384 900	Transistor 2SC2412K(S)	J5222412K0210
D151	960 0132 706	Zener diode MTZJ3.6B	K06003R644520
D152	960 0132 803	Zener diode MTZJ4.7B	K06004R744520
D153-155	960 0117 501	Diode 1SS355	K005035500010
D157	960 0095 704	Zener diode MTZJ6.2B	K06006R244520
D158,159	960 0117 501	Diode 1SS355	K005035500010
D160,161	276 0401 905	Diode 1SS133	K000013300520
D162,163	960 0132 900	Zener diode MTZJ15B	K06015R044520
D164,165	960 0117 608	Diode 1N4004A	K040400400520
D166	960 0133 909	Diode D2SBA60	K047400300020
D170	960 0117 608	Diode 1N4004A	K040400400520
D172	276 0664 904	Zener diode MTZJ5.6B	K06005R644520

Ref. No.	Part No.	Part Name	Remarks
D173-178	960 0117 608	Diode 1N4004A	K040400400520
D181	960 0095 704	Zener diode MTZJ6.2B	K06006R244520
D182,183	960 0117 501	Diode 1SS355	K005035500010
D184	960 0095 704	Zener diode MTZJ6.2B	K06006R244520
D185,186	960 0117 501	Diode 1SS355	K005035500010
D301	9L2 3481 42M	Zener diode MTZJ7.5B	K06007R544520
LD301	960 0134 403	LED PI3-RD/HL	K500032002080
<b>RESISTORS GROUP</b>			
R101L,101R		Carbon chip 100 ohm 1/10W	C200010160200
R102L,102R		Carbon chip 220 ohm 1/10W	C200022160200
R103L,103R		Carbon chip 220 ohm 1/10W	C200022160200
R104L,104R		Carbon chip 8.2 kohm 1/10W	C200082260200
R105L,105R		Carbon chip 4.7 kohm 1/10W	C200047260200
R106L,106R		Carbon chip 4.7 kohm 1/10W	C200047260200
R107L,107R		Carbon chip 220 ohm 1/10W	C200022160200
R110L,110R		Carbon chip 1 kohm 1/10W	C200010260200
R111L,111R		Carbon chip 100 kohm 1/10W	C200010460200
R112L,112R		Carbon chip 100 kohm 1/10W	C200010460200
R114L,114R		Carbon chip 100 kohm 1/10W	C200010460200
R115L,115R		Carbon chip 10 kohm 1/10W	C200010360200
R116L,116R		Carbon chip 27 kohm 1/10W	C200027360200
R117L,117R		Carbon film 470 ohm 1/5W	C00004716P520
R120		Carbon chip 680 ohm 1/10W	C200068160200
R121,122		Carbon chip 3.3 kohm 1/10W	C200033260200
R123		Carbon chip 10 kohm 1/10W	C200010360200
R124-126		Carbon film 1 kohm 1/5W	C00001026P520
R127-133		Carbon chip 100 kohm 1/10W	C200010460200
R135		Carbon chip 220 ohm 1/10W	C200022160200
R136		Carbon chip 10 kohm 1/10W	C200010360200
R137		Carbon chip 430 ohm 1/10W	C200043160200
R138		Carbon chip 220 ohm 1/10W	C200022160200
R139		Metal film 47 ohm 1/4W	C060047063050
R146		Carbon chip 220 ohm 1/10W	C200022160200
R150		Carbon chip 10 kohm 1/10W	C200010360200
R151		Metal film 100 ohm 1/4W	C060010163050
R152		Carbon chip 1.5 kohm 1/10W	C200015260200
R153		Carbon chip 1.6 kohm 1/10W	C200016260200
R154		Metal film 220 ohm 1/4W	C060022163050
R155		Carbon chip 1 kohm 1/10W	C200010260200
R156		Carbon chip 100 ohm 1/10W	C200010160200
R157		Carbon chip 56 ohm 1/10W	C200056060200
R158		Carbon chip 100 kohm 1/10W	C200010460200
R159		Carbon chip 4.7 kohm 1/10W	C200047260200
R160		Metal film 100 ohm 1/4W	C060010163050
R161,162		Metal film 560 ohm 1/4W	C060056165050
R163		Carbon chip 750 ohm 1/10W	C200075160200
R165		Carbon chip 100 ohm 1/10W	C200010160200
R166		Carbon chip 100 kohm 1/10W	C200010460200
R167		Carbon chip 10 kohm 1/10W	C200010360200

Ref. No.	Part No.	Part Name	Remarks	Ref. No.	Part No.	Part Name	Remarks
R168		Carbon chip 2.2 kohm 1/10W	C200022260200	C127		Electrolytic 10 $\mu$ F/50V	D040100087050
R169		Metal film 4.7 ohm 1/4W	C0604R7063050	C128		Ceramic chip 0.1 $\mu$ F/50V	D011104597200
R171-176		Carbon chip 47 kohm 1/10W	C200047360200	C131		Ceramic chip 10 pF/50V	D010100117200
R178		Carbon chip 100 kohm 1/10W	C200010460200	C132		Ceramic chip 10 pF/50V	D010100117200
R180		Carbon chip 1.8 kohm 1/10W	C200018260200	C133		Ceramic chip 0.047 $\mu$ F/50V	D011473597200
R181-183		Carbon chip 10 kohm 1/10W	C200010360200	C134,135		Ceramic chip 0.1 $\mu$ F/50V	D011104597200
R184,185		Carbon chip 22 kohm 1/10W	C200022360200	C136,137		Ceramic chip 0.047 $\mu$ F/50V	D011473597200
R186		Carbon chip 1 kohm 1/10W	C200010260200	C140		Electrolytic 100 $\mu$ F/10V	D040101082060
R187		Carbon chip 100 ohm 1/10W	C200010160200	C141,142		Ceramic chip 0.01 $\mu$ F/50V	D011103597200
R188,189		Carbon chip 10 kohm 1/10W	C200010360200	C144,145		Ceramic chip 0.01 $\mu$ F/50V	D011103597200
R190		Carbon chip 220 ohm 1/10W	C200022160200	C146,147		Ceramic chip 220 pF/50V	D010221167200
R191		Carbon chip 47 kohm 1/10W	C200047360200	C148		Ceramic chip 0.01 $\mu$ F/50V	D011103597200
R195		Carbon chip 100 kohm 1/10W	C200010460200	C149		Electrolytic 1000 $\mu$ F/6.3V	D040102081050
R196		Resistor network 10 kohm $\times$ 4	C180103050500	C150		Electrolytic 470 $\mu$ F/6.3V	D040471081060
R197		Resistor network 10 kohm $\times$ 6	C180103070500	C151		Electrolytic 100 $\mu$ F/10V	D040101082060
R301		Carbon chip 4.7 kohm 1/10W	C200047260200	C152		Electrolytic 10 $\mu$ F/50V	D040100087050
R302		Carbon chip 100 ohm 1/10W	C200010160200	C153,154		Ceramic chip 0.01 $\mu$ F/50V	D011103597200
R303		Carbon chip 47 ohm 1/10W	C200047060200	C155		Electrolytic 10 $\mu$ F/50V	D040100087050
R304		Carbon chip 1.8 kohm 1/10W	C200018260200	C156		Electrolytic 330 $\mu$ F/16V	D040331083200
R305		Carbon chip 2.7 kohm 1/10W	C200027260200	C157,158	960 0133 501	Electrolytic 2200 $\mu$ F/16V	D040222083080
R306		Carbon chip 4.7 kohm 1/10W	C200047260200	C159		Electrolytic 100 $\mu$ F/10V	D040101082060
R307		Carbon chip 8.2 kohm 1/10W	C200082260200	C160		Ceramic chip 0.01 $\mu$ F/50V	D011103597200
R308		Carbon chip 22 kohm 1/10W	C200022360200	C161	960 0133 608	Electric double layer 1 F/5.5V	D090105000010
R309		Carbon chip 1.8 kohm 1/10W	C200018260200	C162		Electrolytic 100 $\mu$ F/10V	D040101082060
R310		Carbon chip 2.7 kohm 1/10W	C200027260200	C163-165		Ceramic chip 0.01 $\mu$ F/50V	D011103597200
R311		Carbon chip 4.7 kohm 1/10W	C200047260200	C166		Electrolytic 470 $\mu$ F/6.3V	D040471081060
R312		Carbon chip 8.2 kohm 1/10W	C200082260200	C168		Electrolytic 22 $\mu$ F/16V	D040220083070
R313		Carbon chip 22 kohm 1/10W	C200022360200	C169		Ceramic chip 0.01 $\mu$ F/50V	D011103597200
R314,315		Carbon chip 100 ohm 1/10W	C200010160200	C170	960 0133 404	Electrolytic 10000 $\mu$ F/16V	D040103083020
R316		Carbon chip 10 kohm 1/10W	C200010360200	C171		Ceramic chip 0.01 $\mu$ F/50V	D011103597200
R320		Carbon chip 27 kohm 1/10W	C200027360200	C172		Electrolytic 1 $\mu$ F/50V	D040010087050
R325		Carbon chip 330 ohm 1/10W	C200033160200	C173		Ceramic chip 0.01 $\mu$ F/50V	D011103597200
<b>CAPACITORS GROUP</b>				C174		Electrolytic 47 $\mu$ F/16V	D040470083080
C101L,101R		Ceramic chip 470 pF/50V	D010471167200	C175		Electrolytic 100 $\mu$ F/50V	D040101087060
C102L,102R		Electrolytic 22 $\mu$ F/16V	D040220083070	C176		Electrolytic 10 $\mu$ F/50V	D040100087050
C103L,103R		Ceramic chip 330 pF/50V	D010331167200	C177		Electrolytic 100 $\mu$ F/50V	D040101087060
C104L,104R		Film 0.0027 $\mu$ F/100V	D02027206C060	C178		Electrolytic 100 $\mu$ F/10V	D040101082060
C110L,110R		Ceramic chip 100 pF/50V	D010101167200	$\Delta$ C179,180		<b>Ceramic 0.01 <math>\mu</math>F/500V</b>	<b>D00410359D050</b>
C111L,111R		Electrolytic 22 $\mu$ F/16V	D040220083070	C181,182		Ceramic chip 0.001 $\mu$ F/50V	D011102777200
C112L,112R		Electrolytic 22 $\mu$ F/16V	D040220083070	$\Delta$ C183-185		<b>Ceramic 0.01 <math>\mu</math>F/500V</b>	<b>D00410359D050</b>
C113L,113R		Electrolytic 22 $\mu$ F/16V	D040220083070	C186-189		Ceramic chip 0.01 $\mu$ F/50V	D011103597200
C114L,114R		Electrolytic 1 $\mu$ F/50V	D040010087050	C194,195		Ceramic chip 0.01 $\mu$ F/50V	D011103597200
C116,117		Ceramic chip 0.1 $\mu$ F/50V	D011104597200	$\Delta$ C196,197	963 0020 804	<b>Ceramic 0.0047 <math>\mu</math>F/250V</b>	<b>D008472089000</b>
C120		Electrolytic 100 $\mu$ F/10V	D040101082060	C301		Ceramic chip 0.01 $\mu$ F/50V	D011103597200
C121		Ceramic chip 0.01 $\mu$ F/50V	D011103597200	C302		Electrolytic 100 $\mu$ F/10V	D040101082050
C122		Electrolytic 100 $\mu$ F/10V	D040101082060	C304		Ceramic chip 100 pF/50V	D010101167200
C123		Ceramic chip 0.01 $\mu$ F/50V	D011103597200	C307		Electrolytic 100 $\mu$ F/10V	D040101082050
C124		Ceramic chip 0.1 $\mu$ F/50V	D011104597200	C310-312		Ceramic chip 0.01 $\mu$ F/50V	D011103597200
C125		Electrolytic 10 $\mu$ F/50V	D040100087050	C315,316		Ceramic chip 0.01 $\mu$ F/50V	D011103597200
C126		Ceramic chip 0.1 $\mu$ F/50V	D011104597200				

**MD RECORDER**

Ref. No.	Part No.	Part Name	Remarks	Q'ty
<b>OTHER PARTS GROUP</b>				
CN101	960 0134 005	4P connector base	L101530140410	1
CN102	960 0134 102	24P FPC connector base	L130358022410	1
CN103	960 0118 801	8P connector base	L102526700800	1
CN104	960 0134 209	19P FPC connector base	L130528061910	1
CN105	960 0123 304	2P connector base	L104353280200	1
			Europe & U.K. Models	
CN105	960 0142 408	3P connector base	L108353280310	1
			Asia Model	
CN106	960 0118 908	2P connector base	L108039602010	1
<b>Δ F101</b>	<b>960 0142 709</b>	<b>Fuse 250V 1A</b>	<b>G650102251100</b> <b>Asia Model only</b>	<b>1</b>
FL301	960 0134 607	FLD (16-ST-13GK)	K530161300110	1
J313,314		Carbon chip 0 ohm 1/8W	C200000061300	2
J316		Carbon chip 0 ohm 1/8W	C200000061300	1
J325		Carbon chip 0 ohm 1/8W	C200000061300	1
JACK101	960 0133 802	4P pin jack	G602040131010	1
JACK102,103	963 0025 304	Optical connector (GP1F32R)	E100132000020	2
JACK104	269 0098 006	Optical connector (GP1F32T)	E100132000010	1
JACK105	960 0004 407	Mini jack	G401031102010	1
JP104	960 0134 704	19P FPC connector base	L130528071910	1
L101	960 0133 705	Coil 1MH	D320111600010	1
RM301	960 0050 105	Remocon sensor	E940460200010	1
<b>Δ SW101</b>	<b>963 0027 700</b>	<b>Slide switch</b>	<b>G060040550010</b> <b>Asia Model only</b>	<b>1</b>
SW301	960 0011 801	Slide switch	G060313012010	1
SW302-312	960 0069 206	Tact switch	G180215050010	11
SW314	960 0134 500	Rotary switch	G120122424010	1
X101	399 0107 900	Ceramic 4.19 MHz	E830419000060	1
	960 0127 805	Earth plate	4470200016010	1
	960 9006 600	GND terminal	3790040876010	3
	960 0005 804	Fuse holder	G645000050010, for F101 Asia Model only	1
		Carbon chip 0 ohm 1/8W	C200000061300	32
	960 0050 309	FL supporter	4070020076010	1



# WIRING DIAGRAM

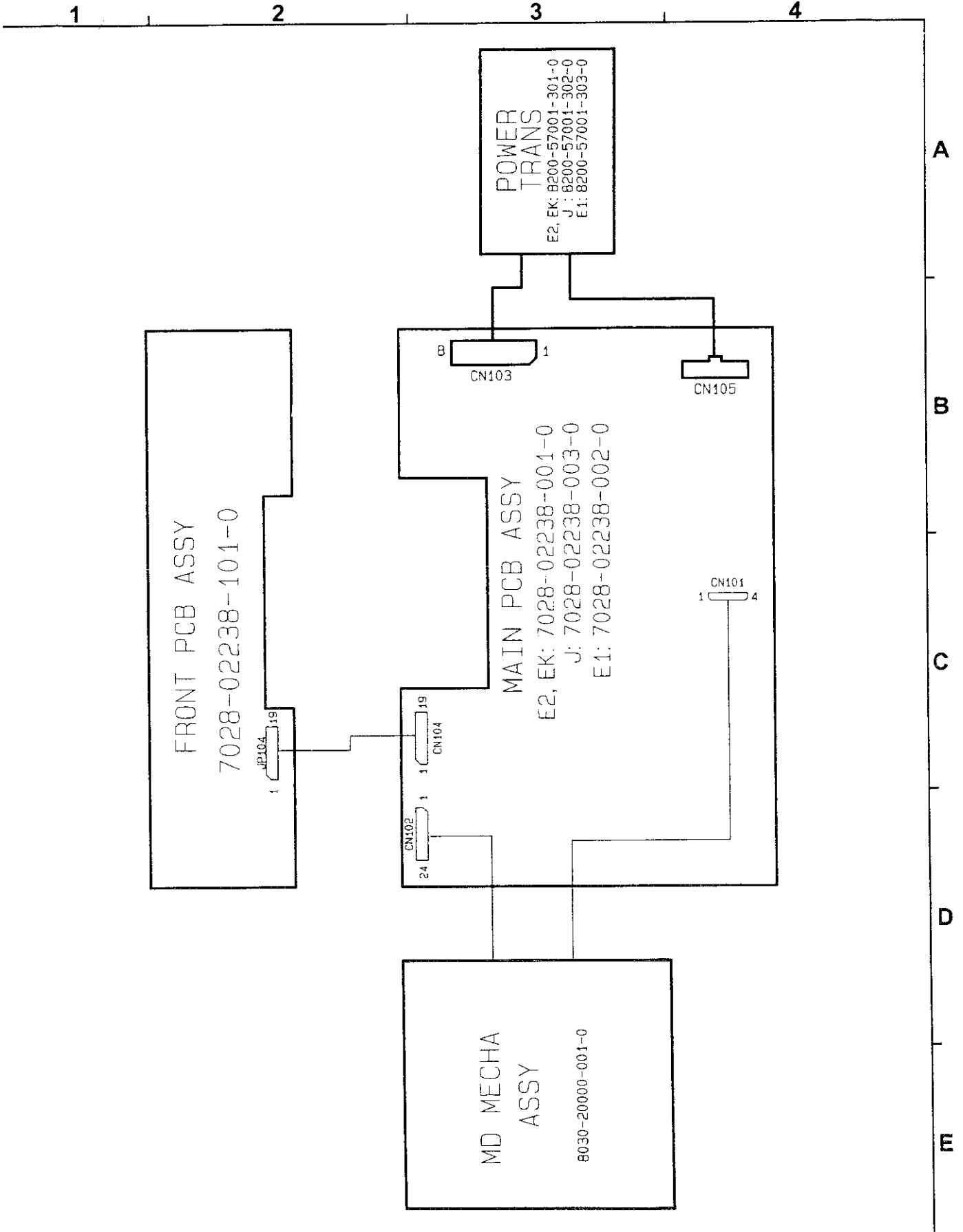

## MD RECORDER

## PARTS LIST OF EXPLODED VIEW

Ref. No.	Part No.	Part Name	Remarks	Q'ty	
13	960 0138 108	Main P.W.B. unit ass'y	7025HM9802010 Europe & U.K. Models	1	
13	960 0132 612	Main P.W.B. unit ass'y	7025HM9802040 Asia Model	1	
7	960 0134 306	Front P.W.B. unit			
1	960 0115 707	DENON badge	5630210008000	1	
2	960 0131 008	Front panel	3067210048110	1	
3	960 0115 309	Display window	5077210043010	1	
4	960 0132 007	Control knob	5087210031010	1	
5	960 0131 105	Front frame	3217210021110	1	
8	960 0003 505	Foot cushion	4050020075010	4	
9	960 0003 408	Foot	4007000061010	2	
10	960 0131 804	Main chassis	3200210086000	1	
11	960 0115 008	Foot	4000210001000	2	
12	960 0003 301	P.W.B. support	4070001601010	1	
14	960 0131 723	Back chassis	3207210046010 Europe & U.K. Models	1	
14	960 0131 736	Back chassis	3207210046110 Asia Model	1	
15	960 0135 305	Cord stopper	4380040162010	1	
△	960 0032 301	AC cord	L061000410010	1	
17	960 0131 901	Mecha. bracket	4010210056000	1	
18	960 0134 801	MD mecha.	8030200000010	1	
△	960 0143 504	Power trans.	8200570013010 Europe & U.K. Models	1	
△	960 0135 606	Power trans.	8200570013030 Asia Model	1	
20	960 0121 306	Selector knob	5087210041010	1	
21	960 0131 406	Door holder	4320020611011	1	
22	960 0131 309	Door spring	3720020316020	1	
23	960 0131 503	MD door	5047020251020	1	
24	960 0131 202	Door base	3407210001010	1	
25	960 0114 708	Remocon window	5070210033000	1	
26	960 0131 600	Function lens	3710210013000	1	
27	960 0121 005	Top cover	3000210006100	1	
★	28	960 0132 201	Caution label	5527067010010	1
	29	960 0135 703	1P wire	8410101220010	1
★	30	960 0135 800	4P connector cord	L000181040030	1
★	31	960 0135 101	19P FPC	L301161190010	1
★	32	960 0135 208	24P FPC	L301171240010	1
<b>SCREWS</b>					
A	960 0108 604	Screw 3×8 CBTS(B)-B	B020030083B10	18	
A	960 0108 604	Screw 3×8 CBTS(B)-B	B020030083B10, for SW101 Asia Model only	2	
B	960 9008 006	Screw 3×8 CFTS(B)-B	B020030083F10	4	
C	963 0018 104	Screw 3×17 CBTS(B)-Z	B020030171B10	1	
D	960 9008 103	Screw 2×5 CBTS(C)-Z	B010920051B10	1	
E	960 9008 200	Screw 2×6 CPTS(C) W-Z	B020020061W10	4	
F	960 9003 001	Screw 4×8 CBTS(S)-Z	B020740081B10	2	
G	963 0018 007	Screw 3×8 CBTS(B)-Z	B020030081B10	6	

EXPLODED VIEW

WARNING: Parts marked with this symbol  have critical characteristics. Use ONLY replacement parts recommended by the manufacturer.

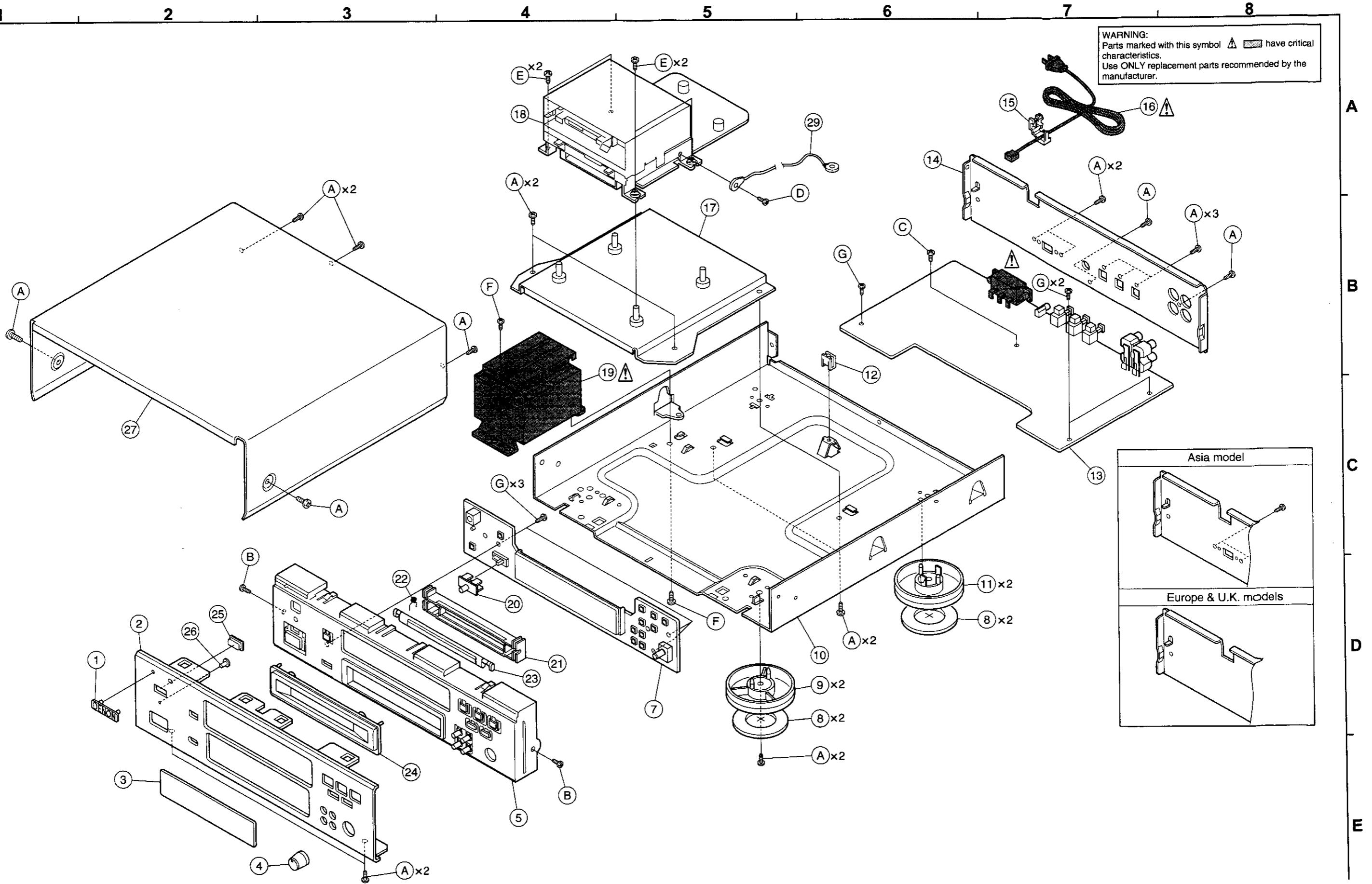

EXPLODED VIEW

WARNING: Parts marked with this symbol  have critical characteristics. Use ONLY replacement parts recommended by the manufacturer.

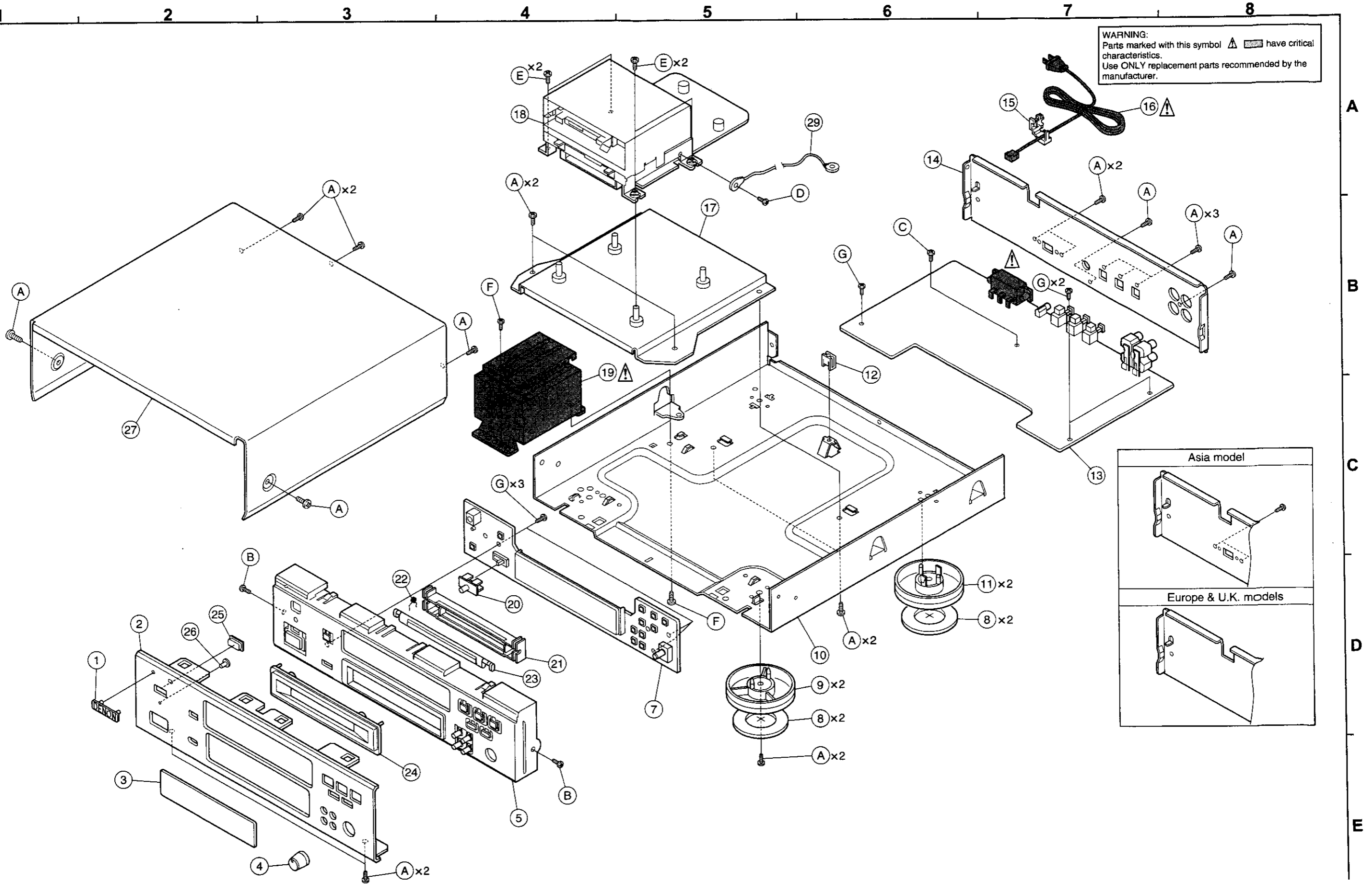

EXPLODED VIEW OF MD MECHANISM UNIT

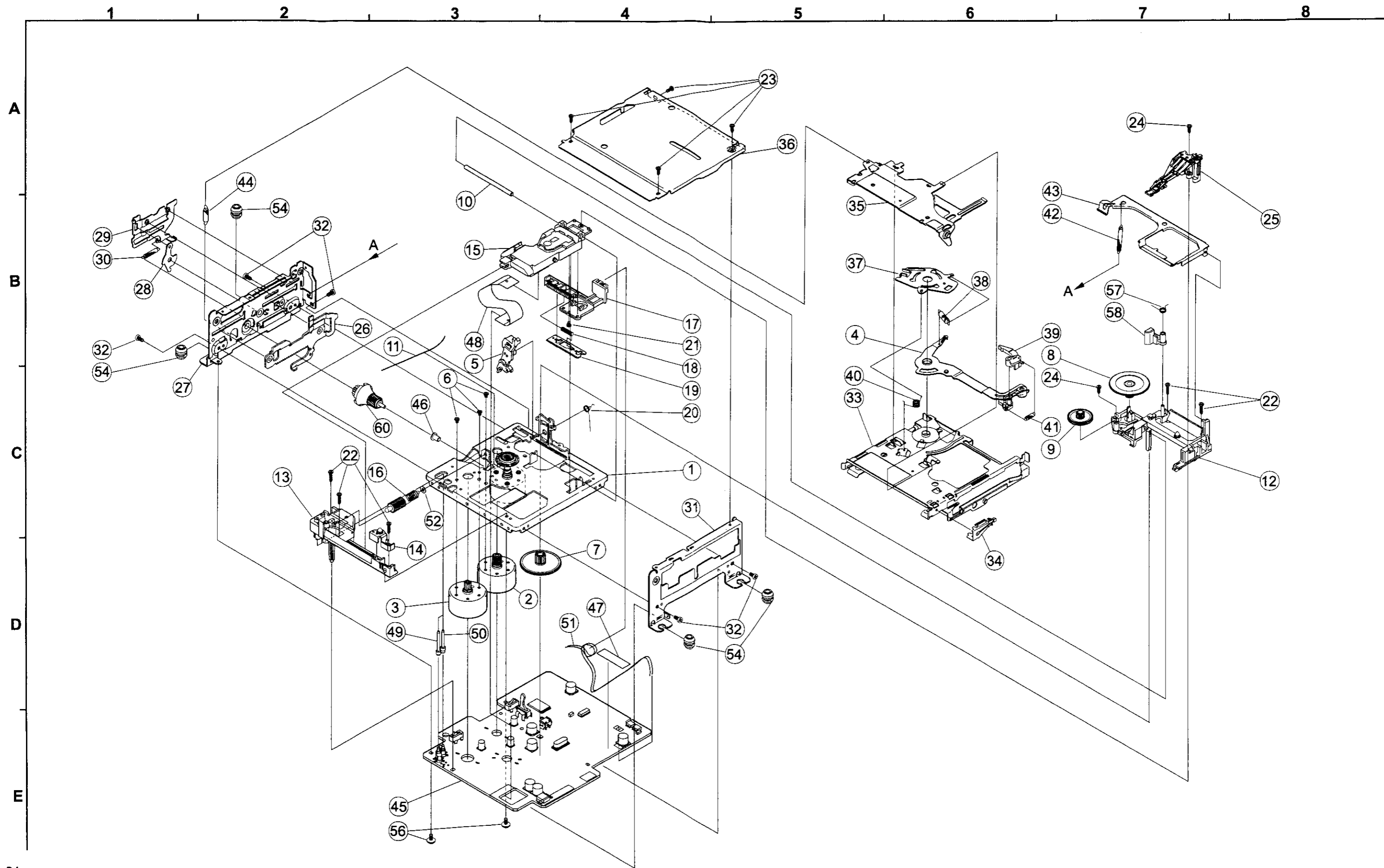

## PARTS LIST OF MD MECHANISM UNIT (DYMC2Z204A)

Ref. No.	Part No.	Part Name	Remarks	Q'ty	Ref. No.	Part No.	Part Name	Remarks	Q'ty
1	9DD 018S 014	Spindle motor ass'y block	D018S014	1	<b>SCREWS</b>				
2	9DD 018S 012	Sled motor ass'y	D018S012	1	6	9DF G164 15	Screw 1.7x2	FG164-15	3
3	9DD 018S 013	Loading motor ass'y	D018S013	1	21	9DU G16C 15	Screw 1.7x3	UG16C-15	1
4	9DD 022S 011	Loading ass'y	D022S011	1	22	9DU G23V 12	Screw 1.7x6	UG23V-12	5
5	9DD D116 22	Switch lever	DD116-22	1	23	9DU G23V 11	Screw 1.7x3	UG23V-11	4
7	9DD N114 12	Sled pinion	DN114-12	1	24	9DU G16C 12	Screw 1.7x4	UG16C-12	2
8	9DD N113 12	2nd gear	DN113-12	1	32	9DK G194 34	Screw 2x4	KG194-34	5
9	9DD N112 12	1st gear	DN112-12	1	56	9DU G23U 12	Screw 2x5-W	UG23U-12	3
10	9DD L111 11	Pick up shaft	DL111-11	1					
11	9DD K112 13	Spindle stabilizer	DK112-13	1					
12	9DD D111 18	Rear guide block	DD111-18	1					
13	9DD D112 17	Front guide block	DD112-17	1					
14	9DD D115 13	Locator	DD115-13	1					
15	9DD V111 11	Pick up unit	DV111-11	1					
16	9DD N116 22	2nd worm	DN116-22	1					
17	9DD D114 15	Sled base	DD114-15	1					
18	9DD K111 11	Rack slide spring	DK111-11	1					
19	9DD C112 12	Rack slider	DC112-12	1					
20	9DD K118 13	Switch lever spring	DK118-13	1					
25	9DD U111 11	O/W Head	DU111-11	1					
26	9DD C115 16	Loading mode rack	DC115-16	1					
27	9DD C113 15	Side bracket (L)	DC113-15	1					
28	9DD C116 12	Link	DC116-12	1					
29	9DD C117 14	REC slider	DC117-14	1					
30	9DD K114 11	Slide spring	DK114-11	1					
31	9DD C114 17	Side bracket (R)	DC114-17	1					
33	9DD C118 18	Holder (auto)	DC118-18	1					
34	9DD C120 52	Shutter spring	DC120-52	1					
35	D9D C119 15	Holder arm	DC119-15	1					
36	9DD C124 22	Top plate (auto)	DC124-22	1					
37	9DD C122 14	Draging plate	DC122-14	1					
38	9DD K113 12	Loading arm spring	DK113-12	1					
39	9DD D118 24	Eject nail	DD118-24	1					
40	9DD K117 30	Turn spring	DK117-30	1					
41	9DD K116 21	Catch arm spring	DK116-21	1					
42	9DD K119 11	Lifter spring	DK119-11	1					
43	9DD C123 13	Head lifter	DC123-13	1					
44	9DD K115 12	Holder arm spring	DK115-12	1					
45	9DD 0160 14	Control P.W.B. block	D016-014	1					
46	9DD D131 11	Bush	DD131-11	1					
47	—	Filament tape	EF14U-00, 20mm	1					
48	9DD P113 11	Pick up FPC	DP113-11	1					
49	9DD L113 12	Switch knob (L)	DL113-12	1					
50	9DD L112 12	Switch knob (S)	DL112-12	1					
51	—	Wire (BLK)	WG57M-10	2					
52	9DF J111 18	Washer poly $\phi 2.1 \times 0.25$	FJ111-18	1					
54	9DD R111 11	Insulator	DR111-11	4					
57	9DD K128 12	Stopper spring	DK128-12	1					
58	9DD C130 12	Holder stopper	DC130-12	1					
60	9DD 022S 013	Loading ass'y	D022S013	1					

MD RECORDER

PARTS LIST OF MD MECHANISM P.W.B. UNIT ASS'Y  
(DYMC2Z204A)

Ref. No.	Part No.	Part Name	Remarks	Ref. No.	Part No.	Part Name	Remarks
<b>SEMICONDUCTORS GROUP</b>				R36		Carbon chip 1 kohm 1/16W	102J1/16
U1	9R5 0000 170	IC CXA2523AR		R37		Carbon chip 100 ohm 1/16W	101J1/16
U21	UDM D331 172	IC CXD2652AR		R40		Carbon chip 150 ohm 1/16W	151J1/16
U22	9R5 0000 191	IC TC7S08FU		R41		Carbon chip 0 ohm 1/16W	000J1/16
U25	9R5 0000 192	IC MSM51V4400		R42,43		Carbon chip 100 kohm 1/16W	104J1/16
U52	9R5 0000 173	IC BH6511FS		R44		Carbon chip 100 ohm 1/16W	101J1/16
U81	9R5 0000 193	IC MC74ACT240		R46		Carbon chip 330 ohm 1/16W	331J1/16
U100	9R5 0000 194	IC TC55257DFTL-70V		R47		Carbon chip 100 ohm 1/16W	101J1/16
U101	9R5 0000 176	IC L88MS33T		R48		Carbon chip 680 ohm 1/16W	681J1/16
U102	9R5 0000 160	IC 24LC01B		R50		Carbon chip 0 ohm 1/16W	000J1/16
U103	9R5 0000 177	IC H8/3048		R58,59		Carbon chip 100 kohm 1/16W	104J1/16
U104	S87 5982 387	IC LB1638M		R61-63		Carbon chip 2.2 kohm 1/16W	222J1/16
U105	S87 5905 860	IC TC7SU04FU		R64		Carbon chip 680 ohm 1/16W	681J1/16
Q1	9R5 0000 195	Transistor DTA114YUA		R65		Carbon chip 100 kohm 1/16W	104J1/16
Q2	9R5 0000 196	Transistor 2SA1576A		R66		Carbon chip 2.2 ohm 1/4W	2R2J1/4(3225)
Q3,4	9R5 0000 198	Transistor DTC114YUA		R67		Carbon chip 4.7 kohm 1/16W	472J1/16
Q10	9R5 0000 159	Transistor UMW1N		R69		Carbon chip 1 ohm 1/10W	1R0J1/10(2125)
Q62	9R5 0000 197	Transistor 2SB798		R72		Carbon chip 0 ohm 1/16W	000J1/16
Q63	9R5 0000 195	Transistor DTA114YUA		R75		Carbon chip 3.3 kohm 1/16W	332J1/16
Q80	9R5 0000 198	Transistor DTC114YUA		R77		Carbon chip 3.3 kohm 1/16W	332J1/16
Q81	S87 2901 875	Transistor 2SJ278MY		R78		Carbon chip 0 ohm 1/16W	000J1/16
Q82	S87 2901 765	Transistor 2SK1764KY		R79		Carbon chip 47 kohm 1/16W	473J1/16
D1	S87 1998 862	Diode 1SS355		R80,81		Carbon chip 10 kohm 1/16W	103J1/16
D81	9R5 0000 199	Diode EC10QS06		R82,83		Carbon chip 47 kohm 1/16W	473J1/16
D83	9R5 0000 199	Diode EC10QS06		R84,85		Carbon chip 10 kohm 1/16W	103J1/16
D100,101	S87 1998 862	Diode 1SS355		R86		Carbon chip 0 ohm 1/16W	000J1/16
<b>RESISTORS GROUP</b>				R88-90		Carbon chip 10 kohm 1/16W	103J1/16
R1		Carbon chip 0 ohm 1/16W	000J1/16	R95,96		Carbon chip 0 ohm 1/16W	000J1/16
R3		Carbon chip 1 kohm 1/16W	102J1/16	R99		Carbon chip 390 ohm 1/16W	391J1/16
R4		Carbon chip 10 kohm 1/16W	103J1/16	R100		Carbon chip 47 kohm 1/16W	473J1/16
R5		Carbon chip 4.7 kohm 1/16W	472J1/16	R101-104		Carbon chip 47 kohm 1/16W	473J1/16
R6		Carbon chip 3.3 Mohm 1/16W	335J1/16	R105		Carbon chip 100 kohm 1/16W	104J1/16
R7		Carbon chip 470 kohm 1/16W	474J1/16	R106		Carbon chip 1 kohm 1/16W	102J1/16
R9		Carbon chip 0 ohm 1/16W	000J1/16	R107		Carbon chip 10 kohm 1/16W	103J1/16
R10		Carbon chip 10 kohm 1/16W	103J1/16	R109,110		Carbon chip 10 kohm 1/16W	103J1/16
R11		Carbon chip 0 ohm 1/16W	000J1/16	R120		Carbon chip 47 kohm 1/16W	473J1/16
R12		Carbon chip 47 kohm 1/16W	473J1/16	R121		Carbon chip 47 kohm 1/16W	473J1/16
R13		Carbon chip 1 kohm 1/16W	102J1/16	R122		Carbon chip 1 kohm 1/16W	102J1/16
R15		Carbon chip 1 kohm 1/16W	102J1/16	R123-126		Carbon chip 47 kohm 1/16W	473J1/16
R17		Carbon chip 470 kohm 1/16W	474J1/16	R127-129		Carbon chip 47 kohm 1/16W	473J1/16
R20		Carbon chip 100 ohm 1/16W	101J1/16	R201		Carbon chip 0 ohm 1/16W	000J1/16
R21		Carbon chip 100 kohm 1/16W	104J1/16	R205		Carbon chip 0 ohm 1/16W	000J1/16
R23-25		Carbon chip 100 ohm 1/16W	101J1/16	R214		Carbon chip 0 ohm 1/16W	000J1/16
R31,32		Carbon chip 10 kohm 1/16W	103J1/16	R502		Carbon chip 0 ohm 1/16W	000J1/16
R33		Carbon chip 3.3 kohm 1/16W	332J1/16	R504		Carbon chip 0 ohm 1/16W	000J1/16
R34		Carbon chip 1 kohm 1/16W	102J1/16	R776		Carbon chip 0 ohm 1/16W	000J1/16
R35		Carbon chip 3.3 kohm 1/16W	332J1/16				

Ref. No.	Part No.	Part Name	Remarks
<b>CAPACITORS GROUP</b>			
C1		Tantalum 10 $\mu$ F/10V	TAJA106M010
C2		Ceramic chip 0.1 $\mu$ F/25V	104Z25F
C3,4		Tantalum 10 $\mu$ F/10V	TAJA106M010
C5		Ceramic chip 0.01 $\mu$ F/50V	103K50B
C6		Ceramic chip 1000 pF/50V	102J50B
C7,8		Ceramic chip 0.1 $\mu$ F/25V	104Z25F
C9		Ceramic chip 0.022 $\mu$ F/25V	223K25B
C11		Ceramic chip 0.068 $\mu$ F/16V	683K16B
C12		Ceramic chip 4700 pF/50V	472J50B
C13		Ceramic chip 1 $\mu$ F/16V	105K16B(2125)
C15		Ceramic chip 0.22 $\mu$ F/10V	224K10B
C16		Ceramic chip 0.022 $\mu$ F/25V	223K25B
C17		Ceramic chip 0.1 $\mu$ F/16V	104K16B
C19		Tantalum 10 $\mu$ F/10V	TAJA106M010
C22		Ceramic chip 0.01 $\mu$ F/50V	103K50B
C23,24		Ceramic chip 0.1 $\mu$ F/25V	104Z25F
C27		Ceramic chip 0.1 $\mu$ F/25V	104Z25F
C28		Ceramic chip 0.01 $\mu$ F/50V	103K50B
C29		Ceramic chip 0.47 $\mu$ F/16V	474K16B(2125)
C30		Ceramic chip 100 pF/50V	101J50CH
C31		Ceramic chip 0.015 $\mu$ F/25V	153K25B
C32		Ceramic chip 0.47 $\mu$ F/16V	474K16B(2125)
C33		Ceramic chip 4700 pF/50V	472J50B
C34		Ceramic chip 0.1 $\mu$ F/25V	104Z25F
C35		Ceramic chip 0.1 $\mu$ F/25V	104Z25F
C36		Electrolytic 100 $\mu$ F/6.3V	UWX0J101MCR1
C41		Ceramic chip 0.1 $\mu$ F/25V	104Z25F
C51		Electrolytic 100 $\mu$ F/6.3V	UWX0J101MCR1
C52		Ceramic chip 0.1 $\mu$ F/25V	104Z25F
C53		Ceramic chip 0.01 $\mu$ F/50V	103K50B
C56,57		Ceramic chip 0.1 $\mu$ F/25V	104Z25F
C58		Ceramic chip 6800 pF/50V	682J50B
C60,61		Electrolytic 10 $\mu$ F/10V	UWP1A100MCR1
C62		Tantalum 10 $\mu$ F/10V	TCFGA1A106M
C63,64		Ceramic chip 0.01 $\mu$ F/50V	103K50B
C67,68		Ceramic chip 0.1 $\mu$ F/25V	104Z25F
C69		Tantalum 10 $\mu$ F/10V	TAJA106M010
C80		Ceramic chip 0.1 $\mu$ F/25V	104Z25F
C81		Electrolytic 100 $\mu$ F/6.3V	UWX0J101MCR1
C82,83		Ceramic chip 0.1 $\mu$ F/25V	104Z25F
C84		Electrolytic 22 $\mu$ F/8V	ECGC0KB220R
C85		Ceramic chip 1000 pF/500V	102K500B(3216)
C88		Ceramic chip 0.01 $\mu$ F/50V	103K50B
C89		Ceramic chip 0.033 $\mu$ F/16V	333K16B
C90		Ceramic chip 1 $\mu$ F/10V	105Z10F
C97,98		Ceramic chip 24 pF/50V	240J50CH
C101~105		Ceramic chip 0.1 $\mu$ F/25V	104Z25F
C106,107		Ceramic chip 0.1 $\mu$ F/25V	104Z25F
C108		Electrolytic 100 $\mu$ F/6.3V	UWX0J101MCR1
C109		Tantalum 10 $\mu$ F/10V	TAJA106M010

Ref. No.	Part No.	Part Name	Remarks	
C111		Ceramic chip 0.1 $\mu$ F/25V	104Z25F	
C112		Electrolytic 100 $\mu$ F/6.3V	UWX0J101MCR1	
C113		Ceramic chip 1 $\mu$ F/10V	105Z10F	
C114		Electrolytic 100 $\mu$ F/6.3V	UWX0J101MCR1	
C115,116		Ceramic chip 1 $\mu$ F/10V	105Z10F	
C117,118		Ceramic chip 0.1 $\mu$ F/25V	104Z25F	
C119		Ceramic chip 1 $\mu$ F/10V	105Z10F	
C121		Ceramic chip 1 $\mu$ F/10V	105Z10F	
C200		Electrolytic 22 $\mu$ F/6.3V	UWX0J220MCR1	
C201~203		Ceramic chip 0.1 $\mu$ F/25V	104Z25F	
<b>OTHER PARTS GROUP</b>				
CN1	9R5 0000 200	22FLZ-SM1 connector	22FLZ-SM1	1
CN2	9R5 0000 188	24FMN-SM connector	24FMN-SM	1
CN3	9R5 0000 189	S 4B-ZR-SM connector	S 4B-ZR-SM	1
L1-3	9R5 00000203	Ferrite bead	N2012Z102T	3
L6,7	9R5 00000203	Ferrite bead	N2012Z102T	2
L22	9R5 00000203	Ferrite bead	N2012Z102T	1
L51,52	9R5 0000 146	Inductor	LQH1C100K	2
L53,54	9R5 0000 147	Inductor	LQH4N101K	2
L61,62	9R5 00000203	Ferrite bead	N2012Z102T	2
L100	9R5 00000203	Ferrite bead	N2012Z102T	1
SW1	9R5 0000 183	Switch	SPVF230100	1
SW2	9R5 0000 184	Switch	SPPB620100	1
SW3,4	9R5 0000 155	Switch	SPVF11006A	2
SW5,6	9R5 0000 185	Switch	SPPB530601	2
X1	9R5 0000 207	Crystal (22.5792MHz)	SMD-49 22.5792MHz	1
X2	9R5 0000 187	Ceramic resonator (8.00MHz)	PBRC8.00BR-A	1



MD RECORDER

PRINTED WIRING BOARD

1

2

3

4

MD MECHANISM P.W.B. UNIT ASS'Y

A

B

C

D

E

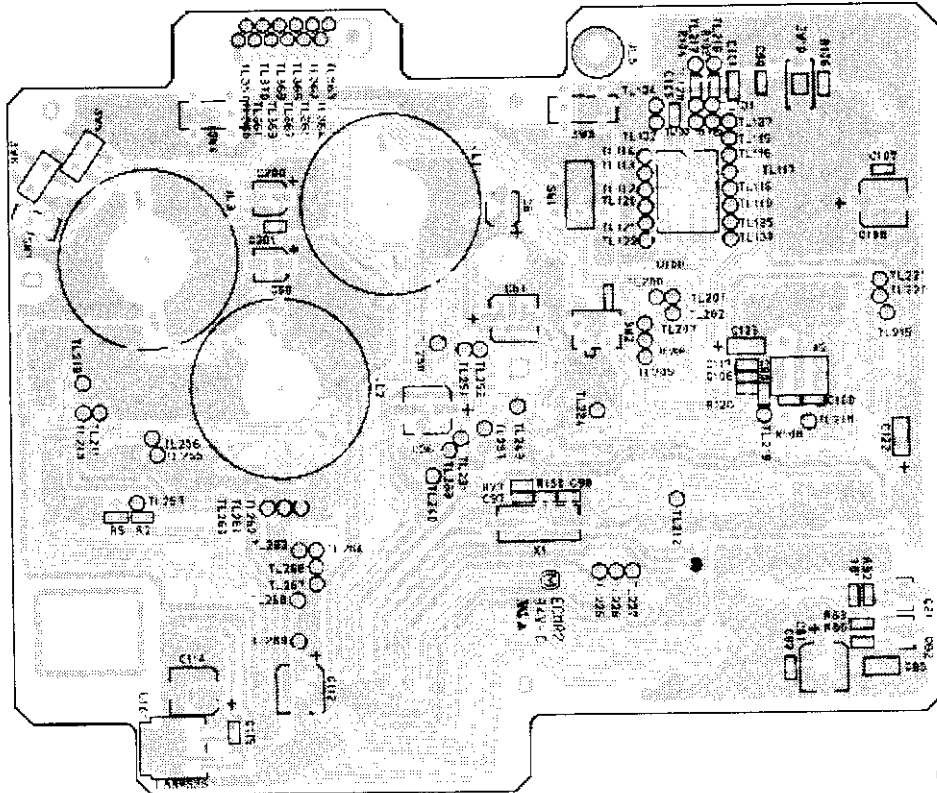

COMPONENT SIDE

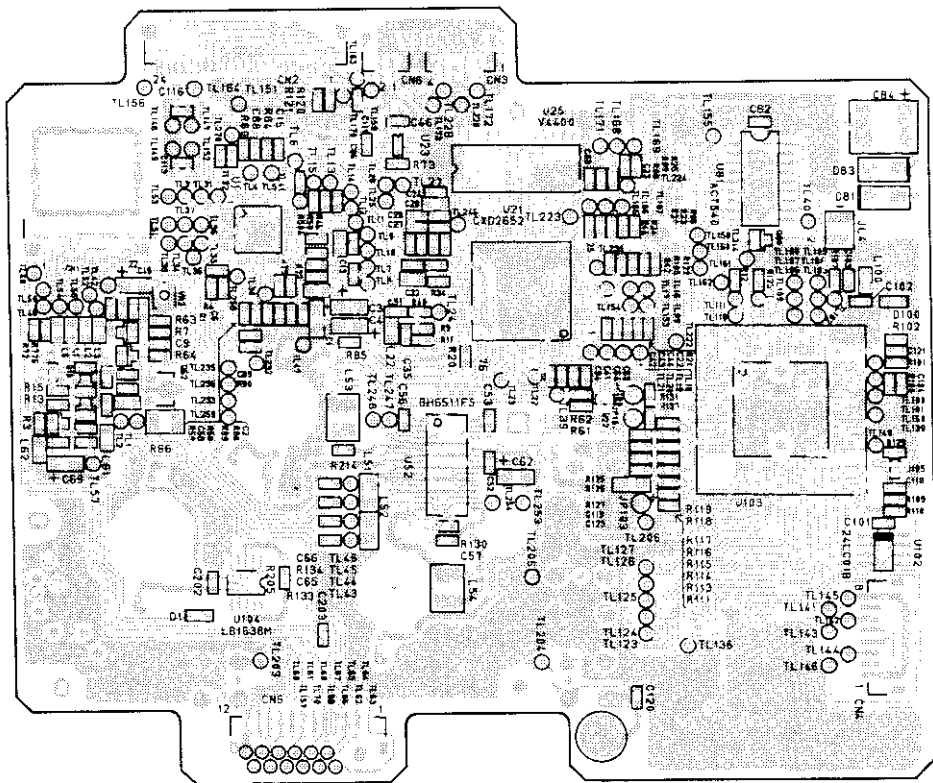

FOIL SIDE

SCHEMATIC DIAGRAMS (1/3)

1 2 3 4 5 6 7 8

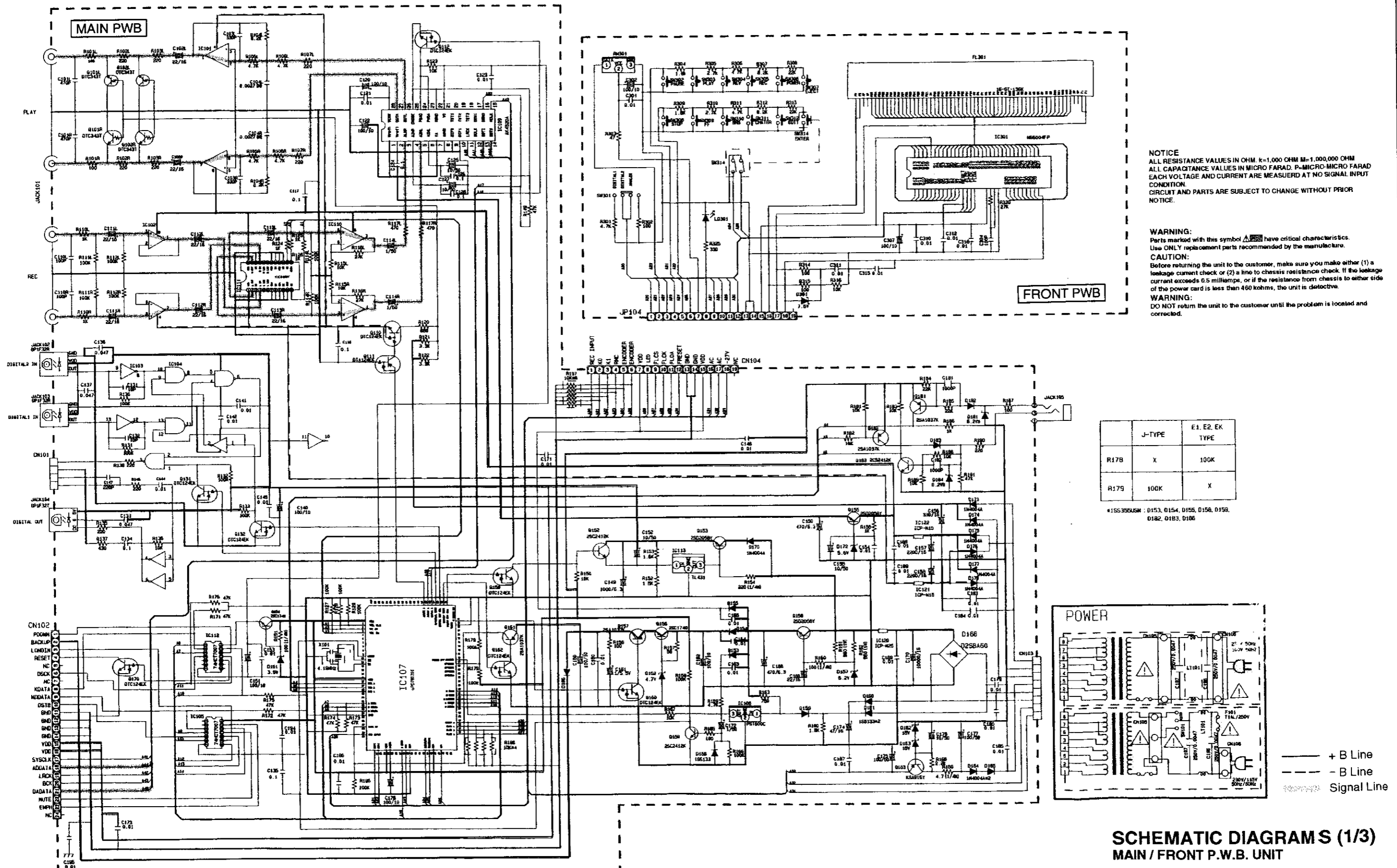

**NOTICE**  
 ALL RESISTANCE VALUES IN OHM. K=1,000 OHM M=1,000,000 OHM  
 ALL CAPACITANCE VALUES IN MICRO FARAD. P=MICRO-MICRO FARAD  
 EACH VOLTAGE AND CURRENT ARE MEASURED AT NO SIGNAL INPUT  
 CONDITION.  
 CIRCUIT AND PARTS ARE SUBJECT TO CHANGE WITHOUT PRIOR  
 NOTICE.

**WARNING:**  
 Parts marked with this symbol have critical characteristics.  
 Use ONLY replacement parts recommended by the manufacturer.

**CAUTION:**  
 Before returning the unit to the customer, make sure you make either (1) a  
 leakage current check or (2) a line to chassis resistance check. If the leakage  
 current exceeds 0.5 millamps, or if the resistance from chassis to either side  
 of the power card is less than 460 kohms, the unit is defective.

**WARNING:**  
 DO NOT return the unit to the customer until the problem is located and  
 corrected.

SCHEMATIC DIAGRAMS (1/3)  
MAIN / FRONT P.W.B. UNIT

A  
B  
C  
D  
E

MD RECORDER  
SCHEMATIC DIAGRAMS (2/3)

1 2 3 4 5 6 7 8

MD MECHA. UNIT (1/2)

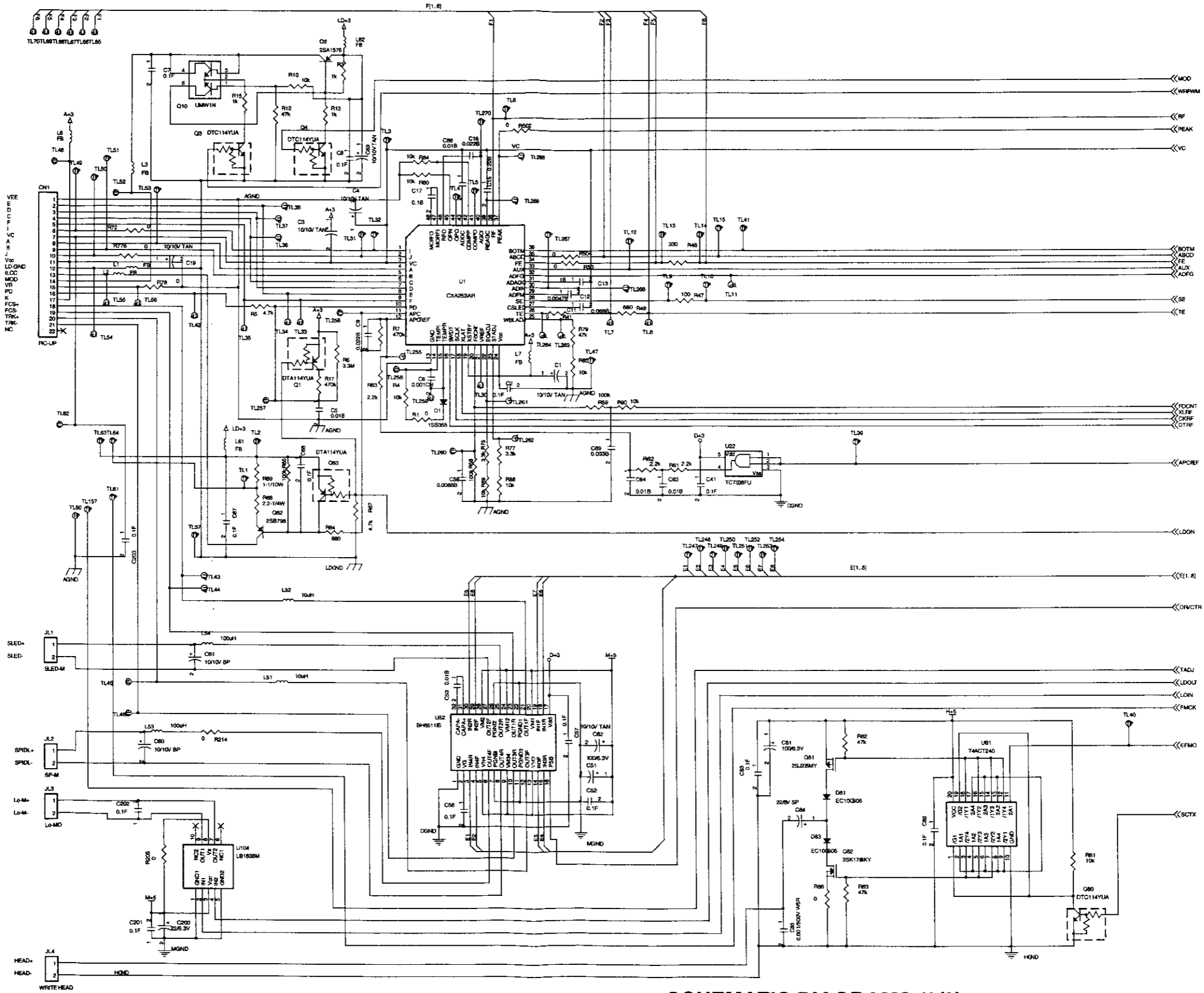

SCHEMATIC DIAGRAMS (2/3)  
MD MECHA. UNIT (1/2)

SCHEMATIC DIAGRAMS (3/3)

MD MECHA. UNIT (2/2)

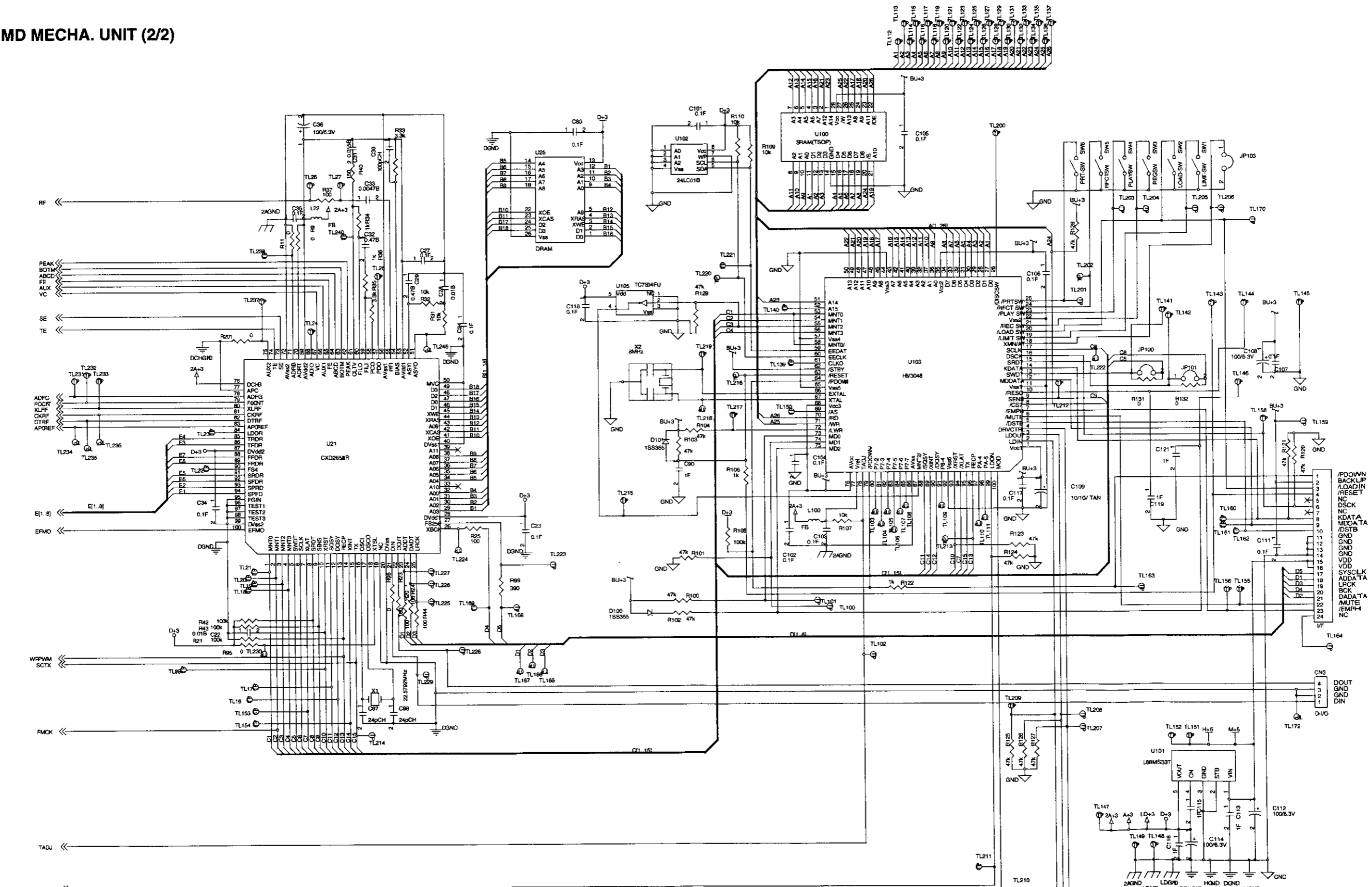

SCHEMATIC DIAGRAMS (3/3)  
MD MECHA. UNIT (2/2)

A  
B  
C  
D  
E

MEMO:

CASSETTE DECK

BLOCK DIAGRAM

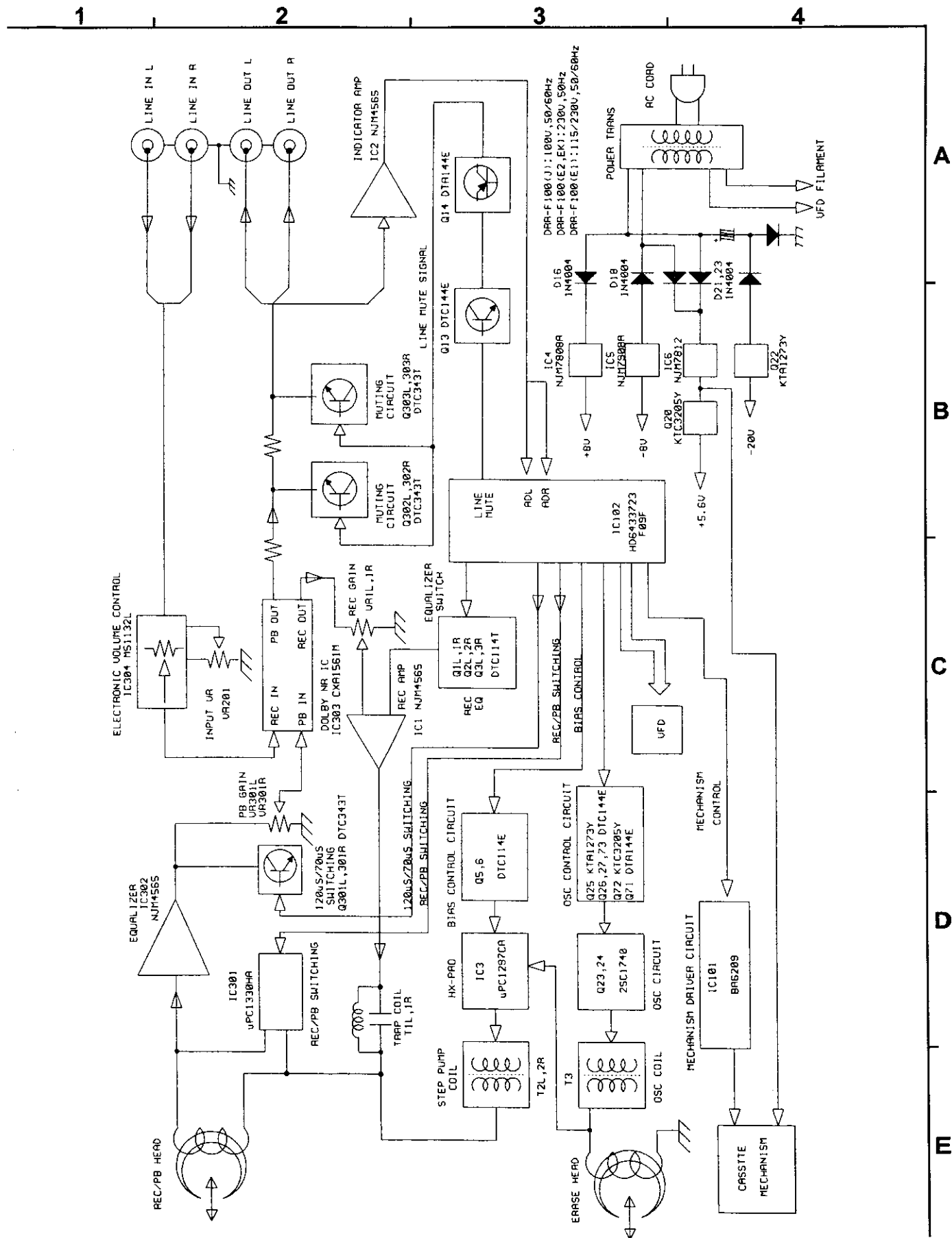

CASSETTE DECK

LEVEL DIAGRAM

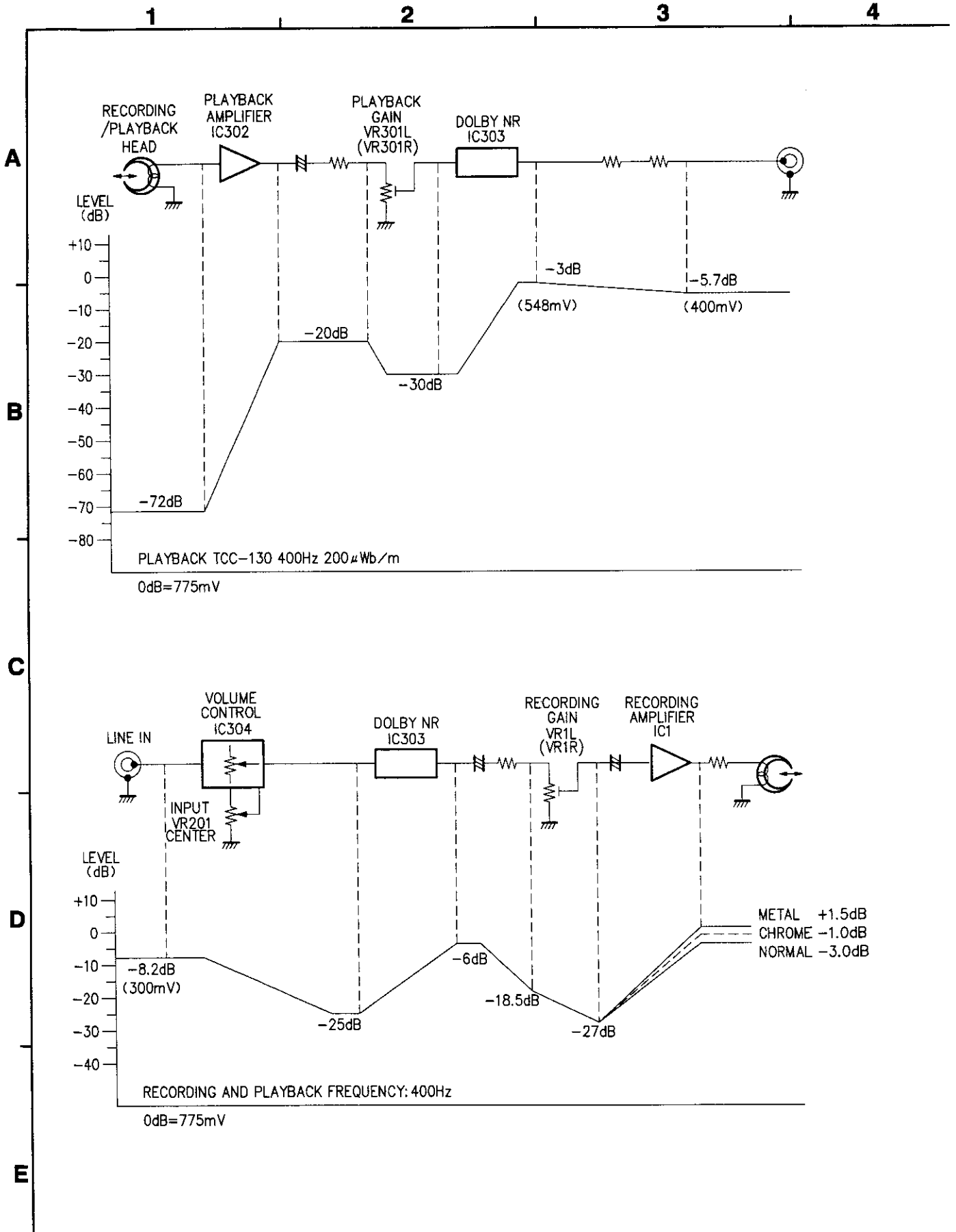

## DISASSEMBLY

(Follow the procedure below in reverse order when reassembling)

### 1. Top Cover & Front Panel

- (1) Remove 5 screws ① fixing the Top Cover.
- (2) Detach the Top Cover as shown in the arrow direction.

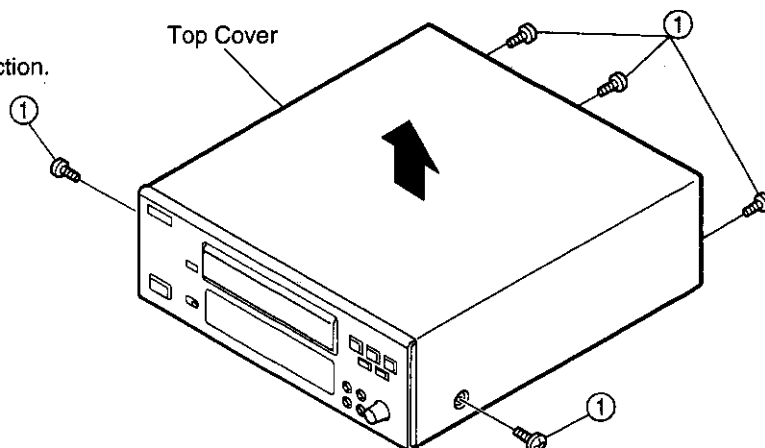

- (3) Remove 4 screws ② on the bottom and both sides.
- (4) Disconnect 28P FPC and 3P Connector Cord from their connector bases.
- (5) Pull the Front Panel in the arrow direction with releasing Hooks on the Front Frame from the Chassis, and it comes off with the Front Frame.

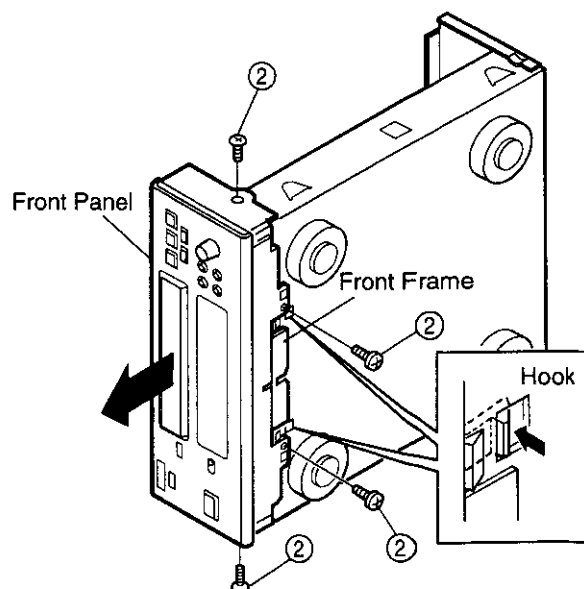

### 2. P.W.B. on Panel

#### FRONT P.W.B.

- (1) Pull out the Control Knob to the arrow direction, and remove 3 screws ③.
- (2) Detach the Front P.W.B. with releasing 5 Hooks.

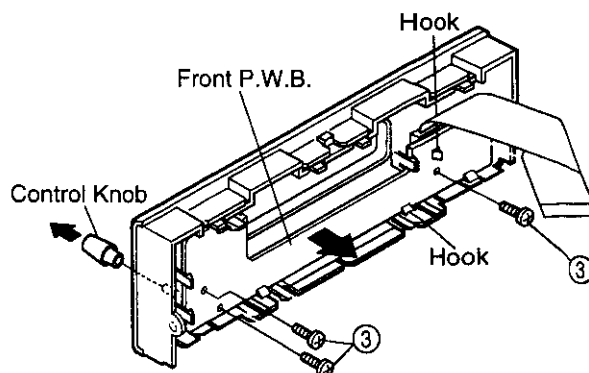



**CASSETTE DECK**

**3. Back Chassis**

- (1) Take off the Cord Stopper from the Back Chassis.
- (2) Remove 4 screws (4), and detach the Back Chassis to the arrow direction.

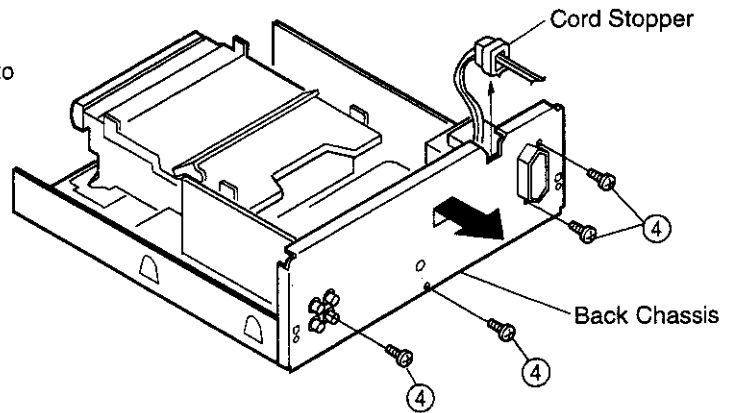

**MICOM P.W.B.**

- (3) Remove 2 screws (5), and detach the Micom P.W.B. to the arrow direction.

**AUDIO P.W.B.**

- (4) Detach the Audio P.W.B. by disconnecting from its connector as shown in the arrow direction.

**4. Cassette Mecha. Ass'y**

- (1) Remove 4 screws (6) fixing the Cassette Mecha. Ass'y.
- (2) Disconnect 2P Shield Connector Cord and 5P, 13P Connector Cord from their connector bases.
- (3) Detach the Cassette Mecha. Ass'y to the arrow direction.

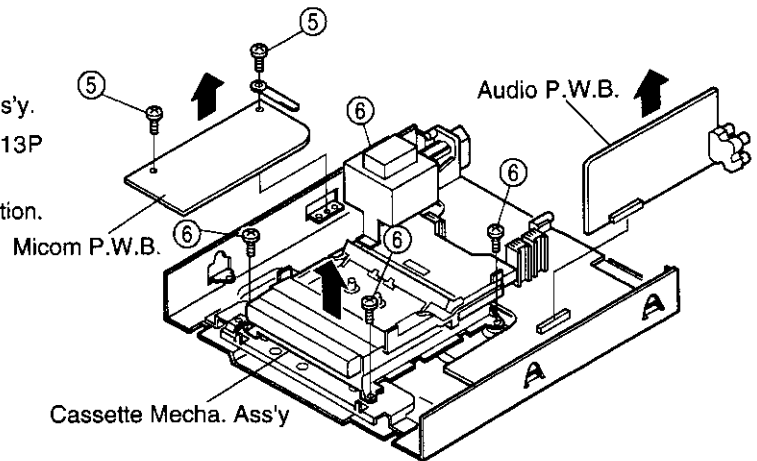

**MAIN P.W.B.**

- (4) Remove 3 screws (7), and detach the Main P.W.B. to the arrow direction.

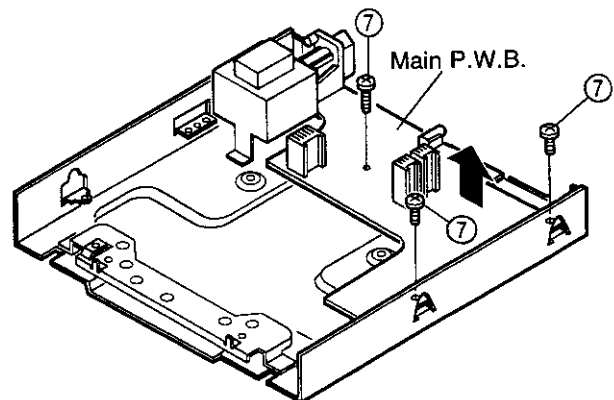

## ADJUSTMENTS

### Adjusting and Checking the Mechanism Section

#### 1. Replacement of the pinch roller

Before replacing the pinch roller, clean the tape contact surface of the pinch roller and the tape contact surface of the capstan shaft. After replacement, run a C-90 tape without a pad and check for the presence of tape curl at the tape guide portion of the head.

#### 2. Checking the pinch roller pressure

Set to the playback condition and hook a bar-type spring scale to the bracket above the center line of the pinch roller. Pull the pinch roller away from the capstan shaft, then allow the pinch roller to come into contact with the capstan shaft and check that the reading of the bar-type spring scale is between 250 g and 350 g when the pinch roller starts to rotate.

Replace the pinch roller when the value falls outside of the specified range.

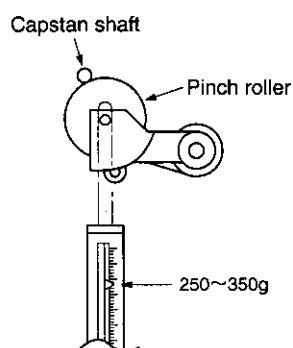

#### 3. Replacement of the recording/playback head assembly

Perform this procedure after removing the front panel.

##### 3-1 Removal of the head assembly

- (1) Remove the 2 head base fastening screws.
- (2) Remove the head base from the reed holder and the wire connector.

##### 3-2 Mounting the recording/playback head assembly

Perform by following the steps of Section 3-1 Removal of the head assembly in reverse.

#### 4. Adjustment of the recording/playback head

Azimuth adjustment

Load side A of the A-BEX TCC-153 test tape facing forward, and adjust.

- (1) Play in the FWD direction and turn the azimuth adjustment nut for the FWD side so that the Lissajous figure becomes maximum at (A) and minimum at (B).
- (2) Play in the REW direction and turn the azimuth adjustment nut for the REW side as adjusting the FWD side method.
- (3) Adjust (1) and (2) again.
- (4) Apply screw lock to the adjustment locations.

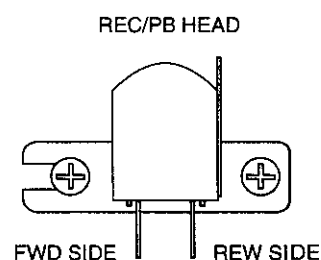
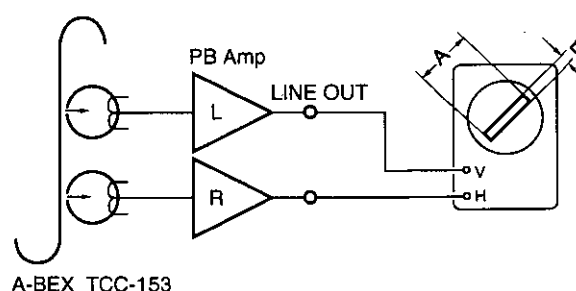

#### 5. Checking the winding torque

Load a cassette type torque meter (Sony TW2111A at the FWD side) and check that the reading of the torque meter during playback is 30 to 70 g-cm at the center value.

When outside of the specified value range, check the voltage of the reel motor (approx. 4 V). When the voltage value is low, the torque is weak, and when high, the torque is strong.

**CASSETTE DECK****6. Checking the back tension torque at the time of recording and playback**

Load a cassette type torque meter (Sony TW2111A at the FWD side) and check that the reading of the torque meter during playback is 1.5 to 6 g-cm and that there is no unevenness.

**7. Checking the FF and REW torque**

Load a cassette type torque meter (Sony TW2231) and check that the value indicated by the torque meter for winding and rewinding is between 70 and 150 g-cm.

**8. Checking the FF and REW time**

Load a DENON HD-X/60 cassette tape, and check that the time for FF and REW is below 120 seconds. When outside of the specified range, check Steps 5 and 6.

**9. Checking the erroneous erasure prevention, and the metal and chrome switch operations**

Check that detection lever is operating the switch properly depending upon the presence or absence of a hole.

**Adjusting and Checking the Electrical Section****Measuring instruments needed for the adjustments**

- (1) Low frequency oscillator
- (2) Variable resistance attenuator
- (3) Electronic voltmeter
- (4) Oscilloscope
- (5) Frequency counter
- (6) Adjustment screwdriver
- (7) 4-sided adjustment rod for trap coil adjustments
- (8) Test tapes
  - (Sony TY-224)
  - (A-BEX TCC-153, TCC-130, TCC-262B/162B)
  - (DENON HD-X/60)
- (9) Mirror cassette for the transport (A-BEX TCC-902)

**Adjustment precaution**

- (1) Before adjustments, use gauze or a swab moistened with alcohol to wipe the surface of the heads, the capstan shaft, and the pinch roller.
- (2) Demagnetize the record/playback head and the erase head with a head eraser.
- (3) Completely demagnetize the driver to be used for the adjustments.
- (4) Unless otherwise specified, set the various operation controls as indicated below.

REC level: Center

Dolby NR switch: Off

**1. Tape transport check**

Load the mirror cassette for the transport, and illuminate the area around the fixed guide of the record/playback head with a lamp and observe.

Check that the tape edge is not hitting the tape guide portion.

Note that the tape transport is the greatest factor affecting the performance of the cassette deck. Never move the inspection locations without good reason.

For information about replacement and adjustment of the record/playback head, see the section "Adjustment and checking of the mechanism".

**2. Azimuth adjustment**

2-1 After making the tape transport check, load the test tape (A-BEX TCC-153).

2-2 Play back the test tape and turn the azimuth adjustment nut so that the Lissajous figure becomes maximum at (A) and minimum at (B).

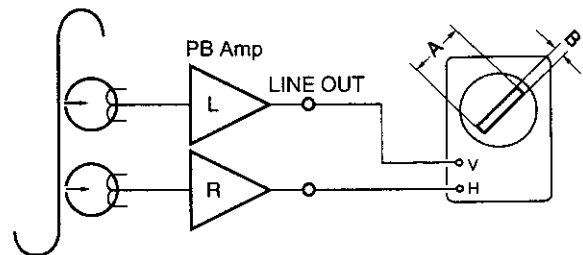

A-BEX TCC-153

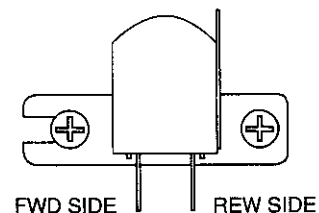
**REC/PB HEAD**

**CASSETTE DECK**

**3. Tape speed check and adjustment**

- 3-1 Connect the frequency counter to the LINE OUT pin and load the test tape (Sony TY-224).
- 3-2 Playback a test tape. At about halfway through the tape, where the tape transport is stable, confirm that the frequency counter will have a reading within the range of 3,000 Hz  $\pm$ 15 Hz.

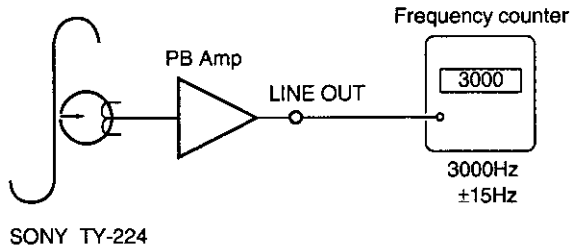

**4-2 Checking the playback frequency responses**

Play back the test tape (A-BEX TCC-262B/162B), and check that the frequency response satisfies the standard.

**NOTE** After making the azimuth adjustment with the 8 kHz at the start of the A-BEX TCC-262B test tape, perform check of the frequency responses. Also, after the check make an azimuth adjustment again with A-BEX TCC-153, then apply screw lock.

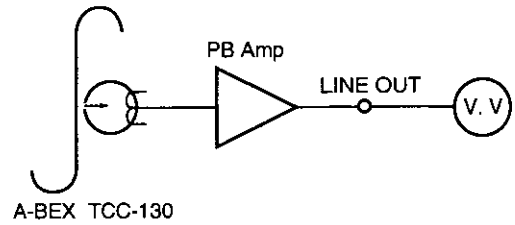

**4. Adjustment of the playback system**

**4-1 Playback level**

Play back the test tape for the Dolby standard level (A-BEX TCC-130), and adjust VR301L (Left channel) and VR301R (right channel) so that the level of the LINE OUT pin becomes -5.7 dBm (400 mV). (Load resistance of 47 kohm)

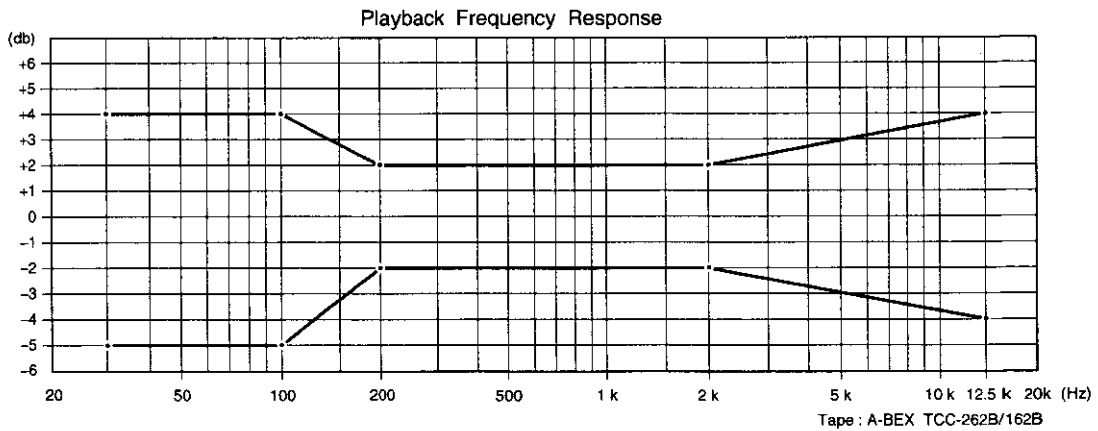
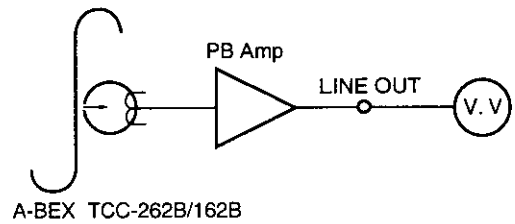

**CASSETTE DECK**

**5. Adjustment of the recording system**

5-1 Adjustment of the recording and playback overall frequency respons

- (1) Load the DENON HD-X/60 test tape, record a signal of -20 dBm (30mV) 1 kHz input level, and play back.
- (2) Set the input signal to 10 kHz, record, and play back. Adjust VR2L (left channel) and VR2R (right channel) so that the response specifications of the diagram below are satisfied with respect to the 1 kHz output level.

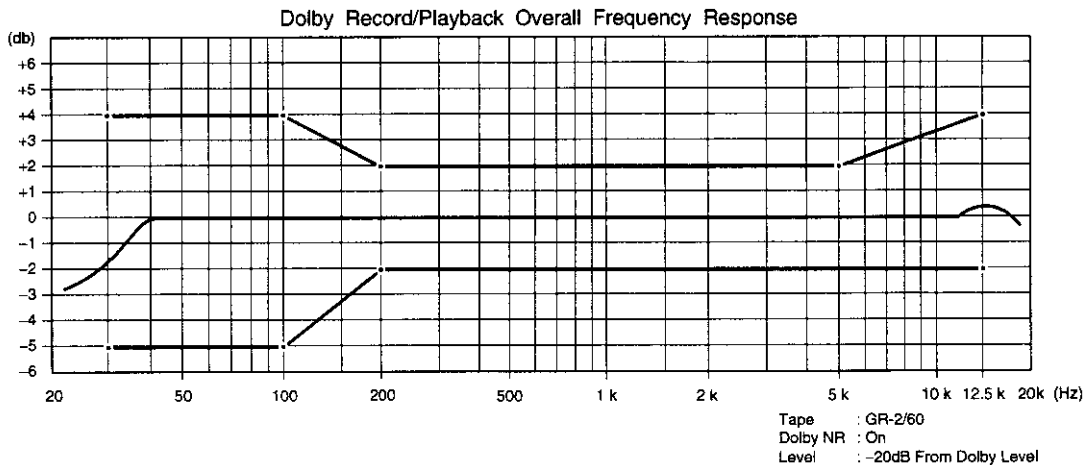
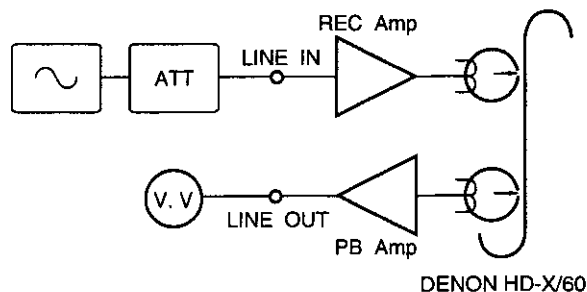

5-2 Adjustment of the recording/playback level

- (1) Load the DENON HD-X/60 test tape, record a signal of 1 kHz (-20 dBm), and play back.
- (2) Adjust VR1L (left channel) and VR1R (right channel) so that the output of the LINE OUT pin becomes the same as the output at the time of the recording monitor.

5-3 Checking the Dolby C recording and playback overall frequency response.

- (1) Set the Dolby NR switch to the "C" positions.
- (2) Use the DENON HD-X/60 test tape to record and play back according to the outline of Section 5-1, then check that the response specifications have been satisfied.

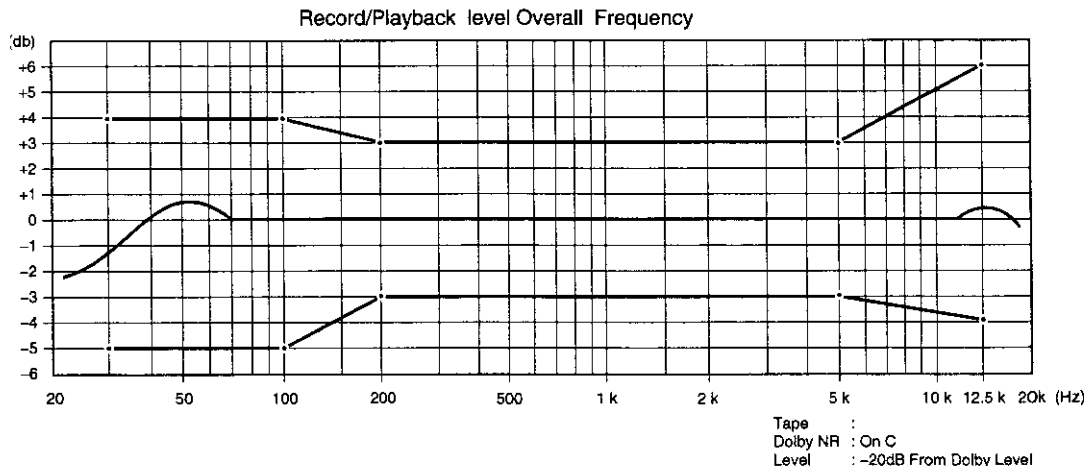

### Adjustment VR Locations

Audio P.W.B. (Component Side)

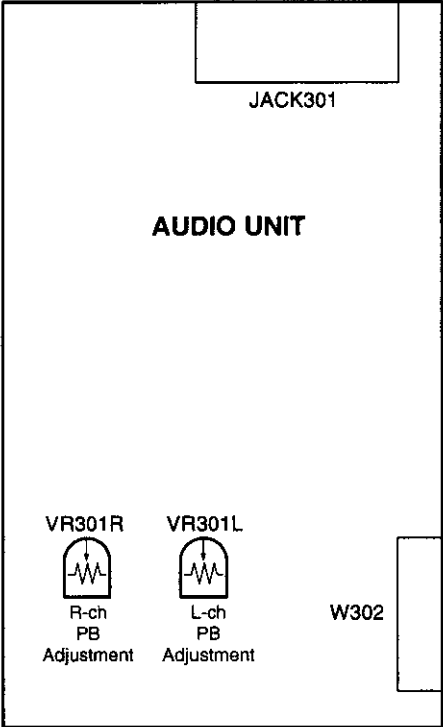

Main P.W.B. (Component Side)

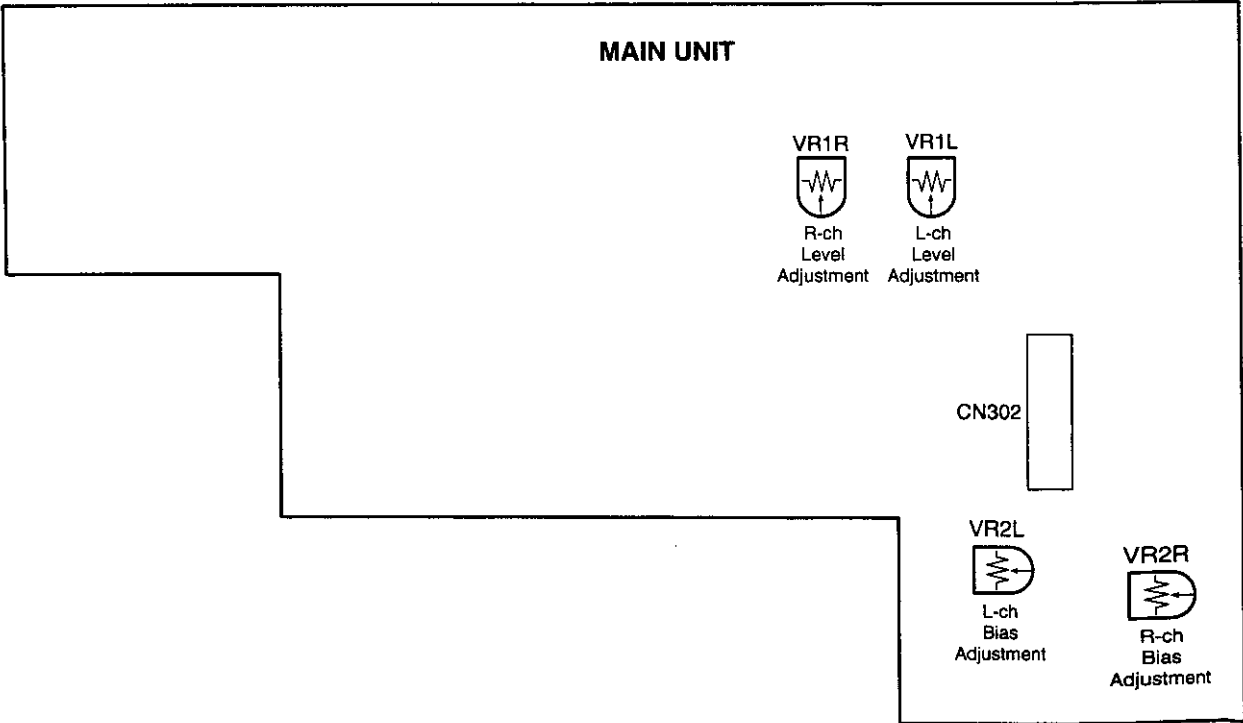

CASSETTE DECK

SEMICONDUCTORS  
HD6433723F09F (IC102)

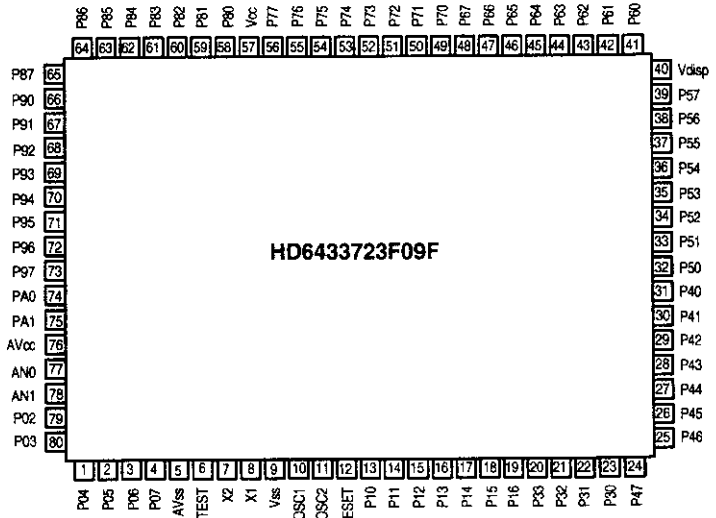
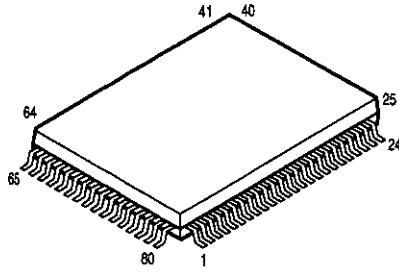

● HD6433723F09F Terminal Function

Pin No.	Name	I/O	PULL U/D	ACT	Symbol	Function
1	P04	I	—	—		Not Used
2	P05	I	—	—		Not Used
3	P06	I	—	—		Not Used
4	P07	I	—	—		Not Used
5	AVss	I	—	—	AVss	A/D GND
6	TEST	I	—	—	TEST	GND
7	X2	O	—	—	X2	Not Used
8	X1	I	—	—	X1	+5V
9	Vss	I	—	—	Vss	GND
10	OSC1	I	—	—	OSC1	System OSC input terminal (4.19 MHz)
11	OSC2	O	—	—	OSC2	System OSC output terminal (4.19 MHz)
12	RESET	I	—	L	RESET	System reset input signal, L: Reset
13	P10	—	—	—		Not Used
14	P11	I	—	H	OPEN SW	When switch open: H
15	P12	I	—	H	CLOSE SW	When switch close: H
16	P13	O	—	H	TARY M/C IN	When tray loading-in: H
17	P14	O	—	H	TRAY M/C OUT	When tray loading-out: H
18	P15	—	—	—		Not Used
19	P16	—	—	—		Not Used
20	P33	I	P/D GND	H	KR4	Key read out signal 4
21	P32	I	P/D GND	H	KR3	Key read out signal 3
22	P31	I	P/D GND	H	KR2	Key read out signal 2
23	P30	I	P/D GND	H	KR1	Key read out signal 1
24	P47	O	P/D GND	H	KS4	Key scan signal 4
25	P46	O	P/D GND	H	KS3	Key scan signal 3
26	P45	O	P/D GND	H	KS2	Key scan signal 2
27	P44	O	P/D GND	H	KS1	Key scan signal 1
28	P43	O	—	H		Not Used
29	P42	O	—	H		Not Used
30	P41	O	—	H		Not Used
31	P40	O	P/D Vdisp	H	S17	FLT display segment terminal 17
32	P50	O	P/D Vdisp	H	S16	FLT display segment terminal 16
33	P51	O	P/D Vdisp	H	S15	FLT display segment terminal 15

## CASSETTE DECK

Pin No.	Name	I/O	PULL U/D	ACT	Symbol	Function
34	P52	O	P/D Vdisp	H	S14	FLT display segment terminal 14
35	P53	O	P/D Vdisp	H	S13	FLT display segment terminal 13
36	P54	O	P/D Vdisp	H	S12	FLT display segment terminal 12
37	P55	O	P/D Vdisp	H	S11	FLT display segment terminal 11
38	P56	O	P/D Vdisp	H	S10	FLT display segment terminal 10
39	P57	O	P/D Vdisp	H	S9	FLT display segment terminal 9
40	Vdisp	I	—	—	Vdisp	Power for FLT
41	P60	O	P/D Vdisp	H	S8	FLT display segment terminal 8
42	P61	O	P/D Vdisp	H	S7	FLT display segment terminal 7
43	P62	O	P/D Vdisp	H	S6	FLT display segment terminal 6
44	P63	O	P/D Vdisp	H	S5	FLT display segment terminal 5
45	P64	O	P/D Vdisp	H	S4	FLT display segment terminal 4
46	P65	O	P/D Vdisp	H	S3	FLT display segment terminal 3
47	P66	O	P/D Vdisp	H	S2	FLT display segment terminal 2
48	P67	O	P/D Vdisp	H	S1	FLT display segment terminal 1
49	P70	O	P/D Vdisp	H	G5	FLT display grid terminal 5
50	P71	O	P/D Vdisp	H	G4	FLT display grid terminal 4
51	P72	O	P/D Vdisp	H	G3	FLT display grid terminal 3
52	P73	O	P/D Vdisp	H	G2	FLT display grid terminal 2
53	P74	O	P/D Vdisp	H	G1	FLT display grid terminal 1
54	P75	—	—	—		Not Used
55	P76	—	—	—		Not Used
56	P77	O	P/D GND	L	LINE MUTE	L: Line mute on, H: Signal
57	VCC	I	—	—	VCC	System power +5V
58	P80	I	—	L	POWER OFF	Power off detect signal, L: OFF
59	P81	O	—	H/L	DOLBY B/C	H: Dolby B, L: Dolby C
60	P82	O	—	L/H	DOLBY REC	L: Dolby REC, H: Dolby PB
61	P83	O	—	L/H	DOLBY ON/OFF	L: Dolby ON, H: Dolby OFF
62	P84	I	—	L	INH-R	L: REV REC inhibited, H: REV REC
63	P85	I	—	H	MODE SW	H: Head up, L: Head down
64	P86	O	—	H	CPM	H: Capstan motor on
65	P87	I	—	H	HALF SW	H: Tape detected, L: Tape non-detect
66	P90	O	—	H	SOL	H: Solenoid on
67	P91	O	—	L	SCK	Serial comm. Clock signal (62.5 μs)
68	P92	I	—	L	SI	Serial data input signal
69	P93	O	—	L	SO	Serial data output signal
70	P94	I	—	H/L	HALL OUT	Reel sensor detect input signal
71	P95	I	—	L	INH-F	L: FWD REC inhibited, H: FWD REC
72	P96	O	—	H	REC-MUTE	H: REC mute, L: REC
73	P97	O	—	H/L	R/P HEAD SW	H: REC/PAUSE/MUTE, L: Others
74	PA0	O	—	H	BIAS	L: In recording, H: Others
75	PA1	—	—	—		Not Used
76	AVCC	I	—	—	AVCC	+5V
77	AN0	I	—	—	LEVEL "R"	Rch level input signal
78	AN1	I	—	—	LEVEL "L"	Lch level input signal
79	P02	I	—	—		Not Used
80	P03	I	—	—		Not Used



CASSETTE DECK

CXA1561M (IC303)

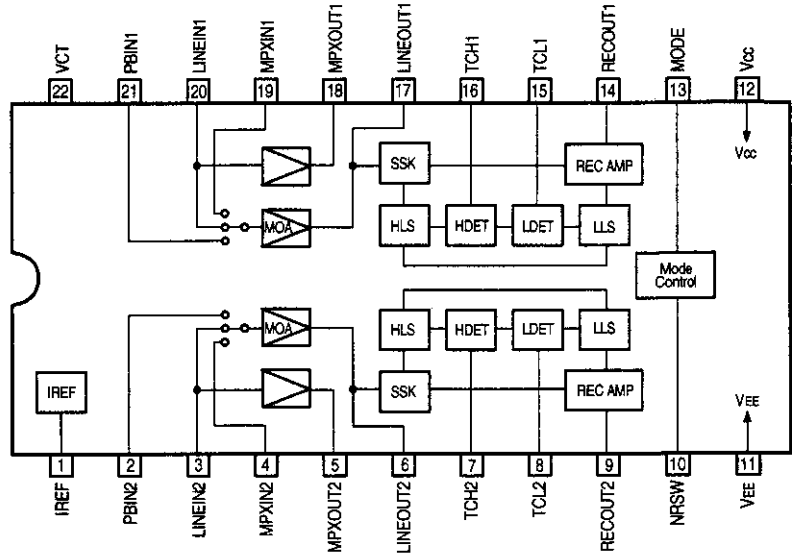
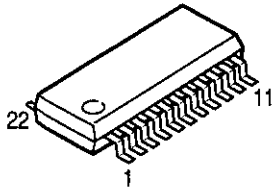

$\mu$ PC1330HA (IC301)

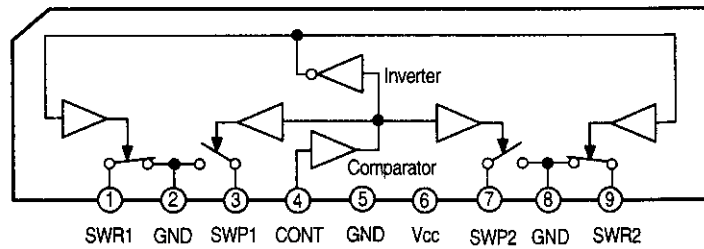
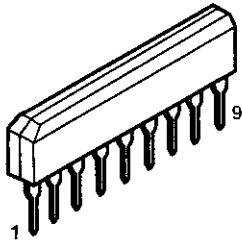

$\mu$ PC1297CA (IC305)

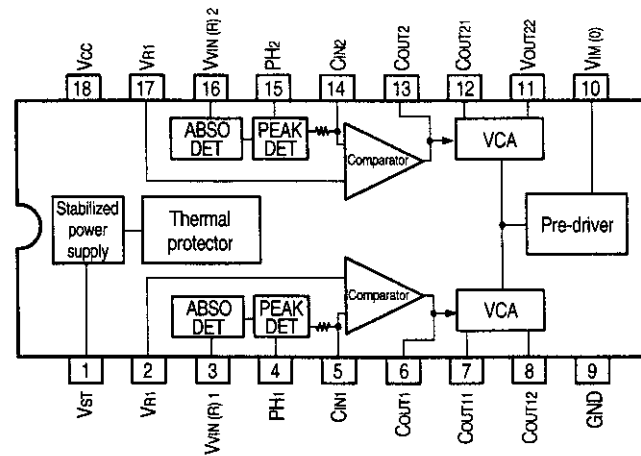
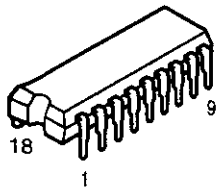

M51132L (IC304)

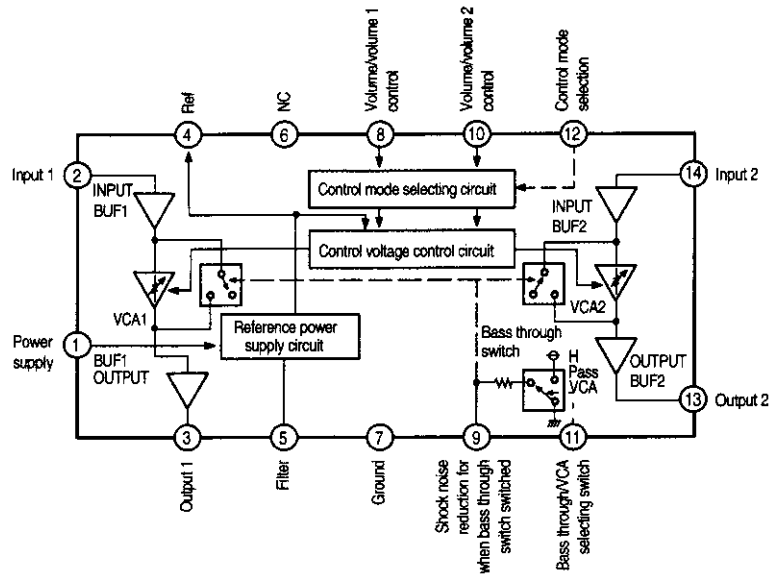
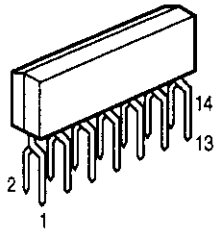

NJM4565MD (IC1,2,302)

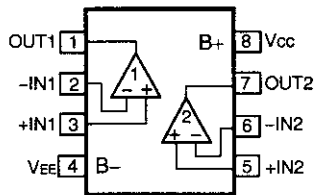
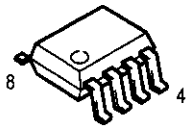

NJM7908FA (IC5)

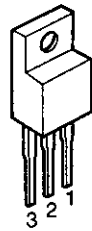

1: Output  
2: Input  
3: GND

NJM7808FA (IC4)  
NJM7812 (IC6)

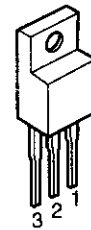

1: Output  
2: GND  
3: Input

BA6209N (IC101)

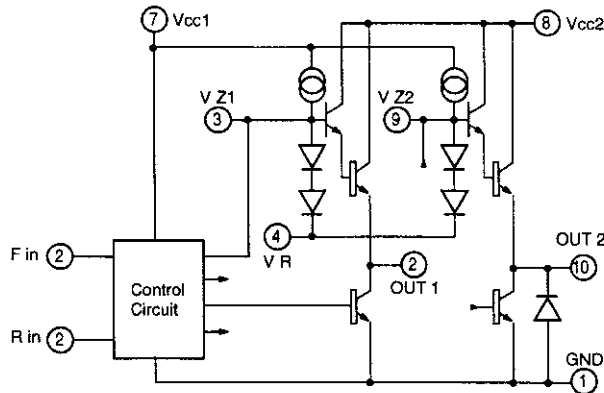
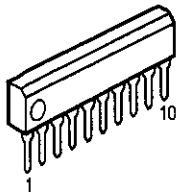

**CASSETTE DECK**

● **Transistors**

**2SC1740S**

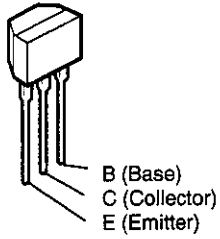

**KTA1273  
KTC3205**

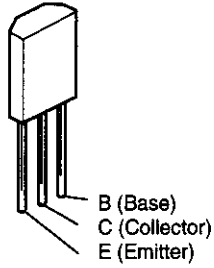

**2SA1037K  
2SC2412K**

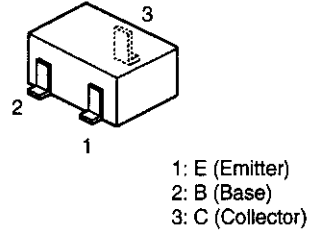

**DTA144EK  
DTC114EK  
DTC124EK  
DTC144EK  
DTC343TK**

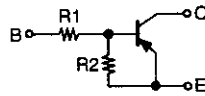
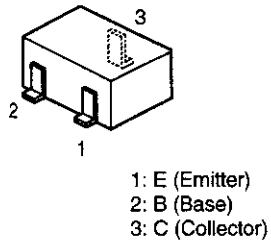

	R1	R2
DTA144EK	47kohm	47kohm

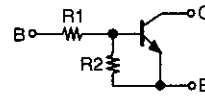

	R1	R2
DTC114EK	10kohm	10kohm
DTC124EK	22kohm	22kohm
DTC144EK	47kohm	47kohm
DTC343TK	4.7kohm	—

● **DIODES**

**1SS133**

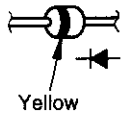

**1N4004A**

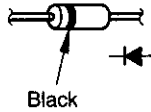

**MTZJ5.6B  
MTZJ6.2B  
MTZJ9.1B  
MTZJ20B**

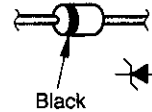

● FL DISPLAY BJ-239GK (FLT201)

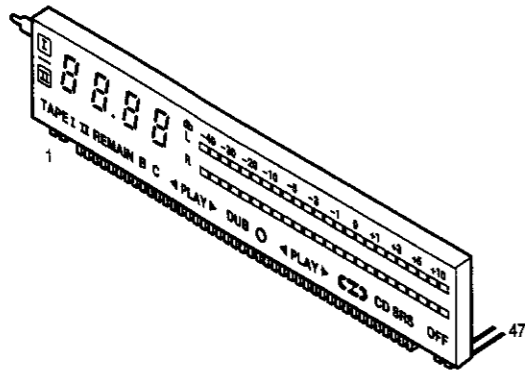

Pin Connection

Pin No.	1	2	3	4	5	6	7	8	9	10	11	12	13	14	15	16	17	18	19	20	21	22	23	24
Connector	F1	F1	NP	NP	1G	2G	3G	4G	5G	NC	NC	NC	NC	NC	NC	NC	NC	NC	NC	NC	NC	NC	NC	NC

Pin No.	25	26	27	28	29	30	31	32	33	34	35	36	37	38	39	40	41	42	43	44	45	46	47
Connector	NC	NC	P17	P16	P15	P14	P13	P12	P11	P10	P9	P8	P7	P6	P5	P4	P3	P2	P1	NP	NP	F2	F2

- NOTE 1) F1, F2 . . . . . Filament  
 2) NP . . . . . No Pin  
 3) NC . . . . . No Connection  
 4) 1G~5G . . . . . Grid

Grid Partition

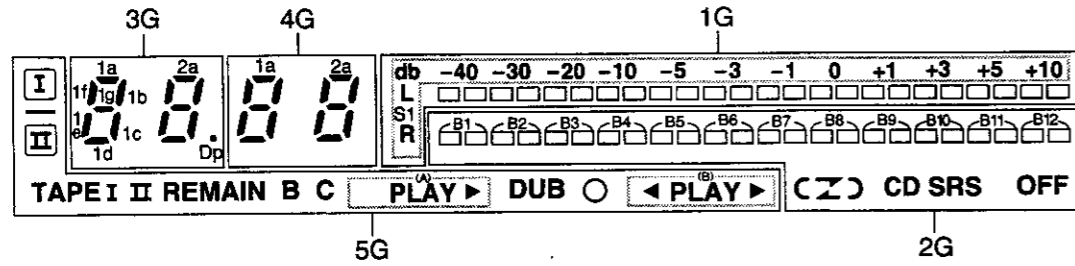

Anode Connection

	5G	4G	3G	2G	1G
P1	TAPE	1a	1a	B1	B1
P2	I	1b	1b	B2	B2
P3	II	1c	1c	B3	B3
P4	REMAIN	1d	1d	B4	B4
P5	B	1e	1e	B5	B5
P6	C	1f	1f	B6	B6
P7	◀ (A)	1g	1g	B7	B7
P8	▶ (A)	2a	2a	B8	B8
P9	▶ (A)	1b	1b	B9	B9
P10	DUB	2c	2c	B10	B10
P11	○	2d	2d	B11	B11
P12	◀ (B)	2e	2e	B12	B12
P13	▶ (B)	2f	2f	C	S1
P14	▶ (B)	2g	2g	Σ	-
P15	I	-	Dp	☾	-
P16	-	-	-	CD SRS	-
P17	II	-	-	OFF	-

CASSETTE DECK  
PRINTED WIRING BOARDS

1 2 3 4 5 6 7 8

MAIN P.W.B. UNIT ASS'Y

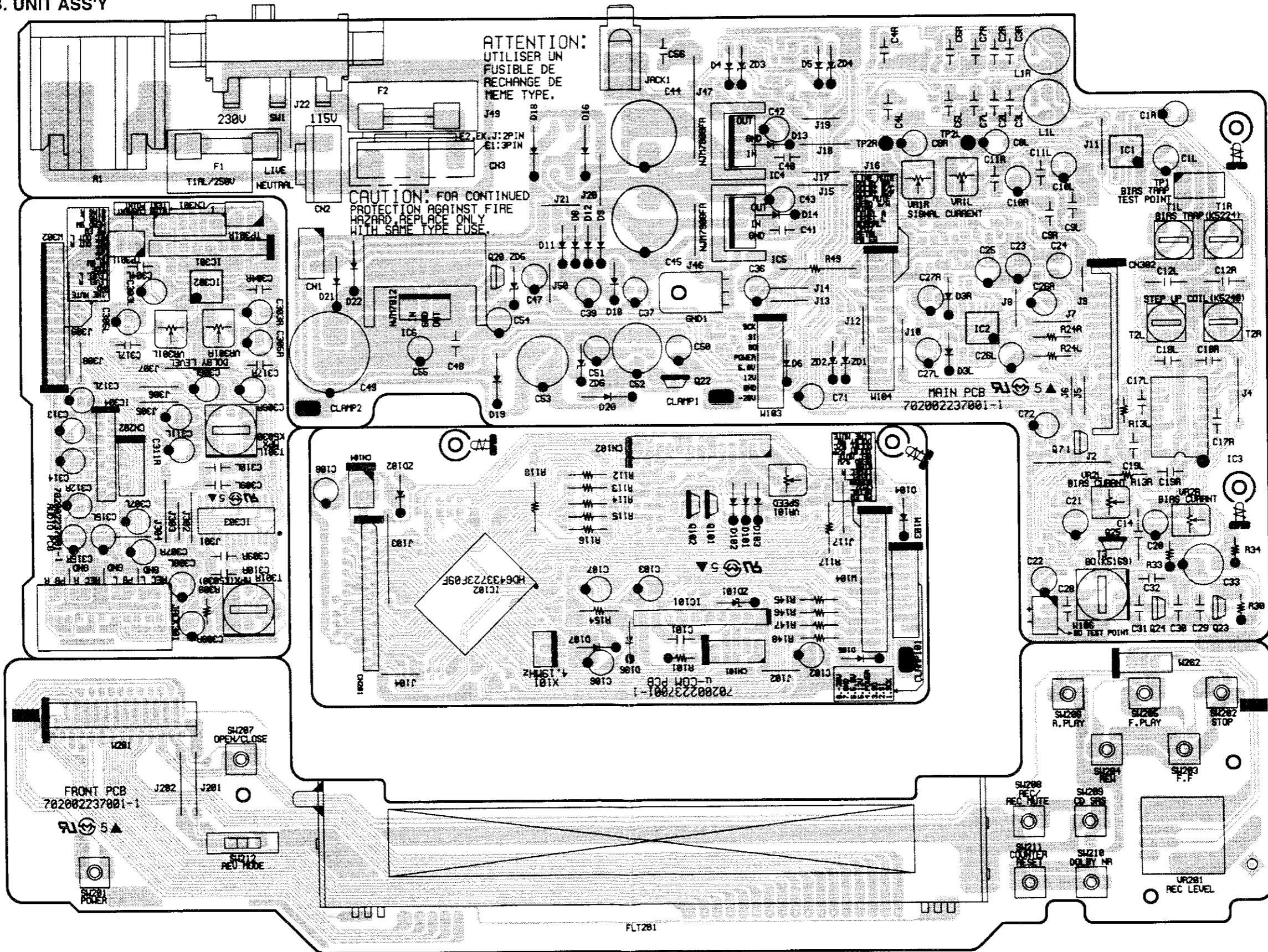

A

B

C

D

E



**CASSETTE DECK**

**NOTE FOR PARTS LIST**

- Part indicated with the mark "⊙" are not always in stock and possibly to take a long period of time for supplying, or in some case supplying of part may be refused.
- When ordering of part, clearly indicate "1" and "1" (i) to avoid mis-supplying.
- Ordering part without stating its part number can not be supplied.
- Part indicated with the mark "★" is not illustrated in the exploded view.
- Not including Carbon Film ±5%, 1/4W Type in the P.W.Board parts list. (Refer to the Schematic Diagram for those parts.)

**WARNING:**

Parts marked with this symbol  have critical characteristics. Use ONLY replacement parts recommended by the manufacturer.

● **Resistors**

Ex.: **RN 14K 2E 182 G ER**  
 Type Shape Power Resist- Allowable Others  
 and performance ance error

RD : Carbon	2B : 1/8W	F : ±1%	P : Pulse-resistant type
RC : Composition	2E : 1/4W	G : ±2%	NL : Low noise type
RS : Metal oxide film	2H : 1/2W	J : ±5%	NB : Non-burning type
RW : Winding	3A : 1W	K : ±10%	FR : Fuse-resistor
RN : Metal film	3D : 2W	M : ±20%	F : Lead wire forming
RK : Metal mixture	3F : 3W		
	3H : 5W		

\* **Resistance**

$\overset{1}{\text{---}}\overset{8}{\text{---}}\overset{2}{\text{---}}$  ⇒ 1800 ohm = 1.8 kohm  
 Indicates number of zeros after effective number.  
 2-digit effective number.

• Units: ohm

$\overset{1}{\text{---}}\overset{R}{\text{---}}\overset{2}{\text{---}}$  ⇒ 1.2 ohm  
 1-digit effective number.  
 2-digit effective number, decimal point indicated by R.

• Units: ohm

● **Capacitors**

Ex.: **CE 04W 1H 2R2 M BP**  
 Type Shape Dielectric Capacity Allowable Others  
 and per- strength error

CE : Aluminum foil electrolytic	0J : 6.3V	F : ±1%	HS : High stability type
CA : Aluminum solid electrolytic	1A : 10V	G : ±2%	BP : Non-polar type
CS : Tantalum electrolytic	1C : 16V	J : ±5%	HR : Ripple-resistant type
CQ : Film	1E : 25V	K : ±10%	DL : For charge and discharge
CK : Ceramic	1V : 35V	M : ±20%	HF : For assuring high frequency
CC : Ceramic	1H : 50V	Z : +80%	U : UL part
CP : Oil	2A : 100V	-20%	C : CSA part
CM : Mica	2B : 125V	P : +100%	W : UL-CSA type
CF : Metallized	2C : 160V	-0%	F : Lead wire forming
CH : Metallized	2D : 200V	C : ±0.25pF	
	2E : 250V	D : ±0.5pF	
	2H : 500V	= : Others	
	2J : 630V		

\* **Capacity (electrolyte only)**

$\overset{2}{\text{---}}\overset{2}{\text{---}}\overset{2}{\text{---}}$  ⇒ 2200µF  
 Indicates number of zeros after effective number.  
 2-digit effective number.

• Units: µF.

$\overset{2}{\text{---}}\overset{R}{\text{---}}\overset{2}{\text{---}}$  ⇒ 2.2µF  
 1-digit effective number.  
 2-digit effective number, decimal point indicated by R.

• Units: µF.

\* **Capacity (except electrolyte)**

$\overset{2}{\text{---}}\overset{2}{\text{---}}\overset{2}{\text{---}}$  ⇒ 2200pF=0.0022µF  
 (More than 2) — Indicates number of zeros after effective number.  
 2-digit effective number.

• Units: µF.

$\overset{2}{\text{---}}\overset{2}{\text{---}}\overset{1}{\text{---}}$  ⇒ 220pF  
 (0 or 1) — Indicates number of zeros after effective number.  
 2-digit effective number.

• Units: pF.

• When the dielectric strength is indicated in AC, "AC" is included after the dielectric strength value.

**PARTS LIST OF P.W.B. UNIT**  
**MAIN P.W.B. UNIT ASS'Y**

Ref. No.	Part No.	Part Name	Remarks
<b>SEMICONDUCTORS GROUP</b>			
IC1,2	928 0035 809	IC NJM4565MD	J121456500040
IC3	263 0354 001	IC UPC1297CA	J081129700000
IC4	263 0502 002	IC NJM7808FA	J126780800030
IC5	263 0503 001	IC NJM7908FA	J126790800020
IC6	263 0516 001	IC NJM7812	J126781200010
IC101	960 0100 806	IC BA6209N	J127620900010
IC102	960 0122 703	IC HD6433723F09F	J020643372390
IC301	263 0590 001	IC UPC1330HA	J040133000010
IC302	928 0035 809	IC NJM4565MD	J121456500040
IC303	960 0124 400	IC CXA1561M	J081156100010
IC304	960 0014 109	IC M51132L	J123511320000
Q2L,2R	269 0088 906	Transistor DTC114TK	J5220114T0210
Q3L,3R	269 0088 906	Transistor DTC114TK	J5220114T0210
Q4L,4R	269 0104 903	Transistor DTC343TK	J5220343T0210
Q5,6	269 0082 902	Transistor DTC114EK	J5220114E0210
Q7	269 0055 900	Transistor DTA144EK	J5200144E0210
Q8	269 0054 901	Transistor DTC144EK	J5220144E0210
Q9	269 0055 900	Transistor DTA144EK	J5200144E0210
Q10,11	269 0054 901	Transistor DTC144EK	J5220144E0210
Q12	269 0055 900	Transistor DTA144EK	J5200144E0210
Q13	269 0054 901	Transistor DTC144EK	J5220144E0210
Q14	269 0055 900	Transistor DTA144EK	J5200144E0210
Q15,16	271 0238 908	Transistor 2SA1037K(S/R)	J5201037K0210
Q17,18	273 0384 900	Transistor 2SC2412K(S)	J5222412K0210
Q19	271 0238 908	Transistor 2SA1037K(S/R)	J5201037K0210
Q20	960 0010 705	Transistor KTC3205Y	J5023205Y0020
Q22	960 0010 501	Transistor KTA1273Y	J5001273Y0050
Q23,24	273 0303 907	Transistor 2SC1740SR	J5021740S0010
Q25	960 0010 501	Transistor KTA1273Y	J5001273Y0050
Q26-28	269 0054 901	Transistor DTC144EK	J5220144E0210
Q101,102	960 0010 501	Transistor KTA1273Y	J5001273Y0050
Q103,104	269 0102 905	Transistor DTC124EK	J5220124E0210
Q105	9L2 3256 91R	Transistor 2SC2412K(S)	J5222412K0210
Q106	269 0102 905	Transistor DTC124EK	J5220124E0210
Q107	269 0083 901	Transistor DTA144EK	J5200144E0210
Q301L,301R	269 0104 903	Transistor DTC343TK	J5220343T0210
Q302L,302R	269 0104 903	Transistor DTC343TK	J5220343T0210
Q303L,303R	269 0104 903	Transistor DTC343TK	J5220343T0210
D3L,3R	276 0401 905	Diode 1SS133	K000013300520
D4-14	276 0401 905	Diode 1SS133	K000013300520
D15-22	960 0117 608	Diode 1N4004A	K040400400520
D101-107	276 0401 905	Diode 1SS133	K000013300520
ZD1,2	960 0085 604	Zener diode MTZJ9.1B	K06009R144520

Ref. No.	Part No.	Part Name	Remarks
ZD3-5	960 0095 704	Zener diode MTZJ6.2B	K06006R244520
ZD6	960 0014 905	Zener diode MTZJ20B	K06020R044520
ZD101	276 0664 904	Zener diode MTZJ5.6B	K06005R644520
ZD102	LA2 100U 125	Zener diode MTZJ6.2B	K06006R244520
<b>RESISTORS GROUP</b>			
R1L,1R		Carbon chip 10 kohm 1/10W	C200010360200
R2L,2R		Carbon chip 56 kohm 1/10W	C200056360200
R3L,3R		Carbon chip 5.6 kohm 1/10W	C200056260200
R4L,4R		Carbon chip 560 ohm 1/10W	C200056160200
R5L,5R		Carbon chip 6.2 kohm 1/10W	C200062260200
R7L,7R		Carbon chip 22 kohm 1/10W	C200022360200
R8L,8R		Carbon chip 15 kohm 1/10W	C200015360200
R9L,9R		Carbon chip 22 kohm 1/10W	C200022360200
R10L,10R		Carbon chip 15 kohm 1/10W	C200015360200
R10L,10R		Electrolytic 0.33 µF/50V	D040R33087070
R11L,11R		Carbon chip 10 kohm 1/10W	C200010360200
R12L,12R		Carbon chip 6.8 kohm 1/10W	C200068260200
R13L,13R		Carbon film 150 kohm 1/5W	C00001546P520
R14L,14R		Carbon chip 22 kohm 1/10W	C200022360200
R15		Carbon chip 1.5 kohm 1/10W	C200015260200
R16		Carbon chip 1.2 kohm 1/10W	C200012260200
R17		Carbon chip 3.3 kohm 1/10W	C200033260200
R18		Carbon chip 47 kohm 1/10W	C200047360200
R19		Carbon chip 10 kohm 1/10W	C200010360200
R20		Carbon chip 100 kohm 1/10W	C200010460200
R21		Carbon chip 22 kohm 1/10W	C200022360200
R22,23		Carbon chip 10 kohm 1/10W	C200010360200
R24L,24R		Carbon film 1 kohm 1/5W	C00001026P520
R25L,25R		Carbon chip 47 kohm 1/10W	C200047360200
R26L,26R		Carbon chip 27 kohm 1/10W	C200027360200
R27L,27R		Carbon chip 15 kohm 1/10W	C200015360200
R28L,28R		Carbon chip 100 ohm 1/10W	C200010160200
R29L,29R		Carbon chip 100 kohm 1/10W	C200010460200
R30		Carbon chip 47 ohm 1/10W	C200047060200
R31,32		Carbon chip 15 kohm 1/10W	C200015360200
R33,34		Metal film 22 ohm 1/4W	C060022063050
R35		Carbon chip 4.7 kohm 1/10W	C200047260200
R36-39		Carbon chip 10 kohm 1/10W	C200010360200
R40,41		Carbon chip 22 kohm 1/10W	C200022360200
R42		Carbon chip 1 kohm 1/10W	C200010260200
R43		Carbon chip 100 ohm 1/10W	C200010160200
R44		Carbon chip 220 ohm 1/10W	C200022160200
R45,46		Carbon chip 10 kohm 1/10W	C200010360200
R47		Carbon chip 47 kohm 1/10W	C200047360200
R48		Carbon chip 100 ohm 1/10W	C200010160200
R49		Carbon film 10 kohm 1/5W	C00001036P520
R50		Carbon chip 4.7 kohm 1/10W	C200047260200
R51,52		Carbon chip 10 kohm 1/10W	C200010360200
R53		Carbon chip 2.2 kohm 1/10W	C200022260200
R54		Carbon chip 8.2 kohm 1/10W	C200082260200

CASSETTE DECK

Ref. No.	Part No.	Part Name	Remarks
R55		Carbon chip 1 kohm 1/10W	C200010260200
R56		Carbon chip 100 ohm 1/10W	C200010160200
R58		Carbon chip 100 ohm 1/10W	C200010160200
R59-61		Carbon chip 10 kohm 1/10W	C200010360200
R101		Metal film 10 ohm 1/4W	C060010063050
R102,103		Carbon chip 1 kohm 1/10W	C200010260200
R104		Carbon chip 470 ohm 1/10W	C200047160200
R105-109		Carbon chip 1 kohm 1/10W	C200010260200
R112-118		Carbon film 1 kohm 1/5W	C00001026P520
R122-127		Carbon chip 100 kohm 1/10W	C200010460200
R128,129		Carbon chip 47 kohm 1/10W	C200047360200
R130,131		Carbon chip 3.3 kohm 1/10W	C200033260200
R132		Carbon chip 100 kohm 1/10W	C200010460200
R133		Carbon chip 10 kohm 1/10W	C200010360200
R134		Carbon chip 5.6 kohm 1/10W	C200056260200
R135,136		Carbon chip 100 kohm 1/10W	C200010460200
R137-140		Carbon chip 47 kohm 1/10W	C200047360200
R141-144		Carbon chip 1 kohm 1/10W	C200010260200
R145-148		Carbon film 1 kohm 1/5W	C00001026P520
R149		Carbon chip 1 Mohm 1/10W	C200010560200
R150		Carbon chip 100 kohm 1/10W	C200010460200
R151-153		Carbon chip 3.9 kohm 1/10W	C200039260200
R154		Carbon film 10 kohm 1/5W	C00001036P520
R155,156		Carbon chip 100 ohm 1/10W	C200010160200
R201		Carbon chip 680 ohm 1/10W	C200068160200
R202		Carbon chip 820 ohm 1/10W	C200082160200
R203		Carbon chip 1.5 kohm 1/10W	C200015260200
R204		Carbon chip 2.2 kohm 1/10W	C200022260200
R205		Carbon chip 4.7 kohm 1/10W	C200047260200
R206		Carbon chip 680 ohm 1/10W	C200068160200
R207		Carbon chip 820 ohm 1/10W	C200082160200
R208		Carbon chip 1.5 kohm 1/10W	C200015260200
R209		Carbon chip 2.2 kohm 1/10W	C200022260200
R210		Carbon chip 3.3 kohm 1/10W	C200033260200
R301L,301R		Carbon chip 10 ohm 1/10W	C200010060200
R302		Carbon chip 1 kohm 1/10W	C200010260200
R303L,303R		Carbon chip 120 kohm 1/10W	C200012460200
R304L,304R		Carbon chip 270 ohm 1/10W	C200027160200
R305L,305R		Carbon chip 24 kohm 1/10W	C200024360200
R306L,306R		Carbon chip 560 kohm 1/10W	C200056460200
R307L,307R		Carbon chip 3.3 kohm 1/10W	C200033260200
R308L,308R		Carbon chip 4.7 kohm 1/10W	C200047260200
R309		Carbon film 20 kohm 1/5W	C00002036P520
R310L,310R		Carbon chip 5.6 kohm 1/10W	C200056260200
R311L,311R		Carbon chip 2.4 kohm 1/10W	C200024260200
R312L,312R		Carbon chip 47 kohm 1/10W	C200047360200
R313L,313R		Carbon chip 1.8 kohm 1/10W	C200018260200
R314L,314R		Carbon chip 1 kohm 1/10W	C200010260200
R315L,315R		Carbon chip 10 kohm 1/10W	C200010360200

Ref. No.	Part No.	Part Name	Remarks
R316L,316R		Carbon chip 7.5 kohm 1/10W	C200075260200
R317L,317R		Carbon chip 24 kohm 1/10W	C200024360200
R318		Carbon chip 47 kohm 1/10W	C200047360200
R319,320		Carbon chip 39 kohm 1/10W	C200039360200
R321L,321R		Carbon chip 75 kohm 1/10W	C200075360200
R322L,322R		Carbon chip 470 ohm 1/10W	C200047160200
VR1L,1R	960 0119 907	Semi fixed resistor 22 kohm	C544223015140
VR2L,2R	960 0122 606	Semi fixed resistor 47 kohm	C544473015130
VR101	960 0091 601	Semi fixed resistor 1 kohm	C544102015130
VR201	960 0124 002	Variable resistor 100 kohm	C452111400420
VR301L,301R	960 0091 601	Semi fixed resistor 10 kohm	C544103015130

CAPACITORS GROUP

Ref. No.	Part No.	Part Name	Remarks
C1L,1R		Electrolytic 10 µF/16V	D040100083050
C2L,2R		Film 0.0039 µF/100V	D02039206C060
C6L,6R		Film 0.01 µF/100V	D02010306C060
C7L,7R		Film 0.0047 µF/100V	D02047206C060
C8L,8R		Electrolytic 1 µF/50V	D040010087050
C9L,9R		Film 0.0018 µF/100V	D02018206C060
C11L,11R		Film 0.0068 µF/100V	D02068206C060
C12L,12R	960 9001 401	Film 300 pF/100V	D02130106C000
C13L,13R		Ceramic chip 100 pF/50V	D010101167200
C14		Ceramic 10 pF/50V	D001100067520
C15L,15R		Ceramic chip 820 pF/50V	D010821167200
C16		Ceramic chip 0.047 µF/50V	D011473597200
C17L,17R		Film 0.033 µF/100V	D02033306C060
C18L,18R		Film 0.022 µF/100V	D02022306C060
C19L,19R		Film 0.01 µF/100V	D02010306C060
C20		Electrolytic 10 µF/25V	D040100084050
C21		Electrolytic 22 µF/16V	D040220083070
C22		Electrolytic 10 µF/25V	D040100084050
C23		Electrolytic 1 µF/50V	D040010087050
C24		Electrolytic 10 µF/16V	D042100083050
C25		Electrolytic 2.2 µF/50V	D0402R2087250
C26L,26R		Electrolytic 2.2 µF/50V	D0402R2087250
C27L,27R		Electrolytic 0.47 µF/50V	D040R47087050
C28		Film 0.0082 µF/100V	D02082206C060
C29		Film 0.0022 µF/100V	D02022206C060
C30,31		Film 0.0033 µF/100V	D02033206C060
C32		Film 0.015 µF/100V	D02015306C060
C33		Electrolytic 220 µF/16V	D040221083090
C34,35		Ceramic chip 0.001 µF/50V	D010102167200
C36,37		Electrolytic 100 µF/25V	D040101084060
C38		Ceramic chip 0.047 µF/50V	D011473597200
C39		Electrolytic 4.7 µF/50V	D0404R7087250
C40,41		Ceramic 0.01 µF/50V	D004103277050
C42,43		Electrolytic 10 µF/25V	D040100084050
C44,45	254 4256 091	Electrolytic 2200 µF/25V	D040222084030

Ref. No.	Part No.	Part Name	Remarks
C46		Ceramic chip 0.01 µF/50V	D011103597200
C47		Electrolytic 10 µF/25V	D040100084050
C48		Ceramic 0.01 µF/50V	D004103277050
C49	254 4256 091	Electrolytic 2200 µF/25V	D040222084030
C50		Electrolytic 10 µF/25V	D040100084050
C51		Electrolytic 47 µF/35V	D040470085100
C52	254 4261 044	Electrolytic 330 µF/50V	D040331087020
C53		Electrolytic 330 µF/25V	D040331084050
C54		Electrolytic 10 µF/25V	D040100084050
C55		Electrolytic 100 µF/16V	D040101083100
C56		Ceramic 0.01 µF/50V	D004103277050
C101		Ceramic 0.1 µF/50V	D006104597050
C102,103		Electrolytic 100 µF/16V	D040101083100
C104,105		Ceramic chip 0.01 µF/50V	D011103597200
C106		Electrolytic 2.2 µF/50V	D0402R2087250
C107,108		Electrolytic 1 µF/50V	D040010087080
C301		Ceramic chip 0.01 µF/50V	D011103597200
C302L,302R		Ceramic chip 470 pF/50V	D010471167200
C303L,303R		Electrolytic 47 µF/16V	D040470083080
C304L,304R		Film 0.0056 µF/100V	D02056206C060
C305L,305R		Electrolytic 1 µF/50V	D040010087080
C306L,306R		Electrolytic 1 µF/50V	D040010087080
C307L,307R		Electrolytic 1 µF/50V	D040010087080
C308L,308R		Electrolytic 1 µF/50V	D040010087080
C309L,309R		Film 0.1 µF/50V	D020104167060
C310L,310R		Film 0.068 µF/50V	D020683167060
C311L,311R		Electrolytic 1 µF/50V	D040010087080
C312L,312R		Electrolytic 4.7 µF/16V	D0404R7083050
C313		Electrolytic 22 µF/16V	D040220083110
C314		Electrolytic 1 µF/50V	D040010087070
C315L,315R		Electrolytic 4.7 µF/16V	D0404R7083050
C316L,316R		Ceramic chip 100 pF/50V	D010101167200
C317L,317R		Film 0.015 µF/100V	D02015306C060

OTHER PARTS GROUP

Ref. No.	Part No.	Part Name	Remarks	Q'ty
▲ A1	960 0143 203	AC outlet	G435040110000	1
CLAMP1,2	—	Wire clamp	4330000120000	2
CN1	960 0123 207	3P connector base	L102526700300	1
CN2	960 0118 908	2P connector base	L108039602010	1
CN3	960 0123 304	2P connector base	L104353280200	1
CN3	960 0128 901	3P connector base	L108353280310	1
CN101	960 0123 508	5P connector base	L101530140510	1
CN102	960 0123 605	13P connector base	L101530141310	1
CN104	960 0123 702	2P connector base	L102526700200	1
CN201	960 0123 809	28P FPC connector base	L130528062810	1

Ref. No.	Part No.	Part Name	Remarks	Q'ty
CN202	960 0124 905	3P connector base	L141521470310	1
CN301	960 0124 701	6P connector base	L101530140610	1
CN302	960 0123 003	14P connector base	L101353361410	1
▲ F1	960 0142 709	Fuse 250V 1A	G650102251160	1
▲ F2	960 0142 709	Fuse 250V 1A	G650102251160	1
Asia Model only				
FLT201	960 0044 001	FLD (BJ-239GK)	K530000280010	1
GND1	960 9006 600	GND terminal	3790040876010	1
JACK1	960 0004 407	Mini jack	G401031102010	1
JACK301	960 0124 507	4P pin jack	G6020401310300	1
L1L,1R	960 0013 618	Inductor 1MH	D330180000000	2
SW201-211	960 0069 206	Tact switch	G180215050010	11
SW212	960 0011 801	Slide switch	G060313012010	1
T1L,1R	960 0013 605	Trap coil	D302126522400	2
T2L,2R	960 0013 702	MW RF osc. coil	D940524000000	2
T3	960 0013 809	OSC bias trans.	E080516900000	1
T301L,301R	960 0125 807	MPX filter	E401503000000	2
TP1	960 0123 207	3P connector base	L102526700300	1
TP301L,301R	960 0124 808	2P connector base	L102526700200	2
W103	960 0122 800	8P connector cord	L000231080010	1
W104	960 0122 907	13P connector cord	L000261130020	1
W106	960 0123 100	2P connector base	L102526700200	1
W201	960 0124 206	28P FPC connector base	L130528072810	1
W202	960 0124 109	3P connector cord	L024032507320	1
W302	960 0124 604	14P connector base	L101352371410	1
X101	399 0107 007	Ceramic 4.19MHZ	E830419000060	1
	960 0122 509	Heat sink	2120000818030	2
	963 0019 501	Heat sink	2120020238030	1
	960 0005 804	Carbon chip 0 ohm 1/8W	C200000061300	43
	960 0005 804	Fuse holder	G645000050010	2
	960 0005 804	Fuse holder	G645000050010	2
for F1				
for F2				
Asia Model only				
▲	963 0027 700	Slide switch	G060040550010	1
Asia Model only				
	960 0143 407	FL supporter	4070210016000	1
	963 0018 007	Screw 3x8 CBTS(B)-Z	B020030081B10	3



# CASSETTE DECK EXPLODED VIEW

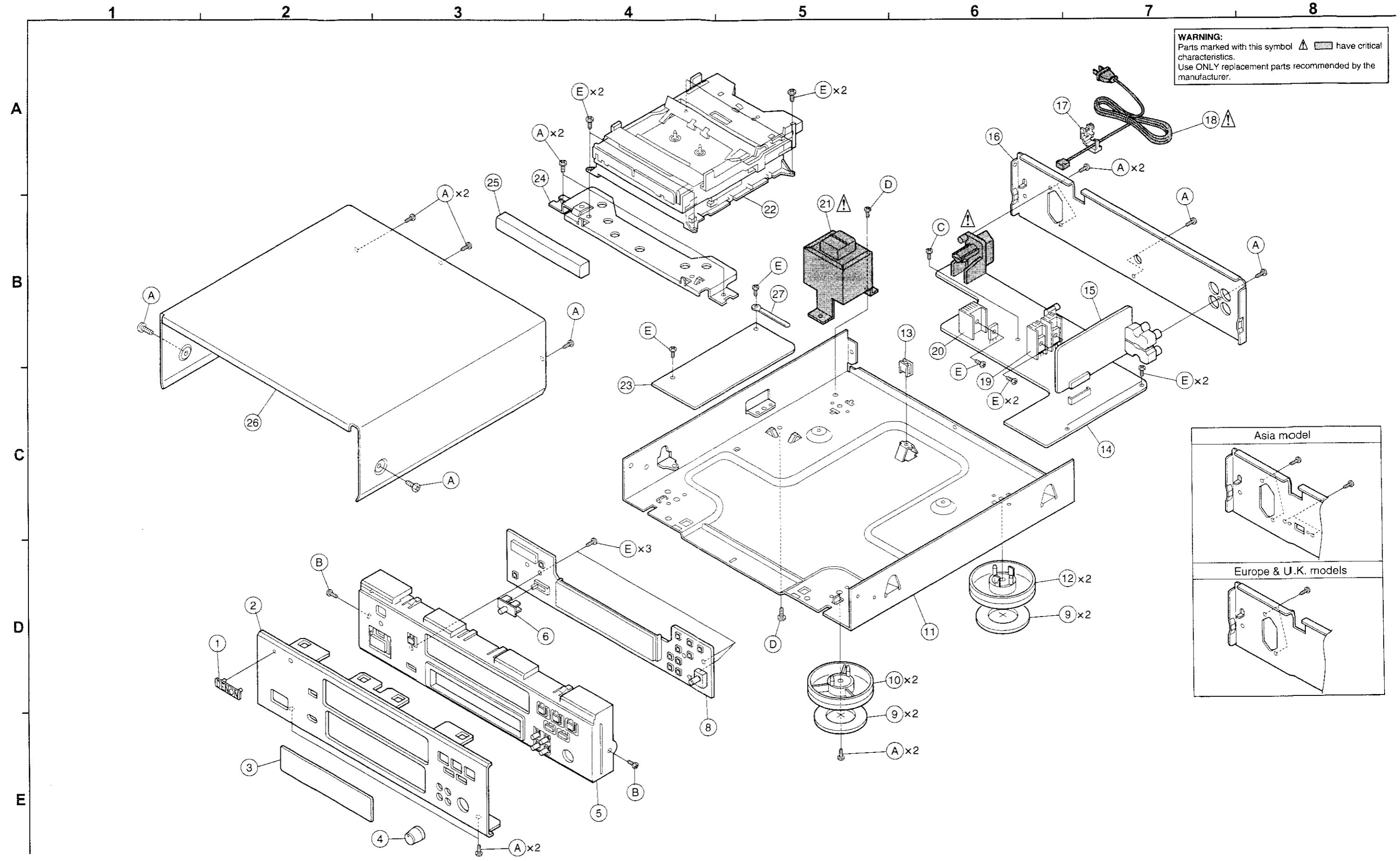

**WARNING:**  
 Parts marked with this symbol  have critical characteristics.  
 Use **ONLY** replacement parts recommended by the manufacturer.

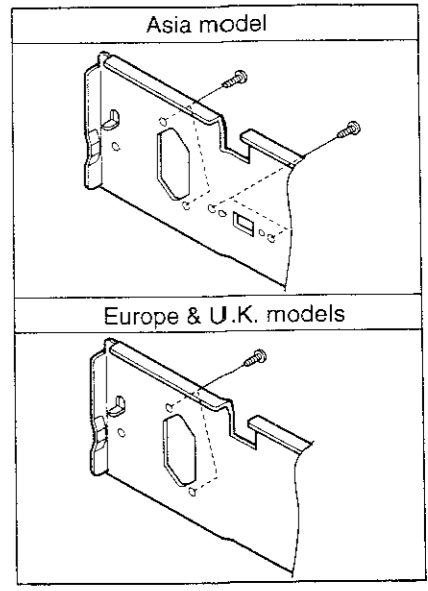

## PARTS LIST OF EXPLODED VIEW

Ref. No.	Part No.	Part Name	Remarks	Q'ty
14	960 0138 205	Main P.W.B. unit ass'y	7025HC9804010 Europe & U.K. Models	1
14	960 0122 415	Main P.W.B. unit ass'y	7025HC9804040 Asia Model	1
8	960 0123 906	Front P.W.B. unit		
15	960 0124 303	Audio P.W.B. unit		
23	960 0123 401	Micom P.W.B. unit		
1	960 0115 707	DENON badge	5630210008000	1
2	960 0121 102	Front panel	3067210048010	1
3	960 0115 309	Display window	5077210043010	1
4	960 0121 801	Control knob	5087210021010	1
5	960 0121 209	Front frame	3217210021010	1
6	960 0121 306	Selector knob	5087210041010	1
9	960 0003 505	Foot cushion	4050020075010	4
10	960 0003 408	Foot	4007000061010	2
11	960 0121 500	Main chassis	3200210076000	1
12	960 0115 008	Foot	4000210001000	2
13	960 0003 301	P.W.B. support	4070001601010	1
16	960 0121 429	Back chassis	3207210036010 Europe & U.K. Models	1
16	960 0121 416	Back chassis	3207210036110 Asia Model	1
17	963 0017 707	Cord stopper	4380040162010	1
△	18 960 0032 301	AC cord	L061000410010	1
△	21 960 0136 003	Power trans.	8200480044010 Europe & U.K. Models	1
△	21 960 0136 100	Power trans.	8200480044030 Asia Model	1
22	960 0125 001	Cassette mecha. ass'y	8158210020010	1
24	960 0121 607	Mecha. bracket	4010210046000	1
25	960 0121 704	Tray cover	4317210011010	1
26	960 0121 005	Top cover	3000210006100	1
27	—	Wire clamp	4330040213010	1
★	28 960 0125 409	2P+6P shield cord	L000161080010	1
★	29 960 0125 506	5P connector cord	L000171050010	1
★	30 960 0125 603	13P connector cord	L000261130010	1
★	31 960 0125 700	28P FPC	L301121280010	1
<b>SCREWS</b>				
A	960 0108 604	Screw 3×8 CBTS(B)-B	B020030083B10	15
A	960 0108 604	Screw 3×8 CBTS(B)-B	B020030083B10, for slide switch Asia Model only	2
B	960 9008 006	Screw 3×8 CFTS(B)-B	B020030083F10	2
C	963 0018 104	Screw 3×17 CBTS(B)-Z	B020030171B10	1
D	960 9003 001	Screw 4×8 CBTS(S)-Z	B020740081B10	2
E	963 0018 007	Screw 3×8 CBTS(B)-Z	B020030081B10	11

## CASSETTE DECK

## CASSETTE MECHANISM PARTS LIST (IDL-03B)

Ref. No.	Part No.	Part Name	Remarks	Q'ty
<b>LOADER MECHA. SECTION</b>				
1	960 0140 002	Mecha. body	341021003100	1
2	960 0140 109	Loading tray	460021000100	1
3	960 0140 206	Back lever	253021002100	1
4	960 0140 303	Front lever	253021001100	1
5	960 0140 400	CST lifter	267021000100	1
6	960 0140 507	Lift slider	264021001301	1
7	960 0140 604	Tray lever	253021000100	1
8	960 0140 701	Chuck holder	432021003300	1
9	960 0140 808	Chuck slider	264021000100	1
10	960 0140 905	Center gear	247004029101	1
11	960 0141 001	Pulley gear	247004034101	1
12	960 0141 108	Motor pulley	250000031000	1
13	960 0141 205	CST chuck	401021009600	1
14	960 0141 302	CST stopper	401021008600	1
15	960 0141 409	Deck GND	307021003600	1
16	960 0141 506	Chuck spring	372021000600	1
17	960 0141 603	Lever spring	372021003600	1
18	960 0141 700	Loading belt	249021000500	1
19	960 0141 807	Motor PCB	702002245001	1
20	960 0141 904	Contact wire	L00021104002	1
22	960 0125 108	Deck mecha. (CMAL2Z714X)	815000039001	1
23	960 0125 205	DC motor	G70032200001	1
24	960 0142 000	Micro switch	G22004013001	2
S1	960 9008 307	Screw 2.6x8 W		5
S2	960 9008 310	Screw 2x6 W		2
S3	960 9008 323	Screw 3x8		4
S4	960 9008 336	Screw 2.6x5		2
<b>DECK MECHA. SECTION (CMAL2Z714X)</b>				
3	9DF 5138 31	Head plate block	8950007150000	1
4	9DF 5253 27	Main motor block	8950007150010	1
5	9DF 5676 26	Control PCB block	8950007150020	1
6	9DF 5220 52	Clutch ass'y block	8950007150030	1
25	9DF F19H 11	Main belt	8950007150040	1
29	9DF 5220 48	Clutch ass'y block	8950007150050	1
31	9DF 5141 29	Pinch roller block R	8950007150060	1
32	9DF 5141 30	Pinch roller block L	8950007150070	1
42	9DF F18W 12	F/R belt	8950007150080	1

# EXPLODED VIEW OF CASSETTE MECHANISM UNIT

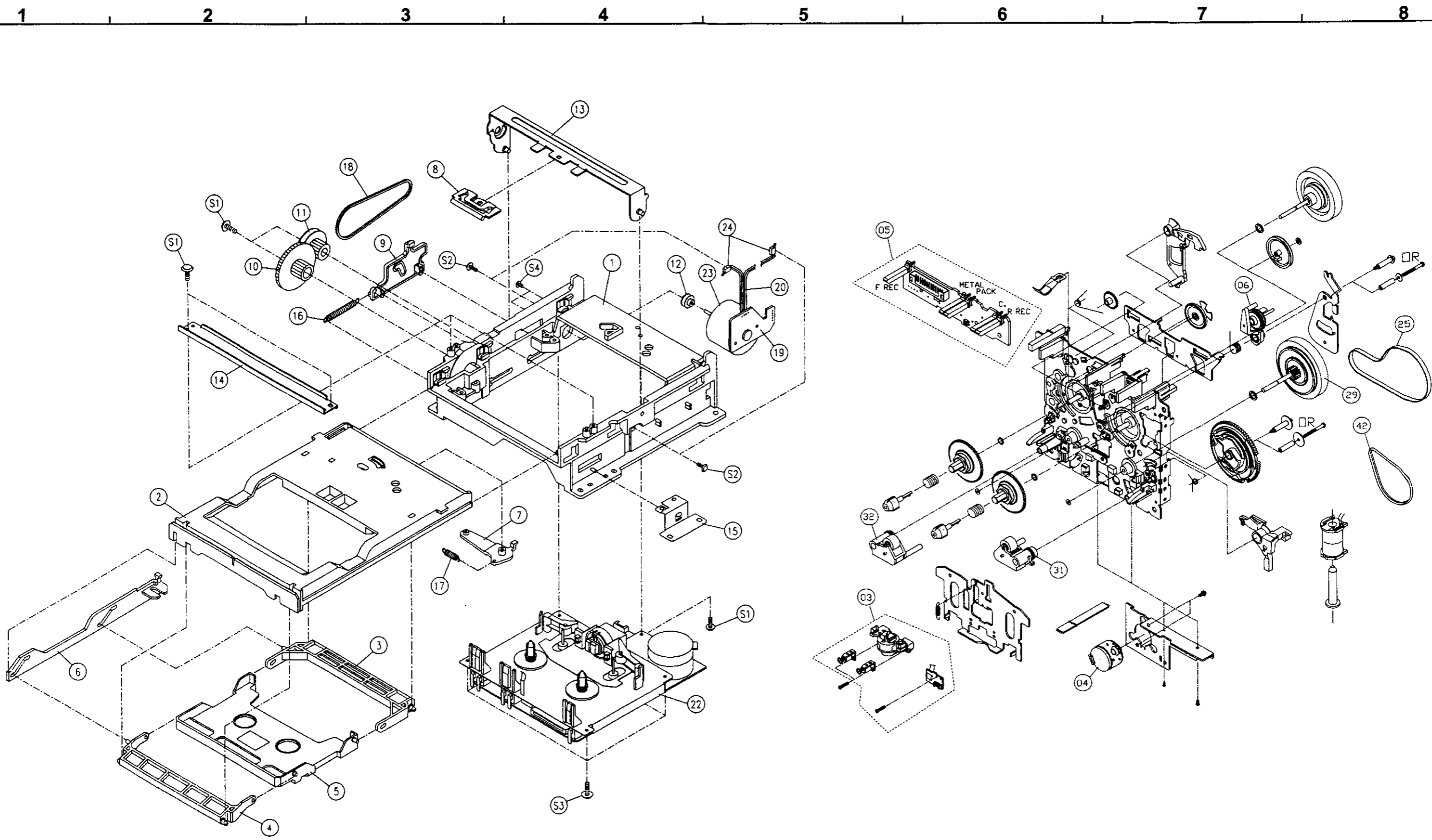

CASSETTE DECK  
WIRING DIAGRAM

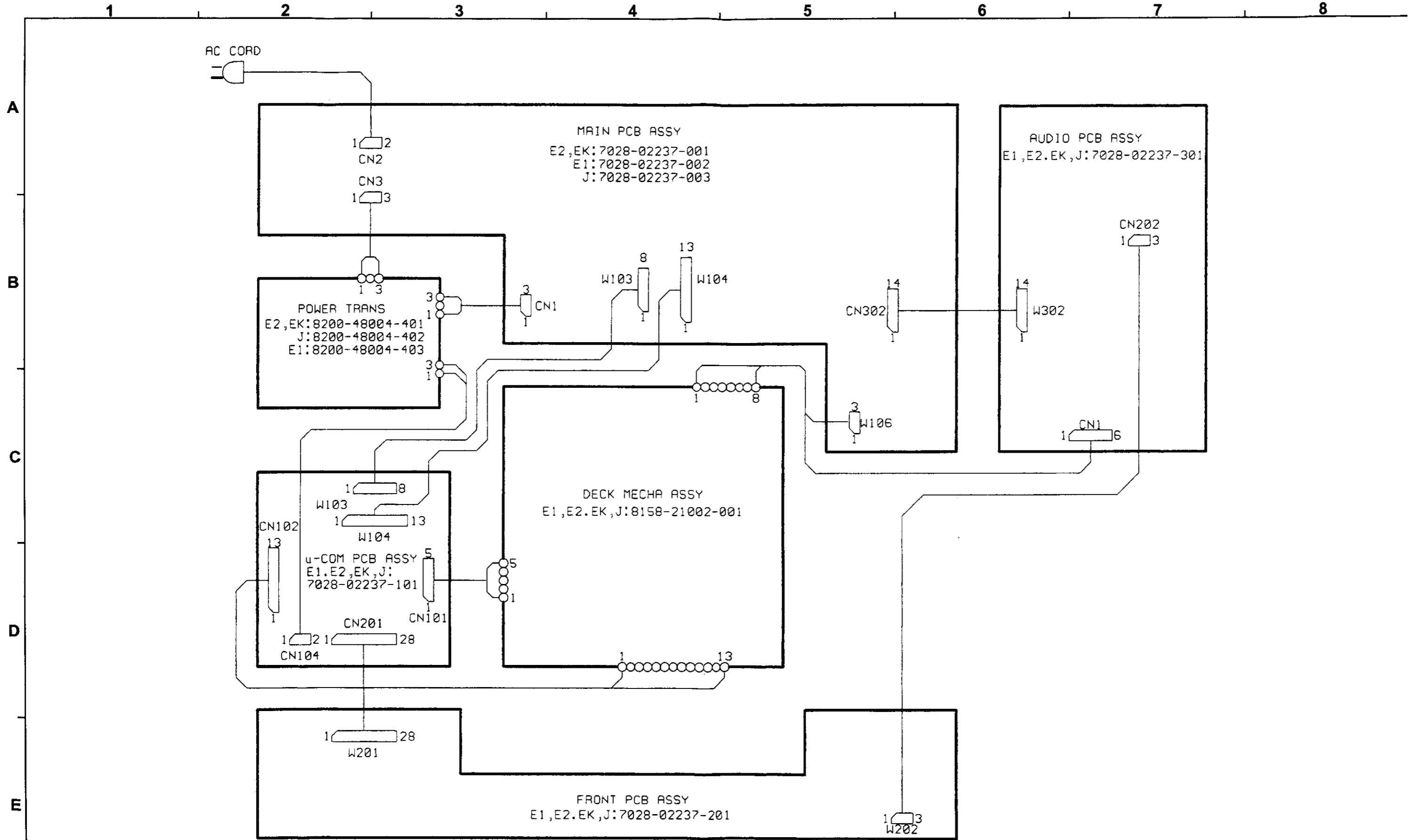

SCHEMATIC DIAGRAMS (1/2)

1 2 3 4 5 6 7 8

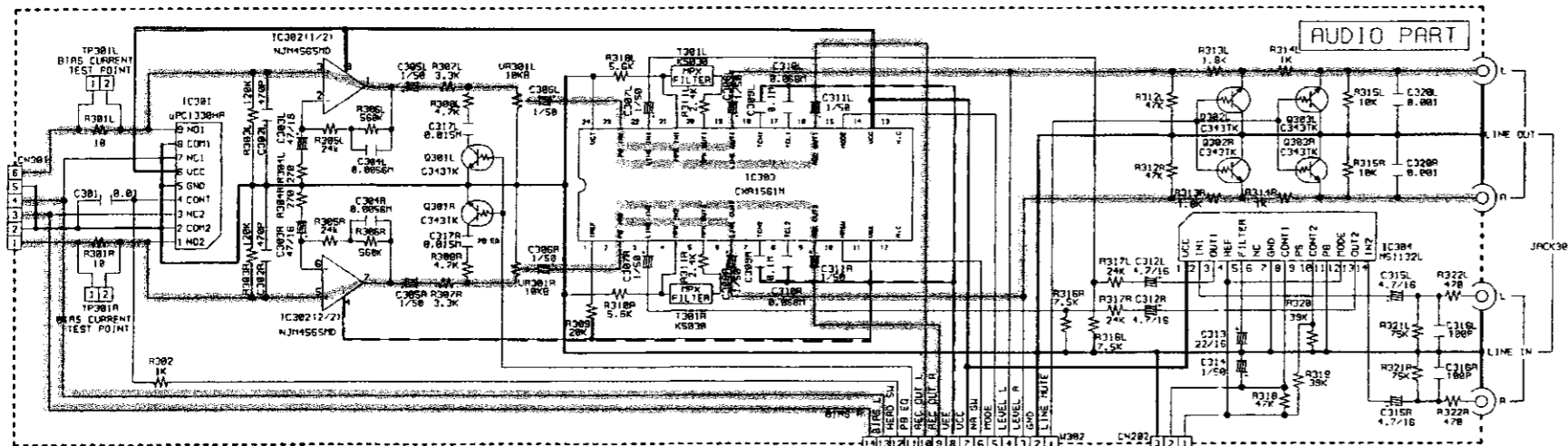

TYPE	E1	E2	EK	J
PART NO	115/230V, 50/60Hz	230V, 50Hz	230V, 50Hz	100V, 50Hz
F1	T1FL / 25BU	T1AL / 25BU	T1AL / 25BU	S82A / 25BU
F2	T1FL / 25BU	NO	NO	NO
J22	NO	YES	YES	YES
J48	NO	YES	YES	YES
SU1	YES	NO	NO	NO
AI	YKE31-8090	YKE31-8090	YKE31-8090	CC1302-02B2
CN2	3 PIN	2 PIN	2 PIN	2 PIN
RC,CORD	KKJ1004A/KKP419C	KKJ1004A/KKP419C	KKJ1004A/KKP419C	KJP251/KKP211
POWER, TRANS	B200-48004-403-0	B200-48004-401-0	B200-48004-401-0	B200-48004-402-0

**NOTICE**  
ALL RESISTANCE VALUES IN OHM. K=1,000 OHM M=1,000,000 OHM  
ALL CAPACITANCE VALUES IN MICRO FARAD. P=MICRO-MICRO FARAD  
EACH VOLTAGE AND CURRENT ARE MEASURED AT NO SIGNAL INPUT  
CONDITION.  
CIRCUIT AND PARTS ARE SUBJECT TO CHANGE WITHOUT PRIOR  
NOTICE.

**WARNING:**  
Parts marked with this symbol have critical characteristics.  
Use ONLY replacement parts recommended by the manufacturer.  
**CAUTION:**  
Before returning the unit to the customer, make sure you make either (1) a  
leakage current check or (2) a line to chassis resistance check. If the leakage  
current exceeds 0.5 milliamps, or if the resistance from chassis to either side  
of the power cord is less than 460 kohms, the unit is defective.  
**WARNING:**  
DO NOT return the unit to the customer until the problem is located and  
corrected.

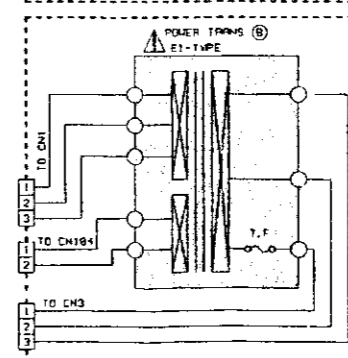
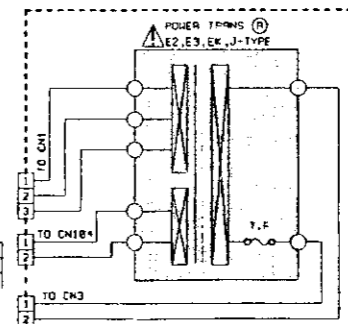
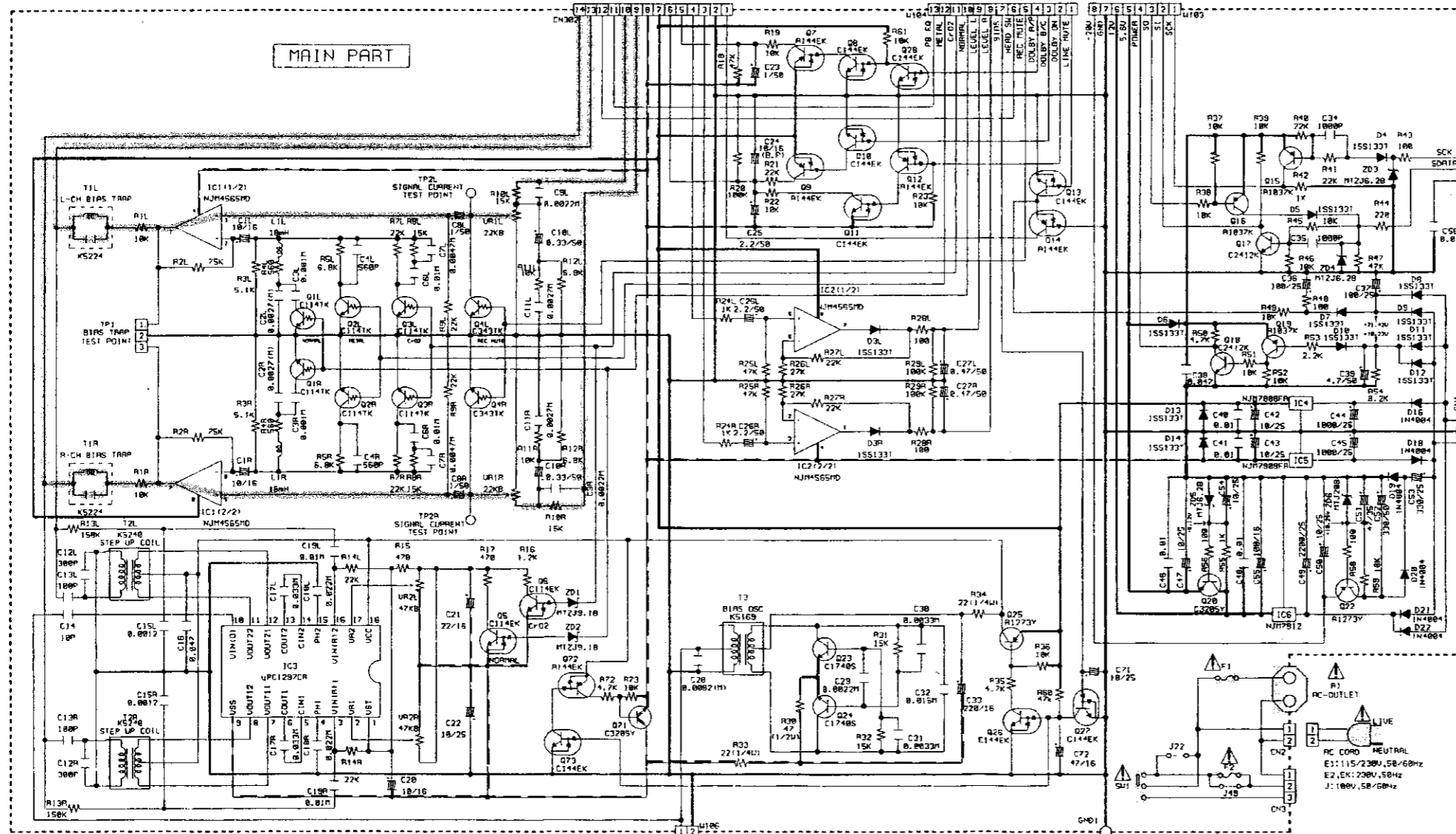

— + B Line  
- - - - - B Line  
Signal Line

SCHEMATIC DIAGRAMS (1/2)  
MAIN / AUDIO P.W.B. UNIT

A  
B  
C  
D  
E

1

2

3

4

5

6

7

8

A

B

C

D

E

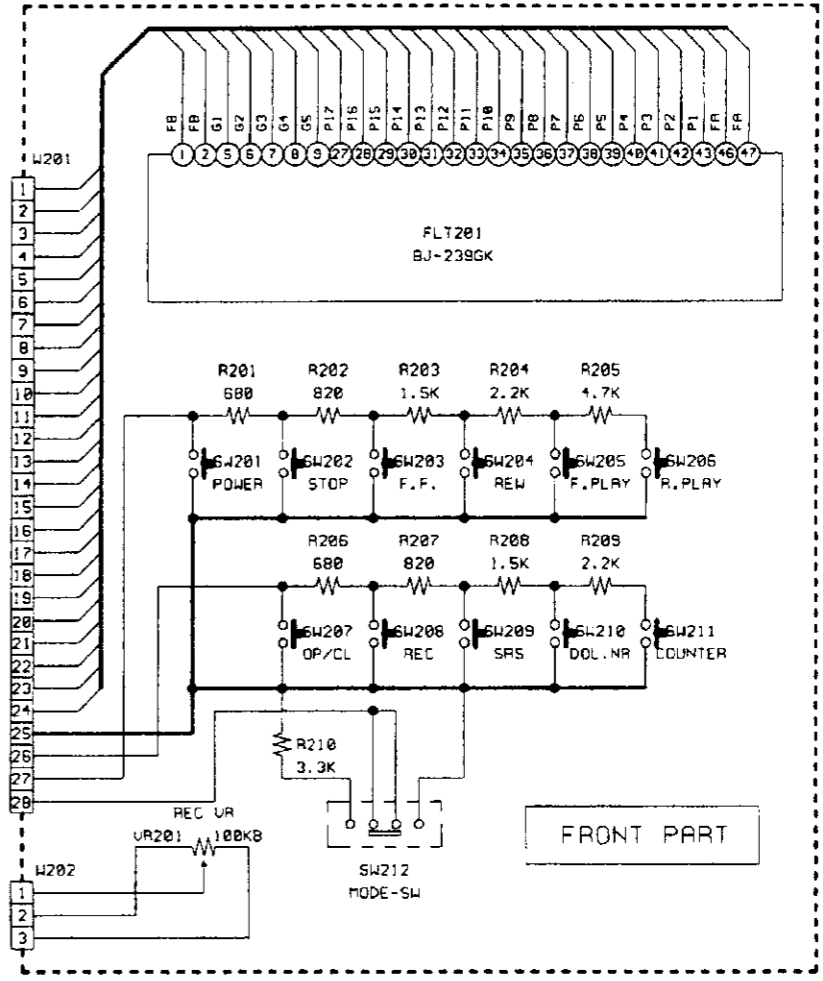
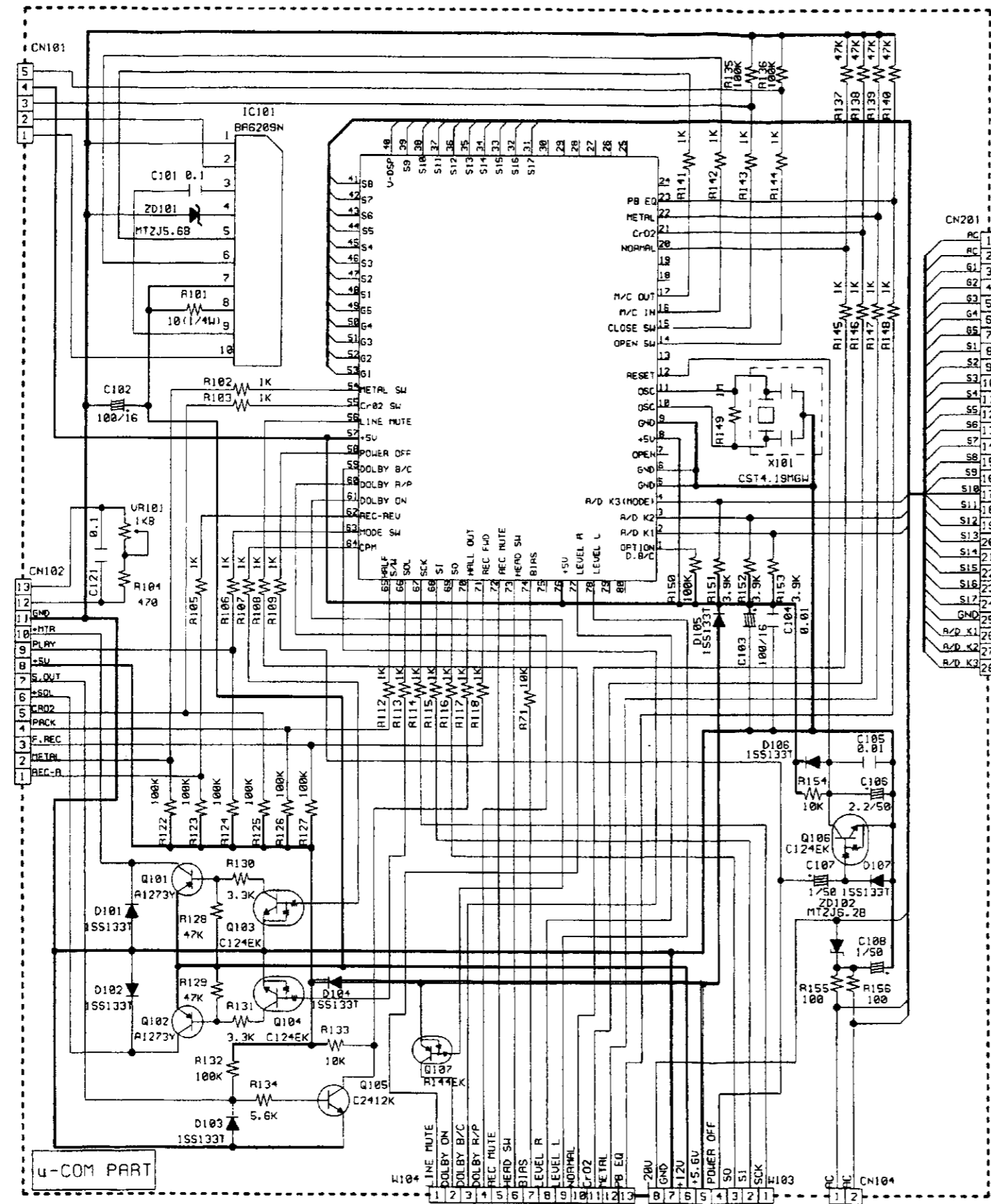
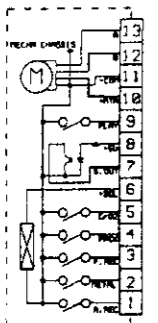
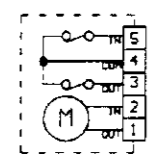

NOTICE  
 ALL RESISTANCE VALUES IN OHM, k=1,000 OHM M=1,000,000 OHM  
 ALL CAPACITANCE VALUES IN MICRO FARAD, p=MICRO-MICRO FARAD  
 EACH VOLTAGE AND CURRENT ARE MEASURED AT NO SIGNAL INPUT  
 CONDITION.  
 CIRCUIT AND PARTS ARE SUBJECT TO CHANGE WITHOUT PRIOR  
 NOTICE.

WARNING:  
 Parts marked with this symbol have critical characteristics.  
 Use ONLY replacement parts recommended by the manufacturer.  
 CAUTION:  
 Before returning the unit to the customer, make sure you make either (1) a  
 leakage current check or (2) a line to chassis resistance check. If the leakage  
 current exceeds 0.5 milliamps, or if the resistance from chassis to either side  
 of the power card is less than 460 kohms, the unit is defective.  
 WARNING:  
 DO NOT return the unit to the customer until the problem is located and  
 corrected.

SCHEMATIC DIAGRAMS (2/2)  
 FRONT / MICOM UNIT

## SPEAKER SYSTEM (Option for Asia model)

### SPECIFICATIONS

Type:	2-way, 2-speakers, Low-leakage-flux	Frequency range:	45Hz ~ 30kHz
Speakers:	14cm cone woofer 2.5cm dome tweeter	Sensitivity:	88dB (1m, 1watt)
Input impedance:	6 ohms	Crossover frequency:	4kHz
Max. input:	60 watts (EIAJ)	Dimensions:	183(W) x 328(H) x 240(D) (mm)
		Weight:	4.3kg

\* For improvement purposes, specifications and design are subject to change without notice.

\* Low-leakage-flux complies with EIAJ standard.

### SCHEMATIC DIAGRAM

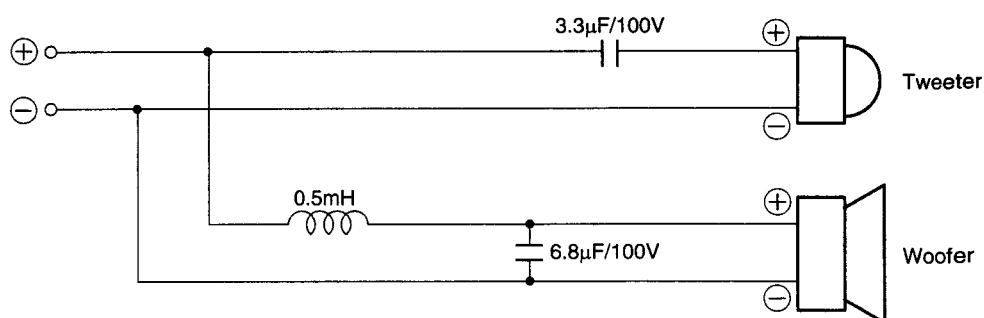

### NETWORK ASS'Y

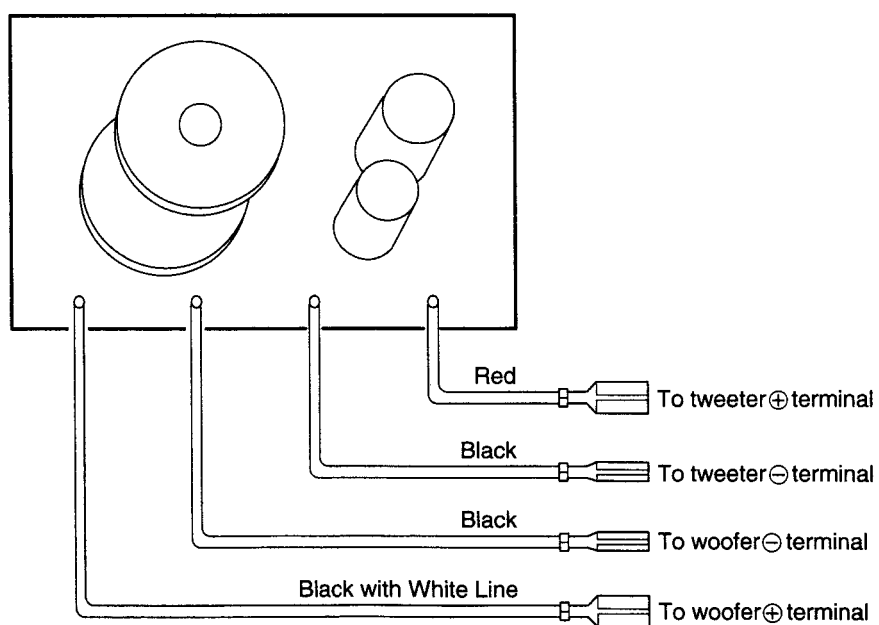



**SPEAKER**

**EXPLODED VIEW**

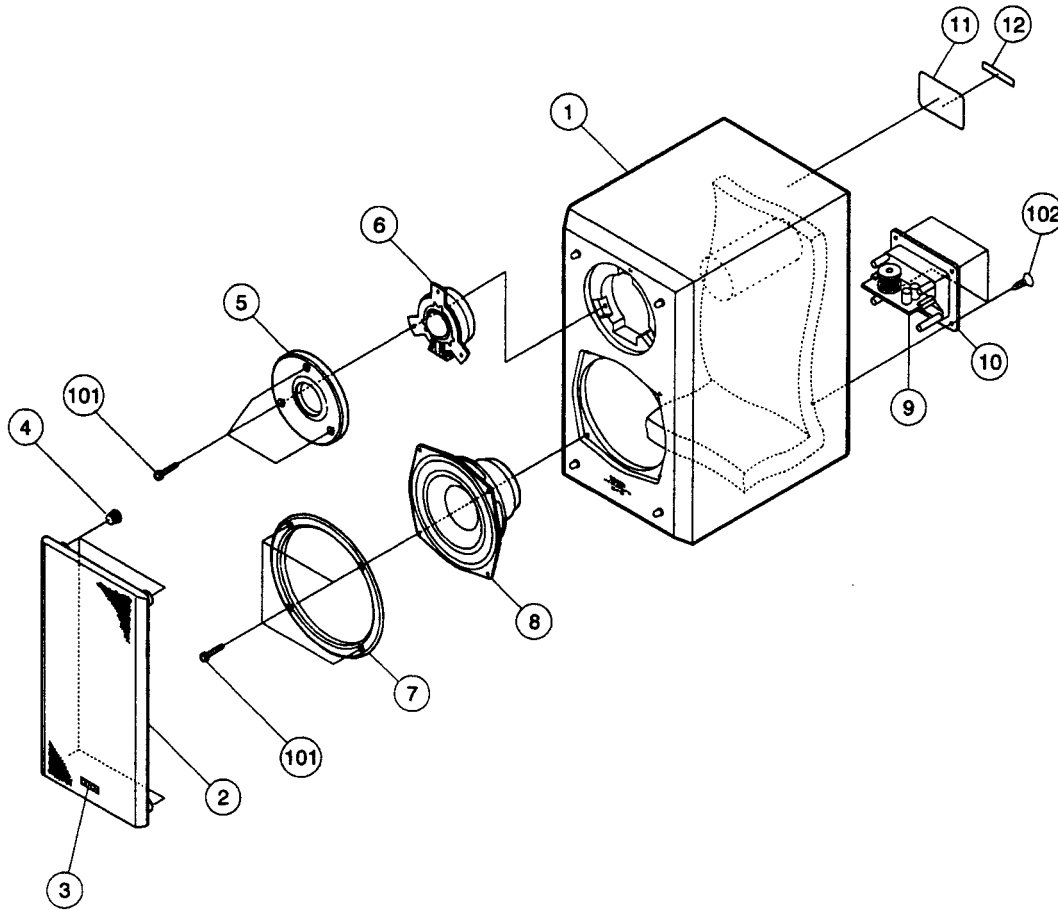

**PARTS LIST OF EXPLODED VIEW**

**PACKING & ACCESSORIES**

(Not indicated in the Exploded View)

Ref. No.	Part No.	Part Name	Remarks	Q'ty
1	SCF 1001 001	Cabinet ass'y		2
2	SCF 1001 002	Grille frame ass'y		2
3	SCF 1001 003	DENON badge		2
4	SCF 1001 004	Catcher		8
5	SCF 1001 005	Tweeter ring ass'y		2
6	SCF 1001 006	Tweeter		2
7	SCF 1001 007	Woofer ring		2
8	SCF 1001 008	Woofer		2
10	SCF 100E 101	2P terminal	include network ass'y Ref. No. 9	2
11	SCF 100E 111	Rating sheet		2
12	SCF 1001 012	Serial No. sheet		2
<b>SCREWS</b>				
101	SCF 1009 001	Screw 4×20 HSHCTS	for speaker	14
102	SCF 1009 002	Screw 3.5×12 CFTS	for 2P terminal	8

Ref. No.	Part No.	Part Name	Remarks	Q'ty
201	SCF 1001 013	Connecting cord ass'y		2
202	SCF 100E 103	Instruction manual		1
203	SCF 100E 104	Carton case		1
204	SCF 1009 005	Cabinet sheet		4
205	SCF 1009 006	Cushion		2
209	SCF 1001 012	Serial No. sheet	for carton case	1
210	SCF 100E 105	Control label	for carton case	2