

# DENON

Hi-Fi Stereo Recorder

## SERVICE MANUAL MODEL DMD-F10 STEREO MD RECORDER

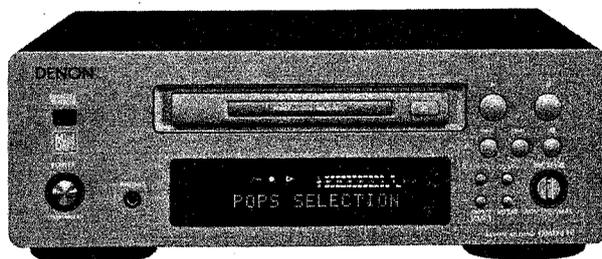
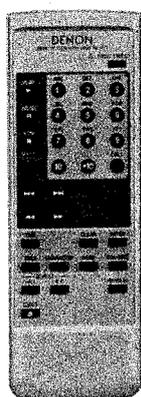

### CONTENTS

CAUTIONS AT A TIME OF SERVICE, NOTES ON RE-SHIPMENT .....	2
OPERATING INSTRUCTIONS .....	3 ~ 20
DISASSEMBLY .....	21
BLOCK DIAGRAM .....	22
LASER PICKUP .....	23, 24
ADJUSTMENT .....	25 ~ 35
SEMICONDUCTORS .....	36 ~ 51
PRINTED WIRING BOARD .....	52 ~ 57
PRINTED WIRING BOARD PARTS LIST .....	58 ~ 62
WIRING DIAGRAM .....	63
EXPLODED VIEW OF CHASSIS AND CABINET .....	64
PARTS LIST OF EXPLODED VIEW .....	65
MD MECHANISM (FG-90) .....	66 ~ 69
SCHEMATIC DIAGRAM AND WAVE FORM (1/3) (2/3) (3/3) .....	70 ~ 75

**NIPPON COLUMBIA CO., LTD.**

## CAUTIONS AT A TIME OF SERVICE

- The Mini Disc (MD) Recorder employs a high-power laser pick-up. Because the pick-up is prone to invite "deterioration", please take utmost care when handling this unit at a time of service.
  - 1) Use a well-grounded mat to avoid surge current due to digital equipments, motor, etc. and perform service on this mat.
  - 2) For preventing "deterioration", ground the human body by means of using a wrist band or so to avoid electrostatic discharge.
  - 3) We recommend to use a ceramic type soldering iron with a good grounding.

## NOTES ON RE-SHIPMENT

- The following notes aiming to protect mechanism against damages when re-shipping this unit. Please be followed the instructions.
  - 1) After completed service, insert the jig to the unit through the cartridge slot.
  - 2) Insert the jig way end until FL lamp shows "Disc Set".
  - 3) When FL lamp shifts the display to "00 Tr m s", pull out the jig.
  - 4) Press the power switch to turn OFF the power. FL lamp then shows "OFF".
  - 5) Unplug the power cord and make re-shipment.

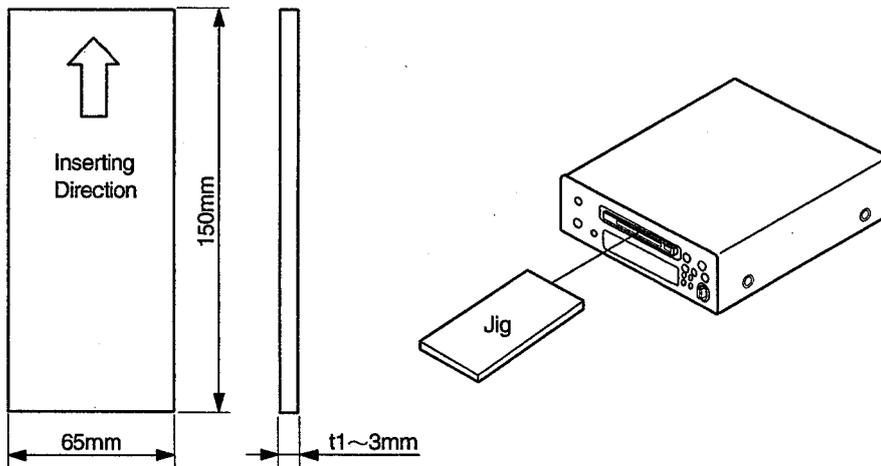

Material: Coated Board

## SPECIFICATIONS

<b>Format:</b>	MiniDisc digital audio system
<b>Wow &amp; flutter:</b>	Below measurable limits ( $\pm 0.001\%$ W. Peak or less)
<b>Sampling frequency:</b>	44.1 kHz
<b>Recording method:</b>	Magnetic field modulation overwrite
<b>Optical source:</b>	Semiconductor
<b>Power supply:</b>	50/60Hz, voltage is shown on rating label
<b>Power consumption:</b>	18W
<b>Maximum external dimensions:</b>	270 (W) $\times$ 96 (H) $\times$ 315 (D) mm (10-5/8" $\times$ 3-25/32" $\times$ 12-13/32") (including feet, controls and terminals)
<b>Weight:</b>	3.9kg (8 lbs. 10 oz)
<b>■ Remote control unit (RC-177)</b>	
<b>Remote control system:</b>	Infrared pulse
<b>Number of buttons:</b>	32
<b>Power supply:</b>	Two DC 1.5V R6P/AA batteries
<b>Maximum external dimensions:</b>	60 (W) $\times$ 177 (H) $\times$ 18 (D) mm (2-23/64" $\times$ 6-31/32" $\times$ 45/64")
<b>Weight:</b>	100g (including batteries) (Approx. 3.5 oz)

\* Maximum dimensions include controls, jacks, and covers.

(W) = width, (H) = height, (D) = depth

● For improvement purposes, specifications and functions are subject to change without advanced notice.

**CAUTION**  
RISK OF ELECTRIC SHOCK  
DO NOT OPEN

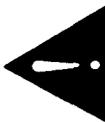

**CAUTION:** TO REDUCE THE RISK OF ELECTRIC SHOCK, DO NOT REMOVE COVER (OR BACK). NO USER SERVICEABLE PARTS INSIDE. REFER SERVICING TO QUALIFIED SERVICE PERSONNEL.

The lightning flash with arrowhead symbol, within an equilateral triangle, is intended to alert the user to the presence of uninsulated "dangerous voltage" within the product's enclosure that may be of sufficient magnitude to constitute a risk of electric shock to persons.



The exclamation point within an equilateral triangle is intended to alert the user to the presence of important operating and maintenance (servicing) instructions in the literature accompanying the appliance.



**WARNING:** TO REDUCE THE RISK OF FIRE OR ELECTRIC SHOCK, DO NOT EXPOSE THIS APPLIANCE TO RAIN OR MOISTURE.

• FOR U.S.A. & CANADA MODEL ONLY

**CAUTION**  
TO PREVENT ELECTRIC SHOCK DO NOT USE THIS (POLARIZED) PLUG WITH AN EXTENSION CORD, RECEPTACLE OR OTHER ADAPTER. THESE DEVICES CAN BE FULLY INSERTED TO PREVENT BLADE EXPOSURE.

• POUR LE MODELE CANADIEN UNIQUEMENT

**ATTENTION**  
POUR PREVENIR LES CHOCS ELECTRIQUES, NE PAS UTILISER CETTE FICHE POLARISEE AVEC UN PROLONGATEUR, UNE PRISE DE COURANT OU UNE AUTRE SORTIE DE COURANT, SAUF SI LES LAMES PEUVENT ETRE INSEREES A FOND SANS EN LAISSER AUCUNE PARTIE A DECOUVERT.

**NOTE:**

This unit may cause interference to radio and television reception if you do not operate it in strict accordance with this OPERATING INSTRUCTIONS.

This unit complies with Class B computing device rules in accordance with the specifications in Sub-part J or Part 15 of the FCC Rules, which are designed to provide reasonable protection against such interference in a residential installation. If the unit does cause interference to any radio or television reception, try to reduce it by one or more of the following means:

- a) Turn the other unit to improve reception
- b) Move this unit
- c) Move this unit away from others
- d) Plug this unit respectively into a different AC outlet

\* This is note in accordance with Section 15.838 of the FCC Rules.

• US and foreign patents licensed from Dolby Laboratories Licensing Corporation.

**NOTE:**  
This MD RECORDER uses the semiconductor laser. To allow you to enjoy music at a stable operation, it is recommended to use this in a room of 5°C (41°F) - 35°C (95°F).

**CAUTION:**  
USE OF CONTROLS OR ADJUSTMENTS OR REFORMANCE OF PROCEDURES OTHER THAN THOSE SPECIFIED HEREIN MAY RESULT IN HAZARDOUS RADIATION EXPOSURE.

THE MD RECORDER SHOULD NOT BE ADJUSTED OR REPAIRED BY ANYONE EXCEPT PROPERLY QUALIFIED SERVICE PERSONNEL.

**HINWEIS:**

Dieser MD-REKORDER wendet einen Halbleiterlaser an. Damit Sie die Musik in gleichbleibend guter Qualität genießen können, ist es empfehlenswert, dieses Gerät bei einer Raumtemperatur zwischen 5°C - 35°C zu betreiben.

**VORSICHT:**

DIE BENUTZUNG DER BEDIENUNGSSELEMENTE, DAS VORNEHMEN VON EINSTELLUNGEN UND DAS DURCHFÜHREN VON VERFAHREN AUF ANDERE ALS IN DIESER BEDIENUNGSANLEITUNG BESCHRIEBENEN ART UND WEISE, KANN GEFÄHRLICHE STRAHLEN FREISETZEN.

DER MD-REKORDER SOLLTE NUR VON QUALIFIZIERTEM FACHPERSONAL EINGESTELLT UND REPARIERT WERDEN.

**REMARQUE:**

Cet ENREGISTREUR MD utilise un laser à semi-conducteur. Pour vous permettre de profiter de la musique avec un fonctionnement stable, il est recommandé de l'utiliser dans une pièce où règne une température entre 5°C (41°F) - 35°C (95°F).

**ATTENTION:**

L'UTILISATION DE COMMANDES OU REGLAGES OU L'EXECUTION DE PROCEDURES AUTRES QUE CELLES DECRIES DANS CE MANUEL PEUVENT PROVOQUER L'EXPOSITION A DES RADIATIONS DANGEREUSES.

L'ENREGISTREUR MD NE DOIT ETRE REGLE OU REPAIRE QUE PAR UN DEPANNEUR QUALIFIE.

**OBSERVERA:**

I den här MD-spelaren används en halvledarlaser. För att undvika funktionsstörningar bör man använda utrustningen endast vid temperaturer mellan 5°C och 35°C.

**WARNING:**

BRUK AV KONTROLLER, JUSTERING ELLER ANVÄNDNING AV UTRUSTNINGEN PÅ ANNAT SÄTT ÄN VAD SOM ANGES I BRUKSANVISNINGEN KAN MEDFÖRA RISK FÖR SKADLIG STRÅLNING.

MD-SPELAREN FÅR ENDAST JUSTERAS OCH REPARERAS AV SERVICEPERSONAL MED TILLRÄCKLIGA KVALIFIKATIONER.

**IMPORTANT (BRITISH MODEL ONLY)**

The wires in this mains lead are coloured in accordance with the following code:

Blue: Neutral Brown: Live

The colours of the wires in the mains lead of this apparatus may not correspond with the coloured markings identifying the terminals in your plug proceed as follows.

The wire which is coloured blue must be connected to the terminal which is marked with the letter N or coloured black.

The wire which is coloured brown must be connected to the terminal which is marked with the letter L or coloured red.

# SAFETY INSTRUCTIONS

1. **Read Instructions** – All the safety and operating instructions should be read before the appliance is operated.
2. **Retain Instructions** – The safety and operating instructions should be retained for future reference.
3. **Heed Warnings** – All warnings on the appliance and in the operating instructions should be adhered to.
4. **Follow Instructions** – All operating and use instructions should be followed.
5. **Water and Moisture** – The appliance should not be used near water – for example, near a bathtub, washbowl, kitchen sink, laundry tub, in a wet basement, or near a swimming pool, and the like.
6. **Carts and Stands** – The appliance should be used only with a cart or stand that is recommended by the manufacturer.
- 6A. An appliance and cart combination should be moved with care. Quick stops, excessive force, and uneven surfaces may cause the appliance and cart combination to overturn.
7. **Wall or Ceiling Mounting** – The appliance should be mounted to a wall or ceiling only as recommended by the manufacturer.
8. **Ventilation** – The appliance should be situated so that its location or position does not interfere with its proper ventilation. For example, the appliance should not be situated on a bed, sofa, rug, or similar surface that may block the ventilation openings; or placed in a built-in installation, such as a bookcase or cabinet that may impede the flow of air through the ventilation openings.
9. **Heat** – The appliance should be situated away from heat sources such as radiators, heat registers, stoves, or other appliances (including amplifiers) that produce heat.
10. **Power Sources** – The appliance should be connected to a power supply only of the type described in the operating instructions or as marked on the appliance.
11. **Grounding or Polarization** – Precautions should be taken so that the grounding or polarization means of an appliance is not defeated.
12. **Power-Cord Protection** – Power-supply cords should be routed so that they are not likely to be walked on or pinched by items placed upon or against them, paying particular attention to cords at plugs, convenience receptacles, and the point where they exit from the appliance.
14. **Cleaning** – The appliance should be cleaned only as recommended by the manufacturer.
15. **Power Lines** – An outdoor antenna should be located away from power lines.
16. **Outdoor Antenna Grounding** – If an outside antenna is connected to the receiver, be sure the antenna system is grounded so as to provide some protection against voltage surges and built-up static charges. Article 810 of the National Electrical Code, ANSI/NFPA 70, provides information with regard to proper grounding of the mast and supporting structure, grounding of the lead-in wire to an antenna-discharge unit, size of grounding conductors, location of antenna-discharge unit, connection to grounding electrodes, and requirements for the grounding electrode. See Figure A.
17. **Nonuse Periods** – The power cord of the appliance should be unplugged from the outlet when left unused for a long period of time.
18. **Object and Liquid Entry** – Care should be taken so that objects do not fall and liquids are not spilled into the enclosure through openings.
19. **Damage Requiring Service** – The appliance should be serviced by qualified service personnel when:
  - A. The power-supply cord or the plug has been damaged; or
  - B. Objects have fallen, or liquid has been spilled into the appliance; or
  - C. The appliance has been exposed to rain; or
  - D. The appliance does not appear to operate normally or exhibits a marked change in performance; or
  - E. The appliance has been dropped, or the enclosure damaged.
20. **Servicing** – The user should not attempt to service the appliance beyond that described in the operating instructions. All other servicing should be referred to qualified service personnel.

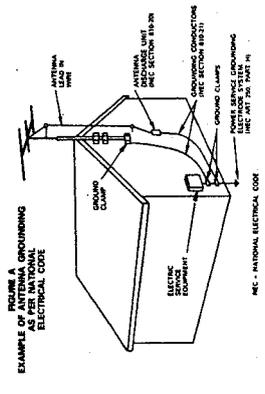

**SAFETY IMPORTANT**

**WARNING:**  
**TO PREVENT FIRE OR SHOCK HAZARD, DO NOT EXPOSE THIS APPLIANCE TO RAIN OR MOISTURE.**

**• NUR FÜR EUROPÄISCHE MODELLE**

**Konformitätserklärung**  
 Die DENON Electronic GmbH  
 Halskestraße 32  
 40880 Ratingen

Erklärt als Hersteller/Importeur, daß das in dieser Bedienungsanleitung beschriebene Gerät den Technischen Vorschriften für Ton- und Fernseh-Rundfunkempfänger nach der Amtsblattverfügung 868/1989 (Amtsblatt des Bundesministers für Post und Telekommunikation vom 31. 8. 1989) entspricht.

**CLASS 1 LASER PRODUCT**  
**LUOKAN 1 LASERLÄITE**  
**KLASS 1 LASERAPPARAT**

**ADVARSEL:**  
 SIKKERHEDSFAKTYDRE ER UDE AF FUNKTION.  
 UNGDÅ UPSÆTTELSE FOR STRÅLING.

**VAROITUS!**

LAITTEEN KÄYTTÄMINEN MUULLA KUIN TÄSSÄ KÄYTTÖOHJEESSA MAINITULLA TAVALLA SAAKTAAN ALITSTAA KÄYTTÄJÄN TURVALLISUUSLUOKAN 1 YLITTAVILLE NÄKYMÄTTÖMÄLLE LASERSÄTEILYLLE.

**VARNING-**

OM APPARATEN ANVÄNDS PÅ ANNAT SÄTT AN I DENNA BRUKSANVISNING SPECIFICERATS, KAN ANVÄNDAREN UTSÄTTAS FÖR OSYNLIG LASERSTRÅLNING SOM ÖVERSKRIDER GRÄNSEN FÖR LASERKLASS 1.



**CAUTION/VORSICHT/ATTENTION/VARNING**  
 • If the system should smoke or produce strange smells, immediately set the power switch to the STANDBY position, unplug the power cord, and contact your store of purchase.

• Sollte das Gerät Rauch produzieren oder eigenartig riechen, stellen Sie den Netzschalter sofort auf die Position STANDBY (Bereitschaft), ziehen Sie den Netzstecker heraus und kontaktieren Sie Ihren Händler.  
 • Si de la fumée sort de la chaîne ou des odeurs bizarres, placez l'interrupteur d'alimentation immédiatement sur la position de veille (STANDBY), débranchez le cordon d'alimentation et contactez le distributeur.  
 • Ställ omedelbart strömbrivaren i beredskapsläge (STANDBY) och dra ur nätkontakten om utrustningen börjar ryka eller lukta konstigt. Vänd dig sedan till din återförsäljare.

**NOTE ON USE/HINWEISE ZUM GEBRAUCH/OBSERVATIONS RELATIVES A L'UTILISATION/OBSERVERA**

<ul style="list-style-type: none"> <li>• Avoid high temperatures. Allow for sufficient heat dissipation when installed on a rack.</li> <li>• Vermeiden Sie hohe Temperaturen. Lassen Sie die ausreichende Luftabströmung beim Einbau des Geräts auf ein Regal gestatten.</li> <li>• Evitez des températures élevées. Laissez une suffisante dissipation de chaleur lors de l'installation sur une étagère.</li> <li>• Evitate di esporre l'unità a temperature alte.</li> <li>• Assicurarsi che ci sia un'adeguata dissipazione del calore quando si installa l'unità in un rack.</li> <li>• Evite altas temperaturas. Permita la suficiente dispersión del calor cuando está instalado en la consola.</li> <li>• Vermijd hoge temperaturen. Laat geen voldoende afvoer van de warmte van het apparaat op een rek plaats.</li> <li>• Se till att det finns möjlighet till god avmejlning vid monteringen i ett rack.</li> <li>• Conceda suficiente dispersão de calor quando o equipamento for instalado numa prateleira.</li> </ul>	<ul style="list-style-type: none"> <li>• Unplug the power cord when not using the set for long periods of time.</li> <li>• Zieh das Netzstecker aus, wenn das Gerät nicht verwendet werden soll.</li> <li>• Debrancher le cordon d'alimentation lorsque l'appareil n'est pas utilisé pendant de longues périodes.</li> <li>• Disinnestare il filo di alimentazione quando avete l'intenzione di non usare il filo di alimentazione per un lungo periodo di tempo.</li> <li>• No desista el cordón de energía cuando no utilice el equipo por mucho tiempo.</li> <li>• Neem altijd het netstekker uit het stopcontact wanneer het apparaat gedurende een lange periode niet wordt gebruikt.</li> <li>• Koppele alltid av strömledningen, inte bara när du använder den, utan även när du inte använder den.</li> <li>• Desligte o filo condutor de força quando o aparelho não tiver que ser usado por um longo período.</li> </ul>	<ul style="list-style-type: none"> <li>• Do not let foreign objects in the set. Keep the set free from moisture, water, and dust.</li> <li>• Verboten is het inbrengen van vreemde voorwerpen in het apparaat.</li> <li>• Evitare l'ingresso di corpi estranei e l'umidità, l'acqua e la polvere.</li> <li>• Ne pas laisser des objets étrangers dans l'appareil.</li> <li>• Impedire che nessun oggetto è inserito nel set.</li> <li>• No dejes objetos extraños dentro del equipo.</li> <li>• Laat geen vreemde voorwerpen in dit apparaat vallen.</li> <li>• Forbjød innføring av fremmede gjenstander i apparaten.</li> <li>• Não deixe objetos estranhos no aparelho.</li> </ul>
<ul style="list-style-type: none"> <li>• Do not let insecticides, benzene, and thinners come in contact with the set.</li> <li>• Verboten is het in contact brengen met insecticiden, benzine of verdunningsmiddelen in de buurt van het apparaat.</li> <li>• Ne pas mettre en contact des insecticides, du benzène et un diluant avec l'appareil.</li> <li>• No permita el contacto de insecticidas, gasolina y diluyentes con el equipo.</li> <li>• Laat geen insectenverdelgende middelen, benzine of dunners in contact met dit apparaat komen.</li> <li>• Se till att inte insektmedel på spraybruk, bensin och thinner kommer i kontakt med apparatens hölje.</li> <li>• Não permita que inseticidas, gasolina ou diluente entrem em contacto com o aparelho.</li> </ul>	<ul style="list-style-type: none"> <li>• Never disassemble or modify the set in any way.</li> <li>• Versuchen Sie niemals das Gerät auseinanderzubauen oder auf jegliche Art zu verändern.</li> <li>• Ne jamais démonter ou modifier l'appareil d'une manière ou d'une autre.</li> <li>• Non smontare mai, né modificare l'unità in nessuna maniera.</li> <li>• Nooit dit apparaat demonteren of op andere wijze modificeren.</li> <li>• Förbjød att demontera eller modifiera apparaten och försök inte bygga om den.</li> <li>• Nunca desmonte o modifique o aparelho de alguma forma.</li> </ul>	<ul style="list-style-type: none"> <li>• Do not obstruct the ventilation holes. Die Belüftungspöffnungen dürfen nicht verdeckt werden.</li> <li>• Ne pas obstruer les trous d'aération.</li> <li>• Non coprire i fori di ventilazione.</li> <li>• Não obstrua as aberturas de ventilação.</li> <li>• De ventilatieopeningen mogen niet worden beblokkeerd.</li> <li>• Täpö inte till ventilationsöppningarna.</li> <li>• Não obstrua os orifícios de ventilação.</li> </ul>
<ul style="list-style-type: none"> <li>• Handle the power cord carefully. Hold the plug when disconnecting the cord.</li> <li>• Behandle das Kabel am Stecker, wenn Sie den Netzstecker ausstecken.</li> <li>• Manipuler le cordon d'alimentation avec précaution. Tenir la prise lors du débranchement du cordon.</li> <li>• Curar con cuidado el filo de alimentación con el cable.</li> <li>• Agite para a spine quando scollegare il cavo dalla presa.</li> <li>• Manuseie el cordón de energía con cuidado. Mantenga el enchufe cuando desconecte el cordón de energía.</li> <li>• Hanterer het netstekker voorzichtig. Hou het snoer bij de stekker vast wanneer deze moet worden aan- of losgekoppeld.</li> <li>• Håll i kablens nät den toppas från eluttaget.</li> <li>• Manuseie com cuidado o fio condutor de energia. Segure o tomado ao desconectar o fio.</li> </ul>	<ul style="list-style-type: none"> <li>• *For sets with ventilation holes</li> <li>• Do not obstruct the ventilation holes. Die Belüftungspöffnungen dürfen nicht verdeckt werden.</li> <li>• Ne pas obstruer les trous d'aération.</li> <li>• Non coprire i fori di ventilazione.</li> <li>• Não obstrua as aberturas de ventilação.</li> <li>• De ventilatieopeningen mogen niet worden beblokkeerd.</li> <li>• Täpö inte till ventilationsöppningarna.</li> <li>• Não obstrua os orifícios de ventilação.</li> </ul>	<ul style="list-style-type: none"> <li>• Never disassemble or modify the set in any way.</li> <li>• Versuchen Sie niemals das Gerät auseinanderzubauen oder auf jegliche Art zu verändern.</li> <li>• Ne jamais démonter ou modifier l'appareil d'une manière ou d'une autre.</li> <li>• Non smontare mai, né modificare l'unità in nessuna maniera.</li> <li>• Nooit dit apparaat demonteren of op andere wijze modificeren.</li> <li>• Förbjød att demontera eller modifiera apparaten och försök inte bygga om den.</li> <li>• Nunca desmonte o modifique o aparelho de alguma forma.</li> </ul>

**"SERIAL NO.**  
**PLEASE RECORD UNIT SERIAL NUMBER ATTACHED TO THE REAR OF THE CABINET FOR FUTURE REFERENCE"**

FRONT PANEL/FRONTPLATTE/PANNEAU AVANT/FRAMSIDA

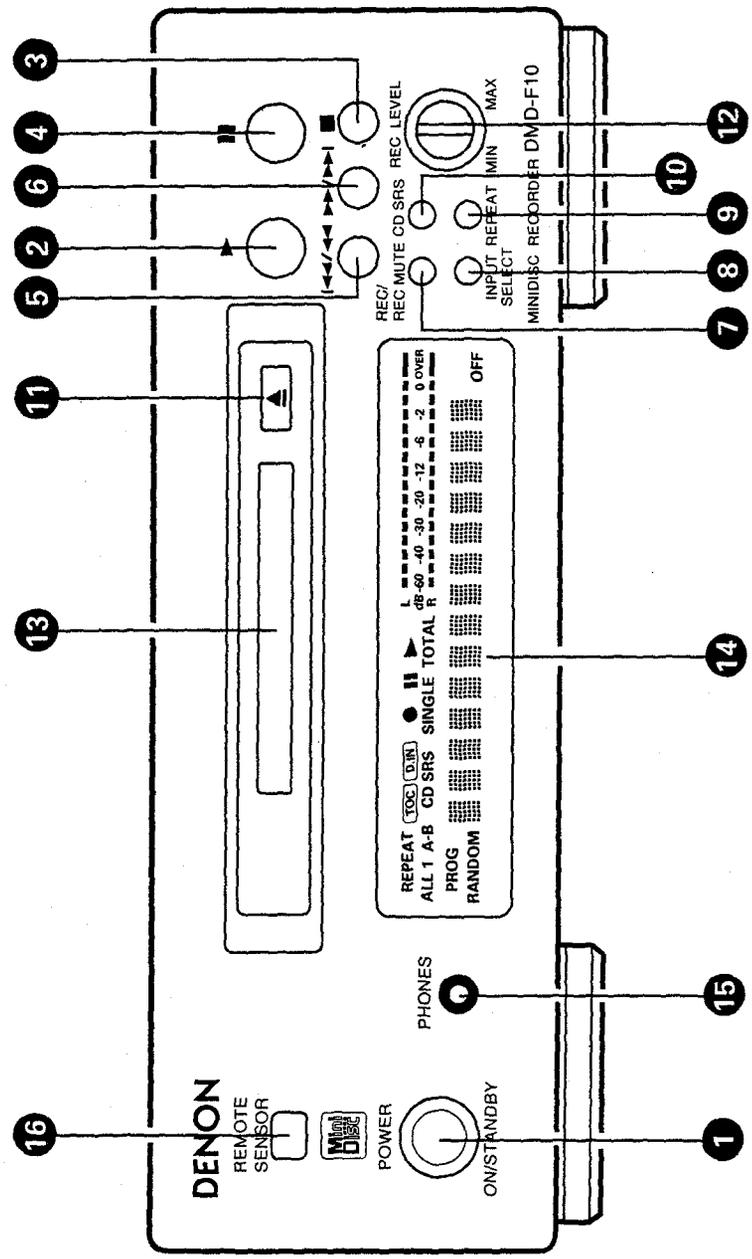

- As an aid to better understanding the operation method, the illustrations used in this manual may differ from the actual system.
- Als Hilfestellung zum besseren Verständnis der Betriebsmethode, erlauben wir uns den Hinweis, daß sich die Abbildungen in dieser Bedienungsanleitung leicht von dem aktuellen System unterscheiden.
- Pour faciliter la compréhension de la méthode de fonctionnement, les illustrations utilisées dans ce manuel peuvent être différentes de celles de la chaîne réelle.
- Illustrationerna i bruksanvisningen hjälper dig förstå de olika funktionerna. Studera dem noga. (Vissa illustrationer kan skilja sig lite från din apparat.)

**CONTENTS**

1	Main Features	6
2	Before Using	6
3	About MiniDiscs	6
4	Connections	7
5	Part Names, Functions and Displays	8
	• Front Panel	8
	• Display	8
6	Remote Control Unit	9, 10
	• Inserting the batteries	9
	• Using the Remote Control Unit	9
	• Remote Control Unit Part Names and Functions	9
7	Normal Playback	10
8	Various Playback Functions	11-13
9	Recording	13, 14
	• Recording Using the Line Input Jacks	13
	• Recording Using the Digital Input Jacks (Digital Recording)	14
10	Various Recording Techniques	14
11	Editing	15, 16
	• Editing	15
	• Examples of Editing Applications	16
	• Giving Titles	16
12	Messages	17
13	System Limitations	17
14	System Functions	17, 18
15	Specifications	18
16	Troubleshooting	18
	DENON Service Network	60, 61

Check that the following parts are included in the package aside from the main unit:

- ① Operating Instructions
- ② Remote Control Unit (RC-177)
- ③ R6P/AA Batteries
- ④ 3P Mini Plug Cord
- ⑤ 2P Pin Cord

**1 MAIN FEATURES**

The DMD-F10 is an audio device using the MiniDisc format, allowing recording for up to 74 minutes on discs and providing the same operability as compact disc (CD) players.

1. **Clear, high sound quality**  
The digital recording format provides clear playback sound.  
In addition, a ".S.L.C." (lambda super linear converter) is used in the playback section, greatly increasing music reproducibility, particularly at low volume levels.
2. **An abundance of playback functions**  
The DMD-F10 offers the same playback functions as compact disc players, including programmed and random playback, as well as all-track, single-track and A-B repeat.

**2 BEFORE USING**

Read the following before using the system.

- **Before turning on the power**  
Check again that all connections are correct and that there are no problems with the connection cords. Be sure to unplug the power cord before connecting or disconnecting the connection cords.
- Humming may be produced if this system is set near a TV or other audio equipment. If this happens, try changing the position of the equipment or the connection cords.
- **Moving the set**  
Be sure to remove discs when moving the set. Discs may be scratched if they are left inside while the set is moved. To prevent short-circuiting or damaging connection cords, be sure to unplug the power cord and disconnect all connection cords with other audio components before moving the set.

**3 ABOUT MINIDISCS**

MiniDiscs offer up to 74 minutes of recording or playback in a compact size. There are two types of MiniDiscs, those for playback only, and those which can be recorded.

**MiniDiscs for playback only**

These are discs which can only be played. The pre-recorded music MDs sold in stores are of this type. These are the same type of optical discs as compact discs. Their tracks cannot be recorded.

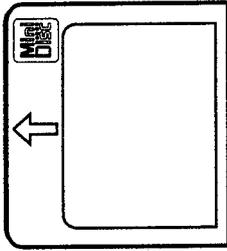

**Recordable MiniDiscs**

These are optical magnetic discs which can be both recorded and played. Recording is performed through magnetic field modulation. The discs can also be re-recorded.

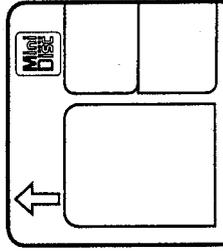

**Handling MiniDiscs**

MiniDiscs are stored in cartridges, so they can be handled easily without worrying about dust and scratches. Dirty or warped cartridges, however, could result in malfunction. Heed the following to ensure high quality sound over a long period of time:

- Do not touch the disc surface directly.
- Do not open the shutter by hand.
- Do not place MiniDiscs in dusty, dirty or humid places.
- Do not place MiniDiscs in places where the temperature is high, such as places exposed to direct sunlight.

**Cleaning**

Wipe dirt or dust off the cartridge using a dry cloth, without applying excess force.

The DMD-F10 provides the convenience only possible with high-speed access discs.

3. **Various editing functions**  
Editing functions for dividing, combining and moving tracks let you control the recorded contents on the disc freely, and disc and track titles can be input so you can easily create your own original discs.
4. **Convenient system functions when used with the D-F10**  
A number of easy operation system functions can be enjoyed when the DMD-F10 is used together with the D-F10, including synchronized recording, timer recording and playback, etc.

**Condensation (dew)**

Condensation (water droplets) may be produced on internal optical lenses or discs in the following cases:

- Directly after a heater is turned on.
- When the system is in a steamy or humid room.
- When the system is moved abruptly from a cold place (room) to a warm room.

**Should condensation occur:**

The signals on the disc cannot be read and the system will not function properly. Remove the disc then let the system set with the power on. The condensation will evaporate in one hour or less, at which time the system will function normally.

- Note that some of the illustrations used for explanations in this manual may differ from the actual system.



## 4 CONNECTIONS

### Connecting to the D-F10

- NOTE:**
- Install in such a way as to not obstruct the ventilation holes on the pre-main amplifier.

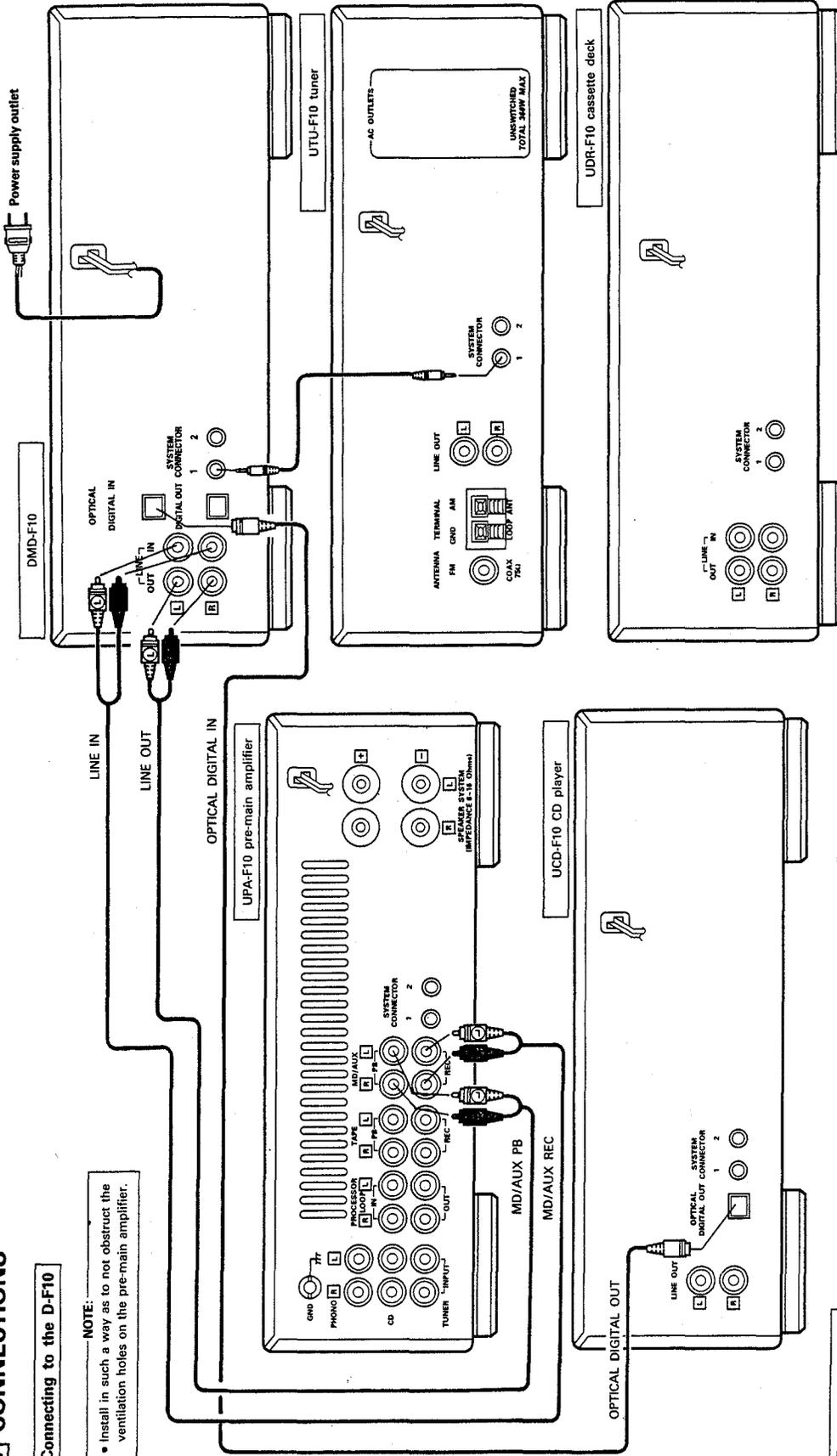

### System operations

The timer, auto on and other system operations will not function unless all of the RCA pin-plug cords and system connector cords are connected between the units. Be sure to connect all the cords securely as shown on the diagram. In addition, disconnecting system connection cords while the system is operating may result in malfunction, so be sure to unplug the power cord from the power outlet before changing the connections. For system connections with the D-F10, refer to the D-F10's operating instructions.

### Optical digital input/output jacks

Digital data is input and output to and from these jacks in optical form. For information on the optical fiber cable used for connections, contact your nearest Denon customer service center or sales office.

### System connector cords

Connect the system connector cords to either the SYSTEM CONNECTOR 1 or 2 jack, whichever is open.

### NOTES:

- Do not plug the power cord into a power outlet until all connections are completed. Be sure to properly interconnect the L (left, white) jacks with the R (right, red) jacks with the R jacks, as shown on the diagram.
- Insert the plugs securely. Incomplete connections may result in noise.
- The DMD-F10 uses digital circuitry, so placing it near a TV may result in color irregularities or other interference. If this happens, move the DMD-F10 and the TV as far apart as possible.
- After unplugging the power cord, wait at least 5 seconds before plugging it back in.
- Note that grouping connection cords (the pin-plug cords) and power cords together may result in humming or other noise.
- If the input selected with the function button is free (if nothing is connected to the corresponding jacks), the sound from a component connected to other input jacks may leak through.
- The DMD-F10 can also be used by connecting its LINE OUT jacks to the MD, CD, AUX or TAPE PLAY L (left) and R (right) input jacks and its LINE IN jacks to the TAPE REC or other jacks of other stereo pre-main amplifiers.

## 5 PART NAMES, FUNCTIONS AND DISPLAYS

Front Panel

- 1 **POWER switch**  
Press this once to turn the power on. Press again to set the power to the standby mode. In the standby mode, "OFF" appears on the display.
- 2 **[play] button**  
Press this button to begin playback or recording. When pressed in the standby mode, the power automatically turns on and playback begins. (Auto on function)  
When pressed during recording, the track number changes.
- 3 **[stop] button**  
Press this to stop playback or recording. Also press it to cancel the editing operation.
- 4 **[II] (pause) button**  
Press this to stop playback or recording temporarily. Press the play button to cancel the pause mode.
- 5 **[REVERSE] button**  
Use this button to move to the beginning of the desired track. When pressed during the play or pause mode, the disc moves backward by a number of tracks equal to the number of times the button is pressed. Also use this button when inputting titles to move the cursor to the left.
- 6 **[FWD] (automatic/manual search forward) button**  
Use this button to move to the beginning of the desired track. When pressed during the play or pause mode, the disc moves forward by a number of tracks equal to the number of times the button is pressed. Also use this button when inputting titles to move the cursor to the right.

- 7 **REC/REC MUTE (record/record mute) button**  
Use this button to record or to create blank sections between tracks. When only the REC/REC MUTE button is pressed, the recording pause mode is set. Recording starts when the [play] button is pressed while in the recording pause mode.  
When this button is pressed during recording, the recording mute mode is set for approximately 4 seconds, after which the recording pause mode is set. To create blank sections more than 4 seconds long, hold the button in. The recording mute mode continues until the button is released, at which point the recording pause mode is set.  
To cancel the recording pause mode, press the [stop] button.
- 8 **INPUT SELECT switch**  
Use this to select the input source for recording.
- 9 **REPEAT button**  
Press this button to set the repeat play mode. The single-track repeat mode is set when the button is pressed once, the all-track repeat mode is set when pressed again. To cancel the repeat mode, press the button once more.
- 10 **CD-SRS (synchronized recording system) button**  
Use this button for easy synchronized recording of CDs.  
For details, refer to Page 18.
- 11 **[EJECT] button**  
Press this button to eject the disc.
- 12 **REC LEVEL (recording level) control**  
Use this control to set the recording level. This control has no effect during digital recording.
- 13 **Disc insertion slot**  
The disc is loaded automatically when it is inserted here.  
\* Be sure to insert the disc in the proper direction.
- 14 **Display**
- 15 **PHONES (headphones) jack**  
To use headphones, plug the headphones into this jack.
- 16 **REMOTE SENSOR**  
Point the remote control unit at this sensor when operating it.  
\* When the DMD-F10 is connected to the D-F10 system, point the remote control unit at the remote sensor on the pre-main amplifier.

Display

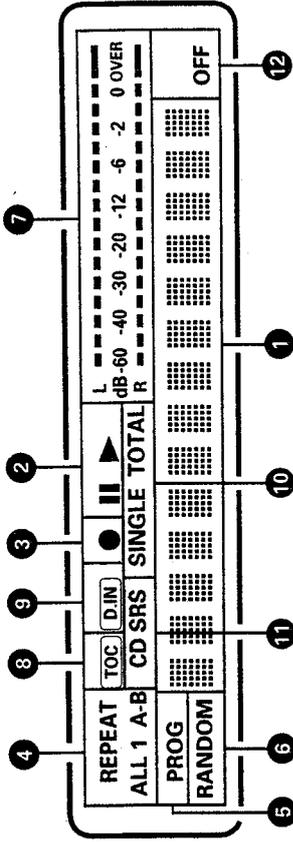

- 1 **Multi-display**  
The track number, playing time, title, operation and messages are displayed here.
- 2 **[play] indicator lights** when a disc is playing or recording. The [II] (pause) indicator lights when the pause mode is set, and flashes when in the recording mute mode.
- 3 **This lights** when in the recording or the recording pause mode.
- 4 **These light** to indicate the repeat mode, as follows:  
In the single-track repeat mode : REPEAT 1  
In the all-track repeat mode : REPEAT ALL  
In the A-B repeat mode : REPEAT A-B
- 5 **This lights** when in the programmed playback mode.
- 6 **This lights** when in the random play mode.
- 7 **This indicates** the playback or recording level.
- 8 **This lights** when recording or editing operations (erasing, etc.) are performed and when titles are input, changing the content of the disc. The indicator flashes when the new contents are being recorded on the disc. Be careful not to subject the set to vibrations or unplug the power cord while this indicator is flashing, or the recording will be lost.
- 9 **This lights** when a digital audio input is selected. If this indicator flashes during recording, check the connection of the digital input jack.
- 10 **These indicate** the time mode.  
When SINGLE is lit: The displayed time is the remaining time for the current track.  
When TOTAL is lit: The displayed time is the total remaining time for all tracks.
- 11 **This lights** during synchronized recording of CDs. Synchronized recording of CDs is possible when the DMD-F10 is connected to the D-F10 with the system connection cord.
- 12 **This lights** when in the standby mode.

## 6 REMOTE CONTROL UNIT

The included RC-177 remote control unit can be used to control the DMD-F10 from a distance.

### Inserting the batteries

**NOTES:**

- Use R6P (AA) batteries in this remote control unit.
- Replace the batteries with new ones approximately once each year, though this depends on how frequently the remote control unit is used.
- Replace the batteries with new ones earlier if the remote control unit does not operate even from a short distance.
- Insert the batteries in the proper + and - direction, following the marks in the battery compartment.
- Remove the batteries when not using the remote control unit for extended periods of time.
- To avoid damage and leakage:
  - Do not use a new battery with an old one.
  - Do not use two different types of batteries.
  - Do not short-circuit, take apart, heat or dispose of batteries in flames.
- If the batteries should leak, carefully wipe the fluid out of the battery compartment, then insert new batteries.

① Remove the remote control unit's sliding cover.

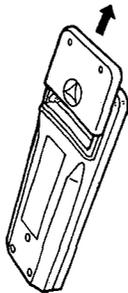

② Insert the two R6P (AA) batteries, following the + and - marks in the battery compartment.

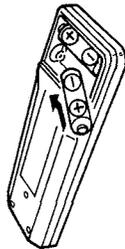

③ Set the sliding cover back in place.

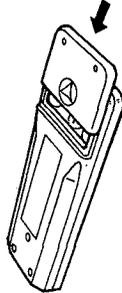

### Using the Remote Control Unit

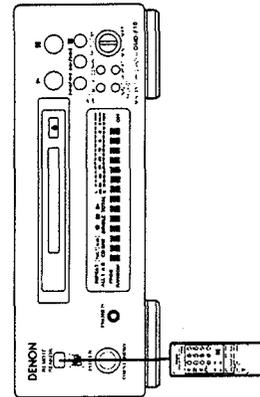

When operating the remote control unit, point it at the remote sensor as shown in the diagram. The remote control unit can be used from a straight distance of approximately 7 meters. However, the distance from which it can be operated decreases if there are obstacles in the way or when operated from a slant. (Operation is possible from a horizontal angle of approximately 30° in either direction.) When the DMD-F10 is connected to the D-F10 system, point the remote control unit at the remote sensor on the pre-main amplifier.

**NOTES**

- The remote control unit may not operate if the remote sensor is exposed to direct sunlight or strong artificial light, or if there is an obstacle between the remote control unit and the remote sensor.
- Do not press buttons on the remote control unit and the set simultaneously. Doing so will result in malfunction.

### Remote Control Unit Part Names and Functions

**PROG/DIRECT (program/direct) button**  
Use this button to switch between the programmed playback and the direct search modes. Normally the mode is set to the direct search mode. When this button is pressed during playback while in the direct search mode, the program mode is set and the track which is currently playing is set as the first track in the program. When this button is pressed during playback the programmed playback mode, the program is cancelled and the disc is played normally from the current track through to the last track.

**▶ PLAY button**  
Press this button to begin playback or recording. When pressed during recording, the track number changes.

**⏸ PAUSE button**  
Press this to stop playback or recording temporarily.

**■ STOP button**  
Press this to stop playback or recording.

**● REC/REC MUTE (record/record mute) button**  
Use this button to record or create blank sections between tracks.

**⏮ and ⏭ (automatic search reverse and forward) buttons**  
Use these buttons to search for tracks. Also use these buttons to move the cursor when inputting titles.

**⏪ and ⏩ (manual search reverse and forward) buttons**  
Use these to fast-forward or fast-reverse the disc. Also use these to select special characters when inputting titles.

**Number buttons 1 to 10**  
Use these buttons for direct search or to set the program. When inputting titles, use these buttons to select numbers, letters and symbols.

**CALL button**  
Press this to check the programmed tracks.

**+10 button**  
Press this to select track numbers of 11 and greater. When inputting titles, use this button to input symbols.

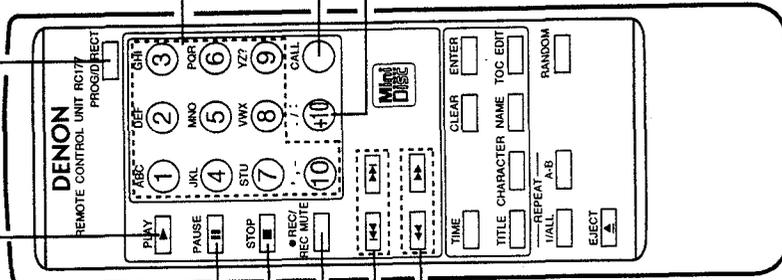

## 7 NORMAL PLAYBACK

First try playing a disc using the procedure below.

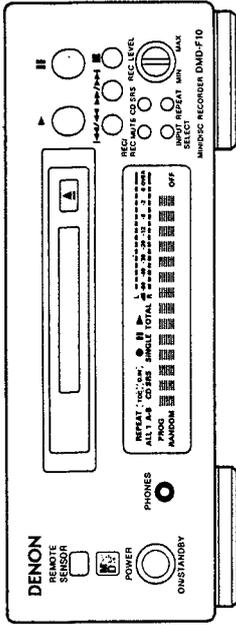

### Starting playback

- Press the POWER switch and load a disc. If a disc is loaded when the power is off, the power turns on automatically. (Auto on function)

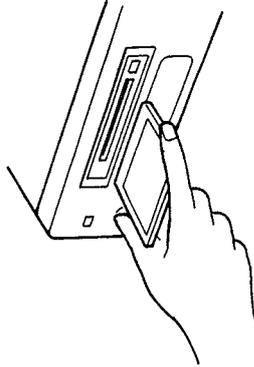

- Press the (play) button. Playback begins.



First the track title is displayed, then the track number, elapsed playing time, etc., are displayed.

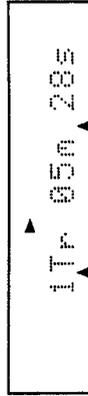

If no track title has been input, the track title is not displayed.

- Stopping playback
- Press the (stop) button.

The stop mode is set automatically once all the tracks recorded on the disc have been played.



### Starting playback

- Press the POWER switch and load a disc. If a disc is loaded when the power is off, the power turns on automatically. (Auto on function)

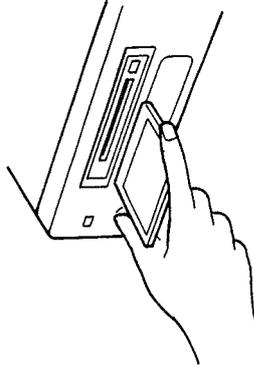

Insert the disc into the insertion slot in the direction of the arrow on the top side of the disc.

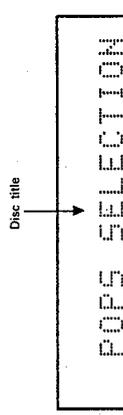

First the disc title is displayed, then the total number of tracks and the total recorded time are displayed.

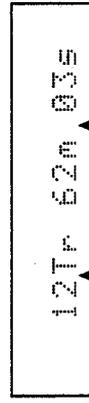

If no disc title has been input, the disc title is not displayed.

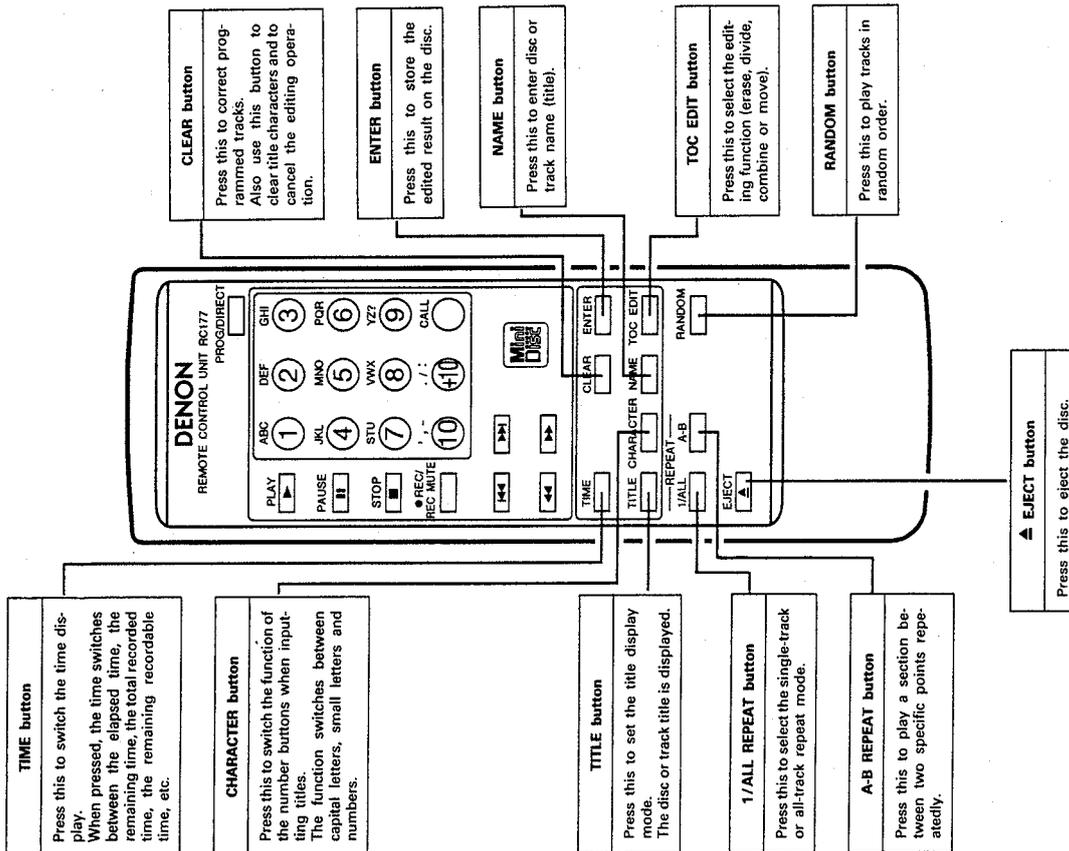

## 8 VARIOUS PLAYBACK FUNCTIONS

In addition to normal playback, the DMD-F10 also offers the playback features listed below.

### 1 Playing a specific track (remote control unit only)

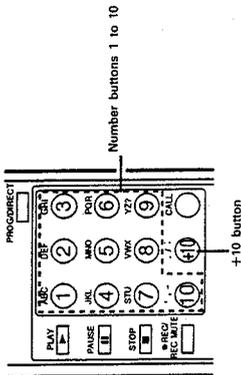

Input the number of the track you want to play using the number buttons and the +10 button.  
For example, press button 4 to play the fourth track, or buttons +10 and 2 to play the 12th track. Playback begins from that track.

### 2 Moving to the next track during playback



(Main unit)

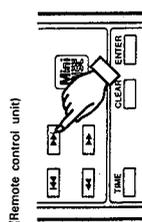

(Remote control unit)

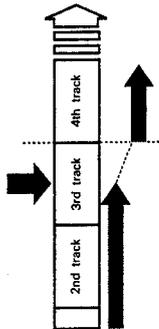

### Quick Search

- 1 Press the automatic search forward button (▶▶/▶▶).
- Press the automatic search forward button (▶▶/▶▶) again during the search operation to move ahead to the beginning of tracks further on.
- Press the automatic search forward button (▶▶/▶▶).

### 3 Moving back to the beginning of the current track during playback

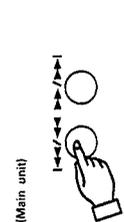

(Main unit)

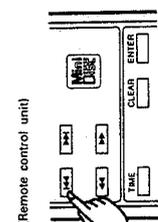

(Remote control unit)

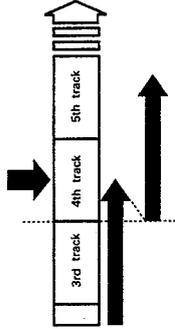

### Quick Search

- 1 Press the automatic search reverse button (◀◀/◀◀).
- Press the automatic search reverse button (◀◀/◀◀) again during the search operation to move back to the beginning of previous tracks.
- Press the automatic search reverse button (◀◀/◀◀).

### 4 Finding the desired spot on the disc while skipping through the disc

- With this function, you can skip through the disc while listening to the sound. This feature comes in handy to find sections in the middle of long tracks.
- When the ▶▶/▶▶ or ◀◀/◀◀ button is pressed and held in for more than 0.5 seconds during playback, the manual search (skip monitor) mode is set, and the disc moves slowly for the first 3 seconds, then moves quickly. Normal playback resumes when the button is released.
- The || (pause) indicator flashes during the manual search operation in the play mode, the || (pause) indicator flashes during the manual search operation in the pause mode. (The sound may be interrupted momentarily when resuming normal playback from the manual search mode.)

#### (1) Manual search forward

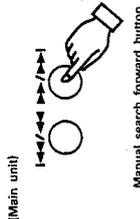

(Main unit)

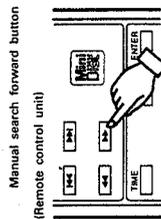

(Remote control unit)

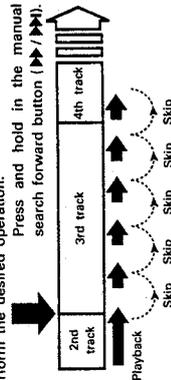

- 1 During playback, press the ▶▶/▶▶ button and hold it in for more than 0.5 seconds.
- The track number and elapsed time of the current track are indicated on the display.
- In the pause mode, the disc moves faster than in the play mode and no sound is heard.
- If the end of the last track on the disc is reached while the ▶▶/▶▶ button is pressed, "JJ" appears on the display and the manual search mode is cancelled.
- To resume playback, first press the ◀◀/◀◀ button until the "JJ" display switches to the track number, then perform the desired operation.

Press and hold in the manual search forward button (▶▶/▶▶).

#### (2) Manual search reverse

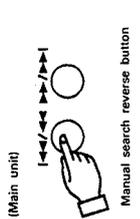

(Main unit)

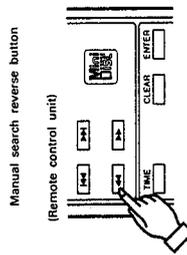

(Remote control unit)

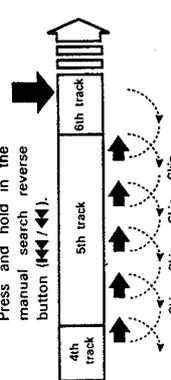

- 1 During playback, press the ◀◀/◀◀ button and hold it in for more than 0.5 seconds.
- The display is the same as during the manual search forward mode.
- In the pause mode, the disc moves faster than in the play mode and no sound is heard.
- If the beginning of the first track on the disc is reached while the ◀◀/◀◀ button is pressed, "LL" appears on the display and the manual search mode is cancelled.
- To resume playback, first press the ▶▶/▶▶ button until the "LL" display switches to the track number, then perform the desired operation.

Press and hold in the manual search reverse button (◀◀/◀◀).

### 5 Stopping playback temporarily

- With this function you can stop playback temporarily then resume from the same position.



(Main unit)

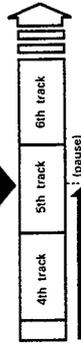

- 1 Press the || (pause) button.

- To resume playback, press the ▶ (play) button.

**Programmed Playback**

**Playing the tracks in a different order**

- With this function, you can program any of the tracks on the disc to play in any order you wish.
- Up to 30 tracks can be programmed.

**(1) Programming tracks (remote control unit only)**

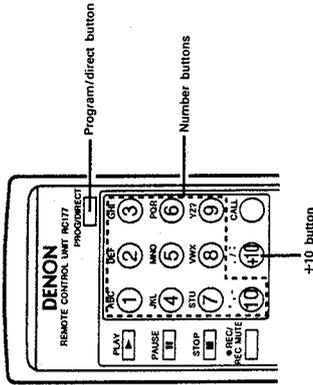

- Press the PROG/DIRECT button and turn the "PROG" indicator on.
- Use the number buttons and the +10 button to select the tracks to be programmed. For example, to program the 3rd, 12th and 7th tracks, press PROG/DIRECT, 3, +10, 2, then 7.
- Each time a track is set in the program, that track number and the total playing time for the programmed tracks are displayed. A certain amount of time after the program is finished, the total number of programmed tracks and the total program playing time are displayed.

**(2) Checking the programmed tracks (remote control unit only)**

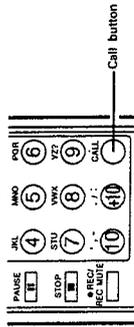

- Press the CALL button.
- The programmed tracks appear on the display in the programmed order each time the button is pressed.

**(3) Playing the programmed tracks**



- Press the play button. The tracks are played in the programmed order.
- New tracks can be added to the program during playback.
- The single-track and A-B repeat functions do not work during programmed playback.

**(4) Correcting programmed tracks (remote control unit only)**

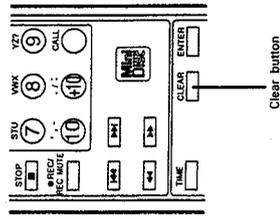

- To correct a programmed track, press the CLEAR button, then input the number of the correct track. The last track in the program is cleared and the new track is set.

**(5) Clearing the entire program**

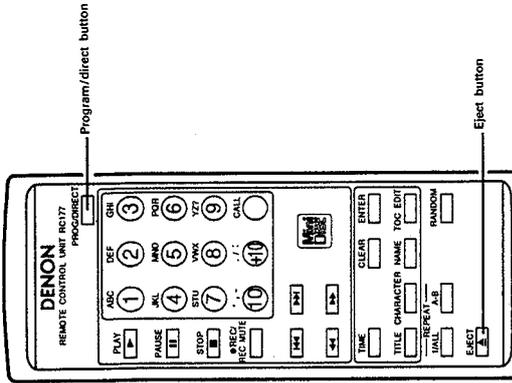

- The entire program is cleared when the PROG/DIRECT button is pressed. The entire program is also cleared when the ▲ (eject) button is pressed.
- When the PROG/DIRECT button is pressed during programmed playback, the program is cleared and normal playback resumes from the track which is currently playing through the last track on the disc.

**Playing the tracks in random order**

**(remote control unit only)**

- With this function, all the tracks on the disc can be played once in random order.

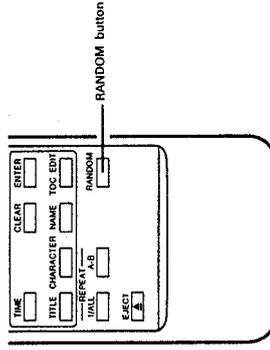

- ① Press the RANDOM button. The "RANDOM" indicator lights. Now press the play button. A track is searched for randomly and playback begins automatically.
- If the RANDOM button is pressed when a program is set, the programmed tracks are played in random order.
- If the RANDOM button is pressed when in the repeat mode, the tracks are each played in random order once, then played again in a different order, and so on, so you can enjoy listening to the tracks in a different order each time.
- The single-track and A-B repeat functions do not work during random playback.

**NOTE:**

- The total remaining time (TOTAL) cannot be displayed during random playback.

## 9 RECORDING

- When using a recordable disc, it is possible to automatically add the new recording after the end of the previous recording. Make sure there is enough remaining time on the disc before doing this.
- To erase all the recordings on a recordable disc and start recording from the beginning of the disc, erase all the tracks before starting to record. (For instructions on erasing all the tracks, refer to "11. EDITING".)

### Recording Using the Line Input Jacks (Analog Recording)

- Play the source you want to record (set the CD player, cassette deck, etc., to the play mode). Press the REC/REC MUTE button.



- Set the recording pause mode is set. The recording pause mode is set.



- Adjust the REC LEVEL control so that the "OVER" indicator does not light even when the volume is maximum. Once the recording level is adjusted, set the source to be recorded to the standby mode.

- Press the play button (▶). Recording starts. Set the source to be recorded to the play mode.



### Stopping recording

- Press the stop button (■). The stop mode is set automatically once the end of the recordable time is reached.



- Press the POWER switch and load the recordable MiniDisc onto which you want to record.

- When using a recordable MiniDisc which already contains a recording, press the TIME button to check the remaining recordable time.

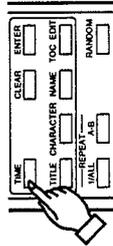

The display switches between the total recorded time and the remaining recordable time each time the TIME button is pressed.

- Press the INPUT SELECT button to display "Analog Auto Tr" or "Analog In".



Set to "Analog Auto Tr" or "Analog In".

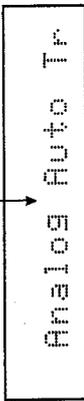

When the INPUT SELECT button is pressed once, the input mode which is currently set is displayed. The previous display reappears after several seconds.

To switch the input mode, press the INPUT SELECT button before the previous display reappears.

When set to "Analog Auto Tr":

The track numbers are assigned automatically when blank (silent) sections in the recording input signal are detected.

When set to "Analog In":

The track numbers are not assigned automatically. (To assign track numbers, refer to "11. EDITING".)

### Single-Track Repeat

- Press the REPEAT button once. "REPEAT 1" appears on the display, and the single-track repeat mode is set.
- Use the ◀ and ▶ buttons to select the track to be played repeatedly.
- Press the play button (▶) to start playback.
- Once the end of the specified track is reached, playback returns to the beginning of that track and the track is played repeatedly.
- If the REPEAT button is pressed during playback, the single-track repeat mode is set for that track.
- To cancel the single-track repeat mode, press the REPEAT button until the "REPEAT" indicator turns off.

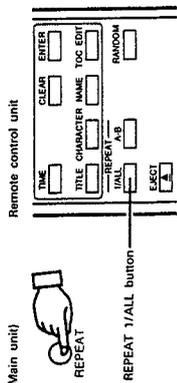

Press the REPEAT button once.

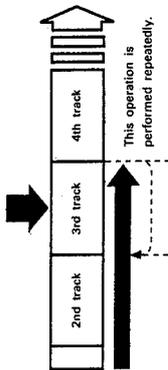

### All-Track Repeat

- Press the REPEAT button twice. "REPEAT ALL" appears on the display, and the all-track repeat mode is set.
- Press the play button (▶) to play all the tracks repeatedly.
- The all-track repeat mode can also be set by pressing the REPEAT button twice during playback.
- To cancel the all-track repeat mode, press the REPEAT button until the "REPEAT" indicator turns off.
- If the REPEAT button is pressed during programmed playback, the tracks are played repeatedly in the programmed order.

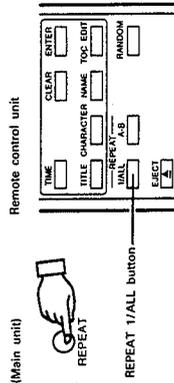

### A-B Repeat

- Playing a section between any two points repeatedly (remote control unit only)

This function allows you to play any section repeatedly, so it comes in handy for practicing karaoke, an instrument, etc.

- During playback, press the A-B repeat button at the point from which you want to start repeating (point A). "A-" appears on the display.
- When the point at which you want to stop repeating (point B) is reached, press the A-B repeat button again. "A-B" appears on the display, the disc returns to point A and the section between points A and B is played repeatedly.
- To cancel the A-B repeat mode, press the A-B repeat button again. "REPEAT A-B" turns off and normal playback resumes.
- The A-B repeat function does not work during programmed playback and random playback.

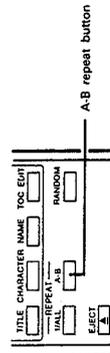

- Press the A-B repeat button. (Point A)
- Press the A-B repeat button. (Point B)

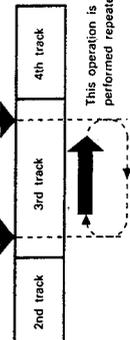

## 10 VARIOUS RECORDING TECHNIQUES

- Assigning track numbers during recording
- Track numbers can be assigned during recording regardless of the recording mode ("Analog Auto Tr.", "Analog In" or "Digital In").
- ① Press the play button (▶).
- ② When the play button is pressed during recording, a new track number is set at that point.

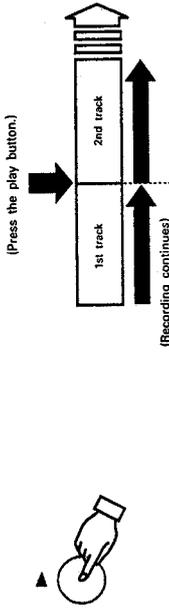

- Stopping recording temporarily
- Recording can be stopped in the middle then resumed from that point.
- ① Press the pause button (||).
- ② When the pause button is pressed during recording, the pause mode is set at that point.

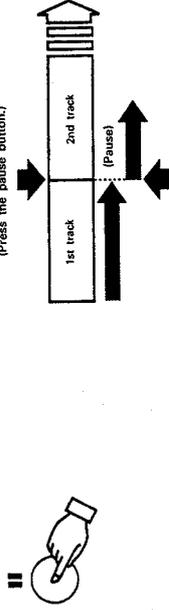

To resume recording, press the play button.  
A new track number is set at the point where the play button is pressed.

### Accidental erasure prevention tabs

Recordable MiniDiscs include the click to prevent accidental erasure. To avoid accidentally erasing the MiniDisc, slide the accidental erasure prevention click and open it. (Refer to the diagram below.) When this is done, "Protected" is displayed if you try to record or edit (erase, etc.) the MiniDisc, and the editing operation is prohibited, thereby protecting the recording. To record, erase, or otherwise edit the MiniDisc again, slide the click back to its original position to close the hole.



### NOTES:

- When recording is started, the [TOC] indicator lights, indicating that the content of the disc has been changed.
- When the [TOC] indicator is flashing, the new content is being stored on the disc. Be careful not to subject the set to vibrations or unplug the power cord while this indicator is flashing, or the recording will be lost.

## Recording Using the Digital Input Jack (Digital Recording)

- Starting digital recording
- ① Press the POWER switch and load the recordable MiniDisc onto which you want to record.
- ② When using a recordable MiniDisc which already contains a recording, press the TIME button to check the remaining recordable time.

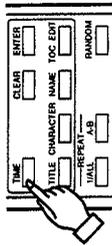

The display switches between the total recorded time and the remaining recordable time each time the TIME button is pressed.

- ③ Press the INPUT SELECT button to display "Digital In".

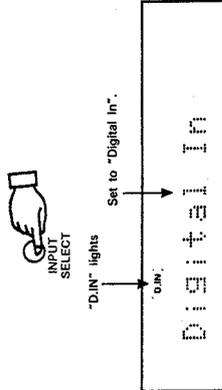

When the INPUT SELECT button is pressed once, the input mode which is currently set is displayed. The previous display reappears after several seconds. To switch the input mode, press the INPUT SELECT button before the previous display reappears.

- ④ Press the REC/REC MUTE button.



If the [DIN] indicator is flashing, check the connection to the digital in jack.

- ⑤ Press the play button (▶).  
Recording starts.



- When using digital recording, there is no need to adjust the recording level. The recording level does not change even if the position of the REC LEVEL control is changed.
- When recording digitally from CDs or MDs, the track numbers are also recorded automatically.
- MiniDiscs recorded digitally can not be digitally recorded again.

The DMD-F10 complies with the Serial Copy Management System specifications. The Serial Copy Management System limits the copying of digital signals between digital audio devices to "one generation". To record a MiniDisc which has been recorded digitally, use analog recording.

- With MiniDiscs, digital recording is only possible if the source to be recorded uses the same sampling frequency (44.1kHz).

Sources which can be recorded digitally:  
CDs, MDs, DATs (only if the sampling frequency is 44.1 kHz), etc.

Sources which cannot be recorded digitally:  
DATs with sampling frequencies of 32 kHz or 48 kHz  
Satellite broadcasts (sampling frequencies of 32 kHz or 48 kHz)

- To record sources which cannot be recorded digitally, use analog recording.

### NOTE:

When recording a MiniDisc digitally, the track number does not change if the same track is programmed twice in a row or when the single-track repeat mode is set.





**Examples of Editing Applications**

The four editing functions can be used to edit MiniDiscs in a variety of ways. Here we give two examples. Refer to these examples and try making your own original discs.

**[Erasing part of a track]**

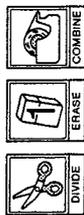

To erase part of a track, first assign that part a track number then erase that track.

- ① Use the divide function to assign the part of the track you want to erase a track number.
- ② Erase the section with that track number.
- ③ Combine the two remaining parts of the track.

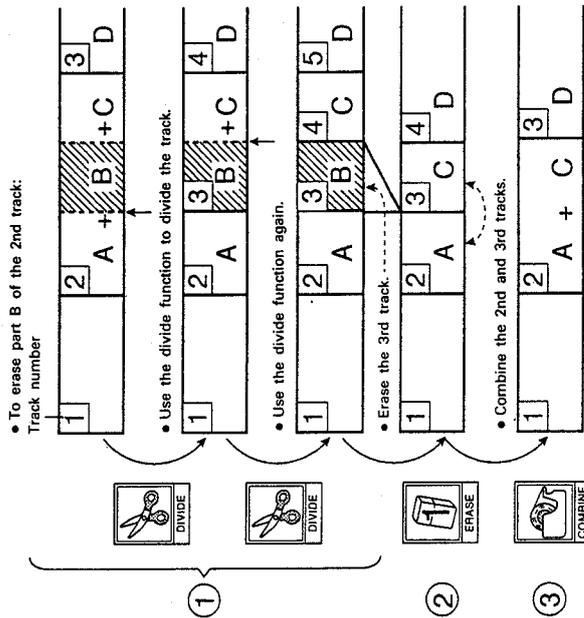

**[Combining two non-adjacent tracks]**

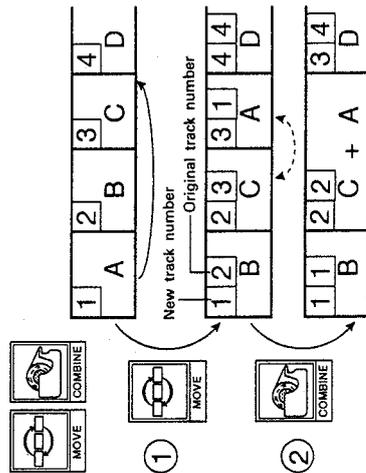

- To add the 1st track to the end of the 3rd track:
- ① Move the 1st track to the end of the 3rd track.
  - ② Combine the 3rd track (now the 2nd track) with the 1st track (now the 3rd track).

**Giving Titles**

Titles containing up to 255 characters can be given to discs and to tracks.

**① Giving titles to discs**

- ① Load the disc to which you want to give a title.
- ② In the stop mode, press the NAME button.

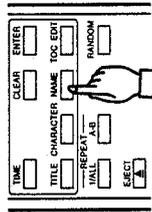

- The cursor indicating the title input standby mode appears.

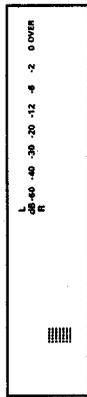

**③ Input the title.**

- Use the letters assigned to the number buttons and the +10 button and the special characters selected with the manual search buttons (◀ and ▶) to input titles. The special characters change in the following order when one of the manual search buttons is pressed.

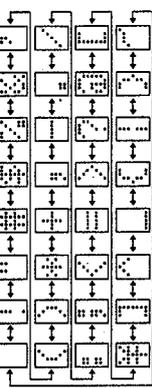

Some characters which can be input on the DMD-F10 cannot be displayed on other sets.

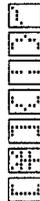

- The shape of the cursor changes when the CHARACTER button is pressed.



**[Cursor shapes]**

- .....Capital letter input mode
- .....Small letter input mode
- .....Number input mode

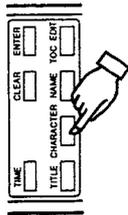

The special characters do not change when the character mode is changed.

- Three letters or symbols are assigned to each number button. The letters change in order each time the button is pressed.

For example, to input "F", press number button "2" three times.

- After setting each character, press the automatic search forward button to move on to the next place.
- The cursor can be moved backwards by pressing the automatic search reverse button. Use this to correct or change characters.

- ③ Store the title on the disc.
- ④ After inputting the title, press the NAME button again.

**④ Giving titles to tracks**

- In the stop mode, use the automatic search buttons to search for the number of the track to which you want to give a title. In the play mode, set the play/pause mode at that track.

**② Press the NAME button.**

- The cursor indicating the title input standby mode appears.

- ③ Input the title.
- ④ Use the procedure described in step ③ for "Giving titles to discs".

- ⑤ Store the title on the track.
- ⑥ After inputting the title, press the NAME button again.

**NOTES:**

- When editing is started, the TOC indicator lights, indicating that the content of the disc has been changed.
- When the TOC indicator is flashing, the new content is being stored on the disc. Be careful not to subject the set to vibrations or unplugging the power cord while this indicator is flashing, or the recording will be lost.
- All characters you can input to one disc (disc title and track titles) are up to 1792 characters.

**12 MESSAGES**

Messages appear on the display to indicate various situations. These messages are explained below.

Message	Description
Blank Disc	Nothing is recorded on the disc which is loaded.
Complete	This indicates that the editing operation is completed.
Copy Prohibit	Digital copying of that source is prohibited by the SCMS (Serial Copy Management System).
Disc Error	There is a problem with the disc (such as scratches or problems in the TOC).
Disc Full	There is no remaining time on the disc, or there are already 255 tracks on the disc.
Impossible	This indicates that the impossible operation of editing has been done.
No Name	This indicates that no title has been input.
No Track	The disc has a title but no tracks are recorded on it.
Playback Only	This appears if you try to record or edit on a disc which can only be used for playback.
Protected	The disc is protected with the accidental erasure prevention click.

**13 SYSTEM LIMITATIONS**

MiniDisc (MD) systems use a different recording system from conventional systems. Because of this, there are various limitations to the system. Note that the set is not malfunctioning when the symptoms described arise.

- **Track number limitations**
  - When tracks are recorded on a blank disc or a no-track disc in sequence starting from track 1, up to 255 tracks can be recorded. However, if the editing functions have been used repeatedly, it may not be possible to record 255 tracks.
  - When using digital recording, if tracks contain much on/off data for emphasis, etc., this data is treated as track divisions (though the track number does not change), so the actual recordable time and the number of recordable tracks may decrease, regardless of the actual recorded time and the number of recorded tracks.
- **Recording function limitations**
  - Recording is no longer possible once the maximum number of tracks is reached, even if they take up less than the maximum recordable time.
  - The disc's remaining time may not increase when short tracks (about 8 seconds or less) are erased.
  - Recording is performed in units of approximately 2 seconds. Sections shorter than 2 seconds also use 2 seconds of space on the disc, so they shorten the actual recordable time.
  - Recording is not possible on scratched sections of the disc, so the recordable time is decreased by the length of the scratched sections.
  - When recording CDs digitally, blank sections of several seconds in length may be produced for some CDs, in which case the number of tracks on the MD will be different from the number of tracks the CD.
- **Editing function limitations**
  - It may not be possible to combine short tracks created using the editing functions.
  - The sound may be interrupted when using the skip monitor on discs which have been recorded and edited repeatedly.

**14 SYSTEM FUNCTIONS**

Using the DMD-F10 together with the D-F10 stereo component system further increases ease of operation. (For connections, refer to "4. CONNECTIONS" on Page 7.)

① **Auto on function**

This function allows you to play MDs simply by pressing the DMD-F10's play button when the overall system is in the standby mode.

- ① When the overall system is in the standby mode, only the DMD-F10's power turns on when a disc is inserted.
- ② When the DMD-F10's play button is pressed, the amplifier's power turns on, the function automatically switches to MD/AUX and the MD starts playing.
- If a disc is loaded and the DMD-F10 is in the standby mode, playback can be started simply by pressing the play button.

② **CD synchronized recording system**

CD SRS

This function allows you to record CDs easily.

- ① Load the recordable MiniDisc which you want to record in the DMD-F10, and set to the stop mode.
- ② Load the disc in the CD player, and set to the stop mode.
- ③ Press the DMD-F10's INPUT SELECT button and select the input mode.
- ④ Press the CD SRS button.



- Recording of the CD starts automatically.
- The CD SRS function does not operate if the CD player is set to the random play or program mode.

③ **Other synchronized recording functions**

- When the DMD-F10 is set to the recording pause mode, recording starts automatically when the play button on the CD player or cassette deck is pressed.
- When the cassette deck is set to the recording pause mode, recording starts automatically when the play button on the DMD-F10 is pressed.

NOTES:

- The system functions will not operate if the system connector cord is not connected.
- When the system connector cord is connected, point the DMD-F10's remote control unit at the pre-main amplifier. If the pre-main amplifier's power cord is not plugged in, the remote control unit will not function, so be sure to plug the power cord of the system's pre-main amplifier into an outlet.

**6 Timer Functions**

The timer can be used to start playback or record radio programs ("air check") at set times.

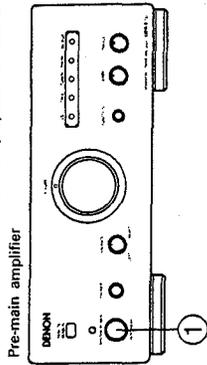

**[Timer Playback]**

- Press the pre-main amplifier's SYSTEM POWER button to turn on the system's power.

SYSTEM POWER



- Load the disc you want to play with the timer into the DMD-F10.
- Press the tuner's TIMER/TIMER STANDBY button for at least 3 seconds.

TIMER/TIMER STANDBY

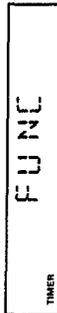

- Use the tuner's UP and DOWN buttons to call out "MD" on the display.

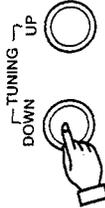

- Now follow steps 6 to 16 under "Setting the Timer" of the D-F10 stereo system component's manual.

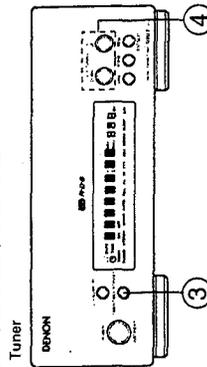

**[Unattended Recording of Radio Programs ("Air Check")]**

- Press the pre-main amplifier's SYSTEM POWER button to turn on the system's power.

SYSTEM POWER



- Load the disc onto which you want to record into the DMD-F10.
- Press the DMD-F10's INPUT SELECT button and select the input mode and set the recording level.
- Press the tuner's TIMER/TIMER STANDBY button for at least 3 seconds.

TIMER/TIMER STANDBY

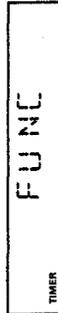

- Use the tuner's UP and DOWN buttons to call out "AIRCH MD" on the display.

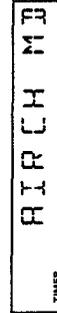
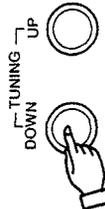

- Now follow steps 4 to 16 under "Setting the Timer" of the D-F10 stereo system component's manual.

**15 SPECIFICATIONS**

- Format:** MiniDisc digital audio system  
 Below measurable limits ( $\pm 0.001\%$  W, Peak or less)  
**Wow & flutter:** 44.1 kHz  
**Recording frequency:** Magnetic field modulation overwrite  
**Optical source:** Semiconductor  
**Power supply:** 50/60Hz, voltage is shown on rating label  
**Power consumption:** 18W  
**Maximum external dimensions:** 270 (W) x 96 (H) x 315 (D) mm  
 (10.5/8" x 3.25/32" x 12.13/32")  
 (including feet, controls and terminals)  
 3.9kg (8 lbs. 10 oz)
- Weight:**
- Remote control unit (RC-177)
  - Remote control system: 32
  - Number of buttons: 32
  - Power supply: Two DC 1.5V R6P/AA batteries
  - Maximum external dimensions: 60 (W) x 177 (H) x 18 (D) mm  
 (2.23/64" x 6.31/32" x .45/64")
  - Weight: 100g (including batteries) (Approx. 3.5 oz)

- \* Maximum dimensions include controls, jacks, and covers.  
 (W) = width, (H) = height, (D) = depth
- For improvement purposes, specifications and functions are subject to change without advanced notice.

**16 TROUBLESHOOTING**

Check the following once more before assuming there is a problem with the system.

- Are connections proper?
  - Is the system being operated as explained in the operating instructions?
- If the system does not seem to be operating properly, check as shown on the table below. If none of these checks apply to the problem, the system may be malfunctioning. Disconnect the power cord immediately and contact your store of purchase.

Symptom	Cause	Countermeasure	Page
Set does not operate.	<ul style="list-style-type: none"> <li>No disc is loaded.</li> <li>Disc is scratched or dirty.</li> </ul>	<ul style="list-style-type: none"> <li>Load a disc.</li> <li>Use another disc.</li> </ul>	6
Disc does not play.	<ul style="list-style-type: none"> <li>Connections are incorrect.</li> <li>Nothing is recorded on disc. ("Blank Disc" or "No Track" is displayed).</li> </ul>	<ul style="list-style-type: none"> <li>Check the connections.</li> <li>Replace with a recorded disc.</li> </ul>	7 17
Recording is not possible.	<ul style="list-style-type: none"> <li>Disc is protected with the accidental erasure prevention click ("Protected" is displayed).</li> <li>There is no remaining time on the disc ("Disc Full" is displayed).</li> <li>There are already 255 tracks on the disc ("Disc Full" is displayed).</li> <li>You are attempting to use digital recording with a digitally recorded source ("Copy Prohibit" is display). (See the section on SCMS.)</li> <li>The INPUT SELECT mode is incorrect.</li> <li>The REC LEVEL control is turned all the way down.</li> </ul>	<ul style="list-style-type: none"> <li>Slide the disc's accidental erasure prevention click to open the hole.</li> <li>Load another disc. If there are any unnecessary parts, erase them to free up space for recording.</li> <li>Load another disc. If there are any unnecessary tracks, erase them to free up space for recording.</li> <li>Record in analog.</li> </ul>	14, 17 17 17 14, 17
		<ul style="list-style-type: none"> <li>Check the recording input mode.</li> <li>Adjust the REC LEVEL control (for analog recording only).</li> </ul>	8 13

## DISASSEMBLY

(For reassembling, do reverse manner as to disassembling.)

### 1. Top Cover and Front Panel

- ① Remove 6 screws mounting the Top Cover.
- ② Lift the Top Cover in the arrow direction.

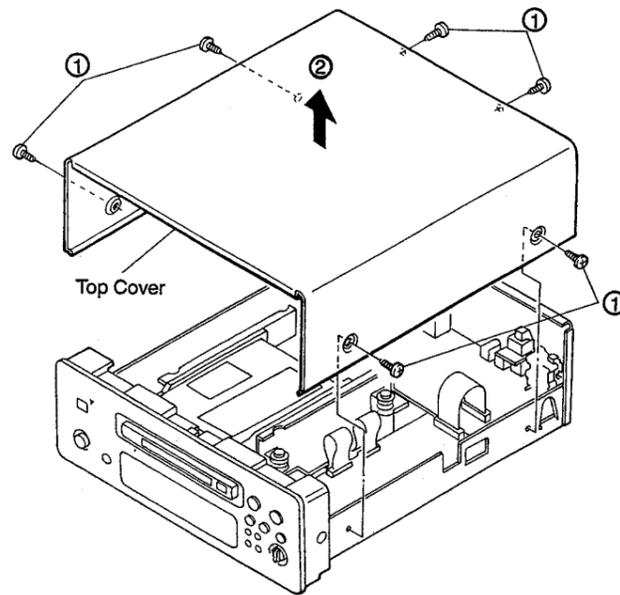

- ③ Remove 2 each screws fastening the Front Panel on the bottom and both sides.
- ④ Remove the wire attached to the chassis.
- ⑤ While releasing hooks of inner panel from the chassis to pull toward arrow direction enables detaching inner panel and Front Panel as a whole.

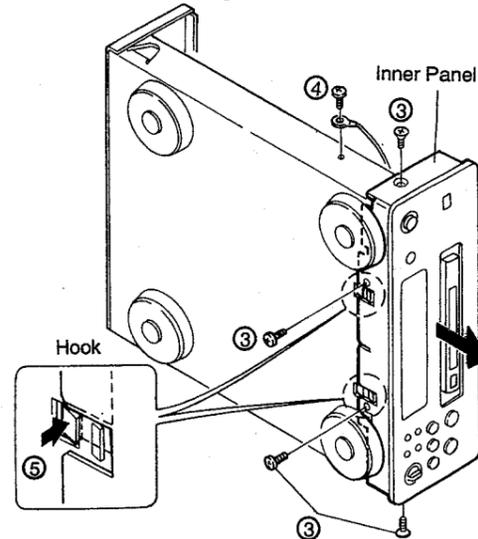

### 2. Rear Panel

- ⑥ Remove cord bushing from the Rear Panel.
- ⑦ Remove 8 screws fixing the Rear Panel.
- ⑧ Detach the Rear Panel in the arrow direction.

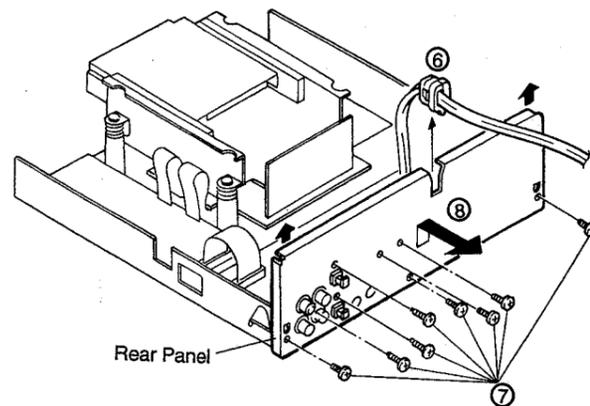

### 3. MD Unit

- ⑨ Remove 4 screws, stopper, bracket, 2 washers and 4 O-rings securing the MD Unit.
- ⑩ Disassemble the MD Unit in the arrow direction.

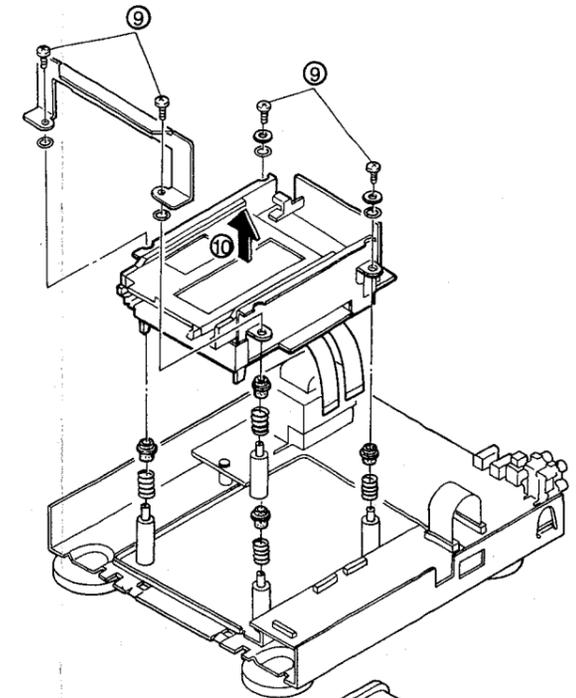

### 4. Each Printed Wiring Board (P.W.B.)

#### ● Display P.W.B. (2U-2705A-2)

- ⑪ Remove 7 screws holding the Display P.W.B..

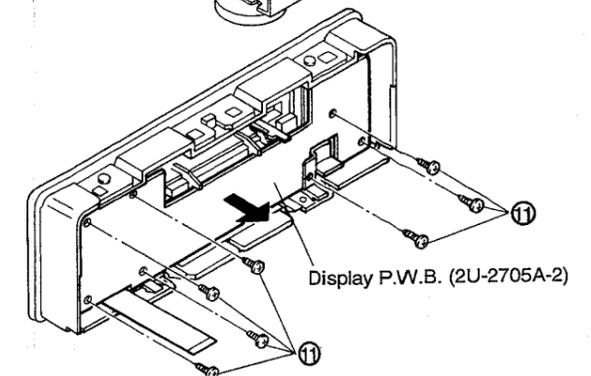

#### ● Audio P.W.B. (2U-2705A-1)

- ⑫ Remove 4 screws fastening the Audio P.W.B..  
Remove 2 screws mounting the transformer.

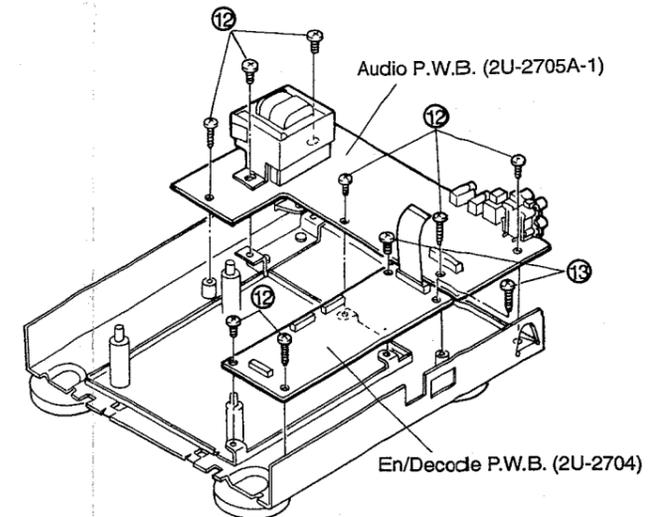

#### ● En / Decode P.W.B. (2U-2704)

- ⑬ Remove 4 screws fixing the En / Decode P.W.B..

# BLOCK DIAGRAM

1 2 3 4 5 6 7 8

A

B

C

D

E

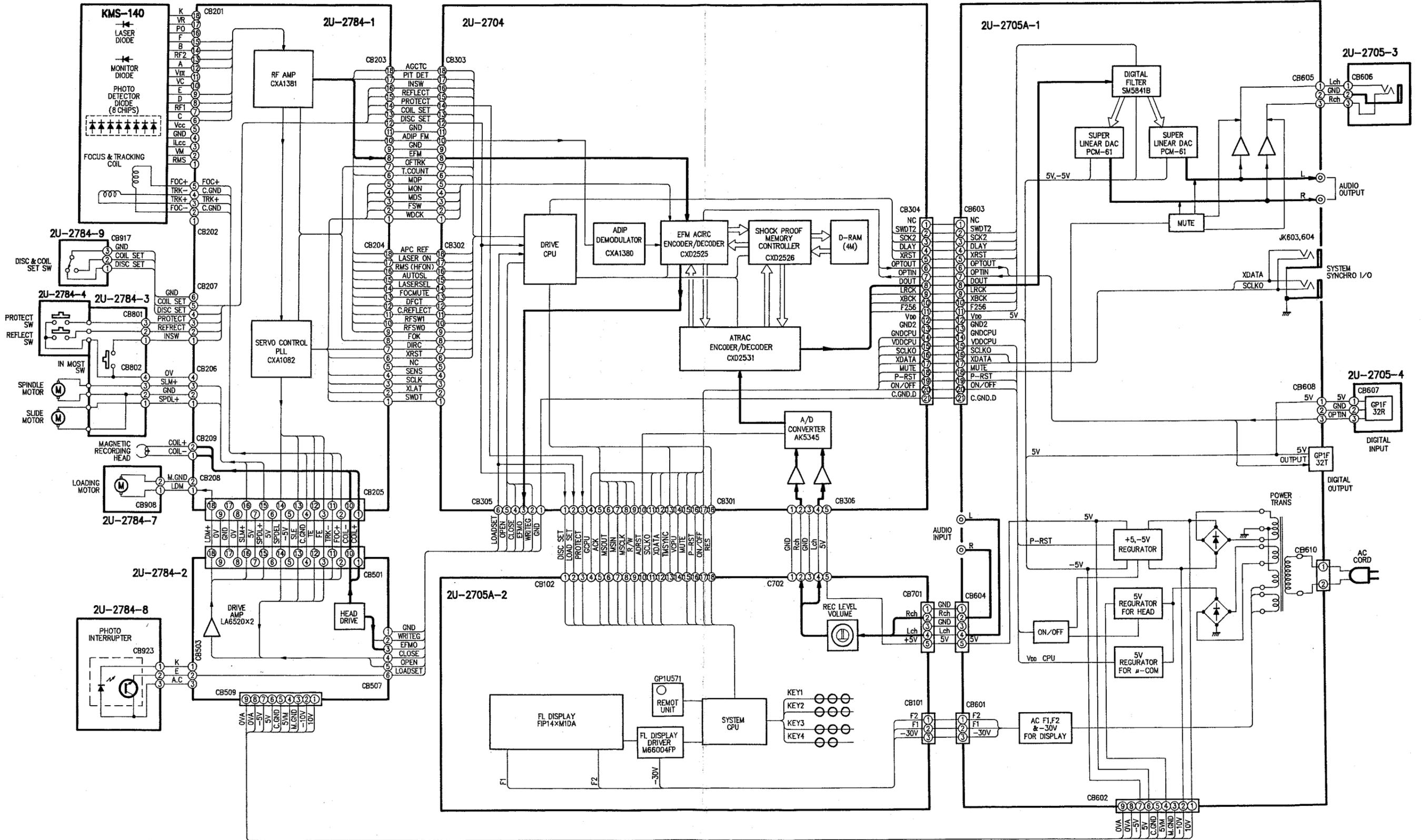

# LASER PICKUP

## DESCRIPTION OF THE COMPONENTS

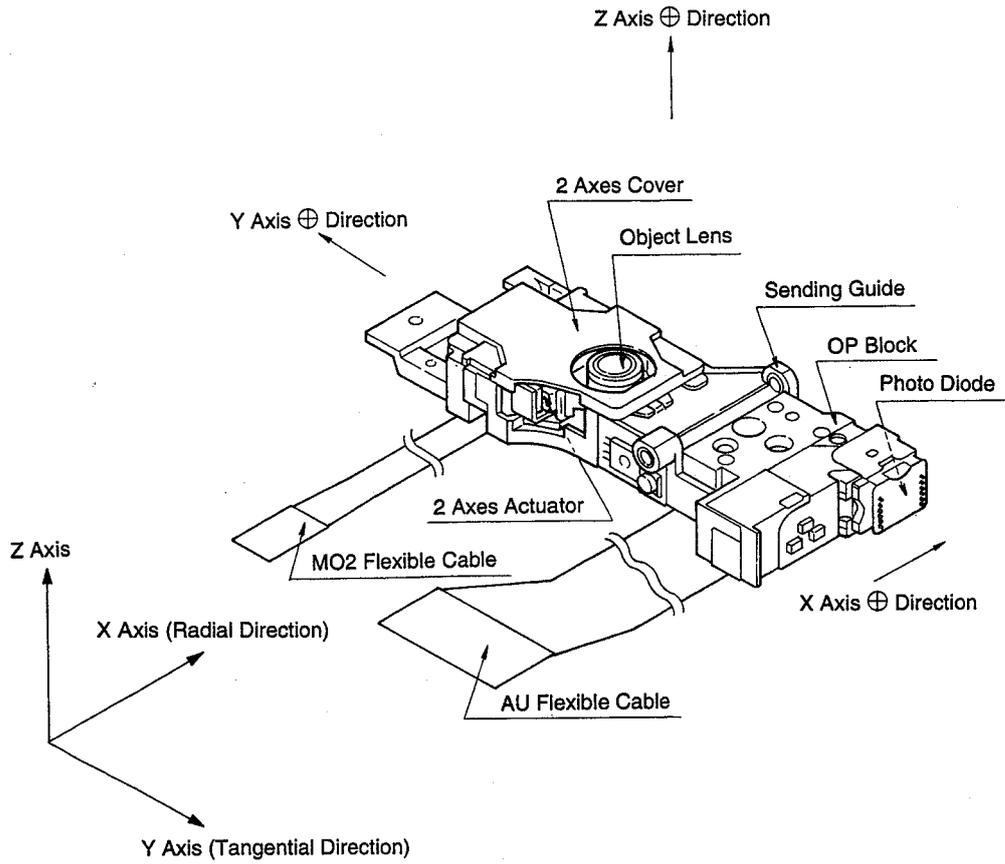

## INDICATION

1) Name Plate

2) Indication Position

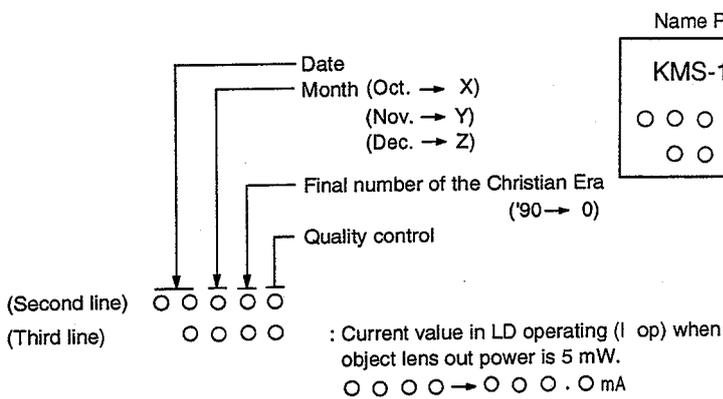

## ● CONNECTION DIAGRAM OF CONNECTOR

PLAM Flexible Cable Terminal

1	K
2	(VR)
3	PD
4	F
5	B
6	I
7	A
8	VEE
9	VC
10	E
11	D
12	J
13	C
14	VCC
15	GND
16	ILCC
17	VM
18	RMS

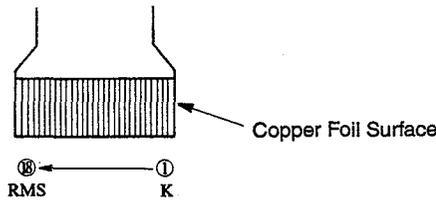

MO2 Flexible Cable Terminal

1	FCS+
2	TRK-
3	TRK+
4	FCS-
5	NC

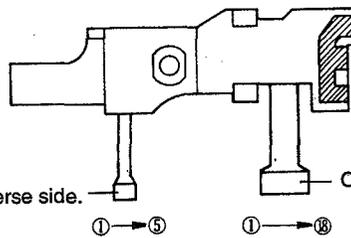
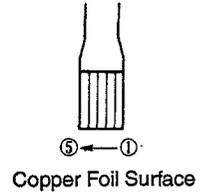

## ● CAUTION FOR HANDING THE LASER PICK-UP

The laser pick-up KMS-140 is assembled and precisely adjusted using a sophisticated manufacturing process in our plant. Do not disassemble or attempt to readjust it. Please keep the following instructions carefully in handling pick-up.

### 1. General Matter

#### (1) Storage

The pick-up must be positioned ⊕ direction of Z-axis upward and ⊕ direction of Y-axis downward as illustrated in figure 1. Also, do not store the pick-up in dusty, high-temperated or high-humidity environments.

#### (2) Handling

Since the pick-up is precisely adjusted, please take good care for preventing from shock by falling down or careless handling.

### 2. Laser Diode(LD)

#### (1) Protect your eyes

LD output is 6.8mW emitting power at object lens however, the intensity of focused spot may reach approx.  $12 \times 10^4 \text{W/cm}^2$ . Do not observe the laser beam either through the object lens directly nor another lens or a mirror. In case to observe it, use an infrared viewer or an ITV camera.

#### (2) Poison of As

Since the LD chip contains As(Arsenic), as GaAs + GaAlAs, as known as the poison, although the poison is relatively weak, in comparing with others, e.g. As<sub>2</sub>O<sub>3</sub>, AsCl<sub>3</sub>, etc., and the amount is small, avoid putting the chip in acid or an alkali solution, heating it over 200C° or putting it into your mouth.

#### (3) Caution for laser deterioration

Inviting deterioration easily occurs as the operation current increase for the high power besides to defect it, utmost care is essential. Deterioration of LD element is caused by its emitting light and by electrical reason.

#### (4) 2 axes portion

##### ● Actuator

Since the actuator has a strong magnetic circuit, the performance of the actuator may be effected if magnetic material is located nearby. Also, do not permit dust to enter through the clearance of the cover.

##### ● Cleaning the lens

The lens changes its characteristics when dust and dirt attaching on the surface. Clean the lens with a water-moistened cleaning paper without applying an excessive force to the lens.

#### (5) Metal bearing

As the bearing of KMS-140 is applied with a lubrication oil SANKORU BASE OIL ME-1(Wadakosan's), do not use any other lubricant other than mentioned.

#### (6) Care

Handling the pick-up must be performed by holding the slide base (die cast part). When human body or an other object touches directly to the printed wiring board causing deterioration. Please take utmost care.



## ADJUSTMENT

A microcomputer adopted to this unit has the service programs so as to perform servo adjustments more easily with the operation buttons.

### 1. Actuating the Service Program

- (1) Short circuit the SRVS land in the reverse side of display PWB attached to the front panel.
  - (2) Plug in the power cord to the power outlet.
- (Service program start actuates and displays **00** Service.)

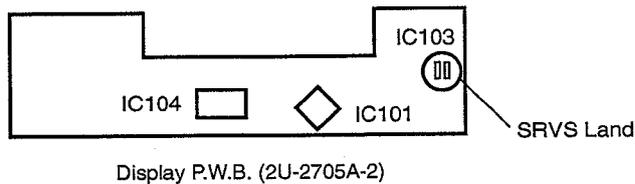

- Note:** The operation buttons do not function when service program actuates.
- (3) When Service program is end, must return to SRVS land initial state.

### 2. Operation Function at Service Program Actuation

Button Operation	Contents	Indication
At service mode actuation	Sets initialization to the disc inserted. Moves PU innermost circle and stops at the position innermost switch turus ON.	<b>00</b> <b>00</b>
▶	(Adjustment mode) Keep pressing ▶ Button for continuous focus search. Releasing for actuating focus. (If focus is unable to actuate, return to <b>00</b> .)	<b>99</b> <b>01</b>
▶	Spindle Rough servo ON (CLV auto mode)	<b>02</b>
	First press) Low gain tracking. Second press) High gain tracking. ↓↑ Third press) Low gain tracking.	<b>03</b> (23: at REC power emitting) <b>04</b> (24: at REC power emitting) <b>03</b>
▶▶	Stops all motions and moves PU to outermost circle (moves only while pressing, use only at stop.)	<b>08</b>
◀◀	Stops all motions and moves PU to innermost circle (moves only while pressing, use only at stop.)	<b>07</b>
▲	Ejects disc, initializes, moves PU to innermost circle.	<b>00</b>
CD SRS	Emits playback laser power. (P. MD)	<b>05</b>
REPEAT	Emits playback laser power. (R. MD)	<b>06</b>
POWER	Set the amount of record laser power.	<b>49</b> Max. record laser output. ↑↑ <b>22,25</b> Min. record laser output.

**Note:** During service program is actuating, do not use remote control.

### 3. Adjustment and Confirmation

(1) Required measuring equipments for adjustment and confirmation.

1. Dual-mode oscilloscope
2. Adjustment disc P.MD disc (Sony TDYS1 MD AUDIO TEST 2)  
R.MD disc (Sony MDW-60)
3. Oscillator(10Hz~10kHz, 0~3Vp-p)
4. Frequency counter(able to measure 5kHz or more)
5. Measuring filter
6. Laser power meter
7. Digital Voltmeter

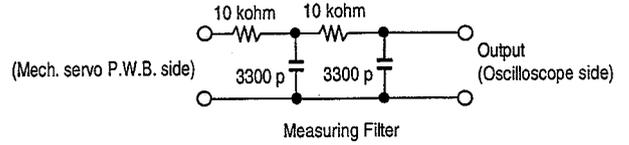

(2) Adjustment location

2U-2784-1 Mechanism Servo PWB

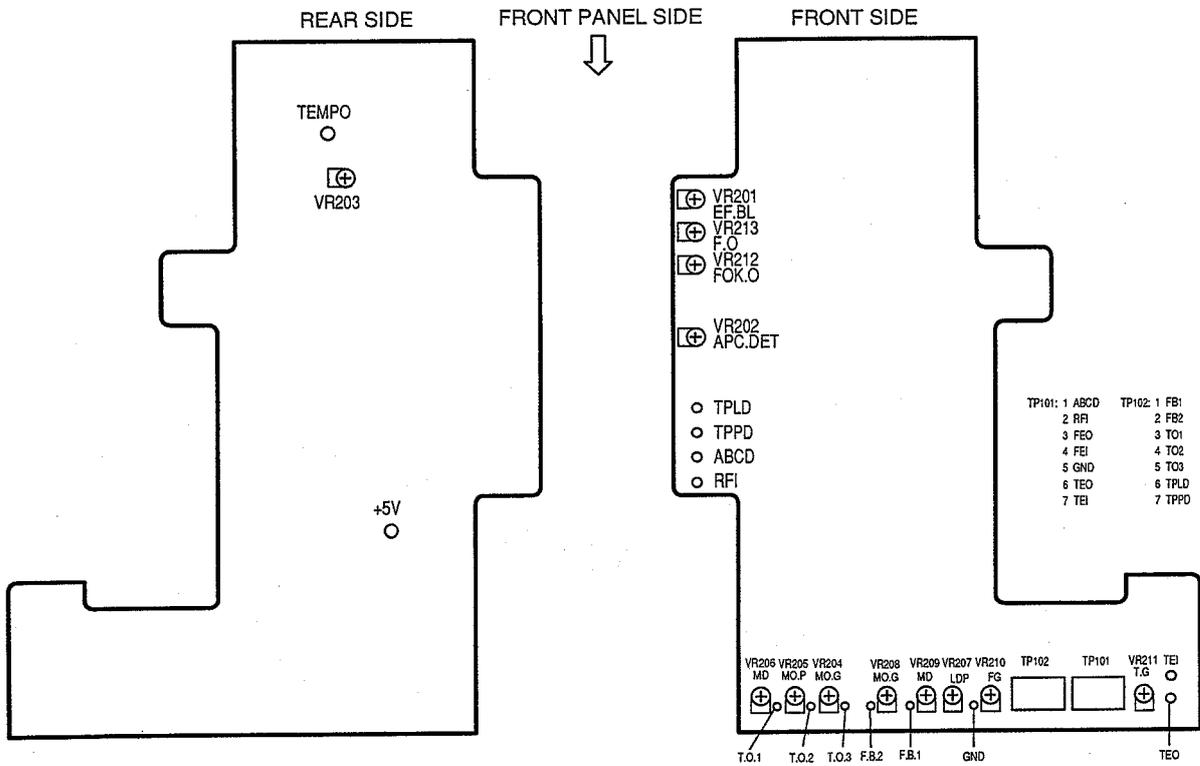

(3)Preparation

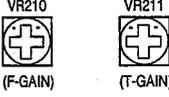
1.	Actuate service program.	
2.	Set the adjustment volumes VR210, VR211 as per indicated in the figures.	
3.	Adjustment procedure.	<p>1. Voltage adjustment of power supply. .... (4)</p> <p>2. Bias adjustment of laser power temperature compensation circuit ..... (5)</p> <p>    Adjustment of PWB circuit offset ..... (6)</p> <p>3. (VR204,VR205,VR206,VR207,VR208,VR209)</p> <p>    Laser power adjustment and signal amplifier offset ..... (7)</p> <p>4. (VR202,VR207,VR212,VR213)</p> <p>5. EF balance adjustment(VR201) ..... (8)</p> <p>6. P.MD adjustment(VR206,VR210,VR211,VR209) ..... (9)</p> <p>7. R.MD adjustment(VR204,VR208,VR205) ..... (10)</p>

(4) Voltage adjustment of power supply

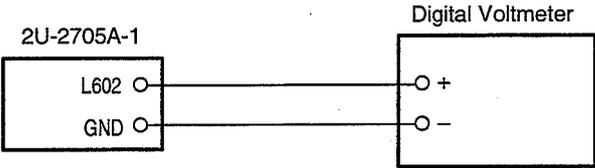
Connection Diagram		
		
Adjustment Item	Contents	Indication
Adjustment circuit : VR603 Measuring point : L602 Adjustment value : 5V ±20mV		00 Service

(5) Bias adjustment of laser power temperature compensation circuit  
 (This adjustment requires only when 2U-2784 P.W.Board unit and IC201,TR204, VR203 are replaced.)

Connection Diagram		
Adjustment Item	Contents	Indication
Adjustment circuit : VR203(TEMP) Measuring point : TP, TEMPO(IC201,CXA1381Q area) Adjustment value : 0V ±20mV(room temperature at 25°C) Center value at T°C (25-T) / 30V	<b>Note:</b> As time drift exists, perform adjustment 5 minutes after the power is turned on.	00 Service

(6) Adjustment of PWB circuit offset

Connection Diagram		
Adjustment Item	Contents	Indication
(0V adjustment) (1) Adjustment circuit : VR204 (MO.G) Measuring point : TP102, Pin5 (TO3) Adjustment value : 0V ±20mV (2) Adjustment circuit : VR205 (MO.P) Measuring point : TP102, Pin4 (TO2) Adjustment value : 0V ±20mV (3) Adjustment circuit : VR206 (MD) Measuring point : TP102, Pin3 (TO1) Adjustment value : 0V ±20mV (4) Adjustment circuit : VR208 (MO.G) Measuring point : TP102, Pin2 (FB2) Adjustment value : 0V ±20mV (5) Adjustment circuit : VR209 (MD) Measuring point : TP102, Pin1 (FB1) Adjustment value : 0V ±20mV		00 Service

## (7) Adjustment of laser power and Amp offset

Connection Diagram		
<p>The diagram shows an optical pick-up assembly mounted on an FG-90 Mech. A laser beam is directed from the pick-up to a Laser Power Meter. The meter is labeled 'Laser Power Meter (Measure by wave length 780 nm)'.</p>		
Adjustment Item	Contents	Indication
<p>1. Adjustment of recording laser power</p> <p>Adjustment circuit : VR202(APC.DET)</p> <p>Measuring point : Optical head object lens (Place the laser power meter on the optical pick-up lens and obtain the position the laser power becomes maximum, then adjust.)</p> <p>Adjustment value : 3.42mW <math>\pm</math>0.05 (at 25°C)</p> <p> <math>\left[ \begin{array}{l} 23^{\circ}\text{C} \dots 3.54\text{mW} \quad 26^{\circ}\text{C} \dots 3.36\text{mW} \\ 24^{\circ}\text{C} \dots 3.48\text{mW} \quad 27^{\circ}\text{C} \dots 3.30\text{mW} \\ 25^{\circ}\text{C} \dots 3.42\text{mW} \end{array} \right]</math> Center value at T°C  <math>3.42 + (25-T) \times 0.06\text{mW}</math> </p>	<p>(1) Press POWER button and emit the laser.</p> <p>(2) Perform adjustment as described in the left.</p> <p>(3) After completed adjustment, press ■ (STOP) button.</p>	<p>22, 25 Service</p> <p>00 Service</p>
<p>2. Adjustment of playback laser power</p> <p>Adjustment circuit : VR207(LDP)</p> <p>Measuring point : Optical head object lens (Place the laser power meter on the optical pick-up lens and obtain the position the laser power becomes maximum, then adjust.)</p> <p>Adjustment value : 0.62mW <math>\pm</math>0.05mW (no temperature dependence)</p>	<p>(1) Press CD SRS button and emit the laser.</p> <p>(2) Perform adjustment as described in the left.</p> <p>(3) After completed adjustment, press ■ (STOP) button.</p>	<p>05 Service</p> <p>00 Service</p>
<p>3. AGC circuit offset adjustment</p> <p>Adjustment circuit : VR212(FOKO)</p> <p>Measuring point : TP101, Pin1 (ABCD)</p> <p>Adjustment value : 0V <math>\pm</math>20mV</p> <p>(Connection is the same as (6).)</p>		00 Service
<p>4. Focus error signal detection amplifier offset adjustment</p> <p>Adjustment circuit : (VR213)(FO)</p> <p>Measuring point : TP101, Pin 3(FEO)</p> <p>Adjustment value : 0V <math>\pm</math>20mV</p> <p>(Connection is the same as (6).)</p>		00 Service

(8) EF Balance Adjustment

Connection Diagram		
Adjustment Item	Contents	Indication
<p>Gain balance adjustment in R.MD Groove Area.</p> <p>Adjustment circuit : VR201(EF.BL)</p> <p>Measuring point : TP101, Pin 6(TEO)</p> <p>Adjustment : Adjust so as the tracking error signal becomes A=B.</p>	<ol style="list-style-type: none"> <li>(1) Insert R.MD disc (Sony MDW60).</li> <li>(2) Press ■ button and initialize service mode.</li> <li>(3) Press ▶▶▶ / ▶▶▶ button and move the pick-up close to the center.(Press ▶▶▶ / ▶▶▶ button for 0.2 – 0.5 second.)</li> <li>(4) Press ▶ button and actuate the focus.</li> <li>(5) Re-press ▶ button and start running the disc.</li> <li>(6) Press POWER button and emit record laser.</li> <li>(7) Perform adjustment as described in the left.</li> <li>(8) After completed adjustment, press ■ (STOP) button.</li> <li>(9) Press ▲ button and take out the disc.</li> </ol>	<p>00 Service</p> <p>08 Service</p> <p>01 Service</p> <p>02 Service</p> <p>22 Service</p> <p>00 Service</p>

(9)P.MD Adjustment

Adjustment Item	Contents	Indication
<p>1. Tracking offset adjustment by P.MD</p> <p>Adjustment circuit : VR206(MD)</p> <p>Measuring point : TP101, Pin 6(TEO)</p> <p>Adjustment : Adjust so as the tracking error signal becomes A=B.</p> <p>(Connection is the same as (8).)</p>	<ol style="list-style-type: none"> <li>(1) Insert P.MD disc(TDYS1 MD AUDIO TEST 2).</li> <li>(2) Press ■ button and initialize service mode.</li> <li>(3) Press ▶ button and actuate the focus.</li> <li>(4) Re-press ▶ button and start running the disc.</li> <li>(5) Perform adjustment as described in the left.</li> <li>(6) After completed adjustment, press ■ (STOP) button.</li> <li>(7) Press ▲ button and take out the disc.</li> </ol>	<p>00 Service</p> <p>00 Service</p> <p>01 Service</p> <p>02 Service</p> <p>00 Service</p>



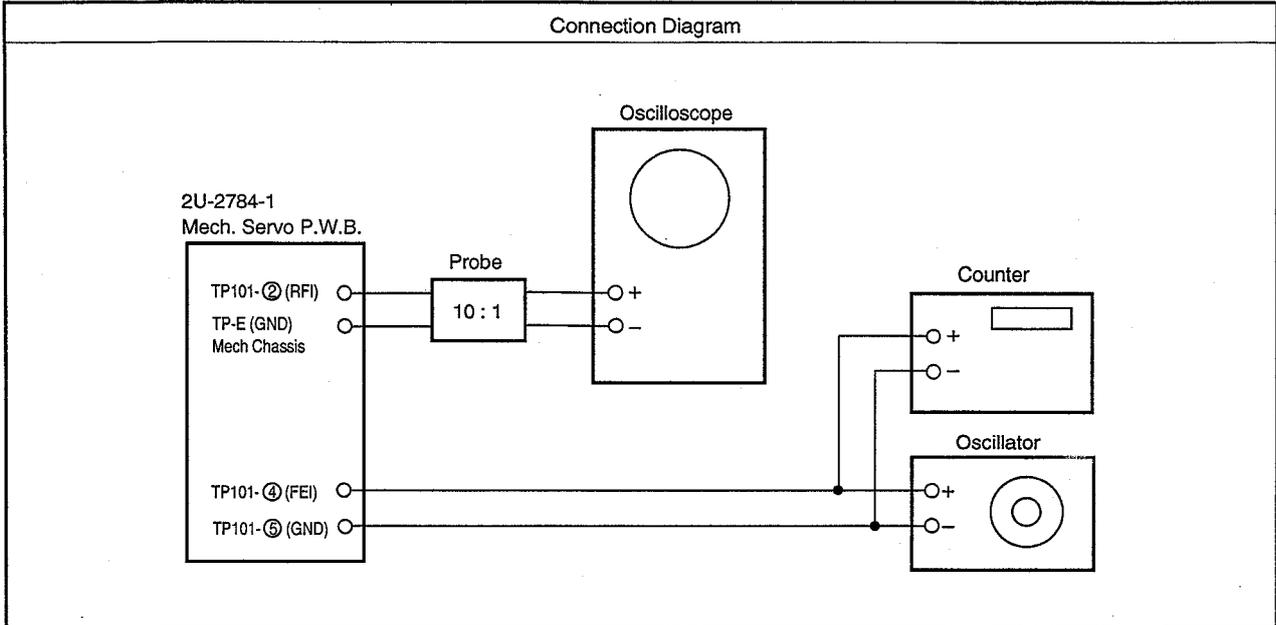

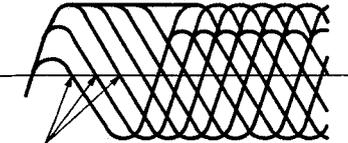
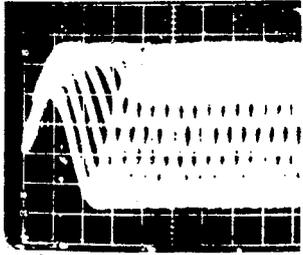
Adjustment Item	Contents	Indication
<p>3. Focus offset adjustment by P.MD</p> <p>Adjustment circuit : VR209 (MD)</p> <p>Measuring point : TP101, Pin2 (RFI)</p> <p>Adjustment : Adjust to obtain best jitter.</p> <p>Oscilloscope range : V 50mV/div or 20mV/div H 0.2u/div or 0.5u/div</p> <p>Confirmation matter</p>  <p>Adjust for most fine waveform.</p>  <p>Eye pattern</p>	<p>(1) Insert P.MD disc(TDYS1 MD AUDIO TEST 2)</p> <p>(2) Press ■ button and initialize service mode.</p> <p>(3) Press ► button and actuate the focus.</p> <p>(4) Re-press ► button and start running the disc.</p> <p>(5) Press    button and turn ON the tracking.</p> <p>(6) Connect to the oscillator setting 1.4kHz 2Vp-p situation.</p> <p>(7) Perform adjustment as describe in the left.</p> <p>(8) After completed adjustment, press ■ (STOP) button.</p> <p>(9) Press ▲ button and take out the disc.</p>	<p>00 Service</p> <p>01 Service</p> <p>02 Service</p> <p>03 Service</p> <p>00 Service</p>



Connection Diagram

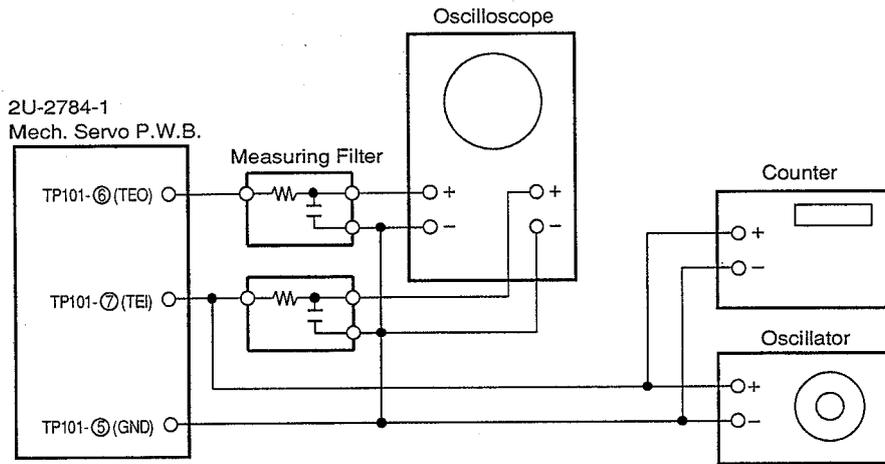

Note: Connect to oscillator after pressed **||** PAUSE button and actuated servo.

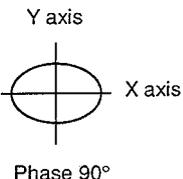
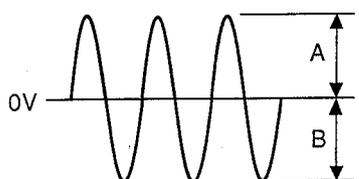
Adjustment Item	Contents	Indication
<p>4. Tracking servo gain adjustment by P.MD</p> <p>Oscillator output : 1.6kHz, 2Vp-p</p> <p>Adjustment circuit : VR211(T.G)</p> <p>Measuring point : TP101, Pin6 (TEO) TP101, Pin7 (TEI)</p> <p>Adjustment : With the oscilloscope in X-Y mode, obtain X-axis and Y-axis of Lissajous figure even.</p> <p>Counter : 1.6kHz</p> <p>Confirmation matter</p> 	<ol style="list-style-type: none"> <li>(1) Insert P.MD disc(TDYS1 MD AUDIO TEST 2)</li> <li>(2) Press <b>■</b> button and initialize service mode.</li> <li>(3) Press <b>▶</b> button and actuate the focus.</li> <li>(4) Re-press <b>▶</b> button and start running the disc.</li> <li>(5) Press <b>  </b> button and turn ON the tracking.</li> <li>(6) Connect to the oscillator setting 1.6kHz 2Vp-p situation.</li> <li>(7) Shift the input of oscilloscope to XY mode.</li> <li>(8) Perform adjustment as describe in the left.</li> <li>(9) After completed adjustment, press <b>■</b> (STOP) button.</li> <li>(10) Press <b>▲</b> button and take out the disc.</li> </ol>	<p>00 Service</p> <p>01 Service</p> <p>02 Service</p> <p>03 Service</p> <p>00 Service</p>
<p>5. Confirmation of tracking offset by P.MD</p> <p>Adjustment circuit : VR206(MD)</p> <p>Measuring point : TP101, Pin 6 (TEO)</p> <p>Adjustment : Adjust so as the tracking error signal becomes A=B.</p> 	<ol style="list-style-type: none"> <li>(1) Insert P.MD disc(TDYS1 MD AUDIO TEST 2).</li> <li>(2) Press <b>■</b> button and initialize service mode.</li> <li>(3) Press <b>▶</b> button and actuate the focus.</li> <li>(4) Re-press <b>▶</b> button and start running the disc.</li> <li>(5) Perform adjustment as described in the left.</li> <li>(6) After completed adjustment, press <b>■</b> (STOP) button.</li> <li>(7) Press <b>▲</b> button and take out the disc.</li> </ol>	<p>00 Service</p> <p>00 Service</p> <p>01 Service</p> <p>02 Service</p> <p>00 Service</p>

(10) R. MD Adjustment

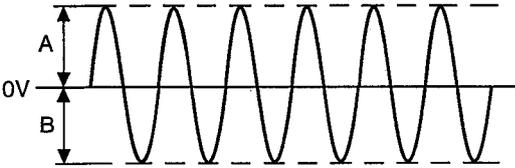
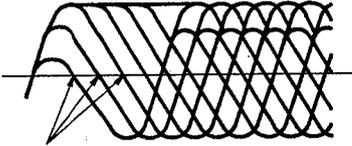
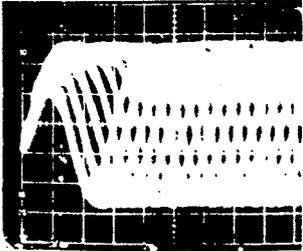
Adjustment Item	Contents	Indication
<p>1. Tracking offset adjustment in R.MD groove area</p> <p>Adjustment circuit : VR204(MO.G)</p> <p>Measuring point : TP101, Pin 6(TEO)</p> <p>Adjustment : Adjust so as the tracking error signal becomes A=B.</p>  <p>(Connection is the same as (8).)</p>	<p>(1) Insert R.MD disc(Sony MDW-60 finish recording).</p> <p>(2) Press ■ button and initialize service mode.</p> <p>(3) Press ►► / ►► button and move the pick-up close to the center. (press ►► / ►► button for 0.2~0.5 second.)</p> <p>(4) Press ► button and actuate the focus.</p> <p>(5) Re-press ► button and start running the disc.</p> <p>(6) Perform adjustment as described in the left.</p> <p>(7) After completed adjustment, press ■ (STOP) button.</p> <p>(8) Press ▲ button and take out the disc.</p>	<p>00 Service</p> <p>00 Service</p> <p>08 Service</p> <p>01 Service</p> <p>02 Service</p> <p>00 Service</p>
<p>2. Focus offset adjustment in R.MD groove area</p> <p>Adjustment circuit : VR208(MO.G)</p> <p>Measuring point : TP101, Pin 2(FRI)</p> <p>Adjustment : Adjust to obtain best jitter.</p> <p>Oscilloscope range : V 50mV/div or 20mV/div H 0.2μ/div or 0.5μ/div</p> <p>(Connection is the same as (9)3.)</p> <p>Confirmation matter</p>  <p>Adjust for most fine waveform.</p>  <p>Eye pattern</p>	<p>(1) Insert R.MD disc(Sony MDW-60 finish recording).</p> <p>(2) Press ■ button and initialize service mode.</p> <p>(3) Press ►► / ►► button and move the pick-up close to the center.(Press►► / ►►button for 0.2 ~ 0.5 second.)</p> <p>(4) Press ► button and actuate the focus.</p> <p>(5) Re-press ► button and start running the disc.</p> <p>(6) Press    button and turn ON the tracking.</p> <p>(7) Connect to the oscillator setting 1.4kHz 2Vp-p situation.</p> <p>(8) Perform adjustment as described in the left.</p> <p>(9) After completed adjustment, press ■ (STOP) button.</p> <p>(10) Press ▲ button and take out the disc.</p> <p><b>Note:</b> No recording disc part is not appeared eye pattern.</p>	<p>00 Service</p> <p>00 Service</p> <p>08 Service</p> <p>01 Service</p> <p>02 Service</p> <p>03 Service</p> <p>00 Service</p>

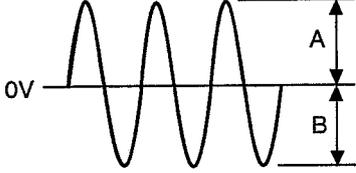
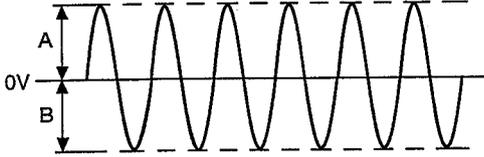
Adjustment Item	Contents	Indication
<p>3. Tracking offset adjustment in R.MD pit area</p> <p>Adjustment circuit : VR205(MO.P)</p> <p>Measuring point : TP101, Pin 6(TEO)</p> <p>Adjustment : Adjust so as the tracking error signal becomes A=B.</p>  <p>(Connection is the same as (8).)</p>	<ol style="list-style-type: none"> <li>(1) Insert R.MD disc(Sony MDW-60 finish recording).</li> <li>(2) Press ■ button and initialize service mode.</li> <li>(3) Press ► button and actuate the focus.</li> <li>(4) Re-press ► button and start running the disc.</li> <li>(5) Perform adjustment as described in the left.</li> <li>(6) After completed adjustment, press ■ (STOP) button.</li> <li>(7) Press ▲ button and take out the disc.</li> </ol>	<p>00 Service</p> <p>00 Service</p> <p>01 Service</p> <p>02 Service</p> <p>00 Service</p>
<p>4. Confirmation of tracking offset by R.MD groove area.</p> <p>Adjustment circuit : VR204(MO.G)</p> <p>Measuring point : TP101, Pin 6(TEO)</p> <p>Adjustment : Adjust so as the tracking error signal becomes A=B.</p>  <p>(Connection is the same as (8).)</p>	<ol style="list-style-type: none"> <li>(1) Insert R.MD disc(Sony MDW-60 finish recording).</li> <li>(2) Press ■ button and initialize service mode.</li> <li>(3) Press ►► / ►► button and move the pick-up close to the center.(Press ►► / ►► button for 0.2 ~ 0.5 second.)</li> <li>(4) Press ► button and actuate the focus.</li> <li>(5) Re-press ► button and start running the disc.</li> <li>(6) Perform adjustment as described in the left.</li> <li>(7) After completed adjustment, press ■ (STOP) button.</li> <li>(8) Press ▲ button and take out the disc.</li> </ol>	<p>00 Service</p> <p>00 Service</p> <p>08 Service</p> <p>01 Service</p> <p>02 Service</p> <p>00 Service</p>

# SEMICONDUCTORS

## ● IC's

NOTE: Symbol previous to IC denotes name of PWB.

M: Mechanism Servo PWB

E: Encode/Decode PWB

A: Audio PWB

HD6433388-A42F-F A: (IC101)

HD6433388-A36F-F E: (IC301)

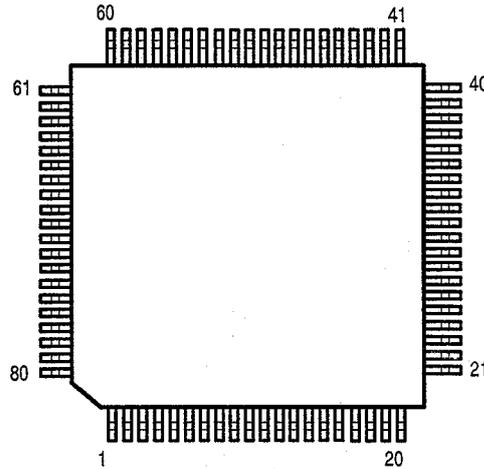
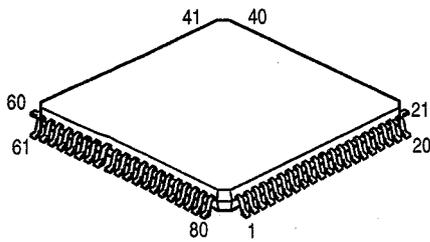

### HD6433388-A42F-F A: (IC101) Terminal Function

Pin No.	Symbol	Function Name	I/O	Det	Res	Ext	Ini	Logical Description
1	IRES	!RESET	I	Lv	L	—	—	Reset signal input (at least 20ms length of "L" is required).
2	XTAL	XTAL	I	—	—	—	—	System clock oscillation input (connect to 16MHz X'tal oscillator/input reverse phase of EXTAL at external Clk supply).
3	EXTAL	EXTAL	I	—	—	—	—	System clock oscillation input (connect to 16MHz X'tal oscillator/external clk supply input).
4	MDI	MDI	I	Lv	—	Pu	—	Mode terminal (supplies "H" at single chip mode), normally "H".
5	MDO	MIEO	I	Lv	—	Pu	—	Mode terminal (supplies "H" at single chip mode), normally "H".
6	!NMI	PRST	I	Ed	—	Pu	—	Reset signal input of M5290.
7	!STBY	!STBY	I	Lv	—	Pu	—	Standby terminal (used in hardware standby mode). (Shifts to standby mode in "L".)
8	VCC	Vcc	I	—	—	—	—	Power supply [connect to Vcpu (+5V)].
9	P52/SCK0	SCLK	I	SCK	—	—	—	DENON bus clock input terminal (SCI clock input/output terminal).
10	P51/RXD0	SIN	I	Si	—	Pu	—	DENON bus data input terminal (SCI data input terminal).
11	P50/TXD0	SOUT	O	So	—	Pu	—	DENON bus data output terminal (SCI data output terminal).
12	VSS	Vss	I	—	—	—	—	Ground [connect to GND (0V)].
13	P97		O	—	—	—	L	Not Used.
14	P96/φ		O	—	—	—	L	Not Used.
15	P95		O	—	—	—	L	Not Used.
16	P94		O	—	—	—	L	Not Used.
17	P93		O	—	—	—	—	Not used.
18	P92/!IRQ0	!ACK	I	Ed	—	Pu	—	Acknowledge signal from drive microcomputer. External interrupt terminal 0.
19	P91/!IRQ1	!TMSYNC	I	Ed	—	Pu	—	Time sync signal from drive microcomputer. External interrupt terminal 1.
20	P90/!ADTRG/!IRQ2	!REMOTE	I	Ed	—	Pu	—	Remote control reception data input. External interrupt terminal 2.
21	P60/FTCI	R/W	O	—	—	Pu	H	Command request signal to drive microcomputer.
22	P61/FTOA		O	Lv	—	—	—	Not used.
23	P62/FTIA		O	Lv	—	—	—	Not used.
24	P63/FTIB		O	Lv	—	—	—	Not used.
25	P64/FTIC		O	Lv	—	—	—	Not used.
26	P65/FTID		O	Lv	—	—	—	Not used.
27	P66/FTOB/!IRQ6		I	Ed	—	Pu	—	DENON bus input (for bus secure).
28	P67/!IRQ7		I	Ed	—	Pu	—	DENON bus input (for bus secure).
29	AVCC	AVCC	I	—	—	—	—	Reference power supply for A/D, D/A converter.
30	P70/ANO	KEY0	I	ALv	—	—	—	Key matrix input 0. Put key into use by using AD conversion function.

Pin No.	Symbol	Function Name	I/O	Det	Res	Ext	Ini	Logical Description
31	P71/ANI	KEY1	I	ALv	—	—	—	Key matrix input 1. Put key into use by using AD conversion function.
32	P72/AN2	KEY2	I	ALv	—	—	—	Key matrix input 2. Put key into use by using AD conversion function.
33	P73/AN3	KEY3	I	ALv	—	—	—	Key matrix input 3. Put key into use by using AD conversion function.
34	P74/AN4		I	ALv	—	—	—	Not used, normally "L".
35	P74/AN5		I	ALv	—	—	—	Not used, normally "L".
36	P76/AN6/DA0		I	ALv	—	—	—	Not used, normally "L".
37	P77/AN7/DAI		I	ALv	—	—	—	Not used, normally "L".
38	AVSS	AVss	I	—	—	—	—	Analog ground [connect to AGND (0V)].
39	P40/TMCIO	ON/OFF	O	—	—	—	—	System power supply ON/OFF state. "H" to ON.
40	P41/TMO0		O	—	—	—	—	Not used.
41	P42/TMRI0		O	—	—	—	—	Not used.
42	P43/TMCI1	!ADRST	O	—	—	Pu	H	A/D converter initialize signal output. 100us pulse output.
43	P44/TMO1		O	—	—	Pu	L	Not used.
44	P45/TMRI1		O	—	—	Pu	L	Not used.
45	P46/PW0	IXRST	O	—	—	Pu	L	Reset signal output to peripheral LSI.
46	P47/PW1	SMUTE	O	—	—	Pu	H	Analog mute signal output terminal ("H" to mute ON).
47	VCC	Vcc	I	—	—	—	—	Power supply[connect to Vcpu (+5V)].
48	P27		O	—	—	—	L	Not used.
49	P26		O	—	—	—	L	Not used.
50	P25		O	—	—	—	L	Not used.
51	P24		O	—	—	—	L	Not used.
52	P23		O	—	—	—	L	Not used.
53	P22		O	—	—	—	L	Not used.
54	P21		O	—	—	—	L	Not used.
55	P20		O	—	—	—	L	Not used.
56	VSS	Vss	I	—	—	—	L	Ground[connect to GND (0V)].
57	P17		O	Lv	—	—	—	Not used.
58	P16		O	Lv	—	—	—	Not used.
59	P15		O	Lv	—	—	—	Not used.
60	P14		O	Lv	—	—	—	Not used.
61	P13	DISCSET	I	Lv	—	Pu	—	Turns to "L" when disc is inserted.
62	P12	LOADSET	I	Lv	—	Pu	—	"L" at disc charging.
63	P11	PROTECT	I	Lv	—	Pu	—	Record inhibit detection signal input ("L" to permit recording).
64	P10	ISRV5	I	Lv	—	Pu	—	Service mode commit detection signal input ("L" to commit service mode).
65	P30	DB0	O	—	—	—	—	Not used.
66	P31	DB1	O	—	—	—	—	Not used.
67	P32	DB2	O	—	—	—	—	Not used.
68	P33	DB3	O	—	—	—	—	Not used.
69	P34	DB4	O	—	—	—	—	Not used.
70	P35	DB5	O	—	—	—	—	Not used.
71	P36	DB6	O	—	—	—	—	Not used.
72	P37	DB7	O	—	—	—	—	Not used.
73	VSS	Vss	I	—	—	—	—	Ground [connect to GND (0V)].
74	P80	FLDA	O	—	—	Pu	H	Serial data output for FL lamp indication.
75	P81	FLCK	O	—	—	Pu	L	Shift clock output for FL lamp indication.
76	P82	FLCP	O	—	—	Pd	L	Chip select output for FL lamp indication.
77	P83	IAFTXD	O	—	—	—	—	Not used.
78	P84/TXD1/ IIRQ3	SOUT	O	So	—	Pu	H	Between microcomputer communication data output terminal.
79	P85/RXD1/ IIRQ4	SIN	I	Si	—	Pu	L	Between microcomputer communication data input terminal.
80	P86/SCK1/ IIRQ5	SCLK	O	SCK	—	—	H	Between microcomputer communication clock output terminal.

HD6433388-A36F-F B: (IC301) Terminal Function

Pin No.	Symbol	Function Name	I/O	Det	Res	Ext	Ini	Logical Description
1	IRES	IRESET	I	Lv	L-H	--	--	Reset signal input (at least 20ms length of "L" is required). (Mode immediate after reset is "H").
2	XTAL	XTAL	I	--	--	--	--	System clock oscillation input (connect to 16MHz X'tal oscillator/reverse phase input of EXTAL at external Clk supply).
3	EXTAL	EXTAL	I	--	--	--	--	System clock oscillation input (Connect to 16MHz X'tal oscillator/external Clk supply input).
4	MDI	Not used.	I	Lv	--	Pu	--	Normally "H".
5	MIDO	Not used.	I	Lv	--	Pu	--	Normally "H".
6	!NMI	Not used.	I	Ed	--	Pu	--	Normally "H".
7	!STBY	Not used.	I	Lv	--	Pu	--	Normally "H".
8	VCC	Vcc	I	--	--	--	--	Power supply [connect to Vcpu (+5V)].
9	P52/SCKO	SCK	I	Sck	--	--	H	Serial clock input for peripheral LSI control. (CXA1082/CXD2525/2526/2527)
10	P51/RXDO	SRDT	I	Si	--	Pu	--	Serial data input for peripheral LSI control. (CXA1082/CXD2525/2526/2527)
11	P50/TXDO	SWDT	O	So	--	Pu	H	Serial data output for peripheral LSI control. (CXA1082/CXD2525/2526/2527)
12	VSS	Vss	I	--	--	--	--	Ground [connect to GND (0V)].
13	P97	R/IW	I	Lv	--	Pu	--	Communication start trigger for microcomputer communication(read/write recognition signal). (System microcomputer)
14	P96 / $\phi$	REFLECT	I	Lv	--	Pu	--	Reflection rate hole detection switch input ("L" to high reflection rate disc).
15	P95	SENS	I	Lv	--	--	--	Sens signal input. (CXA1032/CXD2525)
16	P94	COILSET	I	Lv	--	Pu	--	Head falling detection input ("L" to head falling).
17	P93	CREFLECT	I	Lv	--	--	--	Reflection rate detection signal input ("L" to low reflection rate disc). (CXA1381)
18	P92!!IRQ0	!DQSY	I	Ed	--	--	--	SCOR input of digital in's U-bit CD format. (CXD2525)
19	P91!!IRQ1	RECOU	I	Ed	--	--	--	OFF track signal input.
20	P90!!ADTRG/!!IRQ2	!XINT	I	Ed	--	--	--	Interrupt demand (NADSEN interrupt). (CXD2526)
21	P60/FTCI	!XWRG	O	--	--	Pu	H	Write gate (record EFM magnetic field ON/OFF shifting) signal output ("L" to ON).
22	P61/FTOA	Not used.	O	--	--	--	L	Not used.
23	P62/FTIA	DISCSET	I	Lv	--	--	--	Turns to "L" when disc is inserted.
24	P63/FTIB	PITDETECT	I	--	--	--	--	Pit/groove area detection signal input ("L" to pit area).
25	P64/FTIC	!HDDOWNST	I	--	--	--	--	Not used.
26	P65/FTID	!HDUPST	I	--	--	--	--	Not used.
27	P66/FTOB!!IRQ6	!ADSY	I	Ed	--	--	--	ADIP sync input. (CXD2525)
28	P67!!IRQ7	!SQSY	I	Ed	--	--	--	Sub-code Q sync input. (CXD2525)
29	AVcc	AVcc	I	--	--	--	--	Reference power supply for A/D,D/A convertor.
30	P70/AN0	Not used.	I	--	--	--	--	Not used.
31	P71/ANI	INSW	I	Lv	--	Pu	--	Inner circle switch detection signal input ("L" to inner circle switch ON).
32	P72/AN2	FOK	I	Lv	--	--	--	Focus OK signal input ("H" to focus OK). (CXD2525Q)
33	P73/AN3	LOCK	I	Lv	--	--	--	Spindle lock signal input ("H" to spindle lock). (CXD2525Q)
34	P74/AN4	GFS	I	Lv	--	--	--	GFS signal input ("H" to GFSOK). (CXD2525Q)
35	P74/AN5	RCQL	I	--	--	--	--	Not used.
36	P76/AN6/DA0	APCREF	O	--	--	--	L	Laser power control signal output (D/A output). (CXA1381)
37	P77/AN7/DA1	Not used.	O	--	--	--	L	Not used.
38	AVSS	AVss	I	--	--	--	--	Analog ground (connect to AGND).
39	P40/TMCIO	RFSW0	O	--	--	--	L	Disc mode shifting ("L" to low reflection/"H" to high reflection). (CXA1381)
40	P41/TMO0	RFSW1	O	--	--	--	L	Disc mode shifting ("L" to groove line/"H" to pit line). (CXA1381)

Pin No.	Symbol	Function Name	I/O	Det	Res	Ext	Ini	Logical Description
41	P42/TMRI0	AGCTC	O	—	—	—	L	Auto gain control signal output ("H" to auto gain control ON).
42	P43/TMCI1	DIRC	O	—	—	—	H	Track jump direction control signal output. (CXD2525Q)
43	P44/TMO1	RECOMONI	O	—	—	—	L	Record monitor terminal.
44	P45/TMRI1	CLOSE	O	—	—	Pd	L	Close signal. "H" at disc Lead in.
45	P46/PW0	OPEN	O	—	—	Pd	L	Open signal. "H" at ejection.
46	P47/PW1	LOADSET	I	—	—	—	—	Turns to "L" when disc chucking occurs.
47	VCC	Vcc	I	—	—	—	—	Power supply (connect to Vcpu).
48	P27	SPKICK	O	—	—	—	—	Not used.
49	P26	ROTA+	O	—	—	—	—	Not used.
50	P25	VARION	O	—	—	—	—	Not used.
51	P24	MD2	O	—	—	Pd	L	ON/OFF output terminal of digital audio out ("H" to ON). (CXD2525Q)
52	P23	RCPB	O	—	—	—	L	Mode shifting ("L" to playback/"H" to record). (CXD2526Q)
53	P22	SBMN	O	—	—	—	L	SBMN output (record based on "L" to DCT/"H" to SDCT). (CXD2526Q)
54	P21	WRMN	O	—	—	—	L	Write/monitor mode shifting ("L" to monitor/"H" to write mode). (CXD2526Q)
55	P20	SCTX	O	—	—	—	L	Enable signal output of data output at record mode.
56	Vss	Vss	I	—	—	—	—	Ground [connect to GND (0V)].
57	P17	MODESEL	O	—	—	—	—	Normally ground.
58	P16	SELA	O	—	—	—	—	Not used.
59	P15	LATCHA	O	—	—	—	—	Not used.
60	P14	DLAT	O	—	—	—	H	Latch signal output to digital filter.
61	P13	Not used.	O	—	—	—	L	Not used.
62	P12	XRSTA	O	—	—	—	L	Reset signal output for CXD2527. (CXD2527)
63	P11	XRST	O	—	—	—	L	Reset signal output for peripheral LSI. (CXD2525/2526/CXA1082, etc.)
64	P10	LATCH	O	—	—	—	H	Latch signal output for peripheral LSI. (CXD2525/2526/CXA1082, etc.)
65	P30	DFCT	O	—	—	—	L	Defect route ON/OFF shifting signal output.
66	P31	FOCMUTE	O	—	—	Pd	H	Focus mute signal output in record mode ("L" at focus search).
67	P32	LASERSEL	O	—	—	Pd	L	Offset shifting signal output of pre-mastered/recordable laser power ("L" at pre-mastered).
68	P33	AUTOSEL	O	—	—	Pd	L	Auto slicer shifting signal output ("L" to ON).
69	P34	RMS	O	—	—	Pd	H	Function shifting signal output of high frequency overlap circuit ("L" to ON).
70	P35	LASERON	O	—	—	Pd	L	Laser ON/OFF shifting signal output ("H" to ON).
71	P36	VCOON	O	—	—	Pd	L	VCO control signal output in record mode ("H" to ON).
72	P37	DINEN	O	—	—	—	L	Not used.
73	Vss	Vss	I	—	—	—	—	Ground (connect to GND (0V)).
74	P80	RECST	O	—	—	—	L	Not used.
75	P81		O	—	—	—	L	Not used.
76	P82	TMSYNC	O	—	—	—	H	Time code sync output.
77	P83	ACK	O	—	—	Pu	H	Acknowledge signal output for between microcomputer communication.
78	P84/TXD1/ IIRQ3	DOUT	O	—	—	Pu	H	Data output for between microcomputer communication (to SIN of system microcomputer).
79	P85/RXD1/ IIRQ4	DIN	I	Si	—	Pu	—	Data input for between microcomputer communication (to SOUT of system microcomputer).
80	P86/SCK1/ IIRQ5	DCLK	I	SCK	—	—	—	Serial clock input for between microcomputer communication.

**M66004FP**  
**A: (IC104)**

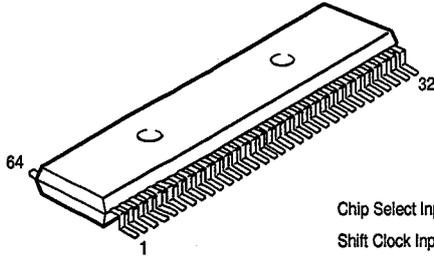

DIG <sub>11</sub>	1	24	DIG <sub>12</sub>
DIG <sub>10</sub>	2	43	DIG <sub>13</sub>
DIG <sub>09</sub>	3	42	DIG <sub>14</sub>
DIG <sub>08</sub>	4	51	DIG <sub>15</sub>
DIG <sub>07</sub>	5	50	Vcc2
DIG <sub>06</sub>	6	39	SEG <sub>00</sub>
DIG <sub>05</sub>	7	38	SEG <sub>01</sub>
DIG <sub>04</sub>	8	37	SEG <sub>02</sub>
DIG <sub>03</sub>	9	56	SEG <sub>03</sub>
DIG <sub>02</sub>	10	55	SEG <sub>04</sub>
DIG <sub>01</sub>	11	54	SEG <sub>05</sub>
DIG <sub>00</sub>	12	53	SEG <sub>06</sub>
RESET	13	52	SEG <sub>07</sub>
CS	14	51	SEG <sub>08</sub>
SCK	15	50	SEG <sub>09</sub>
SDATA	16	49	SEG <sub>10</sub>
PI	17	48	SEG <sub>11</sub>
PO	18	47	SEG <sub>12</sub>
Vcc1	19	46	SEG <sub>13</sub>
XOUT	20	45	SEG <sub>14</sub>
XIN	21	44	SEG <sub>15</sub>
Vss	22	43	SEG <sub>16</sub>
SEG <sub>35</sub>	23	42	SEG <sub>17</sub>
SEG <sub>34</sub>	24	41	SEG <sub>18</sub>
SEG <sub>33</sub>	25	40	SEG <sub>19</sub>
SEG <sub>32</sub>	26	39	SEG <sub>20</sub>
SEG <sub>31</sub>	27	38	SEG <sub>21</sub>
SEG <sub>30</sub>	28	37	SEG <sub>22</sub>
SEG <sub>29</sub>	29	36	SEG <sub>23</sub>
SEG <sub>28</sub>	30	35	SEG <sub>24</sub>
SEG <sub>27</sub>	31	34	SEG <sub>25</sub>
VP	32	33	SEG <sub>26</sub>

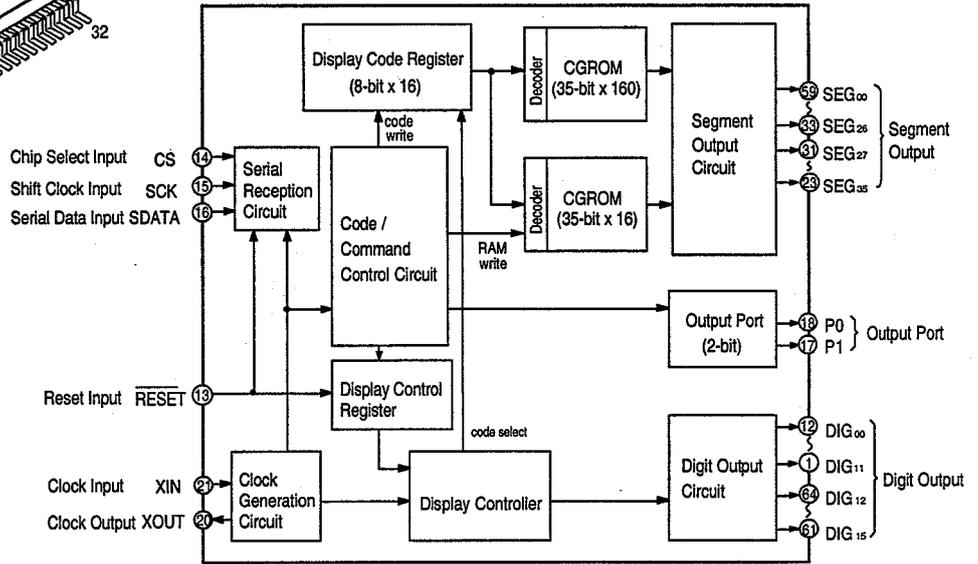

**M66004FP Terminal Function**

Symbol	Name	Function
RESET	Reset Input	Initializes internal state of M66004.
CS	Chip Select Input	Able to communicate with MCU in "L" mode. Command from MCU will be disregarded in "H" mode.
SCK	Shift Clock Input	Shifts input data at rise from "L" to "H".
SDATA	Serial Data Input	Inputs character code or command data needed to display from MSB.
XIN XOUT	Clock Input Clock Output	Sets oscillation frequency by connecting external resistor and capacitor (maximum oscillation frequency fosc(max)=1MHz). Also feasible to apply external clock. In this case, inject external clock to Xin terminal and open Xout terminal.
DIG 00 ~ DIG15	Digit Output	Connect to digit output of VFD. DIG00 ~ DIG15 correspond to the 1st figure ~ 16th figure respectively.
SEG00 ~ SEG35	Segment Output	Connect to segment terminal of VFD. For corresponding SEG00 ~ SEG35 to segment terminals of VFD, refer to the below figure.
P0, P1		Output port(static movement).
Vcc1		Positive power supply terminal for internal logic.
Vcc2		Positive power supply terminal for high tension output port.
Vss		GND terminal.
VP		Negative power supply terminal for VFD drive.

(Forwarding connection of segment output terminal.)

□ in the right figure indicates 1 dot of segment, the figure in □ shows the segment output terminal number (00 ~ 35) to be connected.

00	01	02	03	04
05	06	07	08	09
10	11	12	13	14
15	16	17	18	19
20	21	22	23	24
25	26	27	28	29
30	31	32	33	34

35



**CXA1082BQ**  
M: (IC202)

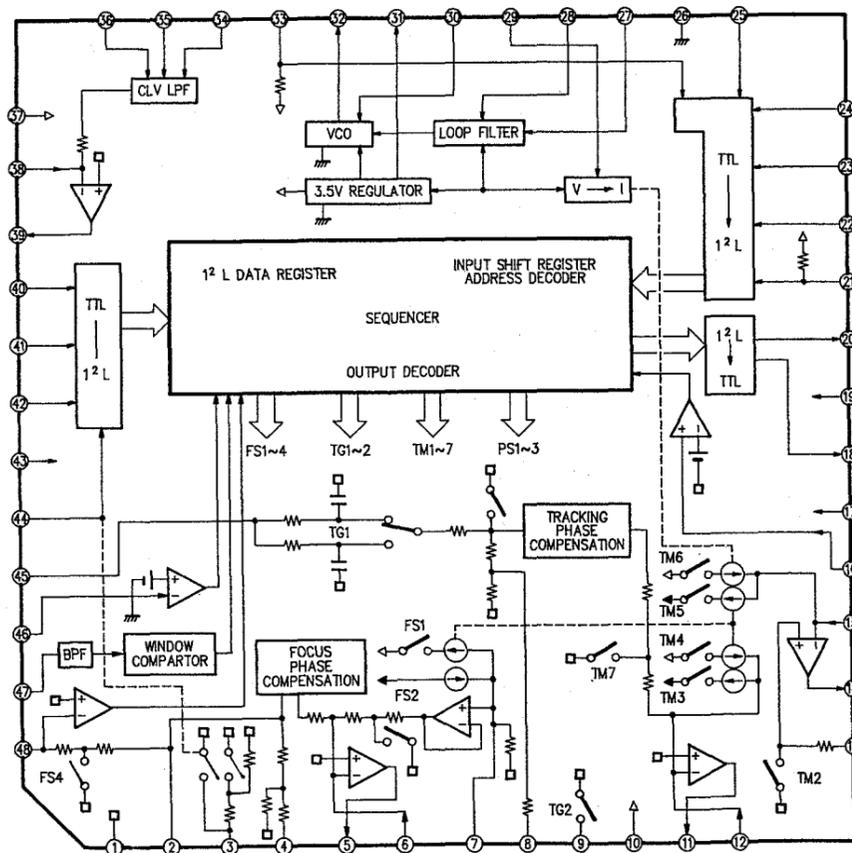
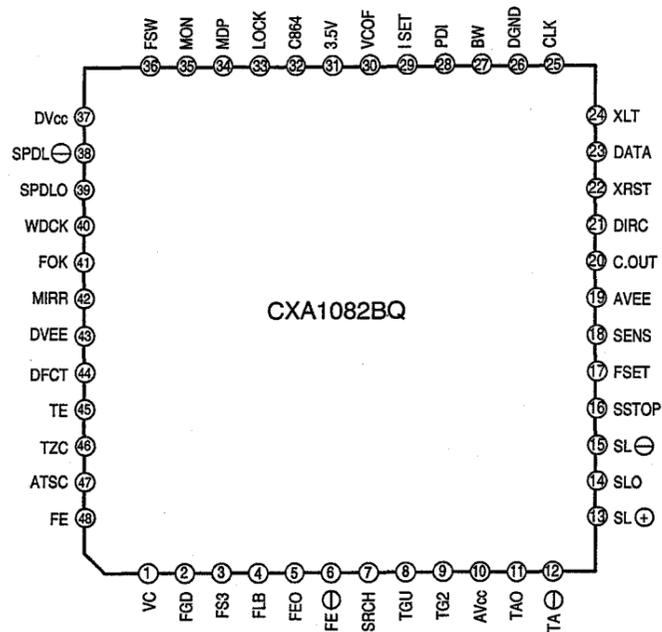
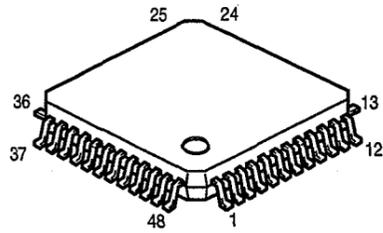

**CXA1082BQ Terminal Function**

Pin No.	Symbol	Function
1	VC	
2	FGD	Connect capacitor between this terminal and FS3 (TG2) in case reducing high frequency range gain of focus servo.
3	FS3	Shift the high frequency range gain of focus servo by FS3 ON/OFF.
4	FLB	External time constant terminal for low frequency range raising of focus servo.
5	FEO	Focus drive output.
6	FE-	Reverse input terminal of focus Amp.
7	SRCH	External time constant terminal for providing focus search waveform.
8	TGU	External time constant terminal for high frequency gain shifting of tracking.
9	TG2	External time constant terminal for high frequency gain shifting of tracking.
10	AVCC	
11	TAO	Tracking drive output.
12	TA-	Reverse input terminal of tracking Amp.
13	SL+	Non-reverse input terminal of thread Amp.
14	SLO	thread drive output.
15	SL-	Reverse input terminal of thread Amp.
16	SSTOP	Terminal of ON/OFF detection for innermost circle of disc detecting limit switch.
17	FSET	Setting terminal for focus tracking phase compensation peak and CLV LPF fo.
18	SENS	Outputs FZC, AS, TZC, SSTOP, BUSY, etc by command from CPU.
19	AVEE	
20	C.OUT	Track count signal output.
21	DIRC	Used for 1-track jump. 47kohms pull-up resistor is inserted.
22	XRST	Reset input terminal. Resets at "L".
23	DATA	Serial data input from CPU.
24	XLT	Latch input from CPU.
25	CLK	Serial data transfer clock input from CPU.
26	DGND	
27	BW	External time constant terminal of loop filter.
28	PDI	Ground (0V).
29	ISET	Flows current deciding height of focus search, track jump, thread kick.
30	VCOF	VCO free-run frequency approx. proportion to the resistance value between this terminal and Pin31 (37).
31	3.5V	
32	C864	8.64 MHz VCO output.
33	LOCK	Thread run away protect circuit at "L". 47 kohm pull-up resistor is inserted.
34	MDP	Connecting terminal of MDP terminal of CX23035/CXD1135.
35	MON	Connecting terminal of MON terminal of CX23035/CXD1135.
36	FSW	External LPF time constant terminal of CLV servo error signal.
37	DVCC	
38	SPDL-	Reverse input terminal of spindle drive amp.
39	SPDLO	Spindle drive output.
40	WDCK	Clock input for auto sequence. Normally 88.2 kHz.
41	FOK	FOK signal input terminal.
42	MIRR	Mirror signal input terminal.
43	DVEE	
44	DFCT	Defect signal input terminal. Actuates defect countermeasure circuit at "H".
45	TE	Tracking error signal input terminal.
46	TZC	Input terminal of tracking zero cross comparator.
47	ATSC	Input terminal of window comparator for ATSC detection.
48	FE	Input terminal of focus error signal.

CXD2531BR  
E: (IC306)

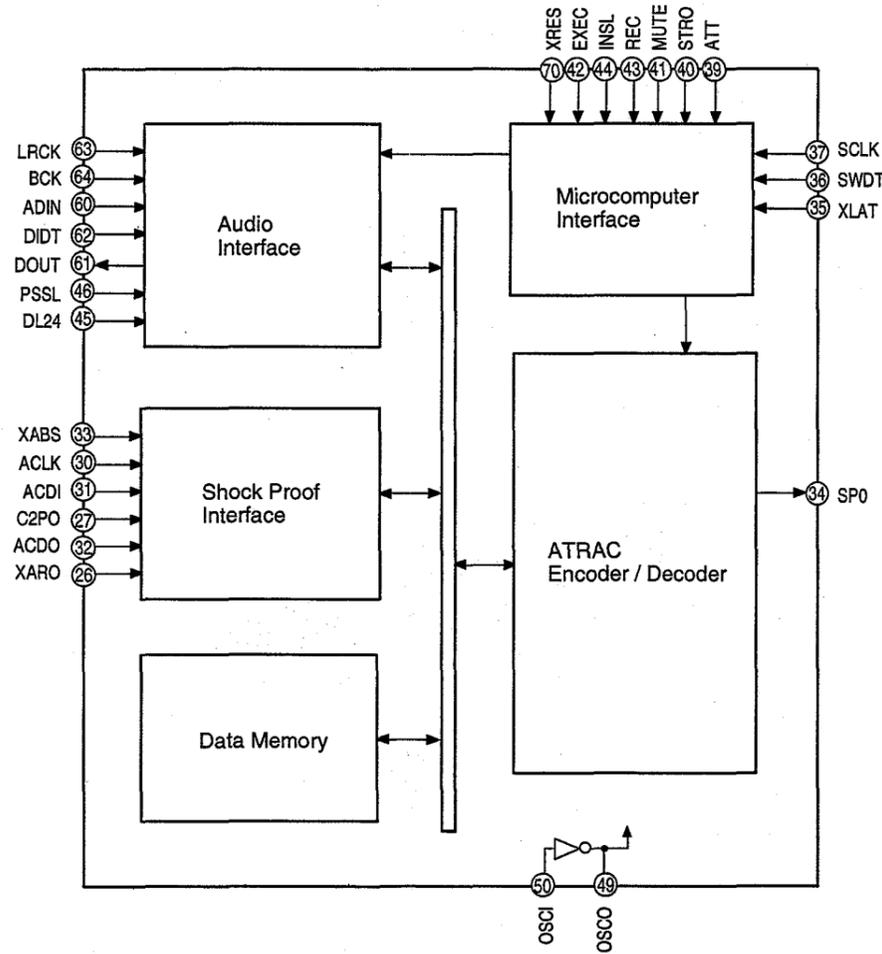
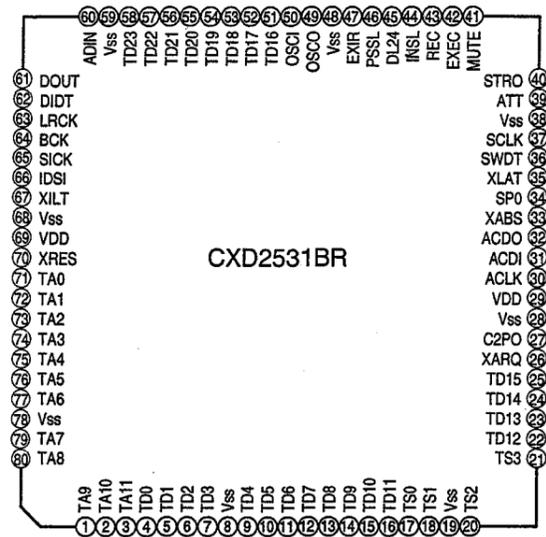
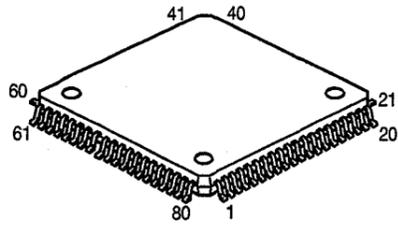

CXD2531BR Terminal Function

Pin No.	Symbol	I/O	Function
1	TA9	I/O	Ground.
2	TA10	I/O	Ground.
3	TA11	I/O	Ground.
4	TD0	I/O	Ground.
5	TD1	I/O	Ground.
6	TD2	I/O	Ground.
7	TD3	I/O	Ground.
8	Vss	—	Ground (0V).
9	TD4	I/O	Ground.
10	TD5	I/O	Ground.
11	TD6	I/O	Ground.
12	TD7	I/O	Ground.
13	TD8	I/O	Ground.
14	TD9	I/O	Ground.
15	TD10	I/O	Ground.
16	TD11	I/O	Ground.
17	TS0	I	Ground.
18	TS1	I	Ground.
19	Vss	—	Ground (0V).
20	TS2	I	Ground.
21	TS3	I	Ground.
22	TD12	I/O	Ground.
23	TD13	I/O	Ground.
24	TD14	I/O	Ground.
25	TD15	I/O	Ground.
26	XARQ	O	Data request output (Low active) to CXD2526AR
27	C2PO	I	Input for CXD2526AR data of error status..
28	Vss	—	Ground.
29	VDD	—	Power supply (+5V).
30	ACLK	I	Clock input of Serial Data transfer from CXD2526AR (128Fs).
31	ACDI	I	Data input from CXD2526AR.
32	ACDO	O	Data output to CXD2526AR.
33	XABS	I	Serial transfer snyc pulse from CXD2526AR.
34	SPO	O	512Fs output.
35	XLAT	I	Serial microcomputer interface latch pulse (Low active).
36	SWDT	I	Serial microcomputer interface data input.
37	SCLK	I	Serial microcomputer interface transfer clock.
38	Vss	—	Ground.
39	ATT	I	Attenuation command (ATT ON at "H").
40	STRO	I	Stereo/monaural command (monaural at "H").
41	MUTE	I	Mute command (mute at ON).
42	EXEC	I	Start/stop command (start at "H").
43	REC	I	Record/playback command (record at "H").
44	INSL	I	Record select input (DIDT at "H", ADIN at "L").
45	DL24	I	Data length select input (24-bit at "H", 16-bit at "L").
46	PSSL	I	ADIN front stuff/rear stuff select input (rear stuff at "H").

Pin No.	Symbol	I/O	Function
47	EXIR	I	Ground.
48	Vss	—	Ground.
49	OSCO	O	Output of 1024Fs X'tal osc circuit.
50	OSCI	I	Input of 1024Fs X'tal osc circuit.
51	TD16	I/O	Ground.
52	TD17	I/O	Ground.
53	TD18	I/O	Ground.
54	TD19	I/O	Ground.
55	TD20	I/O	Ground.
56	TD21	I/O	Ground.
57	TD22	I/O	Ground.
58	TD23	I/O	Ground.
59	Vss	—	Ground.
60	ADIN	I	Input of Analog Rec from A/D Converter.
61	DOUT	O	Monitor output and decoder audio data output.
62	DIDT	I	Digital record input.
63	LRCK	I	44.1kHz (Fs)
64	BCK	I	2.8224MHz (64Fs)
65	SICK	I	+5V.
66	IDSI	I	+5V.
67	XILT	I	+5V.
68	Vss	—	Ground.
69	VDD	—	+5V.
70	XRES	I	Reset input (reset at "L").
71	TA0	I/O	Ground.
72	TA1	I/O	Ground.
73	TA2	I/O	Ground.
74	TA3	I/O	Ground.
75	TA4	I/O	Ground.
76	TA5	I/O	Ground.
77	TA6	I/O	Ground.
78	Vss	—	Ground.
79	TA7	I/O	Ground.
80	TA8	I/O	Ground.

CXD2526AR  
E: (IC304)

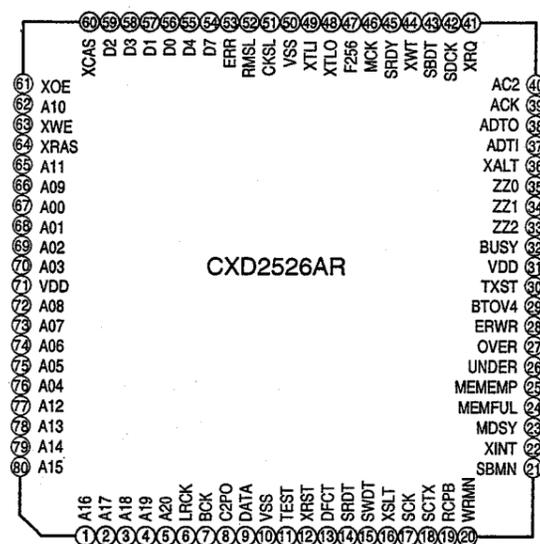
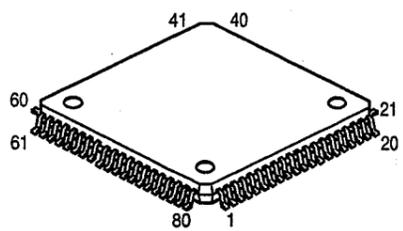

CXD2526AR Terminal Function

Pin No.	Symbol	I/O	Function
1	A16	O	RMSL at "H" SRAM address bus A16, RMSL at "L" WFOVF (see Note).
2	A17	O	RMSL at "H" SRAM address bus A17, RMSL at "L" WDTM (see Note).
3	A18	O	RMSL at "H" SRAM address bus A18, RMSL at "L" ZERO (see Note).
4	A19	O	RMSL at "H" SRAM address bus A19, RMSL at "L" MDTSC (see Note).
5	A20	O	RMSL at "H" SRAM address bus A20, RMSL at "L" CMPSY (see Note).
6	LRCK	I	LRCK input from EFM encoder/decoder.
7	BCK	I	BCK input from EFM encoder/decoder.
8	C2PO	I	C2PO input from EFM decoder.
9	DATA	I/O	Input/output data from decoder at playback, to encoder at record mode.
10	Vss	—	Ground.
11	TEST	I	Test terminal. Normally, fix to "L".
12	XRST	I	Reset input. Reset at "L".
13	MIN	I	Monitor signal input terminal of external input. Input a signal to be monitored.
14	SRDT	(HiZ) O	Serial data output terminal of microcomputer. Becomes HiZ when no read register of CXD2526 is selected.
15	SWDT	I	Serial data input terminal of microcomputer.
16	XSLT	I	Latch signal input terminal of microcomputer's serial data.
17	SCK	I	Shift clock input terminal of microcomputer's serial data.
18	SCTX	I	Enable signal input terminal of data output at record mode.
19	RCPB	I	Playback mode at "L", record mode at "H".
20	WRMN	I	Write mode at "H", monitor mode at "L".
21	SBMN	I	To record input signal based on SDCT at "H", to record input signal based on DCT at "L".
22	XINT	O	Interrupt demand output terminal. When interrupt status occurs, becomes "L".
23	MDSY	O	MD sync detection signal of input data.
24	MEMFUL	O	When data is filled up in main data area, becomes "H".
25	MEMEMP	O	When data is empty in main data area, becomes "H".
26	UNDER	O	Becomes "H" at RMS < THUND.
27	OVER	O	Becomes "H" at RMS ≥ THOVR.
28	ERWR	O	Becomes "H" when stored data of C2PO is wrote to RAM.
29	BTOV4	O	Becomes "H" at BCT ≥ 400(Hex).
30	TXST	O	Becomes "H" at data transfer.
31	VDD	O	Power supply terminal of system.
32	BUSY	I/O	Becomes "H" at RAM access.
33	ZZ2	I	Test signal. Fix to "L".
34	ZZ1	I	Test signal. Fix to "L".
35	ZZ0	I	Test signal. Fix to "L".
36	XALT	O	Data ready or latch signal to CXD2527.
37	ADYI	I	Data input terminal from CXD2527.
38	ADTO	O	Data output terminal to CXD2527.
39	ACK	O	Data input/output clock output terminal to CXD2527.
40	AC2	O	C2PO output terminal of output data to CXD2527.
41	XRQ	I	Data demand signal input terminal from CXD2527.
42	SDCK	I	Shift clock input of external sub-data I/F.
43	SBDT	I/O	External subdata I/F data output terminal at playback mode, data input terminal at record mode.
44	XWT	O	Wait signal of external sub-data I/F. When this terminal is in "L", do not send clock for new data reading.
45	SRDY	O	Access permit signal of external sub-data I/F. When this terminal is in "H", sending clock for sub-data R/W will be disregarded.
46	MCK	O	128fs output terminal.
47	F256	O	256fs output terminal.
48	XTLO	O	System clock output terminal.
49	XTLI	I	System clock input terminal. Input 22.5792MHz.
50	VSS	—	Ground.
51	TEST	I	Fix to "L".
52	RMSL	I	External RAM select terminal. SRAM at "H", DRAM at "L".
53	ERR	I/O	C2PO input/output terminal when EXTC2R at "H".
54	D7	O	When RMSL at "H" and data D7 of SRAM at "L", test signal.
55	D4	I/O	When RMSL at "H" and RAM data bus D4 at "L", test signal.
56	D0	I/O	Data bus D0 of RAM.
57	D1	I/O	Data bus D1 of RAM.
58	D3	I/O	Data bus D3 of RAM.
59	D2	I/O	Data bus D2 of RAM.
60	XCAS	I/O	CAS output of DRAM when RMSL at "L", data bus D6 when RMSL at "H".
61	XOE	O	Output enable of RAM.
62	A10	O	RAM address bus A10.
63	XWE	O	Write enable of RAM.
64	XRAS	I/O	RAS output of DRAM when RMSL at "L", data bus D5 when RMSL at "H".
65	A11	O	RAM address bus A11.
66	A9	O	RAM address bus A9.
67	A0	O	RAM address bus A0.
68	A1	O	RAM address bus A1.
69	A2	O	RAM address bus A2.
70	A3	O	RAM address bus A3.
71	VDD	O	Power supply terminal of system.
72	A8	O	RAM address bus A8.
73	A7	O	RAM address bus A7.
74	A6	O	RAM address bus A6.
75	A5	O	RAM address bus A5.
76	A4	O	RAM address bus A4.
77	A12	O	RAM address bus A12 when RMSL at "H", at "L" CS output.
78	A13	O	RAM address bus A13 when RMSL at "L", at "L" SYOK output.
79	A14	O	SRAM address bus A14 when RMSL at "H", WFFUL when RMS at "L".
80	A15	O	SRAM address bus A15 when RMSL at "H", RFEMP when RMS at "L".

**Note:** WFFUL Turns to "H" when writing FIFO becomes full.  
 RFEMP Turns to "H" when read out FIFO becomes empty.  
 WFOVF Turns to "H" when writing FIFO becomes over flow.  
 WDTM Outputs timing of window in DI block.  
 ZERO Outputs "H" at BCT=0.  
 MDTSC "H" mode when header sector of input data is #00-LIF, in other case "L" mode.  
 CMPSY Inserted sync timing.

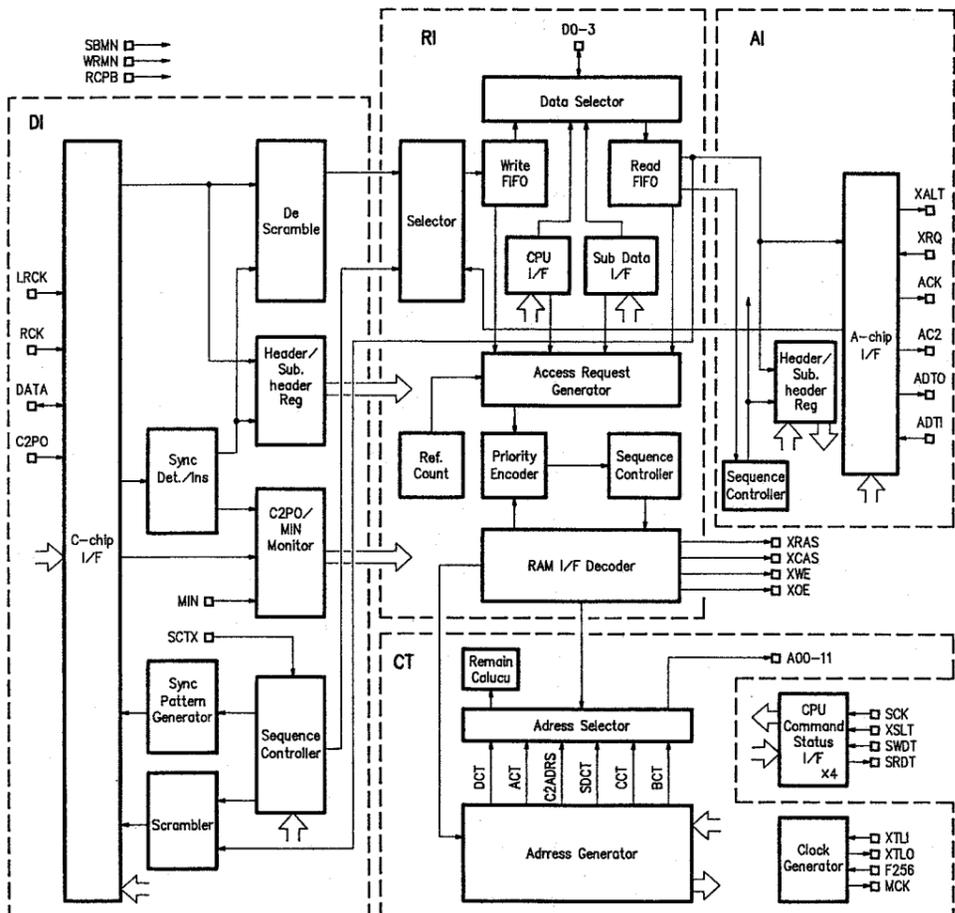

CXA1381R  
M: (IC201)

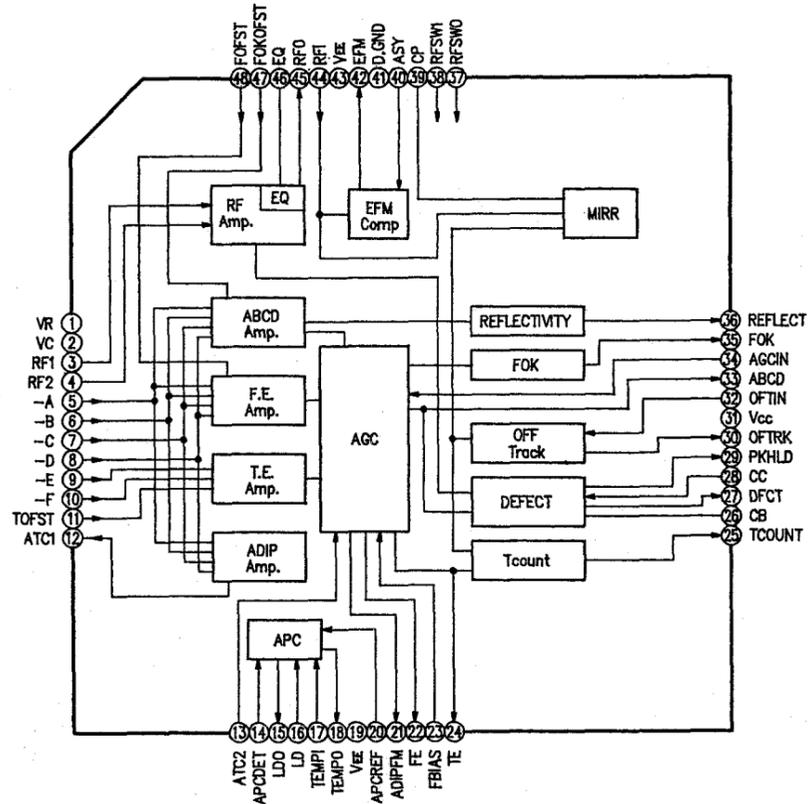
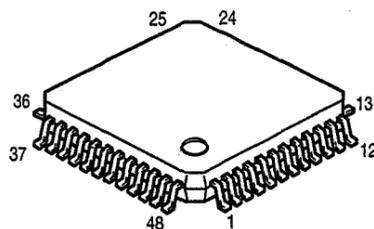

CXA1381R Terminal Function

Pin No.	Symbol	I/O	Reference Voltage	Description
1	VR	O	0V (DC)	(Vcc-V <sub>EE</sub> )/2 Voltage terminal.
2	VC	—	0V (DC)	GND at ± power supply. When only one power supply, connect to Pin1 (VR).
3	RF1	I	160mV (DC)	Input terminal of I-V converted RF signal 1.
4	RF2	I		Input terminal of I-V converted RF signal 2.
5	-A	I	40mVp-p ~ 36mV (DC) Tracking OFF	Input terminal of I-V converted main beam servo signal A.
6	-B	I		Input terminal of I-V converted main beam servo signal B.
7	-C	I		Input terminal of I-V converted main beam servo signal C.
8	-D	I		Input terminal of I-V converted main beam servo signal D.
9	-E	I	11mVp-p ~ 50mV (DC) Tracking OFF	Input terminal of I-V converted side beam servo signal E.
10	-F	I		Input terminal of I-V converted side beam servo signal F.
11	TOFST	I	0V (DC)	Offset adjustment terminal of tracking error.
12	ATC1	O	25mVp-p	Push-pull signal output of main beam, using ADIP signal.
13	ATC2	I		AGC input for ADIP signal, connect to ATC1 with AC couple.
14	APCDET	I	0.35V (DC)	Detects quantity of light by connecting photo diode and I-V conversion by resistor.
15	LDO	O	3.5V (DC)	Output terminal of LD Amp of APC.
16	LD	I	0.35V (DC)	Reversal input terminal of LD Amp.
17	TEMPI	I	0V (DC)	Temperature sensor connecting terminal.
18	TEMPO	O	0V (DC)	Output terminal of temperature signal.
19	VEE	—	-5V (DC)	Negative power supply at ± power supply, GND at only one power supply.
20	APCREF	I	0.35V (DC)	Input terminal for laser power setting.
21	ADIPFM	O	0.5Vp-p	FM signal output terminal of ADIP.
22	FE	O	3.6Vp-p (Focus S Curve p-p)	Focus error signal output terminal.
23	FBIAS	I	0V (DC)	Focus bias adjustment input terminal.
24	TE	O	5Vp-p (at track jump)	Tracking error signal output terminal.
25	TCOUNT	O	Digital output	Tracking count signal output terminal.
26	CB	—	0.5V (DC)	Defect peak hold capacitor connecting terminal.
27	DFCT	O	Digital output (Defect at "H")	Defect comparator output terminal.
28	CC	I	1V (DC)	AC coupling input terminal of defect peak hold signal.
29	PKHLD	O	1V (DC)	Defect peak hold output terminal.
30	OFTRK	O	Digital output (off track at "H")	Off track signal output terminal.
31	VCC	—	5V (DC)	Positive power supply.
32	OFTIN	I	0.3Vp-p (at track jump)	Amount of light signal AC coupling input terminal for off track detection.
33	ABCD	O	1V (DC)	Amount of light signal output terminal of main beam servo detection.
34	AGCIN	I	1V (DC)	Input terminal of AGC control.
35	FOK	O	Digital output (FOK at "H")	Focus OK signal output terminal.
36	REFLECT	O	Digital output (High reflection rate at "H")	High/Low discriminating signal output terminal of disc reflection rate.
37	RFSWO	I	Digital output	Disc mode shifting signal input terminal. H: High reflection rate disc.
38	RFSW1	I		Disc mode shifting signal input terminal. H: Track is bit line. L: Track is groove.
39	CP	—	-3.6V (DC)	MIRR hold capacitor connection terminal.
40	ASY	I	2.5V (DC)	Auto asymmetry control input terminal.
41	D.GND	—	0V (DC)	GND at ± power supply, GND (=V <sub>EE</sub> ) at only one power supply.
42	EFM	O	Digital output	EFM comparator output terminal.
43	VEE	—	-5V (DC)	Negative power supply at ± power supply, GND at only one power supply.
44	RFI	I	1.1Vp-p	Input terminal of equalizer output to be AC coupled.
45	RFO	O	1.1Vp-p	Equalizer output terminal. Eye pattern check point.
46	EQ	—	-3.5V (DC)	External resistor connection terminal for equalizer.
47	FOKOFST	I	0V (DC)	Offset adjustment terminal of ABCD Amp.
48	FOFST	I	0V (DC)	Offset adjustment terminal of focus error Amp.

**CXD1380N**  
E: (IC302)

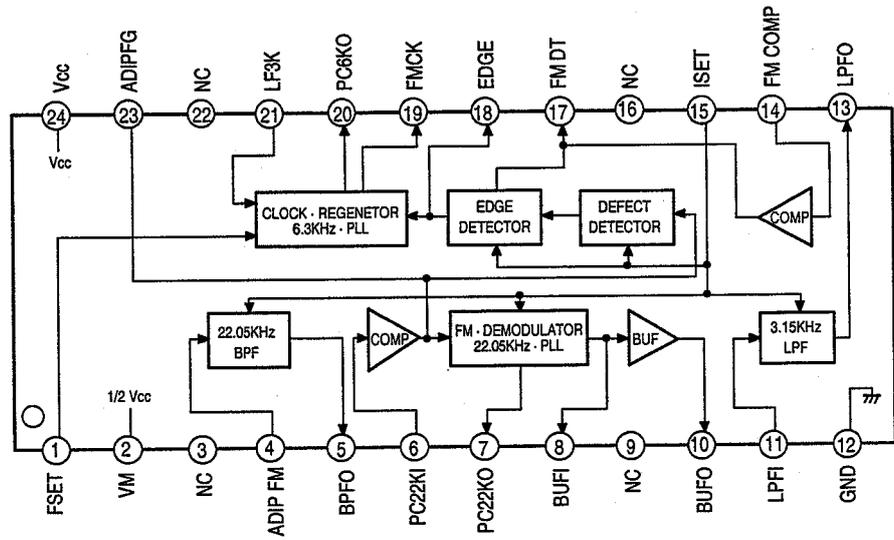
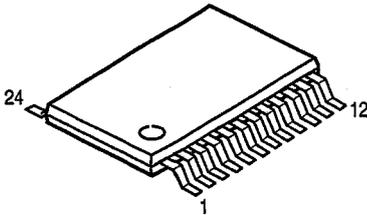

**CXA1380N Terminal Function**

Pin No.	Symbol	Reference Voltage	Function
1	FSET	720mV	Center frequency setting terminal of VCO for ADIP bit clock regenerator.
2	VM	2.5V	1/2Vcc voltage output terminal. Internal circuit bias voltage.
3	NC	OPEN	No internal connection.
4	ADIP FM	450m Vp-p	Input terminal of ADIP FM signal.
5	BPFO	1Vp-p + 2.5V	Output terminal of band pass filter.
6	PC22KI	1Vp-p + 2.5V	Input terminal of phase comparator for FM demodulation. Inputs capacitance coupled outputs of Pin4(5)BPFO.
7	PC22KO	Digital Output	Output terminal of phase comparator for FM demodulation.
8	BUFI	Digital Output	Feedback terminal of PLL for FM demodulation. Inputs of Pin6 (7) PC22KO signal are applied through loop filter.
9	NC	OPEN	No internal connection.
10	BUFO	0.8Vp-p + 2.5V	Output terminal of FM demodulation signal.
11	LPFI	0.8Vp-p + 2.5V	Input terminal of low pass filter. Inputs capacitance coupled outputs of Pin8 (10) BPFO.
12	GND	0V	Ground.
13	LPFO	0.15Vp-p + 2.5V	Output terminal of low pass filter.
14	FM COMP	0.15Vp-p + 2.5V	Input terminal of comparator for ADIP data. Inputs capacitance coupled outputs of Pin11 (13) LPFO.
15	ISET	720mV	Internal circuit stated number setting terminal. <ul style="list-style-type: none"> <li>● Band pass filter fc</li> <li>● Center frequency of VCO for FM demodulation</li> <li>● Defect pulse width</li> <li>● Low pass filter fc</li> <li>● Edge pulse width</li> </ul>
16	NC	OPEN	No internal connection.
17	FM DT	Digital Output	Output terminal of ADIP data.
18	EDGE	Digital Output	Edge detection signal output terminal of ADIP data.
19	FMCK	Digital Output	Output terminal of ADIP bit clock.
20	PC6KO	Digital Output	Output terminal of phase comparator for ADIP bit clock regenerator.
21	LF3K	0.2Vp-p + 2.5V	Feedback terminal of PLL for ADIP bit clock regenerator. Outputs of Pin17(20) EPC6KO are applied through loop filter.
22	NC	OPEN	No internal connection.
23	ADIPFG	Digital Output	Compare output terminal of ADIP FM data.
24	VCC	5V	Power supply terminal.

**CXD2525R**  
E: (IC303)

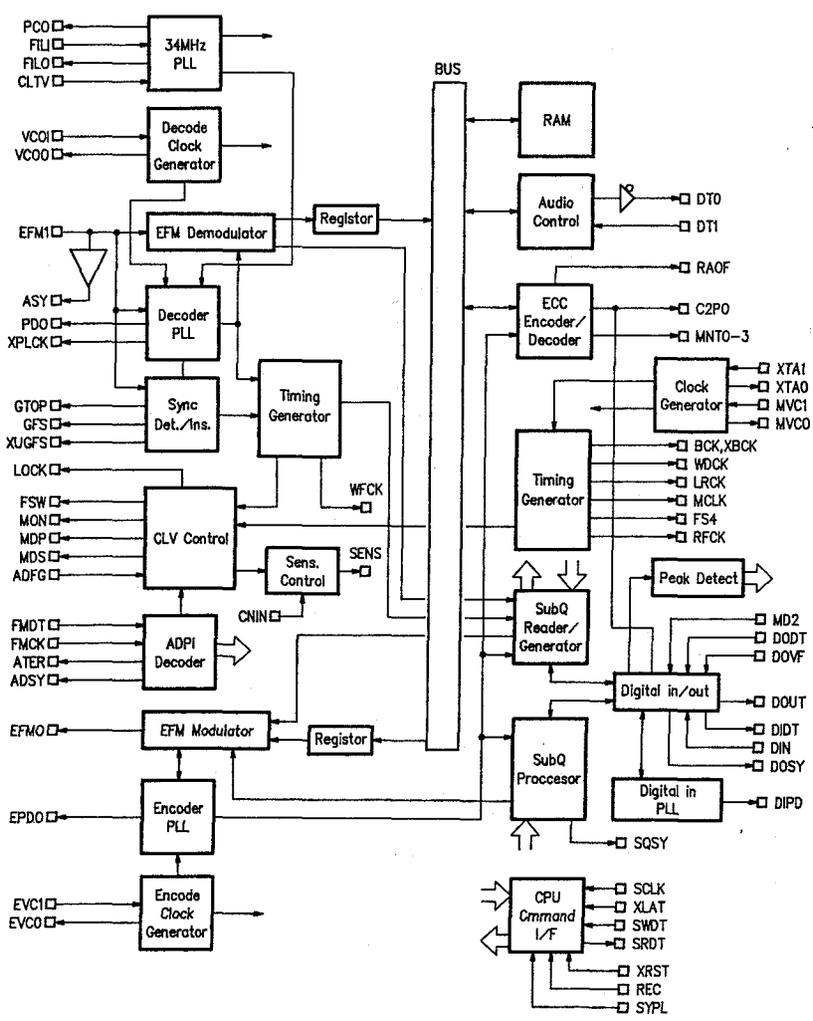
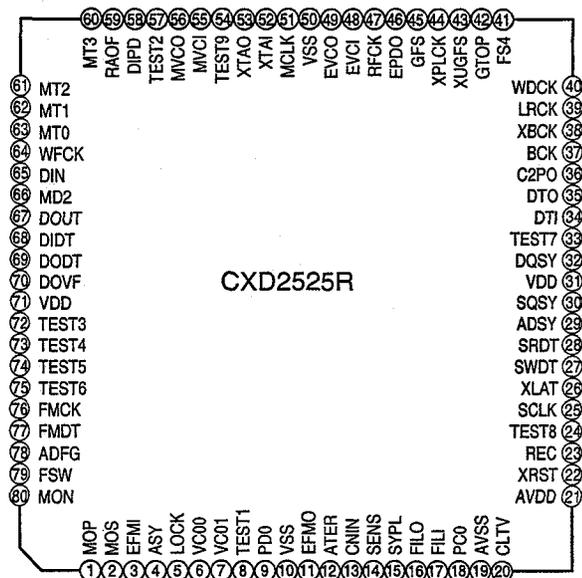
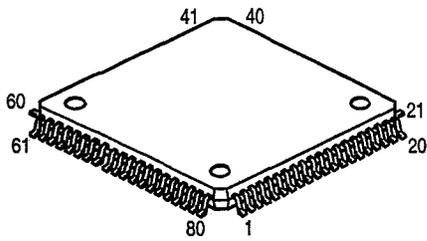

## CXD2525R Terminal Function

Pin No.	Symbol	I/O	Function
1	MDP	O (3)	Servo control of spindle motor.
2	MDS	O (3)	Servo control of spindle motor.
3	EFMI	I	EFM input at playback.
4	ASY	O	EFM full swing output at playback.
5	LOCK	O	Lock condition monitor of spindle servo (CLV). "H" to lock.
6	VCOO	O	EFM decoder analog PLL oscillation output (196Fs=8.6436MHz).
7	VCOI	I	EFM decoder analog PLL oscillation input.
8	TEST1	I	Test terminal. Normally GND.
9	PDO	O (3)	EFM decoder analog PLL phase compare output.
10	Vss	—	Digital ground.
11	EFMO	O	EFM output in record mode.
12	ATER	O	ADIP CRC flag output. "H" to error.
13	CNIN	I	Number of track jump count signal input.
14	SENS	O (3)	Internal status output terminal against serial bus address.
15	SYPL	I	Polarity shifting input terminal of SQSY, ADSY, DQSY. "H" to Active High.
16	FILO	O (A)	Master PLL filter output for digital PLL.
17	FILI	I	Master PLL filter input for digital PLL.
18	PCO	O (3)	Master PLL phase compare output for digital PLL.
19	AVss	—	Analog ground.
20	CLTV	I	Master PLL VCO control voltage input for digital PLL.
21	AVDD	—	Analog power supply.
22	XRST	I	System reset input. Active Low.
23	REC	I	"L" to decoder. "H" to encoder.
24	TEST8	I	Test terminal. Normally GND.
25	SCLK	I	Serial bus clock input.
26	XLAT	I	Serial bus latch input.
27	SWDT	I	Serial bus writing data input.
28	SRDT	O (3)	Serial bus read out data output.
29	ADSY	O	ADIP sync output.
30	SQSY	O	Sub-code Q sync output.
31	VDD	—	Digital power supply.
32	DQSY	O	Sub-code Q sync (SCOR) output of digital U-bit CD format.
33	TEST7	O	Keep opened.
34	DTI	I	Record audio signal input.
35	DTO	O (3)	Playback audio signal output. Turns to high impedance in record mode.
36	C2PO	O	C2PO at playback; D.In-VFLAG at D.REC; 0 at A.REC.
37	BCK	O	2.8224MHz output. (MCLK system)
38	XBCK	O	BCK reverse output. (MCLK system)
39	LRCK	O	44.1kHz. (=Fs) (MCLK system)
40	WDCK	O	88.2kHz. (MCLK system)
41	FS4	O	176.4kHz. (MCLK system)
42	GTOP	O	"H" to sync guard window open. (INPUT EFM SYNC monitor output)
43	XUGFS	O	"L" to unguarded frame sync. (INPUT EFM SYNC monitor output)
44	XPLCK	O	EFM decoder PLL clock output. (98Fs=4.3218MHz)
45	GFS	O	"H" to frame sync OK. (INPUT EFM SYNC monitor output)

Pin No.	Symbol	I/O	Function
46	EPDO	O (3)	EFM encoder external PLL phase compare output. Freq: Low → "H".
47	RFCK	O	7.35kHz output. (MCLK system)
48	EVCI	I	EFM encoder external PLL oscillation input. (196Fs=8.6436MHz)
49	EVCO	O	EFM encoder external PLL oscillation output. (196Fs=8.6436MHz)
50	Vss	—	Digital ground.
51	MCLK	O	22.5792MHz output. Duty is not guaranteed.
52	XTAL	I	X'tal oscillation input. (512Fs=22.5792MHz)
53	XTAO	O	X'tal oscillation output. (512Fs=22.5792MHz)
54	TEST9	I	Fix to "L".
55	MVCI	I	Digital in PLL oscillation input. (512Fs=22.5792MHz)
56	MVCO	O	Digital in PLL oscillation output. (512Fs=22.5792MHz)
57	TEST2	O	Keep opened.
58	DIPD	O (3)	Digital in PLL phase compare output. Freq: Low → "L".
59	RAOF	O	RAM over flow output. (Monitor output of decoder)
60	MT3	O	Correction state monitor output at playback.
61	MT2	O	Correction state monitor output at playback.
62	MY1	O	Correction state monitor output at playback.
63	MY0	O	Correction state monitor output at playback.
64	WFCK	O	7.35kHz output. (EFM decoder PLL system at playback, EFM encoder PLL system in record mode)
65	DIN	I	Digital audio input terminal.
66	MD2	I	ON/OFF terminal of digital audio output. "H" to ON.
67	DOUT	O	Digital audio output terminal.
68	DIDT	O	Audio data output terminal of digital audio input.
69	DODT	I	16-bit data input terminal for digital audio output.
70	DOVF	I	Validity Flag input terminal for digital audio output.
71	VDD	—	Digital power supply.
72	TEST3	I	Fix to "L".
73	TEST4	O	Keep opened.
74	TEST5	I	Fix to "L".
75	TEST6	I	Fix to "L".
76	FMCK	I	Clock input for ADIP read out. (6.3kHz) (TTL Schmitt input)
77	FMDT	I	ADIP data input. (TTL Schmitt input)
78	ADFG	I	ADIP carrier signal input. (22.05kHz) (TTL Schmitt input)
79	FSW	O (3)	Output filter shifting output of spindle monitor. "Z" at CLV-P, others in "L".
80	MON	O	ON/OFF control output of spindle motor. "H" to ON.

- Note:**
- XUGFS is Frame Sync possessed from EFM signal and is negative pulse. signal previous to sync guard.
  - XPLCK is reverse of EFM PLL clock, PLL is so designed to coincide falling edge and varying point of EFM signal.
  - GFS signal becomes "H" when Frame Sync and inserted guard timing coincide.
  - C2PO is a signal to express Data error state.
  - RAOF is a generating signal when 32kRAM exceeds ±4F jitter margin.





**BU4052BC M: (IC204)**  
**BU4053BC M: (IC205, 207)**

**BU4052BC**

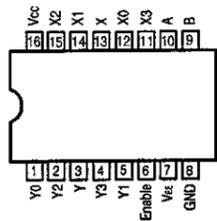

Control Inputs		Select			ON Switches		
Enable	B	A					
L	L	L	L	Y0	X0		
L	L	L	H	Y1	X1		
L	H	L	L	Y2	X2		
L	H	H	L	Y3	X3		
H	X	X				None	

X = Don't Care

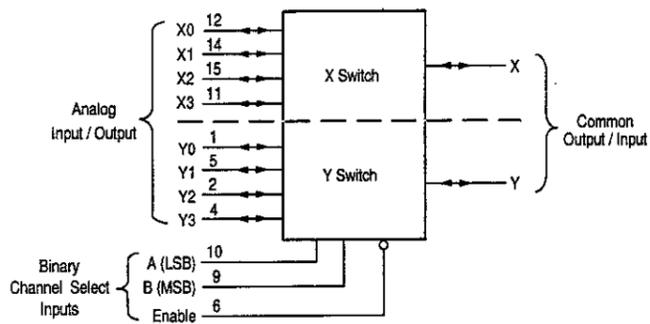
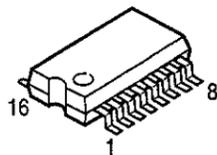

Vcc = 16 (Analog and digital positive power supplies)  
 VEE = 7 (Analog negative power supply)  
 GND = 8 (Digital negative power supply)

**BU4053**

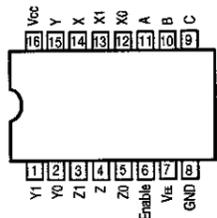

Control Inputs		Select			ON Switches		
Enable	C	B	A				
L	L	L	L	Z0	Y0	X0	
L	L	L	H	Z0	Y0	X1	
L	L	H	L	Z0	Y1	X0	
L	L	H	H	Z0	Y1	X1	
L	H	L	L	Z1	Y0	X0	
L	H	L	H	Z1	Y0	X1	
L	H	H	L	Z1	Y1	X0	
L	H	H	H	Z1	Y1	X1	
H	X	X	X			None	

X = Don't Care

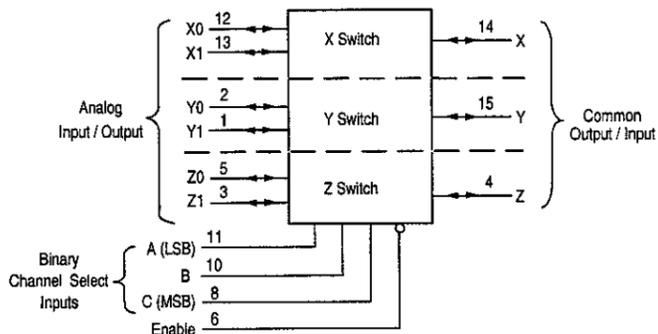

Vcc = 16 (Analog and digital positive power supplies)  
 VEE = 7 (Analog negative power supply)  
 GND = 8 (Digital negative power supply)

**BA15218F E: (IC308), A: (IC613)**

**BA4510F E: (IC311, 312)**  
**BA4560F M: (IC203, 210)**

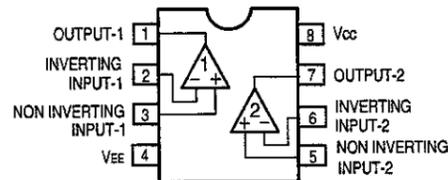
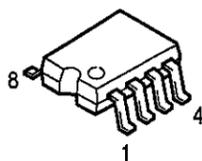

**LA6520 M: (IC501, 502)**

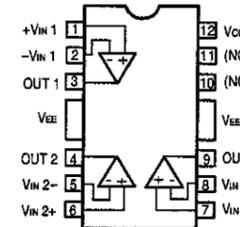
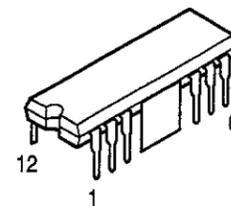

**SM5841BS A: (IC610)**

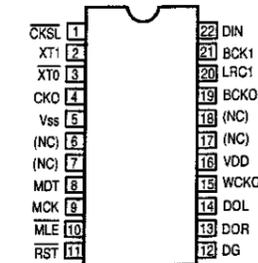
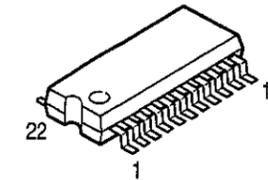

**PCM61P-L A: (IC611, 612)**  
**M5290P A: (IC601)**

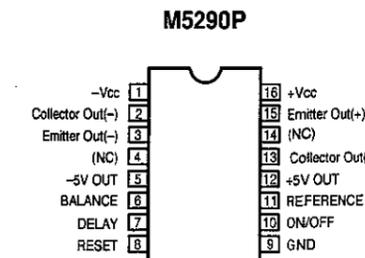
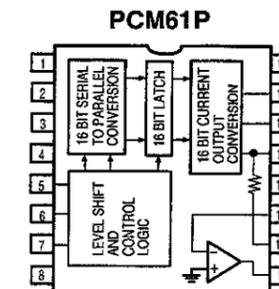
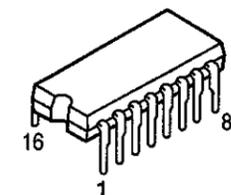

**NJM78L05A A: (IC609)**

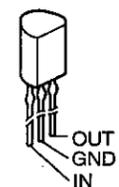

**INTERRUPTOR ON1023 (SW914)**

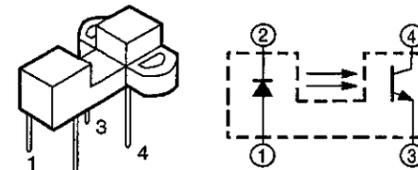

**IC PROTECTOR ICP-N15 A: (IC602, 603, 605-607)**  
**ICP-N20 A: (IC604)**

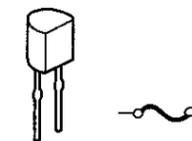

**Remote Control Sensor GP1U571 A: (IC103)**

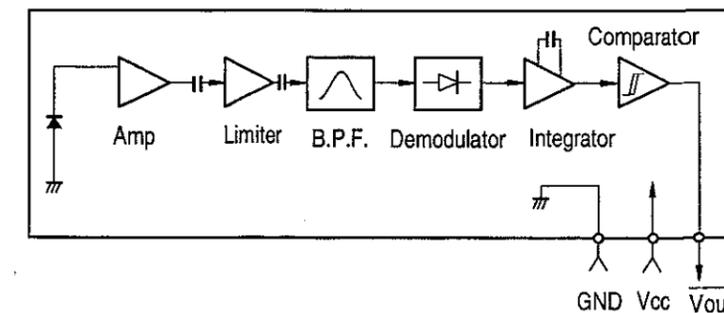
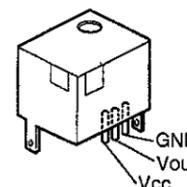

TC4W53F M: (IC208)  
 TC7W74F E: (IC314)  
 TC7WU04F M: (IC209), E: (IC309), A: (IC615)

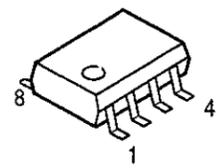

**TC4W53F**

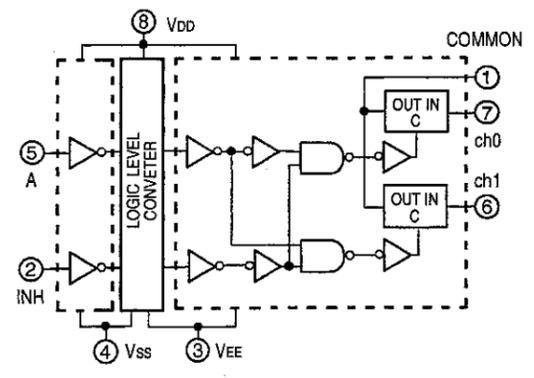
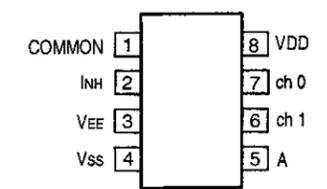

CONTROL C	IMPEDANCE BETWEEN IN - OUT
H	$0.5 \sim 5 \times 10^3 \Omega$
L	$> 10^3 \Omega$

CONTROL INPUT	ON CHANNEL
INH A	ch 0
L L	ch 0
L H	ch 0
H -	NONE

**TC7WU04F**

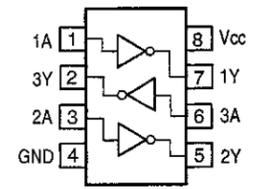

A	Y
L	H
H	L

**TC7W74F**

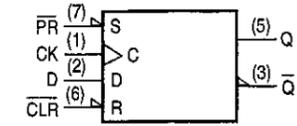
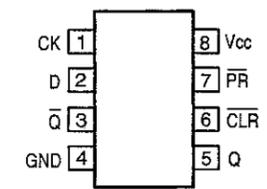

**TC4S30F**  
E: (IC313)

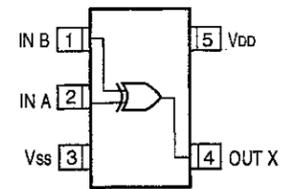
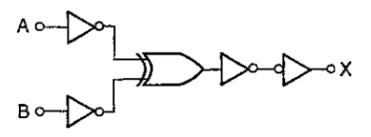
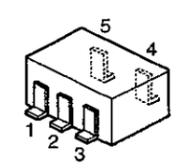

Input	Output
A B	X
L L	L
L H	H
H L	H
H H	L

**PQ05RAI**  
A: (IC608)

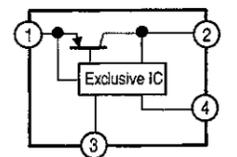
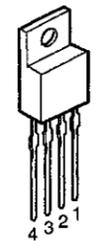

- ① DC Input (Vin)
- ② DC Output (Vo)
- ③ GND
- ④ ON/OFF Control Terminal

● TRANSISTORS

2SA933(Q)  
2SD2114(STPU)

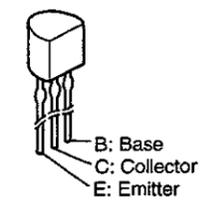

2SB1274  
2SD1913

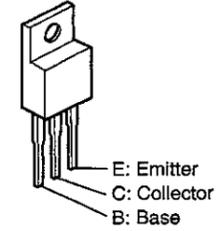

2SJ279STR  
2SK1949STR

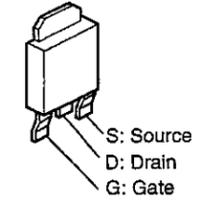

2SB1189

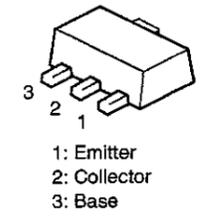

DTA124XS(22K-47K)  
DTC114ES(10-10K)

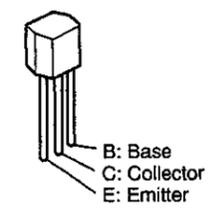

DTA124XS

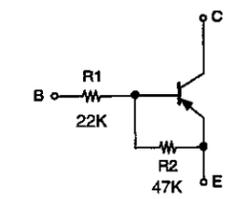

DTC114ES

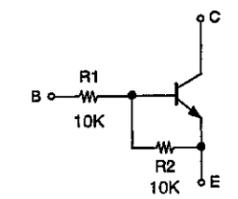

2SA1037K(S/R)  
2SC2412K(S)  
DTC124EK (22K-22K)

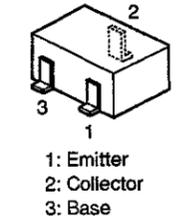

DTC124EK

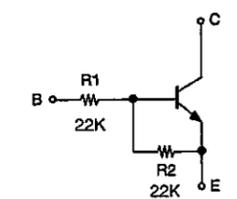

● DIODES

DA204K  
DAN202K  
MA151A

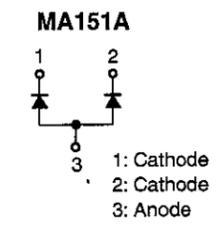
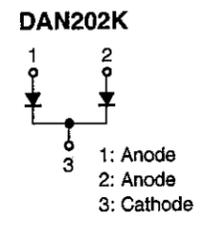
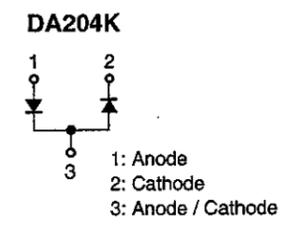
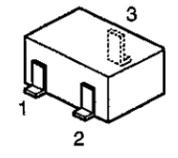

SB01-05CP

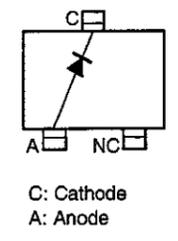
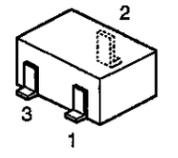

02C3.0Z

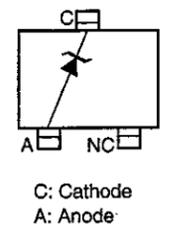
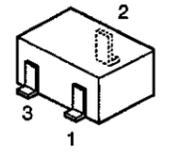

FIP2S

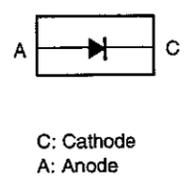
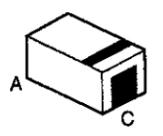

HVU17

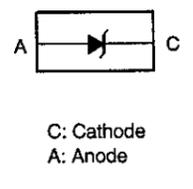
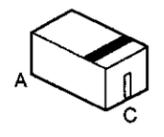

1SS270A

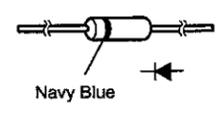

1SR35-200A

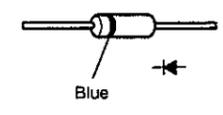

RM10

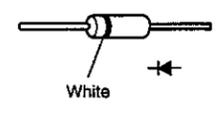

MTZJ33A  
MTZJ7.5(C)  
MTZJ8.2(A)

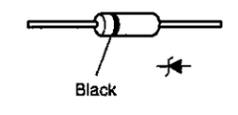

● F.L. TUBE FIP14XM1DA(FL101)

(Parts No: 393 8019 005)

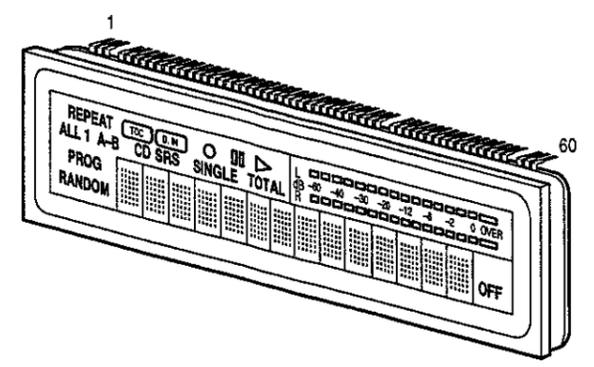

GRID DIVIDE

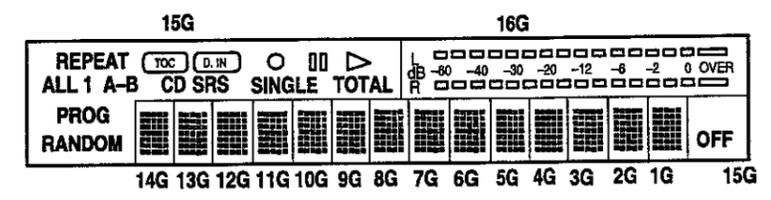

1	2	3	4	5
6	7	8	9	10
11	12	13	14	15
16	17	18	19	20
21	22	23	24	25
26	27	28	29	30
31	32	33	34	35

TERMINAL CONNECT

Terminal No.	1	2	3	4	5	6	7	8	9	10	11	12	13	14	15	16	17	18	19	20
Electrode	F1	F1	F1	NP	P	P	P	P	P	P	P	P	P	P	P	P	P	P	P	P
Terminal No.	21	22	23	24	25	26	27	28	29	30	31	32	33	34	35	36	37	38	39	40
Electrode	P	P	P	P	P	P	P	P	P	P	P	P	P	P	P	P	P	P	P	NP
Terminal No.	41	42	43	44	45	46	47	48	49	50	51	52	53	54	55	56	57	58	59	60
Electrode	16G	15G	14G	13G	12G	11G	10G	9G	8G	7G	6G	5G	4G	3G	2G	1G	NP	F2	F2	F2

Note: F:Filament G: Grid P: Anode NP: No Pin

INTERNAL CONNECTION TABLE

	1-14G	15G	18G
S1	1	TOTAL	1
S2	2	▶	2
S3	3	SINGLE	3
S4	4		4
S5	5	○	5
S6	6	CD SRS	6
S7	7	D, IN	7
S8	8	TOC	8
S9	9	B	9
S10	10	A	10
S11	11	1	11
S12	12	REPEAT	12

	1-14G	15G	18G
S13	13	ALL	13
S14	14	RANDOM	14
S15	15		15
S16	16		16
S17			
S18	18		18
S19	19		19
S20	20		20
S21	21		21
S22	22		22
S23	23		23
S24	24		24

	1-14G	15G	18G
S25	25	ALL	25
S26	26	RANDOM	26
S27	27		27
S28	28		28
S29	29		29
S30	30		30
S31	31		31
S32	32		32
S33	33		33
S34	34		34
S35	35	OFF	

PRINTED WIRING BOARD

2U-2784 MECHA. SERVO UNIT ASS'Y

Component Side

2U-2784 MECH. SERVO UNIT ASS'Y	
-1	Servo Unit
-2	Drive Amp. Unit
-3	Mecha Unit
-4	Hall Sensor Unit
-5	---
-6	---
-7	Loading Motor Unit
-8	Photo Interrupter Unit
-9	Loading Position Sensor Unit

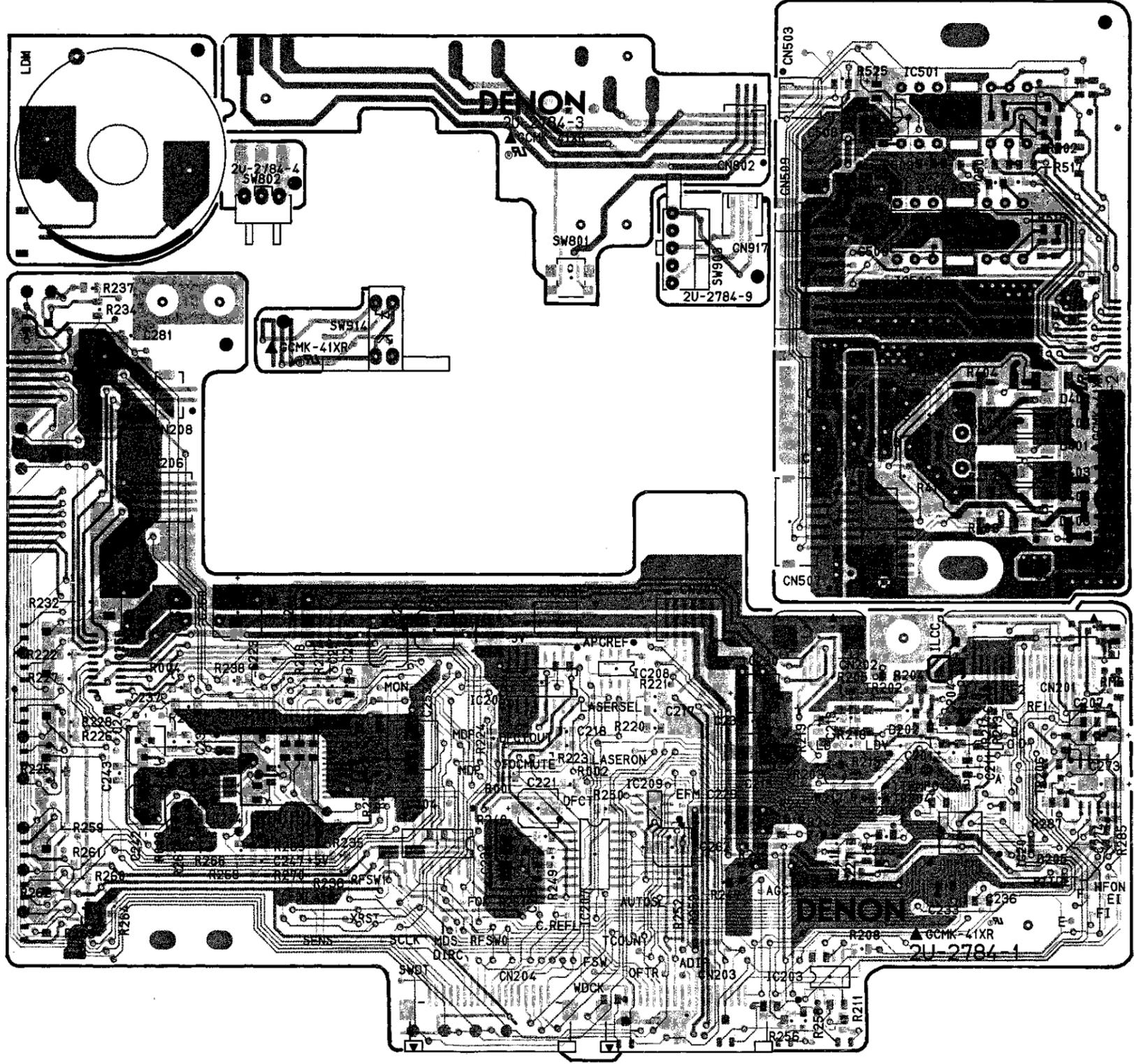

A

B

C

D

E

1 2 3 4 5 6 7 8

Pattern Side

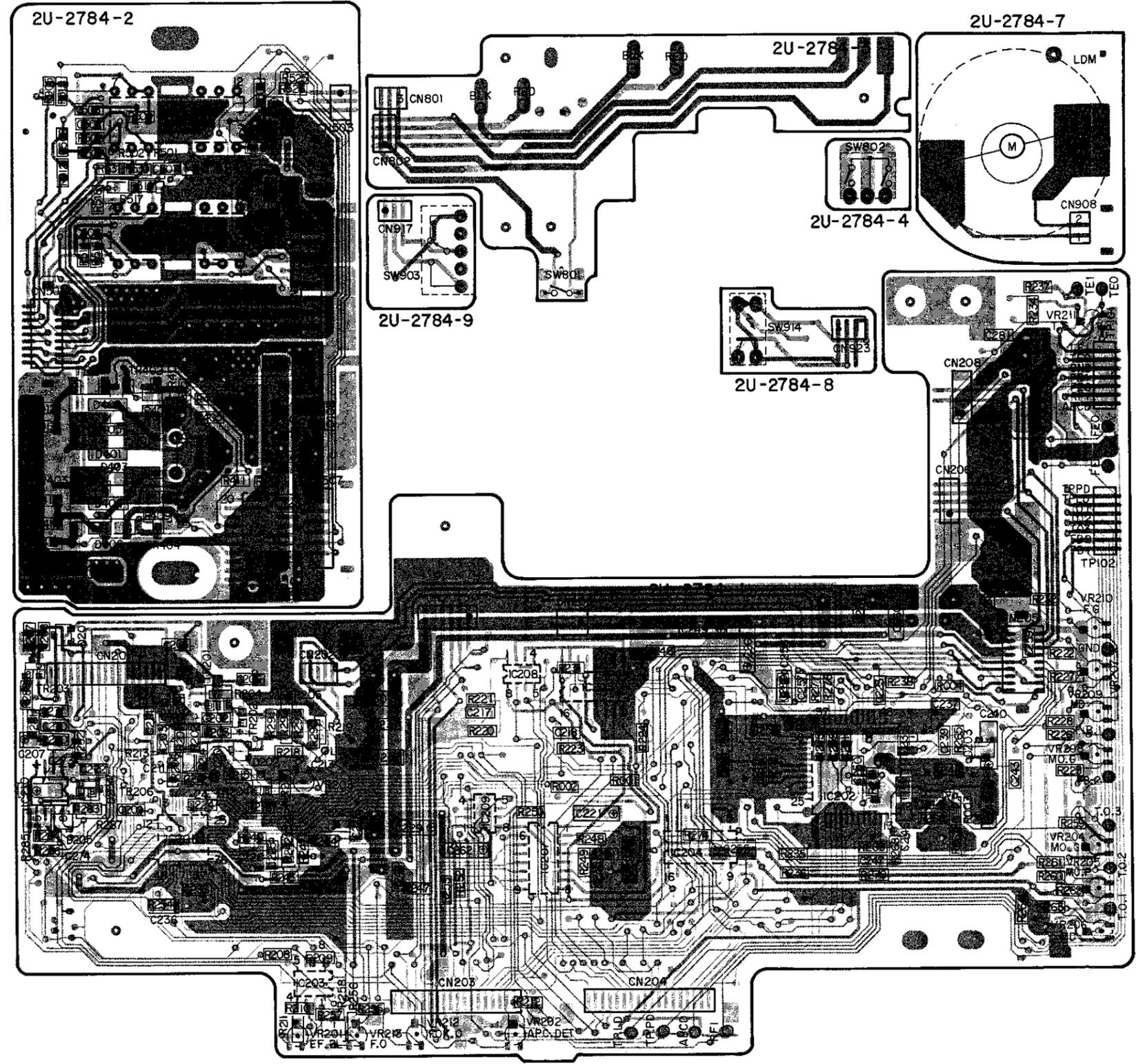

A  
B  
C  
D  
E

1 2 3 4 5 6 7 8

2U-2704 ENCODE / DECODE UNIT ASS'Y

Component Side

A

B

C

D

E

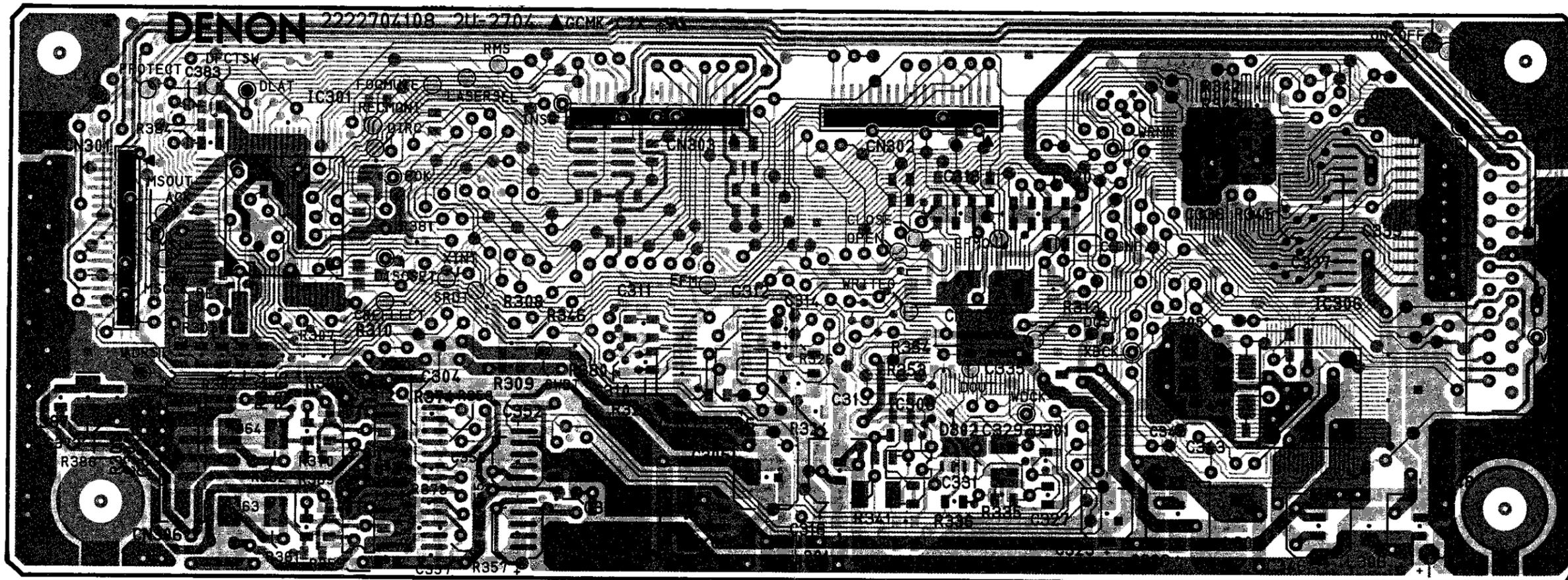

1 2 3 4 5 6 7 8

Pattern Side

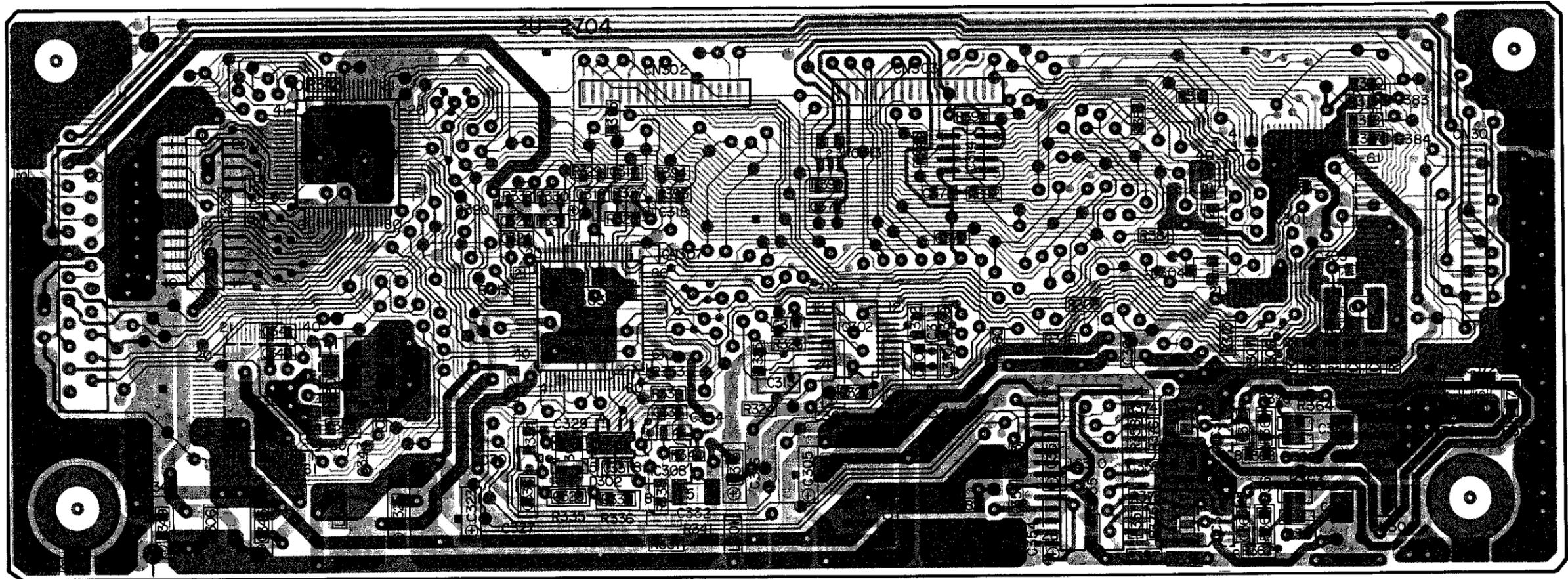

A  
B  
C  
D  
E

1 2 3 4 5 6 7 8

2U-2705A AUDIO UNIT ASS'Y

2U-2705A AUDIO UNIT ASS'Y	
-1	Audio Unit
-2	Display Unit
-3	Head Phone Unit
-4	Optical Output Unit

Component Side

A

B

C

D

E

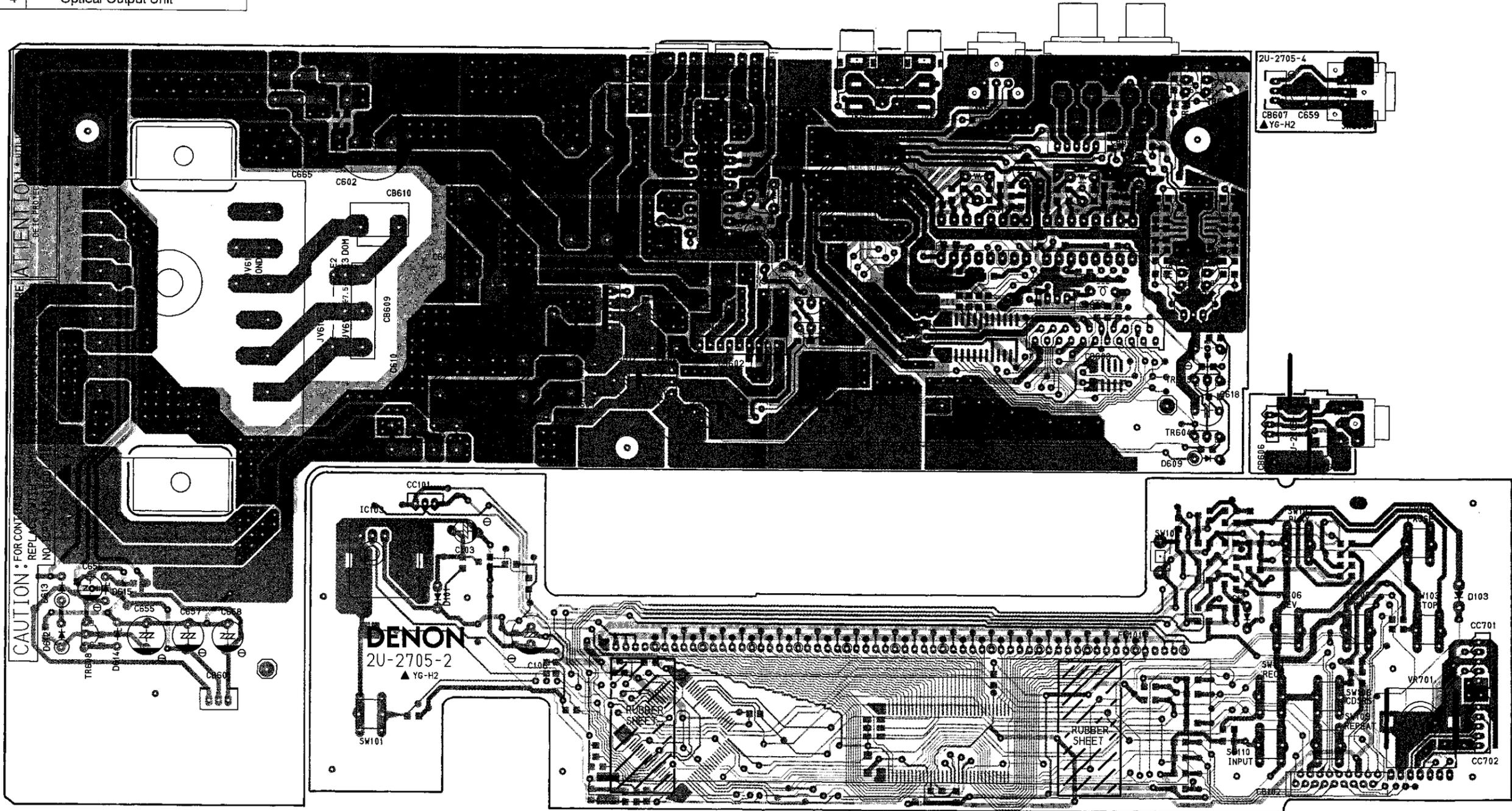



1 2 3 4 5 6 7 8

Pattern Side

A  
B  
C  
D  
E

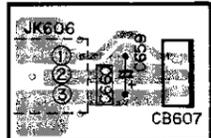

2U-2705-4

2U-2705-3

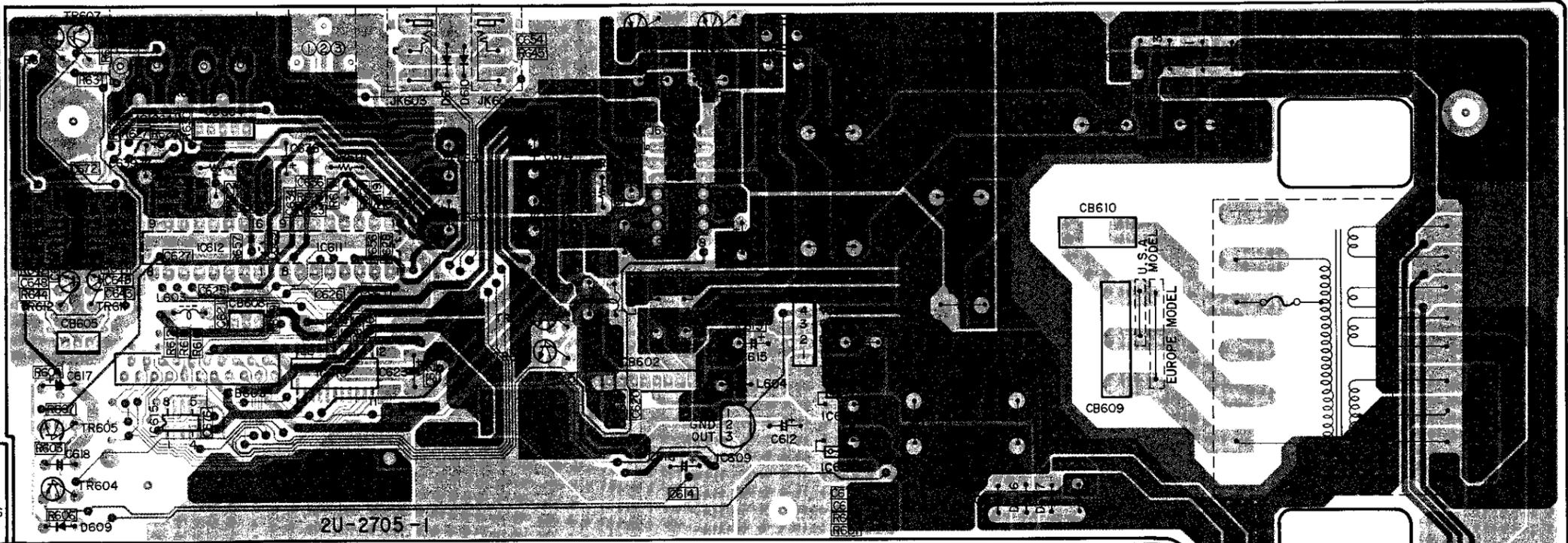
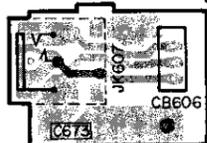

2U-2705-1

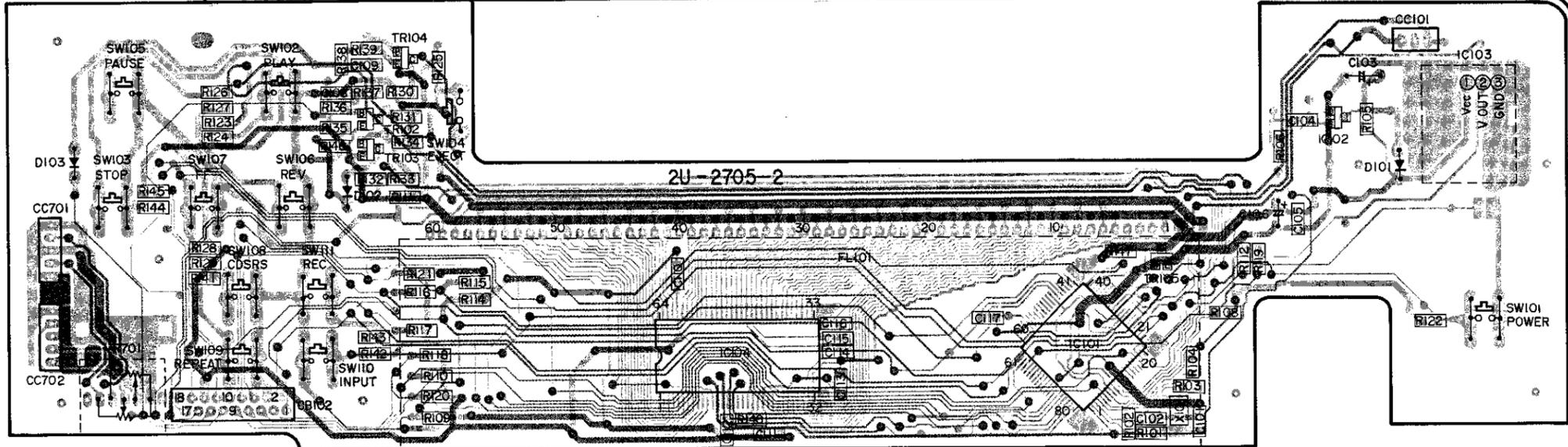

2U-2705-2

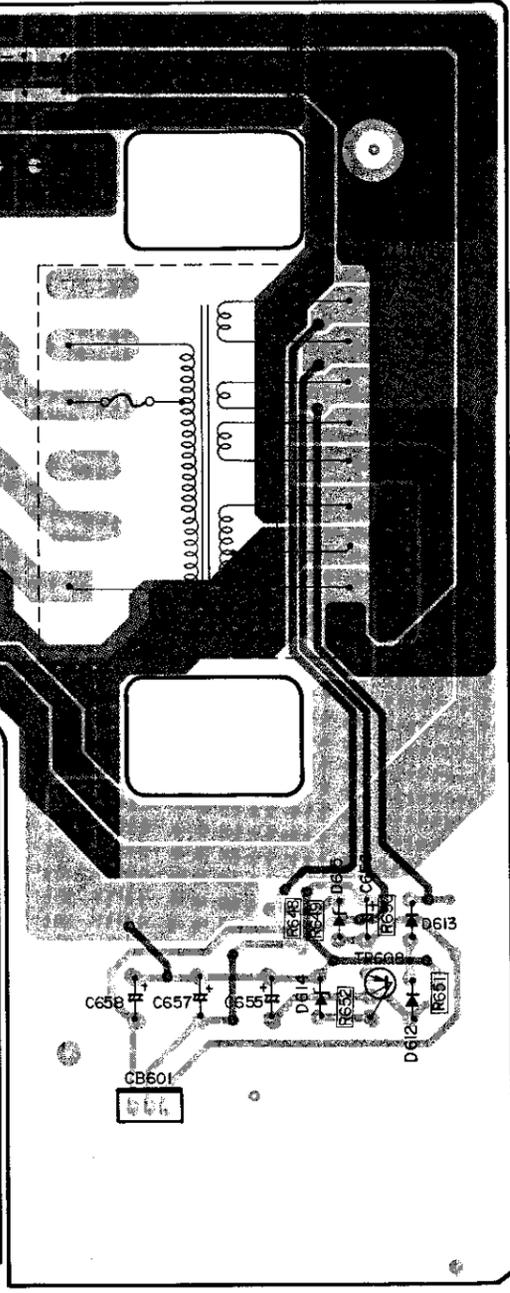

**P.W.B. UNIT ASS'Y PARTS LIST**  
2U-2784 MECH. SERVO UNIT

Ref. No.	Parts No.	Parts Name	Remarks	Ref. No.	Parts No.	Parts Name	Remarks
<b>COMPONENT SIDE (P)</b>				<b>SEMICONDUCTORS GROUP</b>			
IC201	262 1961 005	IC CXA1381R		R269	247 0011 986	Chip Carbon 68kohm 1/10W	RM73B--683J
IC202	262 1959 907	IC CXA1082BQ		R270	247 0010 945	Chip Carbon 18kohm 1/10W	RM73B--183J
IC203	263 0687 901	IC BA4560FT		R272	247 0012 943	Chip Carbon 120kohm 1/10W	RM73B--124J
IC204	262 2012 908	IC BU4052BCF		R273	247 0011 944	Chip Carbon 47kohm 1/10W	RM73B--473J
IC205	262 2013 907	IC BU4053BCF		R277	247 0012 943	Chip Carbon 120kohm 1/10W	RM73B--124J
IC207	262 2013 907	IC BU4053BCF		R278	247 0013 968	Chip Carbon 390kohm 1/10W	RM73B--394J
IC208	262 1793 901	IC TC4W53F		R285	247 0009 914	Chip Carbon 5.1kohm 1/10W	RM73B--512J
IC209	262 1953 903	IC TC7WU04F		R287	247 0010 961	Chip Carbon 22kohm 1/10W	RM73B--223J
IC401	262 1955 901	IC TC74ACT540F		R405-408	247 1001 908	Chip Carbon 2.2ohm 1/8W	RM73B2B2R2K
TR202	271 0238 908	Transistor 2SA1037K(S/R)		R411	247 0012 927	Chip Carbon 100kohm 1/10W	RM73B--104J
TR204	273 0384 900	Transistor 2SC2412K(S)		R417	247 0012 927	Chip Carbon 100kohm 1/10W	RM73B--104J
TR206	273 0384 900	Transistor 2SC2412K(S)		R502	247 0002 966	Chip Carbon 10ohm 1/10W	RM73B--100J
D202	276 0629 907	Zener Diode 02CZ3.0Z	3V	R503	247 0011 960	Chip Carbon 56kohm 1/10W	RM73B--563J
D205	276 0560 901	Diode DAN202K		R505	247 0011 902	Chip Carbon 33kohm 1/10W	RM73B--333J
D401-406	276 0626 900	Diode F1P2S		R516,517	247 0011 902	Chip Carbon 33kohm 1/10W	RM73B--333J
<b>RESISTORS GROUP (Not included Carbon Film ±5%, 1/4W)</b>				<b>CAPACITORS GROUP</b>			
R204	247 0012 927	Chip Carbon 100kohm 1/10W	RM73B--104J	C201	257 2004 943	Chip Tantal 10µF/16V	CS77B1C100M
R205	247 0007 945	Chip Carbon 1kohm 1/10W	RM73B--102J	C204	257 0014 935	Chip Ceramic 0.1µF/25V	CK73F1E104Z
R208	247 0009 914	Chip Carbon 5.1kohm 1/10W	RM73B--512J	C207	254 4464 906	Electrolytic 100µF/6.3V	CE67C0J101M
R211	247 0008 928	Chip Carbon 2.2kohm 1/10W	RM73B--222J	C210	257 0010 900	Chip Ceramic 0.01µF/50V	CK73B1H103K
R213	247 0014 925	Chip Carbon 680kohm 1/10W	RM73B--684J	C211	257 0010 942	Chip Ceramic 0.022µF/50V	CK73B1H223K
R214	247 0011 957	Chip Carbon 51kohm 1/10W	RM73B--513J	C212	257 0004 961	Chip Ceramic 100pF/50V	CC73SL1H101J
R215	247 0008 928	Chip Carbon 2.2kohm 1/10W	RM73B--222J	C213	257 0014 935	Chip Ceramic 0.1µF/25V	CK73F1E104Z
R216	247 0009 901	Chip Carbon 4.7kohm 1/10W	RM73B--472J	C215	254 4465 905	Electrolytic 22µF/16V	CE67C1C220M
R217,218	247 0010 961	Chip Carbon 22kohm 1/10W	RM73B--223J	C217	257 0010 942	Chip Ceramic 0.022µF/50V	CK73B1H223K
R219	247 0008 928	Chip Carbon 2.2kohm 1/10W	RM73B--222J	C218	257 0014 935	Chip Ceramic 0.1µF/25V	CK73F1E104Z
R220	247 0007 945	Chip Carbon 1kohm 1/10W	RM73B--102J	C220	257 0009 924	Chip Ceramic 2200pF/50V	CK73B1H222K
R221	247 0014 967	Chip Carbon 1Mohm 1/10W	RM73B--105J	C221	254 4465 905	Electrolytic 22µF/16V	CE67C1C220M
R222	247 0011 973	Chip Carbon 62kohm 1/10W	RM73B--623J	C223	257 0009 966	Chip Ceramic 4700pF/50V	CK73B1H472K
R223	247 0010 929	Chip Carbon 15kohm 1/10W	RM73B--153J	C226	257 3006 908	Chip Metalized 6800pF/16V	CF73=1C682J
R224	247 0009 972	Chip Carbon 9.1kohm 1/10W	RM73B--912J	C227	257 0014 935	Chip Ceramic 0.1µF/25V	CK73F1E104Z
R225-228	247 0009 943	Chip Carbon 6.8kohm 1/10W	RM73B--682J	C229	254 4466 917	Electrolytic 1µF/50V	CE67C1H010M
R232	247 0011 902	Chip Carbon 33kohm 1/10W	RM73B--333J	C230	254 4465 905	Electrolytic 22µF/16V	CE67C1C220M
R234	247 0009 985	Chip Carbon 10kohm 1/10W	RM73B--103J	C231	257 0014 935	Chip Ceramic 0.1µF/25V	CK73F1E104Z
R235	247 0009 914	Chip Carbon 5.1kohm 1/10W	RM73B--512J	C233	257 0011 967	Chip Ceramic 0.033µF/25V	CK73B1E333K
R236	247 0009 901	Chip Carbon 4.7kohm 1/10W	RM73B--472J	C234	254 4466 904	Electrolytic 0.47µF/50V	CE67C1HR47M
R237	247 0011 902	Chip Carbon 33kohm 1/10W	RM73B--333J	C235	257 0010 900	Chip Ceramic 0.01µF/50V	CK73B1H103K
R238	247 0010 961	Chip Carbon 22kohm 1/10W	RM73B--223J	C236	257 0009 937	Chip Ceramic 2700pF/50V	CK73B1H272K
R241	247 0012 927	Chip Carbon 100kohm 1/10W	RM73B--104J	C237	257 3007 910	Chip Metalized 0.1µF/16V	CF73=1C104J
R244	247 0007 945	Chip Carbon 1kohm 1/10W	RM73B--102J	C239	257 0002 992	Chip Ceramic 20pF/50V	CC73SL1H200J
R245	247 0006 991	Chip Carbon 620ohm 1/10W	RM73B--621J	C240	254 4465 905	Electrolytic 22µF/16V	CE67C1C220M
R246	247 0014 967	Chip Carbon 1Mohm 1/10W	RM73B--105J	C241	257 3007 907	Chip Metalized 0.1µF/16V	CF73=1C104J
R247	247 0007 945	Chip Carbon 1kohm 1/10W	RM73B--102J	C242	254 4465 905	Electrolytic 22µF/16V	CE67C1C220M
R248	247 0012 927	Chip Carbon 100kohm 1/10W	RM73B--104J	C243	257 0014 935	Chip Ceramic 0.1µF/25V	CK73F1E104Z
R249-251	247 0009 985	Chip Carbon 10kohm 1/10W	RM73B--103J	C244	257 0002 921	Chip Ceramic 10pF/50V	CC73SL1H100D
R252	247 0007 945	Chip Carbon 1kohm 1/10W	RM73B--102J	C247	257 0005 902	Chip Ceramic 150pF/50V	CC73SL1H151J
R253	247 0012 927	Chip Carbon 100kohm 1/10W	RM73B--104J	C248	257 0014 935	Chip Ceramic 0.1µF/25V	CK73F1E104Z
R256	247 0011 902	Chip Carbon 33kohm 1/10W	RM73B--333J	C249	254 4465 905	Electrolytic 22µF/16V	CE67C1C220M
R258-264	247 0011 902	Chip Carbon 33kohm 1/10W	RM73B--333J	C253	254 4464 906	Electrolytic 100µF/6.3V	CE67C0J101M
R265,266	247 0012 927	Chip Carbon 100kohm 1/10W	RM73B--104J	C254	257 3007 907	Chip Metalized 0.033µF/16V	CF73=1C333J
R267	247 0012 901	Chip Carbon 82kohm 1/10W	RM73B--823J	C256,257	257 0023 900	Chip Ceramic 0.22µF/16V	CK73B1C224K
R268	247 0011 944	Chip Carbon 47kohm 1/10W	RM73B--473J				

**NOTE FOR PARTS LIST**

- Part indicated with the mark "◎" are not always in stock and possibly to take a long period of time for supplying, or in some case supplying of part may be refused.
- When ordering of part, clearly indicate "1" and "I" (i) to avoid mis-supplying.
- Ordering part without stating its part number can not be supplied.
- Part indicated with the mark "★" is not illustrated in the exploded view.
- Not including Carbon Film ±5%, 1/4W Type in the P.W.Board parts list. (Refer to the Schematic Diagram for those parts.)

**WARNING:**

Parts marked with this symbol have critical characteristics. Use ONLY replacement parts recommended by the manufacturer.

**Resistors**

Ex: **RN** **14K** **2E** **182** **G** **FR**  
Type Shape and performance Power Resistance Allowable error Others

RD : Carbon	2B : 1/8W	F : ±1%	P : Pulse-resistant type
RC : Composition	2E : 1/4W	G : ±2%	NL : Low noise type
RS : Metal oxide film	2H : 1/2W	J : ±5%	NB : Non-burning type
RW : Winding	3A : 1W	K : ±10%	FR : Fuse-resistor
RN : Metal film	3D : 2W	M : ±20%	F : Lead wire forming
RK : Metal mixture	3F : 3W		
	3H : 5W		

**Resistance**

**1 8 2** ⇒ 1800 ohm = 1.8 kohm  
Indicates number of zeros after effective number.  
2-digit effective number.

Units: ohm

**1 R 2** ⇒ 1.2 ohm  
1-digit effective number.  
2-digit effective number, decimal point indicated by R.

Units: ohm

**Capacitors**

Ex: **CE** **04W** **1H** **2R2** **M** **BP**  
Type Shape and performance Dielectric strength Capacity Allowable error Others

CE : Aluminum foil electrolytic	0J : 6.3V	F : ±1%	HS : High stability type
CA : Aluminum solid electrolytic	1A : 10V	G : ±2%	BP : Non-polar type
CS : Tantalum electrolytic	1C : 16V	J : ±5%	HR : Ripple-resistant type
CO : Film	1E : 25V	K : ±10%	DL : For charge and discharge
CK : Ceramic	1V : 35V	M : ±20%	HF : For assuring high frequency
CC : Ceramic	1H : 50V	Z : +80%	U : UL part
CP : Oil	2A : 100V	-20%	C : CSA part
CM : Mica	2B : 125V	P : +100%	W : UL-CSA type
CF : Metallized	2C : 160V	-0%	F : Lead wire forming
CH : Metallized	2D : 200V	C : ±0.25pF	
	2E : 250V	D : ±0.5pF	
	2H : 500V	O : Others	
	2J : 630V		

**Capacity (electrolyte only)**

**2 2 2** ⇒ 2200µF  
Indicates number of zeros after effective number.  
2-digit effective number.

Units: µF.

**2 R 2** ⇒ 2.2µF  
1-digit effective number.  
2-digit effective number, decimal point indicated by R.

Units: µF.

**Capacity (except electrolyte)**

**2 2 2** ⇒ 2200pF = 0.0022µF  
(More than 2) — Indicates number of zeros after effective number.  
2-digit effective number.

Units: µF.

**2 2 1** ⇒ 220pF  
(0 or 1) — Indicates number of zeros after effective number.  
2-digit effective number.

Units: pF.

When the dielectric strength is indicated in AC, "AC" is included after the dielectric strength value.

Ref. No.	Parts No.	Parts Name	Remarks	Ref. No.	Parts No.	Parts Name	Remarks
C258	254 4465 918	Electrolytic 47µF/16V	CE67C1C470M	R271	247 0013 997	Chip Carbon 510kohm 1/10W	RM73B--104J
C259	257 0014 935	Chip Ceramic 0.1µF/25V	CK73F1E104Z	R274	247 0009 985	Chip Carbon 10kohm 1/10W	RM73B--103J
C260	254 4465 918	Electrolytic 47µF/16V	CE67C1C470M	R275	247 0014 967	Chip Carbon 1Mohm 1/10W	RM73B--105J
C261	257 0014 935	Chip Ceramic 0.1µF/25V	CK73F1E104Z	R280,281	247 0008 928	Chip Carbon 2.2kohm 1/10W	RM73B--222J
C262,263	254 4465 905	Electrolytic 22µF/16V	CE67C1C220M	R282--284	247 0011 986	Chip Carbon 68kohm 1/10W	RM73B--683J
C273	254 4466 904	Electrolytic 0.47µF/50V	CE67C1HR47M	R286	247 0012 927	Chip Carbon 100kohm 1/10W	RM73B--104J
C274	257 0010 900	Chip Ceramic 0.01µF/50V	CK73B1H103K	R288	247 0007 945	Chip Carbon 1kohm 1/10W	RM73B--102J
C501	257 0014 935	Chip Ceramic 0.1µF/25V	CK73F1E104Z	R290--293	247 1004 963	Chip Carbon 68ohm 1/8W	RM73B2B680J
C508,509	254 4465 918	Electrolytic 47µF/16V	CE67C1C470M	R401,402	247 0012 927	Chip Carbon 100kohm 1/10W	RM73B--104J
<b>OTHER GROUP</b>				<b>Q'ty</b>			
	—	(P.W.Board)					(1)
SW801	212 1111 902	Push Switch (SPVC21)					1
CN201	205 0861 909	18P FFC Conn. Base					1
CN202	205 0861 912	5P FFC Conn. Base					1
CN203,204	205 0856 901	18P FFC Conn. Base					2
CN209	205 0860 926	2P HP Conn. Base					1
CN503,917	205 0788 930	3P Conn. Base					2
CN206	205 0860 942	4P HP Conn. Base (T)					1
CN802	205 0788 943	4P Conn. Base					1
CN207	205 0860 968	6P HP Conn. Base					1
CN208	205 0894 921	2P ZH-ZR Conn. Base (T)					1
CN507	205 0792 968	6P ZH-ZR Conn. Base (L)					1
CN509	205 0863 907	9P HP Conn. Base (L)					1
<b>PATTERN SIDE(S)</b>							
<b>SEMICONDUCTORS GROUP</b>							
IC210	263 0687 901	IC BA4560F		VR201	211 6092 942	Semi Fixed Resistor 4.7kohm	V03PB472M
TR201	272 0135 907	Transistor 2SB1189		VR202	211 6092 968	Semi Fixed Resistor 3.3kohm	V03PB332M
TR203	271 0238 908	Transistor 2SA1037K(S/R)		VR204--206	211 6092 955	Semi Fixed Resistor 22kohm	V03PB223M
TR401	275 0052 907	FET 2SJ279STR	P Type FET	VR207	211 6092 900	Semi Fixed Resistor 10kohm	V03PB103M
TR402	275 0083 906	FET 2SK1949STR	N Type FET	VR208--213	211 6092 955	Semi Fixed Resistor 22kohm	V03PB223M
TR403	275 0052 907	FET 2SJ279STR	P Type FET	<b>CAPACITORS GROUP</b>			
TR404	275 0083 906	FET 2SK1949STR	N Type FET	C202	257 0007 900	Chip Ceramic 1000pF/50V	CC73SL1H102J
D201	276 0627 909	Diode SB01-05CP		C203	257 0014 935	Chip Ceramic 0.1µF/25V	CK73F1E104Z
D204	276 0558 900	Diode DA204K		C205,206	257 0014 935	Chip Ceramic 0.1µF/25V	CK73F1E104Z
<b>RESISTORS GROUP (Not included Carbon Film ±5%, 1/4W)</b>				C208,209	257 0007 900	Chip Ceramic 1000pF/50V	CC73SL1H102J
R201,202	247 1001 908	Chip Carbon 2.2ohm 1/8W	RM73B2B2R2K	C214	257 0014 935	Chip Ceramic 0.1µF/25V	CK73F1E104Z
R203	247 0012 927	Chip Carbon 100kohm 1/10W	RM73B--104J	C224,225	257 0007 900	Chip Ceramic 1000pF/50V	CC73SL1H102J
R206	247 0007 903	Chip Carbon 680ohm 1/10W	RM73B--681J	C228	257 0007 900	Chip Ceramic 1000pF/50V	CC73SL1H102J
R207	247 0008 928	Chip Carbon 2.2kohm 1/10W	RM73B--222J	C238	257 3007 907	Chip Metalized 0.033µF/16V	CF73=1C333J
R209	247 0009 901	Chip Carbon 4.7kohm 1/10W	RM73B--472J	C245	257 3007 923	Chip Metalized 0.22µF/16V	CF73=1C224J
R210	247 0008 931	Chip Carbon 2.4kohm 1/10W	RM73B--242J	C246	254 4466 920	Electrolytic 3.3µF/50V	CE67C1H3R3M
R212	247 0007 903	Chip Carbon 680ohm 1/10W	RM73B--681J	C250,251	257 0010 900	Chip Ceramic 0.01µF/50V	CK73B1H103K
R231	247 0009 985	Chip Carbon 10kohm 1/10W	RM73B--103J	C252	257 0007 900	Chip Ceramic 1000pF/50V	CC73SL1H102J
R240	247 0007 945	Chip Carbon 1kohm 1/10W	RM73B--102J	C255	254 4466 904	Electrolytic 0.47µF/50V	CE67C1HR47M
R242	247 0008 944	Chip Carbon 2.7kohm 1/10W	RM73B--272J	C270,271	257 0005 902	Chip Ceramic 150pF/50V	CC73SL1H151J
R243	247 0008 957	Chip Carbon 3kohm 1/10W	RM73B--302J	C272	257 0010 900	Chip Ceramic 0.01µF/50V	CK73B1H103K
R254	247 0012 901	Chip Carbon 82kohm 1/10W	RM73B--823J	C502,503	257 0014 935	Chip Ceramic 0.1µF/25V	CK73F1E104Z
R255	247 0011 902	Chip Carbon 33kohm 1/10W	RM73B--333J	C506,507	257 0014 935	Chip Ceramic 0.1µF/25V	CK73F1E104Z
R257	247 0011 902	Chip Carbon 33kohm 1/10W	RM73B--333J				

2U-2704 ENCORD/DECORD UNIT

Ref. No.	Parts No.	Parts Name	Remarks	Q'ty
<b>OTHER GROUP</b>				
CN205	205 0857 913	18P Socket		1
CN501	205 0858 912	18P Pin Header		1
CN923	205 0788 930	3P Conn. Base		1
CN801	205 0860 939	3P HP Conn. Base (T)		1
CN908	205 0792 926	2P ZH-ZR HP Conn. Base (T)		1
TP101,102	205 0860 971	7P HP Conn. Base		2
<b>HAND DIP (D)</b>				
<b>SEMICONDUCTORS GROUP</b>				
IC501,502	263 0891 007	IC LA6520		
<b>CAPACITORS GROUP</b>				
C401	255 4077 082	Film Cap. 0.0022 $\mu$ F/100V	CQ93P2A222J	
<b>OTHER GROUP</b>				
SW802	212 1122 001	Disc Sens. Switch		1
SW903	212 1072 009	Detect Switch (SSCF21)		1
SW914	269 0154 005	Inter Ruptor ON1023		1
	GEN 2847	Motor Pulley Sub. Ass'y		1s
	217 0181 006	:Loading Motor		(1)

Ref. No.	Parts No.	Parts Name	Remarks
<b>COMPONENT SIDE</b>			
<b>SEMICONDUCTORS GROUP</b>			
IC301	262 2010 007	IC HD6433388A36F	$\mu$ -com
IC306	262 2008 006	IC CXD2531BR	
IC308	263 0615 902	IC BA15218F	
IC311,312	263 0934 900	IC BA4510F	
D301	276 0438 910	Diode MA151A	
D302	276 0625 901	Diode HVU17	
<b>RESISTORS (Not included Carbon Film <math>\pm</math>5%, 1/4W)</b>			
R301	247 0009 985	Chip Carbon 10kohm 1/10W	RM73B--103J
R302	247 0018 905	Chip Carbon 0ohm 1/10W	RM73B--0R0K
R303	247 0014 967	Chip Carbon 1Mohm 1/10W	RM73B--105J
R304-309	247 0009 985	Chip Carbon 10kohm 1/10W	RM73B--103J
R310	247 0007 945	Chip Carbon 1kohm 1/10W	RM73B--102J
R313	247 0009 985	Chip Carbon 10kohm 1/10W	RM73B--103J
R323	247 0013 971	Chip Carbon 430kohm 1/10W	RM73B--434J
R324	247 0012 998	Chip Carbon 200kohm 1/10W	RM73B--204J
R326	247 0010 974	Chip Carbon 24kohm 1/10W	RM73B--243J
R335,336	247 0007 945	Chip Carbon 1kohm 1/10W	RM73B--102J
R337	247 0010 929	Chip Carbon 15kohm 1/10W	RM73B--153J
R341-343	247 0009 985	Chip Carbon 10kohm 1/10W	RM73B--103J
R344	247 0011 957	Chip Carbon 51kohm 1/10W	RM73B--513J
R345	247 0018 905	Chip Carbon 0ohm 1/10W	RM73B--0R0K
R346	247 0009 985	Chip Carbon 10kohm 1/10W	RM73B--103J
R353	247 0007 945	Chip Carbon 1kohm 1/10W	RM73B--102J
R354	247 0012 927	Chip Carbon 100kohm 1/10W	RM73B--104J
R355-358	247 0005 947	Chip Carbon 150ohm 1/10W	RM73B--151J
R361,362	247 0018 905	Chip Carbon 0ohm 1/10W	RM73B--0R0K
R369,370	247 0011 928	Chip Carbon 39kohm 1/10W	RM73B--393J
R373-376	247 0009 985	Chip Carbon 10kohm 1/10W	RM73B--103J
R380	247 0011 957	Chip Carbon 51kohm 1/10W	RM73B--513J
R381	247 0012 927	Chip Carbon 100kohm 1/10W	RM73B--104J
R384	247 0012 927	Chip Carbon 100kohm 1/10W	RM73B--104J
R387,388	247 0009 901	Chip Carbon 4.7kohm 1/10W	RM73B--472J
R397-399	247 1018 904	Chip Carbon 0ohm 1/8W	RM73B2B0R0K
<b>CAPACITORS GROUP</b>			
C001,002	257 0004 929	Chip Ceramic 68pF/50V	CC73SL1H680J
C003,004	254 4250 929	Electrolytic 100 $\mu$ F/6.3V	CE04W0J101M
C005,006	254 4299 906	Electrolytic 10 $\mu$ F/16V	CE04W1C100M(SRE)
C301	257 0012 966	Chip Ceramic 0.01 $\mu$ F/50V	CK73F1H103Z
C302	257 0002 921	Chip Ceramic 10pF/50V	CC73SL1H100D
C304	257 0014 935	Chip Ceramic 0.1 $\mu$ F/25V	CK73F1E104Z
C305	254 4465 918	Electrolytic 47 $\mu$ F/16V	CE67C1C470M
C306,307	254 4465 905	Electrolytic 22 $\mu$ F/16V	CE67C1C220M
C310	257 0003 920	Chip Ceramic 27pF/50V	CC73SL1H270J
C311	257 3007 936	Chip Metalized 0.047 $\mu$ F/16V	CF73-1C473J(ECWU)
C312	257 3006 924	Chip Metalized 0.01 $\mu$ F/16V	CF73-1C103J(ECHU)
C313	257 3007 949	Chip Metalized 0.068 $\mu$ F/16V	CF73-1C473J(ECWU)
C314	257 0005 986	Chip Ceramic 330pF/50V	CC73SL1H331J
C316	254 4465 918	Electrolytic 47 $\mu$ F/16V	CE67C1C470M
C318	254 4466 904	Electrolytic 0.47 $\mu$ F/50V	CE67C1HR47M
C320	254 4466 904	Electrolytic 0.47 $\mu$ F/50V	CE67C1HR47M

Ref. No.	Parts No.	Parts Name	Remarks
C323	254 4465 905	Electrolytic 22µF/16V	CE67C1C220M
C326	254 4464 906	Electrolytic 100µF/6.3V	CE67C0J101M
C327	257 0003 962	Chip Ceramic 39pF/50V	CC73SL1H390J
C329	257 0007 900	Chip Ceramic 1000pF/50V	CC73SL1H102J
C335,336	257 0014 935	Chip Ceramic 0.1µF/25V	CK73F1E104Z
C337	254 4465 918	Electrolytic 47µF/16V	CE67C1C470M
C338,339	257 0014 935	Chip Ceramic 0.1µF/25V	CK73F1E104Z
C342	257 0012 966	Chip Ceramic 0.01µF/50V	CK73F1H103Z
C343	257 0001 993	Chip Ceramic 7pF/50V	CC73SL1H7R0D
C346	254 4465 918	Electrolytic 47µF/16V	CE67C1C470M
C348	254 4464 906	Electrolytic 100µF/6.3V	CE67C0J101M
C350	257 0014 935	Chip Ceramic 0.1µF/25V	CK73F1E104Z
C351,352	254 4471 902	Electrolytic 0.47µF/50V	CE67C1V4R7M
C353	257 0014 935	Chip Ceramic 0.1µF/25V	CK73F1E104Z
C354	254 4471 902	Electrolytic 0.47µF/50V	CE67C1V4R7M
C355	257 0014 935	Chip Ceramic 0.1µF/25V	CK73F1E104Z
C356	257 0012 966	Chip Ceramic 0.01µF/50V	CK73F1H103Z
C357,358	257 0007 942	Chip Ceramic 1500pF/50V	CC73SL1H152J
C372	257 2002 916	Chip Tantal 6.8µF/V	CS77B-6R8M
C383	257 0014 935	Chip Ceramic 0.1µF/25V	CK73F1E104Z
<b>OTHER GROUP</b>			
		(P.W.Board)	(1)
L304	235 0107 923	LEM4532T1R2M 1.2µH	1
L305	235 0107 910	LEM4532TR68M 6.8µH	1
CN301-303	205 0896 903	18P FFC Base	3
CN306	205 0895 904	5P KR-PH Conn. Base (T)	1
CN307	205 0894 963	6P ZH-ZR Conn. Base (T)	1
<b>PATTERN SIDE</b>			
<b>SEMICONDUCTORS GROUP</b>			
IC302	262 1965 904	IC CXA1380N	
IC303	262 2100 001	IC CXD2525R	
IC304	262 2015 002	IC CXD2526AR	
IC305	262 2027 906	IC SM514400A-70SJ-ADR1	
IC309	262 1953 903	IC TC7WU04F	
IC310	262 2016 904	IC AK5345-VS-E1	
IC313	262 2018 902	IC TC4S30F	
IC314	262 2019 901	IC TC7W74F	
D304	276 0438 910	Diode MA151A	
<b>RESISTORS GROUP (Not included Carbon Film ±5% 1/4W)</b>			
R311,312	247 0009 985	Chip Carbon 10kohm 1/10W	RM73B-103J
R314	247 0009 985	Chip Carbon 10kohm 1/10W	RM73B-103J
R317-320	247 0009 985	Chip Carbon 10kohm 1/10W	RM73B-103J
R321	247 0012 985	Chip Carbon 180kohm 1/10W	RM73B-184J
R322	247 0014 967	Chip Carbon 1Mohm 1/10W	RM73B-105J
R325	247 0014 967	Chip Carbon 1Mohm 1/10W	RM73B-105J
R327	247 0012 927	Chip Carbon 100kohm 1/10W	RM73B-104J
R328	247 0009 985	Chip Carbon 10kohm 1/10W	RM73B-103J
R329	247 0007 945	Chip Carbon 1kohm 1/10W	RM73B-102J
R330	247 0008 960	Chip Carbon 3.3kohm 1/10W	RM73B-332J

Ref. No.	Parts No.	Parts Name	Remarks
R331,332	247 0009 985	Chip Carbon 10kohm 1/10W	RM73B-103J
R333	247 0014 967	Chip Carbon 1Mohm 1/10W	RM73B-105J
R334	247 0007 945	Chip Carbon 1kohm 1/10W	RM73B-102J
R338	247 0010 929	Chip Carbon 15kohm 1/10W	RM73B-153J
R339	247 0007 903	Chip Carbon 680ohm 1/10W	RM73B-681J
R340	247 0009 985	Chip Carbon 10kohm 1/10W	RM73B-103J
R365,366	247 0009 985	Chip Carbon 10kohm 1/10W	RM73B-103J
R377,378	247 0009 901	Chip Carbon 4.7kohm 1/10W	RM73B-472J
R383	247 0012 927	Chip Carbon 100kohm 1/10W	RM73B-104J
R385,386	247 0012 927	Chip Carbon 100kohm 1/10W	RM73B-104J
R389-394	247 0012 927	Chip Carbon 100kohm 1/10W	RM73B-104J
<b>CAPACITORS GROUP</b>			
C303	257 0002 921	Chip Ceramic 10pF/50V	CC73SL1H100D
C308	257 0009 966	Chip Ceramic 4700pF/50V	CK73B1H472K
C309	257 0009 924	Chip Ceramic 2200pF/50V	CK73B1H222K
C315	257 0014 935	Chip Ceramic 0.1µF/25V	CK73F1E104Z
C317	257 0012 966	Chip Ceramic 0.01µF/50V	CK73F1H103Z
C319	257 0006 927	Chip Ceramic 470pF/50V	CC73SL1H471J
C321	257 3006 924	Chip Metalized 0.01µF/16V	CF73-1C103J(ECHU)
C322	257 0014 935	Chip Ceramic 0.1µF/25V	CK73F1E104Z
C324,325	257 0014 935	Chip Ceramic 0.1µF/25V	CK73F1E104Z
C328	257 0007 900	Chip Ceramic 1000pF/50V	CC73SL1H102J
C330	257 0010 942	Chip Ceramic 0.022µF/50V	CK73F1H223Z
C332	257 3007 910	Chip Metalized 0.1µF/16V	CF73-1C104J(ECWU)
C333	257 0004 961	Chip Ceramic 100pF/50V	CC73SL1H101J
C334	257 0014 935	Chip Ceramic 0.1µF/25V	CK73F1E104Z
C344	257 0001 977	Chip Ceramic 5pF/50V	CC73SL1H5R0C
C345	257 0014 935	Chip Ceramic 0.1µF/25V	CK73F1E104Z
C349	257 0014 935	Chip Ceramic 0.1µF/25V	CK73F1E104Z
C361,362	257 2002 945	Chip Tantal 22µF/V	CS77B-220M
C363	257 2002 916	Chip Tantal 6.8µF/V	CS77B-6R8M
C364,365	257 0014 935	Chip Ceramic 0.1µF/25V	CK73F1E104Z
C370	257 0007 900	Chip Ceramic 1000pF/50V	CC73SL1H102J
C371	257 0014 935	Chip Ceramic 0.1µF/25V	CK73F1E104Z
C373,374	257 0004 961	Chip Ceramic 100pF/50V	CC73SL1H101J
C375	257 0014 935	Chip Ceramic 0.1µF/25V	CK73F1E104Z
C382	257 0014 935	Chip Ceramic 0.1µF/25V	CK73F1E104Z
<b>OTHER GROUP</b>			
L303	235 0107 907	LEM4532T2R2M 2.2µH	1
X301	399 0237 906	Ceramic Resonator	CSACS16.00MX040
X302	399 0239 904	Crystal Resonator	45.1584 MHz
CN304	205 0668 047	21P FFC Conn. Base	1
	461 0415 007	Rubber Sheet	2

2U-2705A AUDIO UNIT

Ref. No.	Parts No.	Parts Name	Remarks
<b>SEMICONDUCTORS GROUP</b>			
IC101	262 2011 103	IC HD6433388A42F	µ-com
IC102	262 1647 905	IC MN1382-S	
IC103	499 0264 004	IC GP1U571	Remocon Sensor
IC104	262 1954 902	IC M66004FP	
IC601	263 0693 005	IC M5290P	
IC602,603	268 0073 905	IC ICP-N15	IC Protector 15V
IC604	268 0074 904	IC ICP-N20	IC Protector 20V
IC605-607	268 0073 905	IC ICP-N15	IC Protector 15V
IC608	263 0936 005	IC PQ05RA1	
IC609	263 0432 004	IC NJM78L05A	Regulator +5V
IC610	262 1765 900	IC SM5841BS	
IC611,612	262 1409 004	IC :PCM61P-L	
IC613	263 0615 902	IC BA15218F	
IC615	262 1953 903	IC TC7WU04F	
TR102	273 0384 900	Chip Transistor 2SC2412K(S)	
TR103,104	271 0238 908	Chip Transistor 2SA1037K(S/R)	
TR105	269 0102 905	Chip Transistor DTC124EK	Built in Resistor
TR601	274 0136 009	Transistor 2SD1913	
TR602	272 0093 007	Transistor 2SB1274	
TR604	269 0014 909	Transistor DTA124XS	Built in Resistor
TR605	269 0020 906	Transistor DTC114ES	Built in Resistor
TR606,607	274 0160 907	Transistor 2SD2144STPU	
TR608	271 0192 905	Transistor 2SA933S(S)	
TR609,610	269 0020 906	Transistor DTC114ES	Built in Resistor
TR611,612	274 0160 907	Transistor 2SD2144STPU	
D101-103	276 0432 903	Diode 1SS270A	
D601-604	276 0589 005	Diode RM10	
D605-607	276 0553 905	Diode 1SR35-200A	
D609	276 0432 903	Diode 1SS270A	
D610,611	276 0644 924	Zener Diode MTZJ8.2A	8.2V
D612,613	276 0553 905	Diode 1SR35-200A	
D614	276 0645 965	Zener Diode MTZJ33A	33V
D615	276 0635 904	Zener Diode MTZJ7.5C	7.5V
D616	276 0553 905	Diode 1SR35-200A	
<b>RESISTORS GROUP</b>			
R101	247 0018 905	Chip Carbon 0ohm 1/10W	RM73B-0R0K
R103,104	247 0009 985	Chip Carbon 10kohm 1/10W	RM73B-103J
R105	247 0007 945	Chip Carbon 1kohm 1/10W	RM73B-102J
R106	247 0009 985	Chip Carbon 10kohm 1/10W	RM73B-103J
R108	247 0009 985	Chip Carbon 10kohm 1/10W	RM73B-103J
R112	247 0009 985	Chip Carbon 10kohm 1/10W	RM73B-103J
R114,115	247 0009 985	Chip Carbon 10kohm 1/10W	RM73B-103J
R117-119	247 0009 985	Chip Carbon 10kohm 1/10W	RM73B-103J
R122	247 0007 945	Chip Carbon 1kohm 1/10W	RM73B-102J
R123	247 0005 947	Chip Carbon 150ohm 1/10W	RM73B-151J
R124	247 0005 963	Chip Carbon 180ohm 1/10W	RM73B-181J
R125	247 0007 945	Chip Carbon 1kohm 1/10W	RM73B-102J
R126	247 0005 947	Chip Carbon 150ohm 1/10W	RM73B-151J
R127	247 0005 963	Chip Carbon 180ohm 1/10W	RM73B-181J
R128	247 0007 945	Chip Carbon 1kohm 1/10W	RM73B-102J
R129	247 0005 947	Chip Carbon 150ohm 1/10W	RM73B-151J
R130-132	247 0009 985	Chip Carbon 10kohm 1/10W	RM73B-103J
R133,134	247 0010 961	Chip Carbon 22kohm 1/10W	RM73B-223J
(C653)	247 0018 905	Chip Carbon 0ohm 1/10W	RM73B-0R0K
(C672)	247 0018 905	Chip Carbon 0ohm 1/10W	RM73B-0R0K
VR601,602	211 6077 938	Semi Fixed Resistor 100kohm	V06PB104
VR603	211 6077 909	Semi Fixed Resistor 1kohm	V06PB102
VR701	211 0833 000	Variable Resistor 20kohm	
<b>CAPACITORS GROUP</b>			
C007,008	253 1120 907	Ceramic Cap. 4700pF/50V	CK45B1H472K
C101,102	257 0001 977	Chip Ceramic 5pF/50V	CC73SL1H5R0C
C103	254 4299 906	Electrolytic 10µF/16V	CE04W1C100M(SRE)
C104	257 0010 900	Chip Ceramic 0.01µF/50V	CK73B1H103K
C105	257 0014 935	Chip Ceramic 0.1µF/25V	CK73F1E104Z
C106	254 4360 000	Electrolytic 220µF/10V	CE04W1A221M(SRA)
C108,109	257 0007 900	Chip Ceramic 1000pF/50V	CC73SL1H102J
C110,111	257 0014 935	Chip Ceramic 0.1µF/25V	CK73F1E104Z
C112	257 0004 961	Chip Ceramic 100pF/50V	CC73SL1H101J
C113	257 1015 920	Chip Ceramic 0.1µF/50V	CK73F1H104Z

Ref. No.	Parts No.	Parts Name	Remarks
R135	247 0005 989	Chip Carbon 220ohm 1/10W	RM73B-221J
R136-139	247 0010 961	Chip Carbon 22kohm 1/10W	RM73B-223J
R140	247 0010 987	Chip Carbon 27kohm 1/10W	RM73B-273J
R141	247 0005 963	Chip Carbon 180ohm 1/10W	RM73B-181J
R142	247 0007 945	Chip Carbon 1kohm 1/10W	RM73B-102J
R143	247 0005 947	Chip Carbon 150ohm 1/10W	RM73B-151J
R144,145	247 0009 985	Chip Carbon 10kohm 1/10W	RM73B-103J
R146	247 0011 944	Chip Carbon 47kohm 1/10W	RM73B-473J
R147	247 0009 985	Chip Carbon 10kohm 1/10W	RM73B-103J
R601,602	247 0009 901	Chip Carbon 4.7kohm 1/10W	RM73B-472J
R603	247 0007 945	Chip Carbon 1kohm 1/10W	RM73B-102J
R604	247 0004 922	Chip Carbon 47ohm 1/10W	RM73B-470J
R605	247 0009 985	Chip Carbon 10kohm 1/10W	RM73B-103J
R606	247 0007 945	Chip Carbon 1kohm 1/10W	RM73B-102J
R607	247 0012 998	Chip Carbon 200kohm 1/10W	RM73B-204J
R609	247 0006 962	Chip Carbon 470ohm 1/10W	RM73B-471J
R610-616	247 0007 945	Chip Carbon 1kohm 1/10W	RM73B-102J
R617,618	247 0012 998	Chip Carbon 200kohm 1/10W	RM73B-204J
R619,620	247 0013 984	Chip Carbon 470kohm 1/10W	RM73B-474J
R621,622	247 0014 967	Chip Carbon 1Mohm 1/10W	RM73B-105J
R623,624	247 0007 929	Chip Carbon 820ohm 1/10W	RM73B-821J
R625,626	247 0011 944	Chip Carbon 47kohm 1/10W	RM73B-473J
R627,628	247 0010 990	Chip Carbon 30kohm 1/10W	RM73B-303J
R629,630	247 0007 903	Chip Carbon 680ohm 1/10W	RM73B-681J
R631,632	247 0008 944	Chip Carbon 2.7kohm 1/10W	RM73B-272J
R633,634	247 0010 990	Chip Carbon 30kohm 1/10W	RM73B-303J
R635,636	247 0008 999	Chip Carbon 4.3kohm 1/10W	RM73B-432J
R637,638	247 0008 986	Chip Carbon 3.9kohm 1/10W	RM73B-392J
R639,640	247 0010 945	Chip Carbon 18kohm 1/10W	RM73B-183J
R641,642	247 0004 948	Chip Carbon 56ohm 1/10W	RM73B-560J
R643,644	247 0008 944	Chip Carbon 2.7kohm 1/10W	RM73B-272J
R648,649	247 0005 905	Chip Carbon 100ohm 1/10W	RM73B-101J
R650	247 0011 944	Chip Carbon 47kohm 1/10W	RM73B-473J
R651	247 0012 927	Chip Carbon 100kohm 1/10W	RM73B-104J
R652	247 0008 960	Chip Carbon 3.3kohm 1/10W	RM73B-332J
R653	247 0008 915	Chip Carbon 2kohm 1/10W	RM73B-202J
R662	247 0009 985	Chip Carbon 10kohm 1/10W	RM73B-103J
R663	247 0008 957	Chip Carbon 3kohm 1/10W	RM73B-302J
(C653)	247 0018 905	Chip Carbon 0ohm 1/10W	RM73B-0R0K
(C672)	247 0018 905	Chip Carbon 0ohm 1/10W	RM73B-0R0K
VR601,602	211 6		

Ref. No.	Parts No.	Parts Name	Remarks	Ref. No.	Parts No.	Parts Name	Remarks	Q'ty
C114-116	257 0005 931	Chip Ceramic 200pF/50V	CC73SL1H201J	CB102	205 0892 017	18P FFC Base (P=1)		1
C117	257 0014 935	Chip Ceramic 0.1μF/25V	CK73F1E104Z	CB803	205 0668 047	21P FFC Conn. Base		1
C603,604	257 0014 935	Chip Ceramic 0.1μF/25V	CK73F1E104Z					
C605,606	254 4250 932	Electrolytic 220μF/6.3V	CE04W0J221M					
C607,608	254 4260 964	Electrolytic 3.3μF/50V	CE04W1H3R3M					
C611,612	254 4254 941	Electrolytic 100μF/16V	CE04W1C101M					
C613,614	257 0014 935	Chip Ceramic 0.1μF/25V	CK73F1E104Z	CC701	203 8280 081	5P KR-DA Conn. Cord		1
C615,616	254 4254 941	Electrolytic 100μF/16V	CE04W1C101M	CC702	203 8280 049	5P KR-DA Conn. Cord		1
C617	254 4254 954	Electrolytic 220μF/16V	CE04W1C221M	CB607	203 5029 009	3P KR-DA Conn. Cord		1
C621	257 0014 935	Chip Ceramic 0.1μF/25V	CK73F1E104Z	CB606	203 5029 012	3P KR-DA Conn. Cord		1
C622	257 0010 900	Chip Ceramic 0.01μF/50V	CK73B1H103K	CC101	203 5030 001	3P KR-DA Conn. Cord		1
C623	254 4254 941	Electrolytic 100μF/16V	CE04W1C101M	CB602	204 2697 000	9P PH-SAN Conn. Cord		1
C624-631	257 0014 935	Chip Ceramic 0.1μF/25V	CK73F1E104Z		204 0457 006	6P ZR Conn. Cord		1
C632,633	254 4254 941	Electrolytic 100μF/16V	CE04W1C101M					
C634,635	257 0006 969	Chip Ceramic 680pF/50V	CC73SL1H681J		205 0452 004	Style Pin		2
C636,637	257 0009 979	Chip Ceramic 5600pF/50V	CK73B1H562K					
C638,639	254 4254 909	Electrolytic 10μF/16V	CE04W1C100M		461 0415 007	Rubber Sheet		1
C640,641	257 0007 900	Chip Ceramic 1000pF/50V	CC73SL1H102J					
C642,643	257 0014 935	Chip Ceramic 0.1μF/25V	CK73F1E104Z					
C654	257 0014 935	Chip Ceramic 0.1μF/25V	CK73F1E104Z					
C655	254 4262 946	Electrolytic 47μF/63V	CE04W1J330M					
C656	254 4260 980	Electrolytic 10μF/50V	CE04W1H100M					
C657,658	254 4261 905	Electrolytic 33μF/50V	CE04W1H330M					
C659	254 4254 912	Electrolytic 22μF/16V	CE04W1C220M					
C660	257 0014 935	Chip Ceramic 0.1μF/25V	CK73F1E104Z					
C663	254 4403 705	Electrolytic 6800μF/25V	CE04W1E682MC(SMG)					
C665	254 4254 792	Electrolytic 2200μF/16V	CE04W1C222MC					
C667	254 4403 705	Electrolytic 6800μF/25V	CE04W1E682MC(SMG)					
C669,670	257 0010 900	Chip Ceramic 0.1μF/50V	CK73B1H103KT					
C673	257 0014 935	Chip Ceramic 0.1μF/25V	CK73F1E104Z					
<b>OTHER GROUP</b>								
		(P.W.Board)						(1)
L601-604	235 0049 007	Beads Inductor						4
SW101-103	212 5604 910	Tact Switch						3
SW104	212 4746 002	Tact Switch (SKHLAA)						1
SW105-111	212 5604 910	Tact Switch						7
X101	399 0237 906	Ceramic Resonator	CSACS16.00MX040					1
FL101	393 8019 005	FL Tube FIP14XM1CA						1
	461 0862 003	FL Spacer						2
	412 3850 104	Headphone Bracket						1
JK601	204 8266 008	4P Pin Jack (S-GND)						1
JK603,604	204 8421 005	Mini Jack						2
JK605	269 0098 006	Optical Output GP1F32T						1
JK606	269 0097 007	Optical Input GP1F32R						1
JK607	204 8372 002	Mini Jack (3.5)						1
CB610	205 0581 001	2P VH Conn. Base						1
CB601	205 0343 032	3P Conn. Base (KR-PH)						1
CB608	205 0321 038	3P Conn. Base (Red)						1
CB605	205 0323 036	3P Conn. Base (Black)						1
CB604	205 0321 054	5P Conn. Base(Red)						1

# WIRING DIAGRAM

1      2      3      4      5      6

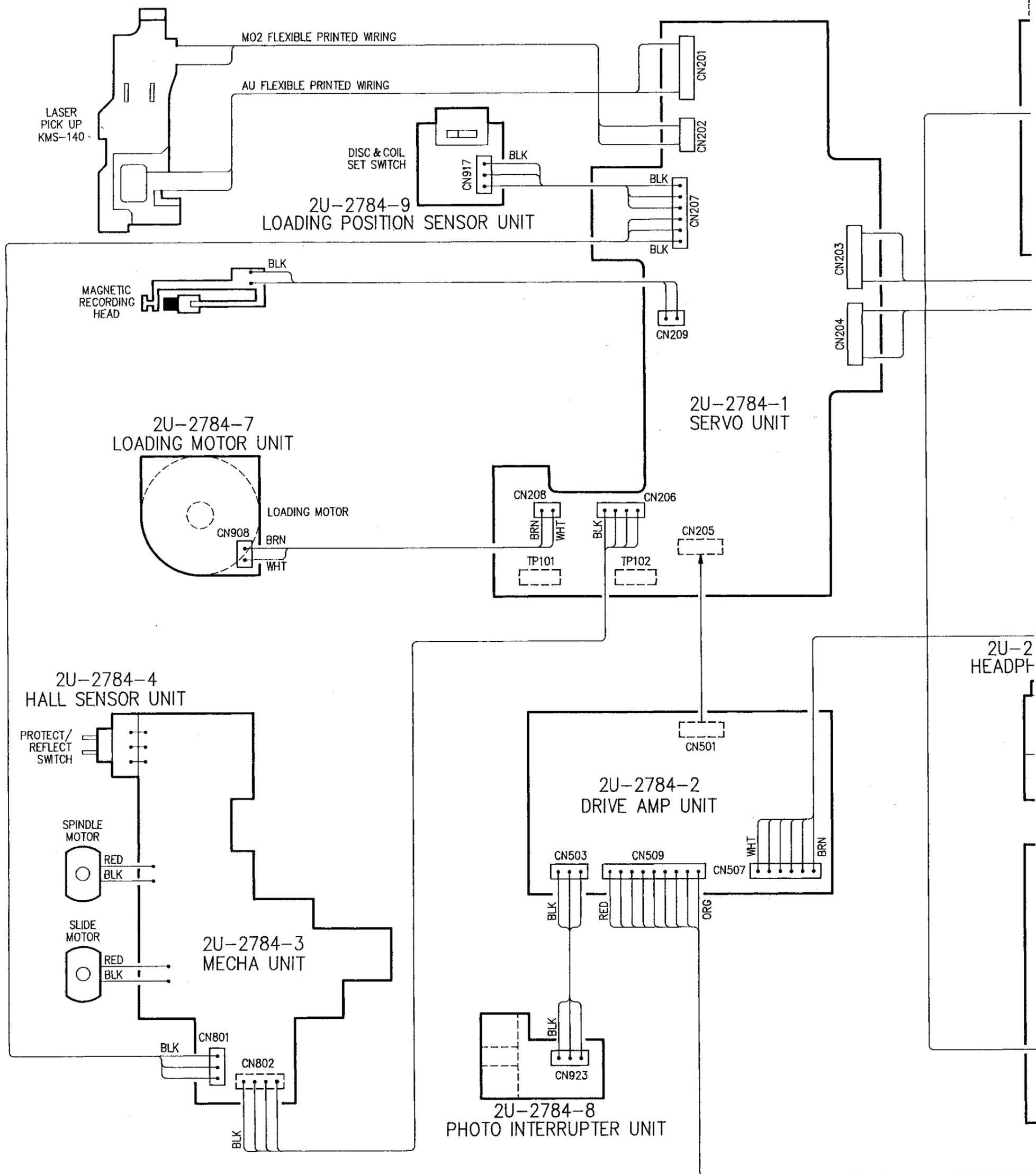

7

8

9

10

11

A

B

C

D

E

F

G

H

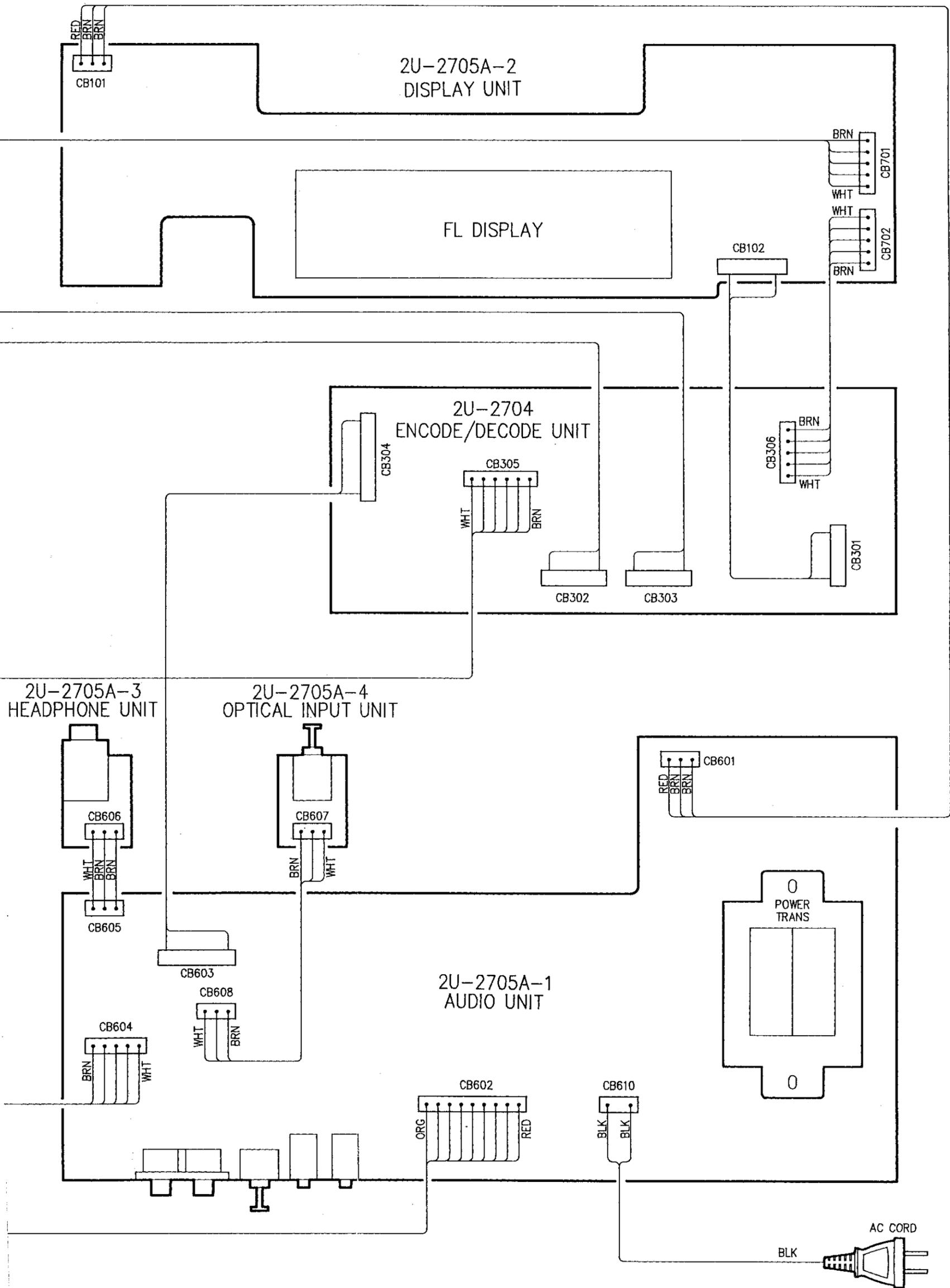



# EXPLODED VIEW OF CHASSIS AND CABINET

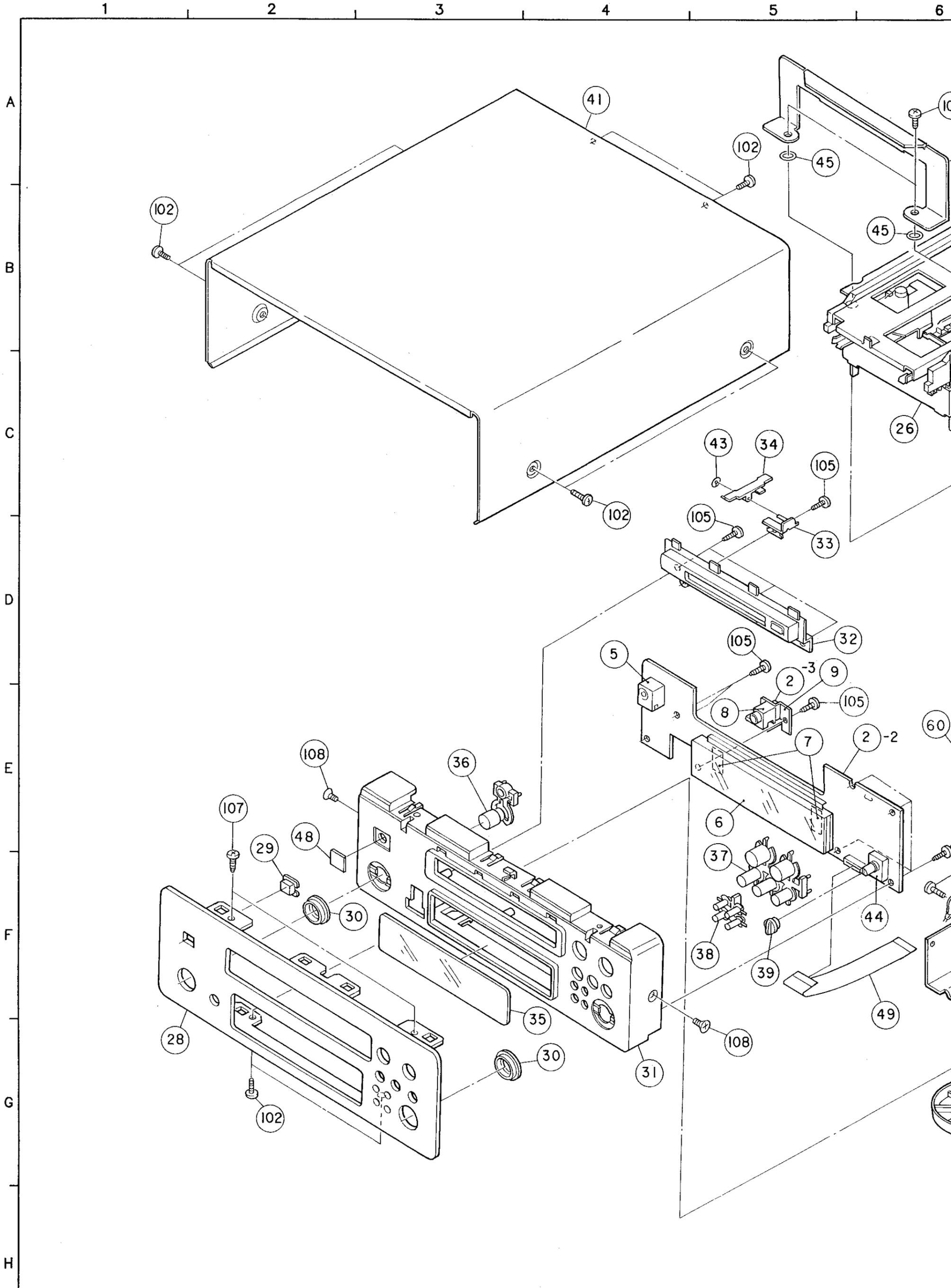

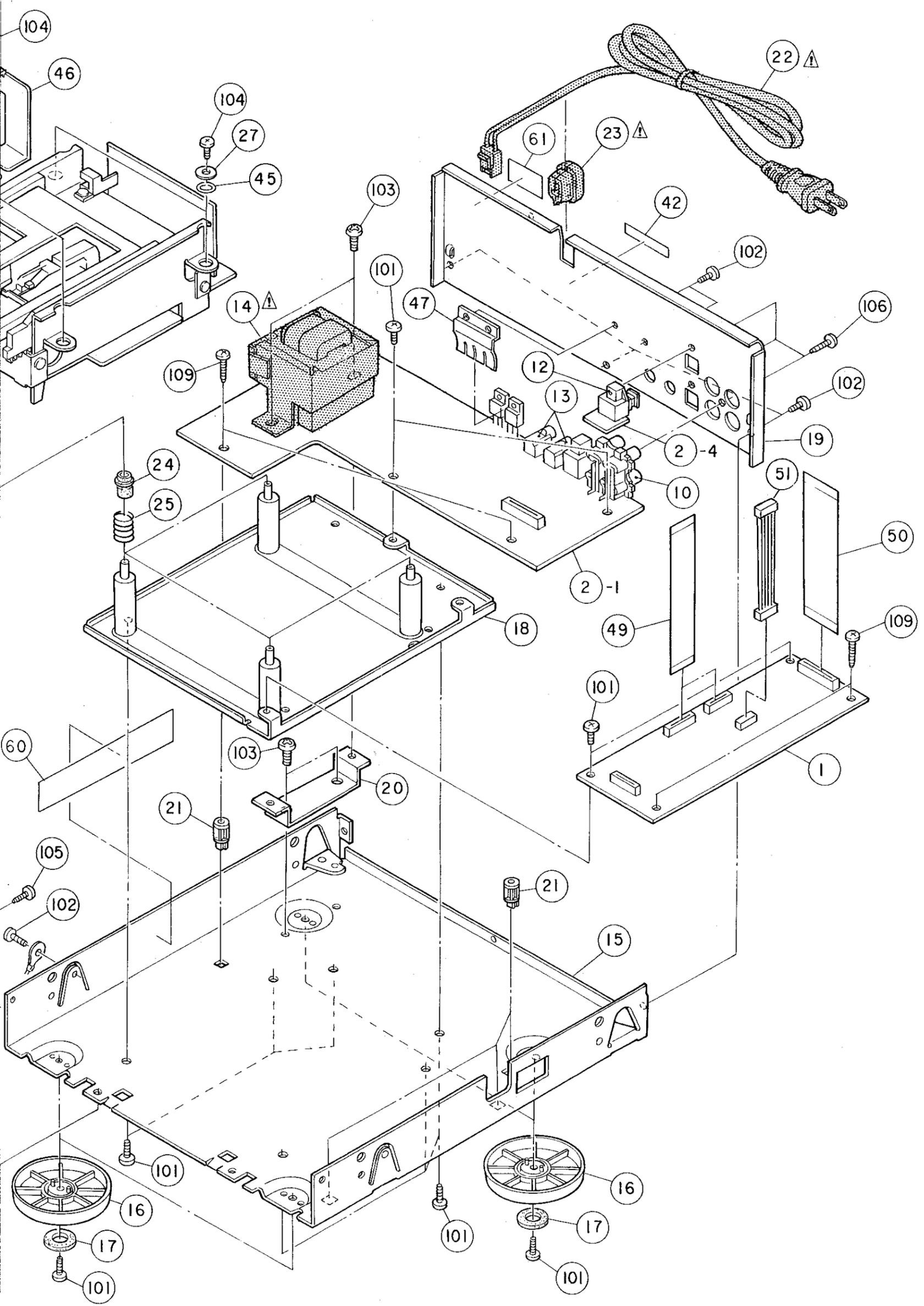

**PARTS LIST OF EXPLODED VIEW**

Ref. No.	Parts No.	Parts Name	Remarks	Q'ty	Ref. No.	Parts No.	Parts Name	Remarks	Q'ty
1	2U- 2704	Encord/Decord Unit Ass'y		1s	<b>SCREWS</b>				
2	2U- 2705	Audio Unit Ass'y		1s	101	473 7002 018	Tapping Screw (S)3x8		14
2-1	—	Audio Unit		(1)	102	473 7015 018	Tapping Screw (S)3x8	Black	14
2-2	—	Display Unit		(1)	103	473 7026 007	Tapping Screw (S)4x6	Black	4
2-3	—	Head Phone Unit		(1)	104	471 3303 016	Bind Screw 3x6		4
2-4	—	Optical Input Unit		(1)	105	473 7505 007	Tapping Screw (P)2.6x8		11
3	254 4254 792	Chemicon 2200µF/16V	C665	1	106	477 0064 107	Fixing Screw		3
4	254 4403 705	Chemicon 6800µF/25V	C663,667	2	107	473 7500 015	Tapping Screw (P)3x8		2
5	499 0264 004	Remocon Sensor GP1U571	IC103	1	108	473 7003 020	F.H.Tapping Screw (S)3x6	Black	2
6	393 8019 005	F.L. Tube FIP14XM1DA	FL101	1	109	473 7508 046	Tapping Screw (P)3x16	Black	4
7	461 0862 003	FL Spacer		2	110				
8	204 8373 002	Mini Jack (3.5)	JK607	1	<b>PACKING &amp; ACCESSORIES (Not included EXPLODED VIEW)</b>				
9	412 3850 104	Head Phohe Bracket		1	201	505 0102 089	Stylen Paper		1
10	204 8266 008	4 P Pin Jack (S-GND)	JK601	1	202	503 1115 202	Cushion		1
11	269 0098 006	Optical Output GP1F32T	JK605	1	203	GEN 2860	Envelope Sub. Ass'y		1s
12	269 0097 007	Optical input GP1F32R	JK606	1	203-1	505 8006 019	Envelope		(1)
13	204 8421 005	Mini Jack	JK603,604	2	203-2	511 2669 004	Inst. Manual	RC177	(1)
14	233 6127 008	Power Trans		1	203-3	499 0279 002	Remote Control		(1)
15	411 1277 045	Main Chassis		1	203-4	203 2360 004	2 P Pin Cord		(2)
16	104 0273 113	*Foot		4	203-5	203 5013 015	3 P Mini Plug Cord		(1)
17	461 0655 003	Rubber Pad		4	204	503 1116 201	Top Cushion		1
18	412 3848 307	Mech. Bracket Ass'y		1	205	501 1810 022	Carton Case		1
19	105 1131 011	*Rear Panel		1	206				
20	412 3847 007	Trans Bracket		1					
21	412 3548 005	P.W.B. Catcher		4					
22	206 2089 106	AC Cord		1					
23	445 0056 008	Cord Bush		1					
24	462 0083 005	H. Dumper		4					
25	463 0785 005	Floating Spring		4					
26	FG9 0	MD Mech. Unit		1					
27	477 0018 001	Washer (P-87)		2					
28	144 2391 208	Front Panel		1					
29	143 0874 106	RemoconWindow		1					
30	146 9294 126	*Knob Ring (A)		2					
31	146 1515 007	*Inner Panel		1					
32	146 1516 103	Front ESC. Ass'y		1					
33	421 0707 005	Door Lever Bracket Ass'y		1					
34	433 0605 100	Door Lever		1					
35	143 0872 001	Window		1					
36	113 1654 104	Power Button Ass'y		1					
37	113 9276 128	*Button (5 Key)		1					
38	113 9277 114	*Button (4 Key)		1					
39	112 9100 110	*Knob (Fuji Type)		1					
40	445 0033 005	Wire Clamp Band		2					
41	102 0547 034	*Top Cover Ass'y		1					
42	513 1581 011	Serial No. Sheet		1					
43	475 1157 059	SlitWasher T0.5		1					
44	211 0833 000	Variable Resistor 20kohm	VR701	1					
45	462 0142 001	O Ring (P9)		4					
46	412 3902 007	Stopper Bracket		1					
47	412 9371 001	Spring Plate		1					
48	143 0901 008	Remocon Sheet		1					
49	009 0103 001	18 P FF Cable		3					
50	009 0079 025	21 P FF Cable		1					
51	204 0457 006	6P Wire Ass'y		1					
52	513 2065 002	Laser Caution		1					
60	513 0985 003	Inst. Label		1					
61	—	—		1					
62	—	—		1					

**NOTE FOR PARTS LIST**

- Part indicated with the mark "◎" are not always in stock and possibly to take a long period of time for supplying, or in some case supplying of part may be refused.
- When ordering of part, clearly indicate "1" and "1" (1) to avoid mis-supplying.
- Ordering part without stating its part number can not be supplied.
- Part indicated with the mark "★" is not illustrated in the exploded view.

**WARNING:**

Parts marked with this symbol  have critical characteristics. Use ONLY replacement parts recommended by the manufacturer.

## MD MECHANISM (FG-90)

### DISASSEMBLY

(For reassembling, do reverse manner as to disassembling)

#### 1. Mechanism Base

(In order easier for performing work, move optical pick-up outer circle)

- ① Remove screw securing the head arm.
- ② Detach the head arm in the arrow direction.

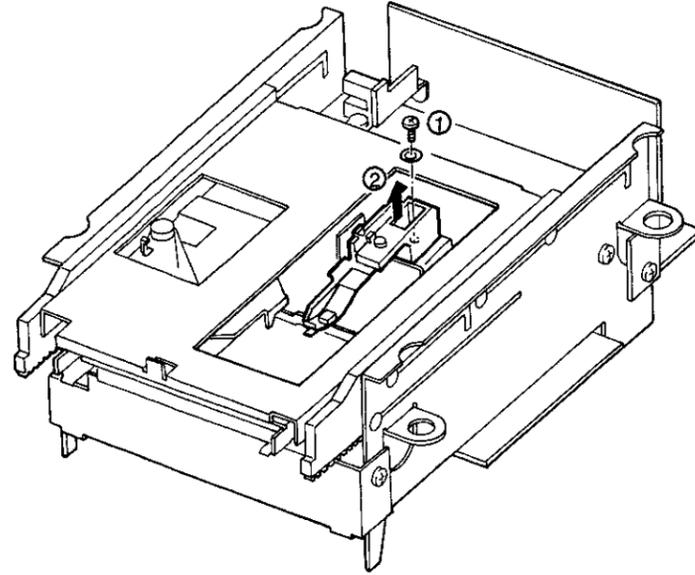

- ③ Remove 4 screws tightening the servo P.W.B.
- ④ Detach the servo P.W.B. in the arrow direction.

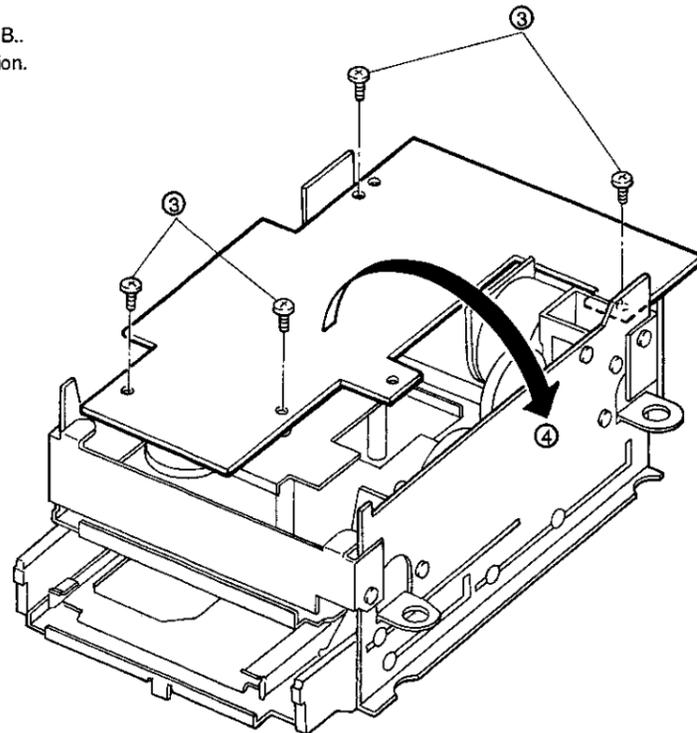

- ⑤ Short circuit the short land on the flexible cable of optical pick-up with a solder and detach the servo P.W.B.
- ⑥ Remove 4 screws fixing the Mechanism Base.
- ⑦ Detach the Mechanism Base in the arrow direction.

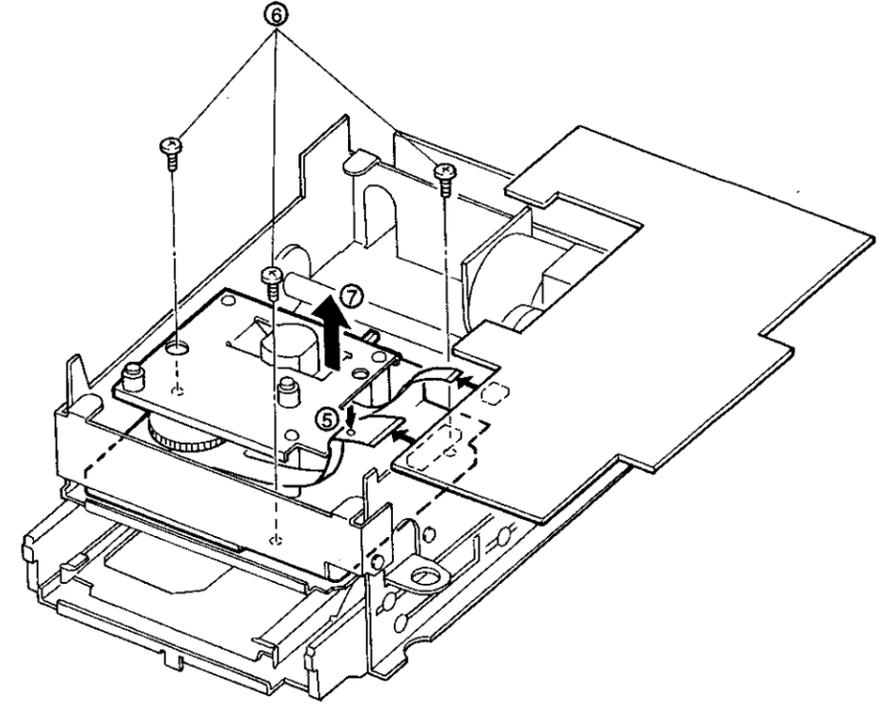

## 2. Optical Pick-up

(Be careful and not to apply any stress to the extruded objects on the turntable, etc. when performing work.)

- ⑧ Remove 4 screws mounting the gear base plate.)
- ⑨ Detach the gear base plate toward arrow direction.
- ⑩ Remove 3 screws securing the head guide bracket.
- ⑪ Detach the head guide bracket in the arrow direction.

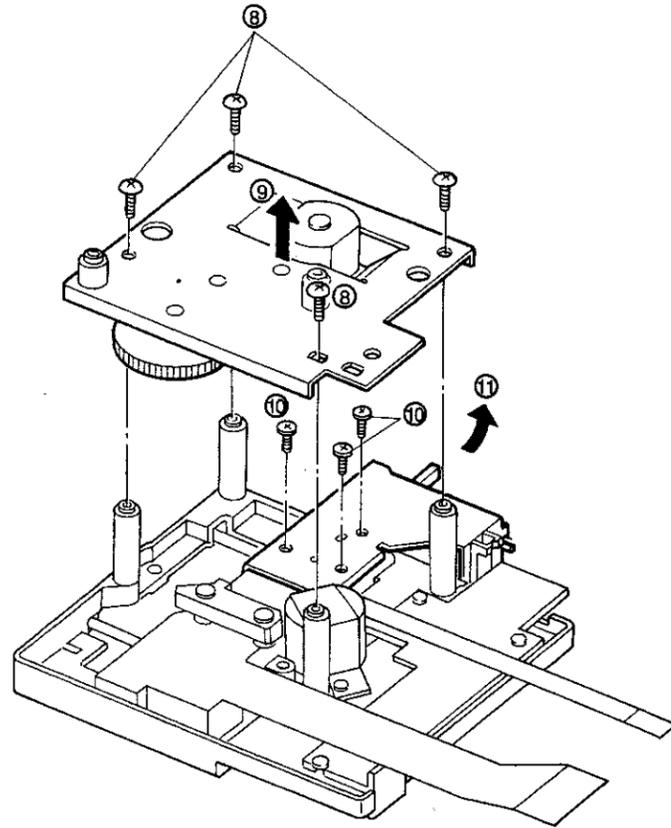

- ⑫ Remove screw mounting the shaft.
- ⑬ Remove screw securing the shaft bracket.
- ⑭ Detach the shaft bracket in the arrow direction.
- ⑮ Pull out the shaft in the arrow direction.
- ⑯ Disassemble the Optical Pick-up toward arrow direction.

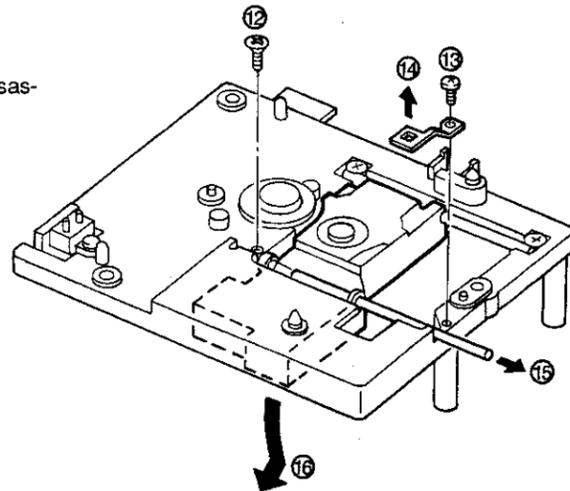

**Note:** Not touch the Optical Pick-up terminal when disassembling the Optical Pick-up.

## 3. Spindle Motor

- ⑰ Remove 3 screws fastening the mechanism P.W.B..
- ⑱ Remove solder in the portion indicated with arrow.
- ⑲ Detach the mechanism P.W.B. in the arrow direction.
- ⑳ Remove 2 screws fixing the Spindle Motor bracket.
- ㉑ Detach the Spindle Motor bracket in the arrow direction.
- ㉒ Disassemble the spindle Motor in the arrow direction.

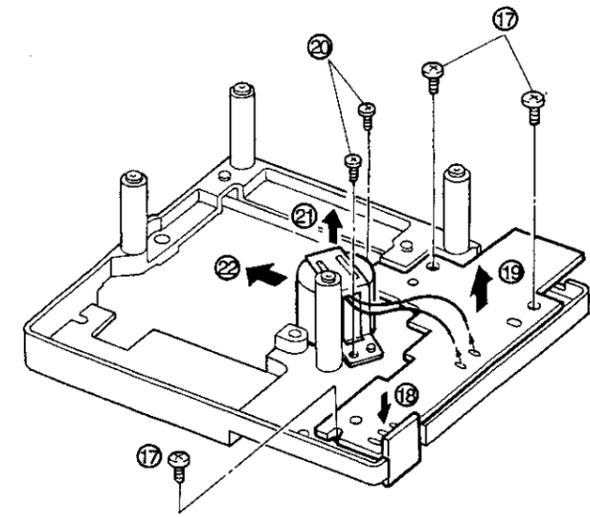

## 4. Mounting Position Adjustment of Magnetic Head

- Be sure to adjust the mounting position of Magnetic Head or optical Pick-up whenever it is replaced.
- In order easier to adjust the mounting position, move the Optical Pick-up in the center position, then adjust it.
- ㉓ Temporarily fasten the head arm with a screw.
- ㉔ Move the slide rack (L) in the arrow direction and load a transparent adjustment disc on the turntable.
- ㉕ Adjust the position of Magnetic Head so that the center of Pick-up object lens and the Head coincide in the center when viewed from the above of mechanism and secure with screw ㉓.

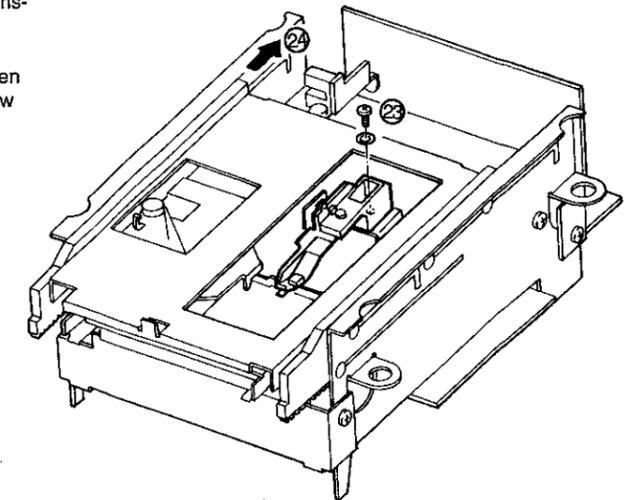
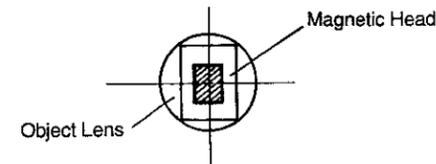

PARTS LIST OF EXPLODED VIEW FG-90

Ref. No.	Parts No.	Parts Name	Remarks	Q'ty	Ref. No.	Parts No.	Parts Name	Remarks	Q'ty
1	2U-2784	Mecha. Servo Unit Ass'y		1s	50	441 1601 007	Wire Holder		1
1-1	—	Servo Unit		(1)	51	217 0196 004	Spindle Motor		(1)
1-2	—	Drive Amp. Unit		(1)	52	421 0704 008	Turn Table		(1)
1-3	—	Mecha Sw. Unit		(1)	53	463 0786 004	Turn Table Spring		(1)
1-4	—	Hall Sensor Unit		(1)	54	421 0705 104	Slide Ring		(1)
1-5	—	—			55	421 0706 103	Stopper Ring		(1)
1-6	—	—			56	341 0047 003	Clamp Magnet		(1)
1-7	—	Loading Motor Unit		(1)	57	421 3840 004	Spindle Motor Bracket		1
1-8	—	Photo Inter. Unit		(1)	58	—	Motor Gear Ass'y		(1)
1-9	—	Loading Position Sensor Unit		(1)	59	—	Gear Base Plate Ass'y		(1)
2	212 1111 902	Push Switch (SPVC21)T.	SW801	1	60	475 1142 006	Washer		(2)
3	212 1072 009	Detector Switch (SSCF21)	SW903	1	61	—	Slide Gear (A)		(1)
4	212 1122 001	Disc Sens. Swith	SW802	1	62	—	Slide Gear (B)		(1)
5	269 0154 005	Interruptor (ON1023)	SW914	1	63	—	Slide Gear (C)		(1)
6	GEN 2847	Motor Pulley Sub. Ass'y	included 7	1s	64	475 1157 059	SlitWasher T0.5		(5)
7	217 0181 006	Loading Motor		(1)	65	342 0017 007	Magnet Head (RF320-74F)		1
8	411 1295 108	Center Chassis		1	66	441 1595 003	Head Arm		1
9	411 1296 107	Chassis (L) Ass'y		1	67	475 1142 019	Washer		1
10	412 3846 008	Load. Motor Bracket		1	68	475 1000 009	Washer φ2		1
11	424 0231 004	Cam Gear		1	69	GEN 2855	Turn Table Sub. Ass'y	included 51-56	1s
12	433 0603 102	Cam Lever		1	70	412 3804 215	SL Base Gen. Ass'y	included 58-64	1s
13	424 0229 003	Loading Gear (A)		1	71	445 0106 000	Mini Clamp		1
14	424 0230 005	Loading Gear (B)		1	72				
15	424 0228 004	Pulley Gear		1	<b>SCREWS</b>				
16	475 1157 046	SlitWasher T0.5		7	101	471 3802 012	Bind Screw 2.6x3		2
17	475 1157 062	SlitWasher T0.5		11	102	473 7016 020	Tapping Screw (S)2.6x5	Black	21
18	423 0070 000	Loading Belt		1	103	473 7001 048	Tapping Screw (S)2.6x8		1
19	449 0106 002	Switch Holder		1	104	471 2203 010	Flat Head Screw 2.6x6		3
20	431 0376 006	Slide Rack (L) Ass'y		1	105	471 1101 016	Pan Screw 2x4		4
21	412 3843 302	Cartridge Holder Ass'y		1	106	471 1829 000	Pan Screw 1.4x3		1
22	412 3841 100	Loading Plate Ass'y		1	107	471 1828 001	Pan Screw 1.7x4	Black	6
23	433 0602 404	Loading Arm		1	108	471 9013 012	Camera Screw 1.7x6		1
24	463 0782 008	Loading Arm Spring		1	109	471 1823 019	Pan Screw 1.7x1.6		2
25	463 0783 104	Loading Plate Spring		1	110	471 1826 016	Pan Screw 2x6 (B)		4
26	463 0784 006	Cartridge Spring		3	111	473 7521 007	Tapping Screw (P)1.7x4	Black	1
27	411 1301 102	Loading Chassis Ass'y		1	112	471 1830 002	Pan Screw 1.7x4 (N)		2
28	422 0478 104	Rack Gear Shaft Ass'y		1	113				
29	424 0225 007	Rack Gear (A)		2	114				
30	411 1298 105	Chassis (R) Ass'y		1					
31	431 0378 004	Slide Rack (R) Ass'y		1					
32	412 3845 009	Head Cam Lever Bracket		1					
33	433 0604 101	Head Cam Lever		1					
34	422 0480 008	Head Cam Lever Shaft		1					
35	411 1300 103	Front Chassis		2					
36	443 1355 207	Mecha. Base Ass'y		1					
37	431 0361 008	SL Shaft		1					
38	499 0274 007	Optical Pickup (KSM-140B)		1					
39	431 0358 202	Pickup Spring Plate		1					
40	431 0375 007	SL Shaft (REF)		1					
41	412 3839 002	SL Shaft Bracket		1					
42	435 0121 004	Slide Rack Ass'y		1					
43	463 0770 007	Rack Spring		1					
44	421 0685 101	Head Plate		1					
45	421 0702 107	Head Arm Lever		1					
46	431 0359 007	Arm Guide Shaft		1					
47	441 1594 004	Head Guide Bracket		1					
48	433 0593 005	Head Guide Shaft Ass'y		1					
49	463 0771 103	Head Arm Spring		1					

**NOTE FOR PARTS LIST**

- Part indicated with the mark "◎" are not always in stock and possibly to take a long period of time for supplying, or in some case supplying of part may be refused.
- When ordering of part, clearly indicate "1" and "1" (i) to avoid mis-supplying.
- Ordering part without stating its part number can not be supplied.
- Part indicated with the mark "★" is not illustrated in the exploded view.

**WARNING:**

Parts marked with this symbol  have critical characteristics. Use ONLY replacement parts recommended by the manufacturer.



7

8

9

10

11

A

B

C

D

E

F

G

H

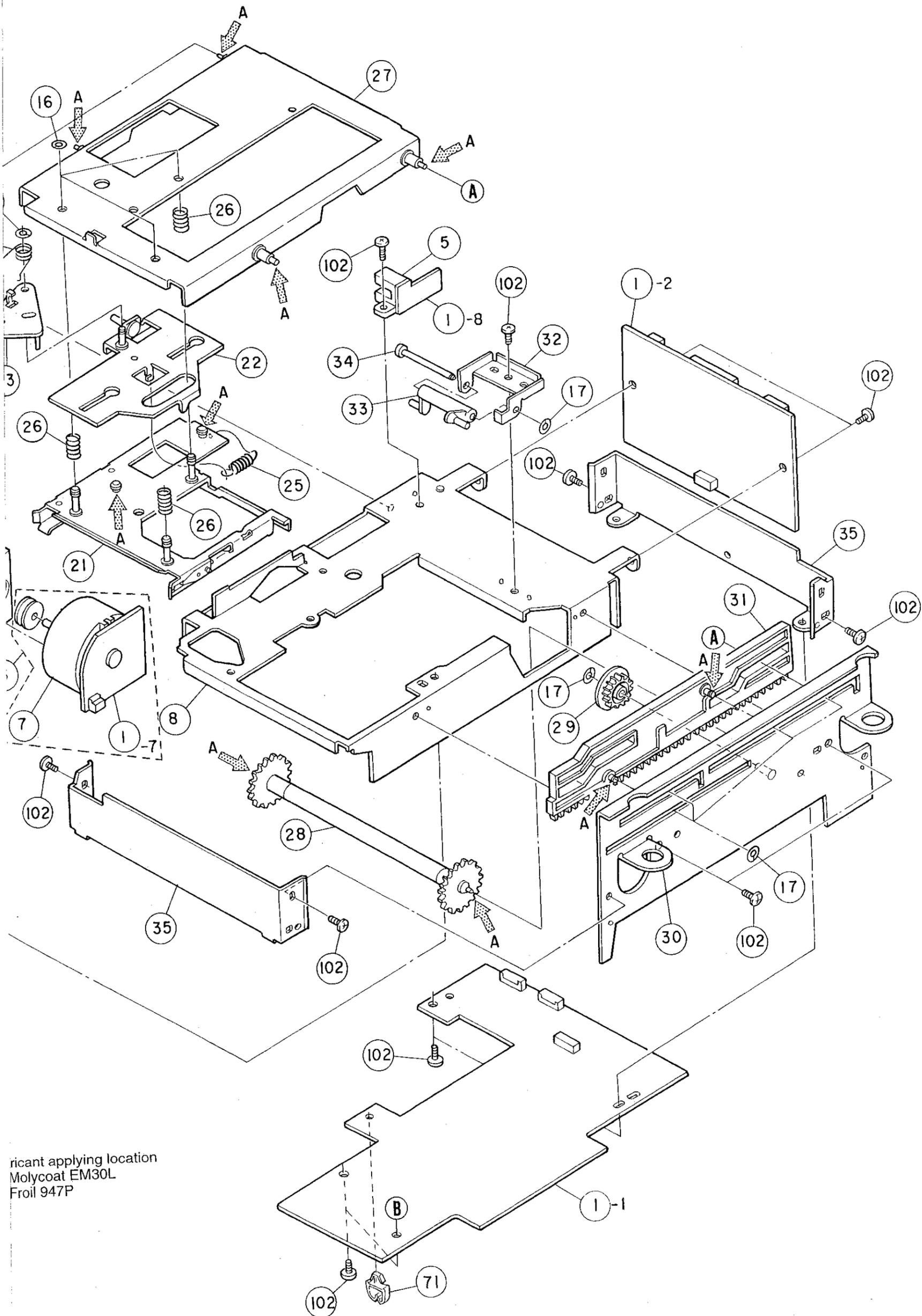

lubricant applying location  
 Molycoat EM30L  
 Froil 947P







WAVEFORMS ON SCHEMATIC DIAGRAM  
(MECH AND SERVO SECTION)

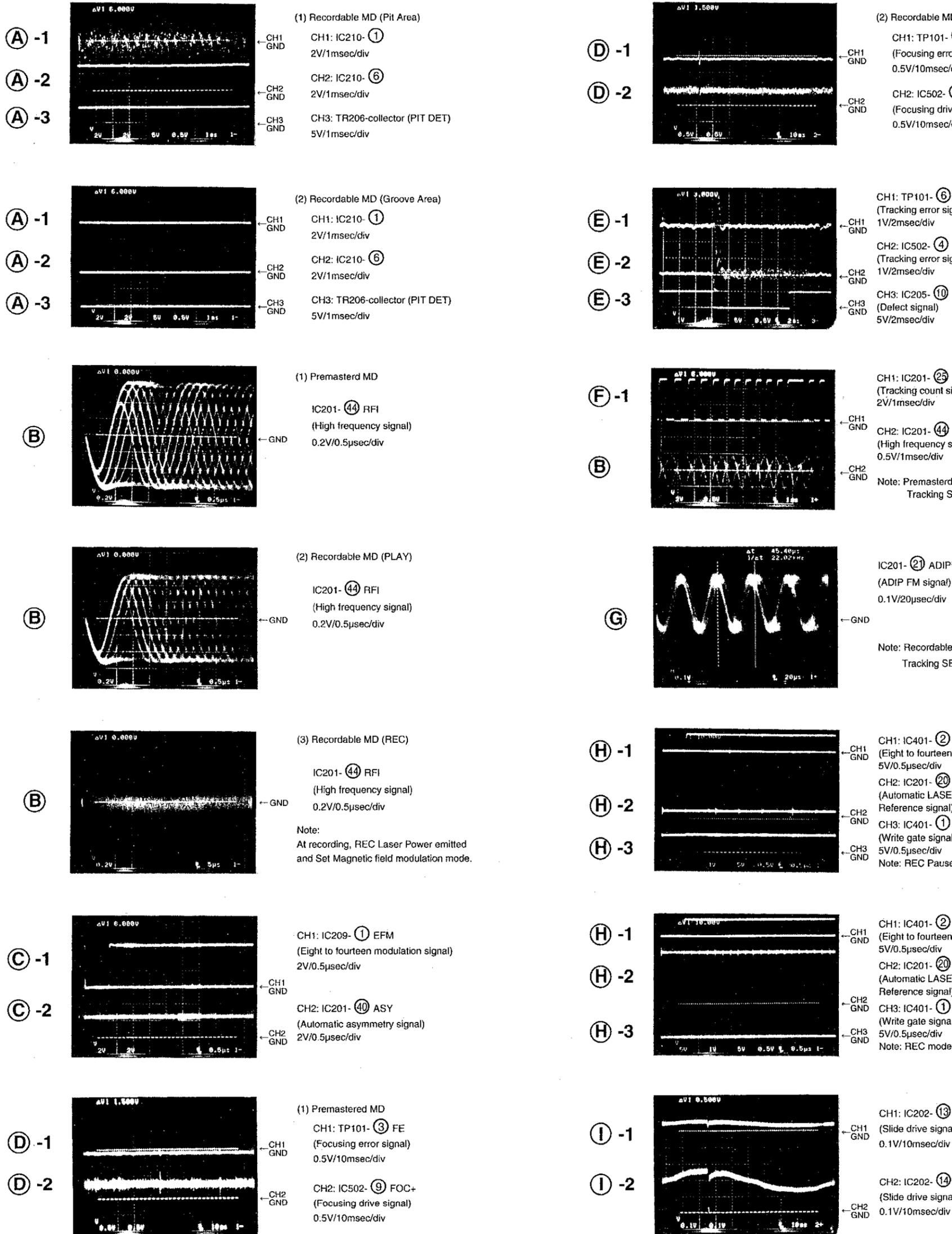

(2) Recordable MD  
 CH1: TP101- ③ FE  
 (Focusing error signal)  
 0.5V/10msec/div  
 CH2: IC502- ⑨ FOC+  
 (Focusing drive signal)  
 0.5V/10msec/div

(H) -1  
 (J) -1  
 (J) -2

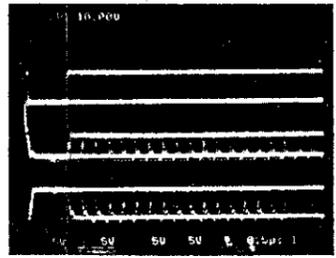

(1) Recordable MD,  
 When magnetic field modulation is ON  
 CH1: IC401- ② EFMO  
 (Eight to fourteen modulation output)  
 5V/0.5µsec/div  
 CH2: IC401- ⑮  
 5V/0.5µsec/div  
 CH3: IC401- ⑱  
 5V/0.5µsec/div

CH1: TP101- ⑥ TE  
 (Tracking error signal)  
 1V/2msec/div  
 CH2: IC502- ④ TRK+  
 (Tracking error signal)  
 1V/2msec/div  
 CH3: IC205- ⑩ DFCT  
 (Defect signal)  
 5V/2msec/div

(H) -1  
 (J) -1  
 (J) -2

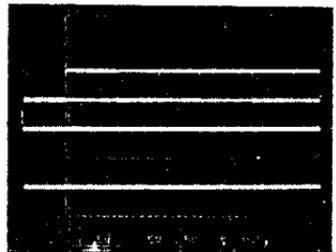

(2) Recordable MD,  
 When magnetic field modulation is OFF  
 CH1: IC401- ② EFMO  
 (Eight to fourteen modulation output)  
 5V/0.5µsec/div  
 CH2: IC401- ⑮  
 5V/0.5µsec/div  
 CH3: IC401- ⑱  
 5V/0.5µsec/div

CH1: IC201- ⑳ TCOUNT  
 (Tracking count signal)  
 2V/1msec/div  
 CH2: IC201- ④ RFI  
 (High frequency signal)  
 0.5V/1msec/div

(K) -1  
 (K) -2

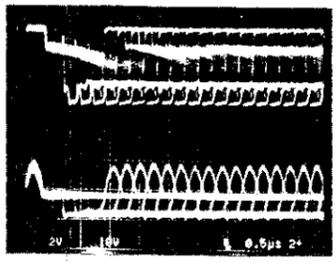

CH1: D401- anode  
 2V/0.5µsec/div  
 CH2: D402- cathode  
 10V/0.5µsec/div  
 Note:  
 When Recording, magnetic field modulation is ON and WRITEG is "0V".

Note: Premasterd MD, Test mode,  
 Tracking SERVO OFF

IC201- ② ADIPFM  
 (ADIP FM signal)  
 0.1V/20µsec/div

(L) -1  
 (L) -2

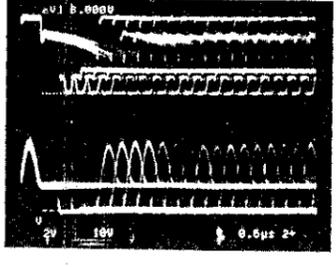

CH1: D403- anode  
 2V/0.5µsec/div  
 CH2: D404- cathode  
 2V/0.5µsec/div  
 Note:  
 When Recording, magnetic field modulation is ON and WRITEG is "0V".

Note: Recordable MD, Test mode,  
 Tracking SERVO ON

CH1: IC401- ② FEMO  
 (Eight to fourteen modulation output)  
 5V/0.5µsec/div  
 CH2: IC201- ⑳ APCREF  
 (Automatic LASER Power Control  
 Reference signal) 1V/0.5µsec/div  
 CH3: IC401- ① WRITEG  
 (Write gate signal)  
 5V/0.5µsec/div  
 Note: REC Pause mode

(M) -1  
 (M) -2

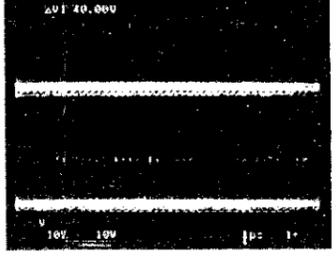

CH1: D401- cathode  
 (Magnetic Head, Coil+)  
 10V/1µsec/div  
 CH2: D403- cathode  
 (Magnetic Head, Coil-)  
 10V/1µsec/div  
 Note:  
 When Recording, magnetic field modulation is ON and WRITEG is "0V".

CH1: IC401- ② FEMO  
 (Eight to fourteen modulation output)  
 5V/0.5µsec/div  
 CH2: IC201- ⑳ APCREF  
 (Automatic LASER Power Control  
 Reference signal) 1V/0.5µsec/div  
 CH3: IC401- ① WRITEG  
 (Write gate signal)  
 5V/0.5µsec/div  
 Note: REC mode

CH1: IC202- ⑬ SL+  
 (Slide drive signal)  
 0.1V/10msec/div

CH2: IC202- ⑭ SLE  
 (Slide drive signal)  
 0.1V/10msec/div



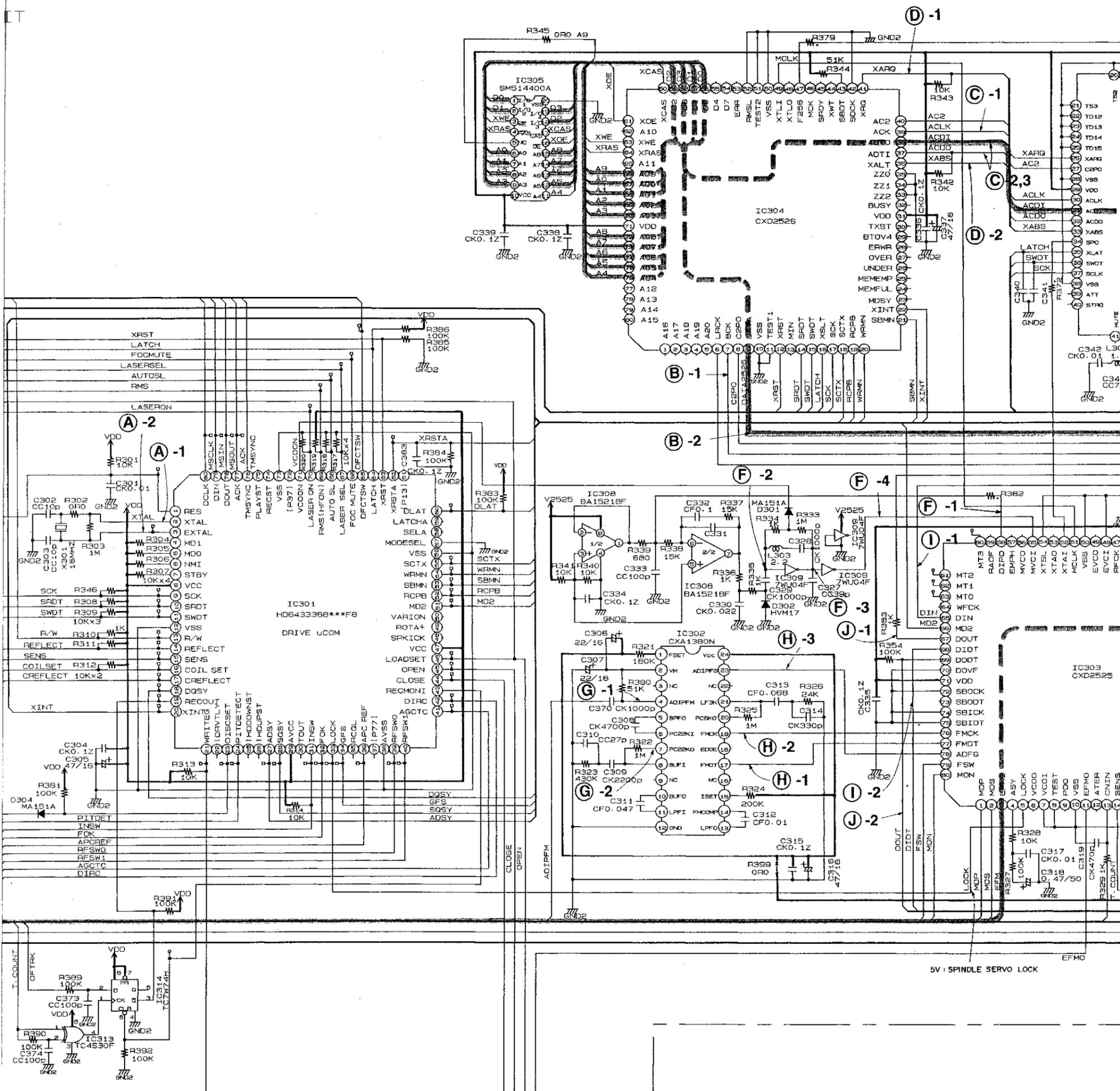

2U-2704  
EN/DECO UNIT

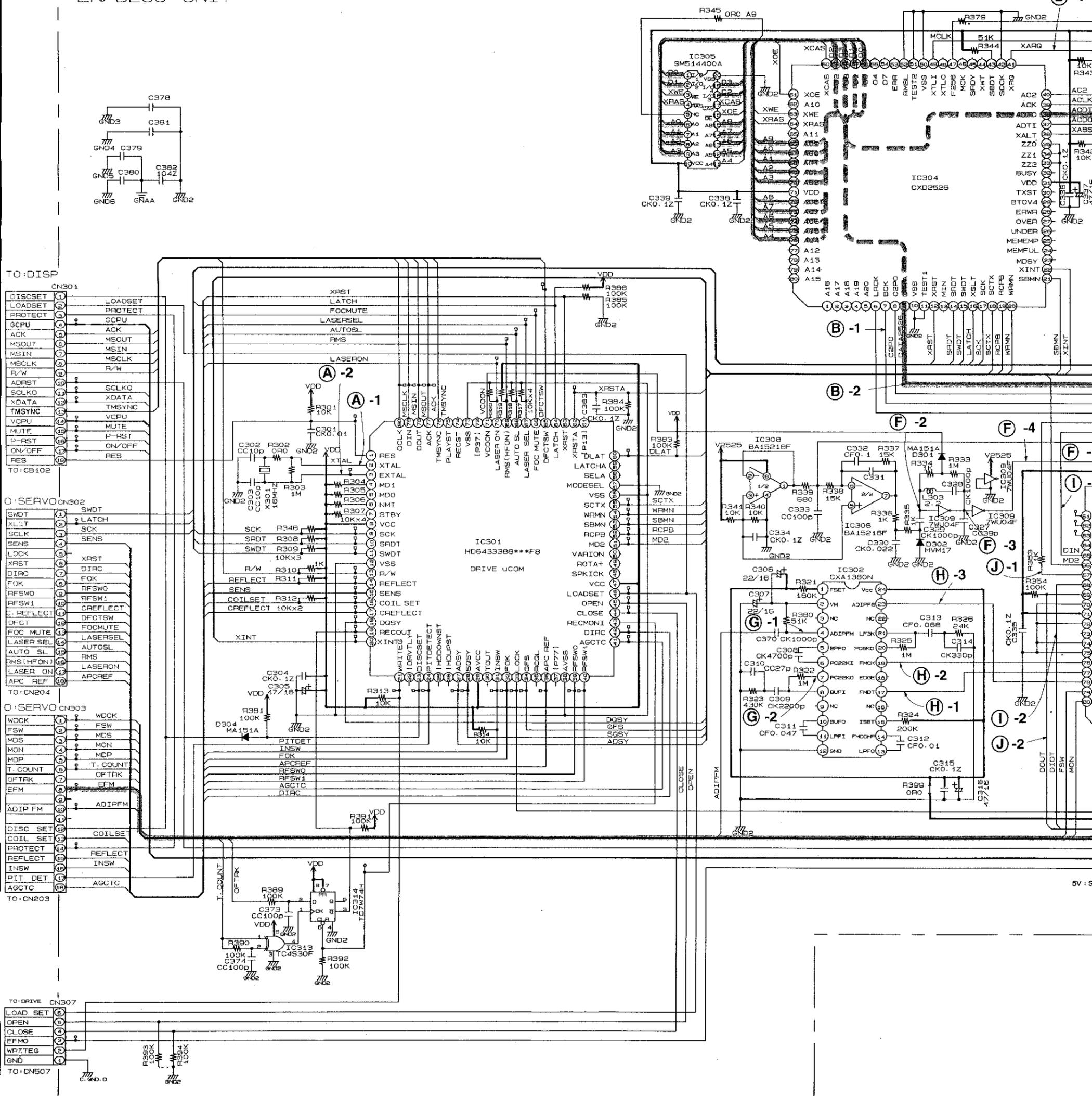

**WARNING:**  
Parts marked with this symbol have critical characteristics. Use ONLY replacement parts recommended by the manufacturer.

**CAUTION:**  
Before returning the unit to the customer, make sure you make either (1) a leakage current check or (2) a line to chassis resistance check. If the leakage current exceeds 0.5 millamps, or if the resistance from chassis to either side of the power cord is less than 240 kohms, the unit is defective.

**WARNING:**  
DO NOT return the unit to the customer until the problem is located and corrected.

RES  
RESISTANCE VALUES IN OHM. k=1,000 OHM, M=1,000,000 OHM  
CAPACITANCE VALUES IN MICRO FARAD. P=MICRO-MICRO FARAD  
VOLTAGE AND CURRENT ARE MEASURED AT NO SIGNAL INPUT  
CONDITION.  
CIRCUIT AND PARTS ARE SUBJECT TO CHANGE WITHOUT PRIOR  
NOTICE.





WAVE FORM - 2/3

WAVEFORMS ON SCHEMATIC DIAGRAM  
(ENCODE AND DECODE SECTION)

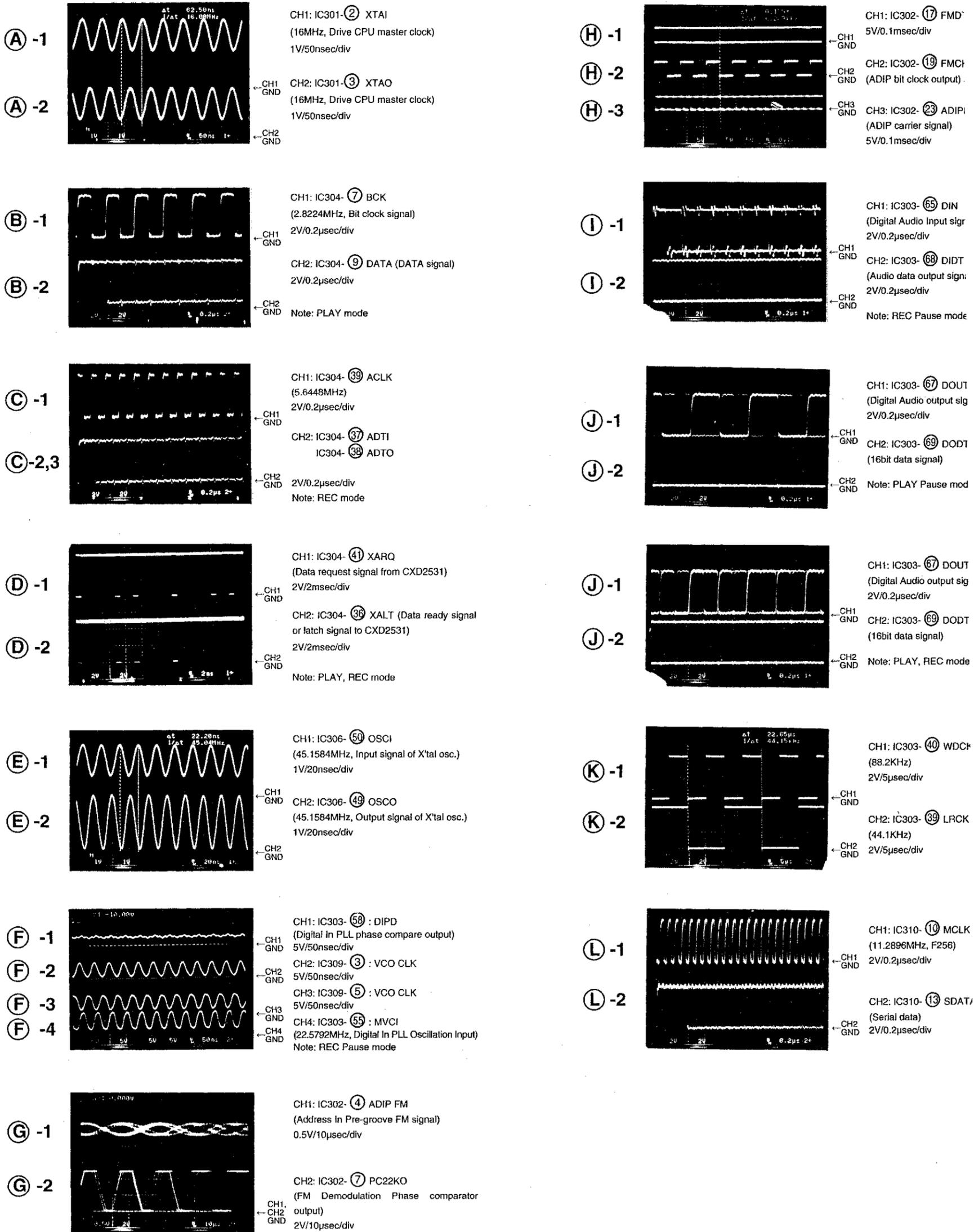

CH1: IC302- (17) FMDT (ADIP data output)  
5V/0.1msec/div

CH2: IC302- (19) FMCK  
(ADIP bit clock output) 5V/0.1msec/div

CH3: IC302- (23) ADIFFG  
(ADIP carrier signal)  
5V/0.1msec/div

CH1: IC303- (65) DIN  
(Digital Audio Input signal)  
2V/0.2μsec/div

CH2: IC303- (68) DIDT  
(Audio data output signal of DIN)  
2V/0.2μsec/div

Note: REC Pause mode

CH1: IC303- (67) DOUT  
(Digital Audio output signal)  
2V/0.2μsec/div

CH2: IC303- (69) DODT  
(16bit data signal)

Note: PLAY Pause mode

CH1: IC303- (67) DOUT  
(Digital Audio output signal)  
2V/0.2μsec/div

CH2: IC303- (69) DODT  
(16bit data signal)

Note: PLAY, REC mode

CH1: IC303- (40) WDCK  
(88.2KHz)  
2V/5μsec/div

CH2: IC303- (39) LRCK  
(44.1KHz)  
2V/5μsec/div

CH1: IC310- (10) MCLK  
(11.2896MHz, F256)  
2V/0.2μsec/div

CH2: IC310- (13) SDATA  
(Serial data)  
2V/0.2μsec/div

SCHEMATIC DIAGRAM - 3/3

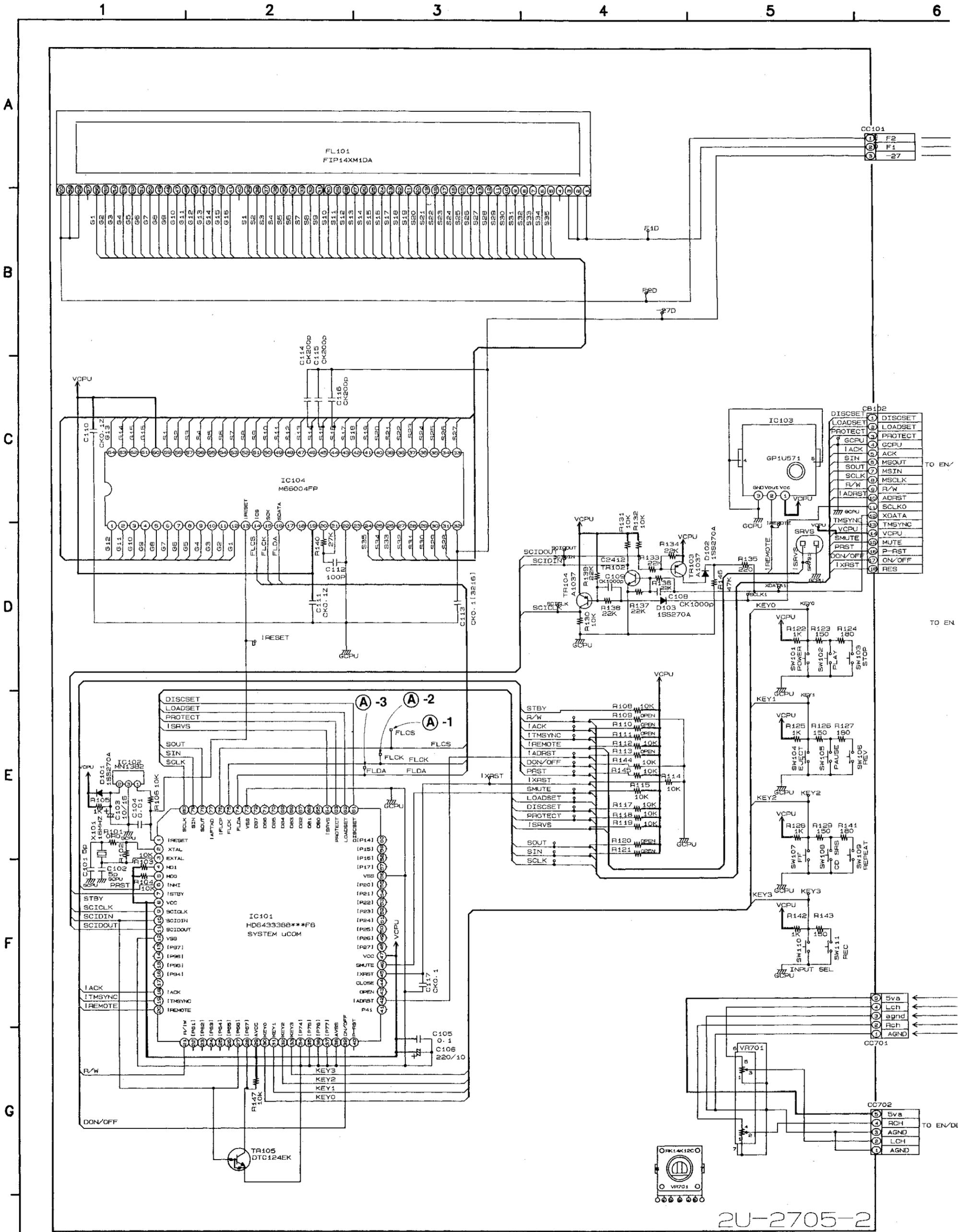

2U-2705-2

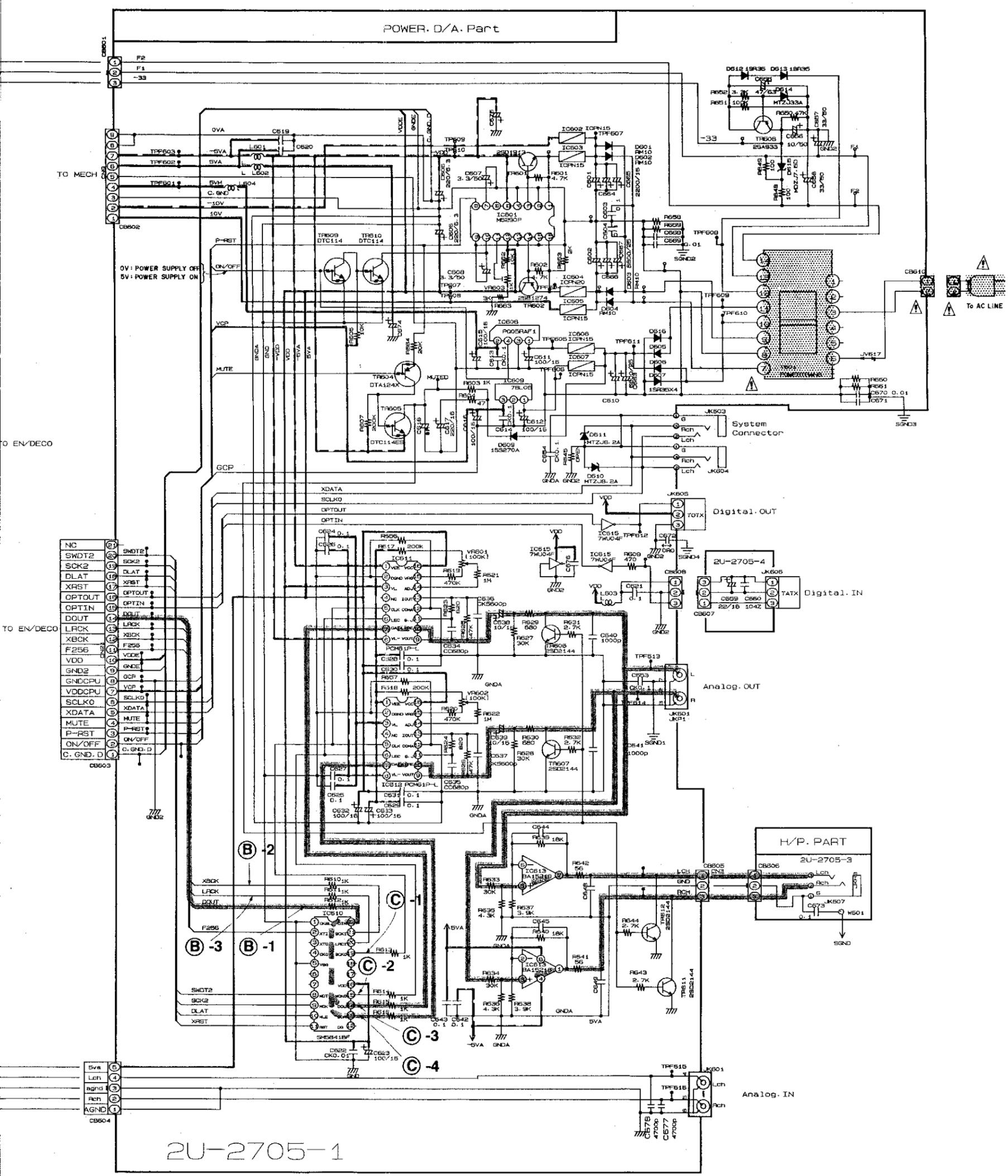

**NOTES**  
 ALL RESISTANCE VALUES IN OHM. k=1,000 OHM, M=1,000,000 OHM  
 ALL CAPACITANCE VALUES IN MICRO FARAD. P=MICRO-MICRO FARAD  
 EACH VOLTAGE AND CURRENT ARE MEASURED AT NO SIGNAL INPUT  
 CONDITION.  
 CIRCUIT AND PARTS ARE SUBJECT TO CHANGE WITHOUT PRIOR  
 NOTICE.

**WARNING:**  
 Parts marked with this symbol have critical characteristics.  
 Use ONLY replacement parts recommended by the manufacturer.

**CAUTION:**  
 Before returning the unit to the customer, make sure you make either (1) a  
 leakage current check or (2) a line to chassis resistance check. If the leakage  
 current exceeds 0.5 milliamps, or if the resistance from chassis to either side  
 of the power cord is less than 240 kohms, the unit is defective.

**WARNING:**  
 DO NOT return the unit to the customer until the problem is located and  
 corrected.

WAVE FORM - 3/3

WAVEFORMS ON SCHEMATIC DIAGRAM  
(DISPLAY SECTION)

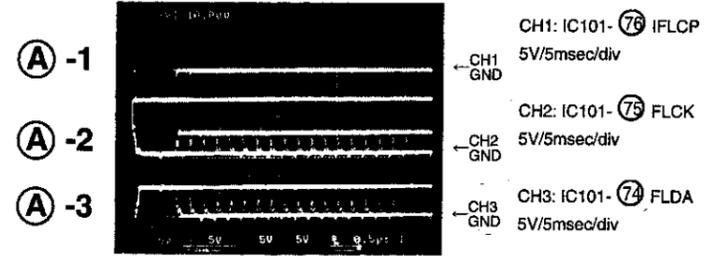

WAVEFORMS ON SCHEMATIC DIAGRAM  
(AUDIO AND POWER SECTION)

