

DENON

Hi-Fi Component

SERVICE MANUAL MODEL DN-720R STEREO CASSETTE TAPE DECK



— TABLE OF CONTENTS —

OPERATING INSTRUCTIONS	2~8
SPECIFICATIONS	9
BLOCK DIAGRAM	10
LEVEL DIAGRAM	11
DISASSEMBLY INSTRUCTIONS	12~13
ADJUSTING AND CHECKING THE MECHANISM SECTION	14
ADJUSTING THE ELECTRICAL SECTIONS	15~16
PARTS LIST OF 3U-2584 AUDIO METER UNIT	17~19
PARTS LIST OF 3U-2063 POWER SUPPLY UNIT	19
PARTS LIST OF EXPLODED VIEW	20
PARTS LIST OF PACKING & ACCESSORIES	20
EXPLODED VIEW	21
EXPLODED VIEW OF CASSETTE MECHANISM	22
PARTS LIST OF CASSETTE MECHANISM EXPLODED VIEW	23
P.W. BOARD OF 3U-2584 AUDIO/METER UNIT	24
P.W. BOARD OF 3U-2063 POWER SUPPLY UNIT	25
SEMICONDUCTORS	26~27
BUNDLE DIAGRAM	28
WIRING DIAGRAM	29
SCHEMATIC DIAGRAM	30~31

NIPPON COLUMBIA CO., LTD.

IMPORTANT TO SAFETY

WARNING:

TO PREVENT FIRE OR SHOCK HAZARD, DO NOT EXPOSE THIS APPLIANCE TO RAIN OR MOISTURE.

CAUTION:

1. **Handle the power supply cord carefully**
Do not damage or deform the power supply cord. If it is damaged or deformed, it may cause electric shock or malfunction when used. When removing it from wall outlet, be sure to remove by holding the plug attachment and not by pulling the cord.
2. **Do not open the top cover**
In order to prevent electric shock, do not open the top cover. If problems occur, contact your DENON DEALER.
3. **Do not place anything inside**
Do not place metal objects or spill liquid inside the cassette tape deck. Electric shock or malfunction may result.

Please, record and retain the Model name and serial number of your set shown on the rating label.

Model No. DN-720R

Serial No. _____

• **FOR U.S.A. & CANADA MODEL ONLY**

CAUTION

TO PREVENT ELECTRIC SHOCK DO NOT USE THIS (POLARIZED) PLUG WITH AN EXTENSION CORD, RECEPTACLE OR OTHER OUTLET UNLESS THE BLADES CAN BE FULLY INSERTED TO PREVENT BLADE EXPOSURE.

• **POUR LES MODELES AMERICAINS ET CANADIENS UNIQUEMENT**

ATTENTION

POUR PREVENIR LES CHOCS ELECTRIQUES NE PAS UTILISER CETTE FICHE POLARISEE AVEC UN PROLONGATEUR UNE PRISE DE COURANT OU UNE AUTRE SORTIE DE COURANT, SAUF SI LES LAMES PEUVENT ETRE INSEREES A FOND SANS EN LAISSER AUCUNE PARTIE A DECOUVERT.

IMPORTANT (BRITISH MODEL ONLY)

The wires in this mains lead are coloured in accordance with the following code:

Blue: Neutral Brown: Live

The colours of the wires in the mains lead of this apparatus may not correspond with the coloured markings identifying the terminals in your plug proceed as follows.

The wire which is coloured blue must be connected to the terminal which is marked with the letter N or coloured black.

The wire which is coloured brown must be connected to the terminal which is marked with the letter L or coloured red.



CAUTION
RISK OF ELECTRIC SHOCK
DO NOT OPEN



CAUTION: TO REDUCE THE RISK OF ELECTRIC SHOCK, DO NOT REMOVE COVER (OR BACK). NO USER SERVICEABLE PARTS INSIDE. REFER SERVICING TO QUALIFIED SERVICE PERSONNEL.



The lightning flash with arrowhead symbol within an equilateral triangle is intended to alert the user of the presence of uninsulated "dangerous voltage" within the product's enclosure that may be of sufficient magnitude to constitute a risk of electric shock to persons.



The exclamation point within an equilateral triangle is intended to alert the user of the presence of important operating and maintenance (servicing) instruction in the literature accompanying the appliance.

DENON

STEREO CASSETTE TAPE DECK

DN-720R





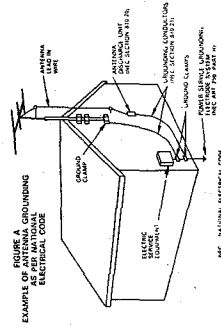

OPERATING INSTRUCTIONS

SAFETY INSTRUCTIONS

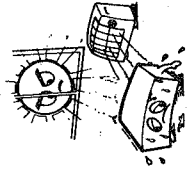
1. Read Instructions - All the safety and operating instructions should be read before the appliance is operated.
2. Retain Instructions - The safety and operating instructions should be retained for future reference.
3. Heat Warnings - All warnings on the appliance and in the operating instructions should be adhered to.
4. Follow Instructions - All operating and use instructions should be followed.
5. Water and Moisture - The appliance should not be used near water - for example, near a bathtub, washbowl, kitchen sink, laundry tub, in a wet basement, or near a swimming pool, and the like.
6. Carts and Stands - The appliance should be used only with a cart or stand that is recommended by the manufacturer.
- 6A. An appliance and cart combination should be moved with care. Quick stops, excessive force, and uneven surfaces may cause the appliance and cart combination to overturn.
7. Wall or Ceiling Mounting - The appliance should be mounted to a wall or ceiling only as recommended by the manufacturer.
8. Ventilation - The appliance should be situated so that its location or position does not interfere with its proper ventilation. For example, the appliance should not be situated on a bed, sofa, rug, or similar surface that may block the ventilation openings; or, placed in a built-in installation, such as a bookcase or cabinet that may impede the flow of air through the ventilation openings.
9. Heat - The appliance should be situated away from heat sources such as radiators, heat registers, stoves, or other appliances (including amplifiers) that produce heat.
10. Power Sources - The appliance should be connected to a power supply only of the type described in the operating instructions or as marked on the appliance.
11. Grounding or Polarization - Precautions should be taken so that the grounding or polarization means of an appliance is not defeated.
12. Power-Cord Protection - Power-supply cords should be routed so that they are not likely to be walked on or pinched by items placed upon or against them, paying particular attention to cords at plugs, convenience receptacles, and the point where they exit from the appliance.
14. Cleaning - The appliance should be cleaned only as recommended by the manufacturer.
15. Power Lines - An outdoor antenna should be located away from power lines.
16. Outdoor Antenna Grounding - If an outside antenna is connected to the receiver, be sure the antenna system is grounded so as to provide some protection against voltage surges and built-up static charges. Article 810 of the National Electrical Code, ANSI/NFPA 70, provides information with regard to proper grounding of the mast and supporting structure, grounding of the lead-in wire to antenna-discharge devices, and other related information. See the antenna discharge and grounding code book for grounding electrodes, and requirements for the grounding electrodes. See Figure A.
17. Nonuse Periods - The power cord of the appliance should be unplugged from the outlet when left unused for a long period of time.
18. Object and Liquid Entry - Care should be taken so that objects do not fall and liquids are not spilled into the enclosure through openings.
19. Damage Requiring Service - The appliance should be serviced by qualified service personnel when:
 - A. The power-supply cord or the plug has been damaged; or
 - B. Objects have fallen, or liquid has been spilled into the appliance; or
 - C. The appliance has been exposed to rain; or
 - D. The appliance does not appear to operate normally or exhibits a marked change in performance; or
 - E. The appliance has been dropped, or the enclosure damaged.
20. Servicing - The user should not attempt to service the appliance beyond that described in the operating instructions. All other servicing should be referred to qualified service personnel.

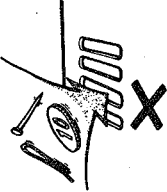

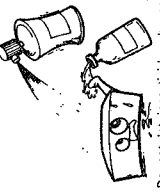
NOTE ON USE/OBSERVATIONS RELATIVES A L'UTILISATION/NOTAS SOBRE EL USO

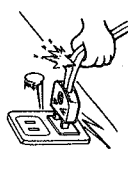
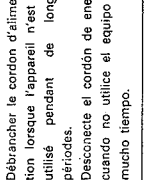
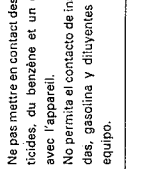
 <ul style="list-style-type: none"> • Avoid high temperatures. Allow for sufficient heat dispersion when installed on a rack. • Eviter des températures élevées. Tenir compte d'une dispersion de chaleur suffisante lors de l'installation sur une étagère. • Evite altas temperaturas. Permite la suficiente dispersión del calor cuando está instalado en la consola. 	 <ul style="list-style-type: none"> • Keep the set free from moisture, water, and dust. • Protéger l'appareil contre l'humidité, l'eau et la poussière. • Mantenga el equipo libre de humedad, agua y polvo. 	 <ul style="list-style-type: none"> • Do not let foreign objects in the set. • Ne pas laisser des objets étrangers dans l'appareil. • No deje objetos extraños dentro del equipo.
 <ul style="list-style-type: none"> • Unplug the power cord when not using the set for long periods of time. • Débrancher le cordon d'alimentation lorsque l'appareil n'est pas utilisé pendant de longues périodes. • Desconecte el cordón de energía cuando no utilice el equipo por mucho tiempo. 	 <ul style="list-style-type: none"> • Do not let insecticides, benzene, and thinner come in contact with the set. • Ne pas mettre en contact des insecticides, du benzène et un diluant avec l'appareil. • No permita el contacto de insecticidas, gasolina y diluyentes con el equipo. 	 <ul style="list-style-type: none"> • Never disassemble or modify the set in any way. • Ne jamais démonter ou modifier l'appareil d'une manière ou d'une autre. • Nunca desarme o modifique el equipo de ninguna manera.
 <ul style="list-style-type: none"> • Handle the power cord carefully. Hold the plug when unplugging the cord. • Manipuler le cordon d'alimentation avec précaution. Tenir la prise lors du débranchement du cordon. • Maneje el cordón de energía con cuidado. Sostenga el enchufe cuando desconecte el cordón de energía. 	 <ul style="list-style-type: none"> • Do not obstruct the ventilation holes. • Ne pas obstruer les trous d'aération. • No obstruya los orificios de ventilación. 	 <ul style="list-style-type: none"> • Never disassemble or modify the set in any way. • Ne jamais démonter ou modifier l'appareil d'une manière ou d'une autre. • Nunca desarme o modifique el equipo de ninguna manera.

Thank you very much for purchasing the DENON component stereo cassette tape deck. DENON proudly presents this advanced tape deck to audiophiles and music lovers as a further proof of DENON's non-compromising pursuit of the ultimate in sound quality. The high quality performance and easy operation are certain to provide you with many hours of outstanding listening pleasure.

— TABLE OF CONTENTS —

FEATURES 5
 CONNECTION 5
 NAMES AND FUNCTION OF PARTS 6,7
 CASSETTE TAPES 7
 AUTO TAPE SELECT FEATURE 7
 PLAYBACK 8
 RECORDING 8,9
 RECORDING BIAS ADJUSTMENT 9
 RECORDING ADJUSTING 9
 REC/REC MUTE BUTTON 10
 MUSIC SEARCH SYSTEM 10,11
 TAPE COUNTER AND MEMORY STOP 10,11
 DOLBY B & C NOISE REDUCTION SYSTEM 11
 DOLBY HX-PRO HEADROOM EXTENSION SYSTEM 11
 MAINTENANCE 12
 TROUBLESHOOTING 13

FEATURES

- Computer Controlled Mechanism
- Non-slip Reel Drive for Stabilizing Tape Tension
- Dual Power Supply
- 2-Head Design Utilizes The Amorphous Head
- Dolby HX PRO System
- Dolby B & C Noise Reduction System
- Manual Bias Adjustment Controls (Left/Right Independent)
- Computing Linear or Real Time Tape Counter With 4-Digit Read out and Memory Stop
- Auto Tape Selector
- 19-inch Rack Mountable
- Speed Control of Approximately ±12%
- Accurate Music Search System
- Display Memory Back-up

Please check to make sure the following items are included with the main unit in the carton:

- (1) Operating instructions 1
- (2) Connection Cards 2
- (3) Remote control box connection wire 1
- (4) Adjustment sheet 1
- (5) Remote control box schematic diagram 1

CONNECTION

- Leave your entire system (including this cassette deck) turned off until all connections between the deck and other components have been completed.
- Connecting the Deck to an Amplifier
 - Before connecting the deck to your amplifier, it is a good practice to review your amplifier's instruction manual.
 - Use the white plugs for the left channel and red plugs for the right channel.
- Tape Dubbing
 - Many stereo amplifiers and receivers have tape dubbing circuitry so that tape duplication can be performed between two or more tape decks. Review your amplifier's instruction manual for a full explanation of this mode of operation.

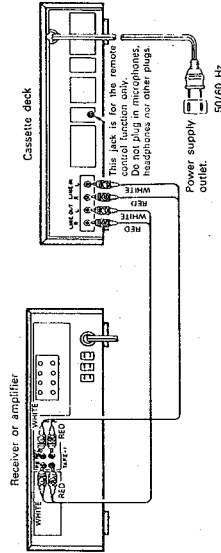

- Systems Remote Control
 - A wired remote control box can be connected to this unit. No remote control box is included.
 - To connect a remote control box referring to the included schematic diagram (remote control box schematic diagram).
 - Connect the remote control terminal to the remote control jack on the rear panel.
 - Connecting Headphones
 - To listen through headphones, plug your headphones into the PHONES jack.
 - Installation Precautions
 - If the deck is placed near an amplifier or tuner, noise (induced hum) or other interference may result (especially during AM or FM reception). If this occurs, separate the deck from other components or reorient its position.
- NOTE:**
 Use this unit in a horizontal orientation. When the unit is used with the front panel facing upward (and the unit is in a vertical orientation) or when the front panel is on an incline, the unit will not operate properly.

NAMES AND FUNCTIONS OF PARTS

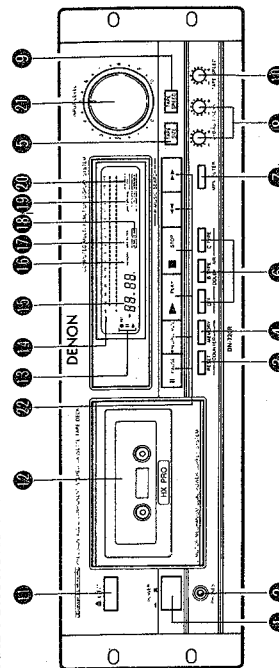

- 1 **Power Switch (POWER)**
Controls the supply of AC power to the deck. One push turns the deck on, a second push turns it off. The deck remains in a stand-by (non-operative) mode for approximately 2 seconds after it is switched on.
- 2 **PHONES jack**
For enjoyment without disturbing others, or for monitoring a recording, a set of headphones may be plugged in. Impedance should be from 8 to 1200 ohms.
- 3 **COUNTER RESET button**
(for the real time counter and the linear counter too)
Operation of the button resets the counter to all zero.
- 4 **MEMORY STOP button**
During recording, if the tape will stop at the "0000" counter point automatically, when this button is pressed in.
- 5 **TAPE SIZE button**
You can know accurate elapsed time of the tape by adjusting the TAPE SIZE button to the tape size used. When the TAPE SIZE button is pressed, the current tape size is displayed for 1 sec in the 4-figures counter. If you further press the button during the display, the tape size will change in the following cycle.
C-90 C-74 C-60 C-100
- 6 **DOLBY NR button**
There are independent buttons for the Dolby NR "OFF", "B" and "C" positions.
When recording tapes, set the Dolby NR function as desired.
When playing tapes, set the Dolby NR function to the same position as when the tape was recorded.
- 7 **MPX FILTER button**
The MPX FILTER button should be used to prevent interference with the Dolby NR circuit when making Dolby NR encoded recordings of FM stereo programs. When making Dolby NR encoded recordings from any program source other than FM stereo, leave this button in the "OFF" position.
- 8 **BIAS control (left channel/right channel independent) (NORMAL, C-0, and METAL tape)**
Adjust the bias according to the tape characteristics. Standard biasing is obtained at the center click-stop position.
- 9 **TAPE SPEED button**
This button is for setting the tape speed to the fixed speed (FIX) or variable speed (VARIABLE) position.
When set at the FIX position, the tape is played at the standard fixed speed regardless of the position of the tape speed control knob. When set at the VARIABLE position, the tape speed changes according to the position of the tape speed control knob.
- 10 **TAPE SPEED control**
Use this knob to vary the tape speed.
First set the tape speed button to the VARIABLE position.
The speed can be varied within a range of approximately ±12% according to the position of the tape speed control knob.
- 11 **EJECT button**
To eject the cassette, when the deck is operating (tape is running), press the stop button first to stop the tape transport, then press the EJECT button.
- 12 **Cassette compartment cover**
If this compartment cover is not closed completely, the deck's transport controls will remain inoperative.
- 13 **PLAY, PAUSE and REC indicator**
When the PLAY, PAUSE and REC buttons are pressed, this indicator will light.
- 14 **Fluorescent peak meters**
These meters indicate recording or playback peak levels for each channel. For peak levels exceeding -7 dB, the Auto Peak Hold Feature holds the peak level reading for approximately 1 second.
- 15 **Tape counter**
The tape counter is indicated digitally, in minutes and seconds.
When "M" and "S" are lit, the counter is set to the real time display mode.
When "M" and "S" are off, the counter is set to the linear display mode.
For an explanation of the real time and linear time display modes, refer to the section "TAPE COUNTER AND MEMORY STOP".
- 16 **MEMORY indicator**
This indicator light is interlocked with the memory stop button. (MEMORY)
- 17 **FILTER indicator**
This indicator light is interlocked with the MPX FILTER button. (MPX FILTER)
- 18 **NR system indicator**
This indicator light is interlocked with the DOLBY NR button and interlocks the user that DOLBY NR is in use as well as which B-TYPE or C-TYPE.
- 19 **TAPE SELECT indicator**
This indicator light is interlocked with the Auto Tape Select feature which automatically adjusts the deck to the type of tape in use. (TYPE I (TYPE II) or TYPE IV).
- 20 **TAPE SPEED indicator**
This indicator light is interlocked with the TAPE SPEED button. The tape speed can be controlled when "VARIABLE" is lit.
- 21 **INPUT LEVEL control**
The recording input level is adjusted by this knob. The levels in the left and right channels can be changed simultaneously.

22 Tape transport controls

▶ PLAY	Press to play-back tape.
■ STOP	Press to stop tape in any mode.
◀◀ REW	Press for fast rewind.
▶▶ FF	Press fast forward tape winding.
● REC/REC MUTE	To begin recording, press the RECORD and PLAY button simultaneously. If only the RECORD button is pressed, the deck is placed in the REC MUTE mode. Pressing the REC MUTE button when this button is pressed for making a non-recorded part between two maulades, about 5 sec of non-recorded part can automatically be created.
⏸ PAUSE	Press this button to enter the recording pause mode from the recording, or recording/ mute mode. Press this button to enter the playback pause mode from playback mode.

CASSETTE TAPES

- **Handling Precautions**
 - C-120 cassette tapes are not recommended as they use a very thin tape base which may become tangled around the capstan or pinchroller.
 - Tape Slack
 - This cassette deck incorporates an automatic tape slackness preventive mechanism, but it can not prevent such a slackness as shown below. Remove it with a pencil or the like prior to use.
- **Storage Precautions**
 - Do not store cassette tapes in a place where they will be subject to:
 - Excessively high temperature or excessive moisture
 - Excessive dust
 - Direct sunlight
 - Magnetic fields (near TV sets or speakers)
 - To eliminate tape slack, store your cassettes in cassette cases with hub stops.
- **Erasure Prevention**
 - Every cassette has erasure prevention tabs for each side. To protect your valuable recorded tapes from accidental or inadvertent erasure, remove the tab for the appropriate side with a screwdriver or other tools.
 - To record on a tape with the erasure prevention tabs removed, cover the tab holes with plastic tape.

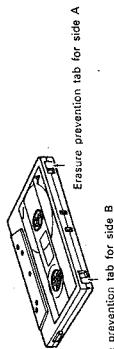
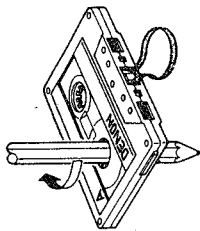

Erasure prevention tab for side B

AUTO TAPE SELECT FEATURE

This Stereo Cassette Deck contains an Auto Tape Select feature which automatically selects the optimum bias and equalization for the tape in use. This is accomplished by detection of tape type detection holes in the cassette housing.

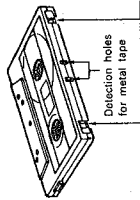

If a tape without tape type detection holes is used, the deck will automatically adjust itself for normal tapes.

Detection holes for metal tape

Detection holes for chrome tape

PLAYBACK

- Switch on your amplifier or receiver.
- Set the TAPE MONITOR switch on your amplifier or receiver to the TAPE position.
- Operate the deck in numerical order as illustrated below:

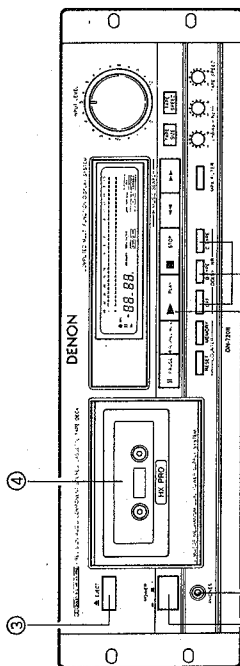

- 1 PHONES Playback sound is fed into the headphones set.
- 2 POWER Push the switch to turn "ON" () the power.
- 3 EJECT Press the EJECT button to open the cassette compartment.
- 4 Cassette Compartment Cover Load the cassette tape.
- 5 DOLBY NR For recordings made without Dolby NR, set to "OFF". For recordings made with Dolby B NR, set to "B". (The [B] indicator will light up.) For recordings made with Dolby C NR, set to "C". (The [C] indicator will light up.)
- 6 PLAY Push the PLAY button (The D-PLAY indicator will light up).
 - When playback is finished, press the stop (STOP) button.
 - To restart the tape, press the PLAY (PLAY) button.
 - If different types of Dolby Noise Reduction are used for record and playback, playback response will be adversely affected.

RECORDING

- Switch on the source component (tuner, amplifier, etc.).
- Set the TAPE MONITOR switch on your amplifier or receiver to the SOURCE position.

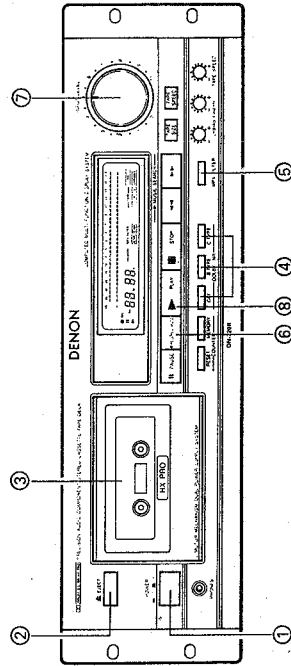

- 1 POWER Push the switch to turn "ON" () the power.
- 2 EJECT Press the EJECT button to open the cassette compartment.
- 3 Cassette Compartment Cover (Make sure the ejection prevention tab has not been removed from the cassette shell tail.)
- 4 DOLBY NR Set, in accordance with the recording to be made. For recordings without Dolby NR, set to "OFF". For recordings with Dolby B NR, set to "B". (The [B] indicator will light up.) For recordings with Dolby C NR, set to "C". (The [C] indicator will light up.) Future mistakes during playback can be avoided if the cassette is so marked for Dolby NR encoded recordings.
- 5 MPX FILTER Button "ON" for the DOLBY NR recording of FM broadcasts (The MPX FILTER indicator will light up).

Caution:

- Be careful not to erase important recordings by mistake. Mis-erasing can be avoided by following the two steps below:
1. If the PLAY (PLAY) button is pressed while the OREC indicator is on, the tape will be recorded.
 2. If the PLAY (PLAY) and RECORD (REC) button are pressed at the same time, the tape will be recorded.
 3. Performing the record pause or the stop operation during recording will create a discontinuous portion in the recording signal. The previously recorded signal may remain after erasure at this connecting portion. Also, a very small amount of the end portion of the previous song may be erased.

PROPER RECORDING LEVEL

A too high recording level can saturate the tape and cause distortion. On the other hand, if the recording levels are set too low, soft passages will be marked by residual noise. Proper recording level is the single most important factor for making well-balanced recordings.

Guideline for maximum recording level

Normal tape TYPE I	+1 dB levels on peaks
C-O ₂ tape TYPE II	+3 dB levels on peaks
Metal tape TYPE IV	+5 dB levels on peaks

Note: Optimum recording levels can differ depending on program sources or the type of tape used.

RECORDING BIAS ADJUSTMENT

For best recording results, monitoring during the recording process and comparing various recordings using your own judgment are essential. The following steps should be followed to assist you in setting the proper bias for different types and brands of recording tapes. At the center-click-stop position, the deck is set for a reference bias level for NORMAL, C-O₂ and METAL tapes. If the resulting recording in this position has too much or too little high frequency content, varying the bias adjustment control can be useful to achieve better results.

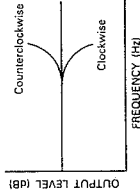

If the high frequencies (treble sounds) are to be boosted, turn the bias control counter-clockwise to decrease bias. To decrease bias, turn the control clockwise to increase bias current. By the use of this control, you can record tapes with response that matches your personal listening tastes.

RECORDING ADJUSTING

The recording and bias levels can be fine-adjusted for the tape being used. For details, refer to the enclosed adjustment sheet.

REC/REC MUTE BUTTON

- REC/REC MUTE is the DEWON's unique and convenient function. By using this button, it is easily possible to insert a suitable space (the non-recorded part) between two melodies.
- When you want to make about 5 seconds of non-recorded part after the recording stage:
Press the REC/REC MUTE button. The recorder will automatically create about 5 seconds of non-recorded part and will stay in the recording standby state.
 - To create about 5 seconds of non-recorded part after the standby state:
Press the REC/REC MUTE button, and the recorder will enter the recording standby state, automatically create about 5 seconds of non-recorded part and stay in the standby state.

MUSIC SEARCH SYSTEM

This device is a convenient system which detects the non-recorded part of more than 4 seconds between melodies, cues the next melody while the present melody is being reproduced or automatically detects the beginning of the melody now being reproduced and makes it into the reproducible state.

- For cueing the next melody while the present melody is being reproduced:
At PLAY mode, depress the PLAY button and the FF button simultaneously. This device will detect the interval between melodies with the CUE state on, automatically become the PLAY mode and begin performing the next melody.
- For cueing again the melody being reproduced:
At PLAY mode, depress the PLAY button and the REW button simultaneously. This device will detect the interval between melodies with the REVIEW state on, automatically become the PLAY mode, detect the beginning of the melody now being performed and play it from the first again.

TAPE COUNTER AND MEMORY STOP

- To cancel the non-recording state (the REC MUTE state): Press the PAUSE button, and the recorder will cancel the non-recording state and will stay in the standby state.
- To cancel the non-recording state (the REC MUTE state) for further 5 seconds or recording:
Press the REC/REC MUTE button, and the non-recorded part will automatically be extended for another 5 seconds.

NOTE: Note about MUSIC SEARCH action:
MUSIC SEARCH is a function which operates by detecting a comparatively long non-recorded part on the tape. Therefore, MUSIC SEARCH may not operate normally in the following cases.

- Long periods of monosyllabic (softly played music) or non-recorded part on the tape.
- The tape has picked up in a non-recorded interval.
- Non-recorded intervals on the tape are less than 4 seconds in length.
- Noise-emitting electrical appliances are in operation nearby, i.e., Electric razors, drills, refrigerators, etc.

Operation of the Real Time Tape Counter and the Linear Tape Counter

- Real Time Tape Counter
The time of the tape travelling at a constant speed is indicated in "M" (minutes) and "S" (seconds).
A microcomputer measures and displays the time with high precision.
Display example: 32x10, 32 minutes, 10 seconds.
- Linear Tape Counter
The tape speed is indicated with a 4-digit value. The first two digits indicate the "real time" mode, and the last two digits indicate the "M" (minutes) and "S" (seconds) mode.
Display example: 3655 34 minutes, 55 seconds.

- Press the RESET button to reset the counter to:
 - "M" and "S" are not displayed when "VARIABLE" is displayed.
 - They are also not displayed when "FIX" is displayed during the fast-forward, rewind, music search operations or when the STOP button has been pressed during an operation.

(2) Select "FIX" using the TAPE SPEED button. "FIX" appears on the display, and the counter is set to the real time mode, and "M" (minutes) and "S" (seconds) are set to the real time mode.

(3) The counter remains in the real time mode when the play, record forward or rewind mode is selected at this time.

(4) If the music search mode is selected, the counter automatically switches to the linear mode, then switches back to the real time mode once playback begins after the music search operation.

* Note
The method of measuring the time and the precision differ for the real time tape counter (fixed speed travel) and the linear tape counter. The tape may not be returned to the precise position when the fast-forward, rewind, music search or memory rewind operations are used, but this is not a malfunction.

Use the real time tape counter to measure the accumulated time of tape without counting the time in which the pause, stop and rewind operations are performed.

(5) The counter is reset to "0000" when the EJECT button is pressed.

Operation of MEMORY STOP

- During recording or playback operations, MEMORY STOP can be used to locate a particular point on the tape. At the desired point, rest the counter to "00:00". With the MEMORY STOP button in the "ON" position, the deck will stop at the "0000" point (usually "-0002" and "0000") during REWIND operations.

(2) The MEMORY indicator will light when this function is activated.

(3) Notes:

- When the power is turned "OFF", this function is automatically deactivated.
- The MEMORY STOP is accurate to -5 on the counter, and will stop below "0000" and "0000".
- The MEMORY STOP is released by pressing the EJECT button.

Display Back-up

- The DOLBY NR, MPX FILTER, COUNTER VALUE, TAPE SPEED and TAPE SIZE functions are protected for approximately one month by a memory back-up.

Once the back-up period is up, the DOLBY NR and MPX FILTER settings are set to off, the TAPE SIZE setting is reset to "C-90", the Tape Speed setting is set to FIX, and the counter is reset to "0000".

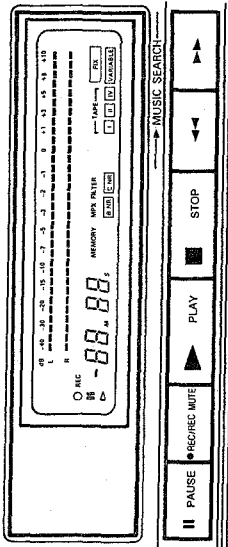

DOLBY B & C NOISE REDUCTION SYSTEM

The Dolby noise reduction system substantially reduces the tape background noise inherent in the cassette medium. Dolby B NR is a much more recent development and represents significantly improvements over Dolby B NR.

Tape background noise consists primarily of high frequency information, which is particularly annoying during soft passages. The Dolby NR system increases the level of low volume mid and high frequency signal during recording and reduces the level of these signals by an identical amount during playback. As a result, the playback signal is identical to the original source signal, but the level of background noise generated by the tape is greatly reduced.

DOLBY HX-PRO HEADROOM EXTENSION SYSTEM

This deck is equipped with the Dolby HX-PRO headroom extension system. Since the system functions automatically during recording, no switching operation or adjustment is required. The system is effective with any type of metal tape.

The Dolby HX-PRO headroom extension system functions during recording to lift up the saturation level in the treble range. Therefore, the treble range components distorted or lost during recording on conventional cassette decks are more faithfully recorded on the new cassette deck.

Features of the Dolby HX-PRO Headroom Extension System

- Performance of Normal and C/O tapes can be upgraded closer to that of Metal tapes.
- The dynamic range in the treble is improved significantly.
- Since no decoding in playback is necessary, the improvement can be easily enjoyed on any high playback system, including portable components and car stereos.
- The system functions whether the Dolby B/C NR is engaged or not.

The operating principle of Dolby C NR is similar to that of Dolby B NR except for the encoding/decoding response curves. The noise reduction effect obtained with Dolby C NR is up to 20 dB, compared to 10 dB with Dolby B NR. In addition, Dolby C NR uses an anti-saturation circuit and spectral leveling circuitry for a significant improvement in the dynamic range of the mid- to high-frequencies.

MAINTENANCE

- **Removing the cassette compartment cover**
It will be more convenient if the cassette compartment cover is removed during the cleaning of the pinchroller and heads, or during demagnetizing of heads.
Follow these procedures:
1. Press the EJECT button to open the cassette compartment.
2. Hold only the cover of the cassette compartment and pull it up. The compartment cover is removed from the front.
When attaching the cassette compartment cover, reverse the above procedure.

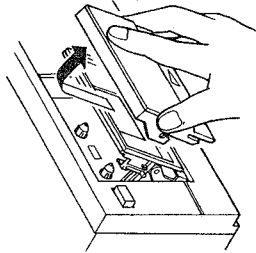

- **Cleaning the Pinchroller and the Capstan**
If the pinchroller or the capstan accumulates dust, tape transport may become unstable resulting from slippage during recording or playback. The tape can also be damaged by being rolled up around the capstan. Clean them with a cotton swab or soft cloth moistened with cleaning solution (such as alcohol).

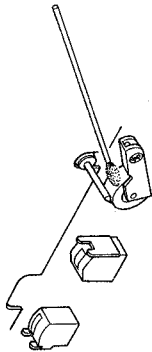

- **Demagnetizing the Heads**
The heads may become magnetized after long usage or by having a strongly magnetized object brought near them. The result is a drop in recording level, drop in playback level, or noise. Clean the heads by using the treble components of pre-recorded tapes and adding noise. Demagnetize the heads on a regular basis.

- **Procedure**
1. Be sure to turn "off" the power supply.
2. Turn the demagnetizer "on" while it is more than 30cm away from the heads. Bring the demagnetizer near the heads and slowly move in a small circle four or five times.
3. Slowly demagnetize away from the heads and turn "off" the power of the demagnetizer when it is about 30cm away from the heads.

- **Head Cleaning**
After long use, tape coating or dust may adhere to the heads, causing deterioration of sound. Clean them regularly. Use a cotton swab moistened with cleaning solution (such as alcohol).
Note:
1. Some cleaning cassettes on the market have a strong abrasive effect and scratch the heads. Use cotton swab instead of cleaning cassettes.
2. Since the use of metal tapes is apt to collect more dust on the heads, clean the heads more often to enjoy optimum sound.

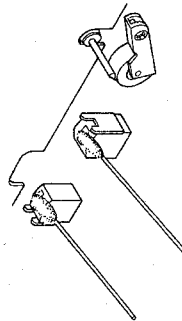

TROUBLESHOOTING

- Make sure of the following before you consider as any malfunctions:
1. Are all the connections correct?
 2. Is the set being operated correctly in accordance with the operating instructions?
 3. Are the speakers and amplifiers functioning correctly?
- If the tape deck still does not function properly, check it again, using the check list below. If the symptom does not correspond to the check list, please contact your DENON dealer.

Problem	Cause	Remedy
Tape does not run.	<ul style="list-style-type: none"> • Power cord is off. • Tape is completely wound up. • Tape is loose. • Cassette is not loaded properly. • Dirty cassette. 	<ul style="list-style-type: none"> • Check power cord. • Rewind tape. • Tighten tape with a pencil, etc. • Load cassette properly. • Replace cassette.
Tape is not recorded when recording button is pressed.	<ul style="list-style-type: none"> • No cassette is loaded. • Erase prevention tab is broken off. 	<ul style="list-style-type: none"> • Load cassette. • Cover hole with plastic tape.
Sound is warbled or distorted.	<ul style="list-style-type: none"> • Heads, capstan or pinchroller are contaminated. • Tape is wound too tight. • Recording input level is too high. • Tape is worn out and has "drop-outs". 	<ul style="list-style-type: none"> • Clean them. • Fast forward or rewind to loosen tape. • Adjust recording input level. • Replace tape.
Excessive noise.	<ul style="list-style-type: none"> • Tape is worn. • Heads, capstan or pinchroller are contaminated. • Heads are magnetized. • Recording input level is too low. 	<ul style="list-style-type: none"> • Replace tape. • Clean them. • Demagnetize heads. • Adjust recording input level.
High frequency (treble) is emphasized.	<ul style="list-style-type: none"> • Dolby NR button is set improperly. 	<ul style="list-style-type: none"> • Set Dolby NR button properly.
High frequency (treble) is lost.	<ul style="list-style-type: none"> • Heads are contaminated. • Tape is worn. 	<ul style="list-style-type: none"> • Clean them. • Replace tape.
When a C/O or metal tape is placed in the deck, a different tape indicator comes on.	<ul style="list-style-type: none"> • The cassette housing is of an older design without tape type detection holes. 	<ul style="list-style-type: none"> • Use the latest cassettes with tape type detection holes.
The cassette tape cannot be removed.	<ul style="list-style-type: none"> • If the power switch is turned off in either the recording or playback mode, and the unit is stopped, the tape lock mechanism will be engaged. The tape cannot be removed, even if the EJECT button is pressed. 	<ul style="list-style-type: none"> • Turn the power switch ON again, and then press the stop (■) button. • Press the stop button once more, and then the EJECT button to remove the cassette tape.

SPECIFICATIONS

Type	Vertical tape loading; 4-track 2-channel stereo cassette deck	Outputs	
Heads	Recording/playback head (Amorphous) × 1 Erase head (Double-gap ferrite) × 1	Line	775 mV (0 dB) output level at maximum (with 47 kohm load, recorded level of 200 pwb/mm)
Motors	Capstan (DC servo motor) × 1 Reel (DC motor) × 1	Headphone	1.2 mW output level at maximum (optimum load impedance 8 ohm ~ 1.2 kohm)
Tape Speed	4.8 cm/sec. (FIX)	Power supply	Voltage is shown on rating label
Variable (PLAY)	Approx. ±12%	Power Consumption	16 W
Fast Forward, Rewind Time	Approx. 110 sec. with a C-60 cassette	Dimensions	483 (W) × 134 (H) × 275 (D) mm
Recording Bias	Approx 105 kHz	Weight	4.7 kg
Overall S/N Ratio (at 3% THD level)	Dolby C NR on: more than 74 dB (CCIR/ARM)	Installation	19-inch rack mountable (3U)
Overall Frequency Response	25 ~ 19,000 Hz ±3 dB (at -20 dB, Metal tape)		
Channel Separation	More than 40 dB (at 1 kHz)	■ Above specifications and design styling are subject to change for improvement.	
Crosstalk	More than 65 dB (at 1 kHz)	■ Dolby noise reduction and HX Pro headroom extension manufactured under license from Dolby Laboratories Licensing Corporation. HX Pro originated by Bang & Olufsen.	
Wow & Flutter	0.055% WRMS (JIS method), ±0.14% w. peak	"DOLBY", the double-D symbol  and "HX PRO" are trademarks of Dolby Laboratories Licensing Corporation.	
Inputs			
Line	80 mV (-20 dBm) input level at maximum Input impedance: 50 kohm unbalanced		

Best results will be obtained with use of DENON DX and HD Series cassette tapes.

BLOCK DIAGRAM

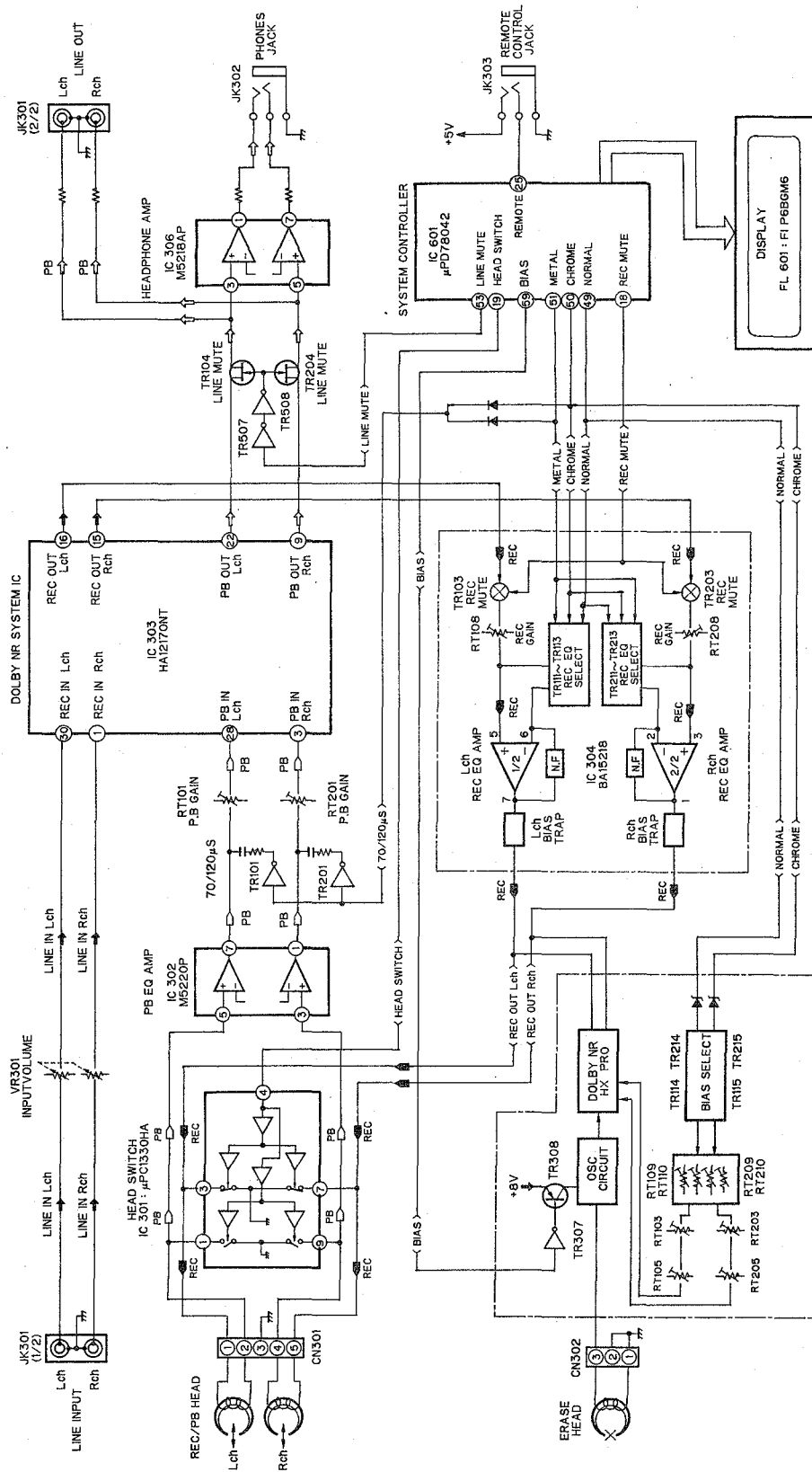

LEVEL DIAGRAM

PLAYBACK SYSTEM
TCC-130 DOLBY B-TYPE
400 Hz 200 nwb/m

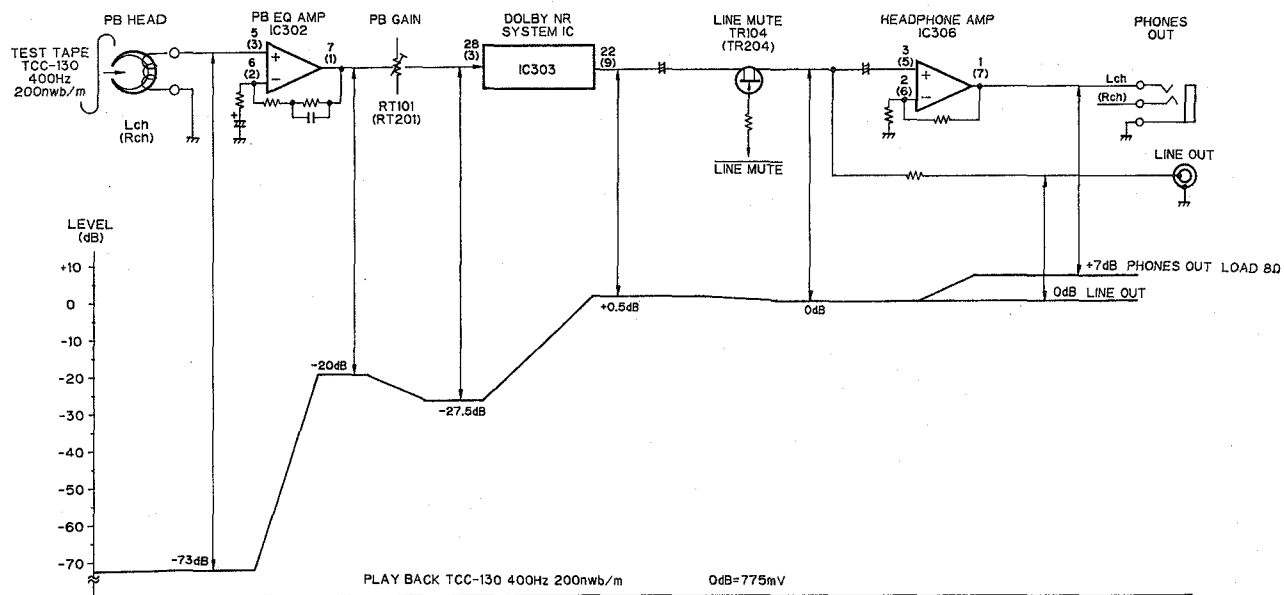

RECORDING SYSTEM
INPUT FREQUENCY
400 Hz

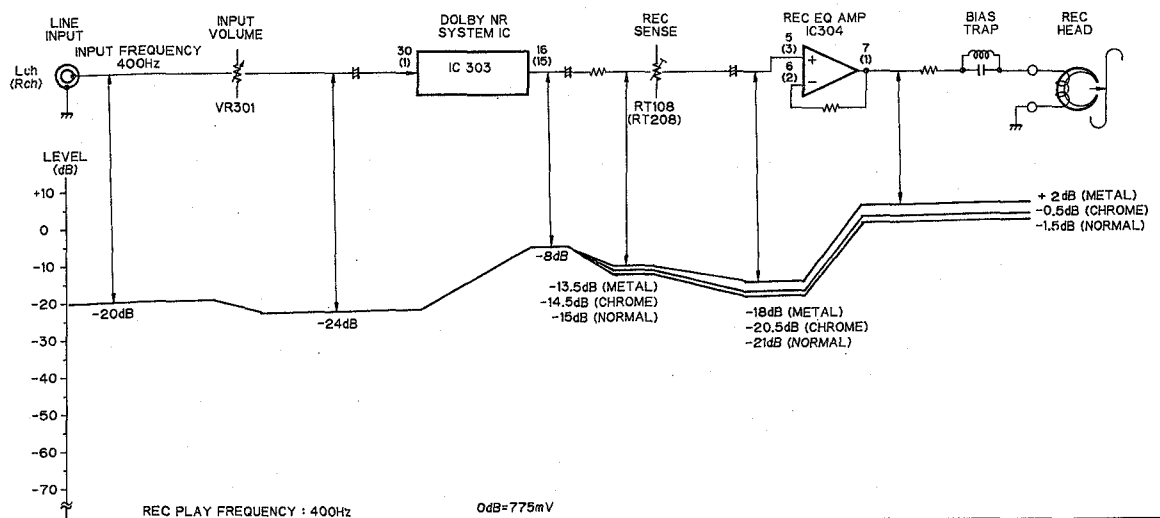

DISASSEMBLY INSTRUCTIONS

1. How to Remove the Front Panel

- (1) Remove the four screws (4 × 12 CBTS-P) in the side of the top cover. Move the top cover to the rear and rise it to remove it.
- (2) Press the eject knob, open the cassette box and remove the cassette window as shown in the figure.
Note: Handle the cassette window with care because it can be scratched easily.
- (3) Remove the three screws (3 × 10 CBTS-P) on top of the front panel, the two hooks on the top, the three hooks on the bottom and pull the unit forward to detach it.

- (3) Disconnect all lead connectors.

C Mechanism	}	W151 (7P) → CN151 Head wire → CN301 Head wire → CN302	} Audio circuit board
Meter circuit board	}	W131 (3P) → CN131 21PFFC → CB121	
- (4) Remove Volume Knob and Volume Knob (C).
- (5) Remove the four retaining screws (2.6 × 6 CBTS(S)-Z) (3 × 10 CBTS(P)-B) holding the Mecha Bracket.
- (6) Remove the Hooks at the left and right of the front face of the Front Esc. Ass'y, and the two hooks on the bottom, Front Ass'y can be removed towards the front.

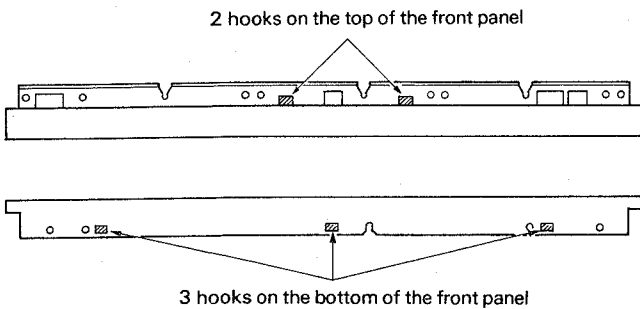
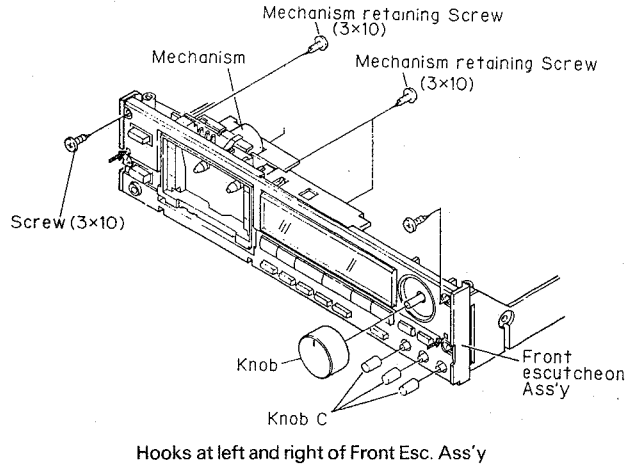
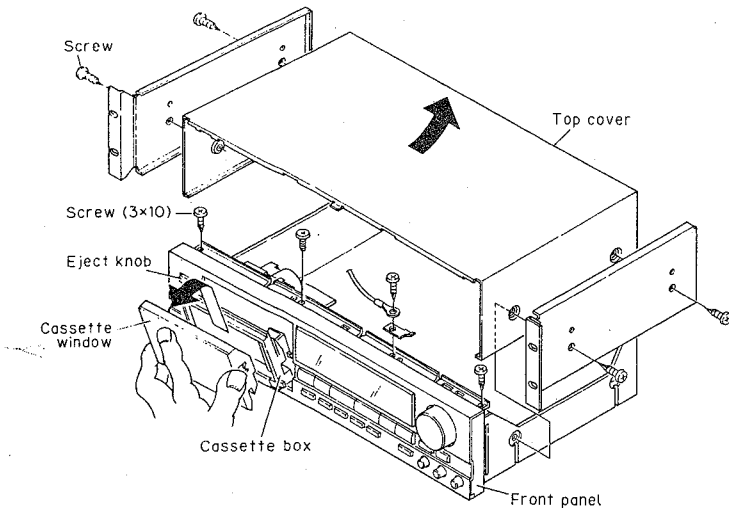

2. How to Remove the Front Escutcheon Ass'y

- (1) Remove the top cover and front panel. (Refer to Step 1.)
- (2) Remove the three retaining screws 3 × 10 CBTS-(P)-B holding the Front Escutcheon at the front.

3. How to Remove the Mechanisms

Remove the four Mechanism retaining screws 3 × 10 CBTS(P)-B and take out C Mechanism.

4. How to Remove the Meter Circuit Board

- (1) Remove the top cover and the front panel. (Refer to section 1.)
- (2) Remove the front esc. ass'y. (Refer to section 2.)
- (3) If you remove the five binding screws (3 × 8 CBTS ·P tight) of the meter circuit board, and loosening the five hooks, the meter circuit board can be taken off.

Note: When replacing the tact switch, check to make sure that it is not floating above the circuit board. If it is floating, the switch will be in the on condition when the set is assembled.



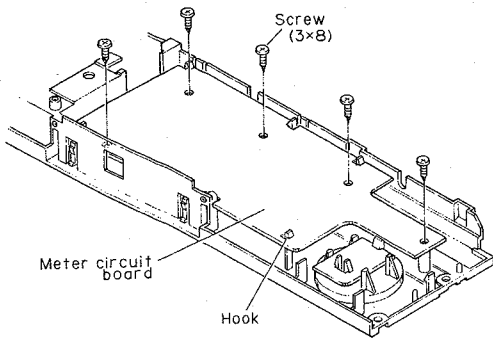

Meter Circuit Board

5. How to Remove the Cassette Door

- (1) Remove the MINI DAMPER retaining screw 3 × 8 CBTS(P)-B and take out the MINI DAMPER.
- (2) Hold the legs of the CASSETTE BOX folded inwards and pull up to remove the CASSETTE BOX and BOX SPRING.

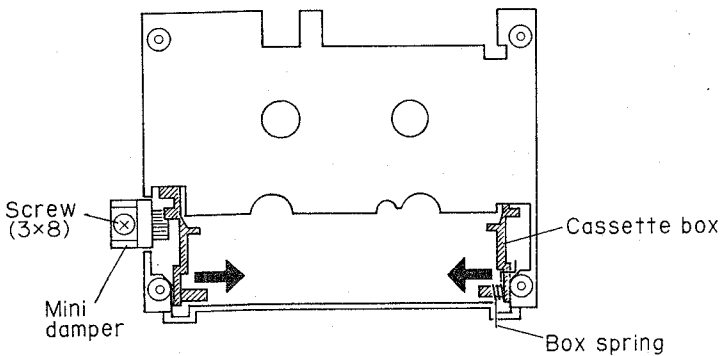

Front surface of Front Ass'y

6. How to Remove the Audio Circuit Board

- (1) Remove the top cover and the front panel. (Refer to section 1.)
- (2) Remove the front esc. ass'y. (Refer to section 2.)
- (3) Remove the connectors from the audio circuit board and power supply circuit board.

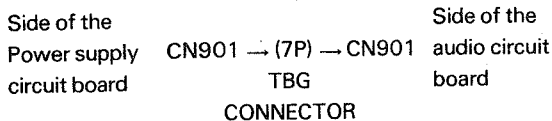

- (4) Remove the screw (3 × 10 CBTS-P tight) (3 × 8 CBTS-S tight) that is holding down the 4P pin jack and circuit board. By removing the two catches (left and right) of the chassis holding down the circuit board in the directions of the arrows shown below, the audio circuit board can be pulled forward.

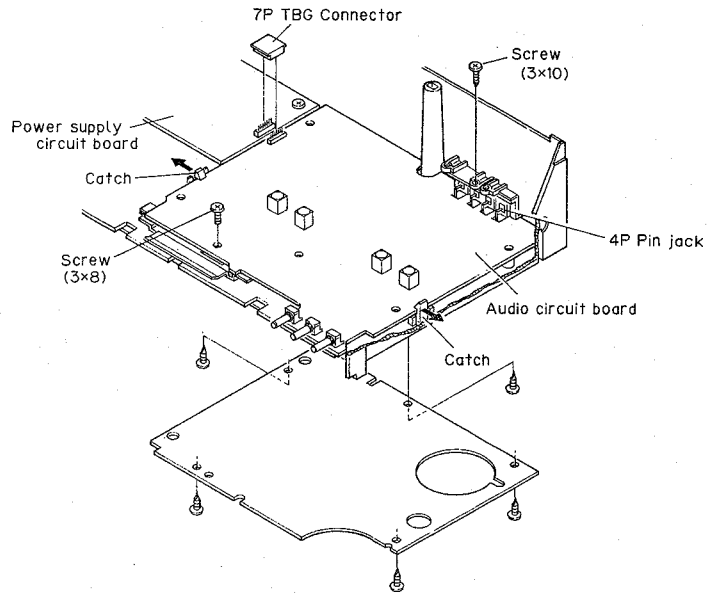

Note:

- Almost all of the service repairs to the audio circuit board can be performed by removing the bottom cover on the rear side of the chassis. Only when it is unavoidable should you refer to the removal method mentioned above.
- When reassembling, follow the procedures in the reverse order. However, if each of the various parts are not assembled properly in their respective position, the set cannot be assembled in some cases. Therefore, check the work of each step carefully when assembling.

7. How to Remove the Power Supply Circuit Board

- (1) Remove the top cover and the front panel. (Refer to section 1.)
- (2) Remove the bushing that is fixing the power supply cord from the chassis.
- (3) When the five screws (4 × 10 CBTS-P tight) (3 × 10 CBTS-P tight) that are holding the power transformer and chicuit board are removed, the power supply circuit board can be removed by raising it.

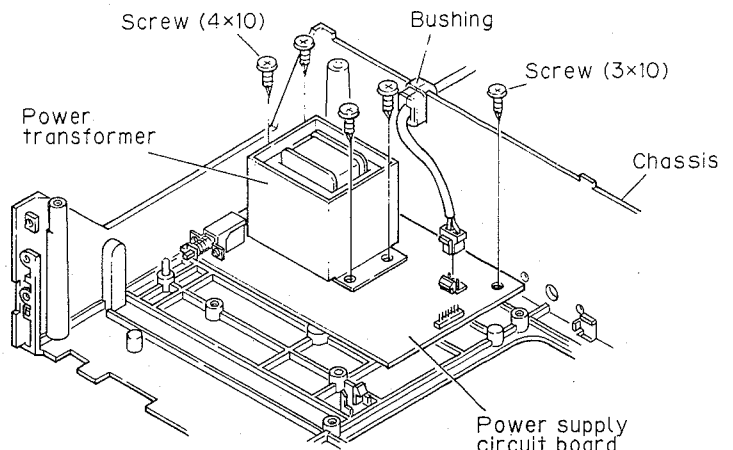

ADJUSTING AND CHECKING THE MECHANISM SECTION

1. Replacing the Pinch Roller (36)

Before replacing the pinch roller, clean the tape contact surface of the pinch roller and the capstan shaft.

Most causes of poor tape transport can be traced to dirty pinch roller and capstan shaft.

Remove the clips that press the pinch roller and pull the pinch roller forward to remove it.

After replacing, run a padless C-90 tape to check for tape curls at the tape guide section of the head.

2. Checking the Pressure Force of the Pinch Roller (36).

In the playback mode, hook a spring weight onto the bracket at the center of the pinch roller. After separating the pinch roller from the capstan shaft, allow the pinch roller to contact the capstan shaft again. Check to make sure the spring weight reads between 250 ~ 350 g when the pinch roller starts to rotate.

Replace the pinch roller (36) when it does not conform to the standard specification values.

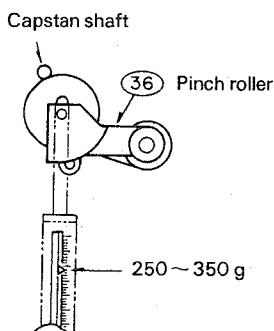

3. Replacing the Record/Playback Head (14)

- (1) How to remove the R/P HEAD.
 - 1) Remove securing screw (1) and azimuth adjusting screw (1) from the record/playback head.
 - 2) Remove the soldered head wire and disassemble the mechanical unit to remove the record/playback head.

- (2) How to assemble the R/P HEAD.
 - Reverse the above 1 procedures for removing the R/P HEAD.

* Solder the HEAD WIRE according to the diagram.

mechanism (recording/playback head)

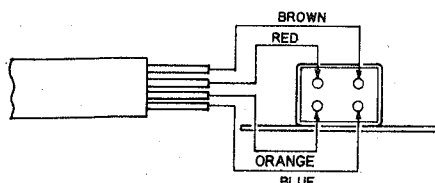

4. Replacing the ERASE HEAD (15)

- (1) Unscrew the erase head holding screws (53).
- (2) By unsoldering the HEAD WIRES can be taken off the mechanism unit.
- (3) When the replacement is completed, secure the screws with the screw lock.

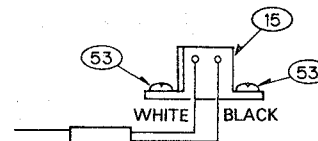

5. Checking the Take-up Torque

Load the cassette type torque meter (SONY TW2111). Check to make sure that the average torque meter reading is within 30-70 g-cm during playback. If it is not within this range, check the voltage (approx. 4V) of the reel motor. If the voltage is low, the torque will be weak; if it is high, the torque will be strong.

6. Checking the FF and REW Torques

Load the cassette type torque meter (SONY TW2231). Check to make sure the torque meter indicates within 90 ~ 180 g-cm at the end of FF and REW.

7. Checking the Back Tension Torque During Record/Playback

Load the cassette type torque meter (SONY TW2111); check to make sure the torque meter reads between 2 ~ 6 g-cm during playback and that there is no unevenness. If it is not within this range, replace the reel ass'y (5) or Washer.

8. Checking the FF and REW Times

Load a C-60 cassette tape (DENON HD7E/60); check to make sure the tape is fast forwarded or rewound within 110 seconds. If it is not within this range, check sections 5 and 6.

9. Checking the Existence of a Cassette Housing and the Operation of the Erase Prevention, Metal and Chrome Switch

Confirm that the sensor arm properly detecting the tape type detection holes on the cassette housing.

ADJUSTING AND CHECKING THE ELECTRICAL SECTION

Caution on adjusting

- 1) Before adjusting, clean the head surface, capstan and the pinch roller with a gauze or a cotton swab moistened with alcohol.
- 2) Demagnetize the R/P HEAD and the E. HEAD with a head eraser.
- 3) Completely demagnetize the adjustment screwdriver.
- 4) Unless instructed otherwise, set the various controls as follows.
 - INPUT volume maximum
 - DOLBY NR switch OFF
 - BIAS FINE volume Center click position
 - BALANCE volume Center click position
 - TAPE SPEED volume Center click position

1. Tape Transport Check

Load the transport check cassette. In the operational mode, illuminate the fixing guides of the R/P HEAD with a lamp and check to make sure the tape edge does not come in contact with the tape guide section.

The tape transport is the most important element in determining the performance of a cassette deck.

Avoid moving the various adjustment screws, nuts, etc., as much as possible. Refer to the pages on "Adjusting and Checking the Mechanism Section" when replacing or adjusting the R/P HEAD.

2. Adjusting the Azimuth

- (1) After completing the tape transport check, load the test tape (A-BEX TCC-153). Fig. 2-1
- (2) Playback the test tape; adjust the azimuth screw so that section A of the resurge wave form is maximum and section B is minimum. Fig. 2-2

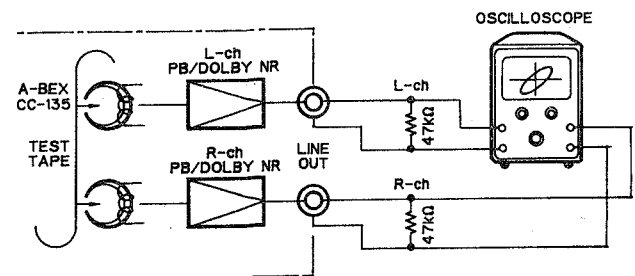

Fig. 2-1

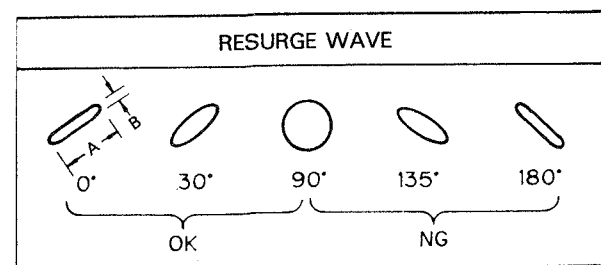

Fig. 2-2

3. Checking and Adjusting the Tape Speed

- (1) Connect the frequency counter to the LINE OUT terminal and load test tape (SONY TY-224).
- (2) Playback a test tape. At about halfway through the tape, where the tape transport is stable, adjust the adjustment points (RT305) on the P.W. BOARD (222 2584 001) so that the frequency counter will have a reading within the range of 3,000 Hz \pm 6 Hz. Fig. 3-1

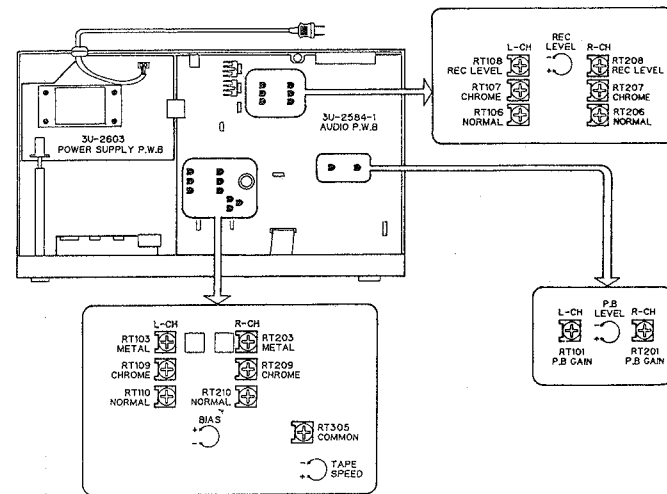
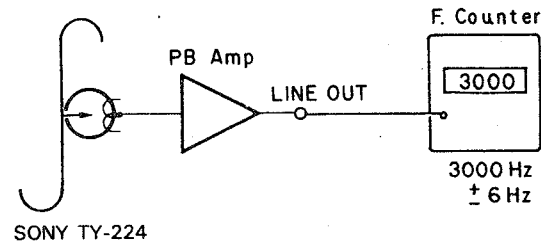

Fig. 3-1

4. Adjusting the Playback and Recording Section

Procedure	Item	Usage tape — input condition	Response	Mode	Adjustment location	Adjustment procedure
1	PLAYBACK GAIN	A-BEX TCC-130	Fig. 4-1	PLAYBACK	RT-101 (L) RT-201 (R)	Adjust the LINEOUT output to 775 mV (0 dBs).
2	P.B. Frequency	A-BEX TCC-162B, 262B	Fig. 4-1	PLAYBACK		Make sure the playback characteristics conform to Figure 4-2.
3	REC/P.B. Frequency	HD7E/60 1 kHz, -40 dB 10 kHz, -40 dB	Fig. 4-2	REC. PLAY ↓ PLAYBACK	RT-103 (L) RT-203 (R)	Record 1 kHz and 10 kHz alternately. Adjust each volume so the 10 kHz playback output is 0.5 dB in relation to the 1 kHz playback output.
4	REC GAIN	HD7E/60 1 kHz, -30 dB	Fig. 4-2	REC. PLAY ↓ PLAYBACK	RT-108 (L) RT-208 (R)	Adjust each volume to the playback output is the same as when the recording monitor is output.
5	REC/P.B. Frequency	HD7E/60 Dolby NR C	Fig. 4-3	REC. PLAY ↓ PLAYBACK		Make sure that the DOLBY NR C recording and playback characteristics conform to Figure 4-3.

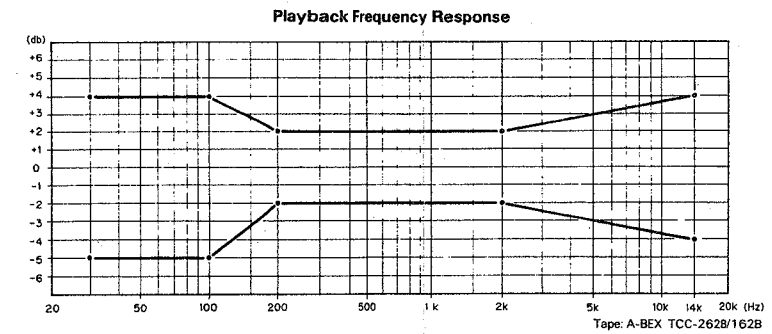

Fig. 4-1

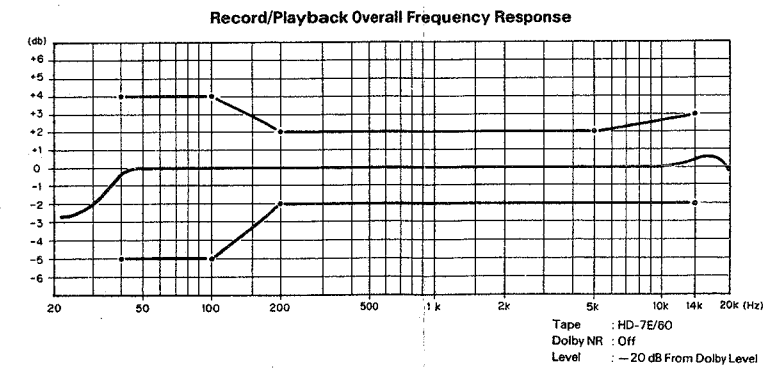

Fig. 4-2

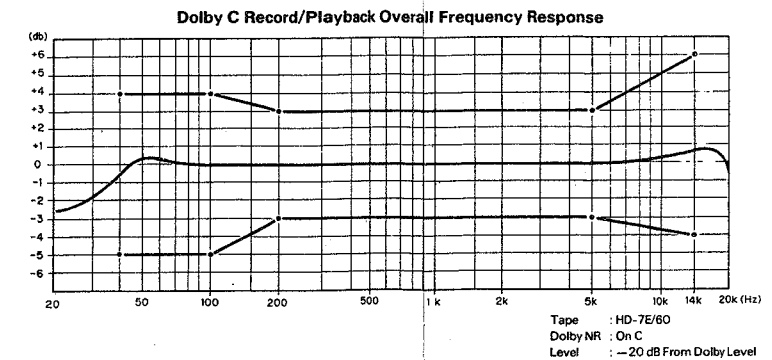

Fig. 4-3

● **Adjusting recording levels**

The trimmer resistors used for making fine adjustments are RT107 and RT207 for the chrome position and RT106 and RT206 for the normal position.

In the case of recording level adjustments, first set the trimmer resistors RT107, RT207, RT106 and RT206 at the centre click and use a chrome tape to adjust the recording level with RT108 (L ch) and RT208 (R ch).

● **Adjusting frequency characteristics**

The trimmer resistors used for making fine adjustments are RT109 and RT209 for the chrome position and RT110 and RT210 for the normal position.

In the case of frequency characteristic adjustments, first set the trimmer resistors RT109, RT209, RT110 and RT210 at the centre click and use a chrome tape to adjust the frequency characteristics with RT103 (L ch) and RT203 (R ch).

* Please refer to the illustration below (Figure 4-4) for adjusting the trimmer resistors.

EQUIPMENT FOR ADJUSTING AND CHECKING

1) MEASURING TAPE			TYPE NAME, BRAND AND USES
TYPE NAME	BRAND	USES	
TW-2111A/2121A	SONY	Checking the Take-up Torque and Back Tension.	
TY-2231	SONY	Checking the FF and REW Torque.	
HD-7E/60	DENON	Checking the FF and REW Times.	
TCC-153	A-BEX	Adjusting the Azimuth.	
TY-224	SONY	Checking and Adjusting the Tape Speed.	
TCC-130	A-BEX	Adjusting the Playback Level.	
TCC-162/262B	A-BEX	Checking the Playback Frequency Response.	
TCC-902	A-BEX	Transport checking cassette tape.	

2) MEASURING INSTRUMENT		
Tension gauge		
Audio signal generator		
Variable resistance attenuator		
Electronic voltmeter		
Oscilloscope		
Frequency counter		
Adjustment screwdriver		
Trap coil adjustment square stick		

Fig. 4-4

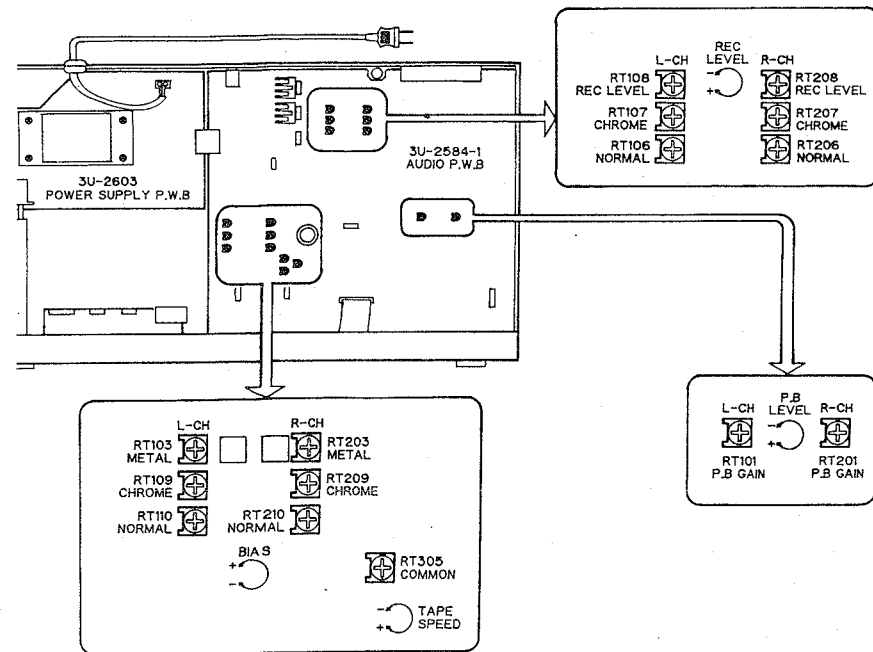

PARTS LIST OF 3U-2584 AUDIO/METER UNIT

Ref. No.	Part No.	Part Name	Remarks
SEMICONDUCTORS GROUP			
IC301	262 0590 001	IC UPC1330HA	
IC302	262 0864 006	IC UPC4570C	
IC303	263 0720 004	IC HA12170NT	
IC304	263 0565 007	IC BA15218	
IC306	263 0711 000	IC M5218AP	
IC307	263 0354 001	IC UPC1297CA	
IC309	263 0565 007	IC BA15218	
IC501	262 0447 009	IC BA6109U1	
IC601	262 1818 006	μ Computer UPD78042-027	
IC602	262 1711 909	IC X24C00S	
IC901	263 0656 000	IC MC7808	
IC902	263 0657 009	IC MC7908	
IC903	263 0648 005	IC MC7806CT	
IC904	263 0432 907	IC NJM78L05AT	
TR101	269 0074 907	Transistor DTA114TS(10K)	Built in Resistor
TR102	269 0102 905	Transistor DTC124EKT146	Built in Resistor
TR103	273 0245 900	Transistor 2SC2603E/F T	
TR104	275 0048 912	Transistor 2SK381(B)/(C)-T	
TR108, 109	269 0088 906	Transistor DTC114TKT96	Built in Resistor
TR111	269 0088 906	Transistor DTC114TKT96	Built in Resistor
~113			
TR114, 115	269 0102 905	Transistor DTC124EKT146	Built in Resistor
TR201	269 0074 907	Transistor DTA114TS(10K)	Built in Resistor
TR202	269 0102 905	Transistor DTC124EKT146	Built in Resistor
TR203	273 0245 900	Transistor 2SC2603E/F T	
TR204	275 0048 912	Transistor 2SK381(B)/(C)-T	
TR208, 209	269 0088 906	Transistor DTC114TKT96	Built in Resistor
TR211	269 0088 906	Transistor DTC114TKT96	Built in Resistor
~213			
TR214, 215	269 0102 905	Transistor DTC124EKT146	Built in Resistor
TR307	269 0040 902	Transistor DTC144ES(47K-47K)	Built in Resistor
TR308	272 0025 907	Transistor 2SB562(C)TF	
TR309, 310	273 0245 900	Transistor 2SC2603E/F T	
TR370	269 0018 905	Transistor DTC143ES(4.7K-4.7K)	Built in Resistor
TR371	269 0022 904	Transistor DTA143ES(4.7K-4.7K)	Built in Resistor
TR507	269 0062 906	Transistor DTC124ES(22K-22K)	Built in Resistor
TR508	269 0016 907	Transistor DTA144WS(47K-22K)	Built in Resistor
TR515	269 0018 905	Transistor DTC143ES(4.7K-4.7K)	Built in Resistor
TR552, 553	269 0091 906	Transistor DTC143TKT96	Built in Resistor
TR554	274 0036 905	Transistor 2SD468(C)TF	
~556			
TR557	269 0015 908	Transistor DTC124XS(22K-47K)	Built in Resistor
TR558	269 0082 902	Transistor DTC114EKT96	Built in Resistor
TR559	269 0054 901	Transistor DTC144EKT96	Built in Resistor
TR560, 561	271 0183 927	Transistor 2SA933(R/S)T93	
TR601	269 0122 901	Transistor DTC144WKT146	Built in Resistor
TR904	272 0025 907	Transistor 2SB562(C)TF	
D155	276 0432 903	Diode 1SS270A TE	
D255	276 0432 903	Diode 1SS270A TE	
D315, 316	276 0432 903	Diode 1SS270A TE	
D320	276 0432 903	Diode 1SS270A TE	
D503	276 0553 905	Diode 1SR35-200A(T93X)	
D517, 518	276 0432 903	Diode 1SS270A TE	
D553	276 0553 905	Diode 1SR35-200A(T93X)	
D554	276 0432 903	Diode 1SS270A TE	

Ref. No.	Part No.	Part Name	Remarks
D601, 602	276 0432 903	Diode 1SS270A TE	
D901 ~904	276 0553 905	Diode 1SR35-200A(T93X)	
D910, 911	276 0553 905	Diode 1SR35-200A(T93X)	
D915, 916	276 0553 905	Diode 1SR35-200A(T93X)	
ZD304, 305	276 0468 906	Zener Diode HZS9B-1TD	
ZD410	276 0468 906	Zener Diode HZS9B-1TD	
ZD531	276 0468 906	Zener Diode HZS9B-1TD	
ZD551	276 0457 904	Zener Diode HZS4C-1TD	
ZD552	276 0465 909	Zener Diode HZS7B-1TD	
ZD907	276 0463 901	Zener Diode HZS6C-1TD	
ZD912	276 0482 908	Zener Diode HZS27-1TD	
ZD913	276 0472 905	Zener Diode HZS11C-1TD	
RESISTORS GROUP (not included Carbon Film ±5% 1/4 W type)			
VR101	211 6093 967	Adjust 47K ohm	V06PB473T
VR103	211 6093 967	Adjust 47K ohm	V06PB473T
VR105	211 0706 001	Variable 1K ohm (BIAS)	V09V25FB502K
VR106, 107	211 6093 912	Adjust 4.7K ohm	V06PB472T
VR108	211 6093 954	Adjust 22K ohm	V06PB223T
VR109	211 6093 912	Adjust 4.7K ohm	V06PB472T
VR110	211 6093 938	Adjust 1K ohm	V06PB102T
VR201	211 6093 967	Adjust 47K ohm	V06PB473T
VR203	211 6093 967	Adjust 47K ohm	V06PB473T
VR205	211 0706 001	Variable 1K ohm (BIAS)	V09V25FB502K
VR206, 207	211 6093 912	Adjust 4.7K ohm	V06PB472T
VR208	211 6093 954	Adjust 22K ohm	V06PB223T
VR209	211 6093 912	Adjust 4.7K ohm	V06PB472T
VR210	211 6093 938	Adjust 1K ohm	V06PB102T
VR301	211 0570 004	Variable 100K ohm (INPUT)	V14V25FA104R
VR304	211 0799 005	Variable 5K ohm	V09V25FB502K
VR305	211 6093 912	Adjust 4.7K ohm	V06PB472T
R101	247 0010 987	Chip 27K ohm	RM73B-273JT
R102	247 0011 973	Chip 62K ohm	RM73B-623JT
R103	247 0005 947	Chip 150 ohm	RM73B-151JT
R104	247 0010 974	Chip 24K ohm	RM73B-243JT
R105	247 0014 912	Chip 620K ohm	RM73B-624JT
R111	247 0008 960	Chip 3.3K ohm	RM73B-332JT
R112	247 0009 943	Chip 6.8K ohm	RM73B-682JT
R118	247 0009 985	Chip 10K ohm	RM73B-103JT
R120	247 0010 929	Chip 15K ohm	RM73B-153JT
R129	247 0009 956	Chip 7.5K ohm	RM73B-752JT
R132	247 0006 962	Chip 470 ohm	RM73B-471JT
R135	247 0009 901	Chip 4.7K ohm	RM73B-472JT
R140	247 0011 986	Chip 68K ohm	RM73B-683JT
R141	247 0011 944	Chip 47K ohm	RM73B-473JT
R142	247 0012 927	Chip 100K ohm	RM73B-104JT
R143	247 0010 929	Chip 15K ohm	RM73B-153JT
R144	247 0011 902	Chip 33K ohm	RM73B-333JT
R145	247 0005 905	Chip 100 ohm	RM73B-101JT
R150	247 0012 969	Chip 150K ohm	RM73B-154JT
R151	247 0010 929	Chip 15K ohm	RM73B-153JT
A R152	241 2315 912	Carbon Film 10 ohm 1/4 W (Fusible)	RD14B2E100GFRST
R156	247 0005 905	Chip 100 ohm	RM73B-101JT
R160	247 0010 961	Chip 22K ohm	RM73B-223JT
R161	247 0012 927	Chip 100K ohm	RM73B-104JT
R162	247 0010 961	Chip 22K ohm	RM73B-223JT
R163	247 0006 988	Chip 560 ohm	RM73B-561JT

Ref. No.	Part No.	Part Name	Remarks
R164	247 0010 990	Chip 30K ohm	RM73B-303JT
R175	247 0014 967	Chip 1M ohm	RM73B-105JT
R177	247 0007 974	Chip 1.3K ohm	RM73B-132JT
R180	247 0007 958	Chip 1.1K ohm	RM73B-112JT
R181	247 0007 945	Chip 1K ohm	RM73B-102JT
R185	247 0013 984	Chip 470K ohm	RM73B-474JT
R189	247 0017 906	Chip 10M ohm	RM73B-106KT
R199	247 0010 974	Chip 24K ohm	RM73B-243JT
R201	247 0010 987	Chip 27K ohm	RM73B-273JT
R202	247 0011 973	Chip 62K ohm	RM73B-623JT
R203	247 0005 947	Chip 150 ohm	RM73B-151JT
R204	247 0010 974	Chip 24K ohm	RM73B-243JT
R205	247 0014 912	Chip 620K ohm	RM73B-624JT
R212	247 0009 943	Chip 6.8K ohm	RM73B-682JT
R218	247 0009 985	Chip 10K ohm	RM73B-103JT
R220	247 0010 929	Chip 15K ohm	RM73B-153JT
R229	247 0009 956	Chip 7.5K ohm	RM73B-752JT
R232	247 0006 962	Chip 470 ohm	RM73B-471JT
R235	247 0009 901	Chip 4.7K ohm	RM73B-472JT
R240	247 0011 986	Chip 68K ohm	RM73B-683JT
R241	247 0011 944	Chip 47K ohm	RM73B-473JT
R242	247 0012 927	Chip 100K ohm	RM73B-104JT
R243	247 0010 929	Chip 15K ohm	RM73B-153JT
R244	247 0011 902	Chip 33K ohm	RM73B-333JT
R245	247 0005 905	Chip 100 ohm	RM73B-101JT
R250	247 0012 969	Chip 150K ohm	RM73B-154JT
R251	247 0010 929	Chip 15K ohm	RM73B-153JT
R252	241 2315 912	Carbon Film 10 ohm 1/4 W (Fusible)	RD14B2E100GFRST
R253	247 0009 914	Chip 5.1K ohm	RM73B-512JT
R256	247 0005 905	Chip 100 ohm	RM73B-101JT
R260	247 0010 961	Chip 22K ohm	RM73B-223JT
R261	247 0012 927	Chip 100K ohm	RM73B-104JT
R262	247 0010 961	Chip 22K ohm	RM73B-223JT
R263	247 0006 988	Chip 560 ohm	RM73B-561JT
R264	247 0010 990	Chip 30K ohm	RM73B-303JT
R275	247 0014 967	Chip 1M ohm	RM73B-105JT
R277	247 0007 974	Chip 1.3K ohm	RM73B-132JT
R280	247 0007 958	Chip 1.1K ohm	RM73B-112JT
R281	247 0007 945	Chip 1K ohm	RM73B-102JT
R285	247 0013 984	Chip 470K ohm	RM73B-474JT
R289	247 0017 906	Chip 10M ohm	RM73B-106KT
R299	247 0010 974	Chip 24K ohm	RM73B-243JT
R301	247 0010 961	Chip 22K ohm	RM73B-223JT
R302	247 0007 945	Chip 1K ohm	RM73B-102JT
R321	247 0010 945	Chip 18K ohm	RM73B-183JT
R330	247 0009 985	Chip 10K ohm	RM73B-103JT
R331	247 0009 901	Chip 4.7K ohm	RM73B-472JT
R334	247 0009 901	Chip 4.7K ohm	RM73B-472JT
R336, 337	247 0008 957	Chip 3K ohm	RM73B-302JT
R360, 361	247 0012 943	Chip 120K ohm	RM73B-124JT
R362, 363	241 2315 925	Carbon Film 22 ohm 1/4W (Fusible)	RD14B2E220GFRST
R364	247 0009 901	Chip 4.7K ohm	RM73B-472JT
R365	247 0009 985	Chip 10K ohm	RM73B-103JT
R370, 371	247 0001 983	Chip 4.7 ohm	RM73B-4R7KT
R501 ~506	247 0012 927	Chip 100K ohm	RM73B-104JT
R507	247 0011 944	Chip 47K ohm	RM73B-473JT
R508	247 0015 940	Chip 2.2M ohm	RM73B-225JT
R510, 511	247 0011 944	Chip 47K ohm	RM73B-473JT
R513, 514	247 0012 927	Chip 100K ohm	RM73B-104JT
R516	247 0018 905	Chip 0 ohm	RM73B-0R0KT

Ref. No.	Part No.	Part Name	Remarks
R540	247 0009 985	Chip 10K ohm	RM73B-103JT
R556	247 0008 928	Chip 2.2K ohm	RM73B-222JT
R557	247 0009 985	Chip 10K ohm	RM73B-103JT
R558	247 0010 961	Chip 22K ohm	RM73B-223JT
R559	247 0009 985	Chip 10K ohm	RM73B-103JT
R560	247 0007 945	Chip 1K ohm	RM73B-102JT
R561	244 2055 970	Metal oxide film 560 ohm 1 W	RS14B3A560JST(S)
R562	247 0007 987	Chip 1.5K ohm	RM73B-152JT
R563	241 2315 912	Carbon Film 10 ohm 1/4 W (Fusible)	RD14B2E100GFRST
R564, 565	247 0009 985	Chip 10K ohm	RM73B-103JT
R571	247 0018 905	Chip 0 ohm	RM73B-0R0KT
R573	247 0009 956	Chip 7.5K ohm	RM73B-752JT
R574	247 0009 985	Chip 10K ohm	RM73B-103JT
R577	247 0012 927	Chip 100K ohm	RM73B-104JT
R602	247 0010 958	Chip 20K ohm	RM73B-203JT
R603, 604	247 0007 945	Chip 1K ohm	RM73B-102JT
R605, 606	247 0012 927	Chip 100K ohm	RM73B-104JT
R612	247 0007 945	Chip 1K ohm	RM73B-102JT
R613	247 0009 985	Chip 10K ohm	RM73B-103JT
R650	247 0005 947	Chip 150 ohm	RM73B-151JT
R652	247 0005 963	Chip 180 ohm	RM73B-181JT
R654	247 0006 917	Chip 300 ohm	RM73B-301JT
R660	247 0005 947	Chip 150 ohm	RM73B-151JT
R662	247 0005 963	Chip 180 ohm	RM73B-181JT
R664	247 0006 917	Chip 300 ohm	RM73B-301JT
R666	247 0006 956	Chip 430 ohm	RM73B-431JT
R670	247 0005 947	Chip 150 ohm	RM73B-151JT
R672	247 0005 963	Chip 180 ohm	RM73B-181JT
R674	247 0006 917	Chip 300 ohm	RM73B-301JT
R676	247 0006 959	Chip 430 ohm	RM73B-431JT

CAPACITORS GROUP

C101	257 0006 943	Chip (Ceramic) 560 pF/50 V	CC73SL1H561JT
C103	257 0009 979	Chip (Ceramic) 0.0056 μF/50 V	CK73B1H562KT
C109	257 0009 937	Chip (Ceramic) 0.0027 μF/50 V	CK73B1H272KT
C127	257 0005 902	Chip (Ceramic) 150 pF/50 V	CC73SL1H151JT
C142	257 0005 944	Chip (Ceramic) 220 pF/50 V	CC73SL1H151JT
C150	257 0008 996	Chip (Ceramic) 0.0012 μF/50 V	CK73B1H122KT
C151	257 0010 900	Chip (Ceramic) 0.01 μF/50 V	CK73B1H103KT
C152	257 0004 961	Chip (Ceramic) 100 pF/50 V	CC73SL1H101JT
C153	253 1131 909	Chip (Ceramic) 390 pF/500 V	CK45B2H391KT
C154	257 0011 967	Chip (Ceramic) 0.033 μF/25 V	CK73B1E333KT
C155	257 0010 942	Chip (Ceramic) 0.022 μF/50 V	CK73B1H223KT
C201	257 0006 943	Chip (Ceramic) 560 pF/50 V	CC73SL1H561JT
C203	257 0009 979	Chip (Ceramic) 0.0056 μF/50 V	CK73B1H562KT
C209	257 0009 937	Chip (Ceramic) 0.0027 μF/50 V	CK73B1H272KT
C227	257 0005 902	Chip (Ceramic) 150 pF/50 V	CC73SL1H151JT
C242	257 0005 944	Chip (Ceramic) 220 pF/50 V	CC73SL1H151JT
C250	257 0008 996	Chip (Ceramic) 0.0012 μF/50 V	CK73B1H122KT
C251	257 0010 900	Chip (Ceramic) 0.01 μF/50 V	CK73B1H103KT
C252	257 0004 961	Chip (Ceramic) 100 pF/50 V	CC73SL1H101JT
C253	253 1131 909	Chip (Ceramic) 390 pF/500 V	CK45B2H391KT
C254	257 0011 967	Chip (Ceramic) 0.033 μF/25 V	CK73B1E333KT
C255	257 0010 942	Chip (Ceramic) 0.022 μF/50 V	CK73B1H223KT
C350	257 0013 907	Chip (Ceramic) 0.047 μF/50 V	CK73B1H473ZT
C352	257 0002 921	Chip (Ceramic) 10 pF/50 V	CC73SL1H100DT
C353	257 0009 940	Chip (Ceramic) 0.0033 μF/50 V	CK73B1H332KT
C354	257 0009 940	Chip (Ceramic) 0.0033 μF/50 V	CK73B1H332KT
C355	257 0010 900	Chip (Ceramic) 0.01 μF/50 V	CK73B1H103KT
C356	257 0009 995	Chip (Ceramic) 0.0082 μF/50 V	CK73B1H822KT
C501 ~504	257 0008 983	Chip (Ceramic) 0.001 μF/50 V	CK73B1H102KT
C507	257 0008 983	Chip (Ceramic) 0.001 μF/50 V	CK73B1H102KT

Ref. No.	Part No.	Part Name	Remarks
C509, 510	257 0010 900	Chip (Ceramic) 0.01 μ F/50 V	CK73B1H103KT
C512, 513	257 0008 983	Chip (Ceramic) 0.001 μ F/50 V	CK73B1H102KT
C515, 516	257 0008 983	Chip (Ceramic) 0.001 μ F/50 V	CK73B1H102KT
C517	257 0013 910	Chip (Ceramic) 0.068 μ F/50 V	CK73B1H683ZT
C551, 552	257 0010 900	Chip (Ceramic) 0.01 μ F/50 V	CK73B1H103KT
C553	257 0011 941	Chip (Ceramic) 0.022 μ F/25 V	CK73B1E223KT
C554	257 0010 900	Chip (Ceramic) 0.01 μ F/50 V	CK73B1H103KT
C555	254 4403 718	Electrolytic 1000 μ F/25 V	CE04W1E102MC SMG
C601	257 0008 983	Chip (Ceramic) 0.001 μ F/50 V	CK73B1H102KT
-603			
C604	257 1015 917	Chip (Ceramic) 0.068 μ F/50 V	CK73B1H683ZT
C902, 903	254 4403 718	Electrolytic 1000 μ F/25 V	CE04W1E102MC SMG
C906, 907	257 0013 910	Chip (Ceramic) 0.068 μ F/50 V	CK73B1H683ZT
C908	254 4403 721	Electrolytic 2200 μ F/25 V	CE04W1E222MC SMG
C910	254 4250 796		CE04W0J472MC (SMC)
C911	257 0013 910	Chip (Ceramic) 0.068 μ F/50 V	CK73B1H683ZT
C913	254 4414 707	Electrolytic 470 μ F/50 V	CE04W1H471MC SMG
C918	257 0013 910	Chip (Ceramic) 0.068 μ F/50 V	CK73B1H683ZT
R126	257 0008 983	Chip (Ceramic) 0.001 μ F/50 V	CK73B1H102KT
R169	257 0008 967	Chip (Ceramic) 680 pF/50 V	CK73B1H681KT
R226	257 0008 983	Chip (Ceramic) 0.001 μ F/50 V	CK73B1H102KT
R269	257 0008 967	Chip (Ceramic) 680 pF/50 V	CK73B1H681KT

OTHER PARTS

L101	232 0109 003	MPX Filter	
L103	235 0020 945	Inductor 153JT	
L104	235 0020 916	Inductor 822JT	
L105	239 0010 009	HX Step up coil	
L201	232 0109 003	MPX Filter	
L203	235 0020 945	Inductor 153JT	
L204	235 0020 916	Inductor 822JT	
L205	239 0010 009	HX Step up coil	
L301	231 0078 005	OSC Coil	
XT501	399 0107 007	Ceramic Oscillator	CTS4.19MGW
FL601	393 8002 009	FL Tube	FIP6BGM6
SW610, 612, 614, 616, 620, 622, 624, 626, 628, 630, 632, 634, 636, 638	212 5604 910	Tact Switch	
JK301	204 8261 003	4P Pin Jack	LINE IN, OUT
JK302	204 8264 071	Head phone Jack	HEAD PHONE
JK303	204 8416 007	Mini Jack	CD SYNCRO.
CN121	205 0491 049	21P FFC Connector Base	
CN122	205 0343 061	6P Connector Base (KR-PH)	
CN131	205 0343 032	3P Connector Base (KR-PH)	
CN141	205 0343 058	5P Connector Base (KR-PH)	
CN191	205 0711 075	7P TBG Connector Base	
CN301	205 0343 058	5P Connector Base (KR-PH)	
CN302	205 0343 032	3P Connector Base (KR-PH)	
W122	204 0265 078	6P KR-DA Connector Cord	

Ref. No.	Part No.	Part Name	Remarks
W131	203 4753 046	3P KR-DA Connector Cord	
W141	203 8207 006	5P KR-DA Connector Cord	
W151	204 2326 009	7P KR-DA Connector Cord	
W251	203 6236 066	4P KR-DA Connector Cord	
W252	203 8216 042	5P KR-DA Connector Cord	

WARNING:

- Parts marked with \triangle and/shading have special characteristics important to safety.
Be sure to use the specified parts for replacement.

PARTS LIST OF 3U-2603 POWER SUPPLY UNIT

Ref. No.	Part No.	Part Name	Remarks
SW?	212 0286 003	Power Switch	
CN191	205 0711 075	7P TBG Connector Base	
CN901	205 0581 001	2P VH Connector Base	For AC Cord
\triangle C901	253 8014 702	Ceramic Capacitor 0.01 μ F/400VAC	CK45F2GAC103MC
\triangle	445 0056 008	Cord Bush	
\triangle	206 2089 009	AC Cord With Connector	Europe
\triangle	206 2090 108	AC Cord With Connector	U.K.
\triangle	206 2100 001	AC Cord With Connector	U.S.A. Canada
\triangle	206 2088 000	AC Cord With Connector	Multi-Voltage
\triangle	233 5985 005	Power Transformer	Europe-U.K.
\triangle	233 5758 009	Power Transformer	U.S.A. Canada
\triangle	233 5760 000	Power Transformer	Multi-Voltage
\triangle F901	206 1031 045	Fuse (0.25A)	Multi-Voltage Only
\triangle	202 0022 008	Fuse Holder	Multi-Voltage Only
\triangle	212 4698 008	Voltage Selector (D)	Multi-Voltage Only

WARNING:

- Parts marked with \triangle and/shading have special characteristics important to safety.

PARTS LIST OF EXPLODED VIEW

Ref. No.	Part No.	Part Name	Remarks
● 1	411 1000 555	CHASSIS	Europe, U.K.
●	411 1000 584	CHASSIS	U.S.A., Canada
●	411 1000 568	CHASSIS	Multi-Voltage
● 2	412 2523 115	EARTH BRACKET	
● 3	105 0787 000	BOTTOM COVER	
4	338 0168 009	CASSETTE MECHANISM	
△ 5	233 5985 005	POWER TRANSFORMER	Europe, U.K.
△	233 5758 009	POWER TRANSFORMER	U.S.A., Canada
△	233 5760 000	POWER TRANSFORMER	Multi-Voltage
△ 6	212 0286 003	POWER SWITCH	(SW001)
△ 7	206 2089 106	AC CORD WITH CONNECTOR	Europe
△	206 2090 205	AC CORD WITH CONNECTOR	U.K.
△	206 2100 001	AC CORD WITH CONNECTOR	U.S.A., Canada
△	206 2088 000	AC CORD WITH CONNECTOR	Multi-Voltage
△ 8	445 0056 008	CORD BUSH	
● 9	412 2008 012	BUSHING PLATE	
● 11	414 0637 009	SHIELD LABEL	
12	104 0208 214	FOOT ASS'Y	
● 13	3U- 2584	AUDIO/METER P.W.B. UNIT	
● 13-1	—	AUDIO P.W.B.	
● 13-2	—	METER P.W.B.	
● 13-3	—	H/P JACK P.W.B.	
● 13-4	—	INPUT VOL. P.W.B.	
● 14	3U-2603	POWER TRANS. P.W.B. UNIT	
15	205 0712 074	7P TBG-S CONNECTOR	
16	204 8261 003	4P PIN JACK	(JK301)
23	393 8002 009	FL TUBE (FIP6BGM6)	(FL601)
25	431 0310 004	POWER SWITCH LEVER ASS'Y	
	431 0310 017	POWER SWITCH LEVER ASS'Y	U.S.A., Canada Only
26	113 1481 335	PUSH KNOB (B)	
	113 1481 348	PUSH KNOB (B)	U.S.A., Canada Only
27	113 1436 364	FUNCTION KEY	
	113 1436 377	FUNCTION KEY	U.S.A., Canada Only
28	113 1480 200	PUSH KNOB (A)	
	113 1480 213	PUSH KNOB (A)	U.S.A., Canada Only
29	113 1438 003	EJECT KNOB	
	113 1438 016	EJECT KNOB	U.S.A., Canada Only
30	112 0515 131	VOLUME KNOB	
	112 0515 128	VOLUME KNOB	U.S.A., Canada Only
31	112 0727 000	VOLUME KNOB (C)	
● 33	103 1509 362	FRONT ESCUTCHEON ASS'Y	
●	103 1509 375	FRONT ESCUTCHEON ASS'Y	U.S.A., Canada Only
● 34	144 2309 106	FRONT PANEL	
35	103 1511 305	CASSETTE BOX	
	103 1511 318	CASSETTE BOX	U.S.A., Canada Only
36	463 0655 009	CASSETTE SPRING	
37	463 0659 018	BOX SPRING (R)	
38	103 1451 232	CASSETTE WINDOW (A) ASS'Y	
	103 1451 245	CASSETTE WINDOW (A) ASS'Y	U.S.A., Canada Only
39	421 9007 007	MINI DAMPER	
● 40	414 0595 015	EARTH PLATE	
● 41	203 2279 014	2C TERMINAL WIRE 3T	
● 45	102 0434 406	TOP COVER	
● 46	473 8047 001	SPECIAL SCREW	
● 47	412 3676 207	EJECT LEVER	
● 48	412 3628 006	LEVER STAY (B)	
● 49	463 8238 004	SPRING	
● 50	412 3677 002	MOUNT BRACKET	
● 51	445 8028 009	CORD HOLDER	
● 52	513 2160 004	POWER TRANS. P.W.B. SHEET	
● 53	513 2150 001	WARNING SHEET	
101	473 7508 017	3 × 10 CBTS(P)-B	

Ref. No.	Part No.	Part Name	Remarks
102	477 0262 006	SPECIAL SCREW	
103	473 7502 013	4 × 10 CBTS(P)-Z	
104	473 7509 058	4 × 12 CBTS(P)-B	
105	473 7500 044	3 × 8 CBTS(P)-B	
106	473 7002 018	3 × 8 CBTS(S)-Z	
107	473 7007 039	4 × 20 CBTS(S)-B	

WARNING:

- Parts marked with ● and/shading have special characteristics important to safety.
Be sure to use the specified parts for replacement.
- Part indicated with the mark △ are not always in stock and possibly to take a long period of time for supplying, or in some case supplying of part may be refused.

PARTS LIST OF PACKING & ACCESSORIES

Ref. No.	Part No.	Part Name	Remarks	Q'ty
	505 0131 050	CABINET COVER	FOR SET	1
	504 0092 060	STYRENE PAPER	FOR AC CORD	1
	503 1079 005	CUSHION		2
	501 1698 008	CARTON CASE		1
	505 0038 030	POLY COVER		1
	511 2487 008	INST. MANUAL (8)	Europe	1
	511 2488 007	INST. MANUAL (3)	U.S.A. Canada U.K. Multiple-Voltage	1
	203 2223 002	2P PIN CORD		2
	203 4880 003	3P MINI PLUG CORD		1
	515 0626 009	DAI WARRANTY HOME	U.S.A. Only	1
△	203 3667 007	PLUG ADAPTER	Multi-Voltage Only	1

WARNING:

- Parts marked with △ and/shading have special characteristics important to safety.
Be sure to use the specified parts for replacement.

1 2 3 4 5 6 7 8

EXPLODED VIEW

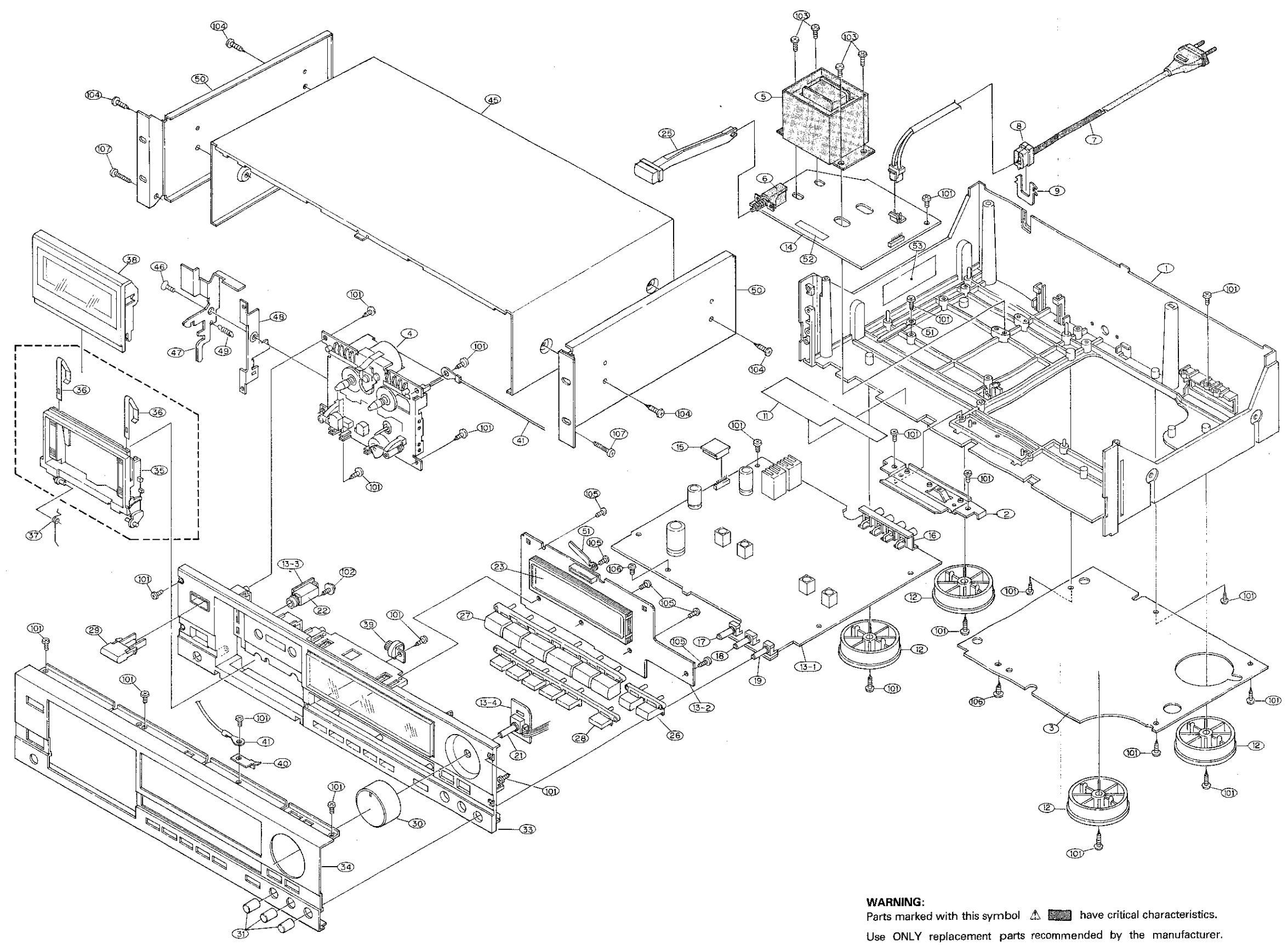

A
B
C
D
E

WARNING:
 Parts marked with this symbol  have critical characteristics.
 Use ONLY replacement parts recommended by the manufacturer.

EXPLODED VIEW OF CASSETTE MECHANISM

A

B

C

D

E

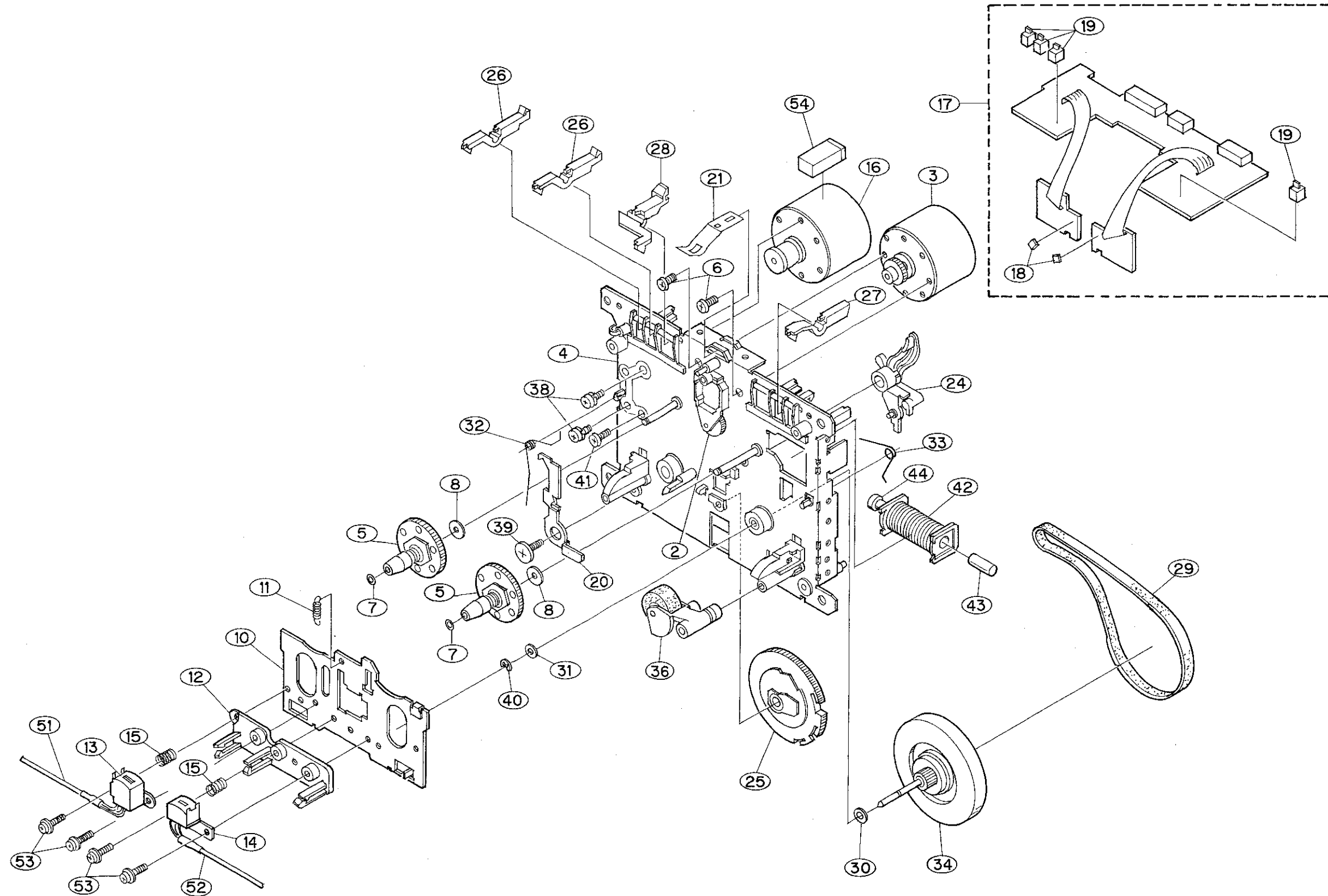

ARTS LIST OF CASSETTE MECHANISM EXPLODED VIEW

Ref. No.	Part No.	Part Name	Remarks
2	9DF 517C 49	IDLER	
3	9DF 5642 85	REEL MOTOR	
4	9DF 6121 51	CHASSIS BASE	
5	9DF 623C 37	REEL BASE	
6	9DF G156 11A	SCREW 2.6 × 6.4 ZN	
7	9DF J111 17	WASHER 1.7 × 0.25T	
8	9DU J12V 11	POLY WASHER 2.1 × 0.25T	
10	9DF C52E 47	HEAD BASE	
11	9DF K26N 14	HB SPRING	
12	9DF D45T 17	HEAD SPACER	
13	9DF U192 11	ERASE HEAD	
14	9DF U18K 12	R/P HEAD	
15	9DF K21 U 11	SPRING	
16	9DF 5252 56	MAIN MOTOR	
17	9DF 5673 52	CONTROL P.W.B. Ass'y	
18	9DA W1 3G 00	REEL SENSOR (GP2S04B)	
19	9DU E16E 11	PUSH SWITCH	
20	9DF C39S 33	EJECT PROTECT ARM	
21	9DF C52H 12	CASSETTE SPRING	
24	9DF D45G 21	PLAY ARM	
25	9DF D45B 16	CAM GEAR (3R)	
26	9DF D44T 14	REC. SENSOR LEVER	
27	9DF D44Y 12	PACK SENSOR LEVER	
28	9DF D44V 12	METAL SENSOR LEVER	
29	9DF F17W 31	MAIN BELT	
30	9DF J111 30	POLY WASHER 2.6 × 0.25T	
31	9DF J111 14	POLY WASHER 2.6 × 0.5T	
32	9DF K28M 12	EJECT PROTECT SPRING	
33	9DF K28R 11	SLIDE SPRING	
34	9DF R22H 11	FLYWHEEL Ass'y	
36	9DF R20L 22	PINCH ROLLER Ass'y (R)	
38	9DF G114 14	SCREW 2.6 × 5 ZN	
39	9DF G15S 11A	SCREW WITH STEP (7.7)	
40	9DU G13U 15	E RING	
41	9DU G20B 11	WAVE SCREW 3 × 8 ZN	
42	9DF 7652 63	SOLENOID	
43	9DF L39H 12A	IRON CORE	
44	9DF L39K 12	PLUNGER	
51	9DW H63P 05	ERASE HEAD CORD	
52	9DW H55L 05A	R/P HEAD CORD	
53	9DF G137 18	2 × 9F LOCK SCREW	
54	9DF F17C 12	HOLDER CUSHION	

NOTE FOR PARTS LIST

- Part indicated with the mark "◎" are not always in stock and possibly to take a long period of time for supplying, or in some case supplying of part may be refused.
- When ordering of part, clearly indicate "1" and "I" (i) to avoid mis-supplying.
- Ordering part without stating its part number can not be supplied.
- Part indicated with the mark "★" is not illustrated in the exploded view.
- Not including Carbon Film ±5%, 1/4W Type in the P.W.Board parts list. (Refer to the Schematic Diagram for those parts.)

WARNING:

Parts marked with this symbol  have critical characteristics. Use ONLY replacement parts recommended by the manufacturer.

● **Resistors**

Ex.: RN 14K 2E 182 G FR
 Type Shape and performance Power Resist-ance Allowable error Others

RD : Carbon	2B : 1/8W	F : ±1%	P : Pulse-resistant type
RC : Composition	2E : 1/4W	G : ±2%	NL : Low noise type
RS : Metal oxide film	2H : 1/2W	J : ±5%	NB : Non-burning type
RW : Winding	3A : 1W	K : ±10%	FR : Fuse-resistor
RN : Metal film	3D : 2W	M : ±20%	F : Lead wire forming
RK : Metal mixture	3F : 3W		
	3H : 5W		

* **Resistance**

1 8 2 ——— 1800 ohm = 1.8 kohm
 ↑ ↓
 Indicates number of zeros after effective number.
 2-digit effective number.

● Units: ohm

1 R 2 ——— 1.2 ohm
 ↑ ↓
 1-digit effective number.
 2-digit effective number, decimal point indicated by R.

● Units: ohm

* **Capacity (electrolyte only)**

2 2 2 ——— 2200µF
 ↑ ↓
 Indicates number of zeros after effective number.
 2-digit effective number.

● Units: µF.

2 R 2 ——— 2.2µF
 ↑ ↓
 1-digit effective number.
 2-digit effective number, decimal point indicated by R.

● Units: µF.

● **Capacitors**

Ex.: CE 04W 1H 2R2 M BP
 Type Shape and performance Dielectric strength Capacity Allowable error Others

CE : Aluminum foil electrolytic	0J : 6.3V	F : ±1%	HS : High stability type
CA : Aluminum solid electrolytic	1A : 10V	G : ±2%	BP : Non-polar type
CS : Tantalum electrolytic	1C : 16V	J : ±5%	HR : Ripple-resistant type
CO : Film	1E : 25V	K : ±10%	DL : For charge and discharge
CK : Ceramic	1V : 35V	M : ±20%	HF : For assuring high frequency
CC : Ceramic	1H : 50V	Z : +80%	U : UL part
CP : Oil	2A : 100V	-20%	C : CSA part
CM : Mica	2B : 125V	P : +100%	W : UL-CSA type
CF : Metalized	2C : 150V	-0%	F : Lead wire forming
CH : Metalized	2D : 200V	C : ±0.25µF	
	2E : 250V	D : ±0.5µF	
	2H : 500V	-	
	2J : 630V	-	

* **Capacity (except electrolyte)**

2 2 2 ——— 2200µF = 0.0022µF
 ↑ ↓
 (More than 2) ——— Indicates number of zeros after effective number.
 2-digit effective number.

● Units: µF.

2 2 1 ——— 220PF
 ↑ ↓
 (0 or 1) ——— Indicates number of zeros after effective number.
 2-digit effective number.

● Units: PF.

● When the dielectric strength is indicated in AC, "AC" is included after the dielectric strength value.

P.W. BOARD OF 3U-2584 AUDIO/METER UNIT

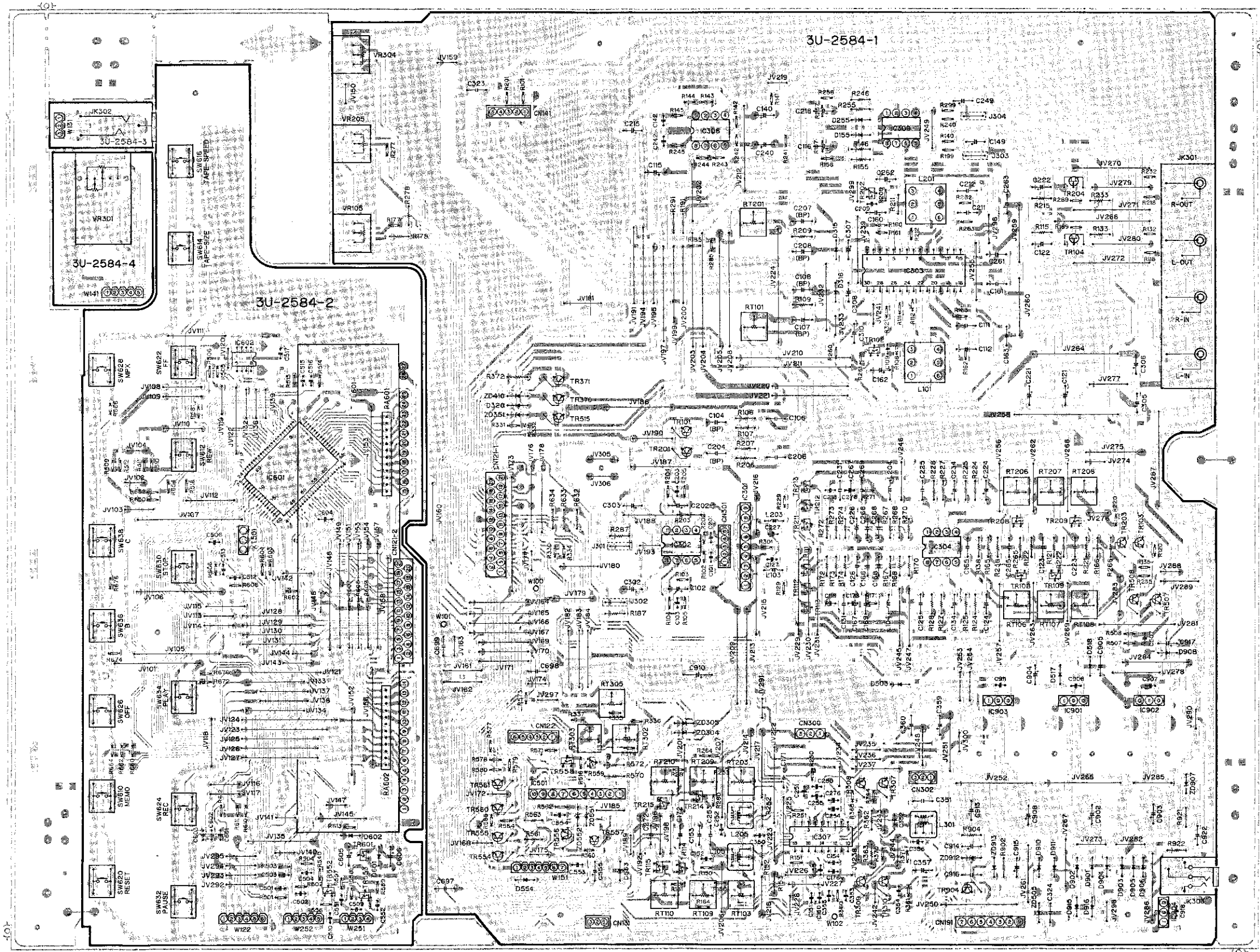

P.W. BOARD OF 3U-2603 POWER SUPPLY UNIT

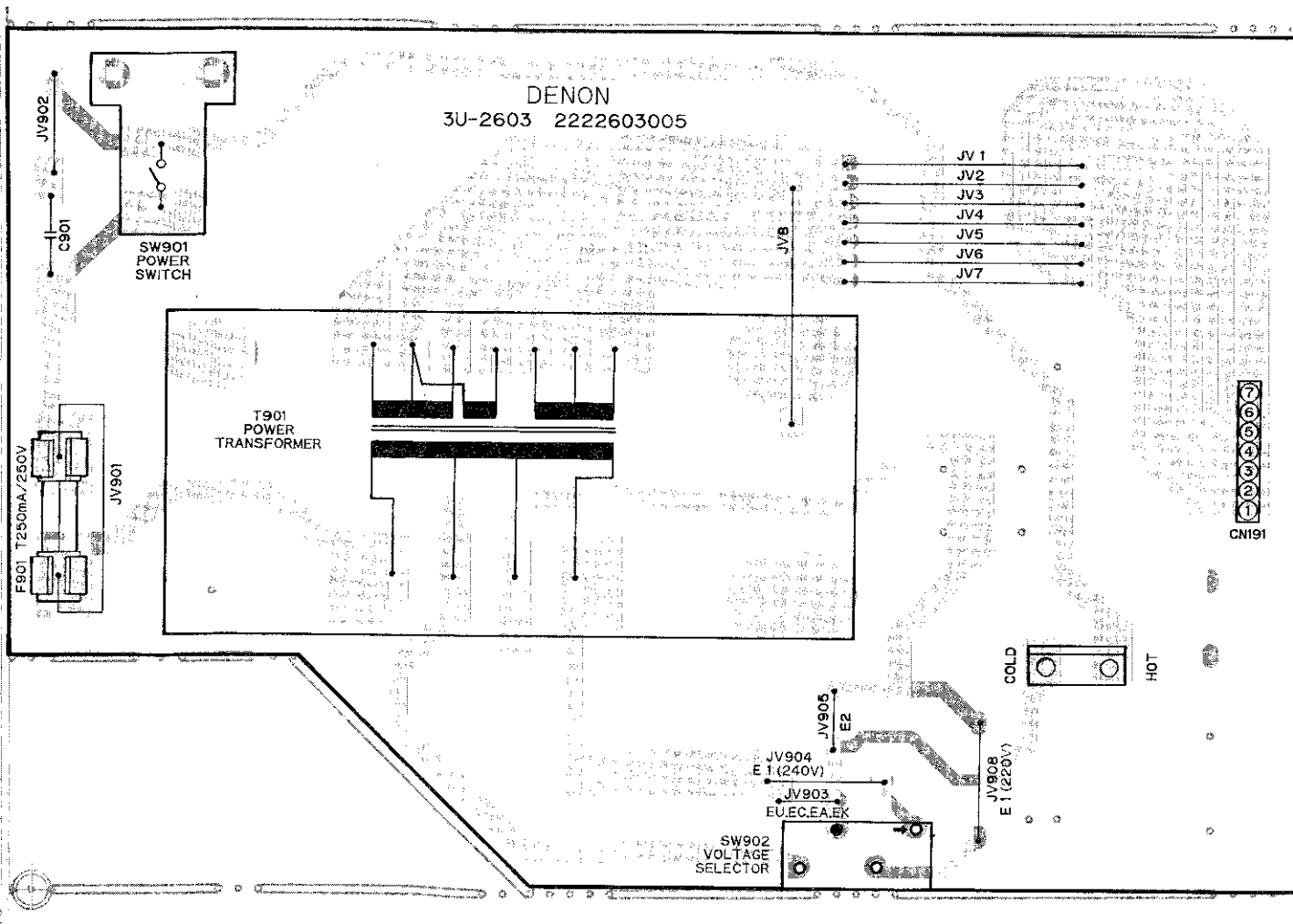

Remarks

1. The following table shows the power circuit parts used for the 3U-2603 board by area.
2. Parts used are marked ○, parts not used —.

Areas	Ref.No.	Power Trans part No.	Voltage Selector	FUSE F901	JV901	JV903	JV904	JV905	JV908
Europe (E2)	2335985005	2335985005	—	—	○	—	—	○	—
U.K. (EK)			—	—	○	○	—	—	—
Multi-Voltage (E1)	2335760000	2335760000	○	○	—	—	○	—	○
U.S.A. & Canada (E3)	2335758009	2335758009	—	—	○	○	—	—	—

SEMICONDUCTORS

• IC

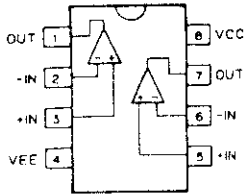
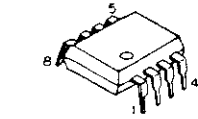

- M15218AP
- μ PC4570C

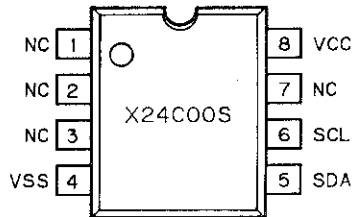
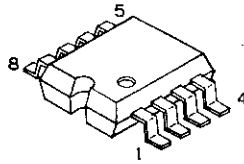

- X24C00S

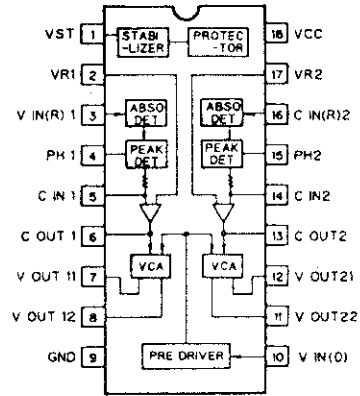
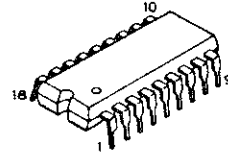

- μ PC1297CA

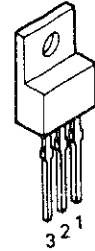

3 GND
2 INPUT
1 OUTPUT

- MC7908

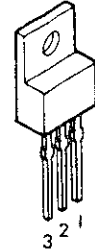

3 INPUT
2 GND
1 OUTPUT

- MC7808
- MC7806

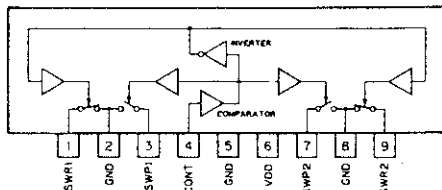
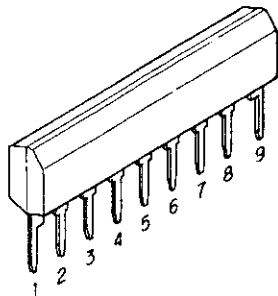

- μ PC1330HA

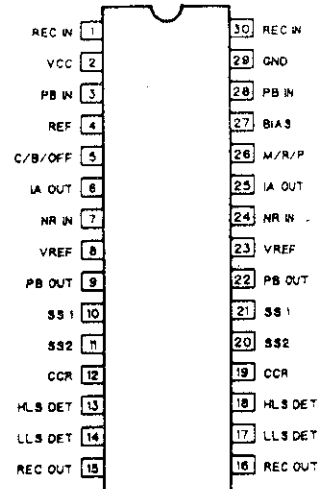
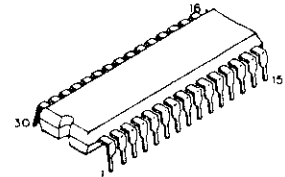

- HA1217ONT

● Transistors

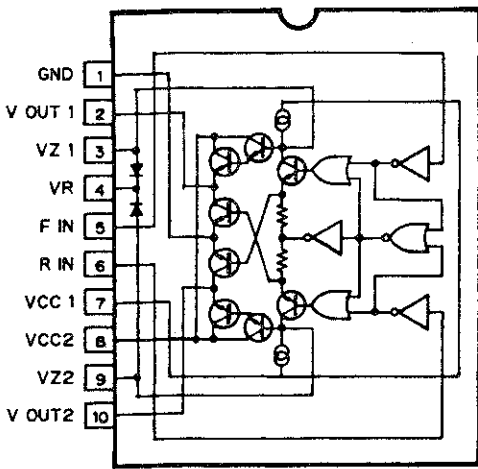
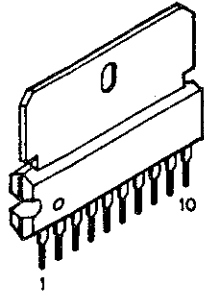

● BA6109U1



- 2SA933
- 2SC2603
- 2SC1740



- 2SB562
- 2SD468



● 2SK381

S (Source)
G (Gate)
D (Drain)



- 1: Emitter
2: Collector
3: Base

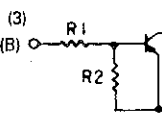

- DTA143ES
- DTA144WS

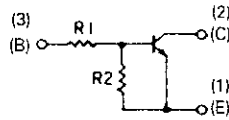

- DTC124ES
- DTC124XS
- DTC143ES
- DTC144ES

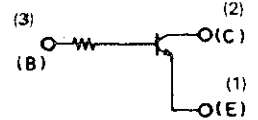

- DTC114TS

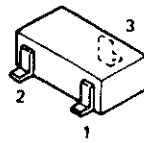

- 1: Emitter
2: Base
3: Collector

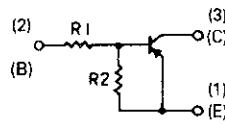

- DTA114EK
- DTA124EK

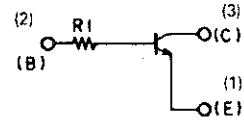

- DTC114TK
- DTC143TK

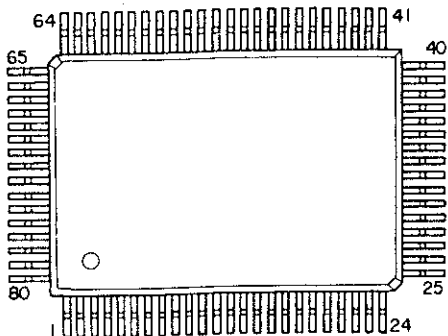

● UPD78042-027
(μ COM)

● Diodes

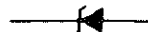

- ISS270A
- ISR35-200A

- HZS4C-1
- HZS6C-1
- HZS6B-3
- HZS6C-2
- HZS9B-1

- HZS11C-1
- HZS27-1
- HZS7B-2
- HZS9B-2

- DTC144WK
- DTC144EK
- DTC124EK

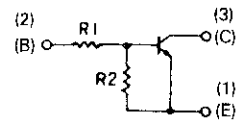

BUNDLE DIAGRAM

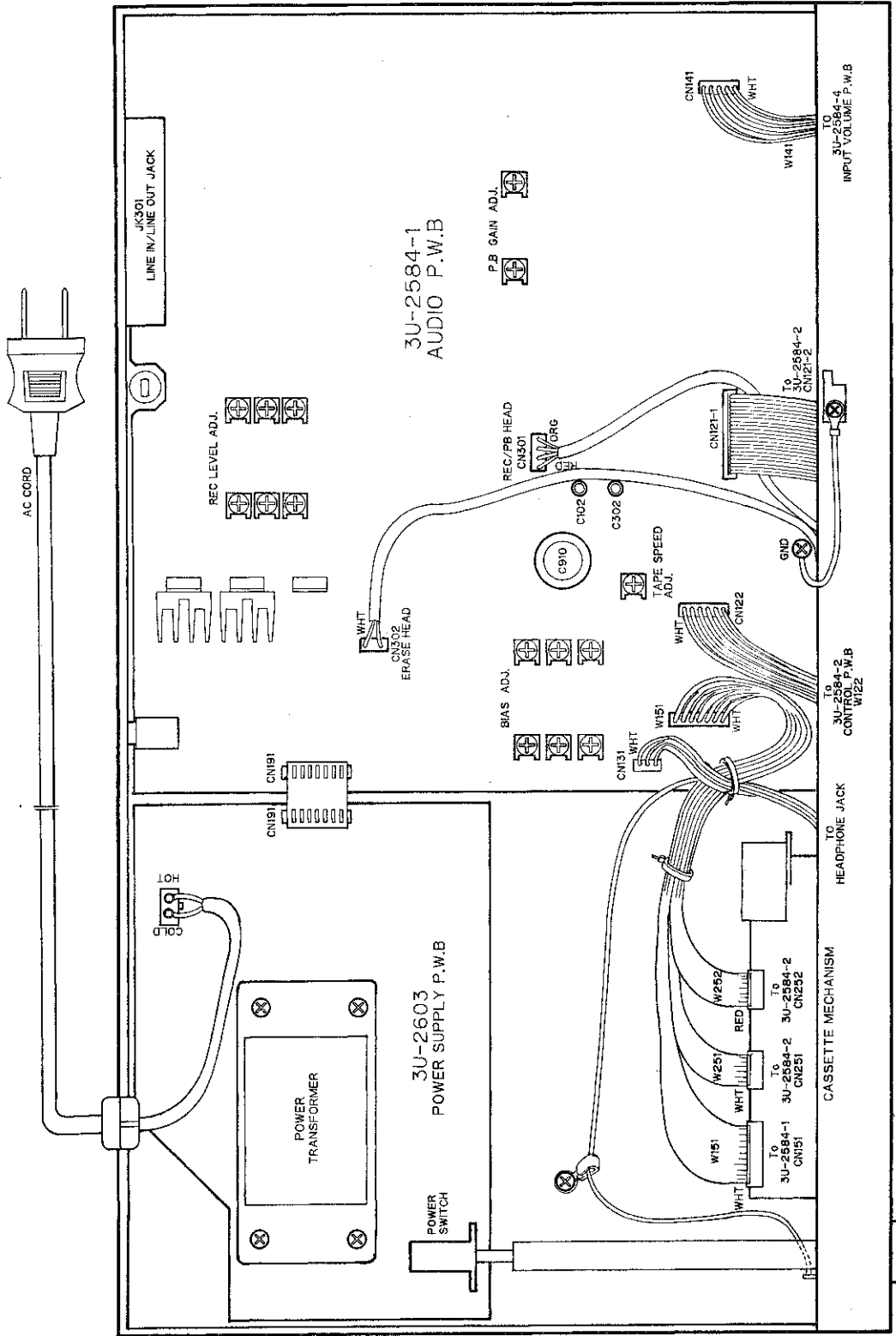

WIRING DIAGRAM

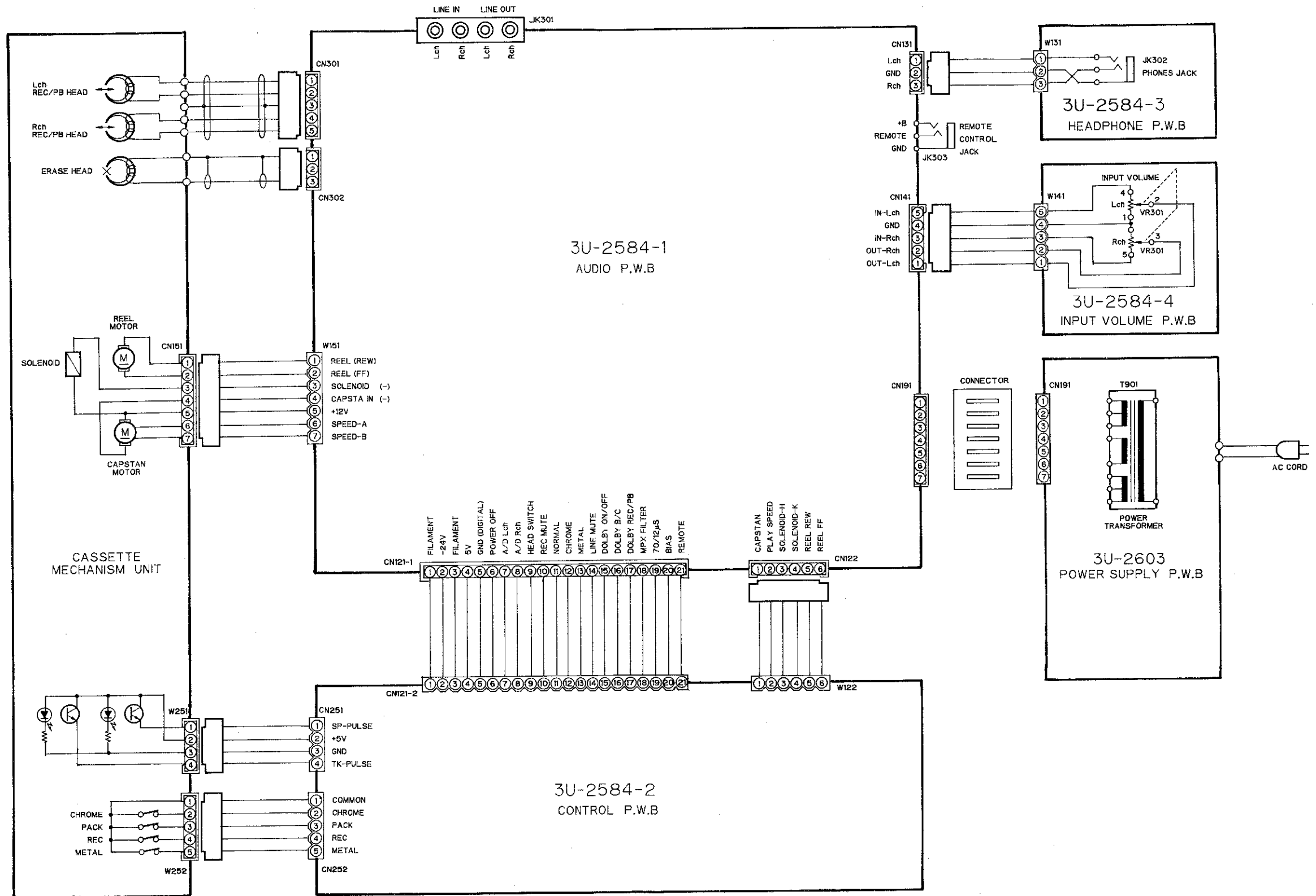

SCHEMATIC DIAGRAM

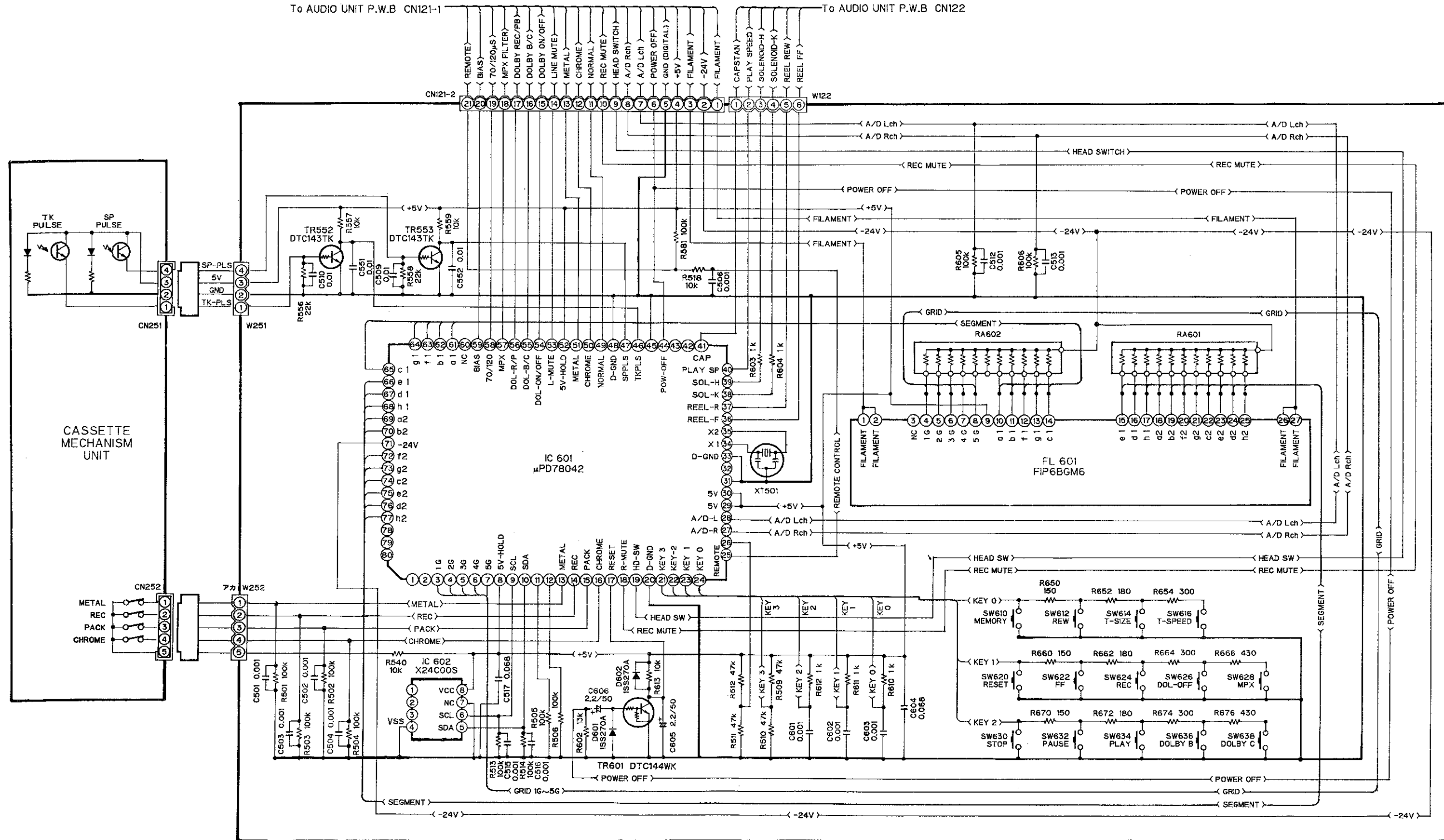

Note:

- Resistance shall be 1/4 W unless otherwise specified and the unit is ohm.
- The unit of capacitor is μF , P is pF unless otherwise specified.
- This circuit diagram shows the basic circuit. It is subject to change for the purpose of improvement.

SCHEMATIC DIAGRAM

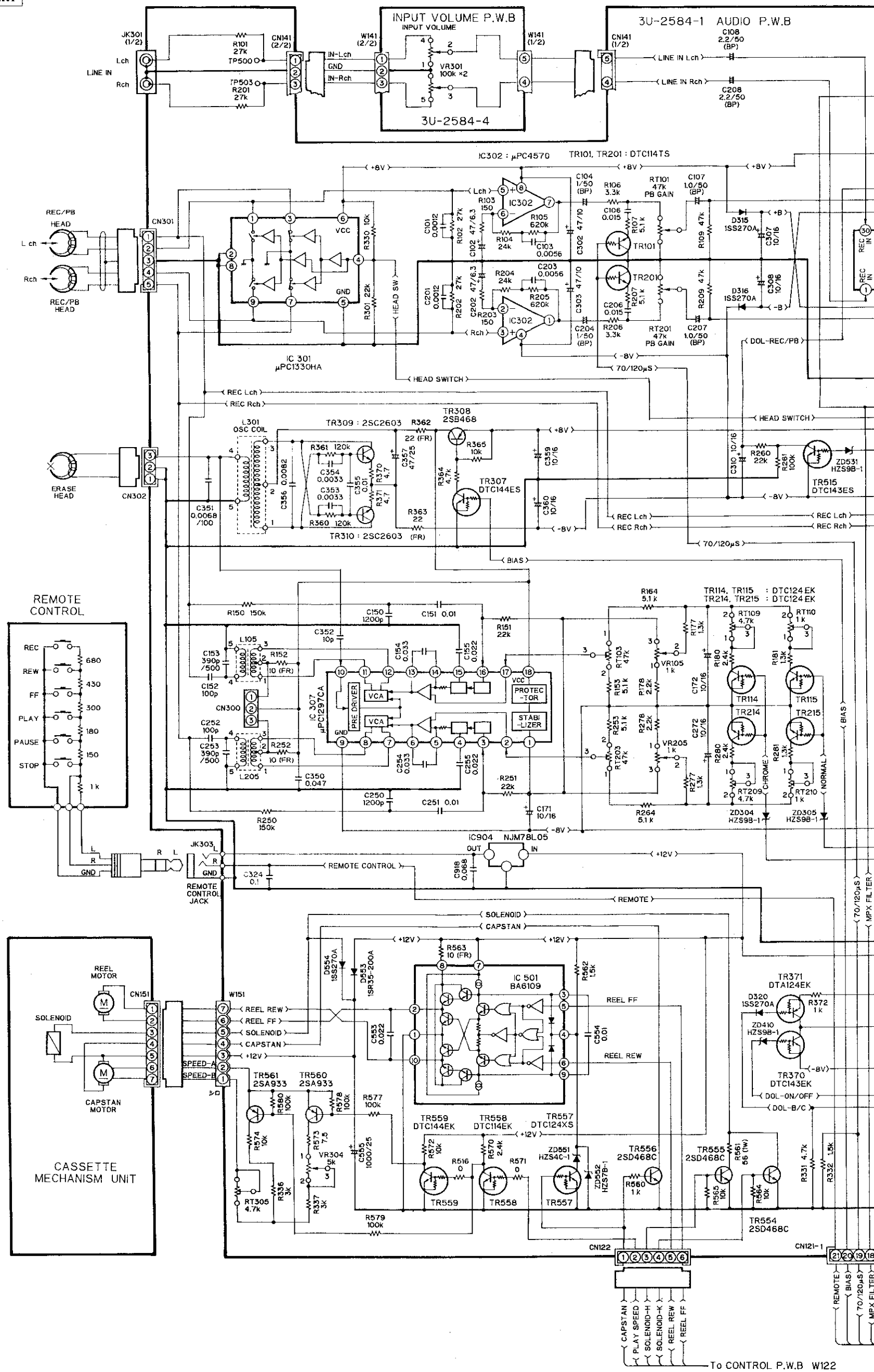

To CONTROL P.W.B W122

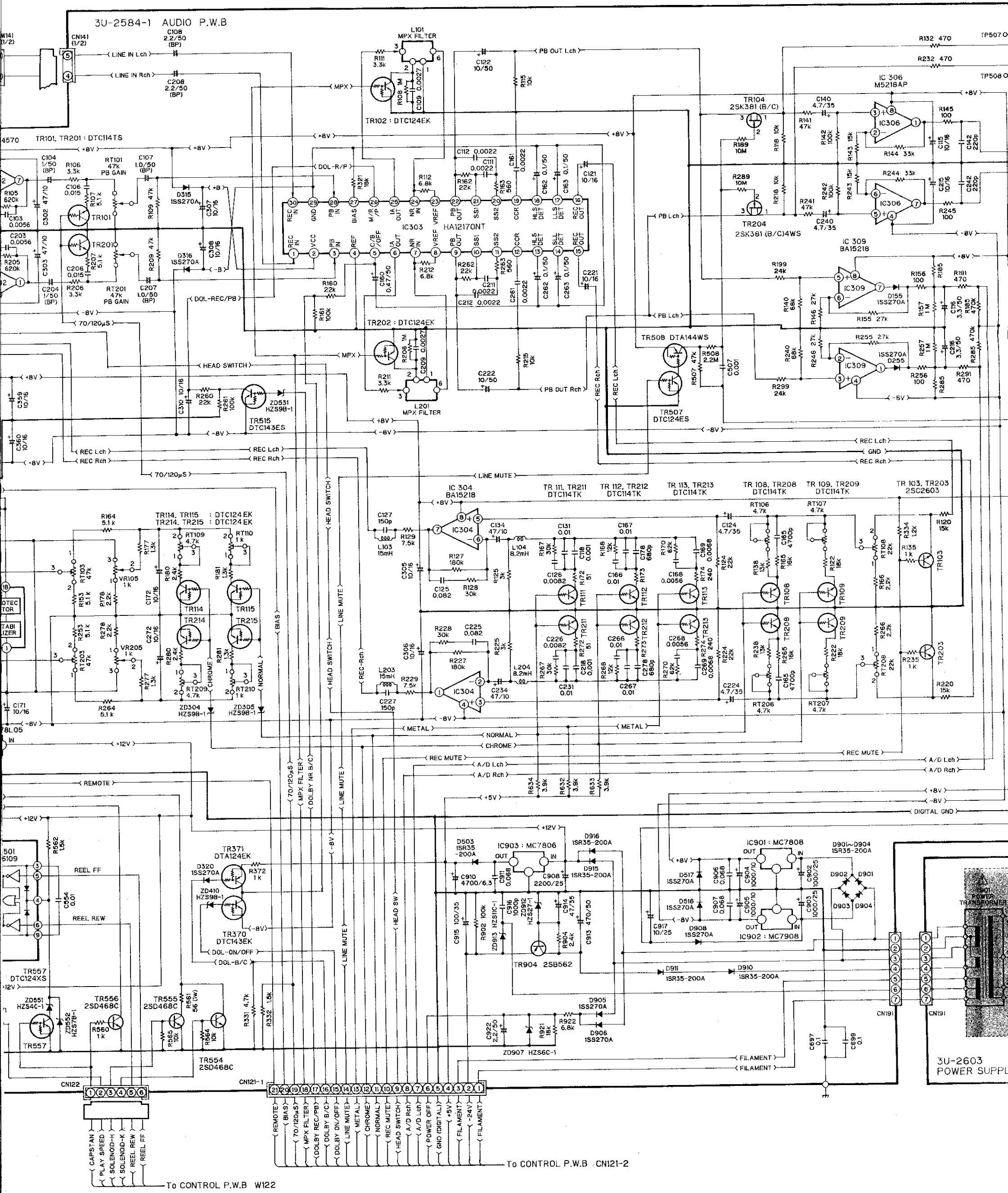

Note:

- Resistance shall be 1/4 W unless otherwise specified and the unit is ohm.
- The unit of capacitor is μF , P is pF unless otherwise specified.
- This circuit diagram shows the basic circuit. It is subject to change for the purpose of improvement.

Parts marked with this symbol  have critical characteristics. Use ONLY replacement parts recommended by the manufacturer.

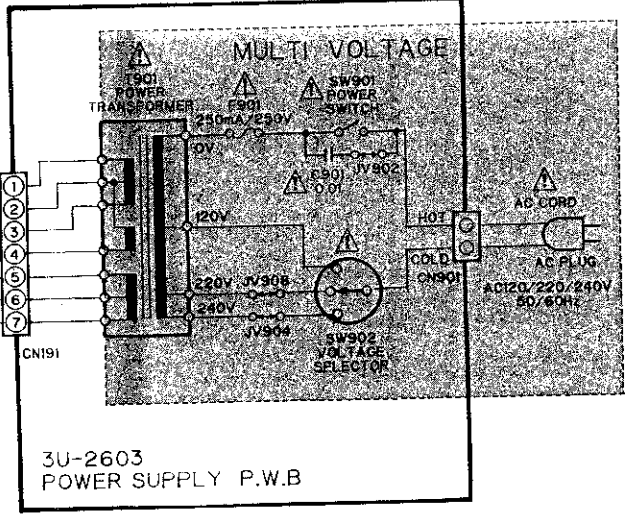
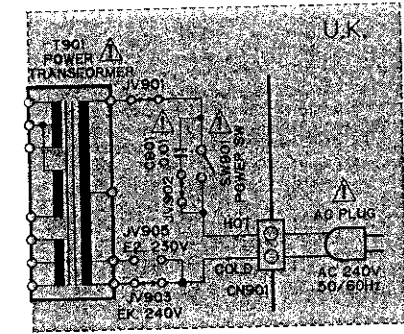
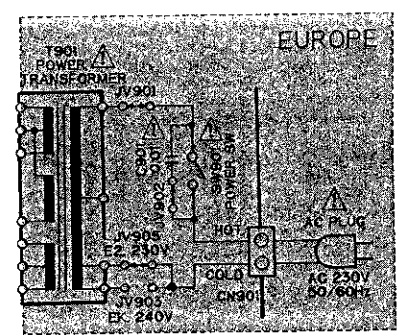
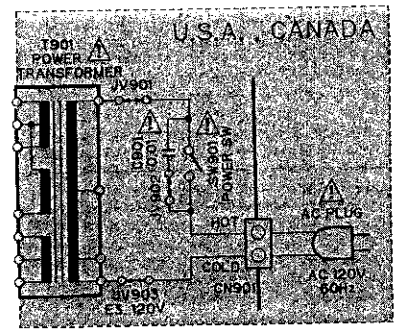
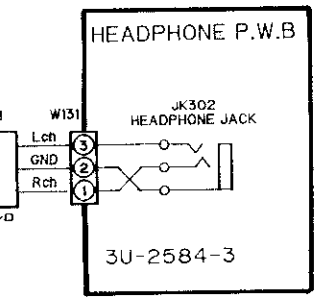
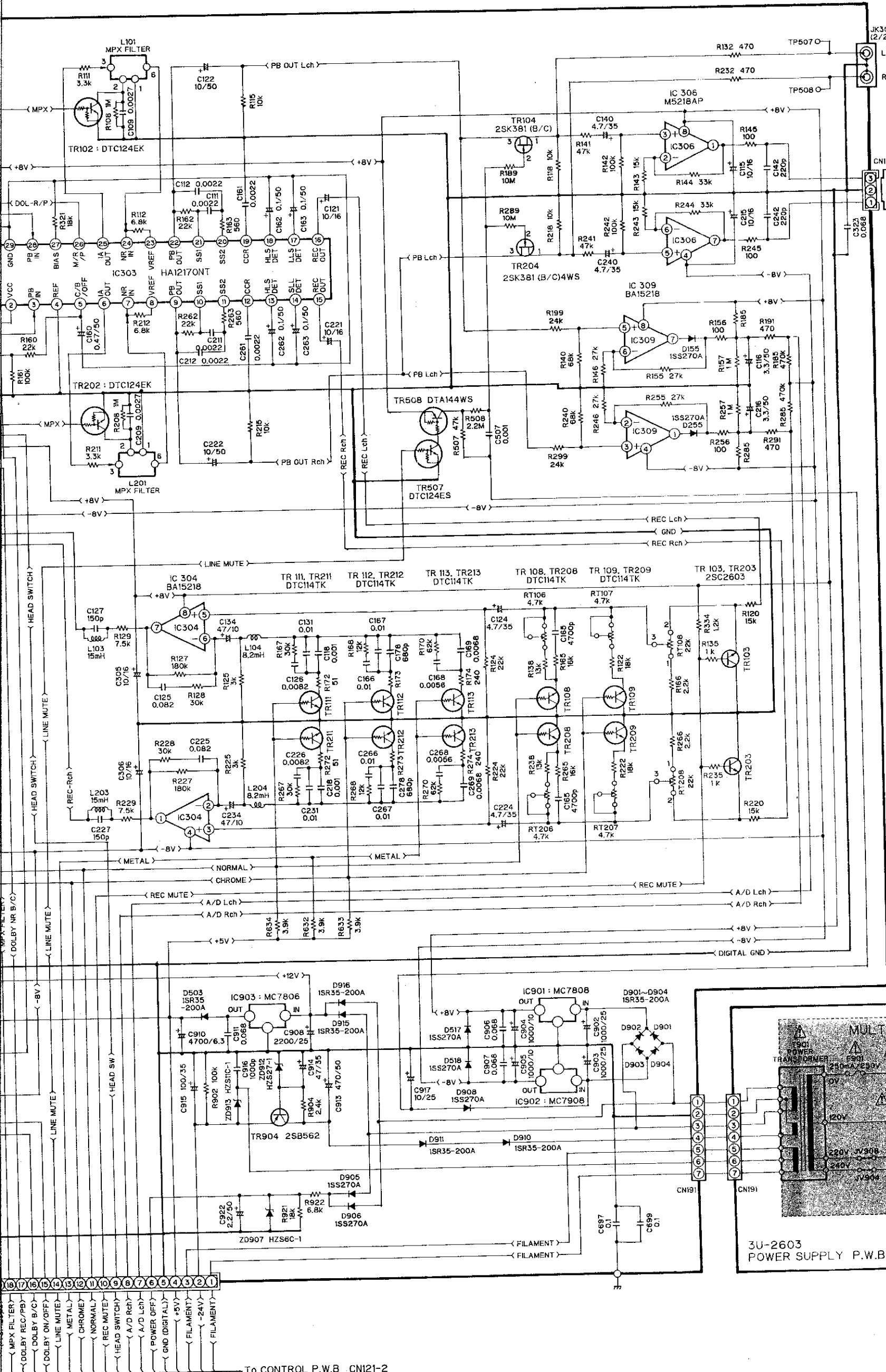

Note:

- Resistance shall be 1/4 W unless otherwise specified and the unit is ohm.
- The unit of capacitor is μ F, P is pF unless otherwise specified.
- This circuit diagram shows the basic circuit. It is subject to change for the purpose of improvement.

Parts marked with this symbol have critical characteristics. Use ONLY replacement parts recommended by the manufacturer.