

DENON

Hi-Fi Component

SERVICE MANUAL

MODEL DN-990R MD CART RECORDER

MODEL DN-980F MD CART PLAYER



DN-990R



DN-980F

— TABLE OF CONTENTS —

OPERATING INSTRUCTIONS	2-27
SPECIFICATIONS	28, 29
SOFTWARE SPECIFICATIONS	30-43
BLOCK DIAGRAM	44-48
NOTE FOR HANDLING OF OPTICAL PICK-UP	49, 50
DISASSEMBLY	51-62
JUDGEMENT STANDARDS FOR OPTICAL PICK-UP (KMS-140B) REPLACEMENT	63-70
ERROR CODE LIST	71
TEST MODE FUNCTION	72, 73
ELECTRICAL ADJUSTMENT	74-85
SCHEMATIC DIAGRAM AND WAVEFORMS	86-91
PRINTED WIRING BOARD & WIRING DIAGRAM	93-96
NOTE FOR PARTS LIST	97
PRINTED WIRING BOARD PARTS LIST	97-100
SEMICONDUCTORS	101-112
PARTS LIST OF EXPLODED VIEW	112
EXPLODED VIEW	113
EXPLODED VIEW OF MD MECHA UNIT	114
PARTS LIST OF EXPLODED VIEW OF MD MECHA UNIT	115
PACKING & ACCESSORIES	116

NIPPON COLUMBIA CO., LTD.

DENON

MD CART RECORDER

DN-990R

MD CART PLAYER

DN-980F

OPERATING INSTRUCTIONS

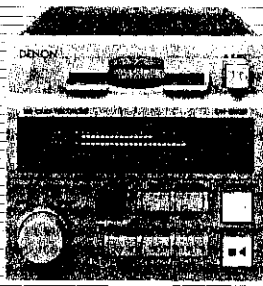

DN-990R

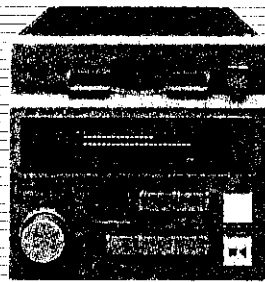

DN-980F



CAUTION
RISK OF ELECTRIC SHOCK
DO NOT OPEN



CAUTION: TO REDUCE THE RISK OF ELECTRIC SHOCK, DO NOT REMOVE COVER (OR BACK). NO USER SERVICEABLE PARTS INSIDE. REFER SERVICE TO QUALIFIED SERVICE PERSONNEL.



The lightning flash with arrowhead symbol within an equilateral triangle is intended to alert the user of the presence of unisolated "dangerous voltage" within the product's enclosure that may be of sufficient magnitude to constitute a risk of electric shock to persons.



The exclamation point within an equilateral triangle is intended to alert the user of the presence of important operating and maintenance (servicing) instructions in the literature accompanying the appliance.

IMPORTANT (BRITISH MODEL ONLY)

The wires in the mains leads are coloured in accordance with the following codes:

Blue: Neutral, Brown: Live, Yellow-Green: Earth.

If the colours of the wires in the mains leads of this apparatus do not correspond with the coloured markings identifying the terminals in your plug, proceed as follows: The wire which is coloured blue must be connected to the terminal which is marked with the letter N or coloured black. The wire which is coloured brown must be connected to the terminal which is marked with the letter L or coloured red.

VAROITUS:
SUOJAKOULLI OALEN SAATAVAI. LAITTE SISÄLLÄ TÄÄ LASERIDIOIN, JOKA EI AHTEI TÄÄ SILMÄLLE VAARALLISTA LASERISÄTELYÄ.

DN 990R
LABELS

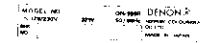
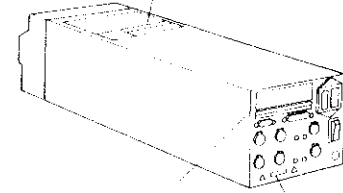

CAUTION: USE OF CONTROLS OR ADJUSTMENTS OR REFORMATION OF PROCEDURES OTHER THAN THOSE SPECIFIED HEREIN MAY RESULT IN HAZARDOUS RADIATION EXPOSURE.

THE MD CART RECORDER SHOULD NOT BE ADJUSTED OR REPAIRED BY ANYONE EXCEPT PROPERLY QUALIFIED SERVICE PERSONNEL.

NOTE:

This unit may cause interference to radio and television reception if you do not operate it in strict accordance with these OPERATING INSTRUCTIONS.

This unit complies with Class A computing device rules in accordance with the specifications in Subpart J or Part 15 of the FCC Rules, which are designed to provide reasonable protection against such interference in a residential installation. If the unit does cause interference to any radio or television reception, try to reduce it by one or more of the following means:

- a) Turn the other unit to improve reception.
- b) Move this unit.
- c) Move this unit away from others.
- d) Plug this unit respectively into a different AC outlet.

* This is note in accordance with Section 15.838 of the FCC Rules.



**DN-980F
LABELS**

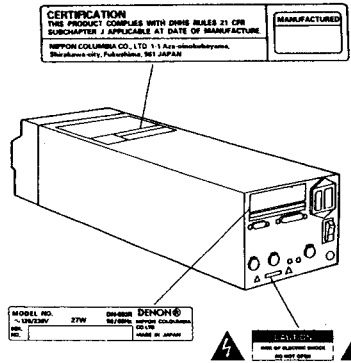

CAUTION:
USE OF CONTROLS OR ADJUSTMENTS OR REFORM-
ANCE OF PROCEDURES OTHER THAN THOSE SPECIFIED
HEREIN MAY RESULT IN HAZARDOUS RADIATION EXPO-
SURE.

THE MD CART PLAYER SHOULD NOT BE ADJUSTED OR
REPAIRED BY ANYONE EXCEPT PROPERLY QUALIFIED
SERVICE PERSONNEL.

Please record and retain the model name and serial
number of your set shown on the rating label.

Model No. DN-990R Serial No. _____
Model No. DN-980F

IMPORTANT TO SAFETY

WARNING:
TO PREVENT FIRE OR SHOCK HAZARD, DO NOT EXPOSE THIS APPLIANCE TO RAIN OR MOISTURE.





NOTE:
The DN-990R MD Cart Recorder and DN-980F MD Cart Player use a semiconductor laser. To allow you to enjoy music with stable operation, we recommend using them in a room whose temperature is between 5°C and 35°C.

CAUTION:

1. **Handle the power supply cord carefully.**
Do not damage or deform the power cord. If it is damaged or deformed, it may cause electric shock or malfunction when using. When disconnecting it from wall outlet, be sure to hold the plug attachment. Do not pull on the cord.
2. **Do not open the top cover.**
In order to prevent electric shock, do not open the top cover. If problems occur, contact your DENON dealer.
3. **Do not place anything inside.**
Do not place metal objects or spill liquid inside the MD Cart Recorder and MD Cart Player, as this may result in electric shocks or malfunction.

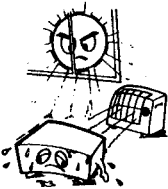
"US and foreign patents licensed from Dolby Laboratories Licensing Corporation"

NOTE ON USE

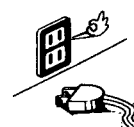
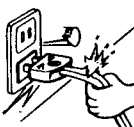
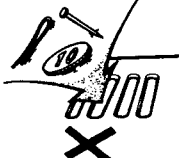
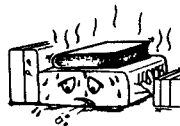
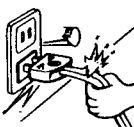
 <p>Be careful of high temperatures</p> <ul style="list-style-type: none"> • Do not place the set in a location where it will be exposed to direct sunlight or near a heating appliance. <p>Caution on rack/cabinet installation</p> <ul style="list-style-type: none"> • Avoid installing the set in a closed-type rack. • When installing in a rack or cabinet, provide a sufficiently large ventilation opening to promote heat radiation. 	 <p>Caution on humidity, water, and dust</p> <ul style="list-style-type: none"> • Do not place the set in a location where there is high humidity or a lot of dust. Flower vases or other items containing water should not be placed on top of the set. 	 <p>Do not open the case</p> <ul style="list-style-type: none"> • Opening the top cover or the bottom plate of the case and inserting your hand is dangerous. Do not open the case. <p>If some trouble arises with the performance of the set, remove the power plug soon and contact the store where the set was purchased or a nearby dealer.</p>
 <p>Care of the case</p> <ul style="list-style-type: none"> • Avoid the use of pesticides near the set as well as wiping the case with benzene, thinner or other solvents since they may cause a change in quality or color. Use a soft cloth when wiping away dirt and follow the instructions carefully when using chemically treated cloths. 	 <p>During your absence</p> <ul style="list-style-type: none"> • When not using the set for an extended period such as when taking a trip, be sure to disconnect the plug from the receptacle. 	 <p>Care with the power cord</p> <ul style="list-style-type: none"> • When removing the plug from the receptacle, do not pull the power cord; be sure to hold the plug when removing it.
 <p>Do not allow foreign matter into the equipment</p> <ul style="list-style-type: none"> • Be especially careful of needles, hair pins, and coins getting into the set. 	 <p>Do not block the ventilation holes of the set</p> <ul style="list-style-type: none"> • Blocking of the ventilation holes will lead to damage of the set. • The ventilation holes are very important for heat radiation from within the set. Care must be taken since placing an object against the holes will result in an extreme rise of temperature within the set. <p style="text-align: center; font-size: small;">For sets with ventilation holes</p>	 <p>Care with the power cord</p> <ul style="list-style-type: none"> • When removing the plug from the receptacle, do not pull the power cord; be sure to hold the plug when removing it.

NAMES OF PARTS ON THE DN-990R AND DN-980F

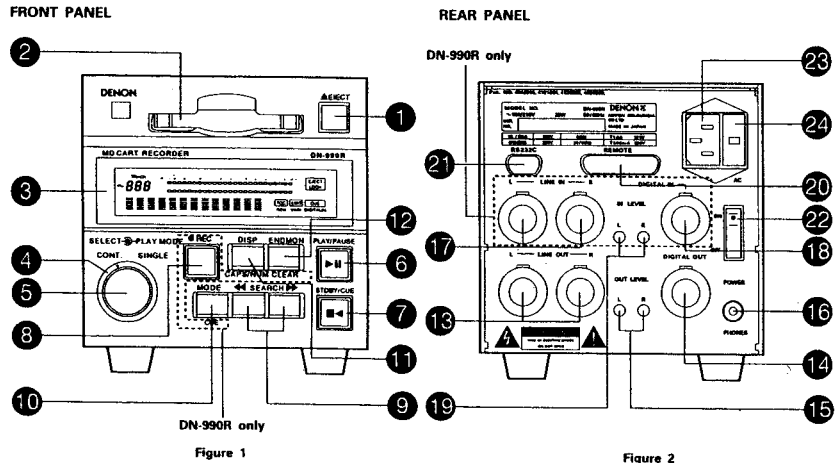

DISPLAY WINDOW

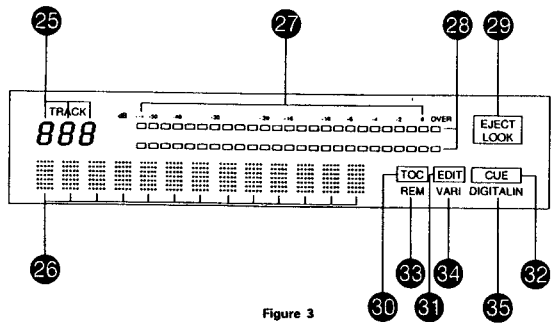

DIMENSIONS

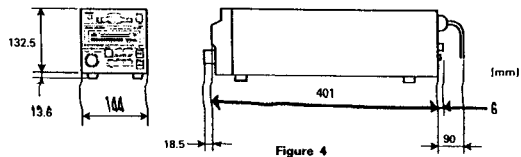

MAIN FEATURES

The DN-990R MD Cart Recorder is an MD (Mini-Disc) recorder/player using MDs as the recording medium. It is a table-top MD recorder designed for high reliability for professional use, and is equipped with recording, playback and editing functions. It can be used to edit discs, and record and call out such information as disc titles, etc.
 The DN-980F MD Cart Player is a table-top MD player equipped with the playback functions necessary for broadcast stations and studios.
 The DN-990R MD Cart Recorder and DN-980F MD Cart Player are both equipped with interface for automation and systematization, and up to three units can be installed on 19-inch racks (3U) using rack shelves.

Features of the medium (MDs)

- Digital recording — 44.1 kHz sampling frequency, 16-bit quantization, audio compression (ATRAC)
- High endurance — Optical pickup (semiconductor laser, non-contact)
- Recording — Magneto-optical overwriting system (magnetic modulation)
- Long recording time — 74 minutes maximum
- Quick access — Disc media, dividable into up to 255 tracks
- Low operating costs — Inexpensive commercially available medium, long recording time, dividable into multiple track
- Space savings for storage — 72mm × 68mm × 5mm cartridges

Features of the DN-990R and DN-980F

Playback functions

- **Instant start**
Sound is produced virtually instantaneously when the play (PLAY/PAUSE) button is pressed.
- **Auto cue**
The pickup is cued not to the beginning of the track but to the position at which the sound starts and the standby mode is set there. The level at which the beginning of the sound is detected can be set within a range of -36 to -72 dB. (For the operation, see Page 15.)
- **Back cue**
When the standby (STDBY/CUE) button is pressed during playback, the standby mode is set with the pickup at the position where playback was last started. This makes it easy to standby at exact position where playback is to start after checking the recording. (For the operation, see Page 24.)
- **End monitor**
When the end monitor (END MON) button is pressed in the standby mode, the end of the track is searched for and the track's ending can be monitored. After monitoring, the standby mode is set and the pickup is set at the play start position. End monitor start position can be set within a range of 35 to 5 seconds from the end of the track. (For the operation, see Page 26.)
- **Track search**
A pulse encoder type rotary selector is used for the track search operation. The tracks can also be selected in units of 10 by pressing the selector while turning it. This makes it possible to select from among up to 255 tracks simply and speedily. (For the operation, see Pages 22 and 27.)
- **Play mode selection**
The ending mode can be selected separately for single-track playback and continuous playback. (For the operation, see Pages 27 and 16.)
 - Single-track playback
 - Stop
 - Return to play start position and standby
 - Standby at next track
 - Repeat
 - Continuous playback
 - Stop
 - Return to play start position and standby
 - Standby at beginning of disc
 - Repeat
- **Stereo/monaural selection**
Stereo sources can be played in monaural. (For the operation, see Page 16.)
- **EOM (End Of Message)**
A message indicating the track is about to end is displayed. The position at which the message appears can be set within a range of 35 to 5 seconds from the end of the track. (For the operation, see Page 15.)

- **Fader start**
The unit is equipped with a photocoupler play start input connector and delay start function, so it can be used with a mixing console fader.
- **Variable pitch (2%)**
The playing speed can be increased by 2%. (For the operation, see Page 15.)
- **End mark**
The play end position can be changed. The operation can be performed while listening to the sound in the end monitor mode. (For the operation, see Pages 26 and 15.)
- **Fade in (20ms)**
This suppresses irregular sound due to sudden increases in the sound level when playback is started.

Recording functions (DN-990R only)

- **Instant recording**
Recording starts virtually instantaneously when the recording operation is performed.
- **Auto track increment**
The tracks are automatically incremented when blank sections are detected. The blank detection level can be set within a range of -36 to -72 dB. The tracks are incremented at the position at which the sound begins to prevent missing the beginning of the sound. (For the operation, see Pages 33 and 15.)
Tracks can also be incremented using the digital audio interface's track switching data. (For the operation, see Pages 33 and 15.)
- **Track marking**
Tracks can be incremented during recording by pressing the recording standby (REC) button. (For the operation, see Page 33.)

Editing functions (DN-990R only)

- **End trim**
The blank sections recorded at the ends of tracks can be trimmed easily and accurately. This is a non-destructive editing function, so the original track can be restored. This operation can be performed in the end monitor mode. (For the operation, see Page 34.)
- **Erasing**
A whole track can be erased. (For the operation, see Page 40.)
- **Dividing**
A track can be divided in two to create two tracks. (For the operation, see Page 42.)
- **Combining**
The track at the current position can be combined with the preceding track. (For the operation, see Page 43.)
- **Moving**
Tracks can be moved to any track number. (For the operation, see Page 44.)

Example of editing: Tracks can be cut or combined using a combination of editing functions

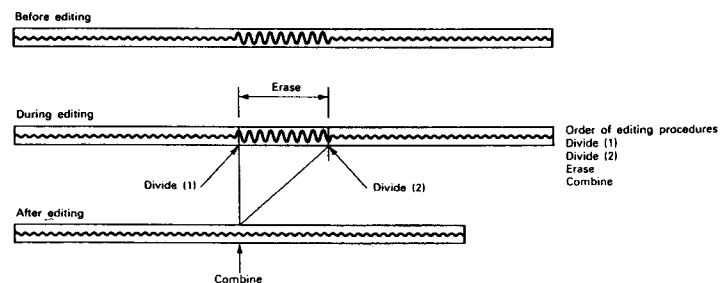

Figure 5

- **Title**
Discs and tracks can be given names (titles) using capital and small letters, numbers and symbols. The operation is done using a rotary selector, so the characters can be selected quickly. Up to 255 characters can be written for each disc or track, but the maximum total characters for all track and disc titles is 1700. The number of characters which can be written decreases when cue signals, end trim are used. (For the operation, see Page 45.)

Functions for automation and systematization (recording functions are only available on the DN-990R)

- **Cue signal recording (CUE)**
Up to five cue signals can be recorded within a track. These can be used as start signals for devices connected to the unit. (For the operation, see Page 47.)
- **End cue**
This is a signal indicating the timing of the end of the track. It can be used as a start signal for devices connected to the unit. It can be set to 3, 2 or 1 second from the end of the track or at the end position. (For the operation, see Page 16.)
- **Parallel remote**
The unit is equipped with a Dsub 25-pin connector, a tally output using a TTL or dry contact and a command input using a photocoupler or CMOS. (For the operation, see Pages 13 and 11.)
- **Serial remote**
The unit can be connected to and controlled from a personal computer via the RS-232C, Dsub 9-pin connector. (For the operation, see Page 14.)

Error backup functions (recording functions are only available on the DN-990R)

- **Shockproof recording**
An audio memory is used to ensure uninterrupted recording even if the pickup skips due to shocks during recording.
- **Shockproof playback**
An audio memory is used to ensure continuous sound even if the pickup skips due to shocks during playback.
- **Protection from power failures during recording**
If there is a power failure during recording, it is still possible to play the tracks recorded up to the point directly before the power failed. (For the operation, see Page 16.)

Other functions (recording functions are only available on the DN-990R)

- **Display selection**
The display can be switched between the elapsed time, remaining time, track title or disc title, as necessary. (For the operation, see Page 29.)
 - **Preset functions**
Functions can be stored in the memory using the buttons on the front panel. The settings are not erased even when the power is turned off. (For the operation, see Page 15.)
 - **Fluorescent tube display**
3-digit track number display
13-digit character display
Level meter display
Status display section
- | | | | | | | |
|----------------------------|------------------|-----------------------------------|-------------------------------------|----------------------|----------------------------|-----------------------|
| Minutes, seconds and frame | Disc/track title | Operating messages/error messages | 24-segment bar graph, peak response | Over-level indicator | EJECT LOCK, TOC, EDIT, CUE | REM, VARI, DIGITAL IN |
|----------------------------|------------------|-----------------------------------|-------------------------------------|----------------------|----------------------------|-----------------------|
- **SCMS**
Recording from digital inputs is possible without copy inhibit restrictions. Selection of ON/OFF for writing copy prohibit code is possible. (For the operation, see Page 15.)
 - **A/D converter**
16-bit quantization, delta/sigma, 64 times oversampling
 - **Loading**
FDD-like manual loading. Discs can be loaded or ejected even when the power is off. Cartridges and labels are visible through the loading slot. Eject lock can be set to protect recordings, etc. (For the operation, see Pages 16 and 22.)
 - **Operation button locking**
The operation of the buttons can be inhibited, as necessary. (For the operation, see Page 15.)

CONTENTS

1 PREPARATIONS		9 EDITING (only available on the DN-990R)	
(1) Checking the accessories	10	(1) Description of editing functions	36
(2) Installation	10	(2) Description of editing operations	37
(3) Connections	10	(3) Erasing track (track erase function)	40
(4) Presettings	11	(4) Erasing all the tracks on a disc (all erase function)	40, 41
2 PART NAMES AND FUNCTIONS		(5) Dividing a track in two (divide function)	42
(1) Front panel	12	(6) Combining two adjacent tracks (combine function)	43
(2) Rear panel	13	(7) Moving a track (move function)	44
(3) Display window	14	(8) Entering disc and track titles (title function)	45
3 PRESETTING FUNCTIONS AND OPERATIONS		10 RECORDING CUE SIGNALS (only available on the DN-990R)	47
(1) Table of preset functions	15	(1) Cue signal recording function	47
(2) Presetting procedures	16	(2) Procedure for recording cue signals	47
(3) Description of preset functions ("*" indicates the initial setting)	18	(3) Procedure for clearing cue signals	48
4 LOADING AND EJECTING CARTRIDGES	22	11 RESETTING THE MICROPROCESSOR	49
5 PLAYBACK		12 HANDLING CARTRIDGES	49
(1) Selecting the play mode	22	(1) Cautions on handling	49
(2) Selecting the track	22	(2) Cautions on storage	49
(3) Starting playback	23	13 LIST OF MESSAGES	50
(4) Stopping playback	23	14 SYSTEM LIMITATIONS	50
(5) PLAY/PAUSE button operation	24	15 TROUBLESHOOTING	51
(6) STDBY/CUE button operation	24		
(7) Search operations	25		
(Starting playback from the middle of a track)			
(8) Monitoring the play start position	26		
(9) Using the end monitor function	26		
(10) Changing the play end position (end mark function)	26		
(11) Presetting the next track to be played during playback	27		
(12) Setting the operation when playback finishes (stop, standby or repeat)	27		
6 SWITCHING THE DISPLAY			
(1) Items which can be displayed	29		
(2) Switching the display	29		
7 RECORDING (only available on the DN-990R)			
(1) Before starting to record	30		
(2) Disc recording methods	30		
(3) User TOC area	30		
(4) Starting recording	31		
(5) Stopping recording	32		
(6) Incrementing track numbers manually	33		
(7) Incrementing track numbers automatically	33		
(8) Protecting recordings from being erased	33		
8 END TRIMMING (only available on the DN-990R)			
(1) Description of end trimming function	34		
(2) End trimming operation	34		

1 PREPARATIONS

- (1) Checking the accessories**
Check that the following items are included in the package:
- 1) DN-990R or DN-980F
 - 2) Operating instructions (this manual)
 - 3) AC cord (3-pin type), 1 pc
 - 4) Fuse, 1 pc

- (2) Installation**
Up to three units can be installed in a 19-inch EIA rack or console. Install shelves on the rack.

NOTES:

- To be ensure proper operation of the DN-990R and DN-980F units, set them so that the slant of their front panel is within 15° of the perpendicular.
- The display window (fluorescent tube) is designed so that all indications can be seen from within the angles shown on Figure 7. Install the units so that the visual angle is within this range.

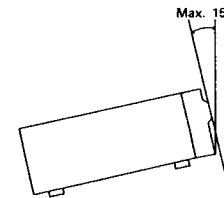

Figure 6

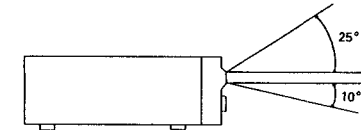

Figure 7

- To prevent the temperature inside the units from rising, do not install them in such a way that the ventilation holes are obstructed. When installing them in a rack, provide sufficient openings in the rack to dispel the heat.
 - Avoid installing in hot, humid or dusty places.
- (3) Connections**
- 1) Output signal connections
 - a) Analog output signal connections
Connect the LINE OUT L and R output connectors to the balanced inputs of an amplifier or console using 3-pin cords.
 - b) Digital output signal connections
To use digital output signals, connect the DIGITAL OUT output connector to the balanced digital input of an amplifier or console using a 3-pin cord.
 - 2) Input signal connections
 - a) Analog input signal connections
Connect the LINE IN L and R input connectors to the balanced outputs of an amplifier or console using 3-pin cords.
 - b) Digital input signal connections
To use digital input signals, connect the DIGITAL IN input connector to the balanced digital output of an amplifier or console using a 3-pin cord.

3) Parallel remote signal connections

- a) To use parallel remote function, set the preset function to "Remote ENA". (For the operation, see Page 15.)
- b) To use this unit remotely, connect the remote connector (REMOTE) with the remote control circuit using a 25-pin Dsub cord. Refer to the example of the remote control circuit in Figure 8.

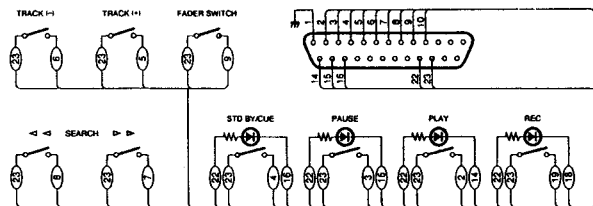

Figure 8

4) Serial remote signal connections

When using this unit connected to a controller or personal computer, connect the remote connector (RS232C) to the controller using a 9-pin Dsub cord.

5) Power supply connections

- a) Turn the POWER switch off.
- b) Use the included power cord to connect the unit to the power supply.

NOTES:

- Power supply
 - This unit's power supply is set as follows upon shipment from the factory.
 - AC 120V for U.S. and Canadian models
 - AC 230V for European and other models
- Analog output connectors
 - To receive this unit's output in unbalanced format, first convert it to unbalanced format using a transformer, etc.
 - Connecting the cold or hot pins to the ground terminal may result in damage.
- Digital output connector
 - This unit uses a balanced digital output. A conversion circuit is necessary for connection to an unbalanced circuit.
 - Example of balanced/unbalanced conversion circuit

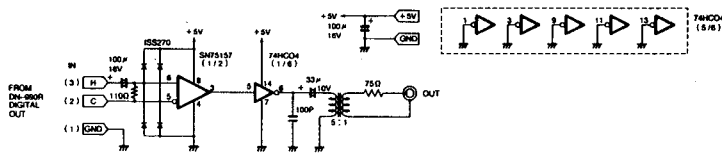

Figure 9

- Digital input terminal
 - This unit uses a balanced digital input. A conversion circuit is necessary for connection to an unbalanced circuit.
 - Example of unbalanced/balanced conversion circuit

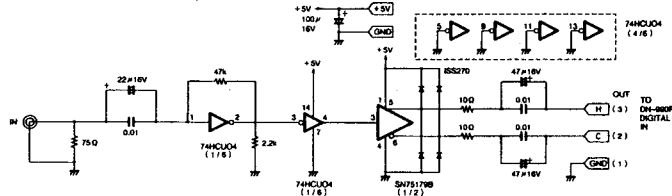

Figure 10

(4) Presettings

- 1) Various functions can be preset. The presettings are set using the buttons on the front panel and stored in the internal indelible memory.
- 2) Set the presettings according to the usage purpose. (For the operation, see Page 15.)

2 PART NAMES AND FUNCTIONS

The following is a description of the functions of the parts shown on Page 5.

(1) Front panel

1 EJECT button

- Press this button to eject the cartridge. If the EJECT LOCK indicator is lit (during recording or playback), the cartridge will not be ejected when the button is pressed.

2 Cartridge loading slot

- Insert the cartridge in the direction of its arrow with the arrow on the top side. Press the cartridge in with your finger to load it.
- The label on the cartridge is visible through the loading slot.

3 Display window (fluorescent tube display)

- This display window displays the track number, various characters (time code, operating messages, error messages and disc and track titles), the level meter and the status.

4 PLAY MODE switch

- Use this to select the play mode, single-track playback (SINGLE) or continuous (CONT.) playback. The presettings determine whether the stop mode, standby mode or repeat mode is set after playback is finished.

5 SELECT knob

- Use this knob to select the track number, for editing operations and for presetting operations. The knob functions as a selector when it is turned, and the selected item is set when the knob is pressed.
- The editing mode is set when the knob is pressed while selecting the editing function. (DN-990R only)

6 ▶|| PLAY/PAUSE button

- Use this button to start playback or recording or to stop temporarily (pause). The button lights (green) when playback or recording is started and flashes (yellow) when the pause mode is set.
- Depending on the presettings, information is written in the UTOC when the pause mode is set from the recording mode.

7 ■ STDBY/CUE button

- When this button is pressed during playback or recording, the pickup returns to the position at which playback or recording started, the standby mode is set and the button turns yellow. If the button is pressed during recording, information is written in the UTOC for approximately 3 seconds.

8 ● REC button (DN-990R only)

- This button is pressed before starting recording to set the recording standby mode. To start recording, press the PLAY/PAUSE button. When the REC button is pressed during recording, the track number is incremented. Also press this button after editing is completed to write the information on the disc.

9 ◀◀ SEARCH and ▶▶ SEARCH buttons

- Use these buttons to change the play start position and for editing operations.

10 MODE/CUE button

- Use this button to switch between the normal mode (recording and playback) and the editing mode.
- When pressed at the same time as the REC button, a cue signal is registered in the recorded track. The cue signal can be cleared by pressing this button while pressing the END MON/CLEAR button. (DN-990R only)
- When pressed at the same time as the STDBY/CUE button, the presetting mode is set. (DN-990R only)

11 DISP/CAPS/NUM button

- Pressing this button switches the character display. The display can be switched between the elapsed time, remaining time, track title or disc title.
- Press this button while editing titles to select capital or small letters, numbers or symbols. (DN-990R only)

12 END MON/CLEAR button

- Press this button while in the standby mode to monitor the end of the track.
- This button is also used for editing operations and for clearing cue signals. (DN-990R only)

(2) Rear panel

- 18 Analog output connectors (LINE OUT L and R)**
 a) These are active balanced outputs using XLR type connectors (XLR-3-32). Connected them to the balanced input terminals on an amplifier or console.
 b) Pin layout:
 Pin 1 — Common; Pin 2 — Cold; Pin 3 — Hot
 c) Applicable connector: XLR-3-11C or the equivalent.
NOTE: Do not short-circuit the hot or cold pin with the common pin.

- 14 Digital output connector (DIGITAL OUT)**
 a) This is an active balanced output using an XLR type connector (XLR-3-32). Connected it to the balanced digital input terminal on an amplifier or console.
 b) Pin layout:
 Pin 1 — Common; Pin 2 — Cold; Pin 3 — Hot
 c) Applicable connector: XLR-3-11C or the equivalent.

- 15 Output level adjustment controls (OUT LEVEL L and R)**
 These controls adjust the level of the signals output from the analog output connectors (LINE OUT L and R). The output level can be adjusted between the range of +22 dBm and -20 dBm when playing at the maximum level.

- 16 Headphones jack (PHONES)**
 Connect headphones with an impedance of 30 to 40 ohm.

- 17 Analog input connectors (LINE IN L and R)**
 a) These are active balanced inputs using XLR type connectors (XLR-3-32). Connected them to the balanced output terminals on an amplifier or console.
 b) Pin layout:
 Pin 1 — Common; Pin 2 — Cold; Pin 3 — Hot
 c) Applicable connector: XLR-3-12C or the equivalent.
NOTE: Do not short-circuit the hot or cold pin with the common pin.

- 18 Digital input connector (DIGITAL IN)**
 a) This is an active balanced input using an XLR type connector (XLR-3-32). Connected it to the balanced digital output terminal on an amplifier or console.
 b) Pin layout:
 Pin 1 — Common; Pin 2 — Cold; Pin 3 — Hot
 c) Applicable connector: XLR-3-12C or the equivalent.

- 19 Input level adjustment controls (IN LEVEL L and R)**
 These controls adjust the input sensitivity of the signals input from the analog input connectors (LINE IN L and R). The input level for recording can be adjusted between the range of +22 dBm and -6 dBm to attain the maximum recording level.

- 20 Remote connector (REMOTE)**
 a) This is a connector for parallel remote connection. The recording and playback operations can be controlled remotely.
 b) Applicable connector: 25-pin D-sub plug.
 c) Pin layout:

Pin No.	Signal name	I/O	Level
1	FG	—	—
14	PLAY TALLY	O	TTL (Iol=48 mA)
2	PLAY COMMAND	I	HCMOS (Ii=-3 mA)
15	PAUSE TALLY	O	TTL (Iol=48 mA)
3	PAUSE COMMAND	I	HCMOS (Ii=-3 mA)
16	STDBY/CUE TALLY	O	TTL (Iol=48 mA)
4	STDBY/CUE COMMAND	I	HCMOS (Ii=-3 mA)
17	END CUE TALLY	O	TTL (Iol=48 mA)
5	TRACK (+) COMMAND	I	HCMOS (Ii=-3 mA)
18	REC TALLY	O	TTL (Iol=48 mA)
6	TRACK (-) COMMAND	I	HCMOS (Ii=-3 mA)
19	REC COMMAND	I	HCMOS (Ii=-3 mA)
7	SEARCH (FWD) COMMAND	I	HCMOS (Ii=-3 mA)
20	CUE TALLY	O	TTL (Iol=48 mA)
8	SEARCH (REV) COMMAND	I	HCMOS (Ii=-3 mA)
21	NC	—	— (Ii=-10 mA)
9	FADER START	I	PHOTO COUPLER
22	TALLY POWER SUPPLY	O	+5 V, 20 mA
10	FADER START (RETURN)	—	—
23	F & COMMAND COMMON	—	—
11	NC	—	—
24	E.O.M./CUE/END CUE	O	DRY CONTACT
12	NC	—	—
25	E.O.M./CUE/END CUE	O	DRY CONTACT
13	NC	—	—

Table 1

- 21 Serial remote connector (RS232C)**
 a) This is a connector for serial remote connection. When connected to a personal computer or other external controller, the playback, recording and editing operations can be controlled and track and disc titles written from the controller.
 b) Applicable connector: 9-pin D-sub plug.
 c) Baud rate: 9600 bps or 19,200 bps, selectable
 d) Pin layout:

Pin No.	Signal name	I/O	Level
1	NC	—	—
2	6 NC	—	—
3	7 Tx/D	O	RS-232C
4	8 NC	—	—
5	9 RxD	I	RS-232C
	NC	—	—
	S. GROUND	—	—

Table 2

- 22 POWER switch**
 The set's power turns on when this switch is set to the ON side, off when it is set to the OFF side.
- 23 AC inlet (AC)**
 Connect the included power cord here.

- (3) Display window**
- 24 Track number display (3 digits)**
 This indicates the number of the track at the current position. The display blinks when the number of the next track to be played is displayed. The display also flashes when searching for a track and when switching to the standby mode. Track numbers of up to 99 are displayed in two digits, while track numbers of 100 and over are displayed in three digits.
- 25 Character display (13 digits)**
 The current position is displayed in minutes (m), seconds (s) and frames (f). Though MDs themselves do not have frames, 75 frames per second can be displayed in the same way as with CDs. When the DISP button is pressed, the track or disc title is displayed. In the editing mode and during presetting operations, operating messages are displayed. Capital and small letters, numbers and symbols can be displayed.
- 27 Level meter display**
 Digital signal processing and a 24-segment bar graph are used to display the peak response with high precision and no change over time. The peak values are held for 1.5 seconds.
- 28 OVER level warning indicators**
 These are lit (red) if the headroom is 0.2 dB or less, and are held for 1.5 seconds.
- 29 EJECT LOCK indicator**
 When this indicator is lit, the disc cannot be ejected. This indicator is lit when the play lock function is set, or in the recording mode, or when information is being written in the UTOC.

- 24 Fuse holder**
- To replace the fuse, use small screwdrivers, etc., to push the catches (A) and (B) at the top and bottom of the holder inward and remove the fuse holder outward.
 - Replace the old fuse with one with the rating indicated on the panel.
 Type of fuse: T1.60 A 125 V for 120 V operation
 T500 mA 250 V for 230 V operation

- PRESET VOLTAGE CHANGE**
 DN-990R and DN-980F allows selection of either 120 V or 230 V operation. The unit has been preset at 230 V prior to shipment except for U.S.A. & Canada. In order to use the unit at 120 V, follow the procedures below.
- The fuse holder serves as a voltage selector.
 - Turn the voltage selector block so that the proper voltage setting (120) appears in the indication window and refit it. Be sure to replace a fuse described in the above when operate the unit with 120 V.
 - Press in the fuse holder back to the main body. Make sure of the click action of the fixing tabs for secure fitting.

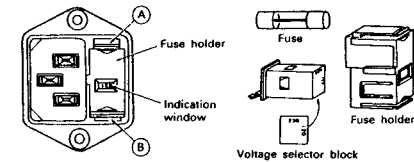

- 30 TOC indicator**
 This is lit when recording is started or when editing is ended (the information has not yet been written in the UTOC). The indicator flashes when recording or editing is finished and the UTOC information is being written on the disc.
- 31 EDIT indicator**
 This is lit when editing is started, and flashes when the edited UTOC information is written on the disc.
- 32 CUE detect/write indicator**
 This is lit for 3 seconds when CUE signals are detected in the track and when they are recorded.
- 33 REM (remaining time) indicator**
 This is lit when the remaining time is displayed.
- 34 VARI (variable speed) indicator**
 This is lit when the playing speed is other than the standard speed (2% faster).
- 35 DIGITAL IN mode indicator**
 This is lit when the digital recording input is selected. When in the recording mode, it flashes if the digital input connection is disconnected or if the digital PLL is unlocked.

3 PRESETTING FUNCTIONS AND OPERATIONS

(1) Table of preset functions

- These functions can be set using the buttons on the front panel, rather than DIP switches. The settings are stored in an indelible memory, so they are not erased when the power is turned off.
- The functions shown on the table below can be preset. Use these according to the purpose to perform high quality recording or playback with greater efficiency. (Table 3)
- Information on the set (the microprocessor version) can be displayed during the presetting operation.

Function	Description	Character Display (as set upon shipment from factory)	No.
Recording: Input selection	Selection of recording input (analog or digital)	Analog Input	(1)
Playback: Stereo/monaural	Selection of stereo or monaural playback	Stereo	(2)
Playback: Speed	Selection of playback speed (normal or +2% (variable))	Normal speed	(3)
Recording: SCMS	Selection of copy prohibit code to be recorded on the disc or not (subject to SCMS/copy the copy inhibit codes)	SCMS ENA	(4)
Recording: Auto track increment	Selection of whether or not to automatically increment track numbers Selection of whether to increment tracks when blank sections are detected or using digital interface	Auto Inc OFF	(5)
Recording: Auto track increment	Setting of blank detection level	Inc. Det. -60dB	(6)
Playback: Auto cue	Selection of whether or not to perform auto cue and setting of sound startup level	Cue Det. -60dB	(7)
Recording: UTOC	Setting of UTOC writing timing	UTOC Normal	(8)
Parallel remote	Selection of whether to enable or inhibit the parallel remote function	Remote ENA	(9)
Operation: Switch protect	Selection of whether to enable or inhibit the function of the panel switches	Switch ENA	(10)
Playback: Play lock	Selection of whether to enable or inhibit the function of the panel switches during playback	Playlock OFF	(11)
Playback: End mark	Selection of whether or not to change the play end position	End Mark ON	(12)
Parallel remote	Selection of remote fader input method (play pause or play)	Fader P-Pause	(13)
Playback: E.O.M.	Selection of whether or not to display the EOM message and display time setting	E.O.M. 10sec	(14)
Playback: End monitor	Selection of whether or not to perform the end monitor function and monitor time setting	End Mon 10sec	(15)
Playback: Standby position	Setting of standby position	Stdby 0ms	(16)
Playback: Delay start	Setting of delay start time	Delay 0ms	(17)

(continued from previous page)

Function	Description	Character Display (as set upon shipment from factory)	No.
Serial remote	Baud rate setting	9600bps	(18)
Parallel remote	Setting of tally output signal with dry contact	Tally End Cue	(19)
Parallel remote	Setting of end cue output timing	End Cue -2sec	(20)
Playback: Finishing mode	Setting of playback finishing mode	Finish Stop	(21)
Parallel remote	Selection of tally output lit or flashing	Flash ON	(22)
Display: Frame display	Selection of whether or not to display frames	FR Disp ON	(23)
Recording: UTOC	Selection of whether or not to protect the recording from power failures (Selection of whether or not to write the pre-UTOC information)	Pre UTOC OFF	(24)
Operation: Eject lock	Selection of whether or not to lock ejecting during playback	Ejectlock OFF	(25)
Serial remote	Selection of whether or not to set the unit's ID number with serial communications Setting of ID number	Player ID 00	(26)
Set information	Microprocessor version display	Ver. **** ** (* indicates numbers)	(27)

Table 3

(2) Presetting procedures

- The functions can be preset using the buttons on the front panel.
- Presetting is also possible from the controller connected to the serial remote connector (RS-232C).
- Presetting can also be performed when no disc is loaded and in the stop, standby and recording pause modes.

1) First press the STDBY/CUE button while pressing the MODE/CUE button to enter the preset mode.

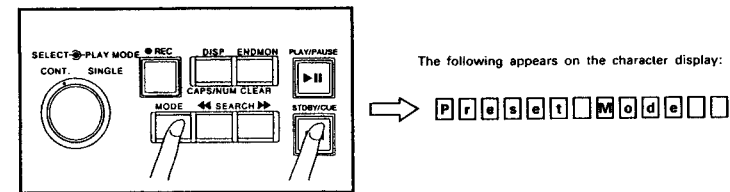
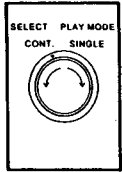
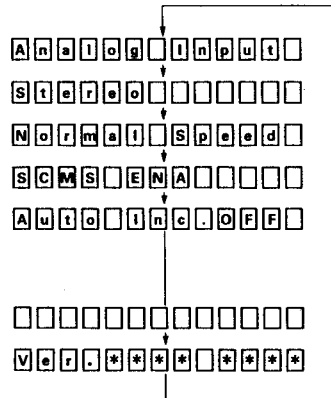

Figure 11

2) Turn the SELECT knob to select the function to be preset.



The character display changes as shown below.



The preset functions change in the order of the arrow when the knob is turned clockwise, in the opposite order when the knob is turned counterclockwise.

Figure 12

3) Press the SELECT knob to change the presetting.



The character display changes as shown below.

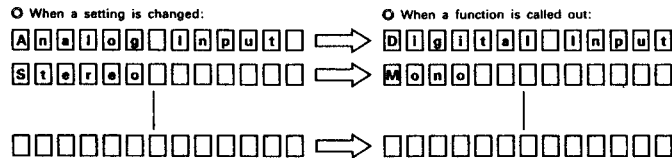
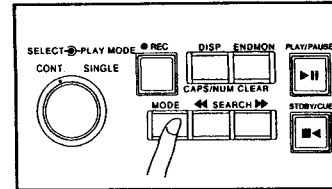

Figure 13

4) Press the MODE/CUE button to cancel the preset mode during the presetting operation.



The time reappears on the character display.

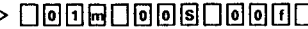
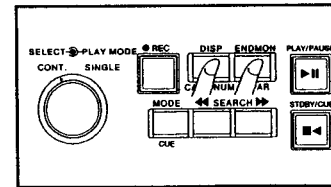

Figure 14

5) To set the presettings back to the initial settings (the settings set upon shipment from the factory), turn the power on while holding in both the DISP/CAPS/NUM and the END MON buttons. For the initial settings, refer to "(1) Table of preset functions".



The character display changes as shown below.



Figure 15

(3) Description of preset functions ("*" indicates the initial setting)

- 1) "Analog (Digital) Input"
 - * Analog Input
 - Digital Input
- 2) "Stereo (Mono)"
 - * Stereo:
 - Stereo signals (L and R) are output from the LINE OUT connectors.
 - Mono:
 - The L and R signals are mixed and output from the LINE OUT connectors.
- 3) "Normal (+2%) speed"
 - * Normal speed:
 - Playback at normal speed.
 - +2% speed:
 - Playback at variable (+2%) speed.
- 4) "SMCS ENA (INH)"
 - * SMCS ENA:
 - Copy inhibit codes are recorded on the disc subject to the SCMS.
 - SMCS INH:
 - The same copy inhibit codes as the original source are recorded on the disc.
- 5) "Auto Inc (Dig./Det./OFF)"
 - Auto Inc Dig.:
 - Tracks are incremented automatically when subcodes and start IDs are detected during digital recording from CDs and DATs.
 - Auto Inc Det.:
 - Tracks are incremented when blank sections are detected during digital or analog recording.
 - * Auto Inc OFF:
 - Tracks are not incremented automatically.

- 6) "Inc. Det. (-**jdB"
Inc. Det. (-**jdB):
This sets the level for incrementing tracks when blank sections are detected. (-72/-66/*-60/-54/-48/-42/-36)
Tracks are incremented if the blank section is over 3 seconds long.
- 7) "Cue Det. (-**jdB"
Cue Det. (-**jdB):
This sets the level for sound detection when cueing. (OFF/-72/-66/*-60/-54/-48/-42/-36)
Cue Det. OFF:
Auto cueing is not performed.
- 8) "UTOOC Normal (Pause)"
* UTOOC Normal:
The information is written in the UTOC directly before the standby mode is set when recording is completed.
UTOOC Pause:
The information is written in the UTOC directly before the recording pause mode is set when recording is paused.
- 9) "Remote ENA (INH)"
* Remote ENA:
Control inputs to the parallel remote connector are accepted.
Remote INH:
Control inputs to the parallel remote connector are not accepted.
- 10) "Switch ENA (INH)"
* Switch ENA:
All of the switches on the front panel operate.
Switch INH:
Only the following switches operate: PLAY MODE switch, DISP button, resetting operation, presetting operation
- 11) "Playlock ON (OFF)" (The following setting is valid when function 12, "Switch ENA (INH)", is set to Switch ENA.)
Playlock ON:
During playback, only the following switches operate: PLAY/PAUSE button, PLAY MODE switch, DISP button, resetting operation
* Playlock OFF:
Other operations can be performed in the play mode.
- 12) "End Mark ON (OFF)"
* End Mark ON:
The play end position is changed when the PLAY/PAUSE button is pressed in the end monitor mode.
End Mark OFF:
The play end position is not changed when the PLAY/PAUSE button is pressed in the end monitor mode.
- 13) "Fader P-Pause (Play)"
* Fader P-Pause:
Playback starts when fader switch turned on.
Fader Play:
Playback starts when fader switch turned on, set to pause mode when fader switch turned off.
- 14) "E.O.M. (**)sec"
E.O.M. (**)sec:
This sets the end of message time. (5/*10/15/20/25/30/35)
E.O.M. OFF:
The end of message is not displayed.
- 15) "End Mon (**)sec"
End Mon (**)sec:
This sets the end monitor time. (5/*10/15/20/25/30/35)
End Mon OFF:
The end monitor function is not performed.

- 16) "Stdby (**)ms"
Stdby (**)ms:
This changes the standby position. (*0/-100/-200/-300)
Example: When auto cue and advance time from cue up position are set:
First the track search operation is performed, then the level search operation is performed. After the level search operation is completed, the pickup returns the preset amount of time "t" and set to the standby mode. ("Level search": Automatic cueing to the position where the sound starts.)
1. Track start position
2. Standby position after auto cue
3. Final standby position

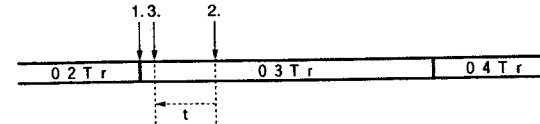

Figure 16

- 17) "Delay (**)ms"
Delay (**)ms:
This sets the delay time from which the playback operation is started until playback starts. (*0/100/200/300)
- 18) "9600 (19200)bps" (This cannot be set from the RS-232C (serial remote) connector.)
* 9600 bps:
The baud rate is set to 9600 bps.
19200 bps:
The baud rate is set to 19200 bps.
- 19) "Tally (E.O.M./EndCue/Cue)"
Tally E.O.M.:
The end of message tally signal is output from the REMOTE connector (pins 24 and 25).
* Tally End Cue:
The end cue tally signal is output from the REMOTE connector (pins 24 and 25).
Tally Cue:
The cue tally signal is output from the REMOTE connector (pins 24 and 25).
- 20) "End Cue -(*)sec"
End Cue -(*)sec:
The end cue tally signal is output (*) seconds before from the play end position. (0/-1/*-2/-3)
- 21) "Finish (****)"
* Finish Stop:
The stop mode is set immediately when playback is finished.
Finish Recue:
When playback is finished, the pickup returns to the play start position and the standby mode is set.
Finish Next:
When playback is finished, the pickup moves to the play start position for the next track and the standby mode is set. After the playback of the final track is finished, the standby mode is set at the first track.
Finish Repeat:
The tracks are repeated according to the play mode.
- 22) "Flash ON (OFF)"
* Flash ON:
PLAY TALLY blinks during the EOM for parallel remote tally output, PAUSE TALLY blinks when playback ends, and STDBY TALLY blinks during the search operation. (The same display as on the front panel is output.)
Flash OFF:
The parallel remote tally output does not blink.
The tally signal is output only when the PLAY/PAUSE and STDBY/CUE buttons' displays are lit.
- 23) "FR Disp ON (OFF)"
* FR Disp ON:
The frames are displayed on the time display during playback.
FR Disp OFF:
The frames are not displayed on the time display during playback. (They are displayed in the manual search, standby, pause and end monitor modes.)

24) "Pre UTOC ON (OFF)"

Pre UTOC ON:

The recording is protected from power failures. The information is written in the UTOC directly after recording starts. (The pre-UTOC information is written.)

If preset setting is set to "UTOC Normal", pre-UTOC will not be written when recording is resumed after recording was once paused by REC/PAUSE. Track transition information will also not be written onto the pre-UTOC. In order to write the pre-UTOC each time recorded is started, set the preset setting to "UTOC Pause".

* Pre UTOC OFF:

The recording is not protected from power failures. The information is written in the UTOC according to the UTOC Normal (Pause) setting.

Since normally information is written in the UTOC after recording is completed, if there is a power failure during recording or directly after recording is completed, the recording is not registered on the disc. When this function is turned on, the pre-UTOC information (*1) is recorded on the disc directly after recording starts. When recording is completed normally, the actual UTOC information (*2) is written. If there is a power failure before this, the disc can be played according to the pre-UTOC information, so precious recordings are not lost.

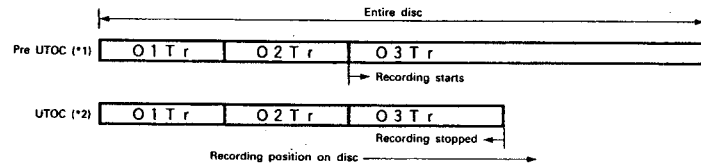

Figure 17

If recording is interrupted due to an unforeseen problem, UTOC information can be modified to match the actual recording content following these edit operations: Use the divide function to divide track 03 on the figure No. 16 at the point where recording was interrupted, then use the erase function to erase track 04.

25) "Ejectlock ON (OFF)" (Regardless of this setting eject lock is set during the recording and recording pause modes and when the UTOC information is being written.)

Ejectlock ON:

The EJECT button is locked during playback.

* Ejectlock OFF:

The EJECT button is not locked during playback.

26) "Player ID (**)"

Player ID (**):

This sets the player ID. (The ID is a number from 0 to 15. "0" means there is no ID. The initial setting is "0".)

27) "Ver. **** *":

The microprocessor's version is displayed.

4 LOADING AND EJECTING CARTRIDGES

(1) Loading cartridges

- 1) If a cartridge is already loaded, press the EJECT button and remove it.
- 2) Insert the cartridge into the cartridge loading slot. (Figure 19)
- 3) Be sure to insert the cartridge in the proper direction, following the arrow on the top of the cartridge as shown in Figure 18.
- 4) Press the cartridge in with your finger to load it. The disc is now automatically loaded, it turns, the STDBY/CUE button flashes and the beginning of the first track is located.

(2) Ejecting cartridges

- 1) If the EJECT LOCK indicator on the display window is lit, the eject mechanism is locked and the EJECT button cannot be pressed in. Do not try to force it.
- 2) Press the EJECT button with your index finger to eject the cartridge. (Figure 20)

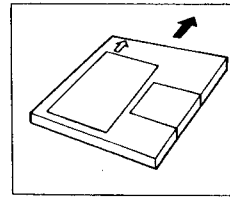

Figure 18

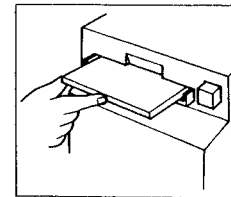

Figure 19

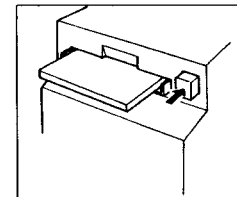

Figure 20

5 PLAYBACK

(1) Selecting the play mode

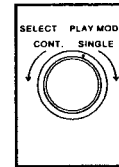

Figure 21

Set the PLAY MODE switch to "SINGLE" or "CONT.":

(2) Selecting the track

- When the SELECT knob is turned, the track number display increases or decreases by one with each click.
 - If the SELECT knob is pressed in and turned, the track number display increases or decreases by ten with each click.
- Example: For a disc with 4 tracks

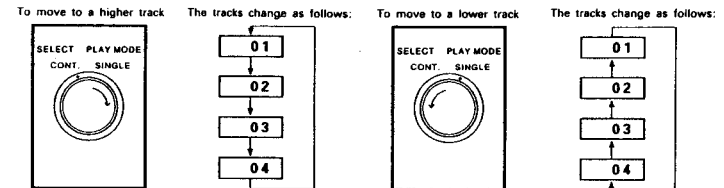

Figure 22

- When a track is selected, that track number is displayed and cueing is performed. (Figure 23)

Track selection

Example: When track 2 is selected

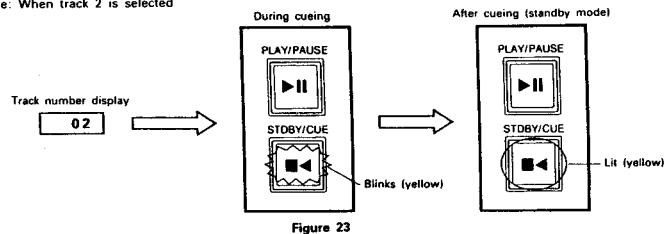

Figure 23

- If the selected track number does not exist on the disc, the display reads as shown in Figure 24. Select a new track. Example: When track 7 is selected for a disc containing 4 tracks

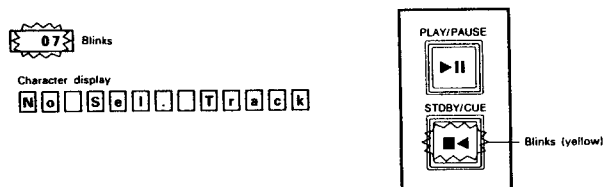

Figure 24

(3) Starting playback

- Press the PLAY/PAUSE button while in the play pause or standby mode to begin playback.
- The sound is reproduced immediately when the button is pressed, without having to wait for the disc to turn. (Instant start)

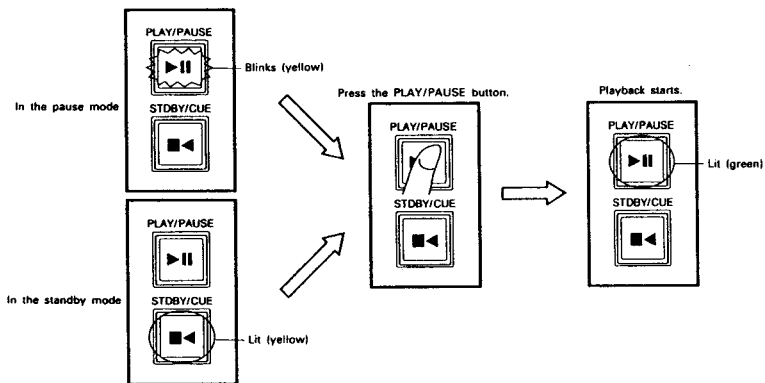

Figure 25

(4) Stopping playback

- There are two ways to stop playback.
 - Press the PLAY/PAUSE button during playback. The pause mode is set at that position.
 - Press the STDBY/CUE button during playback. The pickup cues back to the position at which playback started. If a track is selected with the SELECT knob (if the track number display is flashing), the pickup is set to the standby mode at that track.

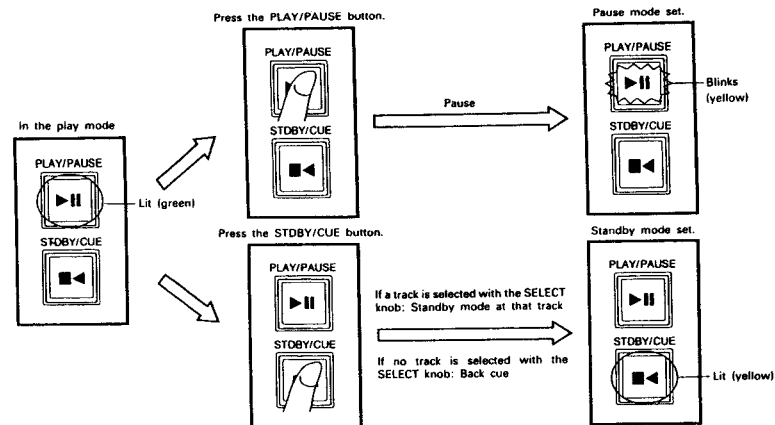
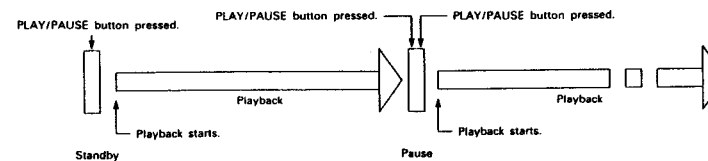

Figure 26

(5) PLAY/PAUSE button operation

- The mode switches between playback and pause each time the PLAY/PAUSE button is pressed. (Figure 27)
- This unit uses an audio memory for playback, so the sound is output immediately when the PLAY/PAUSE button is pressed.
- If the STDBY/CUE button is pressed during playback, the pickup is cued back to the position at which playback started. (Back cue)
- Figure 26 shows how playback proceeds when the PLAY/PAUSE button is pressed.



When the PLAY/PAUSE button is pressed once, playback starts. When it is pressed again, the pause mode is set at that position. When it is pressed once again, playback resumes.

Figure 27

(6) STDBY/CUE button operation

- When the STDBY/CUE button is pressed after playback has been started by pressing the PLAY/PAUSE button, the pickup returns to the position at which playback started and the standby mode is set.
- Press the PLAY/PAUSE button and STDBY/CUE button alternately to start playback from the same position repeatedly.
- This function is called "Back Cue".

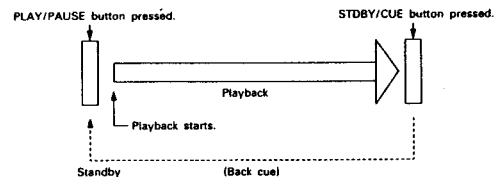

Figure 28

6 SWITCHING THE DISPLAY

(1) Items which can be displayed

- Four types of disc information can be displayed:
 - Remaining time
 - Elapsed time
 - Track title
 - Disc title
- These are displayed on the character display.
- Still messages of up to 13 characters and scrollable messages of up to 255 characters can be displayed.
- The characters which can be displayed are ASCII code characters.
- With the DN-990R, it is possible to give discs and tracks names (titles). For the operation, refer to section 9, "Editing".

(2) Switching the display

- The following items can be displayed in the respective operating modes:

	Stop	Standby	Play	Play pause	Recording pause	Recording
Remaining time	-	○	○	○	○	○
Elapsed time	-	○	○	○	○	○
Track title	-	○	○	○	-	-
Disc title	○	○	-	○	-	-

- The remaining time is displayed when the power is turned on.

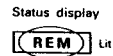

The remaining time is displayed on the character display.



Figure 36

- The display switches each time the DISP/CAPS/NUM button is pressed.

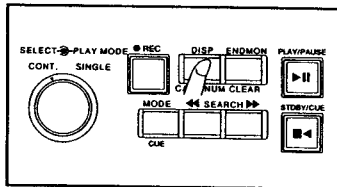

The character display switches as follows:

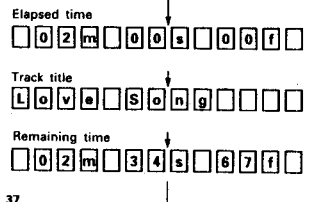
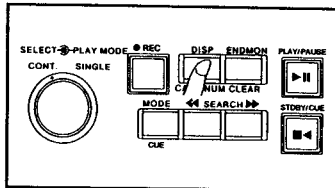

Figure 37

- The disc title appears when the DISP/CAPS/NUM button is pressed for over 0.5 seconds, then turns off when the button is released.



The disc title is displayed on the character display.

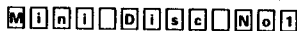

Figure 38

7 RECORDING (only available on the DN-990R)

(1) Before starting to record

- Press the POWER switch. To record from an analog input, we recommend turning the power on at least 30 minutes in advance, since after this time there is no more DC offset fluctuation for the A/D converter, so the DC offset at the recording start position, in the middle and at the end position is low and stable. DC offset hampers the auto cue function which detects the low level beginnings of sound and the auto track increment function which detects blank sections.
- Load a recordable disc. There are two types of recordable discs, 60-minute discs and 74-minute discs. For more information on recordable discs, refer to "(2) Disc recording methods" below. Recording is not possible on discs which have already been fully recorded or on playback-only discs.
- Check and set the following preset functions. For the operation, refer to "[3] Presetting Functions and Operations".
 - Recording input selection
 - SCMS setting
 - Selection of whether or not to automatically increment track numbers and whether to do so using digital interface or by detecting blank sections
 - Setting of the blank detection level for the auto track increment function
 - Setting of the timing at which the UTOC information is recorded

(2) Disc recording methods

Disc on which recording is started	Method of recording on discs
1 When recording on a non-recorded disc	Recording starts from the beginning of the disc. The beginning of the disc is searched for automatically, so cueing is not necessary.
2 When recording on a disc from which all tracks have been erased	Recording starts from the beginning of the disc. The beginning of the disc is searched for automatically, so cueing is not necessary.
3 When recording on an already recorded disc	Recording starts after the end of the last recording. The end of the recording is searched for automatically, so cueing is not necessary. The unit is designed so that it is not possible to record over other recordings, thus preventing previous recordings from being erased accidentally.
4 When erasing an already recorded disc and recording over on it	If there is not enough remaining recording time or if you want to do the recording over, first erase the unnecessary part. To erase one track at a time: Use the track erase function. To erase all tracks at once: Use the all erase function.

- Names of discs
 - Blank discs:
 - Unrecorded discs
 - Newly purchased recordable discs
 - Discs from which all tracks have been erased (using the all erase function)
 - No-track discs:
 - Discs with disc titles but no recording
 - Blank discs on which the disc title has been written
 - Discs on which the track and disc titles have been written but on which all the tracks have been erased one track at a time

(3) User TOC area

- Recordable discs include an area at the inner side of the disc called the User Table of Contents (User TOC or UTOC).
- Information for controlling the data recorded on the disc (start positions, end positions, order of tracks, etc.) is stored in this user TOC area. Editing is possible by simply changing this information without recording again. Unlike tapes, cueing is possible immediately using the edited information.
- The information is recorded in this user TOC after recording is completed. The timing at which this information is recorded depends on the presettings. For the operation, refer to "[3] Presetting Functions". (See Page 15.)

Presetting	Recording in user TOC
UTOC Normal (8)	Information is recorded when the STDBY/CUE button is pressed to stop recording.
UTOC Pause (8)	Information is recorded when the PLAY/PAUSE button is pressed to set the recording pause mode.

(4) Starting recording

■ Load the disc onto which you want to record and set the standby mode. When a blank disc or a no-track disc is loaded, "No Track" is displayed and the stop mode is set.

■ The following two operations must be performed to start recording:

- 1) Press the ● REC button while in the standby mode. The recording pause mode is set at the end of the previous recording. For blank discs and no-track discs, press the ● REC button while in the stop mode. The recording pause mode is set at the beginning of the disc.

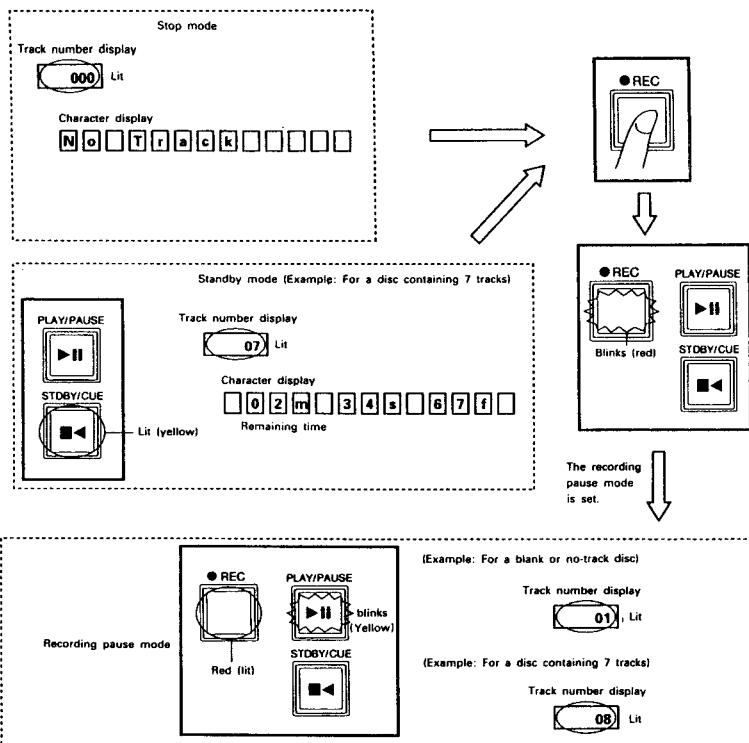

Figure 39

• If there is no recordable time on the disc, the following message appears when the REC button is pressed:

D i s k F u l l

• When recording from a digital input (when the preset function is set to "Digital Input"), the following status display appears if there is no digital input. In this case, it is not possible to start recording.

D I G I T A L I N

- 2) Press the PLAY/PAUSE button while in the recording pause mode to start recording.

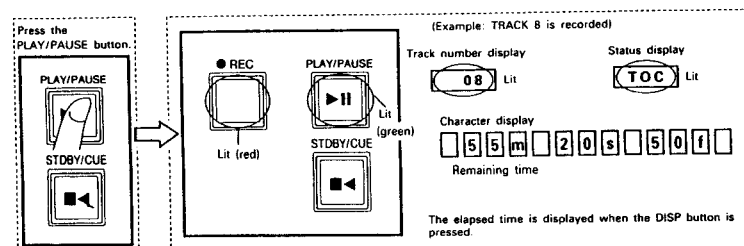

Figure 40

■ If the REC button is pressed while in the recording mode, the track number is incremented. This function comes in handy for setting cue points while recording continuously.

(5) Stopping recording

■ There are two ways to stop recording, as follows:

- 1) Setting the recording pause mode

The recording pause mode is set when the PLAY/PAUSE button is pressed while in the recording mode. The track number changes to the next track number. Recording resumes when the PLAY/PAUSE button is pressed again.

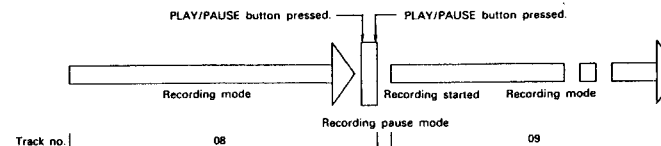

Figure 41

When the STDBY/CUE button is pressed while in the recording mode, the result of the recording (the UTOC information) is written on the disc, after which the standby mode is set.

- 2) Setting the standby mode

When the STDBY/CUE button is pressed while in the recording mode, the result of the recording (the UTOC information) is written on the disc, after which the standby mode is set. It takes about 3 seconds for the UTOC information to be written. After this, the pickup returns to the position at which recording started and the standby mode is set. There is no need to cue in order to check the recording. Simply press the PLAY/PAUSE button.

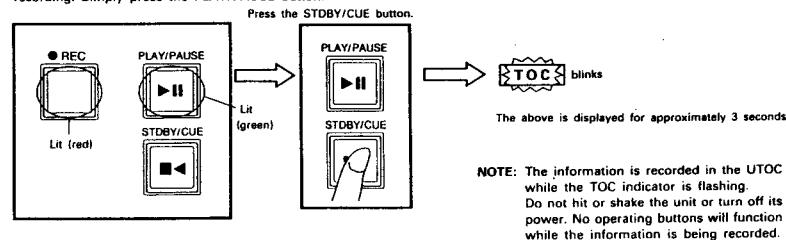
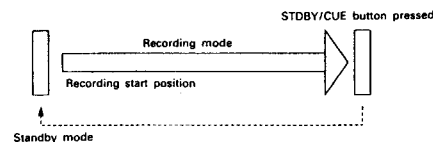

Figure 42



(6) Incrementing track numbers manually

- There are four ways to assign track numbers manually, as follows:
 - Press the **REC** button during recording to increment the track number. The track's recording time must be at least 2 seconds.
 - Press the **PLAY/PAUSE** button during recording to end recording on that track number and set the recording pause mode. When the **PLAY/PAUSE** button is pressed again, recording begins with a new track number.
 - Press the **STDBY/CUE** button during recording to end recording on that track number and set the standby mode. If the recording operation is performed again, recording begins with a new track number.
 - After recording, use the divide function to divide a track in two tracks.

(7) Incrementing track numbers automatically

There are three ways to assign track numbers automatically, depending on the type of input.

Type of input		Method	
Analog input		By detecting blank sections (1)	
Digital input	CD	By detecting blank sections (1)	Using the CD's subcodes (2)
	DAT	By detecting blank sections (1)	Using the DAT's start IDs (3)

Detecting blank sections

- Two preset functions must be set.
 - Set preset function (5), "Auto Inc OFF", to "Auto Inc DET."
 - Set the blank detection level with preset function (6), "Inc. Det. (-60)dB".
- Begin playback and recording on the recorder with a timing at which the beginning will not be missed. The disc's track numbers are automatically incremented when blank sections of 2 seconds or more (sections with a level lower than the preset blank detection level) are detected.

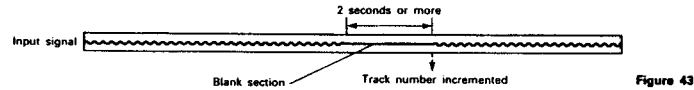

Figure 43

Using the CD's subcodes (with a digital input)

- Preset as follows:
 - Set preset function (5), "Auto Inc OFF", to "Auto Inc DIG."
- Begin playback of the CD and recording on the recorder with a timing at which the beginning will not be missed. The disc's track numbers are automatically incremented when the track numbers on the CD change. Unit does not accept the track change signal within 2 seconds immediately after start of the recording.

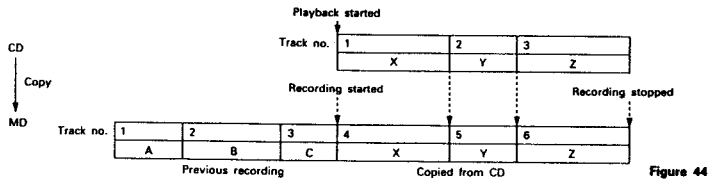

Figure 44

Using the DAT's start IDs (with a digital input)

- Record start IDs on the recorded DAT.
- Preset as follows:
 - Set preset function (5), "Auto Inc OFF", to "Auto Inc DIG."
- Begin playback of the DAT and recording on the recorder with a timing at which the beginning will not be missed. The disc's track numbers are automatically incremented when the DAT's start IDs are detected. Start IDs are not detected for the first 15 seconds after recording is started.

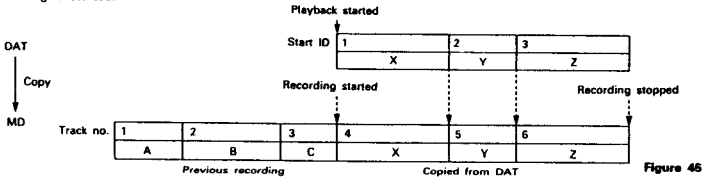

Figure 45

(8) Protecting recordings from being erased

Set the disc's write protect switch so that the hole is open. In this position, the disc cannot be recorded or edited. The "Protected" message appears on the display if you attempt to record or edit.

8 END TRIMMING (only available on the DN-990R)

(1) Description of end trimming function

The ends of tracks can be easily trimmed off. This is a non-destructive editing function which does not erase the trimmed section but simply records the end trim point on the disc. Trimming can be performed again even if the track has already been edited. This function comes in convenient for tracks which fade out or when recording tracks whose ends are difficult to time. The desired position can be determined by recording the end of the track somewhat longer than necessary, then using the **SEARCH** buttons to play the sound at the point to be trimmed repeatedly. With this function, you can record leisurely then edit the ending perfectly and easily.

End trimming is designed to be used in single play mode. This end trimming is not effective in continuous play mode, except when end trimmed track is the first track to play in continuous mode.

NOTE: This function does not actually erase the trimmed section, so the untrimmed original track is played when the disc is played on MD player or recorder other than DENON. If necessary, use the divide and erase functions to actually erase the trimmed section.

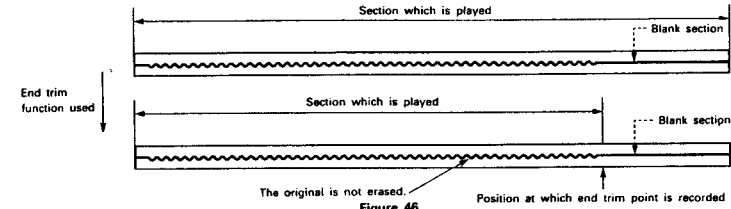

(2) End trimming operation

- The end trimming operation is done in the end monitor mode. First set the unit to standby at the track whose end is to be trimmed. Next set the end monitor mode by pressing the **END MON/CLEAR** button while in the standby mode.

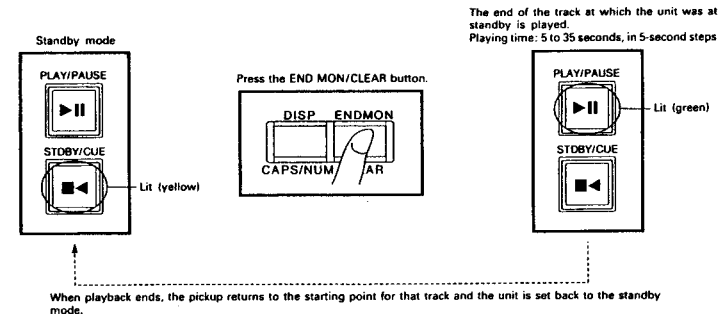
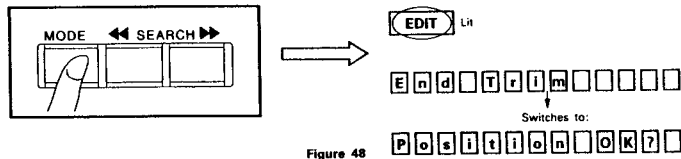
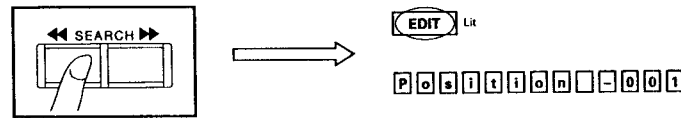

Figure 47

- 2) To set the end trim mode, press the MODE/CUE button while in the end monitor mode. The sound between the trim point and the point 3 seconds before it is played repeatedly.



- 3) Use the SEARCH buttons (▶▶) and (◀◀) to move the trim point. The display changes within the range of -999 to +999 each time the button is pressed, indicating the amount of movement. (±001 equals approximately 0.011 seconds.)



The position can be moved to -999 (about 11 seconds backward)

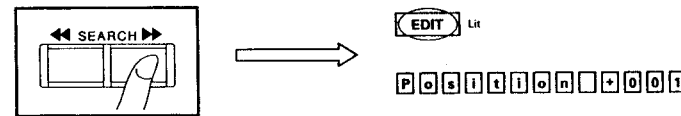

The position can be moved to +999 (about 11 seconds forward)

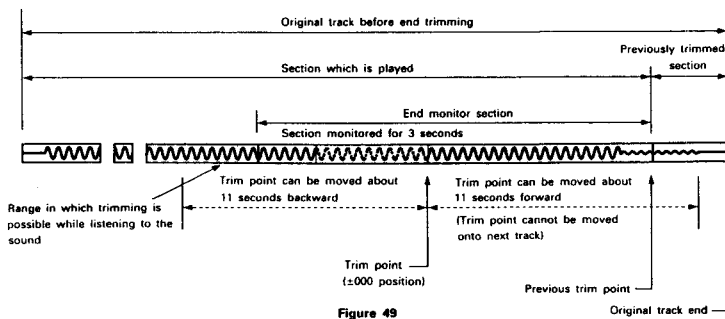

- The trim point can be moved onto the previously trimmed section, so the end can be trimmed again.

- 4) To cancel the trim mode during the operation and return to the playback or recording mode, press the MODE/CUE button.

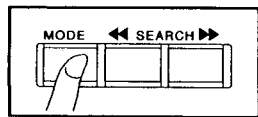

- 5) To set the trim point and complete the end trim function, press the REC button.

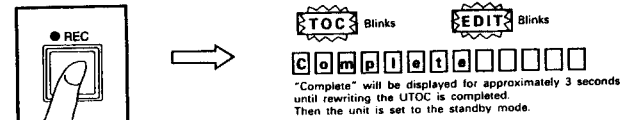

- NOTE:** While "TOC" indicator is blinking, the unit is rewriting the UTOC. Do not hit or shake the unit or turn off its power. No operating buttons will function while the information is being recorded. (For the UTOC, see Page 30.)

- 6) In order to delete the END TRIM point of a track recorded on the disc, press REC button during END MONITORING the selected track. Only the END TRIM point for the track will be erased.

9 EDITING (only available on the DN-990R)

(1) Description of editing functions

- There are six basic editing functions for MDs. Here we give a brief description of each.

(1) Track erase function (for erasing tracks)

- An entire specified track, from the beginning to the end, can be erased instantaneously using the buttons on the front panel. Unlike tapes, there is no need for recording the disc over to erase it or for any operations like cutting the tape.

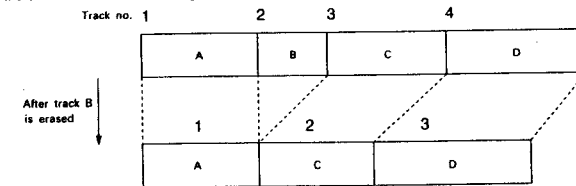

(2) All erase function (for erasing all the tracks on the disc)

- All the tracks on the disc can be erased instantaneously using the buttons on the front panel. Unlike tapes, there is no need to use an eraser or to record the disc over.

(3) Divide function (for dividing a track in two)

- A track can be divided into two. This makes it easy to set a new cueing point after recording, using the buttons on the front panel.

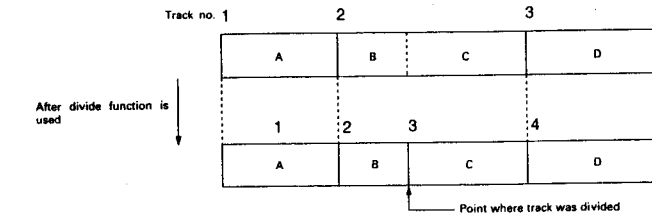

(4) Combine function (for combining two adjacent tracks)

- This function can be used to join fractured recordings into one track, or make a single track out of several cuts of recordings. Unlike tapes, there is no need for making a new copy or for any operations like those required for editing a tape.

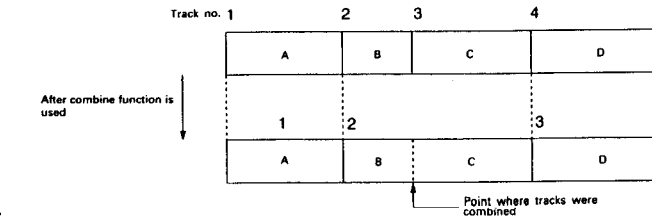

(5) Move function (for moving tracks)

This function can be used to rearrange the order of the tracks. Unlike tapes, there is no need for making a new copy or for any operations like those required for editing a tape.

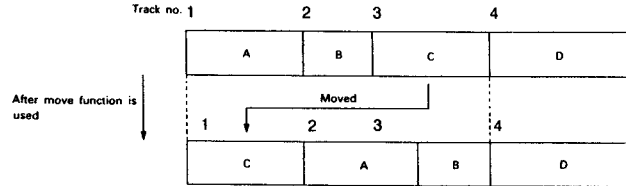

Figure 55

(6) Title function

This function makes it possible to add disc and track names (titles) to recorded disc. You can easily see disc name or track title with Display Function. For the operation, refer to "[6] Switching the Display".

(2) Description of editing operations

- Buttons used and their functions

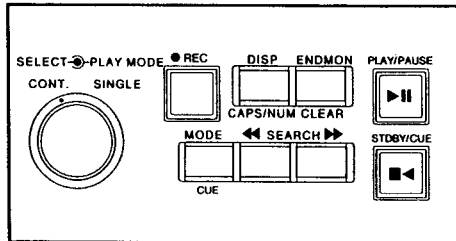

Figure 56

Button	Operation	Function
MODE/CUE button	Press	Entering and exiting the editing mode.
SELECT knob	Turn	Selecting the editing function, track number and characters.
SELECT knob	Press	Setting the editing function, track number and characters.
REC button	Press	Executing the editing function (writing the editing information on the disc).
DISP/CAPS/NUM button	Press	Switching between capital and small letters, numerics and symbols.
END MON/CLEAR button	Press	Clearing title characters.
SEARCH buttons (◀ and ▶)	Press	Moving the dividing position for the divide function, and moving the cursor on the character display for the title function.

■ Button operations common for all editing functions

- 1) Press the MODE/CUE button to enter the editing mode.

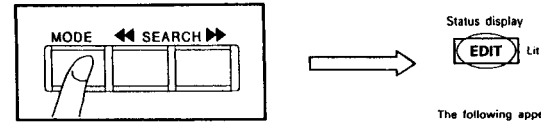
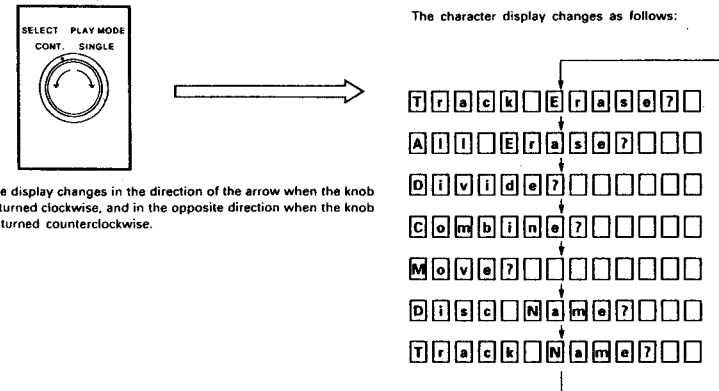

Figure 57

The following appears on the character display:
E d i t M o d e

- 2) To select the editing function, turn the SELECT knob.



The display changes in the direction of the arrow when the knob is turned clockwise, and in the opposite direction when the knob is turned counterclockwise.

Figure 58

- 3) To set the selected editing mode, press the SELECT knob.

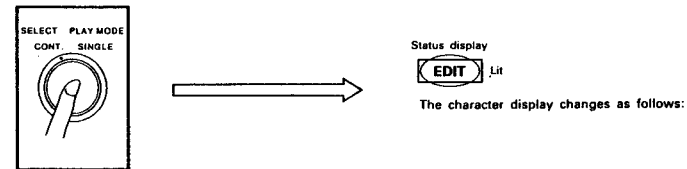

The character display changes as follows:
T r a c k E r a s e ? → T r a c k O K ?
A l l E r a s e ? → A l l E r a s e O K ?

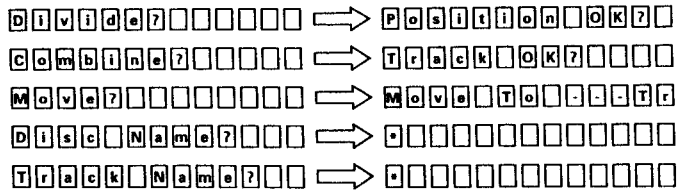

Figure 59

4) Further operations are required for the three editing functions listed below. For details, refer to their respective sections.

- Divide function
- Move function
- Title function

5) To cancel the editing mode in the middle and return to the playback or recording mode, press the MODE/CUE button.

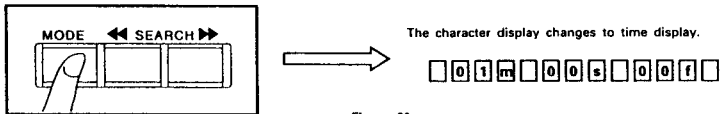
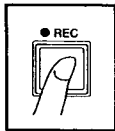

Figure 60

6) To complete the editing function, press the REC button. The information set with the editing function is recorded on the disc.



C o m p l e t e

"Complete" will be displayed for approximately 3 seconds until rewriting the UTOC is completed. Then the unit is set to the standby mode.

NOTE: While "TOC" indicator is blinking, the unit is rewriting the UTOC. Do not hit or shake the unit or turn off its power. No operating buttons will function while the information is being recorded. (For the UTOC, see Page 30.)

Figure 61

(3) Erasing track (track erase function)

■ A specific track can be erased using the buttons on the front panel. Once a track is erased, it cannot be retrieved, so it is recommended that you play the track to confirm the content before erasing.

- 1) First play the track to be erased to check it, then set the standby mode at that track.
- 2) Press the MODE/CUE button to enter the editing mode.

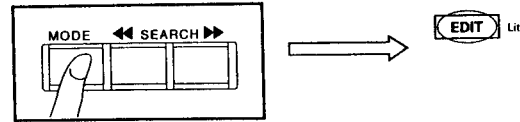

Figure 62

3) To select the track erase function, turn the select knob.

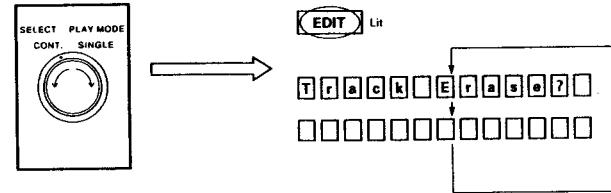

Figure 63

4) Press the SELECT knob to set the selected track erase function. A message appears on the display asking whether it is really OK to erase that track.

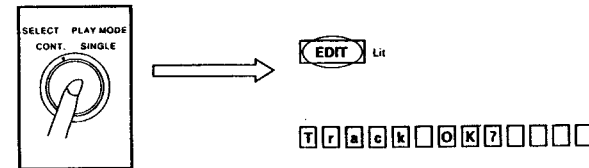

Figure 64

- 5) To cancel the editing mode in the middle and return to the playback or recording mode, press the MODE/CUE button.
- 6) To complete the track erase function, press the REC button.

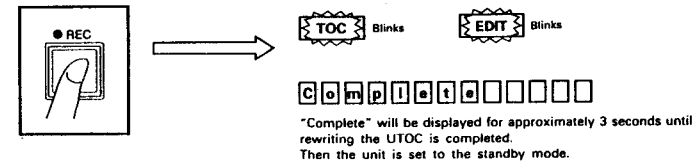

Figure 65

NOTE: While "TOC" indicator is blinking, the unit is rewriting the UTOC. Do not hit or shake the unit or turn off its power. No operating buttons will function while the information is being recorded. (For the UTOC, see Page 30.)

(4) Erasing all the tracks on a disc (all erase function)

- All the tracks on the disc can be erased using the buttons on the front panel. Once the tracks are erased, they cannot be retrieved, so be sure to check the disc first.
 - Set the standby mode, at any track.
 - Press the MODE/CUE button to enter the editing mode.

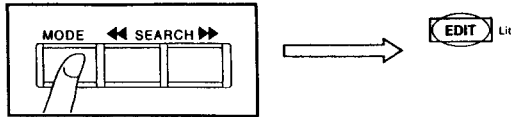

Figure 66

- To select the all erase function, turn the select knob.

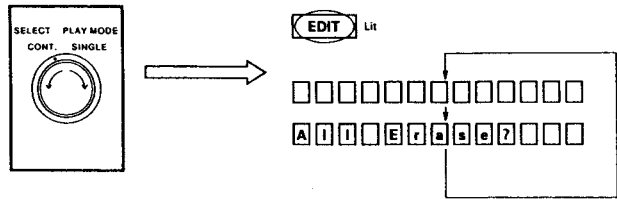

Figure 67

- Press the SELECT knob to set the selected all erase function. A message appears on the display asking whether it is really OK to erase all the tracks.

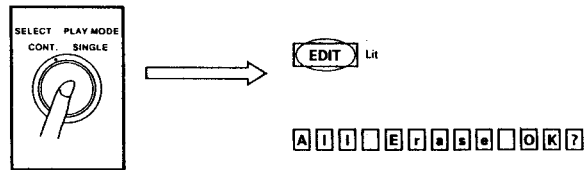
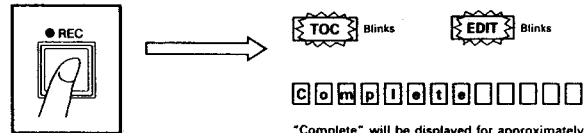

Figure 68

- To cancel the editing mode in the middle and return to the playback or recording mode, press the MODE/CUE button.
- To complete the all erase function, press the REC button.



"Complete" will be displayed for approximately 3 seconds until rewriting the UTOC is completed. Then the unit is set to the standby mode. "No Track" will be displayed. To proceed to recording, press the REC button, the unit will be set to the recording pause mode.

Figure 69

NOTE: While "TOC" indicator is blinking, the unit is rewriting the UTOC. Do not hit or shake the unit or turn off its power. No operating buttons will function while the information is being recorded. (For the UTOC, see Page 30.)

- Dividing a track in two (divide function)

- A track can be divided into two, creating two tracks.
- Tracks containing recorded cue signal or end-trimmed can not be combined, clear cue signals before.
- If the track has a title, the title is given only to the first track.
 - Use the SEARCH buttons (▶▶ and ◀◀) to find the point where the track to be divided, and set to the standby mode.
 - Press the MODE/CUE button to enter the editing mode.

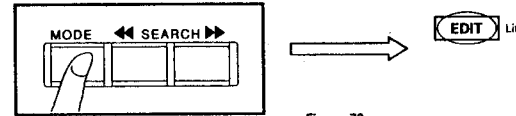

Figure 70

- Turn the SELECT knob and select the divide function.

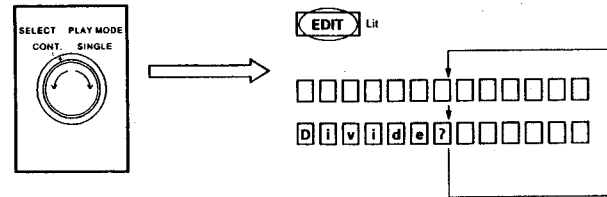

Figure 71

- To select the divide function, press the SELECT knob. A message for confirming the point at which the track is to be divided appears on the display, and the section between that point and a point three seconds before it will be played repeatedly. Monitor the sound and check the position.

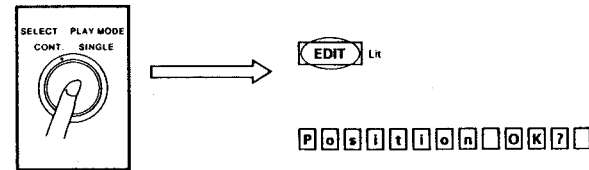
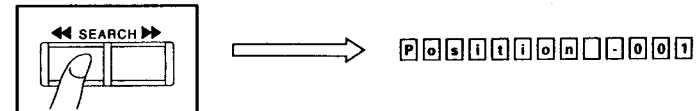
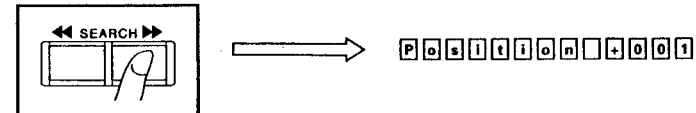

Figure 72

- Use the SEARCH buttons (▶▶ and ◀◀) to move the dividing point. The display changes within the range of -999 to +999, indicating the amount of movement. (±001 equals approximately 0.011 seconds.)



The position can be moved to -999 (about 11 seconds backward)



The position can be moved to +999 (about 11 seconds forward)

Figure 73

- 6) To cancel the editing mode in the middle and return to the playback or recording mode, press the MODE/CUE button.
 7) To set the dividing point and complete the divide function, press the REC button.

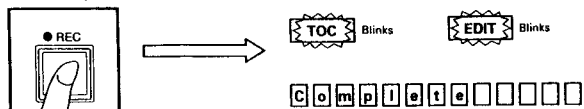

Figure 74

"Complete" will be displayed for approximately 3 seconds until rewriting the UTOC is completed. Then the unit is set to the standby mode.

NOTE: While "TOC" indicator is blinking, the unit is rewriting the UTOC. Do not hit or shake the unit or turn off its power. No operating buttons will function while the information is being recorded. (For the UTOC, see Page 30.)

(6) **Combining two adjacent tracks (combine function)**

- Two adjacent tracks can be combined into one track.
 - Tracks containing recorded cue signal or end-trimmed cannot be divided, clear cue signal before.
 - If both tracks have titles, the new track is given the title of the first track, and the title of the second track is erased.
- 1) First arrange the two tracks to be combined next to each other (use the Move function if necessary), then at the second track, set to the standby mode.
 - 2) Press the MODE/CUE button to enter the editing mode.

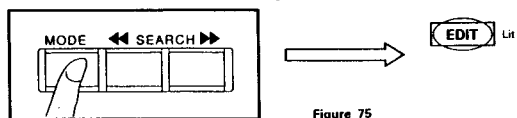

Figure 75

- 3) To select the combine function, turn the SELECT knob.

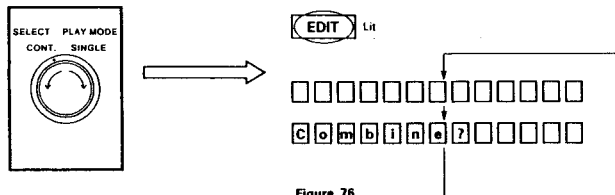

Figure 76

- 4) To select the combine function, press the SELECT knob. A message for confirming that the two tracks are to be combined appears on the display.

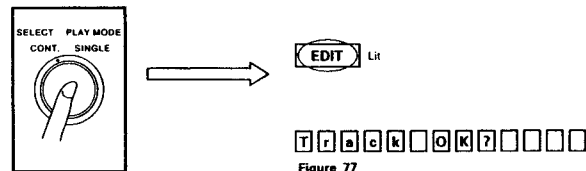

Figure 77

- 5) To cancel the editing mode in the middle and return to the playback or recording mode, press the MODE/CUE button.
 6) To complete the combine function, press the REC button.

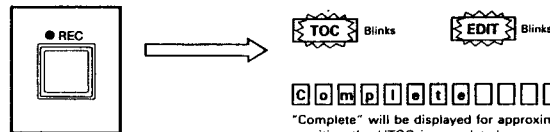

Figure 78

"Complete" will be displayed for approximately 3 seconds until rewriting the UTOC is completed. Then the unit is set to the standby mode.

NOTE: While "TOC" indicator is blinking, the unit is rewriting the UTOC. Do not hit or shake the unit or turn off its power. No operating buttons will function while the information is being recorded. (For the UTOC, see Page 30.)

(7) **Moving a track (move function)**

- The current track can be moved to any track number. Use this to change the order of the tracks and when using the combine function to combine two adjacent tracks.

- 1) First set to the standby mode at the track to be moved.
- 2) Press the MODE/CUE button to enter the editing mode.

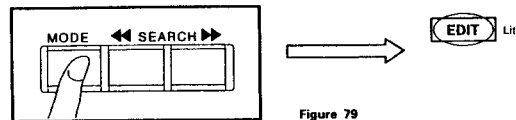

Figure 79

- 3) To select the move function, turn the SELECT knob.

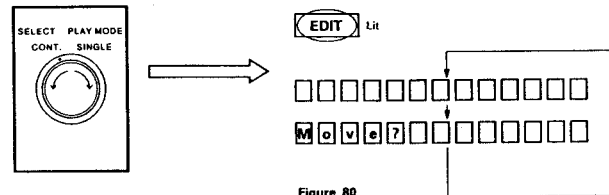

Figure 80

- 4) Press the SELECT knob to set the selected move function. A message will ask for the new track number.

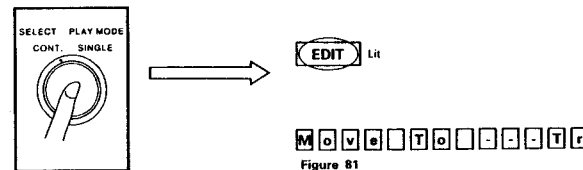

Figure 81

- 5) Turn the SELECT knob to select the new track number.

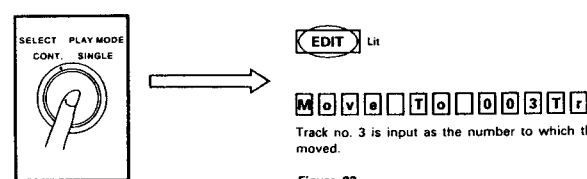

Figure 82

- 6) To cancel the editing mode in the middle and return to the playback or recording mode, press the MODE/CUE button.
 7) To set the new track number and complete the move function, press the REC button.

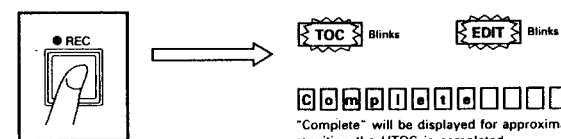

Figure 83

"Complete" will be displayed for approximately 3 seconds until rewriting the UTOC is completed. Then the unit is set to the standby mode.

NOTE: While "TOC" indicator is blinking, the unit is rewriting the UTOC. Do not hit or shake the unit or turn off its power. No operating buttons will function while the information is being recorded. (For the UTOC, see Page 30.)

(8) Entering disc and track titles (title function)

- With this function, names (titles) can be given to disc and tracks using letters, numbers and symbols (ASCII codes). The disc and track titles can contain up to 255 characters, but the maximum total characters for all the track and disc titles is limited to 1700.
- The title functions can be used in the following modes:
 - Disc titles: The disc title can be written (or changed or erased) from any track when in the standby mode.
 - Track titles: Track titles can be written (or changed or erased) when at the standby or play pause mode at the desired track.
- Press the MODE/CUE button to enter the editing mode.

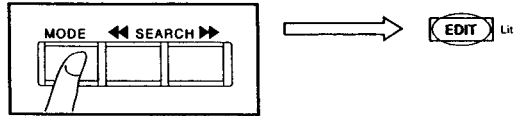

Figure 84

3) To select the title function (Disc Name or Track Name), turn the SELECT knob.

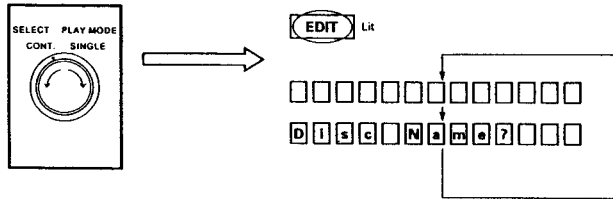

Figure 85

4) Press the SELECT knob to set the selected title function.

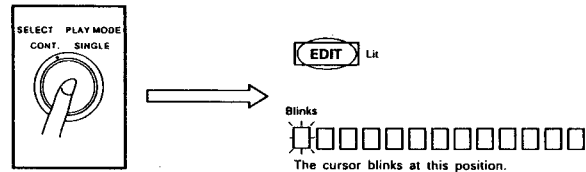

Figure 86

5) Turn the SELECT knob to select characters. Capital letter "A" appears first.

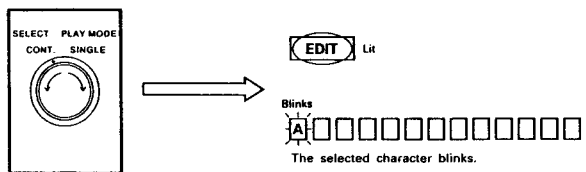

Figure 87

6) Press the SELECT knob to enter the selected character.

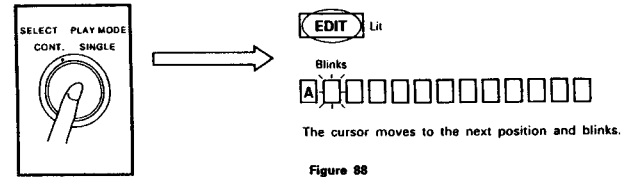

Figure 88

When cursor is blinking with no selected character, pressing the SELECT knob enters "space". When the title is written on the disc, spaces at the end of the title are ignored.

7) Press the DISP/CAPS/NUM button repeatedly to switch between capital letters, small letters, numbers and symbols, in that order.

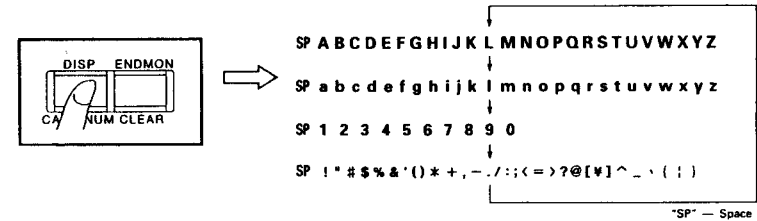

Figure 89

8) Use the SEARCH buttons (right and left arrows) to move the cursor. You can move the cursor to the position where you overwrite, insert or delete the characters.

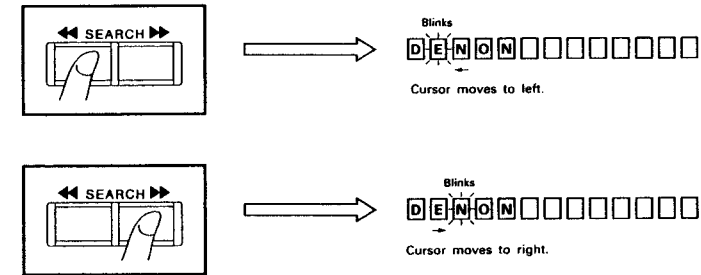

Figure 90

9) To overwrite a character, select a new character by turning the SELECT knob.

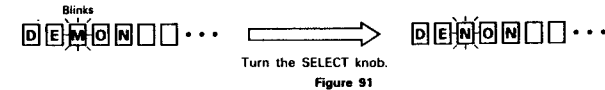

Figure 91

10) To insert a new character, press the SELECT knob to insert a character before currently blinking character. And turn the SELECT knob to select the character.

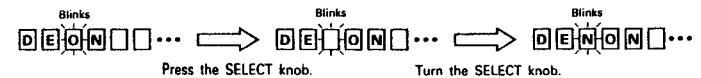

Figure 92

11) Press the END MON/CLEAR button to clear characters. Each time the button is pressed, the character which is flashing is cleared. The character on its right is then moved to the left, and that character starts blinking. Press the button repeatedly to clear other characters.

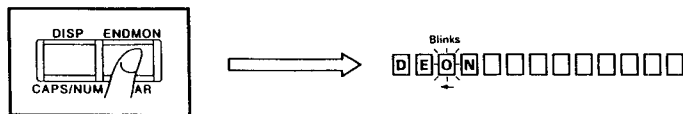

Figure 93

12) To cancel the editing mode in the middle and return to the playback or recording mode, press the MODE/CUE button.
 13) To set the disc or track title and complete the title function, press the REC button.

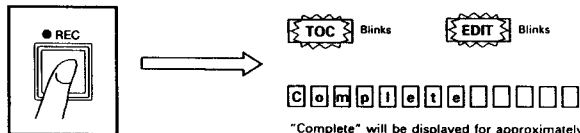

Figure 94

"Complete" will be displayed for approximately 3 seconds until rewriting the UTOC is completed.

Then the unit is set to the standby mode.

NOTE: While "TOC" indicator is blinking, the unit is rewriting the UTOC. Do not hit or shake the unit or turn off its power. No operating buttons will function while the information is being recorded. (For the UTOC, see Page 30.)

10 RECORDING CUE SIGNALS (only available on the DN-990R)

(1) Cue signal recording function

- The cue signal recording position can be specified with the precision of the frames on the time display. Each cue signals, however, should be minimum 5 seconds apart.
- Cue signals are recorded by first setting the pause mode while listening to the sound. If the cue signal must be positioned accurately, use the SEARCH buttons (▶▶ and ◀◀) to determine the position first.
- Cue signals can be detected not only on the DN-990R but also on the DN-980F. The "CUE" indicator lights when a cue signal is detected. Two types of tally signals, open collector and dry contact, are output from the REMOTE connector, so when another player is connected, playback on it can be started at the timing of the cue signals. The dry contact output signal is selectable and can be set with the preset function. (For the presetting operation, see Page 16.)
- There is a restriction to the "CUE" display during MANUAL SEARCH. When MANUAL SEARCH was done beyond the track boundary, "CUE" display will function at the track where MANUAL SEARCH was initiated, but "CUE" display will not be lit in the other track.

(2) Procedure for recording cue signals

- 1) Play the track you want to record the cue signal(s).
- 2) To record cue signals, first set one of the following operating modes:
 - While listening to the sound, press the PLAY/PAUSE button to set the pause mode at the position you want to record the cue signal.
 - Use the search buttons while in the play or pause mode to accurately set the position where the cue signal is to be recorded.

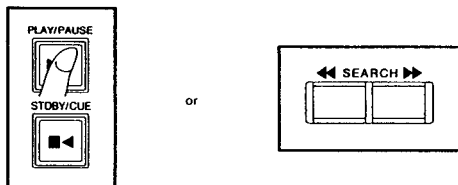

Figure 95

3) To record the cue signals, press and hold down the MODE/CUE button and then press REC button at the same time.

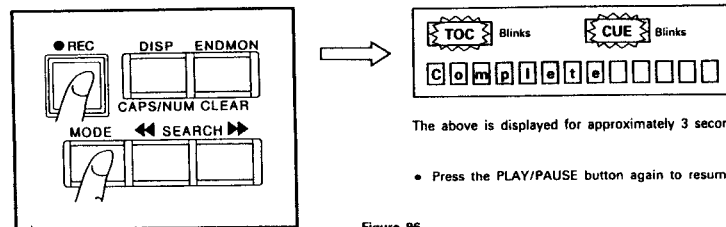

Figure 96

The above is displayed for approximately 3 seconds.

- Press the PLAY/PAUSE button again to resume playback.

NOTE: The cue signal is being recorded on the disc while the TOC and CUE indicators are blinking. Do not hit or shake the unit or turn off its power while this is being done. No operating buttons is accepted while the information is being recorded on the disc.

(3) Procedure for clearing cue signals

- 1) Play the track the cue signal is recorded.
- 2) The CUE indicator appears on the display for 3 seconds when the cue signal is detected during playback. Press the PLAY/PAUSE button while this is lit to set the pause mode.

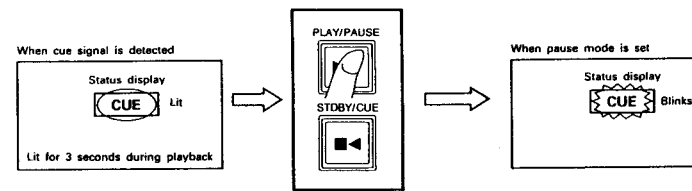

Figure 97

3) To erase the cue signal, press and hold down the MODE/CUE button and then press END MON/CLEAR button at the same time.

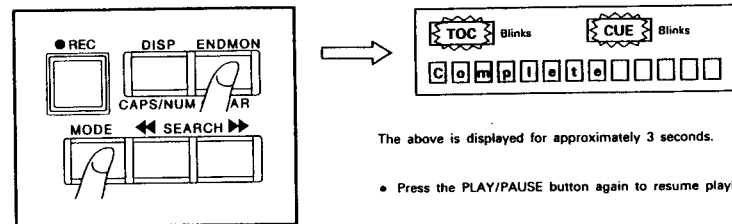

Figure 98

The above is displayed for approximately 3 seconds.

- Press the PLAY/PAUSE button again to resume playback.

NOTE: The cue signal is being cleared from the disc while the TOC and CUE indicators are blinking. Do not hit or shake the unit or turn off its power while this is being done. No operating buttons is accepted while the information is being recorded on the disc.

11 RESETTING THE MICROPROCESSOR

- A microprocessor controls disc drive unit, operation panel unit and the display.
- If for some reason the microprocessor should malfunction and the unit becomes inoperable, press the SELECT knob and the STDBY/CUE button at the same time to reset the microprocessor.

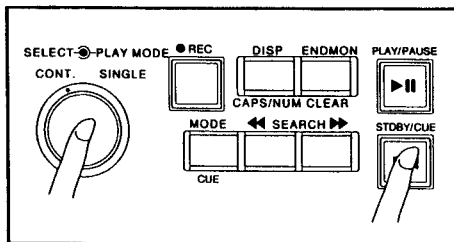

Figure 99

- When the microprocessor is reset, operation is restored to the same status as when the POWER switch is first turned on.

12 HANDLING CARTRIDGES

The disc itself is housed in a cartridge so it can be handled easily without worrying about dirt or fingerprints. Take care of the followings to ensure that recordings can always be played in the optimum conditions.

(1) Cautions on handling

- Do not place recordable disc cartridges near magnets or strong magnetic forces.
- When carrying cartridges, place them in the specified case.
- Do not attach labels onto the cartridges other than those included with the discs.
- Wipe any dirt off the surface of the cartridge with a soft, dry cloth.
- Do not open the shutter.

Trying to force the shutter open may damage it.

Dirt or dust may enter the cartridge if the shutter is opened.

Fingerprints may get on the disc if the shutter is opened.

- Do not bend, heat or throw cartridges.
- Water droplets may form on the surface of the disc if the cartridge is moved suddenly from a cold place to a warm one. If this happens, wait a while before using it.

(2) Cautions on storage

- Always remove cartridges from the unit after recording or playback is finished.
- Do not store cartridges in the following places:
 - Places exposed to direct sunlight.
 - Hot places.
 - Humid or dusty places.

13 LIST OF MESSAGES

Messages may appear on the display during operation. The following is a description of the messages.

No Track

No Track: A new disc for recording or a disc on which all the tracks are erased is loaded.
A disc which contains no recording but has a disc title is loaded.

No Selected Track

No Selected Track: Selected track No. is not on the disc.

No Name

No Name: No disc or track name to display.

Track Full

Track Full: Recording is not possible because the disc already contains the maximum number of tracks which can be recorded.

Disc Full

Disc Full: Recording is not possible because there is no remaining time on the disc.

Disc Type Error

Disc Type Error: You have attempted to record on a pre-mastered disc. (non-recordable)

Cannot Edit

Cannot Edit: You have attempted to use the combine function at the first track in the editing mode. There is no track before this to be combined, so the combine function does not work.
Dividing and combining is not possible for tracks containing cue signals or tracks whose ends have been trimmed.
You have attempted to combine tracks which cannot be combined in the editing mode.

Protected

Protected: Recording or editing is not possible because the cartridge's write protector is set to the protect position.

Cannot Increment

Cannot Increment: Tracks cannot be incremented because the disc already contains the maximum number of track numbers.

Name Full

Name Full: No more titles can be added because the maximum number of characters has already been reached.

Cannot Write

Cannot Write: The area on which cue signals and end trim data is recorded is full.

Record Retry

Record Retry: Re-trying to record due to vibrations or scratches on the disc.

Error

Error: A defective disc is loaded, or there is a problem on the disc preventing it from operating normally.
Continuous vibrations or multiple scratches on the disc have prevented the recording from being completed normally after couple of retry.
There is a problem in the unit, and the unit will not function.

14 SYSTEM LIMITATIONS

(1) Track number limitations

- Up to 255 tracks can be recording when recording in order starting from track 1 on a blank disc or on a no-track disc. The total track number will decrease in following case.
 - Editings are applied.
 - Record retry were performed several time due to disc scratches.

(2) Recording time limitations

- Recording is possible in units of approximately 2 seconds. Sections shorter than 2 seconds also use approx. 2 seconds space on the disc, so the actual recordable time will be shorter.
- Scratched sections of the disc are automatically removed from the recordable time.
- Recording is no longer possible once the maximum number of tracks is reached, even if they did not reach the maximum recordable time. To record more, first erase unnecessary tracks. When this is done, recording is only possible for the amount of time of the tracks which have been erased.

- The disc's remaining time may not increase when short track (about 8 seconds or less) is erased.
 - When tracks contain much emphasis on/off data, etc., this data are handled as track partitions, so the recordable time and the number of recordable tracks may decrease.
- (3) **Editing function limitations**
- It may not be possible to combine short tracks.
 - Divide and Combine function is not possible when the track contain recorded cue signals or end-trimmed.
- (4) **Title function limitations**
- There are limitations to the number of characters which can be used in disc and track titles and the total number of characters for all disc and track titles. Once these limits are reached, "Name Full" appears on the display.
Track names: Up to 250 characters
Disc names: Up to 250 characters
Total of above two: 1700 characters
 - The number of characters which can be written on the disc for the track titles is reduced when the following functions are used:
Cue signal function (takes up 10 characters for each cue signal)
End trim function (takes up 10 characters)
 - When a track with a track title is divided in two with the divide function, no title is given to the second track.
 - When two tracks with track titles are combined with the combine function, the title of the second track is erased.
- (5) **Playback limitations**
- This unit is not designed for playback of monaural format disc.

15 TROUBLESHOOTING

If you think there may be a problem with the set, try checking the following:

- (1) **Operating buttons on panel do not function**
- Is preset function (10) set to "Switch INH"?
→ Reset the preset function.
 - Is preset function (11) set to "Playlock ON"?
→ Reset the preset function.
 - Microprocessor problem.
→ Reset the microprocessor.
- (2) **Discs cannot be played**
- Power is not on.
→ Turn the power on.
 - Internal condensation.
→ Remove the disc and let the set stand with the power on for a while.
 - Disc is not recorded.
→ Use recorded disc.
 - Objective lens is stained.
→ Refer to service manual.
- (3) **Auto cueing function does not work**
- Is preset function (7) set to "Cue Det. (**)"?
→ Reset the preset function.
 - Is the track's volume or offset level too high?
→ Read the section on recording operations and check with a newly recorded disc.
- (4) **No sound is produced, or sound is distorted**
- Are the output level controls adjusted properly?
→ Adjust them properly.
 - Are the output cords properly connected?
→ Connect them properly.
- (5) **Recording is not possible**
- Cartridge's write protector is set to the protect position.
→ Set the switch to the write enable position.
 - Have you forgotten to set preset function (1), "Analog (Digital Input)"?
→ Set it to the proper setting.
 - No remaining time on disc or maximum track number is already reached.
→ Erase unnecessary tracks or use a disc with enough remaining time.
 - Objective lens is stained.
→ Refer to service manual.
- (6) **Recorded sound is distorted or the level is low.**
- Are the input level controls adjusted properly?
→ Adjust them properly.
 - Are the input cords properly connected?
→ Connect them properly.
- (7) **Auto track incrementing (using the detection of blank sections) is not possible**
- Is preset function (6) set to "Inc. Det. (**)"?
→ Reset the preset function.
 - Is the track's volume or offset level too high?
→ Read the section on recording operations and check on a newly recorded disc.

SPECIFICATIONS

Type:	Table-top MD cart recorder (DN-990R) Table-top MD cart player (DN-980F)
Audio channels:	2 channels Playback: Stereo/mono selectable Recording: Stereo
Recordable / playable discs:	Playback: Pre-mastered MDs and recordable MDs Recording: Recordable MDs
Playback system:	Optical pickup system (semiconductor laser, non-contact)
Recording system:	Magneto-optical overwriting system (magnetic field modulation)
Signal compression system:	ATRAC (Adaptive Transform Acoustic Coding)
Rotating-disc speed:	Approx. 400 to 900 rpm
Recording / playback time:	74 minutes max.
Quantization bits:	16-bit linear (A/D converter)
Sampling frequency:	44.1 kHz
Playing speeds:	Standard / +2% (selectable)
Playback startup time:	100 ms or less
Recording startup time:	100 ms or less
Analog inputs:	
1) Method of transfer and connector:	Active balanced output, XLR connector
2) Input level:	+18 dBm
3) Input level adjustment range:	+22 dBm to -6 dBm (adjustable continuously with internal short pin and variable resistors on rear panel)
4) Input impedance:	10 kohms/600 ohms (internal short pin, set to 10 kohms upon shipment)
Analog outputs:	
1) Method of transfer and connector:	Active balanced output, XLR connector
2) Output level:	+18 dBm (600 ohms load impedance, 1 kHz maximum level playback)
3) Output level adjustment range:	+22 dBm to -20 dBm (adjustable continuously with variable resistors on rear panel)
4) Output impedance:	Low impedance
Digital input:	
1) Method of transfer and connector:	Active balanced transfer, XLR connector
2) Signal format:	Conforming to AES/EBU and IEC-958
3) Input level:	3 to 10 Vp-p (110 ohms load impedance)
Digital output:	
1) Method of transfer and connector:	Active balanced transfer, XLR connector
2) Signal format:	Conforming to IEC-958
3) Output level:	3 Vp-p or greater (110 ohms load impedance connected to output connector)
Headphones output:	Stereo
1) Applicable load:	30 to 40 ohms
2) Output level:	20 mW or greater (32 ohms load impedance, 1 kHz maximum level playback)
REMOTE connector:	Parallel remote, Dsub 25-pin connector
RS232C connector:	Serial remote, Dsub 9-pin connector

Audio performance

1) Playback performance

Frequency response	20 ~ 20,000 Hz ± 0.5 dB
Total harmonic distortion:	0.012% or less (at maximum level, 1 kHz)
S/N ratio:	92 dB or greater (at maximum level, 1 kHz, "A" weighted)
Channel separation:	86 dB or greater (at maximum level, 1 kHz)

2) Recording/playback performance

Frequency response	20 ~ 20,000 Hz ± 0.5 dB
Total harmonic distortion:	0.02% or less (at maximum level, 1 kHz)
S/N ratio:	84 dB or greater (at maximum level, 1 kHz, "A" weighted)
Channel separation:	80 dB or greater (at maximum level, 1 kHz)

Environmental conditions: 5 to 35°C, 25 to 85% relative humidity (no condensation)

Duty: Continuous

Power supply: AC 120V (108 to 132V)/230V (207 to 255V), 50/60 Hz
32W (DN-990R), 27W (DN-980F)

Dimensions: Without feet: 144 (W) × 133 (H) × 401 (D) mm

With feet: 144 (W) × 146 (H) × 401 (D) mm

Weight: Approx. 5.8 kg

Design and specifications are subject to change for improvement without notice.

SOFTWARE SPECIFICATIONS

1. Serial Command List (ASCII code is used to the commands)

Code	Command	Parameter	Description																																																																								
A	Scan	1 byte, SCAN mode *(1)	Skips and plays at 1, 2, 8, 16 times speed.																																																																								
	(1)	<table border="1"> <tr> <th>D7</th> <th>D6</th> <th>D5</th> <th>D4</th> <th>D3</th> <th>D2</th> <th>D1</th> <th>D0</th> <th></th> </tr> <tr> <td>X</td> <td>0</td> <td>0</td> <td>0</td> <td>0</td> <td>0</td> <td>0</td> <td>1</td> <td>= Normal speed</td> </tr> <tr> <td>X</td> <td>0</td> <td>0</td> <td>0</td> <td>0</td> <td>0</td> <td>1</td> <td>0</td> <td>= 2 times speed</td> </tr> <tr> <td>X</td> <td>0</td> <td>0</td> <td>0</td> <td>0</td> <td>1</td> <td>0</td> <td>0</td> <td>= 4 times speed</td> </tr> <tr> <td>X</td> <td>0</td> <td>0</td> <td>0</td> <td>1</td> <td>0</td> <td>0</td> <td>0</td> <td>= 8 times speed</td> </tr> <tr> <td>X</td> <td>0</td> <td>0</td> <td>1</td> <td>0</td> <td>0</td> <td>0</td> <td>0</td> <td>= 16 times speed</td> </tr> <tr> <td>0</td> <td>X</td> <td>X</td> <td>X</td> <td>X</td> <td>X</td> <td>X</td> <td>X</td> <td>= Forward</td> </tr> <tr> <td>1</td> <td>X</td> <td>X</td> <td>X</td> <td>X</td> <td>X</td> <td>X</td> <td>X</td> <td>= Reverse</td> </tr> </table>	D7	D6	D5	D4	D3	D2	D1	D0		X	0	0	0	0	0	0	1	= Normal speed	X	0	0	0	0	0	1	0	= 2 times speed	X	0	0	0	0	1	0	0	= 4 times speed	X	0	0	0	1	0	0	0	= 8 times speed	X	0	0	1	0	0	0	0	= 16 times speed	0	X	X	X	X	X	X	X	= Forward	1	X	X	X	X	X	X	X	= Reverse	
	D7	D6	D5	D4	D3	D2	D1	D0																																																																			
	X	0	0	0	0	0	0	1	= Normal speed																																																																		
	X	0	0	0	0	0	1	0	= 2 times speed																																																																		
	X	0	0	0	0	1	0	0	= 4 times speed																																																																		
	X	0	0	0	1	0	0	0	= 8 times speed																																																																		
X	0	0	1	0	0	0	0	= 16 times speed																																																																			
0	X	X	X	X	X	X	X	= Forward																																																																			
1	X	X	X	X	X	X	X	= Reverse																																																																			
B	Back Cue	Non	Returns to playback start position.																																																																								
C	"Reserved"	Non																																																																									
D	End Monitor	Non	Performs program-end monitoring.																																																																								
E	Send Time	1 byte, TIME mode *(1)	Requests time of standby or playback position.																																																																								
	(1)	<table border="1"> <tr> <th>D7</th> <th>D6</th> <th>D5</th> <th>D4</th> <th>D3</th> <th>D2</th> <th>D1</th> <th>D0</th> <th></th> </tr> <tr> <td>0</td> <td>0</td> <td>0</td> <td>0</td> <td>0</td> <td>0</td> <td>0</td> <td>0</td> <td>= P-time (Elapse)</td> </tr> <tr> <td>0</td> <td>0</td> <td>0</td> <td>0</td> <td>0</td> <td>0</td> <td>0</td> <td>1</td> <td>= P-time (Remain)</td> </tr> </table>	D7	D6	D5	D4	D3	D2	D1	D0		0	0	0	0	0	0	0	0	= P-time (Elapse)	0	0	0	0	0	0	0	1	= P-time (Remain)																																														
	D7	D6	D5	D4	D3	D2	D1	D0																																																																			
0	0	0	0	0	0	0	0	= P-time (Elapse)																																																																			
0	0	0	0	0	0	0	1	= P-time (Remain)																																																																			
<p>Note: During recording or recording pause mode, elapsed recording time (Elapse) or recordable remaining time (Remain) is indicated. During unloading of disc, search or reading the TOC/UTOC, Invalid (I) is issued.</p>																																																																											
F	"Reserved"	Non																																																																									
G	Contents of presetting	Non	Requests the contents of presetting.																																																																								
H	"Reserved"	Non																																																																									
I	"Reserved"	Non																																																																									
J	Jump	1 byte, JUMP mode *(1)	Allows Track No. up or down.																																																																								
	(1)	<table border="1"> <tr> <th>D7</th> <th>D6</th> <th>D5</th> <th>D4</th> <th>D3</th> <th>D2</th> <th>D1</th> <th>D0</th> <th></th> </tr> <tr> <td colspan="8" style="text-align: center;">Number (Binary)</td> <td></td> </tr> <tr> <td colspan="8" style="text-align: center;">1 = Track</td> <td></td> </tr> <tr> <td colspan="8" style="text-align: center;">0 = Forward</td> <td></td> </tr> <tr> <td colspan="8" style="text-align: center;">1 = Reverse</td> <td></td> </tr> </table>	D7	D6	D5	D4	D3	D2	D1	D0		Number (Binary)									1 = Track									0 = Forward									1 = Reverse																																				
D7	D6	D5	D4	D3	D2	D1	D0																																																																				
Number (Binary)																																																																											
1 = Track																																																																											
0 = Forward																																																																											
1 = Reverse																																																																											
K	Cueing	1 byte, Frames *(1)	Playback point moves as many frames as parameter specifies. Plays back audio approx. 0.3sec. repeatedly.																																																																								
	(1)	<table border="1"> <tr> <th>D7</th> <th>D6</th> <th>D5</th> <th>D4</th> <th>D3</th> <th>D2</th> <th>D1</th> <th>D0</th> <th></th> </tr> <tr> <td colspan="8" style="text-align: center;">Frames (Binary)</td> <td></td> </tr> <tr> <td colspan="8" style="text-align: center;">0 = Forward</td> <td></td> </tr> <tr> <td colspan="8" style="text-align: center;">1 = Reverse</td> <td></td> </tr> </table>	D7	D6	D5	D4	D3	D2	D1	D0		Frames (Binary)									0 = Forward									1 = Reverse																																													
D7	D6	D5	D4	D3	D2	D1	D0																																																																				
Frames (Binary)																																																																											
0 = Forward																																																																											
1 = Reverse																																																																											
L	"Reserved"	Non																																																																									

Code	Command	Parameter	Description																																																																																																																
M	Mode set	1 byte, SYS mode * (1)	Sets various modes for the DN-990R/DN-980F.																																																																																																																
	(1)	<table border="1"> <tr> <th>D7</th><th>D6</th><th>D5</th><th>D4</th><th>D3</th><th>D2</th><th>D1</th><th>D0</th> </tr> <tr> <td>X</td><td>0</td><td>0</td><td>0</td><td>0</td><td>0</td><td>0</td><td>1</td> </tr> <tr> <td>X</td><td>0</td><td>0</td><td>0</td><td>0</td><td>0</td><td>1</td><td>1</td> </tr> <tr> <td>**</td><td>X</td><td>0</td><td>0</td><td>0</td><td>1</td><td>0</td><td>0</td> </tr> <tr> <td></td><td>0</td><td>X</td><td>X</td><td>X</td><td>X</td><td>X</td><td>X</td> </tr> <tr> <td></td><td>1</td><td>X</td><td>X</td><td>X</td><td>X</td><td>X</td><td>X</td> </tr> </table>	D7	D6	D5	D4	D3	D2	D1	D0	X	0	0	0	0	0	0	1	X	0	0	0	0	0	1	1	**	X	0	0	0	1	0	0		0	X	X	X	X	X	X		1	X	X	X	X	X	X	(When cancelled) = SINGLE / (CONTINUE) = REMAIN / (ELAPSE) = S.REM multi (ID) mode = Cancellation = Set																																																																
	D7	D6	D5	D4	D3	D2	D1	D0																																																																																																											
	X	0	0	0	0	0	0	1																																																																																																											
X	0	0	0	0	0	1	1																																																																																																												
**	X	0	0	0	1	0	0																																																																																																												
	0	X	X	X	X	X	X																																																																																																												
	1	X	X	X	X	X	X																																																																																																												
Note: ** The command sets the mode when ID (Player No) is used.																																																																																																																			
N	Control	1 byte * (1)	ON/OFF of the Display and the Eject Lock.																																																																																																																
	(1)	<table border="1"> <tr> <th>D7</th><th>D6</th><th>D5</th><th>D4</th><th>D3</th><th>D2</th><th>D1</th><th>D0</th> </tr> <tr> <td>1</td><td>0</td><td>0</td><td>0</td><td>0</td><td>0</td><td>0</td><td>1</td> </tr> <tr> <td>0</td><td>0</td><td>0</td><td>0</td><td>0</td><td>0</td><td>0</td><td>1</td> </tr> <tr> <td>1</td><td>0</td><td>0</td><td>0</td><td>0</td><td>0</td><td>1</td><td>0</td> </tr> <tr> <td>0</td><td>0</td><td>0</td><td>0</td><td>0</td><td>0</td><td>1</td><td>0</td> </tr> </table>	D7	D6	D5	D4	D3	D2	D1	D0	1	0	0	0	0	0	0	1	0	0	0	0	0	0	0	1	1	0	0	0	0	0	1	0	0	0	0	0	0	0	1	0	= Eject Lock functions. = Cancels the Lock. = Indicates Display. = Does not indicate Display.																																																																								
	D7	D6	D5	D4	D3	D2	D1	D0																																																																																																											
	1	0	0	0	0	0	0	1																																																																																																											
0	0	0	0	0	0	0	1																																																																																																												
1	0	0	0	0	0	1	0																																																																																																												
0	0	0	0	0	0	1	0																																																																																																												
Option																																																																																																																			
O	Option	2 bytes, Track No. and Option No. * (1) ~ (2)	Requests System, Disc and track No. information.																																																																																																																
	(1)	<table border="1"> <tr> <th>D7</th><th>D6</th><th>D5</th><th>D4</th><th>D3</th><th>D2</th><th>D1</th><th>D0</th> </tr> <tr> <td>0</td><td>0</td><td>0</td><td>0</td><td>0</td><td>0</td><td>0</td><td>0</td> </tr> <tr> <td>0</td><td>0</td><td>0</td><td>0</td><td>0</td><td>0</td><td>0</td><td>1</td> </tr> <tr> <td>-</td><td>-</td><td>-</td><td>-</td><td>-</td><td>-</td><td>-</td><td>-</td> </tr> <tr> <td>1</td><td>1</td><td>1</td><td>1</td><td>1</td><td>1</td><td>1</td><td>1</td> </tr> </table>	D7	D6	D5	D4	D3	D2	D1	D0	0	0	0	0	0	0	0	0	0	0	0	0	0	0	0	1	-	-	-	-	-	-	-	-	1	1	1	1	1	1	1	1	= System/Disc information. = Track No. (binary) 1 ~ 255 Tracks																																																																								
	D7	D6	D5	D4	D3	D2	D1	D0																																																																																																											
	0	0	0	0	0	0	0	0																																																																																																											
	0	0	0	0	0	0	0	1																																																																																																											
	-	-	-	-	-	-	-	-																																																																																																											
	1	1	1	1	1	1	1	1																																																																																																											
	(2)	<table border="1"> <tr> <th>D7</th><th>D6</th><th>D5</th><th>D4</th><th>D3</th><th>D2</th><th>D1</th><th>D0</th> </tr> <tr> <td>[0]</td><td>0</td><td>0</td><td>0</td><td>0</td><td>0</td><td>0</td><td>0</td> </tr> <tr> <td>[1]</td><td>0</td><td>0</td><td>0</td><td>0</td><td>0</td><td>1</td><td>0</td> </tr> <tr> <td>[2]</td><td>0</td><td>0</td><td>0</td><td>0</td><td>1</td><td>0</td><td>0</td> </tr> <tr> <td>[3]</td><td>0</td><td>0</td><td>0</td><td>1</td><td>0</td><td>0</td><td>0</td> </tr> <tr> <td>[4]</td><td>0</td><td>0</td><td>1</td><td>0</td><td>0</td><td>0</td><td>0</td> </tr> <tr> <td>[5]</td><td>0</td><td>0</td><td>1</td><td>1</td><td>0</td><td>0</td><td>0</td> </tr> <tr> <td>[6]</td><td>0</td><td>1</td><td>0</td><td>0</td><td>0</td><td>0</td><td>0</td> </tr> <tr> <td>[7]</td><td>0</td><td>1</td><td>0</td><td>1</td><td>0</td><td>0</td><td>0</td> </tr> <tr> <td>[8]</td><td>0</td><td>1</td><td>1</td><td>0</td><td>0</td><td>0</td><td>1</td> </tr> <tr> <td>[9]</td><td>0</td><td>1</td><td>1</td><td>0</td><td>0</td><td>0</td><td>1</td> </tr> <tr> <td>[10]</td><td>0</td><td>1</td><td>1</td><td>0</td><td>0</td><td>0</td><td>1</td> </tr> <tr> <td>[11]</td><td>0</td><td>1</td><td>1</td><td>0</td><td>0</td><td>1</td><td>0</td> </tr> <tr> <td>[12]</td><td>0</td><td>1</td><td>1</td><td>0</td><td>0</td><td>1</td><td>0</td> </tr> </table>	D7	D6	D5	D4	D3	D2	D1	D0	[0]	0	0	0	0	0	0	0	[1]	0	0	0	0	0	1	0	[2]	0	0	0	0	1	0	0	[3]	0	0	0	1	0	0	0	[4]	0	0	1	0	0	0	0	[5]	0	0	1	1	0	0	0	[6]	0	1	0	0	0	0	0	[7]	0	1	0	1	0	0	0	[8]	0	1	1	0	0	0	1	[9]	0	1	1	0	0	0	1	[10]	0	1	1	0	0	0	1	[11]	0	1	1	0	0	1	0	[12]	0	1	1	0	0	1	0	Option No. = TOC data of the Disc. = Contents of System mode. = CPU No. of DN-990R/980F = Track playback time and Track Mode. = Track recording data. = Disc type. = Remaining recording time on the disc. = End tally = Cue 1 tally = Cue 2 tally = Cue 3 tally = Cue 4 tally = Cue 5 tally
	D7	D6	D5	D4	D3	D2	D1	D0																																																																																																											
	[0]	0	0	0	0	0	0	0																																																																																																											
	[1]	0	0	0	0	0	1	0																																																																																																											
	[2]	0	0	0	0	1	0	0																																																																																																											
	[3]	0	0	0	1	0	0	0																																																																																																											
[4]	0	0	1	0	0	0	0																																																																																																												
[5]	0	0	1	1	0	0	0																																																																																																												
[6]	0	1	0	0	0	0	0																																																																																																												
[7]	0	1	0	1	0	0	0																																																																																																												
[8]	0	1	1	0	0	0	1																																																																																																												
[9]	0	1	1	0	0	0	1																																																																																																												
[10]	0	1	1	0	0	0	1																																																																																																												
[11]	0	1	1	0	0	1	0																																																																																																												
[12]	0	1	1	0	0	1	0																																																																																																												
Note: Invalid (I) is issued when unspecified parameter is used.																																																																																																																			
P	Play	Non	Starts Playback.																																																																																																																
Q	Track Search	1 byte, Track No. * (1)	Searches specified Track no. and stands by after cueing funcOn.																																																																																																																
	(1)	<table border="1"> <tr> <th>D7</th><th>D6</th><th>D5</th><th>D4</th><th>D3</th><th>D2</th><th>D1</th><th>D0</th> </tr> </table>	D7	D6	D5	D4	D3	D2	D1	D0	Track No. (Binary), 1 ~ 255 Tracks.																																																																																																								
D7	D6	D5	D4	D3	D2	D1	D0																																																																																																												
R	Reset	Non	Initialises DN-990R/980F																																																																																																																
S	Stop	Non	Stops playback (Servo=OFF)																																																																																																																
	Note: Accepts the command during PLAY, STAND-BY, PAUSE, MANUAL SEARCH and CUEING modes.																																																																																																																		

Code	Command	Parameter	Description																																																																																																																																																
T	Time Search	5 bytes, Track No. and P-Time *(1) ~ (5)	Searches specified time (P-time) within the Track and stands by.																																																																																																																																																
	(1)	<table border="1"> <tr><td>D7</td><td>D6</td><td>D5</td><td>D4</td><td>D3</td><td>D2</td><td>D1</td><td>D0</td></tr> </table>	D7	D6	D5	D4	D3	D2	D1	D0	Track No. (Binary), 1 ~ 255 Tracks.																																																																																																																																								
	D7	D6	D5	D4	D3	D2	D1	D0																																																																																																																																											
	(2)	<table border="1"> <tr><td>D7</td><td>D6</td><td>D5</td><td>D4</td><td>D3</td><td>D2</td><td>D1</td><td>D0</td></tr> </table>	D7	D6	D5	D4	D3	D2	D1	D0	Min. x 100 (BCD)																																																																																																																																								
	D7	D6	D5	D4	D3	D2	D1	D0																																																																																																																																											
	(3)	<table border="1"> <tr><td>D7</td><td>D6</td><td>D5</td><td>D4</td><td>D3</td><td>D2</td><td>D1</td><td>D0</td></tr> </table>	D7	D6	D5	D4	D3	D2	D1	D0	Min. x 1 (BCD) Min. x 10 (BCD)																																																																																																																																								
D7	D6	D5	D4	D3	D2	D1	D0																																																																																																																																												
(4)	<table border="1"> <tr><td>D7</td><td>D6</td><td>D5</td><td>D4</td><td>D3</td><td>D2</td><td>D1</td><td>D0</td></tr> </table>	D7	D6	D5	D4	D3	D2	D1	D0	Sec. x 1 (BCD) Sec. x 10 (BCD)																																																																																																																																									
D7	D6	D5	D4	D3	D2	D1	D0																																																																																																																																												
(5)	<table border="1"> <tr><td>D7</td><td>D6</td><td>D5</td><td>D4</td><td>D3</td><td>D2</td><td>D1</td><td>D0</td></tr> </table>	D7	D6	D5	D4	D3	D2	D1	D0	Frame x 1 (BCD) Frame X 10 (BCD)																																																																																																																																									
D7	D6	D5	D4	D3	D2	D1	D0																																																																																																																																												
Note: Issues Invalid (I) when the Track differs or specified time has not been set. Accepts the command only when the Track is in the PLAY,STANDBY, PAUSE, SEARCH, MANUAL SEARCH and CUEING mode.																																																																																																																																																			
U	Preset Memory	1 byte *(1)	Changes a specific bit of the Preset memory.																																																																																																																																																
	(1)	<table border="1"> <tr><td>D7</td><td>D6</td><td>D5</td><td>D4</td><td>D3</td><td>D2</td><td>D1</td><td>D0</td></tr> <tr><td>X</td><td>X</td><td>X</td><td>X</td><td>X</td><td>0</td><td>0</td><td>0</td></tr> <tr><td>X</td><td>X</td><td>X</td><td>X</td><td>X</td><td>0</td><td>0</td><td>1</td></tr> <tr><td>X</td><td>X</td><td>X</td><td>X</td><td>X</td><td>0</td><td>1</td><td>0</td></tr> <tr><td>X</td><td>X</td><td>X</td><td>X</td><td>X</td><td>0</td><td>1</td><td>1</td></tr> <tr><td>X</td><td>X</td><td>X</td><td>X</td><td>X</td><td>1</td><td>0</td><td>0</td></tr> <tr><td>X</td><td>X</td><td>X</td><td>X</td><td>X</td><td>1</td><td>0</td><td>1</td></tr> <tr><td>X</td><td>X</td><td>X</td><td>X</td><td>X</td><td>1</td><td>1</td><td>0</td></tr> <tr><td>X</td><td>X</td><td>X</td><td>X</td><td>X</td><td>1</td><td>1</td><td>1</td></tr> <tr><td>X</td><td>0</td><td>0</td><td>0</td><td>0</td><td>X</td><td>X</td><td>X</td></tr> <tr><td>X</td><td>0</td><td>0</td><td>0</td><td>1</td><td>X</td><td>X</td><td>X</td></tr> <tr><td>X</td><td>0</td><td>0</td><td>1</td><td>0</td><td>X</td><td>X</td><td>X</td></tr> <tr><td>X</td><td>0</td><td>0</td><td>1</td><td>1</td><td>X</td><td>X</td><td>X</td></tr> <tr><td>X</td><td>0</td><td>1</td><td>0</td><td>0</td><td>X</td><td>X</td><td>X</td></tr> <tr><td>X</td><td>0</td><td>1</td><td>0</td><td>1</td><td>X</td><td>X</td><td>X</td></tr> <tr><td>X</td><td>0</td><td>1</td><td>1</td><td>0</td><td>X</td><td>X</td><td>X</td></tr> <tr><td>0</td><td>X</td><td>X</td><td>X</td><td>X</td><td>X</td><td>X</td><td>X</td></tr> <tr><td>1</td><td>X</td><td>X</td><td>X</td><td>X</td><td>X</td><td>X</td><td>X</td></tr> </table>	D7	D6	D5	D4	D3	D2	D1	D0	X	X	X	X	X	0	0	0	X	X	X	X	X	0	0	1	X	X	X	X	X	0	1	0	X	X	X	X	X	0	1	1	X	X	X	X	X	1	0	0	X	X	X	X	X	1	0	1	X	X	X	X	X	1	1	0	X	X	X	X	X	1	1	1	X	0	0	0	0	X	X	X	X	0	0	0	1	X	X	X	X	0	0	1	0	X	X	X	X	0	0	1	1	X	X	X	X	0	1	0	0	X	X	X	X	0	1	0	1	X	X	X	X	0	1	1	0	X	X	X	0	X	X	X	X	X	X	X	1	X	X	X	X	X	X	X	= Bit 1 = Bit 2 = Bit 3 = Bit 4 = Bit 5 = Bit 6 = Bit 7 = Bit 8 = d1 = d2 = d3 = d4 = d5 = d6 = d7 = Cancellation = Set
	D7	D6	D5	D4	D3	D2	D1	D0																																																																																																																																											
	X	X	X	X	X	0	0	0																																																																																																																																											
	X	X	X	X	X	0	0	1																																																																																																																																											
	X	X	X	X	X	0	1	0																																																																																																																																											
	X	X	X	X	X	0	1	1																																																																																																																																											
	X	X	X	X	X	1	0	0																																																																																																																																											
	X	X	X	X	X	1	0	1																																																																																																																																											
	X	X	X	X	X	1	1	0																																																																																																																																											
X	X	X	X	X	1	1	1																																																																																																																																												
X	0	0	0	0	X	X	X																																																																																																																																												
X	0	0	0	1	X	X	X																																																																																																																																												
X	0	0	1	0	X	X	X																																																																																																																																												
X	0	0	1	1	X	X	X																																																																																																																																												
X	0	1	0	0	X	X	X																																																																																																																																												
X	0	1	0	1	X	X	X																																																																																																																																												
X	0	1	1	0	X	X	X																																																																																																																																												
0	X	X	X	X	X	X	X																																																																																																																																												
1	X	X	X	X	X	X	X																																																																																																																																												
V	"Reserved"	Non																																																																																																																																																	
W	Pause	Non	Pauses playback function.																																																																																																																																																
X	Send Status	Non	Sends the status of DN-990R/980F.																																																																																																																																																
Y	Standby	Non	Stands by after Cueing.																																																																																																																																																
Z	"Reserved"	Non																																																																																																																																																	
a	Name	2 bytes *(1) ~ (2)	Requests Disc Name and track Name.																																																																																																																																																
	(1)	<table border="1"> <tr><td>D7</td><td>D6</td><td>D5</td><td>D4</td><td>D3</td><td>D2</td><td>D1</td><td>D0</td></tr> <tr><td>0</td><td>0</td><td>0</td><td>0</td><td>0</td><td>0</td><td>0</td><td>0</td></tr> <tr><td>0</td><td>0</td><td>0</td><td>0</td><td>0</td><td>0</td><td>0</td><td>1</td></tr> <tr><td>-</td><td>-</td><td>-</td><td>-</td><td>-</td><td>-</td><td>-</td><td>-</td></tr> <tr><td>1</td><td>1</td><td>1</td><td>1</td><td>1</td><td>1</td><td>1</td><td>1</td></tr> </table>	D7	D6	D5	D4	D3	D2	D1	D0	0	0	0	0	0	0	0	0	0	0	0	0	0	0	0	1	-	-	-	-	-	-	-	-	1	1	1	1	1	1	1	1	= Disc Name = } Track No. (binary) = } 1 ~ 255 Tracks																																																																																																								
	D7	D6	D5	D4	D3	D2	D1	D0																																																																																																																																											
0	0	0	0	0	0	0	0																																																																																																																																												
0	0	0	0	0	0	0	1																																																																																																																																												
-	-	-	-	-	-	-	-																																																																																																																																												
1	1	1	1	1	1	1	1																																																																																																																																												
(2)	<table border="1"> <tr><td>D7</td><td>D6</td><td>D5</td><td>D4</td><td>D3</td><td>D2</td><td>D1</td><td>D0</td></tr> </table>	D7	D6	D5	D4	D3	D2	D1	D0	Request starting byte (Binary).																																																																																																																																									
D7	D6	D5	D4	D3	D2	D1	D0																																																																																																																																												
Note: The Name is transferred in a 10-byte unit sequentially. Therefore, "request Starting Byte" is to be "1" at the first, "11" at the second and "21" at the third times.																																																																																																																																																			

Code	Command	Parameter	Description																																																																																																																																																																																																																																																																																																								
	Edit Command	8 bytes * (1) ~ (10)	Edits Discs and Tracks.																																																																																																																																																																																																																																																																																																								
<p>Note: Edit Command is accepted only when the track to be edited is being standby.</p> <p>1) Erase: Disc or Tracks is erased.</p> <p>(1) <table border="1" style="display: inline-table; vertical-align: middle;"><tr><td>D7</td><td>D6</td><td>D5</td><td>D4</td><td>D3</td><td>D2</td><td>D1</td><td>D0</td></tr><tr><td>0</td><td>0</td><td>0</td><td>0</td><td>0</td><td>0</td><td>0</td><td>1</td></tr></table> = Erase Command</p> <p>(2) <table border="1" style="display: inline-table; vertical-align: middle;"><tr><td>D7</td><td>D6</td><td>D5</td><td>D4</td><td>D3</td><td>D2</td><td>D1</td><td>D0</td></tr><tr><td>-</td><td>-</td><td>-</td><td>-</td><td>-</td><td>-</td><td>-</td><td>-</td></tr></table> "Reserved"</p> <p>}</p> <p>(9) <table border="1" style="display: inline-table; vertical-align: middle;"><tr><td>D7</td><td>D6</td><td>D5</td><td>D4</td><td>D3</td><td>D2</td><td>D1</td><td>D0</td></tr><tr><td>-</td><td>-</td><td>-</td><td>-</td><td>-</td><td>-</td><td>-</td><td>-</td></tr></table> "Reserved"</p> <p>(10) <table border="1" style="display: inline-table; vertical-align: middle;"><tr><td>D7</td><td>D6</td><td>D5</td><td>D4</td><td>D3</td><td>D2</td><td>D1</td><td>D0</td></tr><tr><td>0</td><td>0</td><td>0</td><td>0</td><td>0</td><td>0</td><td>0</td><td>0</td></tr><tr><td>0</td><td>0</td><td>0</td><td>0</td><td>0</td><td>0</td><td>0</td><td>1</td></tr><tr><td>-</td><td>-</td><td>-</td><td>-</td><td>-</td><td>-</td><td>-</td><td>-</td></tr><tr><td>1</td><td>1</td><td>1</td><td>1</td><td>1</td><td>1</td><td>1</td><td>1</td></tr></table> = Erasing Disc } Track No. (binary) 1 ~ 255 Tracks</p> <p>2) Combine: Tracks can be connected. * Combines a Track being standby with the previous Track.</p> <p>(1) <table border="1" style="display: inline-table; vertical-align: middle;"><tr><td>D7</td><td>D6</td><td>D5</td><td>D4</td><td>D3</td><td>D2</td><td>D1</td><td>D0</td></tr><tr><td>0</td><td>0</td><td>0</td><td>0</td><td>0</td><td>0</td><td>1</td><td>0</td></tr></table> = Track combining Command</p> <p>(2) <table border="1" style="display: inline-table; vertical-align: middle;"><tr><td>D7</td><td>D6</td><td>D5</td><td>D4</td><td>D3</td><td>D2</td><td>D1</td><td>D0</td></tr><tr><td>-</td><td>-</td><td>-</td><td>-</td><td>-</td><td>-</td><td>-</td><td>-</td></tr></table> "Reserved"</p> <p>}</p> <p>(10) <table border="1" style="display: inline-table; vertical-align: middle;"><tr><td>D7</td><td>D6</td><td>D5</td><td>D4</td><td>D3</td><td>D2</td><td>D1</td><td>D0</td></tr><tr><td>-</td><td>-</td><td>-</td><td>-</td><td>-</td><td>-</td><td>-</td><td>-</td></tr></table> "Reserved"</p> <p>b 3) Move: Moves the track in standby mode.</p> <p>(1) <table border="1" style="display: inline-table; vertical-align: middle;"><tr><td>D7</td><td>D6</td><td>D5</td><td>D4</td><td>D3</td><td>D2</td><td>D1</td><td>D0</td></tr><tr><td>0</td><td>0</td><td>0</td><td>0</td><td>0</td><td>0</td><td>1</td><td>1</td></tr></table> = Track moving command.</p> <p>(2) <table border="1" style="display: inline-table; vertical-align: middle;"><tr><td>D7</td><td>D6</td><td>D5</td><td>D4</td><td>D3</td><td>D2</td><td>D1</td><td>D0</td></tr><tr><td>-</td><td>-</td><td>-</td><td>-</td><td>-</td><td>-</td><td>-</td><td>-</td></tr></table> "Reserved"</p> <p>}</p> <p>(9) <table border="1" style="display: inline-table; vertical-align: middle;"><tr><td>D7</td><td>D6</td><td>D5</td><td>D4</td><td>D3</td><td>D2</td><td>D1</td><td>D0</td></tr><tr><td>-</td><td>-</td><td>-</td><td>-</td><td>-</td><td>-</td><td>-</td><td>-</td></tr></table> "Reserved"</p> <p>(10) <table border="1" style="display: inline-table; vertical-align: middle;"><tr><td>D7</td><td>D6</td><td>D5</td><td>D4</td><td>D3</td><td>D2</td><td>D1</td><td>D0</td></tr><tr><td>-</td><td>-</td><td>-</td><td>-</td><td>-</td><td>-</td><td>-</td><td>-</td></tr></table> Track No. after moved (Binary), 1~255 Tracks.</p> <p>4) Divide: Divides the track at the specified position.</p> <p>(1) <table border="1" style="display: inline-table; vertical-align: middle;"><tr><td>D7</td><td>D6</td><td>D5</td><td>D4</td><td>D3</td><td>D2</td><td>D1</td><td>D0</td></tr><tr><td>0</td><td>0</td><td>0</td><td>0</td><td>0</td><td>1</td><td>0</td><td>0</td></tr></table> = Track dividing command.</p> <p>(2) <table border="1" style="display: inline-table; vertical-align: middle;"><tr><td>D7</td><td>D6</td><td>D5</td><td>D4</td><td>D3</td><td>D2</td><td>D1</td><td>D0</td></tr><tr><td>-</td><td>-</td><td>-</td><td>-</td><td>-</td><td>-</td><td>-</td><td>-</td></tr></table> "Reserved"</p> <p>}</p> <p>(5) <table border="1" style="display: inline-table; vertical-align: middle;"><tr><td>D7</td><td>D6</td><td>D5</td><td>D4</td><td>D3</td><td>D2</td><td>D1</td><td>D0</td></tr><tr><td>-</td><td>-</td><td>-</td><td>-</td><td>-</td><td>-</td><td>-</td><td>-</td></tr></table> "Reserved"</p> <p>(6) <table border="1" style="display: inline-table; vertical-align: middle;"><tr><td>D7</td><td>D6</td><td>D5</td><td>D4</td><td>D3</td><td>D2</td><td>D1</td><td>D0</td></tr><tr><td>-</td><td>-</td><td>-</td><td>-</td><td>-</td><td>-</td><td>-</td><td>-</td></tr></table> Track No. (Binary), 1 ~ 255 Tracks.</p> <p>(7) <table border="1" style="display: inline-table; vertical-align: middle;"><tr><td>D7</td><td>D6</td><td>D5</td><td>D4</td><td>D3</td><td>D2</td><td>D1</td><td>D0</td></tr><tr><td>-</td><td>-</td><td>-</td><td>-</td><td>-</td><td>-</td><td>-</td><td>-</td></tr></table> Dividing position (P-time) Min. x 100 (BCD)</p> <p>(8) <table border="1" style="display: inline-table; vertical-align: middle;"><tr><td>D7</td><td>D6</td><td>D5</td><td>D4</td><td>D3</td><td>D2</td><td>D1</td><td>D0</td></tr><tr><td>-</td><td>-</td><td>-</td><td>-</td><td>-</td><td>-</td><td>-</td><td>-</td></tr></table> Dividing position (P-time) Min. x 1 (BCD) Min. x 10 (BCD)</p>				D7	D6	D5	D4	D3	D2	D1	D0	0	0	0	0	0	0	0	1	D7	D6	D5	D4	D3	D2	D1	D0	-	-	-	-	-	-	-	-	D7	D6	D5	D4	D3	D2	D1	D0	-	-	-	-	-	-	-	-	D7	D6	D5	D4	D3	D2	D1	D0	0	0	0	0	0	0	0	0	0	0	0	0	0	0	0	1	-	-	-	-	-	-	-	-	1	1	1	1	1	1	1	1	D7	D6	D5	D4	D3	D2	D1	D0	0	0	0	0	0	0	1	0	D7	D6	D5	D4	D3	D2	D1	D0	-	-	-	-	-	-	-	-	D7	D6	D5	D4	D3	D2	D1	D0	-	-	-	-	-	-	-	-	D7	D6	D5	D4	D3	D2	D1	D0	0	0	0	0	0	0	1	1	D7	D6	D5	D4	D3	D2	D1	D0	-	-	-	-	-	-	-	-	D7	D6	D5	D4	D3	D2	D1	D0	-	-	-	-	-	-	-	-	D7	D6	D5	D4	D3	D2	D1	D0	-	-	-	-	-	-	-	-	D7	D6	D5	D4	D3	D2	D1	D0	0	0	0	0	0	1	0	0	D7	D6	D5	D4	D3	D2	D1	D0	-	-	-	-	-	-	-	-	D7	D6	D5	D4	D3	D2	D1	D0	-	-	-	-	-	-	-	-	D7	D6	D5	D4	D3	D2	D1	D0	-	-	-	-	-	-	-	-	D7	D6	D5	D4	D3	D2	D1	D0	-	-	-	-	-	-	-	-	D7	D6	D5	D4	D3	D2	D1	D0	-	-	-	-	-	-	-	-
D7	D6	D5	D4	D3	D2	D1	D0																																																																																																																																																																																																																																																																																																				
0	0	0	0	0	0	0	1																																																																																																																																																																																																																																																																																																				
D7	D6	D5	D4	D3	D2	D1	D0																																																																																																																																																																																																																																																																																																				
-	-	-	-	-	-	-	-																																																																																																																																																																																																																																																																																																				
D7	D6	D5	D4	D3	D2	D1	D0																																																																																																																																																																																																																																																																																																				
-	-	-	-	-	-	-	-																																																																																																																																																																																																																																																																																																				
D7	D6	D5	D4	D3	D2	D1	D0																																																																																																																																																																																																																																																																																																				
0	0	0	0	0	0	0	0																																																																																																																																																																																																																																																																																																				
0	0	0	0	0	0	0	1																																																																																																																																																																																																																																																																																																				
-	-	-	-	-	-	-	-																																																																																																																																																																																																																																																																																																				
1	1	1	1	1	1	1	1																																																																																																																																																																																																																																																																																																				
D7	D6	D5	D4	D3	D2	D1	D0																																																																																																																																																																																																																																																																																																				
0	0	0	0	0	0	1	0																																																																																																																																																																																																																																																																																																				
D7	D6	D5	D4	D3	D2	D1	D0																																																																																																																																																																																																																																																																																																				
-	-	-	-	-	-	-	-																																																																																																																																																																																																																																																																																																				
D7	D6	D5	D4	D3	D2	D1	D0																																																																																																																																																																																																																																																																																																				
-	-	-	-	-	-	-	-																																																																																																																																																																																																																																																																																																				
D7	D6	D5	D4	D3	D2	D1	D0																																																																																																																																																																																																																																																																																																				
0	0	0	0	0	0	1	1																																																																																																																																																																																																																																																																																																				
D7	D6	D5	D4	D3	D2	D1	D0																																																																																																																																																																																																																																																																																																				
-	-	-	-	-	-	-	-																																																																																																																																																																																																																																																																																																				
D7	D6	D5	D4	D3	D2	D1	D0																																																																																																																																																																																																																																																																																																				
-	-	-	-	-	-	-	-																																																																																																																																																																																																																																																																																																				
D7	D6	D5	D4	D3	D2	D1	D0																																																																																																																																																																																																																																																																																																				
-	-	-	-	-	-	-	-																																																																																																																																																																																																																																																																																																				
D7	D6	D5	D4	D3	D2	D1	D0																																																																																																																																																																																																																																																																																																				
0	0	0	0	0	1	0	0																																																																																																																																																																																																																																																																																																				
D7	D6	D5	D4	D3	D2	D1	D0																																																																																																																																																																																																																																																																																																				
-	-	-	-	-	-	-	-																																																																																																																																																																																																																																																																																																				
D7	D6	D5	D4	D3	D2	D1	D0																																																																																																																																																																																																																																																																																																				
-	-	-	-	-	-	-	-																																																																																																																																																																																																																																																																																																				
D7	D6	D5	D4	D3	D2	D1	D0																																																																																																																																																																																																																																																																																																				
-	-	-	-	-	-	-	-																																																																																																																																																																																																																																																																																																				
D7	D6	D5	D4	D3	D2	D1	D0																																																																																																																																																																																																																																																																																																				
-	-	-	-	-	-	-	-																																																																																																																																																																																																																																																																																																				
D7	D6	D5	D4	D3	D2	D1	D0																																																																																																																																																																																																																																																																																																				
-	-	-	-	-	-	-	-																																																																																																																																																																																																																																																																																																				

Code	Command	Parameter	Description
(9)	D7 D6 D5 D4 D3 D2 D1 D0		Dividing position (P-time) Sec. x 1 (BCD) Sec. x 10 (BCD)
(10)	D7 D6 D5 D4 D3 D2 D1 D0		Dividing position (P-time) Frame x 1 (BCD) Frame x 10 (BCD)
5) Section Erase: Erases the specified selection.			
(1)	D7 D6 D5 D4 D3 D2 D1 D0 0 0 0 0 0 1 0 1		= Section erasing command
(2)	D7 D6 D5 D4 D3 D2 D1 D0		Track No. (Binary) 1 ~ 255 Tracks.
(3)	D7 D6 D5 D4 D3 D2 D1 D0		Starting Position (P-time) Min. x 100 (BCD)
(4)	D7 D6 D5 D4 D3 D2 D1 D0		Starting position (P-time) Min. x 1 (BCD) Min. x 10 (BCD)
(5)	D7 D6 D5 D4 D3 D2 D1 D0		Starting position (P-time) Sec. x 1 (BCD) Sec. x 10 (BCD)
(6)	D7 D6 D5 D4 D3 D2 D1 D0		Starting position (P-time) Frame x 1 (BCD) Frame x 10 (BCD)
(7)	D7 D6 D5 D4 D3 D2 D1 D0		Ending position (P-time) Min. x 100 (BCD)
(8)	D7 D6 D5 D4 D3 D2 D1 D0		Ending position (P-time) Min. x 1 (BCD) Min. x 10 (BCD)
(9)	D7 D6 D5 D4 D3 D2 D1 D0		Ending position (P-time) Sec. x 1 (BCD) Sec. x 10 (BCD)
(10)	D7 D6 D5 D4 D3 D2 D1 D0		Ending position (P-time) Frame x 1 (BCD) Frame x 10 (BCD)
6) Start: Changes Starting position.			
(1)	D7 D6 D5 D4 D3 D2 D1 D0 0 0 0 0 0 1 1 0		= Starting position changing command.
(2)	D7 D6 D5 D4 D3 D2 D1 D0 - - - - - - - -		"Reserved"
(5)	D7 D6 D5 D4 D3 D2 D1 D0		"Reserved"
(6)	D7 D6 D5 D4 D3 D2 D1 D0		Track No. (Binary) 1 ~ 255 Tracks.
(7)	D7 D6 D5 D4 D3 D2 D1 D0		Starting position (P-time) Min x 100 (BCD)

Code	Command	Parameter	Description																																								
b	(8)	<table border="1"> <tr><td>D7</td><td>D6</td><td>D5</td><td>D4</td><td>D3</td><td>D2</td><td>D1</td><td>D0</td></tr> </table>	D7	D6	D5	D4	D3	D2	D1	D0	Starting position (P-time) Min x 1 (BCD) Min x 10 (BCD)																																
	D7	D6	D5	D4	D3	D2	D1	D0																																			
	(9)	<table border="1"> <tr><td>D7</td><td>D6</td><td>D5</td><td>D4</td><td>D3</td><td>D2</td><td>D1</td><td>D0</td></tr> </table>	D7	D6	D5	D4	D3	D2	D1	D0	Starting position (P-time) Sec. x 1 (BCD) Sec. x 10 (BCD)																																
	D7	D6	D5	D4	D3	D2	D1	D0																																			
	(10)	<table border="1"> <tr><td>D7</td><td>D6</td><td>D5</td><td>D4</td><td>D3</td><td>D2</td><td>D1</td><td>D0</td></tr> </table>	D7	D6	D5	D4	D3	D2	D1	D0	Starting position (P-time) Frame x 1 (BCD) Frame x 10 (BCD)																																
	D7	D6	D5	D4	D3	D2	D1	D0																																			
	7) End: Change Ending position.																																										
	(1)	<table border="1"> <tr><td>D7</td><td>D6</td><td>D5</td><td>D4</td><td>D3</td><td>D2</td><td>D1</td><td>D0</td></tr> <tr><td>0</td><td>0</td><td>0</td><td>0</td><td>0</td><td>1</td><td>1</td><td>1</td></tr> </table>	D7	D6	D5	D4	D3	D2	D1	D0	0	0	0	0	0	1	1	1	= Ending position changing command.																								
	D7	D6	D5	D4	D3	D2	D1	D0																																			
	0	0	0	0	0	1	1	1																																			
(2)	<table border="1"> <tr><td>D7</td><td>D6</td><td>D5</td><td>D4</td><td>D3</td><td>D2</td><td>D1</td><td>D0</td></tr> <tr><td>-</td><td>-</td><td>-</td><td>-</td><td>-</td><td>-</td><td>-</td><td>-</td></tr> </table>	D7	D6	D5	D4	D3	D2	D1	D0	-	-	-	-	-	-	-	-	"Reserved"																									
D7	D6	D5	D4	D3	D2	D1	D0																																				
-	-	-	-	-	-	-	-																																				
(5)	<table border="1"> <tr><td>D7</td><td>D6</td><td>D5</td><td>D4</td><td>D3</td><td>D2</td><td>D1</td><td>D0</td></tr> <tr><td>-</td><td>-</td><td>-</td><td>-</td><td>-</td><td>-</td><td>-</td><td>-</td></tr> </table>	D7	D6	D5	D4	D3	D2	D1	D0	-	-	-	-	-	-	-	-	"Reserved"																									
D7	D6	D5	D4	D3	D2	D1	D0																																				
-	-	-	-	-	-	-	-																																				
(6)	<table border="1"> <tr><td>D7</td><td>D6</td><td>D5</td><td>D4</td><td>D3</td><td>D2</td><td>D1</td><td>D0</td></tr> </table>	D7	D6	D5	D4	D3	D2	D1	D0	Track No. (Binary) 1 ~ 255 Tracks.																																	
D7	D6	D5	D4	D3	D2	D1	D0																																				
(7)	<table border="1"> <tr><td>D7</td><td>D6</td><td>D5</td><td>D4</td><td>D3</td><td>D2</td><td>D1</td><td>D0</td></tr> </table>	D7	D6	D5	D4	D3	D2	D1	D0	Ending position (P-time) Min x 100 (BCD)																																	
D7	D6	D5	D4	D3	D2	D1	D0																																				
(8)	<table border="1"> <tr><td>D7</td><td>D6</td><td>D5</td><td>D4</td><td>D3</td><td>D2</td><td>D1</td><td>D0</td></tr> </table>	D7	D6	D5	D4	D3	D2	D1	D0	Ending position (P-time) Min x 1 (BCD) Min x 10 (BCD)																																	
D7	D6	D5	D4	D3	D2	D1	D0																																				
(9)	<table border="1"> <tr><td>D7</td><td>D6</td><td>D5</td><td>D4</td><td>D3</td><td>D2</td><td>D1</td><td>D0</td></tr> </table>	D7	D6	D5	D4	D3	D2	D1	D0	Ending position (P-time) Sec. x 1 (BCD) Sec. x 10 (BCD)																																	
D7	D6	D5	D4	D3	D2	D1	D0																																				
(10)	<table border="1"> <tr><td>D7</td><td>D6</td><td>D5</td><td>D4</td><td>D3</td><td>D2</td><td>D1</td><td>D0</td></tr> </table>	D7	D6	D5	D4	D3	D2	D1	D0	Ending position (P-time) Frame x 1 (BCD) Frame x 10 (BCD)																																	
D7	D6	D5	D4	D3	D2	D1	D0																																				
e	Writing Name		12 bytes * (1) - (12)																																								
			Writes Disc and Track Names.																																								
	(1)	<table border="1"> <tr><td>D7</td><td>D6</td><td>D5</td><td>D4</td><td>D3</td><td>D2</td><td>D1</td><td>D0</td></tr> <tr><td>0</td><td>0</td><td>0</td><td>0</td><td>0</td><td>0</td><td>0</td><td>0</td></tr> <tr><td>0</td><td>0</td><td>0</td><td>0</td><td>0</td><td>0</td><td>0</td><td>1</td></tr> <tr><td>-</td><td>-</td><td>-</td><td>-</td><td>-</td><td>-</td><td>-</td><td>-</td></tr> <tr><td>1</td><td>1</td><td>1</td><td>1</td><td>1</td><td>1</td><td>1</td><td>1</td></tr> </table>	D7	D6	D5	D4	D3	D2	D1	D0	0	0	0	0	0	0	0	0	0	0	0	0	0	0	0	1	-	-	-	-	-	-	-	-	1	1	1	1	1	1	1	1	= Disc Name = Track No. (Binary) 1 ~ 255 Tracks.
	D7	D6	D5	D4	D3	D2	D1	D0																																			
	0	0	0	0	0	0	0	0																																			
0	0	0	0	0	0	0	1																																				
-	-	-	-	-	-	-	-																																				
1	1	1	1	1	1	1	1																																				
(2)	<table border="1"> <tr><td>D7</td><td>D6</td><td>D5</td><td>D4</td><td>D3</td><td>D2</td><td>D1</td><td>D0</td></tr> </table>	D7	D6	D5	D4	D3	D2	D1	D0	Data starting byte (Binary).																																	
D7	D6	D5	D4	D3	D2	D1	D0																																				
(3)	<table border="1"> <tr><td>D7</td><td>D6</td><td>D5</td><td>D4</td><td>D3</td><td>D2</td><td>D1</td><td>D0</td></tr> <tr><td>-</td><td>-</td><td>-</td><td>-</td><td>-</td><td>-</td><td>-</td><td>-</td></tr> </table>	D7	D6	D5	D4	D3	D2	D1	D0	-	-	-	-	-	-	-	-	Data 1 (ASCII)																									
D7	D6	D5	D4	D3	D2	D1	D0																																				
-	-	-	-	-	-	-	-																																				
(12)	<table border="1"> <tr><td>D7</td><td>D6</td><td>D5</td><td>D4</td><td>D3</td><td>D2</td><td>D1</td><td>D0</td></tr> </table>	D7	D6	D5	D4	D3	D2	D1	D0	Data 10 (ASCII)																																	
D7	D6	D5	D4	D3	D2	D1	D0																																				
Note: Data are transferred in a 10-byte/unit. Therefore, the "Data Starting Byte" is to be "1" at the first, "11" at the second and "21" at the third times. NULL Code is transferred at the final data.																																											
f	Recording Pause	Non	Pauses Recording function.																																								
	Note: Accepts the command during STOP, STANDBY and Recording modes.																																										
g	POS Code	Non	Requests POS Code.																																								

Code	Command	Parameter	Description																
h	ISRC Code	1 byte, Track No. * (1)	Requests ISRC Code.																
	(1)	<table border="1" style="display: inline-table; vertical-align: middle;"> <tr> <td>D7</td><td>D6</td><td>D5</td><td>D4</td><td>D3</td><td>D2</td><td>D1</td><td>D0</td> </tr> </table>	D7	D6	D5	D4	D3	D2	D1	D0	Track No. (Binary) 1 ~ 255 Tracks.								
D7	D6	D5	D4	D3	D2	D1	D0												
j	Recording	Non	Starts recording.																
	Note: Accepts the command during recording pause mode.																		
k	Track Increment	Non	Increments track No. during recording.																
m	Setting Tally	5 bytes, P-time * (1) ~ (5)	Sets tally starting position.																
	(1)	<table border="1" style="display: inline-table; vertical-align: middle;"> <tr> <td>D7</td><td>D6</td><td>D5</td><td>D4</td><td>D3</td><td>D2</td><td>D1</td><td>D0</td> </tr> <tr> <td>X</td><td>X</td><td>X</td><td>X</td><td>X</td><td>X</td><td>1</td><td>X</td> </tr> </table>	D7	D6	D5	D4	D3	D2	D1	D0	X	X	X	X	X	X	1	X	CUE Tally
	D7	D6	D5	D4	D3	D2	D1	D0											
	X	X	X	X	X	X	1	X											
	(2)	<table border="1" style="display: inline-table; vertical-align: middle;"> <tr> <td>D7</td><td>D6</td><td>D5</td><td>D4</td><td>D3</td><td>D2</td><td>D1</td><td>D0</td> </tr> </table>	D7	D6	D5	D4	D3	D2	D1	D0	Min. x 100 (BCD)								
	D7	D6	D5	D4	D3	D2	D1	D0											
(3)	<table border="1" style="display: inline-table; vertical-align: middle;"> <tr> <td>D7</td><td>D6</td><td>D5</td><td>D4</td><td>D3</td><td>D2</td><td>D1</td><td>D0</td> </tr> </table>	D7	D6	D5	D4	D3	D2	D1	D0	Min x 1 (BCD) Min x 10 (BCD)									
D7	D6	D5	D4	D3	D2	D1	D0												
(4)	<table border="1" style="display: inline-table; vertical-align: middle;"> <tr> <td>D7</td><td>D6</td><td>D5</td><td>D4</td><td>D3</td><td>D2</td><td>D1</td><td>D0</td> </tr> </table>	D7	D6	D5	D4	D3	D2	D1	D0	Sec. x 1 (BCD) Sec. x 10 (BCD)									
D7	D6	D5	D4	D3	D2	D1	D0												
(5)	<table border="1" style="display: inline-table; vertical-align: middle;"> <tr> <td>D7</td><td>D6</td><td>D5</td><td>D4</td><td>D3</td><td>D2</td><td>D1</td><td>D0</td> </tr> </table>	D7	D6	D5	D4	D3	D2	D1	D0	Frame x 1 (BCD) Frame x 10 (BCD)									
D7	D6	D5	D4	D3	D2	D1	D0												
r	Reading UTOC	Non	Reads the UTOC.																
t	Editing Work Status	Non	Requests the Status for Editing Work.																
w	Writing UTOC	Non	Writes the UTOC.																
y	Canceling Recording	Non	Enters to Standby mode from Recording or Recording Pause mode. Writes the UTOC.																

To control the player while attaching the ID (Player Number);

- 1) Set the Mode at first. [M]-[10001000]
After the above, the player accepts commands with ID.
- 2) Attach and transfer the ID (1 byte) subsequent to the control command.

Example: With ID [COMMAND]-[ID]-[DATA]
 Without ID [COMMAND]-[DATA]

- 3) When the ID is [11111111], all players accept the command.

2. Status and Answer List

Code	Status	Parameter	Description
A	Acknowledge	Non	Receipt of Command (Answer for A, B, D, J, K, M, N, P, Q, S, T, U, W, Y, b, e, f, j, k, m, r, w, and y Commands).
B	Standby	Non	During standby. (Answer for X Command)
C	End Monitor	Non	During End Monitor. (Answer for X Command)
D	Tray-down	Non	During Tray-down. (Answer for X Command)
E	Error	1 byte * (1)	Transmits an Error Code. (Answer for X Command)
	Note: Details of the Error Code will be explained separately. Refer to "ERROR CODE LIST" page 71.		
F	Finish	Non	Completion of Playback.

Code	Status	Parameter	Description								
G	Preset	7 bytes * (1) ~ (7)	Transfers the contents of presetting. (Answer for G command)								
	(1)	<table border="1" style="display: inline-table; vertical-align: middle;"> <tr> <td>D7</td><td>D6</td><td>D5</td><td>D4</td><td>D3</td><td>D2</td><td>D1</td><td>D0</td> </tr> </table> 	D7	D6	D5	D4	D3	D2	D1	D0	1 = (D1-Bit 0) ON 1 = (D1-Bit 1) ON 1 = (D1-Bit 2) ON 1 = (D1-Bit 3) ON 1 = (D1-Bit 4) ON 1 = (D1-Bit 5) ON 1 = (D1-Bit 6) ON 1 = (D1-Bit 7) ON
	D7	D6	D5	D4	D3	D2	D1	D0			
	(2)	<table border="1" style="display: inline-table; vertical-align: middle;"> <tr> <td>D7</td><td>D6</td><td>D5</td><td>D4</td><td>D3</td><td>D2</td><td>D1</td><td>D0</td> </tr> </table>	D7	D6	D5	D4	D3	D2	D1	D0	D2 (Bit 0 ~ Bit 7)
	D7	D6	D5	D4	D3	D2	D1	D0			
	(3)	<table border="1" style="display: inline-table; vertical-align: middle;"> <tr> <td>D7</td><td>D6</td><td>D5</td><td>D4</td><td>D3</td><td>D2</td><td>D1</td><td>D0</td> </tr> </table>	D7	D6	D5	D4	D3	D2	D1	D0	D3 (Bit 0 ~ Bit 7)
	D7	D6	D5	D4	D3	D2	D1	D0			
	(4)	<table border="1" style="display: inline-table; vertical-align: middle;"> <tr> <td>D7</td><td>D6</td><td>D5</td><td>D4</td><td>D3</td><td>D2</td><td>D1</td><td>D0</td> </tr> </table>	D7	D6	D5	D4	D3	D2	D1	D0	D4 (Bit 0 ~ Bit 7)
D7	D6	D5	D4	D3	D2	D1	D0				
(5)	<table border="1" style="display: inline-table; vertical-align: middle;"> <tr> <td>D7</td><td>D6</td><td>D5</td><td>D4</td><td>D3</td><td>D2</td><td>D1</td><td>D0</td> </tr> </table>	D7	D6	D5	D4	D3	D2	D1	D0	D5 (Bit 0 ~ Bit 7)	
D7	D6	D5	D4	D3	D2	D1	D0				
(6)	<table border="1" style="display: inline-table; vertical-align: middle;"> <tr> <td>D7</td><td>D6</td><td>D5</td><td>D4</td><td>D3</td><td>D2</td><td>D1</td><td>D0</td> </tr> </table>	D7	D6	D5	D4	D3	D2	D1	D0	D6 (Bit 0 ~ Bit 7)	
D7	D6	D5	D4	D3	D2	D1	D0				
(7)	<table border="1" style="display: inline-table; vertical-align: middle;"> <tr> <td>D7</td><td>D6</td><td>D5</td><td>D4</td><td>D3</td><td>D2</td><td>D1</td><td>D0</td> </tr> </table>	D7	D6	D5	D4	D3	D2	D1	D0	D7 (Bit 0 ~ Bit 7)	
D7	D6	D5	D4	D3	D2	D1	D0				
I	Invalid Command	Non	Invalid Command. (Answer for A, B, D, J, K, M, N, P, Q, S, T, U, W, Y, b, e, f, j, k, m, r, w, and y commands). (Answer for Parameter error.)								
O	Option	6 bytes * (1) ~ (6)	Answer for the Option Command.								
	1) Answer for the option Command [0], disc's TOC data.										
	(1)	<table border="1" style="display: inline-table; vertical-align: middle;"> <tr> <td>D7</td><td>D6</td><td>D5</td><td>D4</td><td>D3</td><td>D2</td><td>D1</td><td>D0</td> </tr> </table>	D7	D6	D5	D4	D3	D2	D1	D0	First Track No. (Binary)
	D7	D6	D5	D4	D3	D2	D1	D0			
	(2)	<table border="1" style="display: inline-table; vertical-align: middle;"> <tr> <td>D7</td><td>D6</td><td>D5</td><td>D4</td><td>D3</td><td>D2</td><td>D1</td><td>D0</td> </tr> </table>	D7	D6	D5	D4	D3	D2	D1	D0	Last Track No. (Binary)
	D7	D6	D5	D4	D3	D2	D1	D0			
	(3)	<table border="1" style="display: inline-table; vertical-align: middle;"> <tr> <td>D7</td><td>D6</td><td>D5</td><td>D4</td><td>D3</td><td>D2</td><td>D1</td><td>D0</td> </tr> </table> 	D7	D6	D5	D4	D3	D2	D1	D0	Total time, Min. x 100 (BCD)
	D7	D6	D5	D4	D3	D2	D1	D0			
(4)	<table border="1" style="display: inline-table; vertical-align: middle;"> <tr> <td>D7</td><td>D6</td><td>D5</td><td>D4</td><td>D3</td><td>D2</td><td>D1</td><td>D0</td> </tr> </table> 	D7	D6	D5	D4	D3	D2	D1	D0	Total time, Min. x 1 (BCD) Total time, Min. x 10 (BCD)	
D7	D6	D5	D4	D3	D2	D1	D0				
(5)	<table border="1" style="display: inline-table; vertical-align: middle;"> <tr> <td>D7</td><td>D6</td><td>D5</td><td>D4</td><td>D3</td><td>D2</td><td>D1</td><td>D0</td> </tr> </table> 	D7	D6	D5	D4	D3	D2	D1	D0	Total time, Sec. x 1 (BCD) Total time, Sec. x 10 (BCD)	
D7	D6	D5	D4	D3	D2	D1	D0				
(6)	<table border="1" style="display: inline-table; vertical-align: middle;"> <tr> <td>D7</td><td>D6</td><td>D5</td><td>D4</td><td>D3</td><td>D2</td><td>D1</td><td>D0</td> </tr> </table> 	D7	D6	D5	D4	D3	D2	D1	D0	Total time, Frame x 1 (BCD) Total time, Frame x 10 (BCD)	
D7	D6	D5	D4	D3	D2	D1	D0				

Code	Status	Parameter	Description
2) Answer for the Option Command [1].			
(1)	D7 D6 D5 D4 D3 D2 D1 D0		"Reserved"
	{ - - - - - }		
(4)	D7 D6 D5 D4 D3 D2 D1 D0		"Reserved"
(5)	D7 D6 D5 D4 D3 D2 D1 D0		1 = Disp (EJECT LOCK) ON 1 = Disp (VARI) ON 1 = Disp (REM) ON 1 = Disp (DIGITAL IN) ON 1 = Disp (CUE) ON 1 = Disp (EDIT) ON 1 = Disp (TOC) ON
(6)	D7 D6 D5 D4 D3 D2 D1 D0		1 = (PLAY MODE) SINGLE
3) Answer for the Option Command [2], CPU number.			
(1)	D7 D6 D5 D4 D3 D2 D1 D0		"Reserved"
(2)	D7 D6 D5 D4 D3 D2 D1 D0		"Reserved"
(3)	D7 D6 D5 D4 D3 D2 D1 D0		System CPU No. Upper 2-digit, (BCD)
(4)	D7 D6 D5 D4 D3 D2 D1 D0		System CPU No. Lower 2-digit, (BCD)
(5)	D7 D6 D5 D4 D3 D2 D1 D0		Servo CPU No. Upper 2-digit, (BCD)
(6)	D7 D6 D5 D4 D3 D2 D1 D0		Servo CPU No. Lower 2-digit, (BCD)
4) Answer for the Option Command [3], Track playing duration and Track mode.			
(1)	D7 D6 D5 D4 D3 D2 D1 D0		"Reserved"
(2)	D7 D6 D5 D4 D3 D2 D1 D0		Min. x 100 (BCD)
(3)	D7 D6 D5 D4 D3 D2 D1 D0		Min. x 1 (BCD) Min. x 10 (BCD)
(4)	D7 D6 D5 D4 D3 D2 D1 D0		Sec. x 1 (BCD) Sec. x 10 (BCD)
(5)	D7 D6 D5 D4 D3 D2 D1 D0		Frame x 1 (BCD) Frame x 10 (BCD)

Code	Status	Parameter	Description						
(6)	D7	D6	D5	D4	D3	D2	D1	D0	
	X	X	1	0	X	X	X	0	= Write protected
	X	X	1	0	X	X	X	1	= Write permitted
	X	X	1	0	X	X	0	X	= Copy right protected
	X	X	1	0	X	X	1	X	= Not protected
	X	X	1	0	X	0	X	X	= Original
	X	X	1	0	X	1	X	X	= 1st or higher generation
	X	X	1	0	0	X	X	X	= Audio
	X	X	1	0	1	X	X	X	= Reserved
	X	0	1	0	X	X	X	X	= Mono
	X	1	1	0	X	X	X	X	= Stereo
	0	X	1	0	X	X	X	X	= Emphasis off
	1	X	1	0	X	X	X	X	= Emphasis 50/15µs.
	5) Answer for the Option Command [4], Track recording data.								
(1)	D7	D6	D5	D4	D3	D2	D1	D0	
	-----				-----				Year x 1 (BCD)
				-----				Year x 10 (BCD)	
(2)	D7	D6	D5	D4	D3	D2	D1	D0	
	-----				-----				Month x 1 (BCD)
				-----				Month x 10 (BCD)	
(3)	D7	D6	D5	D4	D3	D2	D1	D0	
	-----				-----				Date x 1 (BCD)
				-----				Date x 10 (BCD)	
(4)	D7	D6	D5	D4	D3	D2	D1	D0	
	-----				-----				Hour x 1 (BCD)
				-----				Hour x 10 (BCD)	
(5)	D7	D6	D5	D4	D3	D2	D1	D0	
	-----				-----				Minute x 1 (BCD)
				-----				Minute x 10 (BCD)	
(6)	D7	D6	D5	D4	D3	D2	D1	D0	
	-----				-----				Second x 1 (BCD)
				-----				Second x 10 (BCD)	
6) Answer for the Option Command [5], Disc type.									
(1)	D7	D6	D5	D4	D3	D2	D1	D0	"Reserved"
	-	-	-	-	-	-	-	-	
(4)	D7	D6	D5	D4	D3	D2	D1	D0	"Reserved"
(5)	D7	D6	D5	D4	D3	D2	D1	D0	
	0	0	0	0	0	0	0	0	= Write permitted
	0	0	0	0	0	0	0	1	= Write protected
(6)	D7	D6	D5	D4	D3	D2	D1	D0	
	0	0	1	1	1	1	0	1	= Prerecorded MD
	0	0	1	1	1	1	1	0	= Recordable MD
	0	0	1	1	1	1	1	1	= Hybrid MD

Code	Status	Parameter	Description
	7) Answer for the Option Command [6], Remaining recordable duration.		
(1)	D7 D6 D5 D4 D3 D2 D1 D0	"Reserved"	
(2)	D7 D6 D5 D4 D3 D2 D1 D0	"Reserved"	
(3)	D7 D6 D5 D4 D3 D2 D1 D0		Min. x 100 (BCD)
(4)	D7 D6 D5 D4 D3 D2 D1 D0		Min. x 1 (BCD) Min. x 10 (BCD)
(5)	D7 D6 D5 D4 D3 D2 D1 D0		Sec. x 1 (BCD) Sec. x 10 (BCD)
(6)	D7 D6 D5 D4 D3 D2 D1 D0		Frame x 1 (BCD) Frame x 10 (BCD)
O	8) Answer for the Option Command [7]. End tally and [8] ~ [12], Cue tallies.		
(1)	D7 D6 D5 D4 D3 D2 D1 D0	"Reserved"	
(2)	D7 D6 D5 D4 D3 D2 D1 D0		0 0 0 0 0 0 0 0 = Tally has not been set. 0 0 0 0 0 0 0 1 = Tally has been set.
(3)	D7 D6 D5 D4 D3 D2 D1 D0		Min. x 100 (BCD)
(4)	D7 D6 D5 D4 D3 D2 D1 D0		Min. x 1 (BCD) Min. x 10 (BCD)
(5)	D7 D6 D5 D4 D3 D2 D1 D0		Sec. x 1 (BCD) Sec. x 10 (BCD)
(6)	D7 D6 D5 D4 D3 D2 D1 D0		Frame x 1 (BCD) Frame x 10 (BCD)
P	Play	Non	During Play (Answer for X command)
Q	Manual Search (Cueing)	Non	Audio Signal is being output during Manual Search. (Answer for X command)
R	Ready	Non	No Disc is loaded. (Answer for X command)
S	Search	Non	Pick-up is moving during the search function. (Answer for X command)

Code	Status	Parameter	Description
T	Time	5 bytes * (1) ~ (5)	Sends the Time. (Answer for E command)
	(1)	D7 D6 D5 D4 D3 D2 D1 D0	Track No. (Binary)
	(2)	D7 D6 D5 D4 D3 D2 D1 D0	Min. x 100 (BCD)
	(3)	D7 D6 D5 D4 D3 D2 D1 D0	Min. x 1 (BCD) Min. x 10 (BCD)
	(4)	D7 D6 D5 D4 D3 D2 D1 D0	Sec. x 1 (BCD) Sec. x 10 (BCD)
	(5)	D7 D6 D5 D4 D3 D2 D1 D0	Frame x 1 (BCD) Frame x 10 (BCD)
U	Pause	Non	During Pause. (Answer for X command)
a	Recording	Non	During Recording. (Answer for X command)
b	Recording Pause	Non	During Recording Pause. (Answer for X command)
d	UTOC Writing	Non	During UTOC Writing. (Answer for X command)
e	Name	10 bytes * (1) ~ (10)	Sends Disc Name/Track Name (Answer for a command)
	(1)	D7 D6 D5 D4 D3 D2 D1 D0	Data 1 (ASCII)
	(10)	D7 D6 D5 D4 D3 D2 D1 D0	Data 10 (ASCII)
g	POS	1 or 14 bytes * (1) or (1) ~ (14)	Sends out POS Code. (Answer for g command)
	[1] Not available (1 byte)		
	(1)	D7 D6 D5 D4 D3 D2 D1 D0 1 0 0 0 0 1 0 0	POS Code N1 (ASCII)
	[2] Not Code (1 byte)		
	(1)	D7 D6 D5 D4 D3 D2 D1 D0 1 0 0 0 0 0 1 0	
	[3] Code available (14 bytes)		
	(1)	D7 D6 D5 D4 D3 D2 D1 D0 1 0 0 0 0 0 0 1	
	(2)	D7 D6 D5 D4 D3 D2 D1 D0	POS Code N1 (ASCII)
	(3)	D7 D6 D5 D4 D3 D2 D1 D0	POS Code N2 (ASCII)
	(4)	D7 D6 D5 D4 D3 D2 D1 D0	POS Code N3 (ASCII)
(5)	D7 D6 D5 D4 D3 D2 D1 D0	POS Code N4 (ASCII)	
(6)	D7 D6 D5 D4 D3 D2 D1 D0	POS Code N5 (ASCII)	

Code	Status	Parameter	Description
g	(7)	D7 D6 D5 D4 D3 D2 D1 D0	POS Code N6 (ASCII)
	(8)	D7 D6 D5 D4 D3 D2 D1 D0	POS Code N7 (ASCII)
	(9)	D7 D6 D5 D4 D3 D2 D1 D0	POS Code N8 (ASCII)
	(10)	D7 D6 D5 D4 D3 D2 D1 D0	POS Code N9 (ASCII)
	(11)	D7 D6 D5 D4 D3 D2 D1 D0	POS Code N10 (ASCII)
	(12)	D7 D6 D5 D4 D3 D2 D1 D0	POS Code N11 (ASCII)
	(13)	D7 D6 D5 D4 D3 D2 D1 D0	POS Code N12 (ASCII)
	(14)	D7 D6 D5 D4 D3 D2 D1 D0	POS Code N13 (ASCII)
	ISRC	1 or 13 bytes * (1) or (1) ~ (13)	Sends out ISRC (Answer for g Command)
h	[1] Not available (1 byte)		
	(1)	D7 D6 D5 D4 D3 D2 D1 D0 1 0 0 0 0 1 0 0	
	[2] No Code (1 byte)		
	(1)	D7 D6 D5 D4 D3 D2 D1 D0 1 0 0 0 0 0 1 0	
	[3] Code available (13 bytes)		
	(1)	D7 D6 D5 D4 D3 D2 D1 D0 1 0 0 0 0 0 0 1	
	(2)	D7 D6 D5 D4 D3 D2 D1 D0	Country Code (ASCII)
	(3)	D7 D6 D5 D4 D3 D2 D1 D0	
	(4)	D7 D6 D5 D4 D3 D2 D1 D0	Owner's Code (ASCII)
	(5)	D7 D6 D5 D4 D3 D2 D1 D0	
	(6)	D7 D6 D5 D4 D3 D2 D1 D0	
	(7)	D7 D6 D5 D4 D3 D2 D1 D0	Year of Recording (ASCII)
	(8)	D7 D6 D5 D4 D3 D2 D1 D0	
(9)	D7 D6 D5 D4 D3 D2 D1 D0	Serial Number of the Recording (ASCII)	
(10)	D7 D6 D5 D4 D3 D2 D1 D0		
(11)	D7 D6 D5 D4 D3 D2 D1 D0		
(12)	D7 D6 D5 D4 D3 D2 D1 D0		
(13)	D7 D6 D5 D4 D3 D2 D1 D0		

Code	Status	Parameter	Description																																
t	Editing Operation	1 byte, * (1)	Editing Operation Status (Answer for t Command)																																
	(1)	<table border="1"> <thead> <tr> <th>D7</th> <th>D6</th> <th>D5</th> <th>D4</th> <th>D3</th> <th>D2</th> <th>D1</th> <th>D0</th> </tr> </thead> <tbody> <tr> <td>0</td> <td>0</td> <td>0</td> <td>0</td> <td>0</td> <td>0</td> <td>0</td> <td>0</td> </tr> <tr> <td>0</td> <td>0</td> <td>0</td> <td>0</td> <td>0</td> <td>0</td> <td>0</td> <td>1</td> </tr> <tr> <td>0</td> <td>0</td> <td>0</td> <td>0</td> <td>0</td> <td>0</td> <td>1</td> <td>0</td> </tr> </tbody> </table>	D7	D6	D5	D4	D3	D2	D1	D0	0	0	0	0	0	0	0	0	0	0	0	0	0	0	0	1	0	0	0	0	0	0	1	0	= Completes Edit Operation. = During Edit Operation. = Unable to perform Edit Operation.
	D7	D6	D5	D4	D3	D2	D1	D0																											
	0	0	0	0	0	0	0	0																											
0	0	0	0	0	0	0	1																												
0	0	0	0	0	0	1	0																												
x	UTOOC Writing	Non	Writes the UTOC after Editing.																																

3. Command Sequence

Apply the SEND STATUS COMMAND [X] from the Host Controller at all times for reading out the status of the DN-990R/980F. Then take necessary steps.

4. Notice upon designing the Controller

- 1) After turning on the power or receipt of the Resetting Command [R], the unit will not accept new command for 0.5sec. in order for internal-unit initializing.
- 2) When a command is issued from the controller, send out next command after the acknowledge [A], Invalid [I] or the STATUS CODE is received.
- 3) Some of the commands may not be accepted except the unit is in the specific status mode.
- 4) Please do not apply other commands except the SEND STATUS [X] or RESET [R] during the search function (at STATUS [S]).

These specifications and ratings are subject to change for improvement.

BLOCK DIAGRAM

DN-990R / 980F SYSTEM

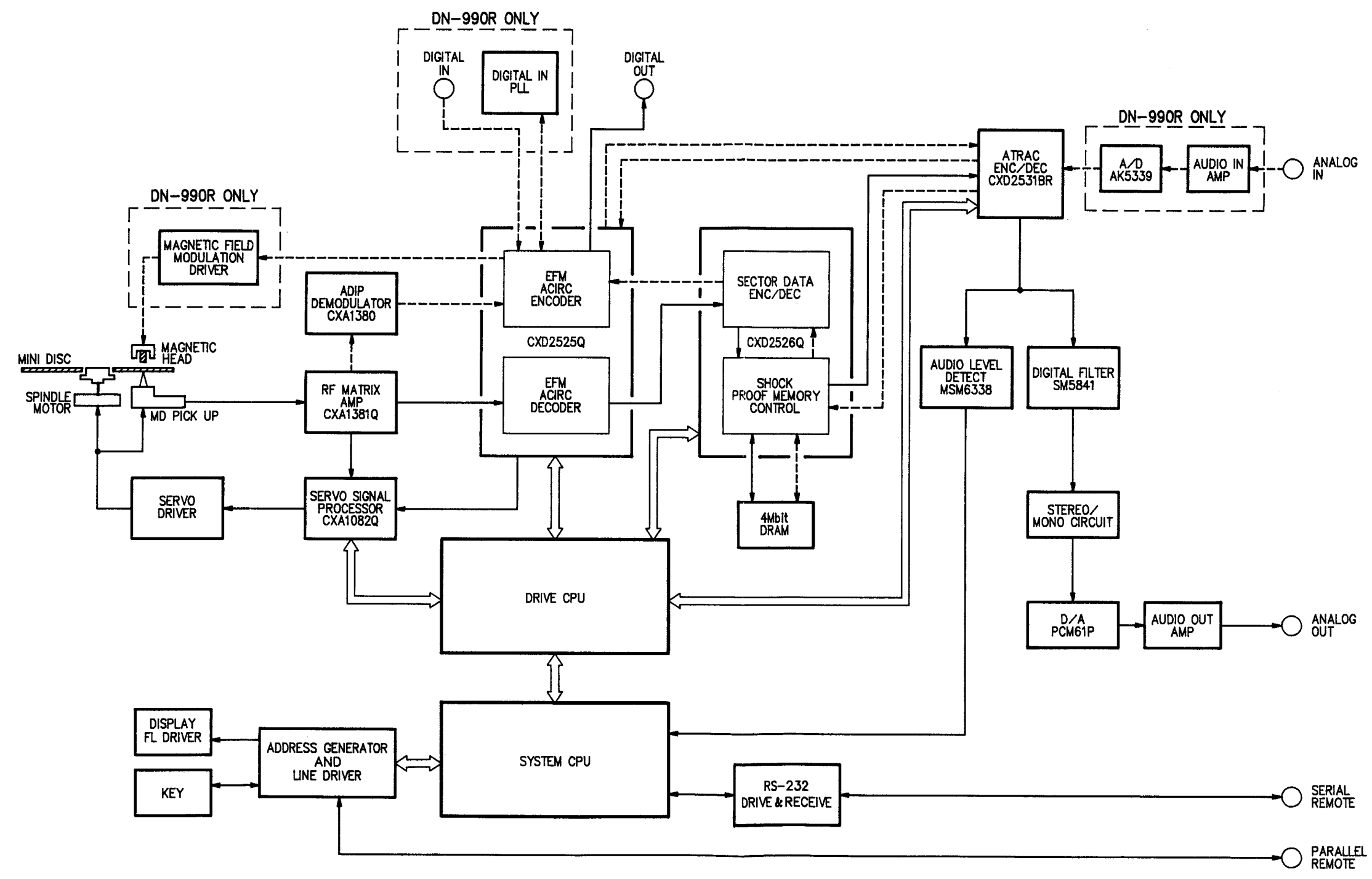

Note: — : AT READ MODE
- - - : AT RECORDING MODE

SERVO & SERVO DRIVER SECTION

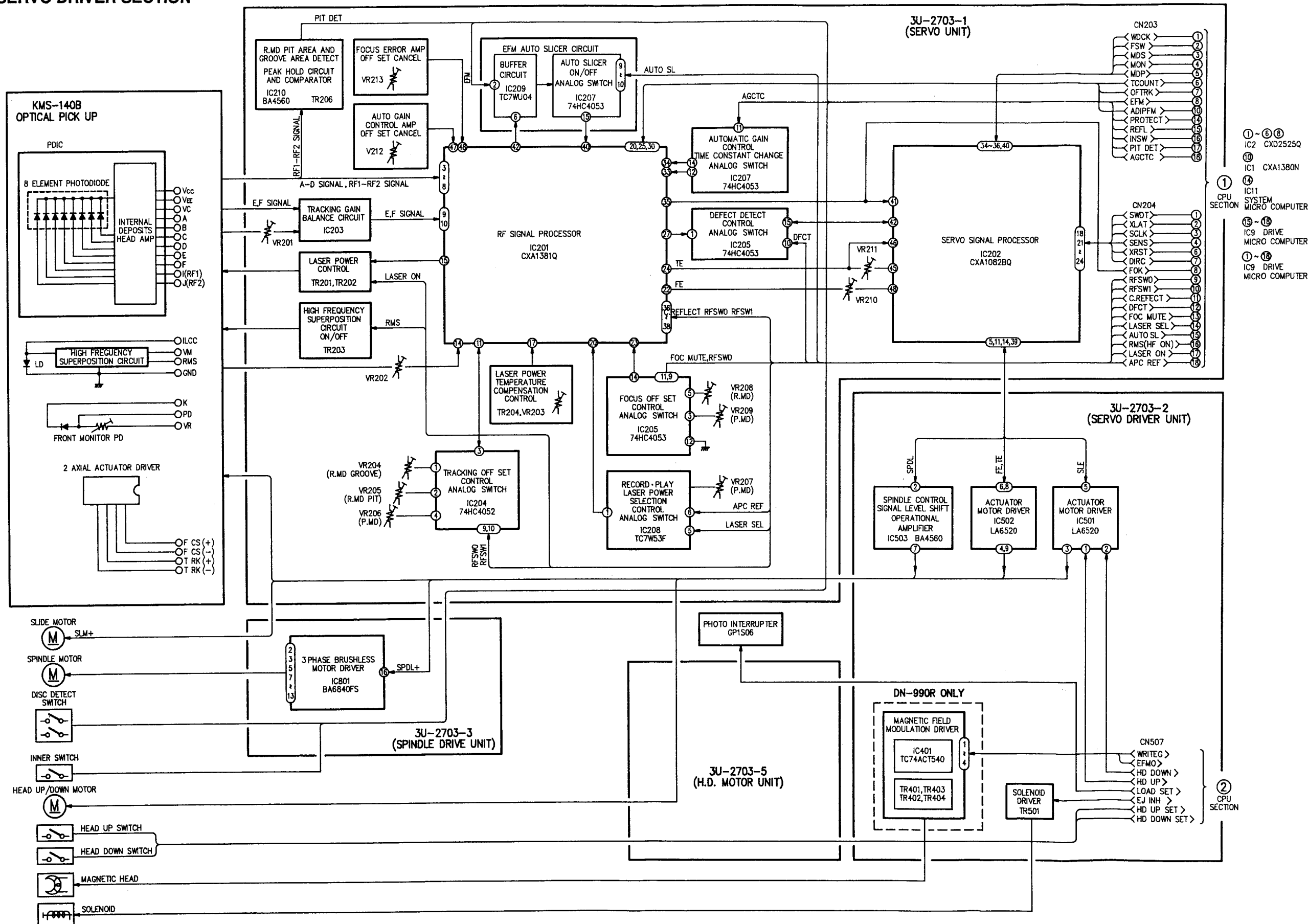

CPU SECTION

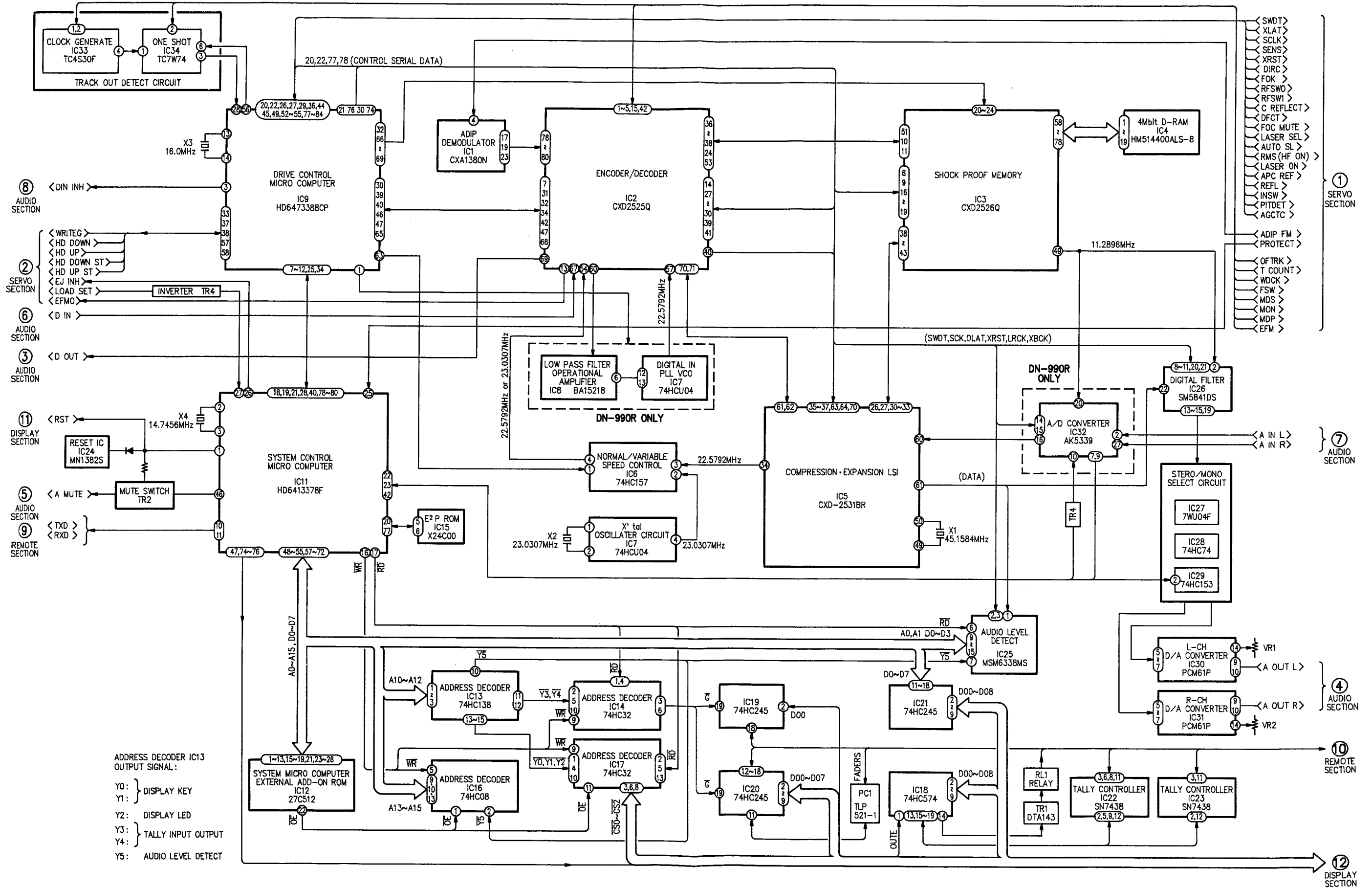

AUDIO & REMOTE SECTION

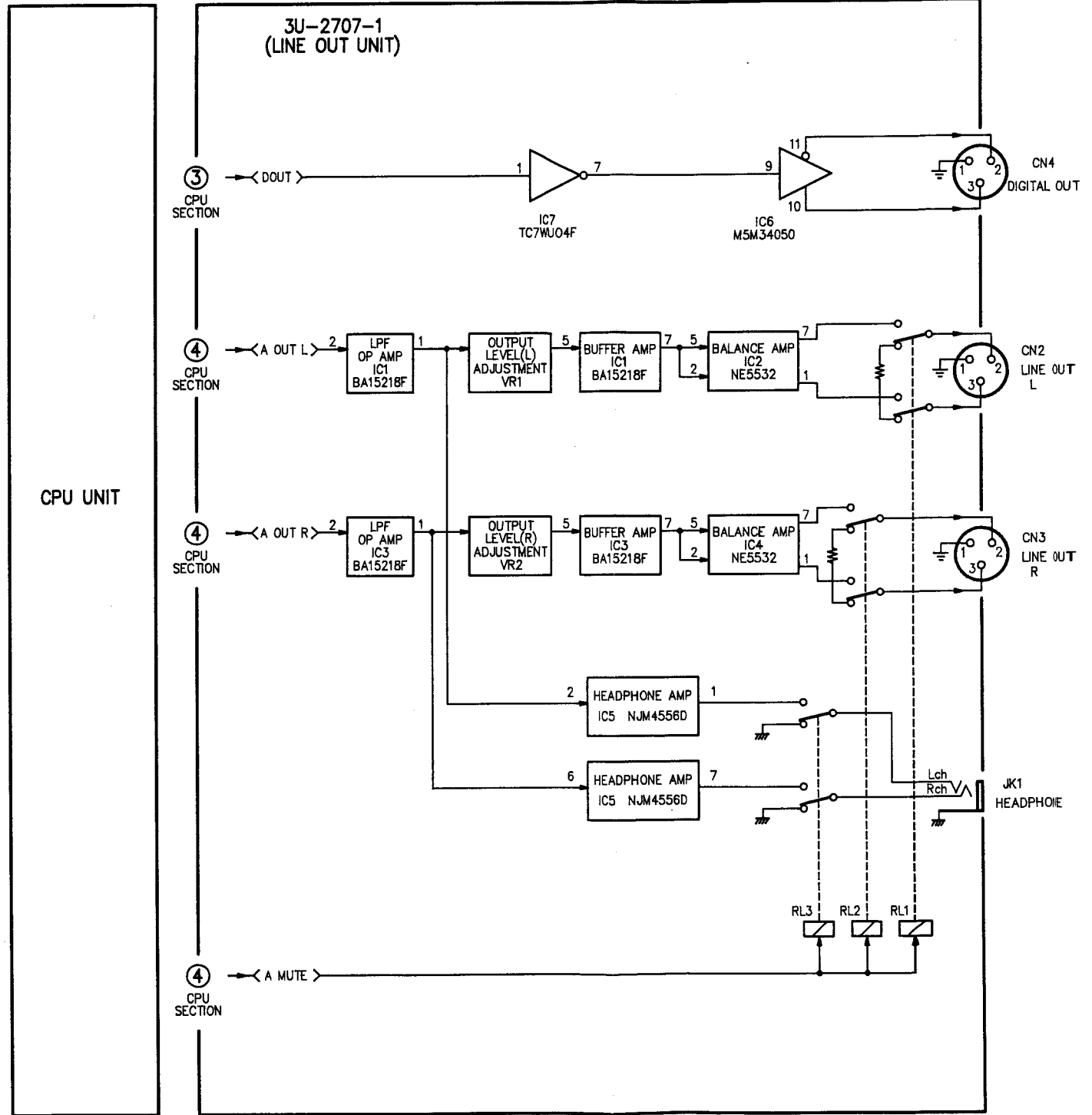
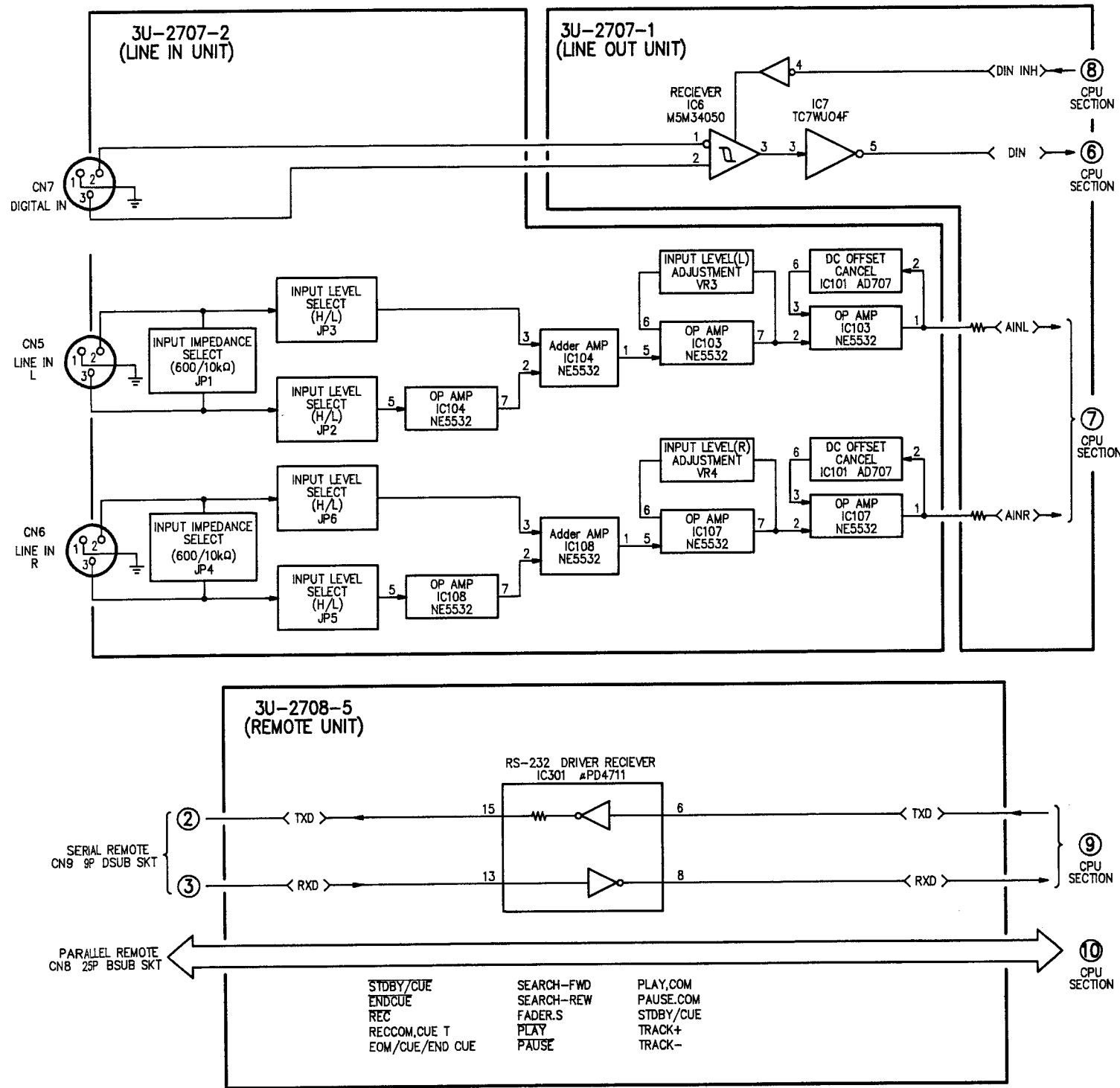

DISPLAY & POWER SUPPLY SECTION

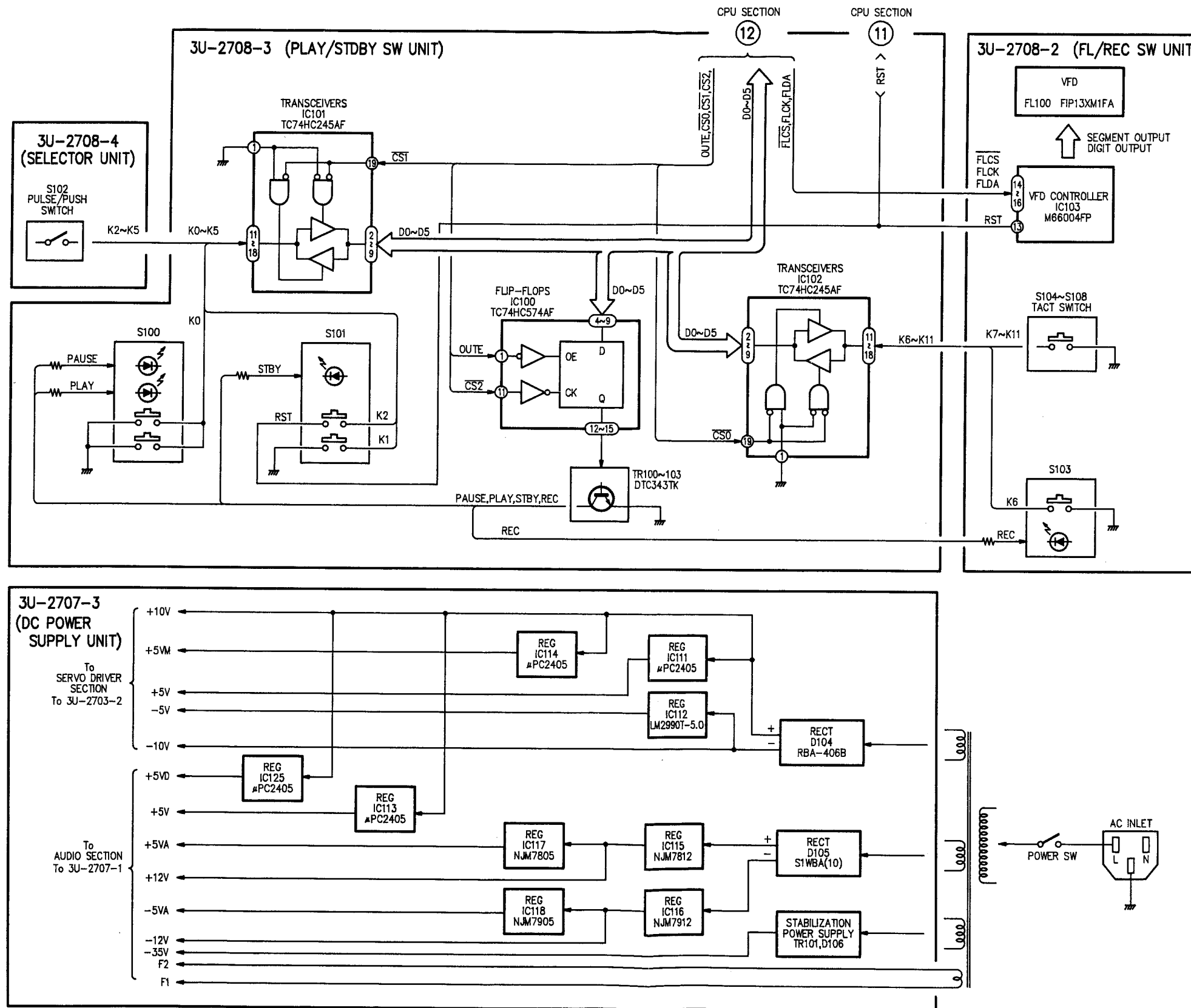

- 2) Set track number "2" and press PLAY/PAUSE button.
- 3) While reading VTVM indication, adjust VR1(L-ch) and VR2(R-ch) so that the output level attains +18dBm(or desired level).

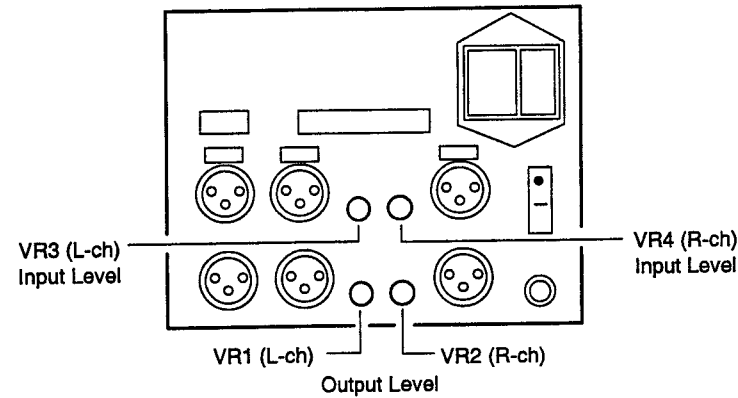

Fig.27 Location of Level Adjustment VRs

5. Input Level Adjustment

[In case to set the input level(peak recording level) to +22dBm~+8dBm]

- 1) Set the output of oscillator to 1kHz, +18dBm(or desired level) and connect to LINE IN connector of DN-990R.
Use 1:1 600 ohm Audio Transformer between the Oscillator and the units in order for matching the unbalanced output of Oscillator and the active balanced input of DN-990R as shown in Fig. 28.

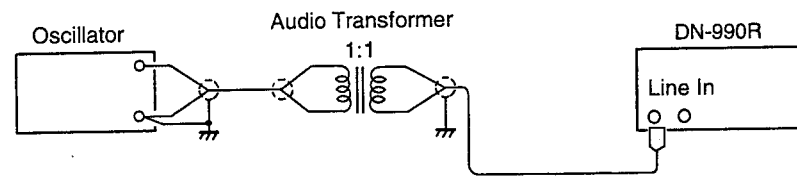

Fig.28 Connection for Input Level Adjustment (1)

- 2) Load the RMD.
 - 3) Press REC button. (Front panel level meter will light in respond to the input level.)
 - 4) While observing the level meter, rotate VR3(L-ch) and VR4(r-ch) clockwise.
Set it to the position 0dB indication of level meter lights. (Refer to Fig. 27.)
- Note:** In case the maximum output level of oscillator is lower than +18dBm, follow the adjustment as described below.

Oscillator Output Level	+12dBm	+14dBm	+16dBm
Level Meter Indication	-6dB	-4dB	-2dB

- Input level adjustment can be performed by connecting DN-990R, DN-980F, DN-951FA or DN-961FA in stead of oscillator.
- 1) Connect LINE OUT of standardizing DN-990R(DN-980F) to LINE IN connector of DN-990R to be adjusted.
 - 2) Load the Reference Disc(Sony TDYS-1) to standardizing DN-990R(DN-980F) and playback Track "2".
 - 3) Press REC button of DN-990R to be adjusted.
 - 4) While observing the level meter, rotate VR3(L-ch) and VR4(R-ch) clockwise and set it to the position 0dB indication of level meter lights.

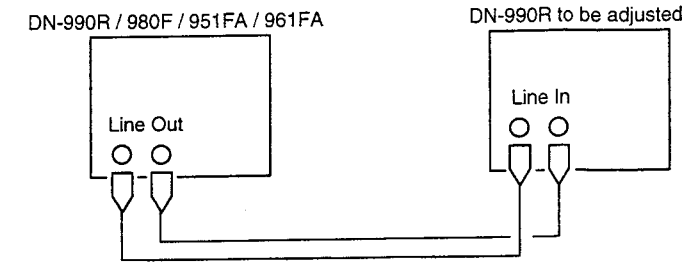

Fig.29 Connection for input Level Adjustment (2)

[In case to set the input level(peak recording level) to +8dBm ~ -6dBm]

By shifting the jumper pin of Line In Unit, input level can be lowered approx. 14dB (+8dBm ~ -6dBm).

- 1) Turn the power switch OFF.
- 2) Detach the Rear Panel Unit. (Refer to Page 52 "Rear Panel" disassembly.)
- 3) Shift the jumper pins JP2, JP3, JP5, JP6 of Line In Unit to "L" side.

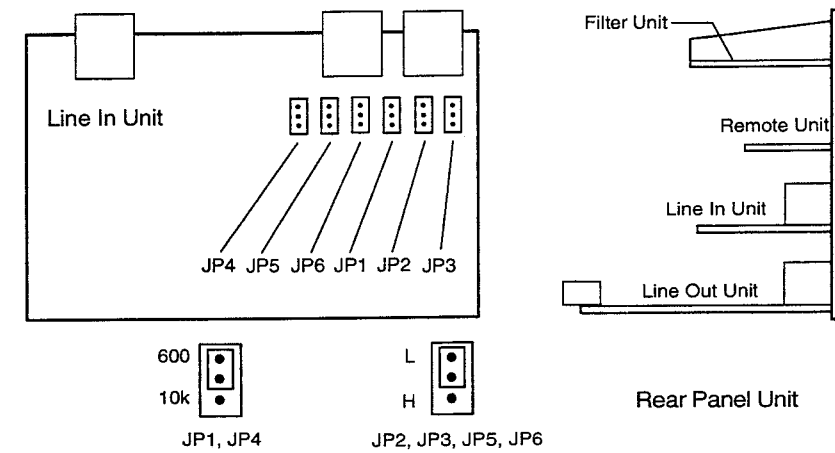

Fig.30 Location of Jumper Pins

- 4) Mount the Rear Panel Unit to the main body and adjust the input level as per mentioned previously.

6. Setting of Input Impedance

The input impedance of LINE IN is set at 10k ohms at the time shipped from the factory. However, the input impedance can be changed to 600 ohms by shifting the jumper pin of Line In Unit.

- 1) Turn the power switch OFF.
- 2) Detach the Rear Panel Unit. (Refer to Page 52 "Rear Panel" disassembly.)
- 3) Shift the jumper pins JP1, JP4 of Input Unit to "600" side. (Refer to Fig. 30.)
- 4) Mount the Rear Panel Unit to main body.

NOTE FOR HANDLING OF OPTICAL PICK-UP

KMS-140B is assembled and precisely adjusted in exclusive plant. Do not disassemble or attempt to re-adjust it. Please read the following instructions carefully before handling.

1. GENERAL

1) Storage

As for the position during storage and shipping, Z + direction shown in Fig-1 should be top and Y + direction bottom. Do not store this unit in dusty, high-temperature or high-humidity environments.

2) Handling

Since this unit is precisely adjusted, keep this protected from vibration and impact caused by a careless handling.

2. LASER DIODE (LD)

1) Protect your eyes

LD output may reach approximately $12 \times 10^4 \text{ W/cm}^2$ at the intensity of the focused spot even if the intensity at the object lens is about 6.8 mW.

Do not look at the laser light beam through the object lens directly nor another lens or a mirror. The laser beam may damage the human eye.

Use an IR viewer or ITV camera to observe the laser beam.

2) Toxicity of As

The LD chip contains "As" known as a poison by GaAs + GaAl As.

Compared with As_2O_3 , AsCl_3 or the like, the poison is far weak and the amount per one chip is small. However, avoid putting the chip in an acid or an alkali solution, heating it over 200°C or putting it into your mouth.

Defective service parts should be put in a waste box together, and make the waste treatment in your specified manner.

3. PRECAUTION AGAINST DAMAGE OF LASER

As to high power, it doesn't develop into destruction, but it is easy to cause what you call "deterioration" operating current increases, so please be more careful.

LD chip deteriorate by laser from itself or by something electric. Of these causes, as to deterioration (mainly on edge side) by laser and the deterioration by over reverse voltage, their fixed number of time is extremely short, comparing with the deterioration by IV product, so it is need to pay much attention to the transition characteristic.

Handling the P.U. assemble on the high quality earth mat which is no surge from the digital machine or the motor. The LD terminal is made short-circuited by short solder to prevent the destruction caused by electrostatic discharge while shipping for spare parts. Make the solder open after assembled and connected on the DN-990R/980F unit. In this case, a grounding ceramic soldering iron is better.

4. DETERIORATION JUDGEMENT

Deterioration is judged by shift of Iop curve and linearity.

Though it is used properly, deterioration arise by the life, we judge that it is the deterioration or the life an increase of 20% a power current in operation in the same temperature.

For details, refer to "Judgment for Optical Pick-up Replacement" column.

5. ACTUATOR BLOCK

1) Actuator

The actuator has the strong magnetic field, therefore, the performance is effected by an approach of magnetic substance. Also, keep this protected from a foreign materials, etc., coming from clearance of unit cover.

2) Cleaning the lens

The performance is effected if there is dust or the like on the object lens. When cleaning, soak a lens cleaning paper with a little amount of isopropyl alcohol and gently wipe out the lens without giving excessive force to the lens.

(For details, refer to Page 63.)

6. HANDLING

Handle the optical pick-up with holding the slide base (die cast section).

Take care that contacting the body or other objects with the circuit on the board, it may cause a deterioration.

7. DESCRIPTION OF THE COMPONENTS

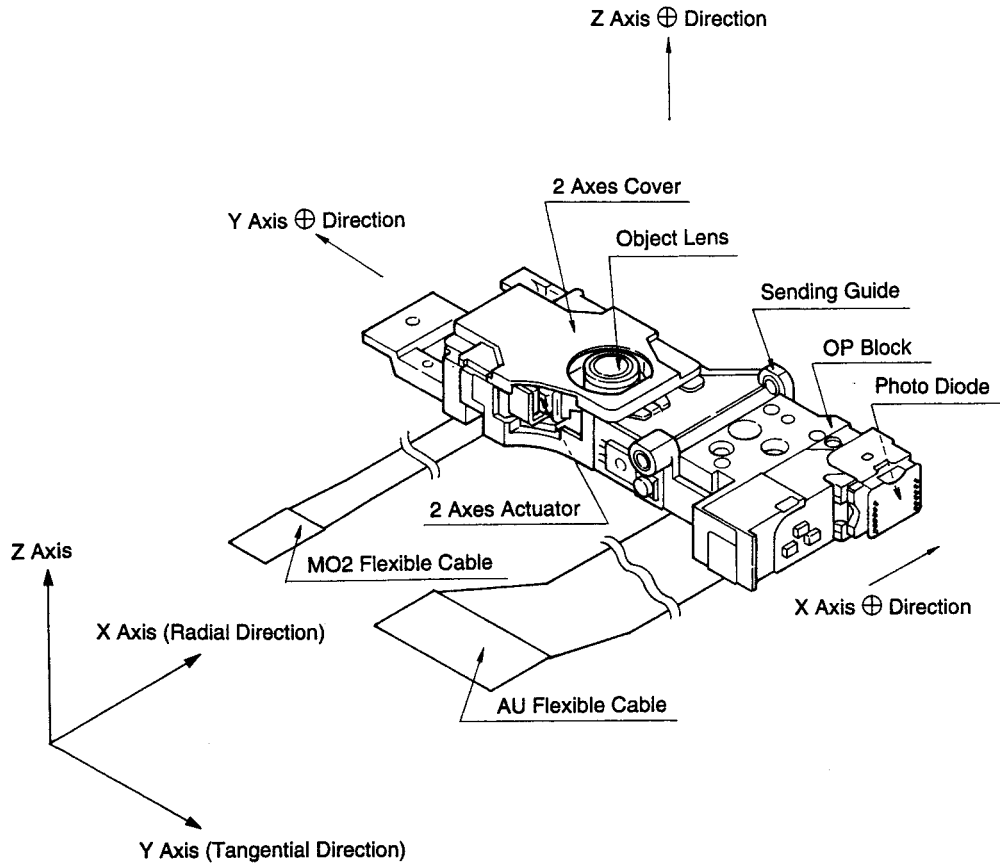

8. INDICATION

1) Name Plate

2) Indication Position

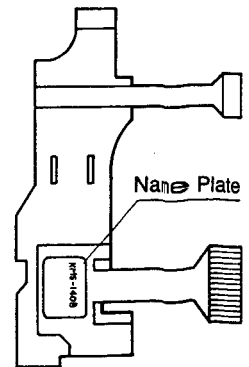
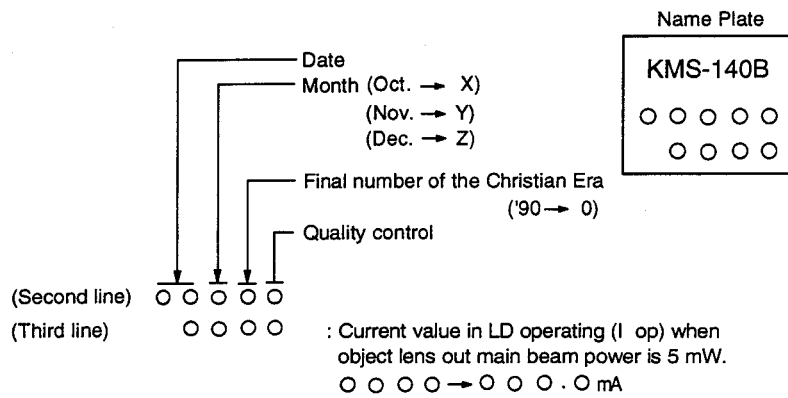

DISASSEMBLY

CAUTION:

The Optical Pick-up used for MD recorder/MD player may invite deflection by an external noise, such as electrostatic, etc., please pay the following attention.

1. Use a conductive mat on a working table to avoid electrostatic change.
2. A working personnel should use a wrist strap to ground human body.
3. Tools, etc., specially for a soldering iron must use with its tip grounded and without leakage of electricity. Utmost care must be taken to your clothes for electrostatic changing in a low humidity environment.

● TOP COVER

Remove 4 screws (201) and pull the Top Cover to arrow direction.

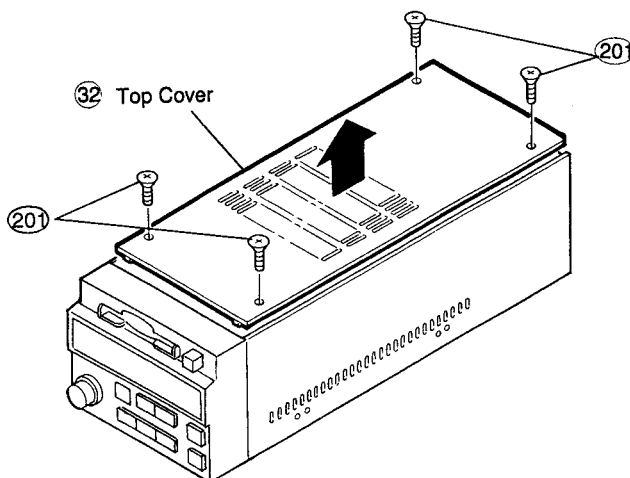

● FRONT PANEL

1. Remove 2 screws (201) and detach the Front Panel in A, B order, and disconnect the CN2 from the CPU unit.
2. When attaching the Front Panel, set the mechanism chassis lug to Front Panel assembly groove as per complementary figure.

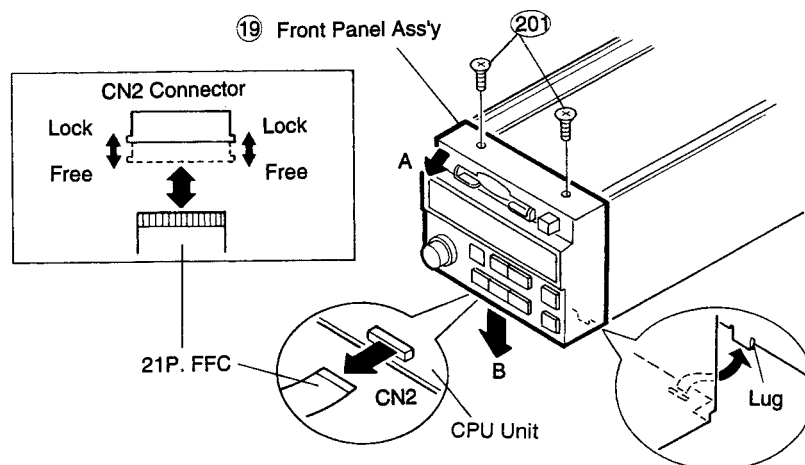

● BOTTOM COVER

Remove 4 screws (204) and pull the Bottom Cover to arrow direction.

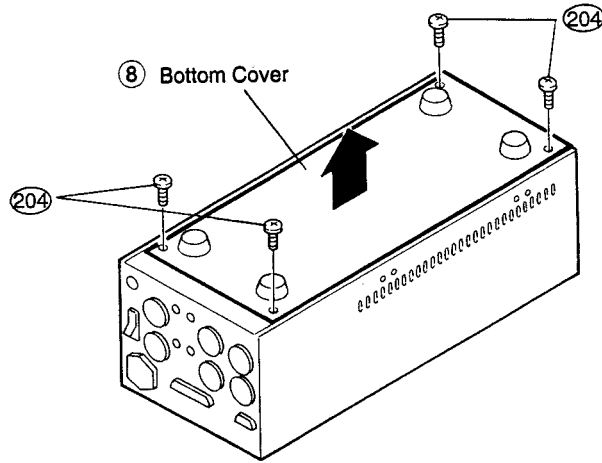

● REAR PANEL

1. Remove 2 screws (201) on both sides, 2 screws (202) on the top.
2. Detach portion CN23 of the CPU unit and pull it out backwards.
3. Disconnect CN12 (lead wire from the power transformer) of the filter unit.
4. Disconnect CN18 (lead wire from the DC power unit) of the line out unit.
5. Remove screw of GND wire fixed to the chassis.

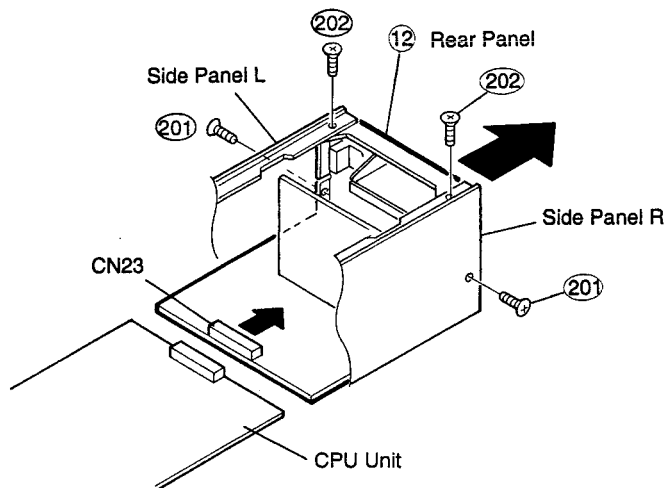

● CPU UNIT

1. After removing front panel and bottom cover, remove 4 screws (203) fixing the CPU Unit.

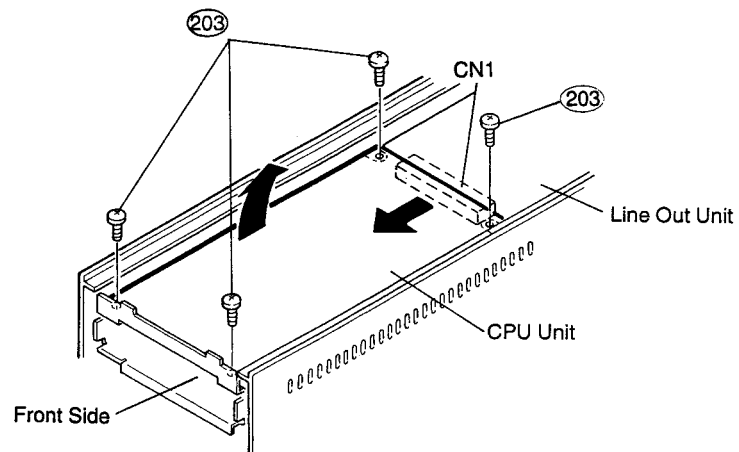

2. Pull out connector portion (CN1) connected to Line Out unit forward. Detach the CPU Unit from mechanism chassis.
3. After detaching of the CPU Unit, disconnect each connector wire.

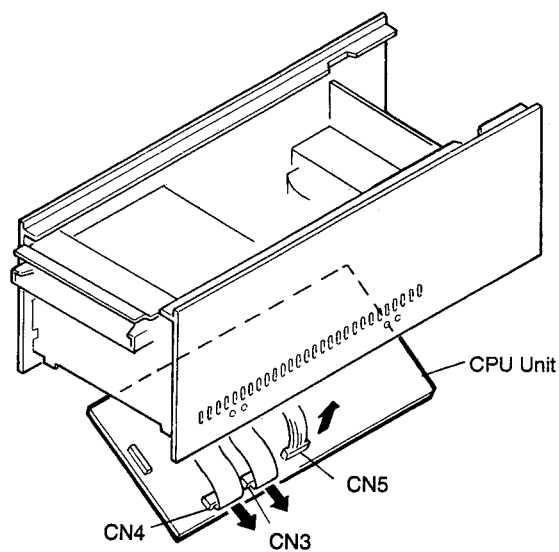

● **AUDIO UNIT**

1. Line Out Unit

Remove 7 screws (204), jack bracket and disconnect each connector wire.

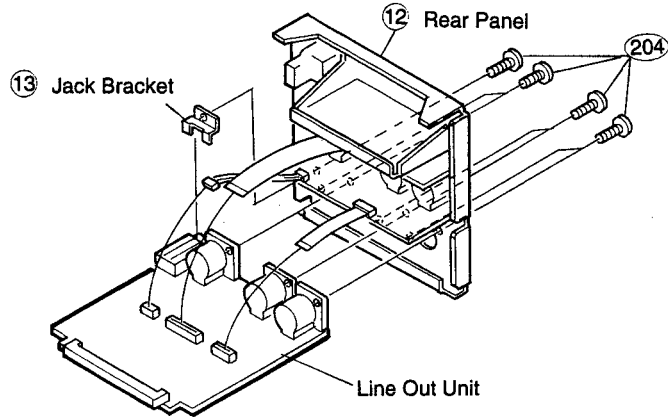

2. Line In Unit

- 1) Remove 3 XLR connector levers. (While lifting the finger pressing portion and pull it toward this side to disengage the lever.)
- 2) Remove 6 screws (204).
- 3) Disconnect CN25 (lead wire from the Input Unit) at the line out unit side.
- 4) Disconnect CN19 (lead wire from the output unit) of the line in Unit.

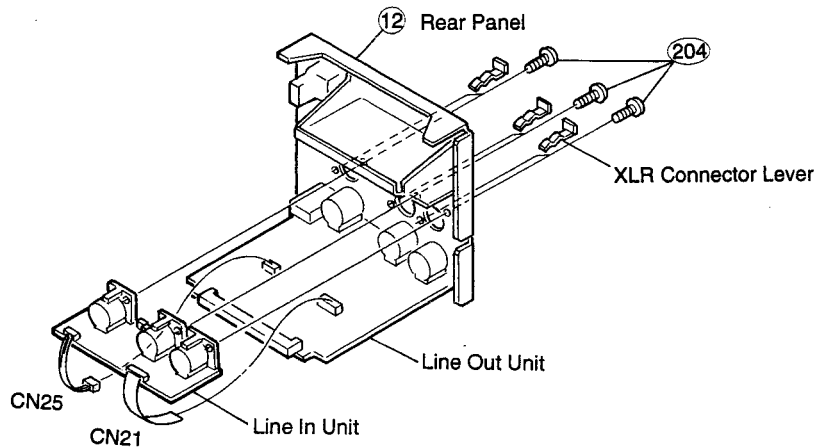

● **DC POWER SUPPLY UNIT**

1. Remove one screw (201) on the side panel L.
2. Disconnect each connector wire.
3. Detach DC Power Supply Unit from 2 places on the locking card spacer.

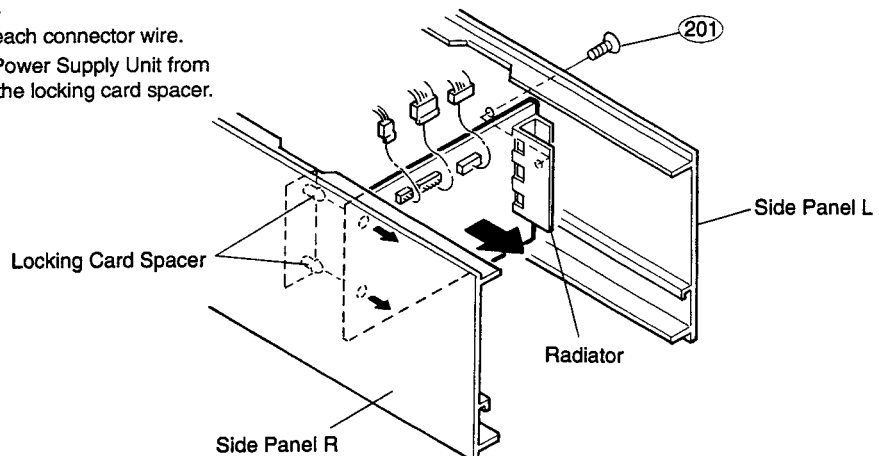

● MECHANISM UNIT

1. Remove 2 screws (202) and detach front bracket.

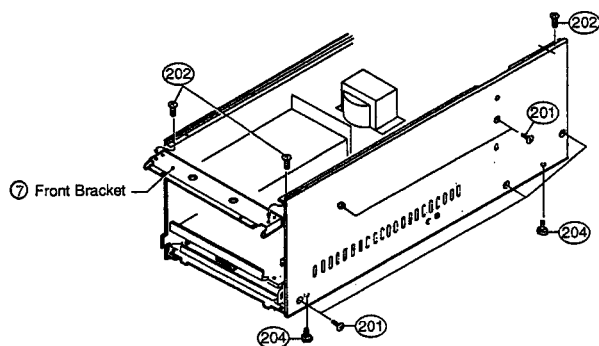

2. Remove 2 screws (201) fixing FL stopper on both sides.

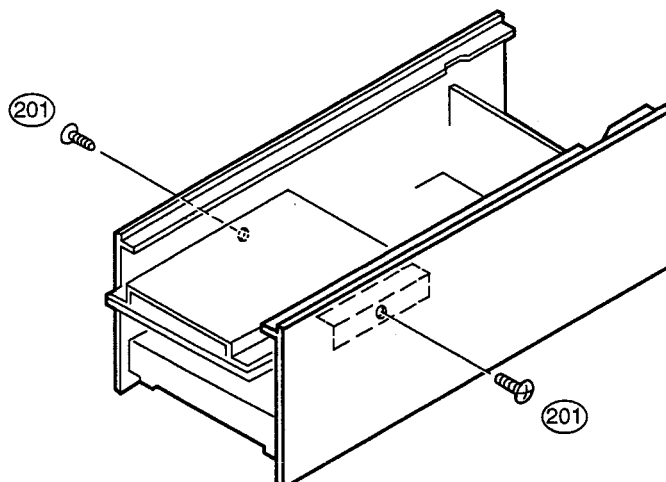

- 3) Remove 2 screws (201) and detach the side panel R.

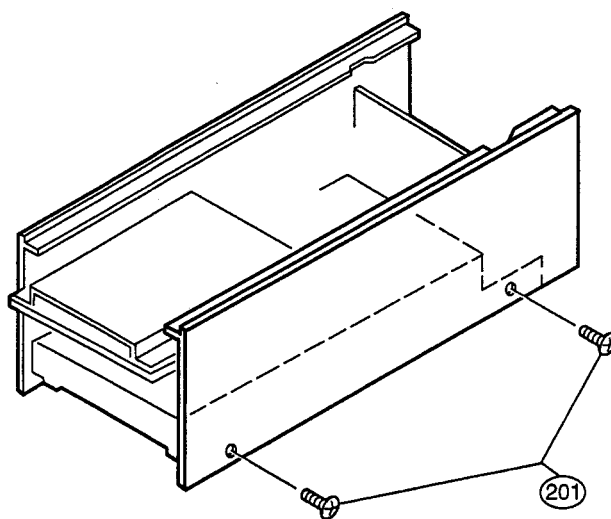

4. Remove 4 screws (210) , and detach the FL stopper L and R.

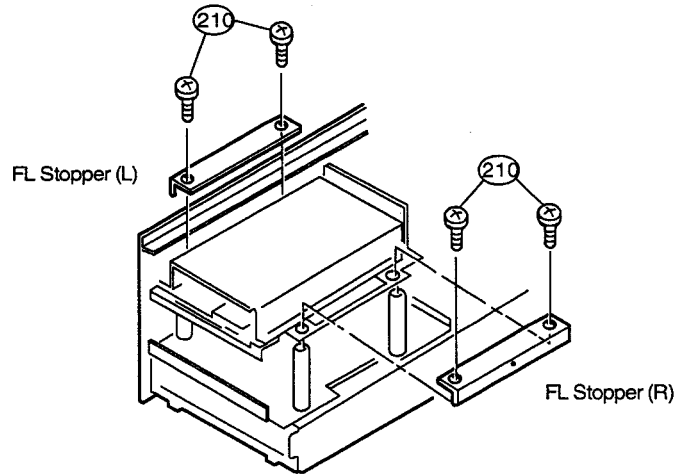

5. Disconnect each connector wire, then detaching of the Mechanism Unit.

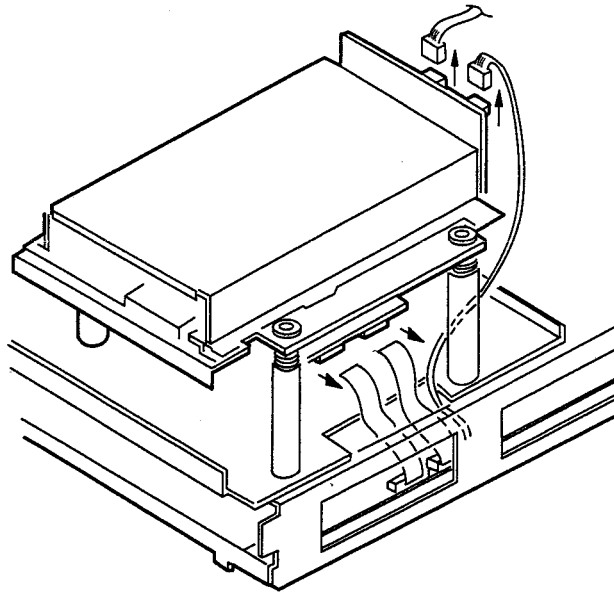

● **LOADING UNIT**

1. Remove 4 screws (208) , disconnect the CN502(Solenoid) and CN508(magnetic head) from the drive unit.

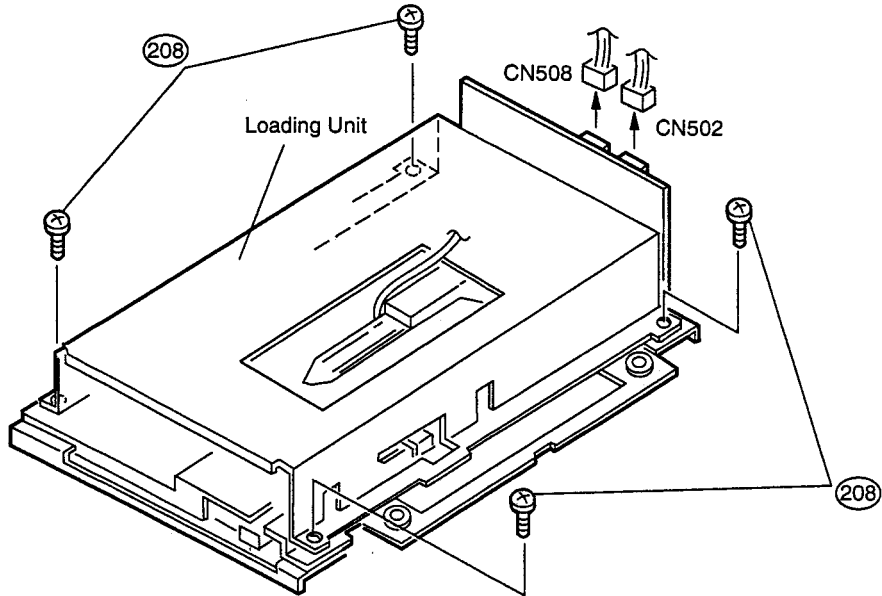

2. Turn over the Loading Unit and disconnect connector wire CN913 of interrupter unit.

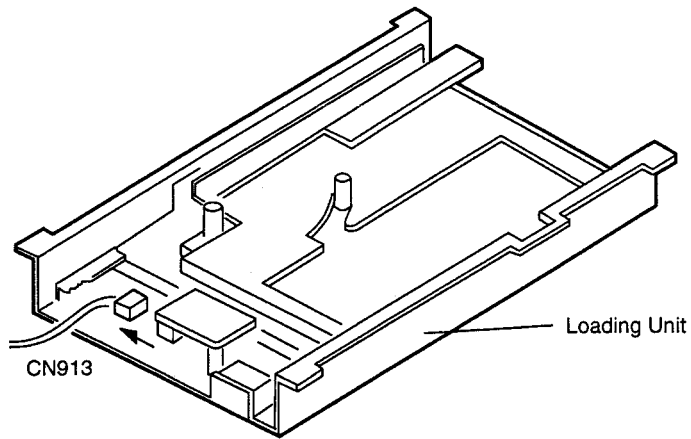

● MAGNETIC HEAD

Remove one screw (203) and detach the Magnetic Head Assembly.

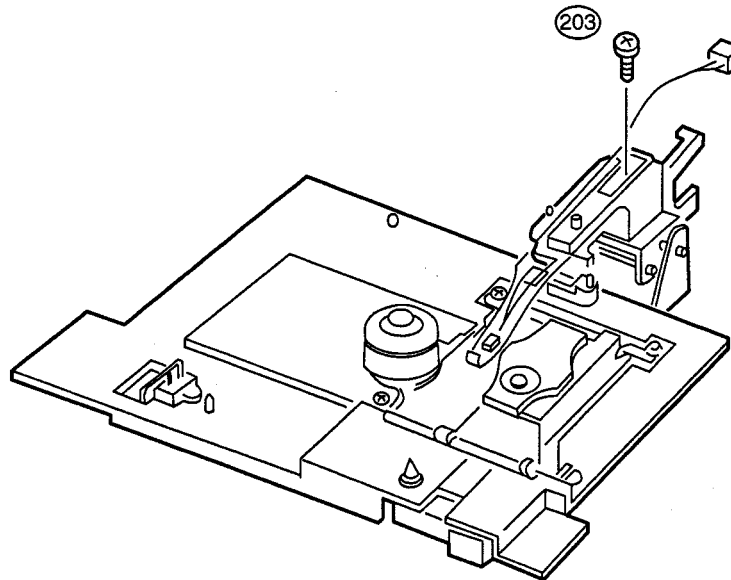

● SERVO PWB UNIT

1. Turn over the mechanism unit and short circuit the short land located on the flexible cable of laser pick-up with solder.
2. Unplug connector wires of CN206, CN207 connected to Servo Unit.
3. Release the lock of connectors CN201, CN202 and pull out the flexible cable.
4. Remove 4 screws (208), lift the Servo Unit and pull out connector CN205 connected to drive unit.

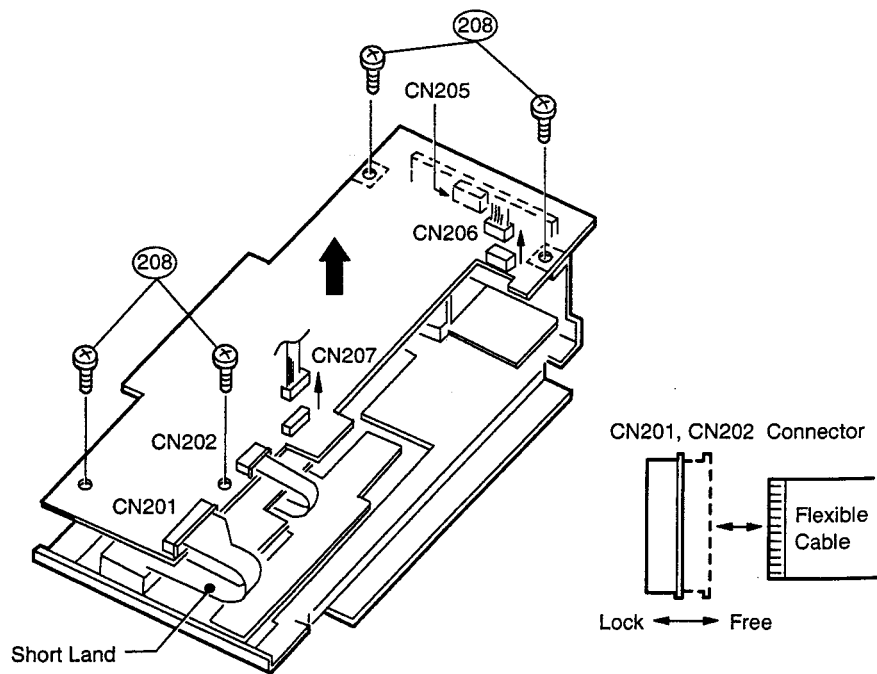

● SLIDE BASE GEN. ASS'Y

1. Remove lead wire of slide motor connected with solder to the spindle drive unit.
2. Remove 4 screws (206) and detach Slide Base Gen. Ass'y.

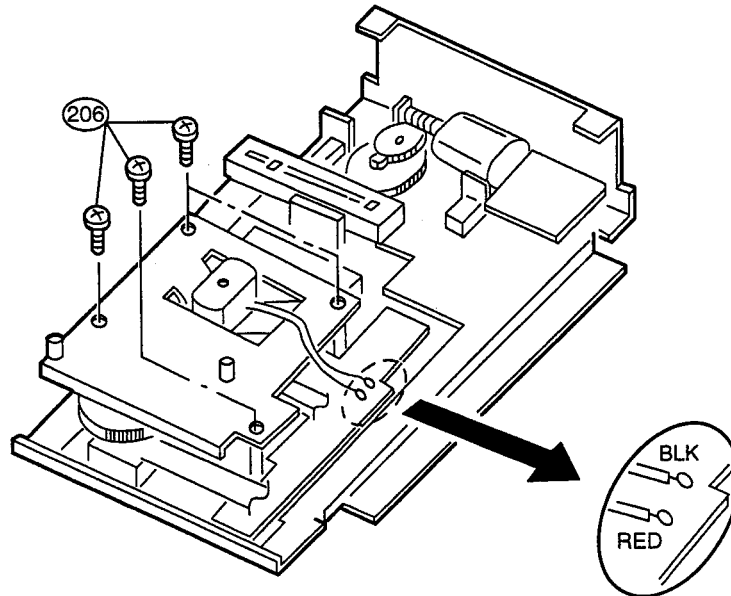

● OPTICAL PICK-UP

1. Turn the shaft of LM motor to arrow direction and move the lift cam to the right side.

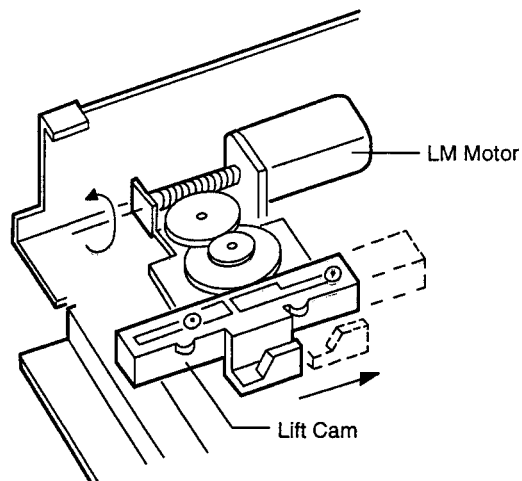

2. Remove 2 screws (203) , one screw (211) and detach head guide bracket downward.

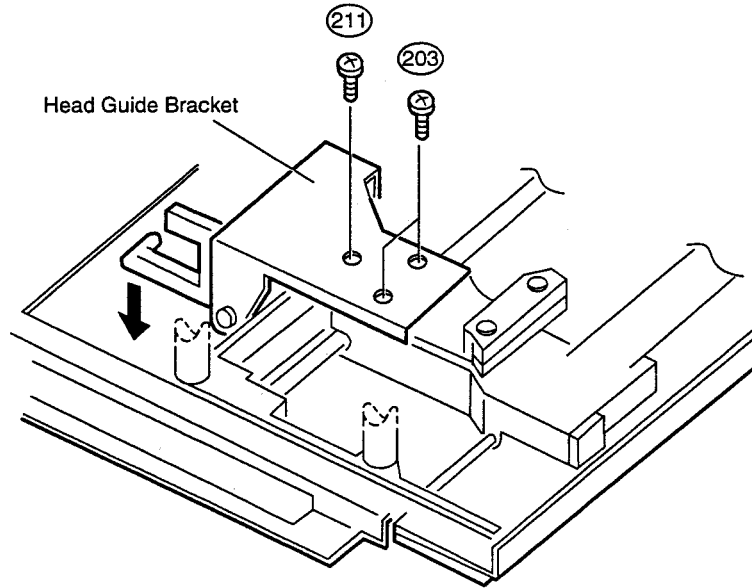

3. Remove one screw (203) and detach the slide rack ass'y.

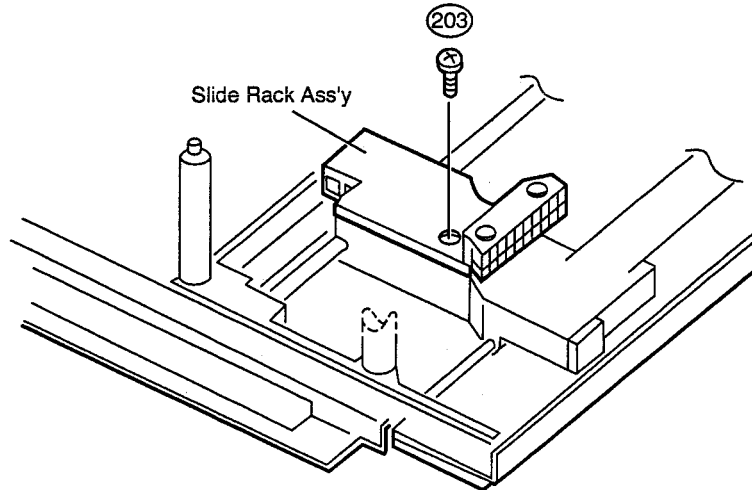

4. Turn over the mechanism unit and place the lens surface of Pick-up upward.
5. Remove 2 screws (209).
6. Lift this side of Pick-up from the bottom and pull out the SL shaft (A).
7. After pulled out SL shaft, detach the Pick-up downward (B).

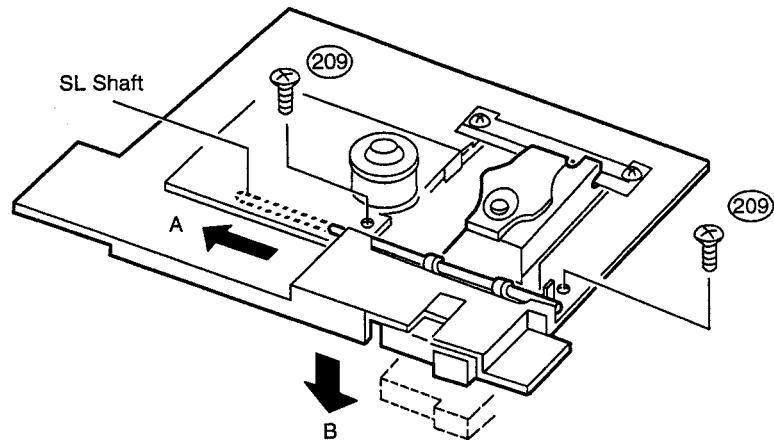

8. Remove one screw (202) and take out PU spring plate.

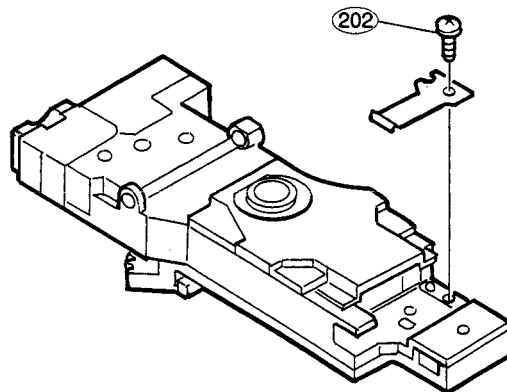

Note: When assembling Pick-up, do reverse manner as to disassembling.
When removing short land of Pick-up, follow the same manner as to laser power adjustment. (Refer to Page 74 "Electrical Adjustment".)

● ASSEMBLING MAGNETIC HEAD

1. Use the Head Adjustment Jig for mounting the Magnetic Head to the mechanism unit.

2. Assembling Procedure

- 1) Fit the Head Adjustment Jig(SGK0077) on the pick-up upper side.
- 2) Move the Magnetic Head Assembly (E) toward arrow direction (Y) and secure with screw (C) at the position the tip portion of head and the A side of Jig touch slightly.
- 3) Rotate the head guide shaft ass'y (D) and adjust so as the side of Head and B side of Jig slightly touch.
- 4) After finished adjustment apply a locking agent on the screw to prevent loosening of head guide ass'y.

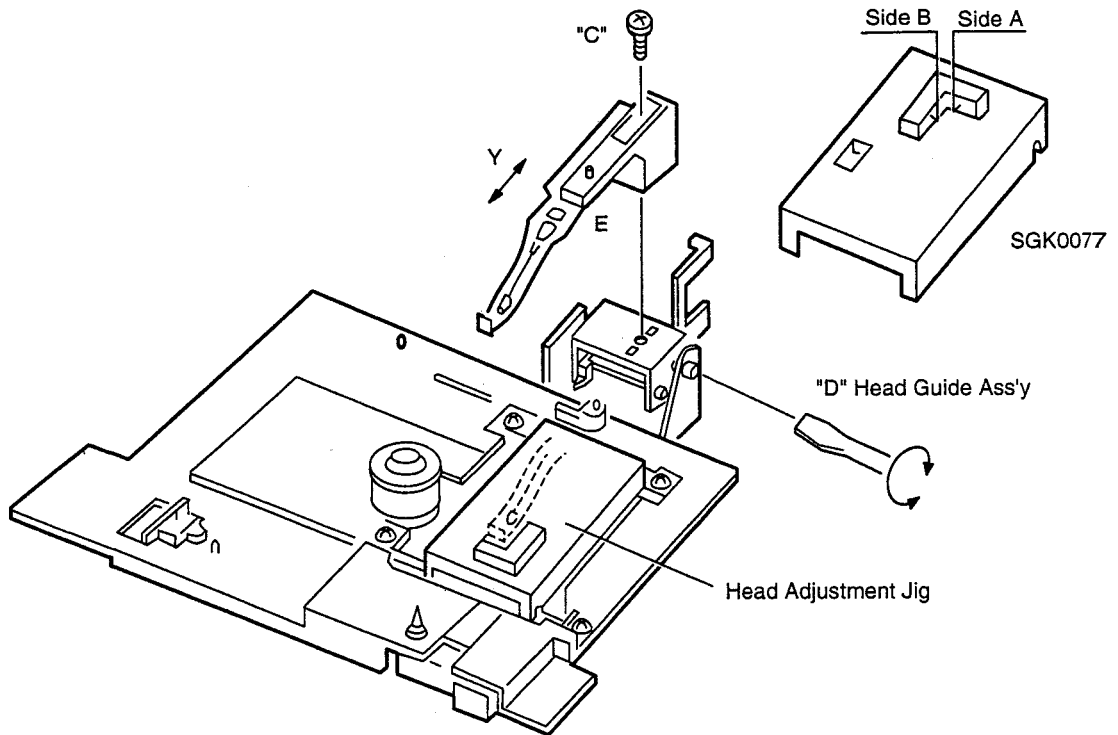

JUDGEMENT STANDARDS FOR OPTICAL PICK-UP (KMS-140B) REPLACEMENT

1. PICK-UP REPLACEMENT

The pick-up (PU) replacement must be executed upon checking the following 7 items and found the abnormality in the PU. Also, refer to "TEST MODE FUNCTION" on Page 72 and "ELECTRICAL ADJUSTMENT" on Page 74 for checking the PU.

Note: In case the Optical PU is replaced, your cooperation will be very much appreciated if you would be kind enough to notify us your judgement regarding the cause of detection with the PU to be returned.

1) Judgement by Confirming of Laser Current and Laser Power (Iop - Pw)

(Cause of PU abnormality: Unable to obtain specified emission of laser power due to deterioration of PU Laser diode.)

2) Judgement by Confirming of Focus Search

(Cause of PU abnormality: Focus search does not function.)

3) Judgement by checking of Focus Error Signal

(Cause of PU abnormality: No proper emission of focus error signal.)

4) Judgement by Checking of Tracking Error Signal

(Cause of PU abnormality: No proper emission of tracking error signal.)

5) Judgement by Checking of HF Level

(Cause of PU abnormality: No proper emission of HF waveform.)

6) Judgement by Adjusting of Focus Gain

(Cause of PU abnormality: Adjustment of focus gain is out of VR control range.)

7) Judgement by Adjusting of Tracking Gain

(Cause of PU abnormality: Adjustment of tracking gain is out of VR control range.)

2. DISC TO BE USED FOR CONFIRMATION

Servo Adjustment Disc Sony MD AUDIO TEST 2 (TDYS 1)

3. LASER POWER METER

We recommend to use the laser power meter of
Anritsu Type ML9002A Main Unit
Anritsu Type MA9422A Optical Sensor

4. PICK-UP LENS CLEANING

Gently wipe out the lens surface with a little amount of isopropyl alcohol soaked lens cleaning paper without apply excessive force to the lens.

5. JUDGEMENT FOR OPTICAL PICK-UP REPLACEMENT

1-1) Judgement by Confirming of Laser Current and Laser Power (Iop - Pw) in Case of DN-990R
 (Check for laser power emitting specified output to laser current. For in case of unable to recorded, etc.)

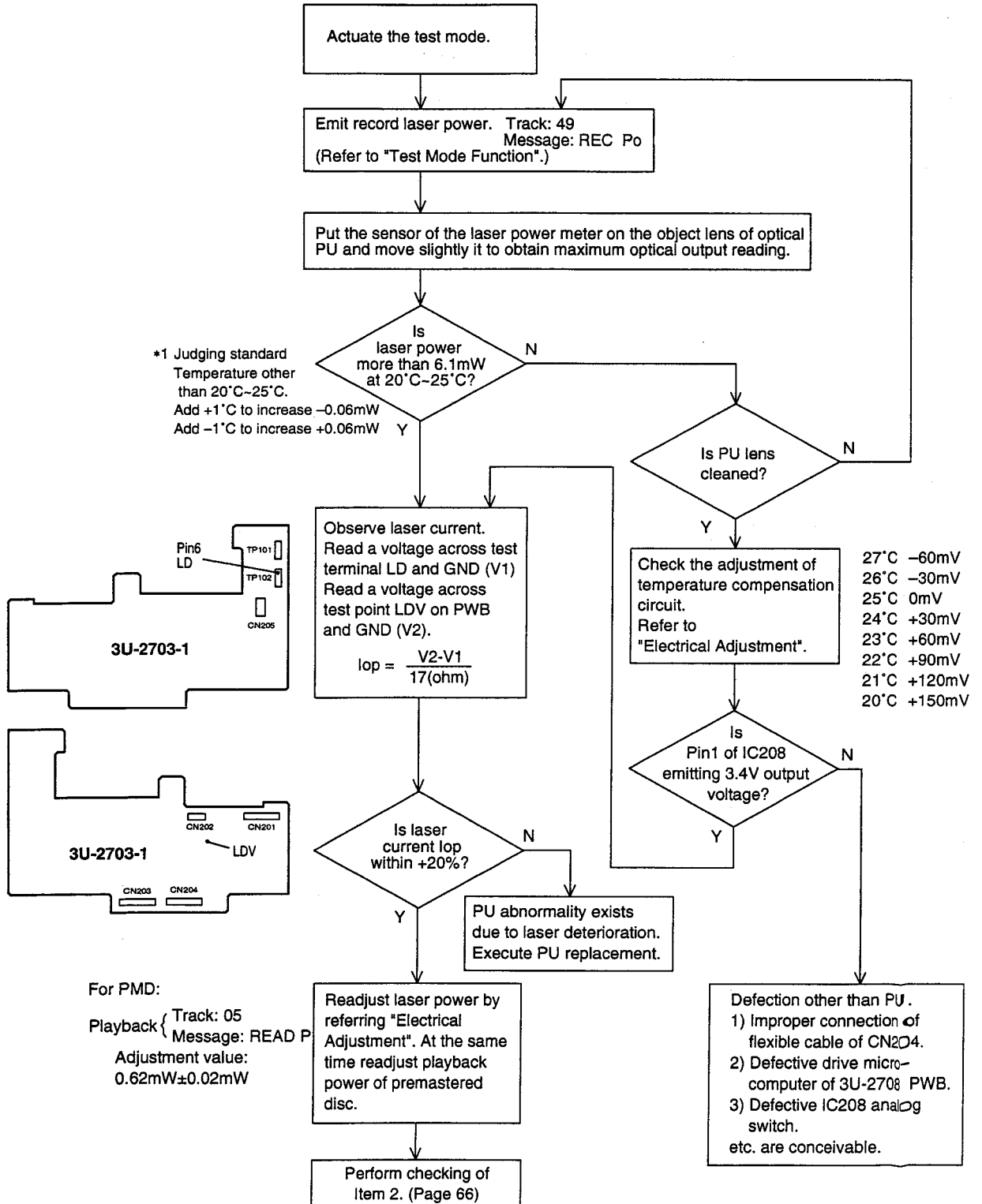

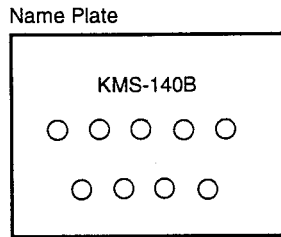
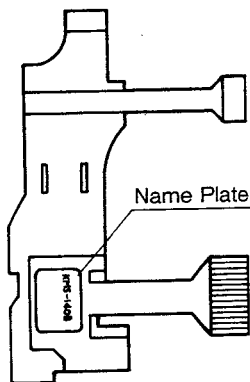

Numericals:
(Third line) ○ ○ ○ ○ → ○ ○ ○ ○ mA

Example: 0966 → 96.6mA

:Current value in LD operating (I op) when object lens out main beam power is 5mW*.
(Sub-beams power are not included)

* Object lens output power i.e. the amount of main beam and sub-beam out is

Formula: Main beam output power × $\frac{1}{(0.73 \pm 0.02)}$
 Example: 5mW × $\frac{1}{0.73}$ = 6.8mW

1-2) Judgement by Confirming of Laser Current and Laser Power in case of DN-980F

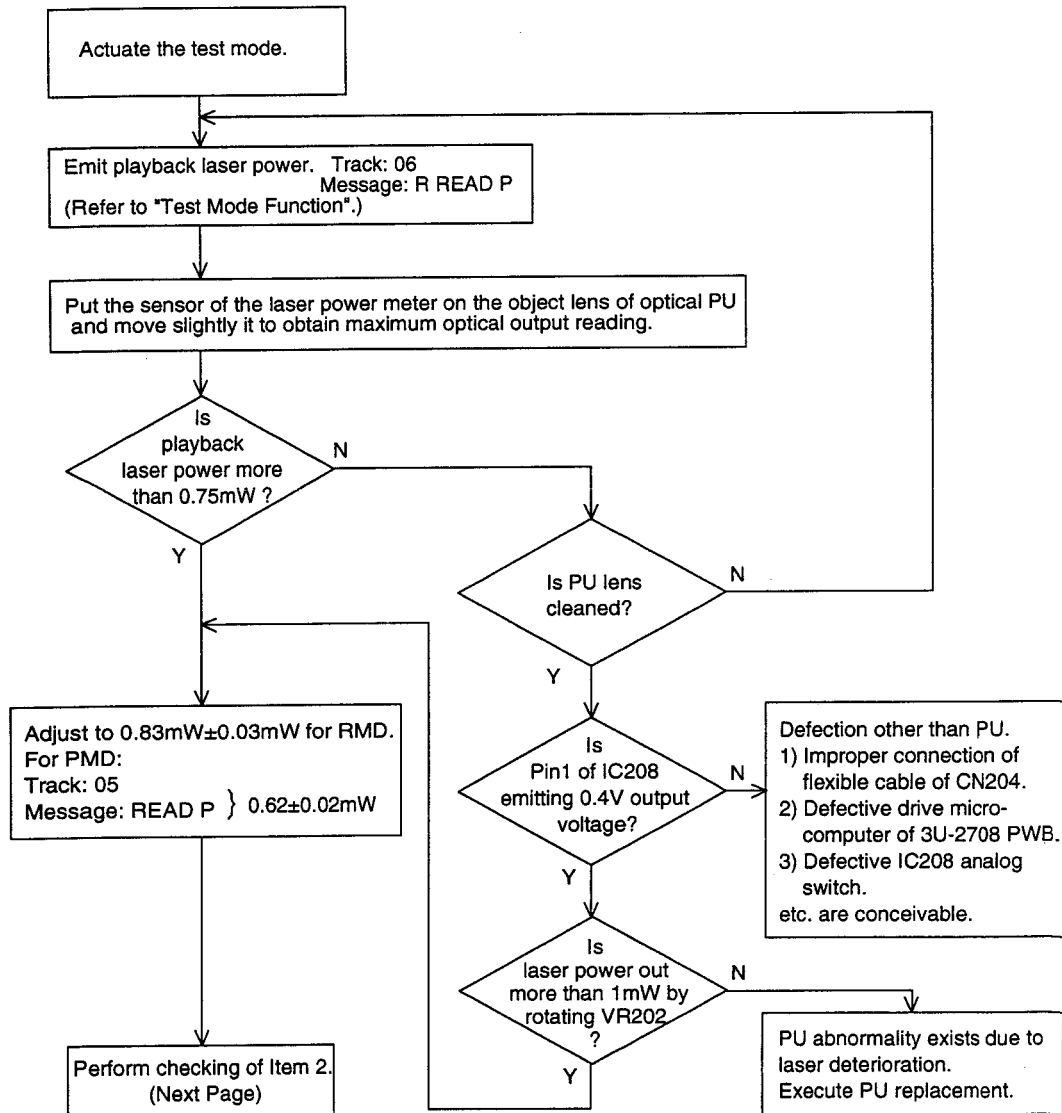

2) Judgement by Confirming of Focus Search (DN-990R, DN-980F)
 (Check for focus search function of PU lens)

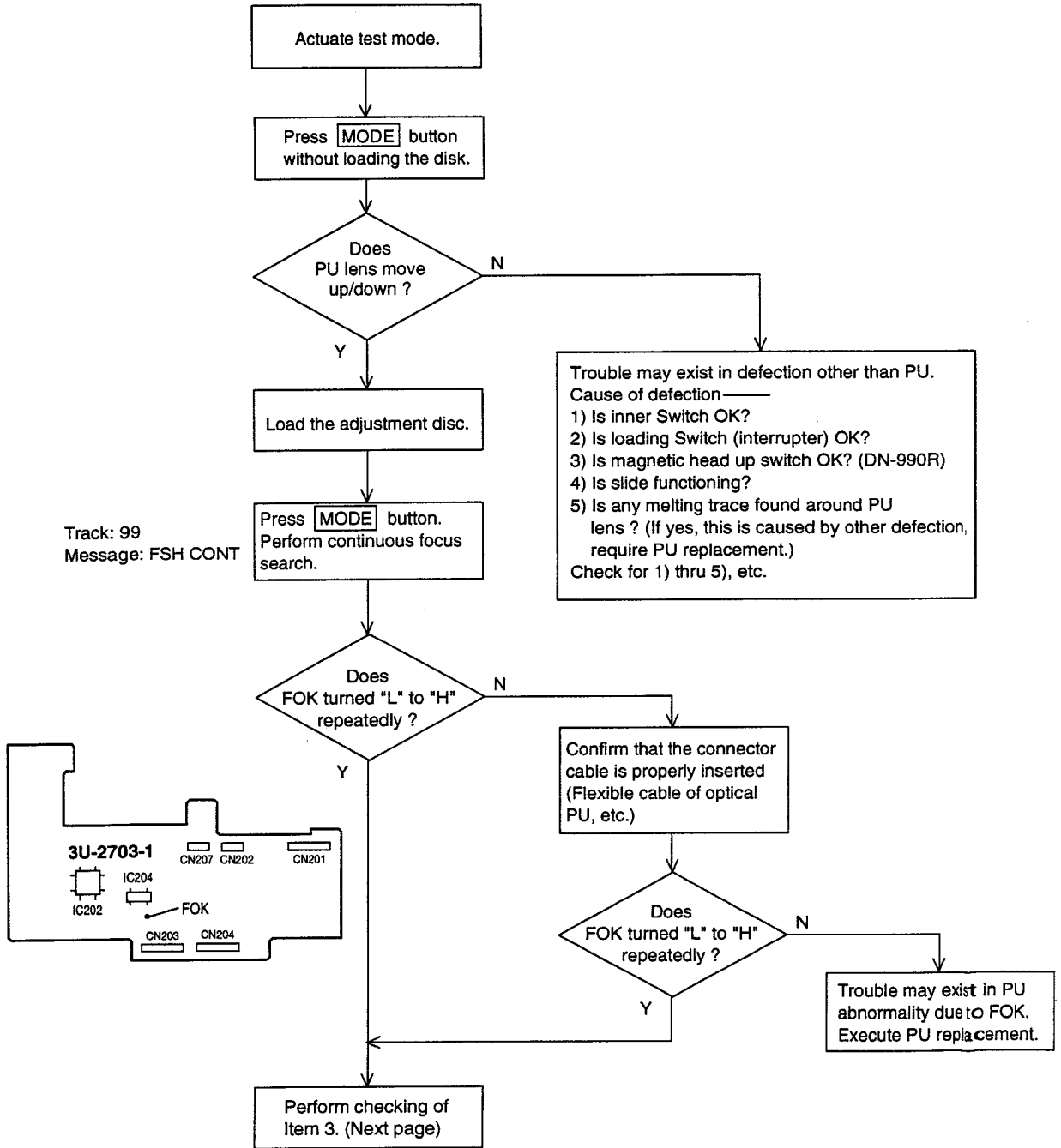

3) Judgement by checking of focus error signal (S-curve) (DN-990R, DN-980F)
 (Check for proper S-curve.)

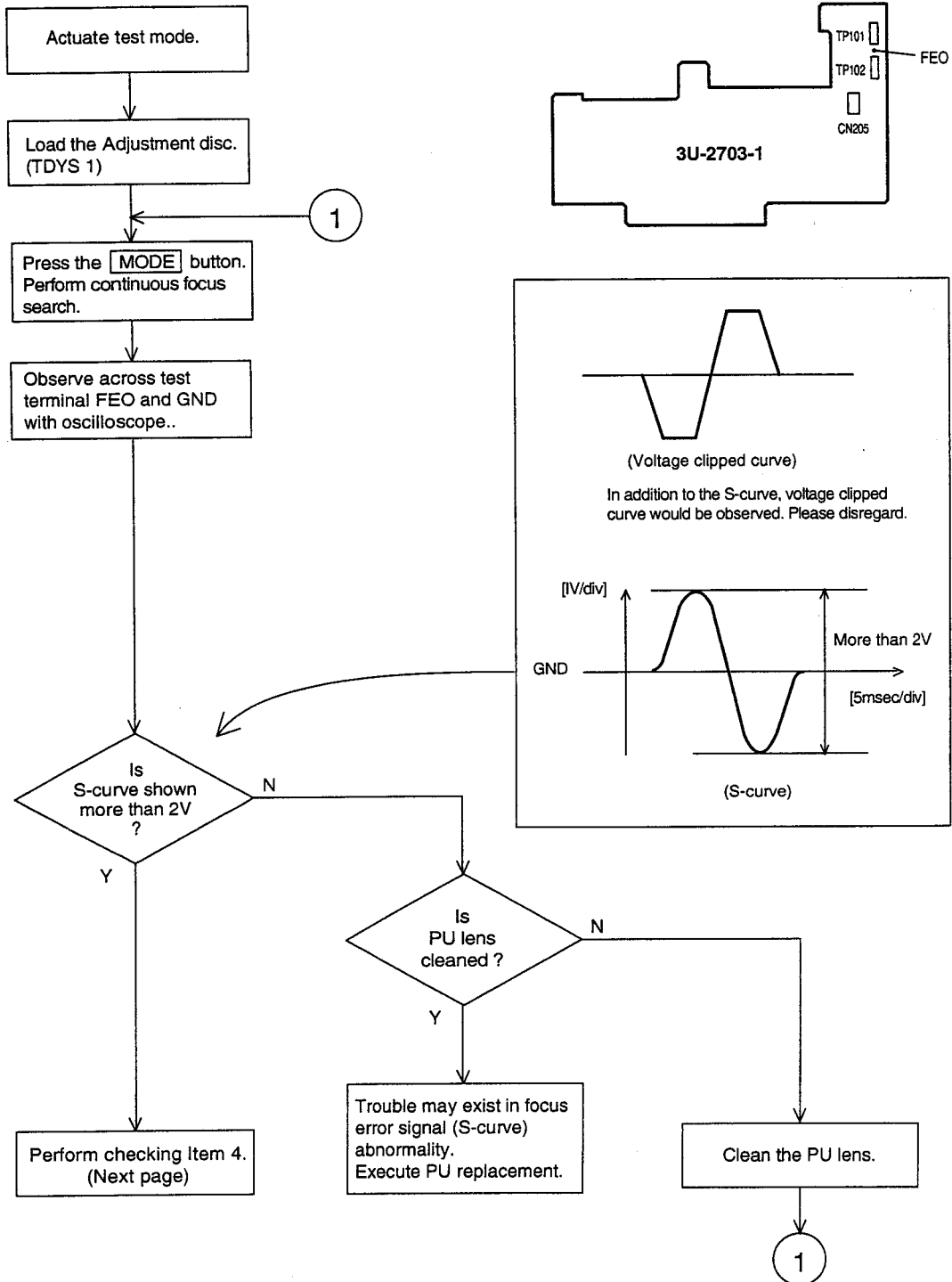

4) Judgement by checking of Tracking Error signal. (DN-990R/980F)
(Check for proper tracking error signal.)

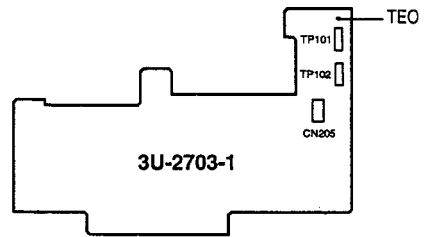
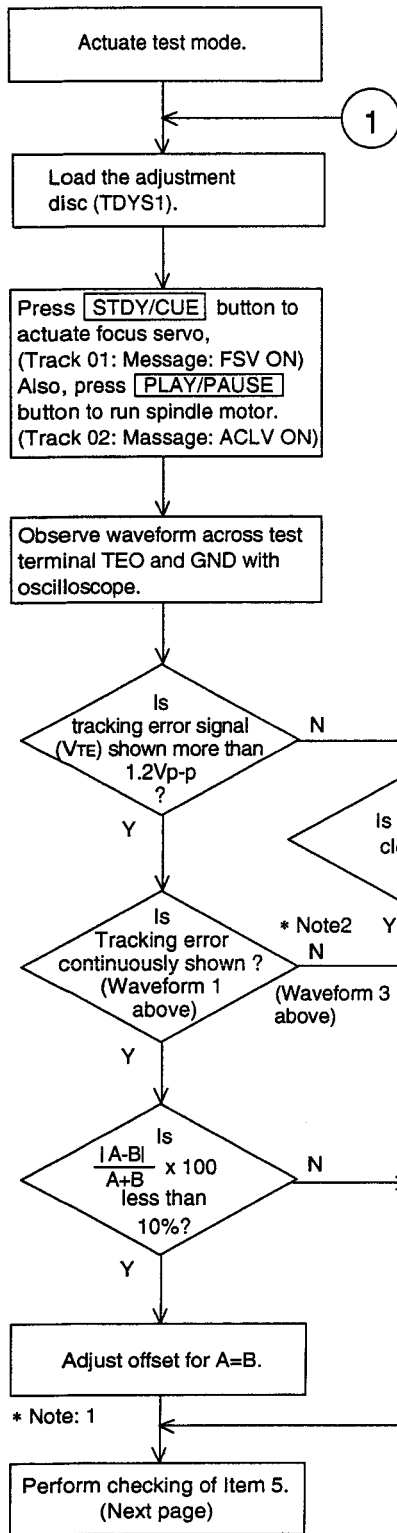

1. Tracking error signal level without undulation.

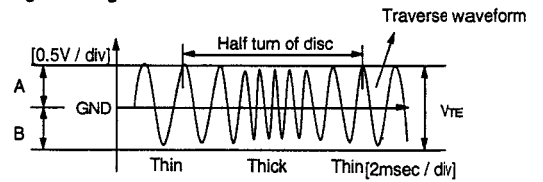

2. Tracking error signal level with undulation.

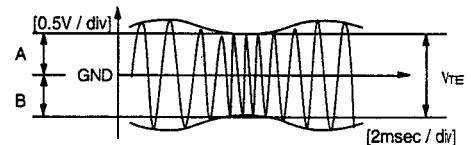

3. Occasionally no tracking error signal level.

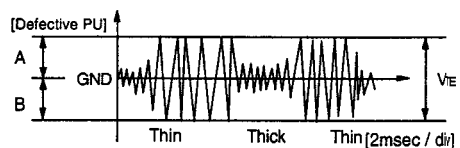

* Note1: Confirm the adjustment of tracking offset in pit area and groove area for recordable MD (R. MD). For procedure, refer to "Electrical Adjustment."

* Note2: In case of waveform 2, Improper focus offset adjustment or disc setting are conceivable.

5) Judgement by checking of HF level (DN-990R/980F)
(Check for proper HF waveform.)

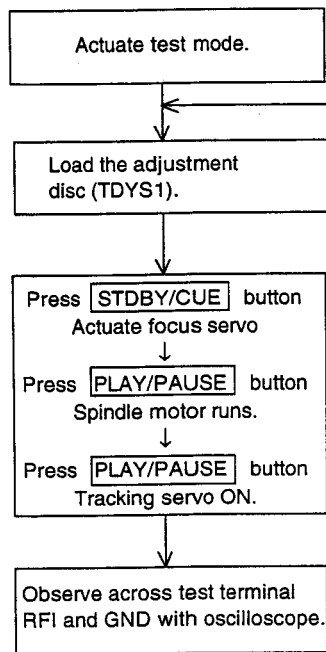

Track: 01
Message: FSV ON

Track: 02
Message: ACLV ON

Track: 03
Message: LOW G

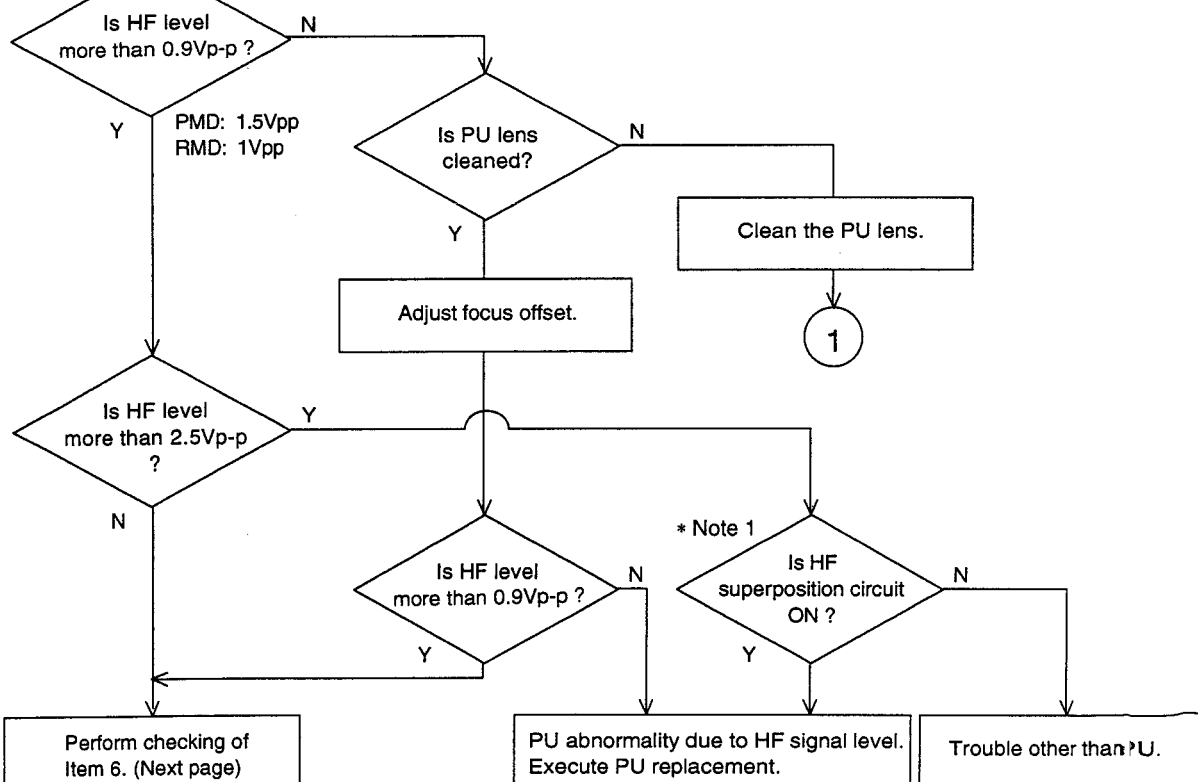
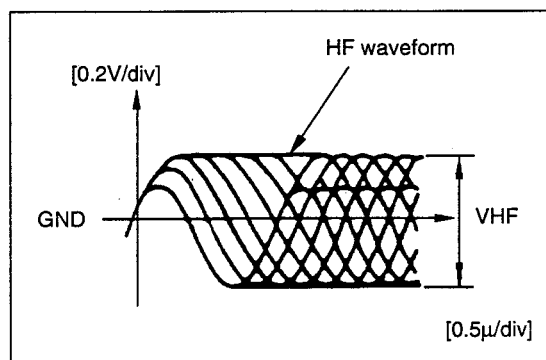
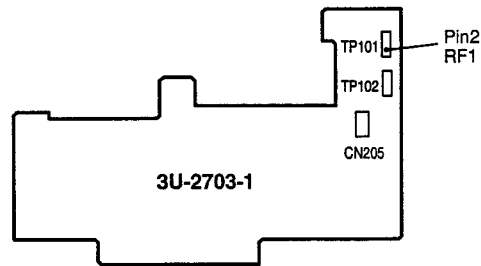

* Note 1: Pin1 of PU flexible cable connector CN201 is applied approx. 5V (ON), during Playback (0V (OFF) during Recording).

**6) Judgement by adjusting of Focus Gain
(Check for enabling focus servo gain adjustment.)**

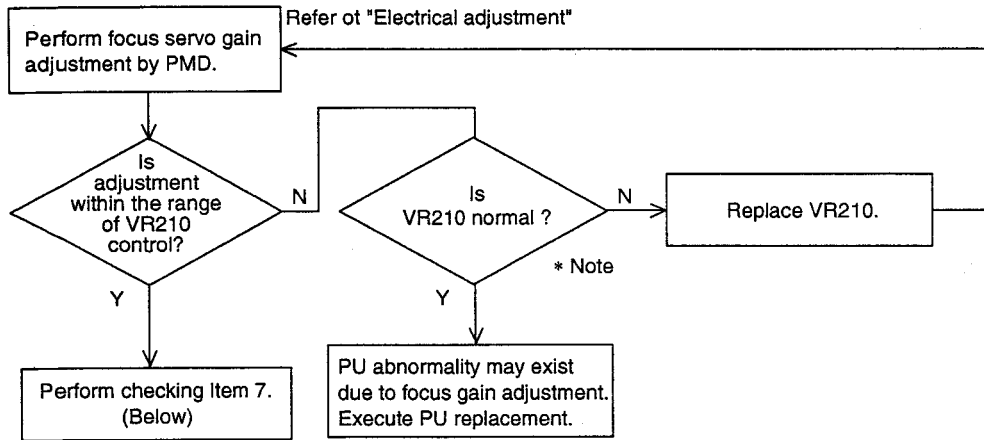

**7) Judgement by Adjustment of Tracking Gain
(Check for enabling tracking servo gain adjustment.)**

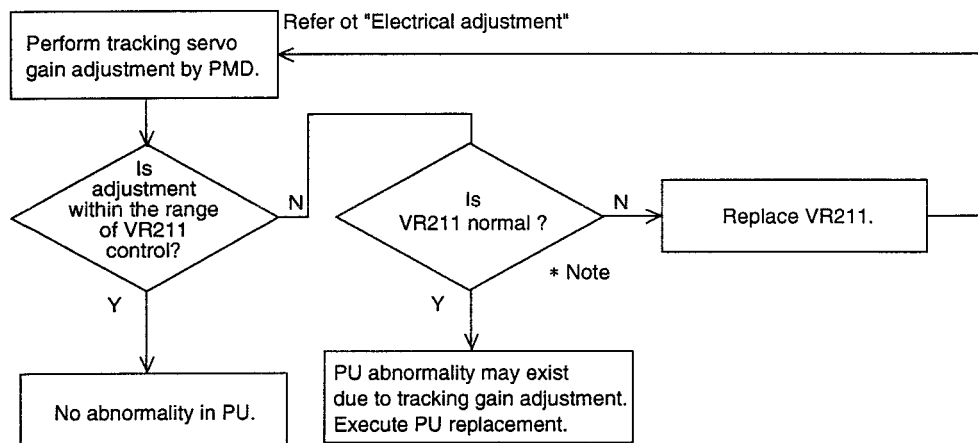

* Note: Because of chip VR, no turning stopper is provided. If VR is turned too far, linear variation of resistance value against VR rotation is unable to obtain, be sure to rotate the VR within the range the resistance value is linear for adjustment.

ERROR CODE LIST

When message display indicate "ERROR", Set the PLAY MODE Switch to "SINGLE" and press MODE button and then press both END MON and PLAY/PAUSE buttons simultaneously while pressing MODE button, that the ERROR CODE will be displayed.

ERROR CODE	MODE	CONTENTS
01	REC	Time-over error of the magnetic head descending motion.
04		Synch. error of spindle motor revolution with address header write (Revolution is too fast or de-tracking happened).
05		Synch. error of spindle motor revolution with address header write (Revolution is too slow or de-tracking happened).
07		DRAM Over-flow error in writing data.
09		UTOC table is full, Editing or recording is not possible.
0B		Tried to record to the pre-mastered disc.
0C		Tried to record to the Blank area smaller than the minimum size.
0D		Tried to record over maximum track number (255).
0E		Tried to record when there is no recordable area left.
0F		Recordable area's address is not normal.
11	UTOC-WRITE	Time-over error of the magnetic head descending motion.
12		ADIP read motion time-over error.
13		Retry error of search motion (5 times).
14		Synch. error of spindle motor revolution with address header write (Revolution is too fast, or de-tracking happened).
15		Synch. error of spindle motor revolution with address header write (Revolution is too slow, or de-tracking happened).
16		ADIP is not contiguous (Jump).
17		UTOC write operation's retry error (10 times).
30	REC PLAY INITIAL	Focus servo activation error (10 times).
37		Focus servo retry error (10 times).
40		Spindle servo activation error (10 times).
47		Spindle servo retry error (10 times).
50	INITIAL STOP	Time-over error (5 sec) of Internal Switch-ON.
51		Time-over error (5 sec) of Internal Switch-OFF.
60	TOC/UTOC READ	Search motion's error.
61		Format error (Disc type or recording power is not normal).
62		DRAM access error (Communication error between MD and LSI, or error in LSI).
63		Address non-contiguous error.
70	REC, PLAY,SEARCH	Retry error of search motion.

TEST MODE FUNCTION

The recorder/player must be in the test mode when adjusting its servo system.
 During the test mode, each button on the front panel is allocated with the special function.

1. SETTING OF THE TEST MODE

1. Test Mode ON.

While pressing PLAY/PAUSE button and STDBY/CUE button turn the power switch ON.



Track indication: 00 / Message indication: INIT

2. Release of Test Mode

Turn the power switch OFF or simultaneously press SELECT knob and STDBY/CUE button.

2. FUNCTION

1. Function From Stop Mode (Track Indication "00")

Operation	Indication	Function
Press PLAY/PAUSE button	Track 00 → 00 Message INIT	Initialize test mode. Automatically set to the loaded disc (R.MD or P.MD).
Press REC button	Track 00 → 25 Message REC P	Emits recording laser power. (Recordable MD)
Press DISP button	Track 00 → 06 Message R READ P	Emits playback laser power. (Recordable MD)
Press END MON button	Track 00 → 05 Message READ Po	Emits playback laser power. (Premastered MD)
Press SEARCH  button	Track 00 → 08 Message F SLIDE	Moves the slide outer side while pressing the button.
Press SEARCH  button	Track 00 → 07 Message R SLIDE	Moves the slide inner side while pressing the button.
Press MODE button	Track 00 → 99 Message FSH CONT	Continuously functions focus search.
Press STDBY/CUE button	Track 00 → 01 Message FSV ON	Actuates focus servo when the disc is loaded. * Refer to "Electrical Adjustment" column.

2. Function From Focus Servo Actuating Mode (Track Indication "01")

Operation	Indication	Function
Press PLAY/PAUSE button	Track 01 → 02 Message ACLV ON	Runs the spindle motor. (CLV: AUTO mode)

3. Function From Spindle Motor Running Mode (Track Indication "02")

Operation	Indication	Function
Press PLAY/PAUSE button	Track 02 → 03 Message LOW G	Actuates tracking servo. (Low gain)
Press STDBY/CUE button	Track 02 → 04 Message HIGH G	Actuate tracking servo. (High gain)
Press REC button	Track 02 → 23 Message REC Po	Emits record laser power. (* Only for DN-990R)

4. Function From Tracking Servo Actuating Mode (Track Indication "03" or "04")

Operation	Indication	Function
Press MODE button	Track ** → 04 Message HIGH G	Shifts tracking servo to High gain.
Press END MON button	Track ** → 03 Message LOW G	Shifts tracking servo to Low gain.

5. Function From Record Laser Power Emitting Mode (Track Indication "23" or "25")

Operation	Indication	Function
Press MODE button	Track ** → 25 ~ 49 Message REC Po	Sets the quantity of recording laser power emission.

* Each pressing of MODE button varies laser power as per below table.

Mode	Initiation	1	2	3	4	5	6	7	8
Track No.	25 *	28	31	34	37	40	43	46	49
Pw (mW) "A"	2.5	2.8	3.1	3.4	3.7	4.0	4.3	4.6	4.9
Pw (mW) "B"	3.42	3.84	4.25	4.66	5.07	5.48	5.89	6.30	6.71

Note: Pressing SELECT knob stops all functions and reverts to initial state.

* Initial indication "23" shows only when pressing REC button from "02".

Pw "A" values indicated above are only main beam power of the laser diode (Can not be measured by the Laser Power Meter).

Pw "B" values indicated above were calculated figure of the object lens output power for reference, that is amount of Main beam and Sub beams out of the laser diode (Can be measured by the Laser Power Meter).

$$\text{Formula: } B = A \times \frac{1}{0.73}$$

ELECTRICAL ADJUSTMENT

CAUTION:

The Optical Pick-up used for MD recorder/MD player may invite deflection by an external noise, such as electrostatic, etc., please pay the following attention.

1. Use a conductive mat on a working table to avoid electrostatic charge.
2. A working personnel should use a wrist strap to ground human body.
3. Tools, etc., specially for a soldering iron must use with its tip grounded and without leakage of electricity. Utmost care must be taken to your clothes for electrostatic charging in a low humidity environment.

● SERVO SECTION

1. Necessary Equipments for Adjustment

- Dual-trace Oscilloscope
- Frequency Counter
- AF Oscillator (10Hz ~ 10kHz, 0 ~ 3Vp-p)
- Laser Power Meter
- Reference Disc: Sony TDYS-1 [PMD]
- Recordable Mini Disc (Non recorded) [RMD]
- Recordable Mini Disc (Recorded) [RMD]
- Servo Adjustment Jig: SGK0076

2. Prior to the Adjustment

- 1) Remove 4 screws (201) securing the Top Cover and detach it.

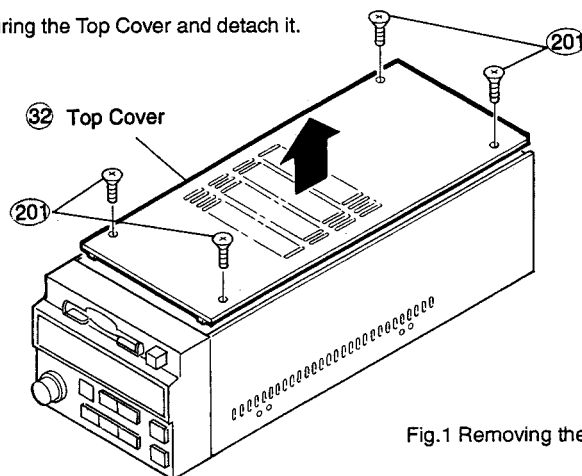

Fig.1 Removing the Top Cover

- 2) Connect Servo Adjustment Jig.

- Disconnect CN509 of Servo Unit and CN16 of DC Power Supply Unit.
- Connect TP101, TP102 of Servo Unit to TP101, TP102 of Adjustment Jig.
- Connect CN509 of Servo Unit to CN509 of Adjustment Jig and CN16 of DC Power Supply Unit to CN16 of Adjustment Jig.

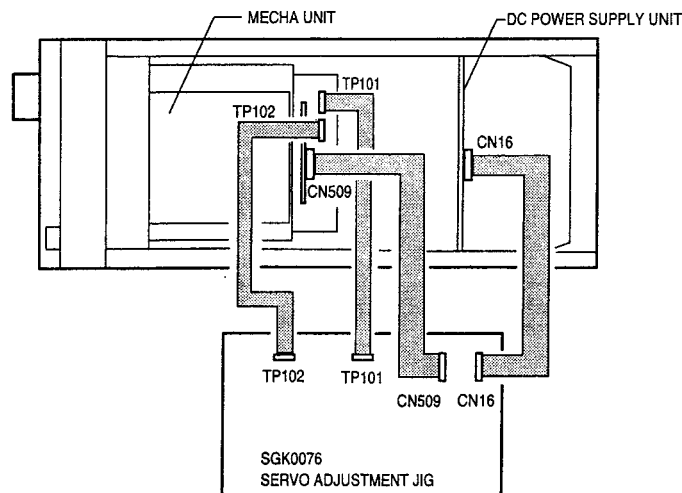

Fig.2 Connection of Servo Adjustment Jig

3. Pre-adjustment of offset

- 1) Turn the power switch ON.
- 2) Connect probe cold side (GND) of oscilloscope to Adjustment Jig (GND) and hot side to the Jig (T01). Use a probe 10:1.



Fig.3 Pre-adjustment of Offset

- 3) Set oscilloscope input to CH-1.
- 4) Set oscilloscope input to GND and 0V line to match center scale.
- 5) Set oscilloscope input to DC.
- 6) Adjust the voltage to $0V \pm 20mV$ with VR204 (MO.G).

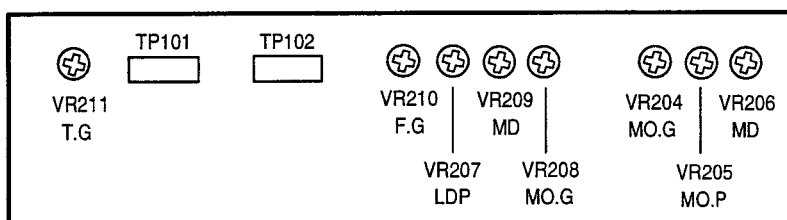

Fig.4 Location of Servo Unit VR

- 7) Connect hot side of probe to Pin11 (T02) of Jig.
- 8) Adjust the voltage to $0V \pm 20mV$ with VR205 (MO.P).
- 9) Connect hot side of probe to Pin 12 (TO3) of Jig.
- 10) Adjust the voltage to $0V \pm 20mV$ with VR206 (MD).
- 11) Connect hot side of probe to Pin9 (FB2) of Jig.
- 12) Adjust the voltage to $0V \pm 20mV$ with VR208 (MO.G).
- 13) Connect hot side of probe to Pin8 (FB1) of Jig.
- 14) Adjust the voltage to $0V \pm 20mV$ with VR209 (MD).
- 15) Turn the power switch OFF and disconnect Servo Adjustment Jig.

4. Bias Adjustment for Temperature Compensation Circuit of Laser Power

Note: This adjustment is aiming to compensate against the variation of ambient temperature in record mode of laser power.
 This adjustment is only required when replaced IC201 (CXA1381Q) or TR204.
 • This adjustment is not essential when replacing only laser pick-up.

- 1) Remove 2 screws (201) fixing the Front Panel and detach it.

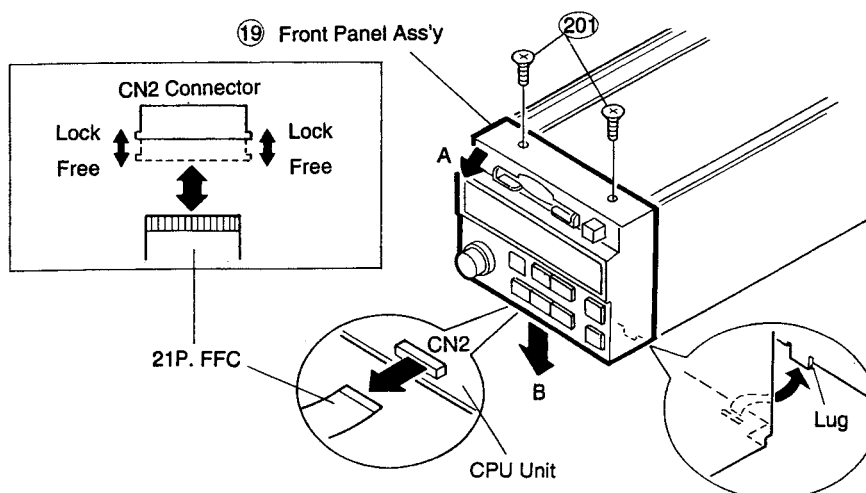

Fig5. Removing the Front Panel

- 2) Remove 2 screws (202) holding the Front Bracket and detach it.
 Remove 5 screws (201), 1 screw (202), 2 screws (204) securing the Side Panel (R) and detach it.

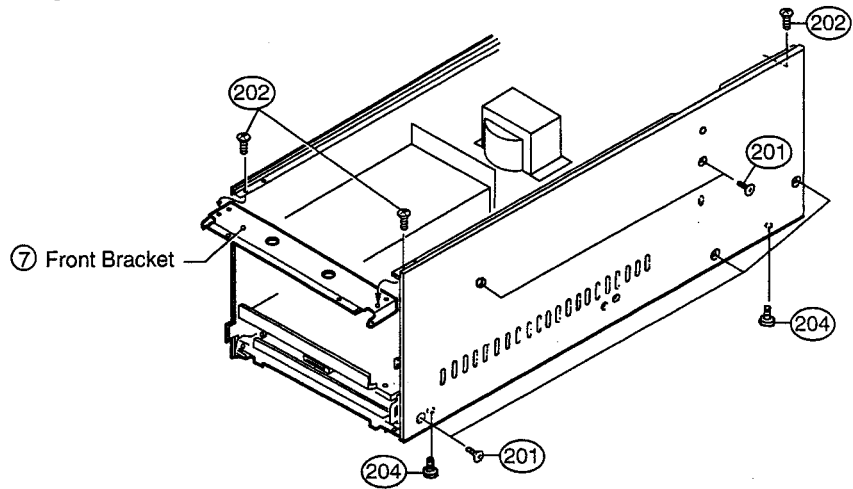

Fig. 6 Removing the Front Bracket and Side Panel (R)

- 3) Remove 1 screw (201) on the Side Panel (L), 4 screws (210) tightening the FG Mechanism Unit, detach 2 FL stoppers and turn over the unit.

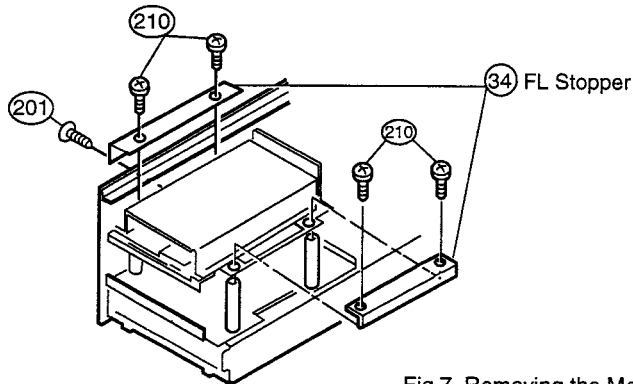

Fig.7 Removing the Mechanism Unit

- 4) Turn the power switch ON.
 5) Connect cold side (GND) of probe to the chassis and hot side to test point (TEMP).

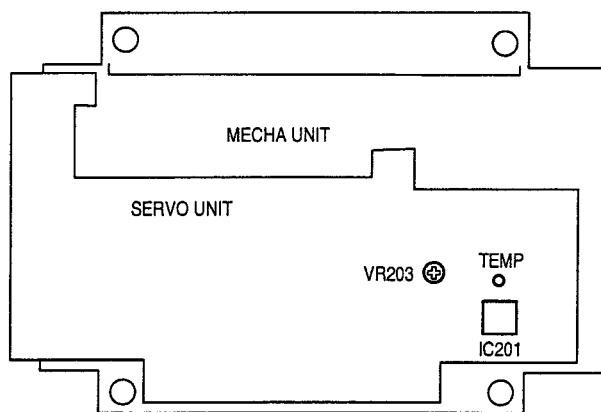

Fig.8 Bias Adjustment for Temperature Compensation Circuit

- 6) Adjust the value to the below table corresponding to ambient temperature with VR203 (TEMP).

Ambient Temperature	23°C	24°C	25°C	26°C	27°C	28°C
Adjustment Value (mV)	+60 ±20	+30 ±20	0 ±20	-30 ±20	-60 ±20	-90 ±20

Add +1°C to increase -30mV
 Add -1°C to increase +30mV

- 7) Turn the power switch OFF.

5. Adjustment of AGC Offset

1) When replace the laser pick-up, connect flexible cable to the unit then unsolder 3-place of short land located on the flexible cable of laser pick-up.

Note: Do not disconnect flexible cable from connector. after unsolder the short lands.

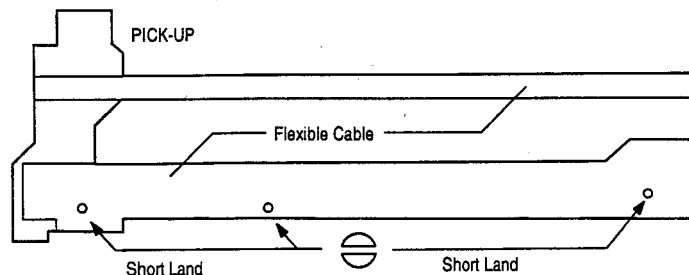

Fig.9 Location of Short Land

- 3) Mount the FG Mechanism Unit in proper location.
- 4) Connect Servo Adjustment Jig.
- 5) Turn the power switch ON.
- 6) Connect cold side (GND) of probe to Jig (GND) and hot side to Jig (ABCD).
- 7) Adjust the voltage to $0V \pm 20mV$ with VR212 (FOKO).

6. Offset Adjustment of Focus Error Amp

- 1) Connect hot side of probe to Jig (F.OFFSET). Set S1 of Jig to FOCUS side.
- 2) Adjust the voltage to $0V \pm 20mV$ with VR213 (FO).
- 3) Turn the power switch OFF.

7. Adjustment of Laser Power

Note: Adjustment procedures of laser power differ for recorder (DN-990R) and for player (DN-980F).
Follow the procedures below and make adjustment.

DN-990R

1. Adjustment of RMD (Recordable MD) Record Laser Power
 - 1) Connect 21P FFC cable of front panel to connector CN2 of CPU Unit.
 - 2) Make test mode setting. Track indication: 00/Message: INIT
 - 3) Press PLAY/PAUSE button. Track indication: 00/Message: INIT
 - 4) Press REC button.
Track indication: 25 / Message indication: REC P
 - 5) Put the sensor of Laser Power Meter on the object lens of pick-up and place it to maximum sensitivity.

Note: Be sure that the sensor of Laser Power Meter must not be touched to the magnetic head.

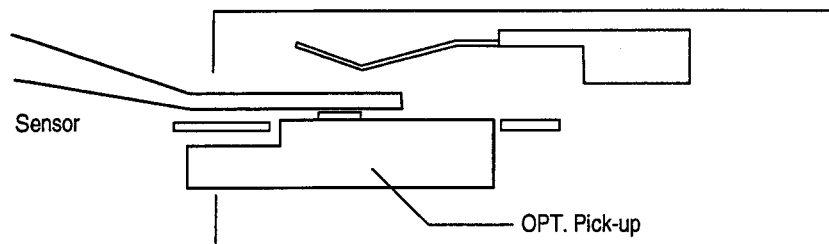

Fig.10 Adjustment of Laser Power

6) Adjust the value to the below table corresponding to ambient temperature with VR202 (APC.DET).

Ambient Temperature	23°C	24°C	25°C	26°C	27°C	28°C
Adjustment Value (mW)	3.54 ± 0.03	3.48 ± 0.03	3.42 ± 0.03	3.36 ± 0.03	3.30 ± 0.03	3.24 ± 0.03

Add +1°C to increase $-0.06mW$
Add -1°C to increase $+0.06mW$

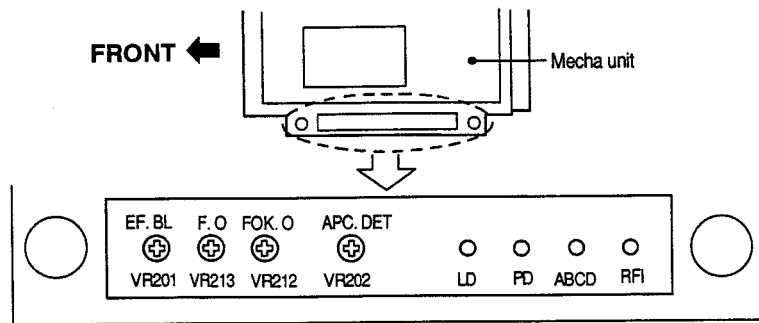

Fig.11 Location of VR

7) Press SELECT knob. (Laser stops emitting light.)
Track indication: 00 / Message indication : INIT.

2. Confirmation of RMD Playback Laser Power

- 1) Press DISP button.
Track indication: 06 / Message indication: R READ Po
- 2) Put the sensor of Laser Power Meter on the object lens of pick-up and confirm that the laser is emitting light. (Approx. 0.83mW at ambient temperature 25°C.)
- 3) Press SELECT knob. (Laser stops emitting light.)
Track indication: 00 / Message indication: INIT

DN-980F

1. Adjustment of RMD Playback Laser Power

- 1) Press DISP button.
Track indication: 06 / Message indication: R READ P
- 2) Put the sensor of Laser Power Meter on the object lens of pick-up and place it for maximum sensitivity.
- 3) Adjust the value to the $0.83\text{mW} \pm 0.03\text{mW}$ with VR202(APC.DET).
- 4) Press SELECT knob. (Laser stops emitting light.)
Track indication: 00 / Message indication: INIT

DN-990R, DN-980F

1. Adjustment of PMD(Premastered MD) Playback Laser Power

- 1) Press END.MON button.
Track indication: 05 / Message indication: READ Po
- 2) Put the sensor of Laser Power Meter on the object lens of pick-up and place it for maximum sensitivity.
- 3) Adjust the value to $0.62\text{mW} \pm 0.02\text{mW}$ with VR207(LDP).
- 4) Press SELECT knob. (Laser stops emitting light.)
Track indication: 00 / Message indication: INIT

8. Adjustment of Gain Balance by RMD Groove Area

- 1) Connect cold side(GND) of probe of oscilloscope to the Jig (GND) and hot side to Jig (T.OFFSET).
- 2) Load RMD (Non recorded).
- 3) Press PLAY/PAUSE button.
Track indication: 00 / Message indication: INIT
- 4) Press SEARCH(▶▶) button. (Pick-up moves to group area.)
Track indication: 08 / Message indication: F SLIDE
- 5) Press STDBY/CUE button. (Focus servo actuates.)
Track indication: 01 / Message indication: FSV ON
- 6) Press PLAY/PAUSE button. (Spindle runs and becomes CLV AUTO mode.)
Track indication: 02 / Message indication: ACLV ON
- 7) Press REC button. (Record laser power emits light.)
Track indication: 23 / Message indication: REC Po

8) Adjust VR201(EF. BL) so as to become A=B.

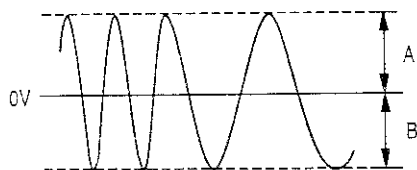

Fig.12 Balancing of Waveform

- 9) Press SELECT knob. (Test mode stops.)
Track indication: 00 / Message indication: INIT
- 10) Eject the disc(cartridge).

9. Adjustment of Tracking Offset by PMD(Premastered MD)

- 1) Load the PMD.
- 2) Press PLAY/PAUSE button.
Track indication: 00 / Message indication: INIT
- 3) Press STDBY/CUE button. (Focus servo actuates.)
Track indication: 01 / Message indication: FSV ON
- 4) Press PLAY/PAUSE button. (Spindle runs and becomes CLV AUTO mode.)
Track indication: 02 / Message indication: ACLV ON
- 5) Adjust VR206(MD) so as to become A=B. (Refer to Fig. 12.)

10. Adjustment of Focus Servo Gain by PMD

- 1) Set the output of oscillator to 1.4kHz, 2Vp-p and connect to OSC terminal of Jig.
- 2) Connect cold side (GND) of oscilloscope probe CH-1 to Jig (GND) and hot side to Jig (FEO).
- 3) Connect cold side (GND) of oscilloscope probe CH-2 to Jig (GND) and hot side to Jig (FEI).
- 4) Shift the switches S1, S2 to FOCUS side.

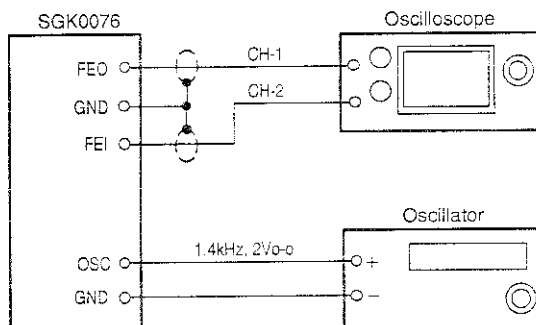

Fig.13 Focus Gain Adjustment

- 5) Set the oscilloscope to X-Y mode.
- 6) Press STDBY/CUE button. (Tracking servo actuates.)
Track indication: 04 / Message indication: HIGH G
- 7) Adjust VR210(F.G) so that X axis and Y axis of Lissajous waveform become even.



Fig.14 Adjustment of Waveform

- 8) Press SELECT knob. (Test mode stops.)
Track indication: 00 / Message indication: INIT
- 9) Disconnect probe of CH-2 from the Jig.
- 10) Put the switches S1, S2 of Jig back to center position.

11. Adjustment of Focus Offset by PMD

- 1) Release X-Y mode and Set the oscilloscope to CH-1 mode.
- 2) Connect hot side of CH-1 probe to Jig (RFI).
- 3) Press STDBY/CUE button. (Focus servo actuates.)
Track indication: 01 / Message indication: FSV ON
- 4) Press PLAY/PAUSE button. (Spindle runs and becomes CLV AUTO mode.)
Track indication: 02 / Message indication: ACLV ON
- 5) Press STDBY/CUE button. (Tracking servo actuates.)
Track indication: 04 / Message indication: HIGH G
- 6) Shift the switch S1 of Jig to FOCUS side.

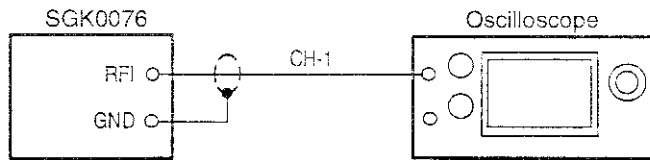

Fig.15 Focus Offset Adjustment

- 7) Adjust VR209(MD) and obtain maximum amplitude of signal.

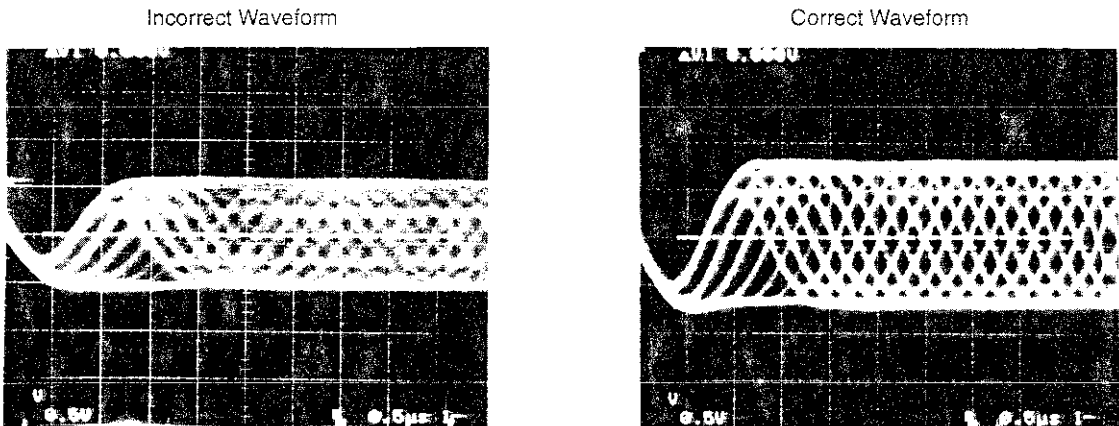

Fig.16 Adjustment Waveform

- 8) Press SELECT knob. (Test mode stops.)
Track indication: 00 / Message indication: INIT
- 9) Put the switch S1 of Jig back to center position.

12. Adjustment of Tracking Servo Gain by PMD

- 1) Set the oscillator output to 1.6kHz, 2Vp-p.
- 2) Connect cold side (GND) of oscilloscope probe CH-1 to Jig (GND) and hot side to Jig (TEO).
- 3) Connect cold side (GND) of oscilloscope probe CH-2 to Jig (GND) and hot side to Jig (TEI).

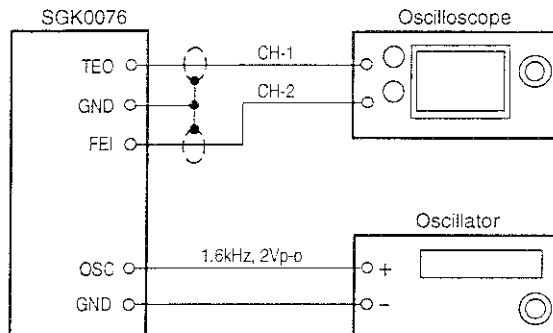

Fig.17 Tracking Gain Adjustment

- 4) Set the oscilloscope to X-Y mode.
- 5) Press STDBY/CUE button. (Focus servo actuates.)
Track indication: 01 / Message indication: FSV ON
- 6) Press PLAY/PAUSE button. (Spindle runs and becomes CLV AUTO mode.)
Track indication: 02 / Message indication: ACLV ON
- 7) Press PLAY/PAUSE button.
Track indication: 03 / Message indication: LOW G
- 8) Shift the switches S1, S2 of Jig to TRACK side.
- 9) Adjust VR211(T.G) and obtain X axis and Y axis of Lissajous waveform become even.

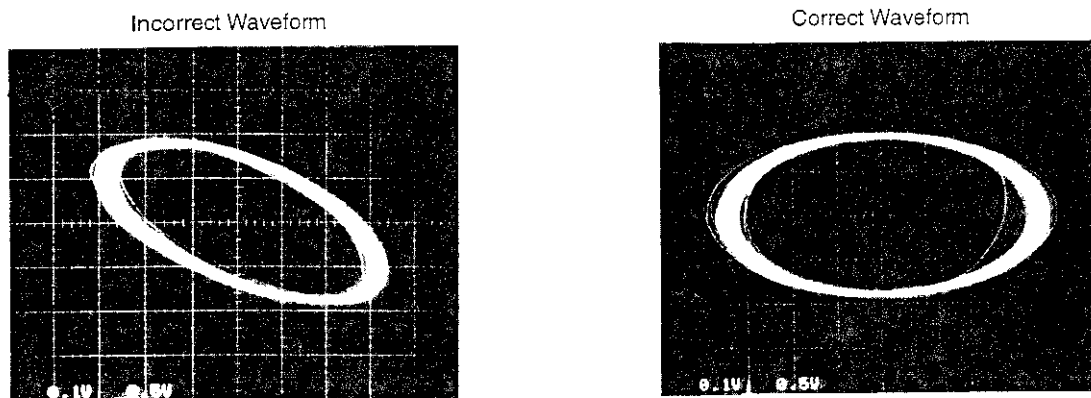

Fig.18 Adjustment Waveform

- 10) Press SELECT knob. (Test mode stops.)
Track indication: 00 / Message indication: INIT
- 11) Disconnect the output of oscillator and probe of CH-2 from the Jig.
- 12) Put the switch S1, S2 of Jig back to center position.

13. Confirmation of Tracking Offset by PMD

- 1) Set the oscilloscope to CH-1 mode. Connect hot side of probe CH-1 to Jig (T.OFFSET). Set the switch S1, S2 of Jig to center position.

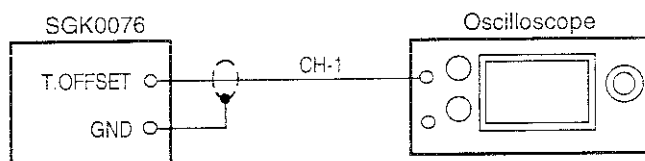

Fig.19 Tracking Offset Confirmation and Adjustment

- 2) Press STDBY/CUE button. (Focus servo actuates.)
Track indication: 01 / Message indication: FSV ON
- 3) Press PLAY/PAUSE button. (Spindle runs and becomes CLV AUTO mode.)
Track indication: 02 / Message indication: ACLV ON
- 4) Observe tracking error signal and adjust VR206(MD) so as to obtain A=B at a time out of offset. (Refer to Page 79 "9. Adjustment of Tracking Offset by PMD".)
- 5) Press SELECT knob. (Test mode stops.)
Track indication: 00 / Message indication: INIT
- 6) Eject the disc(cartridge).

14. Adjustment of Tracking Offset by RMD pit Area

- 1) Set the oscilloscope to CH-1 mode. Connect hot side of probe CH-1 to Jig (T.OFFSET). Set the switch S1, S2 of Jig to center position.
- 2) Load the RMD. (Recorded)
- 3) Press PLAY/PAUSE button.
Track indication: 00 / Message indication: INIT
- 4) Press STDBY/CUE button. (Focus servo actuates.)
Track indication: 01 / Message indication: FSV ON

- 5) Press PLAY/PAUSE button. (Spindle runs and becomes CLV AUTO mode.)
Track indication: 02 / Message indication: ACLV ON
- 6) Adjust VR205 (MO.P) so as to obtain A=B.

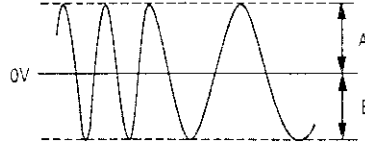

Fig.20 Balancing Waveform

- 7) Press SELECT knob. (Test mode stops.)
Track indication: 00 / Message indication: INIT

15. Adjustment of Tracking Offset by RMD Groove Area

- 1) Press SEARCH(▶▶) button. (Pick-up moves to group area.)
Track indication:08 / Message indication F SLIDE
- 2) Press STBY/CUE button. (Focus servo actuates.)
Track indication: 01 / Message indication: FSV ON
- 3) Press PLAY/PAUSE button. (spindle runs and becomes CLV AUTO mode.)
Track indication: 02 / Message indication: ACLV ON
- 4) Adjust VR204(MO.G) so as to obtain A=B.

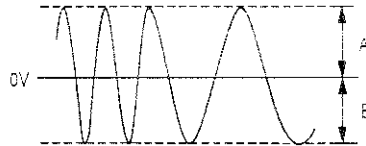

Fig.21 Balancing Waveform

16. Adjustment of Focus Offset by RMD Groove Area

- 1) Set the oscillator output to 1.6kHz, 2Vp-p and connect to OSC terminal of Jig.
- 2) Connect hot side of probe CH-1 to Jig(RFI).

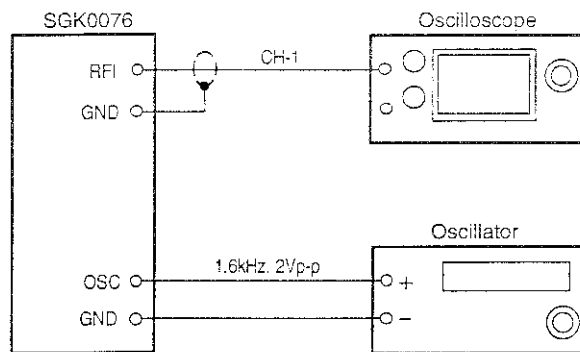

Fig.22 Focus Offset Adjustment

- 3) Shift the switch S1 of Jig to FOCUS side. (Set S2 to center position)
- 4) Press STDBY/CUE button. (Tracking servo actuates.)
Track indication: 04 / Message indication: HIGH G
- 5) Adjust VR208 (MO.G) so that the amplitude of signal becomes maximum.

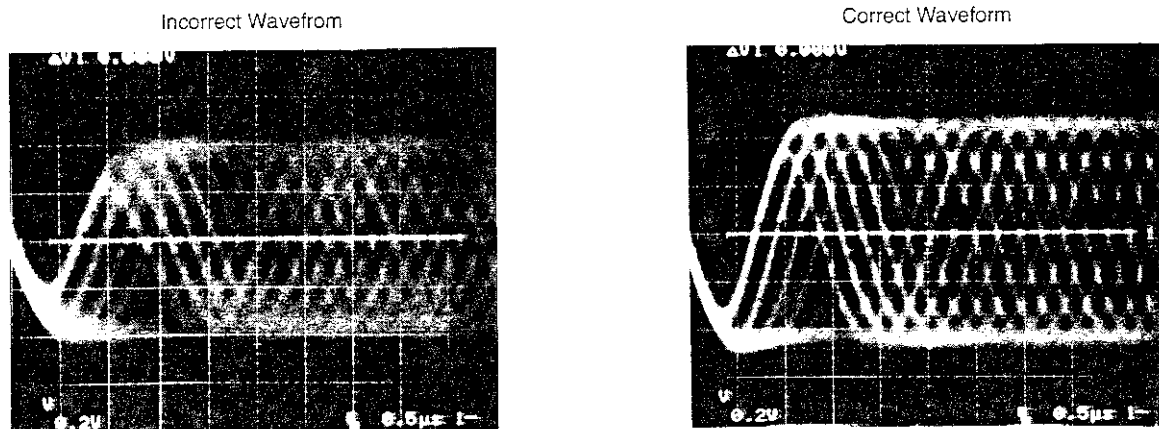

Fig.23 Adjustment Waveform

- 6) Press SELECT knob. (Test mode stops.)
Track indication: 00 / Message indication: INIT
- 7) Put the switch S1 of Jig back to center position.

17. Confirmation of Tracking Offset by RMD Groove Area

- 1) Connect hot side of probe CH-1 to Jig (T.OFFSET). Set the switch S1, S2 of Jig to center position.

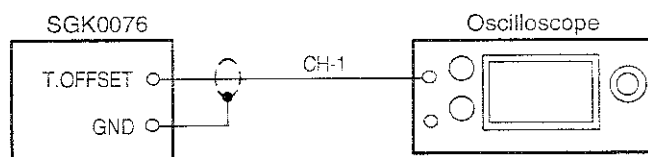

Fig.24 Tracking Offset Confirmation

- 2) Press SEARCH(▶▶) button. (Pick-up moves to groove area.)
Track indication: 08 / Message indication: F SLIDE
- 3) Press STDBY/CUE button. (Focus servo actuates.)
Track indication: 01 / Message indication: FSV ON
- 4) Press PLAY/PAUSE button. (Spindle runs and becomes CLV AUTO mode.)
Track indication: 02 / Message indication: ACLV ON
- 5) Observe tracking error signal and adjust VR204(MO.G) for A=B in case out of offset. (Refer to Page 82 "15. Adjustment of Tracking Offset by RMD Groove Area".)
- 6) Press SELECT knob. (Test mode stops.)
Track indication: 00 / Message indication: INIT
- 7) Eject the disc(cartridge).
- 8) Upon completion of all adjustments, turn the power switch OFF and disconnect connections between main body and the Jig.

● AUDIO SECTION

1. Necessary Equipment for Adjustment

- Distortion--Factor Meter
- VTVM
- Low-Pass Filter(20kHz)
- AF Oscillator(20Hz~20kHz, +18dBm)
- Reference Disc; Sony TDYS-1
- Recordable Mini Disc

2. Prior to Starting the Adjustment

- 1) Audio circuit shall be adjusted after adjustment of servo circuit.

3. Adjustment of Super Linear Converter

Adjustment of Super Linear Converter is only performed at a time the IC30, 31 (PCM61P) DA converter is replaced.

- 1) Connect the LINE OUT to the distortion-factor meter through the low-pass filter.

Note: If your distortion-factor meter has unbalanced input terminals, 1:1 ratio audio transformer is required between the unit and the measuring instrument in order to float the active balanced outputs from the ground.

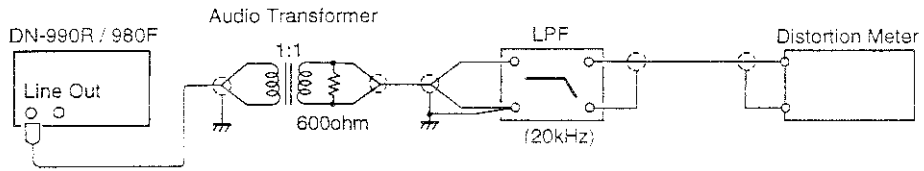

Fig.24 Super Linear Converter Adjustment

- 2) Turn the power switch ON.
- 3) Load the reference disc(Sony TDYS-1) to the Recorder(Player).
- 4) Set track number "2" with SELECT knob and press PLAY/PAUSE button.
- 5) Turn VR1(L-ch) or VR2(R-ch) on the CPU unit so that distortion-factor meter shows minimum distortion figures. (Distortion figures standard is less than 0.008%.)

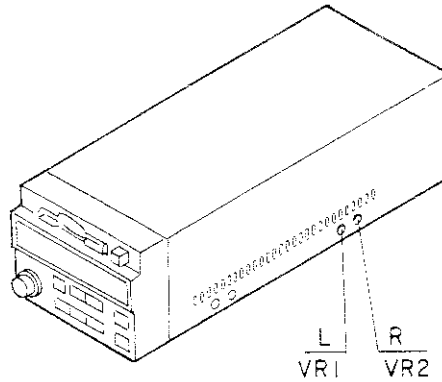

Fig.25 Location of Distortion-Factor Adjustment VRs

4. Output Level Adjustment

- 1) Connect VTVM to the output connector of DN-990R(DN-980F). Use 1:1 600 ohm Audio Transformer between the unit and VTVMs in order for matching the unbalanced input of VTVM and the active balanced output of DN-990R(DN-980F) as shown in Fig. 26.

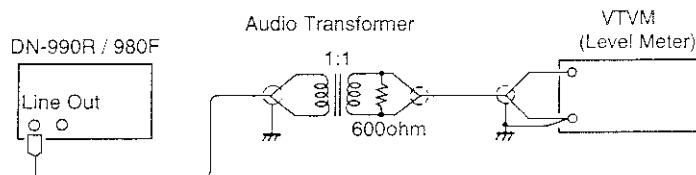

Fig.26 Connection for Output Level Adjustment

stead of oscillator.
sted.

0dB indication of level meter



it impedance can be changed

SCHEMATIC DIAGRAM (SERVO & SERVO DRIVER SECTION)

1 2 3 4 5 6 7 8

A

B

C

D

E

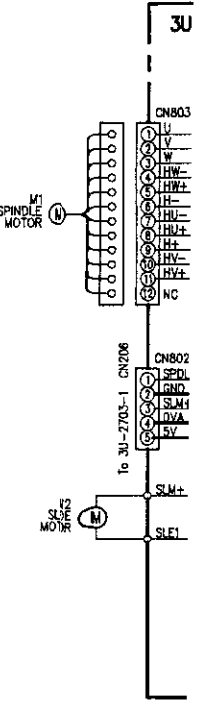
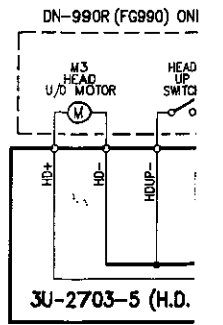
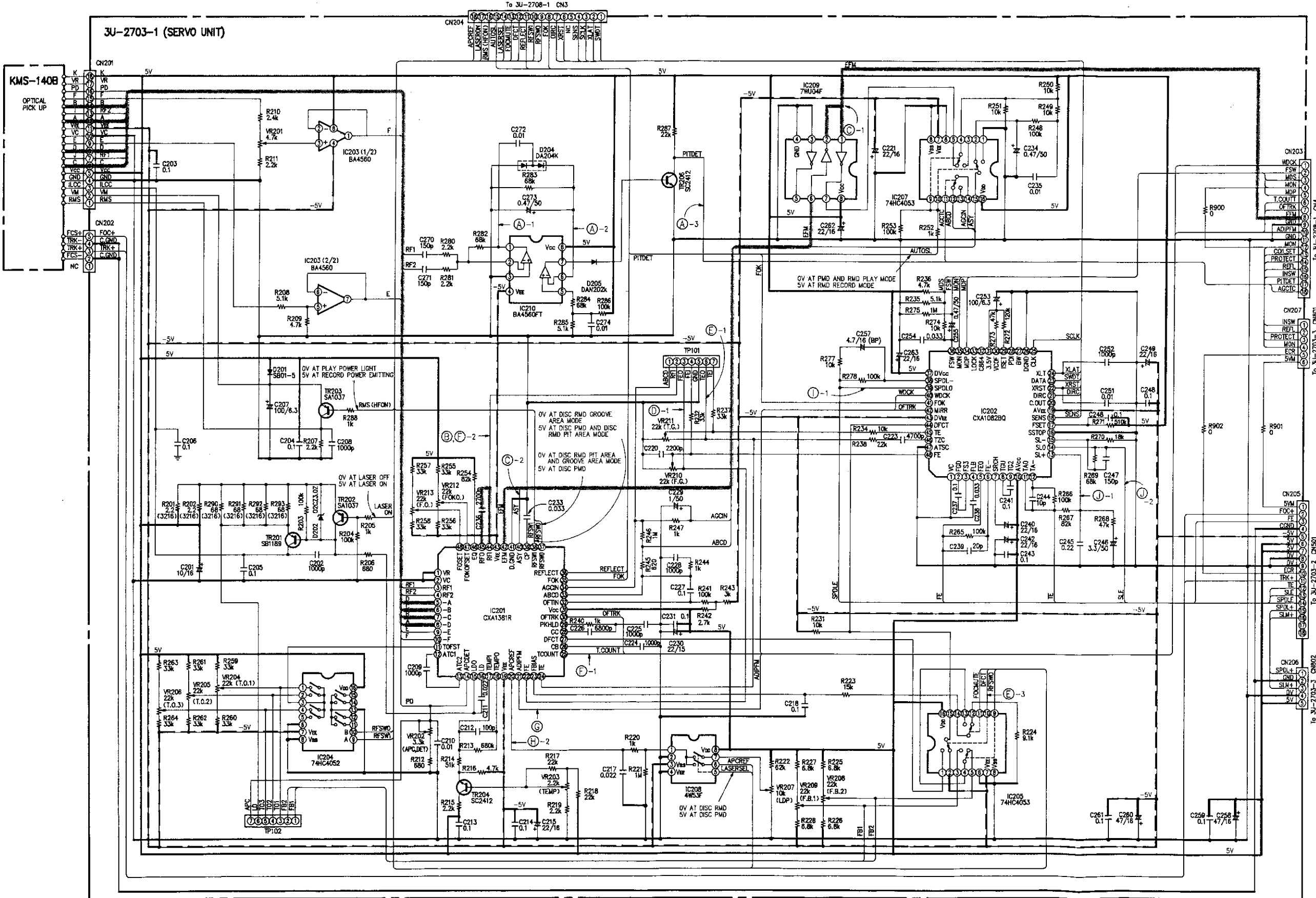

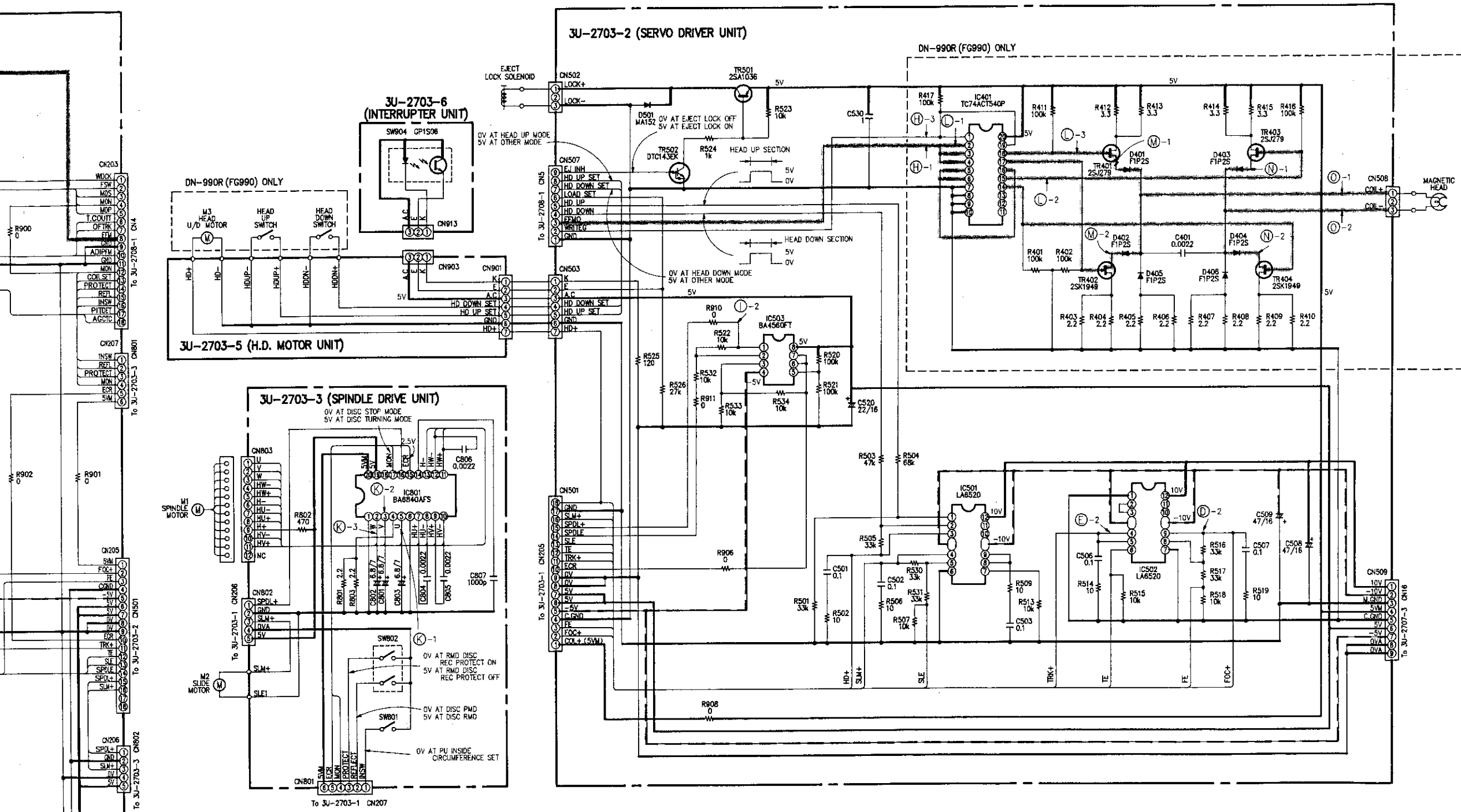

——— +B LINE
 - - - -B LINE
 ——— SIGNAL LINE

NOTES
 ALL RESISTANCE VALUES IN OHM. k=1,000 OHM,
 M=1,000,000 OHM
 ALL CAPACITANCE VALUES IN MICRO FARAD. P=MICRO-MICRO FARAD
 EACH VOLTAGE AND CURRENT ARE MEASURED AT NO SIGNAL INPUT CONDITION.
 CIRCUIT AND PARTS ARE SUBJECT TO CHANGE WITHOUT PRIOR NOTICE.

WARNING:
 Parts marked with this symbol have critical characteristics. Use ONLY replacement parts recommended by the manufacturer.

CAUTION:
 Before returning the unit to the customer, make sure you make either (1) a leakage current check or (2) a line to chassis resistance check. If the leakage current exceeds 0.5 milliamps, or if the resistance from chassis to either side of the power cord is less than 240 kohms, the unit is defective.

WARNING:
 DO NOT return the unit to the customer until the problem is located and corrected.

NOTES:
 Circuit and parts are subject to change without prior notice.

**WAVEFORMS ON SCHEMATIC DIAGRAM
(SERVO SECTION)/(SERVO DRIVER SECTION)**

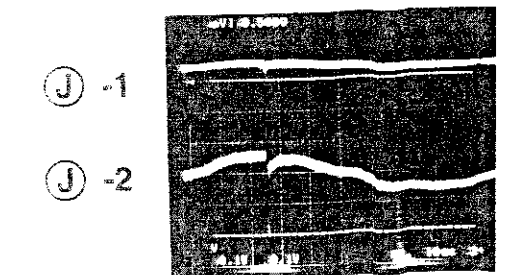
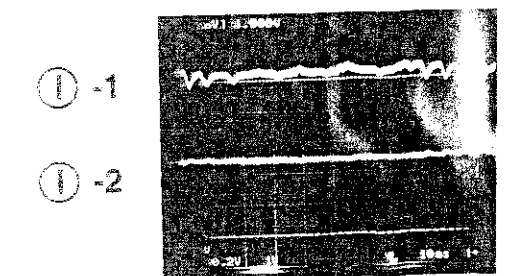
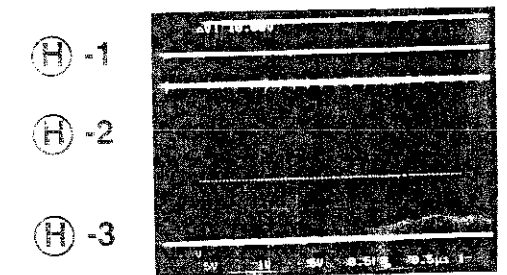
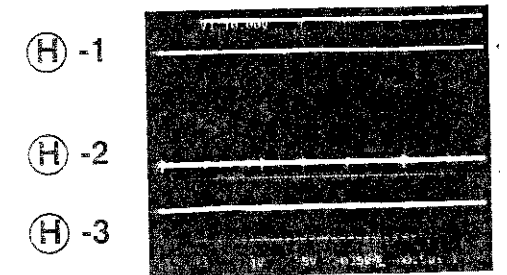
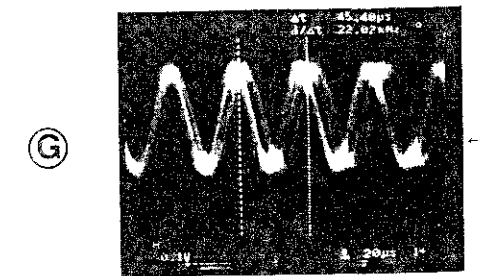
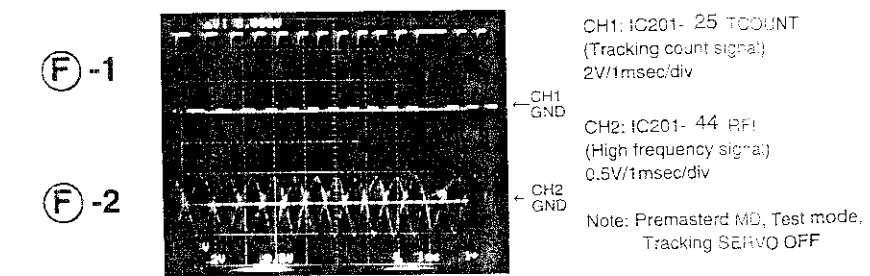
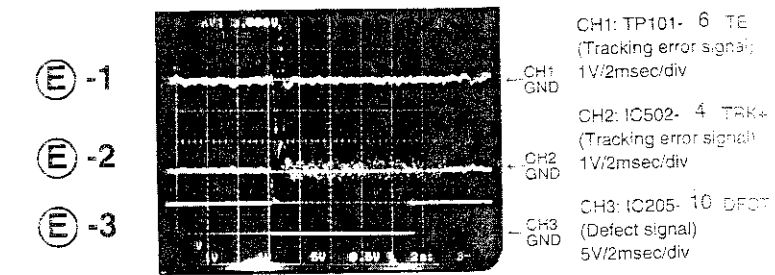
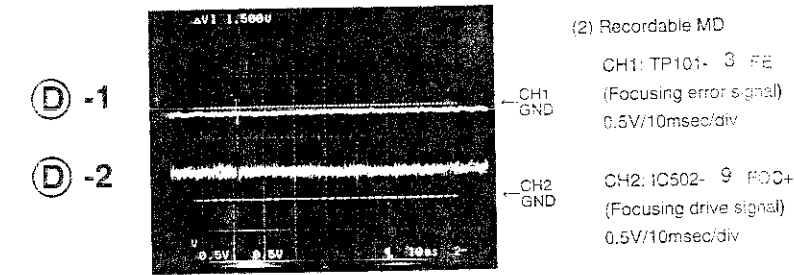
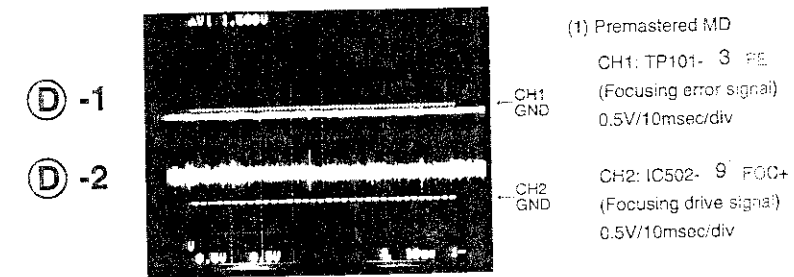
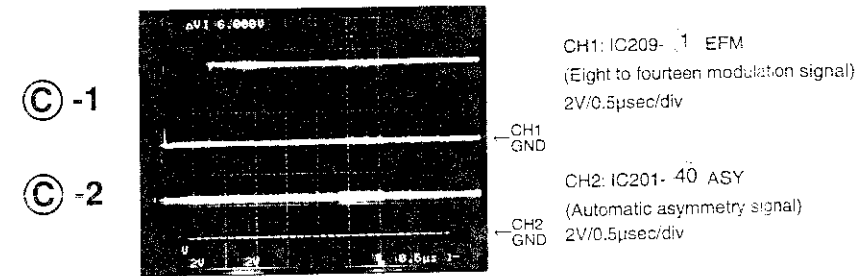
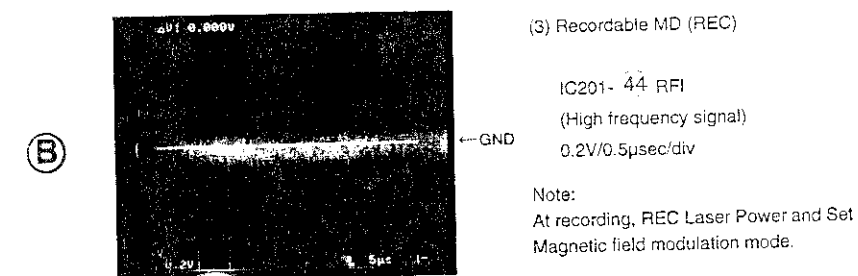
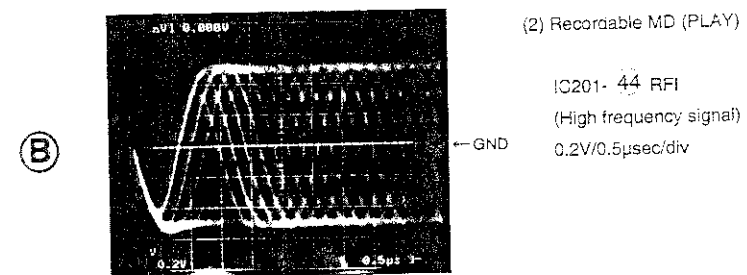
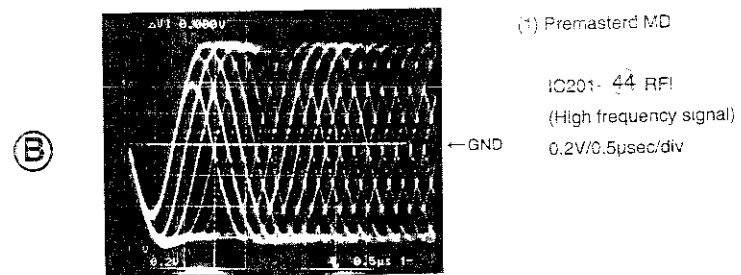
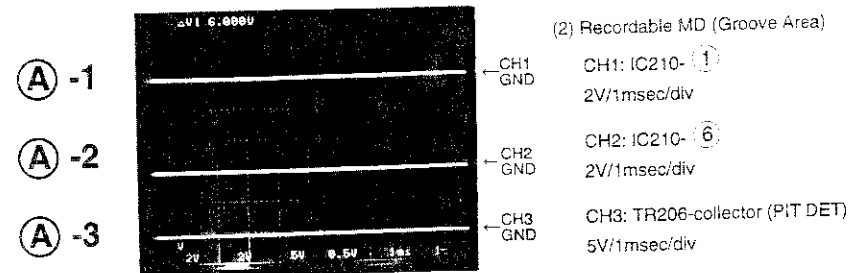
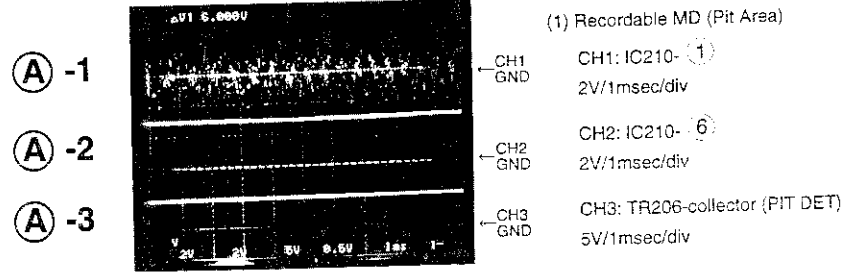

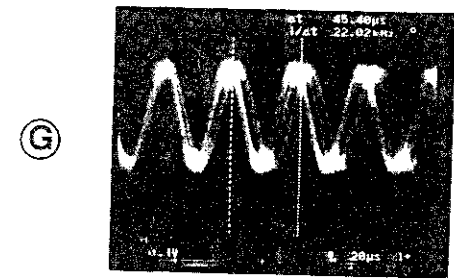

IC201- 21 ADIPFM
(ADIP FM signal)
0.1V/20µsec/div

Note: Recordable MD, Test mode,
Tracking SERVO ON

(K) -1
(K) -2
(K) -3

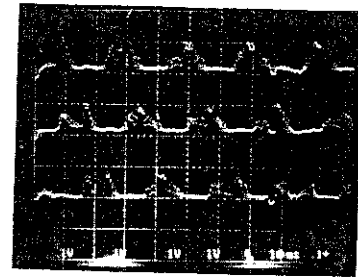

CH1: IC801- 5 U
1V/10msec/div
CH2: IC801- 3 V
1V/10msec/div
CH3: IC601- 2 W
1V/10msec/div

Note: Premastered MD, Track. No1 STDBY

(O) -1
(O) -2

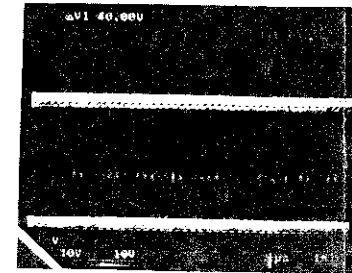

CH1: D401- cathode
(Magnetic Head, Coil+)
10V/1µsec/div
CH2: D403- cathode
(Magnetic Head, Coil-)
10V/1µsec/div

Note:
When Recording, magnetic field
modulation is ON and WRITEG is "0V".

(H) -1
(H) -2
(H) -3

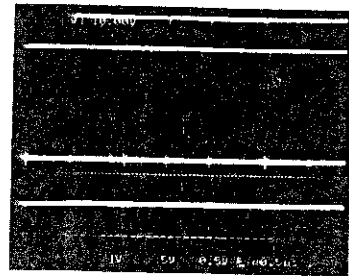

(1) Recordable MD, STDBY
CH1: IC401- 2 FEMO
(Eight to fourteen modulation output)
5V/0.5µsec/div
CH2: IC201- 20 APCREF
(Automatic LASER Power Control
Reference signal) 1V/0.5µsec/div
CH3: IC401- 1 WRITEG
(Write gate signal)
5V/0.5µsec/div

(L) -1
(L) -2
(L) -3

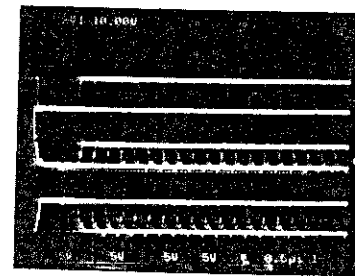

(1) Recordable MD,
When magnetic field modulation is ON
CH1: IC401- 2 EFMO
(Eight to fourteen modulation output)
5V/0.5µsec/div
CH2: IC401- 15
5V/0.5µsec/div
CH3: IC401- 18
5V/0.5µsec/div

(H) -1
(H) -2
(H) -3

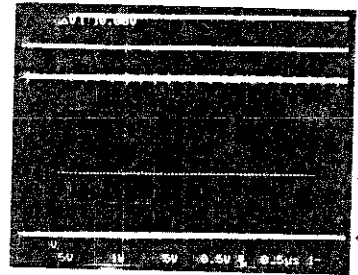

(2) Recordable MD, REC
CH1: IC401- 2 FEMO
(Eight to fourteen modulation output)
5V/0.5µsec/div
CH2: IC201- 20 APCREF
(Automatic LASER Power Control
Reference signal) 1V/0.5µsec/div
CH3: IC401- 1 WRITEG
(Write gate signal)
5V/0.5µsec/div

(L) -1
(L) -2
(L) -3

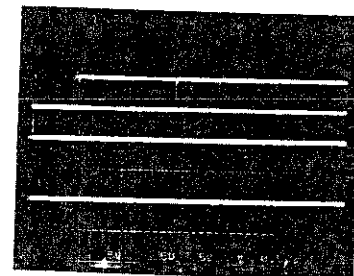

(2) Recordable MD,
When magnetic field modulation is
OFF
CH1: IC401- 2 EFMO
(Eight to fourteen modulation output)
5V/0.5µsec/div
CH2: IC401- 15
5V/0.5µsec/div
CH3: IC401- 18
5V/0.5µsec/div

(M) -1
(M) -2

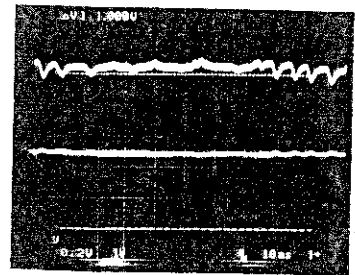

CH1: IC202- 39 SPDLE
(Spindle drive signal)
0.2V/10msec/div
CH2: IC503- 1 SPDL+
(Spindle drive signal)
1V/10msec/div

(M) -1
(M) -2

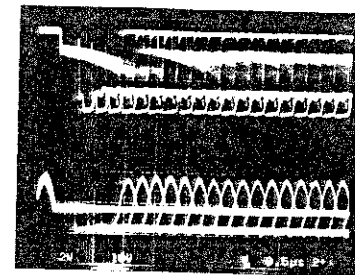

CH1: D401- cathode
2V/0.5µsec/div
CH2: D402- anode
10V/0.5µsec/div
Note:
When Recording, magnetic field
modulation is ON and WRITEG is "0V".

(N) -1
(N) -2

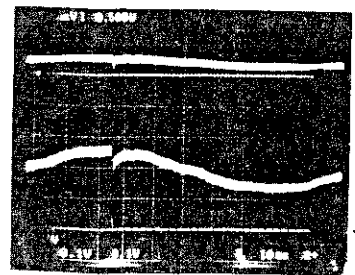

CH1: IC202- 13 SL+
(Slide drive signal)
0.1V/10msec/div
CH2: IC202- 14 SLE
(Slide drive signal)
0.1V/10msec/div

(N) -1
(N) -2

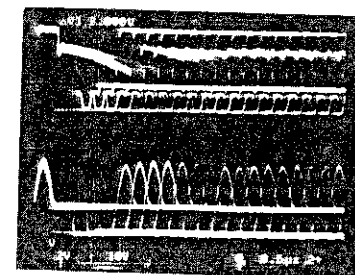

CH1: D403- anode
2V/0.5µsec/div
CH2: D404- cathode
2V/0.5µsec/div
Note:
When Recording, magnetic field
modulation is ON and WRITEG is "0V".

SCHEMATIC DIAGRAM (CPU SECTION)

1 2 3 4 5 6 7 8

A
B
C
D
E

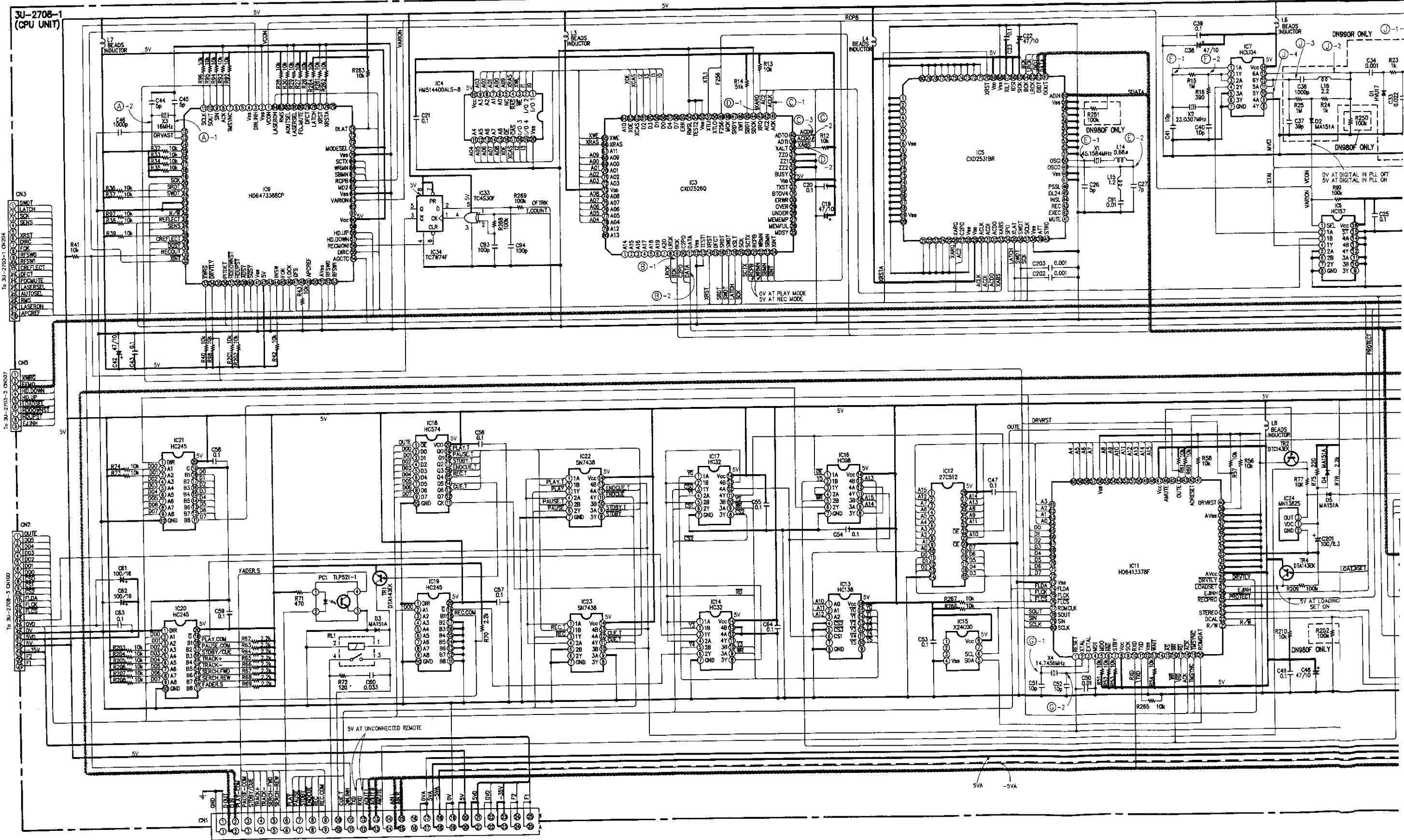

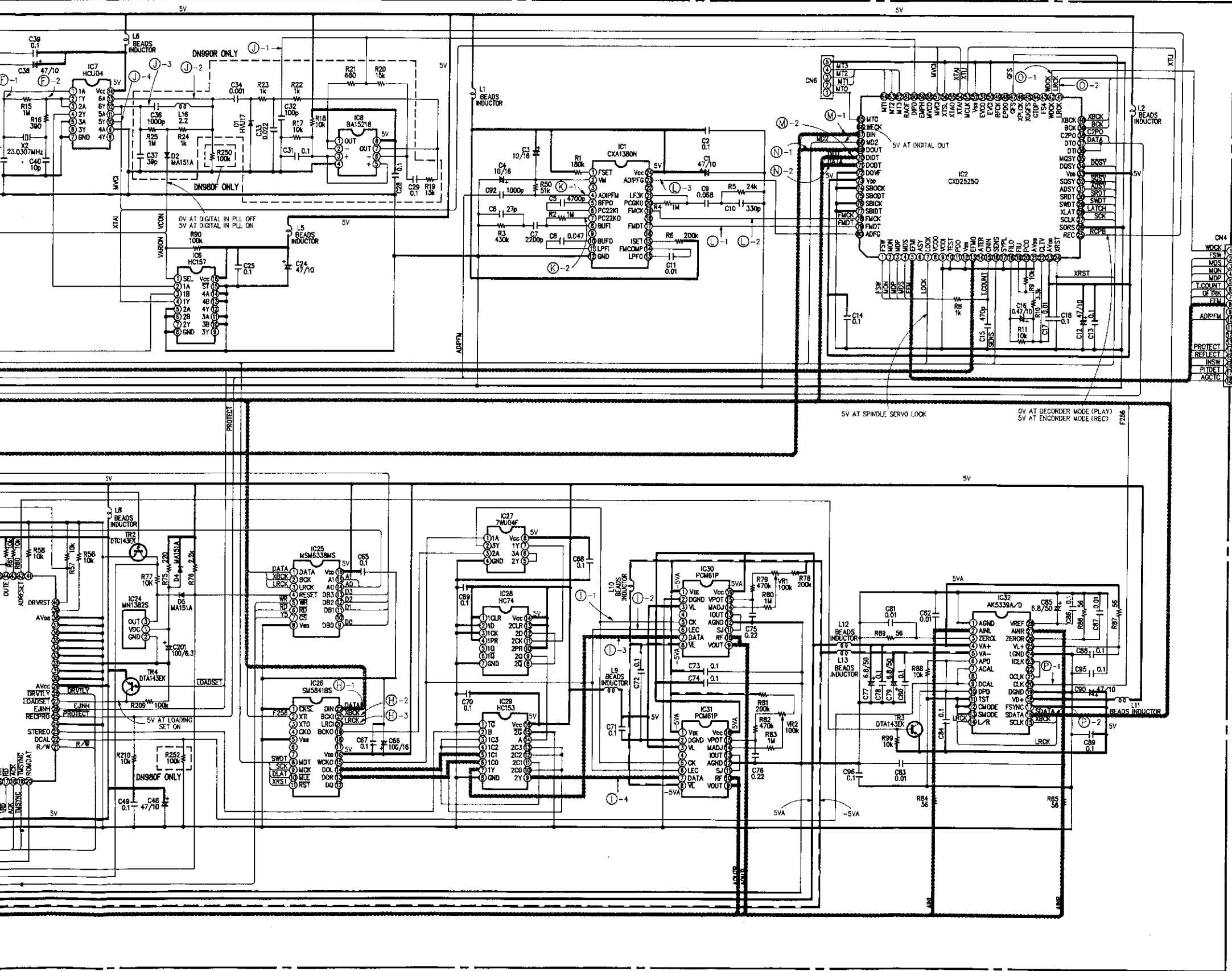

NOTES
 ALL RESISTANCE VALUES IN OHM. k=1,000 OHM,
 M=1,000,000 OHM
 ALL CAPACITANCE VALUES IN MICRO FARAD. P=MICRO-MICRO
 FARAD
 EACH VOLTAGE AND CURRENT ARE MEASURED AT NO SIGNAL
 INPUT CONDITION.
 CIRCUIT AND PARTS ARE SUBJECT TO CHANGE WITHOUT PRIOR
 NOTICE.

WARNING:
 Parts marked with this symbol  have critical characteristics.
 Use ONLY replacement parts recommended by the manufacturer.

CAUTION:
 Before returning the unit to the customer, make sure you make either (1) a leakage current
 check or (2) a line to chassis resistance check. If the leakage current exceeds 0.5
 milliamps, or if the resistance from chassis to either side of the power cord is less than 24k
 kohms, the unit is defective.

WARNING:
 DO NOT return the unit to the customer until the problem is located and corrected.

NOTES:
 Circuit and parts are subject to change without prior notice.

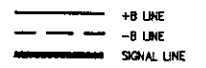

WAVEFORMS ON SCHEMATIC DIAGRAM
(CPU SECTION)

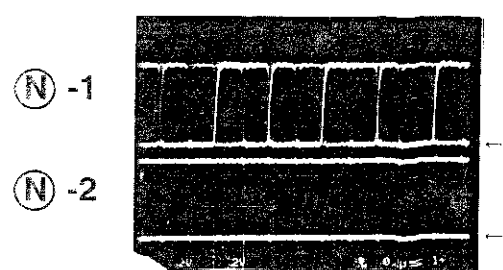
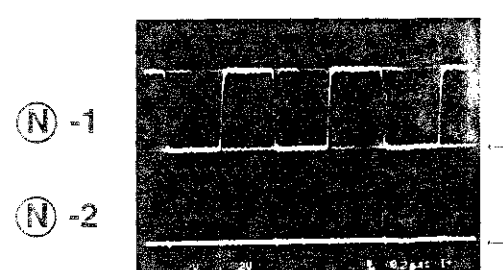
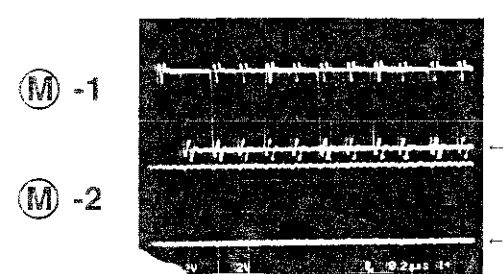
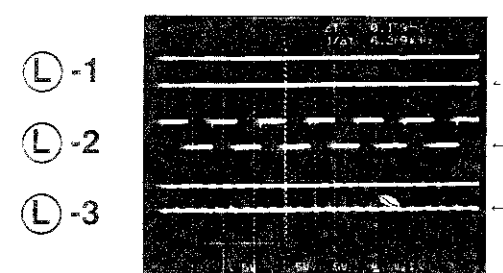
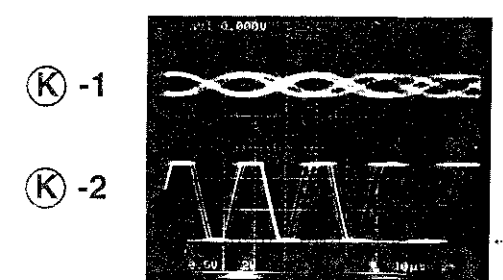
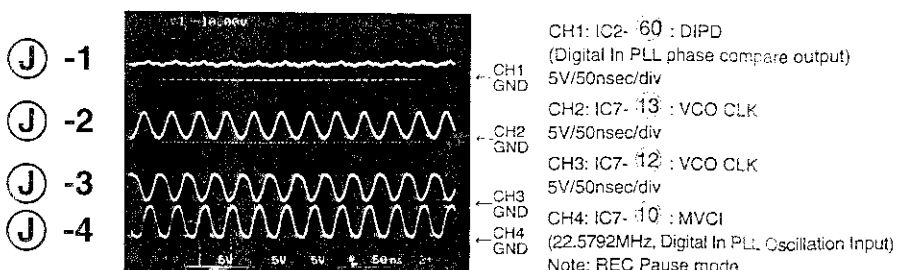
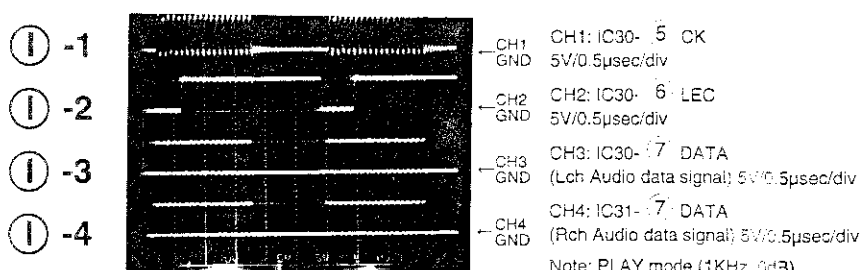
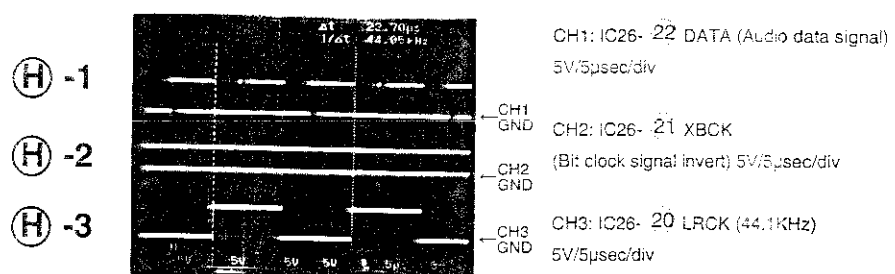
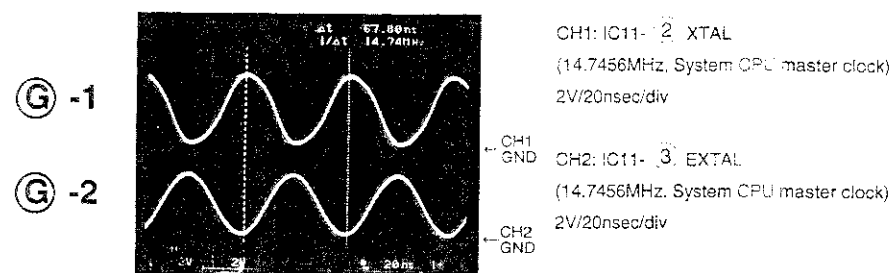
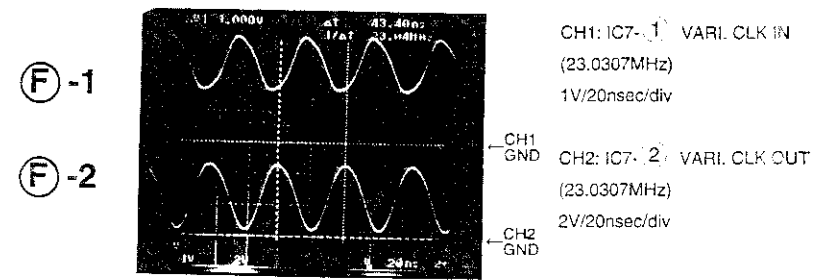
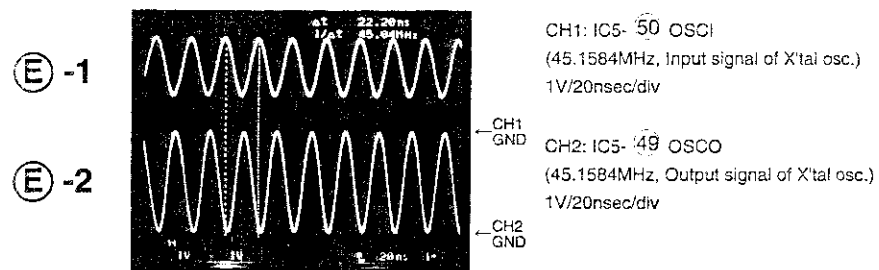
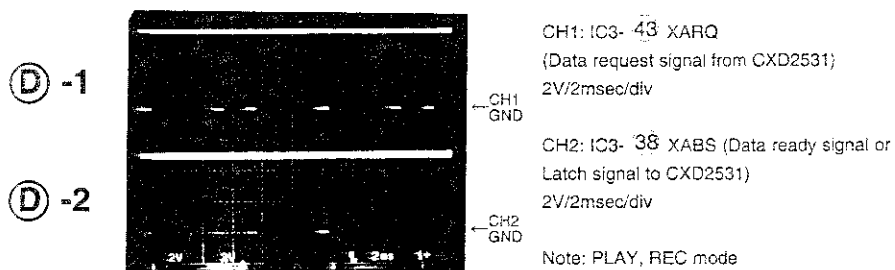
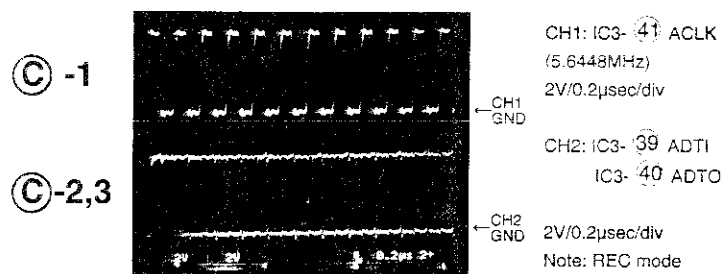
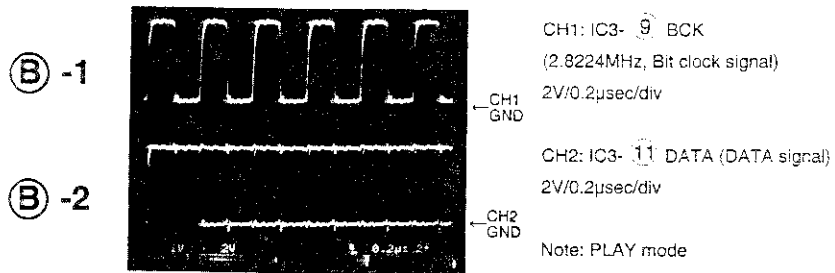
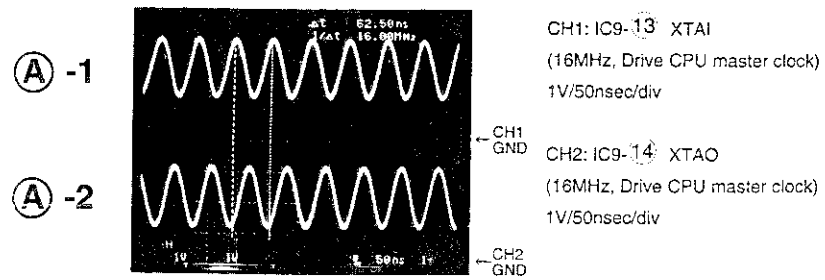

-1

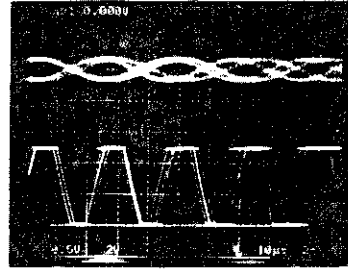

CH1: IC1- 4 ADIP FM
(Address In Pre-groove FM signal)
0.5V/10µsec/div

CH2: IC1- 7 PC22KO
(FM Demodulation Phase comparator
output)
2V/10µsec/div

CH1,
CH2
GND

Ⓞ -1

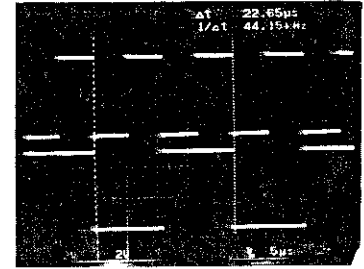

CH1: IC2- 42 WOCK
(88.2KHz)
2V/5µsec/div

CH2: IC2- 41 LRCK
(44.1KHz)
2V/5µsec/div

CH1
GND

CH2
GND

Ⓞ -2

-1

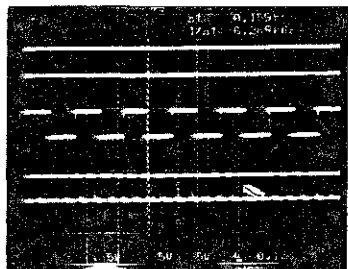

CH1: IC1- 17 FMDT (ADIP data output)
5V/0.1msec/div

CH2: IC1- 19 FMCK
(ADIP bit clock output) 5V/0.1msec/div

CH3: IC1- 23 ADIPFG
(ADIP carrier signal)
5V/0.1msec/div

CH1
GND

CH2
GND

CH3
GND

Ⓟ -1

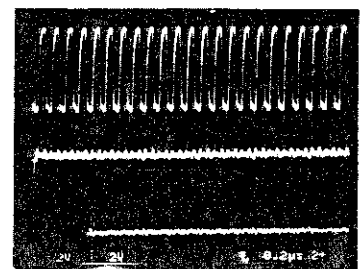

CH1: IC32- 20 CLK
(11.2896MHz, F256)
2V/0.2µsec/div

CH2: IC32- 15 SDATA
(Serial data)
2V/0.2µsec/div

CH1
GND

CH2
GND

Ⓟ -2

-1

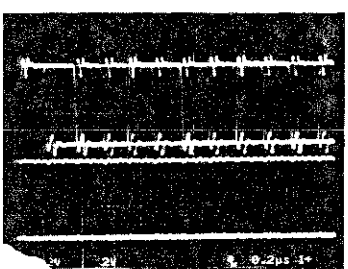

CH1: IC2- 67 DIN
(Digital Audio Input signal)
2V/0.2µsec/div

CH2: IC2- 70 D1DT
(Audio data output signal of DIN)
2V/0.2µsec/div

Note: REC Pause mode

CH1
GND

CH2
GND

-2

-1

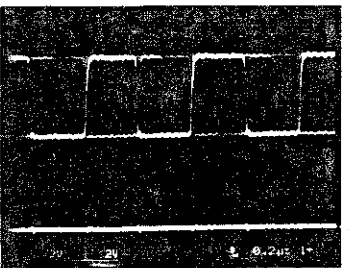

CH1: IC2- 69 DOUT
(Digital Audio output signal)
2V/0.2µsec/div

CH2: IC2- 71 DODT
(16bit data signal)

Note: STDBY/CUE mode

CH1
GND

CH2
GND

-2

-1

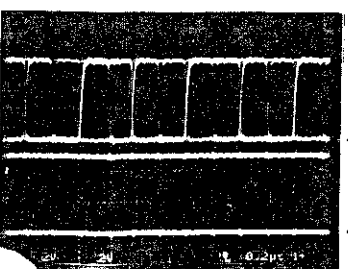

CH1: IC2- 69 DOUT
(Digital Audio output signal)
2V/0.2µsec/div

CH2: IC2- 71 DODT
(16bit data signal)

Note: PLAY, REC mode

CH1
GND

CH2
GND

-2

SCHEMATIC DIAGRAM (AUDIO SECTION)

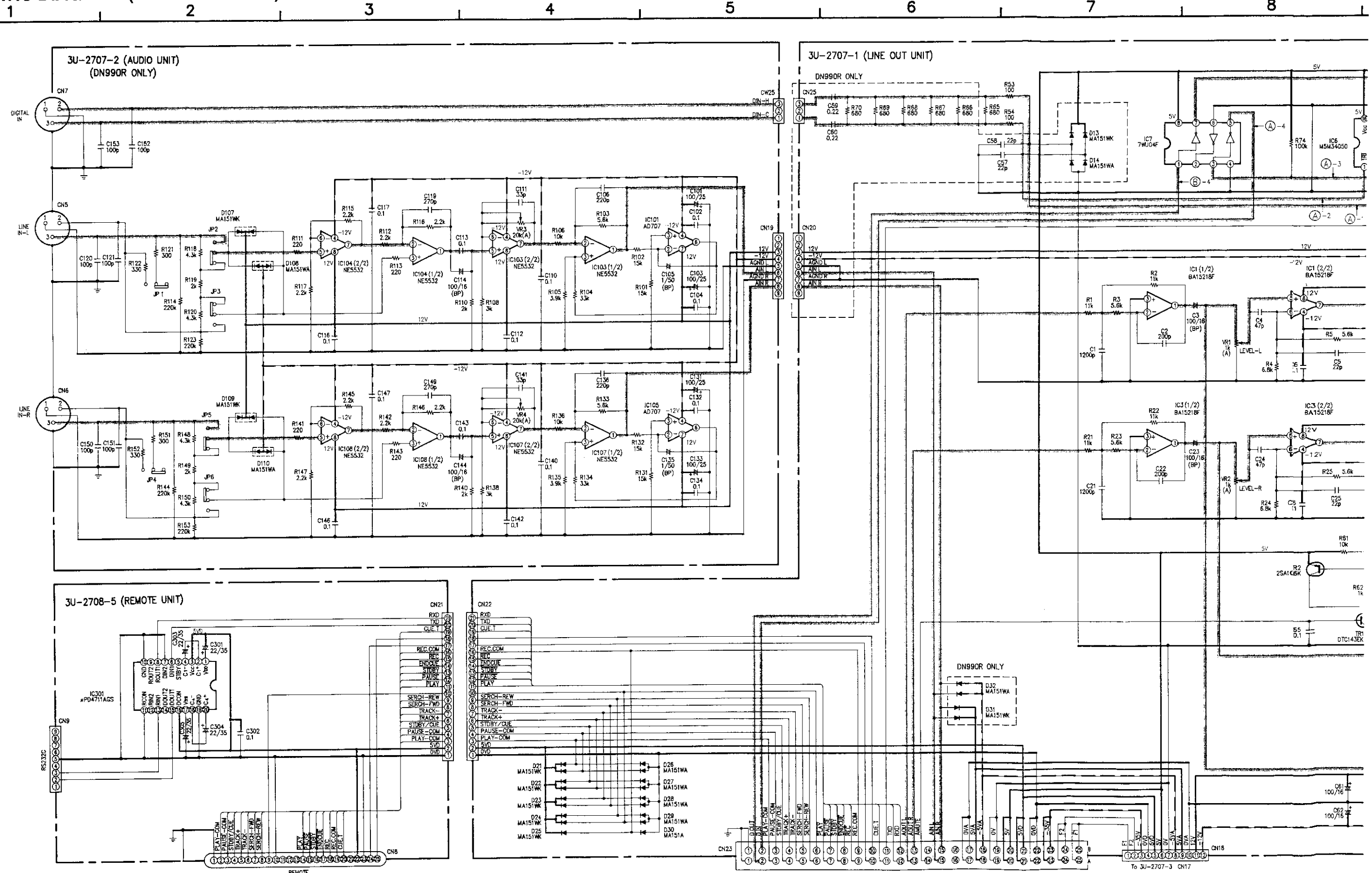

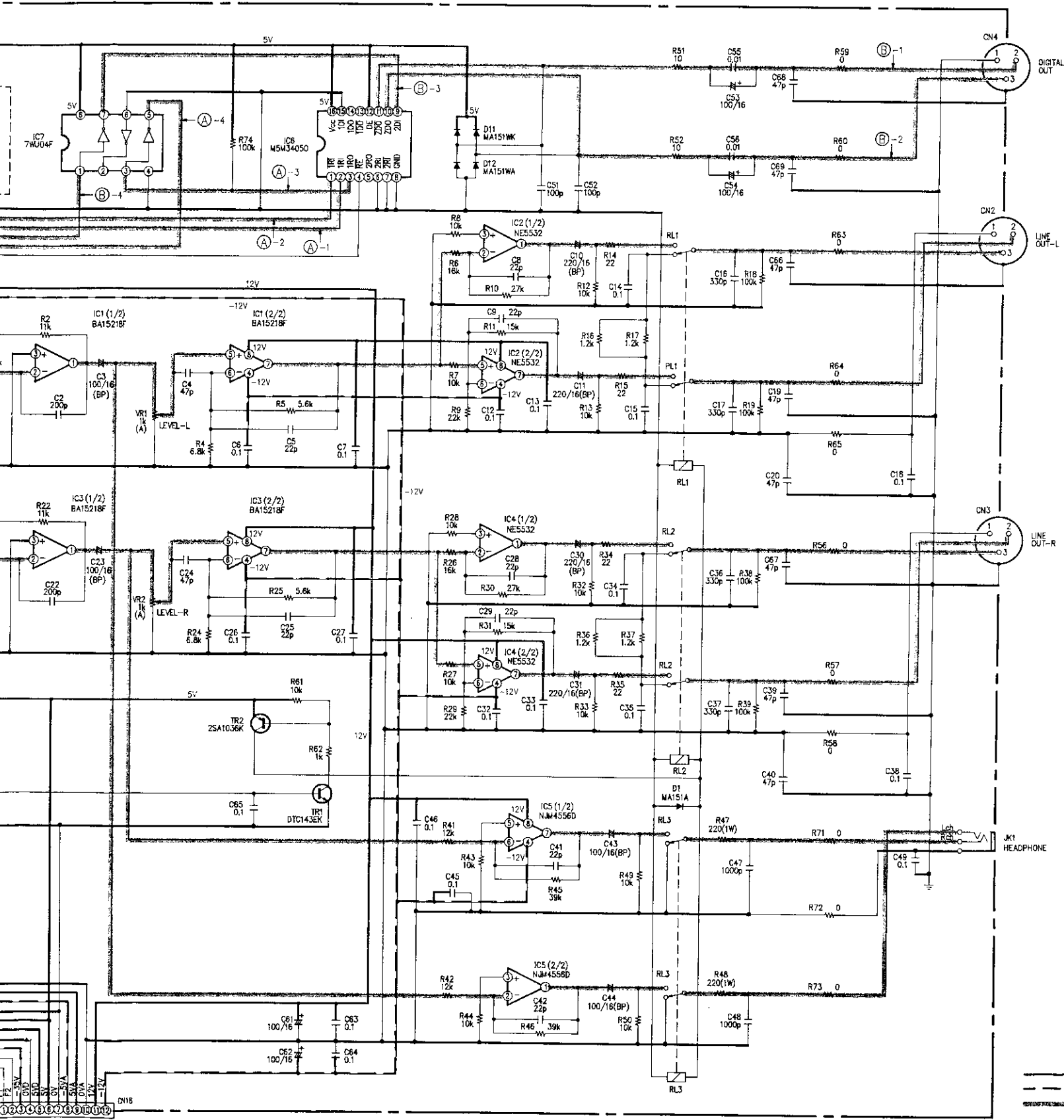

WAVEFORMS ON SCHEMATIC DIAGRAM (AUDIO SECTION)

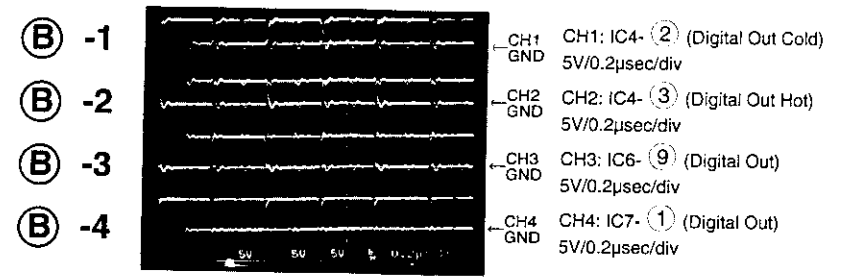
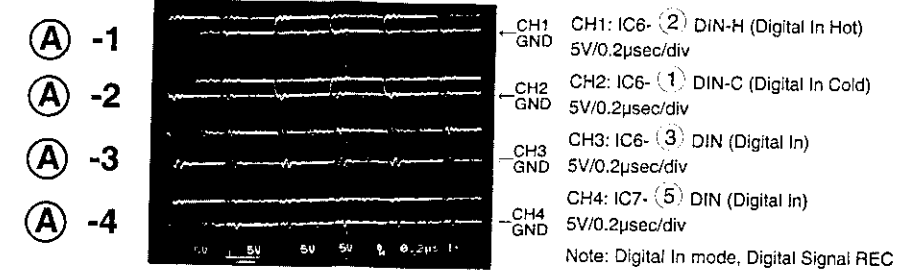

NOTES
ALL RESISTANCE VALUES IN OHM. k=1,000 OHM,
M=1,000,000 OHM
ALL CAPACITANCE VALUES IN MICRO FARAD. P=MICRO-MICRO FARAD
EACH VOLTAGE AND CURRENT ARE MEASURED AT NO SIGNAL INPUT CONDITION.
CIRCUIT AND PARTS ARE SUBJECT TO CHANGE WITHOUT PRIOR NOTICE.

WARNING:
Parts marked with this symbol have critical characteristics. Use ONLY replacement parts recommended by the manufacturer.

CAUTION:
Before returning the unit to the customer, make sure you make either (1) a leakage current check or (2) a line to chassis resistance check. If the leakage current exceeds 0.5 milliamps, or if the resistance from chassis to either side of the power cord is less than 240 kohms, the unit is defective.

WARNING:
DO NOT return the unit to the customer until the problem is located and corrected.

NOTES:
Circuit and parts are subject to change without prior notice.

SCHEMATIC DIAGRAM (DISPLAY SECTION)

1 2 3 4 5 6 7 8

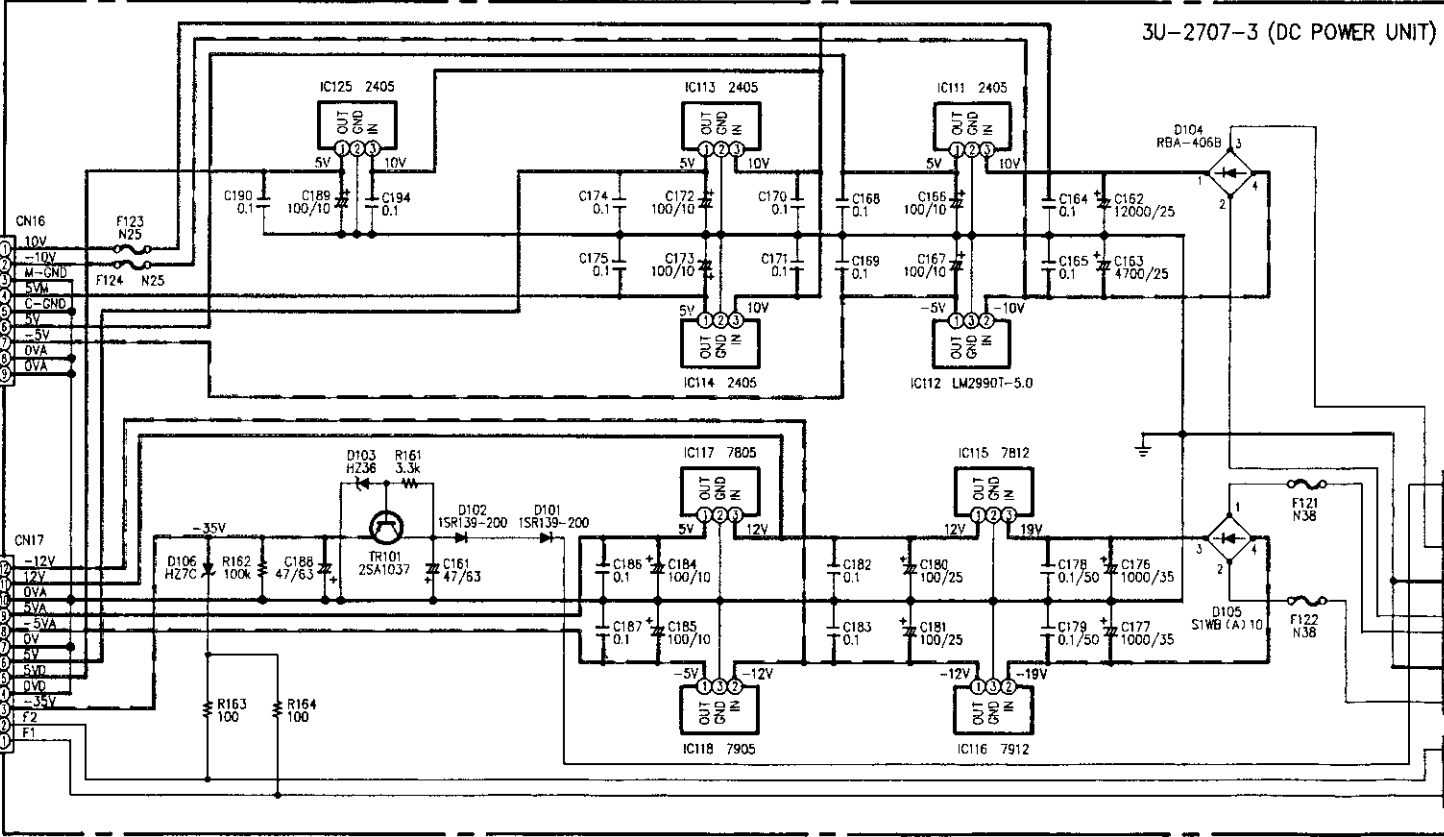
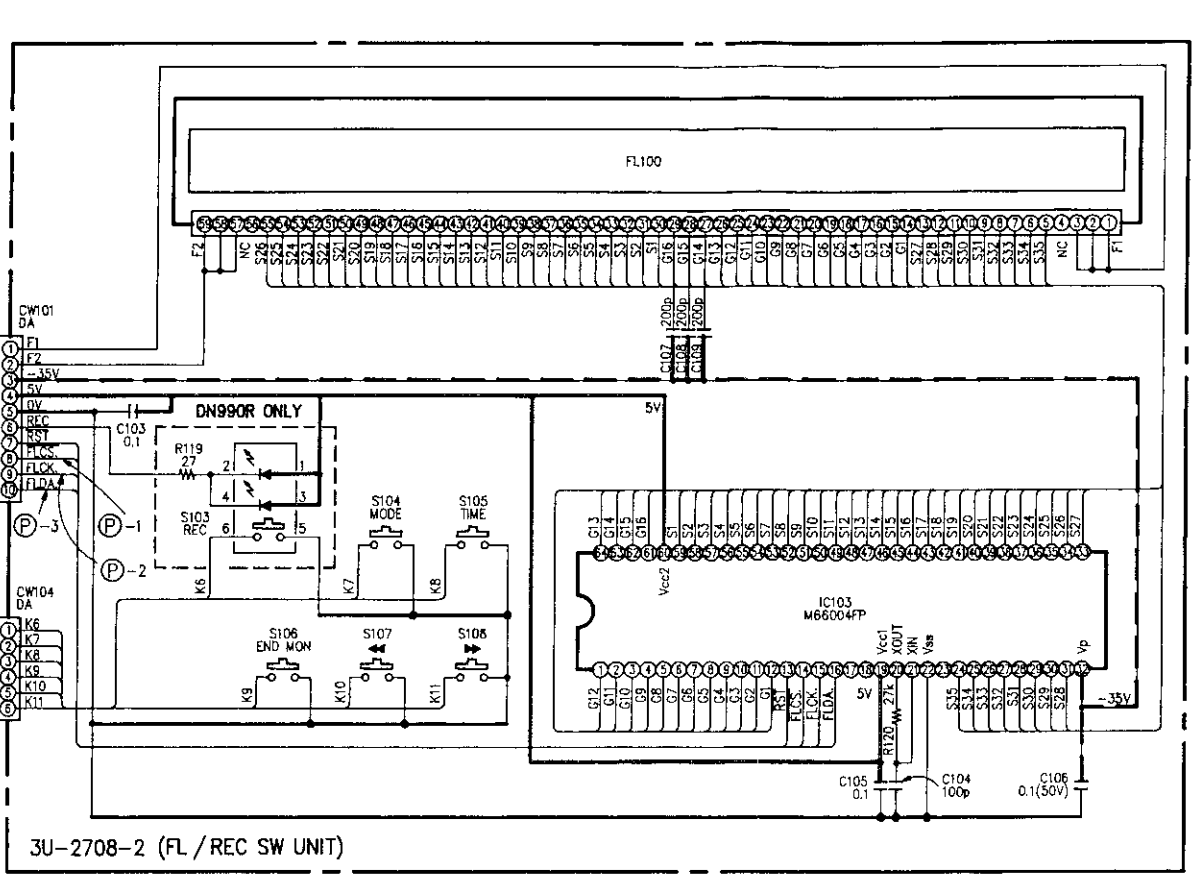
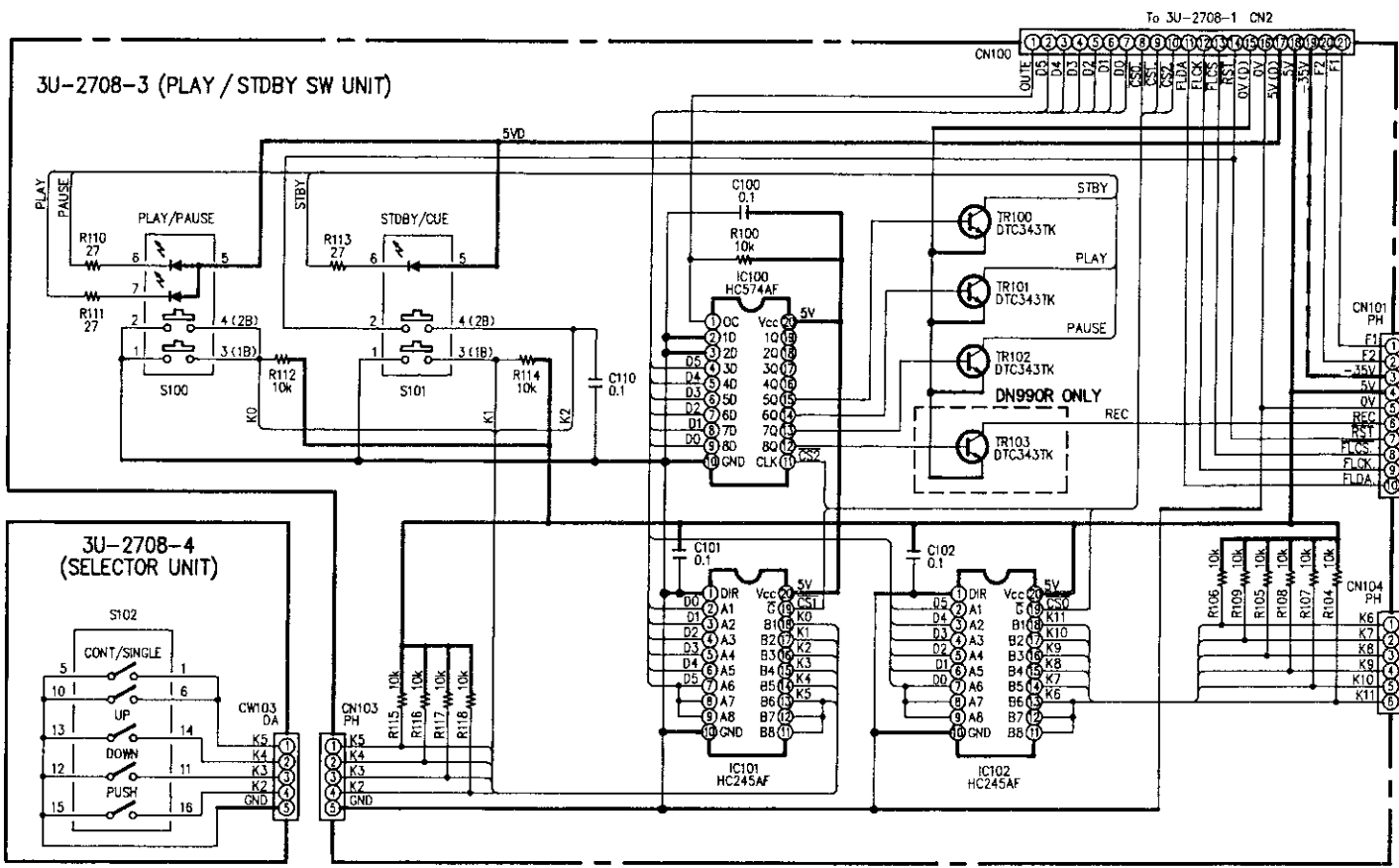

WAVEFORMS ON SCHEMATIC DIAGRAM (DISPLAY SECTION)

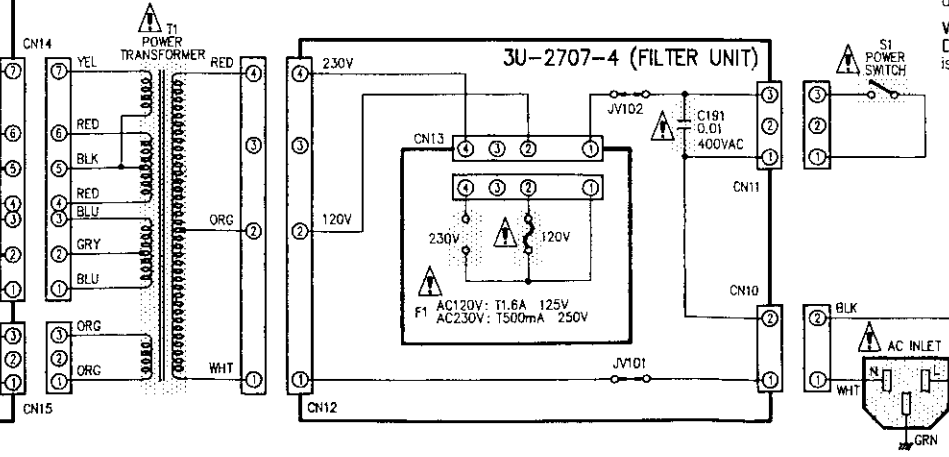
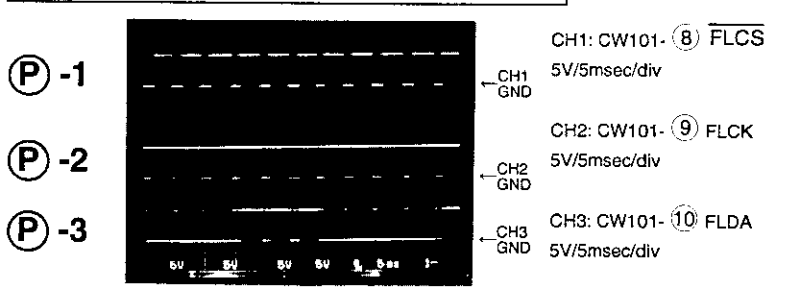

NOTES
 ALL RESISTANCE VALUES IN OHM. k=1,000 OHM, M=1,000,000 OHM
 ALL CAPACITANCE VALUES IN MICRO FARAD.
 P=MICRO-MICRO FARAD
 EACH VOLTAGE AND CURRENT ARE MEASURED AT NO SIGNAL INPUT CONDITION.
 CIRCUIT AND PARTS ARE SUBJECT TO CHANGE WITHOUT PRIOR NOTICE.

WARNING:
 Parts marked with this symbol have critical characteristics. Use ONLY replacement parts recommended by the manufacturer.

CAUTION:
 Before returning the unit to the customer, make sure you make either (1) a leakage current check or (2) a line to chassis resistance check. If the leakage current exceeds 0.5 milliamps, or if the resistance from chassis to either side of the power cord is less than 240 kohms, the unit is defective.

WARNING:
 DO NOT return the unit to the customer until the problem is located and corrected.

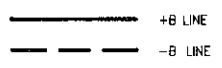

P.W.BOARD & WIRING DIAGRAM (SERVO & SERVO DRIVER SECTION)

1 2 3 4 5 6 7 8

3U-2703-1

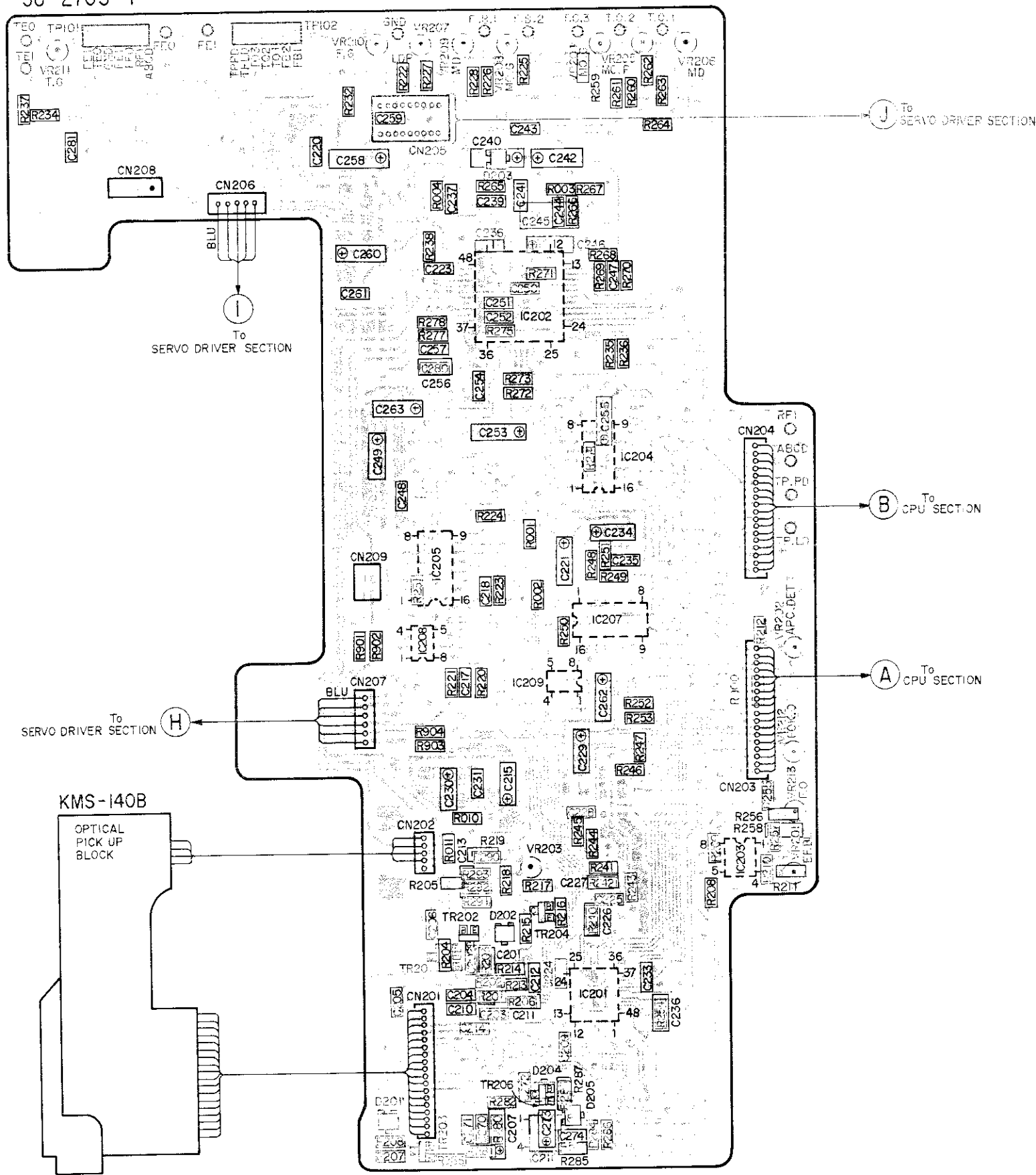

3U-2703-4

3U-2703-3

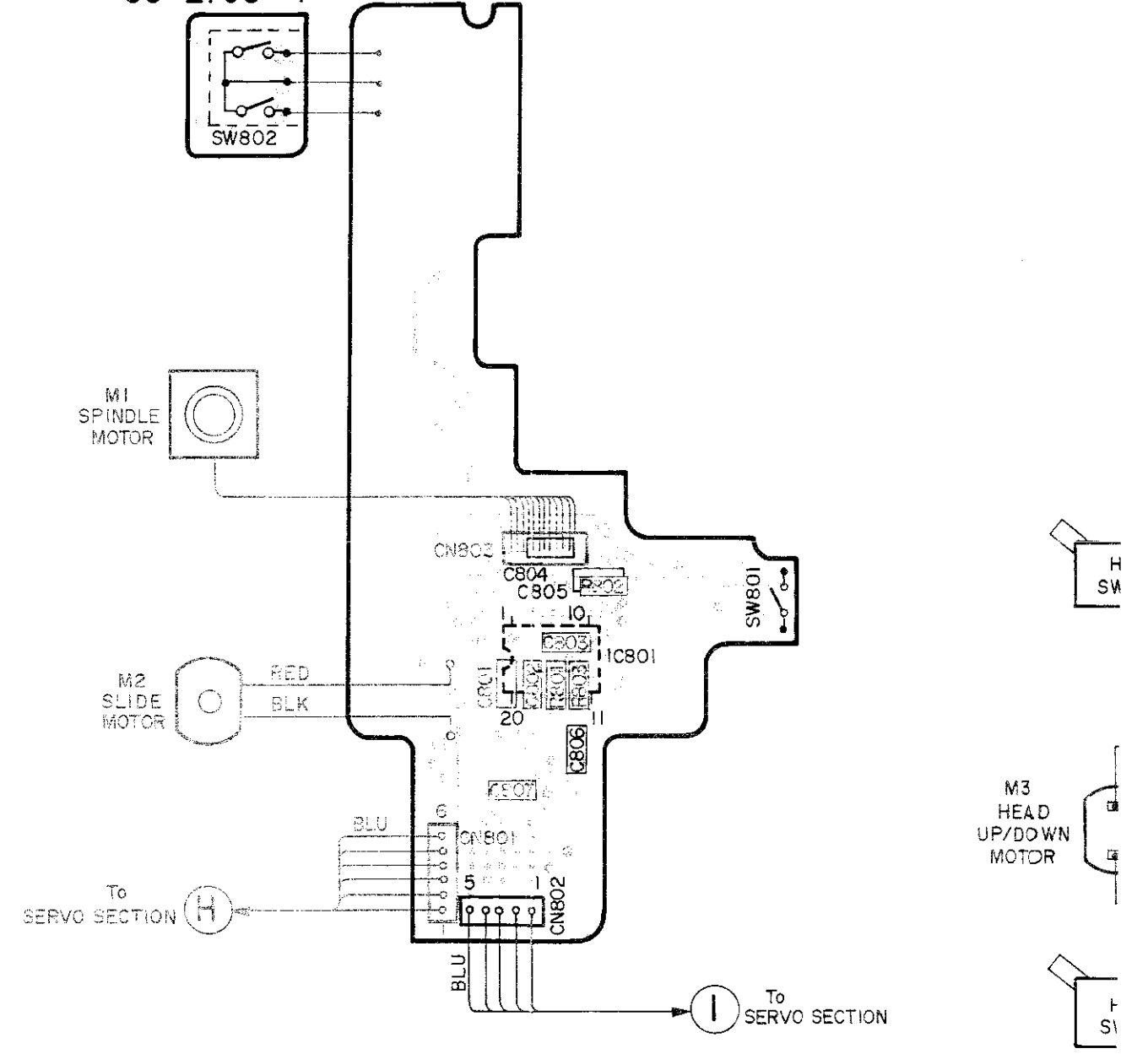

8 9 10 11 12 13 14 15

A
B
C
D
E



To SERVO SECTION

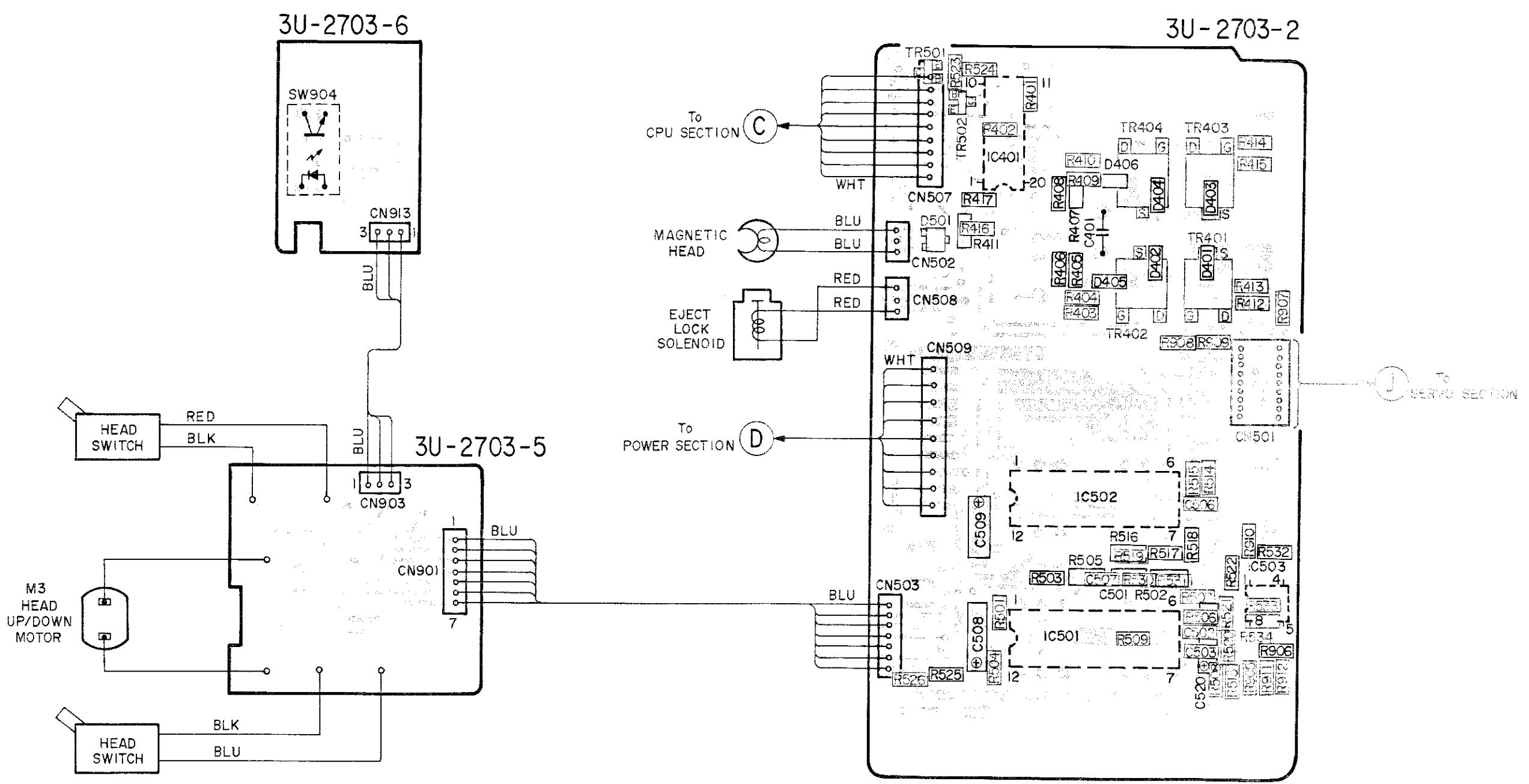

P.W.BOARD & WIRING DIAGRAM (AUDIO SECTION)

1 2 3 4 5 6 7 8

A

3U-2707-2

CN7
DIGITAL
IN

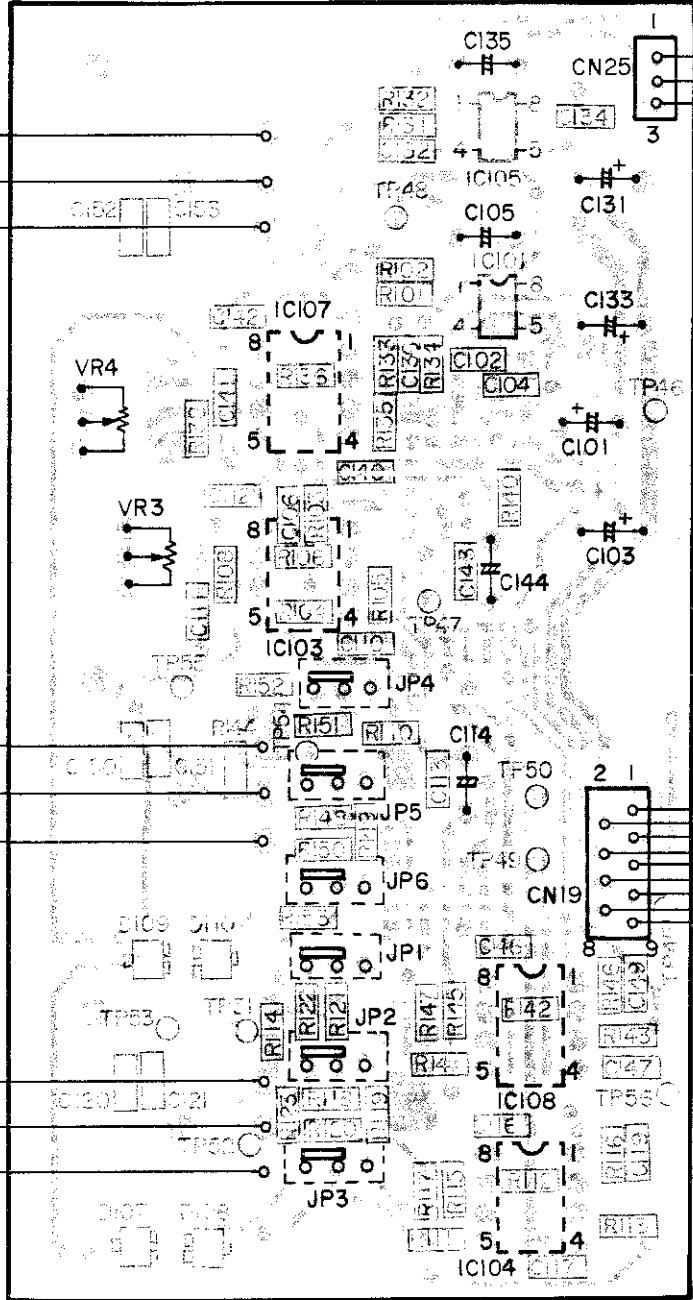
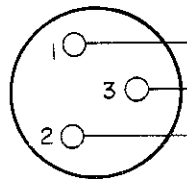

BRN
BRN
WHT

B

C

CN6
LINE IN
Rch

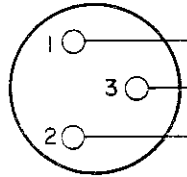

CN5
LINE IN
Lch

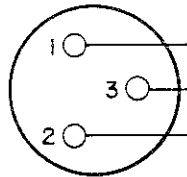

D

E

2 1

3U-2708-5

CN21

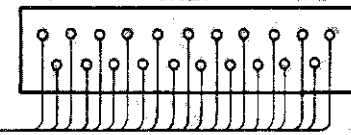

CN8

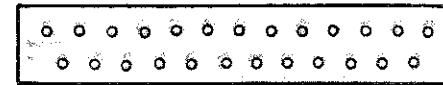

CN8
REMOTE

CN9



CN9
RS232C

3U-2707-1

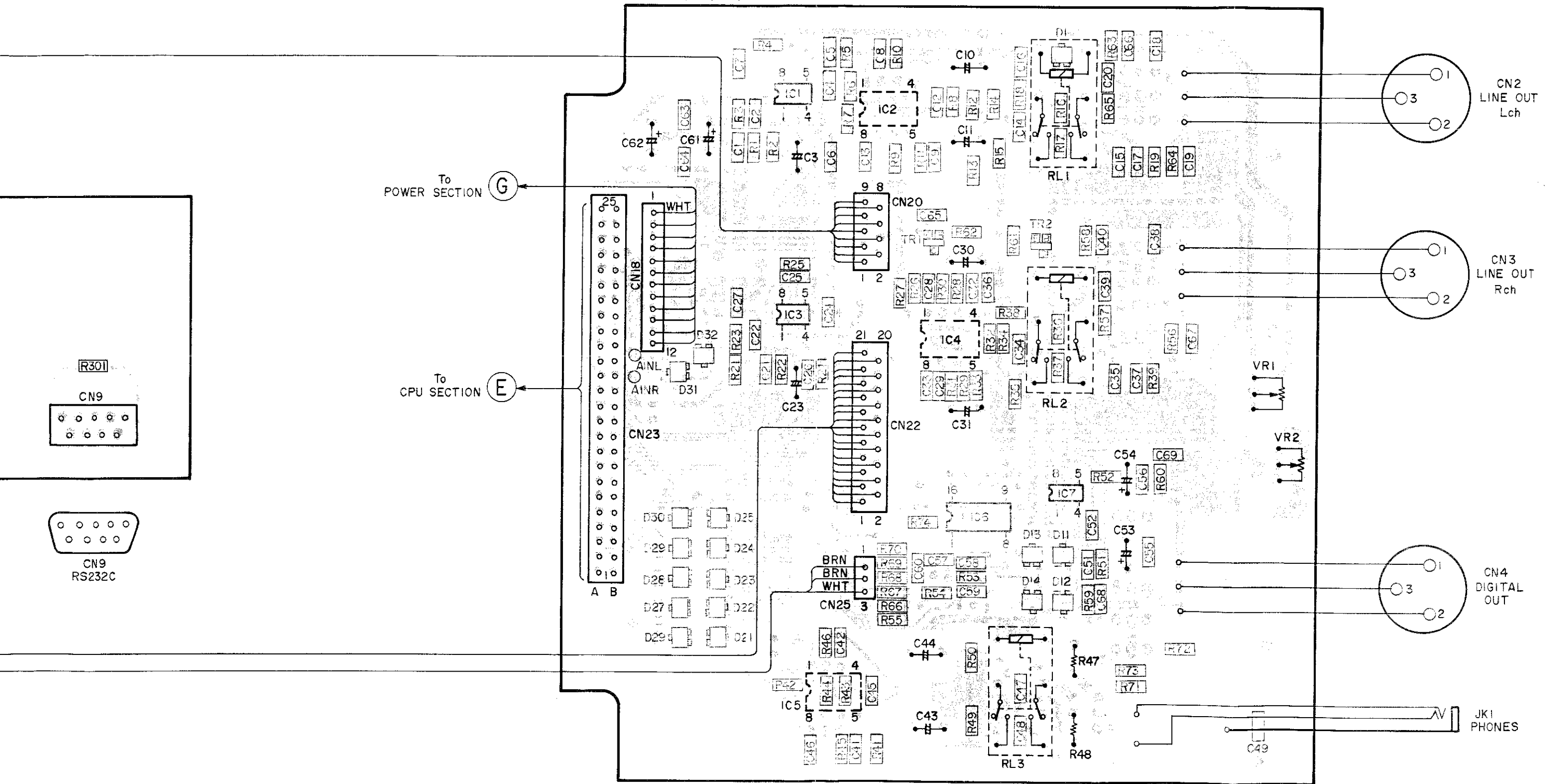

To POWER SECTION (G)

To CPU SECTION (E)

CN2
LINE OUT
Lch

CN3
LINE OUT
Rch

CN4
DIGITAL
OUT

JK1
PHONES

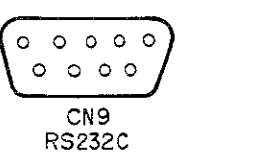
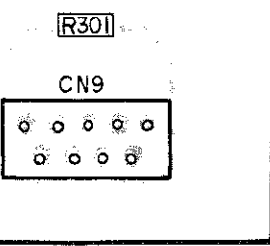

P.W.BOARD & WIRING DIAGRAM (CPU SECTION)

1

2

3

4

5

6

7

8

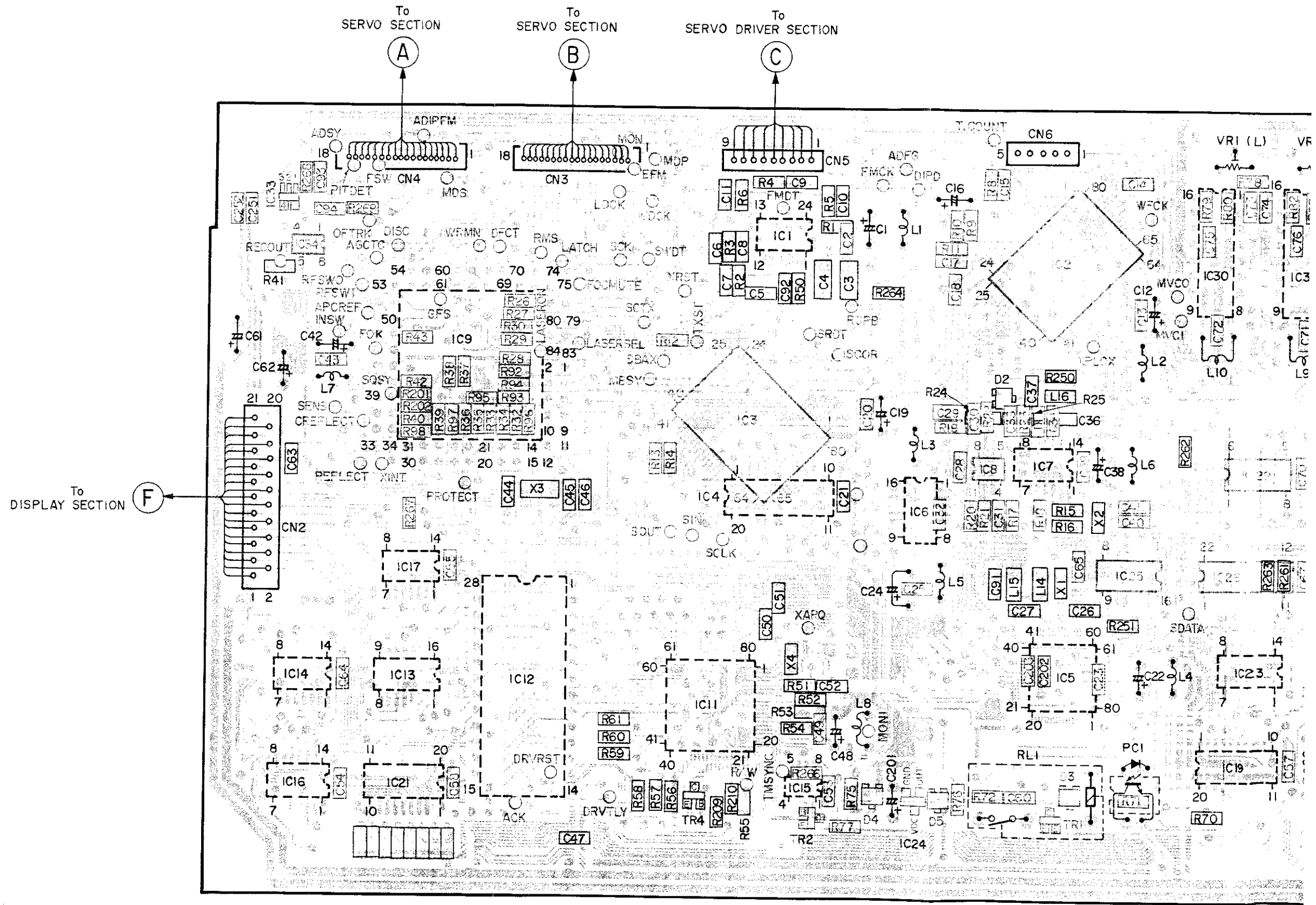

4 5 6 7 8 9 10 11

To SECTION
A

To SECTION
B

To SECTION
C

3U-2708-1

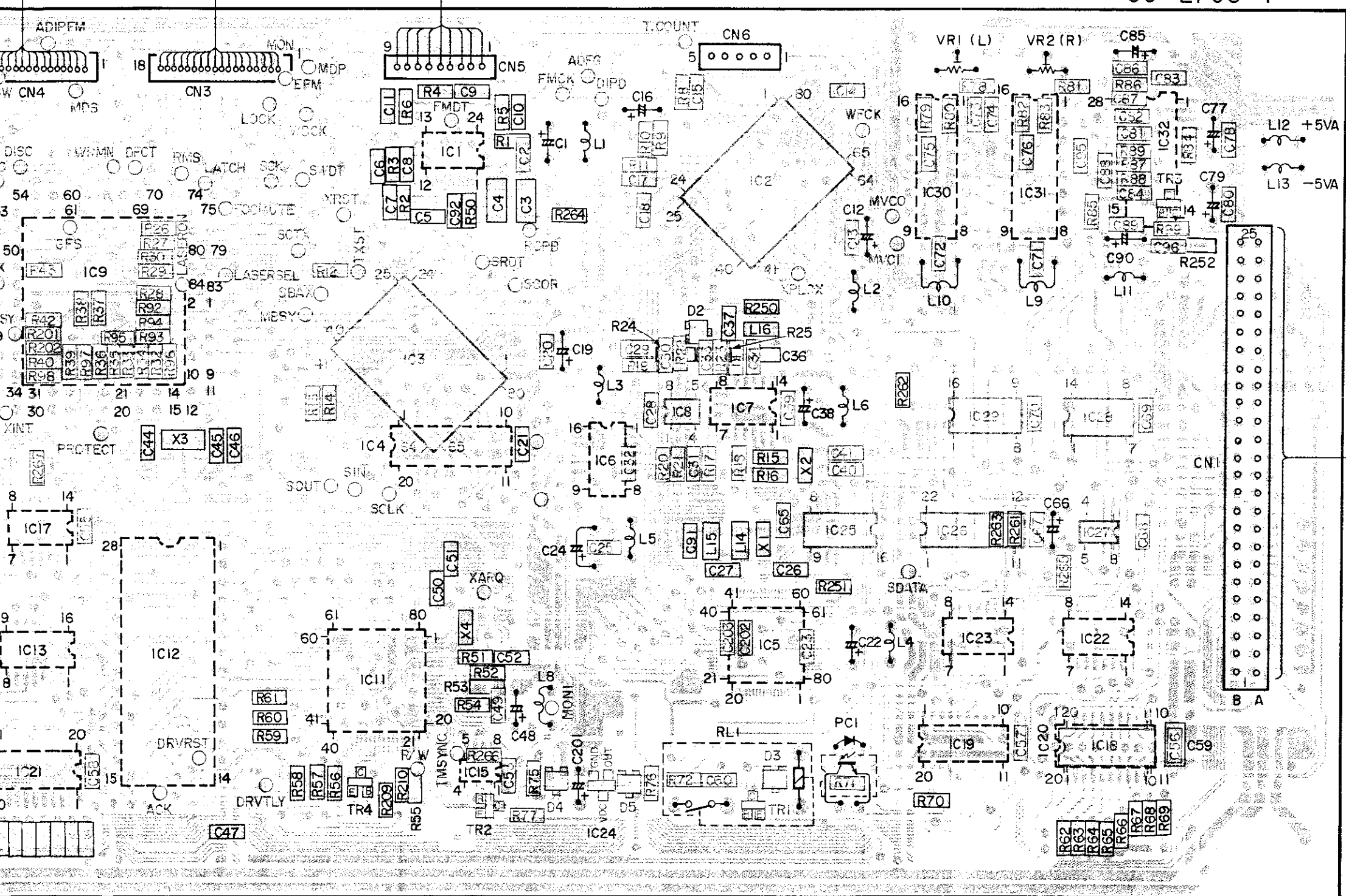

To SECTION
E
AUDIO SECTION

A
B
C
D
E

P.W.BOARD & WIRING DIAGRAM (DISPLAY & POWER SECTION)

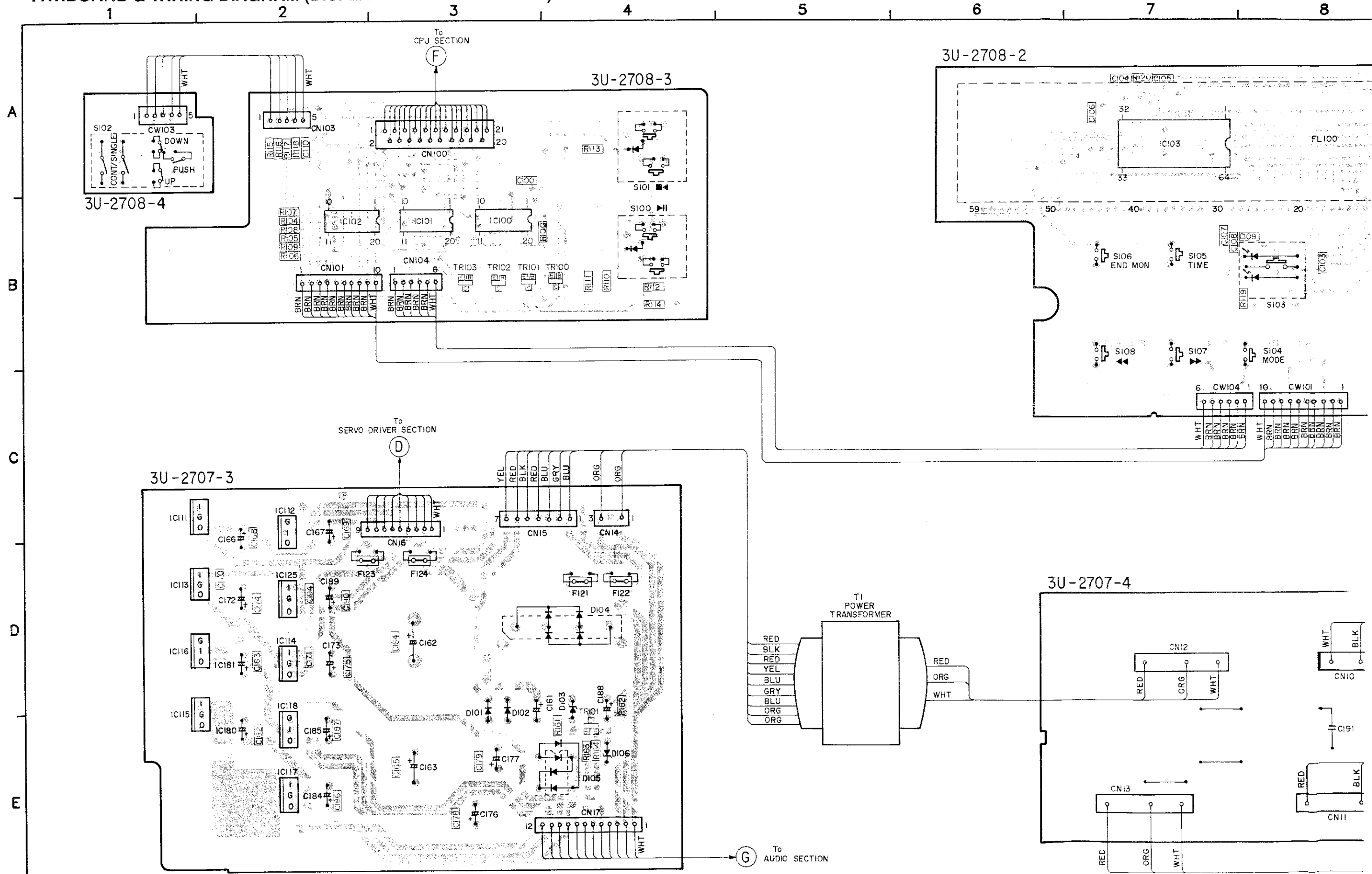

3U-2708-3

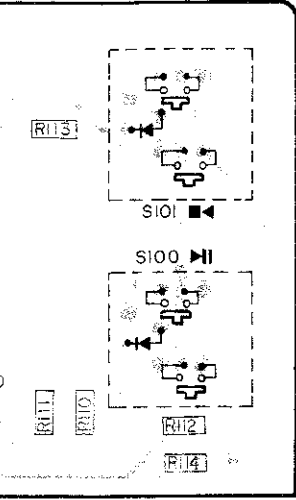

3U-2708-2

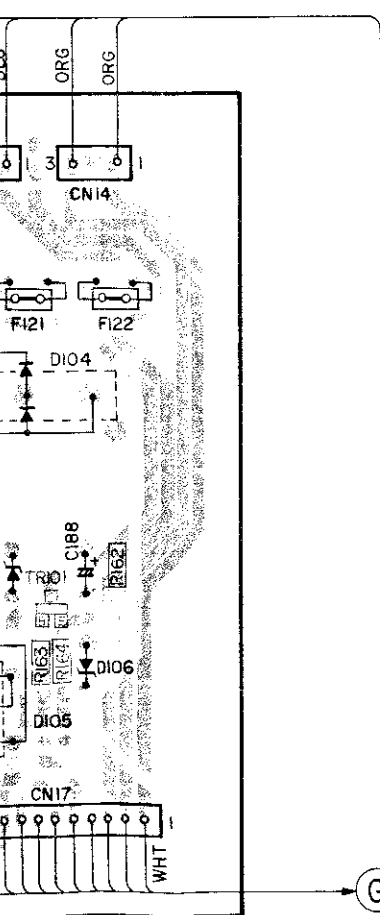
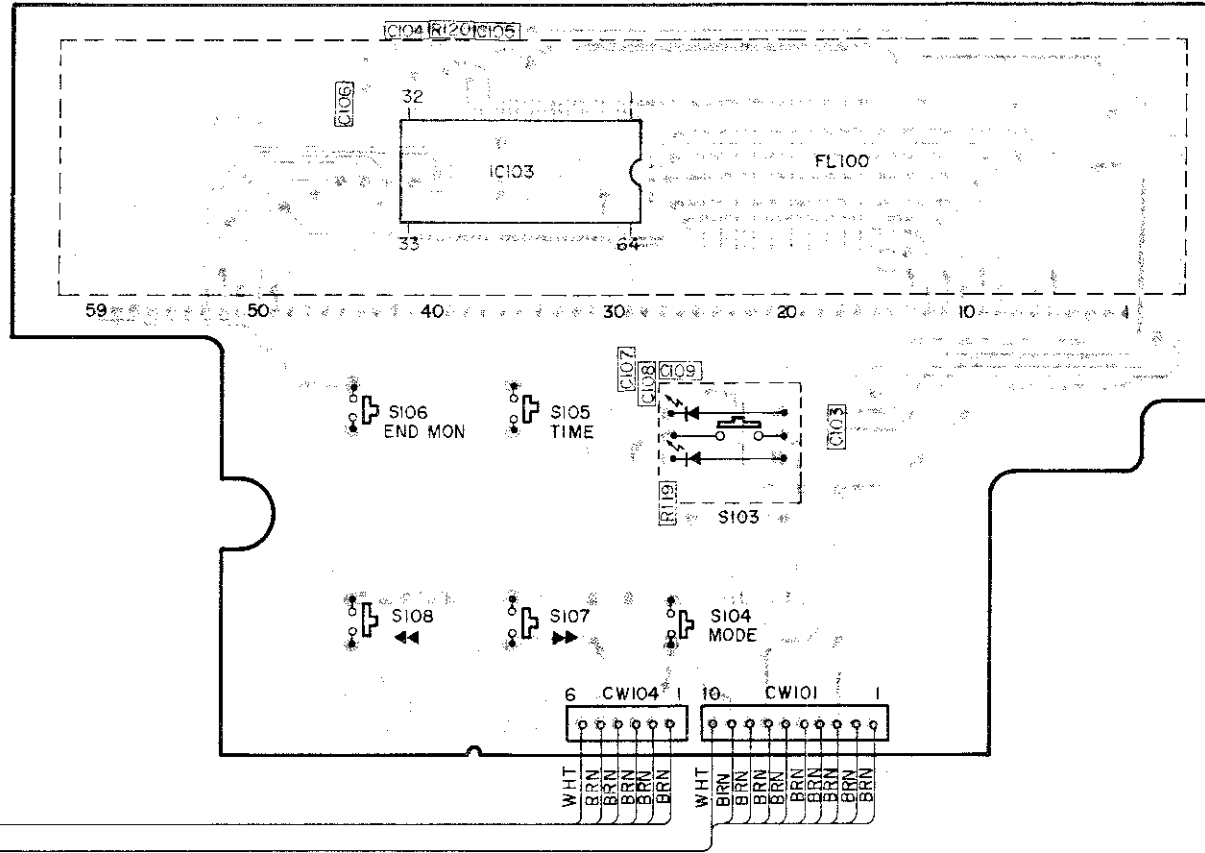

3U-2707-4

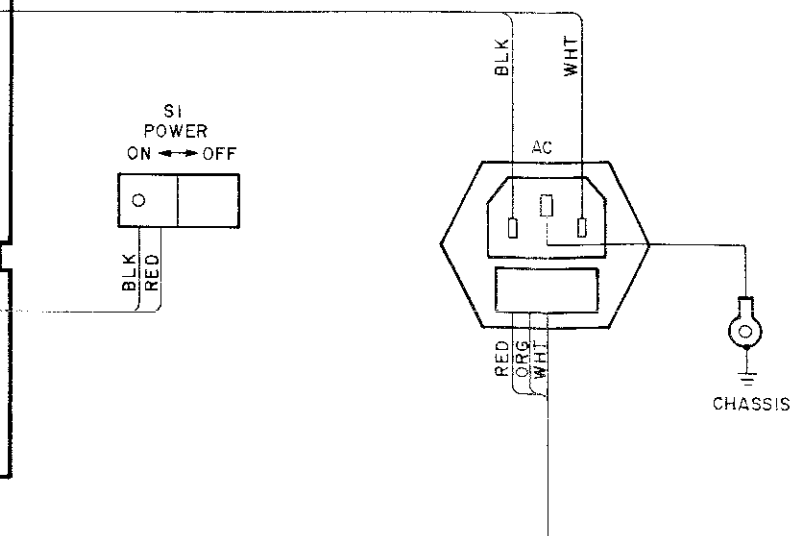
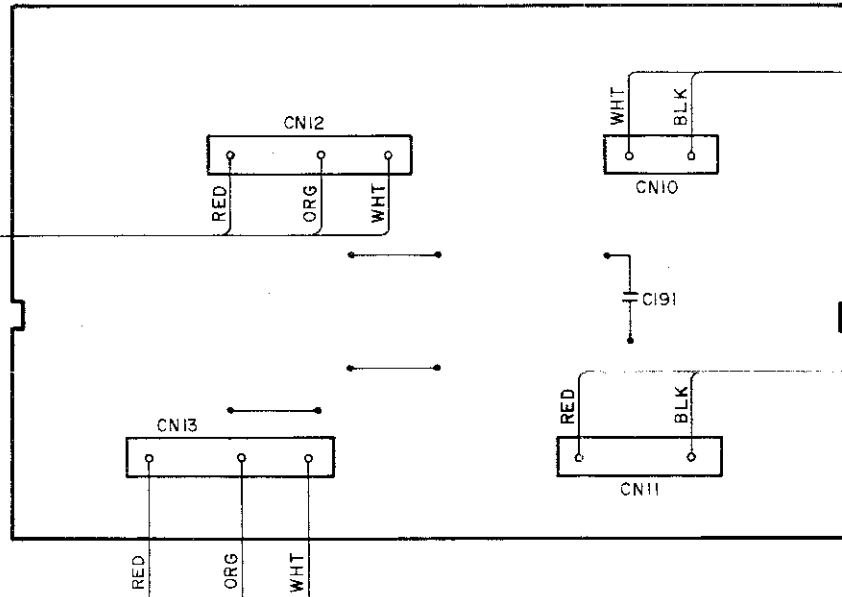

Ref. No.	Part No.	Part Name	Remarks
CAPACITORS GROUP			
C001	257 0007 926	Ceramic(Chip)1200pF/50V	CC73SL1H122JT +2125
C002	257 0005 931	Ceramic(Chip)200pF/50V	CC73SL1H201JT +2125
C003	254 3053 949	Electrolytic 100μF/16V (Bipolar)	CE04D1C101MBPT (SME)
C004	257 0003 988	Ceramic(Chip)47pF/50V	CC73SL1H470JT +2125
C005	257 0003 904	Ceramic(Chip)22pF/50V	CC73SL1H220JT +2125
C006,007	257 0014 935	Ceramic(Chip)0.1μF/25V	CK73F1E104ZT +2125
C008,009	257 0003 904	Ceramic(Chip)22pF/50V	CC73SL1H220JT +2125
C010,011	254 3053 708	Electrolytic 220μF/16V (Bipolar)	CE04D1C221MBPC(SME)
C012-015	257 0014 935	Ceramic(Chip)0.1μF/25V	CK73F1E104ZT +2125
C016,017	257 0005 986	Ceramic(Chip)330pF/50V	CC73SL1H331JT +2125
C018	257 0014 935	Ceramic(Chip)0.1μF/25V	CK73F1E104ZT +2125
C019,020	257 0003 988	Ceramic(Chip)47pF/50V	CC73SL1H470JT +2125
C021	257 0007 926	Ceramic(Chip)1200pF/50V	CC73SL1H122JT +2125
C022	257 0005 931	Ceramic(Chip)200pF/50V	CC73SL1H201JT +2125
C023	254 3053 949	Electrolytic 100μF/16V (Bipolar)	CE04D1C101MBPT (SME)
C024	257 0003 988	Ceramic(Chip)47pF/50V	CC73SL1H470JT +2125
C025	257 0003 904	Ceramic(Chip)22pF/50V	CC73SL1H220JT +2125
C026,027	257 0014 935	Ceramic(Chip)0.1μF/25V	CK73F1E104ZT +2125
C028,029	257 0003 904	Ceramic(Chip)22pF/50V	CC73SL1H220JT +2125
C030,031	254 3058 708	Electrolytic 220μF/16V (Bipolar)	CE04D1C221MBPC(SME)
C032-035	257 0014 935	Ceramic(Chip)0.1μF/25V	CK73F1E104ZT +2125
C036,037	257 0005 986	Ceramic(Chip)330pF/50V	CC73SL1H331JT +2125
C038	257 0014 935	Ceramic(Chip)0.1μF/25V	CK73F1E104ZT +2125
C039,040	257 0003 988	Ceramic(Chip)47pF/50V	CC73SL1H470JT +2125
C041,042	257 0003 904	Ceramic(Chip)22pF/50V	CC73SL1H220JT +2125
C043,044	254 3053 949	Electrolytic 100μF/16V (Bipolar)	CE04D1C101MBPT (SME)
C045,046	257 0014 935	Ceramic(Chip)0.1μF/25V	CK73F1E104ZT +2125
C047,048	257 0007 900	Ceramic(Chip)1000pF/50V	CC73SL1H102JT +2125
C049	257 0014 935	Ceramic(Chip)0.1μF/25V	CK73F1E104ZT +2125
C051,052	257 0004 961	Ceramic(Chip)100pF/50V	CC73SL1H101JT +2125
C053,054	254 4254 841	Electrolytic 100μF/16V	CE04W1C101MT (SME)
C055,056	257 0012 966	Ceramic(Chip)0.01μF/50V	CK73F1H103ZT +2125 (3U-2707 only)
C057,058	257 0003 904	Ceramic(Chip)22pF/50V	CC73SL1H220JT +2125
C059,060	257 1016 932	Ceramic(Chip)0.22μF/25V	CK73F1H224ZT +3216
C061,062	254 4254 841	Electrolytic 100μF/16V	CE04W1C101MT (SME)
C063-065	257 0014 935	Ceramic(Chip)0.1μF/25V	CK73F1E104ZT +2125
C066,067	257 0003 988	Ceramic(Chip)47pF/50V	CC73SL1H470JT +2125
C068,069	257 0003 988	Ceramic(Chip)47pF/50V	CC73SL1H470JT +2125 (3U-2707 only)
C101	254 4256 952	Electrolytic 220μF/25V	CE04W1E221MT (SME)
C102	257 0014 935	Ceramic(Chip)0.1μF/25V	CK73F1E104ZT +2125
C103	254 4256 952	Electrolytic 220μF/25V	CE04W1E221MT (SME)
C104	257 0014 935	Ceramic(Chip)0.1μF/25V	CK73F1E104ZT +2125
C105	254 3056 917	Electrolytic 1μF/50V (Bipolar)	CE04D1H010MBPT (SME)
C106	257 0005 944	Ceramic(Chip)220pF/50V	CC73SL1H221JT +2125
C110	257 0014 935	Ceramic(Chip)0.1μF/25V	CK73F1E104ZT +2125
C111	257 0003 946	Ceramic(Chip)33pF/50V	CC73SL1H330JT +2125
C112,113	257 0014 935	Ceramic(Chip)0.1μF/25V	CK73F1E104ZT +2125
C114	254 3053 949	Electrolytic 100μF/16V (Bipolar)	CE04D1C101MBPT (SME)
C116,117	257 0014 935	Ceramic(Chip)0.1μF/25V	CK73F1E104ZT +2125
C119	257 0005 960	Ceramic(Chip)270pF/50V	CC73SL1H271JT +2125
C120,121	257 0004 961	Ceramic(Chip)100pF/50V	CC73SL1H101JT +2125
C131	254 4256 952	Electrolytic 220μF/25V	CE04W1E221MT (SME)
C132	257 0014 935	Ceramic(Chip)0.1μF/25V	CK73F1E104ZT +2125
C133	254 4256 952	Electrolytic 220μF/25V	CE04W1E221MT (SME)
C134	257 0014 935	Ceramic(Chip)0.1μF/25V	CK73F1E104ZT +2125

Ref. No.	Part No.	Part Name	Remarks
C135	254 3056 917	Electrolytic 1μF/50V (Bipolar)	CE04D1H010MBPT (SME)
C136	257 0005 944	Ceramic(Chip)220pF/50V	CC73SL1H221JT +2125
C140	257 0014 935	Ceramic(Chip)0.1μF/25V	CK73F1E104ZT +2125
C141	257 0003 946	Ceramic(Chip)33pF/50V	CC73SL1H330JT +2125
C142,143	257 0014 935	Ceramic(Chip)0.1μF/25V	CK73F1E104ZT +2125
C144	254 3053 949	Electrolytic 100μF/16V (Bipolar)	CE04D1C101MBPT (SME)
C146,147	257 0014 935	Ceramic(Chip)0.1μF/25V	CK73F1E104ZT +2125
C149	257 0005 960	Ceramic(Chip)270pF/50V	CC73SL1H271JT +2125
C150-153	257 0004 961	Ceramic(Chip)100pF/50V	CC73SL1H101JT +2125
C161	254 4262 946	Electrolytic 47μF/63V	CE04W1J470MT (SME)
C162	254 6150 014	Electrolytic 12000μF/25V	CE68W1E123M (SMH)
C163	254 4256 790	Electrolytic 2200μF/25V	CE04W1E222MC (SME)
C164,165	257 0014 935	Ceramic(Chip)0.1μF/25V	CK73F1E104ZT +2125
C166,167	254 4252 930	Electrolytic 100μF/10V	CE04W1A101MT (SME)
C168-171	257 0014 935	Ceramic(Chip)0.1μF/25V	CK73F1E104ZT +2125
C172,173	254 4252 930	Electrolytic 100μF/10V	CE04W1A101MT (SME)
C164,175	257 0014 935	Ceramic(Chip)0.1μF/25V	CK73F1E104ZT +2125
C176,177	254 4258 798	Electrolytic 1000μF/35V	CE04W1V102MC
C178,179	257 1015 920	Ceramic(Chip)0.1μF/50V	CK73F1H104ZT +3216
C180,181	254 4256 949	Electrolytic 100μF/25V	CE04W1E101MT (SME)
C182,183	257 0014 935	Ceramic(Chip)0.1μF/25V	CK73F1E104ZT +2125
C184,185	254 4252 930	Electrolytic 100μF/10V	CE04W1A101MT (SME)
C186,187	257 0014 935	Ceramic(Chip)0.1μF/25V	CK73F1E104ZT +2125
C188	254 4262 946	Electrolytic 47μF/63V	CE04W1J470MT (SME)
C189	254 4252 930	Electrolytic 100μF/10V	CE04W1A101MT (SME)
C190	257 0014 935	Ceramic(Chip)0.1μF/25V	CK73F1E104ZT +2125
C191	253 9314 702	Ceramic(Chip)0.1μF/50VAC	CK73F1E104ZT +2125
C194	257 0014 935	Ceramic(Chip)0.1μF/25V	CK73F1E104ZT +2125

OTHER PARTS GROUP			
BF004-006	235 0089 009	EMI filter	
RL001-003	214 0109 005	Relay	
JK001	204 8198 008	H/P jack	
CN002-004	205 0428 009	3P CANNON connector	
CN005-007	205 0450 006	3P CANNON connector	(3U-2707 only)
CN010	205 0217 029	2P ULTR connector base	
CN011	205 0217 032	3P ULTR connector base	
CN012,013	205 0217 045	4P ULTR connector base	
CN014	205 0190 036	3P NH connector base	
CN015	205 0190 078	7P NH connector base	
CN016	205 0343 090	9P KR-PH connector base	
CN017	205 0375 026	12P KR-PH connector base	
CN018	205 0375 026	12P KR-PH connector base	
CN019	205 0702 055	9P FFC connector base (L)	(3U-2707 only)
CN020	205 0668 092	9P FFC connector base	
CN022	205 0668 047	21P FFC connector base	
CN023	205 0783 003	50P DIN connector base (S)	
JP001-006	205 0341 018	3P RE header	(3U-2707 only)
JP001-006	205 0339 004	JM jumper connector	(3U-2707 only)

WARNING:
 ● Parts marked with "△" and/shading have special characteristics important to safety. Be sure to use the specified parts for replacement.

SEMICONDUCTORS

• IC's

HD6413378F (IC11)

Micro-computer for Master Control
(3U-2708-1 CPU Unit)

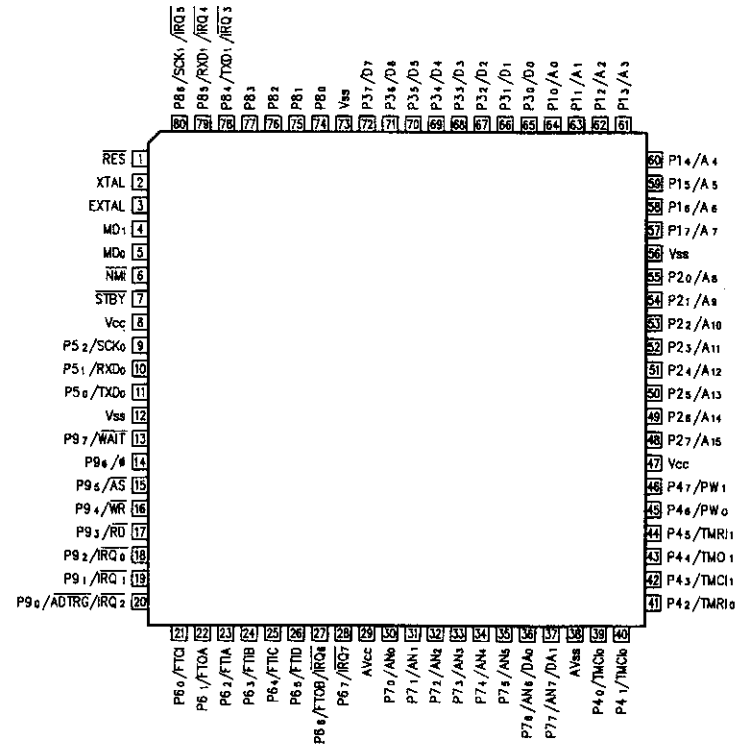
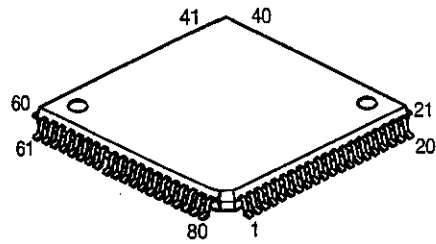

HD6413378F Terminal Function

Pin No.	Symbol	I/O	Function
1	RESET	I	System reset. "L" = Reset.
2	XTAL	I	14.7456MHz clock input.
3	EXTAL	O	14.7456MHz Clock Output.
4	MD1	I	GND.
5	MD0	I	Connect to pull up.
6	NMI	I	
7	STBY	I	
8	VCC	—	VDD (+5V).
9	SCK		
10	RXD	I	Serial remote data input.
11	TXD	O	Serial remote data output.
12	VSS	—	Ground (0V).
13	WAIT	I	Connect to pull up resistance.
14	φ	O	System clock output terminal.
15	AS	O	Address strobe terminal, "L": effective for address bus.
16	WR	O	External address write terminal.
17	RD	O	External address read terminal.
18	ACK	I	Acknowledge signal from Mech control micro computer (IC9).
19	TMSYNC	I	Time code sync signal from Mech control micro computer (IC9).
20	ROMDAT	I/O	Serial Data terminal for E ² PROM (IC15 X24C00).
21	R/W	O	Signal for request command to Mech control micro computer (IC9).
22	DCAL	O	Signal for finish calibration ("L": Finished).
23	STEREO	O	Control signal for mono and stereo ("H": Stereo).
24	—	I	
25	RECPRO	I	Record inhibit input terminal ("L": Record Inhibit).
26	EJINH	O	Eject lock output terminal ("H": Eject Inhibit).
27	LOADSET	I	Disc loading detect switch ("H": Disc Loading).

Pin No.	Symbol	I/O	Function
28	DRVTLY	I	Function mode select signal at REC and PLAY mode.
29	AVCC	—	Power supply (+5V).
30	—	I	Ground (0V).
31	—	I	Ground (0V).
32	—	I	Ground (0V).
33	—	I	Ground (0V).
34	—	I	Ground (0V).
35	—	I	Ground (0V).
36	—	I	Ground (0V).
37	—	I	Ground (0V).
38	AVSS	—	Ground.
39	—	I	
40	DAVRST	O	Reset signal for Mech control micro computer (IC9).
41	—	I	
42	ADRESET	O	Control signal for A/D converter offset calibration.
43	—	I	
44	OUTE	O	Enable signal for tally output and display (LED).
45	—	O	
46	AMUTE	O	Analogue mute signal output ("H": mute ON).
47	VCC	—	Power supply (+5V).
48	A15	O	External ROM address 15.
49	A14	O	External ROM address 14.
50	A13	O	External ROM address 13.
51	A12	O	External ROM address 12.
52	A11	O	External ROM address 11.
53	A10	O	External ROM address 10.
54	A9	O	External ROM address 9.
55	A8	O	External ROM address 8.
56	VSS	—	Ground (0V).
57	A7	O	External ROM address 7.
58	A6	O	External ROM address 6.
59	A5	O	External ROM address 5.
60	A4	O	External ROM address 4.
61	A3	O	External ROM address 3.
62	A2	O	External ROM address 2.
63	A1	O	External ROM address 1.
64	A0	O	External ROM address 0.
65	D0	I/O	External data bus 0.
66	D1	I/O	External data bus 1.
67	D2	I/O	External data bus 2.
68	D3	I/O	External data bus 3.
69	D4	I/O	External data bus 4.
70	D5	I/O	External data bus 5.
71	D6	I/O	External data bus 6.
72	D7	I/O	External data bus 7.
73	VSS	—	Ground (0V).
74	FLDA	O	Serial data output for FL display tube.
75	FLCK	O	Shift clock output for FL display tube.
76	FLCS	O	Chip select output for FL display tube.
77	ROMCLK	O	Read / Write clock output for E ² PROM IC15 X24C00.
78	SOUT	O	Serial data output terminal to Mech control micro computer IC9.
79	SIN	I	Serial data input terminal from Mech control micro computer IC9.
80	SCLK	O	Clock output for serial communication between Mech control micro computer IC9.

HD6473388GP (IC9)
Micro-computer for Mechanism Control
(3U-2708-1 CPU Unit)

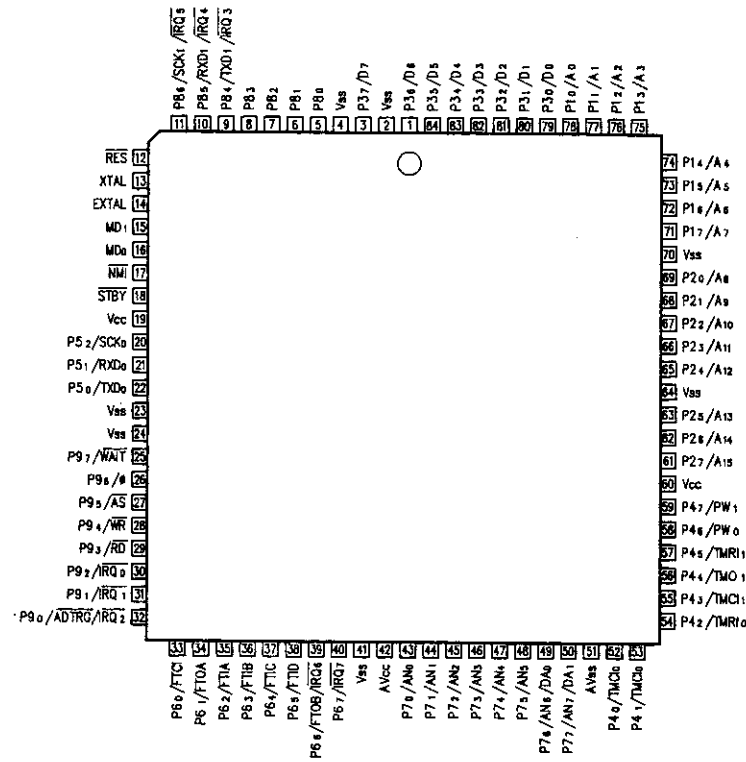
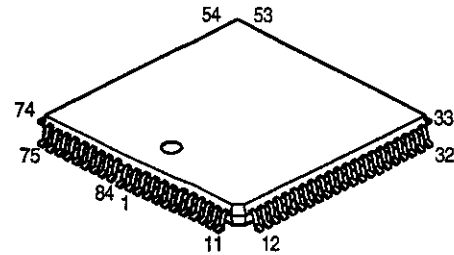

HD6473388GP Terminal Function

Pin No.	Symbol	I/O	Function
1	VCOON	O	VCO control signal ("H": on) at REC.
2	VSS	—	Ground (0V).
3	DIN. INH	O	Digital in control signal ("L": ON) at REC.
4	VSS	—	Ground (0V).
5			Not used.
6			Not used.
7	TMSYNC	O	Time code sync output signal.
8	ACK	O	Output terminal of interface acknowledge signal between servo control (IC9) and system control (IC11).
9	SIN	O	Serial data output for system control (IC11).
10	SOUT	I	Signal data input from system control (IC11).
11	SCLK	I	Clock input for serial communication between system control (IC11).
12	DRVRST	I	Reset signal input from system control (IC11) ("L": Reset).
13	XTAL	I	16.0MHz clock input.
14	EXTAL	O	16.0MHz clock output.
15			VDD (+5V).
16			VDD (+5V).
17			VDD (+5V).
18			VDD (+5V).
19	VCC		VDD (+5V).
20	SCK	O	Serial clock output for applying command input to IC2, IC3, IC5, IC26, & IC202.
21	SRDT	I	Serial data input for applying command to IC2 and IC3.
22	SWDT	O	Serial data output for applying command to IC2 and IC3.
23	VSS	—	VSS
24	VSS	—	VSS
25	R/W	I	Communication start trigger for Micro Computer (Read/Write recognition Signal).
26	REFLECT	I	Reflection ratio detect switching signal input ("L": High reflection, "H": Low reflection).
27	SENS	I	Status line for control of CD input of sense from IC202 and IC2.
28			
29	CRELECT	I	Reflection ratio detect signal in the circuit ("L": Low reflection).
30	DQSY	I	U-bit CD format sub-code Q sync input signal from IC2.

Pin No.	Symbol	I/O	Function
31	RECOUT	I	Off track detect signal during recording status.
32	XINT	I	Input for request of interrupt, comes to "L" when interrupt status.
33	XWRG	O	Magnetic modulation drive ON control ("L": ON).
34	DRVTLY	O	Tally output signal (PLAY/REC start). "L": Tally output.
35			Not used.
36	PITDET	I	Recordable MD pit area or groove area detect signal ("H": Pit area).
37	HDDOWNST	I	Magnetic head down position detect ("L": Down position).
38	HDUPST	I	Magnetic head up position detect ("L": Up position).
39	ADSY	I	ADIP sync input signal from IC2 CXD2525.
40	SQSY	I	Sub-code Q sync. input signal from IC2 CXD2525.
41	VSS	—	Ground (0V).
42	5V		VDD (+5V).
43			Ground (0V).
44	INSW	I	When pick-up is around the innermost circle detected by inner circle, inner switch to "L".
45	FOK	I	Indication of condition for focus servo. Normally "H" when focus servo is proper.
46	LOCK	I	Indication of lock condition for CLV servo. Normally "H" when CLV servo is proper.
47	GFS	I	Indication of condition for frame synchro. Normally "H" when CLV is proper.
48			Ground (0V).
49	APCREF	O	Read laser power and REC laser power control D/A output (Read power 0.42V, Rec Power 1.75V-3.5V).
50			Not used.
51	AVSS	—	Ground (0V).
52	RFSW0	O	Servo control ("H": High reflection disc, "L": low reflection disc).
53	RFSW1	O	Servo control ("H": Pit line, "L": Groove).
54	AGCTC	O	Auto gain control (AGC), Time constant select ("H": Large, "L": Small).
55	DIRC	O	Directional reversion control at time of track jump ("L": Directional reversion).
56	RECMONI	O	Track out defect circuit control during recording.
57	HD. DOWN	O	Magnetic head down control ("H": Head down control).
58	HD. UP	O	Magnetic head up control ("H": Head up control).
59			Not used.
60	VCC	—	Power supply (+5V).
61			Not used.
62			Not used.
63	VARION	O	Clock selection for variable pitch ("H": Normal, "L": +2% speed)
64	VSS	—	Ground (0V).
65	MD2	O	ON/OFF control for digital audio output ("H": ON).
66	RCPB	O	"L" for playback mode, "H" for recording mode.
67	SBMN	O	SBMN output, record depend on "L": DCT, "H": SDCT.
68	WRMN	O	Write/Monitor mode select, "L": Monitor, "H": Write.
69	SCTX	O	Enable signal output for output the data at recording status.
70	VSS	—	Ground (0V).
71	MODESEL	I	+5V
72			Not used.
73			Not used.
74	DLAT	O	Latch output for applying command input to IC26 SM5841.
75			Not used.
76	XRSTA	O	Reset signal for IC5 CXD2531 ("L": Reset).
77	XRST	O	Reset signal for IC202, 2, & 3 ("L": Reset).
78	LATCH	O	Latch output for applying command input to IC202, 2, 3 & 5.
79	DFCT	O	Defect detection circuit ON/OFF control signal ("H" ON, "L": OFF).
80	FOCMUTE	O	Focus offset "OFF" control at Focus servo "ON", ("L": at Focus search, "H": Normal).
81	LASERSEL	O	Laser power select control ("L": RMD, "H": PMD).
82	AUTOSEL	O	ON/OFF control for auto slicer circuit. ("L": ON, "H": OFF).
83	RMS	O	Laser power HF super position circuit control ("L": ON, "H": OFF).
84	LASERON	O	Laser power ON/OFF control ("H": ON, "L": OFF).

**CXD2531BR (IC5)
ATRAC Encoder/Decoder
(3U-2708-1 CPU Unit)**

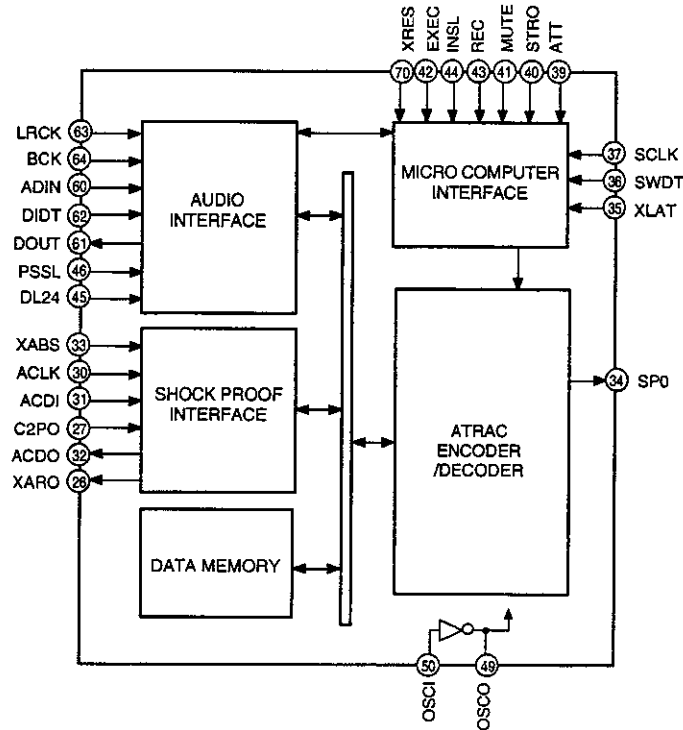
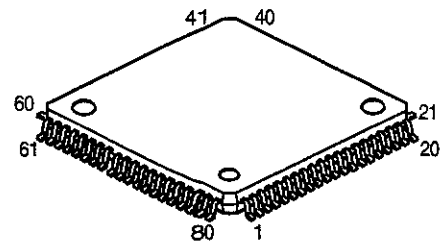

CXD2531BR Terminal Function

Pin No.	Symbol	I/O	Function
1	TA9	I/O	Ground (0V).
2	TA10	I/O	Ground (0V).
3	TA11	I/O	Ground (0V).
4	TD0	I/O	Ground (0V).
5	TD1	I/O	Ground (0V).
6	TD2	I/O	Ground (0V).
7	TD3	I/O	Ground (0V).
8	Vss	—	Ground (0V).
9	TD4	I/O	Ground (0V).
10	TD5	I/O	Ground (0V).
11	TD6	I/O	Ground (0V).
12	TD7	I/O	Ground (0V).
13	TD8	I/O	Ground (0V).
14	TD9	I/O	Ground (0V).
15	TD10	I/O	Ground (0V).
16	TD11	I/O	Ground (0V).
17	TS0	I	Ground (0V).
18	TS1	I	Ground (0V).
19	Vss	—	Ground (0V).
20	TS2	I	Ground (0V).
21	TS3	I	Ground (0V).
22	TD12	I/O	Ground (0V).
23	TD13	I/O	Ground (0V).
24	TD14	I/O	Ground (0V).
25	TD15	I/O	Ground (0V).
26	XARQ	O	Data request output to Shock Proof Memory Controller.
27	C2PO	I	C2PO input of output data from Shock Proof Memory Controller.
28	Vss	—	Ground (0V).
29	VDD	—	Power supply (+5V).
30	ACLK	I	Clock input of Serial Data transfer from Shock Proof Memory Controller.

Pin No.	Symbol	I/O	Function
31	ACDI	I	Data input from Shock Proof Memory Controller.
32	ACDO	O	Data output to Shock Proof Memory Controller.
33	XABS	I	Latch input from Shock Proof Memory Controller.
34	SPO	O	22.5792MHz (512Fs) output.
35	XLAT	I	Latch input from CPU.
36	SWDT	I	Data input from CPU.
37	SCLK	I	Clock input from CPU.
38	Vss	—	Ground (0V).
39	ATT	I	Not used.
40	STRO	I	Not used.
41	MUTE	I	Not used.
42	EXEC	I	Not used.
43	REC	I	Not used.
44	INSL	I	Not used.
45	DL24	I	Not used.
46	PSSL	I	Not used.
47	EXIR	I	Ground (0V).
48	Vss	—	Ground (0V).
49	OSCO	O	Output of 45.1584MHz (1024Fs) X'tal osc circuit.
50	OSCI	I	Input of 45.1584MHz X'tal osc circuit.
51	TD16	I/O	Ground (0V).
52	TD17	I/O	Ground (0V).
53	TD18	I/O	Ground (0V).
54	TD19	I/O	Ground (0V).
55	TD20	I/O	Ground (0V).
56	TD21	I/O	Ground (0V).
57	TD22	I/O	Ground (0V).
58	TD23	I/O	Ground (0V).
59	Vss	—	Ground.
60	ADIN	I	Audio data input of Analog Rec from A/D Converter.
61	DOUT	O	Audio data output to EFM/ACIRC Encoder/Decoder.
62	DIDT	I	Audio data input of Digital Rec from EFM/ACIRC Encoder/Decoder.
63	LRCK	I	44.1kHz (Fs) input from EFM/ACIRC Encoder/Decoder.
64	BCK	I	2.8224MHz (64Fs) input from EFM/ACIRC Encoder/Decoder.
65	SICK	I	Connect to power supply (+5V).
66	IDSI	I	Connect to power supply (+5V).
67	XILT	I	Connect to power supply (+5V).
68	Vss	—	Ground.
69	VDD	—	Power supply (+5V).
70	XRES	I	System reset. At "L" = Reset.
71	TA0	I/O	Ground (0V).
72	TA1	I/O	Ground (0V).
73	TA2	I/O	Ground (0V).
74	TA3	I/O	Ground (0V).
75	TA4	I/O	Ground (0V).
76	TA5	I/O	Ground (0V).
77	TA6	I/O	Ground (0V).
78	Vss	—	Ground.
79	TA7	I/O	Ground (0V).
80	TA8	I/O	Ground (0V).

CXD2525Q (IC2)
EFM/ACIRC Encoder/Decoder
(3U-2708-1 CPU Unit)

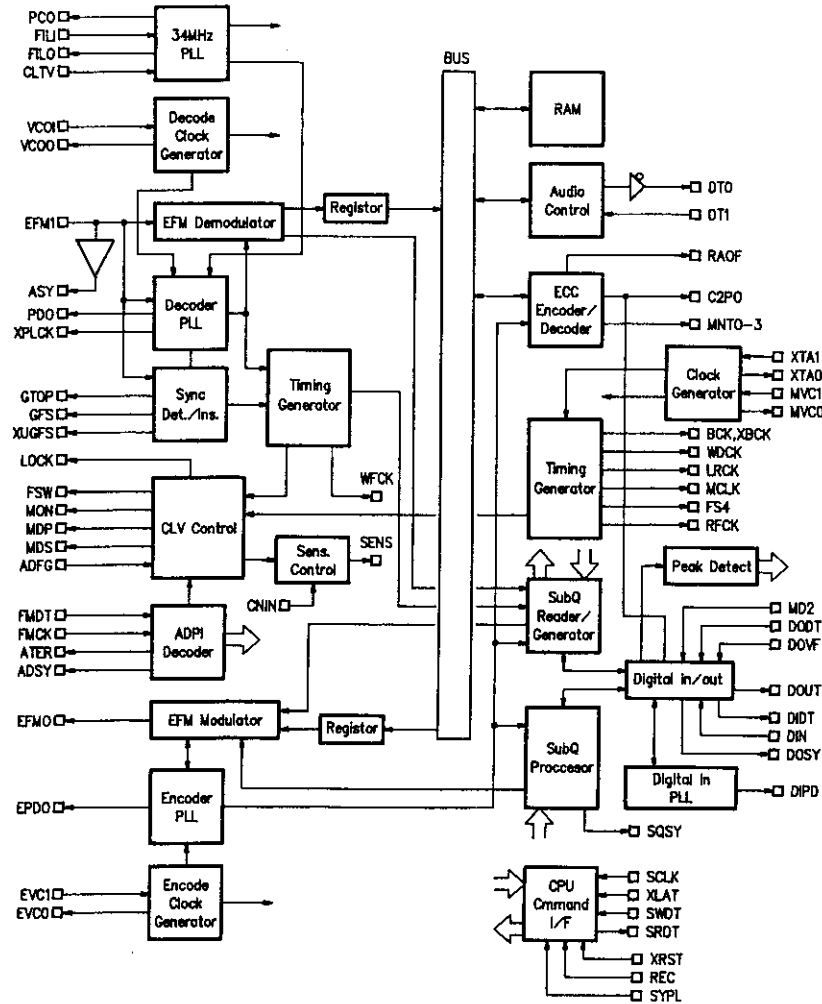
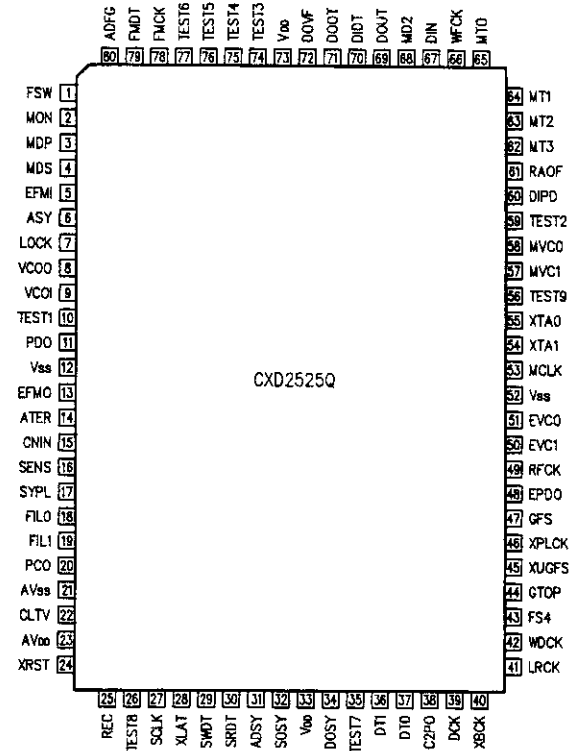
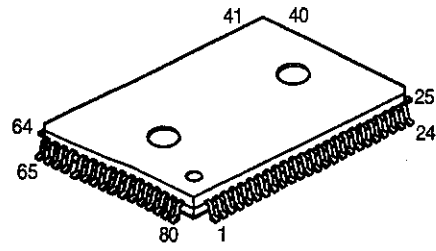

CXD2525Q Terminal Function

Pin No.	Symbol	I/O	Function
1	FSW	O 1,Z,0	Output filter shifting output of spindle motor. At CLV-P: "Z", others: "L".
2	MON	O 1,0	ON/OFF control output for spindle motor. At "H": On
3	MDP	O 1,Z,0	Servo control for spindle motor.
4	MDS	O 1,Z,0	Servo control for spindle motor.
5	EFMI	I	EFM input at playback.
6	ASY	O 1,0	EFM full swing output at playback.
7	LOCK	O 1,0	Lock mode monitor of spindle servo (CLV). Lock at "H".
8	VCOO	O 1,0	EFM decoder. Analog PLL oscillation output (196Fs=8.6436MHz).
9	VCOI	I	EFM decoder. Analog PLL oscillation input.
10	TEST1	I	Ground (0V).
11	PDO	O 1,Z,0	EFM decoder. Analog PLL phase comparing output.
12	VSS	—	Digital ground.
13	EFMO	O 1,0	EFM output at record mode.
14	ATER	O 1,0	ADIP CRC flag output. "H" to error.
15	CNIN	I	Number of track jump count signal input.
16	SENS	O 1,Z,0	Inner status output to address of serial bus.
17	SYPL	I	Polarity shifting input of SQSY, ADSY, DQSY, MQSY. "H" to active High.
18	FILO	O Analog	Filter output for Master PLL.
19	FILI	I	Filter input for Master PLL.
20	PCO	O 1,Z,0	Charge Pump output for Master PLL.
21	AVSS	—	Analog ground.
22	CLTV	I	VCO control voltage input for Master PLL.
23	AVDD	—	Analog power supply (+5V).
24	XRST	I	System reset. "L": Active.
25	REC	I	"L" = Decoder, "H" = Encoder.
26	TEST8	I	Connect to ground.
27	SCLK	I	Clock input of Serial Bus.
28	XLAT	I	Latch input of Serial Bus.
29	SWDT	I	Data input of Serial Bus.
30	SRDT	O 1,Z,0	Data output of Serial Bus.
31	ADSY	O 1,0	Sync output of ADIP.
32	SQSY	O 1,0	Sync output of Sub-Q.
33	VDD	—	Digital power supply (+5V).
34	DQSY	O 1,0	Sub-code Q sync (SCOR) output of digital in U-bit CD format.
35	TEST7	O 1,0	Not used.
36	DTI	I	Audio data input from Shock Proof Memory Controller.
37	DT0	O 1,Z,0	Audio data output to Shock Proof Memory Controller. At "Z": Rec
38	C2PO	O 1,0	C2PO at playback, D in-VFLAG at Digital REC, O at Analogue REC.
39	BCK	O 1,0	2.8224MHz output. (MCLK system)
40	XBCK	O 1,0	BCK reverse output. (MCLK system)
41	LRCK	O 1,0	44.1kHz (Fs) output. (MCLK system)
42	WDCK	O 1,0	88.2kHz output. (MCLK system)
43	FS4	O 1,0	176.4kHz output. (MCLK system)
44	GTOP	O 1,0	"H" to release of sync protection window. (INPUT EFM SYNC monitor output)
45	XUGFS	O 1,0	"L" to unguarded frame sync. (INPUT EFM SYNC monitor output)
46	XPLCK	O 1,0	EFM decoder. PLL clock output. (98Fs=4.3218MHz)
47	GFS	O 1,0	"H" to frame sync OK. (INPUT EFM SYNC monitor output)
48	EPDO	O 1,Z,0	EFM encoder. External PLL phase comparing output. Freq.: Low → "H".
49	RFCK	O 1,0	7.35kHz output. (MCLK system)
50	EVCI	I	VCO input for EFM Encoder PLL. (196Fs=8.6436MHz)
51	EVCO	O 1,0	VCO output for EFM Encoder PLL. (196Fs=8.6436MHz)
52	VSS	—	Digital ground.
53	MCLK	O 1,0	22.5792MHz output.
54	XTAI	I	Input of 22.5792MHz (512Fs) X'tal osc circuit.

Pin No.	Symbol	I/O	Function
55	XTAO	O	1,0 Output of 22.5792MHz X'tal osc circuit.
56	TEST9	I	Ground (0V).
57	MVCI	I	VCO input for Digital in PLL. (512Fs=22.5792MHz)
58	MVCO	O	1,0 VCO output for Digital in PLL. (512Fs=22.5792MHz)
59	TEST2	O	1,0 Not used.
60	DIPD	O	1,Z,0 Charge Pump output for Digital in PLL. Freq.: low → "L".
61	RAOF	O	1,0 RAM overflow output. (Monitor output of decoder)
62	MT3	O	1,0 Correction state monitor output in playback.
63	MT2	O	1,0 Correction state monitor output in playback.
64	MT1	O	1,0 Correction state monitor output in playback.
65	MT0	O	1,0 Correction state monitor output in playback.
66	WFCK	O	1,0 7.35kHz output. (EFM decoder PLL system at playback, EFM encoder PLL system at record)
67	DIN	I	Digital-in input terminal.
68	MD2	I	Digital-out ON/OFF control. At "H": ON.
69	DOUT	O	1,0 Digital-out output terminal.
70	DIDT	O	1,0 Audio data output of Digital Rec to ATRAC Encoder/Decoder.
71	DODT	I	Audio data input from ATRAC Encoder/Decoder.
72	DOVF	I	Ground (0V).
73	VDD	—	Digital power supply (+5V).
74	TEST3	I	Ground (0V).
75	TEST4	O	1,0 Not used.
76	TEST5	I	Ground (0V).
77	TEST6	I	Ground (0V).
78	FMCK	I	Clock input for ADIP read out. (6.3kHz)
79	FMDT	I	ADIP data input.
80	ADFG	I	ADIP carrier signal input. (22.05kHz)

CXA1082BQ Terminal Function

Pin No.	Symbol	I/O	Function
1	VC	—	Ground (0V).
2	FGD	I	Connect capacitor between this terminal and FS3 in case reducing high frequency range gain of focus servo.
3	FS3	O	Shift the high frequency range gain of focus servo by FS3 ON/OFF.
4	FLB	—	External time constant terminal for low frequency range raising of focus servo.
5	FEO	O	Focus drive output.
6	FE-	I	Reverse input terminal of focus amp.
7	SRCH	—	External time constant terminal for providing focus servo waveform.
8	TGU	—	External time constant terminal for high frequency range gain shifting of tracking.
9	TG2	—	External time constant terminal for high frequency range gain shifting of tracking.
10	AVCC	—	VCC (+5V).
11	TAO	O	Tracking drive output.
12	TA-	I	Reverse input terminal of tracking amp.
13	SL+	I	Non-reverse input terminal of sled amp.
14	SLO	O	Sled drive output.
15	SL-	I	Reverse input terminal of sled amp.
16	SSTOP	I	Terminal of ON/OFF detection for innermost circle of disc detecting limit switch.
17	FSET	I	Setting terminal for focus tracking phase compensation peak and CLV LPF fo.
18	SENS	O	Outputs FZC, AS, TZC, SSTOP, BUSY, etc by command from CPU.
19	AVEE	—	VEE (-5V).
20	C.OUT	O	Not used.
21	DIRC	I	Used for 1-track jump. A 47kohms pull-up resistor is inserted.
22	XRST	I	Reset input terminal. Resets at "L".
23	DATA	I	Serial data input from CPU.
24	XLT	I	Latch input from CPU.
25	CLK	I	Serial data transfer clock input from CPU.
26	DGND	—	Ground (0V).
27	BW	I	Not used.
28	PDI	I	Ground (0V).
29	ISET	—	Flows current deciding height of focus search, track jump, sled kick.
30	VCOF	—	VCO free-run frequency approx. proportion to the resistance value between this terminal and Pin31.
31	3.5V	—	Not used.
32	C864	O	Not used.
33	LOCK	I	Not used.
34	MDP	—	Connecting terminal of MDP terminal of CXD2525.
35	MON	—	Connecting terminal of MON terminal of CXD2525.
36	FSW	—	External LPF time constant terminal of CLV servo error signal.
37	DVCC	—	VCC (5V).
38	SPDL-	I	Reverse input terminal of spindle drive amp.
39	SPDLO	O	Spindle drive output.
40	WDCK	I	Clock input for auto sequence.
41	FOK	I	FOK signal input terminal.
42	MIRR	I	Mirror signal input terminal.
43	DVEE	—	VEE (-5V).
44	DFCT	I	Defect signal input terminal. Actuates defect countermeasure circuit at "H".
45	TE	I	Tracking error signal input terminal.
46	TZC	I	Input terminal of tracking zero cross comparator.
47	ATSC	I	Input terminal of window comparator for ATSC detection.
48	FE	I	Input terminal of focus error signal.

**CXA1082BQ (IC202)
SERVO SIGNAL PROCESSOR
(3U-2703-1 Servo Unit)**

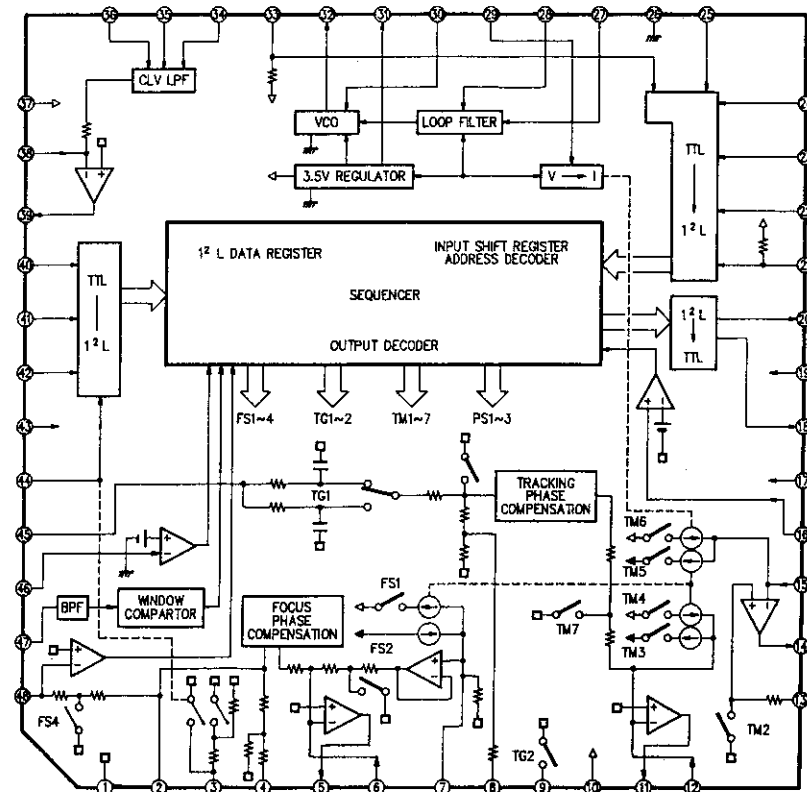
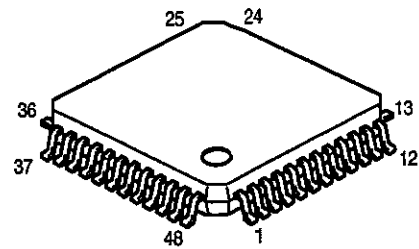

**CXD2526Q (IC3)
SHOCK PROOF MEMORY
(3U-2708-1 CPU Unit)**

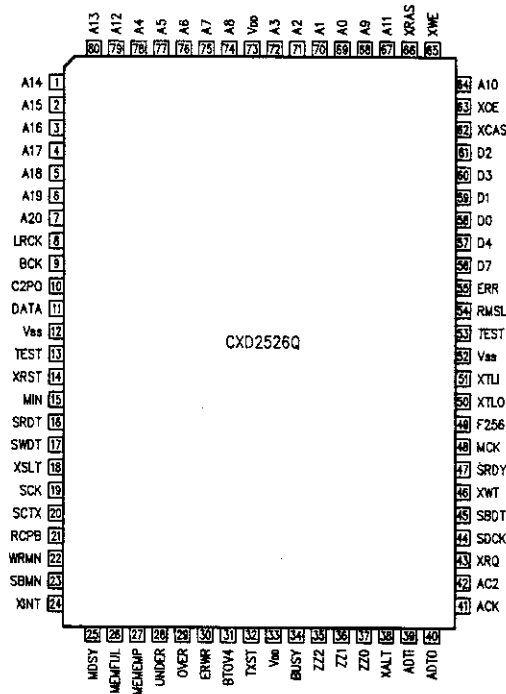
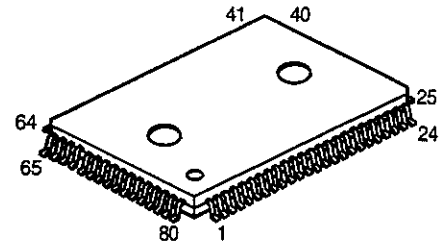

CXD2526Q Terminal Function

Pin No.	Symbol	I/O	Function
1	A14	O	Not used.
2	A15	O	Not used.
3	A16	O	Not used.
4	A17	O	Not used.
5	A18	O	Not used.
6	A19	O	Not used.
7	A20	O	Not used.
8	LRCK	I	LRCK input from EFM Decoder/Encoder.
9	BCK	I	BCK input from EFM Decoder/Encoder.
10	C2PO	I	C2PO input from EFM Decoder.
11	DATA	I/O	At playback: Outputs data from decoder. At record: Inputs data to encoder.
12	VSS	—	Ground (0V).
13	TEST	I	Ground (0V).
14	XRST	I	System reset. At "L" = Reset.
15	MIN	I	Not used.
16	SRDT	O	Serial Data output to CPU.
17	SWDT	I	Serial Data input from CPU.
18	XSLT	I	Latch input from CPU.
19	SCK	I	Clock input of Serial Data transfer from CPU.
20	SCTX	I	In record mode, enable signal input of data output.
21	RCPB	I	"L" : Playback mode/"H" : Record mode.
22	WRMN	I	"H" : Write mode/"L" : Monitor mode.
23	SBMN	I	"H" : Record input signal based on SDCT/"L" : Record based on DCT.
24	XINT	O	Interrupt request output terminal. Interrupt status occurs : "L".
25	MDSY	O	MD sync detection signal of input data.
26	MFMFUL	O	Not used.
27	MEMEMP	O	Not used.
28	UNDER	O	Not used.
29	OVER	O	Not used.
30	ERWR	O	Not used.
31	BTOV4	O	Not used.
32	TXST	O	Not used.
33	VDD	—	Power supply (+5V).
34	BUSY	I/O	Not used.
35	ZZ2	I	Ground (0V).
36	ZZ1	I	Ground (0V).
37	ZZ0	I	Ground (0V).
38	XALT	O	Latch output to ATRAC Encoder/Decoder.
39	ADTI	I	Data input from ATRAC Encoder/Decoder.
40	ADTO	O	Data output to ATRAC Encoder/Decoder.
41	ACK	O	Clock output of Serial Data transfer to ATRAC Encoder/Decoder.
42	AC2	O	C2PO output of output data to ATRAC Encoder/Decoder.
43	XRQ	I	Data request input from ATRAC Encoder/Decoder.
44	SDCK	I	Ground (0V).
45	SBDT	I/O	Power supply (+5V).
46	XWT	O	Not used.
47	SRDY	O	Not used.
48	MCK	O	Not used.
49	F256	O	256Fs output.
50	XTLO	O	Not used.
51	XTLI	I	System clock input (22.5792MHz).
52	VSS	—	Ground (0V).
53	TEST	I	Ground (0V).
54	RMSL	I	Ground (0V).

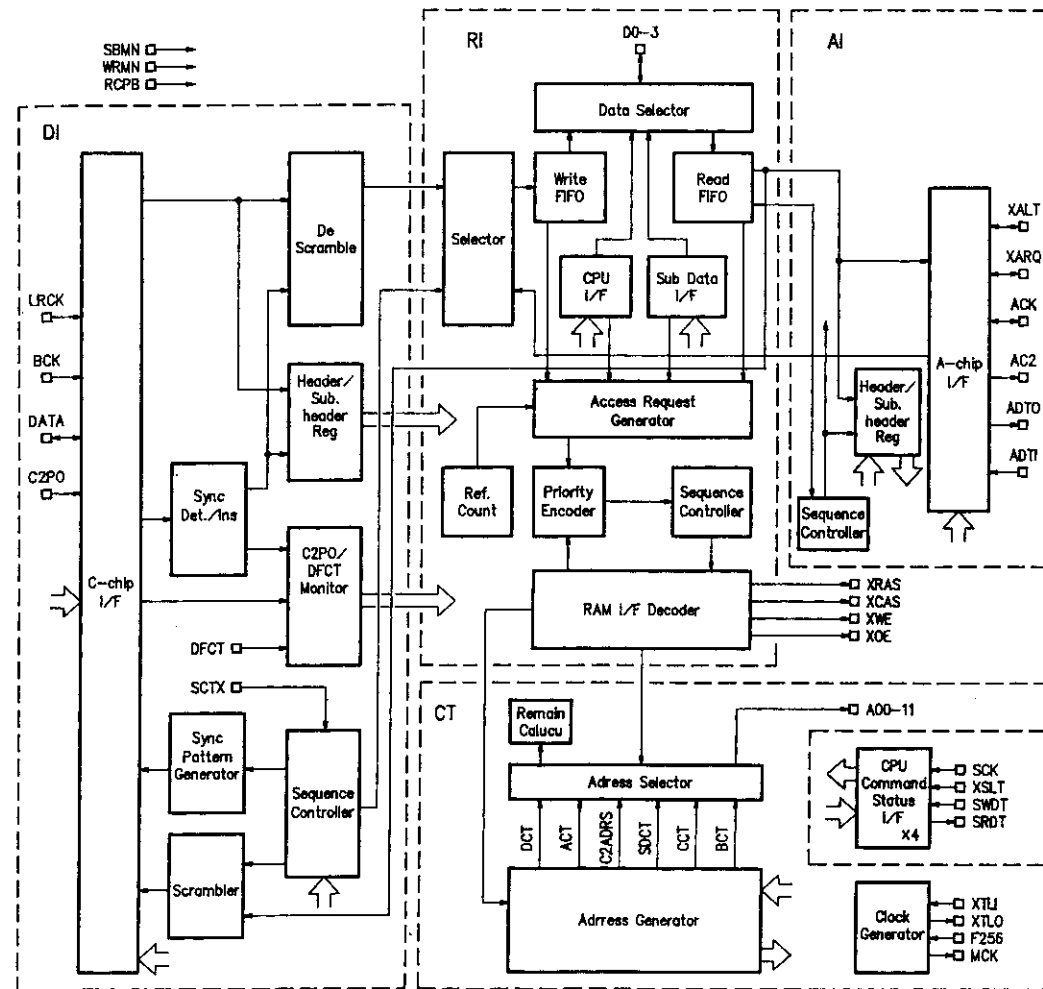

Pin No.	Symbol	I/O	Function
55	ERR	I/O	Not used.
56	D7	O	Not used.
57	D4	I/O	Not used.
58	DO	I/O	External RAM data 0.
59	D1	I/O	External RAM data 1.
60	D3	I/O	External RAM data 3.
61	D2	I/O	External RAM data 2.
62	XCAS	I/O	CAS output to DRAM.
63	XOE	O	Enable output to DRAM.
64	A10	O	Not used.
65	XWE	O	Write enable output to DRAM.
66	XRAS	I/O	RAS output to DRAM.
67	A11	O	Not used.
68	A9	O	External RAM address 9.
69	A0	O	External RAM address 0.
70	A1	O	External RAM address 1.
71	A2	O	External RAM address 2.
72	A3	O	External RAM address 3.
73	VDD	—	Power supply (+5V).
74	A8	O	External RAM address 8.
75	A7	O	External RAM address 7.
76	A6	O	External RAM address 6.
77	A5	O	External RAM address 5.
78	A4	O	External RAM address 4.
79	A12	O	Not used.
80	A13	O	Not used.

CXA1381Q Terminal Function

Pin No.	Symbol	I/O	Reference Voltage	Function
1	VR	O	0V (DC)	Ground (0V).
2	VC	—	0V (DC)	Ground (0V).
3	RF1	I	160mV (DC)	Input terminal of I-V converted RF signal 1.
4	RF2	I		Input terminal of I-V converted RF signal 2.
5	-A	I	40mVp-p ~ 36mV (DC) Tracking OFF	Input terminal of I-V converted main beam servo signal A.
6	-B	I		Input terminal of I-V converted main beam servo signal B.
7	-C	I		Input terminal of I-V converted main beam servo signal C.
8	-D	I	11mVp-p ~ 50mV (DC) Tracking OFF	Input terminal of I-V converted main beam servo signal D.
9	-E	I		Input terminal of I-V converted side beam servo signal E.
10	-F	I		Input terminal of I-V converted side beam servo signal F.
11	TOFST	I	0V (DC)	Offset adjustment terminal of tracking error.
12	ATC1	O	25mVp-p	Push-pull signal output of main beam.
13	ATC2	I		AGC input for ADIP signal.
14	APCDET	I	0.35V (DC)	Detects quantity of light by connecting photo diode and I-V conversion by resistor.
15	LDO	O	3.5V (DC)	Output terminal of LD amp of APC.
16	LD	I	0.35V (DC)	Reversal input terminal of LD AMP.
17	TEMPI	I	0V (DC)	Temperature sensor connecting terminal.
18	TEMPO	O	0V (DC)	Output terminal of temperature signal.
19	VEE	—	-5V (DC)	VEE (-5V).
20	APCREF	I	0.35V (DC)	Input terminal for laser power setting.
21	ADIPFM	O	0.5Vp-p	FM signal output terminal of ADIP.
22	FE	O	3.6Vp-p (Focus S Curve p-p)	Focus error signal output terminal.
23	FBIAS	I	0V (DC)	Focus bias adjustment input terminal.
24	TE	O	5Vp-p (at track jump)	Tracking error signal output terminal.
25	TCOUNT	O	Digital output	Tracking count signal output terminal.
26	CB	—	0.5V (DC)	Defect peak hold capacitor connecting terminal.
27	DFCT	O	Digital output (Defect at "H")	Defect comparator output terminal.
28	CC	I	1V (DC)	AC coupling input terminal of defect peak hold signal.
29	PKHLD	O	1V (DC)	Defect peak hold output terminal.
30	OFTRK	O	Digital output (off track at "H")	Off track signal output terminal.
31	VCC	—	5V (DC)	VCC (+5V).
32	PFTIN	I	0.3Vp-p (at track jump)	Amount of light signal AC coupling input terminal for off track detection.
33	ABCD	O	1V (DC)	Amount of light signal output terminal of main beam servo detection.
34	AGCIN	I	1V (DC)	Input terminal of AGC control.
35	FOK	O	Digital output (FOK at "H")	Focus OK signal output terminal.
36	REFLECT	O	Digital output (High reflection rate at "H")	High/Low discriminating signal output terminal of disc reflection rate.
37	RFSWO	I	Digital output	Disc mode shifting signal input terminal. H: High reflection rate disc.
38	RDSW1	I		Disc mode shifting signal input terminal. H: Track is bit line. L: Track is groove.
39	CP	—	-3.6V (DC)	MIRR hold capacitor connection terminal.
40	ASY	I	2.5V (DC)	Auto asymmetry control input terminal.
41	D.GND	—	0V (DC)	Ground (0V).
42	EFM	O	Digital output	EFM comparator output terminal.
43	VEE	—	-5V (DC)	VEE (-5V).
44	RF1	I	1.1Vp-p	Input terminal of equalizer output to be AC coupled.
45	RFO	O	1.1Vp-p	Equalizer output terminal.
46	EQ	—	-3.5V (DC)	External resistor connection terminal for equalizer.
47	FOKOFST	I	0V (DC)	Offset adjustment terminal of ABCD amps.
48	FOFST	I	0V (DC)	Offset adjustment terminal of focus error amp.

**CXA1381Q (IC201)
RF MATRIX AMP.
(3U-2703-1 Servo Unit)**

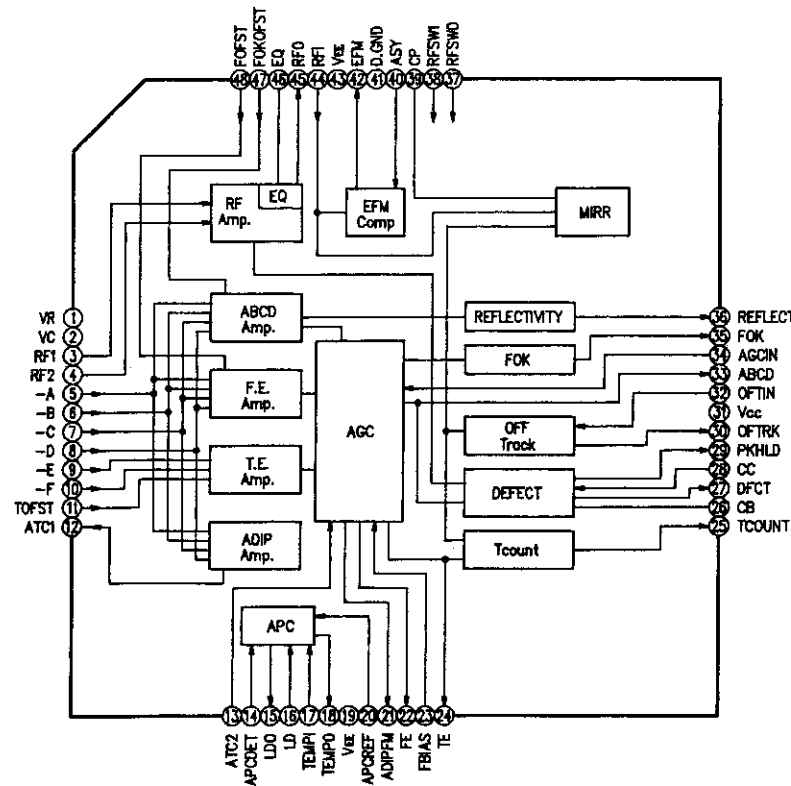
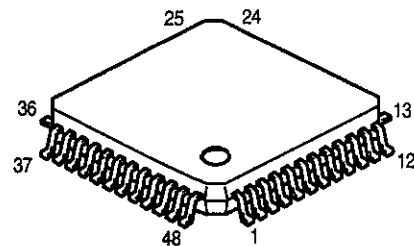

MSM6338MS

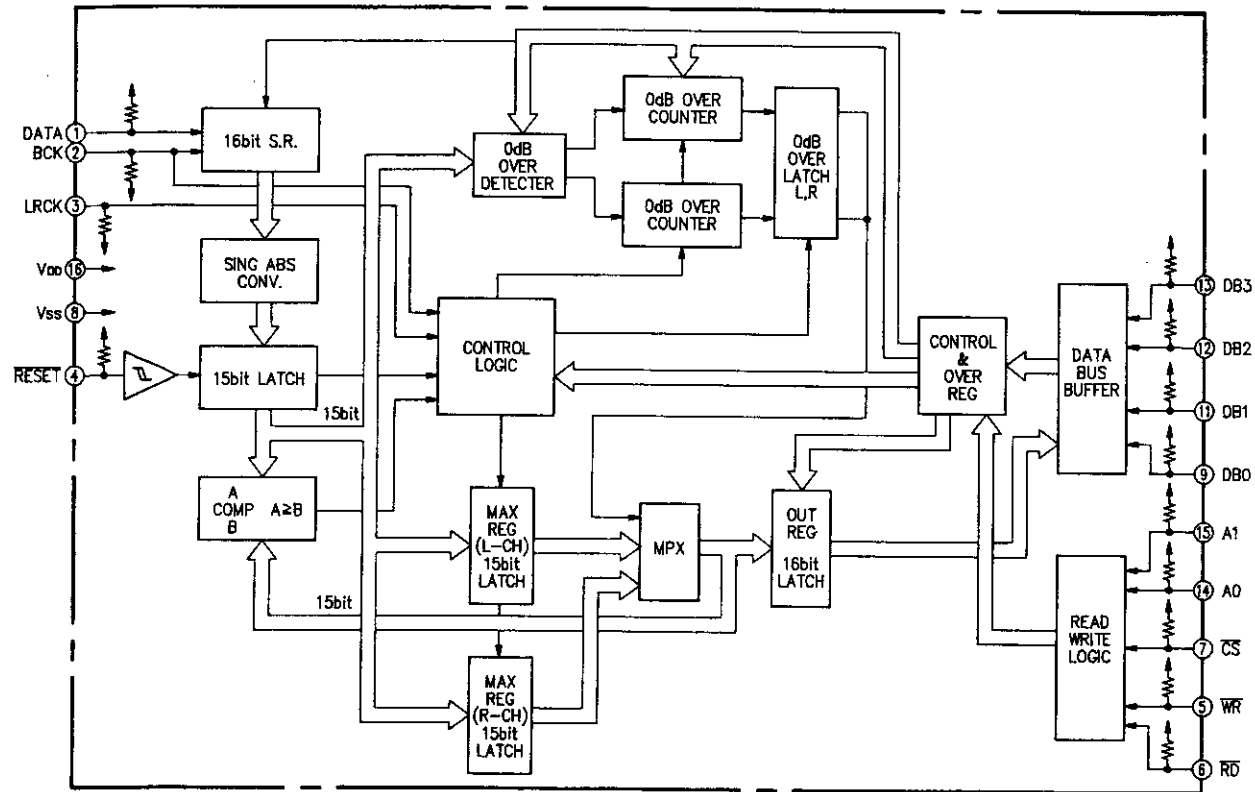
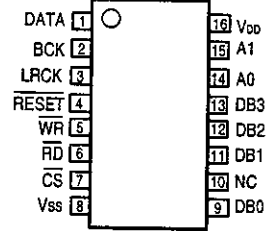
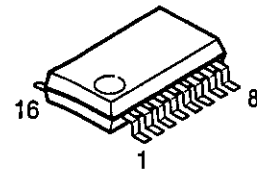

CXA1380N

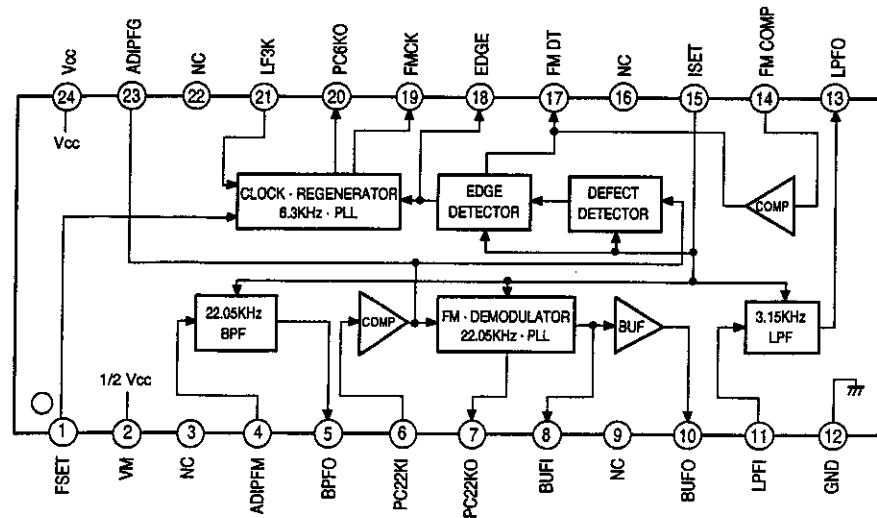
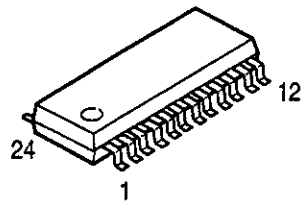

BA6840AFS

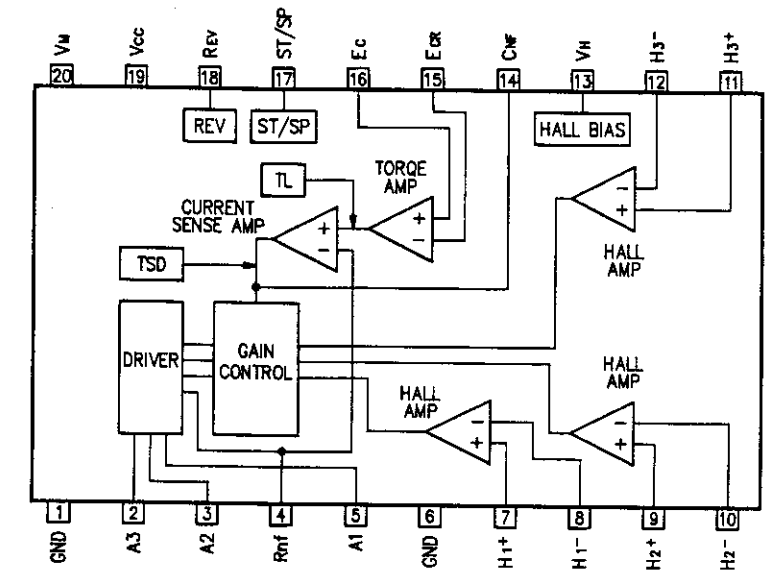
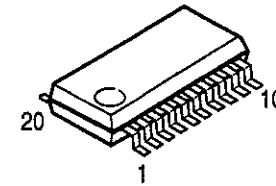

AK5339

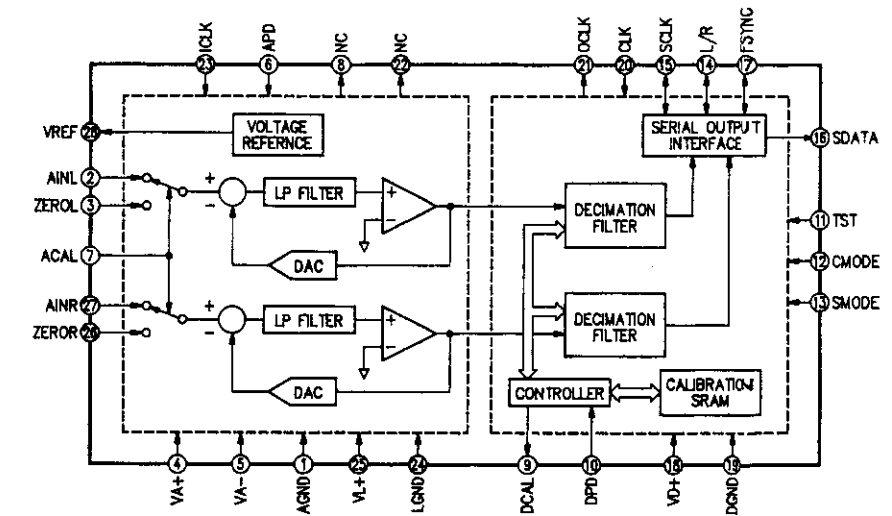
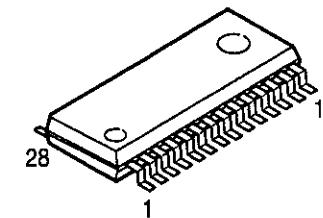

TC74HC245A

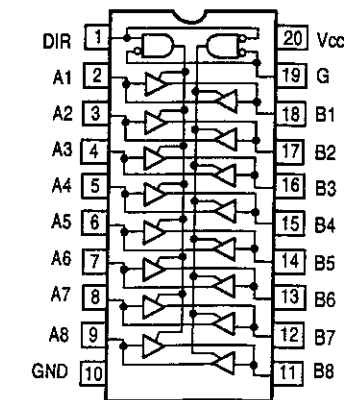
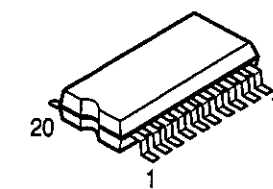

TC7W74F

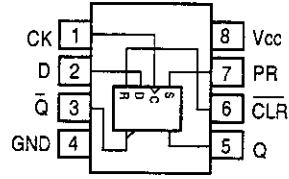
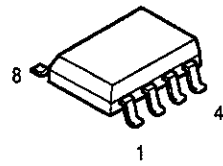

BA4560F
BA15218F

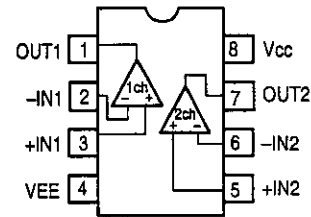
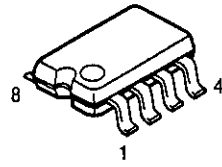

HD74HC153F
HD74HC157F

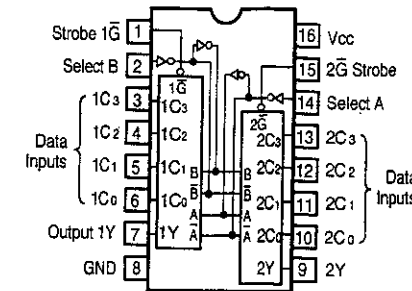
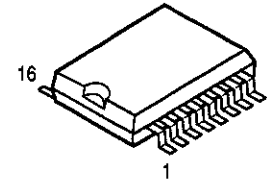

HD74HC157FP

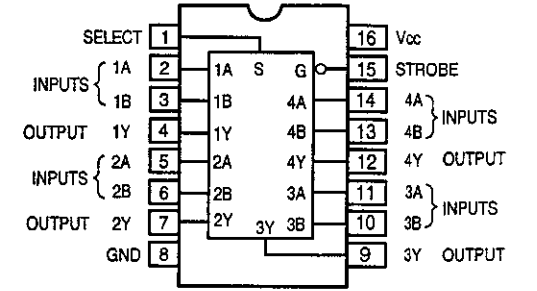

AD707JR

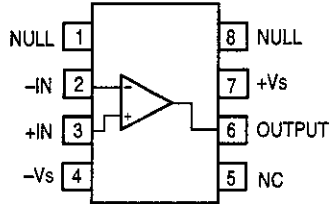
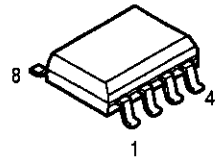

TC4S30F

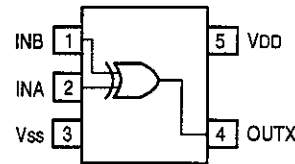
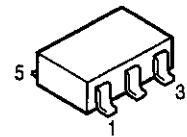

HD74HC74F

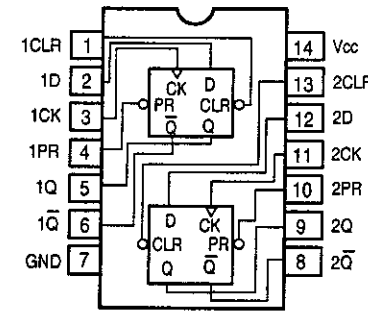
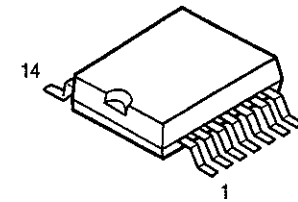

X24C00S

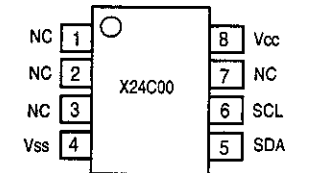
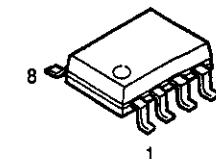

TC74HCU04AF

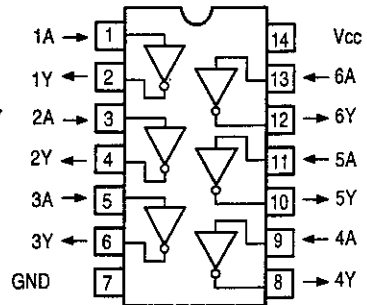
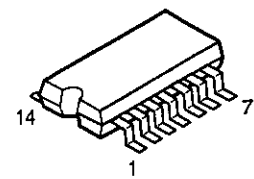

TC74HC32AF

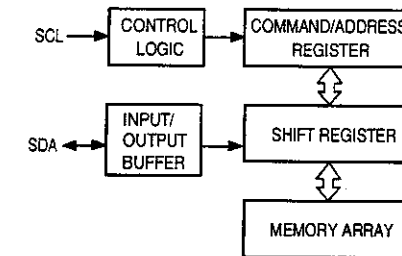
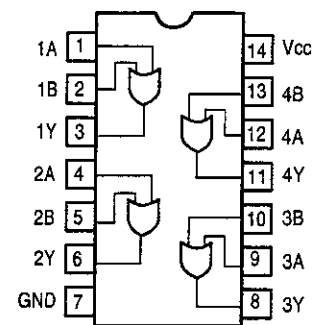
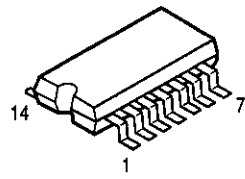

TC74HC574A

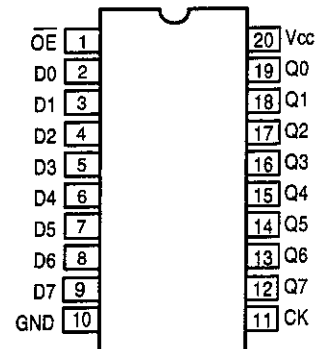
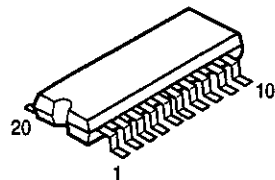

TC74HC08AF

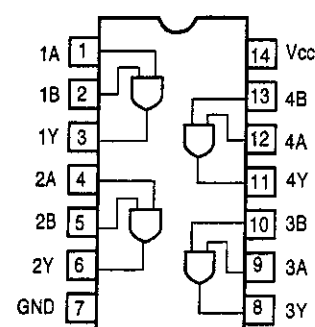
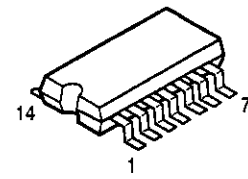

TC74HC138AF

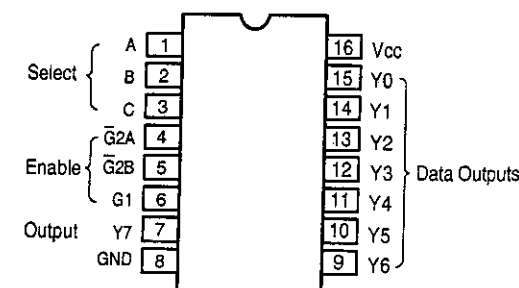
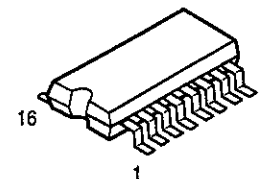

TMS27C512

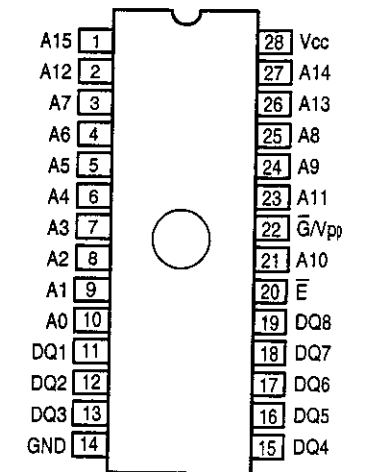
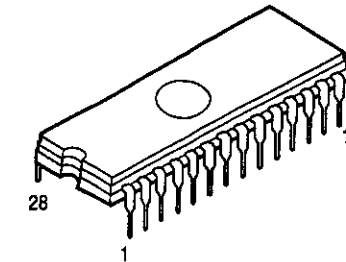

TC74ACT540

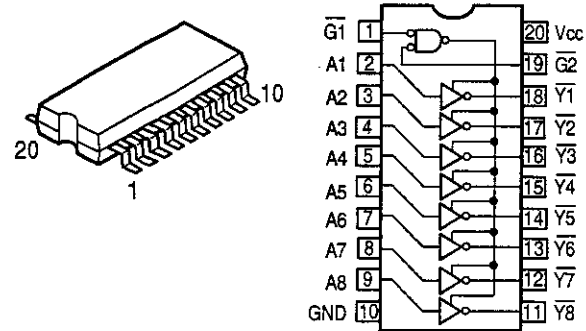

HM514400ALS

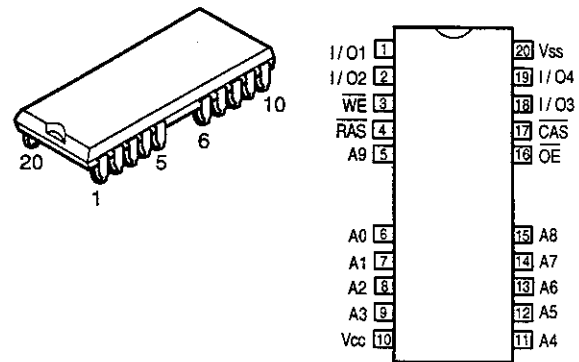

M5M34050FP

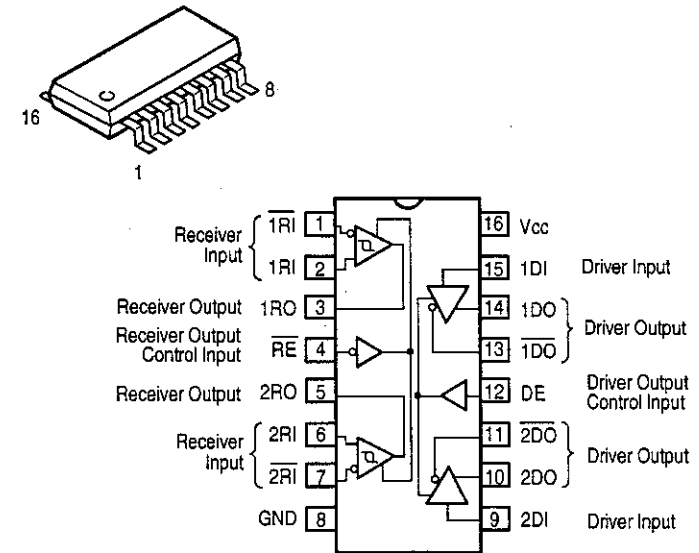

LA6520

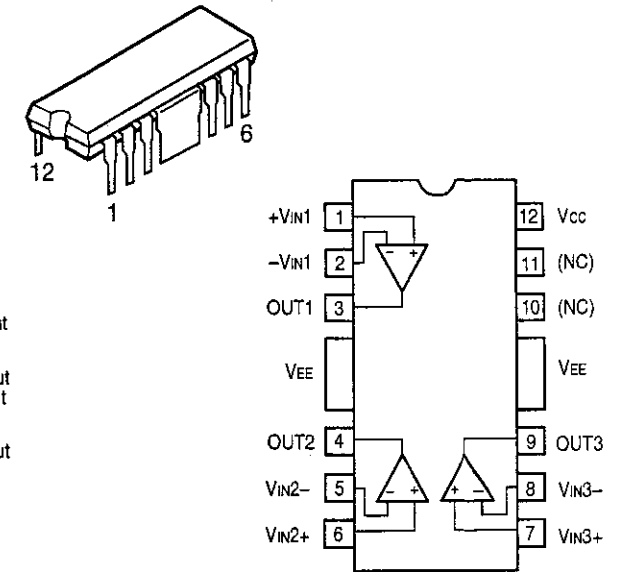

M66004FP

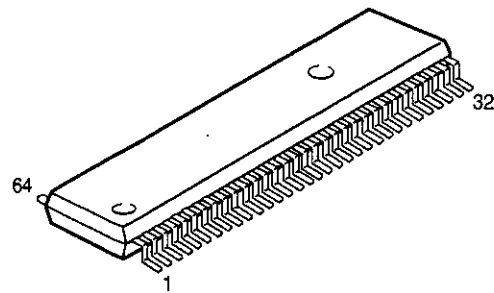

TC74HC4052AF
TC74HC4053AF

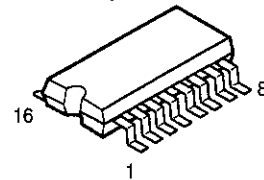

UPD4711AGS

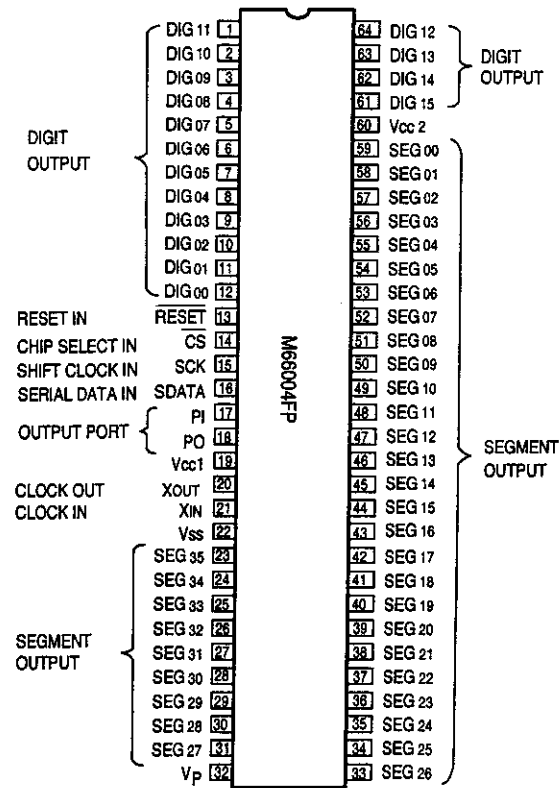
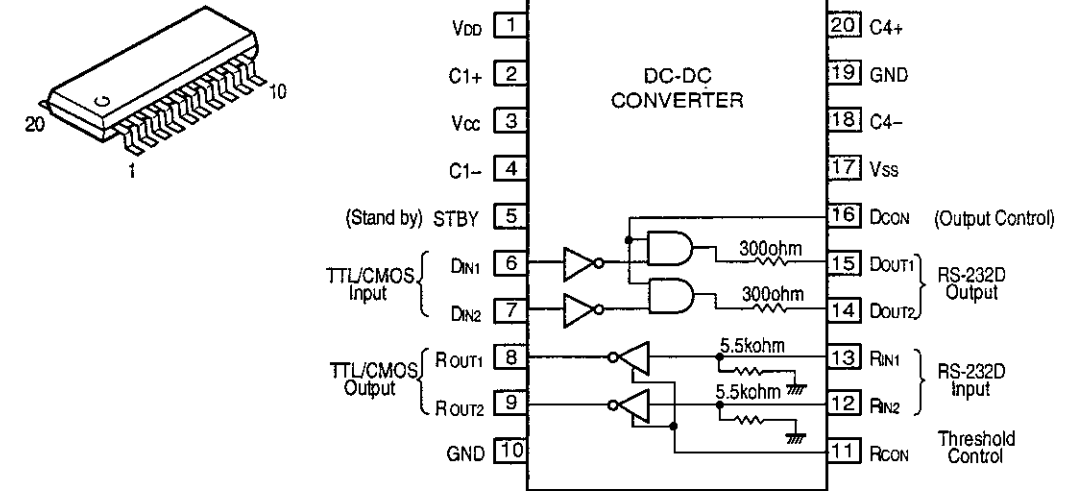

TC74HC4052AF

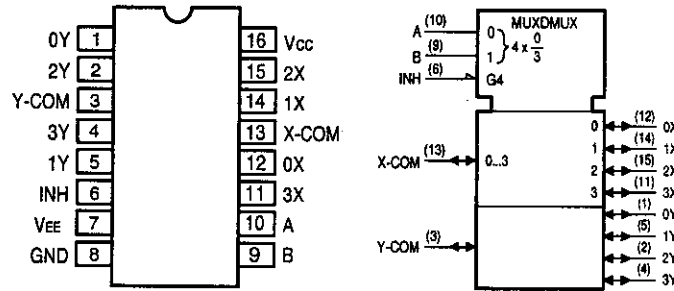

TC74HC4053AF

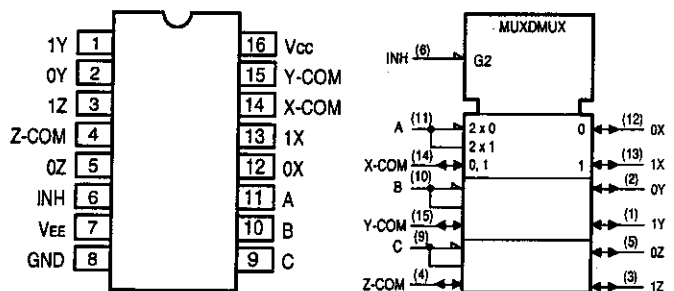

SN7438NS-R

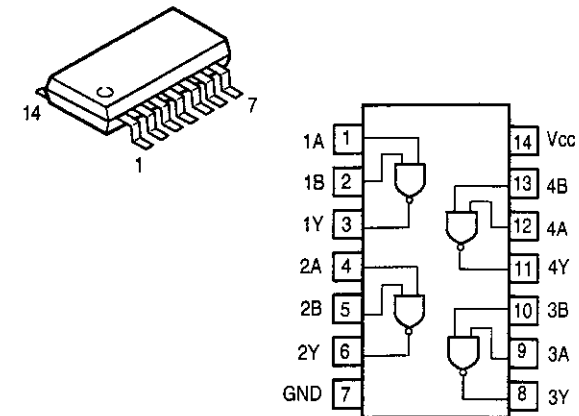

NE5532
NJM4556D

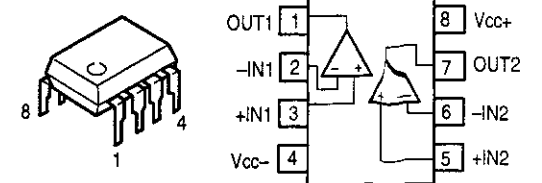

TC4W53F
TC7WU04F

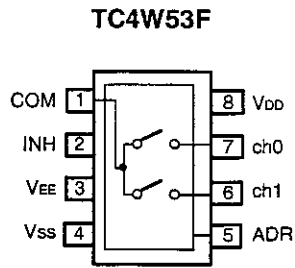
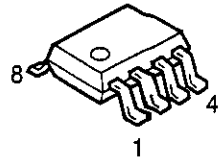

TC7WU04F

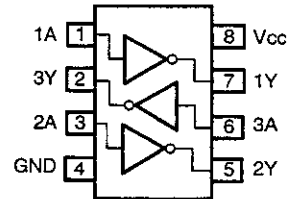

PCM61P-L

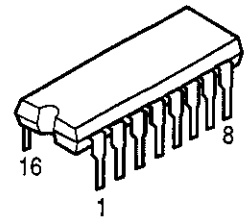

SM5841BS

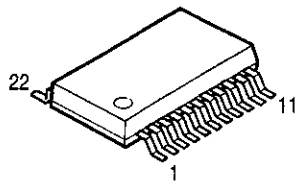

NJM7905FA
NJM7912FA

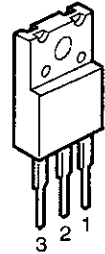

1: Output
2: Input
3: Common

NJM7805FA(S)
NJM7812FA(S)
UPC2405HF

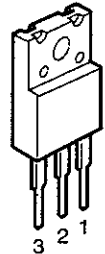

1: Output
2: Common
3: Input

● DIODE

HVU17

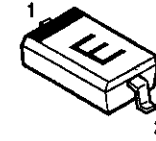

1. Cathode
2. Anode

F1P2S

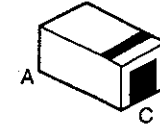

1SR139-200T-62

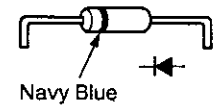

Navy Blue

LM2990T-5.0



1: Output
2: Input
3: Common

MN1382-S

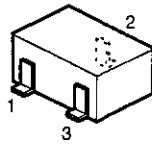

1: OUT
2: V_{DD}
3: V_{SS}

● IC PROTECTOR
ICP-N38T
ICP-N25T

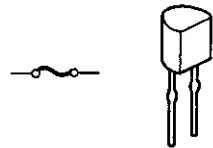

MA151A
MA151WA
MA151WK

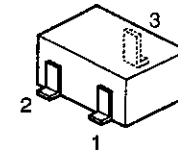

MA151A

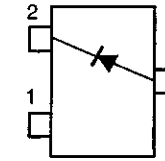

MA151WA

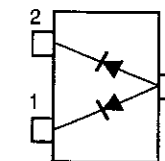

MA151WK

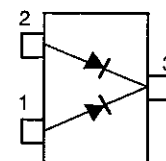

02CZ3.0Z
DA204K
DAN202K
MA152WK
SB01-05CP

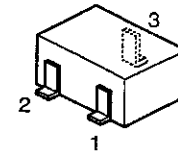

02CZ3.0Z

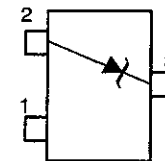

DA204K

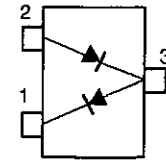

DAN202K
MA152WK

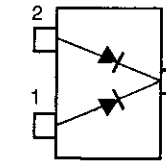

SB01-05CP

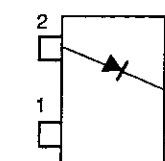

● TRANSISTOR

2SB1189

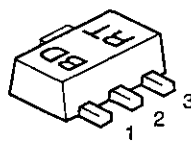

1. Base
2. Collector
3. Emitter

2SA1036K DTA143EK
2SA1037K DTC143EK
2SC2412K DTC343TK

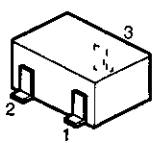

1: GND/Emitter
2: In/Base
3: Out/Collector

● FET

2SK1949
2SJ279

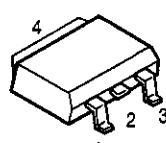

1. Gate
2. Drain
3. Source
4. Drain

S1WB(A)10

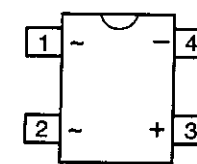
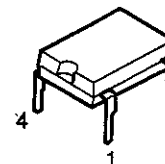

RBA-406B

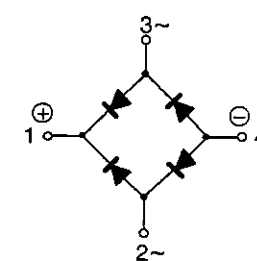
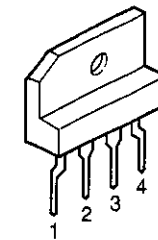

● ZENER DIODE

HZS7C-1TD
HZS36-1TD

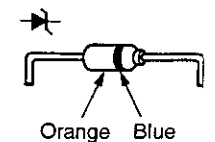

Orange Blue

● FL TUBE
FIP13XM1FA

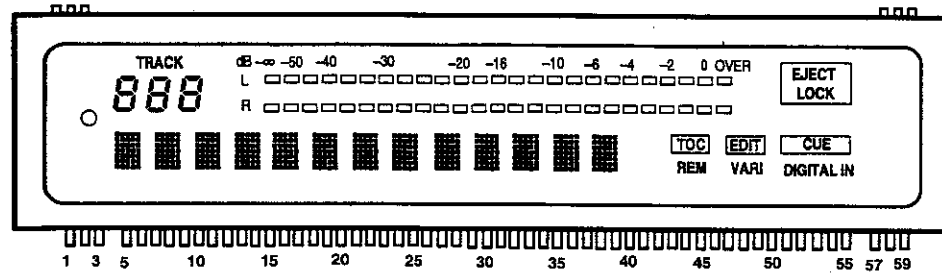

TERMINAL NO.	1	2	3	4	5	6	7	8	9	10	11	12	13	14	15	16	17	18	19	20
ELECTRODE	F	F	F	NP	P	P	P	P	P	P	P	P	P	1G	2G	3G	4G	5G	6G	7G
TERMINAL NO.	21	22	23	24	25	26	27	28	29	30	31	32	33	34	35	36	37	38	39	40
ELECTRODE	8G	9G	10G	11G	12G	13G	14G	15G	16G	P	P	P	P	P	P	P	P	P	P	P
TERMINAL NO.		41	42	43	44	45	46	47	48	49	50	51	52	53	54	55	56	57	58	59
ELECTRODE		P	P	P	P	P	P	P	P	P	P	P	P	P	P	NP	F	F	F	F

Notes F: Filament NP: No Pin G: Grid P: Anode

PARTS LIST OF EXPLODED VIEW

Ref No.	Part No.	Part Name	Remarks	Q'ty
1	3U-2707	AUDIO/POWER Unit	(DN-990R only)	1
	3U-2707A	AUDIO/POWER Unit	(DN-980F only)	1
-1-1	3U-2707-1	LINE OUT Unit	(DN-990R only)	1
	3U-2707A-1	LINE OUT Unit	(DN-980F only)	1
-1-2	3U-2707-2	LINE IN Unit	(DN-990R only)	1
-1-3	3U-2707-3	DC POWER Unit		1
-1-4	3U-2707-4	FILTER Unit		1
2	3U-2708	CPU/DISPLAY Unit	(DN-990R only)	1
	3U-2708A	CPU/DISPLAY Unit	(DN-980F only)	1
-2-1	3U-2708-1	CPU Unit	(DN-990R only)	1
	3U-2708A-1	CPU Unit	(DN-980F only)	1
-2-2	3U-2708-2	FL/REC SW Unit	(DN-990R only)	1
	3U-2708A-2	FL/REC SW Unit	(DN-980F only)	1
-2-3	3U-2708-3	PLAY/STDBY SW Unit		1
-2-4	3U-2708-4	SELECTOR Unit		1
-2-5	3U-2708-5	REMOTE Unit		1
3	FG990	MD. CART Mecha. Unit	(DN-990R only)	1
	FG980	MD. CART Mecha. Unit	(DN-980F only)	1
4	203 3381 008	Power Transformer E3/E1		1
5	441 1468 428	Side Panel (R)		1
6	441 1467 212	Side Panel (L)		1
7	412 3581 004	Front Bracket		1
8	105 1071 016	Bottom Cover		1
9	104 0159 004	Foot		4
10	412 3582 100	PWB Bracket		1
11	449 0074 037	Locking Card Spacer		2
12	105 1113 039	Rear Panel	(DN-990R only)	1
	105 1113 042	Rear Panel	(DN-980F only)	1
13	412 2285 107	Jack Bracket		1
14	412 3805 007	Filter Bracket		1
15	414 0715 002	Insulating Sheet		1
16	203 3381 008	Power Transformer E3/E1		1
	203 2363 001	2P ULTREX Cord		1
	203 0599 000	1P Terminal Wire		1
	203 6452 002	4P ULTREX Cord		1
	203 1039 030	Power Transformer E3/E1	(120V: USA & Canada)	1
	203 1039 035	Power Transformer E3/E1	(230V: Others)	1
	203 6452 002	Power Transformer E3/E1		1
18	203 4494 004	3P ULTREX Cord		1
19	414 0719 008	Insulating Sheet (P)		1
	103 1629 200	Front Panel Ass'y	(DN-990R only)	1
	103 1629 213	Front Panel Ass'y	(DN-980F only)	1
20	103 1634 208	Trap Door		1
21	463 0778 009	Door Spring		1
22	441 1613 008	Door Fix Plate		1
23	112 0526 405	Select Knob (A)		1
24	112 0527 404	Select Knob (B)		1
25	441 1634 003	Protection Plate		1
26	113 1349 105	Push Knob		5
27	463 0531 000	Knob Spring		5
28	103 1601 008	Knob Frame (A)		1
29	103 1602 007	Knob Frame (B)		1
30	113 1667 201	Eject Knob		1
31	463 0781 009	Eject Spring		1
32	105 1072 125	Top Cover		1

Ref No.	Part No.	Part Name	Remarks	Q'ty
WIRES				
101	009 0079 009	21P FFC		1
102	009 0103 001	18P FFC		2
103	009 0102 002	9P FFC		1
104	203 4585 036	3P KR-DS CON. Cord		1
105	009 0079 025	21P FFC		1
106	204 6493 006	9P ZR CON. Cord		1
SCREWS AND NUTS				
201	471 2304 058	Screw 3x8 (CFS)	NIP	16
202	471 2303 017	Screw 3x6 (CFS)		4
203	471 3303 018	Screw 3x6 (CBS)		4
204	473 7015 018	Tapping Screw 3x8 (S)	Black	21
205	473 7004 016	Tapping Screw 4x6 (S)		4
206	473 7002 018	Tapping Screw 3x8 (S)		5
207	473 7003 020	Tapping Screw 3x6 (S)	Black	2
208	470 0017 001	Screw 4x6 SW (CPS)		1
209	473 7506 006	Tapping Screw 2x5 (P)		3
210	473 7500 015	Tapping Screw 3x8 (P)		5
211	475 1157 017	Slit Washer T0.5		1

WARNING:
 ● Parts marked with "Δ" and/shading have special characteristics important to safety. Be sure to use the specified parts for replacement.
 ● Part indicated with the mark "⊙" are not always in stock and possibly to take a long period of time for supplying, or in some case supplying of parts may be refused.

EXPLODED VIEW (DN-990R/DN-980F)

1 2 3 4 5 6 7 8

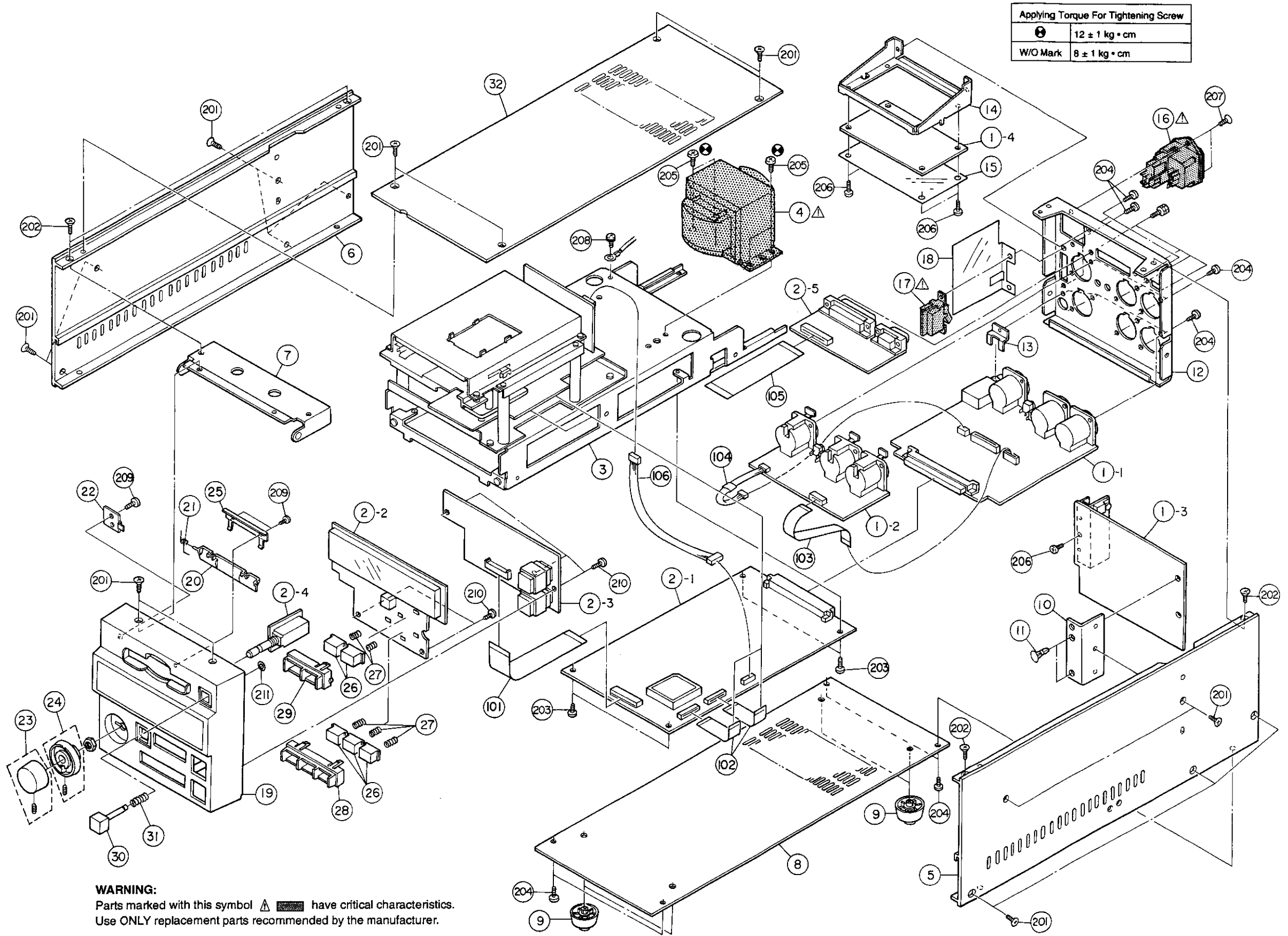

A
B
C
D
E

EXPLODED VIEW OF FG990 (DN-990R)/FG980 (DN-980F) MD MECHA UNIT

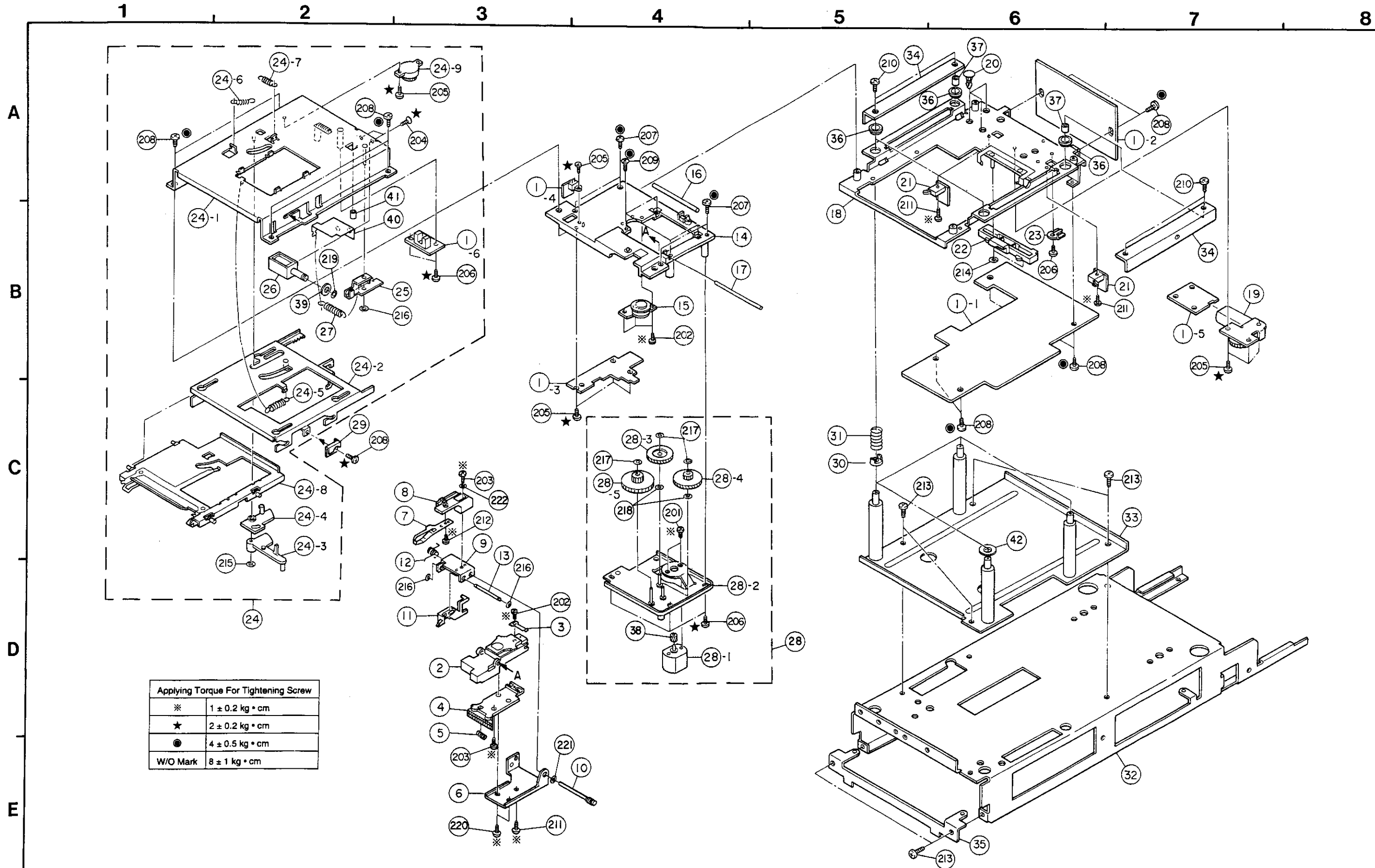

PARTS LIST OF FG990 (DN-990R)/FG980 (DN-980F) MECHA UNIT

Ref No.	Part No.	Part Name	Remarks	Q'ty	Ref No.	Part No.	Part Name	Remarks	Q'ty
1	3U-2703	MECHA. SERVO Unit	(FG990 only)	1		204 0440 000	6P HP Connector Cord		1
	3U-2703A	MECHA. SERVO Unit	(FG980 only)			203 8401 006	5P HP Connector Cord		1
1-1	3U-2703-1	SERVO Unit				204 2675 006	7P HP Connector Cord		1
1-2	3U-2703-2	SERVO DRIVER Unit	(FG990 only)			203 4996 007	3P PH Connector Cord		1
	3U-2703A-2	SERVO DRIVER Unit	(FG980 only)			001 0114 054	Vinyl Wire		1
1-3	3U-2703-3	SPINDLE DRIVE Unit				001 0114 067	Vinyl Wire		1
1-4	3U-2703-4	DISC SENSOR Switch Unit				001 0114 070	Vinyl Wire		1
1-5	3U-2703-5	H.D. MOTOR Unit	(FG990 only)			001 0114 083	Vinyl Wire		1
1-6	3U-2703-6	INTERRUPTER Unit							
2	499 0274 007	Optical PU (KMS-140B)		1	SCREWS AND NUTS				
3	431 0358 202	PU Spring Plate		1	201	471 1823 135	Screw 1.7x1.6 (CPS)		2
4	435 0121 004	Slide Rack Ass'y		1	202	471 1829 000	Screw 1.4x3 (CPS)		4
5	463 0770 007	Rack Spring		1	203	471 1828 001	Screw 1.7x4 (CPS)	Black	2
6	441 1594 004	Head Guide Bracket	(FG990 only)	1	204	471 2802 013	Screw 2x4 (CFS)		2
7	342 0017 007	Magnetic Head (Rf320-74f)	(FG990 only)	1	205	471 1101 016	Screw 2x4 (CPS)		8
	203 4997 006	3P HP Connector Cord	(FG990 only)	1	206	471 3101 014	Screw 2x4 (CBS)		7
8	441 1595 003	Head Arm	(FG990 only)	1	207	471 1201 013	Screw 2.6x4 (CPS)		4
9	421 0685 101	Head Plate	(FG990 only)	1	208	471 3201 011	Screw 2.6x4 (CBS)		11
10	433 0593 005	Head Guide Shaft Ass'y	(FG990 only)	1	209	471 2203 010	Screw 2.6x6 (CFS)		4
11	421 0686 207	Head Arm Lever	(FG990 only)	1	210	471 3303 016	Screw 3x6 (CBS)		4
12	463 0771 103	Head Arm Spring	(FG990 only)	1	211	471 8013 012	Camera Screw 1.7x6		3
13	431 0359 007	Arm Guide Shaft	(FG990 only)	1	212	473 7521 007	Tapping Screw 1.7x4 (P)	Black	1
14	443 1328 108	Mecha Base Ass'y		1	213	473 7015 018	Tapping Screw 3x8 (S)	Black	6
15	217 0195 005	Spindle Motor		1	214	475 1157 062	Slit Washer T0.5		2
16	431 0360 009	Slide Shaft (REF)		1	215	475 1157 046	Slit Washer T0.5		1
17	431 0361 008	Slide Shaft		1	216	475 1157 059	Slit Washer T0.5		3
18	412 3792 107	Mecha. Plate Ass'y	(FG990 only)	1	217	475 1142 022	Washer		3
	412 3792 110	Mecha. Plate Ass'y	(FG980 only)	1	218	475 1142 066	Washer		2
19	416 0111 000	Lm Motor Ass'y	(FG990 only)	1	219	475 1174 003	Slit Washer t0.25		1
20	449 0074 011	Locking Card Spacer		3	220	471 1823 022	1.7xL CPS		2
21	212 4650 004	Leaf Switch	(FG990 only)	2	221	475 1142 019	Washer		1
22	435 0124 108	Lift Cam	(FG990 only)	1	222	475 1000 009	2W		1
23	445 0091 005	Mini Clamp (MNC)	(FG990 only)	1					
24	412 3803 504	Loading Gen. Ass'y		1					
24-1	412 3794 105	Loader Base Ass'y							
24-2	431 0364 209	Slider Ass'y							
24-3	421 0690 303	Eject Arm							
24-4	421 0695 007	Eject Sub Arm							
24-5	463 0773 004	Eject Spring							
24-6	463 0774 100	Arm Spring							
24-7	463 0776 001	Sub Arm Spring							
24-8	412 3797 403	Cart. Holder Ass'y							
24-9	412 0505 032	Mini Damper							
25	421 0692 107	Lock Arm		1					
26	214 0177 008	Solenoid		1					
27	463 0790 003	Solenoid Spring		1					
28	412 3804 202	Slide Base Gen. Ass'y		1					
28-1	217 0194 006	Slide Motor							
28-2	412 3790 002	Gear Base Plate Ass'y							
28-3	424 0214 102	Slide Gear (A)							
28-4	424 0215 004	Slide Gear (B)							
28-5	424 0216 003	Slide Gear (C)							
29	431 0368 001	Eject Plate		1					
30	462 0138 109	Damper B		4					
31	463 0789 001	Sus Spring		4					
32	411 1198 519	Mecha Chassis		1					
33	441 1606 303	Base Plate Ass'y		1					
34	412 3810 102	FL Stopper		2					
35	412 3584 001	Hook Bracket		1					
36	462 0137 100	Damper A		4					
37	443 1407 003	D. Spacer		2					
38	424 0213 103	Rack Motor Gear		1					
39	462 0140 003	SOL. Spacer		1					
40	412 3881 005	Spacer		1					
41	462 0141 002	Damp Tube		1					
42	414 0727 003	Spring Spacer		1					

PACKING & ACCESSORIES PACKING METHOD VIEW

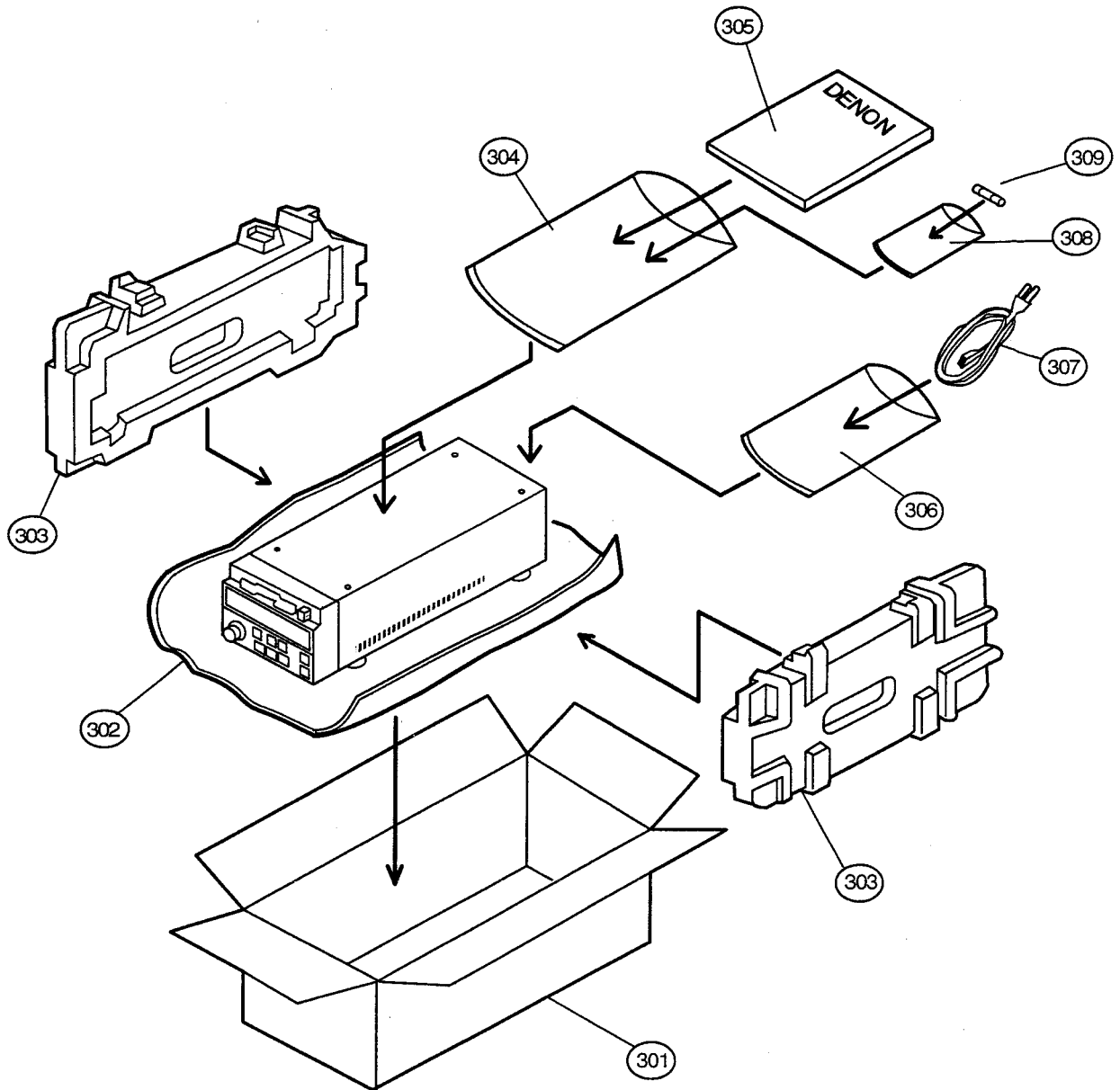

PACKING ASSEMBLY PARTS LIST (DN-990R/980F)

Ref No.	Part No.	Part Name	Remarks	Q'ty
301	501 1789 001	Carton Case	(DN990R only)	1
	501 1789 014	Carton Case	(DN980F only)	1
302	505 0102 089	Stylen Paper		1
303	503 1052 006	Cushion Ass'y		1
304	503 0061 010	Envelope		1
305	511 2607 008	Inst. Manual		1
306	505 8017 024	Envelope		1
Δ 307	206 2069 000	3P AC Cord	(USA & Canada Model)	1
Δ	206 2068 004	3P AC Cord	(Others)	1
308	505 8006 006	Envelope		1
Δ 309	206 1033 050	Fuse T1.6A, 125V	(120V, USA & Canada)	1
Δ	206 1015 000	Fuse 1500mA, 250V	(230V, Others)	1

WARNING :

Parts marked with " Δ " and/shading have special characteristics important to safety.

Be sure to use the specified parts for replacement.

Parts indicated with the mark " * @ " are not always in stock and possibly to take a long period of time for supplying, or in some case supplying of parts may be refused.