

DENON

Hi Fi Component/Record Player

SERVICE MANUAL

SERVO-CONTROLLED
DIRECT DRIVE RECORD PLAYER

MODEL DP-33F SERIES



Model DP-33F

NIPPON COLUMBIA CO., LTD.

TABLE OF CONTENTS

SAFETY PRECAUTIONS	1
FEATURES	2
NAMES OF PARTS AND FUNCTIONS	2
THEORY OF OPERATION	3
SEQUENCE OF ADJUSTMENT	5
EXPLODED VIEW OF TONEARM	6
PARTS LIST OF EXPLODED VIEW	7
EXPLODED VIEW OF MAIN PARTS	8
ARM SERVO CIRCUIT DIAGRAM (European models and American models)	9
PRINTED CIRCUIT BOARD	10
MOTOR DRIVE CIRCUIT DIAGRAM (European models)	11
PRINTED CIRCUIT BOARD (European models)	12
MOTOR DRIVE CIRCUIT DIAGRAM (American models)	13
PRINTED CIRCUIT BOARD (American models)	14
LEAD CONNECTION OF SEMICONDUCTORS	15
PARTS LIST OF KU-324 ARM DRIVE AMP. UNIT AND KU-327 SWITCH UNIT	16
PARTS LIST OF KU-364 SERVO AMP. UNIT AND PS-141 POWER SUPPLY UNIT	17
PARTS LIST OF KU-373 MOTOR SERVO AMP. UNIT (American models)	18
SPECIFICATIONS	19

SAFETY PRECAUTIONS

Model DP-33F is designed and manufactured with careful consideration about product safety. For continued product safety, read following precautions and practice proper servicing.

1. Since the printed circuit board of 120V version of Model DP-33F have high voltage potential from the metal chassis regardless of the polarity of the AC supply, use an isolating transformer (1:1) for servicing.
2. Replace always with correct parts having correct rating, shape and material, etc. Especially the component with shading and  mark must be replaced only by the specified component for safety reasons.
3. For setting up the record player;
 - A) Do not damage the power cord by placing a heavy object on it, or by pinching it between angular objects. Do not fix the power cord by nails, etc. on wall.
 - B) Make sure any metal objects such as needle, hair pin or coin are not remaining inside the appliance.
 - C) Give sufficient clearance for ventilation holes at bottom. Allow more than 10cm clearance between the rear of cabinet and wall.

NOTE

The DP-33F series can be divided into two groups, the American models (including U.S.A. and Canadian models) and the European models (including continental European, U.K., Australian and Asian models).

FEATURES

- Electrically servo-controlled tonearm automatically functions causing no deterioration of performance of the tonearm or turntable.
- Tonearm returns swiftly to the playback position in repeat mode without returning to the arm rest.
- Opto-electronic sensor detects the end of record without touching any part for eliminating load on the tonearm.
- MM type angular control motor lifts and lowers the tonearm surely and smoothly.
- Electronic logic control allows random access of function instead of mechanically programmed conventional sequence.
- Easy-to-operate front panel controls allow operation with dust cover closed.
- Special high density compound with higher specific gravity than wood is used for the base, accomplishing smaller but heavier base.
- The turntable is servo-controlled by the firmly established DENON high precision speed detection system with the magnetic recording. Stable rotation is accomplished by combination of the above and the phase locked loop control synchronized to a quartz crystal oscillation.
- Smooth rotation and little vibration AC motor spins the platter.

NAMES OF PARTS AND FUNCTIONS

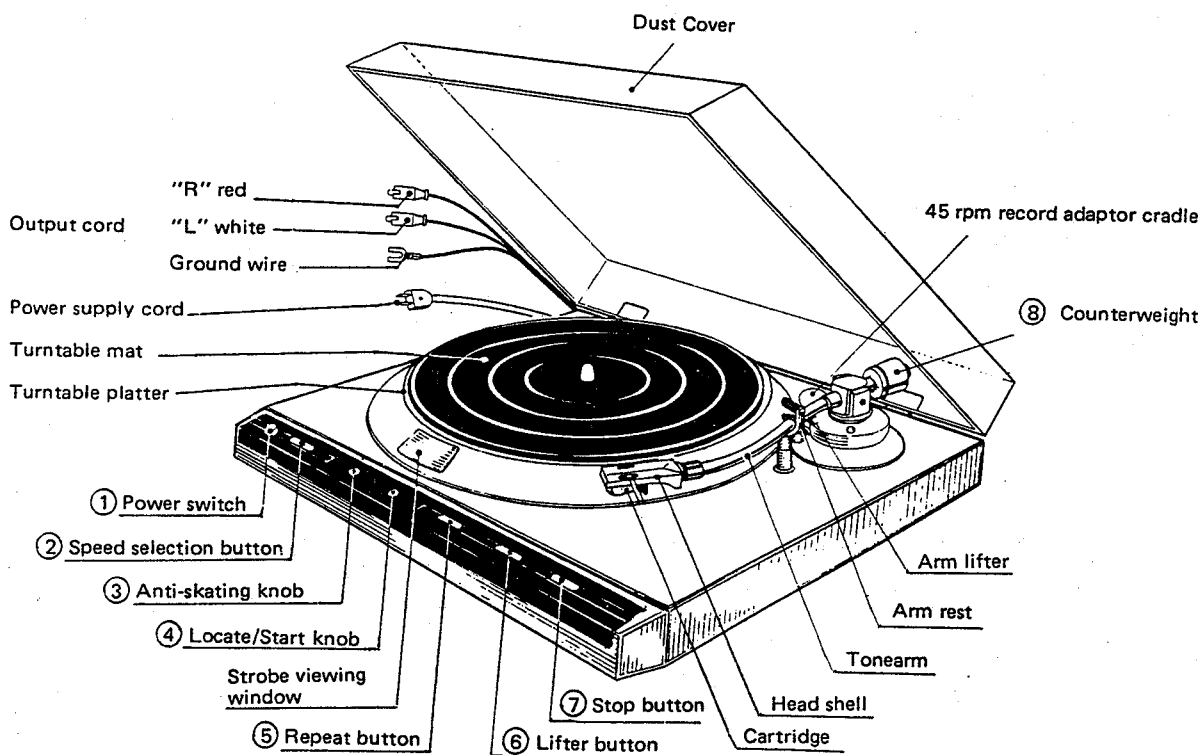







Fig. 1 Names of Parts and Function

- (1) Power switch**
Turns the power ON () and OFF ()
- (2) Speed selection button**
When this button is pressed the speed is changed.
33 () for record at 33-1/3 rpm.
45 () for record at 45 rpm.
- (3) Anti-skating knob**
In playback of record, an attraction force toward inside of record is introduced at the stylus resulting in an unfavourable effect on reproduced sound. This force is cancelled by adjusting this knob.
- (4) Locate/Start knob**
Turning this knob brings tonearm to where you wish to start playing. When this knob is pressed for automatic play, the tonearm is driven and starts playing.
- (5) Repeat button**
Press out () this button for repeated play.
- (6) Lifter button**
Functions the arm lifter up and down.
- (7) Stop button**
The tonearm returns to the arm rest and the turntable stops when this button is pressed. Because of inertia, the platter continues rotation for a while before it stops.
- (8) Counterweight**
The stylus force applied to the cartridge is adjusted by this weight.

THEORY OF OPERATION

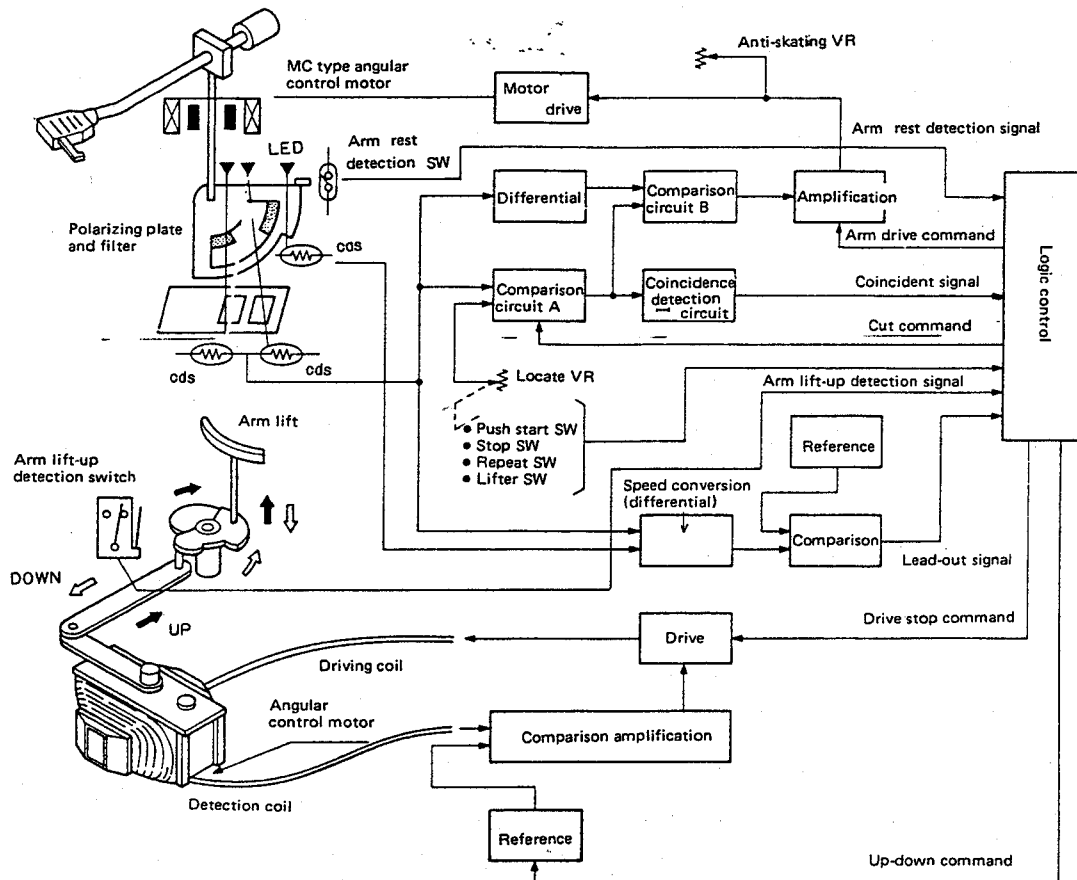

Fig. 2 Tonearm Drive Block Diagram

1. Electronically Servo Controlled Tonearm

A signal is sent from the push start SW through the logic control, which converts the signal to the arm drive command. It energizes the MC type angular control motor, which rotates the tonearm.

The position of the tonearm is detected by change of transparency quantity of the light. This is done by the polarizing plate fitted to the rotation arm shaft and 2 fixed polarizing plates which are at a 90° optical angle to each other. The center voltage of two CDS's connected in series energizes the MC type angular control motor until it is equal to the reference position signal set in advance by the variable resistor. When in the position of 30 cm and 17 cm, a filter with a 30% transparency factor added to the above mentioned polarizing plate makes the change of light transparency quantity larger. Accordingly the change of voltage of the CDS center point becomes larger. This leads to an increase in the position detection sensitivity, which provides less position displacement. If the voltage at the CDS center point would have a larger change than a position change, the detection sensitivity would increase as the rotation speed of the tonearm is detected by its differential output. Accordingly, the tonearm will rotate slower at the positions of 30 cm and 17 cm.

2. Electronically Servo Controlled Arm Lifter

The logic control gives the reference signal for the up-or-down-command. This signal can be compared with the signal given by the detection coil of the angular control motor, amplified to perform the speed servo control. As the compared and amplified signal is constructed so that its speed is changed by the reference signal level, the speed for lifting-up and -down can have different speeds by providing a difference in the speed of the reference signal level.

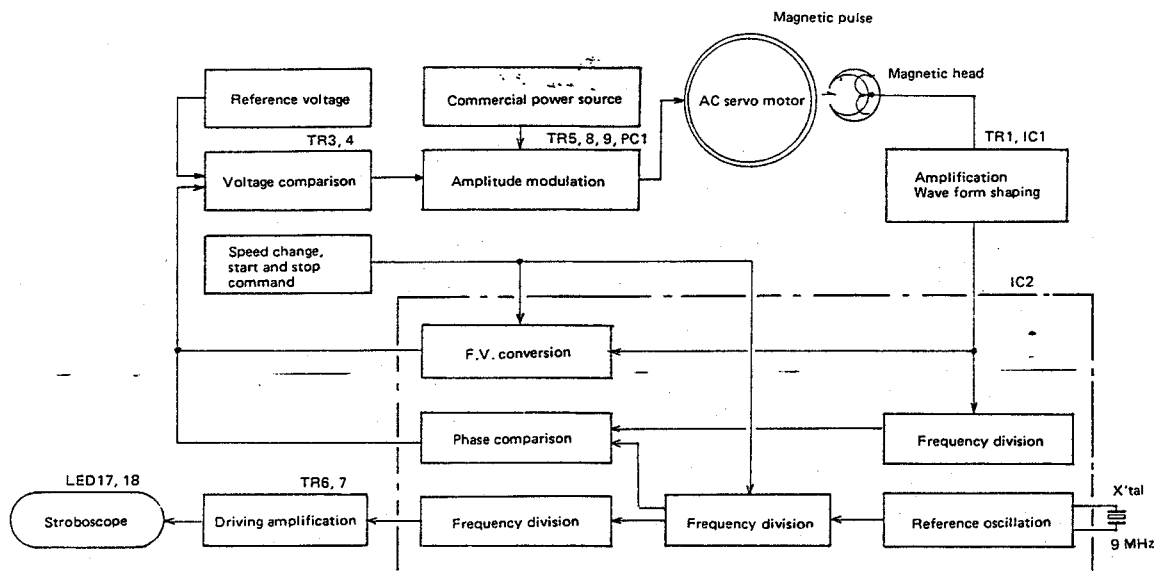

Fig. 3 Phono Motor Servo Block Diagram

3. Phono Motor Servo

The output detected by the magnetic head (555.5 Hz at 33 rpm, 750 Hz at 45 rpm) becomes a rectangular wave through the amplifying circuit (limiter circuit). Output of this wave form shaping circuit is supplied to the input terminal of the IC2 (SC3120A). Within the IC2, a signal input from the input terminal is converted into a voltage inversely proportional to the speed (frequency). At the same time, the oscillating frequency (9 MHz), generated by the crystal oscillator, is divided into proper frequencies (138.9 Hz at 33 rpm, 187.5 Hz at 45 rpm). Its signal is compared in phase, to the signal coming from the input terminal which performs the coincident operation with the number of rotations.

The voltage inversely proportional to the speed and the voltage compared in phase are compared with the reference voltage. The difference in voltage after comparison modulates the amplitude of the motor driving wave form to control the rotation of the motor.

The change-over of the speed is performed by changing the dividing proportion of the oscillating frequency of the crystal oscillator and simultaneously changing the proportion of the voltage inversely proportional to the speed. The stroboscope is flashed by 1/2 the value of frequency that is divided from the oscillating frequency of the crystal oscillator.

SEQUENCE OF ADJUSTMENT

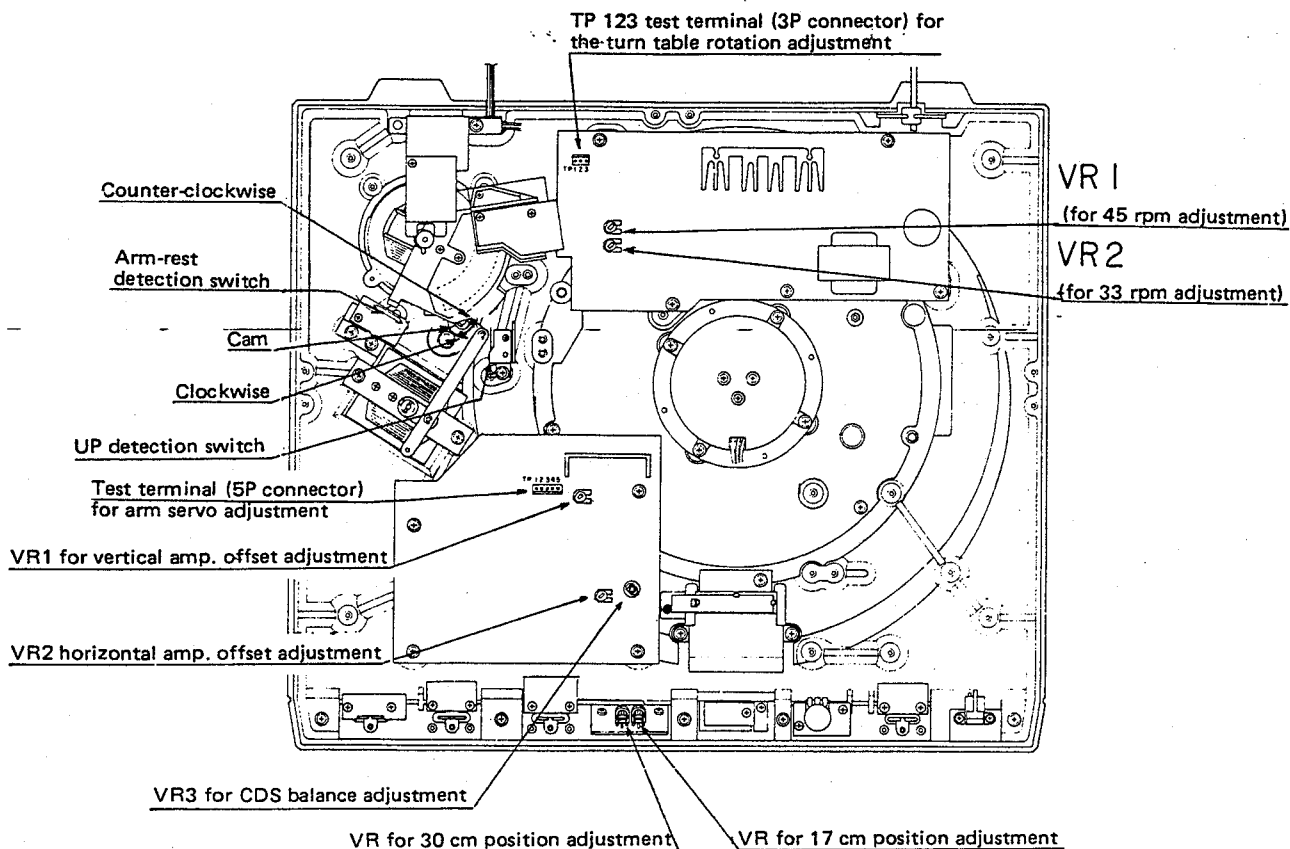

Fig. 4 Adjustment Points

1. Adjustment for Up-detection Switch

- (1) Remove the clammer of the arm-rest
- (2) Rotate cam counter-clockwise until it stops
- (3) Loosen the fitting screw of the up-switch fitting plate to adjust it so that the switch actuator can be pressed and the NO (normally open) terminal will make contact.

2. Adjustment for Rest-detection Switch

Adjust the fitting position so that the rest-switch will make contact after returning the arm to the up-position. (At this time, the rest-switch must not be "OFF" and the arm lifter should be in the UP-state. When returning the arm to rest in the DOWN state, be sure that the rest switch will not make contact on the way.

3. Adjustment for Shutter Fitting Angle (refer to Fig. 2)

- (1) Clamp the arm to the arm rest
- (2) Fit the slot of motor (A) to the half-circle hole of the shield case by rotating the motor (A). Then fit it with a hexagon screw.

- (3) Move the arm by pushing and turning the locate knob to confirm that the center of the range where the arm can move slowly at 30 cm position is located approximately at the lead-in position of the 30 cm disc (radius of 147.5 mm).
- (4) If it is deflected in the outer circumferential direction, loosen the fixing screw to rotate the motor (A) clockwise, and fix it. In this case, the error of 1 mm at the top of the needle corresponds to approximately 0.2 mm of shutter fringe. Rotate the motor (A) counter-clockwise if tonearm deflects toward inside.

Fit motor (A) slot to the semi-circle hole of the shield cover

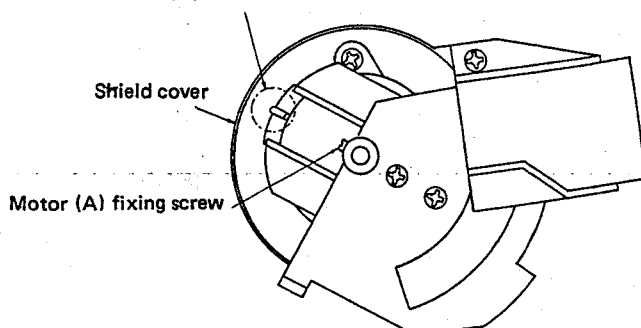

Fig. 5 Motor (A)

4. Adjustment Method for Turntable Rotation Speed

- (1) Connect the respective probes of the dual trace oscilloscope to the test terminals for rotation adjustment, TP1 and TP3 to observe the wave form (earth grounding terminal TP2) on motor drive P.W.B.
- (2) Turn 33/45 selector switch of front panel (— 33 — 45) to — 45.
- (3) Adjust the wave form as shown in Fig. 3 by means of "VR1" 45 rotation VR.
- (4) Turn the 33/45 selector switch on the front panel to — 33.
- (5) Adjust the wave form as shown in Fig. 3 by means of "VR2" 33 rotation VR.

Note: Adjust 45 first always.

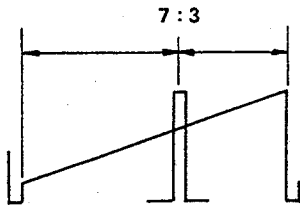

Fig. 6 Adjustment Wave Form

5. Adjusting Method for Arm Screw

- (1) Vertical amplifier offset adjustment
 - 1 Turn the lifter SW (—down— up) to the — up position to confirm that the lifter is at the up position.
 - 2 Preform the short-circuit between terminals T.P.2 and T.P.4.
 - 3 Place the arm on the arm rest and adjust the "VR1" so that voltage at T.P.1 becomes $0V \pm 0.1V$. Remove the short circuit between T.P.2 and T.P.4 after adjustment. (earth terminal T.P.4)
- (2) CDS balance adjustment

Adjust the "VR3" so that the voltage at wrapping terminal 17 is $0V \pm 0.05V$ with the cartridge stylus tip set at the 110 mm radius position.
- (3) Horizontal amp. offset adjustment

With the stylus force at 0g, rotate the locate knob, to the "30" cm position while pushing it and adjust the "VR2" so that the T.P.3 voltage is at $-0.1V \pm 0.05V$, keeping the knob pressed.

EXPLODED VIEW OF TONEARM

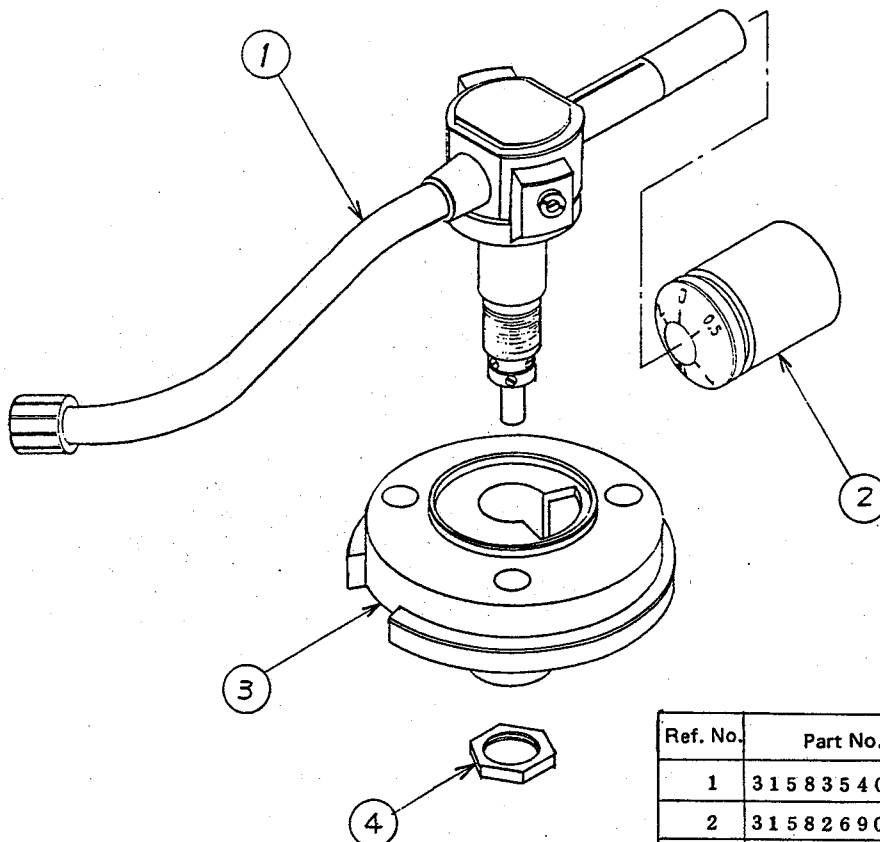

Ref. No.	Part No.	Part Name
1	3158354003	MAIN BODY ASS
2	3158269017	BALANCE WEIGHT ASS
3	3158339109	ARM BASE
4	3158287002	BASE NUT

PARTS LIST OF EXPLODED VIEW (European and American models)

Ref. No.	Part No.	Part Name	Remarks	Ref. No.	Part No.	Part Name	Remarks
1	4731803022	3 x 25 CPTS		53	4148022001	BLIND	
2	WA-1074	WASHER		54	1468051001	STROBO WINDOW	
3	1048013401	INSULATOR		55	4713303029	3 x 6 CBS	
4	4498017407	POLARIZED PLATE		56	FPU-840A	TONE ARM UNIT	
5	1298013002	DOUBLE FACE TAPE		57	4628006107	BUSHING	
6	4498027109	FILTER		58	4690012006	RUBBER CUSHION	
7	4713303016	3 x 6 CBS		59	1038081304	CABINET ASS'Y	
8	4338125103	SHUTTER (A)		60	4218146105	RECORDED TURN TABLE	
9	4744201019	3 x 4 BSS		61	4218094040	RUBBER SHEET	
10	2178029403	MOTOR (A)		62	4018031009	HINGE	
12	4148037708	SHIELD COVER		63	4418461004	HINGE PLATE	
13	1058047001	BOTTOM COVER ASS'Y		64	4715404049	4 x 8 COS	
14	4713304015	3 x 8 CBS		65	1468081411	DUST COVER ASS'Y	
15	4713301018	3 x 4 CBS		66	4730305013	3 x 10 CBRTS	
16	4712309011	3 x 16 CFS		67	KU-327(61D)	SWITCH UNIT	
17	KU-327(61F)	SWITCH UNIT		68	1138077205	PUSH SWITCH KNOB	
18	4418229408	CDS HOLDER		69	4638100103	SPRING	
19	4498018105	POLARIZED PLATE (B)		70	4038001006	CAP	
20	4418228409	LED HOLDER		71	KU-324(54A)	ARM DRIVING UNIT	
21	KU-327(61F)	SWITCH UNIT		72	KU-327(61B)	SWITCH UNIT	
22	4731803006	3 x 12 CPTS		73	KU-327(61J)	SWITCH UNIT	
23	4731803019	3 x 16 CPTS		74	4418325001	V.R. SUPPORT (C)	
△ 25	2178028404	MOTOR ASS	European models only	75	KU-327(61C)	SWITCH UNIT	
△	2178036205	MOTOR ASS	American models only	76	4418316104	SWITCH SUPPORT	
26	4148054309	SHIELD PLATE		77	4418317200	VOLUME SUPPORT (A)	
27	2033642103	OUTPUT CORD ASS		78	4638094002	PUSH SPRING	
△ 28	2062019008	AC CORD	American models only	79	KU-364	SERVO AMP UNIT	European models only
29	4450020005	BUSHING	European models only		KU-373	SERVO AMP UNIT	American models only
	MD-2982H	CORD BUSH	Australian models only	80	2118036003	V16N15KB502	
	MD-3802	BUSHING	American models only	△ 81	2129088024	POWER SWITCH	European models only
30	4418321005	BUSH PLATE	European models only	△	2129088011	POWER SWITCH	American models only
	4418314009	BUSH PLATE	American models only	82	4418318005	VOLUME SUPPORT	
31	KU-364	SERVO AMP UNIT	European models only	83	1038069504	FRONT PANEL	
	KU-373	SERVO AMP UNIT	American models only	84	1138091100	KNOB (A)	
32	2129018007	REED SWITCH		85	1138092002	KNOB (B)	
33	3918423006	MAGNETIC HEAD		86	1138033207	KNOB	
34	4761003009	3E RING		87	4733800007	3 x 6 CBTS	
35	4770090058	WASHER		88	KU-327(61A)	SWITCH UNIT	
36	4761001001	2E RING		89	4730353010	3 x 6 CBRTS	
37	4418220203	CONNECTION PLATE		90	4794102024	3 x 3 S'S	
38	4248009005	CAM		91	2118035004	V16N15KB502K	
39	4218121007	MOTOR ARM		92	4418311303	SHIELD COVER	
40	2178038203	MOTOR (C) ASS'Y		93	3418009108	MAGNET	
41	4418323100	M. SHIELD PLATE		94	4338129109	SHUTTER (A) ASS	
42	4128023202	REED SW BRACKET		△ 95	2339023109	POWER TRANSFORMER	European models only
43	4723303016	2.3 x 8 CBS		△	2339033005	POWER TRANSFORMER	American models only
44	2129053004	MICRO SWITCH		△	2339032006	POWER TRANSFORMER	Canadian models only
45	4418331202	SWITCH SUPPORTER		96	4713309010	3 x 16 CBS	
46	1468083105	STROBO SHUTTER		97	WA-01074	WASHER	
47	KU-373	SERVO AMP UNIT		98	4438156108	SPACER	
48	1468082106	MIRROR CASE ASS'Y		99	1298010005	CUSHION RUBBER	
49	3158265118	LIFTER SHAFT		△ 100	2062002031	AC CORD	European models only
50	3158288001	ARM LIFTER		△	2006019307	AC CORD	Australian models only
51	3158273100	ARM REST ASS		△	2006031026	AC CORD	Asian models only
52	KU-324	ARM DRIVE AMP UNIT		△ 101	PS-141	POWER SUPPLY UNIT	European models only

Note: See NOTE on Page 1 for country designation.

EXPLODED VIEW OF MAIN PARTS

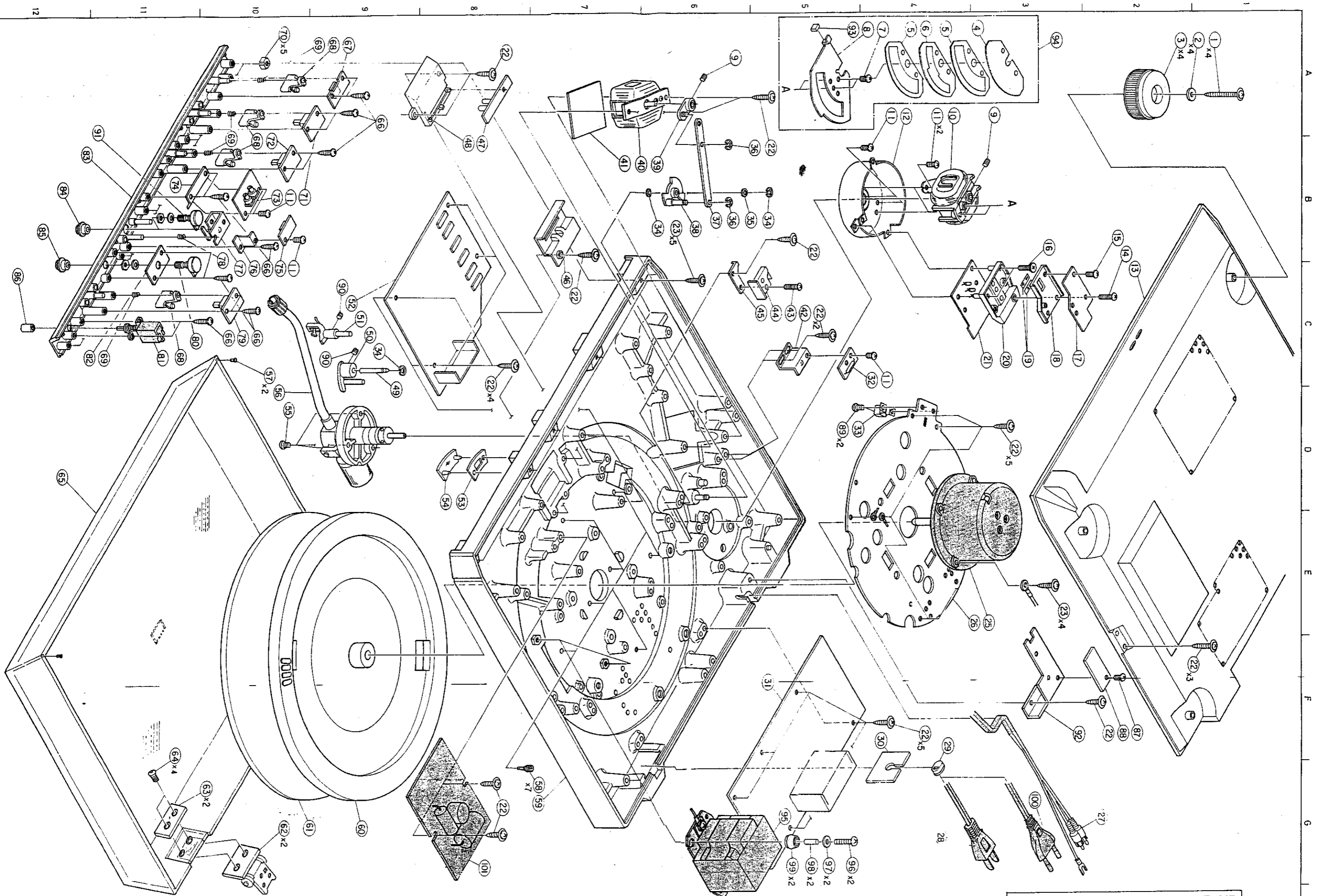

DP-33F ARM SERVO CIRCUIT DIAGRAM (European models and American models)

DP-33F WIRING DIAGRAM

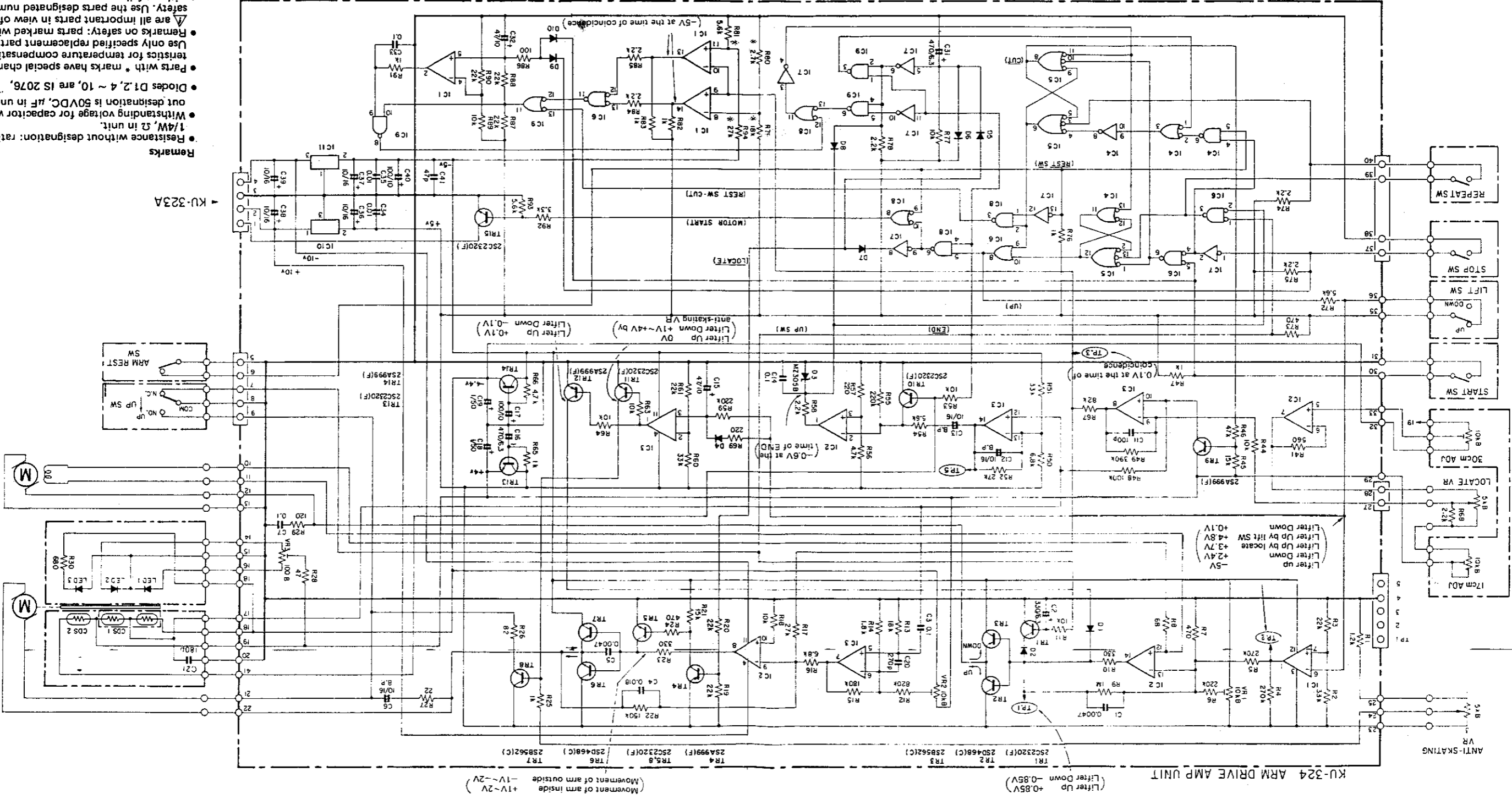

(Movement of arm inside +1V~2V)
TR7 25C2320(F) 25B562(C)
TR6 25D468(C) 25B562(C)
TR5 25C2320(F)
TR4 25A999(F)
TR3 25D468(C) 25B562(C)

(Lifter Up +0.85V)
TR1 25C2320(F)
TR2 25D468(C) 25B562(C)

KU-324 ARM DRIVE AMP UNIT
Lifter up -5V
Lifter Up by locate +2.4V
Lifter Up by lift SW +4.8V
Lifter Down +0.1V

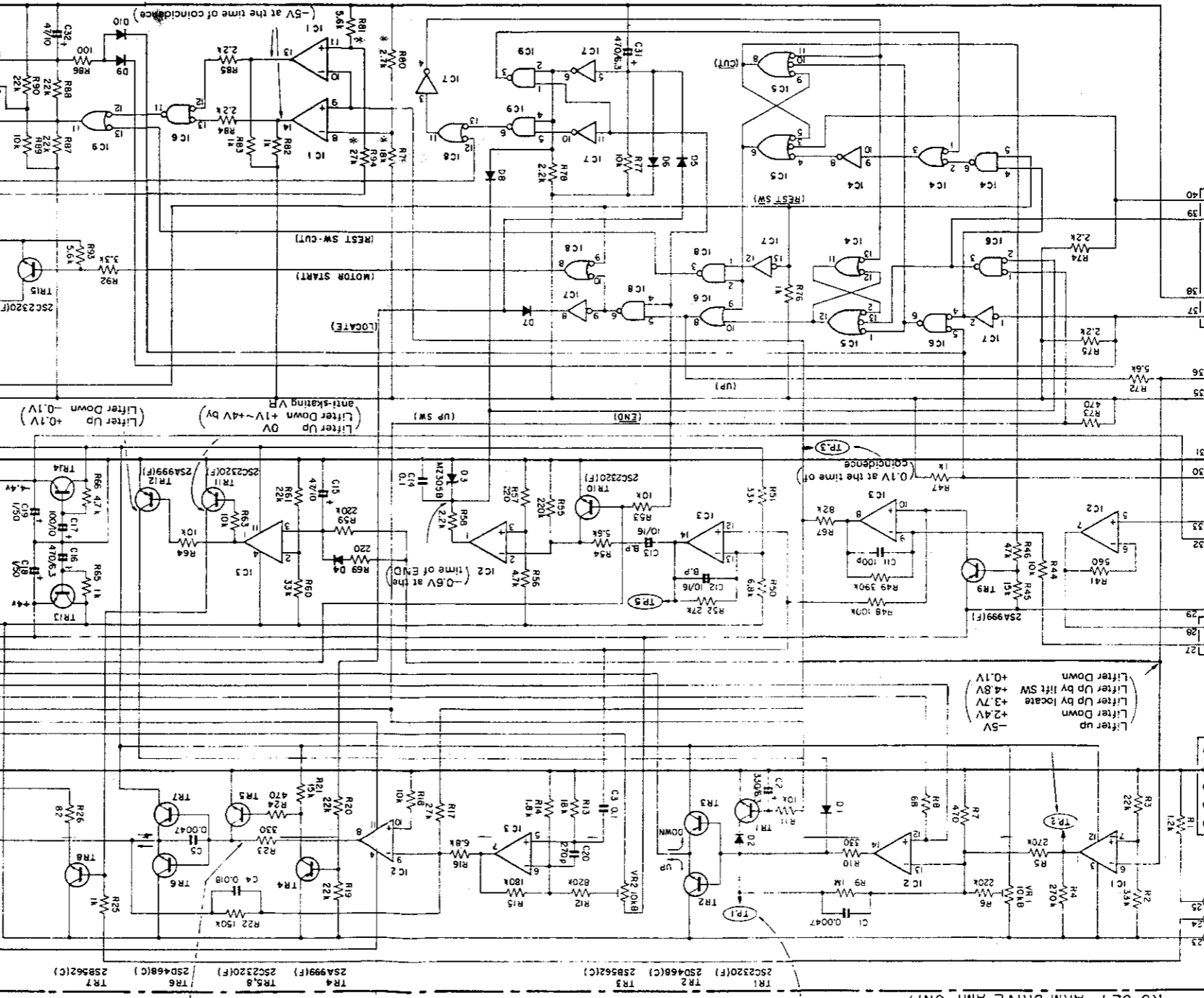

KU-323A

Remarks

- Resistance without designation: rating 1/4W, Ω in unit.
- Withstanding voltage for capacitor without designation is 50VDC, μ F in unit.
- Diodes D1, 2, 4 ~ 10, are IS 2076.
- Parts with * marks have special characteristics for temperature compensation.
- Use only specified replacement part.
- Remarks on safety: parts marked with Δ are all important parts in view of safety. Use the parts designated numbers without fail.
- This circuit is fundamental. Subject to alternation for improvement.

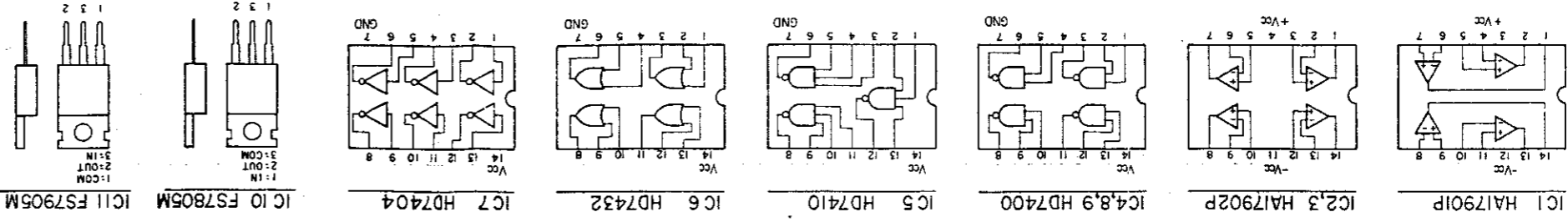

PRINTED CIRCUIT BOARD (European and American models)

61E CDS H. MOTOR

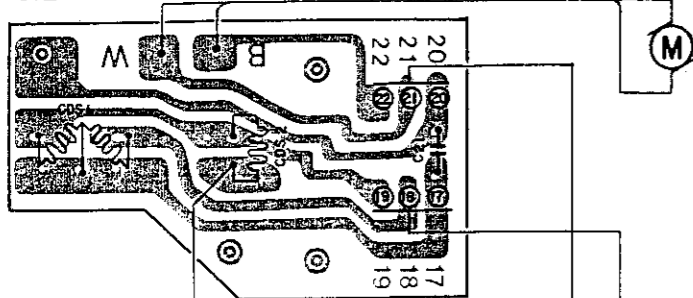

KU-323 A
SERVO AMP UNIT

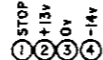

LIFTER MOTOR

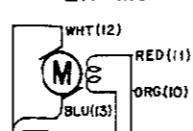

KU-324 ARM DRIVE AMP UNIT

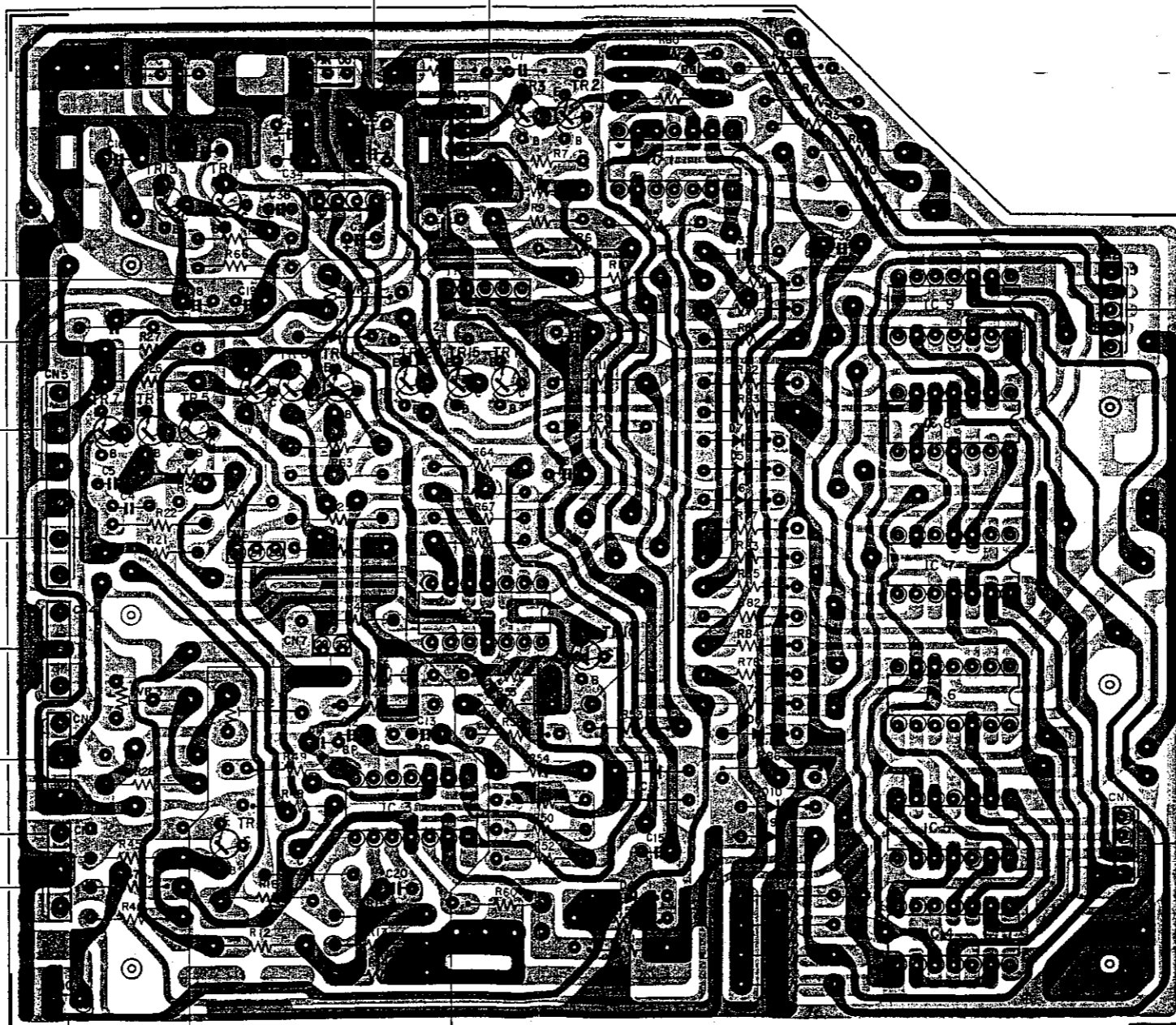

61A OUTPUT TERMINAL

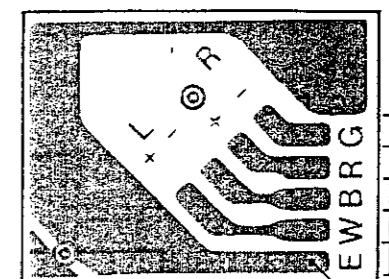

61F LED

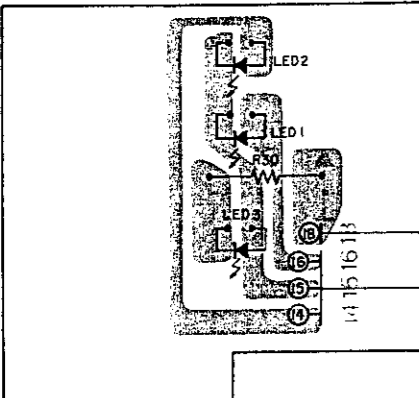

61J 30/17 ADJ.

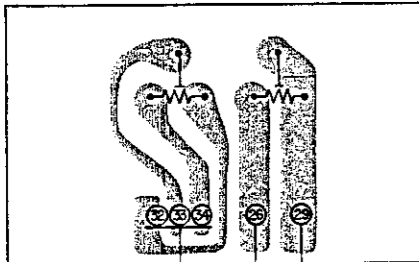

61C START



54A LIFT

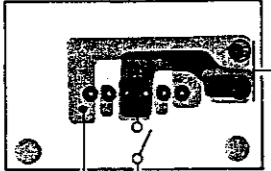

KU-327 SWITCH UNIT

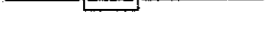

LOCATE VR

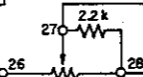

ANTI-SKATING VR

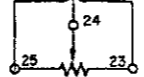

61G UP SW

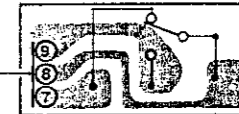

61H REST

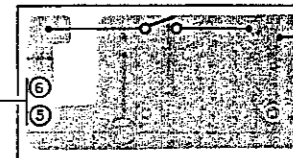

61B REPEAT

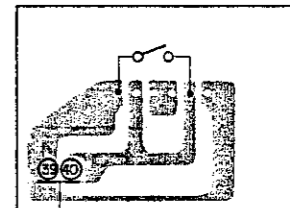

61D STOP

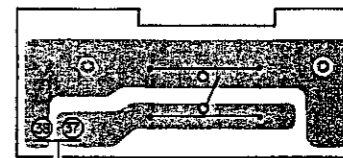

DP-33F MOTOR DRIVE CIRCUIT DIAGRAM (European models)

DP-33F WIRING DIAGRAM

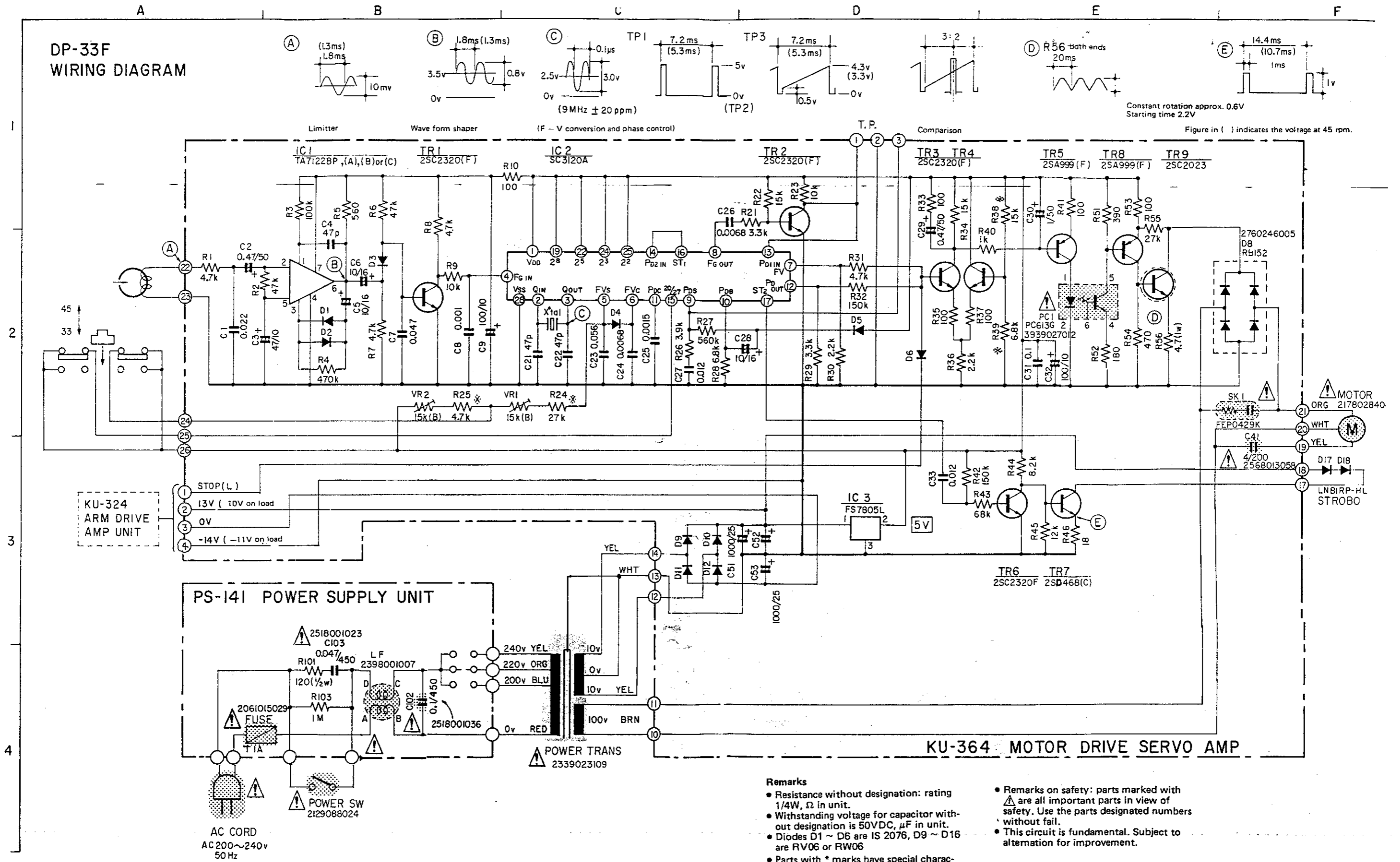

Remarks

- Resistance without designation: rating 1/4W, Ω in unit.
- Withstanding voltage for capacitor without designation is 50VDC, μF in unit.
- Diodes D1 ~ D6 are IS 2076, D9 ~ D16 are RV06 or RW06
- Parts with * marks have special characteristics for temperature compensation. Use only specified replacement part.

- Remarks on safety: parts marked with ⚠ are all important parts in view of safety. Use the parts designated numbers without fail.
- This circuit is fundamental. Subject to alternation for improvement.

PRINTED CIRCUIT BOARD (European models)

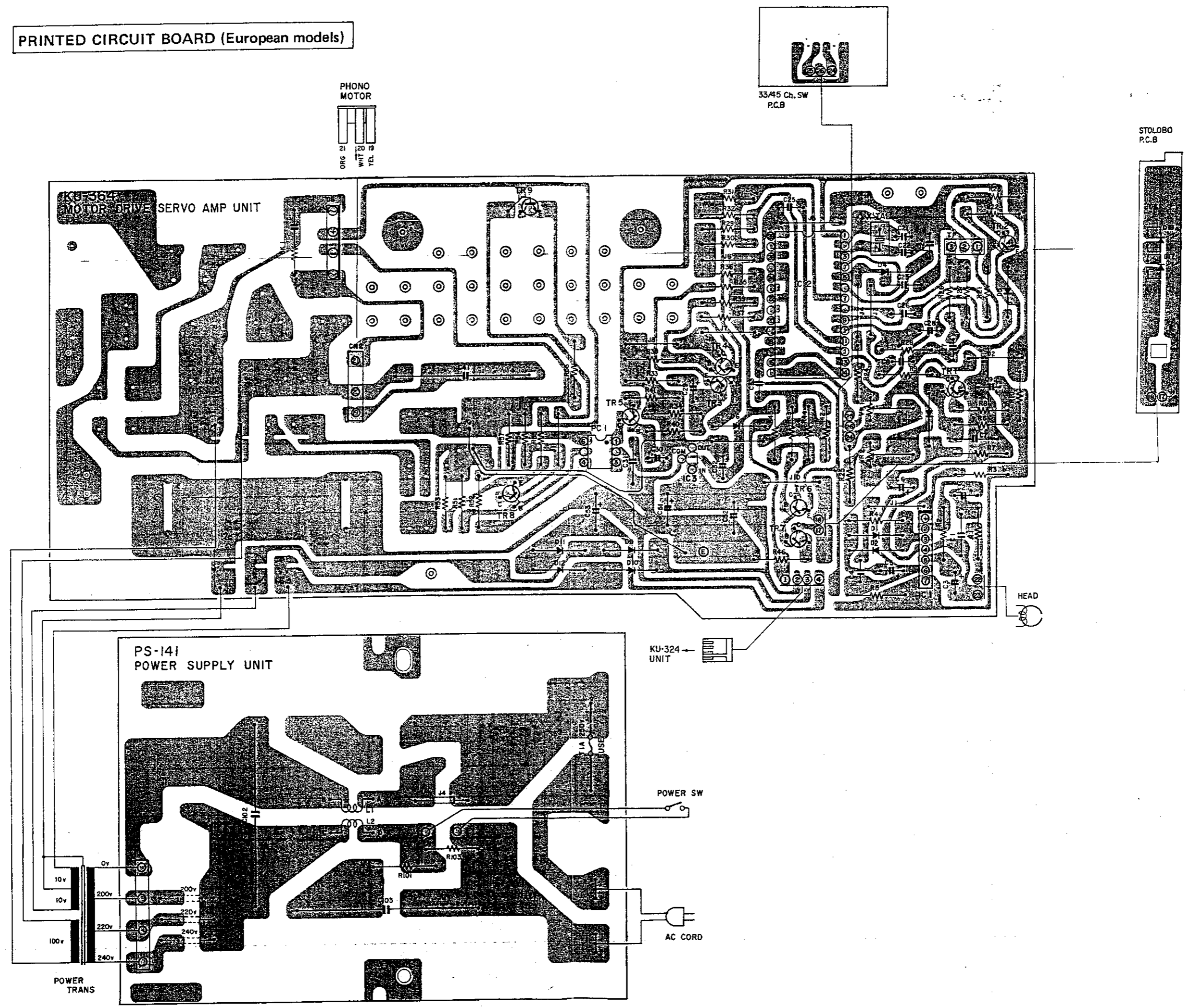

DP-33F MOTOR DRIVE CIRCUIT DIAGRAM (American models)

DP-33F WIRING DIAGRAM

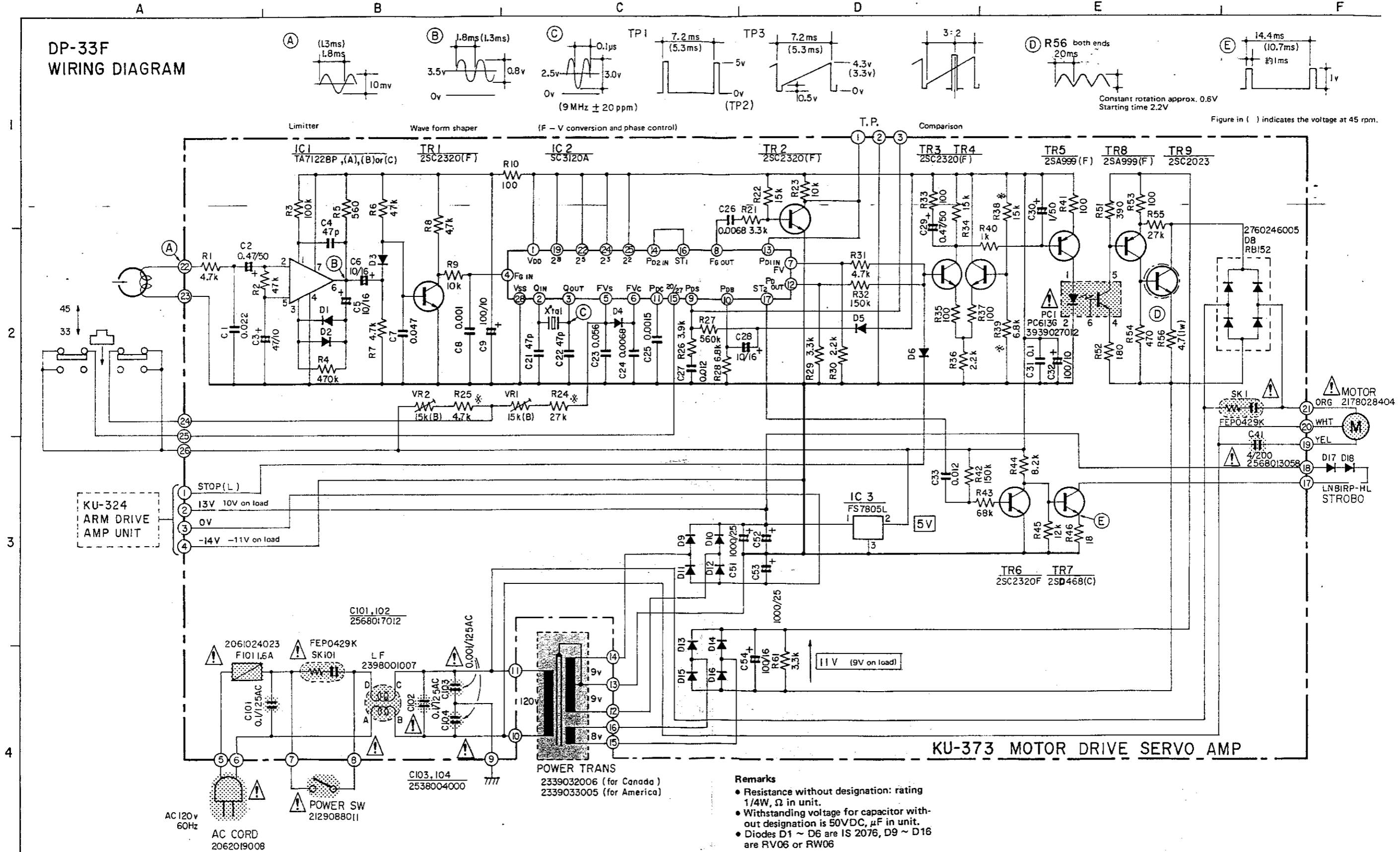

- Remarks**
- Resistance without designation: rating 1/4W, Ω in unit.
 - Withstanding voltage for capacitor without designation is 50VDC, μF in unit.
 - Diodes D1 ~ D6 are IS 2076, D9 ~ D16 are RV06 or RW06
 - Parts with * marks have special characteristics for temperature compensation. Use only specified replacement part.
 - Remarks on safety: parts marked with ⚠ are all important parts in view of safety. Use the parts designated numbers without fail.
 - This circuit is fundamental. Subject to alternation for improvement.

PRINTED CIRCUIT BOARD (American models)

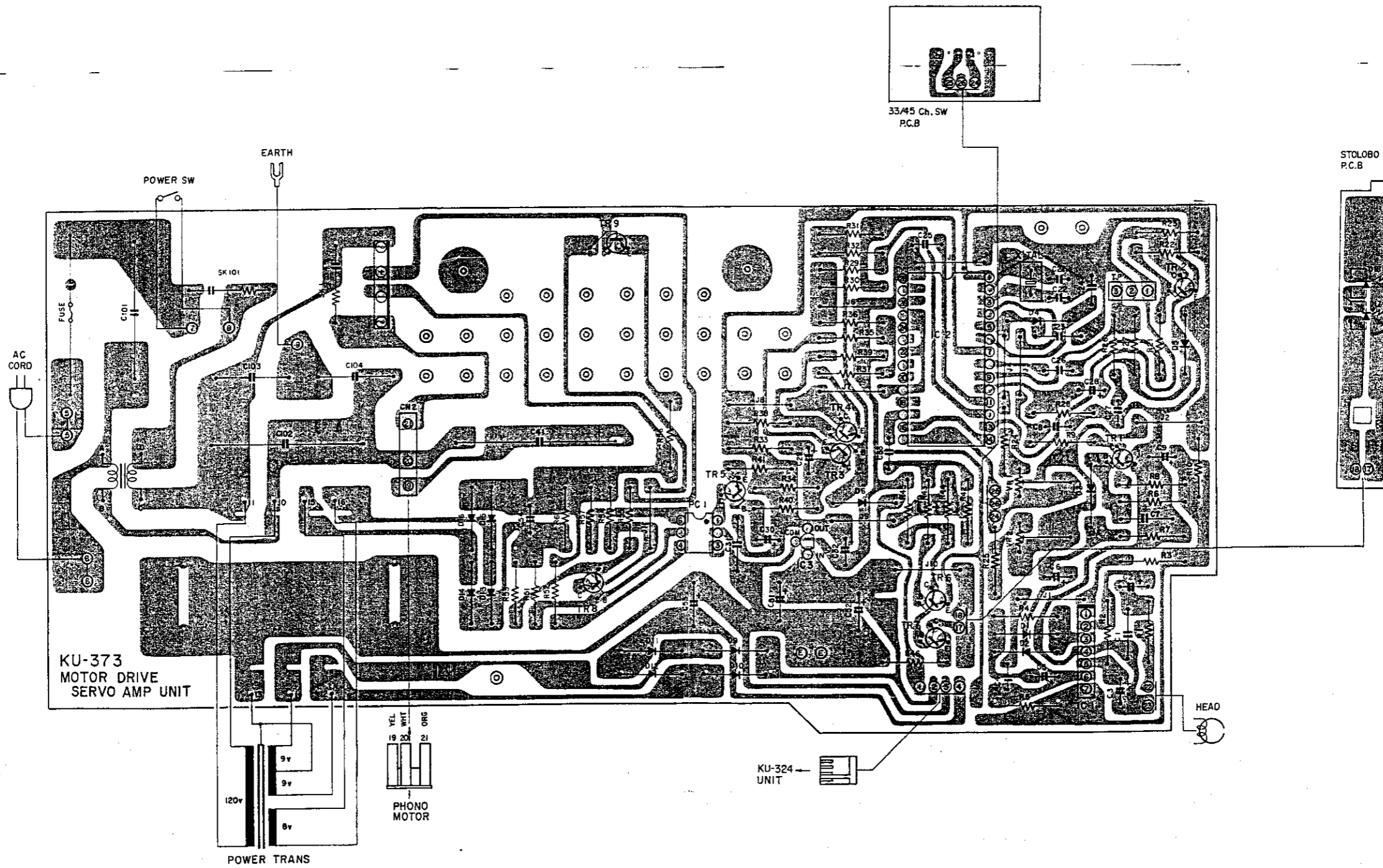

LEAD CONNECTION OF SEMICONDUCTORS

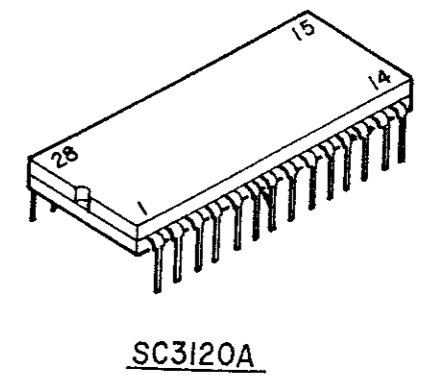
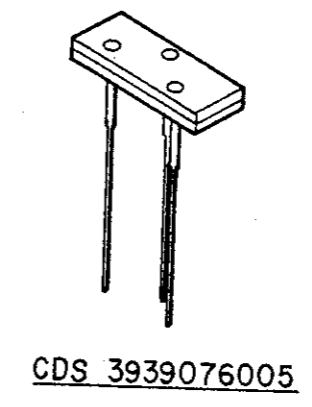
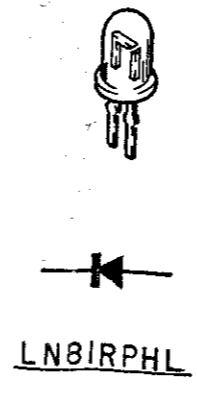
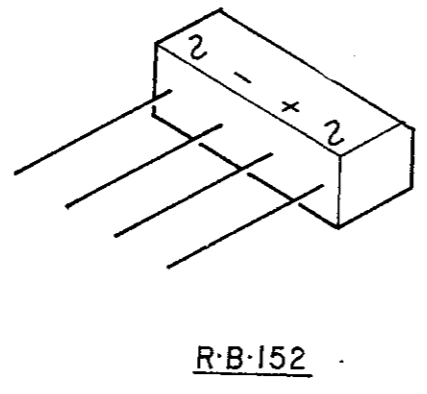
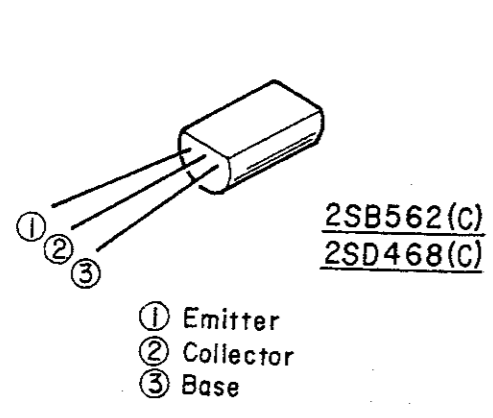
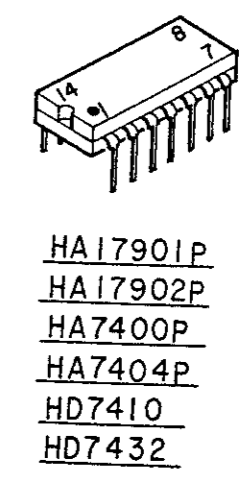
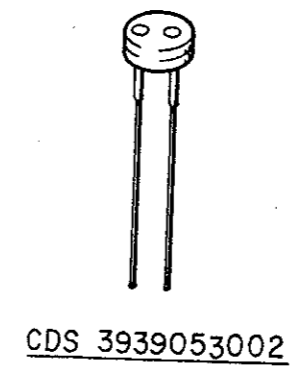
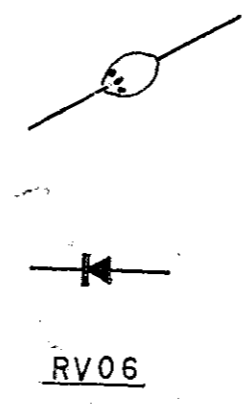
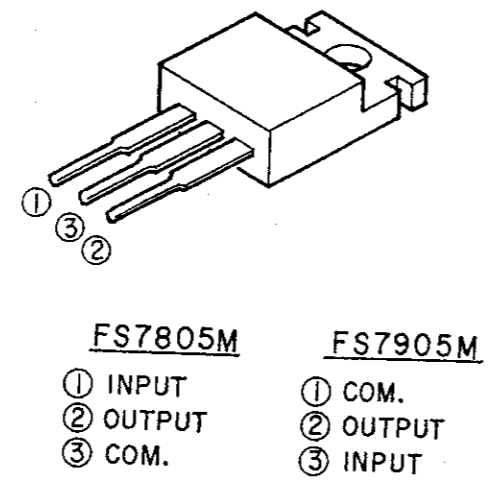
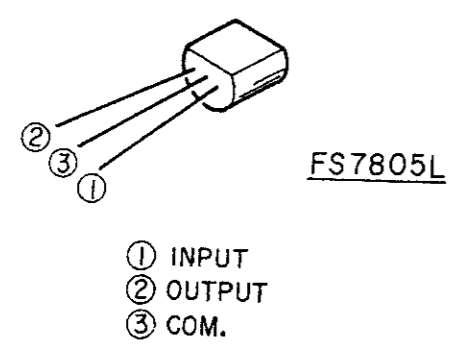
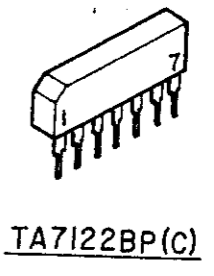
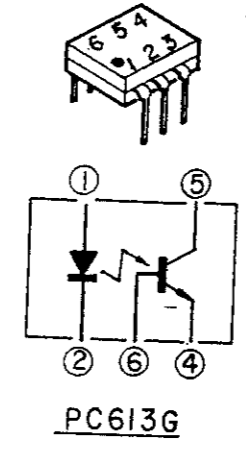
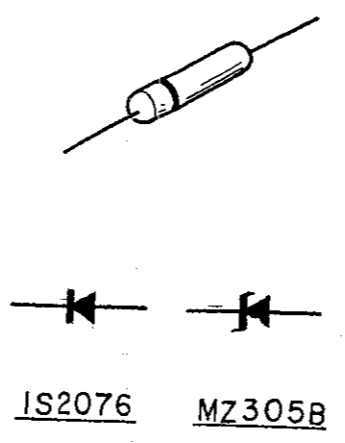
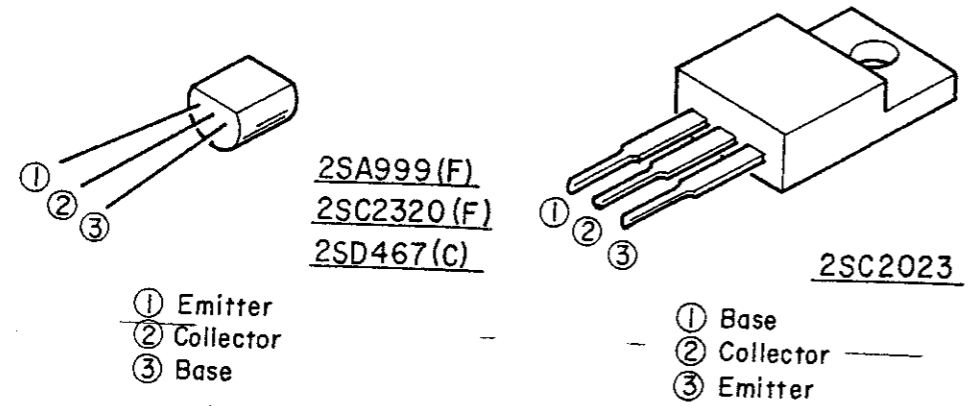

KU-324 ARM DRIVE AMP UNIT
(European and American models)

Ref. No.	Part No.	Part Name	Remarks
SEMI CONDUCTOR GROUP			
IC1	2630076004	HA17901P	OP AMP IC 2 NAND IC INVERTER IC 3 NAND IC 2 OR IC
IC2, 3	2630075005	HA17902P	
IC4, 8, 9	2620056005	HD7400P	
IC7	2620080000	HD7404	
IC5	2620076001	HD7410	
IC6	2620082008	HD7432	
IC10	268009005	FS-7805M	
IC11	2680017000	FS-7905M	
TR4, 9, 12, 14	2710113007	2SA999 (F)	
TR3, 7	2720025004	2SB562 (C)	
TR1, 5, 8, 10, 11, 13, 15	2730204019	2SC2320 (F)	
TR2, 6	2740036002	2SD468 (C)	
D1, 2, 4~10	2760049008	1S2076	
D3	2760241000	MZ305B	
RESISTOR GROUP			
			Carbon film
R27	2410274000	RD14B2E220J	22ΩJ ¼W
R28	2410282005	RD14B2E470J	47ΩJ ¼W
R8	2410286001	RD14B2E680J	68ΩJ ¼W
R26	2410288009	RD14B2E820J	82ΩJ ¼W
R86	2410290000	RD14B2E101J	100ΩJ ¼W
R29	2410292008	RD14B2E121J	120ΩJ ¼W
R57, 69	2410298002	RD14B2E221J	220ΩJ ¼W
R10, 23	2410302008	RD14B2E331J	330ΩJ ¼W
R7, 24, 73	2410306004	RD14B2E471J	470ΩJ ¼W
R41	2410308002	RD14B2E561J	560ΩJ ¼W
R25, 47, 65, 76, 82, 83, 91	2410314009	RD14B2E102J	1KΩJ ¼W
R1	2410316007	RD14B2E122J	1.2KΩJ ¼W
R14	2410320006	RD14B2E182J	1.8KΩJ ¼W
R58, 68, 74, 75, 78, 84, 85	2410322004	RD14B2E222J	2.2KΩJ ¼W
R92	2410326000	RD14B2E332J	3.3KΩJ ¼W
R56, 66	2410330609	RD14B2E472J	4.7KΩJ ¼W
R54, 72, 93	2410332007	RD14B2E562J	5.6KΩJ ¼W
R16, 50	2410334005	RD14B2E682J	6.8KΩJ ¼W
R11, 18, 44, 53, 63, 64, 77, 89	2410338001	RD14B2E103J	10KΩJ ¼W
R21, 45	2410342000	RD14B2E153J	15KΩJ ¼W
R13	2410344008	RD14B2E183J	18KΩJ ¼W
R3, 19, 20, 61, 87, 88, 90	2410346006	RD14B2E223J	22KΩJ ¼W
R17, 52	2410348004	RD14B2E273J	27KΩJ ¼W
R2, 51, 60	2410350005	RD14B2E333J	33KΩJ ¼W
R46	2410354001	RD14B2E473J	47KΩJ ¼W
R67	2410360008	RD14B2E823J	82KΩJ ¼W
R48	2410362006	RD14B2E104J	100KΩJ ¼W
R22	2410366002	RD14B2E154J	150KΩJ ¼W
R15	2410368000	RD14B2E184J	180KΩJ ¼W
R6, 55, 59	2410370001	RD14B2E224J	220KΩJ ¼W
R4, 5	2410372009	RD14B2E274J	270KΩJ ¼W
R49	2410376005	RD14B2E394J	390KΩJ ¼W
R12	2410763003	RD14B2E824J	820KΩJ ¼W
R9	2410765001	RD14B2E105J	1MΩJ ¼W
			Metal film
R80	FEP101139	RN¼PS 2.7KΩG	2.7KΩG ¼W
R81	FEP101120	RN¼PS 5.6KΩG	5.6KΩG ¼W
R79	FEP101122	RN¼PS 18KΩG	18KΩG ¼W
R94	FEP101125	RN¼PS 27KΩG	27KΩG ¼W

Ref. No.	Part No.	Part Name	Remarks
VR3	2116016009	V08PB101	100ΩB
VR1, 2	2116019019	K08PB103	10KΩB
CAPACITOR GROUP			
C2	2544005006	CE04W0J331=	Electrolitic 330μF 6.3V
C16, 31	2544006005	CE04W0J471=	470μF 6.3V
C15, 32	2544009002	CE04W1A470=	47μF 10V
C17, 40	2544010004	CE04W1A101=	100μF 10V
C36~39	2544015009	CE04W1C100=	10μF 16V
C18, 19	2544044009	CE04W1H010=	1μF 50V
C6, 12, 13	2543014027	CE04D1C100MBP	10μF 16V
			Film
C4	2551075003	CQ93M1H183K	0.018μF 50V
C3	2551084007	CQ93M1H104K	0.1μF 50V
			Ceramic
C41	2533619005	CC45SL1H470J	47pF 50V
C11	2533657009	CC45SL1H101K	100pF 50V
C20	2533662007	CC45SL1H271K	270pF 50V
C1, 5	2531023004	CK45F1H472Z	0.0047μF 50V
C34, 35	2531024003	CK45F1H103Z	0.01μF 50V
C7, 14, 33	2531027000	CK45F1H104Z	0.1μF 50V
OTHER PARTS GROUP			
	2228154202	ARM DRIVE P.C. BOARD	
	4178028004	HEAT SINK	
	2129089007	MINI PUSH SWITCH	Lift S.W.
	2035622024	4P MINI CONNE PIN	Lifter Motor
	2035622066	5P MINI CONNE PIN	T.P.
	2032075001	2P CONNECTOR BASE	Locate V.R.
	2050082034	3P WRAPPING TERMINAL	
	2058010008	6P WRAPPING TERMINAL	

KU-327 SWITCH UNIT
(European and American models)

Ref. No.	Part No.	Part Name	Remarks
SEMI CONDUCTOR GROUP			
LED1~3	3939075006	LED	
CDS1	3939076005	CDS	
CDS2	3939053002	CDS	
RESISTOR GROUP			
R30	2410310003	RD14B2E681J	Carbon film 680ΩJ ¼W
	2116020008	K08C06MB103	10KΩB
CAPACITOR GROUP			
C21	2533660009	CC45SL1H181K	Ceramic 180pF 50V
OTHER PARTS GROUP			
	2129089007	MINI PUSH SWITCH	Repeat S.W.
	2129059008	PUSH SWITCH	Start & Stop S.W.
	2129053004	MICRO SWITCH	Up S.W.
	2129018007	REED SWITCH	Rest S.W.
	2228161208	P. CIRCUIT BOARD	
	2037622019	4P EI CON. RIBBON	
	2039621018	5P EI CON. WITH WIRE	

KU-364 MOTOR SERVO AMP UNIT
(European models)

Ref. No.	Part No.	Part Name	Remarks
SEMI CONDUCTOR GROUP			
IC1	2630094028	TA7122BP (C)	
IC2	2620186001	SC3120A	
IC3	2680016001	FS7805L	
TR5, 8	2710113007	2SA999 (F)	
TR9	2730196017	2SC2023	
TR1~4, 6	2730204019	2SC2320 (F)	
TR7	2740038000	2SD467 (C)	
D1~6	2760049008	1S2076	
D9~12	2760237001	RV06	
△ PC1	3939027012	PC613G	
D17, 18	3939041001	LN81RPHL	
D8	2760246005	RB152	
RESISTOR GROUP			
R46	2410272002	RD14B2E180J	Carbon film 18ΩJ ¼W
R10, 33, 35, 37, 41, 53	2410290000	RD14B2E101J	100ΩJ ¼W
R52	2410296004	RD14B2E181J	180ΩJ ¼W
R51	2410304006	RD14B2E391J	390ΩJ ¼W
R54	2410306004	RD14B2E471J	470ΩJ ¼W
R5	2410308002	RD14B2E561J	560ΩJ ¼W
R40	2410314009	RD14B2E102J	1KΩJ ¼W
R30, 36	2410322004	RD14B2E222J	2.2KΩJ ¼W
R21, 29	2410326000	RD14B2E332J	3.3KΩJ ¼W
R26	2410328008	RD14B2E392J	3.9KΩJ ¼W
R1, 7, 8, 31	2410330009	RD14B2E472J	4.7KΩJ ¼W
R28	2410334005	RD14B2E682J	6.8KΩJ ¼W
R44	2410336003	RD14B2E822J	8.2KΩJ ¼W
R9, 23	2410338001	RD14B2E103J	10KΩJ ¼W
R45	2410340002	RD14B2E123J	12KΩJ ¼W
R22, 34	2410342000	RD14B2E153J	15KΩJ ¼W
R55	2410348004	RD14B2E273J	27KΩJ ¼W
R2, 6	2410354001	RD14B2E473J	47KΩJ ¼W
R43	2410358007	RD14B2E683J	68KΩJ ¼W
R3	2410362006	RD14B2E104J	100KΩJ ¼W
R32, 42	2410366002	RD14B2E154J	150KΩJ ¼W
R4	2410378003	RD14B2E474J	470KΩJ ¼W
R27	2410759004	RD14B2E564J	560KΩJ ¼W
R56	2440013024	RS14B3A4R7JNBF	Metal oxide 4.7ΩJ 1W
R25	FEP101119	RN¼PS 4.7KΩG	4.7KΩG ¼W
R39	FEP101121	RN¼PS 6.8KΩG	6.8KΩG ¼W
R38	FEP10112	RN¼PS 15KΩG	15KΩG ¼W
R24	FEP101125	RN¼PS 27KΩG	27KΩG ¼W
VR1, 2	2116019022	K08PB153	15KΩB SPEED ADJ
CAPACITOR GROUP			
C3	2544009002	CE04W1A470=	Electrolitic 47μF 10V
C9, 32	2544010004	CE04W1A101=	100μF 10V
C5, 6, 8	2544018006	CE04W1C100=	10μF 16V
C51~53	2544032008	CE04W1E102=	1000μF 25V
C2, 29	2544043000	CE04W1HR47	0.47μF 50V
C30	2544044009	CE04W1H010	1μF 50V
C4, 21, 22	2533619005	CC45SL1H470J	Ceramic 47μF 50V
C8	2531004007	CK45B1H102K	0.001μF 50V
C1	2531025002	CK45F1H223Z	0.022μF 50V
C7	2531026001	CK45F1H473Z	0.047μF 50V
C31	2531027000	CK45F1H104Z	0.1μF 50V
C25	2551062003	CQ93M1H152K	Film 0.0015μF 50V
C24, 26	2551070008	CQ93M1H682K	0.0068μF 50V
C27, 33	2551121038	CQ93M1H123J	0.012μF 50V
C23	2551122011	CQ93M1H563J	0.056μF 50V
△ C102	2558000039	CO93P2CAC104M	0.1μF 160V AC Metalized
△ C41	2568013058	CF99-2DAC405J	4μF 200V AC

Ref. No.	Part No.	Part Name	Remarks
OTHER PARTS GROUP			
	2228153203	SERVO AMP P.C. BOARD	
	2618007008	CRYSTAL	9 MHZ
△ SK1	FEP0429K	SPARK KILLER	
	2090008117	JUMPER	
	4178020413	HEAT SINK	
	2033625010	MINI CONNE PIN ASS	
	2035622008	3P MINI CONNE PIN	
	2039617019	4P EI. CON. WITH WIRE	
	2129089007	MINI PUSH SWITCH	Speed select
	2058007008	BOARD IN TERMINAL	

PS-141 POWER SUPPLY UNIT
(European models)

Ref. No.	Part No.	Part Name	Remarks
RESISTOR GROUP			
R101	2410163001	RD14B2H121J	Carbon film 120ΩJ ¼W
R103	2410765001	RD14B2E105J	1MΩJ ¼W
CAPACITOR GROUP			
C102	2518001036	CP05C--AC104M	0.1μF 450VAC
C103	2518001023	CP05C--AC473M	0.047μF 450VAC
OTHER PARTS GROUP			
	2228148205	POWER SUPPLY P.C.B.	
	2061015029	FUSE	1A
	FEP1287	FUSE HOLDER	
	2398001007	LINE FILTER COIL	
LF	2050087042	WRAPPING TERMINAL	
	EE-1656	BASE TERMINAL	
	2090008117	JUMPER	

KU-373 MOTOR SERVO AMP UNIT
(American models)

Ref. No.	Part No.	Part Name	Remarks
SEMI CONDUCTOR GROUP			
IC1	2630094028	TA7122BP (C)	
IC2	2620186001	SC3120A	
IC3	2680016001	FS7805L	
TR5, 8	2710113007	2SA999 (F)	
TR9	2730196017	2SC2023	
TR1~4, 6	2730204019	2SC2320 (F)	
TR7	2740038000	2SD467 (C)	
D1~6	2760049008	1S2076	
D9~16	2760237001	RV06	
D8	2760246005	RB152	
D17, 18	3939041001	LN81RPHL	
△ PC1	3939027012	PC613G	
RESISTOR GROUP			
R46	2410272002	RD14B2E180J	Carbon film 18ΩJ ¼W
R10, 33, 35, 37, 41, 53	2410290000	RD14B2E101J	100ΩJ ¼W
R52	2410296004	RD14B2E181J	180ΩJ ¼W
R51	2410304006	RD14B2E391J	390ΩJ ¼W
R54	2410306004	RD14B2E471J	470ΩJ ¼W
R5	2410308002	RD14B2E561J	560ΩJ ¼W
R40	2410314009	RD14B2E102J	1KΩJ ¼W
R30, 36	2410322004	RD14B2E222J	2.2KΩJ ¼W
R21, 29, 61	2410326000	RD14B2E332J	3.3KΩJ ¼W
R26	2410328008	RD14B2E392J	3.9KΩJ ¼W
R1, 7, 8, 31	2410330009	RD14B2E472J	4.7KΩJ ¼W
R28	2410334005	RD14B2E682J	6.8KΩJ ¼W
R44	2410336003	RD14B2E822J	8.2KΩJ ¼W
R9, 23	2410338001	RD14B2E103J	10KΩJ ¼W
R45	2410340002	RD14B2E123J	12KΩJ ¼W
R22, 34	2410342000	RD14B2E153J	15KΩJ ¼W
R55	2410348004	RD14B2E273J	27KΩJ ¼W
R2, 6	2410354001	RD14B2E473J	47KΩJ ¼W
R43	2410358007	RD14B2E683J	68KΩJ ¼W
R3	2410362006	RD14B2E104J	100KΩJ ¼W
R32, 42	2410366002	RD14B2E154J	150KΩJ ¼W
R4	2410378003	RD14B2E474J	470KΩJ ¼W
R27	2410759004	RD14B2E564J	560KΩJ ¼W
R56	2440013024	RS14B3A4R7JNBF	Metal oxide 4.7ΩJ 1W
R25	FEP101119	RN¼PS	4.7KΩG ¼W
R39	FEP101121	RN¼PS	6.8KΩG ¼W
R38	FEP10112	RN¼PS	15KΩG ¼W
R24	FEP101125	RN¼PS	27KΩG ¼W
VR1, 2	2116019022	K08PB153	15KΩB SPEED ADJ

Ref. No.	Part No.	Part Name	Remarks
CAPACITOR GROUP			
C3	2544009002	CE04W1A470=	Electrolytic 47μF 10V
C9, 32	2544010004	CE04W1A101=	100μF 10V
C5, 6, 28	2544015009	CE04W1C100=	10μF 16V
C54	2544018006	CE04W1C101=	100μF 16V
C51~53	2544032008	CE04W1E102=	1000μF 25V
C2, 29	2544043000	CE04W1HR47=	0.47μF 50V
C30	2544044009	CE04W1H010=	1μF 50V
C4, 21, 22	2533619005	CC45SL1H470J	Ceramic 47μF 50V
C1	2531025002	CK45F1H223Z	0.022μF 50V
C7	2531026001	CK45F1H473Z	0.047μF 50V
C31	2531027000	CK45F1H104Z	0.1μF 50V
G8	2531004007	CK45B1H102K	0.001μF 50V
△ C103, 104	2538004000	CK45B2BAC102KW	0.001μF 125V AC
C25	2551062003	CQ93M1H152K	Film 0.0015μF 50V
C24, 26	2551070008	CQ93M1H682K	0.0068μF 50V
C27, 33	2551121038	CQ93M1H123K	0.012μF 50V
C23	2551122011	CQ93M1H563K	0.056μF 50V
△ C101, 102	2568017012	CF99B2BAC104MW	Metalized 0.1μF 125V AC
△ C41	2568013058	CF99-2DAC405J	4μF 200V AC
OTHER PARTS GROUP			
	2228316008	P.C. BOARD	
	2618007008	CRYSTAL	X'TAL 9 MHZ
△	2398001007	LINE FILTER COIL	L.F.
△ SK1, 101	FEP0429K	SPARK KILLER	
△ F101	2061024023	FUSE	1.6A 125V
	2090008117	JUMPER	
	4178020413	HEAT SINK	
	2035622008	3P MINI CONNE PIN	
	2050087026	2P WRAPPING TERMINAL	
	2050087039	3P WRAPPING TERMINAL	
	EP-1656	BASE TERMINAL	
	2058007008	BOARD IN TERMINAL	
	2129089007	MINI PUSH SWITCH	

SPECIFICATIONS

PHONO MOTOR

Drive system	Direct drive by AC motor
Speed	33-1/3 rpm, 45 rpm
Wow/flutter	Less than 0.015% wrms (1)
S/N	More than 78dB (DIN-B)
Starting time	Less than 1.5 sec. to reach 33-1/3 rpm nominal speed.
Turntable platter	Diecast aluminum 300 mm diam. Weight: 1.5 kg Moment of inertia: 200 kg-cm ² (including turntable mat)
Motor	AC servomotor
Speed control system	Speed servo control by frequency detection combined with phase servo control.

TONARM

Type	Static balance type
Effective length	220 mm
Overhang	16 mm
Tracking error	Within 3°
Stylus force range	0-2.5 g/rot. (1 division is 0.1 g) direct reading
Acceptable cartridge weight	5-9g (for use with head shell provided)
Weight of head shell	9 g (excluding screws and nuts)
Shell connector	EIA standard 4P connector
Arm lifter	Servo controlled by angular control motor

GENERAL

Power supply	(2) AC 120V 60Hz, (American models) AC 200V 220V 240V 50Hz (European models)
Power consumption	16 W
Dimension	450W x 403D x 140H (mm) (dust cover closed)
Weight	9.8 kg Approx.

Note: (1) Measured by DENON's method using magnetic pulse wheel.
(2) AC voltage is shown on rating label.

** The above specifications and outward appearance are subject to alteration for improvement.

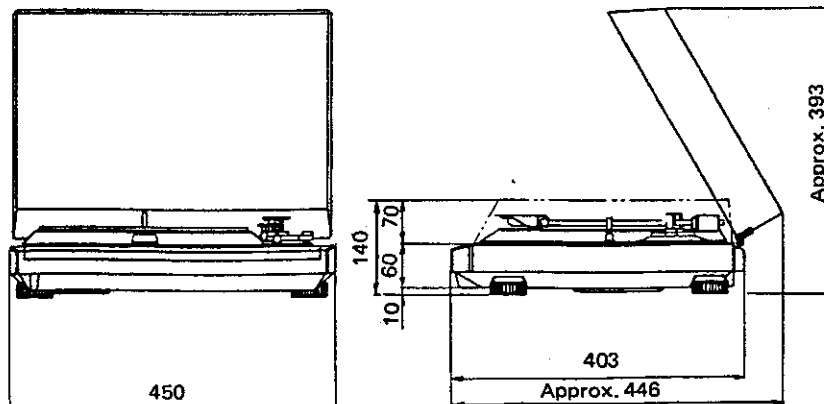

Dimensions (mm)