

DENON

Hi Fi Component

SERVICE MANUAL

FULLY AUTOMATIC DIRECT DRIVE TURNTABLE SYSTEM

MODEL DP-47F SERIES

U.S. and Canadian models do not include cartridge.



NIPPON COLUMBIA CO., LTD.

TABLE OF CONTENTS

FEATURES	2
SPECIFICATIONS	3
BLOCK DIAGRAM	4
PART NAMES AND FUNCTION	5
EXPLANATION OF THE MICROPROCESSOR	6 ~ 9
ADJUSTMENT METHOD	10 ~ 11
PARTS LIST OF EXPLODED VIEW	12
EXPLODED VIEW	13
SCHEMATIC DIAGRAM	14
CONNECTIONS OF P.W. BOARD	15
P. W. BOARD OF KU-5580 SERVO CONTROL UNIT	16
P. W. BOARD OF KU-5010 MOTOR DRIVE UNIT	17
PARTS LIST OF P. W. BOARD	17

FEATURES

1. Microprocessor controlled, contactless servo tonearm

A unique microprocessor controlled, contactless servo tonearm ensures safe, easy to use automatic operation with no deterioration in sound quality.

2. Q-damping method (Dynamic servo tracer)

Low frequency resonance caused by the cartridge compliance and the effective tonearm mass is electronically damped both horizontally and vertically to effectively suppress crosstalk and inter-modulation distortion. The dynamic servo tracer maximizes the performance of the low mass tonearm and results in a record reproduction of excellent sound image with minimum noise and distortion.

3. Low mass straight arm

Having an outstanding tracing ability, this arm maximizes the performance of the high compliance cartridge to the full extent. Even with the most up-to-date high grade records, its tracing ability is excellent.

4. Locate function

Just by pressing the locate button, the tone-arm is moved to any desired location where the record play is started.

5. Record size detector and automatic speed selector

The record size and the speed are automatically set, when playing 12 inch records (33 1/3 rpm) or 7 inch records (45 rpm) in the automatic play mode. The unit provides a safety measure which causes the tonearm to stop and return to the arm rest to protect the stylus tip when there is no record on the turntable, even if the start button is pressed.

6. DENON quartz on bi-directional servo

Bi-directional servo and electronic braking system have been added to the combination of the magnetic recording detector and the quartz lock to ensure a stable performance of rotation and a sharp operation.

7. Finely-finished wood cabinet design

Mirror-like finish, large cabinet with 85 mm in height, and a new howling-proof insulator have been incorporated into the DP-47F.

8. Newly-developed high-output MC cartridge (for U.K. model only)

The DP-47F is equipped with a high-output MC cartridge DL-80MC which has a superb tracing capability and resolution and it allows a clear sound to be reproduced.

9. Newly-developed cartridge (for European model only)

A high-output MC cartridge comparable to MM cartridges. The DL-160 MC cartridge can be connected directly to the MM position of the amplifier.

Note: • U.S., Canadian & Asian models do not include cartridge.

• U.K. model includes the DL-80 MC cartridge.

SPECIFICATION

MOTOR

Drive System:	Servo controlled direct drive
Turntable Speeds:	33-1/3, 45 rpm
Wow & Flutter:	Below 0.010% wrms (servo system) Below 0.020% (JIS)
S/D Ratio:	Over 78 dB (DIN-B)
Rise Time:	Nominal speed within 2 seconds (at 33-1/3 rpm)
Turntable Platter:	Aluminum die-cast; 310 mm diameter
Motor:	Linear drive motor
Speed Control System:	Speed servo by frequency detection, phase servo control
Speed deviation:	Below 0.01%
Load characteristics:	0% (80 g tracking force; outermost groove)

GENERAL

Power Supply:	50/60 Hz, Voltage is shown on rating label
Power Consumption:	Approx. 8 W
Dimensions:	434 x 179 x 410 mm (W x H x D) 17 x 7.3 x 16.1 in
Weight:	Approximately 8.5 kg (19 lb)

TO NEARM SECTION

Arm Type:	Dynamically balanced, straight tube tonearm
Effective Length:	220 mm
Overhang:	16 mm
Tracking Error:	Within 3°
Automatic Mechanism:	Electronically controlled, fully automatic
Adjustable Tracking Force Range:	0 ~ 3.0 g (1 scale = 0.1 g)
Suitable Cartridge Weight Range:	Approximately 3.0 ~ 12.0 g (including screws, nuts)

CARTRIDGE

	DL-80MC	DL-160 (European model only)
Output Voltage	1.6mV	1.6mV
Frequency Response:	20 Hz ~ 45 kHz	20 Hz ~ 45 k Hz
Tracking Force:	1.8 ± 0.3 g.	1.8 ± 0.3 g.
	High-output MC type	High-output MC type

U.S., Canadian and Asian models do not include cartridge.

*For product improvement purposes, the specifications are subject to change without notice.

WARNING:

1. Component parts

Parts marked with \triangle and/or shading in this service manual have special characteristics important to safety. Be sure to use the specified parts for replacement.

2. Leakage current

Before returning the appliance to customer, test the leakage current when the power plug is connected. Use a calibrated (with an error of not more than 5%) leakage current tester and measure the leakage current from any exposed metal to the earth ground. Reverse the power plug polarity and test the above again.

Any current measured MUST NOT EXCEED 0.5 milliamps. Corrective measure must be taken if it exceeds the limit.

BLOCK DIAGRAM

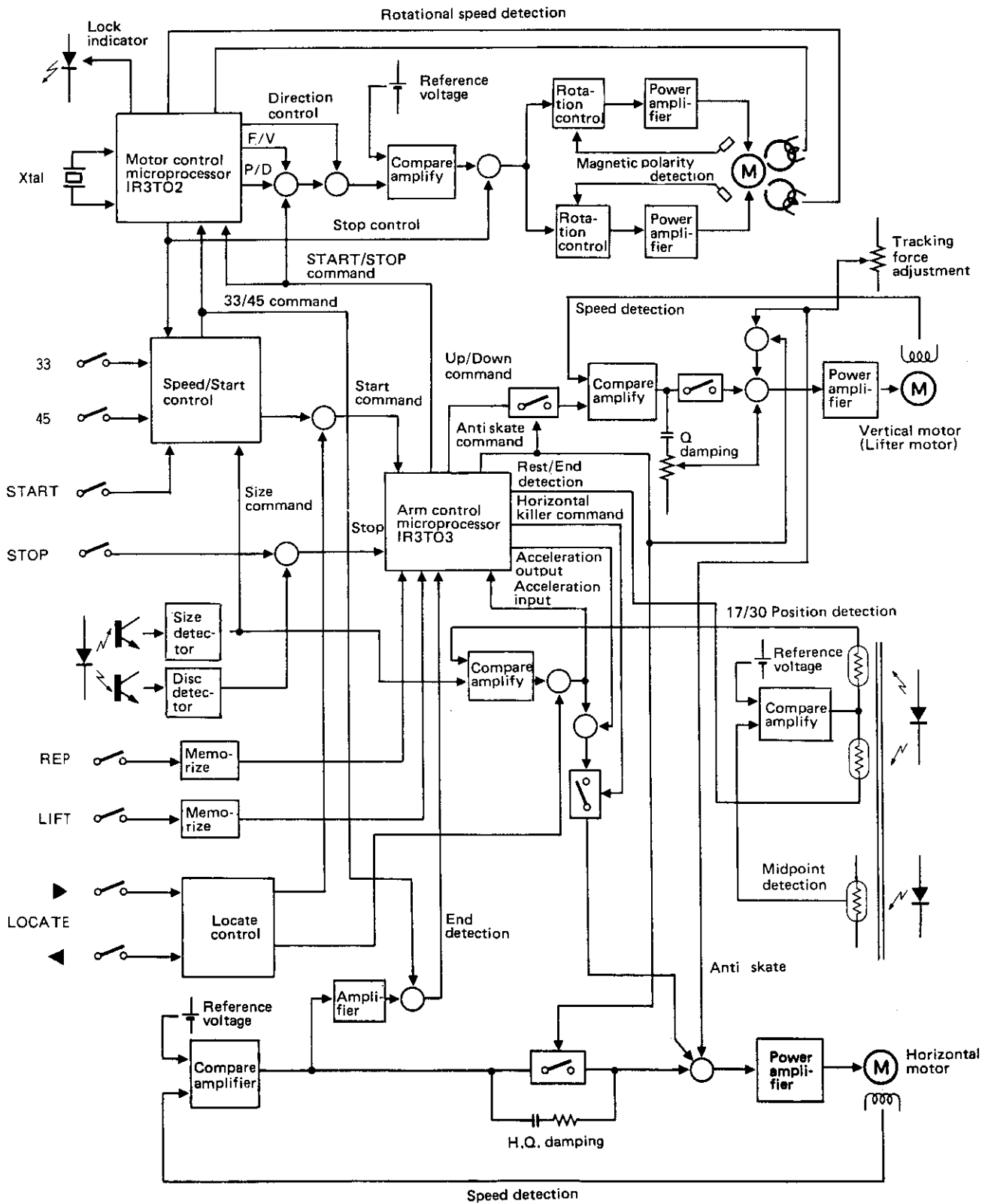

PART NAMES AND FUNCTION

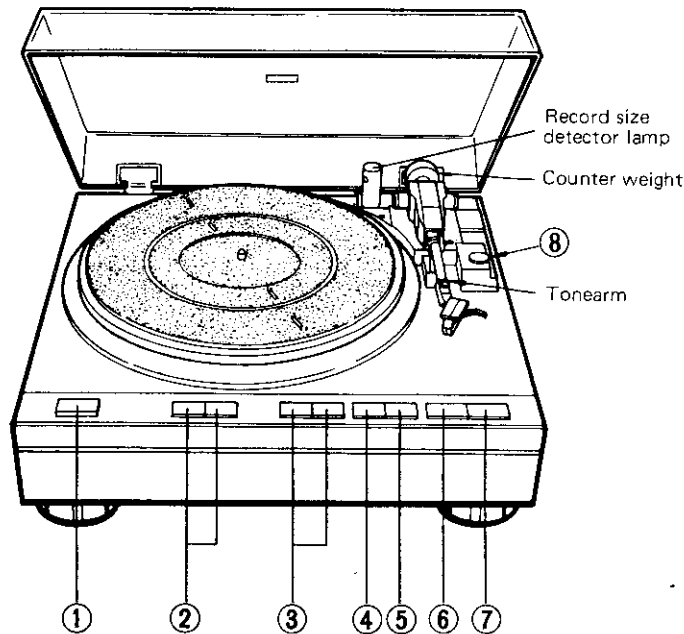

1. Power switch POWER

This switch is used to turn on or off power. Press this button to allow the record size detector lamp to light up. For turning off power, move the arm back to the arm rest, clamp it, then press that button again.

2. Speed button 33. START/LOCK. 45

For playing records manually, press the button corresponding to the record speed.

- 33 1/3 rpm records (33.Start)
- 45 rpm records (45. Start)

In the automatic play mode, the switch will automatically be set to "33" for 12 inch records and "45" for 7 inch records.

The Speed Indication lamp also shows the "LOCK" indication and it keeps blinking until the turntable reaches a specified number of rotations, when it lights up again.

3. Locate button LOCATE

Use this for moving the tone arm horizontally to the position from which you wish to start playing.

4. Arm Lifter button UP LIFTER

Press this button to raise or lower the tonearm during play, or when playing records manually. The "UP" indicator will light up.

5. Repeat button REPEAT

Press this button for playing the same record repeatedly: the "ON" indicator will light up.

6. Start button START

Press this button to start records automatically.

7. Stop button STOP

Press this button to stop a record during play.

8. Tracking force adjustment knob TRACKING FORCE/ANTI-SKATE

Operate this knob for adjusting the tracking force. The anti-skate and Q damping are adjusted simultaneously.

EXPLANATION OF THE MICROPROCESSOR

● **Motor Control IC ... IR3T02 (at standard revolution of 33 rpm)**

The numbers on the left hand side indicates the terminal number.

1. Strove drive

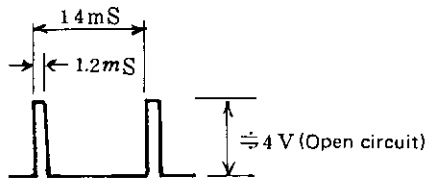

2. 4.5MHz OSC

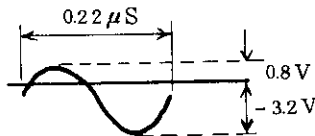

3. 4.5MHz OSC

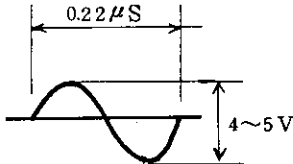

4. rpm selector

H: 45 rpm
L: 33 rpm

5. Power source input

Vcc: 5V ± 0.5V

6. FGI bypass terminal

E6 = 1/2 Vcc

7. FGI lowpass terminal

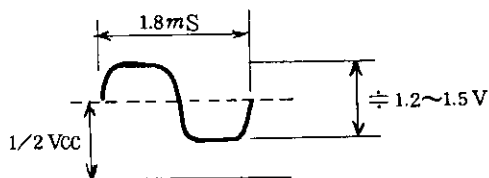

8. FG I output

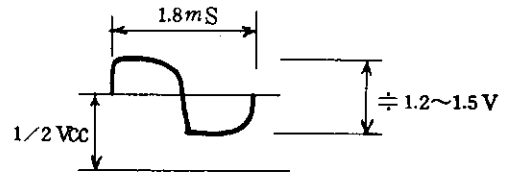

9. FG I inverse input

The gain set element is connected.
E9 = 1/2 Vcc

10. FG I non-inverse input

10mVpp ~ 100mVpp
E10 = 1/2 Vcc

11. FG II non-inverse input

10mVpp ~ 100mVpp
E11 = 1/2 Vcc

12. FG II inverse input

The gain set element is connected.
E12 = 1/2 Vcc

13. FG II output

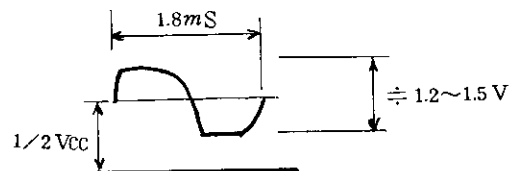

14. Ground terminal

15. F/V output

slower than normal revolution: 2 ~ 4.5V
normal revolution: ≈ 2V
faster than normal revolution: 0 ~ 2V

16. F/V hold terminal

same as terminal 15

17. F/V triangular wave

slower than normal revolution

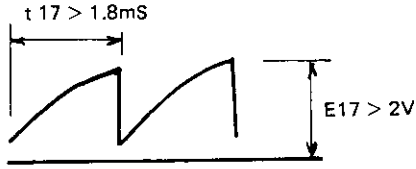

normal revolution

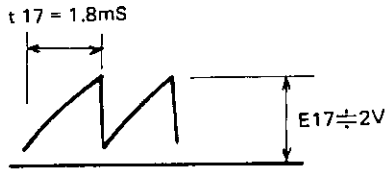

faster than normal revolution

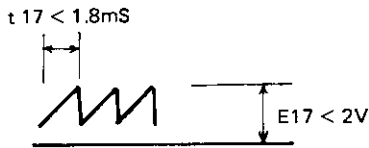

18. Timing pulse width-set terminal

E18 = 0.6V

19. PD triangular wave

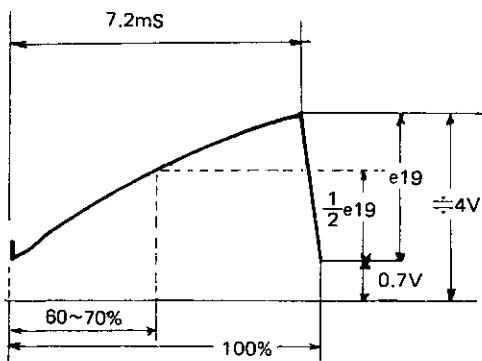

Note:
PD: Phase Detector

20. Sample pulse monitor terminal

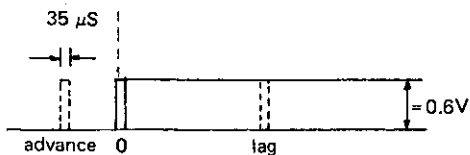

21. PD hold terminal

slow phase: 2 ~ 4V
normal phase: ≐ 2V
advanced phase: 1 ~ 3V

22. PD output

same as terminal 21

23. Lock detector time set terminal

during lock: 0.6V
lock disengaged: 0V

24. Direction detector output

normal revolution: 0V
reverse revolution: ≐ 4V

25. Revolution detector

during revolution: ≐ 4
stop: 0V

26. START/STOP terminal

H → START
L → STOP

27. Stop output

during stop control: 0V
during start: open

28. Lock indicator

during lock (LED lit dimly)

69 Hz

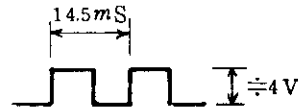

stop (LED lit)

during transition . . (LED flashes)

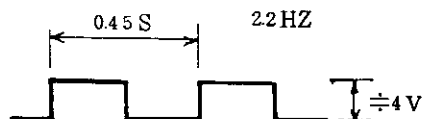

• Arm Control IC IR3T03

The numbers on the left side indicates the terminal number of the IR3T03.

1. Acceleration input

Except for the matching range of the lead-in detector ($E7 \leq |\pm 0.6V|$), it will recognize the situation and control the acceleration during automatic tonearm operation.

2. Acceleration output

$E1 \leq |\pm 2.37V \pm 0.1V|$ open (will not control the acceleration within the matching range)

$E1 \geq |\pm 2.37V \pm 0.1V|$ $E2 \doteq \pm 3.95V$

-3.95V: will accelerate toward the inside from rest.

+3.95V: will accelerate toward rest from the inside.

3. UP/DOWN selection of the arm lifter

When $E9$ is H, the control output for lifting the arm will be made at $E3 \doteq -V_{cc}$.

When $E9$ is L, the control output for lowering the arm will be made at $E3 \doteq +V_{cc}$.

4. Detection of the rest position

$E4 \leq -2.64V$ will be recognized as the arm being at rest.

5. Detection of the END position

When $E5 \geq 2.64V$, it will be recognized to be within the END detection range.

6. End control

Within the END detection range of 5 (above), ($E5 \geq 2.64V$), the arm will be returned by the END control when $E6 \geq 0.23V$.

7. Matching input

$E7 \leq |\pm 0.6V|$ will be recognized as the match range for lead-in.

8. Drive output

Connect to GND.

9. UP control output

When the lifter is in the UP position during automatic arm operations or when the UP signal is sent by pressing the arm lifter button, pin 9 will be at H level.

$E9H \doteq 4V$

$E9L \doteq 0V$

10. DOWN time constant

To ensure that the arm is lowered completely before proceeding to the next movement, a resistor between pins 9 and 10 and a capacitor on pin 10 has a preset discharge time constant which is somewhat longer than the time required for the arm to be lowered. Thus, when pin 9 becomes L ($E9L \doteq 0V$), and the fixed amount of time elapses, the arm will be recognized to be DOWN as soon as $E10 < 2V$.

11. ANT (Anti-skating) control

When $E10 < 2V$, then $E11 \doteq -4V$ will be the control output needed for the anti-skating to be engaged.

When $E10 \geq 2V$, then $E11 \doteq +4V$ will be the control output needed for the anti-skating to be disengaged.

12. Negative power source

Supplies $-5V$.

14. SUB (substratum)

To prevent any interference from the inner elements of the LSI, the substratum terminal is connected to the unregulated side of the negative power source, since it has the lowest electric potential.

15. GND

Standard zero electric potential is the GND.

17. Return control

When the stop command is given, or when the repeat is disengaged and the END is detected ($E6 \geq 0.23V$), a control signal output ($E17H > 4V$) is made to return the arm to rest.

$E17H > 4V$

$E17L$: release

18. Horizontal drive control

When the arm is in resting position, or when the arm reaches the lead-in position during automatic play, and comes into the matching range ($E7 \leq |\pm 0.6V|$), a control signal output ($E18H \doteq 4V$) is made to stop the horizontal motion of the arm.

19. Initial set

This is the preparation time setting terminal when the power source is turned on. The resistor in the LSI and the outer capacitor will set the charge time constant and carry out the initial set.

20. LCTD (Located) time constant

The LSI and its outer circuits will set the LCTD time constant to improve the detection accuracy of the lead-in position and the arm rest position.

$E20H \doteq 1.2V$ A few moments after the arm reaches the range of detection, in other words, after the set LCTD time constant elapses, it will become H level, where it is memorized immediately and then reset to the L level.

$E20L \doteq 0V$ Before and after detection, it will become L level.

21. Turntable (T/T) Drive Control

E21L \neq 0V the turntable stops

E21H release the turntable rotates

(refer to the operational explanations for pin 22)

22. Turntable (T/T) Start Position

This terminal establishes the turntable start position. The turntable will start when the arm separates from the arm rest and pin 22 is released, under manual and auto modes.

23. Start

Will start automatically at the GND level.

24. Auto stop

Will stop automatically at the GND level.

25. Lifter

Will raise the lifter automatically at the GND level.

26. Repeat

Will engage the repeat automatically at the GND level.

27. UP SW

When the arm lifter is raised, this terminal will be opened and made H level, otherwise, the UP detector will control it to make it GND level.

28. Positive power supply

Supplies +5V.

ADJUSTMENT METHOD

● PHONO MOTOR ADJUSTMENT

1. Off-set adjustment

- 1) Set the X-axis and Y-axis sensitivity of the oscilloscope to 100mV/cm by using a 10:1 probe.
- 2) Connect the X-axis terminal of the probe with TP-203 on the motor drive base board and the Y-axis terminal of the probe with TP-204. Use pin No. 8 as the ground.
- 3) Connect pin No. 5 and pin No. 8 and make a low resistance circuit on the input terminal.
- 4) Stop the rotor at the maximum position of the X-axis amplitude of the Lissajous' figure of the oscilloscope while turning the motor by hand.
- 5) Set the maximum amplitude at the X-axis by adjusting VR-201. $A = A'$
- 6) Stop the rotor at the maximum position of the Y-axis amplitude of the Lissajous' figure.
- 7) Set the maximum amplitude at the Y-axis by adjusting VR-202. $B = B'$
- 8) Adjust the center of the circle to $\pm 50\text{mV}$.

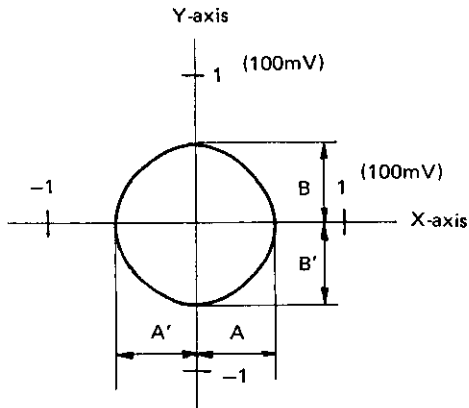

- 9) Disconnect pin No. 5 and pin No. 8 after adjustment.

2. Amplitude adjustment

- 1) Check the X-axis and Y-axis sensitivity of the oscilloscope by using $\pm 5\text{V}$ power supply.
- 2) Cover the photo transistor of the size detecting light receiver with a black rubber sheet or something to avoid that light enters.
- 3) Remove the arm from the arm rest and remove the turntable. Then, turn the motor with full speed.
- 4) Set the amplitude of the X-axis and Y-axis of the Lissajous' figure to 15 VP-P by adjusting VR-203 and VR-204. Make sure that there is no voltage difference between the X-axis and the Y-axis.

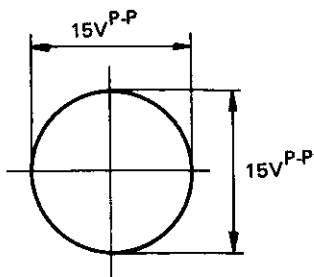

3. Center adjustment

- 1) Adjust the X-axis and Y-axis sensitivity of the oscilloscope to 2V/cm.
- 2) Set the amplitude of the X-axis and Y-axis of the Lissajous' figure to exactly the same point from the center by adjusting VR-205 and VR-206. After the adjustment, the amplitude should be as shown in the figure below.

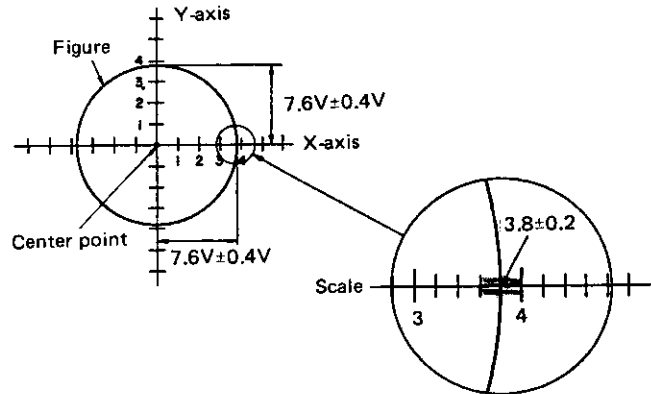

4. Adjusting the head gap

Adjust, so that the gap between the turntable magnetic coating surface and the detection head is 0.18 mm.

5. Lock adjustments for 45 rpm

Hereafter, the earth reference point of the measuring instrument should be connected to wrapping terminal 42 of the servo control circuit board.

- 1) Connect the two-channel oscilloscope to TP-1 and TP-2.
- 2) Set the speed selector to 45 rpm.
- 3) Take the arm off the arm rest and move it toward the turntable to rotate the phonomotor.
- 4) Adjust VR-1 so that the pulse from TP-1 is positioned to 50% of the triangular wave length from T.P. 2.

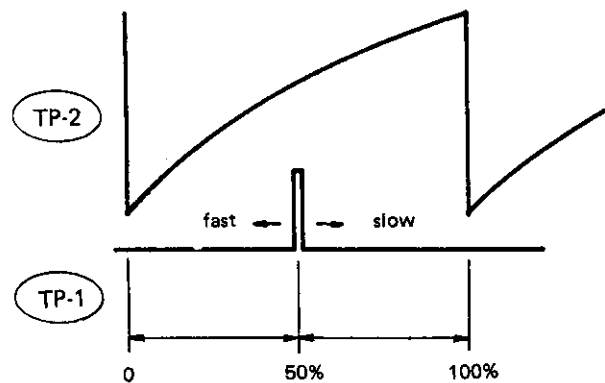

6. Lock adjustments for 33 rpm

- 1) Connect the oscilloscope in the same manner as the 45 rpm lock adjustments. Set the speed selector to 33 rpm.
- 2) Make sure that the sampling pulse is positioned between 40% and 80% of the triangular wave length.

NOTE:

Phase lock position for 33 rpm is fixed (relative to 45 rpm) by R12 (metal film resistor).

• ADJUSTING THE ARM CONTROL SECTION

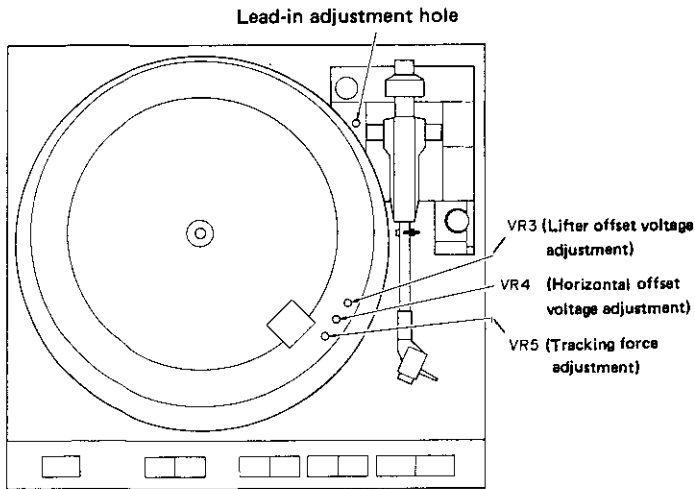

1. Adjusting the horizontal OP amp. offset voltage

- 1) Fix the tonearm to the arm rest and connect the oscilloscope to TP-6.
- 2) Set the lifter switch to the UP condition.
- 3) Turn VR-4 and adjust to $0V \pm 0.01V$.

2. Adjusting the lifter OP amp. offset voltage

- 1) Fix the tonearm to the arm rest and connect the oscilloscope to TP-5.
- 2) Set the lifter switch to the DOWN condition.
- 3) After about 7 seconds, adjust to $0V \pm 0.01V$ by turning VR-3.

3. Adjusting the tracking force

- 1) Turn the power supply switch OFF.
- 2) Take the arm off the arm rest. Rotate the balance weight so that the tonearm becomes parallel to the turntable surface when let go.
- 3) Return the arm to the arm rest and turn the power supply switch ON.
(Note) Cover the size detecting photo transistors (2 pieces) with a rubber sheet or something to avoid that light enters.
- 4) Wait seven seconds after the arm has lowered. Place the cartridge stylus tip onto a stylus force gauge and set the stylus force adjustment knob to 1.5 g.
(Note) At this time, the stylus tip height should be adjusted so that it is about the same height as during play.
- 5) Turn VR-5 and adjust, so that the stylus force gauge reads 1.5 g. (Turn VR slowly.)

4. Adjusting the 30 cm lead-in position

- 1) Place a 30 cm record on the turntable and set the record size selector switch to "30".
(Note) Keep the bottom cover closed.
- 2) Move the arm so that the stylus tip is at approximately the 30 cm lead-in position. Insert a small flat-headed screwdriver into the lead-in adjustment hole; move the arm back and forth and fit the screw driver into the groove of the cam inside gently.

- 3) After turning the screwdriver, pull it out once. Press the start switch and adjust so that the stylus position stops at the 30 cm lead-in position.

(Note) The 30 cm lead-in adjustments cannot be performed unless the stylus tip position is approximately in the 30 cm lead-in position. In addition, if the screwdriver is left inserted, the arm will not move.

5. Adjusting the 17 cm lead-in position

Adjust as necessary, such as when parts of the sensor section have been replaced.

However, the following procedures should only be used when a discrepancy is found for the 17 cm lead-in position, after the 30 cm lead-in position has been adjusted.

- 1) Set the record size selector to 17 cm.
(Note) The size is automatically changed by placing a 17 cm record on the turntable.
- 2) By continuously pressing the start switch, the arm will move over and stop. At this time, check how many millimeters, toward the inside or outside, the stylus tip deviates from the required 17 cm lead-in position.
- 3) Take off the bottom cover of the cabinet and check the adjustment scale position of the shutter. (One adjustment scale corresponds to a stylus tip movement of 0.5 mm.)
- 4) Untighten the screw holding the sub shutter and place a small flat-headed screwdriver into the slot of the shutter. When the stylus position is toward the inside, compared to the required position, move the sub shutter toward the right of the scale; when the stylus position is toward the outside, move the sub shutter toward the left. When completed, tentatively tighten the screw holding the sub shutter.
- 5) After the adjustments are made, press the start switch and check whether or not the stylus stops at the 17 cm lead-in position.
- 6) If the stylus stops at the required position, then tighten the sub shutter screw.

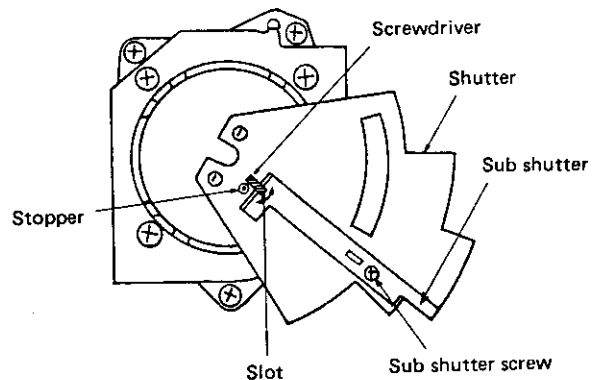

PARTS LIST OF EXPLODED VIEW

Ref. No.	Part No.	Part Name	Remarks
1	1011677308	CABINET ASS'Y	E2 only
	1011677418	CABINET ASS'Y	
2	1460735309	FRAME	E1 only
	1460735419	FRAME	
3	4310153009	FRICITION SHEET	
4	3150317103	ARM REST ASS'Y	
5	4498066209	LED STAND	
6	1468153116	LED COVER	
7	4121743103	JOINT PLATE	
8	4751106042	WASHER	
9	1030786500	FRONT PANEL ASS'Y	
10	1130665107	POWER KNOB ASS'Y	
11	1130663303	KNOB (A) ASS'Y	
12	1130664302	KNOB (B) ASS'Y	
13	4428163101	HEAD SUPPORT	
14	4418846014	WASHER	
15	4428030108	VOLUME BRACKET	
16	KV-5580	SERVO CONTROL UNIT	
△	17	2339046212	POWER TRANS E1
△		2339045213	POWER TRANS E2, EK
△		2334072210	POWER TRANS EU
	18	1298010005	CUSHION RUBBER
	19	4438158096	COLLAR
△	20	2006031026	AC CORD E1
△		2062002031	AC CORD WITH PLUG E2
△		2062024006	AC CORD WITH LABEL EK
△		2062019008	AC CORD WITH PLUG EU
	21	2098019043	EARTH LEAD
△	22	MD-3802	BUSHING E1, EU
△		4450020005	BUSHING E2, EK
	23	3150305005	TONE ARM ASS'Y
	24	3150314009	BALANCE WEIGHT
	25	4756133007	14N
	26	4338175205	YOKE (A) ASS'Y
	27	2398013215	COIL ASS'Y
	28	3418025205	MAGNET ASS'Y
	29	4248019202	ADJUST CAM
	30	3158451003	FRICITION WASHER
	31	4751005004	4W
	32	4761003009	3E RING
	33	4338241100	SHUTTER
	34	4338243001	SUB SHUTTER
	35	4438545201	COLLER
	36	4751003006	3W
	37	4638225004	SPRING
	38	2033642103	OUTPUT CORD ASS'Y
		2031640000	OUTPUT CORD ASS'Y EU only
	39	EP-7376	CORD STOPPER
	40	4148181007	SHIELD SHEET
	41	1050635408	BOTTOM BOARD
	42	4618156009	DAMPER PLATE
	43	1040122109	INSURATOR ASS'Y
	44	4770236003	SPECIAL SCREW
	45	3918425004	MAGNETIC HEAD ASS'Y
	46	1128085058	VOLUME KNOB

Ref. No.	Part No.	Part Name	Remarks
47	3160006006	CARTRIDGE UNIT	EK, only
	DL-160M	PICK UP CARTRIDGE	E2 only
48	4210298006	RECORDED TURNTABLE	
49	4218361003	RUBBER SHEET	EU only
	4218361016	RUBBER SHEET	
50	1468151105	DUST COVER ASS'Y	
51	4628023009	BUSHING	
52	4018041015	HINGE	
53	4420018005	POWER SW BRACKET	
54	FG-300	MOTOR UNIT	
55	2123315023	VOLTAGE SELECTOR	E1 only
61	4732309017	3x16 CFTS (1)	
62	4711810019	2x3 CPS	
63	4733812011	3x10 CBTS (1)	
64	4730306012	3x13 CBRTS (1)	
65	4730308010	3x14 CBRTS (1)	
66	4733808009	3x25 CBTS (1)	
67	4730305013	3x10 CBRTS (1)	
68	4733813010	3x20 CBTS (1)	
69	4713808003	3x25 CBS	
70	4733811009	3x25 CBRTS (1)	
71	4744304000	3x3 BSS (D)	
72	4733808012	3x12 CBTS (1)	
73	4713303016	3x6 CBS	
74	4711303018	3x6 CPS	
75	4700009019	3x6 CPSW	
76	4730204017	2.6x8 CRTS (1)	E1 only

ACCESSORIES AND PACKING GROUP

Ref. No.	Part No.	Part Name	Remarks
	5011022221	CARTON CASE	
	5011023000	BOTTOM PLATE	
	5011024009	UPPER PLATE	
	5030488202	PACKING ACS'Y	
	5030505004	BACK PACKING	
	5020610006	PROTECTION PLATE	
	5058092036	LAMINATE ENVELOPE	
	5058006006	ENVELOPE	60x100
	5058023018	ENVELOPE	350x640
	5058017011	ENVELOPE	60x260
	5198006002	45 ADAPTOR	
	5111304001	INST. MANUAL	E1, E2, EK
	5111303002	INST. MANUAL	EU
	3158547001	SHEEL ACCOES- SORY ASS'Y	E1, EU only
	2033667007	PLUG ADAPTER	E1 only

WARNING:

Parts marked with △ and/or shading have special characteristics important to safety. Be sure to use the specified parts for replacement.

Remarks symbols in the parts list refer to the following countries and areas.

EK: United Kingdom

EU: U.S.A.

E1: Multiple voltage model

E2: European continent

EXPLODED VIEW

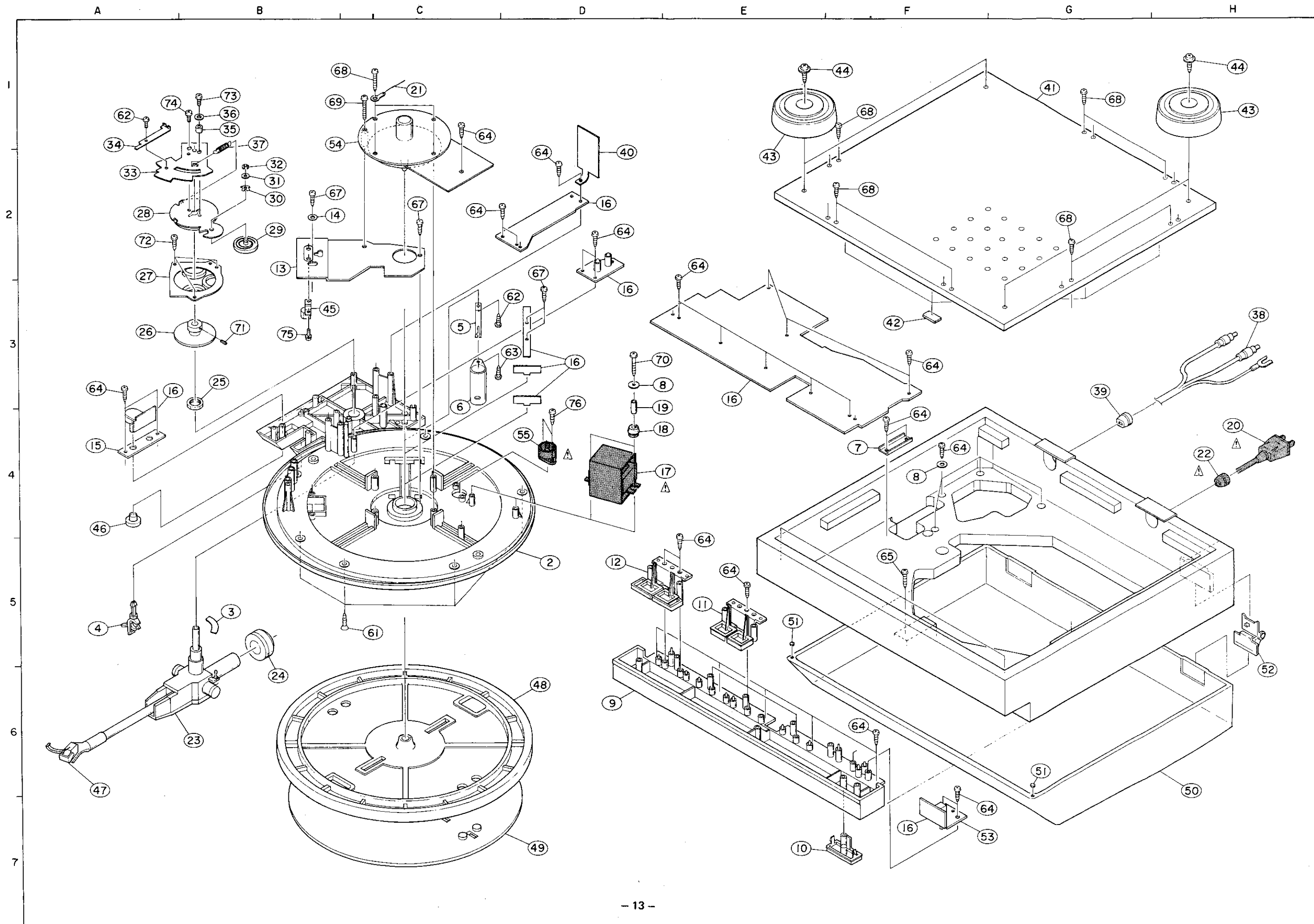

SCHEMATIC DIAGRAM

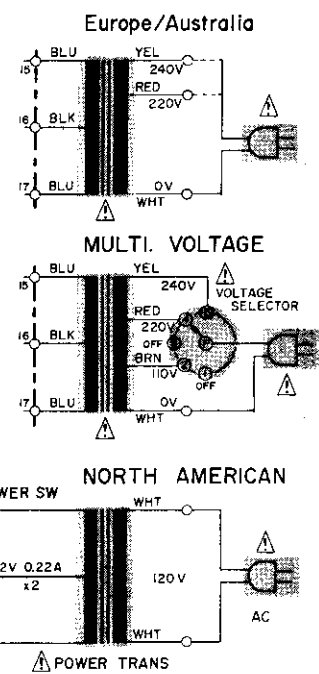
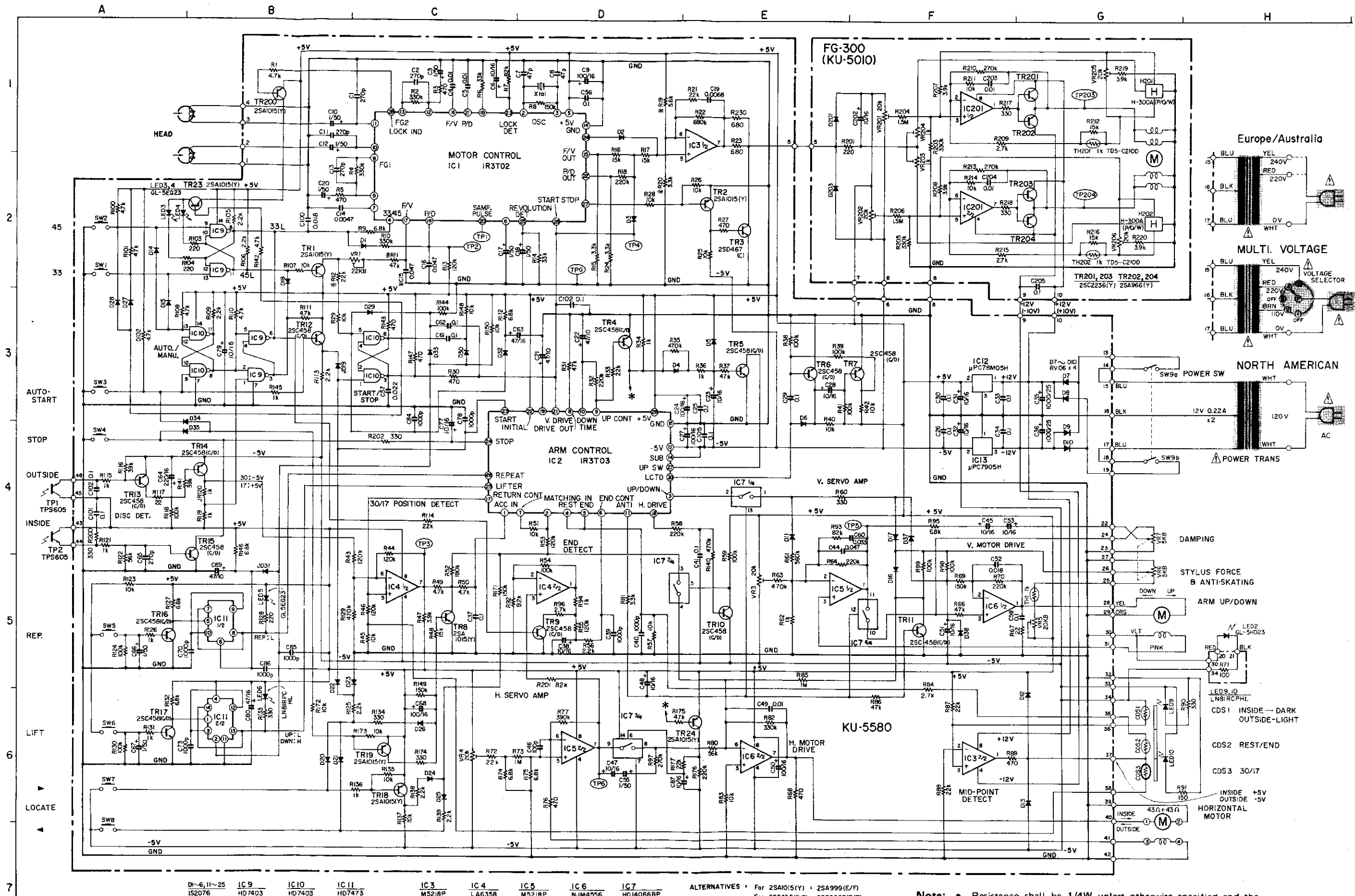

DI-6,11-25	IC 9	IC 10	IC 11	IC 3	IC 4	IC 5	IC 6	IC 7	ALTERNATIVES
IS2076	HD7403	HD7403	HD7473	M5218P	LA6358	M5218P	NUM4556	HD14066BP	For 25A1015(Y) = 25A999(E/F) For 25C458(C/D) = 25C2603(E/F)

- Note:**
- Resistance shall be 1/W unless otherwise specified and the unit is Ω.
 - The unit of capacitor is μF, P is pF unless otherwise specified.
 - This circuit diagram shows the basic circuit. It is subject to change for the purpose of improvement.
 - Parts marked with Δ are of importance in respect to the safety, use the specified type without fail.

CONNECTIONS OF P.W. BOARD

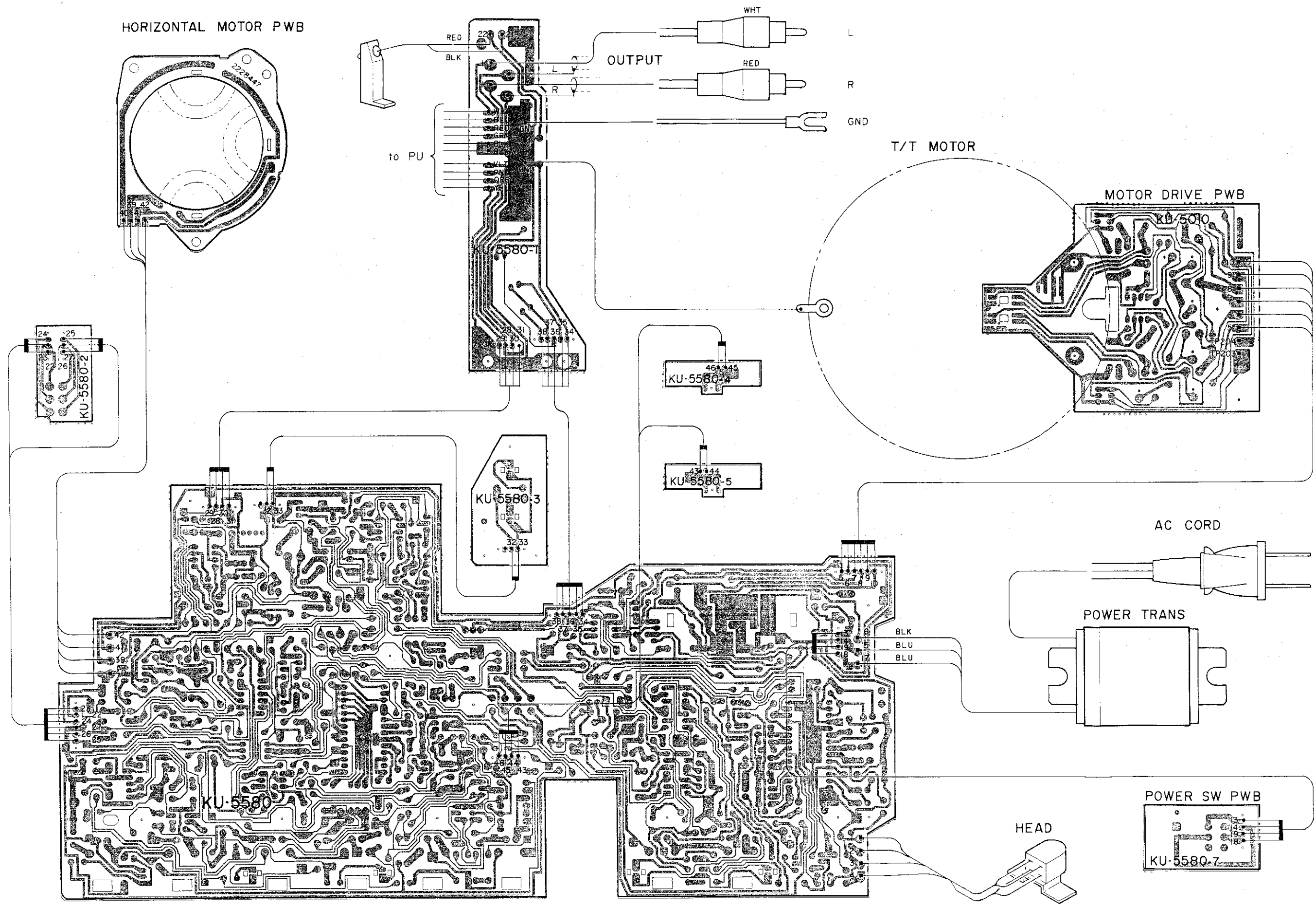

P.W. BOARD OF KU-5010 MOTOR DRIVE UNIT

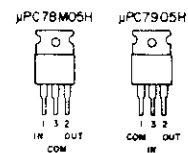
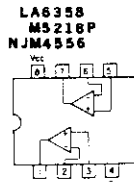
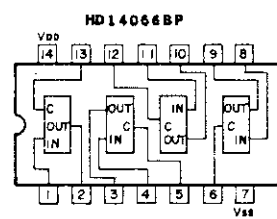
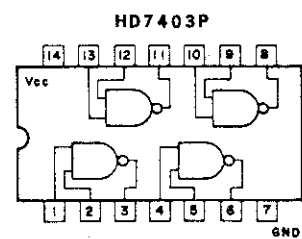
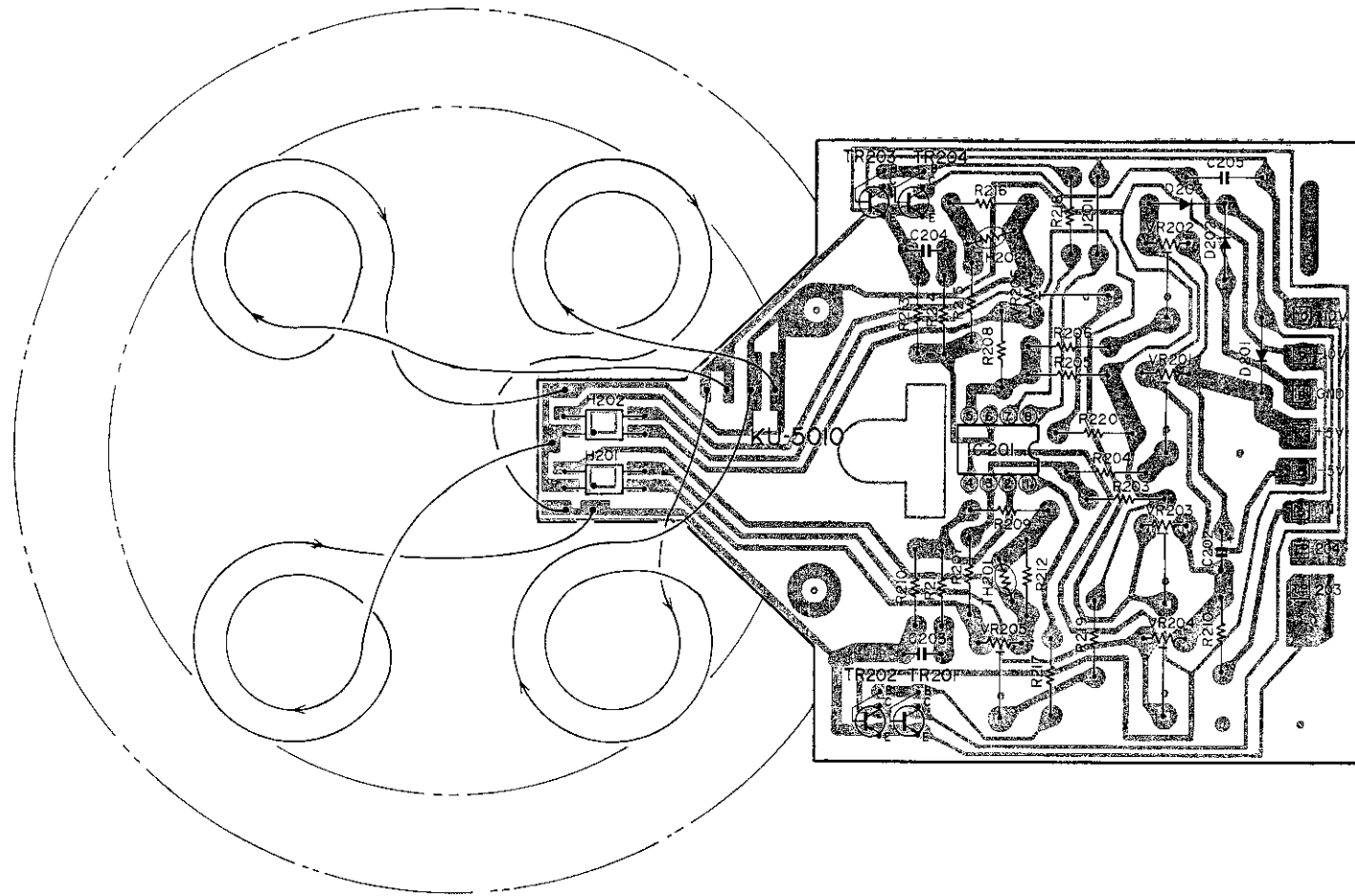

2SA966 (Y)
2SA1015 (Y)
2SC458 (C/D)
2SC2236 (Y)
2SD467 (C)

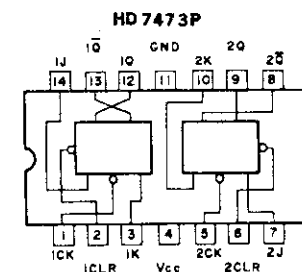
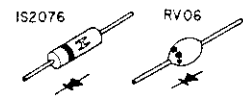

PARTS LIST OF P.W. BOARD

KU-5580 SERVO CONTROL UNIT

Ref. No.	Part No.	Part Name	Remarks
SEMICONDUCTOR GROUP			
IC1	2630173004	IR3T02	
IC2	2630174003	IR3T03	
IC3, 5	2630257001	M-5218P	
IC4	2630237005	LA6358	
IC6	2630198005	NJM4556D	
IC7	2620276005	HD14066BP	
IC9, 10	2620218005	HD7403P	
IC11	2620057004	HD7473P	
IC12	2630147001	μPC78M05H	
IC13	2630160004	μPC7905H	
TR1, 2, 8, 18, 19 23, 24, 200	2710102005	2SA1015(Y)	
TR3	2740038000	2SD467(C)	
TR4~7 9~17	2730021030	2SC458(C/D)	
D1~6 11~38	2760049008	2S2076	
D7~10	2760237001	RV06	
TH1	2760311008	TD5C210D	
CD1~2	3939053002	CDS	
CD3	3939053028	CDS	
LE3~5	3939219008	GL-5EG23	
LE6, 9, 10	3939041001	LN81RP-HL	
TP1, 2	3939157005	TPS605	
RESISTOR GROUP			
R11	2452223006	RN14K2E473G	47KΩ ¼W
R12	2452215001	RN14K2E223G	22KΩ ¼W
R19	2452201002	RN14K2E562G	5.6KΩ ¼W
R20	2452195008	RN14K2E332G	3.3KΩ ¼W
VR1	EP-5462H15	SOLID VR (223)	22KΩB
VR3~5	2116000073	V08PB203	20KΩB
VR6, 7	2118064017	V1620V20K8502 B502	5KΩB
CAPACITOR GROUP			
C1, 2, 11, 13, 65	2533637007	CC45SL1H271J	Ceramic 270PF 50V
C7, 8	2533619005	CC45SL1H470J	47PF 50V
C14	2531008003	CK45B1H472K	0.0047μF 50V
C25, 26 29 30 33, 34 37 41 56, 58 61 62 102, 103	2539036006	CK45=1E104Z	0.1μF 25V
C39, 40 70, 73 78, 84~86	2531004007	CK45B1H102K	0.001μF 50V
C46	2533627000	CC45SL1H101J	100PF 50V
C57, 101	2531024003	CK45F1H103Z	0.01μF 50V
C3, 10 12, 17 '18, 20 55, 66 67	2544044009	CE04W1H010=	Electrolytic 1μF 50V

Ref. No.	Part No.	Part Name	Remarks
C6, 23 28, 31 32, 38 45, 47 48, 51 53, 77 79, 87	2544132005	CE04W1C100=	10μF 16V
C9, 24 27, 50 68	2544136001	CE04W1C101=	100μF 16V
C21, 22	2544129005	CE04W1A470=	47μF 10V
C35, 36	2544080005	CE04=1E102M	1000μF 25V
C63, 69 80	2544135002	CE04W1C470=	47μF 16V
C64	2544019005	CE04W1C221=	220μF 16V Film
C4, 5	2551072006	CQ93M1H103K	0.01μF 50V
C15	2554194017	CQ93P1H473J	0.047μF 50V
C16, 44	2551122008	CQ93M1H473J	0.047μF 50V
C19, 49	2551070008	CQ93M1H682K	0.0068μF 50V
C52, 100	2551075003	CQ93M1H183K	0.018μF 50V
C60	2551078000	CQ93M1H333K	0.033μF 50V
OTHER PARTS GROUP			
SW1~8	4178028101 2129218001	HEAT SINK TACT SW	
SW9	4438568107 2129180003 4420018005 4428030108	LED HOLDER PUSH SW POWER SW BRACKET VOLUME BRACKET	

• The carbon resistors rated at ¼W are not listed herein.

KU-5010 MOTOR DRIVE UNIT

Ref. No.	Part No.	Part Name	Remarks
SEMICONDUCTOR			
IC101	2630257001	M5218P	
H201, 202	2680042004	H-300A	
TR201 203	2730201009	2SC2236(Y)	
TR202 204	2710105002	2SA966(Y)	
D201, 203	2760049008	1S2076	
TH201 202	2760311008	THERMISTOR	1KΩ
RESISTOR GROUP			
V201, 202 205, 206	2116000073	V08PB203	20KΩB
V203, 204	2116000031	V08PB102	1KΩB
CAPACITOR GROUP			
C202	2544015009	CE04W1C100=	Electrolytic 10μF 16V
C203, 204	2551072006	CQ93M1H103K	Film 0.01μF 50V
C205	2531027000	CK45F1H104Z	Ceramic 0.1μF 50V

• The carbon resistors rated at ¼W are not listed herein.