

DENON

Hi-Fi Component/Record Player

SERVICE MANUAL

SERVO-CONTROLLED
DIRECT DRIVE RECORD PLAYER

MODEL DP-59L

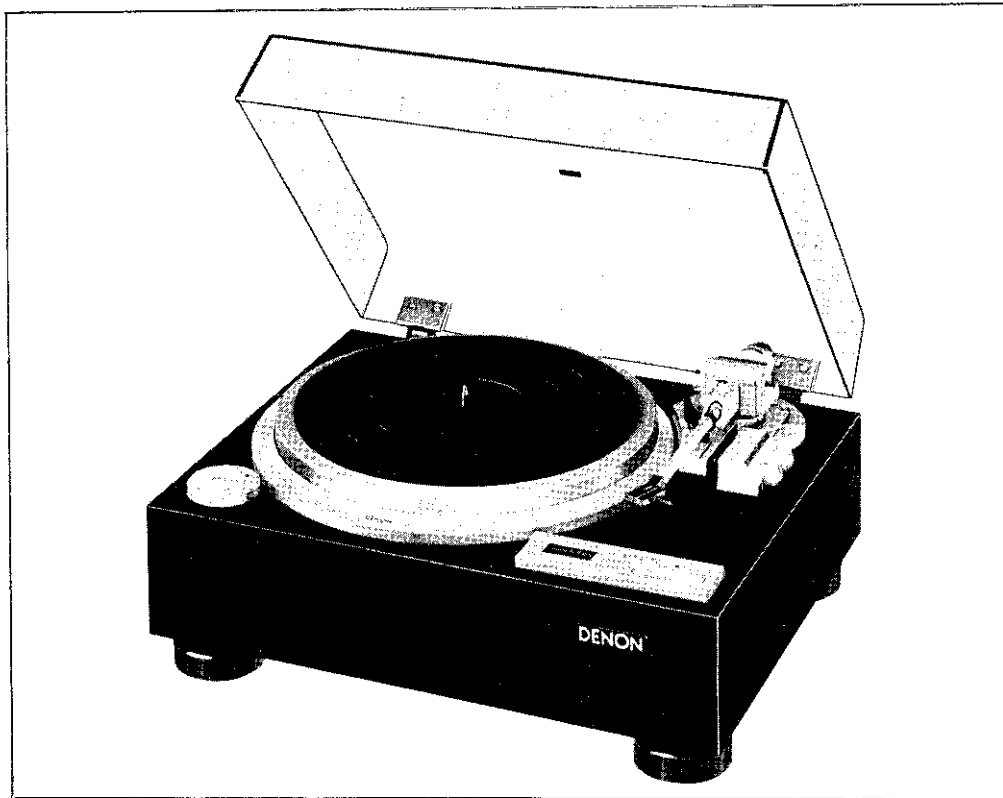

NIPPON COLUMBIA CO., LTD.

TABLE OF CONTENTS

FEATURES	2
MAIN SPECIFICATIONS	3
BLOCK DIAGRAM	4
NAMES OF PARTS AND FUNCTION	5
EXPLANATION OF THE MICROPROCESSOR	6~ 7
TERMINAL FUNCTION EXPLANATION OF LF3735	
PLL SPEED CONTROL	8~ 9
ADJUSTMENT METHOD	10~11
PARTS LIST OF EXPLODED VIEW	12
EXPLODED VIEW	13
SCHEMATIC DIAGRAM	14
P.W. BOARD OF MOTOR SERVO UNIT	15
P.W. BOARD OF POWER SUPPLY UNIT AND PARTS	
LIST OF P.W. BOARD	16
PARTS LIST OF P.W. BOARD	17

FEATURES

1. Electronic Q-damping (Dynamic Servo Tracer)

Low frequency resonance, dependent upon cartridge compliance and the effective mass of the tonearm, is electronically damped both horizontally and vertically to eliminate crosstalk and inter-modulation distortion. This optimizes the performance of the DP-59L's arm and results in record reproduction with outstanding stereo imaging characteristics and a minimum of noise or vibration.

2. Low-mass straight arm tube with lamination damped headshell

Dual construction of the arm tube greatly reduces headshell resonance. This, together with the lowmass straight arm tube improves tracing ability and further contributes to the DP-59L's clarity and stable stereo imaging.

3. Thick precision turntable platter exhibits superb acoustic characteristics

The use of a thick turntable platter to minimize vibrations transmitted from external sources is essential for clear sound reproduction.

4. Quartz-lock speed control

The system uses phase-locked loop speed control (PLL method) to increase/decrease the turntable speed precisely (within $\pm 9.9\%$).

5. Excellent rotational characteristics

The DP-59L's high performance AC servo motor; magnetic record head speed detection system; quartz lock, bi-directional servo result in phenomenal performance specifications: 0.006% wrms (rotation system) wow and flutter; 82 dB (DIN-B) S/N ratio and rotational accuracy of 0.002%.

6. Auto-lift mechanism with non-contact end-of-record detection system

When the record is finished, the stylus automatically lifts off the record and the turntable stops rotation. This avoids unnecessary wear of the stylus tip.

7. Beautifully finished wood cabinet

The cabinet has a mirror-finish surface, measures 110 mm in height, and uses a new insulator to prevent howling.

8. Interchangeable straight and S-shape arm tubes via standard 4P connectors

Optimum cartridge matching can be achieved quickly and easily through interchangeable tonearm tubes.

Note:

The S-shape arm tube and headshell are sold separately from the system.

MAIN SPECIFICATIONS

Turntable motor

Drive method:	Servo controlled direct drive
Speeds:	33-1/3rpm, 45 rpm
Wow and flutter:	less than 0.006% wrms (servo system) less than 0.02% wrms (JIS)
S/N ratio:	more than 82dB (DIN-B)
Rise time:	Nominal speed within 1.6 seconds (at 33-1/3rpm)
Turntable platter:	Aluminum die-cast, 325mm diameter Moment of inertia 430kg · cm ² (incl. turntable sheet)
Motor type:	AC servo motor
Speed control method:	Speed servo via frequency detection and phase servo control
Load characteristics:	0% (stylus force 200g, outermost groove)
Brake method:	Electronic brake
Speed deviation:	less than 0.002%

Tonearm

Type:	Static balance type tonearm with electronic damping mechanism (interchangeable tube section)
Effective length:	244mm
Overhang:	14mm
Tracking error:	within 2.5°
Stylus force range:	0 – 3g (1g per 1 rotation, 1 scale = 0.1g)
Suitable cartridge weight range:	approx. 3~14g (using the straight type arm tube, incl. screws, nuts)
Arm height adjustment range:	approx. 7mm
Output cable:	Low capacitance type
Arm lifter:	Servo control via the angular control motor (Cueing device)

General

Power supply:	50Hz/60Hz compatible. The rated voltage is indicated on the rating label at the rear of cabinet.
Power consumption:	10W
Dimensions:	490 x 219 x 410mm (W x H x D) 19.3 x 8.6 x 16.1 in (dust cover closed)
Weight:	15 kg 33 lb

* For product improvement purposes, the above specifications are subject to change without notice.

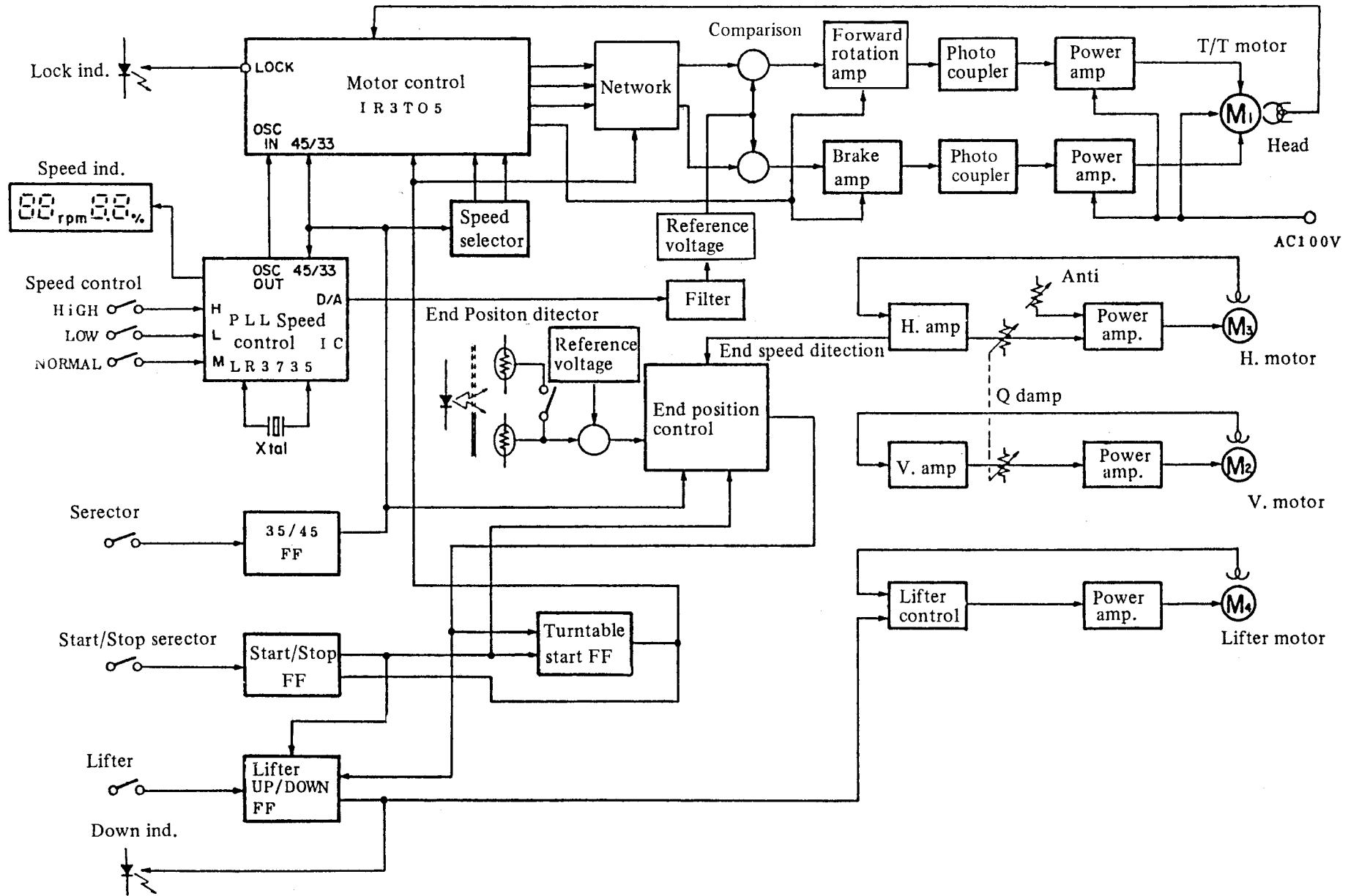

BLOCK DIAGRAM

NAMES OF PARTS AND FUNCTION

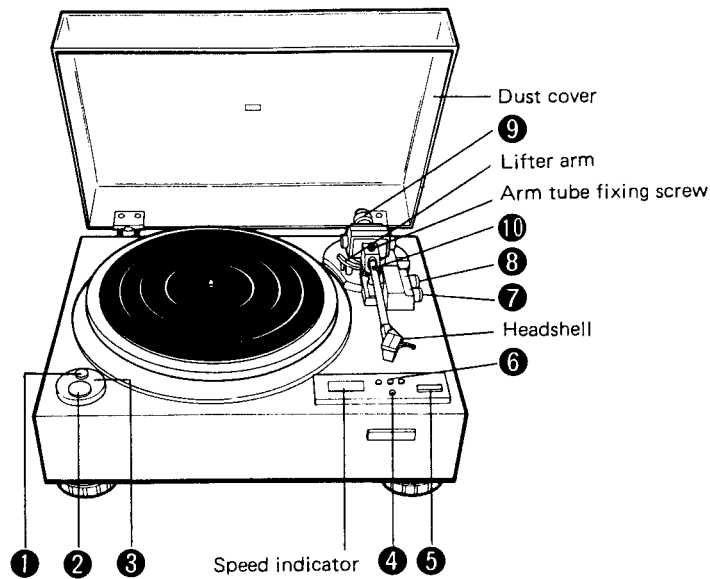

① Power switch POWER

Press the power switch (⏻) to turn on the power supply, and the "LOCK" LED and "33 rpm 0.0%" are displayed on the speed indicator. If the power switch (⏻) is pressed when the arm lift is in its lower most position, it will move up.

② Start/Stop button START/STOP

If the start/stop button is pressed when the turntable is at rest, it will rotate, the arm lift will move down and the "DOWN" LED lights up. Pressing the button while the turntable is rotating causes the arm lift to move up and the "DOWN" LED goes off. The turntable stops when the arm lift reaches its uppermost position.

③ Lock indicator LOCK

The lock indicator will light when the turntable speed reaches the specified phase-lock state. It flickers when the turntable speed is in transition, such as when stopping, starting or changing speeds. It remains off during stop.

④ Speed button SPEED 33/45

When the power switch (⏻) goes on, it automatically sets the turntable speed to 33-1/3 rpm. Press the speed button once to change the speed to 45 rpm, and once again to reset it to 33-1/3. Speed selection can be repeated this way.

⑤ Arm Lifter button LIFTER UP/DOWN

Each time the button is pressed, the arm lifter moves up/down. The lamp will light when the lifter is down.

⑥ Pitch control button PITCH CONTROL

The turntable speed can be increased or decreased precisely by the quartz-lock system. The speed increases 0.1% every time the "HIGH" button is pressed, and automatically increases 0.4% per second if the button is kept pressed in. The speed can be increased up to a maximum of +9.9%, and it is displayed on the digital speed indicator. The "LOW" button decreases the speed up to (9.9% max.) in a similar way to the "HIGH" button.

Pressing the "NORMAL" button resets the speed which was changed by pressing either the "HIGH" or "LOW" button, to the predetermined value (0.0%).

⑦ Anti-skating knob

When a record is being played, a force which pulls the stylus towards the center of the turntable is generated. This force is compensated for by adjusting the Anti-skating knob.

⑧ Q damping knob Q DAMPING

The recommended amount of Q damping can be achieved by setting the Q damping knob to the same value as the stylus force.

⑨ Weight ring

Use this ring to obtain zero balance of the tonearm.

⑩ Arm rest

By holding the finger grip of the headshell and moving it to the left, the tonearm lock is disengaged. When locking the tonearm, push it in the opposite direction.

EXPLANATION OF THE MICROPROCESSOR

• **Motor Control IC IR3T05 (at standard revolution of 33 rpm)**

The numbers on the left hand side indicates the terminal number.

1. Stop output

during stop control: 0V
 during start: open

2. Lock indicator

during lock (LED lit dimly)
 69HZ

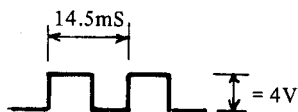

stop (LED lit)

during transition (LED flashes)

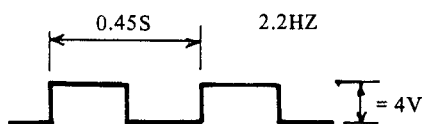

3. 0.22μs (0%)

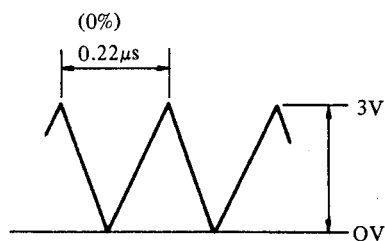

* Frequency will vary by changing turntable revolution within the range of ±9.9%.

4. rpm selector

H: 45 rpm
 L: 33 rpm

5. Power source input

Vcc: 5V ±0.5V

6. FGI bypass terminal

E6 ≙ ½ Vcc

7. FGI lowpass terminal

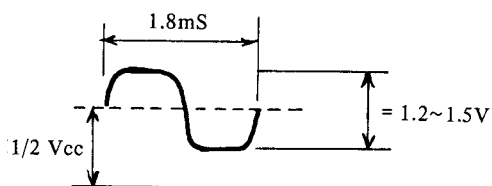

8. FGI output

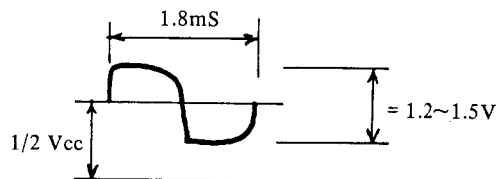

9. FGI inverse input

The gain set element is connected.
 E9 ≙ ½ Vcc

10. FGI non-inverse input

10mVpp ~ 100mVpp
 E10 ≙ ½ Vcc

11. FG II non-inverse input

10mVpp ~ 100mVpp
 E11 ≙ ½ Vcc

12. FG II inverse input

The gain set element is connected.
 E12 ≙ ½ Vcc

13. FG II output

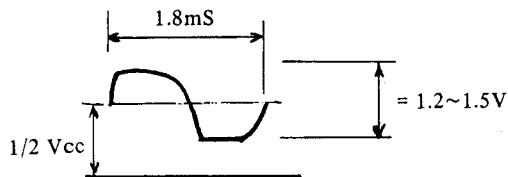

20. PD triangular wave

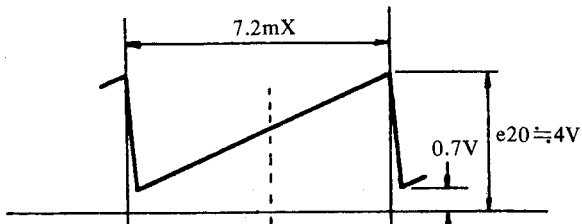

14. ground terminal

15. F/V output

slower than normal revolution: 2 ~ 4.5V
 normal revolution: $\approx 2V$
 faster than normal revolution: 0 ~ 2V

21. Sample pulse monitor terminal

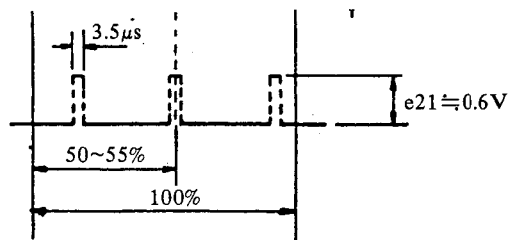

16. F/V hold terminal

same as terminal 15

23. PD hold terminal

slow phase: 2 ~ 4V
 normal phase: $\approx 2V$
 advanced phase: 1 ~ 3V

17. F/V triangular wave

slower than normal revolution

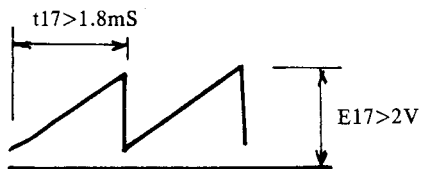

24. PD output

same as terminal 23

normal revolution

25. Lock detector time set terminal

during lock: 0.6V
 lock disengaged: 0V

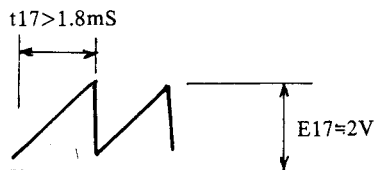

26. Direction detector output

normal revolution: 0V
 reverse revolution: $\approx 4V$

faster than normal revolution

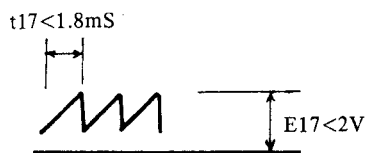

27. Revolution detector

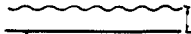
during revolution  $\approx 4V$
 stop: 0V

28. START/STOP terminal

H → START
 L → STOP

• TERMINAL FUNCTION EXPLANATION OF LF3735 PLL SPEED CONTROL

The serial numbers on the left hand side indicate the terminal numbers of LF3735.

- | | | |
|-----------------------|-----|--|
| 1) LCD segment output | S8 | } Output of converted pulses for indicating turntable revolution 33 or 45 and their $\pm 9.9\%$ variable revolution range. |
| 2) " " | S9 | |
| 3) " " | S10 | |
| 4) " " | S11 | |
| 5) " " | S6 | |
| 6) " " | S7 | |
| 7) LCD common output | H2 | |
| 8) " " | H1 | |
| 9) D/A output | | |

Output of periodic pulses inversely proportional to oscillation frequency.

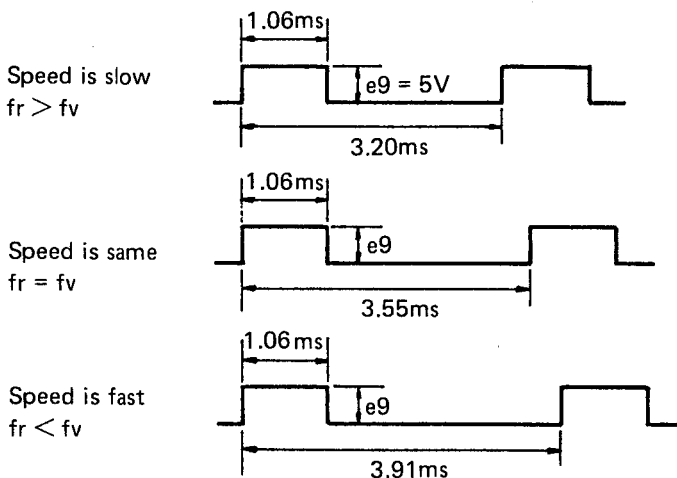

10) UP KEY input

Pushing the HIGH button momentarily shifts the input terminal from L to H and to increase the speed 0.1%.

Hold pushing the HIGH button increases the speed 0.4% per second until releasing the button, then the speed is set at this value.

11) DOWN KEY input

Each time to push the LOW button momentarily shifts the input terminal from L to H and to decrease the speed 0.1%.

Continuously pushing the LOW button decreases the speed 0.4% per second until releasing the button, then the speed is set at this value.

12) NORMAL KEY input

The speed is set to 0.0% when NORMAL KEY input terminal shifts from L to H.

13) 45/33rpm change input

Input terminal for LCD revolution indication.

H = 45rpm; L = 33rpm

14) X'tal input

By connecting 4.5MHz crystal oscillator to pins 14) 15) oscillates standard 4.5MHz frequency.

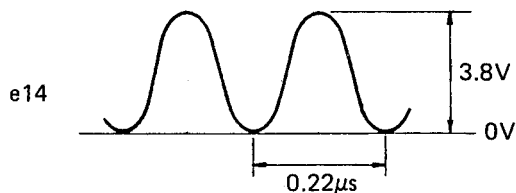

15) X'tal input

By connecting 4.5MHz crystal oscillator to pins 14) 15) oscillates standard 4.5MHz frequency.

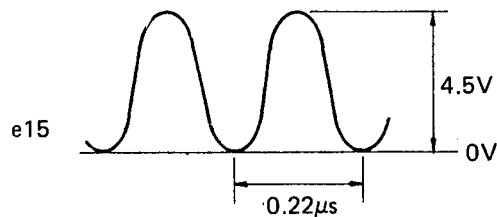

16) P terminal

The terminal normally not used. The terminal to compensate internal voltage controlled oscillator (VCO).

17) Reference frequency oscillation output

$f_0 = 4.5\text{MHz} \pm 9.9\%$ variable range

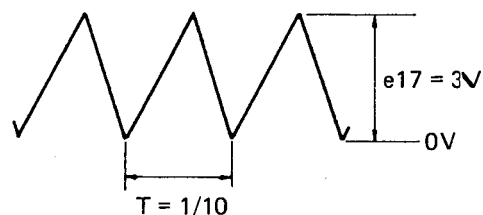

18) Power supply voltage

$V_{DD} = 5V$

19) Voltage controlled oscillator (VCO) input

+ 9.9%	0%	- 9.9%
3.43V	3.08V	2.78V

Approx. 3.08VDC input for speed 0.0%

- 20) L.P.F. output
Output terminal to provide ripple signal in proportion to the phase difference to external Low Pass Filter (L.P.F.).
- 21) L.P.F. input
Input terminal to apply output signal from external Low Pass Filter (L.P.F.) to control voltage controlled oscillator (VCO).
- 22) Phase difference detection output
Output terminal of generated voltage in proportion to the phase difference of divided frequency f_r (phase ϕ_r) from X'tal and the frequency to set revolution f_v (phase ϕ_v).
- When phase ϕ_r is advanced from phase ϕ_v : L level
When phase ϕ_r is equal to phase ϕ_v : Open
When phase ϕ_r is delayed from phase ϕ_v : H level

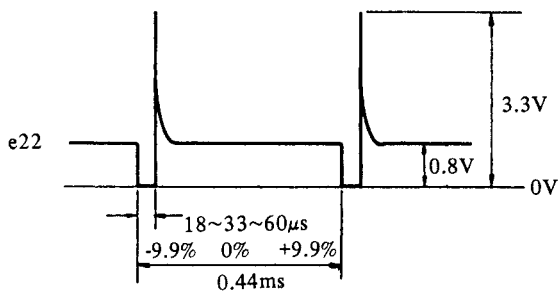

- 23) GND
Standard 0V potential for GND.
- 24) TEST
Test terminal for IC. By injecting a 250Hz or more higher frequency of clock pulse within the operating limits to increase UP/DOWN counting thus reduces time for operation test.
- 25) ACL
Immediately after the power is turned on, the primary input level becomes L level once prior to the operation starts.
- | | | |
|-----|----------------|--|
| 26) | LCD segment S1 | } Output of converted pulses for indicating turntable revolution 33 or 45 and their ±9.9% variable revolution range. |
| 27) | " S2 | |
| 28) | " S3 | |
| 29) | " S4 | |
| 30) | " S5 | |

ADJUSTMENT METHOD

• Adjusting the phonomotor section

Prepare a two-channel oscilloscope for the measuring instrument; make the adjustments in the following order.

CH-1 Probe connect to test point TP1 of the motor control circuit board, and CH-2 Probe connect to test point TP2.

Both probe ground terminal connect to G.

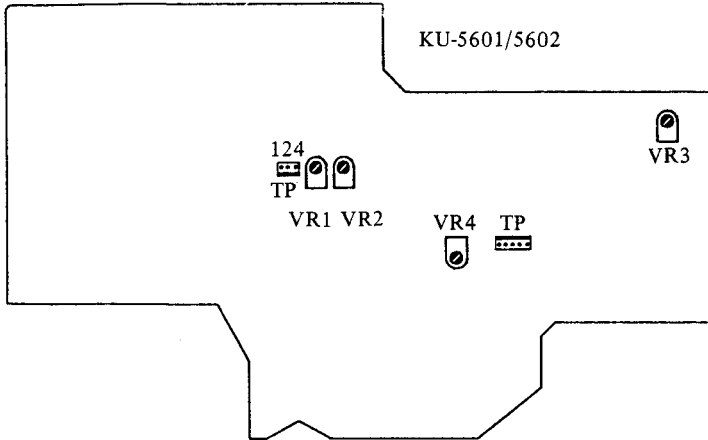

1. Adjusting the head gap

Make sure the detection head is Perpendicular to the magnetic coating surface of the turntable. The gap of the detection head should be adjusted to 0.18mm. Be careful the head is not tilted to the left or the right.

Note: If a gap is greater than the value, turntable will not stop promptly, and if a gap is lesser, turntable may revolute reversely after it stoped.

2. Lock adjustments for 45 rpm

- 1) Fix the arm to the armrest.
- 2) After pressing the start button, set the speed selector switch to 45 rpm.

Note: Make sure that the speed indication shows 0.0%.

- 3) Adjust VR2 so that the positions of the triangular wave form and the pulse form TP2 are as shown in the diagram below.

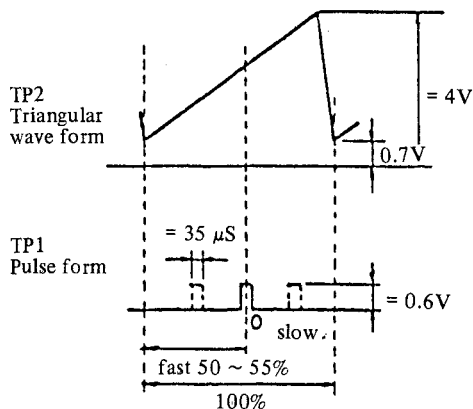

3. Lock adjustments for 33 rpm

- 1) Set the speed selector switch to 33 rpm and proceed to adjust VR1, just as in the adjustments for 45 rpm.

• Adjusting the arm control section

1. Horizontal Amp Off-set Voltage Adjustment

- 1) Fix the tonearm to the arm rest. Connect the high input resistance DC voltmeter (tester) between TP3 and TP4.
- 2) Adjust the voltage to $0 \pm 0.01V$ with VR3.

2. Lifter Amp Off-set Voltage Adjustment

- 1) Connect the DC voltmeter (tester) to TP303 and TP304 while short circuiting the test points TP302 and TP304.
- 2) Adjust the voltage to $0 \pm 0.1V$ with VR4.

3. End Detecting Position Adjustment

- 1) Fix the stylus point at a position 60 mm from the center spindle by using the straight arm.
- 2) Connect the DC voltmeter (tester) to the test points TP301 and TP304.
- 3) Adjust the voltage to $1.55 \pm 0.05V$ by adjusting the cam with a flat headed screwdriver. The cam adjustment hole is located at the back of the arm base.

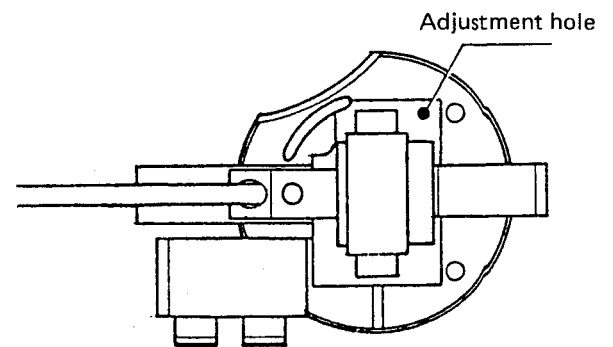

NOTE:

1. Be sure not to interfere with the function of any parts when connecting the measuring instrument for adjusting. Check that there is no loading resistance or loading capacity problem. Refer to the following example for the exact measuring technique.
2. While adjusting or measuring the detecting positions, close the bottomplate or cover the unit with a black cloth or paper so that no light enters. Also when adjusting the speed detector, be sure no magnetic sources are near and that there are no vibrations.

*** Speed Adjustment**

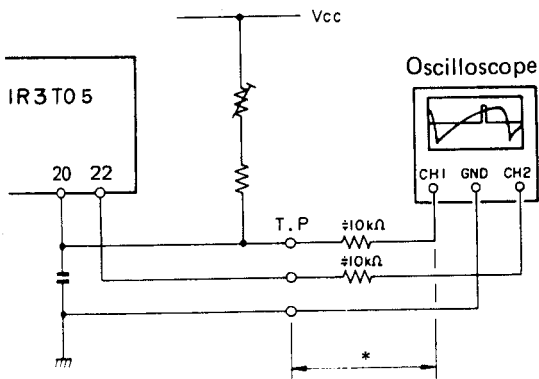

* Keep the wire as short as possible. If it is long, connect the resistors in series.

*** Off-set Voltage Measurement**

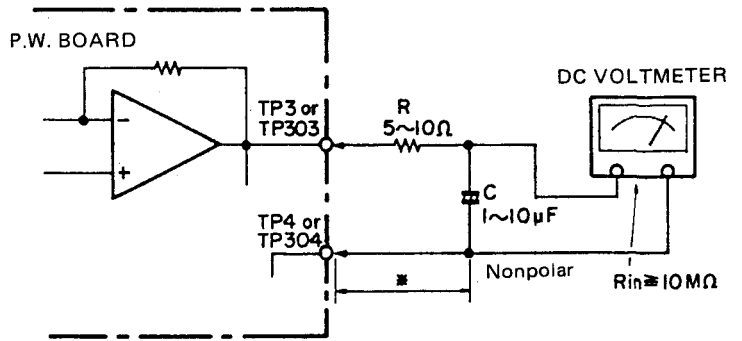

* This distance should be as short as possible.

*** FG Signal Check or Wow/Flutter Measurement**

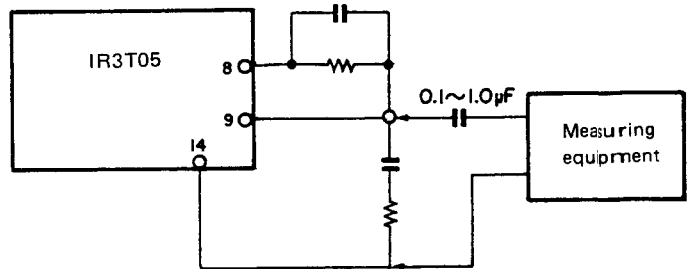

By utilizing the legs of parts as much closer to the IC pins as possible to connect a measuring equipment.

WARNING:

1. Component parts

Parts marked with \triangle and/or shading in this service manual have special characteristics important to safety. Be sure to use the specified parts for replacement.

2. Leakage current

Before returning the appliance to customer, test the leakage current when the power plug is connected. Use a calibrated (with an error of not more than 5%) leakage current tester and measure the leakage current from any exposed metal to the earth ground. Reverse the power plug polarity and test the above again.

Any current measured MUST NOT EXCEED 0.5 milliamps. Corrective measure must be taken if it exceeds the limit.

PARTS LIST OF EXPLODED VIEW

Ref. No.	Part No.	Part Name	Remarks
1	1468173303	FRAME	
2	4118312602	SHIELD PLATE	
2	4118312615	SHIELD PLATE	(E1)
△	3	2178077109	MOTOR
4	4753100004	4TWA	
5	4713411018	4x25 CBS	
6	1018437716	CABINET ASS'Y	
6	1018437729	CABINET ASS'Y	(E1)
7	4418245000	BUSHING PLATE (D)	
7	4418244302	BUSHING PLATE (C)	(E1)
8	4418584004	BUSHING PLATE (H)	
9	4018006209	HINGE	
10	4720307034	3.1x13 CRWS	
11	4498079005	LOCKING SUPPORT	
12	EP-4772	CORD HOLDER	
13	4733305010	3x10 CBTS (1)	
14	FPR0464-3	DENON MARK	
15	4732309017	3x16 CFTS (1)	
16	4733808009	3x25 CBTS (1)	
17	3918425004	MAGNETIC HEAD ASS'Y	
18	4700010011	3x8 CPS W	
19	3159000408	TONE ARM ASS'Y	
20	4128864108	VOLUME BRACKET	
21	1128093202	VOLUME KNOB	
22	4733809011	4x25 CBTS (1)	
23	4128865204	OVER PLATE	
24	4730306012	3x12 CBRTS (1)	
25	WA-0107H4	WASHER	
26	1038267306	CONTROL PANEL ASS'Y	
27	1138204308	LIFTER KNOB ASSY	
28	4610224007	CUSHION	
29	1138205307	PUSH KNOB (B) ASS'Y	
30	KU-56011	SERVO CONTROL UNIT	(E2)
30	KU-56021	SERVO CONTROL UNIT	(E1)
31	4730304014	3x8 CBRTS (1)	
32	4428228101	FIXING BASE	
33	1038268305	POWER SW PANEL ASS'Y	
34	1138027307	PUCH KNOB (A) ASS'Y	
35	4610222106	CUSHION	
36	4751106042	WASHER	
37	KU-56012	SERVO CONTROL UNIT	(E2)
37	KU-56022	SERVO CONTROL UNIT	(E1)
△	38	2129136015	POWER SWITCH
39	4428229100	POWER SW BRACKET	
40	4713303016	3x6 CBS	
41	1140056007	FLEXIBLE RING	
42	1138206209	POWER KNOB ASS'Y	
43	4737002005	3x6 CBTS (S)	
△	44	2335497001	POWER TRANS (E2)
△	44	2335496002	POWER TRANS (E1)
45	4620027003	RUBBER BUSH	
46	4438158067	COLLAR	
47	4730310011	3x20 CBRTS (1)	
48	4118452106	ARM CHASSIES	
49	4248019202	ADJUST CAM	
50	3158451003	FRICTION WASHER	
51	4751005004	4W	
52	4761003009	3E RING	
53	4358022008	COLLAR	
54	4418938207	SENSOR PLATE	
55	4338180009	YOKE (A) ASS'Y	
56	4744304000	3x3 BSS (D)	
57	3468136102	COIL ASS'Y	
58	4730356017	3x12 CBRTS (2)	

Ref. No.	Part No.	Part Name	Remarks
59	4638221008	SPRING	
60	3418017200	MAGNET ASS'Y	
61	KU-56014	SERVO CONTROL UNIT	(E2)
61	KU-56024	SERVO CONTROL UNIT	(E1)
62	KU-56015	SERVO CONTROL UNIT	(E2)
62	KU-56025	SERVE CONTROL UNIT	(E1)
63	4468100205	SENSOR HOLDER	
64	4713314018	3x35 CBS	
65	2178065205	MOTOR C ASS'Y	
66	4128681006	MOTOR BRACKET	
67	4148170018	PLATE	
68	4148170005	PLATE	
69	4248021203	LIFTER CAM	
70	4730812001	3x8 CPTS (2)	
71	4338212000	SHUTTER	
72	4712304016	3x8 CFS	
73	4418926206	ARM BRACKET	
74	KU-56013	SERVO CONTROL UNIT	(E2)
74	KU-56023	SERVO CONTROL UNIT	(E1)
△	75	2062002031	AC CORD WITH PLUG (E2)
△	75	2006031026	AC CORD (E1)
76	-	-	
△	77	4450020005	CORD BUSH (E2)
△	77	MD-3802	BUSHING (E1)
78	2039616010	OUTPUT CORD	
79	4458024003	CORD BUSH	
80	2098309009	SOLDERING WIRE	
81	4148173002	SHIELD COVER	
82	1058111306	BOTTOM BOARD ASS'Y	
83	4610219009	DAMPER PLATE	
84	4420007003	DAMPING BLOCK	
85	1048081307	INSULATOR ASS'Y	
86	4218417106	RECORDED TURNTABLE	
87	4218094040	RUBBER SHEET	
88	KU-5601	SERVO CONTROL UNIT	(E2)
88	KU-5602	SERVO CONTROL UNIT	(E1)
89	1468076031	DUST COVER ASS'Y	
90	FPR0460	DENON MARK	
91	4628006107	BUSHING	
92	FTS0701	HINGE PLATE	
93	4712404055	4x8 CFS	
94	-	-	
95	4713809002	4x25 CBS (R)	
96	2118082002	V16V15KB102	ANTI
97	2118081003	V1620V15KB102B102	Q. DAMP
98	4730812001	3x8 CPTS (2)	
99	PS-1680	POWER SUPPLY UNIT	(E1)
99	PS-1670	POWER SUPPLY UNIT	(E2)
100	2123315023	VOLTAGE SELECTOR	(E1)
101	4730205016	2.6x10 CPTS (1)	(E1)

Remarks symbols in the parts list refer to the following countries and areas.

EU : U.S.A.

E1 : Multiple voltage model

E2 : European continent

EXPLODED VIEW

1 2 3 4 5 6 7 8

A
B
C
D
E

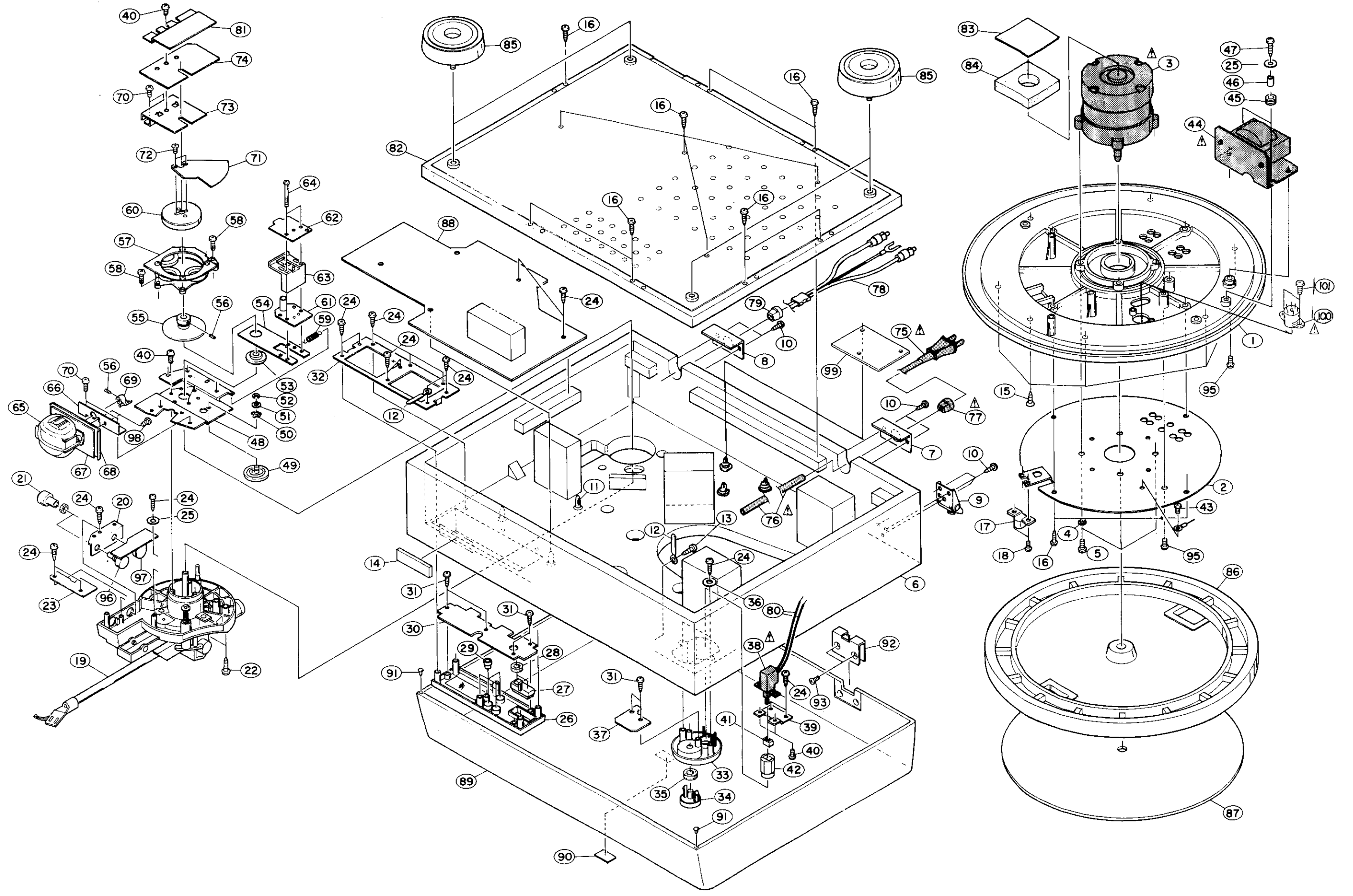

SCHEMATIC DIAGRAM

**DP-59 L
CIRCUIT DIAGRAM**

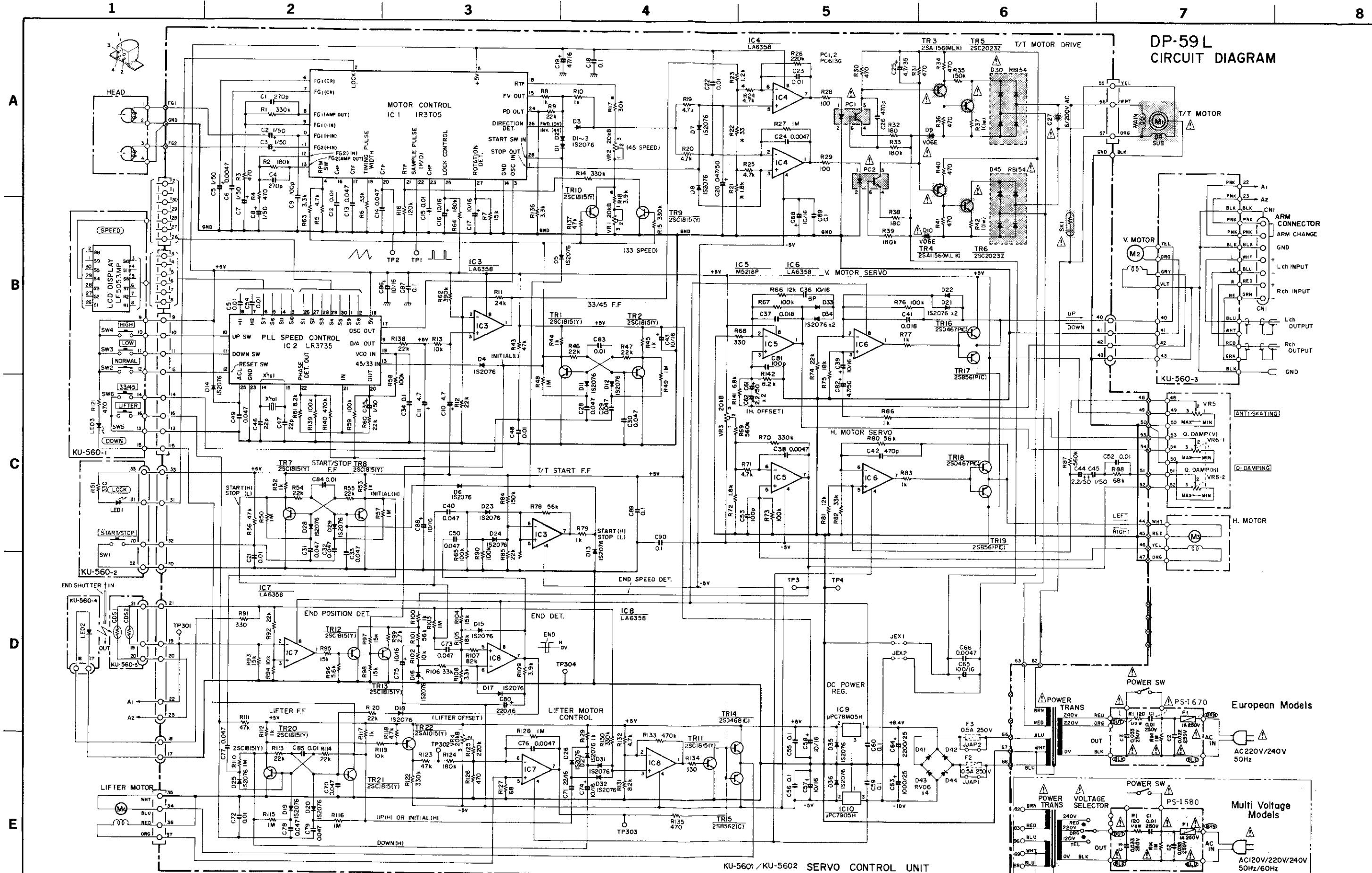

A
B
C
D
E
F

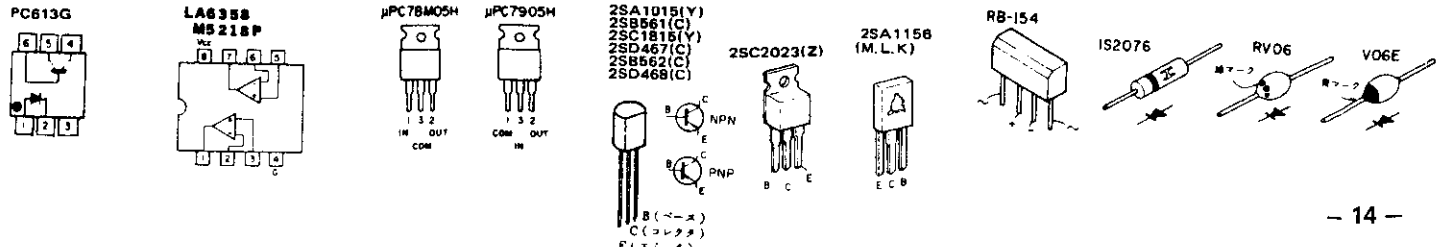

Note:

- Resistance shall be 1/4W unless otherwise specified and the unit is Ω.
- The unit of capacitor is μF, P is pF unless otherwise specified.
- This circuit diagram shows the basic circuit. It is subject to change for the purpose of improvement.
- Parts marked with Δ are of importance in respect to the safety, use the specified type without fail.

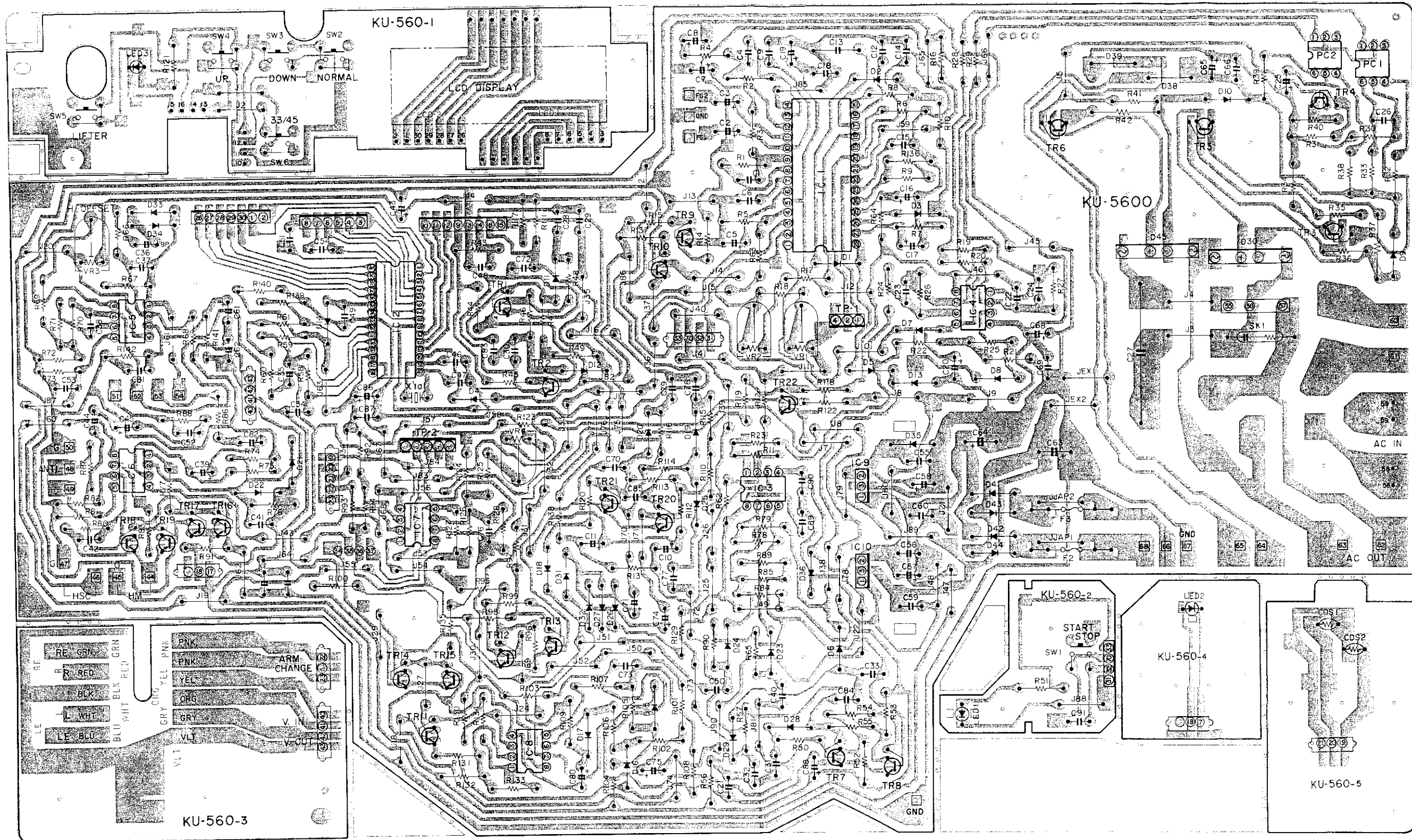

PARTS LIST OF P.W. BOARD

KU-5601/5602 SERVO CONTROL UNIT

Ref. No.	Part No.	Part Name	Remarks
SEMICONDUCTOR GROUP			
IC1	2630320006	IR3T05	
IC2	2620556000	LR3735	
IC3, 4	2630237005	LA6358	
6, 7, 8			
IC5	2630257001	M5218P	
IC9	2630147001	μPC78M05H	
IC10	2630160004	μPC7905H	
TR1, 2	2730198002	2SC1815 (Y)	
7~13			
20, 21			
TR3, 4	2710159003	2SA1156 (M.L.K)	
TR5, 6	2730196004	2SC2023Z	
TR14	2740036002	2SD468 (C)	
TR15	2720025004	2SB562 (C)	
TR16, 18	2740038000	2SD467 (P)	
TR17, 19	2720046009	2SB561P (C)	
TR22	2710102005	2SA1015 (Y)	
D1~8	2760049008	1S2076	
11~29			
31~36			
D9, 10	2760057029	V06E	
D30, 45	2760280003	RB154	
D41~44	2760237001	RV06	
PC1, 2	3939027012	PC-613G	
CD1, 2	3939053028	CDS	
LE1, 2	3939041001	LN81RP-HL	
LE3	3939223007	LD101VR	
	3939267005	LF5053MP	
RESISTOR GROUP			
R17	2452218008	RN14K2E303G	Metal film 30KΩ ¼W
R18	2452197006	RN14K2E392G	3.9KΩ ¼W
R21	2452189001	RN14K2E182G	1.8KΩ ¼W
R22	2452147001	RN14K2E330G	33Ω ¼W
R23	2452185005	RN14K2E122G	1.2KΩ ¼W
R37, 42	2440005029	RS14B3A010JNBF	1Ω 1W
VR1~4	2116019035	K08PB203	20KΩB
CAPACITOR GROUP			
C21, 48	2531024003	CK45F1H103Z	Ceramic 0.01μF 50V
51, 54			
72, 83			
84, 91			
C26, 42	2531002009	CK45B1H471K	470PF 50V
C24, 66	2531008003	CK45B1H472K	4700PF 50V
76			
C18, 34	2539036006	CK45=1E104Z	0.1μF 25V
55, 56			
59, 60, 69			
87, 89, 90			

Ref. No.	Part No.	Part Name	Remarks
C85	2531024003	CK45F1H103Z	0.01μF 50V
C46, 47	2533611003	CC45SL1H220J	22PF 50V
C1, 4	2533637003	CC45SL1H271J	270PF 50V
C53, 81, 9	2533627000	CC45SL1H101J	100PF 50V Electrolytic
C20	2544145005	CE04W1HR47=	0.47μF 50V
C2, 3	2544146004	CE04W1H010=	1μF 50V
5, 7			
8, 35			
45			
C44,	2544147003	CE04W1H2R2=	2.2μF 50V
61, 62			
C11, 25	2544140000	CE04W1V4R7=	4.7μF 35V
82			
C16, 17	2544132005	CE04W1C100=	10μF 16V
39, 57			
58, 68			
74, 75			
43, 86			
88			
C19	2544135002	CE04W1C470=	47μF 16V
C65	2544136001	CE04W1C101=	100μF 16V
C71	2544133004	CE04W1C220=	22μF 16V
C80	2544131006	CE04W1A221=	220μF 10V
C63	2544080005	CE04W1E102M	1000μF 25V
C64	2544086009	CE04W1E222M	2200μF 25V
C10	2544140000	CE04W1V4R7=	4.7μF 35V
C36	2543014027	CE04D1C100MBP	10μF 16V
C12, 15	2551072006	CQ93M1H103K	0.01μF 50V
22, 23			
53			
C37, 41	2551121054	CQ93M1H183J	0.018μF 50V
C14	2551122008	CQ93M1H473J	0.047μF 50V
C28~33	2551080001	CQ93M1H473K	0.047μF 50V
40, 49			
50, 70			
73			
77~79			
C6, 38	2551068007	CQ93M1H472K	4700PF 50V
C13	2554194017	CQ93P1H473J	0.047μF 50V
C27	2568013087	CF99=2DAC605J	6μF AC200V
OTHER PARTS GROUP			
	4178028101	HEAT SINK	
	4178020400	HEAT SINK	
	4618161007	CUSHION	
	3998023002	CRYSTAL	4.5MHZ
SK1	FEP0429K	SPARK KILLER	
	2124388004	TACT SWITCH	
	4438568107	LED HOLDER	

• The carbon resistors rated at ¼W are not listed herein.

P. V. BOARD OF POWER SUPPLY UNIT

PS-1670/1680 POWER SUPPLY UNIT

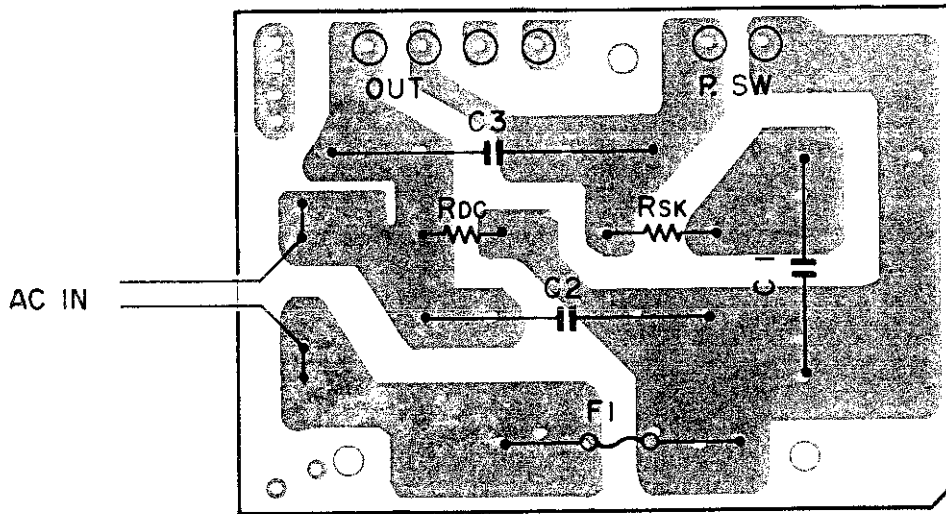

PARTS LIST OF P.W. BOARD

PS-1670 POWER SUPPLY UNIT

Ref. No.	Part No.	Part Name	Remarks
RESISTOR GROUP			
R-DC	2410765001	RD14B2E105J	1MΩ ¼W
R-SK	2410163001	RD14B2H121J	120Ω ¼W
CAPACITOR GROUP			
C1	2568023006	CF93A2EAC103M	0.01μF 250VAC
C2	2568023019	CF93A2EAC223M	0.022μF 250VAC
C3	2568023022	CF93A2EAC333M	0.033μF 250VAC
OTHER PARTS GROUP			
	EE-1656	BASE TERMINAL	1A/250V
	2061015029	FUSE	
	FEP1287	FUSE HOLDER	
	2050087042	4P TERMINAL	
	2050087026	2P TERMINAL	

PS-1680 POWER SUPPLY UNIT

Ref. No.	Part No.	Part Name	Remarks
RESISTOR GROUP			
R-DC	2410765001	RD14B2E105J	1MΩ ¼W
R-SK	2410163001	RD14B2E121J	120Ω ¼W
CAPACITOR GROUP			
C1	2568023019	CF93A2EAC223M	0.022μF 250VAC
C2, 3	2568023022	CF93A2EAC333M	0.033μF 250VAC
OTHER PARTS GROUP			
	EE-1656	BASE TERMINAL	1A/250V
	EP-72663	FUSE	
	2050087042	4P TERMINAL	
	2050087026	2P TERMINAL	

WARNING:
Parts marked with and/or shading have special characteristics important to safety. Be sure to use the specified parts for replacement.

ACCESSORIES AND PACKING GROUP

Ref. No.	Part No.	Part Name	Remarks
	5050025072	CABINET COVER	
	5058133102	PACKING (D)	
	5058134208	PACKING (U)	
	5298004004	MINI DRIVER	
	3158547001	SHELL ACCESSORY ASS'Y	
	5298006002	45 ADAPTOR	
	5058006006	ENVELOPE	
	5298042105	OVER HANG GAUGE	
	5028010103	ACCESSORY COVER	
	5050112008	SIDE PACKING	
	5028014206	PACKING	
	5111288004	INSTRUCTION MANUAL	
	2033667007	PLUG ADAPTER	(E1 only)

DENON

NIPPON COLUMBIA CO., LTD.

No. 14-14, 4-CHOME AKASAKA,
MINATO-KU, TOKYO JAPAN

TEL: 03-584-8111

TLX: JAPANOLA J22591

CABLE: NIPPON COLUMBIA TOKYO