

# DENON

Hi-Fi Component

## SERVICE MANUAL

FULLY AUTOMATIC  
DIRECT DRIVE TURNTABLE SYSTEM

MODEL DP-61F SERIES



**NIPPON COLUMBIA CO., LTD.**

## TABLE OF CONTENTS

FEATURES .....	2
MAIN SPECIFICATIONS .....	3
BLOCK DIAGRAM .....	4
NAMES AND PARTS AND FUNCTIONS .....	5
EXPLANTATION OF THE MICROPROCESSOR .....	6 ~ 9
ADJUSTMENT METHOD .....	10 ~ 11
PARTS LIST OF EXPLODED VIEW .....	12
EXPLODED VIEW .....	13
SCHEMATIC DIAGRAM .....	14
CONNECTIONS OF P.W. BOARD .....	15
P.W. BOARD OF KU-5190 SERVO CONTROL UNIT .....	16
P.W. BOARD OF KU-5181 MOTOR DRIVE UNIT .....	17
PARTS LIST OF P.W. BOARD .....	18 ~ 19

### WARNING:

#### 1. Component parts

Parts marked with  and/or shading in this service manual have special characteristics important to safety. Be sure to use the specified parts for replacement.

#### 2. Leakage current

Before returning the appliance to customer, test the leakage current when the power plug is connected. Use a calibrated (with an error of not more than 5%) leakage current tester and measure the leakage current from any exposed metal to the earth ground. Reverse the power plug polarity and test the above again.

Any current measured MUST NOT EXCEED 0.5 milliamps. Corrective measure must be taken if it exceeds the limit.

## FEATURES

### 1. The use of a microprocessor controlled, contactless servo tonearm

An innovative microprocessor controlled, contactless servo tonearm ensure safe, easy to use automatic operations with little loss in sound quality.

### 2. Q-damping method (Dynamic servo tracer)

Low frequency resonance caused by cartridge compliance and the tonearm mass is electronically damped horizontally and vertically. Crosstalk and inter-modulation distortion are effectively suppressed. The dynamic servo tracer maximizes the performance of the low mass tonearm and realizes excellent stability of sound image with little noise or distortion.

### 3. Low mass straight arm

This arm is fully capable of maximizing the performance of high compliance cartridges with outstanding tracing ability. Even with the newest, high grade records, its tracing ability is outstanding.

### 4. Locate function

Just by pressing the locate button, the tonearm is moved to any desired location where the record play is started.

### 5. Record size detector and the automatic speed selector mechanism

The record size and the speed are automatically set when using LP records (33 1/3 rpm) or single records (45 rpm). When there are no records placed on the turntable, the tonearm does not move, even if the start button is pressed. This protects the stylus tip from unexpected damages.

### 6. Thick precision turntable platter exhibits superb acoustic characteristics

The use of a thick turntable platter to minimize vibrations transmitted from external sources is essential for clear sound reproduction.

### 7. Excellent rotational characteristics

The DP61F's high performance AC servo motor; magnetic record head speed detection system; quartz lock, bi-directional servo result in phenomenal performance specifications: 0.008% wrms (rotation system) wow and flutter; 82 dB (DIN-B) S/N ratio and rotational accuracy of 0.002%.

### 8. Beautifully finished wood cabinet

DENON's tradition of products superbly crafted from the finest materials is continued with the DP-61F.

## MAIN SPECIFICATIONS

<b>Drive system:</b>	Servo controlled direct drive
<b>Turntable speeds:</b>	33-1/3 rpm, 45 rpm
<b>Wow flutter:</b>	Below 0.008% wrms (servo system) Below 0.02% wrms (JIS)
<b>S/N ratio:</b>	Over 82 dB (DIN-B)
<b>Rise time:</b>	Normal speed within 1.5 seconds (at 33-1/3 rpm)
<b>Turntable:</b>	Aluminum die-cast; 300 mm diameter
<b>Motor:</b>	AC servo motor
<b>Speed control system:</b>	Speed servo by frequency and phase servo control
<b>Load influence:</b>	0% (80 g stylus force, outer most groove)
<b>Brake system:</b>	Electronic brake
<b>Speed deviation:</b>	Below 0.002%
<b>Power supply:</b>	60/60 Hz, Voltage is shown on the rating label at the back of cabinet.
<b>Power consumption:</b>	13 W
<b>Dimensions:</b>	455 x 150 x 445 mm (W x H x D)
<b>Weight:</b>	Approx. 11 kg
<b>Arm type:</b>	Dynamically balance, straight tube tonearm
<b>Effective length:</b>	244 mm
<b>Overhang:</b>	14 mm
<b>Tracking error:</b>	Within 2.5°
<b>Automatic mechanism:</b>	Electronically controlled fully automatic
<b>Q-damping method:</b>	Electronic; horizontal vertical directions
<b>Adjustable tracking force range:</b>	0~3 g (1 scale=0.1 g)
<b>Head shell:</b>	Specially hardened resin head shell (Approx. 3.3 g)
<b>Suitable cartridge weight range:</b>	Approx. 3~12 g (including nuts, screws)
<b>Anti-skating:</b>	Electronically controlled

\* The above specifications are subject to change without notice.

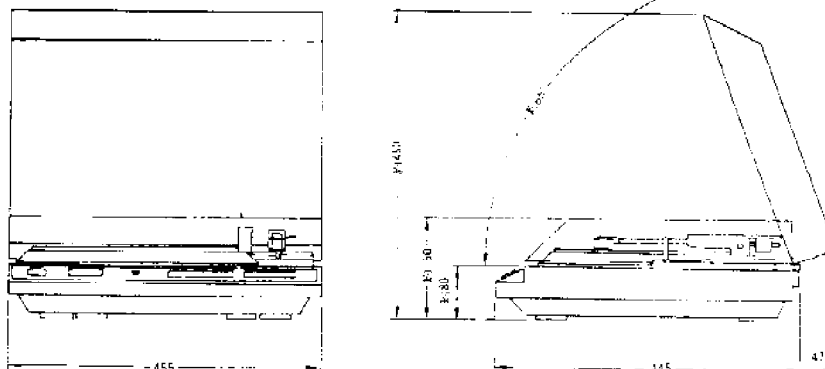

OUTER DIMENSIONS (mm)

**BLOCK DIAGRAM**

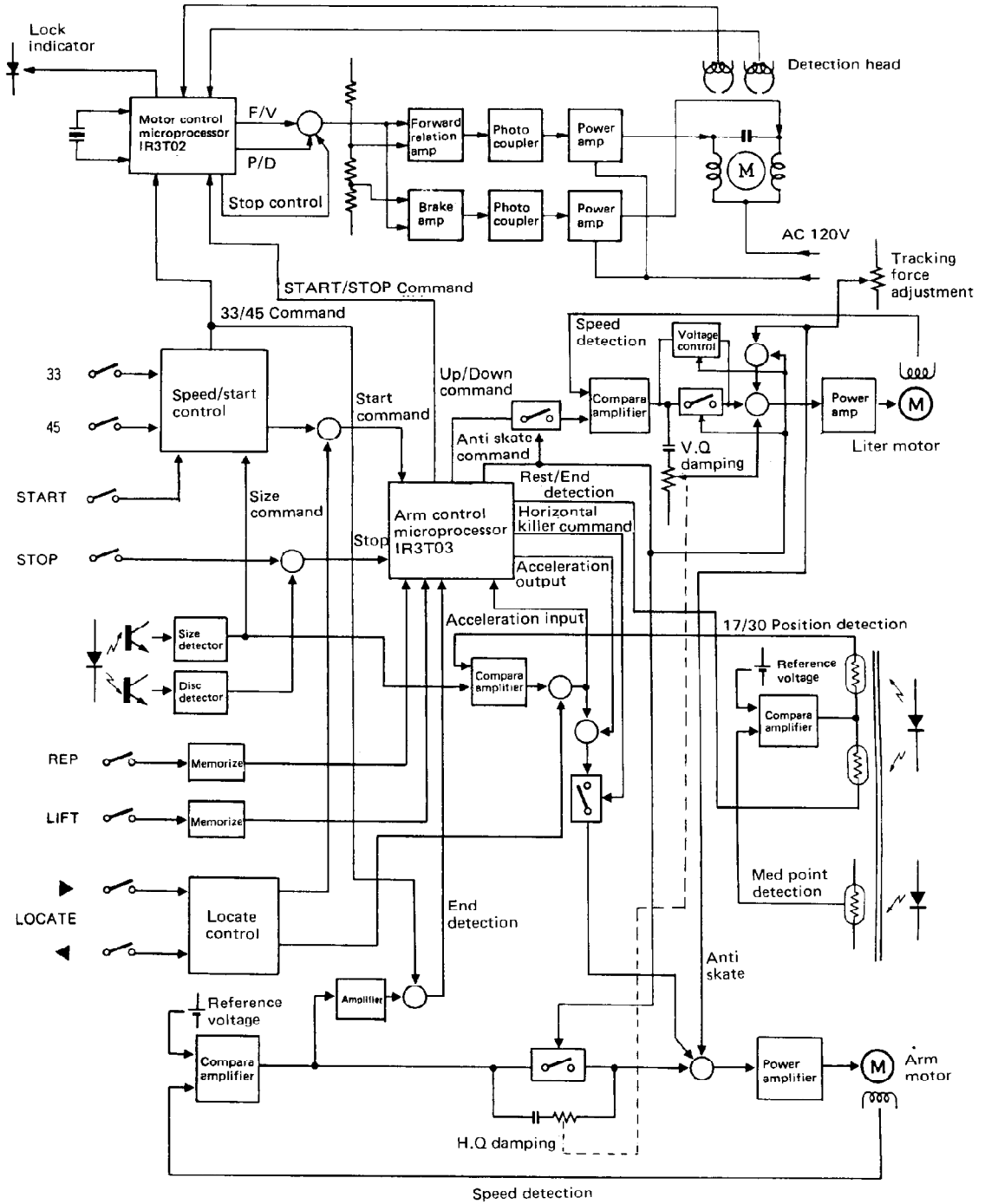

## NAMES AND PARTS AND FUNCTIONS

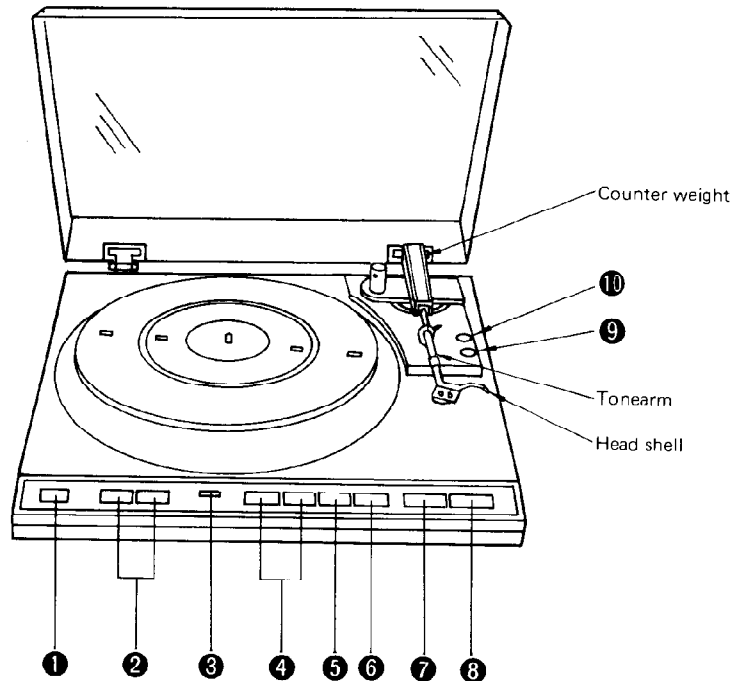

### 1 Power switch POWER

This turns the power supply on and off. Push the button down until it locks in position. The power will turn on and the lock, indicator (LOCK) will light up. When turning the power off, press the button until the lock is disengaged. In addition, always return the tonearm to the arm rest and hold it in place with the clamp.

### 2 Speed selector switch 33 SPEED 45

Set to the desired record speed.

33-1/3 rpm records . . . . . "33"

45 rpm records . . . . . "45"

In automatic play, the switch is set to "33" for 30 cm records and "45" for 17 cm records.

### 3 Lock indicator LOCK

The "LOCK" will light up when the power is on. During play, the lamp will flicker until the proper turntable speed is reached. Once the proper speed is obtained, the lamp will, again, stay lit.

### 4 Locate button LOCATE

Press this button to move the tonearm to the right or left, away from the record center, to start the record at any desired location.

### 5 Arm lifter button UP LIFTER

This button is used to raise and lower the arm during play, or when playing the records manually.

### 6 Repeat button ON REPEAT

Press this button when playing records repeatedly: the "REPEAT" lamp will be lit.

### 7 Start button START

Press this button when starting the records automatically.

### 8 Stop button STOP

Press this button when stopping the record during play.

### 9 Tracking force adjustment knob TRACKING FORCE

This is used to adjust the tracking force.

### 10 Q-damping adjustment knob Q-DAMPING

## EXPLANATION OF THE MICROPROCESSOR

- Motor Control IC ... IR3T02 (at standard revolution of 33 rpm)

The numbers on the left hand side indicates the terminal number.

### 1. Strobe drive

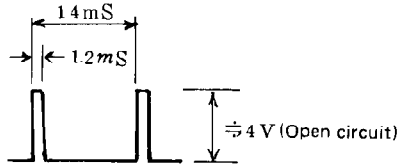

### 2. 4.5MHz OSC

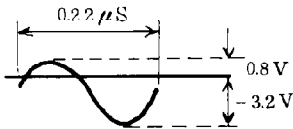

### 3. 4.5MHz OSC

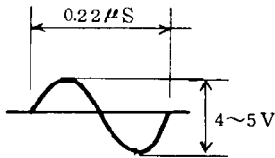

### 4. rpm selector

H: 45 rpm  
L: 33 rpm

### 5. Power source input

$V_{cc} = 5V \pm 0.5V$

### 6. FGI bypass terminal

$E6 = \frac{1}{2}V_{cc}$

### 7. FGI lowpass terminal

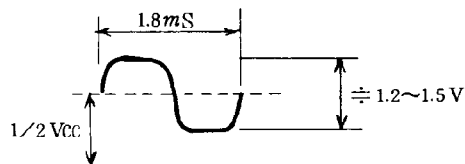

### 8. FG I output

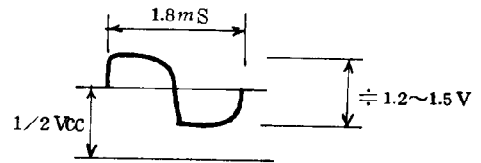

### 9. FG I inverse input

The gain set element is connected.  
 $E9 = \frac{1}{2}V_{cc}$

### 10. FG I non-inverse input

$10mV_{pp} \sim 100mV_{pp}$   
 $E10 = \frac{1}{2}V_{cc}$

### 11. FG II non-inverse input

$10mV_{pp} \sim 100mV_{pp}$   
 $E11 = \frac{1}{2}V_{cc}$

### 12. FG II inverse input

The gain set element is connected.  
 $E12 = \frac{1}{2}V_{cc}$

### 13. FG II output

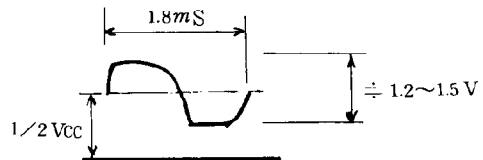

### 14. Ground terminal

### 15. F/V output

slower than normal revolution: 2 ~ 4.5V  
normal revolution:  $\pm 2V$   
faster than normal revolution: 0 ~ 2V

### 16. F/V hold terminal

same as terminal 15

**17. F/V triangular wave**

slower than normal revolution

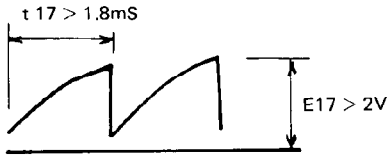

normal revolution

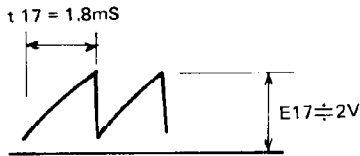

faster than normal revolution

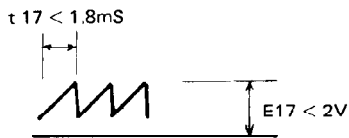

**18. Timing pulse width-set terminal**

$E18 = 0.6V$

**19. PD triangular wave**

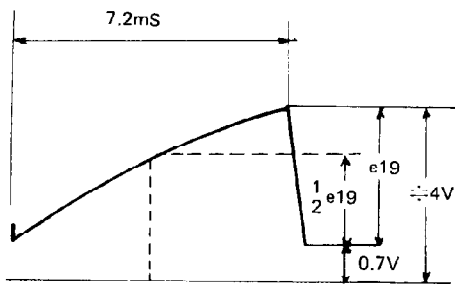

Note:  
PD: Phase Detector

**20. Sample pulse monitor terminal**

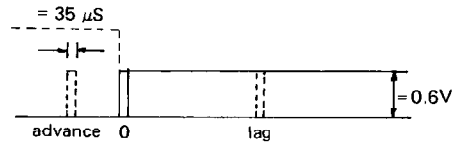

**21. PD hold terminal**

slow phase: 2 ~ 4V  
normal phase: ≈ 2V  
advanced phase: 1 ~ 3V

**22. PD output**

same as terminal 21

**23. Lock detector time set terminal**

during lock: 0.6V  
lock disengaged: 0V

**24. Direction detector output**

normal revolution: 0V  
reverse revolution: ≈ 4V

**25. Revolution detector**

during revolution: ≈ 4

stop: 0V

**26. START/STOP terminal**

H → START  
L → STOP

**27. Stop output**

during stop control: 0V  
during start: open

## 28. Lock indicator

during lock . . . . . (LED lit dimly)  
69 Hz

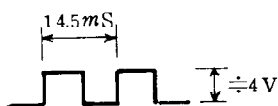

stop . . . . . (LED lit)

during transition . . (LED flashes)

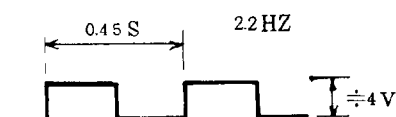

## ● Arm Control IC IR3T03

The numbers on the left side indicates the terminal number of the IR3T03.

### 1. Acceleration input

Except for the matching range of the lead-in detector ( $E7 \leq |\pm 0.6V|$ ), it will recognize the situation and control the acceleration during automatic tonearm operation.

### 2. Acceleration output

$E1 \leq |\pm 2.37V \pm 0.1V|$  . . . . open (will not control the acceleration within the matching range)

$E1 \geq |\pm 2.37V \pm 0.1V|$  . . . .  $E2 \doteq \pm 3.95V$

-3.95V: will accelerate toward the inside from rest.

+3.95V: will accelerate toward rest from the inside.

### 3. UP/DOWN selection of the arm lifter

When  $E9$  is H, the control output for lifting the arm will be made at  $E3 \doteq -V_{cc}$ .

When  $E9$  is L, the control output for lowering the arm will be made at  $E3 \doteq +V_{cc}$ .

### 4. Detection of the rest position

$E4 \leq -2.64V$  will be recognized as the arm being at rest.

### 5. Detection of the END position

When  $E5 \geq 2.64V$ , it will be recognized to be within the END detection range.

### 6. End control

Within the END detection range of 5 (above), ( $E5 \geq 2.64V$ ), the arm will be returned by the END control when  $E6 \geq 0.23V$ .

### 7. Matching input

$E7 \geq |\pm 0.6V|$  will be recognized as the match range for lead-in.

### 8. Drive output

Connect to GND.

### 9. UP control output

When the lifter is in the UP position during automatic arm operations or when the UP signal is sent by pressing the arm lifter button, pin 9 will be at H level.

$E9H \doteq 4V$

$E9L \doteq 0V$

### 10. DOWN time constant

To ensure that the arm is lowered completely before proceeding to the next movement, a resistor between pins 9 and 10 and a capacitor on pin 10 has a preset discharge time constant which is somewhat longer than the time required for the arm to be lowered. Thus, when pin 9 becomes L ( $E9L \doteq 0V$ ), and the fixed amount of time elapses, the arm will be recognized to be DOWN as soon as  $E10 < 2V$ .



### 11. ANT (Anti-skating) control

When  $E10 < 2V$ , then  $E11 \doteq -4V$  will be the control output needed for the anti-skating to be engaged.

When  $E10 \geq 2V$ , then  $E11 \doteq +4V$  will be the control output needed for the anti-skating to be disengaged.

### 12. Negative power source

Supplies  $-5V$ .

### 14. SUB (substratum)

To prevent any interference from the inner elements of the LSI, the substratum terminal is connected to the unregulated side of the negative power source, since it has the lowest electric potential.

### 15. GND

Standard zero electric potential is the GND.

### 17. Return control

When the stop command is given, or when the repeat is disengaged and the END is detected ( $E6 \geq 0.23V$ ), a control signal output ( $E17H > 4V$ ) is made to return the arm to rest.

$E17H > 4V$

$E17L$ : release

### 18. Horizontal drive control

When the arm is in resting position, or when the arm reaches the lead-in position during automatic play, and comes into the matching range ( $E7 \leq |\pm 0.6V|$ ), a control signal output ( $E18H \doteq 4V$ ) is made to stop the horizontal motion of the arm.

### 19. Initial set

This is the preparation time setting terminal when the power source is turned on. The resistor in the LSI and the outer capacitor will set the charge time constant and carry out the initial set.

### 20. LCTD (Located) time constant

The LSI and its outer circuits will set the LCTD time constant to improve the detection accuracy of the lead-in position and the arm rest position.

$E20H \doteq 1.2V$  . . . . A few moments after the arm reaches the range of detection, in other words, after the set LCTD time constant elapses, it will become H level, where it is memorized immediately and then reset to the L level.

$E20L \doteq 0V$  . . . . Before and after detection, it will become L level.

### 21. Turntable (T/T) Drive Control

$E21L \doteq 0V$  . . . . the turntable stops

$E21H$  release . . . . the turntable rotates

(refer to the operational explanations for pin 22)

### 22. Turntable (T/T) Start Position

This terminal establishes the turntable start position. The turntable will start when the arm separates from the arm rest and pin 22 is released, under manual and auto modes.

### 23. Start

Will start automatically at the GND level.

### 24. Auto stop

Will stop automatically at the GND level.

### 25. Lifter

Will raise the lifter automatically at the GND level.

### 26. Repeat

Will engage the repeat automatically at the GND level.

### 27. UP SW

When the arm lifter is raised, this terminal will be opened and made H level, otherwise, the UP detector will control it to make it GND level.

With this model, photo reflectors to detect the presence of reflected light from a light emitting diode and a sensor is placed opposite to the reflector cam. When the lifter is in the UP position, the reflector cam blocks the ray of light, and the raised lifter position is detected, as there is no reflection.

### 28. Positive power supply

Supplies  $+5V$ .

## ADJUSTMENT METHOD

### • Adjusting the phonomotor section

Prepare a two-channel oscilloscope for the measuring instrument; make the adjustments in the following order.

CH-1 Probe connect to test point TP1 of the motor control circuit board, and CH-2 Probe connect to test point TP'2.

Both probe ground terminal connect to G.

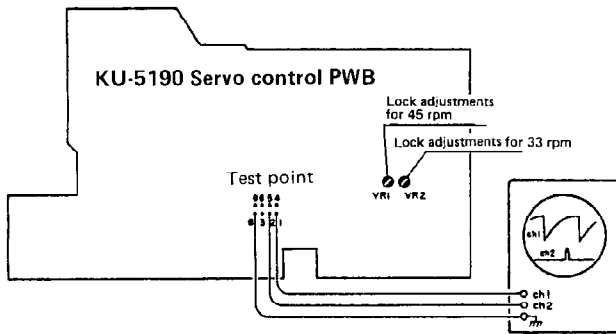

#### 1. Adjusting the head gap

Make sure the detection head is in right angle to the magnetic coating surface of the turntable. The gap of the detection head should be adjusted to 0.18 mm. Be careful the head is not tilted to the left or the right.

#### 2. Lock adjustments for 45 rpm

- 1) Place a record on the turntable; fix the arm to the armrest.
- 2) After pressing the start button, set the speed selector switch to 45 rpm.
- 3) Adjust VR1 so that the positions of the triangular wave form and the pulse form TP2 are as shown in the diagram below.

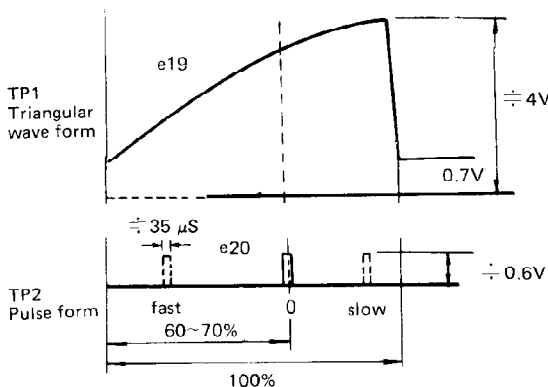

#### 3. Lock adjustments for 33 rpm

- 1) Set the speed selector switch to 33 rpm and proceed to adjust VR2, just as in the adjustments for 45 rpm.

### • Adjusting the arm control section

#### 1. Adjusting the horizontal OP amp. offset voltage

- 1) Fix the tonearm to the arm rest and connect the oscilloscope to TP5.
- 2) Set the lifters switch to the UP condition.
- 3) Turn VR-6 and adjust to  $0V \pm 0.01V$ .

#### 2. Adjusting the lifter OP amp. offset voltage

- 1) Fix the tonearm to the arm rest and connect the oscilloscope to TP-6.
- 2) Set the lifter switch to the DOWN condition.
- 3) After about 7 seconds, adjust to  $0V \pm 0.01V$  by turning VR-4.

#### 3. Adjusting the tracking force

- 1) Turn the power supply switch OFF.
- 2) Take the arm off the arm rest. Rotate the balance weight so that the tonearm becomes parallel to the turntable surface when let go.
- 3) Return the arm to the arm rest and turn the power supply switch ON.  
(Note) Cover the size detecting photo transistors (2 pieces) with a rubber sheet or something to avoid that light enters.
- 4) Wait 7 seconds after the arm has lowered. Place the cartridge stylus tip onto a stylus force gauge and set the tracking force adjustment knob to 1.5 g.  
(Note) At this time, the stylus tip height should be adjusted so that it is about the same height as during play.
- 5) Turn VR-5 and adjust, so that the stylus force gauge reads 1.5 g. (Turn VR slowly.)

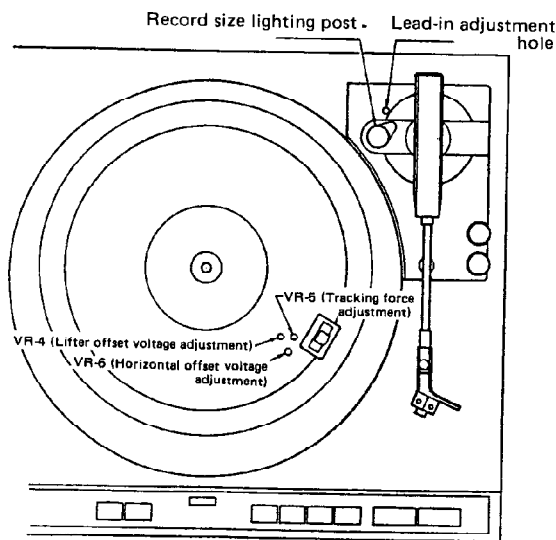

#### 4. Adjusting the 30 cm lead-in position

- 1) Place a 30 cm record on the turntable and set the record size selector switch to "30".  
(Note) Keep the bottom cover closed.
- 2) Move the arm so that the stylus tip is at approximately the 30 cm lead-in position. Insert a small flat-headed screwdriver into the lead-in adjustment hole; move the arm back and forth and fit the screw driver into the groove of the cam inside gently.

- 3) After the turning the screwdriver, pull it out once. Press the start switch and adjust so that the stylus position stops as the 30 cm lead-in position.

(Note) The 30 cm lead-in adjustments cannot be performed unless the stylus tip position is approximately in the 30 cm lead-in position. In addition, if the screwdriver is left inserted, the arm will not move.

#### 5. Adjusting the 17 cm lead-in position

Adjust as necessary, such as when parts of the sensor section have been replaced.

However, the following procedures should only be used when a discrepancy is found for the 17 cm lead-in position, after the 30 cm lead-in position has been adjusted.

- 1) The size is automatically changed by placing a 17 cm record on the turntable.
- 2) By continuously pressing the start switch, the arm will move over and stop. At this time, check how many millimeters, toward the inside or outside, the stylus tip deviates from the required 17 cm lead-in position.
- 3) Take off the bottom cover of the cabinet and check the adjustment scale position of the shutter. (One adjustment scale corresponds to a stylus tip movement of 0.5 mm.)
- 4) Untighten the screw holding the sub shutter and place a small flat-headed screwdriver into the slot of the shutter. When the stylus position is toward the inside, compared to the required position, move the sub shutter toward the right of the scale; when the stylus position is toward the outside, move the sub shutter toward the left. When completed, tentatively tighten the screw holding the sub shutter.
- 5) After the adjustments are made, press the start switch and check whether or not the stylus stops at the 17 cm lead-in position.
- 6) If the stylus stops at the required position, then tighten the sub shutter screw.

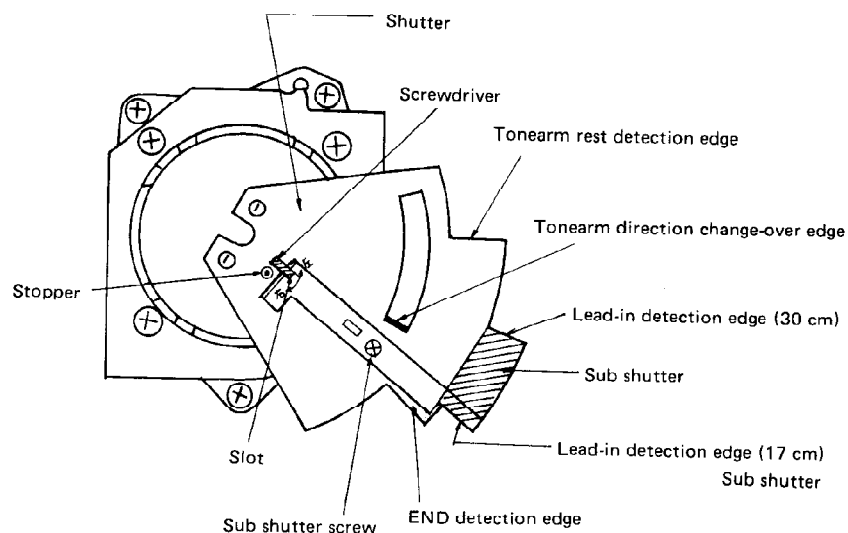

**PARTS LIST OF EXPLODED VIEW**

Ref. No.	Part No.	Part Name	Remarks
1	1018448006	CABINET	
2	4018054002	HINGE HOI DER	
3	4418551008	BUSHING PLATE (F)	
4	4418313204	BUSHING PLATE (E)	
5	4128818206	SHIELD PLATE	
6	1468158519	FRAME	
7	4318095101	FRICTION SHEET	
8	3158911103	ARM LEST ASS	
9	4498074000	LED STAND	
10	3939220000	LED WITH WIRE	
11	1468159000	TOWER	
12	1038238704	FRONT PANEL	
13	1038240307	SUB PANEL	
14	1138009006	DENON MARK	
15	1138169508	BUTTON (A) ASS'Y	
16	1138171305	BUTTON (B) ASS'Y	
17	1138172207	P.S. BUTTON ASS'Y	
18	4638637304	SPRING	
19	4428123206	POWER S.W. BRACKET	
<b>⚠</b> 20	<b>2129136028</b>	<b>POWER SW</b>	
<b>⚠</b> 21	<b>2178078001</b>	<b>MOTOR ASS'Y</b>	
22	KU-5190	SERVO CONTROL UNIT	
23	KU-5181	MOTOR DRIVE UNIT	
24	3158962000	TONE ARM ASS'Y	
25	3158958001	WEIGHT ASS'Y	
26	4338175205	YOKE (A) ASS'Y	
27	3158712108	LATERAL WEIGHT	
28	2398013215	COIL ASS'Y	
29	3418025205	MAGNET ASS'Y	
30	4248019202	ADJUST CAM	
31	3158451003	FRICTION WASHER	
32	4751005004	4W	
33	4761003009	3E RING	
34	4338281005	SHUTTER	
35	4338280006	SUB SHUTTER	
36	4438545201	COLLAR	
37	4638225004	SPRING	
38	4428155009	CORD BRACKET	
39	2031640000	OUTPUT CORD	
40	EP-7376	CORD STOPPER	
41	4148181007	SHIELD SHEET	
<b>⚠</b> 42	<b>2339062005</b>	<b>POWER TRANS</b>	
43	4620027003	RUBBER BUSH	
<b>⚠</b> 44	<b>2062019008</b>	<b>AC CORD</b>	
<b>⚠</b> 45	<b>MD-3802</b>	<b>BUSHING</b>	
46	1058241108	BOTTOM COVER	
47	FMD05241	INSULATOR	
48	3918425004	MAGNETIC HEAD	
49	1128077309	KNOB	
50			
51	3158600003	HEAD SHEEL ASS	
52	4218387113	RUBBER SHEET	
53	4218397103	TURNTABLE	
54	1468160109	DUST COVER ASS'Y	
55	4628023009	BUSHING	

Ref. No.	Part No.	Part Name	Remarks
56	3158898006	FRICTION SCREW	
57	4730309019	3x16 CBRTS (1)	
58	4732309017	3x16 CFTS (1)	
59	4730306012	3x12 CBRTS (1)	
60	4733812008	3x12 CBTS (1)	
61	4730310011	3x20 CBRTS (1)	
62	4730308010	3x14 CBRTS (1)	
63	4713302017	3x5 CBS	
64	4730305013	3x10 CBRTS (1)	
65	4756133007	14N	
66	4712306014	3x12 CFS	
67	4734304000	3x3 BSS (D)	
68	4711810019	2x3 CPS	
69	4713303045	3x6 CBS	
70	4711303018	3x6 CPS	
71	4770192008	SPECIAL SCREW	
72	4725802000	2.7x20 COWS	
73	4700009019	3x6 CPSW	
74	4018041028	HINGE	
75	4770018001	WASHER (P-87)	
76	4618155000	PAD	
77	4751003006	3W	
78	4733808012	3X12 CBTS (1)	

**WARNING:**

Parts marked with **⚠** and/or shading have special characteristics important to safety. Be sure to use the specified parts for replacement.

EXPLODED VIEW

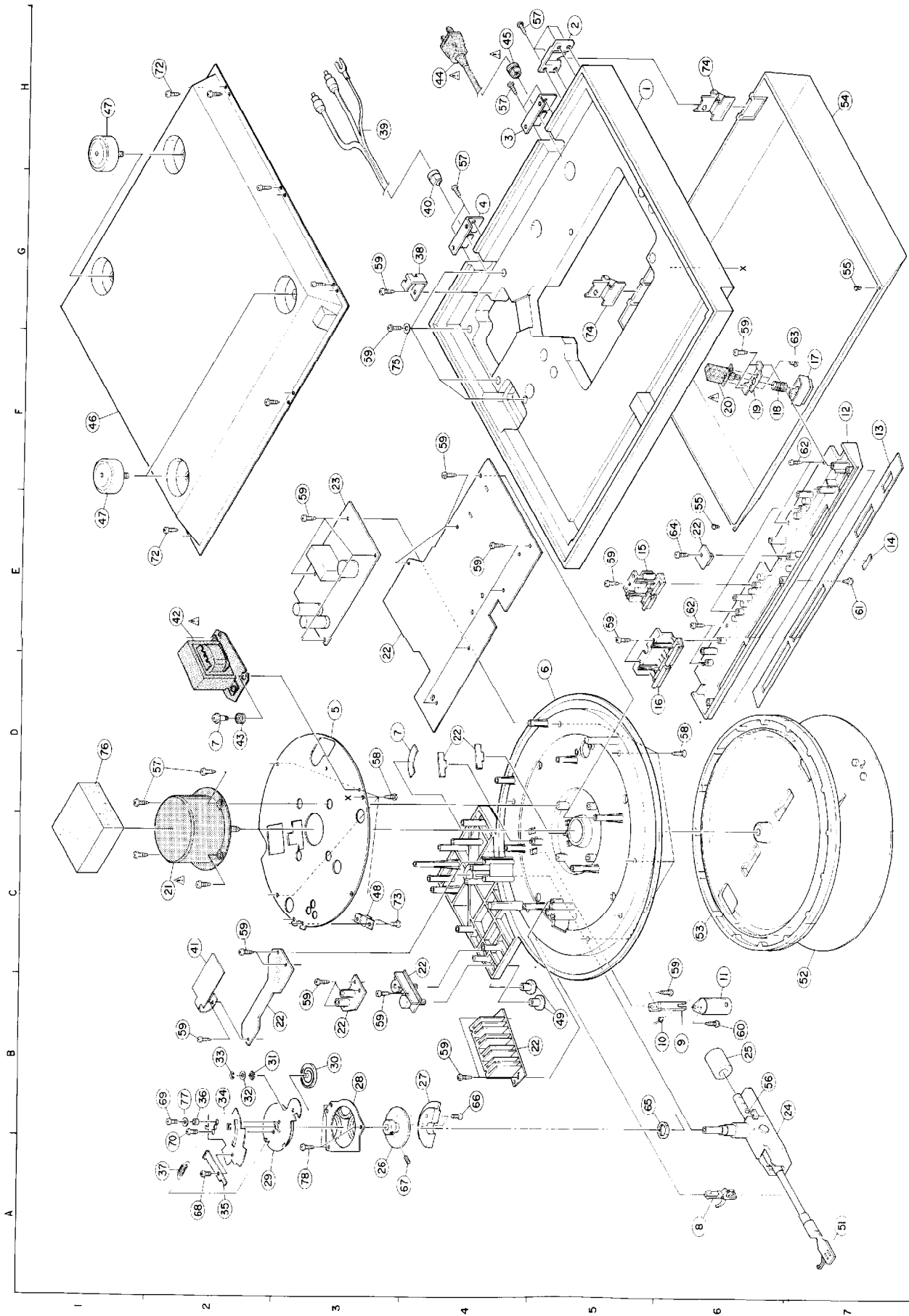

**SCHEMATIC DIAGRAM**

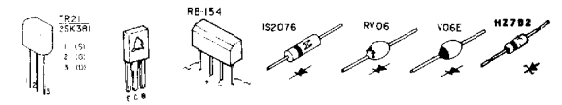
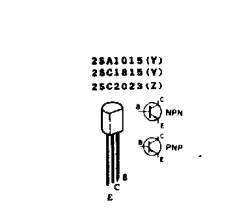
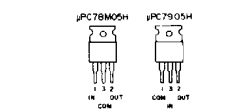
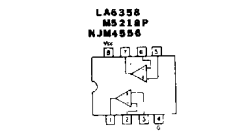
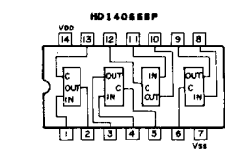
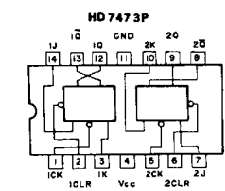
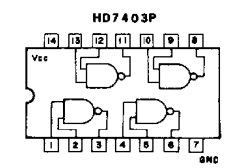
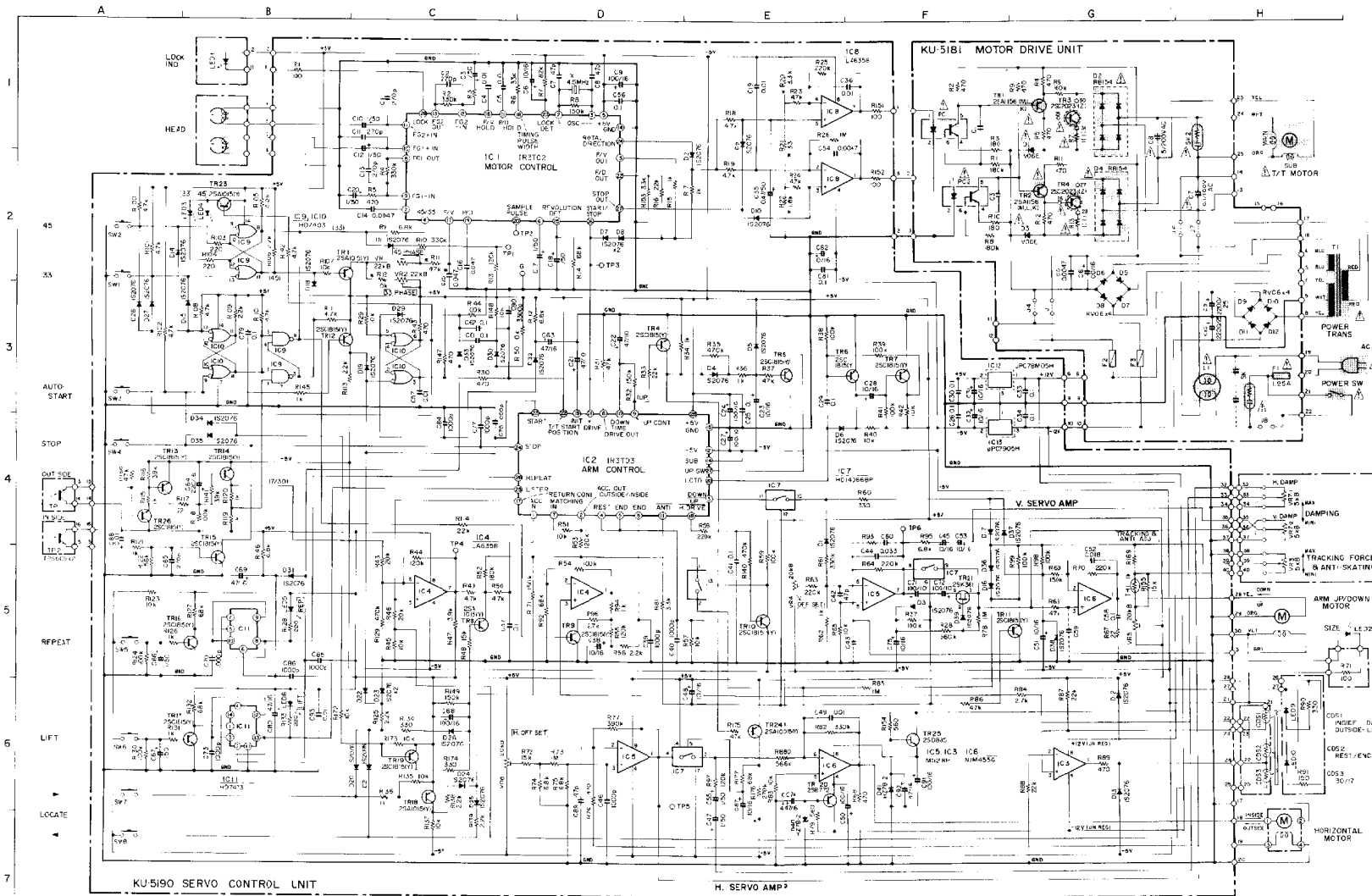

28A1156 (M.L.K)  
28B772 (Q/P)  
28D682 (Q/P)

- Note:**
- Resistance shall be 1/4W unless otherwise specified and the unit is Ω.
  - The unit of capacitor is μF, P is pF unless otherwise specified.
  - This circuit diagram shows the basic circuit. It is subject to change for the purpose of improvement.
  - Parts marked with  $\Delta$  are of importance in respect to the safety, use the specified type without fail.

CONNECTIONS OF P.W. BOARD

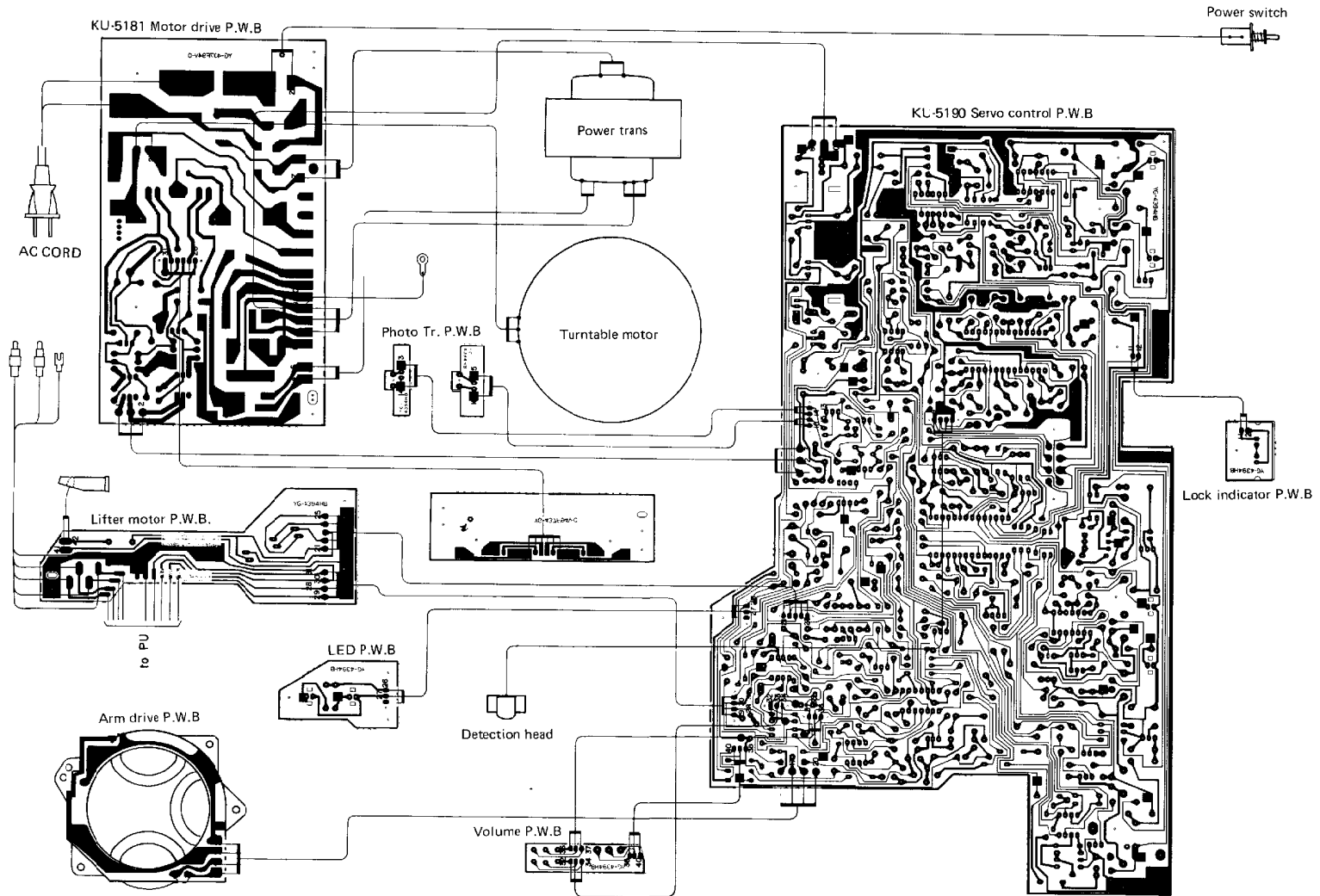

P.W. BOARD OF KU-5190 SERVO CONTROL UNIT

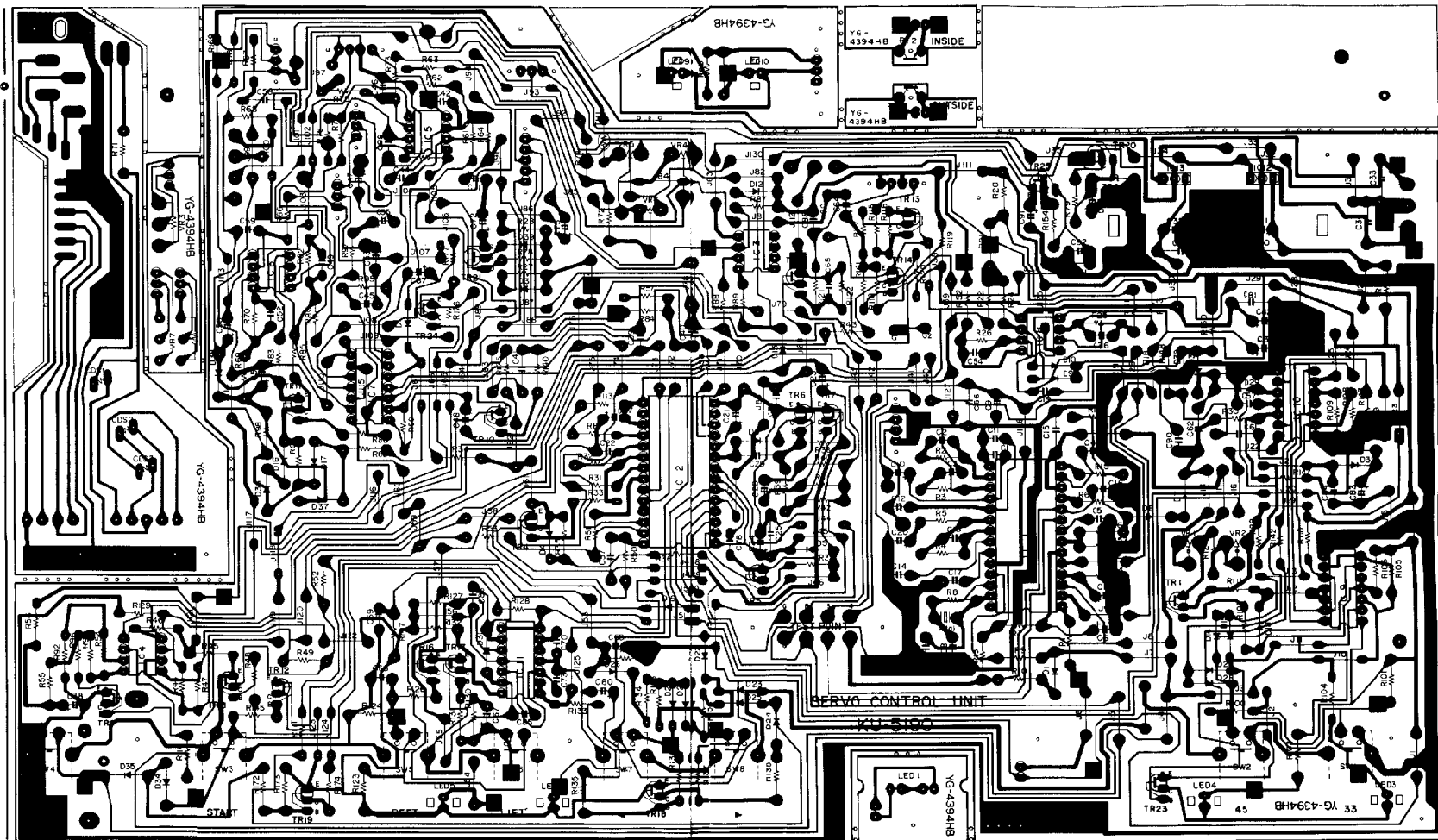



P.W. BOARD OF KU-5181 MOTOR DRIVE UNIT

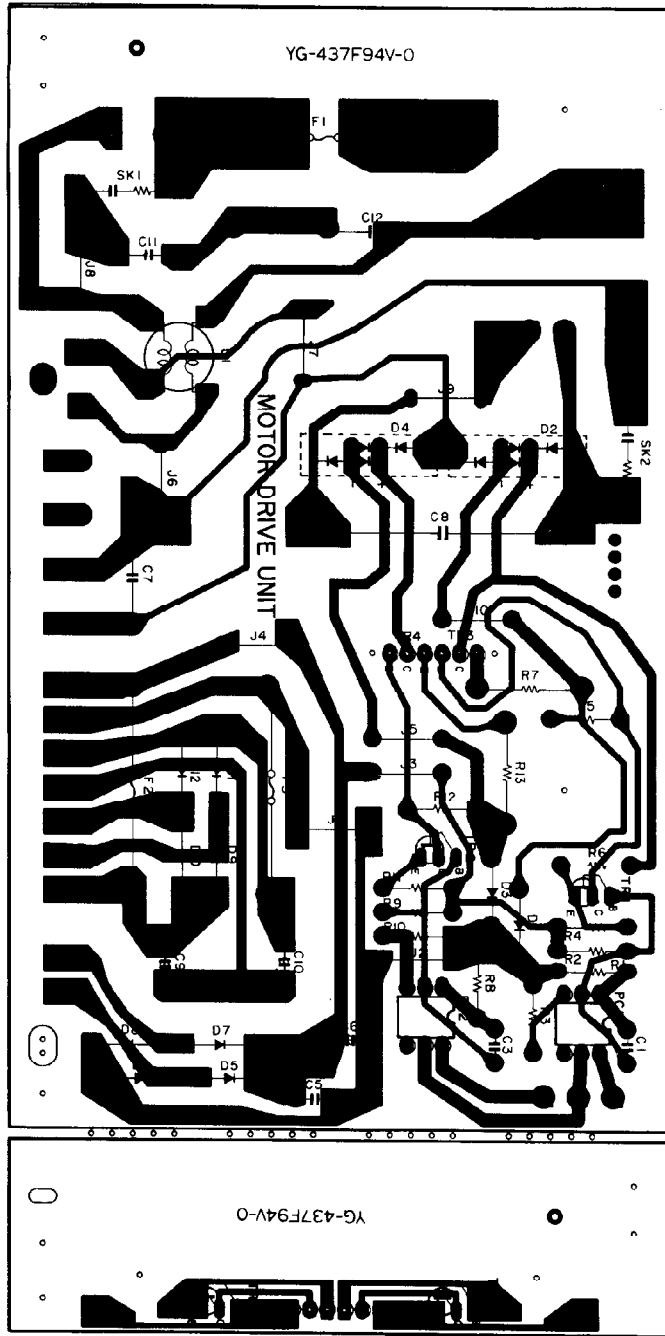

# PARTS LIST OF P.W. BOARD

## KU-5190 SERVO CONTROL UNIT

Ref. No.	Part No.	Part Name	Remarks
<b>SEMICONDUCTOR GROUP</b>			
IC1	2630173004	IR3T02	
IC2	2630174003	IR3T03	
IC3, 5	2630257001	M5218P	
IC4, 8	2630237005	LA6358	
IC6	2630198005	NJM4556D	
IC7	2620276006	HD14066BP	
IC9, 10	2620218005	HD7403P	
IC11	2620057004	HD7473P	
IC12	2630147001	μPC78M05H	
IC13	2630160004	μPC7905H	
TR1, 8 18, 19 23, 24	2710102005	2SA1015 (Y)	
TR20	2720055029	2SB772 (Q/P)	
TR4~7 9~17	2730198002	2SC1815 (Y)	
TR25	2740078031	2SD882 (Q/P)	
TR21	2750043014	2SK381 (C/D)	
D1~39	2760049008	1S2076	
D40	2760051038	HZ7B-2	
TH1	2760311008	TD5C210D	
LE1	3939185006	LN202GP2	
LE3~6	3939219008	GL-5EG23	
LE6, 9 10	3939041001	LN202GP2	
CD1, 2	3939063002	CDS	
CD3	3939053028	CDS	
T1, 2	3939157005	TPS605	
<b>RESISTOR GROUP</b>			
R11	2452223006	RN14K2E473G	Metal film 47KΩ ¼W
R12	2452207006	RN14K2E103G	10KΩ ¼W
R20	2452195008	RN14K2E332G	3.3KΩ ¼W
R21	2452147001	RN14K2E330G	33Ω ¼W
R22	2452189001	RN14K2E182G	1.8KΩ ¼W
VR1, 2	EP-5462H15	SOLID VR	Variable resistor 22KΩ
VR3~5	2116000073	V08PB203	20KΩ
VR6	2118024015	V16V20KB502	5KΩ
VR7	2118064017	V1620V20KB502 B502	5KΩ x2
<b>CAPACITOR GROUP</b>			
C39, 40 46, 70 73, 77 78, 84 85, 86	2531004007	CK45B1H102K	Ceramic 0.001μF 50V
C90	2531007004	CK45B1H332K	0.0033μF 50V
C14, 54	2531008003	CK45B1H472K	0.0047μF 50V
C19, 36 57, 88	2531024003	CK45F1H103Z	0.01μF 50V
C93	2531024003	CK45F1H103Z	0.01μF 50V

Ref. No.	Part No.	Part Name	Remarks
C25, 26 29, 30 33, 34 37, 41 56, 58 61, 62 79, 81 C7, 8 42, 89	2531027000	CK45F1H104Z	0.1μF 50V
C1, 2 11, 13 65	2533619005	CC45SL1H470J	47PF 50V
C71, 72 C21, 22 C6, 23 28, 31 32, 38 45, 48 51, 53 75, 82 87	2533637003	CC45SL1H271J	270PF 50V
C63, 69 74, 80 92	2544130007	CE04W1A101=	Electrolytic 100μF 10V
C9, 24 27, 50 68, 91	2544009002	CE04W1A470-	47μF 10V
C64 C35 C3, 10 12, 17 18, 20 47, 55 66, 67	2544015009	CE04W1C100=	10μF 16V
C4, 5 49	2544017007	CE04W1C470=	47μF 16V
C52 C44	2544018006	CE04W1C101=	100μF 16V
C16 C15	2544019005	CE04W1C221=	220μF 16V
	2544145005	CE04W1HR47=	0.47μF 50V
	2544146004	CE04W1H010=	1μF 50V
	2551072006	CQ93M1H103K	Film 0.01μF 50V
	2551075003	CQ93M1H183K	0.018μF 50V
	2551078000	CQ93M1H333K	0.033μF 50V
	2551122008	CQ93M1H473J	0.047μF 50V
	2554194017	CQ93P1H473J	0.047μF 50V
<b>OTHER PARTS GROUP</b>			
X1 SW1~8	4178028101 4428122207 3998023002 2129218001 4438568107 2050158049 2050185038 2050185041 2050185054	HEAD SINK VR BRACKET CRYSTAL TACT SW LED HOLDER 4P WRAPPING TERMINAL 3P WIRE HOLDER 4P WIRE HOLDER 5P WIRE HOLDER	IC12, 13 VR3, 7 4.5 MHZ

• The carbon resistors rated at ¼W are not listed herein.

### KU-5181 MOTOR DRIVE UNIT

Ref. No.	Part No.	Part Name	Remarks
<b>SEMICONDUCTOR GROUP</b>			
⚠ TR1, 2	2710159003	2SA1156 (M.L.K)	
⚠ TR3, 4	2730196004	2SC2023Z	
⚠ D1, 3	2760057029	V06E	
⚠ D2, 4	2760280003	RB154	
D5~12	2760237001	RV06	
⚠ PC1, 2	3939027012	PC-613G	
<b>RESISTOR GROUP</b>			
⚠ R7, 13	2440005029	RS14B3A010JNBF	1Ω 1W
<b>CAPACITOR GROUP</b>			
C1, 3	2531002009	CK45B1H471K	Ceramic 470PF 50V
C6	2531008003	CK45B1H472K	0.0047μF 50V
C5	2544018006	CE04W1C101=	Electrolytic 100μF 16V
C6, 9	2544086009	CE04W1E222M	2200μF 25V
⚠ C7	2558000039	CQ93P2CAC104M	Film 0.1μF 160VAC
⚠ C8	2568026016	CF93=2DAC505J	Metallized 5μF 200VAC
<b>OTHER PARTS GROUP</b>			
SK1, 2	2618006009	SPARK KILLER	
L1	2398001007	LINE FILTER COIL	
F1	2061024010	FUSE 1.25A	
	FEP12802	MINI CONNE PIN	
	EE-1656	BASE TERMINAL	
	2050087026	2P TERMINAL	
	2050185067	6P WIRE HOLDER	
	2058007008	TERMINAL	
	5138211041	FUSE RATING LABEL	
	4178020400	HEAT SINK	TR3, 4

• The carbon resistors rated at ¼W are not listed herein.

#### WARNING:

Parts marked with ⚠ and/or shading have special characteristics important to safety. Be sure to use the specified parts for replacement.

### ACCESSORIES AND PACKING GROUP

Ref. No.	Part No.	Part Name	Remarks
	5058023018	ENVELOPE	T/T
	5058017011	ENVELOPE	ARM
	5018321213	CARTON CASE	
	5018322005	BOTTOM PALTE	
	5018323101	UPPER PLATE	
	5018331106	BACK PACKING	
	5138279038	RATING SHEET	
	5028142000	PAD	ARM
	5038050108	PACKING ASSY	
	5058092036	LAMINATE ENVELOPE	
	5298006002	45 ADAPTOR	
	4018041028	HINGE	
	5298042008	OVER HANG GAUGE	
	5118286009	INSTRUCTION MANUAL	
	3158547001	SHELL ACCES- SORY ASS	

**DENON**

**NIPPON COLUMBIA CO., LTD.**

No. 14-14, 4-CHOME AKASAKA,  
MINATO-KU, TOKYO JAPAN  
TEL: 03 584-8111  
TLX: JAPANOLA J22591  
CABLE: NIPPON COLUMBIA TOKYO