

DENON

Hi Fi Component/Record Player

SERVICE MANUAL

SERVO-CONTROLLED
DIRECT DRIVE RECORD PLAYER

MODELS DP-57L/62L
DP-67L/72L



Model DP-67L

NIPPON COLUMBIA CO., LTD.

TABLE OF CONTENTS

FEATURES	1
MAIN SPECIFICATIONS	2
NAMES OF PARTS AND FUNCTION	3~4
BLOCK DIAGRAM	5
EXPLANATION OF THE MICROPROCESSOR	6~7
ADJUSTMENT METHOD	8~9
PARTS LIST OF P.W. BOARD	10
EXPLODED VIEW OF MAIN PARTS (DP-57L/62L)	11
PARTS LIST OF EXPLODED VIEW (DP-57L/62L)	12
PARTS LIST OF EXPLODED VIEW (DP-67L/72L)	13
EXPLODED VIEW OF MAIN PARTS (DP-67L/72L)	14
EXPLODED VIEW OF TONEARM (DP-57L/62L)	15
EXPLODED VIEW OF TONEARM (DP-67L/72L)	16
CONNECTIONS OF P.W. BOARD (DP-57L/67L)	17
SCHEMATIC DIAGRAM OF DP-57L/67L	18
CONNECTIONS OF P.W. BOARD (DP-62L/72L)	19
SCHEMATIC DIAGRAM OF DP-62L/72L	20
P.W. BOARD OF KU-4650/5050 MOTOR SERVO UNIT	21
P.W. BOARD OF KU-4680/5040 MOTOR SERVO UNIT	22
P.W. BOARD OF KU-4590 LIFTER SERVO UNIT	23
AND PS-1670/1680 POWER SUPPLY UNIT	

FEATURES

Electronic Q-damping (Dynamic Servo Tracer)

Low frequency resonance, dependent upon cartridge compliance and the effective mass of the tonearm, is electronically damped both horizontally and vertically to eliminate crosstalk and inter-modulation distortion. This optimizes the performance of the DP-57L's/DP-62L's/DP-67L's/DP-72L's arm and results in record reproduction with outstanding stereo imaging characteristics and a minimum of noise or vibration.

Low-mass straight arm tube with lamination damped headshell

Dual construction of the arm tube greatly reduces headshell resonance. This, together with the lowmass straight arm tube improves tracing ability and further contributes to the DP-57L's/DP-62L's/DP-67L's/DP-72L's clarity and stable stereo imaging.

Thick precision turntable platter exhibits superb acoustic characteristics.

The use of a thick turntable platter to minimize vibrations transmitted from external sources is essential for clear sound reproduction.

Excellent rotational characteristics

The DP-57L's/DP-62L's/DP-67L's/DP-72L's high performance AC servo motor; magnetic record head speed detection system; quartz lock, bi-directional servo result in phenomenal performance specifications: 0.008% wrms (rotation system) wow and flutter; 82dB (DIN-B) S/N ratio and rotational accuracy of 0.002%.

Auto-lift mechanism with non-contact end-of-record detection system

When the record is finished, the stylus automatically lifts off the record and the turntable stops rotation. This avoids unnecessary wear of the stylus tip.

Beautifully finished wood cabinet

DENON's tradition of products superbly crafted from the finest materials is continued with the DP-57L's/DP-62L's/DP-67L/DP-72L.

Interchangeable straight and S-type arm tubes via standard 4P connectors.

Optimum cartridge matching can be achieved quickly and easily through interchangeable tonearm tubes.

MAIN SPECIFICATIONS

Turntable motor

Drive method:	Servo controlled direct drive
Speeds:	33-1/3rpm, 45rpm
Wow and flutter:	less than 0.008% wrms (servo system) less than 0.02% wrms (JIS)
S/N ratio:	more than 82dB (DIN-B)
Rise time:	Nominal speed within 1.5 seconds (at 33-1/3rpm) (DP-57L's/ DP-62L's) Nominal speed within 1.3 seconds (at 33-1/3rpm) (DP-67L's/ DP-72L's)
Turntable platter:	Aluminum die-cast, 300mm diameter Moment of inertia 280kg · cm ² (incl. turntable sheet)
Motor type:	AC servo motor
Speed control method:	Speed servo via frequency detection and phase servo control
Load characteristics:	0% (stylus force 150g, outermost groove) (DP-57L's/DP-62L's) 0% (stylus force 200g, outermost groove) (DP-67L's/DP-72L's)
Brake method:	Electronic brake
Speed deviation:	less than 0.002%

Tonearm

Type:	Static balance type tonearm with electronic damping mechanism (interchangeable tube section)
Effective length:	244mm
Overhang:	14mm
Tracking error:	within 2.5°
Stylus force range:	0 – 3g (1g per 1 rotation, 1 scale = 0.1g)
Suitable cartridge weight range:	approx. 4 – 15g (using the straight type arm tube, incl. screws, nuts) approx. 11 – 20g (using the S-type arm tube, incl. headshell, screws, nuts)
Head connector:	Standard 4P connector (S-type arm tube)
Arm height adjustment range:	approx. 5mm (DP-57L's/DP-62L's) approx. 6mm (DP-67L's/DP-72L's)
Output cable:	Low capacitance type
Arm lifter:	Servo control via the angular control motor (Cueing device)

General

Power supply:	50Hz/60Hz compatible. The rated voltage is indicated on the rating label at the rear of cabinet.
Power consumption:	15W
Dimensions:	485 x 185 x 410mm (W x H x D) (DP-57L's/DP-62L's) 19.1 x 7.3 x 16.1 in 485 x 195 x 410mm (W x H x D) (DP-67L's/DP-72L's) 19.1 x 7.7 x 16.1 in (dust cover closed)
Weight:	11.5 kg 25.4 lb (DP-57L's/DP-62L's) 15 kg 33 lb (DP-67L's/DP-72L's)



* For product improvement purposes, the above specifications are subject to change without notice.

NAMES OF PARTS AND FUNCTION

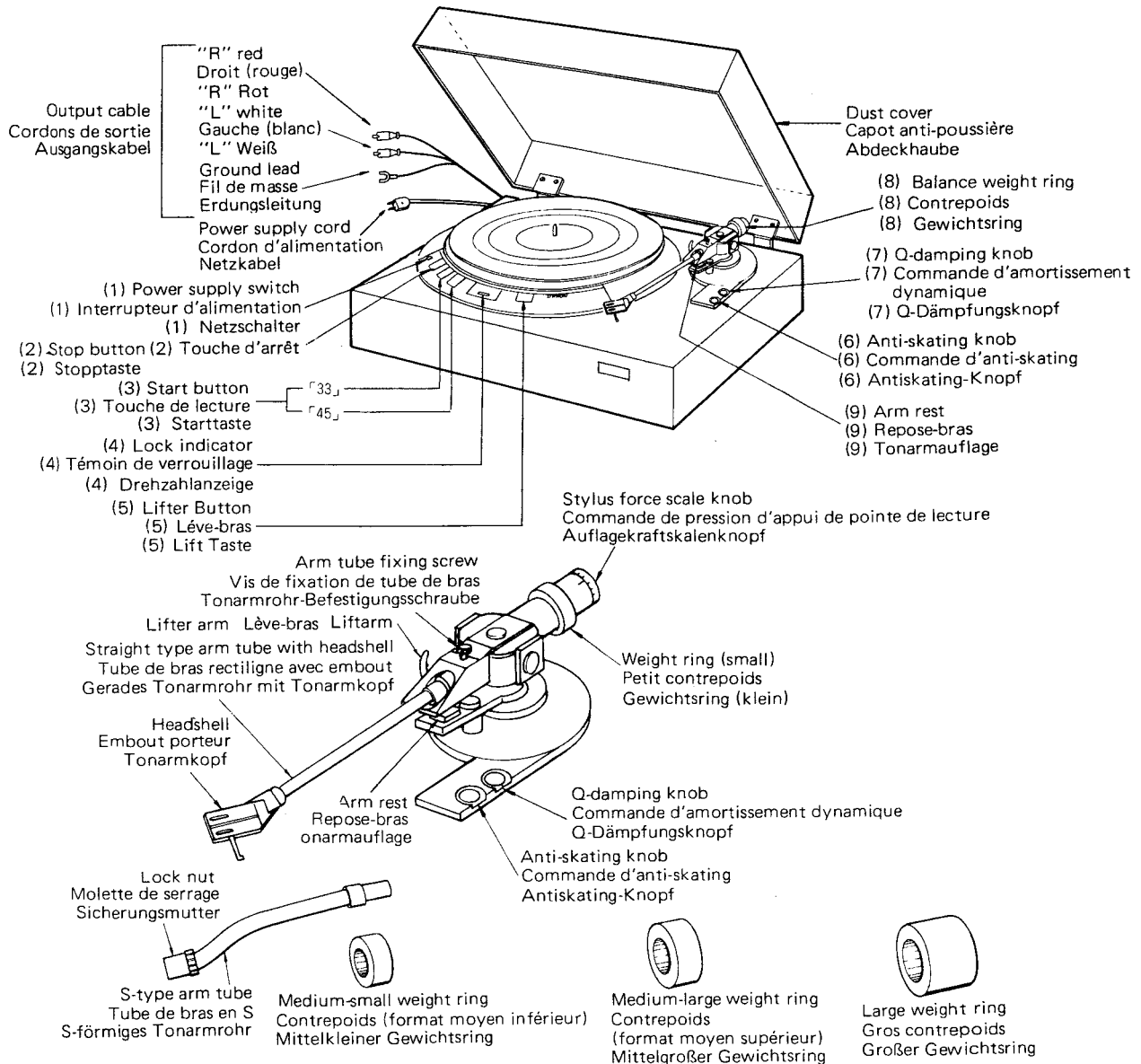
(DP-67L's/DP-72L's)



1. Power switch

When the switch is pressed (ON ) , the power is turned ON and the stop button will light. When the switch is pressed again (OFF ) , the power is turned OFF and the lamp is turned OFF. If the power switch is turned ON () while the arm lifter is lowered, the tonearm will rise.

2. Stop button

When this button is pressed, the lifter button lamp is turned OFF. The arm lifter rises and after a short pause, the "33" or "45" button lamp is turned OFF, the stop button lamp will light and the turntable will then stop.

3. Start button 33 START 45

Press "33" for 33-1/3 rpm records, "45" for 45 rpm records.

When the start button is pressed, the button lamp will light and the turntable will start to rotate.

The lifter button will light and the arm lifter is lowered.

4. Lock indicator

The lock indicator will light when the turntable speed reaches the specified phase-lock state. It flickers when the turntable speed is in transition, such as when stopping, starting or changing speeds. It remains off during stop.

(DP-57L's/DP-62L's)

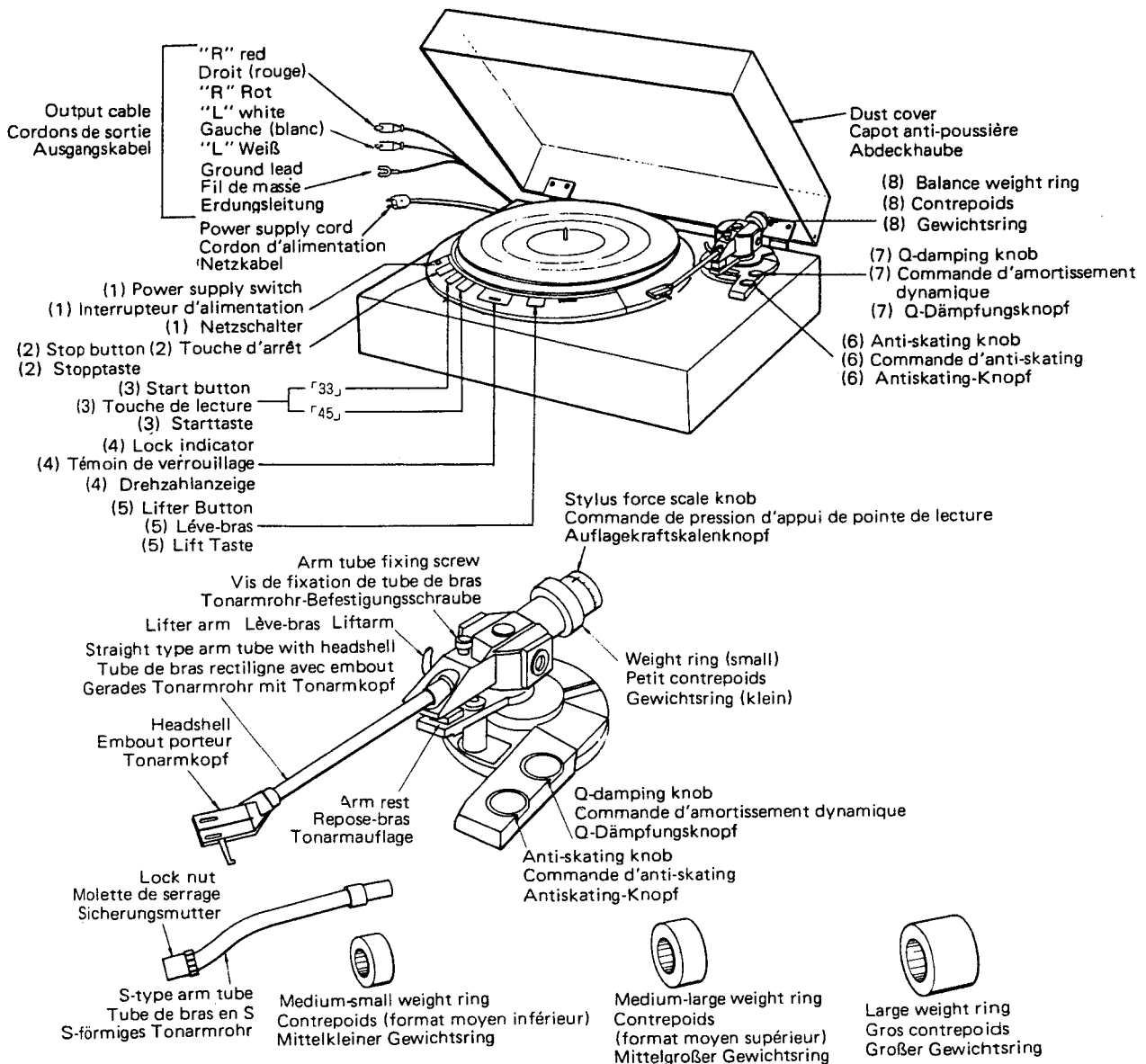

5. Lifter up/down (cueing) button

Each time the button is pressed, the arm lifter moves up/down. The lamp will light when the lifter is down.

6. Anti-skating knob

When a record is being played, a force which pulls the stylus towards the center of the turntable is generated. This force is compensated for by adjusting the Anti-skating knob.

7. Q damping knob

The recommended amount of Q damping can be achieved by setting the Q damping knob to the same value as the stylus force.

8. Weight ring

Use this ring to obtain zero balance of the tonearm.

9. Arm rest

By holding the finger grip of the headshell and moving it to the left, the tonearm lock is disengaged. When locking the tonearm, push it in the opposite direction.

BLOCK DIAGRAM

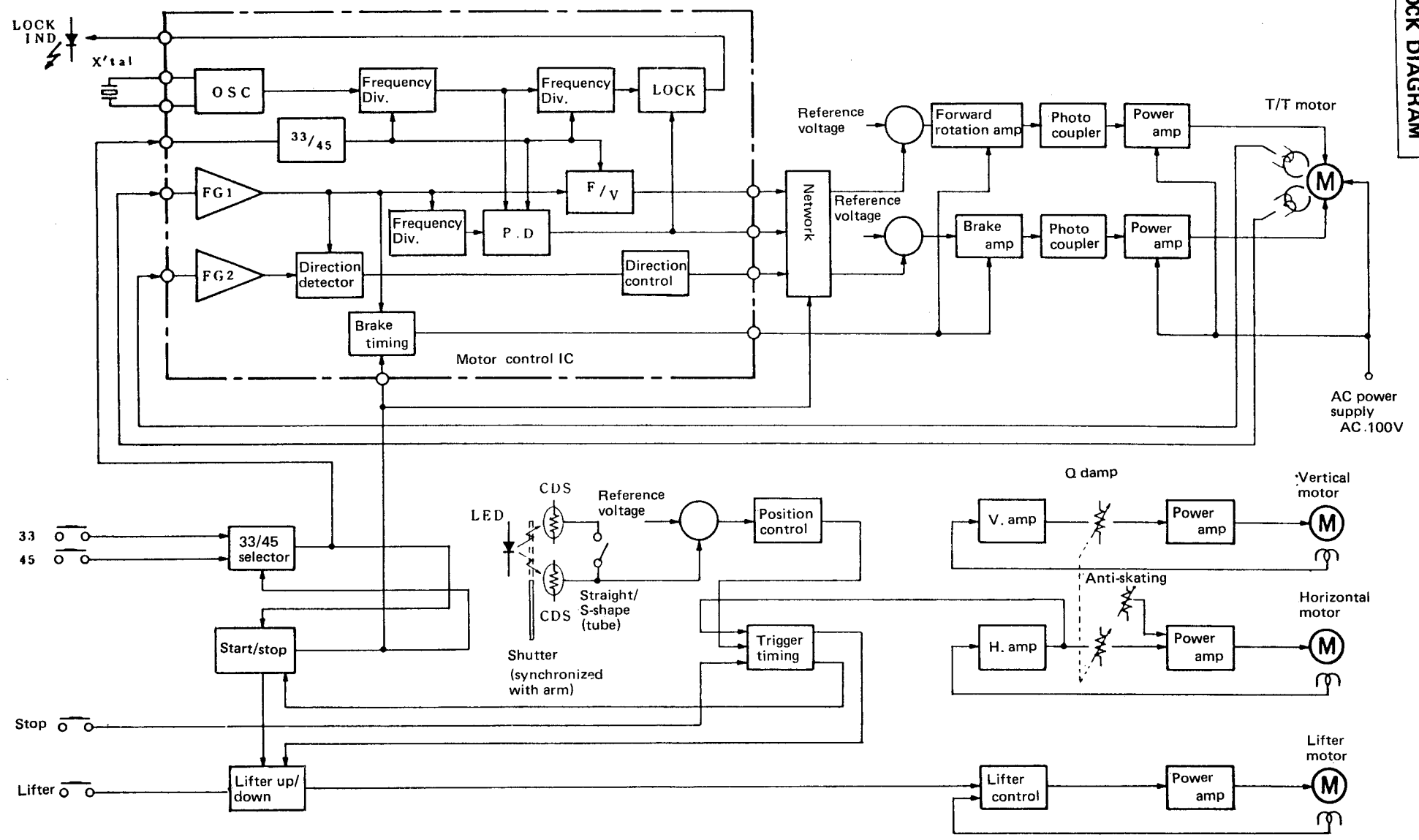

EXPLANATION OF THE MICROPROCESSOR

● Motor Control IC . . . IR3T02 (at standard revolution of 33 rpm)

The numbers on the left hand side indicates the terminal number.

2. 4.5MHz OSC

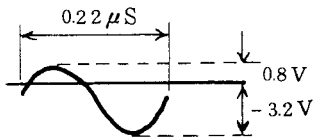

3. 4.5MHz OSC

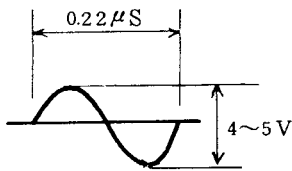

4. rpm selector

H: 45 rpm
L: 33 rpm

5. power source input

V_{cc} : 5V \pm 0.5V

6. FG I bypass terminal

$E6 \doteq \frac{1}{2}V_{cc}$

7. FG I lowpass terminal

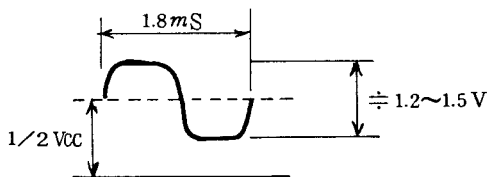

8. FG I output

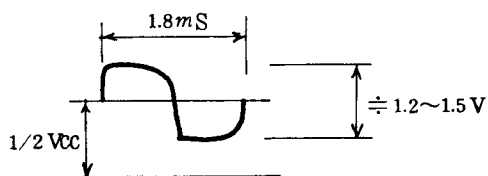

9. FG I inverse input

The gain set element is connected.
 $E9 \doteq \frac{1}{2}V_{cc}$

10. FG I non-inverse input

10mVpp \sim 100mVpp
 $E10 \doteq \frac{1}{2}V_{cc}$

11. FG II non-inverse input

10mVpp \sim 100mVpp
 $E11 \doteq \frac{1}{2}V_{cc}$

12. FG II inverse input

The gain set element is connected.
 $E12 \doteq \frac{1}{2}V_{cc}$

13. FG II output

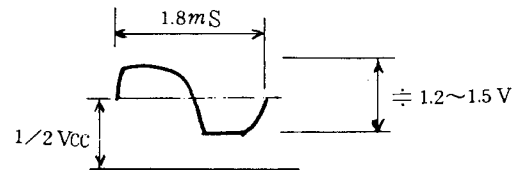

14. ground terminal

15. F/V output

slower than normal revolution: 1.8 \sim 4.5V
normal revolution: \doteq 1.8V
faster than normal revolution: 0 \sim 1.8V

16. F/V hold terminal

same as terminal 15

17. F/V triangular wave

slower than normal revolution

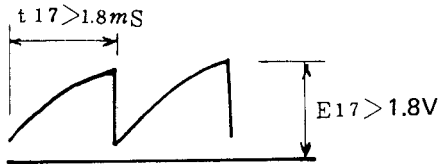

normal revolution

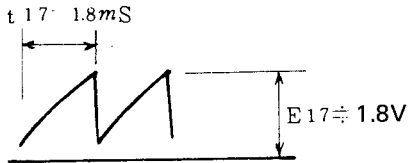

faster than normal revolution

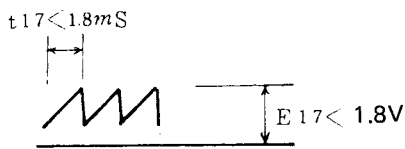

18. timing pulse width-set terminal

$E_{18} \approx 0.6V$

19. PD triangular wave

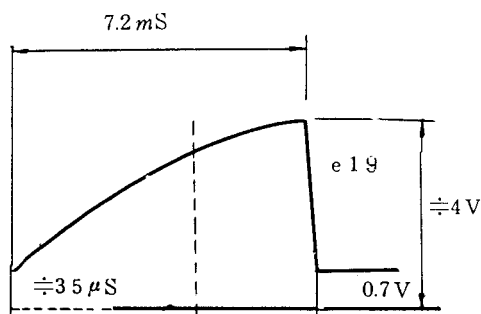

20. sample pulse monitor terminal

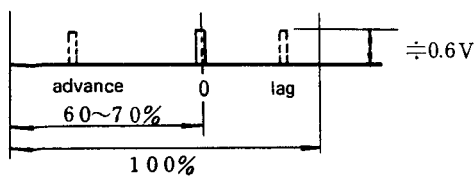

21. PD hold terminal

slow phase: 1.8 ~ 4V
 normal phase: $\approx 1.8V$
 advanced phase: 1 ~ 1.8V

22. PD output

same as terminal 21

23. Lock detector time set terminal

during lock: 0.6V
 lock disengaged: 0V

24. Direction detector output

normal revolution: 0V
 reverse revolution: $\approx 4V$

25. Revolution detector

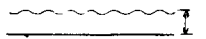
during revolution:  $\approx 4V$

stop: 0V

26. START/STOP terminal

H \rightarrow START
 L \rightarrow STOP

27. Stop output

during stop control: 0V
 during start: open

28. Lock indicator

during lock (LED lit dimly)

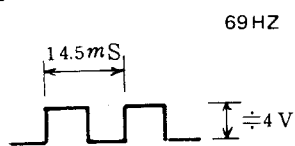

stop (LED lit)

during transition . . (LED flashes)

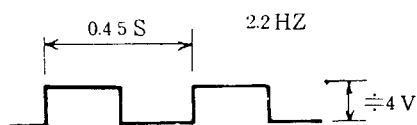

ADJUSTMENT METHOD

• PHONO MOTOR ADJUSTMENT

1. Speed Adjustment

- 1) Connect TP1 and TP2 to CH1 and CH2 terminals and connect TP4 to the ground terminal when using the dual trace oscilloscope.
- 2) Set the turntable speed to 45 position. Adjust the TP1 pulse to stop at a position of between 60% and 70% of the TP2 triangle wave cycle with VR2. (Refer to Fig.1)
- 3) Set the turntable to 33 position. Adjust in the same way as above with VR1.

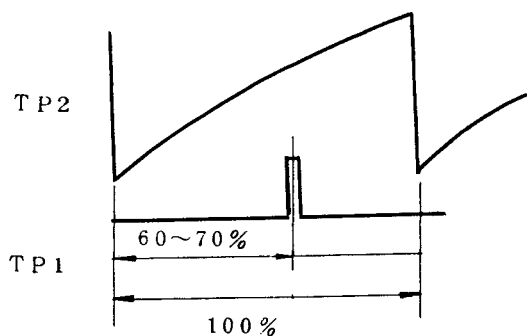

(Fig. 1)

• TONEARM CONTROL ADJUSTMENT

1. Horizontal Amp Off-set Voltage Adjustment

- 1) Fix the tonearm to the arm rest. Connect the high input resistance DC voltmeter (tester) between TP3 and TP4.
- 2) Adjust the voltage to $0 \pm 0.01V$ with VR3.

2. Lifter Amp Off-set Voltage Adjustment

- 1) Connect the DC voltmeter (tester) to TP303 and TP304 while short circuiting the test points TP302 and TP304.
- 2) Adjust the voltage to $0 \pm 0.1V$ with VR301.

3. End Detecting Position Adjustment

- 1) Fix the stylus point at a position 60 mm from the center spindle by using the straight arm.
- 2) Connect the DC voltmeter (tester) to the test points TP301 and TP304.
- 3) Adjust the voltage to $1.55 \pm 0.05V$ by adjusting the cam with a flat headed screwdriver. The cam adjustment hole is located at the back of the arm base. (Refer to Fig. 2)

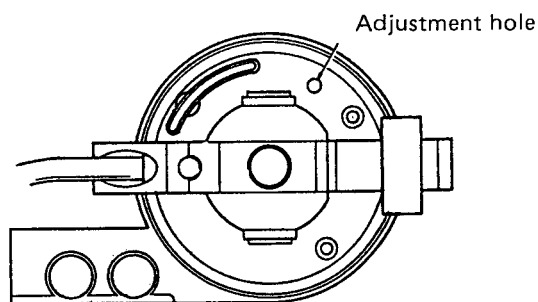

(Fig. 2)

NOTE:

1. Be sure not to interfere with the function of any parts when connecting the measuring instrument for adjusting. Check that there is no loading resistance or loading capacity problem. Refer to the following example for the exact measuring technique.
2. While adjusting or measuring the detecting positions, close the bottomplate or cover the unit with a black cloth or paper so that no light enters. Also when adjusting the speed detector, be sure no magnetic sources are near and that there are no vibrations.

*** Speed Adjustment**

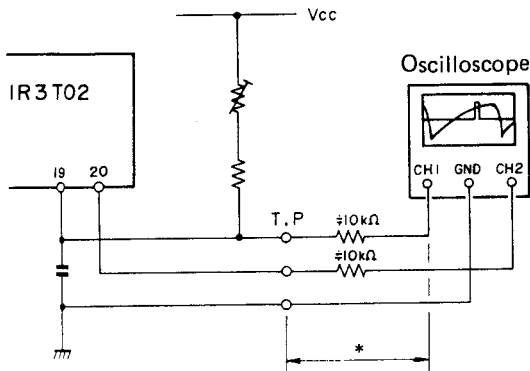

* Keep the wire as short as possible. If it is long, connect the resistors in series.

WARNING:

1. Component parts

Parts marked with \triangle and/or shading in this service manual have special characteristics important to safety. Be sure to use the specified parts for replacement.

2. Leakage current

Before returning the appliance to customer, test the leakage current when the power plug is connected. Use a calibrated (with an error of not more than 5%) leakage current tester and measure the leakage current from any exposed metal to the earth ground. Reverse the power plug polarity and test the above again.

Any current measured **MUST NOT EXCEED 0.5 milliamps**. Corrective measure must be taken if it exceeds the limit.

*** Off-set Voltage Measurement**

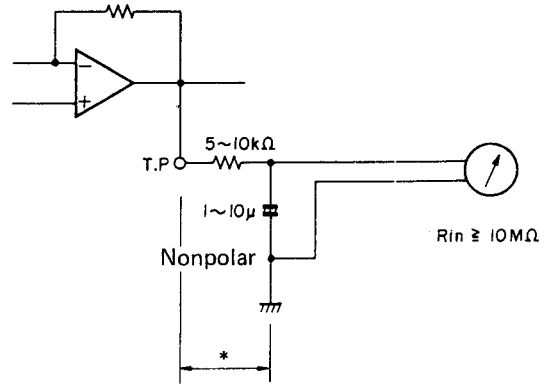

* This distance should be as short as possible.

*** FG Signal Check or Wow/Flutter Measurement**

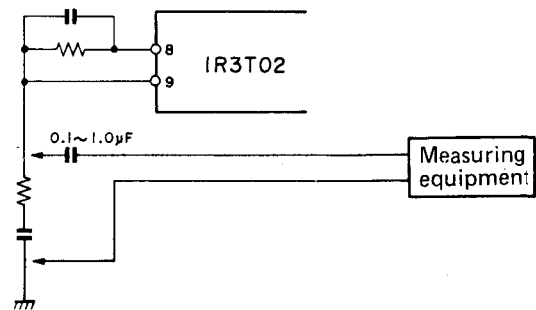

PARTS LIST OF P.W. BOARD

KU-4650/4680/5040/5050 MOTOR SERVO UNIT

Ref. No.	Part No.	Part Name	Remarks
SEMICONDUCTOR GROUP			
IC3	2620416001	HD7406P	
IC1	2630173004	IR3T02	
IC4	2630189001	M5218L	
IC2, 5	2630161003	μPC358C	
IC6	2630147001	μPC78M05H	
IC7	2630160004	μPC7905H	
TR31	2710141037	2SA768(Y,G)	
TR2, 15	2710102005	2SA1015(Y)	
TR3, 4	2710159003	2SA1156(M,L,K)	
TR17, 19	2720046009	2SB561(C)	
TR8~10,12	2720025004	2SB562(C)	
TR1,7,14,22	2730198002	2SC1815(Y)	
TR30	2730276021	2SC1826(Y,G)	
TR5, 6	2730196004	2SC2023(Z)	
TR16, 18	2740038000	2SD467(C)	
D1~8	2760049008	1S2076TD	
11~20			
23~25			
28~30			
D44, 45	2760237001	RV06	
52~55			
D48~51	2760237001	RV06	
D9, 10	2760057029	V06E	
D56, 57	2760280003	RB154	
PC1, 2	3939027012	PC613G	
CDS1, 2	3939053028	CDS (10~15KΩ)	
LED1	3939174004	LED (LN0202RP2)	
LED2	3939041001	LED	
RESISTOR GROUP			
R22	2452147001	RN14K2E330G	Metal film 33Ω ¼W
R21	2452189001	RN14K2E182G	1.8KΩ ¼W
R23	2452195008	RN14K2E332G	3.3KΩ ¼W
R18	2452207006	RN14K2E103G	10KΩ ¼W
R17	2452223006	RN14K2E473G	47KΩ ¼W
R37, 42	2440005029	RS14B3A010JNBF	1Ω 1W
R114, 115	2440035028	RS14B3A331JNBF	330Ω 1W
			Variable Resistor
VR6	2118054014	V1620V25KB102B102	1KΩ Bx2
VR7	2118073008	V16V25KB102	1kΩ B
VR1~3	2116019035	K08PB203	20KΩ B
CAPACITOR GROUP			
C10, 11	2533619005	CC45SL1H470J	Ceramic 47PF 50V
C9, 51	2533627000	CC45SL1H101J	100PF 50V
C1, 4	2533637003	CC45SL1H271J	270PF 50V
C25, 26	2531002009	CK45B1H471K	470PF 50V
C24, 31~34	2531008003	CK45B1H472K	4700PF 50V
66			
C18, 35, 49	2531027000	CK45F1H104Z	0.1μF 50V
55, 56			
C68, 69	2538004000	CK45=2BAC102P	0.001μF AC125V
			Electrolitic
C30	2544130007	CE04W1A101=	100μF 10V
C10, 16, 17	2544132005	CE04W1C100=	10μF 16V
36, 39, 47			
48, 57~60			
C40, 43	2544135002	CE04W1C470=	47μF 16V
C65	2544136001	CE04W1C101=	100μF 16V

Ref. No.	Part No.	Part Name	Remarks
C61, 62	2544138009	CE04W1E470=	47μF 25V
C64	2544032008	CE04W1E102=	1000μF 25V
C63	2544086009	CE04W1E222=	2200μF 25V
C46	2544140000	CE04W1V4R7=	4.7μF 35V
C20	2544145005	CE04W1HR47=	0.47μF 50V
C2, 3, 5	2544146004	CE04W1H010=	1μF 50V
7, 8, 45			
C21, 44	2544147003	CE04W1H2R2=	2.2μF 50V Film
C6	2551068007	CQ93M1H472K	0.0047μF 50V
C12, 15, 22	2551072006	CQ93M1H103K	0.01μF 50V
23, 38			
C37, 41	2551121054	CQ93M1H183J	0.018μF 50V
C14, 42	2551122008	CQ93M1H473J	0.047μF 50V
C13	2554194017	CQ93P1H473J	0.047μF 50V
C70	2558000092	CE04W1C100=	0.1μF AC160V EU only
C67	2558000039	CQ93P2CAC103M	0.01μF AC160V
C29	2568013090	CF99-25AC505J	5μF AC200V EU
C29	2568013091	CF99-25AC505J	5μF AC200V E2,EK,EG,E1
OTHER PARTS GROUP			
	4418764109	LED HOLDER	
	3998023002	CRYSTAL (4.5MHz)	
	4178028101	HEAT SINK	
	4178020439	HEAT SINK	EU, E1
	4178020400	HEAT SINK	E2, EK, EG
	FEP0429K	SPARK KILLER	
SK1	2061018013	FUSE (1.25A)	EU
F1	2398001007	LINE FILTER	EU
L1		COIL	
	EE-1656	BASE TERMINAL	EU
	2124237003	TACT SWITCH	
	3930047033	PILOT LAMP	GREEN
	3930047046	PILOT LAMP	WHITE
	FEP12802	3P MINI CONNE.	
		PIN	
	2035622024	4P MINI CONNE.	
		PIN	

• The carbon resistors rated at ¼W are not listed herein.

Remark symbols in the parts list refer to the following countries and areas.

- EK: United Kingdom
- EU: U.S.A.
- E1: Multiple voltage model
- E2: European continent
- EG: German

DP-57L/67L	E2,EK,EG	..	KU-4650
DP-57L/67L	E1	..	KU-5050
DP-62L	EU	..	KU-4680
DP-72L	EU	..	KU-5040

KU-4590 LIFTER SERVO UNIT

Ref. No.	Part No.	Part Name	Remarks
SEMICONDUCTOR GROUP			
IC301,302	2630161003	μPC358C	
TR304	2710102005	2SA1015(Y)	
TR303	2720025004	2SB562(C)	
TR301	2730198002	2SC1815(Y)	
305~308			
TR302	2740036002	2SD468(C)	
D301~308	2760049008	1S2076	
310~312			
RESISTOR GROUP			
VR301	2116019035	K08PB203	Variable resistor 20KΩ B
CAPACITOR GROUP			
C306	2531008003	CK45B1H472K	Ceramic 0.0047μF 50V
C312	2531025002	CK45F1H223Z	0.022μF 50V
			Electrolitic
C301, 305	2544132005	CE04W1C100=	10μF 16V
C311	2544133004	CE04W1C220=	22μF 16V
C302	2544131006	CE04W1A221=	220μF 10V Film
C303, 304	2551080001	CQ93M1H473K	0.047μF 50V
307~310			
OTHER PARTS GROUP			
	2035622024	4P MINI CONNE.	
		PIN	

• The carbon resistors rated at ¼W are not listed herein.

ACCESSORIES GROUP

Ref. No.	Part No.	Part Name	Remarks
	5298006002	45 ADAPTOR	
	4218094040	RUBBER SHEET	
	5118229105	INSTRUCTION MANUAL	DP-57L/62L
	5118242001	INSTRUCTION MANUAL	DP-67L/72L
	5158053001	WARRANTY CARD	EU only
	5298004004	MINI DRIVER	
	3158547001	SHELL ACCESSORY ASS'Y	
	3158239021	HEAD SHELL ASS'Y	EU only
	2033667007	PLUG ADAPTOR	E1 only

PS-1670 POWER SUPPLY UNIT

Ref. No.	Part No.	Part Name	Remarks
RESISTOR GROUP			
RDC	2410765001	RD14B2E105J	Carbon film 1MΩ ¼W
RSK	2410163001	RD14B2H121J	120Ω ¼W
CAPACITOR GROUP			
C1	2558002008	CQ93P2EAC103M	Film 0.01μF 250VAC
C2	2558002011	CQ93P2EAC223M	0.022μF 250VAC
C3	2558002024	CQ93P2EAC333M	0.033μF 250VAC
OTHER PARTS GROUP			
	EE-1656	BASE TERMINAL	
	2061015029	FUSE	1A/250V
	FEP1287	FUSE CLIP	
	2050087042	4P TERMINAL	
	2050087026	2P TERMINAL	

PS-1680 POWER SUPPLY UNIT

Ref. No.	Part No.	Part Name	Remarks
RESISTOR GROUP			
RDC	2410765001	RD14B2E105J	Carbon film 1MΩ ¼W
RSK	2410163001	RD14B2H121J	120Ω ¼W
CAPACITOR GROUP			
C1	2558002008	CQ93P2EAC103M	Film 0.01μF 250VAC
C2, 3	2558002024	CQ93P2EAC333M	0.033μF 250VAC
OTHER PARTS GROUP			
	EE-1656	BASE TERMINAL	
	EP-72663	FUSE	1A/250V
	2050087042	4P TERMINAL	
	2050087026	2P TERMINAL	

WARNING:

Parts marked with and/or shading have special characteristics important to safety. Be sure to use the specified parts for replacement.

PACKING GROUP

Ref. No.	Part No.	Part Name	Remarks
	5018299002	CARTON CASE ASS'Y	DP-57L/62L EU
	5018282006	CARTON CASE ASS'Y	DP-57L/62L E2,EK,EG,E1
	5018303008	CARTON CASE ASS'Y	DP-67L/72L EU
	5018301000	CARTON CASE ASS'Y	DP-67L/72L E2,EK,EG,E1
	5058093103	PACKING ASS'Y	
	5038040008	ARM PAD	
	5058092007	LAMINATE ENVELOPE	600x700
	5058017011	ENVELOPE	60x260
	5058006006	ENVELOPE	60x100
	5058023008	ENVELOPE	350x640

EXPLODED VIEW OF MAIN PARTS

MODEL DP-57L/62L

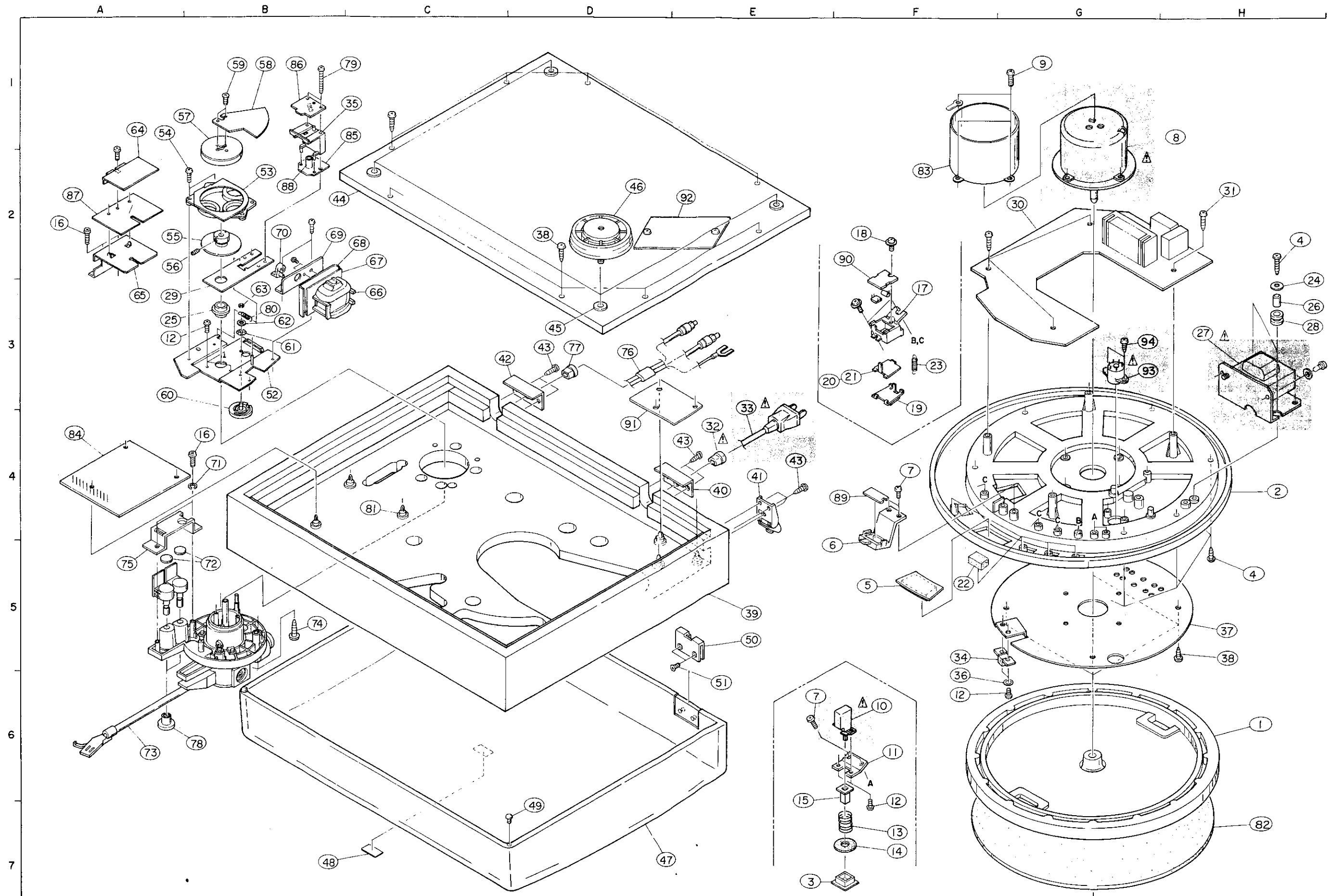

PARTS LIST OF EXPLODED VIEW

(MODEL DP-57L/62L)

Ref. No.	Part No.	Part Name	Remarks
1	4218317002	RECORDED TURNTABLE	
2	1468143320	FRAME	EU
	1468143304	FRAME	E2,EK,EG,E1
3	1148013000	KNOB GUIDE	
4	4730309019	3x20 CBTS (1)	
5	1468148008	WINDOW	
6	4498063202	LED HOLDER	
7	4730305013	3x10 CBRTS (1)	
⚠	8	2178078001 MOTOR ASS'Y	
	9	4713308011 3x14 GBS	
⚠	10	2129136028 POWER SWITCH	EU
		2129136015 POWER SWITCH	E2,EK,EG,E1
11	4418532108	POWER SW BRACKET	
12	4713303016	3x6 CBS	
13	4638606005	SPRING	
14	4618094006	CUSHION	
15	1138100101	PUSH KNOB	
16	4730340014	3x8 CBRTS	
17	4498062106	SW HOLDER	
18	4700028003	3x12 CBRTSW	
19	1138148202	KNOB	
20	1138149308	KNOB PLATE	
21	1138149311	KNOB PLATE	
22	5028098002	PAD	
23	4638009000	2F COIL SPRING	
24	WA01074	WASHER	
25	4358022008	COLLAR	
26	4438158067	COLLAR	
⚠	27	2339066001 POWER TRANS	EU
		2339063004 POWER TRANS	E2, EK, EG
		2339069008 POWER TRANS	E1
28	4620027003	RUBBER BUSH	
29	4418938207	SENSOR PLATE	
30	KU-4680	MOTOR SERVO AMP	EU
	KU-4650	MOTOR SERVO AMP	E2, EK, EG
	KU-5050	MOTOR SERVO AMP	E1
31	4730356017	3x12 CRTS	
⚠	32	MD-3802 BUSHING	EU, E1
		4450020005 BUSHING	E2, EK, EG
⚠	33	2062019008 AC CORD	EU
		2062002031 AC CORD	E2, EG
		2062024006 AC CORD	EK
		2006031026 AC CORD	E1
34	3918425004	MAGNETIC HEAD ASS'Y	
35	4468100205	SENSOR HOLDER	
36	4751003006	3W	
37	4118312301	SHIELD PLATE	EU,E2,EK,EG
	4118312314	SHIELD PLATE	E1
38	4733808009	3x25 CBTS (1)	
39	1018351520	CABINET ASS'Y	EU
	1018378105	CABINET ASS'Y	E2, EK, EG
	1018378118	CABINET ASS'Y	E1
40	4418244205	BUSHING PLATE (C)	EU, E1
	4418245000	BUSHING PLATE (D)	E2, EK, EG
41	4018006102	HINGE	
42	4418313204	BUSHING PLATE (E)	
43	4720307034	3x13 CRWS	

Ref. No.	Part No.	Part Name	Remarks
44	1058088303	BOTTOM BOARD	EU
	1058093000	BOTTOM BOARD	E2,EK,EG,E1
45	FSC0102	SPECIAL NUT (A)	
46	1048024403	INSULATOR	
47	1468076031	DUST COVER ASS'Y	
48	FPR0460	DENON MARK	
49	4628006107	BUSHING	
50	FTS0701	HINGE PLATE	
51	4712404055	4x8 CFS	
52	4118316200	ARM CHASSIS	
53	3468136102	COIL ASS'Y	
54	4730812001	3x8 CBTS	
55	4338180009	YOKE (A) ASS'Y	
56	4744200010	3x3 BSS	
57	3418017200	MAGNET ASS'Y	
58	4338191001	SHUTTER	
59	4712304016	3x8 CFS	
60	4248019202	ADJUST CAM	
61	3158451003	FRICTION WASHER	
62	4751005004	4W	
63	4761003009	3E RING	
64	4148173002	SHIELD COVER	
65	4418926206	ARM BRACKET	
66	2178065205	MOTOR (C) ASS'Y	
67	4148170018	PLATE	
68	4148170005	PLATE	
69	4128681006	MOTOR BRACKET	
70	4248021106	LIFTER CAM	
71	4752003005	3SW	
72	4148034002	WASHER	
73	FPU890	TONE ARM UNIT	
74	4733410031	4x20 CBTS (1)	
75	4418947104	VR BRACKET	
76	2033642116	OUTPUT CORD	
77	EP-7376	CORD BUSH	
78	1128077309	KNOB	
79	4713314018	3x35 CBS	
80	4638221008	SPRING	
81	4498041004	C.B LOCKING SUPPORT	
82	4218094040	RUBBER SHEET	
83	4148171004	MOTOR COVER	
84	KU-4590	LIFTER SERVO UNIT	
85		LED P.C.B	10F
86		CDS P.C.B	10B
87		OUTPUT P.C.B	10A
88	4438568107	LED HOLDER	
89		LED P.C.B	10L
90		PUSH SW P.C.B	10G, H, J, K
91	KU-1670	POWER SUPPLY UNIT	E2, EK, EG
	KU-1680	POWER SUPPLY UNIT	E1
92	4128753002	PLATE	E2,EK,EG,E1
93	2123315023	VOLTAGE SELECTOR	E1
94	4730205016	2.6x10 CPTS (1)	E1

WARNING:

Parts marked with ⚠ and/or shading have special characteristics important to safety. Be sure to use the specified parts for replacement.

Remark symbols in the parts list refer to the following countries and areas.

- EU: United Kingdom
- EU: U.S.A.
- E1: Multiple voltage model
- E2: European continent
- EG: German

PARTS LIST OF EXPLODED VIEW (MODEL DP-67L/72L)

Ref. No.	Part No.	Part Name	Remarks
1	4218317002	RECORDED TURNTABLE	
2	4468103215	MOTOR BOARD	EU
	4468103202	MOTOR BOARD	E2, EK, EG
	4468103228	MOTOR BOARD	E1
3	1148013000	KNOB GUIDE	
4	4713411018	4x25 CBS	
5	1468051014	STROBO WINDOW	
6	4418991105	LED SUPPORT	
7	4733800007	3x6 CBTS (2)	
8	2178077002	MOTOR ASS'Y	
9	4713406010	4x12 CBS	
10	2129136015	POWER SW.	
	2129136028	POWER SW.	EU only
11	4418532108	PUSH SW BRACKET	
12	4713303016	3x6 CBS	
13	4638606005	SPRING	
14	4618094006	CUSHION	
15	1138100101	PUSH BUTTON	
16	4733800010	3x8 CBTS (2)	
17	4498065103	SW HOLDER	
18	4700026005	3x8 CBRTS W (2)	
19	1138148202	KNOB	
20	1138149308	KNOB PLATE	
21	1138149311	KNOB PLATE	
22	4700029004	3x10 CBRTS W (2)	
23	4638009000	2F COIL SPRING	
24	4770192008	SPECIAL SCREW	
25	4358022008	COLLAR	
26	4733410031	4x20 CBTS (1)	
27	2339066001	POWER TRANS	EU
	2339063004	POWER TRANS	E2, EK, EG
	2339069008	POWER TRANS	E1
28	4620027003	RUBBER BUSH	
29	4418938207	SENSOR PLATE	
30	KU-5040	MOTOR SERVO AMP UNIT	EU
	KU-5050	MOTOR SERVO AMP UNIT	E1
	KU-4650	MOTOR SERVO AMP UNIT	E2, EK, EG
31	4498046009	C.B.L SUPPORT	
32	MD-3802	BUSHING	EU, E1
	4450020005	BUSHING	E2, EK, EG
33	2062019008	AC CORD	EU
	2062002031	AC CORD	E2, EG
	2062024006	AC CORD	EK
	2006031026	AC CORD	E1
34	3918425004	MAGNETIC HEAD	
35	4468100205	SENSOR HOLDER	
36	4700010011	3x8 CPS W	
37	4148102109	SHIELD PLATE	
	4148126004	SHIELD PLATE	E1 only
38	4733800010	3x8 CBTS (2)	
39	1018396006	CABINET ASS'Y	EU
	1018398004	CABINET ASS'Y	E2, EK, EG
	1018398017	CABINET ASS'Y	E1
40	4418551008	BUSHING PLATE (F)	EU, E1
	4418552007	BUSHING PLATE (G)	E2, EK, EG
41	4018027000	HINGE	

Ref. No.	Part No.	Part Name	Remarks
42	4418584004	BUSHING PLATE (H)	
43	4733309032	3x16 CBTS (1)	
44	1058094009	BOTTOM BOARD	
	1058090100	BOTTOM BOARD	EU only
45	FSC0102	SPECIAL NUT (A)	
46	1048024403	INSULATOR	
47	1468022519	DUST COVER	
48	4733809008	4x35 CBTS (1)	
49	4628006107	BUSHING	
50	FTS0701	HINGE PLATE	
51	4712404055	4x8 CFS	
52	4118316200	ARM CHASSIS	
53	3468136102	COIL ASS'Y	
54	4730356017	3x12 CBRTS (2)	
55	4338180009	YOKE (A) ASS'Y	
56	4744200010	3x3 BSS	
57	3418017800	MAGNET ASS'Y	
58	4338191001	SHUTTER	
59	4712304016	3x8 CFS	
60	4248019202	ADJUST CAM	
61	3158451003	FRICTION WASHER	
62	4751005004	4W	
63	4761003009	3E RING	
64	4148173002	SHIELD COVER	
65	4418926206	ARM BRACKET	
66	2178065205	MOTOR (C) ASS'Y	
67	4148170018	PLATE	
68	4148170005	PLATE	
69	4128681006	MOTOR BRACKET	
70	4248021203	LIFTER CAM	
71	4752003005	3SW	
72	4148034002	WASHER	
73	FPU0870	TO NEARM UNIT	
74	4733410031	4x20 CBTS (1)	
75	4428022200	VR BRACKET	
76	2039616010	OUTPUT CORD	
77	4458024003	CORD BUSH	
78	1128077309	KNOB	
79	4713314018	3x35 CBS	
80	4638221008	SPRING	
81	4498041004	C.B LOCKING SUPPORT	
82	4218094040	RUBBER SHEET	
83	4738170005	3x8 CBTS (2)	
84	KU-0459	LIFTER SERVO UNIT	
85		LED P.C.B	10F
86		CDS P.C.B	10B
87		OUTPUT P.C.B	10A
88	4438568107	LED HOLDER	
89		LED P.C.B	10L
90		PUSH SW P.C.B	10G, H, J, K
91	PS-1670	POWER SUPPLY UNIT	E2, EK, EG
	PS-1680	POWER SUPPLY UNIT	E1
93	2123315023	VOLTAGE SELECTOR	E1 only
94	4713205017	2.6x10 CBS	E1 only

WARNING:

Parts marked with  and/or shading have special characteristics important to safety. Be sure to use the specified parts for replacement.

Remark symbols in the parts list refer to the following countries and areas.

- EK: United Kingdom
- EU: U.S.A.
- E1: Multiple voltage model
- E2: European continent
- EG: German

EXPLODED VIEW OF MAIN PARTS

MODEL DP-67L/72L

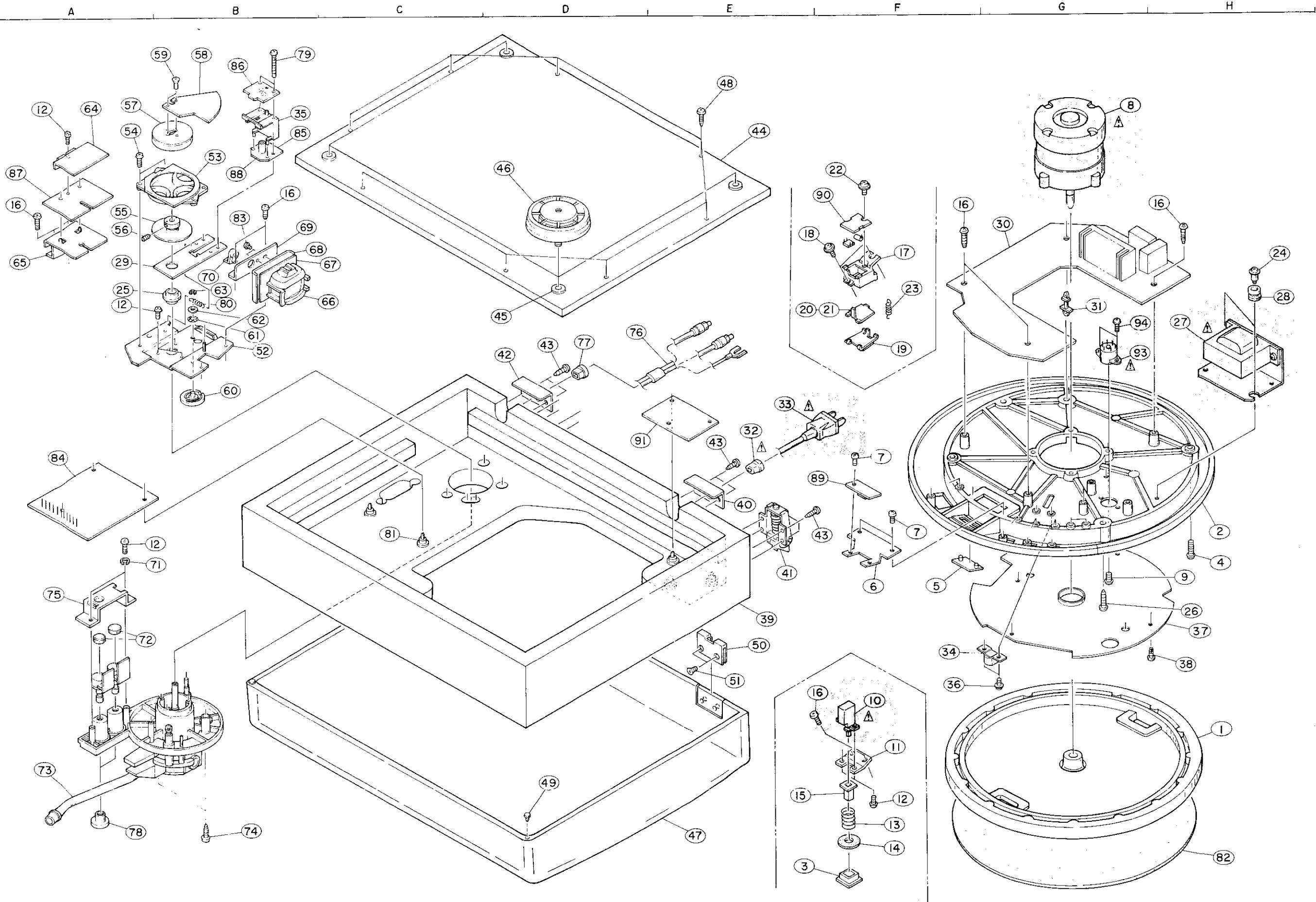

EXPLODED VIEW OF TONEARM

MODEL DP-57L/62L

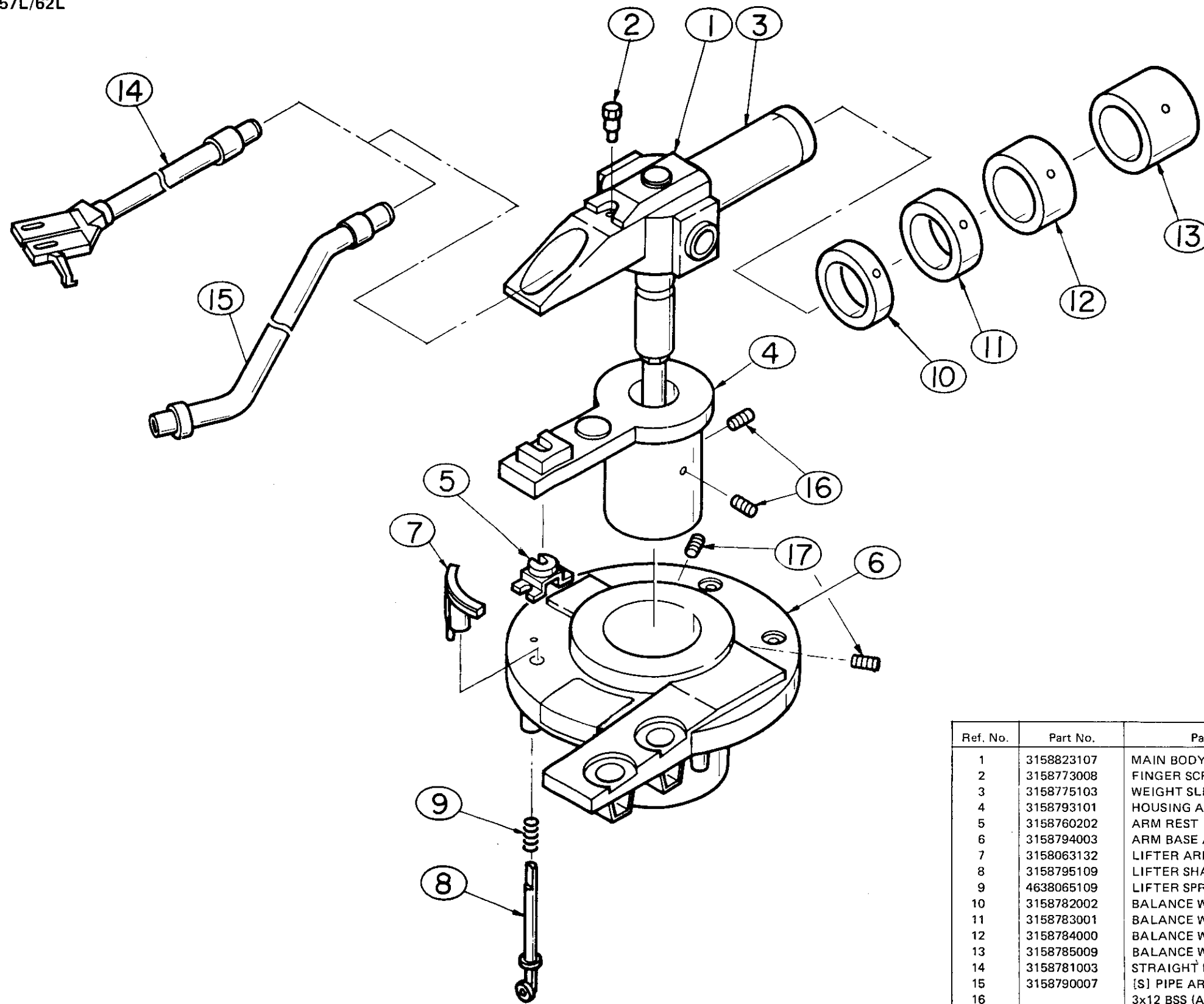

Ref. No.	Part No.	Part Name
1	3158823107	MAIN BODY ASS'Y
2	3158773008	FINGER SCREW
3	3158775103	WEIGHT SLEEVE ASS'Y
4	3158793101	HOUSING ASS'Y
5	3158760202	ARM REST
6	3158794003	ARM BASE ASS'Y
7	3158063132	LIFTER ARM ASS'Y
8	3158795109	LIFTER SHAFT ASS'Y
9	4638065109	LIFTER SPRING
10	3158782002	BALANCE WEIGHT(V) ASS'Y
11	3158783001	BALANCE WEIGHT (VI)
12	3158784000	BALANCE WEIGHT (VII)
13	3158785009	BALANCE WEIGHT (VIII)
14	3158781003	STRAIGHT PIPE ASS'Y
15	3158790007	[S] PIPE ARM ASS'Y
16		3x12 BSS (A)
17		4x16 SS (A)

EXPLODED VIEW OF TONEARM

MODEL DP-67L/72L

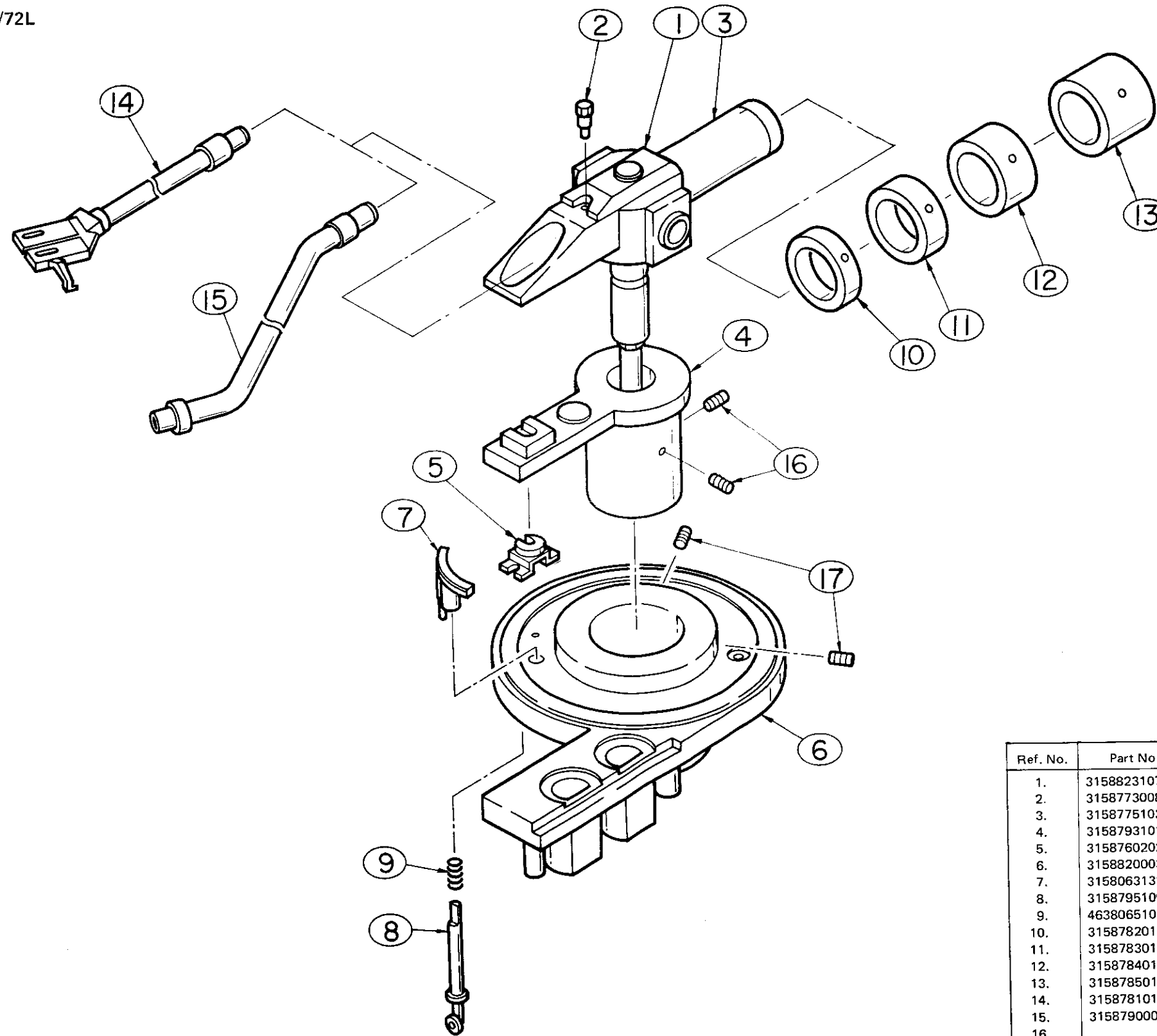

Ref. No.	Part No.	Part Name
1.	3158823107	MAIN BODY ASS'Y
2.	3158773008	FINGER SCREW
3.	3158775103	WEIGHT SLEEVE ASS'Y
4.	3158793101	HOUSING ASS'Y
5.	3158760202	ARM REST
6.	3158820003	ARM BASE ASS'Y
7.	3158063132	LIFTER ARM ASS'Y
8.	3158795109	LIFTER SHAFT ASS'Y
9.	4638065109	LIFTER SPRING
10.	3158782015	BALANCE WEIGHT(V)ASS'Y
11.	3158783014	BALANCE WEIGHT (VI)
12.	3158784013	BALANCE WEIGHT (VII)
13.	3158785012	BALANCE WEIGHT (VIII)
14.	3158781016	STRAIGHT PIPE ASS'Y
15.	3158790007	[S] PIPE ARM ASS'Y
16.		3x12 BSS (A)
17.		4x16 SS (A)

CONNECTIONS OF P.W. BOARD

MODEL DP-57L/67L

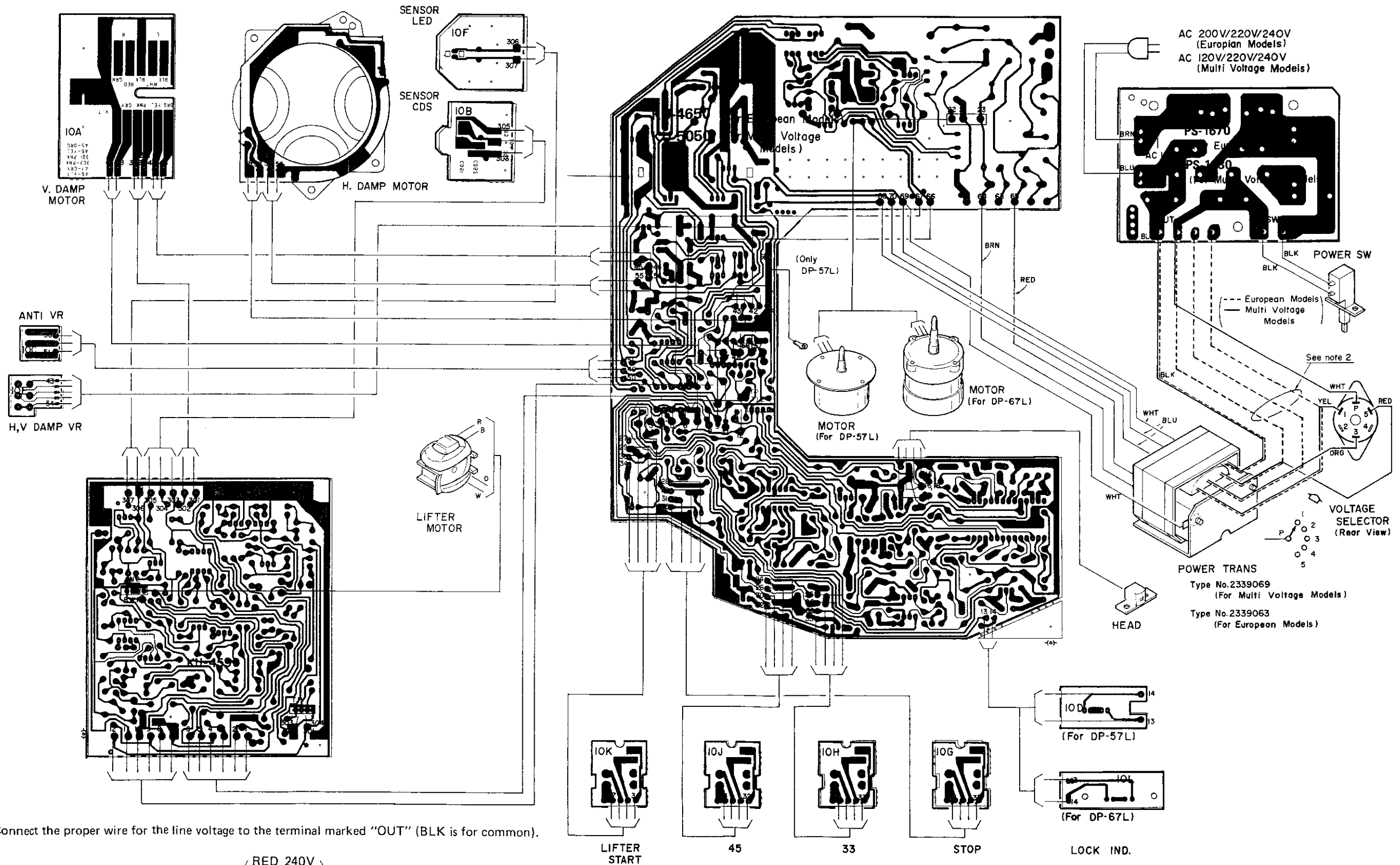

Note: Connect the proper wire for the line voltage to the terminal marked "OUT" (BLK is for common).

(RED 240V)
(ORG 220V)
(YEL 200V)

Pri. wire color of European Models.

SCHEMATIC DIAGRAM OF DP-57L/67L

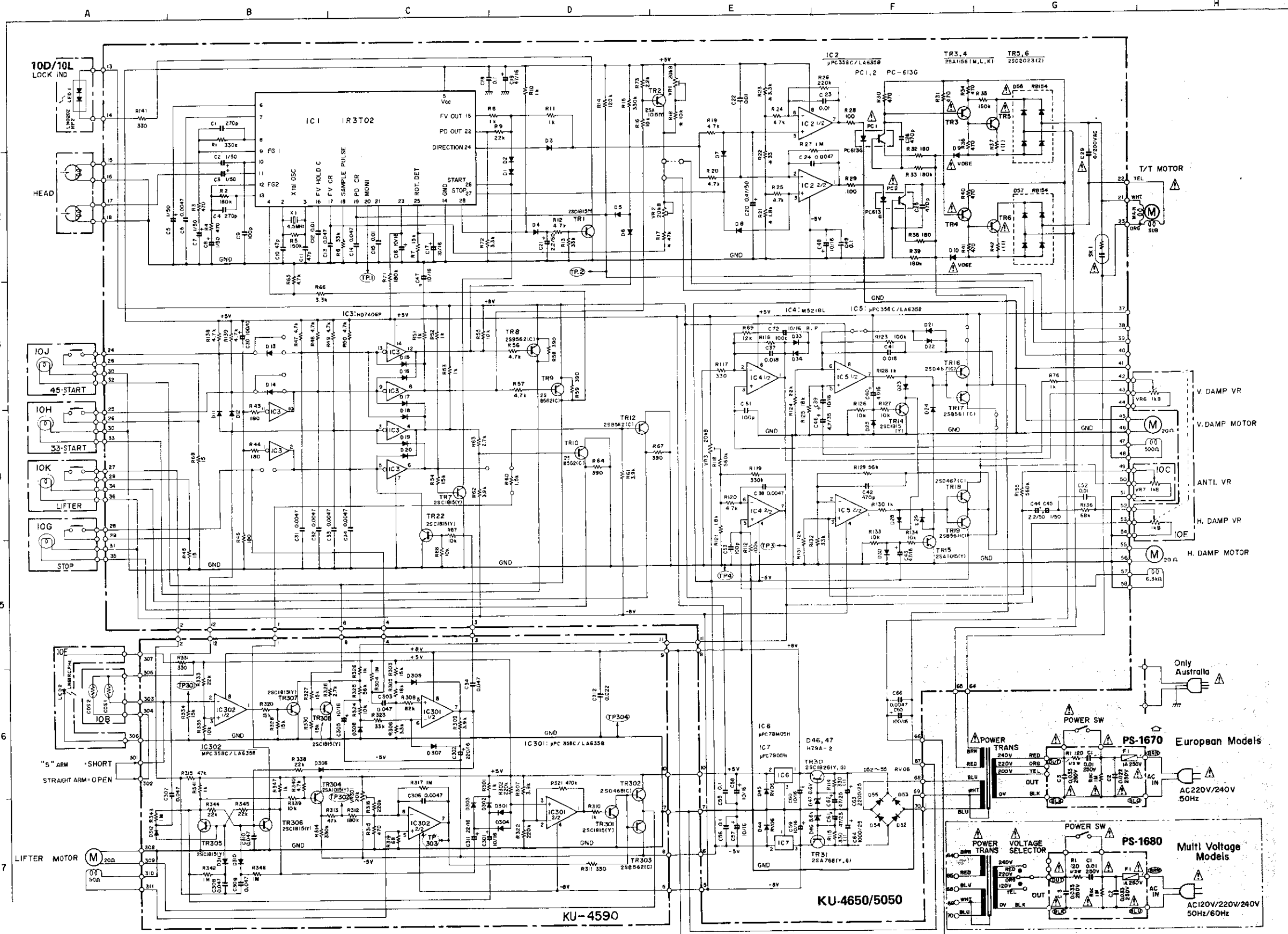

- (Note)
1. Resistors are in Ω . All the resistors without remarks are $\frac{1}{4}W$.
 2. All the capacitors without remarks are in μF . All the capacitors marked p are in pF.
 3. Specified components should be used for parts with "*" marks. (Temperature compensating parts)
 4. All parts and components with " Δ " marks have special characteristics important to safety. Be sure to use the specified parts.
 5. This circuit diagram shows the basic circuit. It is subject to change for the purpose of improvement.

CONNECTIONS OF P.W. BOARD

MODEL DP-62L/72L

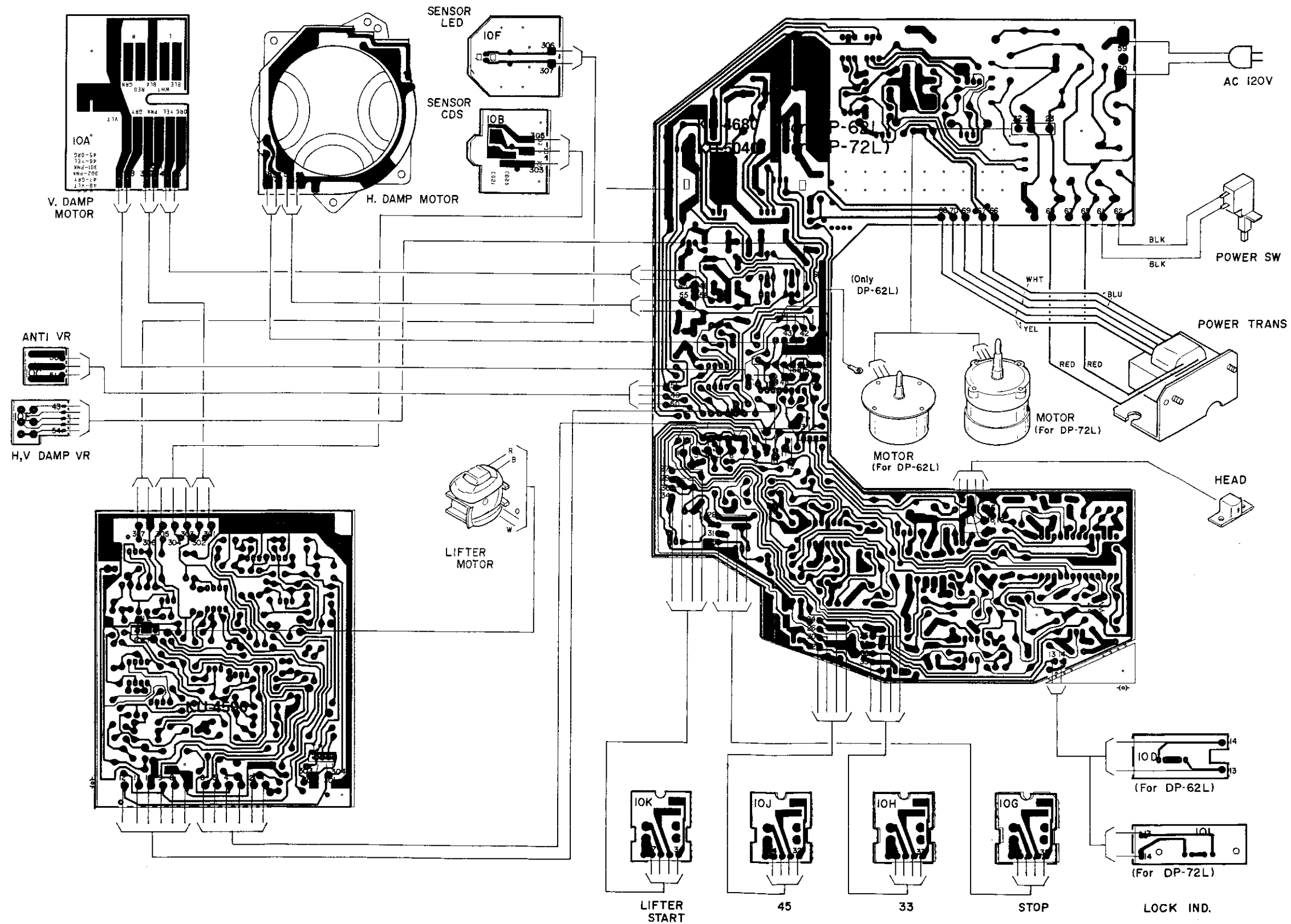

SCHEMATIC DIAGRAM OF DP-62L/72L

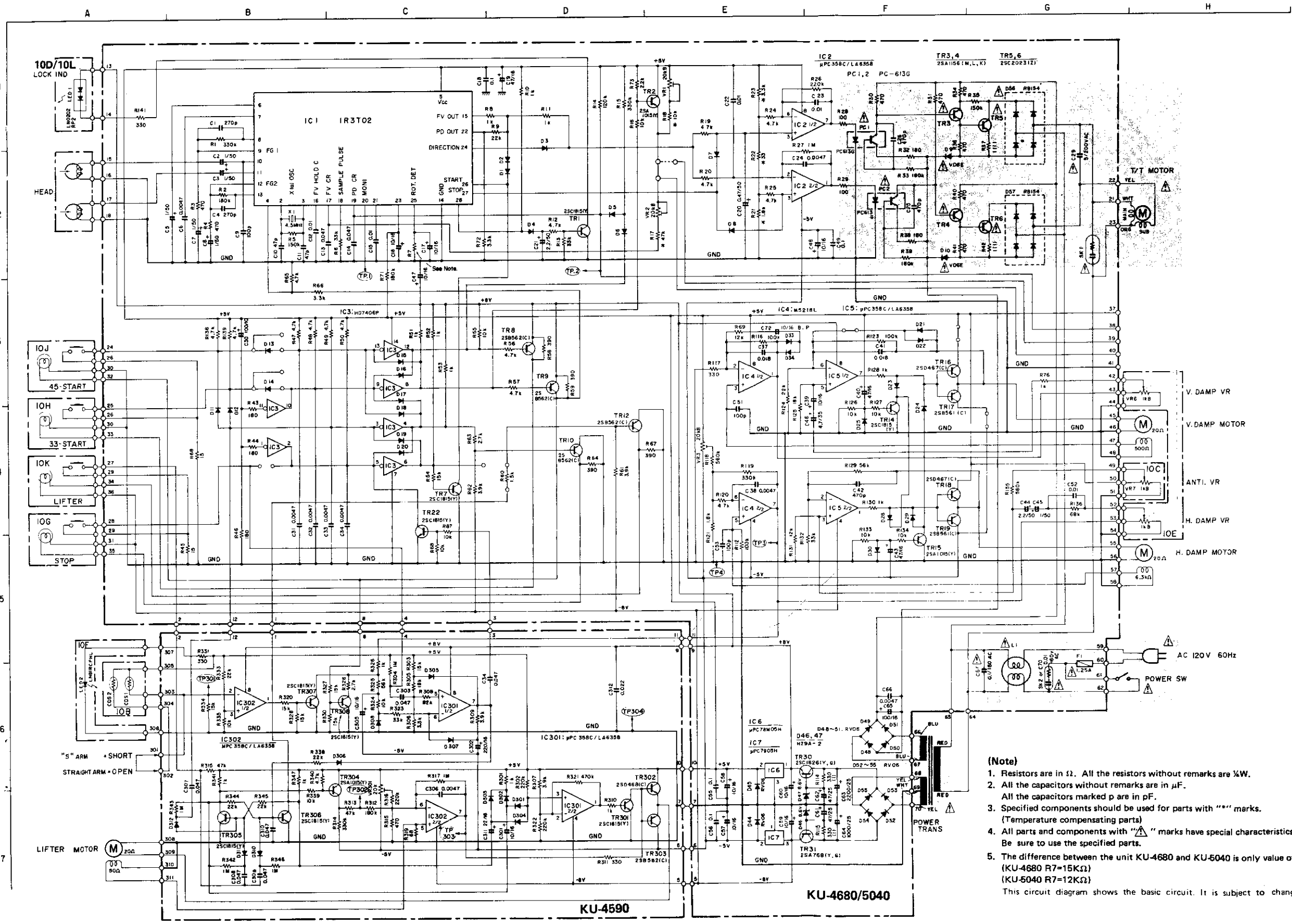

- (Note)**
1. Resistors are in Ω . All the resistors without remarks are in $\frac{1}{2}W$.
 2. All the capacitors without remarks are in μF . All the capacitors marked p are in pF.
 3. Specified components should be used for parts with "*" marks. (Temperature compensating parts)
 4. All parts and components with "▲" marks have special characteristics important to safety. Be sure to use the specified parts.
 5. The difference between the unit KU-4680 and KU-5040 is only value of resistor marked R7. (KU-4680 R7=15K Ω) (KU-5040 R7=12K Ω)
- This circuit diagram shows the basic circuit. It is subject to change for the purpose of improvement.

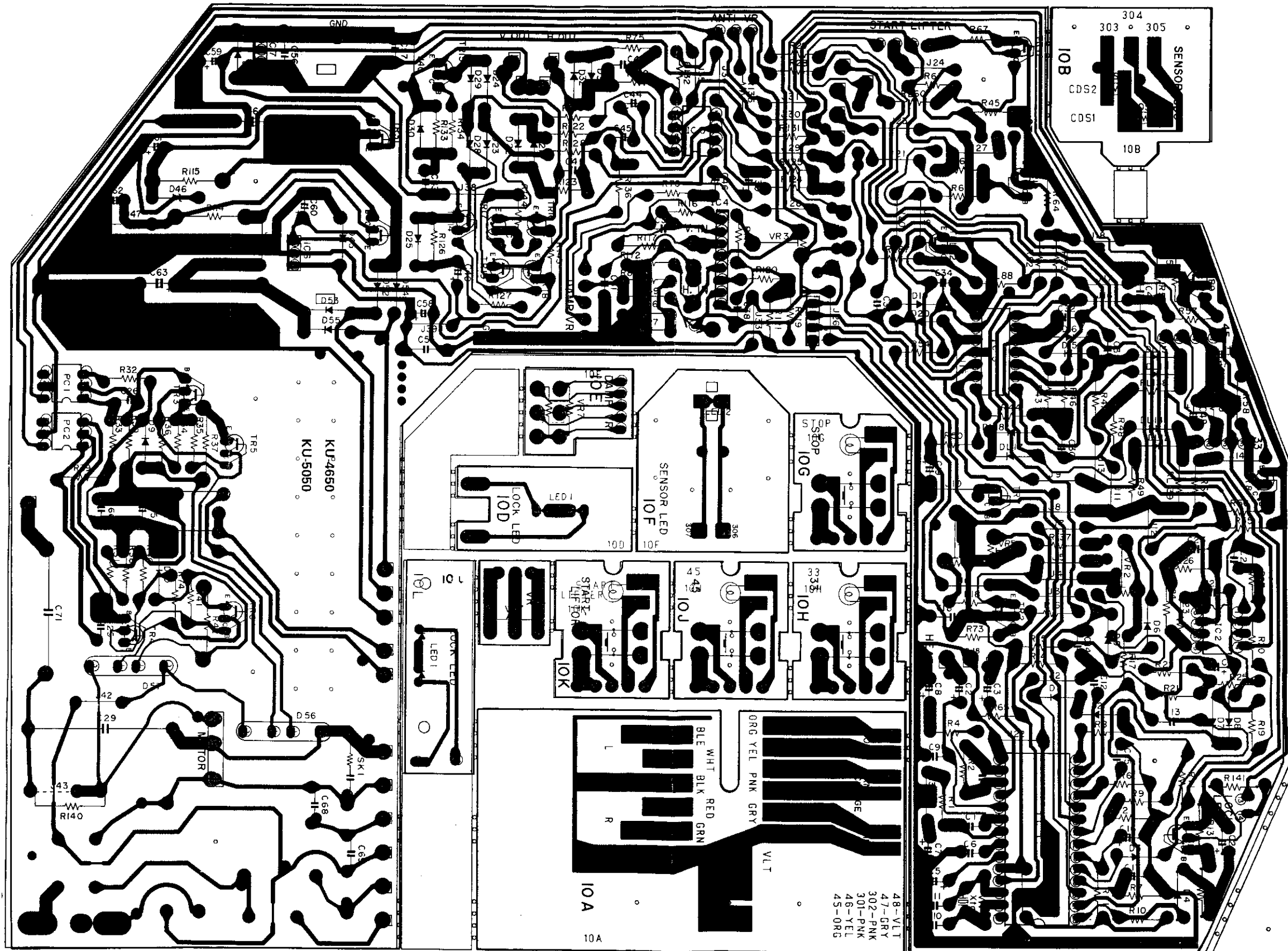

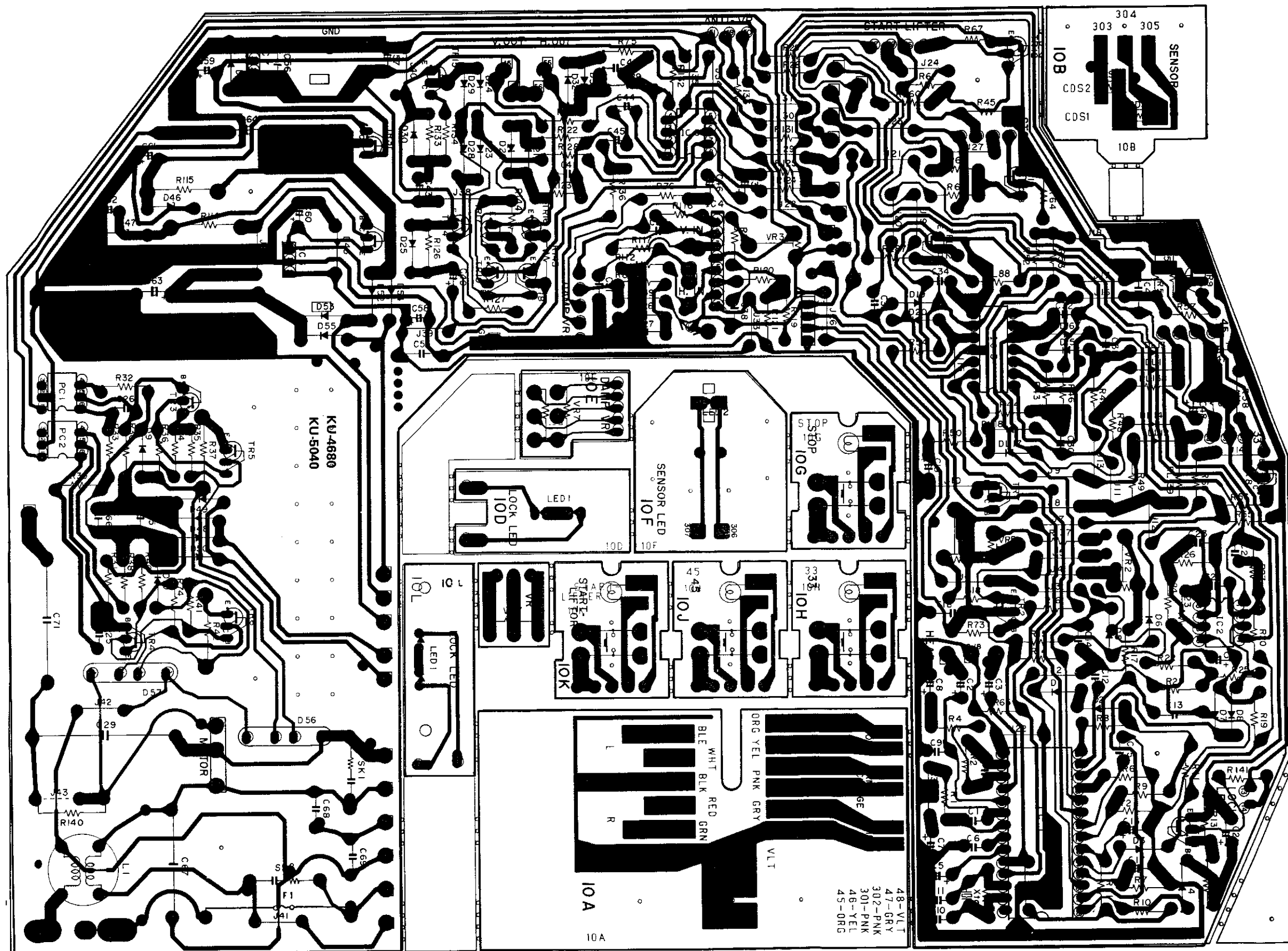

KU-4590 LIFTER SERVO UNIT

LEAD CONNECTION OF SEMICONDUCTORS

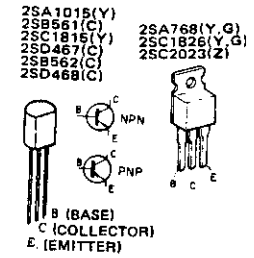
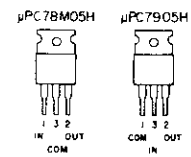
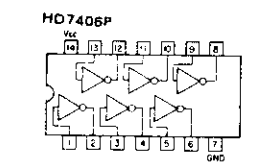
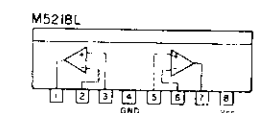
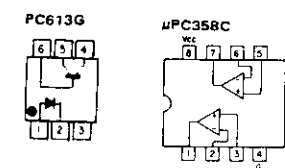
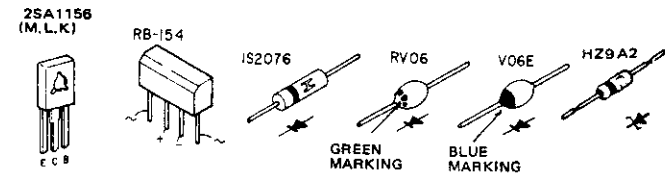
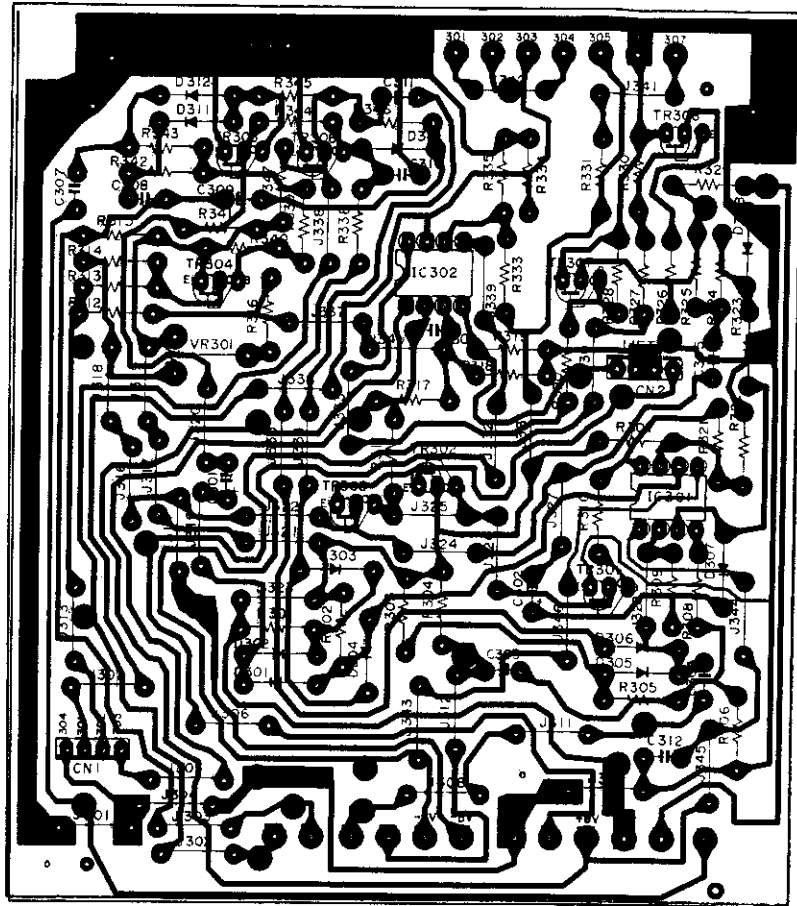

PS-1670/1680 POWER SUPPLY UNIT

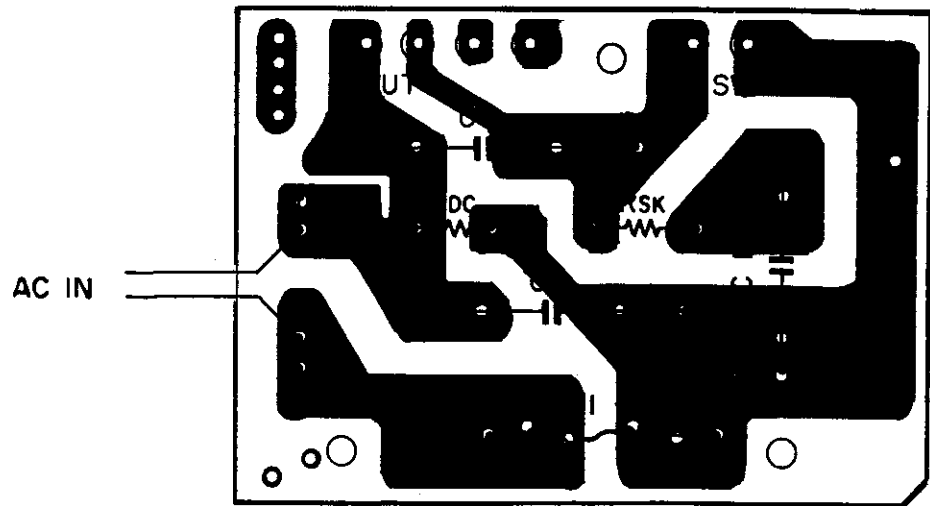

DENON

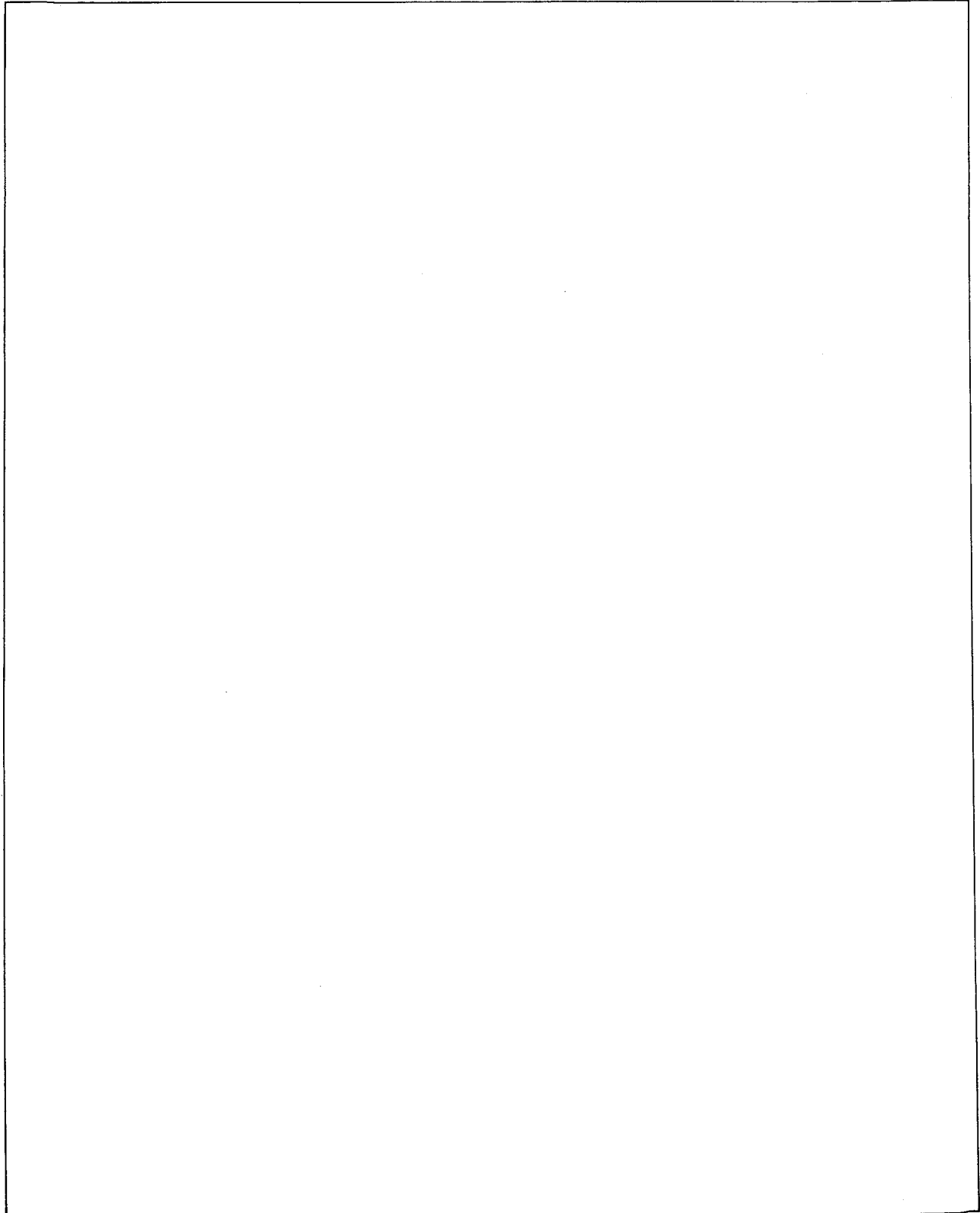

NIPPON COLUMBIA CO., LTD.

No. 14-14, 4-CHOME AKASAKA,
MINATO-KU, TOKYO JAPAN

TEL: 03-584-8111

TLX: JAPANOLA J22591

CABLE: NIPPON COLUMBIA TOKYO