

DENON



DENO-00187

STEREO

Hf Fi Component Record Player

SERVICE MANUAL

Denon Electronic GmbH

**SERVO-CONTROLLED
DIRECT DRIVE TURNTABLE
WITH AUTOMATIC ARM LIFT**

MODEL DP-1200 SERIES

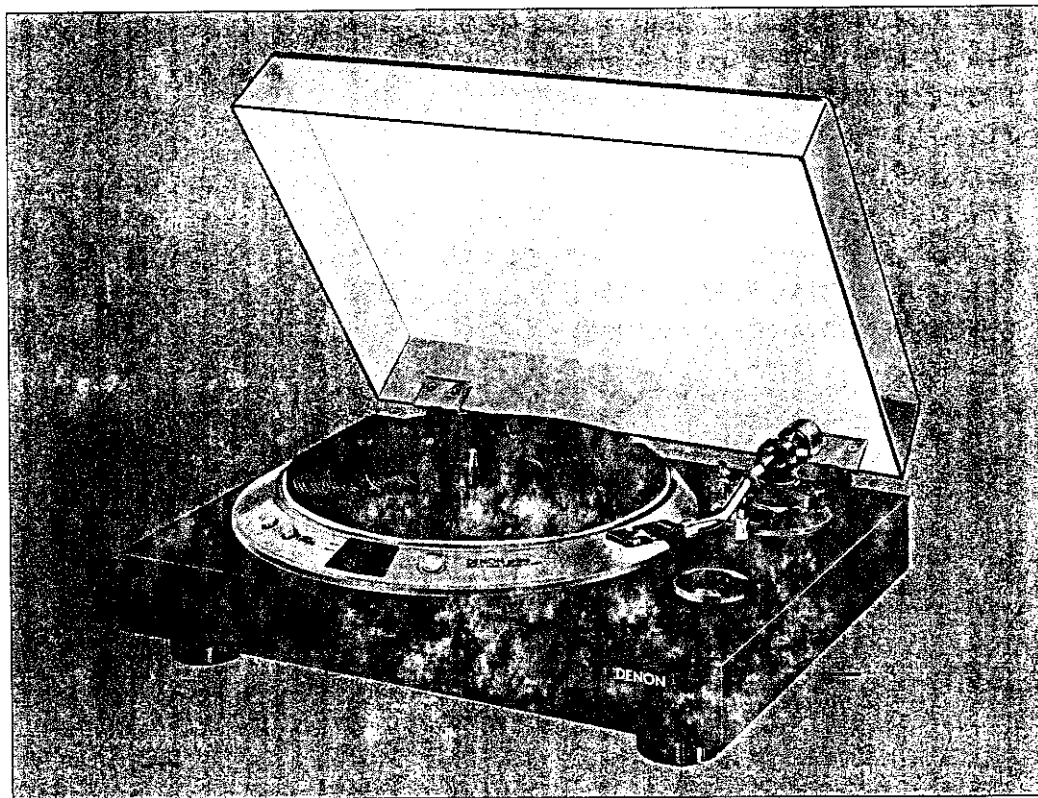

Model DP-1200

NIPPON COLUMBIA CO., LTD.

127

SPECIFICATION

PHONO MOTOR

Drive system:	Direct drive by AC servo motor
Speed control:	Frequency detection servo system
Speed:	33-1/3 rpm, 45 rpm.
Speed adjustable range:	Over $\pm 3\%$
Wow/flutter:	Less than 0.018% Wrms ¹⁾
S/N ratio:	Over 75 dB (DIN-B)
Starting time:	Less than 1.5 sec. (33-1/3 rpm.)
Turntable:	Aluminum alloy diecast, 1.5 kg, 30 cm diam. Moment of inertia of 190 kg cm ² (including turntable mat)

TO NEARM

Type:	Static balance type, Automatic arm lift
Effective length:	244 mm
Overhang:	14 mm
Tracking error:	Less than 2.5°
Acceptable weight of cartridge:	5 ~ 11 g
Stylus force range:	0 ~ 2.5 g (1 degree corresponding to 0.1 g), direct reading
Height adjustment range:	39 ~ 43 mm
Cueing:	Oil damped system

GENERAL

Power supply:	AC 120/200/220/240 V 50/60 Hz ²⁾
Power consumption:	17 W
Dimensions:	485(W) x 163(H) x 396(D) mm
Weight:	Approx. 11 kg

Note:

- 1) Measured by DENON method using a magnetic pulse wheel.
- 2) Rated voltage and frequency are preset to match those used in the country of original shipment. They are shown on the rating label on the set.

* The above specifications and outward appearance are subject to change for improvement without notice.

TABLE OF CONTENTS

SPECIFICATIONS	1
FEATURES	2
THEORY OF OPERATION	3
BLOCK DIAGRAM	3
FUNCTION OF SPEED SERVO CONTROL	3
(1) Limiter Amplifier	3
(2) Servo IC	3
(3) Start and Stand-by	4
(4) Motor Drive Amplifier	4
(5) Record-end Sensor	4
ADJUSTMENTS	7
(1) Speed	7
(2) Tonearm Height	7
(3) Record-End Position	7
(4) Spring Lever Force	7
(5) Power Switch Position	7
PARTS LIST FOR MODEL DP-1200 SERIES	8
BOTTOM VIEW	8
EXPLODED VIEW (Parts of Tonearm)	9
EXPLODED VIEW (Parts of Sensor)	10, 11
PC BOARD (KU-255A)	12
PC BOARD (KU-266A)	13
PC BOARD ARM SENSOR UNIT (KU-255B · 266B)	14
PC BOARD POWER SUPPLY UNIT (PS-138)	15
SCHEMATIC DIAGRAM (KU-255)	16
SCHEMATIC DIAGRAM (KU-266)	17

WARNING:
 THE COMPONENT WITH SHADING AND SYMBOL  MUST BE REPLACED ONLY BY THE SPECIFIED COMPONENT FOR SAFETY REASONS.

Since the printed circuit boards of 120-V version of Model DP-1200 have a high potential from the metal frame regardless of the polarity of the AC supply, use an isolation transformer (1:1) for servicing.

FEATURES

Model DP-1200 has combined an automatic arm lift for easy operation with the high performance DENON servo controlled direct drive record player. The automatic arm lift is accomplished by a non-contact type record end sensor, without affecting the motor torque or tonearm motion.

Model DP-1200 is a unique record player system featuring

other facilities such as tonearm height adjustment or stand-by switch-for cueing start. The electronics circuit is simplified by use of servo IC or speed selector and start/stand-by switches of mechanical holding type without employing semiconductor memory circuit.

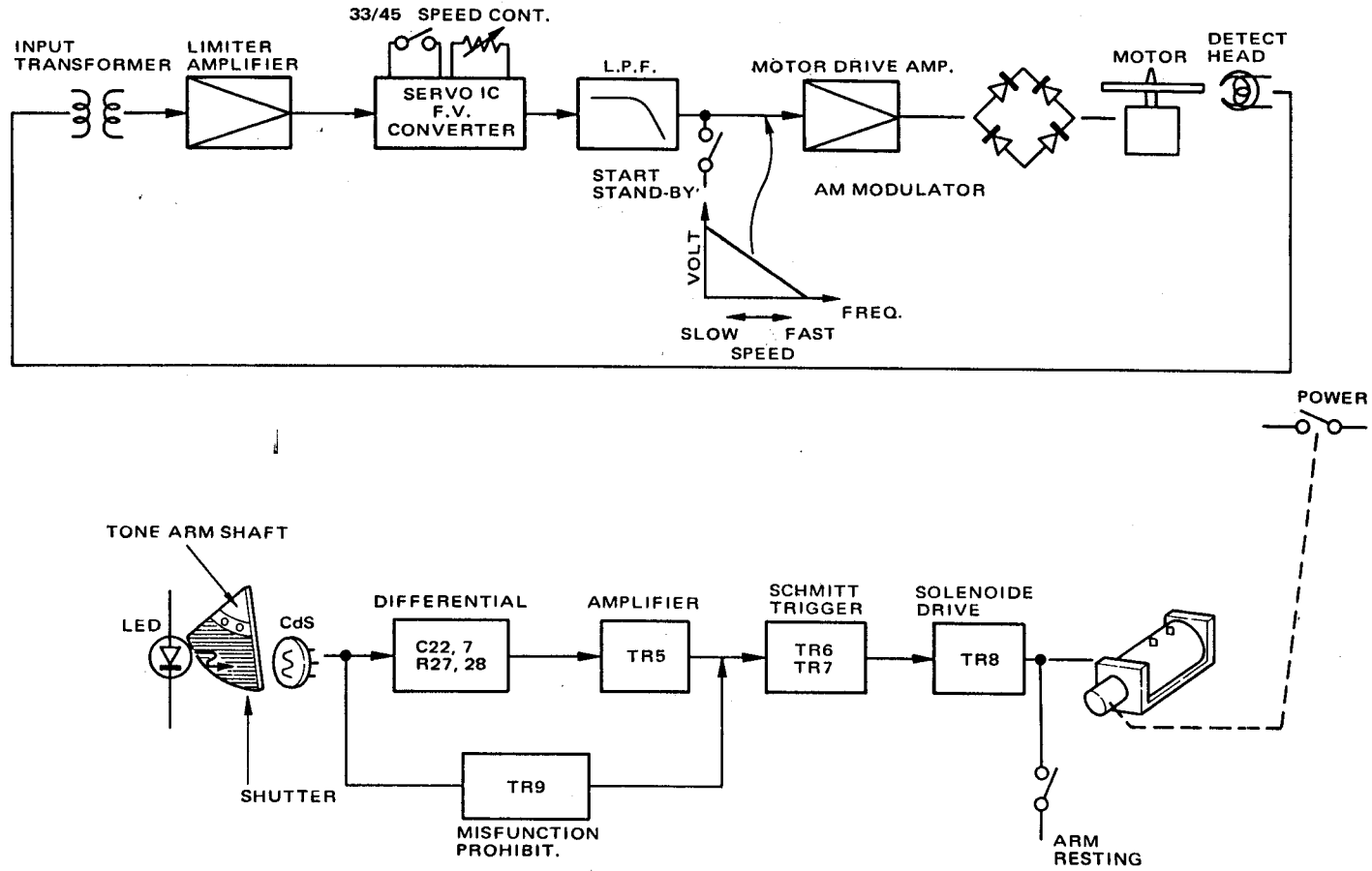

Fig. 1 Block Diagram of Model DP-1200 Series

THEORY OF OPERATION

BLOCK DIAGRAM

The block diagram is shown in Fig. 1.

The principle of speed servo loop is same as other DENON servo control system. 1,000 magnetic pulses per revolution are detected by the magnetic head and amplified by the limiter amplifier. The servo IC is basically a Frequency to DC voltage converter. The error signal out of the Low Pass Filter (L.P.F.) varies the impedance of motor drive amplifier (AM modulator) to keep platter speed constant. The record end sensor consists of a Light Emitting Diode (LED) and a CdS photo sensor. The speed of tonearm travel changes when the stylus moves from the sound (fine) groove to the lead-out (coarse) groove causing the shutter to vary the intensity of light and its velocity. The solenoid triggers power switch cum to bring the power off. The detail of each block is explained below.

FUNCTION OF SPEED SERVO CONTROL

1. Limiter Amplifier (Head Amplifier)

Fig. 2 shows the head (limiter) amplifier composed of an insulation transformer and 2 transistors.

The insulation transformer isolates the accessible parts (magnetic head, etc.) from the live current carrying parts of 120 V version which is power transformer-less.

Caution:

Since the printed circuit boards of 120 V version of Model DP-1200 have a high potential from the metal frame regardless of the polarity of the AC supply, use an insulation transformer (1 : 1) for servicing.

The head amplifier can be considered as a general amplifier but the difference is that D1 and D2 are used in the feedback circuit, and that when the collector voltage of TR2 increases over a certain value, it permits the feedback voltage to pass through the diodes giving change of the feedback quantity and control the gain of amplifier.

When D5 and D6 are "OFF", the degree of amplification is decided by the potential proportion between R6 and R2. Consequently, when the amplitude of input signal is small, the amplification is about 53 dB under condition that D1 and D2 are "OFF", but with increase of amplitude of input signal, the feedback quantity reaches 100% and the amplification degree corresponds to 1 under condition that both D1 and D2 are "ON".

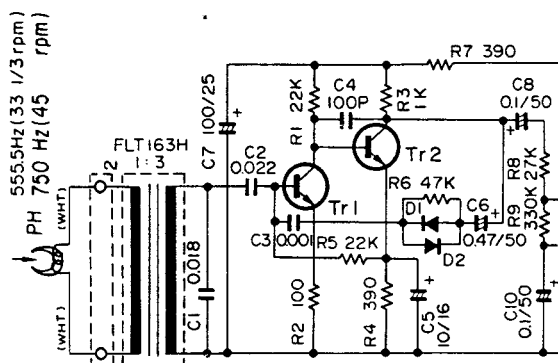

Fig. 2 Head Amplifier

Thus, the use of diodes in feedback circuit permits to produce the limiter function and, at the same time, to amplify because it has a certain gain. Further, it is the advantage of using diodes to obtain the well-balanced limiter effect for both positive and negative cycles.

2. Servo IC

The output of limiter amplifier is fed to Pin 3 of the servo IC and the demodulated output is taken out of Pin 16 of the IC. The block diagram of the servo IC is shown in Fig. 3. The input amplifier is a differential amplifier having a voltage gain of 80 dB, where the input signal is shaped into a square pulse and sent to the frequency doubler. Frequency to DC voltage conversion is accomplished by a mono-flop mutivibrator whose pulse duration, t_0 is determined by the outside network R1 X C2. The mono-flop output is differentiated by the IC internal resistance R and integrator capacitor C3 to generate DC voltage V_{c3} proportional to the revolution speed. The AC voltage component, i.e., the triangular wave voltage V_{c3} (p-p) and the combined DC voltage create the actual value signal. The amplitude of this ripple component depends on the revolution speed and the time constant.

The succeeding comparator will compare the actual voltage V_{c3} of Pin 8 and the reference voltage $V_{ref} = \frac{1}{2}V_{stab}$. When the actual value is less than the reference value, the output stage is driven. The comparator stage is so sensitive that the switching occurs in vibration status in accordance with the AC voltage variation.

As servo response is limited by the filter time constant, the V_{c3} charging will be delayed in determination of the actual value when the motor is turned on. Consequently, in the case of a quick-starting motor, it suffers over run. To tackle this annoyance, the precharge circuit serves to charge capacitor C3 instantly 81% of the reference voltage so that the additional charging time of the capacitor may be reduced and the over run will be damped.

The IC operating voltage is designed to be 4.8 – 16 V (necessary to conduct the sufficient performance of internal voltage regulator (at Pin 15) while the stabilized Pin 11 voltage is 3 V.

The explanation of switching frequency oscillator circuit is omitted here since it is not utilized in Model DP-1200. (S0275 lacks this switching freq. oscillator only.)

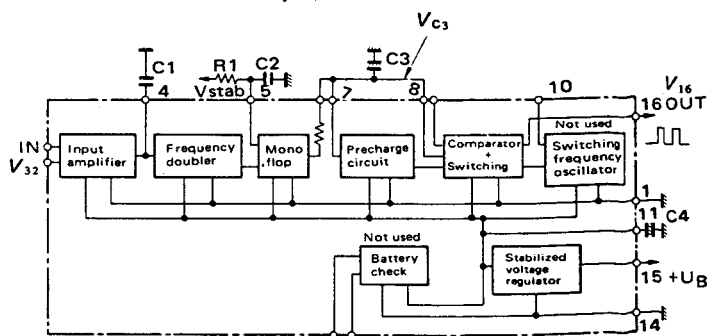

Fig. 3 Inside Block Diagram of TCA955

The above is the outline of each block of the servo IC. Fig. 4 and Fig. 5 indicate the wave form of each part.

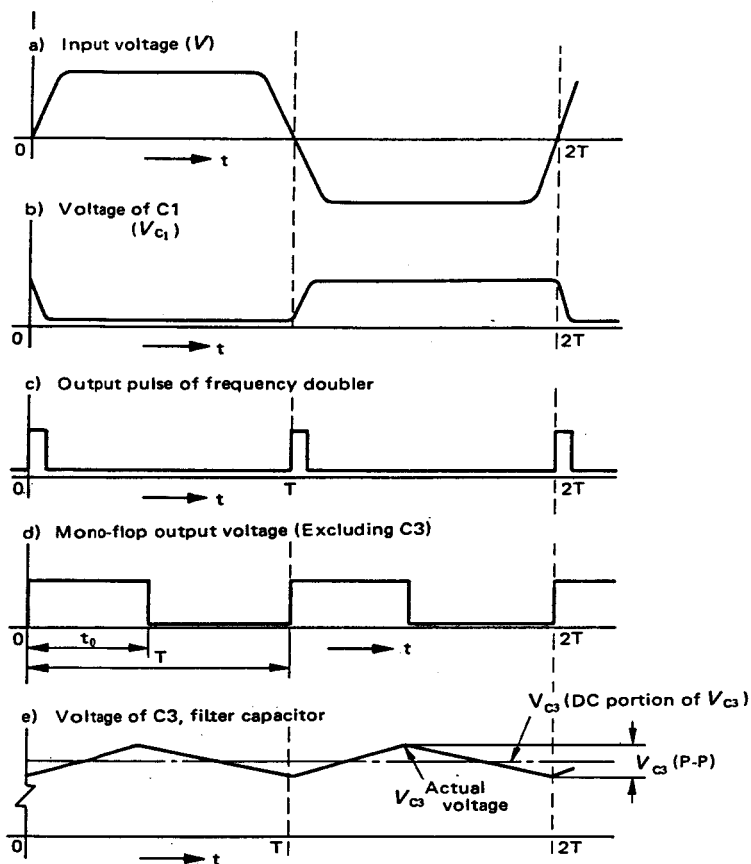

Fig. 4 Timing Chart of Frequency vs DC Converter

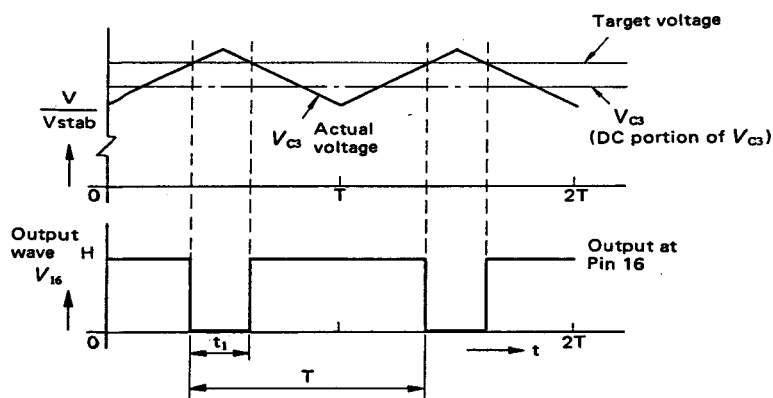

Fig. 5 Comparison Duty Cycle of Target Voltage vs Actual Voltage Without Using Switching Oscillator

3. Start/Stand-by

Start/Stand-by switch, SW2 is provided to lower the arm lifter without turning platter for program cueing and stylus force adjustment.

This switch by-passes the output DC voltage from the L.P.F. to presume an over speeding condition of the platter so that the motor drive stage does not conduct. When SW2 is disengaged, the speed variation (error) signal is fed to the motor drive stage to rotate the platter normally.

4. Motor Drive Amplifier (Amplitude Modulator)

In the same way as other DENON AC motor control, a DC voltage variation at the bases of TR3 and TR4 causes impedance variation of TR4 accomplishing an amplitude modulation (AM) of motor drive current.

The positive and negative cycles of AC current pass through the bridge diode, D3.

5. Record-end Sensor

Figs. 6, 7 and 8 show the record-end sensor mechanism and circuit.

(1) Light source and detection circuit

A butterfly wing shutter interrupts the light from Light Emitting Diode (LED) to the sensor (CdS). As the arm moves towards the end of record, the intensity of light flux detected by CdS and consequently the voltage at TP increase. A relation of detected voltage vs. stylus position is shown in Fig. 9.

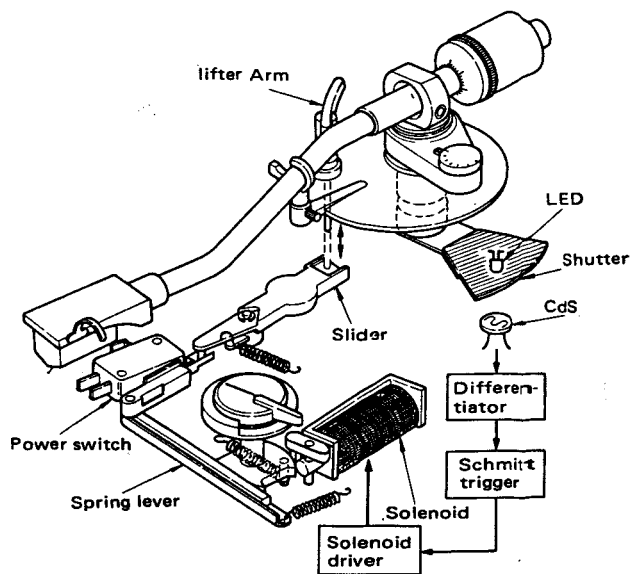

Fig. 6 Record-End Sensor Mechanism

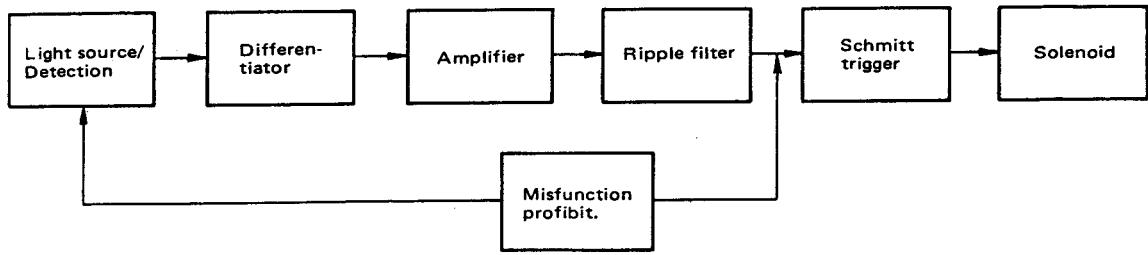

Fig. 7 Block Diagram of Record-End Sensor

(2) Detected voltage and its differentiation

The detected voltage at TP is differentiated by C27 and input resistance of TR5. This differentiated voltage is relative to the increase rate of tonearm velocity (acceleration).

The pitches on a standard record between sound grooves, between musics and between lead-out grooves are approx. 0.1 mm, less than 1 mm and more than 4 mm respectively. Therefore, if the threshold voltage is set at more than the differentiated voltage of 1 mm pitch, V_{b1} and at less than that of 4 mm pitch, V_{b2} , a lead-out (record-end) can be determined.

Voltage transition vs. stylus travel (groove diameter) are shown in Fig. 10. Also see Fig. 8.

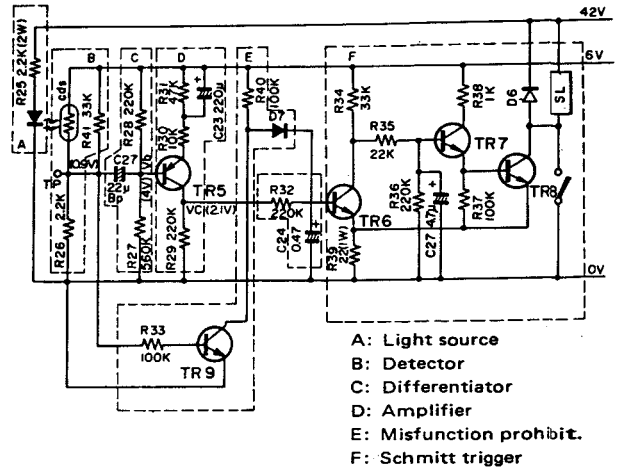

Fig. 8 Detection Circuit

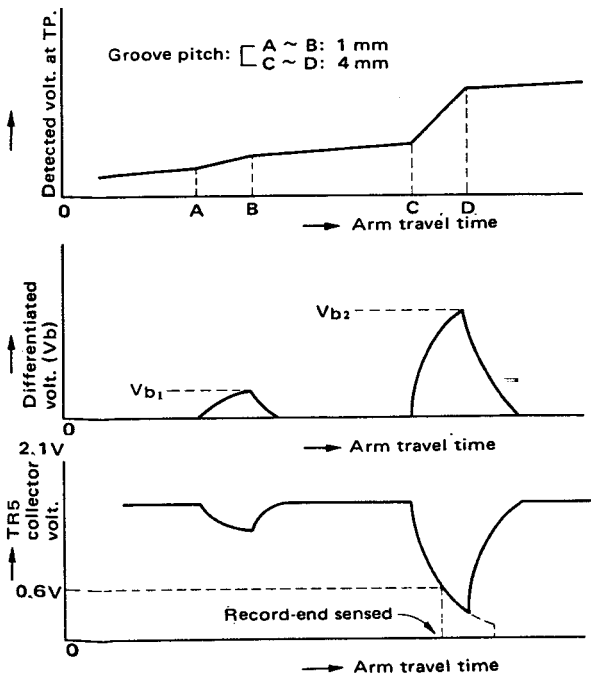

Fig. 10 Differentiated Voltage

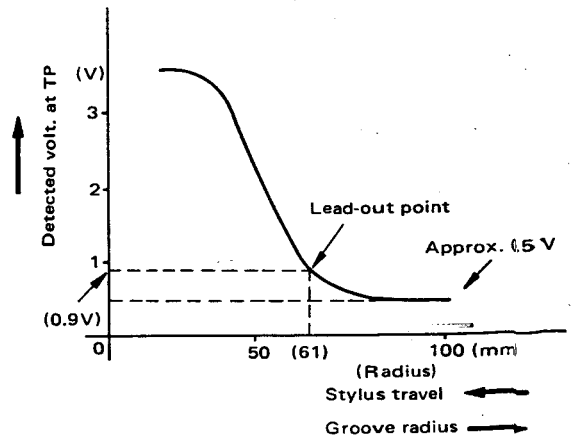
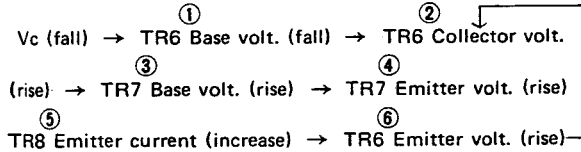

Fig. 9 Voltage Transition vs Stylus Travel

(3) Amplifier and Schmitt trigger circuit

As the differentiated voltage V_b increases, the TR5 base voltage increases and consequently the TR5 collector voltage V_c decreases. At this moment, the tone-arm (shutter) is moved around the end of record. The CdS receives most of the light, and the detected voltage at TP is high. Therefore, TR9 is ON and D7 is OFF. The following Schmitt trigger circuit can be actuated by the TR5 collector voltage V_c only when D7 is OFF. The right half of the circuit in Fig. 11 composes a Schmitt trigger circuit and it functions as follows: When TR5 collector voltage V_c falls;



A positive feedback loop is thus accomplished and TR8 becomes ON to energize the solenoid SL. The solenoid actuates the power switch cum and also the tonearm lifter.

R35 and C27 make a charging delay to damp a sudden rise of TR7 base voltage. The solenoid works gently so that a shock noise will be suppressed.

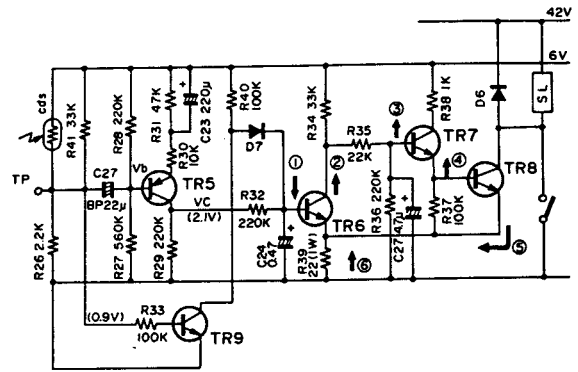

Fig. 11 Detection Circuit

(4) Misfunction prohibition

At the moment when the power is turned on, misfunction prohibition circuit works to prohibit solenoid engagement. The absence of detection voltage at TP when the arm is on the arm rest makes TR9 OFF, allowing TR6 base current to flow through R40 and D7. TR6 turns ON and therefore, the solenoid remains disengaged as the Schmitt circuit is untriggered. As the stylus travels on record groove, a DC voltage at TP becomes sufficient to turn TR9 ON and consequently D7 becomes OFF. The Schmitt trigger circuit is ready for accepting record-end signal. (Ref. to Par. 5-3)

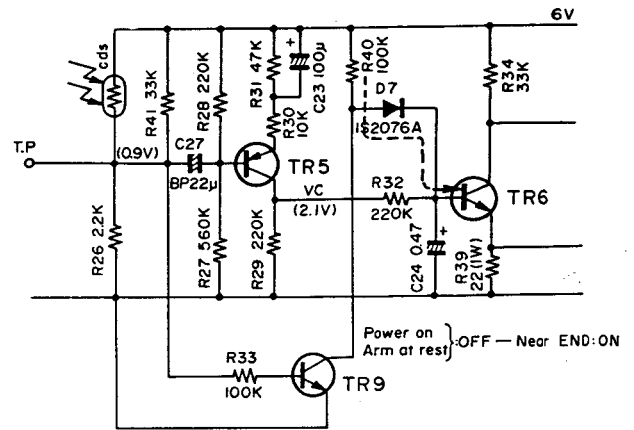

Fig. 12 Misfunction Prohibition Circuit

(5) Reset switch

Parallel to TR8, a reset micro switch is provided. This switch is closed only when the tonearm is at full rest position. Even if the power switch lever is operated while the tonearm is at full rest, it will not be locked since the solenoid is energized as the power is on. This function is illustrated in Page 16 "ON ARM REST" of the owner's manual.

Note:

If the power switch lever is held ON by hand, the platter will rotate (while START button pushed in) even if the tonearm is at full rest position energizing the solenoid.

ADJUSTMENTS

1. Speed

- (1) First, make sure that the neon lamp housing under the platter is screwed to a proper frequency position. 5 is for 50 Hz and 6 is for 60 Hz.
- (2) Turn on the power switch while placing the tonearm on the inner position of the arm rest.
- (3) Adjust 45 rpm. speed first. Observe in the strobo window and bring the 45 rpm. pattern still by turning the speed control knob (VR2) on the control surface.
- (4) Without touching the speed control knob, change the speed selector switch to 33 rpm. 33 rpm. speed is adjusted by turning the preset resistor VR1 on the printed circuit board from bottom.

2. Tonearm Height

- (1) Loosen two arm fixing screws at the back of the tonearm base as described on Page 12 of the owners manual (OPERATING INSTRUCTIONS FOR DP-1200) for adjusting the tonearm height. Obtain a parallel between the tonearm pipe and the platter surface.
- (2) When the tonearm height is adjusted, the arm lifter height must be also adjusted. Refer to the same paragraph in the owners manual.

Note:

If the tonearm movement becomes irregular, make sure that the shutter attached to the arm shaft is not in contact with the LED or CdS, etc.

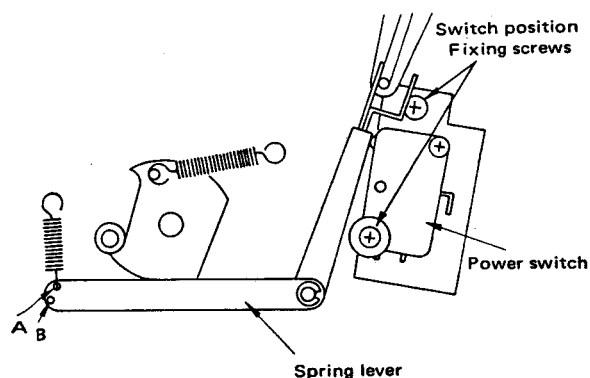

Fig. 13 Power Switch Actuator

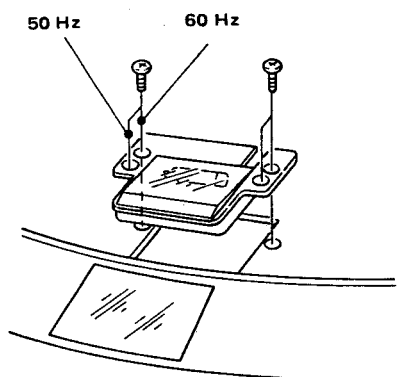

Fig. 14 Neon Lamp Housing

3. Record End (Lead-out) Position

- (1) Provide an electronic DC voltmeter whose input impedance is more than 100 K Ohms to observe the DC voltage between TPs 1 and 2.
- (2) Adjust the tonearm height at center of arm pipe from cabinet surface to be 44 mm before adjusting the lead-out position.
- (3) Place the stylus on the record at 61 mm away from the spindle.
- (4) Insert a (-) driver through the shutter adjustment hole at the back of tonearm base and turn the cum inside to obtain 0.9 ± 0.1 V on the voltmeter connected to TPs 1 and 2.

Note:

Before adjustment, close the bottom cover so that the photo sensor is not disturbed by external light sources.

- (5) Turn the cum clockwise seen from top to quicken the lead-out (shut off). In this condition, the DC voltage at TP becomes higher for the same stylus position, 61 mm away from spindle. To have more delayed lead-out, turn the cum counterclockwise.

4. Spring Lever Force (Power Switch Actuator)

There are two holes for spring at the cum side of the spring lever (switch actuator). Normally the spring is hooked at the weaker position A in Fig. 14. However, if the power switch cannot be actuated at this position, change the spring to stronger position, B.

Note:

If the spring is used at Position B, the arm lifter movement will be faster and a pop-up of arm may result.

5. Power Switch Position

When the power switch is replaced or when it does not function, adjust the switch position as follows:

- (1) Set the power switch lever on control surface to OFF position.
- (2) Loosen the switch position fixing screws shown in Fig. 5. Adjust the switch position so that the projection of the power switch is pushed in and then tighten the screws. The wires are connected to the normally closed terminals of the switch.

PARTS LIST FOR MODEL DP-1200 SERIES

U.S.A. and Canadian Models (American Models)

Ref. No.	Part No.	Part name	Remarks
1	1018058409	CABINET ASS. (Walnut)	
1	1018058412	CABINET ASS. (Ash)	
	FWD0554K-2	DUST COVER ASS.	
	1058007119	BOTTOM PLATE	
	△ 1058007122	BOTTOM PLATE (Canada only)	
2	1048006104	INSULATOR LEG	
3	1058008008	INSULATOR COVER	
4	4468014207	MOTOR BOARD ASS.	
5	△ 2178023001	MOTOR	
	4148019001	SHIELD PLATE	
	FPU0610	TONEARM UNIT	
	FPU0376N	HEAD SHELL ASS.	
	FPU0431H	SHELL ACCESSORY ASS.	
	2039607003	OUTPUT CORD	
	4218090002	RUBBER MAT	
	FMD0541H	45 ADAPTOR	
6	△ KU-255A	SERVO AMP UNIT	cf. P. 12
7	△ KU-255B	ARM SENSOR UNIT	cf. P. 14
8	△ KU-255C	SPEED SELECT UNIT	cf. P. 15
9	△ KU-255D	START/STAND-BY UNIT	cf. P. 15
10	△ KU-255E	SPEED CONTROL UNIT	cf. P. 15
12	△ 3933010106	NEON LAMP UNIT	
13	△ 2129010005	MICRO SWITCH (Power SW.)	
14	△ 4158005005	SEPARATOR	
15	△ FWA0019	WASHER (Nylon)	
16	△ 2618006009	SPARK KILLER	
17	△ 4158006004	CONDENSER COVER	

European, Australian and Asian Models (European Models)

Ref. No.	Part No.	Part name	Remarks
1	1018092106	CABINET ASS. (Walnut)	
1	1018092119	CABINET ASS. (Black)	
	FMD0554K-2	DUST COVER ASS.	
	1058016003	BOTTOM PLATE	
	1058017002	TRANSFORMER PROTECTOR	
2	1048006104	INSULATOR LEG	
3	1058008008	INSULATOR COVER (Leg protector)	
4	4468014210	MOTOR BOARD ASS.	
5	△ 2178018207	MOTOR	
	4148029004	SHIELD PLATE	
	FPU0610E-1	TONEARM UNIT	
	FPU0376N	HEAD SHELL ASS.	
	FPU0431H	SHELL ACCESSORY ASS.	
	2033622013	OUTPUT CORD (Fixed type)	
	4218092000	RUBBER SHEET	
	FMD0541H	45 ADAPTOR	
6	△ KU-266A	SERVO AMP UNIT	cf. P. 13
7	△ KU-266B	ARM SENSOR UNIT	cf. P. 14
8	△ KU-266C	SPEED SELECT UNIT	cf. P. 15
9	△ KU-266D	START/STAND BY UNIT	cf. P. 15
10	△ KU-266E	SPEED CONTROL UNIT	cf. P. 15
11	△ PS-138	POWER SUPPLY UNIT	cf. P. 15
12	△ 3933013006	NEON LAMP ASS.	
18	△ 2339014008	POWER TRANSFORMER (200-240 V)	
13	△ 2129046008	MICRO SWITCH (Power SW.)	

Note:

American models include U.S.A. and Canadian models.

European models include European, Australian and Asian models.

WARNING

The component with shading and symbol △ must be replaced ONLY by the specified component for SAFETY reasons.

PARTS LAYOUT

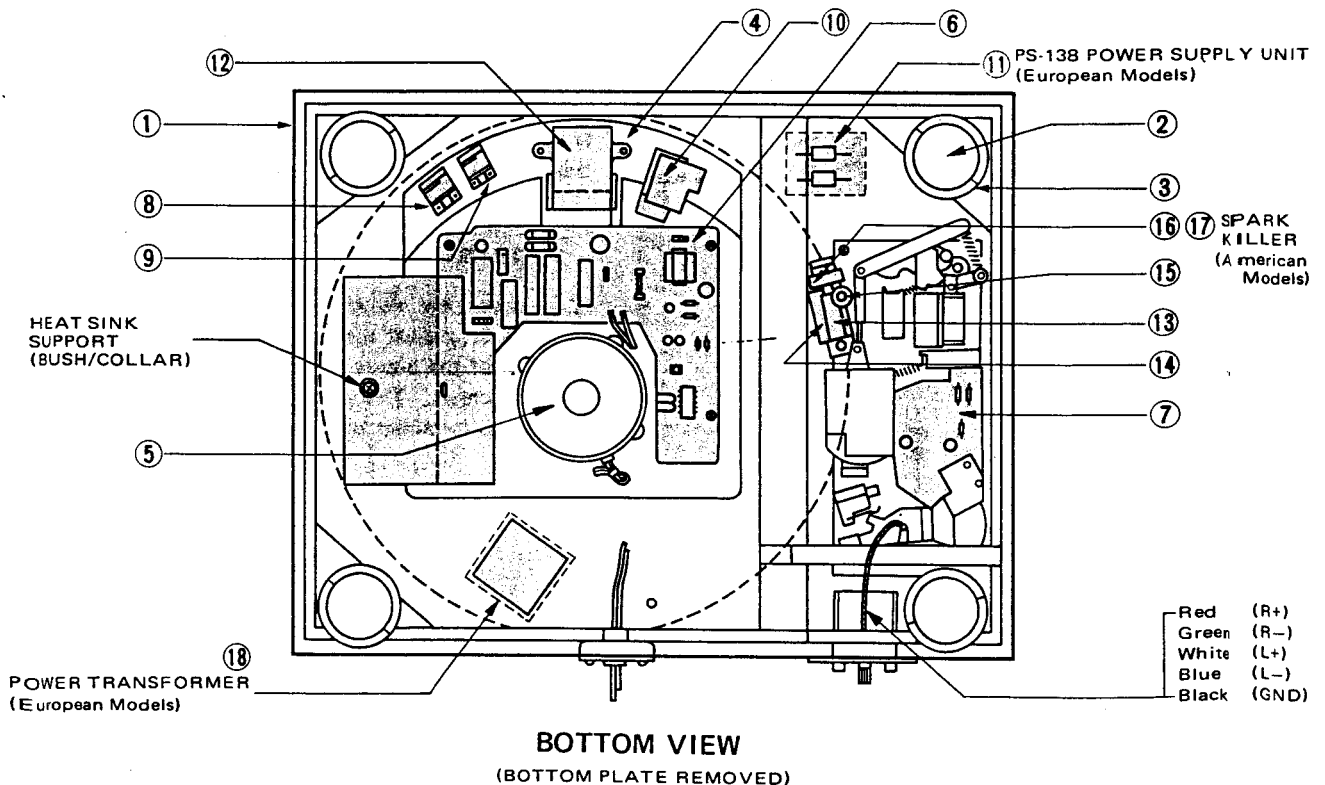

EXPLODED VIEW (Parts of Sensor)

No.	Part No.	Part name	Q'ty
1	4713303016	3 x 6 CBS	2
2	Δ2148013106	SOLENOID	1
3	4618040102	RUBBER PAD	1
4	4770070065	WASHER	1
5	4638064100	SOLENOID SPRING	1
6	4418136106	SOLENOID SUPPORT	1
7	4713202010	26 x 5 CBS	2
8	4638074006	LEVER SPRING	1
9	4761001001	2E RING	1
10	4338075004	LOCK LEVER	1
11	4713303016	3 x 6 CBS	2
12	4638072008	CAM SPRING	1
13	4248003205	CAM ASS	1
14	4338068202	SPRING LEVER	1
15	FMD0537-5	O RING (P3)	1
16	4713301018	3 x 4 CBS	1
17	4418157004	L. SW. PLATE	1
18	4118015608	CHASSIS ASS	1
19	4711801031	26 x 14 CPS	2
20	Δ2129010005	MICRO SWITCH (American)	1
20	Δ2129045008	MICRO SWITCH (European)	1
21	4761003009	3 ERING	1
22	4756006008	3 N	2
23		LAMP P.C.B.	1
24	4438126002	COLLAR	2

(Continued to right)

Note:

- Two varieties of DAMPER ASSEMBLY are shown. The differences are shown by black shading. The parts list applies to both pages.
- Spring ends with arrows \Rightarrow must be pinched  so that they cannot become loose until they touch current carrying parts.
- American models are provided with SPARK KILLER with PVC cover fixed and soldered on the Item 20 MICRO SWITCH.

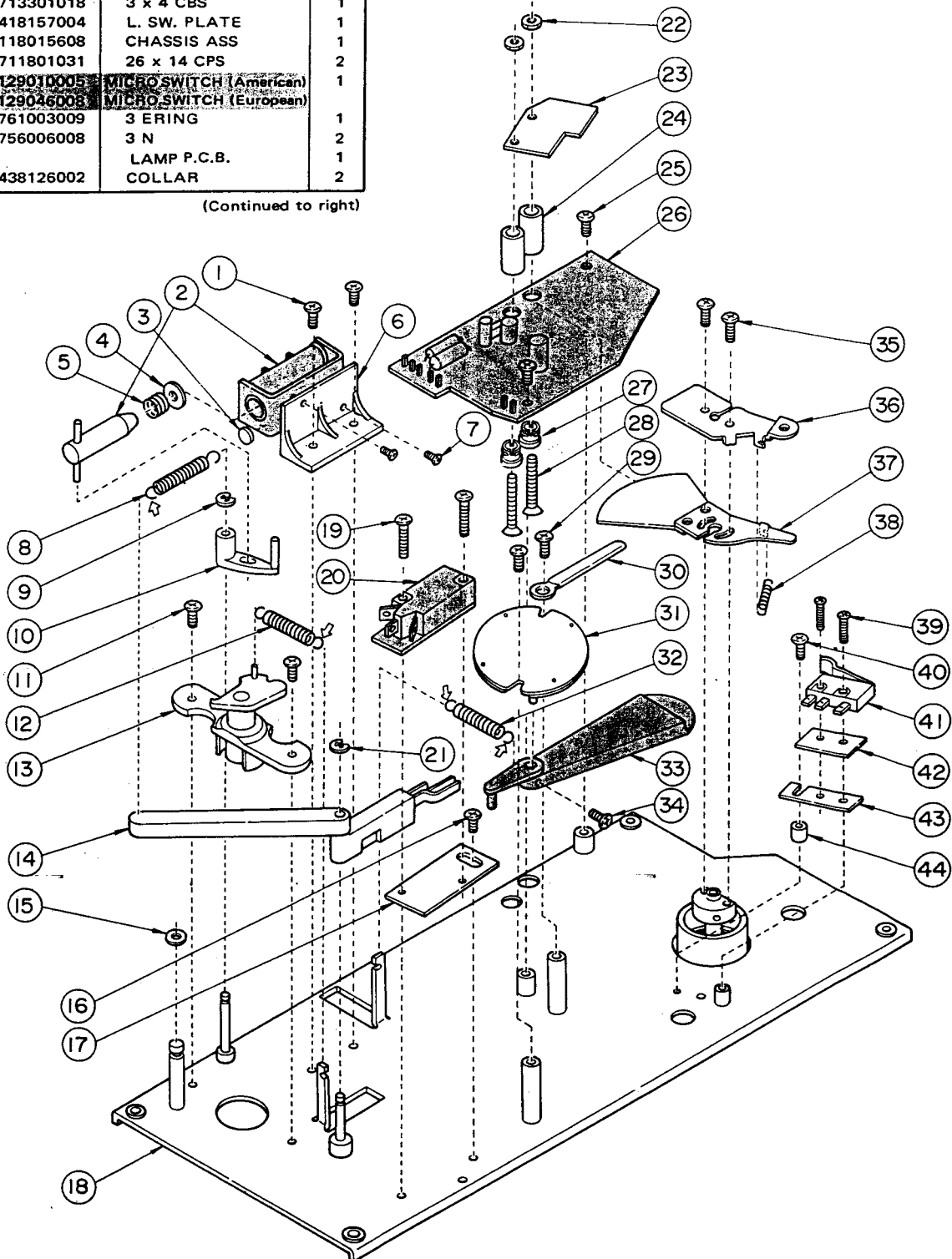

(Continued)

No.	Part No.	Part name	Q'ty
25	4713303016	3 x 6 CBS	2
26	KU-2558/KU-2668	ARM SENSOR P.C.B.	1
27	4438127001	BUSH	2
28	4713311011	3 x 25 CBS	2
29	4713303016	3 x 6 CBS	2
30	EP-4772	CORD HOLDER	1
31	4318019501	DAMPER ASS	1
32	4638070000	SLIDER SPRING	1
33	4338067300	SLIDER	1
34	4713303016	3 x 6 CBS	1
35	4713301018	3 x 4 CBS	2
36	4418152106	SHUTTER BASE ASS	1
37	4418150001	SHUTTER ASS	1
38	4638073007	SHUTTER SPRING	1
39	4713801000	2 x 10 CBS	2
40	4713306013	3 x 12 CBS	1
41	2129024004	MICRO SWITCH	1
42	FE-2261J	INSULATION SHEET	1
43	4418158003	S. SW. PLATE	1
44	4438129009	COLLAR	1
50	4118025009	SLIDER PLATE	1
51	4438160000	ROTARY ARM	1
52	4338088004	SLIDER	1

WARNING

The component with red shading and symbol \triangle must be replaced ONLY by the specified component for SAFETY reasons.

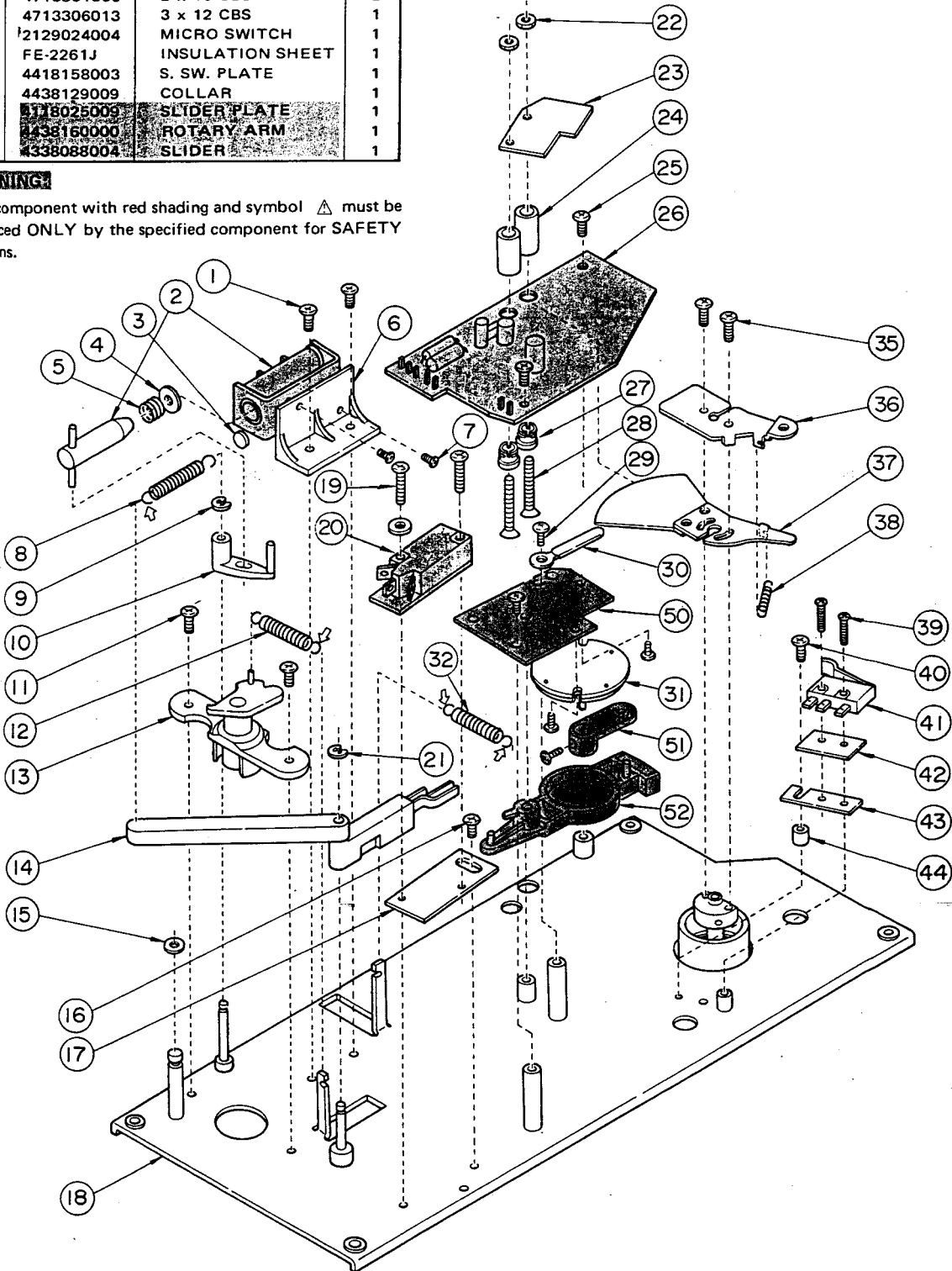

PC BOARD (KU-255A)

American Models

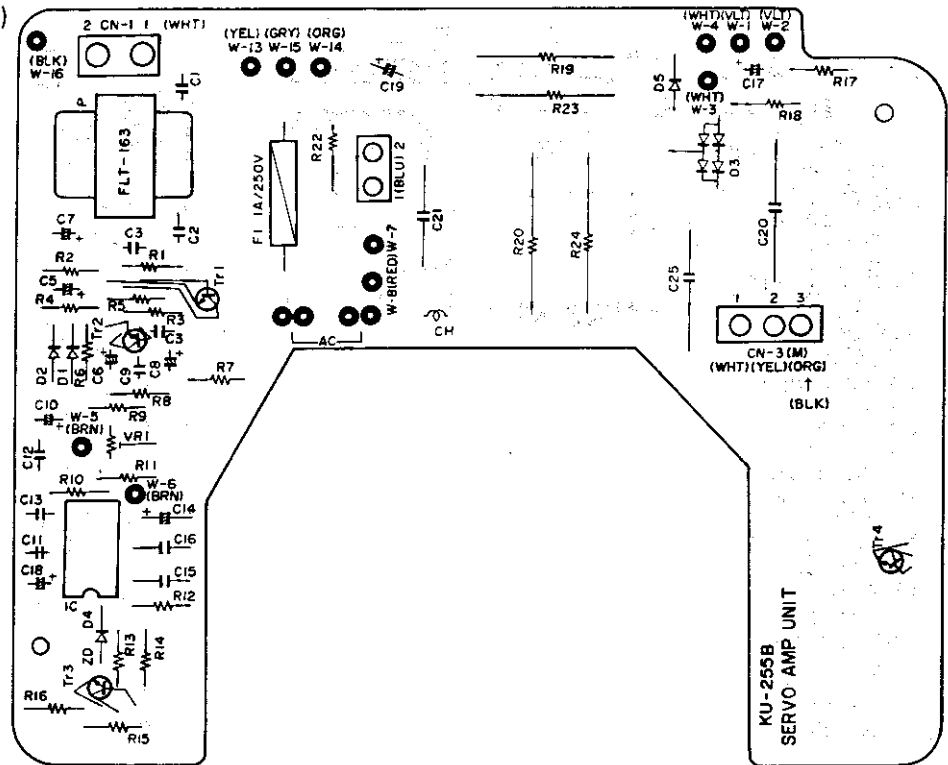

KU-255A SERVO AMP UNIT (American Models)

Ref. No.	Part No.	Part name	Remarks	Ref. No.	Part No.	Part name	Remarks
T CH F	△ 2228068314	P. CIRCUIT BOARD		R19	△ 2440155018	RS14B3F152JNB	1.5kΩJ 3W
	4178018108	HEAT SINK		R20, 24	△ 2432012017	RW78A4A122KF	Metal oxide 10W
	4438125003	BUSH		R22	△ 2440054009	RS14B3A123JNB	1.2kΩK 1W
	4438124004	COLLAR		VR1	△ 2116008017	V10P08MB103	12kΩJ 1W
	△ FLT0163J	INSULATION TRANS					10kΩ
	△ 2328008106	INDUCTOR					Speed preset VR
	△ EP-72663	FUSE 1A 250V					
	△ FEP1258H2	FUSE CAP					
SEMICONDUCTORS				CAPACITORS			
IC	2688002004	TCA953 or S0275		C1	2551075003	CQ93M1H183K	0.018μFK 50V
TR1, 2, 3	2730021043	25C458 (D)		C2	2551076002	CQ93M1H223K	0.022μFK 50V
TR4	2738004004	25C2168(O)		C3, 9, 11	2531004007	CK45B1H102K	0.001μFK 50V
D1, 2	2760049011	1S2076A		C4	2533627000	CC45SL1H101K	100pFK 50V
D3	△ 2760213009	1S2372A		C5, 14	2544015009	CE04W1C100=	10μF 16V
D4	2760177019	MZ306 (A)		C6	2554404300	CE04W1HR47=	0.47μF 50V
D5	△ 2760057029	V06E		C7, 18	2544028009	CE04W1E101=	100μF 25V
RESISTORS				C8, 10	2549014005	CE04W1HR10M	0.1μFM 50V
R1, 5, 17	2410346006	RD14B2E223J	22kΩJ 1/4W	C12	2551121025	CQ93M1H103K	0.01μFJ 50V
R2	2410290000	RD14B2E101J	100ΩJ 1/4W	C13	2541047009	CS45E1VR68K	0.68μFK 50V
R3	2410314009	RD14B2E102J	1kΩJ 1/4W	C15, 16	2551088003	CQ93M1H224K	0.22μFK 50V
R4, 7	2410304006	RD14B2E391J	390ΩJ 1/4W	C17	2544070015	CE04W2CR47=	0.47μF 160V
R6	2410354001	RD14B2E473J	47kΩJ 1/4W	C19	2544059010	CE04W1J221=	220μF 63V
R8	2410346004	RD14B2E273J	27kΩJ 1/4W	C20	△ 2568007080	CF99=2EAC205J	2μFJ 250VAC
R9	2410374009	RD14B2E334J	330kΩJ 1/4W	C21, 25	△ 2568017012	CF99B2BAC104MW	0.1μF 125VAC
R10 *	FEP101125	RN1/4PSS	5.6kΩG 1/4W	C28	2533639001	CC45SL1H331J	330pFJ 50V
R11 *	FEP101120	RN1/4PS	27kΩG 1/4W				
R12	2410322004	RD14B2E222J	2.2kΩJ 1/4W				
R13	2410350005	RD14B2E333J	3.3kΩJ 1/4W				
R14	2410342000	RD14B2E153J	15kΩJ 1/4W				
R15	2410300000	RD14B2E271J	270ΩJ 1/4W				
R16	2410306004	RD14B2E471J	470ΩJ 1/4W				
R18	244005003	RS14B3A01GJNB	15J 1W				
				Note: G: ±2%, J: ±5%, K: ±10%, M: ±20% * Parts with asterisks are temperature compensating devices.			
				WARNING: The component with shading and symbol △ must be replaced ONLY by the specified component for SAFETY reasons.			

PC BOARD (KU-266A)

European Models

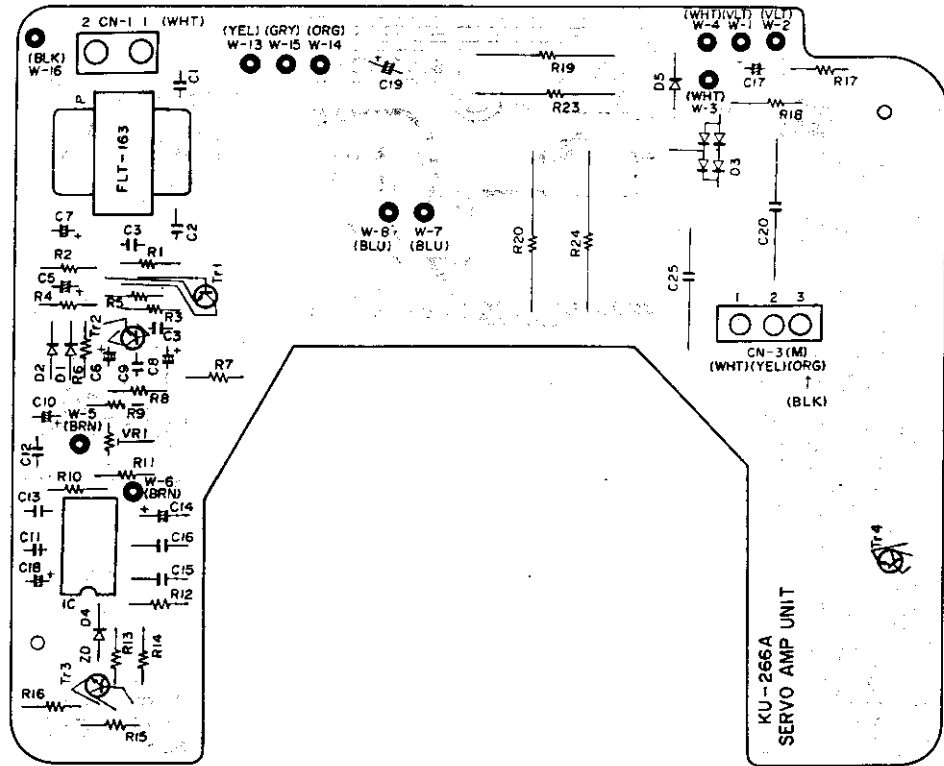

KU-266A SERVO AMP UNIT (European Models)

Ref. No.	Part No.	Part name	Remarks	Ref. No.	Part No.	Part name
T1	△2228079316	P. CIRCUIT BOARD		R19	△2440155018	RS14B3F152JNB 1.5kΩJ 3W
	4178018108	HEAT SINK		R20, 24	△2432012017	RW78A4A122KF Metal oxide 1.2kΩK 10W
	4438125003	BUSH		VR1	△2116008017	V10P08MB103 10kΩ Speed preset VR
	4438124004	COLLAR				
	FLT0163J	INSULATION TRANS				
SEMICONDUCTORS				CAPACITORS		
IC	2688002004	TCA955 or S0275		C1	2551075003	CQ93M1H183K 0.018μFK 50V
TR1, 2, 3	2730021043	2SC458 (D)		C2	2551076002	CQ93M1H223K 0.022μFK 50V
TR4	2738004004	2SC2168(O)		C3, 9, 11	2531004007	CK45B1H102K 0.001μFK 50V
D1, 2	2760049011	1S2076A		C4	2533627000	CC45SL1H101K 100pFK 50V
D3	△2760213009	1S2372A.		C5, 14	2544015009	CE04W1C100= 10μF 16V
D4	2760177019	MZ306 (A)		C6	2544043000	CE04W1HR47= 0.47μF 50V
D5	△2760057029	V06B		C7, 18	2544028009	CE04W1E101= 100μF 25V
RESISTORS				C8, 10	2549014005	CE04W1HR10M 0.1μFM 50V
R1, 5, 17	2410346006	RD14B2E223J	22kΩJ 1/4W	C12	2551121025	CQ93M1H103J 0.01μFJ 50V
R2	2410290000	RD14B2E101J	100ΩJ 1/4W	C13	2541047009	CS45E1VR68K 0.68μFK 50V
R3	2410314009	RD14B2E102J	1kΩJ 1/4W	C15, 16	2551088003	CQ93M1H224K 0.22μFK 50V
R4, 7	2410304006	BD14B2E391J	390ΩJ 1/4W	C17	2544070015	CE04W2CR47= 0.47μF 160V
R6	2410354001	RD14B2E473J	47kΩJ 1/4W	C19	2544059010	CE04W1J221= 220μF 63V
R8	2410348004	RD14B2E273J	27kΩJ 1/4W	C20	△2568013029	CF99=2DAC305J 3μFJ 200VAC
R9	2410374009	RD14B2E334J	330kΩJ 1/4W	C25	△2568017012	CF99B2BAC104MW 0.1μFM 125VAC
R10 *	FEP101125	RN1/4PS	5.6kΩG 1/4W	C28	2533639001	CC45SL1R331J 330pFJ 50V
R11 *	FEP101120	RN1/4PS	27kΩG 1/4W			
R12	2410322004	RD14B2E222J	2.2kΩJ 1/4W			
R13	2410350005	RD14B2E333J	3.3kΩJ 1/4W			
R14	2410342000	RD14B2E153J	15kΩJ 1/4W			
R15	2410300000	RD14B2E271J	270ΩJ 1/4W			
R16	2410306004	RD14B2E471J	470ΩJ 1/4W			
R18	2440005003	RS14B3A010JNB	1ΩJ 1W			
			Metal oxide			

Note: G: ±2%, J: ±5%, K: ±10%, M: ±20%
 * Parts with asterisks are temperature compensating devices.
WARNING:
 The component with shading and symbol △ must be replaced ONLY by the specified component for SAFETY reasons.

PC BOARD ARM SENSOR UNIT (KU-255B · 266B)

American and European Models

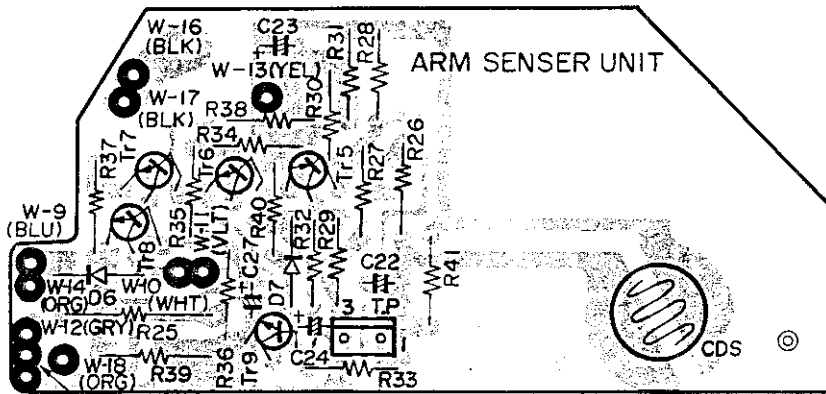

W-15 W-19
(GRY)(BRN)

KU-255B ARM SENSER UNIT
KU-266B

Ref. No.	Part No.	Part name	Remarks
	△ 2228068327	ARM SENSER PCB (KU-255B)	
	△ 2228079329	ARM SENSER PCB (KU-266B)	
	2228068369	LAMP PCB (KU-255B)	
	2228079361	LAMP PCB (KU-266B)	
	4438126002	COLLAR	
	44438127001	BUSH	
SEMICONDUCTOR			
TR5	271-40031	2SA673 (D)	
TR6,7,9	2730021043	2SC458 (D)	
TR8	2740057010	2SD667 (C)	
D6,7	2760049011	1S2076A	
D8	3939017006	TLR108 (D) LED	
CDS	3939019101	CDS	
RESISTORS			
R25	△ 2440102029	RS14B3D222JNBF 2.2kΩJ 2W	
			Metal oxide
R26	2410322004	RD14B2E222J	2.2kΩJ 1/4W Carbon film
R27	2410759004	RD14B2E564J	560kΩJ 1/4W Carbon film
R28,29,32,36	2410370001	RD14B2E224J	220kΩ 1/4W Carbon film
R30	241033 8001	RD14B2E103J	10kΩJ 1/4W Carbon film
R31	2410354001	RD14B2E473J	47kΩJ 1/4W Carbon film
R33, 37, 40	2410362006	RD14B2E104J	100kΩJ 1/4W Carbon film
R34, 41	2410350005	RD14B2E333J	33kΩJ 1/4W Carbon film
R35	2410346006	RD14B2E223J	22kΩJ 1/4W Carbon film
R38	2410314009	RD14B2E102J	1kΩJ 1/4W Carbon film
R39	△ 2440021029	RS14B3A220JNBF 22ΩJ 1W	
			Metal oxide
CAPACITORS			
C22	2543014043	CE04D1C220MBP	22μF 16V Elec. bipolar
C23	2544004007	CE04W0J221=	220μF 6.3V Electrolytic
C24	2544043000	CE04W1HR47=	0.47μF 50V Electrolytic
C27	2544024007	CE04W1E4R7=	4.7μF 25V Electrolytic
<p>Note: J: ±5%,</p> <p>WARNING: The component with shading and symbol △ must be replaced ONLY by the specified component for SAFETY reasons.</p>			

PC BOARD POWER SUPPLY UNIT (PS-138)

European Models (200V ~ 240V)

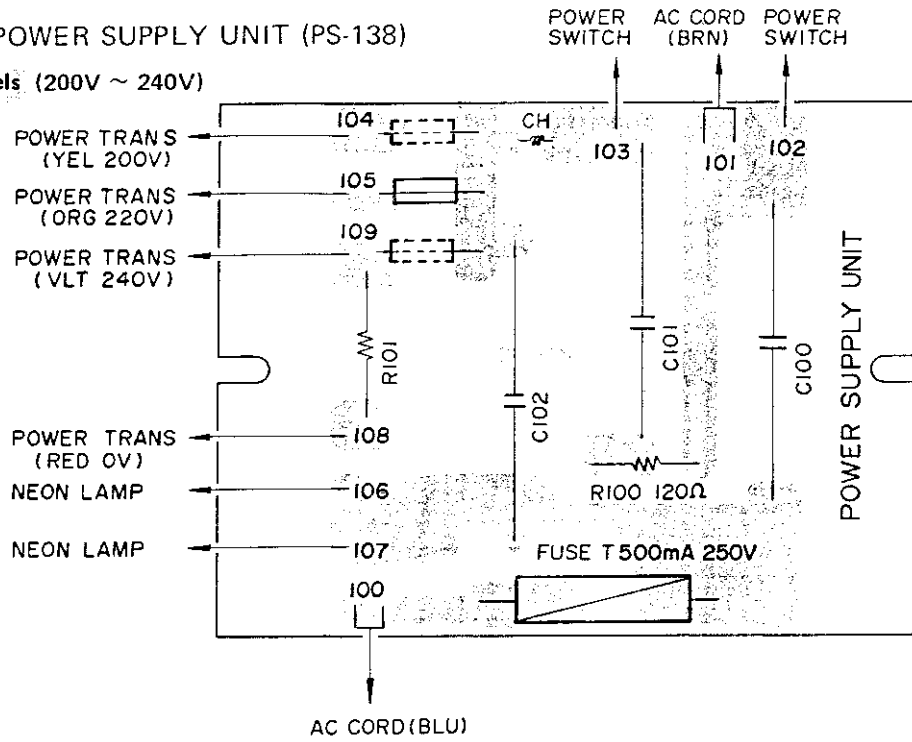

PS-138 POWER SUPPLY UNIT
(European, Australian and Asian Models only)

Ref. No.	Part No.	Part name	Remarks
	△ 2228084107	POWER SUPPLY PCB	
	△ 2061015003	FUSE T500mA 250V	
	FEP1287	FUSE HOLDER	
CH	△ 2328008106	INDUCTOR 1μH	
R100	△ 2410163001	RD14B2H121J 120Ω	1/2W
R101	△ 2440115003	RS14B3D273JNB 27kΩ	2W Metal oxide
C100,101,102	△ 2518001023	CP05C=AC473M 0.047μFM	Oil cap

Note: J: ±5%, M: ±20%

WARNING:
The component with shading and symbol △ must be replaced ONLY by the specified component for SAFETY reasons.

OTHER UNITS

American and European Models

START/STAND-BY UNIT

Ref. No.	Part No.	Part name	Remarks
	2228068343	ST. SWITCH PCB (KU-255D)	(Canada et al.)
	2228079545	ST. SWITCH PCB (KU-266D)	
SW4	△ 2129038003	PUSH SWITCH	
	1138041105	PUSH SWITCH KNOB	
	4418149106	SWITCH SUPPORTER (ST.)	

SPEED CONTROL UNIT

Ref. No.	Part No.	Part name	Remarks
	2228068356	VR PCB (KU-255E)(Canada et al.)	
	2228079358	VR PCB (KU-266E)	
VR2	△ 2118019101	RV16N26KB10K	
	1128021203	VOLUME KNOB	
	4418132207	VOLUME SUPPORTER	

WARNING:
The component with shading and symbol △ must be replaced ONLY by the specified component for SAFETY reasons.

SPEED SELECT UNIT

Ref. No.	Part No.	Part name	Remarks
	2228068330	SPEED SELECT PCB (KU-255C)	(Canada et al.)
	2228077332	SPEED SELECT PCB (KU-266C)	
SW3	△ 2129038003	PUSH SWITCH	
	1138041105	PUSH SWITCH KNOB	
	4418148107	SWITCH SUPPORTER (3)	

SCHMATIC DIAGRAM (KU-255) **U.S. and Canadian Models**

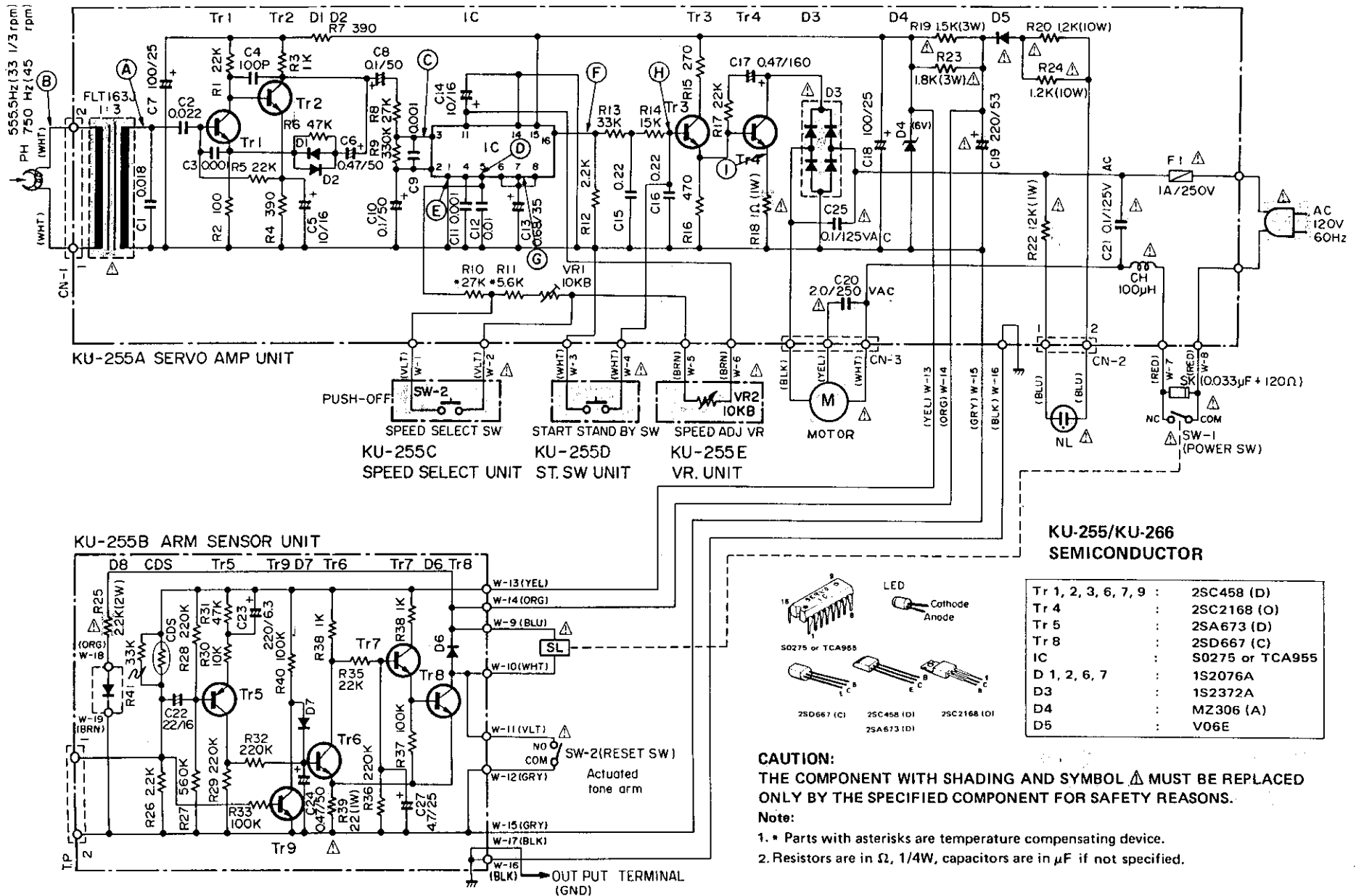

SEMICONDUCTOR	
Tr 1, 2, 3, 6, 7, 9 :	2SC458 (D)
Tr 4 :	2SC2168 (O)
Tr 5 :	2SA673 (D)
Tr 8 :	2SD667 (C)
IC :	S0275 or TCA955
D 1, 2, 6, 7 :	1S2076A
D3 :	1S2372A
D4 :	MZ306 (A)
D5 :	VO6E

DENON

NIPPON COLUMBIA CO., LTD.

No. 14-14, AKASAKA 4-CHOME
MANATO-KU, TOKYO, JAPAN
TEL: 03-584-8111
TELEX: JAPANOLA J22591
CABLE: NIPPONCOLUMBIA TOKYO