

DENON

Hi-Fi AM-FM Stereo Receiver

For EUROPEAN, U.K. AND OTHER Models

SERVICE MANUAL MODEL DRA-25/25L AM-FM STEREO RECEIVER



DRA-25



DRA-25L

CONTENTS

PRECAUTIONS FOR INSTALLATION	2
ADVICE FOR USE	2
SPECIFICATIONS	3
NAME OF EACH PART	4
CONNECTION	6
ANTENNA INSTALLATION	7
REMOVAL OF EACH SECTION	8
METHOD OF ADJUSTMENTS	10
CONNECTION DIAGRAM OF MEASURING INSTRUMENTS	11
SEMICONDUCTORS	12
DRA25 BLOCK DIAGRAM	13
PRINTED WIRING BOARD PATTERNS AND PARTS LIST	14 ~ 16
PRINTED WIRING BOARD	16
EXPLODED VIEW OF CHASSIS AND CABINET & PARTS LIST	18
EXPLODED VIEW OF CHASSIS AND CABINET	19
WIRING DIAGRAM	20
SCHEMATIC DIAGRAM	21, 22

NIPPON COLUMBIA CO., LTD.

PRECAUTIONS FOR INSTALLATION

DRA-25/25L uses a newly developed heat emitting unit by employing heat pipes. Since the heat pipes contain a coolant, the DRA-25/25L must be set level or the desired heat emitting effect cannot be achieved. Always install this unit horizontally.

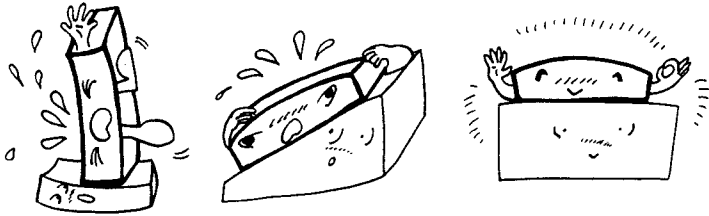

ADVICE FOR USE

- Do not place the set in direct sunlight, in hot areas such as near heating equipment, with high humidity or dust levels. This may cause damage to the unit.
- Check that all parts are connected correctly before turning on the power source.
- When user is absent for long periods, be sure to remove plug from wall socket.
- Do not use insecticide, benzene or thinner near the unit, or the cabinet color will fade. Avoid using polish: use a soft cloth (e.g. silicon cloth).
- It is not recommended to place players, decks and other objects on the DRA-25 or DRA-25L so that the vents are blocked. This will cause internal temperature rise and equipment failure. Do not use the DRA-25 or DRA-25L in a closed cabinet or container. This will cause internal temperature rise abnormally.

For United Kingdom model only.

WARNING:

As the colours of the wires in the mains lead of this appliance may not correspond with the coloured markings identifying the terminals in your plug proceed as follows:

The wire which is coloured blue must be connected to the terminal which is marked with the letter N or coloured black. The wire which is coloured brown must be connected to the terminal which is marked with the letter L or coloured red.

The wire which is coloured BROWN must be connected to the terminal which is marked with the letter L or coloured RED.

IMPORTANT

The wires in this mains lead are coloured in accordance with the following code:

Blue: Neutral
Brown: Live

SPECIFICATIONS

AMPLIFIER SECTION

Rated Output Power:

30W + 30W per channel minimum RMS, both channels driven at 8 ohms from 20 Hz ~ 20 kHz no more than 0.05% total harmonic distortion
45W + 45W per channel minimum RMS, both channels driven at 4 ohms from 1 kHz DIN no more than 1% total harmonic distortion

Power Bandwidth (IHF):

10 Hz ~ 40 kHz (T.H.D. 0.1% both ch. driven at 8 ohms)

Total Harmonic Distortion (20 Hz to 20 kHz):

-3 dB power into 8 ohms 0.04%

Frequency Response:

PHONO RIAA Standard Curve (Recording Output)

MM 20 Hz ~ 20 kHz ± 0.5 dB
20 Hz ~ 50 kHz ± 1.5 dB

Input Sensitivity and Impedance:

PHONO
MM 2.5 mV 47 k ohms
AUX, TAPE, CD
150 mV 33 k ohms

Maximum Input Level (at 1 kHz):

PHONO
MM 150 mV

Signal to Noise Ratio (IHF-A):

PHONO
MM 78 dB at 5.0 mV input
AUX, TAPE, CD
95 dB at 150 mV input

Tone Controls:

BASS ± 10 dB at 100 Hz
TREBLE ± 10 dB at 10 kHz

Loudness, Control Effect:

VARIABLE LOUDNESS 10 positions, 50 Hz/10 kHz, +10 dB/+5 dB

TUNER SECTION

[FM] (note: μ V at 75 ohms, 0 dBf = 1×10^{-15} W)

Receiving Range: 87.5 ~ 108 MHz

Usable Sensitivity: 0.9 μ V (10.3 dBf)

S/N 50 dB Quieting Sensitivity:

MONO 1.6 μ V (15.3 dBf)
STEREO 23 μ V (38.5 dBf)

Signal to Noise Ratio (IHF-A):

MONO 82 dB
STEREO 78 dB

Total Harmonic Distortion (at 1 kHz):

MONO 0.2%
STEREO 0.4%

Capture Ratio:

1.5 dB

Image Rejection:

70 dB

AM Suppression:

50 dB

Selectivity (± 300 kHz):

60 dB

Frequency Response:

30 Hz ~ 15 kHz $+0.2$ dB
 -1.5 dB

Stereo Separation (at 1 kHz):

40 dB

[MW]

Receiving Range:

522 ~ 1611 kHz

Usable Sensitivity:

18 μ V

Signal to Noise Ratio:

53 dB

[LW] (DRA-25L only)

Receiving Range:

153 ~ 360 kHz

Usable Sensitivity:

30 μ V

GENERAL

Power Supply:

AC 220 V 50 Hz (for Europe)
AC 240 V 50 Hz (for U.K. & Australia)

Power Consumption:

120 W

Dimensions:

434 mm (17-3/32") W x 112 mm
(4-13/32") H x 278 mm
(10-15/16") D

Weight:

5.5 kg (12 lbs 2 oz)

Design and specifications are subject to change without prior notice.

NOTE: The following codes correspond to the appropriate models.
E2 for Europe, EA for Australia and EK for U.K.
This Service Manual is prepared based on E2 Black Version.

NAME OF EACH PART

FRONT PANEL

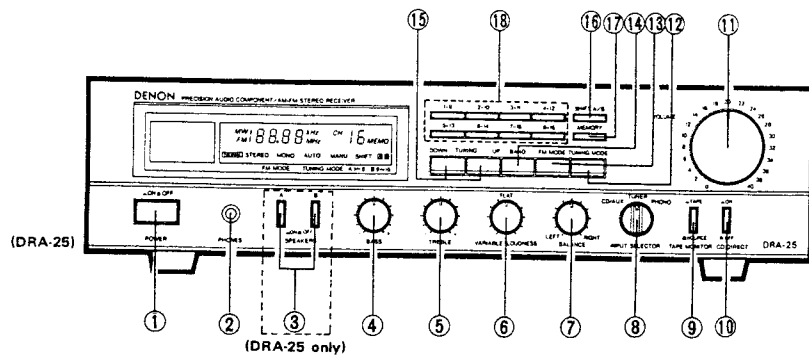

DISPLAY

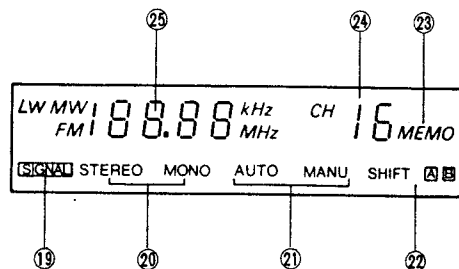

FRONT PANEL

- | | |
|--|--|
| ① POWER (Power Switch) | ⑪ VOLUME (Volume Control) |
| ② PHONES (Headphones Jack) | ⑫ TUNING MODE (Tuning Mode Button) |
| ③ SPEAKERS (Speaker Select Switch) (DRA-25 only) | ⑬ FM MODE (FM Mode Button) |
| ④ BASS (Bass Control) | ⑭ BAND SELECT (Band Selector Button) |
| ⑤ TREBLE (Treble Control) | ⑮ TUNING (Tuning Buttons) |
| ⑥ VARIABLE LOUDNESS (Loudness Control) | ⑯ SHIFT (Shift Button) |
| ⑦ BALANCE (Balance Control) | ⑰ MEMORY (Memory Button) |
| ⑧ INPUT SELECTOR (Sound Input Select Knob) | ⑱ PRESET CHANNEL 1 ~ 16 (Station Presetting Buttons) |
| ⑨ TAPE MONITOR (TAPE Monitor Switch) | |
| ⑩ CD DIRECT (CD Direct Switch) | |

DISPLAY

- | | |
|---------------------------------------|---|
| ⑱ SIGNAL (Signal Strength Indicator) | ⑲ MEMORY (Memory Indicator) |
| ⑳ STEREO/MONO (Stereo/Mono Indicator) | ⑳ CHANNEL |
| ㉑ TUNING MODE (AUTO/MANUAL) | ㉑ FREQUENCY DISPLAY (Frequency Indicator) |
| ㉒ SHIFT (Shift Indicator) | |

BACK PANEL

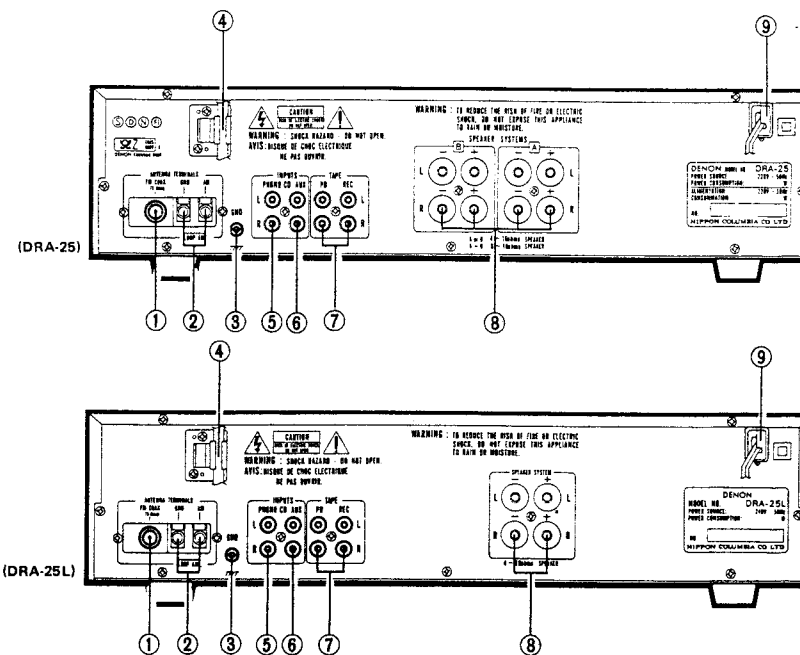

BACK PANEL

- | | |
|---------------------------------|---|
| ① FM ANT (FM Antenna Terminals) | ⑥ CD/AUX |
| ② AM ANT (AM Antenna Terminals) | ⑦ TAPE (Audio Playback and Recording Terminals) |
| ③ GND (Grounding Terminal) | ⑧ SPEAKER SYSTEMS (Speaker Terminals) |
| ④ AM LOOP ANT (AM Loop Antenna) | ⑨ AC CORD (Power Cord) |
| ⑤ PHONO (Phono Input Terminals) | |

CONNECTION (This is a figure of the DRA-25L)

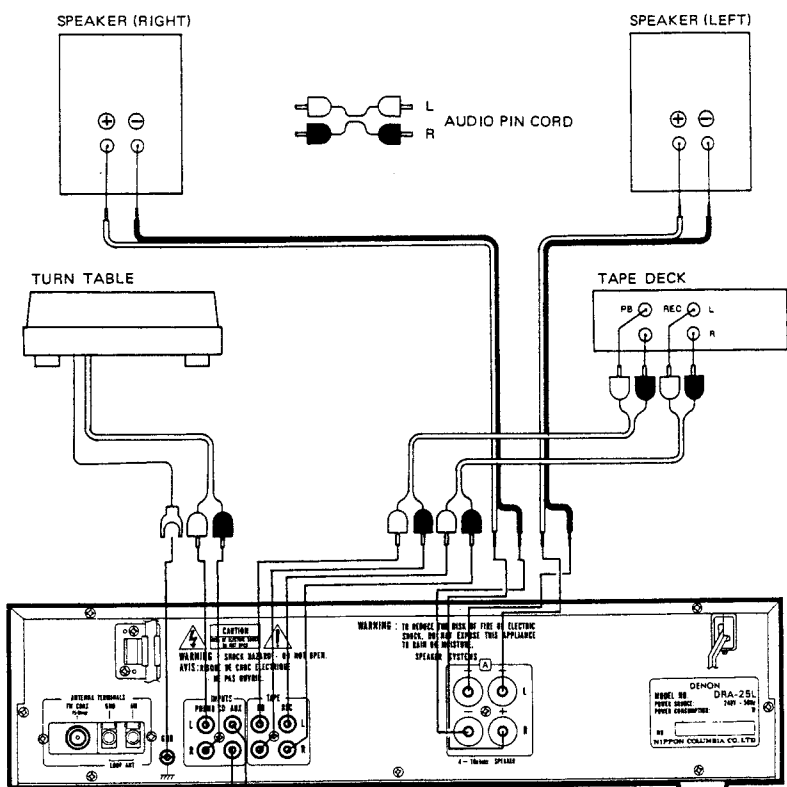

SPEAKER CONNECTION
 Confirm polarity (+, -) and left and right channels (L, R). Connect the speaker pairs to the SPEAKER terminals A or B on the back panel. Connections must be made with power cord disconnected.

1. Peel off the sheathing from the end of the cord.
2. Twist the wire strands.
3. Loosen the speaker terminal, insert the wire lead portion of the cord, and then tighten the terminal.

ANTENNA INSTALLATION

- **FM ANTENNA**
 The accessory T-type indoor antenna (300 ohms) can be used inside wooden houses for local FM stations and strong signals. Orient the T-shaped part for optimum reception and mount the antenna on the wall or ceiling. (FM indoor antennas may not consistently ensure stable reception, due to environment changes. In such cases use an FM indoor antenna temporarily until an outdoor antenna is installed.)
 75 ohms coaxial cable (3C-2V, 5C-2V) is preferable to obtain better performance of the tuner. (To use of a 300 ohms FM outdoor antenna, connect to the 300 ohms terminals.)
- **AM ANTENNA**
 Attach the accessory AM loop antenna to the antenna holder on the back panel. Connect the leads to AM and GND terminal. Use this terminal also for an outdoor antenna. Orient the loop antenna horizontally to obtain optimum reception. Where broadcast stations are distant and only weak signals are received, or where signals are blocked by obstacles, install an AM outdoor antenna.
- **GROUNDING**
 If there is reception noise, use of grounding wire is recommended. Connect a thick insulated wire to the "GND" terminal, and attach the unconnected bare end to a metal water pipe, grounding rod, or grounded copper plate.
 * Never connect the grounding wire to a gas pipe. This could cause fire or explosion.

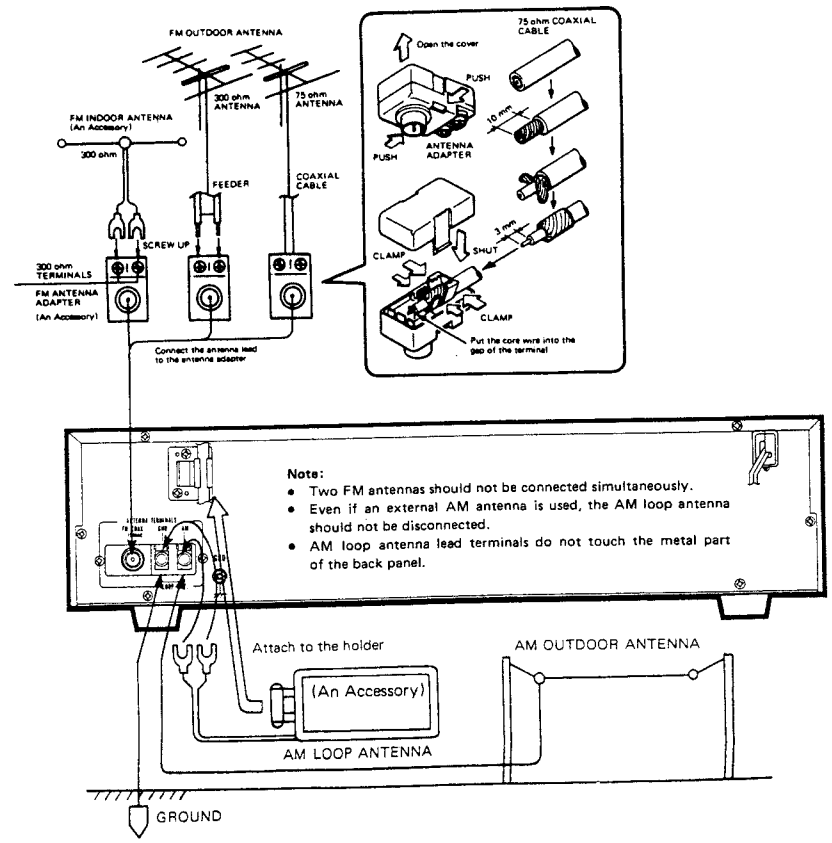

REMOVAL OF EACH SECTION

1. Top Cover

- 1) Unfasten the 7 screws.
- 2) Detach the top cover by means of lifting it upward.

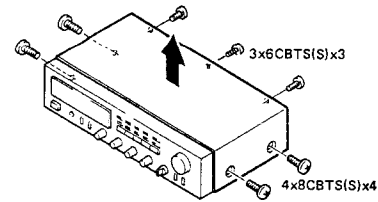

Fig. 4

2. Front Panel

- 1) Pull out the knobs. (Main volume control knob x 1; input selector knob x 1; tone, balance, etc. x 4.)
- 2) Remove the 4 screws from the bottom.
- 3) Push downward the 4 claws on the top of inner panel to release catching of front panel, then pull the front panel forward and detach.

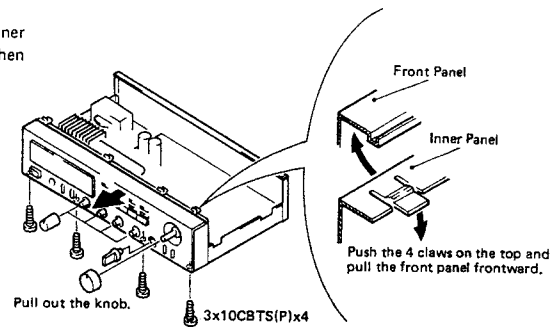

Fig. 5

3. PCB

- 1) Remove the power knob.
- 2) Unfasten the 4 screws. (Inner panel x 2; power switch x 2.)
- 3) Remove the 5 screws on the back panel.
- 4) Remove the 2 screws securing the heat pipe fin.
- 5) Detach the AC cord bushing.
- 6) Remove the 3 heads of PCB holder and pull the holder upward to detach.

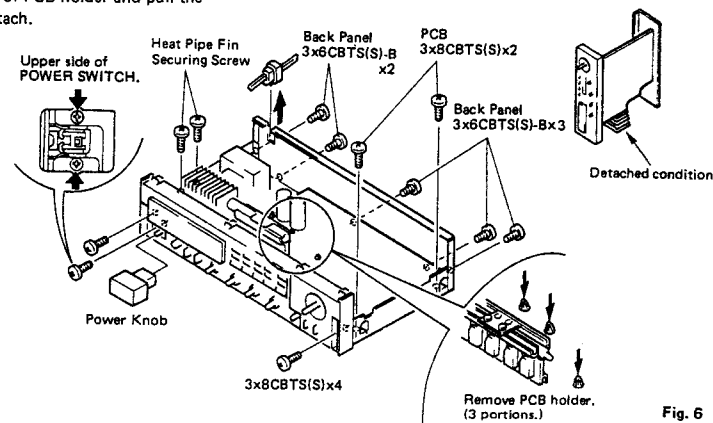

Fig. 6

4. Inner Panel

- 1) Take out the speed nut of headphone jack.
- 2) Pull out the speaker selector switch knob and remove the 1 screw fixing the switch. (For EK and LE2 versions, disregard this step.)
- 3) Unfasten the 1 screw holding the tone volume controls.
- 4) Remove the screw tightening the input selector.
- 5) Remove the nut and washer securing the main volume control.
- 6) Pull forward the inner panel to detach.

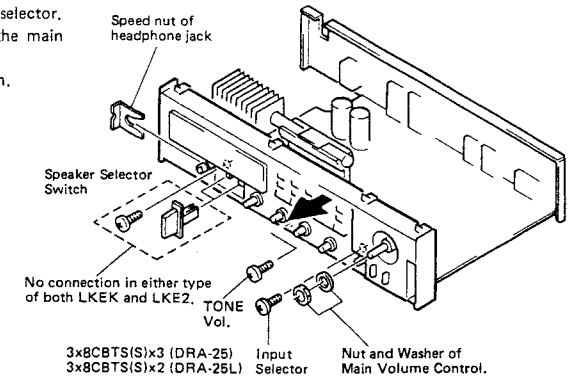

Fig. 7

5. FLD, Tact Switch PCBs

Remove the push-rivet holding the respective PCB to remove each PCB.

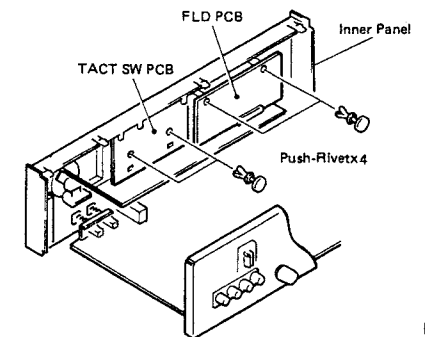
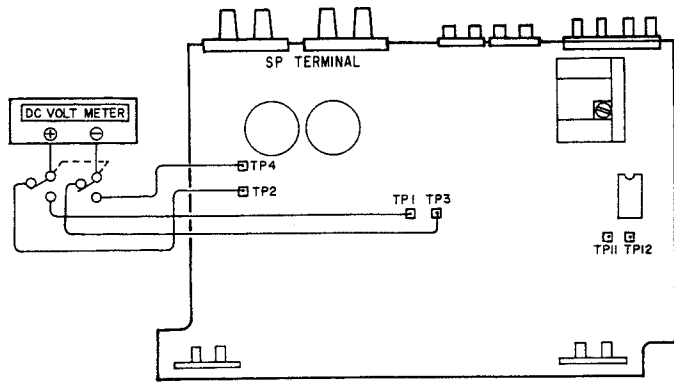

Fig. 8

METHOD OF ADJUSTMENTS



IDLE CURRENT ADJUSTMENT (Fig. 4)

1. Keep the unit away from direct wind blown by an air-conditioner and an electric fan, and keep the unit under normal conditions. Adjust the range of ambient temperature to 15 – 30°C.
2. Set the following switches as follows:
 - POWER (power switch) to off
 - VOLUME (VOLUME CONTROL) to 0 (↺)
 - SPEAKERS (speaker terminal) to no load (speakers disconnected)
3. Remove the top cover and connect a DC digital voltmeter to the test points (between the positive terminal TP3 ⊕ and the negative terminal TP1 ⊖), and between the positive TP4 ⊕ and the negative terminal TP2 (⊖).
4. (1) Connect the power source cord to an AC outlet and turn on the power switch; read the measured value after 3 minutes or when the measured value is within a tolerance 6 mV ~ 90 mV (DC), adjust the idling current manually as follows.
 (2) When the voltmeter reads 3 mV (DC) or less under the condition of item (1), disconnect the 39 ohm from resistance R517 and R518.

- AC OUTLETS . . . For U.S.A., Canada and Asia models.
 AC outlets are used for connecting amplifier component units, such as tuner, turntable, tape deck, etc.
- SWITCHED (Capacity: 100 W):
 This outlet is turned on/off when main power switch is turned on/off.
- UNSWITCHED (Total capacity: 250 W):
 These outlets are always ON whether power switch is on or off.
- LINE VOLTAGE (Voltage select switch) . . . For Asia model only.
 - * The desired voltage may be set with the VOLTAGE SELECTOR KNOB on the back panel using a screw driver.
 - * Do not twist the VOLTAGE SELECTOR KNOB with excessive force. It may be damaged.
 - * If the voltage select switch does not turn smoothly, see a qualified serviceman.

CONNECTION DIAGRAM OF MEASURING INSTRUMENTS

• FM

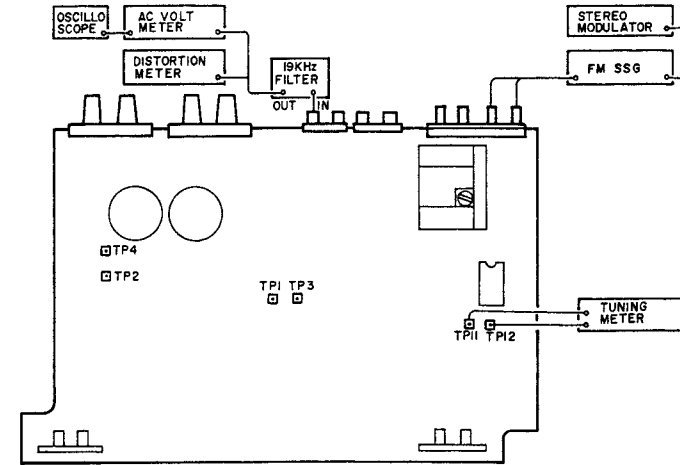

• MW

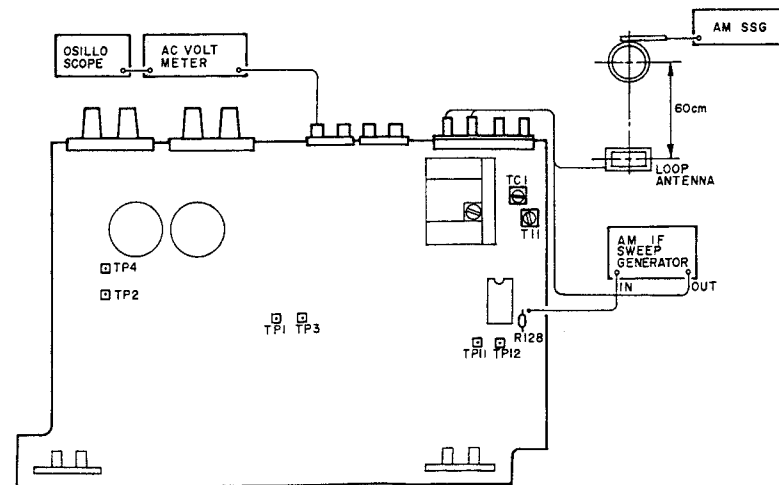

FM/MPX ALIGNEMENT

Table 1

Step	Alignment Item	Tuning Frequency Setting	Input					Output				Adjust	Remarks
			Type	Frequency	Input Level	Modulation	Coupling	Type	Connect to	Points	Adjust to		
1	Tuning Center	98 MHz	FM SSG, Mono	98 MHz	60 dB μ	None	Antenna Terminal	Center Meter	T.P. 11, 12	T-1	Center of Tuning Meter	Function: FM Mode: Auto	
2	Distortion (Mono)	98 MHz	FM SSG, Mono	98 MHz	60 dB μ	1 kHz 100%	Antenna Terminal	Distortion Meter	TAPE REC (L)	T-2	Minimum Distortion	Function: FM Mode: Auto	
3	Distortion (Stereo)	98 MHz	FM SSG Stereo (L)	98 MHz	60 dB μ	Main: 1 kHz L-ch 90% Pilot: 10%	Antenna Terminal	Distortion Meter	TAPE REC (L)	IFT on Front End	Minimum Distortion	Function: FM Mode: Auto	
4	Noise Center & Distortion		Repeat 1, 2 and 3 to obtain minimum distortion and same time indicating of center meter at center condition.										

MW ALIGNMENT

Table 2

1	AM IF	--	AM IF Sweep	--	Input Level is not over to Works A.G.C.	--	AM Antenna Terminal	Monitor-scope	R128 GND	T3	Maximum Height and Best Symmetry Curve	Function: AM Center of Wave Form: 450 kHz
2	Receiving Band Alignment	520 kHz	AM SSG	520 kHz	Input Level is not over to Works A.G.C.	400 Hz 30%	Loop Antenna	Electric DC Voltmeter	R208 GND	T-12	1.2V \pm 20mV	Function: AM
3	Tracking Alignment	600 kHz	AM SSG	600 kHz	Input Level is not over to Works A.G.C.	400 Hz 30%	Loop Antenna	Audio V.M.	TAPE REC (L)	T-11	Maximum Output	Function: AM
		1400 kHz	AM SSG	1400 kHz	Input Level is not over to Works A.G.C.	400 Hz 30%	Loop Antenna	Audio V.M.	TAPE REC (L)	TC-1	Maximum Output	Function: AM

LW ALIGNMENT (DRA-25L only)

Table 3

1	Receiving Band	153 kHz	AM SSG	153 kHz	Input Level is not over to Works A.G.C.	400 Hz 30%	Loop Antenna	Audio V.M.	R208 GND	T22	1.2V \pm 100mV	Function: AM
2	Tracking Alignment	163 kHz	AM SSG	163 kHz	Input Level is not over to Works A.G.C.	400 Hz 30%	Loop Antenna	Audio V.M.	TAPE REC (L)	T21	Maximum Output	Function: AM
		330 kHz	AM SSG	330 kHz	Input Level is not over to Works A.G.C.	400 Hz 30%	Loop Antenna	Audio V.M.	TAPE REC (L)	TC-2	Maximum Output	Function: AM

SEMICONDUCTORS

• IC

M5218P

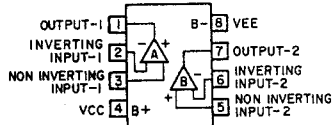
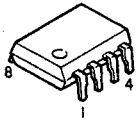

TC9172P

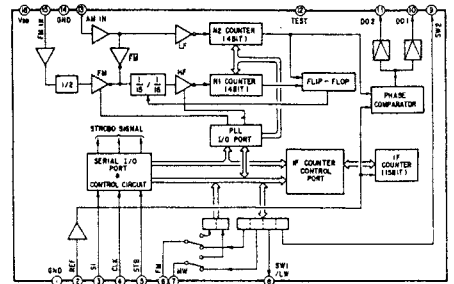
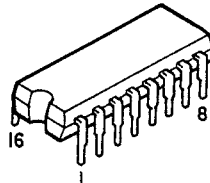

LA3401

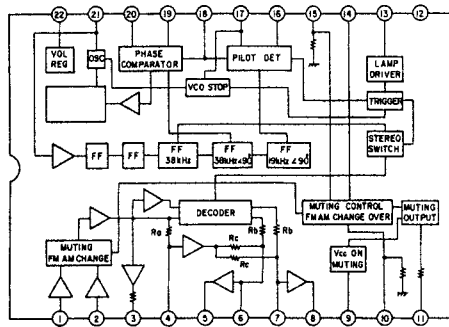
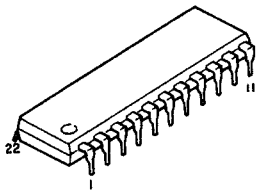

μPC1225H

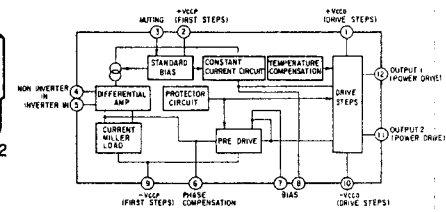
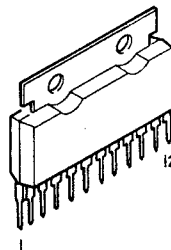

LA1266

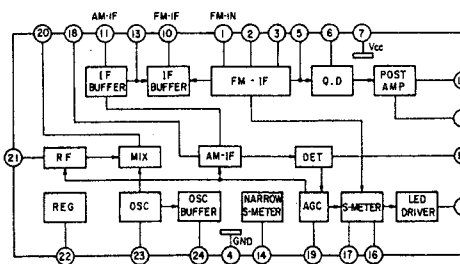
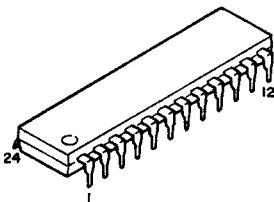

L78M12ML

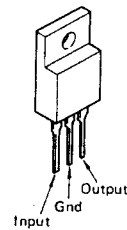

TC9303AN012

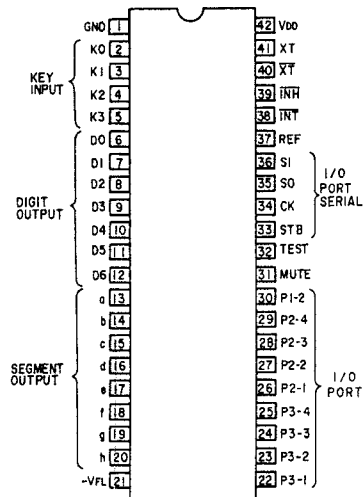
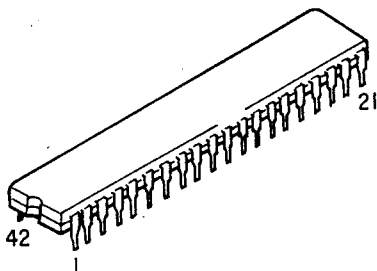

DRA25 BLOCK DIAGRAM (E2)

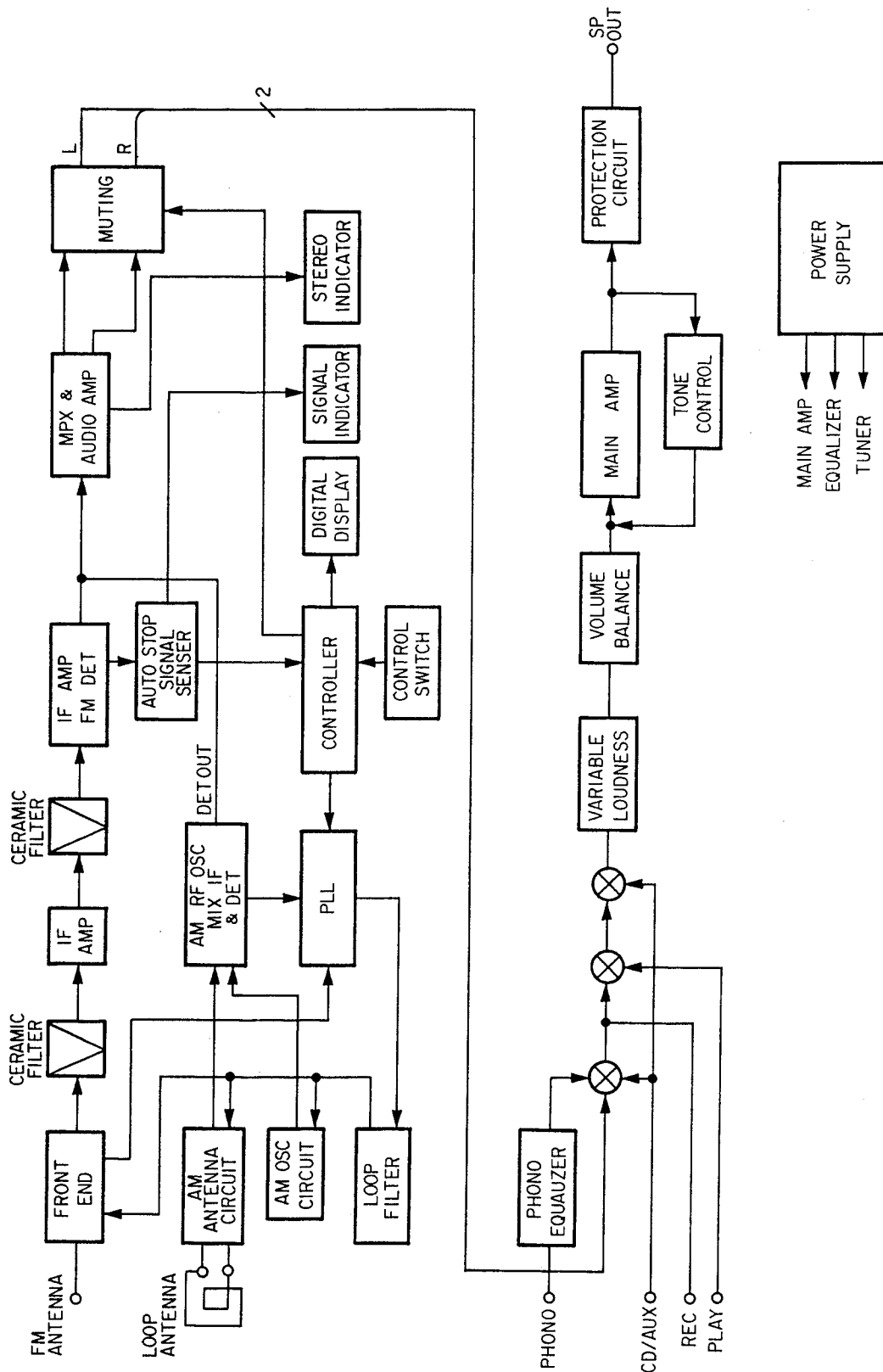

PRINTED WIRING BOARD PATTERNS AND PARTS LIST
1U-1525B AMP TUNER UNIT PARTS LIST (for DRA-25 E2)

Ref. No.	Part No.	Part Name	Remarks	Ref. No.	Part No.	Part Name	Remarks
SEMICONDUCTORS				SEMICONDUCTORS			
IC001	2630438008	LA1266		R519-522	2442018080	RS14B3AR21NBF	100kΩ, 1W, ±5%
IC002	2630439007	LA3401		R530-632	2440017020	RS14B3A10NBF	100kΩ, 1W, ±5%
IC003	2620905004	TC9172P		R633-534	2442322026	RS14B2E15NBF	100kΩ, 1W, ±5%
IC301	2630257001	M5218P		R601-602	2442379937	RS14B2E10NBF	100kΩ, 1W, ±5%
IC501,502	2630206007	μPC1225H		R603-604	2442379937	RS14B2E10NBF	100kΩ, 1W, ±5%
IC701	2630475003	L78M12ML		R614	2440046020	RS14B3A27NBF	100kΩ, 1W, ±5%
TR001	2730025023	2SC461(C)		R615	2440066025	RS14B3DB8NBF	100kΩ, 1W, ±5%
TR002	2710191003	2SA1048(GR)		R617-618	2442381046	RS14B2E10NBF	100kΩ, 1W, ±5%
TR003,004	2730317003	2SC2458(BL)		R701-702	2442379933	RS14B2E10NBF	100kΩ, 1W, ±5%
TR005	2710191003	2SA1048(GR)		R707	2440066006	RS14B3AG9NBF	100kΩ, 1W, ±5%
TR006,007	2730317003	2SC2458(BL)		R710-711	2442379985	RS14B2E15NBF	100kΩ, 1W, ±5%
TR008	2710191003	2SA1048(GR)		VR401	2119041000	V16==V25FB104R	100kΩ, TONE VR VARIABLE RESISTOR
TR009	2730317003	2SC2458(BL)		VR501	2119040001	V1604V20F-----K	MAIN VR
TR010,011	2710191003	2SA1048(GR)		CAPACITORS			
TR014~016	2730317003	2SC2458(BL)		TC001	2130022008	TRIMMER CONDENCER	
TR021	2750053004	2SK365(BL/GR)		C001,002	2538014003	CK45F2GAC103M	0.01μF/400VAC ±20%
TR022	2730317003	2SC2458(BL)		C101,102	2531024003	CK45F1H103Z	0.01μF/50V +80,-20%
TR025,026	2750051006	2SK161(GR)		C103,104	2531025002	CK45F1H223Z	0.022μF/50V +80,-20%
TR501,502	2730198015	2SC1815(BL)		C105	2531024003	CK45F1H103Z	0.01μF/50V +80,-20%
TR503,504	2730343006	2SC3853(O/Y)		C106,107	2544254938	CE04W1C470M	47μF/16V ±20%
TR505,506	2710213004	2SA1489(O/Y)		C108	2531024003	CK45F1H103Z	0.01μF/50V +80,-20%
TR601,602	2730235020	2SC1841(E/F)		C111	2544254938	CE04W1C470M	47μF/16V ±20%
TR603	2710094032	2SA970(BL/GR)		C112	2544196041	CE04W1H010M	1μF/50V ±20%
TR604~607	2730198015	2SC1815(BL)		C113	2544260074	CE04W1H4R7M	4.7μF/50V ±20%
TR608	2730253015	2SC2878(A)/(B)		C114	2544254006	CE04W1C100M	10μF/16V ± ±20%
TR701	2730198015	2SC1815(BL)		C115	2544260061	CE04W1H3R3M	3.3μF/50V ±20%
TR702	2710102021	2SA1015(GR)		C117	2539031001	CK45=1E473K	0.047μF/25V ±10%
D001~004	2760432000	1SS270A		C118	2533627000	CC45SL1H101J	100pF/50V ±5%
D005	2760049011	1S2076A		C119	2531024003	CK45F1H103Z	0.01μF/50V +80,-20%
D011,012	2760302004	SVC321D2-SP		C120	2539031001	CK45=1E473K	0.047μF/25V ±10%
D505,506	2760432000	1SS270A		C141	2544254006	CE04W1C100M	10μF/16V ±20%
D601~603	2760432000	1SS270A		C151	2544254006	CE04W1C100M	10μF/16V ±20%
D605	2760495005	DSA1A2-4		C152	2544254048	CE04W1C101M	100μF/16V ±20%
D606	2760427015	DSA1A2 (TYPE-3)		C153	2544196041	CE04W1H010M	1μF/50V ±20%
D706	2760432000	1SS270A		C154	2544260032	CE04W1HR47M	0.47μF/50V ±20%
D707	2760427015	DSA1A2 (TYPE-3)					
D708	2760511002	1SS104TP3					
D709	2760305001	S4VB20					
D710	2760527009	1B4B1					
ZD604	2760465022	HZS7B-3					
ZD701,702	2760478019	HZS18-2					
ZD703	2760473027	HZS12A-3					
ZD704	2760463011	HZS6C-2					
ZD705	2760462009	HZS6B-1					
ZD711	2760473027	HZS12A-3					
SC801	2790016001	SF0R1A42					
RESISTORS (not included Carbon Film ±5% 1/4W type)							
R001	2420073000	RC05GF2H225K	2.2MΩ, 1/4W ±10%				

1U-1526B T. CONT. UNIT PARTS LIST
(for DRA-25 E2)

Ref. No.	Part No.	Part Name	Remarks	Ref. No.	Part No.	Part Name	Remarks
C155,156	2544196041	CE04W1H010M	1μF/50V ±20%	C401,402	2554201081	CQ93P1H561J	560pF/50V ±5%
C157	2539031001	CK45=1E473K	0.047μF/25V ±10%	C403,404	2551121067	CQ93M1H223J	0.022μF/50V ±5%
C158	2533639001	CC45SL1H331J	330pF/50V ±5%	C405,406	2561034005	CF93A1H273J	0.027μF/50V ±5%
C159	2544254006	CE04W1C100M	10μF/16V ±20%	C407,408	2561034089	CF93A1H124J	0.12μF/50V ±5%
C160,161	2534350004	CC45SL1H681J	680pF/50V ±5%	C411,412	2551120026	CQ93M1H152J	1500pF/50V ±10%
C162~165	2544260061	CE04W1H3R3M	3.3μF/50V ±20%	C413,414	2551121025	CQ93M1H103J	0.01μF/50V ±5%
C166,167	2539030028	CK45=1E222K	2200pF/25V ±10%	C501,502	2561035033	CF93A1H334J	0.33μF/50V ±5%
C168,169	2539031056	CK45=1E182K	1800pF/25V ±10%	C505,506	2554200008	CQ93P1H101J	100pF/50V ±5%
C170,171	2539030002	CK45=1E102K	1000pF/25V ±10%	C507,508	2533627000	CC45SL1H101J	100pF/50V ±5%
C171,172	2531024003	CK45F1H103Z	0.01μF/50V +80,-20%	C509,510	2533603008	CC45SL1H100D	10pF/50V ±0.5pF
C181	2544260032	CE04W1HR47M	0.47μF/50V ±20%	C511,512	2544254006	CE04W1C100M	100μF/16V ±20%
C201	2544254048	CE04W1C101M	100μF/16V ±20%	C513,514	2551072006	CQ93M1H103K	0.01μF/50V ±5%
C202	2531025002	CK45F1H223Z	0.022μF/50V +80,-20%	C515,516	2554125002	CQ93P1H151J	150pF/50V ±5%
C203	2543016009	CE04D1H010MBP	1μF/50V ±20%	C517,518	2551120068	CQ93M1H332J	3300pF/50V ±5%
C204	2544196041	CE04W1H010M	1μF/50V ±20%	C521,522	2561034076	CF93A1H104J	0.1μF/50V ±5%
C205	2531024003	CK45F1H103Z	0.01μF/50V +80,-20%	C523~526	2561035059	CF93A1H474J	0.47μF/50V ±5%
C206	2544196041	CE04W1H010M	1μF/50V ±20%	C527,528	2543014056	CE04D1C330MBP	33μF/16V ±20%
C210	2531024003	CK45F1H103Z	0.01μF/50V +80,-20%	C529,530	2544196041	CE04W1H010M	1μF/50V ±20%
C211	2544252037	CE04W1A101M	100μF/10V ±20%	C601,602	2531025002	CK45F1H223Z	0.022μF/50V +80,-20%
C221	2531025002	CK45F1H223Z	0.022μF/50V +80,-20%	C603	2531024003	CK45F1H103Z	0.01μF/50V +80,-20%
C222	2533607004	CC45SL1H150J	15pF/50V ±5%	C604	2544250026	CE04W0J101M	100μF/6.3V ±20%
C223	2554201049	CQ93P1H391J	390pF/50V ±5%	C605	2544211007	CE04W1A101M	100μF/10V ±20%
C301,302	2533627000	CC45SL1H101J	100pF/50V ±5%	C606	2544260032	CE04W1HR47M	0.47μF/50V ±20%
C303,304	2544254006	CE04W1C100M	10μF/16V ±20%	C607	2544196041	CE04W1H010M	1μF/50V ±20%
C305,306	2551120000	CQ93M1H102J	1000pF/50V ±5%	C701,702	2544212019	CE04W==822M	8200μF/50V ±20%
C307,308	2544250039	CE04W0J221M	220μF/6.3V ±20%	C703,704	2531052004	CK45E2H472P	4700pF/500V +100,-0%
C309,310	2554199999	CQ92M1H243J	0.024μF/50V ±5%	C706	2544258918	CE04W1V100M	10μF/35V ±20%
C311,312	2551121009	CQ93M1H682J	6800pF/50V ±5%	C707~710	2531024003	CK45F1H103Z	0.01μF/50V +80,-20%
C315,316	2544260058	CE04W1H2R2M	2.2μF/50V ±20%	C711	2544256088	CE04W1E102M	1000μF/25V ±20%
C317,318	2544196041	CE04W1H010M	1μF/50V ±20%	C712	2544254006	CE04W1C100M	10μF/16V ±20%
C331,332	2533619005	CC45SL1H470J	47pF/50V ±5%	C713	2544252037	CE04W1A101M	100μF/10V ±20%
C333,334	2533619005	CC45SL1H470J	47pF/50V ±5%	C714	2590004006	SBCAP=223=	22mF/5.5V ±20%
C341	2544260061	CE04W1H3R3M	3.3μF/50V ±20%	C715,716	2544256004	CE04W1E100M	10μF/25V ±20%
C342	2531024003	CK45F1H103Z	0.01μF/50V +80,-20%				

Ref. No.	Part No.	Part Name	Remarks
C717,718	2544196041	CE04W1H010M	1μF/50V ±20%
C719	2544260058	CE04W1H2R2M	2.2μF/50V ±20%
SWITCH & RELAY & COIL			
SW401	2124664003	ROTARY SWITCH	FUNCTION
SW402,403	2124676004	2P PUSH SWITCH	TAPE, CD
SW501,502	2129532004	2P PUSH SW (SP)	SPEAKER
T001	2312065003	FM IF DET TRANS(P)	
T002	2312066002	FM IF DET TRANS(S)	
T003	2313029006	AM IFT	
T004	2320121007	ANTI BIRDIE FILTER	
T011	2311127007	MW ANT TRANS	
T012	2311130007	MW OSC COIL	
CF001,002	2610064007	SFT10.7MS2	
CF003	2610031001	BFU450C4 (C.F.)	
L101,102	2350020990	INDUCTOR 393J	
CF004	2610079005	CSB456F11	
L301,302	2359003002	FTZ CHOKE COIL	
L501,502	2350007007	INDUCTOR	
RL601	2149003005	RELAY	
OTHER PARTS			
F001	2160065006	FRONT END	1
	2050433007	3P ANT TERMINAL (DIN)	1
	2048254007	4P PIN JACK	2
	2050351105	4P TERMINAL	2
	2048209007	H/P JACK	1
	2050442001	2P WRAPPING TERMINAL	2
	2020022008	FUSE HOLDER	2
	2061015016	FUSE (1.25A)	1
	2090149034	3C RIBBON CABLE	1
	2090147010	6C RIBBON CABLE	1
CN3A	2050185038	3P WIRE HOLDER	2
CN4	2050343045	4P CONN. BASE (KR-PH)	1
CN5	2050343058	5P CONN. BASE (KR-PH)	1
CN6	2050343061	6P CONN. BASE (KR-PH)	1
	4170300005	RADIATOR BLOCK	1
	4736007009	CUP SCREW 3x12	4
	4737508017	TAPPING SCREW(P)	2
		3x10 BLACK F.S WASHER	2
CN6A	2050185067	6P WIRE HOLDER	2
	5130654033	FUSE LABEL (1.25A)	1

Ref. No.	Part No.	Part Name	Remarks
SEMICONDUCTORS			
IC251	2620906003	TC9303AN012	
D251~255	2760049011	1S2076A	
D257	2760049011	1S2076A	
D259	2760049011	1S2076A	
D262,263	2760049011	1S2076A	
RESISTORS			
R251,252	2412132001	RD14B2E473J	47kΩ, 1/4W ±5%
CAPACITORS			
C251,252	2533603008	CC45SL1H100D	10pF/50V ±0.5pF
C253	2531024003	CK45F1H103Z	0.01μF/50V +80,-20%
C254	2544250026	CE04W0J101M	100μF/6.3V ±20%
C255	2544258057	CE04W1V101M	100μF/35V ±20%
C256	2561034076	CF93A1H104J	0.1μF/50V ±5%
SWITCH			
	2124407008	TACT SWITCH	15
OTHER PARTS			
XL001	3990040009	X'TAL (7.2MHz)	1
	3934043004	FLD (FIP10TM7)	1
	4122268108	FLD BRACKET	1
CN4	2090174038	5C RIBBON CABLE	2
	2036172010	4P CONNECTOR	1
CN5	2038203000	CORD	1
		5P CONNECTOR	1
CN6	2040143019	CORD	1
		6P CONNECTOR	1
CN010	2050185009	CORD	2
		10P WIRE HOLDER	2

1U-1525C for (DRA-25L E2, EK)

[Same as 1U-1525B (for DRA-25, E2 Black) except the followings]

Ref. No.	Part No.	Part Name	Remarks
SEMICONDUCTORS			
TR031	2710191003	2SA1048(GR)	ADD
TR032~038	2730317003	2SC2458(BL)	ADD
D021,022	2760302004	SV C321D2-5P	ADD
D031,032	2760432000	1S5270A	ADD
RESISTORS (not included Carbon Film $\pm 5\%$ 1/4W type)			
R561,562	2432039029	RW99=3HR22K	0.22 Ω , 5W $\pm 10\%$ ADD
CAPACITORS			
TC002	2130041063	TRIMMER CONDENSER	ADD
C231	2531025002	CK45F1H223Z	0.022 μ F/50V +80,-20% ADD
C232	2533625002	CC45SL1H820J	82pF/50V $\pm 5\%$ ADD
C233	2554127000	CQ93P1H181J	180pF/50V $\pm 5\%$ ADD
C301,302	2556084002	CO09S1H241J	240pF/50V $\pm 5\%$ ADD
C301,302	2533627000	CC45SL1H101J	100pF/50V $\pm 5\%$ DELETE
C331,332	2533619005	CC45SL1H470J	47pF/50V $\pm 5\%$ DELETE
C333,334	2533619005	CC45SL1H470J	47pF/50V $\pm 5\%$ DELETE
C507,508	2533627000	CC45SL1H101J	100pF/50V $\pm 5\%$ DELETE
SWITCH & RELAY & COIL			
SW501,502	2129532004	2P PUSH SW (SP)	DELETE
L301,302	2359003002	FTZ CHOKE COIL	DELETE
T021	2311128006	LW ANT TRANS	ADD
T022	2311131006	LW OSC COIL	ADD
OTHER PARTS			
	2050351105	4P TERMINAL (1)	DELETE

1U-1526C for (DRA-25L E2, EK)

[Same as 1U-1526B (for DRA-25 E2 Black) except the followings]

Ref. No.	Part No.	Part Name	Remarks
SEMICONDUCTORS			
D258	2760049011	1S2076A	ADD

PRINTED WIRING BOARD

1U-1526-1 TUNER CONTROL UNIT

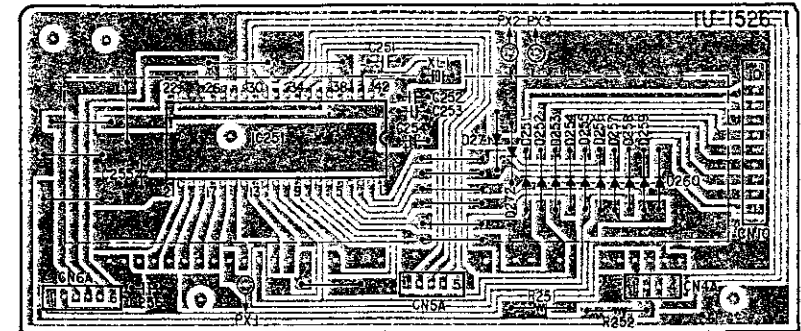

1U-1526-2 TUNER CONTROL UNIT

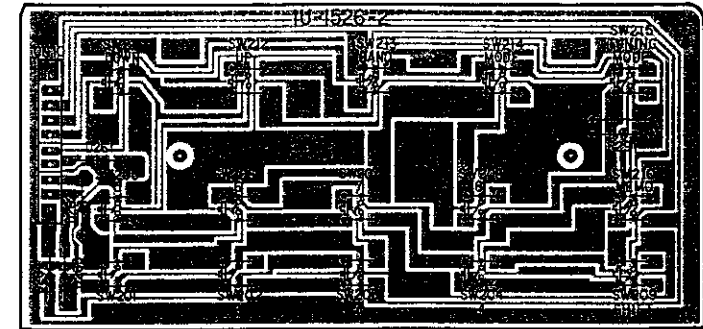

1U-1525B AMP TUNER UNIT (for DRA-25 E2 Black)

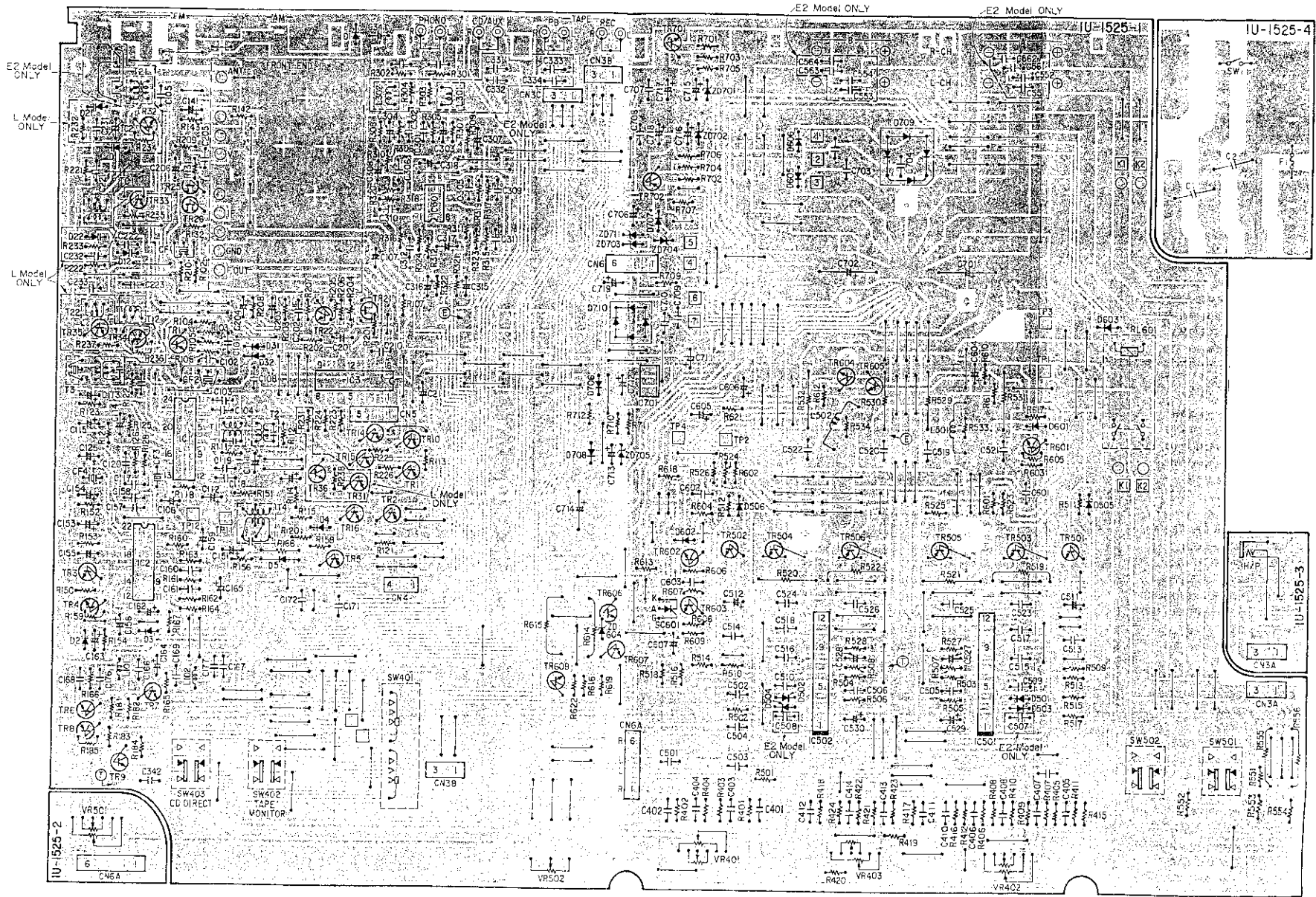

EXPLODED VIEW OF CHASSIS AND CABINET & PARTS LIST (DRA-25/25L)

PARTS LIST OF EXPLODED VIEW
DRA-25 (for E2 Black)

Ref. No.	Part No.	Part Name	Q'ty
* 1	1U-1525B	AMP TUNER UNIT	1
* 2	1U-1526B	TUNER CONTROL UNIT	1
* 3	1050735162	BACK PANEL	1
4	—	—	—
5	2050071016	ACCORD WITH PLUG	1
6	2050071016	ACCORD WITH PLUG	1
7	2050071016	TERMINAL ASS'Y	1
8	4770018001	WASHER (P-87)	1
9	1460899009	ANTENNA HOLDER	1
**10	5131144005	MASKING SHEET	1
11	—	—	—
12	—	—	—
13	2335623008	POWER TRANS	1
14	4430518029	P.C.B. HOLDER	3
15	4170301004	H.P RADIATOR-25	1
16	4129082002	RADIATOR BRACKET	1
17	4610346008	SPACER-RUBBER	1
18	1460894208	INNER PANEL	1
19	1130969104	PUSH KNOB (T)	1
20	4770210016	PUSH RIVET	4
21	—	—	—
22	1430519102	WINDOW	1
23	4770288006	PUSH RIVET	4
24	4140422104	SHIELD PLATE	1
* 25	1130867002	PUSH KNOB (D)	4
26	1130854002	PUSH KNOB (P)	1
27	1190059106	KNOB JOINT	1
28	—	—	1
29	—	—	—
* 30	1441639204	FRONT PANEL ASS'Y	1
31	1120515005	VOL. KNOB	1
32	1120517003	KNOB (TONE, BALANCE)	3
33	1120517016	KNOB (LOUDNESS)	1
34	1120516004	KNOB (SELECTOR)	1
35	1020283123	TOP COVER	1
36	4110686103	MAIN CHASSIS	1
37	1040111000	FOOT	4
38	4140426003	SAFETY PLATE	2
* 39	4610357000	SPACER-RUBBER	1
* 40	1220069066	SPACER	2
SCREWS & NUTS & WASHER			
*101	4737002021	TAPPING SCREW(S) 3 x 8 (BLACK)	13
102	4737004016	TAPPING SCREW(S) 4 x 6	4
103	4737500044	TAPPING SCREW(P) 3 x 8 (BLACK)	1
104	4737508017	TAPPING SCREW(P) 3 x 10 (BLACK)	8
*105	4730305026	TAPPING SCREW(I) 3 x 10	2

Ref. No.	Part No.	Part Name	Q'ty
106	4737015005	TAPPING SCREW(S) 3 x 6 (BLACK)	8
107	—	φ9 WASHER	1
108	—	φ9 NUT	1
109	—	SPEED NUT	1
*110	4737007000	TAPPING SCREW(S) 4 x 8 (BLACK)	4
PACKING & ACCESSORIES (not included EXPLODED VIEW)			
201	5058006019	ENVELOPE	1
202	5111590006	INST. MANUAL	1
203	—	—	—
204	2311129005	LOOP ANTENNA	1
205	5290040008	FM ANT ADAPTOR	1
206	5050143019	CABINET COVER	1
207	5030634108	CUSHION	2
* 208	5011196115	CARTON CASE	1
* 209	5139111014	COLOR LABEL (BLACK)	2
210	5020658000	PAD	1
* 211	5131167008	CONTROL CARD	1

DRA25 (for E2 Gold)

[Same as parts list (for DRA-25 E2 Black) except the followings]

Ref. No.	Part No.	Part Name	Q'ty
18	1460894211	INNER PANEL	1
19	1130969117	PUSH KNOB (T)	1
25	1130867015	PUSH KNOB (D)	4
26	1130854015	PUSH KNOB (P)	1
30	1441639220	FRONT PANEL ASS'Y	1
31	1120515018	VOL. KNOB	1
32	1120517029	KNOB(TONE,BALANCE)	3
33	1120517032	KNOB(LLOUDNESS)	1
34	1120516017	KNOB(SELECTOR)	1
35	1020283136	TOP COVER	1
SCREW			
110	4737014006	TAPPING SCREW(S) 4 x 8 (MFCR)	4
PACKING & ACCESSORIES (not included EXPLODED VIEW)			
208	5011196128	CARTON CASE	1
209	5139111001	COLOR LABEL (GOLD)	2

ADDENDUM LIST

Ref. No.	Part Name & Descriptions	Version	DRA-25L		
			Part No.	E.K for U.K	E ₂ for Europe
1	AMP TUNER UNIT	—	1U-1525C	1U-1525C	1U-1525C
2	TUNER CONTROL UNIT	—	1U-1526C	1U-1526C	1U-1526C
3	BACK PANEL	—	1050735175	1050735188	1050735188
5	ACCORD WITH LABEL	2050071016	—	—	—
6	ACCORD WITH PLUG	2050071016	—	2050071016	2050071016
* 10	MASKING SHEET	—	—	—	—
13	POWER TRANS	2335623008	2335623008	2335623008	2335623008
25	PUSH KNOB (D)	1130867002 (2)	1130867002 (2)	1130867015 (2)	1130867015 (2)
30	FRONT PANEL ASS'Y	1441639217	1441639217	1441639233	1441639233
101	TAPPING SCREW(S) 3x8 (BLACK)	4737002021 (12)	4737002021 (12)	4737002021 (12)	4737002021 (12)
105	TAPPING SCREW(1) 3x10	4730305026 (1)	4730305026 (1)	4730305026 (1)	4730305026 (1)
110	TAPPING SCREW(S) 4x8	4737007000 (BLACK)	4737007000 (BLACK)	4737014006 (MFCR)	4737014006 (MFCR)
208	CARTON CASE	5011196131	5011196131	5011196144	5011196144
209	COLOR LABEL	5139111014	5139111014	5139111011	5139111011
211	CONTROL CARD	—	5131167008	5131167008	5131167008
212	HAYDEN BROCHURE	5111583000	—	—	—

Note 1. See addendum list above for the parts with asterisk (*) on the Ref. No. and the other parts not included in the list.
 2. * marked not included EXPLODED VIEW OF CHASSIS AND CABINET.
 3. This list is prepared based on E2 BLACK VERSION.

EXPLODED VIEW OF CHASSIS AND CABINET (DRA-25/25L)

1 2 3 4 5 6 7 8

⚠ Means important safety item, which must be replaced, when necessary, by a part specified or meeting the specification by the manufacturer.

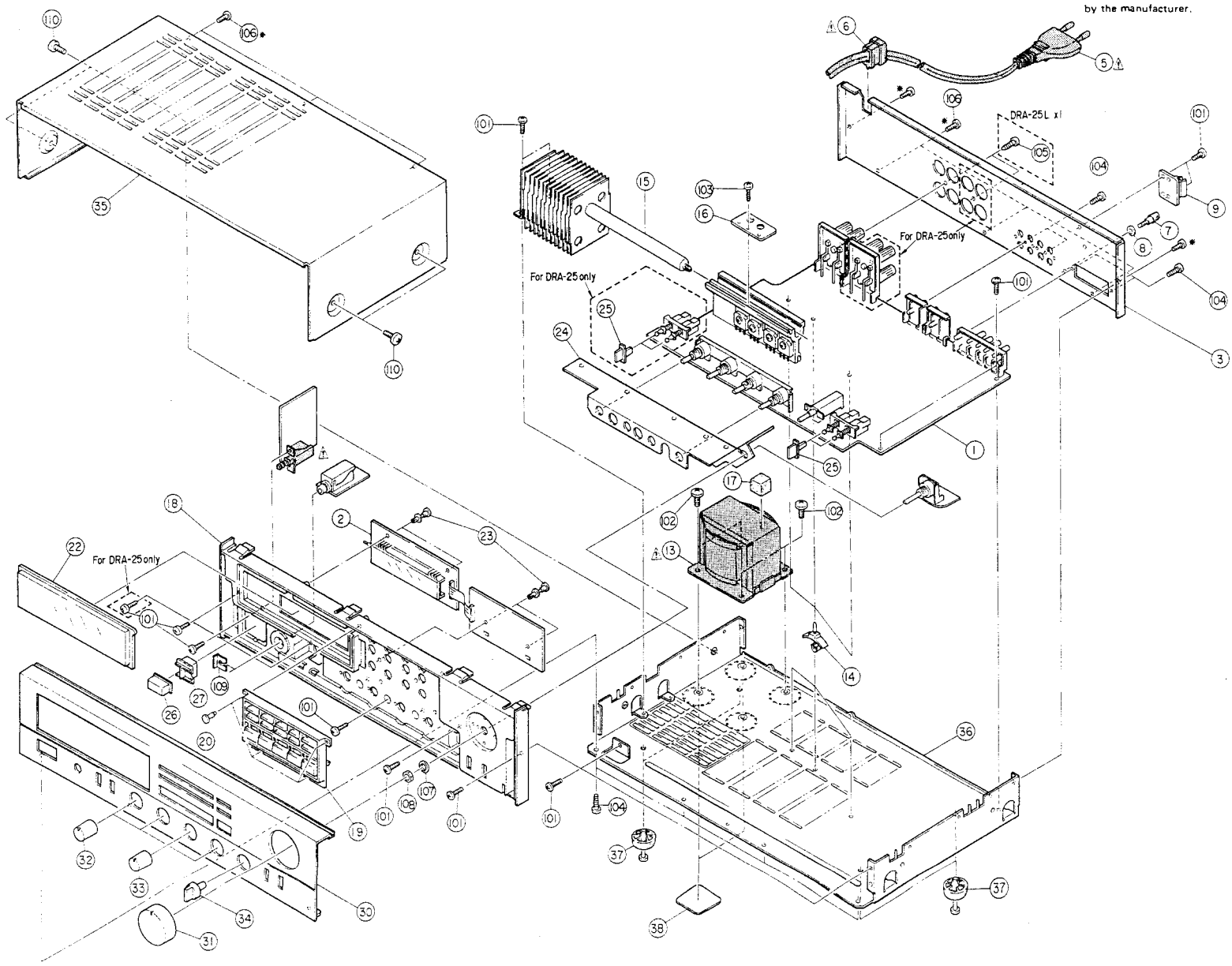

A
B
C
D
E

WIRING DIAGRAM

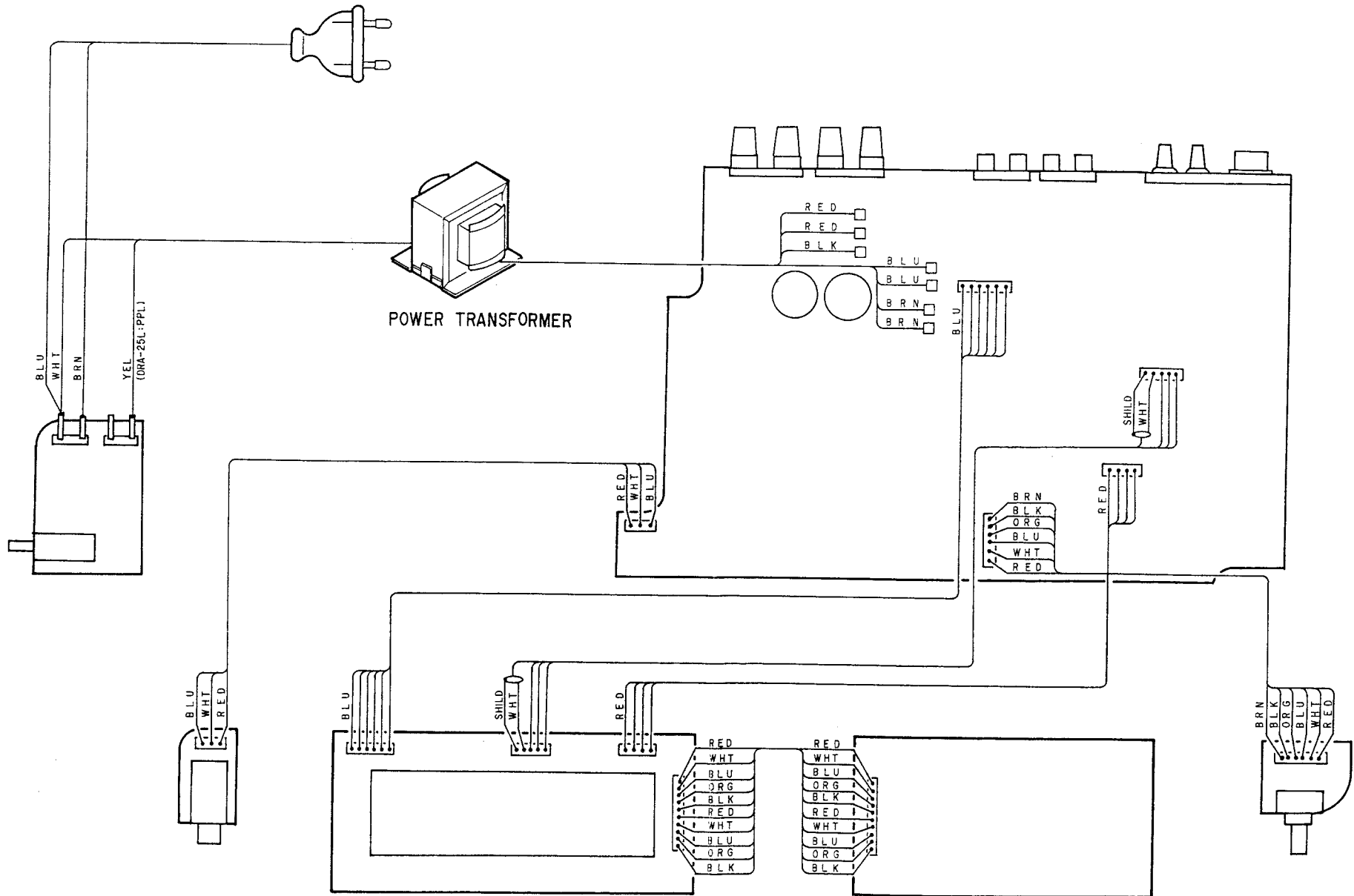

⚠ Means important safety item, which must be replaced, when necessary, by a part specified or meeting the specification by the manufacturer.

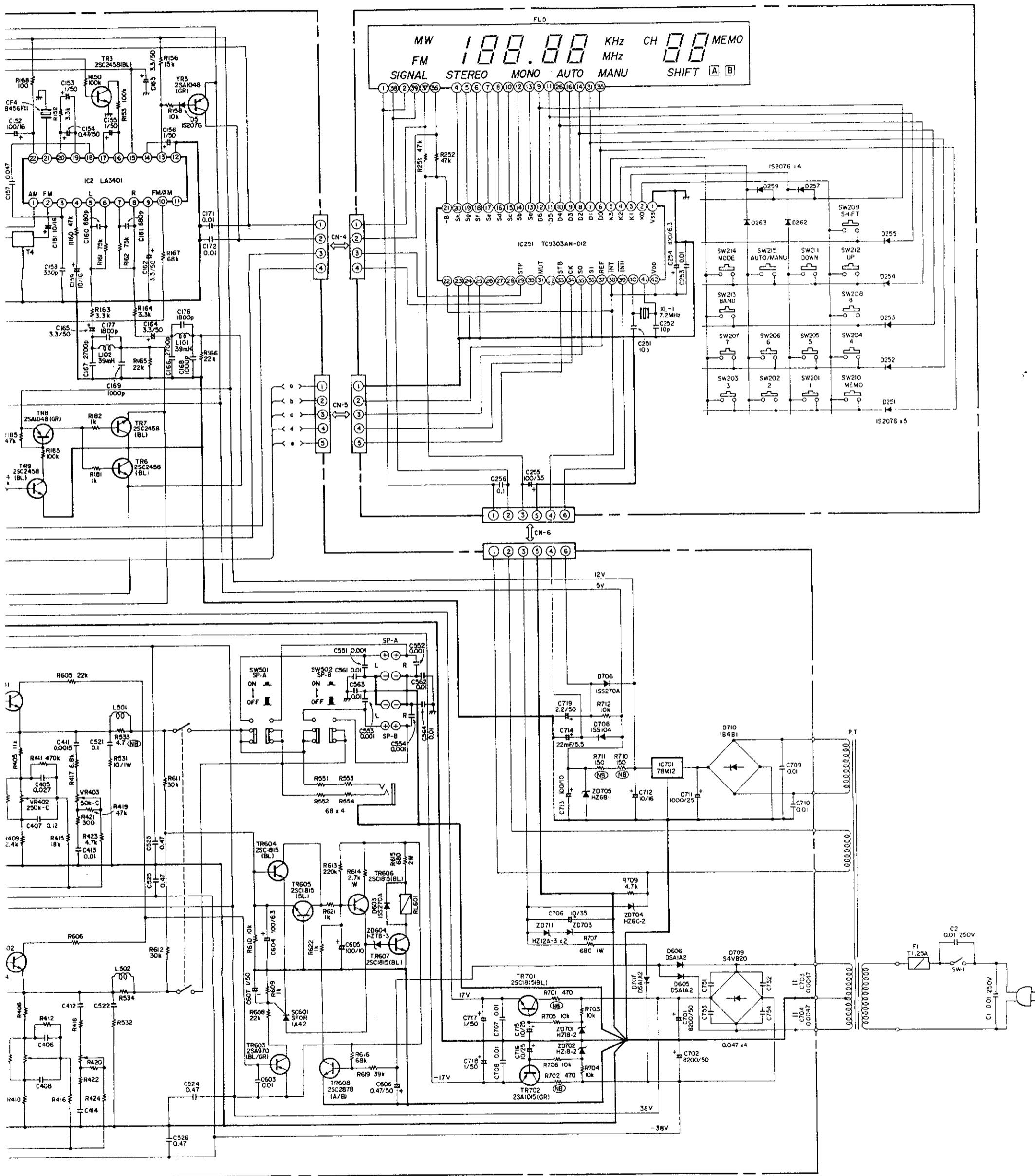

NOTES:
 ALL RESISTANCE VALUES IN OHM, k = 1,000 OHM, M = 1,000,000 OHM.
 ALL CAPACITANCE VALUES IN MICROFARAD, P = MICRO-MICRO FARAD.
 EVERY VOLTAGES AND CURRENTS IS MEASURED AT NO SIGNAL INPUT CONDITION.
 CIRCUIT AND PARTS ARE SUBJECT TO CHANGE WITHOUT PRIOR NOTICE.

SCHEMATIC DIAGRAM (for DRA-25L)

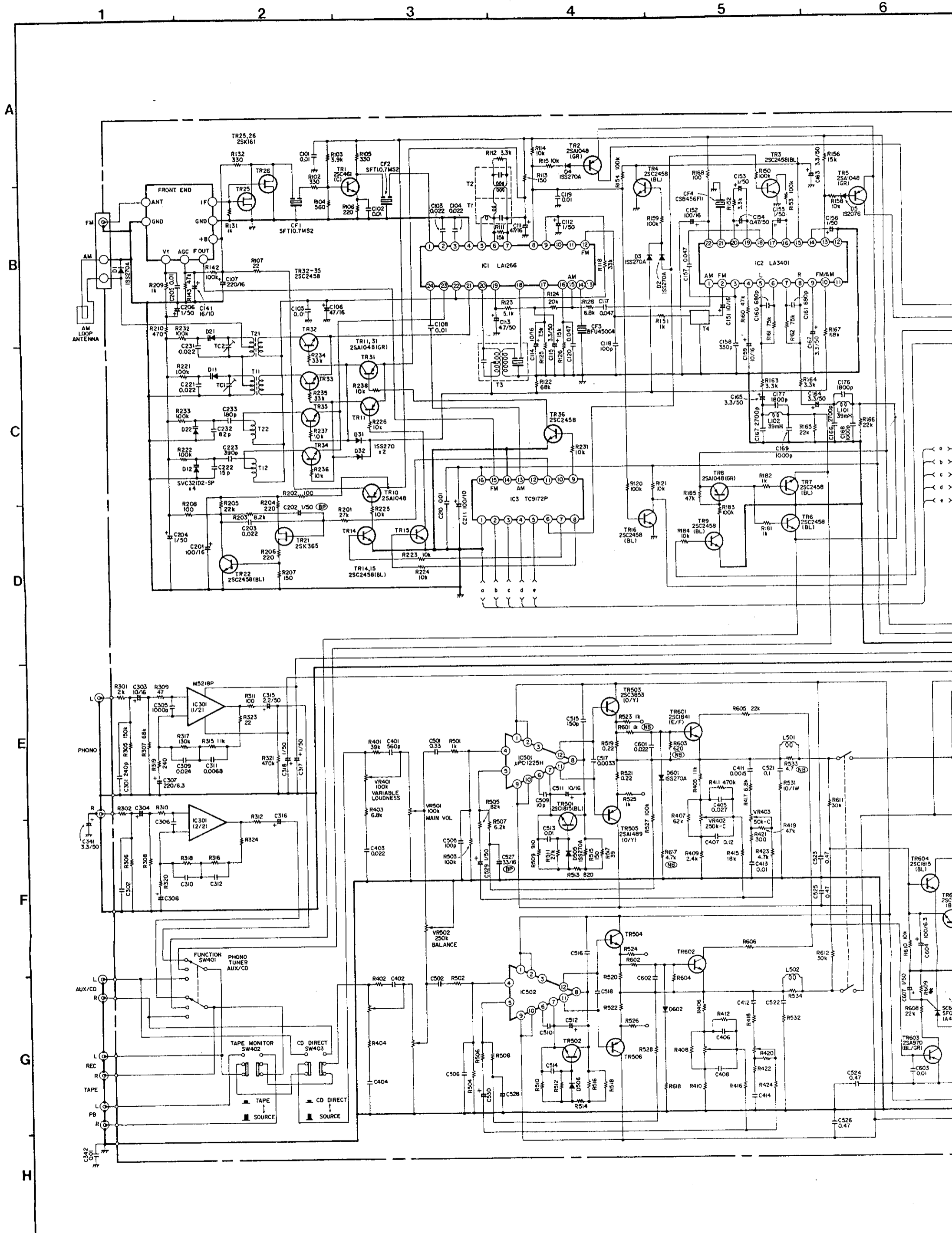

⚠ Means important safety item, which must be replaced, when necessary, by a part specified or meeting the specification by the manufacturer.

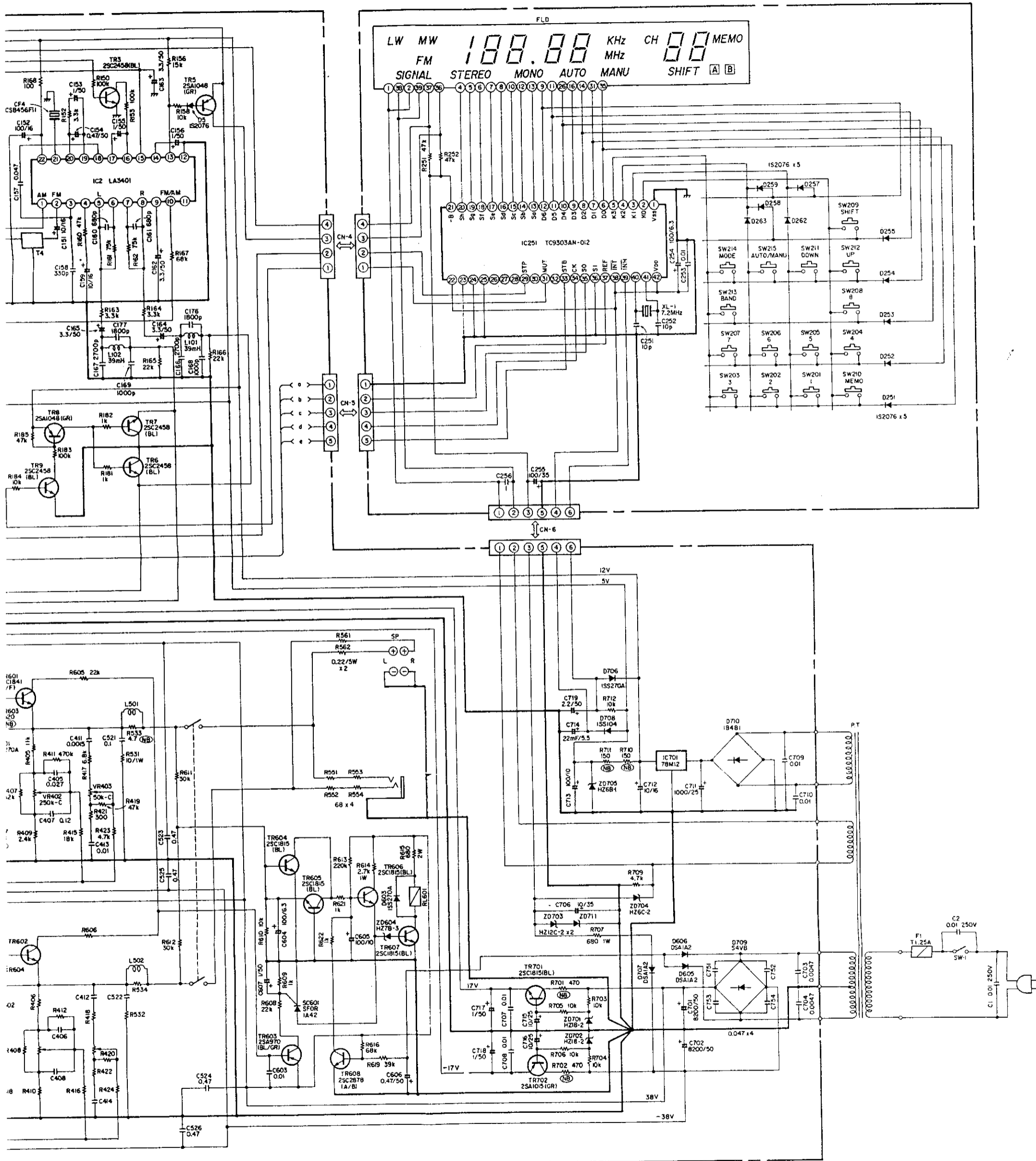

NOTES
 ALL RESISTANCE VALUES IN OHM k = 1,000 OHM M = 1,000,000 OHM
 ALL CAPACITANCE VALUES IN MICRO FARAD P = MICRO-MICRO FARAD
 EACH VOLTAGE AND CURRENT ARE MEASURED AT NO SIGNAL INPUT CONDITION
 CIRCUIT AND PARTS ARE SUBJECT TO CHANGE WITHOUT PRIOR NOTICE.