

SERV. 33484

DENON

Hi-Fi AV RECEIVER

SERVICE MANUAL MODEL DRA-75VR

FOR EUROPEAN, AUSTRALIA
AND OTHER MODELS

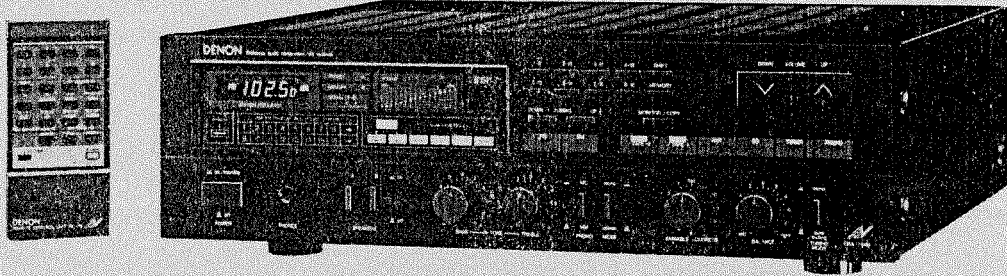

CONTENTS

SPECIFICATIONS	2
NAMES AND FUNCTIONS OF PARTS	3
BLOCK DIAGRAM	4 ~ 5
REMOVAL OF EACH SECTION	5
ANTENNA INSTALLATION	7
CONNECTIONS	8 ~ 9
METHOD OF ADJUSTMENTS	10 ~ 11
SEMICONDUCTORS	12 ~ 13
P.W.B. UNIT	19 ~ 21
P.W.B. PARTS LIST	21 ~ 25
WIRING DIAGRAM	26 ~ 27
EXPLODED VIEW OF CHASSIS AND CABINET, AND PARTS LIST	28 ~ 30
SCHEMATIC DIAGRAM	31 ~ 34

NIPPON COLUMBIA CO., LTD.

SPECIFICATIONS

AMPLIFIER SECTION

Rated Output Power
(Both Channels driven): 100 W + 100 W
(4 ohms 1 kHz T.H.D. 1%)
65 W + 65 W (8 ohms
20 Hz ~ 20 kHz T.H.D. 0.015%)
[65 watts per channel minimum
RMS, both channels driven at 8
ohms from 20 Hz ~ 20 kHz no
more than 0.015% total harmonic
distortion]

Power Bandwidth (IHF): 5 Hz ~ 40 kHz (T.H.D. 0.05% both
ch. driven at 8 ohms)

Total Harmonic Distortion
(20 Hz to 20 kHz): -3 dB power into 8 ohms 0.0095%

Intermodulation Distortion
(60 Hz: 7 kHz,
4: 1 SMPTE): Rated power into 8 ohms 0.025%

Output Impedance: 0.1 ohm (at 1 kHz, 8 ohms)

Frequency Response: PHONO RIAA Standard Curve
(Recording Output)
MM 20 Hz ~ 20 kHz ± 0.5 dB
MC 50 Hz ~ 20 kHz ± 0.5 dB
VCR/TAPE2, AUX, CD, VIDEO/TAPE1
20 Hz ~ 50 kHz ± 1.5 dB

Input Sensitivity and Impedance: PHONO
MM 2.5 mV 47 k ohms
MC 0.25 mV 100 ohms
VCR/TAPE2, AUX, CD, VIDEO/TAPE1
150 mV 47 k ohms

Maximum Input Level
(at 1 kHz): PHONO MM 150 mV
MC 15 mV

Signal to Noise Ratio
(IHF-A): PHONO
MM 88 dB at 5.0 mV input
MC 68 dB at 0.5 mV input
VCR/TAPE2, AUX, CD, VIDEO/TAPE1
98 dB at 150 mV input

Tone Controls: BASS ±8 dB at 100 Hz
TREBLE ±8 dB at 10 kHz

Loudness, Control Effect: VARIABLE LOUDNESS 10
positions, 50 Hz/10 kHz,
+10 dB/+5 dB

TUNER SECTION
(FM)

Receiving Range: 87.5 MHz ~ 108 MHz
[87.5 MHz ~ 108 MHz
(100 kHz ~ 50 kHz separation)]

Usable Sensitivity: 0.8 μV (9.3 dBf)

S/N 50 dB Quieting
Sensitivity
(μV at 75 ohms and
0 dB at 10 ~ 15 W): MONO 1.5 μV (14.7 dBf)
[1.8 μV (16.4 dBf)]
STEREO 20 μV (37.3 dBf)

Signal to Noise Ratio

(IHF-A): MONO 82 dB
STEREO 80 dB
Total Harmonic Distortion: MONO 0.1% at 1 kHz
STEREO 0.3% at 1 kHz
[MONO 0.07% at 1 kHz]
[STEREO 0.12% at 1 kHz]

Capture Ratio: 1.2 dB
Image Rejection: 75 dB
[40 dB]

AM Suppression: 60 dB
Selectivity: 70 dB (±400 kHz)
[60 dB (±400 kHz)]

Frequency Response: 20 Hz ~ 15 kHz +0.3 dB
-0.5 dB

Stereo Separation: 40 dB at 1 kHz
[50 dB at 1 kHz]

[AM]

Receiving Range: 522 kHz ~ 1611 kHz
[520 kHz ~ 1710 kHz
(10 kHz separation)
or 522 kHz ~ 1611 kHz
(9 kHz separation)]

Usable Sensitivity: 18 μV

Signal to Noise Ratio: 55 dB

VIDEO SECTION

Video Input/Output
Input Terminal VIDEO, IN: 1 Vp-p/75 ohm

Output Terminal OUT,
MONITOR: 1 Vp-p/75 ohm

Frequency Response: 5 Hz ~ 6 MHz ± 1.5 dB

GENERAL

Power Supply: AC 220 V or 240 V/50 Hz
[AC 110/120/220/240 V, 50/60 Hz]
[Multiple (120 V Preset)]

Power Consumption: 140 W
[113 W]

Power Outlets: [SWITCHED 100 W/]
[UNSWITCHED 250 W]

Dimensions: 434 mm (17-3/32") W x 137 mm
(5-1/16") H x 386 mm (15-13/64") D
[434 mm (17-3/32") W x 137 mm
(5-1/16") H x 378 mm (14-7/8") D]

Weight: 8.9 kg (19 lbs. 10 oz)

REMOTE CONTROL UNIT RC-75

Remote control system: Infrared pulse system

Power supply: 3 V DC Two SUM-4 (standard size
four) dry cell batteries

External dimensions: 60 (2-23/64") W x 150 (5-29/32") H
x 17 (43/64") D mm

Weight: 87 g (Includes batteries)
(about 3 oz)

[] is for Asian (EP1) model

Design and specifications are subject to change without prior notice.

NAMES AND FUNCTIONS OF PARTS

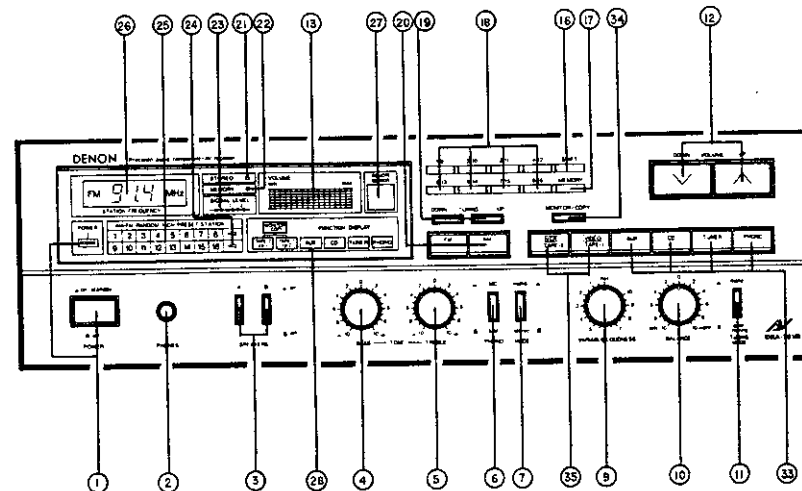

- ① POWER and LED indicator
(Power supply button and LED indicator)
- ② PHONES (Headphone jack)
- ③ SPEAKERS (Speaker select switches)
• A, • B
- ④ BASS (Bass control)
- ⑤ TREBLE (Treble control)
- ⑥ PHONO (Cartridge select switch)
• MC, • MM
- ⑦ MODE (Mode button)
• stereo, • mono
- ⑧ -
- ⑨ VARIABLE LOUDNESS (Loudness control)
- ⑩ BALANCE (Balance control)
- ⑪ TUNING MODE (FM mode, muting and tuning mode
switch)
• auto/muting, • mono
- ⑫ VOLUME (Volume control)
• UP, • DOWN
- ⑬ VOLUME INDICATOR
- ⑭ -
- ⑮ -
- ⑯ SHIFT (Shift button)
- ⑰ MEMORY (Memory button)
- ⑱ PRESET CHANNEL 1 ~ 16 (Press station buttons)
- ⑲ TUNING (Tuning buttons)
• UP, • DOWN
- ⑳ BAND SELECT (Band selector buttons)
• FM, • AM
- ㉑ STEREO (Stereo indicator)
- ㉒ MEMORY INDICATOR
- ㉓ SIGNAL (Signal-strength indicator)
- ㉔ SHIFT INDICATOR
- ㉕ PRESET CHANNEL INDICATOR
- ㉖ FREQUENCY INDICATOR
- ㉗ REMOTE CONTROL PHOTOSENSITIVE WINDOW
- ㉘ FUNCTION INDICATOR
- ㉙ -
- ㉚ -
- ㉛ -
- ㉜ -
- ㉝ INPUT SELECTOR (Input select buttons)
• PHONO, • TUNER, • CD, • AUX.
- ㉞ MONITOR/COPY (VCR and tape monitor/copy
switch)
- ㉟ VIDEO/TAPE SELECTOR (Video/tape selector
switch)
• VIDEO/TAPE-1, • VCR/TAPE-2

NOTE: The following codes correspond to the appropriate models.
EP1 for Asia, E2 for Europe, EA for Australia, New Zealand, EK for U.K., EU for U.S.A. and
EC for Canada.
This Service Manual is prepared based on E2 Black Version.

BLOCK DIAGRAM
(for E2 and EA)

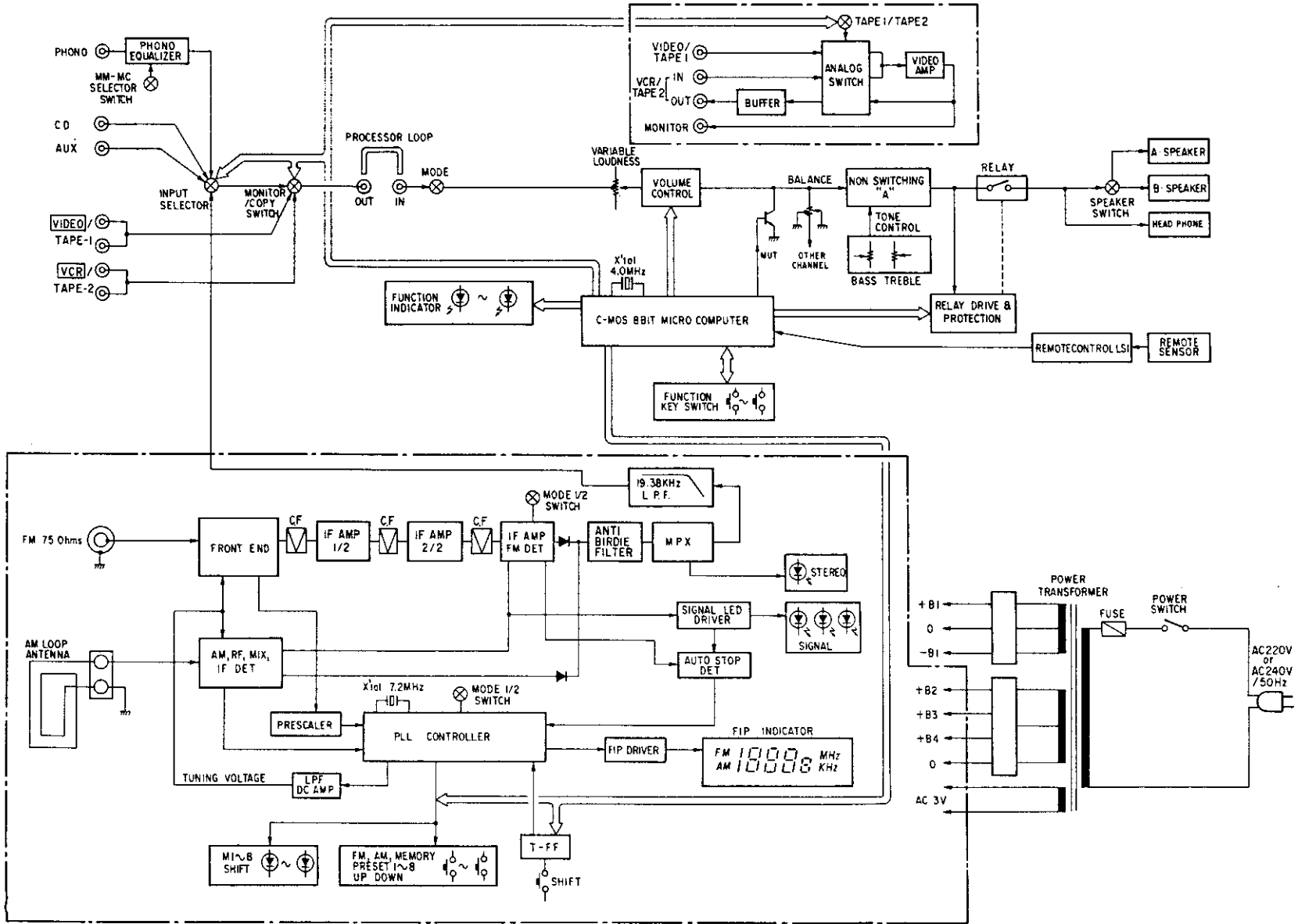

(for Ep1)

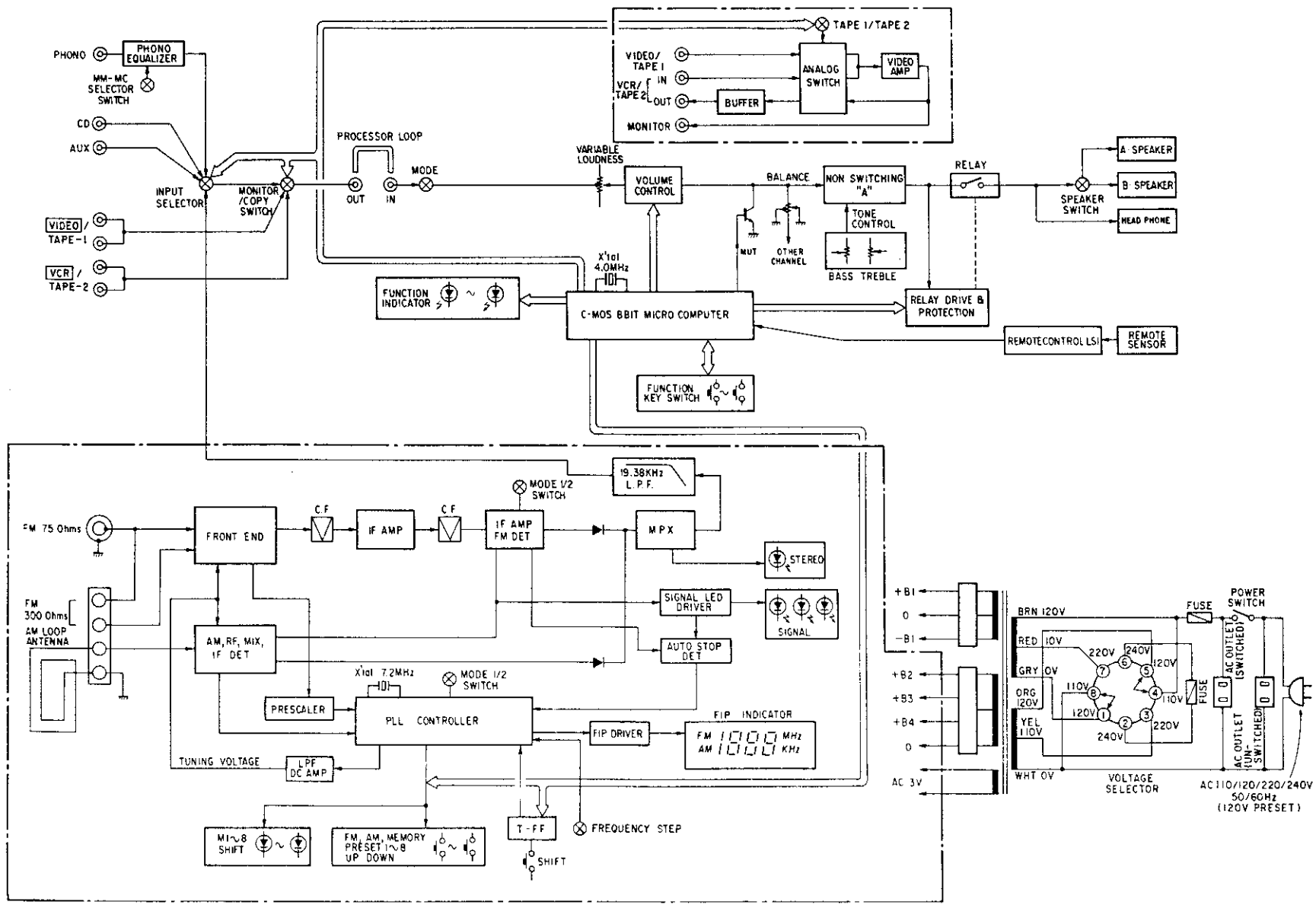

REMOVAL OF EACH SECTION

1. Top Cover

Remove 6 screws (A), 2 screws (B), and lift the Top Cover upward to detach.

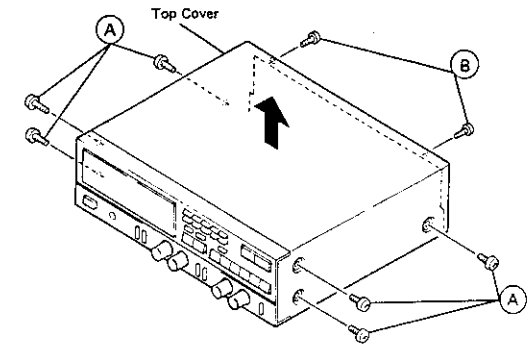

2. Front Panel

Remove 7 screws (A) and draw out the Front Panel forward to detach.

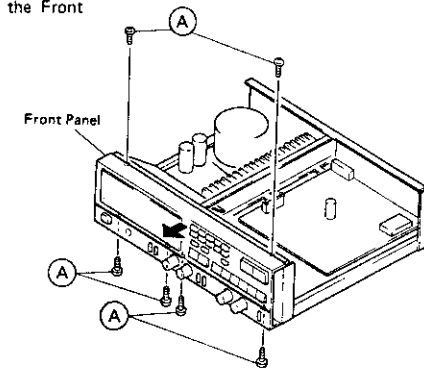

3. Back Panel

Remove 4 screws (A), 6 screws (B), and pull out the Back Panel backward to dismantle.

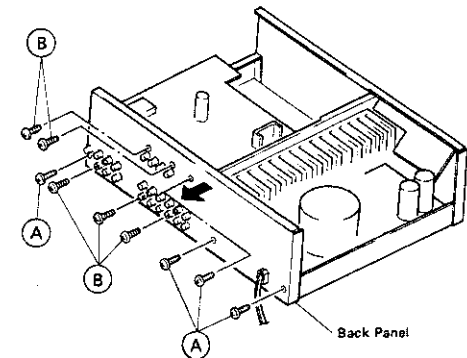

ANTENNA INSTALLATION (for E2 and EA)

● **FM ANTENNA**

T-type indoor antenna (300 ohms) can be used inside wooden houses for local FM stations and strong signals. Orient the T-shaped part for optimum reception and mount the antenna on the wall or ceiling. (FM indoor antennas may not consistently ensure stable reception, due to environment changes. In such cases use an FM indoor antenna temporarily until an outdoor antenna is installed.)

75 ohms coaxial cable (3C-2V, 5C-2V) is preferable to obtain better performance of the tuner. (To use of a 300 ohm FM outdoor antenna, connect to the 300 ohm terminals of the attached FM antenna adapter.)

● **AM ANTENNA**

Attach the accessory AM loop antenna to the antenna holder on the back panel. Connect the leads to AM and GND terminal. Use this terminal also for an outdoor antenna. Orient the loop antenna horizontally to obtain optimum reception. Where broadcast stations are distant and only weak signals are received, or where signals are blocked by obstacles, install an AM outdoor antenna.

● **GROUNDING**

If there is reception noise, use of grounding wire is recommended. Connect a thick insulated wire to the "GND" terminal, and attach the unconnected bare end to a metal water pipe, grounding rod, or grounded copper plate.

* Never connect the grounding wire to a gas pipe. This could cause fire or explosion.

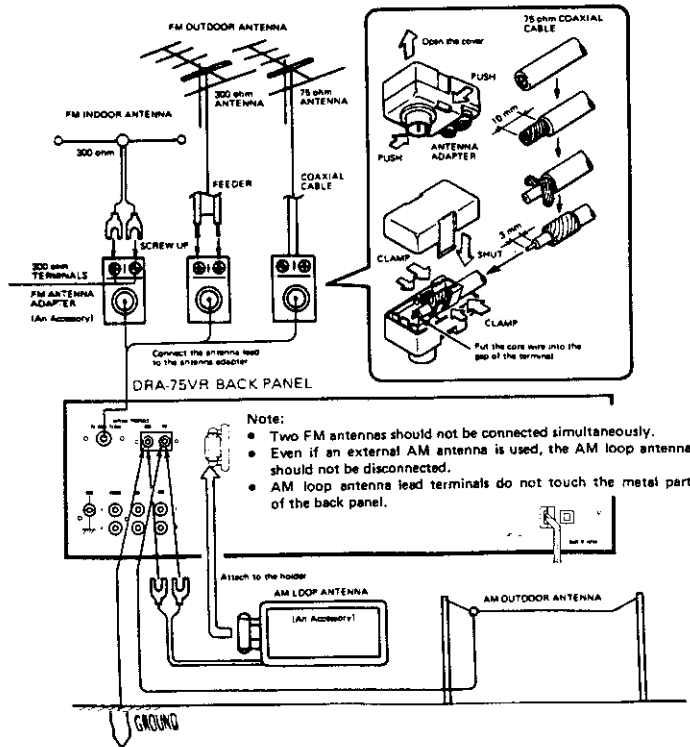

ANTENNA INSTALLATION (for EP1)

● **FM ANTENNA**

The accessory T-type indoor antenna (300 ohm) can be used inside wooden houses for local FM stations and strong signals. Orient the T-shaped part for optimum reception and mount the antenna on the wall or ceiling. FM indoor antennas may not consistently ensure stable reception, due to environment changes. In such cases an FM outdoor antenna is necessary for best reception.

Either 300 ohm twin lead (cable or 75 ohm coaxial cable may be used for outdoor antenna. But, coaxial cable is preferable when electrical interferences is a problem.

* Connect either an indoor T-type antenna or an outdoor antenna but not both.

● **AM ANTENNA**

Attach the accessory AM loop antenna to the antenna holder on the back panel. Connect the leads to AM and GND terminal. Use this terminal also for an outdoor antenna. Orient the loop antenna horizontally to obtain optimum reception. Where broadcast stations are distant and only weak signals are received, or where signals are blocked by obstacles, install an AM outdoor antenna.

* Never disconnect the AM loop antenna leads when use an outdoor antenna.

● **GROUNDING**

If there is reception noise, use of grounding wire is recommended. Connect a thick insulated wire to the "GND" terminal, and attach the unconnected bare end to a metal water pipe, grounding rod, or grounded copper plate.

* Never connect the grounding wire to a gas pipe. This could cause fire or explosion.

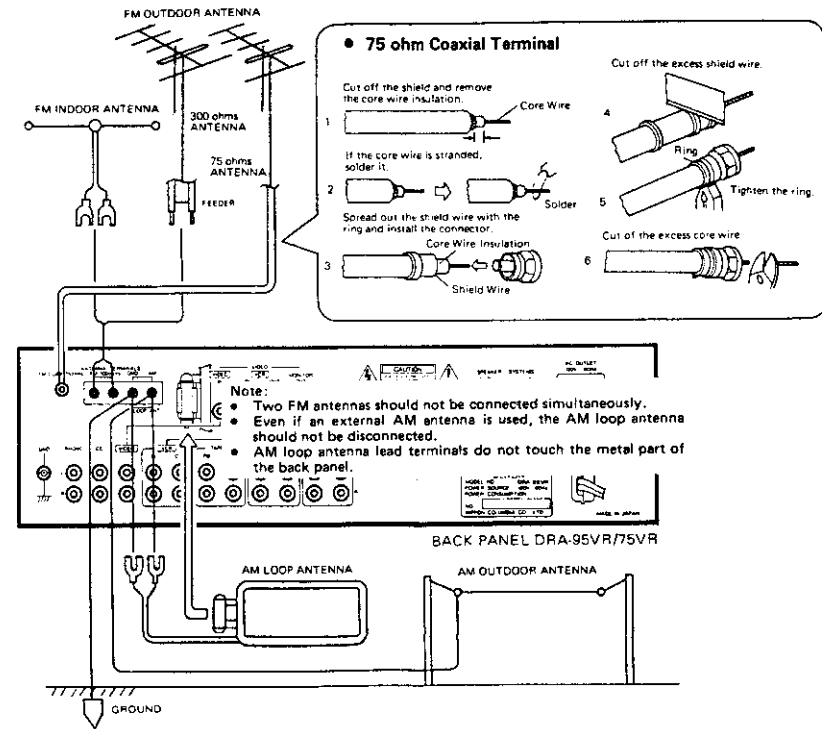

CONNECTIONS (for E2 and EA)

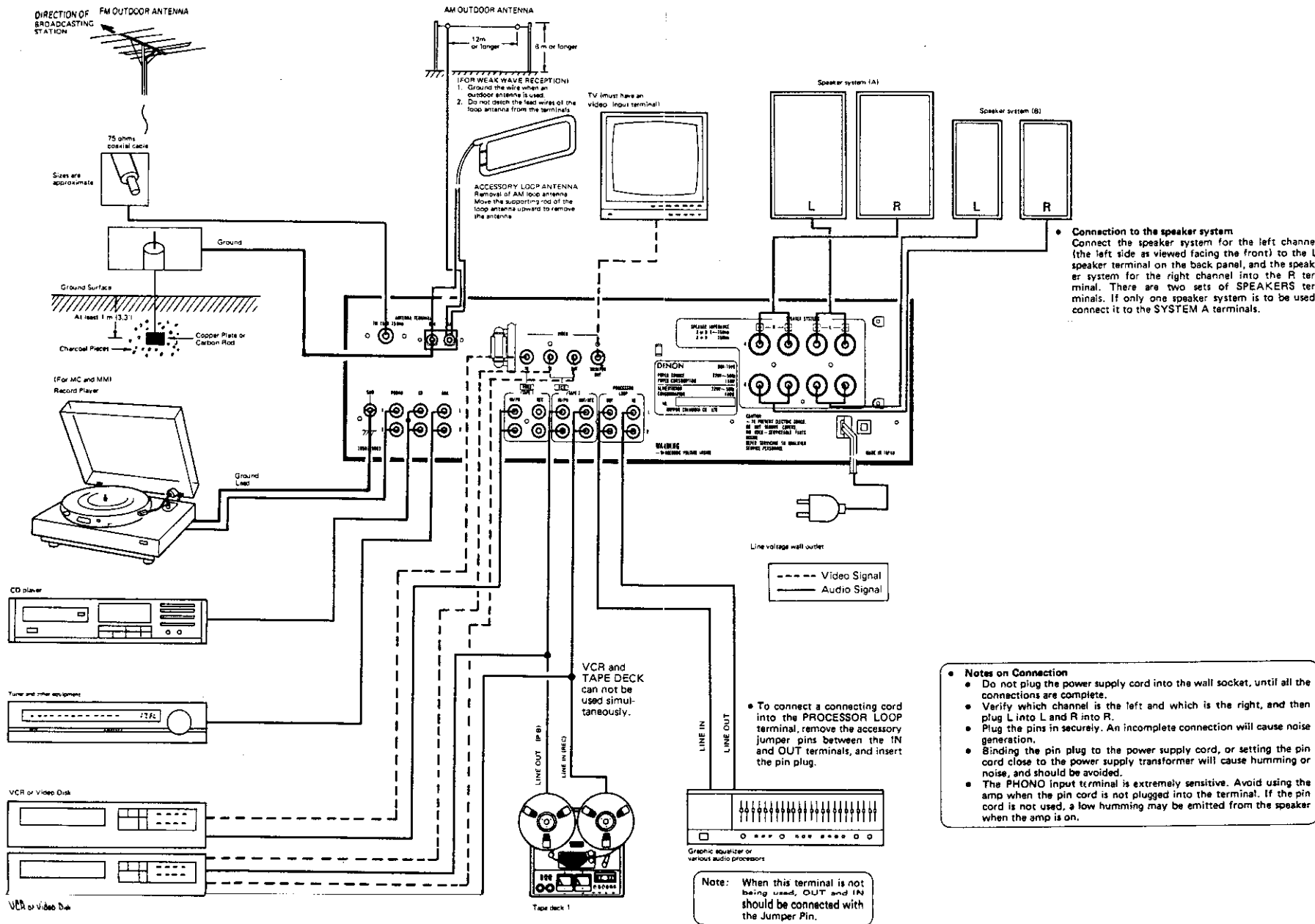

CONNECTIONS (for EP1)

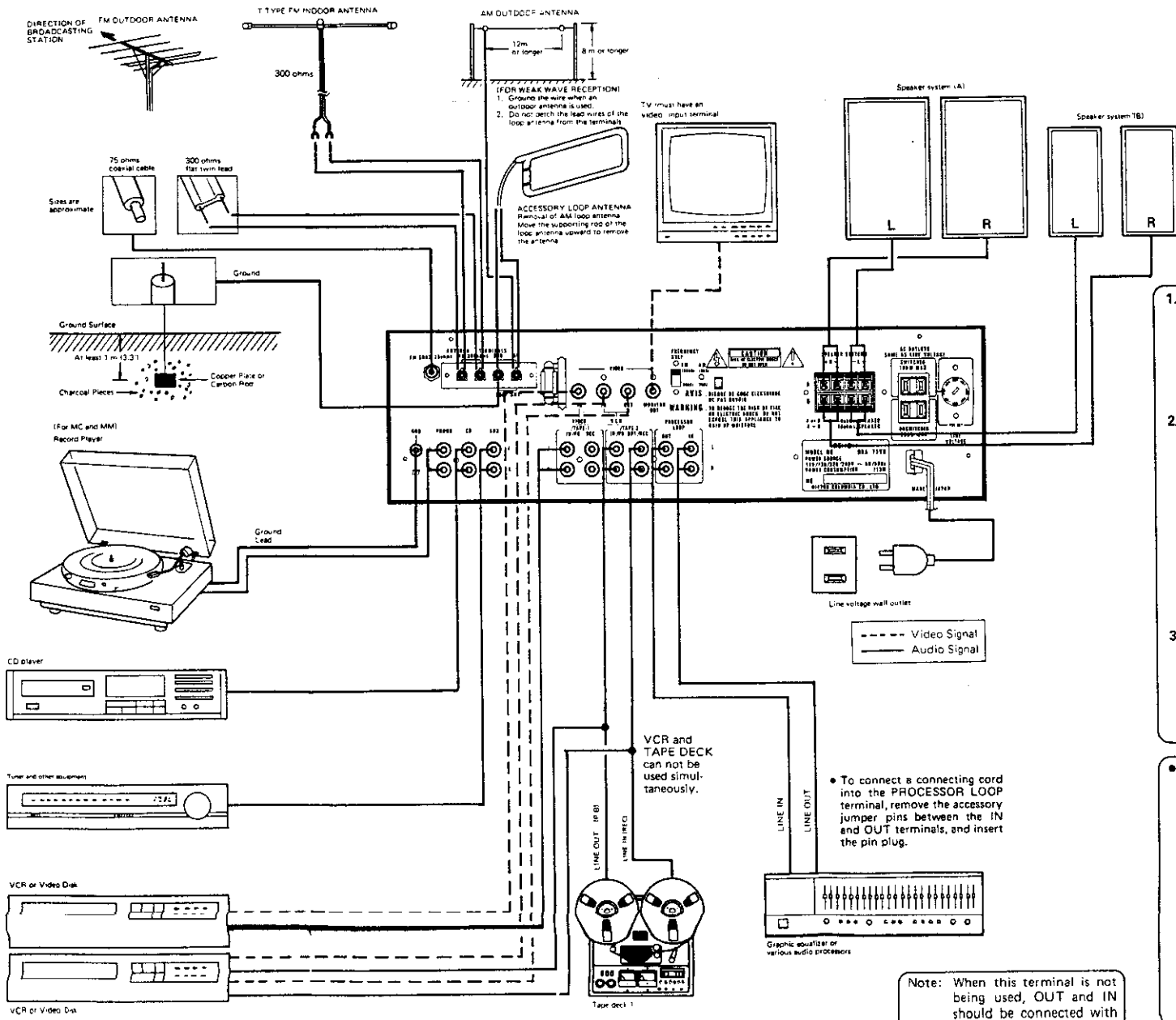

● **Connection to the speaker system**
 Connect the speaker system for the left channel (the left side as viewed facing the front) to the L speaker terminal on the back panel, and the speaker system for the right channel into the R terminal. There are two sets of SPEAKERS terminals. If only one speaker system is to be used, connect it to the SYSTEM A terminals.

- 1. AC OUTLETS . . . For Asia model**
 AC outlets are used for connecting amplifier component units, such as tuner, turntable, tape deck, etc.
 - **SWITCHED (Capacity: 100 W):**
 This outlet is turned on/off when main power switch is turned on/off.
 - **UNSWITCHED (Total capacity: 250 W)**
 These outlets are always ON whether power switch is on or off.
- 2. SETTING THE FREQUENCY STEP**
 Set the FREQUENCY STEP switch as described below.
 - In the U.S.A. and Canada – set the switch to the upper side. With this setting, the frequency varies in 100 kHz steps in the range of 87.5 to 108.0 MHz (FM) and in 10 kHz steps in 520 to 1710 kHz (AM).
 - Elsewhere – set the switch to the lower side. With this setting, the frequency varies in 50 kHz steps in the range of 87.50 to 108.00 MHz (FM) and in 9 kHz steps (AM) in 522 to 1611 kHz (AM).

Note: Don't change the switch setting with power on. If the FREQUENCY STEP switch is changed with power on, turn off and on the unit again to reset the circuit.
- 3. SETTING THE LINE VOLTAGE**
 - The customer can set the VOLTAGE SELECTOR KNOB on the back panel for appropriate line voltage by using a screwdriver.
 - Do not use excessive force in setting the VOLTAGE SELECTOR KNOB – you may damage it.
 - If the VOLTAGE SELECTOR KNOB does not turn smoothly, call qualified service personnel.

- **Notes on Connection**
- Do not plug the power supply cord into the wall socket, until all the connections are complete.
 - Verify which channel is the left and which is the right, and then plug L into L and R into R.
 - Plug the pins in securely. An incomplete connection will cause noise generation.
 - Do not use the AC OUTLETS terminals to provide power for a hair drier or other electrical appliance after the power supply cords of the audio components have been plugged in.
 - Binding the pin plug to the power supply cord, or setting the pin cord close to the power supply transformer will cause humming or noise, and should be avoided.
 - The PHONO input terminal is extremely sensitive. Avoid using the amp when the pin cord is not plugged into the terminal. If the pin cord is not used, a low humming may be emitted from the speaker when the amp is on.

Note: When this terminal is not being used, OUT and IN should be connected with the Jumper Pin.

TUNER SECTION

INSTRUMENT CONNECTIONS AND SETTING

Preparation

1. Connection of Measuring Equipment

FM

- Connect the output end of the Stereo/Mono FM signal generator to the antenna terminal (75 ohm) of the unit. Set the stereo modulator to the following conditions:
L + R: 67.5 kHz deviation 1 kHz (internal modulation frequency)
Pilot: 7.5 kHz deviation
- Connect a filter jig of 19 kHz to the recout terminal L of the unit. Then, connect the output of the filter jig to a distortion meter, the output of which is in turn connected to an oscilloscope for monitoring.
- Connect tuning jigs to TP. 1 and 2.
- Connect frequency counters to TP.3, TP.4.

AM

- The AM signal generator should be set as follows:
Modulation: 30%, modulation frequency: 400 Hz
(Antenna input signal level: about 80 dB/m).

FM/MPX ALIGNMENT

Table 1

Step	Alignment Item	Tuning Frequency Setting	Input					Output		Adjustment		Remarks
			Type	Frequency	Input Level	Modulation	Coupling	Type	Connect to	Points	Adjust to	
1	76 kHz	98 MHz	FM Standard Signal Generator Mono	98 MHz	60 dBμ	1 kHz 75 kHz Dev.	Antenna Terminal	Frequency Counter	(+) T.P.4 (-) T.P.3	VR100	76 kHz ± 50 Hz	Function: FM Tuning mode: Auto (Front Panel)
2	Tuning Center	98 MHz	FM SSG, Mono	98 MHz	60 dBμ	None	Antenna Terminal	Center Meter	T.P. 1, 2	T-100	Center of Tuning Meter	Function: FM Tuning mode: Mono
3	Distortion (Mono)	98 MHz	FM SSG, Mono	98 MHz	60 dBμ	1 kHz 75 kHz Dev.	Antenna Terminal	Distortion Meter	Output Terminal (L)	T-101	Minimum Distortion	Function: FM Tuning mode: Mono
4	Distortion (Stereo)	98 MHz	FM SSG, Stereo (L)	98 MHz	60 dBμ	Main: 1 kHz L-ch 67.5 kHz Dev. Pilot: 7.5 kHz Dev.	Antenna Terminal	Distortion Meter	Output Terminal (L)	IFT on Front End	Minimum Distortion	Function: FM Tuning mode: Auto
5	Noise Center & Distortion	Repeat 2, 3 and 4 to obtain minimum distortion and at the same time center meter should read center condition.										
6	Separation	98 MHz	FM SSG, Stereo (L)	98 MHz	60 dBμ	Main: 1 kHz L-ch 67.5 kHz Dev. Pilot: 7.5 kHz Dev.	Antenna Terminal	Distortion Meter	Output Terminal (L)	VR101	Max. Separation	Function: FM Tuning mode: Auto

AM ALIGNMENT

() is for Asian (EP1) model.

Table 2

1	IF	-	IF Sweep	-	Input Level is not to saturate A.G.C.	-	Antenna Terminal	Oscilloscope	R154	T-103	Maximum Height and Best Symmetry Curve	Function: AM Center of Wave Form: 450 kHz
2	Tracking Alignment AM	603 kHz (600)	AM SSG	603 kHz (600)	Input Level is not to saturate A.G.C.	400 Hz 30%	Loop Antenna	Audio V.T.V.M.	Output Terminal (L)	T-105	Maximum Output	Function: AM
		1404 kHz (1500)	AM SSG	1404 kHz (1500)	Input Level is not to saturate A.G.C.	400 Hz 30%	Loop Antenna	Audio V.T.V.M.	Output Terminal (L)	TC-100	Maximum Output	Function: AM

Tuning Meter Jig

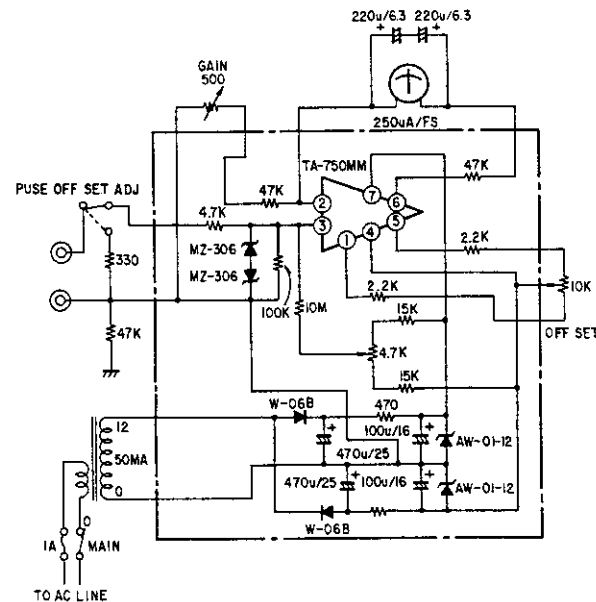

ROUGH DIAGRAM OF ADJUSTMENT POINT ETC0841D or ETC0841E Tuner Unit

Component Side

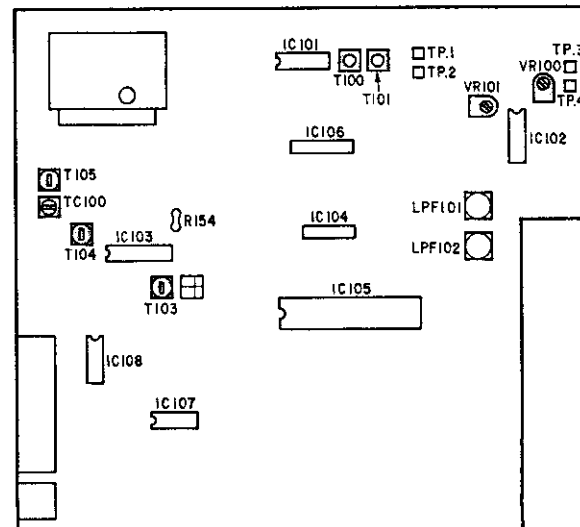

SEMICONDUCTORS

• IC

HD14011BP
HD14066BP
HD14082BP
(Hitachi)

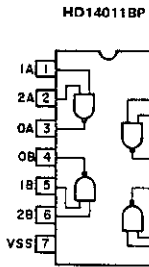
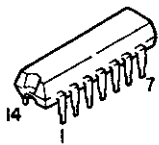

HD14066BP

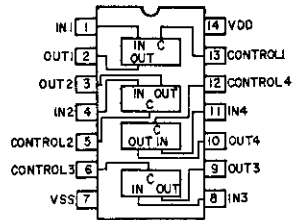

HD14082BP

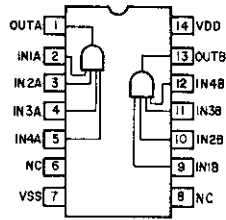

HA11225
(Hitach)

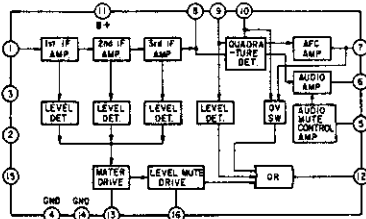

μPC1235C
(NEC)

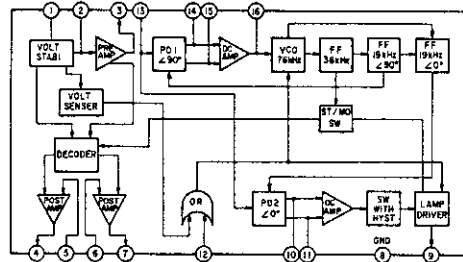
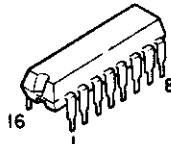

L78M05ML
(JRC)

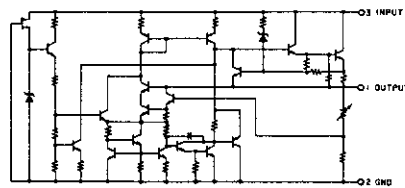
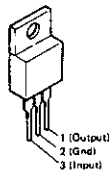

M-5218P (Mitsubishi)

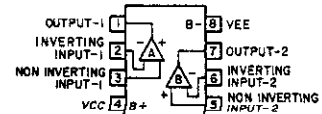
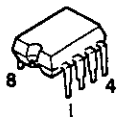

M-5218P

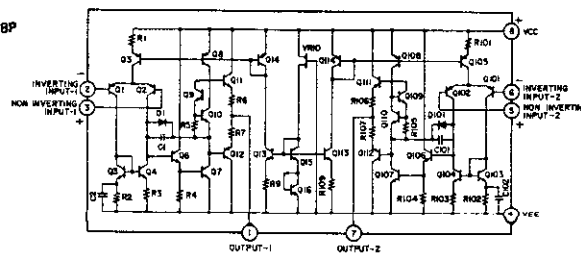

NJM2043DD (JRC)
NJM2068DD (JRC)
LA1222 (Sanyo)

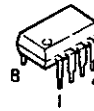

NJM2043DD
NJM2068DD

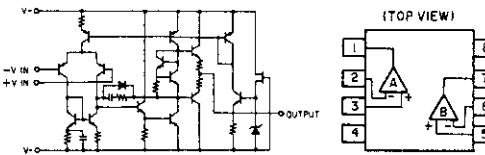

LA1222

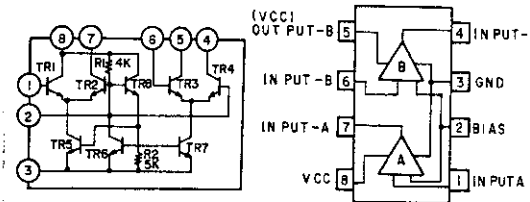

LA1245
(Sanyo)

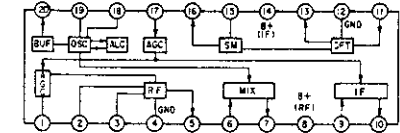
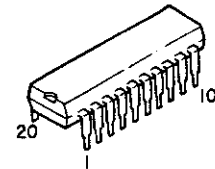

TD6301AP
(Toshiba)

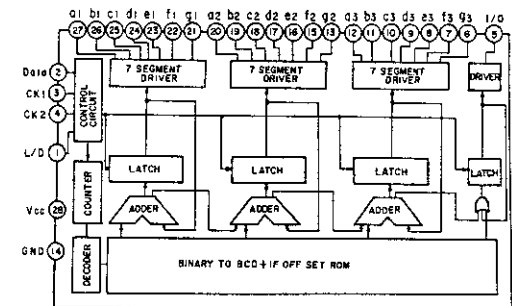
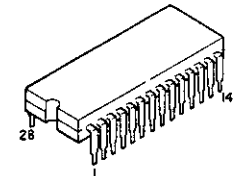

FUNCTIONS OF TERMINALS (TD6301AP)

Pin No.	Name	Function
1	L/D	Output status select input terminal. Input terminal for selecting output status by the indicator (LED, FL, LCD).
2	Data	Receiving frequency data input terminal. Input serially by the system controller LSI.
3, 4	CK1 CK2	Received frequency data input control timing input terminal. Transferred simultaneously with data by the system controller LSI.
5	1/0	Segment drive output terminal. 100 MHz-unit display at FM time. Only 1 pin is used for output because of 1 to 0 in both FM/AM.

Pin No.	Name	Function
6~12	a ³ ~g ³	7-segment drive output terminal. 10 MHz-unit display at FM time. 100 kHz-unit display at AM time.
13, 15~20	a ¹ ~g ¹	7-segment drive output terminal. 1 MHz-unit display at FM time. 10 kHz-unit display at AM time.
21~27	a ¹ ~g ¹	7-segment drive output terminal. 100 kHz-unit display at FM time. 1 kHz-unit display at AM time.
14, 28	Vcc GND	Supply voltage applying terminal.

FUNCTIONS OF TERMINALS (TD6104P)

Pin No.	Name	Functions
5	f _{IN}	FM station signal input terminal Frequency range 60 - 140 MHz Input level 75 - 300 mVrms
3	OUT-1	Dividing an input signal into 1/30 or 1/32 through dividing output terminal f _{IN} . Output level 0.5V/MIN
2	OUT-2	OUT 1 inverted signal output. Because of open emitter system, if it is to be used. External resistor is necessary. Open in general.
7	PSC	Dividing value select control terminal 1/32 when V _{pcc} ≥ 2(V), 1/30 when V _{pcc} ≤ 1(V)
6	C	for bias circuit. Connect C = 2200 pF (approx. between the unit and the GND.
1	V _{cc}	Power terminal V _{cc} = 5V
4	GND	I _{cc} = 5 mA (standard), 10 mA (max.)

TD6104P (Toshiba)

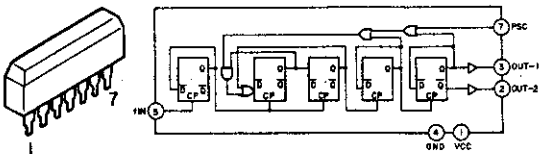

LB1403N (Sanyo)

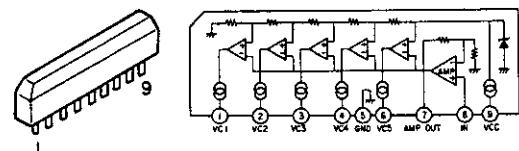

TC9147BP (Toshiba)

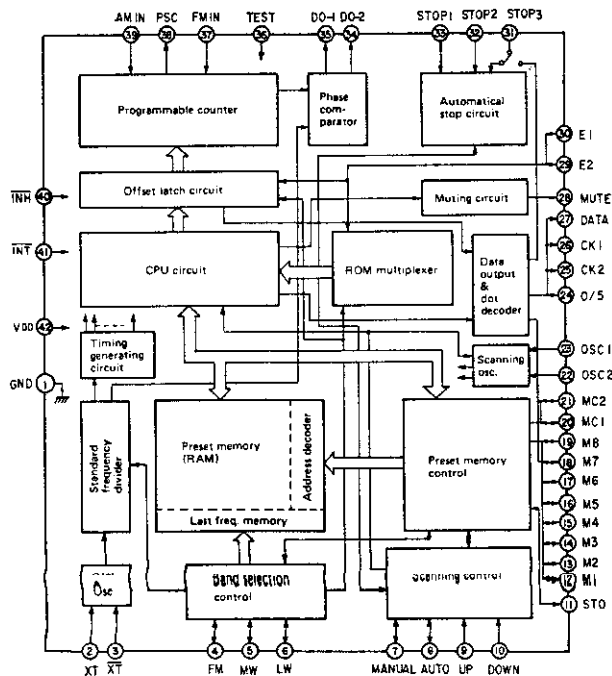
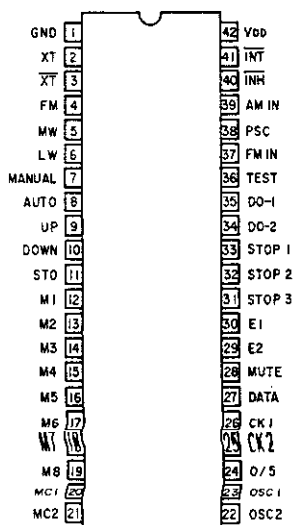
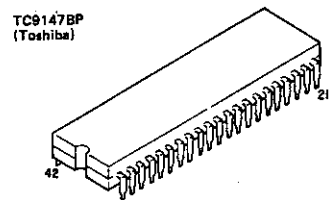

Pin No.	Symbol	Assignment	Function	Remark
2	XT	X-tal oscillator terminal	Connect reference frequency X-tal 7.2 MHz	Internal feedback resistor
3	XT			
4	FM	FM band specific input	Mutual reset type FM/MW/LW band switching	A
5	MW	MW band specific input		
6	LW	LW band specific input		
7	Manual	Manual tuning mode specific input	Mutual reset type switch manual UP/DOWN and auto search mode	A
8	Auto	Auto tuning mode specific input		
9	UP	UP key input	UP/DOWN selection	B
10	DOWN	DOWN key input		
11	STO	Memory store command input	Set to preset memory write	A
12-19	M1-M8	Preset memory channel command input	With MC1, MC2, write/read 16 preset stations	A
20	MC1	Memory control input	Set FM/AM (MW+LW) preset each 8 stations out of 16 stations to fixed ones, or FM + MW + LW 3 band, 16 stations random selection.	C
21	MC2			C
22		Clock for AM scanning	Determines AM sensing speed	-
23		Clock for FM scanning	Determines FM scanning speed	-
24	O/5	50 kHz output	50 kHz step for South Africa and Europe area. 50 kHz: H level	D
25	CK2	Rx frequency data Serial output	Output serial data and timing clock for Rx frequency digital display. CK1 output is common with Beep.	D
26	CK1			
27	DATA			
28	MUTE	Mute signal output	Mute: "H" level	D
29	E ₂	Area command input	Japan, America, Europe, South Africa, Area command.	E
30	E ₃			
31	STOP3	AM, IF signal input	When AM Rx, counts IF 450 kHz and stops auto search	F
32	STOP2	Auto search stop signal input	When "H" is applied to STOP1 input, if "H" is applied to STOP2, stops auto search. Also, ARI is used for Stereo Station identification.	E
33	STOP1	Scanning speed slow input	Reduces auto search scanning speed to 1/2 when "H" level applied.	E
34	DO-2	Phase comparator output	Outputs 2 tristate buffer in parallel from a comparator	G
35	DO-1			
36	TEST	TEST port	"H": test mode	B
37	FM _{IN}	FM programmable counter input	Connects pre-scaler TD6104P output	F
38	PSC	Pre-scaler control output	Controls frequency divider 1/30, 1/32 of pre-scaler TD6104P	D
39	AM _{IN}	AM programmable counter input	Inputs AM local oscillation signal	F
40	INH	Inhibit input	"H" level: normal operation "L" level: inhibit	E
41	INT		"H" level: normal "L" level: initialize	E
42	VDD	Power supply	Apply 5 ± 0.5 V. Backup can be reduced to 2 V	-
1	GND			

I/O equivalent circuit

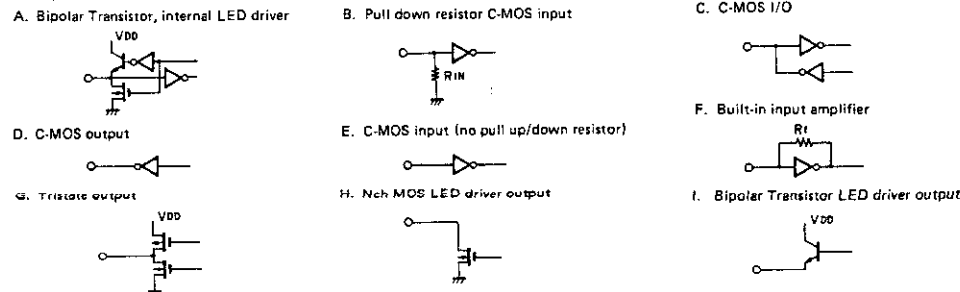

TC9176P
(Toshiba)

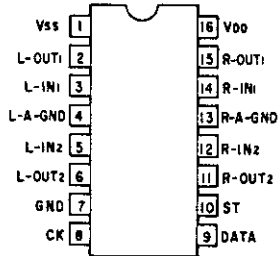
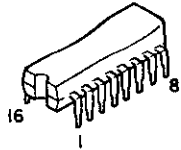

TC9176P

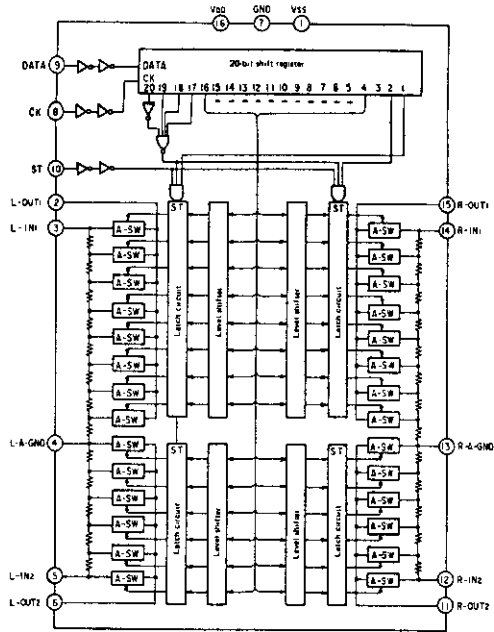

Pin No.	Symbol	Function	Remark
2 15	L-out1 R-out2	10 dB step attenuator output Attenuates signal applied to IN in 10 dB step: 0 ~ 70 dB in 8 steps	(L/R) 2/15
3 14	L-in R-in	10 dB attenuator input	3/14
4 13	A-GND	AC ground	4/13
5 12	L-in2 L-in2	2 dB attenuator input	5/12
6 11	L-out2 R-out2	2 dB attenuator output Attenuates signal applied to IN in 2 dB step: 0 ~ 8 dB in 5 steps	6/11
9	DATA	Attenuation, channel selection data input. Comprises 20 bit, and applied as CK signal.	Input inverter for low threshold value.
8	CK	Clock input Clock input to take in DATA port data	
10	ST	Strobe input Latches DATA, attenuation taken from CK port, channel selection data, by turning ST to "H" level. When "H" is not applied to the port, previous data remain as are.	
16 7 1	VDD GND VSS	(+) B Terminal Ground Terminal (-) B Terminal	

Function

Attenuation Setting

Input optional attenuation data to DATA, CK, ST ports.

Data comprise 20 bit.

(TC9176P has no loudness control, and 3rd bit is always at "L" level)

TC9176P

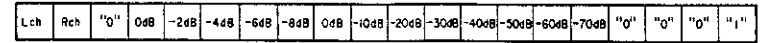

CK

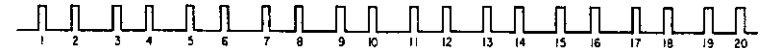

e.g. when data {11001000001000000001} entered, it result in -22 dB attenuation.

Data bit 1, 2 : select Lch, Rch

Bit 4 ~ 8 : 2 dB step attenuator setting

Bit 9 ~ 16 : 10 dB step attenuator setting

Bit 17 ~ 20 : chip select bit, (0001) is select mode, other than (0001) is inoperative.

Infinite attenuation is obtained at -78 dB. Then one step below the infinite attenuation is -76 dB.

Change to the taken in data synchronize ST signal rise.

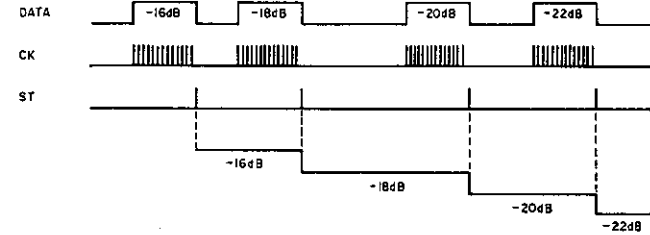

To input DATA, CK, ST, refer to timing chart below.

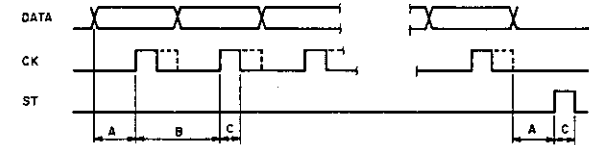

LC4966 (Sanyo)

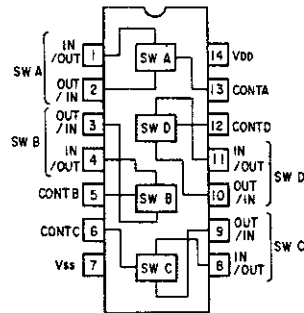
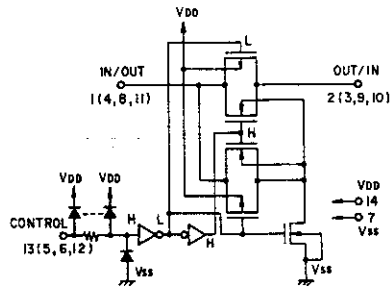
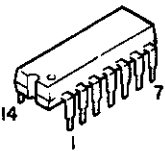

TC9164N (Toshiba)

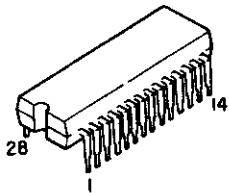

TC9164N

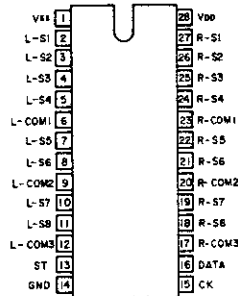

TC9164N

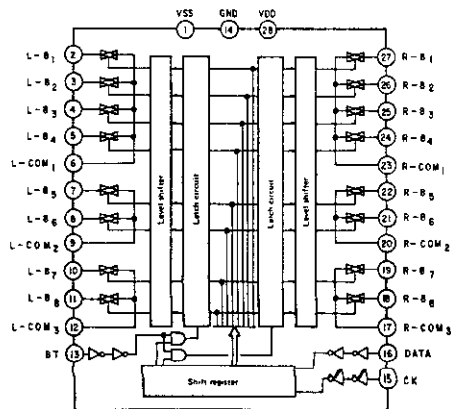

Function

Data input

TC9162/63/64N: input the specific data to DATA, CK, ST ports, and each analog switch can be optionally controlled. Data comprise 14 bit as per below:

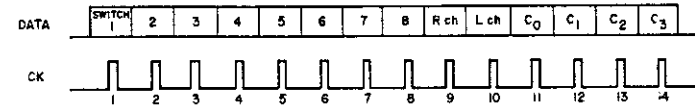

Bit 1 ~ 8 correspond with analog switch 1 ~ 8: set "ON" switch bit to "1" level. (Note)

Bit 9, 10 are for left/right channel selection.

"1" level selects the channel: able to set the level ("1", "1"), ("1", "0") or ("0", "1").

Bit 11 ~ 14 are code bit used for chip selection.

e.g. When employ TC9162N, TC9163N, TC9164N simultaneously, make common connection with DATA, CK, ST ports, and the code bit data selects one of TC9162N, TC9163N, or TC9164.

Each code is set as below.

	C ₀	C ₁	C ₂	C ₃
TC9162N	0	0	0	0
TC9163N	1	0	0	0
TC9164N	0	1	0	0

DATA, CK, ST Timing

Refer to figure below for DATA, CK, ST timing input.

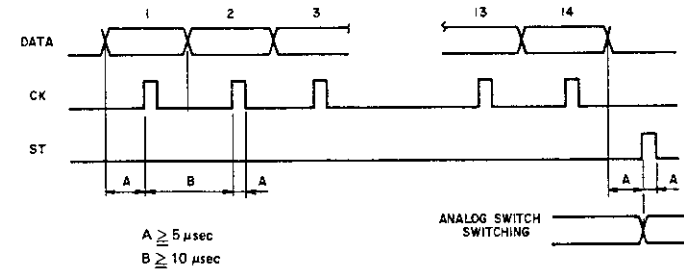

MN1280S
(Matsushita)

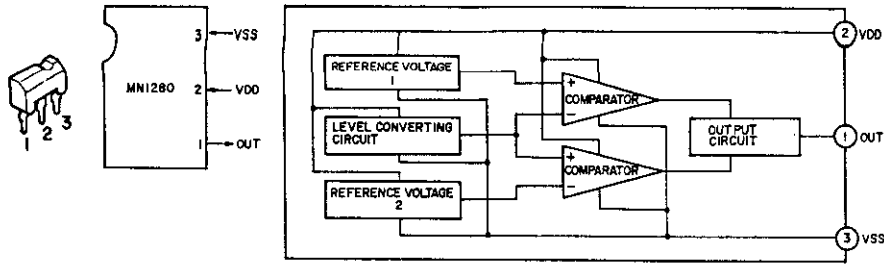

TMS1035NE
(T.I.)

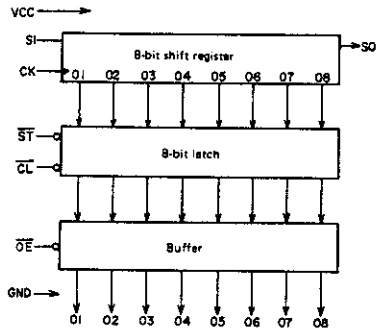
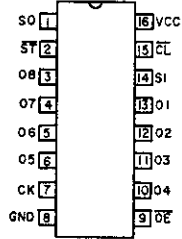
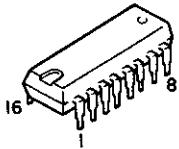

CL	CK	OE	ST	SI	PO		SO
					O1	O _n	
L	X	L	X	X	H	H	X
X	X	H	X	X	Z	Z	X
H	↑	L	L	L	L	O _{n-1}	Q _B
H	↑	L	L	H	H	O _{n-1}	Q _B
H	↑	L	H	X	NC	NC	Q _B
H	↑	H	X	X	Z	Z	Q _B
H	↓	L	X	X	NC	NC	NC
H	↓	H	X	X	Z	Z	NC
H	L	L	⌊	X	Q1	O _n	Q _B

CL = clear
 CK = clock
 OE = enable output
 ST = strobe
 SI = serial input
 SO = serial output
 PO = parallel output (O1-O8)
 X = infinite
 NC = no change
 Z = high impedance

LU59002
(Sharp)

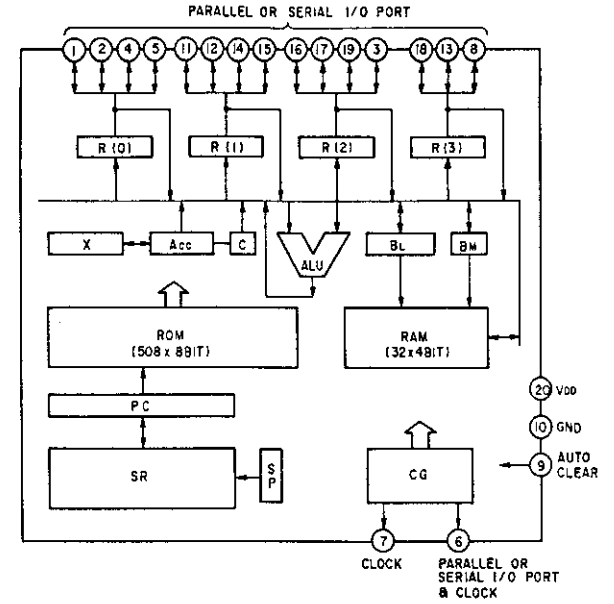
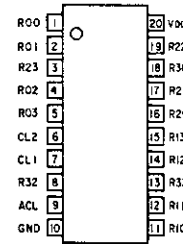
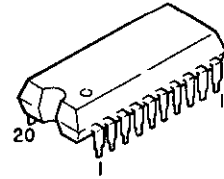

Symbol description
 Acc : Accumulator
 BL, BM : RAM address register
 CG : Clock generator
 SR : Stack register
 X : Temporary register
 C : Carry F/F
 PC : Program counter
 ALU : Arithmetic logic unit
 SP : Stack pointer
 R (0) ~ R (3) : Output latch

Pin No.	Name	Function
1	SDO	Serial Date Output
2	-	NC
3	CKI	Serial data transfer, clock input
4	RDY	Data output, cut into IC701 port D6 39
5	VDD	5V
6	OSC	455kHz OSC
7	OSC	455kHz OSC
8	-	GND
9	ACL	Input for "HIGH" pulse from IC701 at the time of power ON
10	GND	
11	DIN	Remote control code input from RM77
12	SYSTEM ADDRESS	0V

Pin No.	Name	Function
13	SYSTEM ADDRESS	0V
14	SYSTEM ADDRESS	0V
15	SYSTEM ADDRESS	5V
16	MODE ADDRESS	0V
17	MODE ADDRESS	5V
18	SYSTEM ADDRESS	5V
19	MODE ADDRESS	5V
20	SYSTEM ADDRESS	5V

CH	System address				Data				Data extension		K	DRA-75VR			
	C ₁	C ₂	C ₃	C ₄	C ₅	C ₆	C ₇	C ₈	C ₉	C ₁₀		C ₁₁	C ₁₂	C ₁₃	RECEIVER
1	0	0	1	1	0	1	0	0	0	0	1	0	0	-	-
2	0	0	1	1	0	0	1	0	0	0	0	1	0	1	1
3	0	0	1	1	0	1	1	0	0	0	0	1	0	2	2
4	0	0	1	1	0	0	0	1	0	0	0	1	0	3	3
5	0	0	1	1	0	1	0	1	0	0	0	1	0	4	4
6	0	0	1	1	0	0	1	1	0	0	0	1	0	5	5
7	0	0	1	1	0	1	1	1	0	0	0	1	0	6	6
8	0	0	1	1	0	0	0	1	0	0	0	1	0	7	7
9	0	0	1	1	0	1	0	0	1	0	0	1	0	8	8
10	0	0	1	1	0	0	1	0	1	0	0	1	0	9	9
11	0	0	1	1	0	1	1	0	1	0	0	1	0	10	10
12	0	0	1	1	0	0	0	1	1	0	0	1	0	-10	-10
13	0	0	1	1	0	1	0	1	1	0	0	1	0	PROGRAM	PROGRAM
14	0	0	1	1	0	0	1	1	0	0	0	1	0	-	-
15	0	0	1	1	0	1	1	1	0	0	0	1	0	-	-
16	0	0	1	1	0	0	0	0	1	0	0	1	0	POWER ON/OFF	OPEN/CLOSE
17	0	0	1	1	0	1	0	0	0	1	0	1	0	-	-
18	0	0	1	1	0	0	1	0	0	1	0	1	0	VCR	CALL
19	0	0	1	1	0	1	1	0	0	1	0	1	0	V. SOURCE	MODE
20	0	0	1	1	0	0	0	1	0	1	0	1	0	VIDEO	REPEAT
21	0	0	1	1	0	1	0	1	0	1	0	1	0	-	-
22	0	0	1	1	0	0	1	1	0	1	0	1	0	-	-
23	0	0	1	1	0	1	1	1	0	1	0	1	0	DIRECT	DIRECT
24	0	0	1	1	0	0	0	0	1	1	0	1	0	PHONO	▶
25	0	0	1	1	0	1	0	0	1	1	0	1	0	TUNER	▶
26	0	0	1	1	0	0	1	0	1	1	0	1	0	CD	▶▶
27	0	0	1	1	0	1	1	0	1	1	0	1	0	AUX	▶▶▶
28	0	0	1	1	0	0	0	1	1	1	0	1	0	MONITOR	▶▶▶▶
29	0	0	1	1	0	1	0	1	1	1	0	1	0	TAPE 1	▶▶▶▶▶
30	0	0	1	1	0	0	1	1	1	1	0	1	0	TAPE 2	▶▶▶▶▶▶
31	0	0	1	1	0	1	1	1	1	1	0	1	0	-	▶▶▶▶▶▶▶

NOTE: Remote Control Commander in DRA-75VR is also feasible to control CD player by switching C₃ bit of system address.

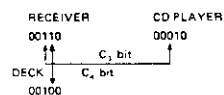

HD6305XOAB1P (Hitach)

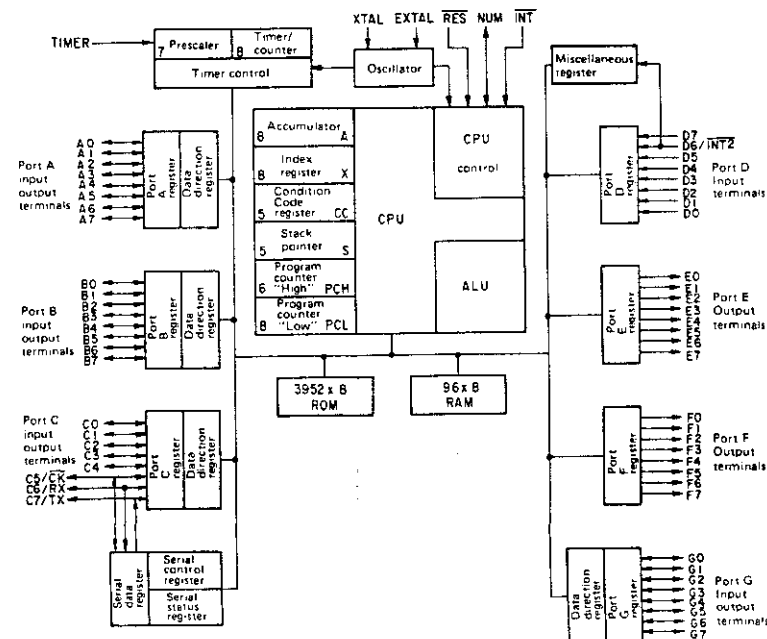
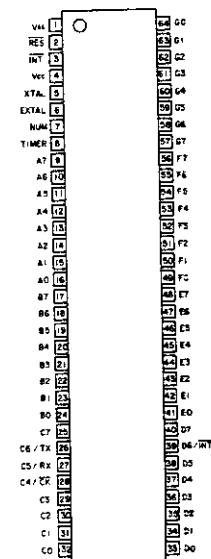
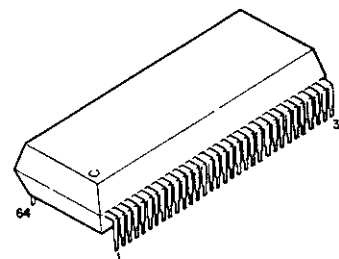

FUNCTIONS OF TERMINALS (HD6305X0A81P)
IC701: Microcomputer for system controlling HD6305X0A81P
1-chip type 8 bit microcomputer

Terminal No.	Description	I/O	Function
1	VSS	-	Connected to 0V of power supply
2	RES	IN	RESET input terminal
3	INT	IN	Interrupt request input terminal
4	STBY	IN	Connected to 5V of power supply
5	XTAL	IN	Input terminal for built-in clock
6	EXTAL	IN	
7	NUM	IN	
8	TIMER	IN	Connected to 0V of power supply
9	A7	OUT	OUTPUT LATCH "LOW" ACTIVE PHONO
10	A6	OUT	OUTPUT LATCH "LOW" ACTIVE TUNER
11	A5	OUT	OUTPUT LATCH "LOW" ACTIVE CD
12	A4	OUT	OUTPUT LATCH "LOW" ACTIVE MONITOR
13	A3	OUT	OUTPUT LATCH "LOW" ACTIVE TAPE 1
14	A2	OUT	OUTPUT LATCH "LOW" ACTIVE TAPE 2
15	A1	OUT	OUTPUT LATCH "LOW" ACTIVE AUX
16	A0	OUT	OUTPUT LATCH "LOW" ACTIVE MUTING
17	B7	OUT	OUTPUT LATCH "LOW" ACTIVE VIDEO
18	B6	OUT	OUTPUT LATCH "LOW" ACTIVE VCR
19	B5	-	NC
20	B4	OUT	OUTPUT LATCH "LOW" ACTIVE VIDEO, SOURCE
21	B3	-	NC
22	B2	-	NC
23	B1	OUT	CLOCK CLOCK OUTPUT port for TMS1035
24	B0	OUT	STROBE STROBE OUTPUT port for TMS1035
25	TX/C7	-	NC
26	RX/C6	-	NC
27	CK/C5	-	NC
28	C4	OUT	DATA DATA OUTPUT port for TMS1035
29	C3	OUT	CL CL OUTPUT port for TMS1035
30	C2	IN	Connected to 5V of power supply
31	C1	OUT	"Low" output at power off
32	C0	OUT	ACL pulse output for LU59002
33	VCC	-	Connected to 5V of power supply
34	D1	IN	
35	D2	IN	Function key ASSIGN input terminal
36	D3	IN	
37	D4	IN	
38	D5	IN	SDD input for LU59002
39	D6/INT	IN	RDY input interrupt for LU59002
40	D7	IN	Connected to 5V of power supply
41	E0	OUT	CLOCK output for LU59002
42	E1	OUT	"HIGH" ACTIVE LATCH at output RELAY ON
43	E2	OUT	"LOW" ACTIVE LATCH at → MUTING ON
44	E3	OUT	"LOW" ACTIVE LATCH at → 20 dB ON
45	E4	OUT	TUNER KEY CONTROL pulse output "LOW" ACTIVE
46	E5	OUT	TUNER SHIFT KEY pulse output "HIGH" ACTIVE
47	E6	-	NC
48	E7	-	NC
49	F0	OUT	TUNER KEY pulse output 8 "HIGH" ACTIVE
50	F1	OUT	TUNER KEY pulse output 7 "HIGH" ACTIVE
51	F2	OUT	TUNER KEY pulse output 6 "HIGH" ACTIVE
52	F3	OUT	TUNER KEY pulse output 5 "HIGH" ACTIVE
53	F4	OUT	TUNER KEY pulse output 4 "HIGH" ACTIVE
54	F5	OUT	TUNER KEY pulse output 3 "HIGH" ACTIVE
55	F6	OUT	TUNER KEY pulse output 2 "HIGH" ACTIVE
56	F7	OUT	TUNER KEY pulse output 1 "HIGH" ACTIVE
57	G0	OUT	} FUNCTION KEY STROBE pulse
58	G1	OUT	
59	G2	OUT	
60	G3	OUT	
61	G4	OUT	STROBE } Output for TC9164, TC9163, TC9176
62	G5	OUT	CLOCK } Output for TC9164, TC9163, TC9176
63	G6	OUT	DATA } Output for TC9164, TC9163, TC9176
64	G7	OUT	DATA } Serial data output for TC9176

• TRANSISTORS (included FET)

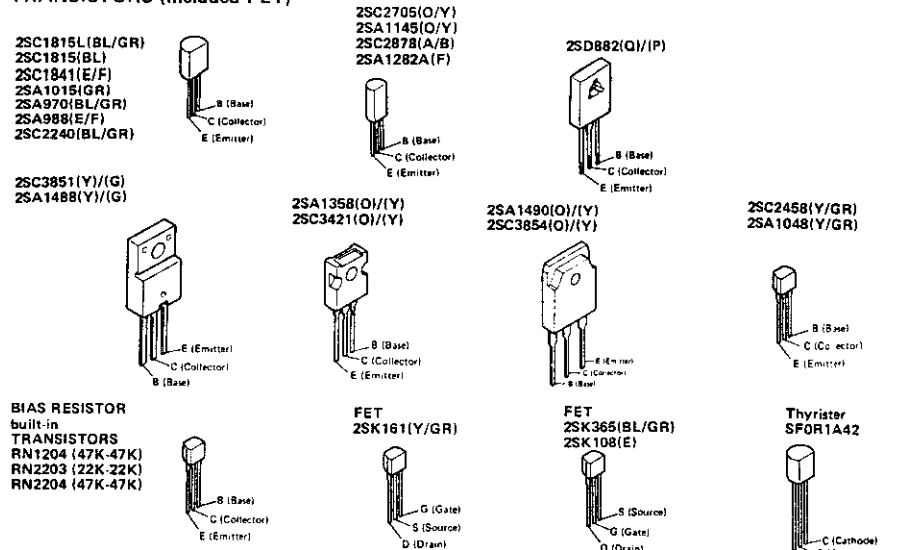

• DIODES

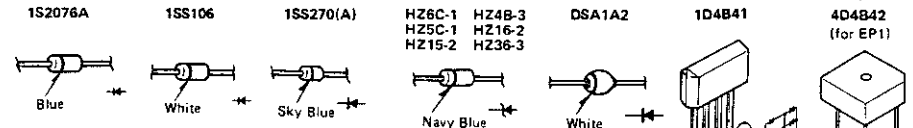

• LED'S

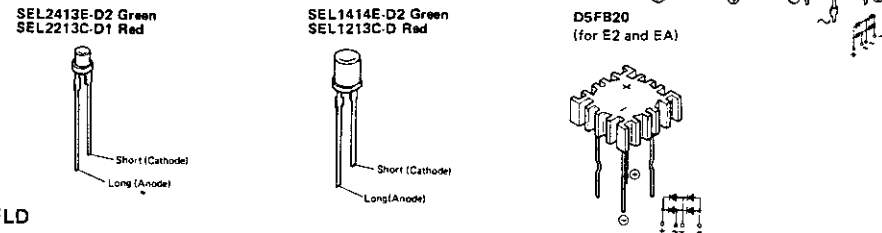

• FLD

FIP7B8GS (NEC)

$$FM = \frac{1}{\sum_{n=1}^{\infty} \frac{1}{f_n}} = \text{MHz}$$

$$AM = \frac{1}{\sum_{n=1}^{\infty} \frac{1}{f_n}} = \text{kHz}$$

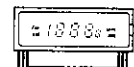

Polarity connection

Terminal number	1	2	3	4	5	6	7	8	9	10	11	12	13	14	15	16	17	18
Connected polarity	F	$\begin{pmatrix} D_0 \\ C_0 \end{pmatrix}$	P1(a)	P1(a)	P1(a)	P1(a)	P1(a)	(C) P1(a)	P1(a)	P1(a)	P1(f)	P1(g)	P1(d)	P1(c)	P1(g)	P1(b)	P1(g)	
Terminal number	19	20	21	22	23	24	25	26	27	28	29	30	31	32	33	34	35	
Connected polarity	IC	P1(f)	P1(g)	P1(d)	P1(c)	P1(g)	P1(b)	$\begin{pmatrix} D_1 \\ C_1 \end{pmatrix}$	P1(g)	P1(k)	P1(h)	P1(MHz)	P1(DP)	P1(AM)	$\begin{pmatrix} D_2 \\ C_2 \end{pmatrix}$	C	G	F

ETC0839D POWER UNIT

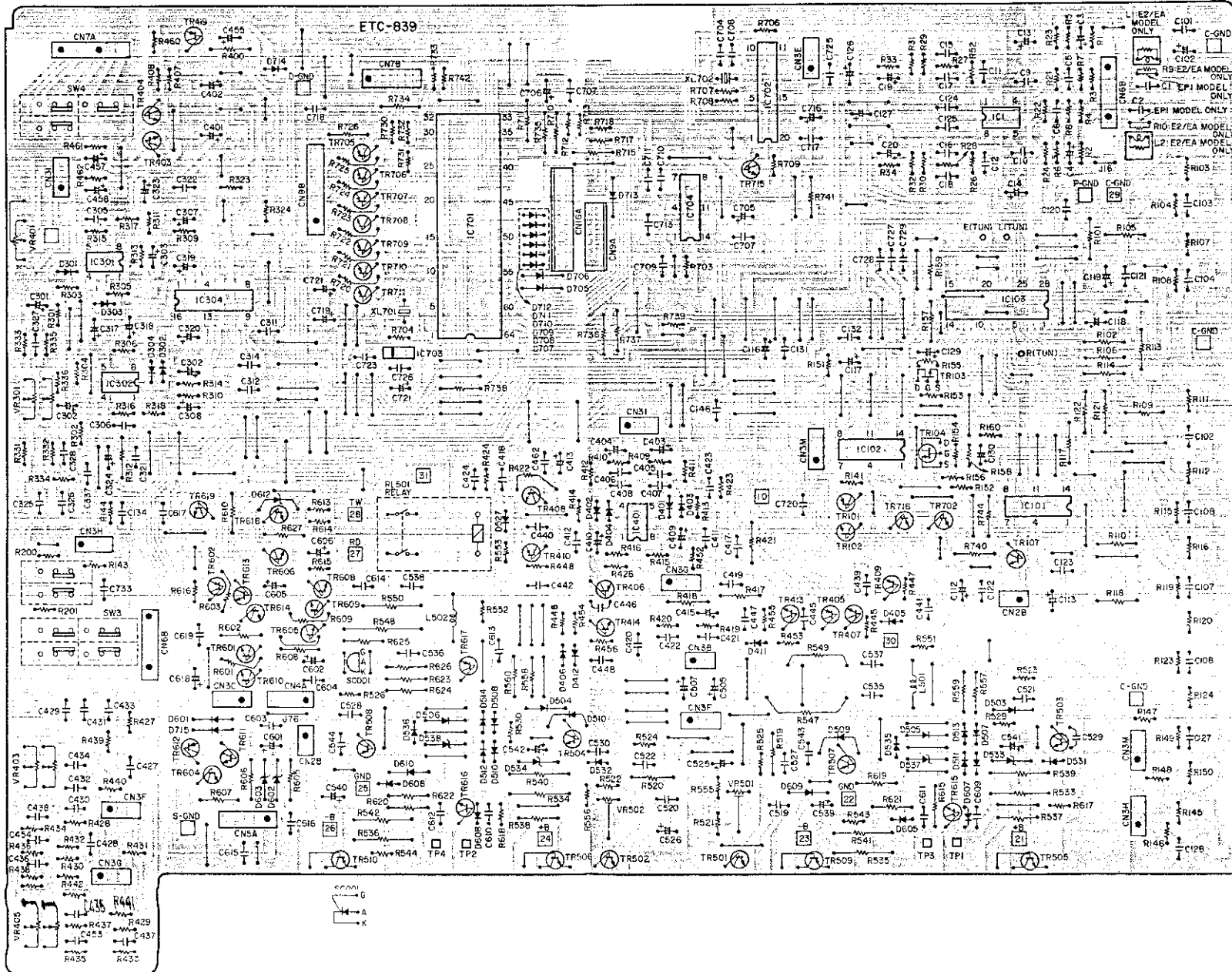

ETC0841D TUNER

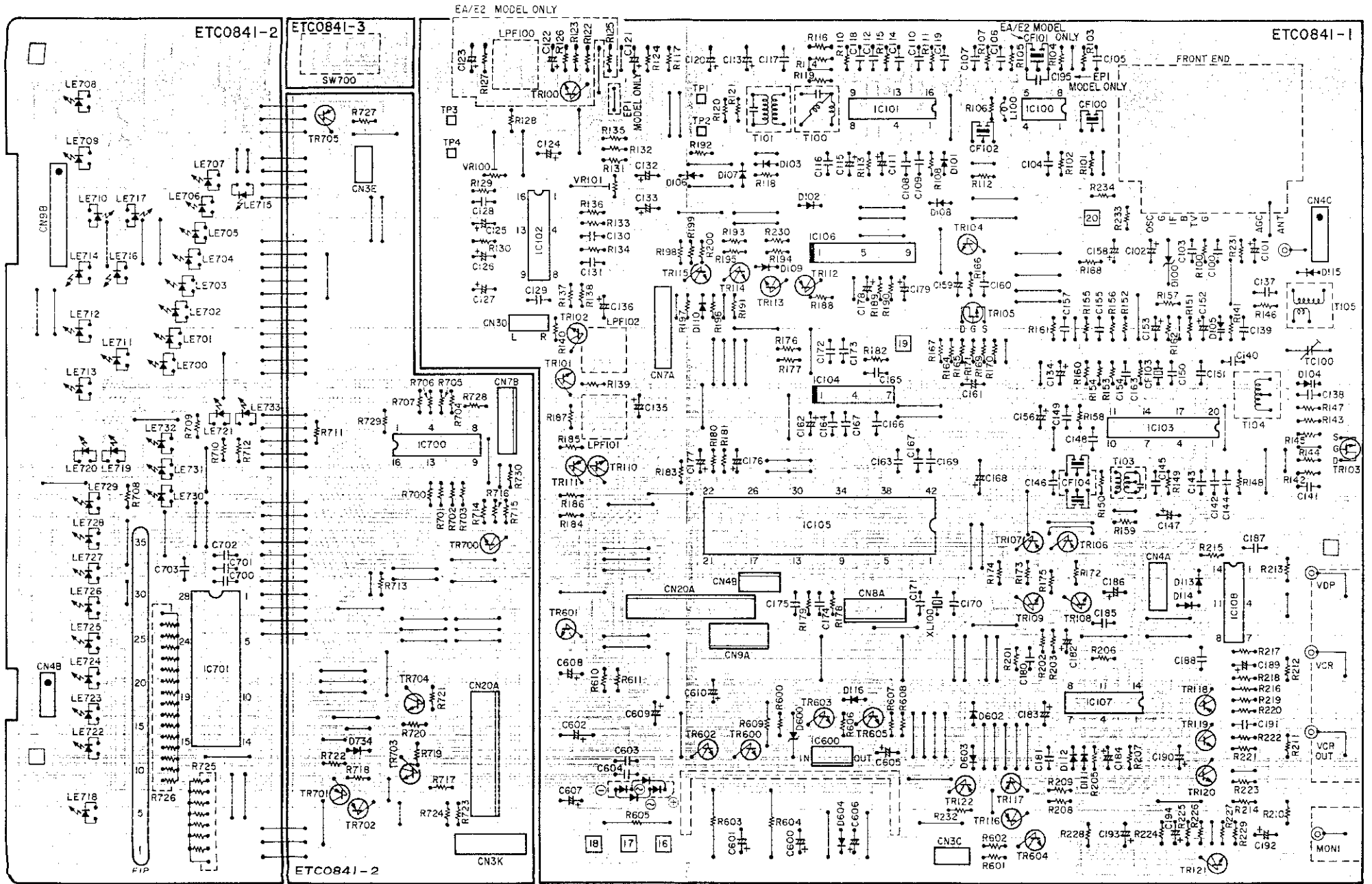

ETC0840D P. SUPPLY & CONTROL UNIT

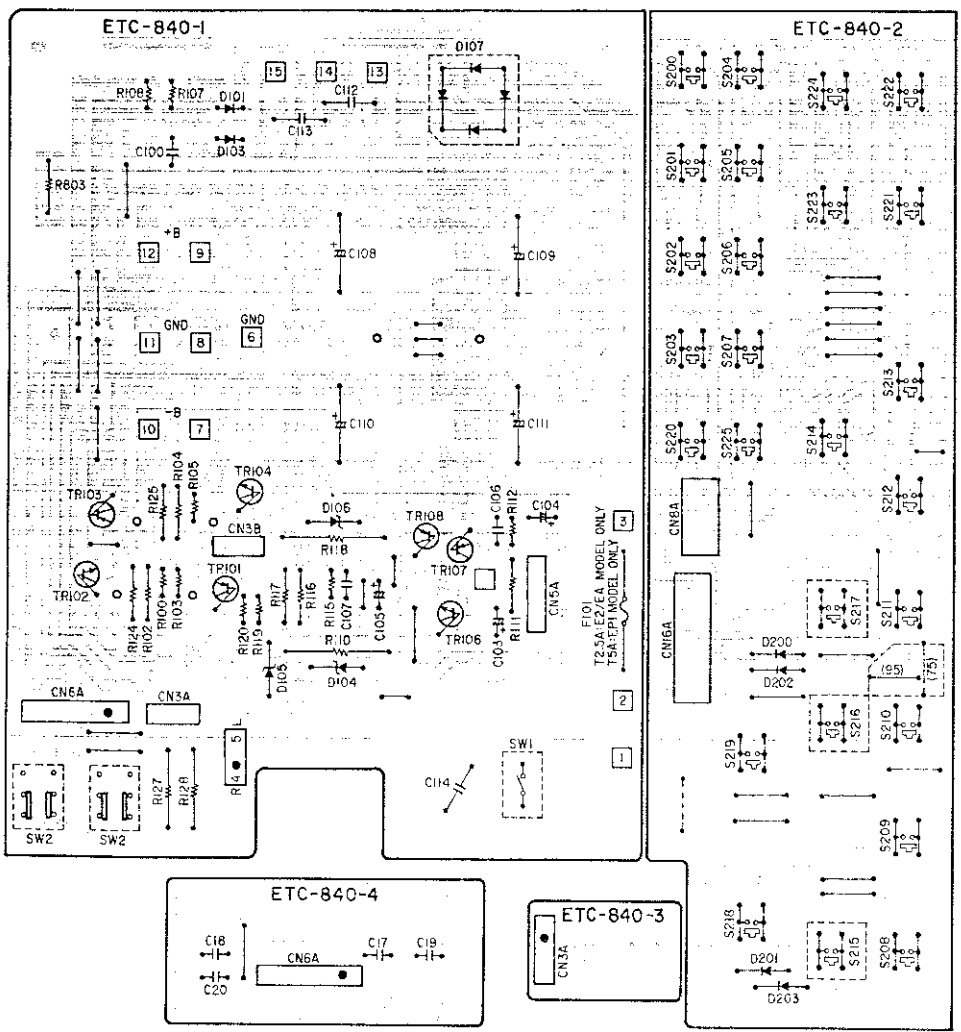

ETC0839D POWER UNIT PARTS LIST (for E2, EA)

Ref. No.	Part No.	Part Name & Descriptions
SEMICONDUCTORS		
IC001	2650377004	NJM-2068DD (JRC) IC
IC101	2620276005	HD14066BP (Hitachi) IC
IC102	2630359006	LC4966 (Sanvot) IC
IC103	2620699006	TC9164N (Toshiba) IC
IC301, 302	2630377004	NJM2068DD (JRC) IC
IC304	2620625009	TC9176P (Toshiba) IC
IC401	2630377004	NJM2068DD (JRC) IC
IC701	2620696106	HD6305X0A81P (Hitachi) IC
IC702	2620728003	LL59002 (Sharp) IC
IC703	2620678001	MN12805 (Matsushita) IC
IC704	2620575007	HD14082BP (Hitachi) IC
TR101	2690030006	RN2204 (47K-47K) Digital Transistor
TR102	2690029004	RN1204 (47K-47K) Digital Transistor
TR103, 104	2750041003	25K108(E) FET
TR403, 404	2730253015	25C2878(A/B) Transistor
TR405, 406	2710131021	25A988(E/F) Transistor
TR407, 408	2730235020	25C1841(E/F) Transistor
TR409, 410	2710131021	25A988(E/F) Transistor
TR413, 414	2730235020	25C1841(E/F) Transistor
TR419	2690030006	RN2204 (47K-47K) Digital Transistor
TR501, 502	2730198015	25C1815(BL) Transistor
TR503, 504	2730232000	25C3421(O/Y) Transistor
TR507, 508	2710195009	25A1358(O/Y) Transistor
TR601	2730198015	25C1815(BL) Transistor
TR602	2710211006	25A1282A(F) Transistor
TR604, 605	2730253015	25C2878(A/B) Transistor
TR606	2730235020	25C1841(E/F) Transistor
TR608, 609	2730198015	25C1815(BL) Transistor
TR610, 611	2690029004	RN1204 (47K-47K) Digital Transistor
TR612, 613	2670630006	RN2204 (47K-47K) Digital Transistor
TR614	2690029004	RN1204 (47K-47K) Digital Transistor
TR615, 616	2730281003	25C2705(O/Y) Transistor
TR617	2710159007	25A1145(O/Y) Transistor
TR618	2730198015	25C1815(BL) Transistor
TR619	2690029004	RN1204 (47K-47K) Digital Transistor
TR701	2690029004	RN1204 (47K-47K) Digital Transistor
TR702	2690030006	RN2204 (47K-47K) Digital Transistor
TR705	2690028005	RN2203 (22K 22K) Digital Transistor
TR715	2690029004	RN1204 (47K-47K) Digital Transistor
TR716	2690030006	RN2204 (47K-47K) Digital Transistor
SC001	2790016001	SF0R1A42 Thyristor
D001,002	2760432000	1S5270A Diode
D301-304	2750432000	1S5270A Diode
D401-406	2760432000	1S5270A Diode
D411,412	2760432000	1S5270A Diode
D503-506	2760049011	1S2076A Diode
D507,508	2760432000	1S5270A Diode
D509,510	2760049011	1S2076A Diode
D511-514	2760432000	1S5270A Diode
D517,518	2760432000	1S5270A Diode
D527	2760432000	1S5270A Diode
D601	2760444001	H5P22 Schottky Diode
D602,603	2760173084	H25C.1 Zener
D605,608	2760432000	1S5270A Diode

Ref. No.	Part No.	Part Name & Descriptions
RESISTORS (no included Carbon Film ±5%, 1/4W, 1/6W Type)		
AR445,446	2412379026	560 ohm ±5% 1/4W Carbon (NBS)
AR447,448	2412377044	100 ohm ±5% 1/4W Carbon (NBS)
AR453,454	2412379026	560 ohm ±5% 1/4W Carbon (NBS)
AR455,456	2412377044	100 ohm ±5% 1/4W Carbon (NBS)
AR523-526	2412379053	750 ohm ±5% 1/4W Carbon (NBS)
AR529,530	2412378027	220 ohm ±5% 1/4W Carbon (NBS)
AR533-536	2442013080	0.22 ohm ±5% 1W Metal Oxide (NB)
AR539-542	2442013080	0.22 ohm ±5% 1W Metal Oxide (NB)
AR547,548	2440072023	6.8 ohm ±5% 2W Metal Oxide (NBF)
AR549,550	2440015022	6.8 ohm ±5% 1W Metal Oxide (NBF)
AR551,552	2412375004	10 ohm ±5% 1/4W Carbon (NBS)
AR553	2412377060	120 ohm ±5% 1/4W Carbon (NBS)
AR571,618	2412380057	2 kohm ±5% 1/4W Carbon (NBS)
AR626	2440048028	3.9 kohm ±5% 1W Metal Oxide (NBF)
AR629,630	2412370041	2 kohm ±5% 1/4W Carbon (NBF)
VR301	2110465008	Variable Resistor 100 kohm Loudness
VR401	2110467007	Variable Resistor 250 kohm Balance
VR403	2110465009	Variable Resistor 50 kohm Treble
VR405	2110465012	Variable Resistor 250 kohm Bass
VR501, 502	2115000002	Semi Fixed Resistor 5 kohm
CAPACITORS		
C001,002	2553627000	100pF ±5% 50V Ceramic
C003,004	2544254006	10µF ±20% 16V Electrolytic
C005,006	2533623004	68pF ±5% 50V Ceramic
C009,010	2533635005	220pF ±5% 50V Ceramic
C011,012	2551034050	0.068µF ±5% 50V Metallized
C013,014	2544250080	1000µF ±20% 6.3V Electrolytic
C015,016	2551121054	0.015µF ±5% 50V Plastic Film
C017,018	2533643000	470pF ±5% 50V Ceramic
C019,020	2544254006	10µF ±20% 16V Electrolytic
C035,038	2533627000	100pF ±5% 50V Ceramic
C101	2551025002	0.022µF ±80,-20% 50V Ceramic
C102	2544260045	1µF ±20% 50V Electrolytic
C103-108	2551025002	0.022µF ±80,-20% 50V Ceramic
C112,113	2544260045	1µF ±20% 50V Electrolytic
C116	2544260045	1µF ±20% 50V Electrolytic
C117-119	2544260045	1µF ±20% 50V Electrolytic
C120-125	2551025002	0.022µF ±80,-20% 50V Ceramic
C126,127	2544260045	1µF ±20% 50V Electrolytic
C127,128	2551025002	0.022µF ±80,-20% 50V Ceramic
C129,130	2544260045	1µF ±20% 50V Electrolytic
C131,132	2551025002	0.022µF ±80,-20% 50V Ceramic
C133,134	2553631009	150pF ±5% 50V Ceramic
C301-304	2544260045	1µF ±20% 50V Electrolytic
C305,306	2533627000	100pF ±5% 50V Ceramic
C307,308	2544254006	10µF ±20% 16V Electrolytic
C317-320	2544260045	1µF ±20% 50V Electrolytic
C321,322	2551025002	0.022µF ±80,-20% 50V Ceramic
C323,324	2544260045	1µF ±20% 50V Electrolytic
C325,326	2551121054	0.018µF ±5% 50V Plastic Film
C327,328	2551055030	390pF ±10% 50V Ceramic

ETC0841D TUNER UNIT PARTS LIST (for E2, EA)

Ref. No.	Part No.	Part Name & Descriptions
C401~404	2544260045	1μF ±20% 50V Electrolytic
C405~408	2533627000	100pF ±5% 50V Ceramic
C409,410	2544254006	10μF ±20% 16V Electrolytic
C411,412	2533599002	6pF ±0.5pF 50V Ceramic
C413	2544260045	1μF ±20% 50V Electrolytic
C415	2544260045	1μF ±20% 50V Electrolytic
C417~420	2551120000	0.001μF ±5% 50V Plastic Film
C421~424	2533639001	330pF ±5% 50V Ceramic
C427,428	2551121009	0.0068μF ±5% 50V Plastic Film
C429,430	2533633007	180pF ±5% 50V Ceramic
C431,432	2551120013	0.0012μF ±5% 50V Plastic Film
C433,434	2561034047	0.056μF ±5% 50V Metalized
C435,436	2561034089	0.12μF ±5% 50V Metalized
C439,440	2534494009	100pF ±5% 500V Ceramic
C441,442	2551121067	0.022μF ±5% 50V Plastic Film
C445,446	2534494009	100pF ±5% 500V Ceramic
C447,448	2551121067	0.022μF ±5% 50V Plastic Film
C453,454	2551121041	0.015μF ±5% 50V Plastic Film
C455	2544260045	1μF ±20% 50V Electrolytic
C457	2544260045	1μF ±20% 50V Electrolytic
C458	2544260045	1μF ±20% 50V Electrolytic
C461,462	2531025002	0.022μF ±80,-20% 50V Ceramic
C475,476	2533635005	220pF ±5% 50V Ceramic
C505	2543046008	1μF ±20% 100V Electrolytic (B.P)
C507	2543046008	1μF ±20% 100V Electrolytic (B.P)
C519,520	2531024003	0.01μF ±80,-20% 50V Ceramic
C521,522	2551120000	0.001μF ±5% 50V Plastic Film
C525,526	2544260045	1μF ±20% 50V Electrolytic
C527,528	2551120000	0.001μF ±5% 50V Plastic Film
C529,530	2534498005	150pF ±5% 500V Ceramic
C535,536	2561034076	0.1μF ±5% 50V Metalized
C537,538	2561034047	0.056μF ±5% 50V Metalized
C539~542	2543046008	1μF ±20% 100V Electrolytic (B.P)
C543,544	2534498005	150pF ±5% 500V Ceramic
C601,602	2544254006	10μF ±20% 16V Electrolytic
C603,604	2531024003	0.01μF ±80,-20% 50V Ceramic
C605	2544250045	1μF ±20% 50V Electrolytic
C606	2544250042	330μF ±20% 6.3V Electrolytic
C609,610	2551120084	0.0047μF ±5% 50V Plastic Film
C613	2531025002	0.022μF ±80,-20% 50V Ceramic
C614	2531024003	0.01μF ±80,-20% 50V Ceramic
C615~617	2531025002	0.022μF ±80,-20% 50V Ceramic
C618	2544260045	1μF ±20% 50V Electrolytic
C619	2531025002	0.022μF ±80,-20% 50V Ceramic
C701	2544254006	10μF ±20% 16V Electrolytic
C704	2533635005	220pF ±5% 50V Ceramic
C705,706	2544260045	1μF ±20% 50V Electrolytic
C707	2531024003	0.01μF ±80,-20% 50V Ceramic
C708	2533635005	220pF ±5% 50V Ceramic
C709~711	2531055056	220pF ±10% 50V Ceramic
C713	2531055056	220pF ±10% 50V Ceramic
C716	2544252037	100μF ±20% 10V Electrolytic
C717,718	2531024003	0.01μF ±80,-20% 50V Ceramic
C719	2544260045	1μF ±20% 50V Electrolytic
C720	2531024003	0.01μF ±80,-20% 50V Ceramic
C721	2544260044	1μF ±20% 50V Electrolytic
C723	2531024003	0.01μF ±80,-20% 50V Ceramic
C725	2531025002	0.022μF ±80,-20% 50V Ceramic
C726	2531024003	0.01μF ±80,-20% 50V Ceramic
C777	2531024003	0.01μF ±80,-20% 50V Ceramic
E.U.P.		
L001,002 L501,502	2359003002 2359001004	FTZ Choke Coil Inductor

Ref. No.	Part No.	Part Name & Descriptions	Q'ty
XL701	3990034002	OSC Element (CST4,00MG)	
XL702	2610037005	OSC Element (CSB455E)	
SW003	2124607002	2P Push SW. (Phono. Mode)	
SW004	2124620001	1P Push SW. (Tuner. Mode)	
RL501	2140037009	Relay	
OTHER PARTS			
	2221317208	(P.W. Board)	1
	2090008146	Jumper Wire P=5mm	12
	2090008120	Jumper Wire P=10mm	98
	EP-5667H1	Terminal Pin	18
	2050152003	6P Connector Base	3
	2050298043	9P FFC Con. Base (S1)	1
	2050298019	16P FFC Con. Base (S)	1
	2050185038	3P Wire Holder	14
	2050185041	4P Wire Holder	1
	2050185054	5P Wire Holder	1
	2050185067	6P Wire Holder	2
	2050185070	7P Wire Holder	1
	2050185025	2P Wire Holder	3
	2050271094	9P PH Connector Base	1
	2042171018	7P Connector Cord	1
	2042170006	7P EH Connector Cord	1
	2038166008	5P EH Connector Cord	1
	203156023	4P EH Connector Cord	1
	2034340006	3P EH Connector Cord	1
	2034353006	3P EH Connector Cord Ass'y	1
	2034304013	3P EH Connector Cord	1
	2034338005	3P EH Connector Cord	1
	2090121023	T.S.W. Ass'y	1
	2090121036	T.S.W. Ass'y	1
	2090121049	T.S.W. Ass'y	1
	2090172001	T.S.W. Ass'y	1
	2090121065	T.S.W. Ass'y	1
	2090146008	2C Shield Wire	1
	2090146011	2C Shield Wire	1
	2090151006	2C Ribbon Cable	1
	2090153004	Vinyl Wire	1
	2090153020	Vinyl Wire	1
	2090153033	Vinyl Wire	1
	2090164035	T.S.W. Contact Ass'y	1
	2090164048	T.S.W. Contact Ass'y	1

Ref. No.	Part No.	Part Name & Descriptions
SEMICONDUCTORS		
IC100	2630414006	LA1222 (Sanyo) IC
IC101	2630083000	HA11225 (Hitachi) IC
IC102	2630384000	μPC1235C (NEC) IC
IC103	2630145003	LA1245 (Sanyo) IC
IC104	2630232000	TD6104P (Toshiba) IC
IC105	2620452104	TC9147BP (Toshiba) IC
IC106	2630371000	LB1403N (Sanyo) IC
IC107	2620300007	HD14011BP (Hitachi) IC
IC108	2620276005	HD14066BP (Hitachi) IC
IC600	2630459003	L78M05ML (JRC) IC
IC700	2620700005	TMS1035NE (T.I.) IC
IC701	2620452006	TD6301AP (Toshiba) IC
TR100	2730222004	2SC2458(Y/GR) Transistor
TR103	2750051006	2SK161(GR) FET
TR104	2730222004	2SC2458(Y/GR) Transistor
TR105	2750053004	2SK365(BL/GR) FET
TR106	2710194000	2SA1048(Y/GR) Transistor
TR108	2730222004	2SC2458(Y/GR) Transistor
TR110	2710194000	2SA1048(Y/GR) Transistor
TR111, 112	2730222004	2SC2458(Y/GR) Transistor
TR113	2730222004	2SC2458(Y/GR) Transistor
TR115	2710194000	2SA1048(Y/GR) Transistor
TR116	2730222004	2SC2458(Y/GR) Transistor
TR118	2710194000	2SA1048(Y/GR) Transistor
TR119	2730222004	2SC2458(Y/GR) Transistor
TR121	2710194000	2SA1048(Y/GR) Transistor
TR122	2730380008	2SC3851(Y/I/G) Transistor
TR600	2740078031	2SD882(Q/P) Transistor
TR601	2730222004	2SC2458(Y/GR) Transistor
TR700	2730222004	2SC2458(Y/GR) Transistor
TR701, 702	2710194000	2SA1048(Y/GR) Transistor
TR703	2730222004	2SC2458(Y/GR) Transistor
TR704	2710194000	2SA1048(Y/GR) Transistor
TR705	2690030006	RN2204 (47K-47K) Digital Transistor
D100	2760185014	1SS270 Diode
D101~103	2760417009	1SS270 Diode
D104,105	2760302004	SV321D2-5P Varactor
D106~116	2760417009	1SS270 Diode
D600	2760253001	HZ15-2 Zener
D601	2760422007	1D4B41 Diode
D602~604	2760417009	1SS270 Diode
D734	2760417009	1SS270 Diode
LE700	3939345008	SEL2413E-D2 Green (3) LED
LE708	3939344009	SEL1413E-D2 Green (5) LED
LE718	3939342001	SEL1213C-D Red (5) LED
LE719	3939345008	SEL2413E-D2 Green (3) LED
LE721	3939344009	SEL1413E-D2 Green (5) LED
LE722	3939345008	SEL2413E-D2 Green (3) LED
LE730	3939343000	SEL2213C-D1 Red (3) LED
LE732		
LE733		
RESISTORS (not included Carbon Film ±5%, 1/6W, 1/4W Type)		
AR603	2440037026	470 ohm ±5% 1W Metal Oxide (NB)
AR604	2440033020	220 ohm ±5% 1W Metal Oxide (NB)
AR605	2440005029	1 ohm ±5% 1W Metal Oxide (NB)

Ref. No.	Part No.	Part Name & Descriptions
AR609	2412313082	4.7 ohm ±5% 1/4W Carbon (NB)
R725	2462029009	10 kohm x 8 Resistor Array
R726	2462029012	10 kohm x 16 Resistor Array
VR100	2116000002	Semi Fixed Resistor 5 kohm
VR101	2116000028	Semi Fixed Resistor 100 kohm
CAPACITORS		
C100	2531024003	0.01μF ±80,-20% 50V Ceramic
C101,102	2544254006	10μF ±20% 16V Electrolytic
C103~110	2531024003	0.01μF ±80,-20% 50V Ceramic
C111	2544254019	22μF ±20% 16V Electrolytic
C112	2531024003	0.01μF ±80,-20% 50V Ceramic
C113	2544260032	0.47μF ±20% 50V Electrolytic
C114	2531024003	0.01μF ±80,-20% 50V Ceramic
C115	2544260045	1μF ±20% 50V Electrolytic
C116	2533629008	120pF ±5% 50V Ceramic
C117~119	2531024003	0.01μF ±80,-20% 50V Ceramic
C120	2544254048	100μF ±20% 16V Electrolytic
C121~123	2544254006	10μF ±20% 16V Electrolytic
C124	2544254051	220μF ±20% 16V Electrolytic
C125	2544260061	3.3μF ±20% 50V Electrolytic
C126	2544260058	2.2μF ±20% 50V Electrolytic
C127	2544260032	0.47μF ±20% 50V Electrolytic
C128	2556091008	470pF ±5% 50V Plastic Film
C129	2561034034	0.047μF ±5% 50V Metalized
C130,131	2539030015	1500pF ±10% 25V Ceramic
C132,133	2544214006	10μF ±10% 16V Electrolytic
C135,136	2544260058	2.2μF ±20% 50V Electrolytic
C137	2531024003	0.01μF ±80,-20% 50V Ceramic
C138	2533635005	220pF ±5% 50V Ceramic
C139	2533609002	18pF ±5% 50V Ceramic
C140	2554201049	390pF ±5% 50V Plastic Film
C141	2531024003	0.01μF ±80,-20% 50V Ceramic
C142	2531004007	1000pF ±10% 50V Ceramic
C143	2531025002	0.022μF ±80,-20% 50V Ceramic
C144,145	2531024003	0.01μF ±80,-20% 50V Ceramic
C146	2533619005	47pF ±5% 50V Ceramic
C147	2544254006	10μF ±20% 16V Electrolytic
C148	2531024003	0.01μF ±80,-20% 50V Ceramic
C149	2531004007	1000pF ±10% 50V Ceramic
C150,151	2531024003	0.01μF ±80,-20% 50V Ceramic
C152	2544260061	3.3μF ±20% 50V Electrolytic
C153	2544258002	4.7μF ±20% 35V Electrolytic
C154,155	2531024003	0.01μF ±80,-20% 50V Ceramic
C156	2544254035	47μF ±20% 16V Electrolytic
C157	2531025002	0.022μF ±80,-20% 50V Ceramic
C158	2544228061	1μF ±20% 50V Electrolytic (Low leak)
C159	2544214020	1μF ±20% 50V Electrolytic (B.P)
C160	2531025002	0.022μF ±80,-20% 50V Ceramic
C161	2544254048	100μF ±20% 16V Electrolytic
C162	2544252024	47μF ±20% 10V Electrolytic
C163~167	2531024003	0.01μF ±80,-20% 50V Ceramic
C168	2590004006	22000μF 5.5V for Backup
C169	2531024003	0.01μF ±80,-20% 50V Ceramic
C170,171	2533599002	6pF ±0.5pF 50V Ceramic
C172~175	2531024003	0.01μF ±80,-20% 50V Ceramic
C176,177	2544260058	2.2μF ±20% 50V Electrolytic
C178,179	2544260032	0.47μF ±20% 50V Electrolytic
C180,181	2531024003	0.01μF ±80,-20% 50V Ceramic
C182	2544260032	0.47μF ±20% 50V Electrolytic
C183,184	2544258002	4.7μF ±20% 35V Electrolytic
C185	2531024003	0.01μF ±80,-20% 50V Ceramic
C186	2544252024	47μF ±20% 10V Electrolytic
C187,188	2531024003	0.01μF ±80,-20% 50V Ceramic
C189	2544254035	47μF ±20% 16V Electrolytic
C190	2544254077	470μF ±20% 16V Electrolytic
C191	2531024003	0.01μF ±80,-20% 50V Ceramic

ETC0840D P. SUPPLY & CONTROL UNIT
PARTS LIST (for E2, EA)

ETC0839 POWER UNIT PARTS LIST (for EP1)

Ref. No.	Part No.	Part Name & Descriptions	Q'ty
C192	2544254077	470µF ±20% 16V Electrolytic	1
C193	2544254080	1000µF ±20% 16V Electrolytic	1
C194	2544254035	47µF ±20% 16V Electrolytic	1
C195	2531024003	0.01µF +80,-20% 50V Ceramic	1
C197	2531024003	0.01µF +80,-20% 50V Ceramic	1
C600	2544254006	10µF ±20% 16V Electrolytic	1
C601	2544256046	100µF ±20% 25V Electrolytic	1
C602	2544258099	1000µF ±20% 35V Electrolytic	1
C603,604	2531024003	0.01µF +80,-20% 50V Ceramic	1
C605,606	2544254006	10µF ±20% 16V Electrolytic	1
C607	2544254093	2200µF ±20% 16V Electrolytic	1
C608	2544254048	100µF ±20% 16V Electrolytic	1
C609	2544254006	10µF ±20% 16V Electrolytic	1
C610	2544254077	470µF ±20% 16V Electrolytic	1
C611	2544250013	47µF ±20% 6.3V Electrolytic	1
C700-702	2531060005	2200pF ±10% 50V Ceramic	1
C703	2531024003	0.01µF +80,-20% 50V Ceramic	1
C704,705	2533639001	330pF ±5% 50V Ceramic	1
C706	2531025002	0.022µF +80,-20% 50V Ceramic	1
TC100	2130022008	Trimmer Condenser	1
COIL, TRANS			
L100	2350026020	Inductor 10µH	1
T100	2312901002	FM IF Det (A) (50kHz)	1
T101	2312902001	FM IF Det (B) (50kHz)	1
T103	2313026009	AM IFT	1
T104	2311118003	MW OSC. Coil	1
T105	2311113008	MW Ant. Coil	1
LP101, 102	2320085004	Low Pass Filter	1
LPF100	2320096006	Anti Birdie Filter	1
CF100 ~102	2610023006	FM C. Filter (SFE10.7MHZ A)	1
CF103	2610031001	AM C. Filter (BFU450C4)	1
CF104	2610065006	AM C. Filter (SFZ450F3L)	1
E.U.P.			Q'ty
X100	2160039003	Front End	1
	3934022009	FIP7B8GS FLD	1
	3990040009	X-tal (7.2MHz)	1
	4990049009	RM-577 (Remote Control)	1
F001	2048178002	1P Pin Jack	1
	2061015029	Fuse (1AT)	1
	2020022008	Fuse Holder	2
OTHER PARTS			Q'ty
	2221313202	(P.W. Board)	1
	2090008146	Jumper Wire P=5mm	34
	2090008120	Jumper Wire P=10mm	152
	EP-5667H1	Terminal Pin	10
	4178028101	Heat Sink	1
	4713304015	Bind Screw 3x8	2
	2030262007	Ant. Pin Cord Ass'y	1
	2050240009	3P Connector Base	1
	2050185041	4P Wire Holder	1
	1460822209	LED Holder (A)	1
	1460821200	LED Holder (B)	1
	4610294008	Rubber Sheet	1
	2050233024	7P EH Connector Base	1
	2050233045	4P EH Connector Base	1
	2050233032	3P EH Connector Base	3
	2050271049	4P PH Connector Base	1
	2050271078	7P PH Connector Base	1
	2050241037	3P Connector Pin Ass'y	1

Ref. No.	Part No.	Part Name & Descriptions	Q'ty
	2050298051	20P FFC Con. Base (S)	2
	2050298048	9P FFC Con. Base (S)	1
	2050298035	8P FFC Con. Base (S)	1
	2042172004	9P Connector Cord	1
	2036172007	4P Connector Cord	1
	4150309013	P.V.C. Tube	4
	2090154003	Vinyl Wire	1
	2090154016	Vinyl Wire	2
	2090168015	Shield Wire Ass'y	1
	5130637034	Fuse Label	1

Ref. No.	Part No.	Part Name & Descriptions	Q'ty
SEMICONDUCTORS			
TR101	2710206008	2SA1488(Y)/(G) Transistor	1
TR102	2730187039	2SC2240(BL/GR) Transistor	1
TR103	2710094032	2SA970(BL/GR) Transistor	1
TR104	2730338008	2SC3851(Y)/(G) Transistor	1
TR106	2730338008	2SC3851(Y)/(G) Transistor	1
TR107	2710102021	2SA1015(GR) Transistor	1
TR108	2710206008	2SA1488(Y)/(G) Transistor	1
D101	2760427015	DSA1A2 (Type-3) Diode	1
D103	2760427015	DSA1A2 (Type-3) Diode	1
D104	2760221020	HZ36-3 Zener	1
D105	2760256008	HZ16-2 Zener	1
D106	2760221020	HZ36-3 Zener	1
D107	2760356005	D5FB20 Diode	1
D200-203	2760370007	1SS106TD Diode	1
RESISTORS (not included Carbon Film ±5%, 1/4W, 1/4W Type)			
AR110	2440093028	390 ohm ±5% 2W Metal Oxide (NBF)	1
AR118	2440093028	390 ohm ±5% 2W Metal Oxide (NBF)	1
AR119,120	2412387047	4.7 ohm ±5% 1/4W Carbon (NBS)	1
AR127,128	2440033020	220 ohm ±5% 1W Metal Oxide (NBF)	1
CAPACITORS			
C100	2544263042	1µF ±20% 100V Electrolytic	1
C103,104	2544260045	1µF ±20% 50V Electrolytic	1
C105	2544261015	47µF ±20% 50V Electrolytic	1
C106	2533619005	47pF ±5% 50V Ceramic	1
C107	2531055014	560pF ±10% 50V Ceramic	1
C108	2544216002	9200µF ±20% 63V Electrolytic	1
C110	2544216002	9200µF ±20% 63V Electrolytic	1
C112,113	2531053003	0.01µF ±100,-0% 500V Ceramic	1
AC114	2538014003	0.01µF ±20% 400V Ceramic(AC)	1
C119	2544260045	1µF ±20% 50V Electrolytic	1
C120	2544089022	100µF ±20% 50V Electrolytic	1
AC199	2568024018	0.1µF ±20% 250V Metallized(AC)	1
E.U.P.			Q'ty
S200-214	2124388004	Tact Switch	15
S218-225	2124388004	Tact Switch	8
ASW001	2124574009	Power Switch	1
SW002	2124604005	2P Push Switch	1
	2048187000	Headphone Jack	1
A	2020022008	Fuse Holder	2
AF101	2061015032	Fuse (2.5A)	1
OTHER PARTS			Q'ty
	2221315200	(P.W. Board)	1
	2090008146	Jumper Wire P=5mm	6
	2090008120	Jumper Wire P=10mm	27
	EP-5667H1	Terminal Pin	15
	2050269006	8P FFC Con. Base (R)	1
	2050233032	3P EH Connector Base	1
	2050233028	5P EH Connector Base	1
	2050185025	2P Wire Holder	1
	2050185038	3P Wire Holder	1
	2050185041	4P Wire Holder	1
	2034304026	3P EH Connector Cord	1
	2090170016	4C Ribbon Cable	1
	2090169001	Vinyl Wire Ass'y	1
	5130637021	Fuse Label	1
	4150299000	Condenser Cover	1

Ref. No.	Part No.	Part Name & Descriptions	Q'ty
SEMICONDUCTORS			
IC001	2650037007	NJM-2043DD (JRC) IC	1
IC101	2620276005	HD14066BP (Hitachi) IC	1
IC102	2630359006	LC4966 (Sanyo) IC	1
IC103	2620699006	TC9164N (Toshiba) IC	1
IC301,302	2630377004	NJM2068DD (JRC) IC	1
IC304	2620625009	TC9176P (Toshiba) IC	1
IC401	2630377004	NJM2068DD (JRC) IC	1
IC701	2620696106	HD6305X0A81P (Hitachi) IC	1
IC702	2620728003	LU59002 (Sharp) IC	1
IC703	2620678001	MN1280S (Matsushita) IC	1
IC704	2620575007	HD14082BP (Hitachi) IC	1
TR101	2690030006	RN2204 (47K-47K) Digital Transistor	1
TR102	2690029004	RN1204 (47K-47K) Digital Transistor	1
TR103, 104	2750041003	2SK108(E) FET	1
TR403, 404	2730253015	2SC2878(A/B) Transistor	1
TR405, 406	2710131021	2SA988(E/F) Transistor	1
TR407, 408	2730235020	2SC1841(E/F) Transistor	1
TR409, 410	2710131021	2SA988(E/F) Transistor	1
TR413, 414	2730235020	2SC1841(E/F) Transistor	1
TR419	2690030006	RN2204 (47K-47K) Digital Transistor	1
TR501, 502	2730198015	2SC1815(BL) Transistor	1
TR503, 504	2730323000	2SC3421(O/Y) Transistor	1
TR507, 508	2710195009	2SA1358(O/Y) Transistor	1
TR601	2730198015	2SC1815(BL) Transistor	1
TR602	2710211006	2SA1282A(F) Transistor	1
TR604, 605	2730253015	2SC2878(A/B) Transistor	1
TR606	2730235020	2SC1841(E/F) Transistor	1
TR608, 609	2730198015	2SC1815(BL) Transistor	1
TR610, 611	2690029004	RN1204 (47K-47K) Digital Transistor	1
TR612, 613	2670030006	RN2204 (47K-47K) Digital Transistor	1
TR614	2690029004	RN1204 (47K-47K) Digital Transistor	1
TR615, 616	2730281003	2SC2705(O)/(Y) Transistor	1
TR617	2710168007	2SA1145(O)/(Y) Transistor	1
TR618	2730198015	2SC1815(BL) Transistor	1
TR619	2690029004	RN1204 (47K-47K) Digital Transistor	1
TR701	2690029004	RN1204 (47K-47K) Digital Transistor	1
TR702	2690030006	RN2204 (47K-47K) Digital Transistor	1
TR705 ~711	2690028005	RN2203 (22K-22K) Digital Transistor	1
TR715	2690029004	RN1204 (47K-47K) Digital Transistor	1
TR716	2690030006	RN2204 (47K-47K) Digital Transistor	1
SC001	2790016001	SF0R1A42 Thyristor	1
D001,002	2760432000	1SS270A Diode	1
D301-304	2760432000	1SS270A Diode	1
D401-406	2760432000	1SS270A Diode	1
D411,412	2760432000	1SS270A Diode	1
D503-506	2760049011	1S2076A Diode	1
D507,508	2760432000	1SS270A Diode	1
D509,510	2760049011	1S2076A Diode	1
D511-514	2760432000	1SS270A Diode	1
D517,518	2760432000	1SS270A Diode	1
D527	2760432000	1SS270A Diode	1
D601	2760444001	HRP22 Schottky Diode	1
D602,603	2760173084	HZ6C-1 Zener	1
D605-608	2760432000	1SS270A Diode	1

ETC0841E TUNER UNIT PARTS LIST (for EP1)

Ref. No.	Part No.	Part Name & Descriptions
D609,610	2760049011	1S2076A Diode
D612	2760236031	H25C-1 Zener
D705,706	2760049011	1S2076A Diode
D707~712	2760432000	1S5270A Diode
D713	2760049011	1S2076A Diode
D714	2760432000	1S5270A Diode
D715	2760049011	1S2076A Diode
RESISTORS (no included Carbon Film ±5%, 1/4W, 1/6W Type)		
AR445,446	2412379026	560 ohm ±5% 1/4W Carbon (NBS)
AR447,448	2412377044	100 ohm ±5% 1/4W Carbon (NBS)
AR453,454	2412379026	560 ohm ±5% 1/4W Carbon (NBS)
AR455,456	2412377044	100 ohm ±5% 1/4W Carbon (NBS)
AR523~526	2412379053	750 ohm ±5% 1/4W Carbon (NBS)
AR529,530	2412378027	220 ohm ±5% 1/4W Carbon (NBS)
AR533~536	2442013080	0.22 ohm ±5% 1W Metal Oxide (NB)
AR539~542	2442013080	0.22 ohm ±5% 1W Metal Oxide (NB)
AR547,548	2440072023	6.8 ohm ±5% 2W Metal Oxide (NBF)
AR549,550	2440015022	6.8 ohm ±5% 1W Metal Oxide (NBF)
AR551,552	2412375004	10 ohm ±5% 1/4W Carbon (NBS)
AR553	2412377060	120 ohm ±5% 1/4W Carbon (NBS)
AR617,618	2412380057	2 kohm ±5% 1/4W Carbon (NBS)
AR626	2440048028	3.9 kohm ±5% 1W Metal Oxide (NBF)
AR629,630	2412370041	2 kohm ±5% Carbon (NBF)
VR301	2110466008	Variable Resistor 100 kohm Loudness
VR401	2110467007	Variable Resistor 250 kohm Balance
VR403	2110465009	Variable Resistor 50 kohm Treble
VR405	2110465012	Variable Resistor 250 kohm Bass
VR501,502	2116000002	Semi Fixed Resistor 5 kohm
CAPACITORS		
C003,004	2544254006	10µF ±20% 16V Electrolytic
C005,006	2533627000	100pF ±5% 50V Ceramic
C011,012	2561034050	0.068µF ±5% 50V Metalized
C013,014	2544250068	1000µF ±20% 6.3V Electrolytic
C015,016	2551121054	0.018µF ±5% 50V Plastic Film
C017,018	2533643000	470pF ±5% 50V Ceramic
C019,020	2544254006	10µF ±20% 16V Electrolytic
C101	2531025002	0.022µF +80, -20% 50V Ceramic
C102	2544260045	1µF ±20% 50V Electrolytic
C103~108	2531025002	0.022µF +80, -20% 50V Ceramic
C112,113	2544260045	1µF ±20% 50V Electrolytic
C116	2544260045	1µF ±20% 50V Electrolytic
C117~119	2544260045	1µF ±20% 50V Electrolytic
C120~125	2531025002	0.022µF +80, -20% 50V Ceramic
C126,127	2544260045	1µF ±20% 50V Electrolytic
C127,128	2531025002	0.022µF +80, -20% 50V Ceramic
C129,130	2544260045	1µF ±20% 50V Electrolytic
C131,132	2531025002	0.022µF +80, -20% 50V Ceramic
C133,134	2533631009	150pF ±5% 50V Ceramic
C301~304	2544260045	1µF ±20% 50V Electrolytic
C305,306	2533627000	100pF ±5% 50V Ceramic
C307,308	2544254006	10µF ±20% 16V Electrolytic
C317~320	2544260045	1µF ±20% 50V Electrolytic
C321,322	2531025002	0.022µF +80, -20% 50V Ceramic
C323,324	2544260045	1µF ±20% 50V Electrolytic
C325,326	2551121054	0.018µF ±5% 50V Plastic Film
C327,328	2531055030	390pF ±10% 50V Ceramic
C401~404	2544260045	1µF ±20% 50V Electrolytic
C405~408	2533627000	100pF ±5% 50V Ceramic
C409,410	2544254006	10µF ±20% 16V Electrolytic

Ref. No.	Part No.	Part Name & Descriptions
C413	2544260045	1µF ±20% 50V Electrolytic
C415	2544260045	1µF ±20% 50V Electrolytic
C417~420	2551120000	0.001µF ±5% 50V Plastic Film
C421~424	2533639001	330pF ±5% 50V Ceramic
C427,428	2551121009	0.0068µF ±5% 50V Plastic Film
C429,430	2533633007	180pF ±5% 50V Ceramic
C431,432	2551120013	0.0012µF ±5% 50V Plastic Film
C433,434	2561034047	0.056µF ±5% 50V Metalized
C435,436	2561034089	0.12µF ±5% 50V Metalized
C439,440	2534494009	100pF ±5% 500V Ceramic
C441,442	2551121067	0.022µF ±5% 50V Plastic Film
C445,446	2534494009	100pF ±5% 500V Ceramic
C447,448	2551121067	0.022µF ±5% 50V Plastic Film
C453,454	2551121041	0.015µF ±5% 50V Plastic Film
C455	2544260045	1µF ±20% 50V Electrolytic
C457	2544260045	1µF ±20% 50V Electrolytic
C458	2544260045	1µF ±20% 50V Electrolytic
C461,462	2531025002	0.022µF +80, -20% 50V Ceramic
C505	2543046008	1µF ±20% 100V Electrolytic (B.P)
C507	2543046008	1µF ±20% 100V Electrolytic (B.P)
C519,520	2531024003	0.01µF +80, -20% 50V Ceramic
C521,522	2533639001	330pF ±5% 50V Ceramic
C525,526	2544260045	1µF ±20% 50V Electrolytic
C527,528	2533639001	330pF ±5% 50V Ceramic
C529,530	2534498005	150pF ±5% 500V Ceramic
C535,536	2561034076	0.1µF ±5% 50V Metalized
C537,538	2551121067	0.022µF ±5% 50V Plastic Film
C539~542	2543046008	1µF ±20% 100V Electrolytic (B.P)
C543,544	2534498005	150pF ±5% 500V Ceramic
C601,602	2544254006	10µF ±20% 16V Electrolytic
C603,604	2531024003	0.01µF +80, -20% 50V Ceramic
C605	2544250045	330µF ±20% 50V Electrolytic
C606	2544250042	330µF ±20% 6.3V Electrolytic
C609,610	2551120084	0.0047µF ±5% 50V Plastic Film
C613	2531025002	0.022µF +80, -20% 50V Ceramic
C614	2531024003	0.01µF +80, -20% 50V Ceramic
C615~617	2531025002	0.022µF +80, -20% 50V Ceramic
C618	2544260045	1µF ±20% 50V Electrolytic
C619	2531025002	0.022µF +80, -20% 50V Ceramic
C701	2544254006	10µF ±20% 16V Electrolytic
C704	2533635005	220pF ±5% 50V Ceramic
C705,706	2544260045	1µF ±20% 50V Electrolytic
C707	2531024003	0.01µF +80, -20% 50V Ceramic
C708	2533635005	220pF ±5% 50V Ceramic
C709~711	2531055056	220pF ±10% 50V Ceramic
C713	2531055056	220pF ±10% 50V Ceramic
C716	2544252037	100µF ±20% 10V Electrolytic
C717,718	2531024003	0.01µF +80, -20% 50V Ceramic
C719	2544260045	1µF ±20% 50V Electrolytic
C720	2531024003	0.01µF +80, -20% 50V Ceramic
C721	2544260044	1µF ±20% 50V Electrolytic
C723	2531024003	0.01µF +80, -20% 50V Ceramic
C725	2531025002	0.022µF +80, -20% 50V Ceramic
C726	2531024003	0.01µF +80, -20% 50V Ceramic
C777	2531024003	0.01µF +80, -20% 50V Ceramic
E.U.P.		
L501,502	2359001004	Inductor
XL701	3990034002	OSC Element (CST4.00MG)
XL702	2610037005	OSC Element (CSB455E)
SW003	2124607002	2P Push SW. (Phono. Mode)
SW004	212462001	1P Push SW. (Tuner. Mode)
RL501	2140037009	Relay

Ref. No.	Part No.	Part Name & Descriptions	Q'ty
OTHER PARTS			
	2221317208	(P.W. Board)	
	2090008146	Jumper Wire P=5mm	12
	2090008120	Jumper Wire P=10mm	98
	EP-5667H1	Terminal Pin	18
	2050152003	6P Connector Base	3
	2050298048	9P FFC Con. Base (S)	1
	2050298019	16P FFC Con. Base (S)	1
	2050185038	3P Wire Holder	14
	2050185041	4P Wire Holder	1
	2050185054	5P Wire Holder	1
	2050185067	6P Wire Holder	2
	2050185070	7P Wire Holder	1
	2050185025	2P Wire Holder	3
	2050271094	9P PH Connector Base	1
	2042171018	7P Connector Cord	1
	2042170006	7P EH Connector Cord	1
	2038166008	5P EH Connector Cord	1
	2036156023	4P EH Connector Cord	1
	2034340006	3P EH Connector Cord	1
	2034353006	3P EH Connector Cord Ass'y	1
	2034304013	3P EH Connector Cord	1
	2034338005	3P EH Connector Cord	1
	2090121023	T.S.W. Ass'y	1
	2090121036	T.S.W. Ass'y	1
	2090121049	T.S.W. Ass'y	1
	2090172001	T.S.W. Ass'y	1
	2090121065	T.S.W. Ass'y	1
	2090146008	2C Shield Wire	1
	2090146011	2C Shield Wire	1
	2090151006	2C Ribbon Cable	1
	2090153004	Vinyl Wire	1
	2090153020	Vinyl Wire	1
	2090153033	Vinyl Wire	1
	2090164003	T.S.W. Contact Ass'y	1
	2090164048	T.S.W. Contact Ass'y	1

Ref. No.	Part No.	Part Name & Descriptions
SEMICONDUCTORS		
IC100	2630414006	LA1222 (Sanyo) IC
IC101	2630083000	HA11225 (Hitachi) IC
IC102	2630384000	µPC1235C (NEC) IC
IC103	2630145003	LA1245 (Sanyo) IC
IC104	2630232000	TD6104P (Toshiba) IC
IC105	2620452104	TC9147BP (Sanyo) IC
IC106	2630371000	LB1403N (Toshiba) IC
IC107	2620300007	HD14011BP (Hitachi) IC
IC108	2620276005	HD14066BP (Hitachi) IC
IC600	2630459003	L78M05ML (JRC) IC
IC700	2620700005	TMS1035NE (T.I.) IC
IC701	2620453006	TD6301AP (Toshiba) IC
TR101, 102	2730222004	25C2458(Y/GR) Transistor
TR103	2750051006	2SK161(GR) FET
TR104	2730222004	25C2458(Y/GR) Transistor
TR105	2750053004	25C365(BL/GR) FET
TR106, 107	2710194000	25A1048(Y/GR) Transistor
TR108	2730222004	25C2458(Y/GR) Transistor
~110		
TR111, 112	2710194000	25A1048(Y/GR) Transistor
TR113	2730222004	25C2458(Y/GR) Transistor
~115		
TR116	2710194000	25A1048(Y/GR) Transistor
~118		
TR119	2730222004	25C2458(Y/GR) Transistor
~121		
TR122	2710194000	25A1048(Y/GR) Transistor
TR600	2730338008	25C3851(Y)/(G) Transistor
TR601	2740078031	25D882(Q/P) Transistor
TR602	2730222004	25C2458(Y/GR) Transistor
~605		
TR700	25C2458(Y/GR)	25C2458(Y/GR) Transistor
TR701, 702	2710194000	25A1048(Y/GR) Transistor
TR705	2690030006	RN2204 (47K-47K) Digital Transistor
D100	2760185014	HZ48-3 Zener
D101~103	2760417009	1SS270 Diode
D104,105	2760302004	SVC321D2-SP Varactor
D106~116	2760417009	1SS270 Diode
D600	2760253001	HZ15-2 Zener
D601	2760422007	1D4841 Diode
D602~604	2760417009	1SS270 Diode
LE700	3939345008	SEL2413E-D2 Green (3) LED
~707		
LE708	3939344009	SEL1413E-D2 Green (5) LED
~714		
LE718	3939342001	SEL1213C-D Red (5) LED
LE719, 721	3939345008	SEL2413E-D2 Green (3) LED
LE722	3939344009	SEL1413E-D2 Green (5) LED
~729		
LE730	3939345008	SEL2413E-D2 Green (3) LED
~732		
LE733	3939343000	SEL2213C-D1 Red (3) LED
RESISTORS (not included Carbon Film ±5%, 1/6W, 1/4W Type)		
AR603	2440037026	470 ohm ±5% 1W Metal Oxide (NB)
AR604	2440033020	220 ohm ±5% 1W Metal Oxide (NB)
AR605	2440005028	1 ohm ±5% 1W Metal Oxide (NB)
AR609	2412313082	4.7 ohm ±5% 1/4W Carbon (NB)
R725	2462029009	10 kohm x 8 Resistor Array
R726	2462029012	10 kohm x 16 Resistor Array

ETC0840B P. SUPPLY & CONTROL UNIT
PARTS LIST (for EP1)

Ref. No.	Part No.	Part Name & Descriptions
VR100	2116000002	Semi Fixed Resistor 5 kohm
VR101	2116000028	Semi Fixed Resistor 100 kohm
CAPACITORS		
C100	2531024003	0.01µF +80,-20% 50V Ceramic
C102	2544254006	10µF ±20% 16V Electrolytic
C103~109	2531024003	0.01µF +80,-20% 50V Ceramic
C111	2544254019	22µF ±20% 16V Electrolytic
C112	2531024003	0.01µF +80,-20% 50V Ceramic
C113	2544260032	0.47µF ±20% 50V Electrolytic
C114	2531024003	0.01µF +80,-20% 50V Ceramic
C115	2544260045	1µF ±20% 50V Electrolytic
C116	2533629008	120pF ±5% 50V Ceramic
C117~119	2531024003	0.01µF +80,-20% 50V Ceramic
C120	2544254048	100µF ±20% 16V Electrolytic
C121	2544254006	10µF ±20% 16V Electrolytic
C124	2544254051	220µF ±20% 16V Electrolytic
C125	2544260061	3.3µF ±20% 50V Electrolytic
C126	2544260058	2.2µF ±20% 50V Electrolytic
C127	2544260032	0.47µF ±20% 50V Electrolytic
C128	2556091008	470pF ±5% 50V Plastic Film
C129	2561034034	0.047µF ±5% 50V Metalized
C130,131	2539030028	2200pF ±10% 25V Ceramic
C132,133	2544214006	10µF ±10% 16V Electrolytic
C135,136	2544260058	2.2µF ±20% 50V Electrolytic
C137	2531024003	0.01µF +80,-20% 50V Ceramic
C138	2533635005	220pF ±5% 50V Ceramic
C139	2533609002	18pF ±5% 50V Ceramic
C140	2554201049	390pF ±5% 50V Plastic Film
C141	2531024003	0.01µF +80,-20% 50V Ceramic
C142	2531004007	1000pF ±10% 50V Ceramic
C143	2531025002	0.022µF +80,-20% 50V Ceramic
C144,145	2531024003	0.01µF +80,-20% 50V Ceramic
C146	2533619005	47pF ±5% 50V Ceramic
C147	2544254006	10µF ±20% 16V Electrolytic
C148	2531024003	0.01µF +80,-20% 50V Ceramic
C149	2531004007	1000pF ±10% 50V Ceramic
C150,151	2531024003	0.01µF +80,-20% 50V Ceramic
C152	2544260061	3.3µF ±20% 50V Electrolytic
C153	2544258002	4.7µF ±20% 35V Electrolytic
C154,155	2531024003	0.01µF +80,-20% 50V Ceramic
C156	2544254035	47µF ±20% 16V Electrolytic
C157	2531025002	0.022µF +80,-20% 50V Ceramic
C158	2544228061	1µF ±20% 50V Electrolytic (Low leak)
C159	2544214020	1µF ±20% 50V Electrolytic (B.F)
C160	2531025002	0.022µF +80,-20% 50V Ceramic
C161	2544254048	100µF ±20% 16V Electrolytic
C162	2544252024	47µF ±20% 10V Electrolytic
C163~167	2531024003	0.01µF +80,-20% 50V Ceramic
C168	2590004006	22000µF 5.5V for Backup
C169	2531024003	0.01µF +80,-20% 50V Ceramic
C170,171	2533599002	6pF ±0.5pF 50V Ceramic
C172~175	2531024003	0.01µF +80,-20% 50V Ceramic
C176,177	2544260058	2.2µF ±20% 50V Electrolytic
C178,179	2544260032	0.47µF ±20% 50V Electrolytic
C180,181	2531024003	0.01µF +80,-20% 50V Ceramic
C182	2544260032	0.47µF ±20% 50V Electrolytic
C185	2531024003	0.01µF +80,-20% 50V Ceramic
C186	2544252024	47µF ±20% 10V Electrolytic
C187,188	2531024003	0.01µF +80,-20% 50V Ceramic
C189	2544254035	47µF ±20% 16V Electrolytic

Ref. No.	Part No.	Part Name & Descriptions
C190	2544254077	470µF ±20% 16V Electrolytic
C191	2531024003	0.01µF +80,-20% 50V Ceramic
C192	2544254077	470µF ±20% 16V Electrolytic
C193	2544254080	1000µF ±20% 16V Electrolytic
C194	2544254035	47µF ±20% 16V Electrolytic
C195	2531024003	0.01µF +80,-20% 50V Ceramic
C197	2531024003	0.01µF +80,-20% 50V Ceramic
C600	2544254006	10µF ±20% 16V Electrolytic
C601	2544256046	100µF ±20% 25V Electrolytic
C602	2544258099	1000µF ±20% 35V Electrolytic
C603,604	2531024003	0.01µF +80,-20% 50V Ceramic
C605,606	2544254006	10µF ±20% 16V Electrolytic
C607	2544254093	2200µF ±20% 16V Electrolytic
C608	2544254048	100µF ±20% 16V Electrolytic
C609	2544254006	10µF ±20% 16V Electrolytic
C610	2544254077	470µF ±20% 16V Electrolytic
C611	2544250013	47µF ±20% 6.3V Electrolytic
C700~702	2531006005	2200pF ±10% 50V Ceramic
C703	2531024003	0.01µF +80,-20% 50V Ceramic
C704,705	2533639001	330pF ±5% 50V Ceramic
C706	2531025002	0.022µF +80,-20% 50V Ceramic
TC100	2130022008	Trimmer Condenser
COIL, TRANS		
L100	2350026020	Inductor 10µH
T100	2312901002	FM IF Det (A) (50kHz)
T101	2312902001	FM IF Det (B) (50kHz)
T103	2313026009	AM IFT
T104	2314901000	MW OSC. Coil
T105	2311113008	MW Ant. Coil
LP101, 102	2320085004	Low Pass Filter
CF100	2610078006	FM C. Filter (SFE10.7MM)
CF102	2610078006	FM C. Filter (SFE10.7MM)
CF103	2610031001	AM C. Filter (BFU450C4)
CF104	2610065006	AM C. Filter (SFZ450F3L)
E.U.P.		
	2160041004	Front End
	3934022009	FIP7B8GS FLD
X100	3990040009	X-tal (7.2MHz)
	4990049009	RM-577 (Remote Control)
	2048178002	1P Pin Jack
	2020022008	Fuse Holder
	2124293005	Slide Switch
OTHER PARTS		
	(2221313202)	P.W. Board
	2090008146	Jumper Wire P=5mm
	2090008120	Jumper Wire P=10mm
	EP-5667H1	Terminal Pin
	4178028101	Heat Sink
	4713304015	Bind Screw 3x8
	2030262007	Ant. Pin Cord Ass'y
	2050240009	3P Connector Base
	2050185041	4P Wire Holder
	1460822209	LED Holder (A)
	1460821200	LED Holder (B)
	4610294008	Rubber Sheet
	2050233074	7P EH Connector Base
	2050233074	4P EH Connector Base
	2050233032	3P EH Connector Base
	2050271049	4P PH Connector Base
	2050271078	7P PH Connector Base
	2050241037	3P Connector Pin Ass'y

Ref. No.	Part No.	Part Name & Descriptions	Q'ty
*	2050298051	20P FFC Con. Base (S)	2
*	2050298048	9P FFC Con. Base (S)	1
*	2050298035	8P FFC Con. Base (S)	1
*	2042172004	9P Connector Cord	1
*	2036172007	4P Connector Cord	1
*	4150309013	P.V.C. Tube	4
*	2090154003	Vinyl Wire	1
*	2090154016	Vinyl Wire	4
*	2090168015	Shield Wire Ass'y	1

Ref. No.	Part No.	Part Name & Descriptions	Q'ty
SEMICONDUCTORS			
TR101	2710206008	2SA1488(Y)/(G)	Transistor
TR102	2730187039	2SC2240(BL/GR)	Transistor
TR103	2710094032	2SA970(BL/GR)	Transistor
TR104	2730338008	2SC3851(Y)/(G)	Transistor
TR106	2730338008	2SC3851(Y)/(G)	Transistor
TR107	2710102021	2SA1015(GR)	Transistor
TR108	2710206008	2SA1488(Y)/(G)	Transistor
D101	2760427015	DSA1A2 (Type-3)	Diode
D103	2760427015	DSA1A2 (Type-3)	Diode
D104	2760221020	HZ36-3	Zener
D105	2760256008	HZ16-2	Zener
D106	2760221020	HZ36-3	Zener
D107	2760424005	4D4842(LC1)	Diode
D200-203	2760370007	1S5106TD	Diode
RESISTORS (not included Carbon Film ±5%, 1/4W, 1/4W Type)			
AR110	2440093028	390 ohm ±5% 2W Metal Oxide (NBF)	
AR118	2440093028	390 ohm ±5% 2W Metal Oxide (NBF)	
AR119,120	2412387047	4.7 ohm ±5% 1/4W Carbon (NBS)	
R121	2420073000	2.2 Mohm ±10% 1/2W Carbon Composite	
AR127,128	2440033020	220 ohm ±5% 1W Metal Oxide (NBF)	
CAPACITORS			
C100	2544263042	1µF ±20% 100V Electrolytic	
C103,104	2544260045	1µF ±20% 50V Electrolytic	
C105	2544261015	47µF ±20% 50V Electrolytic	
C106	2533619005	47pF ±5% 50V Ceramic	
C107	2531055014	560pF ±10% 50V Ceramic	
C109	2544216002	9200µF ±20% 63V Electrolytic	
C111	2544216002	9200µF ±20% 63V Electrolytic	
C112,113	2531053003	0.01µF +100,-0% 500V Ceramic	
AC114	2538014003	0.01µF ±20% 400V Ceramic(AC)	
C119	2544260045	1µF ±20% 50V Electrolytic	
C120	2544089022	100µF ±20% 50V Electrolytic	
C801	2531024503	0.01µF +80,-20% 50V Ceramic	
E.U.P.			
S200-214	2124388004	Tact Switch	15
S218-225	2124388004	Tact Switch	8
ASW001	2124574009	Power Switch	1
SW002	2124604005	2P Push Switch	1
	2048167000	Headphone Jack	1
	2050254008	Terminal Board (8P) For SP.	1
A	2020022008	Fuse Holder	2
AF101	2061046001	Fuse (3A) UL (20mm)	1
OTHER PARTS			
	(2221315200)	P.W. Board	1
	2090008146	Jumper Wire P=5mm	6
	2090008120	Jumper Wire P=10mm	28
	EP-5667H1	Terminal Pin	17
	2050269006	8P FFC Con. Base (R)	1
	2050269064	16P FFC Con. Base (R)	1
	2050233032	3P EH Connector Base	2
	2050233058	5P EH Connector Base	1
	2050185025	2P Wire Holder	1
	2050185038	3P Wire Holder	1
	2050185041	4P Wire Holder	2
	2034304026	3P EH Connector Cord	1
	2090170003	4C Ribbon Cable	1
	2090169001	Vinyl Wire Ass'y	1

WIRING DIAGRAM (for EP1)

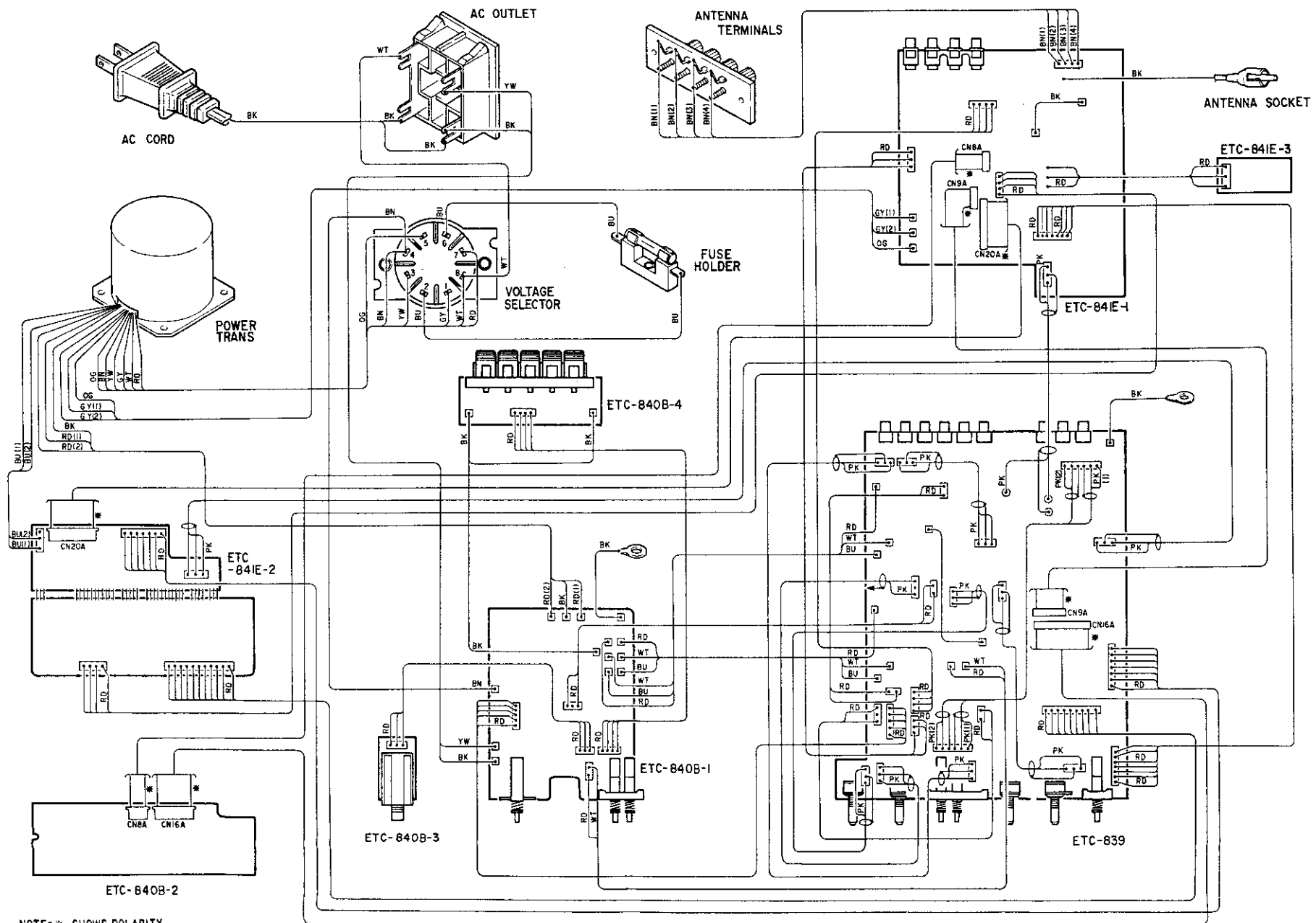

NOTE: * SHOWS POLARITY

EXPLODED VIEW OF CHASSIS AND CABINET

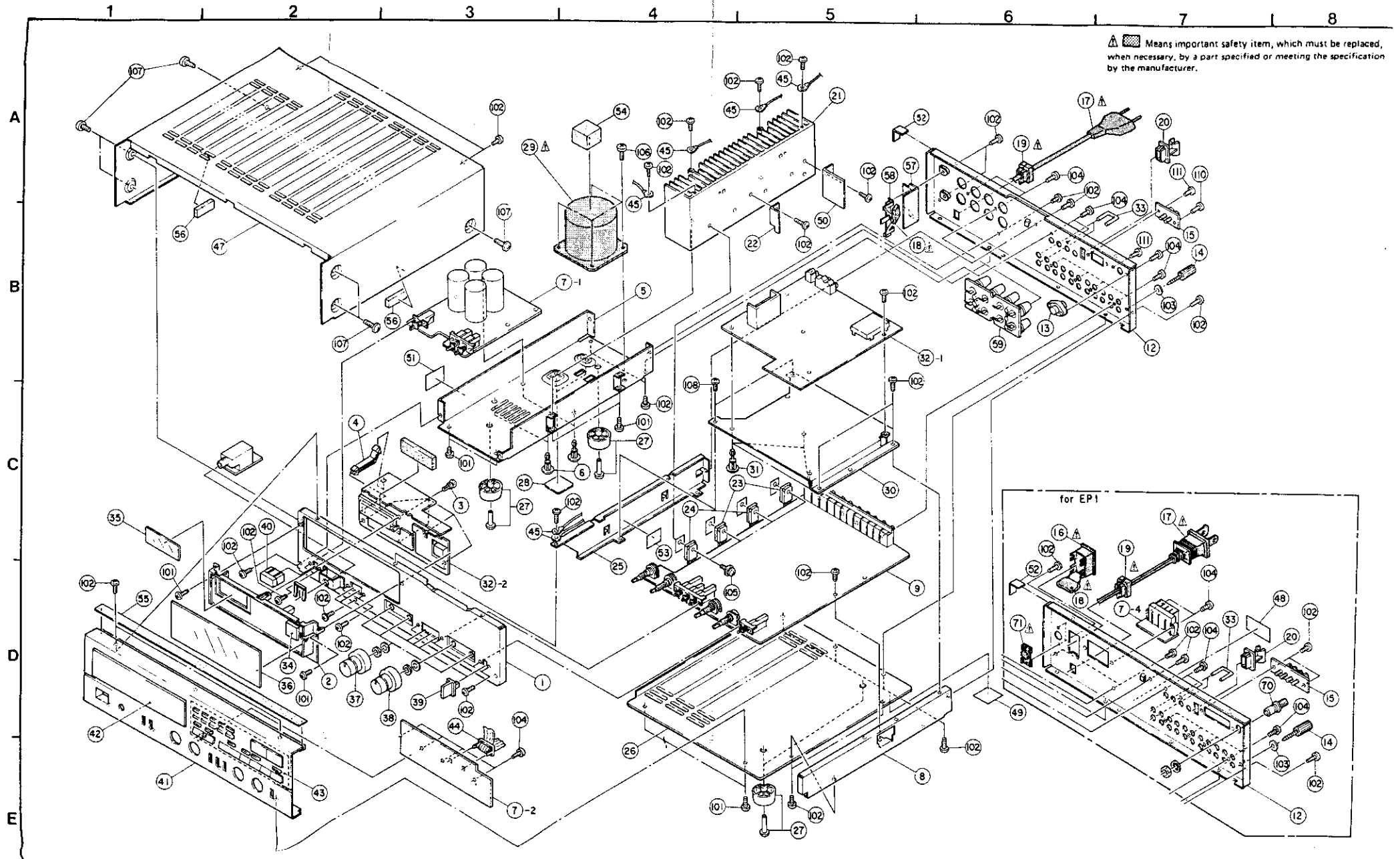

EXPLODED VIEW OF PARTS LIST

Ref. No.	Part No.	Part Name & Descriptions	Q'ty
1	4110568108	FRONT CHASSIS ASS'Y	1
2	1460820308	LED FRAME	1
3	4770096007	PUSH RIVET	5
4	4150313009	P.C.B. SUPPORT	1
5	4110569301	TRANS CHASSIS	1
6	4121979029	P.C.B. HOLDER	4
7	ETC0840D	P. SUPPLY & CONTROL UNIT	1s
8	4119020508	SIDE CHASSIS	1
9	ETC0839D	POWER UNIT	1s
10	-	-	1
11	-	-	1s
12	1050726003	BACK PANEL	1
13	2050215005	ANTENNA TERMINAL	1
14	2050071016	TERMINAL ASS'Y	1
15	2050165003	2P TERMINAL	1
▲ 16	2062002031	AC CORD	1
▲ 17	2538014003	CAPACITOR 0.01μF/400V (AC)	1
▲ 18	4450056008	CORD BUSH	1
20	1460494006	ANTENNA HOLDER	1
21	4170272104	POWER RADIATOR	1
22	4129044008	BRACKET	1
23	2730336000	TRANSISTOR 2SC3854(O)/(Y)	2
		TR505,506	
24	2710204000	TRANSISTOR 2SA1490(O)/(Y)	2
		TR507,508	
25	4122022205	RADIATOR BRACKET	1
26	1059044207	BOTTOM COVER	1
27	1040128006	FOOT	4
28	4140411005	SAFETY PLATE	2
▲ 29	2335591004	POWER TRANS.	1
30	4122021002	SHIELD PLATE	1
31	4121979032	P.C.B. HOLDER	3
32	ETC0841D	TUNER UNIT	1s
33	2050073001	SHORT PIN	2
34	1438044103	WINDOW (C)	1
35	1430470005	FILTER	1
36	1410294201	DISPLAY SHEET	1
37	1120487201	KNOB ASS'Y	3
38	1120487214	KNOB ASS'Y	1
39	1139071006	PUSH KNOB (T)	5
40	1139070104	PUSH KNOB (P)	1
41	1441479406	FRONT PANEL ASS'Y	1
42	1430466006	WINDOW	1
43	1130811126	PUSH KNOB ASS'Y	1
44	4150342106	WIRE HOLDER	1
45	4450048003	CORD HOLDER (r: 76mm)	7
▲46	4450033005	WIRE CLAMP BAND	30
47	1029013404	TOP COVER	1
▲48	2030289006	1P CONTACT ASS'Y	1
▲49	2030289019	1P CONTACT ASS'Y	1
50	4122062003	SHIELD BRACKET	1
▲51	2090153075	VINYL WIRE	2
52	4410733002	CORNER BRACKET	1
▲53	2090153062	VINYL WIRE	1
54	4610294024	RUBBER SHEET	1
55	1229006017	SPACER	1
56	4619001001	RUBBER SHEET	2
57	4150374006	INSULATING SHEET	1
58	2050089011	7P W TERMINAL	1
59	2050186008	8P SP TERMINAL	1
▲60	2551120084	CAPACITORS 0.0047μF/50V (C-151 ~ 154)	4
61	2090116038	16P FFC	1
62	2090145012	8P FFCU	1

E2 Gold Version PARTS LIST
(Same as E2 BLACK VERSION (Left P/List)
except the followings.)

Ref. No.	Part No.	Part Name & Descriptions	Q'ty
37	1120487227	KNOB ASS'Y	3
38	1120487230	KNOB ASS'Y	1
39	1139071019	PUSH KNOB (T)	5
40	1139070117	PUSH KNOB (P)	1
41	1441479435	FRONT PANEL ASS'Y	1
43	1130811139	PUSH KNOB ASS'Y	1
47	1029013420	TOP COVER	1
107	4737014006	TAPPING SCREW (S) 4x8	6
205	5011117042	CARTON CASE	1
210	5139111001	COLOR LABEL (GOLD)	2

Ref. No.	Part No.	Part Name & Descriptions	Q'ty
63	2090143001	20P FFCU	1
64	2090144000	9P FFCU	1
▲65	2531024003	CERAMIC CAPACITOR 0.01μF/50V (C-612)	1
▲66	2090153088	VINYL WIRE	2
SCREWS			
101	4737002021	TAPPING SCREW (S) 3x8 BLACK	9
102	4737002034	TAPPING SCREW (S) 3x6 BLACK	42
103	4770018001	WASHER (P-87)	1
104	4737500044	TAPPING SCREW (P) 3x8 BLACK	10
105	4700012022	PAN SCREW WITH W.SW 3x12	4
106	4737004016	TAPPING SCREW (S) 4x6	4
107	4737007000	TAPPING SCREW (S) 4x8 BLACK	6
108	4730354019	TAPPING SCREW 3x8	2
109	2050003107	3T LUG	1
110	4770064107	FIXING SCREW	2
111	4770276005	EARTH SCREW	2
PACKING & ACCESSORIES (not including EXPLODED VIEW)			
201	5049102003	STYLEN PAPER	1
202	5059102006	POLYCOVER	1
203	5030552109	CUSHION	2
204	4990051000	REMOTE CONTROL (RC-75)	1
205	5011117039	CARTON CASE	1
206	5050061007	ENVELOPE	1
207	5111504005	INST. MANUAL	1
208	2311060009	LOOP ANTENNA	1
209	3950005107	FM ANT. ASS'Y	1
210	8139111014	COLOR LABEL (BLACK)	2
211	5101167008	CONTROL CARD	1
212	5290040008	FM ANT. ADAPTOR	1

NOTE: 1. See addendum list next page for the parts with asterisk (*) on the Ref. No. and the other parts not included in the list.
 2. * Mark not included EXPLODED VIEW.
 3. The list is prepared based on E2 for Black Version.
 4. * indicates the parts newly used in this unit.

ADDENDUM LIST

Ref. No.	Part Name & Descriptions	Part No.			
		EA for Australia	EP1 for Asia		
7	P. SUPPLY & CONT. UNIT	ETC0840D	ETC0840B		
9	POWER UNIT	ETC0839D	ETC0839		
12	BACK PANEL	1050726016	1050676056		
13	ANTENNA TERMINAL	2050215005	-		
15	(n)P TERMINAL	2050165003(2P)	2050050008(4P)		
Δ 16	AC OUTLET	-	2033924009		
Δ 17	AC CORD	2062025005	2006031026		
Δ 29	POWER TRANS	2335592003	2335597008		
32	TUNER UNIT	ETC0841D	ETC0841E		
*51	VINYL WIRE	2090153017	2090153017		
54	RUBBER SHEET	4610294024	4619001027		
58	7P W TERMINAL	2050089008	-		
59	8P SP TERMINAL	2050186008	-		
*60	CAPACITOR 0.0047μF/50V (C151 ~ 154)	-	-		
*66	VINYL WIRE	-	-		
*70	F-RCA CONNECTOR	-	2050313004		
Δ *71	VOLTAGE SEL. SW	-	2120186006		
Δ *72	FUSE HOLDER	-	2020013101		
*73	FUSE LABEL	5130637034	5131083072		
*74	PRESET LABEL	-	5150290008		
*75	DANGEROUS MARK	-	5138266009		
*76	NOTICE SHEET	5130212006	-		
102	TAPPING SCREW (S) 3x6 BLACK	4737002034(42)	4737002034(44)		
205	CARTON CASE	5011117039	5011117000		
207	INST. MANUAL	5111504005	5111443108		
210	COLOR LABEL (BLACK)	5139111014	-		
211	CONTROL CARD	5131167008	-		
212	FM ANT. ADAPTOR	5290040008	-		
215	R.C.C. LABEL	-	5131198006		
216	INSTRUCTION SHEET	-	5111511001		

⚠ Means important safety item, which must be replaced, when necessary, by a part specified or meeting the specification by the manufacturer.

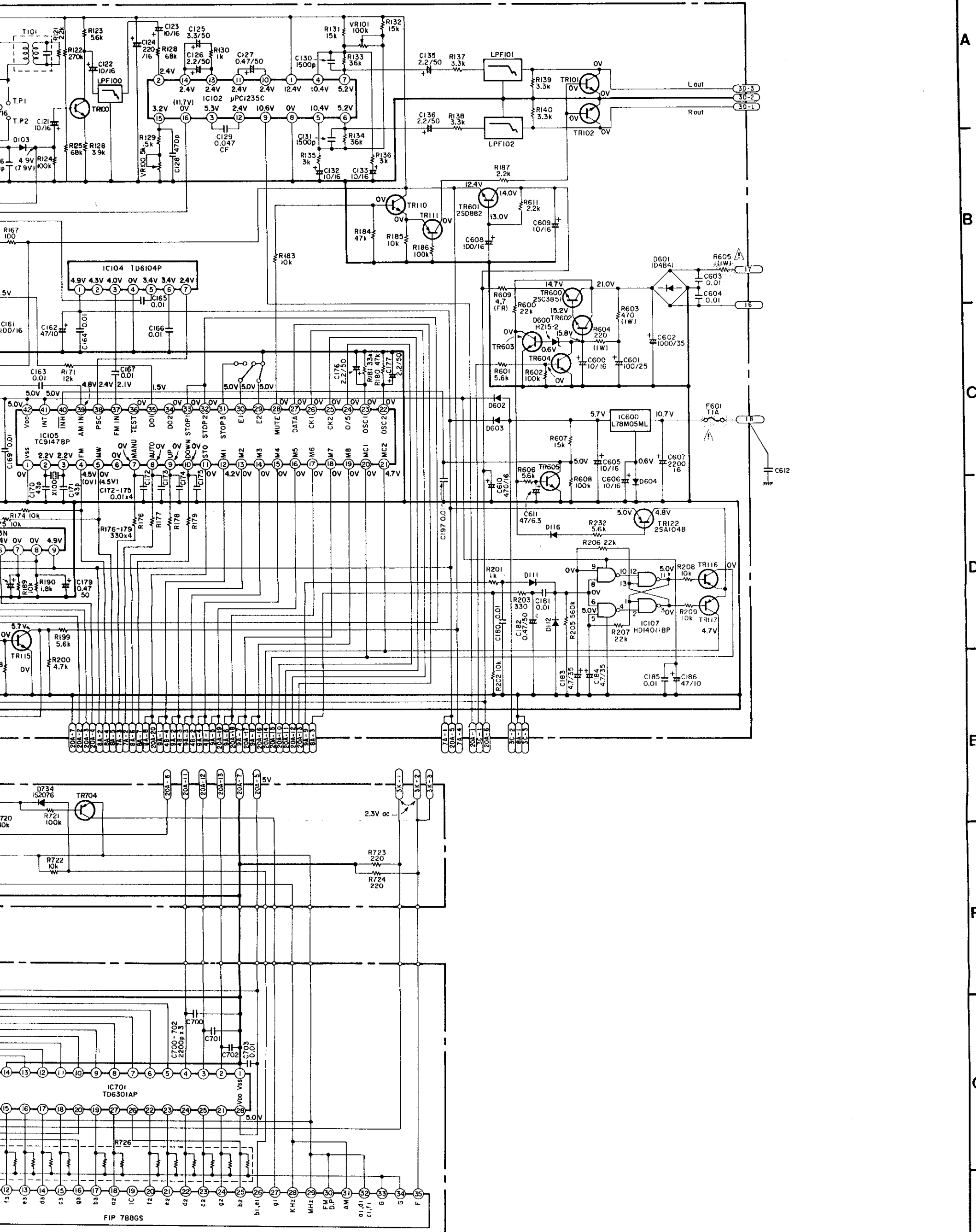

NOTES:
 ALL RESISTANCE VALUES IN OHM, K = 1,000 OHM, M = 1,000,000 OHM.
 ALL CAPACITANCE VALUES IN MICROFARAD, P = MICRO-MICRO FARAD.
 EVERY VOLTAGES AND CURRENTS IS MEASURED AT NO SIGNAL INPUT CONDITION.
 CIRCUIT AND PARTS ARE SUBJECT TO CHANGE WITHOUT PRIOR NOTICE.

SCHEMATIC DIAGRAM (for E2, EA)
AMP. RECT. SECTION

1 2 3 4 5 6

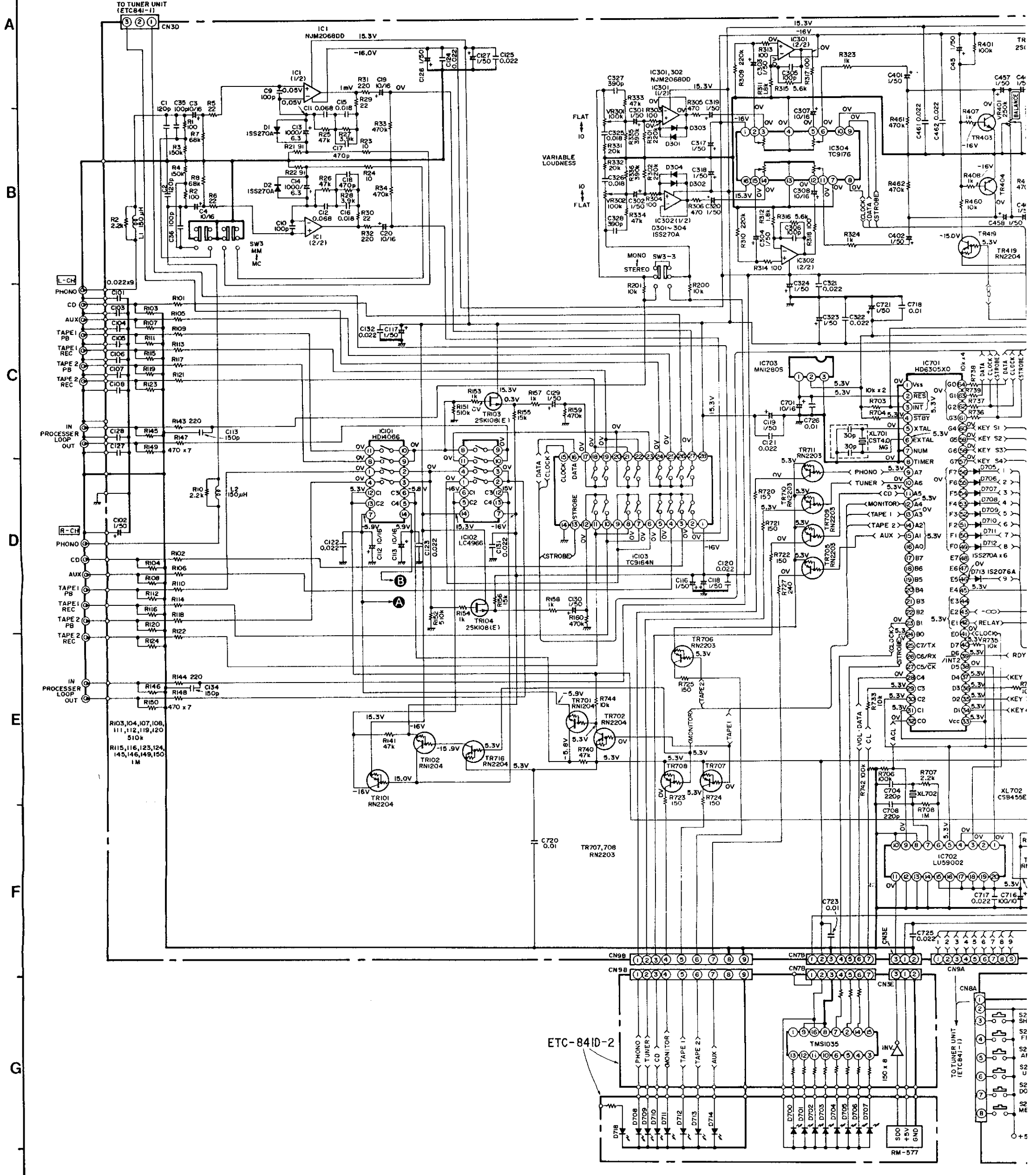

⚠ Means important safety item, which must be replaced, when necessary, by a part specified or meeting the specification by the manufacturer.

ETC-839D

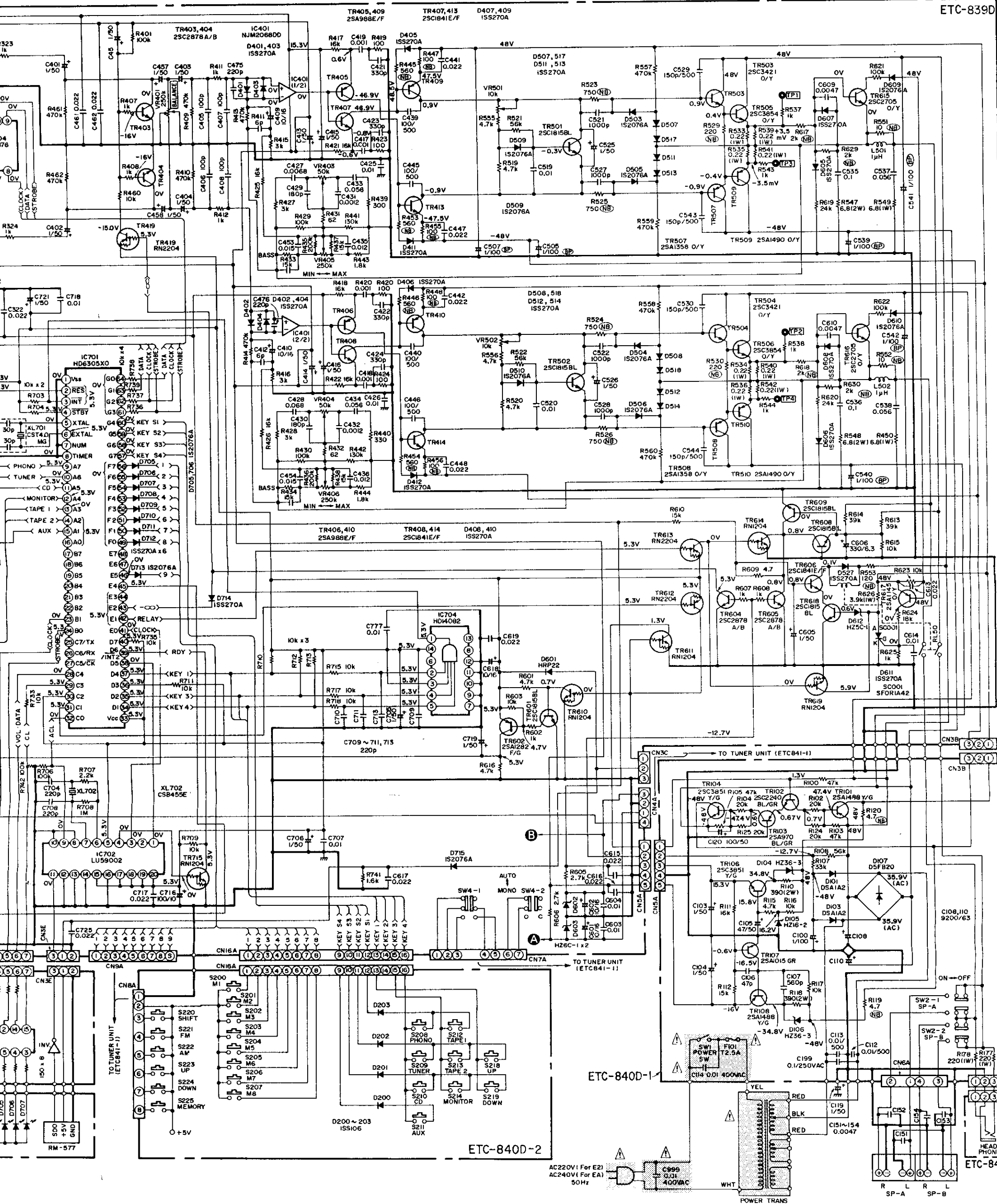

NOTES:
 ALL RESISTANCE VALUES IN OHM, K = 1,000 OHM, M = 1,000,000 OHM.
 ALL CAPACITANCE VALUES IN MICROFARAD, P = MICRO-MICRO FARAD.
 EVERY VOLTAGE AND CURRENTS IS MEASURED AT NO SIGNAL INPUT CONDITION.
 CIRCUIT AND PARTS ARE SUBJECT TO CHANGE WITHOUT NOTICE.

SCHEMATIC DIAGRAM (for EP1)
TUNER SECTION

2 3 4 5 6 7

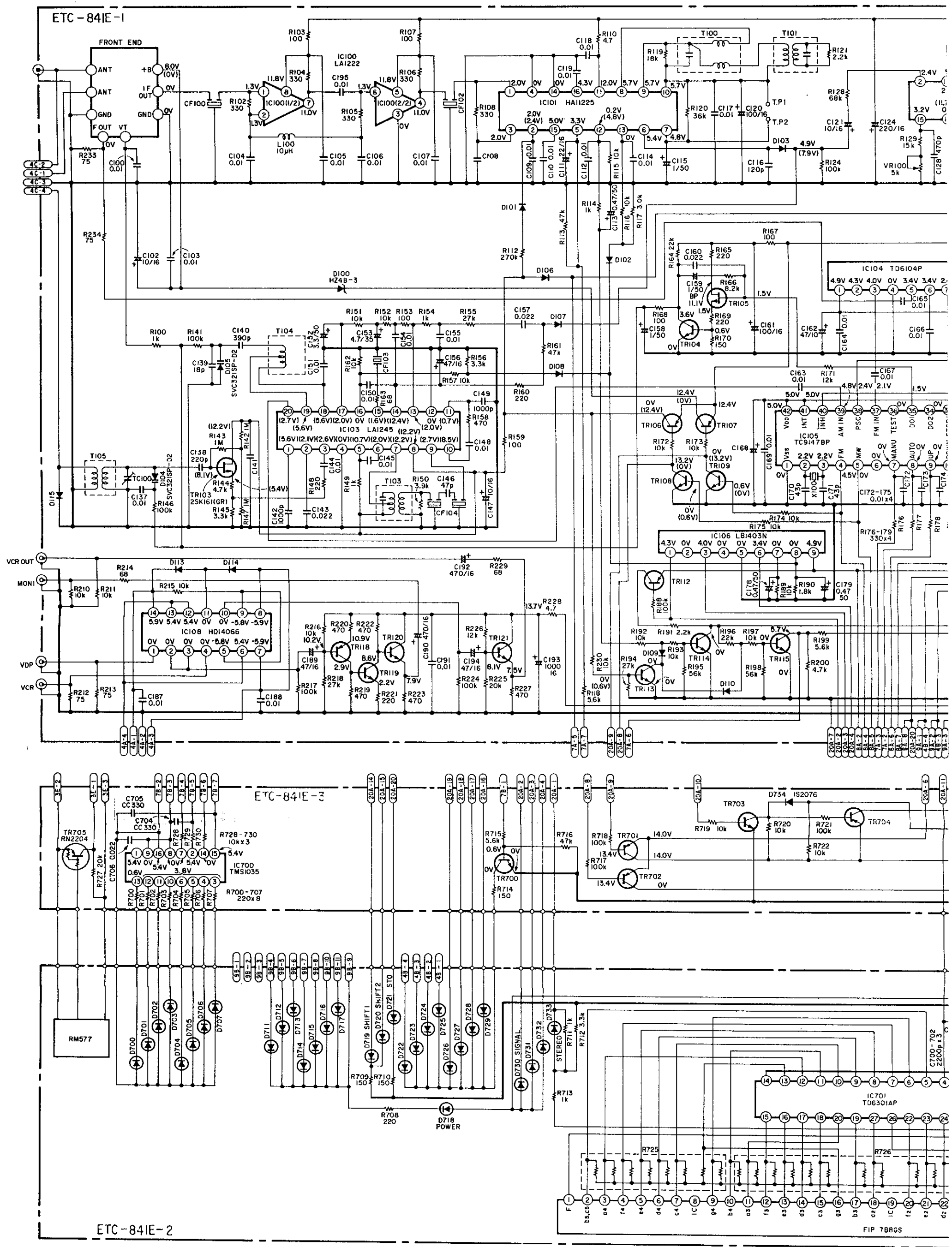

ETC-84IE-2

FIP 788GS

⚠ Means important safety item, which must be replaced, when necessary, by a part specified or meeting the specification by the manufacturer.

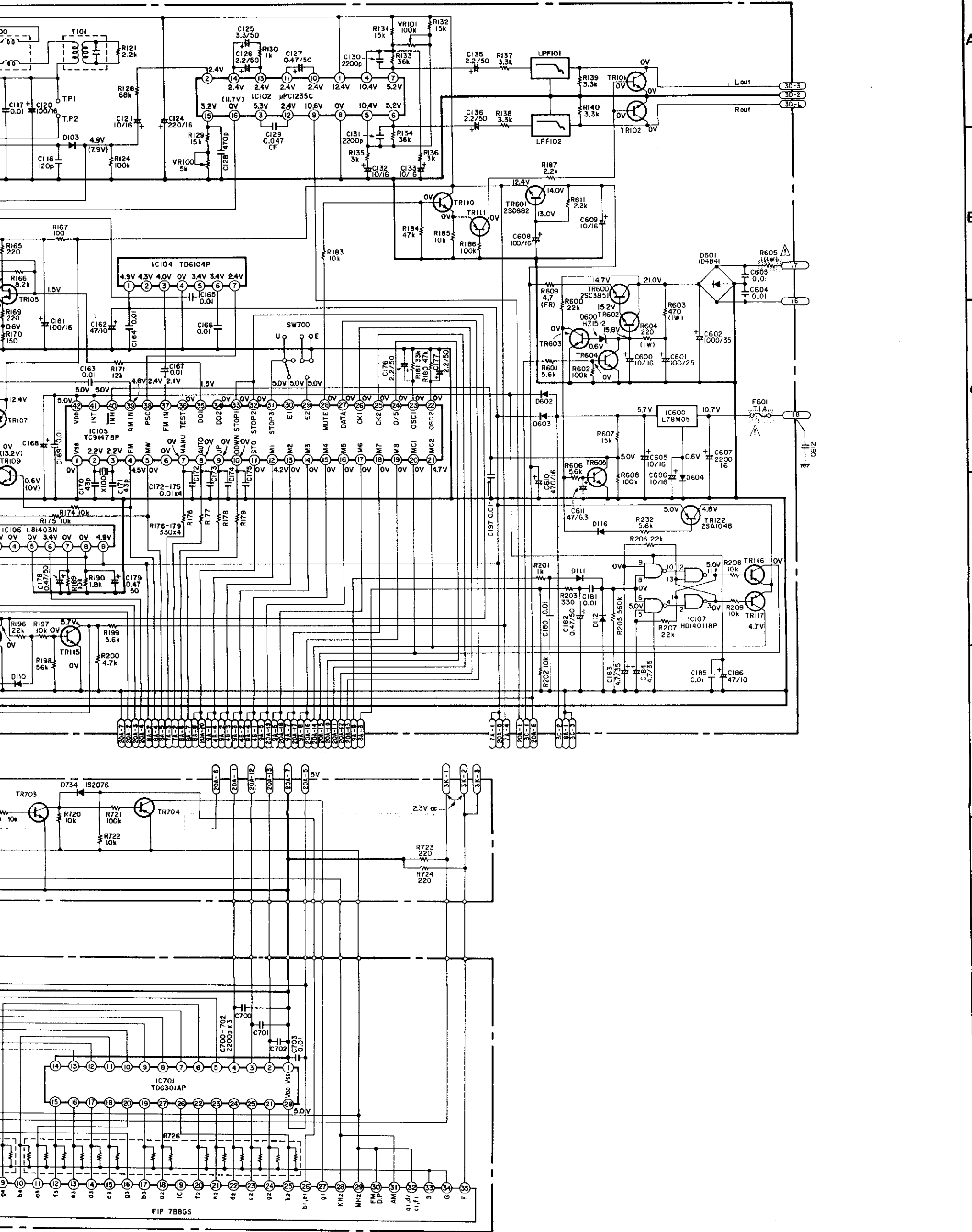

NOTES:
 ALL RESISTANCE VALUES IN OHM, K = 1,000 OHM, M = 1,000,000 OHM.
 ALL CAPACITANCE VALUES IN MICROFARAD, P = MICRO-MICRO FARAD.
 EVERY VOLTAGES AND CURRENTS IS MEASURED AT NO SIGNAL INPUT CONDITION.
 CIRCUIT AND PARTS ARE SUBJECT TO CHANGE WITHOUT PRIOR NOTICE.

**SCHEMATIC DIAGRAM (for EP1)
AMP. RECT. SECTION**

1 2 3 4 5 6

A
B
C
D
E
F
G
H

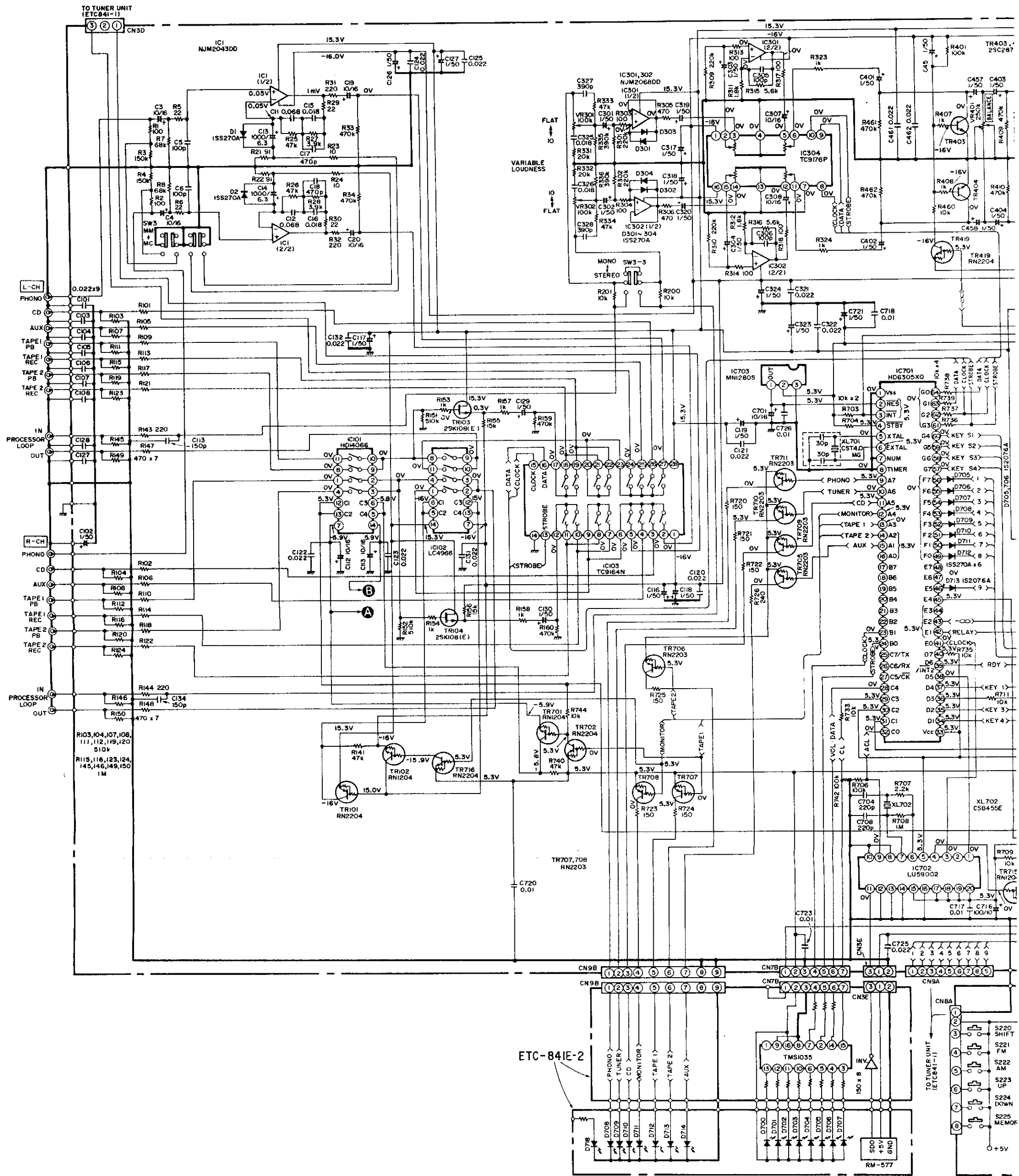

ETC-84IE-2

⚠ Means important safety item, which must be replaced, when necessary, by a part specified or meeting the specification by the manufacturer.

ETC-839

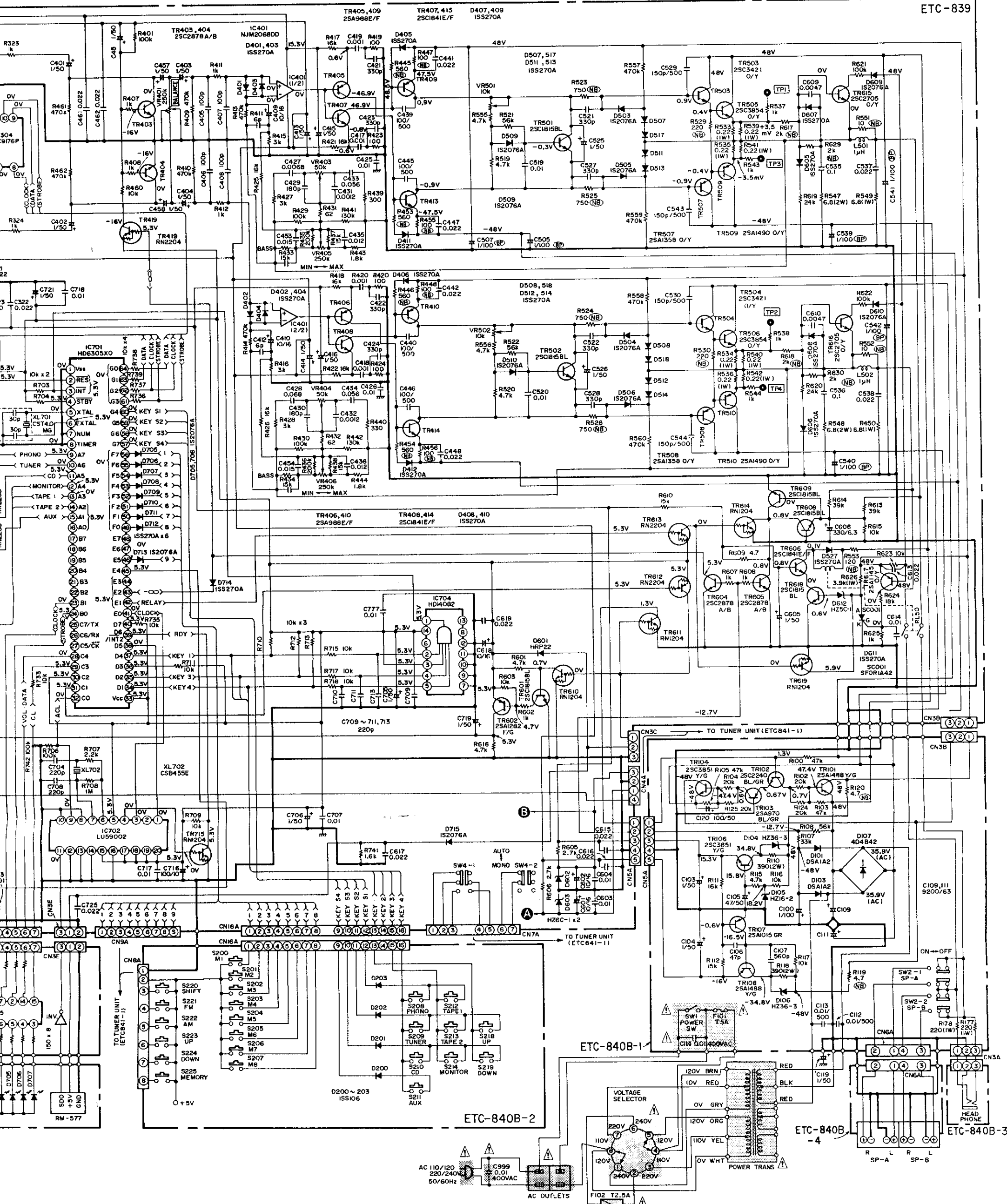

NOTES:
 ALL RESISTANCE VALUES IN OHM, K = 1,000 OHM, M = 1,000,000 OHM.
 ALL CAPACITANCE VALUES IN MICROFARAD, P = MICRO-MICRO FARAD.
 EVERY VOLTAGES AND CURRENTS IS MEASURED AT NO SIGNAL INPUT CONDITION.
 CIRCUIT AND PARTS ARE SUBJECT TO CHANGE WITHOUT PRIOR NOTICE.