

# DENON

For Europe model

Hi-Fi AM-FM Stereo Receiver

## SERVICE MANUAL

# MODEL DRA-201SA

### AM-FM STEREO RECEIVER

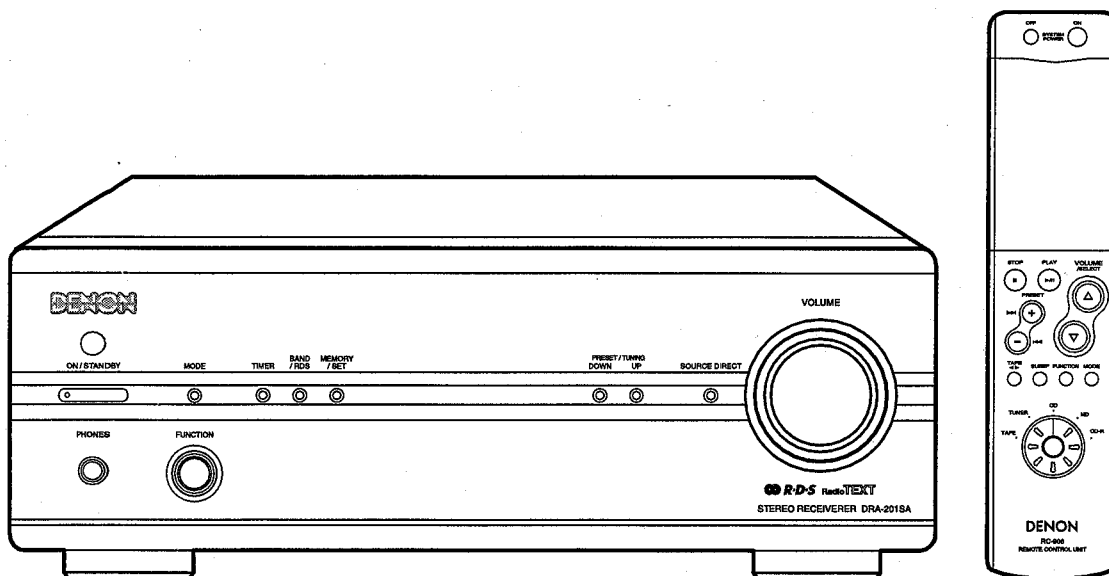

• Some illustrations using in this service manual are slightly different from the actual set.

## DENON, Ltd.

16-11, YUSHIMA 3-CHOME, BUNKYU-KU, TOKYO 113-0034 JAPAN  
Telephone: 03 (3837) 5321

## SAFETY PRECAUTIONS

The following check should be performed for the continued protection of the customer and service technician.

### LEAKAGE CURRENT CHECK

Before returning the unit to the customer, make sure you make either (1) a leakage current check or (2) a line to chassis resistance check. If the leakage current exceeds 0.5 milliamps, or if the resistance from chassis to either side of the power cord is less than 460 kohms, the unit is defective.

## SPECIFICATIONS

### • POWER AMPLIFIER SECTION

<b>Rated Output Power:</b> 4 $\Omega$ /ohms Load (DIN, 1 kHz, T.H.D. 0.7%)	50W + 50W
<b>Output terminals:</b>	4 to 16 $\Omega$ /ohms

### • PRE AMPLIFIER SECTION

<b>Rated Output:</b> (Recout Terminal)	150 mV
<b>Input Sensitivity/Input Impedance:</b> PHONO:	2.5 mV/47 k $\Omega$ /ohms
CD, TUNER, DVD/AUX, TAPE, MD, AUX-2:	100 mV/16 k $\Omega$ /ohms
<b>RIAA Deviation:</b> PHONO:	20 HZ to 20 kHz $\pm$ 0.5 dB

### • TUNER SECTION

<b>Reception frequency range:</b>	FM: 87.50 MHz~108.00 MHz	AM: 522 kHz~1611 kHz
<b>Practical sensitivity:</b>	FM: 1.2 $\mu$ V/75 $\Omega$ /ohms (12.8 dBf)	AM: 18 $\mu$ V
<b>FM stereo isolation:</b>	40 dB (1 kHz)	
<b>FM S/N ratio:</b>	Monaural: 77 dB	Stereo: 71 dB
<b>FM harmonic distortion:</b>	Monaural: 0.3%	Stereo: 0.4%
<b>Timer functions:</b>	Everyday timer (1 setting) Once timer (1 setting) Sleep timer (maximam 60 min.)	

### • OVERALL CHARACTERISTICS

<b>SN Ratio (IHF A Network):</b> (input terminals short-circuited)	PHONO: 80 dB (at 5 mV input) (input terminals shout-circuited)
<b>Frequency Response:</b> <b>Tone Control Adjustable Range:</b>	CD, TUNER, DVD/AUX, TAPE, MD, AUX-2: 102 dB (SOURCE DIRECT: ON) 5 Hz to 100 kHz: +0, -3 dB (SOURCE DIRECT: ON)
<b>BASS:</b>	100 Hz $\pm$ 8 dB
<b>TREBLE:</b>	10 kHz $\pm$ 8 dB
<b>LOUDNESS:</b>	100 Hz +8 dB 10 kHz +6 dB

### • OTHERS

<b>Power supply:</b>	AC 230 V, 50 Hz
<b>Power consumption:</b>	110 W (IEC) 1 W MAX (Standby)
<b>Dimensions:</b>	250 (W) $\times$ 90 (H) $\times$ 371 (D) mm
<b>Net Mass:</b>	6.2 kg

### • REMOTE CONTROL UNIT (RC-906)

<b>Remote control system:</b>	Infrared pulse system
<b>Power supply:</b>	3 V DC, Two size R03 ("AAA") dry cell batteries
<b>External dimensions:</b>	48 (W) $\times$ 210 (H) $\times$ 29 (D) mm
<b>Mass:</b>	120 g

\* Maximum dimensions include controls, jacks, and covers.

(W) = width, (H) = height, (D) = depth

\* For improvement purposes, specifications and functions are subject to change without advanced notice.

## DISASSEMBLY

(Follow the procedure below in reverse order when reassembling)

### 1. Top Cover

1. Remove 4 screws ① on both sides.
2. Remove 5 screws ② on the Rear Panel.
3. Detach the Cover as shown in the arrow direction.

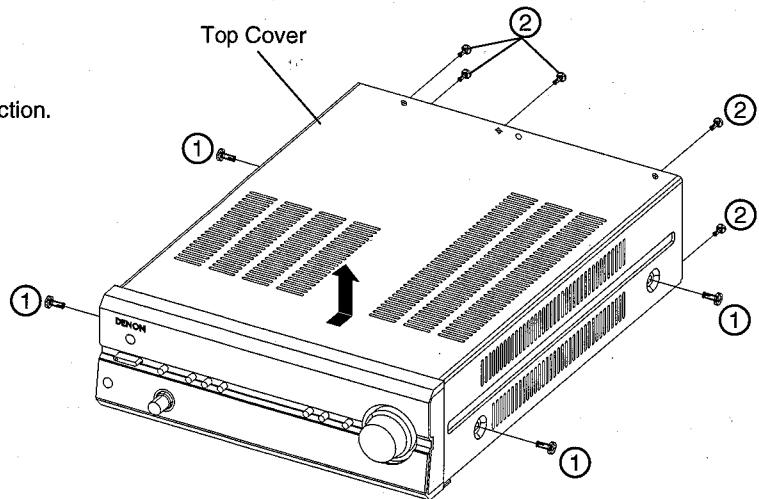

### 2. Front Panel

1. Pull out 2 Knobs.
2. Remove each 2 screws ③ and ④ from the bottom edge of the Front Panel.
3. To detach the Front Panel, release 4 hooks of the Inner Panel by pressing in the arrow direction.

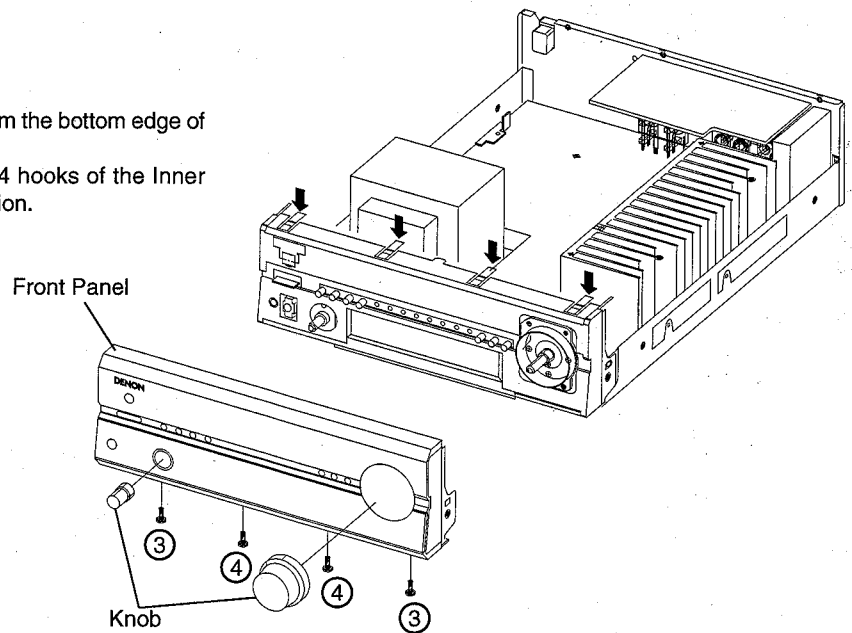

### 3. Inner Panel

1. Remove 2 screws ⑤ on both sides.
2. Widen both sides of the Inner Panel in the arrow direction to release from the hooks of the Chassis.

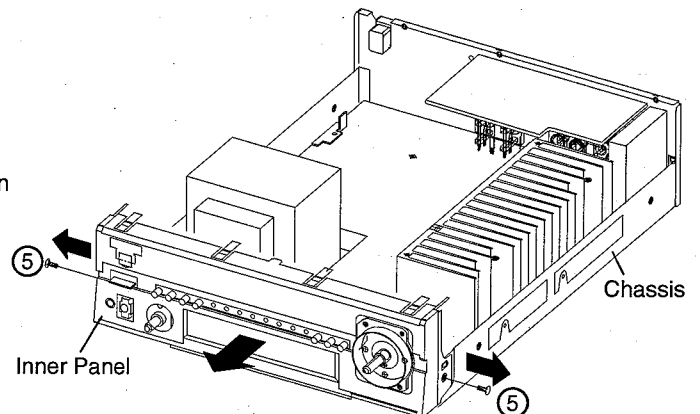

**4.  $\mu$ -com P.W.B. (1U-3382C-3)**

1. Remove 2 screws ⑥ to detach the Power SW Unit.
2. Remove the Nut and 5 screws ⑦.

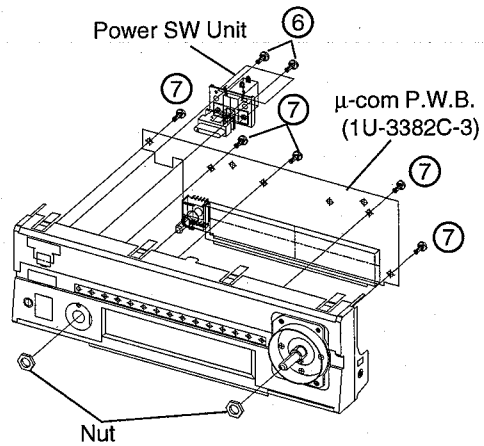

**5. Input PWB (1U-3382C-2)**

- Remove 3 screws ⑧ and 1 screw ⑨.

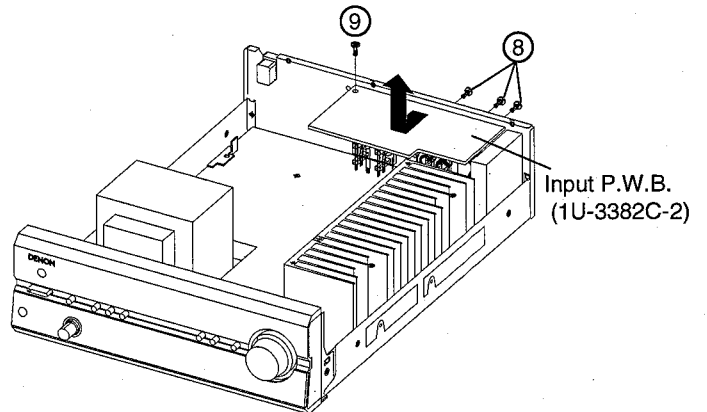

**6. TUNER PACK**

1. Disconnect the FFC coming out of the Main P.W.B.
2. Remove 3 screws ⑩.

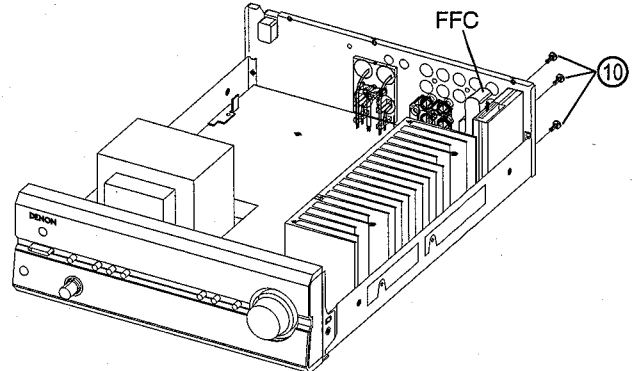

**7. Main P.W.B. (1U-3382C-1)**

1. Remove 4 screws ⑪, 1 screw ⑫, 4 screws ⑬, 2 screws ⑭.
2. The Main P.W.B. and Power radiator can be detached in the arrow direction with the Back Panel.

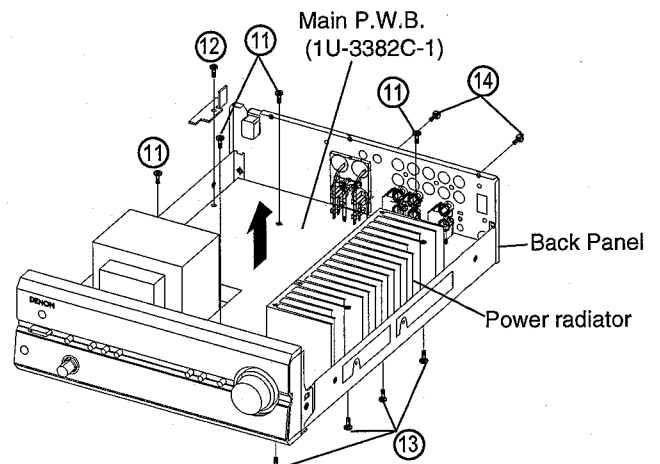

# BLOCK AND LEVEL DIAGRAM

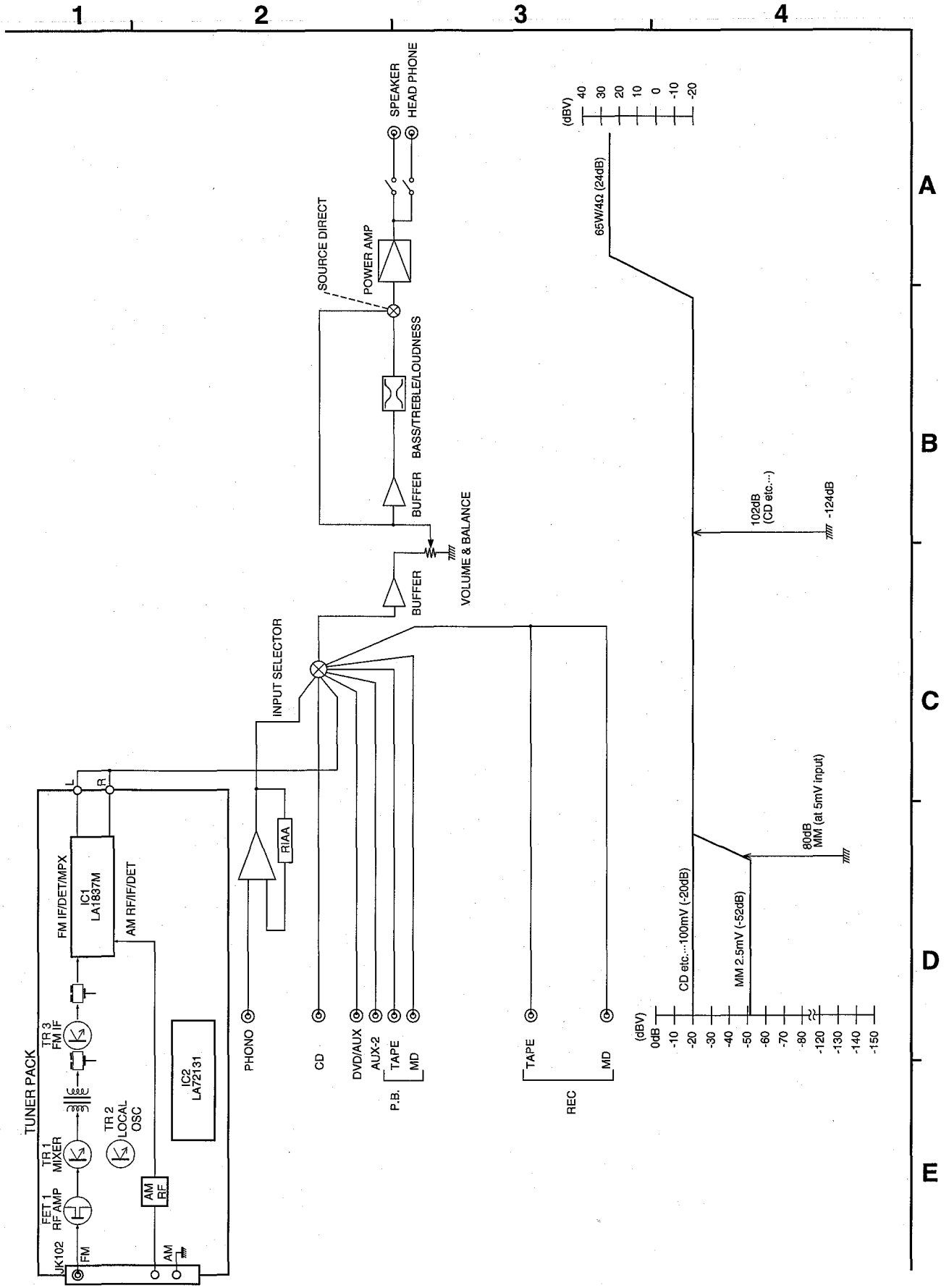

## ADJUSTMENT

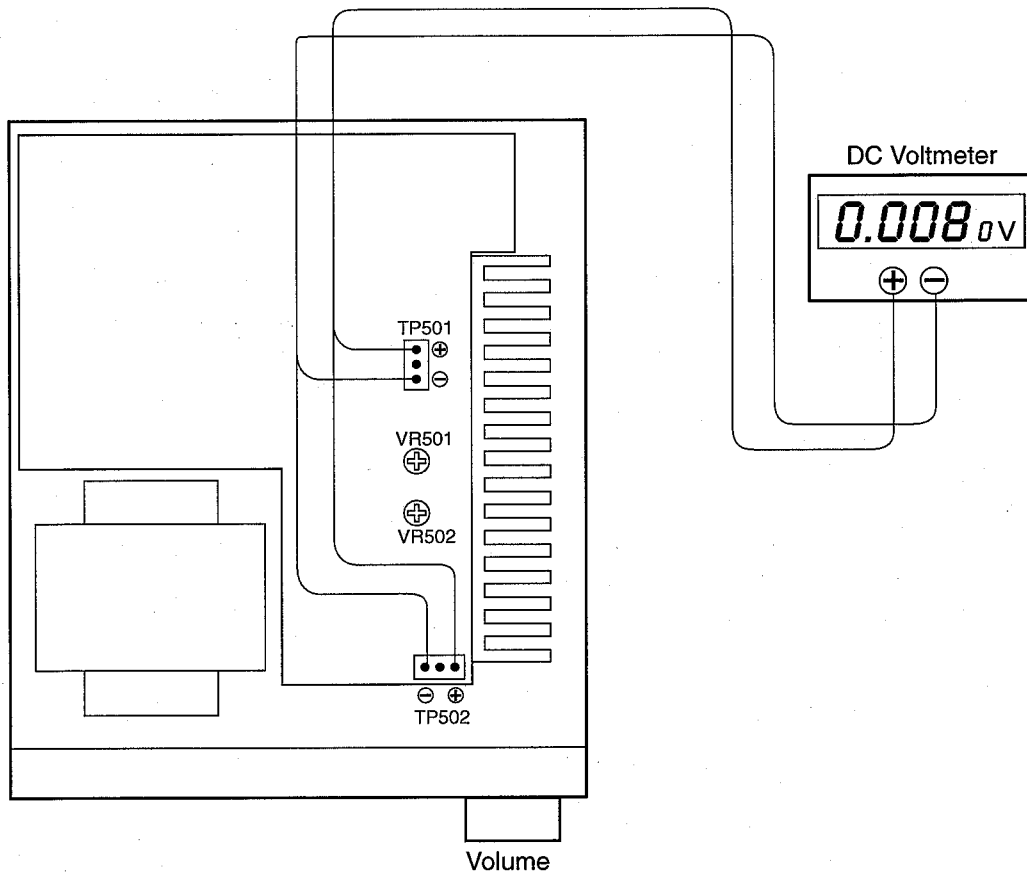

## IDLING CURRENT

### ● Setup

1. Place the unit at an ordinary position avoiding direct air flow from an air-conditioner or fan. Do the adjustment at a temperature between 15 °C (59 °F) and 30 °C (86 °F).
2. Set control as follows.
 

VOLUME control	→	fully counterclockwise (⤴ min.)
SPEAKER terminals	→	open: do not connect the speakers, dummy load etc.

### ● Adjustment

1. Remove top cover. And then connect DC voltmeter to the test points TP501 and TP502 of MAIN P.W.B.
2. Connect power cord to AC230V (218 ~ 242V) wall outlet, and turn POWER switch "ON".
3. Right after power on, adjust VR501 and VR502 so that the DC voltmeter reads  $10 \pm 1\text{mV}$ .
4. Then after 2 minutes warmup adjust VR501 and VR502 so that the DC voltmeter reads  $10 \pm 1\text{mV}$ .
5. And after 10 minutes warmup adjust VR501 and VR502 so that the DC voltmeter reads  $10 \pm 0.5\text{mV}$ .

# CHECK

## ● Connection Diagram

1U-3393-1 Main P.W.B. (Component Side)

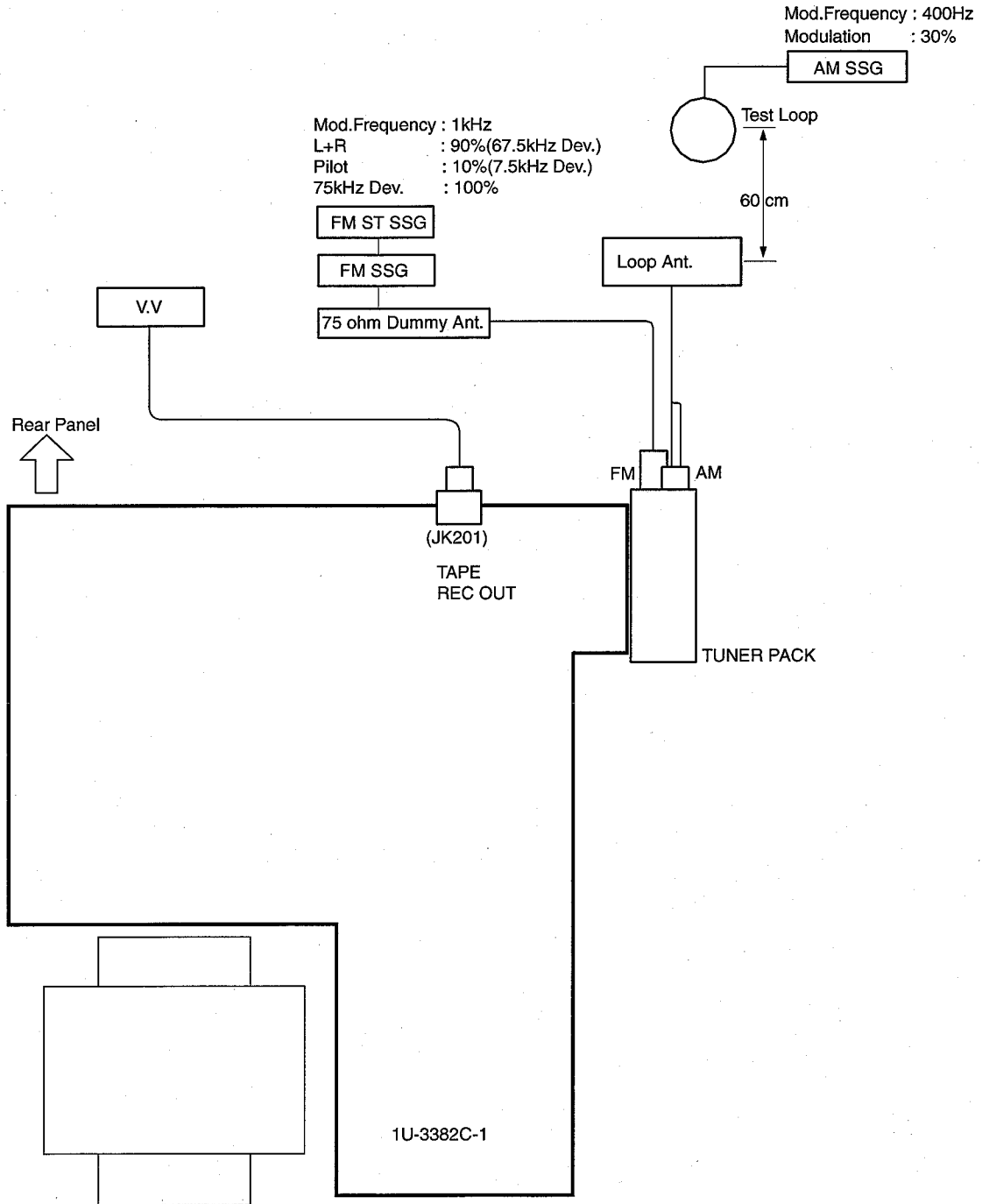

# SEMICONDUCTORS

● IC's

μPD780208GF-114 (IC901)

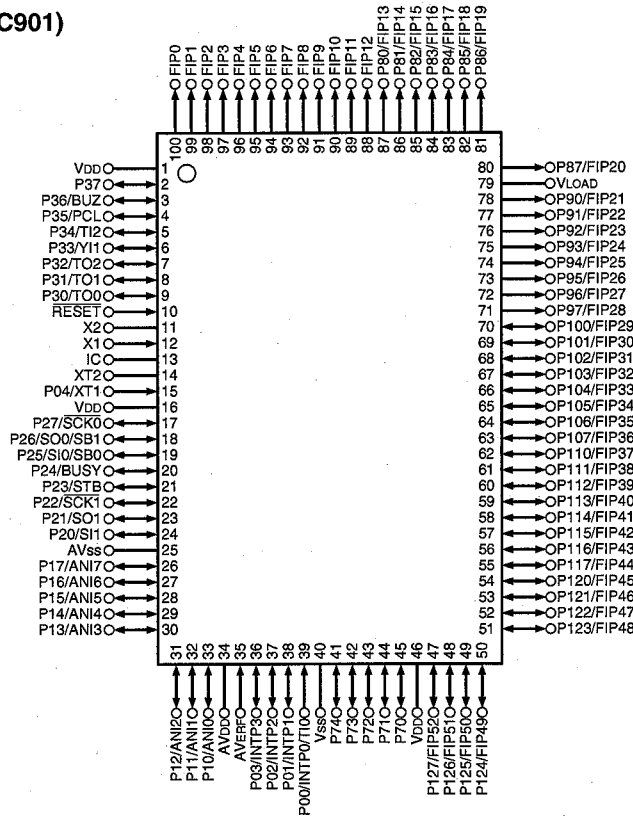

μPD780208GF-114 Terminal Function

Pin No.	Pin Name	Symbol	I/O	Det	Res	Ext	Act	INIT	MO	Function
1	VDD	+5V	—	—	—	—	—	—	—	Positive power, Output relay on/off, H: Output on
2	P37	RL-HP	O	Lv	Z	—	H	L	—	Headphone
3	P36/BUZ	LED-G	O	—	Z	—	H	L	—	Power on LED drive output
4	P35/PCL	LED-R	O	—	Z	—	H	L	—	Standby LED drive output
5	P34/TI2	RL-CD	O	—	Z	Pd	H	L	—	CD input select relay output
6	P33/TI1	RL-DVD	O	—	Z	Pd	H	L	—	DVD input select relay output
7	P32/TO2	VOL.UP	O	—	Z	—	—	L	—	Not used
8	P31/TO1	VOL.DOWN	O	—	Z	—	—	L	—	Not used
9	P30/TO0	RL-SD	O	—	Z	Pd	H	L	—	Source direct relay output
10	RESET	RESET	I	—	—	—	L	—	—	m-com reset input
11	X2	X2	—	—	—	—	—	—	—	X'tal connection for main clock oscillation
12	X1	X1	I	—	—	—	—	—	—	X'tal connection for main clock oscillation 4.19 MHz
13	IC	IC	—	—	—	—	—	—	—	Internal connection, Connect to Vss directly
14	XT2	XT2	—	—	—	—	—	—	—	X'tal connection for sub clock oscillation, Not used: NC
15	P04/XT1	P04/XT1	I	—	Z	—	—	—	—	X'tal connection for sub clock oscillation, Not used: To Vss or VDD
16	VDD	VDD	—	—	—	—	—	—	—	Positive power
17	P27/SCK0	DB_CLK	O	—	Z	—	—	H	—	DENON bus clock output
18	P26/SO0/SB1	DB_TXD	O	—	Z	—	—	H	—	DENON bus data output
19	P25/SO0/SB0	DB_RXD	I	Ed	Z	—	—	—	—	DENON bus data input
20	P24/BUSY	RDSRST	O	—	Z	—	L	H	—	RDS IC reset output
21	P23/STB	DATA_CE	O	—	Z	—	H	L	—	Data bus (PLL, VOL, RDS IC comm.) chip enable output
22	P22/SCK1	DATA_CLK	O	—	Z	—	—	H	—	Data bus (PLL, VOL, RDS IC comm.) clock output
23	P21/SO1	DATA_TXD	O	—	Z	—	—	H	—	Data bus (PLL, VOL, RDS IC comm.) data output
24	P20/SI1	DATA_RXD	I	Ed	Z	—	—	—	—	Data bus (PLL, VOL, RDS IC comm.) data input
25	AVSS	AVSS	—	—	—	—	—	—	—	GND potential of A/D converter
26	P17/ANI7	RL-PRE	O	—	Z	—	H	L	—	Not Used
27	P16/ANI6	F-STB	O	—	Z	—	H	L	—	Function select IC strobe output
28	P15/ANI5	V-STB	O	—	Z	—	H	L	—	Volume IC strobe output
29	P14/ANI4	T-STB	O	—	Z	—	H	L	—	Tone control IC strobe output
30	P13/ANI3	CE-R	O	—	Z	—	H	L	—	EEPROM chip enable output
31	P12/ANI2	NC	O	—	Z	—	—	L	—	Not used



Pin No.	Pin Name	Function Name	I/O	Det	Res	Ext	Act	INIT	MO	Function
32	P11/ANI1	KEY2	I	A	Z	Pu	—	—	—	Key input 2
33	P10/ANI0	KEY1	I	A	Z	Pu	—	—	—	Key input 1
34	AVDd	AVDD	—	—	—	—	—	—	—	Analog power for A/D converter
35	AVREF	AVREF	I	—	—	—	—	—	—	Ref. V input for A/D converter
36	P03/INTP3	PROTECT	I	—	Z	—	L	—	—	Amp protect input
37	P02/INTP2	DBRXD	I	Ed	Z	—	—	—	—	DENON bus data input
38	P01/INTP1	50/60	I	Ed	Z	Pu	—	—	—	50/60 Hz AC input
39	P00/INTP0	REMOCON	I	—	Z	—	H	—	—	Remote control input
40	Vss	VSS	—	—	—	—	—	—	—	GND
41	P74	RL-SPA	O	—	Z	Pd	H	L	—	Not Used
42	P73	RL-SPB	O	—	Z	Pd	H	L	—	Speaker B relay output, H: Output
43	P72	CLOCK	O	—	Z	—	H	L	—	Clock output for function, tone, volume IC
44	P71	DATA	O	—	Z	—	—	L	—	Data output for function, tone, volume IC
45	P70	TMUTE	O	—	Z	Pu	L	L	N	Tuner mute output, L: Mute on
46	VDD	VDD	—	—	—	—	—	—	—	Positive power
47	P127/FIP52	ENC-A	I	—	Z	—	—	—	—	Rotary encoder input A for volume
48	P126/FIP51	ENC-B	I	—	Z	—	—	—	—	Rotary encoder input B for volume
49	P125/FIP50	SEL-A	I	—	Z	—	—	—	—	Rotary encoder input A for select
50	P124/FIP49	SEL-B	I	—	Z	—	—	—	—	Rotary encoder input B for select
51	P123/FIP48	NC	O	—	Z	—	—	L	—	Not used
52	P122/FIP47	AM STEREO	I/O	Lv	Z	—	L	—	N	AM stereo demodulation detect input, L: Stereo
53	P121/FIP46	SD	I	Lv	Z	Pu	L	—	N	FM/AM tune signal input, L: Tuned
54	P120/FIP45	ST IND	I	Lv	Z	Pu	L	—	N	FM stereo demodulation detect input, L: Stereo
55	P117/FIP44	USA	I	Lv	Z	—	—	—	N	Initial setting input
56	P116/FIP43	EUR	I	Lv	Z	—	—	—	N	Initial setting input
57	P115/FIP42	FREQ	I	Lv	Z	—	—	—	N	Initial setting input
58	P114/FIP41	RDS	I	Lv	Z	—	—	—	N	Initial setting input
59	P113/FIP40	NC	O	—	Z	—	—	L	—	Not used
60	P112/FIP39	NC	O	—	Z	—	—	L	—	Not used
61	P111/FIP38	NC	O	—	Z	—	—	L	—	Not used
62	P110/FIP37	NC	O	—	Z	—	—	L	—	Not used
63	P107/FIP36	NC	O	—	Z	—	—	L	—	Not used
64	P106/FIP35	NC	O	—	Z	—	—	L	—	Not used
65	P105/FIP34	NC	O	—	Z	—	—	L	—	Not used
66	P104/FIP33	NC	O	—	Z	—	—	L	—	Not used
67	P103/FIP32	V.MUTE	O	—	Z	—	H	L	—	Mute output at volume 00, H: Mute
68	P102/FIP31	POWER	O	—	Z	Pd	L	L	N	Amp circuit power on/off output, L: On
69	P101/FIP30	AUTO/MONO	O	—	Z	Pd	—	—	N	FM auto/mono switching, H: Mono
70	P100/FIP29	SP-OFF	I	—	Z	Pd	L	L	N	Headphone SW input, H: Speaker, pre-out off
71	P97/FIP28	NC	O	—	Z	—	—	L	—	Not used
72	P96/FIP27	NC	O	—	Z	—	—	L	—	Not used
73	P95/FIP26	SEG1	O	—	Z	Pd	—	—	N	Segment output 2
74	P94/FIP25	SEG2	O	—	Z	Pd	—	—	N	Segment output 3
75	P93/FIP24	SEG3	O	—	Z	Pd	—	—	N	Segment output 4
76	P92/FIP23	SEG4	O	—	Z	Pd	—	—	N	Segment output 5
77	P91/FIP22	SEG5	O	—	Z	Pd	—	—	N	Segment output 6
78	P90/FIP21	SEG6	O	—	Z	Pd	—	—	N	Segment output 7
79	VLOAD	VLOAD	—	—	—	—	—	—	—	FL driver pull-down R connection (-30V power)
80	P87/FIP20	SEG7	O	—	Z	Pd	—	—	N	Segment output 8
81	P86/FIP19	SEG8	O	—	Z	Pd	—	—	N	Segment output 9
82	P85/FIP18	SEG9	O	—	Z	Pd	—	—	N	Segment output 10
83	P84/FIP17	SEG10	O	—	Z	Pd	—	—	N	Segment output 11
84	P83/FIP16	SEG11	O	—	Z	Pd	—	—	N	Segment output 12
85	P82/FIP15	SEG12	O	—	Z	Pd	—	—	N	Segment output 13
86	P81/FIP14	SEG13	O	—	Z	Pd	—	—	N	Segment output 14
87	P80/FIP13	SEG14	O	—	Z	Pd	—	—	N	Segment output 15
88	FIP12	SEG15	O	—	Z	Pd	—	—	—	Segment output 16
89	FIP11	SEG16	O	—	Z	Pd	—	—	—	Digit output 12
90	FIP10	DIG11	O	—	Z	Pd	—	—	—	Digit output 11
91	FIP9	DIG10	O	—	Z	Pd	—	—	—	Digit output 10
92	FIP8	DIG9	O	—	Z	Pd	—	—	—	Digit output 9
93	FIP7	DIG8	O	—	Z	Pd	—	—	—	Digit output 8
94	FIP6	DIG7	O	—	Z	Pd	—	—	—	Digit output 7
95	FIP5	DIG6	O	—	Z	Pd	—	—	—	Digit output 6
96	FIP4	DIG5	O	—	Z	Pd	—	—	—	Digit output 5
97	FIP3	DIG4	O	—	Z	Pd	—	—	—	Digit output 4
98	FIP2	DIG3	O	—	Z	Pd	—	—	—	Digit output 3
99	FIP1	DIG2	O	—	Z	Pd	—	—	—	Digit output 2
100	FIP0	DIG1	O	—	Z	Pd	—	—	—	Digit output 1

**TC9273N-004 (IC201)**

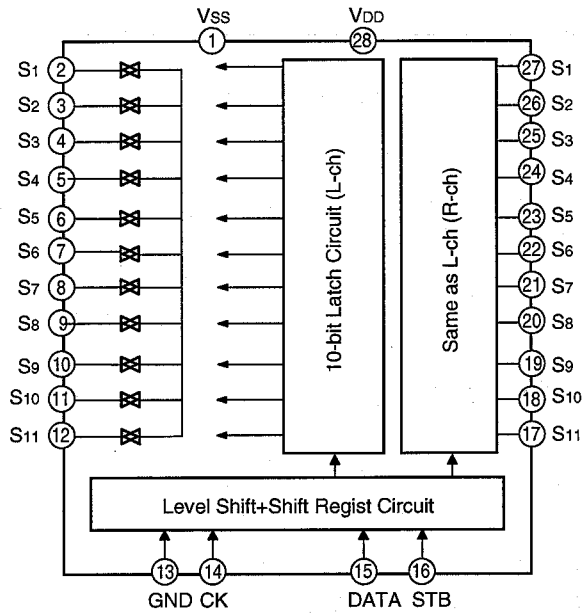
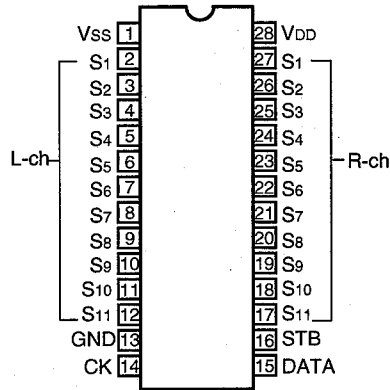

**TC9459F (IC302)**

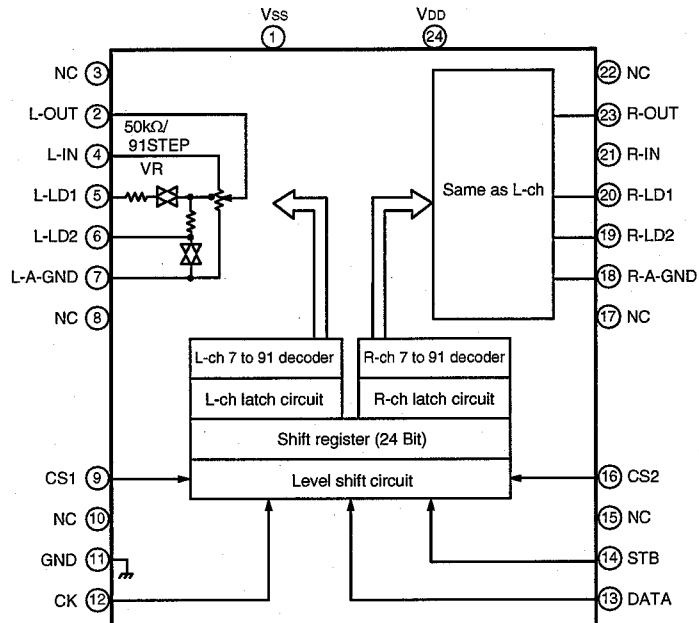
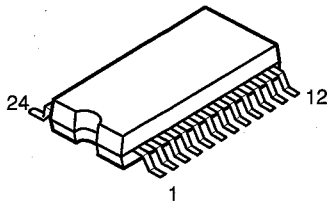

**LC72720NM (IC303)**

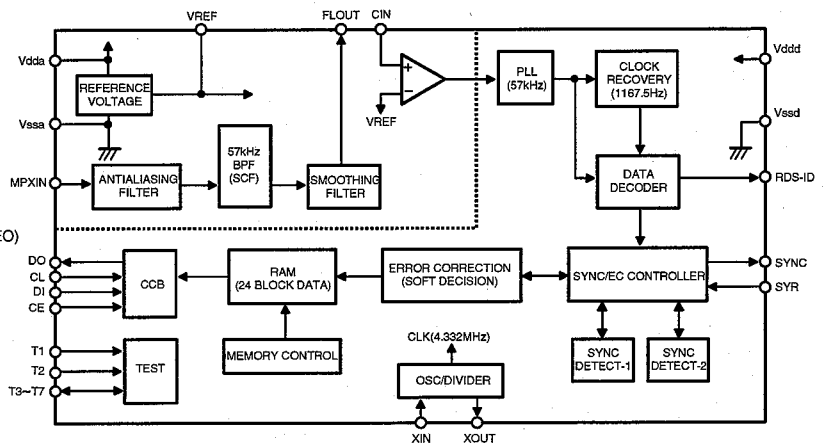
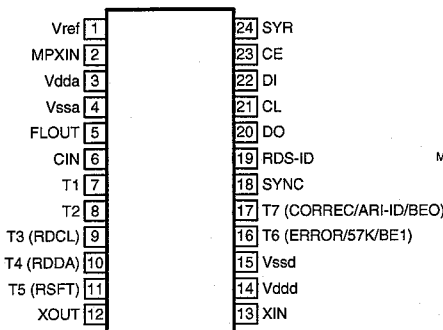

**TC9184AP (IC304)**

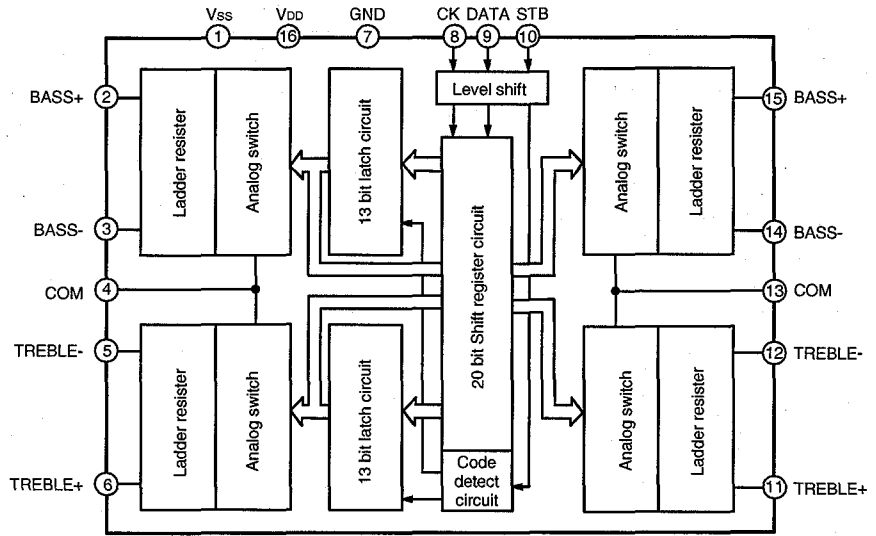
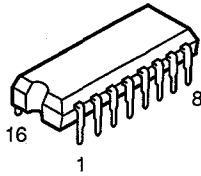

**93LC66 (IC905)**

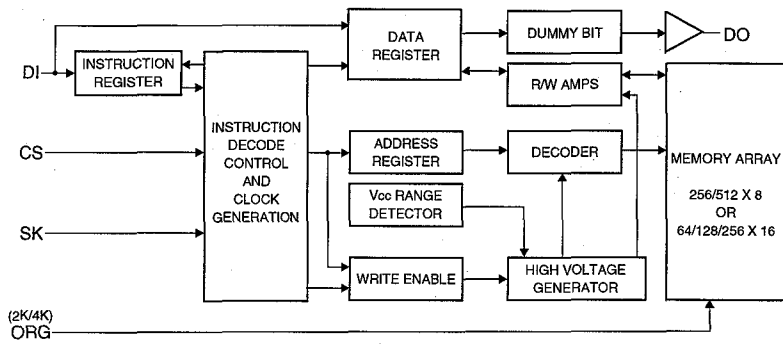
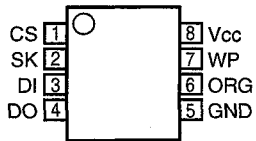

**NJM2068MD-T1 (IC301, IC303)  
NJM2068DDC (IC401)**

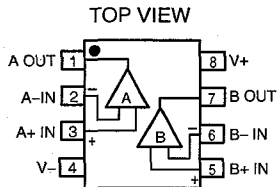

**M51957BFP (IC903)**

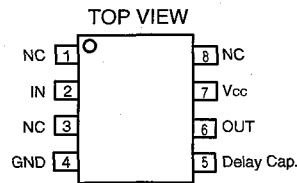

**BA05T (IC907)  
NJM7812FA(S) (IC101)**

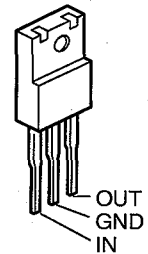

● TRANSISTORS

2SA988 (E/F)  
2SC1841 (E/F)

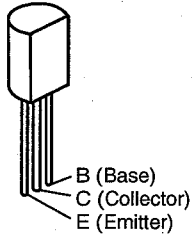

2SA1837 (Y)  
2SC4793 (Y)

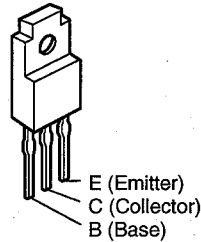

2SC4495 (O/Y)

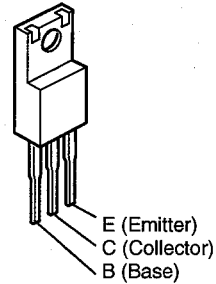

2SK184C (GR)/(BL)

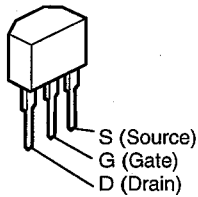

2SB1383 (P/Y)  
2SD2083 (P/Y)

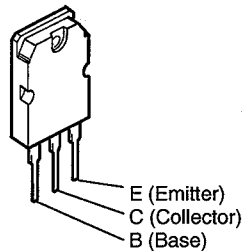

2SB1328

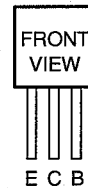

2SC2412K (S)  
2SA1037K (S/R)

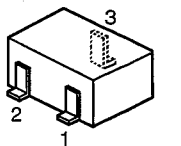

1: E (Emitter)  
2: B (Base)  
3: C (Collector)

DTA114EK  
DTA114YK  
DTA115TK  
DTA143TK  
DTC114YK  
DTC323TK

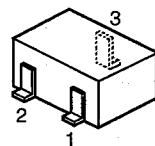

1: E (Emitter)  
2: B (Base)  
3: C (Collector)

DTA114EK  
DTA114YK  
DTA115TK  
DTA143TK

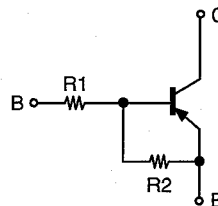

DTC114YK  
DTC323TK

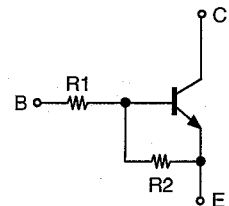

	R1	R2
DTA114EK	10 KΩ	10 KΩ
DTA114YK	10 KΩ	47 KΩ
DTA115TK	100 KΩ	—
DTA143TK	4.7 KΩ	—

	R1	R2
DTC114YK	10 KΩ	47 KΩ
DTC323TK	2.2 KΩ	—

● DIODES (including LED)

1N4148  
1SS270A

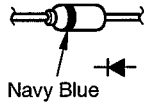

1SR35-400A

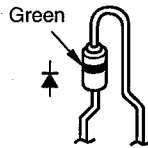

MTZJ2.7A  
MTZJ3.3A  
MTZJ5.6A  
MTZJ6.2A  
MTZJ7.5C  
MTZJ18A  
MTZJ39A

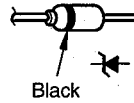

SLR-9335DS-91 (LD901)

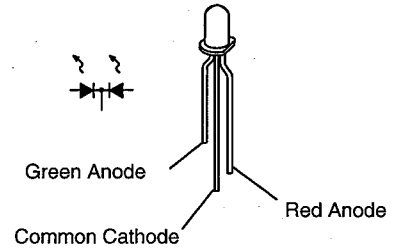

FMG22S

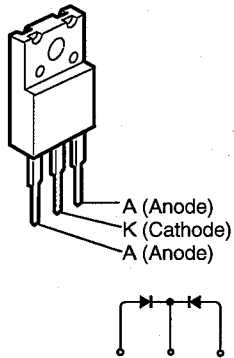

FMG22R

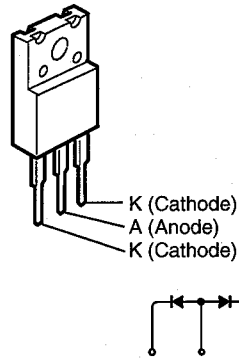

● POSISTOR

PTH9M04BC222TS2F333 (TH701)

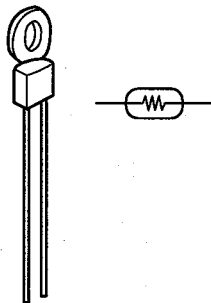

● IC PROTECTOR

ICP-N15 (IC102, 103, 906, 908)

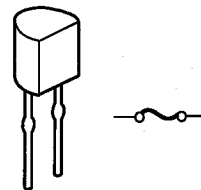

● IR SENSOR

RPM6938-V4 (IC902)

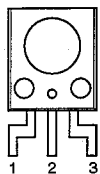

1:ROUT  
2:GND  
3:Vcc

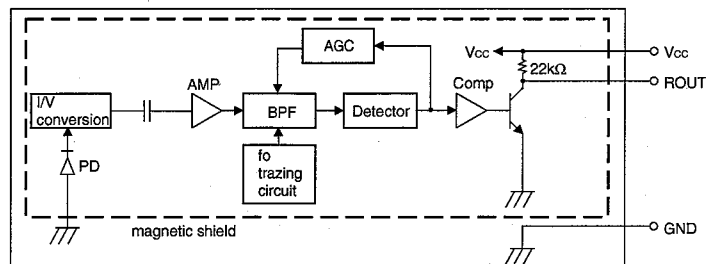

● FL DISPLAY (FL901)

11-BT-187GNK (Part No.:393 8054 002)

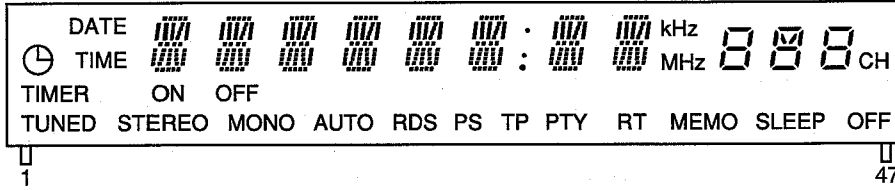

Pin Connection

Pin No.	1	2	3	4	5	6	7	8	9	10	11	12	13	14	15	16	17	18	19	20	21	22	23	24
Connection	F1	F1	NP	NP	1G	2G	3G	4G	5G	6G	7G	8G	9G	10G	11G	NC	NC	NC	NC	NC	NC	NC	NC	NC
Pin No.	25	26	27	28	29	30	31	32	33	34	35	36	37	38	39	40	41	42	43	44	45	46	47	
Connection	NC	NC	NC	P16	P15	P14	P13	P12	P11	P10	P9	P8	P7	P6	P5	P4	P3	P2	P1	NP	NP	F2	F2	

NOTE 1) F1, F2 --- Filament 2) NP ----- No Pin 3) NC ----- No Connection 4) 1G~11G - Grid

Grid Assignment/Pattern Layout

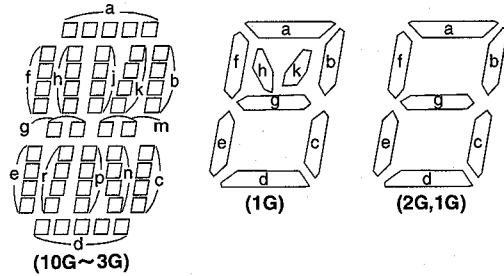
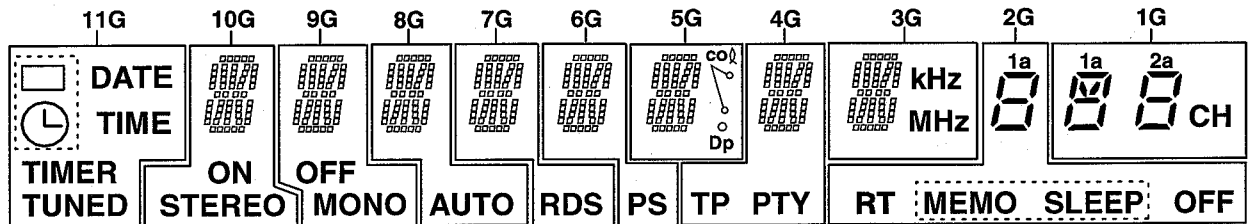

Illumination Color

Reddish Orange ----- Above pattern part  
Green ----- Others

Anode Connection

	11G	10G	9G	8G	7G	6G	5G	4G	3G	2G	1G
P1		a	a	a	a	a	a	a	a	1a	1a
P2	DATE	b	b	b	b	b	b	b	b	1b	1b
P3		c	c	c	c	c	c	c	c	1c	1c
P4	TIME	d	d	d	d	d	d	d	d	1d	1d
P5	TIMER	e	e	e	e	e	e	e	e	1e	1e
P6	TUNED	f	f	f	f	f	f	f	f	1f	1f
P7	-	g	g	g	g	g	g	g	g	1g	1g
P8	-	h	h	h	h	h	h	h	h	RT	1h,1k
P9	-	j	j	j	j	j	j	j	j	MEMO	2a
P10	-	k	k	k	k	k	k	k	k	SLEEP	2b
P11	-	m	m	m	m	m	m	m	m	OFF	2c
P12	-	n	n	n	n	n	n	n	n	-	2d
P13	-	p	p	p	p	p	p	p	p	-	2e
P14	-	r	r	r	r	r	r	r	r	-	2f
P15	-	ON	OFF	AUTO	RDS	PS	co <sub>l</sub>	TP	kHz	-	2g
P16	-	STEREO	MONO	-	-	-	Dp	PTY	MHz	-	CH

PRINTED WIRING BOARD

1U-3382C MAIN P.W.B. UNIT Ass'y

1 2 3 4 5 6 7 8

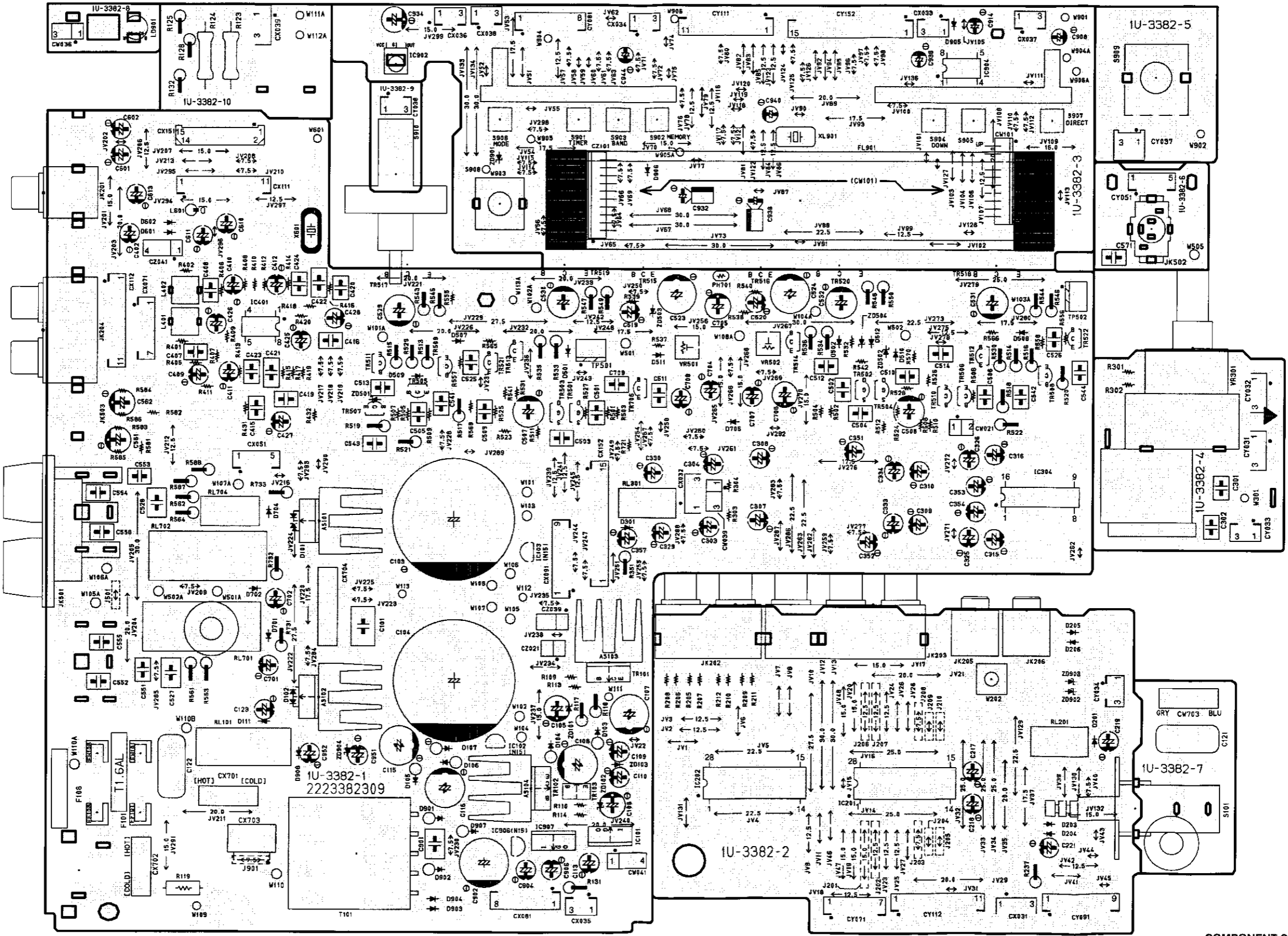

A  
B  
C  
D  
E

COMPONENT SIDE

1U-3382C MAIN P.W.B. UNIT Ass'y

1 2 3 4 5 6 7 8

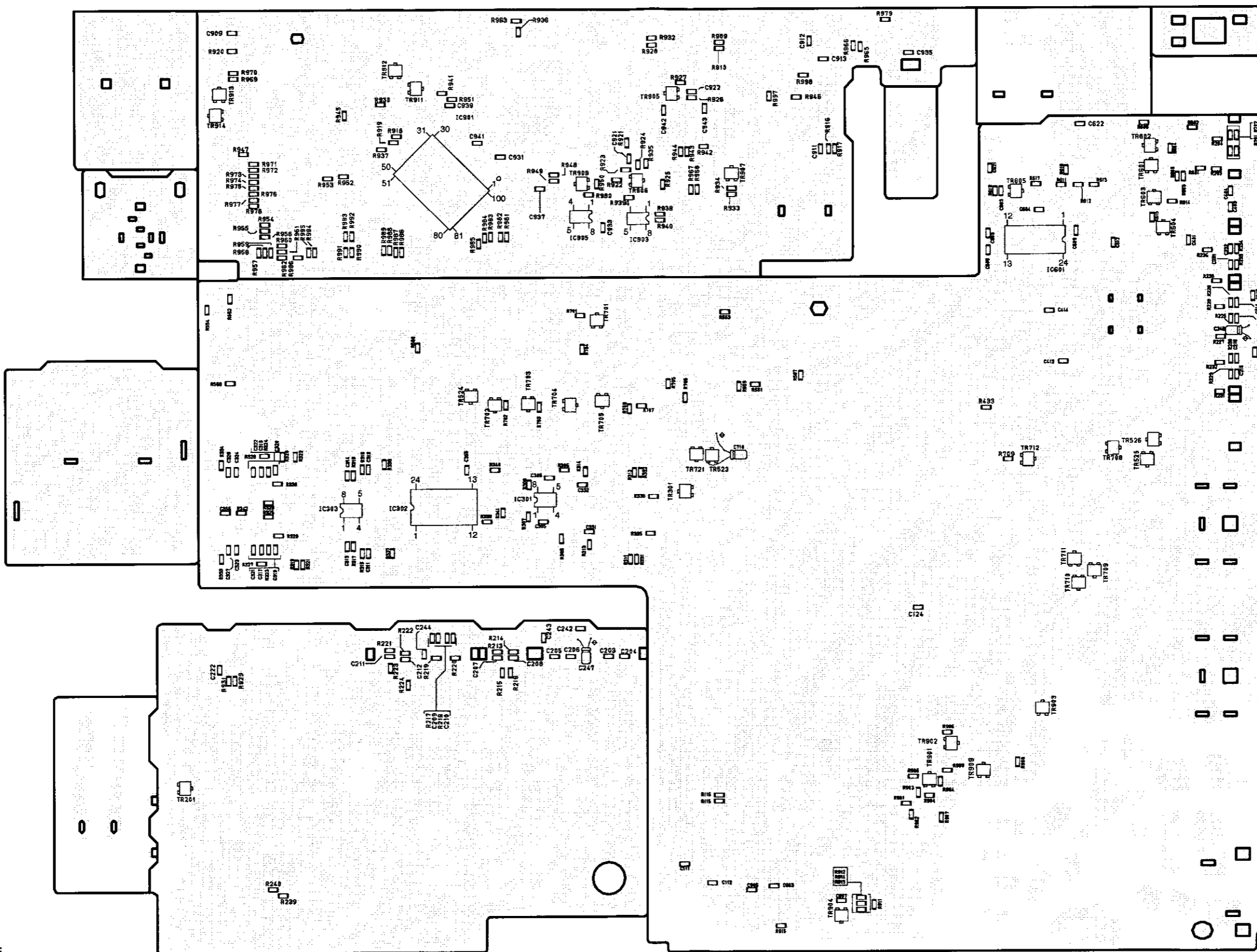

A  
B  
C  
D  
E

FOIL SIDE



## NOTE FOR PARTS LIST

- Part indicated with the mark "⊗" are not always in stock and possibly to take a long period of time for supplying, or in some case supplying of part may be refused.
- When ordering of part, clearly indicate "1" and "I" (i) to avoid mis-supplying.
- Ordering part without stating its part number can not be supplied.
- Part indicated with the mark "★" is not illustrated in the exploded view.
- Not including Carbon Film ±5%, 1/4W Type in the P.W.Board parts list. (Refer to the Schematic Diagram for those parts.)

**WARNING:**

Parts marked with this symbol  have critical characteristics.  
Use ONLY replacement parts recommended by the manufacturer.

### ● Resistors

Ex.: **RN** **14K** **2E** **182** **G** **FR**  
 Type Shape and performance Power Resistance Allowable error Others

RD : Carbon	2B : 1/8W	F : ±1%	P : Pulse-resistant type
RC : Composition	2E : 1/4W	G : ±2%	NL : Low noise type
RS : Metal oxide film	2H : 1/2W	J : ±5%	NB : Non-burning type
RW : Winding	3A : 1W	K : ±10%	FR : Fuse-resistor
RN : Metal film	3D : 2W	M : ±20%	F : Lead wire forming
RK : Metal mixture	3F : 3W		
	3H : 5W		

**\* Resistance**

$1 \overset{\uparrow}{\underset{\uparrow}{8}} \overset{\uparrow}{\underset{\uparrow}{2}} \Rightarrow 1800 \text{ ohm} = 1.8 \text{ kohm}$   
 Indicates number of zeros after effective number.  
 2-digit effective number.

• Units: ohm

$1 \overset{\uparrow}{\underset{\uparrow}{R}} \overset{\uparrow}{\underset{\uparrow}{2}} \Rightarrow 1.2 \text{ ohm}$   
 1-digit effective number.  
 2-digit effective number, decimal point indicated by R.

• Units: ohm

### ● Capacitors

Ex.: **CE** **04W** **1H** **2R2** **M** **BP**  
 Type Shape and performance Dielectric strength Capacity Allowable error Others

CE : Aluminum foil electrolytic	0J : 6.3V	F : ±1%	HS : High stability type
CA : Aluminum solid electrolytic	1A : 10V	G : ±2%	BP : Non-polar type
CS : Tantalum electrolytic	1C : 16V	J : ±5%	HR : Ripple-resistant type
CQ : Film	1E : 25V	K : ±10%	DL : For charge and discharge
CK : Ceramic	1V : 35V	M : ±20%	HF : For assuring high frequency
CC : Ceramic	1H : 50V	Z : +80%	U : UL part
CP : Oil	2A : 100V	-20%	C : CSA part
CM : Mica	2B : 125V	+100%	P : UL-CSA type
CF : Metallized	2C : 160V	-0%	W : UL-CSA type
CH : Metallized	2D : 200V	C : ±0.25pF	F : Lead wire forming
	2E : 250V	D : ±0.5pF	
	2H : 500V	= : Others	
	2J : 630V		

**\* Capacity (electrolyte only)**

$2 \overset{\uparrow}{\underset{\uparrow}{2}} \overset{\uparrow}{\underset{\uparrow}{2}} \Rightarrow 2200\mu\text{F}$   
 Indicates number of zeros after effective number.  
 2-digit effective number.

• Units: μF.

$2 \overset{\uparrow}{\underset{\uparrow}{R}} \overset{\uparrow}{\underset{\uparrow}{2}} \Rightarrow 2.2\mu\text{F}$   
 1-digit effective number.  
 2-digit effective number, decimal point indicated by R.

• Units: μF.

**\* Capacity (except electrolyte)**

$2 \overset{\uparrow}{\underset{\uparrow}{2}} \overset{\uparrow}{\underset{\uparrow}{2}} \Rightarrow 2200\text{pF} = 0.0022\mu\text{F}$   
 (More than 2) — Indicates number of zeros after effective number.  
 2-digit effective number.

• Units: pF.

$2 \overset{\uparrow}{\underset{\uparrow}{2}} \overset{\uparrow}{\underset{\uparrow}{1}} \Rightarrow 220\text{pF}$   
 (0 or 1) — Indicates number of zeros after effective number.  
 2-digit effective number.

• Units: pF.

• When the dielectric strength is indicated in AC, "AC" is included after the dielectric strength value.

**PARTS LIST OF P.W.B. UNIT ASS'Y**  
**1U-3382C MAIN P.W.B. ASS'Y**

Ref. No.	Part No.	Part Name	Remarks
<b>SEMICONDUCTORS GROUP</b>			
IC101	263 0801 004	IC NJM7812FA(S)	
IC102,103	268 0073 905	IC ICP-N15T	
IC201	262 2033 000	IC TC9273N-004	
IC301	263 0896 909	IC NJM2068MD-T1	
IC302	262 2540 904	IC TC9459F-EL	
IC303	263 0896 909	IC NJM2068MD-T1	
IC304	262 2616 003	IC TC9184AP	
IC401	263 0609 002	IC NJM2068DDC	
IC601	262 2547 907	IC LC72720NM	
IC901	262 3076 008	IC UPD780208GF-114-3BA	
IC902	499 0301 006	IC RPM6938-V4	
IC903	263 0454 901	IC M51957BFP(TP1)	
IC905	262 2986 005	IC 93LC66	
IC906	268 0073 905	IC ICP-N15T	
IC907	263 1092 003	IC BA05T	
IC908	268 0073 905	IC ICP-N15T	
TR101	273 0423 007	Transistor 2SC4793-Y	
TR102	271 0272 003	Transistor 2SA1837-Y	
TR103	272 0107 919	Transistor 2SB1328 (P/Q)T105	
TR301	269 0144 905	Transistor DTC114YK-T146	
TR501-504	275 0055 015	FET 2SK184C (GR)/(BL)	
TR505-508	273 0235 923	Transistor 2SC1841-T(E/F)	
TR509-512	271 0131 924	Transistor 2SA988-T(E/F)	
TR513,514	273 0235 923	Transistor 2SC1841-T(E/F)	
TR521,522	273 0235 923	Transistor 2SC1841-T(E/F)	
TR523,524	269 0066 902	Transistor DTC323TK	
TR601,602	269 0066 902	Transistor DTC323TK	
TR603	269 0083 901	Transistor DTA114EK	
TR604	269 0082 902	Transistor DTC114EK	
TR605	273 0384 900	Transistor 2SC2412KT96(S)	
TR701-703	273 0384 900	Transistor 2SC2412KT96(S)	
TR704	271 0238 908	Transistor 2SA1037KT96(S/R)	
TR705	273 0384 900	Transistor 2SC2412KT96(S)	
TR706	271 0131 924	Transistor 2SA988-T(E/F)	
TR710,711	269 0091 906	Transistor DTC143TKT96	
TR721	269 0087 907	Transistor DTA143TKT96	
TR901-905	273 0384 900	Transistor 2SC2412KT96(S)	
TR906	271 0238 908	Transistor 2SA1037KT96(S/R)	
TR907	273 0384 900	Transistor 2SC2412KT96(S)	
TR908	269 0185 906	Transistor DTA115TKAT146	
TR909	269 0054 901	Transistor DTC144EK	

Ref. No.	Part No.	Part Name	Remarks
TR912	269 0101 906	Transistor DTA114YKT146	
TR913	269 0083 901	Transistor DTA114EK	
TR914	269 0054 901	Transistor DTC144EK	
D101	276 0681 000	Diode FMG-22S	
D102	276 0682 009	Diode FMG-22R	
D103-106	276 0704 903	Diode 1SR35-400A(T93X)	
D111	276 0432 903	Diode 1SR35-400A(T93X)	
D203-206	276 0432 903	Diode 1SR35-400A(T93X)	
D301	276 0432 903	Diode 1SR35-400A(T93X)	
D501,502	276 0432 903	Diode 1SR35-400A(T93X)	
D507-512	276 0432 903	Diode 1SR35-400A(T93X)	
D601,602	276 0432 903	Diode 1SR35-400A(T93X)	
D702	276 0432 903	Diode 1SR35-400A(T93X)	
D704,705	276 0432 903	Diode 1SR35-400A(T93X)	
D901,902	276 0704 903	Diode 1SR35-400A(T93X)	
D903,904	276 0432 903	Diode 1SR35-400A(T93X)	
D906	276 0432 903	Diode 1SR35-400A(T93X)	
D907	276 0704 903	Diode 1SR35-400A(T93X)	
D908	276 0432 903	Diode 1SR35-400A(T93X)	
ZD101,102	276 0645 907	Zener diode MTZJ18A T77	
ZD103	276 0645 981	Zener diode MTZJ39A T77	
ZD501-504	276 0643 925	Zener diode MTZJ2.7A T77	
ZD901	276 0643 996	Zener diode MTZJ5.6A T77	
ZD902,903	276 0637 902	Zener diode MTZJ6.2AT77	
ZD904	276 0634 905	Zener diode MTZJ3.3A	
LD901	393 9594 008	LED SLR-9335DS-91	
<b>RESISTORS GROUP</b>			
R115	247 2010 969	Carbon chip 22 kohm 1/16W	RM73B--223JT
R116	247 2007 943	Carbon chip 1 kohm 1/16W	RM73B--102JT
R123,124	244 0087 021	Metal oxide 120 ohm 2W(NB)	RS14B3D121JNBF
R213,214	247 2013 940	Carbon chip 330 kohm 1/16W	RM73B--334JT
R215,216	247 2005 987	Carbon chip 220 ohm 1/16W	RM73B--221JT
R217,218	247 2013 940	Carbon chip 330 kohm 1/16W	RM73B--334JT
R219,220	247 2005 987	Carbon chip 220 ohm 1/16W	RM73B--221JT
R221,222	247 2013 940	Carbon chip 330 kohm 1/16W	RM73B--334JT
R223,224	247 2005 987	Carbon chip 220 ohm 1/16W	RM73B--221JT
R225,226	247 2015 964	Carbon chip 2.7 Mohm 1/16W	RM73B--275KT
R227,228	247 2005 987	Carbon chip 220 ohm 1/16W	RM73B--221JT
R229,230	247 2015 964	Carbon chip 2.7 Mohm 1/16W	RM73B--275KT

Ref. No.	Part No.	Part Name	Remarks
R231,232	247 2005 987	Carbon chip 220 ohm 1/16W	RM73B--221JT
R239,240	247 2010 956	Carbon chip 20 kohm 1/16W	RM73B--203JT
R305,306	247 2005 903	Carbon chip 100 ohm 1/16W	RM73B--101JT
R307,308	247 2012 925	Carbon chip 100 kohm 1/16W	RM73B--104JT
R311,312	247 2009 967	Carbon chip 8.2 kohm 1/16W	RM73B--822JT
R315-318	247 2013 982	Carbon chip 470 kohm 1/16W	RM73B--474JT
R319,320	247 2012 909	Carbon chip 82 kohm 1/16W	RM73B--823JT
R321,322	247 2009 909	Carbon chip 4.7 kohm 1/16W	RM73B--472JT (1608)
R323,324	247 2011 926	Carbon chip 39 kohm 1/16W	RM73B--393JT
R325,326	247 2014 907	Carbon chip 560 kohm 1/16W	RM73B--564JT
R327,328	247 2009 925	Carbon chip 5.6 kohm 1/16W	RM73B--562JT
R329,330	247 2010 985	Carbon chip 27 kohm 1/16W	RM73B--273JT
R331,332	247 2007 972	Carbon chip 1.3 kohm 1/16W	RM73B--132JT
R333,334	247 2007 943	Carbon chip 1 kohm 1/16W	RM73B--102JT
R335-338	247 2012 925	Carbon chip 100 kohm 1/16W	RM73B--104JT
R339,340	247 2010 969	Carbon chip 22 kohm 1/16W	RM73B--223JT
R351	241 2378 988	Carbon film 390 ohm 1/4W(NB)	RD14B2E391JNBST
R513-520	241 2378 962	Carbon film 330 ohm 1/4W(NB)	RD14B2E331JNBST
R521,522	244 2064 932	Metal oxide 3.9 kohm 1W(NB)	RS14B3A392JNBST(S)
R529,530	241 2377 921	Carbon film 82 ohm 1/4W(NB)	RD14B2E820JNBST
R533-536	241 2377 992	Carbon film 160 ohm 1/4W(NB)	RD14B2E161JNBST
R543-550	244 2043 982	Metal oxide 1W(NB)	RS14B3AR22JNBST(S)
R551-554	247 2009 983	Carbon chip 10 kohm 1/16W	RM73B--103JT
R559,560	247 2011 926	Carbon chip 39 kohm 1/16W	RM73B--393JT
R561-564	244 2043 937	Metal oxide 10 ohm 1W(NB)	RS14B3A100JNBST(S)
R567,568	247 2010 969	Carbon chip 22 kohm 1/16W	RM73B--223JT
R587,588	244 2052 931	Metal oxide 390 ohm 1W(NB)	RS14B3A391JNBST(S)
R601,602	247 2012 925	Carbon chip 100 kohm 1/16W	RM73B--104JT
R605,606	247 2007 943	Carbon chip 1 kohm 1/16W	RM73B--102JT
R611,612	247 2011 968	Carbon chip 56 kohm 1/16W	RM73B--563JT
R613	247 2009 983	Carbon chip 10 kohm 1/16W	RM73B--103JT
R614,615	247 2009 909	Carbon chip 4.7 kohm 1/16W	RM73B--472JT (1608)
R616	247 2008 913	Carbon chip 2kohm 1/16W	RM73B--202JT
R617	247 2009 983	Carbon chip 10 kohm 1/16W	RM73B--103JT
R618	247 2007 943	Carbon chip 1 kohm 1/16W	RM73B--102JT
R701	247 2005 903	Carbon chip 100 ohm 1/16W	RM73B--101JT
R702	247 2010 956	Carbon chip 20 kohm 1/16W	RM73B--203JT
R703,704	247 2012 925	Carbon chip 100 kohm 1/16W	RM73B--104JT
R705	247 2007 943	Carbon chip 1 kohm 1/16W	RM73B--102JT
R706,707	247 2009 983	Carbon chip 10 kohm 1/16W	RM73B--103JT
R708	247 2007 943	Carbon chip 1 kohm 1/16W	RM73B--102JT
R732	244 2051 961	Metal oxide 100 ohm 1W(NB)	RS14B3A101JNBST(S)
R733	241 2378 988	Carbon film 390 ohm 1/4W(NB)	RD14B2E391JNBST
R901	247 2011 968	Carbon chip 56 kohm 1/16W	RM73B--563JT
R902	247 2009 983	Carbon chip 10 kohm 1/16W	RM73B--103JT
R903-907	247 2009 909	Carbon chip 4.7 kohm 1/16W	RM73B--472JT (1608)
R908	247 2011 942	Carbon chip 47 kohm 1/16W	RM73B--473JT

Ref. No.	Part No.	Part Name	Remarks
R909,910	247 2018 903	Carbon chip 0 ohm 1/16W	RM73B--0R0KT
R911	247 2009 983	Carbon chip 10 kohm 1/16W	RM73B--103JT
R912	247 2008 968	Carbon chip 3.3kohm 1/16W	RM73B--332JT
R913,914	247 2009 983	Carbon chip 10 kohm 1/16W	RM73B--103JT
R915	247 2009 909	Carbon chip 4.7 kohm 1/16W	RM73B--472JT (1608)
R916,917	247 2005 903	Carbon chip 100 ohm 1/16W	RM73B--101JT
R918,919	247 2007 943	Carbon chip 1 kohm 1/16W	RM73B--102JT
R921,922	247 2009 983	Carbon chip 10 kohm 1/16W	RM73B--103JT
R923,924	247 2010 969	Carbon chip 22 kohm 1/16W	RM73B--223JT
R925	247 2008 926	Carbon chip 2.2 kohm 1/16W	RM73B--222JT
R926,927	247 2010 969	Carbon chip 22 kohm 1/16W	RM73B--223JT
R928	247 2007 943	Carbon chip 1 kohm 1/16W	RM73B--102JT
R929	247 2005 903	Carbon chip 100 ohm 1/16W	RM73B--101JT
R930	247 2011 942	Carbon chip 47 kohm 1/16W	RM73B--473JT
R931	247 2005 987	Carbon chip 220 ohm 1/16W	RM73B--221JT
R932	247 2011 942	Carbon chip 47 kohm 1/16W	RM73B--473JT
R933,934	247 2010 969	Carbon chip 22 kohm 1/16W	RM73B--223JT
R935	247 2009 983	Carbon chip 10 kohm 1/16W	RM73B--103JT
R936,937	247 2011 942	Carbon chip 47 kohm 1/16W	RM73B--473JT
R938	247 2011 900	Carbon chip 33 kohm 1/16W	RM73B--333JT
R939	247 2010 927	Carbon chip 15 kohm 1/16W	RM73B--153JT
R940	247 2009 983	Carbon chip 10 kohm 1/16W	RM73B--103JT
R941	247 2007 943	Carbon chip 1 kohm 1/16W	RM73B--102JT
R942	247 2005 945	Carbon chip 150 ohm 1/16W	RM73B--151JT
R943	247 2005 961	Carbon chip 180ohm 1/16W	RM73B--181JT
R944	247 2006 915	Carbon chip 270ohm 1/16W	RM73B--271JT
R945	247 2006 944	Carbon chip 390ohm 1/16W	RM73B--391JT
R946	247 2007 943	Carbon chip 1 kohm 1/16W	RM73B--102JT
R947	247 2005 945	Carbon chip 150 ohm 1/16W	RM73B--151JT
R948-950	247 2009 983	Carbon chip 10 kohm 1/16W	RM73B--103JT
R951-962	247 2011 942	Carbon chip 47 kohm 1/16W	RM73B--473JT
R963	247 2018 903	Carbon chip 0 ohm 1/16W	RM73B--0R0KT
R964	247 2009 983	Carbon chip 10 kohm 1/16W	RM73B--103JT
R965	247 2005 987	Carbon chip 220 ohm 1/16W	RM73B--221JT
R966	247 2006 902	Carbon chip 330 ohm 1/16W	RM73B--331JT (1608)
R967-970	247 2009 983	Carbon chip 10 kohm 1/16W	RM73B--103JT
R972,973	247 2011 942	Carbon chip 47 kohm 1/16W	RM73B--473JT
R976,977	247 2011 942	Carbon chip 47 kohm 1/16W	RM73B--473JT
R979	247 2004 920	Carbon chip 47 ohm 1/16W	RM73B--470JT
R980	247 2011 942	Carbon chip 47 kohm 1/16W	RM73B--473JT
R981-996	247 2012 925	Carbon chip 100 kohm 1/16W	RM73B--104JT
R997	247 2006 944	Carbon chip 390ohm 1/16W	RM73B--391JT
R998	247 2007 901	Carbon chip 680ohm 1/16W	RM73B--681JT
R999	247 2012 925	Carbon chip 100 kohm 1/16W	RM73B--104JT
VR501,502	211 6075 024	Semi fixed resistor 4.7 kohm	V06PB472 (CERMET)
CAPACITORS GROUP			
C101	256 1042 903	Metalized 0.1uF/250V	CF93A2E104KT
C103,104	254 6221 008	Electrolytic 8200uF/63V	CE68W1J822M(DL)
C105,106	254 4583 955	Electrolytic 22uF/50V	CE04W1H220MT(ROB)
C107,108	254 4580 712	Electrolytic 100uF/50V	CE04W1H101MC(ROB)

Ref. No.	Part No.	Part Name	Remarks	Ref. No.	Part No.	Part Name	Remarks
C109,110	254 4524 985	Electrolytic 10uF/50V	CE04W1H100MT SMG/RE3	C541-544	255 1264 940	Mylar film 2200pF/50V	CQ93M1H222JT(B)
C111,112	257 0512 903	Ceramic chip 0.1uF/25V	CK73F1E104ZT	C553,554	255 1265 936	Mylar film 0.01uF/50V	CQ93M1H103JT(B)
C113	254 4538 900	Electrolytic 10uF/16V	CE04W1C100MT SMG/RE3	C556	255 1264 940	Mylar film 2200pF/50V	CQ93M1H222JT(B)
C115,116	254 4528 729	Electrolytic 100uF/100V	CE04W2A101MC SMG/RE3				
△ C122	253 8022 707	Ceramic 0.01 uF/250V(AC)	CK45F2EAC103MC	C601,602	254 4524 998	Electrolytic 22 uF/50V	CE04W1H220MT SMG/RE3
C123	254 4313 921	Electrolytic 22uF/50V	CE04W1H220MT(ASF)	C603	257 0507 976	Ceramic chip 330pF/50V	CC73CH1H331JT
				C604	257 0508 933	Ceramic chip 560pF/50V	CC73CH1H561JT
C203-216	257 0505 907	Ceramic chip 56 pF/50V	CC73CH1H560JT	C605,606	257 0504 908	Ceramic chip 22 pF/50V	CC73CH1H220JT
C217,218	254 4313 963	Electrolytic 1uF/50V	CE04W1H010MT(ASF)	C609	257 0511 904	Ceramic chip 0.01uF/50V	CK73F1H103ZT
C221	254 4313 963	Electrolytic 1uF/50V	CE04W1H010MT(ASF)	C610	254 4538 900	Electrolytic 10uF/16V	CE04W1C100MT SMG/RE3
C222	257 0511 904	Ceramic chip 0.01uF/50V	CK73F1H103ZT	C611	254 4522 903	Electrolytic 4.7 uF/35V	CE04W1V4R7MT SMG/RE3
C241-245	257 0511 904	Ceramic chip 0.01uF/50V	CK73F1H103ZT	C612	257 0511 904	Ceramic chip 0.01uF/50V	CK73F1H103ZT
C246	254 4524 985	Electrolytic 10uF/50V	CE04W1H100MT SMG/RE3	C613	254 4538 900	Electrolytic 10uF/16V	CE04W1C100MT SMG/RE3
C247	254 4305 968	Electrolytic 1 uF/50V	CE04W1H010MT(SRE)	C622	257 0511 904	Ceramic chip 0.01uF/50V	CK73F1H103ZT
				C702	254 4313 921	Electrolytic 22uF/50V	CE04W1H220MT(ASF)
C303,304	254 4313 918	Electrolytic 10uF/50V	CE04W1H100MT(ASF)	C704	254 4524 914	Electrolytic 0.22uF/50V	CE04W1HR22MT SMG/RE3
C305,306	257 0506 951	Ceramic chip 100pF/50V	CC73CH1H101JT	C705	254 4541 900	Electrolytic 10uF/25V	CE04W1E100MT SMG/RE3
C307-309	254 4524 985	Electrolytic 10uF/50V	CE04W1H100MT SMG/RE3	C706	254 4533 947	Electrolytic 330uF/6.3V	CE04W0J331MT SMG/RE3
C310	254 4313 918	Electrolytic 10uF/50V	CE04W1H100MT(ASF)	C707	254 4524 943	Electrolytic 1uF/50V	CE04W1H010MT SMG/RE3
C313,314	257 0506 951	Ceramic chip 100pF/50V	CC73CH1H101JT	C708	254 4524 972	Electrolytic 4.7uF/50V	CE04W1H4R7MT SMG/RE3
C315,316	254 4524 969	Electrolytic 3.3uF/50V	CE04W1H3R3MT SMG/RE3	C709	255 1265 936	Mylar film 0.01uF/50V	CQ93M1H103JT(B)
C317,318	257 0517 924	Ceramic chip 0.056uF/16V	CK73B1C563KT	C710	254 4524 956	Electrolytic 2.2uF/50V	CE04W1H2R2MT SMG/RE3
C321,322	257 0510 963	Ceramic chip 8200pF/50V	CK73B1H822KT				
C323,324	257 0509 987	Ceramic chip 1800pF/50V	CK73B1H182KT	C901	254 3056 917	Electrolytic 1 uF/50V	CE04D1H010MBPT (SME)
C325,326	254 4524 972	Electrolytic 4.7uF/50V	CE04W1H4R7MT SMG/RE3	C902	254 4403 721	Electrolytic 2200uF/25V	CE04W1E222MC (SMG)
C327,328	257 0501 914	Ceramic chip 0.012uF/25V	CK73B1H123KT	C903	257 0512 903	Ceramic chip 0.1uF/25V	CK73F1E104ZT
C329,330	254 4524 972	Electrolytic 4.7uF/50V	CE04W1H4R7MT SMG/RE3	C904	254 4541 900	Electrolytic 10uF/25V	CE04W1E100MT SMG/RE3
C331,332	257 0506 951	Ceramic chip 100pF/50V	CC73CH1H101JT	C905	257 0512 903	Ceramic chip 0.1uF/25V	CK73F1E104ZT
C333,334	254 4524.972	Electrolytic 4.7uF/50V	CE04W1H4R7MT SMG/RE3	C906	254 4541 900	Electrolytic 10uF/25V	CE04W1E100MT SMG/RE3
C351,352	254 4313 918	Electrolytic 10uF/50V	CE04W1H100MT(ASF)	C907	257 0511 904	Ceramic chip 0.01uF/50V	CK73F1H103ZT
C353,354	254 4524 972	Electrolytic 4.7uF/50V	CE04W1H4R7MT SMG/RE3	C908	254 4299 906	Electrolytic 10uF/16V	CE04W1C100MT(SRE)
C357	254 4313 921	Electrolytic 22uF/50V	CE04W1H220MT(ASF)	C909	257 0511 904	Ceramic chip 0.01uF/50V	CK73F1H103ZT
				C911-913	257 0511 904	Ceramic chip 0.01uF/50V	CK73F1H103ZT
C403,404	257 0506 977	Ceramic chip 120pF/50V	CC73CH1H121JT	C921,922	257 0509 929	Ceramic chip 1000pF/50V	CK73B1H102KT
C407,408	255 1273 957	Mylar film 270pF/50V	CQ93M1H271KT(B)	C931	257 0512 903	Ceramic chip 0.1uF/25V	CK73F1E104ZT
C409,410	254 4538 900	Electrolytic 10uF/16V	CE04W1C100MT SMG/RE3	C932	254 4305 984	Electrolytic 2.2uF/50V	CE04W1H2R2MT(SRE)
C411,412	254 4536 931	Electrolytic 220uF/10V	CE04W1A221MT SMG/RE3	C933	257 0511 904	Ceramic chip 0.01uF/50V	CK73F1H103ZT
C413,414	257 0506 951	Ceramic chip 100pF/50V	CC73CH1H101JT	C934	254 4299 964	Electrolytic 47uF/16V	CE04W1C470MT(SRE)
C419,420	255 1265 907	Mylar film 6800pF/50V	CQ93M1H682JT(B)	C935	257 0511 904	Ceramic chip 0.01uF/50V	CK73F1H103ZT
C421,422	255 1265 978	Mylar film 6800pF/50V	CQ93M1H223JT(B)	C936	254 4299 906	Electrolytic 10uF/16V	CE04W1C100MT(SRE)
C423,424	255 1264 940	Mylar film 6800pF/50V	CQ93M1H222JT(B)	C937	257 0511 904	Ceramic chip 0.01uF/50V	CK73F1H103ZT
C425,426	254 4313 963	Mylar film 6800pF/50V	CE04W1H010MT(ASF)	C938	254 4299 906	Electrolytic 10uF/16V	CE04W1C100MT(SRE)
C427,428	254 4524 956	Mylar film 6800pF/50V	CE04W1H2R2MT SMG/RE3	C939	257 0511 904	Ceramic chip 0.01uF/50V	CK73F1H103ZT
				C940	254 4299 906	Electrolytic 10uF/16V	CE04W1C100MT(SRE)
C501-504	255 1273 902	Mylar film 100pF/50V	CQ93M1H101KT(B)	C941-943	257 0511 904	Ceramic chip 0.01uF/50V	CK73F1H103ZT
C505,506	255 1264 940	Mylar film 2200pF/50V	CQ93M1H222JT(B)	C944	254 4299 906	Electrolytic 10uF/16V	CE04W1C100MT(SRE)
C507,508	254 4583 971	Electrolytic 47uF/50V	CE04W1H470MT(ROB)	C951	254 4524 956	Electrolytic 2.2uF/50V	CE04W1H2R2MT SMG/RE3
C509,510	255 4232 924	Mylar film 39pF/100V	CQ93P2A390JT(NH)	C952	254 4524 930	Electrolytic 0.47 uF/50V	CE04W1H4R7MT SMG/RE3
C519,520	254 4313 963	Electrolytic 1uF/50V	CE04W1H010MT(ASF)				
C523,524	254 4580 712	Electrolytic 100uF/50V	CE04W1H101MC(ROB)				
C525,526	255 1264 908	Mylar film 1000pF/50V	CQ93M1H102JT(B)				
C527,528	256 1058 971	Metalized 0.1uF/50V	CF93A1H104JT (JL)				

Ref. No.	Part No.	Part Name	Remarks	Q'ty	Ref. No.	Part No.	Part Name	Remarks	Q'ty
<b>OTHER PARTS GROUP</b>									
AS101,102	417 0476 007	Radiator		2	JK204	204 8635 008	4P pin jack (C-GND)		1
AS103	417 0476 049	Radiator		1	JK205,206	204 8637 006	Mini jack (STEREO)		2
AS104	417 0476 007	Radiator		1	JK501	205 0526 008	4P SP terminal (EU)		1
AS105-108	471 3304 028	Screw 3x8 CBS-B		4	JK502	204 8636 007	Mini jack (ST.SW)		1
AS122	415 0299 000	Condenser cover		1	L401,402	235 9003 002	FTZ choke coil		2
AS902	449 0172 007	Sensor holder		1	L601	235 0060 918	Inductor 4.7uH		1
AS903,904	461 1110 000	FL spacer(D-SIDE)		2	△ RL101	214 0214 000	Relay (SDT-S-109LMR)		1
CW21	203 2318 001	2P SAN-SAN cord		1	RL301	214 0203 008	Relay (NA12W-K)		1
CW36	203 5266 008	3P KR-DS connector cord		1	RL702	214 0195 006	Relay FTR-F1		1
CW39	203 5103 022	3P SAN-SAN connector cord		1	RL704	214 0203 008	Relay (NA12W-K)		1
CW41	203 6573 004	4P SAN-SAN cord R		1	S901-907	212 4813 003	Tact switch		7
CW101	204 2896 005	10P DS-DS connector cord		1	S908	212 0465 002	Rotary encoder (F)		1
CX31,32	205 0233 032	3 P EH connector base		2	S909	212 0461 006	Rotary encoder (V)		1
CX34	205 0323 036	3P connector base (BLK)		1	S910	212 0476 004	1P push switch (non lock)		1
CX35	205 0321 038	3P connector base (KR-PH RED)		1	△ T101	233 6383 004	Power trans. (SUB/E2)		1
CX36	205 0406 034	3P connector base (KR-PH)		1	TP501,502	205 0190 036	3P NH connector base		2
CX37	205 0543 036	3P connector base (YEL)		1	W101	203 0689 017	1P SIN-SIN wire		1
CX38	205 0321 038	3P connector base (KR-PH RED)		1	W102	203 0689 033	1P SIN-SIN wire		1
CX51	205 0343 058	5P connector base (KR-PH)		1	W103	203 0689 020	1P SIN-SIN wire		1
CX71	205 0343 074	7P connector base (KR-PH)		1	W104	203 0689 046	1P SIN-SIN wire		1
CX81	205 0343 087	8P connector base (KR-PH)		1	W105	203 0689 004	1P SIN-SIN wire		1
CX91	205 0343 090	9P connector base (KR-PH)		1	W107	203 0689 075	1P SIN-SIN wire		1
CX111,112	205 0375 013	11P connector base (KR-PH)		2	W108	203 0689 088	1P SIN-SIN wire		1
CX151	205 0736 076	15P FFC connector base		1	W111,112	203 0604 050	1P contact ass'y		2
CX152	205 0375 055	15P connector base (KR-PH)		1	W501	203 0689 059	1P SIN-SIN wire		1
CX701,702	205 0606 025	2P wrapping terminal		2	W502	203 0689 062	1P SIN-SIN wire		1
CX704	205 0087 039	3P wrapping terminal		1	W905	001 0026 087	Wire cord		1
CY34	205 0323 036	3P connector base (BLK)		1	W906	203 0525 016	1P SIN cord Ass'y		1
CY37	205 0687 031	3P connector base (YEL)L		1	X601	399 0178 007	Crystal 4.332MHz		1
CY38	205 0321 038	3P connector base (RED)		1	XL901	399 0107 900	Ceramic 4.19 MHz		1
CY51	205 0343 058	5P connector base (KR-PH)		1	001 0036 080	Vinyl wire		1	
CY71	205 0343 074	7P connector base (KR-PH)		1	001 0172 096	Vinyl wire		1	
CY81	205 0343 087	8P connector base (KR-PH)		1	461 0415 007	Rubber sheet		3	
CY91	205 0343 090	9P connector base (KR-PH)		1	513 3681 003	Fuse label (T1.6AL)		1	
CY111,112	205 0375 013	11P connector base (KR-PH)		2					
CY152	205 0375 055	15P connector base (KR-PH)		1					
△ F101	206 1075 027	Fuse (1.6A)		1					
FF101	202 0040 909	Fuse clip		1					
FH101	202 0040 909	Fuse clip		1					
FL901	393 8054 002	11-BT-187GNK		1					
JK201	204 8639 004	2P pin jack (C-GND)		1					
JK202	204 8635 024	4P pin jack (C-GND)		1					
JK203	204 8638 021	6P pin jack (C-GND)		1					

# EXPLODED VIEW

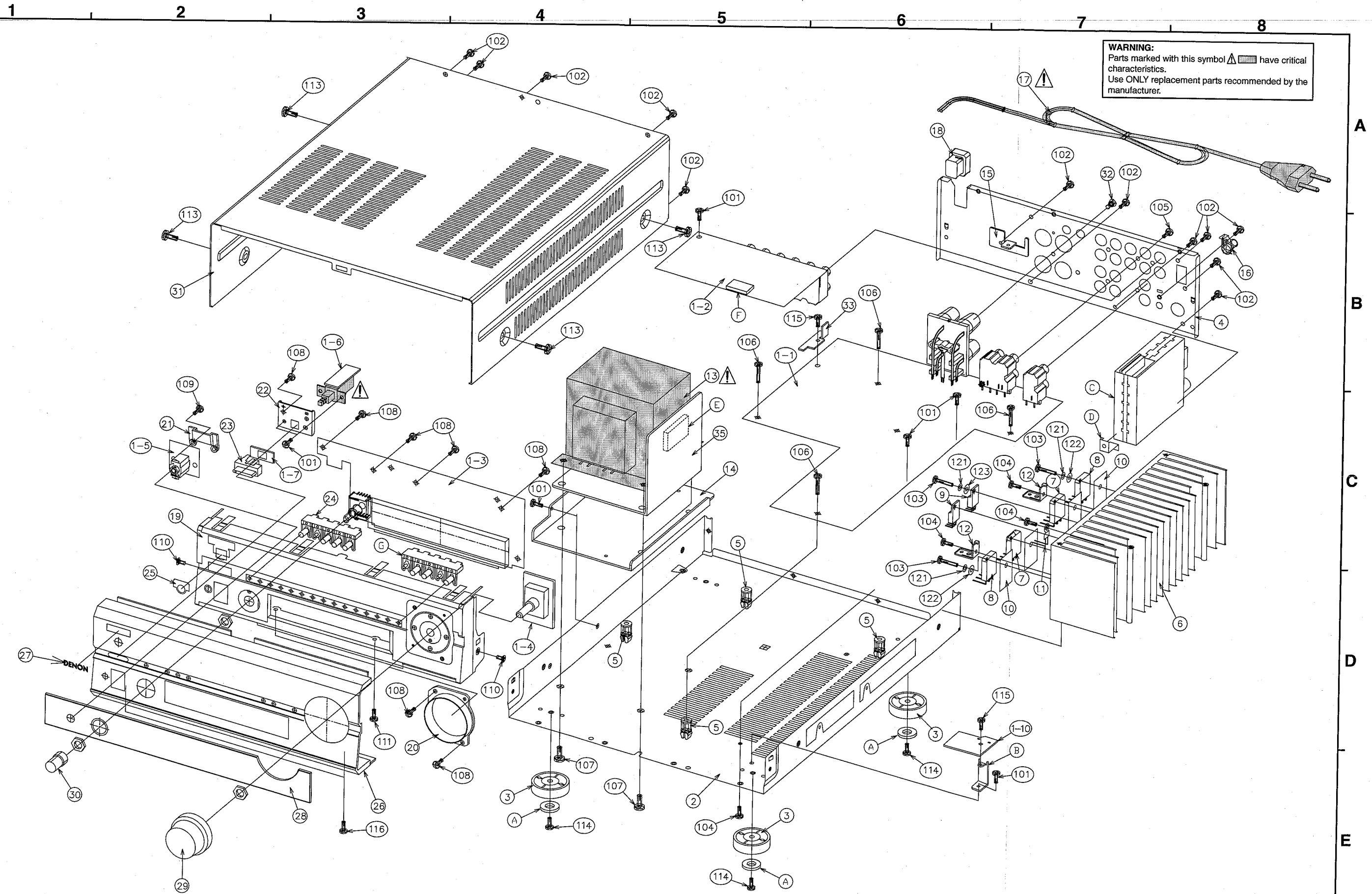

## PARTS LIST OF EXPLODED VIEW

Ref. No.	Part No.	Part Name	Remarks	Q'ty	Ref. No.	Part No.	Part Name	Remarks	Q'ty
1	1U-3382C	Main P.W.B. unit Ass'y		1	★	009 0209 015	15P FFC cable (1.25)	CN151	1
-1-1		Main unit			★	204 6362 098	15P KR-KR ribbon 250	CN152	1
1-2		Input unit			★	203 5110 057	3P EH-EH shield	CN31	1
1-3		U-CON unit			★	203 4872 037	3P KR-KR ribbon 350	CN34	1
1-4		Encoder unit			★	203 4871 038	3P KR-KR ribbon 100	CN37,38	2
1-5		Headphone jack unit			★	203 8342 055	5P KR-KR ribbon 400	CN51	1
1-6		P. SW. unit			★	204 2543 031	7P KR-KR ribbon 100	CN71	1
1-7		LED unit			★	204 2547 024	8P KR-KR ribbon 325	CN81	1
-1-10		Resistor unit			★	204 2549 035	9P KR-KR ribbon 100	CN91	1
2	411 1993 332	Main chassis		1	★	415 0309 055	P.V.C tube(L=07)		2
3	104 0324 004	Foot		4	★	445 0048 016	Cord holder (L50)		1
A	461 1066 002	Felt		4	★	445 8027 000	Cord clamper		2
4	105 1385 029	Back panel		1	★	445 8004 007	Wire clamper		10
5	412 3548 005	P.W.B catcher		4	★	412 4845 008	PWB bracket(C)		1
6	417 0620 112	Power radiator		1	★	415 0382 030	UL tube (4.2) L=30		2
7	272 0152 003	2SB1383(P/Y)	TR519,520	2	<b>SCREWS</b>				
8	274 0190 003	2SD2083(P/Y)	TR517,518	2	101	473 7002 005	Screw 3X6 CBTS(S)-Z	3X6 CBTS(S)-Z	6
9	273 0450 009	2SC4495(O/Y)	TR515,516	2	102	473 7015 005	Screw 3X6 CBTS(S)-B	3X6 CBTS(S)-B	12
10	415 0234 007	Insulating sheet		4	103	473 8034 072	Screw 3X16 CBTS(B)Z	3X16 CBTS(B)Z	6
11	279 0034 054	PTH9M04BC222TS2F333	TH701	1	104	473 8034 030	Screw 3X10 CBTS(B)-Z	3X10 CBTS(B)-Z	9
12	412 3225 205	P.W.B bracket(A)		2	105	477 0064 107	Fixing screw	FIXING SCREW	6
B	412 4622 001	PCB support(A)		1	106	473 7500 060	Screw 3X18 CBTS (P)	3X18 CBTS (P)	4
C	216 0114 009	AM FM tuner(E2)		1	107	473 7004 029	Screw 4X10 CBTS (S)-Z	4X10 CBTS (S)-Z	4
D	412 4839 001	Earth plate(H/P)		1	108	473 7500 015	Screw 3X8 CBTS (P)-Z	3X8 CBTS (P)-Z	9
△	13	233 6405 005	Power trans E2	1	109	473 7501 014	Screw 3X14 CBTS (P)-Z	3X14 CBTS (P)-Z	2
14	412 4828 106	Trans bracket		1	110	473 7003 017	Screw 3X8 CFTS (S)-B	3X8 CFTS (S)-B	2
F	461 1067 001	FL spacer		1	111	473 7002 021	Screw 3X8 CBTS (S)-B	3X8 CBTS (S)-B	2
15	412 4844 009	PWB bracket(B)		1	113	477 0263 018	3P. swelling screw	3P.SWELLING SCREW	4
16	205 1116 006	Terminal Ass'y		1	114	473 7002 034	Screw 3X6 CBTS (S)-B	3X6 CBTS (S)-B	4
△	17	206 2063 009	AC cord with plug	1	115	473 7002 018	Screw 3X8 CBTS (S)-Z	3X8 CBTS (S)-Z	2
18	445 0056 008	Cord bush		1	116	473 7015 018	Screw 3X8 CBTS (S)-B	3X8 CBTS (S)-B	2
19	146 2252 217	Inner panel		1					
20	119 0113 000	Knob esc.		1					
21	103 1751 000	Holder		1					
22	412 4911 000	Knob bracket		1					
23	113 1919 001	Power knob Ass'y		1					
24	113 1912 037	Knob 5 REN Ass'y		1					
G	113 1912 040	Knob 5 REN Ass'y		1					
25	143 1131 000	Remocon filter		1					
26	144 2777 217	Front panel		1					
27	131 0156 106	DENON badge		1					
28	143 1129 012	Window		1					
29	112 0886 019	Knob(M) Ass'y		1					
30	112 0884 105	Knob(F) Ass'y		1					
31	102 0653 009	Top cover		1					
32	477 0096 007	Push rivet		4					
33	412 4845 008	PWB bracket (C)		1					
E	461 1110 000	FL spacer(D-SIDE)		1					
35	414 0947 100	Shield plate		1					
121	475 2003 005	3 spring washer		6					
122	475 1003 006	3 washer		4					
123	475 1106 013	Washer		2					
★	204 6351 054	11P KR-KR ribbon 400	CN111	1					
★	204 6350 039	11P KR-KR ribbon 100	CN112	1					

### PACKING VIEW

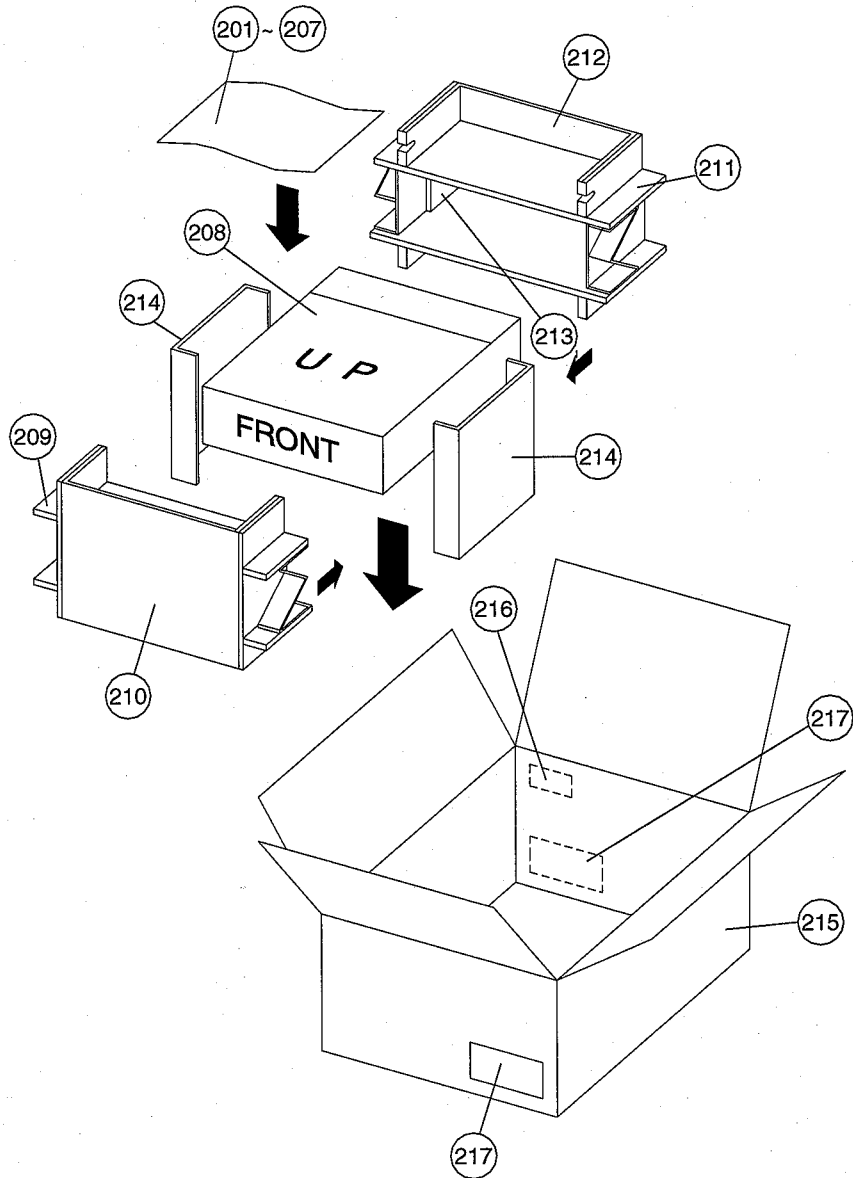

### PARTS LIST OF PACKING & ACCESSORIES

Ref. No.	Part No.	Part Name	Remarks	Q'ty	Ref. No.	Part No.	Part Name	Remarks	Q'ty
201	505 0038 030	Poly cover		1	210	502 0965 007	Cushion(F-B)		1
202	511 3850 003	Inst manual(E2)		1	211	502 0966 006	Cushion(R-A)		1
203	515 0867 101	S.S.list(EX)		1	212	502 0967 005	Cushion(R-B)		1
204	394 0012 003	Battery (UM-4) Ass		1	213	502 0980 008	Cushion pad		1
205	399 0766 008	Remocon (RC-906)		1	214	502 0968 101	Spacer pad		2
206	231 0922 009	Loop antenna		1	215	501 2157 001	Carton case		1
207	395 0026 005	FM ant. wire		1	216	517 1417 051	E2 POS label		1
208	505 0335 005	Cabinet cover		1	217	—	Control Card		1
209	502 0964 008	Cushion(F-A)		1					



# FORMING CUSHIONS

## Cushion (F) Ass'y

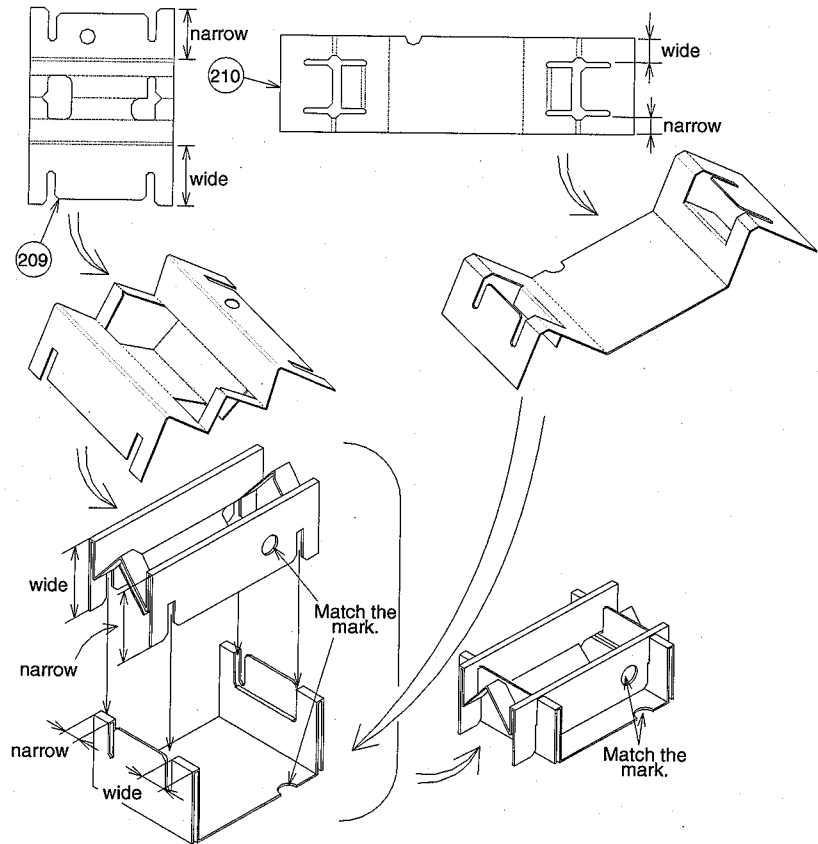

## Cushion (R) Ass'y

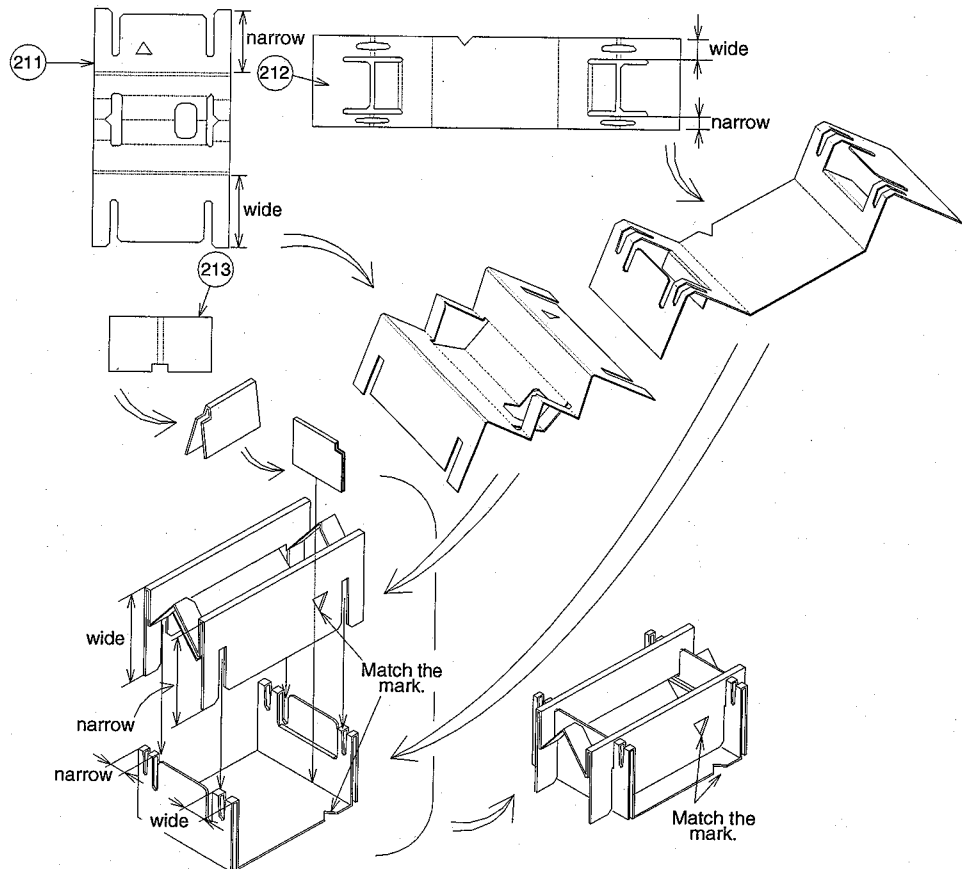

# WIRING DIAGRAM

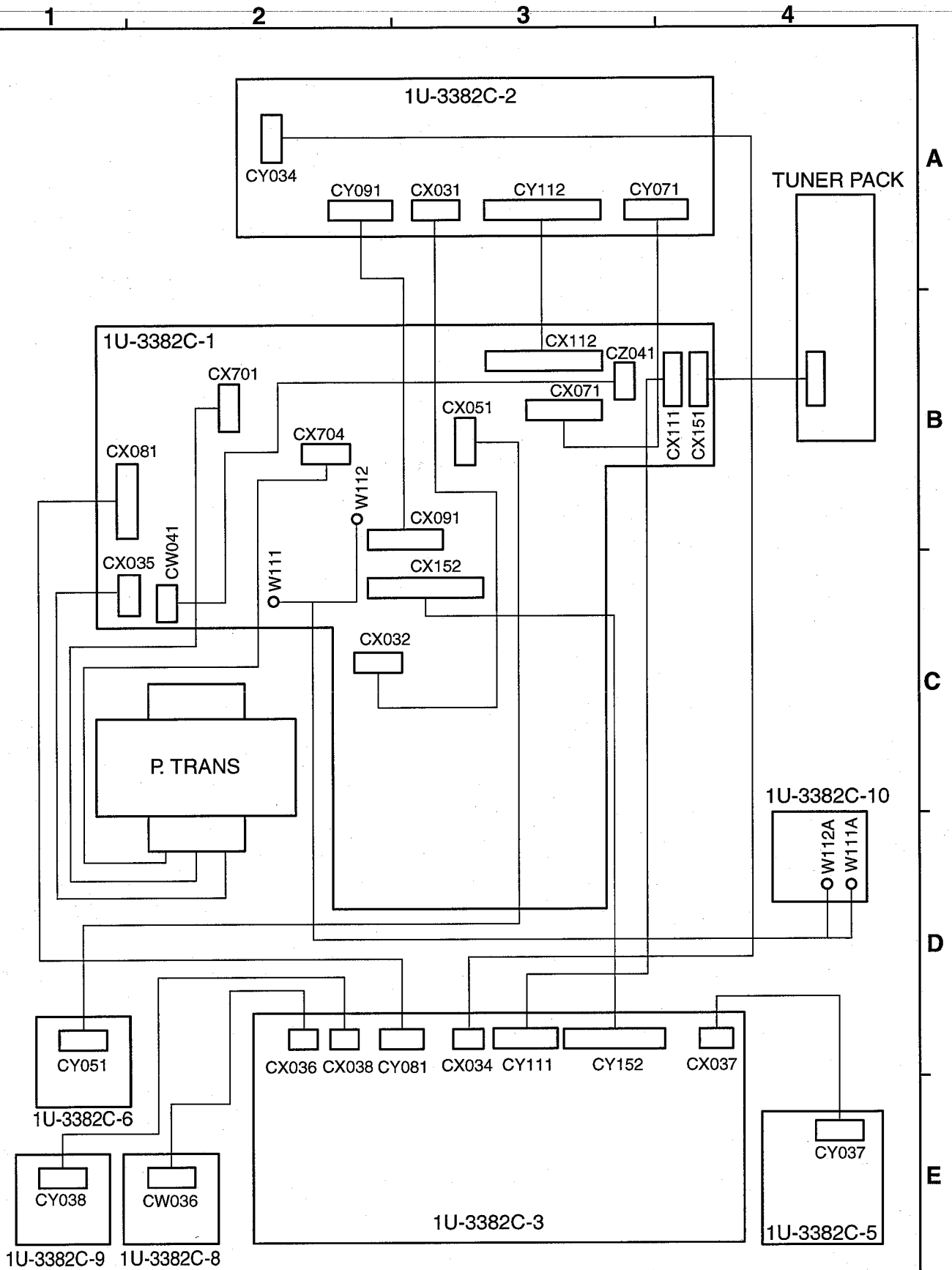

# SCHEMATIC DIAGRAMS (1/2)

1

2

3

4

5

6

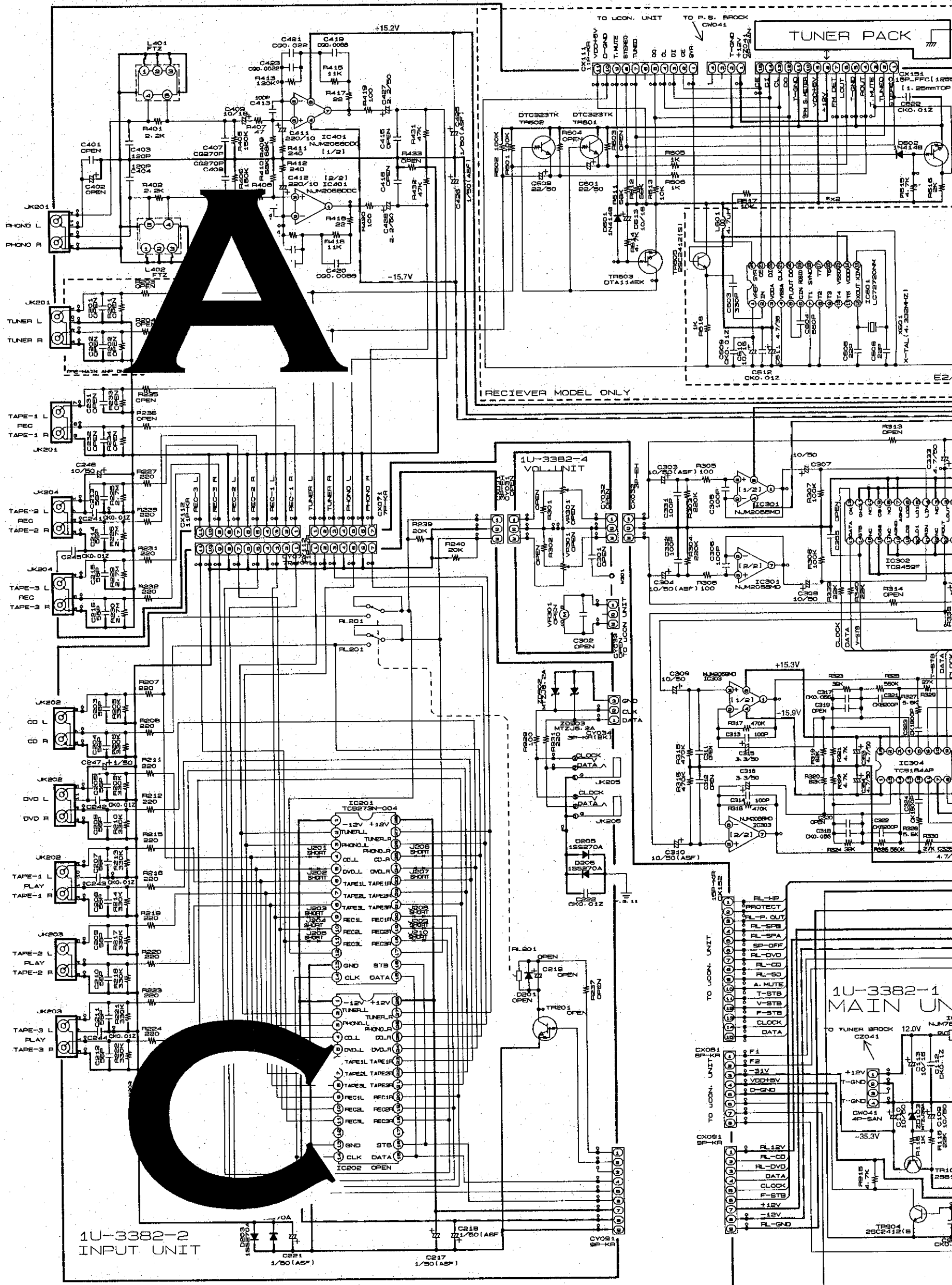

NOTICE  
ALL RESISTANCE VALUES IN C  
ALL CAPACITANCE VALUES IN C  
EACH VOLTAGE AND CURRENT  
CONDITION.  
CIRCUIT AND PARTS ARE SUB  
NOTICE.

6 7 8 9 10 11

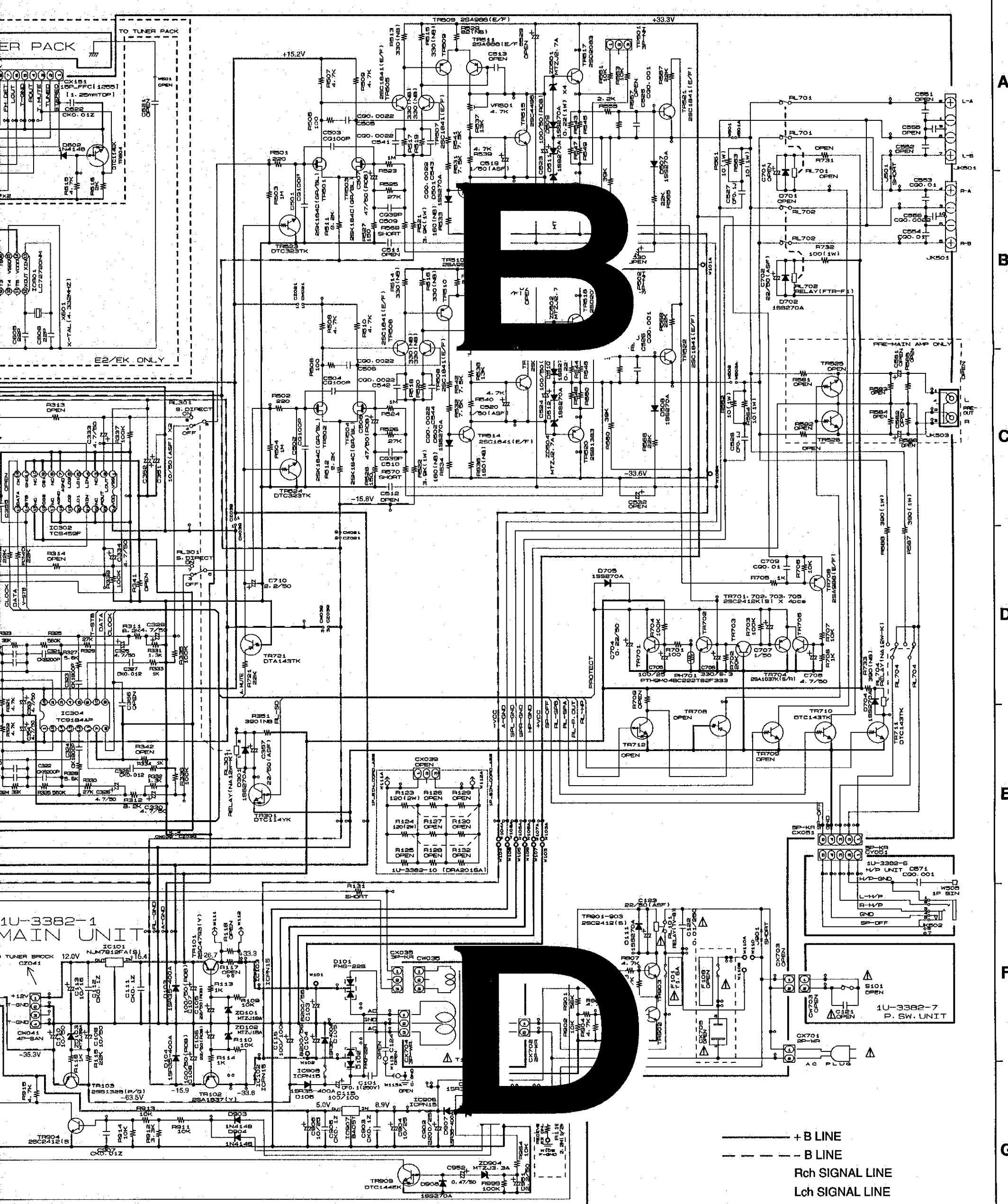

**WARNING:**  
RESISTANCE VALUES IN OHM. k=1,000 OHM M=1,000,000 OHM  
CAPACITANCE VALUES IN MICRO FARAD. P=MICRO-MICRO FARAD  
VOLTAGE AND CURRENT ARE MEASURED AT NO SIGNAL INPUT  
CONDITION.  
COMPONENTS AND PARTS ARE SUBJECT TO CHANGE WITHOUT PRIOR  
NOTICE.

**WARNING:**  
Parts marked with this symbol  $\Delta$  have critical characteristics.  
Use ONLY replacement parts recommended by the manufacturer.

**CAUTION:**  
Before returning the unit to the customer, make sure you make either (1) a  
leakage current check or (2) a line to chassis resistance check. If the leakage  
current exceeds 0.5 millamps, or if the resistance from chassis to either side  
of the power card is less than 460kohms, the unit is defective.

**WARNING:**  
DO NOT return the unit to the customer until the problem is located and  
corrected.

— + B LINE  
- - - B LINE  
- - - Rch SIGNAL LINE  
- - - Lch SIGNAL LINE

**SCHEMATIC DIAGRAMS (1/2)**  
1U-3382C-1 MAIN UNIT  
1U-3382C-2 INPUT UNIT  
1U-3382C-6 H/P UNIT

A  
B  
C  
D  
E  
F  
G  
H

# SCHEMATIC DIAGRAMS (1/2)

1

2

3

4

5

6

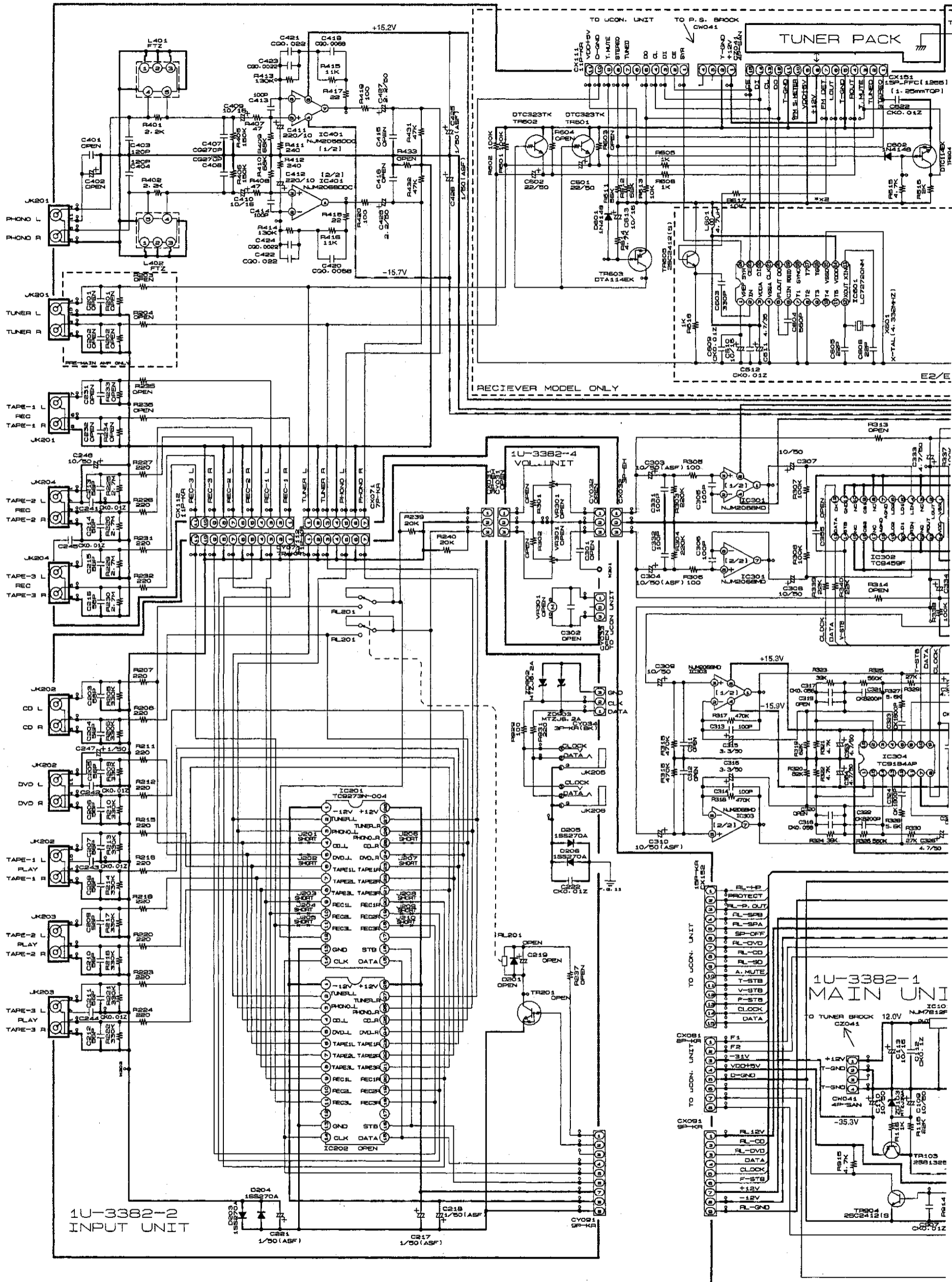

**NOTICE**  
 ALL RESISTANCE VALUES IN OHM  
 ALL CAPACITANCE VALUES IN MIC  
 EACH VOLTAGE AND CURRENT A  
 CONDITION.  
 CIRCUIT AND PARTS ARE SUBJEC  
 NOTICE.

6 7 8 9 10 11

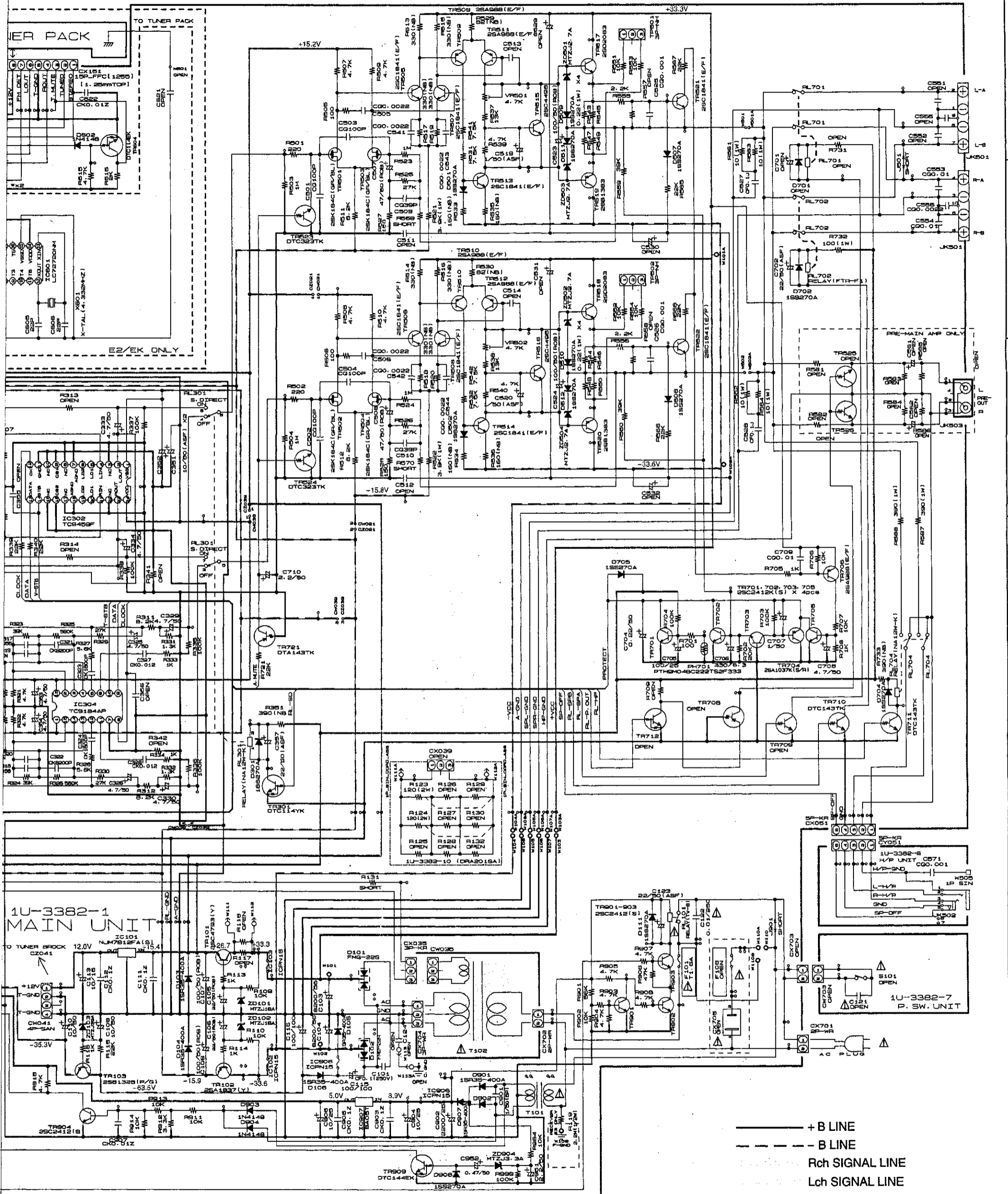

——— + B LINE  
 - - - - - - B LINE  
 ——— Rch SIGNAL LINE  
 ——— Lch SIGNAL LINE

**WARNING:**  
 RESISTANCE VALUES IN OHM. k=1,000 OHM M=1,000,000 OHM  
 CAPACITANCE VALUES IN MICRO FARAD. P=MICRO-MICRO FARAD  
 VOLTAGE AND CURRENT ARE MEASURED AT NO SIGNAL INPUT  
 CONDITION.  
 PARTS AND PARTS ARE SUBJECT TO CHANGE WITHOUT PRIOR  
 NOTICE.

**WARNING:**  
 Parts marked with this symbol  $\Delta$  have critical characteristics.  
 Use ONLY replacement parts recommended by the manufacturer.  
**CAUTION:**  
 Before returning the unit to the customer, make sure you make either (1) a  
 leakage current check or (2) a line to chassis resistance check. If the leakage  
 current exceeds 0.5 milliamperes, or if the resistance from chassis to either side  
 of the power card is less than 460kohms, the unit is defective.  
**WARNING:**  
 DO NOT return the unit to the customer until the problem is located and  
 corrected.

**SCHEMATIC DIAGRAMS (1/2)**  
 1U-3382C-1 MAIN UNIT  
 1U-3382C-2 INPUT UNIT  
 1U-3382C-6 H/P UNIT

**SCHEMATIC DIAGRAMS (2/2)**

1                      2                      3                      4                      5                      6

1U-3382-3

FL UNIT

FL901 11

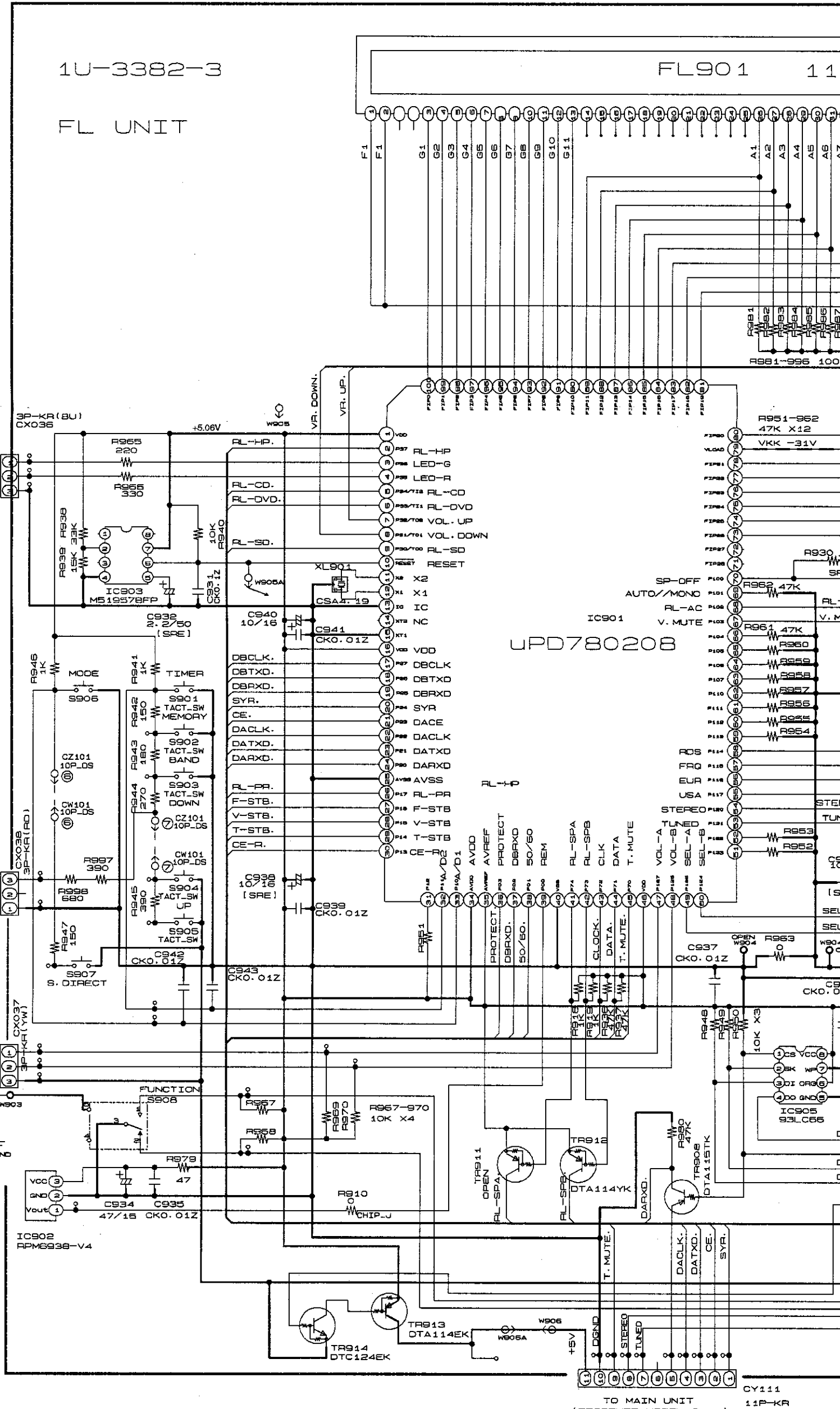
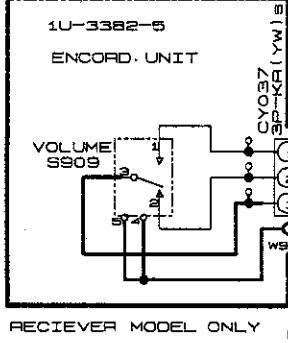
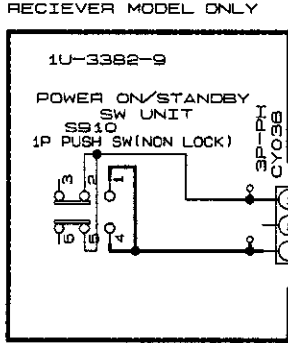
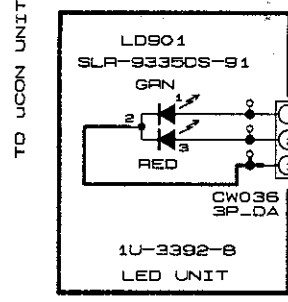

**NOTICE**  
 ALL RESISTANCE VALUES IN OHM.  
 ALL CAPACITANCE VALUES IN MICR.  
 EACH VOLTAGE AND CURRENT ARE  
 CONDITION.  
 CIRCUIT AND PARTS ARE SUBJECT  
 NOTICE.

6 7 8 9 10 11

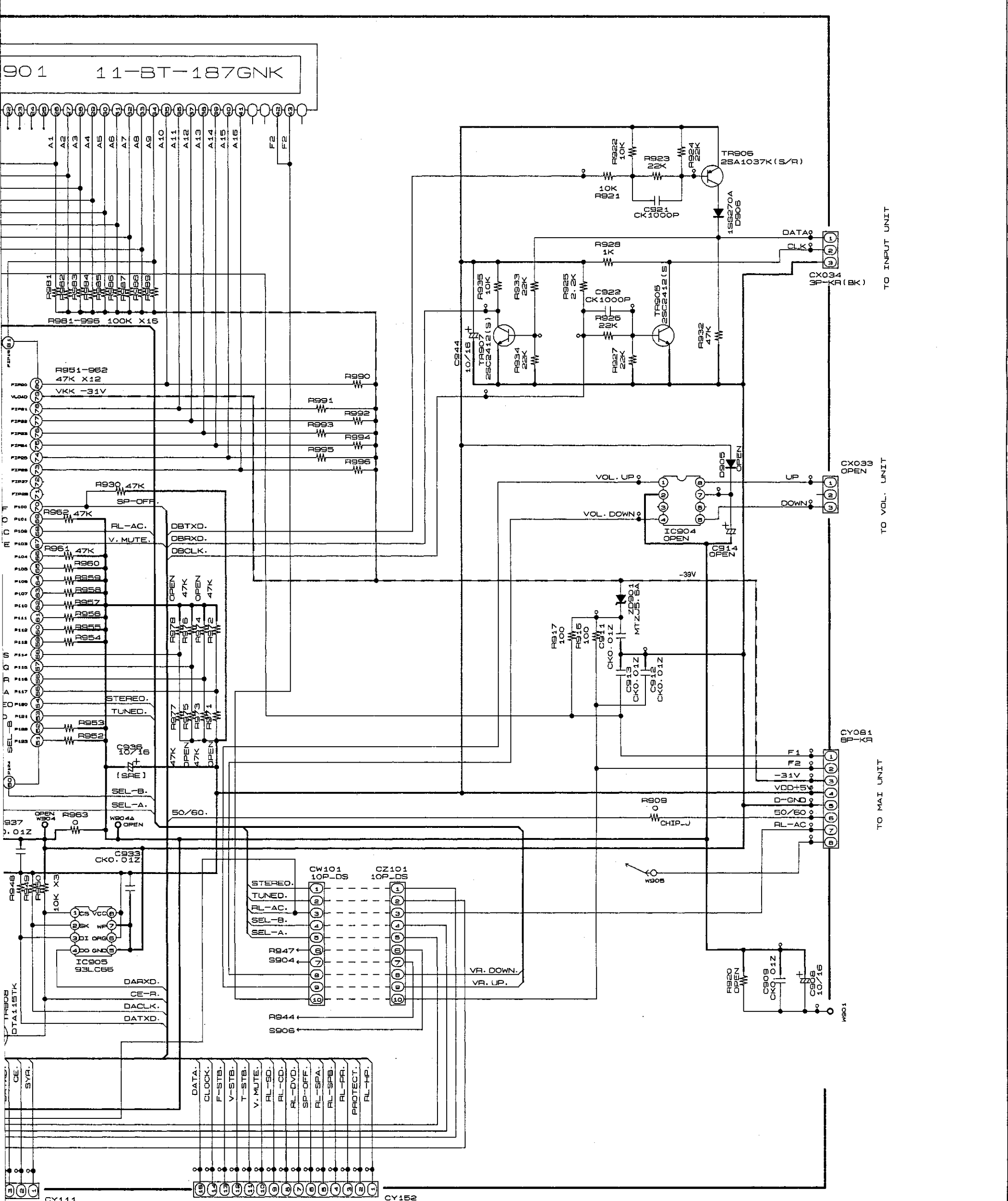

A B C D E F G H

90 1 11-BT-187GNK

TO MAIN UNIT

CY111 11P-KR

CY152 15P-KR

**WARNING:**  
Parts marked with this symbol  $\Delta$  have critical characteristics. Use ONLY replacement parts recommended by the manufacturer.

**CAUTION:**  
Before returning the unit to the customer, make sure you make either (1) a leakage current check or (2) a line to chassis resistance check. If the leakage current exceeds 0.5 millamps, or if the resistance from chassis to either side of the power card is less than 460kohms, the unit is defective.

**WARNING:**  
DO NOT return the unit to the customer until the problem is located and corrected.

— + B LINE  
- - - B LINE

**SCHEMATIC DIAGRAMS (2/2)**  
1U-3382C-3 FL UNIT  
1U-3382C-5 ENCORD UNIT  
1U-3382C-8 LED UNIT



# SCHEMATIC DIAGRAMS (2/2)

1 2 3 4 5 6

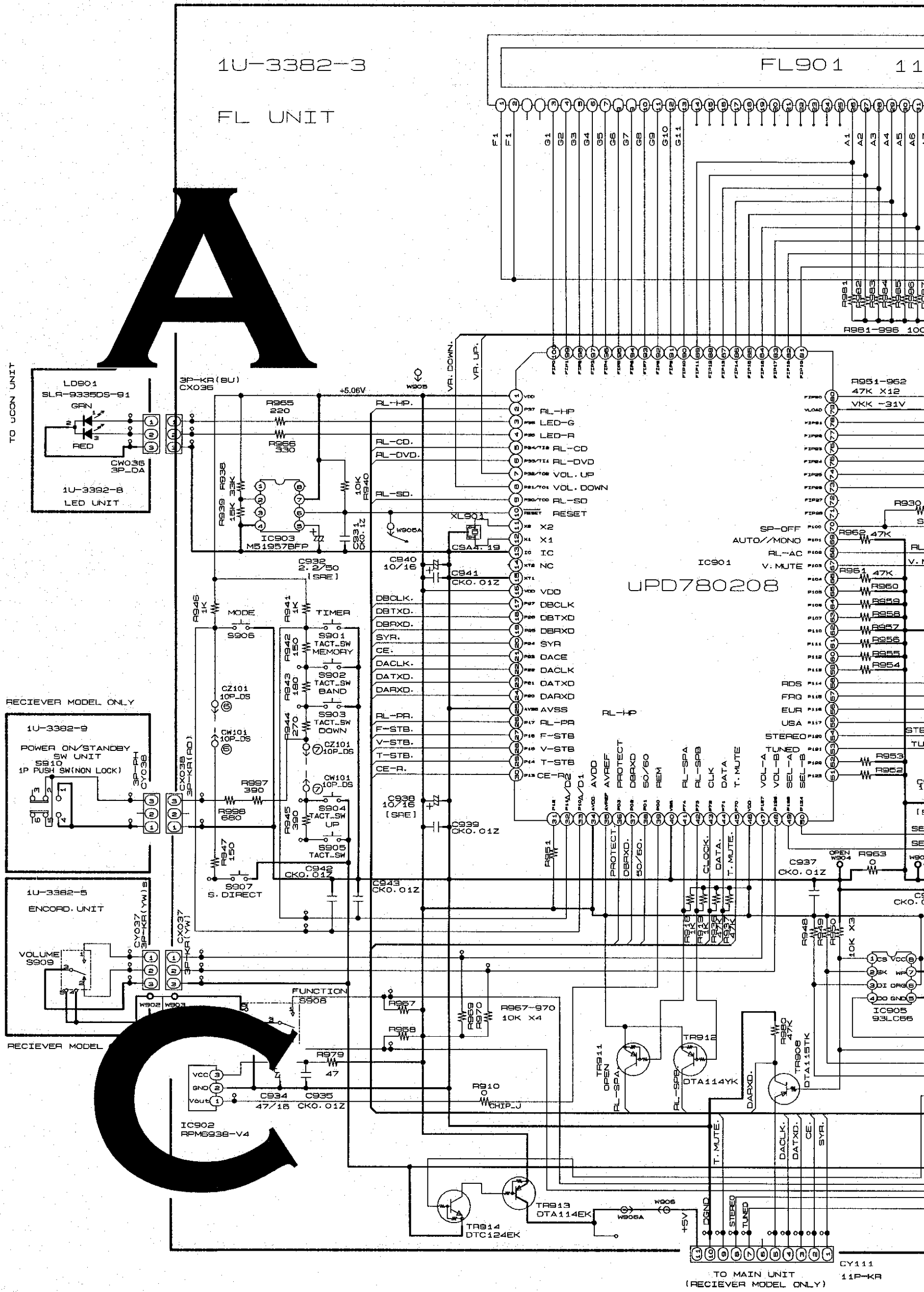

**NOTICE**  
ALL RESISTANCE VALUES IN OHM  
ALL CAPACITANCE VALUES IN MICROFARAD  
EACH VOLTAGE AND CURRENT AT NORMAL OPERATING CONDITION.  
CIRCUIT AND PARTS ARE SUBJECT TO CHANGE WITHOUT NOTICE.

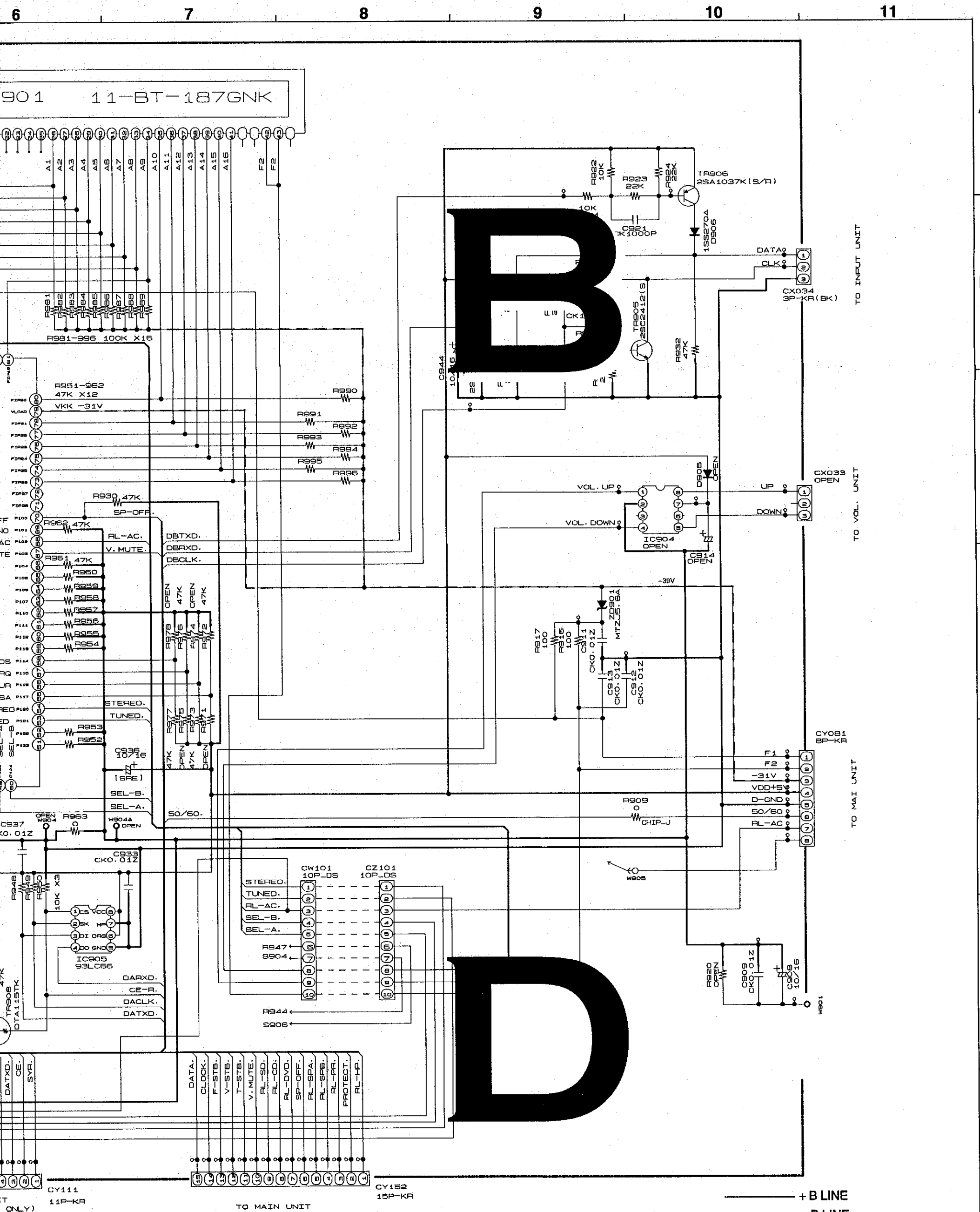

RESISTANCE VALUES IN OHM. k=1,000 OHM M=1,000,000 OHM  
 CAPACITANCE VALUES IN MICRO FARAD. P=MICRO-MICRO FARAD  
 VOLTAGE AND CURRENT ARE MEASURED AT NO SIGNAL INPUT CONDITION.  
 PARTS AND PARTS ARE SUBJECT TO CHANGE WITHOUT PRIOR NOTICE.

**WARNING:**  
 Parts marked with this symbol  $\Delta$  have critical characteristics. Use ONLY replacement parts recommended by the manufacturer.

**CAUTION:**  
 Before returning the unit to the customer, make sure you make either (1) a leakage current check or (2) a line to chassis resistance check. If the leakage current exceeds 0.5 milliamps, or if the resistance from chassis to either side of the power card is less than 460kohms, the unit is defective.

**WARNING:**  
 DO NOT return the unit to the customer until the problem is located and corrected.

**SCHEMATIC DIAGRAMS (2/2)**  
 1U-3382C-3 FL UNIT  
 1U-3382C-5 ENCORD UNIT  
 1U-3382C-8 LED UNIT