

# DENON

Hi-Fi AM-FM Stereo Receiver

## SERVICE MANUAL

# DRA-265R

## AM-FM STEREO RECEIVER

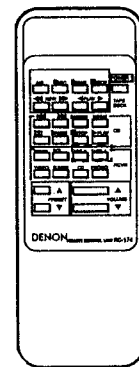
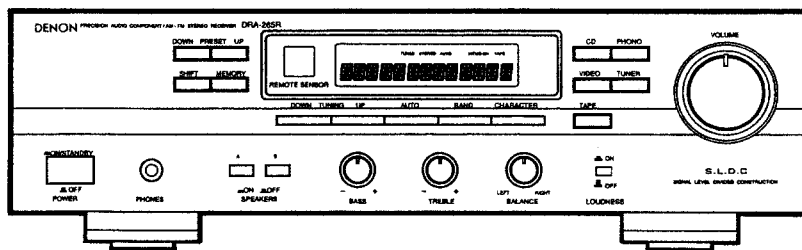

### TABLE OF CONTENTS

OPERATING INSTRUCTIONS .....	2 ~ 7
DISASSEMBLY .....	8
METHOD OF ADJUSTMENTS .....	9
CONNECTION DIAGRAM OF MEASURING INSTRUMENTS .....	10
BLOCK/LEVEL DIAGRAM .....	11
NOTE FOR PARTS LIST .....	12
PRINTED WIRING BOARD PARTS LIST .....	13 ~ 17
PRINTED WIRING BOARD PATTERNS .....	18, 19
1U-2817 MAIN UNIT ASS'Y. ....	18
1U-2819 DISPLAY UNIT ASS'Y .....	19
1U-2818 TUNE UNIT ASS'Y .....	19
EXPLODED VIEW OF CHASSIS AND CABINET .....	20
PARTS LIST OF EXPLODED VIEW .....	21
WIRING DIAGRAM .....	22
SCHEMATIC DIAGRAM .....	23
SEMICONDUCTORS .....	24, 25

# NIPPON COLUMBIA CO., LTD.

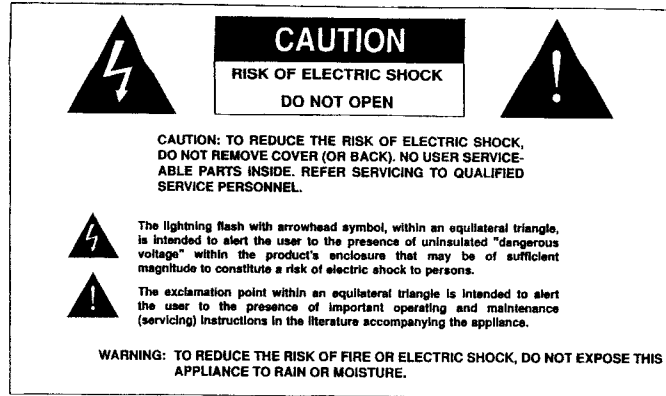

#### PRECAUTIONS FOR INSTALLATION

Install DRA-265R always horizontally. And leave at least 10 cm of space between the unit and other component placed above.

#### VOORKEHRUNGEN FÜR DIE AUFSTELLUNG

Stellen Sie den DRA-265R stets waagrecht auf. Achten Sie ebenfalls darauf, daß ein Mindestabstand von 10 cm zwischen dem Gerät und der Komponente, die darüber gestellt wird, eingehalten wird.

#### PRECAUTIONS D'INSTALLATION

Le DRA-265R doit toujours être installé horizontalement. Laissez au moins un espace de 10 cm entre cet appareil et tout autre composant qui serait placé au-dessus.

#### PRECAUZIONI PER L'INSTALLAZIONE

Installare il DRA 265R sempre in posizione orizzontale, avendo cura di lasciare almeno 10 cm fra l'unità ed altri componenti posti al di sopra.

#### PRECAUCIONES PARA LA INSTALACION

Instale siempre el DRA-265R en posición horizontal. Asegúrese también de dejar un espacio de por lo menos 10 cm entre esta unidad y el componente que sea colocado encima.

#### VOORZORGSMAATREGELEN VOOR INSTALLATIE

De DRA-265R altijd horizontaal plaatsen. Laat ten minste 10 cm ruimte tussen dit apparaat en het andere component dat u erboven plaatst.

#### FÖRBEREDELSE FÖR INSTALLATION

Installera alltid DRA-265R horisontellt. Lämna åtminstone 10 cm mellan denna apparat och en annan komponent som placeras ovanpå.

#### PRECAUÇÕES DURANTE A INSTALAÇÃO

Instale sempre o DRA-265R em posição horizontal. E deixe pelo menos 10 cm de espaço entre esta unidade e o outro componente colocado acima.

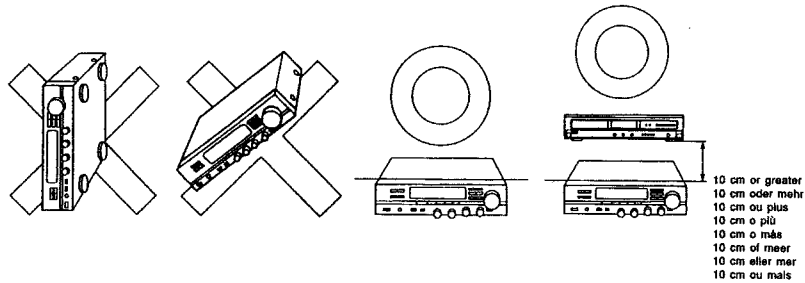

#### FRONT PANEL VORDERSEITE PANNEAU AVANT PANNELLO ANTERIORE PANEL FRONTAL VOORPANEEL FRAMPANELEN PAINEL FRONTAL

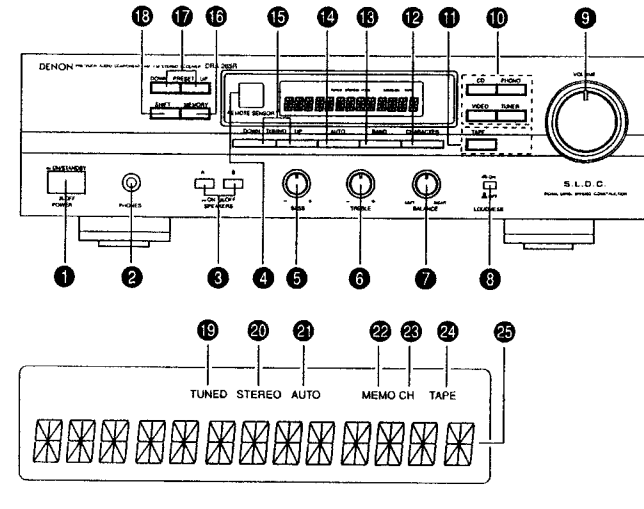

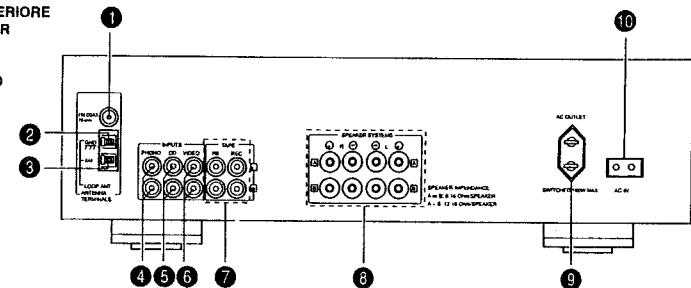

#### DISPLAY ANZEIGE AFFICHAGE DISPLAY VISUALIZADOR DISPLAY DISPLAYEN MOSTRADOR

#### REAR PANEL RÜCKSEITE PANNEAU ARRIÈRE PANNELLO POSTERIORE PANEL POSTERIOR ACHTERPANEEL BAKSIDAN PAINEL TRASEIRO

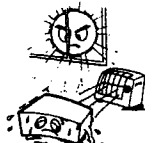
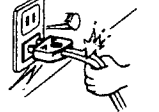

**NOTE ON USE / HINWEISE ZUM GEBRAUCH / OBSERVATIONS RELATIVES A L'UTILISATION  
NOTE SULL'USO / NOTAS SOBRE EL USO / ALVORENS TE GEBRUIKEN / OBSERVERA  
OBSERVAÇÕES SOBRE O USO**

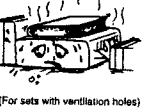
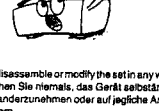
 <ul style="list-style-type: none"> <li>Avoid high temperatures. Allow for sufficient heat dispersion when installed on a rack.</li> <li>Vermijden Sie hohe Temperaturen. Beachten Sie, daß eine ausreichende Luftzirkulation gewährleistet sein muß, wenn das Gerät in einem Regal aufgestellt werden soll.</li> <li>Éviter des températures élevées. Tenir compte d'une dispersion de chaleur suffisante lors de l'installation sur une armoire.</li> <li>Evitare di esporre l'unità ad alte temperature. Accertarsi che ci sia un'adeguata dispersione del calore quando l'unità è installata in un rack o in un mobile.</li> <li>Evite temperaturas elevadas. Asegúrese de garantizar una dispersión de calor suficiente al instalar la unidad en una consola.</li> <li>Vermijd hoge temperaturen. Zorg voor een degelijk hitteafvoer indien het apparaat op een rek wordt geplaatst.</li> <li>Undvik höga temperaturer. Se til at det finns möjlighet till god värmeledning vid monteringen i ett rack.</li> <li>Evita temperaturas altas. Quando instalar o equipamento numa prateleira coloque-o de modo a permitir uma dissipação suficiente do calor.</li> </ul>	 <ul style="list-style-type: none"> <li>Keep the set free from moisture, water and dust.</li> <li>Halten Sie das Gerät von Feuchtigkeit, Wasser und Staub fern.</li> <li>Protéger l'appareil contre l'humidité, l'eau et la poussière.</li> <li>Mantenero l'unità lontana da umidità, acqua e polvere.</li> <li>Mantenga el equipo libre de humedad, agua y polvo.</li> <li>Lastgeen vochtigheid, water of stof in het apparaat binnendringen.</li> <li>Uthåll inte apparaten för fukt, vatten och damm.</li> <li>Mantenha o equipamento livre de humidade, água ou pó.</li> </ul>	 <ul style="list-style-type: none"> <li>Do not let foreign objects in the set.</li> <li>Lassen Sie keinerlei Gegenstände in das Gehäuseinnere eindringen.</li> <li>Non lasciare alcun oggetto all'interno dell'appareil.</li> <li>No inserir objetos extraños en el equipo.</li> <li>Laat geen vreemde voorwerpen in dit apparaat vallen.</li> <li>Se til at fremmede föremål inte tränger in i apparaten.</li> <li>Evite deixar objectos estranhos sobre o aparelho.</li> </ul>
 <ul style="list-style-type: none"> <li>Handle the power cord carefully. Hold the plug when unplugging the cord.</li> <li>Gehen Sie vorsichtig mit dem Netzkabel um. Halten Sie das Kabel am Stecker, wenn Sie es aus der Steckdose ziehen.</li> <li>Manipuler le cordon d'alimentation avec précaution. Tenir la prise lors du débranchement du cordon.</li> <li>Maneggiare con cura il cavo di alimentazione. Quando si scollega il cavo dalla presa, non tirare il cavo.</li> <li>Maneje el cordón de alimentación con cuidado. Sostenga el enchufe cuando desconecte el cordón de alimentación.</li> <li>Hanteer het netsnoer voorzichtig. Hou het snoer bij de steeker vast wanneer deze moet worden aan- of losgemaakt.</li> <li>Hanteer nätkabeln varsamt. Håll i kontakt när du drar ut den. Dra inte i kablarna.</li> <li>Manuseie o cabo de alimentação com cuidado. Agarre na ficha para desligar o cabo de alimentação da tomada.</li> </ul>	 <ul style="list-style-type: none"> <li>Unplug the power cord when not using the set for long periods of time.</li> <li>Ziehen Sie das Netzkabel aus der Steckdose, wenn Sie das Gerät über einen längeren Zeitraum hinweg nicht verwenden.</li> <li>Débrancher le cordon d'alimentation lorsque l'appareil n'est pas utilisé pendant de longues périodes.</li> <li>Quando si prevede di non utilizzare l'unità per lunghi periodi di tempo, disinnestare il cavo di alimentazione dalla presa.</li> <li>Desconecte el cordón de alimentación cuando no utilice el equipo por mucho tiempo.</li> <li>Neem altijd het netsnoer uit het stopcontact wanneer het apparaat gedurende een lange periode niet wordt gebruikt.</li> <li>Dra un nätkontakt om apparaten inte kommer att användas på länge.</li> <li>Desligue o cabo de alimentação quando não utilizar o equipamento durante períodos prolongados.</li> </ul>	 <ul style="list-style-type: none"> <li>Do not let insecticides, benzene, and thinner come in contact with the set.</li> <li>Lassen Sie das Gerät nicht mit Insektiziden, benzenthäligen oder anderen Verdünnungsmitteln in Berührung kommen.</li> <li>Ne pas mettre en contact des insecticides, du benzène et un diluant avec l'appareil.</li> <li>Evitare di utilizzare insetticidi, benzolo e solventi sull'unità.</li> <li>No vierta insecticidas, benceno o disolventes en la unidad.</li> <li>Laat geen insektenverdelgende middelen, benzine of verfverdunder met dit apparaat in contact komen.</li> <li>Se til at inte insektmiddel, bensin och thinner kommer i kontakt med apparatens hölje.</li> <li>Evite que insecticidas, benzina e diluente entrem em contacto com o equipamento.</li> </ul>
 <ul style="list-style-type: none"> <li>Never disassemble or modify the set in any way.</li> <li>Versuchen Sie niemals, das Gerät selbständig auseinanderzunehmen oder auf jegliche Art zu verändern.</li> <li>Ne jamais démonter ou modifier l'appareil d'une manière ou d'une autre.</li> <li>Non smontare o modificare in alcun modo l'unità.</li> <li>Nunca desarme o modifique el equipo de ninguna manera.</li> <li>Neoli di apparat demonteren of op andere wijze modifieren.</li> <li>Ta inte isär apparaten och försök inte byggs om den.</li> <li>Nunca desmonte o modifique o equipamento de alguma forma.</li> </ul>	 <ul style="list-style-type: none"> <li>Do not obstruct the ventilation holes.</li> <li>Die Lüftungsschlitze dürfen nicht verdeckt werden.</li> <li>Ne pas obstruer les trous d'aération.</li> <li>Non ostruire i fori per la ventilazione.</li> <li>No tape las ranuras de ventilación.</li> <li>De ventilatieopeningen mogen niet worden blokkeerd.</li> <li>Täpp inte till ventilationsöppningarna.</li> <li>Não tape os orifícios de ventilação.</li> </ul> <p>(For sets with ventilation holes)</p>	 <ul style="list-style-type: none"> <li>Never disassemble or modify the set in any way.</li> <li>Versuchen Sie niemals, das Gerät selbständig auseinanderzunehmen oder auf jegliche Art zu verändern.</li> <li>Ne jamais démonter ou modifier l'appareil d'une manière ou d'une autre.</li> <li>Non smontare o modificare in alcun modo l'unità.</li> <li>Nunca desarme o modifique el equipo de ninguna manera.</li> <li>Neoli di apparat demonteren of op andere wijze modifieren.</li> <li>Ta inte isär apparaten och försök inte byggs om den.</li> <li>Nunca desmonte o modifique o equipamento de alguma forma.</li> </ul>

Please check the following items are included with the main unit in the carton:

- Operating Instructions ..... 1
- AM Loop Antenna ..... 1
- FM Antenna ..... 1
- Remote Control RC-174 ..... 1
- Batteries R6 (AA) ..... 2
- AC Cord ..... 1

Vergewissern Sie sich, daß folgende Teile vollständig im Lieferumfang enthalten sind:

- Bedienungsanleitung ..... 1
- MW-Rahmenantenne ..... 1
- UKW-Antenne ..... 1
- Fernbedienungsgerät RC-174 ..... 1
- Trockenzellen-Batterien R6 (AA) ..... 2
- Netzkabel ..... 1

Veuillez vérifier que les articles suivants sont bien joints à l'appareil principal dans le carton:

- Mode d'emploi ..... 1
- Antenne-cadre AM ..... 1
- Antenne FM ..... 1
- Télécommande RC-174 ..... 1
- Piles de format R6 (AA) ..... 2
- Cordon secteur ..... 1

Controllare che le parti seguenti si trovino imballate con l'apparecchio nella scatola di spedizione:

- Istruzioni per l'uso ..... 1
- Antenna AM a telaio ..... 1
- Antenna FM ..... 1
- Telecomando RC-174 ..... 1
- Batteria a secco R6 (AA) ..... 2
- Cavo di alimentazione ..... 1

Verifique que los artículos siguientes hayan sido suministrados con la unidad principal:

- Instrucciones de operación ..... 1
- Antena AM de cuadro ..... 1
- Antena de FM ..... 1
- Unidad de control remoto RC-174 ..... 1
- Pilas secas R6 (AA) ..... 2
- Cable de alimentación ..... 1

Controleer of de volgende accessoires bij het hoofdtoestel in de doos zijn verpakt:

- Gebruiksaanwijzing ..... 1
- AM-raamantenne ..... 1
- FM-antenne ..... 1
- Afstandsbediening RC-174 ..... 1
- R6 (AA) droge cel batterij ..... 2
- Netsnoer ..... 1

Kontrollera att följande tillbehör har packats ner i kartongen tillsammans med huvudentheten:

- Bruksanvisning ..... 1
- Ramantenn för AM-bruk ..... 1
- FM-antenn ..... 1
- Fjärrkontroll RC-174 ..... 1
- R6 (AA) torr batteri ..... 2
- Nätkabeln ..... 1

Verifique se os itens que se seguem estão incluídos na caixa cartão com a unidade principal

- Instruções de funcionamento ..... 1
- Antena de quadro AM ..... 1
- Antena FM ..... 1
- Telecomando RC-174 ..... 1
- Pilhas R6 (AA) ..... 2
- Cabo de alimentação ..... 1

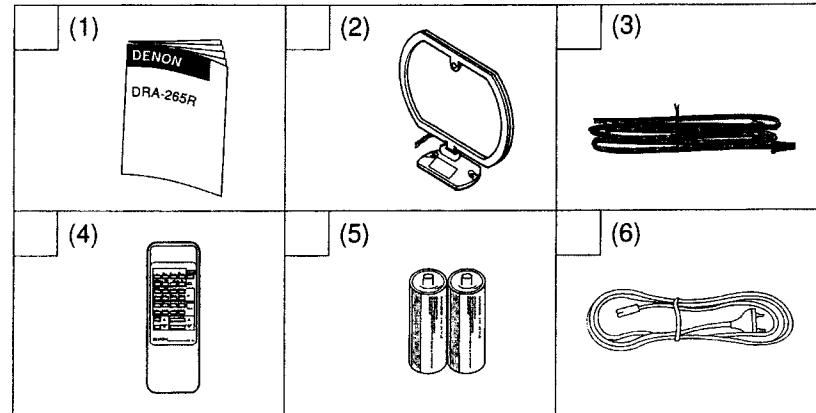

**Konformitätserklärung**

Die DENON Elektronik GmbH  
Haiskestr. 32  
40880 Ratingen

erklärt als Hersteller/Importeur, daß das in dieser Bedienungsanleitung beschriebene Gerät den Technischen Vorschriften für Ton- und Fernseh-Rundfunkempfänger nach der Amtsblattverfügung 868/1989 (Amtsblatt des Bundesministers für Post und Telekommunikation vom 31.8.1989) entspricht.

## CONNECTIONS

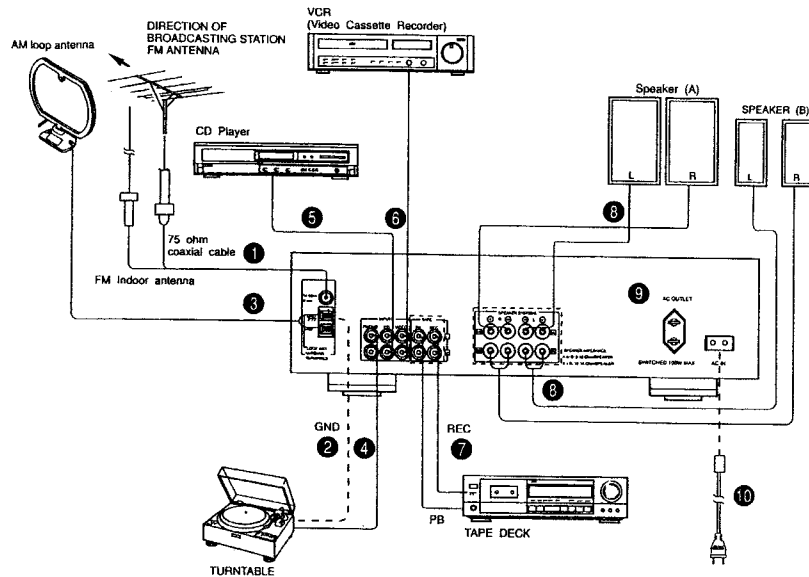

### REAR PANEL

- 1 FM ANT (FM antenna terminals)**  
75-ohm coaxial cable can be connected to this terminal. For antenna connecting procedure, see the ANTENNA INSTALLATION.
- 2 GND (Grounding terminal)**  
The grounding wire of the turntable is connected here.
  - Hum or noise may be generated if the grounding wire is not connected.
- 3 AM ANT (AM antenna terminals)**  
Connect the attached AM loop antenna. (Refer to page 7 for connections).  
Connect to this terminal when a medium wave outdoor antenna is used.
- 4 PHONO (Phono input terminals)**  
The output cord of the turntable is connected here. Since the input sensitivity of "PHONO" is extremely high, do not use the unit without the input pin cord. If used without this cord, the speakers may generate hum.
- 5 CD**  
The output cord of the CD player is connected here.
- 6 VIDEO**  
A VIDEO, such as a VCR or Video Disc may be connected here.
- 7 TAPE**  
Tape decks can be connected for full use including playing or copying.
- 8 SPEAKER SYSTEMS (Speaker terminals)**  
Two pairs of speakers A and B can be connected to these terminals.
- 9 AC OUTLET (AC power outlet)**  
This AC outlet is controlled by the power switch.
- 10 AC Inlet**  
Connect the included AC cord here.

6

### SPEAKER CONNECTION

Confirm polarity (+, -) and left and right channels (L, R). Connect the speaker pairs to the SPEAKER terminals A or B on the back panel. Connections must be made with power cord disconnected.

#### Preparing the cord

1. Peel of the sheath.
2. Twist the wires.



### ANTENNA INSTALLATION

#### FM ANTENNA

The supplied indoor FM antenna can be used inside wooden houses for receiving local FM stations and other strong FM signals. Stretch out the end of the antenna and mount the antenna on the wall or ceiling where optimum reception is achieved. An indoor FM antenna may not consistently ensure stable reception, due to environment changes. In such cases, the indoor FM antenna should only be used temporarily until an outdoor FM antenna has been installed. When connecting an outdoor FM antenna, the use of 75 ohm coaxial cable (3C-2V, 6C-2V) is strongly recommended.

#### AM ANTENNA

Attach the supplied AM loop antenna even when using an outdoor AM antenna. Connect the leads to the AM and GND terminals. Also use the AM terminals for connecting an outdoor AM antenna (when making such a connection do not disconnect the AM loop antenna). Adjust the loop antenna to obtain optimum reception. Where broadcast stations are distant and only weak signals are received or where signals are blocked, it is best to install an outdoor AM antenna.

#### Connecting the front speaker terminals

1. Loosen by turning counterclockwise.
2. Insert the cord and tighten by turning clockwise.



#### Assembling the Loop Antenna



- Remove the tie fastening the loop antenna's lead and connect the lead to the antenna terminals.

#### Notes:

- Do not connect two FM antennas simultaneously.
- Even if an external AM antenna is used, do not disconnect the AM loop antenna.
- Make sure AM loop antenna lead terminals do not touch metal parts of the panel.

#### Notes on Connection

- Do not plug the power cord into the AC wall outlet until all connections have been completed.
- Make sure channels are correctly connected. Connect Left channels to Left channels and Right channels to Right channels. Follow the color markings of plugs and terminals to make sure mistakes are not made.
- Connect all pin-plugs securely, pushing them completely into the jacks. Incomplete connections will cause noise generation.
- Binding the connection cables to power cords, or running such cables close to power supply transformers will cause humming or noise, and should thus be avoided.

### CAUTION

#### Protective Circuit

This set is equipped with a high speed protective circuit. This circuit protects the internal circuitry from damage due to large currents flowing when the speaker jacks are not completely connected or when an output is generated by a short circuit. This protective circuit's operation cuts off the output to the speakers. In such a case, be sure to turn the power to the set off and check the connections to the speakers. Then turn the power on again. After muting for several seconds, the set will operate normally.

7

## DESIGNATIONS AND FUNCTIONS OF PANEL CONTROLS (Refer to Page 3.)

### FRONT PANEL

- 1 POWER (Power ON-STANDBY/OFF Switch)**  
This switch turns the unit ON or OFF. There is a delay of approximately 3 seconds before the unit will operate after this power switch is turned ON. If the unit is turned OFF from the remote control, the unit will be in the STANDBY mode. When in the STANDBY mode, the unit can be turned ON with the power button on the remote control. If the unit will not be used for extended period, be sure to turn the unit OFF from the front panel power switch.
- NOTE:** This unit includes a STANDBY protection feature. This feature is designed to prevent accidental turn-on from the STANDBY mode in the event of a power failure. Should AC power be disconnected and then reconnected when the unit is in STANDBY mode, the unit will return the STANDBY mode.  
To turn the unit ON from the STANDBY mode without the remote control, operate the front panel power switch four times. The unit will then operate normally.
- 2 PHONES (Headphones jack)**  
Connect a pair of headphones (sold separately) to this jack for private listening.
- 3 SPEAKERS (Speaker selector switches)**  
These switches are used to select speaker system A and B. No sound is heard through the speakers when both switches are reset to the (A) position.
- 4 REMOTE SENSOR (Remote control sensor)**  
This sensor receives the infra-red light transmitted from the wireless remote control unit.  
For remote control, point the wireless remote control unit towards the sensor.
- 5 BASS (Bass control)**  
Use this control to adjust the low-range response. When the control is set to the center position, the frequency characteristic curve (below 1,000 Hz) is flat. Turn the control clockwise to increase the bass response and counterclockwise to decrease it.
- 6 TREBLE (Treble control)**  
Use this control to adjust the high-range response. When the control is set to the center position, the frequency characteristic curve (above 1,000 Hz) is flat. Turn the control clockwise to increase the treble response and counterclockwise to decrease it.
- 7 BALANCE (Balance control)**  
Use this control to balance the volume levels between left and right channels. The volume levels in both channels are equal when the control is set to the center position.
- 8 LOUDNESS (Loudness ON/OFF switch)**  
At low volumes, the human ear is less sensitive to low (BASS) and high (TREBLE) frequencies. Press this switch to compensate for this deficiency when listening at low volume levels.

#### NOTES

- This receiver has a full back-up system. When the power is turned on, the INPUT SELECTOR buttons are set to the last mode set before the power was turned off.
- When using this receiver in close proximity to video equipment (TV, VCR, VDP, etc.) noise may be generated in AM broadcasts.

- 9 VOLUME (Volume control)**  
This knob is used to adjust the volume level of both channels. Turn the knob clockwise to raise the volume and counterclockwise to lower it.
- 10 Input selector (Input selector buttons)**  
These buttons are used to select the audio input source.
- PHONO: Press to play a record on a record player connected to the PHONO input jacks.
  - CD: Press to listen to a compact disc player or another component connected to the CD input jacks.
  - TUNER: Press to listen to FM or AM programs.
  - VIDEO: Use when playing back the audio from a Hi-Fi video, video disc player or other component connected to the VIDEO terminal.
- 11 TAPE (Tape monitor button)**  
Press this button once, TAPE indicator will light up and then you can play tape source on the TAPE terminal. Press again the button currently accessed, to play sources selected by input selector 10, indicator goes out.
- 12 CHARACTER**  
This button is used to input the station name (refer to page 9).
- 13 BAND (Band selector button)**  
Press this button to select the FM or AM (MW) band.
- 14 AUTO (Tuning mode button)**  
This switches between auto and manual tuning.  
Auto tuning: When the UP button is pressed, the radio is tuned automatically to a higher frequency. Press the DOWN button to tune to a lower frequency. Use this position to eliminate noise when no signals or weak signals are being received.  
Manual tuning: In this position, the radio can be tuned manually. Reception is automatically monaural when in the manual mode.
- 15 TUNING (Tuning buttons)**  
Use these to change the received frequency to a higher frequency (UP) or a lower frequency (DOWN).  
When writing station names, use these buttons to select the letters. (Refer to Page 9.)
- 16 MEMORY (Memory button)**  
This switch is used to store the desired radio station to a memory.
- 17 Preset (Preset station buttons)**  
These buttons are used for storing stations or recalling stations which have been preset. Using the SHIFT button you can preset a total of 40 FM or AM stations into preset channels.  
Once a radio has been memorized, the same station can later be tuned in instantly simply by recalling the corresponding preset channel with PRESET UP or DOWN button.
- 18 SHIFT**  
Use this button to select the memory blocks, A (1 to 8), B (1 to 8), C (1 to 8), D (1 to 8) or E (1 to 8).  
When writing station names, use this button to set the writing position.

To avoid this, keep the receiver as far away from other video components as possible, or place the AM loop antenna where noise is reduced. If the noise is not reduced, turn off the power of the video components when listening to AM broadcasts.

### DISPLAY

- 19 TUNED indicator**  
This lights when a station is properly tuned in.
- 20 STEREO indicator**  
This lights when receiving stereo broadcasts. It remains off when receiving AM broadcasts.
- 21 AUTO indicator**  
This indicates the tuning mode. It lights in the auto mode and remains off in the manual mode.
- 22 MEMO Indicator**  
This indicator lights for approximately 10 seconds when the MEMORY button has been pressed and a station can be stored on a PRESET CHANNEL button.  
This flashes continuously during the auto memory operation.
- 23 CH indicator**  
This lights when the preset channel number and shift mode (A, B, C, D or E) are displayed.
- 24 TAPE indicator**  
The TAPE indicator lights when the TAPE source is selected with the tape selector buttons.
- 25 Multi function display**  
This displays the frequency, station name, program type, etc.

### Using the Various Functions

#### 1. Presetting stations in the memory

The frequency and the name of the radio station which you have input yourself are also stored in the memory.

How to preset the memory

Press the MEMORY button 16. The "MEMO" indicator on the display 22 lights. Next use SHIFT button 18 to select the memory block A, B, C, D or E. Now press the PRESET UP or DOWN button 17 to specify the preset channel number, and then press the MEMORY button 16 to store the station in the memory.

The preset channel numbers for the different memory blocks are as follows.

Memory block A:	1 to 8
Memory block B:	1 to 8
Memory block C:	1 to 8
Memory block D:	1 to 8
Memory block E:	1 to 8

#### 2. Auto Memory (FM only)

The DRA-265 is equipped with an auto memory function.

Connect the antenna, set it so that stations can be received, then hold in the MEMORY button and press the POWER button to turn the power on. Stations for which the auto stop function operates are stored in the preset memory in the order A1 to A8, B1 to B8, and so on, through E8. Channel A1 is tuned in after the auto memory operation is completed. Using this function makes it possible to find out the overall reception conditions of the receivable stations. The memory can be used effectively by recalling the channels in the preset memory and replacing stations whose reception is poor with stations whose reception is good, using the procedure described in 1 above.

#### 3. Recalling preset stations

Use the SHIFT button 18 to select memory block A, B, C, D or E, then press the PRESET UP or DOWN button 17 to recall the station stored in the memory.

If the PRESET UP or DOWN buttons are pressed without pressing the SHIFT button 18, the stations are recalled in the order A1 to A8, B1 to B8, and so on, through E8.

#### 4. Writing station names

You can write in station names yourself (up to 8 characters). (Refer to the table of characters on shown below.)

Operation	Display
1. Press the CHARACTER button once.	First character flashes.
2. Use the TUNING UP and DOWN buttons 14 to select the desired characters.	First letter flashes.
3. Use the SHIFT button 18 to move to the next place.	Specified place flashes.
4. After writing the entire station name, store it in the memory. (Refer to page 8.)	

#### 5. Clearing station names

- Recall the station name you want to clear.
- Press the CHARACTER button once, the character at the first place flashes.
- Then press the SHIFT button for at least 2 seconds. The current station name will then be cleared.

**Note:** Station names must be stored in a preset memory to be retained. If the power is turned off, or if the band (AM/FM) is changed, the station name will be lost. Be sure to store the entered station name in a Preset Memory before changing the band or tuning the power switch OFF.

#### Table of characters

The characters are input in the order shown to the right. Use the TUNING buttons 14 to select the desired characters.

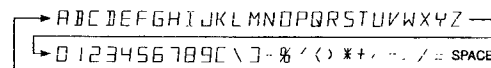

## PLAYBACK USING THE REMOTE CONTROL

The accessory RC-174 remote control unit is used to control the RECEIVER from a distance.

### (1) Inserting the dry cell batteries

1. Remove the rear cover on the remote control unit.

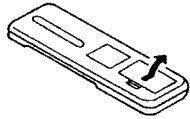

2. Insert two size "AA" (R6) dry cell batteries as shown in the diagram on the battery supply unit.

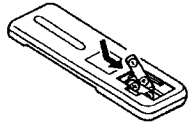

3. Replace the rear cover.

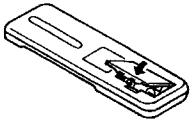

### (2) Directions for use

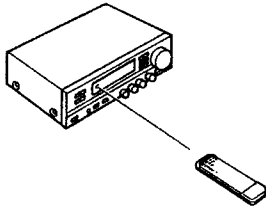

#### Notes on Use of the Batteries

- The remote control unit uses size "AA" (R6) dry cell batteries.
- The batteries will need to be replaced approximately once a year. This will depend upon how often the remote control is used.
- If, in less than a year from the time new batteries were inserted, the remote control fails to operate the receiver from a near-by position, it is time to replace the batteries.
- Insert the batteries properly, following the diagram on the remote control battery supply unit, and making sure to align the plus and minus sides of each battery.
- Batteries are prone to damage and leakage. Therefore:
  - Do not combine new batteries with used ones.
  - Do not combine different types of batteries.
  - Do not jumper the opposite poles of the batteries, expose them to heat or break them open, or put them into open fire.
- When the remote control is not to be used for a long period of time, remove the batteries from the unit.
- If the batteries have leaked, remove any battery fluid from the inside of the battery supply unit by wiping it out thoroughly and insert new batteries.

- Operate the remote control unit while pointing it towards the remote control sensor on the receiver as shown in the diagram left.
- The remote control unit can be used at distances up to about 8 meters in a straight line from the receiver. This distance will decrease if there are obstructions blocking the infra-red light transmission or if the remote control unit is not directed straight at the receiver.

#### Note on Operation

- Do not press the operating buttons on the receiver and the remote control unit at the same time. This will cause misoperation.
- Operation of the remote control unit will become less effective or erratic if the infrared remote control sensor on the receiver is exposed to strong light or if there are obstructions between the remote control unit and the sensor.
- In case you operate your VCR, TV or other components by remote control, do not operate buttons on two different remote control units at the same time. This will cause misoperation.

Besides being able to operate the DRA-265R receiver with this remote control unit, you can also operate a DENON cassette deck and CD player from this handy full-system remote control unit.

#### Remote Control Section

##### Full-system Remote Control Unit

The full-system remote control unit operates all major functions of the receiver such as function switching, volume control, and preset station selection. But that's not all! The same control pad can also control the major functions of a DENON CD player and cassette deck to create a remarkably ergonomic and versatile DENON system with all the quality sound reproduction that the devoted audiophile expects.

#### Remote Control Unit RC-174 supplied with DRA-265R

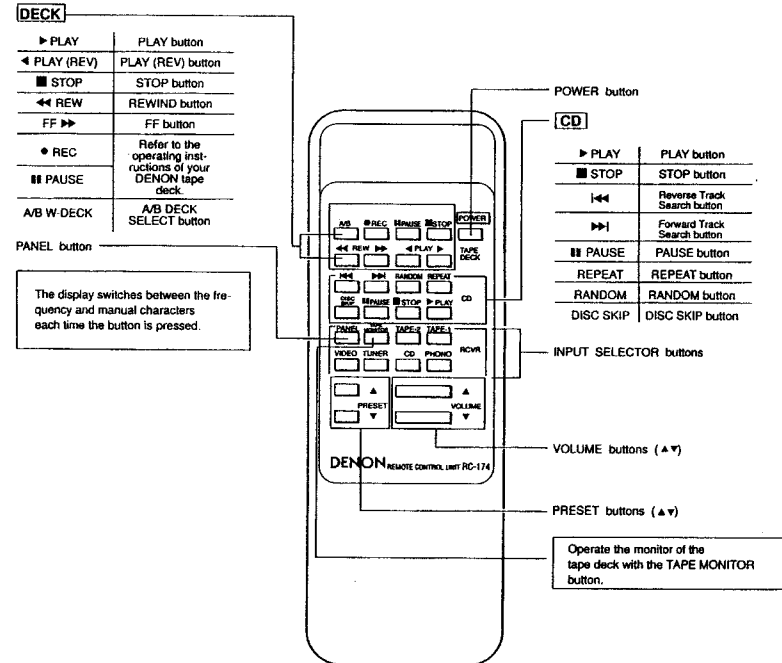

- The RC-174 Remote Control Unit can control CD players and cassette decks made by DENON.
- Note the operation may not be possible for some models.
- Buttons are conveniently separated into groups, each group controlling one specific component. The groups are RECEIVER; CD and DECK.

For details on operating other components, refer to the instruction manuals for the CD player and/or cassette deck.

#### CAUTION:

- If the power is turned off with the remote control unit, the receiver is switched to the power stand-by state. If you are to be absent for a long period of time, be sure to turn the power off using the POWER switch on the receiver.
- A part of 1st digit of fluorescent display light while the receiver is in the power stand-by state.
- You may experience erratic operation of the remote control unit if it is operated in fluorescent light and direct sunlight, in particular if this light strikes the remote control sensor on the receiver. However, this is not a malfunction, and if this should happen, protect the sensor against such light.

## TROUBLESHOOTING

1. Have all connections been made PROPERLY?
2. Have you followed all operational instructions correctly?
3. Check speaker and the turntable systems for proper operation.

When your unit does not seem to be operating correctly, first check the items in the following table. If the symptom does not correspond to any of the problems as shown below, turn off the power sources immediately and contact your DENON dealer.

Problem	Cause	Remedy
<b>FM AND AM RECEPTION</b>		
Radio program can not be received.	<ul style="list-style-type: none"> <li>• Antenna connection is wrong.</li> <li>• A signal strength is weak.</li> </ul>	<ul style="list-style-type: none"> <li>• Check the connection.</li> <li>• Check the antenna installation.</li> </ul>
Noise is reproduced.	<ul style="list-style-type: none"> <li>• A signal strength is weak.</li> <li>• Automobile ignition noise interferes with reception.</li> <li>• Other electrical equipment interferes with reception.</li> </ul>	<ul style="list-style-type: none"> <li>• Install an outdoor antenna.</li> <li>• Keep the antenna away from the street.</li> <li>• Keep the equipment away from this set, or turn off the power of the other equipment.</li> </ul>
The preset frequencies are erased.	<ul style="list-style-type: none"> <li>• The memory back-up term (about 1 month) passed.</li> </ul>	<ul style="list-style-type: none"> <li>• Preset again.</li> </ul>
In automatic tuning, the frequency doesn't stop at the radio station.	<ul style="list-style-type: none"> <li>• A signal strength is weak.</li> </ul>	<ul style="list-style-type: none"> <li>• Use manual tuning.</li> </ul>
In automatic tuning, it stops at the one step lower or higher frequency than the radio station.	<ul style="list-style-type: none"> <li>• Noise or strong signal strength is received.</li> </ul>	<ul style="list-style-type: none"> <li>• Use manual tuning for optimum reception.</li> </ul>
<b>PLAYBACK OF THE AUDIO EQUIPMENTS</b>		
No sound is produced with power on.	<ul style="list-style-type: none"> <li>• Input and speaker cords connection are wrong.</li> <li>• Speaker switch is off.</li> <li>• The INPUT SELECTOR buttons are in wrong position.</li> <li>• The protective circuit is operating.</li> <li>• The fuse has blown out.</li> </ul>	<ul style="list-style-type: none"> <li>• Check the connection.</li> <li>• Turn on speaker switch.</li> <li>• Check these position.</li> <li>• Turn the power off once, check the connections to the speakers, then turn the power on again.</li> <li>• Ask your dealer, or the nearest DENON representative.</li> </ul>
Audible hum when playing records.	<ul style="list-style-type: none"> <li>• The input and grounding cords connection of the turntable are wrong.</li> <li>• The cords connection of the cartridge are wrong.</li> <li>• The interference from the nearby TV or radio transmission antenna</li> </ul>	<ul style="list-style-type: none"> <li>• Check the connection.</li> <li>• Check the connection.</li> <li>• Ask your dealer, or the nearest DENON representative.</li> </ul>
Howling is produced when the volume control is turned up too high while playing records.	<ul style="list-style-type: none"> <li>• The vibrations and sounds transmit from the speakers to the turntable.</li> </ul>	<ul style="list-style-type: none"> <li>• Insulate the vibrations, or keep the speakers away from the turntable.</li> </ul>
Cracking noise is produced when playing records.	<ul style="list-style-type: none"> <li>• The record is stained with dust.</li> <li>• The stylus tip of the cartridge is stained with the dust.</li> <li>• The cartridge is defective.</li> </ul>	<ul style="list-style-type: none"> <li>• Clean the record.</li> <li>• Clean the stylus tip.</li> <li>• Try the other cartridge.</li> </ul>

## SPECIFICATIONS

### AMPLIFIER SECTION

Continuous Power Output (DIN):	55 W + 55 W (4 ohms, 1 kHz)
Power Bandwidth (IHF):	10 Hz - 40 kHz (T.H.D. 0.15% both channels driven into 8 ohms)
Total Harmonic Distortion:	0.02% (-3 dB at rated output, 8 ohms)
Frequency Response:	PHONO RIAA Standard Curve (Recording Output) MM 20 Hz - 20 kHz ± 0.5 dB CD, VIDEO, 20 Hz - 50 kHz ± 1.5 dB TAPE (at 1 W)

### Input Sensitivity and Impedance:

PHONO MM	2.5 mV	47 kohms
CD, VIDEO, TAPE	150 mV	25 kohms

### Maximum Input Level: (at 1 kHz)

PHONO MM	120 mV
Signal to Noise Ratio (IHF-A):	PHONO MM 78 dB (at 5.0 mV input) CD, VIDEO, TAPE 95 dB

### Tone Controls:

BASS	± 10 dB at 100 Hz
TREBLE	± 10 dB at 10 kHz

### Loudness:

50 Hz/10 kHz, + 10 dB/±6 dB

### TUNER SECTION

[FM] (note: $\mu\text{V}$ at 75 ohms, 0 dB = $1 \times 10^{-14}$ W)	
Receiving Range:	87.5 - 108 MHz
Useable Sensitivity:	0.9 $\mu\text{V}$ (10.3 dB)
Signal to Noise Ratio (IHF-A):	MONO 82 dB STEREO 78 dB
Image Rejection:	65 dB
Selectivity (± 300 kHz):	55 dB
Frequency Response:	30 Hz - 15 kHz ± 0.2 dB
Stereo Separation (at 1 kHz):	40 dB
[AM]	
Receiving Range:	522 - 1611 kHz
Useable Sensitivity:	18 $\mu\text{V}$
Signal to Noise Ratio:	55 dB
General	
Power Supply:	AC 230 V 50 Hz
Power Consumption:	104 W
Power Outlet:	SWITCHED 100 W
Dimensions:	434 mm (W) x 119 mm (H) x 305 mm (D)
Weight:	5.7 kg
REMOTE CONTROL UNIT	RC-174
Remote control system:	Infrared pulse system
Power supply:	3V DC Two size "AA" (R6) dry cell batteries
External dimensions:	90 mm (W) x 175 mm (H) x 18 mm (D)
Weight:	120 g (includes batteries)

Design and specifications are subject to change without prior notice.

## DISASSEMBLY

(To reassemble reverse disassembly)

### 1. Top Cover

- (1) Remove 4 screws ①.
- (2) Remove 2 screws ②.

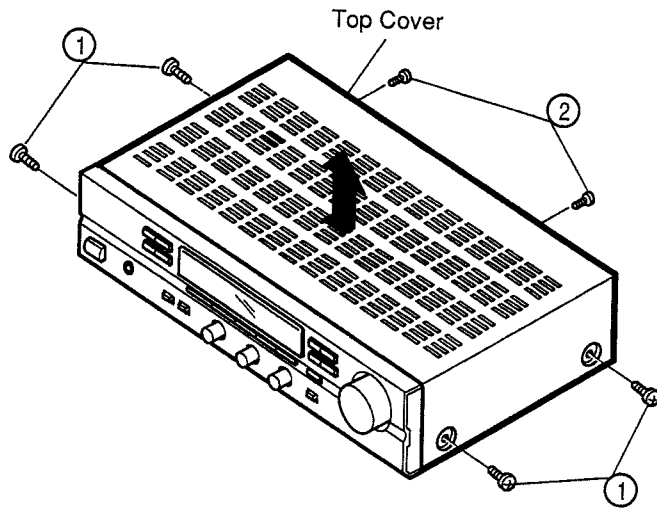

### 2. Front Panel

- (1) Pull out Master Volume knob ③.
- (2) Remove nut ④.
- (3) Remove 5 screws ⑤ and undo hooks at 3 places.

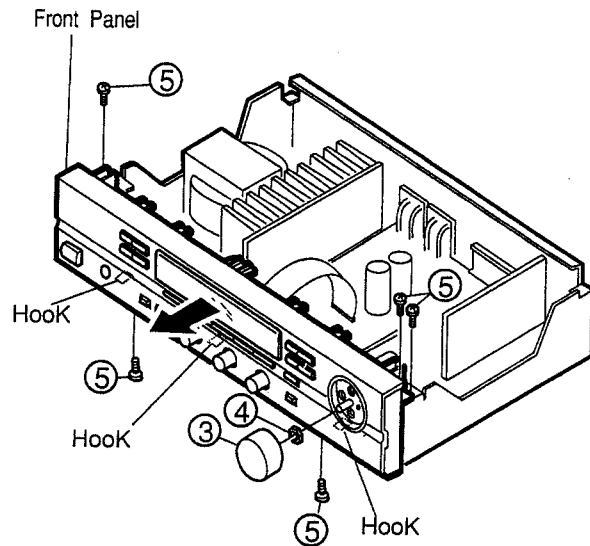

### 3. Rear Panel

- (1) Remove 2 screws ⑥ and 11 fixing screws ⑦.
- (2) Remove hooks at 3 places in arrow direction.

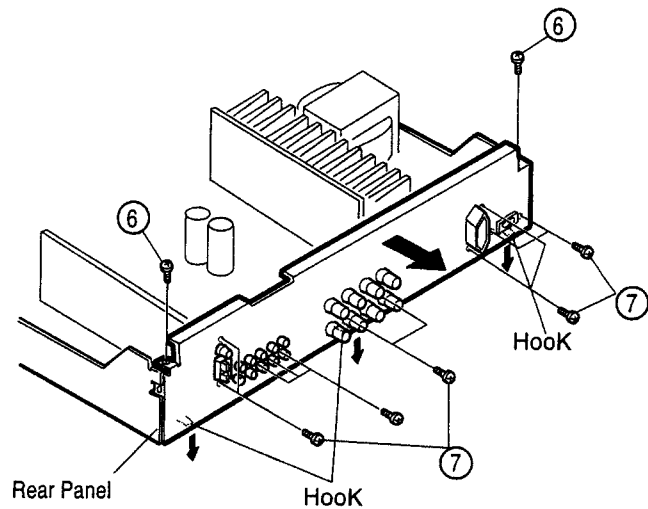



## METHOD OF ADJUSTMENTS

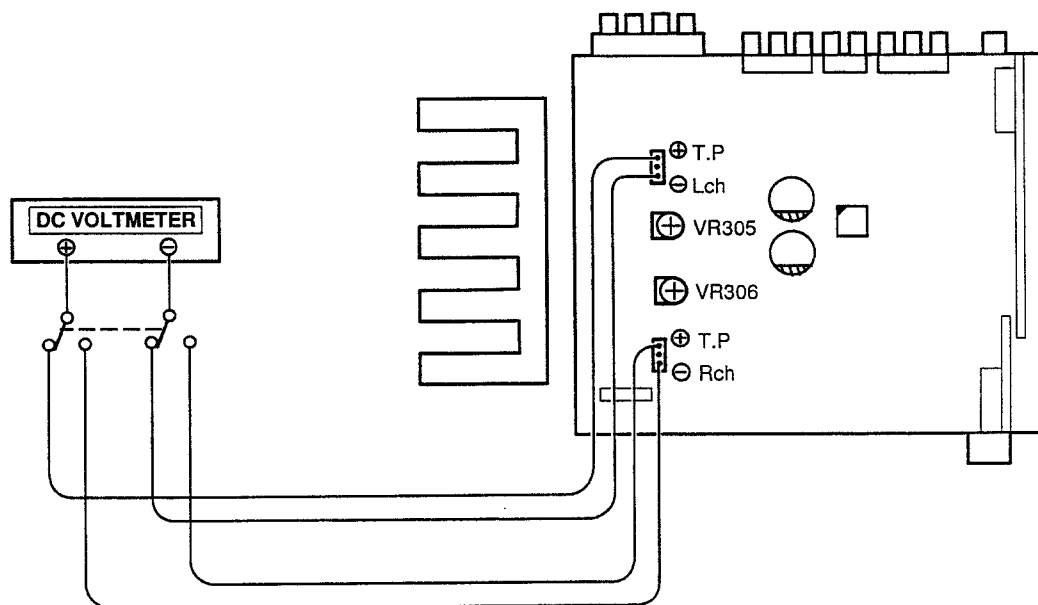

### IDLING CURRENT

(1) Set controls as follows.

POWER Switch → off (■)

VOLUME Control → 0 (min.)

SPEAKERS → off (■)

Temperature → 15°C ~ 30°C (59°F ~ 86°F)

VR305 and VR306 of the 1U-2817-1 (Main Unit) → MIN. (↻)

(2) Connect DC Voltmeter to the T.P Lch and T.P Rch of the 1U-2817-1.

(3) Turn the Power Switch on and rotate VR305 clockwise so that the DC Voltmeter reads 2.5 mV ±0.2 mV DC at the T.P Lch. Follow the same procedure to VR306 for T.P Rch.

(4) Warm up for three minutes, then readjust VR305 and VR306 so that the DC Voltmeter reads 2.5 mV ±0.5 mV DC.

(5) Warm up for 10 minutes, then readjust VR 305 and VR306 so that the DC Voltmeter reads 2.5 mV ±0.5 mV DC.

# CONNECTINON DIAGRAM OF MEASURING INSTRUMENTS

## ● FM SECTION

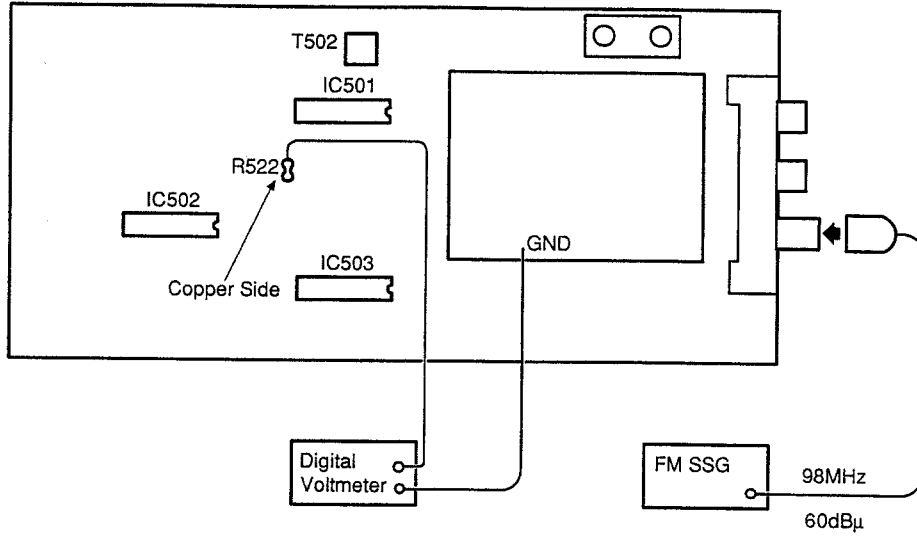

Adjust T502, Potential difference across R522 should be within 50mV.

# BLOCK/LEVEL DIAGRAM

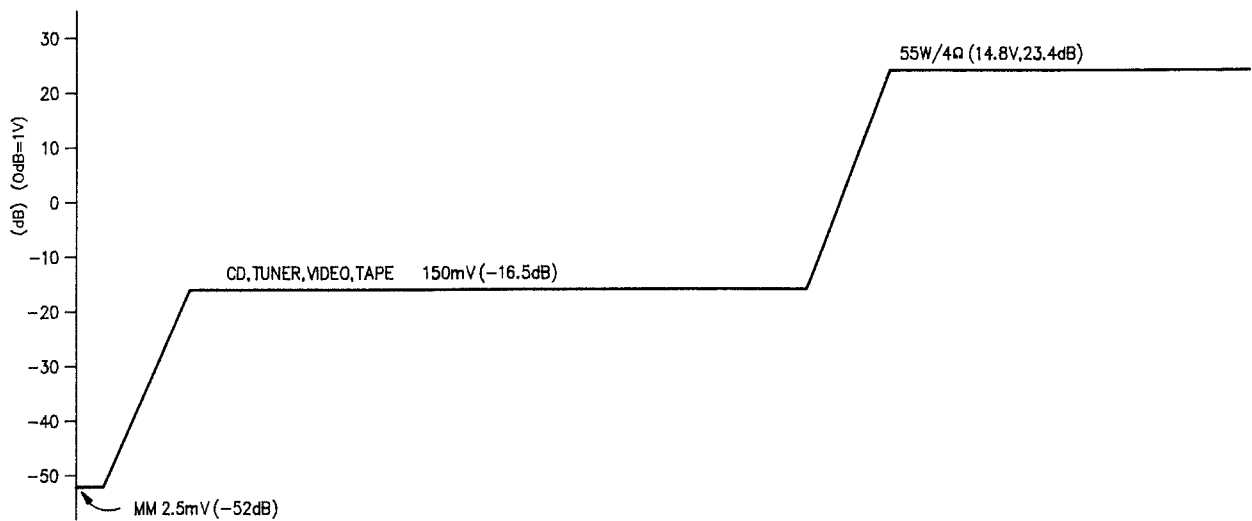
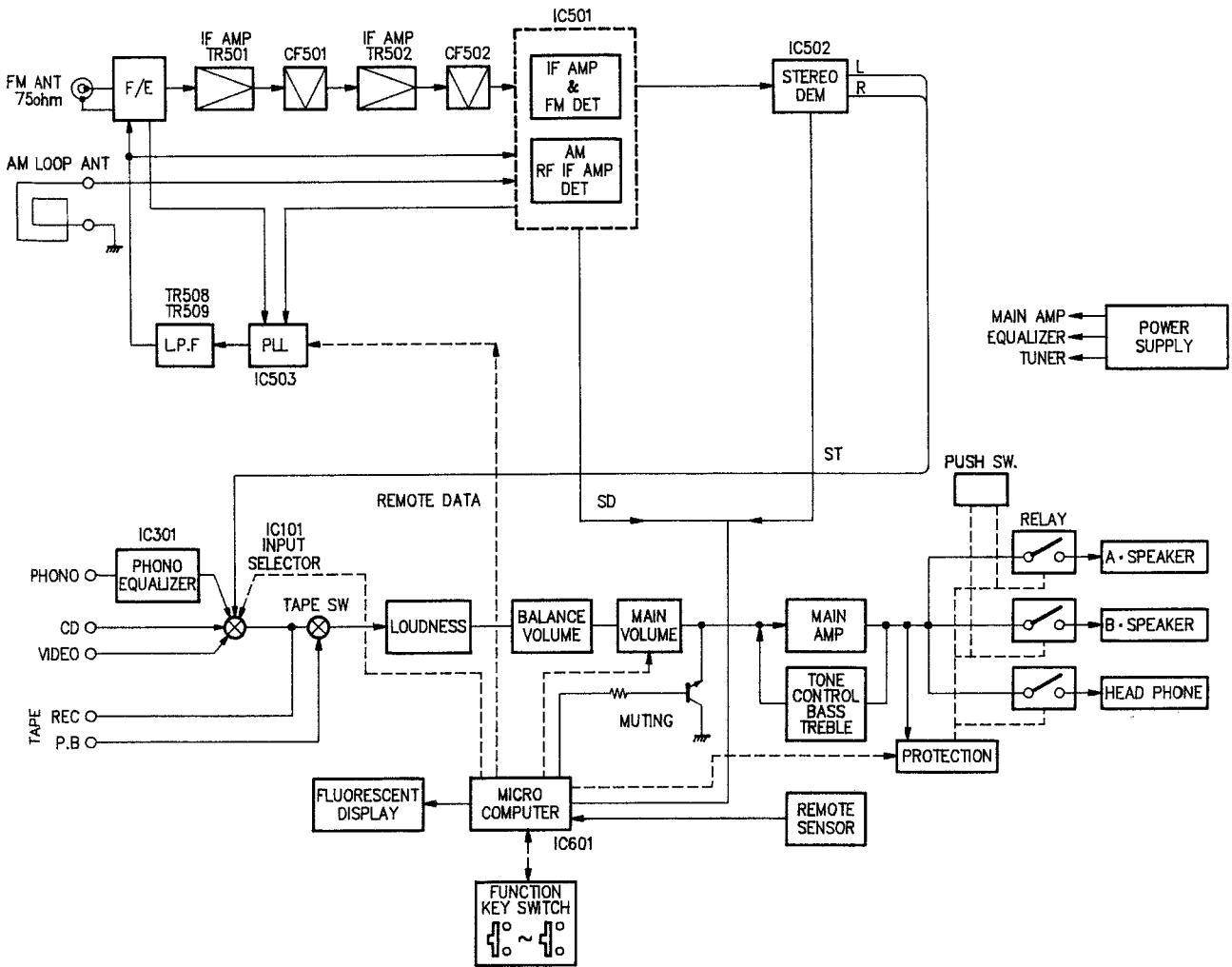

**NOTE FOR PARTS LIST**

- Part indicated with the mark "◎" are not always in stock and possibly to take a long period of time for supplying, or in some case supplying of part may be refused.
- When ordering of part, clearly indicate "1" and "1" (i) to avoid mis-supplying.
- Ordering part without stating its part number can not be supplied.
- Part indicated with the mark "★" is not illustrated in the exploded view.
- Not including Carbon Film ±5%, 1/4W Type in the P.W.Board parts list. (Refer to the Schematic Diagram for those parts.)

**WARNING:**

Parts marked with this symbol  have critical characteristics.  
Use ONLY replacement parts recommended by the manufacturer.

● **Resistors**

Ex.: RN 14K 2E 182 G FR  
Type Shape and performance Power Resistance Allowable error Others

RD : Carbon	2B : 1/8W	F : ±1%	P : Pulse-resistant type
RC : Composition	2E : 1/4W	G : ±2%	NL : Low noise type
RS : Metal oxide film	2H : 1/2W	J : ±5%	NB : Non-burning type
RW : Winding	3A : 1W	K : ±10%	FR : Fuse-resistor
RN : Metal film	3D : 2W	M : ±20%	F : Lead wire forming
RK : Metal mixture	3F : 3W		
	3H : 5W		

\* **Resistance**

1 8 2 ⇒ 1800 ohm = 1.8 kohm  
Indicates number of zeros after effective number.  
2-digit effective number.

• Units: ohm

1 R 2 ⇒ 1.2 ohm  
1-digit effective number.  
2-digit effective number, decimal point indicated by R.

• Units: ohm

● **Capacitors**

Ex.: CE 04W 1H 2R2 M BP  
Type Shape and performance Dielectric strength Capacity Allowable error Others

CE : Aluminum foil electrolytic	0J : 6.3V	F : ±1%	HS : High stability type
CA : Aluminum solid electrolytic	1A : 10V	G : ±2%	BP : Non-polar type
CS : Tantalum electrolytic	1C : 16V	J : ±5%	HR : Ripple-resistant type
CO : Film	1E : 25V	K : ±10%	DL : For charge and discharge
CK : Ceramic	1V : 35V	M : ±20%	HF : For assuring high frequency
CC : Ceramic	1H : 50V	Z : +80%	U : UL part
CP : Oil	2A : 100V	-20%	C : CSA part
CM : Mica	2B : 125V	P : +100%	W : UL-CSA type
CF : Metallized	2C : 160V	-0%	F : Lead wire forming
CH : Metallized	2D : 200V	C : ±0.25pF	
	2E : 250V	D : ±0.5pF	
	2H : 500V	= : Others	
	2J : 630V		

\* **Capacity (electrolyte only)**

2 2 2 ⇒ 2200µF  
Indicates number of zeros after effective number.  
2-digit effective number.

• Units: µF.

2 R 2 ⇒ 2.2µF  
1-digit effective number.  
2-digit effective number, decimal point indicated by R.

• Units: µF.

\* **Capacity (except electrolyte)**

2 2 2 ⇒ 2200pF = 0.0022µF  
(More than 2) — Indicates number of zeros after effective number.  
2-digit effective number.

• Units: µF.

2 2 1 ⇒ 220pF  
(0 or 1) — Indicates number of zeros after effective number.  
2-digit effective number.

• Units: pF.

• When the dielectric strength is indicated in AC, "AC" is included after the dielectric strength value.

**PRINTED WIRING BOARD PARTS LIST**  
**1U-2817 MAIN UNIT ASS'Y**

Ref. No.	Part No.	Part Name	Remarks	Ref. No.	Part No.	Part Name	Remarks
<b>SEMICONDUCTORS GROUP</b>				<b>RESISTORS GROUP</b>			
IC101	262 1227 008	IC LC7821		D651	276 0616 907	Diode 1SS252	
IC301	263 0615 902	IC BA15218F		SC451	279 0016 904	Thyristor SF0R1A42	
IC401	263 0793 002	IC NJM7806FA(S)		ZD101	276 0634 905	Zener diode MTZJ3.3A	
IC701	263 0892 903	IC NJM2082M		ZD251,252	276 0637 902	Zener diode MTZJ6.2A	
TR251	274 0151 903	Transistor 2SD2004(P)		ZD401	276 0634 905	Zener diode MTZJ3.3A	
TR252	272 0107 906	Transistor 2SB1328(P)		ZD402	276 0633 906	Zener diode MTZJ6.8C	
TR253	273 0388 906	Transistor 2SC1740S(E)		ZD403	276 0632 907	Zener diode MTZJ27D	
TR254	271 0192 905	Transistor 2SA933S(S)		ZD451-453	276 0635 904	Zener diode MTZJ7.5C	
TR255	273 0388 906	Transistor 2SC1740S(E)		<b>RESISTORS GROUP</b>			
TR256	271 0280 901	Transistor 2SA1038S(S/E)		VR305,306	211 6093 912	Semi fixed 4.7Kohm	V06PB472
TR257	273 0432 904	Transistor 2SC2389S(S/E)		R002	247 0018 905	Chip 0ohm 1/10W	RM73B-0R0K
TR301,302	269 0107 900	Transistor RN1241(A/B)	Built in resistor	R101-108	247 0014 967	Chip 1Mohm 1/10W	RM73B-105J
TR303,304	273 0235 923	Transistor 2SC1841(E/F)		R109-116	247 0006 962	Chip 470ohm 1/10W	RM73B-471J
TR305-308	271 0131 924	Transistor 2SA988(E/F)		R117	247 0014 925	Chip 680kohm 1/10W	RM73B-684J
TR309,310	273 0235 923	Transistor 2SC1841(E/F)		△ R201,202	244 2052 931	Metal oxide film 390ohm 1W	RS14B3A391JNBS(S)
TR315,316	273 0198 002	Transistor 2SC1815(Y)		R259,260	241 2387 940	Carbon 4.7ohm 1/4W	RD14B2E4R7JNBS
TR317,318	274 0060 900	Transistor 2SD667A(C)TZ		R263	247 0009 985	Chip 10kohm 1/10W	RM73B-103J
TR319,320	272 0053 908	Transistor 2SB647A(C)		R264	247 0012 927	Chip 100kohm 1/10W	RM73B-104J
TR321,322	273 0430 003	Transistor 2SC4278 F31(E-F)		R305,306	247 0012 969	Chip 150kohm 1/10W	RM73B-154J
TR323,324	271 0276 009	Transistor 2SA1633 F31(E-F)		R307,308	247 0006 962	Chip 470ohm 1/10W	RM73B-471J
TR325,326	273 0235 923	Transistor 2SC1841(E/F)		R309,310	247 0009 914	Chip 5.1kohm 1/10W	RM73B-512J
TR401	273 0384 900	Transistor 2SC2412K(S)		R311,312	241 2379 932	Carbon 620ohm 1/4W	RD14B2E621JNBS
TR402	269 0048 904	Transistor DTC143EK	Built in resistor	R323,324	247 0007 945	Chip 1kohm 1/10W	RM73B-102J
TR403	273 0384 900	Transistor 2SC2412K(S)		R329,330	241 2378 920	Carbon 220ohm 1/4W	RD14B2E221JNBS
TR404	272 0131 901	Transistor 2SB1041(R)		△ R331-334	244 2043 982	Metal oxide film 0.22ohm 1W	RS14B3AR22JNBS(S)
TR451	271 0131 924	Transistor 2SA988(E/F)		R335,336	247 0013 984	Chip 470kohm 1/10W	RM73B-474J
TR452	273 0388 906	Transistor 2SC1740S(E)		R351,352	247 0012 901	Chip 82kohm 1/10W	RM73B-823J
TR453	269 0054 901	Transistor DTC144EK	Built in resistor	R353,354	247 0012 969	Chip 150kohm 1/10W	RM73B-154J
TR454	273 0384 900	Transistor 2SC2412K(S)		R355,356	247 0004 922	Chip 47ohm 1/10W	RM73B-470J
TR455	273 0388 906	Transistor 2SC1740S(E)		R357	247 0009 901	Chip 4.7kohm 1/10W	RM73B-472J
TR456	271 0192 905	Transistor 2SA933S(S)		R358	247 0011 944	Chip 47kohm 1/10W	RM73B-473J
TR457-459	273 0388 906	Transistor 2SC1740S(E)		R385,386	241 2379 932	Carbon 620ohm 1/4W	RD14B2E621JNBS
TR460	273 0384 900	Transistor 2SC2412K(S)		R387-390	241 2377 989	Carbon 150ohm 1/4W	RD14B2E151JNBS
TR471	269 0083 901	Transistor DTA114EK	Built in resistor	△ R391,392	244 2043 937	Metal oxide film 10ohm 1W	RS14B3A100JNBS(S)
TR473	269 0054 901	Transistor DTC144EK	Built in resistor	△ R393,394	244 2051 987	Metal oxide film 4.7ohm 1W	RS14B3A47JNBS(S)
D251	276 0338 007	Diode S4VB20F		R401	247 0013 900	Chip 220kohm 1/10W	RM73B-224J
D252	276 0553 905	Diode 1SR35-200A		R402	247 0009 985	Chip 10kohm 1/10W	RM73B-103J
D303-306	276 0619 904	Diode 1S2471		R403	247 0009 901	Chip 4.7kohm 1/10W	RM73B-472J
D307-312	276 0616 907	Diode 1SS252		R404,405	247 0007 945	Chip 1kohm 1/10W	RM73B-102J
D401,402	276 0616 907	Diode 1SS252		R406	247 0009 985	Chip 10kohm 1/10W	RM73B-103J
D403-410	276 0553 905	Diode 1SR35-200A					
D411,412	276 0616 907	Diode 1SS252					
D451-453	276 0616 907	Diode 1SS252					

Ref. No.	Part No.	Part Name	Remarks
R407	247 0010 958	Chip 20kohm 1/10W	RM73B--203J
R408	247 0009 985	Chip 10kohm 1/10W	RM73B--103J
R409	247 0007 945	Chip 1kohm 1/10W	RM73B--102J
R410	247 0009 901	Chip 4.7kohm 1/10W	RM73B--472J
△R411	244 2051 987	Metal oxide film 4.7ohm 1W	RS14B3A4R7JNBS(S)
R412	241 2377 947	Carbon 100ohm 1/4W	RD14B2E101JNBS
R415	241 2387 908	Carbon 1ohm 1/4W	RD14B2E010JNBS
△R451	244 2051 974	Metal oxide film 1kohm 1W	RS14B3A102JNBS(S)
△R453	244 2051 990	Metal oxide film 4.7kohm 1W	RS14B3A472JNBS(S)
R460	247 0011 944	Chip 47kohm 1/10W	RM73B--473J
△R465	244 2051 974	Metal oxide film 1kohm 1W	RS14B3A102JNBS(S)
△R467	244 2052 902	Metal oxide film 2.7kohm 1W	RS14B3A272JNBS(S)
R475	247 0010 929	Chip 15kohm 1/10W	RM73B--153J
R701,702	247 0009 901	Chip 4.7kohm 1/10W	RM73B--472J
R703,704	247 0012 969	Chip 150kohm 1/10W	RM73B--154J
R705,706	247 0011 986	Chip 68kohm 1/10W	RM73B--683J
R707,708	247 0004 922	Chip 47ohm 1/10W	RM73B--470J
R709,710	247 0005 992	Chip 240ohm 1/10W	RM73B--241J
R711,712	247 0012 956	Chip 130kohm 1/10W	RM73B--134J
R713,714	247 0009 998	Chip 11kohm 1/10W	RM73B--113J
R715,716	247 0003 949	Chip 22ohm 1/10W	RM73B--220J
R717,718	247 0005 905	Chip 100ohm 1/10W	RM73B--101J
R719,720	247 0012 927	Chip 100kohm 1/10W	RM73B--104J

**CAPACITORS GROUP**

C101~108	257 0004 903	Chip(Ceramic) 56pF/50V	CC73SL1H560J
C109,110	255 1264 908	Film 1000pF/50V	CQ93M1H102J(B)
C111	257 0002 921	Chip(Ceramic) 10pF/50V	CC73SL1H100D
C112,113	257 0012 982	Chip(Ceramic) 0.022μF/50V	CK73F1H223Z
C124,125	257 0012 982	Chip(Ceramic) 0.022μF/50V	CK73F1H223Z
C127	257 0012 982	Chip(Ceramic) 0.022μF/50V	CK73F1H223Z
C129,130	254 4260 980	Electrolytic 10μF/50V	CE04W1H100M
C201~204	255 1265 907	Film 6800pF/50V	CQ93M1H682J(B)
C205,206	257 0006 985	Chip(Ceramic) 820pF/50V	CC73SL1H821J
C251	254 4261 031	Electrolytic 220μF/50V	CE04W1C221M
C252~254	254 4258 918	Electrolytic 10μF/35V	CE04W1V100M
C257,258	254 4355 002	Electrolytic 6800μF/50V	CE04W1H682MDL
C259	253 1181 904	Ceramic 0.01μF/50V	CK45F1H103Z
C307,308	257 0006 927	Chip(Ceramic) 220pF/50V	CC73SL1H221J
C309,310	256 1034 979	Metalized 0.1μF/50V	CF93A1H104J
C311~314	253 4536 909	Ceramic 10pF/50V	CC45SL1H100D
C321,322	256 1034 979	Metalized 0.1μF/50V	CF93A1H104J
C323,324	254 4260 948	Electrolytic 1μF/50V	CE04W1H010M
C325,326	255 1265 978	Film 0.022F/50V	CQ93M1H223J(B)
C327~330	254 4262 904	Electrolytic 4.7μF/63V	CE04W1J4R7M
C331,332	254 4260 948	Electrolytic 1μF/50V	CE04W1H010M
C333,334	254 4260 922	Electrolytic 0.33μF/50V	CE04W1HR33M

Ref. No.	Part No.	Part Name	Remarks
C335,336	257 0004 961	Chip(Ceramic) 100pF/50V	CC73SL1H101J
C337,338	257 0002 921	Chip(Ceramic) 10pF/50V	CC73SL1H100D
C339,340	254 4254 925	Electrolytic 33μF/16V	CE04W1C330M
C341,342	257 0004 961	Chip(Ceramic) 100pF/50V	CC73SL1H101J
C353,354	256 1034 979	Metalized 0.1μF/50V	CF93A1H104J
C355,356	255 1265 978	Film 0.022F/50V	CQ93M1H223J(B)
C357	254 4260 948	Electrolytic 1μF/50V	CE04W1H010M
C358	253 9030 060	Ceramic 0.01μF/25V	CK45=1E103K
C359,360	254 4260 948	Electrolytic 1μF/50V	CE04W1H010M
C401	254 4258 905	Electrolytic 4.7μF/35V	CE04W1V4R7M
C402	257 0012 966	Chip(Ceramic) 0.01μF/50V	CK73F1H103Z
C403	254 4260 948	Electrolytic 1μF/50V	CE04W1H010M
C404,405	253 1181 904	Ceramic 0.01μF/50V	CK45F1H103Z
C406	259 0007 702	For Back up 8200μF	SB CAP=822=C
C407	254 4254 909	Electrolytic 10μF/16V	CE04W1C100M
C408	254 4403 734	Electrolytic 4700μF/25V	CE04W1E472MC(SMG)
C409	254 4261 921	Electrolytic 100μF/50V	CE04W1C101M
C410	254 4260 948	Electrolytic 1μF/50V	CE04W1H010M
△C411	253 8014 702	Ceramic 0.01μF/400VAC	CC45F2GAC100MC
C451	254 4260 980	Electrolytic 10μF/50V	CE04W1H100M
C452	254 4254 909	Electrolytic 10μF/16V	CE04W1C100M
C453	254 4250 945	Electrolytic 330μF/6.3V	CE04W0J331M
C456	255 1265 936	Film 0.01μF/50V	CQ93M1H103J(B)
△C459,460	253 1151 905	Ceramic 4700pF/500V	CK45E2H472P
△C461	256 1042 903	Metalized 0.1μF/250V	CF93A2E104K
C462	254 4254 938	Electrolytic 47μF/16V	CE04W1C470M
C549	254 4252 927	Electrolytic 47μF/10V	CE04W1A470M
C701,702	257 0003 988	Chip(Ceramic) 47pF/50V	CC73SL1H470J
C703,704	257 0005 944	Chip(Ceramic) 470pF/50V	CC73SL1H471J
C705,706	254 4254 909	Electrolytic 10μF/16V	CE04W1C100M
C709,710	254 4250 929	Electrolytic 100μF/6.3V	CE04W0J101M
C711,712	255 4199 999	Film 0.024μF/50V	CQ92M1H243J(MFZ)
C713,714	255 1265 907	Film 6800pF/50V	CQ93M1H682J(I)
C715,716	254 4254 909	Electrolytic 10μF/16V	CE04W1C100M
C717,718	254 4260 948	Electrolytic 1μF/50V	CE04W1H010M
C724	254 4260 948	Electrolytic 1μF/50V	CE04W1H010M
C725	257 0012 982	Chip(Ceramic) 0.022μF/50V	CK73F1H223Z

**OTHERS PARTS GROUP**

△AC401	203 3961 004	1P AC outlet	Except to U.K.
CB3C	205 0343 032	3P connector base(KR-PH)	
CB6A,6C	205 0918 001	6P bottom socket	
CB8A	205 0918 014	6P bottom socket	
CB8B,8C	205 0806 090	8P connector base (9115)	
CB29D	205 0549 027	29P FFC connector base	

1U-2818 TUNER UNIT ASS'Y

Ref. No.	Part No.	Part Name	Remarks
△CN2A	203 2349 009	2P Inlet	
CN3A	205 0581 001	2P VH connector base	
CN3C	203 4482 045	3P KR-DS connector cord	
CN7A	205 0653 078	7P VH connector base	
△F401	206 1075 014	Fuse(1.25A)	
△F402	206 1075 001	Fuse(1A)	Except to U.K.
△SW401	212 1031 008	Power switch(TV-5)	
L391,392	235 0104 007	Inductor(1Mz)	
L701,702	235 9003 002	FTZ choke coil	
RL451,452	214 0167 005	Relay(G5Z-2A)	
RL453	214 0127 003	Relay(RY-12W)	
TH451	279 0034 041	Posistor	PTH9M04BD222TS2F333
TP001,002	205 0190 036	3P NH Connector base	TEST POINT
	415 0309 055	P.V.C. tube (L=07)	
	202 0040 909	Fuse clip	
	205 0472 013	8P speaker terminal	U.K. model
	205 0484 001	8P speaker terminal	Europe model
	204 8485 009	4P pin jack(S-GND)	
	009 9037 013	1PWire Ass'y	
	204 8486 008	6P pin jack(S-GND)	

Ref. No.	Part No.	Part Name	Remarks
<b>SEMICONDUCTORS GROUP</b>			
IC501	263 0891 001	IC LA1265(S)	
IC502	263 0439 007	IC LA3401	
IC503	263 0791 907	IC LM7001M	
IC504	263 0794 001	IC NJM78M12FA(S)	
TR501	275 0074 902	Transistor 2SK211-Y/GR	
TR502	273 0438 908	Transistor 2SC2413K (Q)	
TR503	269 0157 905	Transistor DTB123EK	Built in resistor
TR504	269 0083 901	Transistor DTA114EK	Built in resistor
TR505,506	269 0054 901	Transistor DTC144EK	Built in resistor
TR507	271 0279 909	Transistor 2SA1515(R)	
TR508	275 0075 901	Transistor 2SK209-Y/GR	
TR509	273 0403 904	Transistor 2SC2712-Y/GR	
D501	276 0559 909	Diode DAP202K	
<b>RESISTORS GROUP (Not included carbon film ±5% 1/4W)</b>			
R001-016	247 0018 905	Chip 0ohm 1/10W	RM73B-0R0K
R501	247 0004 906	Chip 39ohm 1/10W	RM73B-390J
R502	247 0007 945	Chip 1kohm 1/10W	RM73B-102J
R503	247 0009 985	Chip 10kohm 1/10W	RM73B-103J
R504	247 0009 927	Chip 5.6kohm 1/10W	RM73B-562J
R505	247 0006 920	Chip 330ohm 1/10W	RM73B-331J
R506	247 0009 901	Chip 4.7kohm 1/10W	RM73B-472J
R507	247 0005 989	Chip 220ohm 1/10W	RM73B-221J
R508,509	247 0006 920	Chip 330ohm 1/10W	RM73B-331J
R510	247 0006 988	Chip 560ohm 1/10W	RM73B-561J
R511	247 0012 927	Chip 100kohm 1/10W	RM73B-104J
R512	247 0009 914	Chip 5.1kohm 1/10W	RM73B-512J
R513	247 0005 905	Chip 100ohm 1/10W	RM73B-101J
R514	247 0008 986	Chip 3.9kohm 1/10W	RM73B-392J
R515	247 0006 946	Chip 390ohm 1/10W	RM73B-391J
R516	247 0005 947	Chip 150ohm 1/10W	RM73B-151J
R517	247 0009 985	Chip 10kohm 1/10W	RM73B-103J
R518	247 0018 905	Chip 0ohm 1/10W	RM73B-0R0K
R519	247 0009 901	Chip 4.7kohm 1/10W	RM73B-472J
R520	247 0004 980	Chip 82ohm 1/10W	RM73B-820J
R521	247 0007 990	Chip 1.6kohm 1/10W	RM73B-162J
R522	247 0011 902	Chip 33kohm 1/10W	RM73B-333J
R523-525	247 0009 985	Chip 10kohm 1/10W	RM73B-103J
R526	247 0008 957	Chip 3kohm 1/10W	RM73B-302J
R527	247 0011 986	Chip 68kohm 1/10W	RM73B-683J
R528	247 0009 956	Chip 7.5kohm 1/10W	RM73B-752J
R529	247 0008 960	Chip 3.3kohm 1/10W	RM73B-332J
R530	247 0012 927	Chip 100kohm 1/10W	RM73B-104J
R532	247 0009 985	Chip 10kohm 1/10W	RM73B-103J
R533	247 0007 945	Chip 1kohm 1/10W	RM73B-102J
R534	247 0011 915	Chip 36kohm 1/10W	RM73B-363J

Ref. No.	Part No.	Part Name	Remarks
R535	247 0011 944	Chip 47kohm 1/10W	RM73B--473J
R536	247 0012 985	Chip 180kohm 1/10W	RM73B--184J
R537	247 0012 998	Chip 200kohm 1/10W	RM73B--204J
R538	247 0012 985	Chip 180kohm 1/10W	RM73B--184J
R539	247 0012 998	Chip 200kohm 1/10W	RM73B--204J
R540,541	247 0008 902	Chip 1.8kohm 1/10W	RM73B--182J
R542,543	247 0009 901	Chip 4.7kohm 1/10W	RM73B--472J
R544	247 1007 986	Chip 1.5kohm 1/8W	RM73B2B152J
R545	247 0009 985	Chip 10kohm 1/10W	RM73B--103J
R546	247 0012 927	Chip 100kohm 1/10W	RM73B--104J

**CAPACITORS GROUP**

C501-506	257 0012 966	Chip(Ceramic) 0.01μF/50V	CK73F1H103Z
C507	257 0002 947	Chip(Ceramic) 12pF/50V	CC73SL1H120J
C508	254 4254 909	Electrolytic 10μF/16V	CE04W1C100M
C509	257 0004 961	Chip(Ceramic) 100pF/50V	CC73SL1H101J
C510	257 0012 966	Chip(Ceramic) 0.01μF/50V	CK73F1H103Z
C511	254 4260 906	Electrolytic 0.1μF/50V	CE04W1H0R1M
C513	254 3056 917	Electrolytic 1μF/50V	CE04D1H010MBP
C514	257 0012 982	Chip(Ceramic) 0.022μF/50V	CK73F1H223Z
C515,516	257 0002 976	Chip(Ceramic) 16pF/50V	CC73SL1H160J
C517	254 4254 938	Electrolytic 47μF/16V	CE04W1C470M
C518,519	257 0012 966	Chip(Ceramic) 0.01μF/50V	CK73F1H103Z
C520	254 4260 922	Electrolytic 0.33μF/50V	CE04W1HR33M
C521	257 0012 966	Chip(Ceramic) 0.01μF/50V	CK73F1H103Z
C522	254 4256 936	Electrolytic 47μF/25V	CE04W1E470M
C523	254 4260 948	Electrolytic 1μF/50V	CE04W1H010M
C524	254 4260 964	Electrolytic 3.3μF/50V	CE04W1H3R3M
C525	257 0012 982	Chip(Ceramic) 0.022μF/50V	CK73F1H223Z
C526	257 0012 966	Chip(Ceramic) 0.01μF/50V	CK73F1H103Z
C527	254 4260 948	Electrolytic 1μF/50V	CE04W1H010M
C528	254 4254 909	Electrolytic 10μF/16V	CE04W1C100M
C529	257 1013 951	Chip(Ceramic) 0.047μF/25V	CK73F1E473K
C530	254 4254 912	Electrolytic 22μF/16V	CE04W1C220M
C531	257 0004 961	Chip(Ceramic) 100pF/50V	CC73SL1H101J
C532	254 4260 948	Electrolytic 1μF/50V	CE04W1H010M
C533	254 4260 919	Electrolytic 0.22μF/50V	CE04W1HR22M
C534	254 4260 948	Electrolytic 1μF/50V	CE04W1H010M
C535,536	257 0012 966	Chip(Ceramic) 0.01μF/50V	CK73F1H103Z
C537	254 4254 912	Electrolytic 22μF/16V	CE04W1C220M
C538	254 4254 938	Electrolytic 47μF/16V	CE04W1C470M
C539,540	257 0005 986	Chip(Ceramic) 330pF/50V	CC73SL1H331J
C541	254 4260 951	Electrolytic 2.2μF/50V	CE04W1H2R2M
C548	254 4260 951	Electrolytic 2.2μF/50V	CE04W1H2R2M
C550,551	254 4260 948	Electrolytic 1μF/50V	CE04W1H010M
C553,554	257 0012 966	Chip(Ceramic) 0.01μF/50V	CK73F1H103Z
C555	256 1034 937	Film 0.047μF/50V	CF93A1H473J

Ref. No.	Part No.	Part Name	Remarks
<b>OTHERS PARTS GROUP</b>			
CF501,502	261 0064 007	Ceramic filter	SFT10.7MS2
CF504	261 0101 009	:Ceramic filter	BFU450C4N
CN	205 0847 004	3P antenne terminal(PAL/F)	
CN8B,8C	205 0805 091	8P connector socket	
FE501	216 0065 006	Front end	
T501	231 1913 004	MW antenne OSC coil	
T502	231 2099 008	FM DET trans	
T503	231 3034 004	:AM IFT	
T504	232 9010 009	Antibirdie filter	
T505,506	232 0085 004	:LPF	
XL502	261 0103 007	:Resonetopr	CSB456F11
XL503	399 0075 003	Crystal	7.2MHz



## 1U-2819 DISPLAY UNIT ASS'Y

Ref. No.	Part No.	Part Name	Remarks	Ref. No.	Part No.	Part Name	Remarks
<b>SEMICONDUCTORS GROUP</b>				<b>CAPACITORS GROUP</b>			
IC601	262 2039 017	IC TMP87CM71F-6192		C301,302	255 1264 924	Film 1500pF/50V	CQ93M1H152J(B)
IC602	263 0476 002	IC LB1639		C303,304	257 0011 967	Chip(Ceramic) 0.033μF/25V	CK73F1E333Z
TR601	271 0238 908	Transistor 2SA1037K(S/R)		C306	254 3056 917	Electrolytic 1μF/50V	CE04D1H010MBP
TR602	269 0082 902	Transistor DTC114EK	Built in resistor	C361,362	257 0004 961	Chip(Ceramic) 100pF/50V	CC73SL1H101J
D601	276 0620 906	Diode 1SS354		C363,364	255 1265 981	Film 0.027μF/50V	CQ93M1H273J(B)
D602	276 0503 900	Diode 1SS198		C365,366	256 1034 982	Metallized 0.12μF/50V	CF93A1H124J
ZD651	276 0654 901	Zener diode DTZ8.2B		C367,368	255 1264 924	Film 1500pF/50V	CQ93M1H152J(B)
<b>RESISTORS GROUP (Not included carbon film ±5% 1/4W)</b>				<b>OTHERS PARTS GROUP</b>			
VR301	211 0841 005	Variable 100kohm	V14P22FW104K	C651	257 0012 966	Chip(Ceramic) 0.01μF/50V	CK73F1H103Z
VR302	211 0844 002	Variable 100kohm	V1620V25FB104(MG)	C652	254 4300 963	Electrolytic 100μF/6.3V	CE04W0J101M(SRE)
VR303	211 0842 004	Variable 250kohm	V14P22FC254K	C653	257 0012 966	Chip(Ceramic) 0.01μF/50V	CK73F1H103Z
VR304	211 0843 003	Variable 50kohm	V14P22FC503K	C655	254 4299 964	Electrolytic 47μF/16V	CE04W1C470M(SRE)
R041-049	247 0018 905	Chip 0ohm 1/10W	RM73B-0R0K	C657	257 0012 982	Chip(Ceramic) 0.022μF/50V	CK73F1H223Z
R301,302	247 0010 903	Chip 12kohm 1/10W	RM73B-123J	C658	254 4193 947	Electrolytic 100μF/16V	CE04W1C101M(SRA)
R303,304	247 0009 930	Chip 6.2kohm 1/10W	RM73B-622J				
R337,338	247 0014 967	Chip 1Mohm 1/10W	RM73B-105J				
R361,362	247 0011 973	Chip 62kohm 1/10W	RM73B-623J				
R363,364	247 0009 998	Chip 11kohm 1/10W	RM73B-113J				
R365,366	247 0008 931	Chip 2.4kohm 1/10W	RM73B-242J				
R367,368	247 0013 984	Chip 470kohm 1/10W	RM73B-474J				
R369,370	247 0010 945	Chip 18kohm 1/10W	RM73B-183J				
R371,372	247 0009 943	Chip 6.8kohm 1/10W	RM73B-682J				
R373,374	247 0006 917	Chip 300ohm 1/10W	RM73B-301J				
R375,376	247 0011 944	Chip 47kohm 1/10W	RM73B-473J				
R379,380	247 0009 901	Chip 4.7kohm 1/10W	RM73B-472J				
R651	247 1009 900	Chip 4.7kohm 1/8W	RM73B2B472J				
R652-657	247 0009 985	Chip 10kohm 1/10W	RM73B-103J				
R665	247 0007 945	Chip 1kohm 1/10W	RM73B-102J				
R666	247 0005 976	Chip 200ohm 1/10W	RM73B-201J				
R667	247 0006 917	Chip 300ohm 1/10W	RM73B-301J				
R668	247 0007 945	Chip 1kohm 1/10W	RM73B-102J				
R669	247 0005 976	Chip 200ohm 1/10W	RM73B-201J				
R670	247 0006 917	Chip 300ohm 1/10W	RM73B-301J				
R671	247 0007 945	Chip 1kohm 1/10W	RM73B-102J				
R672	247 0005 976	Chip 200ohm 1/10W	RM73B-201J				
R673	247 0006 917	Chip 300ohm 1/10W	RM73B-301J				
R674	247 0006 975	Chip 510ohm 1/10W	RM73B-511J				
R675	247 0007 945	Chip 1kohm 1/10W	RM73B-102J				
R676	247 0007 945	Chip 1kohm 1/10W	RM73B-102J				
R677	247 0005 976	Chip 200ohm 1/10W	RM73B-201J				
R678	247 0006 917	Chip 300ohm 1/10W	RM73B-301J				
R679	247 0006 975	Chip 510ohm 1/10W	RM73B-511J				
CB5A	205 0806 003	7P connector base(9176)		FL401	393 8020 007	FL tube	814-BT-39GK9
CB7B	205 0919 013	7P JQ socket(Side)			461 0877 014	Rubber sheet	
CN5A	205 0805 004	Connctor socket(9176)			414 0740 006	Shield plate	
CN6A,6C	205 0917 002	6P bottom plug		JA201	204 8354 017	Head phone jack	
CN7B	205 0408 058	7P JQ connector		RM601	499 0150 008	Remote sensor	SBX1610-52
CN8A	205 0917 015	8P bottom plug		SW201,202	212 1140 009	Push switch	ESB6440
CN29D	205 0549 027	29P FFC connector base		SW301	212 1140 009	Push switch	ESB6440
				SW601-615	212 5604 910	Tact switch	
				XL651	399 0191 903	Resonator	CST4.00MGW-TF01
					009 9037 013	1PWire Ass'y	

PRINTED WIRING BOARD PATTERNS

1 2 3 4 5 6 7 8

1U-2817 MAIN UNIT ASS'Y

A

B

C

D

E

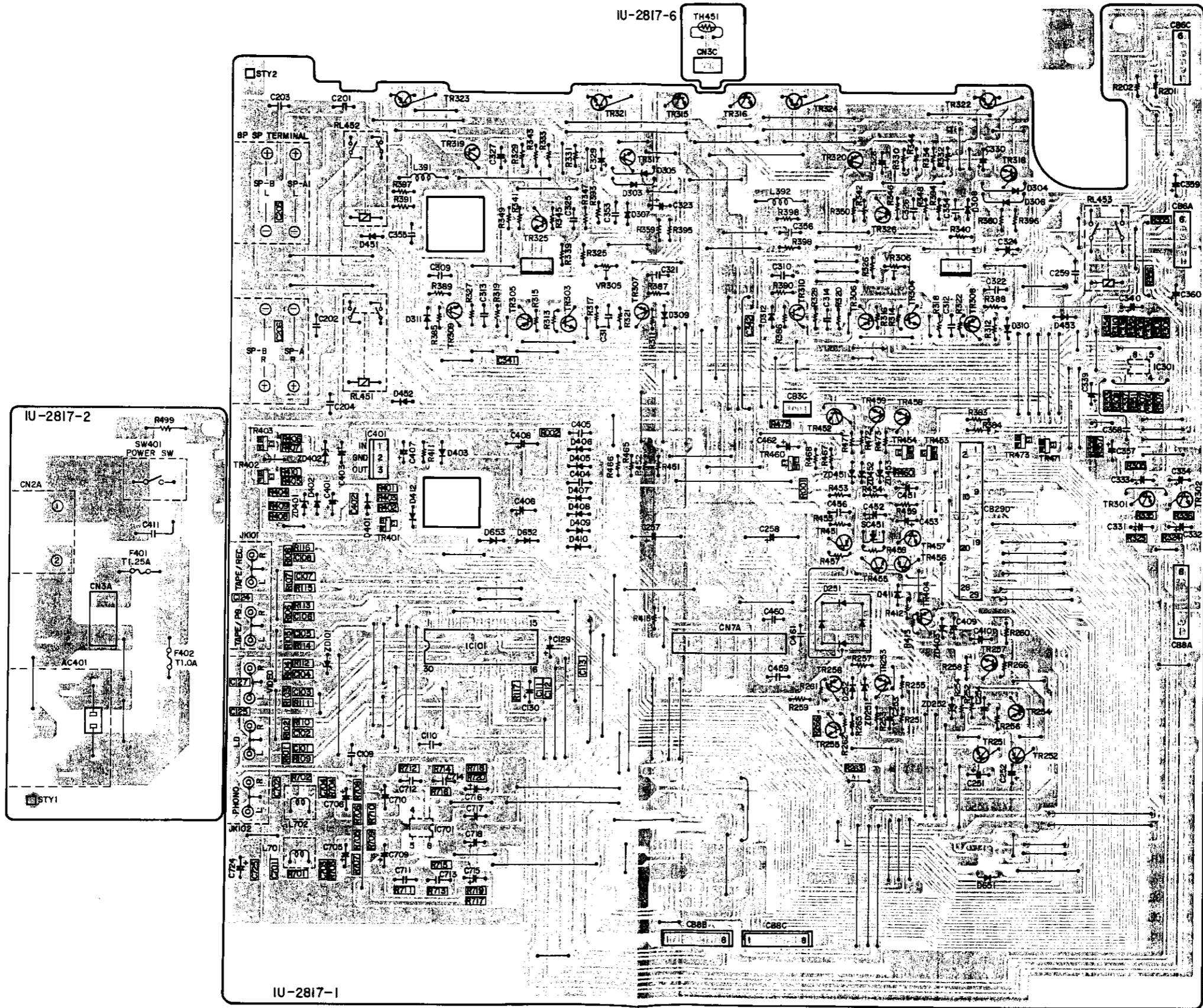

1 2 3 4 5 6 7 8

1U-2819 DISPLAY UNIT ASS'Y

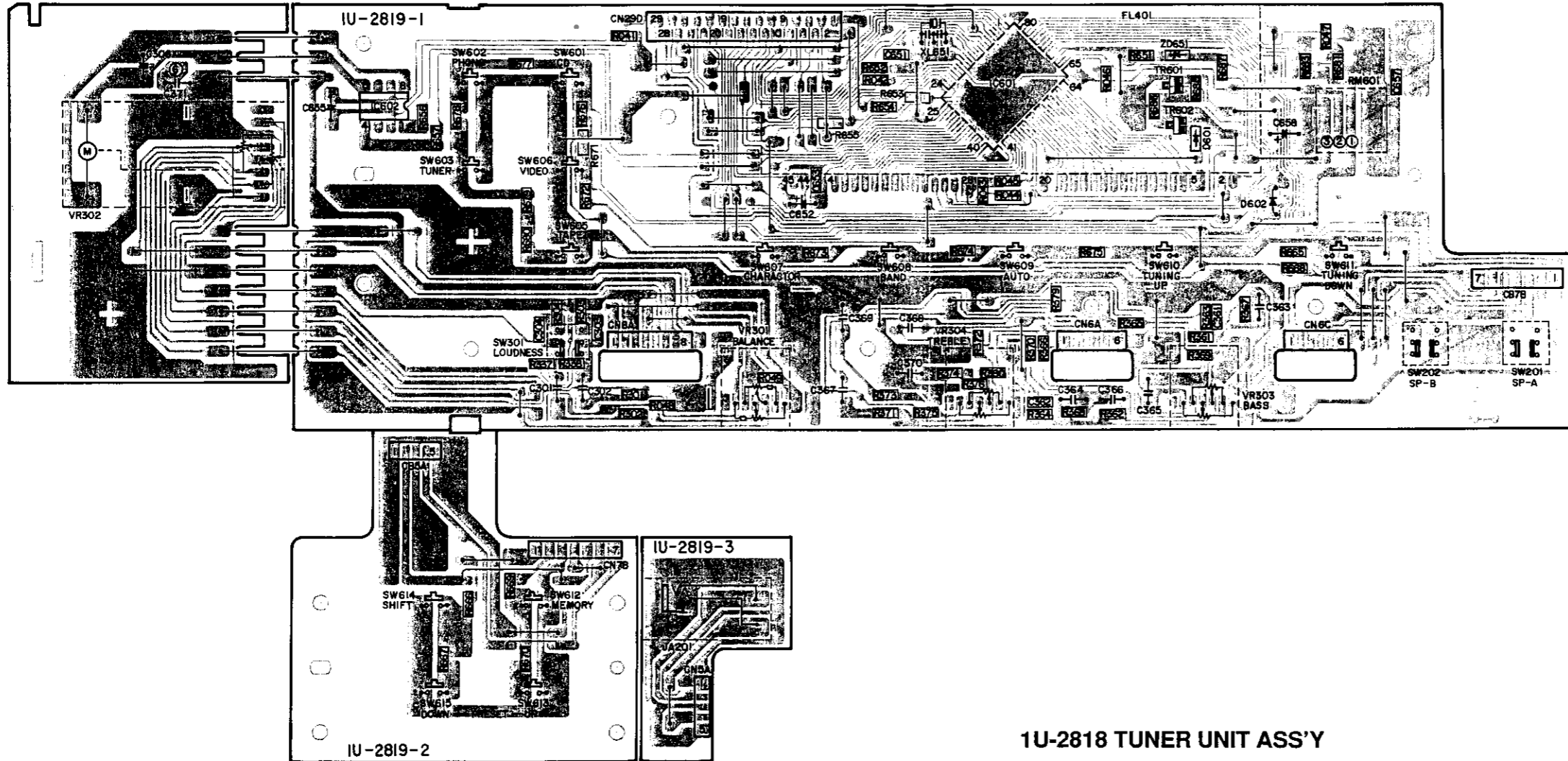

1U-2818 TUNER UNIT ASS'Y

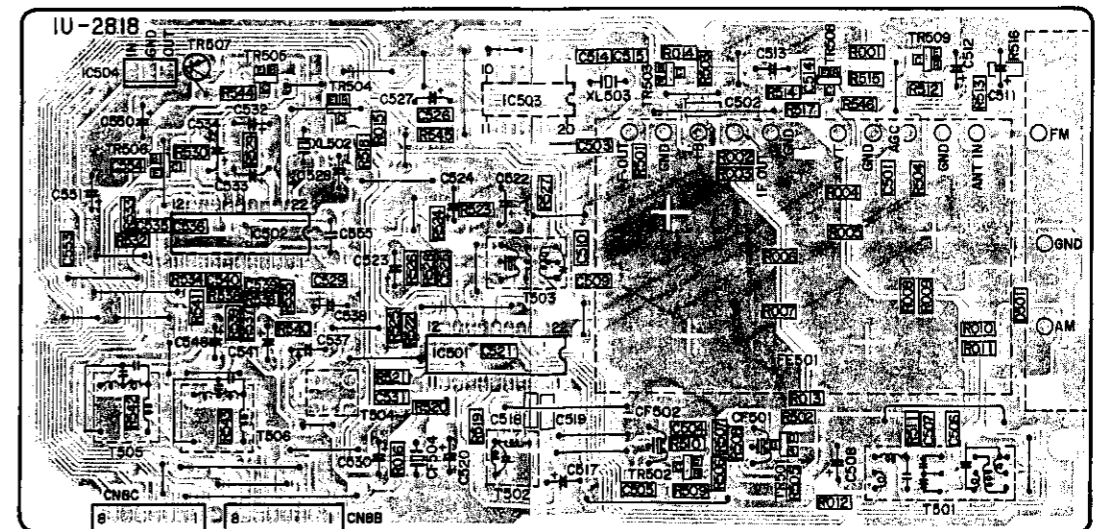

EXPLODED VIEW OF CHASSIS AND CABINET

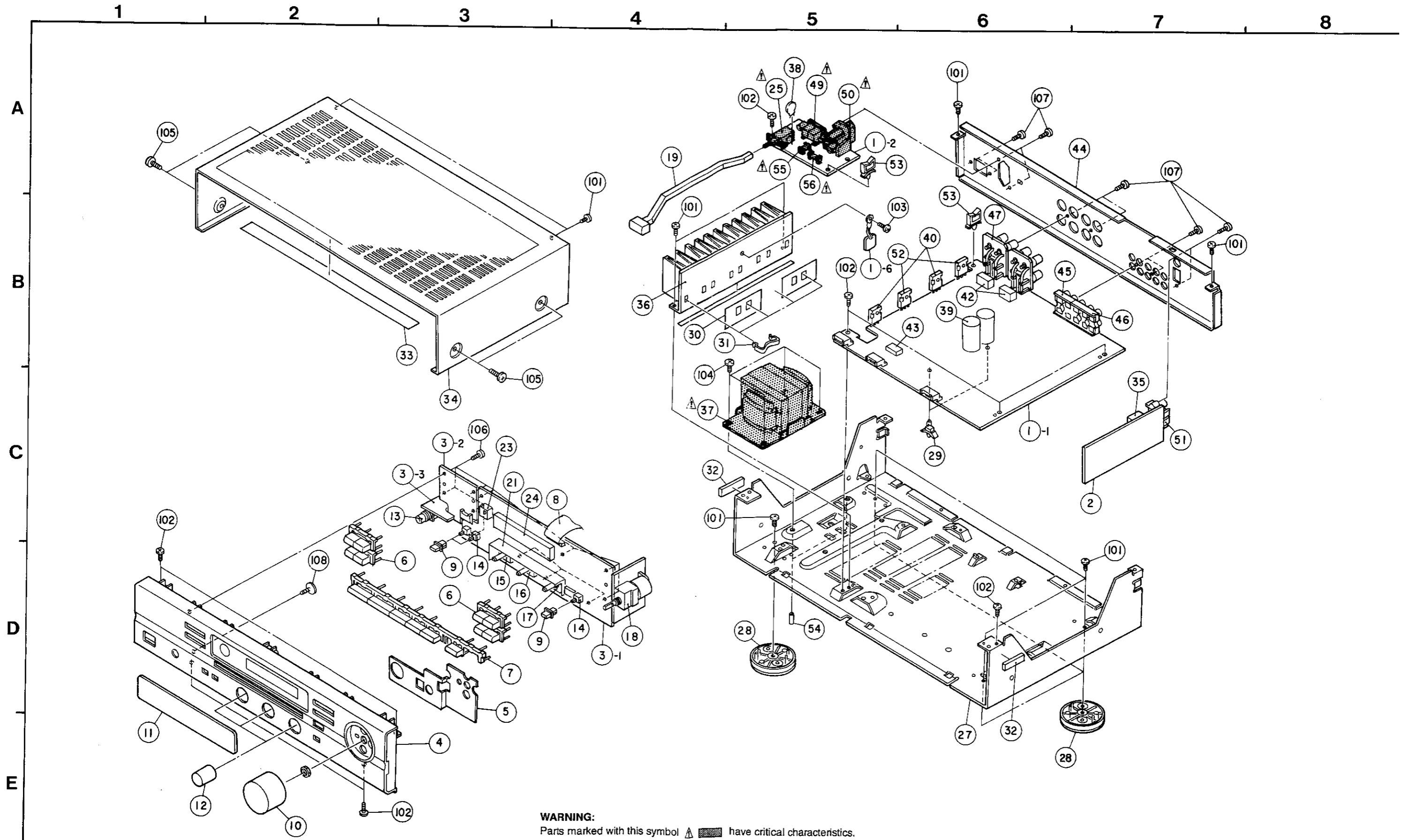

**WARNING:**  
 Parts marked with this symbol  have critical characteristics.  
 Use ONLY replacement parts recommended by the manufacturer.

### PARTS LIST EXPLODED VIEW

Ref. No.	Part No.	Part Name	Remarks	Q'ty	Ref. No.	Part No.	Part Name	Remarks	Q'ty
①	1U-2817	Main unit Ass'y		1	47	205 0472 013	8P speaker terminal	U.K. model	1
├─1-1	—	Main unit			⚠ 49	203 2349 009	2P inlet	CN2A	1
├─1-2	—	Power unit			⚠ 50	203 3961 004	1P AC outlet	Except to U.K.	1
├─1-6	—	Temperature protector unit			51	205 0847 004	3P antenna terminal(PAL/F)		1
②	1U-2818	Tuner unit Ass'y		1	52	271 0276 009	Transistor 2SA1633	TR323,324	2
③	1U-2819	Display unit Ass'y		1	④ 53	449 0068 014	Wire saddle		2
├─3-1	—	Display unit			④ 54	462 0094 036	Screw tube		22
├─3-2	—	Disp B unit			⚠ 55	206 1075 014	Fuse (1.25A)	F401	1
├─3-3	—	Head phone unit			⚠ 56	206 1075 001	Fuse (1A)	Except to U.K.	1
④	146 1550 004	Front panel Ass'y		1	<b>SCRWES</b>				
⑤	414 9178 006	Shield bracket		1	101	473 7015 018	Tapping screw 3×8 (S)	Black	10
6	113 1679 008	Button (4Key)		2	102	473 7002 018	Tapping screw 3×8 (S)		8
7	113 1680 110	Button (7Key)		1	103	473 7500 015	Tapping screw 3×8 (P)		1
8	009 0109 018	29P FFC cable		1	104	473 7007 000	Tapping screw 4×8 (S)	Black	4
9	113 1723 006	Push button (Kaku)		3	105	473 7007 013	Tapping screw 4×10(S)	Black	4
10	112 0647 009	Volume knob		1	106	473 7505 007	Tapping screw 2.6×8 (P)		13
11	143 0924 001	Window		1	107	477 0064 107	Fixing screw 3×10	Black	10
12	112 0739 001	:*Knob (Maru)		3	108	477 0262 006	Special screw		1
13	204 8354 017	Head phone jack	JA201	1	<b>PACKING &amp; ACCESSORIES</b>				
14	212 1140 009	Push switch(ESB6440)	SW201,202,301	3	④	505 0283 018	:Envelope		1
15	211 0842 004	Variable resistor	VR303	1	④	511 2741 003	Operating instructions		1
16	211 0843 003	Variable resistor	VR304	1	231 1914 003	AM lobe antenne		1	
17	211 0841 005	Variable resistor	VR301	1	395 0023 008	:*FM antenne Ass'y		1	
18	211 0844 002	Variable resistor	VR302	1	399 0242 001	Remoto control unit	RC-174	1	
19	113 1721 008	Power button ass'y		1	⚠ 206 2108 003	::AC connectorWith plug	Europe model	1	
④ 21	414 0740 006	Shield plate		1	⚠ 206 2113 001	:AC cordWith connector	U.K. model	1	
23	499 0150 008	Remote sensor	SBX1610-52	1	④	505 0131 050	Cabinet cover		1
24	393 8020 007	FL tube	14-BT-39GK	1	④	503 0939 007	:Cushion		2
⚠ 25	212 1031 008	Power switch (TV-5)		1	④	501 1871 003	Carton case	Europe model	1
26	212 5604 910	Tact switch	SW601-615	14	④	501 1871 016	:Carton case	U.K. model	1
④ 27	411 1323 106	Chassis		1	④	502 0741 056	Pad	U.K. model only	2
④ 28	104 0230 101	:Foot Ass'y		4					
④ 29	449 0033 049	Loking card spacer		2					
④ 30	415 0744 005	Insulating sheet		2					
④ 31	441 1691 004	Retaining spring		4					
④ 32	461 9063 007	Rubber sheet		2					
④ 33	122 9006 004	Spacer		1					
④ 34	102 0558 104	Top cover		1					
④ 35	216 0065 006	Front end		1					
④ 36	417 0514 008	Power radiator		1					
⚠ 37	233 6158 006	Power Transformer		1					
④ 38	415 0299 000	Capacitor cover		1					
39	254 4355 002	Electrolytic capacitor	C257,258	2					
40	273 0430 003	Transistor 2SC4278(E-F)	TR321,322	2					
42	241 0167 005	Relay(G5Z-2A)	RL451,452	2					
43	241 0127 003	Relay(RY-12W)	RL453	2					
④ 44	105 1156 106	Rear panel	Europe model	1					
④ 44	105 1156 119	:Rear panel	U.K. model	1					
45	204 8485 009	4P pin jack(S-GND)		1					
46	204 8486 008	6P pin jack(S-GND)		1					
47	205 0484 001	8P speaker terminal	Europe model	1					

# WIRING DIAGRAM

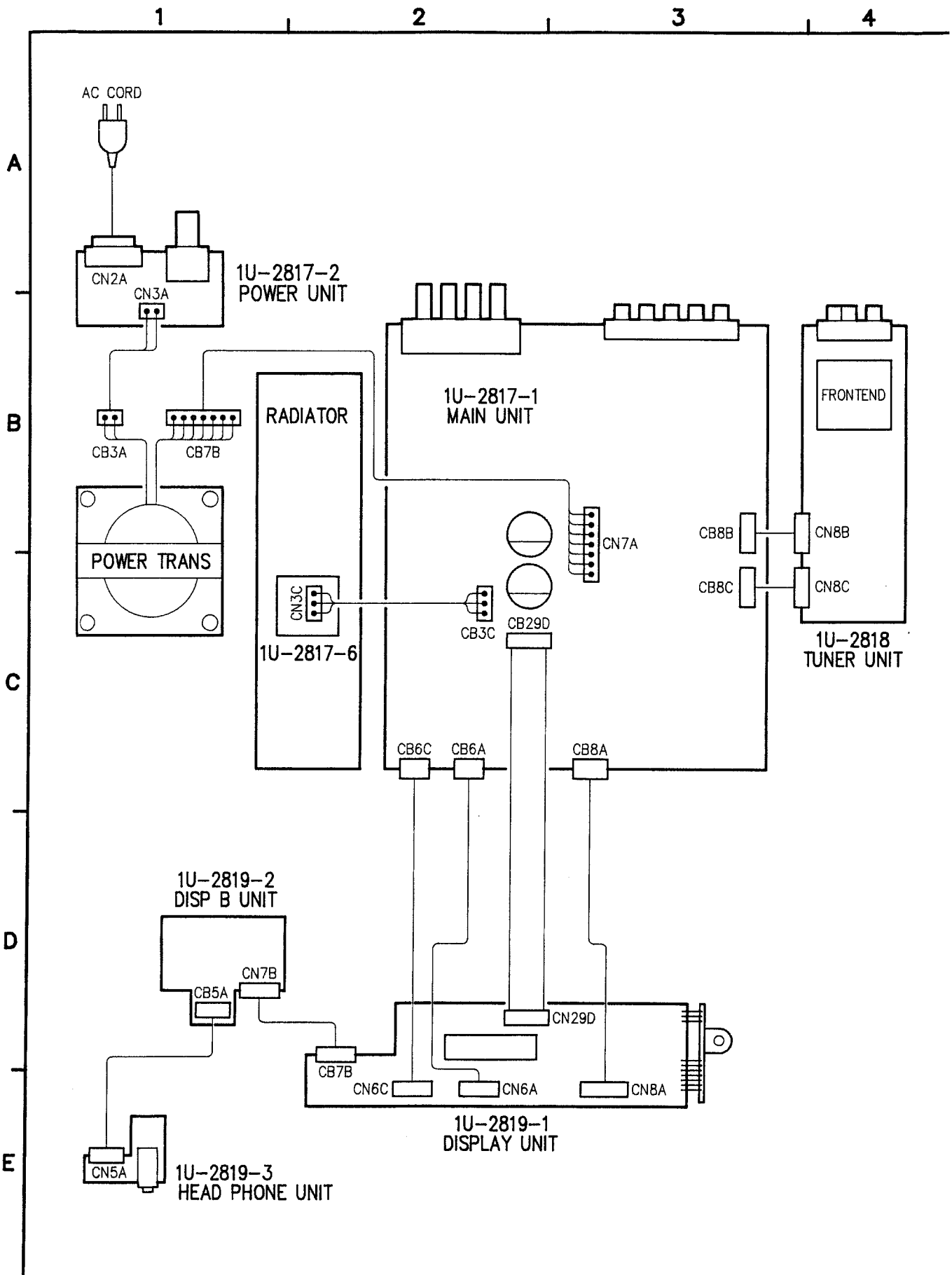

# SCHEMATIC DIAGRAM

1      2      3      4      5      6

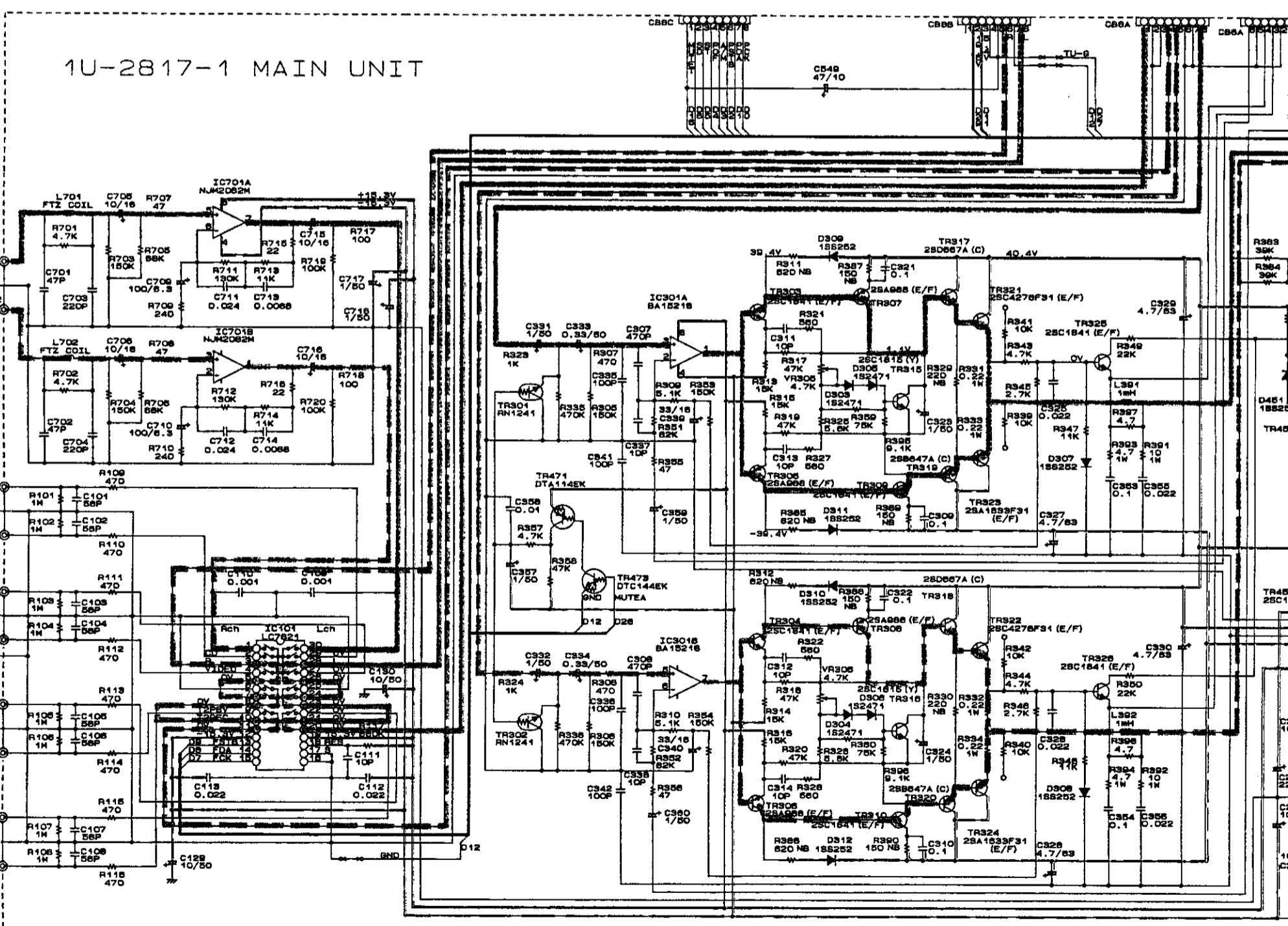
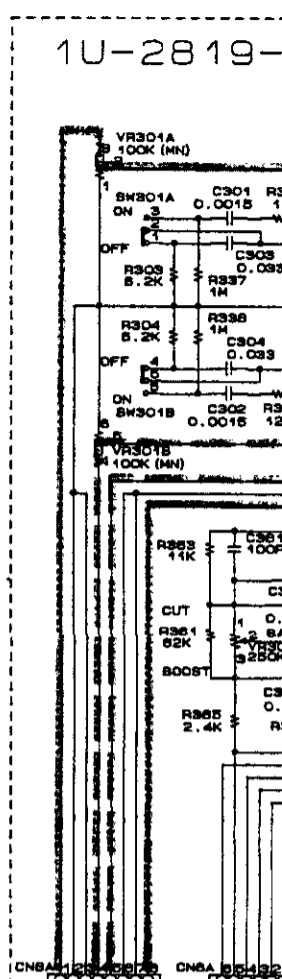
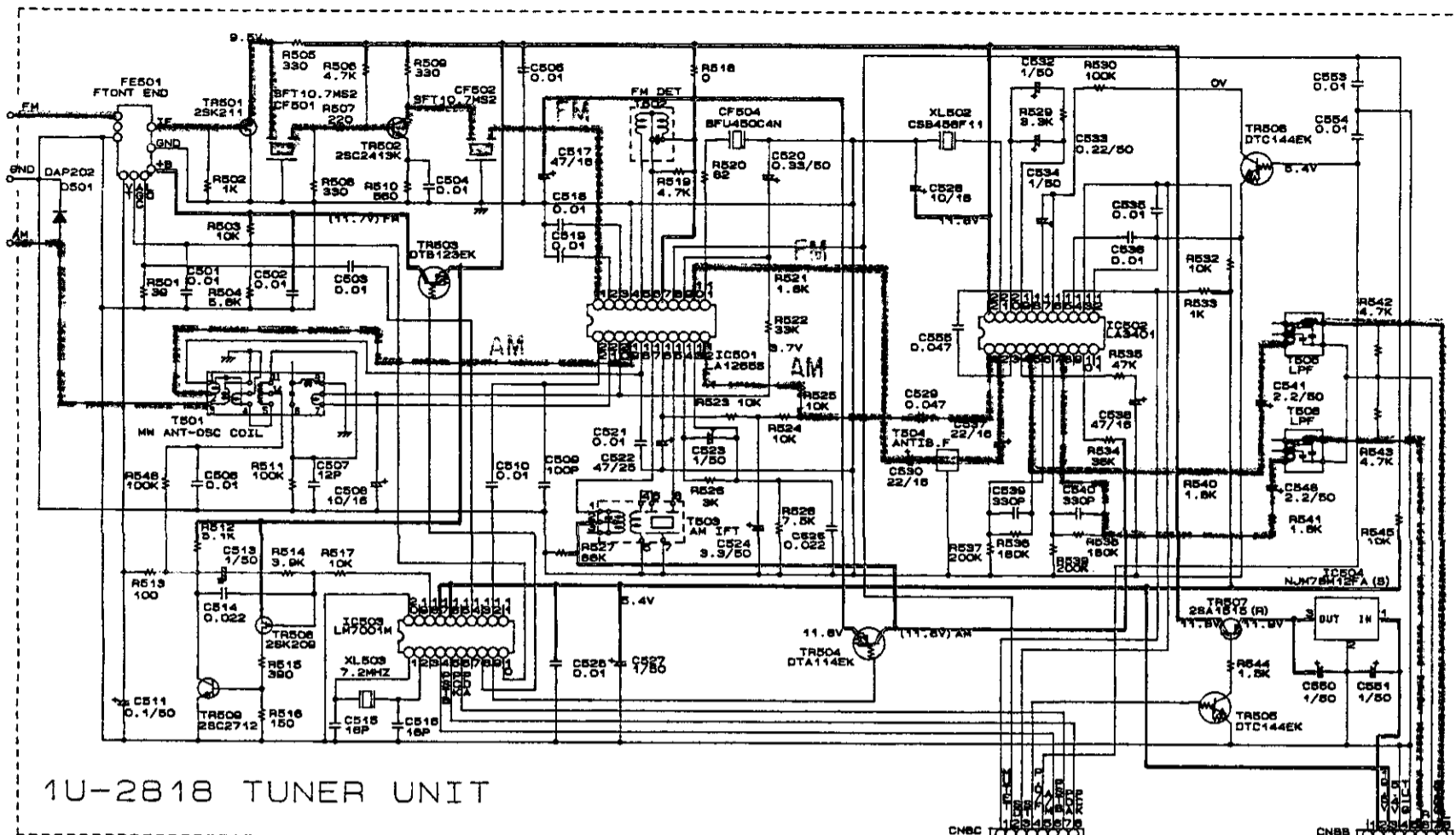

**WARNING:**  
Parts marked with this symbol have critical characteristics. Use ONLY replacement parts recommended by the manufacturer.

**CAUTION:**  
Before returning the unit to the customer, make sure you make either (1) a leakage current exceeds 0.5 milliamperes, or if the resistance from chassis to either side of the power cord is less than 100,000 ohms.

**WARNING:**  
DO NOT return the unit to the customer until the problem is located and corrected.

**NOTES:**  
Circuit and parts are subject to change without prior notice.

7 8 9 10 11

# 2819-1 DISPLAY UNIT

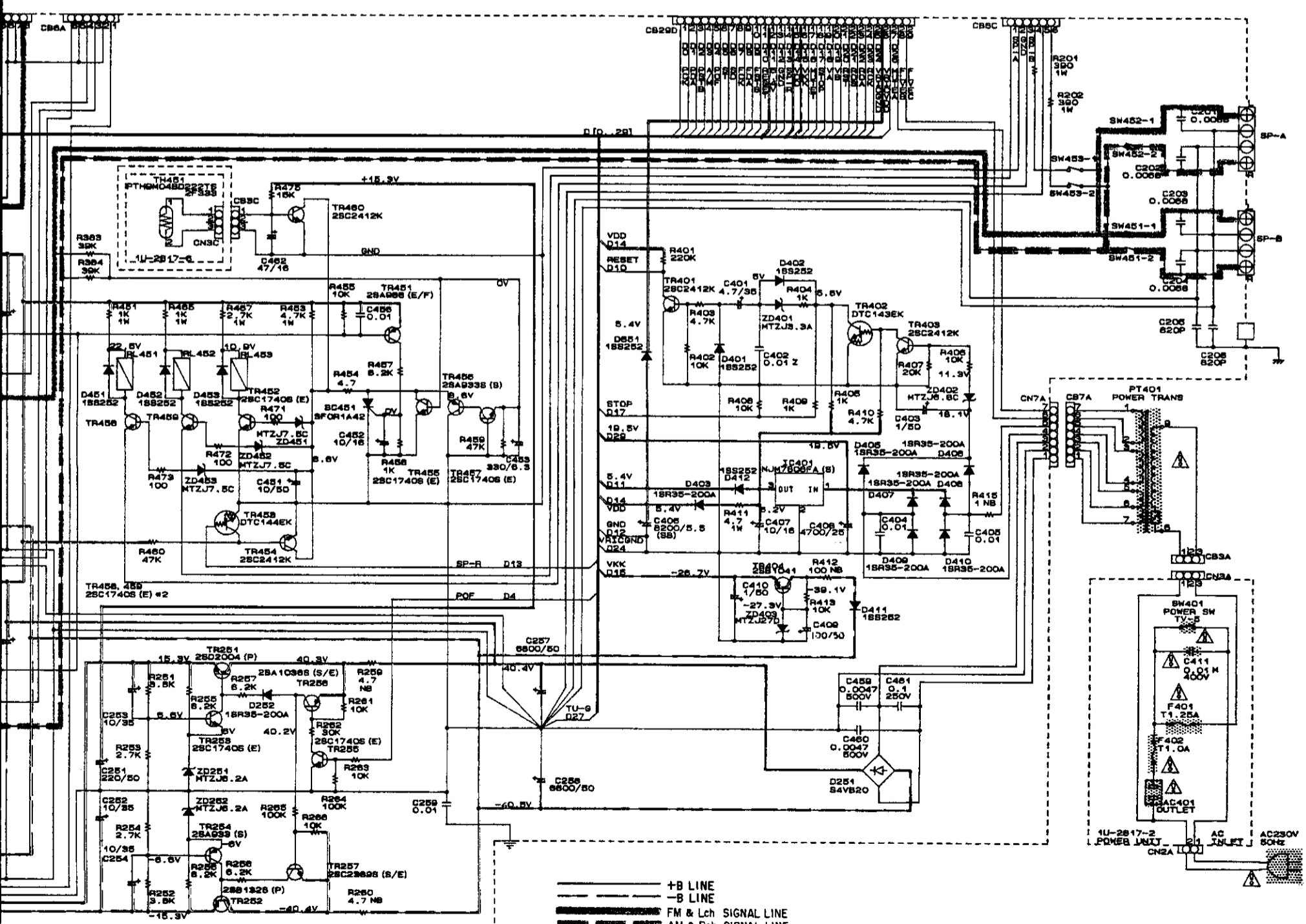
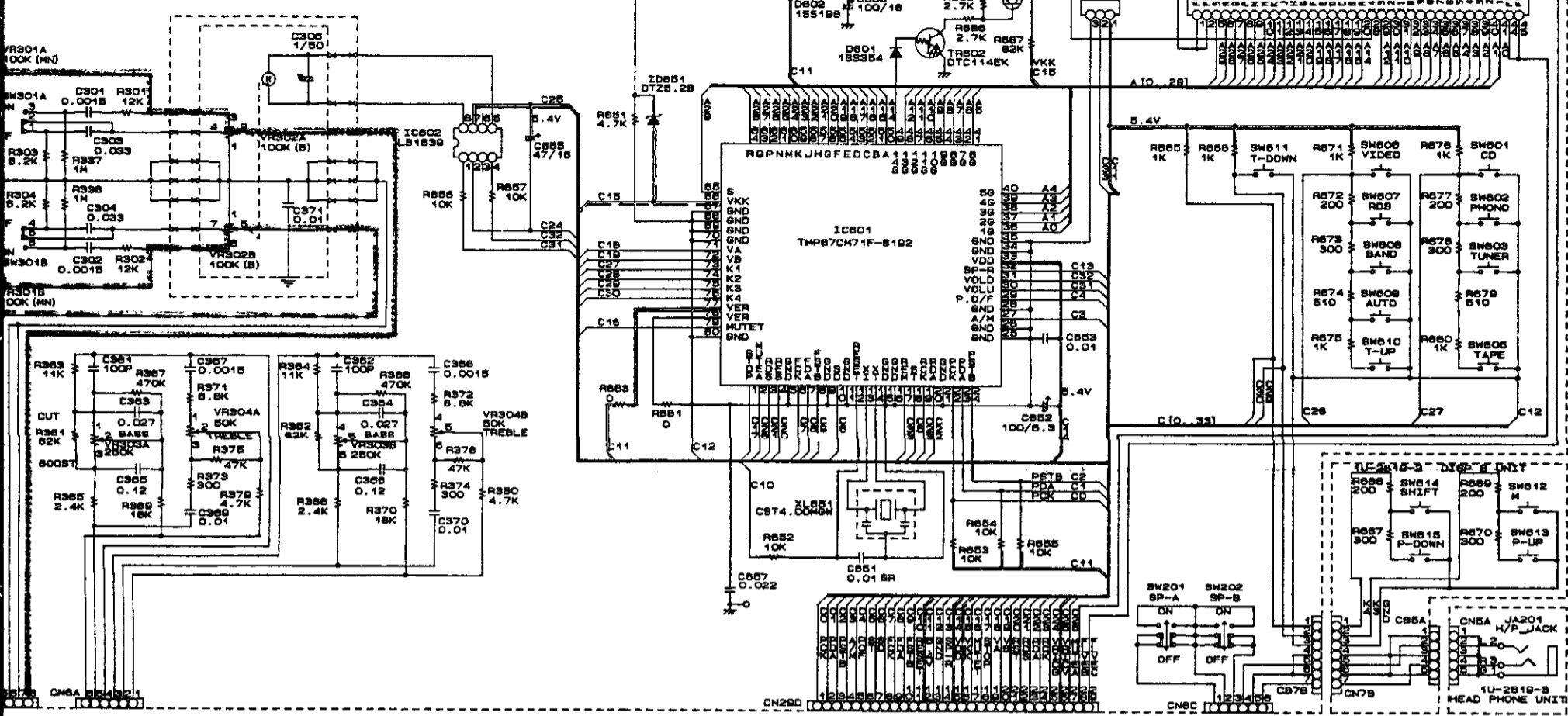

**NOTES**  
 ALL RESISTANCE VALUES IN OHM. k=1,000 OHM, M=1,000,000 OHM  
 ALL CAPACITANCE VALUES IN MICRO FARAD. P=MICRO-MICRO FARAD  
 EACH VOLTAGE AND CURRENT ARE MEASURED AT NO SIGNAL INPUT CONDITION.  
 CIRCUIT AND PARTS ARE SUBJECT TO CHANGE WITHOUT PRIOR NOTICE.

per (1) a leakage current check or (2) a line to chassis resistance check. If the leakage current of the power cord is less than 240 kohms, the unit is defective.

and corrected.

A  
B  
C  
D  
E  
F  
G  
H



# SEMICONDUCTORS

## IC's

### TMP87CM71F (IC601)

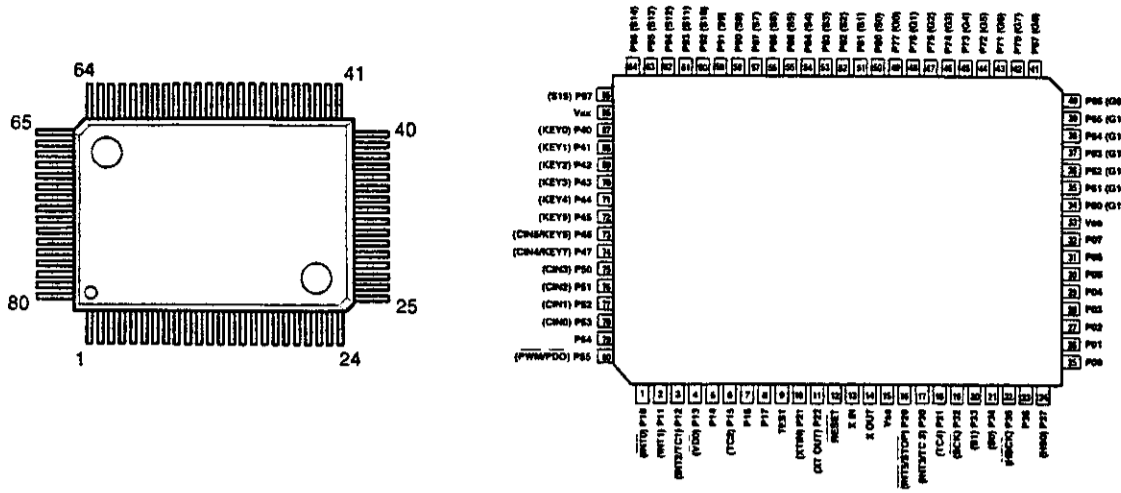

TMP87CM71F Port Allocation Table

Pin No.	Symbol	I/O	Logic	Initial Setting	Function
1	STOP	I	L	---	Power down detection ("L" = at power down).
2	MUTE (A)	I	---	---	MUTE (A) output ("H" = MUTE).
3	RDS	I	Serial	---	RDS data (start) input.
4	RES	O	L	H	LC7074 reset output.
5	GND	I	Serial	---	Not used.
6	FCK	O	Serial	L	Function control output (LC7821) for F-CK.
7	FDA	O	Serial	L	Function control output (LC7821) for F-DATA.
8	F STB	O	H	L	Function control output (LC7821) for F-STB.
9	GND	I	---	---	Connect to GND.
10	SD	I	L	---	Tuned signal input ("L" = at tuned in).
11	GND	I	---	---	Not used.
12	RESET	I	L	---	Reset input.
13	XIN	I	---	---	Oscillation circuit (4MHz).
14	XOUT	I	---	---	Oscillation circuit (4MHz).
15	Yes	PW	---	---	GND.
16	GND	I	---	---	GND.
17	REM	I	L	---	Remote control signal input.
18	ST	I	L	---	Stereo signal input ("L" = at stereo).
19	RCK	I	Serial	---	RDS data (clock) input.
20	RDA	I	Serial	---	RDS data (data) input.
21	GND	I	---	---	Not used.
22	PCK	O	Serial	L	LM7001 control output for PLL-CK (CL).
23	PDA	O	Serial	L	LM7001 control output for PLL-DATA (DATA).
24	PSTB	O	H	L	LM7001 control output for PLL-STB (CE).
25	GND	O	---	L	GND.
26	GND	O	---	L	GND.
27	AM	O	L	L	AUTOMANUAL control.
28	GND	I	---	---	Not used.
29	P OF	O	H	L	Power control output ("H" = ON).
30	VR-UP	O	H	L	Power volume control output (LB1639 ON = at "H").
31	VR-D	O	H	L	Power volume control output (LB1639 ON = at "H").
32	SP-R	O	H	L	Speaker relay control output (ON = at "H").
33	VDD	PW	---	---	+5V.
34	GND	I	---	---	GND.
35	GND	I	---	---	GND.
36	1G	O	---	---	FL tube control output for 1G.
37	2G	O	---	---	FL tube control output for 2G.
38	3G	O	---	---	FL tube control output for 3G.
39	4G	O	---	---	FL tube control output for 4G.
40	5G	O	---	---	FL tube control output for 5G.
41	6G	O	---	---	FL Tube control output for 6G.
42	7G	O	---	---	FL Tube control output for 7G.
43	8G	O	---	---	FL Tube control output for 8G.
44	9G	O	---	---	FL Tube control output for 9G.
45	10G	O	---	---	FL Tube control output for 10G.
46	11G	O	---	---	FL Tube control output for 11G.
47	12G	O	---	---	FL Tube control output for 12G.
48	13G	O	---	---	FL Tube control output for 13G.
49	14G	O	---	---	FL Tube control output for 14G.
50	S0 (a)	O	---	---	FL Tube control output for P(a).
51	S1 (b)	O	---	---	FL Tube control output for P(b).
52	S2 (c)	O	---	---	FL Tube control output for P(c).
53	S3 (d)	O	---	---	FL Tube control output for P(d).
54	S4 (e)	O	---	---	FL Tube control output for P(e).
55	S5 (f)	O	---	---	FL Tube control output for P(f).
56	S6 (g)	O	---	---	FL Tube control output for P(g).
57	S7 (h)	O	---	---	FL Tube control output for P(h).
58	S8 (i)	O	---	---	FL Tube control output for P(i).
59	S9 (k)	O	---	---	FL Tube control output for P(k).
60	S10 (m)	O	---	---	FL Tube control output for P(m).
61	S11 (n)	O	---	---	FL Tube control output for P(n).
62	S12 (p)	O	---	---	FL Tube control output for P(p).
63	S13 (q)	O	---	---	FL Tube control output for P(q).
64	S14 (r)	O	---	---	FL Tube control output for P(r).
65	S15 (s)	O	---	---	FL Tube control output for P(s).
66	Vtk	PW	---	---	-15V.
67	GND	I	---	---	GND.
68	GND	I	---	---	GND.
69	GND	I	---	---	GND.
70	GND	I	---	---	GND.
71	VA	O	L	H	Video In/Out control ("L" = at selection) BV4068.
72	VB	O	L	H	Video In/Out control ("L" = at selection) BV4068.
73	K1	I	---	---	Key input (A/D conversion input).
74	K2	I	---	---	Key input (A/D conversion input).
75	K3	I	---	---	Key input (A/D conversion input).
76	K4	I	---	---	Key input (A/D conversion input).
77	VER	I	---	---	Forwarding country setting.
78	VER	I	---	---	Specification setting.
79	MUTE (T)	O	H	H	MUTE output ("H" = MUTE).
80	GND	I	---	---	GND.

### LM7001 (IC503)

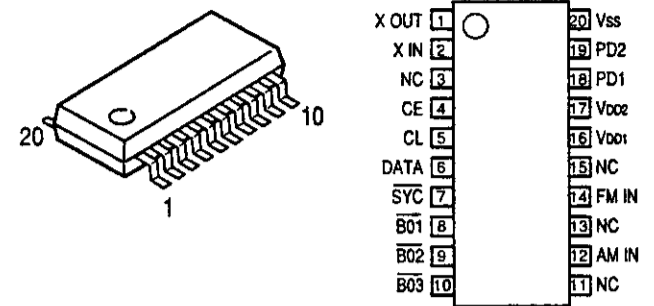

### LA3401 (IC502)

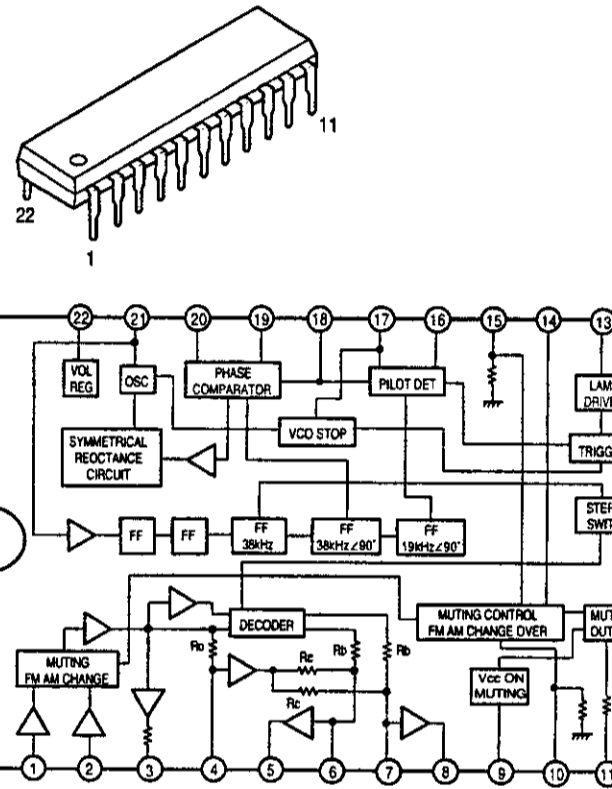

## TRANSISTORS

2SA988(E/F)  
2SA1515(R)  
2SC1815(Y)  
2SC1841(E/F)

2SB647A(C)  
2SB1041(R)  
2SD667A(C)

2SA933S(S)  
2SA1038S(S/E)  
2SC1740S(E)  
2SC2389S(S/E)

2SB1328(P)  
2SD2004(P)

Digital Transistor  
(Built in Resistors)

DTA-DTBEK Series

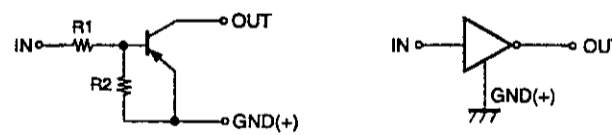

	R1	R2
DTA114EK	10kohm	10kohm
DTB123EK	2.2kohm	2.2kohm

DTCEK Series

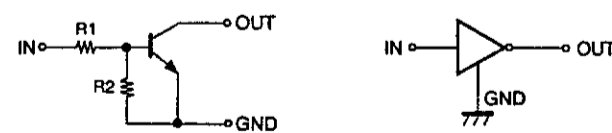

	R1	R2
DTC114EK	10kohm	10kohm
DTC143EK	4.7kohm	4.7kohm
DTC144EK	47kohm	47kohm

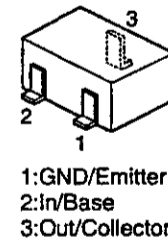
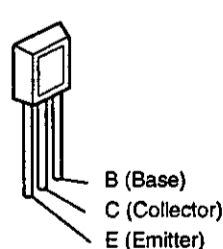
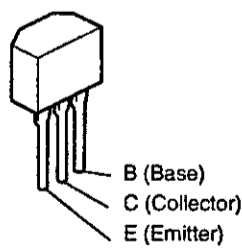
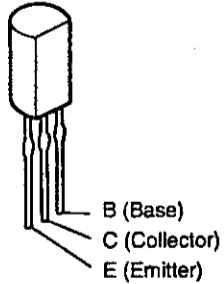
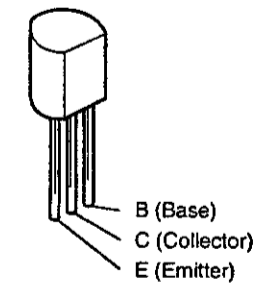

DTA114EK  
DTC114EK  
DTC143EK  
DTC144EK  
(Chip)

2SA1633 (E/F)  
2SC4278 (E/F)

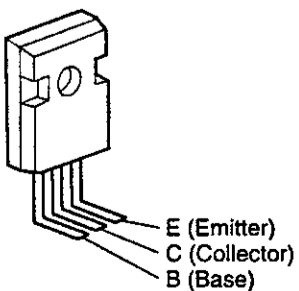

RN-1241(A/B)

RN1241

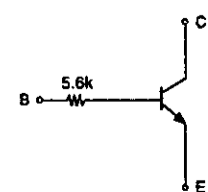
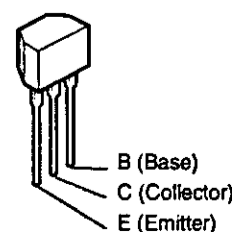

**LA1265 (S)  
(IC501)**

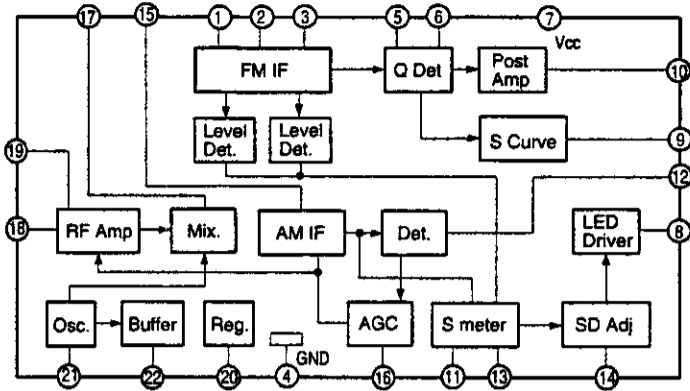
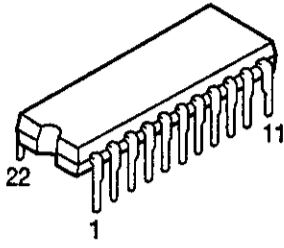

**NJM78M12FA  
(IC504)  
NJM7806FA  
(IC401)**

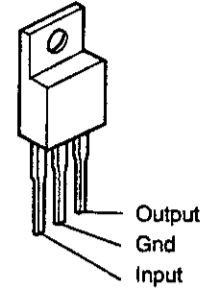

**LC7821 (IC101)**

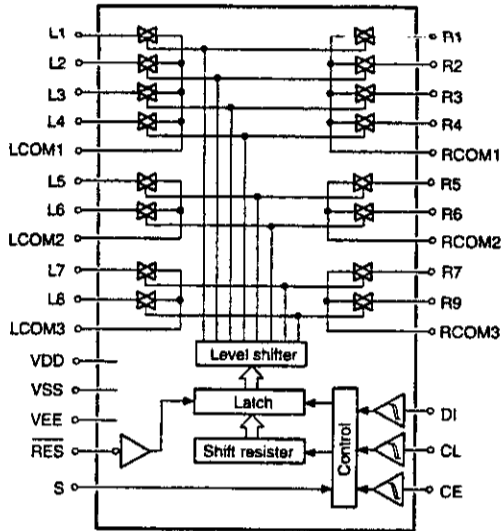
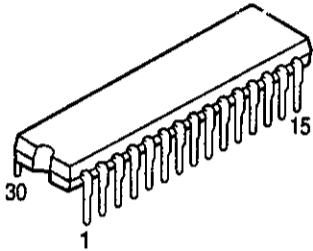

**NJM2082M (IC701)**

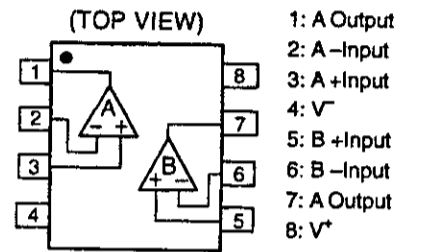
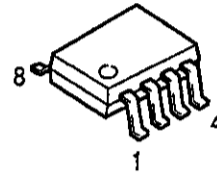

**LB1639 (IC602)**

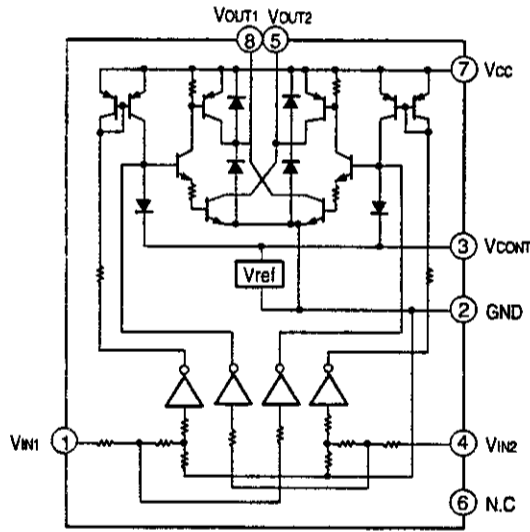
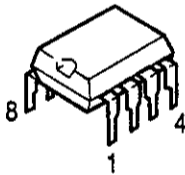

**BA15218 (IC301)**

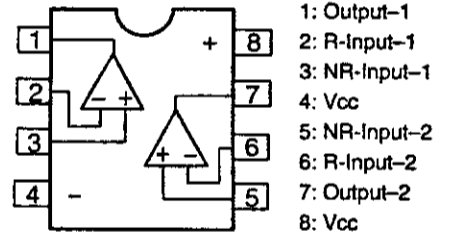
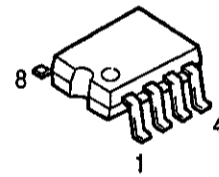

**2SK209 Y/GR**

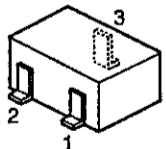

1: Drain  
2: Source  
3: Gate

**2SA1037 (S/R)  
2SC2412 (S)  
2SC2413K (Q)  
2SC2712 (Y/GR)  
DTB123EK**

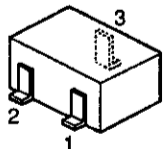

1: Emitter  
2: Base  
3: Collector

**2SK221 Y/RG**

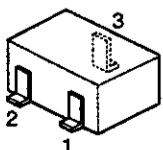

1: Gate  
2: Drain  
3: Source

**DIODES**

**1SS252**

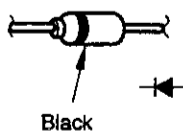

**1S2471**

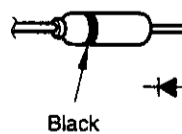

**MTZJ3.3A MTZJ7.5C  
MTZJ6.2A MTZJ27D  
MTZJ6.8C**

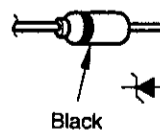

**1SS198**

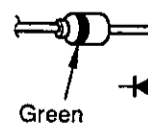

**SFOR1A42**

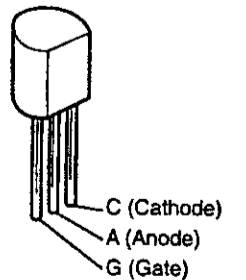

**1SR35-200A**

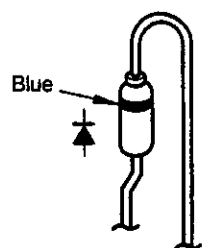

**DAP202K  
(Chip)**

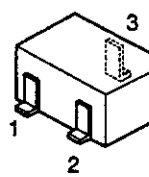

**DAP202K**

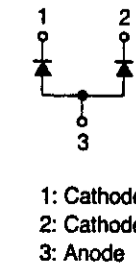

**S4VB20F**

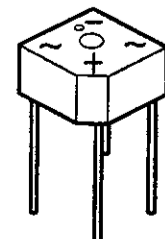

**1SS354  
DTZ8.2B  
(Chip)**

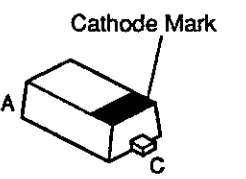

SBX1610-52 (REMOTE SENSOR)

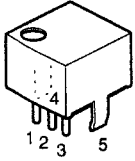

- 1. Vcc
- 2. Output
- 3. GND
- 4. Case Fin
- 5. Case Fin

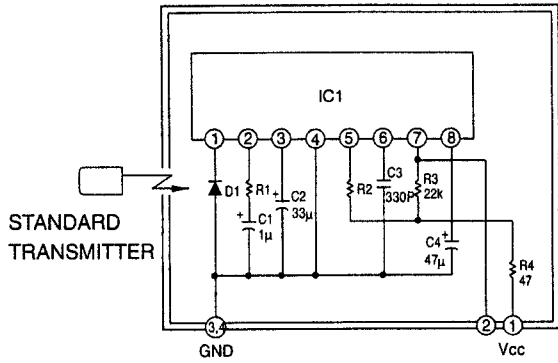

- IC1 : CX20106A Chip
- D1 : PIN Photo Diode Chip
- C1, C2, C4 : Aluminum Electrolytic Capacitor
- C3 : SL Characteristic  $\pm 5\%$
- R1 : Gain Adjuster
- R2 : fo Adjust  $\pm 1\%$  USE
- R3, R4 :  $\pm 5\%$