

DENON

Hi-Fi AM-FM Stereo Receiver

For Europe
And U. K. Models

SERVICE MANUAL

MODEL DRA-385RD

AM-FM STEREO RECEIVER

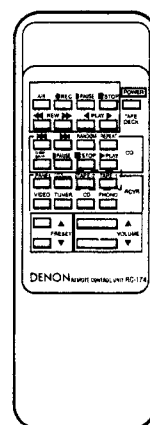
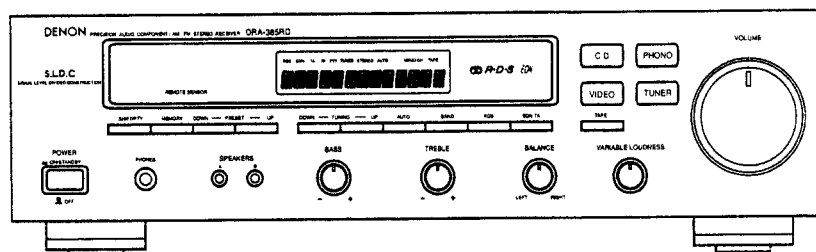

TABLE OF CONTENTS

OPERATING INSTRUCTIONS	3 ~ 9
DISASSEMBLY	10
METHOD OF ADJUSTMENTS	11
CONNECTION DIAGRAM OF MEASURING INSTRUMENTS	12
BLOCK/LEVEL DIAGRAM	13
NOTE FOR PARTS LIST	14
PRINTED WIRING BOARD PARTS LIST	15 ~ 19
PRINTED WIRING BOARD PATTERNS	20, 21
1U-2817 MAIN UNIT ASS'Y.	20
KU-9328 DISPLAY UNIT ASS'Y	21
1U-2818 TUNE UNIT ASS'Y	21
EXPLODED VIEW OF CHASSIS AND CABINET.	22
PARTS LIST OF EXPLODED VIEW	23
WIRING DIAGRAM	24
SCHEMATIC DIAGRAM	25
SEMICONDUCTORS	26, 27

NIPPON COLUMBIA CO., LTD.

SPECIFICATIONS

AMPLIFIER SECTION

Continuous Power Output (DIN):	65 W + 65 W (4 ohms, 1 kHz)		
Power Bandwidth (IHF):	10 Hz ~ 40 kHz (T.H.D. 0.15% both channels driven into 8 ohms)		
Total Harmonic Distortion:	0.03% (-3 dB at rated output, 8 ohms)		
Frequency Response:	PHONO RIAA Standard Curve (Recording Output)		
	MM	20 Hz ~ 20 kHz ± 0.5 dB	
	CD, VIDEO, TAPE	20 Hz ~ 50 kHz ± 1.5 dB (at 1 W)	
Input Sensitivity and Impedance:	PHONO MM	2.5 mV	47 kohms
	CD, VIDEO, TAPE	150 mV	25 kohms
Maximum Input Level: (at 1 kHz)	PHONO MM	120 mV	
Signal to Noise Ratio (IHF-A):	PHONO MM	78 dB (at 5.0 mV input)	
	CD, VIDEO, TAPE	98 dB	
Tone Controls:	BASS	± 10 dB at 100 Hz	
	TREBLE	± 10 dB at 10 kHz	
Loudness Control Effect:	Variable Loudness at maximum position 50 Hz/10 kHz, + 10 dB/+5 dB		

TUNER SECTION

[FM] (note: μV at 75 ohms, 0 dBf = 1×10^{-18} W)	
Receiving Range:	87.5 ~ 108 MHz
Usable Sensitivity:	0.9 μ V (10.3 dBf)
Signal to Noise Ratio (IHF-A):	MONO 82 dB STEREO 78 dB
Image Rejection:	65 dB
Selectivity (± 300 kHz):	55 dB
Frequency Response:	30 Hz ~ 15 kHz +0.2 dB -1.5
Stereo Separation (at 1 kHz):	40 dB
[AM]	
Receiving Range:	522 ~ 1611 kHz
Usable Sensitivity:	18 μ V
Signal to Noise Ratio:	55 dB
General	
Power Supply:	AC 230 V 50 Hz
Power Consumption:	125 W
Power Outlet:	SWITCHED 100 W
Dimensions:	434 mm (W) x 119 mm (H) x 310 mm (D)
Weight:	5.9 kg
REMOTE CONTROL UNIT	RC-174
Remote control system:	Infrared pulse system
Power supply:	3V DC Two size "AA" (R6) dry cell batteries
External dimensions:	60 mm (W) x 175 mm (H) x 18 mm (D)
Weight:	120 g (includes batteries)

Design and specifications are subject to change without prior notice.

CAUTION

**RISK OF ELECTRIC SHOCK
DO NOT OPEN**

CAUTION: TO REDUCE THE RISK OF ELECTRIC SHOCK, DO NOT REMOVE COVER (OR BACK). NO USER SERVICEABLE PARTS INSIDE. REFER SERVICING TO QUALIFIED SERVICE PERSONNEL.

The lightning flash with arrowhead symbol, within an equilateral triangle, is intended to alert the user to the presence of uninsulated "dangerous voltage" within the product's enclosure that may be of sufficient magnitude to constitute a risk of electric shock to persons.

The exclamation point within an equilateral triangle is intended to alert the user to the presence of important operating and maintenance (servicing) instructions in the literature accompanying the appliance.

WARNING: TO REDUCE THE RISK OF FIRE OR ELECTRIC SHOCK, DO NOT EXPOSE THIS APPLIANCE TO RAIN OR MOISTURE.

PRECAUTIONS FOR INSTALLATION

Install DRA-385RD always horizontally. And leave at least 10 cm of space between the unit and other component placed above.

VORKEHRUNGEN FÜR DIE AUFSTELLUNG

Stellen Sie den DRA-385RD stets waagrecht auf. Achten Sie ebenfalls darauf, daß ein Mindestabstand von 10 cm zwischen dem Gerät und der Komponente, die darüber gestellt wird, eingehalten wird.

PRECAUTIONS D'INSTALLATION

Le DRA-385RD doit toujours être installé horizontalement. Laisser au moins un espace de 10 cm entre cet appareil et tout autre composant qui serait placé au-dessus.

PRECAUZIONI PER L'INSTALLAZIONE

Installare il DRA 385RD sempre in posizione orizzontale, avendo cura di lasciare almeno 10 cm fra l'unità ed altri componenti posti al di sopra.

PRECAUCIONES PARA LA INSTALACION

Instale siempre el DRA-385RD en posición horizontal. Asegúrese también de dejar un espacio de por lo menos 10 cm entre esta unidad y el componente que sea colocado encima.

VOORZORGSMAATREGELEN VOOR INSTALLATIE

De DRA-385RD altijd horizontaal plaatsen. Laat ten minste 10 cm ruimte tussen dit apparaat en het andere component dat u erboven plaatst.

FÖRBEREDELSE FÖR INSTALLATION

Installera alltid DRA-385RD horisontellt. Lämna åtminstone 10 cm mellan denna apparat och en annan komponent som placeras ovanpå.

PRECAUÇÕES DURANTE A INSTALAÇÃO

Instale sempre o DRA-385RD em posição horizontal. E deixe pelo menos 10 cm de espaço entre esta unidade e o outro componente colocado acima.

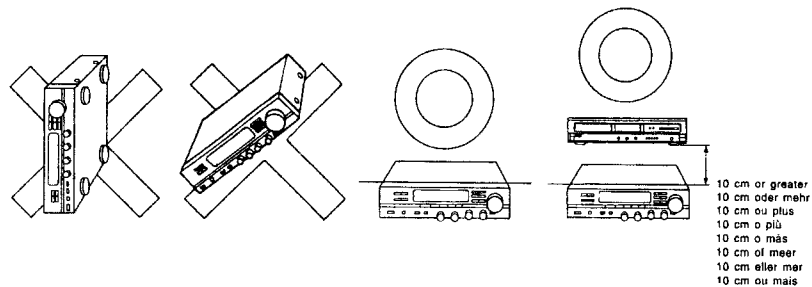

**FRONT PANEL
VORDERSEITE
PANNEAU AVANT
PANNELLO ANTERIORE
PANEL FRONTAL
VOORPANEEL
FRAMPANELEN
PANEL FRONTAL**

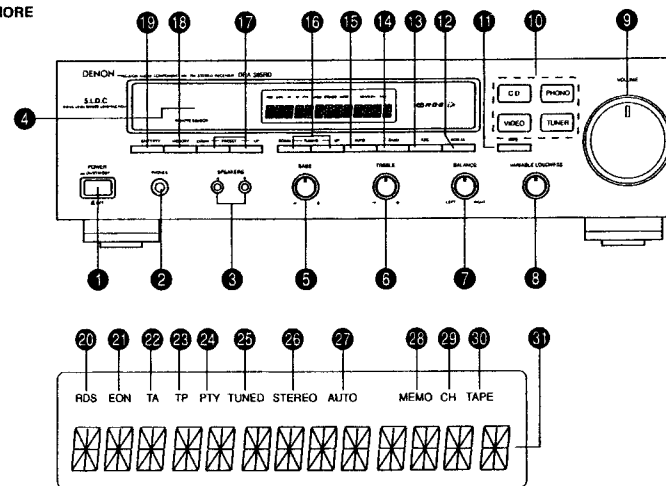

**DISPLAY
ANZEIGE
AFFICHAGE
DISPLAY
VISUALIZADOR
DISPLAY
DISPLAY
MOSTRADOR**

**REAR PANEL
RÜCKSEITE
PANNEAU ARRIÈRE
PANNELLO POSTERIORE
PANEL POSTERIOR
ACHERPANEEL
BAKSIDAN
PANEL TRASEIRO**

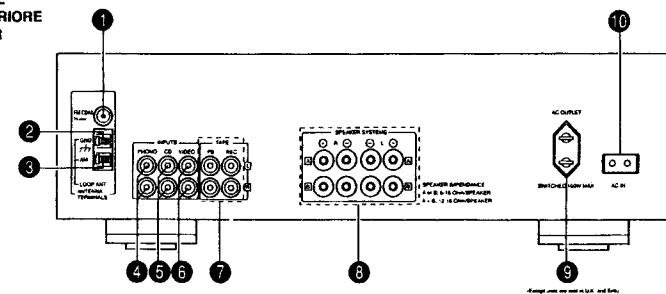

**NOTE ON USE / HINWEISE ZUM GEBRAUCH / OBSERVATIONS RELATIVES A L'UTILISATION
NOTE SULL'USO / NOTAS SOBRE EL USO / ALVORENS TE GEBRUIKEN / OBSERVERA
OBSERVAÇÕES SOBRE O USO**

 <ul style="list-style-type: none"> Avoid high temperatures. Allow for sufficient heat dispersion when installed on a rack. Vermieden Sie hohe Temperaturen. Beachten Sie, daß eine ausreichende Luftzirkulation gewährleistet sein muß, wenn das Gerät in einem Regal aufgestellt werden soll. Éviter des températures élevées. Tenir compte d'une dispersion de chaleur suffisante lors de l'installation sur une étagère. Evitare di esporre l'unità ad alte temperature. Accertarsi che ci sia un'adeguata dispersione del calore quando l'unità è installata in un rack o in un mobile. Evite temperaturas elevadas. Asegúrese de garantizar una dispersión de calor suficiente al instalar la unidad en una consola. Vermijd hoge temperaturen. Zorg voor een degelijk hitteafvoer indien het apparaat op een rek wordt geplaatst. Liikviik hohe temperaturer. Se till att det finns möjlighet till god värmeavledning vid monteringen i ett rack. Evite temperaturas altas. Quando instalar o equipamento numa prateleira coloque-o de modo a permitir uma dissipação suficiente do calor. 	 <ul style="list-style-type: none"> Keep the set free from moisture, water and dust. Halten Sie das Gerät von Feuchtigkeit, Wasser und Staub fern. Protéger l'appareil contre l'humidité, l'eau et la poussière. Mantenga el equipo libre de humedad, agua y polvo. Last geen vochtigheid, water of stof in het apparaat binnendringen. Usälti into apparatit fukt, vatten och damm. Mantenha o equipamento livre de humidade, água ou pó. 	 <ul style="list-style-type: none"> Do not let foreign objects in the set. Lassen Sie keine fremden Gegenstände in das Gehäuseinnere eindringen. Ne pas laisser des objets étrangers dans l'appareil. Non far cadere alcun oggetto all'interno dell'unità. No inserte objetos extraños en el equipo. Laat geen vreemde voorwerpen in dit apparaat vallen. Se till att främmande föremål inte tränger in i apparaten. Evite deixar objectos estranhos sobre o aparelho.
 <ul style="list-style-type: none"> Handle the power cord carefully. Hold the plug when unplugging the cord. Gehen Sie vorsichtig mit dem Netzkabel um. Halten Sie das Kabel am Stecker, wenn Sie es aus der Steckdose ziehen. Manipuler le cordon d'alimentation avec précaution. Tenir la prise lors du débranchement du cordon. Maneggiare con cura il cavo di alimentazione. Quando si scollega il cavo dalla presa, non tirare il cavo. Maneje el cordón de alimentación con cuidado. Sostenga el enchufe cuando desconecte el cordón de alimentación. Hanteer het netsnoer voorzichtig. Houd het snoer bij de stekker vast wanneer deze moet worden aan- of losgekoppeld. Hantiera nálkabein varsamt. Håll i kontakten när du drar ut den. Dra inte i kabein. Manuseie o cabo de alimentação com cuidado. Agarre na ficha para desligar o cabo de alimentação da tomada. 	 <ul style="list-style-type: none"> Unplug the power cord when not using the set for long periods of time. Ziehen Sie das Netzkabel aus der Steckdose, wenn Sie das Gerät über einen längeren Zeitraum hinweg nicht verwenden. Débrancher le cordon d'alimentation lorsque l'appareil n'est pas utilisé pendant de longues périodes. Quando si prevede di non utilizzare l'unità per lunghi periodi di tempo, disinnerte il cavo di alimentazione dalla presa. Desconecte el cordón de alimentación cuando no utilice el equipo por mucho tiempo. Næen abjst het netsnoer uit het stopcontact wanneer het apparaat gedurende een lange periode niet wordt gebruikt. Dra ur nálkabtan om apparaten inte kommer att användas på länge. Desligue o cabo de alimentação quando não utilizar o equipamento durante períodos prolongados. 	 <ul style="list-style-type: none"> Do not let insecticides, benzene, and thinner come in contact with the set. Lassen Sie das Gerät nicht mit Insektiziden, benzenthaligen oder anderen Verdünnungsmitteln in Berührung kommen. Ne pas mettre en contact des insecticides, du benzène et un diluant avec l'appareil. Evitare di utilizzare insetticidi, benzolo e solventi sull'unità. No vierta insecticidas, benceno o disolventes en la unidad. Laat geen insectenverdelgende middelen, benzine of verdunder met dit apparaat in contact komen. Se till att inte insektmedel, bensin och thinner kommer i kontakt med apparatens hölje. Evite que insecticidas, benzina e diluente entrem em contacto com o equipamento.
 <ul style="list-style-type: none"> Never disassemble or modify the set in any way. Verzuchen Sie niemals, das Gerät selbstständig auseinanderzunehmen oder auf jegliche Art zu verändern. Ne jamais démonter ou modifier l'appareil d'une manière ou d'une autre. Non smontare o modificare in alcun modo l'unità. Nunca desarme o modifique el equipo de ninguna manera. Neer di apparaat demonteren of op andere wijze modificeren. Ta inte isär apparaten och försök inte byggs om den. Nunca desmonte o modifique o equipamento de alguma forma. 	 <p>(For sets with ventilation holes)</p> <ul style="list-style-type: none"> Do not obstruct the ventilation holes. Die Lüftungsschlitze dürfen nicht verdeckt werden. Ne pas obstruer les trous d'aération. Non ostruire i fori per la ventilazione. De ventilatieopeningen mogen niet worden blokkeerd. Täpp inte till ventilationsöppningarna. Não tape os orifícios de ventilação. 	

Please check the following items are included with the main unit in the carton:

- (1) Operating Instructions 1
- (2) AM Loop Antenna 1
- (3) FM Antenna 1
- (4) Remote Control RC-174 1
- (5) Batteries R6 (AA) 2
- (6) AC Cord 1

Vergewissern Sie sich, daß folgende Teile vollständig im Lieferumfang enthalten sind:

- (1) Bedienungsanleitung 1
- (2) MW-Rahmenantenne 1
- (3) UKW-Antenne 1
- (4) Fernbedienungsgerät RC-174 1
- (5) Trockenzellen-Batterien R6 (AA) 2
- (6) Netzkabel 1

Veuillez vérifier que les articles suivants sont bien joints à l'appareil principal dans le carton:

- (1) Mode d'emploi 1
- (2) Antenne-cadre AM 1
- (3) Antenne FM 1
- (4) Télécommande RC-174 1
- (5) Piles de format R6 (AA) 2
- (6) Cordon secteur 1

Controllare che le parti seguenti si trovino imballate con l'apparecchio nella scatola di spedizione:

- (1) Istruzioni per l'uso 1
- (2) Antenna AM a telaio 1
- (3) Antenna FM 1
- (4) Telecomando RC-174 1
- (5) Batterie a secco R6 (AA) 2
- (6) Cavo d'alimentazione 1

Verifique que los artículos siguientes hayan sido suministrados con la unidad principal:

- (1) Instrucciones de operación 1
- (2) Antena AM de cuadro 1
- (3) Antena de FM 1
- (4) Unidad de control remoto RC-174 1
- (5) Pilas secas R6 (AA) 2
- (6) Cable de alimentación 1

Controleer of de volgende accessoires bij het hoofdtoestel in de doos zijn verpakt:

- (1) Gebruiksaanwijzing 1
- (2) AM-raamantenne 1
- (3) FM-antenne 1
- (4) Afstandsbediening RC-174 1
- (5) R6 (AA) droge cel batterij 2
- (6) Netsnoer 1

Kontrollera att följande tillbehör har packats ner i kartongen tillsammans med huvudenheten:

- (1) Bruksanvisning 1
- (2) Ramantenn för AM-bruk 1
- (3) FM-antenn 1
- (4) Fjärrkontroll RC-174 1
- (5) R6 (AA) torrbatteri 2
- (6) Nätkabeln 1

Verifique se os itens que se seguem estão incluídos na caixa de cartão com a unidade principal:

- (1) Instruções de funcionamento 1
- (2) Antena de quadro AM 1
- (3) Antena FM 1
- (4) Telecomando RC-174 1
- (5) Pilhas R6 (AA) 2
- (6) Cabo de alimentação 1

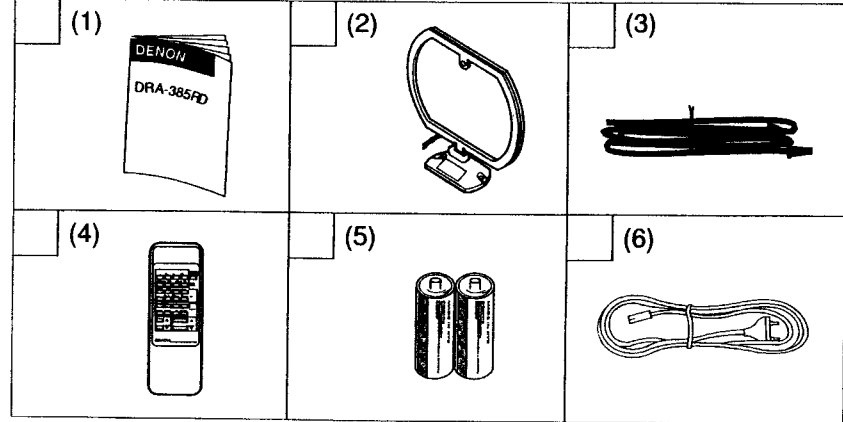

NUR FÜR EUROPÄISCHE MODELLE:
Konformitätsklärung
 Die DENON Elektronik GmbH
 Halskestr. 32
 40880 Ratingen
 erklärt als Hersteller/Importeur, daß das in dieser Bedienungsanleitung beschriebene Gerät den Technischen Vorschriften für Ton- und Fernseh-Rundfunkempfänger nach der Amtsblattverfügung 868/1989 (Amtsblatt des Bundesministers für Post und Telekommunikation vom 31.8.1989) entspricht.

CONNECTIONS

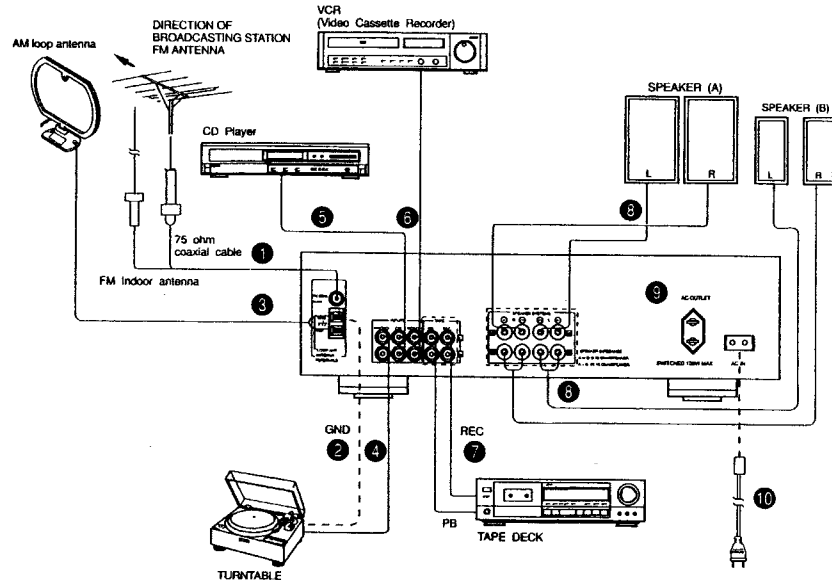

REAR PANEL

- | | |
|---|---|
| <p>1 FM ANT (FM antenna terminals)
75-ohm coaxial cable can be connected to this terminal. For antenna connecting procedure, see ANTENNA INSTALLATION.</p> <p>2 GND (Grounding terminal)
The grounding wire of the turntable is connected here.
• Hum or noise may be generated if the grounding wire is not connected.</p> <p>3 AM ANT (AM antenna terminals)
Connect the attached AM loop antenna. (Refer to page 7 for connections).
Connect to this terminal when a medium wave outdoor antenna is used.</p> <p>4 PHONO (Phono input terminals)
The output cord of the turntable is connected here.
Since the input sensitivity of "PHONO" is extremely high, do not use the unit without the input pin cord. If used without this cord, the speakers may generate hum.</p> | <p>5 CD
The output cord of the CD player is connected here.</p> <p>6 VIDEO
A VIDEO, such as a VCR or Video Disc may be connected here.</p> <p>7 TAPE
Tape decks can be connected for full use including playing or copying.</p> <p>8 SPEAKER SYSTEMS (Speaker terminals)
Two pairs of speakers A and B can be connected to these terminals.</p> <p>9 AC OUTLET (AC power outlet)
This AC outlet is controlled by the power switch.
(Except units are sold in U.K. and Eire)</p> <p>10 AC Inlet
Connect the included AC cord here.</p> |
|---|---|

6

SPEAKER CONNECTION

Confirm polarity (+, -) and left and right channels (L, R). Connect the speaker pairs to the SPEAKER terminals A or B on the back panel. Connections must be made with power cord disconnected.

Preparing the cord

1. Peel of the sheath.
2. Twist the wires.



ANTENNA INSTALLATION

FM ANTENNA

The supplied indoor FM antenna can be used inside wooden houses for receiving local FM stations and other strong FM signals. Stretch out the end of the antenna and mount the antenna on the wall or ceiling where optimum reception is achieved. An indoor FM antenna may not consistently ensure stable reception, due to environment changes. In such cases, the indoor FM antenna should only be used temporarily until an outdoor FM antenna has been installed. When connecting an outdoor FM antenna, the use of 75 ohm coaxial cable (3C-2V, 6C-2V) is strongly recommended.

AM ANTENNA

Attach the supplied AM loop antenna even when using an outdoor AM antenna. Connect the leads to the AM and GND terminals. Also use the AM terminals for connecting an outdoor AM antenna (when making such a connection do not disconnect the AM loop antenna). Adjust the loop antenna to obtain optimum reception. Where broadcast stations are distant and only weak signals are received or where signals are blocked, it is best to install an outdoor AM antenna.

Notes on Connection

- Do not plug the power cord into the AC wall outlet until all connections have been completed.
- Make sure channels are correctly connected. Connect Left channels to Left channels and Right channels to Right channels. Follow the color markings of plugs and terminals to make sure mistakes are not made.
- Connect all pin-plugs securely, pushing them completely into the jacks incomplete connections will cause noise generation.
- Binding the connection cables to power cords, or running such cables close to power supply transformers will cause humming or noise, and should thus be avoided.

Connecting the front speaker terminals

1. Loosen by turning counterclockwise.
2. Insert the cord and tighten by turning clockwise.



Assembling the Loop Antenna



- Remove the tie fastening the loop antenna's lead and connect the lead to the antenna terminals.

Notes:

- Do not connect two FM antennas simultaneously.
- Even if an external AM antenna is used, do not disconnect the AM loop antenna.
- Make sure AM loop antenna lead terminals do not touch metal parts of the panel.

CAUTION

Protective Circuit

This set is equipped with a high speed protective circuit. This circuit protects the internal circuitry from damage due to large currents flowing when the speaker jacks are not completely connected or when an output is generated by a short circuit. This protective circuit's operation cuts off the output to the speakers. In such a case, be sure to turn the power to the set off and check the connections to the speakers. Then turn the power on again. After muting for several seconds, the set will operate normally.

7

DESIGNATIONS AND FUNCTIONS OF PANEL CONTROLS (Refer to Page 3.)

FRONT PANEL

- 1 POWER (Power ON-STANDBY/OFF Switch)**
This switch turns the unit ON or OFF. There is a delay of approximately 3 seconds before the unit will operate after this power switch is turned ON. If the unit is turned OFF from the remote control, the unit will be in the STANDBY mode. When in the STANDBY mode, the unit can be turned ON with the power button on the remote control. If the unit will not be used for extended period, be sure to turn the unit OFF from the front panel power switch.
- NOTE:** This unit includes a STANDBY protection feature. This feature is designed to prevent accidental turn-on from the STANDBY mode in the event of a power failure. Should AC power be disconnected and then reconnected when the unit is in STANDBY mode, the unit will return the STANDBY mode.
To turn the unit ON from the STANDBY mode without the remote control, operate the front panel power switch four times. The unit will then operate normally.
- 2 PHONES (Headphones jack)**
Connect a pair of headphones (sold separately) to this jack for private listening.
- 3 SPEAKERS (Speaker selector switches)**
These switches are used to select speaker system A and B. No sound is heard through the speakers when both switches are reset to the (M) position.
- 4 REMOTE SENSOR (Remote control sensor)**
This sensor receives the infra-red light transmitted from the wireless remote control unit.
For remote control, point the wireless remote control unit towards the sensor.
- 5 BASS (Bass control)**
Use this control to adjust the low-range response. When the control is set to the center position, the frequency characteristic curve (below 1,000 Hz) is flat. Turn the control clockwise to increase the bass response and counterclockwise to decrease it.
- 6 TREBLE (Treble control)**
Use this control to adjust the high-range response. When the control is set to the center position, the frequency characteristic curve (above 1,000 Hz) is flat. Turn the control clockwise to increase the treble response and counterclockwise to decrease it.
- 7 BALANCE (Balance control)**
Use this control to balance the volume levels between left and right channels. The volume levels in both channels are equal when the control is set to the center position.
- 8 VARIABLE LOUDNESS (Loudness control)**
At low volumes, the human ear is less sensitive to low (BASS) and high (TREBLE) frequencies. Use this control to compensate for this deficiency when listening at low volume levels. Turn this control counter-clockwise until a natural balance of bass and treble sound has been restored.

NOTES

- This receiver has a full back-up system. When the power is turned on, the INPUT SELECTOR buttons are set to the last mode set before the power was turned off.
- When using this receiver in close proximity to video equipment (TV, VCR, VDP, etc.) noise may be generated in AM broadcasts.

- 9 VOLUME (Volume control)**
This knob is used to adjust the volume level of both channels. Turn the knob clockwise to raise the volume and counterclockwise to lower it.
- 10 Input selector (Input selector buttons)**
These buttons are used to select the audio input source.
• PHONO: Press to play a record on a record player connected to the PHONO input jacks.
• CD: Press to listen to a compact disc player or another component connected to the CD input jacks.
• TUNER: Press to listen to FM or AM programs.
• VIDEO: Use when playing back the audio from a Hi-Fi video, video disc player or other component connected to the VIDEO terminal.
- 11 TAPE (Tape monitor button)**
Press this button once, TAPE indicator will light up and then you can play tape source on the TAPE terminal. Press again the button currently accessed, to play sources selected by input selector 10, indicator goes out.
- 12 EON TA button**
When a traffic announcement begins on a station in the same network as the station currently tuned in, that network station is automatically tuned in, and the previous station is tuned back in once the traffic announcement is over.
This button is used to turn this mode on and off.
If the station switches from the current station to the network station when this mode is on but the network station cannot be received properly due to weak signals, the previous station is immediately tuned back in. (Refer to page 11.)
- 13 RDS (RDS button)**
This button is used for the RDS search (refer to page 10) and PTY search (refer to page 10, 11) and TP search (refer to page 11) operations, and to input the station name (refer to page 10).
- 14 BAND (Band selector button)**
Press this button to select the FM or AM (MW) band.
- 15 AUTO (Tuning mode button)**
This switches between auto and manual tuning.
Auto tuning: When the UP button is pressed, the radio is tuned automatically to a higher frequency. Press the DOWN button to tune to a lower frequency. Use this position to eliminate noise when no signals or weak signals are being received.
Manual tuning: In this position, the radio can be tuned manually. Reception is automatically monaural when in the manual mode.
- 16 TUNING (Tuning buttons)**
Use these to change the received frequency to a higher frequency (UP) or a lower frequency (DOWN).
When writing station names, use these buttons to select the letters. (Refer to Page 10.)

To avoid this, keep the receiver as far away from other video components as possible, or place the AM loop antenna where noise is reduced. If the noise is not reduced, turn off the power of the video components when listening to AM broadcasts.

- 17 Preset (Preset station buttons)**
These buttons are used for storing stations or recalling stations which have been preset. Using the SHIFT/PTY button you can preset a total of 40 FM or AM stations into preset channels.
Once a radio has been memorized, the same station can later be tuned in instantly simply by recalling the corresponding preset channel with PRESET UP or DOWN button.

- 18 MEMORY (Memory button)**
This switch is used to store the desired radio station to a memory.
- 19 SHIFT / PTY button**
Use this button to select the memory blocks, A (1 to 8), B (1 to 8), C (1 to 8), D (1 to 8) or E (1 to 8).
For PTY search, use this button to select the program type.
When writing station names, use this button to set the writing position.

DISPLAY

- 20 RDS indicator**
This lights when receiving RDS broadcasts, and flashes during the RDS search operation.
- 21 EON indicator**
This lights when receiving EON information.
- 22 TA Indicator**
This lights when receiving traffic announcements.
- 23 TP Indicator**
This flashes during the TP search operation and lights when TP stations are tuned in.
- 24 PTY indicator**
This flashes during the PTY (Programme Type) search operation.
- 25 TUNED indicator**
This lights when a station is properly tuned in.
- 26 STEREO indicator**
This lights when receiving stereo broadcasts. It remains off when receiving AM broadcasts.

- 27 AUTO indicator**
This indicates the tuning mode. It lights in the auto mode and remains off in the manual mode.
- 28 MEMO indicator**
This indicator lights for approximately 10 seconds when the MEMORY button has been pressed and a station can be stored on a PRESET CHANNEL button.
This flashes continuously during the auto memory operation.
- 29 CH indicator**
This lights when the preset channel number and shift mode (A, B, C, D or E) are displayed.
- 30 TAPE indicator**
The TAPE indicator lights when the TAPE source is selected with the tape selector buttons.
- 31 Multi function display**
This displays the frequency, station name, program type, etc.

USING THE VARIOUS FUNCTIONS

1. Using the auto preset memory function

This function automatically stores the FM stations which can be received in the area in which the set is being used in the preset memory. Use this function so that the RDS functions can be used more effectively. Also note that the channel memories can be changed at will even after the preset stations have been stored with this function.

Operation

- Connect the FM antenna and set it so that FM stations can be received.
- Press the POWER button to turn on the power while holding in the MEMORY button.
- Searching begins automatically, and stations are stored in the preset memory in order, beginning from channel A1. (The operation automatically stops once 40 stations have been set in the memory.)

2. Storing new stations at the preset channels

The reception frequency, RDS service information, Tuning mode and input characters can be stored at the different channel memories.
When this operation is performed, the station already stored in that channel memory using the auto preset memory function is cleared.

Operation

- Press the MEMORY button. (The MEMO indicator flashes.)
- Use the SHIFT/PTY button to select the block, A to E.
- Use the PRESET UP or DOWN button to select the channel at which the station is to be stored.
- Press the MEMORY button again to store the station in the memory.

3. Recalling preset channels

Use the following operation to recall preset channels:

Operation

- Use the SHIFT/PTY button to select the block, A to E.
- Use the PRESET UP or DOWN button to recall the station stored in the memory.
If the PRESET UP or DOWN buttons are pressed without pressing the SHIFT/PTY button, the stations are recalled in the order A1 to A8, B1 to B8, and so on through E8.

4. Inputting characters

Any characters can be input (up to 8 characters). The input characters can be stored at the preset channels.

Operation

1. Press the RDS button ● four times. (The cursor flashes at the first place.)

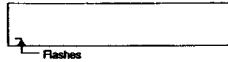

2. Use the TUNING UP or DOWN button ● to select the character for the first place. (The selected character flashes.)

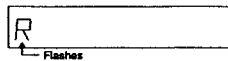

3. Press the SHIFT/PTY button ● to move the cursor to the next place. (The cursor flashes at the second place.)

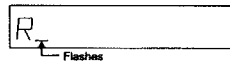

4. Repeat steps 2 and 3 above to input up to 8 characters.

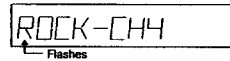

5. The characters are set five seconds after the input procedure is finished. The input characters can be stored in the memory. To keep the input characters, be sure to store them in a channel memory.

6. Clearing characters

1. Recall the character you want to clear.
2. Press the RDS button ● 4 times until the character at the first place flashes.
3. Then press the SHIFT/PTY button ● for at least 2 seconds. The current character will then be cleared.

Table of characters

The characters are input in the order shown to the right. Use the TUNING buttons ● to select the desired characters.

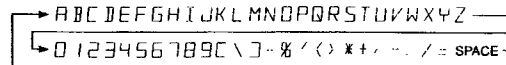

Using the RDS functions (for FM only)

1. RDS search

Use this to automatically search and stop at stations offering RDS services.

Operation

1. Press the RDS button ● once.

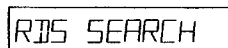

2. Press the PRESET UP or DOWN button ●. (Searching begins.)



3. Searching begins again if the PRESET UP or DOWN button ● is pressed while the RDS indicator is flashing.

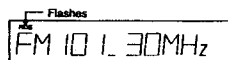

4. If no other RDS station is found when all the frequencies are searched, "NO RDS" is displayed.

2. PTY Search

Use this to automatically search and stop at stations broadcasting the specified programme type (PTY).

Operation

1. Press the RDS button ● twice.

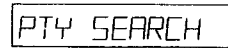

2. Use the SHIFT/PTY button ● to select the programme type.

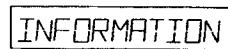

3. Press the PRESET UP or DOWN button ●. (Searching begins.)

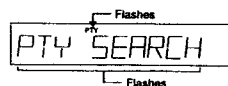

4. Searching begins again if the PRESET UP or DOWN button ● is pressed while the PTY indicator is flashing.

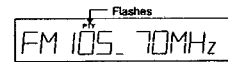

5. If no other station broadcasting the designated programme type is found when all the frequencies are searched, "NO PROGRAMME" is displayed.

List of PTY (Programme Type) displays:

- | | |
|----------------|-----------------------------------|
| 1. NEWS | 9. VARIED |
| 2. AFFAIRS | 10. POP MUSIC |
| 3. INFORMATION | 11. ROCK MUSIC |
| 4. SPORT | 12. M.O.R. MUSIC |
| 5. EDUCATION | 13. L-CLASSICS (Light classics) |
| 6. DRAMA | 14. S-CLASSICS (Serious classics) |
| 7. CULTURE | 15. OTHER MUSIC |
| 8. SCIENCE | 31. ALARM |

NOTE: ALARM cannot be selected during the PTY search operation.

3. TP Search

Use this to automatically search and stop at stations which broadcast traffic announcements (even if the station is not currently broadcasting a traffic announcement).

Operation

1. Press the RDS button ● three times.



2. Press the PRESET UP or DOWN button ●. (Searching begins.)



3. Searching begins again if the PRESET UP or DOWN button ● is pressed while the TP indicator is flashing.

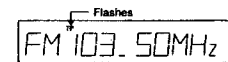

4. If no other TP station is found when all the frequencies are searched, "NO PROGRAMME" is displayed.

4. EON TA

When an RDS station is broadcasting RDS information on other stations within the same network and a traffic announcement begins on another station in the same network based on this information (EON = Enhanced Other Network), that network station is automatically tuned in. The previous station is tuned back in once the traffic announcement is over.

Operation

1. Press the EON TA button ●. (The EON TA indicator lights.)

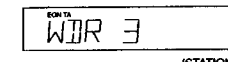

(When a traffic announcement starts, that station is automatically tuned in.)

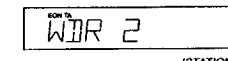

(When the traffic announcement is over, the previous station is tuned back in.)

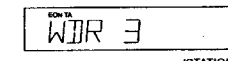

RDS Emergency Alarm

"ALARM" will flash on the display when the unit receives the Emergency Programme Type Code (PTY31) from an RDS station. This feature may not operate properly if the signal from the RDS station is too weak or is subjected to interference. It is not possible to select the "ALARM" display from the PTY search mode.

NOTE:

1. Be sure to turn the EON TA mode off when recording programmes.
2. In the EON TA mode, if the station is switched from the current station to another station in the network but the signals of that network station are weak and it cannot be tuned in properly, "WEAK SIGNAL" is displayed and the original station is immediately tuned back in.
3. In the EON TA mode, the station does not switch to another station in the network if the current station is broadcasting a traffic announcement.
4. Since the RDS services offered differ from station to station, some RDS functions may not operate for some stations, but this is not a malfunction.

PLAYBACK USING THE REMOTE CONTROL

The accessory RC-174 remote control unit is used to control the RECEIVER from a distance.

(1) Inserting the dry cell batteries

1. Remove the rear cover on the remote control unit.

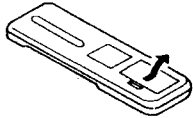

2. Insert two size "AA" (R6) dry cell batteries as shown in the diagram on the battery supply unit.



3. Replace the rear cover.

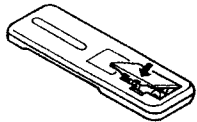

(2) Directions for use

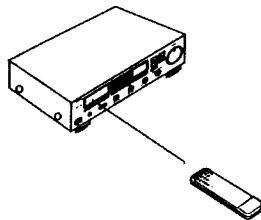

Notes on Use of the Batteries

- The remote control unit uses size "AA" (R6) dry cell batteries.
- The batteries will need to be replaced approximately once a year. This will depend upon how often the remote control is used.
- If, in less than a year from the time new batteries were inserted, the remote control fails to operate the receiver from a near-by position, it is time to replace the batteries.
- Insert the batteries properly, following the diagram on the remote control battery supply unit, and making sure to align the plus and minus sides of each battery.
- Batteries are prone to damage and leakage. Therefore:
 - Do not combine new batteries with used ones.
 - Do not combine different types of batteries.
 - Do not jumper the opposite poles of the batteries, expose them to heat or break them open, or put them into open fire.
- When the remote control is not to be used for a long period of time, remove the batteries from the unit.
- If the batteries have leaked, remove any battery fluid from the inside of the battery supply unit by wiping it out thoroughly and insert new batteries.

- Operate the remote control unit while pointing it towards the remote control sensor on the receiver as shown in the diagram left.
- The remote control unit can be used at distances up to about 8 meters in a straight line from the receiver. This distance will decrease if there are obstructions blocking the infra-red light transmission or if the remote control unit is not directed straight at the receiver.

Note on Operation

- Do not press the operating buttons on the receiver and the remote control unit at the same time. This will cause misoperation.
- Operation of the remote control unit will become less effective or erratic if the infrared remote control sensor on the receiver is exposed to strong light or if there are obstructions between the remote control unit and the sensor.
- In case you operate your VCR, TV or other components by remote control, do not operate buttons on two different remote control units at the same time. This will cause misoperation.

Besides being able to operate the DRA-385RD receiver with this remote control unit, you can also operate a DENON cassette deck and CD player from this handy full-system remote control unit.

Remote Control Section

Full-system Remote Control Unit

The full-system remote control unit operates all major functions of the receiver such as function switching, volume control, and preset station selection. But that's not all! The same control pad can also control the major functions of a DENON CD player and cassette deck to create a remarkably ergonomic and versatile DENON system with all the quality sound reproduction that the devoted audiophile expects.

Remote Control Unit RC-174 supplied with DRA-385RD

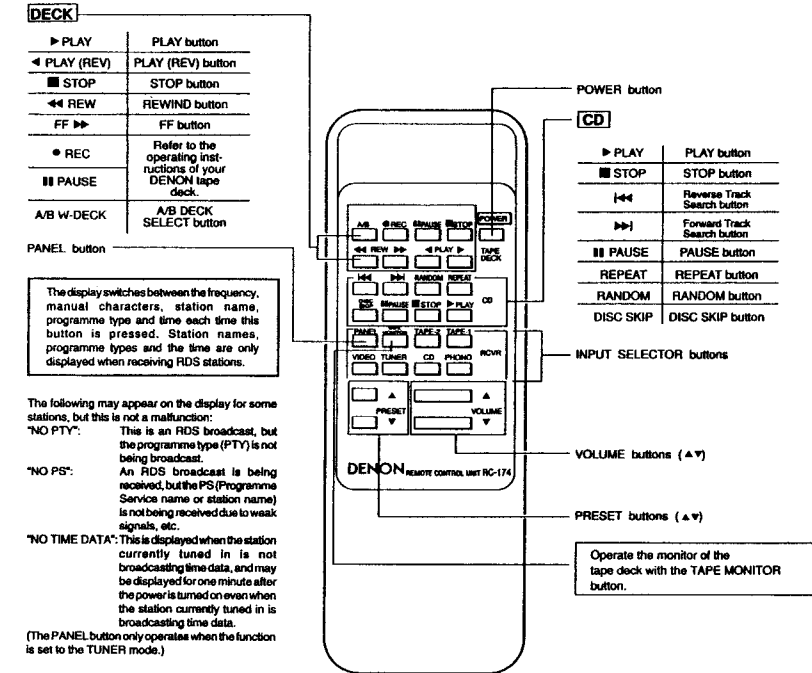

- The RC-174 Remote Control Unit can control CD players and cassette decks made by DENON.
- Note the operation may not be possible for some models.
- Buttons are conveniently separated into groups, each group controlling one specific component. The groups are RECEIVER; CD and DECK.

For details on operating other components, refer to the instruction manuals for the CD player and/or cassette deck.

CAUTION:

- If the power is turned off with the remote control unit, the receiver is switched to the power stand-by state. If you are to be absent for a long period of time, be sure to turn the power off using the POWER switch on the receiver.
- A part of 1st digit of fluorescent display light while the receiver is in the power stand-by state.
- You may experience erratic operation of the remote control unit if it is operated in fluorescent light and direct sunlight, in particular if this light strikes the remote control sensor on the receiver. However, this is not a malfunction, and if this should happen, protect the sensor against such light.

TROUBLESHOOTING

1. Have all connections been made PROPERLY?
2. Have you followed all operational instructions correctly?
3. Check speaker and the turntable systems for proper operation.

When your unit does not seem to be operating correctly, first check the items in the following table. If the symptom does not correspond to any of the problems as shown below, turn off the power sources immediately and contact your DENON dealer.

Problem	Cause	Remedy
FM AND AM RECEPTION		
Radio program can not be received.	<ul style="list-style-type: none"> • Antenna connection is wrong. • A signal strength is weak. 	<ul style="list-style-type: none"> • Check the connection. • Check the antenna installation.
Noise is reproduced.	<ul style="list-style-type: none"> • A signal strength is weak. • Automobile ignition noise interferes with reception. • Other electrical equipment interferes with reception. 	<ul style="list-style-type: none"> • Install an outdoor antenna. • Keep the antenna away from the street. • Keep the equipment away from this set, or turn off the power of the other equipment.
The preset frequencies are erased.	<ul style="list-style-type: none"> • The memory back-up term (about 1 month) passed. 	<ul style="list-style-type: none"> • Preset again.
In automatic tuning, the frequency doesn't stop at the radio station.	<ul style="list-style-type: none"> • A signal strength is weak. 	<ul style="list-style-type: none"> • Use manual tuning.
In automatic tuning, it stops at the one step lower or higher frequency than the radio station.	<ul style="list-style-type: none"> • Noise or strong signal strength is received. 	<ul style="list-style-type: none"> • Use manual tuning for optimum reception.
PLAYBACK OF THE AUDIO EQUIPMENTS		
No sound is produced with power on.	<ul style="list-style-type: none"> • Input and speaker cords connection are wrong. • Speaker switch is off. • The INPUT SELECTOR buttons are in wrong position. • The protective circuit is operating. • The fuse has blown out. 	<ul style="list-style-type: none"> • Check the connection. • Turn on speaker switch. • Check these position. • Turn the power off once, check the connections to the speakers, then turn the power on again. • Ask your dealer, or the nearest DENON representative.
Audible hum when playing records.	<ul style="list-style-type: none"> • The input and grounding cords connection of the turntable are wrong. • The cords connection of the cartridge are wrong. • The interference from the nearby TV or radio transmission antenna 	<ul style="list-style-type: none"> • Check the connection. • Check the connection. • Ask your dealer, or the nearest DENON representative.
Howling is produced when the volume control is turned up too high while playing records.	<ul style="list-style-type: none"> • The vibrations and sounds transmit from the speakers to the turntable. 	<ul style="list-style-type: none"> • Insulate the vibrations, or keep the speakers away from the turntable.
Cracking noise is produced when playing records.	<ul style="list-style-type: none"> • The record is stained with dust. • The stylus tip of the cartridge is stained with the dust. • The cartridge is defective. 	<ul style="list-style-type: none"> • Clean the record. • Clean the stylus tip. • Try the other cartridge.

SPECIFICATIONS

AMPLIFIER SECTION

Continuous Power Output (DR):	65 W + 65 W (4 ohms, 1 kHz)
Power Bandwidth (BWF):	10 Hz - 40 kHz (T.H.D. 0.15% both channels driven into 8 ohms)
Total Harmonic Distortion:	0.03% (-3 dB at rated output, 8 ohms)
Frequency Response:	PHONO RIAA Standard Curve (Recording Output) MM 20 Hz - 20 kHz ± 0.5 dB CD, VIDEO, 20 Hz - 50 kHz ± 1.5 dB TAPE (at 1 W)
Input Sensitivity and Impedance:	PHONO MM 2.5 mV 47 kohms CD, VIDEO, 150 mV 25 kohms TAPE
Maximum Input Level: (at 1 kHz)	PHONO MM 120 mV
Signal to Noise Ratio (SNR-A):	PHONO MM 78 dB (at 5.0 mV input) CD, VIDEO, 98 dB TAPE
Tone Controls:	BASS ± 10 dB at 100 Hz TREBLE ± 10 dB at 10 kHz
Loudness Control Effect:	Variable Loudness at maximum position 50 Hz/10 kHz, +10 dB/+5 dB

TUNER SECTION

[FM] (note: μV at 75 ohms, 0 dB = 1×10^{-4} W)	
Receiving Range:	87.5 - 108 MHz
Usable Sensitivity:	0.9 μV (10.3 dB)
Signal to Noise Ratio (SNR-A):	MONO 82 dB STEREO 78 dB
Image Rejection:	65 dB
Selectivity (± 300 kHz):	55 dB
Frequency Response:	30 Hz - 15 kHz +0.2 dB -1.5
Stereo Separation (at 1 kHz):	40 dB
[AM]	
Receiving Range:	522 - 1611 kHz
Usable Sensitivity:	18 μV
Signal to Noise Ratio:	55 dB
General	
Power Supply:	AC 230 V 50 Hz
Power Consumption:	125 W
Power Output:	SWITCHED 100 W
Dimensions:	434 mm (W) x 119 mm (H) x 310 mm (D)
Weight:	5.9 kg
REMOTE CONTROL UNIT	RC-174
Remote control system:	Infrared pulse system
Power supply:	3V DC two size "AA" (R6) dry cell batteries
External dimensions:	50 mm (W) x 175 mm (H) x 18 mm (D)
Weight:	120 g (includes batteries)

Design and specifications are subject to change without prior notice.

DISASSEMBLY

(To reassemble reverse disassembly)

1. Top Cover

- (1) Remove 4 screws ①.
- (2) Remove 2 screws ②.

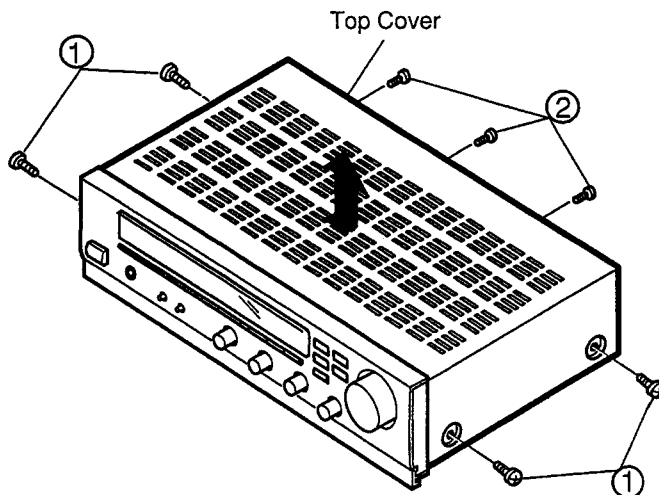

2. Front Panel

- (1) Pull out Volume knob ③.
- (2) Remove nut ④.
- (3) Remove 5 screws ⑤ and undo hooks at 2 places.

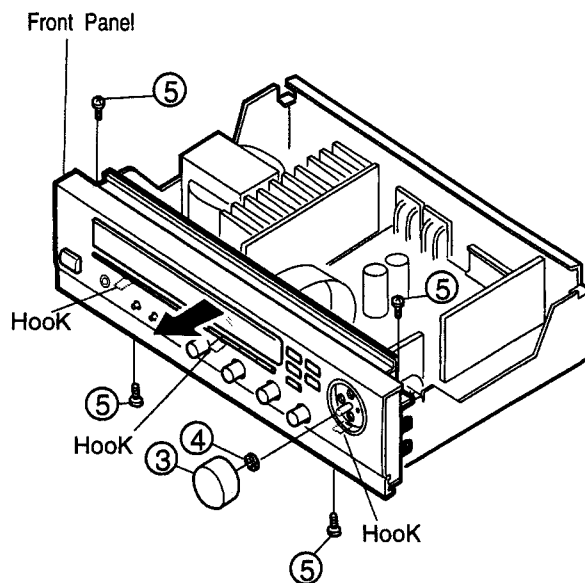

3. Rear Panel

- (1) Remove 2 screws ⑥ and 11 fixing screws ⑦.
- (2) Remove hooks at 3 places in arrow direction.

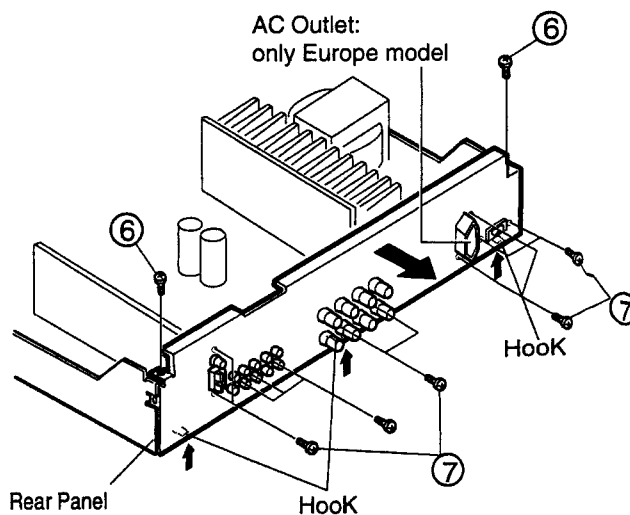

METHOD OF ADJUSTMENTS

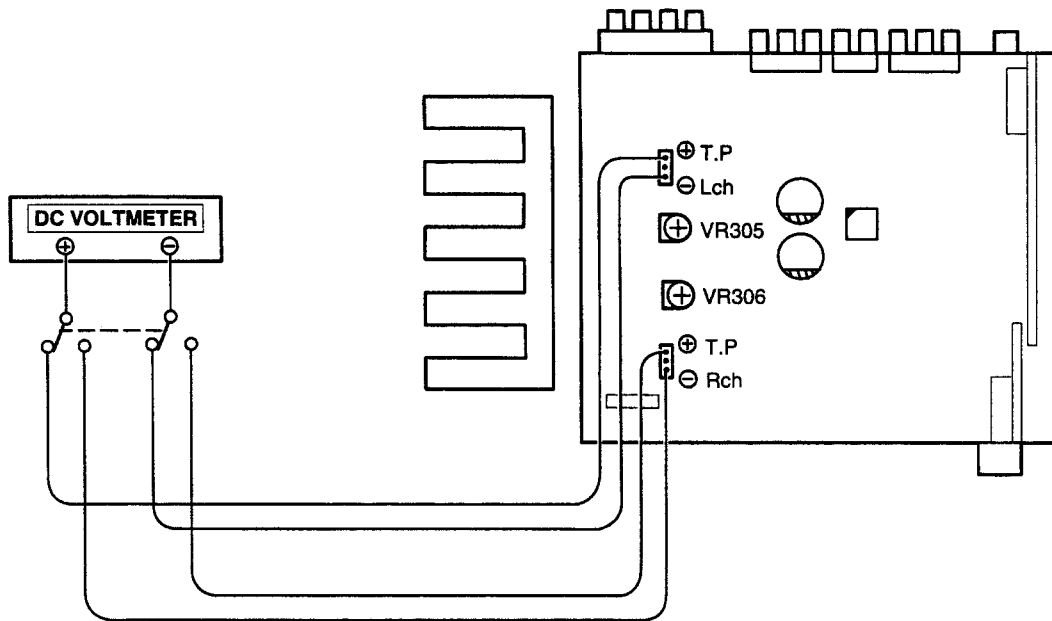

IDLING CURRENT

- (1) Set controls as follows.
 - POWER Switch → off (■)
 - VOLUME Control → 0 (min.)
 - SPEAKERS → off (■)
 - Temperature → 15°C ~ 30°C (59°F ~ 86°F)
 - VR305 and VR306 of the 1U-2817-1 (Main Unit) → MIN. (↻)
- (2) Connect DC Voltmeter to the T.P Lch and T.P Rch of the 1U-2817-1.
- (3) Turn the Power Switch on and rotate VR305 clockwise so that the DC Voltmeter reads 2.5 mV ±0.2 mV DC at the T.P Lch. Follow the same procedure to VR306 for T.P Rch.
- (4) Warm up for three minutes, then readjust VR305 and VR306 so that the DC Voltmeter reads 2.5 mV ±0.5 mV DC.
- (5) Warm up for 10 minutes, then readjust VR 305 and VR306 so that the DC Voltmeter reads 2.5 mV ±0.5 mV DC.

CONNECTINON DIAGRAM OF MEASURING INSTRUMENTS

● FM SECTION

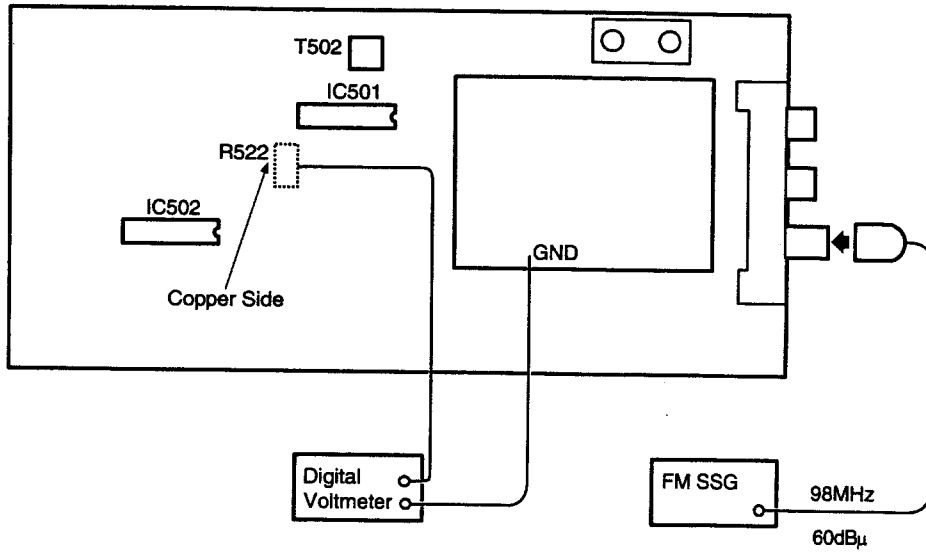

Adjust T502, Potential difference across R522 should be within 50mV.

BLOCK/LEVEL DIAGRAM

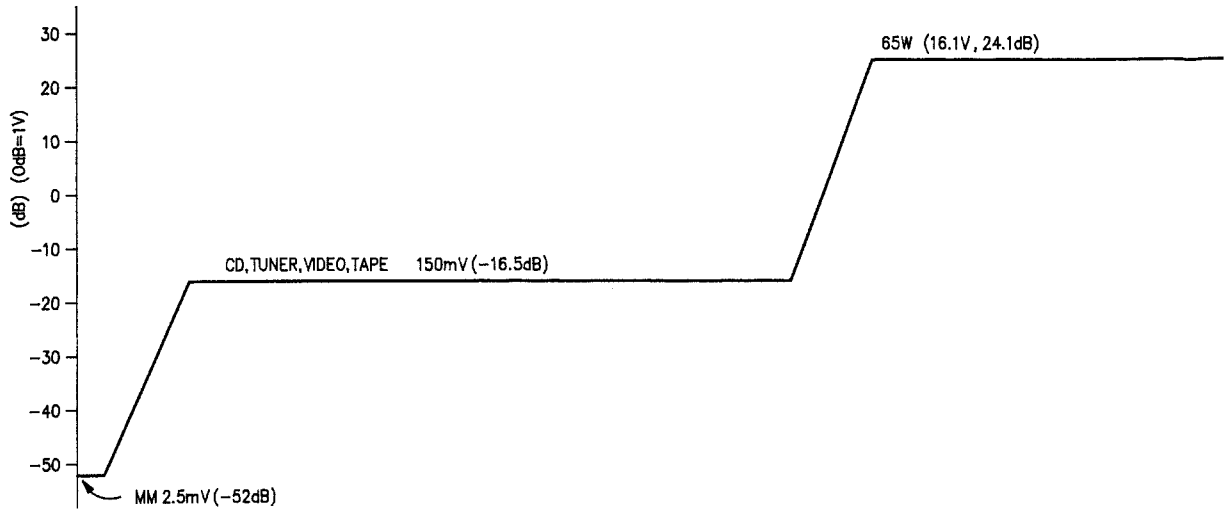
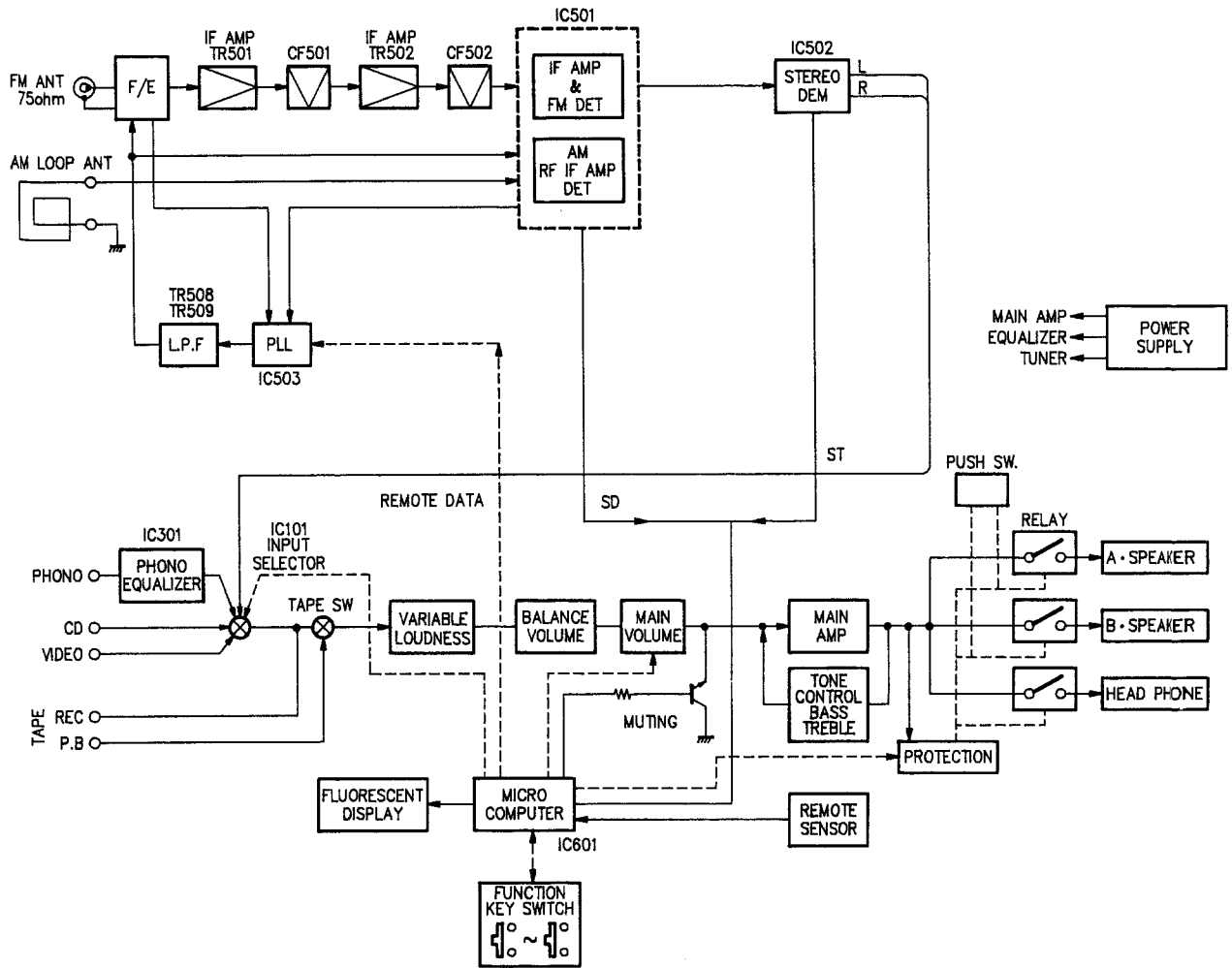

NOTE FOR PARTS LIST

- Part indicated with the mark "◎" are not always in stock and possibly to take a long period of time for supplying, or in some case supplying of part may be refused.
- When ordering of part, clearly indicate "1" and "I" (i) to avoid mis-supplying.
- Ordering part without stating its part number can not be supplied.
- Part indicated with the mark "★" is not illustrated in the exploded view.
- Not including Carbon Film ±5%, 1/4W Type in the P.W.Board parts list. (Refer to the Schematic Diagram for those parts.)

WARNING:

Parts marked with this symbol  have critical characteristics.
Use ONLY replacement parts recommended by the manufacturer.

● **Resistors**

Ex.: RN 14K 2E 182 G FR
 Type Shape and performance Power Resistance Allowable error Others

RD : Carbon	2B : 1/8W	F : ±1%	P : Pulse-resistant type
RC : Composition	2E : 1/4W	G : ±2%	NL : Low noise type
RS : Metal oxide film	2H : 1/2W	J : ±5%	NB : Non-burning type
RW : Winding	3A : 1W	K : ±10%	FR : Fuse-resistor
RN : Metal film	3D : 2W	M : ±20%	F : Lead wire forming
RK : Metal mixture	3F : 3W		
	3H : 5W		

● **Resistance**

1 8 2 ⇒ 1800 ohm = 1.8 kohm
 Indicates number of zeros after effective number.
 2-digit effective number.

• Units: ohm

1 R 2 ⇒ 1.2 ohm
 1-digit effective number.
 2-digit effective number, decimal point indicated by R.

• Units: ohm

● **Capacitors**

Ex.: CE 04W 1H 2R2 M BP
 Type Shape and performance Dielectric strength Capacity Allowable error Others

CE : Aluminum foil electrolytic	0J : 6.3V	F : ±1%	HS : High stability type
CA : Aluminum solid electrolytic	1A : 10V	G : ±2%	BP : Non-polar type
CS : Tantalum electrolytic	1C : 16V	J : ±5%	HR : Ripple-resistant type
CQ : Film	1E : 25V	K : ±10%	DL : For charge and discharge
CK : Ceramic	1V : 35V	M : ±20%	HF : For assuring high frequency
CC : Ceramic	1H : 50V	Z : +80%	U : UL part
CP : Oil	2A : 100V	-20%	C : CSA part
CM : Mica	2B : 125V	P : +100%	W : UL-CSA type
CF : Metallized	2C : 160V	-0%	F : Lead wire forming
CH : Metallized	2D : 200V	C : ±0.25pF	
	2E : 250V	D : ±0.5pF	
	2H : 500V	= : Others	
	2J : 630V		

● **Capacity (electrolyte only)**

2 2 2 ⇒ 2200µF
 Indicates number of zeros after effective number.
 2-digit effective number.

• Units: µF.

2 R 2 ⇒ 2.2µF
 1-digit effective number.
 2-digit effective number, decimal point indicated by R.

• Units: µF.

● **Capacity (except electrolyte)**

2 2 2 ⇒ 2200pF = 0.0022µF
 (More than 2) — Indicates number of zeros after effective number.
 2-digit effective number.

• Units: µF.

2 2 1 ⇒ 220pF
 (0 or 1) — Indicates number of zeros after effective number.
 2-digit effective number.

• Units: pF.

• When the dielectric strength is indicated in AC, "AC" is included after the dielectric strength value.

PRINTED WIRING BOARD PARTS LIST

1U-2817 MAIN UNIT ASS'Y

Ref. No.	Part No.	Part Name	Remarks
SEMICONDUCTORS GROUP			
IC101	262 1227 008	IC LC7821	
IC301	263 0615 902	IC BA15218F	
IC401	263 1010 001	IC BA178M06	
IC701	263 0892 903	IC NJM2082M	
IC801	262 1701 906	IC :SAA6579T	
IC802	262 1929 908	IC LC7074M	
TR251	274 0151 903	Transistor 2SD2004(P)	
TR252	272 0107 906	Transistor 2SB1328(P)	
TR253	273 0388 906	Transistor 2SC1740S(E)	
TR254	271 0192 905	Transistor 2SA933S(S)	
TR255	273 0388 906	Transistor 2SC1740S(E)	
TR256	271 0280 901	Transistor 2SA1038S(S/E)	
TR257	273 0432 904	Transistor 2SC2389S(S/E)	
TR301,302	269 0107 900	Transistor RN1241(A/B)	Built in resistor
TR303,304	273 0235 923	Transistor 2SC1841(E/F)	
TR305-308	271 0131 924	Transistor 2SA988(E/F)	
TR309,310	273 0235 923	Transistor 2SC1841(E/F)	
TR315,316	273 0198 002	Transistor 2SC1815(Y)	
TR317,318	274 0060 900	Transistor 2SD667A(C)TZ	
TR319,320	272 0053 908	Transistor 2SB647A(C)	
TR321,322	273 0443 003	Transistor 2SC4278(E/F)	
TR323,324	271 0283 005	Transistor 2SA1633(E/F)	
TR325,326	273 0235 923	Transistor 2SC1841(E/F)	
TR401	273 0384 900	Transistor 2SC2412K(S)	
TR402	269 0048 904	Transistor DTC143EK	Built in resistor
TR403	273 0384 900	Transistor 2SC2412K(S)	
TR404	272 0131 901	Transistor 2SB1041(R)	
TR451	271 0131 924	Transistor 2SA988(E/F)	
TR452	273 0388 906	Transistor 2SC1740S(E)	
TR453	269 0054 901	Transistor DTC144EK	Built in resistor
TR454	273 0384 900	Transistor 2SC2412K(S)	
TR455	273 0388 906	Transistor 2SC1740S(E)	
TR456	271 0192 905	Transistor 2SA933S(S)	
TR457-459	273 0388 906	Transistor 2SC1740S(E)	
TR460	273 0384 900	Transistor 2SC2412K(S)	
TR471	269 0083 901	Transistor DTA114EK	Built in resistor
TR473	269 0054 901	Transistor DTC144EK	Built in resistor
D251	276 0338 007	Diode S4VB20F	
D252	276 0553 905	Diode 1SR35-200A	
D303-306	276 0619 904	Diode 1S2471	
D307-312	276 0616 907	Diode 1SS252	

Ref. No.	Part No.	Part Name	Remarks
D401,402	276 0616 907	Diode 1SS252	
D403-410	276 0553 905	Diode 1SR35-200A	
D411,412	276 0616 907	Diode 1SS252	
D451-453	276 0616 907	Diode 1SS252	
D651	276 0616 907	Diode 1SS252	
ZD101	276 0634 905	Zener diode MTZJ3.3A	
ZD251,252	276 0637 902	Zener diode MTZJ6.2A	
ZD401	276 0634 905	Zener diode MTZJ3.3A	
ZD402	276 0633 906	Zener diode MTZJ6.8C	
ZD403	276 0632 907	Zener diode MTZJ27D	
ZD451-453	276 0635 904	Zener diode MTZJ7.5C	
SC451	279 0016 904	Thyristor SF0R1A42	
RESISTORS GROUP			
VR305,306	211 6093 912	Semi fixed resistor 4.7Kohm	V06PB472
R001,002	247 0018 905	Chip 0ohm 1/10W	RM73B--0R0K
R101-108	247 0014 967	Chip 1Mohm 1/10W	RM73B--10J
R109-116	247 0006 962	Chip 470ohm 1/10W	RM73B--47J
R117	247 0014 925	Chip 680kohm 1/10W	RM73B--68J
△R201,202	244 2052 931	Metal oxide film 390ohm 1W	RS14B3A39J JNBS(S)
△R259,260	241 2387 940	Carbon 4.7ohm 1/4W	RD14B2E4F7 JNBS
R263	247 0009 985	Chip 10kohm 1/10W	RM73B--10J
R264	247 0012 927	Chip 100kohm 1/10W	RM73B--10J
R305,306	247 0012 969	Chip 150kohm 1/10W	RM73B--15J
R307,308	247 0006 962	Chip 470ohm 1/10W	RM73B--47J
R309,310	247 0009 914	Chip 5.1kohm 1/10W	RM73B--51J
△R311,312	241 2379 932	Carbon 620ohm 1/4W	RD14B2E62 JNBS
R323,324	247 0007 945	Chip 1kohm 1/10W	RM73B--10J
△R329,330	241 2378 920	Carbon 220ohm 1/4W	RD14B2E22 JNBS
△R331-334	244 2049 982	Metal oxide film 0.22ohm 1W	RS14B3AF22 JNBS(S)
R335,336	247 0013 984	Chip 470kohm 1/10W	RM73B--47J
R351,352	247 0012 901	Chip 82kohm 1/10W	RM73B--82J
R353,354	247 0012 969	Chip 150kohm 1/10W	RM73B--15J
R355,356	247 0004 922	Chip 47ohm 1/10W	RM73B--47J
R357	247 0009 901	Chip 4.7kohm 1/10W	RM73B--47J
R358	247 0011 944	Chip 47kohm 1/10W	RM73B--47J
△R385,386	241 2379 932	Carbon 620ohm 1/4W	RD14B2E62 JNBS
△R387-390	241 2377 989	Carbon 150ohm 1/4W	RD14B2E15 JNBS
△R391,392	244 2043 937	Metal oxide film 100ohm 1W	RS14B3A10J JNBS(S)
△R393,394	244 2051 967	Metal oxide film 4.7ohm 1W	RS14B3A4F7 JNBS(S)
R401	247 0013 900	Chip 220kohm 1/10W	RM73B--22J
R402	247 0009 985	Chip 10kohm 1/10W	RM73B--10J

Ref. No.	Part No.	Part Name	Remarks	Ref. No.	Part No.	Part Name	Remarks
R403	247 0009 901	Chip 4.7kohm 1/10W	RM73B--472J	C327--330	254 4262 904	Electrolytic 4.7μF/63V	CE04W1J4R7M
R404,405	247 0007 945	Chip 1kohm 1/10W	RM73B--102J	C331,332	254 4260 948	Electrolytic 1μF/50V	CE04W1H010M
R406	247 0009 985	Chip 10kohm 1/10W	RM73B--103J	C333,334	254 4260 922	Electrolytic 0.33μF/50V	CE04W1HR33M
R407	247 0010 958	Chip 20kohm 1/10W	RM73B--203J	C335,336	257 0004 961	Chip(Ceramic) 100pF/50V	CC73SL1H101J
R408	247 0009 985	Chip 10kohm 1/10W	RM73B--103J	C337,338	257 0002 992	Chip(Ceramic) 20pF/50V	CC73SL1H200J
R409	247 0007 945	Chip 1kohm 1/10W	RM73B--102J	C339,340	254 4254 925	Electrolytic 33μF/16V	CE04W1C330M
R410	247 0009 901	Chip 4.7kohm 1/10W	RM73B--472J	C341,342	257 0004 961	Chip(Ceramic) 100pF/50V	CC73SL1H101J
△R411	244 2051 987	Metal oxide film 4.7ohm 1W	RS14B3A4R7JNBS(S)	C353,354	256 1034 979	Metalized 0.1μF/50V	CF93A1H104J
△R412	241 2377 947	Carbon 100ohm 1/4W	RD14B2E101JNBS	C355,356	255 1265 978	Film 0.022F/50V	CQ93M1H223J(B)
△R415	241 2387 908	Carbon 1ohm 1/4W	RD14B2E010JNBS	C357	254 4260 948	Electrolytic 1μF/50V	CE04W1H010M
△R451	244 2051 974	Metal oxide film 1kohm 1W	RS14B3A102JNBS(S)	C358	253 9030 060	Ceramic 0.01μF/25V	CK45=1E103K
△R453	244 2051 980	Metal oxide film 4.7kohm 1W	RS14B3A472JNBS(S)	C359,360	254 4260 948	Electrolytic 1μF/50V	CE04W1H010M
R460	247 0011 944	Chip 47kohm 1/10W	RM73B--473J	C401	254 4258 905	Electrolytic 4.7μF/35V	CE04W1V4R7M
△R465	244 2051 974	Metal oxide film 1kohm 1W	RS14B3A102JNBS(S)	C402	257 0012 966	Chip(Ceramic) 0.01μF/50V	CK73F1H103Z
△R467	244 2052 902	Metal oxide film 2.7kohm 1W	RS14B3A272JNBS(S)	C403	254 4260 948	Electrolytic 1μF/50V	CE04W1H010M
R475	247 0010 929	Chip 15kohm 1/10W	RM73B--153J	C404,405	253 1181 904	Ceramic 0.01μF/50V	CK45F1H103Z
R701,702	247 0009 901	Chip 4.7kohm 1/10W	RM73B--472J	C406	259 0007 702	For Back up 8200μF	SB CAP=822=C
R703,704	247 0012 969	Chip 150kohm 1/10W	RM73B--154J	C407	254 4254 909	Electrolytic 10μF/16V	CE04W1C100M
R705,706	247 0011 986	Chip 68kohm 1/10W	RM73B--683J	C408	254 4403 734	Electrolytic 4700μF/25V	CE04W1E472MC(SMG)
R707,708	247 0004 922	Chip 47ohm 1/10W	RM73B--470J	C409	254 4261 921	Electrolytic 100μF/50V	CE04W1C101M
R709,710	247 0005 992	Chip 240ohm 1/10W	RM73B--241J	C410	254 4260 948	Electrolytic 1μF/50V	CE04W1H010M
R711,712	247 0012 956	Chip 130kohm 1/10W	RM73B--134J	△C411	253 8014 702	Ceramic 0.01μF/400VAC	CC45F2GAC103MC
R713,714	247 0009 998	Chip 11kohm 1/10W	RM73B--113J	C451	254 4260 980	Electrolytic 10μF/50V	CE04W1H100M
R715,716	247 0003 949	Chip 22ohm 1/10W	RM73B--220J	C452	254 4254 909	Electrolytic 10μF/16V	CE04W1C100M
R717,718	247 0005 905	Chip 100ohm 1/10W	RM73B--101J	C453	254 4250 945	Electrolytic 330μF/6.3V	CE04W0J331M
R719,720	247 0012 927	Chip 100kohm 1/10W	RM73B--104J	C456	255 1265 936	Film 0.01μF/50V	CQ93M1H103J(B)
CAPACITORS GROUP				△C459,460	253 1151 905	Ceramic 4700pF/500V	CK45E2H472P
C101--108	257 0004 903	Chip(Ceramic) 56pF/50V	CC73SL1H560J	△C461	256 1042 903	Metalized 0.1μF/250V	CF93A2E104K
C109,110	255 1264 908	Film 1000pF/50V	CQ93M1H102J(B)	C462	254 4254 938	Electrolytic 47μF/16V	CE04W1C470M
C111	257 0002 921	Chip(Ceramic) 10pF/50V	CC73SL1H100D	C549	254 4252 927	Electrolytic 47μF/10V	CE04W1A470M
C112,113	257 0012 982	Chip(Ceramic) 0.022μF/50V	CK73F1H223Z	C701,702	257 0003 988	Chip(Ceramic) 47pF/50V	CC73SL1H470J
C124,125	257 0012 982	Chip(Ceramic) 0.022μF/50V	CK73F1H223Z	C703,704	257 0005 944	Chip(Ceramic) 220pF/50V	CC73SL1H221J
C127	257 0012 982	Chip(Ceramic) 0.022μF/50V	CK73F1H223Z	C705,706	254 4254 909	Electrolytic 10μF/16V	CE04W1C100M
C129,130	254 4260 980	Electrolytic 10μF/50V	CE04W1H100M	C709,710	254 4250 929	Electrolytic 100μF/6.3V	CE04W0J101M
C201--204	255 1265 907	Film 6800pF/50V	CQ93M1H682J(B)	C711,712	255 4199 999	Film 0.024μF/50V	CQ92M1H243J(MRZ)
C205,206	257 0006 985	Chip(Ceramic) 820pF/50V	CC73SL1H821J	C713,714	255 1265 907	Film 6800pF/50V	CQ93M1H682J(B)
C251	254 4261 031	Electrolytic 220μF/50V	CE04W1C221M	C715,716	254 4254 909	Electrolytic 10μF/16V	CE04W1C100M
C252--254	254 4258 918	Electrolytic 10μF/35V	CE04W1V100M	C717,718	254 4260 948	Electrolytic 1μF/50V	CE04W1H010M
C257,258	254 4349 720	Electrolytic 6800μF/56V	CE04W==682MC(DL)	C724	254 4260 948	Electrolytic 1μF/50V	CE04W1H010M
C259	253 1181 904	Ceramic 0.01μF/50V	CK45F1H103Z	C725	257 0012 982	Chip(Ceramic) 0.022μF/50V	CK73F1H223Z
C307,308	257 0006 927	Chip(Ceramic) 470pF/50V	CC73SL1H471J	C801,802	257 0016 962	Chip(Ceramic) 27pF/50V	CC73CH1H270J
C309,310	256 1034 979	Metalized 0.1μF/50V	CF93A1H104J	C803--805	254 4250 916	Electrolytic 47μF/6.3V	CE04W0J470M
C311--314	253 4536 909	Ceramic 10pF/50V	CC45SL1H100D	C807,808	257 0003 933	Chip(Ceramic) 30pF/50V	CC73SL1H300J
C321,322	256 1034 979	Metalized 0.1μF/50V	CF93A1H104J	C809	257 0012 966	Chip(Ceramic) 0.01μF/50V	CK73F1H103Z
C323,324	254 4260 948	Electrolytic 1μF/50V	CE04W1H010M	C810	254 4250 916	Electrolytic 47μF/6.3V	CE04W0J470M
C325,326	255 1265 978	Film 0.022F/50V	CQ93M1H223J(B)	C811	257 0006 943	Chip(Ceramic) 560pF/50V	CC73SL1H561J

1U-2818 TUNER UNIT ASS'Y

Ref. No.	Part No.	Part Name	Remarks	Ref. No.	Part No.	Part Name	Remarks
OTHERS PARTS GROUP				SEMICONDUCTORS GROUP			
△AC401	203 9961 004	1P AC outlet	Except to U.K.	IC501	263 0891 001	IC LA1265(S)	
CB29D	205 0549 027	29P FFC connector base		IC502	263 0439 007	IC LA3401	
CB3C	205 0343 032	3P connector base(KR-PH)		IC503	263 0791 907	IC LM7001M	
CB6A,6C	205 0918 001	6P bottom socket		IC504	263 0794 001	IC NJM78M12FA(S)	
CB8A	205 0918 014	8P bottom socket		TR501	275 0074 902	Transistor 2SK211(Y/GR)	
CB8B,8C	205 0806 090	8P connector base (9115)		TR502	273 0438 908	Transistor 2SC2413K (Q)	
△CN2A	203 2349 009	2P Inlet		TR503	269 0157 905	Transistor DTB123EK	Built in resistor
CN3A	205 0581 001	2P VH connector base		TR504	269 0083 901	Transistor DTA114EK	Built in resistor
CN3C	203 4585 007	3P KR-DS connector cord		TR505,506	269 0054 901	Transistor DTC144EK	Built in resistor
CN7A	205 0653 078	7P VH connector base		TR507	271 0279 909	Transistor 2SA1515(R)	
△F401	206 1075 030	Fuse(2.0A)		TR508	275 0075 901	Transistor 2SK209(Y/GR)	
△F402	206 1075 001	Fuse(1A)	Except to U.K.	TR509	273 0403 904	Transistor 2SC2712(Y/GR)	
L391,392	235 0104 007	Inductor(1MHz)		D501	276 0559 909	Diode DAP202K	
L701,702	235 9003 002	FTZ choke coil		RESISTORS GROUP (Not included carbon film ±5% 1/4W)			
RL453	214 0127 003	Relay(RY-12W)		R001-016	247 0018 905	Chip 0ohm 1/10W	RM73B-0R0K
RL451,452	214 0167 005	Relay(G5Z-2A)		R501	247 0004 906	Chip 39ohm 1/10W	RM73B--390J
△SW401	212 1031 009	Power switch(TV-5)		R502	247 0007 945	Chip 1kohm 1/10W	RM73B--102J
TH451	279 0034 067	Posistor	PTH9M04BB222TS2F333	R503	247 0009 985	Chip 10kohm 1/10W	RM73B--103J
TP001,002	205 0190 036	3P NH Connector base	TEST POINT	R503	247 0012 927	Chip 100kohm 1/10W	RM73B--104J
XL601	399 0178 007	Crystal	4.332MHz	R504	247 0009 927	Chip 5.6kohm 1/10W	RM73B--562J
XT801	399 0041 901	Resonator	CSA4.00MG	R505	247 0006 920	Chip 330ohm 1/10W	RM73B--331 J
	202 0040 909	Fuse clip		R506	247 0009 901	Chip 4.7kohm 1/10W	RM73B--472J
	204 8486 008	6P pin jack(S-GND)		R507	247 0005 989	Chip 220ohm 1/10W	RM73B--221 J
	204 8485 009	4P pin jack(S-GND)		R508,509	247 0006 920	Chip 330ohm 1/10W	RM73B--331 J
	415 0309 055	P.V.C. tube (L=07)		R510	247 0006 988	Chip 560ohm 1/10W	RM73B--561 J
	009 9037 013	1PWire Ass'y		R511	247 0012 927	Chip 100kohm 1/10W	RM73B--104J
	203 0475 072	1P contact Ass'y		R512	247 0009 914	Chip 5.1kohm 1/10W	RM73B--512J
	205 0484 001	8P speaker terminal	Europe model	R513	247 0005 905	Chip 100ohm 1/10W	RM73B--101 J
	205 0472 013	8P speaker terminal	U.K model	R514	247 0008 986	Chip 3.9kohm 1/10W	RM73B--392J
				R515	247 0006 946	Chip 390ohm 1/10W	RM73B--391 J
				R516	247 0005 947	Chip 150ohm 1/10W	RM73B--151 J
				R517	247 0009 985	Chip 10kohm 1/10W	RM73B--103J
				R518	247 0018 905	Chip 0ohm 1/10W	RM73B-0R0K
				R519	247 0009 901	Chip 4.7kohm 1/10W	RM73B--472J
				R520	247 0004 980	Chip 82ohm 1/10W	RM73B--820J
				R521	247 0008 944	Chip 2.7kohm 1/10W	RM73B--272J
				R522	247 0011 902	Chip 33kohm 1/10W	RM73B--333J
				R523-525	247 0009 985	Chip 10kohm 1/10W	RM73B--103J
				R526	247 0008 957	Chip 3kohm 1/10W	RM73B--32J
				R527	247 0011 986	Chip 68kohm 1/10W	RM73B--683J
				R528	247 0009 956	Chip 7.5kohm 1/10W	RM73B--752J
				R529	247 0008 960	Chip 3.3kohm 1/10W	RM73B--332J
				R532	247 0009 985	Chip 10kohm 1/10W	RM73B--103J
				R533	247 0007 945	Chip 1kohm 1/10W	RM73B--102J
				R534	247 0011 915	Chip 36kohm 1/10W	RM73B--363J

Ref. No.	Part No.	Part Name	Remarks
R535	247 0010 974	Chip 24kohm 1/10W	RM73B--243J
R536	247 0012 985	Chip 180kohm 1/10W	RM73B--184J
R537	247 0012 998	Chip 200kohm 1/10W	RM73B--204J
R538	247 0012 985	Chip 180kohm 1/10W	RM73B--184J
R539	247 0012 998	Chip 200kohm 1/10W	RM73B--204J
R540,541	247 0008 902	Chip 1.8kohm 1/10W	RM73B--182J
R542,543	247 0009 901	Chip 4.7kohm 1/10W	RM73B--472J
R544	247 1007 986	Chip 1.5kohm 1/8W	RM73B2B152J
R545	247 0009 985	Chip 10kohm 1/10W	RM73B--103J
R546	247 0012 927	Chip 100kohm 1/10W	RM73B--104J

CAPACITORS GROUP

C501-506	257 0012 966	Chip(Ceramic) 0.01µF/50V	CK73F1H103Z
C507	257 0002 947	Chip(Ceramic) 12pF/50V	CC73SL1H120J
C508	254 4254 909	Electrolytic 10µF/16V	CE04W1C100M
C509	257 0004 961	Chip(Ceramic) 100pF/50V	CC73SL1H101J
C510	257 0012 966	Chip(Ceramic) 0.01µF/50V	CK73F1H103Z
C511	254 4260 906	Electrolytic 0.1µF/50V	CE04W1H0R1M
C513	254 3056 917	Electrolytic 1µF/50V (Non-polar)	CE04D1H010MBP
C514	257 0012 982	Chip(Ceramic) 0.022µF/50V	CK73F1H223Z
C515,516	257 0002 976	Chip(Ceramic) 16pF/50V	CC73SL1H160J
C517	254 4254 938	Electrolytic 47µF/16V	CE04W1C470M
C518,519	257 0012 966	Chip(Ceramic) 0.01µF/50V	CK73F1H103Z
C520	254 4260 922	Electrolytic 0.33µF/50V	CE04W1HR33M
C521	257 0012 966	Chip(Ceramic) 0.01µF/50V	CK73F1H103Z
C522	254 4256 936	Electrolytic 47µF/25V	CE04W1E470M
C523	254 4260 948	Electrolytic 1µF/50V	CE04W1H010M
C524	254 4260 964	Electrolytic 3.3µF/50V	CE04W1H3R3M
C525	257 0012 982	Chip(Ceramic) 0.022µF/50V	CK73F1H223Z
C526	257 0012 966	Chip(Ceramic) 0.01µF/50V	CK73F1H103Z
C527	254 4260 948	Electrolytic 1µF/50V	CE04W1H010M
C528	254 4254 909	Electrolytic 10µF/16V	CE04W1C100M
C529	257 1013 951	Chip(Ceramic) 0.047µF/25V	CK73F1E473K
C530	254 4254 912	Electrolytic 22µF/16V	CE04W1C220M
C531	257 0004 961	Chip(Ceramic) 100pF/50V	CC73SL1H101J
C532	254 4260 948	Electrolytic 1µF/50V	CE04W1H010M
C533	254 4260 919	Electrolytic 0.22µF/50V	CE04W1HR22M
C534	254 4260 948	Electrolytic 1µF/50V	CE04W1H010M
C535,536	257 0012 966	Chip(Ceramic) 0.01µF/50V	CK73F1H103Z
C537	254 4254 912	Electrolytic 22µF/16V	CE04W1C220M
C538	254 4254 938	Electrolytic 47µF/16V	CE04W1C470M
C539,540	257 0005 960	Chip(Ceramic) 270pF/50V	CC73SL1H271J
C541	254 4260 951	Electrolytic 2.2µF/50V	CE04W1H2R2M
C545	253 1181 904	Ceramic 0.01µF/50V	CK45F1H103Z
C548	254 4260 951	Electrolytic 2.2µF/50V	CE04W1H2R2M
C550,551	254 4260 948	Electrolytic 1µF/50V	CE04W1H010M
C553,554	257 0012 966	Chip(Ceramic) 0.01µF/50V	CK73F1H103Z
C555	256 1034 937	Metalized 0.047µF/50V	CF93A1H473J

Ref. No.	Part No.	Part Name	Remarks
OTHERS PARTS GROUP			
CF501,502	261 0064 007	Ceramic filter	SFT10.7MS2
CF504	261 0101 009	:Ceramic filter	BFU450C4N
CN8B,8C	205 0805 091	8P connector socket	
FE501	216 0065 006	Front end	
T501	231 1913 004	MW antenna OSC coil	
T502	231 2099 008	FM DET trans	
T503	231 3904 008	:AM IFT	
T504	232 9010 009	Antibirdie filter	
T505,506	232 0085 004	:LPF	
XL502	261 0103 007	:Resonator	CSB456F11
XL503	399 0075 003	Crystal	7.2MHz
	205 0847 004	3P antenna terminal(PAL/F)	

KU-9328 DISPLAY UNIT ASS'Y

Ref. No.	Part No.	Part Name	Remarks	Ref. No.	Part No.	Part Name	Remarks
SEMICONDUCTORS GROUP				CAPACITORS GROUP			
IC601	262 2175 007	IC TMP87CM71F-6284		C301,302	257 0006 943	Ceramic 560pF/50V	CC73SL1H561J
IC602	263 0905 900	IC BA6208F		C303,304	255 1265 978	Film 0.022µF/50V	CQ93M1H223J(B)
ZD651	276 0654 901	Zener diode DTZ8.2B		C306	254 3056 917	Electrolytic 1µF/50V (Non-polar)	CE04D1H010MBP
RESISTORS GROUP (Not Included carbon film ±5% 1/4W)							
VR301	211 0841 018	Variable 100kohm	V14P22FW104K	C361,362	257 0004 961	Ceramic 100pF/50V	CC73SL1H101J
VR302	211 0831 002	Variable 100kohm	V1620V25FB104(MG)	C363,364	255 1265 981	Film 0.027µF/50V	CQ93M1H273J(B)
VR303	211 0842 017	Variable 250kohm	V14P22FC254K	C365,366	256 1034 982	Metalized 0.12µF/50V	CF93A1H124J
VR304	211 0843 016	Variable 50kohm	V14P22FC503K	C367,368	255 1264 924	Film 1500pF/50V	CQ93M1H152J(B)
VR307	211 9131 004	Variable 100kohm	V14P22FB104K	C369,370	255 1265 936	Film 0.01µF/50V	CQ93M1H103J(B)
R301,302	247 0011 928	Chip 39kohm 1/10W	RM73B--393J	C552	254 4300 963	Electrolytic 100µF/6.3V	CE04W0J101M(SRE)
R303,304	247 0009 943	Chip 6.8kohm 1/10W	RM73B--682J	C651	257 0012 966	Chip(Ceramic) 0.01µF/50V	CK73F1H103Z
R361,362	247 0011 973	Chip 62kohm 1/10W	RM73B--623J	C653	257 0012 966	Chip(Ceramic) 0.01µF/50V	CK73F1H103Z
R363,364	247 0009 998	Chip 11kohm 1/10W	RM73B--113J	C655	254 4299 964	Electrolytic 47µF/16V	CE04W1C470M(SRE)
R365,366	247 0008 931	Chip 2.4kohm 1/10W	RM73B--242J	C657	257 0012 982	Chip(Ceramic) 0.022µF/50V	CK73F1H223Z
R367,368	247 0013 984	Chip 470kohm 1/10W	RM73B--474J	C660	253 1179 903	Ceramic 100pF/50V	CK45B1H101Z
R369,370	247 0010 945	Chip 18kohm 1/10W	RM73B--183J	OTHERS PARTS GROUP			
R371,372	247 0009 943	Chip 6.8kohm 1/10W	RM73B--682J	CB8D	205 0919 026	8P JQ socket(Side)	
R373,374	247 0006 917	Chip 300ohm 1/10W	RM73B--301J	CN29D	205 0549 027	29P FFC connector base	
R375,376	247 0011 944	Chip 47kohm 1/10W	RM73B--473J	CN6A,6C	205 0917 002	6P bottom plug	
R379,380	247 0009 901	Chip 4.7kohm 1/10W	RM73B--472J	CN8A	205 0917 015	8P bottom plug	
R651	247 1009 900	Chip 4.7kohm 1/8W	RM73B2B472J	CN8D	205 0408 045	8P JQ socket	
R652-657	247 0009 985	Chip 10kohm 1/10W	RM73B--103J	FL401	393 4155 002	FL tube	FIP14AM7R
R665	247 0007 945	Chip 1kohm 1/10W	RM73B--102J	JK201	204 8354 017	Head phone jack	Black model
R666	247 0005 976	Chip 200ohm 1/10W	RM73B--201J	JK201	204 8355 003	Head phone jack	Gold model
R667	247 0006 917	Chip 300ohm 1/10W	RM73B--301J	RM601	499 0150 008	Remote sensor	SBX1610-52
R668	247 0007 945	Chip 1kohm 1/10W	RM73B--102J	SW302,303	212 1140 009	Push switch(ESB6440)	
R669	247 0005 976	Chip 200ohm 1/10W	RM73B--201J	SW601-616	212 5604 910	Tact switch	
R670	247 0006 917	Chip 300ohm 1/10W	RM73B--301J	XL651	399 0261 901	Resonator	DCRH4.00M
R671	247 0007 945	Chip 1kohm 1/10W	RM73B--102J		009 9037 013	1PWire Ass'y	
R672	247 0005 976	Chip 200ohm 1/10W	RM73B--201J		414 0740 006	Shield plate	
R673	247 0006 917	Chip 300ohm 1/10W	RM73B--301J				
R674	247 0006 975	Chip 510ohm 1/10W	RM73B--511J				
R675	247 0007 945	Chip 1kohm 1/10W	RM73B--102J				
R676	247 0007 945	Chip 1kohm 1/10W	RM73B--102J				
R677	247 0005 976	Chip 200ohm 1/10W	RM73B--201J				
R678	247 0006 917	Chip 300ohm 1/10W	RM73B--301J				
R679	247 0006 975	Chip 510ohm 1/10W	RM73B--511J				
R680	247 0007 945	Chip 1kohm 1/10W	RM73B--102J				
R681	247 0008 915	Chip 2kohm 1/10W	RM73B--202J				
R682,683	247 0009 985	Chip 10kohm 1/10W	RM73B--103J				
R685	247 0008 957	Chip 3kohm 1/10W	RM73B--302J				

PRINTED WIRING BOARD PATTERNS

1U-2817 MAIN UNIT ASS'Y

IU-2817-6

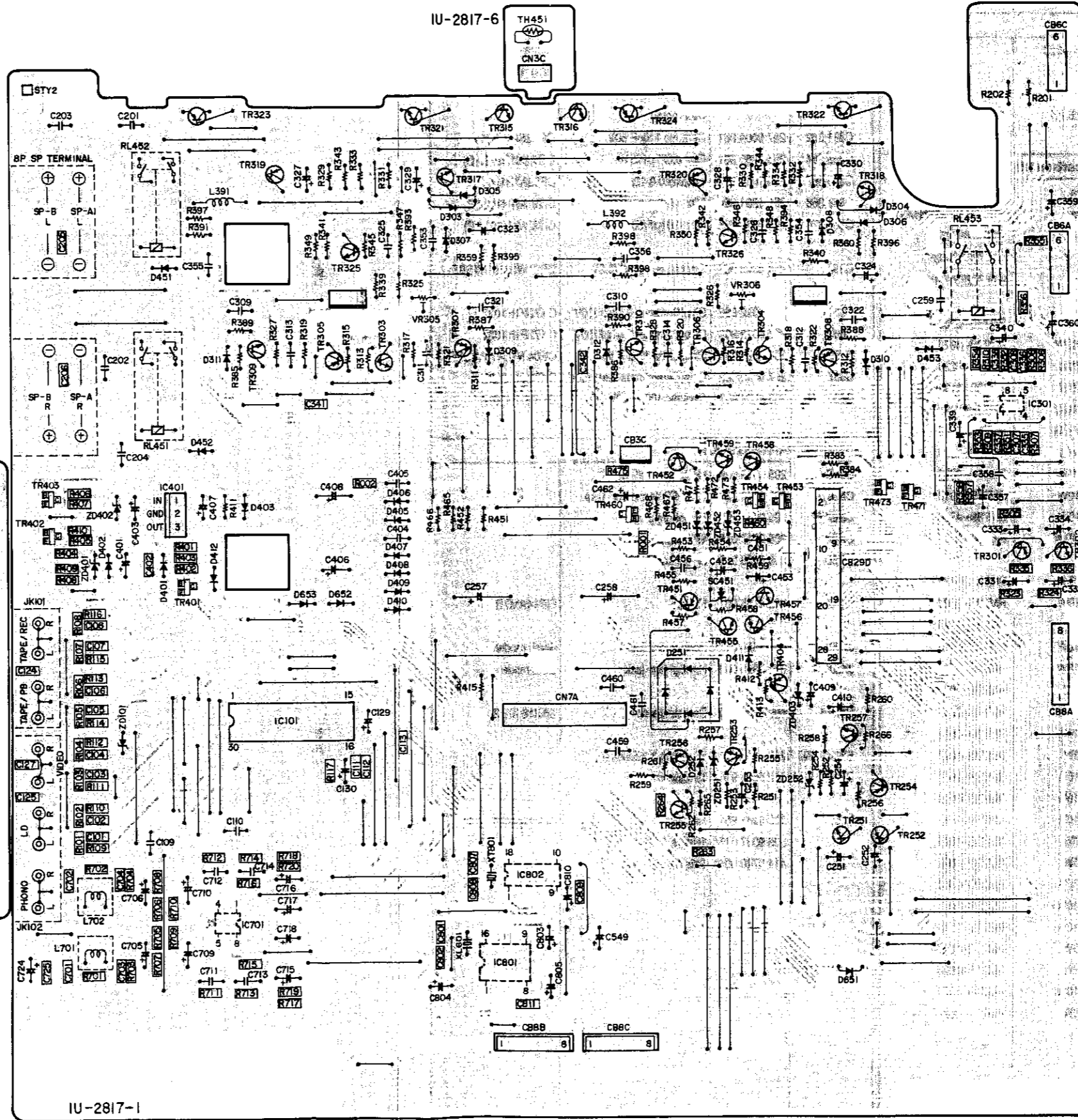
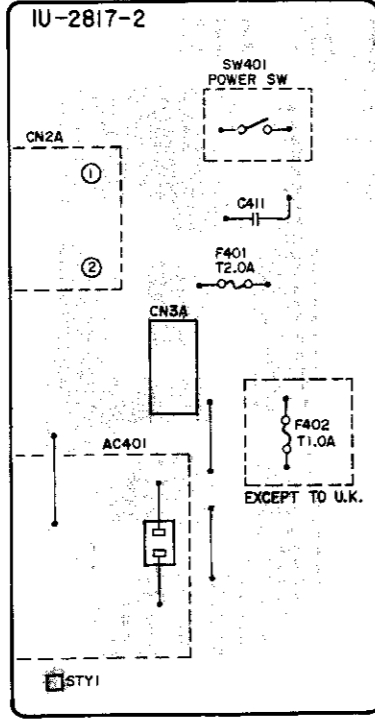

IU-2817-1

A
B
C
D
E

1 2 3 4 5 6 7 8

1 2 3 4 5 6 7 8

KU-9328 DISPLAY UNIT ASS'Y

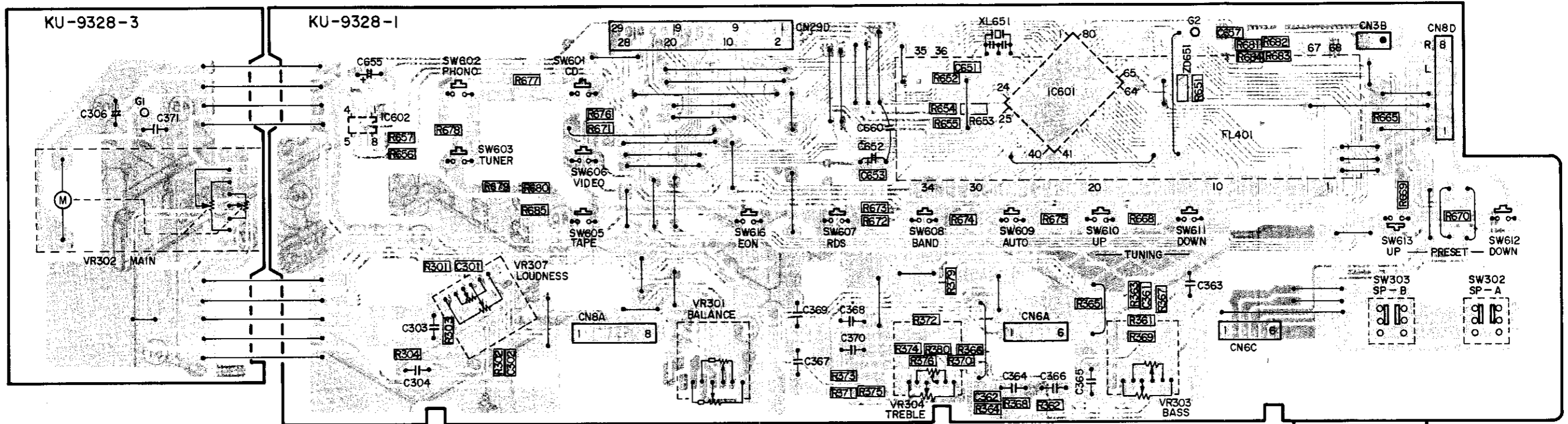

IU-2818 TUNER UNIT ASS'Y

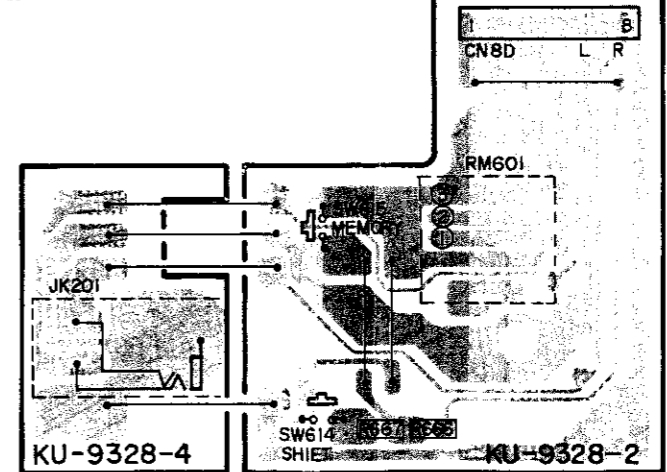
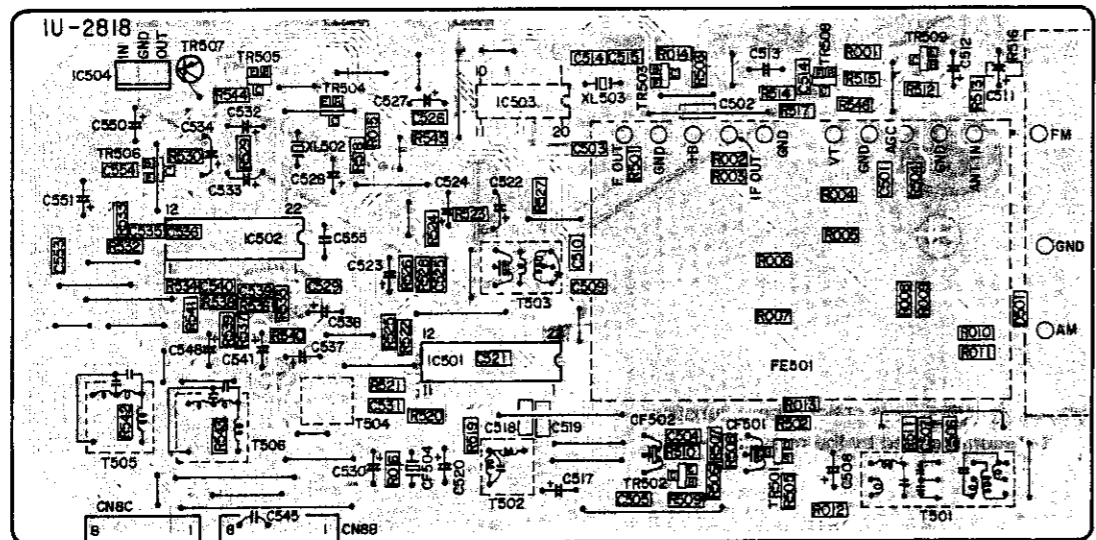

A
B
C
D
E

EXPLODED VIEW OF CHASSIS AND CABINET

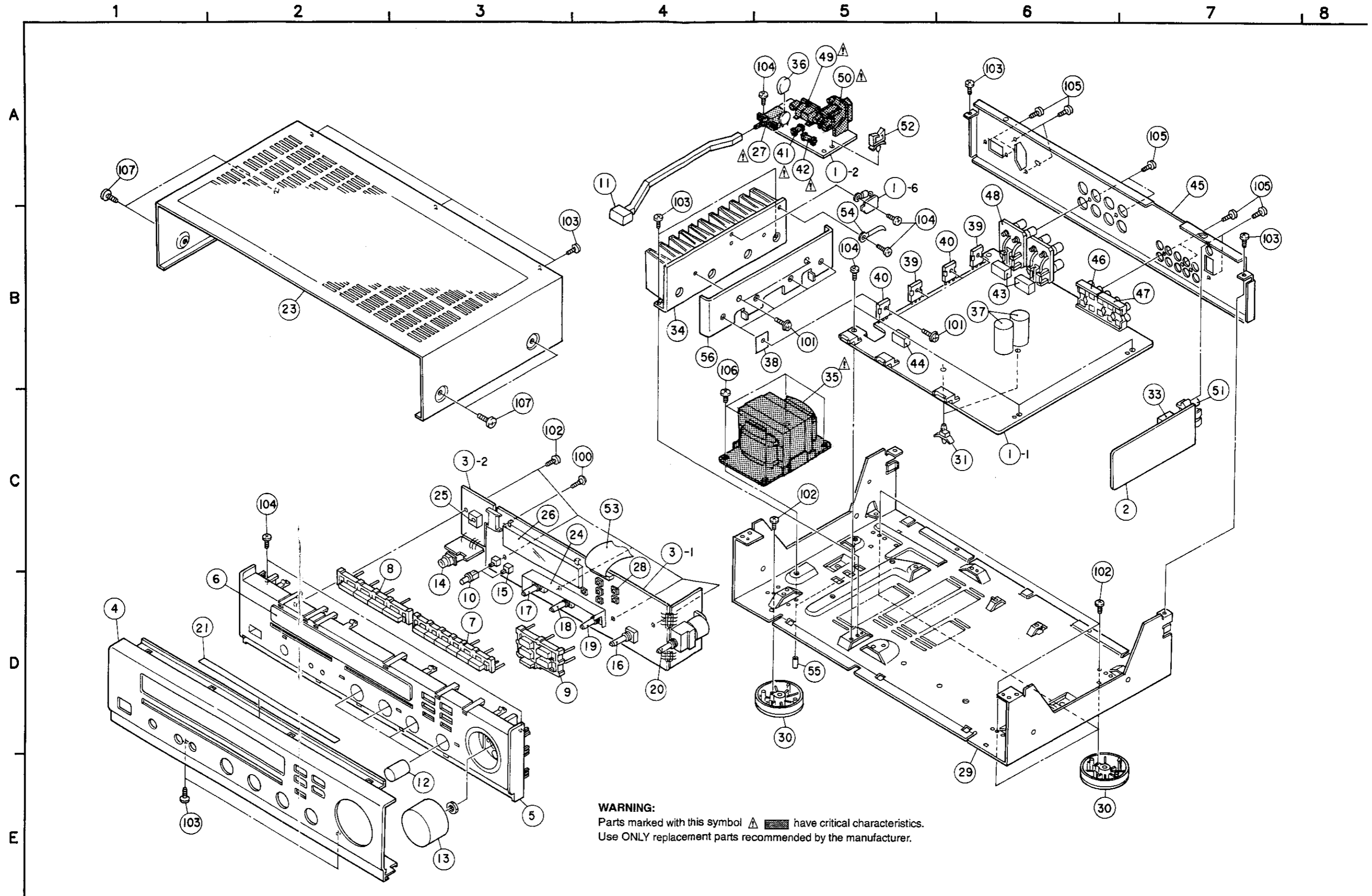

PARTS LIST EXPLODED VIEW

* Gold model = Except to U.K.

Ref. No.	Part No.	Part Name	Remarks	Q'ty	Ref. No.	Part No.	Part Name	Remarks	Q'ty
1	1U- 2817 B	Main unit Ass'y	Europe model	1	30	104 0230 101	:Foot Ass'y		4
1-1	—	Main unit			31	449 0033 049	Locking card spacer		2
1-2	—	Power unit			33	216 0065 006	Front end		1
1-6	—	Protection unit			34	417 9090 002	:Power radiator		1
1	1U- 2817 D	Main unit Ass'y	U.K. model	1	35	233 9681 004	:Power Transformer		1
1-1	—	Main unit			36	415 0299 000	Capacitor cover		1
1-2	—	Power unit			37	254 4349 720	Electrolytic capacitor	C257,258	2
1-6	—	Protection unit			38	415 0234 007	Insulating sheet		4
2	1U- 2818	Tuner unit Ass'y		1	39	271 0283 005	Transistor 2SA1633(E/F)	TR323,324	2
3	KU- 9328	Display unit Ass'y		1	40	273 0443 003	Transistor 2SC4278(E/F)	TR321,322	2
3-1	—	Display & Volume unit			41	206 1075 030	Fuse (2.0A)	F401	1
3-2	—	H/P J.& Remocon unit			42	206 1075 001	Fuse (1A)	Except to U.K.	1
4	144 9230 207	Front panel	Black model	1	43	214 0167 005	Relay(G5Z-2A)	RL451,452	2
4	144 9230 210	Front panel	Gold model	1	44	214 0127 003	Relay(RY-12W)	RL453	1
5	146 9337 009	Inner panel Ass'y WithWindow	Black model	1	45	105 1156 122	:Rear panel	Europe model	1
5	146 9337 012	Inner panel Ass'y WithWindow	Gold model	1	45	105 1156 135	:Rear panel	U.K model	1
(6)	(143 9187 001	Window)		1	46	204 8485 009	4P pin jack(S-GND)		1
7	113 9325 008	Series button (A)	Black model	1	47	204 8486 008	6P pin jack(S-GND)		1
7	113 9325 011	Series button (A)	Gold model	1	48	205 0484 001	8P speaker terminal	Europe model	1
8	113 9326 007	Series button (B)	Black model	1	48	205 0472 013	8P speaker terminal	U.K model	1
8	113 9326 010	Series button (B)	Gold model	1	49	203 2349 009	2P inlet	CN2A	1
9	113 9324 106	Function button	Black model	1	50	203 9681 004	1P AC outlet	Except to U.K.	1
9	113 9324 119	Function button	Gold model	1	51	205 0847 004	3P antenna terminal(PAL/F)		1
10	113 9323 000	Push button (SP)	Black model	2	52	499 0068 014	Wire saddle		1
10	113 9323 013	Push button (SP)	Gold model	2	53	009 0190 018	29P FFC cable		1
11	113 1721 008	Power button Ass'y	Black model	1	54	445 0048 003	Cord holder(L=76)		1
11	113 1721 011	Power button Ass'y	Gold model	1	55	462 0094 036	Screw tube		2
12	112 0739 001	:*Knob (Maru)	Black model	4	56	417 0520 005	Sub radiator		1
12	112 0739 014	:*Knob (Maru)	Gold model	4	★	513 2018 091	Fuse label(T2.0A)		1
13	112 0737 029	:*Volume knob	Black model	1	SCREWS				
13	112 0737 032	:*Volume knob	Gold model	1	100	477 0262 006	Special screw		1
14	204 8354 017	Head phone jack	Black model	1	101	473 8007 009	Cup screw 3x12		6
14	204 8355 003	Head phone jack	Gold model	1	102	473 7500 044	Screw 3x8 (P) BK		9
15	212 1140 009	Push switch(ESB6440)	SW3002,303	2	103	473 7015 018	Screw 3x8 (S) BK		9
16	211 9131 004	Variable resistor	VR307	1	104	473 7002 018	Screw 3x8 (S)		8
17	211 0842 017	Variable resistor	VR303	1	105	477 0064 107	Fixing screw 3x10 BK		11
18	211 0843 016	Variable resistor	VR304	1	106	473 7007 000	Screw 4x8 (S) BK		4
19	211 0841 018	Variable resistor	VR301	1	107	473 7007 013	Screw 4x10 (S) BK	Black model	4
20	211 0831 002	Variable resistor	VR302	1	107	473 4801 005	Screw 4x8	Gold model	4
21	122 0187 100	Top cover spacer		1					
23	102 0558 104	Top cover	Black model	1					
23	102 0558 117	Top cover	Gold model	1					
24	414 0740 006	Shield plate		1					
25	499 0150 008	Remote sensor	SBX1610-52	1					
26	393 4155 002	FL tube	FIP14AM7R	1					
27	212 1031 008	Power switch (TV-S)		1					
28	212 5604 910	Tact switch SW601-603,605-616		15					
29	411 1323 203	Chassis		1					

PACKING & ACCESSORIES

Ref. No.	Part No.	Part Name	Remarks	Q'ty
●	505 0283 018	:Envelope		1
●	511 9425 005	Operating instructions		1
	231 1914 003	AM loop antenna		1
	395 0023 008	:*FM antenna Ass'y		1
	399 0242 001	Remoto control unit	RC-174	1
△	206 2108 003	:AC connectorWith plug	Europe model	1
△	206 2113 001	:AC cordWith connector	U.K model	1
●	505 9125 009	:Poly cover	U.K model only	
●	505 0131 050	Cabinet cover		1
●	503 0939 104	:Cushion		2
●	501 1871 029	Carton case	Europe model	1
●	501 1871 032	Carton case	U.K model	1
●	502 0741 056	Pad	U.K model only	2

WIRING DIAGRAM

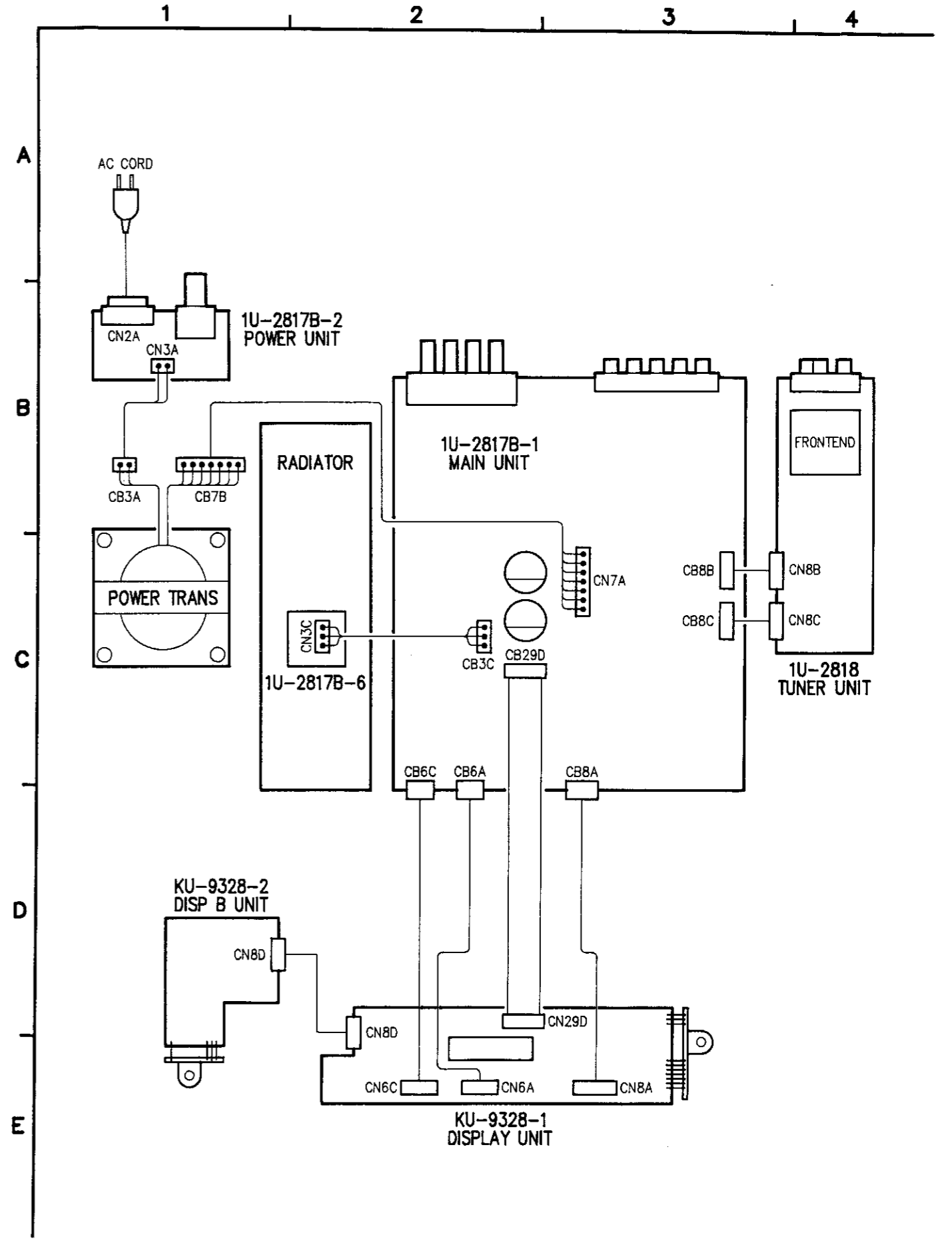

SCHEMATIC DIAGRAM

1

2

3

4

5

6

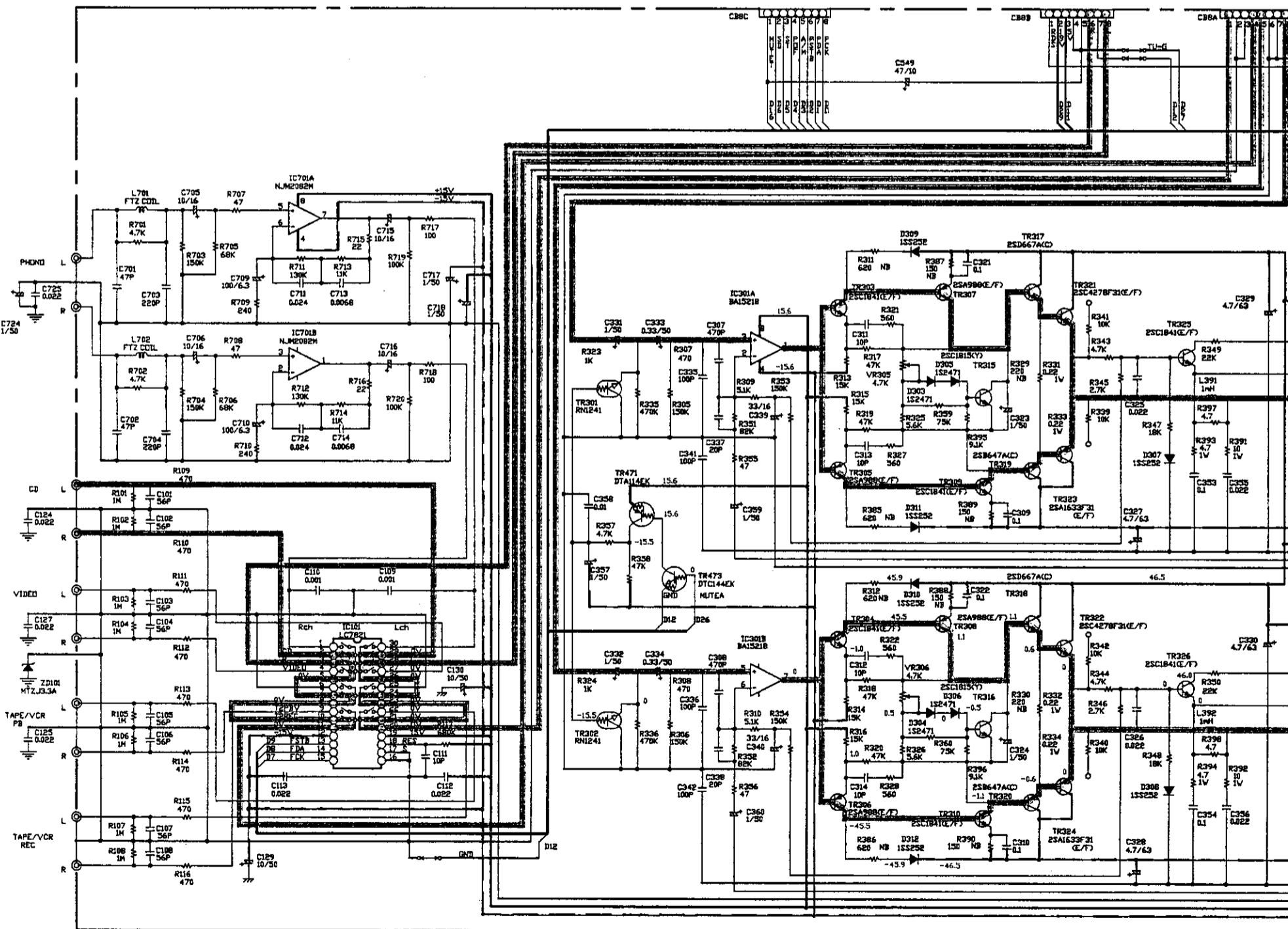
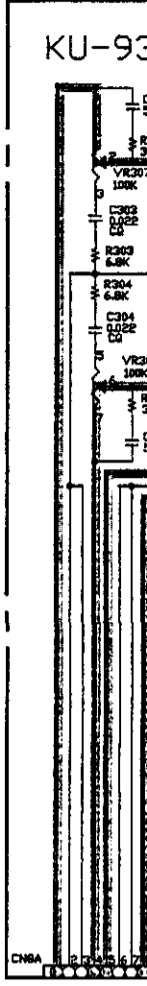
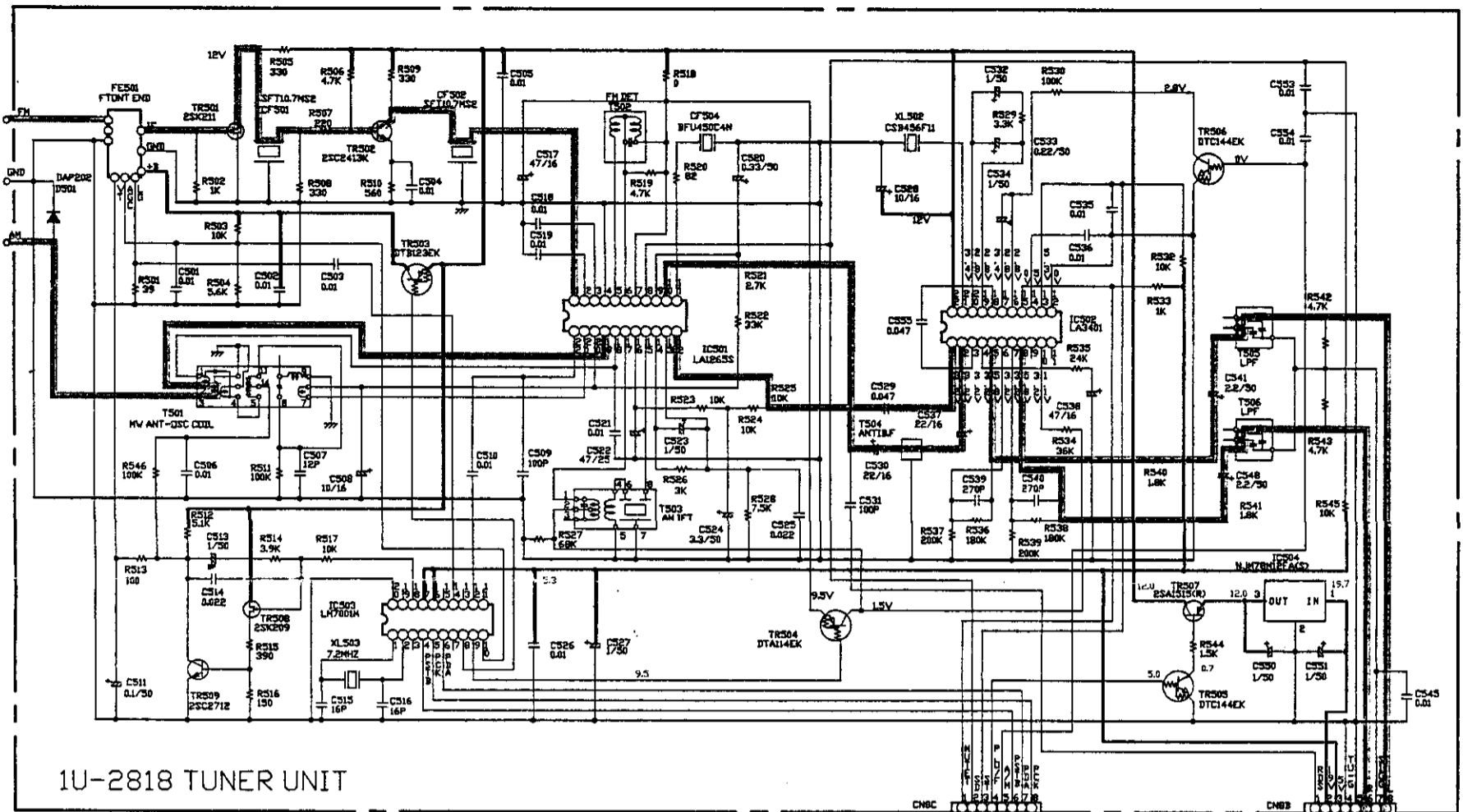

WARNING:
Parts marked with this symbol  Use **ONLY** replacement parts recommended by the manufacturer.

CAUTION:
Before returning the unit to the customer, check (1) the current check or (2) a line to check for shorts. If the current exceeds 0.5 millamps, or if the resistance is less than 240 kohms, the unit must be repaired.

WARNING:
DO NOT return the unit to the customer until it has been repaired.

NOTES:
Circuit and parts are subject to change without notice.

9328-1 DISPLAY UNIT

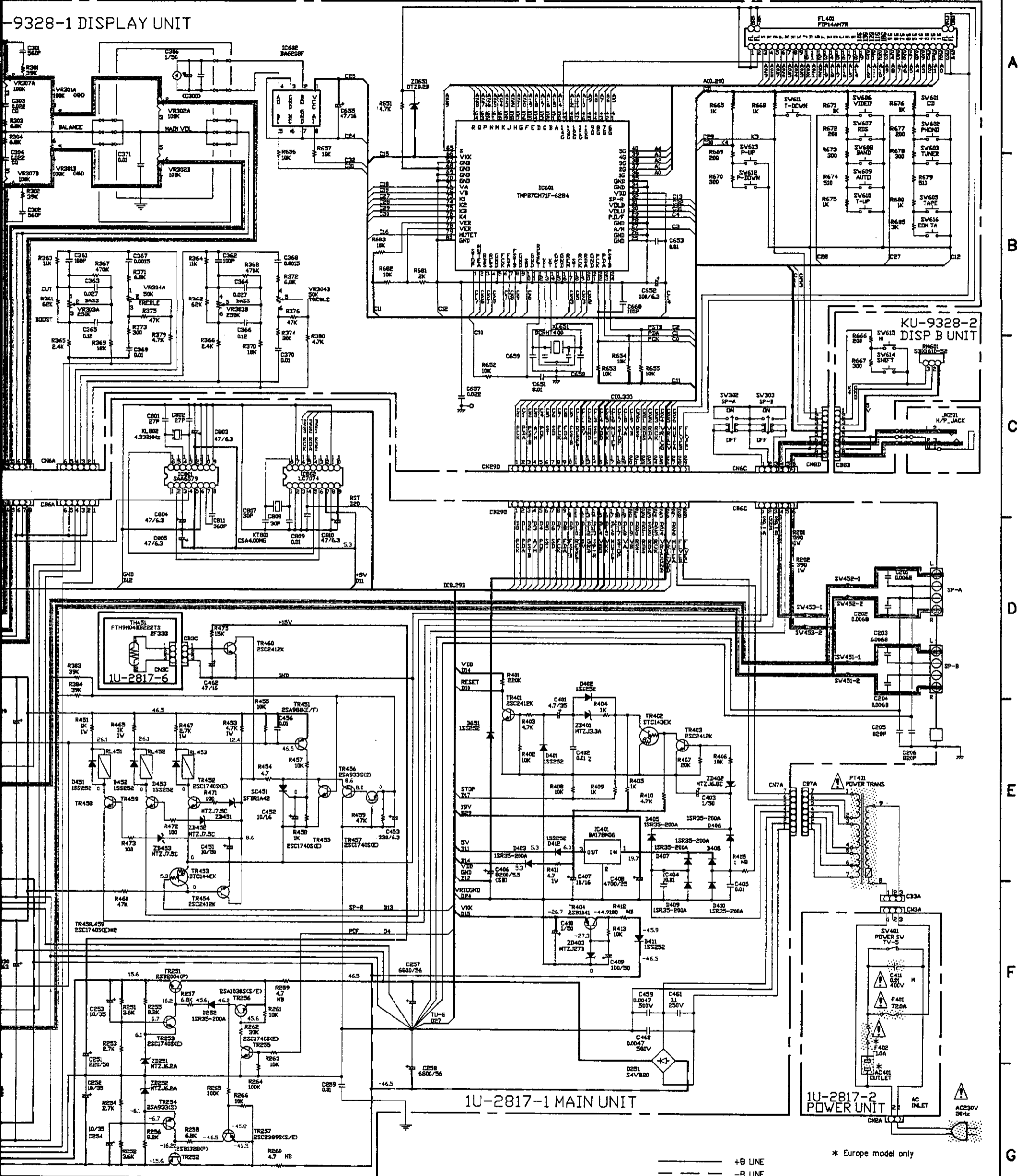

Symbol have critical characteristics. Parts recommended by the manufacturer.

To the customer, make sure you make either (1) a leakage to chassis resistance check. If the leakage current is high, if the resistance from chassis to either side of the power lines, the unit is defective.

To the customer until the problem is located and corrected.

Subject to change without prior notice.

NOTES

ALL RESISTANCE VALUES IN OHM. k=1,000 OHM, M=1,000,000 OHM
 ALL CAPACITANCE VALUES IN MICRO FARAD.
 P=MICRO-MICRO FARAD
 EACH VOLTAGE AND CURRENT ARE MEASURED AT NO SIGNAL INPUT CONDITION.
 CIRCUIT AND PARTS ARE SUBJECT TO CHANGE WITHOUT PRIOR NOTICE.

A
 B
 C
 D
 E
 F
 G
 H

SEMICONDUCTORS

● IC's

TMP87CM71F-6284 (IC601)

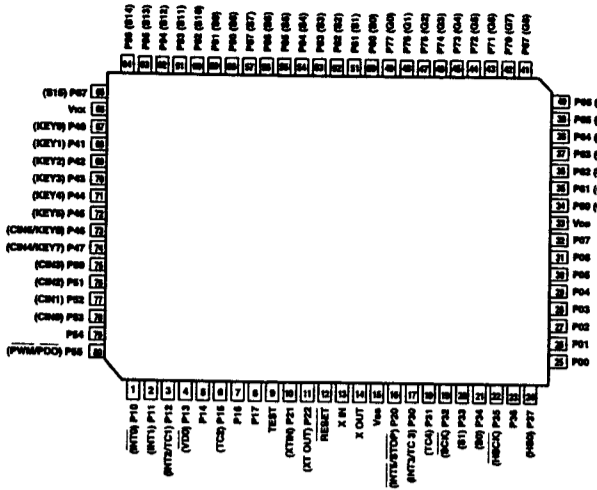
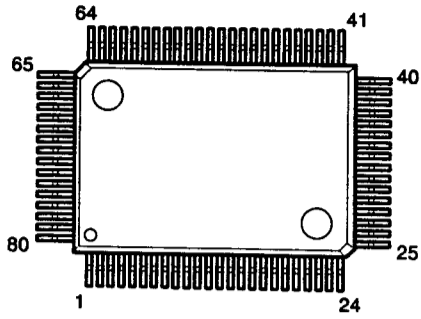

TMP87CM71F Port Allocation Table

Pin No.	Symbol	I/O	Logic	Initial Setting	Function
1	STOP	I	L	—	Power down detection ("L" = at power down).
2	MUTE (A)	I	—	—	MUTE (A) output ("H" = MUTE).
3	RDS	I	Serial	—	RDS data (start) input.
4	RES	O	L	H	LC7074 reset output.
5	GND	I	Serial	—	Not used.
6	FCK	O	Serial	L	Function control output (LC7821) for F-CK.
7	FDA	O	Serial	L	Function control output (LC7821) for F-DATA.
8	F STB	O	H	L	Function control output (LC7821) for F-STB.
9	GND	I	—	—	Connect to GND.
10	SD	I	L	—	Tuned signal input ("L" = at tuned in).
11	GND	I	—	—	Not used.
12	RESET	I	L	—	Reset input.
13	XIN	I	—	—	Oscillation circuit (4MHz).
14	XOUT	I	—	—	Oscillation circuit (4MHz).
15	Vss	PW	—	—	GND.
16	GND	I	—	—	GND.
17	REM	I	L	—	Remote control signal input.
18	ST	I	L	—	Stereo signal input ("L" = at stereo).
19	RCK	I	Serial	—	RDS data (clock) input.
20	RDA	I	Serial	—	RDS data (data) input.
21	GND	I	—	—	Not used.
22	PCK	O	Serial	L	LM7001 control output for PLL-CK (CL).
23	PDA	O	Serial	L	LM7001 control output for PLL-DATA (DATA).
24	PSTB	O	H	L	LM7001 control output for PLL-STB (CE).
25	GND	O	—	L	GND.
26	GND	O	—	L	GND.
27	A/M	O	L	L	AUTOMANUAL control.
28	GND	I	—	—	Not used.
29	P.O.F	O	H	L	Power control output ("H" = ON).
30	VR-UP	O	H	L	Power volume control output (LB1839 ON = at "H").
31	VR-D	O	H	L	Power volume control output (LB1839 ON = at "H").
32	SP-R	O	H	L	Speaker relay control output (ON = at "H").
33	VDD	PW	—	—	+5V.
34	GND	I	—	—	GND.
35	GND	I	—	—	GND.
36	1G	O	—	—	FL tube control output for 1G.
37	2G	O	—	—	FL tube control output for 2G.
38	3G	O	—	—	FL tube control output for 3G.
39	4G	O	—	—	FL tube control output for 4G.
40	5G	O	—	—	FL tube control output for 5G.
41	6G	O	—	—	FL tube control output for 6G.
42	7G	O	—	—	FL tube control output for 7G.
43	8G	O	—	—	FL tube control output for 8G.
44	9G	O	—	—	FL tube control output for 9G.
45	10G	O	—	—	FL tube control output for 10G.
46	11G	O	—	—	FL tube control output for 11G.
47	12G	O	—	—	FL tube control output for 12G.
48	13G	O	—	—	FL tube control output for 13G.
49	14G	O	—	—	FL tube control output for 14G.
50	S0 (a)	O	—	—	FL Tube control output for P(a).
51	S1 (b)	O	—	—	FL Tube control output for P(b).
52	S2 (c)	O	—	—	FL Tube control output for P(c).
53	S3 (d)	O	—	—	FL Tube control output for P(d).
54	S4 (e)	O	—	—	FL Tube control output for P(e).
55	S5 (f)	O	—	—	FL Tube control output for P(f).
56	S6 (g)	O	—	—	FL Tube control output for P(g).
57	S7 (h)	O	—	—	FL Tube control output for P(h).
58	S8 (i)	O	—	—	FL Tube control output for P(i).
59	S9 (k)	O	—	—	FL Tube control output for P(k).
60	S10 (m)	O	—	—	FL Tube control output for P(m).
61	S11 (n)	O	—	—	FL Tube control output for P(n).
62	S12 (p)	O	—	—	FL Tube control output for P(p).
63	S13 (q)	O	—	—	FL Tube control output for P(q).
64	S14 (r)	O	—	—	FL Tube control output for P(r).
65	S15 (s)	O	—	—	FL Tube control output for P(s).
66	Vkk	PW	—	—	-15V.
67	GND	I	—	—	GND.
70	GND	I	—	—	GND.
71	VA	O	L	H	Video In/Out control ("L" = at selection) BV4066.
72	VB	O	L	H	Video In/Out control ("L" = at selection) BV4066.
73	K1	I	—	—	Key input (A/D conversion input).
74	K2	I	—	—	Key input (A/D conversion input).
75	K3	I	—	—	Key input (A/D conversion input).
76	K4	I	—	—	Key input (A/D conversion input).
77	VER	I	—	—	Forwarding country setting.
78	VER	I	—	—	Specification setting.
79	MUTE (T)	O	H	H	MUTE output ("H" = MUTE).
80	GND	I	—	—	GND.

LM7001 (IC503)

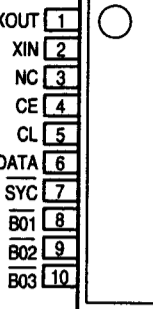
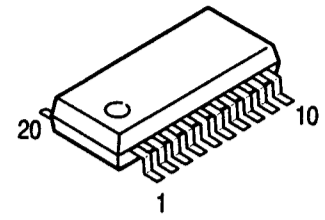

LA3401 (IC502)

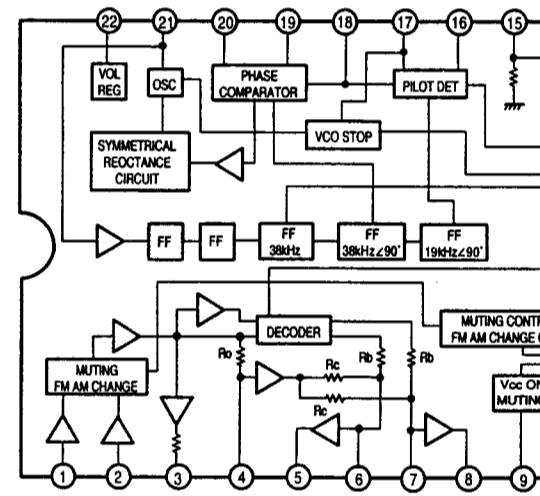
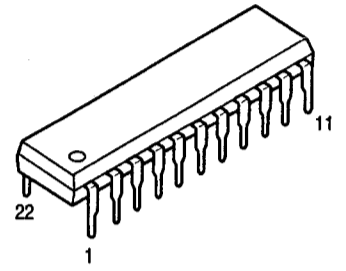

● TRANSISTORS

2SA988(E/F)
2SA1515(R)
2SC1815(Y)
2SC1841(E/F)

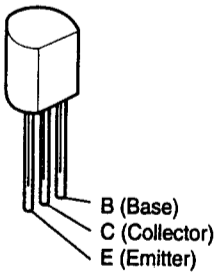

2SB647A(C)
2SB1041(R)
2SD667A(C)

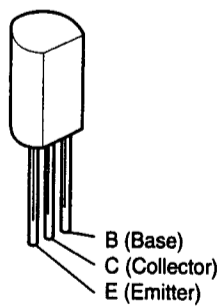

2SA933S(S)
2SA1038S(S/E)
2SC1740S(E)
2SC2389S(S/E)

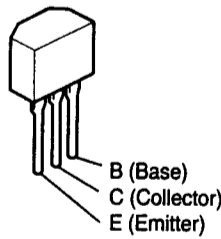

2SB1328(P)
2SD2004(P)

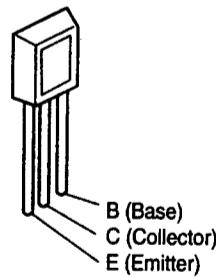

Digital Transistor (Built in Resistors)

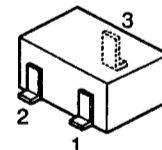

1:GND/Emitter
2:In/Base
3:Out/Collector

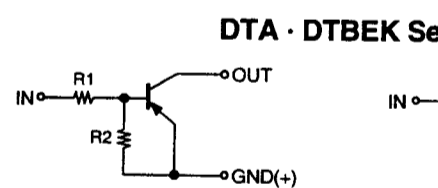

Model	R1	R2
DTA114EK	10kohm	1
DTB123EK	2.2kohm	2

DTCEK Series

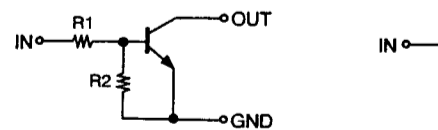

Model	R1	R2
DTC114EK	10kohm	1
DTC143EK	4.7kohm	4
DTC144EK	47kohm	4

2SA1633 (E/F) (TR605,606)
2SC4278 (E/F) (TR603,604)

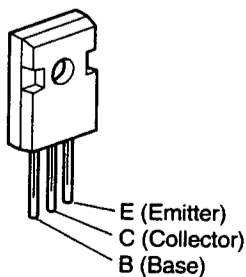

RN-1241(A/B)

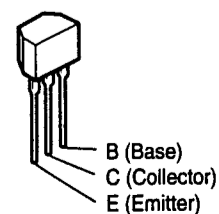

RN-1241

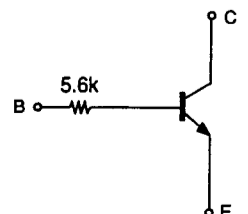

LA1265 (S)
(IC501)

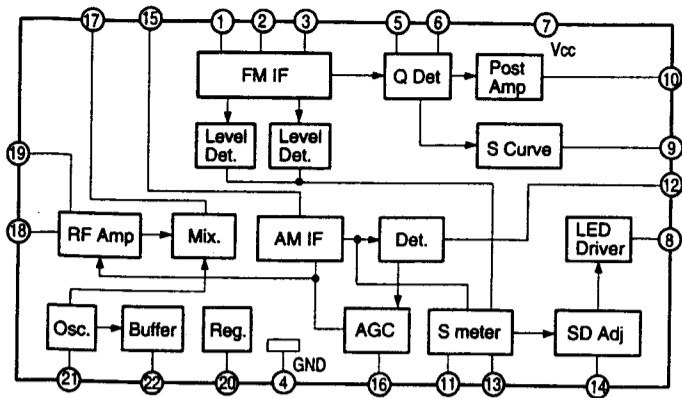
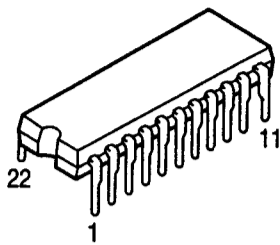

NJM78M12FA (IC504)
BA178M06 (IC401)

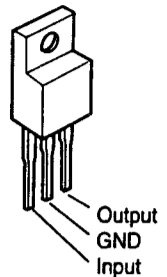

LC7821 (IC101)

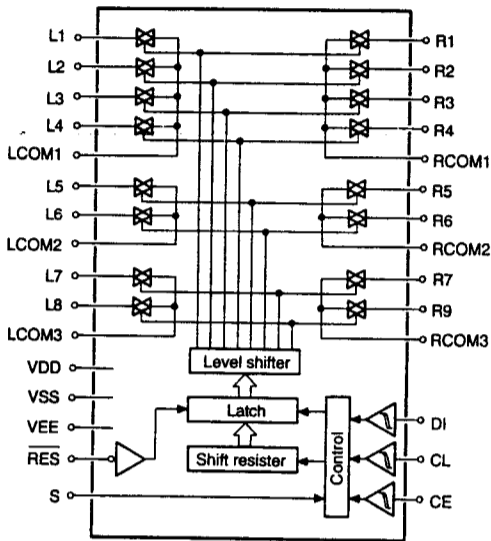
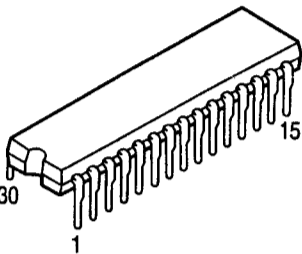

NJM2082M (IC701)

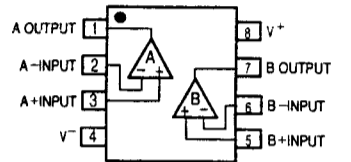
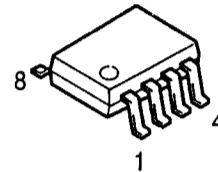

BA6208F (IC602)

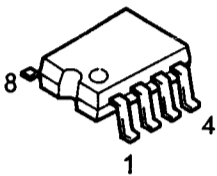

BA15218F (IC301)

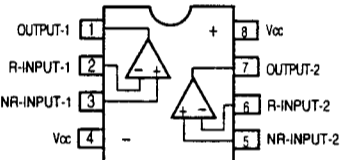
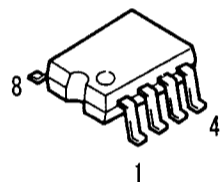

SAA6579T (IC801)

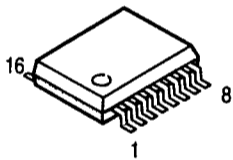

Pin No.	Symbol	Description
1	QUAL	Quality indication output.
2	RDDA	RDS data output.
3	V _{ref}	Reference voltage output (0.5 V _{DDA}).
4	MUX	Multiplex signal input.
5	V _{DDA}	+5 V supply voltage for analog part.
6	V _{SSA}	Ground for analog part (0 V).
7	CIN	Subcarrier input to comparator.
8	SCOUT	Subcarrier output of reconstruction filter.
9	TSTLD	Test control.
10	TEST	Test enable.
11	V _{SSD}	Ground for digital part (0 V).
12	V _{DDD}	+5 V supply voltage for digital part.
13	OSCI	Oscillator input.
14	OSCO	Oscillator output.
15	T57	57 kHz clock signal output.
16	RDCL	RDS clock output.

LC7074M (IC802)

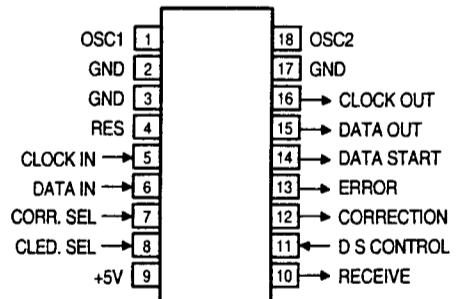
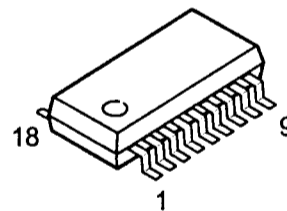

Series

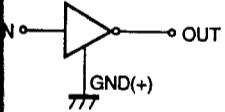

R2
10kohm
2.2kohm

R2
10kohm
4.7kohm
47kohm

2SK209 Y/GR

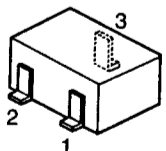

1: Drain
2: Source
3: Gate

2SA1037 (S/R)
2SC2412 (S)
2SC2413K (Q)
2SC2712 (Y/GR)
DTB123EK

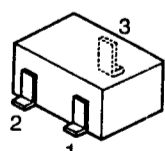

1: Emitter
2: Base
3: Collector

● DIODES (included LED)

1SS252

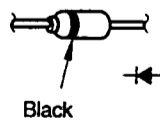

Black

1S2471

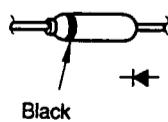

Black

MTZJ3.3A
MTZJ6.2A
MTZJ6.8C

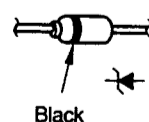

Black

MTZJ7.5C
MTZJ27D

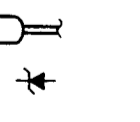

S4VB20F

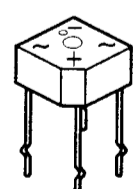

SF0R1A42

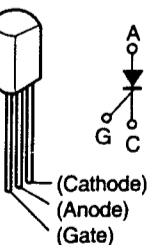

2SK221 Y/RG

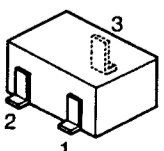

1: Gate
2: Drain
3: Source

1SR35-200 A

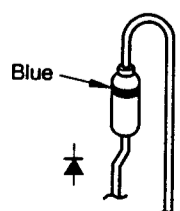

Blue

DAP202K (Chip)

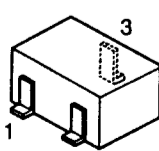

DAP202K

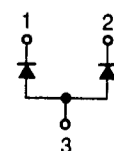

1: Cathode
2: Cathode
3: Anode

DT8.2B

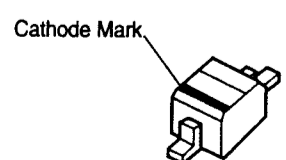

SBX1610-52 (Remote Control Sensor)

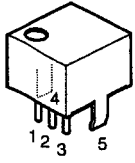

- 1. Vcc
- 2. Output
- 3. GND
- 4. Case Fin
- 5. Case Fin

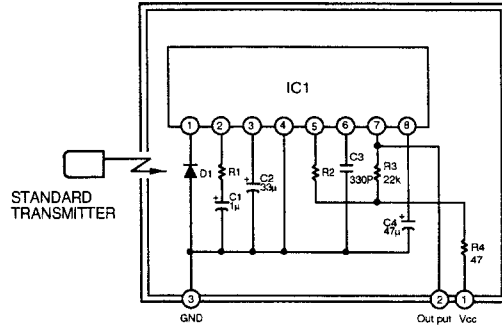

- IC1 : CX20106A Chip
- D1 : PIN Photodiode Chip
- C1,C2,C4 : Aluminum Electrolytic Capacitor
- C3 : SL Characteristic ±5%
- R1 : Gain control resistor
- R2 : for control resistor (Using ±1%)
- R (Other than above items) : ±5%