

DENON

Hi-Fi AM-FM Stereo Receiver

For EUROPEAN, U.K.
AND OTHER Models

SERVICE MANUAL

MODEL DRA-625R/425R

AM-FM STEREO RECEIVER



DRA-625R

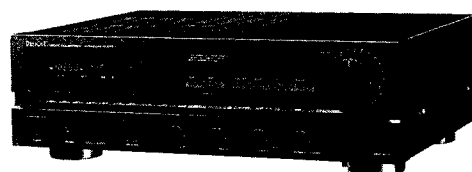

DRA-425R

TABLE OF CONTENTS

OPERATING INSTRUCTIONS	2 ~ 11
REMOVAL OF EACH SECTION	12, 13
METHOD OF ADJUSTMENTS	14, 15
CONNECTION DIAGRAM OF MEASURING INSTRUMENTS	15
SEMICONDUCTORS	16~19
PRINTED WIRING BOARD PATTERNS AND PARTS LIST	
1U-1596S MAIN UNIT P.W.BOARD (DRA-625R)	20
1U-1606S MAIN UNIT P.W.BOARD (DRA-425R)	21
1U-1597S (DRA-625R), 1U-1597S (DRA-425R) DISPLAY UNIT P.W.BOARD	22
1U-1742 CONTROL UNIT P.W.BOARD (DRA-625R/425R)	22
1U-1596S MAIN UNIT PARTS LIST (DRA-625R)	23, 24
1U-1606S MAIN UNIT PARTS LIST (DRA-425R)	24
1U-1597S (DRA-625R), 1U-1597S (DRA-425R) DISPLAY UNIT PARTS LIST	25
1U-1742 CONTROL UNIT PARTS LIST (DRA-625R/425R)	25
EXPLODED VIEW OF CHASSIS AND CABINET & PARTS LIST	
PARTS LIST OF EXPLODED VIEW (DRA-625R/425R Europe Black Version)	26
PARTS LIST OF EXPLODED VIEW (DRA-625R/425R Europe Gold Version)	26
EXPLODED VIEW OF CHASSIS AND CABINET (DRA-625R/425R)	27
WIRING DIAGRAM (DRA-625R/425R)	28
SCHEMATIC DIAGRAM (DRA-625R)	29
SCHEMATIC DIAGRAM (DRA-425R)	30
BLOCK DIAGRAM (DRA625R/425R)	31

NIPPON COLUMBIA CO., LTD.

PRECAUTIONS FOR INSTALLATION

DRA-625R/425R uses a newly developed heat emitting unit by employing heat pipes. Since the heat pipes contain a coolant, the DRA-625R/425R must be set level or the desired heat emitting effect cannot be achieved. Always install this unit horizontally.

WICHTIGER HINWEIS ZUR AUFSTELLUNG

Der DRA-625R/425R wird durch eine Wärmeabgabereinheit mit Wärmeableitungsrohren gekühlt. Da die Röhre Kühlflüssigkeit enthalten, muß der DRA-625R/425R für ausreichende Kühlung eben stehen. Das Gerät daher immer auf einer waagrechten Fläche aufstellen.

PRECAUTIONS DE MISE EN PLACE

Le DRA-625R/425R emploie une unité thermique nouvellement développée comportant des tuyaux thermiques. Ces tuyaux contenant un liquide réfrigérant toujours placer le DRA-625R/425R en position horizontale, faute de quoi l'effet de radiation thermique ne pourra être obtenu. Toujours placer cet appareil en position horizontale.

PRECAUZIONI PER L'INSTALLAZIONE

Il DRA-625R/425R impiega una unità d'emissione del calore di nuova progettazione impiegante tubi termici. Contenendo i tubi termici un refrigerante, il DRA-625R/425R deve essere sistemato orizzontale, altrimenti non è possibile ottenere l'effetto d'emissione del calore desiderato. Installare sempre questo apparecchio in posizione orizzontale.

PRECAUCIONES PARA LA INSTALACION

El DRA-625R/425R utiliza una unidad emisora de calor nuevamente desarrollada que emplea conductos de calor. Debido a que los conductos de calor contienen refrigerante, el DRA-625R/425R debe ajustarse al nivel o de otra forma el efecto deseado no podrá ser alcanzado. Instale siempre horizontalmente esta unidad.

VOORZORGSMAATREGELEN VOOR INSTALLATIE

De DRA-625R/425R maakt gebruik van een recentelijk ontwikkeld toestel dat warmte uitstraalt door gebruik van warmtebuizen. Aangezien de warmtebuizen een koelvloeistof bevatten, moet de DRA-625R/425R het ingestelde niveau hebben of het gewenste warmte uitstraaleffect kan niet verkregen worden. Dit toestel moet horizontaal geplaatst worden.

OBSERVERA VID INSTALLERING

DRA-625R/425R har en nyutvecklad anordning för värmeavledning med rör. Dessa rör innehåller en kylvätska och därför måste DRA-625R/425R placeras på ett vågrätt underlag eftersom annars korrekt värmeavledningseffekt inte kan erhållas. Ställ alltid upp apparaten horisontellt.

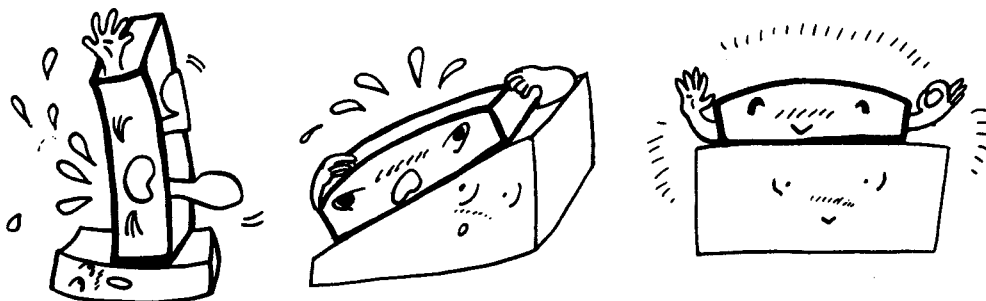

**"SERIAL NO. _____
PLEASE RECORD UNIT SERIAL NUMBER ATTACHED TO THE REAR OF THE
CABINET FOR FUTURE REFERENCE"**

For United Kingdom Model only.

WARNING:

As the colours of the wires in the mains lead of this appliance may not correspond with the coloured markings identifying the terminals in your plug proceed as follows:

- The wire which is coloured blue must be connected to the terminal which is marked with the letter N or coloured black.
- The wire which is coloured brown must be connected to the terminal which is marked with the letter L or coloured red.

IMPORTANT

The wires in this mains lead are coloured in accordance with the following code:

- Blue: Neutral
- Brown: Live

Die Deutsche Bundespost informiert**Sehr geehrter Rundfunkteilnehmer,**

Dieses Gerät ist von der Deutschen Bundespost als Ton- bzw. Fernseh-Rundfunkempfänger zugelassen. Es entspricht den zur Zeit geltenden Technischen Vorschriften der Deutschen Bundespost und ist zum Nachweis dafür mit der DBP-Prüfnummer... gekennzeichnet. Bitte überzeugen Sie sich selbst. Dieses Gerät darf im Rahmen der nachstehend abgedruckten »Allgemeinen Genehmigung für Ton- und Fernseh-Rundfunkempfänger« in der Bundesrepublik Deutschland betrieben werden. Beachten Sie aber bitte, daß aufgrund dieser Allgemeinen Genehmigung nur Sendungen des Rundfunks empfangen werden dürfen. *) Wer unbefugt andere Sendungen (z.B. des Polizeifunks, des Seefunks, der öffentlichen beweglichen Landfunkdienste) empfängt, verstößt gegen die Genehmigungsaufgaben und macht sich daher nach § 15 Absatz 2a des Gesetzes über Fernmeldeanlagen strafbar.

Die Kennzeichnung mit der DBP-Prüfnummer bietet Ihnen die Gewähr, daß dieses Gerät keine anderen Fernmeldeanlagen einschließlich Funkanlagen stört. Die Zusatzbuchstaben S, SE oder SK bei der DBP Prüfnummer besagen außerdem, daß das Gerät gegen störende Beeinflussungen durch andere Funkanlagen (z.B. des Amateurfunks, des CB-Funks) weitgehend unempfindlich ist. Sollten ausnahmsweise trotzdem Störungen auftreten, so wenden Sie sich bitte an die örtlich zuständige Funkstörungsstelle.

Allgemeine Genehmigung für Ton- und Fernseh-Rundfunkempfänger

Die Allgemeine Ton- und Fernseh-Rundfunkgenehmigung vom 11.12.1970 (veröffentlicht im Bundesanzeiger Nr. 234 vom 16.12.1970) wird unter Bezug auf Abschnitt III der Genehmigung durch folgende Fassung der Allgemeinen Genehmigung für Ton- und Fernseh-Rundfunkempfänger gemäß den §§ 1 und 2 des Gesetzes über Fernmeldeanlagen ersetzt.

Genehmigung für Ton- und Fernseh-Rundfunkempfänger

1. Die Errichtung und der Betrieb von Ton- und Fernseh-Rundfunkempfängern werden nach §§ 1 und 2 des Gesetzes über Fernmeldeanlagen in der Fassung der Bekanntmachung vom 17.3.1977 (BGBl. I, S. 459) allgemein genehmigt.
2. Ton- und Fernseh-Rundfunkempfänger im Sinne dieser Genehmigung sind Funkanlagen gemäß § 1 Abs. 1 des Gesetzes über Fernmeldeanlagen, die ausschließlich die für Rundfunkempfänger zugelassenen Frequenzbereiche**) aufweisen und zum Aufnehmen und gleichzeitigen Hör- oder Sichtbarmachen von Ton- oder Fernseh-Rundfunksendungen bestimmt sind. Zum Empfänger gehören auch eingebaute oder mit ihm fest verbundene Antennen sowie bei Unterteilung in mehrere Geräte die funktionsmäßig zugehörigen Geräte. Außer für den Empfang von Rundfunksendungen dürfen Ton- und Fernseh-Rundfunkempfänger nur mit besonderer Genehmigung der Deutschen Bundespost für andere Fernmeldeziele zusätzlich benutzt werden. In den Empfängern eingebaute oder sonst mit ihm verbundene Zusatzgeräte (z.B. Ultraschallfermeldeanlagen, Infrarotfermeldeanlagen) werden von dieser Genehmigung nicht erfaßt (ausgenommen die Einrichtungen zum Empfang des Verkehrsfunks). Desgleichen sind andere technische Empfangseigenschaften, die über den eigentlichen Zweck eines Rundfunkempfängers hinausgehen (z.B. zum Empfang anderer Funkdienste, für die Wiedergabe im Rahmen von Textübertragungsverfahren) hierdurch nicht genehmigt. Hierfür gelten besondere Regelungen.

II

Diese Genehmigung wird unter nachstehenden Auflagen erteilt.

1. Ton- und Fernseh-Rundfunkempfänger müssen den jeweils geltenden Technischen Vorschriften für Ton- und Fernseh-Rundfunkempfänger entsprechen. Eingebaute Zusatzgeräte müssen den für sie geltenden Bestimmungen und technischen Vorschriften genügen. Änderungen der Technischen Vorschriften, die im Amtsblatt des Bundesministers für das Post- und Fernmeldewesen veröffentlicht werden, muß bei schon errichteten und in Betrieb genommenen Ton- und Fernseh-Rundfunkempfängern nachgekommen werden, wenn durch den Betrieb dieser Rundfunkempfänger andere elektrische Anlagen gestört werden. Serienmäßig hergestellte Ton- und Fernseh-Rundfunkempfänger müssen zum Nachweis dafür, daß sie den Technischen Vorschriften entsprechen, mit einer DBP-Prüfnummer gekennzeichnet sein.**) Die DBP-Prüfnummer sagt über die elektrische und mechanische Sicherheit und die Einhaltung der Strahlenschutzbestimmungen nichts aus.

*) Zum Empfang anderer Sendungen darf dieses Gerät nur mit Genehmigung der Deutschen Bundespost benutzt werden. Allgemein genehmigt ist zur Zeit der Empfang der Aussendungen von Amateurfunkstellen und der Normalfrequenz- und Zeitzeichensendungen.

**) Siehe Technische Vorschriften für Ton- und Fernseh-Rundfunkempfänger, veröffentlicht im Amtsblatt des Bundesministers für das Post- und Fernmeldewesen.

***) Für ausnahmsweise noch nicht gekennzeichnete, vor dem 1.7.1979 errichtete und in Betrieb genommene Ton-Rundfunkempfänger wird die Kennzeichnung nicht verlangt.

2. Ton- und Fernseh-Rundfunkempfänger dürfen an ortsfesten oder nichtortsfesten Rundfunk-Empfangsantennenanlagen, -Verteilanlagen oder Kabelfernsehanlagen betrieben und im Rahmen der Bestimmungen über private Drahtfermeldeanlagen mit Drahtfermeldeanlagen verbunden werden. Auf demselben Grundstück oder innerhalb eines Fahrzeuges dürfen Ton- und Fernseh-Rundfunkempfänger mit anderen Geräten oder sonstigen Gegenständen (z.B. Plattenspieler, Magnetaufzeichnungs- und -Wiedergabegeräte, Antennen) verbunden werden, sofern diese Geräte von der Deutschen Bundespost genehmigt sind oder keiner Genehmigung bedürfen. Die räumliche Kombination von Funkanlagen mit Ton- oder Fernseh-Rundfunkempfängern ist nur dann zulässig, wenn die betreffenden Funkanlagen je für sich genehmigt sind.
3. Mit Ton- oder Fernseh-Rundfunkempfängern dürfen aufgrund dieser Genehmigung nur Sendungen des Rundfunks empfangen werden, also übertragene Tonsignale (Musik, Sprache) und Fernsehsignale (nur Bildinformationen). Andere Sendungen (z.B. des Polizeifunks, der öffentlichen beweglichen Landfunkdienste, Datenübertragungen) dürfen nicht aufgenommen werden, werden sie jedoch unbeabsichtigt empfangen, so dürfen sie weder aufgezeichnet, noch anderen mitgeteilt, noch für irgendwelche Zwecke ausgewertet werden. Das Vorhandensein solcher Sendungen darf auch nicht anderen zur Kenntnis gebracht werden.
4. Durch Ton- oder Fernseh-Rundfunkempfänger darf der Betrieb anderer elektrischer Anlagen nicht gestört werden.
5. Änderungen der Ton- oder Fernseh-Rundfunkempfänger, die die zulässigen Frequenzabstimmbereiche der Rundfunks empfangen werden, also übertragene Tonsignale (Musik, Sprache) und Fernsehsignale (nur Bildinformationen) der Deutschen Bundespost. Wer aufgrund dieser Genehmigung einen Ton- oder Fernseh-Rundfunkempfänger betreibt, hat bei einer Änderung der kennzeichnenden Merkmale von Ton- oder Fernseh-Rundfunksendern (insbesondere bei Änderung des Sendeverfahrens oder bei Frequenzwechsel) die ggf. notwendig werdenden Änderungen an den Rundfunkempfängern auf seine Kosten vornehmen zu lassen.
6. Die Deutsche Bundespost ist berechtigt, Rundfunkempfänger und mit ihnen verbundene Geräte darauf zu prüfen, ob die Auflagen der Genehmigung und die Technischen Vorschriften eingehalten werden. Den Beauftragten der Deutschen Bundespost ist das Betreten der Grundstücke oder Räume, in denen sich Ton- oder Fernseh-Rundfunkempfänger befinden, zu den verkehrsüblichen Zeiten zu gestatten. Betreten sich die Rundfunkempfänger oder mit ihnen verbundene Geräte nicht im Verfügungsbereich desjenigen, der die Empfänger betreibt, so hat er den Beauftragten der Deutschen Bundespost Zutritt zu diesen Teilen zu ermöglichen.

III

Bei Funkstörungen die nicht durch Mängel der Rundfunkempfänger oder der mit ihnen verbundenen Geräte verursacht werden, können die Funkdienste der Deutschen Bundespost zur Feststellung der Störung in Anspruch genommen werden.

IV

1. Diese Genehmigung kann allgemein oder durch die örtlich zuständige Oberpostdirektion einem einzelnen Betreiber gegenüber für einen bestimmten Rundfunkempfänger widerrufen werden. Ein Widerruf ist insbesondere zulässig, wenn die unter Abschnitt II aufgeführten Auflagen nicht erfüllt werden. Anstatt die Genehmigung zu widerrufen, kann die Deutsche Bundespost anordnen, daß bei ihrem Verstoß gegen eine Auflage ein Ton- oder Fernseh-Rundfunkempfänger außer Betrieb zu setzen ist und erst bei Einhaltung der Auflagen wieder betrieben werden darf. Die Auflagen dieser Genehmigung können jederzeit ergänzt oder geändert werden.
2. Diese Genehmigung ersetzt die Allgemeine Ton- und Fernseh-Rundfunkgenehmigung vom 11.12.1970, sie gilt ab 1.7.1979.

Bonn, den 14.5.1979

Der Bundesminister
für das Post- und Fernmeldewesen
im Auftrag
Haist

NAME AND FUNCTION OF PARTS

FRONT PANEL

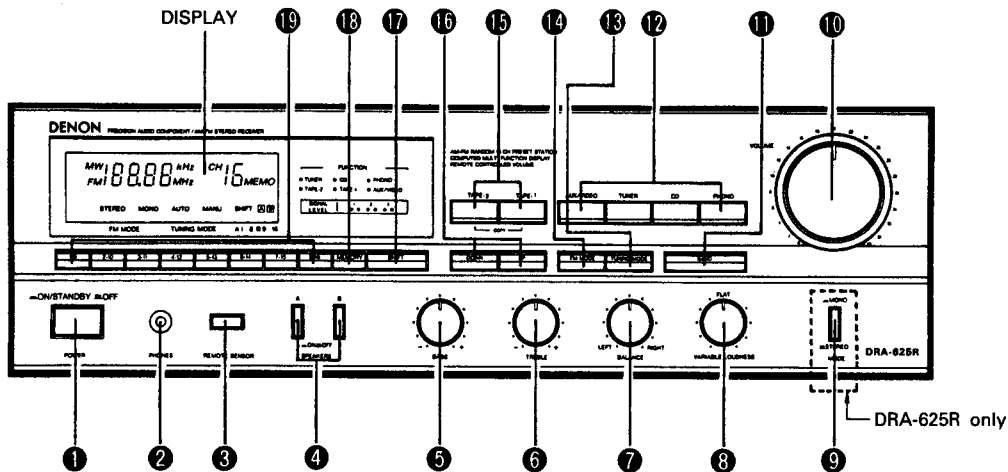

- 1 POWER (Power Switch)**
When the switch is pushed, power is supplied, and the DISPLAY is lit. It takes several seconds for the system to operate after power on. This is normal since the built-in muting circuit suppresses noise generated at power on or off.
- 2 PHONES (Headphones Jack)**
The jack is used for connecting the headphones.
- 3 REMOTE SENSOR (Remote Control Photosensitive Window)**
 - This window receives the light transmitted from the wireless remote control unit.
 - The RC-111 wireless remote control unit should be operated to the direction of the photosensitive window.
- 4 SPEAKERS (Speaker Select Switch)**
A desired speaker system can be selected in three way: speaker system A, speaker system B, and speaker systems A + B. When the switch is "off", no sound is produced through speakers, and sound is produced only at the headphones.
- 5 BASS (Bass Control)**
Use the control to adjust bass sound quality. When the knob is at the center, frequency characteristics under 100 Hz are flattened. When the knob is turned clockwise, bass is emphasized, and when turned counterclockwise, bass is de-emphasized.
- 6 TREBLE (Treble Control)**
Use the control to adjust treble. When the control knob is at the center, frequency characteristics over 10,000 Hz are flattened. When the knob is turned clockwise, treble is emphasized, and when turned counterclockwise, treble is de-emphasized.
- 7 BALANCE (Balance Control)**
Use to control the balance between the two channels. When the knob is at the center, the amplitude of the amplifier at both channels is equal.
- 8 VARIABLE LOUDNESS (Loudness Control)**
At low volumes human hearing is less sensitive to low (BASS) and high (TREBLE) sound. Use the variable loudness to compensate the insensitivity at low listening levels, rotate this control counterclockwise until natural balance of BASS and TREBLE has been restored.
- 9 MODE (Mode Switch) (DRA-625R only)**
 - stereo: This position is set for stereo signal. ().
 - mono: This position is set for monophonic signal. It can be used to check the speaker phase or the stereo balance. ().

- 10 VOLUME (Volume Control)**
This controls the overall volume level. When the knob is turned in the clockwise direction, volume, increases. When turned counterclockwise, volume decreases.
 - 11 BAND SELECT (Band Selector Button)**
This switch selects the Band, AM or FM, AM is displayed in MW in the indicator ⑦.
 - 12 INPUT SELECTOR (Input select buttons)**
This button is used to select the audio program source.
 - PHONO: Used to select the output from a record player that is connected to the PHONO terminal.
 - CD: Used to listen to a compact disc player or other component that is connected to the CD terminal.
 - TUNER: Used to listen FM or AM radio.
 - AUX/VIDEO: Use when playing back the audio from a Hi-Fi video, TV tuner, video disc player or other component connected to the VIDEO or VCR terminal.
- This receiver used a microcomputer. When the power is turned ON, the INPUT SELECTOR is initialized to TUNER position.
- 13 TUNING MODE (Tuning Mode Button)**
This switch selects the tuning mode, automatic or manual tuning. The mode changes alternatively between AUTO and MANU each time the button is pressed.
 AUTO/MANU Tights up the display.
 AUTO: The FM or AM signal is tuned automatically.
 MANU: The desired signal can be tuned manually.
 - 14 FM MODE (FM Mode Button)**
This switch selects the FM mode, Mono or Stereo. In the Mono mode, MONO lights up and in the Stereo mode, STEREO lights up when a stereo signal is being received. Furthermore, the FM mode can be sotred at the preset channels along with the frequencies.
 STEREO: FM stereo and mono signals can be received. FM noise in no signal reception is eliminated in this position.
 MONO: All FM signals are received in Monaural. AM is not affected. If there is a lot of noise in the STEREO position, set the switch in the MONO position.

- 15 TAPE SELECTOR (Tape selector switch)**
Toggle keys have been used for selection of TAPE-1 and TAPE-2. Pressing them an uneven number of times turns the function on, pressing them an even number of times turns the function off.
- TAPE-1: Used to play a tape deck connected to the TAPE-1 terminal.
 - TAPE-2: Used to play a tape deck connected to the TAPE-2 terminal.
- Tape-to-Tape Dubbing**
- ① Connect the two tape decks to this unit as shown in the connections.
 - ② Load the original tape in tape deck 1 and the blank tape in tape deck 2.
 - ③ Press the TAPE-1 Selector Button 15 (indicator lights).
 - ④ Put tape deck 1 in the playback mode and tape deck 2 in the recording mode. Follow tape deck operating instructions.
 - ⑤ The recording can be monitored through the speakers or headphones. (If tape deck 2 has three heads, the just-recorded signal can be monitored when the tape 2 button is pressed.)

- 16 TUNING (Tuning Buttons)**
Use these buttons for either manual tuning or automatic tuning.
- UP: When this button is pressed, the tuning goes up the band.
 - DOWN: When this button is pressed, the tuning goes down the band.
 - Manual Tuning (Set the TUNING MODE 21 "MANU" by pushing the TUNING MODE Button 16.)
In FM mode, the frequency indicator moves in 50 kHz steps. In am, the indicator moves in 9 kHz steps. If the button is pressed for more than 1 second, the indicator moves quickly and continuously up or down until released.

- Automatic Tuning (Set the TUNING MODE 21 "AUTO" by pushing the TUNING MODE Button 16.)
For example, when the "up" button is pressed, the frequency indicator moves up the band until a broadcast signal is received.
If no more signals are detected, the indicator moves to the upper limit and starts from the lower end.
(When the "down" button is pressed, the indicator travels down in the same way.)
While the button is continuously pressed, broadcast signals cannot be tuned; the indicator continuously travels up or down the band. Automatic tuning is only provided for radio stations of usable strength; a sudden strong noise may disturb automatic tuning.
When the desired signal is weak, use manual tuning.

- 17 SHIFT (Shift Button)**
This switch is used to change eight preset buttons 19 to 1 ~ 8 channels or 9 ~ 16 channels. The SHIFT [A]/[B] is then on. Each recycle shifts from SHIFT [A] to SHIFT [B]. If storing or retrieving data into or from the preset 1 ~ 8 channels, specify SHIFT [A]. Similarly, to use preset 9 ~ 16 channels, specify SHIFT [B].

- 18 MEMORY (Memory Button)**
This switch is used to register the desired radio station to one of the preset buttons memory. When pressing this button, the memory indicator 25 lights for approximately 5 seconds. During this interval, the desired station can be registered in the memory.

- 19 PRESET CHANNEL 1 ~ 16 (Station Presetting Buttons)**
These buttons are used for storing or calling station. With the shift button 17 you can preset 1 ~ 8 and 9 ~ 16 channels, a total of 16 AM and FM stations in eight preset buttons. When the preset channel buttons are in operation, an indicator (SHIFT [A]/[B]) illuminates. When radio stations are memorized with these buttons, a desired station can be easily tuned in without pressing the tuning buttons.

DISPLAY

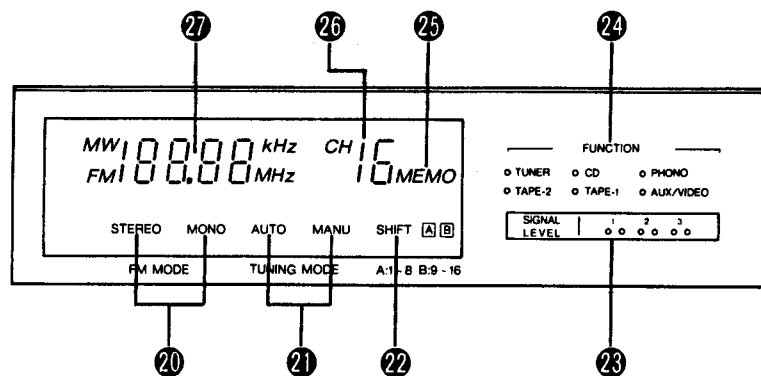

- 20 FM MODE (STEREO/MONO Indicator)**
Lights automatically when receiving a stereo signal in the "STEREO" mode. Does not light for stereo reception in the "MONO" mode.
- 21 TUNING MODE (AUTO/MANUAL)**
Pressing TUNING MODE 16 causes AUTO and MANU to light up alternately.
- 22 SHIFT [A]/[B] (Shift Indicator)**
The preset channel which is selected with the Shift Button 17 is displayed by the SHIFT [A] or [B].
- 23 SIGNAL LEVEL (Signal-Level Indicators)**
This indicator shows the signal strength level of AM and FM broadcast station. The best position for reception is obtained when the maximum number of indicator lamps are illuminated.
- 24 FUNCTION (Input Selector Indicator)**
The program source selected by Input Select Switch or Tape Select Switch is displayed by the indicator.
- 25 MEMO (Memory Indicator)**
This indicator lights when the MEMORY button 18 is pressed.
- 26 CHANNEL**
When using the channel preset button 19, the channel is displayed and the frequency for that channel stored in memory is displayed in 27.
- 27 FREQUENCY DISPLAY (Frequency Indicator)**
The frequency is displayed in numerals. It is displayed in MHz for FM and in kHz for MW.

BACK PANEL

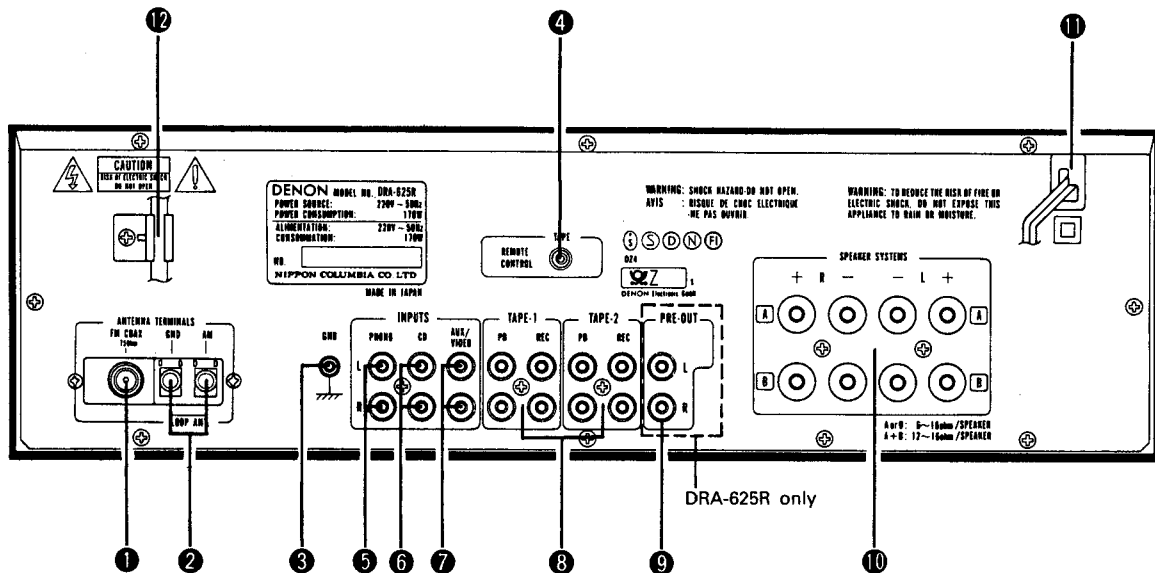

- 1 FM ANT (FM Antenna Terminals)**
75-ohms coaxial cable can be connected to this terminal. For antenna connecting procedure, see the ANTENNA INSTALLATION (page 7).
- 2 AM ANT (AM Antenna Terminals)**
Connect the attached AM loop antenna. (Refer to page 7 for connection).
Connect to this terminal when a medium wave outdoor antenna is used.
- 3 GND (Grounding Terminal)**
The grounding wire of the turntable is connected here.
• Hum or noise may be generated if the grounding wire is not connected.
- 4 TAPE/REMOTE CONTROL**
This terminal is exclusively used for sending the remote control signals to the tape deck. Connect it with a 3.5mm mini-jack cord.
- Note:**
Do not hook up a headphones or microphone jack cord. Use this jack to connect a Denon cassette deck with a remote control jack (wired).
If the cassette deck does not have this jack, wired remote control is not possible.
- 5 PHONO (Phono Input Terminals)**
The output cord of the turntable is connected here. Since the input sensitivity of "PHONO" is extremely high, do not use the unit without the input pin cord. If used without this cord, the speakers may generate hum.
- 6 CD**
The output cord of the CD player is connected here.
- 7 AUX/VIDEO**
An AUX/VIDEO, such as a VCR or Video Disk may be connected here.
- 8 TAPE-1, TAPE-2 (Audio Playback and Recording Terminals)**
Tape decks can be connected for full use including playing or copying.
- 9 PRE-OUT (DRA-625R only)**
Output signals for power amplifiers are sent from these jacks. The rated output is 1.0 volts.
The signals do not pass through the bass and treble circuits.
- 10 SPEAKER SYSTEMS (Speaker Terminals)**
Two pairs of speakers A and B can be connected to these terminals.
- 11 AC CORD (Power Cord)**
Connect this cord into the wall outlet.
- 12 AM LOOP ANT (AM Loop Antenna)**
Correctly connect the AM loop antenna to the antenna terminal. Broadcasting cannot be received when the connection is incomplete.
Adjust the antenna for optimum reception while receiving the medium wave broadcasting. Do not place a pin cord, SP cord or electric cord near the antenna. This may cause noise generation.
- Note:**
• Two FM antennas should not be connected simultaneously.
• Even if an external AM antenna is used, the AM loop antenna should not be disconnected.
• AM loop antenna lead terminals do not touch the metal part of the back panel.

ANTENNA INSTALLATION

FM ANTENNA

The T-type indoor antenna (300 ohm) can be used inside wooden houses for local FM stations and strong signals. Orient the T-shaped part for optimum reception and mount the antenna on the wall or ceiling. (FM indoor antennas may not consistently ensure stable reception, due to environment changes. In such cases use an FM indoor antenna temporarily until an outdoor antenna is installed.)

75 ohms coaxial cable (3C-2V, 5C-2V) is preferable to obtain better performance of the tuner.

(To use of a 300 ohm FM outdoor antenna, connect to the 300 ohm terminals.)

AM ANTENNA

Attach the accessory AM loop antenna to the antenna holder on the back panel.

Connect the leads to AM and GND terminal. Use this terminal also for an outdoor antenna.

Orient the loop antenna horizontally to obtain optimum reception. Where broadcast stations are distant and only weak signals are received, or where signals are blocked by obstacles, install an AM outdoor antenna.

GROUNDING

If there is reception noise, use of grounding wire is recommended.

Connect a thick insulated wire to the "GND" terminal, and attach the unconnected bare end to a metal water pipe, grounding rod, or grounded copper plate.

* Never connect the grounding wire to a gas pipe. This could cause fire or explosion.

CONNECTIONS

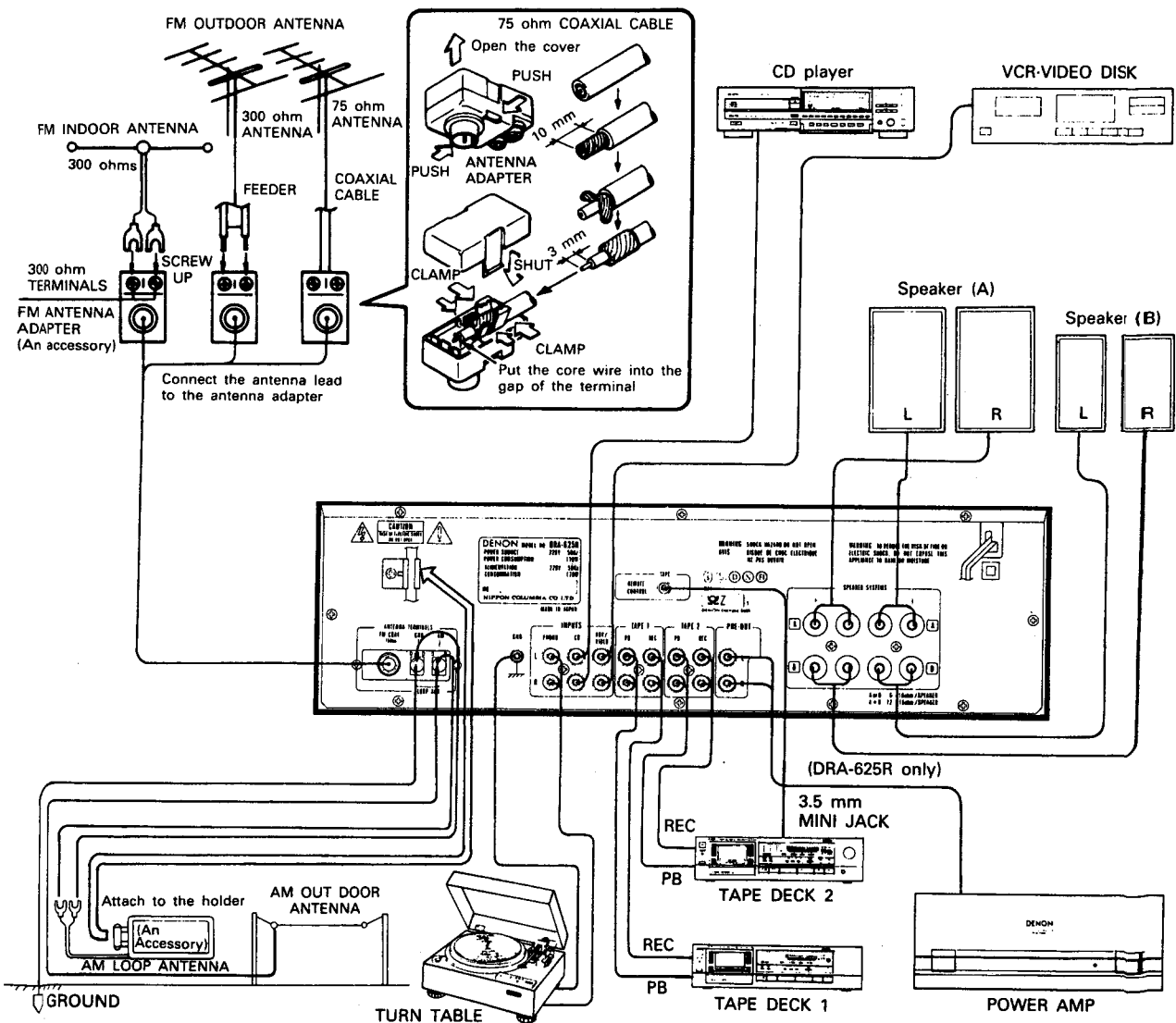

SPEAKER CONNECTION

Confirm polarity (+, -) and left and right channels (L, R). Connect the speaker pairs to the SPEAKER terminals A or B on the back panel. Connections must be made with power cord disconnected.

1. Peel off the sheathing from the end of the cord.
2. Twist the wire strands.
3. Loosen the speaker terminal, insert the wire lead portion of the cord, and then tighten the terminals.

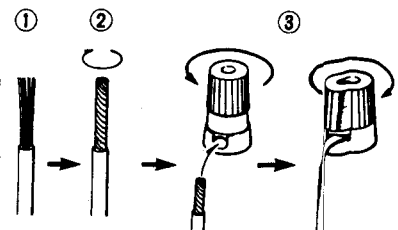

CAUTION

Protective Circuit

This set is equipped with a high speed protective circuit. This circuit protects the internal circuitry from damage due to large currents flowing when the speaker jacks are not completely connected or when an output is generated by a short circuit. This protective circuit's operation cuts off the output to the speakers. In such a case, be sure to turn the power to the set off and check the connections to the speakers. Then turn the power on again. After muting for several seconds, the set will operate normally.

HOW TO PRESET THE STATION

1. Set the BAND SELECT button to "AM" or "FM", and press the TUNING button to tune the desired station.
2. Specify the preset buttons 1 ~ 8 or 9 ~ 16 by the SHIFT button.
3. Press the MEMORY buttons and MEMORY indicator lights for about 5 seconds. During this time, press one of the eight PRESET channel buttons.
4. The channel corresponding to the pressed button is displayed and the indicated frequency is stored in memory for that channel.

NOTE: If preset button is inoperative with MEMORY illuminated, press MEMORY and preset buttons again.

- This model has a last channel memory system. It stores the last channel used power off.
- This model is designed to store and retain the stations that have been previously registered in the memory, even if the tuner is deenergized temporarily. The memory can hold registered data for approximately about a month [Temperature: 68°F (20°C), relative humidity: 65%]. If the memory is erased reset the preset data.

PLAYBACK USING THE REMOTE CONTROL

The accessory RC-111 remote control unit is used to control the RECEIVER from a distance.

(1) Inserting the dry cell batteries

- 1 Remove the rear cover on the remote control unit.

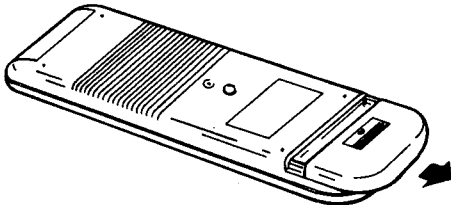

- 2 Insert two size R03 (AAA) dry cell batteries as shown in the diagram on the battery supply unit.

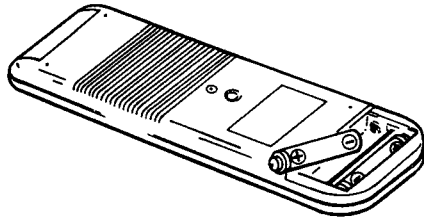

- 3 Replace the rear cover.

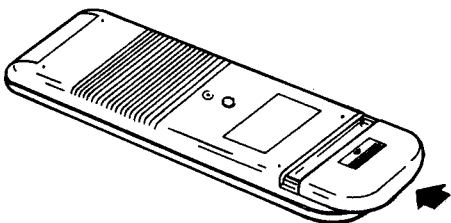

Notes on Use of the Batteries

- The remote control unit uses size R03 (AAA) dry cell batteries.
- The batteries will need to be replaced approximately once a year. this will depend upon how often the remote control is used.
- If, in less than a year from the time new batteries were inserted, the remote control fails to operate this unit from a near-by position, it is time to replace the batteries.
- Insert the batteries properly, following the diagram on the remote control battery supply unit, and making sure to align the plus and minus sides of each battery.
- Batteries are prone to damage and leakage. Therefore:
 - Do not combine new batteries with used ones.
 - Do not combine different types of batteries.
 - Do not jumper the opposite poles of the batteries, expose them to heat or break them open, or put them into open fire.
- When the remote control is not to be used for a long period of time, remove the batteries from the unit.
- If the batteries have leaked, remove any battery fluid from the inside of the battery supply unit by wiping it out thoroughly, and insert new batteries.

CAUTION

It may be difficult to operate the remote unit with a fluorescent light near the set, in particular near the remote control sensor, but this is not a malfunction. Should this happen, move the fluorescent light away from the set.

(2) Directions for use

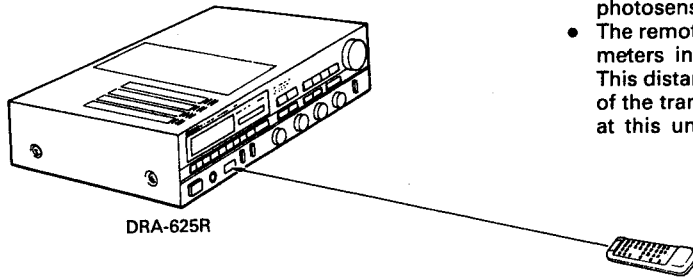

- Operate the remote control unit while it is pointed toward the photosensitive window, as shown in the diagram below.
- The remote control unit can be used at distances up to about 8 meters in a straight line away from this unit. This distance will decrease if there are obstructions in the way of the transmission or if the light shaft is not directed straight at this unit.

Note on Operation

- Do not press the operating buttons on the receiver and the remote control unit at the same time. This will cause misoperation.
- Operation of the remote control will become less effective if the infrared photosensitive window is exposed to strong light or if there are obstructions between the remote control unit and the photosensitive window.
- In case you operate your VCR, TV or other components by remote control, do not operate buttons on two different remote control units at the same time. This will cause mis-operation.

Operate not only the DRA 625R or 425R receiver but also a cassette deck and a CD player from the handy full-system remote control pad.

Remote Control Section

Full-system Remote Control

The full-system remote control operates all of the important functions of the receiver such as function switching, volume control, and tuner memory. But that's not all! The same control pad can also control the important functions of a CD player and cassette deck when combined with the DRA 625R or 425R to create a remarkably ergonomic and versatile DENON system with all the quality sound reproduction that the devoted audiophile expects.

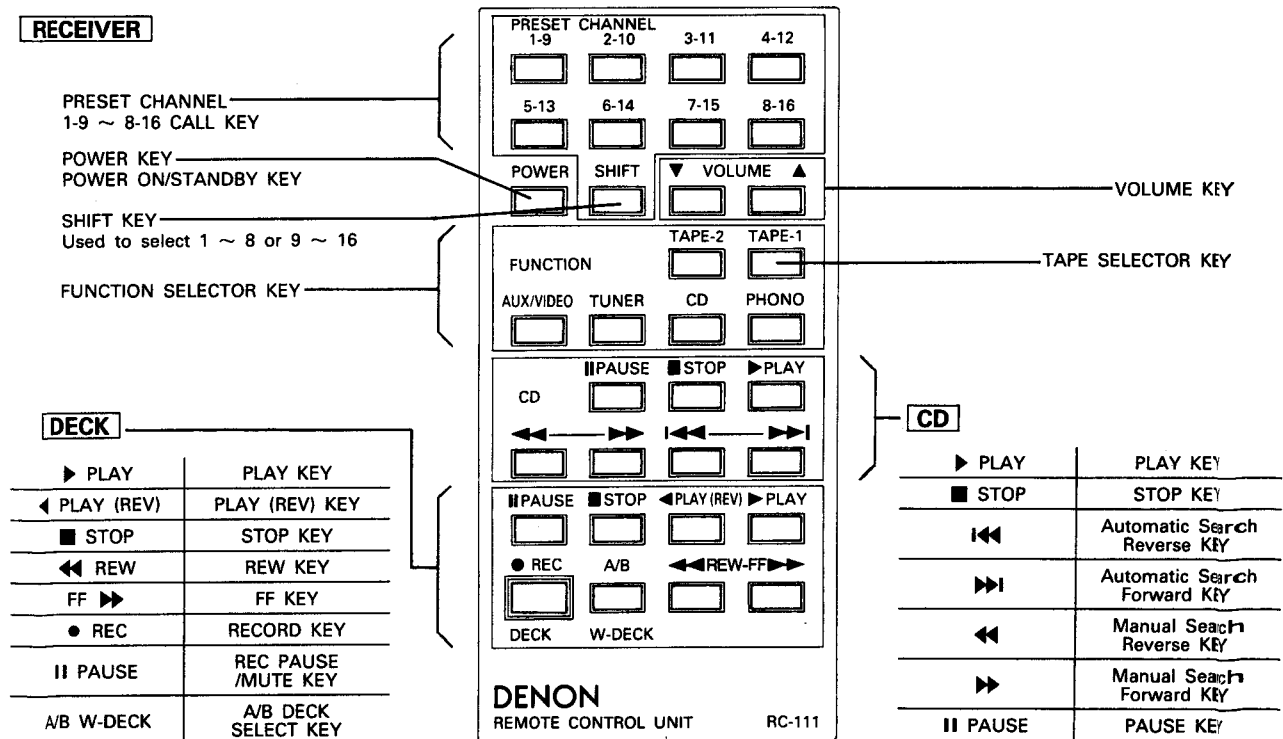

- The RC-111 Remote Control Units control CD players (exclude DCD-1800R) and cassette decks made by DENON.
- The upper row is the indicator for RECEIVER and the lower row is the indicator for CD player and Cassette Deck.

For details of each operation, see the instruction manual for the CD player or cassette deck.

CAUTION:

- If the power is turned off with the remote control unit, the receiver is switched to the power stand-by state. If you are to be absent for a long period of time, be sure to turn the power off using the POWER switch on the receiver.
- In the standby mode, one of the input selector indicators remains lit.
- You may experience erratic operation of the remote control unit if it is operated in fluorescent light and direct sunlight, in particular if this light strikes the remote control sensor on the receiver. However, this is not a malfunction, and if this should happen, protect the sensor against such light.

TROUBLESHOOTING

1. Have all connections been made properly?
2. Have you followed all operational instructions correctly?
3. Check speaker and the turntable systems for proper operation.

When your unit does not seem to be operating correctly, first check the items in the following table. If the symptom does not correspond to any of the problems as shown below, turn off the power sources immediately and contact your DENON dealer.

Problem	Cause	Remedy
FM AND AM RECEPTION		
Radio program can not be received.	<ul style="list-style-type: none"> • Antenna connection is wrong. • A signal strength is weak. 	<ul style="list-style-type: none"> • Check the connection. • Check the antenna installation.
Noise is reproduced.	<ul style="list-style-type: none"> • A signal strength is weak. • Automobile ignition noise interferes with reception. • Other electrical equipment interferes with reception. 	<ul style="list-style-type: none"> • Install an outdoor antenna. • Keep the antenna away from the street. • Keep the equipment away from this set, or turn off the power of the other equipment.
The preset frequencies are erased.	<ul style="list-style-type: none"> • The memory back-up term (about 1 month) passed. 	<ul style="list-style-type: none"> • Preset again.
In automatic tuning, the frequency doesn't stop at the radio station.	<ul style="list-style-type: none"> • A signal strength is weak. 	<ul style="list-style-type: none"> • Use manual tuning
In automatic tuning, it stops at the one step lower or higher frequency than the radio station.	<ul style="list-style-type: none"> • Noise or strong signal strength is received. 	<ul style="list-style-type: none"> • Use manual tuning for optimum reception.
PLAYBACK OF THE AUDIO EQUIPMENTS		
No sound is produced with power on.	<ul style="list-style-type: none"> • Input and speaker cords connection are wrong. • Speaker switch is off. • The INPUT SELECTOR buttons are in wrong position. • The protective circuit is operating. • The fuse has blown out. 	<ul style="list-style-type: none"> • Check the connection. • Turn on speaker switch. • Check these position. • Turn the power off once, check the connections to the speakers, then turn the power on again. • Ask your dealer, or the nearest DENON representative.
Audible hum when playing records.	<ul style="list-style-type: none"> • The input and grounding cords connection of the turntable are wrong. • The cords connection of the cartridge are wrong. • The interference from the nearby TV or radio transmission antenna. 	<ul style="list-style-type: none"> • Check the connection. • Check the connection. • Ask your dealer, or the nearest DENON representative.
Howling is produced when the volume control is turned up too high while playing records.	<ul style="list-style-type: none"> • The vibrations and sounds transmit from the speakers to the turntable. 	<ul style="list-style-type: none"> • Insulate the vibrations, or keep the speakers away from the turntable.
Cracking noise is produced when playing records.	<ul style="list-style-type: none"> • The record is stained with the dust. • The stylus tip of the cartridge is stained with the dust. • The cartridge is defective. 	<ul style="list-style-type: none"> • Clean the record. • Clean the stylus tip. • Try the other cartridge.

SIGNAL FLOWING TABLE

SOURCE	TAPE-1	TAPE-2	SOUND		
			SPEAKER	TAPE 1 REC	TAPE 2 REC
PHONO	OFF	OFF	SOURCE	SOURCE	SOURCE
or CD	ON	OFF	TAPE-1	SOURCE	TAPE 1
or TUNER	OFF	ON	TAPE-2	SOURCE	SOURCE
or AUX/VIDEO	ON	ON	TAPE-2	SOURCE	TAPE 1

SPECIFICATIONS

AMPLIFIER SECTION

Continuous Power Output:	DRA625R: 90 W + 90 W (4 ohms, DIN 1 kHz T.H.D. 1%) 65 W + 65 W (8 ohms, 20 Hz ~ 20 kHz T.H.D. 0.05%) DRA425R: 70 W + 70 W (4 ohms, DIN 1 kHz T.H.D. 1%) 50 W + 50 W (8 ohms, 20 Hz ~ 20 kHz T.H.D. 0.05%)
Power Bandwidth (IHF):	5 Hz ~ 40 kHz (T.H.D. 0.05% both channels driven at 8 ohms)
Total Harmonic Distortion:	-3 dB power into 8 ohms 0.009% (DRA-625R) 0.01% (DRA-425R)
Frequency Response:	PHONO RIAA Standard Curve (Recording Output)
	MM 20 Hz ~ 20 kHz ±0.5 dB
	TAPE-1-2, CD, 20 Hz ~ 50 kHz ±1.5 dB
	AUX/VIDEO (at 1W)
Input Sensitivity and Impedance:	PHONO MM 2.5 mV 47 k ohms
	TAPE-1-2, CD, 150 mV 29 k ohms
	AUX/VIDEO
Maximum Input Level (at 1 kHz):	PHONO MM 110 mV
Signal to Noise Ratio (IHF-A):	PHONO MM 86 dB at 5.0 mV input
	TAPE-1-2, CD, 95 dB
	AUX/VIDEO
Tone Controls:	BASS ±8 dB at 100 Hz
	TREBLE ±8 dB at 10 kHz
Loudness, Control Effect:	VARIABLE LOUDNESS at 10 positions, 50 Hz/10 kHz, +10 dB/+5 dB
Pre-out terminals	
Rated output power: (DRA-625R only)	1 V (at 100 k ohms load)

TUNER SECTION

[FM] (note: μV at 75 ohms, 0 dBf = 1×10^{-15} W)	
Receiving Range:	87.5 ~ 108 MHz
Usable Sensitivity:	0.9 μV (10.3 dBf)
50 dB Quieting Sensitivity:	MONO 1.6 μV (15.3 dBf)
	STEREO 23 μV (38.5 dBf)
Signal to Noise Ratio (IHF-A):	MONO 82 dB
	STEREO 78 dB
Total Harmonic Distortion (at 1 kHz):	MONO 0.12% (DRA-625R)
	0.15% (DRA-425R)
	STEREO 0.25% (DRA-625R)
	0.3% (DRA-425R)
Capture Ratio:	1.2 dB
Image Rejection:	70 dB
AM Suppression:	60 dB
Selectivity (± 300 kHz):	60 dB
Frequency Response:	30 Hz ~ 15 kHz +0.2 -1.5 dB
Stereo Separation (at 1 kHz):	40 dB
[AM]	
Receiving Range:	522 ~ 1611 kHz
Usable Sensitivity:	18 μV
Signal to Noise Ratio:	55 dB
General	
Power Supply:	AC 220V, 240V/50 Hz
Power Consumption:	170W (DRA-625R)
	140W (DRA-425R)
Dimensions:	434 mm (17-3/32")W x 140 mm (5-1/2")H x 350 mm (13-25/32")D
Weight:	7.4 kg (16 lbs 5 Oz) (DRA-625R)
	7.3 kg (16 lbs 1 Oz) (DRA-425R)
REMOTE CONTROL UNIT	
Remote control system:	Infrared pulse system
Power supply:	3V DC Two size R03 (AAA) dry cell batteries
External dimensions:	60 mm (2-23/64")W x 165 mm (6-31/64")H x 16 mm (5/8")D (Includes batteries)
Weight:	80 g (about 2 oz) (Includes batteries)

Design and specifications are subject to change without prior notice.

REMOVAL OF EACH SECTION

1. Top Cover

- 1) Unfasten 7 screws.
- 2) Detach the top cover by means of lifting it upward.

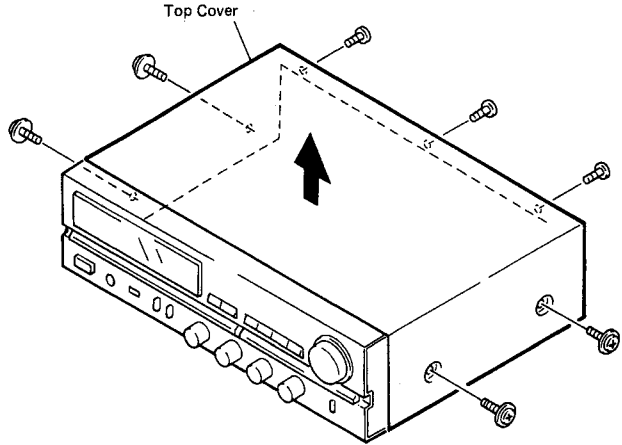

2. Front Panel

- 1) Remove 4 screws, and push 4 claws in the arrow direction to release the Front panel.
- 2) Draw out the Front Panel frontward.

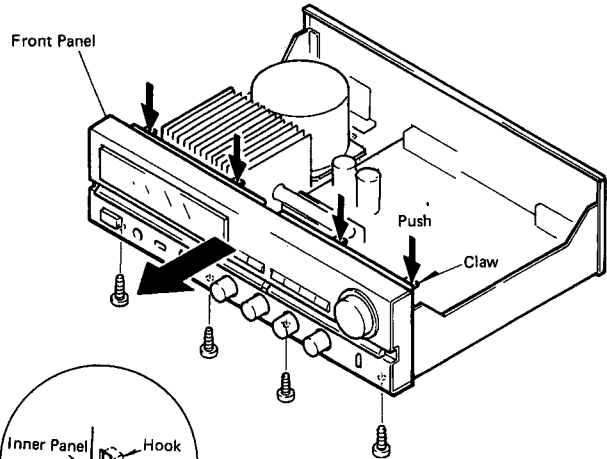

3. Inner Panel

- Unfasten 8 screws (A) with nuts, and draw out the Inner Panel frontward.

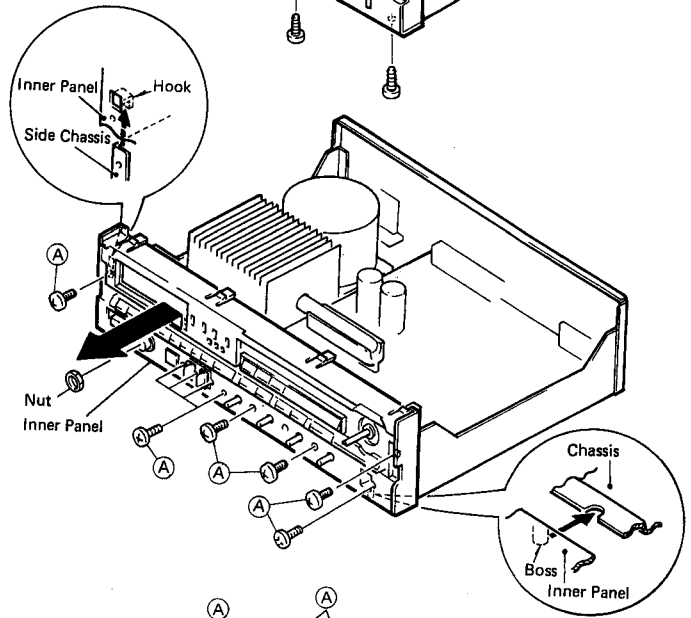

4. Bottom Cover

- Remove 4 screws (A). Then pinch the head of P.C.Board holder at the two places and detach the Bottom Cover.

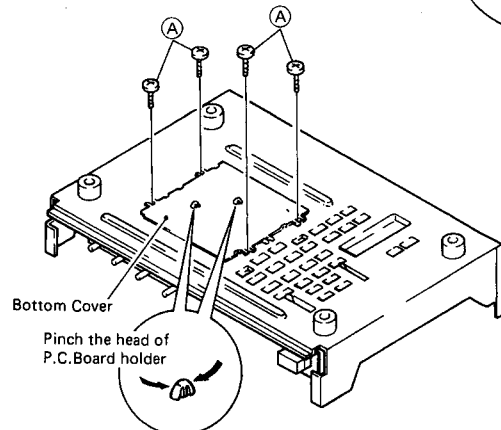

5. Power Transistor

- 1) Remove screws for the transistor to be exchanged.
- 2) Unsolder the soldered joint and remove.

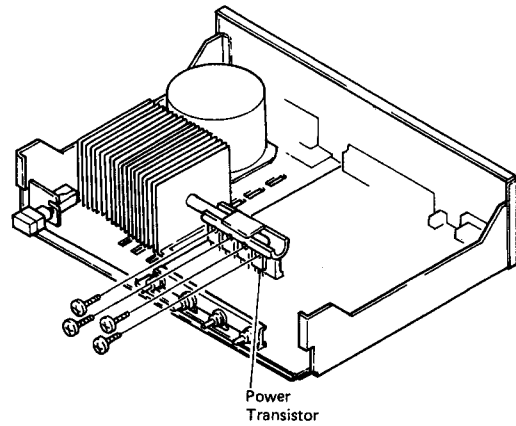

6. Heat Pipe Radiator

Remove 4 screws (A), and unfasten 2 screws (B) holding the radiator bracket. Then pull the Heat Pipe Radiator upward from the chassis.

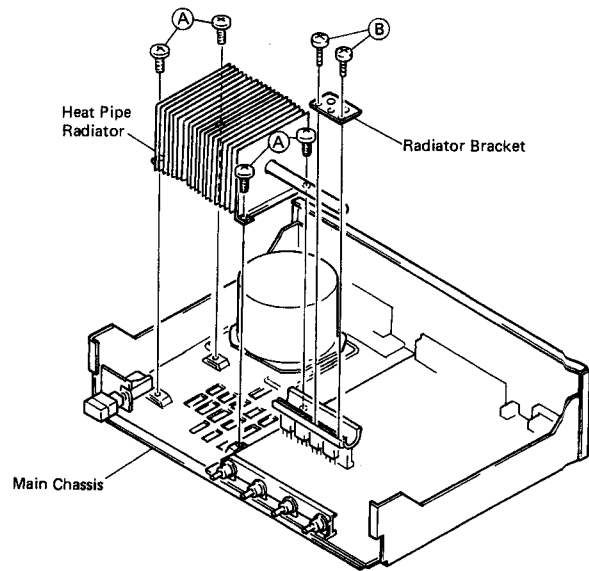

7. Amp-tuner P.W.Board

Remove 1 screw (A) securing the Board and 5 screws (B) from the Back Panel side. Then pinch the head of P.C.Board holder at the two places and take out the Board in the direction arrow shows.

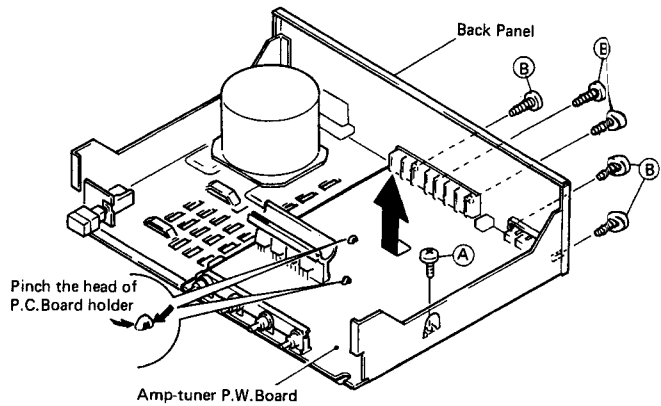

METHOD OF ADJUSTMENTS

When making adjustments, be sure the power supply is at the rated voltage and the room air is in normal condition with respect to temperature and humidity.

• Amplifier Section

1. IDLING CURRENT

(1) Set controls as follows.

POWER Switch → off (**■**)

VOLUME Control → 0 (min.)

SPEAKERS → off (**■**)

Temperature → 15°C ~ 30°C

VR305 and VR306 of the 1U-1596S-1 (DRA-625R) (1U-1606S-1, DRA-425R) (AMP. TUNER Unit) → Center

Power supply → Rated Voltage ±1%, 50 Hz.

(2) Connect Digital Voltmeter to the test points 1 (-), 3 (+) and 2 (+), 4 (-) of the 1U-1596S-1.

(3) Turn the Power Switch on and rotate VR305 clockwise so that the Digital Voltmeter reads 5.0 mV ±0.2 mV DC at the test point 1,3 Follow the same procedure to VR306 for test point 2, 4.

(4) Warm up three minutes, then readjust VR305 and VR306 as in step (3) so that the Digital Voltmeter reads 5.0 mV ±0.5 mV DC.

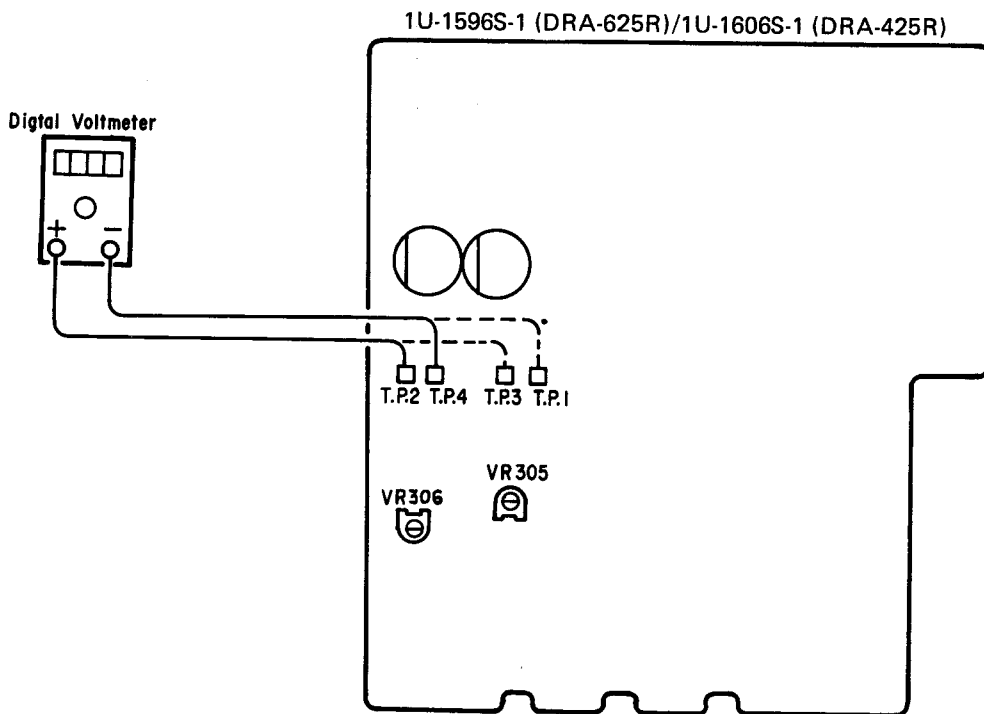

FM/MPX ALIGNMENT

Table 1

Step	Alignment Item	Tuning Frequency Setting	Input			Modulation	Coupling	Output		Adjust		Remarks
			Type	Frequency	Input Level			Type	Connect to	Points	Adjust to	
1	Tuning Center	98 MHz	FM SSG, Mono	98 MHz	60 dBμ	None	Antenna Terminal	Center Meter	T.P. 11, 12	T701	Center of Tuning Meter	Function: FM Mode: Auto
2	Distortion (Mono)	98 MHz	FM SSG, Mono	98 MHz	60 dBμ	1 kHz 100%	Antenna Terminal	Distortion Meter	TAPE REC (L)	T702	Minimum Distortion	Function: FM Mode: Auto
3	Distortion (Stereo)	98 MHz	FM SSG Stereo (L)	98 MHz	60 dBμ	Main: 1 kHz L-ch 90% Pilot: 10%	Antenna Terminal	Distortion Meter	TAPE REC (L)	IFT on Front End	Minimum Distortion	Function: FM Mode: Auto
4	Noise Center & Distortion											

Repeat 1, 2 and 3 to obtain minimum distortion and same time indicating of center meter at center condition.

AM ALIGNMENT

Table 2

1	AM IF		AM IF Sweep			Input Level is not over to work A.G.C.	AM Antenna Terminal	Monitor-scope	R728 GND	T703	Maximum Height and Best Symmetry Curve	Function: AM Center of Wave Form: 450 kHz
2	Receiving Band Alignment	522 kHz	AM SSG	522 kHz	Input Level is not over to work A.G.C.	400 Hz 30%	Loop Antenna	Electric DC Voltmeter	R808 GND	T712	1.2V±20mV	Function: AM
3	Tracking Alignment	603 kHz	AM SSG	603 kHz	Input Level is not over to work A.G.C.	400 Hz 30%	Loop Antenna	Audio V.M.	TAPE REC (L)	T711	Maximum Output	Function: AM
		1404 kHz	AM SSG	1404 kHz	Input Level is not over to work A.G.C.	400 Hz 30%	Loop Antenna	Audio V.M.	TAPE REC (L)	TC701	Maximum Output	Function: AM

CONNECTION DIAGRAM OF MEASURING INSTRUMENTS

• FM

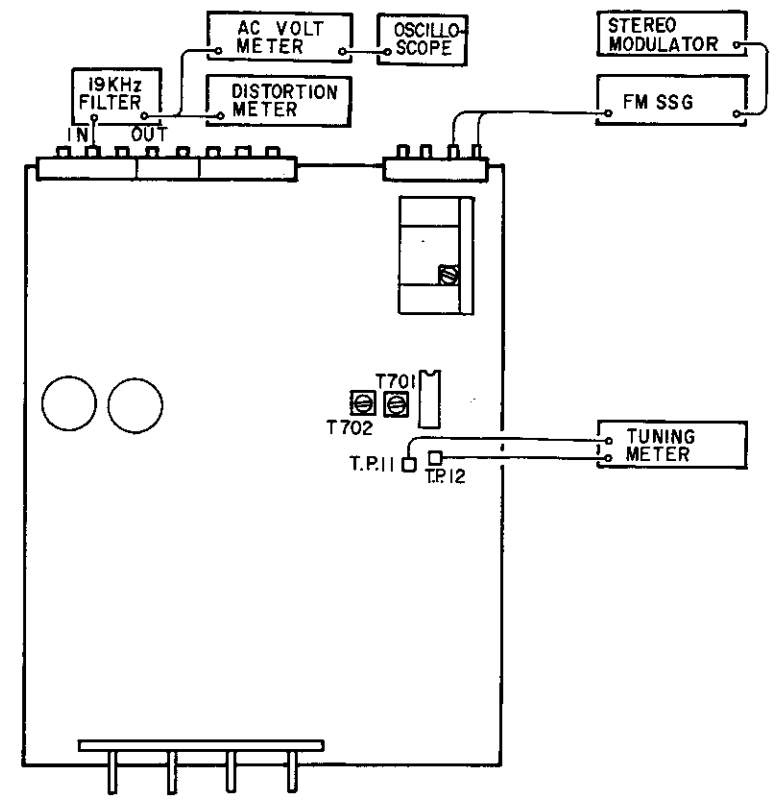

• AM

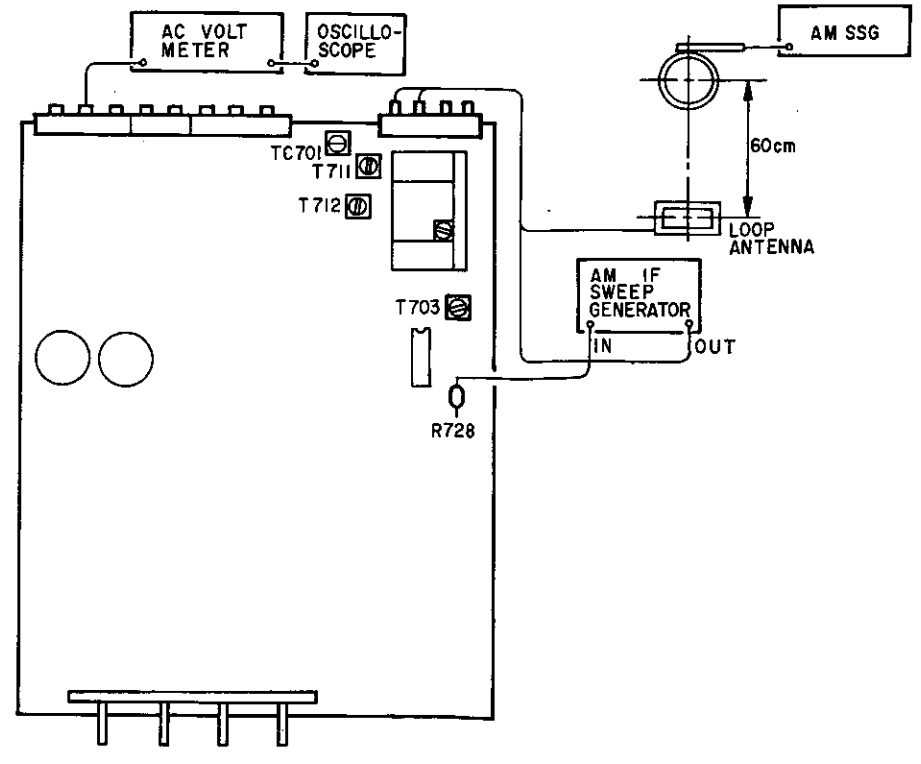

SEMICONDUCTORS

- IC's
- MN1280S (Matsushita)

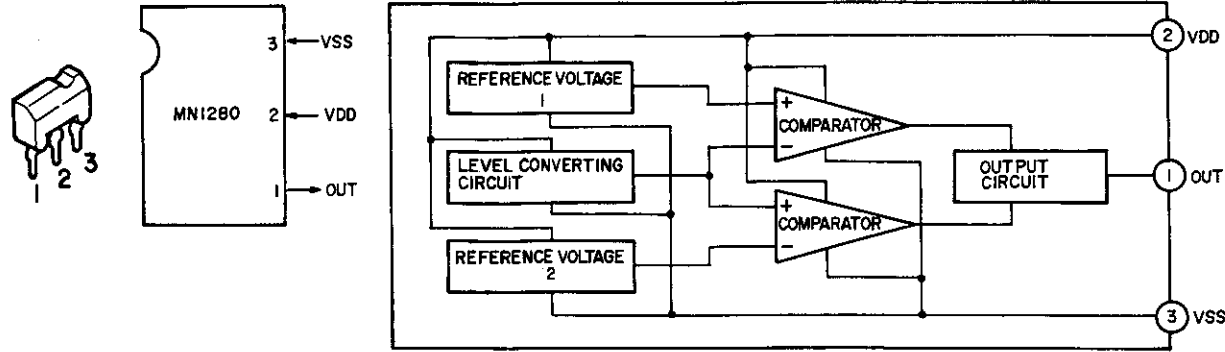

- LC4966 (Sanyo)

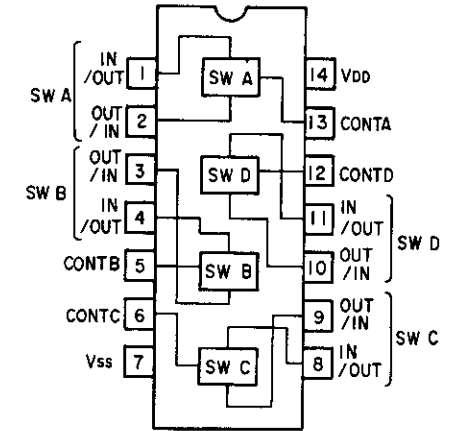
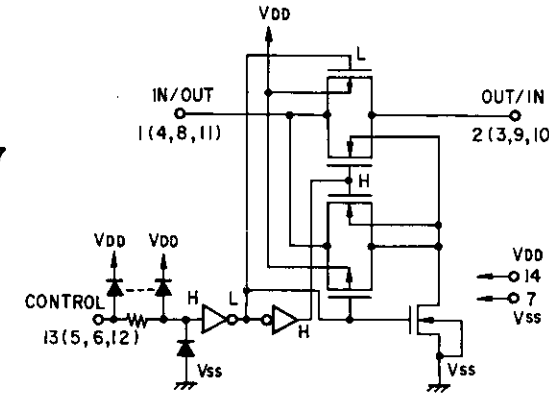
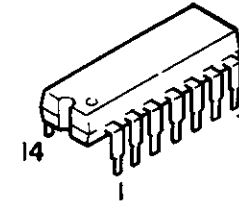

- M5238P (Mitsubishi)

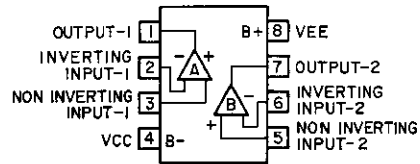
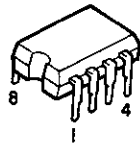

- NJM2043DD (JRC)

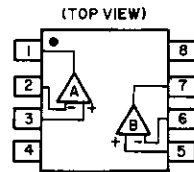
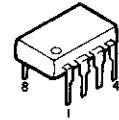

- TC9172AP

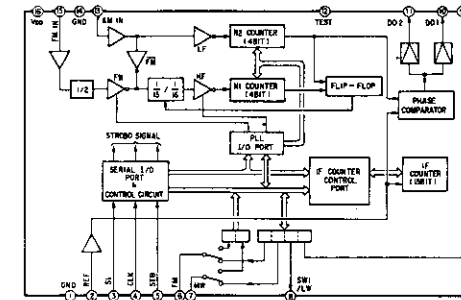
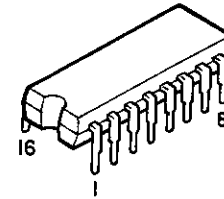

- L78M12ML

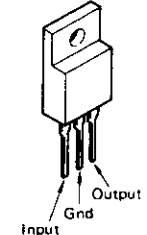

- L78M05ML (Sanyo)

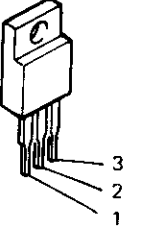

- 1 (Input)
- 2 (Common)
- 3 (Output)

- LB1403N (Sanyo)

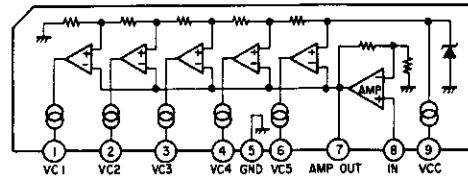
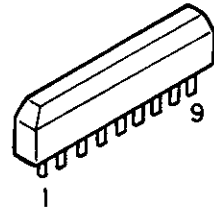

- BA6229

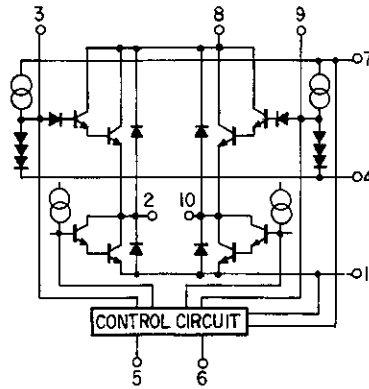
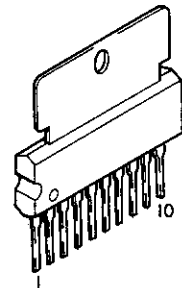

- LB1294

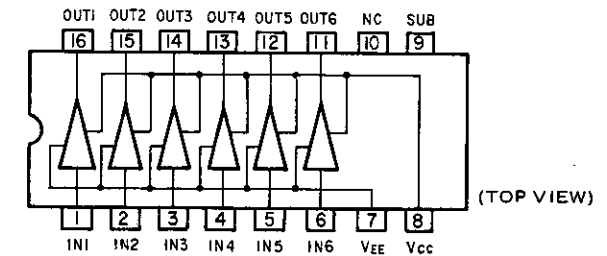
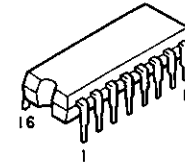

- HD14082BP (Hitachi)

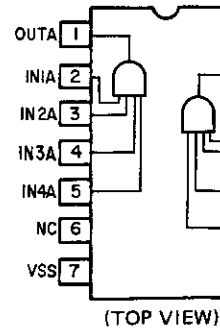
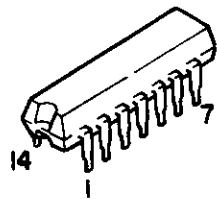

TC9173P

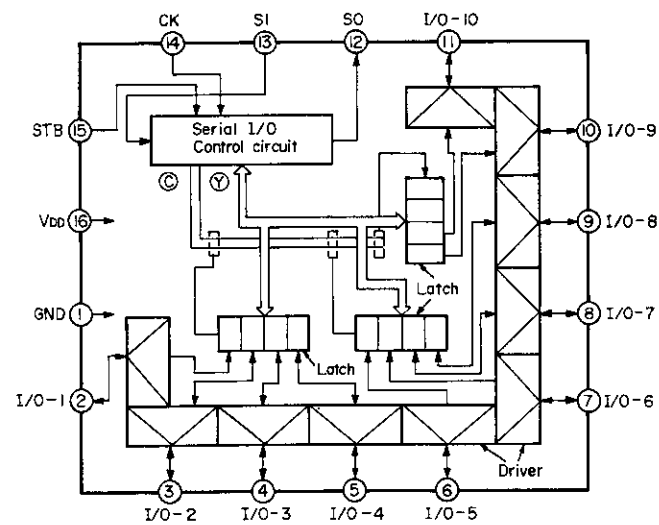
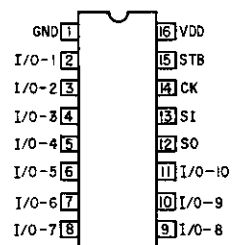
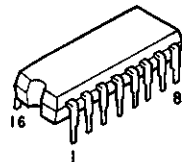

LA3401

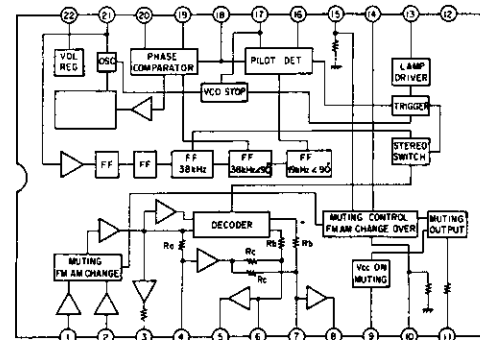
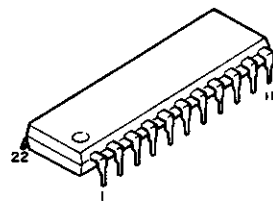

LA1266

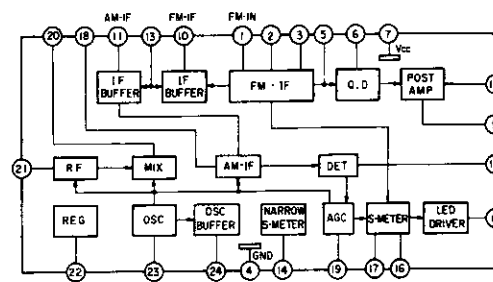
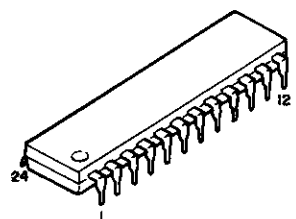

HD6305U0A63P

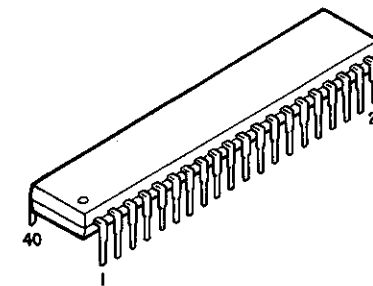

(TOP VIEW)

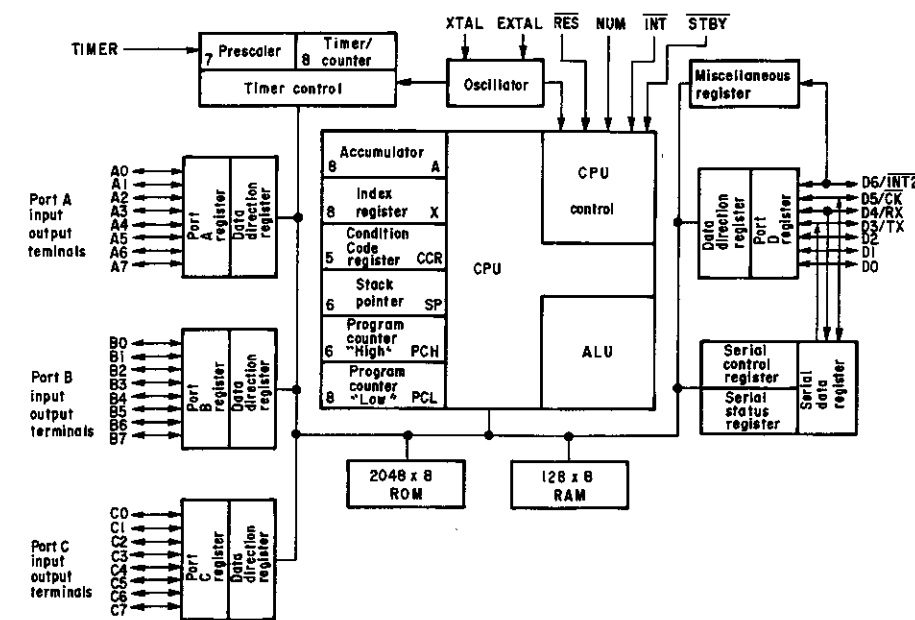
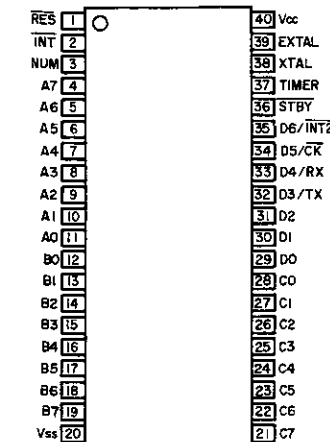

TC9303AN013

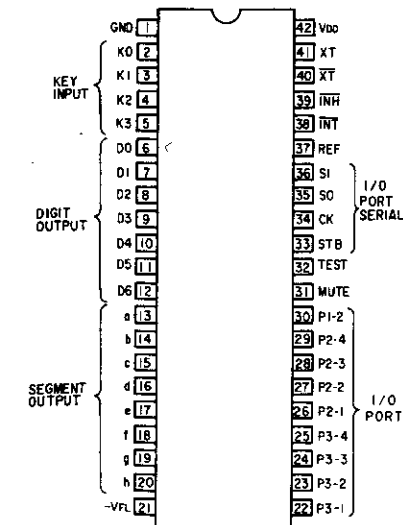
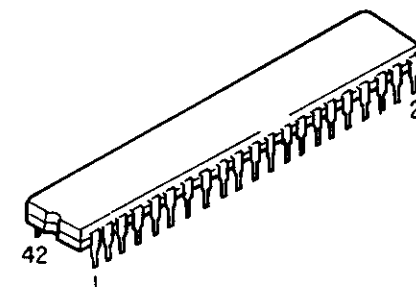

• Transistors

2SA988 (E/F)
2SC461P (C)
2SC1815 (BL)
2SC1841 (E/F)
2SC2878 (A)/(B)
2SA970 (GR)/(BL)
2SC2240 (GR)/(BL)

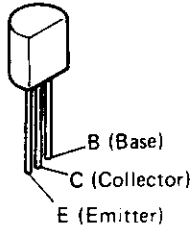

2SC1408 (GR)
2SC2458 (BL)
2SC2458 (Y/GR)

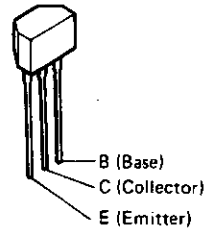

2SK365 (BL/GR)

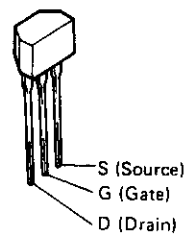

2SA1490 (O/Y)
2SC3854 (O/Y) DRA-425R only
2SA1491 (O/Y)
2SC3855 (O/Y) DRA-625R only

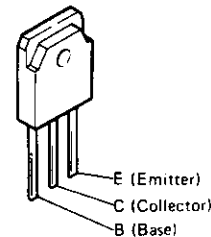

2SA1145 (O/Y)
2SB647A (C)
2SC2705 (O/Y)
2SD667A (C)

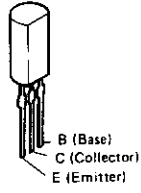

RN1204
RN2204

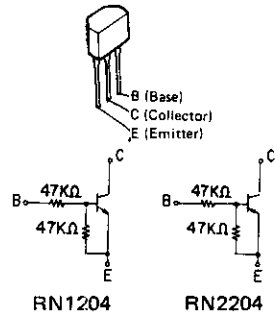

2SC3851 (Y)/(G)
2SB941A (P)/(Q)
2SD1266A (P)/(Q)

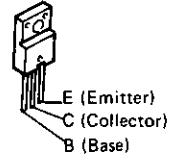

2SA1358 (O)/(Y)
2SC3421 (O)/(Y)

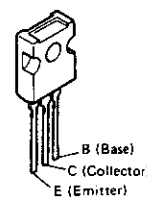

• Tuner Remote Control

TUNER REMOTE CONTROL

TC9173

	DATA4	DATA3	DATA2	DATA1	DATA0
1/9	0	0	0	0	1
2/10	0	0	0	1	0
3/11	0	0	0	1	1
4/12	0	0	1	0	0
5/13	0	0	1	0	1
6/14	0	0	1	1	0
7/15	0	0	1	1	1
8/16	0	1	0	0	0
SHIFT	1	1	0	0	0

VOLUME DATA

	C ₁ (27)	C ₂ (26)
VOLUME UP	LOW	HIGH
VOLUME DOWN	HIGH	LOW

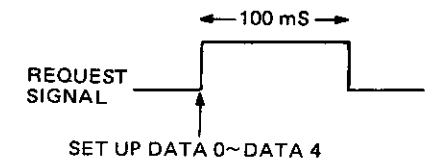

• Diodes & LED

1S2076A

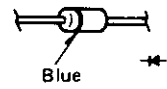

1SS106

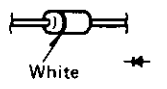

1SS104

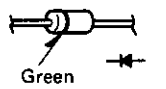

1SS270A

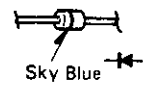

DSA1A2

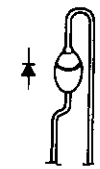

DSM1A2 (type-2)

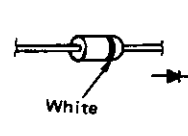

HZS5C-2 HZS7B-3
HZS6C-1 HZS12A-1
HZS6C-2 HZS12A-3

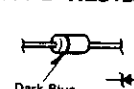

SVC321D2-SP

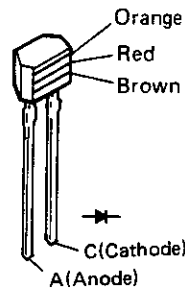

S4VB20F

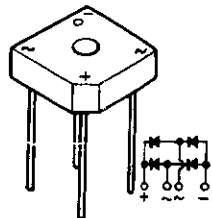

SFOR1A42
Thyristor

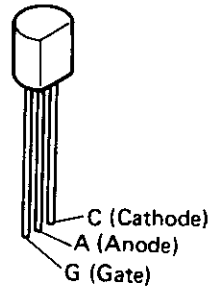

SEL1321G (Green)

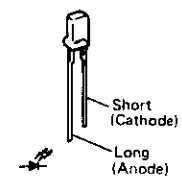

D5FB20
(DRA-625 only)

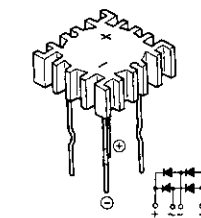

FLD (FIP10TM7)

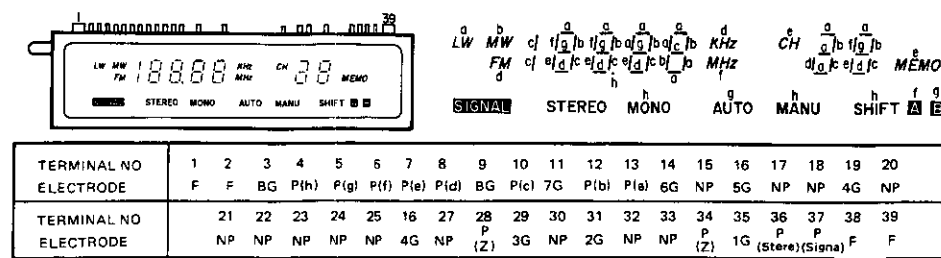

Notes: F: Filament NP: No Pin
G: Grd
P: Anode

● IC601: Microcomputer for system controlling HD6305U0A63P 1-chip type 8 bit microcomputer

CH	C ₆	C ₇	DATA		C ₁₀	C ₁₁	EXPAND		C ₁₄	K	SYSTEM ADDRESS C ₁ C ₂ C ₃ C ₄ C ₅ → 0 0 1 1 0		SYSTEM ADDRESS 0 0 0 1 0	SYSTEM ADDRESS 0 0 1 0 0
			C ₈	C ₉			C ₁₂	C ₁₃			RECEIVER DRA-625	RECEIVER DRA-425	CD PLAYER EXPAND 1 0	DECK EXPAND 1 0
1	1	0	0	0	0	0	1	0	0		1-9	1-9		
2	0	1	0	0	0	0	1	0	0		2-10	2-10		
3	1	1	0	0	0	0	1	0	0		3-11	3-11		
4	0	0	1	0	0	0	1	0	0		4-12	4-12		
5	1	0	1	0	0	0	1	0	0		5-13	5-13		
6	0	1	1	0	0	0	1	0	0		6-14	6-14		
7	1	1	1	0	0	0	1	0	0		7-15	7-15		
8	0	0	0	1	0	0	1	0	0		8-16	8-16		
9	1	0	0	1	0	0	1	0	0		SHIFT	SHIFT		
10	0	1	0	1	0	0	1	0	0					
11	1	1	0	1	0	0	1	0	0					
12	0	0	1	1	0	0	1	0	0		VOL ▼	VOL ▼		
13	1	0	1	1	0	0	1	0	0		VOL ▲	VOL ▲		
14	0	1	1	1	0	0	1	0	0					
15	1	1	1	1	0	0	1	0	0					
16	0	0	0	0	1	0	1	0	0		POWER ON/OFF	POWER ON/OFF		
17	1	0	0	0	1	0	1	0	0					
18	0	1	0	0	1	0	1	0	0					
19	1	1	0	0	1	0	1	0	0				A/B	
20	0	0	1	0	1	0	1	0	0					
21	1	0	1	0	1	0	1	0	0					
22	0	1	1	0	1	0	1	0	0					
23	1	1	1	0	1	0	1	0	0				◀PLAY(REV)	
24	0	0	0	1	1	0	1	0	0		PHONO	PHONO		
25	1	0	0	1	1	0	1	0	0		TUNER	TUNER		
26	0	1	0	1	1	0	1	0	0		CD	CD		
27	1	1	0	1	1	0	1	0	0		AUX/VIDEO	AUX/VIDEO		FF ▶▶
28	0	0	1	1	1	0	1	0	0				▶▶ PLAY	◀◀ REW
29	1	0	1	1	1	0	1	0	0				▯ PAUSE	▶▶ PLAY
30	0	1	1	1	1	0	1	0	0		TAPE 1	TAPE 1	▯ PAUSE	▯ STOP
31	1	1	1	1	1	0	1	0	0		TAPE 2	TAPE 2	▯ STOP	● REC
32	0	0	0	0	0	1	1	0	0					
33	1	0	0	0	0	1	1	0	0					
34	0	1	0	0	0	1	1	0	0					
35	1	1	0	0	0	1	1	0	0					
36	0	0	1	0	0	1	1	0	0					
37	1	0	1	0	0	1	1	0	0					
38	0	1	1	0	0	1	1	0	0					
39	1	1	1	0	0	1	1	0	0					
40	0	0	0	1	0	1	1	0	0					
41	1	0	0	1	0	1	1	0	0					
42	0	1	0	1	0	1	1	0	0					
43	1	1	0	1	0	1	1	0	0					
44	0	0	1	1	0	1	1	0	0					
45	1	0	1	1	0	1	1	0	0					
46	0	1	1	1	0	1	1	0	0					
47	1	1	1	1	0	1	1	0	0					
48	0	0	0	0	1	1	1	0	0					
49	1	0	0	0	1	1	1	0	0					
50	0	1	0	0	1	1	1	0	0					
51	1	1	0	0	1	1	1	0	0					
52	0	0	1	0	1	1	1	0	0					
53	1	0	1	0	1	1	1	0	0					
54	0	1	1	0	1	1	1	0	0					
55	1	1	1	0	1	1	1	0	0					
56	0	0	0	1	1	1	1	0	0					

Terminal No.	Description	I/O	Function
1	RES	IN	RESET input terminal
2	INT	IN	Interrupt request input terminal
3	NUM	IN	Connected to 0V of power supply
4	A ₇	OUT	OUTPUT LATCH "HIGH" ACTIVE PHONO
5	A ₆	OUT	OUTPUT LATCH "HIGH" ACTIVE CD
6	A ₅	OUT	OUTPUT LATCH "HIGH" ACTIVE TUNER
7	A ₄	OUT	OUTPUT LATCH "HIGH" ACTIVE AUX-1
8	A ₃	OUT	NC
9	A ₂	OUT	OUTPUT LATCH "HIGH" ACTIVE TAPE-1
10	A ₁	OUT	OUTPUT LATCH "HIGH" ACTIVE TAPE-2
11	A ₀	OUT	NC
12	B ₀	OUT	NC
13	B ₁	IN	FUNCTION key ASSIGN input terminal
14	B ₂	IN	FUNCTION key ASSIGN input terminal
15	B ₃	IN	FUNCTION key ASSIGN input terminal
16	B ₄	OUT	FUNCTION key STROBE pulse
17	B ₅	OUT	FUNCTION key STROBE pulse
18	B ₆	OUT	FUNCTION key STROBE pulse
19	B ₇	OUT	FUNCTION key STROBE pulse
20	V _{SS}	-	Connected to 0V of power supply
21	C ₇	IN	TAPE
22	C ₆	OUT	"LOW" ACTIVE LATCH at REMOTE POWER OFF
23	C ₅	OUT	"LOW" ACTIVE LATCH at REMOTE POWER OFF (RELAY DRIVE)
24	C ₄	OUT	NC
25	C ₃	OUT	"LOW" ACTIVE LATCH at -∞ MUTING ON
26	C ₂	OUT	VOLUME DATA
27	C ₁	OUT	VOLUME DATA
28	C ₀	OUT	D ₅ TUNER REMOTE CONTROL REQUEST SIGNAL
29	D ₀	OUT	D ₄ TUNER REMOTE CONTROL DATA
30	D ₁	OUT	D ₃ TUNER REMOTE CONTROL DATA
31	D ₂	OUT	D ₂ TUNER REMOTE CONTROL DATA
32	D ₃	OUT	D ₁ TUNER REMOTE CONTROL DATA
33	D ₄	OUT	D ₀ TUNER REMOTE CONTROL DATA
34	D ₅	IN	REMOTE CONTROL DIN INPUT TERMINAL
35	D ₆ /INT 2	IN	REMOTE CONTROL
36	STBY	IN	Connected to 5V of power supply
37	TIMER	IN	Connected to 0V of power supply
38	XTAL	IN	Input terminal for built-in clock
39	EXTAL	IN	Input terminal for built-in clock
40	V _{CC}	-	Connected to 5V of power supply

PRINTED WIRING BOARD PATTERNS AND PARTS LIST
1U-1596S MAIN UNIT (DRA-625R)

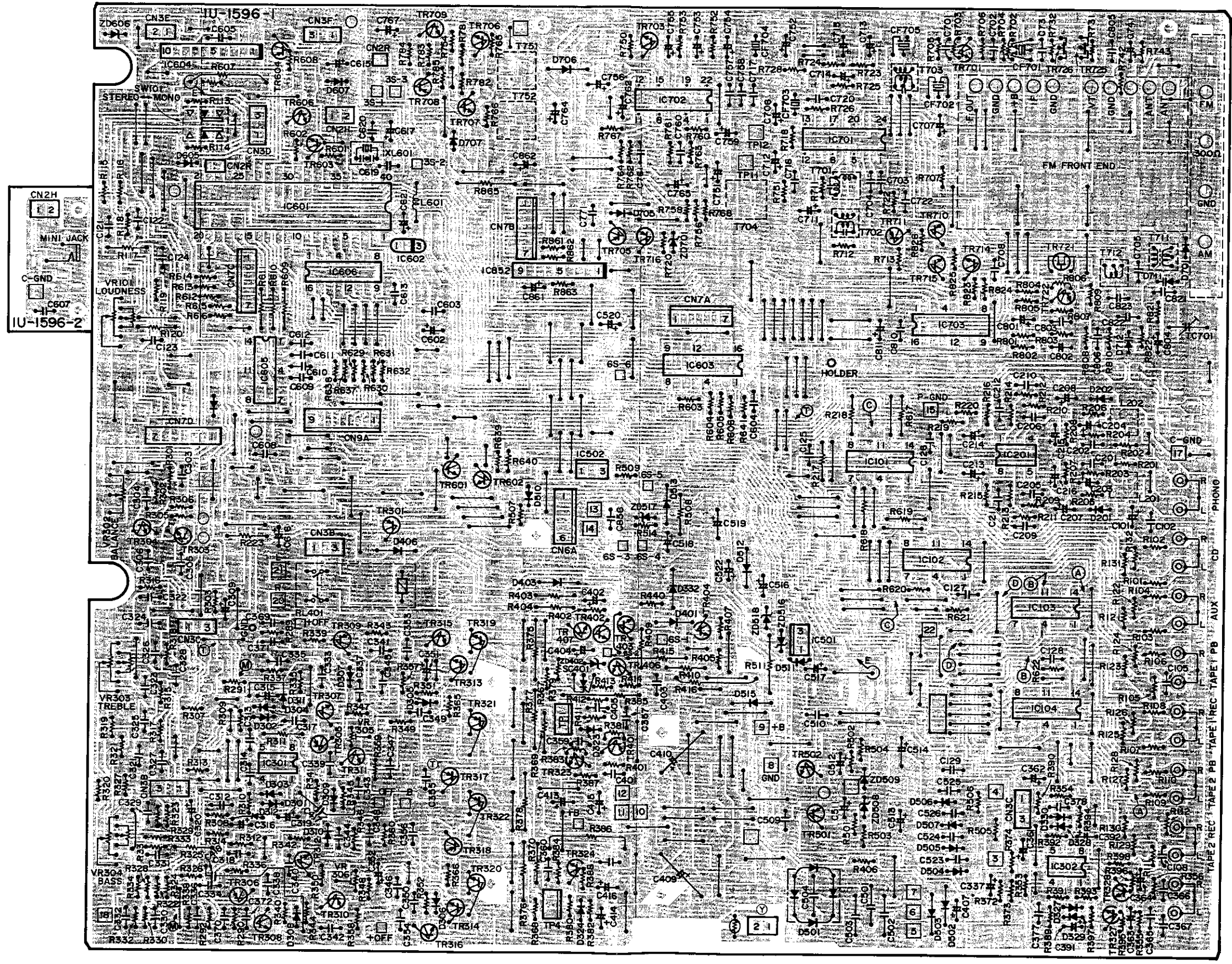

1U-1606S MAIN UNIT (DRA-425R)

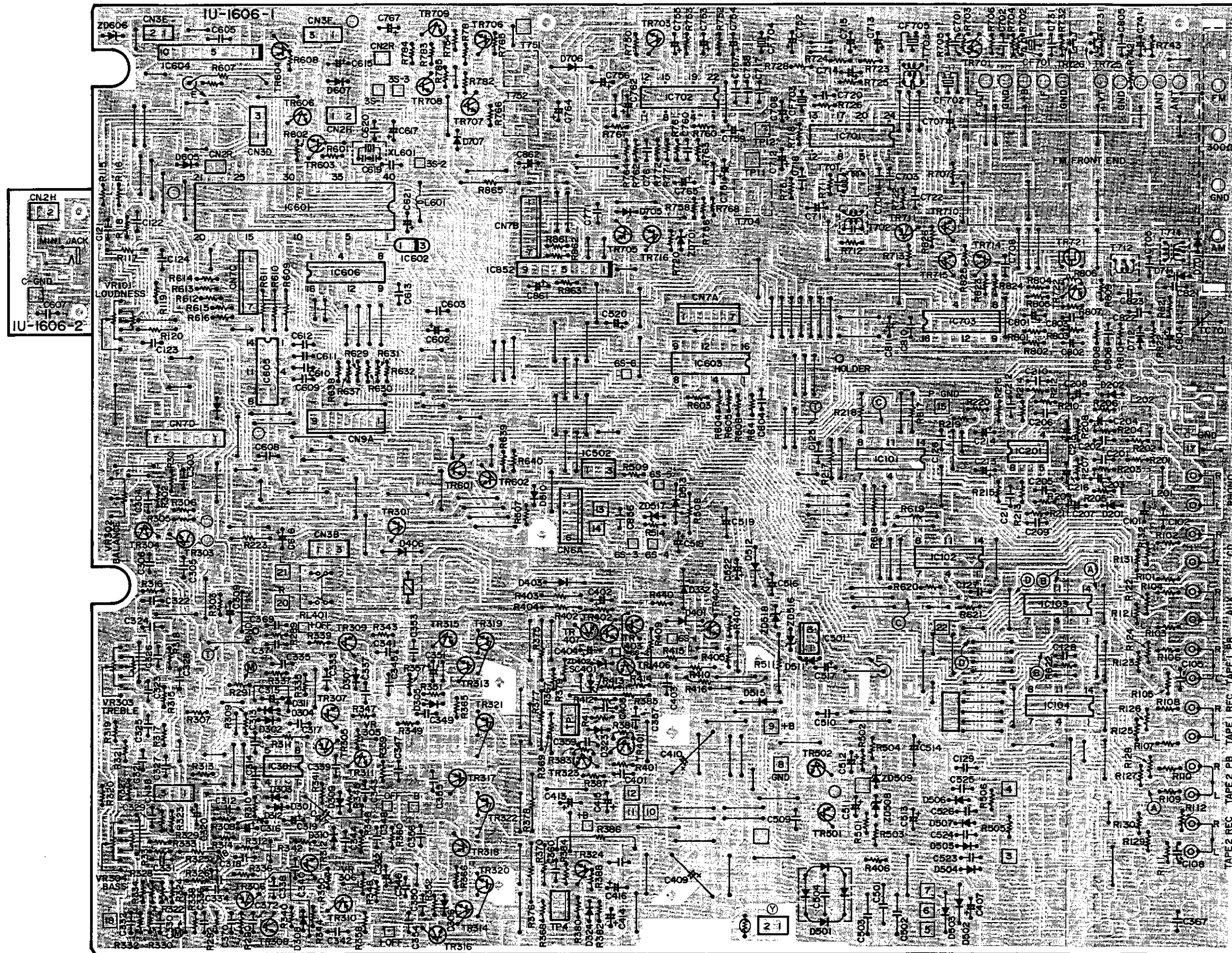

1U-1597S (DRA-625R), 1U-1597S (DRA-425R) DISPLAY UNIT

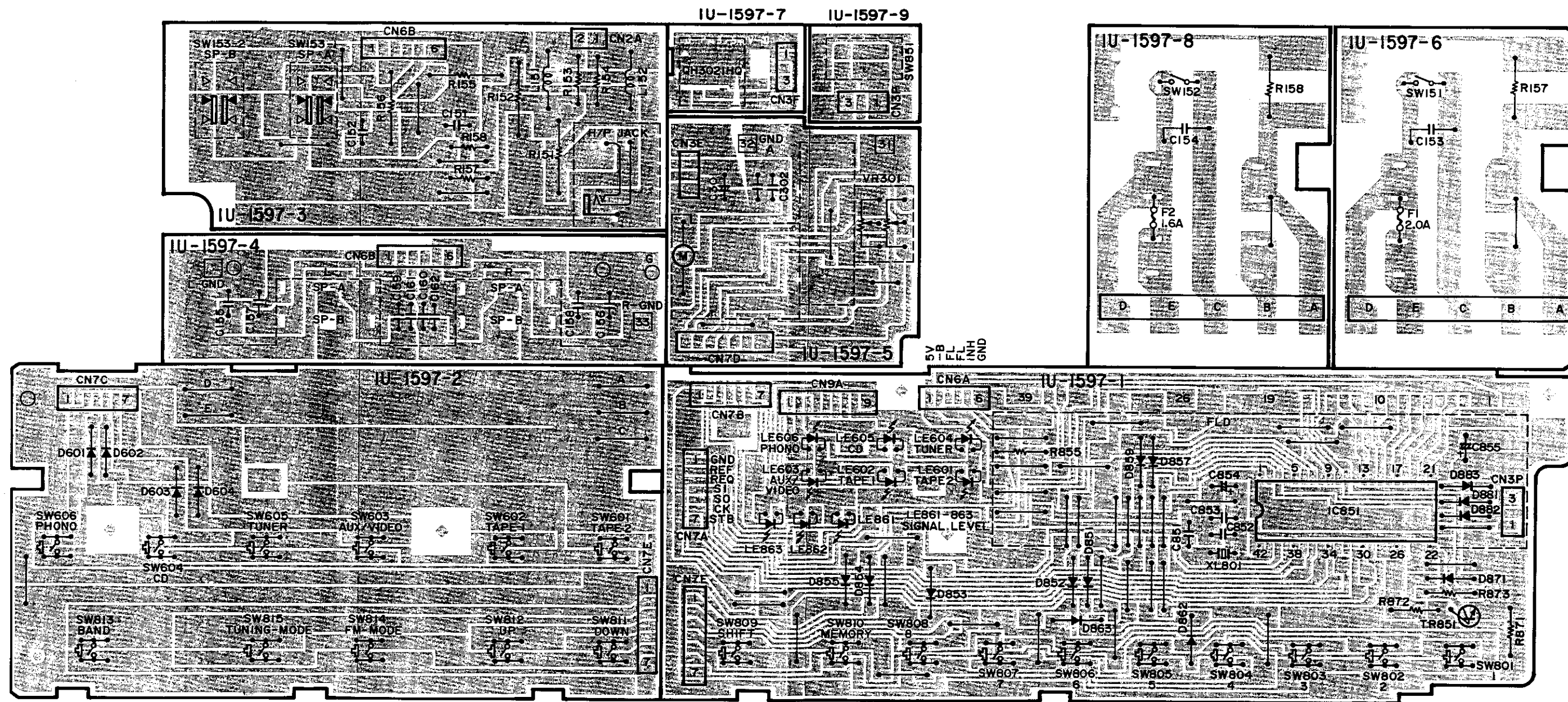

1U-1742 CONTROL UNIT (DRA-625R/425R)

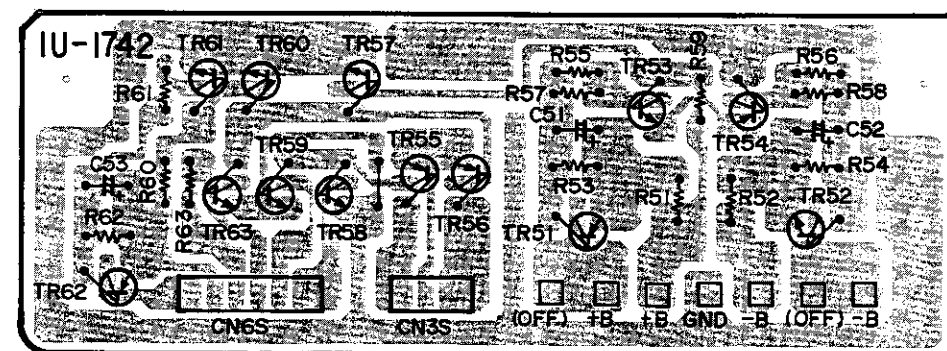

1U-1606S MAIN UNIT PARTS LIST (DRA-425R)
 [Same as 1U-1596S (for DRA-625R) except the followings]

NOTE: A: ADD, C: CHANGE, D: DELETE

Ref. No.	Part No.	Part Name	Remarks
C522	2544258015	CE04W1V100M (SME)	10μF/35V
C602	2544254006	CE04W1C100M (SME)	10μF/16V
C615	2544254006	CE04W1C100M (SME)	10μF/16V
C616	2544256046	CE04W1E101M (SME)	100μF/25V
C617	2544250026	CE04W0J101M (SME)	100μF/6.3V
C621	2544250026	CE04W0J101M (SME)	100μF/6.3V
C706	2544254035	CE04W1C470M (SME)	47μF/16V
C707	2544254080	CE04W1C102M (SME)	1000μF/16V
C711	2544254035	CE04W1C470M (SME)	47μF/16V
C712	2544260045	CE04W1H010M (SME)	1μF/50V
C713	2544260074	CE04W1H4R7M	4.7μF/50V
C714	2544254006	CE04W1C100M (SME)	10μF/16V
C715	2544260061	CE04W1H3R3M (SME)	3.3μF/50V
C741	2544254006	CE04W1C100M (SME)	10μF/16V
C751	2544254006	CE04W1C100M (SME)	10μF/16V
C752	2544254048	CE04W1C101M (SME)	100μF/16V
C753	2544260045	CE04W1H010M (SME)	1μF/50V
C754	2544260032	CE04W1HR47M (SME)	0.47μF/50V
C755,756	2544260045	CE04W1H010M (SME)	1μF/50V
C759	2544254006	CE04W1C100M (SME)	10μF/16V
C762	2544260061	CE04W1H3R3M (SME)	3.3μF/50V
C764,765	2544260061	CE04W1H3R3M (SME)	3.3μF/50V
C767	2544260003	CE04W1H0R1M (SME)	0.1μF/50V
C801	2544254048	CE04W1C101M (SME)	100μF/16V
C802	2543056014	CE04D1H010MBP (SME)	1μF/50V
C804	2544260045	CE04W1H010M (SME)	1μF/50V
C806	2544260061	CE04W1H3R3M (SME)	3.3μF/50V
C811	2544250026	CE04W0J101M (SME)	100μF/6.3V

Ref. No.	Part No.	Part Name	Remarks
C861	2544254006	CE04W1C100M (SME)	10μF/16V
C862	2544254048	CE04W1C101M (SME)	100μF/16V
C123,124	2554199960	CQ92M1H223J (MRZ)	0.022μF/50V
C201,202	2533635005	CC45SL1H221J	220pF/50V
C209,210	2554199999	CQ92M1H243J (MRZ)	0.024μF/50V
C211,212	2554213956	CQ93M1H682J (B)	6800pF/50V
C313,314	2554200008	CQ93P1H101J	100pF/50V
C323,324	2551120013	CQ93M1H122J	1200pF/50V
C327,328	2551121009	CQ93M1H682J	6800pF/50V
C331,332	2551121041	CQ93M1H153J	0.015μF/50V
C333,334	2551212905	CQ93M1H103J	0.01μF/50V
C341~344	2554199960	CQ92M1H223J (MRZ)	0.022μF/50V
C371,372	2551212905	CQ93M1H103J	0.01μF/50V
C823	2554135005	CQ93P1H391J	390pF/50V
C303~306	2561035075	CF93A1H684J	0.68μF/50V
C321,322	2561034047	CF93A1H563J	0.056μF/50V
C329,330	2561034089	CF93A1H124J	0.12μF/50V
C357,358	2561034076	CF93A1H104J	0.1μF/50V
C359,360	2561034005	CF93A1H273J	0.027μF/50V
C502	2561042000	CF93A2E104K	0.1μF/250V
C509,510	2561035075	CF93A1H684J	0.68μF/50V
C856	2561034076	CF93A1H104J	0.1μF/50V
C519	2590004006	SB CAP=223=	
TRANS COIL, FILTERS, RELAY, SWITCH GROUP			
L201,202	2359003002	FTZ CHOKE COIL	
L601	2350016988	INDUCTOR	120μH
RL401	2149003005	RELAY	
T701	2312065003	FM IF DET TRANS(P)	
T702	2312066002	FM IF DET TRANS(S)	
T703	2310056001	AM IFT	
T711	2311127007	MW ANT TRANS	
T712	2311130007	MW OSC COIL	
T751,752	2320085004	LPF	
SW101	2129520003	1P PUSH SWITCH	MODE
CF701,702	2610064007	SFT10.7MS2	
CF703	2610031001	BFU450C4 (C.F)	
CF704	2610079005	CSB456F11	
CF705	2610034008	SFP450H	
XL601	3990034002	CST4.00MG	4MHz
T704	2320121007	ANTI. BIRDIE FILTER	

Ref. No.	Part No.	Part Name	Q'ty	Remarks
OTHER PARTS GROUP				
	4179021107	RADIATOR BLOCK	1	
	4738007009	3x12 CUP SCREW	4	
	4737500044	TAPPING SCREW(P) 3x8 (BLACK)	2	
	2048260004	MINI JACK	1*	3.5mm
	2050346000	4P CONNECTOR BASE	1	
	2050347009	6P CONNECTOR BASE	2	
	2050433007	3P ANT TERMINAL (DIN)	1	
	2160065006	FRONT END	1	
	2050185038	3P WIRE HOLDER	6	
	2050185025	2P WIRE HOLDER	1	
	2050343061	6P CONN. BASE (KR-PH)	1	CN6A
	2050343074	7P CONN. BASE (KR-PH)	3	CN7A,B,C
	2050343090	9P CONN. BASE (KR-PH)	1	CN-9A
	2050190036	3P NH CONNECTOR BASE	2	
	2050233032	3P EH CONNECTOR BASE	1	CN-3F
	2030322060	1P CONTACT Ass'y	1	

Ref. No.	Part No.	Part Name	Remarks
SEMICONDUCTORS GROUP			
IC302	2620679000	M5238P	D
TR315,316	2740060007	2SD667A (C)	C
TR317,318	2720053005	2SB647A (C)	C
TR319,320	2730336000	2SC3854 (O/Y)	C
TR321,322	2710204000	2SA1490 (O/Y)	C
TR323,324	2730235020	2SC1841 (E/F)	C
TR327,328	2730253015	2SC2878 (A/B)	D
TR401	2710131021	2SA988 (E/F)	C
D327~330	2760432000	1SS270A	D
D332	2760432000	1SS270A	D
D501	2760338007	S4VB20F	C
CAPACITORS GROUP			
C271,272	2533627000	CC45SL1H101J	100pF/50V D
C365,366	2533627000	CC45SL1H101J	100pF/50V D
C377,378	2533627000	CC45SL1H101J	100pF/50V D
C361~364	2544260045	CE04W1H010M (SME)	1μF/50V D
C374	2544260045	CE04W1H010M (SME)	1μF/50V D
C391,392	2544260045	CE04W1H010M (SME)	1μF/50V D
C409,410	2546089004	CE04W==822M	8200μF/56V C
TRANS, COIL, FILTERS RELAY, SWITCH			
SW101	2129520003	1P PUSH SWITCH	MODE D
OTHER PARTS GROUP			
	2050346000	4P CONNECTOR BASE	2 C
	2050347009	6P CONNECTOR BASE	1 C
	2050185038	3P WIRE HOLDER	4 C

1U-1597S (DRA-625R), 1U-1597S (DRA-425R)
DISPLAY UNIT PARTS LIST

NOTE: ■ DRA-625R only ● DRA-425R only

Ref. No.	Part No.	Part Name	Remarks
SEMICONDUCTORS GROUP			
IC851	2620998008	TC9303AN013	
TR851	2730322001	2SC2458 (Y/GR)	
D601~604	2760370007	1S106TD	
D851~855	2760049011	1S2076A	
D857	2760049011	1S2076A	
D859	2760049011	1S2076A	
D862,863	2760049011	1S2076A	
D871	2760049011	1S2076A	
LE601~606	3939261027	LED SEL1321G (D2/3)	
LE861~863	3939261027	LED SEL1321G (D2/3)	
RESISTORS GROUP (not included Carbon Film ±5% ¼W type)			
▲ R151,152	2440033020	RS14B3A221JNBF	220Ω, ¼W
R153,154	2412036000	RD14B2E4R7J	4.7Ω, ¼W
▲ R155,156	2440015022	RS14B3A6R8JNBF	6.8Ω, ¼W
R855	2412132001	RD14B2E473J	47kΩ, ¼W
R871~873	2412116001	RD14B2E103J	10kΩ, ¼W
R896~899	2412116001	RD14B2E103J	10kΩ, ¼W
VR301	2110521011	V1620V30FB104R	MOTOR DRIVE VR
CAPACITORS GROUP			
C151,152	2561034937	CF93A1H473J	0.047μF/50V
▲ C153	2538014003	CK45F2GAC103M	0.01μF/400V AC
▲ C154	2538014003	CK45F2GAC103M	0.01μF/400V AC
C155~158	2551121025	CQ93M1H103J	0.01μF/50V
C159	2531024003	CK45F1H103Z	0.01μF/50V
C162	2531024003	CK45F1H103Z	0.01μF/50V
C301	2543056014	CE04D1H010MBP (SME)	1μF/50V
C302	2539031027	CK45=1E104K	0.1μF/25V
C851,852	2533603008	CC45SL1H100D	10pF/50V
C853	2531024003	CK45F1H103Z	0.01μF/50V
C854	2544250026	CE04W0J101M (SME)	100μF/6.3V
C855	2544258057	CE04W1V101M (SME)	100μF/35V
SWITCHES, COILS GROUP			
L151,152	2359001004	INDUCTOR	
▲ SW151	2124686007	POWER SW TV-5	
▲ SW152	2124686007	POWER SW TV-5	
SW153	2129532004	2P PUSH SW	SP SW
SW601~606	2124407901	TACT SWITCH (IM)	
SW801~815	2124407901	TACT SWITCH (IM)	

WARNING:
Parts marked with this symbol ▲ have critical characteristics.
Use ONLY replacement parts recommended by the manufacturer.

Ref. No.	Part No.	Part Name	Remarks
OTHER PARTS GROUP			
	2020022008	FUSE HOLDER	
▲ F001	2061015061	FUSE 2A	
▲ F002	2061015068	FUSE 1.6A	
	2050149032	5P WRAPPING TERMINAL	
	2048167026	HEADPHONES JACK	
	2050484001	8P SP TERMINAL	(Europe)
	2050472013	8P SP TERMINAL	(Australia, U.K.)
	4990088002	QH3031H0	REMOCON
	1460921100	LED HOLDER	
XL801	3990040009	X'TAL (7.2MHz)	
	3934043004	FLD (FIP10TM7)	
	4122268302	FLD BRACKET	
	2050185025	2P WIRE HOLDER	CN-2A
	2050185067	6P WIRE HOLDER	CN-6BB
	2050185070	7P WIRE HOLDER	CN-7EE
	2050233032	3P EH CONNECTOR BASE	CN-3E
	2050233074	7P EH CONNECTOR BASE	CN-7D
	4150299000	CONDENSER COVER	
	■5131390008	FUSE LABEL	
	●5131390011	FUSE LABEL	

1U-1742 CONTROL UNIT PARTS LIST
(DRA-625R/425R)

Ref. No.	Parts No.	Part Name	Remarks
SEMICONDUCTORS GROUP			
TR051	2720085002	2SB941A(Q)/(P)	
TR052	2740121001	2SD1266A(Q)/(P)	
TR053	2730187039	2SC2240(BL/GR)	
TR054	2710094032	2SA970(BL/GR)	
TR055,056	2690030006	RN2204(47k-47k)	
TR057~060	2690029004	RN1204(47k-47k)	
TR061	2730198015	2SC1815(BL)	
TR062	2720053005	2SB647A(C)	
TR063	2690029004	RN1204(47k-47k)	
RESISTORS GROUP (not included Carbon Film ±5% ¼W type)			
▲ R051,052	2412387908	RD14B2E010JNBST	10ohm, ¼W ±5%
R053,054	2412402058	RD14B2E473J(5)	47kohm, ¼W ±5%
R055~058	2412401062	RD14B2E203J(5)	20kohm, ¼W ±5%
R059	2412402058	RD14B2E473J(5)	47kohm, ¼W ±5%
R060	2412401017	RD14B2E123J(5)	12kohm, ¼W ±5%
R061	2412399035	RD14B2E222J(5)	2.2kohm, ¼W ±5%
R062	2412402058	RD14B2E473J(5)	47kohm, ¼W ±5%
R063	2412398052	RD14B2E102J(5)	1kohm, ¼W ±5%
CAPACITORS GROUP			
C051,052	2544261028	CE04W1H101M (SME)	100μF/50V
C053	2544258057	CE04W1V101M (SME)	100μF/35V
OTHER PARTS GROUP			
	2050233032	3P EH CONNECTOR BASE	Q'ty 1
	2050233061	6P EH CONNECTOR BASE	Q'ty 1

EXPLODED VIEW OF CHASSIS AND CABINET & PARTS LIST
PARTS LIST OF EXPLODED VIEW
(DRA-625R/425R Europe Black Version)

NOTE: ■ DRA-625R only ● DRA-425R only

WARNING:

Parts marked with this symbol  have critical characteristics. Use ONLY replacement parts recommended by the manufacturer.

Ref. No.	Part No.	Part Name	Q'ty	Remarks
⊙ 1	4110751203	MAIN CHASSIS	1	
2	4122462108	BRACKET-A	1	
3	1040173103	FOOT Ass'y	4	
4	4140478006	SAFETY PLATE	1	
5	1050758107	BOTTOM COVER	1	
6	4430518003	P.C.B. HOLDER	2	
7	4122197017	CARD STAND	1	
⊙ 8■	1U-1596S	MAIN UNIT	1	
⊙ 8●	1U-1606S	MAIN UNIT	1	
⊙ 9■	1U-1597SZ	DISPLAY UNIT	1	
⊙ 9●	1U-1597S	DISPLAY UNIT	1	
10■	4122528000	BRACKET C	1	
11■	4140426045	SAFETY PLATE	1	
12	4610386013	SPACER RUBBER	1	
13■	4140477007	SHIELD PLATE	1	
14■	4140426029	SAFETY PLATE	1	
15	4140483004	SAFETY PLATE	1	
16	5131144005	MASKING SHEET	1	
17	4122548006	BRACKET	1	
⊙ 18	1U-1742	CONTROL UNIT	1	
19	4150299000	CONDENSER COVER	1	
20	1430568001	FILTER	1	
21■	1050809124	BACK PANEL	1	
21●	1050809137	BACK PANEL	1	
▲ 22	2538014003	CK45F2GAC103M	1	C-151 0.01μF/ 400V AC
23	-	-	-	
▲ 24	2062063008	AC CORD WITH PLUG	1	
▲ 25	4450056008	CORD BUSH	1	
▲ 26	2050071016	TERMINAL Ass'y	1	
27	4770018001	WASHER (P-87)	1	
28	1460925009	ANT. HOLDER	1	
▲ 29■	2335667103	POWER TRANS	1	
▲ 29●	2335668104	POWER TRANS	1	
30■	4170322216	H.P RADIATOR	1	
30●	4170322203	H.P RADIATOR	1	
⊙ 31	4129082002	RADIATOR BRACKET	1	
32	-	-	-	
33	4458004007	WIRE CLAMPER	14	
34	4122463000	BRACKET-B	1	
35	2030322060	1PCONNECTOR	1	
36	4122431003	BRACKET	1	
37	1460922400	INNER PANEL	1	
38	1131018106	KNOB-TACT-1	1	
39	1131019105	KNOB-TACT-2	1	
40	1131020204	KNOB-FUNCTION	1	
41	1430541109	WINDOW	1	
42	4770288006	PUSH RIVET	4	
⊙ 43	4140453102	SHIELD PLATE	1	
44	1131054102	POWER KNOB Ass'y	1	
45	-	-	-	

Ref. No.	Part No.	Part Name	Q'ty	Remarks
46	1441805009	FRONT PANEL Ass'y	1	
46	1441807007	FRONT PANEL Ass'y	1	
47	-	-	-	
48	1139071006	PUSH KNOB (T)	3	
48	1139071006	PUSH KNOB (T)	2	
49	1120529101	VOLUME KNOB	1	
50	1120530103	KNOB	3	Tone, Balance Loudness
51	1120530116	KNOB	1	
52	1020314005	TOP COVER	1	
53	1220146002	HIMERON SHEET	2	100x11x 0.5t UL Himeron
54	-	-	-	
55	4610390070	RUBBER SHEET	2	
56	2048167026	HEADPHONES JACK	1	M12 Nut
57	2129532004	2P PUSH SWITCH	1	Speaker Select
58	2110521011	V1620V30FB104R	1	Motor Drive 100 kohm VR
59	2124686007	POWER SWITCH	1	TV-5
60	2110522007	V1604V20F ... K (VR BLOCK)	1	Bass, Treble, Balance, Variable Loudness
61■	2544216002	CE04W1J922M	2	C409,410 9200μF/ 63V
61●	2546089004	CE04W==822M	1	8200μF/ 63V
62	2050347009	6P CONNECTOR BASE	2	C409,410 Phono, CD, Aux/ Video
63	2050346000	4P CONNECTOR BASE	1	Tape-2 (PB, REC) Pre-Out Input Terminal Tape-1 (PB, REC)
64	2050433007	3P ANT. TERMINAL (DIN)	1	
65	2048260004	3.5M MINI JACK	1	Remote Control
66	2050484001	8P SPEAKER TERMINAL	1	
67	4179021107	RADIATOR BLOCK	1	
68■	2710205009	2SA1491(O)/(Y)	2	Power TR. TR321, 322,

Ref. No.	Part No.	Part Name	Q'ty	Remarks
68●	2710204000	2SA1490(O)/(Y)	1	Power TR TR321, 322
69■	2730337009	2SC3855(O)/(Y)	2	Power TR TR319, 320
69●	2730336000	2SC3854(O)/(Y)	1	Power TR. TR319, 320
70■	2129520003	1P PUSH SWITCH	1	Mode
71	2149003005	RELAY	1	RL401
72	2160065006	FRONT END	1	
73	4990088002	QH3031H0	1	Remote Sensor
74	3934043004	FLD (FIP 10TM7)	1	
75■	2061015061	FUSE (2A)	1	F-001
75●	2061015058	FUSE (1.6A)	1	F-002
76	4122528000	BRACKET C	1	
SCREWS & NUTS				
101■	4737002034	TAPPING SCREW(S) (BLACK) 3x6	35	
101●	4737002034	TAPPING SCREW(S) (BLACK) 3x6	34	
102	4737002021	TAPPING SCREW(S) (BLACK) 3x8	5	
103	4737004016	TAPPING SCREW(S) (BLACK) 4x6	4	
104	4737500044	TAPPING SCREW(P) (BLACK) 3x8	2	
105	4737508017	TAPPING SCREW(P) (BLACK) (3x10)	7	
106	4737015018	TAPPING SCREW(S) (BLACK) 3x8	11	
110	4770263005	3P SWELLING SCREW	4	
111	4770064107	FIXING SCREW	4	
PACKING & ACCESSORIES (not included EXPLODED VIEW)				
201	5058006019	ENVELOPE	1	
202	5111762009	INST. MANUAL	1	
203	-	-	1	
204	2311129005	LOOP ANTENNA	1	
205	5290040008	FM ANT ADAPTOR	1	
206	4990120009	RC-111	1	
207	5050149000	POLY-COVER	1	
208	5059102006	POLY COVER	1	
209	5049102003	STYLEN PAPER	2	
210	5030674003	CUSHION	2	
211■	5011312009	CARTON CASE	1	
211●	5011313008	CARTON CASE	1	
212	5020658013	PAD	1	
213	5131389006	CONTROL CARD BASE	1	
214	5131349004	THERMAL CARBON FILM	1	

PARTS LIST OF EXPLODED VIEW
(DRA-625R/425R Europe Gold Version)
 [Same as parts list (for DRA-625R/425R Europe Black Version) except the followings]

Ref. No.	Part No.	Part Name	Remarks
37	1460922413	INNER PANEL	
38	1131018119	KNOB-TACT-1	
39	1131019118	KNOB-TACT-2	
40	1131020217	KNOB-FUNCTION	
44	1131054115	POWER KNOB-Ass'y	
46■	1441805012	FRONT PANEL Ass'y	
46●	1441807010	FRONT PANEL Ass'y	
48	1139071019	PUSH KNOB (T)	
49	1120529114	VOLUME KNOB	
50	1120530129	KNOB	
51	1120530132	KNOB	
52	1020314018	TOP COVER	
SCREW			
110	4770263018	3P SWELLING SCREW	
PACKING & ACCESSORIES (not included Exploded view)			
211■	5011312012	CARTON CASE	
211●	5011313011	CARTON CASE	
215	5139111001	COLOR LABEL (GOLD)	

NOTE : ■ DRA-625R only
 ● DRA-425R only

ADDENDUM LIST

Ref. No.	Part Name & Descriptions	DRA-425R	
		U.K.	
⊙ 9	DISPLAY UNIT	1U-1597U	
16	MASKING SHEET	5131144005(3)	
24	AC CORD		
29	AC CORD WITH LABEL	2062024006	
	POWER TRANS(EA)	2335680009	
	VOLTAGE LABEL	5130362008(2)	

NOTE FOR PARTS LIST

- Part indicated with the mark "⊙" are not always in stock and possibly to take a long period of time for supplying, or in some case supplying of part may be refused.
- When ordering of part, clearly indicate "1" and "1" (i) to avoid mis-supplying.
- Ordering part without stating its part number can not be supplied.
- Part indicated with the mark "▲" is not illustrated in the exploded view.

EXPLODED VIEW OF CHASSIS AND CABINET (DRA-625R/425R)

WARNING: Parts marked with this symbol  have critical characteristics. Use ONLY replacement parts recommended by the manufacturer.

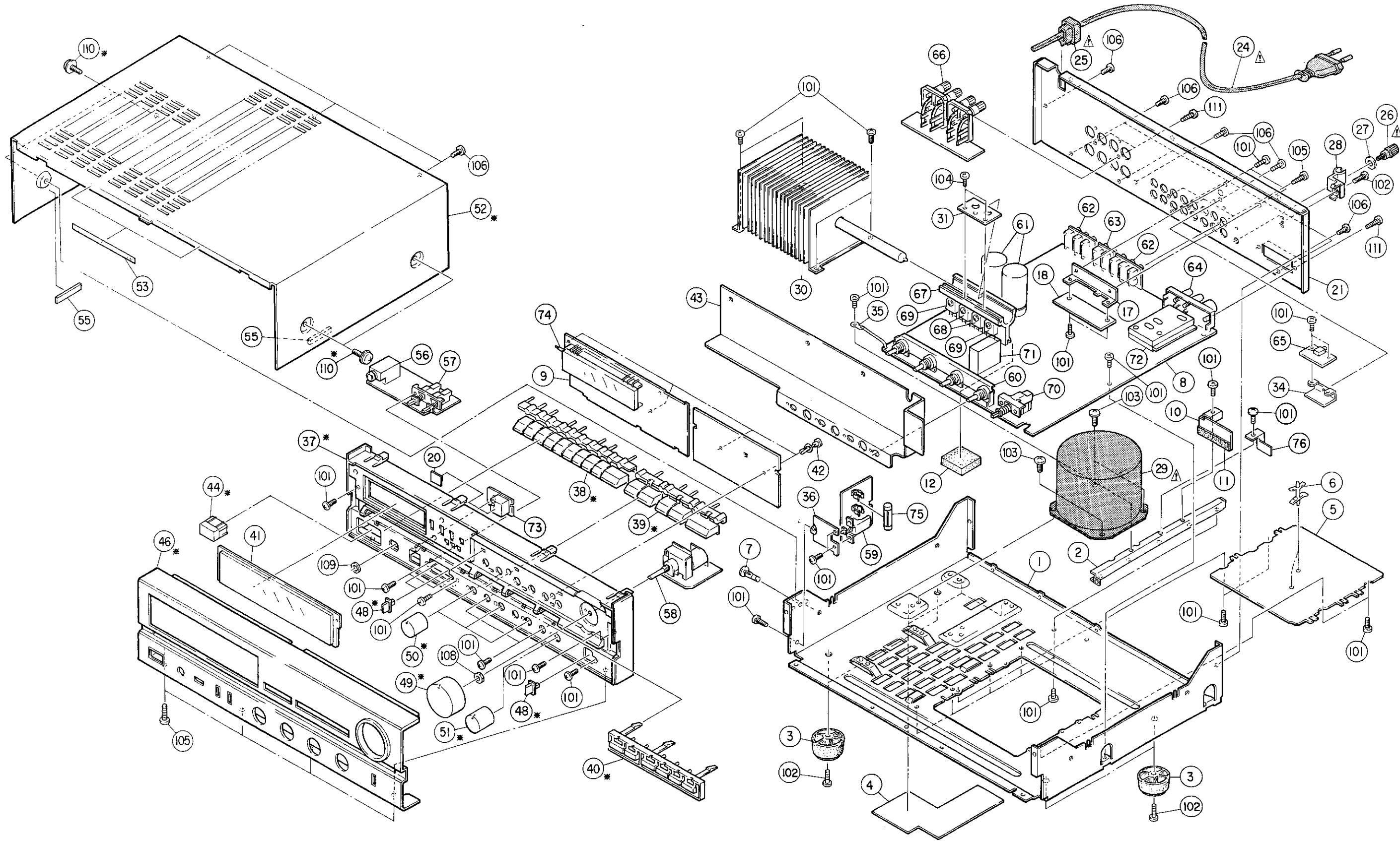

(Those parts marked * in the Black Version should be changed the part number in the Gold Version.)

WIRING DIAGRAM (DRA-625R/425R)

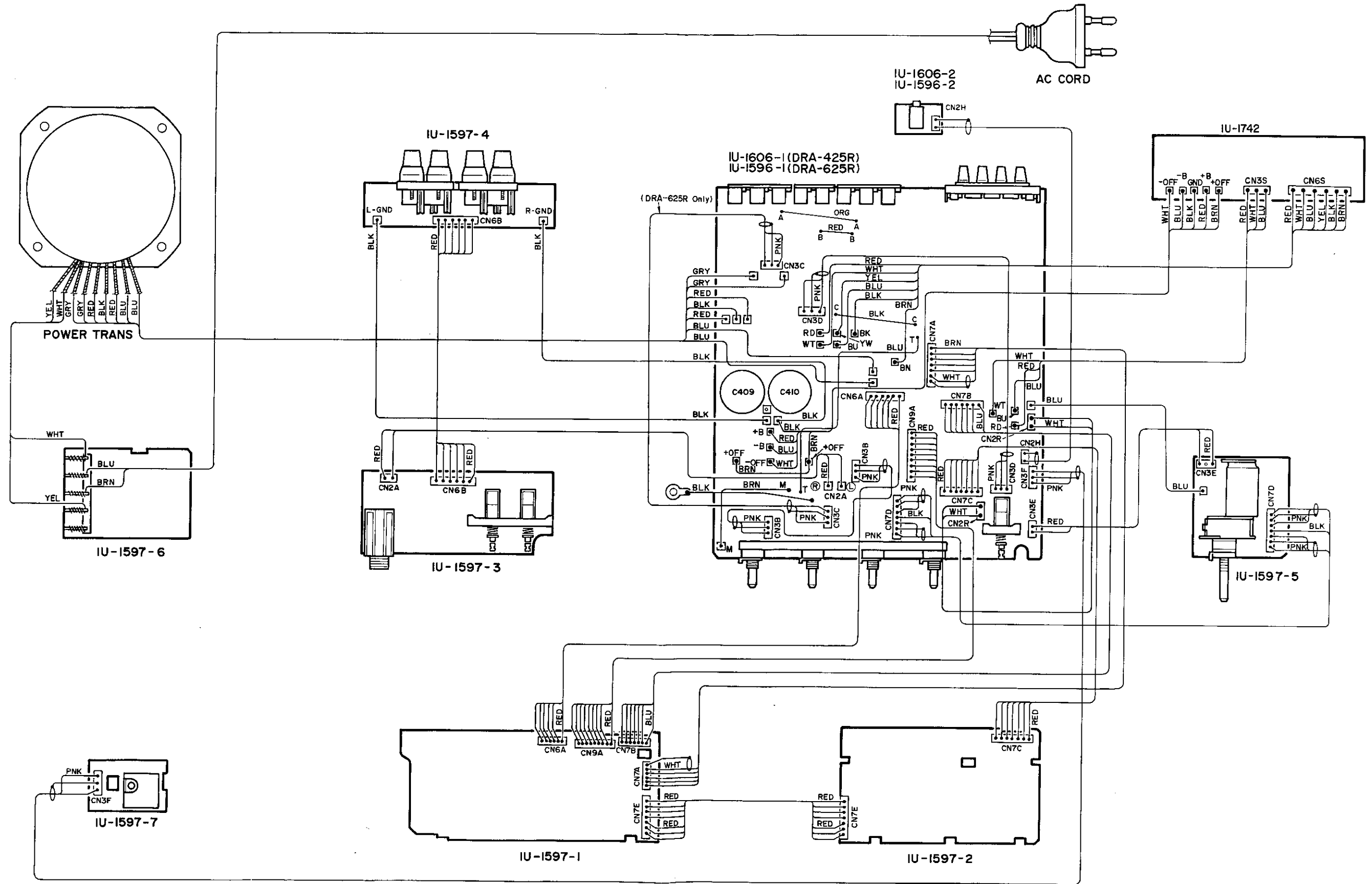

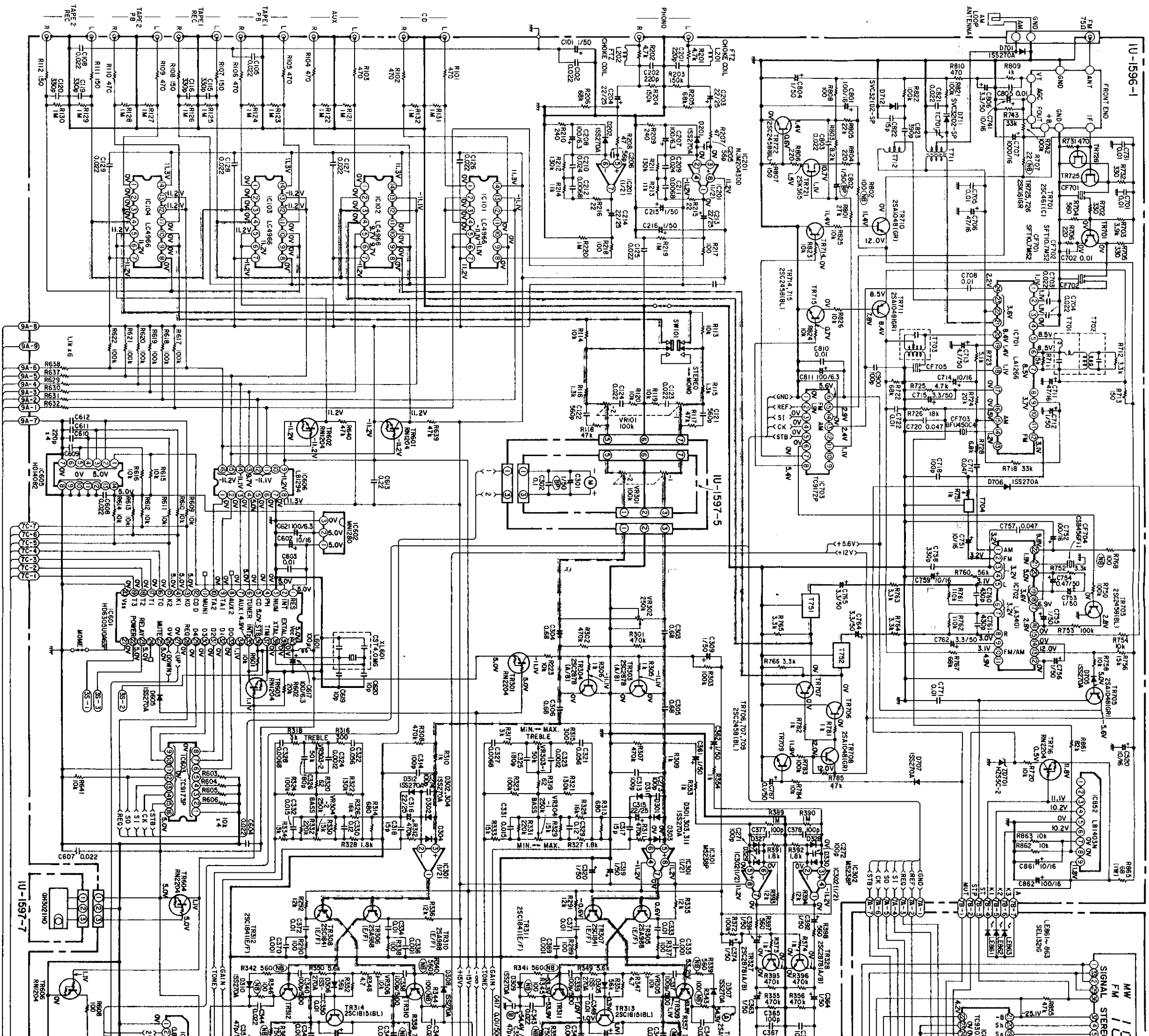

NOTES
 ALL RESISTANCE VALUES IN OHM K - 1000 OHM M -
 ALL CAPACITANCE VALUES IN MICRO FARAD P - MICRO
 EACH VOLTAGE AND CURRENT ARE MEASURED AT NO
 CIRCUIT AND PARTS ARE SUBJECT TO CHANGE WITHO

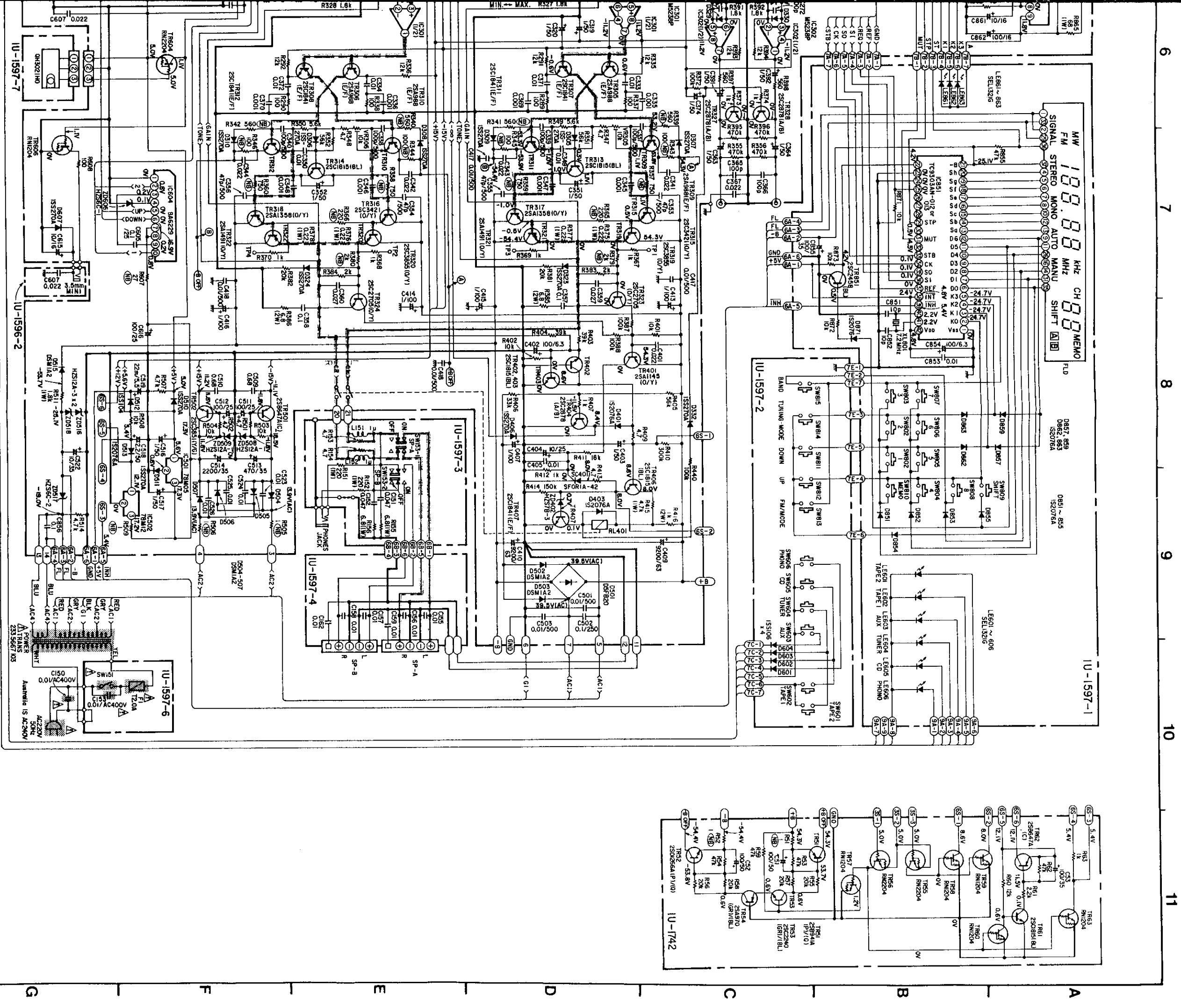

FM or L-CH SIGNAL LINE
 AM or R-CH SIGNAL LINE

WARNING:
 Parts marked with this symbol  have critical characteristics.
 Use ONLY replacement parts recommended by the manufacturer.

CAUTION:
 Before returning the unit to the customer, make sure you make either (1) a leakage current check or (2) a line to chassis resistance check, if the leakage current exceeds 0.5 milliamperes, or if the resistance from chassis to either side of the power cord is less than 240 k ohms, the unit is defective.

WARNING:
 DO NOT return the unit to the customer until the problem is located and corrected.

RESISTANCE VALUES IN OHM K = 1,000 OHM M = 1,000,000 OHM
 CAPACITANCE VALUES IN MICRO FARAD P = MICRO-MICRO FARAD
 VOLTAGE AND CURRENT ARE MEASURED AT NO SIGNAL INPUT CONDITION.
 UNIT AND PARTS ARE SUBJECT TO CHANGE WITHOUT PRIOR NOTICE.

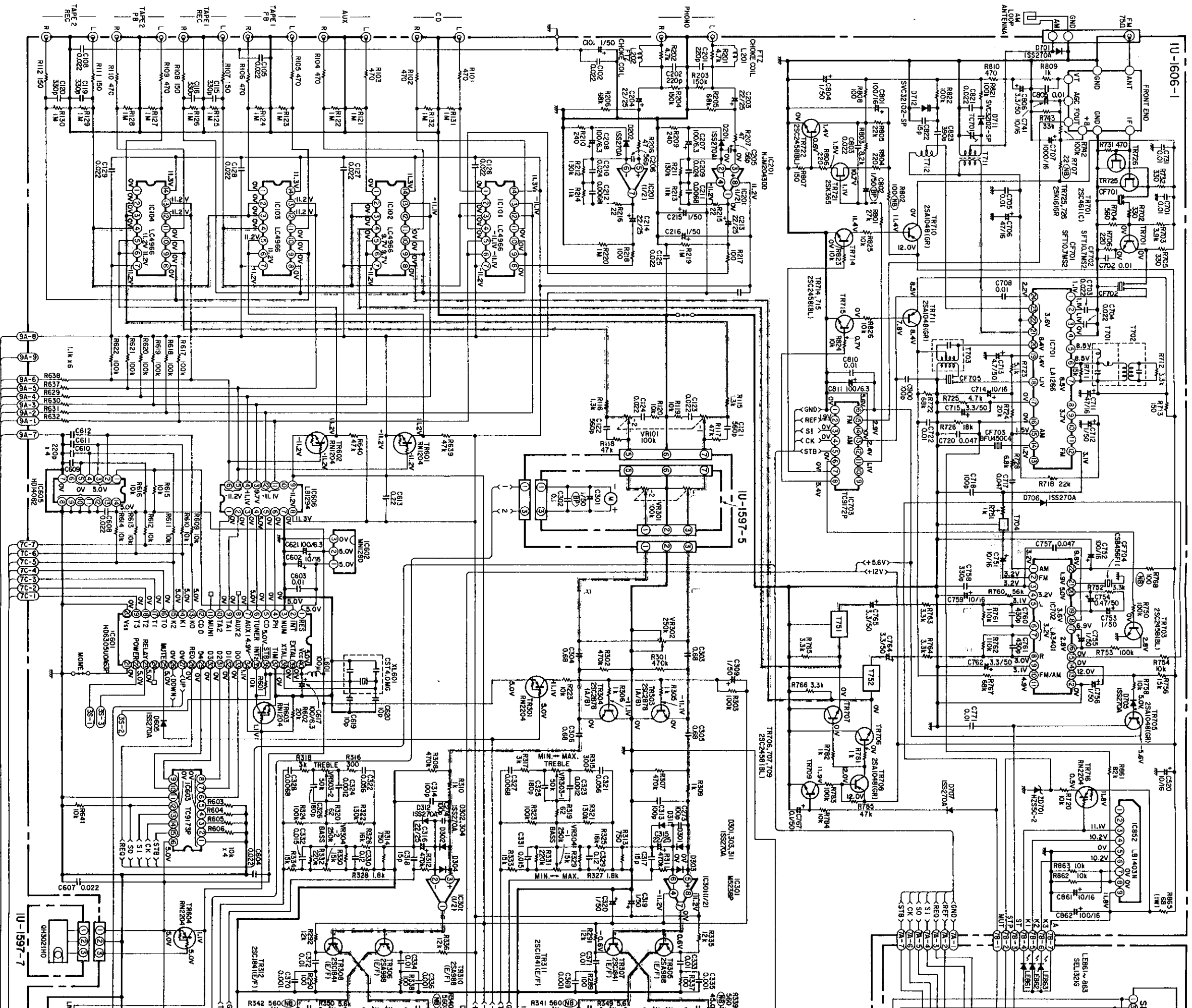

NOTES
 ALL RESISTANCE VALUES IN OHM K - 1,000 OHM M - 1,000,000 OHM
 ALL CAPACITANCE VALUES IN MICRO FARAD P - MICROMICRO FARAD
 EACH VOLTAGE AND CURRENT ARE MEASURED AT NO SIGNAL INPUT CONDITION.
 CIRCUIT AND PARTS ARE SUBJECT TO CHANGE WITHOUT PRIOR NOTICE.

WARNING:
 Parts marked with this symbol  have critical characteristics.
 Use ONLY replacement parts recommended by the manufacturer.

CAUTION:
 Before returning the unit to the customer, make sure you make either (1) a leakage current check or (2) a line to chassis resistance check. If the leakage current exceeds 0.5 milliamperes, or if the resistance from chassis to either side of the power cord is less than 100 ohms, the unit is defective.

WARNING:
 DO NOT return the unit to the customer until the problem is located and corrected.

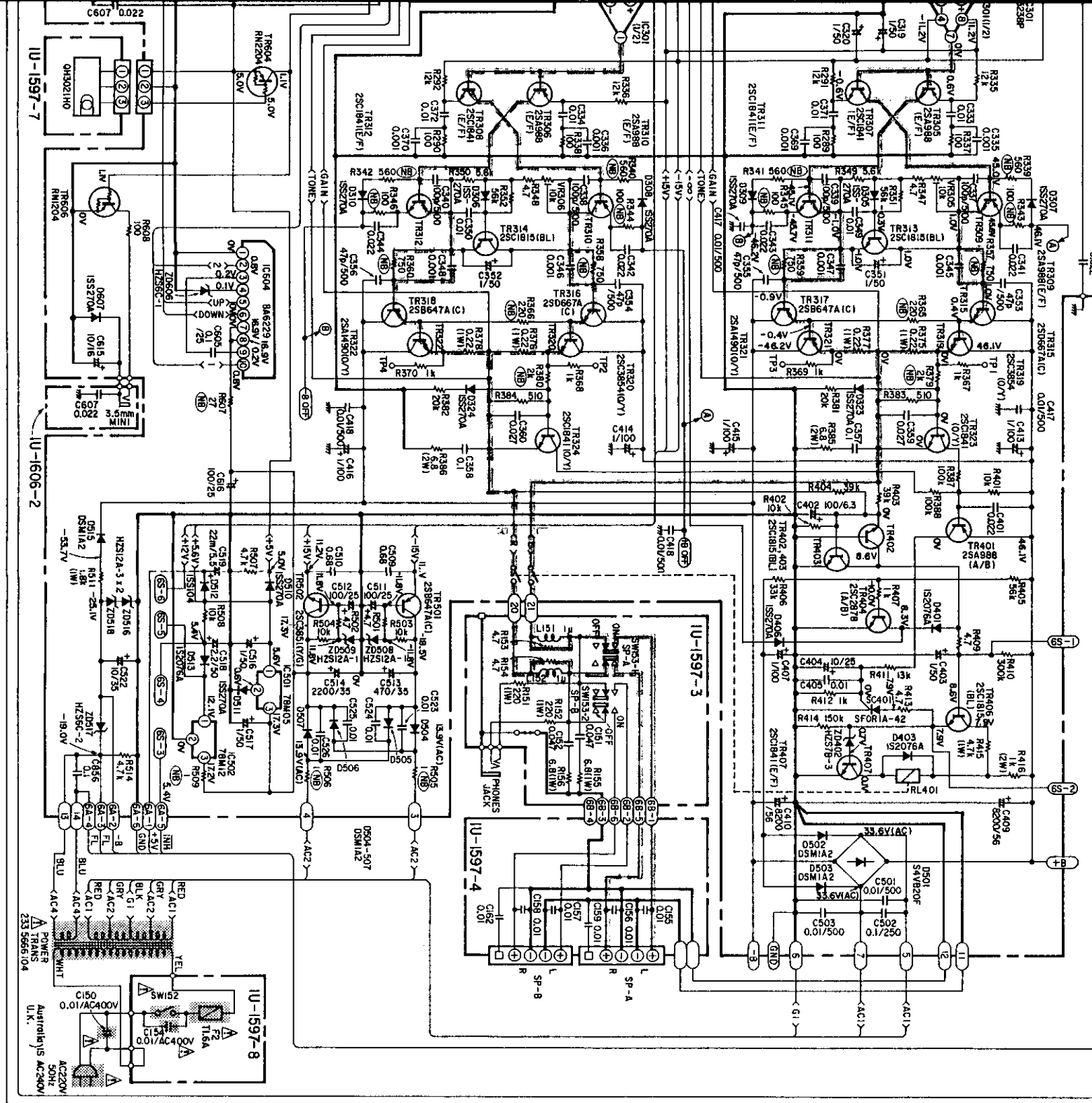
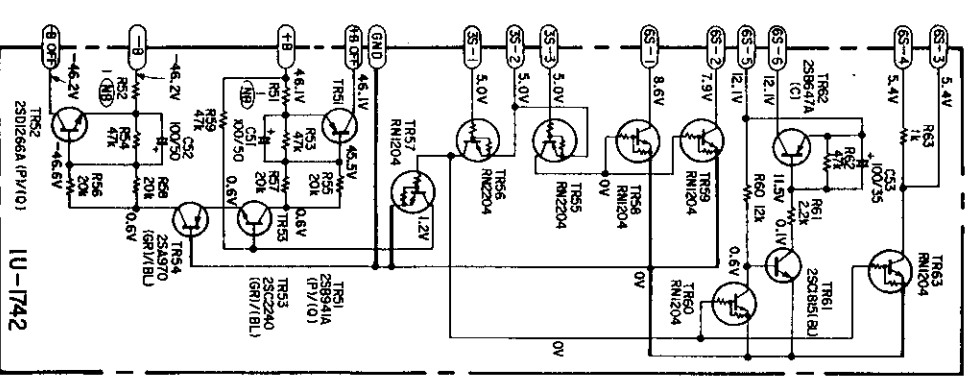
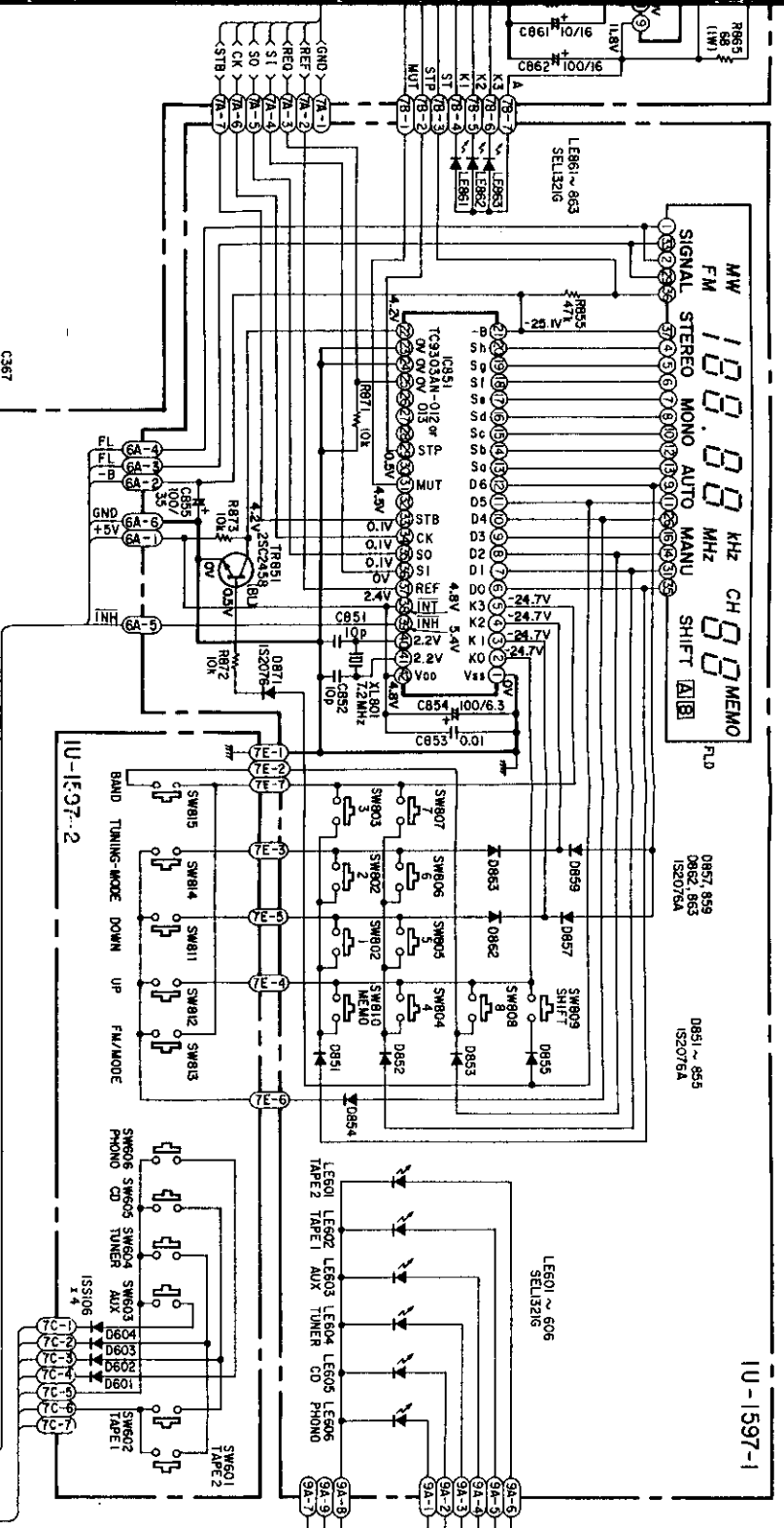

check or (2) a line to chassis resistance
side of the power cord is less than 240 K

FM or L-CH SIGNAL LINE
AM or R-CH SIGNAL LINE

BLOCK DIAGRAM

DRA-625R

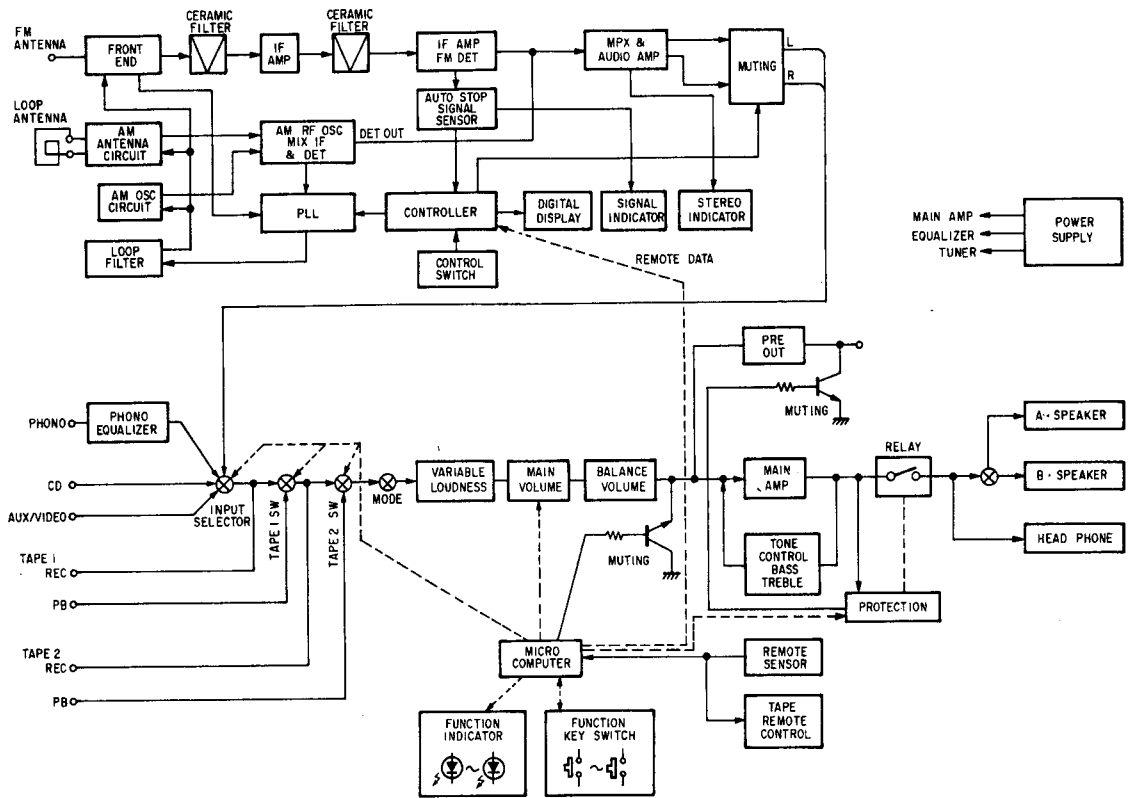

DRA-425R

