

# DENON

Hi-Fi Component

## SERVICE MANUAL STEREO CASSETTE TAPE DECK DRM-600

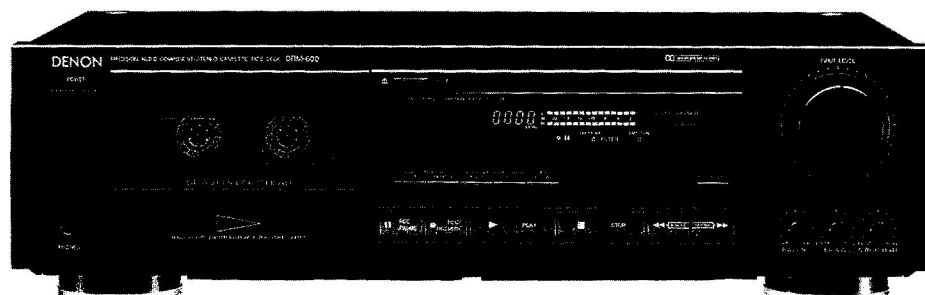

### TABLE OF CONTENTS

OPERATING INSTRUCTIONS.....	2~11
BLOCK DIAGRAM.....	12
LEVEL DIAGRAM.....	13
DISASSEMBLY INSTRUCTIONS.....	14~15
ADJUSTING AND CHECKING THE MECHANISM SECTION.....	16~17
ADJUSTING THE ELECTRICAL SECTIONS.....	17~19
PARTS LIST OF AUDIO/METER UNIT/POWER SUPPLY UNIT.....	20~21
PARTS LIST OF EXPLODED VIEW.....	22
EXPLODED VIEW OF CABINET AND CHASSIS GROUP.....	23
PARTS LIST OF MECHANISM UNIT.....	24
EXPLODED VIEW OF MECHANISM UNIT.....	25
P.W. BOARD OF 4U-1875 AUDIO/METER UNIT.....	26
P.W. BOARD OF 4U-1876 POWER SUPPLY UNIT.....	27
WIRING DIAGRAM.....	27
SEMICONDUCTORS.....	28
SCHEMATIC DIAGRAM.....	29
BUNDLE DIAGRAM.....	30

**NIPPON COLUMBIA CO., LTD.**

## IMPORTANT TO SAFETY

### WARNING :

**TO PREVENT FIRE OR SHOCK HAZARD, DO NOT EXPOSE THIS APPLIANCE TO RAIN OR MOISTURE.**

### CAUTION :

#### 1. Handle the power supply cord carefully

Do not damage or deform the power supply cord. If it is damaged or deformed, it may cause electric shock or malfunction when used. When removing from wall outlet, be sure to remove by holding the plug attachment and not by pulling the cord.

#### 2. Do not open back plate

In order to prevent electric shock, do not open the back plate. If problems occur, contact your DENON dealer.

#### 3. Do not place anything inside

Do not place metal objects or spill liquid inside the cassette deck. Electric shock or malfunction may result.

Please, record and retain the Model name and serial number of your set shown on the rating label.

Model No. DRM-600      Serial No. \_\_\_\_\_

## SAFETY INSTRUCTIONS FOR AUDIO SET

### ■ INSTALLATION

- Operate the set only from a power source which is indicated on the rating label (indication) at the back of the set.
- Frayed cords and broken plugs may cause a fire or shock hazard. Do not damage the power cord.
  - Do not cut and splice the power cord.
  - When removing the power cord from wall outlet, be sure to unplug by holding the plug attachment and not by pulling the cord. Do not hot the plug by wet hand.
  - Call your service technician for replacement of damaged cords and plugs.

- Select a place so that the location or position does not interfere with the proper ventilation of the set for releasing heat generated during operation.
  - Select a flat and level surface allowing enough space for setting up and operation.
  - Never block the bottom ventilation holes placing the set on a bed, sofa, rug, etc.
  - Never place the set in a "builtin" enclosure unless proper ventilation is provided.
  - Never place the set near or over a radiator, heat register or stove.
  - Avoid locations where the set is exposed directly to the sun light.

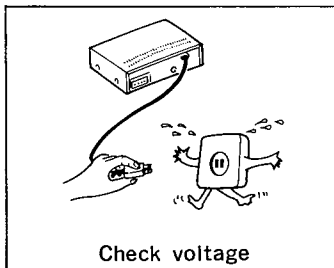

Check voltage

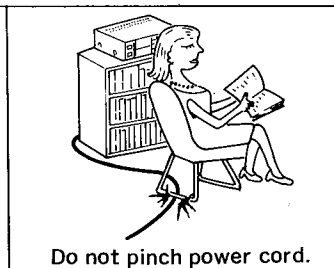

Do not pinch power cord.

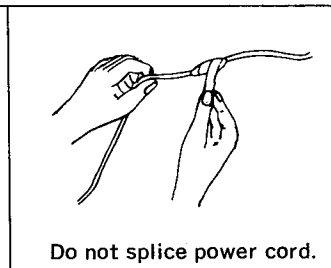

Do not splice power cord.

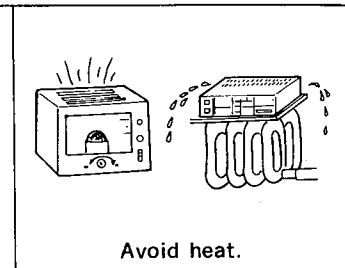

Avoid heat.

### ■ USE

- Do not expose the set to rain or water (liquid). Do not spill liquid or insert metal objects inside the set. Rain, water or liquid such as cosmetics as well as metal may cause electric shorts which can result in fire or shock hazard. If any thing gets inside, unplug the power cord and have a DENON service technician check your set before further use.
- Never leave your set switched on which leaving the house. For added protection of your audio system during lightning storm or when the set is to be left unused for a long period of time, be sure to unplug the power cord from the wall outlet.
- Take care so that the set is not dropped to avoid damaging the cabinet which defeats safeguards or injuring yourself. If the set has been dropped or the cabinet has been damaged, unplug the set and have it checked by a DENON service technician to restore the safeguards.

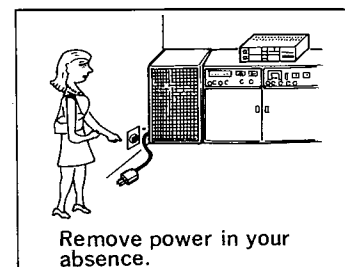

Remove power in your absence.

### ■ SERVICING

- The servicing of set must not be attempted by yourself beyond that described in the operating instructions. In case of problems that cannot be settled by referring to your operating instructions, unplug the power cord and contact your DENON dealer. No user-servicable parts are inside the set. Only qualified service inside your set.
- Refer to the operating instructions for maintenance and cleaning.



Do not drop.

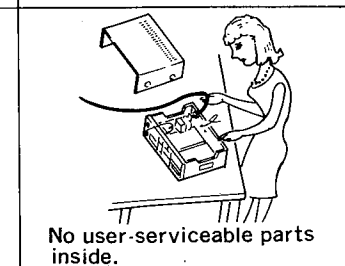

No user-servicable parts inside.

### IMPORTANT

#### (BRITISH MODEL ONLY)

The wires in this mains lead are coloured in accordance with the following code :

Blue :                      Neutral  
Brown :                    Live

The colours of the wires in the mains lead of this apparatus may not correspond with the coloured markings identifying the terminals in your plug proceed as follows. The wire which is coloured blue must be connected to the terminal which is marked with the letter N or coloured black.

The wire which is coloured brown must be connected to the terminal which is marked with the letter L or coloured red.

### FOR YOUR SAFETY

#### (AUSTRALIAN MODEL ONLY)

To ensure safe operation, the three-pin plug supplied must be connected only with a standard three-pin power point which is effectively earthed through the normal household wiring.

Extension cords used with the equipment must be three-core and be correctly wired to provide connection to earth. Wrongly wired extension cords are a major cause of fatalities.

The fact that the equipment operates satisfactorily does not imply that the power point is earthed and that the installation is completely safe. For your safety, if in any doubt about the effective earthing of the power point, contact a qualified electrician.

Thank you very much for purchasing the DENON component DRM-600.

THE DENON DRM-600 is a top-line stereo cassette tape deck, capable of outstanding performance in combination with high grade hi-fi systems.

DENON proudly presents this advanced tape deck to audiophiles and music lovers as a further proof of DENON's non-compromising pursuit of the ultimate in sound quality. The high quality performance and easy operation are certain to provide you with many hours of outstanding listening pleasure.

## FEATURES

- Computer controlled mechanism
- Non-slip reel drive for stabilizing tape tension
- Dual power supply
- High Performance SF Amorphous R/P head
- Dolby HX PRO system
- Dolby B & C noise reduction systems
- Manual bias adjustment control
- Computing linear tape counter with 4-digit readout and memory stop.
- Music search system
- REC return system
- FL peak level meters
- Auto tape selector

## CONNECTION

- Leave your entire system (including this cassette deck) turned off until all connections between the deck and other components have been made.

### ■ Connecting the deck to an amplifier

- Before connecting the deck to your amplifier, it is a good practice to review your amplifier's instruction manual.
- Use the white plugs for the left channel, and the red plugs for the right channel.

### ■ Tape dubbing

- Many stereo amplifiers and receivers have tape dubbing circuitry so that tape duplication can be performed between two or more tape decks. Review your amplifier's instruction manual for a full explanation of this mode of operation.

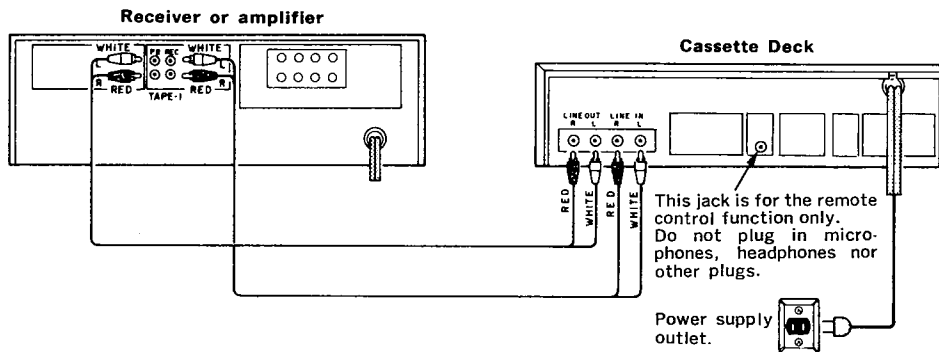

### ■ Connecting Headphones

To listen through headphones, plug your headphones into the PHONES jack.

### ■ Installation Precautions

If the deck is placed on or too near an amplifier or tuner, noise (induced hum) or beat interference may result (especially during FM • AM reception). If this occurs, separate the deck from other components or reorient its position.

### ■ Systems remote control

If you connect the remote control jacks of this cassette deck and a DENON's separately available receiver model (DRA series receiver for IS) which has the remote control provision with a mini-plug cable, each of "PLAY, FF, REW, STOP, REC/REC MUTE and REC PAUSE" functions can be remote controlled with the wireless handset of the receiver.

- Use the attached mini-plug cable.

# NAMES AND FUNCTIONS OF PARTS

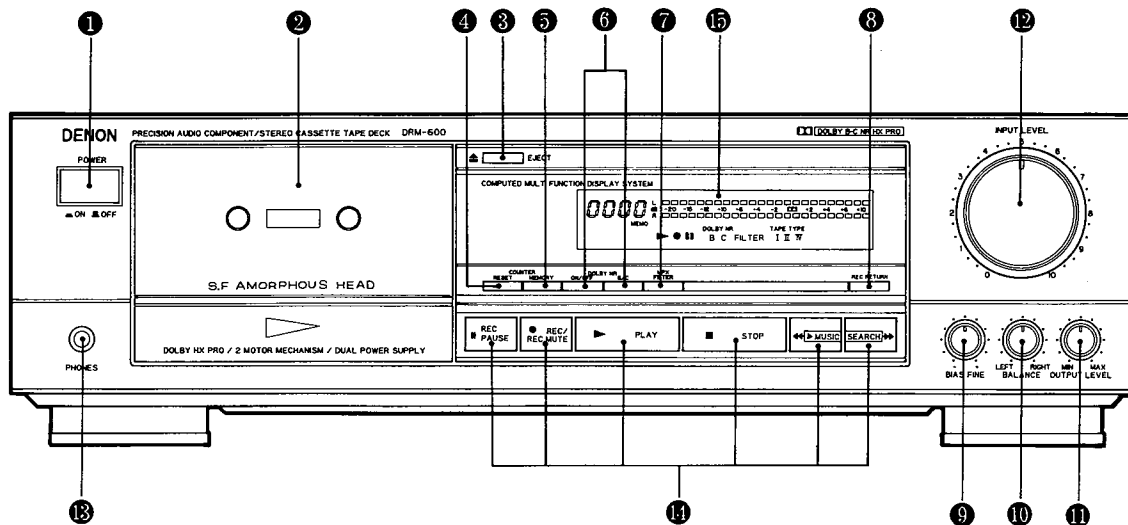

## 1 POWER switch

Controls the supply of AC power to the deck. One push turns the deck on, a second push turns it off. The deck remains in a stand-by (non-operative) mode for approximately 2 seconds after it is switched on.

## 2 Cassette compartment cover

If this compartment cover is not closed completely, the deck's transport controls will remain inoperative.

## 3 EJECT button

Press this button to eject the cassette. When the deck is operating (tape is running), press the stop (■) button first to stop the tape transport; then press the EJECT button.

## 4 COUNTER RESET button

Operation of the button resets the counter to all zero.

## 5 MEMORY button

During rewinding operations, the tape will stop at the "0000" counter point automatically when this button is pressed in.

## 6 DOLBY NR button

Immediately after the power source is turned on, DOLBY NR becomes the "OFF" state. When the left-side DOLBY NR button is pressed once with DOLBY NR being at the "ON" state. DOLBY B NR is preferred and turned on. Every time when the right-side B/C button is pressed, B-NR and C-NR are selected alternatively.

## 7 MPX FILTER button

The MPX FILTER button should be used to prevent interference with the Dolby NR circuit when making Dolby NR encoded recordings of FM stereo programs. When making Dolby NR encoded recordings from any program source other than FM stereo, leave this button in the "OFF" position.

## 8 REC RETURN Button

When this key is pressed at the recording state, the tape is rewound to the starting point. When the starting point is automatically reached, the record standby mode (rec pause state) comes.

## 9 BIAS FINE control

(for NORMAL, CrO<sub>2</sub> and METAL tape)

Adjust the bias according to the tape characteristics. Standard biasing is obtained at the center click-stop position.

## 10 BALANCE control

This is the knob to adjust the recording level balance between the left and right channels. Turn it counter-clockwise to reduce the right channel's level and clockwise to reduce the left channel's. Usually, put the knob at the center click position.

## 11 OUTPUT LEVEL control

This control adjusts playback, recording monitor, and headphones output levels for the both channels simultaneously.

## 12 INPUT LEVEL control

The recording input level is adjusted by this knob. The levels in the left and right channels can be changed simultaneously.

## 13 PHONES jack

For private music enjoyment without disturbing others, or for monitoring a recording, a set of headphones may be plugged in. Impedance should be from 8 to 1200 ohms.

## 14 Tape transport controls

▶ PLAY	PLAY button	Press to playback tape.
■ STOP	STOP button	Press to stop tape in any mode.
◀◀	REW button	Press for fast rewind.
▶▶	FF button	Press for fast forward tape winding.
● REC/REC MUTE	RECORD/MUTE button	To begin recording, press the RECORD and PLAY button simultaneously. If only the RECORD button is pressed, the deck is placed in the REC PAUSE (record standby) mode. When this button is pressed under the REC PAUSE state, the mode shifts to the Auto Rec Mute. When this button is pressed for making a non-recorded part between two melodies, about 5 sec of non-recorded part can automatically be created.
REC PAUSE	REC PAUSE button	Press this button if you want to change from the rec mute or recording state into the rec pause state. "Pause" is effective during "RECORDING" only.

## 5 DISPLAY

The indicators with an encircled number light up by pressing the corresponding button.

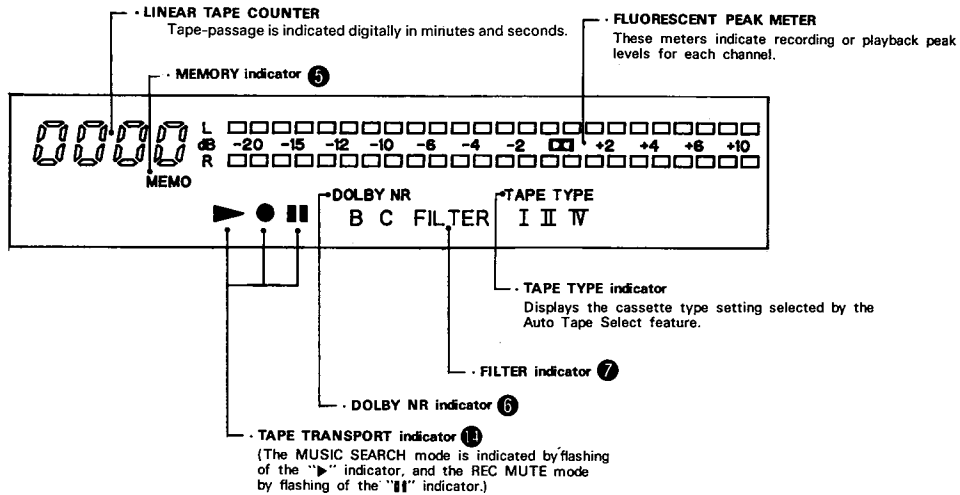

## CASSETTE TAPE

### ■ Handling Precautions

- C120 cassettes  
C120 cassettes are not recommended as they use a very thin tape base which may become tangled around the capstan or pinchroller.
- Tape slack  
Before putting a tape into the deck, take up any slack with a pencil or your finger tip. This precaution is also to prevent the tape from becoming entangled around the capstan or pinchroller.

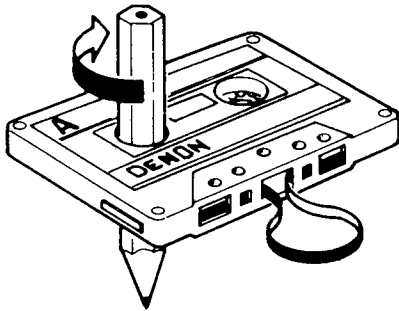

### ■ Storage Precautions

- Do not store cassette tapes in a place where they will be subject to:
  - Extremely high temperature or excessive moisture
  - Excessive dust
  - Direct sunlight
  - Magnetic fields (near TV set or speakers)
- To eliminate tape slack, store your cassettes in cassette cases with hub stops.

### ■ Accidental Erasure Prevention

- Every cassette has erasure prevention tabs for each side. To protect your valuable recorded tapes from accidental or inadvertent erasure, remove the tab for the appropriate side with a screwdriver or other tools.
- To record on a tape with the erasure prevention tabs removed, cover the tab holes with plastic tape.

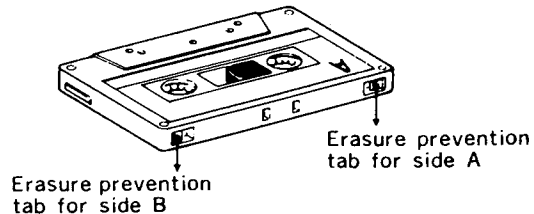

## AUTO TAPE SELECT FEATURE

This Stereo Cassette Deck contains an Auto Tape Select feature which automatically selects the optimum bias and equalization for the tape in use. This is accomplished by detection of tape type detection holes in the cassette housing.

- If a tape without tape type detection holes is used, the TAPE SELECT indicator will not indicate the correct tape type and the deck will automatically adjust itself for normal tapes.

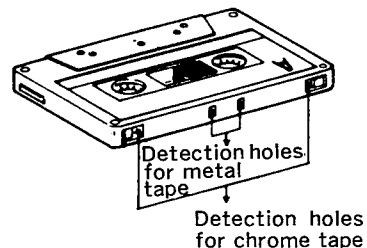

## PLAYBACK

- Switch on your amplifier or receiver.
- Set the TAPE MONITOR switch on your amplifier or receiver to the TAPE position.
- Operate the deck in numerical order as illustrated below :

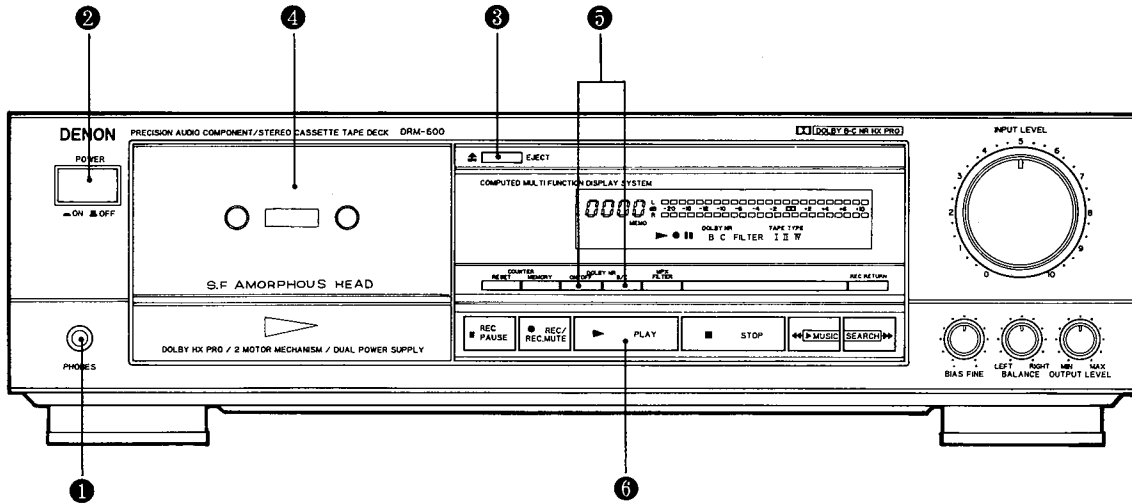

### 1 PHONES

Playback sound is fed into the headphone set.

### 2 POWER

Push the switch to turn "ON" (→) the power.

### 3 EJECT

Press the EJECT button to open the cassette compartment.

### 4 Cassette Compartment Cover

Load the cassette tape.

### 5 DOLBY NR

For recordings made without Dolby NR, set to "OFF".  
 For recordings made with Dolby B NR, set to "B". (The B indicator will light up.)  
 For recordings made with Dolby C NR, Set to "C". (The C indicator will light up.)

### 6 PLAY

Push the PLAY (▶ PLAY) button (The ▶ indicators will light up).

- When playback is finished, press the stop (■ STOP) button.
- To restart the tape, press the PLAY button.
- If different types of Dolby Noise Reduction are used for record and playback, playback response will be adversely effected.
- If the power switch is turned OFF while the tape is moving, the cassette may not be removed, even if the EJECT button is pressed. Turn the power switch back ON, and, press the EJECT button to remove the cassette tape.

## RECORDING

- Switch on the source component (tuner, amplifier, etc.).
- Set the TAPE MONITOR switch on your amplifier or receiver to the SOURCE position.

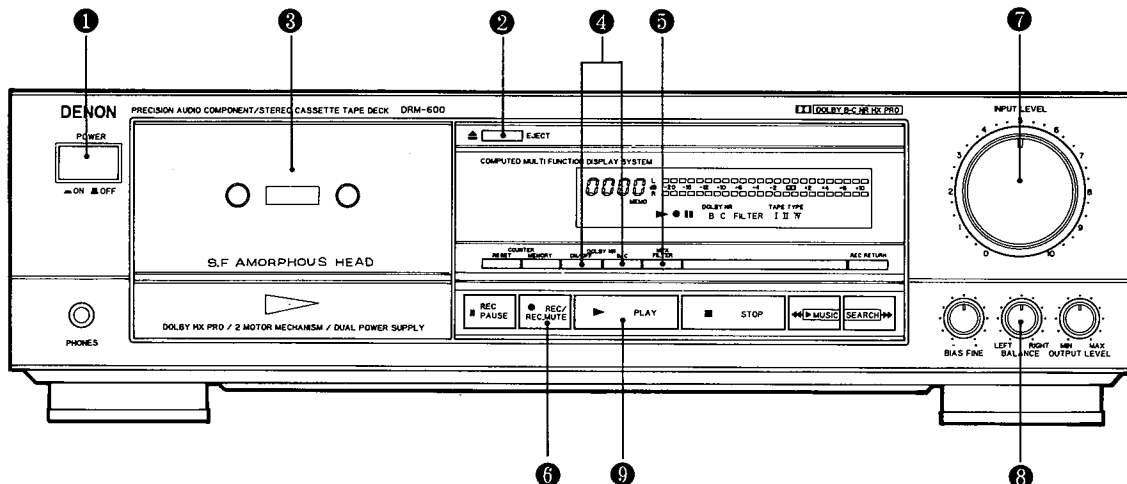

**1 POWER**

Push the switch to turn "ON" (⏻) the power.

**2 EJECT**

Press the EJECT button to open the cassette compartment.

**3 Cassette Compartment Cover**

(Make sure the erasure prevention tab has not been removed from the cassette shell half.)

**4 DOLBY NR**

Set, in accordance with the recording to be made. For recordings without Dolby NR, set to "OFF". For recordings with Dolby B NR, set to "B" (The B indicator will light up). For recordings with Dolby C NR, set to "C" (The C indicator will light up). Future mistakes during playback can be avoided if the cassette is so marked for Dolby NR encoded recordings.

**5 MPX FILTER**

Press it "ON" for the DOLBY NR recording of FM broadcasts (The FILTER indicator will light up).

**6 ● REC**

When pressed, the deck goes into the record standby mode. The ● indicator will light. Initial setting of recording levels should be made in the record standby mode.

**7 INPUT LEVEL**

Used to set the recording level.

**8 BALANCE**

Adjust the recording level balance between the left and right channels.

**9 PLAY**

When pressed, the recording will start. (The ▶ and ● indicator will light up.)

● When recording is finished, press the STOP (■STOP) button.

**Caution :**

Be careful not to erase important recordings by mistake. Mis-erasing can be avoided by following the two steps below :

1. If the PLAY (▶PLAY) button is pressed while the ● indicator is on, the tape will be recorded.
2. If the PLAY (▶PLAY) and RECORD (●REC) button are pressed at the same time, the tape will be recorded.

**PROPER RECORDING LEVEL**

A too high recording level can saturate the tape and cause distortion. On the other hand, if recording levels are set too low, soft passages will be marked by residual noise. Proper recording level is the single most important factor for making well balanced recordings.

**Guideline for maximum recording level**

TYPE I (Normal)	0 dB levels on peaks
TYPE II (CrO <sub>2</sub> )	+2 dB levels on peaks
TYPE IV (Metal)	+4 dB levels on peaks

**Note :** Optimum recording levels can differ depending on program sources or the type of tape used.

**■ Meter reading difference between L and R channels**

The left and right channels readings of the PEAK METER can differ due to variations in input signal levels. In such cases, adjust the individual channels of the BALANCE control until identical meter readings are obtained for both channels.

**RECORDING BIAS ADJUSTMENT**

For best recording results, monitoring during the recording process and comparing various recordings using your own judgement are essential.

The DRM-600 is equipped with a bias adjustment control to assist you in setting the proper bias for different types and brands of recording tape. At the center-stop position, the deck is set for a reference bias level for NORMAL, CrO<sub>2</sub> and METAL tapes. If the resulting recording in this position has too much or too little high frequency

content, varying the bias adjustment control can be useful to achieve better results.

If the high frequencies (treble sounds) are to be boosted, turn the bias control counterclockwise to decrease bias current. If distortion is of more concern than high frequency response, turn the control clockwise to increase bias current. By the use of this control, you can record tapes with response that matches your personal listening tastes.

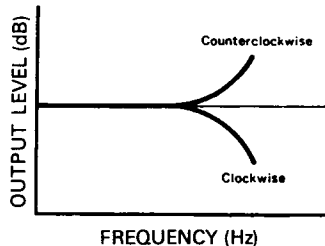

## REC/REC MUTE · REC PAUSE BUTTON

- When you want to make about 5 sec of non-recorded part after the recording state:  
Press the REC/REC MUTE button. The recorder will automatically create about 5 sec of non-recorded part and will stay in the recording standby state.
- To create about 5 sec of non-recorded part after the standby state:  
Press the REC/REC MUTE button, and the recorder will enter the non-recording state, automatically create about 5 sec of non-recorded part and stay in the standby state.
- To cancel the non-recording state (the REC MUTE state):  
Press the REC PAUSE button, and the recorder will cancel the non-recording state and will stay in the standby state.
- To extend the non-recording state (the REC MUTE state) for further 5 sec or more:  
Press the REC/REC MUTE button, and the non-recorded part will automatically be extended for another 5 sec.

## TAPE COUNTER AND MEMORY STOP

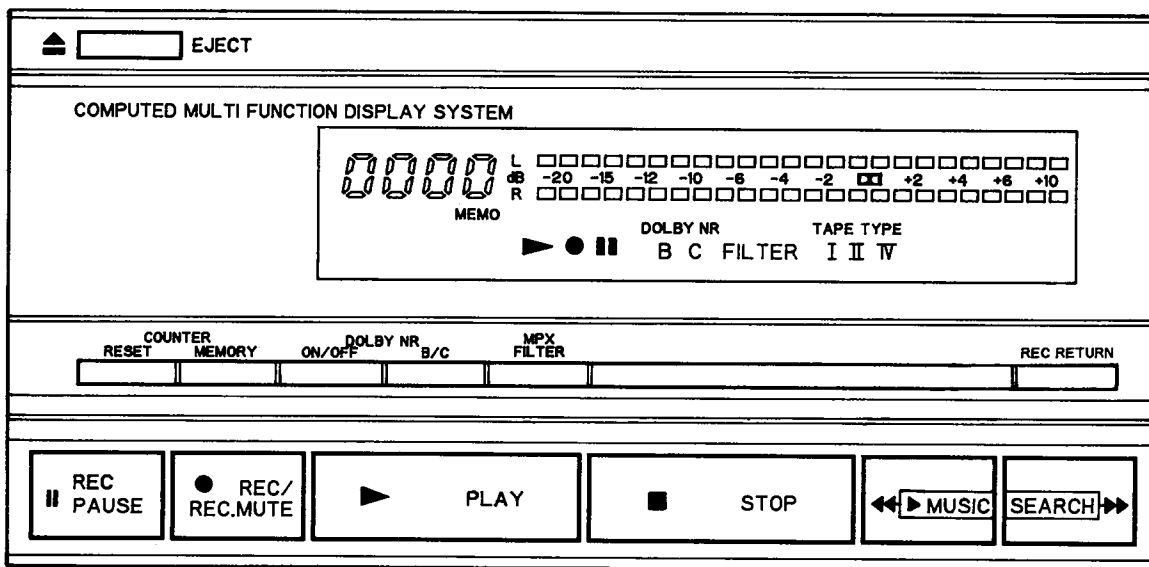

### 1) Operation of the Tape Counter

- Press the RESET button to reset the counter to "0000".
- By using the PLAY, FF, or REW function, the reading of the counter indicate in minutes and seconds. This linear counter is set by the basis of C-90 type.

#### Note

- There may be errors between the counter indication and the real recording time. This is inevitable to some extent due to the fact the counter indicates time during FF and REW as those during recording and playback. The time of the error itself is different among tapes used.
- During recording and playback operations, the counter is useful for noting the location of existing programs or positions where recording is to be started.
- When the power switch is turned "OFF", the counter display turns off. When the deck is turned back "ON", the counter is automatically reset to "0000".

### 2) Operation of MEMORY STOP

- During recording or playback operations, MEMORY STOP can be used to locate a particular point on the tape. At the desired point, reset the counter to "0000". With the MEMORY button in the "ON" position, the deck will stop at the "0000" point during REWIND operations.
- The MEMORY indication will light when this function is activated.
- Notes:
  - When the power is turned "OFF", this function is automatically deactivated.
  - The MEMORY STOP is released by pressing the EJECT button.
  - The MEMORY STOP does not operate during the REC RETURN.
  - During playback operations, the MEMORY STOP is accurate to -5 on the counter, and will stop between "5955" and "0000".
  - During recording operations, the MEMORY STOP accuracy is depend on the number of times pressing PAUSE button.



# DENON

Hi-Fi Component

## SERVICE MANUAL STEREO CASSETTE TAPE DECK MODEL DRM-600

CORRECTION

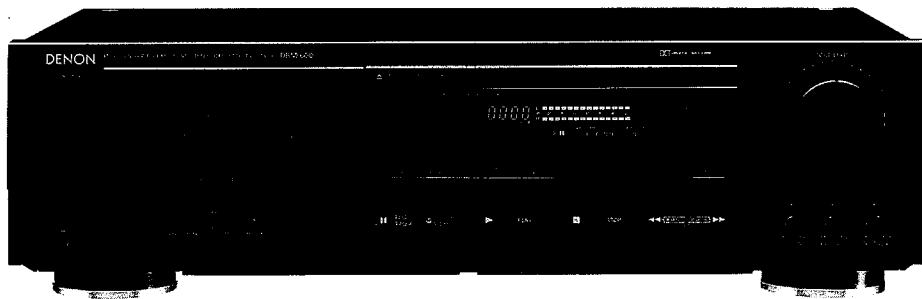

As we have found errors on page 24 and 25 of the service manual (Exploded view of mechanism unit) previously published, please correct it on the reverse side:

### NIPPON COLUMBIA CO., LTD.

## CORRECTION

### PARTS LIST OF MECHANISM UNIT

Ref. No.	Part No.	Part Name	Remarks
⊙ 1		CHASSIS BLK	
2	9DF 5170 49	IDLER BLK	
3	9DF 5252 57	MOTOR MAIN BLK	
4	9DF 6121 56	CHASSIS BASE BLK	
5	9DF 6230 37	REEL BASE BLK	
6	9DF 6230 37	REEL BASE BLK	
7	9DF 7652 63	SOLENOID BLK	
8	9DF L39K 12	PLUNGER	
9	9DF L39H 12A	IRON CORE	
10	9DF J111 17	1.7 × 0.25 WASHER	
11	9DU J12V 11	2.1 × 0.25 WASHER	POLY
12	9DF 5135 39	PLATE HEAD BLK	with HEAD
13	9DF C52E 43	HEAD BASE	
14	9DF D45T 12	HEAD SPACER	
15	9DF U192 11	ERASE HEAD	
16	9DF U18K 12	R/P HEAD	
17	9DF K21U 11	AZIMUTH SPRING	
18	9DF 5642 80	MOTOR REEL BLK	
⊙ 19	9DF 5672 97	CONTROL PWB BLK	
⊙ 20	9DF 5730 97	PLATE HOLD BLK	
21	9DU E16E 11	PUSH SWITCH	
22	9DF C39M 63	EJECT STOPPER	
23	9DF C52H 12	CASSETTE SPRING	
24	9DF D45G 12	PLAY ARM	
25	9DF D45B 13	CAM GEAR	
26	9DF D44T 13	REC SENSER ARM	
27	9DF D44W 12	PACK SENSER ARM	
28	9DF D44U 12	METAL SENSER ARM	
29	9DF F17W 21	MAIN BELT	
30	9DF J111 30	2.6 × 0.25 WASHER	POLY
31	9DF J111 14	2.6 × 0.5 WASHER	POLY
32	9DU G13U 15	E RING	
33	9DF K28L 15	EJECT LOCK SPRING	
34	9DF K28R 11	SLIDE SPRING	
35	9DF R22H 11	FLY WHEEL (FWD)	
36	9DF R20L 21A	PINCH ROLLER (R)	
⊙ 37	9DF C52N 11	BRACKET (L)	
⊙ 38	9DF C52R 11	BRACKET (R)	
39	9DF P472 13		
⊙ 40	9DF C52S 31		
41	9DF K20S 13	DOOR SPRING	
42	9DF D29U 11	DOOR FRAME	
⊙ 43		HOLDER CUSHION	
44	9DF G114 14	2.6 × 5 CPS(W)	
45	9DF G156 11A	2.6 × 6 CPS	
46	9DU G14M 21		
47	9DF K23R 11	SPRING	
48	9DU G12R 11	SCREW	
49	9DK G194 28	2.6 × 4 CPTS (S)	
50	9DU G15S 11	3 × 8 FRANGE SCREW	
51	9DW H51V 05	WIRE CONNECTOR (E)	
52	9DW H51U 05	WIRE CONNECTOR (R/P)	
53	9DF G137 18	F LOCK 2.0 × 9 ZN	
54	9DF K26N 14	HB SPRING	
56	9DU G12H 16	WAVE 3.0 × 8 ZN	
57	9DA Z15S 00	GP2S04B	
⊙ 59	9DF 6840 53	DRESSING BLK	
60	9DU G12T 11	2.6 × 12 CPT(S)	

### PARTS LIST OF PACKING & ACCESSORIES

Ref. No.	Part No.	Part Name	Remarks
	203 2223 002	2P PIN CORD	
	203 2227 008	2P MINI PLUG CORD	
	511 1869 009	INST MANUAL (E2)	Except U.S.A.
	511 1870 001	SPANISH INST MANUAL	Europe only
	511 1871 000	INST. MANUAL	U.S.A. only
	515 0443 004	TAPE CATALOG	Canada only
	505 0131 050	CABINET COVER	
	504 0092 060	STYLEN PAPER	
	503 0704 106	PACKING ASS'Y	
	501 1277 160	CARTON CASE	
	515 0455 005	TAPE CATALOG (E2)	
	513 1349 004	THERMAL CARBON FILM	
	203 3667 007	PLUG ADAPTER	Asia only
	513 9111 001	COLOR LABEL (GOLD)	Europe (Gold)
	515 0439 102	SAFETY INSTRUCTION	U.S.A. only
	515 0418 301	DAI WARRANTY HOME	U.S.A. only
	515 0388 004	DCI WARRANTY	Canada
	515 8030 008	PRESET LABEL	Asia only
	515 8040 001	CAUTION SHEET	Asia only

- Part indicated with the mark "⊙" are not always in stock and possibly to take a long period of time for supplying, or in some case supplying of part may be refused.

EXPLODED VIEW OF MECHANISM UNIT

CORRECTION

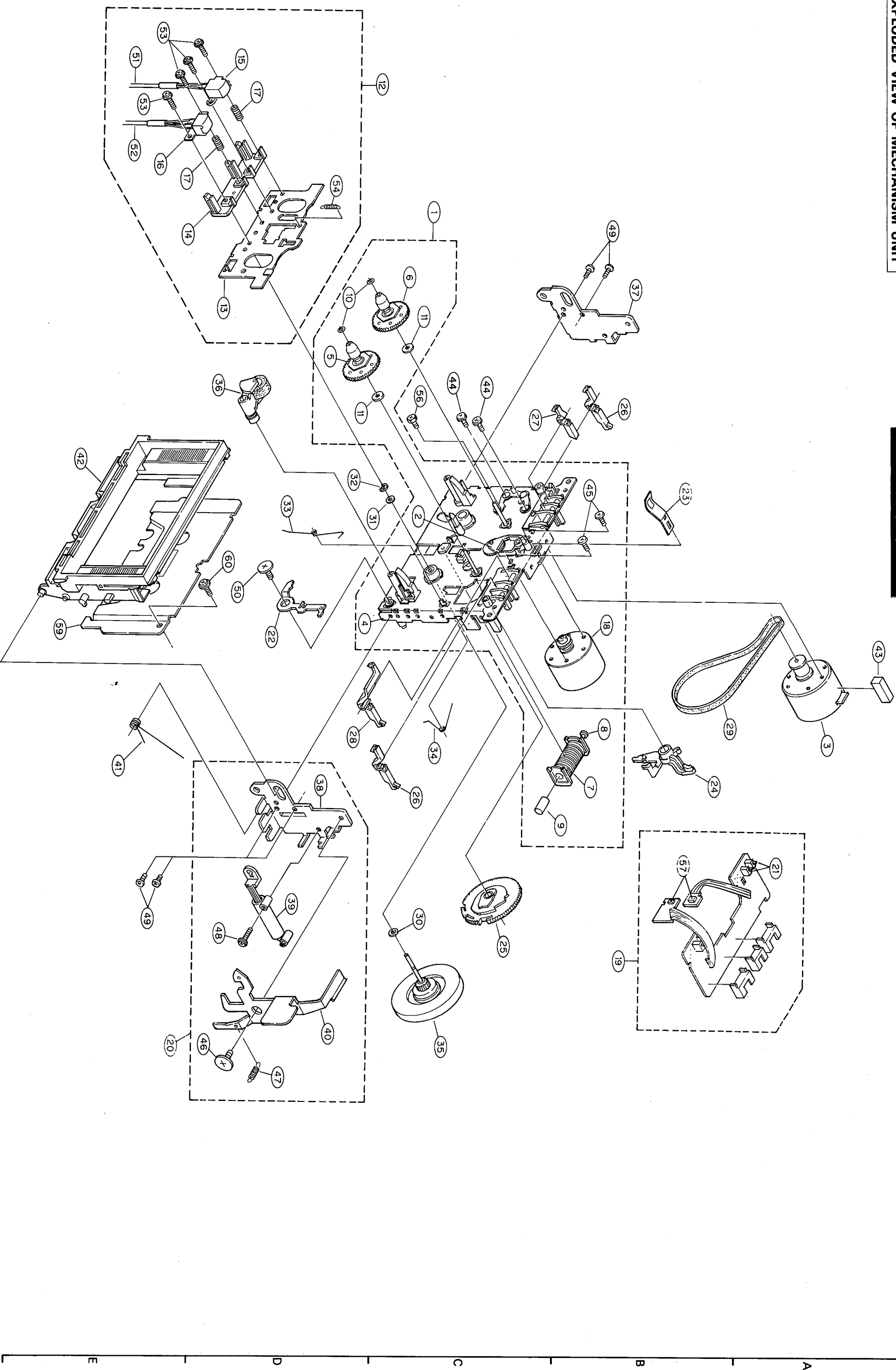



## MUSIC SEARCH SYSTEM

---

This device is a convenient system which detects the non-recorded part of more than 4 seconds between melodies, cues the next melody while the present melody is being reproduced or automatically detects the beginning of the melody now being reproduced and makes it into the reproducible state.

1. For cueing the next melody while the present melody is being reproduced:  
At PLAY mode, depress the "▶" PLAY button and the "▶▶" FF button simultaneously. This device will detect the interval between melodies with the CUE state on, automatically assume the PLAY mode and begin performing the next melody.
2. For hearing again the melody being reproduced:  
At PLAY mode, depress the "▶" PLAY button and the "◀◀" REW button simultaneously. This device will detect the interval between melodies with the REVIEW state on, automatically assume the PLAY mode, detect the beginning of the melody being performed and play it from the beginning again.

MUSIC SEARCH is a function which operates by detecting a comparatively long non-recorded part on the tape. Therefore, MUSIC SEARCH may not operate normally in the following cases.

- Sound on the tape is interrupted by speech or conversation.
- Long periods of pianissimo (softly played music) or non-recorded intervals occur on the tape.
- The tape has picked up noise in a non-recorded interval.
- Non-recorded intervals on the tape are less than 4 seconds in length.
- Noise-emitting electrical appliances are in operation nearby. i.e.; Electric razors, drills, refrigerators, etc.

## DOLBY C NOISE REDUCTION SYSTEM

---

- The Dolby noise reduction system substantially reduces the tape background noise (hiss) inherent in the cassette medium. Dolby B NR is most widely in use. However, Dolby C NR is a much more recent development and represents a significantly improvements over Dolby B NR.
- Tape background noise consists primarily of high frequency information which is particularly annoying during soft passages. The Dolby NR system increase the level of low volume mid and high frequency signal during recording and reduces the level of these signals by an identical amount during playback. As a result, the playback signal is identical to the original source signal, but the level of background noise generated by the tape is greatly reduced.

- The operating principle of Dolby C NR is similar to that of B except for the encoding/decoding response curves. The noise reduction effect obtained by Dolby C NR is up to 20dB, compared to 10dB with Dolby B NR. In addition, Dolby C NR uses an antisaturation network and spectral skewing circuitry, and significantly improves the dynamic range in the mid to high frequencies.

## DOLBY HX-PRO HEADROOM EXTENSION SYSTEM

---

This deck is equipped with the DOLBY HX-PRO headroom extension system. Since the system functions automatically during recording, no switching operation or adjustment is required. The system is effective with any type of Normal, CrO<sub>2</sub> or Metal tapes.

The Dolby HX-PRO headroom extension system functions during recording to lift up the saturation level in the treble range. Therefore, most of the treble range components distorted or lost during recording on conventional cassette decks are more faithfully recorded on the new DRM-600 cassette deck.

### Features of the DOLBY HX-PRO headroom extension system

- (1) Performance of Normal and CrO<sub>2</sub> tapes can be upgraded closer to that of Metal tapes.
- (2) The dynamic range in the treble is improved significantly.
- (3) Since no decoding in playback is necessary, the improvement can be obviously heard on any hi-fi playback system including portable components and car systems.
- (4) The system functions whether the Dolby B/C NR is engaged or not.

## MAINTENANCE

### ■ Removing the cassette compartment cover

It will be more convenient if the cassette compartment cover is removed during the cleaning of the pinchroller and heads, or during demagnetizing of heads.

Follow these procedures :

1. Press the EJECT button to open the cassette compartment.
2. Hold only the cover of the cassette compartment and pull it up. The compartment cover is removed from the front.

When attaching the cassette compartment cover, reverse the above procedure.

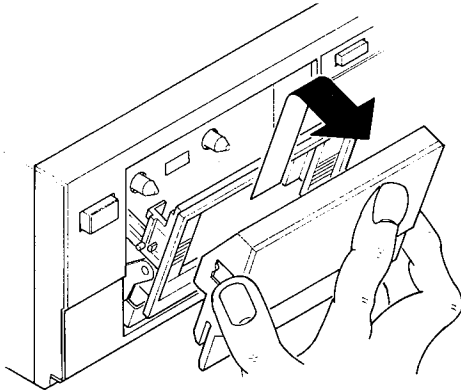

### ■ Head Cleaning

After long usage, tape coating or dust may adhere to the heads causing deterioration of sound. Clean them regularly. Use a cotton swab moistened with cleaning solution (such as alcohol).

#### Note :

1. Some cleaning cassettes on the market have a strong abrasive effect and scratch the heads. Use cotton swabs instead of cleaning cassettes.
2. Since the use of metal tapes is apt to collect more dust on the heads, clean the heads more often to enjoy optimum sound.

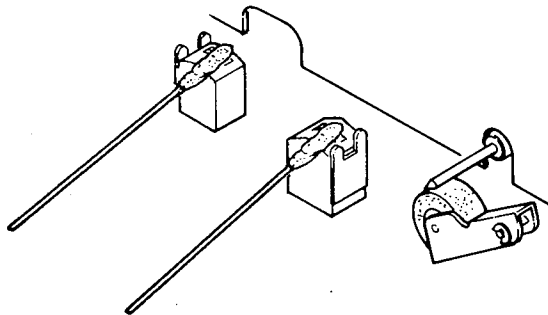

### ■ Cleaning the pinchroller and the capstan

If the pinchroller or the capstan accumulate dust, tape transport may become unstable resulting from slippage during recording or playback. The tape can also be damaged by being rolled up around the capstan. Clean them with a cotton swab or a soft cloth moistened with cleaning solution (such as alcohol).

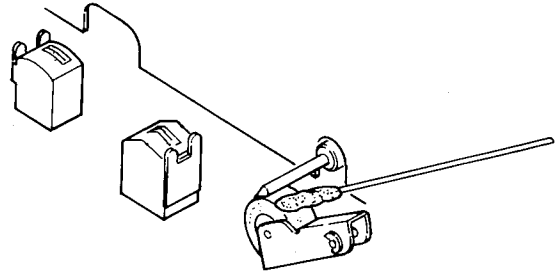

### ■ Demagnetizing the heads

The heads may become magnetized after long usage or by having a strongly magnetized object brought near them. The result is a generation of noise, loss of the high frequency range, or erasing the treble components of pre-recorded tapes and adding noise. Demagnetize the heads on a regular basis.

#### ■ Procedure

1. Be sure to turn "off" the power supply.
2. Turn the demagnetizer "on" while it is more than 30cm away from the heads. Bring the demagnetizer near the heads and slowly move it in a small circle four or five times.
3. Slowly move the demagnetizer away from the heads and turn "off" the power of the demagnetizer when it is about 30cm away from the heads.

## SYMPTOMS OFTEN MISTAKEN AS BREAKDOWNS

Make sure of the followings before you consider as any malfunctions:

1. Are all the connections correct?
2. Is the set being operated correctly in accordance with the operating instructions?
3. Are the speakers and amplifiers functioning correctly?

If the tape deck still does not function properly, check it again, using the check list below. If the symptom does not correspond to the check list, please contact your DENON dealer.

Symptom	Cause	Remedy
Tape does not run	Power cord is off. Tape is loose. Cassette is not loaded properly. Defective cassette.	Check power cord. Tighten tape with pencil, etc. Load cassette properly. Replace cassette.
Tape is not recorded when recording button is pressed.	No cassette is loaded. Erase prevention tab is broken off.	Load cassette. Cover hole with plastic tape.
Sound is warbled or distorted.	Heads, capstan or pinchroller are contaminated. Tape is wound too tight. Recording input level is too high. Tape is worn out and has "drop-outs".	Clean them. Fast forward or rewind to loosen tape winding. Adjust recording input level. Replace tape.
Excessive noise.	Tape is worn. Heads, capstan or pinchroller are contaminated. Heads are magnetized. Recording input level is too low.	Replace tape. Clean them. Demagnetize heads. Adjust recording input level.
High frequency (treble) is emphasized.	Dolby NR button is set improperly.	Set Dolby NR button properly.
High frequency (treble) is lost.	Heads are contaminated. Tape is worn.	Clean them. Replace tape.
When a CrO <sub>2</sub> or metal tape is placed in the deck, a different tape indicator comes on.	The cassette housing is of an older design without tape type detection holes.	Use the latest cassettes with tape type detection holes.
The cassette tape cannot be removed.	If the power switch is turned off in either the recording or playback mode, and the unit is stopped, there may be cases when the cassette cannot be removed, even if the EJECT button is pressed.	Turn the power switch ON again. Then, press the EJECT button to remove the cassette tape.

## SPECIFICATIONS

- Type ..... Vertical tape loading 4-track 2-channel stereo cassette deck
- Heads ..... Record/Playback (Amorphous R/P head) × 1  
Erase head (Double gap ferrite) × 1
- Motors ..... Capstan (DC servo motor) × 1  
Reel (DC motor) × 1
- Tape Speed ..... 4.8 cm/sec.
- Fast forward, rewind time ..... Approx. 110 sec. with a C-60 cassette
- Recording bias ..... Approx. 105 kHz
- Overall S/N ratio (at 3% THD level) .. Dolby C NR on ... more than 74 dB (CCIR/ARM)
- Overall frequency response ..... 20~20,000 Hz ±3 dB (at -20 dB METAL tape)
- Channel separation .. more than 40 dB (at 1 kHz)
- Wow & flutter ..... 0.055% wrms, 0.14% w. peak
- Inputs  
line ..... 80 mV (-20 dBm) input level at maximum  
Input impedance : 50 kohm unbalanced

- Outputs  
line ..... 620 mV (0 dB) output level at maximum (with 47 kohm load, recorded level of 200 pwb/mm)
- headhone ..... 1.2 mW output level at maximum (optimum load impedance 8 ohm~1.2 kohm)
- Accessories ..... Parallel pin cord × 2  
Mini-plug cable × 1
- Power supply ..... 50 Hz/60 Hz compatible, voltage is shown on rating label
- Power consumption .. 18 W
- Dimensions ..... 434(17-3/32") (W) × 125(4-28/32") (H) × 275(10-53/64") (D) mm
- Weight ..... 3.8 kg

■ Above specifications and design styling are subject to change for improvement.

■ Dolby noise reduction and HX PRO headroom extension manufactured under license from Dolby Laboratories Licensing Corporation. HX PRO originated by Bang and Olufsen. "Dolby", the double-D symbol and "HX PRO" are trademarks of Dolby Laboratories Licensing Corporation.

Best results will be obtained with use of DENON DX and HD Series cassette tapes.

**BLOCK DIAGRAM**

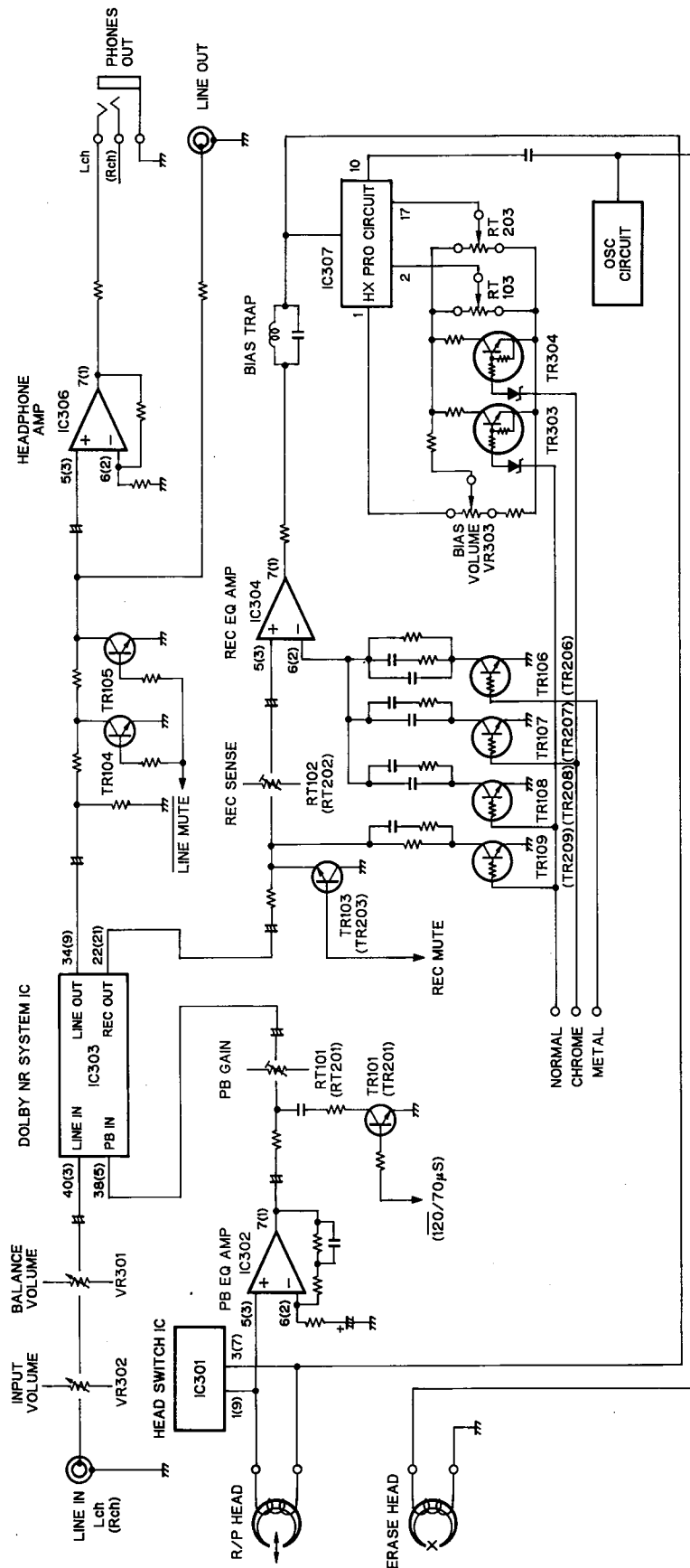



# LEVEL DIAGRAM

## PLAYBACK SYSTEM

TCC-130 DOLBY B-TYPE  
400 Hz 200 nwb/m

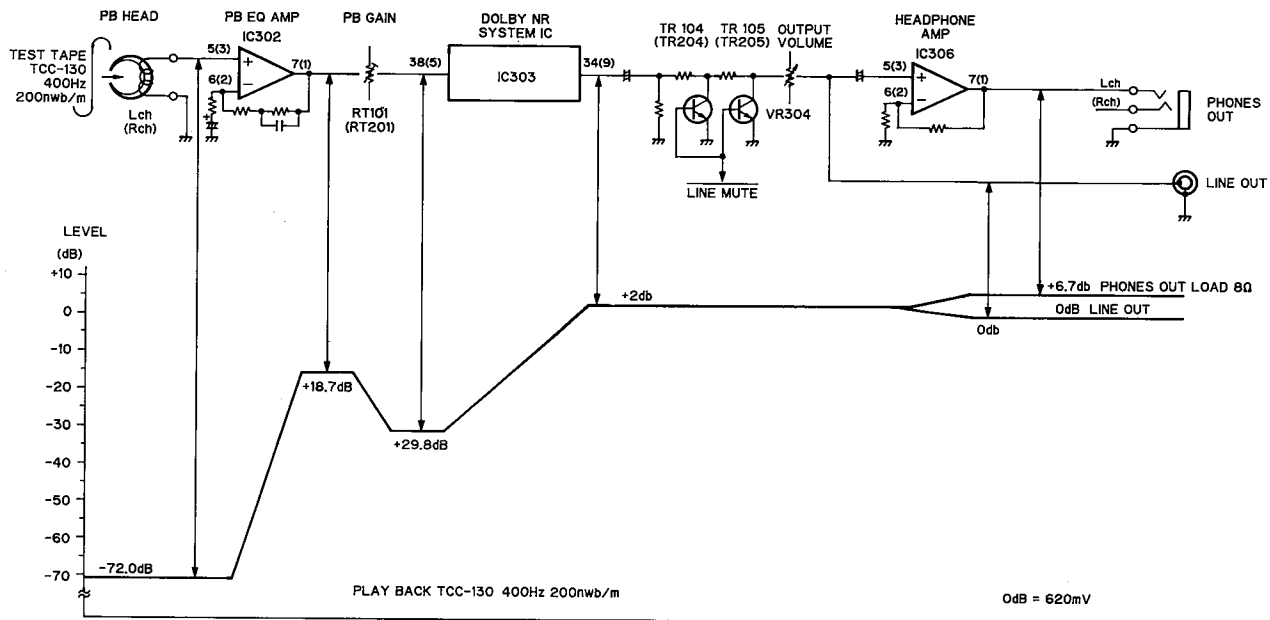

## RECORDING SYSTEM

INPUT FREQUENCY  
400 Hz

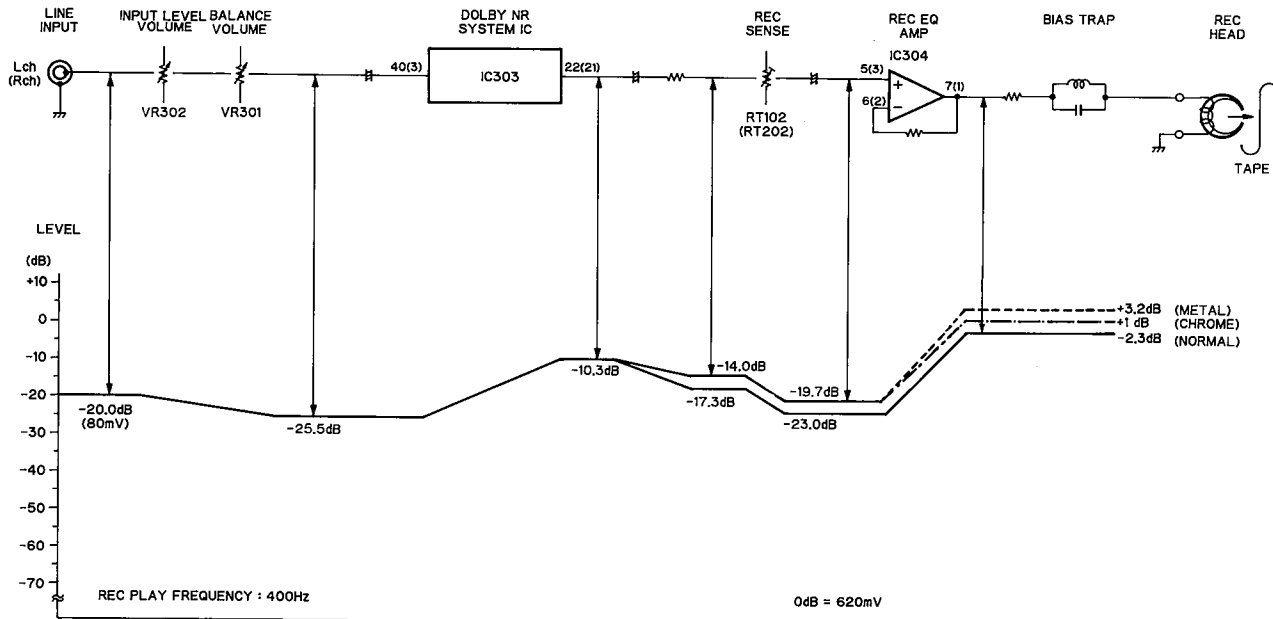

## DISASSEMBLY INSTRUCTIONS

### 1. How to Remove the Front Panel

- Remove the two screws (51) (3 × 10 CBTS(P)BK) from the upper surface of the top cover (25) and take off this top cover while lifting its rear part.
- Press the eject button (19), open the cassette window (26) and take off the mechanism, as shown in the diagram.  
**Note:** Be careful when handling the cassette window, as it is easily scratched.
- The front panel (24) can be removed, pulling it forward, by unscrewing the five upper screws (3 × 10 CBTS · P tight) (51) and the two upper screws (3 × 6 CBTS · S tight) (53) as well as loosening the five top hooks and the three bottom hooks.

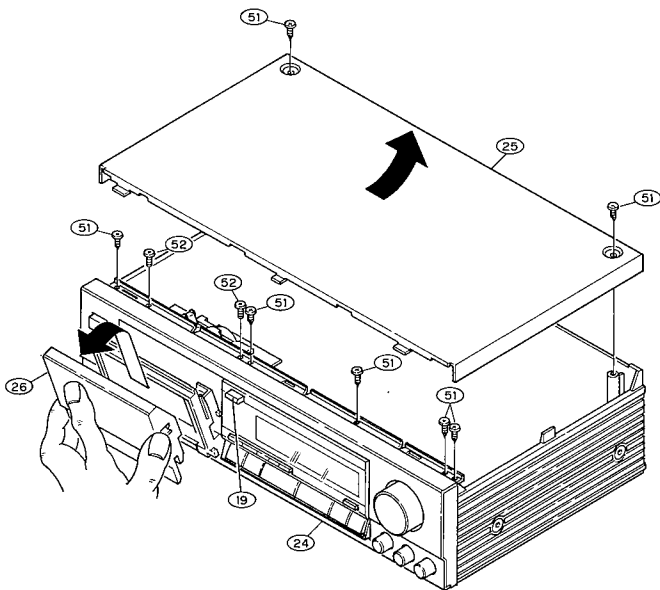

The five top hooks of the front panel

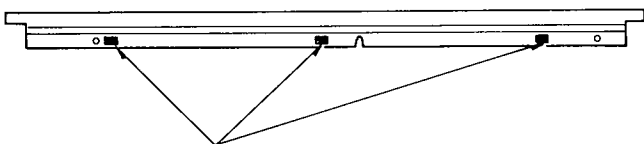
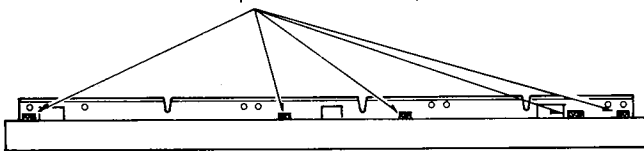

The three bottom hooks of the front panel

### 2. How to Remove the Mechanisms

- Remove the top cover (25) and the front panel (24). (Refer to section 1).
- Unscrew one mechanism holding screw (55) (special screw) and one screw (3 × 6 CBTS · S tight) (53).
- Remove the connectors with lead wires, which run from the mechanism section, from the audio circuit board, and remove the connectors with lead wires, which run from the audio circuit board, from the mechanism section.

Mechanism side		Audio circuit board side
W301	———— (5P) ————>	CN301
W302	———— (3P) ————>	CN302
CN151	<———— (6P) ————	W151
CN152	<———— (5P) ————	W152
CN153	<———— (4P) ————	W153

**Note:** When assembling, check to make sure that the connectors are inserted correctly.

- Lift up the mechanism in order to remove it.

**Note:** When assembling, do so after checking to make sure that the stays on the lower part of the mechanism fit perfectly between the projections of the chassis and that the wires are not interposed between the mechanism and the chassis.

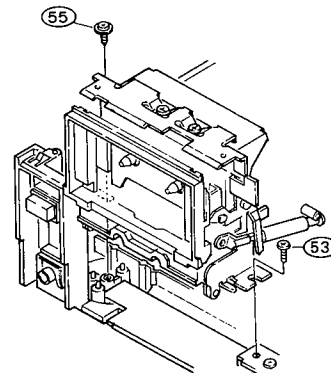

### 3. How to Remove the Front Esc Ass'y

- Remove the top cover (25) and the front panel (24). (Refer to section 1).
- Remove the connectors with lead wires, which run from the front esc ass'y (16), from the audio circuit board.

Front esc ass'y side		Audio circuit board side
W131	———— 4P ————>	CN131
W121	———— 5P ————>	CN121
W133	———— 8P (WHITE) ————>	CN133
W134	———— 8P (RED) ————>	CN134
W135	———— 6P ————>	CN135

- When removing the three front esc hooks from the bottom part of the chassis, the front esc ass'y (16) comes off in the forward direction.

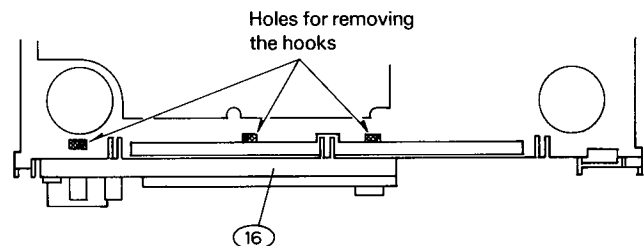

#### 4. How to Remove the Meter Circuit Board

- (1) Remove the top cover (25). (Refer to section 1).
- (2) Remove the single retaining screw ( $3 \times 8$  CBTS·S tight) (53) from the shield bracket (60) and detach the shield bracket.
- (3) If you remove the three binding screws ( $3 \times 10$  CBTS·P tight) (51) of the meter circuit board, and loosening the two hooks (large), the meter circuit board can be taken off.

**Note:** When replacing the tact switch, check to make sure that it is not floating above the circuit board. If it is floating, the switch will be in the on condition when the set is assembled.



#### 5. How to Remove the Audio Circuit Board

- (1) Remove the top cover (25) and the front panel (24). (Refer to section 1).
- (2) Remove the front esc ass'y (16). (Refer to section 3)
- (3) Remove the connectors with lead wires, which run from the mechanism section, from the audio circuit board, and remove the connectors with lead wires, which run from the audio circuit board, from the mechanism section. (Refer to section 2 (3))
- (4) Remove the connector with lead wires, which run from the power supply circuit board, from the audio circuit board.

Audio circuit  
board side

Power supply circuit  
board side

CN191 ← 12P → W191

- (5) Remove the screw ( $3 \times 10$  CBTS·P tight) (51) ( $3 \times 8$  CBTS·S tight) (52) that is holding down the 4P pin jack (27) and circuit board (5). By removing the two catches (left and right) of the chassis holding down the circuit board in the directions of the arrows shown below, the audio circuit board can be pulled forward.

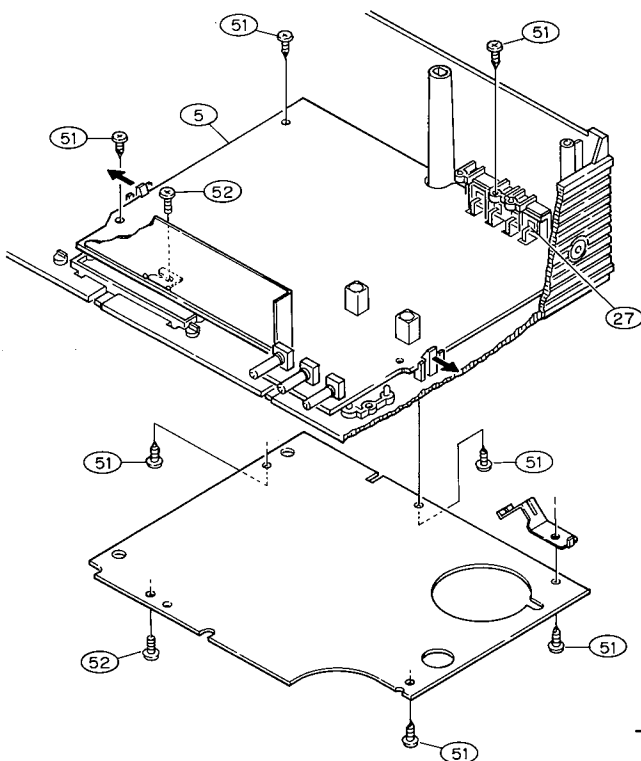

**Note:** ● Almost all of the service repairs to the audio circuit board can be performed by removing the bottom cover on the rear side of the chassis. Only when it is unavoidable should you refer to the removal method mentioned above.

- When reassembling, follow the procedures in the reverse order. However, if each of the various parts are not assembled properly in their respective position, the set cannot be assembled in some cases. Therefore, check the work of each step carefully when assembling.

#### 6. How to Remove the Power Supply Circuit Board

- (1) Remove the top cover (25) and the front panel (24). (Refer to section 1).
- (2) Pull the power switch lever (23) from out of the power supply switch.
- (3) Remove the connector with lead wires, which run from the power supply circuit board, from the audio circuit board. (Refer to section 5 (4))
- (4) Remove the bushing (7) that is fixing the power supply cord from the chassis (1).
- (5) When the four screws ( $4 \times 10$  CBTS·P tight) (54) ( $3 \times 10$  CBTS·P tight) (51) that are holding the power transformer and circuit board are removed, the power supply circuit board can be removed by raising it.

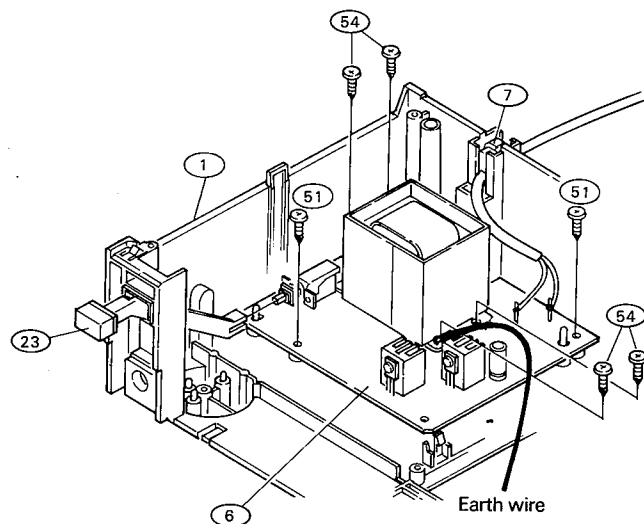

## ADJUSTING AND CHECKING THE MECHANISM SECTION

### 1. Replacing the Pinch Roller (36)

Before replacing the pinch roller, clean the tape contact surface of the pinch roller and the capstan shaft.

Most causes of poor tape transport can be traced to dirty pinch roller and capstan shaft.

#### (1) Removing the Door Frame (42)

Remove the door spring (41) from the protrusion on the door frame (42). Remove the two securing screws in the bracket (L) (37). Detach the bumper (39) from the door frame protrusion, and then remove the door frame.

#### (2) Removing the pinch roller (36)

Remove the clips that press the pinch roller and pull the pinch roller forward to remove it.

After replacing, run a padless C-90 tape to check for tape curls at the tape guide section of the head.

### 2. Checking the Pressure Force of the Pinch Roller

In the playback mode, hook a spring weight onto the bracket at the center of the pinch roller. After separating the pinch roller from the capstan shaft, allow the pinch roller to contact the capstan shaft again. Check to make sure the spring weight reads between 250 ~ 350 g when the pinch roller starts to rotate.

Replace the pinch roller (36) when it does not conform to the standard specification values.

### 3. Replacing the Record/Playback Head (16)

#### (1) How to remove the R/P HEAD.

- 1) Remove securing screw (53) and azimuth adjusting screw (53) from the record/playback head.
- 2) Remove the soldered head wire and disassemble the mechanical unit to remove the record/playback head.

#### (2) How to assemble the R/P HEAD.

Reverse the above 1 procedures for removing the R/P HEAD.

\* Solder the HEAD WIRE according to the diagram.

### 4. Adjusting the R/P HEAD (16)

Azimuth adjustments

Playback the A-BEX TCC-153 test tape. Turn the azimuth adjustment screw and adjust so that A of the surge waveform is maximum and B is minimum.

\* After the adjustments, apply anaerobic adhesive on the positions indicated in the diagram.

**Note:** Only the azimuth adjustment is necessary; no height adjustments are required.

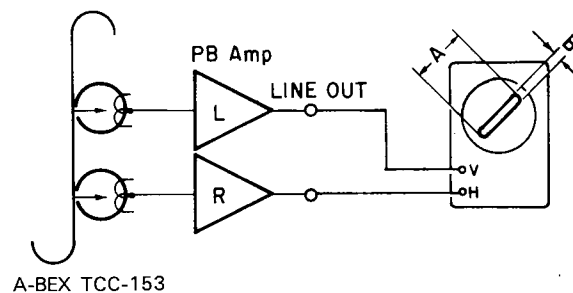
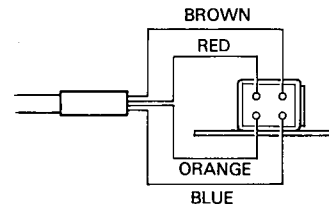
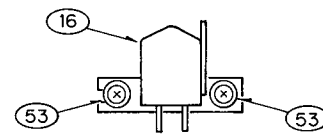
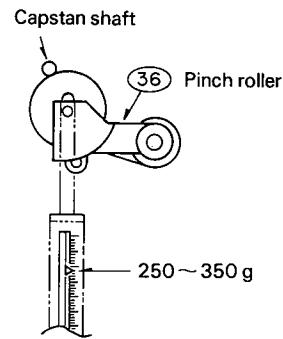

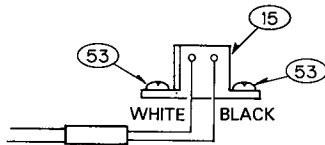
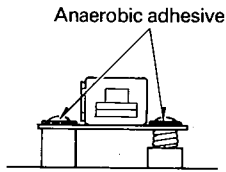

## ADJUSTING THE ELECTRICAL SECTIONS

### • Measuring instruments necessary for adjustments

- (1) Audio signal generator
- (2) Variable resistance attenuator
- (3) Electronic voltmeter
- (4) Oscilloscope
- (5) Frequency counter
- (6) Adjustment screwdriver
- (7) Trap coil adjustment square stick
- (8) Test tapes (SONY TY-224)  
(A-BEX TCC-130, TCC-153, TCC-262B/162B)  
(DENON HD7E/60)
- (9) Transport Check cassette tape (A-BEX TCC-902)

### • Caution on adjusting

- (1) Before adjusting, clean the head surface, capstan and the pinch roller with a gauze or a cotton swab moistened with alcohol.
- (2) Demagnetize the R/P HEAD and the E. HEAD with a head eraser.
- (3) Completely demagnetize the adjustment screwdriver.
- (4) Unless instructed otherwise, set the various controls as follows:
  - INPUT/OUTPUT volume..... maximum
  - DOLBY NR button..... OFF
  - BIAS FINE volume..... Center click position
  - BALANCE volume..... Center click position

## 5. Replacing the ERASE HEAD (15)

- (1) Unscrew the erase head holding screws (53).
- (2) By unsoldering the HEAD WIRES can be taken off the mechanism unit.
- (3) When the replacement is completed, secure the screws with the screw lock.

## 6. Checking the Take-up Torque

Load the cassette type torque meter (SONY TW2111). Check to make sure that the average torque meter reading is within 30-70 g-cm during playback. If it is not within this range, check the voltage (approx. 4V) of the reel motor. After the verification, replace the reel motor (18) if there is no problem with the voltage value.

## 7. Checking the FF and REW Torques

Load the cassette type torque meter (SONY TW2231). Check to make sure the torque meter indicates within 90~180 g-cm at the end of FF and REW.

## 8. Checking the Back Tension Torque During Record/Playback

Load the cassette type torque meter (SONY TW2111); check to make sure the torque meter reads between 2~6 g-cm during playback and that there is no unevenness. If it is not within this range, replace the reel base blk (6).

## 9. Checking the FF and REW Times

Load a C-60 cassette tape (DENON HD7E/60); check to make sure the tape is fast forwarded or rewound within 110 seconds. If it is not within this range, check sections 6 and 8.

## 10. Checking the Operation of the Erase Prevention, Metal and Chrome Switch

Confirm that the sensor arm properly detecting the tape type detection holes on the cassette housing.

## 1. Tape Transport Check

Load the transport check cassette. In the operational mode, illuminate the fixing guides of the R/P HEAD with a lamp and check to make sure the tape edge does not come in contact with the tape guide section.

The tape transport is the most important element in determining the performance of a cassette deck.

Avoid moving the various adjustment screws, nuts, etc., as much as possible. Refer to the pages on "Adjusting and Checking the Mechanism Section" when replacing or adjusting the R/P HEAD.

## 2. Adjusting the Azimuth

- (1) After completing the tape transport check, load the test tape (A-BEX TCC-153).
- (2) Playback the test tape; adjust the azimuth screw so that section A of the resurge wave form is maximum and section B is minimum.

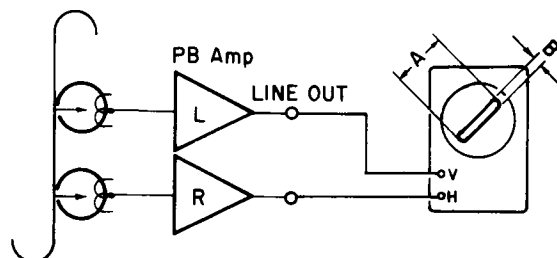

A-BEX TCC-153

### 3. Checking and Adjusting the Tape Speed

- (1) Connect the frequency counter to the LINE OUT terminal and load test tape (SONY TY-224).
- (2) Playback a test tape. At about halfway through the tape, where the tape transport is stable, adjust the adjustment points on the back of the capstan motor so that the frequency counter will have a reading within the range of 3,000 Hz  $\pm 6$  Hz.

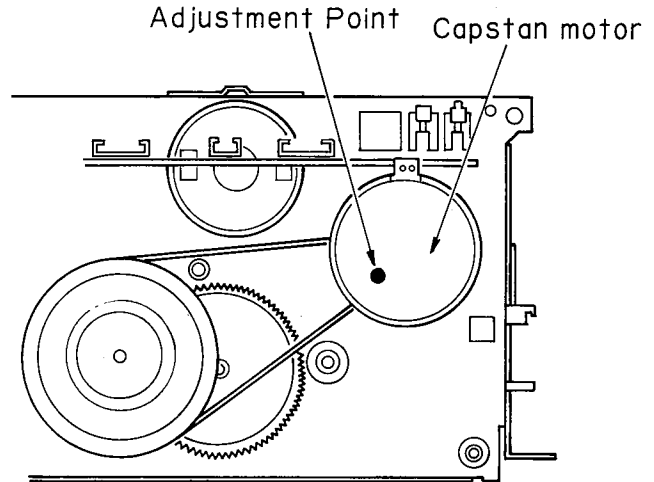
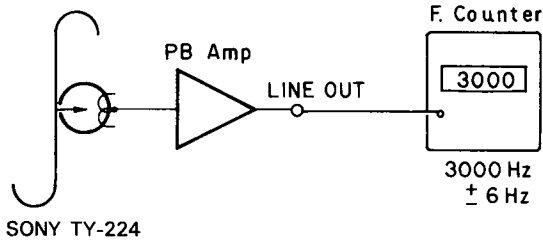

### 4. Adjusting the Playback Section

- (1) Adjusting the playback level  
Playback the Dolby standard level test tape (A-BEX TCC-130) and adjust RT-101 (L ch), RT-201 (R ch) so that the LINE OUT voltage becomes  $-2$  dB (620 mV).

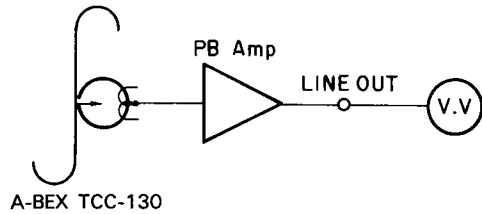

- (2) Adjusting the playback frequency response  
Playback the test tape (A-BEX TCC-262B/162B) and check to make sure that the frequency response meets the specifications in the diagram.

**Note:** Before checking the playback frequency response, first adjust the azimuth using the 8 kHz signal at the beginning of the test tape (A-BEX TCC-262B). Also, after checking the playback frequency, make sure to readjust the azimuth with the test tape (A-BEX TCC-153) and then lock the adjustment screw.

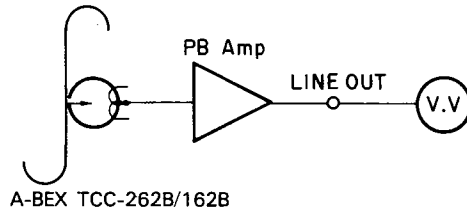

**Playback Frequency Response**

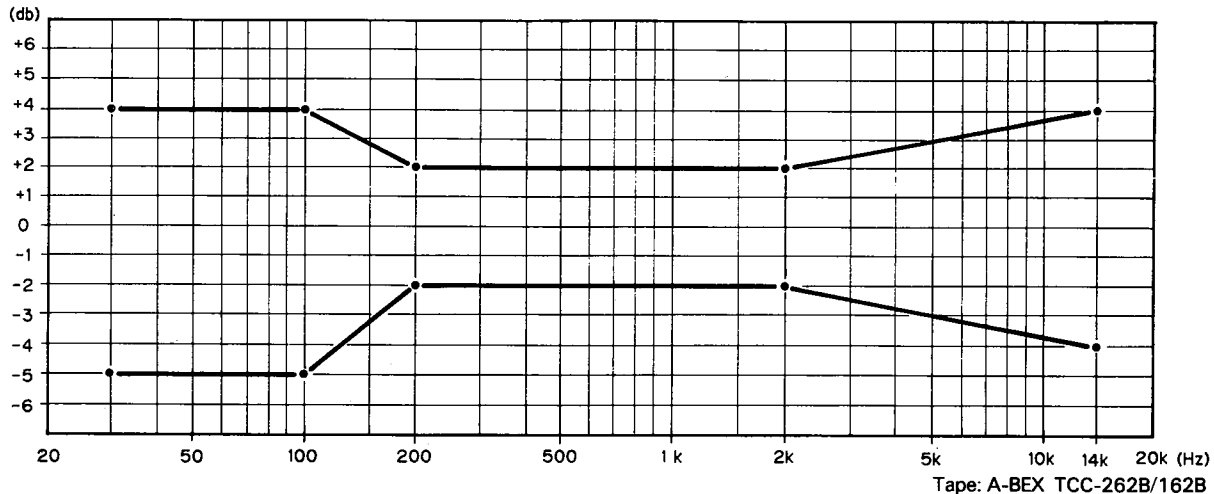

## 5. Adjusting the Recording Section

### (1) Adjusting the record/playback overall frequency response. (CrO<sub>2</sub>)

- 1) Load the test tape HD7E/60, record a signal with an input level of  $-40$  dB, 1 kHz at the LINE IN terminal; playback this recording.
- 2) Change the frequency of the input signal to 10 kHz, record and playback; adjust RT-103 (L ch), RT-203 (R ch) so that the characteristic standards meet the following diagram when compared to the 1 kHz signal output level.

(The other TAPE POSITIONS will automatically be adjusted by finishing of the foregoing adjustments.)

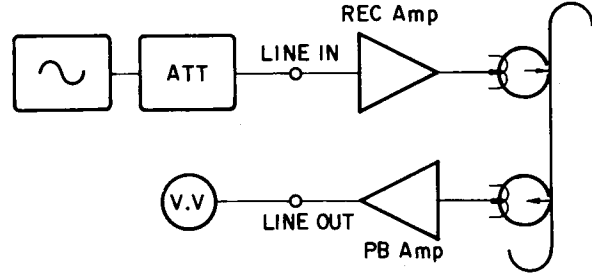

### Record/Playback Overall Frequency Response

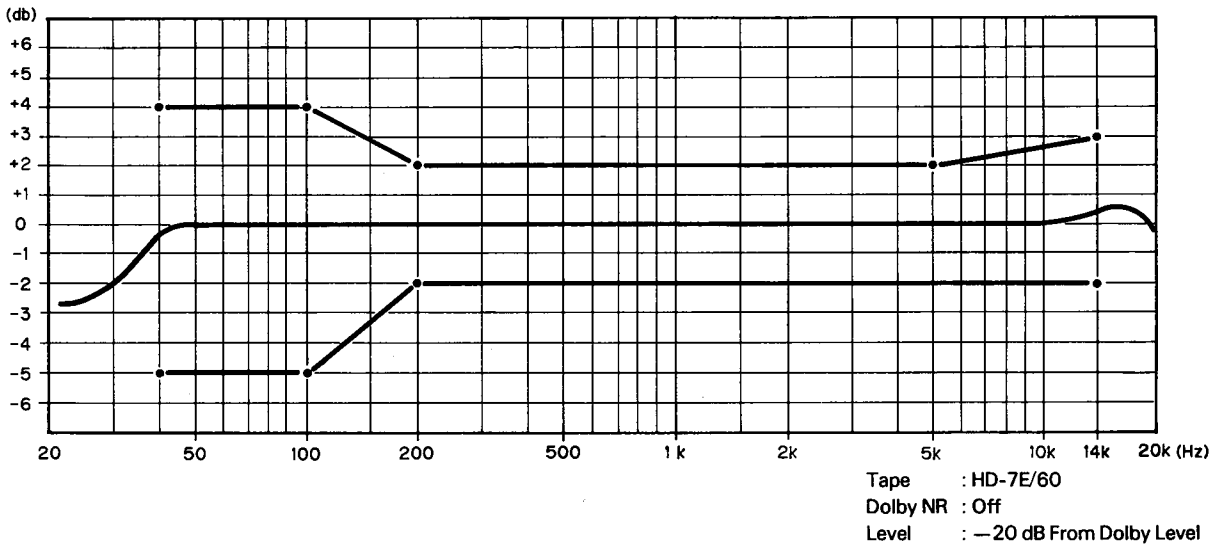

### (2) Adjusting the record/playback levels (CrO<sub>2</sub>)

- 1) Load a HD7E/60 tape and after having recorded a signal of 1 kHz ( $-20$  dB), play it back.
- 2) Adjust RT-102 (L ch) and RT-202 (R ch) so that the output from the line out terminal has the same value as the output when monitoring the recording.

### (3) Checking the Dolby C record/playback overall frequency response

- 1) Set the DOLBY NR switch to the "C" position.
- 2) Using the test tapes HD7E/60, perform record/playback in the same manner as 5-(1).
- 3) Check to make sure that the record/playback overall frequency response meets the specifications in the diagram.

### Dolby C Record/Playback Overall Frequency Response

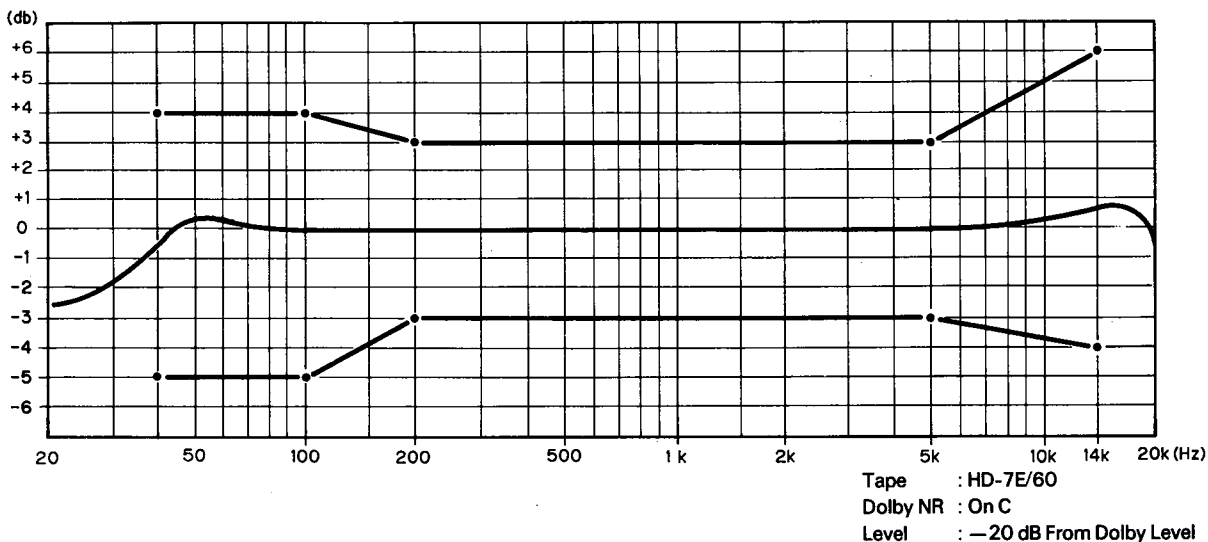

## PARTS LIST OF 4U-1875 AUDIO METER UNIT

Ref. No.	Part No.	Part Name	Remarks
<b>SEMICONDUCTOR GROUP</b>			
IC301	263 0590 001	$\mu$ PC1330HA	
IC302	263 0317 006	M-5220P	
IC303	263 0455 007	CX20187	
IC304, 306 308	263 0257 001	M-5218P	
IC307	263 0354 001	$\mu$ PC1297CA	
IC501	262 1212 000	$\mu$ PD75206CW-000	
IC502	262 0447 009	BA6109U1	
IC601	263 0591 000	HA12067NT	
TR101, 201	273 0178 022	2SC1740 (R/S)	
TR102, 202	269 0062 906	DTC124ES (22K-22K)	
TR103, 203 309, 310	273 0245 023	2SC2603 E/F	
TR104, 204 105, 205	273 0253 918	2SC2878 (A/B)	
TR106~ 109, 206 ~209	269 0074 907	DTC114TS (10K)	
TR305, 306 315	269 0020 906	DTC114ES (10K-10K)	
TR307, 601	269 0040 902	DTC144ES (47K-47K)	
TR308	272 0025 004	2SB562 (C)	
TR502, 510 511	274 0036 002	2SD468 (C)	
TR503	269 0015 908	DTC124XS (22K-47K)	
TR505, 506	269 0099 908	DTC143TS (4.7K)	
TR509	271 0183 927	2SA933 (R/S)	
D301, 302 501, 502 523~527 601, 602 604~613 618, 620 622, 623 625	276 0432 000	ISS270A	
D303, 304 305	276 0468 919	HZS9B-2	
D307	276 0553 905	ISR35-200A (T93X)	
D503, 509	276 0519 907	ISR35-200AT82	
D507	276 0465 912	HZS7B-2	
D508	276 0457 904	HZS4C-1	
<b>RESISTOR GROUP</b>			
R361	244 2036 012	RD14B2H3R9JFRF	3.9 $\Omega$ 1/2 W
R362, 363	244 2033 031	RS14B2E220JFRF	22 $\Omega$ 1/4 W
R509	241 2315 019	RD14B2E100GFRF	10 $\Omega$ 1/4 W
R511	244 0026 024	RS14B3A560JNBF	56 $\Omega$ 1 W
VR301	211 0571 003	V11V25FZ254K	BALANCE
VR302	211 0570 004	V14V25FA104R	INPUT
VR303	211 0608 002	V11V25FB102K	BIAS FINE
VR304	211 0611 002	V14V25FA103	OUT PUT
RT102, 202	211 6064 093	V06PB223	REC
RT103, 203 101, 201	211 6064 019	V06PB473	BIAS CAL, P.B

Ref. No.	Part No.	Part Name	Remarks
<b>CAPACITOR GROUP</b>			
C150, 250	253 1055 027	Ceramic CK45B1H821K	820PF 50 V
C101, 201	253 9030 015	CK45=1E152K	0.0015 $\mu$ F 25 V
C116, 125 216, 225 509	253 9031 014	CK45=1E683K	0.068 $\mu$ F 25 V
C123, 223	253 9030 947	CK45=1E472K	0.0047 $\mu$ F 25 V
C127, 227	253 1102 909	CK45B1H151K	150PF 50 V
C129, 229	253 9030 031	CK45=1E332K	0.0033 $\mu$ F 25 V
C131, 231	253 9031 072	CK45=1E392K	0.0039 $\mu$ F 25 V
C133, 233	253 9031 072	CK45=1E392K	0.0039 $\mu$ F 25 V
C142, 242	253 1179 042	CK45B1H221K	220PF 50 V
C151, 251 519	253 9030 060	CK45=1E103K	0.01 $\mu$ F 25 V
C152, 252	253 1055 069	CK45B1H101K	100PF 50 V
C153, 253	253 1107 904	CK45B2H391K	390PF 500 V
C154, 254	253 9030 099	CK45=1E333K	0.033 $\mu$ F 25 V
C155, 255 353, 520	253 9030 086	CK45=1E223K	0.022 $\mu$ F 25 V
C350	253 9031 001	CK45=1E473K	0.047 $\mu$ F 25 V
C352	253 3603 008	CC45SL1H100D	10PF 50 V
C504~507	253 1179 068	CK45B1H331K	330PF 50 V
C511, 512	253 1024 203	CK45F1H103Z	0.01 $\mu$ F 50V



**PARTS LIST OF 4U-1876 POWER SUPPLY**

Ref. No.	Part No.	Part Name	Remarks
		Electrolytic	
C102, 202	254 4250 013	CE04W0J470M	4.7 $\mu$ F 6.3 V
C104, 204	254 3056 014	CE04D1H010MBP	1 $\mu$ F 50 V
C107, 108 207, 208	254 3056 027	CE04D1H2R2MBP	2.2 $\mu$ F 50 V
C110, 122 210,222	254 3055 002	CE04D1V4R7MBP	4.7 $\mu$ F 35 V
C113, 213	254 4260 032	CE04W1HR47M	0.47 $\mu$ F 50 V
C114, 214	254 4228 016	CE04W1HR15M	0.15 $\mu$ F 50 V
C115, 215	254 4260 016	CE04W1HR22M	0.22 $\mu$ F 50 V
C121, 221 305,306 313,359 360	254 4254 006	CE04W1C100M	10 $\mu$ F 16 V
C124, 224 140, 240 601, 602	254 4258 002	CE04W1V4R7M	4.7 $\mu$ F 35 V
C134, 234 302, 303	254 4252 024	CE04W1A470M	47 $\mu$ F 10 V
C160, 260 C310	254 4260 003	CE04W1HOR1M	0.1 $\mu$ F 50 V
C320	254 4252 008	CE04W1A220M	22 $\mu$ F 10 V
C333	254 4256 059	CE04W1E221M	220 $\mu$ F 25 V
C357	254 4256 936	CE04W1E470M	47 $\mu$ F 25 V
C501	254 4256 046	CE04W1E101M	100 $\mu$ F 25 V
C508	254 4260 058	CE04W1H2R2M	2.2 $\mu$ F 50 V
C103, 203	254 4250 071	CE04W0J222MC	2200 $\mu$ F 6.3 V
C106, 120 206, 220	255 1120 097	CQ93M1H562J	0.0056 $\mu$ F 50 V
C111, 211 354	255 1121 041	CQ93M1H153J	0.015 $\mu$ F 50 V
C112, 212	255 1120 055	CQ93M1H272J	0.0027 $\mu$ F 50 V
C126, 226	255 1120 084	CQ93M1H472J	0.0047 $\mu$ F 50 V
C117, 217	255 1120 068	CQ93M1H332J	0.0033 $\mu$ F 50 V
C118, 218	255 1122 008	CQ93M1H473J	0.047 $\mu$ F 50 V
C119, 219	255 1121 009	CQ93M1H682J	0.0068 $\mu$ F 50 V
C351	255 1121 025	CQ93M1H103J	0.01 $\mu$ F 50 V
	255 4079 925	CQ93P2A822J	0.0082 $\mu$ F 100 V

Ref. No.	Part No.	Part Name	Remarks
TR901	263 0656 000	MC7808	
TR902	263 0657 009	MC7908	
TR903	263 0648 005	MC7806C	
TR904	272 0025 004	2SB562 (C)	
TR905	273 0178 925	2SC1740 (R/S)	
TR906	269 0062 906	DTC124ES (22K-22K)	
D901~911	276 0519 907	1SR35-200A	
D912	276 0480 913	HZS22-2TD	
D913	276 0464 913	HZS7A-2TD	
R901	241 0163 001	RD14B2H121J	120 $\Omega$ 1/2 W
C901	253 8010 007	CK45=2GAC103P	0.01 $\mu$ F 400 VAC
C902, 903	254 4256 088	CE04W1E102MC	1000 $\mu$ F 25 V
C904, 905	254 4252 037	CE04W1A101M	100 $\mu$ F 10 V
C906, 907 911	253 9031 014	CK45=1E683K	0.068 $\mu$ F 25 V
C908	254 4256 091	CE04W1E222MC	2200 $\mu$ F 25 V
C909	254 4256 088	CE04W1E102MC	1000 $\mu$ F 25 V
C910	254 4261 057	CE04W0J472M	4700 $\mu$ F 6.3 V
C913	254 4258 086	CE04W1H471MC	470 $\mu$ F 50 V
C914	254 4256 033	CE04W1E470M	47 $\mu$ F 25 V
C915	254 4256 046	CE04W1E101M	100 $\mu$ F 25 V
C916	254 4256 059	CE04W1E221M	220 $\mu$ F 25 V
C920	254 4260 045	CE04W1H010M	1 $\mu$ F 50 V
C922	254 4260 058	CE04W1H2R2M	2.2 $\mu$ F 50 V
F901	206 1031 045	FUSE (0.25) A	ASIA only
SW901	212 0286 003	POWER SWITCH	
	233 5756 001	TRANSFORMER	EUROPE U.K.
	233 5758 009	TRANSFORMER	AUSTRALIA
	233 5759 008	TRANSFORMER	U.S.A.
	233 5760 000	TRANSFORMER	CANADA
	212 4698 008	VOLTAGE SELECTOR	ASIA
L901	239 8019 002	LINE FILTER COIL	ASIA only

**OTHER PARTS**

L101, 201	232 0109 003	MPX FILTER	
L102, 202	232 9007 009	SKEWING COIL	
L103, 203	235 0020 945	INDUCTOR 153J	
L104, 204	235 0020 916	INDUCTOR 822J	
L105, 205	239 0010 009	HX STEP UP COIL	
L301	232 0135 006	OSC COIL	
SW 601~614	212 4388 004	TACT SWITCH	
P1~5	205 0452 017	STYLE PIN	
XT501	399 0079 009	CST4,19MG	CLOCK
JK301	204 8261 003	4P PIN JACK	
JK302	204 8209 007	H/P JACK	
JK303	204 8260 004	MINI JACK	
FL601	393 4080 009	FIP7AMW6	FL TUBE

**PARTS LIST OF EXPLODED VIEW**

Ref. No.	Part No.	Part Name	Remarks
⊙ 1	411 0794 503	CHASSIS ASS'Y	Europe, U.K. Australia
	411 0794 529	CHASSIS ASS'Y	Europe (Gold)
	411 0794 516	CHASSIS ASS'Y	Asia
	411 0794 532	CHASSIS ASS'Y	U.S.A., Canada
2	414 0545 007	SHIELD SHEET	
⊙ 3	412 2679 001	HOLD BRACKET	
⊙ 4	105 0787 000	BOTTOM COVER	
⊙ 5	4U-1875	AUDIO/METER UNIT	
⊙ 6	4U-1876-Z	POWER SUPPLY UNIT	Europe
	4U-1876M	POWER SUPPLY UNIT	Asia
	4U-1876K	POWER SUPPLY UNIT	U.K., Australia
	4U-1876U	POWER SUPPLY UNIT	U.S.A., Canada
⊙ 7	412 2008 012	BUSHING PLATE	
8	△ 206 2063 009	AC CORD WITH PLUG	Europe
	△ 200 6031 026	AC CORD	Asia
	△ 206 2024 006	AC CORD	U.K.
	△ 206 2025 005	AC CORD	Australia
	△ 206 2061 001	AC CORD	U.S.A., Canada
9	△ 445 0056 008	CORD BUSH	
10	△ 233 5756 001	POWER TRANS	Europe, U.K. Australia
	△ 233 5760 000	POWER TRANS	Asia
	△ 233 5758 009	POWER TRANS	U.S.A.
	△ 233 5759 008	POWER TRANS	Canada
⊙ 11	338 0121 004	CMAY5 C MECHA	
⊙ 12	412 2524 208	FIX BRACKET	
⊙ 13	412 2579 101	EARTH PLATE	
14	112 0515 131	VOL KNOB	INPUT
	112 0515 144	VOL KNOB	Europe (Gold)
	112 0515 128	VOL KNOB	U.S.A.
15	112 0602 002	VOL KNOB (B)	BAL. BIAS
	112 0602 015	VOL KNOB (B)	Europe (Gold)
16	103 1274 435	FRONT ESC. ASS'Y	
	103 1274 448	FRONT ESC. ASS'Y	Europe (Gold)
	103 1274 451	FRONT ESC. ASS'Y	U.S.A., Canada
17	113 1230 007	PUSH KNOB (A)	
	113 1230 023	PUSH KNOB (A)	Europe (Gold)
	113 1230 010	PUSH KNOB (A)	U.S.A.
18	113 1244 035	PUSH KNOB (B)	
	113 1244 051	PUSH KNOB (B)	Europe (Gold)
	113 1244 048	PUSH KNOB (B)	U.S.A.
19	113 1089 203	EJECT KNOB	
	113 1089 216	EJECT KNOB	Europe (Gold)
	113 1089 229	EJECT KNOB	U.S.A.
20	463 0274 095	SPRING	
21			
22			
23	431 0269 032	P.S. LEVER ASS'Y	
	431 0269 058	P.S. LEVER ASS'Y	Europe (Gold)
	431 0269 045	P.S. LEVER ASS'Y	U.S.A.
⊙ 24	144 1898 032	FRONT PANEL	
	144 1898 045	FRONT PANEL	Europe (Gold)
⊙ 25	102 0341 120	TOP COVER	
	102 0341 133	TOP COVER	Europe (Gold)
26	103 1289 006	C. WINDOW	
	103 1289 022	C. WINDOW	Europe (Gold)

Ref. No.	Part No.	Part Name	Remarks
26	103 1289 019	C. WINDOW	U.S.A.
27	204 8261 003	4P PIN JACK	JK301
28	204 8209 007	H/P JACK	JK302
29	204 8260 004	MINI JACK	JK303
30	211 0571 003	BALANCE VR	VR301
31	211 0570 004	INPUT VR	VR302
32	211 0608 002	BIAS FINE VR	VR303
33	211 0611 002	OUTPUT VR	VR304
34	△ 212 0286 003	POWER SWITCH	SW901
37	393 4080 009	FL TUBE	FIP7AMW6
39	113 1228 006	FOOT CAP	
41	461 0206 009	RUBBER SHEET	
43	212 4388 004	TACT SWITCH	
51	473 7508 017	3 × 10 CBTS(P)-B	
	473 7510 005	3 × 10 CBTS(P)-N	Europe (Gold)
52	473 7002 018	3 × 8 CBTS(S)-Z	
53	473 7002 005	3 × 6 CBTS(S)-Z	
54	473 7002 013	4 × 10 CBTS(P)-Z	
55	477 0262 006	SPECIAL SCREW	
56	414 0538 001	BOTTOM EARTH PLATE	
59	412 2815 108	EJECT BRACKET	
60	414 0537 002	SHIELD BRACKET	
61	443 0967 007	WASHER	
*	133 0101 021	SERIAL NO. LABEL	Europe
*	133 0112 007	SERIAL NO. LABEL	Asia
*	133 0103 026	SERIAL NO. LABEL	U.K., Australia
*	133 0109 036	SERIAL NO. LABEL	U.S.A., Canada
*	513 8253 025	APPROVAL MARK	Europe only
*	513 8294 000	VDE LABEL	Europe only
*	515 8030 008	PRESET LABEL	Asia only
*	515 8040 001	CAUTION SHEET	Asia only
*	513 0209 006	NOTICE SHEET	Australia
*	513 8266 009	DANGEROUS MARK	U.S.A.
*	513 1222 008	DATE LABEL	U.S.A., Canada

● (Gold) in the Remarks column refers to models with gold front panels.

- Parts marked with this symbol △ have critical characteristics. Use ONLY replacement parts recommended by the manufacturer.
- Part indicated with the mark "⊙" are not always in stock and possibly to take a long period of time for supplying, or in some case supplying of part may be refused.

EXPLODED VIEW OF CABINET AND CHASSIS GROUP

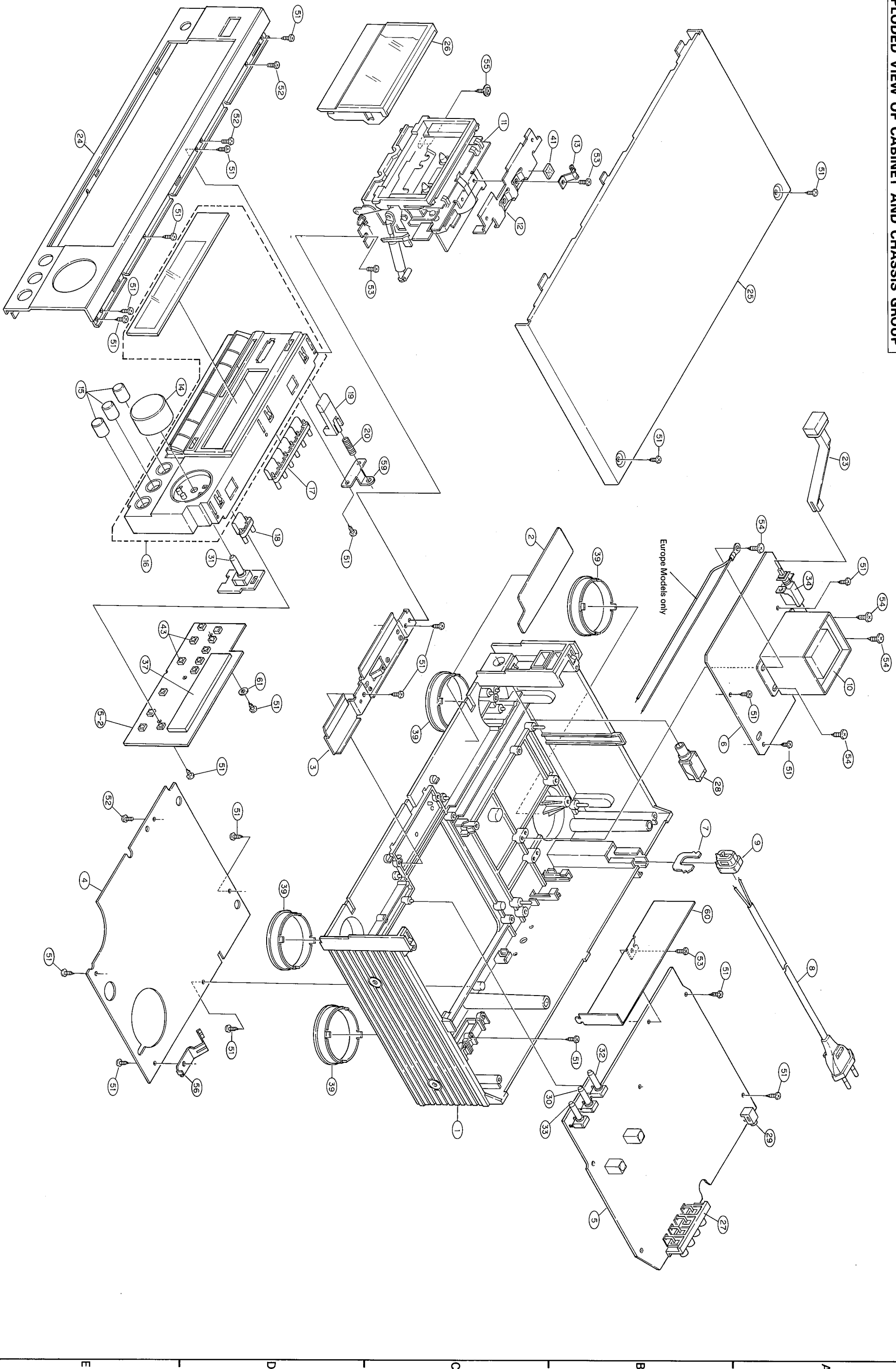

**PARTS LIST OF MECHANISM UNIT**

Ref. No.	Part No.	Part Name	Remarks
①			
1	9DF 5170 49	CHASSIS BLK	
2	9DF 5252 57	IDLER BLK	
3	9DF 6121 46	MOTOR MAIN BLK	
4	9DF 6230 37	CHASSIS BASE BLK	
5	9DF 6231 27	REEL BASE BLK	
6	9DF 7652 63	SOLENOID BLK	
7	9DF L39K 12	PLUNGER	
8	9DF L39H 12A	IRON CORE	
9	9DF J111 17	1.7 × 0.25 WASHER	
10	9DU J12V 11	2.1 × 0.25 WASHER	
11	9DF 5135 38	PLATE HEAD BLK	
12	9DAZ 15S 00		with HEAD
13	9DF R20M 21	PINCH ROLLER (L)	GP2S04B
14	9DA Z13P 00	SPL-320BC	
15	9DF C52F 13	SLIDE PLATE	
16	9DF R22K 13	FLY WHEEL (RVS)	
17	9DF 5642 80	MOTOR REEL BLK	
18	9DF 5672 96	CONTROL PWB BLK	
19			
20	9DU E16E 11	PUSH SWITCH	
21	9DF C39M 63	EJECT STOPPER	
22	9DF C52H 12	CASSETTE SPRING	
23	9DF D45G 12	PLAY ARM	
24	9DF D45B 13	CAM GEAR	
25	9DF D44T 13	REC SENSER ARM	
26	9DF D44W 12	PACK SENSER ARM	
27	9DF D44U 12	METAL SENSER ARM	
28	9DF F17G 21	MAIN BELT	
29	9DF J111 30	2.6 × 0.25 WASHER	
30	9DF J111 14	2.6 × 0.5 WASHER	
31		E RING	
32	9DF K28M 15	EJECT LOCK SPRING	
33	9DF K28R 11	SLIDE SPRING	
34	9DF R22H 11	FLY WHEEL (FWD)	
35	9DF R20L 21A	PINCH ROLLER (R)	
36		BRACKET (L)	
37		BRACKET (R)	
38			
39			
40	9DF K20S 13	DOOR SPRING	
41	9DF D29U 11	DOOR FRAME	
42		HOLDER CUSHION	
43	9DF G114 14	2.6 × 5 CPS(W)	
44		2.6 × 6 CPS	
45		3 × 4 FRANG SCREW	
46		3 × 4 FRANG SCREW	
47		2 × 12CPTS(S)W	
48	9DK G194 28	2.6 × 4 CPTS(S)	
49	9DU G15S 11	3 × 8 FRANGE SCREW	
50	9DF G137 18	2 × 9F LOCK SCREW	
53	9DF K26N 14	HB SPRING	
54	9DW H56P 44	WIRE CONNECTOR (R/P/E)	
56		LEAD HOLDER	
57	9DU D45H 15	REFLECT PLATE	
58	9DU T11R 11	DRESSING BLK	
59	144 1881 007		
60	473 7024 009	2.6 × 12 CPTS(S)	

● Part indicated with the mark "⊙" are not always in stock and possibly to take a long period of time for supplying, or in some case supplying of part may be refused.

**PARTS LIST OF PACKING & ACCESSORIES**

Ref. No.	Part No.	Part Name	Remarks
	203 2223 002	2P PIN CORP	
	203 2227 008	2P MINI PLUG CORP	
	511 1852 003	INST MANUAL (E2)	Except U.S.A.
	511 1853 002	SPANISH INST MANUAL	Europe only
	511 1858 007	INST. MANUAL	U.S.A. only
	515 0443 004	TAPE CATALOG	Canada only
	505 0131 050	CABINET COVER	
	504 0092 060	STYLEN PAPER	
	503 0704 106	PACKING ASS'Y	
	501 1277 144	CARTON CASE	
	501 1277 157	CARTON CASE	
	513 1389 006	CONTROL CARD	Europe (Gold)
		BASE	
	513 1349 004	THERMAL CARBON FILM	
	499 0144 001	REMOTE	RC-406
	203 3667 007	CONTROL PWB	
	513 9111 001	PLUG ADAPTER (GOLD)	Asia only
		COLOR LABEL	Europe (Gold)
	515 0439 102	SAFETY INSTRUCTION	U.S.A. only
	515 0418 107	DAI WARRANTY HOME	U.S.A. only
	515 0388 004	DCI WARRANTY PRESET LABEL	Canada
	515 8030 008	CAUTION SHEET	Asia only
	515 8040 001		Asia only

● Part indicated with the mark "⊙" are not always in stock and possibly to take a long period of time for supplying, or in some case supplying of part may be refused.

**NOTE FOR PARTS LIST**

- Part indicated with the mark "⊙" are not always in stock and possibly to take a long period of time for supplying, or in some case supplying of part may be refused.
- When ordering of part, clearly indicated "1" and "1" (I) to avoid mis-supplying.
- Ordering part without stating its part number can not be supplied.
- Part indicated with the mark "\*" is not illustrated in the exploded view.
- Not including Carbon Film ±5%, 1/6 W, 1/4 W Type in the P. W. Board parts list.
- Parts marked with this symbol  $\Delta$  have critical characteristics. Use ONLY replacement parts recommended by the manufacturer.

● Refer to the following table for the codes of the resistors and capacitors appearing on the parts list.

**● Resistors**

Ex.:  $\frac{RN}{Type}$   $\frac{14K}{Shape}$   $\frac{2E}{and per-}$   $\frac{182}{formance}$   $\frac{G}{Resist-}$   $\frac{FR}{Allowable}$   $\frac{FR}{Others}$

RD : Carbon	2B : 1/4W	F : ±1%	P : Pulse-resistant type
RC : Fixed	2E : 1/2W	G : ±2%	NL : Low noise type
RS : Metallic film	2H : 3/4W	J : ±5%	NB : Non-burning type
RW : Winding	3A : 1W	K : ±10%	FR : Fuse resistor
RN : Metal film	3D : 2W	M : ±20%	F : Lead wire forming
RK : Metal mixture	3H : 5W		

\*Resistance  
 1 8 2  $\rightarrow$  1800Ω = 1.8KΩ  
 Indicates number of zeros after effective number.  
 2-digit effective number, decimal point indicated by R.  
 • Units: Ω

**● Capacitors**

Ex.:  $\frac{CE}{Type}$   $\frac{04W}{Shape}$   $\frac{1H}{and per-}$   $\frac{2R2}{formance}$   $\frac{M}{Capacity}$   $\frac{BP}{Allowable}$   $\frac{BP}{Others}$

CE : Aluminum foil electrolyte	OU : 6.3V	F : ±1%	HS : High stability type
CA : Aluminum solid electrolyte	1A : 10V	G : ±2%	BP : Non-polar type
CS : Tantalum electrolyte	1C : 16V	J : ±5%	HR : Ripple-resistant type
CO : Film	1E : 25V	K : ±10%	DL : For charge and discharge
CK : Ceramic	1V : 35V	M : ±20%	HF : For assuring high frequency
CC : Ceramic	1H : 50V	Z : ±80%	U : UL part
CP : Oil	2A : 100V	P : ±20%	C : CSA part
CM : Mica	2B : 125V	- : 0%	W : UL-CSA type
CF : Metallized	2C : 160V	C : ±0.25pF	F : Lead wire forming
CH : Metallized	2D : 200V	D : ±0.5pF	
	2E : 250V	= : Others	
	2H : 500V		
	2J : 630V		

\*Capacity  
 2 R 2  $\rightarrow$  2.2μF  
 1-digit effective number, decimal point indicated by R.  
 2-digit effective number, decimal point indicated by R.  
 • Units: μF, (for P, pf (μμF))  
 • When the dielectric strength is indicated in AC, "AC" is included after the dielectric strength value.

EXPLODED VIEW OF MECHANISM UNIT

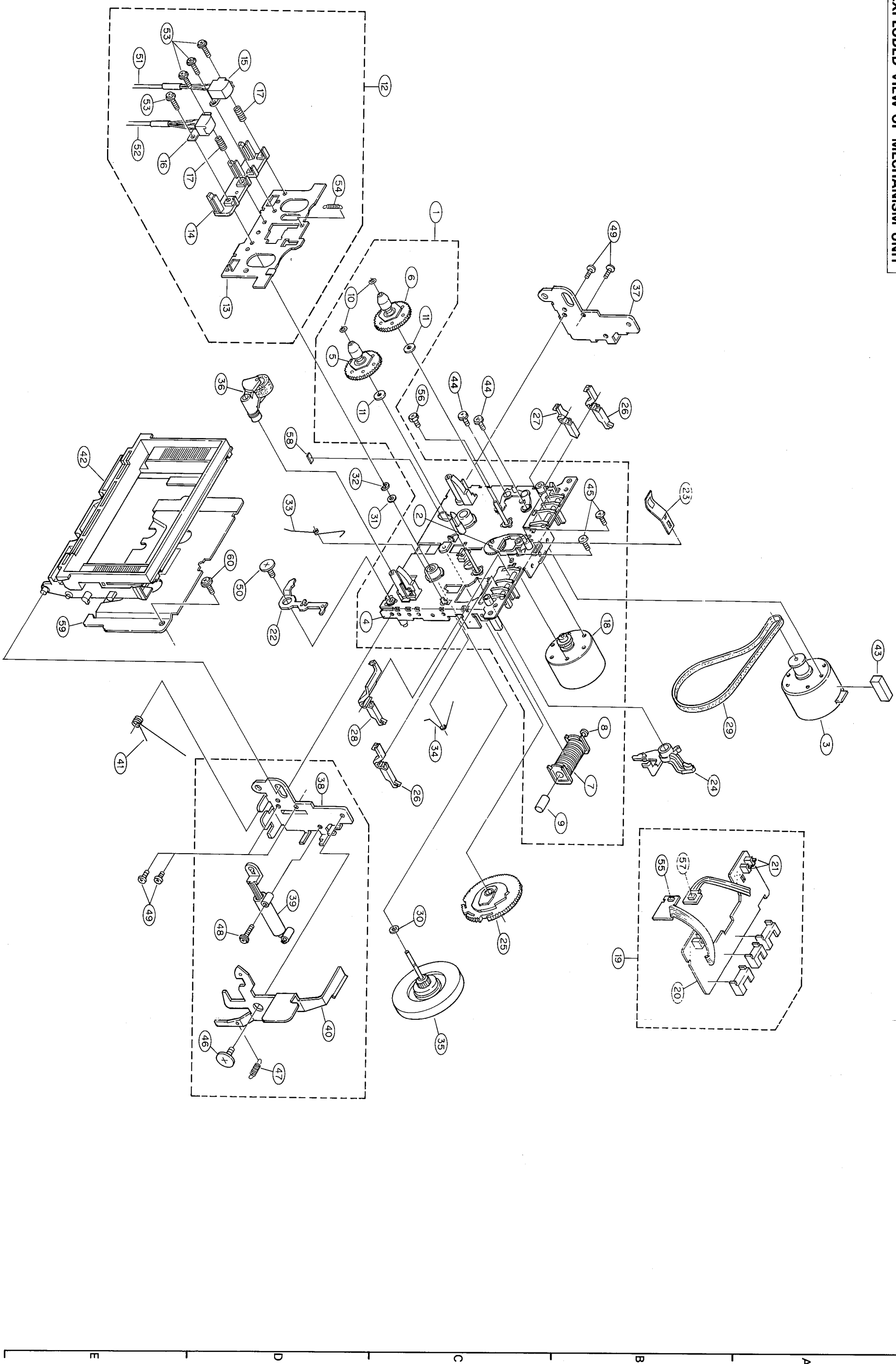

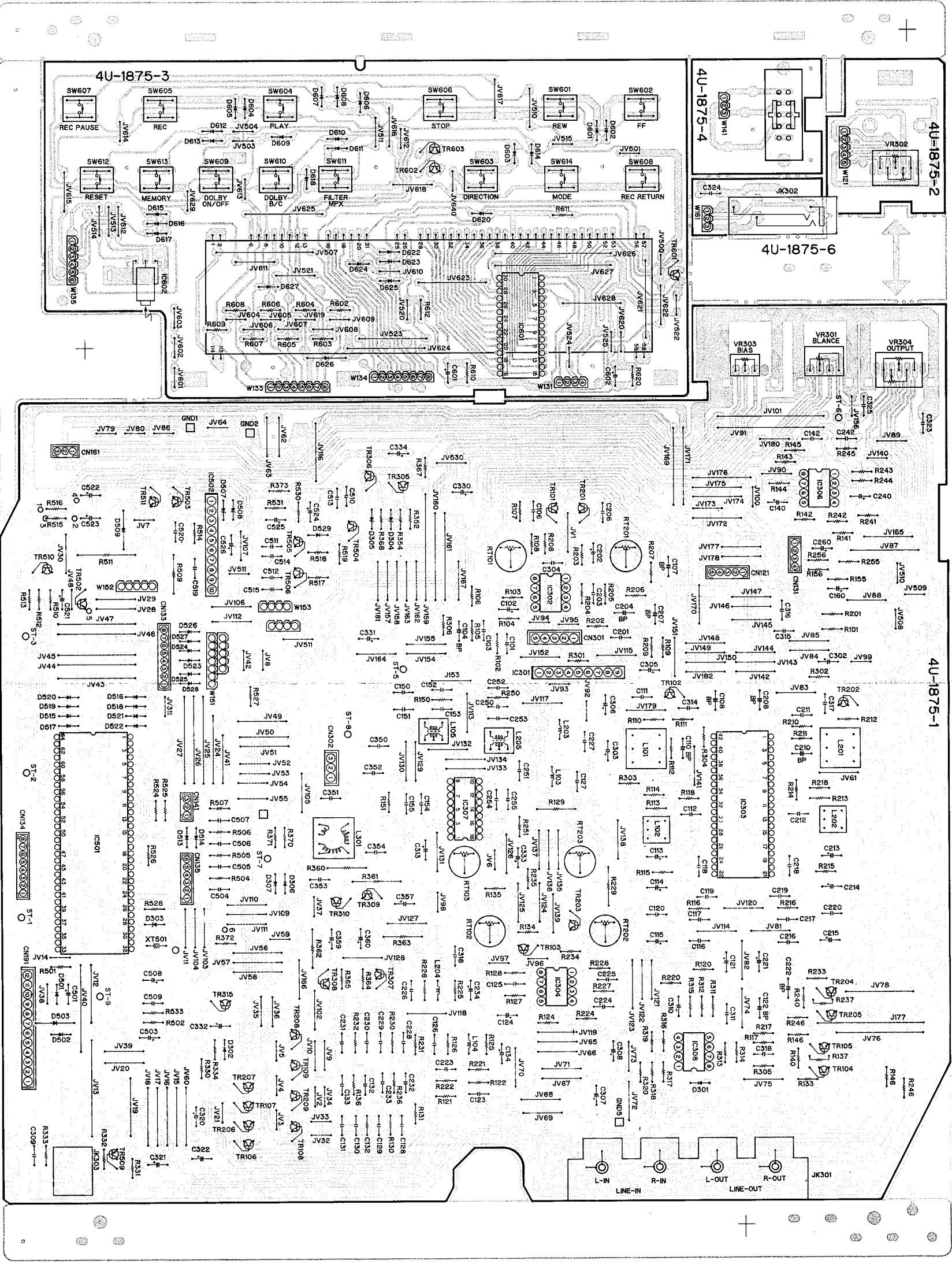

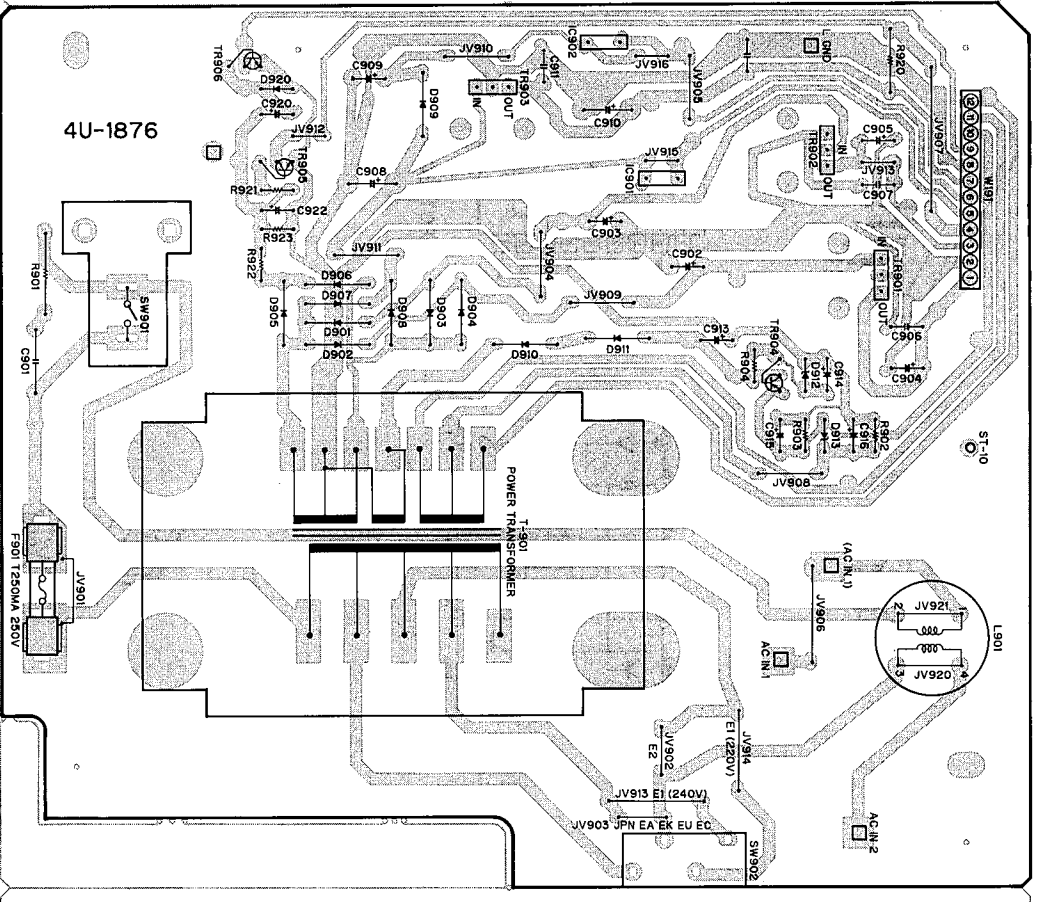

- Remarks**
1. The following table shows the power circuit parts used for the 4U-1876 board by area.
  2. Parts used are marked O, parts not used —.

Ref. No.	JV902	JV903	JV913	JV914	JV920	JV921	L901	SW902
Areas								
Europe (E2)	O	—	—	—	—	—	O	—
U.K. & Australia (EK, EA)	—	O	—	—	O	O	—	—
Asia (EI)	—	—	O	O	O	O	—	O
U.S.A. & Canada (EU, EC)	—	O	—	—	O	O	—	—

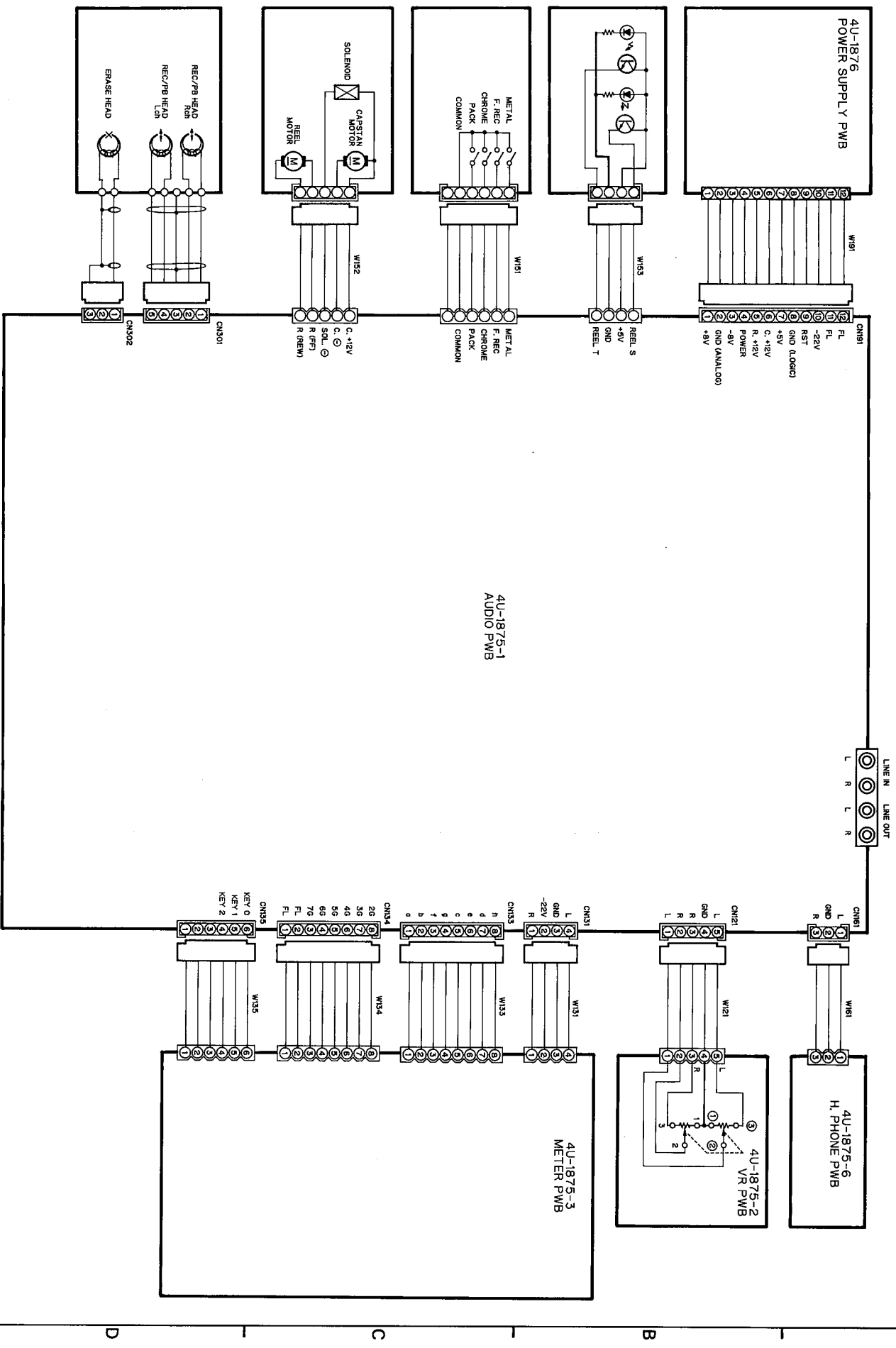

• IC

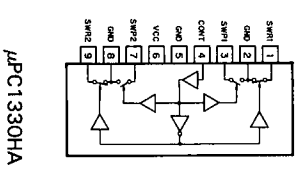
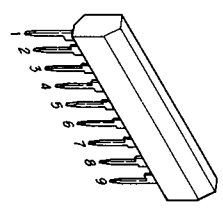
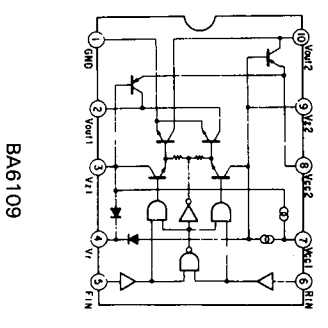
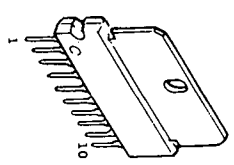
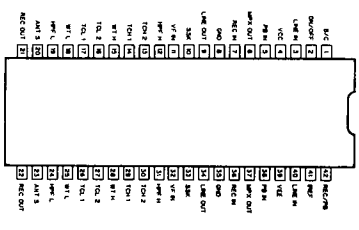
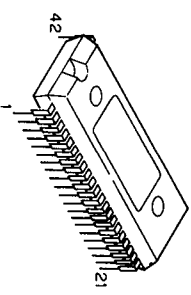
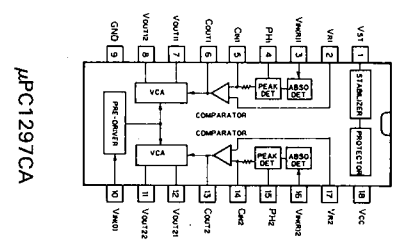
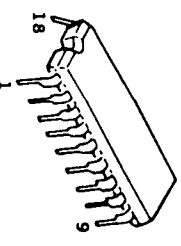
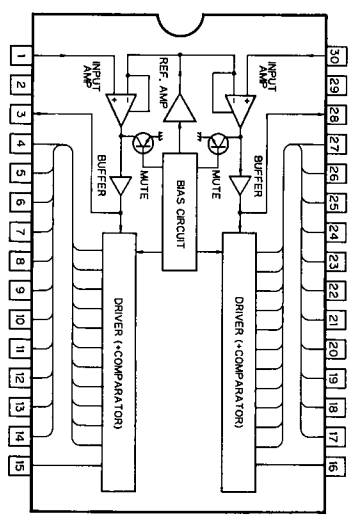
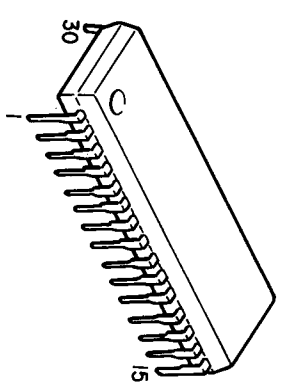
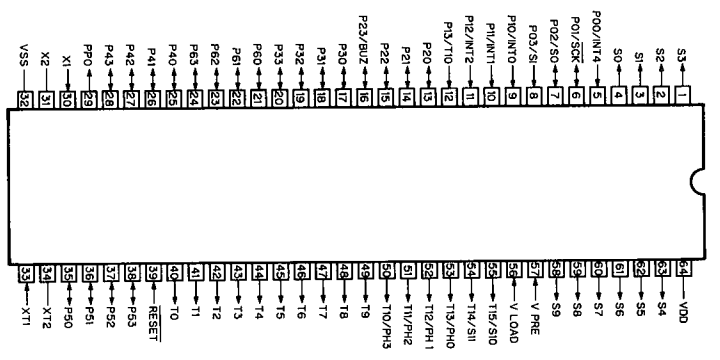
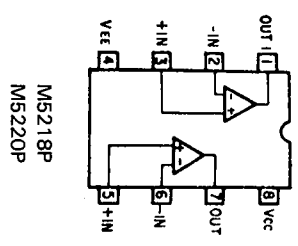
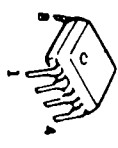

• Transistors

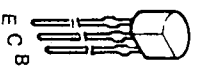

2SA933  
2SC1740  
2SC2878

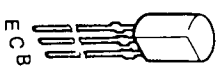

2SD468  
2SB562

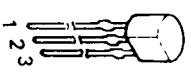

DTC124XS  
DTC144ES  
DTC124ES  
DTC114TS  
DTC143XS

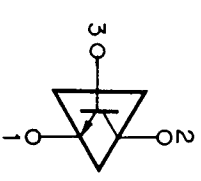

• Diodes



ISS270A  
ISR35-200



HZ4C-1  
HZS7B-2  
HZS22-3  
HZS7A-2





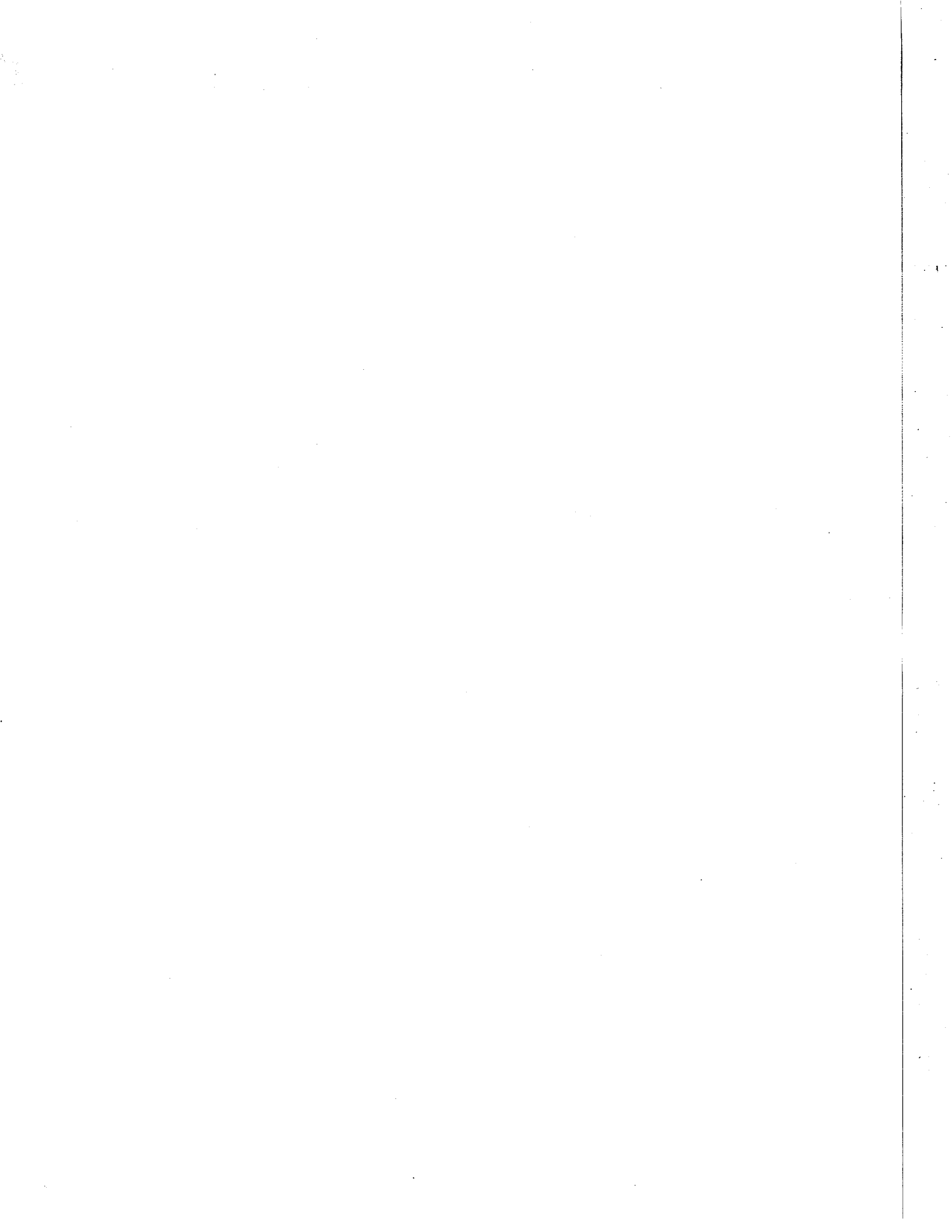

# DENON

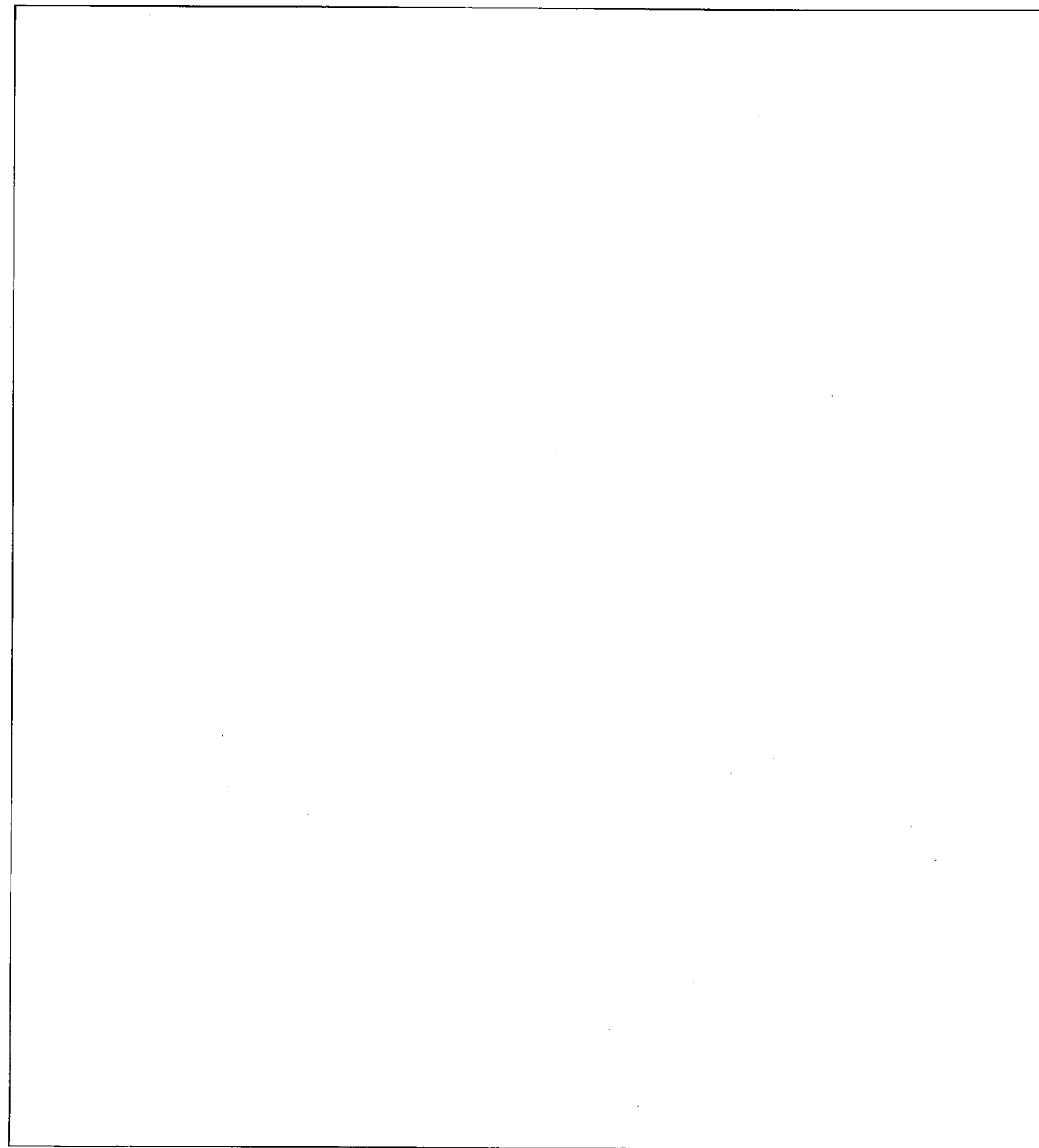

**NIPPON COLUMBIA CO., LTD.**

No. 14-14, 4-CHOME AKASAKA,  
MINATO-KU, TOKYO JAPAN  
TEL: 03-584-8111  
TLX: JAPANOLA J22591  
CABLE: NIPPON COLUMBIA TOKYO

SCHEMATIC DIAGRAM OF AUDIO UNIT

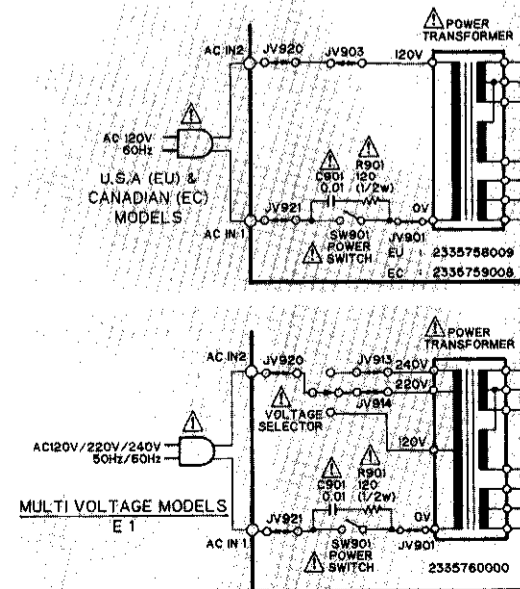
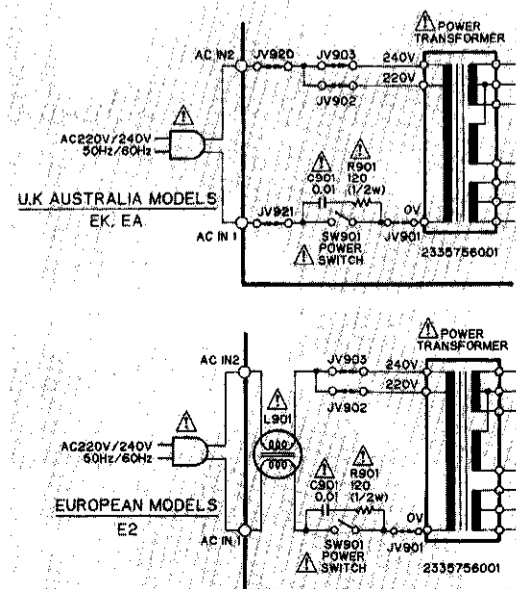
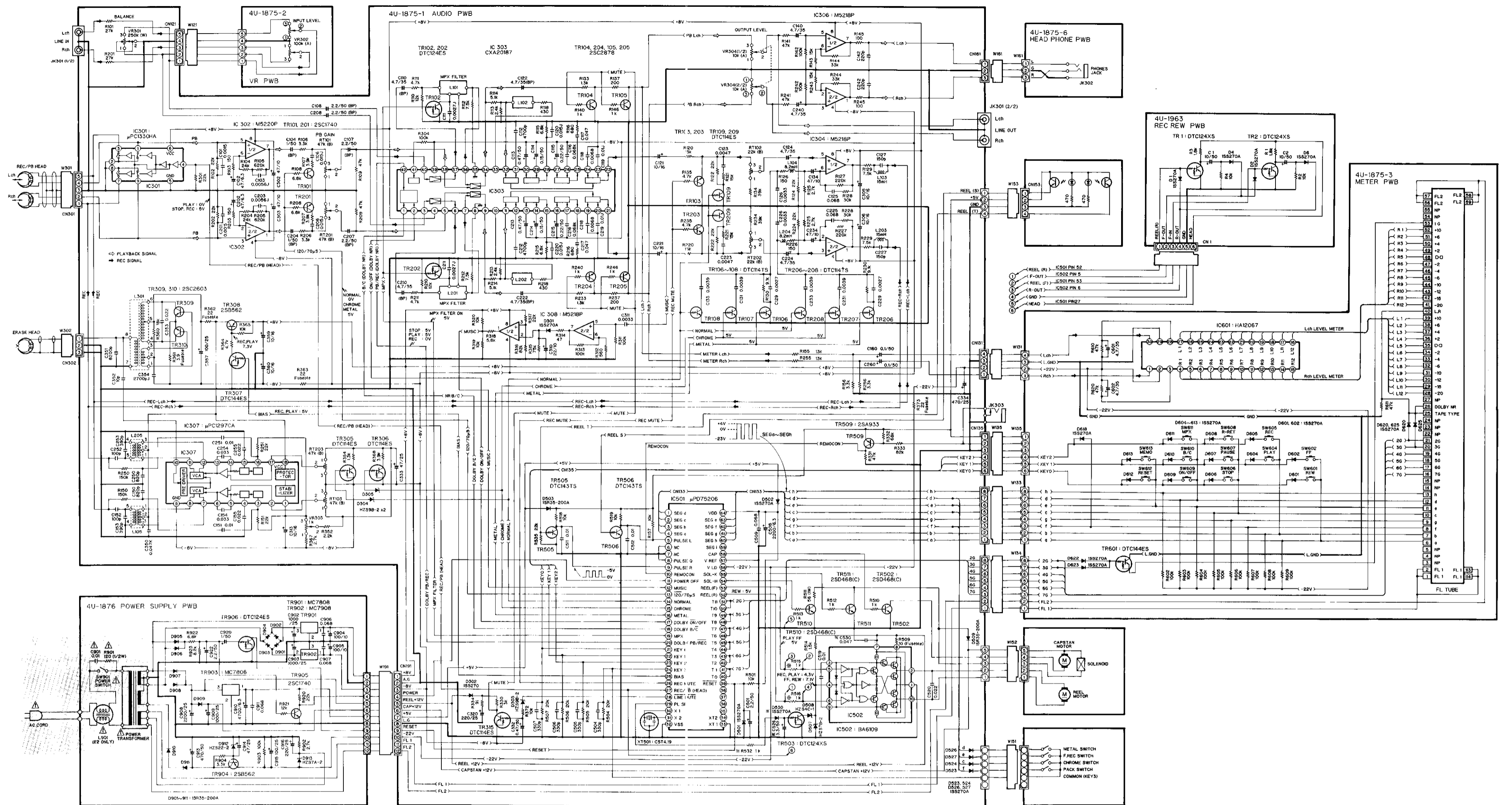

Note: ● Resistance shall be 1/4 W unless otherwise specified and the unit is Ω.  
 ● The unit of capacitor is μF, P is pF unless otherwise specified.  
 ● This circuit diagram shows the basic circuit. It is subject to change for the purpose of improvement.  
 Parts marked with this symbol  $\square$  have critical characteristics. Use ONLY replacement parts recommended by the manufacturer.

BUNDLE DIAGRAM

