

# DENON

## SERVICE MANUAL

### MODEL DRW-580

### STEREO CASSETTE TAPE DECK

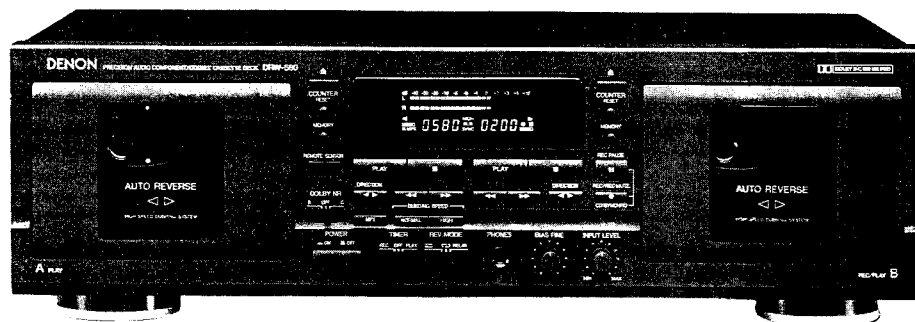

#### TABLE OF CONTENTS

OPERATING INSTRUCTIONS .....	2-7
DISASSEMBLY INSTRUCTIONS .....	8, 9
ADJUSTING AND CHECKING THE MECHANISM SECTION.....	10
ADJUSTING THE ELECTRICAL SECTIONS.....	11-13
BLOCK DIAGRAM .....	14
LEVEL DIAGRAM .....	15
PARTS LIST OF EXPLODED VIEW .....	16
EXPLODED VIEW OF CHASSIS AND CABINET.....	17
KU-9322 AUDIO P.W.B. UNIT ASS'Y .....	18
KU-9323 DISPLAY P.W.B. UNIT ASS'Y.....	19
KU-9324 POWER P.W.B. UNIT ASS'Y.....	20
NOTE FOR PARTS LIST.....	21
PRINTED WIRING BOARD PARTS LIST.....	21-23
BUNDEL DIAGRAM.....	23
WIRING DIAGRAM.....	24
SCHEMATIC DIAGRAM .....	25
SEMICONDUCTOR.....	26

**NIPPON COLUMBIA CO., LTD.**

**IMPORTANT TO SAFETY**

**WARNING:**

**TO PREVENT FIRE OR SHOCK HAZARD, DO NOT EXPOSE THIS APPLIANCE TO RAIN OR MOISTURE.**

**CAUTION:**

1. **Handle the power supply cord carefully**  
Do not damage or deform the power supply cord. If it is damaged or deformed, it may cause electric shock or malfunction when used. When removing it from wall outlet, be sure to remove by holding the plug attachment and not by pulling the cord.
2. **Do not open the top cover**  
In order to prevent electric shock, do not open the top cover. If problems occur, contact your DENON DEALER.
3. **Do not place anything inside**  
Do not place metal objects or spill liquid inside the cassette tape deck. Electric shock or malfunction may result.

Please, record and retain the Model name and serial number of your set shown on the rating label.  
Model No. DRW-580 Serial No. \_\_\_\_\_

**CAUTION**  
 RISK OF ELECTRIC SHOCK  
 DO NOT OPEN

**CAUTION: TO REDUCE THE RISK OF ELECTRIC SHOCK, DO NOT REMOVE COVER (OR BACK). NO USER SERVICEABLE PARTS INSIDE. REFER SERVICING TO QUALIFIED SERVICE PERSONNEL.**

The lightning flash with arrowhead symbol within an equilateral triangle is intended to alert the user of the presence of uninsulated "dangerous voltage" within the product's enclosure that may be of sufficient magnitude to constitute a risk of electric shock to persons.

The exclamation point within an equilateral triangle is intended to alert the user of the presence of important operating and maintenance (servicing) instructions in the literature accompanying the appliance.

• FOR U.S.A. & CANADA MODEL ONLY

**CAUTION**

TO PREVENT ELECTRIC SHOCK DO NOT USE THIS (POLARIZED) PLUG WITH AN EXTENSION CORD, RECEPTACLE OR OTHER OUTLET UNLESS THE BLADES CAN BE FULLY INSERTED TO PREVENT BLADE EXPOSURE.

• POUR LES MODELES AMERICAINS ET CANADIENS UNIQUEMENT

**ATTENTION**





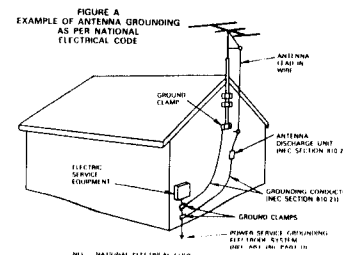

POUR PREVENIR LES CHOCS ELECTRIQUES NE PAS UTILISER CETTE FICHE POLARISEE AVEC UN PROLONGATEUR UNE PRISE DE COURANT OU UNE AUTRE SORTIE DE COURANT, SAUF SI LES LAMES PEUVENT ETRE INSEREES A FOND SANS EN LAISSER AUCUNE PARTIE A DECOUVERT.

**SAFETY INSTRUCTIONS**

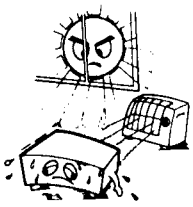
1. **Read Instructions** – All the safety and operating instructions should be read before the appliance is operated.
2. **Retain Instructions** – The safety and operating instructions should be retained for future reference.
3. **Heed Warnings** – All warnings on the appliance and in the operating instructions should be adhered to.
4. **Follow Instructions** – All operating and use instructions should be followed.
5. **Water and Moisture** – The appliance should not be used near water – for example, near a bathtub, washbowl, kitchen sink, laundry tub, in a wet basement, or near a swimming pool, and the like.
6. **Carts and Stands** – The appliance should be used only with a cart or stand that is recommended by the manufacturer.
- 6A. An appliance and cart combination should be moved with care. Quick stops, excessive force, and uneven surfaces may cause the appliance and cart combination to overturn.
7. **Wall or Ceiling Mounting** – The appliance should be mounted to a wall or ceiling only as recommended by the manufacturer.
8. **Ventilation** – The appliance should be situated so that its location or position does not interfere with its proper ventilation. For example, the appliance should not be situated on a bed, sofa, rug, or similar surface that may block the ventilation openings; or, placed in a built-in installation, such as a bookcase or cabinet that may impede the flow of air through the ventilation openings.
9. **Heat** – The appliance should be situated away from heat sources such as radiators, heat registers, stoves, or other appliances (including amplifiers) that produce heat.
10. **Power Sources** – The appliance should be connected to a power supply only of the type described in the operating instructions or as marked on the appliance.
11. **Grounding or Polarization** – Precautions should be taken so that the grounding or polarization means of an appliance is not defeated.
12. **Power-Cord Protection** – Power-supply cords should be routed so that they are not likely to be walked on or pinched by items placed upon or against them, paying particular attention to cords at plugs, convenience receptacles, and the point where they exit from the appliance.
14. **Cleaning** – The appliance should be cleaned only as recommended by the manufacturer.
15. **Power Lines** – An outdoor antenna should be located away from power lines.
16. **Outdoor Antenna Grounding** – If an outside antenna is connected to the receiver, be sure the antenna system is grounded so as to provide some protection against voltage surges and built-up static charges. Article 810 of the National Electrical Code, ANSI/NFPA 70, provides information with regard to proper grounding of the mast and supporting structure, grounding of the lead-in wire to an antenna-discharge unit, size of grounding conductors, location of antenna-discharge unit, connection to grounding electrodes, and requirements for the grounding electrode. See Figure A.
17. **Nonuse Periods** – The power cord of the appliance should be unplugged from the outlet when left unused for a long period of time.
18. **Object and Liquid Entry** – Care should be taken so that objects do not fall and liquids are not spilled into the enclosure through openings.
19. **Damage Requiring Service** – The appliance should be serviced by qualified service personnel when:
  - A. The power-supply cord or the plug has been damaged; or
  - B. Objects have fallen, or liquid has been spilled into the appliance; or
  - C. The appliance has been exposed to rain; or
  - D. The appliance does not appear to operate normally or exhibits a marked change in performance; or
  - E. The appliance has been dropped, or the enclosure damaged.
20. **Servicing** – The user should not attempt to service the appliance beyond that described in the operating instructions. All other servicing should be referred to qualified service personnel.

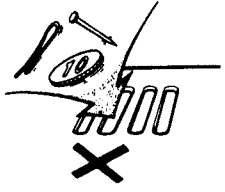
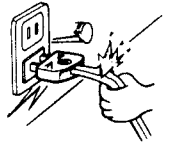
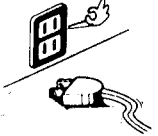

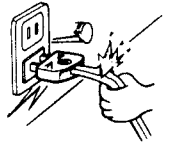
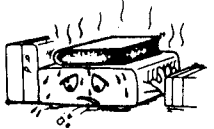
NOTE ON USE/OBSERVATIONS RELATIVES A L'UTILISATION/NOTAS SOBRE EL USO

 <ul style="list-style-type: none"> <li>• Avoid high temperatures. Allow for sufficient heat dispersion when installed on a rack.</li> <li>• Eviter des températures élevées. Tenir compte d'une dispersion de chaleur suffisante lors de l'installation sur une étagère.</li> <li>• Evite altas temperaturas. Permita la suficiente dispersión del calor cuando está instalado en la consola.</li> </ul>	 <ul style="list-style-type: none"> <li>• Keep the set free from moisture, water, and dust.</li> <li>• Protéger l'appareil contre l'humidité, l'eau et la poussière.</li> <li>• Mantenga el equipo libre de humedad, agua y polvo.</li> </ul>	 <ul style="list-style-type: none"> <li>• Do not let foreign objects in the set.</li> <li>• Ne pas laisser des objets étrangers dans l'appareil.</li> <li>• No deje objetos extraños dentro del equipo.</li> </ul>
 <ul style="list-style-type: none"> <li>• Handle the power cord carefully. Hold the plug when unplugging the cord.</li> <li>• Manipuler le cordon d'alimentation avec précaution. Tenir la prise lors du débranchement du cordon.</li> <li>• Maneje el cordón de energía con cuidado. Sostenga el enchufe cuando desconecte el cordón de energía.</li> </ul>	 <ul style="list-style-type: none"> <li>• Unplug the power cord when not using the set for long periods of time.</li> <li>• Débrancher le cordon d'alimentation lorsque l'appareil n'est pas utilisé pendant de longues périodes.</li> <li>• Desconecte el cordón de energía cuando no utilice el equipo por mucho tiempo.</li> </ul>	 <ul style="list-style-type: none"> <li>• Do not let insecticides, benzene, and thinner come in contact with the set.</li> <li>• Ne pas mettre en contact des insecticides, du benzène et un diluant avec l'appareil.</li> <li>• No permita el contacto de insecticidas, gasolina y diluyentes con el equipo.</li> </ul>
 <ul style="list-style-type: none"> <li>• Handle the power cord carefully. Hold the plug when unplugging the cord.</li> <li>• Manipuler le cordon d'alimentation avec précaution. Tenir la prise lors du débranchement du cordon.</li> <li>• Maneje el cordón de energía con cuidado. Sostenga el enchufe cuando desconecte el cordón de energía.</li> </ul>	 <p>*(For sets with ventilation holes)</p> <ul style="list-style-type: none"> <li>• Do not obstruct the ventilation holes.</li> <li>• Ne pas obstruer les trous d'aération.</li> <li>• No obstruya los orificios de ventilación.</li> </ul>	 <ul style="list-style-type: none"> <li>• Never disassemble or modify the set in any way.</li> <li>• Ne jamais démonter ou modifier l'appareil d'une manière ou d'une autre.</li> <li>• Nunca desarme o modifique el equipo de ninguna manera.</li> </ul>

Thank you very much for purchasing the DENON component stereo cassette tape deck. DENON proudly presents this advanced tape deck to audiophiles and music lovers as a further proof of DENON's non-compromising pursuit of the ultimate in sound quality. The high quality performance and easy operation are certain to provide you with many hours of outstanding listening pleasure.

Please check to make sure the following items are included with the main unit in the carton:

- (1) Operating Instructions ..... 1
- (2) Connection Cords ..... 2
- (3) Mini-Plug Cable ..... 1

— TABLE OF CONTENTS —

FEATURES .....	5
CONNECTION .....	5
NAMES AND FUNCTION OF PARTS .....	6, 7
CASSETTE TAPES .....	7
AUTOMATIC TAPE SELECTION .....	8
PLAYBACK .....	8
RELAY PLAY .....	9
MUSIC SEARCH SYSTEM .....	9
RECORDING .....	10
RECORDING LEVEL .....	11
RECORDING BIAS ADJUSTMENT .....	11
REC/REC MUTE AND REC PAUSE BUTTON .....	11
DIMMER ADJUSTMENT .....	11
DUBBING .....	12
SYNCHRONIZED RECORDING FUNCTION .....	12, 13
TAPE COUNTER AND MEMORY STOP .....	13
RECORDING/PLAYBACK .....	14
DOLBY B AND C NOISE REDUCTION SYSTEM .....	14
DOLBY HX-PRO HEADROOM EXTENSION SYSTEM .....	15
MAINTENANCE .....	15
TROUBLESHOOTING .....	16
SPECIFICATIONS .....	16

FEATURES

- Computer Controlled Mechanism
- Dual Power Supply
- Dolby HX-Pro Headroom Extension System
- Dolby B & C Noise Reduction Systems
- Manual Bias Adjustment Control
- Dual Computing Tape Counter with 4-Digit Readout and Memory Stop
- Music Search System
- FL Peak Level Meters
- Auto Tape Selector
- 2-Speed Dubbing
- Relay Playback
- Synchronized Recording
- Timer Play and Timer Recording
- Optional Remote Controllable

CONNECTION

- Leave your entire system (including this cassette deck) turned off until all connections between the deck and other components have been completed.

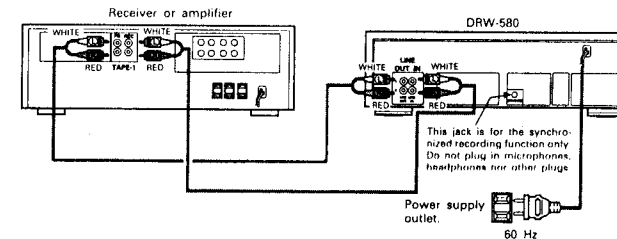

■ Connecting the Deck to an Amplifier

- Before connecting the deck to your amplifier, please review your amplifier's instruction manual.
- Use the white plugs for the left channel and red plugs for the right channel.

■ Tape Dubbing

- Many stereo amplifiers and receivers have tape dubbing circuitry so that tape duplication can be performed between two or more tape decks. Review your amplifier's instruction manual for a full explanation of this mode of operation.

■ Connecting Headphones

- To listen through headphones, plug your headphones into the PHONES jack.

■ Installation Precautions

- If the deck is placed near an amplifier, TV or tuner, noise (induced hum) or beat interference may result, especially during FM or AM reception. If this occurs, place the deck further away from other components or reorient its position.

Caution

A mechanical sound is heard the first time the power switch is set to "ON" after the power cord is plugged into an outlet. This is the sound of the cassette mechanism being set to the proper operating state, and is normal. (When using an AC outlet on a receiver or amplifier, used an "UNSWITCHED" outlet.)

**NAMES AND FUNCTIONS OF PARTS**

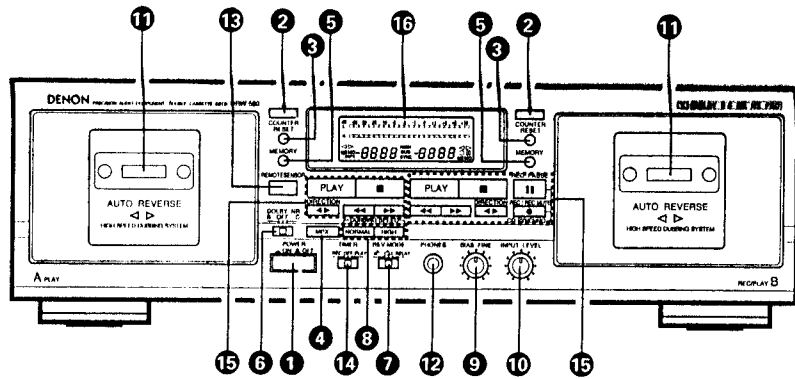

- 1 Power Switch (POWER)**  
Press once to turn the power to deck on, and once more to turn the power off.  
The deck remains in a stand by (non-operative) mode for approximately 2 seconds after it is switched on.
- 2 Eject Button (▲)**  
Press this button to open the cassette compartment cover. When the tape is running, press the STOP (■) button first to stop tape transport, then press the Eject button.
- 3 Counter Reset Button (COUNTER RESET)**  
Press this button to reset the tape counter to zero.
- 4 MPX Filter Button (MPX)**  
The MPX FILTER button should be used to prevent interference with the Dolby NR circuit when making Dolby NR encoded recordings of FM stereo programs.  
When making Dolby NR encoded recordings from any program source other than FM stereo, leave this button in the "OFF" position.
- 5 Counter Memory Button (MEMORY)**  
When this button is pressed during forward tape travel (▶), fast rewinding (◀) will stop automatically at the tape counter position "0000".  
When this button is pressed during reverse tape travel (◀), fast forwarding (▶) will stop automatically at the tape counter position "0000". See page 13.
- 6 Dolby NR Switch (DOLBY NR)**  
To record or playback tapes with Dolby B or C-type noise reduction, set this switch to "B" or "C". Turn it "OFF" when not using the Dolby NR system.
- 7 Reverse Mode Switch (REV. MODE)**  
Select the type of tape transport. The reverse mode can be set to (one side), (continuous playback), RELAY (relay playback).
- 8 Dubbing Speed Buttons (DUBBING SPEED)**  
Pressing the NORMAL button starts regular speed dubbing from deck A to deck B. Press the HIGH button to perform dubbing at double speed. See page 12.

- 9 Bias Fine Control (BIAS FINE)**  
(For Normal, CrO, and Metal tape)  
Use this control to fine-adjust the bias. Standard bias is obtained at the center click-stop position. See page 11.
- 10 Input Level Control (INPUT LEVEL)**  
This knob adjusts the recording input level. It affects the level in both channels. See page 10.
- 11 Cassette Compartment Cover**  
If the cover is not closed completely, the tape transport buttons will remain inoperative.
- 12 Headphone Jack (PHONES)**  
For private music enjoyment without disturbing others, or for monitoring a recording, a headphone set may be connected to this jack. Use a headphone with an impedance rating of 8 to 1200 Ω/ohms.
- 13 Remote Sensor (REMOTE SENSOR)**  
With DRW-580 the remote control unit is not included. Each of "PLAY, FF, REV, STOP, REC PAUSE and REC/REC MUTE" functions can be remote controlled with wireless handset of the receiver (DRA Series receivers). For details refer to the DRA Series operating instructions.  
**NOTE:**  
Note that only the A deck can be operated with remote control units which have no A/B selector button.

**Caution:**  
Whenever the power switch is in the OFF state, the apparatus is still connected on AC line voltage.  
Please be sure to unplug the cord when you leave home for, say, a vacation.

- 14 Timer Switch (TIMER)**  
This switch is provided for use with an optional audio timer for unattended recording or morning-alarm playback.  
For non-timer operation, this switch should be set in the "OFF" position. See page 14.

**15 Tape Transport Buttons**

▶	Play Button	Press to playback tape.
■	Stop Button	Press to stop the tape in any mode.
◀◀	Fast Rewind Button	Press to fast rewind.
▶▶	Fast Forward Button	Press to fast forwarding.
REC/REC MUTE (Deck B only)	Rec/Rec Mute Button	Press the REC/REC MUTE (●) button and PLAY button simultaneously to start recording. If only the REC/REC MUTE (●) button is pressed, the deck enters the Recording Pause mode. Pressing this button in the Recording Pause mode will start Auto Rec Mute, and a 5-second silent space is recorded onto the tape. See page 11.
	Rec Pause Button	Press this button to enter the recording pause mode from the recording or recording mute mode. This button can only be used during recording. See page 11.
◀▶	Direction Button	Changes the tape transport direction from forward "▶" to reverse "◀" and vice versa.

**16 Display Indicators**  
Indicators with an encircled number light up when the corresponding button is pressed.

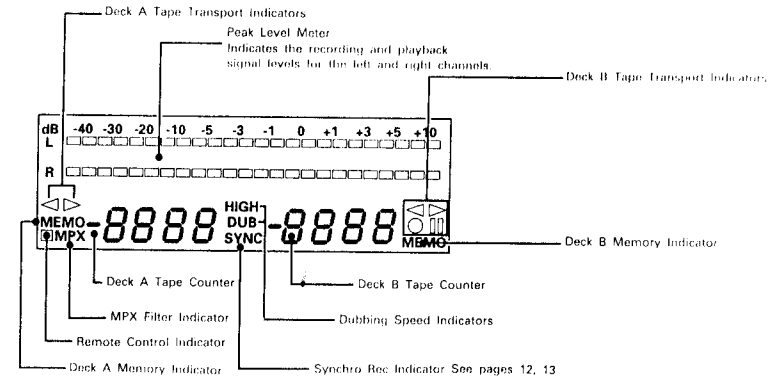

**CASSETTE TAPES**

- Handling Precautions**
  - C 120 Cassettes
  - C 120 cassette tapes are not recommended as they use a very thin tape base which may become tangled around the capstan or pinch roller.
  - Tape Slack  
Before putting a tape into the deck, take up any slack with a pencil or your finger tip. This precaution prevents the tape from becoming entangled around the capstan or pinch roller.
- Storage Precautions**
  - Do not store cassette tapes in a place where they will be subject to:
    - Extremely high temperature or excessive moisture
    - Excessive dust
    - Direct sunlight
    - Magnetic fields (near TV sets or speakers)
  - To eliminate tape slack, store your cassettes in cassette cases with hub stops
- Accidental Erasure Prevention**
  - All cassettes have erasure prevention tabs for each side. To protect valuable recordings from accidental or inadvertent erasure, remove the tab for the appropriate side with a screwdriver or another tool
  - To record on a tape whose erasure prevention tabs have been removed, cover the tab holes with adhesive tape

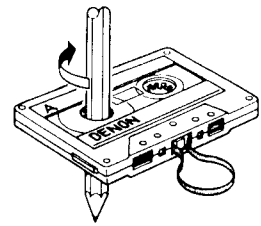

Erasure prevention tab for side B

Erasure prevention tab for side A

## AUTOMATIC TAPE SELECTION

This Stereo Cassette Deck contains an automatic tape selector which automatically selects the optimum bias and equalization for the tape in use. This is accomplished by detection of the tape type detection holes in the cassette housing.

- If a tape without tape type detection holes is used, the deck will be set for normal tapes.

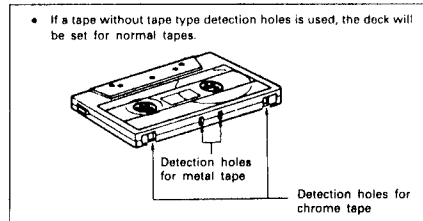

## PLAYBACK

- The operations described below apply to deck A and deck B alike.
- Switch on your amplifier or receiver.
- Set the Tape Monitor switch on your amplifier or receiver to the TAPE position.
- The numbers in the illustration below depict the order in which operation steps are carried out.

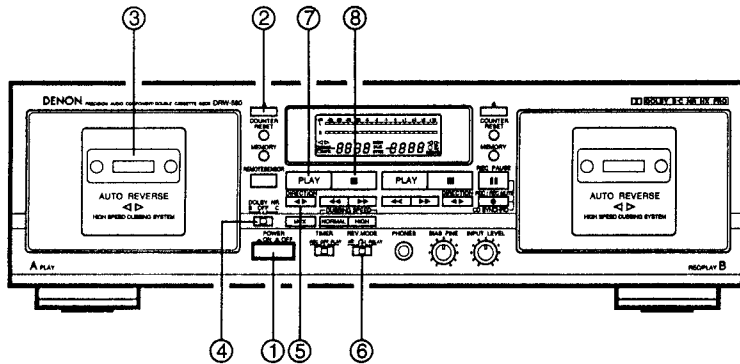

- Press the POWER switch to the ON ( ) position.
- Press the EJECT ( ) button to open the cassette compartment cover.
- Load the cassette tape and close the cassette compartment cover.
- When listening to a tape that has been recorded with Dolby noise reduction, set the DOLBY NR switch to match the system used at the time of recording.



- Press the Direction ( ) button to select the direction of tape transport.

Transport Direction	Indicator
Forward	▷
Reverse	◁

- Select the type of tape transport with the REVERSE MODE switch.



Mode	Switch position
To listen to one side only	←→
To listen to repeat playback of both sides	↻
To listen to continuous playback of both sides and both decks.	RELAY

- Press the PLAY button to begin playback.
- Press the stop ( ) button to stop the playback.
  - In the continuous playback mode (REVERSE MODE set to ), playback of both tape sides will be repeated 5 times and then stop automatically.
  - If different types of Dolby noise reduction are used for record and playback, playback response will be adversely affected.
  - When power is turned off during tape transport, it may not be possible to remove the cassette by pressing the EJECT ( ) button. In this case, turn on power again before you press the EJECT ( ) button.

## RELAY PLAY (continuous playback of the tapes in deck A and deck B)

- Load a cassette tape into deck A and B, and set the Dolby NR button correctly.

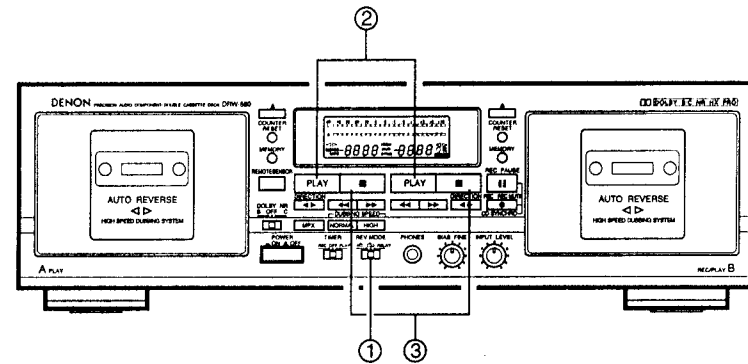

- REVERSE MODE set to "RELAY".
- Press the PLAY button of the deck you first wish to listen to.
- To stop relay play, press the stop ( ) button of the deck currently playing the tape.
  - Relay play will play decks A and B in succession for 5 cycles, upon which playback stops. When playback starts from deck B, when switching to deck A, the first deck A playback cycle will be counted as the second cycle. The completion of 5 cycles will always be at the opposite side of the tape in deck B.

## MUSIC SEARCH SYSTEM

The music search system detects blank sections (lasting for at least 4 seconds) between selections in order to locate the beginning of selections in the forward or reverse direction.

- To advance from the current selection to the beginning of the next selection (CUE):
  - Press the PLAY button, keep it pressed in, and press the Fast Forward ( ) button when the tape is travelling in the forward ( ) direction. Press the PLAY button, keep it pressed in, and press the Rewind ( ) button when the tape is travelling in the reverse ( ) direction. The tape transport indicator flashes.
  - The deck will skip the rest of the current selection and automatically resume play from the beginning of the next selection.
- To repeat playback from the beginning of the current selection (REVIEW):
  - Press the PLAY button, keep it pressed in, and press the Rewind ( ) button when the tape is travelling in the forward ( ) direction. Press the PLAY button, keep it pressed in, and press the Fast Forward ( ) button when the tape is travelling in the reverse ( ) direction. The tape transport indicator flashes.
  - The deck will rewind the tape to the beginning of the current selection and automatically resume play from that point.
  - This is very convenient for repeating playback of the current selection.

## Notes on Music Search Operation:

The search functions operates by detecting comparatively long, blank sections approximately 4 to 5 seconds long, in between recorded selections. Therefore, the system may not operate normally in the following cases:

- Recordings with discontinuous speech or conversation.
- Recordings with long periods of pianissimo (softly played) music.
- Recordings with long silences.
- Blank sections with a high level of noise.
- Blank sections shorter than 4 seconds.
- If noise-emitting appliances, such as electric razors, drills, refrigerators, etc., are operated nearby.
- REV close to the beginning of the program or CUE close to the ending.

## RECORDING (DECK B only)

- Switch on your amplifier or receiver and the source component.
- Set the Tape Monitor switch on your amplifier or receiver to the SOURCE position.

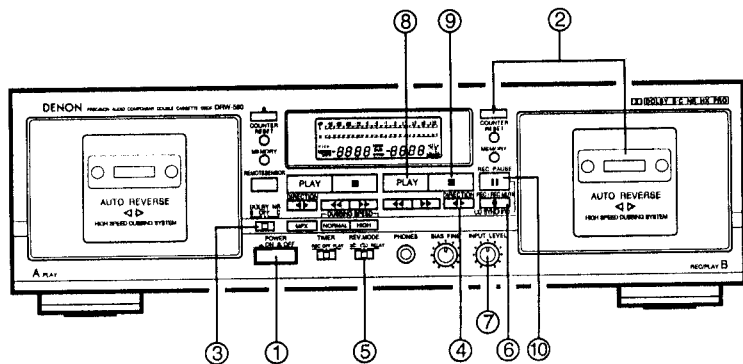

- 1 Press the POWER switch to the ON ( ) position.
- 2 Load the cassette tape.  
(Check that the erasure prevention tabs of the cassette housing have not been broken off.)
- 3 Move the DOLBY NR switch and select the Dolby NR type that suits the recording.



- 4 Press the Direction ( ) button to select the direction of tape transport.
- 5 Select the type of tape transport with the REVERSE MODE switch.

Mode	Switch position
To record on only one side	
To continuously record on both sides	or RELAY

- 6 Press the REC/REC MUTE ( ) button to set the recording pause mode. The indicator will light up.
- 7 Adjust the recording level with the INPUT LEVEL control while watching the Peak Level Meter.
- 8 Press the PLAY button to start the recording. The PLAY ( ) and the indicator will light during recording.
- 9 To stop recording, press the stop ( ) button.
- 10 To pause the recording, press the REC PAUSE ( ) button. Press the PLAY button to resume recording.

### Caution:

- Be careful not to erase important recordings by mistake. Inadvertent start of recording will happen in the following cases:
  1. If the PLAY button is pressed while the indicator lights, recording starts.
  2. If the PLAY and REC/REC MUTE ( ) button are pressed at the same time, recording starts.
 The best way to avoid accidental erasure is to break off the two erasure prevention tabs on the cassette housing.

## PROPER RECORDING LEVEL

A too high recording level can saturate the tape and cause distortion. On the other hand, if the recording level is set too low, soft passages will be marked by residual noise. A proper recording level is the single most important factor for making well balanced recordings.

### Guideline for maximum recording level

TYPE I (Normal)	0 dB level on peaks
TYPE II (CrO <sub>2</sub> )	+1 dB level on peaks
TYPE IV (Metal)	+3 dB level on peaks

Note: The optimum recording level differs depending on the program source and the type of tape used.

## RECORDING BIAS ADJUSTMENT

For best recording results, monitoring during recording and comparing different recordings using your own judgement are essential. The DENON cassette deck is equipped with a BIAS FINE control to assist you in setting the proper bias for different types and brands of tape. At the center stop-click position, the deck is set to the reference bias level for Normal, CrO<sub>2</sub> and Metal tape. If the resulting recording in this position has too much or too little high frequency content, adjusting the BIAS FINE control can be useful to achieve better results.



BIAS FINE

If the high frequencies (treble sounds) are to be boosted, turn the BIAS FINE control counter-clockwise to decrease the bias current. Turn the control clockwise to increase bias current. By the use of this control, you can record tapes with a frequency response that will perfectly match your listening taste.

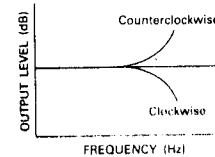

## REC/REC MUTE AND REC PAUSE Button

1. To record a 5-second blank section during recording: Press the REC/REC MUTE ( ) button. A 5-second blank will be recorded and the deck will enter the recording standby mode.
2. To record a 5-second blank section during the recording standby mode: Press the REC/REC MUTE ( ) button from the recording standby mode. A 5 second blank will be recorded and the deck will enter the recording standby mode again.
3. To cancel recording of blank space: Press the REC PAUSE ( ) button. Blank space recording will be cancelled and the deck enters the recording standby mode.
4. To extend the blank section with another 5 seconds or more: Simply press the REC/REC MUTE ( ) button and the blank section will be increased with another 5 seconds.

## DIMMER ADJUSTMENT

With the DRW-580, the brightness of the display can be adjusted in seven steps.

To make the display brighter, press the B deck's fast forward ( ) button while holding in the B deck's STOP button.  
To make the display dimmer, press the fast rewind ( ) button while holding in the STOP button.  
The display is initially set to the maximum brightness.

## DUBBING (from deck A to deck B)

- Switch on the amplifier or receiver.
- Set the Tape Monitor switch on your amplifier or receiver to the TAPE position.

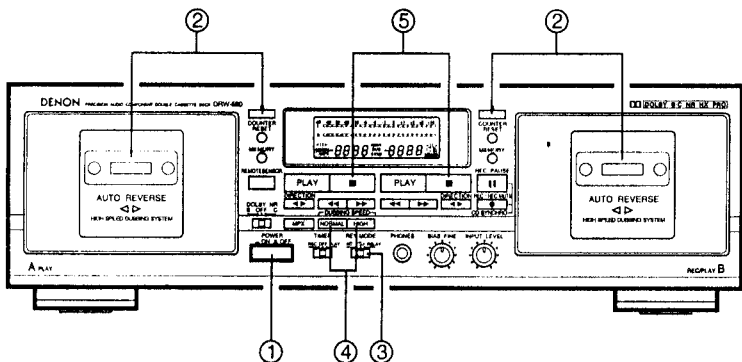

- 1 Press the POWER switch to the ON ( ) position.
- 2 Load the cassette tape to be played in deck A and the one to be recorded in deck B.
- 3 Select the type of tape transport with the REVERSE MODE switch.



Reverse mode	Operation
	Dubbing is performed only for one side. The decks stop when either deck A or B reaches the end of the tape.
	The tape direction is reversed on each deck when they reach the end of the tape. (This is convenient for dubbing to a tape with a different length.)
RELAY	During dubbing of the side facing you, the deck that first reaches the end of the tape will stand by until the other deck reaches the end of the tape, then both decks will reverse the tape direction together. (Depending on the manufacturer, the length of tapes having the same recording time may differ somewhat. Setting this mode permits the arrangement of the beginning portion of the opposite side of the tape.)

- 4 To begin normal speed dubbing, press the DUBBING SPEED NORMAL button. The DUB indicator will light at this time. To high speed dubbing, press the DUBBING SPEED HIGH button. The HIGH indicator will light at this time.
- 5 To stop dubbing, press the stop ( ) button of deck A or deck B.
  - When deck A is in the playback mode and deck B is in the stop condition, setting deck B to the recording pause mode will engage the normal speed dubbing pause mode. Dubbing is then started by pressing the PLAY button.
  - When dubbing, the recording level and the Dolby NR recording will be the same as those of the playback tape, regardless of the positions of the INPUT LEVEL control and the DOLBY NR button.
  - When listening to the playback sound during normal speed dubbing, the DOLBY NR switch remains off even if it is pressed.
  - The playback sound cannot be heard during high speed dubbing.
  - Operation using the REC/REC MUTE ( ) and REC PAUSE ( ) buttons of deck B is permitted during normal speed dubbing.
  - Buttons other than the stop ( ) button cannot be used during high speed dubbing.

## SYNCHRONIZED RECORDING FUNCTION

- Convenient synchronized recording can be performed when used in combination with a DENON CD player equipped for the synchronized recording function.
- SYNCHRO Jack Connection Connect the SYNCHRO Jack with a DENON CD player which is equipped with a SYNCHRO jack, then make a synchronized recording. Use the connection cord supplied with this cassette deck.
- Switch on your amplifier or receiver and the CD player.
- Set the tape Monitor switch on your amplifier or receiver to the source position.

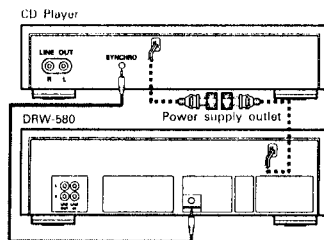

- 1 Operation of the Tape Counter
  - (1) Press the RESET button to reset the counter to "0000".
  - (2) By using the PLAY, FF, or REW functions, the reading of the counter will change to indicate index position.
    - During recording and playback operations, the counter is useful for noting the location of existing programs or positions where recording is to be started.
    - The reading of this counter does not correspond with that of any other deck.
  - (3) deck A and deck B have the memory of their own counter.

### 2) MEMORY STOP Operation

- (1) During recording or playback, the Memory Stop feature can be used to locate a particular point on the tape. Press the COUNTER RESET button at the desired point.
- (2) Then Press the COUNTER MEMORY button, the MEMO indicator lights.

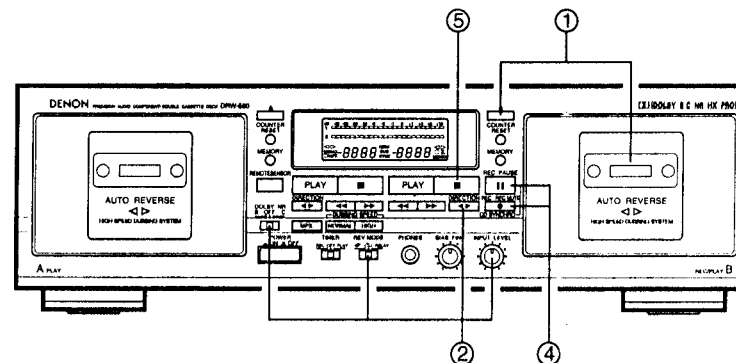

- 1 Load the tape onto which you want to record into deck B, the disc you want to record into the CD player.
- 2 Following the recording instructions on page 10, set the DOLBY NR mode, the direction, the reverse mode and the input level.
- 3 Set the CD player to the stop or pause mode.
- 4 Press the REC/REC MUTE ( ) button and REC PAUSE ( ) button simultaneously. The cassette deck and CD player are automatically set to the synchronized recording mode. The "SYNC" indicator lights on the cassette deck and the synchronized recording mode is indicated on the CD player. (For details, refer to the CD player's operating instructions.)
- 5 To stop synchronized recording, press the stop button on deck B and stop button on CD. The synchronized recording mode is cancelled for both the cassette deck and CD player.
- 6 To stop synchronized recording temporarily, press the stop button on the CD player. A 5-second blank space is created on the tape, after which the recording pause mode is set. The "SYNC" indicator flashes. To resume synchronized recording, press the PLAY button on the CD player.

### Note:

- If synchronized recording is started when the CD player is in a mode other than the stop or pause mode or when no disc is set, the "SYNC" indicator on the cassette deck flashes and the recording pause mode is set until synchronized recording is possible on the CD player.
- In the synchronized recording mode, only the STOP button on deck B will function.

### Caution:

- Do not set the cassette deck to the synchronized recording mode when the CD player is in the play mode. Also, do not turn off the power of the cassette deck or the CD player during synchronized recording. Doing so can result in malfunction.
- During the editing operation, when using the editing functions on the CD player, be sure to select a tape with a sufficiently long recording time. For the CD player's editing functions, refer to the CD player's operating instructions.

## TAPE COUNTER AND MEMORY STOP

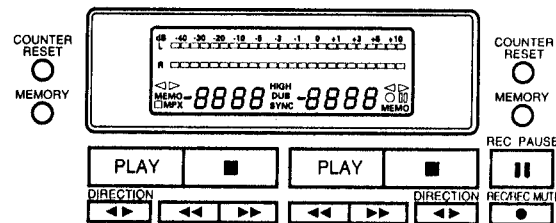

- (3) When the Rewind ( ) button is pressed during forward tape travel ( ), or the Fast Forward ( ) button is pressed during reverse tape travel ( ), the tape is rapidly rewound (or advanced) until the counter indication of "0000" is reached.
  - The Memory Stop feature will rewind or forward the tape to within -5 counts in the forward ( ) direction (from "0000" to " -0005 ") and to within +5 counts in the reverse ( ) direction (from "0000" to "0005 "). After this, several seconds are required for corrective operations.
  - The Memory Stop function operates independently in both directions for deck A and deck B.

### Caution:

- If the memory stop operation is performed after repeated fast-forwarding or rewinding, the tape may not stop at the proper position.

### TIMER RECORDING / PLAYBACK

Timer recording/playback can be made using any audio timer available on the market.

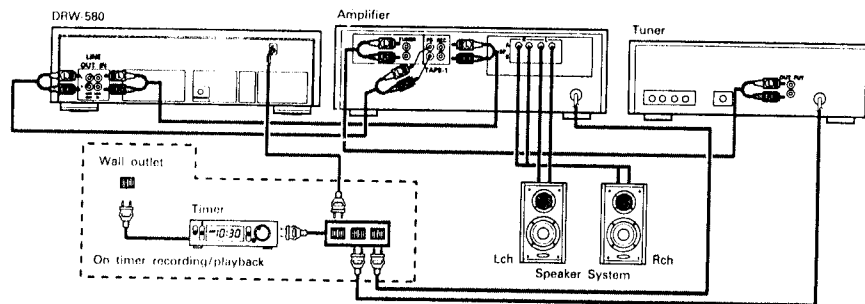

● **Timer recording procedure**

1. Make sure the connections are correct, especially the power supply connections.
2. Turn "on" the power switch of each appliance.
3. Tune the desired station on the tuner.
4. Load the tape for recording. (Make sure the erase prevention tab is not broken off; if it is, cover the hole with plastic tape).
5. Set the Dolby NR switch to the appropriate position.
6. Make sure the monitor switch of the Amplifier is to the SOURCE position.
7. Adjust the recording input level.
8. Set the starting position of the tape.
9. Set the timer switch (TIMER) to the "REC" side.



10. Set the audio timer to the desired time. The audio timer will turn the power supply on at the desired time.

\* With the above procedures, timer controlled recording can be made. When the preset time comes, the power is supplied and the FM broadcast can be recorded.

● **Timer playback procedure**

1. Make sure the connections are correct, especially the power supply connections.
2. Turn "on" the power switch of each appliance.
3. Load the pre-recorded tape to be played back.
4. Set the Dolby NR switches to the appropriate positions.
5. Set the monitor switch of the Amplifier to the TAPE position.
6. Press the PLAY (▶) button and playback the tape; adjust the playback level.
7. Set the timer switch (TIMER) to the "PLAY" side.



8. Set the audio timer to the desired time. The audio timer will turn the power supply on at the desired time.

\* With the above procedures, timer playback can be accomplished. When the preset time comes, the power is supplied and playback will start.

**Note:**

- Please read the operating instructions for the timer before use.
- If the timer recording or playback is not desired, be sure to switch the timer switch (TIMER) to "OFF".
- When using timers that allow several "on/off" operations, timer start functioning can continue an unlimited number of times until the tape in the machine is finished.

### DOLBY B AND C NOISE REDUCTION SYSTEM

- The Dolby noise reduction system substantially reduces the tape background noise (hiss) inherent in the cassette medium. Dolby B NR is most widely in use. However Dolby C NR is a much more recent development and represents significant improvements over Dolby B NR.
- Tape background noise consists primarily of high frequency information, which is particularly annoying during soft passages. The Dolby NR system increases the level of low volume mid- and high-frequency signals during recording and reduces the level of these signals by an identical amount during playback. As a result, the playback signal is identical to the original source, but the level of background noise generated by the tape is greatly reduced.

- The operating principle of Dolby C NR is similar to that of Dolby B NR except for the encoding/decoding response curves. The noise reduction effect obtained with Dolby C NR is up to 20 dB, compared to 10 dB with Dolby B NR. In addition, Dolby C NR uses an anti-saturation network and spectral skewing circuitry for a significant improvement in the dynamic range of the mid- to high frequencies.

### DOLBY HX-PRO HEADROOM EXTENSION SYSTEM

This deck is equipped with the Dolby HX-PRO headroom extension system. Since the system functions automatically during recording, no switching operation or adjustment is required. The system is effective with any type of Normal, CrO<sub>2</sub> and Metal tape. The Dolby HX-PRO headroom extension system functions during recording to raise the saturation level in the treble range. Therefore, most of the treble range components distorted or lost during recording on conventional cassette decks are more faithfully recorded on the new DENON cassette deck.

**Features of the Dolby HX-PRO Headroom Extension System**

- (1) Performance of Normal and CrO<sub>2</sub> tapes can be improved to very close of that offered by Metal tape.
- (2) The dynamics in the treble range are improved significantly.
- (3) Since no decoding is necessary during playback, the improved sound can be enjoyed on any type of tape deck, including portable players and car audio systems.
- (4) The system functions whether the Dolby B/C NR system is engaged or not.

### MAINTENANCE

■ **Head Cleaning**

After long usage, tape coating or dust may adhere to the heads, causing deterioration of sound. Therefore, the parts depicted in the illustration should be cleaned regularly. Use a cotton swab moistened with a tape head cleaning solution (such as alcohol).

**Note:**

1. Some cleaning cassettes on the market have strong abrasive effects and may scratch the heads. Always use cotton swabs instead of cleaning cassettes.
2. Since the use of metal tape is apt to collect more dust on the heads, the heads should be cleaned more often to enjoy the best possible sound.

■ **Cleaning the Pinch Rollers and Capstans**

If the pinch rollers or capstans accumulate dust, tape transport may become unstable, as a result from slippage, during recording or playback. The tape can also be damaged if it gets entangled in the capstan. Clean these parts with a cotton swab or a soft cloth moistened with a tape head cleaning solution (such as alcohol).

■ **Demagnetizing the Heads**

The heads will become magnetized after long usage or if strongly magnetized objects are brought near them. The result is a generation of noise, loss of the high frequency range, and in extreme cases erasure of treble components on pre-recorded tapes in combination with added noise. Thus, the heads should be demagnetized at regular intervals. (Head demagnetizers are separately available from your dealer.)

■ **How to Demagnetize the Tape Heads**

1. Turn off the power.
2. Turn on the demagnetizer while it is at least 30 cm away from the heads. Bring the demagnetizer near the heads and slowly move it in small circles four or five times in front of each head, making sure you do not touch them.
3. Slowly move the demagnetizer away and turn it off when it is at least 30 cm away from the heads.

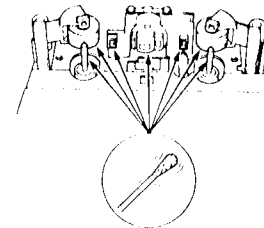



## TROUBLESHOOTING

Check the following before you draw the conclusion that your Stereo Cassette Deck is malfunctioning.

1. Are all the connections correct?
2. Are all system components being operated correctly in accordance with the operating instructions?
3. Are the speakers and amplifier/receiver functioning correctly?

If the tape deck still does not function properly, check the symptom against the list below. If the symptom does not correspond to the check list, please contact your DENON dealer.

Problem	Cause	Remedy
Tape does not run	<ul style="list-style-type: none"> <li>• Power cord is disconnected.</li> <li>• Tape is loose.</li> <li>• Cassette is not loaded properly.</li> <li>• Defective cassette.</li> </ul>	<ul style="list-style-type: none"> <li>• Check power cord.</li> <li>• Tighten tape with a pencil, etc.</li> <li>• Load cassette properly.</li> <li>• Replace cassette.</li> </ul>
Tape is not recorded when REC/REC MUTE (●) button is pressed.	<ul style="list-style-type: none"> <li>• No cassette is loaded.</li> <li>• Erase prevention tabs are broken off.</li> </ul>	<ul style="list-style-type: none"> <li>• Load cassette.</li> <li>• Cover holes with adhesive tape.</li> </ul>
Sound is warbled and distorted.	<ul style="list-style-type: none"> <li>• Heads, capstan or pinch roller are dirty.</li> <li>• Tape is wound too tight.</li> <li>• Recording input level is too high.</li> <li>• Tape is worn out and has "drop-outs".</li> </ul>	<ul style="list-style-type: none"> <li>• Clean them.</li> <li>• Fast forward or rewind to loosen tape winding.</li> <li>• Adjust recording input level.</li> <li>• Replace tape.</li> </ul>
Excessive noise	<ul style="list-style-type: none"> <li>• Tape is worn.</li> <li>• Heads, capstan or pinch roller are dirty.</li> <li>• Heads are magnetized.</li> <li>• Recording input level is too low.</li> </ul>	<ul style="list-style-type: none"> <li>• Replace them.</li> <li>• Clean them.</li> <li>• Demagnetize heads.</li> <li>• Adjust recording input level.</li> </ul>
High frequency range (treble) is emphasized.	<ul style="list-style-type: none"> <li>• Dolby NR switch is set improperly.</li> </ul>	<ul style="list-style-type: none"> <li>• Set Dolby NR Switch properly.</li> </ul>
High frequency range (treble) is lost.	<ul style="list-style-type: none"> <li>• Heads are dirty.</li> <li>• Tape is worn.</li> </ul>	<ul style="list-style-type: none"> <li>• Clean them.</li> <li>• Replace tape.</li> </ul>
The cassette tape cannot be removed.	<ul style="list-style-type: none"> <li>• If the POWER switch is turned off either during recording or playback and the unit is stopped, there may be cases when the cassette cannot be removed, even if the EJECT (▲) button is pressed.</li> </ul>	<ul style="list-style-type: none"> <li>• Turn the POWER switch ON (▶) again, and then press the STOP (■) button.</li> <li>• Now, press the EJECT (▲) button to remove the cassette tape.</li> </ul>

## SPECIFICATIONS

<b>Type</b>	Vertical tape loading; 4-track 2-channel stereo double cassette deck	<b>Input</b>	80 mV (−20 dBm) input level at maximum
<b>Heads</b>	Play back head × 1 recording/playback head × 1 Erase head (Double gap ferrite) × 1	<b>LINE</b>	Input impedance: 50 kΩ /kohms unbalanced
<b>Motors</b>	DC servo motor × 2	<b>Output</b>	775 mV (0 dB) output level at maximum
<b>Tape Speed</b>	4.8 cm/sec.	<b>LINE</b>	(with 47 kΩ /kohms load, recorded level of 200 pwb/mm)
<b>Fast Forward</b>		<b>PHONES</b>	1.2 mW output level at maximum
<b>Rewind Time</b>	Approx. 100 sec. with a C-60 cassette		(optimum load impedance)
<b>Recording Bias</b>	Approx. 105 kHz	<b>Power Supply</b>	60 Hz, voltage is shown on rating label
<b>Overall S/N Ratio</b> (at 3% THD level)	Dolby C NR on: more than 74 dB (CCIR/ARM)	<b>Power Consumption</b>	16 W
<b>Overall Frequency Response</b>	20 - 17,000 Hz ±3 dB (at −20 dB, Metal tape)	<b>Dimensions</b>	434 (W) × 135 (H) × 263 (D) mm
<b>Channel Separation</b>	More than 40 dB (at 1 kHz)	<b>Weight</b>	(17-3/32" × 0-00/00" × 00-00/00")
<b>Wow &amp; Flutter</b>	0.08% WRMS, ±0.14% w. peak		4.0 kg (00 lbs)

\* Above specifications and design are subject to change without prior notice.

Best results will be obtained with use of DENON GR Series cassette tapes.

Dolby noise reduction and HX Pro headroom extension manufactured under license from Dolby Laboratories Licensing Corporation. HX Pro originated by Bang & Olufsen.

"DOLBY", the double-D symbol  and "HX PRO" are trademarks of Dolby Laboratories Licensing Corporation.

## DISASSEMBLY INSTRUCTIONS

### 1. How to Remove the Front PANEL A'ssy

- (1) Remove the six screws (SPECIAL SCREW) (101) in the side of the top cover (35). Move the top cover to the rear and rise it to remove it.
- (2) Disconnect all lead connectors.
 

C. Mecha (A)	P.B. Head wire → CB131	Audio P.W. board
C. Mecha (B)	ERASE Head wire → CB143	Power P.W. board
	PB/REC Head wire → CB141	Audio P.W. board
Display P.W. board	CW121-1A → CN121-2A	Audio P.W. board
	CW121-1B → CN121-2B	
- (3) Remove the Volume knob (26).
- (4) Remove the screw (3X8CBTS(P)-B) (103).
- (5) Remove the screw (3X8CBTS(S)-B) (102).
- (6) Remove the two Hooks on the bottom, Front Panel Ass'y can be removed towards the front.

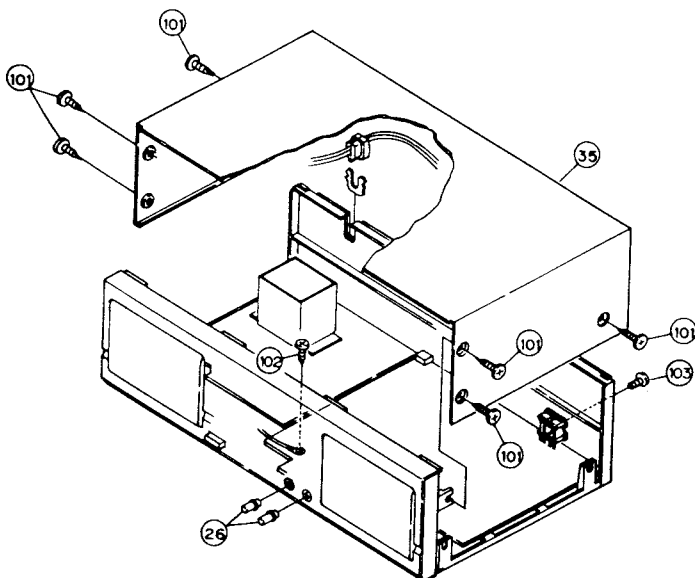
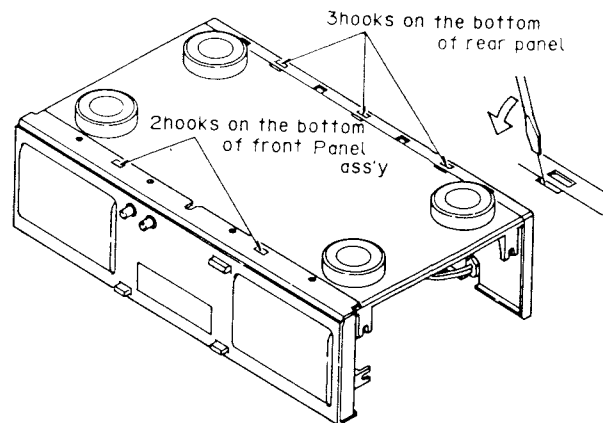

### 2. How to Remove the Cassette Mechanisms

Remove the four mechanism retaining screws (3X8CBTS(P)-B) (103), (3X8CBTS(S)-B) (102) and take out C. Mechanism (A) (22) and C. Mechanism (B) (23).

### 3. How to Remove the Display P.W. board

- (1) Disconnect leads connectors.
 

C. Mecha (A)	→ CN242	Display P.W. board
C. Mecha (B)	→ CN241	
- (2) Remove the six Display P.W. board retaining screws (3X8CBTS(P)-B) (103) and take out the Display P.W. board.

### 4. How to Remove the Cassette Door

- (1) Remove the Mini Damper (11) retaining screw (3X8CBTS(P)-B) (103) and take out the Mini Damper (11).
- (2) Hold the legs of the CASSETTE BOX folded inwards and pull up to remove the CASSETTE BOX (13) and BOX SPRING (15) (16).

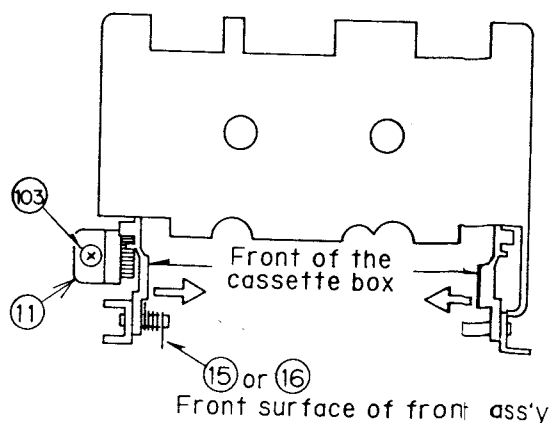

## 5. How to Remove the Back panel

- (1) Remove the top cover (35) and front Panel. Ass'y. (Refer to section 1.)
- (2) Remove the screw (3X8CBTS(P)-B) (103) that is holding the 4P pin jack.
- (3) Remove the busing (6) (7) that is fixing power supply cord from back panel (48).
- (4) Remove the three hooks on the bottom of back panel (48) and pull the unit back to detach it.

## 6. How to Remove the Audio P.W. Board

- (1) Remove the top cover (35) and the front esc. Ass'y. (Refer to section 1.)
- (2) Remove the screw (3X8CBTS(P)-B) (103) that is holding the 4P pin jack.
- (3) Remove the connectors from the audio P.W. board and power P.W. board.  
power P.W. board CW191 → CN191 audio P.W. board
- (4) Remove the five screws (3X8CBTS(P)-B) (103), (3X8CBTS(S)-B) (102) the audio P.W. board can be removed by rising it.

## 7. How to Remove the Power Supply P.W. board

- (1) Remove the top cover (35). (Refer to section 1.)
- (2) Remove the busing (6) (7) that is fixing power supply cord from rear panel (48).
- (3) Remove the connectors from the audio P.W. board and power P.W. board.  
power P.W. board CW191 → CN191 Audio P.W. board
- (4) Remove the seven screws (4X10CBST(P)-Z) (104), (3X8CBST(P)-B) (103) that are holding the power transformer and P.W. board. The power supply P.W. board can be removed by rising it.

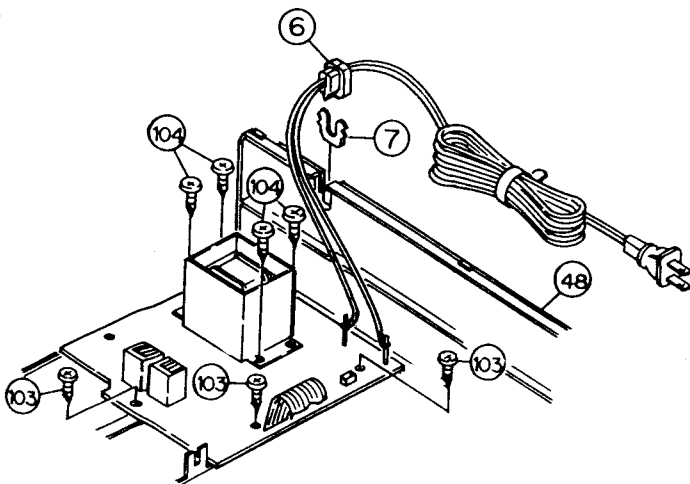

## ADJUSTING AND CHECKING THE MECHANISM SECTION

### 1. Replacing the Pinch Roller

Before replacing the pinch roller, clean the tape contact surface of the pinch roller and the capstan shaft.

Most causes of poor tape transport can be traced to dirty pinch roller and capstan shaft.

Remove the clips that press the pinch roller and pull the pinch roller forward to remove it.

After replacing, run a padless C-90 tape to check for tape curls at the tape guide section of the head.

### 2. Checking the Pressure Force of the Pinch Roller

In the playback mode, hook a spring weight onto the bracket at the center of the pinch roller. After separating the pinch roller from the capstan shaft, allow the pinch roller to contact the capstan shaft again. Check to make sure the spring weight reads between 250 ~ 350 g when the pinch roller starts to rotate.

Replace the pinch roller when it does not conform to the standard specification values.

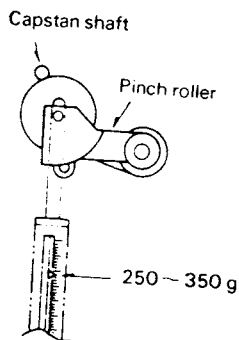

### 3. Replacing the Record/Playback Head

(1) How to remove the R/P HEAD.

- 1) Remove securing screw and azimuth adjusting screw from the record/playback head.
- 2) Remove the soldered head wire and disassemble the mechanical unit to remove the record/playback head.

(2) How to assemble the R/P HEAD.

Reverse the above (1) procedures for removing the R/P HEAD.

\* Solder the HEAD WIRE according to the diagram.

mechanism (recording/playback head)

### 4. Checking the Take-up Torque

Load the cassette type torque meter (SONY TW2111).

Check to make sure that the average torque meter reading is within 30-70 g-cm during playback.

### 5. Checking the FF and REW Torques

Load the cassette type torque meter (SONY TW2231). Check to make sure the torque meter indicates within 80~170 g-cm at the end of FF and REW.

### 6. Checking the Back Tension Torque During Record/Playback

Load the cassette type torque meter (SONY TW2111); check to make sure the torque meter reads between 2 ~ 6 g-cm during playback and that there is no unevenness.

If it is not within this range, replace the reel ass'y or Washer.

### 7. Checking the FF and REW Times

Load a C-60 cassette tape (DENON GR-2/60); check to make sure the tape is fast forwarded or rewound within 120 seconds. If it is not within this range, check sections 5 and 6.

### 8. Checking the Existence of a Cassette Housing and the Operation of the Erase Prevention, Metal and Chrome Switch

Confirm that the sensor arm properly detecting the tape type detection holes on the cassette housing.

## ADJUSTING THE ELECTRICAL SECTIONS

### ● Measuring instruments necessary for adjustments

- (1) Audio signal generator
- (2) Variable resistance attenuator
- (3) Electronic voltmeter
- (4) Oscilloscope
- (5) Frequency counter
- (6) Adjustment screwdriver
- (7) Trap coil adjustment square stick
- (8) Test tapes (SONY TY-224)  
(A-BEX TCC-130, TCC-153, TCC-262B/162B)  
(DENON GR-2/60)
- (9) Transport Check cassette tape (A-BEX TCC-902)
- (10) Lead line with alligator clip

### ● Caution on adjusting

- (1) Before adjusting, clean the head surface, capstan and the pinch roller with a gauze or a cotton swab moistened with alcohol.
- (2) Demagnetize the R/P HEAD and the E. HEAD with a head eraser.
- (3) Completely demagnetize the adjustment screwdriver.
- (4) Unless instructed otherwise, set the various controls as follows:
  - INPUT volume ..... maximum
  - DOLBY NR switch ..... OFF
  - BIAS volume ..... Center click position

### 1. Tape Transport Check

Load the transport check cassette. In the operational mode, illuminate the fixing guides of the R/P HEAD with a lamp and check to make sure the tape edge does not come in contact with the tape guide section.

The tape transport is the most important element in determining the performance of a cassette deck.

Avoid moving the various adjustment screws, nuts, etc., as much as possible. Refer to the pages on "Adjusting and Checking the Mechanism Section" when replacing or adjusting the R/P HEAD.

### 2. Adjusting the Azimuth

- (1) After completing the tape transport check, load the test tape (A-BEX TCC-153).
- (2) Playback the test tape; adjust the azimuth screw so that section A of the resurge wave form is maximum and section B is minimum.

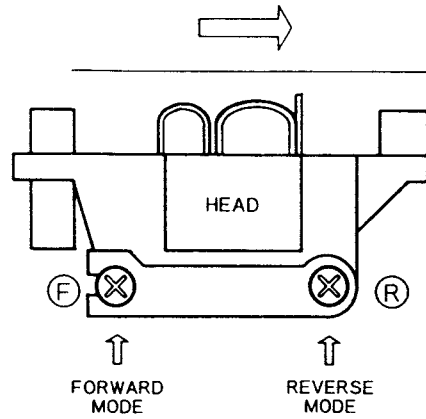
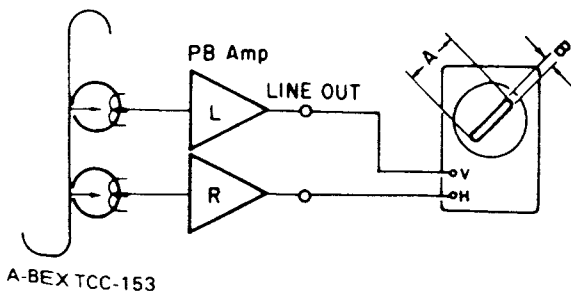

### 3. Checking and Adjusting the Tape Speed

- (1) Connect the frequency counter to the LINE OUT terminal and load test tape (SONY TY-224).
- (2) Load cassette tapes on both cassette decks A and B. Next, on the deck (A or B) whose speed is to be adjusted, while holding down the PLAY, FF and REW buttons together, press the POWER switch. After the power has been on for about two seconds, the Remote Control Indicator "■" in Display will light up and the cassette deck will begin to play in speed adjustment mode.  
(Speed adjustments can not be made, unless this mode is first selected.)
- (3) At first high speed adjustments, press the DUBBING SPEED "HIGH" button and use Meter Unit RT554 for Cassette Deck A and RT552 for Cassette Deck B.  
Next normal speed adjustments, press the DUBBING SPEED "NORMAL" button and use Meter Unit RT553 for Cassette Deck A and RT551 for Cassette Deck B.  
(Note that speed adjustment mode is cancelled when the tape is ejected.)

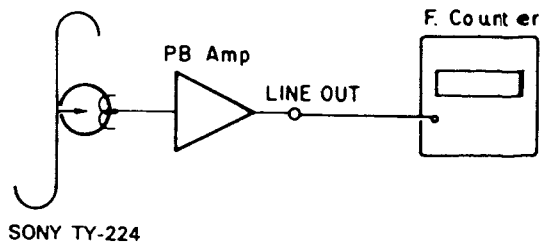

Mode	A/B	Adjusting volume number	F. counter (Hz)
Normal speed	A	RT-553	3020±10
	B	RT-551	3010±10
High speed	A	RT-554	6030±10
	B	RT-552	6020±10

#### 4. Adjusting the Playback Section

(1) Adjusting the playback level

- A-deck Playback the Dolby standard level test tape (A-BEX TTC-130) and adjust RT-101 (L ch), RT-201 (R ch) so that the LINE OUT voltage becomes 0 dB (775 mV).
- B-deck Playback the Dolby standard level test tape (A-BEX TTC-130) and adjust RT-102 (L ch), RT-202 (R ch) so that the LINE OUT voltage becomes 0 dB (775 mV).

(2) Adjusting the playback frequency response

Playback the test tape (A-BEX TCC-262B/162B) and check to make sure that the frequency response meets the specifications in the diagram.

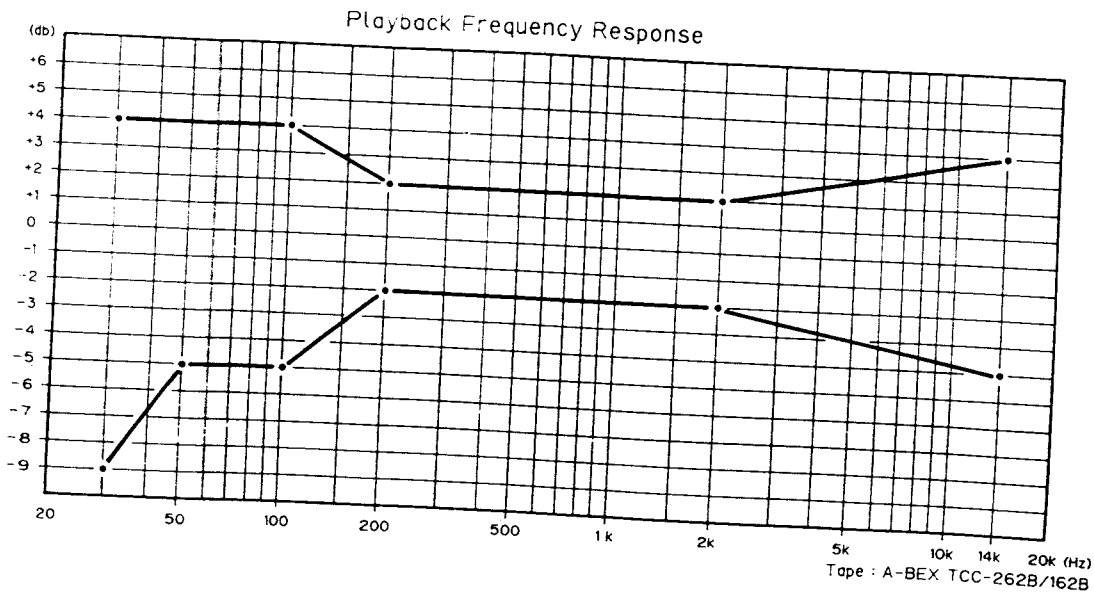
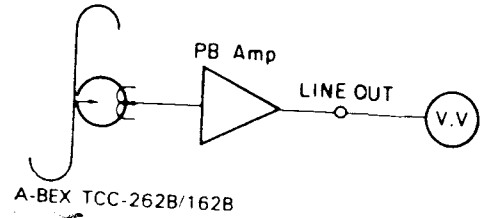
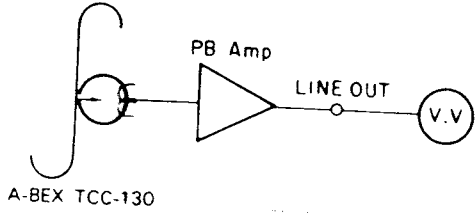

### 5. Adjusting the Recording Section

(1) Adjusting the record/playback overall frequency response. (CrO<sub>2</sub>)

- 1) Load the test tape GR-2/60, record a signal with an input level of -40 dB, 1 kHz at the LINE IN terminal; playback this recording.
- 2) Change the frequency of the input signal to 10 kHz, record and playback; adjust RT-105 (L ch), RT-205 (R ch) so that the characteristic standards meet the following diagram when compared to the 1 kHz signal output level.  
(The other TAPE POSITIONS will automatically be adjusted by finishing of the foregoing adjustments.)

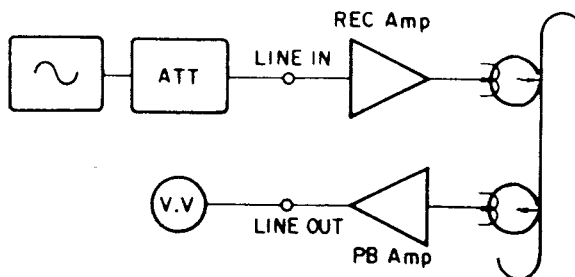

Dolby C Record/Playback Overall Frequency Response

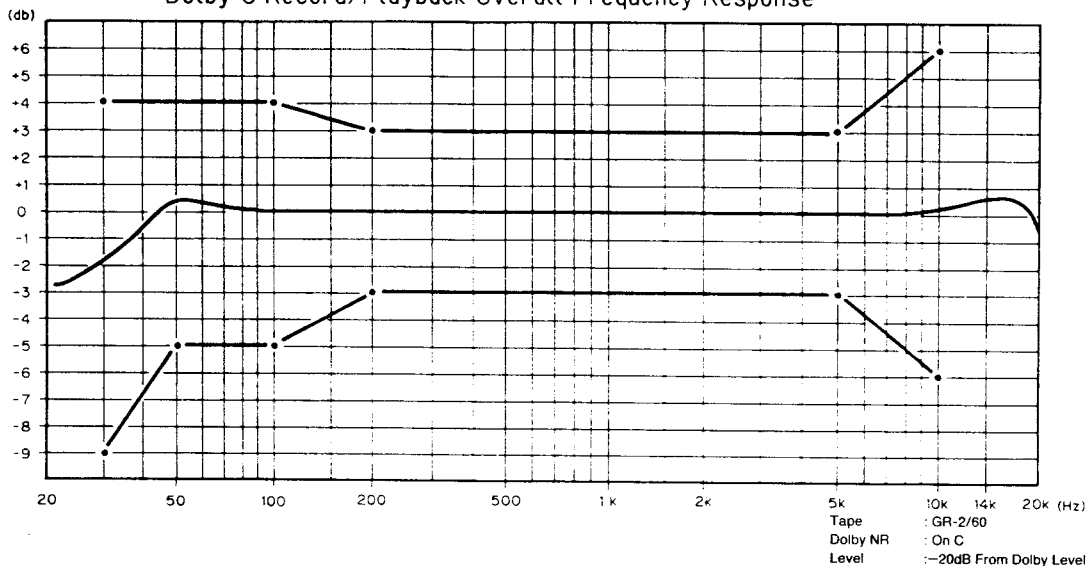

(2) Adjusting the record/playback levels (CrO<sub>2</sub>)

- 1) Load a GR-2/60 tape and after having recorded a signal of 1 kHz (-20 dB), play it back.
- 2) Adjust RT-103 (L ch) and RT-203 (R ch) so that the output from the line out terminal has the same value as the output when monitoring the recording.

(3) Checking the Dolby C record/playback overall frequency response

- 1) Set the DOLBY NR switch to the "C" position.
- 2) Using the test tapes GR-2/60, perform record/playback in the same manner as 5-(1).
- 3) Check to make sure that the record/playback overall frequency response meets the specifications in the diagram.

Record/Playback Overall Frequency Response

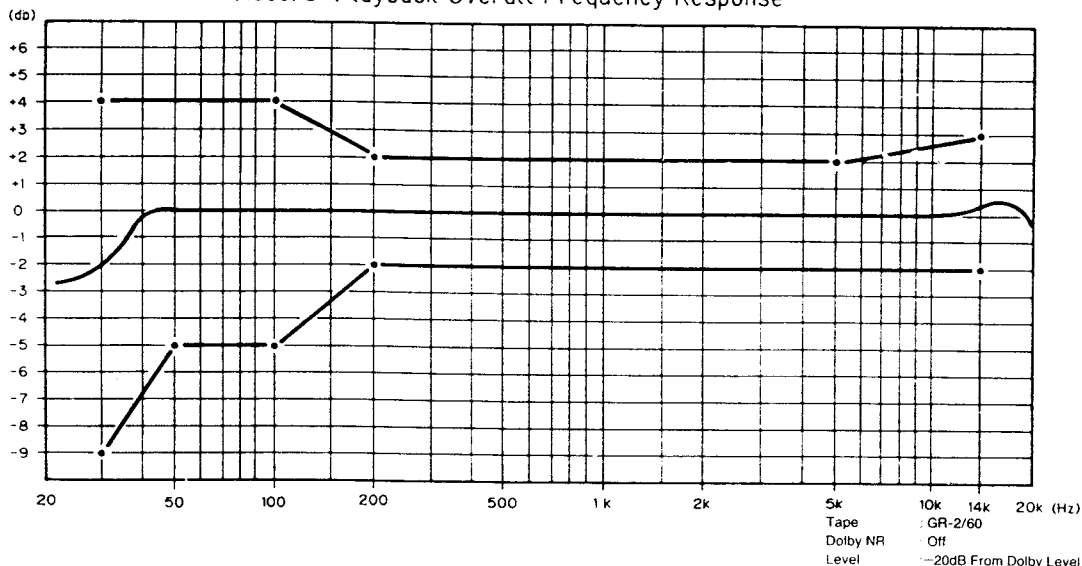





**LEVEL DIAGRAM**

**PLAYBACK SYSTEM**  
TCC-130 DOLBY B-TYPE  
400 Hz 200 nwb/m

PLAYBACK MODE

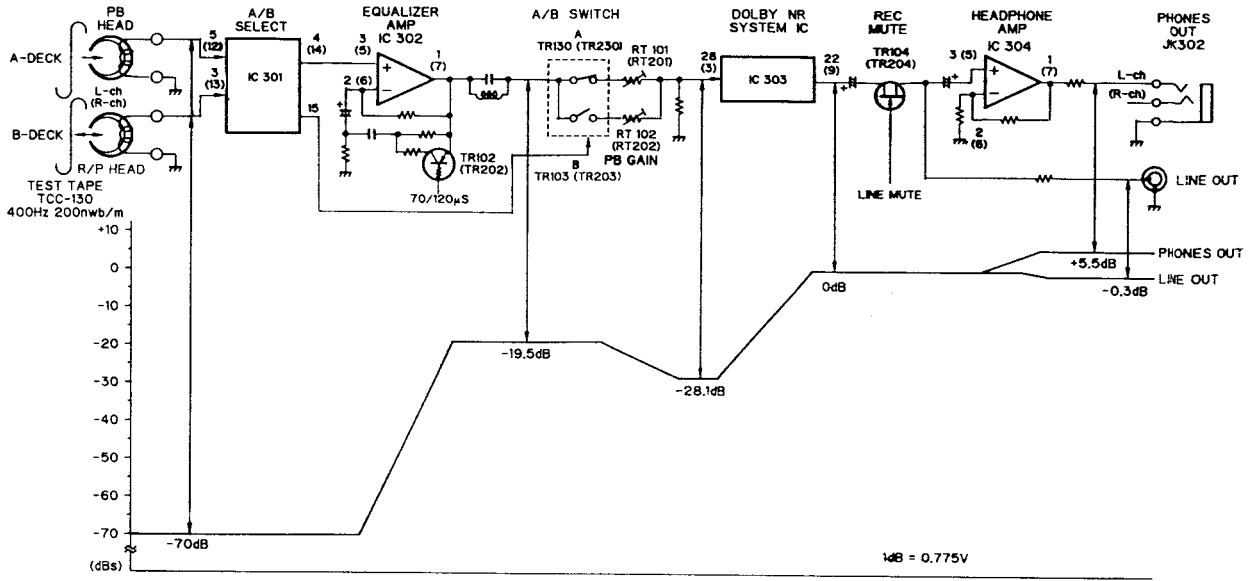

**RECORDING SYSTEM**

INPUT FREQUENCY  
400 Hz

REC MODE

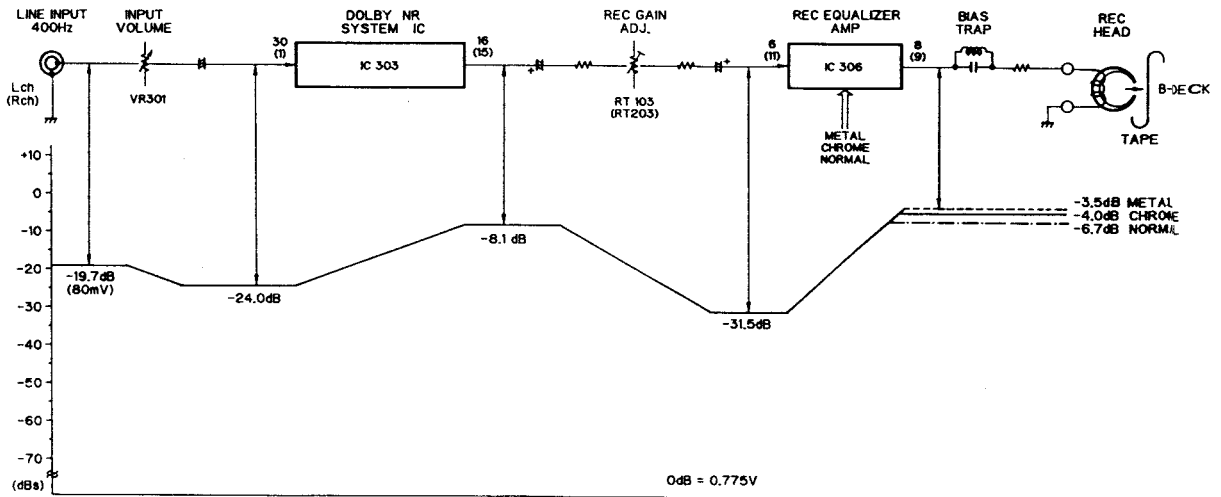

**PARTS LIST EXPLODED VIEW**

Ref. No.	Part No.	Part Name	Remarks	Q'ty
● 1	KU-9322	Audio P.W.B. unit Ass'y		1
● 2	KU-9323	Display P.W.B. unit Ass'y		1
● 3	KU-9324	Power P.W.B. unit Ass'y	U.S.A. and Canada models	1
● 3	KU-9324 Z	Power P.W.B. unit Ass'y	Europe and Australia models	1
● 3	KU-9324 M	Power P.W.B. unit Ass'y	Multi-voltage model	1
△ 4	233 9678 004	Power transformer	U.S.A. and Canada models	1
△ 4	233 9673 006	Power transformer	Europe and Australia models	1
△ 4	233 9677 005	Power transformer	Multi-voltage model	1
△ 5	206 2067 005	AC cord with connector	U.S.A. and Canada models	1
△ 5	206 2060 002	AC cord with connector	Europe and Multi-voltage models	1
△ 5	206 2060 002	AC cord with plug	U.K. model	1
△ 5	206 2122 005	AC cord with connector	Australia model	1
△ 6	445 0056 008	Cord bush		1
● 7	412 2008 012	Bushing plate		1
8	103 9202 205	Front Panel		1
9	143 9180 008	Display window		1
10	129 0163 002	Indicate sheet		2
11	421 9007 007	Mini damper		2
12	415 9086 007	Front stay		1
13	103 1372 502	Cassette box		2
14	463 9079 000	Cassette spring		4
15	463 0659 018	Box spring (R)		1
16	463 0660 010	Box spring (L)		1
● 17	412 9447 207	Eject lever (B)		1
● 18	412 9446 208	Eject lever (A)		1
● 19	412 9448 206	Lever stay (A)		1
20	463 9080 002	Spring		2
22	338 0182 001	C. Mecha (A)	PB	1
23	338 0183 000	C. Mecha (B)	REC	1
24	113 9313 007	Eject button		1
25	113 9314 103	Power button		1
26	112 9136 003	Volume knob		2
27	113 9315 005	Function button		1
● 28	414 9180 007	Earth plate		1
29	212 1039 000	1P push switch	SW523	1
30	143 9181 007	Remocon window		1
31	393 8022 005	FL tube	BJ369GK	1
32	499 0150 008	Remote sensor	SBX1610-52	1
33	103 9206 104	Cassette door		2
34	143 9182 200	Window		2
35	102 9050 108	Top cover		1
● 36	412 9449 205	Lever stay (B)		1
37	212 9572 006	Slide switch	SW520-522	3
38	204 6551 016	15P connector with wire		1
39	204 6550 004	12P connector with wire		1
40	204 6551 003	15P connector with wire		1
41	211 0707 000	Variable 100k ohm	VR301	1
42	211 0706 001	Variable 1k ohm	VR302	1
43	204 8264 026	H/P jack		1
46	113 1228 035	Foot cap		4
● 47	411 9142 004	Chassis		1
● 48	105 9263 208	Rear panel		1
● 48	105 9263 211	Rear panel	Multi-voltage model only	1
49	204 8498 009	4P RCA pin jack		1
● 50	409 9006 008	Attach plate		4

Ref. No.	Part No.	Part Name	Remarks	Q'ty
51	204 8416 007	Mini jack		1
52	414 9187 000	Shield sheet		1
53	113 9316 101	Push button		1
54	203 5121 004	3P connector with wire		4
55	204 0496 009	6P connector with wire		1
56	409 9005 009	Attach plate (B)		2
57	461 0410 109	Rubber pad		4
<b>SCREW</b>				
100	473 8047 001	Special screw		2
101	473 7509 016	Screw 4×10	CBTS (P) B	6
102	473 7002 021	Screw 3×8	CBTS (S) B	5
103	473 7500 044	Screw 3×8	CBTS (P) B	22
104	473 7502 013	Screw 4×10	CBTS (P) Z	4
<b>PACKING &amp; ACCESSORIES</b>				
●	505 8092 010	Laminate envelope		1
●	505 0038 030	Poly cover		1
	203 2360 004	2P pin cord		2
	203 5013 002	3P mini plug cord		1
●	511 9416 001	Operating instructions	U.S.A. and Canada models	1
●	511 9419 008	Operating instructions	Europe and Australia models	1
●	511 9420 000	Operating instructions	Multi-voltage model	1
	202 0042 004	Plug adapter	Multi-voltage model only	1
	515 0690 006	DEL warranty home	U.S.A. model only	1
●	503 9282 001	Cushion		2
●	501 9274 000	Carton case		1

- Part indicated with the mark " ● " are not always in stock and possibly to take a long period of time for supplying, or in some case supplying of part may be refused.
- When ordering of part, clearly indicate "1" and "1" (i) to avoid mis-supplying.

**EXPLODED VIEW CHASSIS AND CABINET**

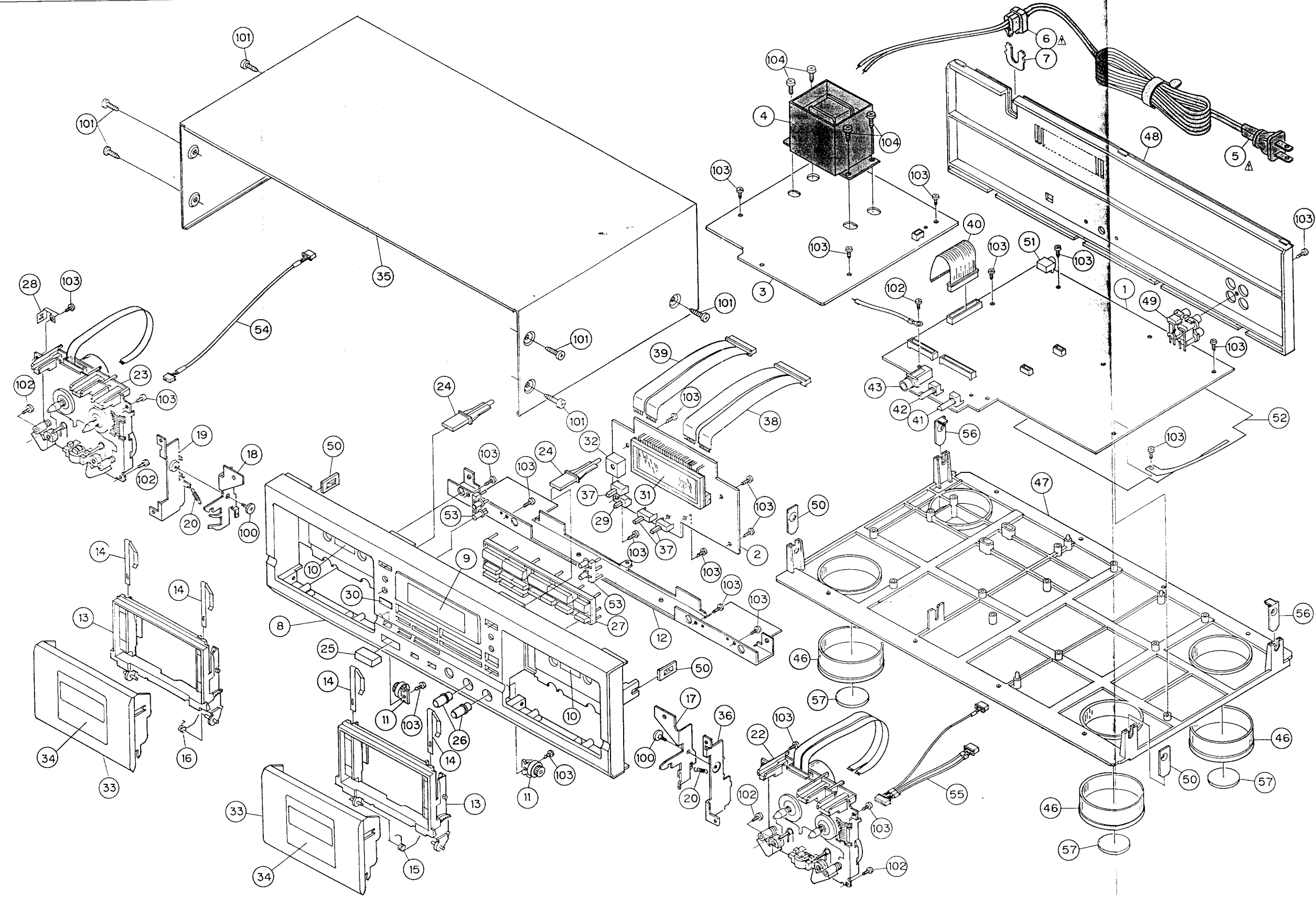

**WARNING:**  
 Parts marked with this symbol  have critical characteristics.  
 Use ONLY replacement parts recommended by the manufacturer.

PRINTED WIRING BOARD PATTERNS

KU-9322 AUDIO P.W.B. UNIT ASS'Y

A  
B  
C  
D  
E

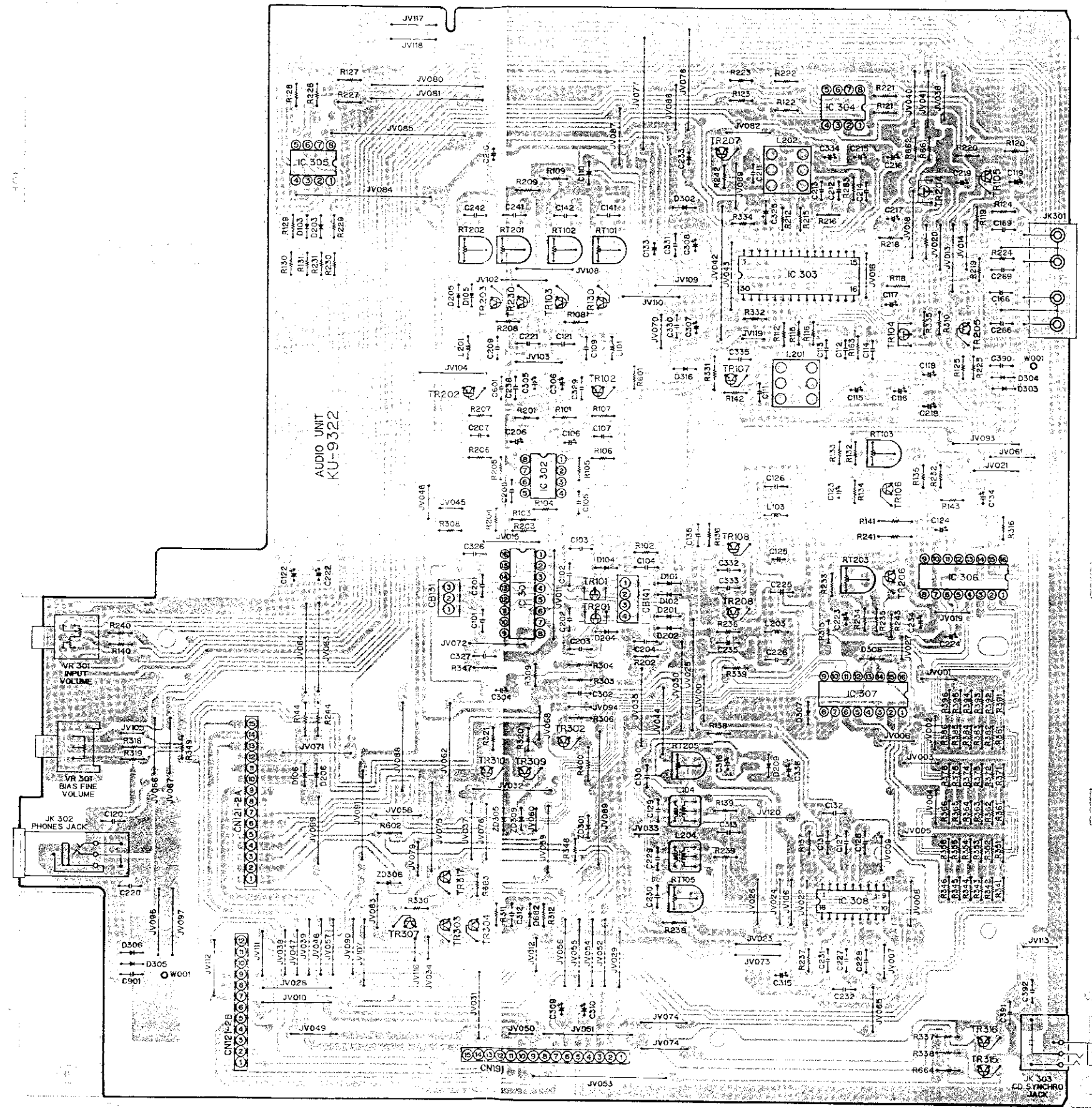

KU-9323 DISPLAY P.W.B. UNIT ASS'Y

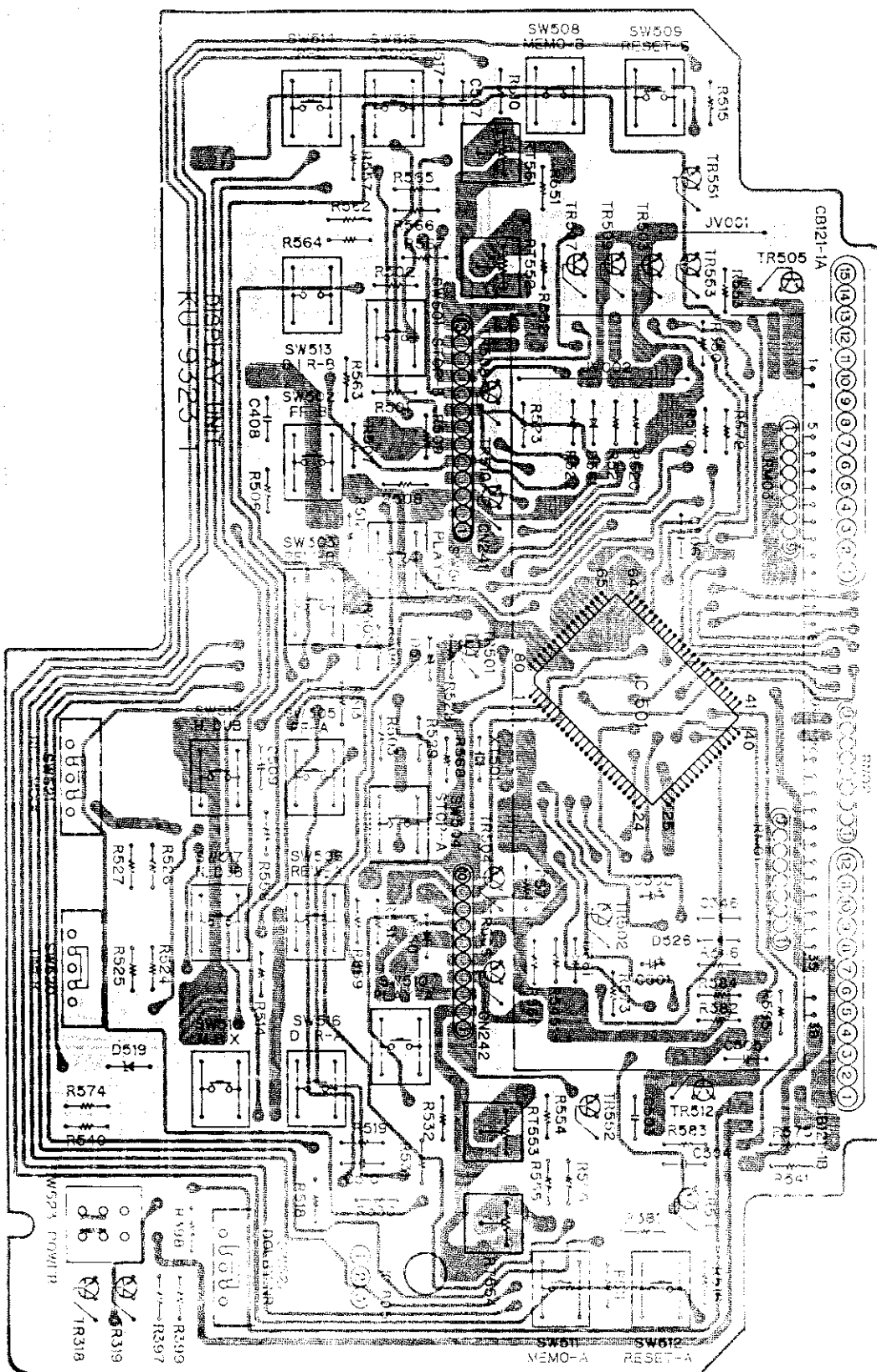

A  
B  
C  
D  
E

4/77



**NOTE FOR PARTS LIST**

- Part indicated with the mark "●" are not always in stock and possibly to take a long period of time for supplying, or in some case supplying of part may be refused.
- When ordering of part, clearly indicate "1" and "1" (i) to avoid mis-supplying.
- Ordering part without stating its part number can not be supplied.
- Part indicated with the mark "★" is not illustrated in the exploded view.
- Not including Carbon Film ±5%, 1/4W Type in the P.W. Board parts list. (Refer to the Schematic Diagram for those parts.)

**WARNING:**  
Parts marked with this symbol  have critical characteristics.  
Use ONLY replacement parts recommended by the manufacturer.

**● Resistors**

Ex.: RN 14K 2E 182 G FR

Type	Shape and performance	Power	Resistance	Allowable error	Others
RD : Carbon	2B : 1/8W	F : ±1%	P : Pulse-resistant type		
RC : Composition	2E : 1/4W	G : ±2%	NL : Low noise type		
RS : Metal oxide film	2H : 1/2W	J : ±5%	NB : Non-burning type		
RW : Winding	3A : 1W	K : ±10%	FR : Fuse-resistor		
RN : Metal film	3D : 2W	M : ±20%	F : Lead wire forming		
RK : Metal mixture	3F : 3W				
	3H : 5W				

**\* Resistance**

1 8 2 — 1800 ohm = 1.8 kohm  
Indicates number of zeros after effective number.  
2-digit effective number.

● Units: ohm

1 R 2 — 1.2 ohm  
1-digit effective number.  
2-digit effective number, decimal point indicated by R.

● Units: ohm

**\* Capacity (electrolyte only)**

2 2 2 — 2200µF  
Indicates number of zeros after effective number.  
2-digit effective number.

● Units: µF.

2 R 2 — 2.2µF  
1-digit effective number.  
2-digit effective number, decimal point indicated by R.

● Units: µF.

**● Capacitors**

Ex.: CE 04W 1H 2R2 M BP

Type	Shape and performance	Dielectric	Capacity	Allowable error	Others
CE : Aluminum foil electrolytic	0J : 6.3V	F : ±1%	HS : High stability type		
CA : Aluminum solid electrolytic	1A : 10V	G : ±2%	BP : Non-polar type		
CS : Tantalum electrolytic	1C : 16V	J : ±5%	HR : Ripple-resistant type		
CQ : Film	1E : 25V	K : ±10%	DL : For charge and discharge		
CK : Ceramic	1V : 35V	M : ±20%	HF : For assuring high frequency		
CC : Ceramic	1H : 50V	Z : +80%	U : UL part		
CP : Oil	2A : 100V	- : -20%	C : CSA part		
CM : Mica	2B : 125V	P : +100%	W : UL-CSA type		
CF : Metalized	2C : 160V	- : -0%	F : Lead wire forming		
CH : Metalized	2D : 200V	C : ±0.25pF			
	2E : 250V	D : ±0.5pF			
	2H : 500V	= : Others			
	2J : 630V				

**\* Capacity (except electrolyte)**

2 2 2 — 2200µF = 0.0022µF  
(More than 2) — Indicates number of zeros after effective number.  
2-digit effective number.

● Units: µF.

2 2 1 — 220PF  
(0 or 1) — Indicates number of zeros after effective number.  
2-digit effective number.

● Units: PF.

● When the dielectric strength is indicated in AC, "AC" is included after the dielectric strength value.

**PRINTED WIRING BOARD PARTS LIST**

**KU-9323 DISPLAY P.W.B. UNIT ASS'Y**

Ref. No.	Part No.	Part Name	Remarks
<b>SEMICONDUCTORS GROUP</b>			
IC501	262 2167 002	IC HD6433724FC80F	
IC805	499 0150 008	IC SBX1610-52	
TR318, 319	269 0018 002	Transistor DTC143ES	Built in resistor
TR501	269 0046 003	Transistor DTA144ES	Built in resistor
TR502	269 0040 009	Transistor DTC144ES	Built in resistor
TR503	269 0018 002	Transistor DTC143ES	Built in resistor
TR504	272 0025 004	Transistor 2SB562C	
TR505	269 0018 002	Transistor DTC143ES	Built in resistor
TR506	272 0025 004	Transistor 2SB562C	
TR507	269 0018 002	Transistor DTC143ES	Built in resistor
TR508	272 0025 004	Transistor 2SB562C	
TR509	269 0018 002	Transistor DTC143ES	Built in resistor
TR510	272 0025 004	Transistor 2SB562C	
TR511, 512	269 0006 906	Transistor DTA124ES	Built in resistor
TR551, 552	271 0192 002	Transistor 2SA933S	
TR553	269 0018 002	Transistor DTC143ES	Built in resistor
D516	276 0468 003	Zener diode HZS9B-1	
D519	276 0468 003	Zener diode HZS9B-1	

Ref. No.	Part No.	Part Name	Remarks
D526	276 0432 000	Diode ISS270A	
D560, 661	276 0432 000	Diode ISS270A	
D561, 662	276 0432 000	Diode ISS270A	
<b>RESISTORS GROUP</b>			
RT551	211 6070 003	Semi fixed 1k ohm	V06QB102
RT552	211 6070 016	Semi fixed 2.2k ohm	V06QB222
RT553	211 6070 003	Semi fixed 1k ohm	V06QB102
RT554	211 6070 016	Semi fixed 2.2k ohm	V06QB222
R397	241 2333 062	Carbon 1k ohm 1/6W	RD14B--102J
R398, 399	241 2336 001	Carbon 10k ohm 1/6W	RD14B--103J
R501	241 2333 062	Carbon 1k ohm 1/6W	RD14B--102J
R502	241 2331 064	Carbon 150 ohm 1/6W	RD14B--181J
R503	241 2331 080	Carbon 180 ohm 1/6W	RD14B--181J
R504	241 2332 021	Carbon 270 ohm 1/6W	RD14B--271J
R505	241 2332 063	Carbon 290 ohm 1/6W	RD14B--391J
R506	241 2333 020	Carbon 680 ohm 1/6W	RD14B--681J
R507	241 2333 062	Carbon 1k ohm 1/6W	RD14B--102J
R508	241 2331 064	Carbon 150 ohm 1/6W	RD14B--181J
R509	241 2331 080	Carbon 180 ohm 1/6W	RD14B--181J

Ref. No.	Part No.	Part Name	Remarks
R510	241 2332 021	Carbon 270 ohm 1/6W	RD14B--271J
R511	241 2332 063	Carbon 290 ohm 1/6W	RD14B--391J
R512	241 2333 062	Carbon 1k ohm 1/6W	RD14B--102J
R513	241 2331 064	Carbon 150 ohm 1/6W	RD14B--181J
R514	241 2331 080	Carbon 180 ohm 1/6W	RD14B--181J
R515	241 2332 021	Carbon 270 ohm 1/6W	RD14B--271J
R516	241 2332 063	Carbon 290 ohm 1/6W	RD14B--391J
R517	241 2333 020	Carbon 680 ohm 1/6W	RD14B--681J
R518	241 2335 031	Carbon 5.1k ohm 1/6W	RD14B--512J
R519	241 2333 033	Carbon 750 ohm 1/6W	RD14B--751J
R520	241 2332 089	Carbon 470 ohm 1/6W	RD14B--471J
R521	241 2336 001	Carbon 10k ohm 1/6W	RD14B--103J
R522	241 2332 089	Carbon 470 ohm 1/6W	RD14B--471J
R523	241 2336 001	Carbon 10k ohm 1/6W	RD14B--103J
-527			
R528	241 2333 062	Carbon 1k ohm 1/6W	RD14B--102J
R529	241 2336 001	Carbon 10k ohm 1/6W	RD14B--103J
R530	241 2331 093	Carbon 200 ohm 1/6W	RD14B--201J
R531, 532	241 2337 068	Carbon 4.7k ohm 1/6W	RD14B--472J
R540, 541	241 2328 093	Carbon 11 ohm 1/6W	RD14B--110J
R545	241 2336 001	Carbon 10k ohm 1/6W	RD14B--103J
R546	241 2336 072	Carbon 20k ohm 1/6W	RD14B--203J
R550	241 2336 001	Carbon 10k ohm 1/6W	RD14B--103J
R551	241 2332 089	Carbon 470 ohm 1/6W	RD14B--471J
R552	241 2334 045	Carbon 2.2k ohm 1/6W	RD14B--222J
R553	241 2338 041	Carbon 100k ohm 1/6W	RD14B--104J
R554	241 2332 089	Carbon 470 ohm 1/6W	RD14B--471J
R555	241 2334 045	Carbon 2.2k ohm 1/6W	RD14B--222J
R556	241 2338 041	Carbon 100k ohm 1/6W	RD14B--104J
R557	241 2333 020	Carbon 680 ohm 1/6W	RD14B--681J
R558	241 2333 091	Carbon 1.3k ohm 1/6W	RD14B--132J
R559	241 2335 028	Carbon 4.7k ohm 1/6W	RD14B--472J
-567			
R568	241 2340 084	Carbon 1M ohm 1/6W	RD14B--105J
R570	241 2332 089	Carbon 470 ohm 1/6W	RD14B--471J
R571	241 2336 001	Carbon 10k ohm 1/6W	RD14B--103J
R572	241 2332 089	Carbon 470 ohm 1/6W	RD14B--471J
R573	241 2336 001	Carbon 10k ohm 1/6W	RD14B--103J
R574, 575	241 2328 093	Carbon 11 ohm 1/6W	RD14B--110J
R581, 582	241 2333 062	Carbon 1k ohm 1/6W	RD14B--102J
R583, 584	241 2336 001	Carbon 10k ohm 1/6W	RD14B--103J
R585	241 2331 064	Carbon 150 ohm 1/6W	RD14B--181J
R661	241 2340 084	Carbon 1M ohm 1/6W	RD14B--105J
<b>CAPACITORS GROUP</b>			
C501	254 4148 002	Electrolytic 3.3µ/50V	CE04W1H3R3=
C502	254 4147 003	Electrolytic 2.2µ/50V	CE04W1H2R2=
C503	253 9036 006	Ceramic 0.1µF/50V	CK45-1E104Z
C504, 505	253 9030 060	Ceramic 0.01µF/50V	CK45-1E103K
C506	253 9036 006	Ceramic 0.1µF/50V	CK45-1E104Z
<b>OTHERS PARTS GROUP</b>			
	129 9025 002	FLD pad	
CB121-1A	204 6551 016	15P connector with wire	
CB121-1B	204 6550 014	12P connector with wire	
CN241 (1/2)	209 0308 008	5P Ribon cable	
CN241 (2/2)	209 0309 007	8P ribon cable	

Ref. No.	Part No.	Part Name	Remarks
N242	209 0308 011	5P ribon cable	
D661, R662	125 9002 010	UL tube	
FL501	393 8022 005	FL tube	BJ369GK
SW501 -519	212 4388 907	Tact switch	
SW520 -522	212 9572 006	Slide switch	
SW523	212 1039 000	1P push switch	
W002	209 0310 009	Vinyl wire	
XT501	399 0107 007	Resonator	CST4.19MGW

**KU-9322 AUDIO P.W.B. UNIT ASS'Y**

Ref. No.	Part No.	Part Name	Remarks
<b>SEMICONDUCTORS GROUP</b>			
IC301	262 0419 008	IC HD14053BP	
IC302	262 0864 006	IC µPC4570C	
IC303	263 0720 004	IC HA12170NT	
IC304, 305	263 0565 007	IC BA15218	
IC306	263 0589 009	IC CXA1198AP	
IC307	262 0621 003	IC HD14051BP	
IC308	263 0354 001	IC µPC1297CA	
TR101	275 0042 002	Transistor 2SK373 (Y)	
TR102, 103	269 0080 904	Transistor DTA114TS	Built in resistor
TR104	275 0055 015	Transistor 2SK184 (GR)	
TR105	271 0192 002	Transistor 2SA933S	
TR106	273 0388 906	Transistor 2SC1740S	
TR107	269 0062 906	Transistor DTC124ES	Built in resistor
TR108	269 0072 909	Transistor DTC323TS	Built in resistor
TR130	269 0074 907	Transistor DTC114TS	Built in resistor
TR201	275 0042 002	Transistor 2SK373 (Y)	
TR202, 203	269 0080 904	Transistor DTA114TS	Built in resistor
TR204	275 0055 015	Transistor 2SK184 (GR)	
TR205	271 0192 002	Transistor 2SA933S	
TR206	273 0388 906	Transistor 2SC1740S	
TR207	269 0062 906	Transistor DTC124ES	Built in resistor
TR208	269 0072 909	Transistor DTC323TS	Built in resistor
TR230	269 0074 907	Transistor DTC114TS	Built in resistor
TR302	269 0046 003	Transistor DTA114ES	Built in resistor
TR303	269 0062 906	Transistor DTC124ES	Built in resistor
TR304	269 0016 907	Transistor DTA114WS	Built in resistor
TR307	269 0018 002	Transistor DTC143ES	Built in resistor
TR309, 310	269 0015 005	Transistor DTC124XS	Built in resistor
TR315, 316	269 0020 906	Transistor DTC114ES	Built in resistor
TR317	269 0080 904	Transistor DTA114TS	Built in resistor
ZD301	276 0461 000	Zener diode HZS6A-1	
ZD305, 306	276 0467 004	Zener diode HZS9A-1	
ZD309	276 0467 004	Zener diode HZS9A-1	
D101 -106	276 0432 000	Diode 1SS270A or 1N4125	
D201	276 0432 000	Diode 1SS270A or 1N4125	
D302	276 0432 000	Diode 1SS270A or 1N4125	
D305 -308	276 0432 000	Diode 1SS270A or 1N4125	
D316	276 0432 000	Diode 1SS270A or 1N4125	
D662	276 0432 000	Diode 1SS270A or 1N4125	



Ref. No.	Part No.	Part Name	Remarks
<b>RESISTORS GROUP</b>			
RT101, 102	211 6047 065	Semi fixed 47k ohm	V06PB473
RT103	211 6047 049	Semi fixed 22k ohm	V06PB223
RT105	211 6047 065	Semi fixed 47k ohm	V06PB473
RT201, 202	211 6047 065	Semi fixed 47k ohm	V06PB473
RT203	211 6047 049	Semi fixed 22k ohm	V06PB223
RT205	211 6047 065	Semi fixed 47k ohm	V06PB473
VR301	211 0707 000	Variable 100k ohm	V0920V25FA104
VR302	211 0706 001	Variable 1k ohm	V09V25FB102K
R101	241 2331 064	Carbon 150 ohm 1/6W	RD14B---151J
R102	241 2324 039	Carbon 2.2M ohm 1/6W	RD14B---225J
R103	241 2338 083	Carbon 150k ohm 1/6W	RD14B---154J
R104	241 2331 022	Carbon 100 ohm 1/6W	RD14B---101J
R105	241 2339 037	Carbon 240k ohm 1/6W	RD14B---244J
R106	241 2336 043	Carbon 18k ohm 1/6W	RD14B---183J
R107	241 2336 098	Carbon 24k ohm 1/6W	RD14B---243J
R108	241 2334 087	Carbon 3.3k ohm 1/6W	RD14B---332J
R109	241 2336 085	Carbon 22k ohm 1/6W	RD14B---223J
R112	241 2334 087	Carbon 3.3k ohm 1/6W	RD14B---332J
R115	241 2335 060	Carbon 6.8k ohm 1/6W	RD14B---682J
R116	241 2336 085	Carbon 22k ohm 1/6W	RD14B---223J
R118	241 2336 001	Carbon 10k ohm 1/6W	RD14B---103J
R119	241 2334 087	Carbon 3.3k ohm 1/6W	RD14B---332J
R120	241 2337 068	Carbon 43k ohm 1/6W	RD14B---473J
R121, 122	241 2337 026	Carbon 33k ohm 1/6W	RD14B---333J
R123	241 2331 051	Carbon 130 ohm 1/6W	RD14B---131J
R124	241 2332 089	Carbon 470 ohm 1/6W	RD14B---471J
R125	241 2340 055	Carbon 750k ohm 1/6W	RD14B---754J
R127	241 2338 009	Carbon 68k ohm 1/6W	RD14B---683J
R128, 129	241 2337 000	Carbon 27k ohm 1/6W	RD14B---273J
R130	241 2331 022	Carbon 100 ohm 1/6W	RD14B---101J
R131	241 2340 084	Carbon 1M ohm 1/6W	RD14B---105J
R132	241 2336 043	Carbon 15k ohm 1/6W	RD14B---153J
R133, 134	241 2334 045	Carbon 2.2k ohm 1/6W	RD14B---222J
R135	241 2336 001	Carbon 10k ohm 1/6W	RD14B---103J
R136	241 2335 057	Carbon 6.2k ohm 1/6W	RD14B---622J
R137	241 2336 043	Carbon 15k ohm 1/6W	RD14B---153J
R138	241 2338 083	Carbon 150k ohm 1/6W	RD14B---154J
<b>RESISTORS</b>			
R140	241 2337 000	Carbon 27k ohm 1/6W	RD14B---273J
R141	241 2331 093	Carbon 200 ohm 1/6W	RD14B---201J
R142	241 2340 084	Carbon 1M ohm 1/6W	RD14B---105J
R144	241 2334 045	Carbon 2.2k ohm 1/6W	RD14B---222J
R163	241 2333 004	Carbon 560 ohm 1/6W	RD14B---561J
R201	241 2331 064	Carbon 150 ohm 1/6W	RD14B---151J
R202	241 2324 039	Carbon 2.2M ohm 1/6W	RD14B---225J
R203	241 2338 083	Carbon 150k ohm 1/6W	RD14B---154J
R204	241 2331 022	Carbon 100 ohm 1/6W	RD14B---101J
R205	241 2339 037	Carbon 240k ohm 1/6W	RD14B---244J
R206	241 2336 043	Carbon 18k ohm 1/6W	RD14B---183J
R207	241 2336 098	Carbon 24k ohm 1/6W	RD14B---243J
R208	241 2334 087	Carbon 3.3k ohm 1/6W	RD14B---332J
R209	241 2336 085	Carbon 22k ohm 1/6W	RD14B---223J
R212	241 2334 087	Carbon 3.3k ohm 1/6W	RD14B---332J
R215	241 2335 060	Carbon 6.8k ohm 1/6W	RD14B---682J
R216	241 2336 085	Carbon 22k ohm 1/6W	RD14B---223J
R218	241 2336 001	Carbon 10k ohm 1/6W	RD14B---103J
R219	241 2334 087	Carbon 3.3k ohm 1/6W	RD14B---332J
R220	241 2337 068	Carbon 43k ohm 1/6W	RD14B---473J
R221, 222	241 2337 026	Carbon 33k ohm 1/6W	RD14B---333J
R223	241 2331 051	Carbon 130 ohm 1/6W	RD14B---131J

Ref. No.	Part No.	Part Name	Remarks
R224	241 2332 089	Carbon 470 ohm 1/6W	RD14B---471J
R225	241 2340 055	Carbon 750k ohm 1/6W	RD14B---754J
R227	241 2338 009	Carbon 68k ohm 1/6W	RD14B---683J
R228	241 2337 000	Carbon 27k ohm 1/6W	RD14B---273J
R229	241 2337 000	Carbon 27k ohm 1/6W	RD14B---273J
R230	241 2331 022	Carbon 100 ohm 1/6W	RD14B---101J
R231	241 2340 084	Carbon 1M ohm 1/6W	RD14B---105J
R232	241 2336 043	Carbon 15k ohm 1/6W	RD14B---153J
R233, 234	241 2334 045	Carbon 2.2k ohm 1/6W	RD14B---222J
R235	241 2336 001	Carbon 10k ohm 1/6W	RD14B---103J
R236	241 2335 057	Carbon 6.2k ohm 1/6W	RD14B---622J
R237	241 2336 043	Carbon 15k ohm 1/6W	RD14B---153J
R238	241 2338 083	Carbon 150k ohm 1/6W	RD14B---154J
<b>△R239</b>	<b>241 2315 912</b>	<b>Carbon 10 ohm 1/4W</b>	<b>RD14B2E100GERS</b>
R240	241 2337 000	Carbon 27k ohm 1/6W	RD14B---273J
R241	241 2331 093	Carbon 200 ohm 1/6W	RD14B---201J
R242	241 2340 084	Carbon 1M ohm 1/6W	RD14B---105J
R244	241 2334 045	Carbon 2.2k ohm 1/6W	RD14B---222J
R263	241 2333 004	Carbon 560 ohm 1/6W	RD14B---561J
R303	241 2338 041	Carbon 100k ohm 1/6W	RD14B---104J
R304	241 2336 001	Carbon 10k ohm 1/6W	RD14B---103J
R306	241 2333 062	Carbon 1k ohm 1/6W	RD14B---102J
R308, 309	241 2332 047	Carbon 330 ohm 1/6W	RD14B---331J
R310	241 2324 039	Carbon 2.2M ohm 1/6W	RD14B---225J
R311	241 2337 068	Carbon 43k ohm 1/6W	RD14B---473J
R312	241 2324 039	Carbon 2.2M ohm 1/6W	RD14B---225J
R315	241 2336 043	Carbon 15k ohm 1/6W	RD14B---153J
R316	241 2336 098	Carbon 24k ohm 1/6W	RD14B---243J
R318	241 2333 075	Carbon 1.1k ohm 1/6W	RD14B---112J
R319	241 2334 045	Carbon 2.2k ohm 1/6W	RD14B---222J
R320	241 2335 044	Carbon 5.6k ohm 1/6W	RD14B---562J
R321	241 2334 029	Carbon 1.8k ohm 1/6W	RD14B---182J
R330	241 2338 041	Carbon 100k ohm 1/6W	RD14B---104J
R331	241 2336 085	Carbon 22k ohm 1/6W	RD14B---223J
R332	241 2336 043	Carbon 18k ohm 1/6W	RD14B---183J
R334	241 2336 085	Carbon 22k ohm 1/6W	RD14B---223J
R335, 336	241 2324 039	Carbon 2.2M ohm 1/6W	RD14B---225J
R337	241 2336 001	Carbon 10k ohm 1/6W	RD14B---103J
R338	241 2336 085	Carbon 22k ohm 1/6W	RD14B---223J
R339	241 2334 045	Carbon 2.2k ohm 1/6W	RD14B---222J
R341	241 2338 083	Carbon 150k ohm 1/6W	RD14B---154J
R342	241 2338 009	Carbon 68k ohm 1/6W	RD14B---683J
R343	241 2338 025	Carbon 82k ohm 1/6W	RD14B---823J
R344	241 2338 067	Carbon 120k ohm 1/6W	RD14B---124J
R345	241 2338 009	Carbon 68k ohm 1/6W	RD14B---683J
R346	241 2339 082	Carbon 390k ohm 1/6W	RD14B---394J
R347, 348	241 2336 001	Carbon 10k ohm 1/6W	RD14B---103J
R349	241 2332 089	Carbon 470 ohm 1/6W	RD14B---471J
R351	241 2338 083	Carbon 150k ohm 1/6W	RD14B---154J
R352, 353	241 2337 071	Carbon 51k ohm 1/6W	RD14B---513J
R354	241 2338 070	Carbon 130k ohm 1/6W	RD14B---134J
R355	241 2337 084	Carbon 56k ohm 1/6W	RD14B---653J
R356	241 2338 041	Carbon 100k ohm 1/6W	RD14B---104J
R361	241 2338 070	Carbon 130k ohm 1/6W	RD14B---134J
R362	241 2338 012	Carbon 75k ohm 1/6W	RD14B---753J
R363	241 2338 054	Carbon 110k ohm 1/6W	RD14B---114J
R364	241 2338 012	Carbon 75k ohm 1/6W	RD14B---753J
R365	241 2337 084	Carbon 56k ohm 1/6W	RD14B---653J
R366	241 2338 041	Carbon 100k ohm 1/6W	RD14B---104J
R371	241 2336 072	Carbon 20k ohm 1/6W	RD14B---203J
R372	241 2337 084	Carbon 56k ohm 1/6W	RD14B---653J
R373	241 2337 000	Carbon 27k ohm 1/6W	RD14B---273J

Ref. No.	Part No.	Part Name	Remarks
R374	241 2337 068	Carbon 43k ohm 1/6W	RD14B---473J
R375, 376	241 2337 068	Carbon 43k ohm 1/6W	RD14B---473J
R381	241 2337 068	Carbon 43k ohm 1/6W	RD14B---473J
R382	241 2338 025	Carbon 82k ohm 1/6W	RD14B---823J
R383	241 2337 084	Carbon 56k ohm 1/6W	RD14B---653J
R384	241 2338 025	Carbon 82k ohm 1/6W	RD14B---823J
R385	241 2337 013	Carbon 30k ohm 1/6W	RD14B---303J
R386	241 2338 083	Carbon 150k ohm 1/6W	RD14B---154J
R391	241 2336 027	Carbon 12k ohm 1/6W	RD14B---123J
R392	241 2338 041	Carbon 100k ohm 1/6W	RD14B---104J
R393	241 2337 084	Carbon 56k ohm 1/6W	RD14B---653J
R394	241 2337 055	Carbon 43k ohm 1/6W	RD14B---433J
R395	241 2337 084	Carbon 56k ohm 1/6W	RD14B---653J
R396	241 2338 041	Carbon 100k ohm 1/6W	RD14B---104J
R400	241 2332 089	Carbon 470 ohm 1/6W	RD14B---471J
R601	241 2335 028	Carbon 4.7k ohm 1/6W	RD14B---472J
R602	241 2333 062	Carbon 1k ohm 1/6W	RD14B---102J
R661	241 2336 098	Carbon 24k ohm 1/6W	RD14B---243J
R662	241 2336 098	Carbon 24k ohm 1/6W	RD14B---243J
R663	241 2335 028	Carbon 4.7k ohm 1/6W	RD14B---472J
R664	241 2336 001	Carbon 10k ohm 1/6W	RD14B---103J
<b>CAPACITORS GROUP</b>			
C101	253 3645 008	Ceramic 560pF/50V	CC45SL1H561J
C102	253 3643 000	Ceramic 470pF/50V	CC45SL1H471J
C104	253 9030 002	Ceramic 1000pF/50V	CK45-1E102K
C105	253 3627 000	Ceramic 100pF/50V	CC45SL1H101J
C106	254 4233 014	Electrolytic 330µ/6.3V	CE04W0J331-
C107	255 1256 000	Metalized 7500pF/50V	CQ92M1H752J
C109	253 3631 009	Ceramic 150pF/50V	CC45SL1H151J
C110	254 3036 034	Electrolytic 1µ/50V	CE04D1H010MBP
C111	255 1135 040	Metalized 2700pF/50V	CQ92M1H272J
C112	255 1134 009	Metalized 2200pF/50V	CQ92M1H222J
~114			
C115, 116	254 4260 906	Electrolytic 0.1µ/50V	CE04W1H0R1-
C117	254 4140 000	Electrolytic 4.7µ/35V	CE04W1V4R7-
C118	254 4132 005	Electrolytic 10µ/16V	CE04W1C100-
C119	254 4140 000	Electrolytic 4.7µ/35V	CE04W1V4R7-
C120	253 3635 005	Ceramic 220pF/50V	CC45SL1H221J
C121	253 9030 002	Ceramic 1000pF/50V	CK45-1E102K
C122	254 4145 005	Electrolytic 0.47µ/50V	CE04W1H047-
C123	254 4243 017	Electrolytic 1µ/50V	CE04W1H010M
C124	254 4148 002	Electrolytic 3.3µ/50V	CE04W1H3R3M
C125	254 3056 030	Electrolytic 3.3µ/50V	CE04D1H3R3MBP
C126	253 3631 009	Ceramic 150pF/50V	CC45SL1H151J
C127	253 9030 086	Ceramic 0.022µF/50V	CK45-1E223K
C128	253 9030 099	Ceramic 0.033µF/25V	CK45-1E333K
C129	253 4283 003	Ceramic 390pF/50V	CC45SL2H391J
C130	253 3627 000	Ceramic 100pF/50V	CC45SL1H101J
C131	253 9030 060	Ceramic 0.01µF/50V	CK45-1E103K
C132	253 9031 043	Ceramic 1200pF/50V	CK45-1E122K
C133	254 3036 034	Electrolytic 1µ/50V	CE04D1H010MBP
C135	253 4350 004	Ceramic 680pF/50V	CC45SL1H681J
C166	253 3641 002	Ceramic 390pF/50V	CC45SL1H391J
C169	253 3641 002	Ceramic 390pF/50V	CC45SL1H391J
C201	253 3645 008	Ceramic 560pF/50V	CC45SL1H561J
C202	253 3643 000	Ceramic 470pF/50V	CC45SL1H471J
C204	253 9030 002	Ceramic 1000pF/50V	CK45-1E102K
C205	253 3627 000	Ceramic 100pF/50	



**KU-9324 POWER P.W.B. UNIT ASS'Y**

Ref. No.	Part No.	Part Name	Remarks
<b>SEMICONDUCTORS GROUP</b>			
IC901	263 0810 008	IC NJM7808FA (S)	
IC902	263 0503 001	IC NJM9808FA	
IC903	263 0793 002	IC NJM7806FA (S)	
TR311	272 0025 004	Transistor 2SB562C	
TR312	269 0018 002	Transistor DTC143ES	Built in resistor
TR314, 313	273 0388 906	Transistor 2SC1740S	
TR904	272 0025 004	Transistor 2SB562C	
D517, 518	276 0432 000	Diode 1SS270A or 1N4125	
D901 -904	276 0519 004	Diode 1SR35-200A	
D905	276 0432 000	Diode 1SS270A or 1N4125	
D906, 908	276 0432 000	Diode 1SS270A or 1N4125	
D910, 911	276 0519 004	Diode 1SR35-200A	
D914 -917	276 0519 004	Diode 1SR35-200A	
ZD660	276 0368 019	Zener diode HZS2C-1	
ZD907	276 0460 001	Zener diode HZS5C-1	
ZD912	276 0482 005	Zener diode HZS27-1	
ZD913	276 0467 004	Zener diode HZS9A-1	
<b>RESISTORS GROUP</b>			
R322	241 2336 001	Carbon 10k ohm 1/6W	RD14B--103J
R323	241 2335 028	Carbon 4.7k ohm 1/6W	RD14B--472J
R324, 325	241 2319 925	Carbon 22 ohm 1/4W	RD14B2E220GFRS
R326, 327	241 2338 041	Carbon 100k ohm 1/6W	RD14B--104J
R328, 329	241 2328 006	Carbon 4.7 ohm 1/6W	RD14B--4R7J
R673	241 2331 022	Carbon 100 ohm 1/6W	RD14B--101J
R674	241 2337 013	Carbon 30k ohm 1/6W	RD14B--303J
R675	241 2336 001	Carbon 10k ohm 1/6W	RD14B--103J
R904	241 2334 058	Carbon 2.4k ohm 1/6W	RD14B--242J
R921	241 2336 072	Carbon 20k ohm 1/6W	RD14B--203J
R922	241 2334 074	Carbon 3k ohm 1/6W	RD14B--302J
R950	241 2338 041	Carbon 100k ohm 1/6W	RD14B--104J
<b>CAPACITORS GROUP</b>			
C314	253 3603 008	Ceramic 10pF/50V	CC45SL1H100D
C317, 318	254 4132 005	Electrolytic 10μ/16V	CE04W1C100-
C319	254 4139 008	Electrolytic 100μ/25V	CE04W1E101-
C320, 321	253 9030 028	Ceramic 10pF/50V	CK45-1E222K
C322	253 9030 060	Ceramic 0.01μF/50V	CK45-1E103K
C323	253 9031 085	Ceramic 5600pF/50V	CK45-1E562K
C324	255 4079 006	Film 6800pF/50V	CQ93P2A682J
C518	254 4233 098	Electrolytic 4700μ/6.3V	CE04W0J472-
C902, 903	254 4239 092	Electrolytic 1000μ/25V	CE04W1E102-
C904, 905	254 4130 007	Electrolytic 100μ/10V	CE04W1A101-
C906, 907	253 9031 014	Ceramic 0.068μF/50V	CK45-1E683Z
C908	254 4240 007	Electrolytic 2200μ/25V	CE04W1E222-
C909	254 4257 715	Electrolytic 4700μ/25V	CE04W1E472-
C910	254 4233 098	Electrolytic 4700μ/6.3V	CE04W0J472-
C911	253 9031 014	Ceramic 0.068μF/50V	CK45-1E683Z
C913	254 4244 029	Electrolytic 470μ/50V	CE04W1H471-
C914	254 4144 006	Electrolytic 47μ/35V	CE04W1V470-

Ref. No.	Part No.	Part Name	Remarks
C915	254 4141 009	Electrolytic 100μ/35V	CE04W1V101-
C917	254 4239 018	Electrolytic 10μ/25V	CE04W1E100-
C922	254 4148 002	Electrolytic 3.3μ/50V	CE04W1H3R3-
<b>OTHERS PARTS GROUP</b>			
CB143	205 0981 009	3P connector base	
CW191	204 6551 003	15P connector with wire	
▲F901	202 0022 008	Fuse holder	Multi-voltage model
▲F901	206 1031 045	Fuse (0.25A)	Multi-voltage model
L301	232 0153 004	OSC coil	
W004	203 0638 000	1P contact Ass'y	
W005	203 0639 012	1P wire	

**BUNDLE DIAGRAM**

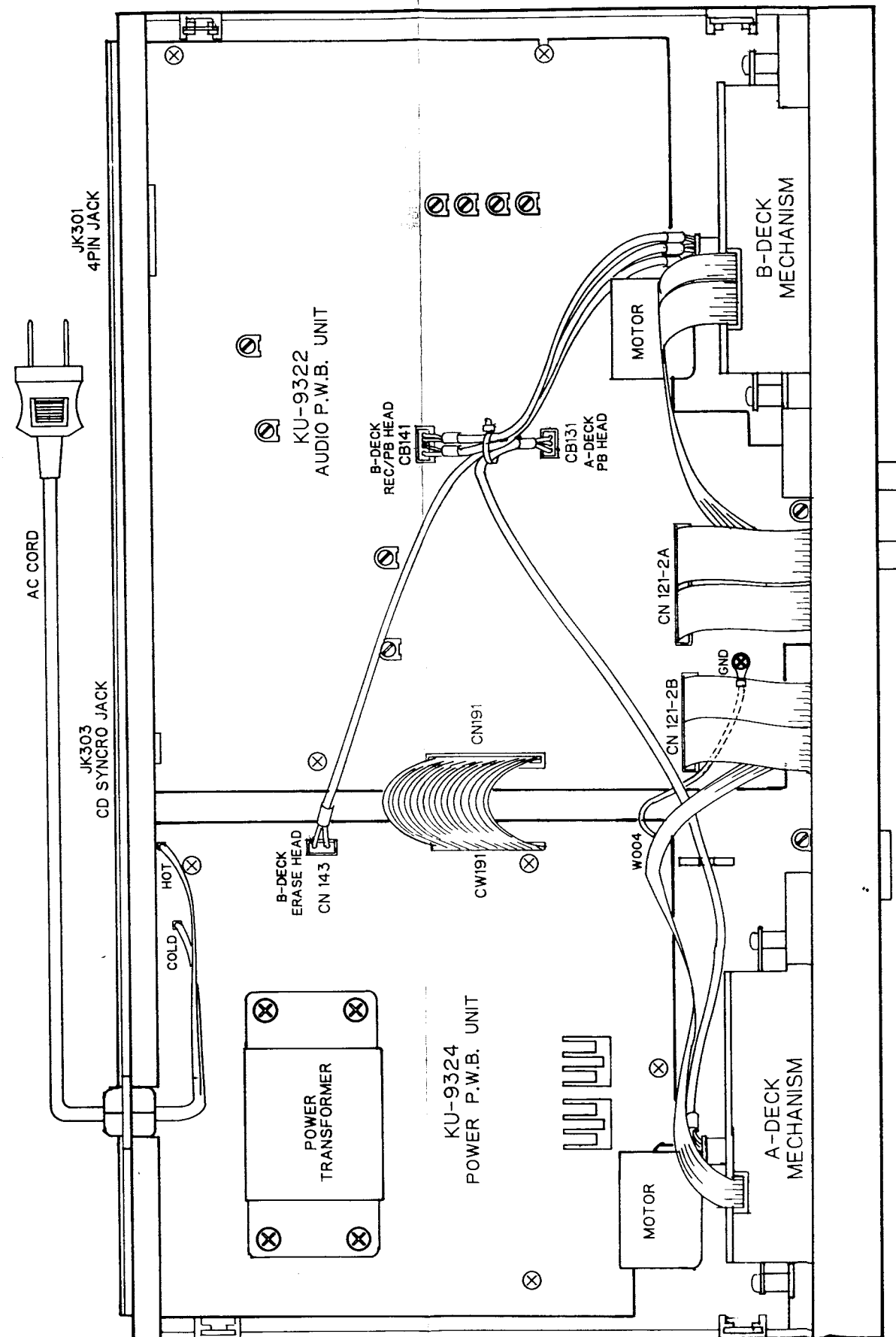

WIRING DIAGRAM

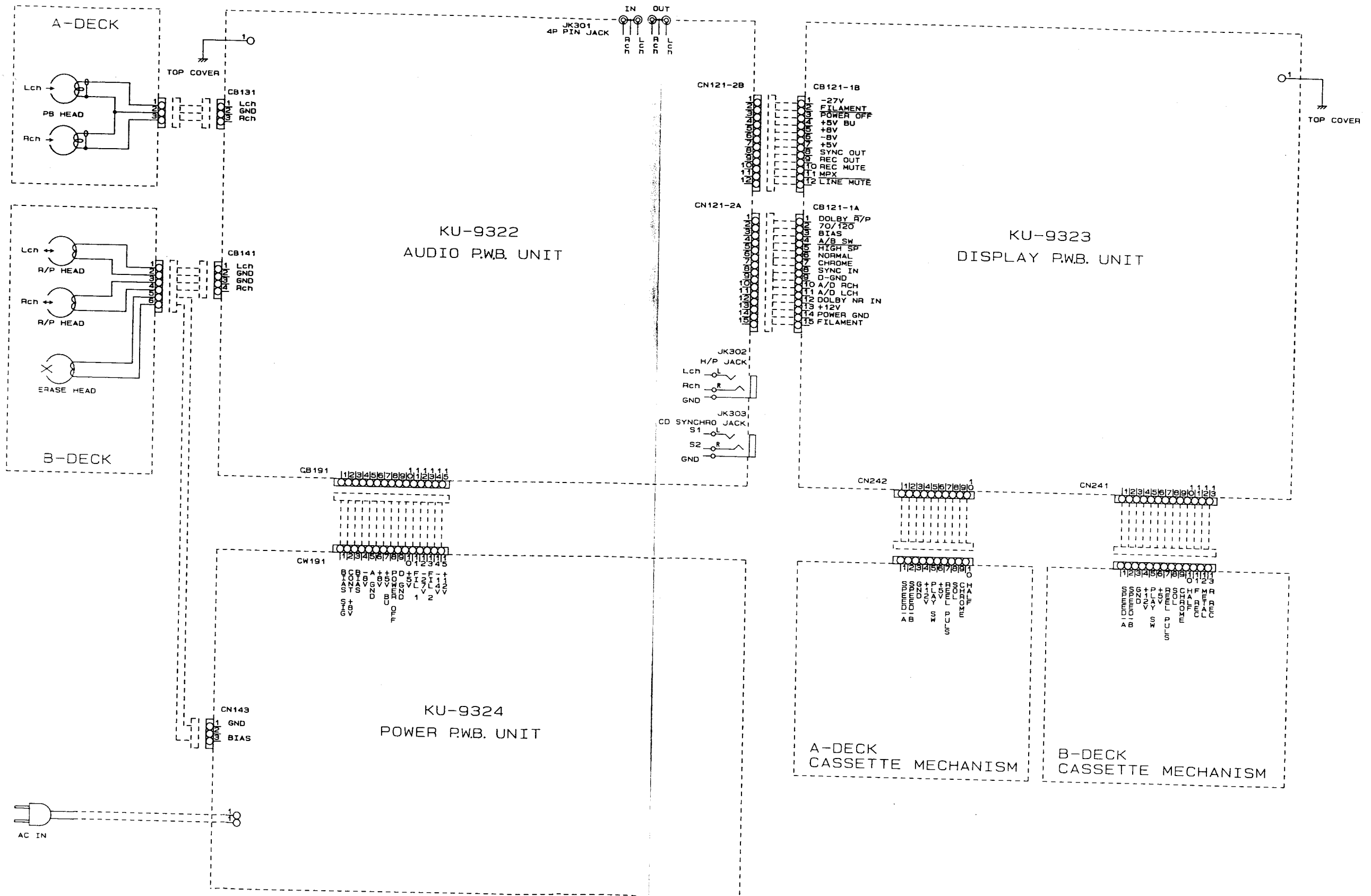

**SCHEMATIC DIAGRAM**

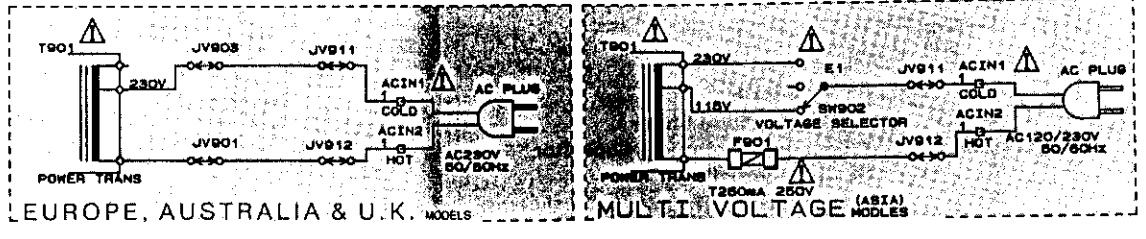
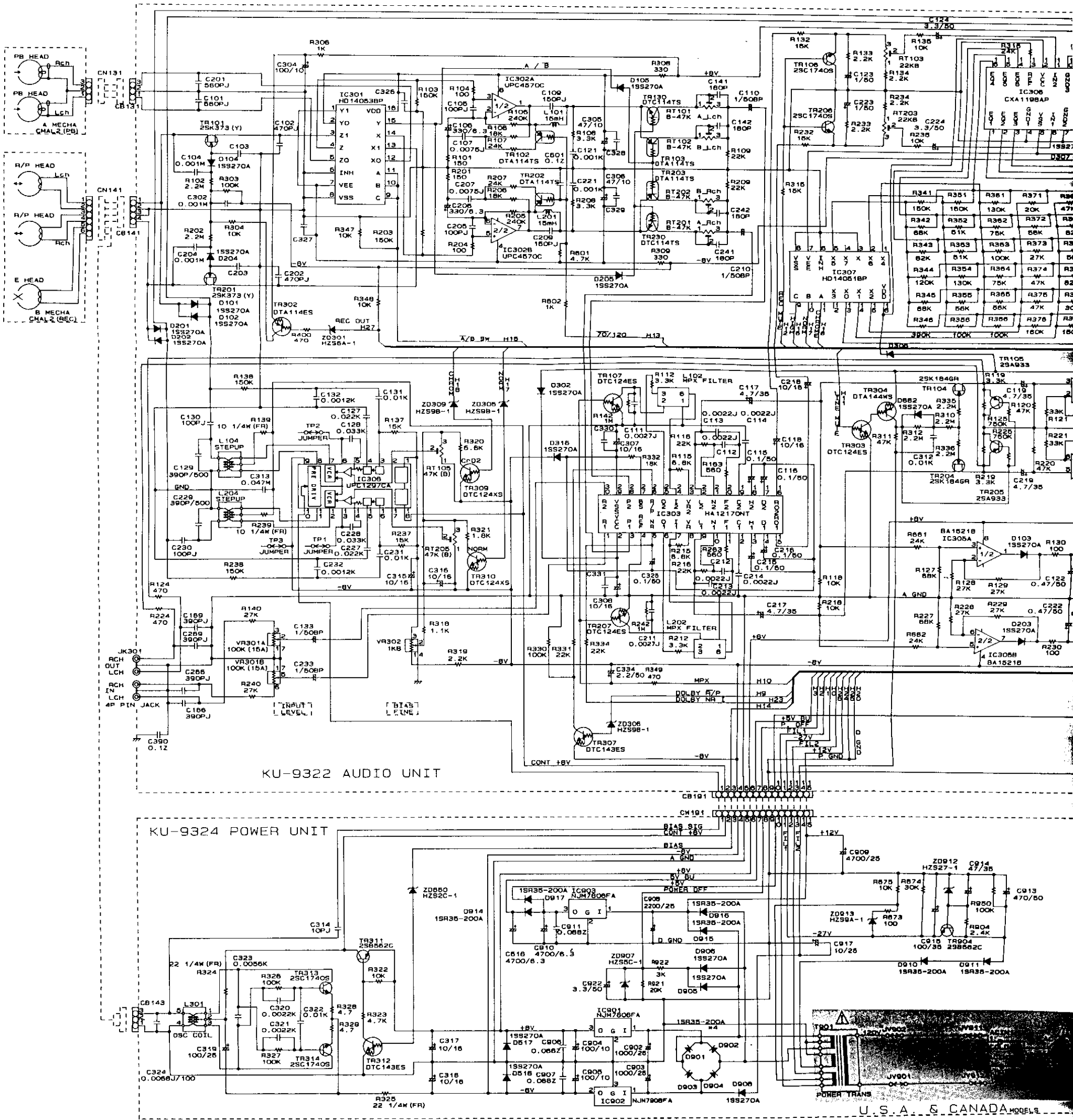



# SEMICONDUCTORS

## ● IC's

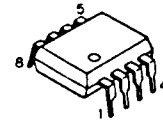

- BA15218
- $\mu$ PC4570C

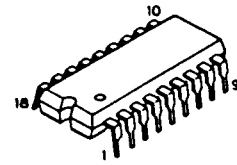
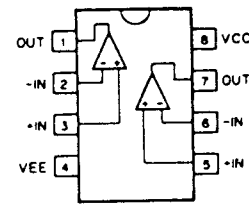

- $\mu$ PC1297CA

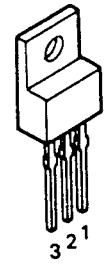
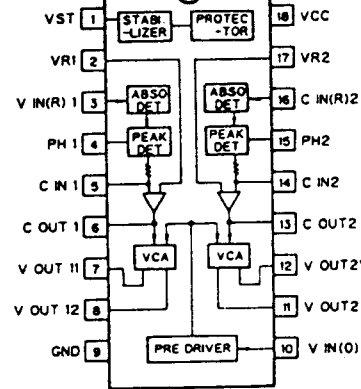

- 3 GND
- 2 INPUT
- 1 OUTPUT

- NJM7908FA

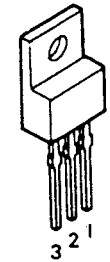

- 3 INPUT
- 2 GND
- 1 OUTPUT

- NJM7808FA
- NJM7806FA

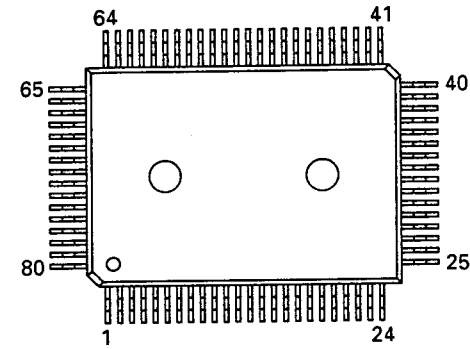

- HD6433724FC80F

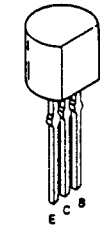

- B (Base)
- C (Collector)
- E (Emitter)

- 2SA933S
- 2SK373
- 2SC1740

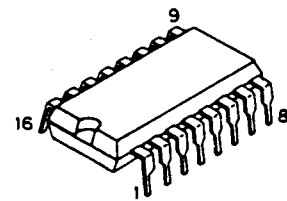

- CXA1198AP
- HD14051BP

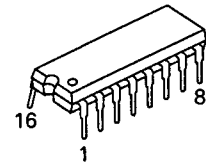

- HD14053BP

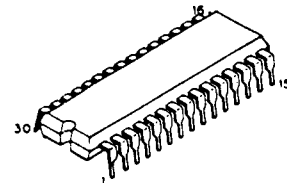

- HA112170NT

## ● REMOTE SENSOR

(SBX1610-52)

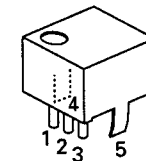

1. Vcc
2. Output
3. GND
4. Case Fin
5. Case Fin

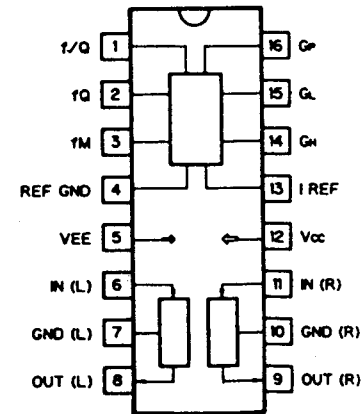

- CXA1198AP

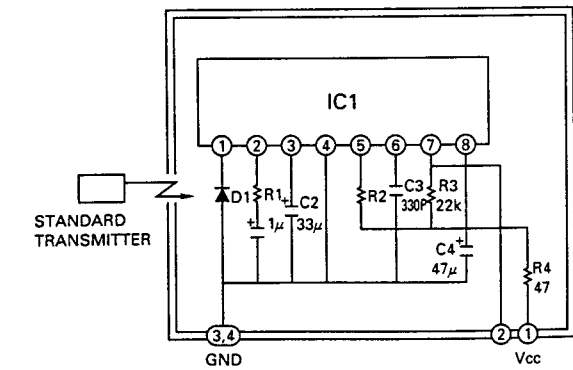
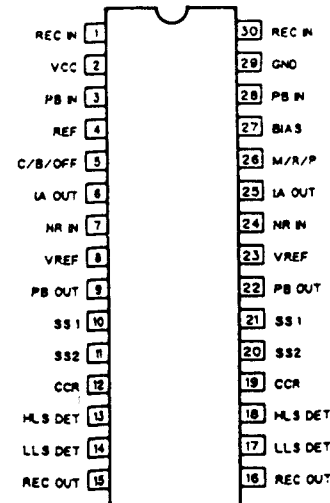
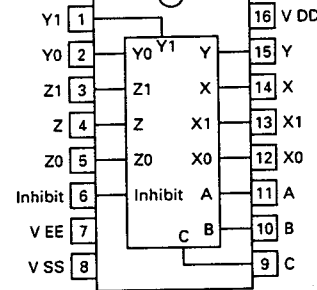
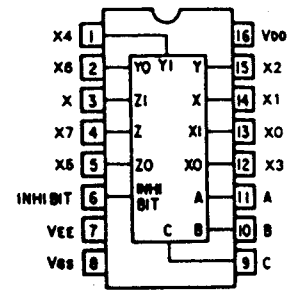

- IC1 : CX20106A Chip
- D1 : PIN Photo Diode Chip
- C1, C2, C4 : Aluminum Electrolytic Capacitor
- C3 : SL Characteristic  $\pm 5\%$
- R1 : Gain Adjuster
- R2 : fo Adjust  $\pm 1\%$  USE
- R3, R4 :  $\pm 5\%$

C: Collector  
B: Base  
E: Emitter

DTA11:  
DTA12:  
DTC32:

## ● DIO

● TRANSISTORS

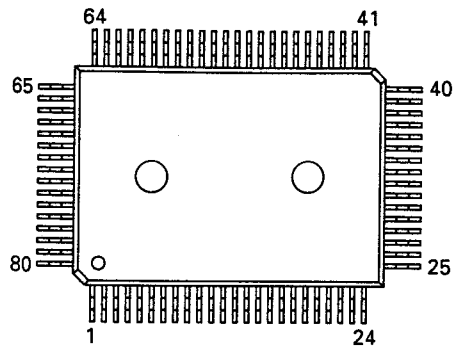

● HD6433724FC80F

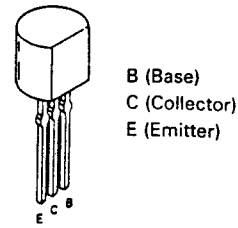

- 2SA933S
- 2SK373
- 2SC1740

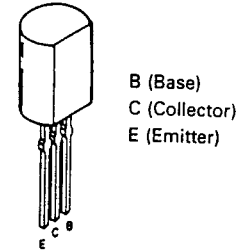

● 2SB562

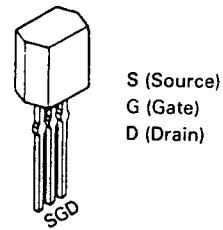

- 2SK184
- 2SK381

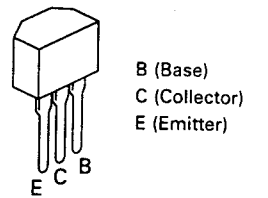

- DTA114ES
- DTA114TS
- DTA124ES
- DTA124TS
- DTA144ES
- DTA144WS
- DTC114ES
- DTC124ES
- DTC124XS
- DTC143ES
- DTC144ES
- DTC323TS

ID  
PUT  
OUTPUT

PUT  
D  
OUTPUT

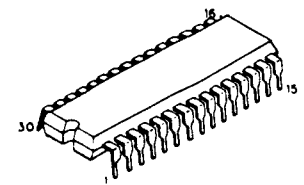

● HA112170NT

● REMOTE SENSOR

(SBX1610-52)

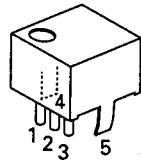

1. Vcc
2. Output
3. GND
4. Case Fin
5. Case Fin

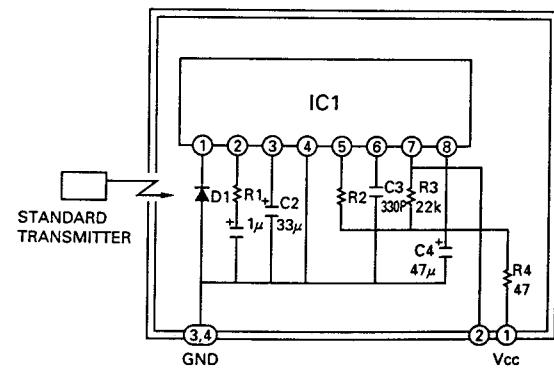

- IC1 : CX20106A Chip
- D1 : PIN Photo Diode Chip
- C1, C2, C4 : Aluminum Electrolytic Capacitor
- C3 : SL Characteristic  $\pm 5\%$
- R1 : Gain Adjuster
- R2 : fo Adjust  $\pm 1\%$  USE
- R3, R4 :  $\pm 5\%$

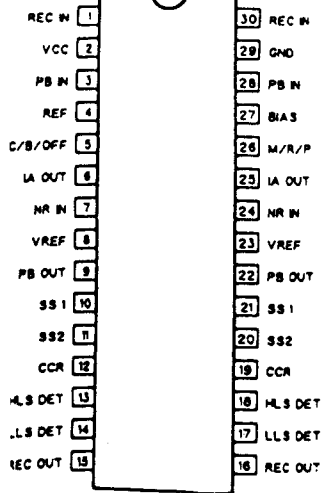

● DIODES

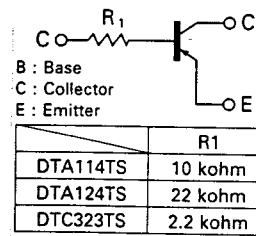

	R1
DTA114TS	10 kohm
DTA124TS	22 kohm
DTC323TS	2.2 kohm

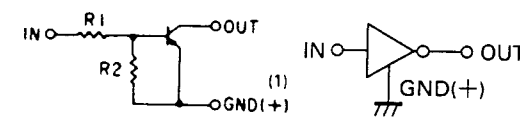

	R1	R2
DTA114ES	10 kohm	10 kohm
DTA124ES	22 kohm	22 kohm
DTA144ES	47 kohm	47 kohm
DTA144WS	47 kohm	22 kohm

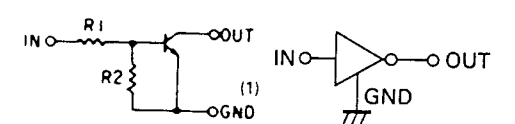

	R1	R2
DTC114ES	10 kohm	10 kohm
DTC124ES	22 kohm	22 kohm
DTC124XS	22 kohm	47 kohm
DTC143ES	4.7 kohm	4.7 ohm
DTC144ES	47 kohm	47 kohm

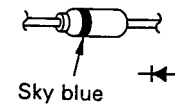

1SS270A

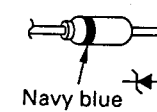

- HZS2C-1
- HZS5C-1
- HZS6A-1
- HZS9A-1
- HZS27-1

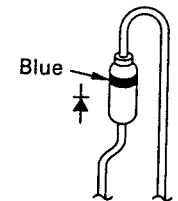

1SR35-200A